



**FCC CFR47 PART 22 SUBPART H
FCC CFR47 PART 24 SUBPART E
FCC CFR47 PART 27 SUBPART H
FCC CFR47 PART 27 SUBPART L**

WWAN

CERTIFICATION TEST REPORT

FOR

GSM/WCDMA/LTE Phone + BT/BLE and DTS b/g/n

MODEL NUMBER : SM-J111M/DS, SM-J111M

FCC ID: A3LSMJ111M

REPORT NUMBER: 16K22699-E4V1

ISSUE DATE: FEB 12, 2016

Prepared for
**SAMSUNG ELECTRONICS CO., LTD.
129 SAMSUNG-RO, YEONGTONG-GU, SUWON-SI,
GYEONGGI-DO, 16677, KOREA**

Prepared by
**UL Korea, Ltd. Suwon Laboratory
218 Maeyeong-ro, Yeongtong-gu,
Suwon-si, Gyeonggi-do, 16675, Korea
TEL: (031) 337-9902
FAX: (031) 213-5433**



Revision History

<u>Rev.</u>	<u>Issue Date</u>	<u>Revisions</u>	<u>Revised By</u>
V1	02/12/16	Initial issue	SungGil Park

TABLE OF CONTENTS

1. ATTESTATION OF TEST RESULTS	5
2. TEST METHODOLOGY	6
3. FACILITIES AND ACCREDITATION	6
4. CALIBRATION AND UNCERTAINTY	6
4.1. <i>MEASURING INSTRUMENT CALIBRATION</i>	6
4.2. <i>SAMPLE CALCULATION</i>	6
4.3. <i>MEASUREMENT UNCERTAINTY</i>	6
5. EQUIPMENT UNDER TEST	7
5.1. <i>DESCRIPTION OF EUT</i>	7
5.2. <i>MAXIMUM OUTPUT POWER (GSM)</i>	7
5.3. <i>MAXIMUM OUTPUT POWER (WCDMA)</i>	7
5.4. <i>MAXIMUM OUTPUT POWER (LTE)</i>	8
5.5. <i>DESCRIPTION OF TEST SETUP</i>	11
6. TEST AND MEASUREMENT EQUIPMENT	13
7. Summary Table	14
8. RF POWER OUTPUT VERIFICATION	15
8.1. <i>GSM/GPRS/EDGE</i>	15
8.1.1. <i>GSM OUTPUT POWER RESULT</i>	16
8.2. <i>UMTS REL 99</i>	18
8.2.1. <i>WCDMA OUTPUT POWER RESULT</i>	22
8.3. <i>LTE OUTPUT VERIFICATION</i>	25
8.3.1. <i>LTE OUTPUT POWER RESULT</i>	26
9. PEAK TO AVERAGE RATIO	32
9.1. <i>CONDUCTED PEAK TO AVERAGE RESULT</i>	32
9.2. <i>CONDUCTED PEAK TO AVERAGE PLOTS</i>	34
10. LIMITS AND CONDUCTED RESULTS	42
10.1. <i>OCCUPIED BANDWIDTH</i>	42
10.1.1. <i>OCCUPIED BANDWIDTH RESULTS</i>	42
10.1.2. <i>OCCUPIED BANDWIDTH PLOTS</i>	47
10.2. <i>BAND EDGE EMISSIONS</i>	70
10.2.1. <i>BAND EDGE PLOTS</i>	76
10.3. <i>OUT OF BAND EMISSIONS</i>	97
10.3.1. <i>OUT OF BAND EMISSIONS RESULT</i>	97

10.3.2.	OUT OF BAND EMISSIONS PLOTS	102
10.4.	<i>FREQUENCY STABILITY</i>	125
10.4.1.	FREQUENCY STABILITY RESULTS.....	126
11.	RADIATED TEST RESULTS	130
11.1.	<i>RADIATED POWER (ERP & EIRP)</i>	130
11.1.1.	ERP/EIRP Results	131
11.1.2.	ERP/EIRP DATA.....	136
11.2.	<i>FIELD STRENGTH OF SPURIOUS RADIATION</i>	159
11.2.1.	SPURIOUS RADIATION PLOTS.....	160
12.	SETUP PHOTOS.....	183

1. ATTESTATION OF TEST RESULTS

COMPANY NAME: SAMSUNG ELECTRONICS CO., LTD.
EUT DESCRIPTION: GSM/WCDMA/LTE Phone + BT/BLE and DTS b/g/n
MODEL NUMBER: SM-J111M/DS, SM-J111M
SERIAL NUMBER: R38GC088Y6B, R38GC08AGKK (RADIATED);
R38GC08AGKK (CONDUCTED)
DATE TESTED: JAN 19, 2016 - FEB 12, 2016

APPLICABLE STANDARDS	
STANDARD	TEST RESULTS
FCC PART 22H, 24E, 27H and 27L	Pass

UL Korea, Ltd. tested the above equipment in accordance with the requirements set forth in the above standards. All indications of Pass/Fail in this report are opinions expressed by UL Korea, Ltd. based on interpretations and/or observations of test results. Measurement Uncertainties were not taken into account and are published for informational purposes only. The test results show that the equipment tested is capable of demonstrating compliance with the requirements as documented in this report.

Note: The results documented in this report apply only to the tested sample, under the conditions and modes of operation as described herein. This document may not be altered or revised in any way unless done so by UL Korea, Ltd. and all revisions are duly noted in the revisions section. Any alteration of this document not carried out by UL Korea, Ltd. will constitute fraud and shall nullify the document. This report must not be used by the client to claim product certification, approval, or endorsement by IAS, any agency of the Federal Government, or any agency of any government.

Approved & Released For
UL Korea, Ltd. By:



CY Choi
Suwon Lab Engineer
UL Korea, Ltd.

Tested By:



SungGil Park
Suwon Lab Engineer
UL Korea, Ltd.

2. TEST METHODOLOGY

The tests documented in this report were performed in accordance with TIA-603-D, FCC CFR 47 Part 22, FCC CFR Part 24 and FCC CFR Part 27.

3. FACILITIES AND ACCREDITATION

The test sites and measurement facilities used to collect data are located at 218 Maeyeong-ro, Yeongtong-gu, Suwon-si, Gyeonggi-do, 16675, Korea. Line conducted emissions are measured only at the 218 address. The following table identifies which facilities were utilized for radiated emission measurements documented in this report. Specific facilities are also identified in the test results sections.

218 Maeyeong-ro	
<input checked="" type="checkbox"/>	Chamber 1
<input checked="" type="checkbox"/>	Chamber 2

UL Korea, Ltd. is accredited by IAS, Laboratory Code TL-637. The full scope of accreditation can be viewed at <http://www.iasonline.org/PDF/TL/TL-637.pdf>.

4. CALIBRATION AND UNCERTAINTY

4.1. MEASURING INSTRUMENT CALIBRATION

The measuring equipment utilized to perform the tests documented in this report has been calibrated in accordance with the manufacturer's recommendations, and is traceable to recognized national standards.

4.2. SAMPLE CALCULATION

Where relevant, the following sample calculation is provided:

EIRP = PSA reading with EUT worst orientation (dBm) + Path loss (dB) – cable loss(between the SG and substitution antenna) + Substitution Antenna Factor (dBi)

ERP = PSA reading with EUT worst orientation (dBm) + Path loss (dB) – cable loss(between the SG and substitution antenna)
 (Path loss = Signal generator output – PSA reading with substitution antenna)

4.3. MEASUREMENT UNCERTAINTY

Where relevant, the following measurement uncertainty levels have been estimated for tests performed on the apparatus:

PARAMETER	UNCERTAINTY
Conducted Disturbance, 0.15 to 30 MHz	2.32 dB
Radiated Disturbance, Below 1GHz	4.14 dB
Radiated Disturbance, Above 1 GHz	5.97 dB

Uncertainty figures are valid to a confidence level of 95%.

5. EQUIPMENT UNDER TEST

5.1. DESCRIPTION OF EUT

The EUT is a GSM/WCDMA/LTE Phone + BT/BLE and DTS b/g/n.

SM-J111M and SM-J111M/DS are same hardware but for different number of SIM card slot.
 SM-J111M has one slot. SM-J111M/DS is dual SIM version.
 SM-J111M/DS was used for the test.

5.2. MAXIMUM OUTPUT POWER (GSM)

The transmitter has a maximum peak conducted and radiated ERP / EIRP output powers as follows:

FCC Part 22/24						
Band	Frequency Range	Modulation	Conducted		Radiated	
	[MHz]		Peak	Avg [dBm]	Avg [mW]	Avg [dBm]
GSM850	824~849	GMSK	32.63	1834.17		
		GPRS	32.63	1832.92	32.04	1599.56
		EGPRS	26.45	441.47	26.70	467.74
GSM1900	1850~1910	GMSK	29.90	978.36		
		GPRS	29.91	978.48	30.32	1076.47
		EGPRS	25.70	371.89	27.35	543.25

5.3. MAXIMUM OUTPUT POWER (WCDMA)

The transmitter has a maximum peak conducted and radiated ERP / EIRP output powers as follows:

FCC Part 22/24						
Band	Frequency Range	Modulation	Conducted		Radiated	
	[MHz]		Peak	Avg [dBm]	Avg [mW]	Avg [dBm]
Band 5	824~849	REL99	22.70	186.08	20.04	100.93
		HSDPA	21.67	147.03	19.99	99.77
		HSUPA	21.00	125.89		
Band 4	1710~1755	REL99	22.17	164.87	23.97	249.46
		HSDPA	21.67	146.89	22.57	180.72
		HSUPA	20.67	116.62		
Band 2	1850~1910	REL99	22.87	193.66	26.64	461.32
		HSDPA	21.80	151.53	24.29	268.53
		HSUPA	21.00	125.89		

5.4. MAXIMUM OUTPUT POWER (LTE)

The transmitter has a maximum peak conducted and radiated ERP / EIRP output powers as follows:

LTE Band 17

FCC Part 27							
Band	Frequency Range [MHz]	BandWidth [MHz]	Modulation Peak	Conducted		Radiated	
				Avg [dBm]	Avg [mW]	Avg [dBm]	Avg [mW]
Band 17	704 ~ 716	10	QPSK	22.59	181.73	14.12	25.82
			16QAM	21.76	150.01	13.42	21.98
		5	QPSK	22.62	183.01	13.50	22.39
			16QAM	21.38	137.54	12.32	17.06

LTE Band 5

FCC Part 22							
Band	Frequency Range [MHz]	BandWidth [MHz]	Modulation Peak	Conducted		Radiated	
				Avg [dBm]	Avg [mW]	Avg [dBm]	Avg [mW]
Band 5	824 ~ 849	10	QPSK	23.21	209.36	20.15	103.51
			16QAM	22.17	164.84	19.52	89.54
		5	QPSK	23.39	218.28	19.81	95.72
			16QAM	22.43	174.98	19.03	79.98
		3	QPSK	23.15	206.71	19.34	85.90
			16QAM	21.78	150.56	18.51	70.96
		1.4	QPSK	23.11	204.59	17.81	60.39
			16QAM	22.24	167.32	17.00	50.12

LTE Band 4

FCC Part 27							
Band	Frequency Range [MHz]	BandWidth [MHz]	Modulation Peak	Conducted		Radiated	
				Avg [dBm]	Avg [mW]	Avg [dBm]	Avg [mW]
Band 4	1710 ~ 1755	20	QPSK	22.54	179.47	22.90	194.98
			16QAM	22.34	171.40	22.80	190.55
		15	QPSK	22.20	165.93	22.84	192.31
			16QAM	22.43	175.03	22.64	183.65
		10	QPSK	22.31	170.10	22.76	188.80
			16QAM	22.50	177.83	22.66	184.50
		5	QPSK	22.36	172.30	22.51	178.24
			16QAM	22.41	174.12	22.60	181.97
		3	QPSK	22.32	170.70	22.61	182.39
			16QAM	22.29	169.47	22.64	183.65
		1.4	QPSK	22.28	169.21	20.43	110.41
			16QAM	22.23	167.23	19.83	96.16

LTE Band 2

FCC Part 24							
Band	Frequency Range [MHz]	BandWidth [MHz]	Modulation Peak	Conducted		Radiated	
				Avg [dBm]	Avg [mW]	Avg [dBm]	Avg [mW]
Band 5	1850 ~ 1910	20	QPSK	23.43	220.29	24.00	251.19
			16QAM	22.48	177.01	23.71	234.96
		15	QPSK	23.27	212.32	24.00	251.19
			16QAM	22.21	166.34	23.73	236.05
		10	QPSK	23.37	217.27	24.49	281.19
			16QAM	22.17	164.82	24.16	260.62
		5	QPSK	23.43	220.29	24.05	254.10
			16QAM	22.12	162.93	23.83	241.55
		3	QPSK	23.37	217.27	24.02	252.35
			16QAM	21.97	157.40	23.87	243.78
		1.4	QPSK	23.27	212.32	22.80	190.55
			16QAM	22.50	177.83	22.52	178.65

DESCRIPTION OF AVAILABLE ANTENNAS

The radio utilizes a FPCB antenna for the [List the bands supported] with a maximum peak gain as follow:

Frequency (MHz)	Peak Gain (dBi)
GSM850 / WCDMA Band 5 / LTE Band 5 824 ~ 849 MHz	-0.34
GSM1900 / WCDMA Band 2 / LTE Band 2 1850 ~ 1910 MHz	0.20
LTE Band 17 704 ~ 716 MHz	-3.68
WCDMA Band 4 / LTE Band 4 1710 ~ 1755 MHz	1.30

5.5. DESCRIPTION OF TEST SETUP

SUPPORT EQUIPMENT

Support Equipment List				
Description	Manufacturer	Model	Serial Number	FCC ID
Charger	SAMSUNG	EP-TA60EBE	R37G95117W1RT3	N/A
Earphone	SAMSUNG	EHS61ASFWE	N/A	N/A

I/O CABLES

I/O Cable List						
Cable No	Port	# of identical ports	Connector Type	Cable Type	Cable Length (m)	Remarks
1	DC Power	1	Mini-USB	Shielded	0.8m	N/A
2	Audio	1	Mini-Jack	Unshielded	1.0m	N/A

TEST SETUP

The EUT is continuously communicated to the call box during the tests.

SETUP DIAGRAM FOR TESTS (CONDUCTED TEST SETUP)

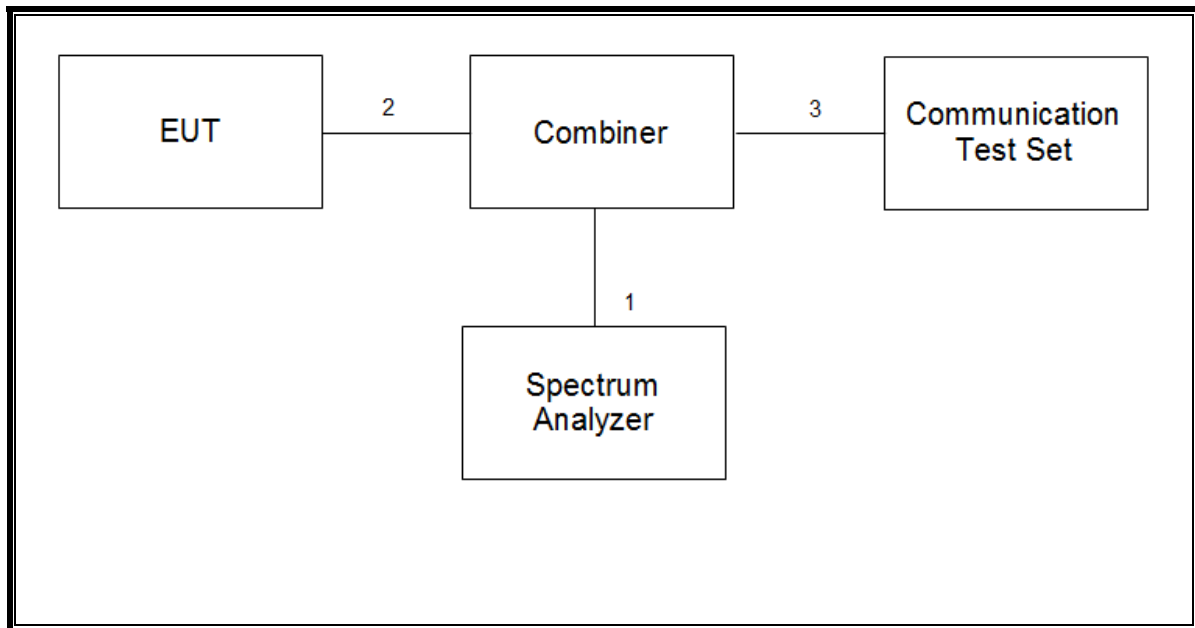

SETUP DIAGRAM FOR TESTS (RADIATED TEST SETUP)

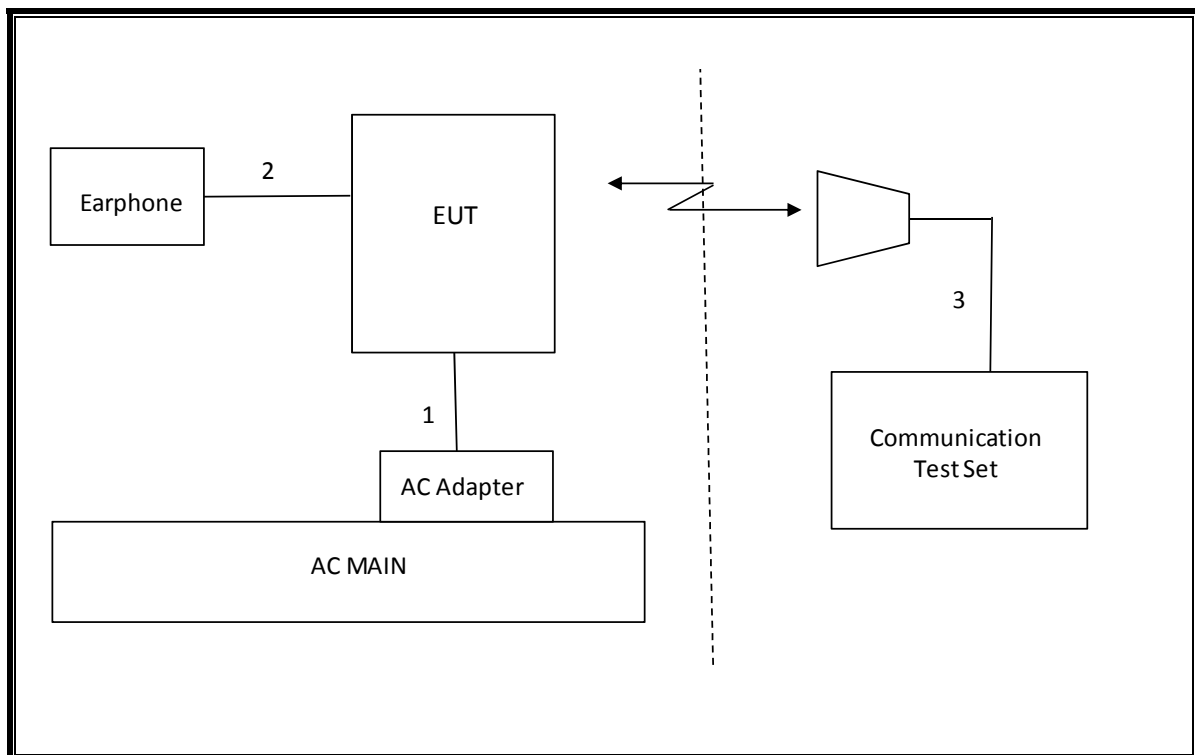

6. TEST AND MEASUREMENT EQUIPMENT

The following test and measurement equipment was utilized for the tests documented in this report:

Test Equipment List				
Description	Manufacturer	Model	S/N	Cal Due
Antenna, Tuned Dipole 400~1000 MHz	ETS	3121D DB4	00164753	07-28-16
Antenna, Horn, 40 GHz	ETS	3116C	00166155	09-23-16
Antenna, Horn, 40 GHz	ETS	3116C-PA	00168841	08-24-17
Antenna, Bilog, 30MHz-1GHz	SCHWARZBECK	VULB9163	750	11-17-16
Antenna, Bilog, 30MHz-1GHz	SCHWARZBECK	VULB9163	749	04-25-17
Antenna, Horn, 18 GHz	ETS	3115	00167211	09-26-16
Antenna, Horn, 18 GHz	ETS	3115	00161451	05-17-17
Antenna, Horn, 18 GHz	ETS	3117	00168724	06-17-17
Antenna, Horn, 18 GHz	ETS	3117	00168717	06-17-17
Combiner	WEINSCHTEL	1575	2151	08-20-16
Communications Test Set	R&S	CMW500	150312	08-18-16
Communications Test Set	R&S	CMW500	115331	08-18-16
Communications Test Set	R&S	CMW500	102271	08-18-16
DC Power Supply	Agilent / HP	E3640A	MY54226395	08-18-16
Preamplifier, 1000 MHz	Sonoma	310N	341282	08-18-16
Preamplifier, 1000 MHz	Sonoma	310N	351741	08-18-16
Preamplifier, 18 GHz	Miteq	AFS42-00101800-25-S-42	1876511	08-18-16
Preamplifier, 18 GHz	Miteq	AFS42-00101800-25-S-42	1896138	08-18-16
Spectrum Analyzer, 44 GHz	Agilent / HP	N9030A	MY54170614	08-19-16
Spectrum Analyzer, 44 GHz	Agilent / HP	N9030A	MY54490312	08-19-16
Bluetooth Tester	TESCOM	TC-3000C	3000C000546	08-18-16
Average Power Sensor	R&S	NRZ-Z91	102681	08-18-16
Average Power Sensor	Agilent / HP	U2000	MY54270007	08-18-16
EMI Test Receive, 40 GHz	R&S	ESU40	100439	08-19-16
EMI Test Receive, 40 GHz	R&S	ESU40	100457	08-19-16
EMI Test Receive, 3 GHz	R&S	ESR3	101832	08-19-16
Attenuator / Switch driver	HP	11713A	3748A04272	N/A
Low Pass Filter 3GHz	Micro-Tronics	LPS17541	009	08-18-16
Low Pass Filter 3GHz	Micro-Tronics	LPS17541	015	08-18-16
High Pass Filter 5GHz	Micro-Tronics	HPS17542	009	08-18-16
High Pass Filter 6GHz	Micro-Tronics	HPM17543	010	08-18-16
High Pass Filter 5GHz	Micro-Tronics	HPS17542	016	08-18-16
High Pass Filter 6GHz	Micro-Tronics	HPM17543	015	08-18-16
LISN	R&S	ENV-216	101836	08-19-16
LISN	R&S	ENV-216	101837	08-19-16

7. Summary Table

FCC Part Section	Test Description	Test Limit	Test Condition	Test Result	Note
2.1049	Occupied Band width (99%)	N/A	Conducted	Pass	17.996 MHz
22.917(a) 24.238(a) 27.53(g)	Band Edge / Conducted Spurious Emission	-13dBm		Pass	-14.31 dBm
2.1046	Conducted output power	N/A		Pass	32.6 dBm
22.355 24.235 27.54	Frequency Stability	2.5PPM		Pass	0.018PPM
22.913(a)(2)	Effective Radiated Power	38 dBm	Radiated	Pass	32.04 dBm
27.50(c)(10)		34.77 dBm		Pass	14.12 dBm
24.232(c)	Equivalent Isotropic Radiated Power	33dBm		Pass	30.32 dBm
27.50(d)(4)		30dBm		Pass	23.97dBm
22.917(a) 24.238(a) 27.53(g)	Radiated Spurious Emission	-13dBm		Pass	-19.8 dBm

GSM						
22H	824.2 - 848.8	1.600	2.5 ppm	244KGXW		GSM850
22H	824.2 - 848.8	0.468	2.5 ppm	248KG7W		EDGE850
24E	1850.2 - 1909.8	1.076	2.5 ppm	250KGXW		GSM1900
24E	1850.2 - 1909.8	0.543	2.5 ppm	243KG7W		EDGE1900
WCDMA						
22H	826.4 - 846.6	0.101	2.5 ppm	4M09F9W		WCDMA
27L	1712.4 - 1752.6	0.249	2.5 ppm	4M09F9W		WCDMA
24E	1852.4 - 1907.6	0.461	2.5 ppm	4M09F9W		WCDMA
LTE Band 2						
24E	1860.0 - 1900.0	0.251	2.5 ppm	18M0G7W	20	QPSK
24E	1860.0 - 1900.0	0.235	2.5 ppm	18M0D7W	20	16QAM
24E	1855.0 - 1905.0	0.281	2.5 ppm	9M01G7W	10	QPSK
24E	1855.0 - 1905.0	0.261	2.5 ppm	9M01D7W	10	16QAM
LTE Band 4						
27L	1720.0 - 1745.0	0.195	2.5 ppm	18M0G7W	20	QPSK
27L	1720.0 - 1745.0	0.191	2.5 ppm	18M0D7W	20	16QAM
LTE Band 5						
22H	829.0 - 844.0	0.104	2.5 ppm	8M99G7W	10	QPSK
22H	829.0 - 844.0	0.090	2.5 ppm	8M99D7W	10	16QAM
LTE Band 17						
27H	709.0 - 711.0	0.026	2.5 ppm	8M97G7W	10	QPSK
27H	709.0 - 711.0	0.022	2.5 ppm	8M96D7W	10	16QAM

8. RF POWER OUTPUT VERIFICATION

8.1. GSM/GPRS/EDGE

Function: Menu select > GSM Mobile Station > GSM 850/900/1800/1900
Press Connection control to choose the different menus
Press RESET > choose all to reset all settings
Connection Press Signal Off to turn off the signal and change settings
Network Support > GSM+GPRS or GSM+EGPRS
Main Service > Packet Data
Service selection > Test Mode A – Auto Slot Config. off
MS Signal Press Slot Config bottom on the right twice to select and change the number of time slots and power setting
 > Slot configuration > Uplink/Gamma
 > 33 dBm for GPRS 850/900
 > 30 dBm for GPRS1800/1900
BS Signal Enter the same channel number for TCH channel (test channel) and BCCH channel
Frequency Offset > + 0 Hz
Mode > BCCH and TCH
BCCH Level > -85 dBm (May need to adjust if link is not stable)
BCCH Channel > choose desire test channel [Enter the same channel number for TCH channel (test channel) and BCCH channel]
Channel Type > Off
P0> 4 dB
Slot Config > Unchanged (if already set under MS Signal)
TCH > choose desired test channel
Hopping > Off
Main Timeslot > 3 (Default)
Network Coding Scheme > CS4 (GPRS) and MCS5 ~ MCS9 (EGPRS)
Bit Stream > 2E9-1PSR Bit Pattern
AF/RF Enter appropriate offsets for Ext. Att. Output and Ext. Att. Input
Connection Press Signal On to turn on the signal and change settings

8.1.1. GSM OUTPUT POWER RESULT

GSM850 Measured Results

Band	Mode	Coding Scheme	Time Slots	Ch No.	Freq. [MHz]	Max. Power		
						Burst Pwr [dBm]	Frame Pwr [dBm]	
850	GSM (Voice)	CS1	1	128	824.2	32.47	23.44	
				190	836.6	32.59	23.56	
				251	848.8	32.63	23.60	
	GPRS (GMSK)	CS1	1	1	128	824.2	32.47	23.44
					190	836.6	32.59	23.56
					251	848.8	32.63	23.60
			2	1	128	824.2	29.07	23.05
					190	836.6	29.24	23.22
					251	848.8	29.33	23.31
			3	1	128	824.2	26.97	22.71
					190	836.6	27.15	22.89
					251	848.8	27.24	22.98
			4	1	128	824.2	26.10	23.09
					190	836.6	26.28	23.26
					251	848.8	26.37	23.36
	EGPRS (8PSK)	MCS5	1	1	128	824.2	26.07	17.04
					190	836.6	26.05	17.02
					251	848.8	26.45	17.42
			2	1	128	824.2	25.78	19.76
					190	836.6	25.90	19.88
					251	848.8	26.14	20.12
			3	1	128	824.2	24.58	20.32
					190	836.6	24.74	20.48
					251	848.8	24.98	20.72
4			1	128	824.2	22.31	19.30	
				190	836.6	22.46	19.45	
				251	848.8	22.70	19.69	

GSM1900 Measured Results

Band	Mode	Coding Scheme	Time Slots	Ch No.	Freq. [MHz]	Max. Power	
						Burst Pwr [dBm]	Frame Pwr [dBm]
1900	GSM (Voice)	CS1	1	512	1850.2	29.90	20.87
				661	1880.0	29.49	20.46
				810	1909.8	29.68	20.65
	GPRS (GMSK)	CS1	1	512	1850.2	29.91	20.87
				661	1880.0	29.49	20.45
				810	1909.8	29.67	20.64
			2	512	1850.2	26.43	20.41
				661	1880.0	26.61	20.58
				810	1909.8	26.69	20.67
			3	512	1850.2	25.00	20.74
				661	1880.0	25.06	20.80
				810	1909.8	25.16	20.90
			4	512	1850.2	23.36	20.35
				661	1880.0	23.54	20.53
				810	1909.8	23.65	20.64
	EGPRS (8PSK)	MCS5	1	512	1850.2	25.68	16.65
				661	1880.0	25.67	16.64
				810	1909.8	25.70	16.67
			2	512	1850.2	25.39	19.36
				661	1880.0	25.38	19.36
				810	1909.8	25.40	19.38
			3	512	1850.2	23.64	19.38
				661	1880.0	23.60	19.34
				810	1909.8	23.60	19.34
4			512	1850.2	21.39	18.38	
			661	1880.0	21.32	18.31	
			810	1909.8	21.29	18.28	

8.2. UMTS REL 99

Release 99 Setup Procedures used to establish the test signals

The following tests were completed according to the test requirements outlined in section 5.2 of the 3GPP TS34.121-1 specification. The DUT supports power Class 3, which has a nominal maximum output power of 24 dBm (+1.7/-3.7).

Mode	Subtest	Rel99
WCDMA General Settings	Loopback Mode	Test Mode 2
	Rel99 RMC	12.2kbps RMC
	Power Control Algorithm	Algorithm2
	β_c/β_d	8/15

HSDPA Setup Procedures used to establish the test signals

The following 4 Sub-tests were completed according to Release 7 procedures in section 5.2 of 3GPP TS34.121. A summary of these settings are illustrated below:

Mode	Subtest	HSDPA	HSDPA	HSDPA	HSDPA
		1	2	3	4
W-CDMA General Settings	Loopback Mode	Test Mode 1			
	Rel99 RMC	12.2kbps RMC			
	HSDPA FRC	H-Set 1			
	Power Control Algorithm	Algorithm 2			
	β_c	2/15	11/15	15/15	15/15
	β_d	15/15	15/15	8/15	4/15
	Bd (SF)	64			
	β_c/β_d	2/15	12/15	15/8	15/4
	β_{hs}	4/15	24/15	30/15	30/15
MPR (dB)	0	0	0.5	0.5	
HSDPA Specific Settings	D_{ACK}	8			
	D_{NAK}	8			
	DCQI	8			
	Ack-Nack repetition factor	3			
	CQI Feedback (Table 5.2B.4)	4ms			
	CQI Repetition Factor (Table 5.2B.4)	2			
	$A_{hs}=\beta_{hs}/\beta_c$	30/15			

HSPA (HSDPA & HSUPA) Setup Procedures used to establish the test signals

The following 5 Sub-tests were completed according to Release 6 procedures in section 5.2 of 3GPP TS34.121. A summary of these settings are illustrated below:

	Mode	HSPA				
	Subtest	1	2	3	4	5
WCDMA General Settings	Loopback Mode	Test Mode 1				
	Rel99 RMC	12.2 kbps RMC				
	HSDPA FRC	H-Set 1				
	HSUPA Test	HSPA				
	Power Control Algorithm	Algorithm 2				Algorithm 1
	β_c	11/15	6/15	15/15	2/15	15/15
	β_d	15/15	15/15	9/15	15/15	0
	β_{ec}	209/225	12/15	30/15	2/15	5/15
	β_c/β_d	11/15	6/15	15/9	2/15	15/1
	β_{hs}	22/15	12/15	30/15	4/15	5/15
	β_{ed}	1309/225	94/75	47/15	56/75	47/15
CM (dB)	1	3	2	3	1	
MPR (dB)	0	2	1	2	0	
HSDPA Specific Settings	DACK	8				0
	DNAK	8				0
	DCQI	8				0
	Ack-Nack repetition factor	3				
	CQI Feedback (Table 5.2B.4)	4ms				
	CQI Repetition Factor (Table 5.2B.4)	2				
	Ahs = β_{hs}/β_c	30/15				
HSUPA Specific Settings	E-DPDCCH	6	8	8	5	7
	DHARQ	0	0	0	0	0
	AG Index	20	12	15	17	21
	ETFCI (from 34.121 Table C.11.1.3)	75	67	92	71	81
	Associated Max UL Data Rate kbps	242.1	174.9	482.8	205.8	308.9
	Reference E-TFCIs	5	5	2	5	1
	Reference E-TFCI	11	11	11	11	67
	Reference E-TFCI PO	4	4	4	4	18
	Reference E-TFCI	67	67	92	67	67
	Reference E-TFCI PO	18	18	18	18	18
	Reference E-TFCI	71	71	71	71	71
	Reference E-TFCI PO	23	23	23	23	23
	Reference E-TFCI	75	75	75	75	75
	Reference E-TFCI PO	26	26	26	26	26
	Reference E-TFCI	81	81	81	81	81
Reference E-TFCI PO	27	27	27	27	27	
Maximum Channelisation Codes	2xSF2				SF4	

DC-HSDPA Setup Procedures used to establish the test signals

The following tests were completed according to procedures in section 7.3.13 of 3GPP TS34.108 v9.5.0. A summary of these settings are illustrated below:

Downlink Physical Channels are set as per 3GPP TS34.121-1 v9.0.0 E.5.0

Table E.5.0: Levels for HSDPA connection setup

Parameter	Unit	Value
During Connection setup		
P-CPICH_Ec/Ior	dB	-10
P-CCPCH and SCH_Ec/Ior	dB	-12
PICH_Ec/Ior	dB	-15
HS-PDSCH	dB	off
HS-SCCH_1	dB	off
DPCH_Ec/Ior	dB	-5
OCNS_Ec/Ior	dB	-3.1

Call is set up as per 3GPP TS34.108 v9.5.0 sub clause 7.3.13

The configurations of the fixed reference channels for HSDPA RF tests are described in 3GPP TS 34.121, annex C for FDD and 3GPP TS 34.122.

Table C.8.1.12: Fixed Reference Channel H-Set 12

Parameter	Unit	Value
Nominal Avg. Inf. Bit Rate	kbps	60
Inter-TTI Distance	TTI's	1
Number of HARQ Processes	Processes	6
Information Bit Payload (N_{INF})	Bits	120
Number Code Blocks	Blocks	1
Binary Channel Bits Per TTI	Bits	960
Total Available SML's in UE	SML's	19200
Number of SML's per HARQ Proc.	SML's	3200
Coding Rate		0.15
Number of Physical Channel Codes	Codes	1
Modulation		QPSK
Note 1: The RMC is intended to be used for DC-HSDPA mode and both cells shall transmit with identical parameters as listed in the table. Note 2: Maximum number of transmission is limited to 1, i.e., retransmission is not allowed. The redundancy and constellation version 0 shall be used.		

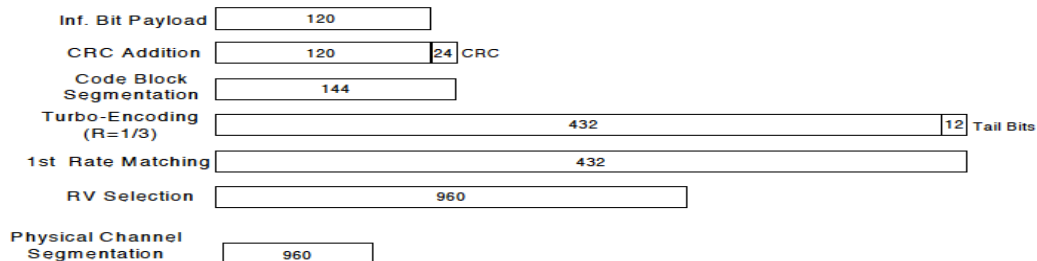

Figure C.8.19: Coding rate for Fixed reference Channel H-Set 12 (QPSK)

The following 4 Sub-tests for HSDPA were completed according to Release 8 procedures in section 5.2 of 3GPP TS34.121. A summary of subtest settings are illustrated below:

	Mode	HSDPA	HSDPA	HSDPA	HSDPA
	Subtest	1	2	3	4
WCDMA General Settings	Loopback Mode	Test Mode 1			
	Rel99 RMC	12.2kbps RMC			
	HSDPA FRC	H-Set 1			
	Power Control Algorithm	Algorithm2			
	β_c	2/15	11/15	15/15	15/15
	β_d	15/15	15/15	8/15	4/15
	β_d (SF)	64			
	β_c/β_d	2/15	11/15	15/8	15/4
	β_{hs}	4/15	24/15	30/15	30/15
MPR (dB)	0	0	0.5	0.5	
HSDPA Specific Settings	DACK	8			
	DNAK	8			
	DCQI	8			
	Ack-Nack Repetition factor	3			
	CQI Feedback	4ms			
	CQI Repetition Factor	2			
	A _{hs} = β_{hs}/β_c	30/15			

HSPA+

Since 16QAM is not used for uplink, the uplink Category and release is same as HSUPA, i.e., CAT 6 Rel 6. Therefore, the RF conducted power is not measured.

8.2.1. WCDMA OUTPUT POWER RESULT

WCDMA Band 5 Measured Results

Band	Mode		UL Ch No.	Freq. [MHz]	MPR [dB]	Avg Pwr [dBm]		
W-CDMA Band V	Rel 99	RMC, 12.2 kbps	4132	826.4	0	22.70		
			4183	836.6	0	22.69		
			4233	846.6	0	22.69		
	HSDPA	Subtest 1		4132	826.4	0	21.36	
				4183	836.6	0	21.32	
				4233	846.6	0	21.54	
		Subtest 2		4132	826.4	0	21.42	
				4183	836.6	0	21.39	
				4233	846.6	0	21.63	
		Subtest 3		4132	826.4	0.5	21.60	
				4183	836.6	0.5	21.44	
				4233	846.6	0.5	21.67	
		Subtest 4		4132	826.4	0.5	21.60	
				4183	836.6	0.5	21.42	
				4233	846.6	0.5	21.65	
		HSUPA	Subtest 1		4132	826.4	0	19.01
					4183	836.6	0	19.39
					4233	846.6	0	19.62
	Subtest 2			4132	826.4	2	17.55	
				4183	836.6	2	17.86	
				4233	846.6	2	18.09	
	Subtest 3			4132	826.4	1	18.32	
				4183	836.6	1	18.62	
				4233	846.6	1	18.85	
	Subtest 4			4132	826.4	2	17.53	
				4183	836.6	2	17.85	
				4233	846.6	2	18.19	
	Subtest 5			4132	826.4	0	20.65	
				4183	836.6	0	20.86	
				4233	846.6	0	21.00	

WCDMA Band 4 Measured Results

Band	Mode		UL Ch No.	Freq. [MHz]	MPR [dB]	Avg Pwr [dBm]	
W-CDMA Band IV	Rel 99	RMC, 12.2 kbps	1312	1712.4	0	21.99	
			1413	1732.6	0	22.05	
			1513	1752.6	0	22.17	
	HSDPA	Subtest 1	1312	1712.4	0	20.63	
			1413	1732.6	0	21.47	
			1513	1752.6	0	20.87	
		Subtest 2	1312	1712.4	0	20.65	
			1413	1732.6	0	21.49	
			1513	1752.6	0	20.96	
		Subtest 3	1312	1712.4	0.5	20.60	
			1413	1732.6	0.5	21.56	
			1513	1752.6	0.5	20.87	
		Subtest 4	1312	1712.4	0.5	20.73	
			1413	1732.6	0.5	21.67	
			1513	1752.6	0.5	21.02	
		HSUPA	Subtest 1	1312	1712.4	0	19.08
				1413	1732.6	0	20.15
				1513	1752.6	0	19.45
	Subtest 2		1312	1712.4	2	17.37	
			1413	1732.6	2	18.25	
			1513	1752.6	2	17.56	
	Subtest 3		1312	1712.4	1	18.68	
			1413	1732.6	1	19.52	
			1513	1752.6	1	18.84	
	Subtest 4		1312	1712.4	2	18.14	
			1413	1732.6	2	19.00	
			1513	1752.6	2	18.32	
	Subtest 5		1312	1712.4	0	19.67	
			1413	1732.6	0	20.67	
			1513	1752.6	0	19.79	

WCDMA Band 2 Measured Results

Band	Mode		UL Ch No.	Freq. [MHz]	MPR [dB]	Avg Pwr [dBm]
W-CDMA Band II	Rel 99	RMC, 12.2 kbps	9262	1852.4	0	22.87
			9400	1880.0	0	22.46
			9538	1907.6	0	22.50
	HSDPA	Subtest 1	9262	1852.4	0	21.62
			9400	1880.0	0	20.79
			9538	1907.6	0	20.77
		Subtest 2	9262	1852.4	0	21.65
			9400	1880.0	0	20.89
			9538	1907.6	0	21.07
		Subtest 3	9262	1852.4	0.5	21.71
			9400	1880.0	0.5	20.93
			9538	1907.6	0.5	21.12
		Subtest 4	9262	1852.4	0.5	21.80
			9400	1880.0	0.5	20.92
			9538	1907.6	0.5	21.12
	HSUPA	Subtest 1	9262	1852.4	0	19.07
			9400	1880.0	0	19.00
			9538	1907.6	0	19.03
		Subtest 2	9262	1852.4	2	17.89
			9400	1880.0	2	17.09
			9538	1907.6	2	17.16
		Subtest 3	9262	1852.4	1	19.20
			9400	1880.0	1	18.39
			9538	1907.6	1	18.45
		Subtest 4	9262	1852.4	2	18.70
			9400	1880.0	2	17.88
			9538	1907.6	2	17.95
		Subtest 5	9262	1852.4	0	21.00
			9400	1880.0	0	20.32
			9538	1907.6	0	20.38

8.3. LTE OUTPUT VERIFICATION

The following tests were conducted according to the test requirements outlined in section 6.2 of the 3GPP TS36.101 specification.

UE Power Class: 3 (23 +/- 2dBm). The allowed Maximum Power Reduction (MPR) for the maximum output power due to higher order modulation and transmit bandwidth configuration (resource blocks) is specified in Table 6.2.3-1 of the 3GPP TS36.101.

Table 6.2.3-1: Maximum Power Reduction (MPR) for Power Class 3

Modulation	Channel bandwidth / Transmission bandwidth (RB)						MPR (dB)
	1.4 MHz	3.0 MHz	5 MHz	10 MHz	15 MHz	20 MHz	
QPSK	> 5	> 4	> 8	> 12	> 16	> 18	≤ 1
16 QAM	≤ 5	≤ 4	≤ 8	≤ 12	≤ 16	≤ 18	≤ 1
16 QAM	> 5	> 4	> 8	> 12	> 16	> 18	≤ 2

The allowed A-MPR values specified below in Table 6.2.4.-1 of 3GPP TS36.101 are in addition to the allowed MPR requirements. All the measurements below were performed with A-MPR disabled, by using Network Signalling Value of "NS_01".

Table 6.2.4-1: Additional Maximum Power Reduction (A-MPR)

Network Signalling value	Requirements (sub-clause)	E-UTRA Band	Channel bandwidth (MHz)	Resources Blocks (N_{RB})	A-MPR (dB)
NS_01	6.6.2.1.1	Table 5.5-1	1.4, 3, 5, 10, 15, 20	Table 5.6-1	NA
NS_03	6.6.2.2.1	2, 4, 10, 23, 25, 35, 36	3	>5	≤ 1
			5	>6	≤ 1
			10	>6	≤ 1
			15	>8	≤ 1
			20	>10	≤ 1
NS_04	6.6.2.2.2	41	5	>6	≤ 1
			10, 15, 20	See Table 6.2.4-4	
NS_05	6.6.3.3.1	1	10, 15, 20	≥ 50	≤ 1
NS_06	6.6.2.2.3	12, 13, 14, 17	1.4, 3, 5, 10	Table 5.6-1	n/a
NS_07	6.6.2.2.3	13	10	Table 6.2.4-2	Table 6.2.4-2
	6.6.3.3.2				
NS_08	6.6.3.3.3	19	10, 15	> 44	≤ 3
NS_09	6.6.3.3.4	21	10, 15	> 40	≤ 1
				> 55	≤ 2
NS_10		20	15, 20	Table 6.2.4-3	Table 6.2.4-3
NS_11	6.6.2.2.1	23 ¹	1.4, 3, 5, 10	Table 6.2.4-5	Table 6.2.4-5
..					
NS_32	-	-	-	-	-

Note 1: Applies to the lower block of Band 23, i.e. a carrier placed in the 2000-2010 MHz region.

8.3.1. LTE OUTPUT POWER RESULT

LTE Band 17 Measured Results

BW (MHz)	Mode	RB Allocation	RB offset	Target MPR	Avg Pwr (dBm)	
					23790	
					710 MHz	
10	QPSK	1	0	0	22.56	
		1	25	0	22.43	
		1	49	0	22.59	
		25	0	1	21.03	
		25	12	1	21.01	
		25	25	1	21.02	
		50	0	1	21.01	
	16QAM	1	0	1	21.71	
		1	25	1	21.67	
		1	49	1	21.76	
		25	0	2	20.20	
		25	12	2	20.16	
		25	25	2	20.18	
		50	0	2	20.17	
BW (MHz)	Mode	RB Allocation	RB offset	Target MPR	Avg Pwr (dBm)	
					23790	
					710 MHz	
5	QPSK	1	0	0	22.52	
		1	12	0	22.49	
		1	24	0	22.62	
		12	0	1	20.99	
		12	7	1	20.99	
		12	13	1	21.04	
		25	0	1	21.03	
	16QAM	1	0	1	21.22	
		1	12	1	21.14	
		1	24	1	21.38	
		12	0	2	20.21	
		12	7	2	20.16	
		12	13	2	20.26	
		25	0	2	20.26	

LTE Band 5 Measured Results

Band	BW (MHz)	Mode	RB Allocation	RB offset	Target MPR	Avg Pwr [dBm]		
						Max. Power		
						829 MHz	836.5 MHz	844 MHz
LTE Band 5	10	QPSK	1	0	0	23.09	22.95	22.63
			1	25	0	23.21	22.84	23.08
			1	49	0	22.96	23.16	22.78
			25	0	1	21.70	21.41	21.72
			25	12	1	21.88	21.20	21.81
			25	25	1	21.46	21.10	21.85
		16QAM	50	0	1	21.80	21.18	21.76
			1	0	1	21.69	21.90	21.08
			1	25	1	21.89	21.71	21.60
			1	49	1	21.47	22.17	21.26
			25	0	2	20.96	20.48	21.11
			25	12	2	21.23	20.33	21.16
			25	25	2	20.69	20.24	21.10
			50	0	2	21.23	20.44	21.18
Band	BW (MHz)	Mode	RB Allocation	RB offset	Target MPR	Avg Pwr [dBm]		
						Max. Power		
						826.5 MHz	836.5 MHz	846.5 MHz
LTE Band 5	5	QPSK	1	0	0	22.87	22.69	23.39
			1	12	0	22.83	22.64	22.81
			1	24	0	23.04	22.51	23.06
			12	0	1	21.68	21.25	21.75
			12	7	1	21.66	21.18	21.37
			12	13	1	21.71	21.22	21.32
		16QAM	25	0	1	21.67	21.32	21.38
			1	0	1	22.24	21.75	22.27
			1	12	1	22.23	21.60	21.94
			1	24	1	22.43	21.55	21.85
			12	0	2	20.90	20.69	21.06
			12	7	2	20.85	20.59	20.63
			12	13	2	20.86	20.54	20.57
			25	0	2	20.93	20.57	20.82
Band	BW (MHz)	Mode	RB Allocation	RB offset	Target MPR	Avg Pwr [dBm]		
						Max. Power		
						825.5 MHz	836.5 MHz	847.5 MHz
LTE Band 5	3	QPSK	1	0	0	22.96	22.93	23.10
			1	8	0	23.10	22.82	23.09
			1	14	0	23.15	22.70	23.07
			8	0	1	21.82	21.42	21.49
			8	4	1	21.80	21.41	21.51
			8	7	1	21.86	21.43	21.49
		16QAM	15	0	1	21.84	21.44	21.51
			1	0	1	21.72	21.76	21.51
			1	8	1	21.77	21.45	21.40
			1	14	1	21.78	21.67	21.31
			8	0	2	21.12	20.56	21.18
			8	4	2	21.10	20.41	21.12
			8	7	2	21.08	20.44	21.14
			15	0	2	21.16	20.59	20.76
Band	BW (MHz)	Mode	RB Allocation	RB offset	Target MPR	Avg Pwr [dBm]		
						Max. Power		
						824.7 MHz	836.5 MHz	848.3 MHz
LTE Band 5	1.4	QPSK	1	0	0	23.02	22.89	22.85
			1	3	0	23.08	22.90	22.94
			1	5	0	23.11	22.62	22.91
			3	0	0	23.02	22.70	22.87
			3	1	0	22.98	22.67	22.85
			3	3	0	22.94	22.76	22.82
		16QAM	6	0	1	21.87	21.34	21.50
			1	0	1	22.24	21.73	21.85
			1	3	1	22.22	21.59	21.84
			1	5	1	22.23	21.52	21.85
			3	0	1	22.08	22.03	21.92
			3	1	1	22.05	22.03	21.91
			3	3	1	22.03	22.03	21.90
			6	0	2	21.07	20.48	21.00

LTE Band 4 Measured Results

Band	BW (MHz)	Mode	RB Allocation	RB offset	Target MPR	Avg Pwr (dBm)		
						20050	20175	20300
						1720 MHz	1732.5 MHz	1745 MHz
LTE Band 4	20	QPSK	1	0	0	22.17	22.50	22.24
			1	49	0	22.12	22.30	22.19
			1	99	0	22.05	22.54	22.22
			50	0	1	21.86	21.61	21.55
			50	24	1	21.83	21.69	21.70
			50	50	1	21.69	21.59	21.62
		16QAM	100	0	1	21.84	21.58	21.66
			1	0	1	22.20	22.03	22.33
			1	49	1	22.21	21.85	22.34
			1	99	1	21.94	21.71	22.31
			50	0	2	21.50	21.50	21.28
			50	24	2	21.50	21.48	21.35
			50	50	2	21.47	21.36	21.33
			100	0	2	21.44	21.39	21.49
Band	BW (MHz)	Mode	RB Allocation	RB offset	Target MPR	Avg Pwr (dBm)		
						20025	20175	20325
						1717.5 MHz	1732.5 MHz	1747.5 MHz
LTE Band 4	15	QPSK	1	0	0	21.96	22.14	21.88
			1	37	0	22.06	22.15	21.91
			1	74	0	22.01	22.20	21.94
			36	0	1	21.46	21.43	21.50
			36	20	1	21.42	21.47	21.48
			36	39	1	21.40	21.36	21.59
		16QAM	75	0	1	21.38	21.43	21.47
			1	0	1	21.14	22.31	22.08
			1	37	1	21.26	22.36	22.08
			1	74	1	21.19	22.43	22.19
			36	0	2	21.24	21.27	21.28
			36	20	2	21.22	21.28	21.13
			36	39	2	21.29	21.18	21.25
			75	0	2	21.24	21.34	21.26
Band	BW (MHz)	Mode	RB Allocation	RB offset	Target MPR	Avg Pwr (dBm)		
						20000	20175	20350
						1715 MHz	1732.5 MHz	1750 MHz
LTE Band 4	10	QPSK	1	0	0	21.91	22.09	22.23
			1	25	0	22.12	22.10	22.31
			1	49	0	22.04	22.05	22.29
			25	0	1	21.40	21.33	21.42
			25	12	1	21.46	21.48	21.62
			25	25	1	21.38	21.38	21.57
		16QAM	50	0	1	21.49	21.44	21.64
			1	0	1	21.16	21.54	22.48
			1	25	1	21.31	21.48	22.50
			1	49	1	21.32	21.45	22.50
			25	0	2	21.28	21.16	21.21
			25	12	2	21.35	21.24	21.35
			25	25	2	21.31	21.21	21.36
			50	0	2	21.34	21.21	21.39

LTE Band 4 Measured Results (continued)

Band	BW (MHz)	Mode	RB Allocation	RB offset	Target MPR	Avg Pwr (dBm)		
						19975	20175	20375
						1712.5 MHz	1732.5 MHz	1752.5 MHz
LTE Band 4	5	QPSK	1	0	0	21.95	22.28	22.27
			1	12	0	22.05	22.36	22.24
			1	24	0	22.10	22.34	22.31
			12	0	1	21.27	21.42	21.63
			12	7	1	21.33	21.51	21.61
			12	13	1	21.38	21.49	21.63
			25	0	1	21.37	21.47	21.51
		16QAM	1	0	1	21.01	21.94	22.36
			1	12	1	21.11	22.00	22.36
			1	24	1	21.20	21.94	22.41
			12	0	2	21.15	21.28	21.44
			12	7	2	21.23	21.37	21.41
			12	13	2	21.27	21.40	21.42
			25	0	2	21.27	21.22	21.21
Band	BW (MHz)	Mode	RB Allocation	RB offset	Target MPR	Avg Pwr (dBm)		
						19965	20175	20385
						1711.5 MHz	1732.5 MHz	1753.5 MHz
LTE Band 4	3	QPSK	1	0	0	21.94	22.04	22.32
			1	8	0	22.12	22.14	22.25
			1	14	0	22.20	22.21	22.20
			8	0	1	21.33	21.39	21.60
			8	4	1	21.33	21.51	21.56
			8	7	1	21.38	21.44	21.57
			15	0	1	21.41	21.54	21.59
		16QAM	1	0	1	21.32	22.29	21.44
			1	8	1	21.42	22.20	21.38
			1	14	1	21.66	22.12	21.33
			8	0	2	21.18	21.17	21.47
			8	4	2	21.17	21.29	21.43
			8	7	2	21.23	21.26	21.48
			15	0	2	21.29	21.43	21.38
Band	BW (MHz)	Mode	RB Allocation	RB offset	Target MPR	Avg Pwr (dBm)		
						19957	20175	20393
						1710.7 MHz	1732.5 MHz	1754.3 MHz
LTE Band 4	1.4	QPSK	1	0	0	22.05	22.13	22.27
			1	3	0	21.89	22.13	22.28
			1	5	0	22.08	22.18	22.22
			3	0	0	21.97	22.10	22.26
			3	1	0	21.97	22.10	22.27
			3	3	0	21.97	22.10	22.27
			6	0	1	21.40	21.49	21.57
		16QAM	1	0	1	21.77	22.20	21.40
			1	3	1	21.76	22.23	21.36
			1	5	1	21.94	22.23	21.40
			3	0	1	21.93	22.07	22.00
			3	1	1	21.93	22.09	21.89
			3	3	1	21.92	22.08	21.90
			6	0	2	21.33	21.28	21.40

LTE Band 2 Measured Results

Band	BW (MHz)	Mode	RB Allocation	RB offset	Target MPR	Avg Pwr [dBm]		
						Max. Power		
						1860 MHz	1880 MHz	1900 MHz
LTE Band 2	20	QPSK	1	0	0	23.43	23.22	22.80
			1	49	0	23.28	22.94	22.62
			1	99	0	23.32	22.78	23.02
			50	0	1	22.19	22.04	21.26
			50	24	1	22.04	21.90	21.19
			50	50	1	21.98	21.84	21.18
		16QAM	100	0	1	22.01	21.86	21.18
			1	0	1	22.42	22.48	22.02
			1	49	1	22.24	22.28	21.66
			1	99	1	22.23	22.19	22.24
			50	0	2	21.50	21.46	20.45
			50	24	2	21.39	21.24	20.38
			50	50	2	21.29	21.29	20.41
			100	0	2	21.41	21.24	20.41
Band	BW (MHz)	Mode	RB Allocation	RB offset	Target MPR	Avg Pwr [dBm]		
						Max. Power		
						1857.5 MHz	1880 MHz	1902.5 MHz
LTE Band 2	15	QPSK	1	0	0	23.27	23.17	22.77
			1	37	0	23.14	23.03	22.76
			1	74	0	23.14	22.85	23.17
			36	0	1	22.11	21.74	21.21
			36	20	1	21.96	21.76	21.15
			36	39	1	21.94	21.76	21.18
		16QAM	75	0	1	22.00	21.77	21.19
			1	0	1	22.21	21.98	21.26
			1	37	1	22.01	21.83	21.22
			1	74	1	21.97	21.56	21.72
			36	0	2	21.50	21.07	20.40
			36	20	2	21.39	21.19	20.49
			36	39	2	21.38	21.18	20.50
			75	0	2	21.43	21.12	20.42
Band	BW (MHz)	Mode	RB Allocation	RB offset	Target MPR	Avg Pwr [dBm]		
						Max. Power		
						1855 MHz	1880 MHz	1905 MHz
LTE Band 2	10	QPSK	1	0	0	23.37	23.35	22.61
			1	25	0	23.35	23.08	22.61
			1	49	0	23.26	23.15	22.98
			25	0	1	22.19	21.77	21.23
			25	12	1	22.08	21.78	21.17
			25	25	1	22.04	21.69	21.58
		16QAM	50	0	1	22.07	21.72	21.14
			1	0	1	22.17	21.94	21.21
			1	25	1	22.07	21.61	21.11
			1	49	1	21.96	21.63	21.59
			25	0	2	21.50	21.00	20.38
			25	12	2	21.50	21.15	20.39
			25	25	2	21.45	21.08	20.98
			50	0	2	21.50	21.17	20.44

LTE Band 2 Measured Results (continued)

Band	BW (MHz)	Mode	RB Allocation	RB offset	Target MPR	Avg Pwr [dBm]		
						Max. Power		
						1852.5 MHz	1880 MHz	1907.5 MHz
LTE Band 2	5	QPSK	1	0	0	23.39	23.21	22.66
			1	12	0	23.43	23.25	22.95
			1	24	0	23.38	23.15	23.04
			12	0	1	22.27	21.95	21.67
			12	7	1	22.34	21.93	21.65
			12	13	1	22.31	21.89	21.73
			25	0	1	22.31	21.81	21.65
		16QAM	1	0	1	22.07	21.88	21.01
			1	12	1	22.12	22.01	21.45
			1	24	1	22.01	22.03	21.52
			12	0	2	21.44	21.35	20.83
			12	7	2	21.48	21.34	20.78
			12	13	2	21.50	21.25	20.90
			25	0	2	21.50	21.16	21.03
Band	BW (MHz)	Mode	RB Allocation	RB offset	Target MPR	Avg Pwr [dBm]		
						Max. Power		
						1851.5 MHz	1880 MHz	1908.5 MHz
LTE Band 2	3	QPSK	1	0	0	23.10	22.79	23.19
			1	8	0	23.24	22.86	23.19
			1	14	0	23.37	22.87	23.16
			8	0	1	22.07	21.72	21.69
			8	4	1	22.08	21.69	21.73
			8	7	1	22.07	21.64	21.79
			15	0	1	22.05	21.71	21.82
		16QAM	1	0	1	21.90	21.91	21.97
			1	8	1	21.97	21.79	21.91
			1	14	1	21.97	21.64	21.87
			8	0	2	21.44	20.99	21.07
			8	4	2	21.46	21.03	21.10
			8	7	2	21.48	20.94	21.17
			15	0	2	21.50	21.05	21.12
Band	BW (MHz)	Mode	RB Allocation	RB offset	Target MPR	Avg Pwr [dBm]		
						Max. Power		
						1850.7 MHz	1880 MHz	1909.3 MHz
LTE Band 2	1.4	QPSK	1	0	0	23.24	22.97	22.95
			1	3	0	23.23	23.01	22.98
			1	5	0	23.25	22.91	22.99
			3	0	0	23.27	22.94	22.95
			3	1	0	23.24	22.94	23.00
			3	3	0	23.21	22.94	23.00
			6	0	1	22.24	21.78	21.80
		16QAM	1	0	1	21.50	22.09	22.29
			1	3	1	21.50	22.19	22.28
			1	5	1	21.50	22.05	22.32
			3	0	1	22.50	22.14	22.38
			3	1	1	22.49	22.13	22.43
			3	3	1	22.49	22.13	22.39
			6	0	2	21.50	21.26	21.09

9. PEAK TO AVERAGE RATIO

Test Procedure

Per KDB 971168 D01 Power Meas License Digital Systems v02r02;

The transmitter output was connected to a CMW500 Test Set and configured to operate at maximum power. The PAR were measured on the Spectrum Analyzer.

Test Spec

In addition, when the transmitter power is measured in terms of average value, the peak-to-average ratio of the power shall not exceed 13 dB.

9.1. CONDUCTED PEAK TO AVERAGE RESULT

GSM

Band	Channel	f [MHz]	Mode	Ratio [dB]	Limit [dB]
GSM850	190	836.6	GPRS	2.82	13.00
			EGPRS	5.76	
GSM1900	661	1880.0	GPRS	2.85	
			EGPRS	5.91	

WCDMA

Band	Channel	f [MHz]	Mode	Ratio [dB]	Limit [dB]
Band 5	4183	836.6	REL99	3.07	13.00
			HSDPA	3.23	
Band 4	1413	1732.6	REL99	3.30	
			HSDPA	3.35	
Band 2	9400	1880.0	REL99	3.14	
			HSDPA	3.28	

LTE

Band	BW [MHz]	Channel	f [MHz]	Mode	Ratio [dB]	Limit [dB]
Band 17	10	23790	710	QPSK	5.03	13.00
				16QAM	6.51	
	5			QPSK	5.04	
				16QAM	6.08	
Band 5	10	20525	836.5	QPSK	5.28	
				16QAM	5.55	
	5			QPSK	5.08	
				16QAM	6.30	
	3			QPSK	5.24	
				16QAM	6.53	
	1.4			QPSK	5.44	
				16QAM	6.46	
Band 4	20	20174	1732.5	QPSK	5.12	
				16QAM	6.12	
	15			QPSK	5.22	
				16QAM	5.99	
	10			QPSK	5.23	
				16QAM	5.89	
	5			QPSK	4.97	
				16QAM	5.90	
	3			QPSK	5.21	
				16QAM	5.87	
1.4	QPSK	5.34				
	16QAM	5.69				
Band 2	20	18900	1880.0	QPSK	5.36	
				16QAM	6.15	
	15			QPSK	5.40	
				16QAM	6.02	
	10			QPSK	5.37	
				16QAM	6.01	
	5			QPSK	5.28	
				16QAM	5.80	
	3			QPSK	5.33	
				16QAM	5.85	
1.4	QPSK	5.42				
	16QAM	5.70				

9.2. CONDUCTED PEAK TO AVERAGE PLOTS

GSM

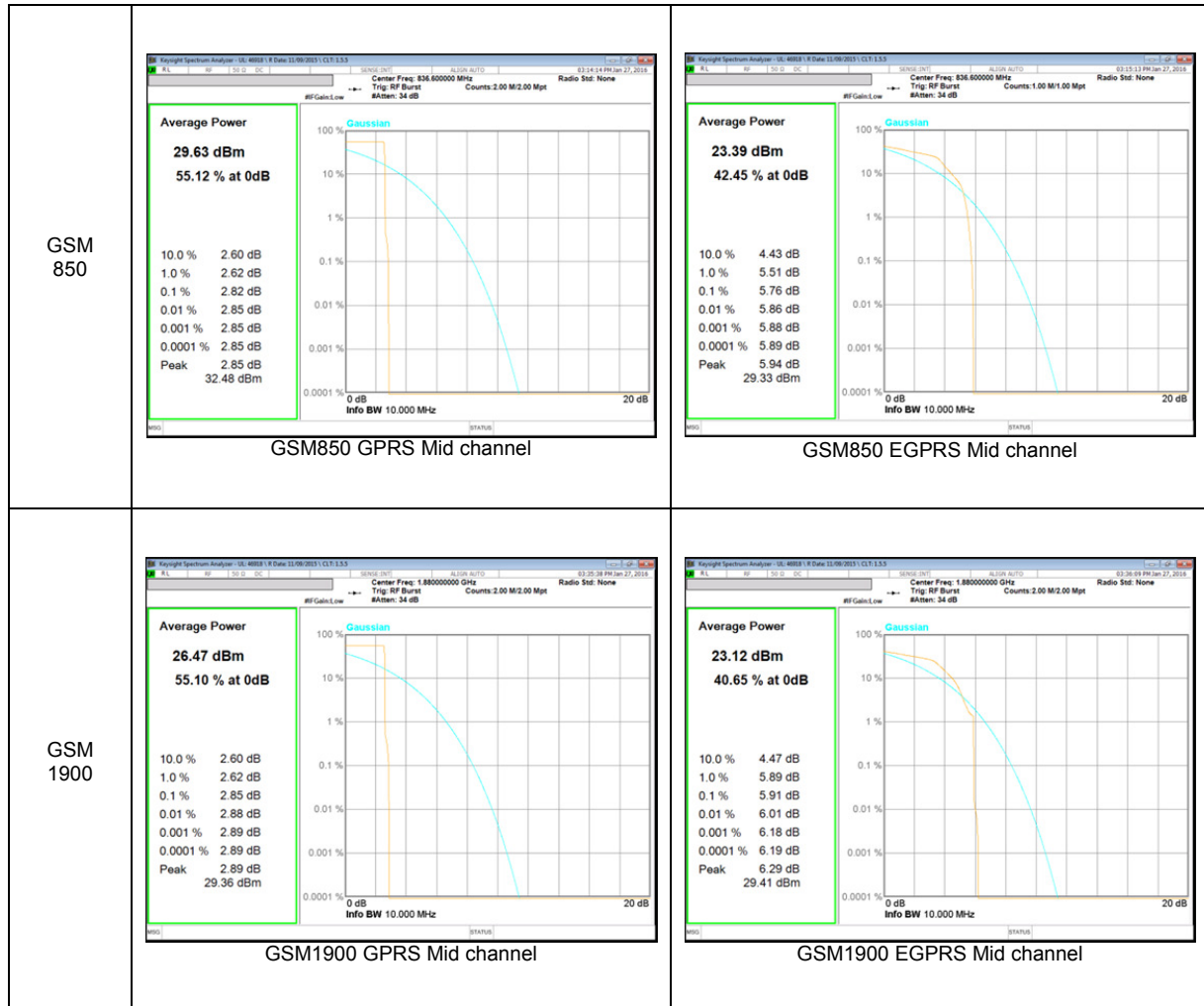

WCDMA

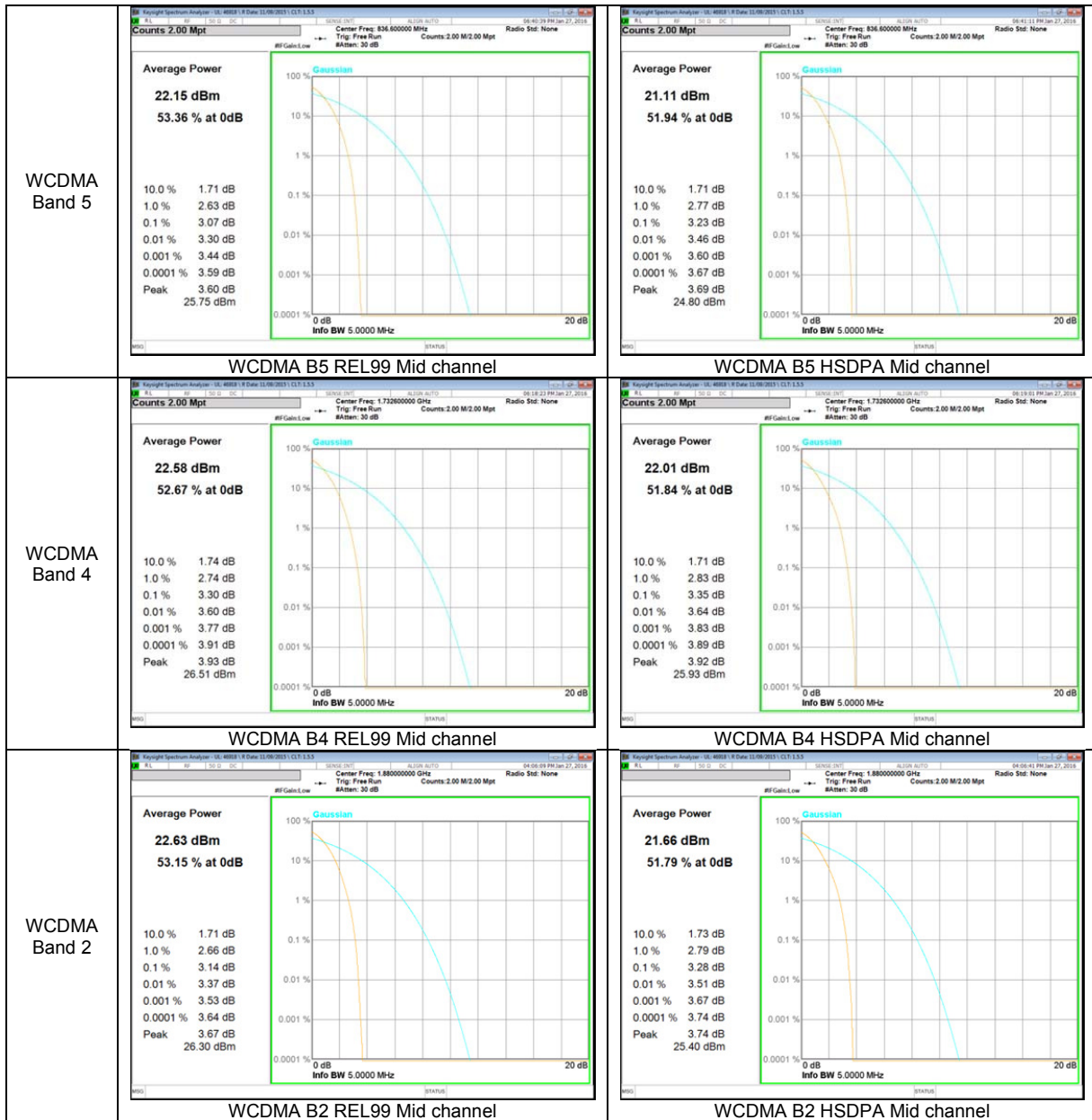

LTE Band 17

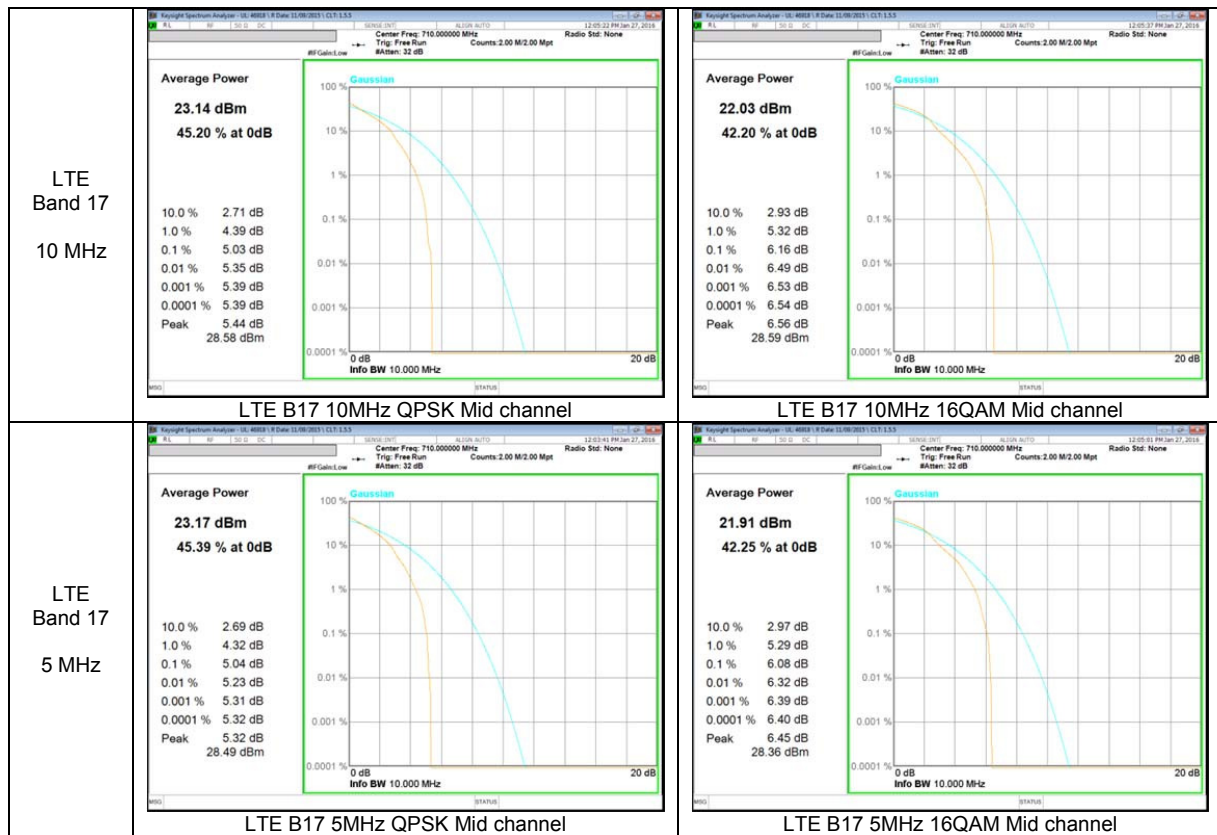

LTE Band 5

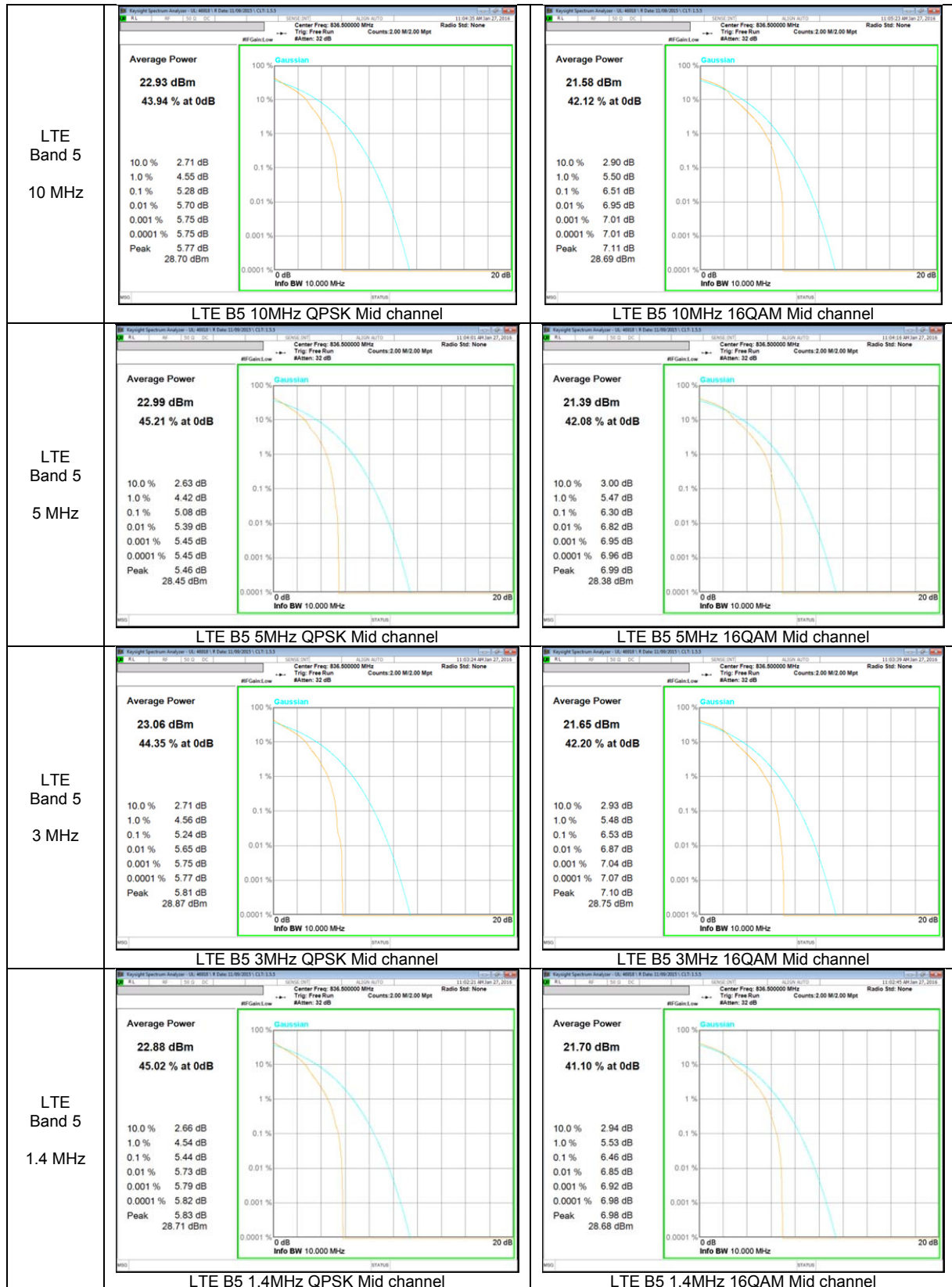

LTE Band 4

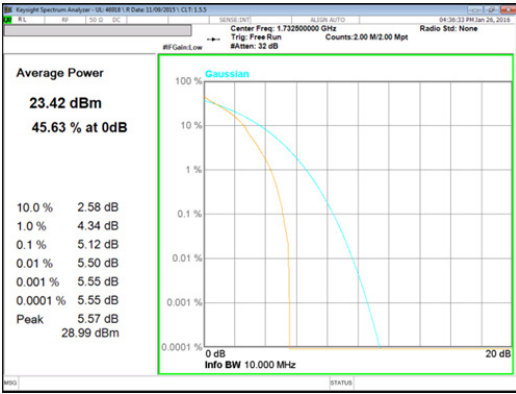
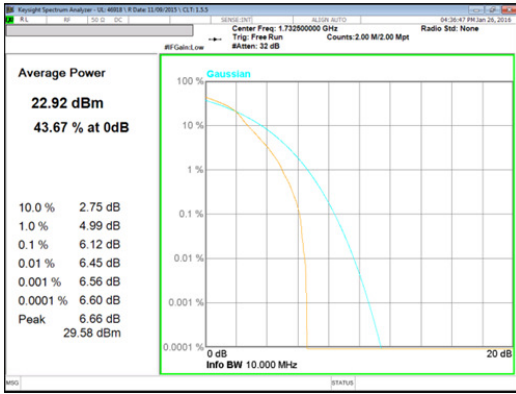
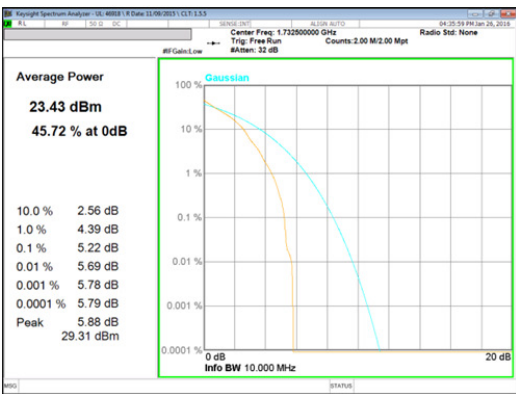
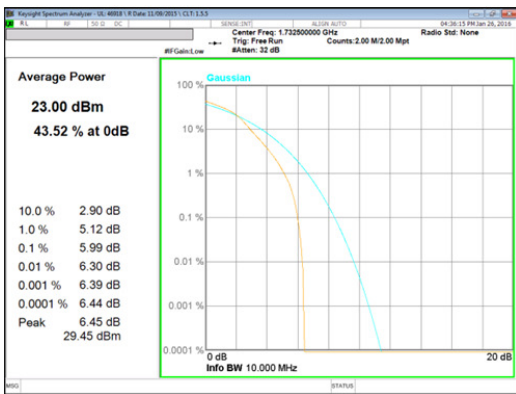
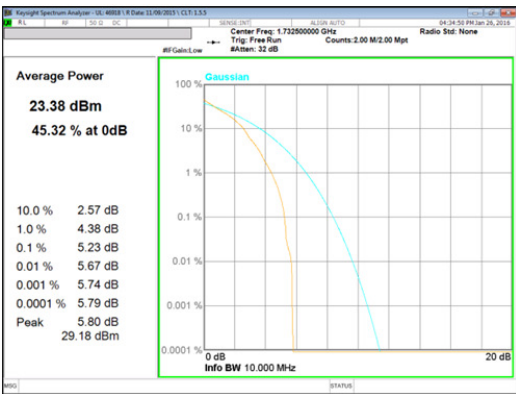
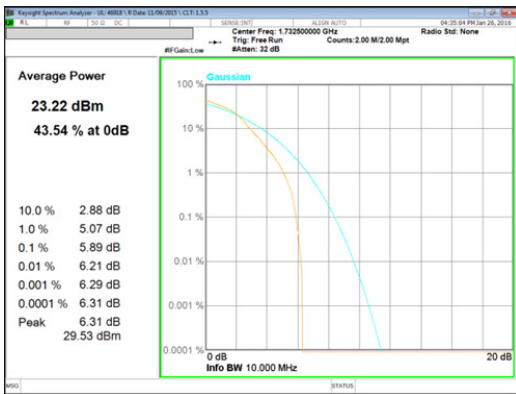
<p>LTE Band 4 20 MHz</p>	 <p>Average Power 23.42 dBm 45.63 % at 0dB</p> <p>10.0 % 2.58 dB 1.0 % 4.34 dB 0.1 % 5.12 dB 0.01 % 5.50 dB 0.001 % 5.55 dB 0.0001 % 5.55 dB Peak 5.57 dB 28.99 dBm</p> <p>LTE B4 20MHz QPSK Mid channel</p>	 <p>Average Power 22.92 dBm 43.67 % at 0dB</p> <p>10.0 % 2.75 dB 1.0 % 4.99 dB 0.1 % 6.12 dB 0.01 % 6.45 dB 0.001 % 6.56 dB 0.0001 % 6.60 dB Peak 6.66 dB 29.58 dBm</p> <p>LTE B4 20MHz 16QAM Mid channel</p>
<p>LTE Band 4 15 MHz</p>	 <p>Average Power 23.43 dBm 45.72 % at 0dB</p> <p>10.0 % 2.56 dB 1.0 % 4.39 dB 0.1 % 5.22 dB 0.01 % 5.69 dB 0.001 % 5.78 dB 0.0001 % 5.79 dB Peak 5.88 dB 29.31 dBm</p> <p>LTE B4 15MHz QPSK Mid channel</p>	 <p>Average Power 23.00 dBm 43.52 % at 0dB</p> <p>10.0 % 2.90 dB 1.0 % 5.12 dB 0.1 % 5.99 dB 0.01 % 6.30 dB 0.001 % 6.39 dB 0.0001 % 6.44 dB Peak 6.45 dB 29.45 dBm</p> <p>LTE B4 15MHz 16QAM Mid channel</p>
<p>LTE Band 4 10 MHz</p>	 <p>Average Power 23.38 dBm 45.32 % at 0dB</p> <p>10.0 % 2.57 dB 1.0 % 4.38 dB 0.1 % 5.23 dB 0.01 % 5.67 dB 0.001 % 5.74 dB 0.0001 % 5.79 dB Peak 5.80 dB 29.18 dBm</p> <p>LTE B4 10MHz QPSK Mid channel</p>	 <p>Average Power 23.22 dBm 43.54 % at 0dB</p> <p>10.0 % 2.88 dB 1.0 % 5.07 dB 0.1 % 5.89 dB 0.01 % 6.21 dB 0.001 % 6.29 dB 0.0001 % 6.31 dB Peak 6.31 dB 29.53 dBm</p> <p>LTE B4 10MHz 16QAM Mid channel</p>

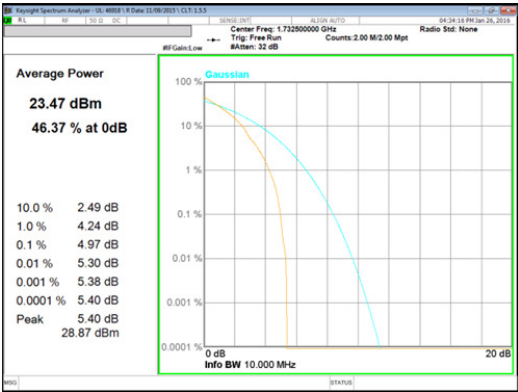
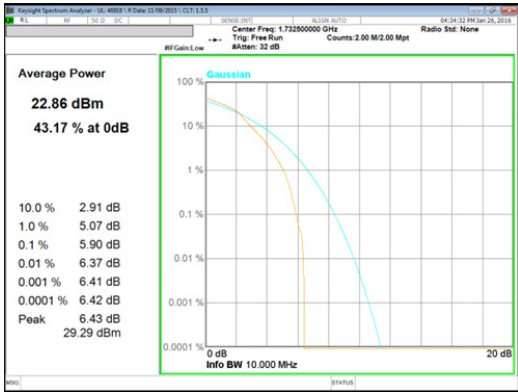
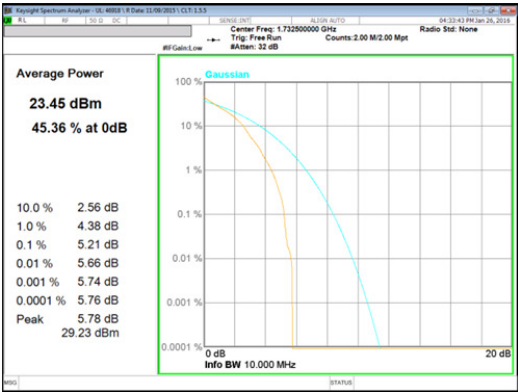
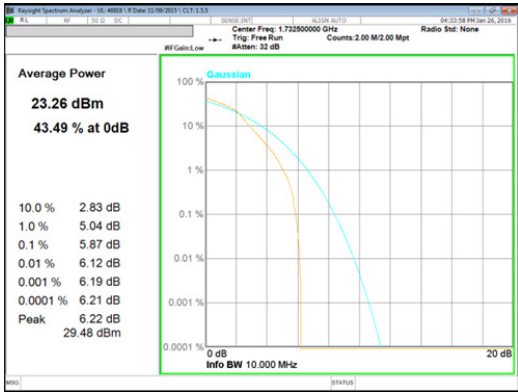
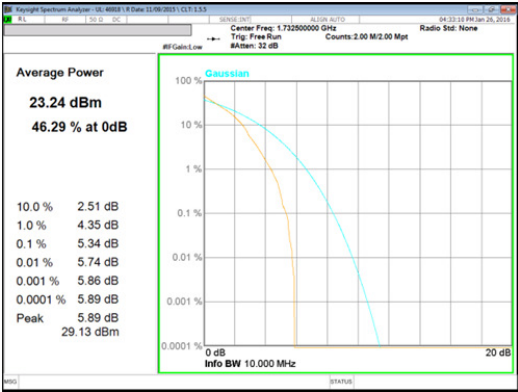
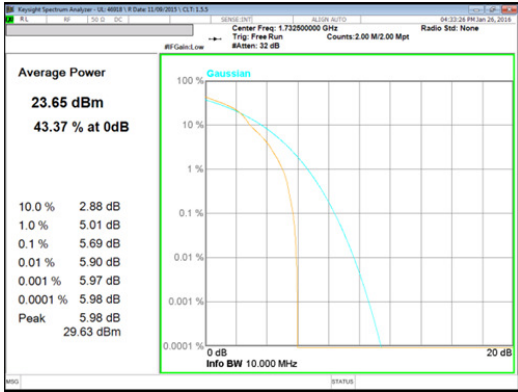
<p>LTE Band 4 5 MHz</p>	 <p>LTE B4 5MHz QPSK Mid channel</p>	 <p>LTE B4 5MHz 16QAM Mid channel</p>
<p>LTE Band 4 3 MHz</p>	 <p>LTE B4 3MHz QPSK Mid channel</p>	 <p>LTE B4 3MHz 16QAM Mid channel</p>
<p>LTE Band 4 1.4 MHz</p>	 <p>LTE B4 1.4MHz QPSK Mid channel</p>	 <p>LTE B4 1.4MHz 16QAM Mid channel</p>

LTE Band 2

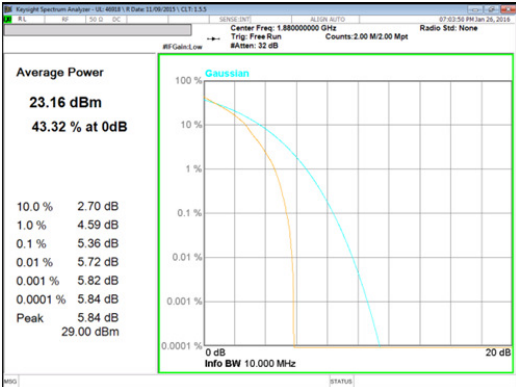
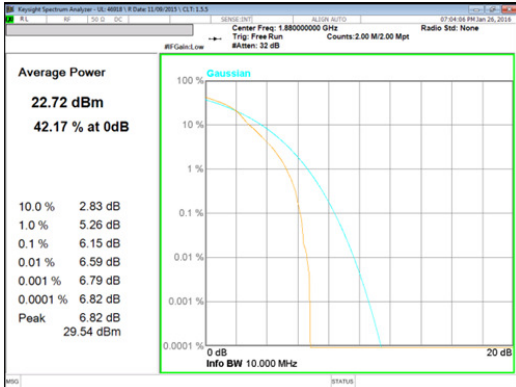
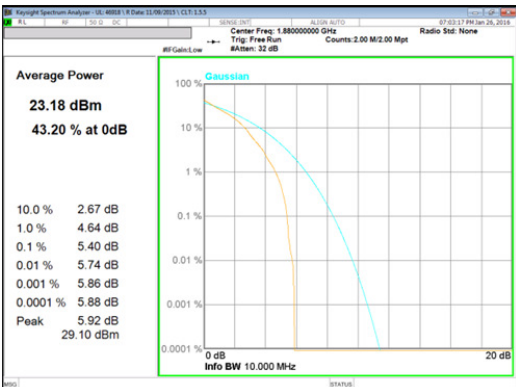
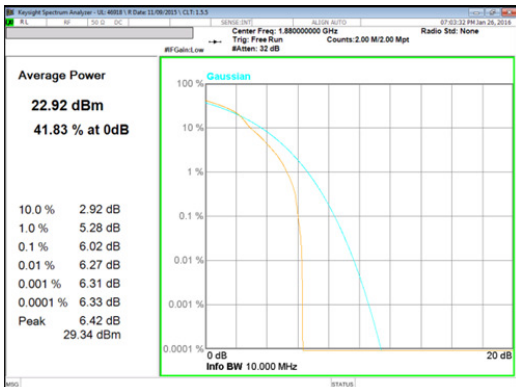
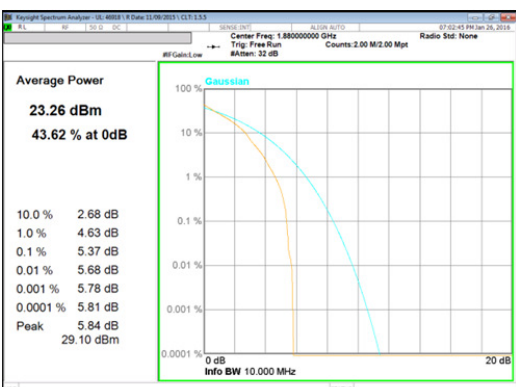
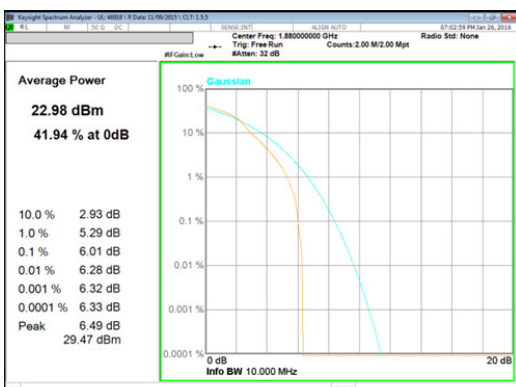
<p>LTE Band 2 20 MHz</p>	 <p>LTE B2 20MHz QPSK Mid channel</p>	 <p>LTE B2 20MHz 16QAM Mid channel</p>
<p>LTE Band 2 15 MHz</p>	 <p>LTE B2 15MHz QPSK Mid channel</p>	 <p>LTE B2 15MHz 16QAM Mid channel</p>
<p>LTE Band 2 10 MHz</p>	 <p>LTE B2 10MHz QPSK Mid channel</p>	 <p>LTE B2 10MHz 16QAM Mid channel</p>

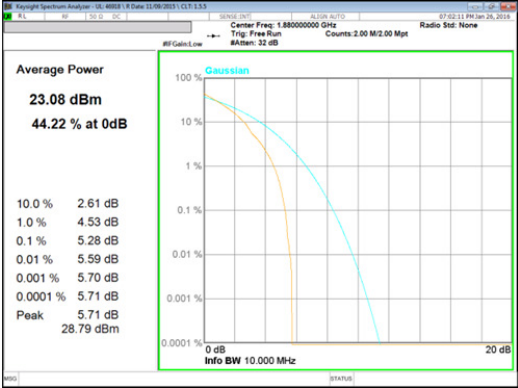
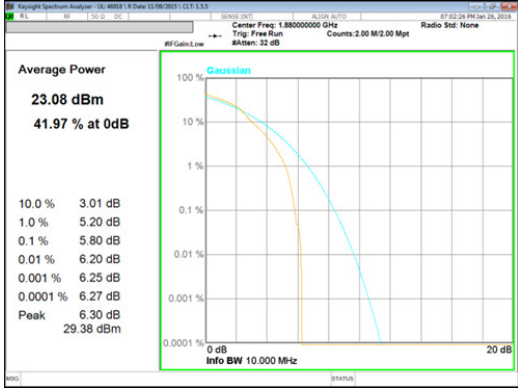
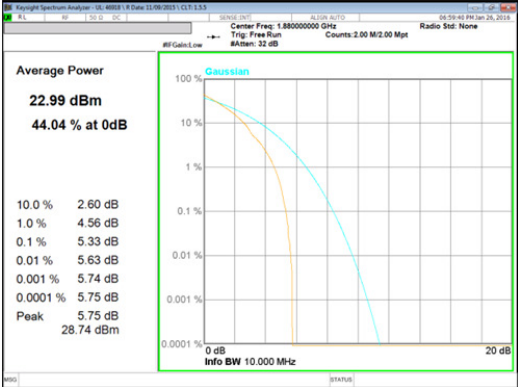
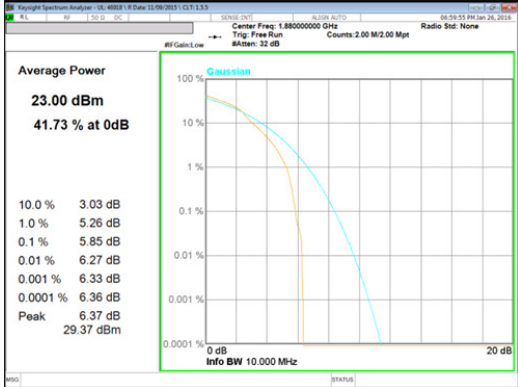
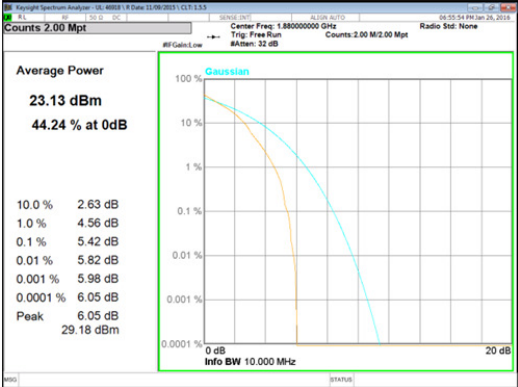
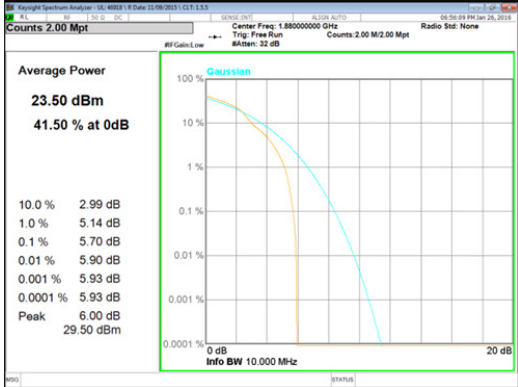
<p>LTE Band 2 5 MHz</p>	 <p>LTE B2 5MHz QPSK Mid channel</p>	 <p>LTE B2 5MHz 16QAM Mid channel</p>
<p>LTE Band 2 3 MHz</p>	 <p>LTE B2 3MHz QPSK Mid channel</p>	 <p>LTE B2 3MHz 16QAM Mid channel</p>
<p>LTE Band 2 1.4 MHz</p>	 <p>LTE B2 1.4MHz QPSK Mid channel</p>	 <p>LTE B2 1.4MHz 16QAM Mid channel</p>

10. LIMITS AND CONDUCTED RESULTS

10.1. OCCUPIED BANDWIDTH

RULE PART(S)

FCC: §2.1049

LIMITS

For reporting purposes only

TEST PROCEDURE

The transmitter output was connected to a calibrated coaxial cable and coupler, the other end of which was connected to a spectrum analyzer. The occupied bandwidth was measured with the spectrum analyzer at the low, middle and high channel in each band. The -26dB bandwidth was also measured and recorded.

(KDB 971168 D01 Power Meas License Digital Systems v02r02)

10.1.1. OCCUPIED BANDWIDTH RESULTS

GSM

Band	Mode	Channel	f [MHz]	99% BW [KHz]	26dB BW [KHz]
GSM850	GPRS	128	824.2	243.95	319.8
		190	836.6	236.76	317.1
		251	848.8	242.44	315.0
	EGPRS	128	824.2	247.11	303.6
		190	836.6	244.50	312.0
		251	848.8	247.50	312.4
GSM1900	GPRS	512	1850.2	241.66	318.7
		661	1880.0	249.87	324.4
		810	1909.8	244.49	309.2
	EGPRS	512	1850.2	242.12	305.3
		661	1880.0	240.08	304.9
		810	1909.8	242.99	303.8

WCDMA

Band	Mode	Channel	f [MHz]	99% BW [MHz]	26dB BW [MHz]
Band 5	REL99	4132	826.4	4.0870	4.607
		4183	836.6	4.0908	4.611
		4233	846.6	4.0812	4.620
	HSDPA	4132	826.4	4.0845	4.596
		4183	836.6	4.0896	4.601
		4233	846.6	4.0793	4.602
Band 4	REL99	1312	1712.4	4.0914	4.633
		1413	1732.6	4.0943	4.600
		1513	1752.6	4.0749	4.607
	HSDPA	1312	1712.4	4.0924	4.603
		1413	1732.6	4.0743	4.611
		1513	1752.6	4.0851	4.620
Band 2	REL99	9262	1852.4	4.0884	4.631
		9400	1880.0	4.0838	4.609
		9538	1907.6	4.0909	4.680
	HSDPA	9262	1852.4	4.0936	4.608
		9400	1880.0	4.0942	4.614
		9538	1907.6	4.0851	4.620

LTE Band 17

Band	BW [MHz]	Channel	f [MHz]	Mode	99% BW [MHz]	26dB BW [MHz]
Band 17	10	23780	709.0	QPSK	8.9628	9.774
				16QAM	8.9399	10.04
		23790	710.0	QPSK	8.9716	9.905
				16QAM	8.9649	10.12
		23799	711.0	QPSK	8.9665	9.757
				16QAM	8.9538	10.05
	5	23755	706.5	QPSK	4.4987	5.299
				16QAM	4.5091	5.402
		23790	710.0	QPSK	4.4928	5.049
				16QAM	4.4974	5.185
		23824	713.5	QPSK	4.4980	5.163
				16QAM	4.5173	5.514

LTE Band 5

Band	BW [MHz]	Channel	f [MHz]	Mode	99% BW [MHz]	26dB BW [MHz]
Band 5	10	20450	829.0	QPSK	8.9874	10.03
				16QAM	8.9864	10.12
		20524	836.5	QPSK	8.9794	9.816
				16QAM	8.9656	9.801
		20599	844.0	QPSK	8.9672	10.16
				16QAM	8.9797	10.34
	5	20425	826.5	QPSK	4.5029	5.165
				16QAM	4.5164	5.457
		20524	836.5	QPSK	4.5021	5.220
				16QAM	4.5065	5.354
		20624	846.5	QPSK	4.4942	5.095
				16QAM	4.5006	5.211
	3	20415	825.5	QPSK	2.6946	3.122
				16QAM	2.6900	3.221
		20524	836.5	QPSK	2.6886	3.172
				16QAM	2.6943	3.079
		20634	847.5	QPSK	2.6892	2.996
				16QAM	2.6897	3.230
	1.4	20407	824.7	QPSK	1.1012	1.600
				16QAM	1.0981	1.420
		20524	836.5	QPSK	1.0921	1.504
				16QAM	1.0905	1.446
		20624	848.3	QPSK	1.0975	1.426
				16QAM	1.0975	1.590

LTE Band 4

Band	BW [MHz]	Channel	f [MHz]	Mode	99% BW [MHz]	26dB BW [MHz]
Band 4	20	20050	1720.0	QPSK	17.977	19.78
				16QAM	17.942	19.80
		20174	1732.5	QPSK	17.996	20.18
				16QAM	17.942	20.03
		20299	1745.0	QPSK	17.971	19.73
				16QAM	17.995	19.93
	15	20025	1717.5	QPSK	13.440	15.18
				16QAM	13.420	14.71
		20174	1732.5	QPSK	13.452	14.76
				16QAM	13.430	14.59
		20324	1747.5	QPSK	13.439	14.67
				16QAM	13.454	15.04
	10	20000	1715.0	QPSK	8.9735	9.815
				16QAM	8.9566	10.06
		20174	1732.5	QPSK	8.9724	10.06
				16QAM	8.9895	10.32
		20349	1750.0	QPSK	8.9721	9.954
				16QAM	8.9884	10.02
	5	19975	1712.5	QPSK	4.4989	5.160
				16QAM	4.5086	5.492
		20174	1732.5	QPSK	4.4931	5.267
				16QAM	4.5119	5.470
		20374	1752.5	QPSK	4.4895	5.108
				16QAM	4.5073	5.198
	3	19965	1711.5	QPSK	2.6909	3.131
				16QAM	2.6907	3.118
		20174	1732.5	QPSK	2.6923	3.103
				16QAM	2.6903	3.275
		20384	1753.5	QPSK	2.6918	3.103
				16QAM	2.6919	3.132
	1.4	19957	1710.7	QPSK	1.0964	1.423
				16QAM	1.0954	1.546
20174		1732.5	QPSK	1.0920	1.509	
			16QAM	1.0923	1.442	
20392		1754.3	QPSK	1.0998	1.540	
			16QAM	1.1022	1.417	

LTE Band 2

Band	BW [MHz]	Channel	f [MHz]	Mode	99% BW [MHz]	26dB BW [MHz]
Band 2	20	18700	1860.0	QPSK	17.979	19.69
				16QAM	17.923	19.89
		18900	1880.0	QPSK	17.992	20.16
				16QAM	17.979	20.32
		19099	1900.0	QPSK	17.943	19.60
				16QAM	17.934	19.58
	15	18675	1857.5	QPSK	13.434	15.13
				16QAM	13.432	14.82
		18900	1880.0	QPSK	13.440	14.81
				16QAM	13.450	15.02
		19124	1902.5	QPSK	13.434	14.69
				16QAM	13.463	15.13
	10	18650	1955.0	QPSK	8.9887	9.890
				16QAM	8.9547	9.911
		18900	1880.0	QPSK	8.9851	9.976
				16QAM	9.0088	10.17
		19149	1905.0	QPSK	9.0099	10.11
				16QAM	8.9898	10.24
	5	18625	1852.5	QPSK	4.5041	5.090
				16QAM	4.5174	5.224
		18900	1880.0	QPSK	4.5081	5.146
				16QAM	4.5214	5.527
		18175	1907.5	QPSK	4.5092	5.280
				16QAM	4.5210	5.457
	3	18615	1815.5	QPSK	2.6890	3.126
				16QAM	2.6929	3.153
		18900	1880.0	QPSK	2.6870	3.189
				16QAM	2.6924	3.117
		19184	1908.5	QPSK	2.6955	3.088
				16QAM	2.6960	3.256
	1.4	18607	1850.7	QPSK	1.0983	1.508
				16QAM	1.1011	1.411
18900		1880.0	QPSK	1.0984	1.439	
			16QAM	1.0946	1.552	
19192		1909.3	QPSK	1.0906	1.493	
			16QAM	1.0912	1.428	

10.1.2. OCCUPIED BANDWIDTH PLOTS

GSM 850

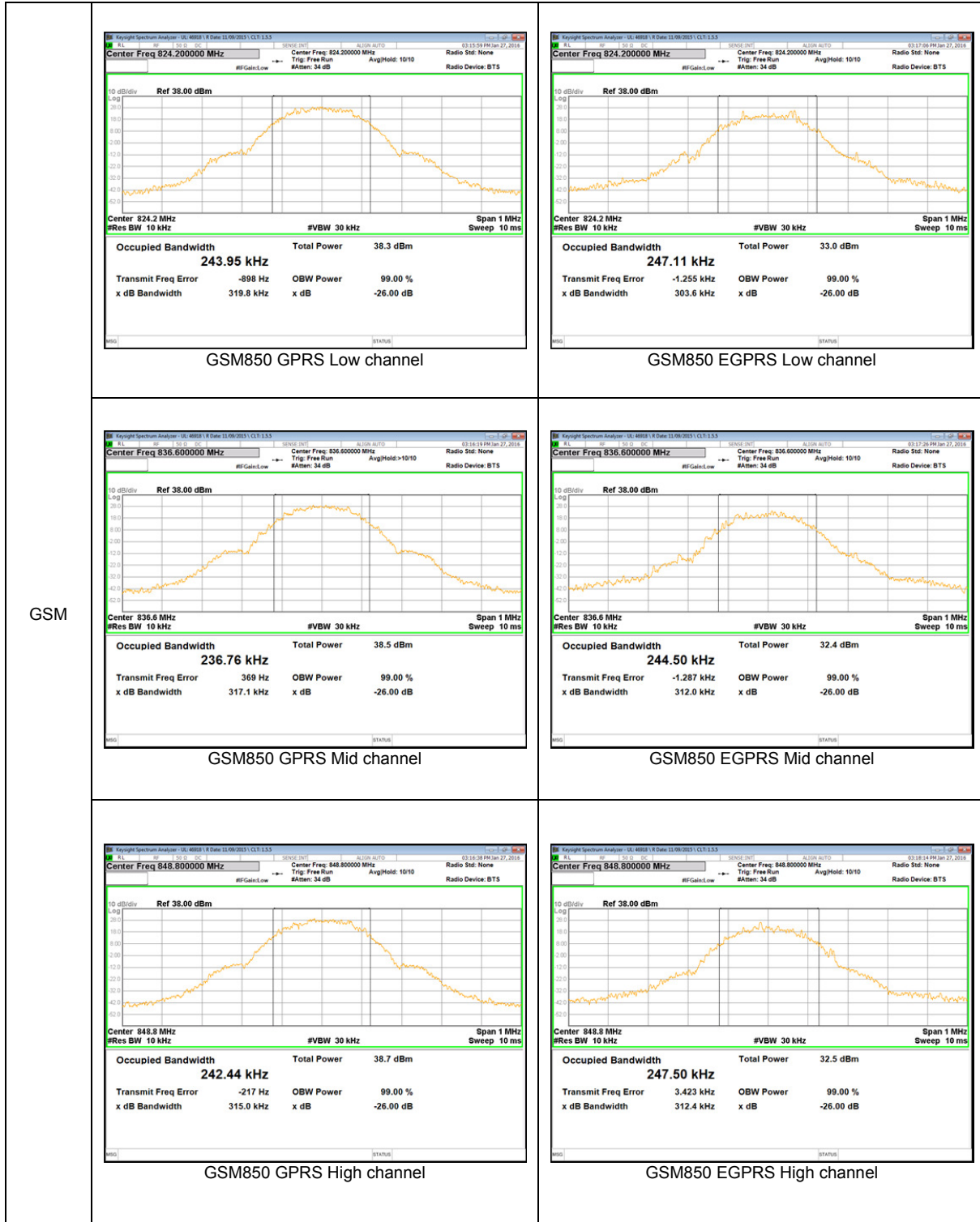

GSM 1900



WCDMA Band 5

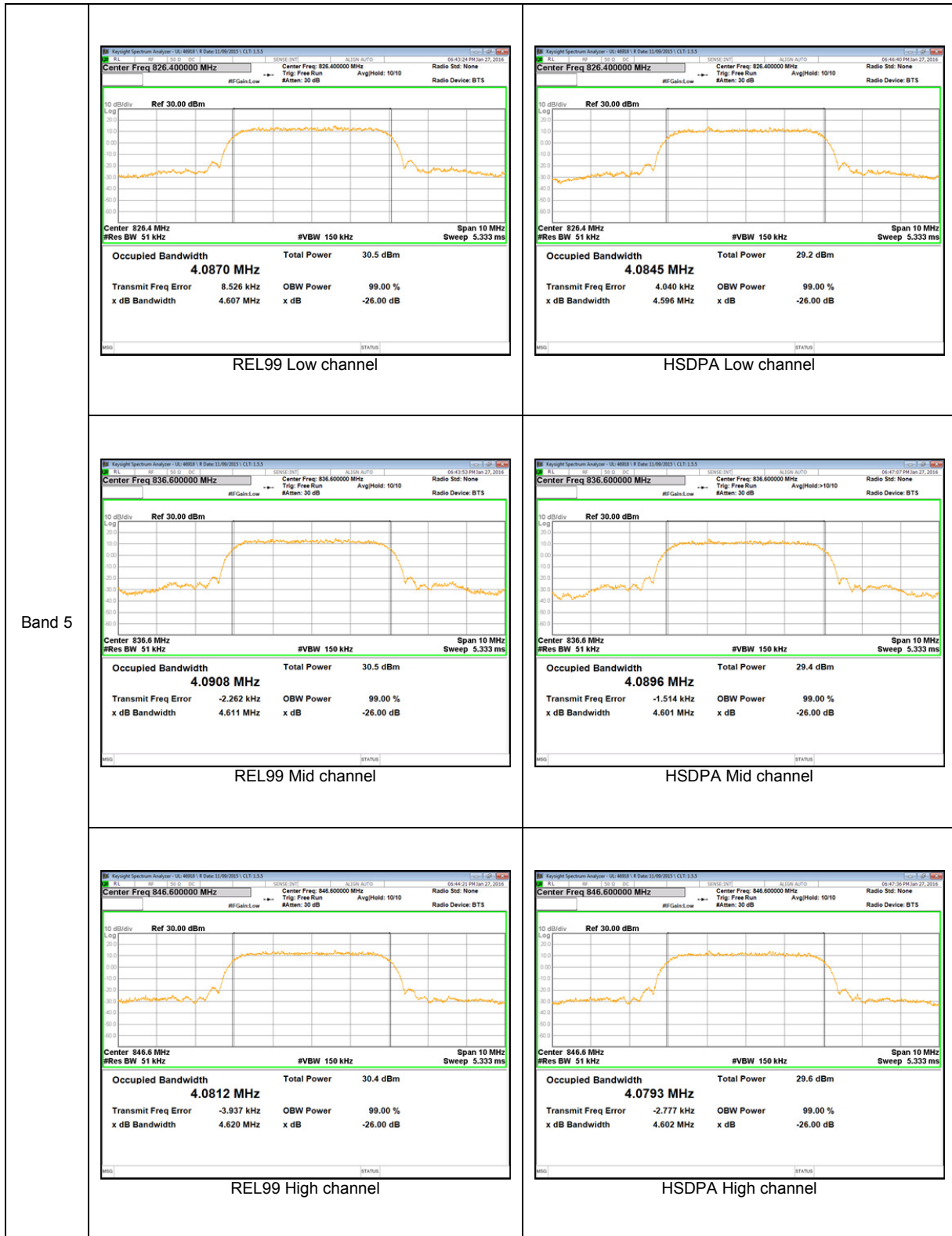

WCDMA Band 4

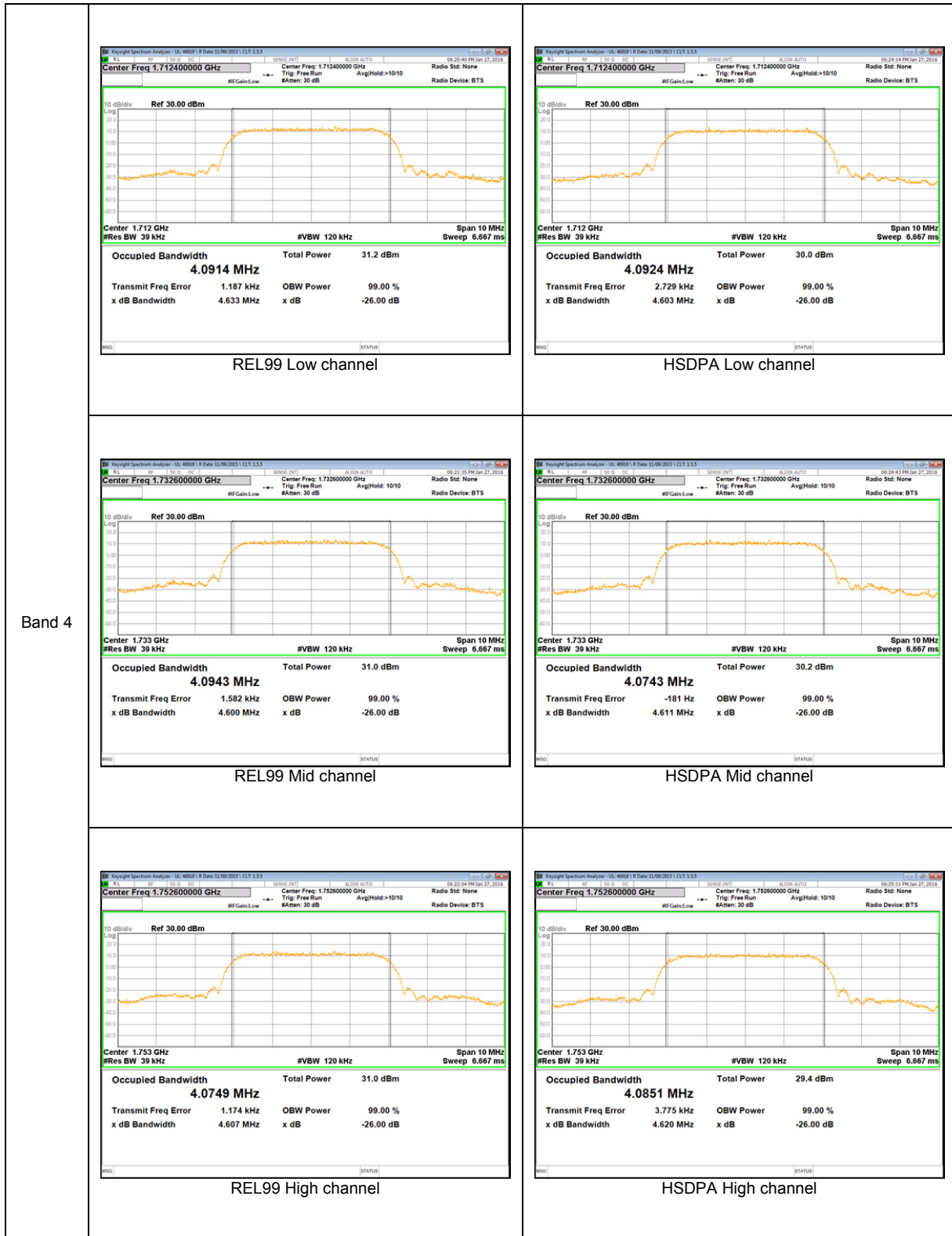

WCDMA Band 2

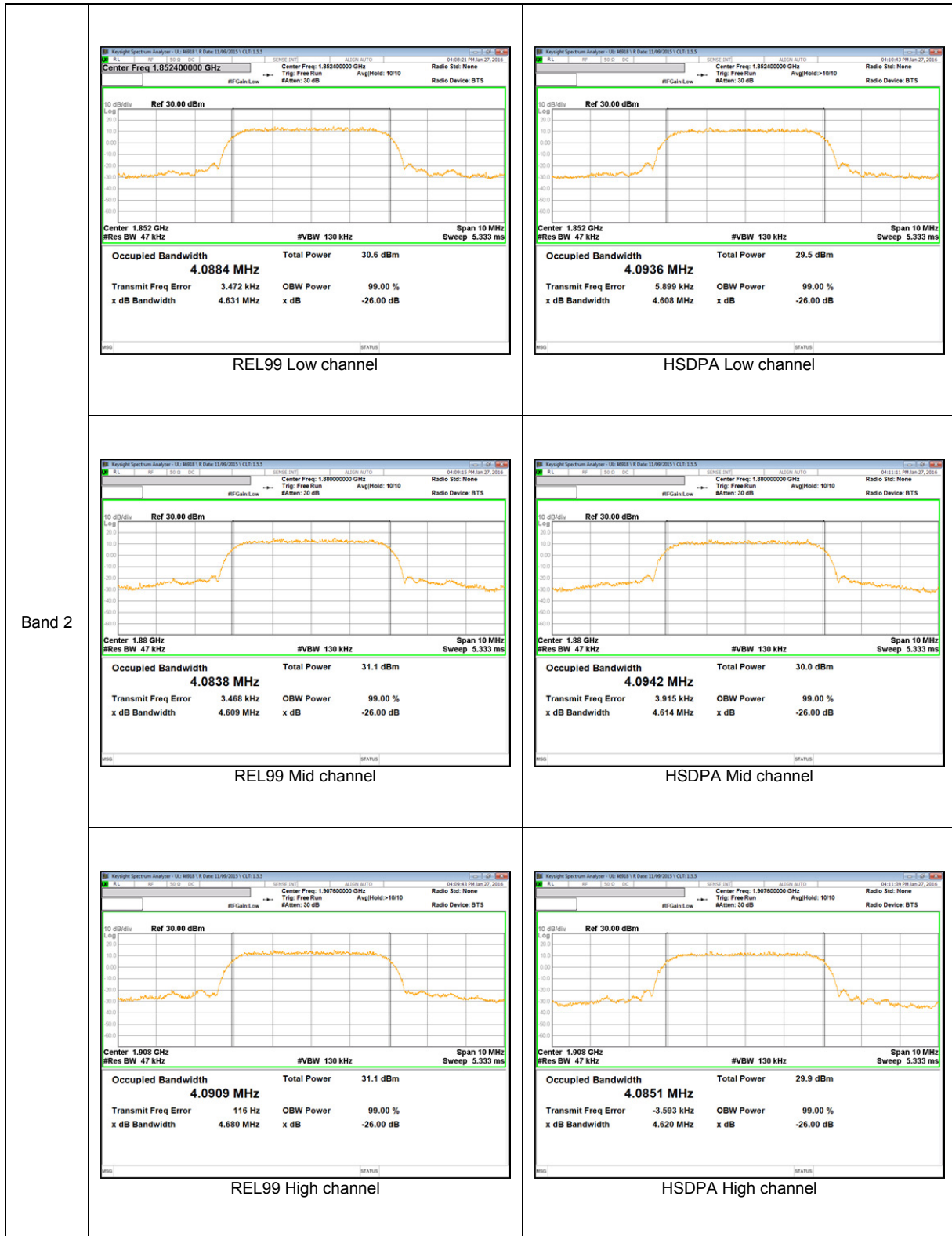

LTE Band 17

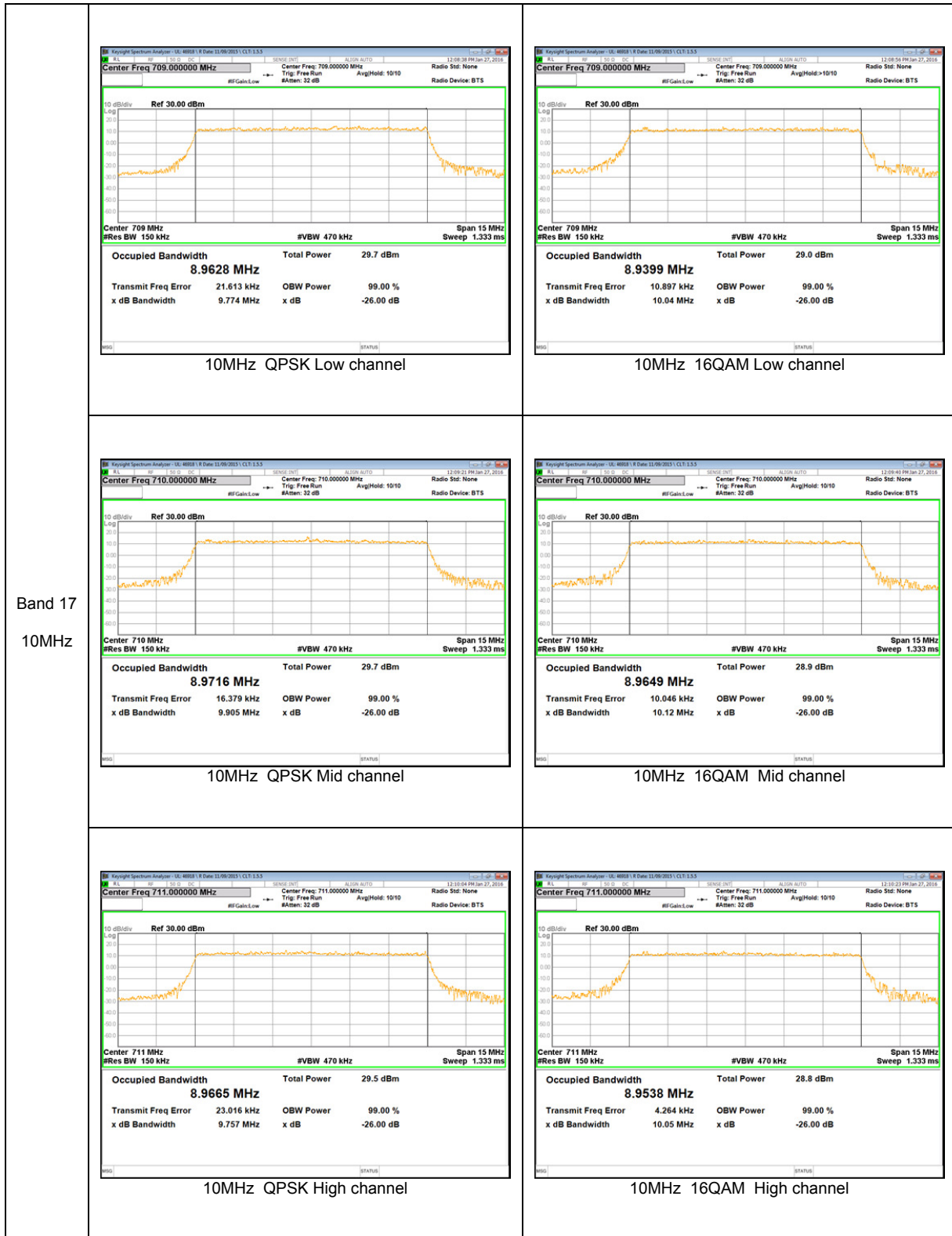

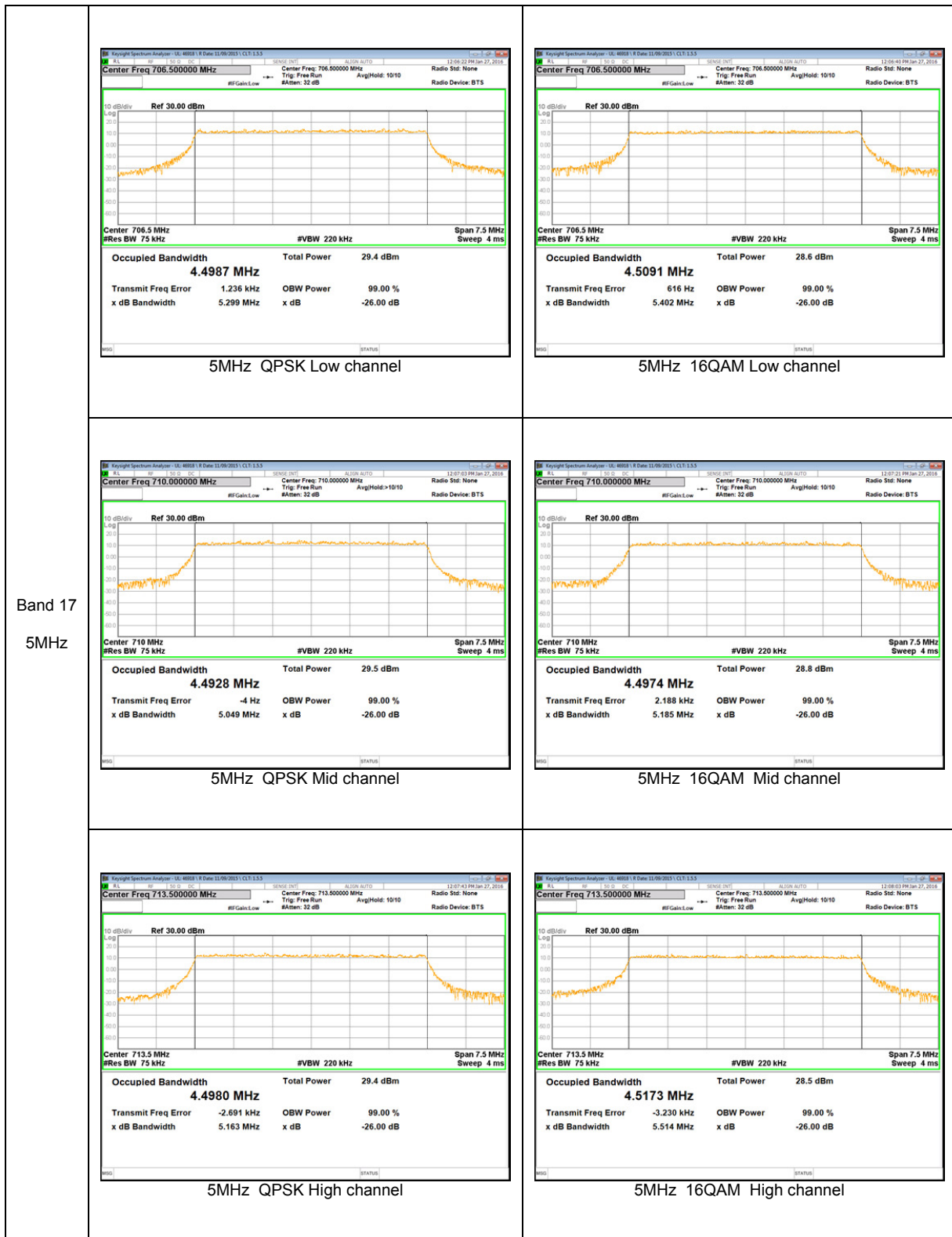

LTE Band 5

