

# FCC Carrier Aggregation REPORT

## Certification

<b>Applicant Name:</b> SAMSUNG Electronics Co., Ltd.	<b>Date of Issue:</b> November 12, 2020
<b>Address:</b> 129, Samsung-ro, Yeongtong-gu, Suwon-si, Gyeonggi-do, 16677, Rep. of Korea	<b>Location:</b> HCT CO., LTD., 74, Seoicheon-ro 578beon-gil, Majang-myeon, Icheon-si, Gyeonggi-do, 17383, Rep. of KOREA
<b>Report No.:</b> HCT-RF-2011-FC012-R1	

**FCC ID:** A3LSMG991U

**APPLICANT:** SAMSUNG Electronics Co., Ltd.

Model(s): SM-G991U  
 Additional Model(s): SM-G991U1  
 EUT Type: Mobile Phone  
 FCC Classification: PCS Licensed Transmitter Held to Ear (PCE)  
 FCC Rule Part(s): §96, §2

Mode (PCC+SCC)	Tx Frequency (MHz)	Modulation	Emission Designator	EIRP	
				Max. Power (dBm)	Max. Power (W)
5MHz+20MHz	3553.3 - 3690.0	QPSK	22M9G7D	20.37	0.109
		16QAM	23M0W7D	20.29	0.107
		64QAM	22M7W7D	18.61	0.073
		256QAM	22M8W7D	17.18	0.052
10MHz+20MHz	3555.5 - 3690.0	QPSK	27M8G7D	20.77	0.119
		16QAM	27M6W7D	20.56	0.114
		64QAM	27M7W7D	18.88	0.077
		256QAM	27M8W7D	17.34	0.054
15MHz+20MHz	3557.8 - 3690.0	QPSK	32M6G7D	20.98	0.125
		16QAM	32M4W7D	20.78	0.120
		64QAM	32M6W7D	18.96	0.079
		256QAM	32M7W7D	17.24	0.053
20MHz+5MHz	3560.0 - 3696.7	QPSK	23M0G7D	20.03	0.101
		16QAM	22M9W7D	19.61	0.091
		64QAM	22M7W7D	18.97	0.079
		256QAM	22M8W7D	17.41	0.055
20MHz+10MHz	3560.0 - 3694.5	QPSK	27M9G7D	20.71	0.118
		16QAM	27M6W7D	20.40	0.110
		64QAM	27M7W7D	18.70	0.074
		256QAM	27M8W7D	17.61	0.058
20MHz+15MHz	3560.0 - 3692.2	QPSK	32M7G7D	20.98	0.125
		16QAM	32M6W7D	20.47	0.111
		64QAM	32M5W7D	19.02	0.080
		256QAM	32M6W7D	17.98	0.063
20MHz+20MHz	3560.0 - 3690.0	QPSK	37M6G7D	21.16	0.131
		16QAM	37M3W7D	20.70	0.117
		64QAM	37M5W7D	18.68	0.074
		256QAM	37M5W7D	18.01	0.063

The measurements shown in this report were made in accordance with the procedures specified in CFR47 section §2.947. I assume full responsibility for the accuracy and completeness of these measurements, and for the qualifications of all persons taking them.

HCT CO., LTD. Certifies that no party to this application has subject to a denial of Federal benefits that includes FCC benefits pursuant to section 5301 of the Anti-Drug Abuse Act of 1998, 21 U.S.C. 853(a)

Report No.: HCT-RF-2011-FC012-R1

---

REVIEWED BY



---

Report prepared by : Jae Ryang Do  
Engineer of Telecommunication Testing Center

---

Report approved by : Jong Seok Lee  
Manager of Telecommunication Testing Center

This test results were applied only to the test methods required by the standard.

This laboratory is not accredited for the test results marked \*.

The above Test Report is the accredited test result by (KS Q) ISO/IEC 17025 and KOLAS(Korea Laboratory Accreditation Scheme), which signed the ILAC-MRA. (HCT Accreditation No.: KT197)

\* The report shall not be reproduced except in full(only partly) without approval of the laboratory.

## Version

TEST REPORT NO.	DATE	DESCRIPTION
HCT-RF-2011-FC012	November 02, 2020	- First Approval Report
HCT-RF-2011-FC012-R1	November 12, 2020	- Revised the Max power table on 1 page.

The result shown in this test report refer only to the sample(s) tested unless otherwise stated.

## Table of Contents

REVIEWED BY .....	2
1. GENERAL INFORMATION .....	5
2. INTRODUCTION .....	6
2.1. DESCRIPTION OF EUT .....	6
2.2. MEASURING INSTRUMENT CALIBRATION .....	6
2.3. TEST FACILITY .....	6
3. DESCRIPTION OF TESTS .....	7
3.1 TEST PROCEDURE .....	7
3.2 RADIATED POWER.....	8
3.3 RADIATED SPURIOUS EMISSIONS .....	9
3.4 PEAK- TO- AVERAGE RATIO.....	10
3.5 OCCUPIED BANDWIDTH. ....	12
3.6 SPURIOUS AND HARMONIC EMISSIONS AT ANTENNA TERMINAL .....	13
3.7 BAND EDGE.....	14
3.8 FREQUENCY STABILITY / VARIATION OF AMBIENT TEMPERATURE .....	16
3.9 End User Device Additional Requirement (CBSD Protocol).....	17
4. LIST OF TEST EQUIPMENT .....	18
5. MEASUREMENT UNCERTAINTY.....	19
6. SUMMARY OF TEST RESULTS .....	20
7. SAMPLE CALCULATION .....	22
8. TEST DATA .....	24
8.1 Conducted Power.....	27
8.2 Equivalent Isotropic Radiated Power.....	30
8.3 Conducted Spurious Emissions .....	33
8.4 Channel Edge.....	58
8.5 Frequency Stability / Variation Of Ambient Temperature .....	78
8.6 Radiated Spurious Emissions.....	86
8.7 Occupied Bandwidth.....	89
8.8 Peak- to- Average Ratio .....	95
9. ANNEX A_ TEST SETUP PHOTO.....	101

# MEASUREMENT REPORT

## 1. GENERAL INFORMATION

<b>Applicant Name:</b>	SAMSUNG Electronics Co., Ltd.
<b>Address:</b>	129, Samsung-ro, Yeongtong-gu, Suwon-si, Gyeonggi-do, 16677, Rep. of Korea
<b>FCC ID:</b>	A3LSMG991U
<b>Application Type:</b>	Certification
<b>FCC Classification:</b>	PCS Licensed Transmitter Held to Ear (PCE)
<b>FCC Rule Part(s):</b>	§96, §2
<b>EUT Type:</b>	Mobile Phone
<b>Model(s):</b>	SM-G991U
<b>Additional Model(s):</b>	SM-G991U1
<b>Tx Frequency:</b>	3553.3 - 3690.0: 10MHz+20MHz 3555.5 - 3690.0: 15MHz+10MHz 3557.8 - 3690.0: 15MHz+15MHz 3560.0 - 3696.7: 15MHz+20MHz 3560.0 - 3694.5: 20MHz+10MHz 3560.0 - 3692.2: 20MHz+15MHz 3560.0 - 3690.0: 20MHz+20MHz
<b>Date(s) of Tests:</b>	September 23, 2020 ~ October 31, 2020
<b>LTE CA :</b>	CA 48C (Uplink)

## **2. INTRODUCTION**

### **2.1. DESCRIPTION OF EUT**

The EUT was a Mobile Phone with GSM/GPRS/EGPRS/UMTS, CDMA(BC0, 1, 10) and LTE, Sub6.

It also supports IEEE 802.11 a/b/g/n/ac/ax (HT20/40/80), Bluetooth, BT LE, NFC, WPT, mmWave(n260/261).

### **2.2. MEASURING INSTRUMENT CALIBRATION**

The measuring equipment, which was utilized in performing the tests documented herein, has been calibrated in accordance with the manufacturer's recommendations for utilizing calibration equipment, which is traceable to recognized national standards.

### **2.3. TEST FACILITY**

The Fully-anechoic chamber and conducted measurement facility used to collect the radiated data are located at the **74, Seoicheon-ro 578beon-gil, Majang-myeon, Icheon-si, Gyeonggi-do, 17383, Rep. of KOREA.**

### 3. DESCRIPTION OF TESTS

#### 3.1 TEST PROCEDURE

Test Description	Test Procedure Used
Occupied Bandwidth	- KDB 971168 D01 v03r01 – Section 4.3 - ANSI C63.26-2015 – Section 5.4.4
Band Edge	- KDB 971168 D01 v03r01 – Section 6.0 - ANSI C63.26-2015 – Section 5.7
Spurious and Harmonic Emissions at Antenna Terminal	- KDB 971168 D01 v03r01 – Section 6.0 - ANSI C63.26-2015 – Section 5.7
Peak- to- Average Ratio	- KDB 971168 D01 v03r01 – Section 5.7 - ANSI C63.26-2015 – Section 5.2.3.4 - ANSI C63.26-2015 – Section 5.2.6(only GSM)
Frequency stability	- ANSI C63.26-2015 – Section 5.6
Effective Radiated Power/ Effective Isotropic Radiated Power	- KDB 971168 D01 v03r01 – Section 5.2 & 5.8 - ANSI/TIA-603-E-2016 – Section 2.2.17
Radiated Spurious and Harmonic Emissions	- KDB 971168 D01 v03r01 – Section 6.2 - ANSI/TIA-603-E-2016 – Section 2.2.12

## 3.2 RADIATED POWER

### Test Overview

Radiated tests are performed in the Fully-anechoic chamber.

The equipment under test is placed on a non-conductive table 3-meters away from the receive antenna in accordance with ANSI/TIA-603-E-2016 Clause 2.2.17.

### Test Settings

1. Radiated power measurements are performed using the signal analyzer's "channel power" measurement capability for signals with continuous operation.
2. RBW = 1 – 5% of the expected OBW, not to exceed 1MHz
3. VBW  $\geq$  3 x RBW
4. Span = 1.5 times the OBW
5. No. of sweep points  $>$  2 x span / RBW
6. Detector = RMS
7. Trigger is set to "free run" for signals with continuous operation with the sweep times set to "auto".
8. The integration bandwidth was roughly set equal to the measured OBW of the signal for signals with continuous operation.
9. Trace mode = trace averaging (RMS) over 100 sweeps
10. The trace was allowed to stabilize

### Test Note

1. The turntable is rotated through 360 degrees, and the receiving antenna scans in order to determine the level of the maximized emission.
2. A half wave dipole is then substituted in place of the EUT. For emissions above 1GHz, a horn antenna is substituted in place of the EUT. The substitute antenna is driven by a signal generator and the previously recorded signal was duplicated.

The power is calculated by the following formula;

$$P_{d(dBm)} = P_{g(dBm)} - \text{cable loss (dB)} + \text{antenna gain (dB)}$$

Where:  $P_d$  is the dipole equivalent power and  $P_g$  is the generator output power into the substitution antenna.

3. The maximum value is calculated by adding the forward power to the calibrated source plus its appropriate gain value.

These steps are repeated with the receiving antenna in both vertical and horizontal polarization. the difference

between the gain of the horn and an isotropic antenna are taken into consideration

4. The EUT was tested in three orthogonal planes(X, Y, Z) and in all possible test configurations and positioning.
5. All measurements are performed as RMS average measurements while the EUT is operating at its maximum duty cycle, at maximum power, and at the appropriate frequencies.



### 3.3 RADIATED SPURIOUS EMISSIONS

#### Test Overview

Radiated tests are performed in the Fully-anechoic chamber.

Radiated Spurious Emission Measurements at 3 meters by Substitution Method according to ANSI/TIA-603-E-2016.

#### Test Settings

1. RBW = 100kHz for emissions below 1GHz and 1MHz for emissions above 1GHz
2. VBW  $\geq$  3 x RBW
3. Span = 1.5 times the OBW
4. No. of sweep points  $>$  2 x span / RBW
5. Detector = Peak
6. Trace mode = Max Hold
7. The trace was allowed to stabilize
8. Test channel : Low/ Middle/ High
9. Frequency range : We are performed all frequency to 10<sup>th</sup> harmonics from 9 kHz.

#### Test Note

1. Measurements value show only up to 3 maximum emissions noted, or would be lesser if no specific emissions from the EUT are recorded (ie: margin  $>$  20 dB from the applicable limit) and considered that's already beyond the background noise floor.
2. The EUT was tested in three orthogonal planes(X, Y, Z) and in all possible test configurations and positioning. The worst case emissions are reported with the EUT positioning, modulations, RB sizes and offsets, and channel bandwidth configurations shown in the test data
3. For spurious emissions above 1GHz, a horn antenna is substituted in place of the EUT. The substitute antenna is driven by a signal generator and the previously recorded signal was duplicated. The spurious emissions is calculated by the following formula;

$$\text{Result}_{(\text{dBm})} = P_{g(\text{dBm})} - \text{cable loss}_{(\text{dB})} + \text{antenna gain}_{(\text{dBi})}$$

Where:  $P_g$  is the generator output power into the substitution antenna.

If the fundamental frequency is below 1GHz, RF output power has been converted to EIRP.

$$\text{EIRP}_{(\text{dBm})} = \text{ERP}_{(\text{dBm})} + 2.15$$

### 3.4 PEAK- TO- AVERAGE RATIO

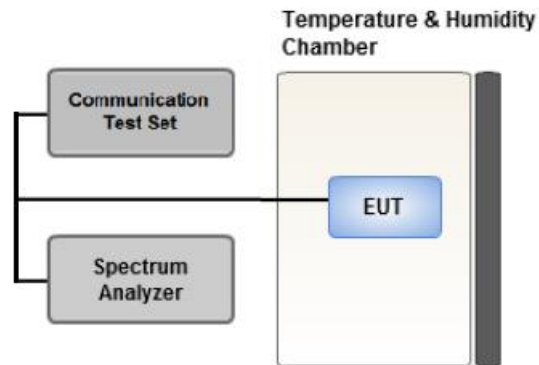

**Test setup**

#### ① CCDF Procedure for PAPR

##### **Test Settings**

1. Set resolution/measurement bandwidth  $\geq$  signal's occupied bandwidth;
2. Set the number of counts to a value that stabilizes the measured CCDF curve;
3. Set the measurement interval as follows:
  - .- for continuous transmissions, set to 1 ms,
  - .- or burst transmissions, employ an external trigger that is synchronized with the EUT burst timing sequence, or use the internal burst trigger with a trigger level that allows the burst to stabilize and set the measurement interval to a time that is less than or equal to the burst duration.
4. Record the maximum PAPR level associated with a probability of 0.1%.

**② Alternate Procedure for PAPR**

Use one of the procedures presented in 5.2(ANSI C63.26-2015) to measure the total peak power and record as  $P_{Pk}$ .

Use one of the applicable procedures presented 5.2(ANSI C63.26-2015) to measure the total average power and record as  $P_{Avg}$ . Determine the P.A.R. from:

$$P.A.R_{(dB)} = P_{Pk (dBm)} - P_{Avg (dBm)} \quad (P_{Avg} = \text{Average Power} + \text{Duty cycle Factor})$$

**Test Settings(Peak Power)**

The measurement instrument must have a RBW that is greater than or equal to the OBW of the signal to be measured and a VBW  $\geq 3 \times$  RBW.

1. Set the RBW  $\geq$  OBW.
2. Set VBW  $\geq 3 \times$  RBW.
3. Set span  $\geq 2 \times$  OBW.
4. Sweep time  $\geq 10 \times$  (number of points in sweep)  $\times$  (transmission symbol period).
5. Detector = peak.
6. Trace mode = max hold.
7. Allow trace to fully stabilize.
8. Use the peak marker function to determine the peak amplitude level.

**Test Settings(Average Power)**

1. Set span to 2  $\times$  to 3  $\times$  the OBW.
2. Set RBW  $\geq$  OBW.
3. Set VBW  $\geq 3 \times$  RBW.
4. Set number of measurement points in sweep  $\geq 2 \times$  span / RBW.
5. Sweep time:  
Set  $\geq [10 \times (\text{number of points in sweep}) \times (\text{transmission period})]$  for single sweep (automation-compatible) measurement. The transmission period is the (on + off) time.
6. Detector = power averaging (rms).
7. Set sweep trigger to "free run."
8. Trace average at least 100 traces in power averaging (rms) mode if sweep is set to auto-couple. (To accurately determine the average power over the on and off period of the transmitter, it can be necessary to increase the number of traces to be averaged above 100 or, if using a manually configured sweep time, increase the sweep time.)
9. Use the peak marker function to determine the maximum amplitude level.
10. Add  $[10 \log (1/\text{duty cycle})]$  to the measured maximum power level to compute the average power during continuous transmission. For example, add  $[10 \log (1/0.25)] = 6 \text{ dB}$  if the duty cycle is a constant 25%.

### 3.5 OCCUPIED BANDWIDTH.

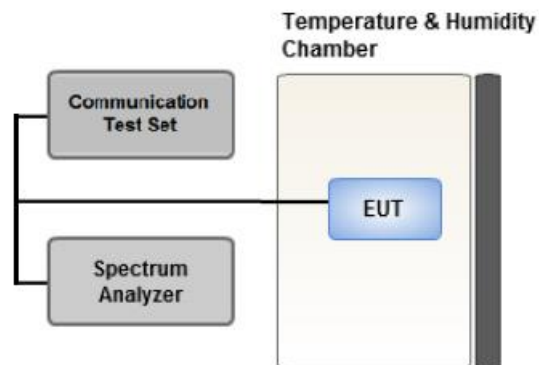

#### Test setup

The width of a frequency band such that, below the lower and above the upper frequency limits, the mean powers emitted are each equal to a specified percentage 0.5 % of the total mean power of a given emission.

The EUT makes a call to the communication simulator.

The conducted occupied bandwidth used the power splitter via EUT RF power connector between simulation base station and spectrum analyzer.

The communication simulator station system controlled a EUT to export maximum output power under transmission mode and specific channel frequency. Use OBW measurement function of Spectrum analyzer to measure 99 % occupied bandwidth

#### Test Settings

1. The signal analyzer's automatic bandwidth measurement capability was used to perform the 99% occupied bandwidth and the 26dB bandwidth. The bandwidth measurement was not influenced by any intermediate power nulls in the fundamental emission.
2. RBW = 1 – 5% of the expected OBW
3. VBW  $\geq 3 \times$  RBW
4. Detector = Peak
5. Trace mode = max hold
6. Sweep = auto couple
7. The trace was allowed to stabilize
8. If necessary, steps 2 – 7 were repeated after changing the RBW such that it would be within 1 – 5% of the 99% occupied bandwidth observed in Step 7

### 3.6 SPURIOUS AND HARMONIC EMISSIONS AT ANTENNA TERMINAL

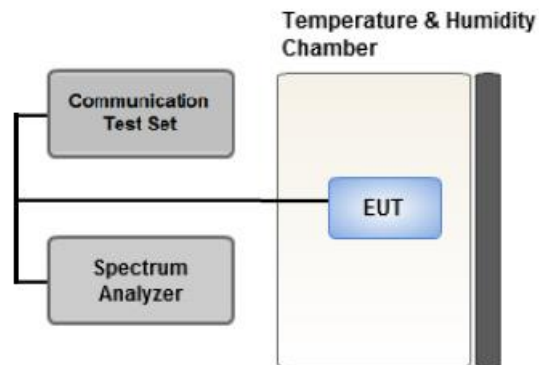

**Test setup**

#### **Test Overview**

The level of the carrier and the various conducted spurious and harmonic frequencies is measured by means of a calibrated spectrum analyzer. The spectrum is scanned from the lowest frequency generated in the equipment up to a frequency including its 10th harmonic.

All out of band emissions are measured with a spectrum analyzer connected to the antenna terminal of the EUT while the EUT is operating at its maximum duty cycle, at maximum power, and at the appropriate frequencies.

All data rates were investigated to determine the worst case configuration. All modes of operation were investigated and the worst case configuration results are reported in this section.

#### **Test Settings**

1. RBW = 1 MHz
2. VBW  $\geq$  3 MHz
3. Detector = RMS
4. Trace Mode = trace average
5. Sweep time = auto
6. Number of points in sweep  $\geq$  2 x Span / RBW

### 3.7 BAND EDGE

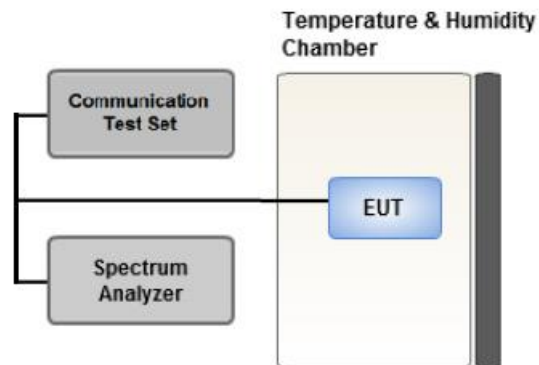

**Test setup**

#### **Test Overview**

All out of band emissions are measured with a spectrum analyzer connected to the antenna terminal of the EUT while the EUT is operating at its maximum duty cycle, at maximum power, and at the appropriate frequencies. All data rates were investigated to determine the worst case configuration. All modes of operation were investigated and the worst case configuration results are reported in this section.

#### **Test Settings**

1. Start and stop frequency were set such that the band edge would be placed in the center of the plot
2. Span was set large enough so as to capture all out of band emissions near the band edge
3. RBW > 1% of the emission bandwidth
4. VBW > 3 x RBW
5. Detector = RMS
6. Number of sweep points  $\geq 2 \times \text{Span/RBW}$
7. Trace mode = trace average
8. Sweep time = auto couple
9. The trace was allowed to stabilize

**Test Notes**

According to FCC 22.917, 24.238, 27.53 specified that power of any emission outside of The authorized operating frequency ranges must be attenuated below the transmitting power (P) by a factor of at least  $43 + 10 \log(P)$  dB. In the 1 MHz bands immediately outside and adjacent to the frequency block a resolution bandwidth of at least one percent of the emission bandwidth of the fundamental emission of the transmitter may be employed.

All measurements were done at 2 channels(low and high operational frequency range.)

The band edge measurement used the power splitter via EUT RF power connector between simulation base station and spectrum analyzer.

### 3.8 FREQUENCY STABILITY / VARIATION OF AMBIENT TEMPERATURE

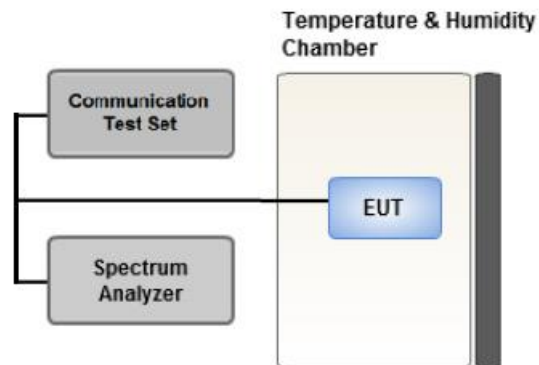

#### Test setup

#### Test Overview

Frequency stability testing is performed in accordance with the guidelines of ANSI C63.26-2015.

The frequency stability of the transmitter is measured by:

1. Temperature:

The temperature is varied from -30°C to +50°C in 10°C increments using an environmental chamber.

2. Primary Supply Voltage:

.- Unless otherwise specified, vary primary supply voltage from 85% to 115% of the nominal value for other than hand carried battery equipment.

.- For hand carried, battery powered equipment, reduce the primary ac or dc supply voltage to the battery operating end point, which shall be specified by the manufacturer.

#### Test Settings

1. The carrier frequency of the transmitter is measured at room temperature

(20°C to provide a reference).

2. The equipment is turned on in a "standby" condition for fifteen minutes before applying power to the transmitter.

Measurement of the carrier frequency of the transmitter is made within one minute after applying power to the transmitter.

3. Frequency measurements are made at 10°C intervals ranging from -30°C to +50°C. A period of at

least one half-hour is provided to allow stabilization of the equipment at each temperature level.



### 3.9 End User Device Additional Requirement (CBSD Protocol)

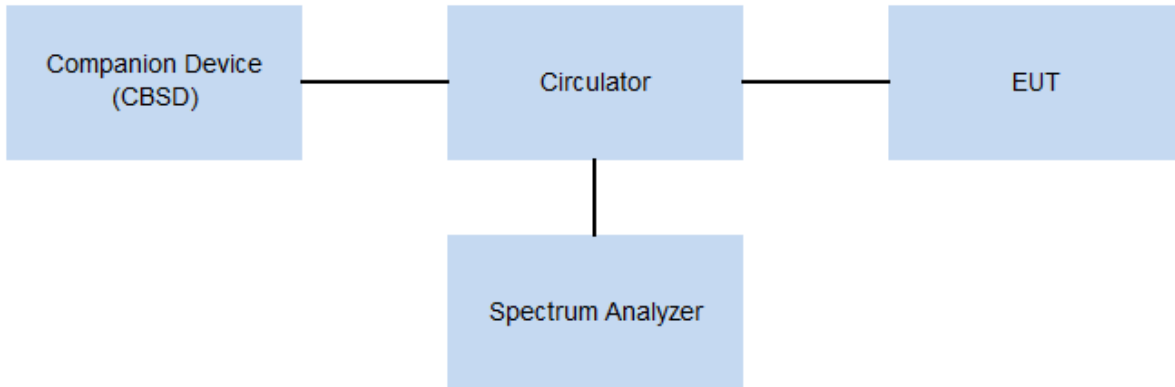

**Test setup**

#### **Test Overview**

End user device additional requirements (CBSD Protocol) are tested per the test procedures listed below. During testing, the EUT is connected to a certified CBSD (FCC ID: 2AS48SC-220) as a companion device to show compliance with Part 96.47.

End User Devices may operate only if they can positively receive and decode an authorization signal transmitted by a CBSD, including the frequencies and power limits for their operation.

#### **Test Settings**

- a. Setup companion device with 3570MHz & 3610MHz.
- b. Enable AP service from companion device.
- c. EUT is connected to a companion device.
- c. Check EUT Tx frequency and power.
- d. Disable AP service from companion device and check EUT stop transmission within 10s .

#### 4. LIST OF TEST EQUIPMENT

Manufacture	Model/ Equipment	Serial Number	Calibration Date	Calibrati on Interval	Calibration Due
T&M SYSTEM	FBSR-02B(WHK1.2/15G-10EF)/H.P.F	-	03/09/2020	Annual	03/09/2021
T&M SYSTEM	FBSR-02B(WHK3.3/18G-10EF)/H.P.F	-	03/09/2020	Annual	03/09/2021
Hewlett Packard	11667B / Power Splitter(DC~26.5 GHz)	11275	04/27/2020	Annual	04/27/2021
Hewlett Packard	E3632A/DC Power Supply	MY40004427	09/16/2020	Annual	09/16/2021
Schwarzbeck	UHAP/ Dipole Antenna	557	03/29/2019	Biennial	03/29/2021
Schwarzbeck	UHAP/ Dipole Antenna	558	03/29/2019	Biennial	03/29/2021
ESPEC	SU-642 / Chamber	93008124	03/18/2020	Annual	03/18/2021
Schwarzbeck	BBHA 9120D/ Horn Antenna(1~18GHz)	147	08/29/2019	Biennial	08/29/2021
Schwarzbeck	BBHA 9120D/ Horn Antenna(1~18GHz)	9120D-1298	09/25/2019	Biennial	09/25/2021
Schwarzbeck	BBHA 9170/ Horn Antenna(15~40GHz)	BBHA9170342	04/29/2019	Biennial	04/29/2021
Schwarzbeck	BBHA 9170/ Horn Antenna(15~40GHz)	BBHA9170124	02/11/2020	Biennial	02/11/2022
Agilent	N9020A/Signal Analyzer(10Hz~26.5GHz)	MY51110063	04/27/2020	Annual	04/27/2021
Hewlett Packard	8493C/ATTENUATOR(20dB)	17280	06/04/2020	Annual	06/04/2021
REOHDE & SCHWARZ	FSV40/Spectrum Analyzer(10Hz~40GHz)	100931	10/14/2020	Annual	10/14/2021
Agilent	8960 (E5515C)/ Base Station	MY48360800	08/26/2020	Annual	08/26/2021
Schwarzbeck	FMZB1513/ Loop Antenna(9kHz~30MHz)	1513-175	04/26/2019	Biennial	04/26/2021
Schwarzbeck	VULB9160/ Bilog Antenna	3150	03/12/2019	Biennial	03/12/2021
Schwarzbeck	VULB9160/ Hybrid Antenna	760	03/22/2019	Biennial	03/22/2021
Anritsu Corp.	MT8821C/Wideband Radio Communication Tester	6262116770	07/22/2020	Annual	07/22/2021
Anritsu Corp.	MT8820C/Wideband Radio Communication Tester	6201026545	01/22/2020	Annual	01/22/2021
REOHDE & SCHWARZ	SMB100A/ SIGNAL GENERATOR (100kHz~40GHz)	177633	07/13/2020	Annual	07/13/2021
KEYSIGHT	N9030B / Signal Analyzer(5Hz~40.0GHz)	MY55480167	06/04/2020	Annual	06/04/2021
HCT CO., LTD.,	FCC LTE Mobile Conducted RF Automation Test Software	-	-	-	-

Note:

- Equipment listed above that has a calibration due date during the testing period, the testing is completed before equipment expiration date.
- Especially, all antenna for measurement is calibrated in accordance with the requirements of C63.5 (Version : 2017).
- Model : FSV40/Spectrum  
- Use date of equipment: September 23, 2020 ~ October 12, 2020, October 14, 2020 ~

## 5. MEASUREMENT UNCERTAINTY

The measurement uncertainties shown below were calculated in accordance with the requirements of ANSI C63.4:2014. All measurement uncertainty values are shown with a coverage factor of  $k = 2$  to indicate a 95 % level of confidence. The measurement data shown herein meets or exceeds the  $U_{\text{CISPR}}$  measurement uncertainty values specified in CISPR 16-4-2 and, thus, can be compared directly to specified limits to determine compliance.

Parameter	Expanded Uncertainty ( $\pm$ dB)
Conducted Disturbance (150 kHz ~ 30 MHz)	1.82
Radiated Disturbance (9 kHz ~ 30 MHz)	3.40
Radiated Disturbance (30 MHz ~ 1 GHz)	4.80
Radiated Disturbance (1 GHz ~ 18 GHz)	5.70
Radiated Disturbance (18 GHz ~ 40 GHz)	5.05

## 6. SUMMARY OF TEST RESULTS

### 6.1 Test Condition : Conducted Test

Test Description	FCC Part Section(s)	Test Limit	Test Result
Occupied Bandwidth	§2.1049	N/A	PASS
Band Edge / Spurious and Harmonic Emissions at Antenna Terminal.	§2.1051, §96.41(e)	<ul style="list-style-type: none"> <li>■ -13 dBm/Mhz at frequencies within 0-10MHz of channel edge</li> <li>■ -25 dBm/MHz at frequencies greater than 10MHz above and below channel edge</li> <li>■ -40 dBm/MHz at frequencies below 3530 MHz and above 3720 MHz</li> </ul>	PASS
Conducted Output Power	§2.1046	N/A	<u>See Note1</u>
Frequency stability / variation of ambient temperature	§2.1055,	Emission must remain in band	PASS
End User Device Additional Requirements (CBSD Protocol)	§96.47	<p>End User Devices may operate only if they can positively receive and decode an authorization signal transmitted by a CBSD, including the frequencies and power limits for their operation.</p> <p>An End User Device must discontinue operations, change frequencies, or change its operational power level within 10 seconds of receiving instructions from its associated CBSD.</p>	PASS (See Note4)

Note:

1. See SAR Report
2. The same samples were used for SAR and EMC
3. The EUT is an End User Device
4. See RF Test Report LTE B48 Report

**6.2 Test Condition : Radiated Test**

Test Description	FCC Part Section(s)	Test Limit	Test Result
Equivalent Isotropic Radiated Power	§96.41(b)	23 dBm/10MHz	PASS
Radiated Spurious and Harmonic Emissions	§2.1053, §96.41(e)	-40 dBm/MHz	PASS

## 7. SAMPLE CALCULATION

### 7.1 ERP Sample Calculation

Ch./ Freq.		Measured Level(dBm)	Substitute Level(dBm)	Ant. Gain (dBd)	C.L	Pol.	ERP	
channel	Freq.(MHz)						W	dBm
128	824.20	-21.37	38.40	-10.61	0.95	H	0.483	26.84

**ERP = Substitute LEVEL(dBm) + Ant. Gain – CL(Cable Loss)**

- 1) The EUT mounted on a non-conductive turntable is 2.5 meter above test site ground level.
- 2) During the test , the turn table is rotated until the maximum signal is found.
- 3) Record the field strength meter’s level.
- 4) Replace the EUT with dipole/Horn antenna that is connected to a calibrated signal generator.
- 5) Increase the signal generator output till the field strength meter’s level is equal to the item (3).
- 6) The signal generator output level with Ant. Gain and cable loss are the rating of effective radiated power.

### 7.2 EIRP Sample Calculation

Ch./ Freq.		Measured Level(dBm)	Substitute Level(dBm)	Ant. Gain (dBi)	C.L	Pol.	EIRP	
channel	Freq.(MHz)						W	dBm
20175	1,732.50	-15.75	18.45	9.90	1.76	H	0.456	26.59

**EIRP = Substitute LEVEL(dBm) + Ant. Gain – CL(Cable Loss)**

- 1) The EUT mounted on a non-conductive turntable is 2.5 meter above test site ground level.
- 2) During the test , the turn table is rotated until the maximum signal is found.
- 3) Record the field strength meter’s level.
- 4) Replace the EUT with dipole/Horn antenna that is connected to a calibrated signal generator.
- 5) Increase the signal generator output till the field strength meter’s level is equal to the item (3).
- 6) The signal generator output level with Ant. Gain and cable loss are the rating of equivalent isotropic radiated power.

**7.3. Emission Designator**

**GSM Emission Designator**

**Emission Designator = 249KGXW**

GSM BW = 249 kHz

G = Phase Modulation

X = Cases not otherwise covered

W = Combination (Audio/Data)

**EDGE Emission Designator**

**Emission Designator = 249KG7W**

GSM BW = 249 kHz

G = Phase Modulation

7 = Quantized/Digital Info

W = Combination (Audio/Data)

**WCDMA Emission Designator**

**Emission Designator = 4M17F9W**

WCDMA BW = 4.17 MHz

F = Frequency Modulation

9 = Composite Digital Info

W = Combination (Audio/Data)

**QPSK Modulation**

**Emission Designator = 4M48G7D**

LTE BW = 4.48 MHz

G = Phase Modulation

7 = Quantized/Digital Info

D = Data transmission; telemetry; telecommand

**QAM Modulation**

Emission Designator = 4M48W7D

LTE BW = 4.48 MHz

W = Amplitude/Angle Modulated

7 = Quantized/Digital Info

D = Data transmission; telemetry; telecommand

## 8. TEST DATA

### Test Overview

The EUT is set up to transmit two contiguous LTE channels. The power level of both carriers and the various conducted spurious and harmonic frequencies is measured by means of a calibrated spectrum analyzer. The spectrum is scanned from the lowest frequency generated in the equipment up to a frequency including its 10<sup>th</sup> harmonic. All out of band emissions are measured with a spectrum analyzer connected to the antenna terminal of the EUT while the EUT is operating at its maximum duty cycle, at maximum power, and at the appropriate frequencies. All data rates were investigated to determine the worst case configuration. All modes of operation were investigated and the worst case configuration results are reported in this section.

### Test Note

1. All tests were evaluated for the two contiguous channels using various combinations of RB size, RB offset, modulation, and channel bandwidth.
2. Channel bandwidth is shown in the tables below based only on the channel bandwidths that were supported in this device.

<b>Channel Bandwidth (PCC)</b>	<b>Channel Bandwidth (SCC)</b>	<b>Maximum aggregated bandwidth (MHz)</b>
5	20	25
10	20	30
15	20	35
20	5	25
20	10	30
20	15	35
20	20	40



3. All modes of operation were investigated and the worst case configuration results are reported in this section.

Please refer to the table below.

- Worst case(Conducted Spurious Emissions, BandEdge)  
: We have selected higher of the Conduction Output Power.
- Worst case(Radiated Spurious Emissions) : We have selected higher of the EIRP.
- Worst case(OBW, PAR, Frequency stability)  
: All modes of operation were investigated and the worst case configuration results are reported.

[ Worst case ]

Test Description	Mod	Operating frequency	PCC					SCC				
			BW (MHz)	Freq. (MHz)	Ch.	RB	RB Offset	BW (MHz)	Freq. (MHz)	Ch.	RB	RB Offset
Conducted Spurious Emissions/ Band Edge	QPSK	Low	20	3560.0	55340	1	99	20	3579.8	55538	1	0
	QPSK	Mid	15	3615.3	55893	1	74	20	3632.4	56064	1	0
	QPSK	High	20	3670.2	56442	1	99	20	3690.0	56640	1	0
	QPSK	Low	20	3560.0	55340	1	0	20	3579.8	55538	1	99
	QPSK	Mid	15	3615.3	55893	1	0	20	3632.4	56064	1	99
	QPSK	High	20	3670.2	56442	1	0	20	3690.0	56640	1	99
	QPSK	Low	20	3560.0	55340	100	0	10	3574.4	55484	50	0
	QPSK	Mid	20	3622.5	55965	100	0	5	3634.2	56082	25	0
	QPSK	High	20	3680.1	56541	100	0	10	3694.5	56685	50	0
	QPSK	Low	20	3560.0	55340	100	0	20	3579.8	55538	100	0
	QPSK	Mid	20	3615.1	55891	100	0	20	3634.9	56089	100	0
	QPSK	High	20	3670.2	56442	100	0	20	3690.0	56640	100	0
Radiated Spurious Emissions	QPSK	Low	20	3560.0	55340	1	99	20	3579.8	55538	1	0
	QPSK	Mid	20	3615.1	55891	1	99	20	3634.9	56089	1	0
	QPSK	High	20	3670.2	56442	1	99	20	3690.0	56640	1	0

[ Worst case ]

Test Description	Mod	Operating frequency	PCC					SCC				
			BW (MHz)	Freq. (MHz)	Ch.	RB	RB Offset	BW (MHz)	Freq. (MHz)	Ch.	RB	RB Offset
OBW, PAR	QPSK, 16QAM, 64QAM, 256QAM	Mid	5	3615.8	55898	25	0	20	3627.5	56015	100	0
			10	3615.6	55896	50	0	20	3630.0	56040	100	0
			15	3615.3	55893	75	0	20	3632.4	56064	100	0
			20	3622.5	55965	100	0	5	3634.2	56082	25	0
			20	3620.1	55941	100	0	10	3634.5	56085	50	0
			20	3617.6	55916	100	0	15	3634.7	56087	75	0
			20	3615.1	55891	100	0	20	3634.9	56089	100	0
Frequency stability	QPSK	Low	5	3553.3	55273	25	0	20	3565.0	55390	100	0
			10	3555.5	55295	50	0	20	3569.9	55439	100	0
			15	3557.8	55318	75	0	10	3574.9	55489	50	0
			20	3560.0	55340	100	0	20	3579.8	55538	100	0
		High	5	3678.3	56523	25	0	20	3690.0	56640	100	0
			10	3675.6	56496	50	0	20	3690.0	56640	100	0
			15	3672.9	56469	75	0	10	3690.0	56640	50	0
			20	3670.2	56442	100	0	20	3690.0	56640	100	0

**8.1 Conducted Power**

Operating frequency	PCC					SCC					Conducted. Power [dBm]
	Bandwidth [MHz]	Freq. (MHz)	Channel	RB	RB Offset	Bandwidth [MHz]	Freq. (MHz)	Channel	RB	RB Offset	
Low	5	3553.3	55273	1	24	20	3565.0	55390	1	0	18.86
	10	3555.5	55295	1	49	20	3569.9	55439	1	0	18.37
	15	3557.8	55318	1	74	20	3574.9	55489	1	0	18.38
	20	3560.0	55340	1	99	5	3571.7	55457	1	0	19.22
	20	3560.0	55340	1	99	10	3574.4	55484	1	0	18.11
	20	3560.0	55340	1	99	15	3577.1	55511	1	0	18.23
	<b>20</b>	<b>3560.0</b>	<b>55340</b>	<b>1</b>	<b>99</b>	<b>20</b>	<b>3579.8</b>	<b>55538</b>	<b>1</b>	<b>0</b>	<b>20.14</b>
Mid	5	3615.8	55898	1	24	20	3627.5	56015	1	0	22.11
	10	3615.6	55896	1	49	20	3630.0	56040	1	0	22.62
	<b>15</b>	<b>3615.3</b>	<b>55893</b>	<b>1</b>	<b>74</b>	<b>20</b>	<b>3632.4</b>	<b>56064</b>	<b>1</b>	<b>0</b>	<b>22.89</b>
	20	3622.5	55965	1	99	5	3634.2	56082	1	0	22.11
	20	3620.1	55941	1	99	10	3634.5	56085	1	0	22.55
	20	3617.6	55916	1	99	15	3634.7	56087	1	0	22.63
	20	3615.1	55891	1	99	20	3634.9	56089	1	0	22.67
High	5	3678.3	56523	1	24	20	3690.0	56640	1	0	19.16
	10	3675.6	56496	1	49	20	3690.0	56640	1	0	18.58
	15	3672.9	56469	1	74	20	3690.0	56640	1	0	18.51
	20	3685.0	56590	1	99	5	3696.7	56707	1	0	19.78
	20	3680.1	56541	1	99	10	3694.5	56685	1	0	18.68
	20	3675.1	56491	1	99	15	3692.2	56662	1	0	18.62
	<b>20</b>	<b>3670.2</b>	<b>56442</b>	<b>1</b>	<b>99</b>	<b>20</b>	<b>3690.0</b>	<b>56640</b>	<b>1</b>	<b>0</b>	<b>20.23</b>

Note:

Modulation : QPSK(1RB)

Operating frequency	PCC					SCC					Conducted.
	Bandwidth [MHz]	Freq. (MHz)	Channel	RB	RB Offset	Bandwidth [MHz]	Freq. (MHz)	Channel	RB	RB Offset	Power [dBm]
Low	5	3553.3	55273	25	0	20	3565.0	55390	100	0	12.53
	10	3555.5	55295	50	0	20	3569.9	55439	100	0	13.56
	15	3557.8	55318	75	0	20	3574.9	55489	100	0	13.54
	20	3560.0	55340	100	0	5	3571.7	55457	25	0	12.59
	<b>20</b>	<b>3560.0</b>	<b>55340</b>	<b>100</b>	<b>0</b>	<b>10</b>	<b>3574.4</b>	<b>55484</b>	<b>50</b>	<b>0</b>	<b>13.74</b>
	20	3560.0	55340	100	0	15	3577.1	55511	75	0	13.54
	20	3560.0	55340	100	0	20	3579.8	55538	100	0	13.49
Mid	5	3615.8	55898	25	0	20	3627.5	56015	100	0	20.23
	10	3615.6	55896	50	0	20	3630.0	56040	100	0	19.74
	15	3615.3	55893	75	0	20	3632.4	56064	100	0	19.68
	<b>20</b>	<b>3622.5</b>	<b>55965</b>	<b>100</b>	<b>0</b>	<b>5</b>	<b>3634.2</b>	<b>56082</b>	<b>25</b>	<b>0</b>	<b>20.38</b>
	20	3620.1	55941	100	0	10	3634.5	56085	50	0	19.80
	20	3617.6	55916	100	0	15	3634.7	56087	75	0	19.79
	20	3615.1	55891	100	0	20	3634.9	56089	100	0	19.80
High	5	3678.3	56523	25	0	20	3690.0	56640	100	0	12.90
	10	3675.6	56496	50	0	20	3690.0	56640	100	0	13.92
	15	3672.9	56469	75	0	20	3690.0	56640	100	0	13.81
	20	3685.0	56590	100	0	5	3696.7	56707	25	0	12.95
	<b>20</b>	<b>3680.1</b>	<b>56541</b>	<b>100</b>	<b>0</b>	<b>10</b>	<b>3694.5</b>	<b>56685</b>	<b>50</b>	<b>0</b>	<b>13.93</b>
	20	3675.1	56491	100	0	15	3692.2	56662	75	0	13.88
	20	3670.2	56442	100	0	20	3690.0	56640	100	0	13.77

Note:

Modulation : QPSK(Full RB)

Operating frequency	PCC					SCC					Conducted. Power [dBm]
	Bandwidth [MHz]	Freq. (MHz)	Channel	RB	RB Offset	Bandwidth [MHz]	Freq. (MHz)	Channel	RB	RB Offset	
Low	20	3560.0	55340	1	99	20	3579.8	55538	1	0	20.12
Mid	15	3615.3	55893	1	74	20	3632.4	56064	1	0	22.74
High	20	3670.2	56442	1	99	20	3690.0	56640	1	0	20.19
Low	20	3560.0	55340	100	0	10	3574.4	55484	50	0	13.73
Mid	20	3622.5	55965	100	0	5	3634.2	56082	25	0	20.27
High	20	3680.1	56541	100	0	10	3694.5	56685	50	0	13.92

Note:

Modulation : 16QAM

Operating frequency	PCC					SCC					Conducted. Power [dBm]
	Bandwidth [MHz]	Freq. (MHz)	Channel	RB	RB Offset	Bandwidth [MHz]	Freq. (MHz)	Channel	RB	RB Offset	
Low	20	3560.0	55340	1	99	20	3579.8	55538	1	0	20.02
Mid	15	3615.3	55893	1	74	20	3632.4	56064	1	0	22.56
High	20	3670.2	56442	1	99	20	3690.0	56640	1	0	20.30
Low	20	3560.0	55340	100	0	10	3574.4	55484	50	0	13.63
Mid	20	3622.5	55965	100	0	5	3634.2	56082	25	0	20.42
High	20	3680.1	56541	100	0	10	3694.5	56685	50	0	13.87

Note:

Modulation : 64QAM

Operating frequency	PCC					SCC					Conducted. Power [dBm]
	Bandwidth [MHz]	Freq. (MHz)	Channel	RB	RB Offset	Bandwidth [MHz]	Freq. (MHz)	Channel	RB	RB Offset	
Low	20	3560.0	55340	1	99	20	3579.8	55538	1	0	19.58
Mid	15	3615.3	55893	1	74	20	3632.4	56064	1	0	19.37
High	20	3670.2	56442	1	99	20	3690.0	56640	1	0	19.81
Low	20	3560.0	55340	100	0	10	3574.4	55484	50	0	13.66
Mid	20	3622.5	55965	100	0	5	3634.2	56082	25	0	19.39
High	20	3680.1	56541	100	0	10	3694.5	56685	50	0	13.92

Note:

Modulation : 256QAM

**8.2 Equivalent Isotropic Radiated Power**

	PCC			SCC			Measured Level (dBm)	Substitute Level (dBm)	Ant. Gain (dBi)	C.L	Pol.	E.I.R.P	
	BW [MHz]	Channel	RB/Offset	BW [MHz]	Channel	RB/Offset						W	dBm
Low	5	55273	1/24	20	55390	1/0	-30.50	8.39	12.14	3.02	H	0.06	17.51
	10	55295	1/49	20	55439	1/0	-30.73	8.16	12.14	3.02	H	0.05	17.28
	15	55318	1/74	20	55489	1/0	-31.13	7.76	12.14	3.02	H	0.05	16.88
	20	55340	1/99	5	55457	1/0	-29.80	9.09	12.14	3.02	H	0.07	18.21
	20	55340	1/99	10	55484	1/0	-31.19	7.70	12.14	3.02	H	0.05	16.82
	20	55340	1/99	15	55511	1/0	-31.02	7.87	12.14	3.02	H	0.05	16.99
	<b>20</b>	<b>55340</b>	<b>1/99</b>	<b>20</b>	<b>55538</b>	<b>1/0</b>	<b>-29.21</b>	<b>9.68</b>	<b>12.14</b>	<b>3.02</b>	<b>H</b>	<b>0.08</b>	<b>18.80</b>
	Mid	5	55898	1/24	20	56015	1/0	-27.89	11.16	12.25	3.05	H	0.11
10		55896	1/49	20	56040	1/0	-27.49	11.56	12.25	3.05	H	0.12	20.77
15		55893	1/74	20	56064	1/0	-27.28	11.77	12.25	3.05	H	0.13	20.98
20		55965	1/99	5	56082	1/0	-28.23	10.82	12.25	3.05	H	0.10	20.03
20		55941	1/99	10	56085	1/0	-27.55	11.50	12.25	3.05	H	0.12	20.71
20		55916	1/99	15	56087	1/0	-27.28	11.77	12.25	3.05	H	0.13	20.98
<b>20</b>		<b>55891</b>	<b>1/99</b>	<b>20</b>	<b>56089</b>	<b>1/0</b>	<b>-27.10</b>	<b>11.95</b>	<b>12.25</b>	<b>3.05</b>	<b>H</b>	<b>0.13</b>	<b>21.16</b>
High	5	56523	1/24	20	56640	1/0	-32.35	6.77	12.37	3.07	H	0.04	16.07
	10	56496	1/49	20	56640	1/0	-33.15	5.97	12.37	3.07	H	0.03	15.27
	15	56469	1/74	20	56640	1/0	-32.75	6.37	12.37	3.07	H	0.04	15.67
	20	56590	1/99	5	56707	1/0	-31.75	7.37	12.37	3.07	H	0.05	16.67
	20	56541	1/99	10	56685	1/0	-33.16	5.96	12.37	3.07	H	0.03	15.26
	20	56491	1/99	15	56662	1/0	-33.01	6.11	12.37	3.07	H	0.03	15.41
	<b>20</b>	<b>56442</b>	<b>1/99</b>	<b>20</b>	<b>56640</b>	<b>1/0</b>	<b>-31.14</b>	<b>7.98</b>	<b>12.37</b>	<b>3.07</b>	<b>H</b>	<b>0.05</b>	<b>17.28</b>

Note:

1. Modulation : QPSK
2. Limit : < 2 Watts

PCC			SCC			Measured Level (dBm)	Substitute Level (dBm)	Ant. Gain (dBi)	C.L	Pol.	E.I.R.P	
BW [MHz]	Channel	RB/Offset	BW [MHz]	Channel	RB/Offset						W	dBm
20	55340	1/99	20	55538	1/0	-29.67	9.22	12.14	3.02	H	0.07	18.34
5	55898	1/24	20	56015	1/0	-27.97	11.08	12.25	3.05	H	0.11	20.29
10	55896	1/49	20	56040	1/0	-27.70	11.35	12.25	3.05	H	0.11	20.56
15	55893	1/74	20	56064	1/0	-27.48	11.57	12.25	3.05	H	0.12	20.78
20	55965	1/99	5	56082	1/0	-28.65	10.40	12.25	3.05	H	0.09	19.61
20	55941	1/99	10	56085	1/0	-27.86	11.19	12.25	3.05	H	0.11	20.40
20	55916	1/99	15	56087	1/0	-27.79	11.26	12.25	3.05	H	0.11	20.47
20	55891	1/99	20	56089	1/0	-27.56	11.49	12.25	3.05	H	0.12	20.70
20	56442	1/99	20	56640	1/0	-31.30	7.82	12.37	3.07	H	0.05	17.12

Note:

1. Modulation : 16QAM
2. Limit : < 2 Watts

PCC			SCC			Measured Level (dBm)	Substitute Level (dBm)	Ant. Gain (dBi)	C.L	Pol.	E.I.R.P	
BW [MHz]	Channel	RB/Offset	BW [MHz]	Channel	RB/Offset						W	dBm
20	55340	1/99	20	55538	1/0	-29.90	8.99	12.14	3.02	H	0.06	18.11
5	55898	1/24	20	56015	1/0	-29.65	9.40	12.25	3.05	H	0.07	18.61
10	55896	1/49	20	56040	1/0	-29.38	9.67	12.25	3.05	H	0.08	18.88
15	55893	1/74	20	56064	1/0	-29.30	9.75	12.25	3.05	H	0.08	18.96
20	55965	1/99	5	56082	1/0	-29.29	9.76	12.25	3.05	H	0.08	18.97
20	55941	1/99	10	56085	1/0	-29.56	9.49	12.25	3.05	H	0.07	18.70
20	55916	1/99	15	56087	1/0	-29.24	9.81	12.25	3.05	H	0.08	19.02
20	55891	1/99	20	56089	1/0	-29.58	9.47	12.25	3.05	H	0.07	18.68
20	56442	1/99	20	56640	1/0	-31.46	7.66	12.37	3.07	H	0.05	16.96

Note:

1. Modulation : 64QAM
2. Limit : < 2 Watts

PCC			SCC			Measured Level (dBm)	Substitute Level (dBm)	Ant. Gain (dBi)	C.L	Pol.	E.I.R.P	
BW [MHz]	Channel	RB/Offset	BW [MHz]	Channel	RB/Offset						W	dBm
20	55340	1/99	20	55538	1/0	-30.91	7.98	12.14	3.02	H	0.05	17.10
5	55898	1/24	20	56015	1/0	-31.08	7.97	12.25	3.05	H	0.05	17.18
10	55896	1/49	20	56040	1/0	-30.92	8.13	12.25	3.05	H	0.05	17.34
15	55893	1/74	20	56064	1/0	-31.02	8.03	12.25	3.05	H	0.05	17.24
20	55965	1/99	5	56082	1/0	-30.85	8.20	12.25	3.05	H	0.06	17.41
20	55941	1/99	10	56085	1/0	-30.65	8.40	12.25	3.05	H	0.06	17.61
20	55916	1/99	15	56087	1/0	-30.28	8.77	12.25	3.05	H	0.06	17.98
20	55891	1/99	20	56089	1/0	-30.25	8.80	12.25	3.05	H	0.06	18.01
20	56442	1/99	20	56640	1/0	-31.60	7.52	12.37	3.07	H	0.05	16.82

Note:

1. Modulation : 256QAM
2. Limit : < 2 Watts



**8.3 Conducted Spurious Emissions**

Operating frequency	PCC				SCC				Measurement	Factor (dB)	Measurement	Result (dBm)
	BW [MHz]	Ch.	Freq. (MHz)	RB/Offset	BW [MHz]	Ch.	Freq. (MHz)	RB/Offset	Maximum Frequency (GHz)		Maximum Data (dBm)	
Low	20	55340	3560.0	1/99	20	55538	3579.8	1/0	7.9791	28.59	-76.55	-47.96
Mid	15	55893	3615.3	1/74	20	56064	3632.4	1/0	4.0848	27.98	-76.40	-48.42
High	20	56442	3670.2	1/99	20	56640	3690.0	1/0	2.5998	27.98	-76.40	-48.43
Low	20	55340	3560.0	1/0	20	55538	3579.8	1/99	6.0579	28.59	-79.31	-50.72
Mid	15	55893	3615.3	1/0	20	56064	3632.4	1/99	4.0639	27.98	-76.07	-48.09
High	20	56442	3670.2	1/0	20	56640	3690.0	1/99	6.0379	28.59	-75.99	-47.40
Low	20	55340	3560.0	100/0	10	55484	3574.4	50/0	7.9965	28.59	-75.44	-46.85
Mid	20	55965	3622.5	100/0	5	56082	3634.2	25/0	6.0409	28.59	-76.27	-47.68
High	20	56541	3680.1	100/0	10	56685	3694.5	50/0	8.0085	28.59	-75.29	-46.70
Low	20	55340	3560.0	100/0	20	55538	3579.8	100/0	8.0549	28.59	-76.03	-47.43
Mid	20	55891	3615.1	100/0	20	56089	3634.9	100/0	7.9990	28.59	-76.05	-47.46
High	20	56442	3670.2	100/0	20	56640	3690.0	100/0	5.7348	28.59	-76.42	-47.83

Note:

1. Modulation : QPSK
2. Factor(dB) = Cable Loss + Ext. Attenuator + Power Splitter
3. Factors for frequency :

Frequency Range (GHz)	Factor [dB]
0.03 – 1	25.270
1 – 5	27.976
5 – 10	28.591
10 – 15	29.116
15 – 20	29.489
Above 20(26.5)	30.131

4. Limit : -40.0 dBm

Frequency Range : 30MHz ~ 10GHz

PCC 15MHz Ch55893 RB1 Offset0 SCC 20MHz Ch56064 RB1 Offset99

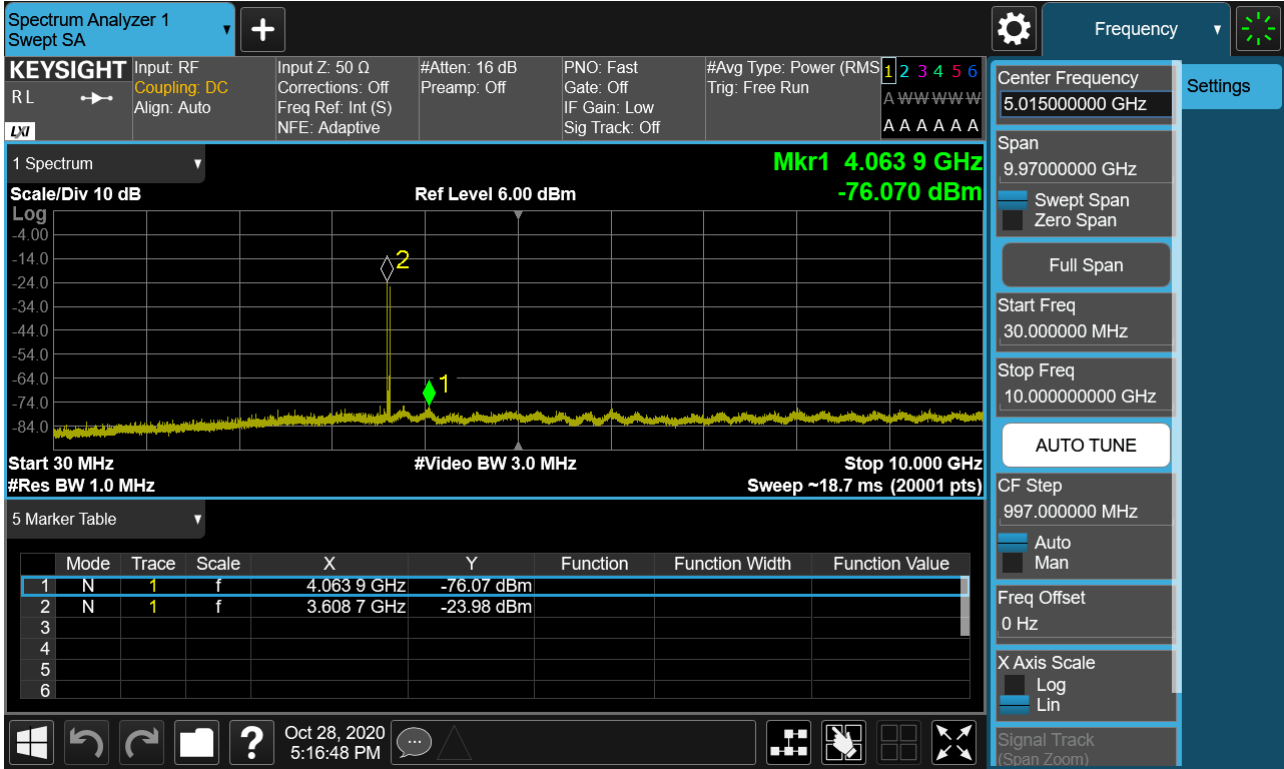

PCC 15MHz Ch55893 RB1 Offset74 SCC 20MHz Ch56064 RB1 Offset0

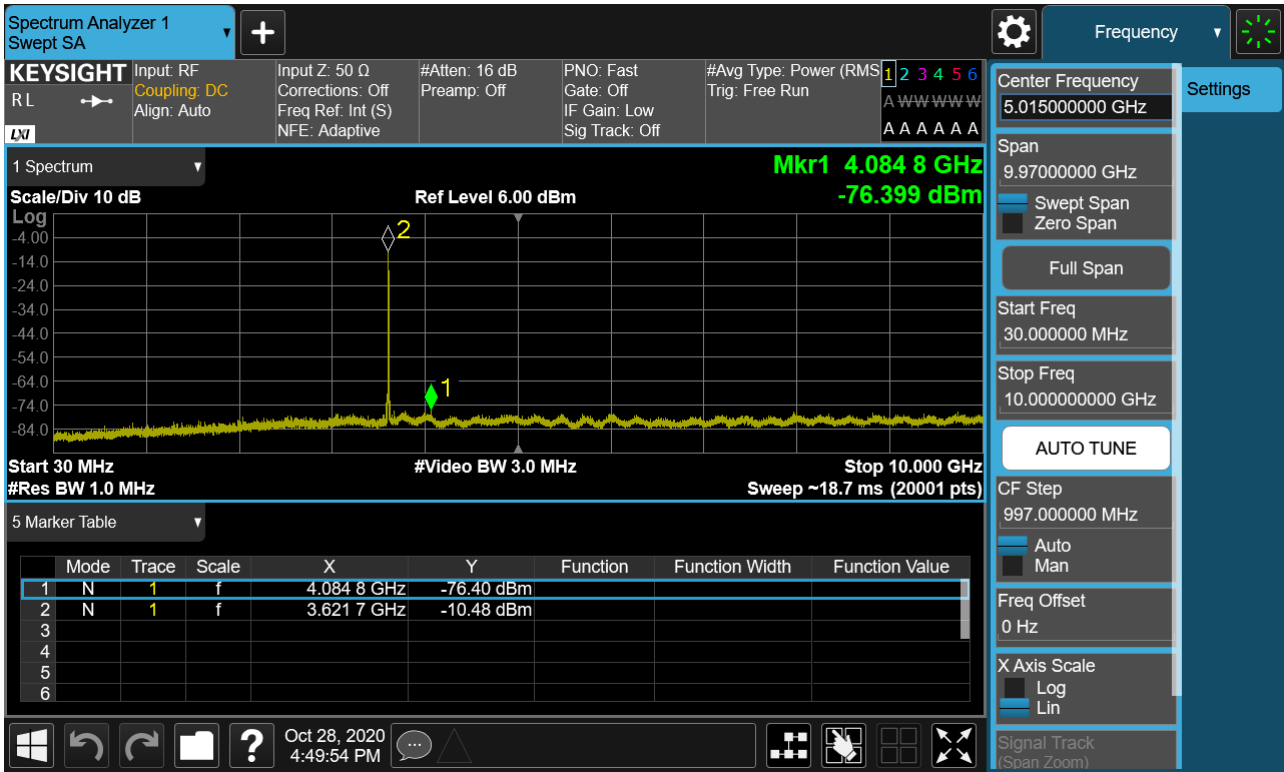

PCC 20MHz Ch55340 RB1 Offset0 SCC 20MHz Ch55538 RB1 Offset99

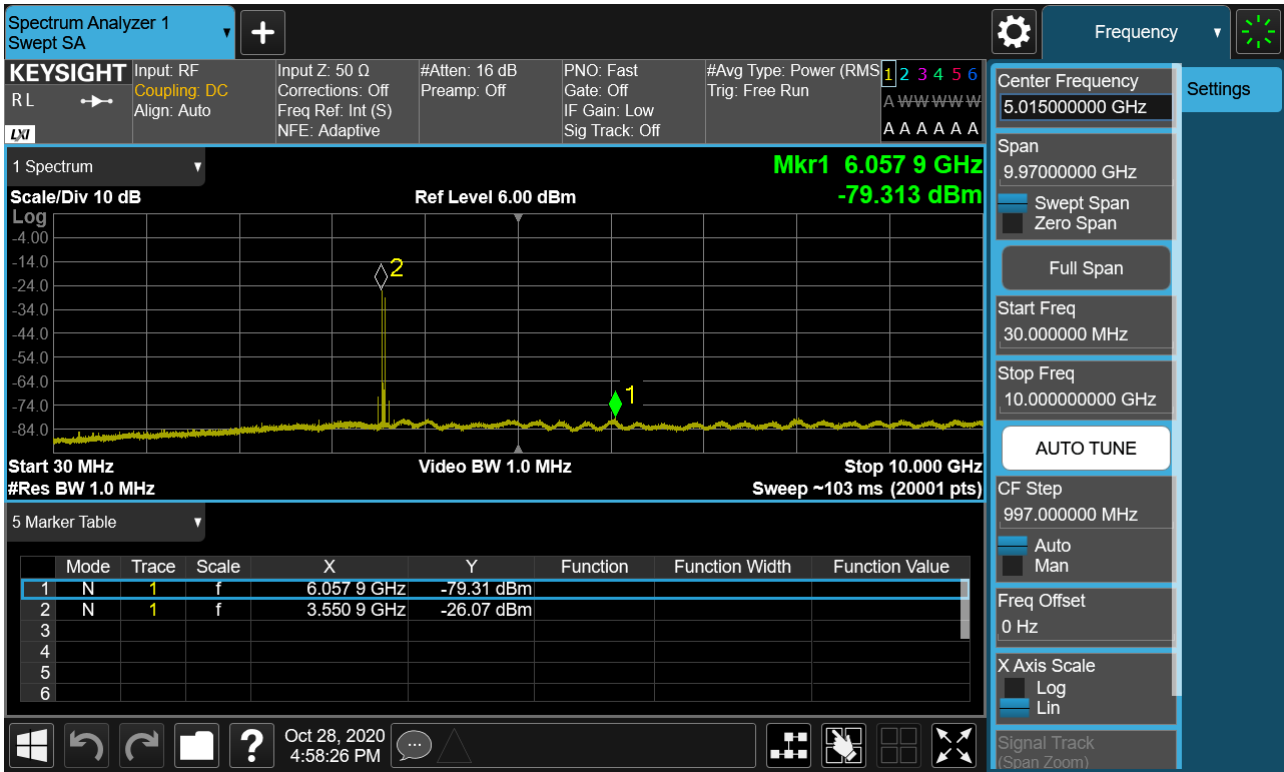

PCC 20MHz Ch55340 RB1 Offset99 SCC 20MHz Ch55538 RB1 Offset0

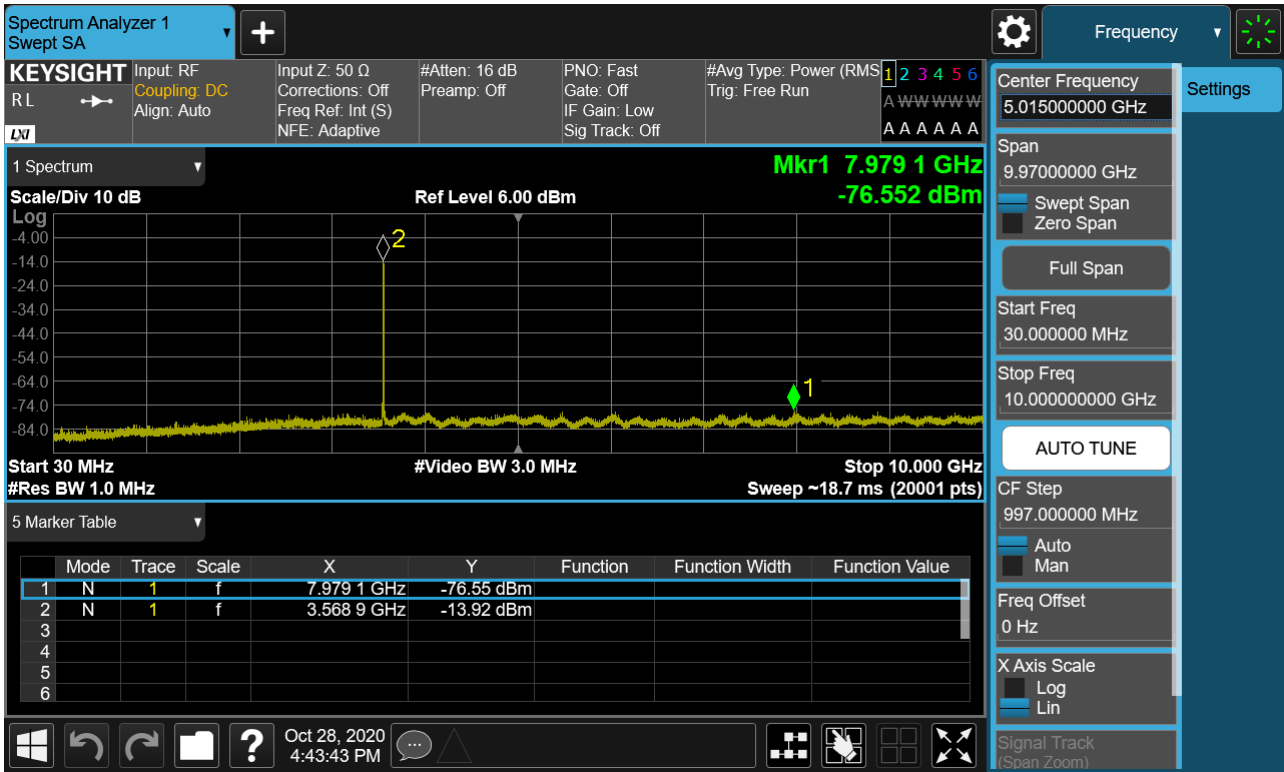

PCC 20MHz Ch55340 RB100 Offset0 SCC 10MHz Ch55484 RB50 Offset0

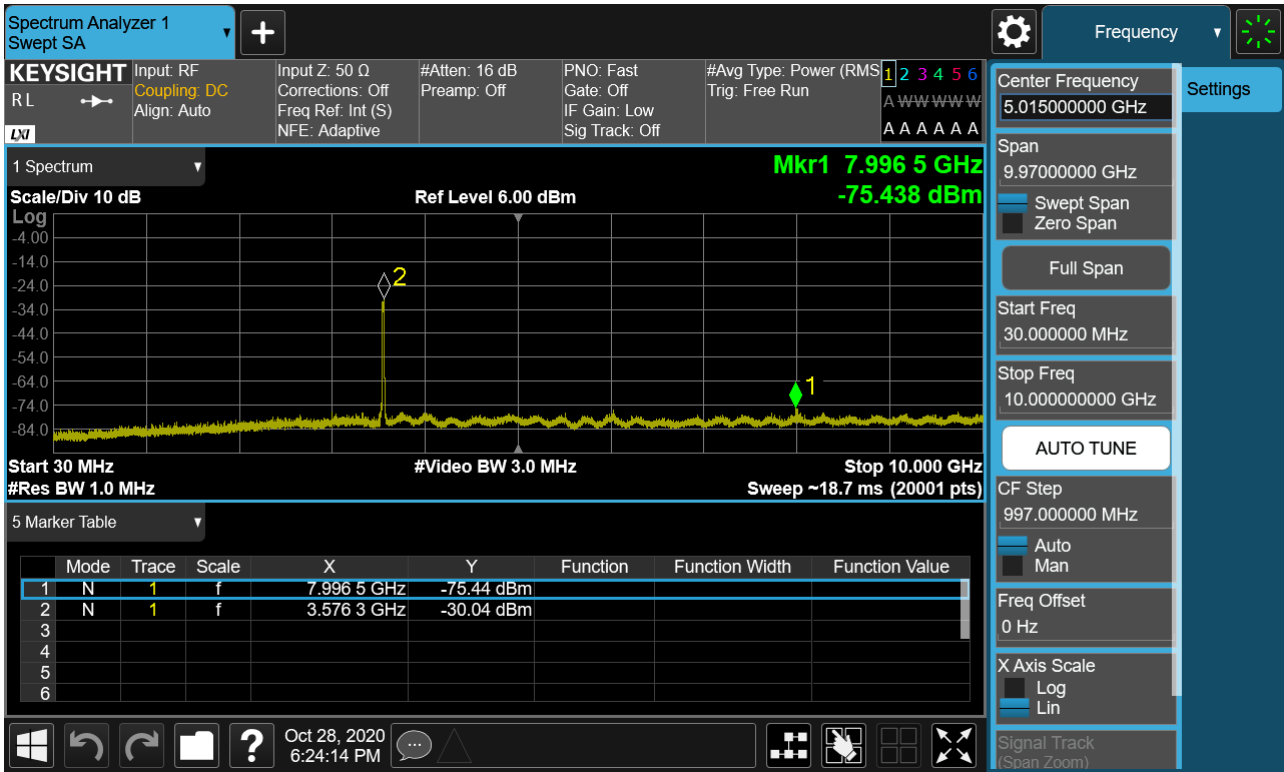

PCC 20MHz Ch55340 RB100 Offset0 SCC 20MHz Ch55538 RB100 Offset0

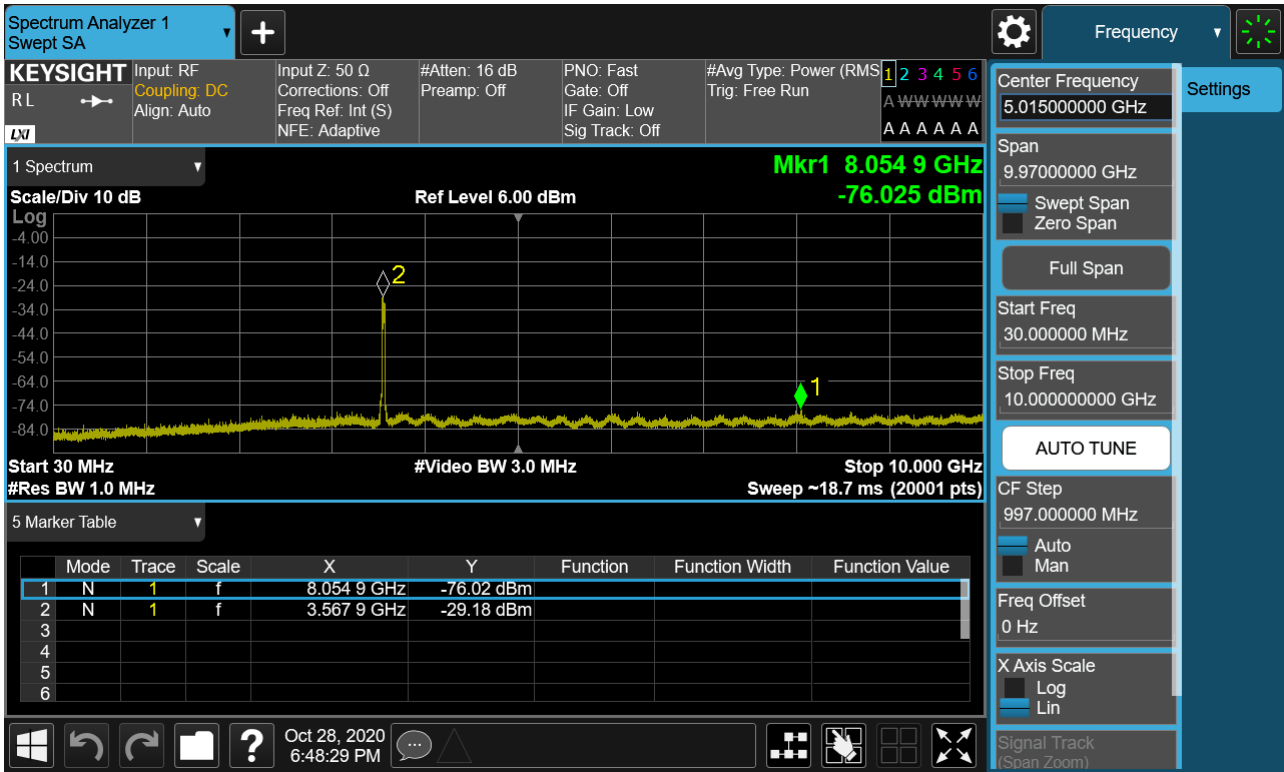

PCC 20MHz Ch55891 RB100 Offset0 SCC 20MHz Ch56089 RB100 Offset0

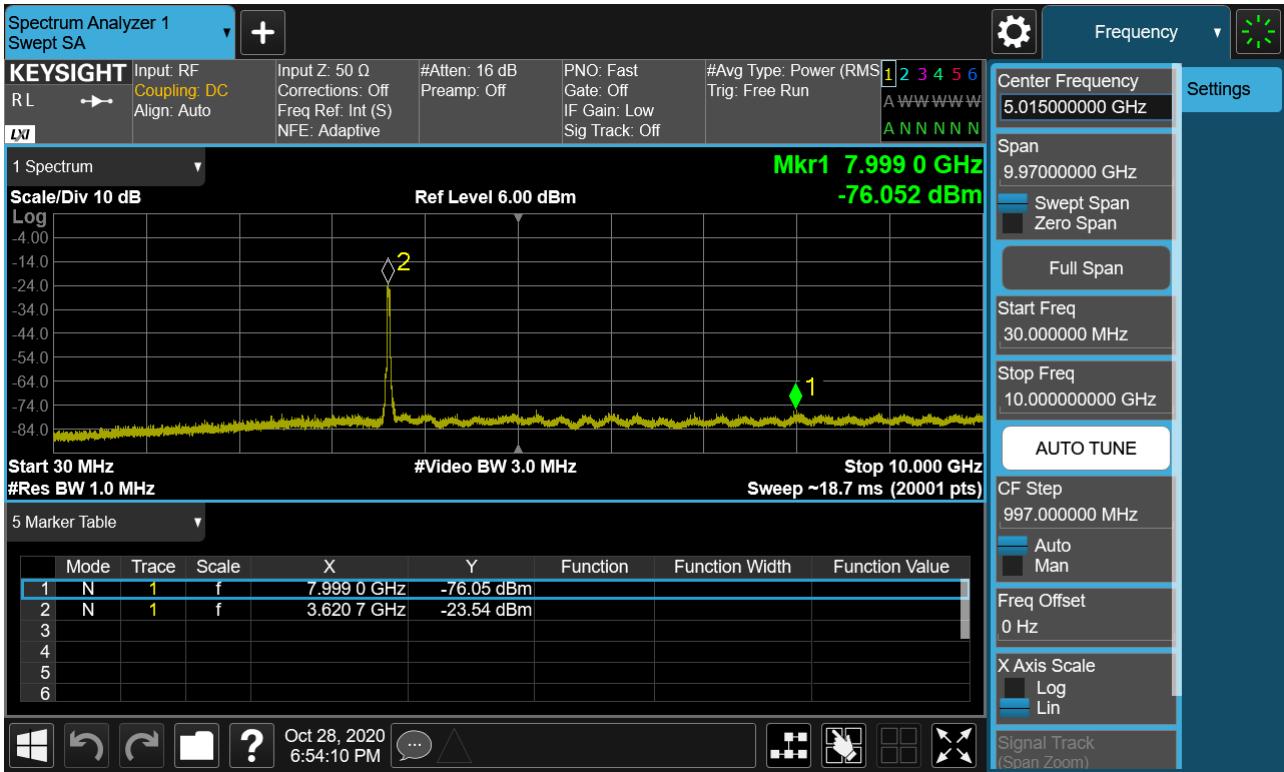



PCC 20MHz Ch55965 RB100 Offset0 SCC 5MHz Ch56082 RB25 Offset0

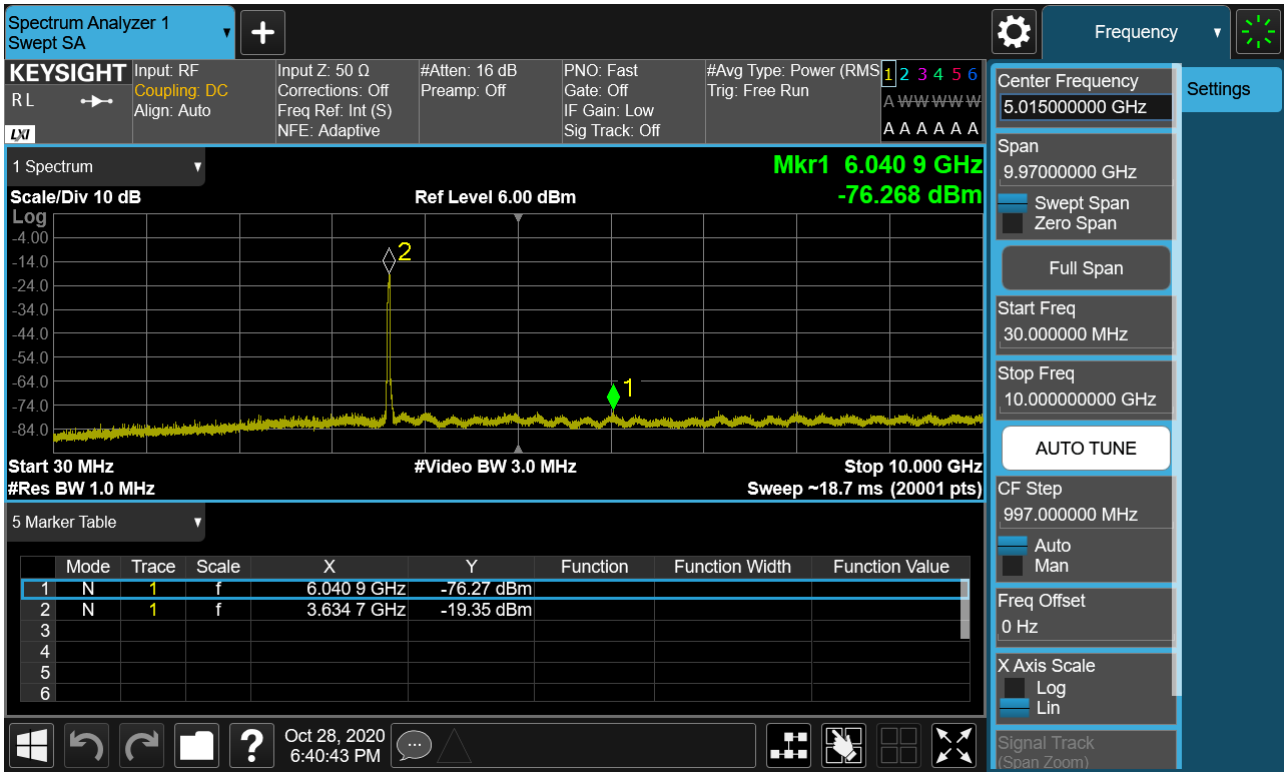

PCC 20MHz Ch56442 RB1 Offset0 SCC 20MHz Ch56640 RB1 Offset99

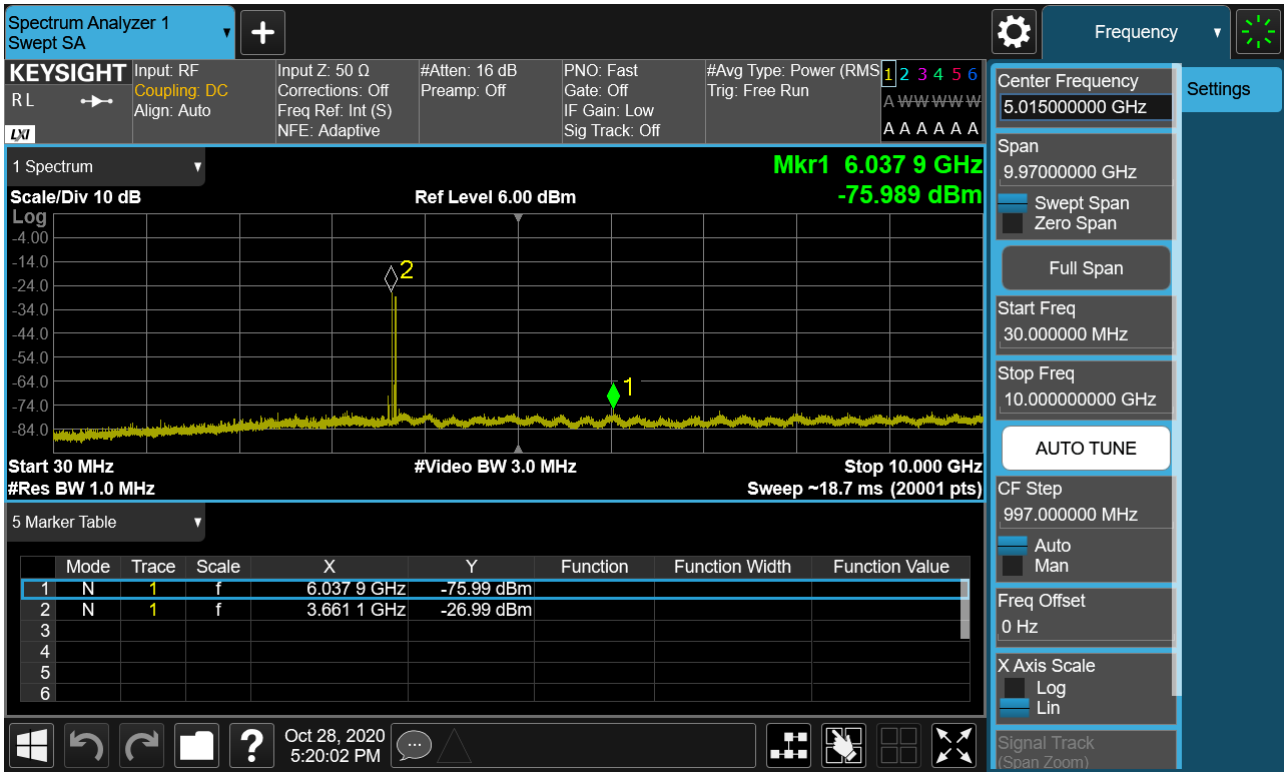

PCC 20MHz Ch56442 RB1 Offset99 SCC 20MHz Ch56640 RB1 Offset0

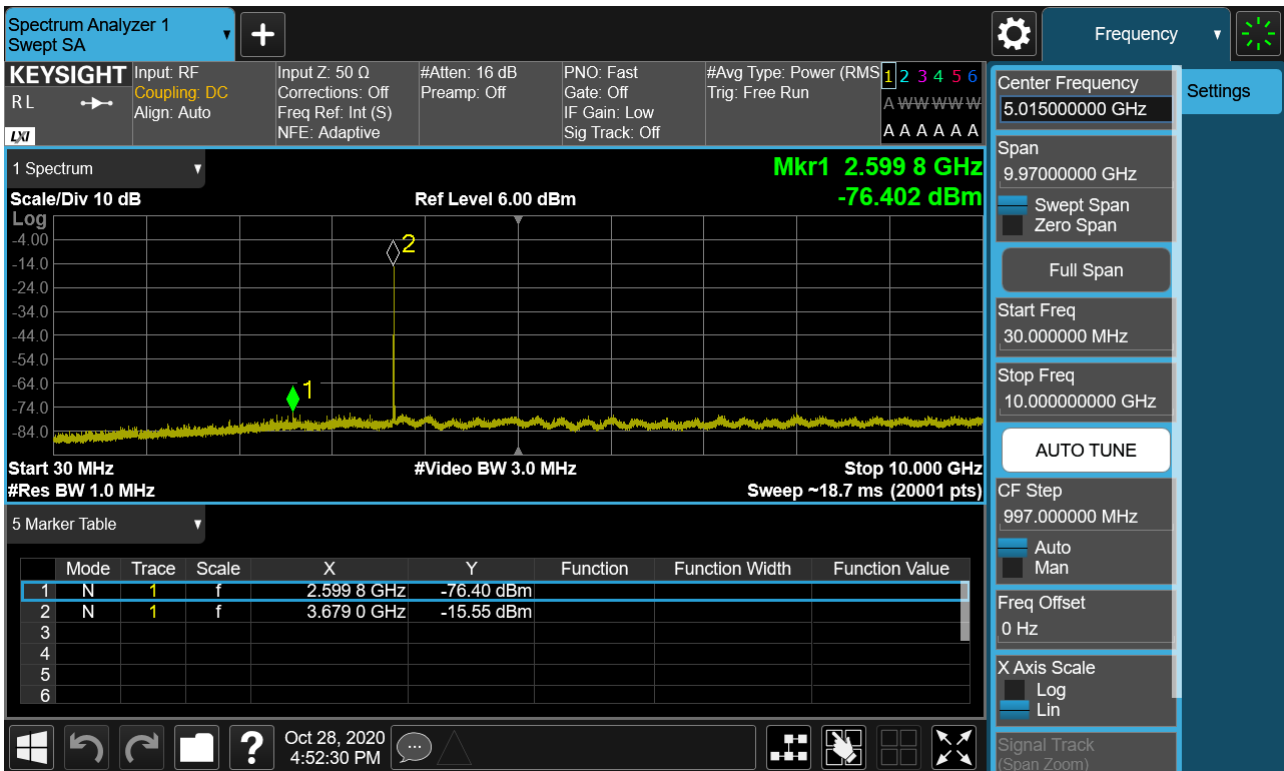

PCC 20MHz Ch56442 RB100 Offset0 SCC 20MHz Ch56640 RB100 Offset0

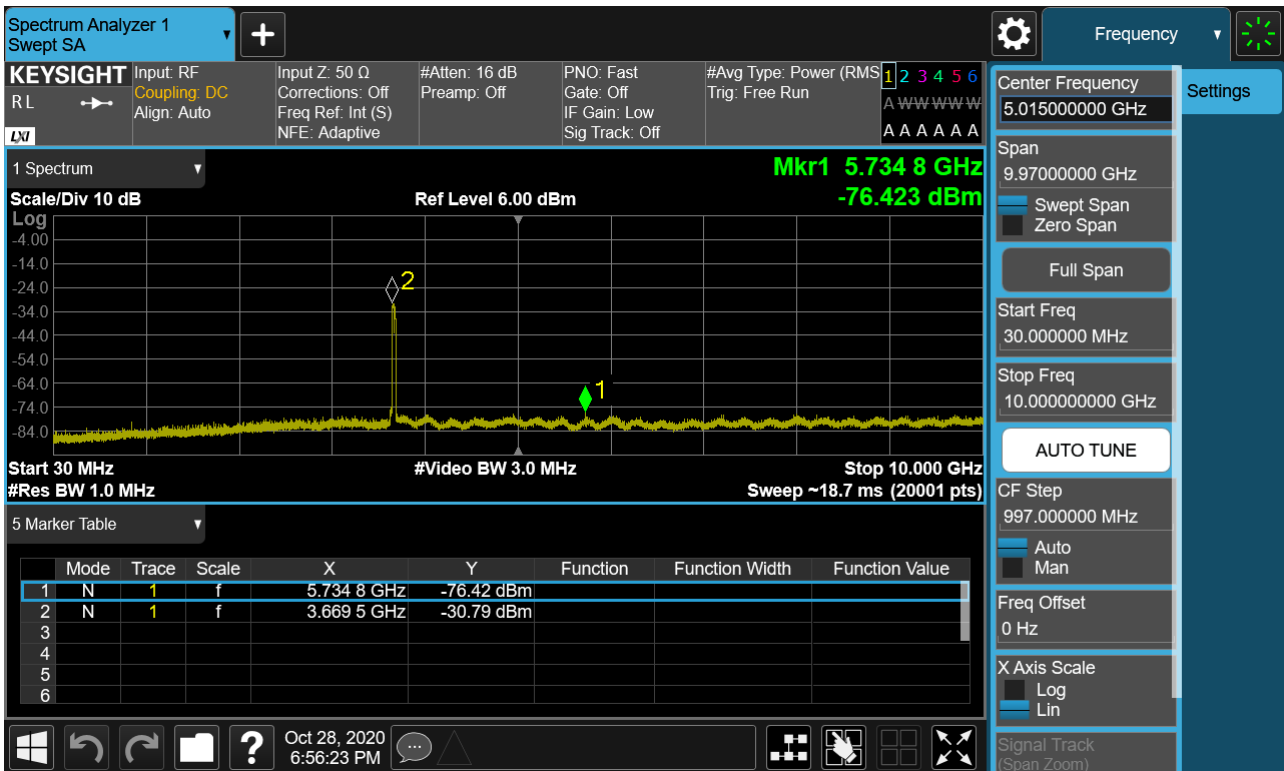

PCC 20MHz Ch56541 RB100 Offset0 SCC 10MHz Ch56685 RB50 Offset0

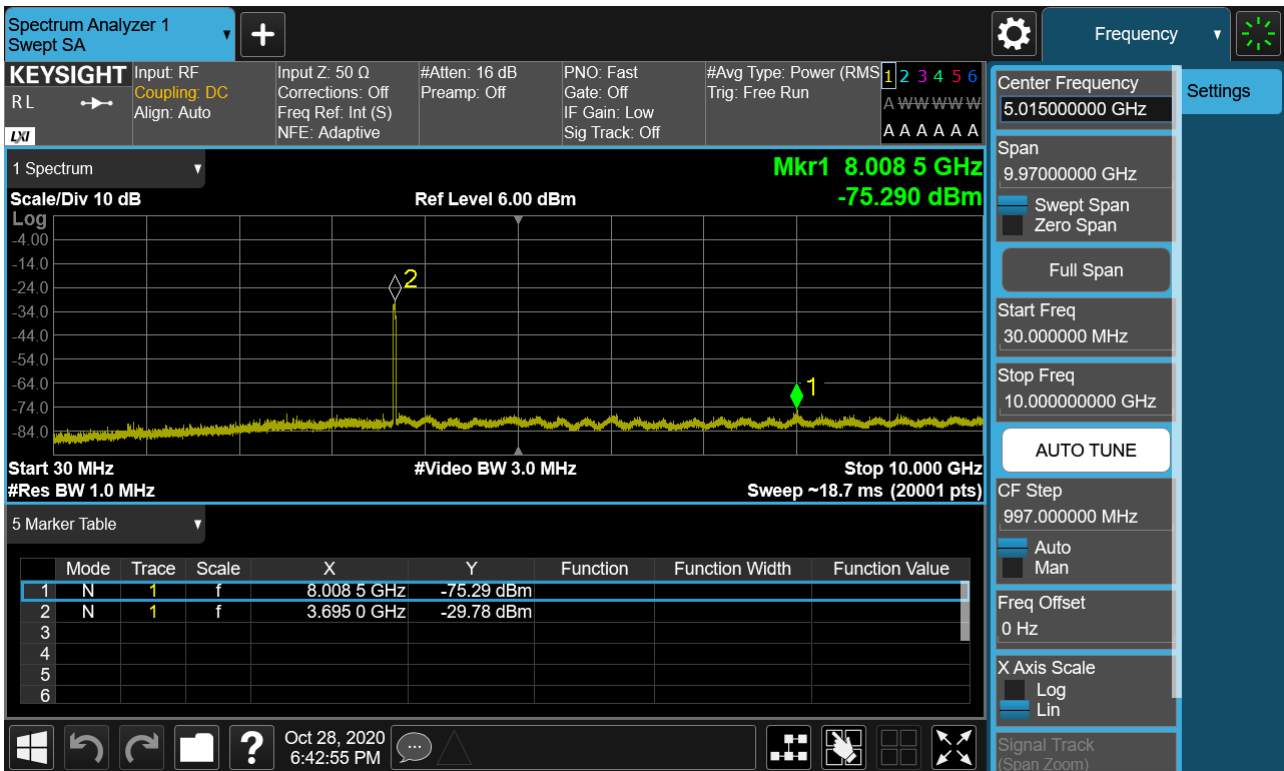

Frequency Range : 10GHz ~ 20.0GHz

PCC 15MHz Ch55893 RB1 Offset0, SCC 20MHz Ch56064 RB1 Offset99

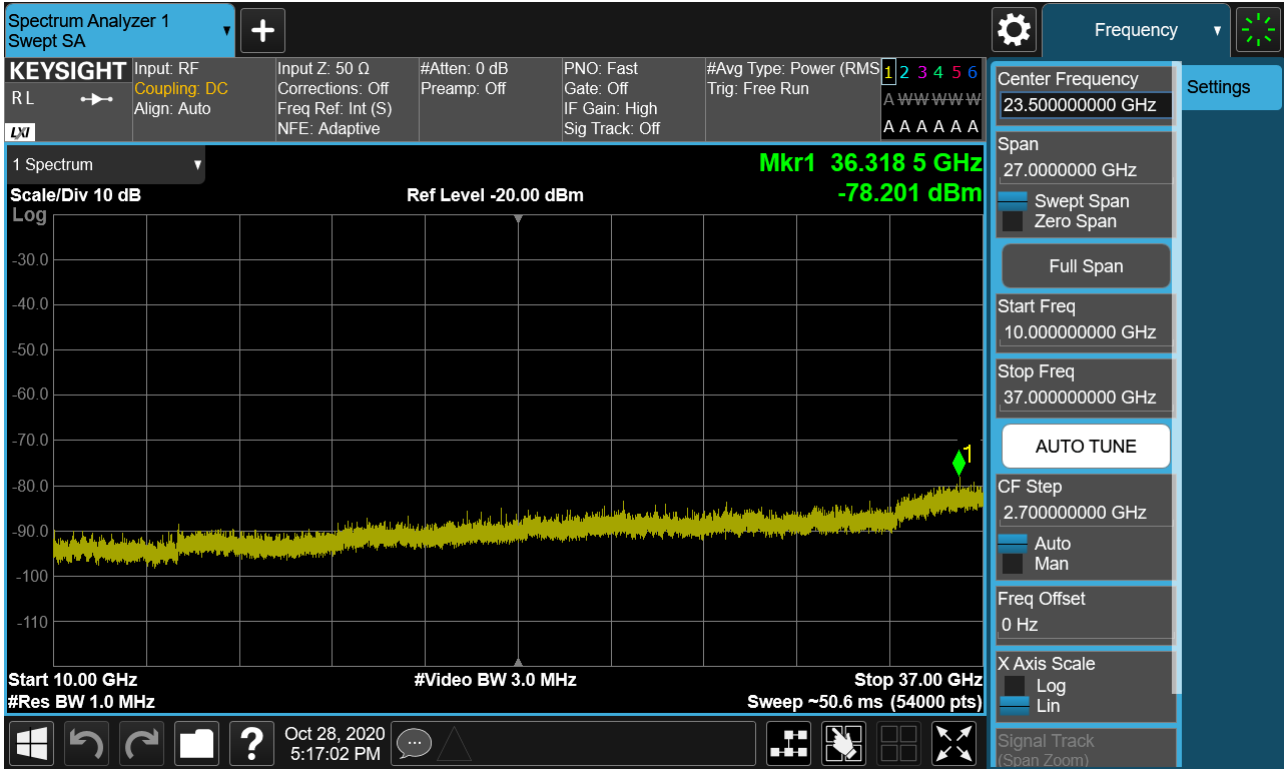

PCC 15MHz Ch55893 RB1 Offset74, SCC 20MHz Ch56064 RB1 Offset0

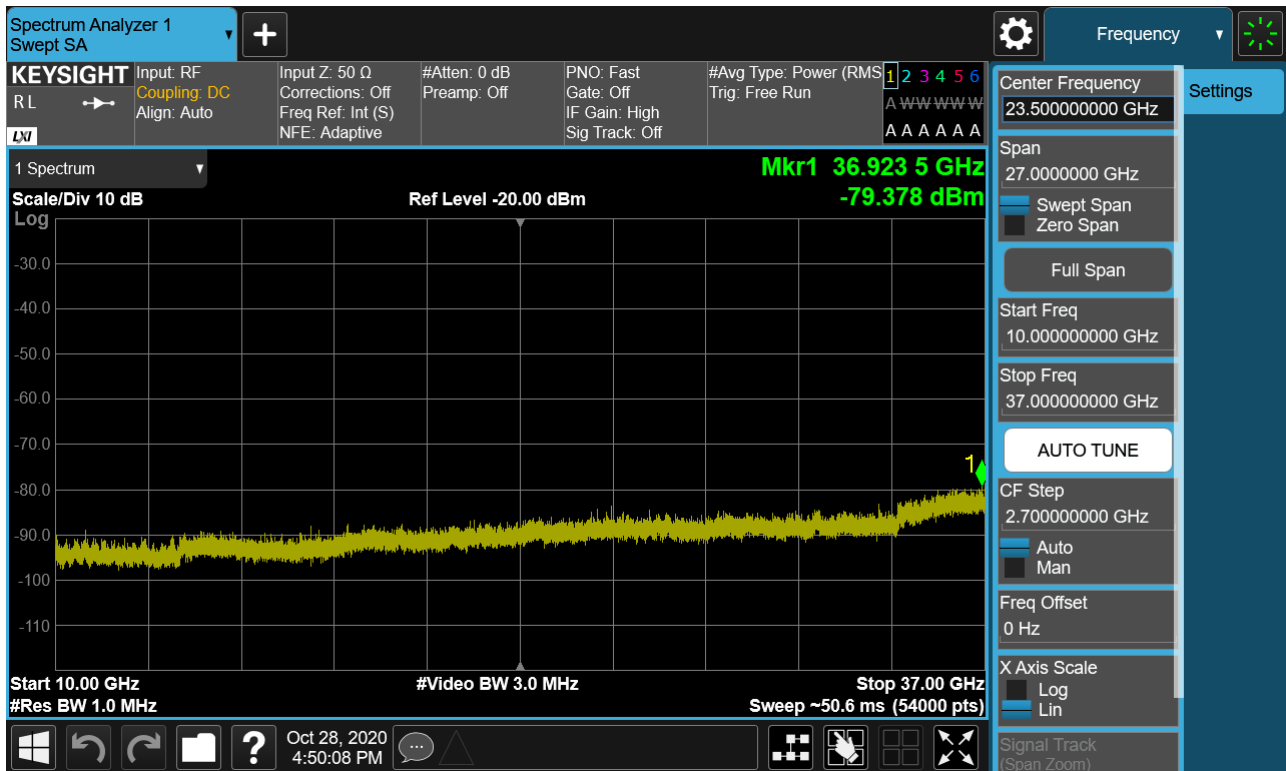

PCC 20MHz Ch55340 RB1 Offset0, SCC 20MHz Ch55538 RB1 Offset99

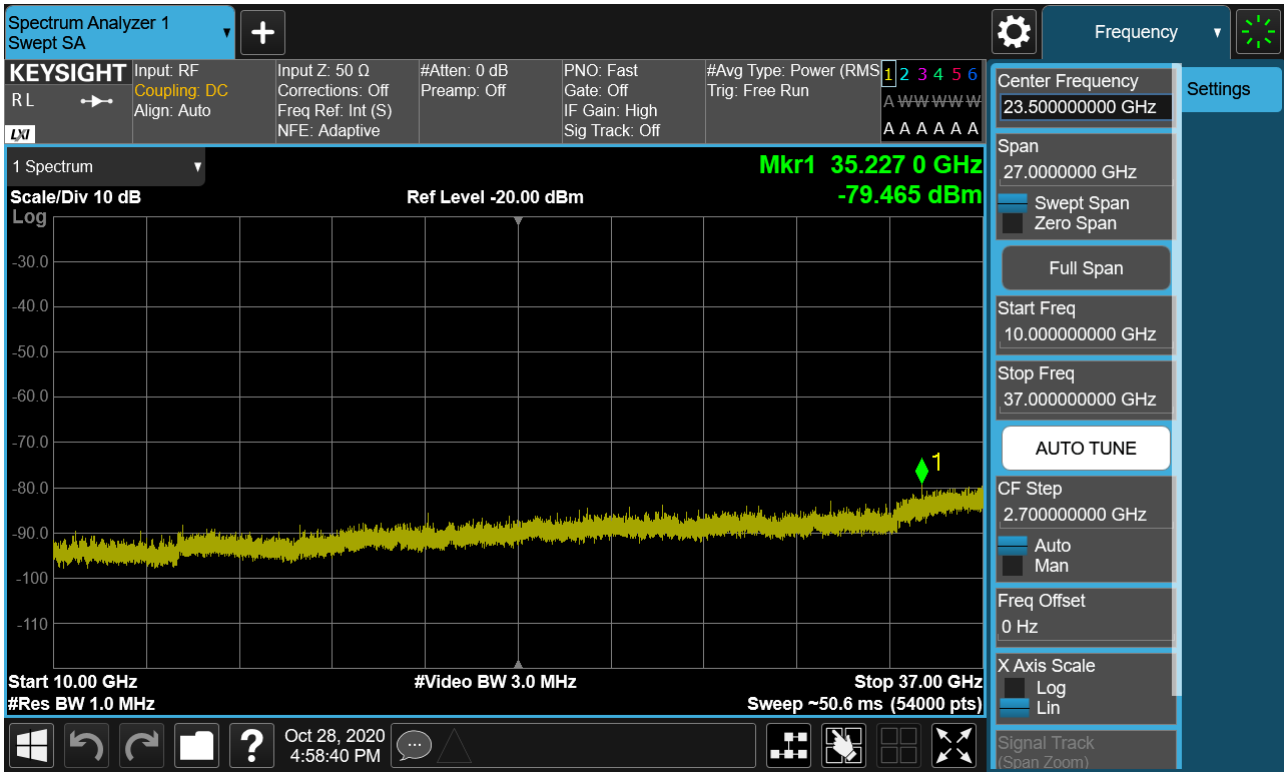



PCC 20MHz Ch55340 RB1 Offset99, SCC 20MHz Ch55538 RB1 Offset0

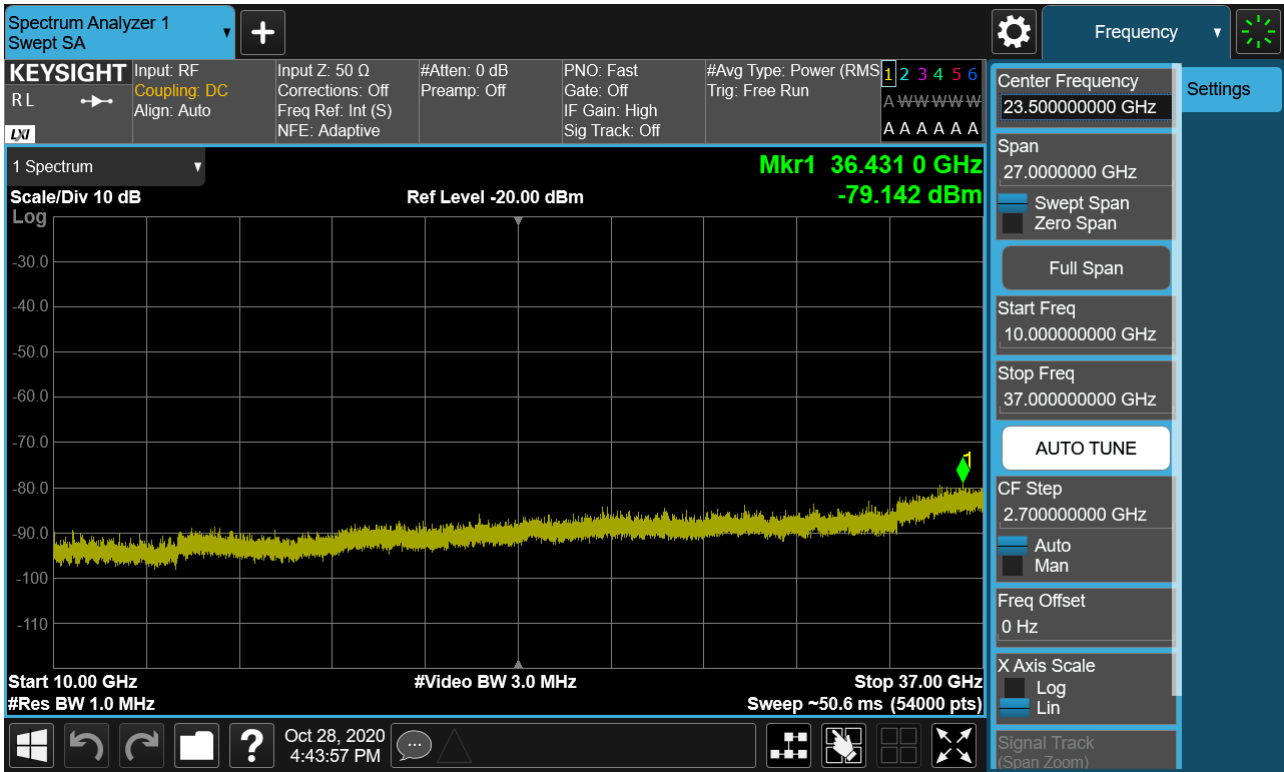

PCC 20MHz Ch55340 RB100 Offset0, SCC 10MHz Ch55484 RB50 Offset0

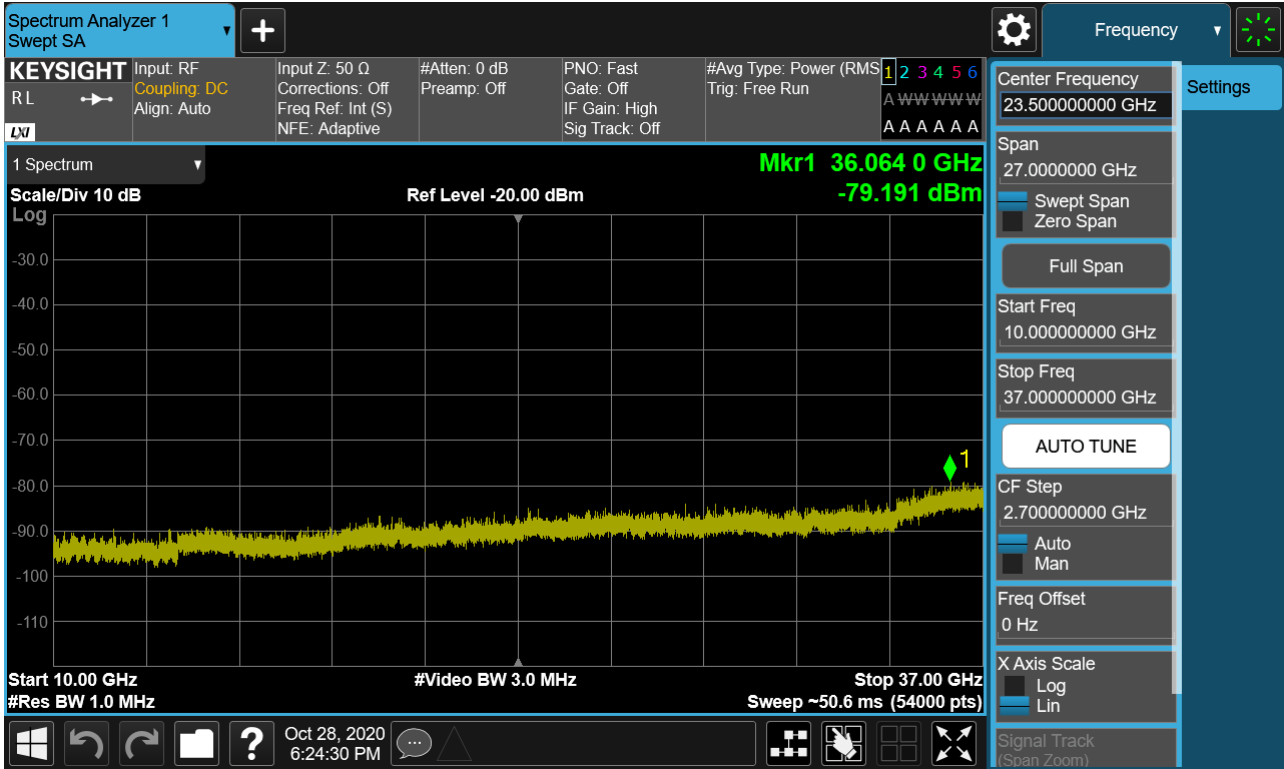

PCC 20MHz Ch55340 RB100 Offset0, SCC 20MHz Ch55538 RB100 Offset0

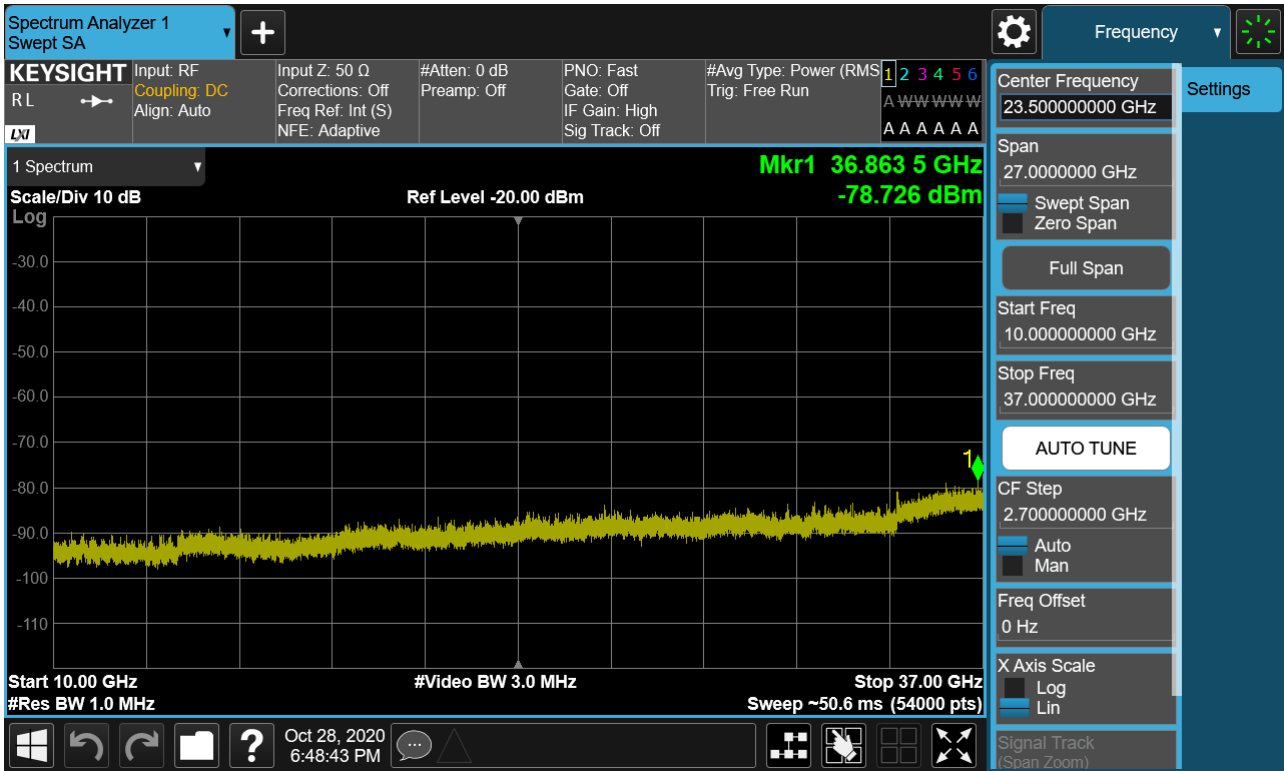

PCC 20MHz Ch55891 RB100 Offset0, SCC 20MHz Ch56089 RB100 Offset0

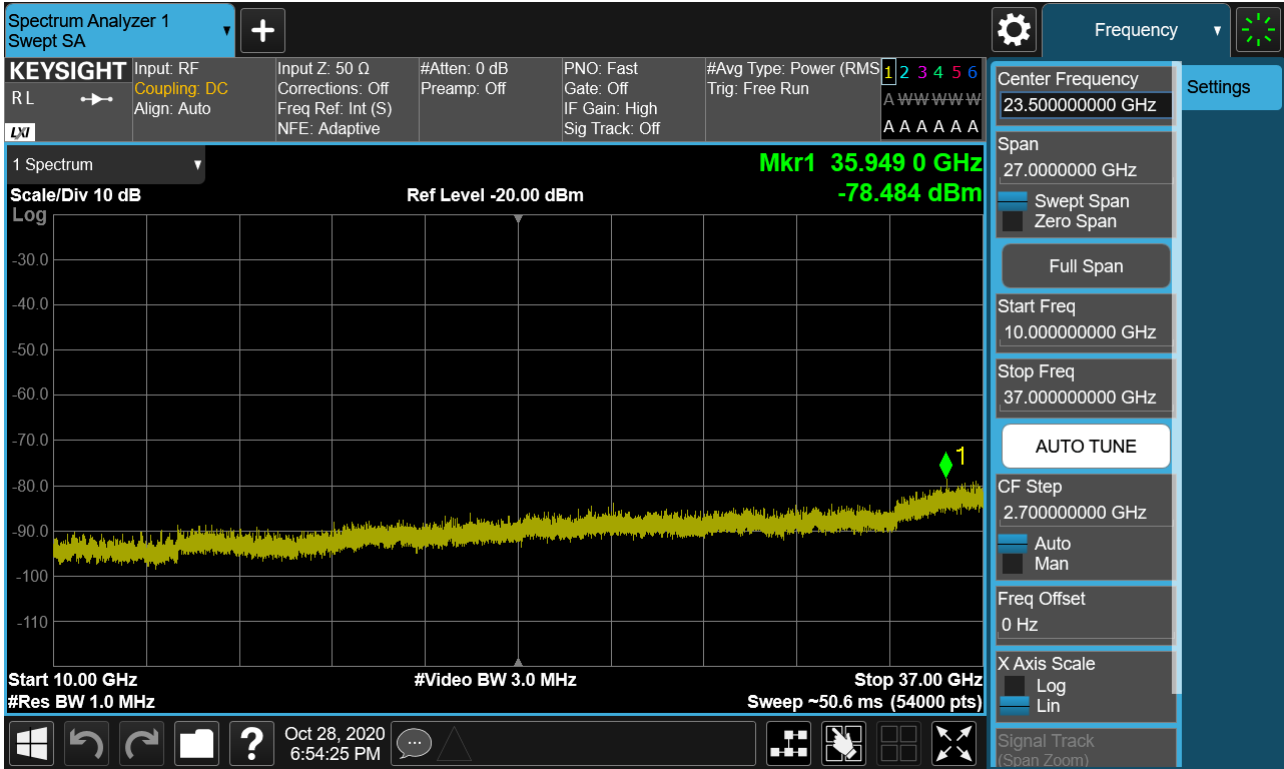

PCC 20MHz Ch55965 RB100 Offset0, SCC 5MHz Ch56082 RB25 Offset0

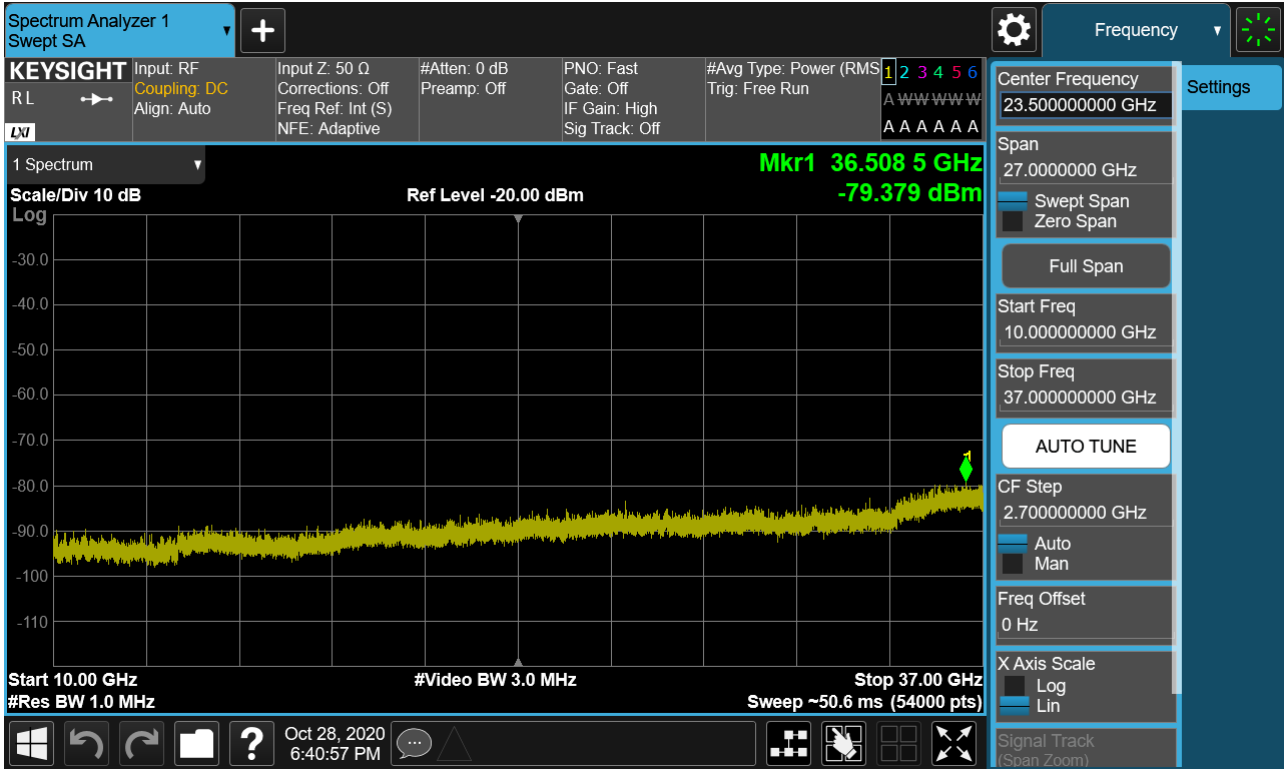

PCC 20MHz Ch56442 RB1 Offset0, SCC 20MHz Ch56640 RB1 Offset99

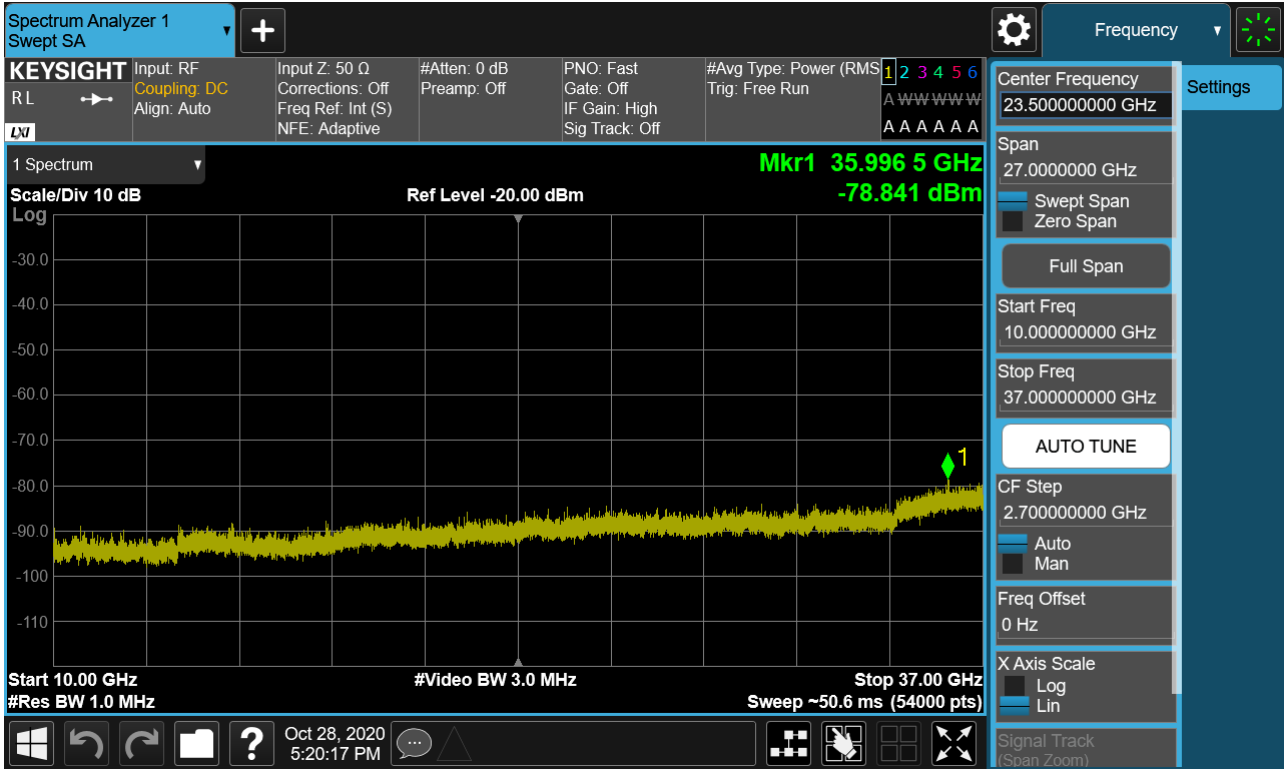

PCC 20MHz Ch56442 RB1 Offset99, SCC 20MHz Ch56640 RB1 Offset0

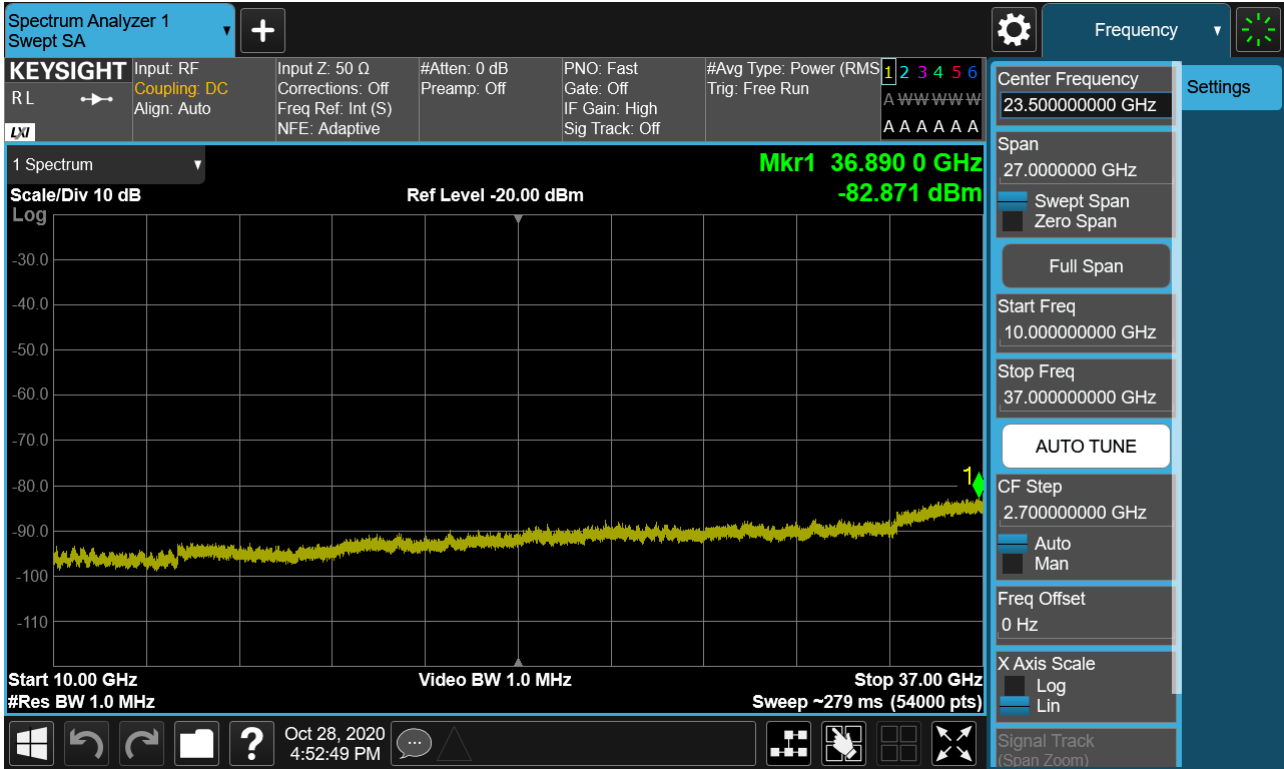

PCC 20MHz Ch56442 RB100 Offset0, SCC 20MHz Ch56640 RB100 Offset0

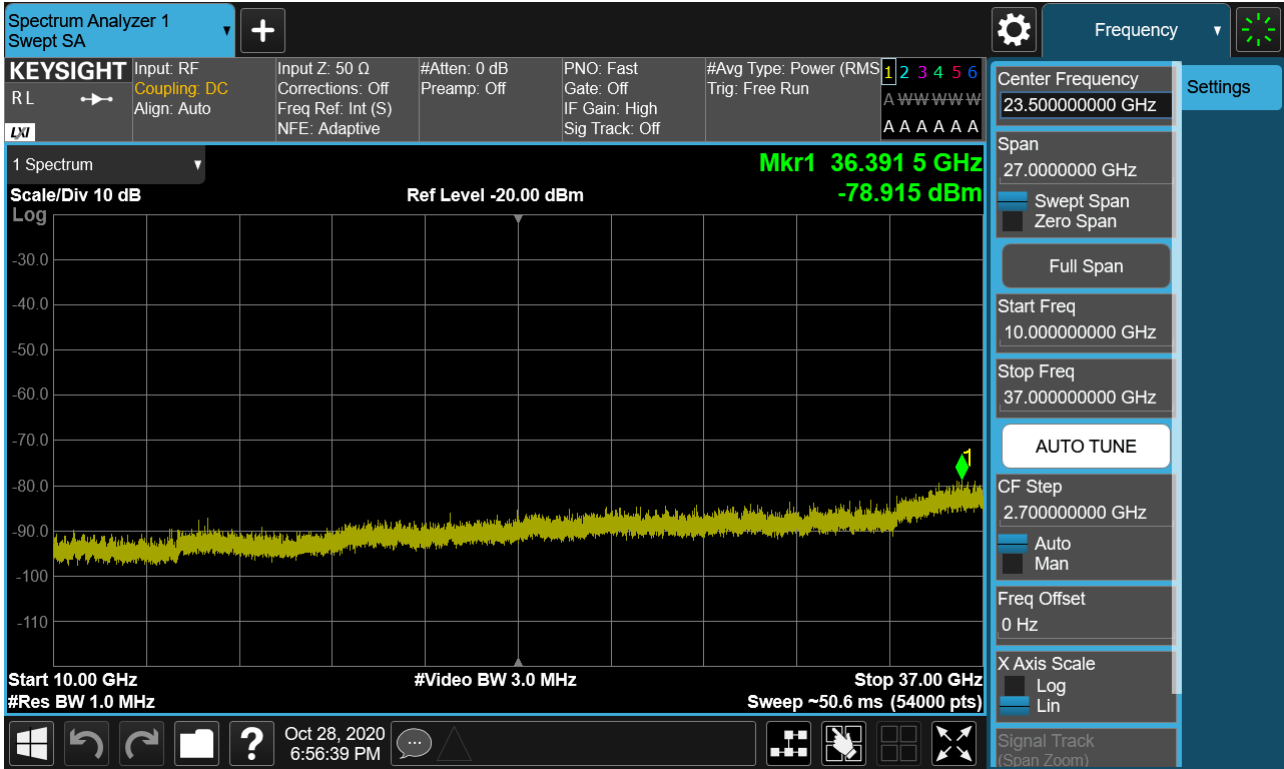



PCC 20MHz Ch56541 RB100 Offset0, SCC 10MHz Ch56685 RB50 Offset0

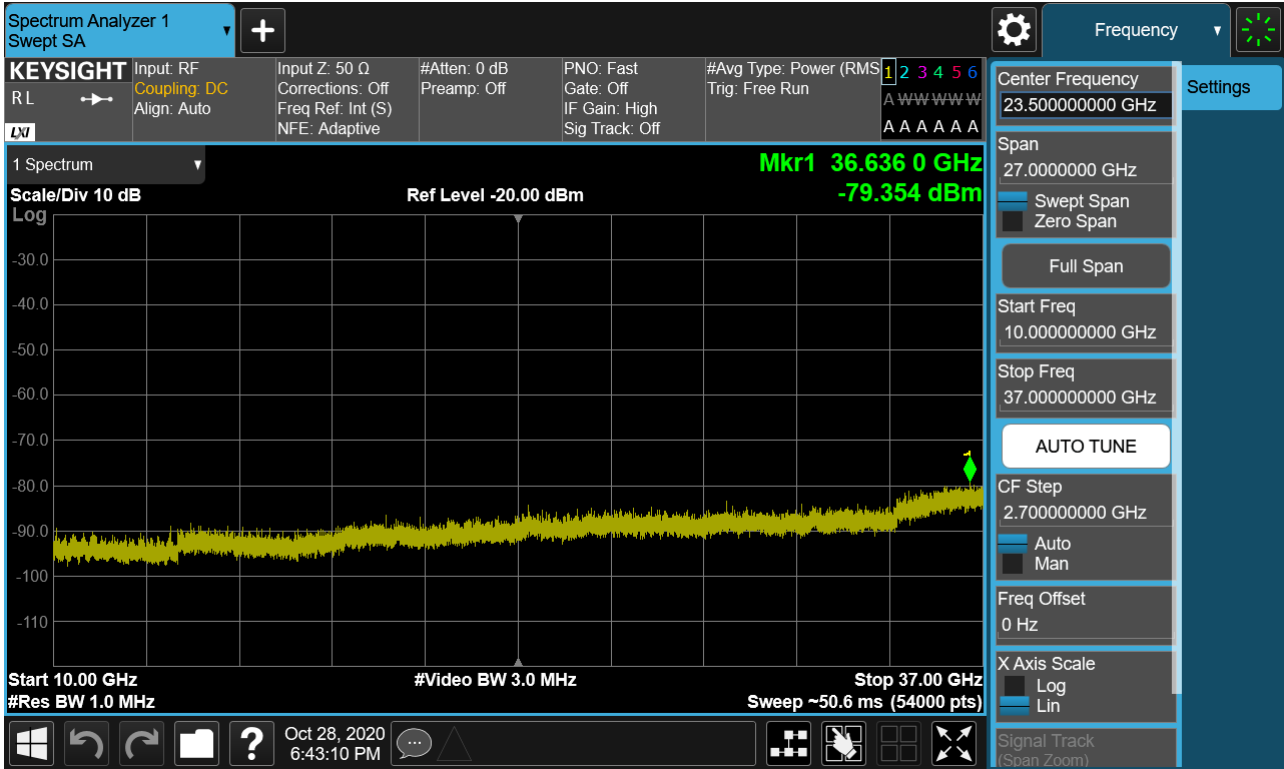

8.4 Channel Edge

PCC 15MHz Ch55893 RB1 Offset0, SCC 20MHz Ch56064 RB1 Offset99

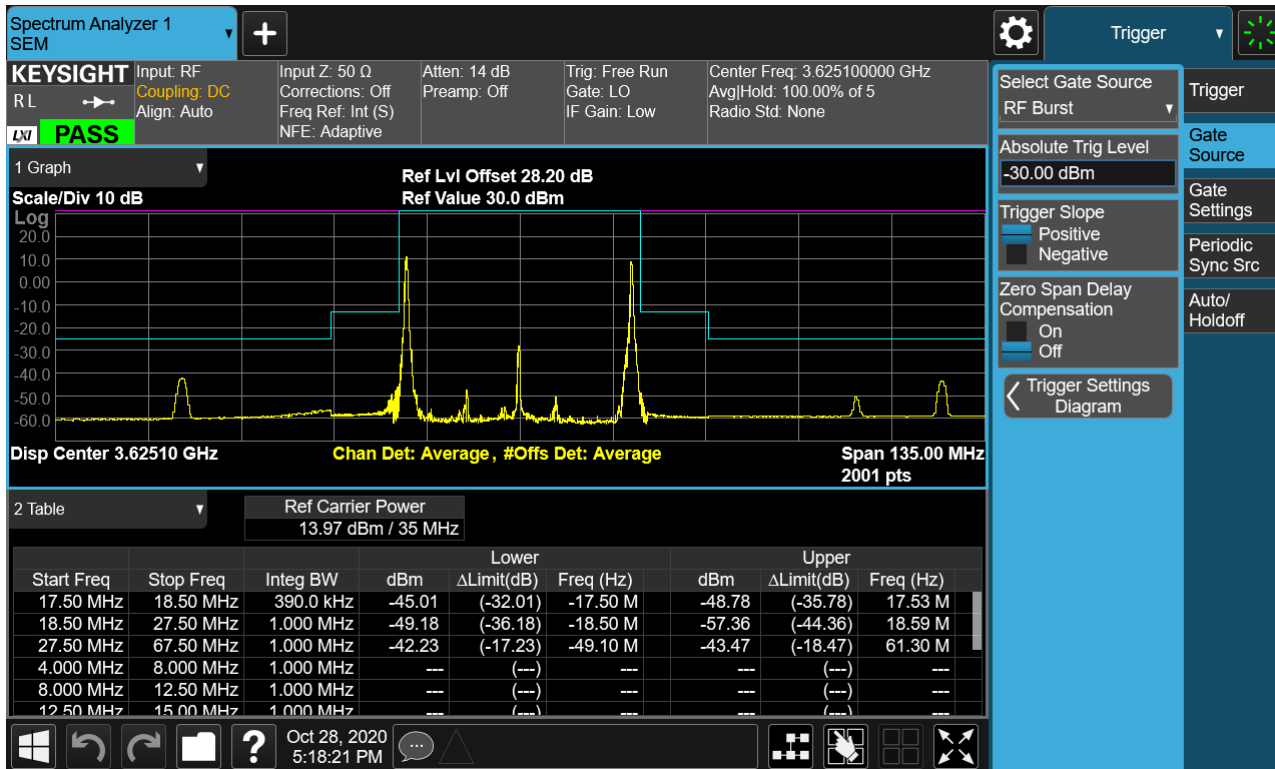

PCC 15MHz Ch55893 RB1 Offset74, SCC 20MHz Ch56064 RB1 Offset0

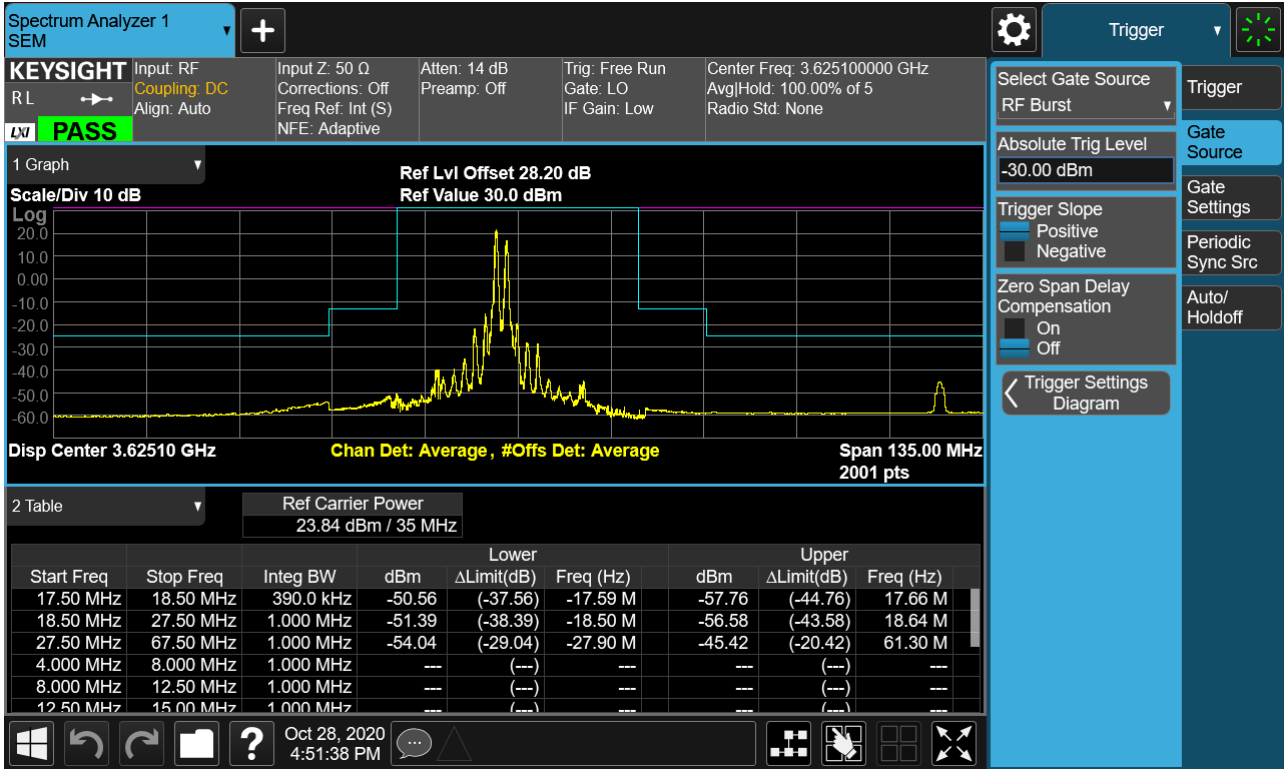

PCC 20MHz Ch55340 RB1 Offset0, SCC 20MHz Ch55538 RB1 Offset99-1

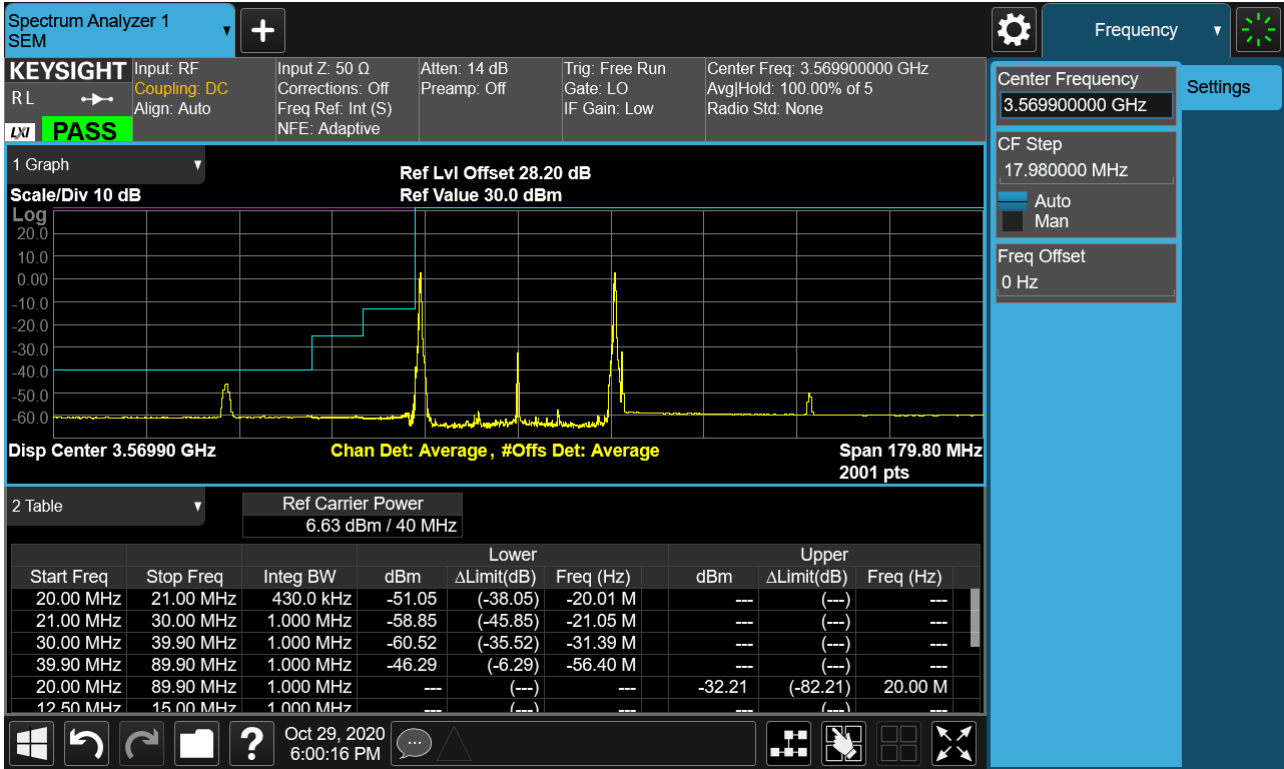

PCC 20MHz Ch55340 RB1 Offset0, SCC 20MHz Ch55538 RB1 Offset99-2

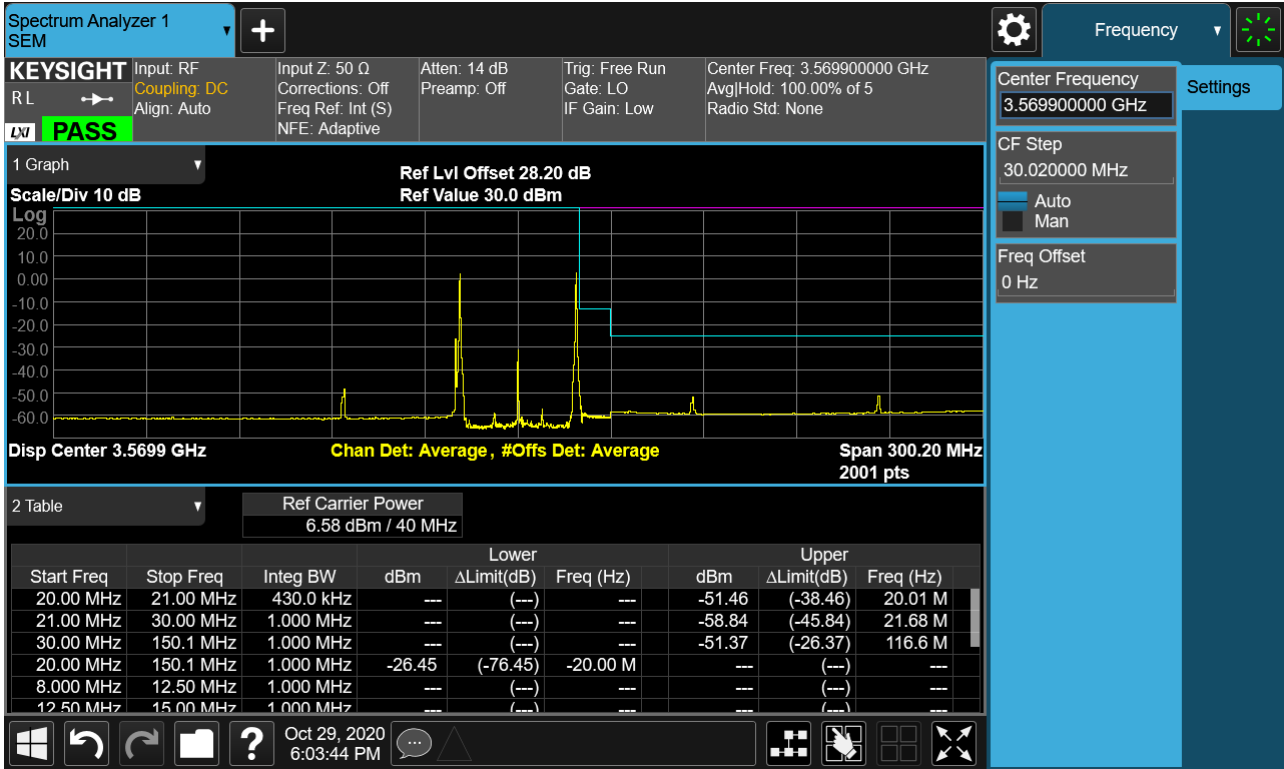

PCC 20MHz Ch55340 RB1 Offset99, SCC 20MHz Ch55538 RB1 Offset0-1

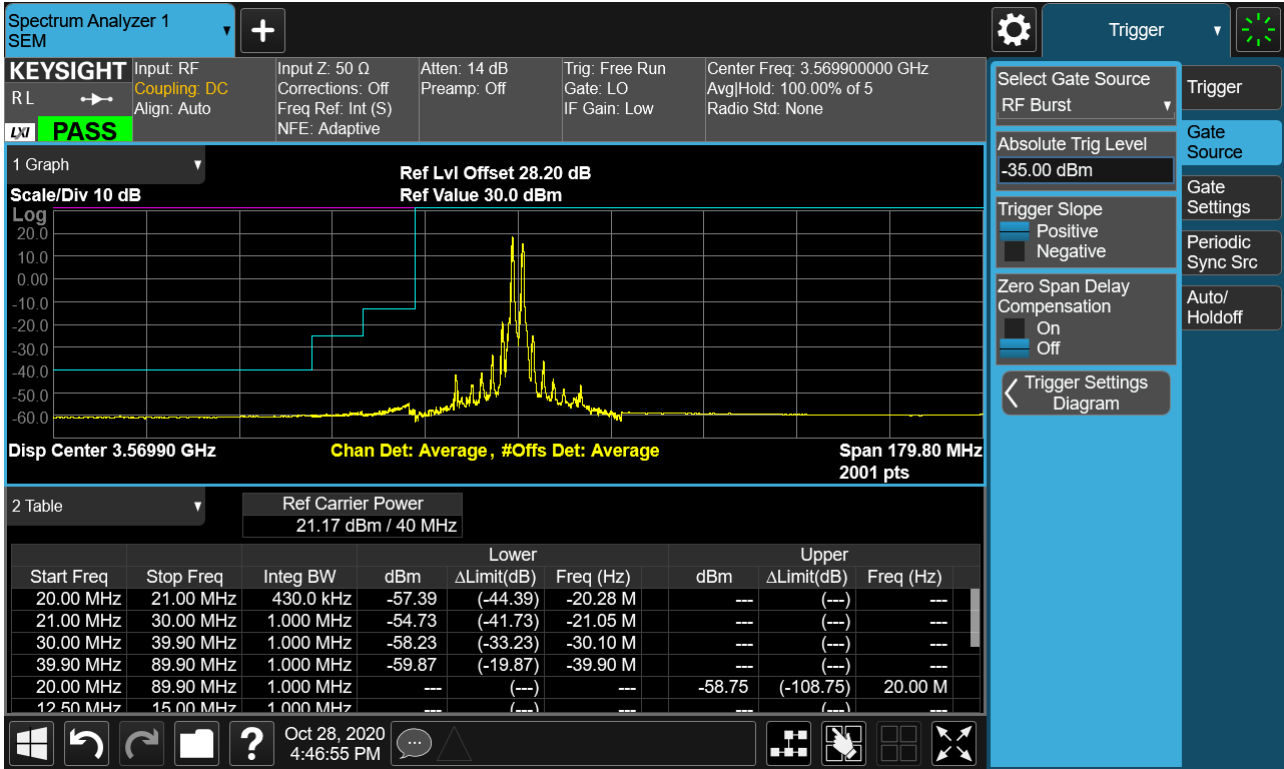

PCC 20MHz Ch55340 RB1 Offset99, SCC 20MHz Ch55538 RB1 Offset0-2

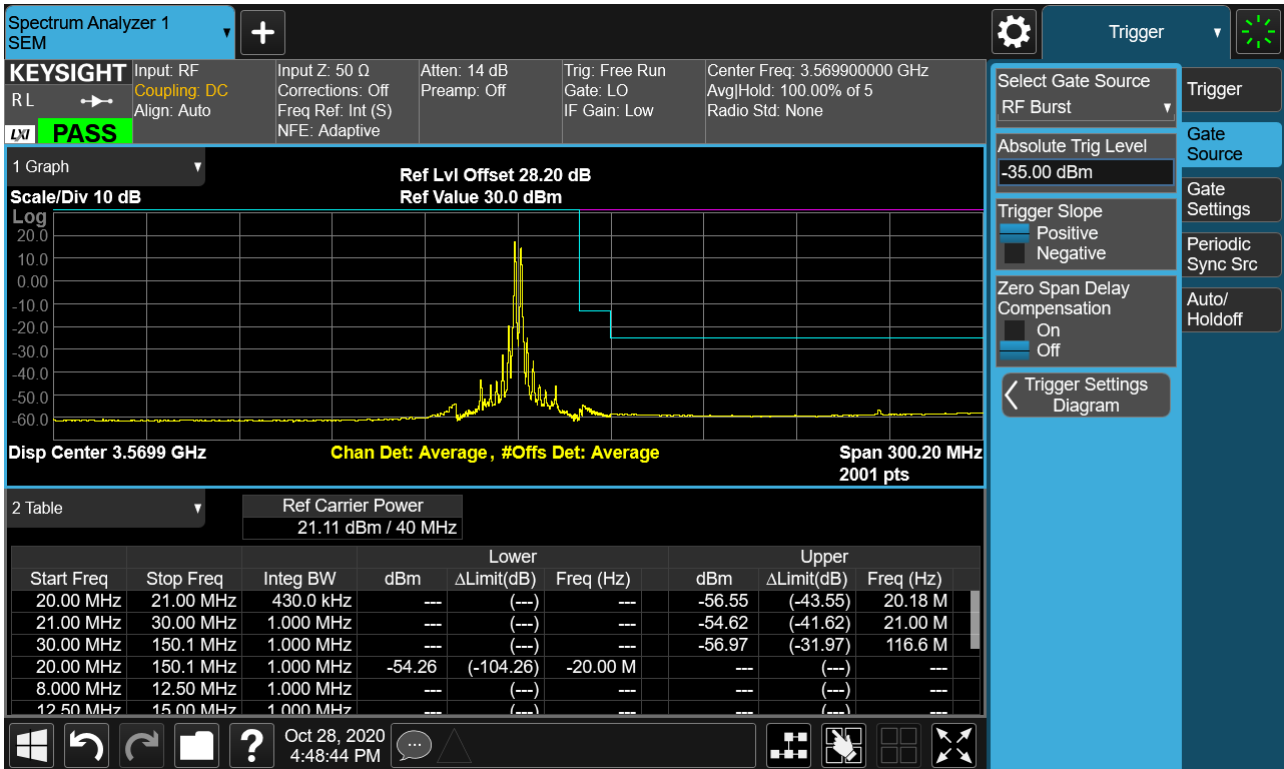

PCC 20MHz Ch55340 RB100 Offset0, SCC 10MHz Ch55484 RB50 Offset0-1

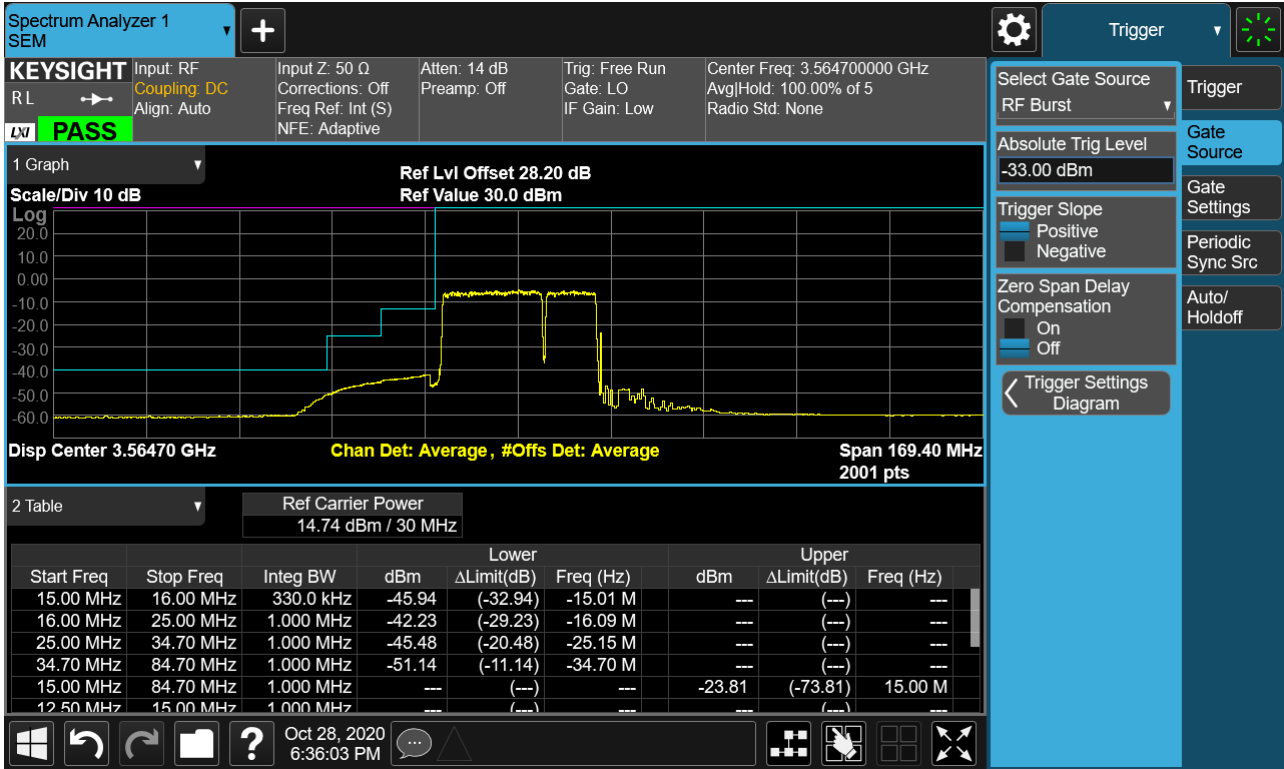



PCC 20MHz Ch55340 RB100 Offset0, SCC 10MHz Ch55484 RB50 Offset0-2

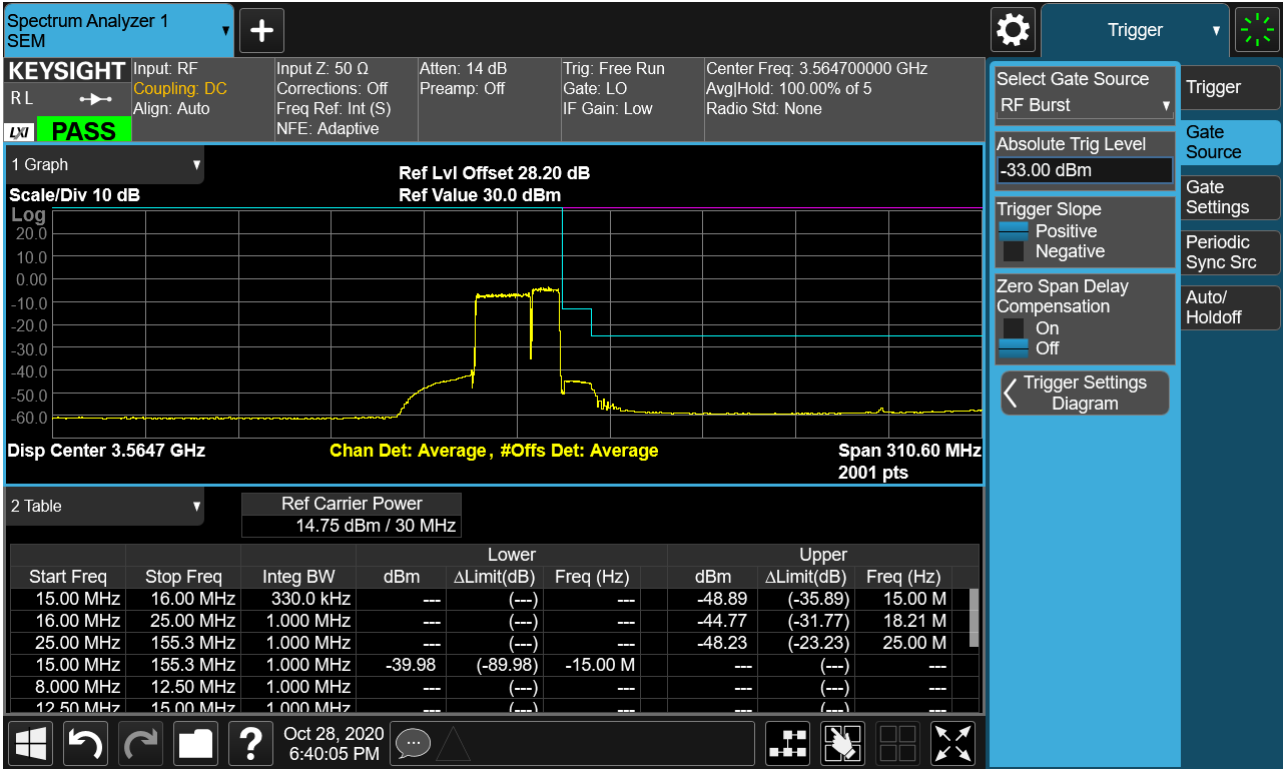

PCC 20MHz Ch55340 RB100 Offset0, SCC 20MHz Ch55538 RB100 Offset0-1

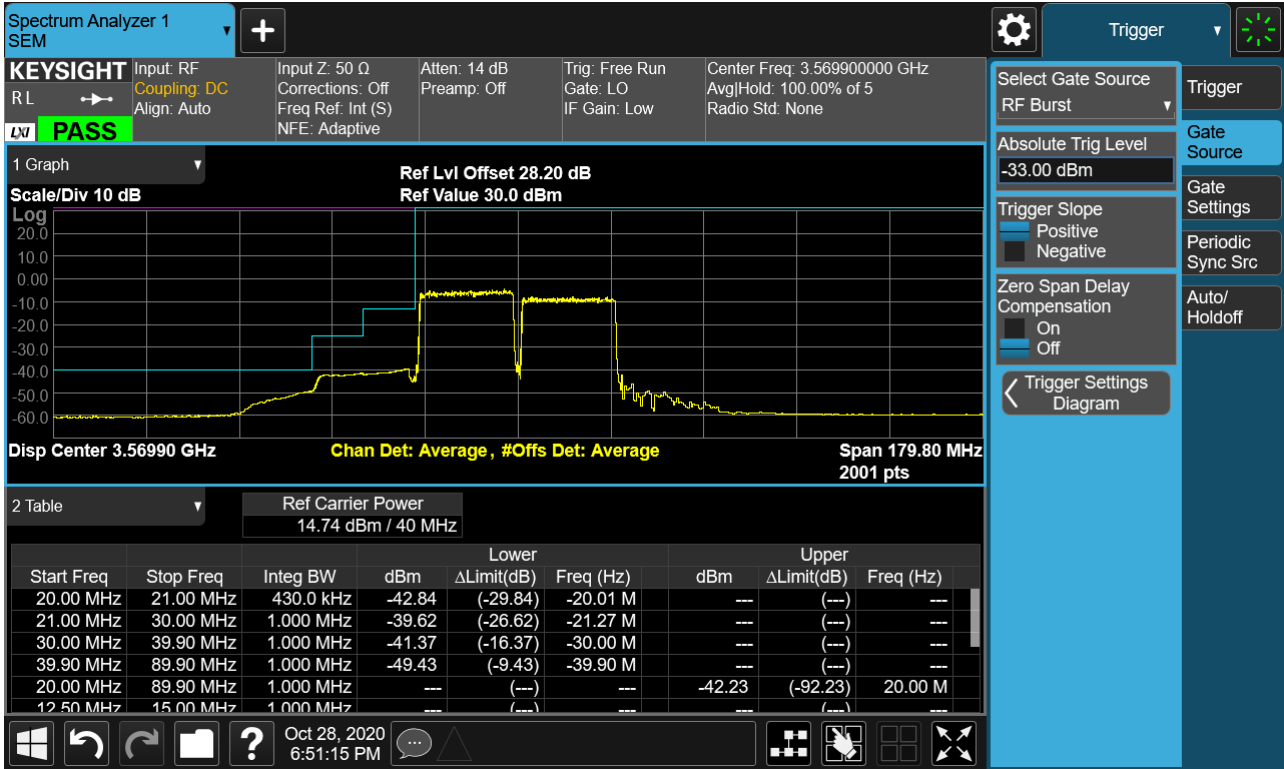

PCC 20MHz Ch55340 RB100 Offset0, SCC 20MHz Ch55538 RB100 Offset0-2

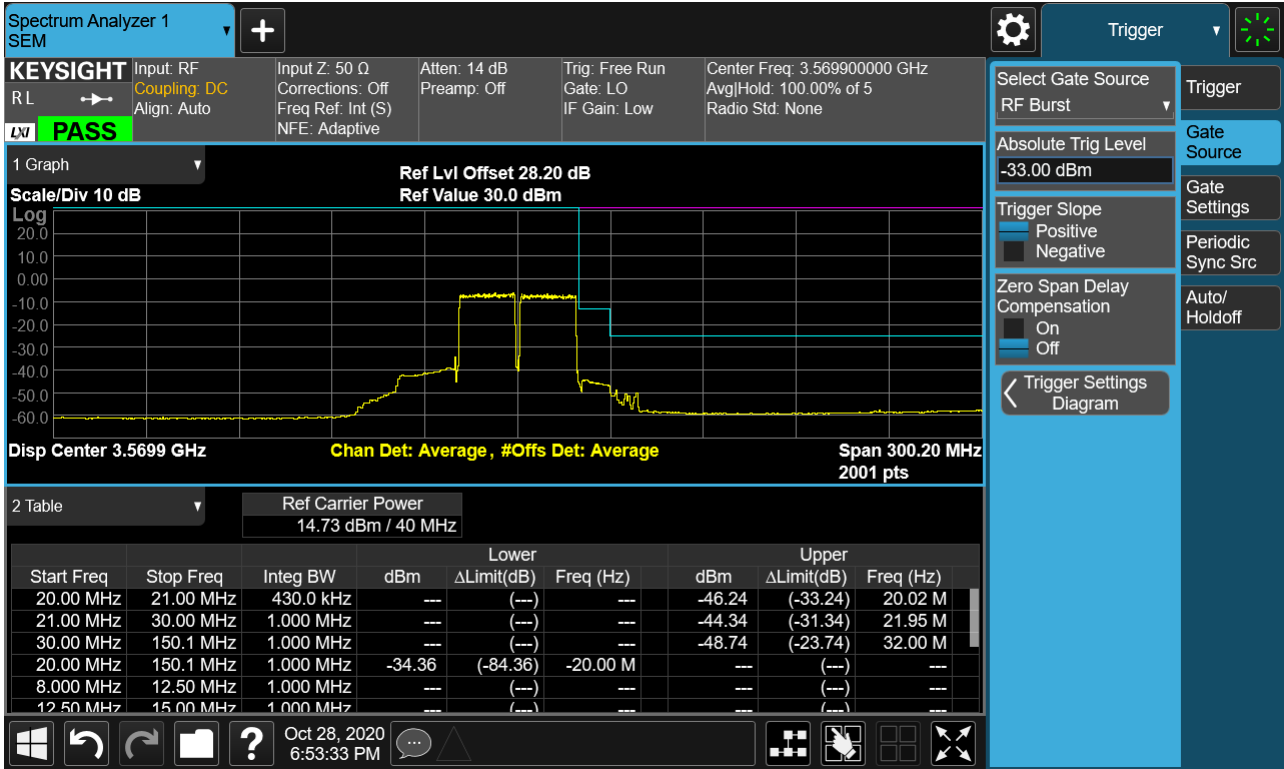

PCC 20MHz Ch55891 RB100 Offset0, SCC 20MHz Ch56089 RB100 Offset0

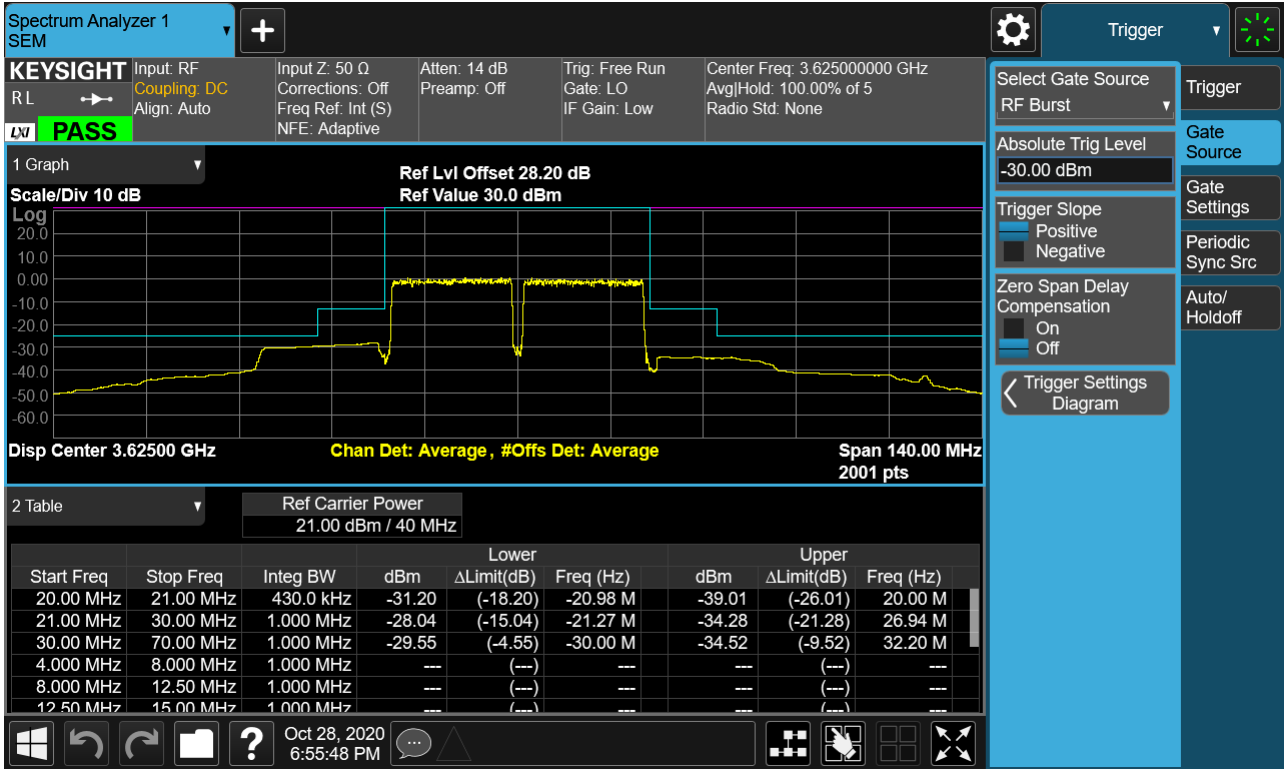

PCC 20MHz Ch55965 RB100 Offset0, SCC 5MHz Ch56082 RB25 Offset0

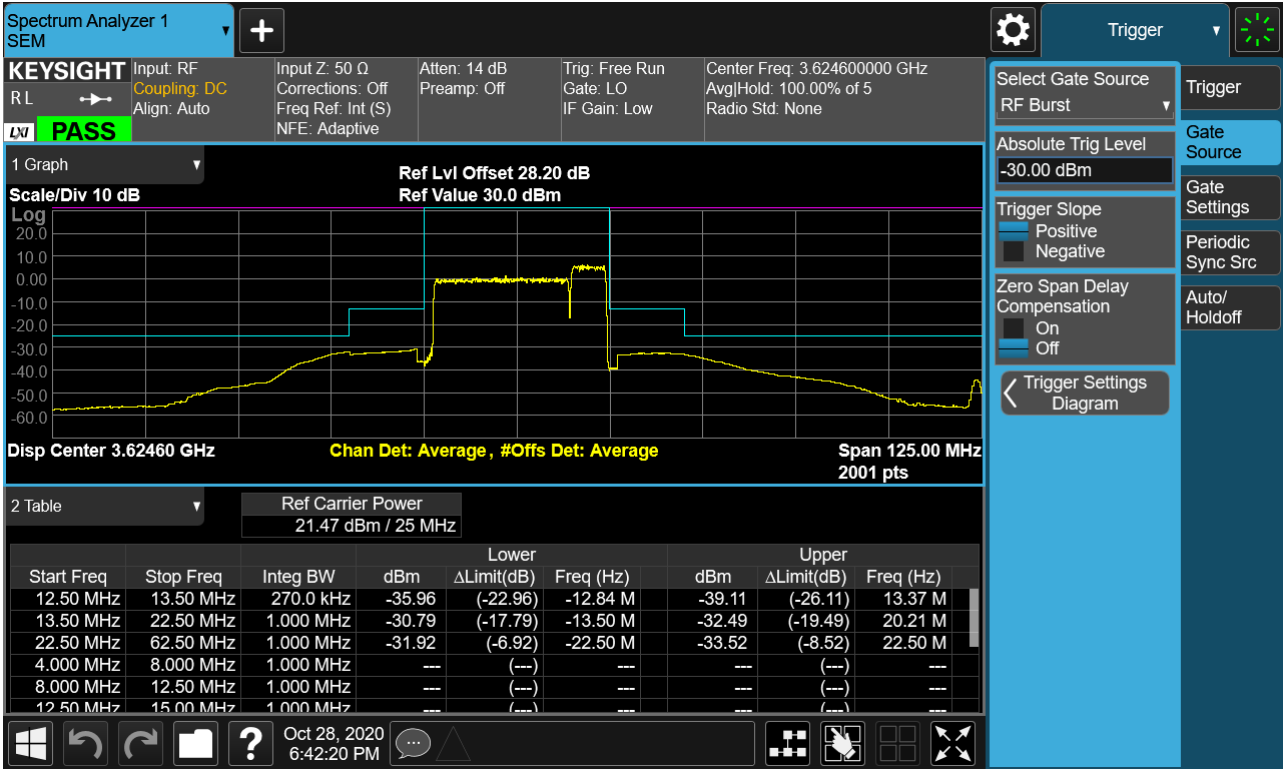

PCC 20MHz Ch56442 RB1 Offset0, SCC 20MHz Ch56640 RB1 Offset99-1

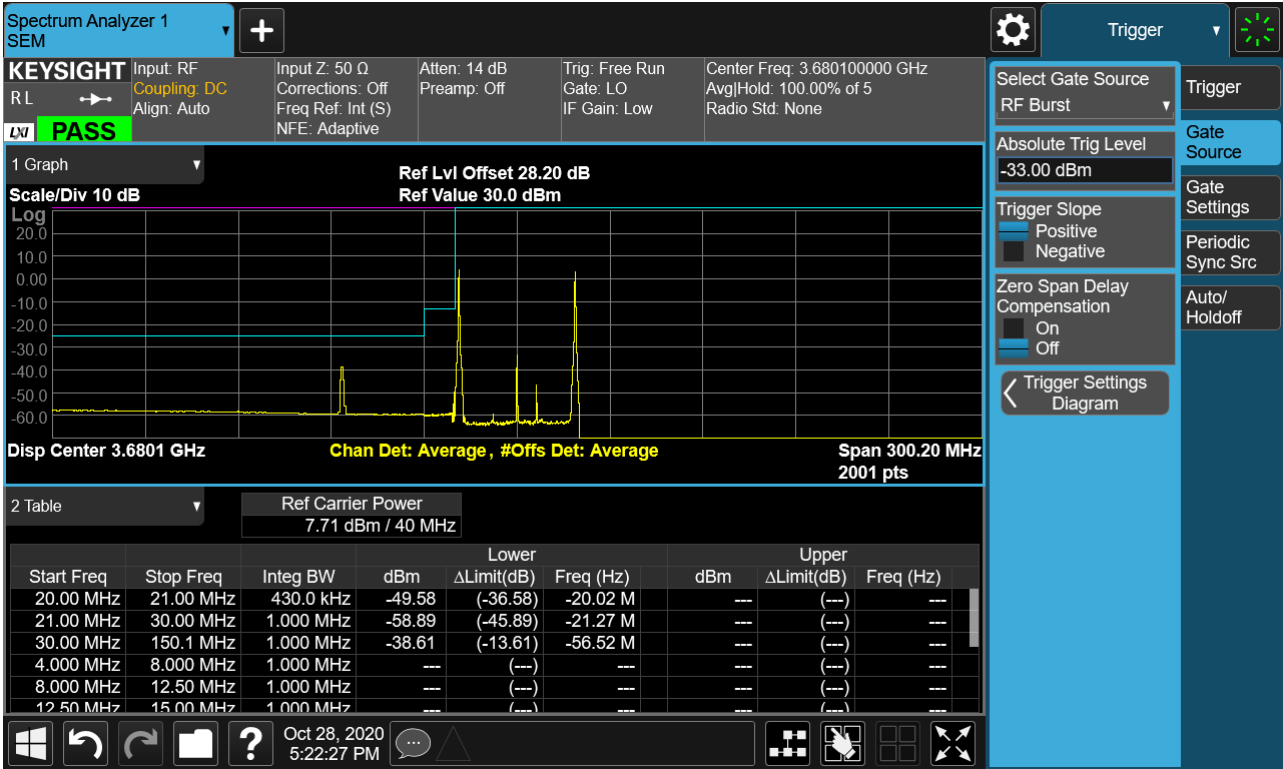

PCC 20MHz Ch56442 RB1 Offset0, SCC 20MHz Ch56640 RB1 Offset99-2

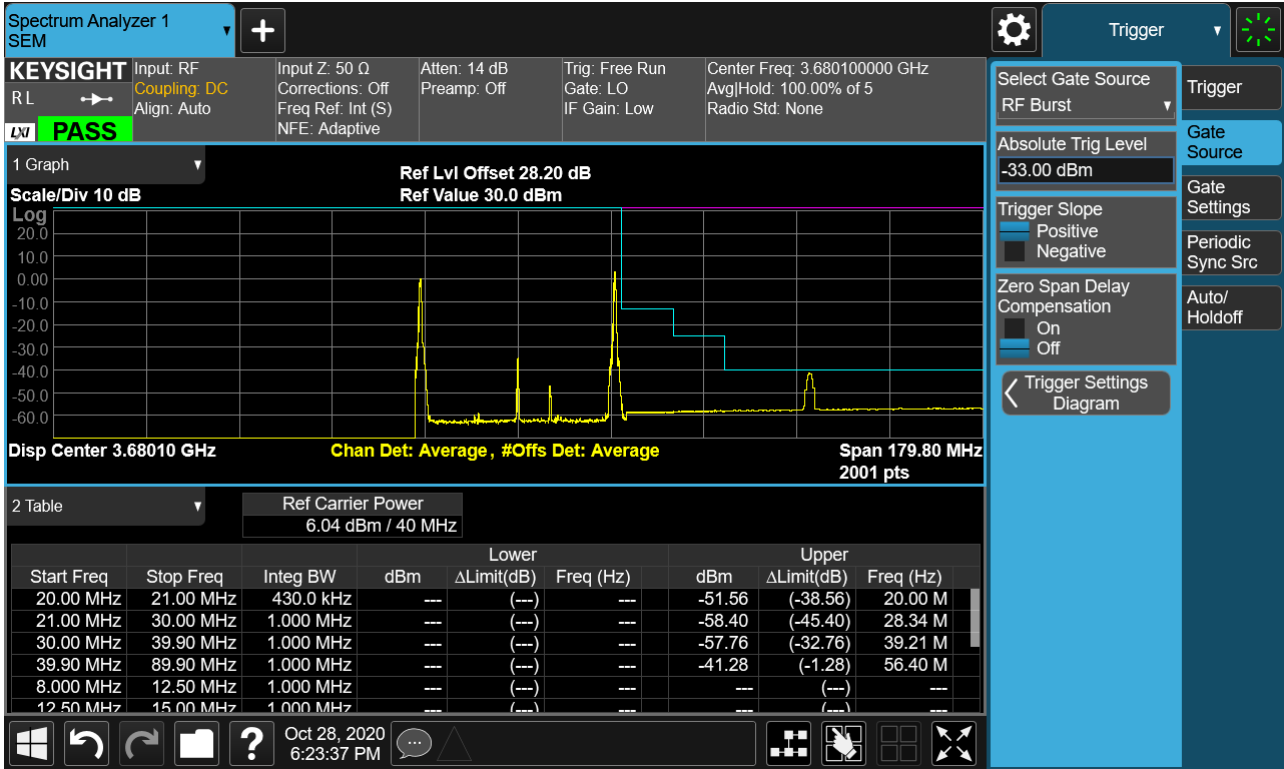

PCC 20MHz Ch56442 RB1 Offset99, SCC 20MHz Ch56640 RB1 Offset0-1

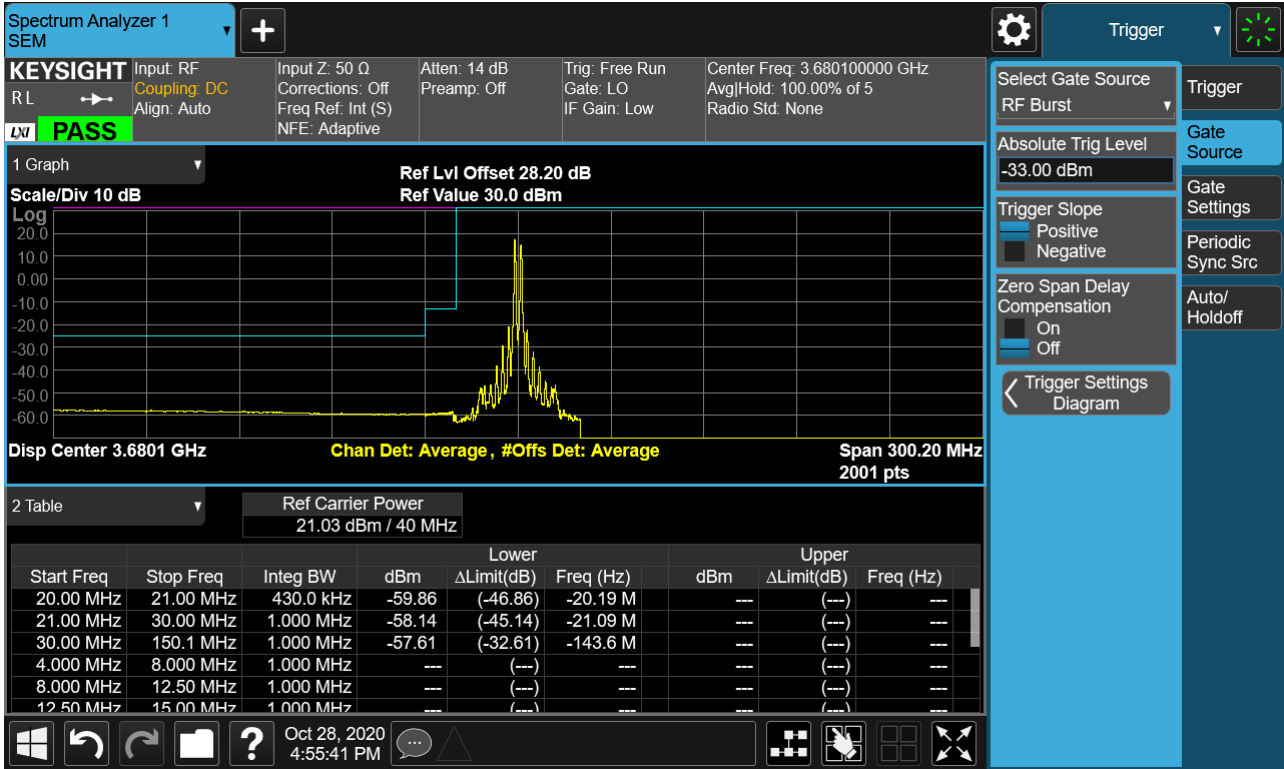



PCC 20MHz Ch56442 RB1 Offset99, SCC 20MHz Ch56640 RB1 Offset0-2

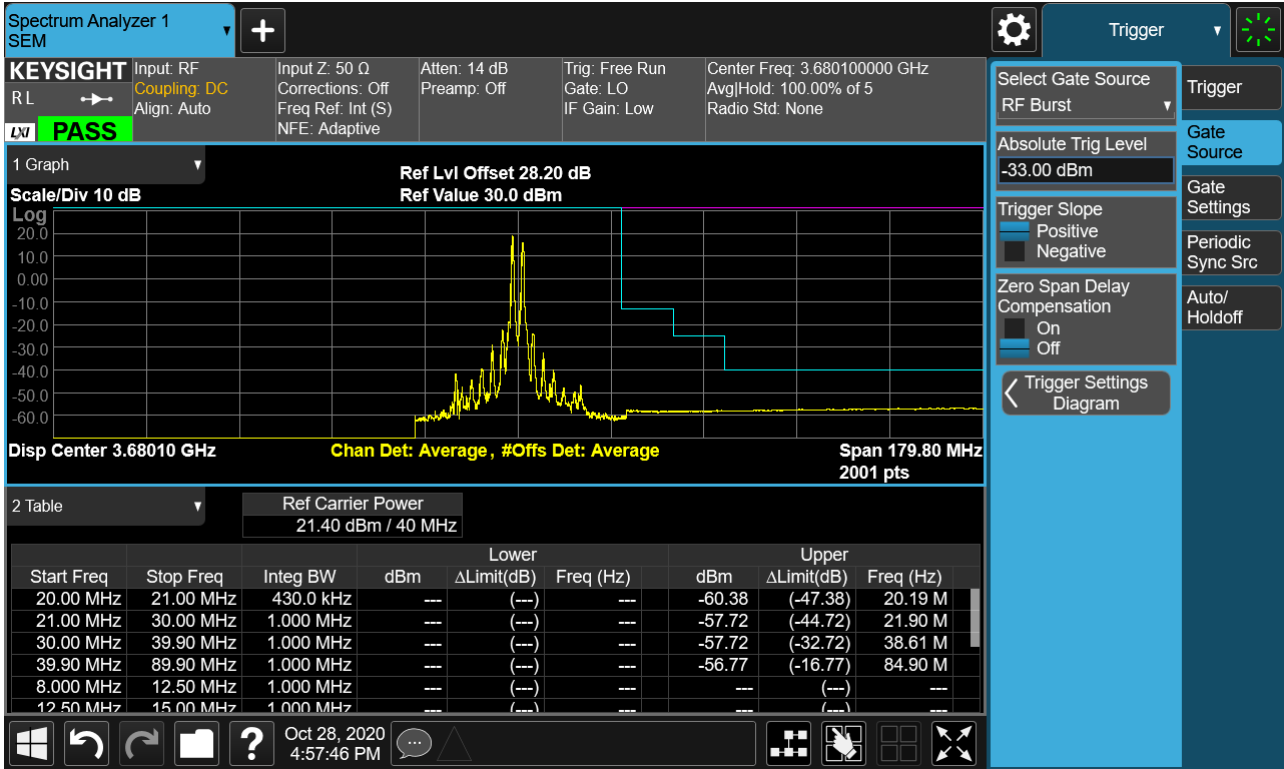

PCC 20MHz Ch56442 RB100 Offset0, SCC 20MHz Ch56640 RB100 Offset0-1

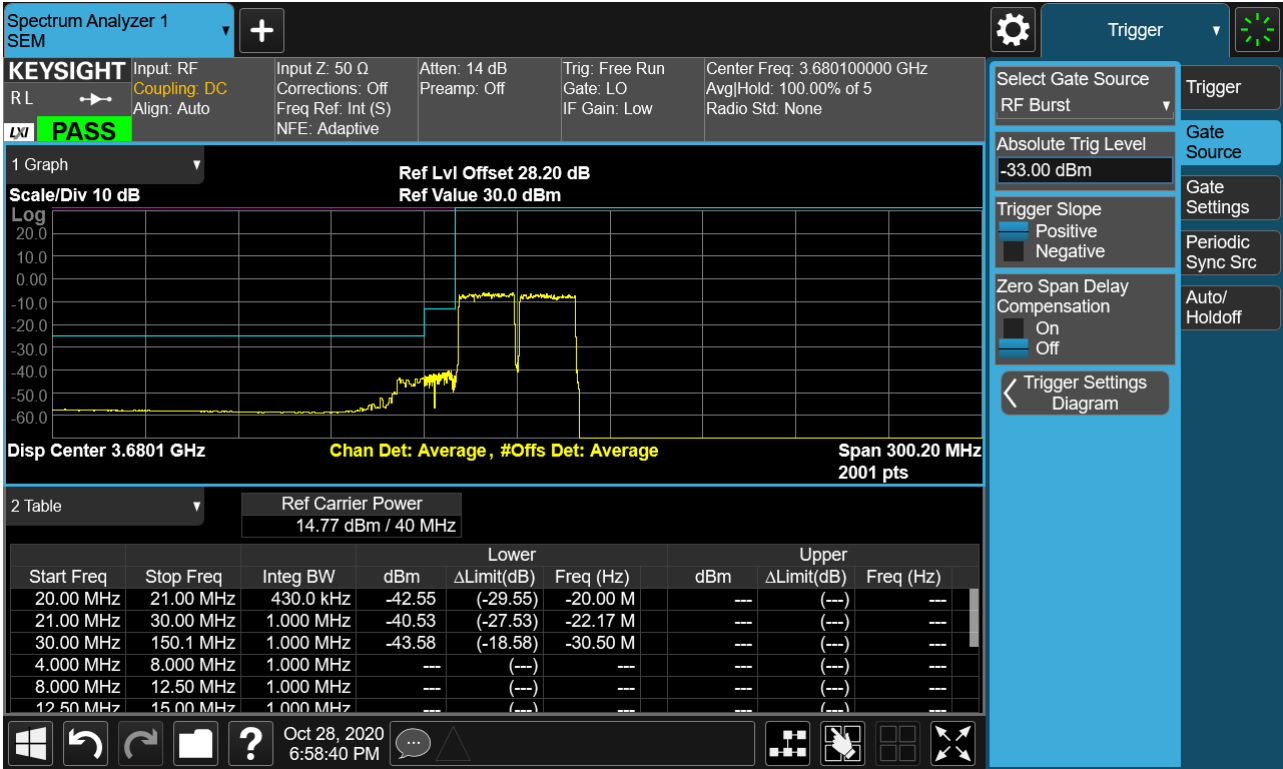

PCC 20MHz Ch56442 RB100 Offset0, SCC 20MHz Ch56640 RB100 Offset0-2

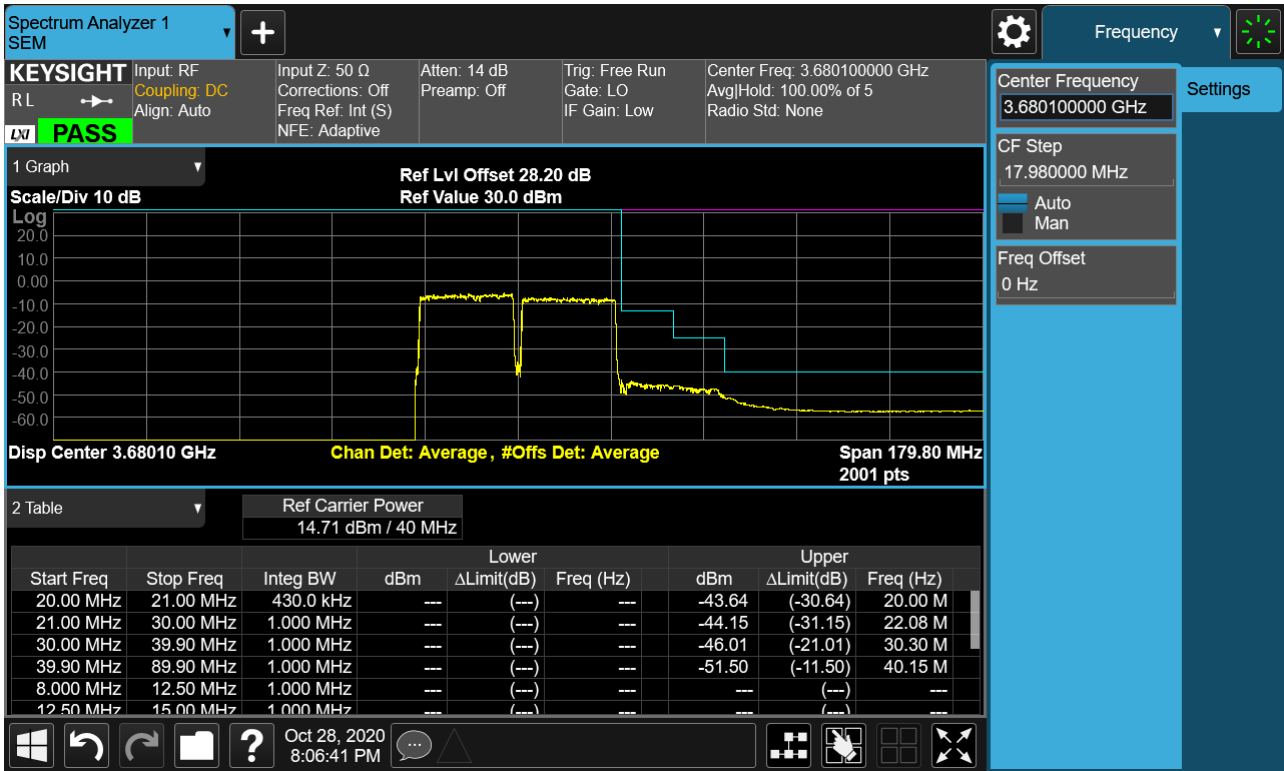

PCC 20MHz Ch56541 RB100 Offset0, SCC 10MHz Ch56685 RB50 Offset0-1

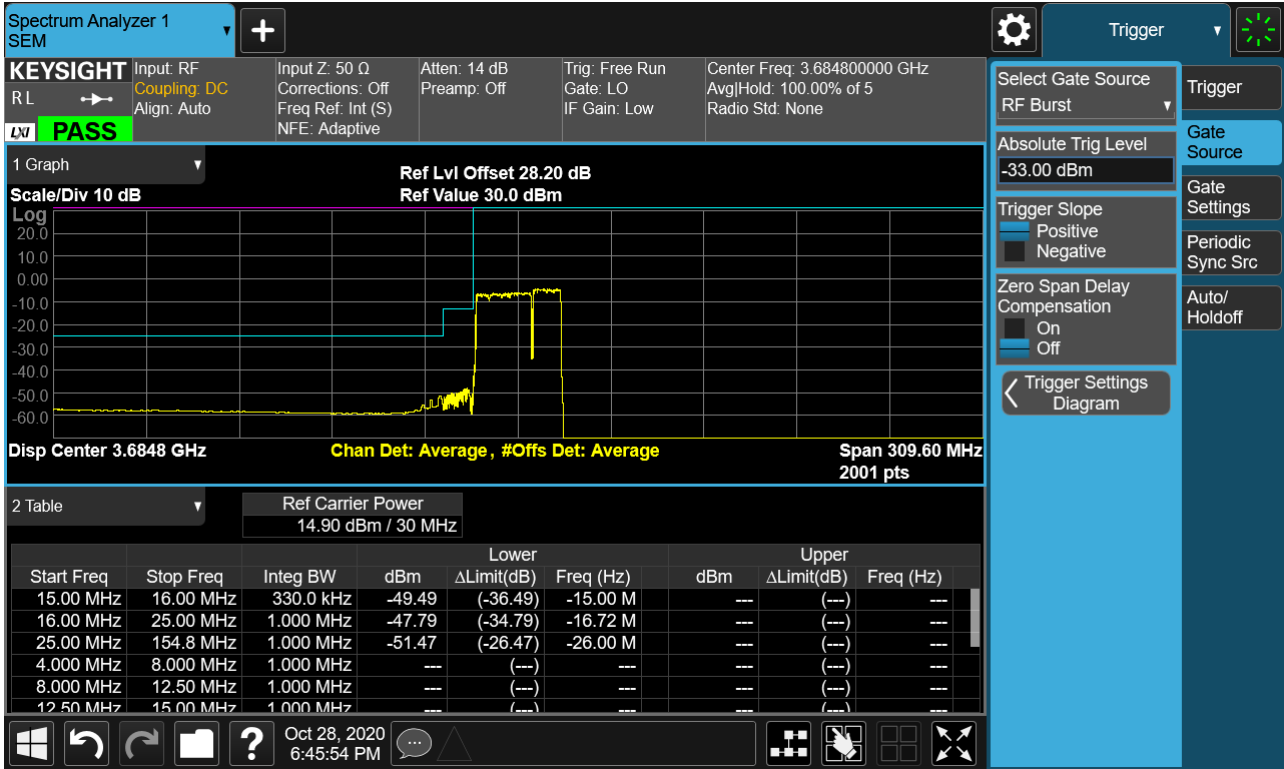

PCC 20MHz Ch56541 RB100 Offset0, SCC 10MHz Ch56685 RB50 Offset0-2

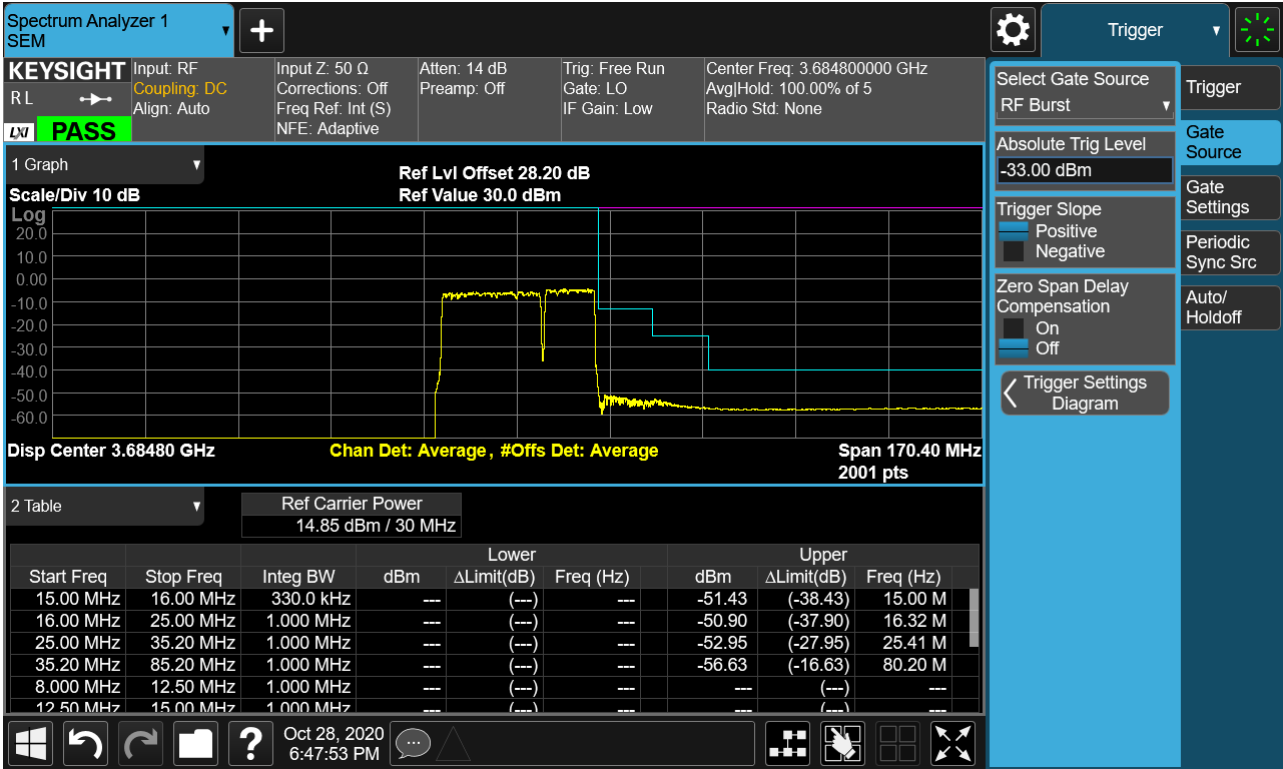

**8.5 Frequency Stability / Variation Of Ambient Temperature**

- ▣ PCC Channel: 55273
- ▣ PCC Frequency: 3553.3 MHz
- ▣ PCC BandWidth: 5 MHz
- ▣ SCC Channel: 55390
- ▣ SCC Frequency: 3565.0 MHz
- ▣ SCC BandWidth: 20 MHz
- ▣ Voltage : 3.880 VDC
- ▣ LIMIT: Emission must remain in band

Voltage (%)	Power (VDC)	Temp. (°C)	PPM		Frequency Error (MHz)	
			PCC	SCC	PCC	SCC
100%	3.880	+20(Ref)	0.033	-0.027	3553.30012	3564.99990
100%		-30	0.036	-0.025	3553.30013	3564.99991
100%		-20	0.032	0.025	3553.30012	3565.00009
100%		-10	-0.034	0.031	3553.29988	3565.00011
100%		0	0.036	0.036	3553.30013	3565.00013
100%		10	0.030	0.026	3553.30011	3565.00009
100%		30	0.028	0.035	3553.30010	3565.00012
100%		40	-0.033	0.040	3553.29988	3565.00014
100%		50	-0.039	0.031	3553.29986	3565.00011
Batt. Endpoint		3.650	20	0.037	-0.034	3553.30013

- PCC Channel: 55295
- PCC Frequency: 3555.5 MHz
- PCC BandWidth: 10 MHz
- SCC Channel: 55439
- SCC Frequency: 3569.9 MHz
- SCC BandWidth: 20 MHz
- Voltage : 3.880 VDC
- LIMIT: Emission must remain in band

Voltage (%)	Power (VDC)	Temp. (°C)	PPM		Frequency Error (MHz)	
			PCC	SCC	PCC	SCC
100%	3.880	+20(Ref)	0.042	0.043	3555.50015	3569.90015
100%		-30	0.028	0.029	3555.50010	3569.90011
100%		-20	0.039	0.042	3555.50014	3569.90015
100%		-10	-0.042	-0.039	3555.49985	3569.89986
100%		0	0.034	0.028	3555.50012	3569.90010
100%		10	0.027	0.027	3555.50009	3569.90010
100%		30	-0.041	0.029	3555.49985	3569.90010
100%		40	0.040	0.024	3555.50014	3569.90009
100%		50	0.041	-0.041	3555.50015	3569.89985
Batt. Endpoint	3.650	20	0.034	0.037	3555.50012	3569.90013

- PCC Channel: 55318
- PCC Frequency: 3557.8 MHz
- PCC BandWidth: 15 MHz
- SCC Channel: 55489
- SCC Frequency: 3574.9 MHz
- SCC BandWidth: 20 MHz
- Voltage : 3.880 VDC
- LIMIT: Emission must remain in band

Voltage (%)	Power (VDC)	Temp. (°C)	PPM		Frequency Error (MHz)	
			PCC	SCC	PCC	SCC
100%	3.880	+20(Ref)	0.027	0.039	3557.80010	3574.90014
100%		-30	0.035	0.042	3557.80012	3574.90015
100%		-20	0.039	-0.027	3557.80014	3574.89991
100%		-10	-0.043	-0.027	3557.79985	3574.89990
100%		0	0.038	-0.040	3557.80014	3574.89986
100%		10	0.031	-0.032	3557.80011	3574.89988
100%		30	0.038	0.032	3557.80013	3574.90012
100%		40	0.026	0.035	3557.80009	3574.90012
100%		50	-0.029	0.031	3557.79990	3574.90011
Batt. Endpoint	3.650	20	0.023	0.039	3557.80008	3574.90014



- PCC Channel: 55340
- PCC Frequency: 3560.0 MHz
- PCC BandWidth: 20 MHz
- SCC Channel: 55538
- SCC Frequency: 3579.8 MHz
- SCC BandWidth: 20 MHz
- Voltage : 3.880 VDC
- LIMIT: Emission must remain in band

Voltage (%)	Power (VDC)	Temp. (°C)	PPM		Frequency Error (MHz)	
			PCC	SCC	PCC	SCC
100%	3.880	+20(Ref)	-0.042	0.032	3559.99985	3579.80011
100%		-30	-0.032	0.026	3559.99989	3579.80009
100%		-20	0.030	0.025	3560.00011	3579.80009
100%		-10	-0.039	0.028	3559.99986	3579.80010
100%		0	0.041	-0.027	3560.00014	3579.79990
100%		10	0.029	0.026	3560.00010	3579.80009
100%		30	0.041	-0.035	3560.00015	3579.79987
100%		40	0.037	-0.039	3560.00013	3579.79986
100%		50	0.038	0.032	3560.00014	3579.80012
Batt. Endpoint		3.650	20	0.042	0.035	3560.00015

- PCC Channel: 56523
- PCC Frequency: 3678.3 MHz
- PCC BandWidth: 5 MHz
- SCC Channel: 56640
- SCC Frequency: 3690.0 MHz
- SCC BandWidth: 20 MHz
- Voltage : 3.880 VDC
- LIMIT: Emission must remain in band

Voltage (%)	Power (VDC)	Temp. (°C)	PPM		Frequency Error (MHz)	
			PCC	SCC	PCC	SCC
100%	3.880	+20(Ref)	-0.035	0.042	3678.29987	3690.00016
100%		-30	0.032	0.031	3678.30012	3690.00011
100%		-20	-0.026	0.029	3678.29990	3690.00011
100%		-10	0.039	-0.038	3678.30014	3689.99986
100%		0	0.042	-0.028	3678.30016	3689.99990
100%		10	0.035	0.028	3678.30013	3690.00010
100%		30	0.028	-0.032	3678.30010	3689.99988
100%		40	0.036	-0.035	3678.30013	3689.99987
100%		50	0.035	0.029	3678.30013	3690.00011
Batt. Endpoint		3.650	20	0.043	0.027	3678.30016

- PCC Channel: 56496
- PCC Frequency: 3675.6 MHz
- PCC BandWidth: 10 MHz
- SCC Channel: 56640
- SCC Frequency: 3690.0 MHz
- SCC BandWidth: 20 MHz
- Voltage : 3.880 VDC
- LIMIT: Emission must remain in band

Voltage (%)	Power (VDC)	Temp. (°C)	PPM		Frequency Error (MHz)	
			PCC	SCC	PCC	SCC
100%	3.880	+20(Ref)	0.043	0.025	3675.60016	3690.00009
100%		-30	0.037	0.023	3675.60014	3690.00009
100%		-20	0.030	-0.032	3675.60011	3689.99988
100%		-10	0.037	0.039	3675.60014	3690.00015
100%		0	0.024	-0.034	3675.60009	3689.99988
100%		10	0.035	0.038	3675.60013	3690.00014
100%		30	-0.033	0.038	3675.59988	3690.00014
100%		40	0.041	0.040	3675.60015	3690.00015
100%		50	-0.029	0.028	3675.59989	3690.00010
Batt. Endpoint		3.650	20	0.042	0.030	3675.60015

- PCC Channel: 56469
- PCC Frequency: 3672.9 MHz
- PCC BandWidth: 15 MHz
- SCC Channel: 56640
- SCC Frequency: 3690.0 MHz
- SCC BandWidth: 20 MHz
- Voltage : 3.880 VDC
- LIMIT: Emission must remain in band

Voltage (%)	Power (VDC)	Temp. (°C)	PPM		Frequency Error (MHz)	
			PCC	SCC	PCC	SCC
100%	3.880	+20(Ref)	0.029	-0.038	3672.90011	3689.99986
100%		-30	-0.042	0.038	3672.89985	3690.00014
100%		-20	-0.030	-0.028	3672.89989	3689.99990
100%		-10	0.038	-0.024	3672.90014	3689.99991
100%		0	0.033	0.027	3672.90012	3690.00010
100%		10	0.028	-0.031	3672.90010	3689.99989
100%		30	0.035	0.039	3672.90013	3690.00014
100%		40	0.043	0.033	3672.90016	3690.00012
100%		50	0.024	0.026	3672.90009	3690.00009
Batt. Endpoint	3.650	20	0.042	0.041	3672.90016	3690.00015

- ▣ PCC Channel: 56442
- ▣ PCC Frequency: 3670.2 MHz
- ▣ PCC BandWidth: 20 MHz
- ▣ SCC Channel: 56640
- ▣ SCC Frequency: 3690.0 MHz
- ▣ SCC BandWidth: 20 MHz
- ▣ Voltage : 3.880 MHz
- ▣ LIMIT: Emission must remain in band

Voltage (%)	Power (VDC)	Temp. (°C)	PPM		Frequency Error (MHz)	
			PCC	SCC	PCC	SCC
100%	3.880	+20(Ref)	0.042	-0.037	3670.20016	3689.99986
100%		-30	0.023	0.028	3670.20009	3690.00010
100%		-20	0.030	0.040	3670.20011	3690.00015
100%		-10	0.035	0.043	3670.20013	3690.00016
100%		0	0.041	-0.039	3670.20015	3689.99986
100%		10	0.037	0.037	3670.20013	3690.00014
100%		30	-0.029	0.036	3670.19990	3690.00013
100%		40	-0.034	0.023	3670.19988	3690.00009
100%		50	-0.028	0.031	3670.19990	3690.00011
Batt. Endpoint		3.650	20	-0.024	0.027	3670.19991

### 8.6 Radiated Spurious Emissions

- ▣ PCC Channel : 55340 (3560.0MHz)
- ▣ PCC BW(MHz) : 20
- ▣ PCC RB/ RB Offset : 1/ 99
- ▣ SCC Channel : 55538 (3579.8MHz)
- ▣ SCC BW(MHz) : 20
- ▣ SCC RB/ RB Offset : 1/ 0
- ▣ DISTANCE: 1 meters
- ▣ LIMIT: -40.0 dBm

Freq.(MHz)	Measured Level [dBm]	Ant. Gain (dBi)	Substitute Level [dBm]	C.L	Pol.	Result (dBm)
7 139.80	-51.12	11.23	-52.79	4.34	H	-45.90
10 709.70	-59.08	10.90	-55.15	5.49	H	-49.74
14 279.60	-60.86	11.75	-49.73	6.42	H	-44.40

- ▣ PCC Channel : 55891 (3615.1MHz)
- ▣ PCC BW(MHz) : 20
- ▣ PCC RB/ RB Offset : 1/ 99
- ▣ SCC Channel : 56089 (3634.9MHz)
- ▣ SCC BW(MHz) : 20
- ▣ SCC RB/ RB Offset : 1/ 0
- ▣ DISTANCE: 1 meters
- ▣ LIMIT: -40.0 dBm

Freq.(MHz)	Measured Level [dBm]	Ant. Gain (dBi)	Substitute Level [dBm]	C.L	Pol.	Result (dBm)
7 250.00	-50.82	11.10	-53.39	4.35	H	-46.64
10 875.00	-59.67	10.65	-53.56	5.57	H	-48.48
14 500.00	-60.14	11.90	-48.82	6.54	V	-43.46

- ▣ PCC Channel : 56442 (3670.2MHz)
- ▣ PCC BW(MHz) : 20
- ▣ PCC RB/ RB Offset : 1/ 99
- ▣ SCC Channel : 56640 (3690.0MHz)
- ▣ SCC BW(MHz) : 20
- ▣ SCC RB/ RB Offset : 1/ 0
- ▣ DISTANCE: 1 meters
- ▣ LIMIT: -40.0 dBm

Freq.(MHz)	Measured Level [dBm]	Ant. Gain (dBi)	Substitute Level [dBm]	C.L	Pol.	Result (dBm)
7 360.20	-55.56	11.18	-56.63	4.39	V	-49.84
11 040.30	-58.30	10.98	-54.08	5.64	H	-48.74
14 720.40	-59.67	11.95	-48.39	6.63	H	-43.07



**8.7 Occupied Bandwidth**

PCC					SCC					Data (MHz)
BW [MHz]	Ch	Freq [MHz]	Mod	RB/Offset	BW [MHz]	Ch	Freq [MHz]	Mod	RB/Offset	
5	55898	3615.8	QPSK	25/ 0	20	56015	3627.5	QPSK	100/ 0	22.937
10	55896	3615.6	QPSK	50/ 0	20	56040	3630.0	QPSK	100/ 0	27.804
15	55893	3615.3	QPSK	75/ 0	20	56064	3632.4	QPSK	100/ 0	32.553
20	55965	3622.5	QPSK	100/ 0	5	56082	3634.2	QPSK	25/ 0	22.962
20	55941	3620.1	QPSK	100/ 0	10	56085	3634.5	QPSK	50/ 0	27.888
20	55916	3617.6	QPSK	100 0	15	56087	3634.7	QPSK	75/ 0	32.629
20	55891	3615.1	QPSK	100/ 0	20	56089	3634.9	QPSK	75/ 0	37.594

PCC					SCC					Data (MHz)
BW [MHz]	Ch	Freq [MHz]	Mod	RB/Offset	BW [MHz]	Ch	Freq [MHz]	Mod	RB/Offset	
5	55898	3615.8	16QAM	25/ 0	20	56015	3627.5	16QAM	100/ 0	22.952
10	55896	3615.6	16QAM	50/ 0	20	56040	3630.0	16QAM	100/ 0	27.592
15	55893	3615.3	16QAM	75/ 0	20	56064	3632.4	16QAM	100/ 0	32.443
20	55965	3622.5	16QAM	100/ 0	5	56082	3634.2	16QAM	25/ 0	22.855
20	55941	3620.1	16QAM	100/ 0	10	56085	3634.5	16QAM	50/ 0	27.629
20	55916	3617.6	16QAM	100 0	15	56087	3634.7	16QAM	75/ 0	32.600
20	55891	3615.1	16QAM	100/ 0	20	56089	3634.9	16QAM	75/ 0	37.347

PCC					SCC					Data (MHz)
BW [MHz]	Ch	Freq [MHz]	Mod	RB/Offset	BW [MHz]	Ch	Freq [MHz]	Mod	RB/Offset	
5	55898	3615.8	64QAM	25/ 0	20	56015	3627.5	64QAM	100/ 0	22.712
10	55896	3615.6	64QAM	50/ 0	20	56040	3630.0	64QAM	100/ 0	27.726
15	55893	3615.3	64QAM	75/ 0	20	56064	3632.4	64QAM	100/ 0	32.626
20	55965	3622.5	64QAM	100/ 0	5	56082	3634.2	64QAM	25/ 0	22.732
20	55941	3620.1	64QAM	100/ 0	10	56085	3634.5	64QAM	50/ 0	27.742
20	55916	3617.6	64QAM	100 0	15	56087	3634.7	64QAM	75/ 0	32.538
20	55891	3615.1	64QAM	100/ 0	20	56089	3634.9	64QAM	75/ 0	37.544

PCC					SCC					Data (MHz)
BW [MHz]	Ch	Freq [MHz]	Mod	RB/Offset	BW [MHz]	Ch	Freq [MHz]	Mod	RB/Offset	
5	55898	3615.8	256QAM	25/ 0	20	56015	3627.5	256QAM	100/ 0	22.833
10	55896	3615.6	256QAM	50/ 0	20	56040	3630.0	256QAM	100/ 0	27.781
15	55893	3615.3	256QAM	75/ 0	20	56064	3632.4	256QAM	100/ 0	32.672
20	55965	3622.5	256QAM	100/ 0	5	56082	3634.2	256QAM	25/ 0	22.844
20	55941	3620.1	256QAM	100/ 0	10	56085	3634.5	256QAM	50/ 0	27.811
20	55916	3617.6	256QAM	100 0	15	56087	3634.7	256QAM	75/ 0	32.595
20	55891	3615.1	256QAM	100/ 0	20	56089	3634.9	256QAM	75/ 0	37.475

Note:

In order to simplify the report, attached plots were only Max.Bandwidth(20+20)

PCC 20MHz Ch55891 RB100 Offset0, SCC 20MHz Ch56089 RB100 Offset0\_(QPSK)

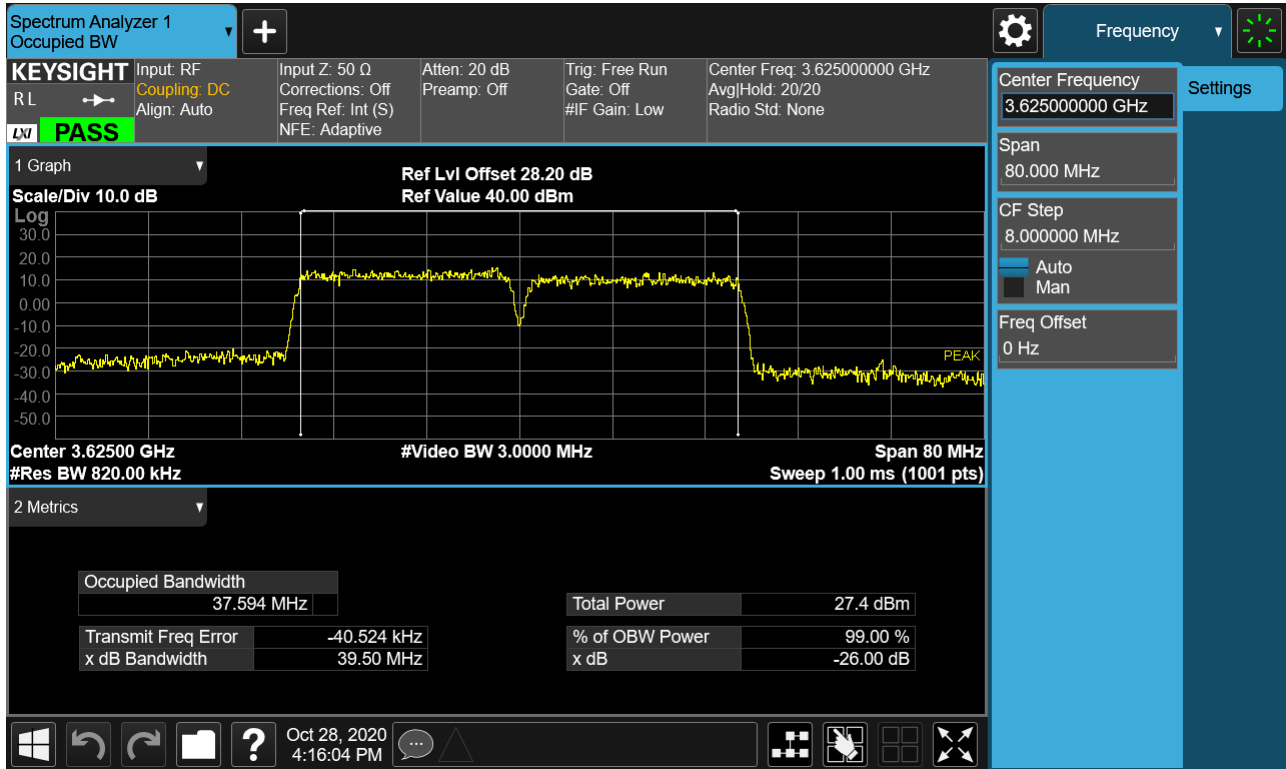

PCC 20MHz Ch55891 RB100 Offset0, SCC 20MHz Ch56089 RB100 Offset0\_(16QAM)

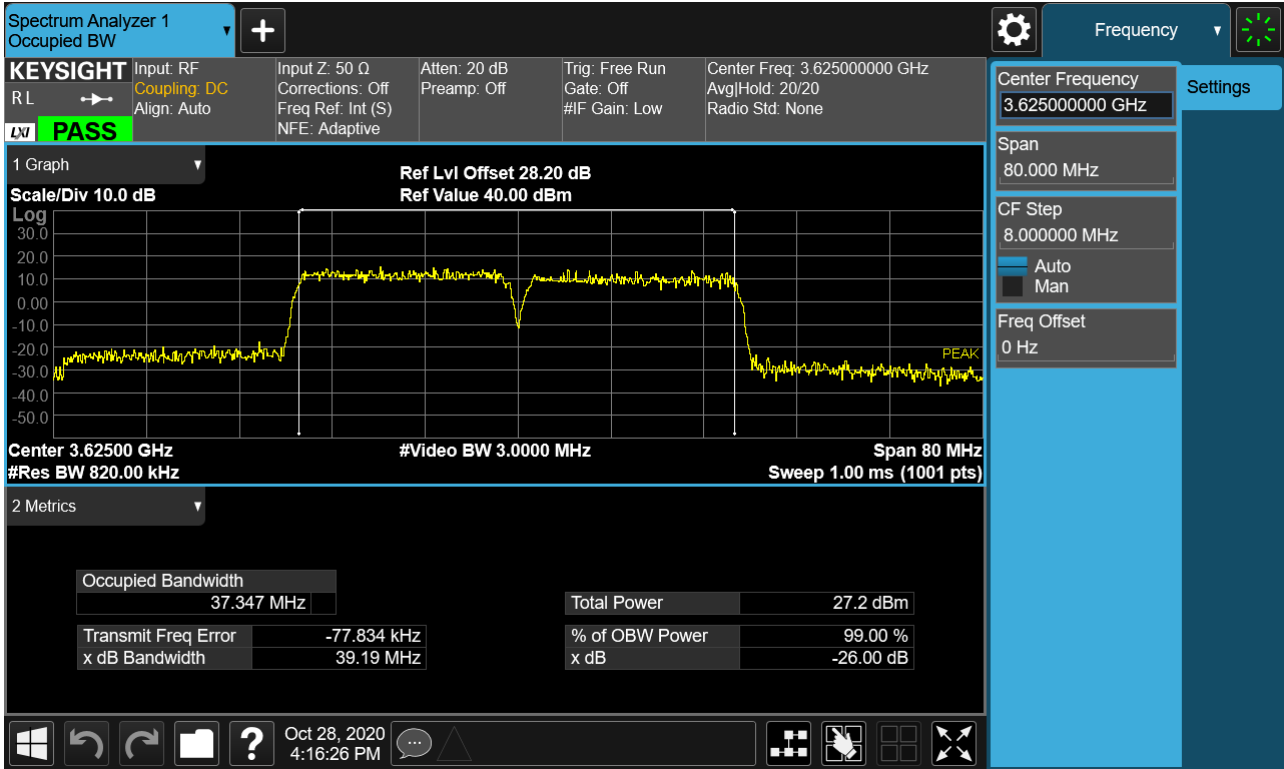

PCC 20MHz Ch55891 RB100 Offset0, SCC 20MHz Ch56089 RB100 Offset0\_(64QAM)

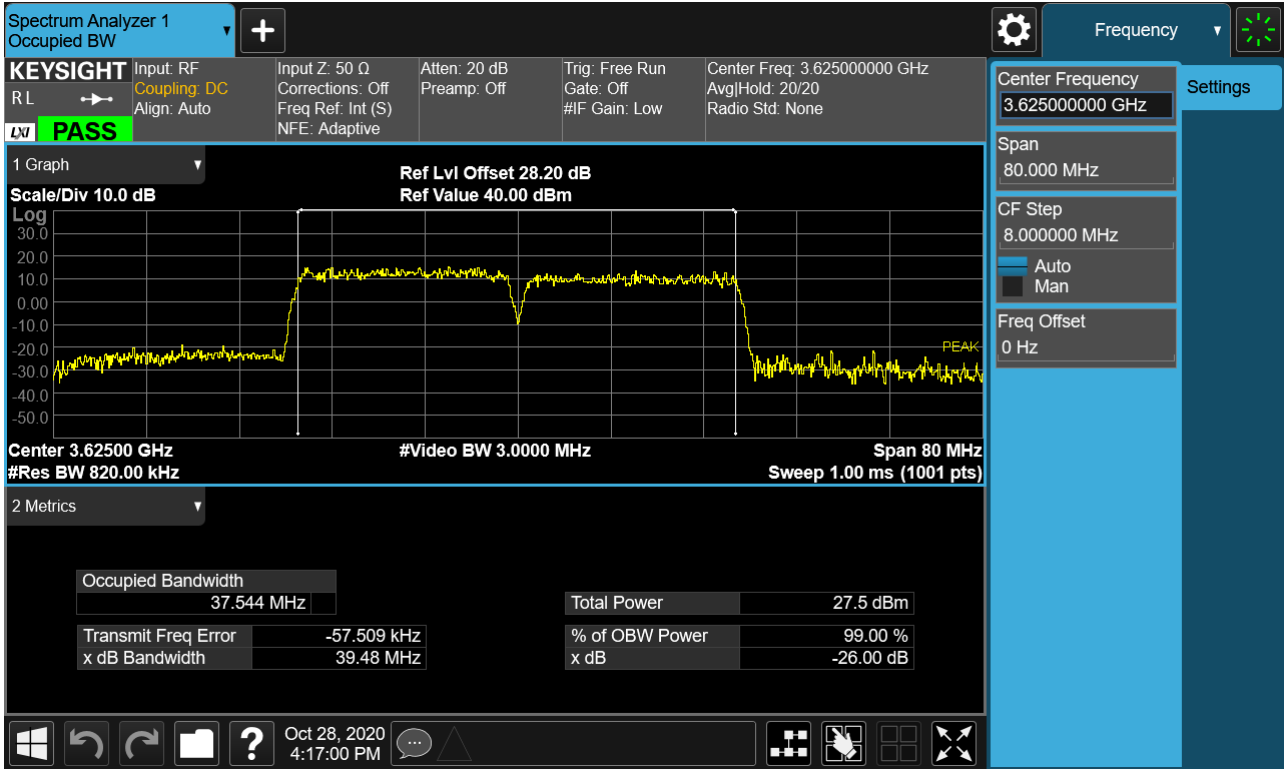

PCC 20MHz Ch55891 RB100 Offset0, SCC 20MHz Ch56089 RB100 Offset0\_(256QAM)

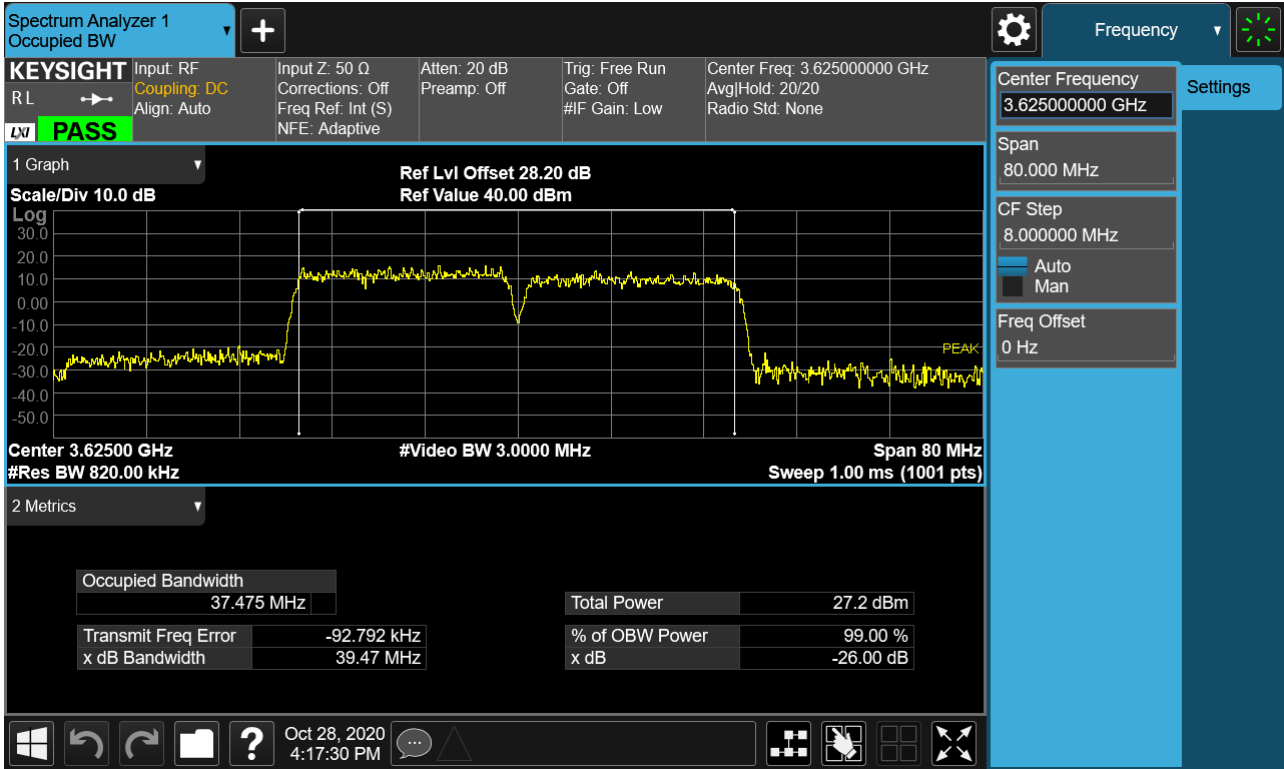

**8.8 Peak- to- Average Ratio**

PCC					SCC					Data (dBm)
BW [MHz]	Ch	Freq [MHz]	Mod	RB/Offset	BW [MHz]	Ch	Freq [MHz]	Mod	RB/Offset	
5	55898	3615.8	QPSK	25/ 0	20	56015	3627.5	QPSK	100/ 0	6.33
10	55896	3615.6	QPSK	50/ 0	20	56040	3630.0	QPSK	100/ 0	6.38
15	55893	3615.3	QPSK	75/ 0	20	56064	3632.4	QPSK	100/ 0	6.39
20	55965	3622.5	QPSK	100/ 0	5	56082	3634.2	QPSK	25/ 0	6.30
20	55941	3620.1	QPSK	100/ 0	10	56085	3634.5	QPSK	50/ 0	6.37
20	55916	3617.6	QPSK	100 0	15	56087	3634.7	QPSK	75/ 0	6.42
20	55891	3615.1	QPSK	100/ 0	20	56089	3634.9	QPSK	75/ 0	6.95

PCC					SCC					Data (dBm)
BW [MHz]	Ch	Freq [MHz]	Mod	RB/Offset	BW [MHz]	Ch	Freq [MHz]	Mod	RB/Offset	
5	55898	3615.8	16QAM	25/ 0	20	56015	3627.5	16QAM	100/ 0	6.85
10	55896	3615.6	16QAM	50/ 0	20	56040	3630.0	16QAM	100/ 0	6.88
15	55893	3615.3	16QAM	75/ 0	20	56064	3632.4	16QAM	100/ 0	6.86
20	55965	3622.5	16QAM	100/ 0	5	56082	3634.2	16QAM	25/ 0	6.85
20	55941	3620.1	16QAM	100/ 0	10	56085	3634.5	16QAM	50/ 0	6.87
20	55916	3617.6	16QAM	100 0	15	56087	3634.7	16QAM	75/ 0	6.88
20	55891	3615.1	16QAM	100/ 0	20	56089	3634.9	16QAM	75/ 0	7.95

PCC					SCC					Data (dBm)
BW [MHz]	Ch	Freq [MHz]	Mod	RB/Offset	BW [MHz]	Ch	Freq [MHz]	Mod	RB/Offset	
5	55898	3615.8	64QAM	25/ 0	20	56015	3627.5	64QAM	100/ 0	7.10
10	55896	3615.6	64QAM	50/ 0	20	56040	3630.0	64QAM	100/ 0	7.03
15	55893	3615.3	64QAM	75/ 0	20	56064	3632.4	64QAM	100/ 0	7.08
20	55965	3622.5	64QAM	100/ 0	5	56082	3634.2	64QAM	25/ 0	7.08
20	55941	3620.1	64QAM	100/ 0	10	56085	3634.5	64QAM	50/ 0	6.99
20	55916	3617.6	64QAM	100 0	15	56087	3634.7	64QAM	75/ 0	7.11
20	55891	3615.1	64QAM	100/ 0	20	56089	3634.9	64QAM	75/ 0	8.17

PCC					SCC					Data (dBm)
BW [MHz]	Ch	Freq [MHz]	Mod	RB/Offset	BW [MHz]	Ch	Freq [MHz]	Mod	RB/Offset	
5	55898	3615.8	256QAM	25/ 0	20	56015	3627.5	256QAM	100/ 0	7.14
10	55896	3615.6	256QAM	50/ 0	20	56040	3630.0	256QAM	100/ 0	7.16
15	55893	3615.3	256QAM	75/ 0	20	56064	3632.4	256QAM	100/ 0	7.06
20	55965	3622.5	256QAM	100/ 0	5	56082	3634.2	256QAM	25/ 0	7.06
20	55941	3620.1	256QAM	100/ 0	10	56085	3634.5	256QAM	50/ 0	7.11
20	55916	3617.6	256QAM	100 0	15	56087	3634.7	256QAM	75/ 0	7.06
20	55891	3615.1	256QAM	100/ 0	20	56089	3634.9	256QAM	75/ 0	8.33



Note:

In order to simplify the report, attached plots were only Max.Bandwidth(20+20)

PCC 20MHz Ch55891 RB100 Offset0, SCC 20MHz Ch56089 RB100 Offset0\_(QPSK)

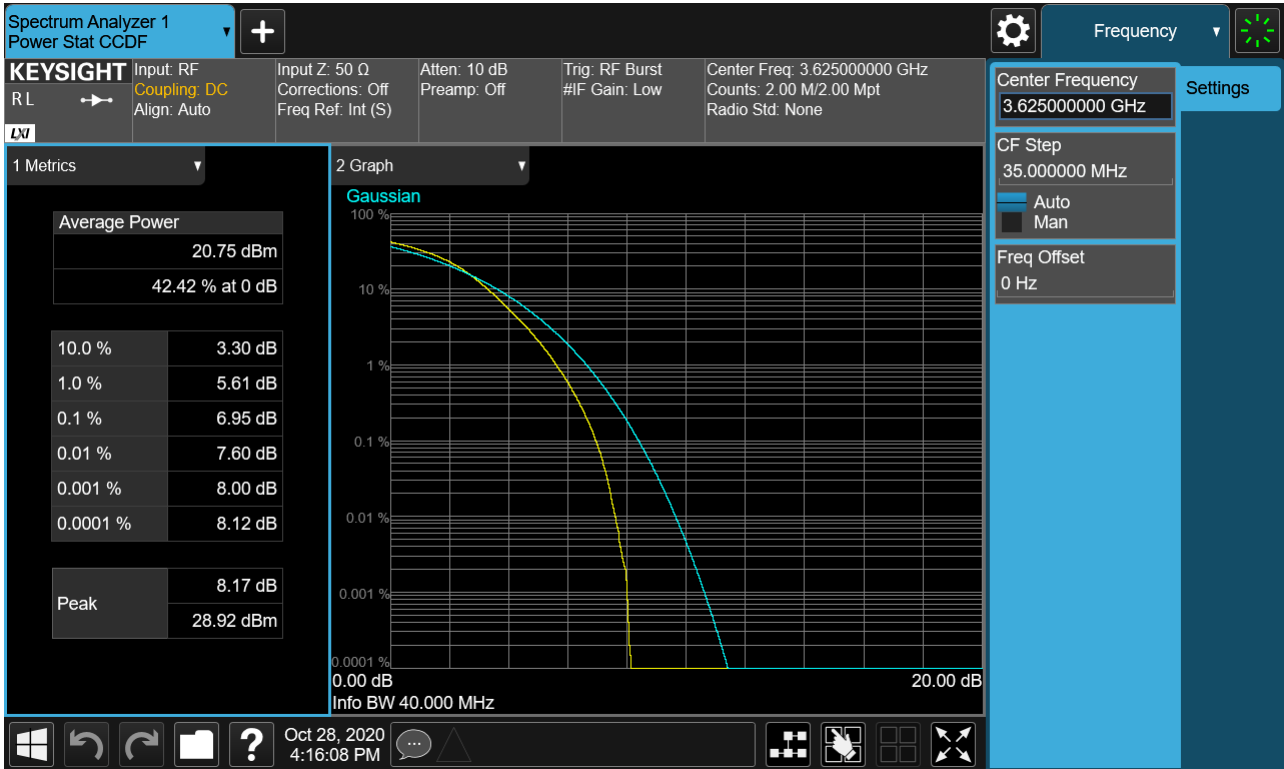

PCC 20MHz Ch55891 RB100 Offset0, SCC 20MHz Ch56089 RB100 Offset0\_(16QAM)



PCC 20MHz Ch55891 RB100 Offset0, SCC 20MHz Ch56089 RB100 Offset0\_(64QAM)

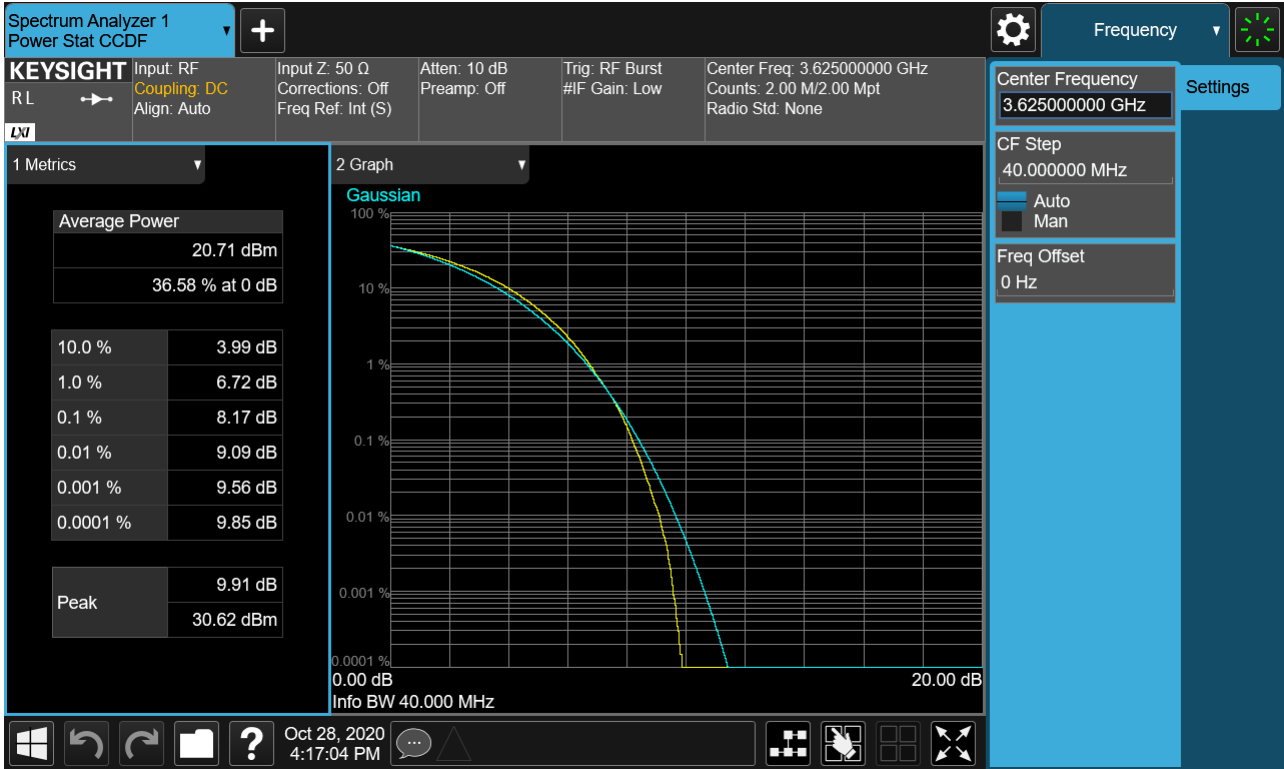

PCC 20MHz Ch55891 RB100 Offset0, SCC 20MHz Ch56089 RB100 Offset0\_(256QAM)

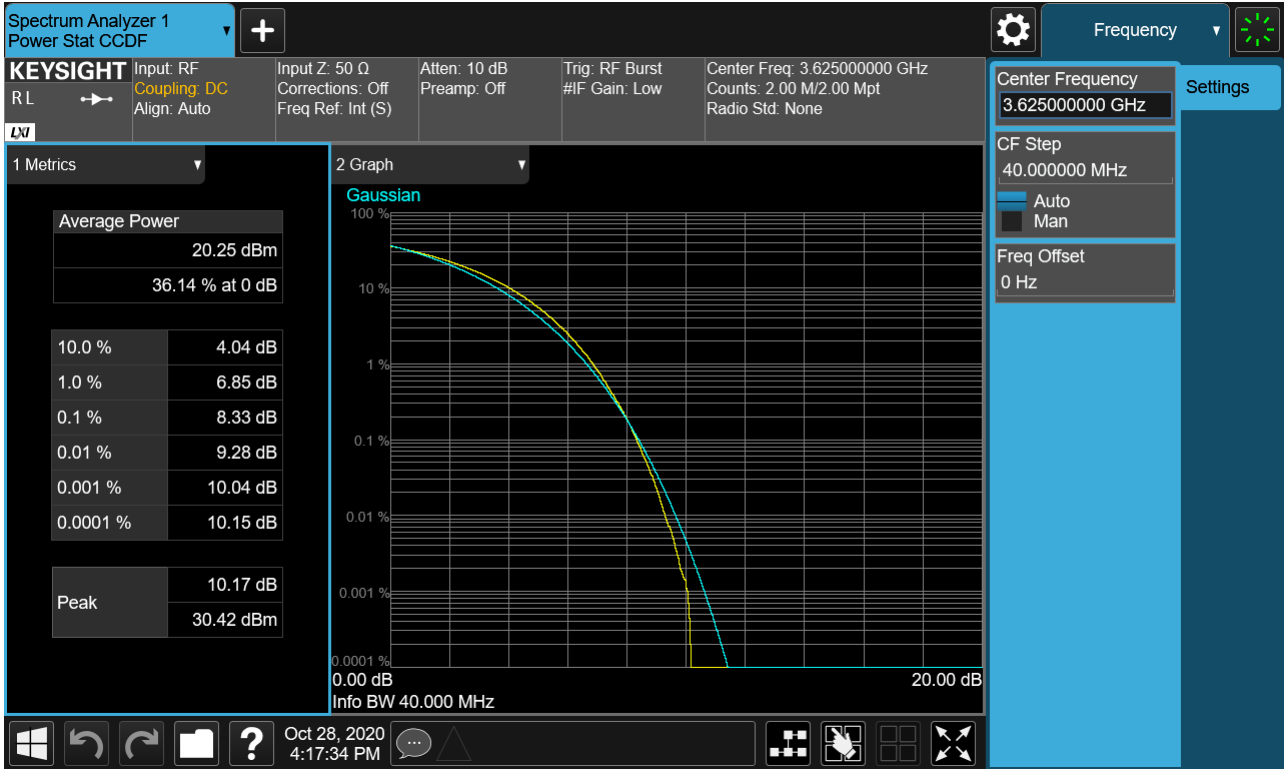

## 9. ANNEX A\_ TEST SETUP PHOTO

Please refer to test setup photo file no. as follows;

No.	Description
1	HCT-RF-2011-FC012-P