



CERTIFICATION TEST REPORT

Report Number. : 12563708-E3V3

Applicant : Samsung Electronics Co., Ltd.
129 Samsung-Ro, Yeongtong-Gu,
Suwon-Si, Gyeonggi-Do, 16677, Korea

Model : SM-G975F/DS and SM-G975F

FCC ID : A3LSMG975F

EUT Description : GSM/WCDMA/LTE phone with BT, DTS/UNII a/b/g/n/ac/11ax HE
20/40/80, ANT+ and NFC

Test Standard(s) : FCC 47 CFR PART 15 SUBPART C

Date Of Issue:
January 28, 2019

Prepared by:
UL Verification Services Inc.
47173 Benicia Street
Fremont, CA 94538 U.S.A.
TEL: (510) 771-1000
FAX: (510) 661-0888



REPORT REVISION HISTORY

Rev.	Issue Date	Revisions	Revised By
V1	1/7/2019	Initial Issue	
V2	1/24/2019	Update per reviewer's comments (sections: 1, 5.5, 6, 7, and 9.2)	Glenn Escano
V3	1/28/2019	Updated Section 5.5	Steven Tran

TABLE OF CONTENTS

REPORT REVISION HISTORY	2
TABLE OF CONTENTS	3
1. ATTESTATION OF TEST RESULTS	5
2. TEST METHODOLOGY	6
3. FACILITIES AND ACCREDITATION	6
4. CALIBRATION AND UNCERTAINTY	7
4.1. <i>MEASURING INSTRUMENT CALIBRATION</i>	<i>7</i>
4.2. <i>SAMPLE CALCULATION</i>	<i>7</i>
4.3. <i>MEASUREMENT UNCERTAINTY.....</i>	<i>7</i>
5. EQUIPMENT UNDER TEST.....	8
5.1. <i>EUT DESCRIPTION.....</i>	<i>8</i>
5.2. <i>MAXIMUM OUTPUT POWER.....</i>	<i>8</i>
5.3. <i>DESCRIPTION OF AVAILABLE ANTENNAS.....</i>	<i>8</i>
5.4. <i>SOFTWARE AND FIRMWARE.....</i>	<i>8</i>
5.5. <i>WORST-CASE CONFIGURATION AND MODE.....</i>	<i>9</i>
5.6. <i>DESCRIPTION OF TEST SETUP.....</i>	<i>10</i>
6. MEASUREMENT METHOD.....	13
7. TEST AND MEASUREMENT EQUIPMENT	14
8. ANTENNA PORT TEST RESULTS.....	15
8.1. <i>ON TIME AND DUTY CYCLE.....</i>	<i>15</i>
8.2. <i>99% BANDWIDTH.....</i>	<i>17</i>
8.2.1. <i>BLE (125kbps).....</i>	<i>18</i>
8.2.2. <i>BLE (500kbps).....</i>	<i>19</i>
8.2.3. <i>BLE (1Mbps).....</i>	<i>20</i>
8.2.4. <i>BLE (2Mbps).....</i>	<i>21</i>
8.3. <i>6 dB BANDWIDTH.....</i>	<i>22</i>
8.3.1. <i>BLE (125kbps).....</i>	<i>23</i>
8.3.2. <i>BLE (500kbps).....</i>	<i>24</i>
8.3.3. <i>BLE (1Mbps).....</i>	<i>25</i>
8.3.4. <i>BLE (2Mbps).....</i>	<i>26</i>
8.4. <i>OUTPUT POWER.....</i>	<i>27</i>
8.4.1. <i>BLE (125kbps).....</i>	<i>28</i>
8.4.2. <i>BLE (500kbps).....</i>	<i>29</i>
8.4.3. <i>BLE (1Mbps).....</i>	<i>30</i>
8.4.4. <i>BLE (2Mbps).....</i>	<i>31</i>

8.5.	AVERAGE POWER	32
8.5.1.	BLE (125kbps).....	33
8.5.2.	BLE (500kbps).....	33
8.5.3.	BLE (1Mbps).....	33
8.5.4.	BLE (2Mbps).....	34
8.6.	POWER SPECTRAL DENSITY	35
8.6.1.	BLE (125kbps).....	36
8.6.2.	BLE (500kbps).....	37
8.6.3.	BLE (1Mbps).....	38
8.6.4.	BLE (2Mbps).....	39
8.7.	CONDUCTED SPURIOUS EMISSIONS	40
8.7.1.	BLE (125kbps).....	41
8.7.2.	BLE (500kbps).....	42
8.7.3.	BLE (1Mbps).....	43
8.7.4.	BLE (2Mbps).....	44
9.	RADIATED TEST RESULTS	45
9.1.	<i>LIMITS AND PROCEDURE</i>	45
9.2.	<i>TRANSMITTER ABOVE 1 GHz</i>	46
9.2.1.	BLE (125kbps).....	46
9.2.2.	BLE (500kbps).....	56
9.2.3.	BLE (1Mbps).....	66
9.2.4.	BLE (2Mbps).....	76
9.2.5.	SPOT CHECK DATA.....	86
9.3.	<i>Worst Case Below 30 MHz</i>	90
9.4.	<i>Worst Case Below 1 GHz</i>	92
9.5.	<i>Worst Case 18-26 GHz</i>	94
10.	AC POWER LINE CONDUCTED EMISSIONS	96
10.1.1.	AC Power Line Norm.....	97
11.	SETUP PHOTOS – SM-G975F (Glass)	99
12.	SETUP PHOTOS – SM-G975F (Ceramic)	102

1. ATTESTATION OF TEST RESULTS

COMPANY NAME: Samsung Electronics Co., Ltd.
129 Samsung-Ro, Yeongtong-Gu,
Suwon-Si, Gyeonggi-Do, 16677, Korea

EUT DESCRIPTION: GSM/WCDMA/LTE phone with BT, DTS/UNII a/b/g/n/ac/11ax HE
20/40/80, ANT+ and NFC

MODEL: SM-G975F/DS and SM-G975F

SERIAL NUMBER: SM-G975F(Glass)Conducted:R38KA093BOT, R38KA0L96BB
SM-G975F(Glass)Radiated:R38KA0L97DV, R38KA0L971T
SM-G975F(Ceramic)Radiated:R38KA092LGJ, R38KA0KV84N

DATE TESTED: NOVEMBER 2, 2018 – JANUARY 22, 2019

APPLICABLE STANDARDS	
STANDARD	TEST RESULTS
CFR 47 Part 15 Subpart C	Complies

UL Verification Services Inc. tested the above equipment in accordance with the requirements set forth in the above standards. The test results show that the equipment tested is capable of demonstrating compliance with the requirements as documented in this report.

The results documented in this report apply only to the tested sample, under the conditions and modes of operation as described herein. It is the manufacturer's responsibility to assure that additional production units of this model are manufactured with identical electrical and mechanical components. All samples tested were in good operating condition throughout the entire test program. Measurement Uncertainties are published for informational purposes only and were not taken into account unless noted otherwise.

This document may not be altered or revised in any way unless done so by UL Verification Services Inc. and all revisions are duly noted in the revisions section. Any alteration of this document not carried out by UL Verification Services Inc. will constitute fraud and shall nullify the document. This report must not be used by the client to claim product certification, approval, or endorsement by NVLAP, NIST, any agency of the Federal Government, or any agency of the U.S. government.

Approved & Released For
UL Verification Services Inc. By:



Dan Corona
Project Engineer/Operations Leader
Consumer Technology Division
UL Verification Services Inc.

Reviewed By:



Steven Tran
Test Engineer
Consumer Technology Division
UL Verification Services Inc.

2. TEST METHODOLOGY

The tests documented in this report were performed in accordance with FCC CFR 47 Part 2, FCC CFR 47 Part 15, ANSI C63.10-2013, and KDB 558074 D01 15.247 Meas Guidance v05.

3. FACILITIES AND ACCREDITATION

The test sites and measurement facilities used to collect data are located at 47173 and 47266 Benicia Street, and 47658 Kato Road, Fremont, California, USA. Line conducted emissions are measured only at the 47173 address. The following table identifies which facilities were utilized for radiated emission measurements documented in this report. Specific facilities are also identified in the test results sections.

47173 Benicia Street	47266 Benicia Street	47658 Kato Rd
<input checked="" type="checkbox"/> Chamber A (ISED:2324B-1)	<input type="checkbox"/> Chamber D (ISED:22541-1)	<input type="checkbox"/> Chamber I (ISED:2324A-5)
<input checked="" type="checkbox"/> Chamber B (ISED:2324B-2)	<input type="checkbox"/> Chamber E (ISED:22541-2)	<input type="checkbox"/> Chamber J (ISED:2324A-6)
<input type="checkbox"/> Chamber C (ISED:2324B-3)	<input type="checkbox"/> Chamber F (ISED:22541-3)	<input type="checkbox"/> Chamber K (ISED:2324A-1)
	<input type="checkbox"/> Chamber G (ISED:22541-4)	<input type="checkbox"/> Chamber L (ISED:2324A-3)
	<input type="checkbox"/> Chamber H (ISED:22541-5)	

The above test sites and facilities are covered under FCC Test Firm Registration # 208313. Chambers above are covered under Industry Canada company address and respective code

UL Verification Services Inc. is accredited by NVLAP, Laboratory Code 200065-0

4. CALIBRATION AND UNCERTAINTY

4.1. MEASURING INSTRUMENT CALIBRATION

The measuring equipment utilized to perform the tests documented in this report has been calibrated in accordance with the manufacturer's recommendations, and is traceable to recognized national standards.

4.2. SAMPLE CALCULATION

RADIATED EMISSIONS

Where relevant, the following sample calculation is provided:

Field Strength (dBuV/m) = Measured Voltage (dBuV) + Antenna Factor (dB/m) + Cable Loss (dB) – Preamp Gain (dB)

$$36.5 \text{ dBuV} + 18.7 \text{ dB/m} + 0.6 \text{ dB} - 26.9 \text{ dB} = 28.9 \text{ dBuV/m}$$

MAINS CONDUCTED EMISSIONS

Where relevant, the following sample calculation is provided:

Final Voltage (dBuV) = Measured Voltage (dBuV) + Cable Loss (dB) + Limiter Factor (dB) + LISN Insertion Loss.

$$36.5 \text{ dBuV} + 0 \text{ dB} + 10.1 \text{ dB} + 0 \text{ dB} = 46.6 \text{ dBuV}$$

4.3. MEASUREMENT UNCERTAINTY

Where relevant, the following measurement uncertainty levels have been estimated for tests performed on the apparatus:

PARAMETER	UNCERTAINTY
Worst Case Conducted Disturbance, 9KHz to 0.15 MHz	3.84 dB
Worst Case Conducted Disturbance, 0.15 to 30 MHz	3.65 dB
Worst Case Radiated Disturbance, 9KHz to 30 MHz	3.15 dB
Worst Case Radiated Disturbance, 30 to 1000 MHz	5.36 dB
Worst Case Radiated Disturbance, 1000 to 18000 MHz	4.32 dB
Worst Case Radiated Disturbance, 18000 to 26000 MHz	4.45 dB
Worst Case Radiated Disturbance, 26000 to 40000 MHz	5.24 dB

Uncertainty figures are valid to a confidence level of 95%.

5. EQUIPMENT UNDER TEST

5.1. EUT DESCRIPTION

The EUT is a GSM/WCDMA/LTE phone with BT, DTS/UNII a/b/g/n/ac/11ax HE 20/40/80, ANT+ and NFC. The model SM-G975F was used for final testing and is representative of the test results in this report.

5.2. MAXIMUM OUTPUT POWER

The transmitter has a maximum peak conducted output power as follows:

Frequency Range (MHz)	Mode	Output Power (dBm)	Output Power (mW)
2402 - 2480	BLE (125kbps)	8.39	6.90
2402 - 2480	BLE (500kbps)	8.40	6.92
2402 - 2480	BLE (1Mbps)	8.69	7.40
2402 - 2480	BLE (2Mbps)	9.62	9.16

5.3. DESCRIPTION OF AVAILABLE ANTENNAS

The radio utilizes an FPCB antenna, with a maximum gain of -0.4 dBi.

5.4. SOFTWARE AND FIRMWARE

The test utility software used during testing was G975F.001.

5.5. WORST-CASE CONFIGURATION AND MODE

WORST-CASE CONFIGURATION AND MODE FOR FINAL TEST

This device may be formed with two different exterior materials: Glass and Ceramic. Glass model was set for full test and additional spot check verification was done with Ceramic model for radiated harmonic spurious and radiated band-edge as documented.

Radiated emissions below 1GHz, above 18GHz, and power line conducted emission were performed with the EUT set to transmit at the channel with highest output power as worst-case scenario.

Band edge and radiated emissions between 1GHz and 18GHz were performed with the EUT set to transmit at the highest power on low, middle and high channels.

The fundamental of the EUT was investigated in three orthogonal orientations X,Y,Z, it was determined that X orientation was worst-case orientation; therefore, all final radiated testing was performed with the EUT in X orientation.

All radios that can be transmitted simultaneously have been evaluated for radiated for all possible combinations of transmission and found to be in compliance.

5.6. DESCRIPTION OF TEST SETUP

SUPPORT EQUIPMENT

Support Equipment List				
Description	Manufacturer	Model	Serial Number	FCC ID
AC Adapter	Samsung	EP-TA300	R3KB5B01S1SE3	N/A
USB Data Cable	Samsung	N/A	N/A	N/A
Earphone	Samsung	N/A	N/A	N/A

I/O CABLES (CONDUCTED TEST)

I/O Cable List						
Cable No	Port	# of identical ports	Connector Type	Cable Type	Cable Length (m)	Remarks
1	Antenna	1	RF	Shielded	0.2	To spectrum Analyzer
2	USB	1	USB	Un-shielded	1	EUT to AC Mains

I/O CABLES (RADIATED AND CONDUCTED EMISSIONS)

I/O Cable List						
Cable No	Port	# of identical ports	Connector Type	Cable Type	Cable Length (m)	Remarks
1	USB	1	USB	Shielded	1	N/A
2	earphone	1	3.5mm	Un-shielded	1	N/A

TEST SETUP

The EUT is a stand alone. Test software exercised the radio card.

CONDCUTED TEST SETUP DIAGRAM

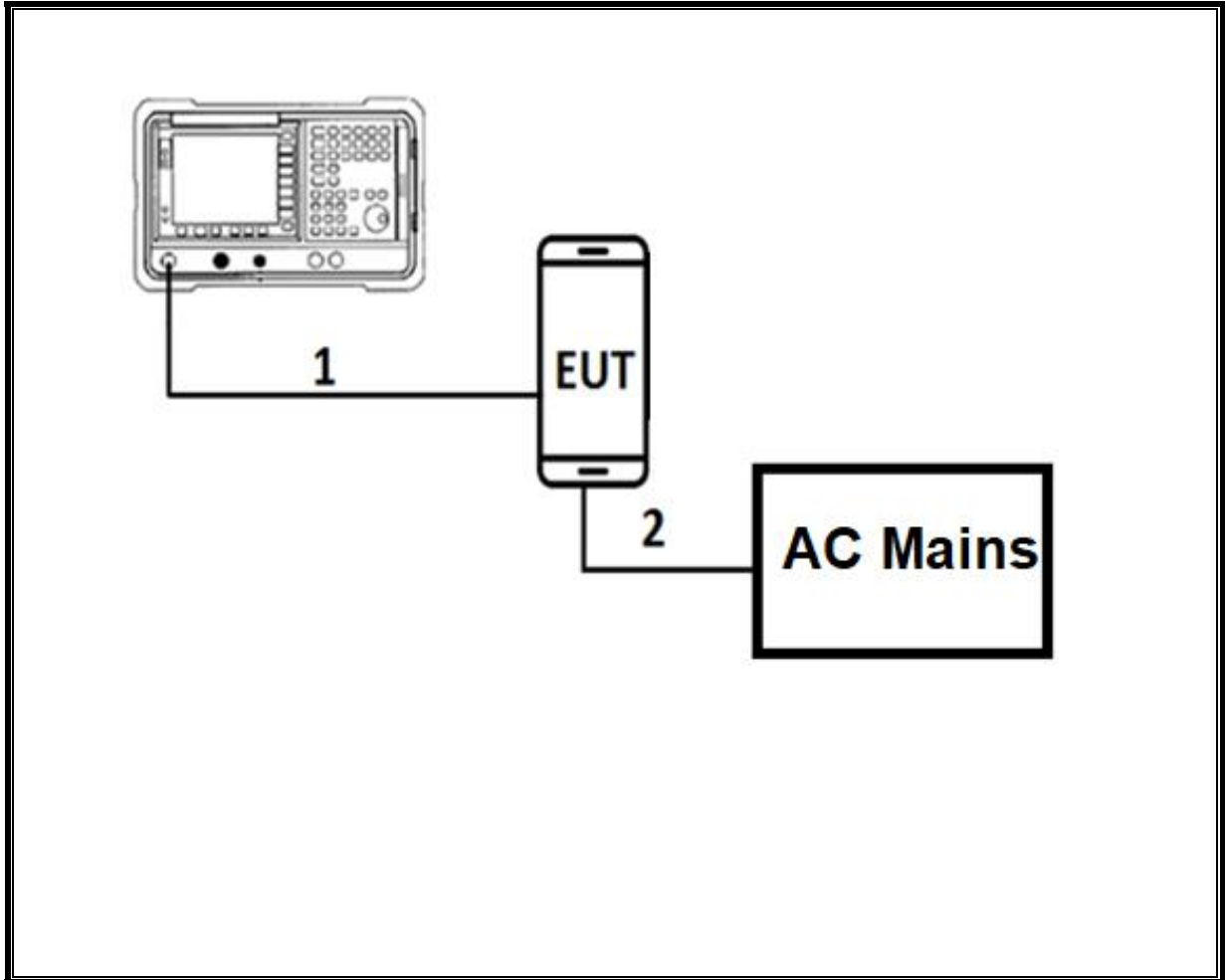

TEST SETUP

For conducted tests: the EUT was Stand alone. The test software exercises the radio.

RADIATED AND AC LINE CONDUCTED EMISSIONS SETUP DIAGRAM

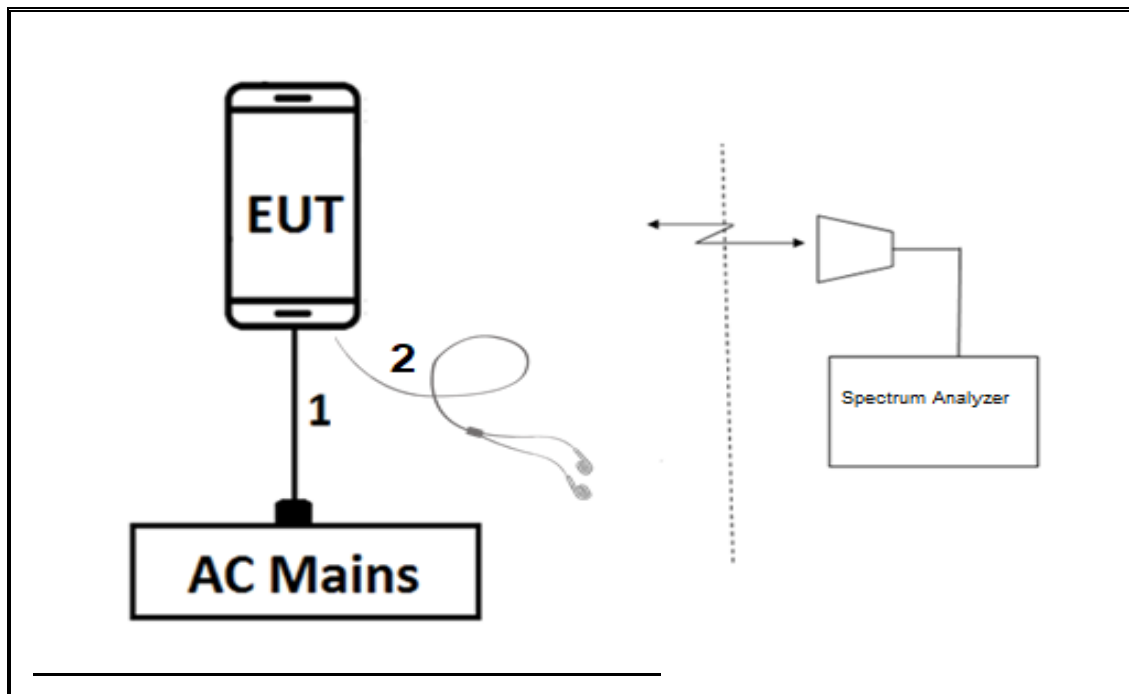

TEST SETUP

For radiated tests: EUT has support equipment (AC Adapter and Headset). The test software exercises the radio.

6. MEASUREMENT METHOD

6 dB BW: ANSI C63.10 Subclause -11.8.1

Occupied BW (99%): ANSI C63.10-2013 Section 6.9.3

Output Power : ANSI C63.10 Subclause -11.9.1.3 Method Peak Power Meter
(Measurement using a broadband peak RF power meter)

Average Power: ANSI C63.10 Subclause -11.9.2.3.2 Method AVGPM-G (Measurement using a gated RF average-reading power meter)

PSD: ANSI C63.10 Subclause -11.10.2 Method PKPSD (peak PSD)

Radiated emissions non-restricted frequency bands: ANSI C63.10 Subclause -11.11

Radiated emissions restricted frequency bands: ANSI C63.10 Subclause -11.12.1

Conducted emissions in restricted frequency bands: ANSI C63.10 Subclause -11.12.2

Band-edge: ANSI C63.10 Subclause -11.13.3.4 Trace averaging across ON and OFF times of the EUT transmissions followed by duty cycle correction

AC Power Line Conducted Emissions: ANSI C63.10-2013, Section 6.2.

7. TEST AND MEASUREMENT EQUIPMENT

The following test and measurement equipment was utilized for the tests documented in this report:

TEST EQUIPMENT LIST					
Description	Manufacturer	Model	ID Num	Cal Due	Last Cal
Antenna, Broadband Hybrid, 30MHz to 2000MHz	Sunol Sciences Corp.	JB3	T407	05/10/2019	05/10/2018
Amplifier, 9kHz to 1GHz, 32dB	Sonoma Instrument	310	170649	11/01/2019	11/01/2018
Antenna, Horn 1-18GHz	ETS-Lindgren	3117	T345	04/25/2019	04/25/2018
Antenna, Horn 1-18GHz	ETS-Lindgren	3117	T863	06/21/2019	06/21/2018
Power Meter, P-series single channel	Agilent (Keysight) Technologies	N1911A	T1271	07/26/2019	07/26/2018
Power Sensor, P-series, 50MHz to 18GHz, Wideband	Agilent (Keysight) Technologies	N1921A	T1224	10/09/2019	10/09/2018
Directional Coupler	Mini-Circuits	ZUDC10-183+	T1136	06/18/2019	06/18/2018
EMI Receiver	Rohde & Schwarz	ESR	T1436	02/21/2019	02/21/2018
L.I.S.N.	FCC INC.	FCC LISN 50/250	T1310	06/15/2019	06/15/2018
L.I.S.N.	FCC INC.	FCC LISN 50/250	T24	03/06/2019	03/06/2018
Antenna, Active Loop 9kHz-30MHz	Com-Power Corp.	AL-130R	PRE0165308	12/13/2018	12/13/2017
18 - 26.5 GHz Horn Antenna	Seavey Division	MWH-1826/B	T89	01/18/2019	01/18/2018
Pre-Amp 1-26.5 GHz	Agilent	8449B	T404	03/09/2019	03/09/2018
RF Amplifier	MITEQ	AFS42-00101800-25-S-42	T493	10/13/2019	10/13/2018
RF Amplifier, 1-18GHz	MITEQ	AFS42-00101800-25-S-42	T1165	10/20/2019	10/20/2018
Spectrum Analyzer, PXA, 3Hz to 44GHz	Agilent (Keysight) Technologies	N9030A	T1113	12/21/2018	12/21/2017
Spectrum Analyzer	Agilent (Keysight) Technologies	E4446A	T146	08/13/2019	08/13/2018
Spectrum Analyzer, PXA, 3Hz to 44GHz	Agilent (Keysight) Technologies	N9030A	T1466	04/16/2019	04/16/2018
Spectrum Analyzer, PXA, 3Hz to 44GHz	Agilent (Keysight) Technologies	N9030A	T1454	01/08/2019	01/08/2018

Test Software List			
Description	Manufacturer	Model	Version
Radiated Software	UL	UL EMC	Ver 9.5, Dec 01, 2016
Antenna Port Software	UL	UL RF	Ver 9.0, Oct 31, 2018

8. ANTENNA PORT TEST RESULTS

8.1. ON TIME AND DUTY CYCLE

LIMITS

None; for reporting purposes only.

PROCEDURE

ON TIME AND DUTY CYCLE RESULTS

Mode	ON Time B (msec)	Period (msec)	Duty Cycle x (linear)	Duty Cycle (%)	Duty Cycle Correction Factor (dB)	1/B Minimum VBW (kHz)
2.4GHz Band						
BLE (125kbps)	3.100	3.750	0.827	82.67%	0.83	0.323
BLE (500kbps)	1.057	1.878	0.563	56.28%	2.50	0.946
BLE (1Mbps)	0.3775	0.6245	0.604	60.45%	2.19	2.649
BLE(2Mbps)	0.1944	0.6252	0.311	31.09%	5.07	5.144

DUTY CYCLE PLOTS

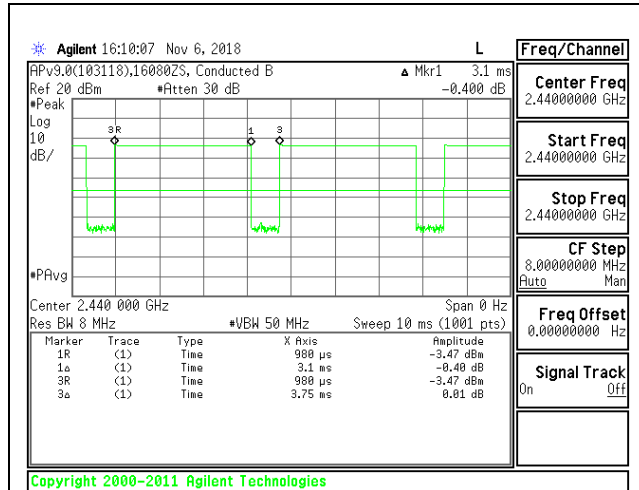

BLE (125kbps)

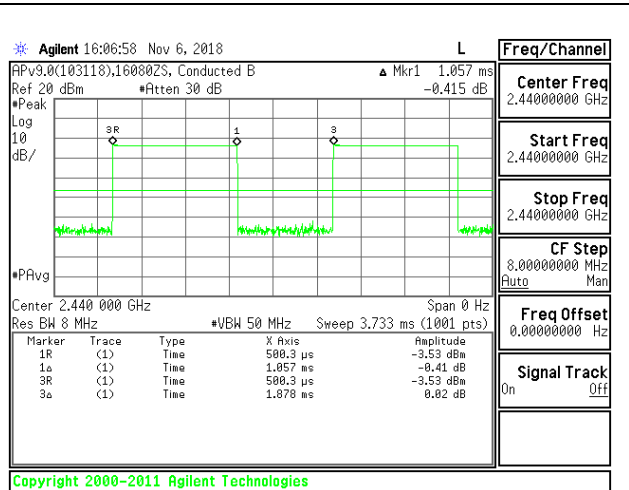

BLE (500kbps)

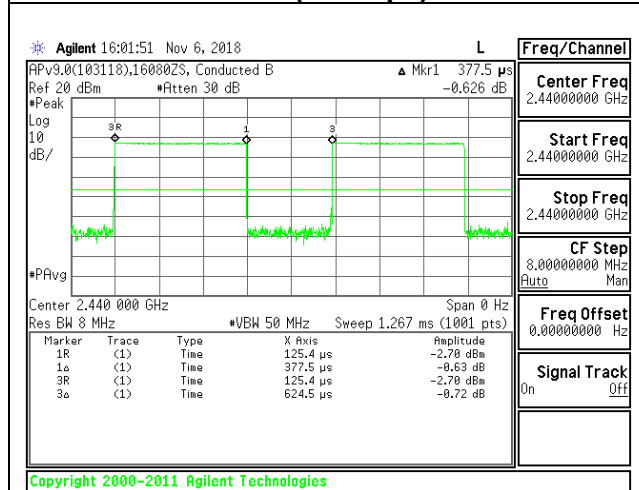

BLE (1Mbps)

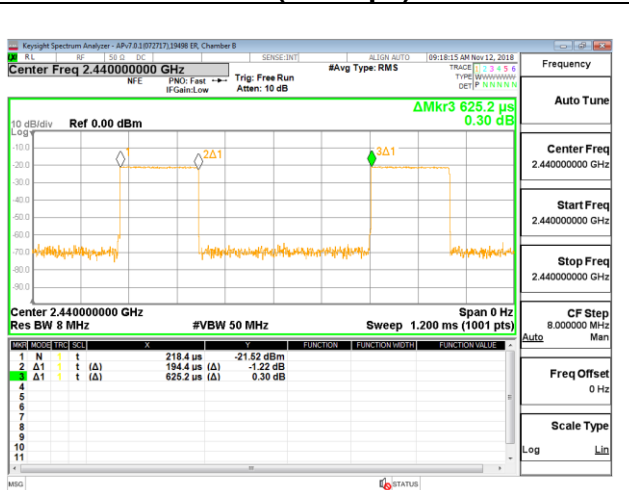

BLE (2Mbps)

8.2. 99% BANDWIDTH

LIMITS

None; for reporting purposes only.

RESULTS

8.2.1. BLE (125kbps)

Channel	Frequency (MHz)	99% Bandwidth (MHz)
Low	2402	1.0598
Middle	2440	1.0607
High	2480	1.0607

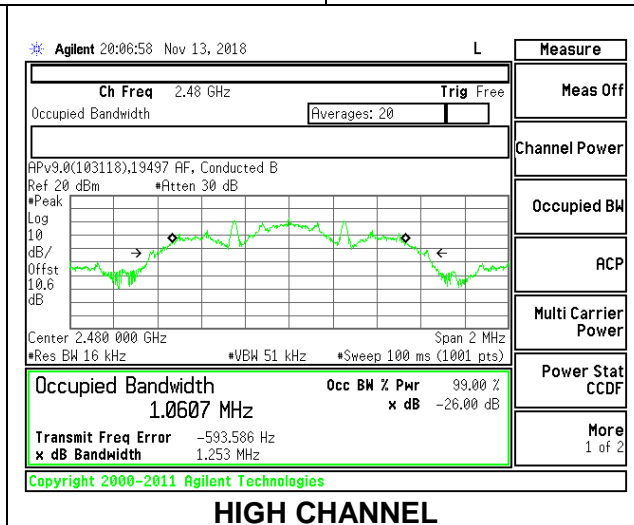
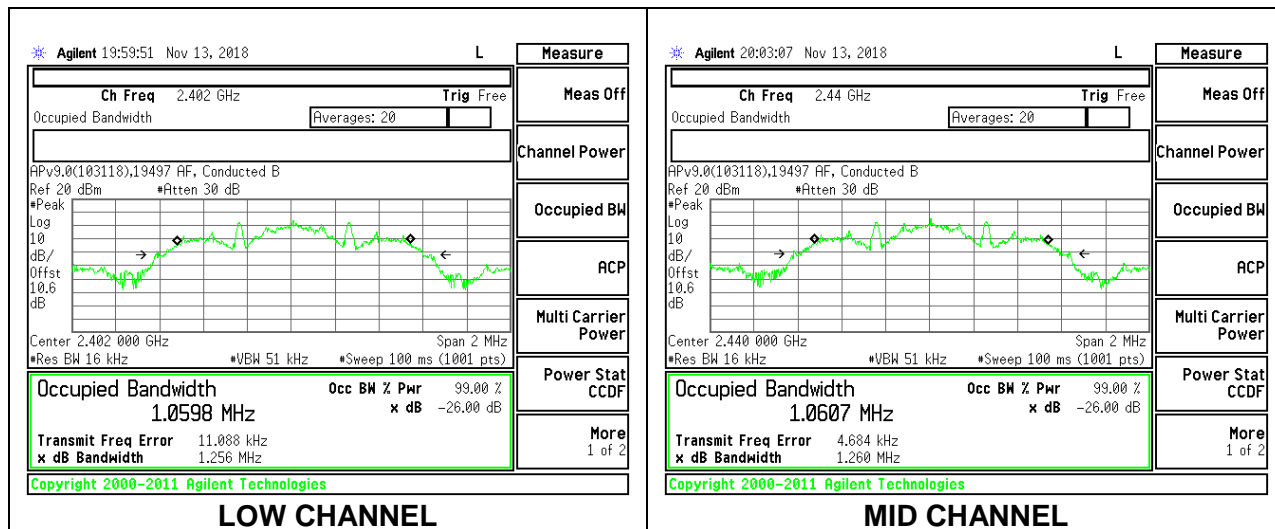

8.2.2. BLE (500kbps)

Channel	Frequency (MHz)	99% Bandwidth (MHz)
Low	2402	1.0318
Middle	2440	1.0327
High	2480	1.0293

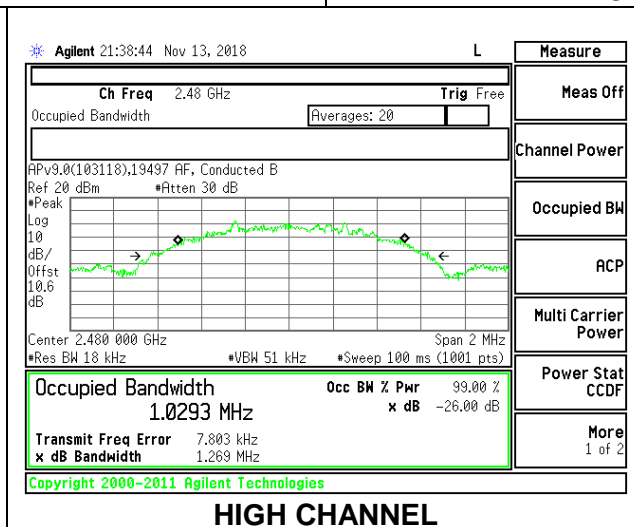
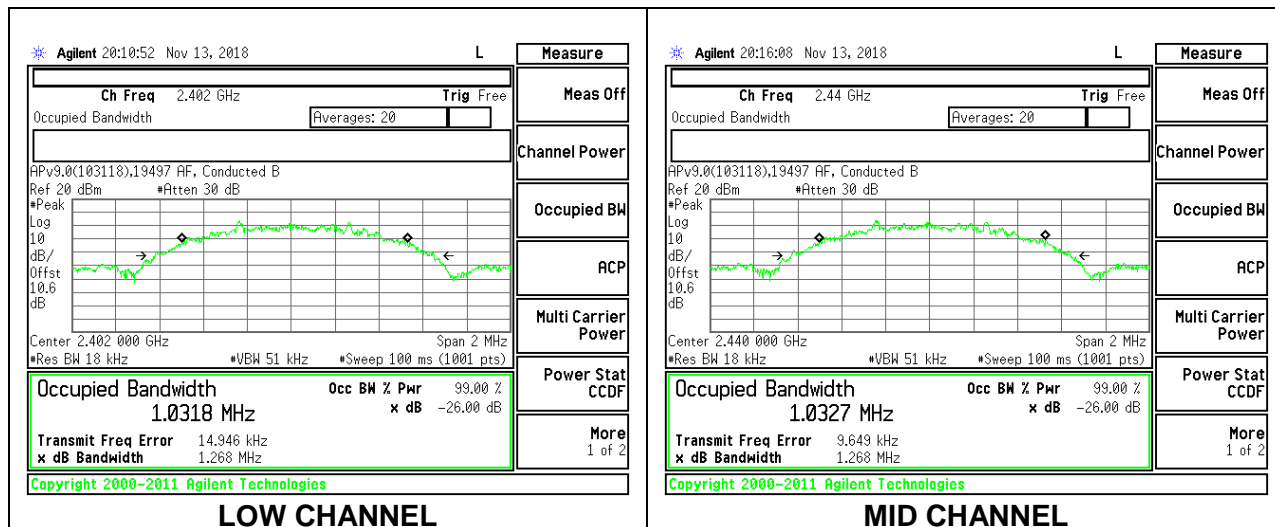

8.2.3. BLE (1Mbps)

Channel	Frequency (MHz)	99% Bandwidth (MHz)
Low	2402	1.0405
Middle	2440	1.0428
High	2480	1.0410

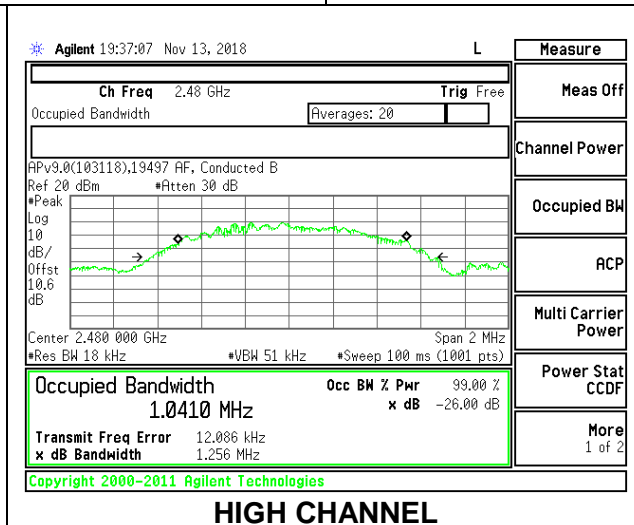
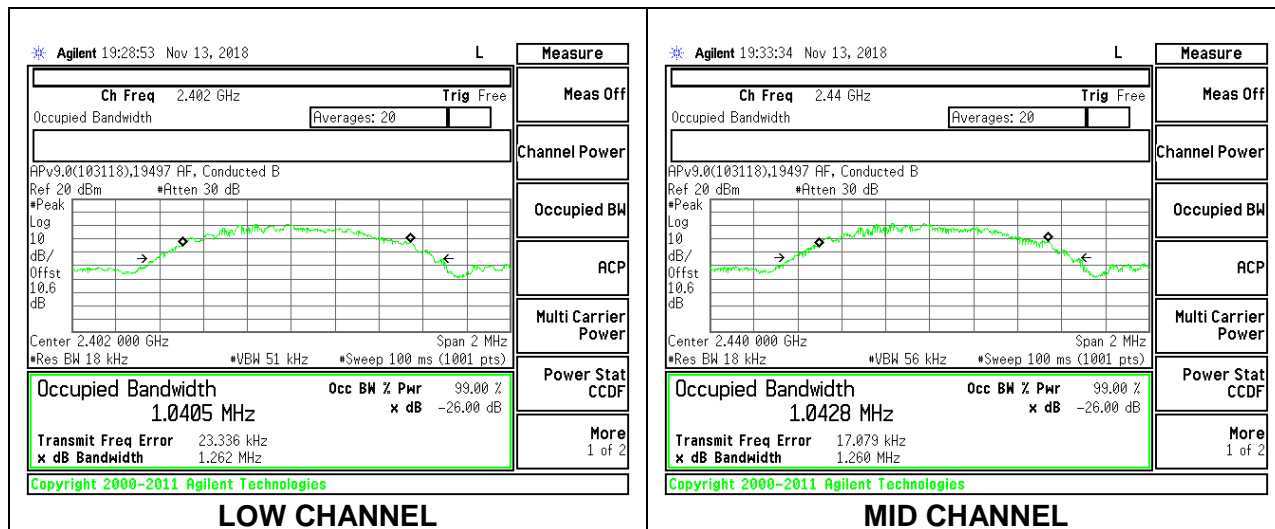

8.2.4. BLE (2Mbps)

Channel	Frequency (MHz)	99% Bandwidth (MHz)
Low	2402	2.0265
Middle	2440	2.0300
High	2480	2.0378

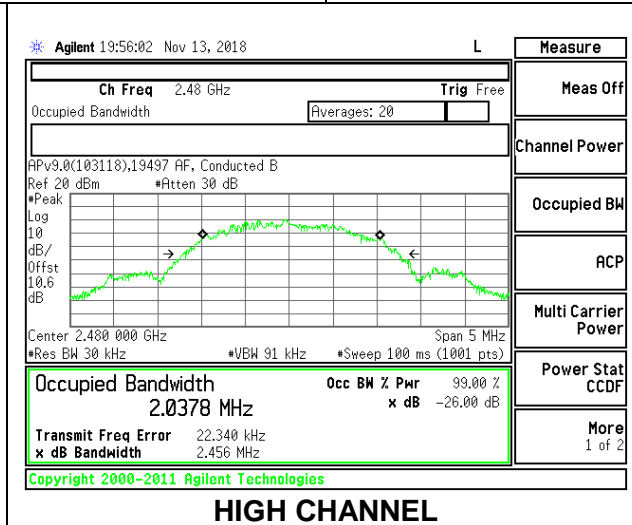
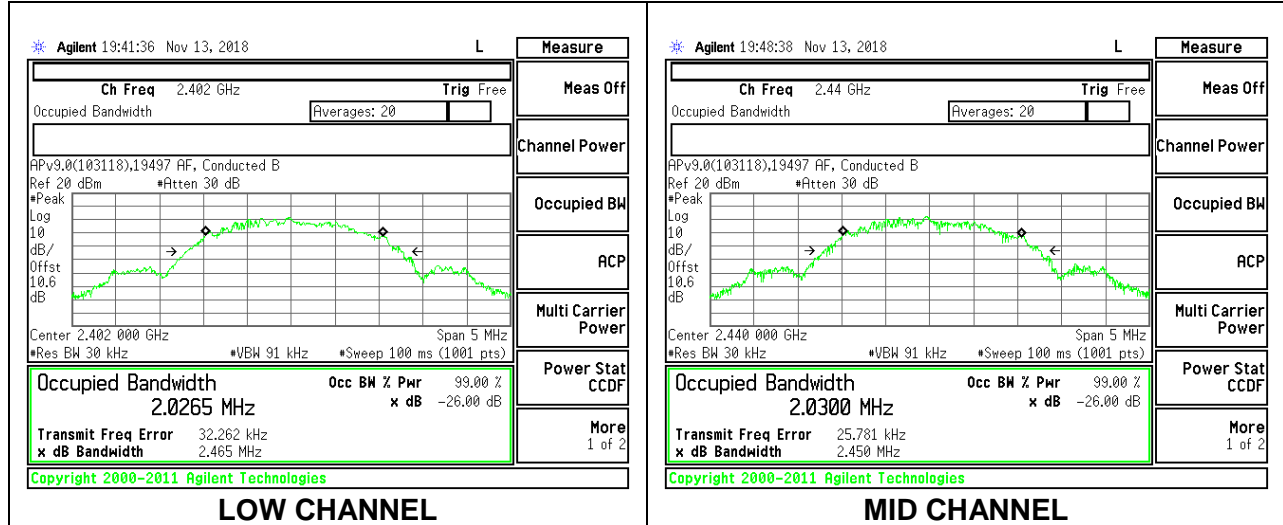

8.3. 6 dB BANDWIDTH

LIMITS

FCC §15.407 (e)

The minimum 6 dB bandwidth shall be at least 500 kHz.

RESULTS

8.3.1. BLE (125kbps)

Channel	Frequency (MHz)	6 dB Bandwidth (MHz)	Minimum Limit (MHz)
Low	2402	0.687	0.5
Middle	2440	0.690	0.5
High	2480	0.684	0.5

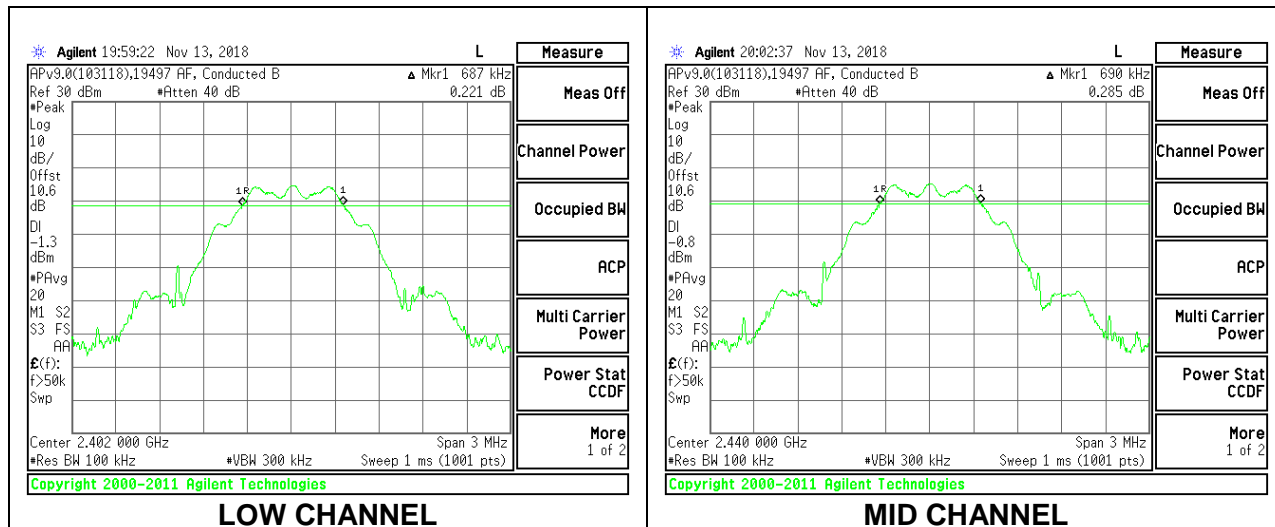

LOW CHANNEL

MID CHANNEL

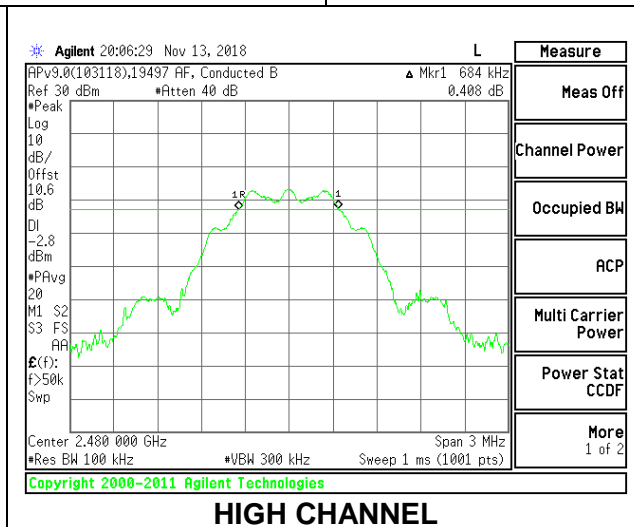

HIGH CHANNEL

8.3.2. BLE (500kbps)

Channel	Frequency (MHz)	6 dB Bandwidth (MHz)	Minimum Limit (MHz)
Low	2402	0.663	0.5
Middle	2440	0.660	0.5
High	2480	0.675	0.5

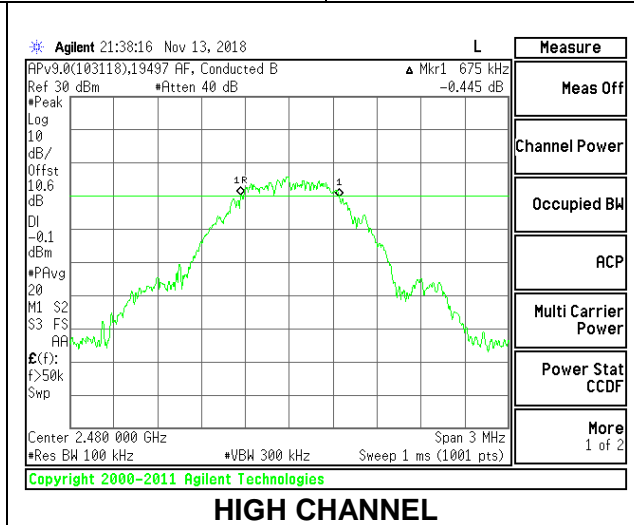
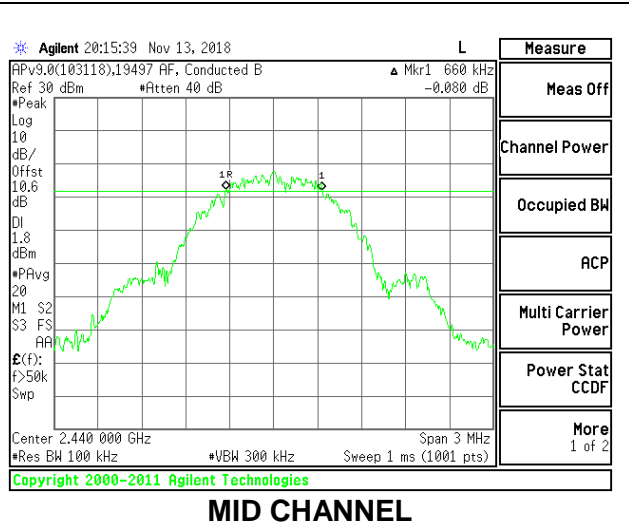
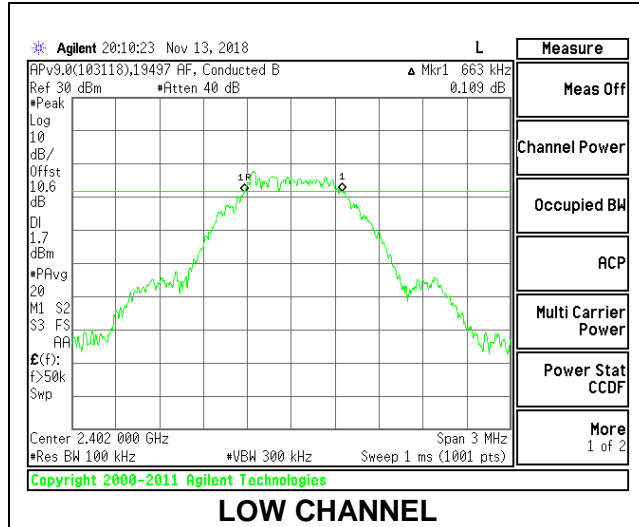

8.3.3. BLE (1Mbps)

Channel	Frequency (MHz)	6 dB Bandwidth (MHz)	Minimum Limit (MHz)
Low	2402	0.678	0.5
Middle	2440	0.684	0.5
High	2480	0.702	0.5

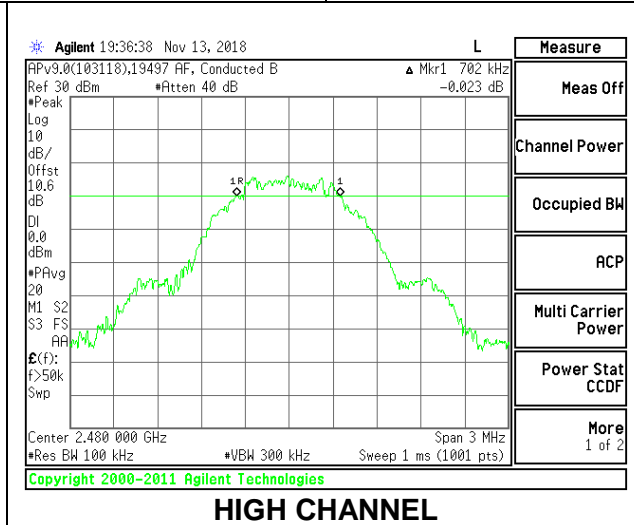
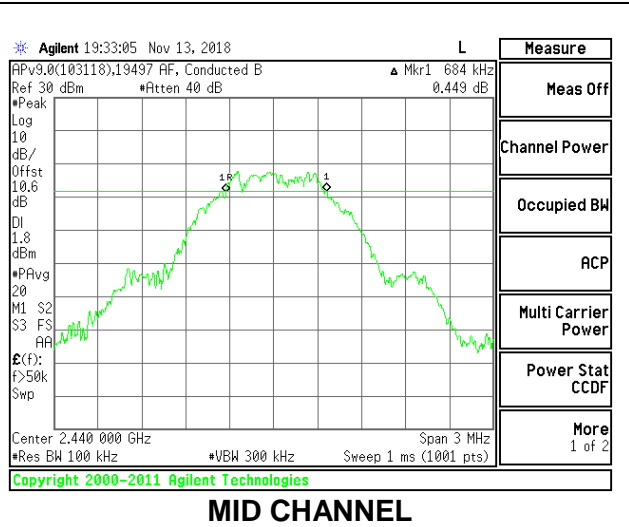
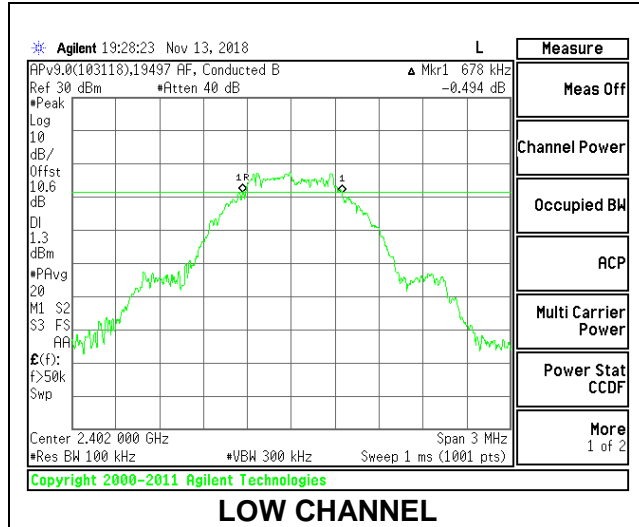

8.3.4. BLE (2Mbps)

Channel	Frequency (MHz)	6 dB Bandwidth (MHz)	Minimum Limit (MHz)
Low	2402	1.218	0.5
Middle	2440	1.224	0.5
High	2480	1.218	0.5

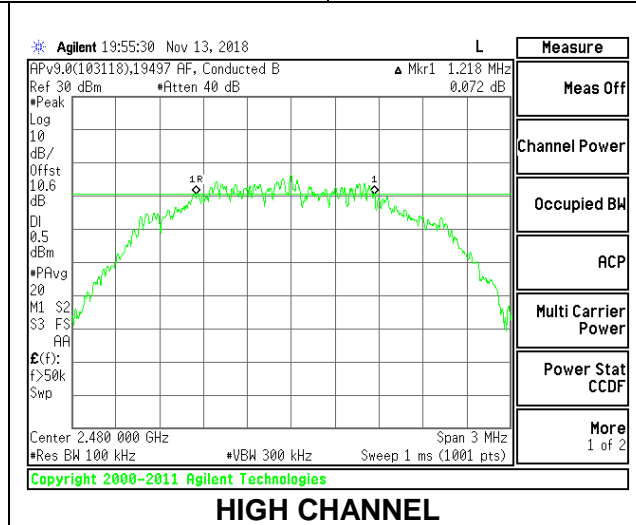
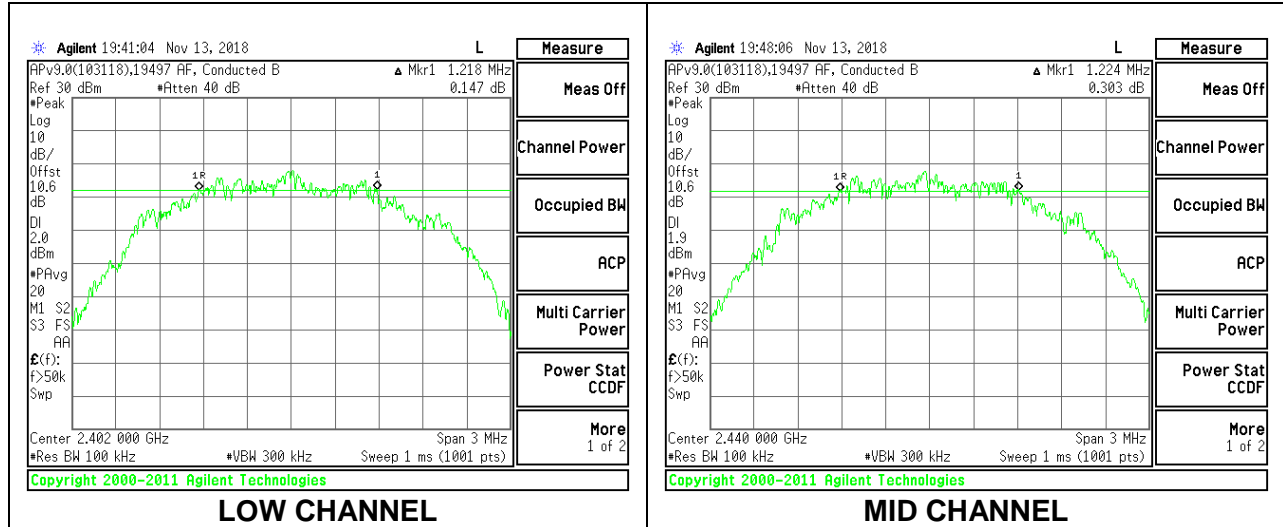

8.4. OUTPUT POWER

LIMITS

FCC §15.247 (b) (3)

The maximum antenna gain is less than or equal to 6 dBi, therefore the limit is 30 dBm.

TEST PROCEDURE

The transmitter output is connected to a power meter. The cable assembly insertion loss was entered as an offset in the power meter to allow for a gated peak reading of power.

RESULTS

8.4.1. BLE (125kbps)

Tested By:	19497AF
Date:	11/13/2018

Channel	Frequency (MHz)	Peak Power Reading (dBm)	Limit (dBm)	Margin (dB)
Low	2402	7.70	30	-22.300
Middle	2440	8.39	30	-21.610
High	2480	6.44	30	-23.560

8.4.2. BLE (500kbps)

Tested By:	19497AF
Date:	11/13/2018

Channel	Frequency (MHz)	Peak Power Reading (dBm)	Limit (dBm)	Margin (dB)
Low	2402	7.73	30	-22.270
Middle	2440	8.40	30	-21.600
High	2480	6.44	30	-23.560

8.4.3. BLE (1Mbps)

Tested By:	19497AF
Date:	11/13/2018

Channel	Frequency (MHz)	Peak Power Reading (dBm)	Limit (dBm)	Margin (dB)
Low	2402	8.09	30	-21.910
Middle	2440	8.69	30	-21.310
High	2480	6.57	30	-23.430

8.4.4. BLE (2Mbps)

Tested By:	19497AF
Date:	11/13/2018

Channel	Frequency (MHz)	Peak Power Reading (dBm)	Limit (dBm)	Margin (dB)
Low	2402	8.97	30	-21.030
Middle	2440	9.62	30	-20.380
High	2480	7.83	30	-22.170

8.5. AVERAGE POWER

LIMITS

None; for reporting purposes only.

TEST PROCEDURE

The transmitter output is connected to a power meter. The cable assembly insertion loss of was entered as an offset in the power meter to allow for a gated average reading of power.

RESULTS

8.5.1. BLE (125kbps)

Tested By:	19497AF
Date:	11/13/2018

Channel	Frequency (MHz)	AV power (dBm)
Low	2402	7.35
Middle	2440	8.05
High	2480	6.08

8.5.2. BLE (500kbps)

Tested By:	19497AF
Date:	11/13/2018

Channel	Frequency (MHz)	AV power (dBm)
Low	2402	7.38
Middle	2440	8.05
High	2480	6.1

8.5.3. BLE (1Mbps)

Tested By:	19497AF
Date:	11/13/2018

Channel	Frequency (MHz)	AV power (dBm)
Low	2402	7.7
Middle	2440	8.33
High	2480	6.23

8.5.4. BLE (2Mbps)

Tested By:	19497AF
Date:	11/13/2018

Channel	Frequency (MHz)	AV power (dBm)
Low	2402	8.26
Middle	2440	8.95
High	2480	7.08

8.6. POWER SPECTRAL DENSITY

LIMITS

FCC §15.247 (e)

The power spectral density conducted from the transmitter to the antenna shall not be greater than 8 dBm in any 3 kHz band during any time interval of continuous transmission.

RESULTS

8.6.1. BLE (125kbps)

Channel	Frequency (MHz)	PSD (dBm/3kHz)	Limit (dBm/3kHz)	Margin (dB)
Low	2402	1.939	8	-6.06
Middle	2440	2.518	8	-5.48
High	2480	0.477	8	-7.52

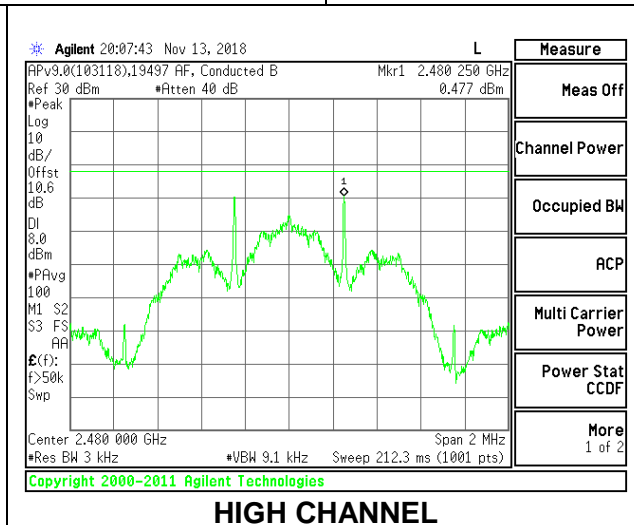
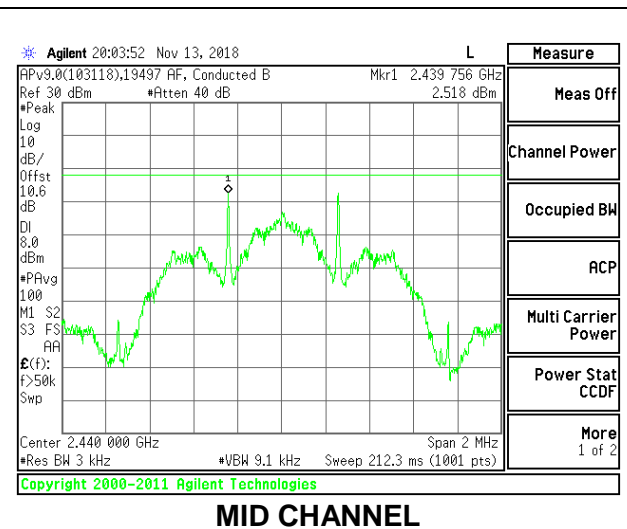
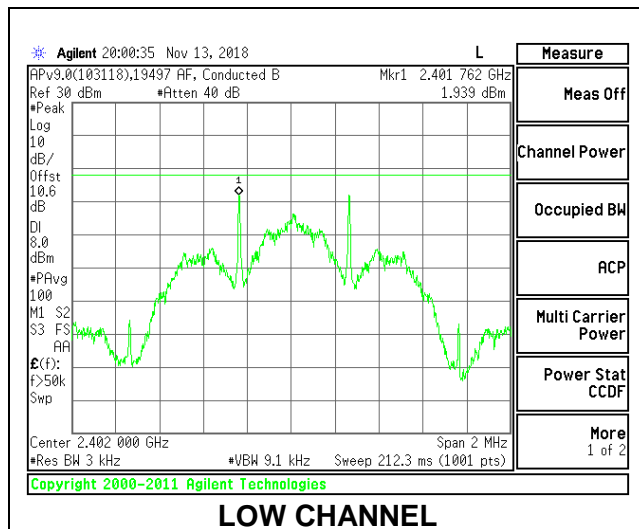

8.6.2. BLE (500kbps)

Channel	Frequency (MHz)	PSD (dBm/3kHz)	Limit (dBm/3kHz)	Margin (dB)
Low	2402	1.837	8	-6.16
Middle	2440	2.416	8	-5.58
High	2480	0.533	8	-7.47

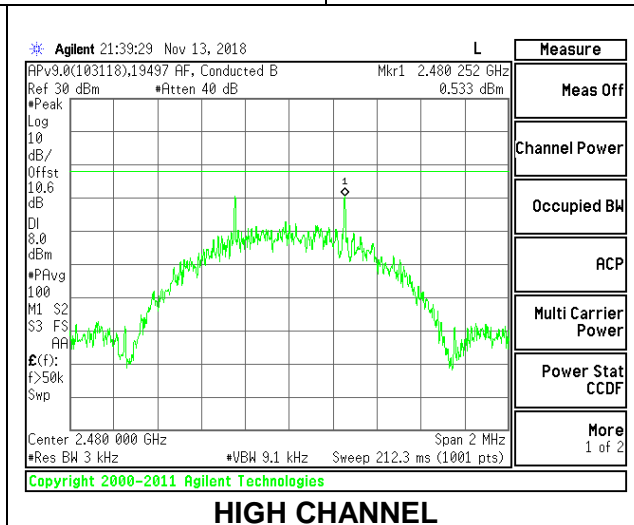
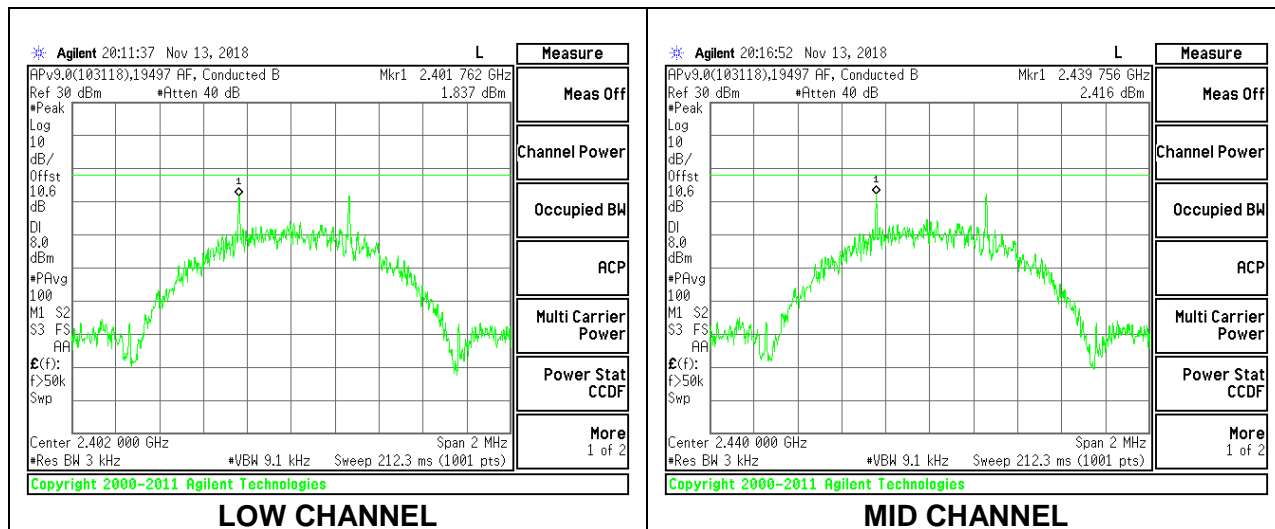

8.6.3. BLE (1Mbps)

Channel	Frequency (MHz)	PSD (dBm/3kHz)	Limit (dBm/3kHz)	Margin (dB)
Low	2402	-7.013	8	-15.01
Middle	2440	-6.553	8	-14.55
High	2480	-8.571	8	-16.57

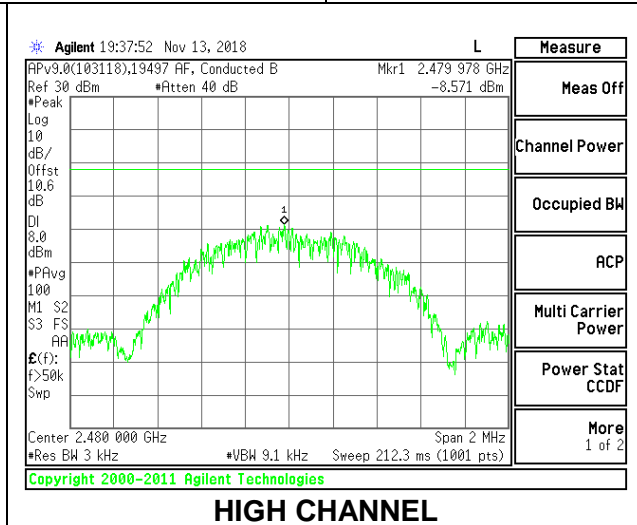
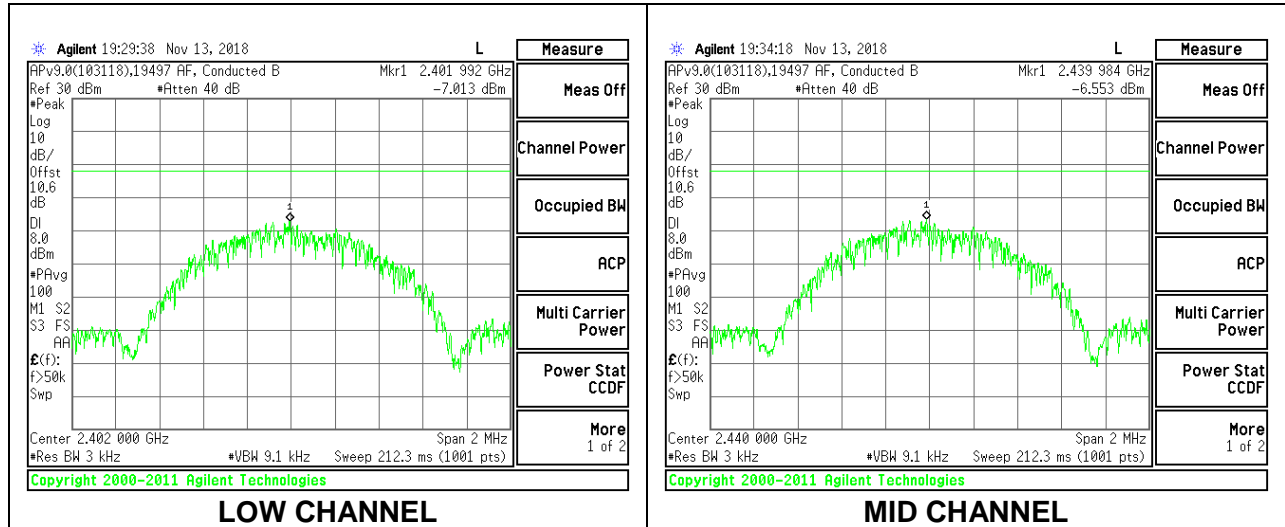

8.6.4. BLE (2Mbps)

Channel	Frequency (MHz)	PSD (dBm/3kHz)	Limit (dBm/3kHz)	Margin (dB)
Low	2402	-8.316	8	-16.32
Middle	2440	-7.884	8	-15.88
High	2480	-9.815	8	-17.82

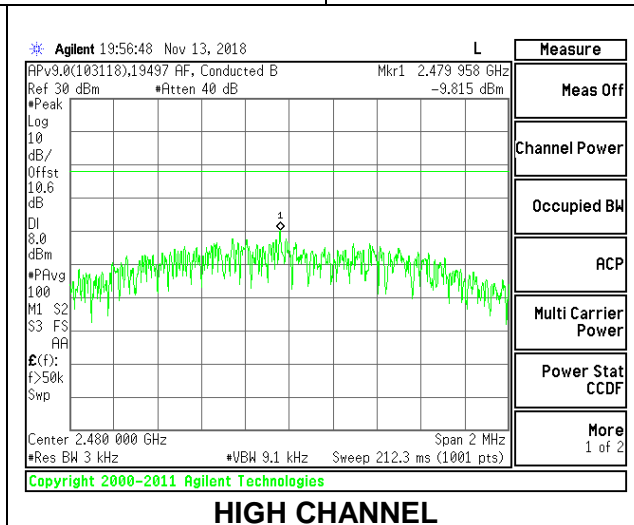
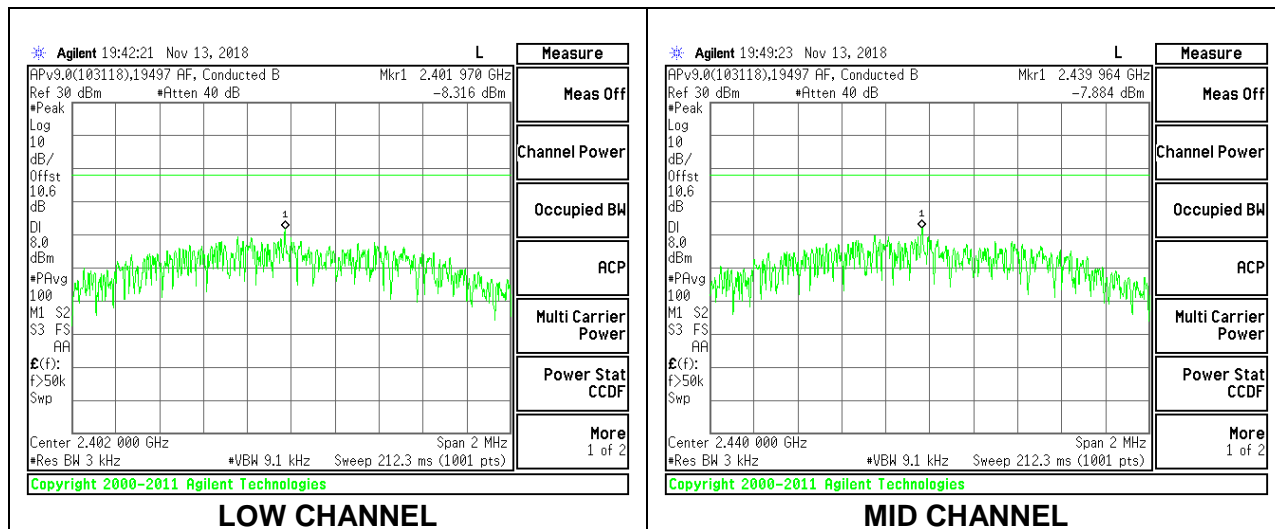

8.7. CONDUCTED SPURIOUS EMISSIONS

LIMITS

FCC §15.247 (d)

Output power was measured based on the use of a peak measurement, therefore the required attenuation is 20 dB.

RESULTS

8.7.1. BLE (125kbps)

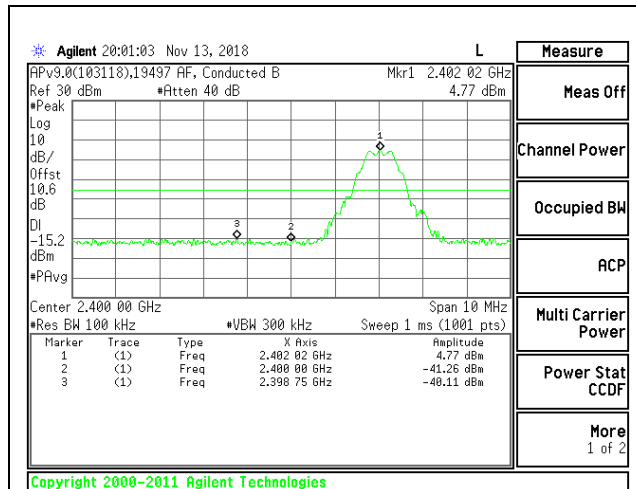

LOW CHANNEL BANDEDGE

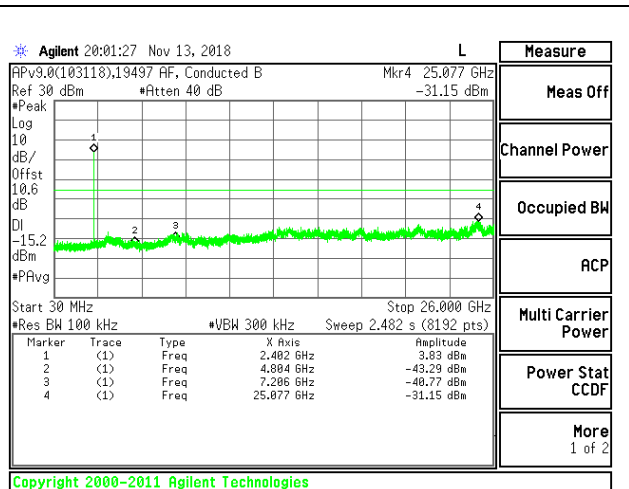

OUT-OF-BAND LOW CHANNEL

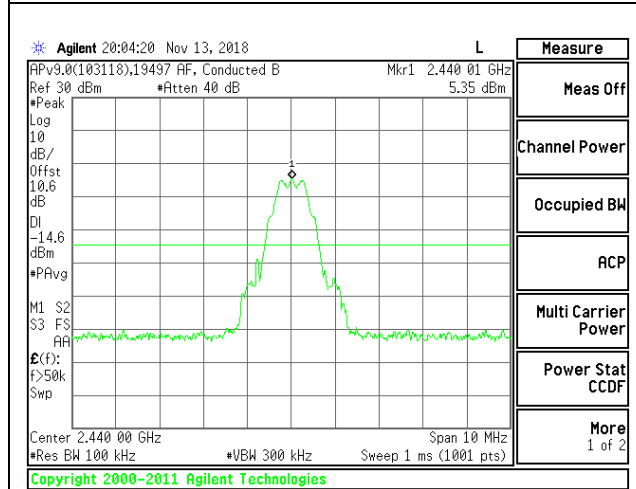

IN-BAND REFERENCE LEVEL

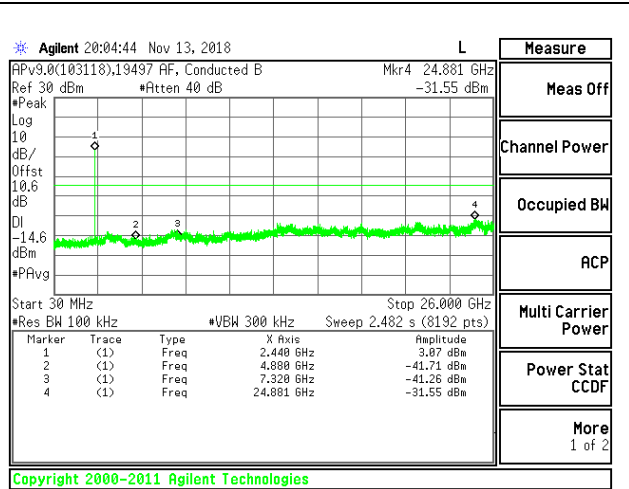

OUT-OF-BAND MID CHANNEL

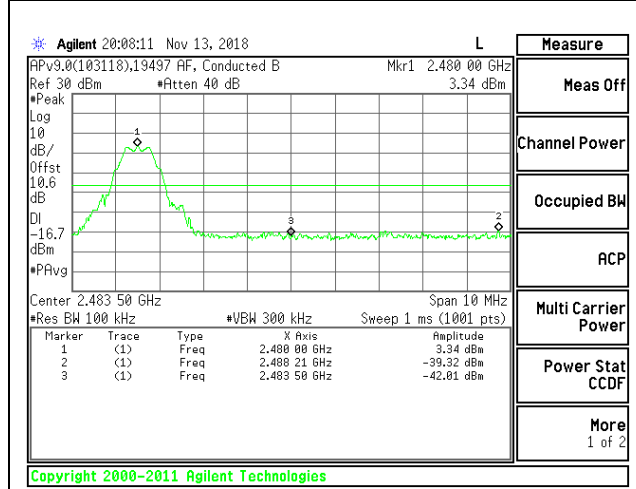

HIGH CHANNEL BANDEDGE

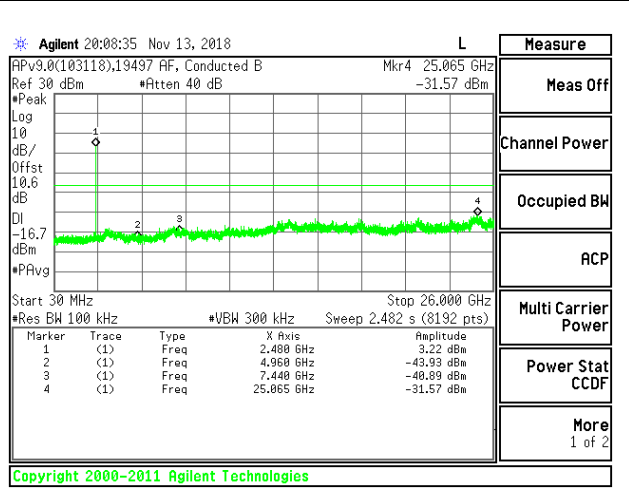

OUT-OF-BAND HIGH CHANNEL

8.7.2. BLE (500kbps)

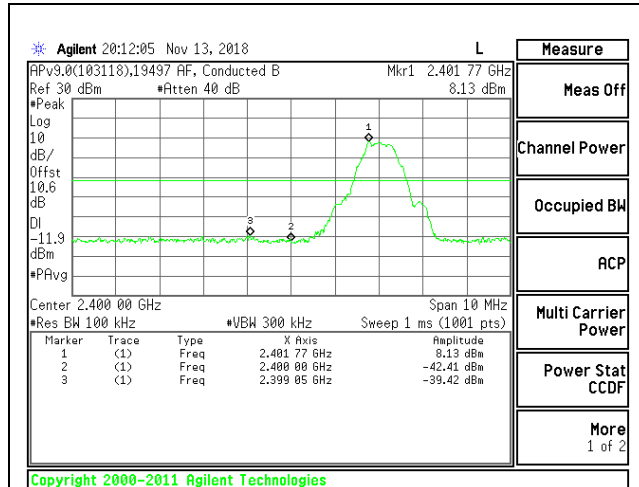

LOW CHANNEL BANDEDGE

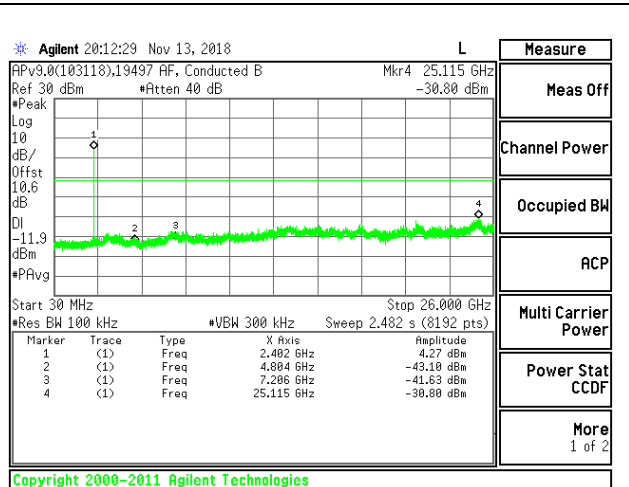

OUT-OF-BAND LOW CHANNEL

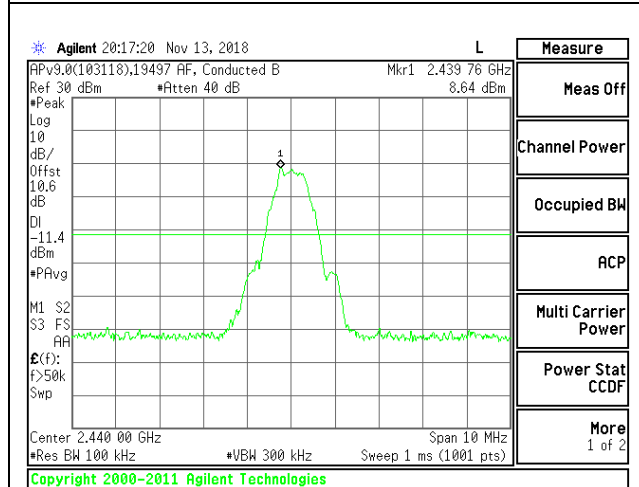

IN-BAND REFERENCE LEVEL

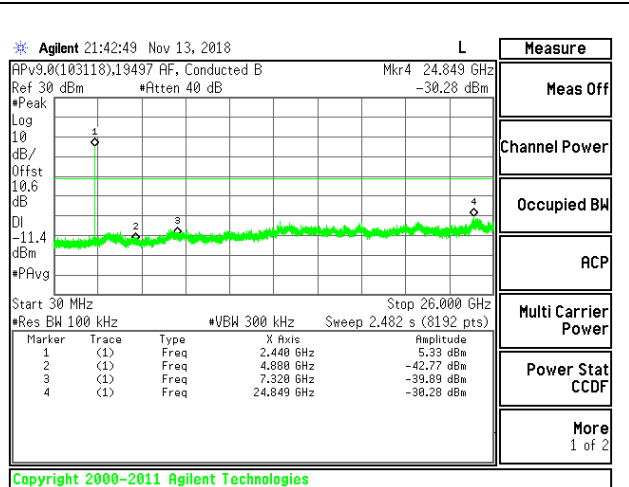

OUT-OF-BAND MID CHANNEL

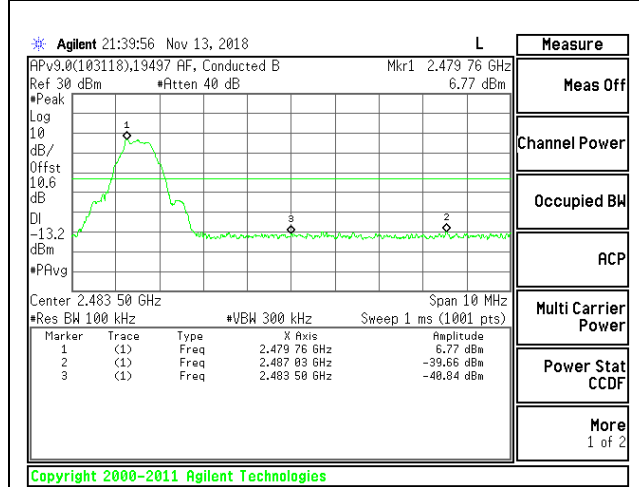

HIGH CHANNEL BANDEDGE

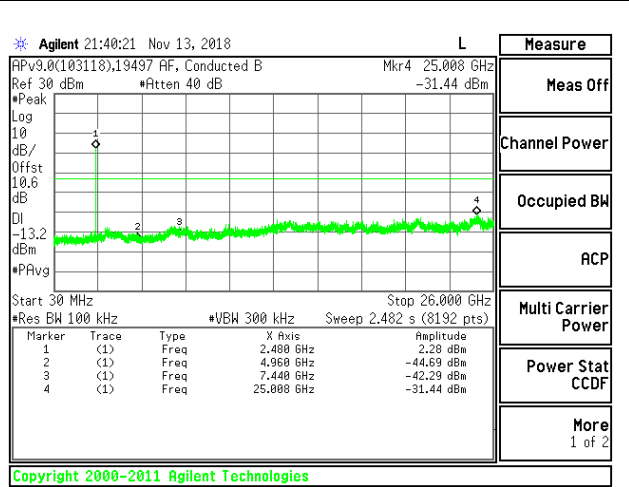

OUT-OF-BAND HIGH CHANNEL

8.7.3. BLE (1Mbps)

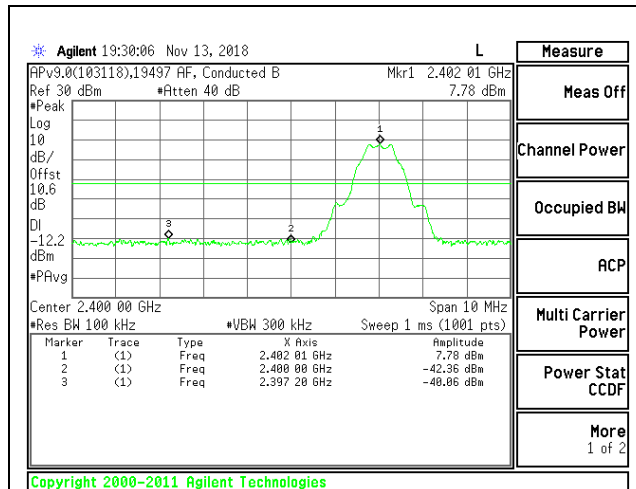

LOW CHANNEL BANDEGE

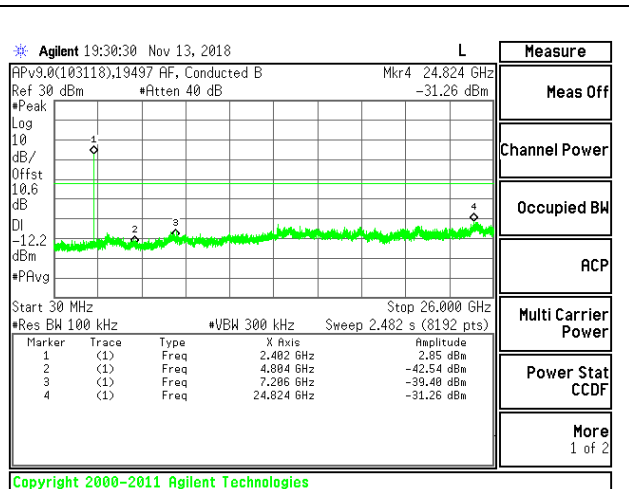

OUT-OF-BAND LOW CHANNEL

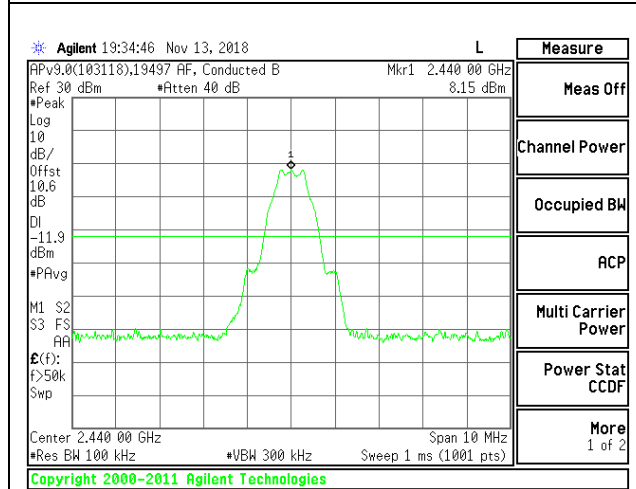

IN-BAND REFERENCE LEVEL

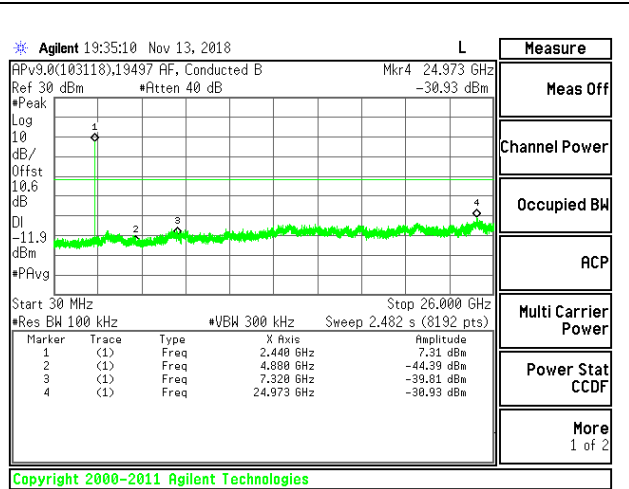

OUT-OF-BAND MID CHANNEL

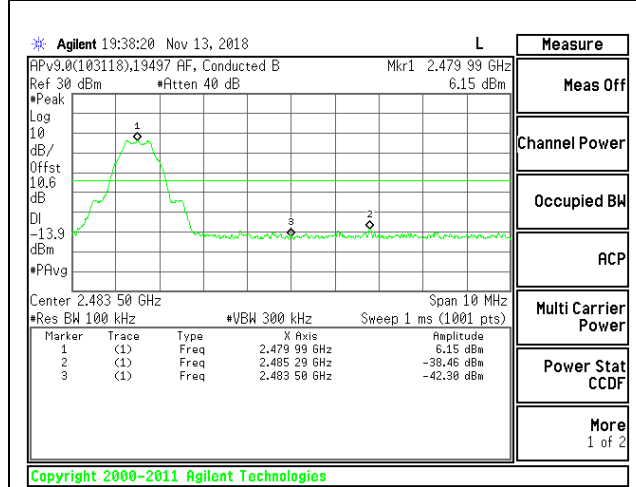

HIGH CHANNEL BANDEGE

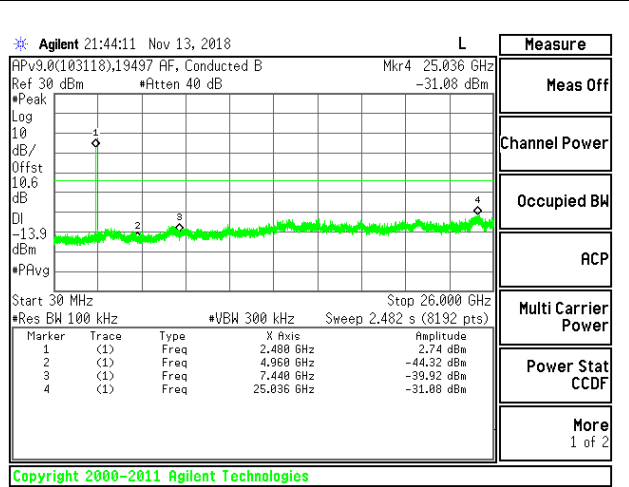

OUT-OF-BAND HIGH CHANNEL

8.7.4. BLE (2Mbps)

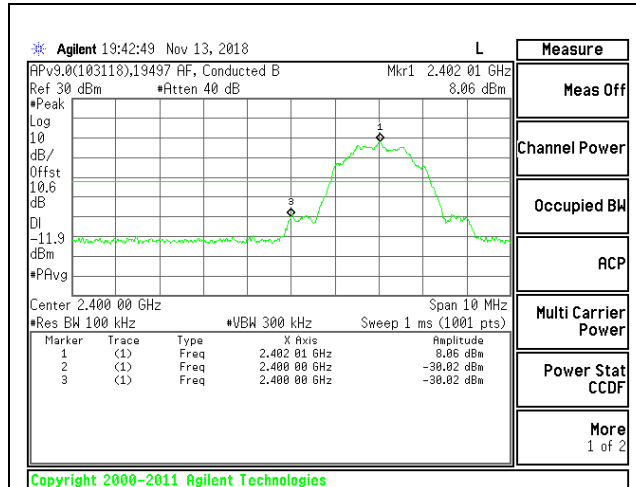

LOW CHANNEL BANDEGE

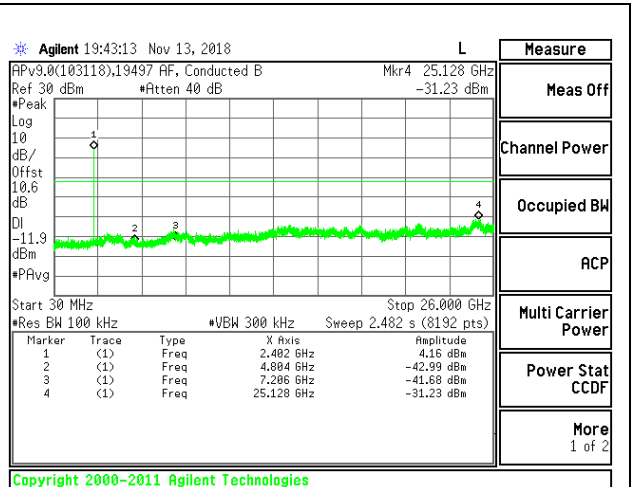

OUT-OF-BAND LOW CHANNEL

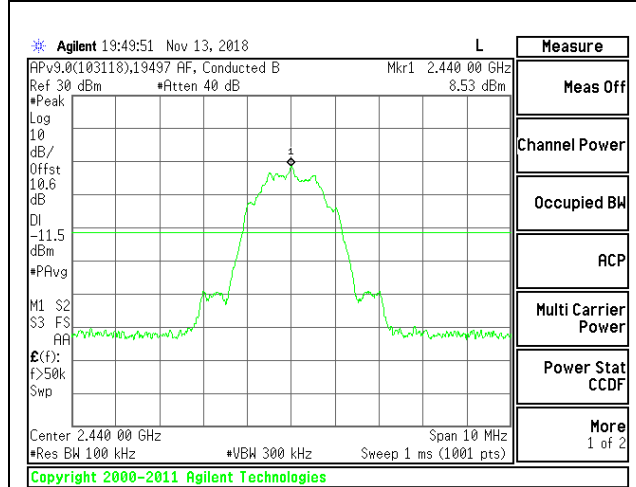

IN-BAND REFERENCE LEVEL

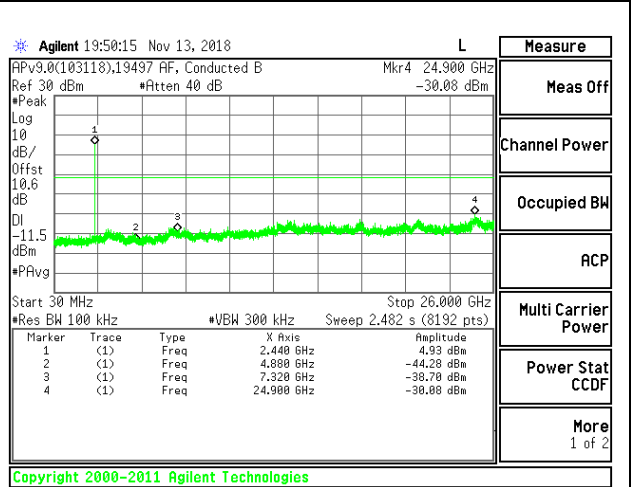

OUT-OF-BAND MID CHANNEL

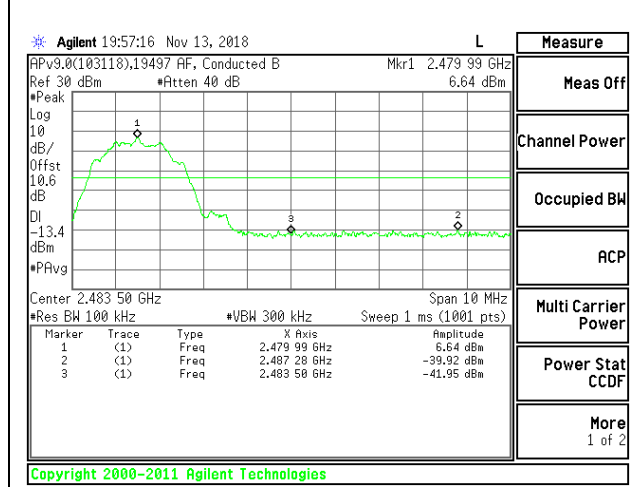

HIGH CHANNEL BANDEGE

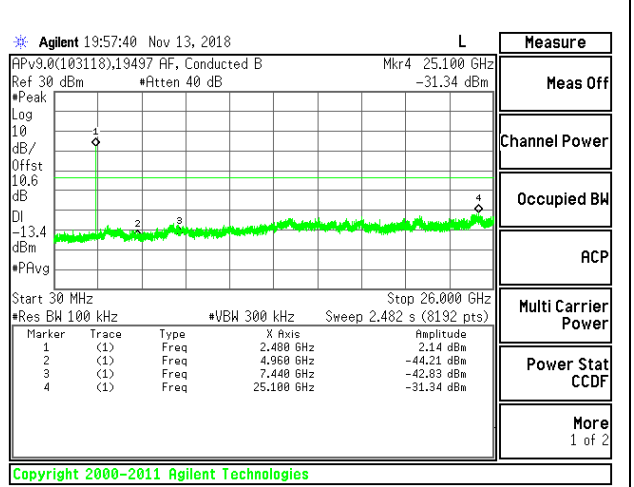

OUT-OF-BAND HIGH CHANNEL

9. RADIATED TEST RESULTS

9.1. LIMITS AND PROCEDURE

LIMITS

FCC §15.205 and §15.209

Frequency Range (MHz)	Field Strength Limit (uV/m) at 3 m	Field Strength Limit (dBuV/m) at 3 m
0.009-0.490	2400/F(kHz) @ 300 m	-
0.490-1.705	24000/F(kHz) @ 30 m	-
1.705 - 30	30 @ 30m	-
30 - 88	100	40
88 - 216	150	43.5
216 - 960	200	46
Above 960	500	54

TEST PROCEDURE

The EUT is placed on a non-conducting table 80 cm above the ground plane for measurement below 1GHz; 1.5 m above the ground plane for measurement above 1GHz. The antenna to EUT distance is 3 meters. The EUT is configured in accordance with ANSI C63.10. The EUT is set to transmit in a continuous mode.

For measurements below 1 GHz the resolution bandwidth is set to 100 kHz for peak detection measurements or 120 kHz for quasi-peak detection measurements. Peak detection is used unless otherwise noted as quasi-peak.

For pre-scans above 1 GHz the resolution bandwidth is set to 1 MHz; the video bandwidth is set to 30 KHz for peak measurements.

For final measurements above 1 GHz the resolution bandwidth is set to 1 MHz; the video bandwidth is set to 3 MHz for peak measurements and as applicable for average measurements.

The spectrum from 1 GHz to 18 GHz is investigated with the transmitter set to the lowest, middle, and highest channels in each applicable band. Below 1GHz and above 18GHz emissions, the channel with the highest output power was tested.

The frequency range of interest is monitored at a fixed antenna height and EUT azimuth. The EUT is rotated through 360 degrees to maximize emissions received. The antenna is scanned from 1 to 4 meters above the ground plane to further maximize the emission. Measurements are made with the antenna polarized in both the vertical and the horizontal positions.

9.2. TRANSMITTER ABOVE 1 GHz

9.2.1. BLE (125kbps)

Antenna 1

BANDEDGE (LOW CHANNEL)

HORIZONTAL RESULT

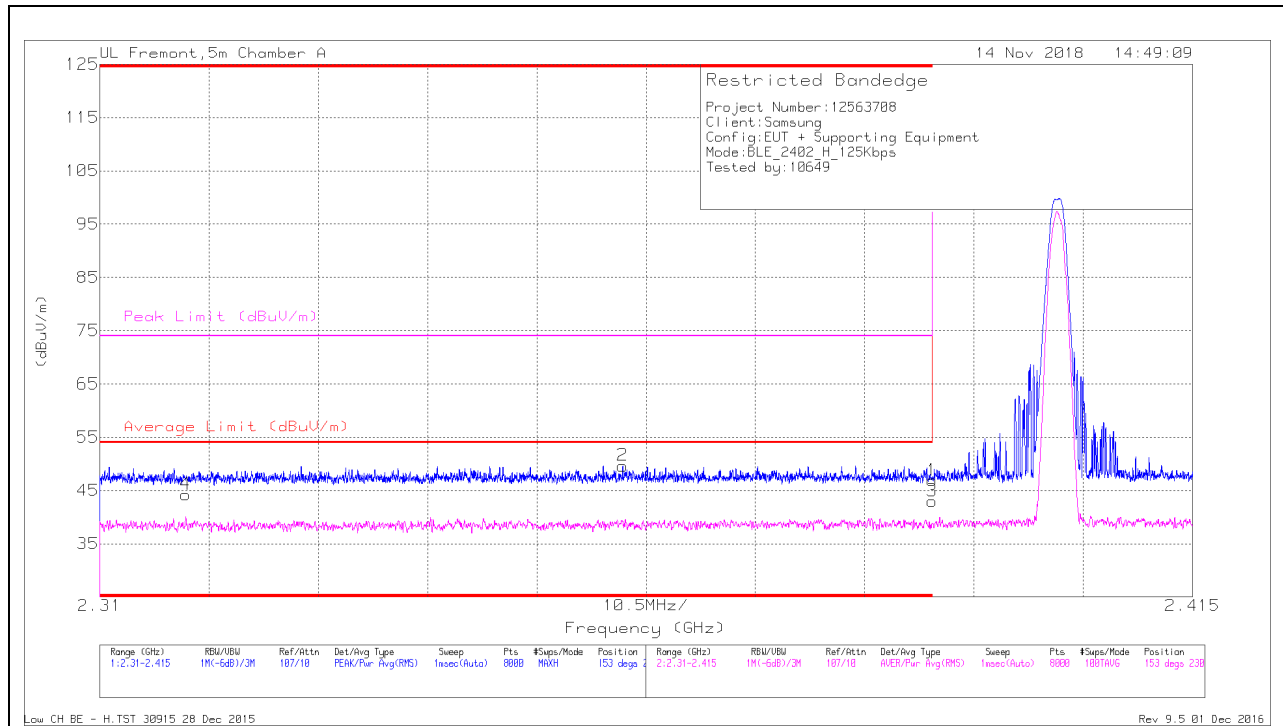

Trace Markers

Marker	Frequency (GHz)	Meter Reading (dBuV)	Det	AF T345 (dB/m)	Amp/Cb/Filtr/Pad (dB)	DC Corr (dB)	Corrected Reading (dBuV/m)	Average Limit (dBuV/m)	Margin (dB)	Peak Limit (dBuV/m)	PK Margin (dB)	Azimuth (Degs)	Height (cm)	Polarity
4	* 2.318	29.8	RMS	31.5	-22.1	.83	40.03	54	-13.97	-	-	153	230	H
2	* 2.36	40.15	Pk	31.6	-22.1	0	49.65	-	-	74	-24.35	153	230	H
1	* 2.39	37.21	Pk	31.8	-22.1	0	46.91	-	-	74	-27.09	153	230	H
3	* 2.39	28.24	RMS	31.8	-22.1	.83	38.77	54	-15.23	-	-	153	230	H

* - indicates frequency in CFR47 Pt 15 / IC RSS-Restricted Band

Pk - Peak detector

RMS - RMS detection

VERTICAL RESULT

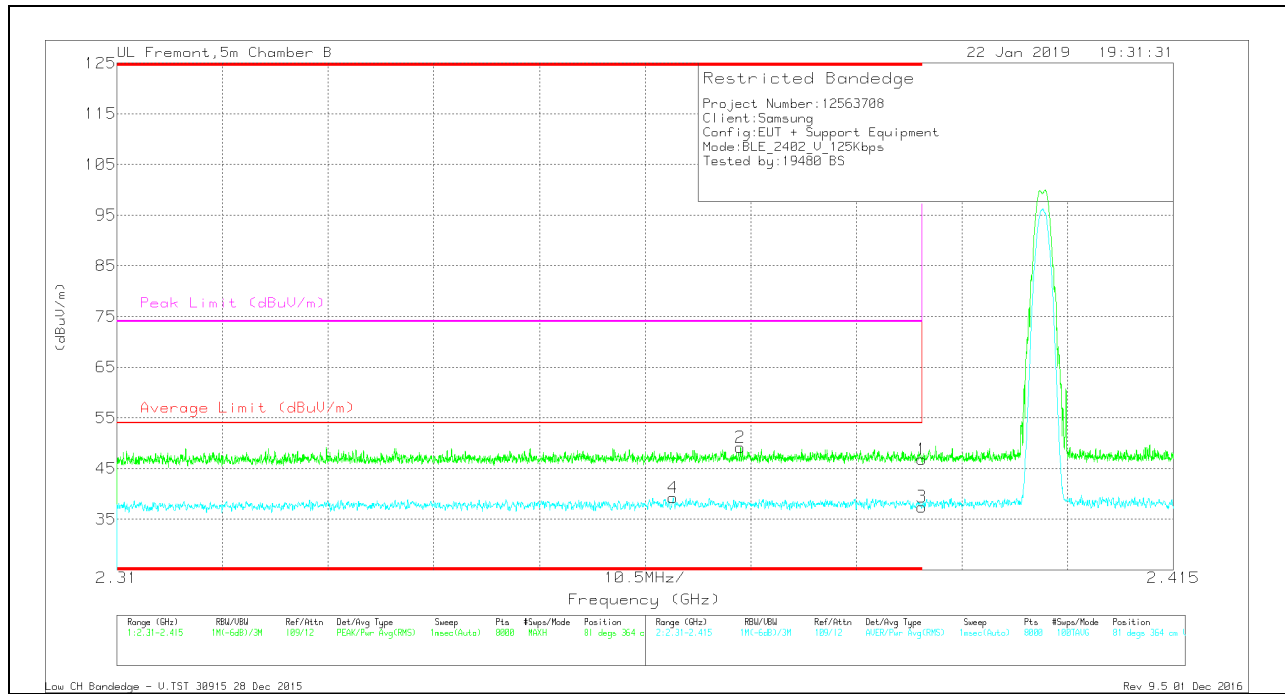

Trace Markers

Marker	Frequency (GHz)	Meter Reading (dBuV)	Det	AF T863 (dB/m)	Amp/Cb/Filtr/Pad (dB)	DC Corr (dB)	Corrected Reading (dBuV/m)	Average Limit (dBuV/m)	Margin (dB)	Peak Limit (dBuV/m)	PK Margin (dB)	Azimuth (Degs)	Height (cm)	Polarity
4	* 2.365	26.89	RMS	32.2	-20.7	.83	39.22	54	-14.78	-	-	81	364	V
2	* 2.372	37.58	Pk	32.3	-20.7	0	49.18	-	-	74	-24.82	81	364	V
1	* 2.39	35.25	Pk	32.3	-20.7	0	46.85	-	-	74	-27.15	81	364	V
3	* 2.39	25.01	RMS	32.3	-20.7	.83	37.44	54	-16.56	-	-	81	364	V

* - indicates frequency in CFR47 Pt 15 / IC RSS-Restricted Band

Pk - Peak detector

RMS - RMS detection

BANEDGE (HIGH CHANNEL)

HORIZONTAL RESULT

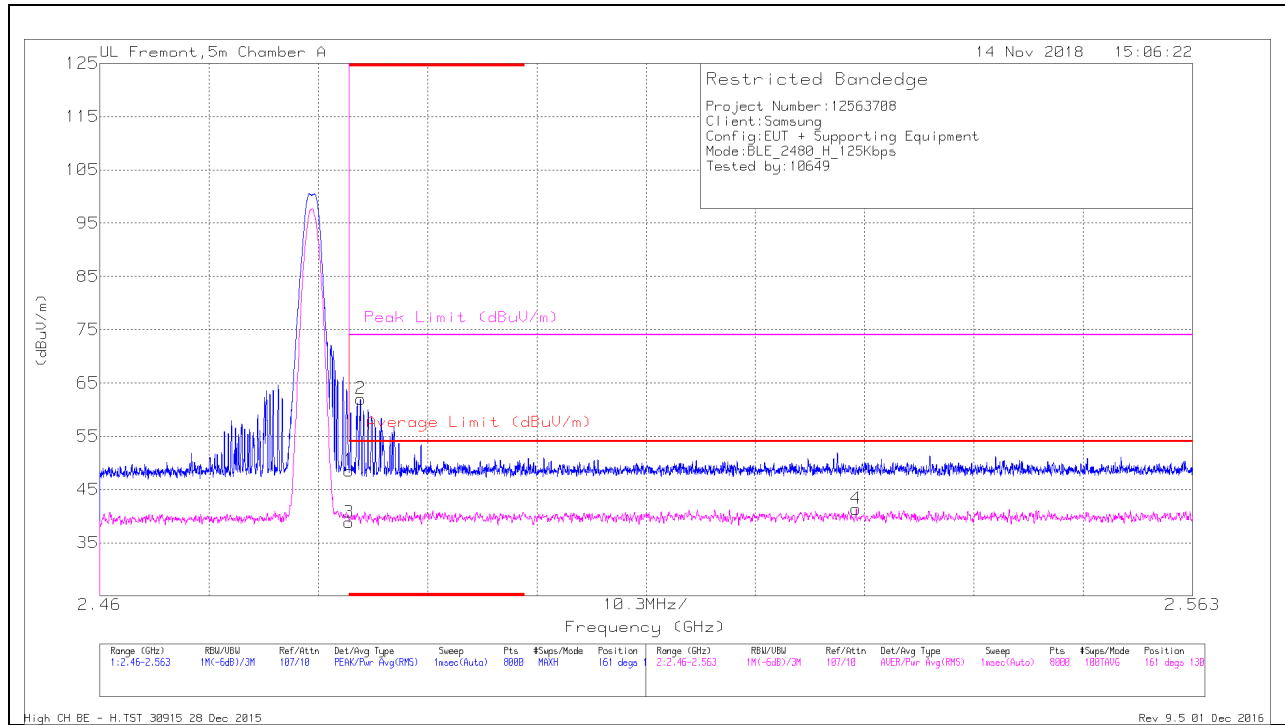

Trace Markers

Marker	Frequency (GHz)	Meter Reading (dBuV)	Det	AFT345 (dB/m)	Amp/Cb/Fitr/Pad (dB)	DC Corr (dB)	Corrected Reading (dBuV/m)	Average Limit (dBuV/m)	Margin (dB)	Peak Limit (dBuV/m)	PK Margin (dB)	Azimuth (Degs)	Height (cm)	Polarity
1	* 2.484	38.05	Pk	32.3	-21.8	0	48.55	-	-	74	-25.45	161	130	H
3	* 2.484	27.48	RMS	32.3	-21.8	.83	38.81	54	-15.19	-	-	161	130	H
2	* 2.485	51.5	Pk	32.3	-21.8	0	62	-	-	74	-12	161	130	H
4	2.531	29.74	RMS	32.4	-21.6	.83	41.37	54	-12.63	-	-	161	130	H

* - indicates frequency in CFR47 Pt 15 / IC RSS-Restricted Band

Pk - Peak detector

RMS - RMS detection

VERTICAL RESULT

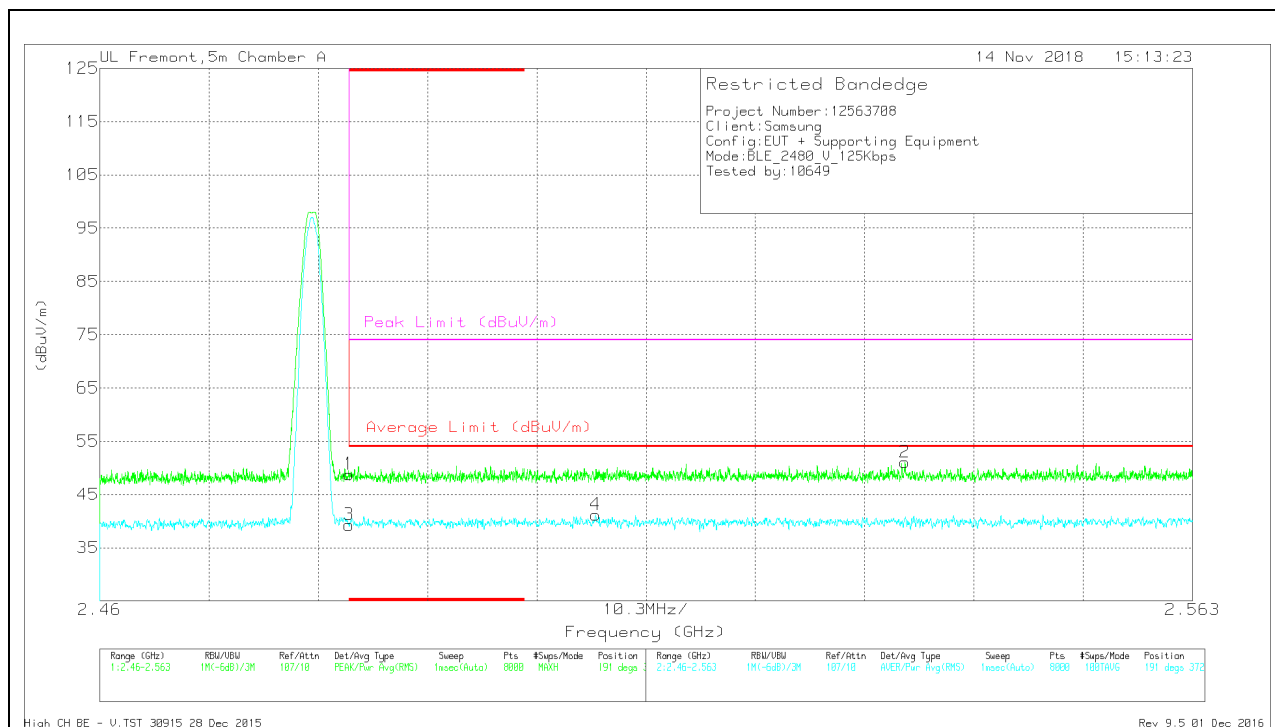

Trace Markers

Marker	Frequency (GHz)	Meter Reading (dBuV)	Det	AF T345 (dB/m)	Amp/Cb/Filtr/Pad (dB)	DC Corr (dB)	Corrected Reading (dBuV/m)	Average Limit (dBuV/m)	Margin (dB)	Peak Limit (dBuV/m)	PK Margin (dB)	Azimuth (Degs)	Height (cm)	Polarity
1	* 2.484	38.29	Pk	32.3	-21.8	0	48.79	-	-	74	-25.21	191	372	V
3	* 2.484	27.96	RMS	32.3	-21.8	.83	39.29	54	-14.71	-	-	191	372	V
4	2.507	29.67	RMS	32.4	-21.7	.83	41.2	54	-12.8	-	-	191	372	V
2	2.536	40.24	Pk	32.4	-21.6	0	51.04	-	-	74	-22.96	191	372	V

* - indicates frequency in CFR47 Pt 15 / IC RSS-Restricted Band

Pk - Peak detector

RMS - RMS detection

HARMONICS AND SPURIOUS EMISSIONS

LOW CHANNEL RESULTS

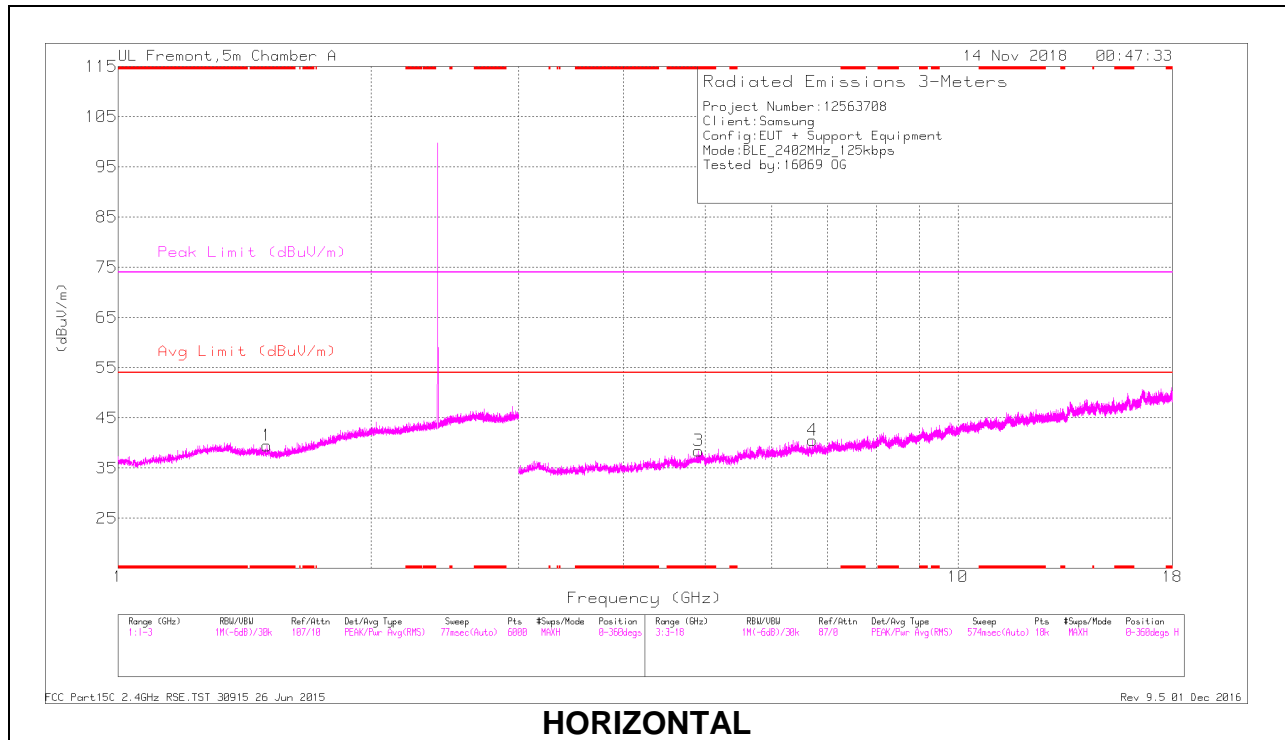

HORIZONTAL

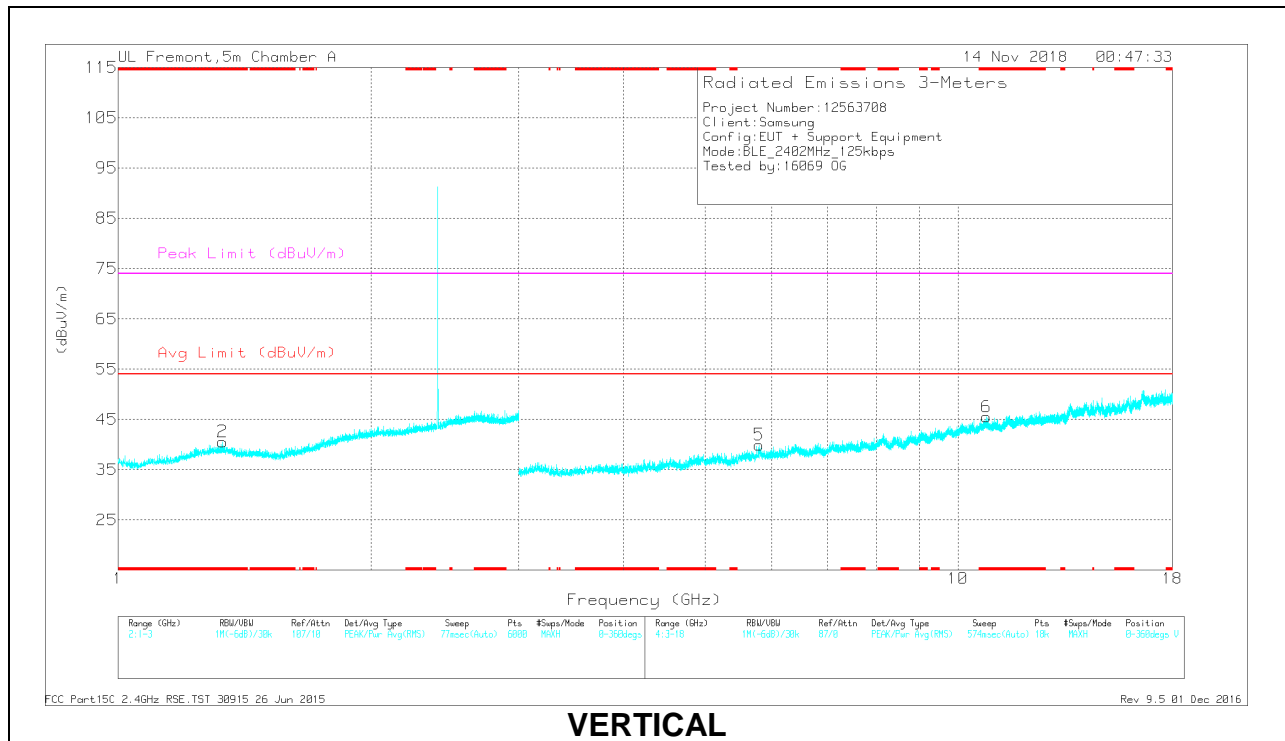

VERTICAL

RADIATED EMISSIONS

Marker	Frequency (GHz)	Meter Reading (dBuV)	Det	AF T345 (dB/m)	Amp/Cbl/Filtr/Pad (dB)	DC Corr (dB)	Corrected Reading (dBuV/m)	Avg Limit (dBuV/m)	Margin (dB)	Peak Limit (dBuV/m)	PK Margin (dB)	Azimuth (Degs)	Height (cm)	Polarity
1	* 1.504	40.65	PK2	28.4	-24	0	45.05	-	-	74	-28.95	123	117	H
	* 1.504	28.73	MAv1	28.3	-24	.83	33.86	54	-20.14	-	-	123	117	H
2	* 1.333	40.26	PK2	29.5	-24.3	0	45.46	-	-	74	-28.54	334	105	V
	* 1.333	28.64	MAv1	29.5	-24.3	.83	34.67	54	-19.33	-	-	334	105	V
3	* 4.913	35.38	PK2	34.1	-26.4	0	43.08	-	-	74	-30.92	216	262	H
	* 4.913	24.02	MAv1	34.1	-26.4	.83	32.55	54	-21.45	-	-	216	262	H
6	* 10.811	31.56	PK2	37.8	-18.2	0	51.16	-	-	74	-22.84	229	215	V
	* 10.813	19.8	MAv1	37.8	-18.2	.83	40.23	54	-13.77	-	-	229	215	V
5	5.802	35.09	PK2	35.1	-24.8	0	45.39	-	-	-	-	216	200	V
4	6.708	33.21	PK2	35.6	-24	0	44.81	-	-	-	-	216	103	H

* - indicates frequency in CFR47 Pt 15 / IC RSS-Restricted Band

PK2 - KDB558074 Method: Maximum Peak

MAv1 - KDB558074 Option 1 Maximum RMS Average

MID CHANNEL RESULTS

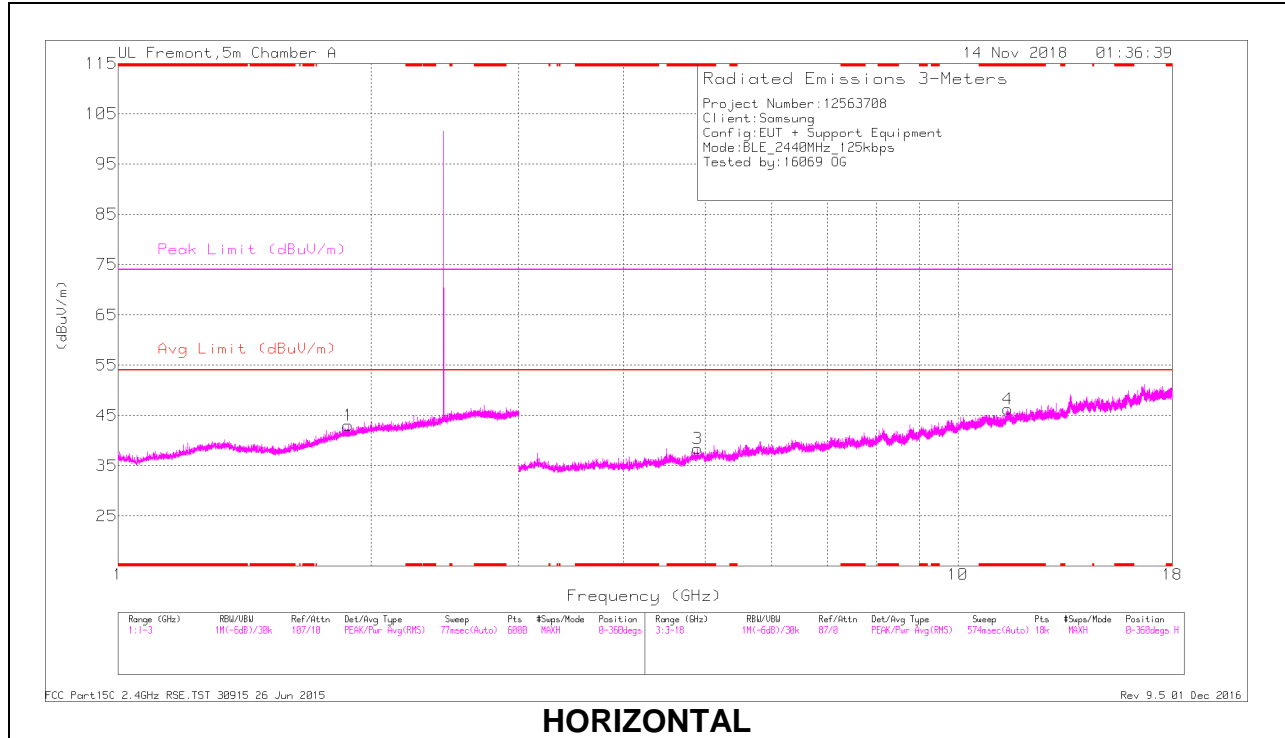

HORIZONTAL

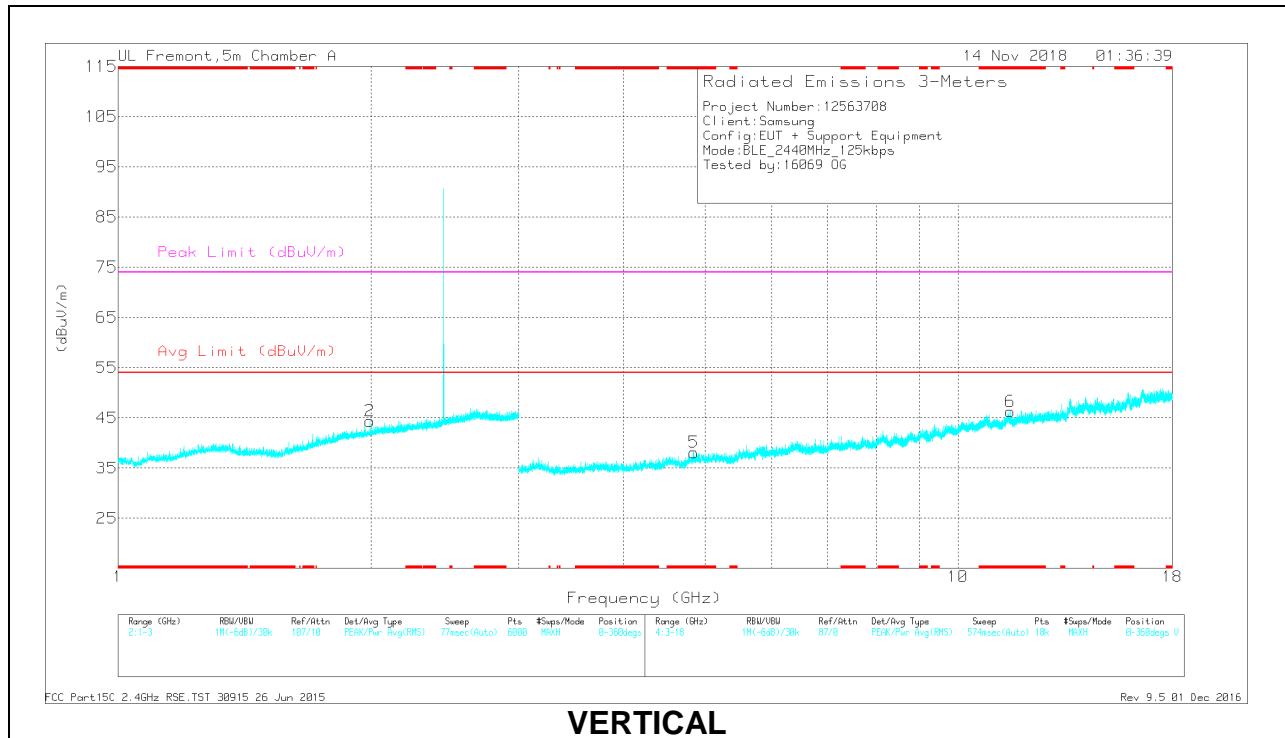

VERTICAL

RADIATED EMISSIONS

Marker	Frequency (GHz)	Meter Reading (dBuV)	Det	AF T345 (dB/m)	Amp/Cbl/Filtr/Pad (dB)	DC Corr (dB)	Corrected Reading (dBuV/m)	Avg Limit (dBuV/m)	Margin (dB)	Peak Limit (dBuV/m)	PK Margin (dB)	Azimuth (Degs)	Height (cm)	Polarity
3	* 4.898	35.75	PK2	34.1	-26.1	0	43.75	-	-	74	-30.25	182	257	H
	* 4.898	24.05	MAv1	34.1	-26.1	.83	32.88	54	-21.12	-	-	182	257	H
4	* 11.462	31.07	PK2	38.3	-18	0	51.37	-	-	74	-22.63	307	126	H
	* 11.462	19.88	MAv1	38.3	-18	.83	41.01	54	-12.99	-	-	307	126	H
5	* 4.849	35.33	PK2	34.2	-25.8	0	43.73	-	-	74	-30.27	123	174	V
	* 4.85	23.65	MAv1	34.2	-25.8	.83	32.88	54	-21.12	-	-	123	174	V
6	* 11.544	31.83	PK2	38.4	-18.6	0	51.63	-	-	74	-22.37	4	125	V
	* 11.544	19.97	MAv1	38.4	-18.6	.83	40.6	54	-13.4	-	-	4	125	V
1	1.878	40.71	PK2	31	-23.2	0	48.51	-	-	-	-	360	199	H
2	1.994	40.59	PK2	31.4	-22.9	0	49.09	-	-	-	-	360	102	V

* - indicates frequency in CFR47 Pt 15 / IC RSS-Restricted Band

PK2 - KDB558074 Method: Maximum Peak

MAv1 - KDB558074 Option 1 Maximum RMS Average

HIGH CHANNEL RESULTS

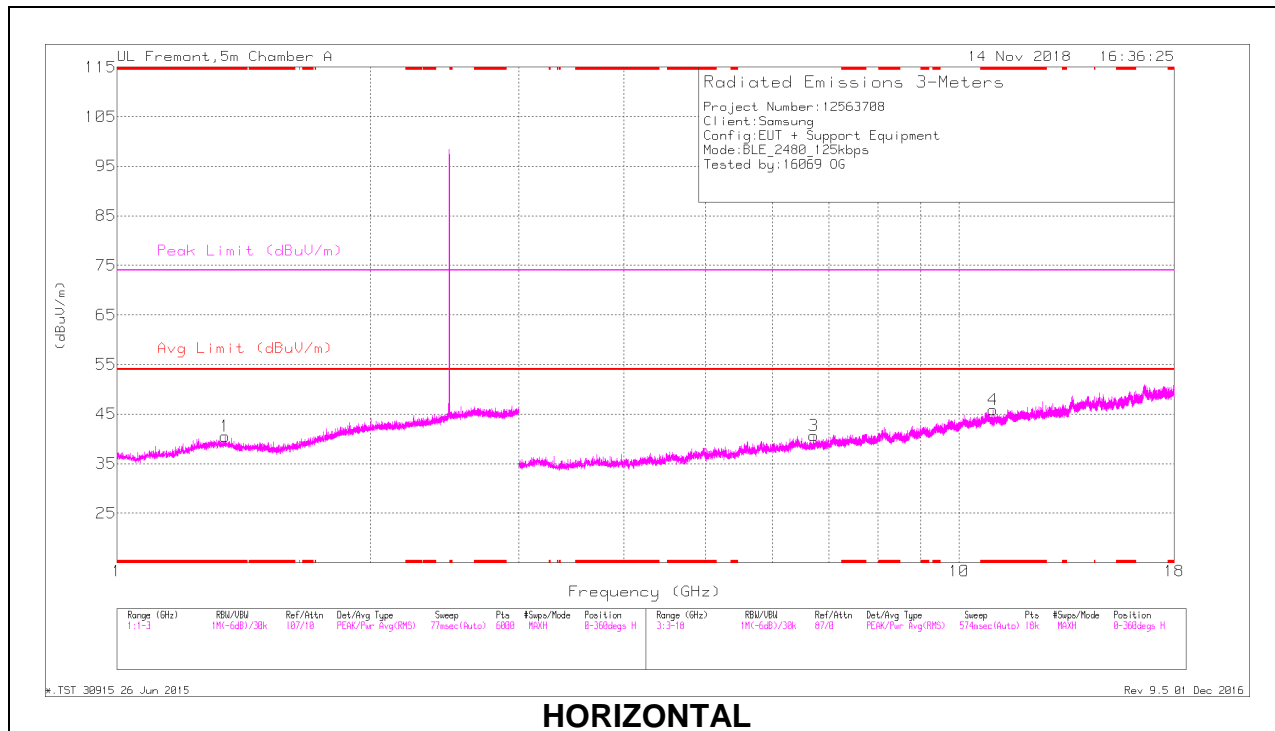

HORIZONTAL

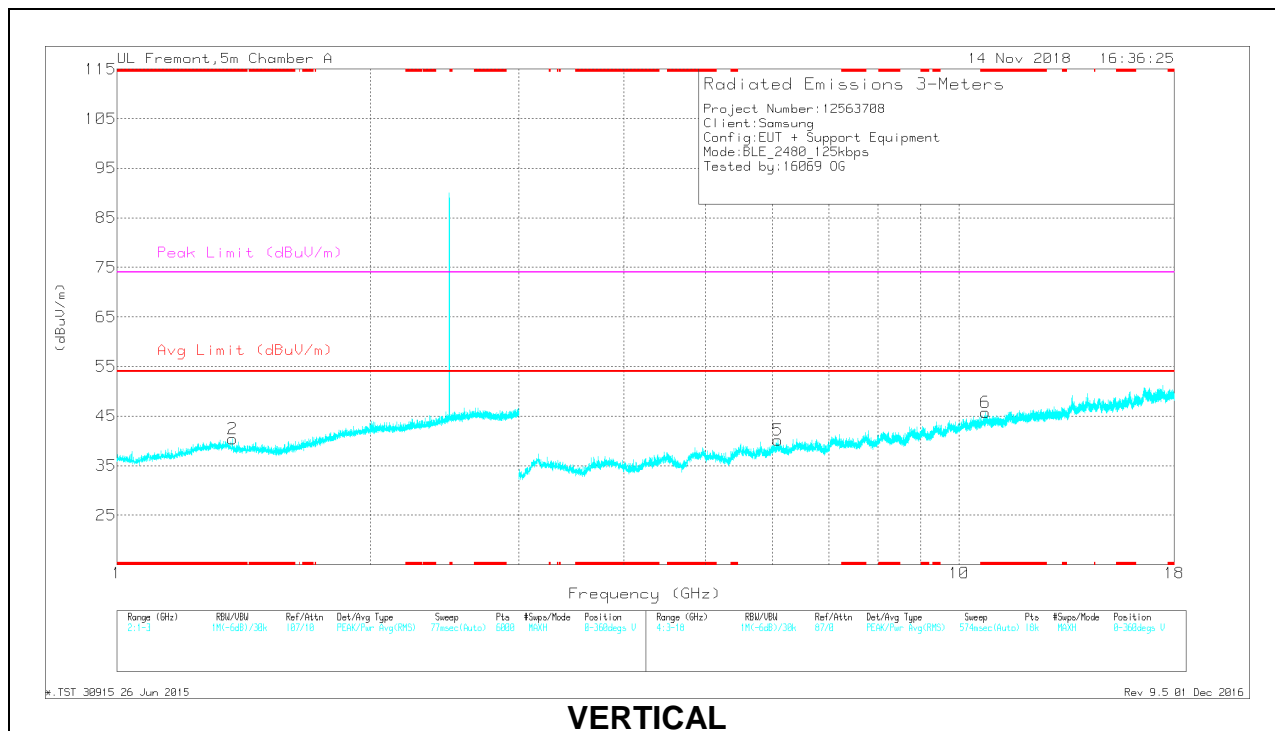

VERTICAL

RADIATED EMISSIONS

Marker	Frequency (GHz)	Meter Reading (dBuV)	Det	AF T345 (dB/m)	Amp/Cbl/Filtr/Pad (dB)	DC Corr (dB)	Corrected Reading (dBuV/m)	Avg Limit (dBuV/m)	Margin (dB)	Peak Limit (dBuV/m)	PK Margin (dB)	Azimuth (Degs)	Height (cm)	Polarity
1	* 1.343	40.77	PK2	29.5	-24.3	0	45.97	-	-	74	-28.03	134	137	H
	* 1.345	28.79	MAv1	29.5	-24.3	.83	34.82	54	-19.18	-	-	134	137	H
2	* 1.373	41.07	PK2	29.1	-24.3	0	45.87	-	-	74	-28.13	17	155	V
	* 1.371	28.72	MAv1	29.1	-24.3	.83	34.35	54	-19.65	-	-	17	155	V
6	* 10.968	30.91	PK2	37.9	-19	0	49.81	-	-	74	-24.19	266	162	H
	* 10.971	20.01	MAv1	37.9	-19	.83	39.74	54	-14.26	-	-	266	162	H
4	* 10.751	31.35	PK2	37.8	-18.7	0	50.45	-	-	74	-23.55	191	181	V
	* 10.75	20.04	MAv1	37.8	-18.7	.83	39.97	54	-14.03	-	-	191	181	V
5	6.092	34.33	PK2	35.5	-24.9	0	44.93	-	-	-	-	266	102	V
3	6.724	33.82	PK2	35.6	-23.7	0	45.72	-	-	-	-	17	199	H

* - indicates frequency in CFR47 Pt 15 / IC RSS-Restricted Band

PK2 - KDB558074 Method: Maximum Peak

MAv1 - KDB558074 Option 1 Maximum RMS Average

9.2.2. BLE (500kbps)

Antenna 1

BANDEDGE (LOW CHANNEL)

HORIZONTAL RESULT

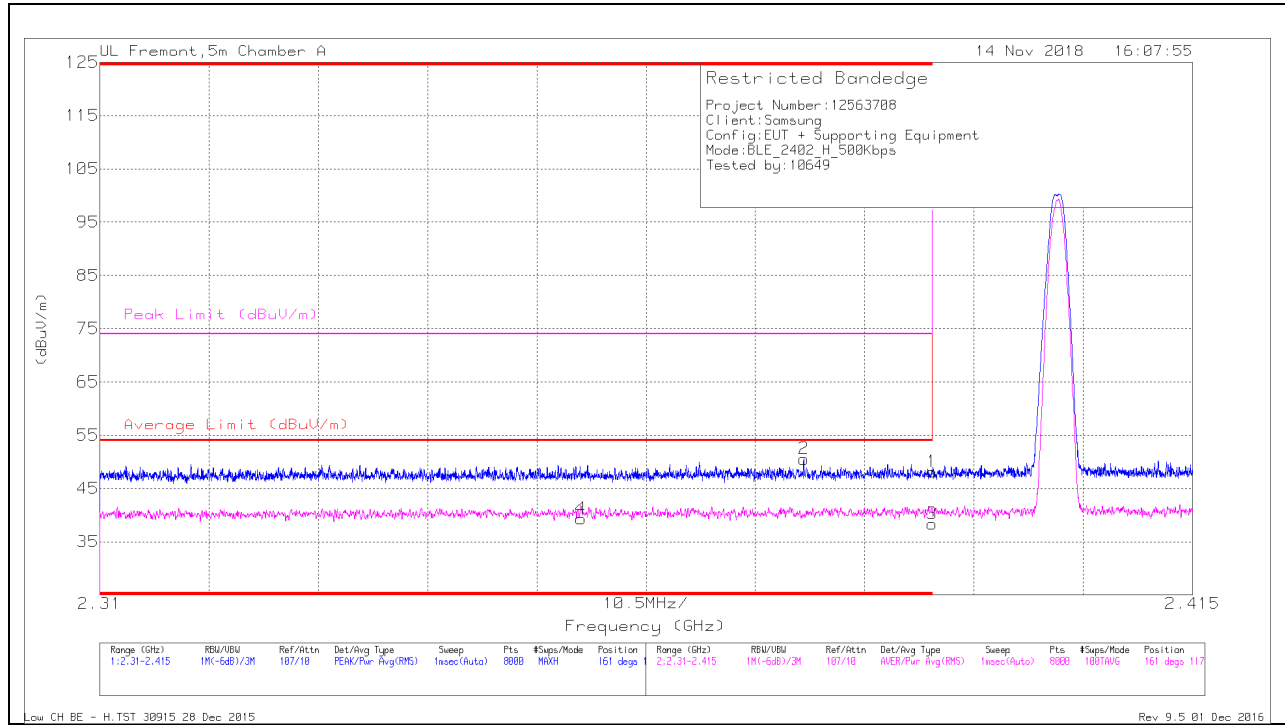

Trace Markers

Marker	Frequency (GHz)	Meter Reading (dBuV)	Det	AFT345 (dB/m)	Amp/Cbi/Fitr/Pad (dB)	DC Corr (dB)	Corrected Reading (dBuV/m)	Average Limit (dBuV/m)	Margin (dB)	Peak Limit (dBuV/m)	PK Margin (dB)	Azimuth (Degs)	Height (cm)	Polarity
4	* 2.356	29.8	RMS	31.6	-22.1	2.5	41.8	54	-12.2	-	-	161	117	H
2	* 2.378	40.93	Pk	31.7	-22.1	0	50.53	-	-	74	-23.47	161	117	H
1	* 2.39	38.41	Pk	31.8	-22.1	0	48.11	-	-	74	-25.89	161	117	H
3	* 2.39	28.63	RMS	31.8	-22.1	2.5	40.83	54	-13.17	-	-	161	117	H

* - indicates frequency in CFR47 Pt 15 / IC RSS-Restricted Band

Pk - Peak detector

RMS - RMS detection

VERTICAL RESULT



Trace Markers

Marker	Frequency (GHz)	Meter Reading (dBuV)	Det	AF T345 (dB/m)	Amp/Cb/Filtr/Pad (dB)	DC Corr (dB)	Corrected Reading (dBuV/m)	Average Limit (dBuV/m)	Margin (dB)	Peak Limit (dBuV/m)	PK Margin (dB)	Azimuth (Degs)	Height (cm)	Polarity
2	* 2.314	40.37	Pk	31.5	-22.1	0	49.77	-	-	74	-24.23	198	401	V
4	* 2.388	29.5	RMS	31.8	-22.1	2.5	41.7	54	-12.3	-	-	198	401	V
1	* 2.39	38.12	Pk	31.8	-22.1	0	47.82	-	-	74	-26.18	198	401	V
3	* 2.39	28.92	RMS	31.8	-22.1	2.5	41.12	54	-12.88	-	-	198	401	V

* - indicates frequency in CFR47 Pt 15 / IC RSS-Restricted Band

Pk - Peak detector

RMS - RMS detection

BANEDGE (HIGH CHANNEL)

HORIZONTAL RESULT

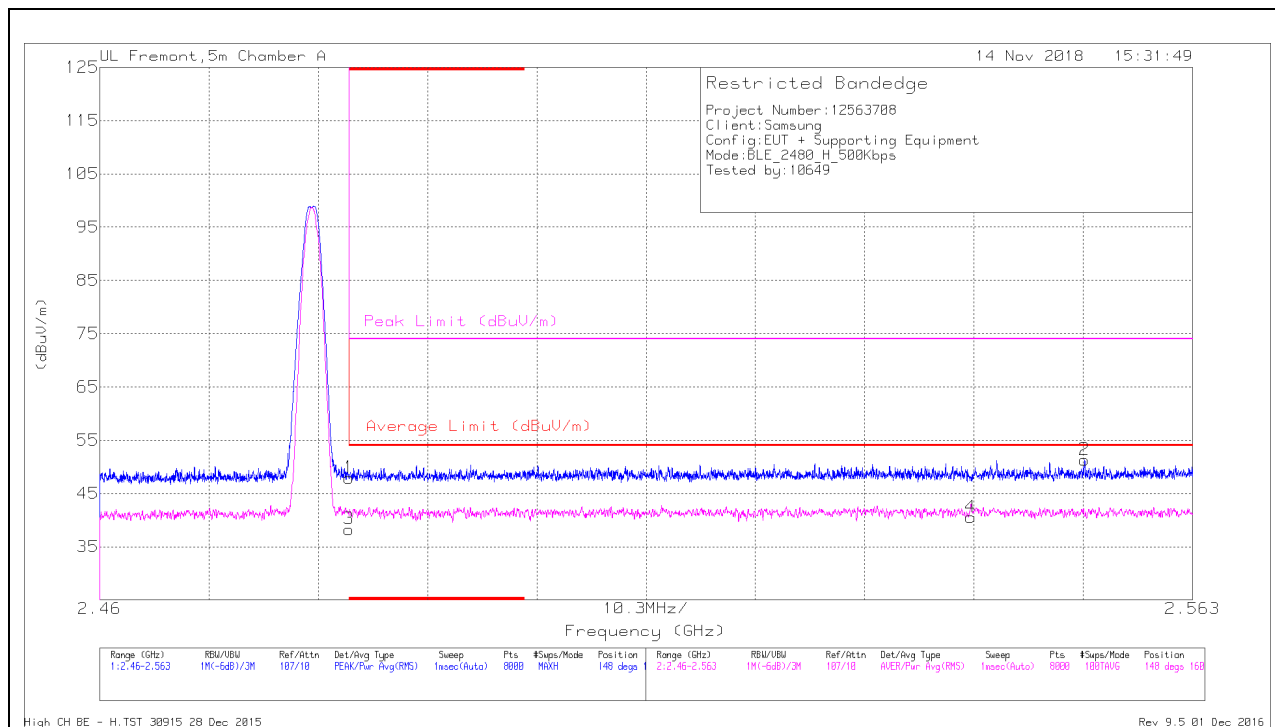

Trace Markers

Marker	Frequency (GHz)	Meter Reading (dBuV)	Det	AF T345 (dB/m)	Amp/Cb/Fitr/Pad (dB)	DC Corr (dB)	Corrected Reading (dBuV/m)	Average Limit (dBuV/m)	Margin (dB)	Peak Limit (dBuV/m)	PK Margin (dB)	Azimuth (Degs)	Height (cm)	Polarity
1	* 2.484	37.44	Pk	32.3	-21.8	0	47.94	-	-	74	-26.06	148	160	H
3	* 2.484	27.79	RMS	32.3	-21.8	2.5	40.79	54	-13.21	-	-	148	160	H
4	2.542	29.82	RMS	32.3	-21.6	2.5	43.02	54	-10.98	-	-	148	160	H
2	2.553	40.63	Pk	32.3	-21.6	0	51.33	-	-	74	-22.67	148	160	H

* - indicates frequency in CFR47 Pt 15 / IC RSS-Restricted Band

Pk - Peak detector

RMS - RMS detection

VERTICAL RESULT

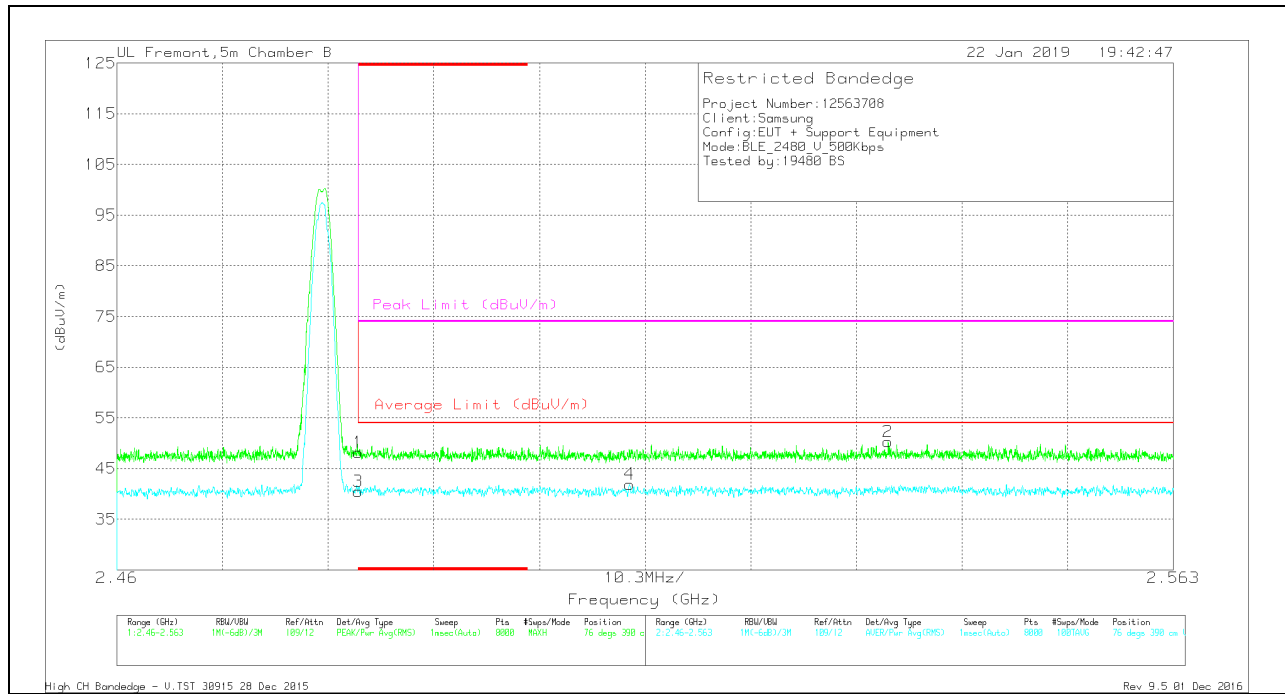

Trace Markers

Marker	Frequency (GHz)	Meter Reading (dBuV)	Det	AF T863 (dB/m)	Amp/Cb/Filtr/Pad (dB)	DC Corr (dB)	Corrected Reading (dBuV/m)	Average Limit (dBuV/m)	Margin (dB)	Peak Limit (dBuV/m)	PK Margin (dB)	Azimuth (Degs)	Height (cm)	Polarity
1	* 2.484	35.93	Pk	32.6	-20.3	0	48.23	-	-	74	-25.77	76	390	V
3	* 2.484	25.73	RMS	32.6	-20.3	2.5	40.53	54	-13.47	-	-	76	390	V
4	2.51	27.31	RMS	32.7	-20.6	2.5	41.91	54	-12.09	-	-	76	390	V
2	2.535	37.9	Pk	32.7	-20.3	0	50.3	-	-	74	-23.7	76	390	V

* - indicates frequency in CFR47 Pt 15 / IC RSS-Restricted Band

Pk - Peak detector

RMS - RMS detection

HARMONICS AND SPURIOUS EMISSIONS

LOW CHANNEL RESULTS

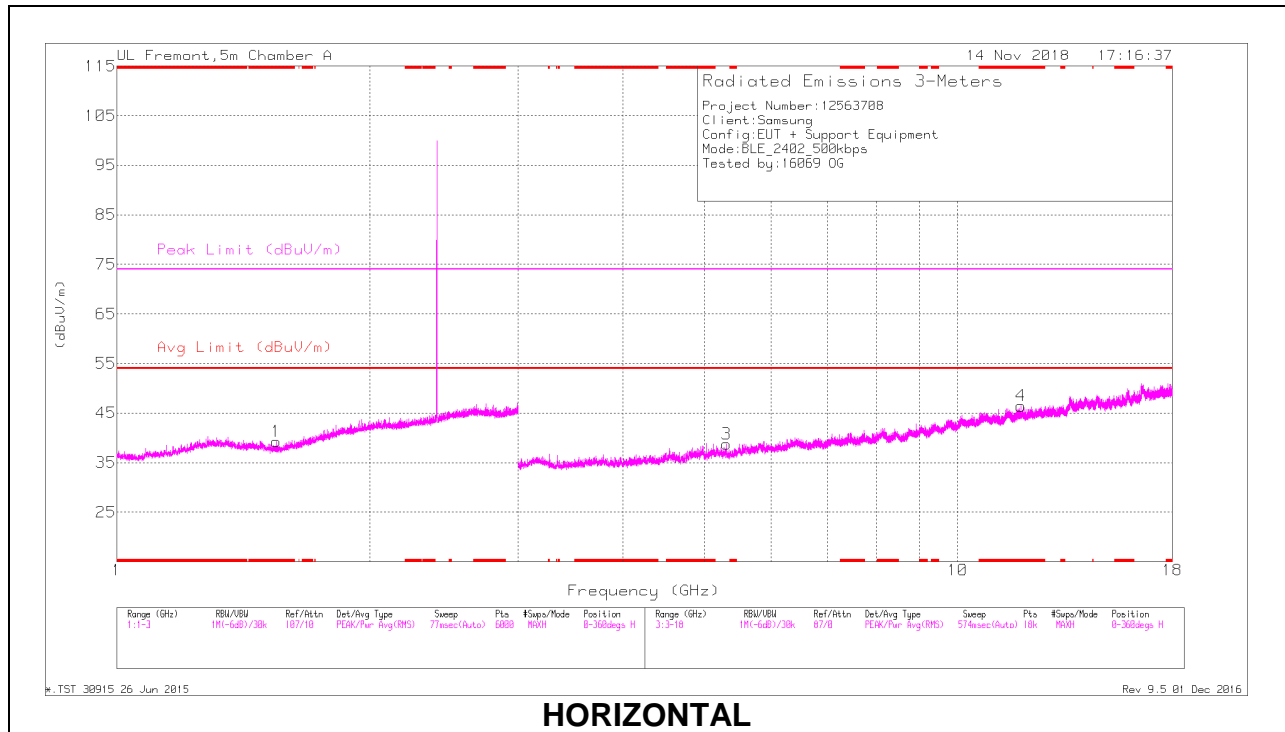

HORIZONTAL

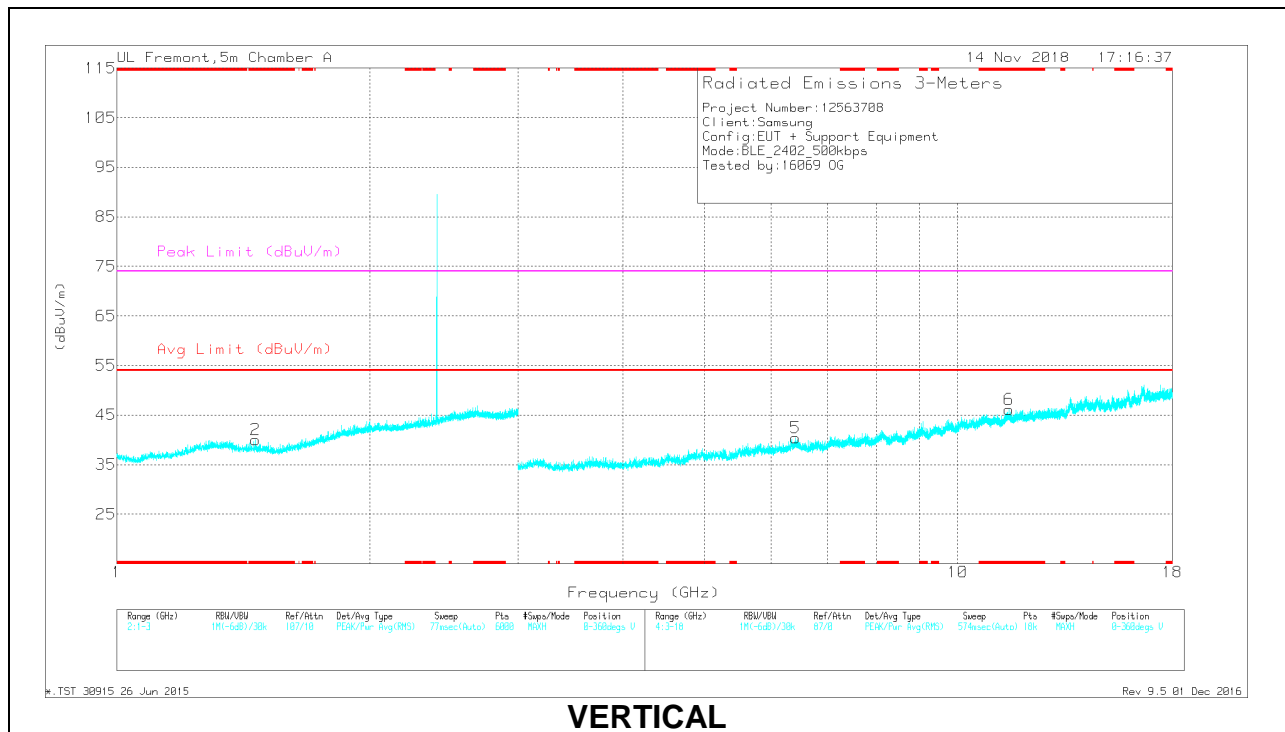

VERTICAL

RADIATED EMISSIONS

Marker	Frequency (GHz)	Meter Reading (dBuV)	Det	AF T345 (dB/m)	Amp/Cbl/Filtr/Pad (dB)	DC Corr (dB)	Corrected Reading (dBuV/m)	Avg Limit (dBuV/m)	Margin (dB)	Peak Limit (dBuV/m)	PK Margin (dB)	Azimuth (Degs)	Height (cm)	Polarity
1	* 1.548	40.68	PK2	27.8	-23.7	0	44.78	-	-	74	-29.22	22	164	H
	* 1.546	28.57	MAv1	27.8	-23.8	2.5	35.07	54	-18.93	-	-	22	164	H
2	* 1.461	40.39	PK2	28.7	-24.1	0	44.99	-	-	74	-29.01	152	152	V
	* 1.461	28.68	MAv1	28.7	-24.1	2.5	35.78	54	-18.22	-	-	152	152	V
4	* 11.888	32.03	PK2	38.8	-18.5	0	52.33	-	-	74	-21.67	11	211	H
	* 11.888	19.61	MAv1	38.8	-18.5	2.5	42.41	54	-11.59	-	-	11	211	H
6	* 11.501	31.38	PK2	38.3	-18.2	0	51.48	-	-	74	-22.52	284	271	V
	* 11.499	19.69	MAv1	38.3	-18.2	2.5	42.29	54	-11.71	-	-	284	271	V
3	5.303	35.45	PK2	34.6	-26.6	0	43.45	-	-	-	-	152	199	H
5	6.409	34.48	PK2	35.8	-23.8	0	46.48	-	-	-	-	11	102	V

* - indicates frequency in CFR47 Pt 15 / IC RSS-Restricted Band

PK2 - KDB558074 Method: Maximum Peak

MAv1 - KDB558074 Option 1 Maximum RMS Average

MID CHANNEL RESULTS

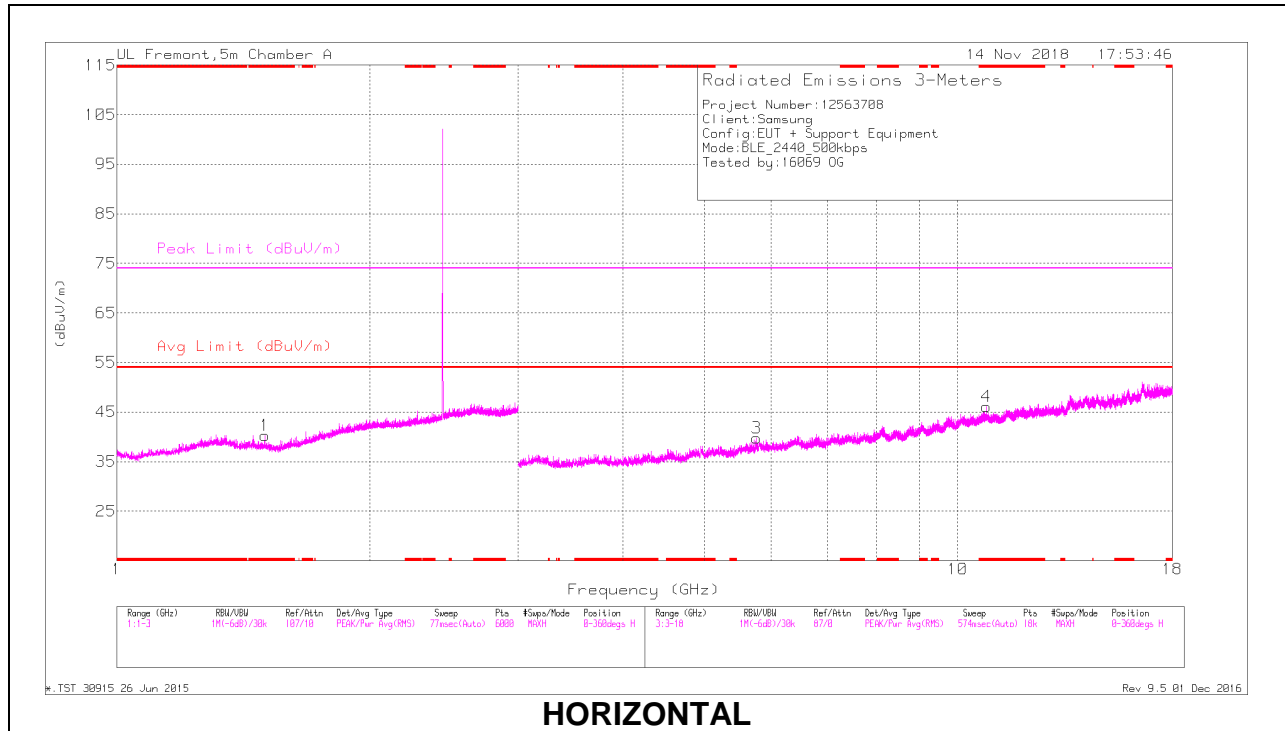

HORIZONTAL

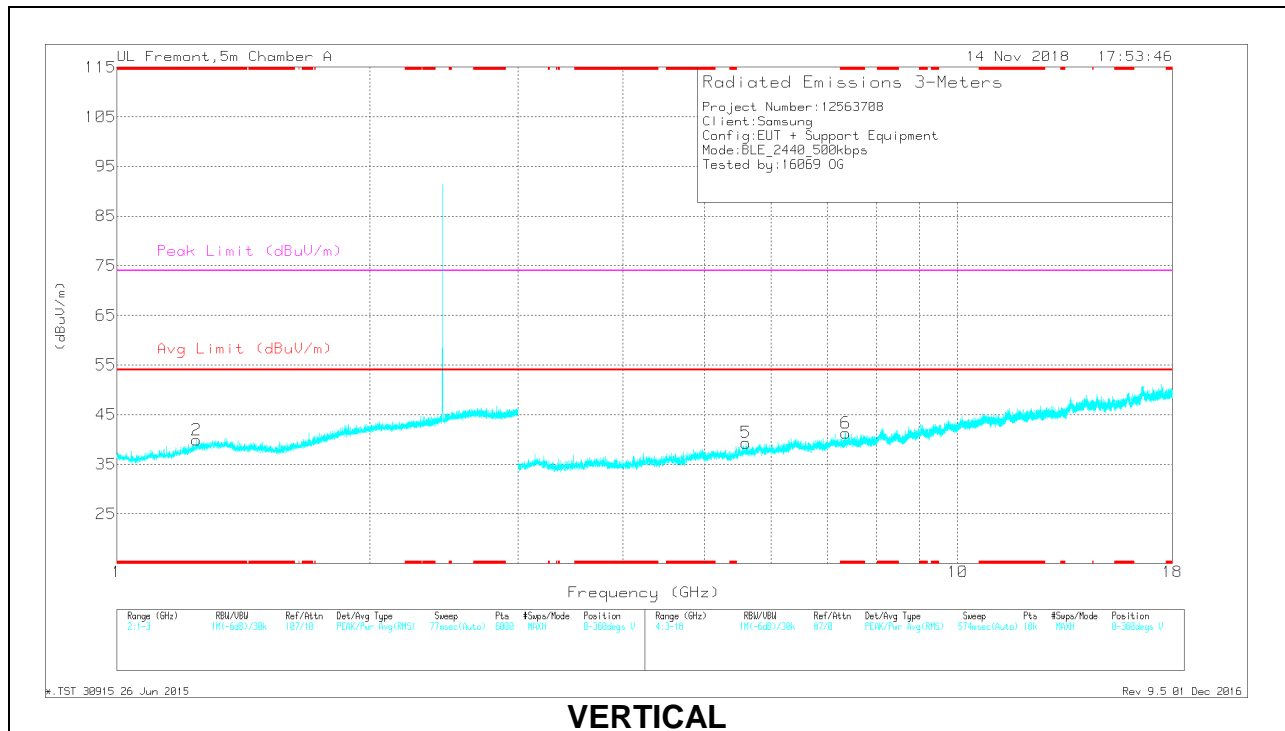

VERTICAL

RADIATED EMISSIONS

Marker	Frequency (GHz)	Meter Reading (dBuV)	Det	AF T345 (dB/m)	Amp/Cbl/Filtr/Pad (dB)	DC Corr (dB)	Corrected Reading (dBuV/m)	Avg Limit (dBuV/m)	Margin (dB)	Peak Limit (dBuV/m)	PK Margin (dB)	Azimuth (Degs)	Height (cm)	Polarity
1	* 1.501	40.6	PK2	28.4	-24	0	45	-	-	74	-29	45	210	H
	* 1.501	28.66	MAv1	28.4	-24	2.5	35.56	54	-18.44	-	-	45	210	H
2	* 1.242	40.79	PK2	29	-24.3	0	45.49	-	-	74	-28.51	242	203	V
	* 1.244	28.76	MAv1	29	-24.3	2.5	35.96	54	-18.04	-	-	242	203	V
4	* 10.816	31.61	PK2	37.8	-18.2	0	51.21	-	-	74	-22.79	327	296	H
	* 10.816	19.78	MAv1	37.8	-18.2	2.5	41.88	54	-12.12	-	-	327	296	H
6	* 7.353	32.93	PK2	35.7	-22.6	0	46.03	-	-	74	-27.97	327	182	V
	* 7.352	21.45	MAv1	35.7	-22.6	2.5	37.05	54	-16.95	-	-	327	182	V
5	5.602	36.17	PK2	35.1	-26.1	0	45.17	-	-	-	-	327	102	V
3	5.77	34.98	PK2	35	-25	0	44.98	-	-	-	-	242	202	H

* - indicates frequency in CFR47 Pt 15 / IC RSS-Restricted Band

PK2 - KDB558074 Method: Maximum Peak

MAv1 - KDB558074 Option 1 Maximum RMS Average

HIGH CHANNEL RESULTS

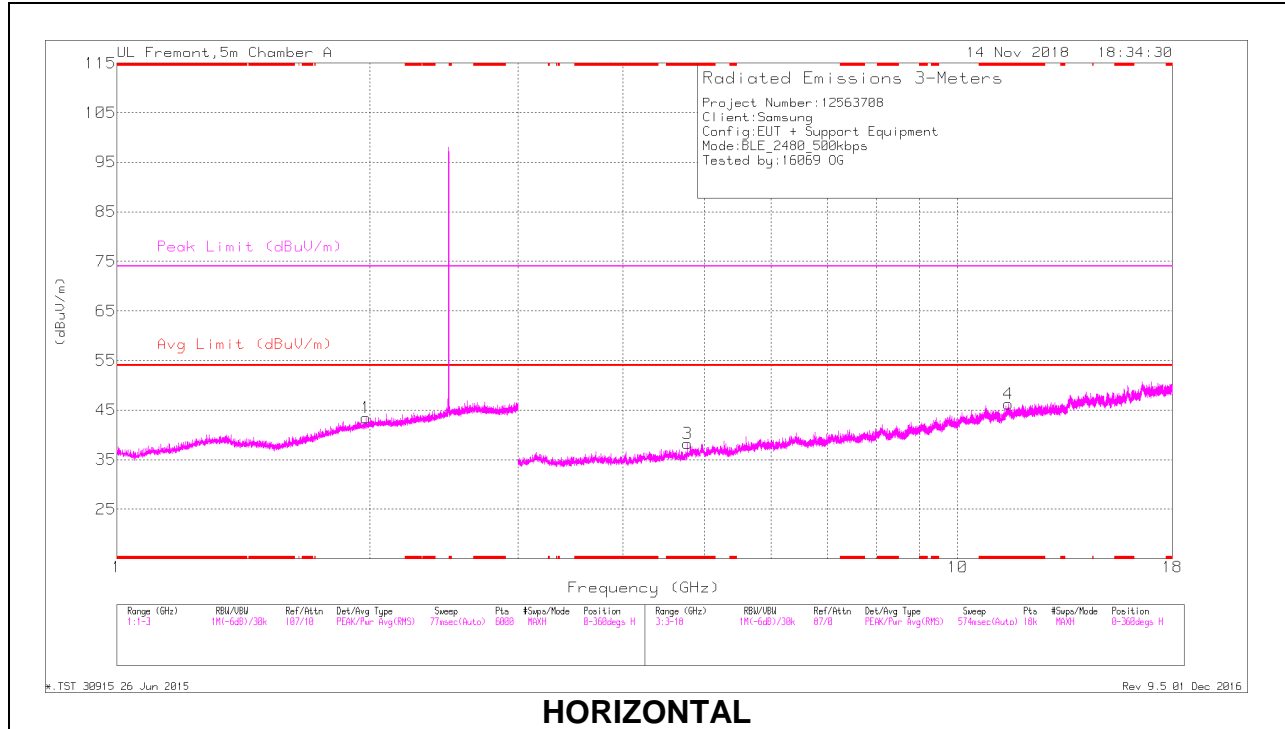

HORIZONTAL

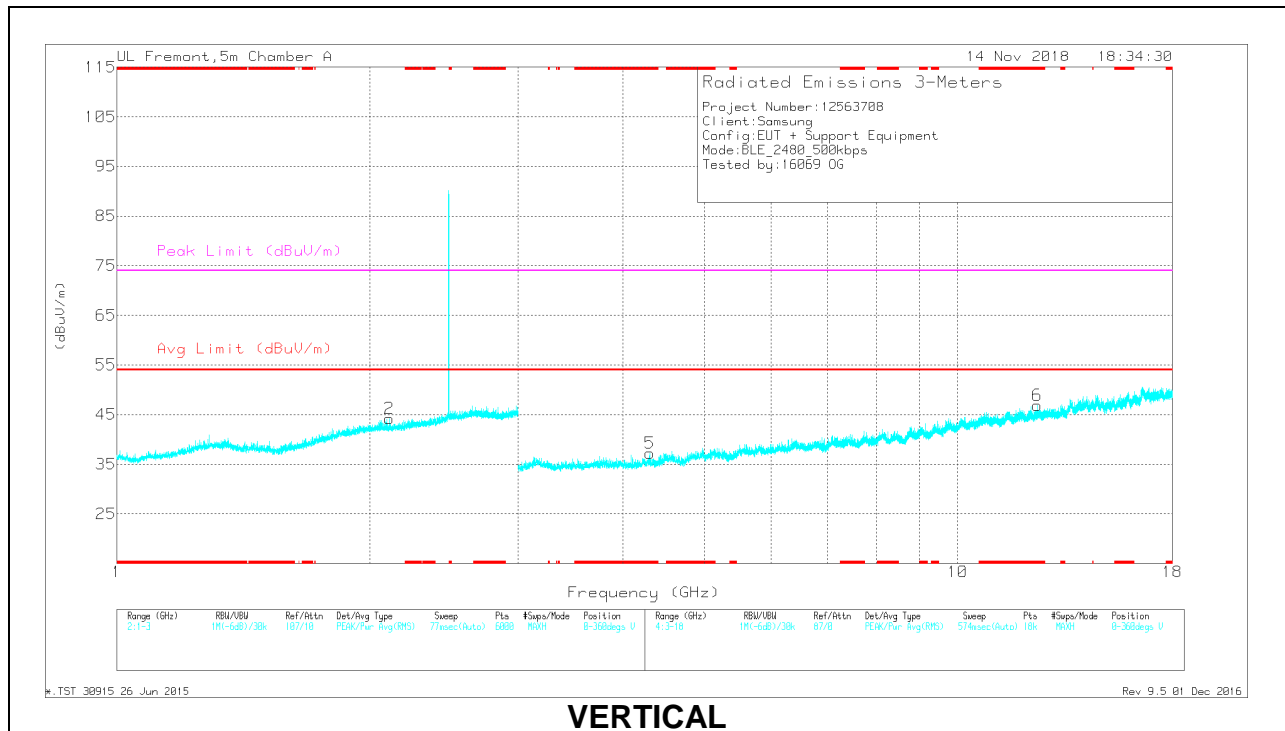

VERTICAL

RADIATED EMISSIONS

Marker	Frequency (GHz)	Meter Reading (dBuV)	Det	AF T345 (dB/m)	Amp/Cbl/Filtr/Pad (dB)	DC Corr (dB)	Corrected Reading (dBuV/m)	Avg Limit (dBuV/m)	Margin (dB)	Peak Limit (dBuV/m)	PK Margin (dB)	Azimuth (Degs)	Height (cm)	Polarity
3	* 4.773	35.82	PK2	34.1	-26.7	0	43.22	-	-	74	-30.78	46	184	H
	* 4.774	23.75	MAv1	34.1	-26.7	2.5	33.65	54	-20.35	-	-	46	184	H
4	* 11.495	31.29	PK2	38.3	-18.1	0	51.49	-	-	74	-22.51	3	255	H
	* 11.497	19.68	MAv1	38.3	-18.1	2.5	42.38	54	-11.62	-	-	3	255	H
5	* 4.304	36.34	PK2	33.6	-27.1	0	42.84	-	-	74	-31.16	334	218	V
	* 4.303	24.74	MAv1	33.6	-27.1	2.5	33.74	54	-20.26	-	-	334	218	V
6	* 12.426	31.42	PK2	38.9	-18.7	0	51.62	-	-	74	-22.38	191	213	V
	* 12.425	19.64	MAv1	38.9	-18.6	2.5	42.44	54	-11.56	-	-	191	213	V
1	1.98	41.08	PK2	31.4	-23	0	49.48	-	-	-	-	360	101	H
2	2.11	40.72	PK2	31.1	-22.3	0	49.52	-	-	-	-	360	200	V

* - indicates frequency in CFR47 Pt 15 / IC RSS-Restricted Band

PK2 - KDB558074 Method: Maximum Peak

MAv1 - KDB558074 Option 1 Maximum RMS Average

9.2.3. BLE (1Mbps)

Antenna 1

BANDEDGE (LOW CHANNEL)

HORIZONTAL RESULT

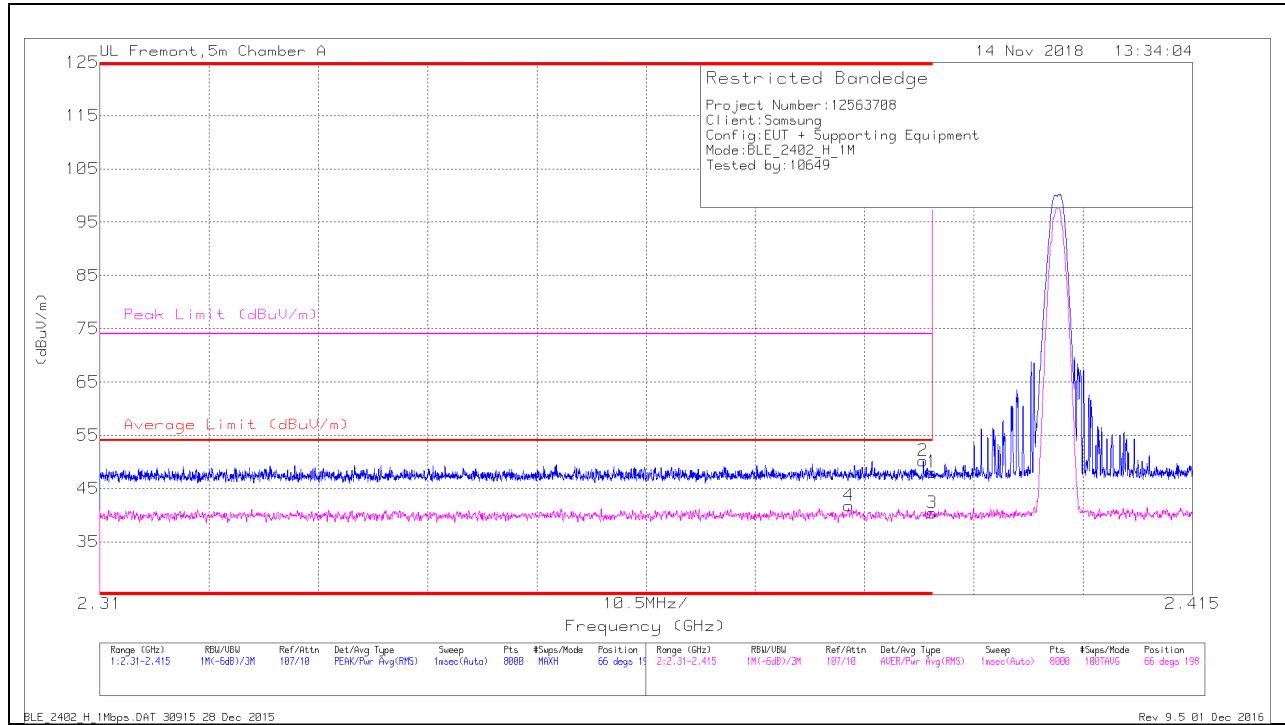

Trace Markers

Marker	Frequency (GHz)	Meter Reading (dBuV)	Det	AFT345 (dB/m)	Amp/Cbi/Fitr/Pad (dB)	DC Corr (dB)	Corrected Reading (dBuV/m)	Average Limit (dBuV/m)	Margin (dB)	Peak Limit (dBuV/m)	PK Margin (dB)	Azimuth (Degs)	Height (cm)	Polarity
4	* 2.382	29.49	RMS	31.7	-22.1	2.19	41.28	54	-12.72	-	-	66	198	H
2	* 2.389	40.47	Pk	31.8	-22.1	0	50.17	-	-	74	-23.83	66	198	H
1	* 2.39	38.34	Pk	31.8	-22.1	0	48.04	-	-	74	-25.96	66	198	H
3	* 2.39	28.04	RMS	31.8	-22.1	2.19	39.93	54	-14.07	-	-	66	198	H

* - indicates frequency in CFR47 Pt 15 / IC RSS-Restricted Band

Pk - Peak detector

RMS - RMS detection

VERTICAL RESULT



Trace Markers

Marker	Frequency (GHz)	Meter Reading (dBuV)	Det	AF T345 (dB/m)	Amp/Cb/Filtr/Pad (dB)	DC Corr (dB)	Corrected Reading (dBuV/m)	Average Limit (dBuV/m)	Margin (dB)	Peak Limit (dBuV/m)	PK Margin (dB)	Azimuth (Degs)	Height (cm)	Polarity
2	* 2.381	41.21	Pk	31.7	-22.1	0	50.81	-	-	74	-23.19	119	346	V
4	* 2.389	29.78	RMS	31.8	-22.1	2.19	41.67	54	-12.33	-	-	119	346	V
1	* 2.39	38.38	Pk	31.8	-22.1	0	48.08	-	-	74	-25.92	119	346	V
3	* 2.39	28.82	RMS	31.8	-22.1	2.19	40.71	54	-13.29	-	-	119	346	V

* - indicates frequency in CFR47 Pt 15 / IC RSS-Restricted Band

Pk - Peak detector

RMS - RMS detection

BANEDGE (HIGH CHANNEL)

HORIZONTAL RESULT

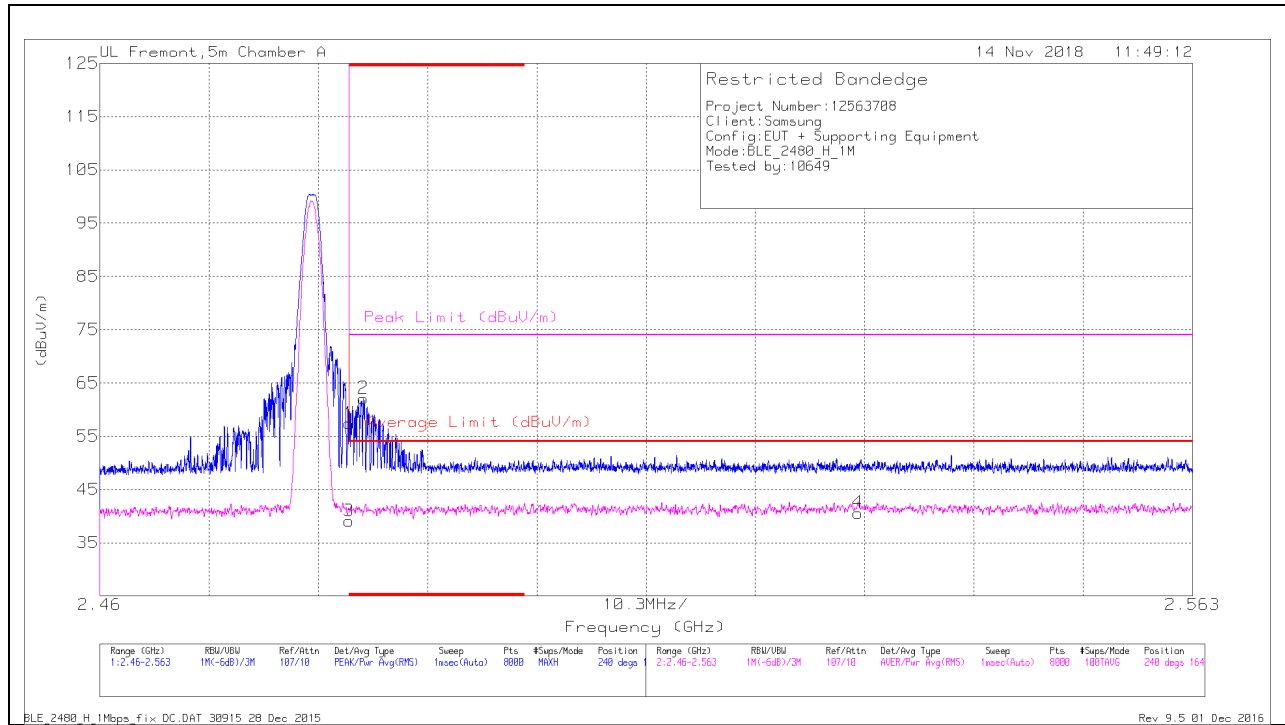

Trace Markers

Marker	Frequency (GHz)	Meter Reading (dBuV)	Det	AFT345 (dB/m)	Amp/Cb/Fitr/Pad (dB)	DC Corr (dB)	Corrected Reading (dBuV/m)	Average Limit (dBuV/m)	Margin (dB)	Peak Limit (dBuV/m)	PK Margin (dB)	Azimuth (Degs)	Height (cm)	Polarity
1	* 2.484	46.88	Pk	32.3	-21.8	0	57.38	-	-	74	-16.62	240	164	H
3	* 2.484	28.57	RMS	32.3	-21.8	2.19	41.26	54	-12.74	-	-	240	164	H
2	* 2.485	51.58	Pk	32.3	-21.8	0	62.08	-	-	74	-11.92	240	164	H
4	2.531	29.81	RMS	32.4	-21.6	2.19	42.8	54	-11.2	-	-	240	164	H

* - indicates frequency in CFR47 Pt 15 / IC RSS-Restricted Band

Pk - Peak detector

RMS - RMS detection

VERTICAL RESULT

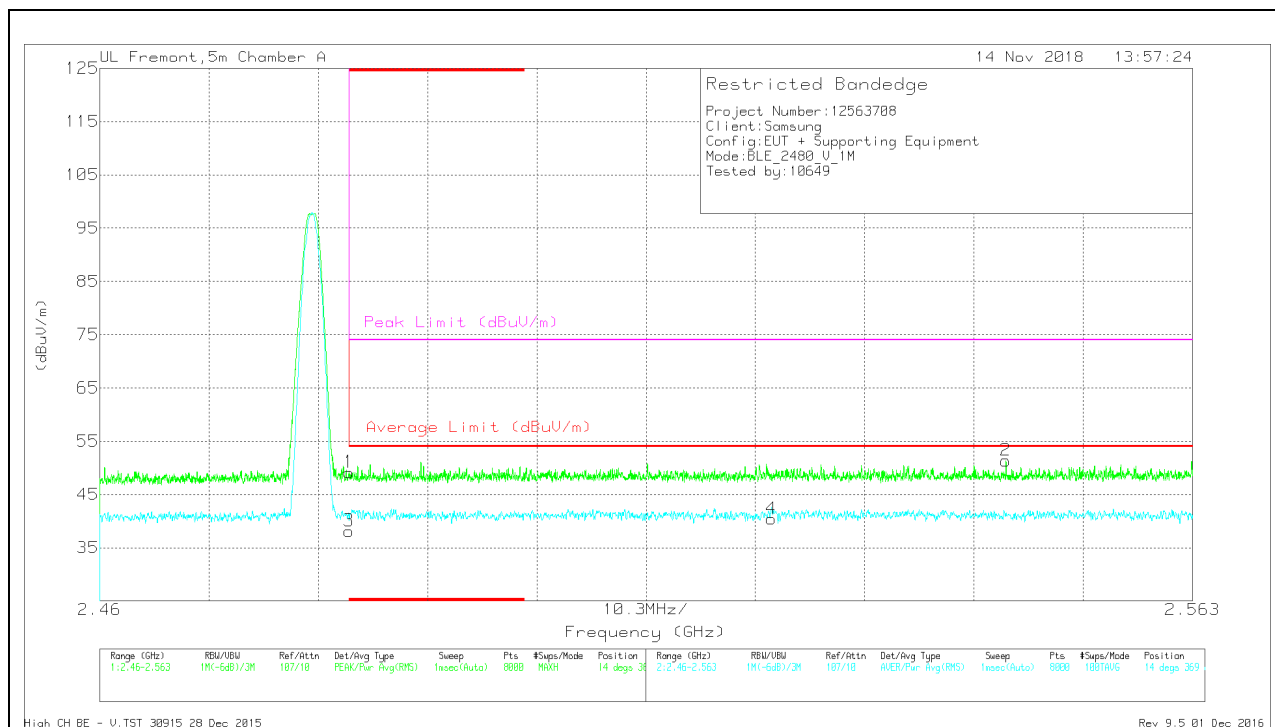

Trace Markers

Marker	Frequency (GHz)	Meter Reading (dBuV)	Det	AF T345 (dB/m)	Amp/Cb/Filtr/Pad (dB)	DC Corr (dB)	Corrected Reading (dBuV/m)	Average Limit (dBuV/m)	Margin (dB)	Peak Limit (dBuV/m)	PK Margin (dB)	Azimuth (Degs)	Height (cm)	Polarity
1	* 2.484	38.63	Pk	32.3	-21.8	0	49.13	-	-	74	-24.87	14	369	V
3	* 2.484	27.64	RMS	32.3	-21.8	2.19	40.33	54	-13.67	-	-	14	369	V
4	2.523	29.7	RMS	32.4	-21.7	2.19	42.59	54	-11.41	-	-	14	369	V
2	2.545	40.67	Pk	32.3	-21.6	0	51.37	-	-	74	-22.63	14	369	V

* - indicates frequency in CFR47 Pt 15 / IC RSS-Restricted Band

Pk - Peak detector

RMS - RMS detection

HARMONICS AND SPURIOUS EMISSIONS

LOW CHANNEL RESULTS

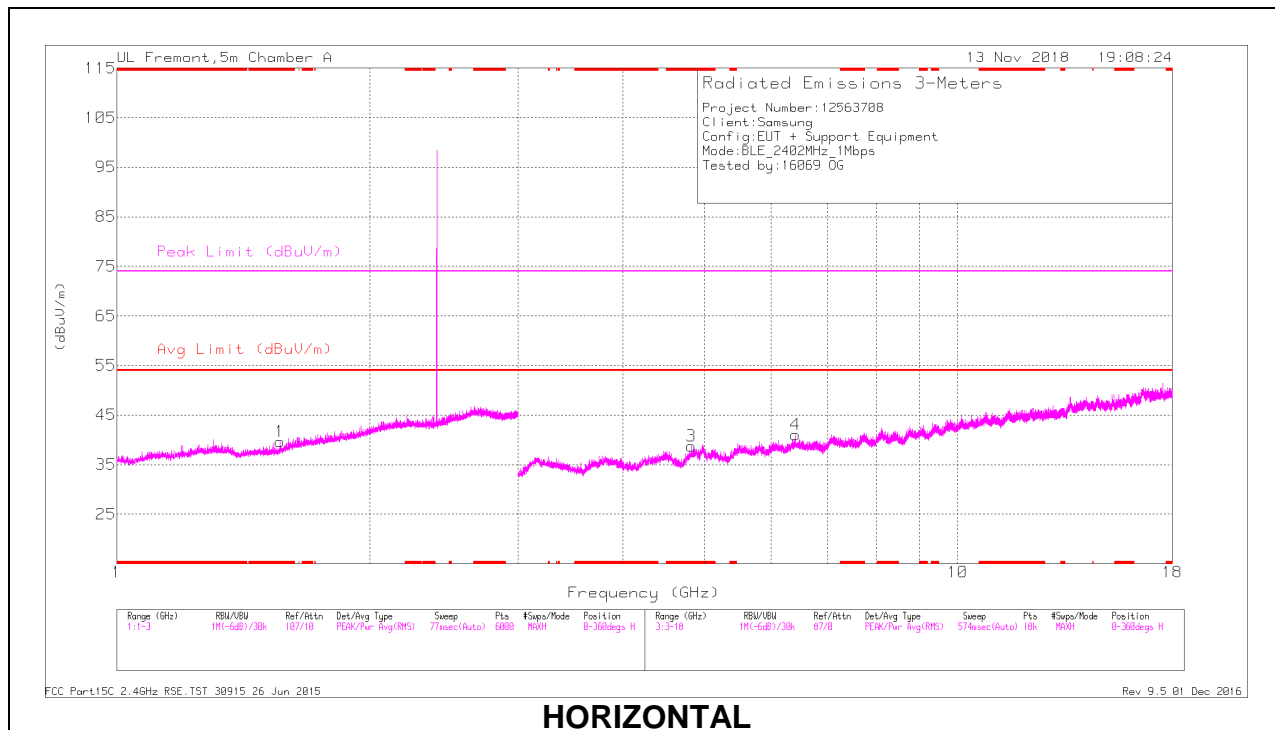

HORIZONTAL

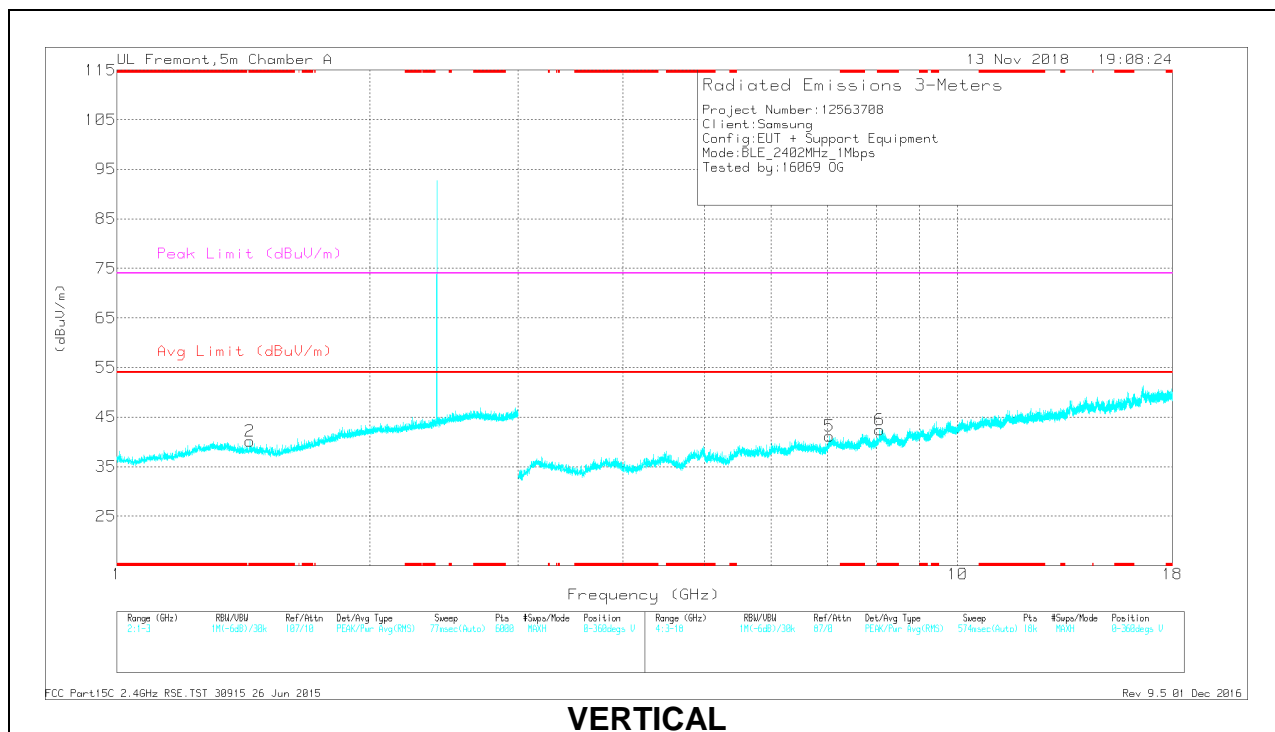

VERTICAL

RADIATED EMISSIONS

Marker	Frequency (GHz)	Meter Reading (dBuV)	Det	AF T345 (dB/m)	Amp/Cbl/Filtr/Pad (dB)	DC Corr (dB)	Corrected Reading (dBuV/m)	Avg Limit (dBuV/m)	Margin (dB)	Peak Limit (dBuV/m)	PK Margin (dB)	Azimuth (Degs)	Height (cm)	Polarity
1	* 1.562	40.57	PK2	27.9	-23.7	0	44.77	-	-	74	-29.23	56	113	H
	* 1.562	28.7	MAv1	27.9	-23.7	2.19	35.09	54	-18.91	-	-	56	113	H
2	* 1.44	40.72	PK2	28.7	-24.2	0	45.22	-	-	74	-28.78	270	347	V
	* 1.439	28.66	MAv1	28.7	-24.2	2.19	35.35	54	-18.65	-	-	270	347	V
3	* 4.825	35.13	PK2	34.2	-25.9	0	43.43	-	-	74	-30.57	352	168	H
	* 4.823	23.59	MAv1	34.2	-25.9	2.19	34.08	54	-19.92	-	-	352	168	H
6	* 8.076	32.32	PK2	35.8	-21.2	0	46.92	-	-	74	-27.08	9	171	V
	* 8.078	21.03	MAv1	35.8	-21.2	2.19	37.82	54	-16.18	-	-	9	171	V
4	6.41	33.95	PK2	35.8	-23.8	0	45.95	-	-	-	-	352	102	H
5	7.031	33.73	PK2	35.6	-23.3	0	46.03	-	-	-	-	352	102	V

* - indicates frequency in CFR47 Pt 15 / IC RSS-Restricted Band

PK2 - KDB558074 Method: Maximum Peak

MAv1 - KDB558074 Option 1 Maximum RMS Average

MID CHANNEL RESULTS

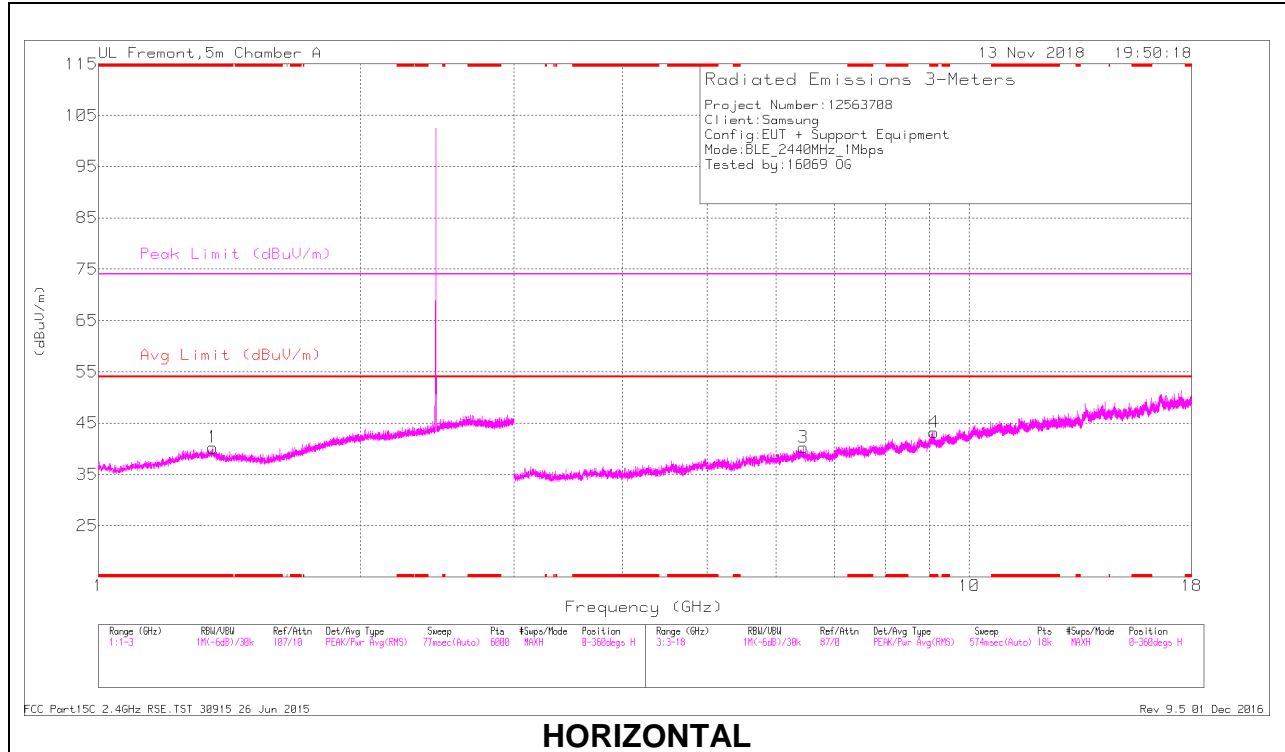

HORIZONTAL

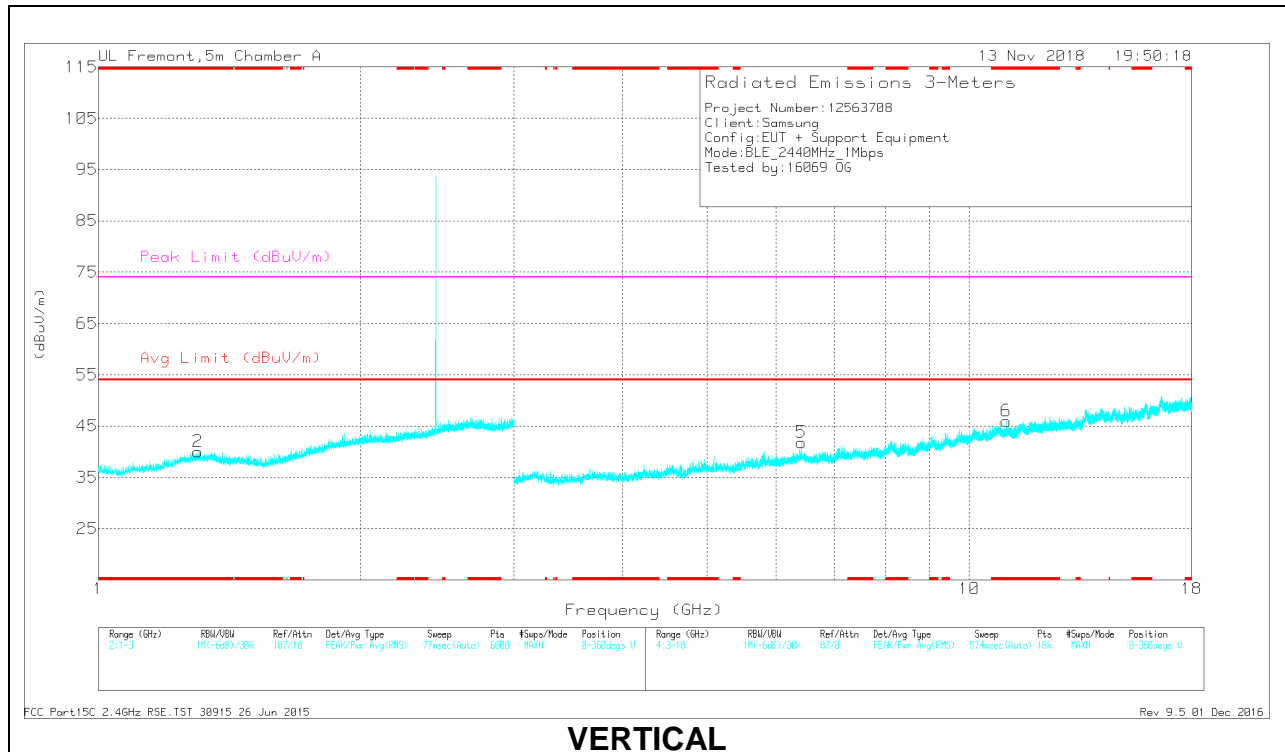

VERTICAL

RADIATED EMISSIONS

Marker	Frequency (GHz)	Meter Reading (dBuV)	Det	AF T345 (dB/m)	Amp/Cbl/Filtr/Pad (dB)	DC Corr (dB)	Corrected Reading (dBuV/m)	Avg Limit (dBuV/m)	Margin (dB)	Peak Limit (dBuV/m)	PK Margin (dB)	Azimuth (Degs)	Height (cm)	Polarity
1	* 1.353	40.96	PK2	29.5	-24.3	0	46.16	-	-	74	-27.84	72	206	H
	* 1.351	28.84	MAv1	29.5	-24.3	2.19	36.23	54	-17.77	-	-	72	206	H
2	* 1.301	40.74	PK2	29.4	-24.3	0	45.84	-	-	74	-28.16	267	279	V
	* 1.301	28.74	MAv1	29.4	-24.3	2.19	36.03	54	-17.97	-	-	267	279	V
4	* 9.107	32.02	PK2	36.3	-20.3	0	48.02	-	-	74	-25.98	310	104	H
	* 9.105	20.78	MAv1	36.3	-20.3	2.19	38.97	54	-15.03	-	-	310	104	H
6	* 11.027	32.19	PK2	37.9	-18.6	0	51.49	-	-	74	-22.51	156	101	V
	* 11.03	19.86	MAv1	37.9	-18.6	2.19	41.35	54	-12.65	-	-	156	101	V
5	6.416	34.38	PK2	35.8	-23.7	0	46.48	-	-	-	-	310	200	V
3	6.451	34.27	PK2	35.8	-24	0	46.07	-	-	-	-	267	103	H

* - indicates frequency in CFR47 Pt 15 / IC RSS-Restricted Band

PK2 - KDB558074 Method: Maximum Peak

MAv1 - KDB558074 Option 1 Maximum RMS Average

HIGH CHANNEL RESULTS

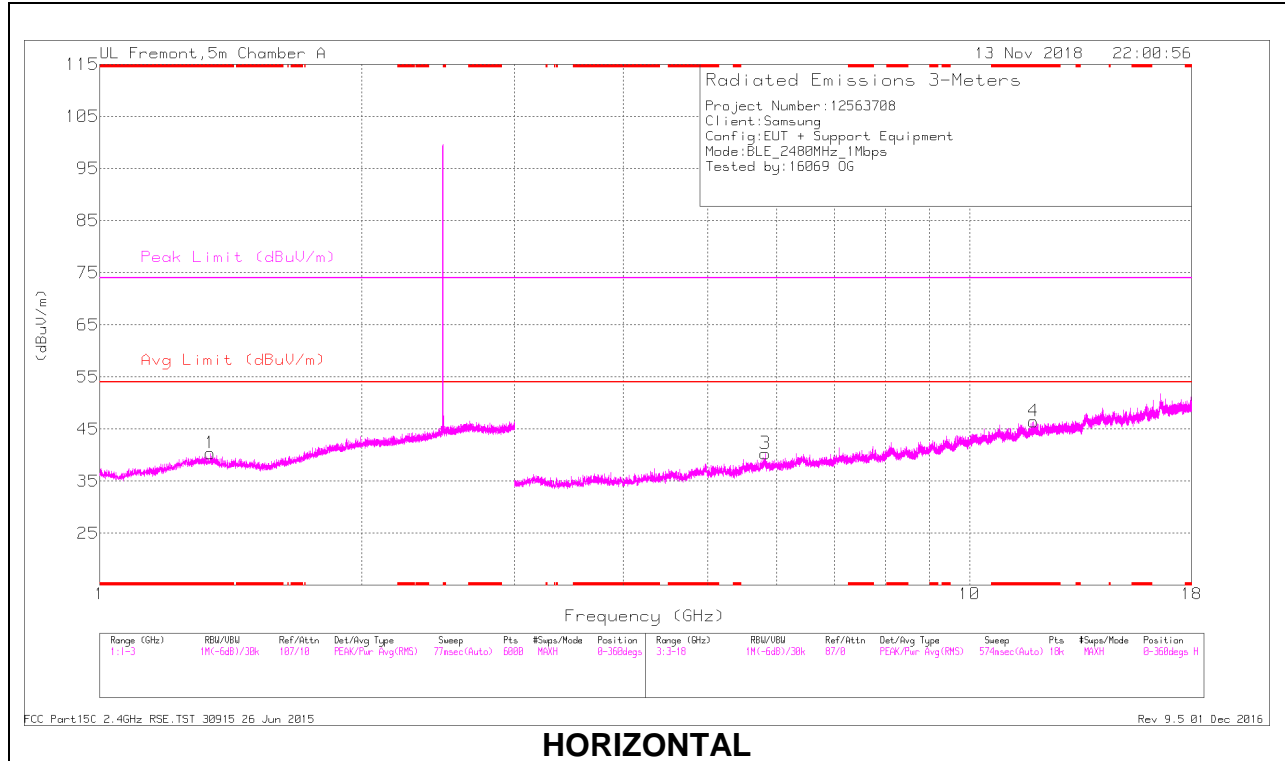

HORIZONTAL

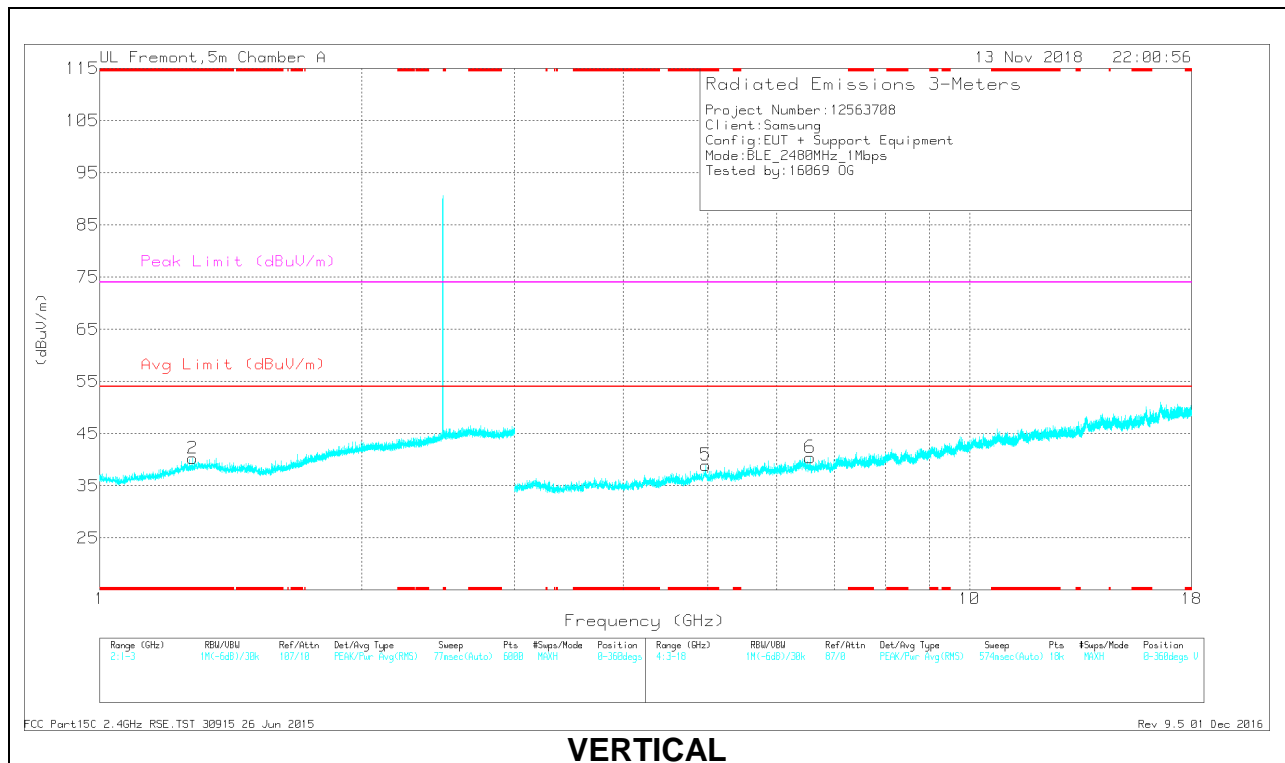

VERTICAL

RADIATED EMISSIONS

Marker	Frequency (GHz)	Meter Reading (dBuV)	Det	AF T345 (dB/m)	Amp/Cbl/Filtr/Pad (dB)	DC Corr (dB)	Corrected Reading (dBuV/m)	Avg Limit (dBuV/m)	Margin (dB)	Peak Limit (dBuV/m)	PK Margin (dB)	Azimuth (Degs)	Height (cm)	Polarity
1	* 1.339	40.87	PK2	29.5	-24.4	0	45.97	-	-	74	-28.03	56	256	H
	* 1.339	28.76	MAv1	29.5	-24.4	2.19	36.05	54	-17.95	-	-	56	256	H
2	* 1.28	40.98	PK2	29.3	-24.3	0	45.98	-	-	74	-28.02	29	224	V
	* 1.281	28.66	MAv1	29.3	-24.3	2.19	35.85	54	-18.15	-	-	29	224	V
4	* 11.844	31.07	PK2	38.8	-18.6	0	51.27	-	-	74	-22.73	328	202	H
	* 11.842	19.72	MAv1	38.8	-18.6	2.19	42.11	54	-11.89	-	-	328	202	H
5	* 4.973	38.42	PK2	34.3	-27	0	45.72	-	-	74	-28.28	12	246	V
	* 4.973	25.59	MAv1	34.3	-27	2.19	35.08	54	-18.92	-	-	12	246	V
3	5.825	35.02	PK2	35.1	-24.7	0	45.42	-	-	-	-	29	200	H
6	6.56	34.36	PK2	35.6	-24.2	0	45.76	-	-	-	-	12	201	V

* - indicates frequency in CFR47 Pt 15 / IC RSS-Restricted Band

PK2 - KDB558074 Method: Maximum Peak

MAv1 - KDB558074 Option 1 Maximum RMS Average

9.2.4. BLE (2Mbps)

Antenna 1

BANDEDGE (LOW CHANNEL)

HORIZONTAL RESULT



Trace Markers

Marker	Frequency (GHz)	Meter Reading (dBuV)	Det	AF T345 (dB/m)	Amp/Cb/Filtr/Pad (dB)	DC Corr (dB)	Corrected Reading (dBuV/m)	Average Limit (dBuV/m)	Margin (dB)	Peak Limit (dBuV/m)	PK Margin (dB)	Azimuth (Degs)	Height (cm)	Polarity
2	* 2.37	40.55	Pk	31.7	-22.1	0	50.15	-	-	74	-23.85	332	99	H
4	* 2.389	29.42	RMS	31.8	-22.1	5.07	44.19	54	-9.81	-	-	332	99	H
1	* 2.39	37.92	Pk	31.8	-22.1	0	47.62	-	-	74	-26.38	332	99	H
3	* 2.39	28.38	RMS	31.8	-22.1	5.07	43.15	54	-10.85	-	-	332	99	H

* - indicates frequency in CFR47 Pt 15 / IC RSS-Restricted Band

Pk - Peak detector

RMS - RMS detection

VERTICAL RESULT



Trace Markers

Marker	Frequency (GHz)	Meter Reading (dBuV)	Det	AF T345 (dB/m)	Amp/Cb/Filtr/Pad (dB)	DC Corr (dB)	Corrected Reading (dBuV/m)	Average Limit (dBuV/m)	Margin (dB)	Peak Limit (dBuV/m)	PK Margin (dB)	Azimuth (Degs)	Height (cm)	Polarity
4	* 2.374	29.48	RMS	31.7	-22.1	5.07	44.15	54	-9.85	-	-	166	336	V
2	* 2.381	40.57	Pk	31.7	-22.1	0	50.17	-	-	74	-23.83	166	336	V
1	* 2.39	38.5	Pk	31.8	-22.1	0	48.2	-	-	74	-25.8	166	336	V
3	* 2.39	28.6	RMS	31.8	-22.1	5.07	43.37	54	-10.63	-	-	166	336	V

* - indicates frequency in CFR47 Pt 15 / IC RSS-Restricted Band

Pk - Peak detector

RMS - RMS detection

BANEDGE (HIGH CHANNEL)

HORIZONTAL RESULT

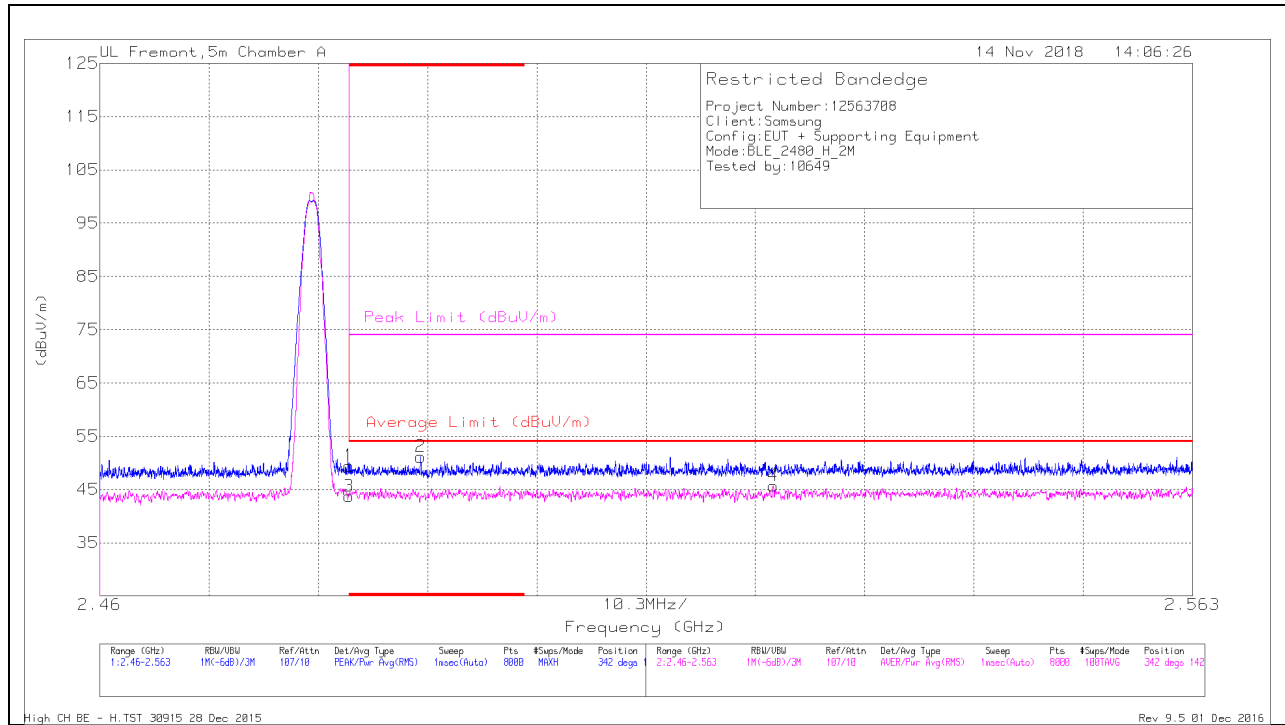

Trace Markers

Marker	Frequency (GHz)	Meter Reading (dBuV)	Det	AFT345 (dB/m)	Amp/Cbl/Fitr/Pad (dB)	DC Corr (dB)	Corrected Reading (dBuV/m)	Average Limit (dBuV/m)	Margin (dB)	Peak Limit (dBuV/m)	PK Margin (dB)	Azimuth (Degs)	Height (cm)	Polarity
1	* 2.484	38.93	Pk	32.3	-21.8	0	49.43	-	-	74	-24.57	342	142	H
3	* 2.484	28.17	RMS	32.3	-21.8	5.07	43.74	54	-10.26	-	-	342	142	H
2	* 2.49	40.53	Pk	32.4	-21.8	0	51.13	-	-	74	-22.87	342	142	H
4	2.523	29.94	RMS	32.4	-21.7	5.07	45.71	54	-8.29	-	-	342	142	H

* - indicates frequency in CFR47 Pt 15 / IC RSS-Restricted Band

Pk - Peak detector

RMS - RMS detection

VERTICAL RESULT

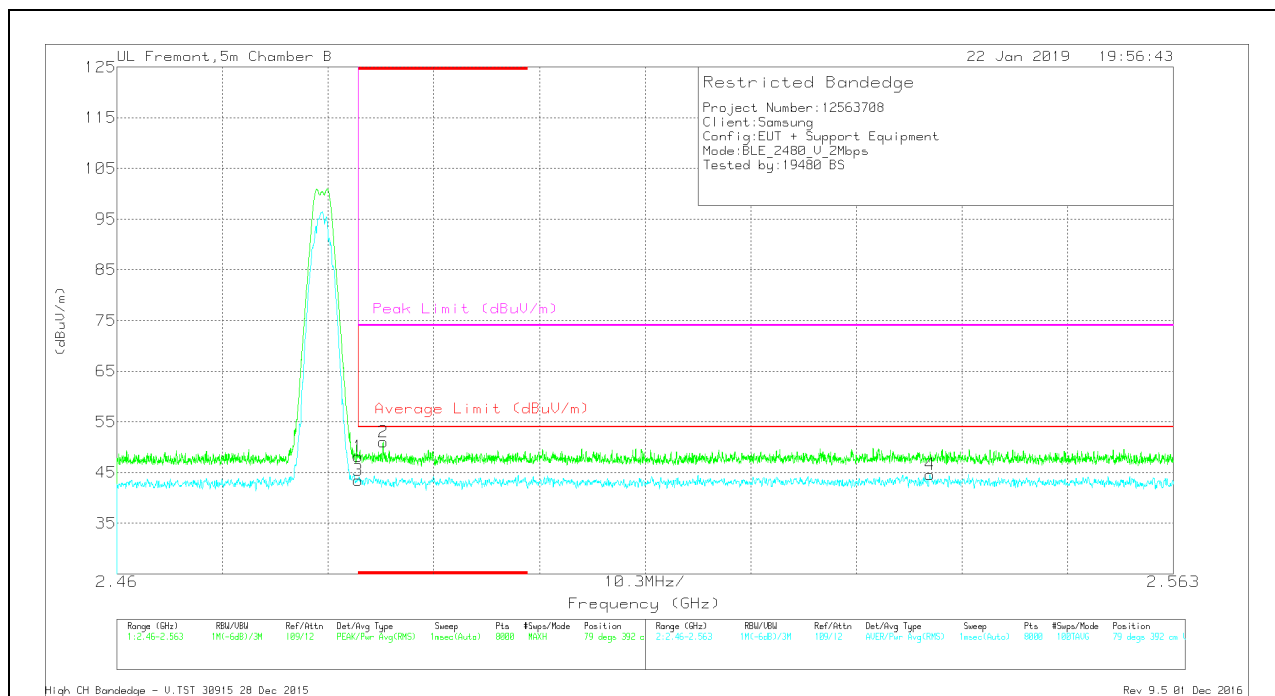

Trace Markers

Marker	Frequency (GHz)	Meter Reading (dBuV)	Det	AF T863 (dB/m)	Amp/Cb/Filtr/Pad (dB)	DC Corr (dB)	Corrected Reading (dBuV/m)	Average Limit (dBuV/m)	Margin (dB)	Peak Limit (dBuV/m)	PK Margin (dB)	Azimuth (Degs)	Height (cm)	Polarity
1	* 2.484	35.86	Pk	32.6	-20.3	0	48.16	-	-	74	-25.84	79	392	V
2	* 2.486	38.83	Pk	32.6	-20.4	0	51.03	-	-	74	-22.97	79	392	V
3	* 2.484	26.15	RMS	32.6	-20.3	5.07	43.52	54	-10.48	-	-	79	392	V
4	2.539	27.17	RMS	32.7	-20.3	5.07	44.64	54	-9.36	-	-	79	392	V

* - indicates frequency in CFR47 Pt 15 / IC RSS-Restricted Band

Pk - Peak detector

RMS - RMS detection

HARMONICS AND SPURIOUS EMISSIONS

LOW CHANNEL RESULTS

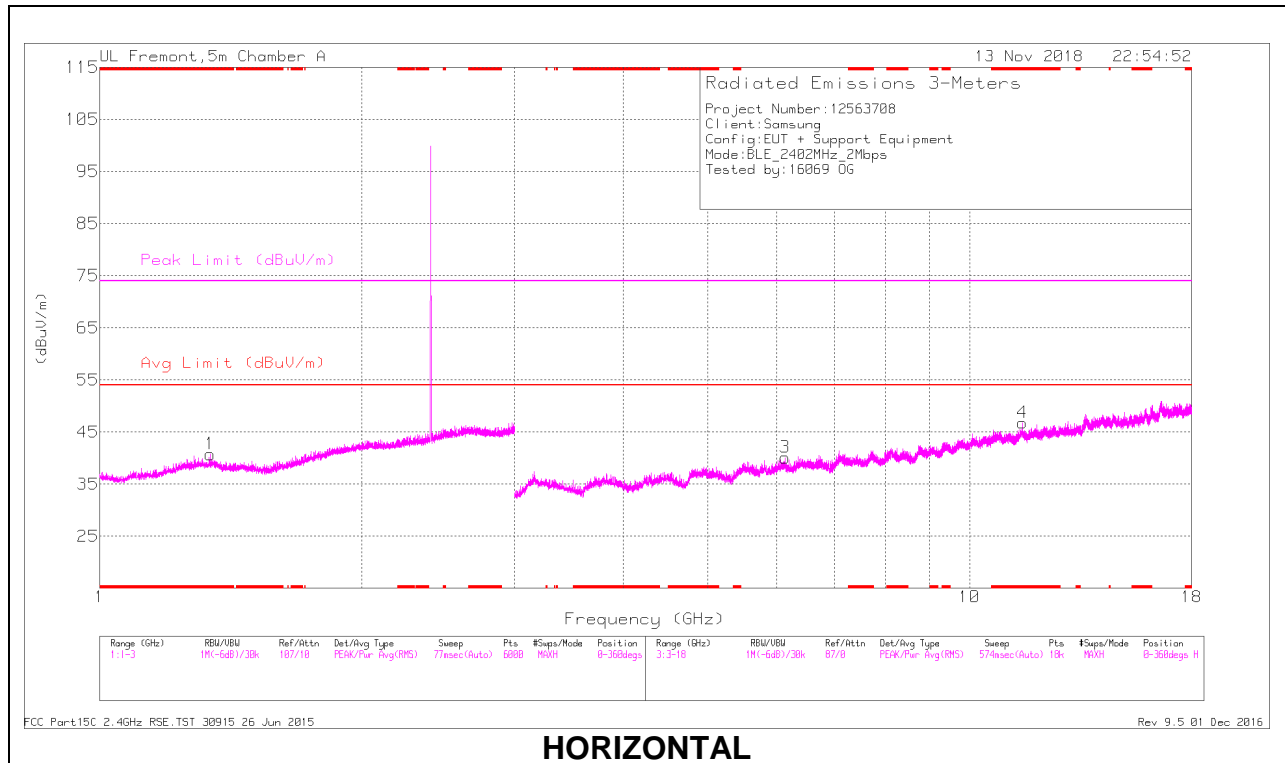

HORIZONTAL

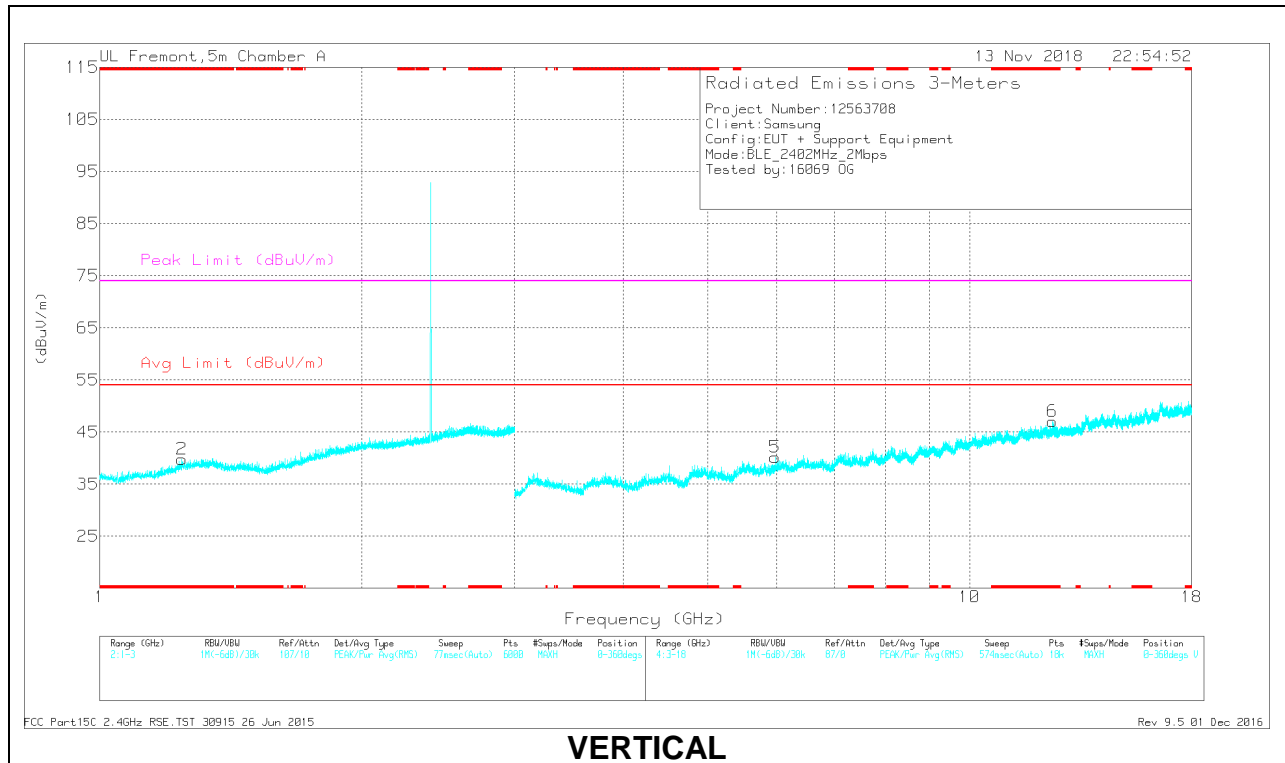

VERTICAL

RADIATED EMISSIONS

Marker	Frequency (GHz)	Meter Reading (dBuV)	Det	AF T345 (dB/m)	Amp/Cbl/Filtr/Pad (dB)	DC Corr (dB)	Corrected Reading (dBuV/m)	Avg Limit (dBuV/m)	Margin (dB)	Peak Limit (dBuV/m)	PK Margin (dB)	Azimuth (Degs)	Height (cm)	Polarity
1	* 1.342	40.14	PK2	29.5	-24.4	0	45.24	-	-	74	-28.76	315	334	H
	* 1.343	28.63	MAv1	29.5	-24.3	5.07	38.9	54	-15.1	-	-	315	334	H
2	* 1.245	41.43	PK2	29	-24.3	0	46.13	-	-	74	-27.87	232	259	V
	* 1.242	28.77	MAv1	29	-24.3	5.07	38.54	54	-15.46	-	-	232	259	V
4	* 11.509	31.73	PK2	38.3	-18.1	0	51.93	-	-	74	-22.07	50	106	H
	* 11.506	19.8	MAv1	38.3	-18.2	5.07	44.97	54	-9.03	-	-	50	106	H
6	* 12.447	32.1	PK2	39	-18.5	0	52.6	-	-	74	-21.4	185	172	V
	* 12.448	19.78	MAv1	39	-18.4	5.07	45.45	54	-8.55	-	-	185	172	V
5	5.979	35.14	PK2	35.3	-25.6	0	44.84	-	-	-	-	50	200	V
3	6.136	34.54	PK2	35.5	-24.5	0	45.54	-	-	-	-	232	103	H

* - indicates frequency in CFR47 Pt 15 / IC RSS-Restricted Band

PK2 - KDB558074 Method: Maximum Peak

MAv1 - KDB558074 Option 1 Maximum RMS Average

MID CHANNEL RESULTS

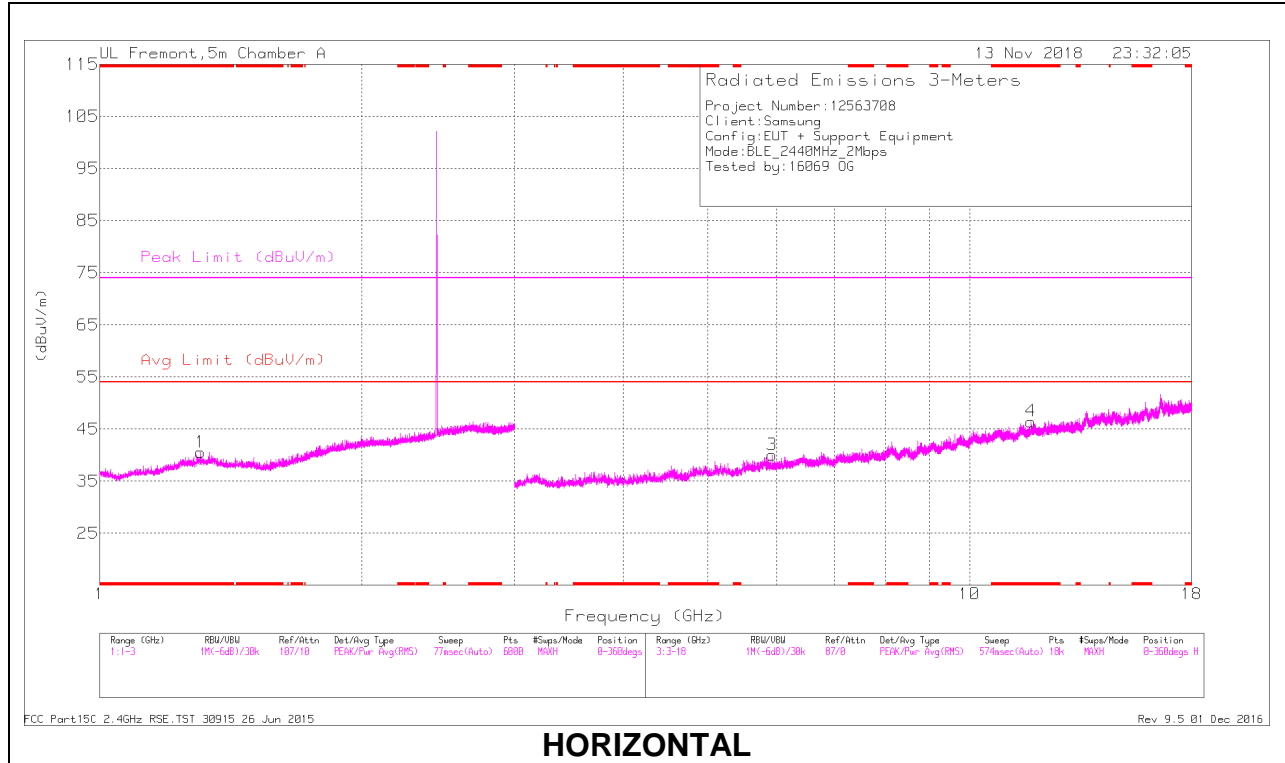

HORIZONTAL

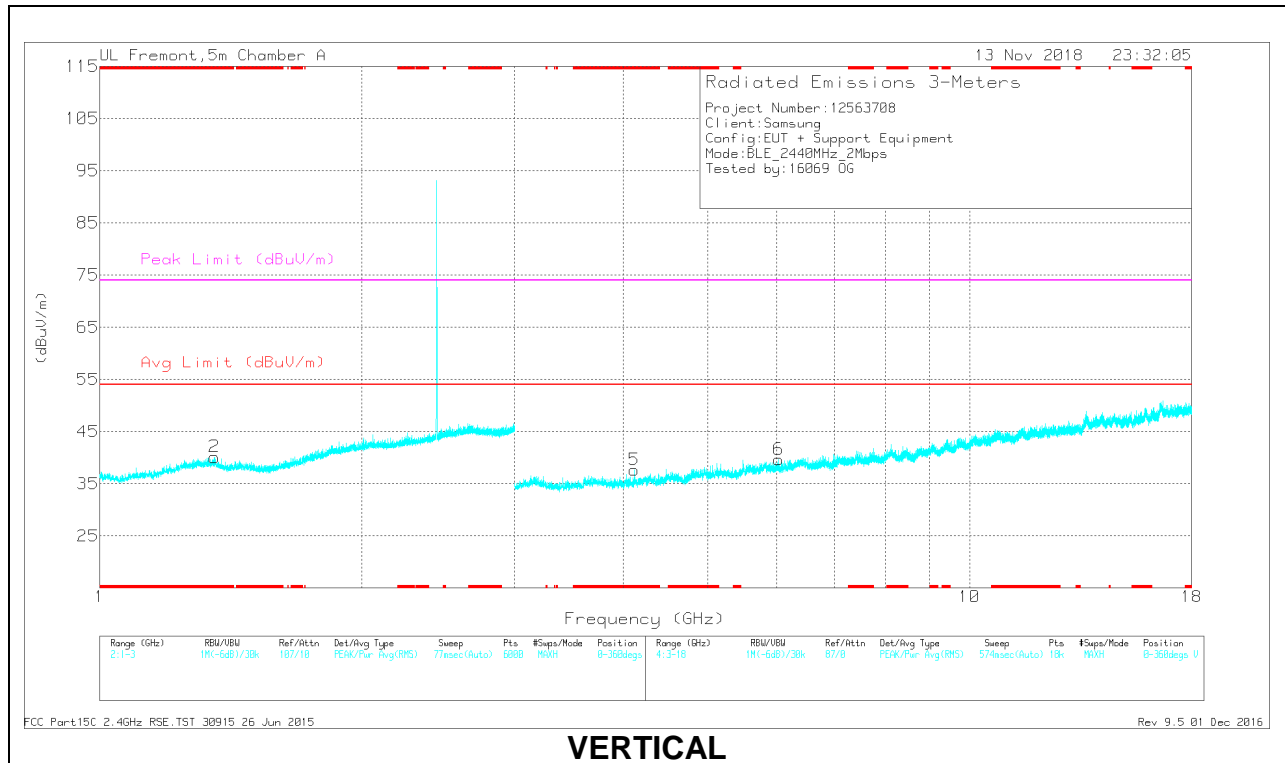

VERTICAL

RADIATED EMISSIONS

Marker	Frequency (GHz)	Meter Reading (dBuV)	Det	AF T345 (dB/m)	Amp/Cbl/Filtr/Pad (dB)	DC Corr (dB)	Corrected Reading (dBuV/m)	Avg Limit (dBuV/m)	Margin (dB)	Peak Limit (dBuV/m)	PK Margin (dB)	Azimuth (Degs)	Height (cm)	Polarity
1	* 1.306	40.82	PK2	29.4	-24.3	0	45.92	-	-	74	-28.08	109	400	H
	* 1.307	28.81	MAv1	29.4	-24.3	5.07	38.98	54	-15.02	-	-	109	400	H
2	* 1.357	41.05	PK2	29.4	-24.3	0	46.15	-	-	74	-27.85	289	234	V
	* 1.357	28.73	MAv1	29.4	-24.3	5.07	38.9	54	-15.1	-	-	289	234	V
4	* 11.757	30.86	PK2	38.7	-18.5	0	51.06	-	-	74	-22.94	336	151	H
	* 11.758	19.49	MAv1	38.7	-18.5	5.07	44.76	54	-9.24	-	-	336	151	H
5	* 4.119	37.03	PK2	33.4	-27.8	0	42.63	-	-	74	-31.37	206	165	V
	* 4.119	24.82	MAv1	33.4	-27.8	5.07	35.49	54	-18.51	-	-	206	165	V
3	5.927	35.61	PK2	35.2	-25.4	0	45.41	-	-	-	-	289	200	H
6	6.032	35.39	PK2	35.3	-25.6	0	45.09	-	-	-	-	206	200	V

* - indicates frequency in CFR47 Pt 15 / IC RSS-Restricted Band

PK2 - KDB558074 Method: Maximum Peak

MAv1 - KDB558074 Option 1 Maximum RMS Average

HIGH CHANNEL RESULTS

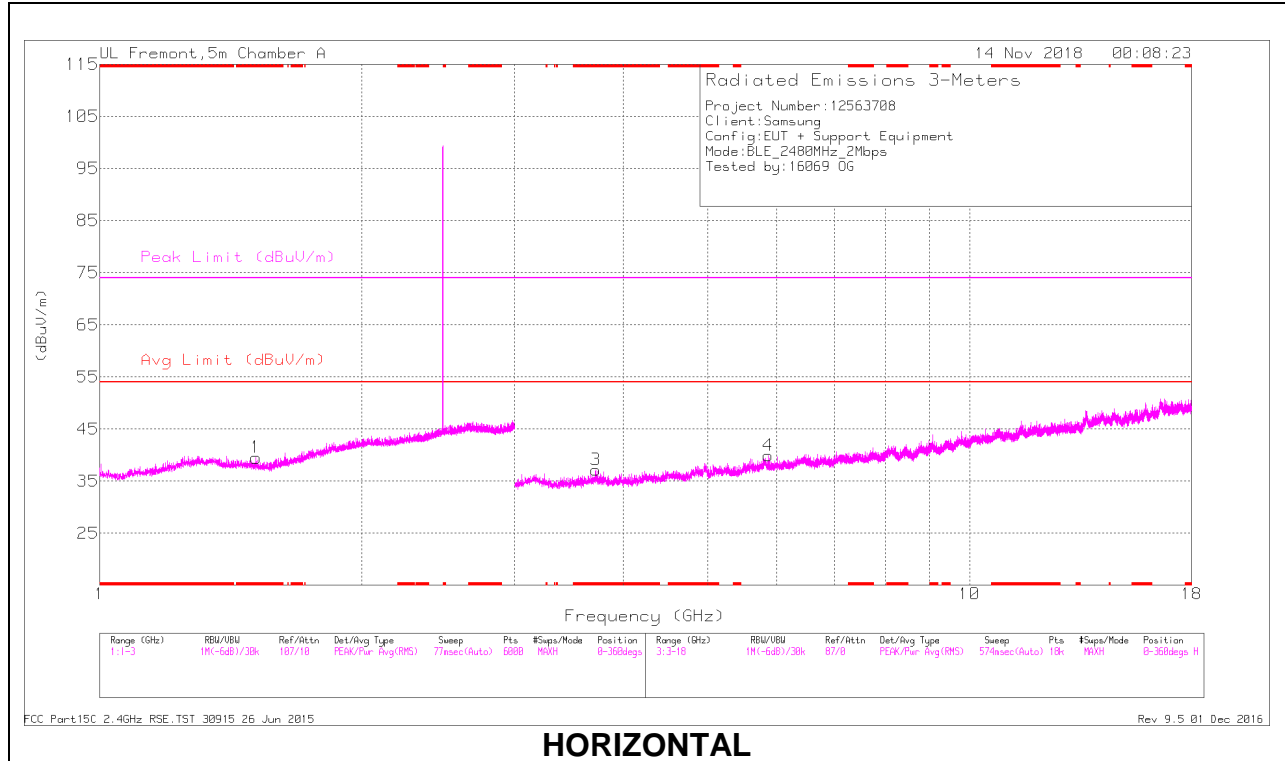

HORIZONTAL

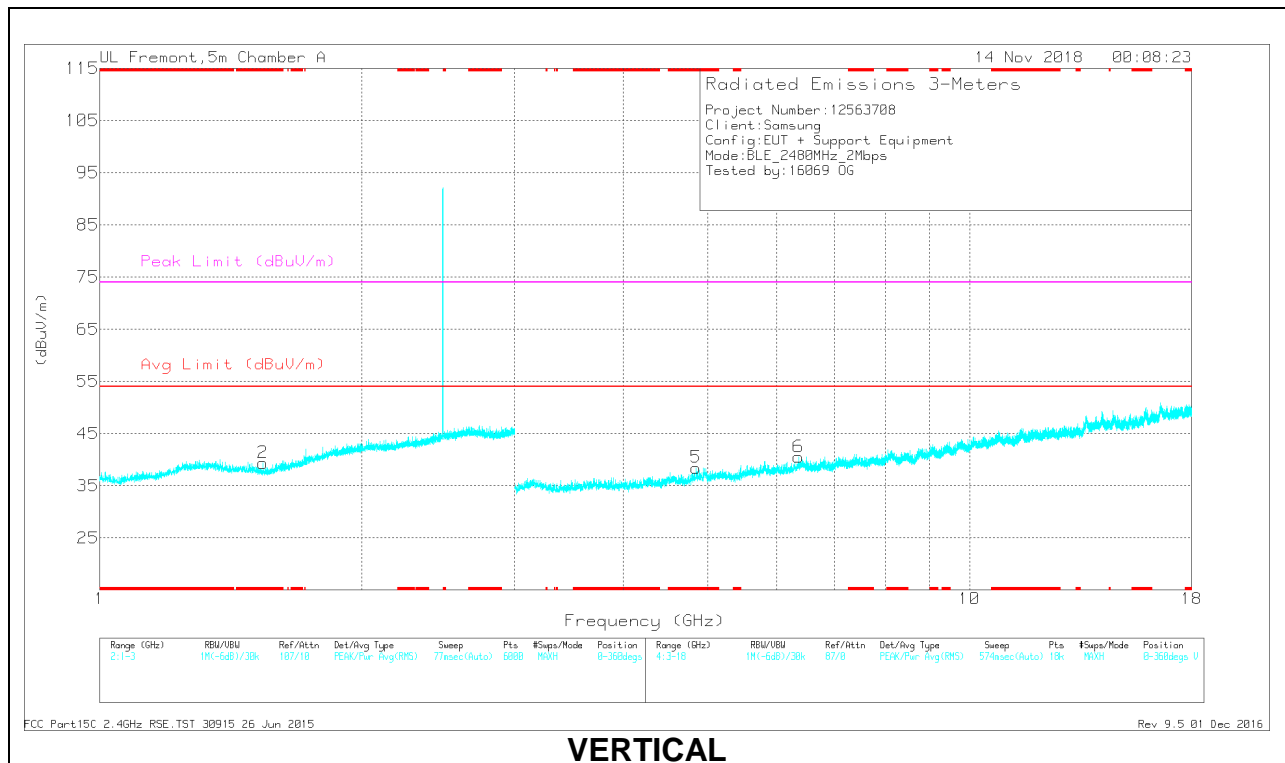

VERTICAL

RADIATED EMISSIONS

Marker	Frequency (GHz)	Meter Reading (dBuV)	Det	AF T345 (dB/m)	Amp/Cbl/Filtr/Pad (dB)	DC Corr (dB)	Corrected Reading (dBuV/m)	Avg Limit (dBuV/m)	Margin (dB)	Peak Limit (dBuV/m)	PK Margin (dB)	Azimuth (Degs)	Height (cm)	Polarity
1	* 1.514	41.41	PK2	28.2	-23.9	0	45.71	-	-	74	-28.29	173	175	H
	* 1.514	28.64	MAv1	28.2	-23.9	5.07	38.01	54	-15.99	-	-	173	175	H
2	* 1.541	40.1	PK2	27.9	-23.8	0	44.2	-	-	74	-29.8	343	341	V
	* 1.543	28.52	MAv1	27.9	-23.8	5.07	37.69	54	-16.31	-	-	343	341	V
3	* 3.72	36.83	PK2	33.1	-27.9	0	42.03	-	-	74	-31.97	185	345	H
	* 3.719	25.09	MAv1	33.1	-27.8	5.07	35.46	54	-18.54	-	-	185	345	H
5	* 4.85	35.05	PK2	34.2	-25.8	0	43.45	-	-	74	-30.55	253	107	V
	* 4.85	23.84	MAv1	34.2	-25.8	5.07	37.31	54	-16.69	-	-	253	107	V
4	5.868	35.18	PK2	35.2	-25	0	45.38	-	-	-	-	185	200	H
6	6.358	34.98	PK2	35.8	-24.4	0	46.38	-	-	-	-	253	103	V

* - indicates frequency in CFR47 Pt 15 / IC RSS-Restricted Band

PK2 - KDB558074 Method: Maximum Peak

MAv1 - KDB558074 Option 1 Maximum RMS Average

9.2.5. SPOT CHECK DATA

BANDEDGE (HIGH CHANNEL)

HORIZONTAL RESULT

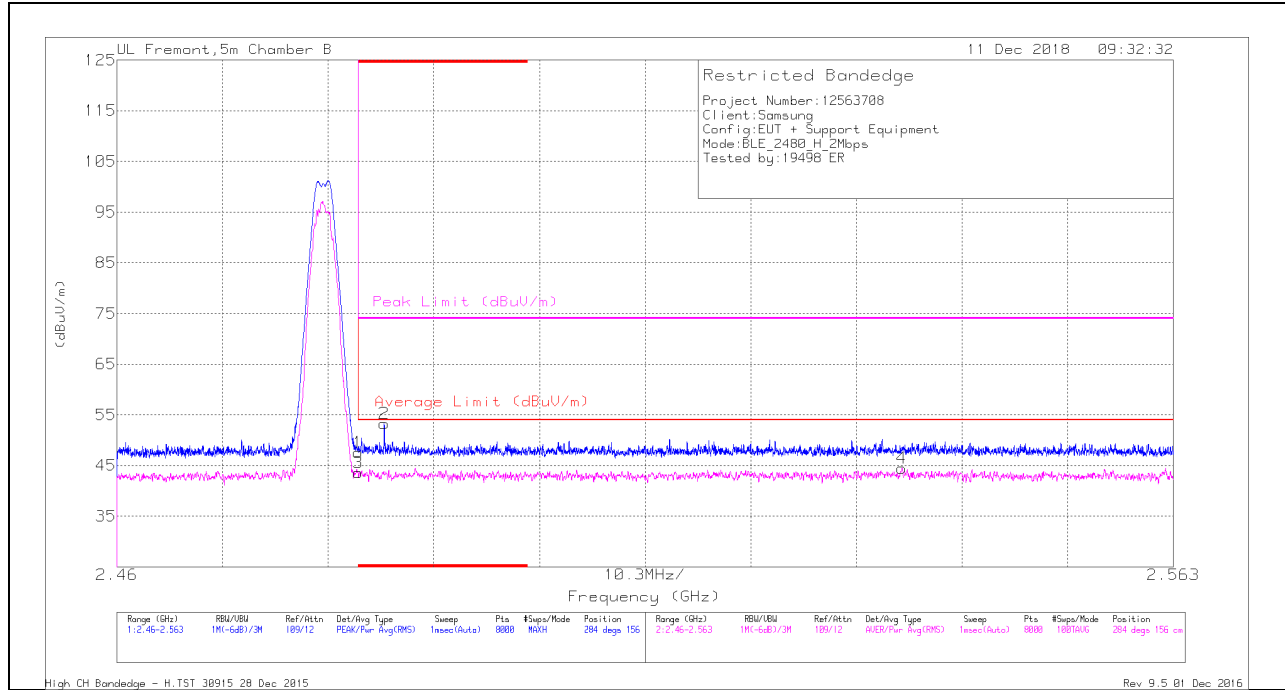

Trace Markers

Marker	Frequency (GHz)	Meter Reading (dBuV)	Det	AFT863 (dB/m)	Amp/Cb/Fitr/Pad (dB)	DC Corr (dB)	Corrected Reading (dBuV/m)	Average Limit (dBuV/m)	Margin (dB)	Peak Limit (dBuV/m)	PK Margin (dB)	Azimuth (Degs)	Height (cm)	Polarity
1	* 2.484	35.24	Pk	32.6	-20.3	0	47.54	-	-	74	-26.46	284	156	H
2	* 2.486	41.05	Pk	32.6	-20.4	0	53.25	-	-	74	-20.75	284	156	H
3	* 2.484	26.12	RMS	32.6	-20.3	5.07	43.49	54	-10.51	-	-	284	156	H
4	2.537	26.88	RMS	32.7	-20.3	5.07	44.35	54	-9.65	-	-	284	156	H

* - indicates frequency in CFR47 Pt 15 / IC RSS-Restricted Band

Pk - Peak detector

RMS - RMS detection

VERTICAL RESULT

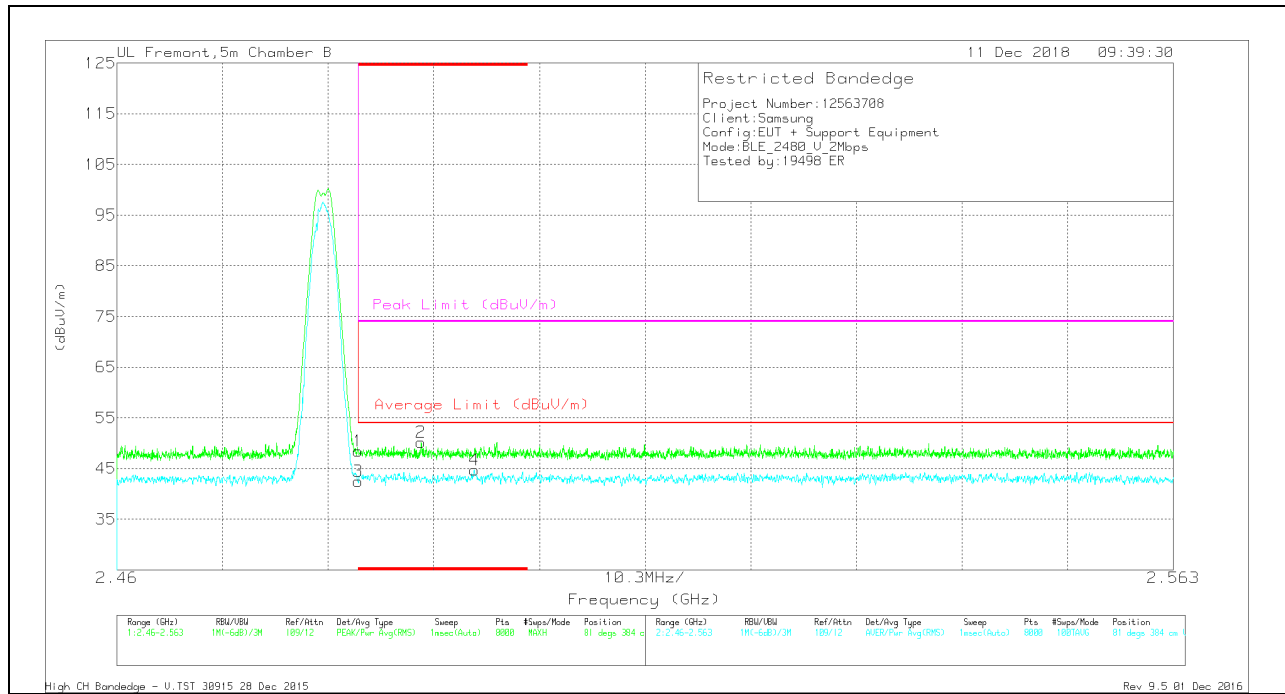

Trace Markers

Marker	Frequency (GHz)	Meter Reading (dBuV)	Det	AF T863 (dB/m)	Amp/Cb/Fltr/Pad (dB)	DC Corr (dB)	Corrected Reading (dBuV/m)	Average Limit (dBuV/m)	Margin (dB)	Peak Limit (dBuV/m)	PK Margin (dB)	Azimuth (Degs)	Height (cm)	Polarity
1	* 2.484	36.15	Pk	32.6	-20.3	0	48.45	-	-	74	-25.55	81	384	V
3	* 2.484	24.98	RMS	32.6	-20.3	5.07	42.35	54	-11.65	-	-	81	384	V
2	* 2.49	37.97	Pk	32.7	-20.5	0	50.17	-	-	74	-23.83	81	384	V
4	* 2.495	27.39	RMS	32.7	-20.5	5.07	44.66	54	-9.34	-	-	81	384	V

* - indicates frequency in CFR47 Pt 15 / IC RSS-Restricted Band

Pk - Peak detector

RMS - RMS detection

HARMONICS AND SPURIOUS EMISSIONS

LOW CHANNEL RESULTS

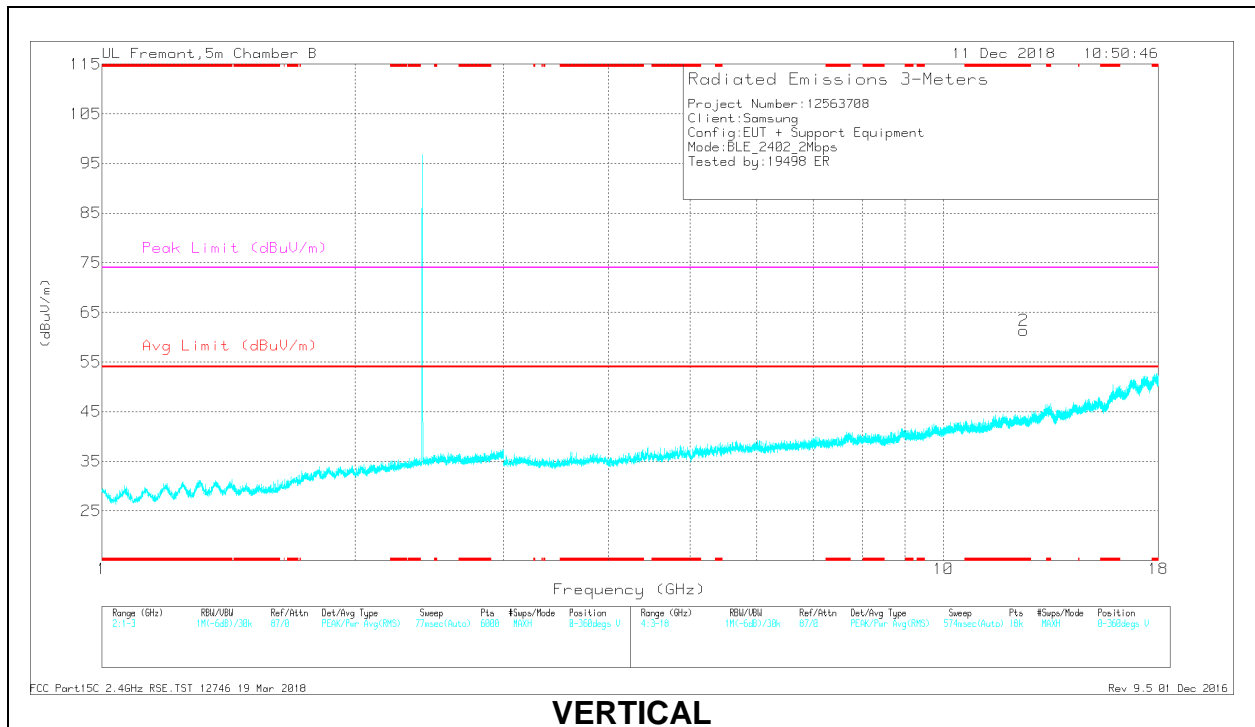
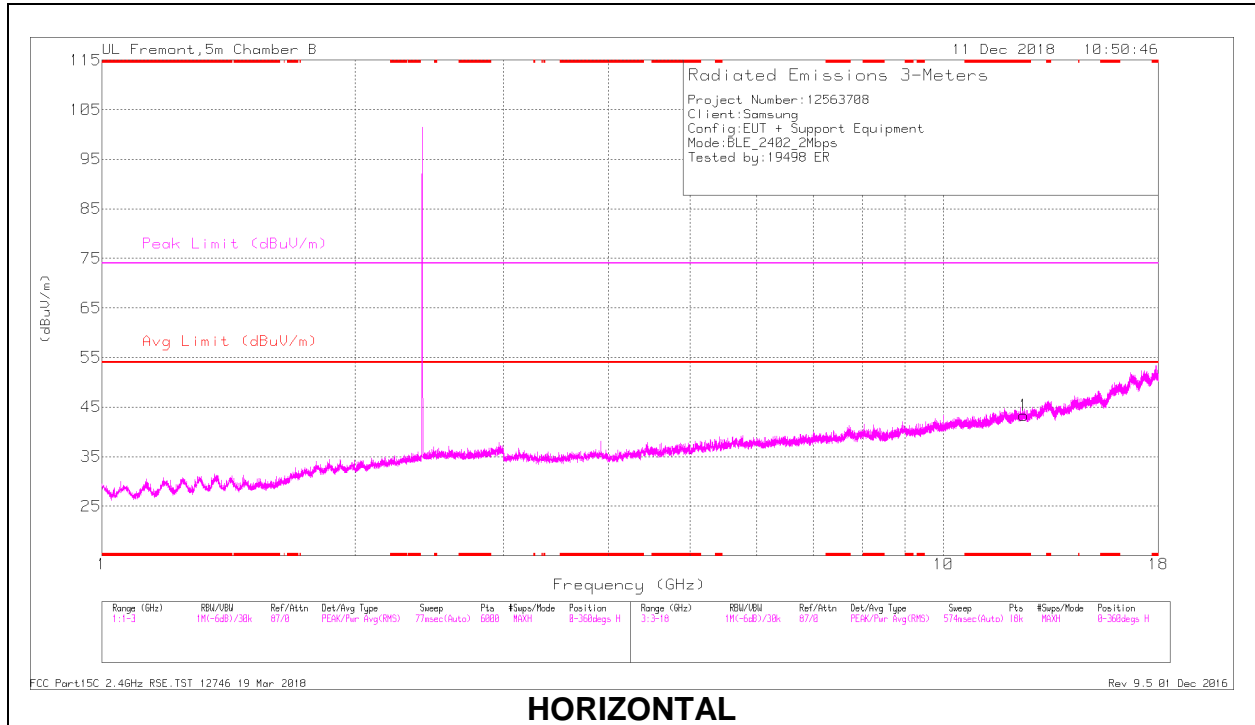

RADIATED EMISSIONS

Marker	Frequency (GHz)	Meter Reading (dBuV)	Det	AF T863 (dB/m)	Amp/Cbl/Filtr/Pad (dB)	DC Corr (dB)	Corrected Reading (dBuV/m)	Avg Limit (dBuV/m)	Margin (dB)	Peak Limit (dBuV/m)	PK Margin (dB)	Azimuth (Degs)	Height (cm)	Polarity
1	* 12.445	32.44	PK2	39	-21.5	0	49.94	-	-	74	-24.06	44	294	H
	* 12.445	21.21	MAv1	39	-21.5	5.07	43.78	54	-10.22	-	-	44	294	H
2	* 12.447	32.78	PK2	39	-21.5	0	50.28	-	-	74	-23.72	303	359	V
	* 12.447	21.22	MAv1	39	-21.5	5.07	43.79	54	-10.21	-	-	303	359	V

* - indicates frequency in CFR47 Pt 15 / IC RSS-Restricted Band

PK2 - KDB558074 Method: Maximum Peak

MAv1 - KDB558074 Option 1 Maximum RMS Average

9.3. Worst Case Below 30 MHz

SPURIOUS EMISSIONS 9 kHz TO 30 MHz (WORST-CASE CONFIGURATION)

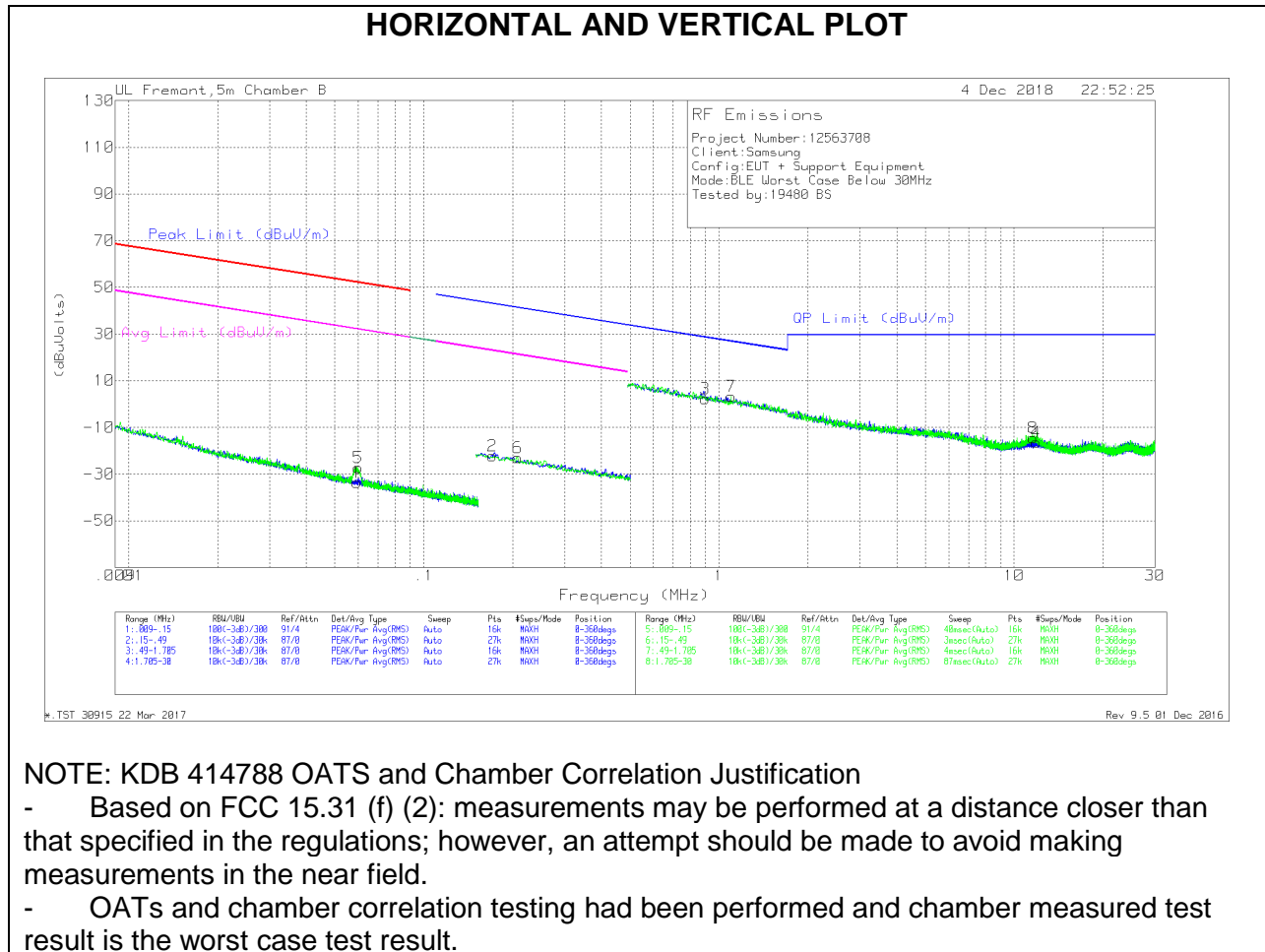

Below 30 MHz Data

Trace Markers

Marker	Frequency (MHz)	Meter Reading (dBuV)	Det	Loop Antenna (dB/m)	Cables (dB)	Dist Corr 300m	Corrected Reading (dBuVolts)	Peak Limit (dBuV/m)	Margin (dB)	Avg Limit (dBuV/m)	Margin (dB)	Peak Limit (dBuV/m)	Margin (dB)	Avg Limit (dBuV/m)	Margin (dB)	Azimuth (Degs)
1	.05939	34.51	Pk	11.8	0	-80	-33.69	52.11	-85.8	32.11	-65.8	-	-	-	-	0-360
5	.05996	41.04	Pk	11.8	0	-80	-27.16	52.03	-79.19	32.03	-59.19	-	-	-	-	0-360
2	.1707	46.61	Pk	11	.1	-80	-22.29	-	-	-	-	42.98	-65.27	22.98	-45.27	0-360
6	.20806	45.78	Pk	11	.1	-80	-23.12	-	-	-	-	41.25	-64.37	21.25	-44.37	0-360

Pk - Peak detector

Marker	Frequency (MHz)	Meter Reading (dBuV)	Det	Loop Antenna (dB/m)	Cables (dB)	Dist Corr (dB) 40Log	Corrected Reading (dBuVolts)	QP Limit (dBuV/m)	Margin (dB)	Peak Limit (dBuV/m)	Margin (dB)	Avg Limit (dBuV/m)	Margin (dB)	Azimuth (Degs)
3	.89793	31.1	Pk	11.1	.1	-40	2.3	28.55	-26.25	-	-	-	-	0-360
7	1.09937	31.84	Pk	11.3	.1	-40	3.24	26.8	-23.56	-	-	-	-	0-360
8	11.59078	14.11	Pk	11	.4	-40	-14.49	29.5	-43.99	-	-	-	-	0-360
4	11.86903	12.05	Pk	11	.5	-40	-16.45	29.5	-45.95	-	-	-	-	0-360

Pk - Peak detector

9.4. Worst Case Below 1 GHz

SPURIOUS EMISSIONS 30 TO 1000 MHz (WORST-CASE CONFIGURATION)

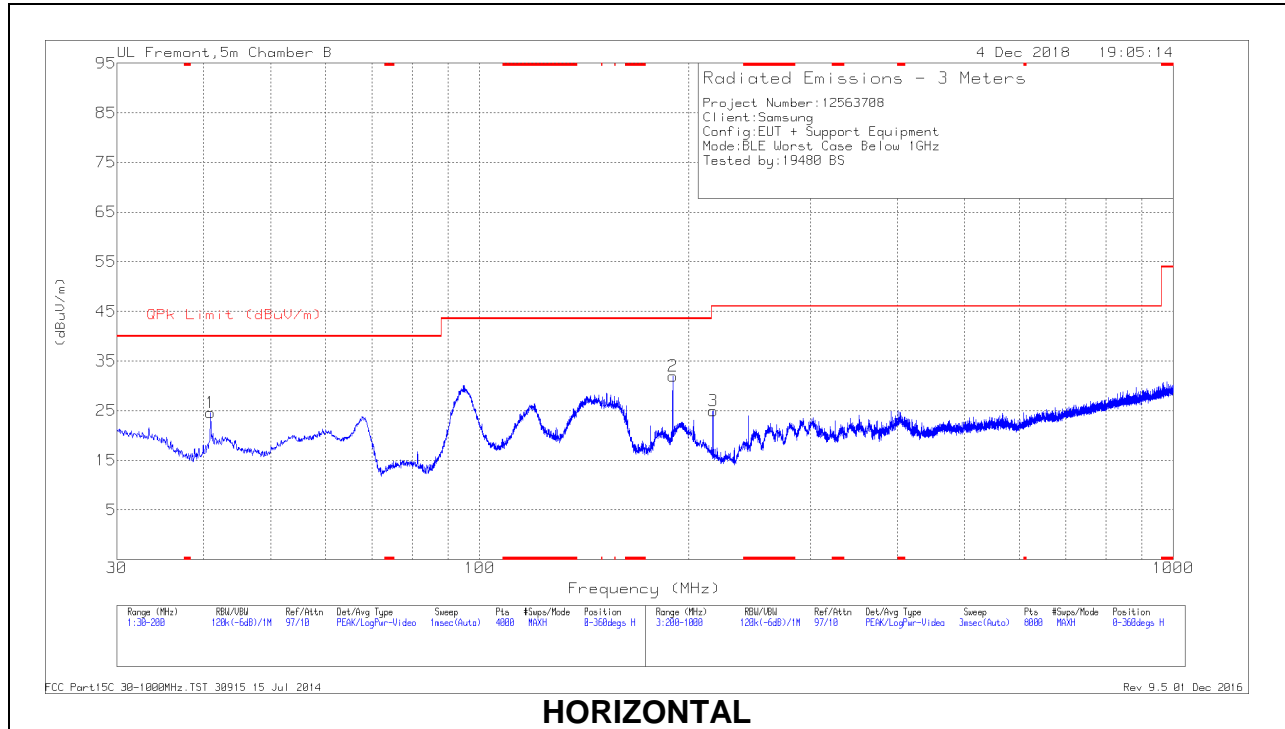

HORIZONTAL

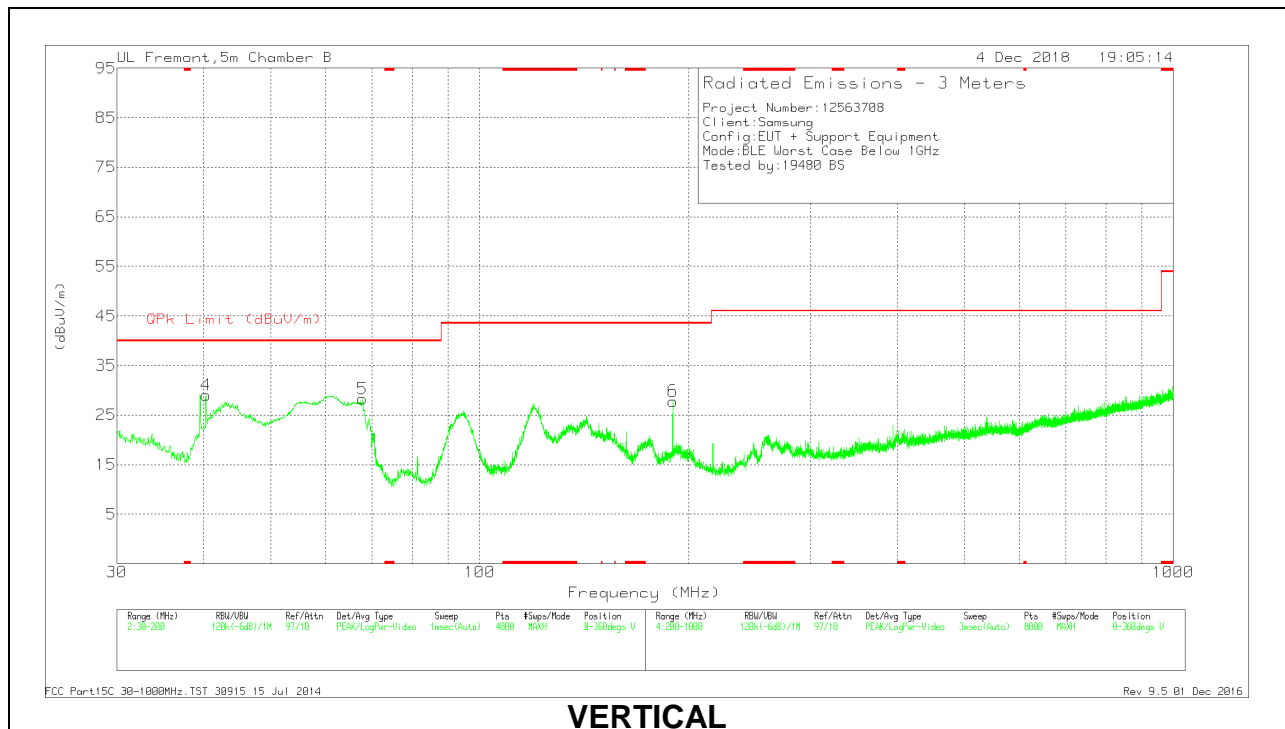

VERTICAL

Below 1GHz Data

Marker	Frequency (MHz)	Meter Reading (dBuV)	Det	AFT407 (dB/m)	Amp/Cbl (dB)	Corrected Reading (dBuV/m)	QPk Limit (dBuV/m)	Margin (dB)	Azimuth (Degs)	Height (cm)	Polarity
4	40.3302	42.67	Pk	17.7	-31.3	29.07	40	-10.93	0-360	100	V
1	40.9253	38.53	Pk	17.3	-31.3	24.53	40	-15.47	0-360	400	H
5	67.7923	47.21	Pk	12.1	-31	28.31	40	-11.69	0-360	100	V
2	189.8414	46.8	Pk	15.3	-30.2	31.9	43.52	-11.62	0-360	200	H
6	189.8414	42.72	Pk	15.3	-30.2	27.82	43.52	-15.7	0-360	100	V
3	217.0022	40.42	Pk	14.6	-30	25.02	46.02	-21	0-360	200	H

Pk - Peak detector

9.5. Worst Case 18-26 GHz

SPURIOUS EMISSIONS 18-26 GHz (WORST-CASE CONFIGURATION)

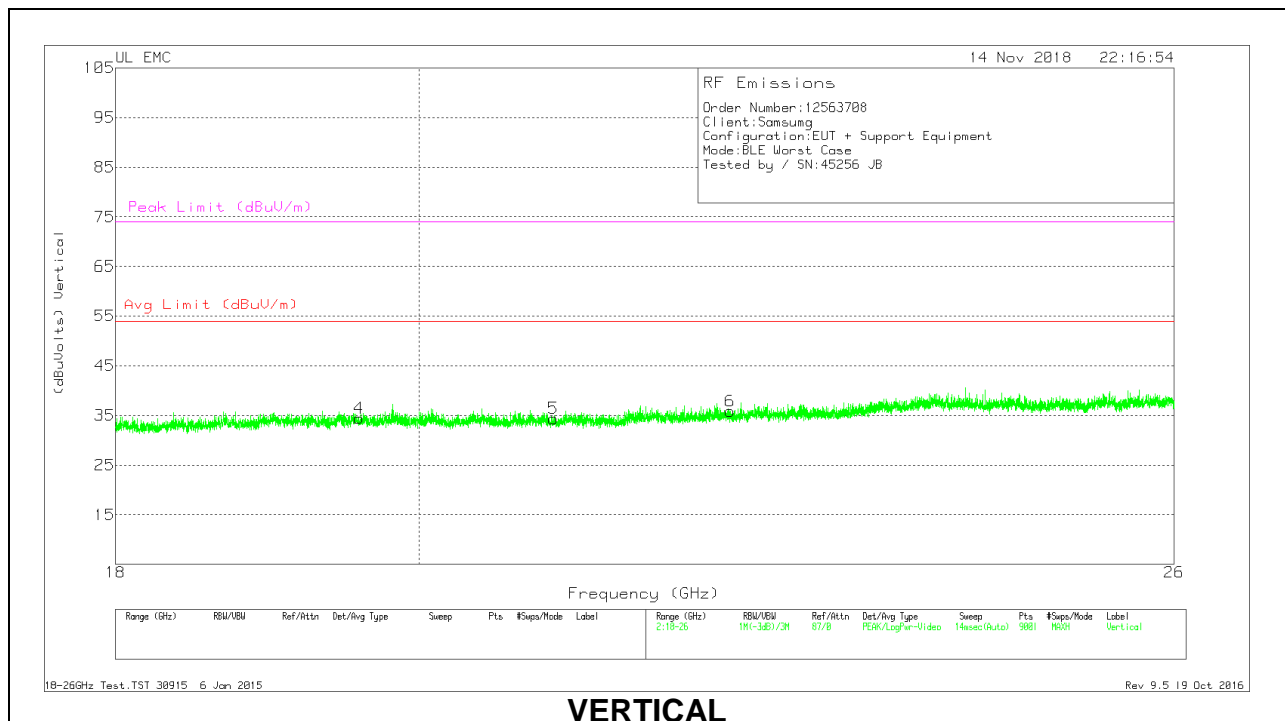
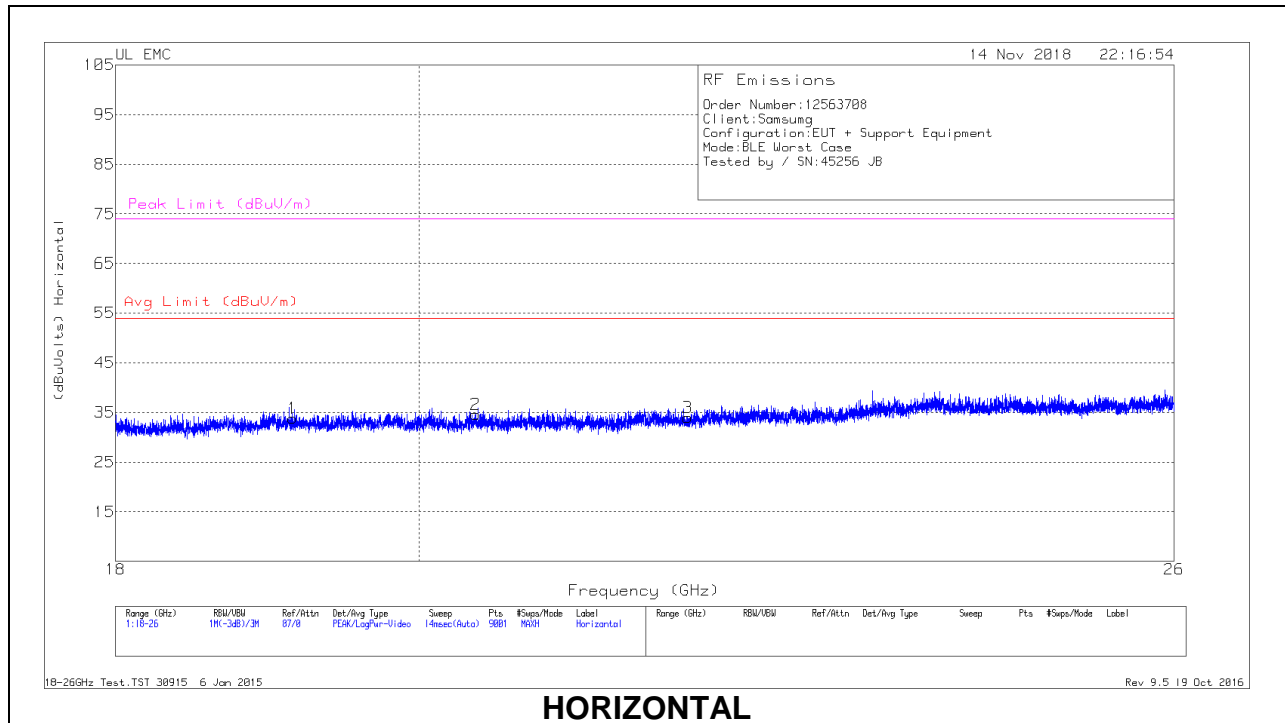

18 – 26GHz DATA

Marker	Frequency (GHz)	Meter Reading (dBuV)	Det	T447 AF (dB/m)	Amp/Cbl (dB)	Dist Corr (dB)	Corrected Reading (dBuVolts)	Avg Limit (dBuV/m)	Margin (dB)	Peak Limit (dBuV/m)	PK Margin (dB)
1	19.142	35.52	Pk	32.6	-24.8	-9.5	33.82	54	-20.18	74	-40.18
2	20.398	36.3	Pk	32.9	-25.1	-9.5	34.6	54	-19.4	74	-39.4
3	21.957	35.38	Pk	33.3	-25.2	-9.5	33.98	54	-20.02	74	-40.02
4	19.588	36.44	Pk	32.8	-25.3	-9.5	34.44	54	-19.56	74	-39.56
5	20.957	36.37	Pk	33.1	-25.6	-9.5	34.37	54	-19.63	74	-39.63
6	22.284	36.46	Pk	33.5	-24.6	-9.5	35.86	54	-18.14	74	-38.14

Pk - Peak detector

10. AC POWER LINE CONDUCTED EMISSIONS

LIMITS

FCC §15.207 (a)

Frequency of Emission (MHz)	Conducted Limit (dBuV)	
	Quasi-peak	Average
0.15-0.5	66 to 56*	56 to 46*
0.5-5	56	46
5-30	60	50

*Decreases with the logarithm of the frequency.

TEST PROCEDURE

The EUT is placed on a non-conducting table 40 cm from the vertical ground plane and 80 cm above the horizontal ground plane. The EUT is configured in accordance with ANSI C63.10.

The receiver is set to a resolution bandwidth of 9 kHz. Peak detection is used unless otherwise noted as quasi-peak or average.

Line conducted data is recorded for both NEUTRAL and HOT lines.

RESULTS

10.1.1. AC Power Line Norm

LINE 1 RESULTS

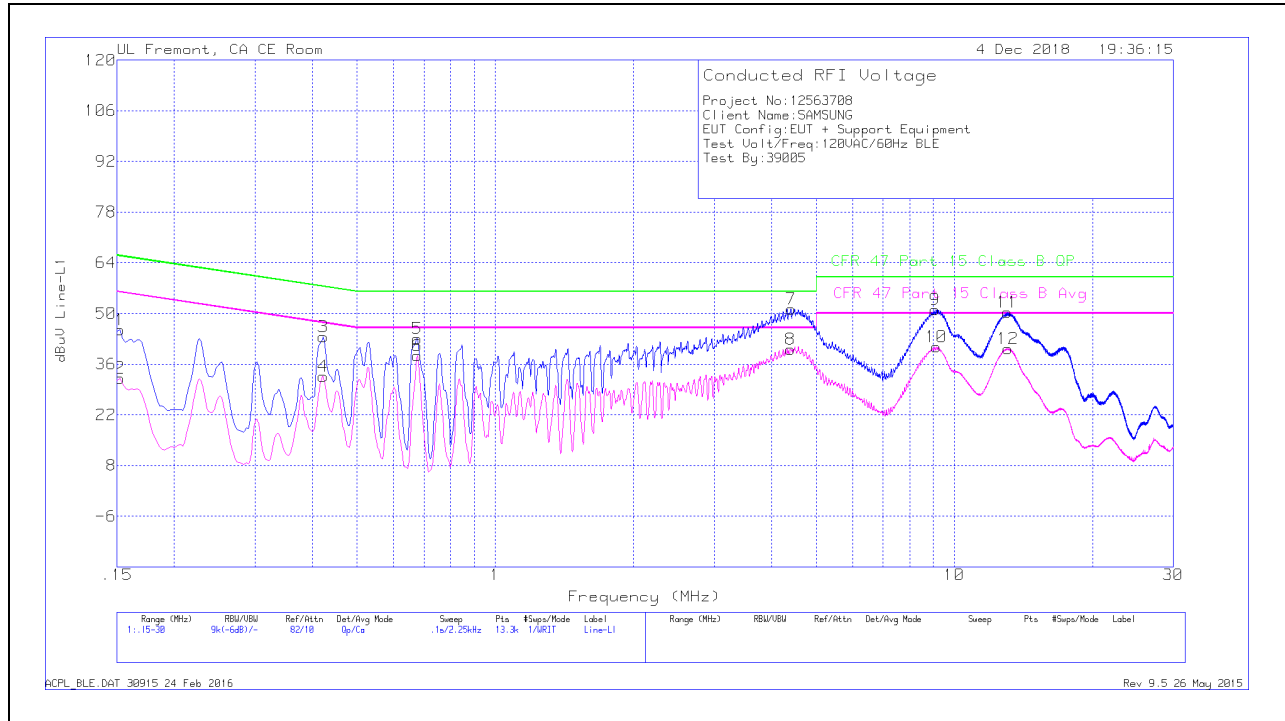

Trace Markers

Range 1: Line-L1 .15 - 30MHz											
Marker	Frequency (MHz)	Meter Reading (dBuV)	Det	LISN L1	LC Cables C1&C3	Limiter (dB)	Corrected Reading dBuV	CFR 47 Part 15 Class B QP	QP Margin (dB)	CFR 47 Part 15 Class B Avg	Av(CISPR) Margin (dB)
1	.15225	35.28	Qp	.1	0	10.1	45.48	65.88	-20.4	-	-
2	.15225	21.98	Ca	.1	0	10.1	32.18	-	-	55.88	-23.7
3	.42225	33.39	Qp	0	0	10.1	43.49	57.4	-13.91	-	-
4	.42225	22.54	Ca	0	0	10.1	32.64	-	-	47.4	-14.76
5	.6765	33	Qp	0	0	10.1	43.1	56	-12.9	-	-
6	.6765	28.26	Ca	0	0	10.1	38.36	-	-	46	-7.64
7	4.407	41	Qp	0	.1	10.1	51.2	56	-4.8	-	-
8	4.4025	29.96	Ca	0	.1	10.1	40.16	-	-	46	-5.84
9	9.0735	40.69	Qp	0	.2	10.2	51.09	60	-8.91	-	-
10	9.13538	30.33	Ca	0	.2	10.2	40.73	-	-	50	-9.27
11	13.06275	39.83	Qp	.1	.2	10.2	50.33	60	-9.67	-	-
12	13.07625	29.84	Ca	.1	.2	10.2	40.34	-	-	50	-9.66

Qp - Quasi-Peak detector
 Ca - CISPR average detection

LINE 2 RESULTS

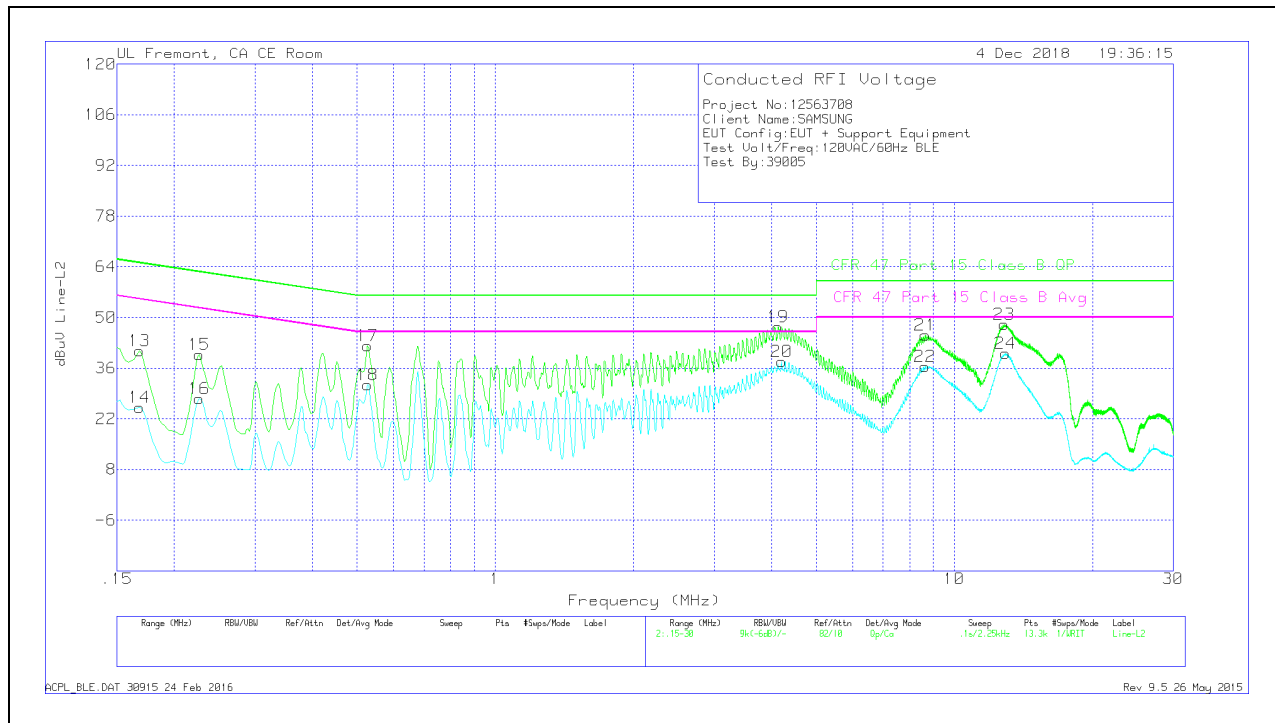

Trace Markers

Range 2: Line-L2 .15 - 30MHz											
Marker	Frequency (MHz)	Meter Reading (dBuV)	Det	LISN L2	LC Cables C2&C3	Limiter (dB)	Corrected Reading dBuV	CFR 47 Part 15 Class B QP	QP Margin (dB)	CFR 47 Part 15 Class B Avg	Av(CISPR) Margin (dB)
13	.168	30.59	Qp	.1	0	10.1	40.79	65.06	-24.27	-	-
14	.168	15	Ca	.1	0	10.1	25.2	-	-	55.06	-29.86
15	.2265	29.61	Qp	0	0	10.1	39.71	62.58	-22.87	-	-
16	.2265	17.54	Ca	0	0	10.1	27.64	-	-	52.58	-24.94
17	.528	32.06	Qp	0	0	10.1	42.16	56	-13.84	-	-
18	.528	21.33	Ca	0	0	10.1	31.43	-	-	46	-14.57
19	4.13025	37.24	Qp	0	.1	10.1	47.44	56	-8.56	-	-
20	4.20675	27.63	Ca	0	.1	10.1	37.83	-	-	46	-8.17
21	8.64825	34.71	Qp	0	.2	10.2	45.11	60	-14.89	-	-
22	8.646	26.08	Ca	0	.2	10.2	36.48	-	-	50	-13.52
23	12.83775	37.53	Qp	.1	.2	10.2	48.03	60	-11.97	-	-
24	12.939	29.59	Ca	.1	.2	10.2	40.09	-	-	50	-9.91

Qp - Quasi-Peak detector
 Ca - CISPR average detection