



FCC 47 CFR PART 15 SUBPART E

UNII (802.11ax)

CERTIFICATION TEST REPORT

FOR

GSM/WCDMA/LTE Phone + BT/BLE, DTS/UNII a/b/g/n/ac/ax, ANT+, NFC and WPT

MODEL NUMBER : SM-G973F/DS, SM-G973F, SM-G973X

FCC ID: A3LSMG973F

REPORT NUMBER: 4788725460-E5V2

ISSUE DATE: DEC 27, 2018

Prepared for
SAMSUNG ELECTRONICS CO., LTD.
129 SAMSUNG-RO, YEONGTONG-GU, SUWON-SI,
GYEONGGI-DO, 16677, KOREA

Prepared by
UL Korea, Ltd.
26th floor, 152, Teheran-ro, Gangnam-gu Seoul, 06236, Korea

Suwon Test Site: UL Korea, Ltd. Suwon Laboratory
218 Maeyeong-ro, Yeongtong-gu,
Suwon-si, Gyeonggi-do, 16675, Korea
TEL: (031) 337-9902
FAX: (031) 213-5433



ACCREDITED*

Testing
Laboratory

TL-637

Revision History

<u>Rev.</u>	<u>Issue Date</u>	<u>Revisions</u>	<u>Revised By</u>
V1	12/20/18	Initial issue	Hoonpyo Lee
V2	12/27/18	Updated to address TCB's question	Hoonpyo Lee

TABLE OF CONTENTS

1. ATTESTATION OF TEST RESULTS	6
2. TEST METHODOLOGY	7
3. FACILITIES AND ACCREDITATION	7
4. CALIBRATION AND UNCERTAINTY	7
4.1. <i>MEASURING INSTRUMENT CALIBRATION</i>	<i>7</i>
4.2. <i>SAMPLE CALCULATION</i>	<i>7</i>
4.3. <i>MEASUREMENT UNCERTAINTY.....</i>	<i>8</i>
5. EQUIPMENT UNDER TEST.....	9
5.1. <i>DESCRIPTION OF EUT</i>	<i>9</i>
5.2. <i>MAXIMUM OUTPUT POWER.....</i>	<i>14</i>
5.3. <i>DESCRIPTION OF AVAILABLE ANTENNAS</i>	<i>15</i>
5.4. <i>List of test reduction and modes covering other modes:</i>	<i>15</i>
5.5. <i>WORST-CASE CONFIGURATION AND MODE.....</i>	<i>16</i>
5.6. <i>DESCRIPTION OF TEST SETUP.....</i>	<i>17</i>
6. TEST AND MEASUREMENT EQUIPMENT	19
7. SUMMARY TABLE	20
8. MEASUREMENT METHODS	21
9. REFERENCE MEASUREMENTS RESULTS	22
9.1. <i>ON TIME AND DUTY CYCLE RESULTS.....</i>	<i>22</i>
9.2. <i>26 dB BANDWIDTH.....</i>	<i>23</i>
9.2.1. <i>802.11ax HE20 MODE IN THE 5.2 GHz BAND</i>	<i>24</i>
9.2.2. <i>802.11ax HE40 MODE IN THE 5.2 GHz BAND</i>	<i>25</i>
9.2.3. <i>802.11ax HE80 MODE IN THE 5.2 GHz BAND</i>	<i>26</i>
9.2.4. <i>802.11ax HE20 MODE IN THE 5.3 GHz BAND</i>	<i>27</i>
9.2.5. <i>802.11ax HE40 MODE IN THE 5.3 GHz BAND</i>	<i>28</i>
9.2.6. <i>802.11ax HE80 MODE IN THE 5.3 GHz BAND</i>	<i>29</i>
9.2.7. <i>802.11ax HE20 MODE IN THE 5.5 GHz BAND</i>	<i>30</i>
9.2.8. <i>802.11ax HE40 MODE IN THE 5.5 GHz BAND</i>	<i>31</i>
9.2.9. <i>802.11ax HE80 MODE IN THE 5.5 GHz BAND</i>	<i>33</i>
10. ANTENNA PORT TEST RESULTS.....	35
10.1. <i>6 dB BANDWIDTH</i>	<i>35</i>
10.1.1. <i>802.11ax HE20 MODE IN THE 5.8 GHz BAND</i>	<i>36</i>
10.1.2. <i>802.11ax HE40 MODE IN THE 5.8 GHz BAND</i>	<i>36</i>
10.1.3. <i>802.11ax HE80 MODE IN THE 5.8 GHz BAND</i>	<i>36</i>

10.2.	OUTPUT POWER AND PPSD	37
10.2.1.	802.11ax HE20 1TX MODE IN THE 5.2 GHz BAND	38
10.2.2.	802.11ax HE40 1TX MODE IN THE 5.2 GHz BAND	40
10.2.3.	802.11ax HE80 1TX MODE IN THE 5.2 GHz BAND	42
10.2.4.	802.11ax HE20 1TX MODE IN THE 5.3 GHz BAND	44
10.2.5.	802.11ax HE40 1TX MODE IN THE 5.3 GHz BAND	46
10.2.6.	802.11ax HE80 1TX MODE IN THE 5.3 GHz BAND	48
10.2.7.	802.11ax HE20 1TX MODE IN THE 5.5 GHz BAND	50
10.2.8.	802.11ax HE40 1TX MODE IN THE 5.5 GHz BAND	52
10.2.9.	802.11ax HE80 1TX MODE IN THE 5.5 GHz BAND	55
10.2.10.	802.11ax HE20 1TX MODE IN THE 5.8 GHz BAND	58
10.2.11.	802.11ax HE40 1TX MODE IN THE 5.8 GHz BAND	60
10.2.12.	802.11ax HE80 1TX MODE IN THE 5.8 GHz BAND	62
10.2.13.	802.11ax HE20 1TX MODE IN THE STRADDLE CHANNEL	64
10.2.14.	802.11ax HE40 1TX MODE IN THE STRADDLE CHANNEL	65
10.2.15.	802.11ax HE80 1TX MODE IN THE STRADDLE CHANNEL	66
10.2.16.	802.11ax HE20 2TX CDD MODE IN THE 5.2 GHz BAND	67
10.2.17.	802.11ax HE40 2TX CDD MODE IN THE 5.2 GHz BAND	69
10.2.18.	802.11ax HE80 2TX CDD MODE IN THE 5.2 GHz BAND	71
10.2.19.	802.11ax HE20 2TX CDD MODE IN THE 5.3 GHz BAND	73
10.2.20.	802.11ax HE40 2TX CDD MODE IN THE 5.3 GHz BAND	75
10.2.21.	802.11ax HE80 2TX CDD MODE IN THE 5.3 GHz BAND	77
10.2.22.	802.11ax HE20 2TX CDD MODE IN THE 5.5 GHz BAND	79
10.2.23.	802.11ax HE40 2TX CDD MODE IN THE 5.5 GHz BAND	81
10.2.24.	802.11ax HE80 2TX CDD MODE IN THE 5.5 GHz BAND	83
10.2.25.	802.11ax HE20 2TX CDD MODE IN THE 5.8 GHz BAND	85
10.2.26.	802.11ax HE40 2TX CDD MODE IN THE 5.8 GHz BAND	87
10.2.27.	802.11ax HE80 2TX CDD MODE IN THE 5.8 GHz BAND	89
10.2.28.	802.11ax HE20 2TX CDD MODE IN THE STRADDLE CHANNEL	91
10.2.29.	802.11ax HE40 2TX CDD MODE IN THE STRADDLE CHANNEL	92
10.2.30.	802.11ax HE80 2TX CDD MODE IN THE STRADDLE CHANNEL	93
11.	TRANSMITTER ABOVE 1 GHz.....	94
11.1.	5.2 GHz_1TX	97
11.1.1.	TX Above 1GHz 802.11ax MODE IN THE 5.2GHz BAND	97
11.2.	5.3 GHz_1TX	169
11.2.1.	TX ABOVE 1GHz 802.11ax MODE IN THE 5.3GHz BAND	169
11.3.	5.5-5.6 GHz_1TX	241
11.3.1.	TX ABOVE 1GHz 802.11ax MODE IN THE 5.5GHz BAND	241
11.4.	5.8 GHz_1TX	353
11.4.1.	TX ABOVE 1GHz 802.11ax MODE IN THE 5.8GHz BAND	353
11.5.	5.2 GHz_2TX	449
11.5.1.	TX Above 1GHz 802.11ax MODE IN THE 5.2GHz BAND	449
11.6.	5.3 GHz_2TX	485
11.6.1.	TX ABOVE 1GHz 802.11ax MODE IN THE 5.3GHz BAND	485
11.7.	5.5-5.6 GHz_2TX	521
11.7.1.	TX ABOVE 1GHz 802.11ax MODE IN THE 5.5GHz BAND	521

11.8. 5.8 GHz_2TX	577
11.8.1. TX ABOVE 1GHz 802.11ax MODE IN THE 5.8GHz BAND	577
12. WORST-CASE BELOW 1 GHz	625
13. AC POWER LINE CONDUCTED EMISSIONS	626
Appendixes	627
4788725460-E5V2 FCC Test setup photo UNII 802.11ax WLAN_App A.....	627
4788725460-E5V2 FCC DUTY test plots UNII 802.11ax WLAN_App B	627
4788725460-E5V2 FCC 26 dB_6dB BW test plots UNII 802.11ax WLAN_App C.....	627
4788725460-E5V2 FCC POWER_PPSD test plots UNII 802.11ax WLAN_App D.....	627

1. ATTESTATION OF TEST RESULTS

COMPANY NAME: SAMSUNG ELECTRONICS CO., LTD.

EUT DESCRIPTION: GSM/WCDMA/LTE Phone + BT/BLE, DTS/UNII a/b/g/n/ac/ax, ANT+, NFC and WPT

MODEL NUMBER: SM-G973F/DS, SM-G973F, SM-G973X

SERIAL NUMBER: R38KA0BE04H,R38KA0BE5CF (RADIATED);
R38KA0BCW8E (CONDUCTED)

DATE TESTED: NOV 09, 2018 - DEC 05, 2018

APPLICABLE STANDARDS	
STANDARD	TEST RESULTS
CFR 47 Part 15 Subpart E	Pass

UL Korea, Ltd. tested the above equipment in accordance with the requirements set forth in the above standards. All indications of Pass/Fail in this report are opinions expressed by UL Korea, Ltd. based on interpretations and/or observations of test results. Measurement Uncertainties were not taken into account and are published for informational purposes only. The test results show that the equipment tested is capable of demonstrating compliance with the requirements as documented in this report.

Note: The results documented in this report apply only to the tested sample, under the conditions and modes of operation as described herein. This document may not be altered or revised in any way unless done so by UL Korea, Ltd. and all revisions are duly noted in the revisions section. Any alteration of this document not carried out by UL Korea, Ltd. will constitute fraud and shall nullify the document. This report must not be used by the client to claim product certification, approval, or endorsement by IAS, any agency of the Federal Government, or any agency of any government.

Approved & Released For
UL Korea, Ltd. By:



SungGil Park
Suwon Lab Engineer
UL Korea, Ltd.

Tested By:



Hoonpyo Lee
Suwon Lab Engineer
UL Korea, Ltd.

2. TEST METHODOLOGY

The tests documented in this report were performed in accordance with following methods.

1. FCC CFR 47 Part 2.
2. FCC CFR 47 Part 15.
3. KDB 789033 D02 General UNII Test Procedures New Rules v02r01
4. KDB 905462 D02 UNII DFS Compliance Procedures New Rules v02
5. KDB 905462 D03 UNII Clients Without Radar Detection New Rules v01r02
6. KDB 662911 D01 v02r01
7. ANSI C63.10-2013.

3. FACILITIES AND ACCREDITATION

The test sites and measurement facilities used to collect data are located at 218 Maeyeong-ro, Yeongtong-gu, Suwon-si, Gyeonggi-do, 16675, Korea. Line conducted emissions are measured only at the 218 address. The following table identifies which facilities were utilized for radiated emission measurements documented in this report. Specific facilities are also identified in the test results sections.

218 Maeyeong-ro	
<input checked="" type="checkbox"/>	Chamber 1
<input checked="" type="checkbox"/>	Chamber 2
<input type="checkbox"/>	Chamber 3

UL Korea, Ltd. is accredited by IAS, Laboratory Code TL-637. The full scope of accreditation can be viewed at <http://www.iasonline.org/PDF/TL/TL-637.pdf>.

4. CALIBRATION AND UNCERTAINTY

4.1. MEASURING INSTRUMENT CALIBRATION

The measuring equipment utilized to perform the tests documented in this report has been calibrated in accordance with the manufacturer's recommendations, and is traceable to recognized national standards.

4.2. SAMPLE CALCULATION

Where relevant, the following sample calculation is provided:

$$\begin{aligned} \text{Field Strength (dBuV/m)} &= \text{Measured Voltage (dBuV)} + \text{Antenna Factor (dB/m)} + \\ &\text{Cable Loss (dB)} - \text{Preamp Gain (dB)} \\ 36.5 \text{ dBuV} + 18.7 \text{ dB/m} + 0.6 \text{ dB} - 26.9 \text{ dB} &= 28.9 \text{ dBuV/m} \end{aligned}$$

4.3. MEASUREMENT UNCERTAINTY

Where relevant, the following measurement uncertainty levels have been estimated for tests performed on the apparatus:

PARAMETER	UNCERTAINTY
Conducted Disturbance, 0.15 to 30 MHz	2.32 dB
Radiated Disturbance, Below 1GHz	3.86 dB
Radiated Disturbance, Above 1 GHz	5.97 dB

Uncertainty figures are valid to a confidence level of 95%.

5. EQUIPMENT UNDER TEST

5.1. DESCRIPTION OF EUT

The EUT is a GSM/WCDMA/LTE Phone + BT/BLE, DTS/UNII a/b/g/n/ac/ax, ANT+, NFC and WPT. This test report addresses the 802.11ax WLAN (UNII) operational mode.

WiFi MIMO Condition

Frequency	Mode	Antenna 1	Antenna 2
2.4GHz	802.11g	TX / RX	TX / RX
	802.11g MIMO	TX / RX	TX / RX
	802.11n	TX / RX	TX / RX
	802.11n MIMO	TX / RX	TX / RX
	802.11ax	TX / RX	TX / RX
	802.11ax MIMO	TX / RX	TX / RX
5 GHz	802.11a	TX / RX	TX / RX
	802.11a MIMO	TX / RX	TX / RX
	802.11n	TX / RX	TX / RX
	802.11n MIMO	TX / RX	TX / RX
	802.11ac	TX / RX	TX / RX
	802.11ac MIMO	TX / RX	TX / RX
	802.11ax	TX / RX	TX / RX
	802.11ax MIMO	TX / RX	TX / RX

Simultaneous TX Condition (RSDB)

	# TX	5GHz WIFI [dBm]		2.4GHz WIFI [dBm]	
		Ant1	Ant2	Ant1	Ant2
2.4 GHz + 5 GHz RSDB Only	2	A	-	-	B
	2	-	A	B	-
	2	A	-	B	-
	2	-	A	-	B
2.4 GHz + 5 GHz RSDB & MIMO	3	A	A	B	-
	3	A	A	-	B
	3	A	-	B	B
	3	-	A	B	B
2.4 GHz + 5 GHz RSDB MIMO	4	A	A	B	B

Simultaneous TX Condition Bluetooth with 5GHz WIFI (Not RSDB)

	# TX	5GHz WIFI		2.4GHz BT
		ANT1	ANT2	ANT1
2.4GHz BT+5GHz WIFI (Not RSDB)	2	A	-	B
	2	-	A	B
	3	A	A	B

Spurious Emissions for Simultaneous Transmission were reported on the UNII test report(4788725460-E4) section 11.5.

802.11ax RU allocations

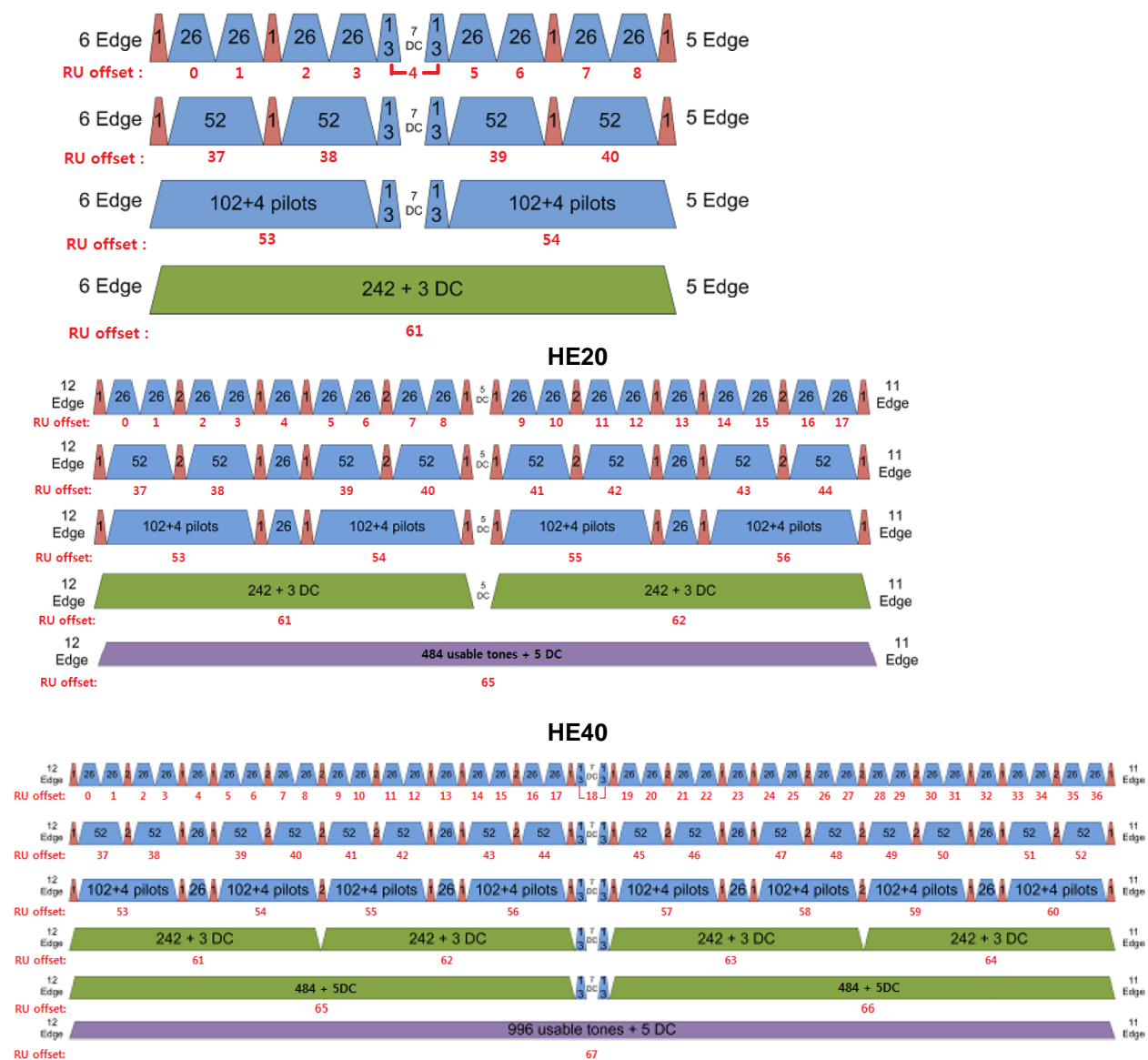

Test RU offset for tones in each modes

Mode	Tones number in RU	RU offset
HE20	26T	0
		4
		8
	52T	37
		38
		40
	106T	53
		54
242T / SU ^{Note 1}	61 / -	
HE40	26T	0
		9
		17
	52T	37
		41
		44
	106T	53
		54
		56
	242T	61
		62
484T / SU ^{Note 1}	63 / -	
HE80	26T	0
		18
		36
	52T	37
		45
		52
	106T	53
		57
		60
	242T	61
		62
		64
	484T	65
		66
996T / SU ^{Note 1}	67 / -	

Note 1: Full RU(Resource Unit) mode and SU(Single Unit) mode have no difference in physical waveform. This report has been described only SU mode with worst output power. For MIMO, the Tx power in each antenna is 3 dB back-off except for SU mode.

Band portion of RU allocation about straddle channels

Mode	Channel	Tones	RU offset	Portion
HE20	Straddle 5720	26T	0	UNII 2C
			4	UNII 2C
			8	UNII 3
		52T	37	UNII 2C
			38	UNII 2C
			40	UNII 3
		106T	53	UNII 2C
			54	UNII 2C & UNII 3
		242T / SU	61 / -	UNII 2C & UNII 3
HE80	Straddle 5710	26T	0	UNII 2C
			9	UNII 2C
			17	UNII 3
		52T	37	UNII 2C
			41	UNII 2C
			44	UNII 3
		106T	53	UNII 2C
			54	UNII 2C
			56	UNII 2C & UNII 3
		242T	61	UNII 2C
			62	UNII 2C & UNII 3
		484T / SU	65 / -	UNII 2C & UNII 3
		HE80	Straddle 5690	26T
18	UNII 2C			
36	UNII 3			
52T	37			UNII 2C
	45			UNII 2C
	52			UNII 3
106T	53			UNII 2C
	57			UNII 2C
	60			UNII 2C & UNII 3
242T	61			UNII 2C
	62			UNII 2C
	64			UNII 2C & UNII 3
484T	65			UNII 2C
	66			UNII 2C & UNII 3
996T / SU	67 / -			UNII 2C & UNII 3

5.2. MAXIMUM OUTPUT POWER

The transmitter has a maximum total conducted average output power as follows:

Frequency Range [MHz]	Mode	Output Power [dBm]		Output Power [mW]	
		Antenna1	Antenna2	Antenna1	Antenna2
5180 - 5240	802.11ax HE20 SISO	13.67	13.42	23.28	21.98
	802.11ax HE20 MIMO	16.48		44.46	
5190 - 5230	802.11ax HE40 SISO	13.45	13.47	22.13	22.23
	802.11ax HE40 MIMO	16.53		44.98	
5210	802.11ax HE80 SISO	13.61	13.41	22.96	21.93
	802.11ax HE80 MIMO	16.26		42.27	
5260 - 5320	802.11ax HE20 SISO	13.63	13.35	23.07	21.63
	802.11ax HE20 MIMO	16.33		42.95	
5270 - 5310	802.11ax HE40 SISO	13.27	13.37	21.23	21.73
	802.11ax HE40 MIMO	16.37		43.35	
5290	802.11ax HE80 SISO	13.32	13.18	21.48	20.80
	802.11ax HE80 MIMO	16.11		40.83	
5500 - 5720	802.11ax HE20 SISO	15.10	15.54	32.36	35.81
	802.11ax HE20 MIMO	17.90		61.66	
5510 - 5710	802.11ax HE40 SISO	13.52	13.67	22.49	23.28
	802.11ax HE40 MIMO	16.47		44.36	
5530 - 5690	802.11ax HE80 SISO	13.10	13.53	20.42	22.54
	802.11ax HE80 MIMO	16.25		42.17	
5745 - 5825	802.11ax HE20 SISO	15.78	16.48	37.84	44.46
	802.11ax HE20 MIMO	19.13		81.85	
5755 - 5795	802.11ax HE40 SISO	13.42	13.67	21.98	23.28
	802.11ax HE40 MIMO	16.34		43.05	
5775	802.11ax HE80 SISO	12.96	13.48	19.77	22.28
	802.11ax HE80 MIMO	16.20		41.69	

5.3. DESCRIPTION OF AVAILABLE ANTENNAS

The radio utilizes a internal antenna, with a maximum gain of:

Frequency Range [MHz]	Antenna Gain [dBi]	
	Antenna 1	Antenna 2
UNII 1 5150 – 5250	-8.40	-7.30
UNII 2A 5250 – 5350	-7.40	-7.20
UNII 2C 5470 – 5725	-7.10	-6.50
UNII 3 5725 – 5850	-7.10	-6.80

5.4. List of test reduction and modes covering other modes:

The output power on covered modes is equal to or less than one referenced.

Authorized Frequency Band			
Band	Frequency Range [MHz]	Mode	Covered by
UNII-1	5180 - 5240	802.11ax HE20 RU_242T 1TX	802.11ax HE20 SU 1TX
		802.11ax HE20 RU_242T 2TX SDM/STBC	802.11ax HE20 SU 2TX CDD
	5190 - 5230	802.11ax HE40 RU_484T 1TX	802.11ax HE40 SU 1TX
		802.11ax HE40 RU_484T 2TX SDM/STBC	802.11ax HE40 SU 2TX CDD
	5210	802.11ax HE80 RU_996T 1TX	802.11ax HE80 SU 1TX
		802.11ax HE80 RU_996T 2TX SDM/STBC	802.11ax HE80 SU 2TX CDD
UNII-2A	5260 - 5320	802.11ax HE20 RU_242T 1TX	802.11ax HE20 SU 1TX
		802.11ax HE20 RU_242T 2TX SDM/STBC	802.11ax HE20 SU 2TX CDD
	5270 - 5310	802.11ax HE40 RU_484T 1TX	802.11ax HE40 SU 1TX
		802.11ax HE40 RU_484T 2TX SDM/STBC	802.11ax HE40 SU 2TX CDD
	5290	802.11ax HE80 RU_996T 1TX	802.11ax HE80 SU 1TX
		802.11ax HE80 RU_996T 2TX SDM/STBC	802.11ax HE80 SU 2TX CDD
UNII-2C	5500 - 5720	802.11ax HE20 RU_242T 1TX	802.11ax HE20 SU 1TX
		802.11ax HE20 RU_242T 2TX SDM/STBC	802.11ax HE20 SU 2TX CDD
	5510 - 5710	802.11ax HE40 RU_484T 1TX	802.11ax HE40 SU 1TX
		802.11ax HE40 RU_484T 2TX SDM/STBC	802.11ax HE40 SU 2TX CDD
	5530 - 5690	802.11ax HE80 RU_996T 1TX	802.11ax HE80 SU 1TX
		802.11ax HE80 RU_996T 2TX SDM/STBC	802.11ax HE80 SU 2TX CDD
UNII-3	5745 - 5825	802.11ax HE20 RU_242T 1TX	802.11ax HE20 SU 1TX
		802.11ax HE20 RU_242T 2TX SDM/STBC	802.11ax HE20 SU 2TX CDD
	5755 -5795	802.11ax HE40 RU_484T 1TX	802.11ax HE40 SU 1TX
		802.11ax HE40 RU_484T 2TX SDM/STBC	802.11ax HE40 SU 2TX CDD
	5775	802.11ax HE80 RU_996T 1TX	802.11ax HE80 SU 1TX
		802.11ax HE80 RU_996T 2TX SDM/STBC	802.11ax HE80 SU 2TX CDD

5.5. WORST-CASE CONFIGURATION AND MODE

Radiated emission below 1GHz and power line conducted emission were performed with the EUT set to transmit at the channel with highest output power as worst-case scenario.

Radiated emission above 1GHz was performed with the EUT set to transmit low/mid/high channels.

The fundamental of the EUT was investigated in three orthogonal orientations X, Y and Z it was determined that X orientation was worst-case orientation; therefore, all final radiated testing was performed with the EUT in X orientation.

The fundamental level of the EUT was investigated on the condition of equipped with keyboard configuration also, but stand-alone configuration is more worse. So only below 1GHz and AC line conducted test were performed on the condition of equipped with keyboard configuration.

Based on the baseline scan, the worst-case data rates were:

802.11ax HE20mode: MCS0
802.11ax HE40mode: MCS0
802.11ax HE80mode: MCS0

Worst-case selection criteria for test items :

- For the radiated band-edge test, it was tested at RU allocations with highest power for each RU Tones across all bandwidths. Also it was tested at RU allocations adjacent to band-edge for each RU Tones.
- For the spurious emissions, it was tested at the bandwidth/RU allocation with actual highest power and bandwidth/RU allocation with actual highest PSD for each bandwidth.
- For the 6dB Bandwidth, it was tested at the RU allocation with lowest tones number for each bandwidth.

NOTE : Some radiated test results performed on the 1Tx antenna condition is worst, so test report described all radiated test results.(Antenna 1-1Tx, Antenna 2-1Tx, Antenna ALL 2Tx CDD)

5.6. DESCRIPTION OF TEST SETUP

SUPPORT EQUIPMENT

Support Equipment List				
Description	Manufacturer	Model	Serial Number	FCC ID
Charger	SAMSUNG	EP-TA200	R37KB5B03T1SE3	N/A
Data Cable	SAMSUNG	EP-DG970BBE	N/A	N/A
Earphone	SAMSUNG	EO-IG955	N/A	N/A

I/O CABLE

I/O Cable List						
Cable No	Port	# of identical ports	Connector Type	Cable Type	Cable Length (m)	Remarks
1	DC Power	1	C Type	Shielded	1.1m	N/A
2	Audio	2	Mini-Jack	Unshielded	1.2m	N/A

TEST SETUP

The EUT is a stand-alone unit during the tests.
 Test software exercised the EUT to enable NII mode.

SETUP DIAGRAM FOR TESTS (CONDUCTED TEST SETUP)

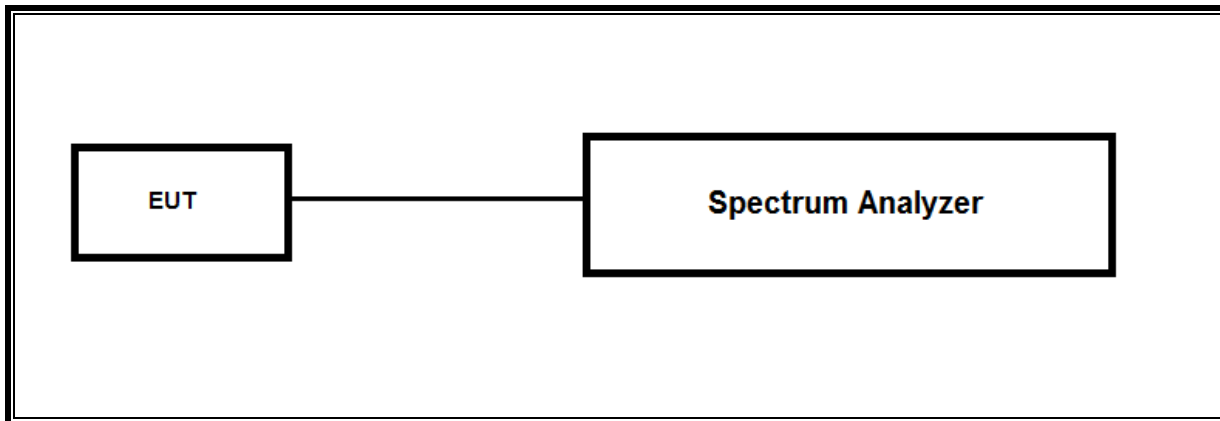

SETUP DIAGRAM FOR TESTS (RADIATED TEST SETUP)

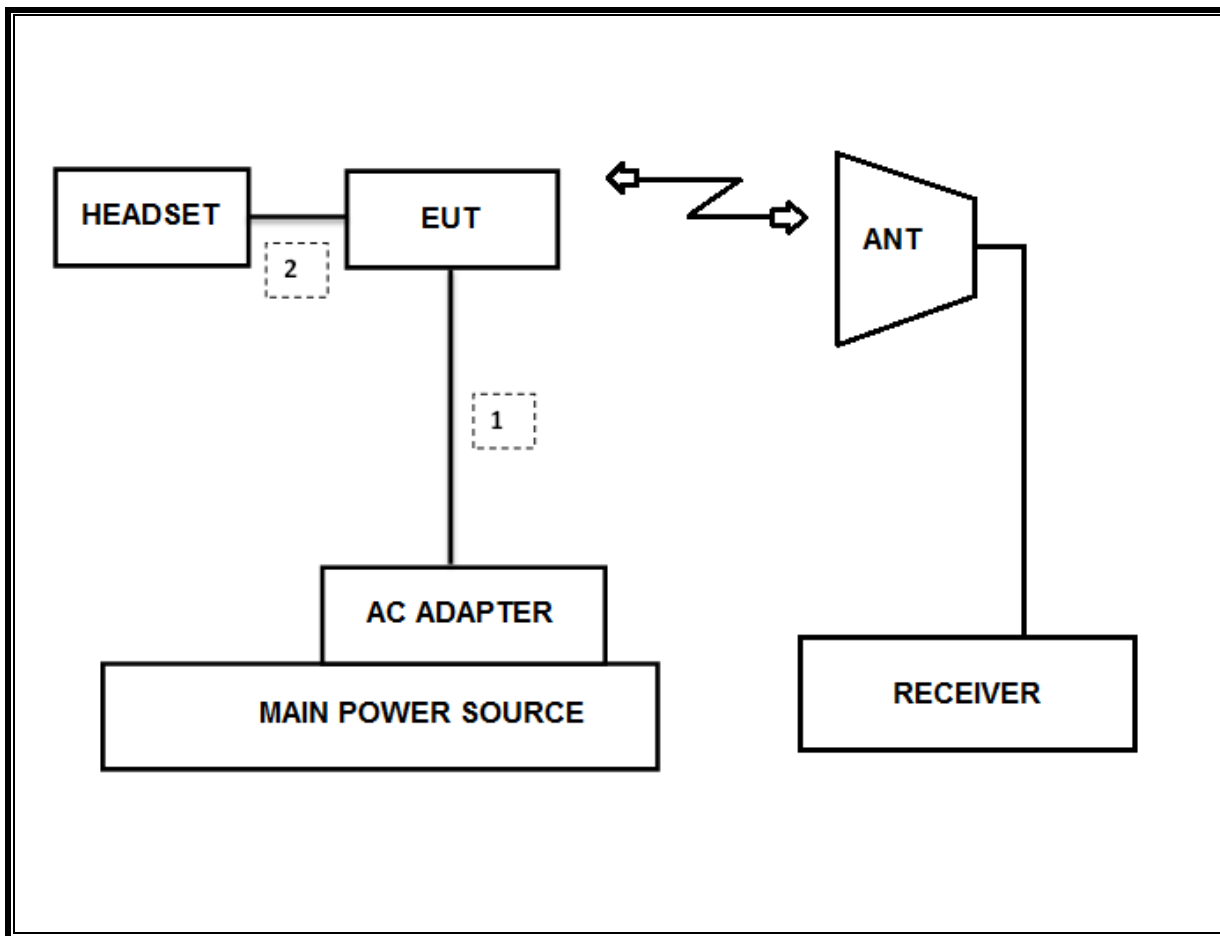

6. TEST AND MEASUREMENT EQUIPMENT

The following test and measurement equipment was utilized for the tests documented in this report:

Test Equipment List				
Description	Manufacturer	Model	S/N	New Cal Due
Antenna, Bilog, 30MHz-1GHz	SCHWARZBECK	VULB9163	750	08-04-20
Antenna, Bilog, 30MHz-1GHz	SCHWARZBECK	VULB9163	749	08-04-20
Antenna, Bilog, 30MHz-1GHz	SCHWARZBECK	VULB9163	845	08-04-20
Antenna, Loop, 9kHz-30MHz	R&S	HFH2-Z2	100418	10-26-19
Antenna, Horn, 18 GHz	ETS	3115	00167211	08-04-20
Antenna, Horn, 18 GHz	ETS	3115	00161451	08-04-20
Antenna, Horn, 18 GHz	ETS	3117	00168724	08-04-20
Antenna, Horn, 18 GHz	ETS	3117	00168717	08-04-20
Antenna, Horn, 18 GHz	ETS	3117	00205959	08-04-20
Antenna, Horn, 40 GHz	ETS	3116C	00166155	12-04-19
Antenna, Horn, 40 GHz	ETS	3116C	00168645	12-04-19
Antenna, Horn, 40 GHz	ETS	3116C-PA	00168841	08-09-19
Preamplifier, 1000 MHz	Sonoma	310N	341282	08-07-19
Preamplifier, 1000 MHz	Sonoma	310N	351741	08-07-19
Preamplifier, 1000 MHz	Sonoma	310N	370599	08-06-19
Preamplifier, 18 GHz	Miteq	AFS42-00101800-25-S-42	1876511	08-07-19
Preamplifier, 18 GHz	Miteq	AFS42-00101800-25-S-42	1896138	08-07-19
Preamplifier, 18 GHz	Miteq	AFS42-00101800-25-S-42	2029169	08-07-19
Spectrum Analyzer, 44 GHz	Agilent / HP	N9030A	MY54170614	08-07-19
Spectrum Analyzer, 44 GHz	Agilent / HP	N9030A	MY54490312	08-06-19
Spectrum Analyzer, 43.5 GHz	R&S	FSW43	104089	08-06-19
Average Power Sensor	Agilent / HP	U2000	MY54270007	08-07-19
Attenuator	PASTERNAK	PE7087-10	A001	08-08-19
Attenuator	PASTERNAK	PE7087-10	A008	08-08-19
Attenuator	PASTERNAK	PE7004-10	2	08-07-19
Attenuator	PASTERNAK	PE7087-10	A009	08-08-19
EMI Test Receive, 40 GHz	R&S	ESU40	100439	08-06-19
EMI Test Receive, 40 GHz	R&S	ESU40	100457	08-06-19
EMI Test Receive, 44 GHz	R&S	ESW44	101590	08-06-19
EMI Test Receive, 3 GHz	R&S	ESR3	101832	08-06-19
Low Pass Filter 5GHz	Micro-Tronics	LPS17541	009	08-07-19
Low Pass Filter 5GHz	Micro-Tronics	LPS17541	015	08-07-19
Low Pass Filter 5GHz	Micro-Tronics	LPS17541	020	08-06-19
High Pass Filter 3GHz	Micro-Tronics	HPM17543	010	08-07-19
High Pass Filter 3GHz	Micro-Tronics	HPM17543	015	08-07-19
High Pass Filter 3GHz	Micro-Tronics	HPM17543	020	08-06-19
High Pass Filter 6GHz	Micro-Tronics	HPS17542	009	08-07-19
High Pass Filter 6GHz	Micro-Tronics	HPS17542	016	08-07-19
High Pass Filter 6GHz	Micro-Tronics	HPS17542	021	08-06-19
LISN	R&S	ENV-216	101837	08-09-19
UL Software				
Description	Manufacturer	Model	Version	
Radiated software	UL	UL EMC	Ver 9.5	
AC Line Conducted software	UL	UL EMC	Ver 9.5	

7. SUMMARY TABLE

FCC Part Section	Test Description	Test Limit	Test Condition	Test Result
15.407(e)	6dB Band width (5.8Ghz)	500KHz	Condcuted	PASS
15.407 (a)(2)	TX Cond. Power 5.15-2.25, 5.25-5.35 & 5.47-5.725	<24dBm or 11+10Log(OBW)		PASS
15.407 (a)(3)	TX Cond. Power 5.725-5.825	< 30dBm or 17+10Log(OBW)		PASS
15.407 (a)(5)	PSD (5.2,5.3,5.5GHz)	<11dBm		PASS
15.407 (a)(5)	PSD (5.8GHz)	30dBm per 500kHz		PASS
15.207 (a)	AC Power Line conducted emissions	Section 10	Radiated	Refer to the UNII 802.11a_n_ac DFS WLAN Test report (No.:4788725460-E4)
15.407 (b) & 15.209	Radiated Spurious Emission	< 54dBuV/m		PASS
15.407 (h)(2)	Dynamic Frequency Selection	N/A	Condcuted	Refer to the UNII 802.11a_n_ac DFS WLAN Test report (No.:4788725460-E4)

8. MEASUREMENT METHODS

On-Time and Duty Cycle : KDB 789033 D02 v02r01, Section B.

6dB Emission BW : KDB 789033 D02 v02r01, Section C.2.

26dB Emission BW : KDB 789033 D02 v02r01, Section C.1.

99% Occupied BW : KDB 789033 D02 v02r01, Section D.

Conducted Output Power : KDB 789033 D02 v02r01, Section E.3.a(Method PM)

Conducted Output Power for Straddle Channel (ch144/142/138 for 20/40/80MHz BW):

KDB 789033 D02 v02r01, Section E.2.d(Method SA-2)

Power Spectral Density : KDB 789033 D02 v02r01, Section F.

Unwanted emissions in restricted bands : KDB 789033 D02 v02r01, Section G.

Unwanted emissions in non-restricted bands : KDB 789033 D02 v02r01, Section G.

AC Power Line Conducted Emission : ANSI C63.10-2013, Section 6.2.

9. REFERENCE MEASUREMENTS RESULTS

9.1. ON TIME AND DUTY CYCLE RESULTS

Mode	ANT	Tone	On Time [mS]	Period [mS]	Duty Cycle X [linear]	Duty Cycle X [%]	Duty Cycle Correction Factor [dB]	1/T Minimum VBW [kHz]			
802.11ax	HE20	SISO	26T	4.802	5.384	0.89	89.19	0.50	0.208		
			52T	5.144	5.724	0.90	89.87	0.46	0.194		
			106T	5.240	5.815	0.90	90.11	0.45	0.191		
			SU	3.873	3.972	0.98	97.51	0.11	0.258		
		MIMO	26T	5.175	5.752	0.90	89.97	0.46	0.193		
			52T	5.253	5.831	0.90	90.09	0.45	0.190		
			106T	5.388	5.965	0.90	90.33	0.44	0.186		
	HE40	SISO	SU	1.972	2.071	0.95	95.22	0.21	0.507		
			26T	4.807	5.386	0.89	89.25	0.49	0.208		
			52T	5.044	5.622	0.90	89.72	0.47	0.198		
			106T	5.238	5.815	0.90	90.08	0.45	0.191		
			242T	5.462	6.038	0.90	90.46	0.44	0.183		
			SU	4.331	4.431	0.98	97.74	0.10	0.231		
			26T	5.169	5.749	0.90	89.91	0.46	0.193		
		MIMO	52T	5.255	5.832	0.90	90.11	0.45	0.190		
			106T	5.384	5.967	0.90	90.23	0.45	0.186		
			242T	5.527	6.105	0.91	90.53	0.43	0.181		
			SU	2.203	2.302	0.96	95.70	0.19	0.454		
			26T	4.806	5.387	0.89	89.21	0.50	0.208		
			HE80	SISO	52T	4.995	5.574	0.90	89.61	0.48	0.200
					106T	5.239	5.815	0.90	90.09	0.45	0.191
	242T	5.462			6.038	0.90	90.46	0.44	0.183		
	484T	5.470			6.046	0.90	90.47	0.43	0.183		
	SU	4.270			4.371	0.98	97.69	0.10	0.234		
	MIMO	26T		5.175	5.629	0.92	91.93	0.37	0.193		
		52T		5.253	5.841	0.90	89.93	0.46	0.190		
	MIMO	106T	5.388	5.981	0.90	90.09	0.45	0.186			
242T		5.478	6.064	0.90	90.34	0.44	0.183				
484T		4.055	4.164	0.97	97.38	0.12	0.247				
SU		2.174	2.282	0.95	95.27	0.21	0.460				

LIMITS

None; for reporting purposes only.

PROCEDURE

KDB 789033 D02 v02r01 Zero-Span Spectrum Analyzer Method.

DUTY CYCLE PLOTS

Please refer to Appendix B.

9.2. 26 dB BANDWIDTH

LIMITS

None; for reporting purposes only.

TEST PROCEDURE

Reference to 789033 D02 General UNII Test Procedures New Rules v02r01: The transmitter output is connected to a spectrum analyzer with the RBW set to approximately 1% of EBW, the VBW > RBW, peak detector and max hold.

NOTE

- Calculation for 26dB Bandwidth of RU allocation and channels included to straddle band in UNII-2C and UNII-3 Straddle Channel

- ex) Marker 2: Lower point of 26 dB bandwidth
Marker 3: Upper point of 26 dB bandwidth
 - Turning Frequency : 5725MHz
 - Marker 2: 5710 MHz
 - Marker 3: 5730 MHz
 - 26dB Bandwidth of UNII-2C band Portion
= $(5725 - 5710) = 15$ MHz
 - 26dB Bandwidth of UNII-3 band Portion
= $(5730 - 5725) = 5$ MHz

- 26dB Bandwidth test were performed each antenna port on SISO mode.

RESULTS

See the next page. (Test plots refer to the Appendix C.)

9.2.1.802.11ax HE20 MODE IN THE 5.2 GHz BAND

Band	Mode	Center Freq.(MHz)	Tones	RU offset	26 dB BW (MHz)	
					ANT1	ANT2
UNII-1	HE20	5180	26T	0	19.62	19.77
				4	18.27	18.61
				8	20.73	20.61
			52T	37	19.87	20.22
				38	18.88	18.17
				40	20.43	20.82
			106T	53	20.77	20.46
				54	19.76	21.12
			SU	-	21.34	21.26
		5200	26T	0	19.38	19.04
				4	18.26	18.20
				8	20.03	20.62
			52T	37	20.27	19.90
				38	19.62	19.31
				40	19.83	20.42
			106T	53	20.12	19.97
				54	21.31	20.47
			SU	-	21.42	21.37
		5240	26T	0	19.39	19.26
				4	19.19	18.00
				8	20.41	19.19
			52T	37	19.62	19.98
				38	18.10	18.61
				40	19.49	20.33
106T	53		20.83	20.16		
	54		21.04	20.67		
SU	-		21.39	21.53		

9.2.2.802.11ax HE40 MODE IN THE 5.2 GHz BAND

Band	Mode	Center Freq.(MHz)	Tones	RU offset	26 dB BW (MHz)	
					ANT1	ANT2
UNII-1	HE40	5190	26T	0	20.10	19.44
				9	21.63	20.53
				17	19.79	20.27
			52T	37	19.78	20.90
				41	25.25	24.44
				44	22.03	20.77
			106T	53	19.55	23.16
				54	28.02	24.91
				56	19.30	24.81
			242T	61	30.14	28.15
				62	30.98	29.60
			SU	-	40.01	39.93
		5230	26T	0	19.58	18.68
				9	23.31	23.17
				17	19.62	20.14
			52T	37	21.11	20.95
				41	24.41	23.44
				44	20.34	21.77
			106T	53	22.33	21.44
				54	26.16	25.64
				56	23.55	21.77
			242T	61	28.87	31.82
				62	30.19	29.17
			SU	-	40.53	40.63

9.2.3.802.11ax HE80 MODE IN THE 5.2 GHz BAND

Band	Mode	Center Freq.(MHz)	Tones	RU offset	26 dB BW (MHz)	
					ANT1	ANT2
UNII-1	HE80	5210	26T	0	20.02	20.96
				18	34.57	41.01
				36	24.63	19.83
			52T	37	20.65	24.07
				45	26.13	27.79
				52	23.34	26.11
			106T	53	23.94	26.23
				57	35.36	35.64
				60	26.24	27.26
			242T	61	37.40	37.24
				62	52.09	50.18
				64	36.87	37.72
			484T	65	54.21	56.21
				66	61.07	64.14
			SU	-	82.06	81.17

9.2.4.802.11ax HE20 MODE IN THE 5.3 GHz BAND

Band	Mode	Center Freq.(MHz)	Tones	RU offset	26 dB BW (MHz)	
					ANT1	ANT2
UNII-2A	HE20	5260	26T	0	19.30	19.24
				4	17.00	17.88
				8	19.36	19.35
			52T	37	19.18	20.58
				38	18.02	19.75
				40	20.68	19.05
			106T	53	20.69	20.49
				54	20.95	21.08
			SU	-	21.28	21.59
		5300	26T	0	18.58	20.13
				4	17.92	18.50
				8	19.99	19.64
			52T	37	20.12	20.42
				38	19.22	18.69
				40	18.10	20.37
			106T	53	19.70	19.68
				54	20.49	20.81
			SU	-	21.49	21.48
		5320	26T	0	19.68	19.24
				4	19.24	19.29
				8	20.29	19.84
			52T	37	19.49	19.42
				38	19.17	18.88
				40	20.92	20.51
106T	53		19.11	19.66		
	54		21.21	20.62		
SU	-		21.47	21.48		

9.2.5.802.11ax HE40 MODE IN THE 5.3 GHz BAND

Band	Mode	Center Freq.(MHz)	Tones	RU offset	26 dB BW (MHz)	
					ANT1	ANT2
UNII-2A	HE40	5270	26T	0	19.49	20.06
				9	23.21	22.46
				17	20.34	20.66
			52T	37	20.20	20.00
				41	22.66	23.13
				44	21.66	21.54
			106T	53	21.40	21.70
				54	25.74	23.89
				56	23.41	21.46
			242T	61	29.63	28.32
				62	31.78	28.46
			SU	-	39.97	39.69
		5310	26T	0	20.44	19.43
				9	21.21	22.14
				17	19.92	19.49
			52T	37	20.54	20.43
				41	23.50	21.74
				44	21.91	20.84
			106T	53	20.32	19.22
				54	27.36	23.88
				56	19.58	23.39
			242T	61	27.78	28.76
				62	30.76	32.36
			SU	-	39.95	39.81

9.2.6. 802.11ax HE80 MODE IN THE 5.3 GHz BAND

Band	Mode	Center Freq.(MHz)	Tones	RU offset	26 dB BW (MHz)	
					ANT1	ANT2
UNII-2A	HE80	5290	26T	0	20.92	20.66
				18	40.37	41.54
				36	23.64	20.81
			52T	37	21.49	21.79
				45	26.20	29.45
				52	24.54	25.87
			106T	53	24.51	26.07
				57	33.89	33.72
				60	25.59	27.00
			242T	61	35.18	35.36
				62	50.17	52.99
				64	36.10	38.18
			484T	65	56.86	54.64
				66	61.45	67.83
			SU	-	82.10	81.26

9.2.7. 802.11ax HE20 MODE IN THE 5.5 GHz BAND

Band	Mode	Center Freq.(MHz)	Tones	RU offset	26 dB BW (MHz)	
					ANT1	ANT2
UNII-2C	HE20	5500	26T	0	18.65	18.60
				4	18.19	17.10
				8	20.45	20.68
			52T	37	20.22	20.01
				38	19.25	18.81
				40	21.11	20.84
			106T	53	19.99	20.64
				54	18.72	20.18
			SU	-	21.41	21.63
		5580	26T	0	18.90	19.53
				4	17.38	18.03
				8	20.44	20.52
			52T	37	19.64	20.12
				38	19.00	19.52
				40	20.98	21.12
			106T	53	18.32	20.83
				54	19.57	21.46
			SU	-	21.64	21.54
		5700	26T	0	19.24	19.75
				4	18.91	18.54
				8	20.07	19.10
			52T	37	18.80	19.32
				38	19.20	18.38
				40	20.30	20.19
106T	53		20.45	20.37		
	54		21.48	21.32		
SU	-		21.38	21.49		
UNII-2C	HE20	Straddle 5720	26T	0	19.60	17.99
				4	18.71	18.36
			52T	37	19.95	20.00
				38	18.91	17.50
			106T	53	20.41	20.81
				54*	15.38	15.25
			SU	- *	15.74	15.73

* RU allocation Included in the straddle band

9.2.8.802.11ax HE40 MODE IN THE 5.5 GHz BAND

Band	Mode	Center Freq.(MHz)	Tones	RU offset	26 dB BW (MHz)	
					ANT1	ANT2
UNII-2C	HE40	5510	26T	0	18.20	19.16
				9	21.22	22.29
				17	18.60	19.82
			52T	37	20.45	17.63
				41	21.36	23.30
				44	22.02	20.53
			106T	53	21.64	23.03
				54	25.71	27.30
				56	23.17	24.50
		242T	61	29.35	29.66	
			62	31.06	28.93	
		SU	-	39.97	39.66	
		5590	26T	0	19.99	20.29
				9	21.15	22.79
				17	18.37	18.07
			52T	37	21.10	21.05
				41	23.36	23.82
				44	21.56	20.93
			106T	53	22.48	21.61
				54	24.92	26.50
				56	24.61	19.04
		242T	61	30.05	28.76	
			62	29.86	30.43	
		SU	-	39.90	39.91	
		5670	26T	0	19.78	18.70
				9	22.12	21.68
				17	18.36	19.15
52T	37		18.96	19.44		
	41		24.36	25.08		
	44		20.53	20.78		
106T	53		22.34	23.34		
	54		26.51	25.93		
	56		24.56	24.42		
242T	61	31.06	30.36			
	62	30.94	30.03			
SU	-	40.44	39.87			

Band	Mode	Center Freq.(MHz)	Tones	RU offset	26 dB BW (MHz)	
					ANT1	ANT2
UNII-2C	HE40	Straddle 5710	26T	0	18.78	18.94
				9	21.17	21.73
			52T	37	19.76	21.16
				41	23.08	20.08
			106T	53	21.40	19.69
				54	27.28	28.20
				56*	20.62	15.79
			242T	61	29.13	29.58
				62*	28.88	26.72
			SU	- *	34.79	34.92

* RU allocation Included in the straddle band

9.2.9.802.11ax HE80 MODE IN THE 5.5 GHz BAND

Band	Mode	Center Freq.(MHz)	Tones	RU offset	26 dB BW (MHz)	
					ANT1	ANT2
UNII-2C	HE80	5530	26T	0	20.83	18.42
				18	34.47	40.38
				36	19.79	22.63
			52T	37	22.56	23.28
				45	29.88	22.68
				52	26.32	22.47
			106T	53	26.15	23.72
				57	29.39	36.42
				60	22.46	28.18
			242T	61	35.65	33.93
				62	51.04	52.51
				64	42.77	39.90
		484T	65	56.52	57.48	
			66	62.59	58.71	
		SU	-	80.73	81.02	
		5610	26T	0	22.21	21.60
				18	41.31	38.87
				36	20.91	23.05
			52T	37	22.68	17.77
				45	28.64	24.29
				52	25.63	24.99
			106T	53	24.27	26.57
				57	28.99	35.33
				60	27.70	30.04
242T	61		34.20	35.98		
	62		52.84	50.42		
	64		38.23	38.37		
484T	65	53.89	61.64			
	66	60.28	63.15			
SU	-	82.18	81.61			

Band	Mode	Center Freq.(MHz)	Tones	RU offset	26 dB BW (MHz)	
					ANT1	ANT2
UNII-2C	HE80	Straddle 5690	26T	0	21.50	21.45
				18	34.38	40.92
			52T	37	23.90	18.05
				45	28.28	25.22
			106T	53	24.65	23.09
				57	29.25	32.41
				60*	22.93	22.15
			242T	61	33.31	38.81
				62	50.11	52.44
				64*	37.55	34.37
			484T	65	52.88	53.93
				66*	65.27	58.43
			SU	- *	75.61	75.45

* RU allocation Included in the straddle band

10. ANTENNA PORT TEST RESULTS

10.1. 6 dB BANDWIDTH

LIMITS

FCC §15.407

The minimum 6 dB bandwidth shall be at least 500 kHz.

TEST PROCEDURE

Reference to 789033 D02 General UNII Test Procedures New Rules v02r01: The transmitter output is connected to a spectrum analyzer with the RBW set to 100KHz, the VBW $\geq 3 \times$ RBW, peak detector and max hold.

NOTE

- Calculation for 6dB Bandwidth of RU allocation included to straddle band in UNII-3 Straddle Channel

- ex) Marker 3: Upper point of 6 dB bandwidth
 - Marker 3: 5728 MHz
 - Starting Frequency of UNII-3 band : 5725MHz
 - 6dB Bandwidth of UNII-3 band Portion
= (5728 - 5725) = 3 MHz

- 6dB Bandwidth test were performed each antenna port on SISO mode.

RESULTS

See the next page. (Test plots refer to the Appendix C.)

10.1.1. 802.11ax HE20 MODE IN THE 5.8 GHz BAND

Band	Mode	Center Freq.(MHz)	Tones	RU offset	6 dB BW (MHz)		Minimum Limit (MHz)
					ANT1	ANT2	
UNII-3	HE20	Straddle 5720	26T	8	2.037	1.994	0.5
			106T	54*	4.530	4.588	
			SU	- *	4.492	4.530	
		5745	26T	0	2.023	2.048	
		5785	26T	0	2.031	2.044	
		5825	26T	0	2.045	2.024	
		Mnimum 6dB Bandwidth					

* RU allocation Included in the straddle band

10.1.2. 802.11ax HE40 MODE IN THE 5.8 GHz BAND

Band	Mode	Center Freq.(MHz)	Tones	RU offset	6 dB BW (MHz)		Minimum Limit (MHz)
					ANT1	ANT2	
UNII-3	HE40	Straddle 5710	26T	17	2.002	1.851	0.5
			106T	56*	3.998	3.954	
			242T	62*	3.634	3.678	
			SU	- *	3.522	3.950	
		5755	26T	0	1.931	2.066	
		5795	26T	0	2.063	2.047	
		Mnimum 6dB Bandwidth					

* RU allocation Included in the straddle band

10.1.3. 802.11ax HE80 MODE IN THE 5.8 GHz BAND

Band	Mode	Center Freq.(MHz)	Tones	RU offset	6 dB BW (MHz)		Minimum Limit (MHz)
					ANT1	ANT2	
UNII-3	HE80	Straddle 5690	26T	36	2.039	2.009	0.5
			106T	60*	3.984	3.980	
			242T	64*	3.774	4.040	
			484T	66*	3.690	3.794	
			SU	- *	3.578	2.610	
		5775	26T	0	2.013	2.040	
		Mnimum 6dB Bandwidth					

* RU allocation Included in the straddle band

10.2. OUTPUT POWER AND PPSD

LIMITS

FCC §15.407 (a) (1) (2) (3)

FCC

For the band 5.15–5.25 GHz, the maximum conducted output power over the frequency band of operation shall not exceed the lesser of 250 mW or 11 dBm + 10 log B, where B is the 26–dB emission bandwidth in MHz. In addition, the peak power spectral density shall not exceed 11 dBm in any 1–MHz band. If transmitting antennas of directional gain greater than 6 dBi are used, both the maximum conducted output power and the peak power spectral density shall be reduced by the amount in dB that the directional gain of the antenna exceeds 6 dBi.

For the 5.25-5.35 GHz and 5.47-5.725 GHz bands, the maximum conducted output power over the frequency bands of operation shall not exceed the lesser of 250 mW or 11 dBm + 10 log B, where B is the 26 dB emission bandwidth in megahertz. In addition, the maximum power spectral density shall not exceed 11 dBm in any 1 megahertz band. If transmitting antennas of directional gain greater than 6 dBi are used, both the maximum conducted output power and the maximum power spectral density shall be reduced by the amount in dB that the directional gain of the antenna exceeds 6 dBi.

For the band 5.725-5.85 GHz, the maximum conducted output power over the frequency band of operation shall not exceed 1 W. In addition, the maximum power spectral density shall not exceed 30 dBm in any 500-kHz band.

TEST PROCEDURE

KDB 789033 Method PM is used for output power.

KDB 789033 Method SA-2 is used for only power of straddle Ch. and PPSD. RBW set to 100kHz (the VBW >= 3 x RBW, RMS detector and trace averaging, add 10 log (1MHz/RBW)). For UNII-3, add 10 log (500kHz/RBW)). Band power function used for power and peak marker value of the spectrum is used for PSD. Add duty cycle correction factor.

DIRECTIONAL ANTENNA GAIN

For OUTPUT POWER and PSD: The TX chains are correlated and the antenna gains are unequal among the chains. The directional gain is:

Frequency Band [MHz]	Antenna1 Gain [dBi]	Antenna2 Gain [dBi]	Correlated Chains Directional Gain [dBi]
UNII 1 5150 - 5250	-8.40	-7.30	-4.82
UNII 2A 5250 - 5350	-7.40	-7.20	-4.29
UNII 2C 5470 - 5725	-7.10	-6.50	-3.78
UNII 3 5725 - 5850	-7.10	-6.80	-3.94

RESULTS

See the next page. (Test plots refer to the Appendix D.)

10.2.1. 802.11ax HE20 1TX MODE IN THE 5.2 GHz BAND

Bandwidth and Antenna Gain

Channel	Frequency [MHz]	Min 26 dB BW [MHz]	Min 99% BW [MHz]	Directional Gain for Power [dBi]
Low	5180	18.17	N/A	-4.82
Mid	5200	18.20	N/A	-4.82
High	5240	18.00	N/A	-4.82

Limits

Channel	Frequency [MHz]	FCC Power Limit [dBm]	IC Power Limit [dBm]	FCC PPSD Limit [dBm]
Low	5180	23.59	N/A	11.00
Mid	5200	23.60	N/A	11.00
High	5240	23.55	N/A	11.00

Included in Calculations of Corr'd Power & PPSD				
Duty Cycle CF [dB]	HE20	26T	0.50	dB
		52T	0.46	dB
		106T	0.45	dB
		SU	0.11	dB

Calculation of Output Power result

Corr'd Power [dBm] = Meas Power [dBm] + Duty CF [dB]

Output Power Results

Channel	Frequency [MHz]	Tones	RU offset	Antenna 1 Meas Power [dBm]	Antenna 2 Meas Power [dBm]	Antenna 1 Corr'd Power [dBm]	Antenna 2 Corr'd Power [dBm]	Power Limit [dBm]	Power Margin [dB]
Low	5180	26T	0	7.61	7.81	8.11	8.31	23.59	-15.28
			4	7.90	7.92	8.40	8.42	23.59	-15.17
			8	7.59	7.44	8.09	7.94	23.59	-15.50
		52T	37	9.09	9.58	9.55	10.04	23.59	-13.55
			38	10.08	9.82	10.54	10.28	23.59	-13.05
			40	9.79	9.56	10.25	10.02	23.59	-13.34
		106T	53	12.06	11.90	12.51	12.35	23.59	-11.08
			54	12.04	11.91	12.49	12.36	23.59	-11.10
		SU	-	13.56	13.31	13.67	13.42	23.59	-9.92
		Mid	5200	26T	0	7.93	7.58	8.43	8.08
4	7.89				8.10	8.39	8.60	23.60	-15.00
8	7.61				7.80	8.11	8.30	23.60	-15.30
52T	37			9.63	9.44	10.09	9.90	23.60	-13.51
	38			9.77	9.45	10.23	9.91	23.60	-13.37
	40			9.45	9.68	9.91	10.14	23.60	-13.46
106T	53			12.04	11.87	12.49	12.32	23.60	-11.11
	54			11.88	11.86	12.33	12.31	23.60	-11.27
SU	-			13.47	13.27	13.58	13.38	23.60	-10.02
High	5240			26T	0	7.65	7.72	8.15	8.22
		4	7.81		7.60	8.31	8.10	23.55	-15.24
		8	7.56		7.69	8.06	8.19	23.55	-15.36
		52T	37	9.62	9.45	10.08	9.91	23.55	-13.47
			38	9.74	9.57	10.20	10.03	23.55	-13.35
			40	9.49	9.35	9.95	9.81	23.55	-13.60
		106T	53	12.04	11.83	12.49	12.28	23.55	-11.06
			54	11.98	11.80	12.43	12.25	23.55	-11.12
		SU	-	13.45	13.25	13.56	13.36	23.55	-9.99

Actual RBW	Ref. Bandwidth	Corr'd factor
100 kHz	1000 kHz	10.00 dB

Calculation of PPSD result

Corr'd PPSD [dBm] = Meas PPSD [dBm] + Duty CF [dB] + Corr'd factor [dB]

PPSD Results

Channel	Frequency [MHz]	Tones	RU offset	Antenna 1 Meas PPSD [dBm]	Antenna 2 Meas PPSD [dBm]	Antenna 1 Corr'd PPSD [dBm]	Antenna 2 Corr'd PPSD [dBm]	PSD Limit [dBm]	Power Margin [dB]
Low	5180	26T	0	-4.27	-5.44	6.23	5.06	11.00	-4.77
			4	-4.18	-4.35	6.32	6.15	11.00	-4.68
			8	-4.62	-4.78	5.89	5.72	11.00	-5.12
		52T	37	-5.76	-5.79	4.70	4.67	11.00	-6.30
			38	-5.03	-5.44	5.43	5.02	11.00	-5.57
			40	-5.95	-5.72	4.51	4.74	11.00	-6.26
		106T	53	-5.95	-6.49	4.50	3.96	11.00	-6.50
			54	-6.55	-6.52	3.90	3.93	11.00	-7.07
		SU	-	-8.04	-8.36	2.07	1.75	11.00	-8.93
		Mid	5200	26T	0	-4.43	-4.08	6.07	6.42
4	-4.48				-4.38	6.02	6.12	11.00	-4.88
8	-4.89				-4.78	5.61	5.72	11.00	-5.28
52T	37			-5.83	-5.77	4.63	4.69	11.00	-6.31
	38			-4.83	-5.22	5.63	5.24	11.00	-5.37
	40			-5.23	-5.70	5.23	4.76	11.00	-5.77
106T	53			-6.29	-6.19	4.16	4.26	11.00	-6.74
	54			-6.13	-6.42	4.32	4.03	11.00	-6.68
SU	-			-7.91	-8.66	2.20	1.45	11.00	-8.80
High	5240			26T	0	-4.96	-4.82	5.54	5.68
		4	-4.24		-4.70	6.26	5.80	11.00	-4.74
		8	-5.28		-4.60	5.22	5.90	11.00	-5.10
		52T	37	-5.35	-6.03	5.11	4.43	11.00	-5.89
			38	-4.99	-5.34	5.47	5.12	11.00	-5.53
			40	-5.69	-5.76	4.77	4.70	11.00	-6.23
		106T	53	-6.18	-6.26	4.27	4.19	11.00	-6.73
			54	-6.32	-6.38	4.13	4.07	11.00	-6.87
		SU	-	-7.87	-8.44	2.24	1.67	11.00	-8.76

10.2.2. 802.11ax HE40 1TX MODE IN THE 5.2 GHz BAND

Bandwidth and Antenna Gain

Channel	Frequency [MHz]	Min 26 dB BW [MHz]	Min 99% BW [MHz]	Directional Gain for Power [dBi]
Low	5190	19.30	N/A	-4.82
High	5230	18.68	N/A	-4.82

Limits

Channel	Frequency [MHz]	FCC Power Limit [dBm]	IC Power Limit [dBm]	FCC PPSD Limit [dBm]
Low	5190	23.86	N/A	11.00
High	5230	23.71	N/A	11.00

Included in Calculations of Corr'd Power & PPSD				
Duty Cycle CF [dB]	HE40	26T	0.49	dB
		52T	0.47	dB
		106T	0.45	dB
		242T	0.44	dB
		SU	0.10	dB

Calculation of Output Power result

Corr'd Power [dBm] = Meas Power [dBm] + Duty CF [dB]

Output Power Results

Channel	Frequency [MHz]	Tones	RU offset	Antenna 1 Meas Power [dBm]	Antenna 2 Meas Power [dBm]	Antenna 1 Corr'd Power [dBm]	Antenna 2 Corr'd Power [dBm]	Power Limit [dBm]	Power Margin [dB]		
Low	5190	26T	0	8.02	7.31	8.51	7.80	23.86	-15.35		
			9	7.69	7.99	8.18	8.48	23.86	-15.38		
			17	7.90	7.67	8.39	8.16	23.86	-15.47		
		52T	37	9.83	9.14	10.30	9.61	23.86	-13.56		
			41	9.81	9.75	10.28	10.22	23.86	-13.58		
			44	9.78	9.55	10.25	10.02	23.86	-13.61		
		106T	53	12.09	11.75	12.54	12.20	23.86	-11.32		
			54	11.96	11.88	12.41	12.33	23.86	-11.45		
			56	11.87	11.54	12.32	11.99	23.86	-11.54		
		242T	61	12.91	12.69	13.35	13.13	23.86	-10.51		
			62	12.69	12.44	13.13	12.88	23.86	-10.73		
		SU	-	13.35	13.37	13.45	13.47	23.86	-10.39		
		High	5230	26T	0	8.06	7.33	8.55	7.82	23.86	-15.31
					9	7.27	7.71	7.76	8.20	23.86	-15.66
17	7.83				7.77	8.32	8.26	23.86	-15.54		
52T	37			10.11	9.23	10.58	9.70	23.86	-13.28		
	41			10.17	9.55	10.64	10.02	23.86	-13.22		
	44			9.85	9.63	10.32	10.10	23.86	-13.54		
106T	53			12.06	11.71	12.51	12.16	23.86	-11.35		
	54			11.91	11.78	12.36	12.23	23.86	-11.50		
	56			11.79	11.52	12.24	11.97	23.86	-11.62		
242T	61			12.76	12.49	13.20	12.93	23.86	-10.66		
	62			12.71	12.45	13.15	12.89	23.86	-10.71		
SU	-			13.29	13.27	13.39	13.37	23.86	-10.47		

Actual RBW	Ref. Bandwidth	Corr'd factor
100 kHz	1000 kHz	10.00 dB

Calculation of PPSD result

Corr'd PPSD [dBm] = Meas PPSD [dBm] + Duty CF [dB] + Corr'd factor [dB]

PPSD Results

Channel	Frequency [MHz]	Tones	RU offset	Antenna 1 Meas PPSD [dBm]	Antenna 2 Meas PPSD [dBm]	Antenna 1 Corr'd PPSD [dBm]	Antenna 2 Corr'd PPSD [dBm]	PSD Limit [dBm]	Power Margin [dB]		
Low	5190	26T	0	-4.73	-5.03	5.76	5.46	11.00	-5.24		
			9	-4.52	-4.61	5.97	5.89	11.00	-5.03		
			17	-4.51	-4.22	5.98	6.27	11.00	-4.73		
		52T	37	-5.15	-5.40	5.32	5.07	11.00	-5.68		
			41	-5.68	-5.17	4.79	5.30	11.00	-5.70		
			44	-5.62	-5.64	4.85	4.83	11.00	-6.15		
		106T	53	-6.15	-6.64	4.30	3.81	11.00	-6.70		
			54	-6.18	-6.52	4.27	3.93	11.00	-6.73		
			56	-6.45	-6.65	4.00	3.80	11.00	-7.00		
		242T	61	-8.64	-9.34	1.80	1.10	11.00	-9.20		
			62	-8.98	-9.13	1.46	1.31	11.00	-9.54		
		SU	-	-10.85	-11.22	-0.75	-1.12	11.00	-11.75		
		High	5230	26T	0	-4.23	-5.41	6.26	5.08	11.00	-4.74
					9	-5.10	-4.63	5.39	5.86	11.00	-5.14
17	-4.41				-4.43	6.08	6.06	11.00	-4.92		
52T	37			-5.05	-5.81	5.42	4.66	11.00	-5.58		
	41			-5.47	-5.84	5.00	4.63	11.00	-6.00		
	44			-5.50	-5.55	4.97	4.92	11.00	-6.03		
106T	53			-6.27	-6.78	4.18	3.67	11.00	-6.82		
	54			-6.37	-6.73	4.08	3.72	11.00	-6.92		
	56			-6.23	-6.70	4.22	3.75	11.00	-6.78		
242T	61			-8.81	-9.09	1.63	1.35	11.00	-9.37		
	62			-8.78	-8.81	1.66	1.63	11.00	-9.34		
SU	-			-10.83	-11.21	-0.73	-1.11	11.00	-11.73		

10.2.3. 802.11ax HE80 1TX MODE IN THE 5.2 GHz BAND

Bandwidth and Antenna Gain

Channel	Frequency [MHz]	Min 26 dB BW [MHz]	Min 99% BW [MHz]	Directional Gain for Power [dBi]
Mid	5210	19.83	N/A	-4.82

Limits

Channel	Frequency [MHz]	FCC Power Limit [dBm]	IC Power Limit [dBm]	FCC PPSD Limit [dBm]
Mid	5210	23.97	N/A	11.00

Included in Calculations of Corr'd Power & PPSD				
Duty Cycle CF [dB]	HE40	26T	0.50	dB
		52T	0.48	dB
		106T	0.45	dB
		242T	0.44	dB
		484T	0.43	dB
		SU	0.10	dB

Calculation of Output Power result

Corr'd Power [dBm] = Meas Power [dBm] + Duty CF [dB]

Output Power Results

Channel	Frequency [MHz]	Tones	RU offset	Antenna 1 Meas Power [dBm]	Antenna 2 Meas Power [dBm]	Antenna 1 Corr'd Power [dBm]	Antenna 2 Corr'd Power [dBm]	Power Limit [dBm]	Power Margin [dB]
Mid	5210	26T	0	7.70	6.81	8.20	7.31	23.97	-15.77
			18	7.81	8.22	8.31	8.72	23.97	-15.25
			36	7.54	7.82	8.04	8.32	23.97	-15.65
		52T	37	9.56	9.78	10.04	10.26	23.97	-13.71
			45	9.64	9.96	10.12	10.44	23.97	-13.53
			52	9.13	9.80	9.61	10.28	23.97	-13.69
		106T	53	11.44	11.23	11.89	11.68	23.97	-12.08
			57	11.71	11.48	12.16	11.93	23.97	-11.81
			60	11.12	10.96	11.57	11.41	23.97	-12.40
		242T	61	11.86	12.01	12.30	12.45	23.97	-11.52
			62	12.04	12.28	12.48	12.72	23.97	-11.25
			64	11.70	11.84	12.14	12.28	23.97	-11.69
		484T	65	12.39	12.54	12.82	12.97	23.97	-11.00
			66	12.34	12.48	12.77	12.91	23.97	-11.06
		SU	-	13.51	13.31	13.61	13.41	23.97	-10.36

Actual RBW	Ref. Bandwidth	Corr'd factor
100 kHz	1000 kHz	10.00 dB

Calculation of PPSD result

Corr'd PPSD [dBm] = Meas PPSD [dBm] + Duty CF [dB] + Corr'd factor [dB]

PPSD Results

Channel	Frequency [MHz]	Tones	RU offset	Antenna 1 Meas PPSD [dBm]	Antenna 2 Meas PPSD [dBm]	Antenna 1 Corr'd PPSD [dBm]	Antenna 2 Corr'd PPSD [dBm]	PSD Limit [dBm]	Power Margin [dB]	
Mid	5210	26T	0	-4.19	-5.17	6.31	5.34	11.00	-4.69	
			18	-4.48	-5.36	6.03	5.14	11.00	-4.98	
			36	-4.56	-5.09	5.94	5.41	11.00	-5.06	
		52T	37	-5.84	-5.31	4.64	5.17	11.00	-5.83	
			45	-5.18	-5.55	5.30	4.94	11.00	-5.70	
			52	-6.33	-5.26	4.15	5.23	11.00	-5.78	
		106T	53	-6.78	-7.10	3.68	3.35	11.00	-7.33	
			57	-6.49	-6.98	3.96	3.47	11.00	-7.04	
			60	-6.69	-7.12	3.76	3.34	11.00	-7.24	
		242T	61	-9.74	-9.94	0.70	0.50	11.00	-10.30	
			62	-9.79	-9.57	0.65	0.87	11.00	-10.13	
			64	-9.87	-9.88	0.57	0.56	11.00	-10.43	
		484T	65	-12.33	-11.96	-1.90	-1.53	11.00	-12.53	
			66	-12.34	-11.81	-1.91	-1.38	11.00	-12.38	
		SU	-	-	-14.61	-14.23	-4.51	-4.13	11.00	-15.13

10.2.4. 802.11ax HE20 1TX MODE IN THE 5.3 GHz BAND

Bandwidth and Antenna Gain

Channel	Frequency [MHz]	Min 26 dB BW [MHz]	Min 99% BW [MHz]	Directional Gain for Power [dBi]
Low	5260	17.00	N/A	-4.29
Mid	5300	17.92	N/A	-4.29
High	5320	18.88	N/A	-4.29

Limits

Channel	Frequency [MHz]	FCC Power Limit [dBm]	IC Power Limit [dBm]	FCC PPSD Limit [dBm]
Low	5260	23.30	N/A	11.00
Mid	5300	23.53	N/A	11.00
High	5320	23.76	N/A	11.00

Included in Calculations of Corr'd Power & PPSD				
Duty Cycle CF [dB]	HE20	26T	0.50	dB
		52T	0.46	dB
		106T	0.45	dB
		SU	0.11	dB

Calculation of Output Power result

Corr'd Power [dBm] = Meas Power [dBm] + Duty CF [dB]

Output Power Results

Channel	Frequency [MHz]	Tones	RU offset	Antenna 1 Meas Power [dBm]	Antenna 2 Meas Power [dBm]	Antenna 1 Corr'd Power [dBm]	Antenna 2 Corr'd Power [dBm]	Power Limit [dBm]	Power Margin [dB]
Low	5260	26T	0	8.19	7.77	8.69	8.27	23.30	-14.61
			4	8.21	7.94	8.71	8.44	23.30	-14.59
			8	7.77	7.58	8.27	8.08	23.30	-15.03
		52T	37	10.02	9.83	10.48	10.29	23.30	-12.82
			38	10.09	9.96	10.55	10.42	23.30	-12.75
			40	9.81	9.71	10.27	10.17	23.30	-13.03
		106T	53	12.07	11.87	12.52	12.32	23.30	-10.78
			54	11.94	11.81	12.39	12.26	23.30	-10.91
		SU	-	13.52	13.23	13.63	13.34	23.30	-9.67
		Mid	5300	26T	0	7.81	7.92	8.31	8.42
4	8.38				8.13	8.88	8.63	23.53	-14.65
8	8.05				7.86	8.55	8.36	23.53	-14.98
52T	37			9.93	9.56	10.39	10.02	23.53	-13.14
	38			9.95	10.12	10.41	10.58	23.53	-12.95
	40			9.40	9.88	9.86	10.34	23.53	-13.19
106T	53			12.02	11.78	12.47	12.23	23.53	-11.06
	54			11.93	11.76	12.38	12.21	23.53	-11.15
SU	-			13.47	13.24	13.58	13.35	23.53	-9.95
High	5320			26T	0	8.07	7.98	8.57	8.48
		4	8.01		8.06	8.51	8.56	23.76	-15.20
		8	7.66		7.77	8.16	8.27	23.76	-15.49
		52T	37	10.16	10.04	10.62	10.50	23.76	-13.14
			38	10.13	10.06	10.59	10.52	23.76	-13.17
			40	9.55	9.78	10.01	10.24	23.76	-13.52
		106T	53	12.07	11.81	12.52	12.26	23.76	-11.24
			54	11.84	11.75	12.29	12.20	23.76	-11.47
		SU	-	13.41	13.21	13.52	13.32	23.76	-10.24

Actual RBW	Ref. Bandwidth	Corr'd factor
100 kHz	1000 kHz	10.00 dB

Calculation of PPSD result

Corr'd PPSD [dBm] = Meas PPSD [dBm] + Duty CF [dB] + Corr'd factor [dB]

PPSD Results

Channel	Frequency [MHz]	Tones	RU offset	Antenna 1	Antenna 2	Antenna 1	Antenna 2	PSD Limit [dBm]	Power Margin [dB]
				Meas PPSD [dBm]	Meas PPSD [dBm]	Corr'd PPSD [dBm]	Corr'd PPSD [dBm]		
Low	5260	26T	0	-4.25	-3.90	6.25	6.60	11.00	-4.40
			4	-4.33	-4.71	6.17	5.79	11.00	-4.83
			8	-4.39	-4.40	6.11	6.10	11.00	-4.89
		52T	37	-5.90	-5.41	4.56	5.05	11.00	-5.95
			38	-5.16	-5.30	5.30	5.16	11.00	-5.70
			40	-5.98	-5.31	4.48	5.15	11.00	-5.85
		106T	53	-6.03	-6.04	4.42	4.41	11.00	-6.58
			54	-6.23	-6.19	4.22	4.26	11.00	-6.74
		SU	-	-7.79	-8.67	2.33	1.44	11.00	-8.68
		Mid	5300	26T	0	-4.34	-4.00	6.16	6.50
4	-4.36				-4.59	6.14	5.91	11.00	-4.86
8	-4.61				-4.33	5.89	6.17	11.00	-4.83
52T	37			-4.90	-5.42	5.56	5.04	11.00	-5.44
	38			-5.08	-5.44	5.39	5.02	11.00	-5.62
	40			-5.41	-5.26	5.05	5.20	11.00	-5.80
106T	53			-6.25	-6.68	4.20	3.77	11.00	-6.80
	54			-6.60	-6.97	3.85	3.48	11.00	-7.15
SU	-			-7.88	-8.26	2.23	1.85	11.00	-8.77
High	5320			26T	0	-4.43	-4.33	6.07	6.17
		4	-3.95		-4.38	6.55	6.12	11.00	-4.45
		8	-4.47		-4.78	6.03	5.72	11.00	-4.97
		52T	37	-5.07	-5.98	5.39	4.48	11.00	-5.61
			38	-5.01	-5.60	5.45	4.86	11.00	-5.55
			40	-5.54	-5.53	4.92	4.93	11.00	-6.07
		106T	53	-6.12	-6.83	4.33	3.62	11.00	-6.67
			54	-6.22	-6.31	4.23	4.14	11.00	-6.77
		SU	-	-8.10	-8.70	2.01	1.41	11.00	-8.99

10.2.5. 802.11ax HE40 1TX MODE IN THE 5.3 GHz BAND

Bandwidth and Antenna Gain

Channel	Frequency [MHz]	Min 26 dB BW [MHz]	Min 99% BW [MHz]	Directional Gain for Power [dBi]
Low	5270	19.49	N/A	-4.29
High	5310	19.22	N/A	-4.29

Limits

Channel	Frequency [MHz]	FCC Power Limit [dBm]	IC Power Limit [dBm]	FCC PPSD Limit [dBm]
Low	5270	23.90	N/A	11.00
High	5310	23.84	N/A	11.00

Included in Calculations of Corr'd Power & PPSD				
Duty Cycle CF [dB]	HE40	26T	0.49	dB
		52T	0.47	dB
		106T	0.45	dB
		242T	0.44	dB
		SU	0.10	dB

Calculation of Output Power result

Corr'd Power [dBm] = Meas Power [dBm] + Duty CF [dB]

Output Power Results

Channel	Frequency [MHz]	Tones	RU offset	Antenna 1 Meas Power [dBm]	Antenna 2 Meas Power [dBm]	Antenna 1 Corr'd Power [dBm]	Antenna 2 Corr'd Power [dBm]	Power Limit [dBm]	Power Margin [dB]		
Low	5270	26T	0	8.02	7.89	8.51	8.38	23.90	-15.39		
			9	7.91	7.91	8.18	8.40	23.90	-15.50		
			17	7.53	8.12	8.39	8.61	23.90	-15.29		
		52T	37	9.89	9.73	10.30	10.22	23.90	-13.60		
			41	9.83	9.71	10.28	10.20	23.90	-13.62		
			44	9.77	9.74	10.25	10.23	23.90	-13.65		
		106T	53	11.86	11.52	12.54	12.01	23.90	-11.36		
			54	11.68	11.41	12.41	11.90	23.90	-11.49		
			56	11.54	11.33	12.32	11.82	23.90	-11.58		
		242T	61	12.70	12.39	13.35	12.88	23.90	-10.55		
			62	12.55	12.24	13.13	12.73	23.90	-10.77		
		SU	-	12.78	12.88	13.45	13.37	23.90	-10.45		
		High	5310	26T	0	7.67	8.06	8.55	8.55	23.90	-15.35
					9	7.80	8.03	7.76	8.52	23.90	-15.38
17	7.82				8.22	8.32	8.71	23.90	-15.19		
52T	37			9.70	10.02	10.58	10.51	23.90	-13.32		
	41			9.75	9.87	10.64	10.36	23.90	-13.26		
	44			10.16	9.86	10.32	10.35	23.90	-13.55		
106T	53			11.92	11.57	12.51	12.06	23.90	-11.39		
	54			11.63	11.41	12.36	11.90	23.90	-11.54		
	56			11.53	11.31	12.24	11.80	23.90	-11.66		
242T	61			12.62	12.40	13.20	12.89	23.90	-10.70		
	62			12.46	12.26	13.15	12.75	23.90	-10.75		
SU	-			12.71	12.81	13.39	13.30	23.90	-10.51		

Actual RBW	Ref. Bandwidth	Corr'd factor
100 kHz	1000 kHz	10.00 dB

Calculation of PPSD result
 Corr'd PPSD [dBm] = Meas PPSD [dBm] + Duty CF [dB] + Corr'd factor [dB]

PPSD Results

Channel	Frequency [MHz]	Tones	RU offset	Antenna 1	Antenna 2	Antenna 1	Antenna 2	PSD Limit [dBm]	Power Margin [dB]		
				Meas PPSD [dBm]	Meas PPSD [dBm]	Corr'd PPSD [dBm]	Corr'd PPSD [dBm]				
Low	5270	26T	0	-4.56	-4.48	5.93	6.01	11.00	-4.99		
			9	-4.65	-4.90	5.84	5.59	11.00	-5.16		
			17	-3.91	-4.01	6.58	6.48	11.00	-4.42		
		52T	37	-4.94	-5.97	5.53	4.50	11.00	-5.47		
			41	-4.68	-5.49	5.79	4.98	11.00	-5.21		
			44	-5.37	-5.35	5.10	5.12	11.00	-5.88		
		106T	53	-6.80	-6.92	3.65	3.53	11.00	-7.35		
			54	-6.77	-6.79	3.68	3.66	11.00	-7.32		
			56	-6.73	-7.08	3.72	3.37	11.00	-7.28		
		242T	61	-8.70	-9.15	1.74	1.29	11.00	-9.26		
			62	-8.98	-9.46	1.46	0.98	11.00	-9.54		
		SU	-	-11.16	-11.19	-1.06	-1.09	11.00	-12.06		
		High	5310	26T	0	-3.74	-4.09	6.75	6.40	11.00	-4.25
					9	-4.35	-4.58	6.14	5.91	11.00	-4.86
17	-5.03				-4.05	5.47	6.44	11.00	-4.56		
52T	37			-5.05	-5.88	5.42	4.59	11.00	-5.58		
	41			-5.64	-5.21	4.83	5.26	11.00	-5.74		
	44			-5.32	-5.36	5.15	5.12	11.00	-5.85		
106T	53			-6.14	-7.04	4.31	3.42	11.00	-6.69		
	54			-6.71	-6.76	3.74	3.69	11.00	-7.26		
	56			-6.78	-6.82	3.67	3.63	11.00	-7.33		
242T	61			-9.02	-9.30	1.42	1.14	11.00	-9.58		
	62			-9.25	-9.25	1.19	1.19	11.00	-9.81		
SU	-			-11.23	-11.27	-1.13	-1.17	11.00	-12.13		

10.2.6. 802.11ax HE80 1TX MODE IN THE 5.3 GHz BAND

Bandwidth and Antenna Gain

Channel	Frequency	Min 26 dB BW [MHz]	Min 99% BW [MHz]	Directional Gain for Power [dBi]
Mid	5290	20.66	N/A	-4.29

Limits

Channel	Frequency	FCC Power Limit	IC Power Limit	FCC PPSD Limit
	[MHz]	[dBm]	[dBm]	[dBm]
Mid	5290	24.00	N/A	11.00

Included in Calculations of Corr'd Power & PPSD				
Duty Cycle CF [dB]	HE80	26T	0.50	dB
		52T	0.48	dB
		106T	0.45	dB
		242T	0.44	dB
		484T	0.43	dB
		SU	0.10	dB

Calculation of Output Power result

Corr'd Power [dBm] = Meas Power [dBm] + Duty CF [dB]

Output Power Results

Channel	Frequency	Tones	RU offset	Antenna 1 Meas Power [dBm]	Antenna 2 Meas Power [dBm]	Antenna 1 Corr'd Power [dBm]	Antenna 2 Corr'd Power [dBm]	Power Limit [dBm]	Power Margin [dB]
	[MHz]								
Mid	5290	26T	0	7.56	6.81	8.06	8.86	24.00	-15.14
			18	7.96	8.22	8.46	8.59	24.00	-15.41
			36	7.36	7.82	7.86	8.36	24.00	-15.64
		52T	37	9.67	9.78	10.15	10.41	24.00	-13.59
			45	9.94	9.96	10.42	10.36	24.00	-13.58
			52	9.10	9.80	9.58	10.16	24.00	-13.84
		106T	53	11.23	11.23	11.68	11.38	24.00	-12.32
			57	11.51	11.48	11.96	11.55	24.00	-12.04
			60	10.94	10.96	11.39	11.04	24.00	-12.61
		242T	61	11.79	12.01	12.23	12.22	24.00	-11.77
			62	12.03	12.28	12.47	12.50	24.00	-11.50
			64	11.53	11.84	11.97	12.18	24.00	-11.82
		484T	65	12.19	12.54	12.62	12.77	24.00	-11.23
			66	12.07	12.48	12.50	12.68	24.00	-11.32
		SU	-	13.22	13.31	13.32	13.18	24.00	-10.68

Actual RBW	Ref. Bandwidth	Corr'd factor
100 kHz	1000 kHz	10.00 dB

Calculation of PPSD result

Corr'd PPSD [dBm] = Meas PPSD [dBm] + Duty CF [dB] + Corr'd factor [dB]

PPSD Results

Channel	Frequency [MHz]	Tones	RU offset	Antenna 1 Meas PPSD [dBm]	Antenna 2 Meas PPSD [dBm]	Antenna 1 Corr'd PPSD [dBm]	Antenna 2 Corr'd PPSD [dBm]	PSD Limit [dBm]	Power Margin [dB]	
Low	5290	26T	0	-3.81	-3.91	6.69	6.59	11.00	-4.31	
			18	-4.22	-4.57	6.28	5.93	11.00	-4.72	
			36	-4.39	-4.44	6.11	6.06	11.00	-4.89	
		52T	37	-5.42	-4.82	5.06	5.67	11.00	-5.34	
			45	-5.14	-5.06	5.34	5.42	11.00	-5.58	
			52	-5.65	-4.95	4.83	5.53	11.00	-5.47	
		106T	53	-6.97	-7.36	3.48	3.09	11.00	-7.52	
			57	-6.48	-7.56	3.97	2.89	11.00	-7.03	
			60	-7.06	-7.46	3.39	2.99	11.00	-7.61	
		242T	61	-9.75	-9.82	0.69	0.63	11.00	-10.31	
			62	-9.94	-9.50	0.50	0.94	11.00	-10.06	
			64	-9.89	-9.74	0.55	0.71	11.00	-10.30	
		484T	65	-12.57	-11.95	-2.14	-1.52	11.00	-12.52	
			66	-12.29	-11.91	-1.86	-1.48	11.00	-12.48	
		SU	-	-	-14.56	-14.05	-4.46	-3.95	11.00	-14.95

10.2.7. 802.11ax HE20 1TX MODE IN THE 5.5 GHz BAND

Bandwidth and Antenna Gain

Channel	Frequency [MHz]	Min 26 dB BW [MHz]	Min 99% BW [MHz]	Directional Gain for Power [dBi]
Low	5500	17.10	N/A	-3.78
Mid	5580	17.38	N/A	-3.78
High	5700	18.88	N/A	-3.78
Stradle	5720	17.50	N/A	-3.78

Limits

Channel	Frequency [MHz]	FCC Power Limit [dBm]	IC Power Limit [dBm]	FCC PPSD Limit [dBm]
Low	5500	23.33	N/A	11.00
Mid	5580	23.40	N/A	11.00
High	5700	23.76	N/A	11.00
Stradle	5720	23.43	N/A	11.00

Included in Calculations of Corr'd Power & PPSD				
Duty Cycle CF [dB]	HE20	26T	0.50	dB
		52T	0.46	dB
		106T	0.45	dB
		SU	0.11	dB

Calculation of Output Power result
 Corr'd Power [dBm] = Meas Power [dBm] + Duty CF [dB]

Output Power Results

Channel	Frequency [MHz]	Tones	RU offset	Antenna 1 Meas Power [dBm]	Antenna 2 Meas Power [dBm]	Antenna 1 Corr'd Power [dBm]	Antenna 2 Corr'd Power [dBm]	Power Limit [dBm]	Power Margin [dB]
Low	5500	26T	0	7.74	8.12	8.24	8.62	23.33	-14.71
			4	7.77	8.09	8.27	8.59	23.33	-14.74
			8	7.41	7.71	7.91	8.21	23.33	-15.12
		52T	37	9.04	9.89	9.50	10.35	23.33	-12.98
			38	9.13	10.00	9.59	10.46	23.33	-12.87
			40	8.74	9.73	9.20	10.19	23.33	-13.14
		106T	53	11.77	12.01	12.22	12.46	23.33	-10.87
			54	11.47	11.84	11.97	12.29	23.33	-11.04
		SU	-	14.99	15.42	15.10	15.53	23.33	-7.80
		Mid	5580	26T	0	7.42	8.03	7.92	8.53
4	7.52				8.21	8.02	8.71	23.40	-14.69
8	7.16				7.83	7.66	8.33	23.40	-15.07
52T	37			8.81	9.58	9.27	10.04	23.40	-13.36
	38			8.86	9.15	9.32	9.61	23.40	-13.79
	40			8.90	8.94	9.36	9.40	23.40	-14.00
106T	53			11.67	11.93	12.12	12.38	23.40	-11.02
	54			11.42	11.80	11.92	12.25	23.40	-11.15
SU	-			14.96	15.37	15.07	15.48	23.40	-7.92
High	5700			26T	0	7.61	8.23	8.11	8.73
		4	7.74		8.30	8.24	8.80	23.76	-14.96
		8	7.36		7.92	7.86	8.42	23.76	-15.34
		52T	37	8.92	10.04	9.38	10.50	23.76	-13.26
			38	9.44	10.16	9.90	10.62	23.76	-13.14
			40	8.79	9.92	9.25	10.38	23.76	-13.38
		106T	53	11.58	11.96	12.03	12.41	23.76	-11.35
			54	11.37	11.82	11.87	12.27	23.76	-11.49
		SU	-	14.99	15.43	15.10	15.54	23.76	-8.22

Channel	Frequency [MHz]	Tones	RU offset	Antenna 1 Meas Power [dBm]	Antenna 2 Meas Power [dBm]	Antenna 1 Corr'd Power [dBm]	Antenna 2 Corr'd Power [dBm]	Power Limit [dBm]	Power Margin [dB]
Straddle	5720	26T	0	7.33	8.30	7.83	8.80	23.43	-14.63
			4	7.43	8.39	7.93	8.89	23.43	-14.54
		52T	37	9.05	10.05	9.51	10.51	23.43	-12.92
			38	9.16	10.16	9.62	10.62	23.43	-12.81
		106T	53	11.56	11.89	12.01	12.34	23.43	-11.09

Actual RBW	Ref. Bandwidth	Corr'd factor
100 kHz	1000 kHz	10.00 dB

Calculation of PPSD result

Corr'd PPSD [dBm] = Meas PPSD [dBm] + Duty CF [dB] + Corr'd factor [dB]

PPSD Results

Channel	Frequency [MHz]	Tones	RU offset	Antenna 1 Meas PPSD [dBm]	Antenna 2 Meas PPSD [dBm]	Antenna 1 Corr'd PPSD [dBm]	Antenna 2 Corr'd PPSD [dBm]	PSD Limit [dBm]	Power Margin [dB]
Low	5500	26T	0	-4.90	-4.17	5.61	6.33	11.00	-4.67
			4	-4.58	-4.32	5.92	6.18	11.00	-4.82
			8	-5.24	-4.50	5.26	6.00	11.00	-5.00
		52T	37	-6.47	-5.37	3.99	5.09	11.00	-5.91
			38	-6.20	-5.66	4.26	4.81	11.00	-6.20
			40	-6.67	-5.32	3.79	5.14	11.00	-5.86
		106T	53	-6.54	-6.01	3.91	4.44	11.00	-6.56
			54	-6.81	-6.61	3.64	3.84	11.00	-7.16
		SU	-	-7.04	-6.50	3.07	3.61	11.00	-7.39
Mid	5580	26T	0	-5.61	-4.52	4.90	5.98	11.00	-5.02
			4	-5.28	-4.71	5.22	5.79	11.00	-5.21
			8	-4.73	-4.69	5.77	5.81	11.00	-5.19
		52T	37	-6.13	-5.70	4.33	4.76	11.00	-6.24
			38	-6.41	-5.48	4.05	4.98	11.00	-6.02
			40	-5.87	-5.95	4.59	4.52	11.00	-6.41
		106T	53	-6.34	-5.86	4.11	4.59	11.00	-6.41
			54	-6.50	-6.41	3.95	4.04	11.00	-6.96
		SU	-	-6.85	-6.22	3.26	3.89	11.00	-7.11
High	5700	26T	0	-4.44	-3.70	6.06	6.80	11.00	-4.20
			4	-4.67	-3.48	5.83	7.02	11.00	-3.98
			8	-4.79	-4.08	5.71	6.42	11.00	-4.58
		52T	37	-5.90	-4.79	4.56	5.67	11.00	-5.33
			38	-5.82	-4.80	4.64	5.66	11.00	-5.34
			40	-6.19	-4.92	4.27	5.54	11.00	-5.46
		106T	53	-6.03	-6.00	4.42	4.45	11.00	-6.55
			54	-6.13	-6.12	4.32	4.33	11.00	-6.67
		SU	-	-6.67	-6.35	3.44	3.76	11.00	-7.24
Straddle	5720	26T	0	-5.49	-4.64	5.01	5.86	11.00	-5.14
			4	-5.11	-4.42	5.39	6.08	11.00	-4.92
		52T	37	-6.07	-5.12	4.39	5.34	11.00	-5.66
			38	-6.36	-5.07	4.10	5.39	11.00	-5.61
		106T	53	-6.68	-6.40	3.78	4.05	11.00	-6.95

10.2.8. 802.11ax HE40 1TX MODE IN THE 5.5 GHz BAND

Bandwidth and Antenna Gain

Channel	Frequency [MHz]	Min 26 dB BW [MHz]	Min 99% BW [MHz]	Directional Gain for Power [dBi]
Low	5510	17.63	N/A	-3.78
Mid	5590	18.07	N/A	-3.78
High	5670	18.36	N/A	-3.78
Stradle	5710	18.78	N/A	-3.78

Limits

Channel	Frequency [MHz]	FCC Power Limit [dBm]	IC Power Limit [dBm]	FCC PPSD Limit [dBm]
Low	5510	23.46	N/A	11.00
Mid	5590	23.57	N/A	11.00
High	5670	23.64	N/A	11.00
Stradle	5710	23.74	N/A	11.00

Included in Calculations of Corr'd Power & PPSD				
Duty Cycle CF [dB]	HE40	26T	0.49	dB
		52T	0.47	dB
		106T	0.45	dB
		242T	0.44	dB
		SU	0.10	dB

Calculation of Output Power result
 Corr'd Power [dBm] = Meas Power [dBm] + Duty CF [dB]

Output Power Results

Channel	Frequency [MHz]	Tones	RU offset	Antenna 1 Meas Power [dBm]	Antenna 2 Meas Power [dBm]	Antenna 1 Corr'd Power [dBm]	Antenna 2 Corr'd Power [dBm]	Power Limit [dBm]	Power Margin [dB]		
Low	5510	26T	0	7.87	7.78	8.36	8.27	23.46	-15.10		
			9	7.65	7.99	8.14	8.48	23.46	-14.98		
			17	7.35	7.66	7.84	8.15	23.46	-15.31		
		52T	37	10.01	9.86	10.48	10.33	23.46	-12.98		
			41	9.89	9.73	10.36	10.20	23.46	-13.10		
			44	9.43	9.71	9.90	10.18	23.46	-13.28		
		106T	53	11.52	11.77	11.97	12.22	23.46	-11.24		
			54	11.61	11.73	12.06	12.18	23.46	-11.28		
			56	11.45	11.59	11.90	12.04	23.46	-11.42		
		242T	61	12.29	12.69	12.73	13.13	23.46	-10.33		
			62	12.29	12.75	12.73	13.19	23.46	-10.27		
		SU	-	13.42	13.57	13.52	13.67	23.46	-9.79		
		Mid	5590	26T	0	7.52	7.79	8.01	8.28	23.57	-15.29
					9	7.63	7.93	8.12	8.42	23.57	-15.15
17	7.22				7.64	7.71	8.13	23.57	-15.44		
52T	37			10.05	9.82	10.52	10.29	23.57	-13.05		
	41			10.00	9.75	10.47	10.22	23.57	-13.10		
	44			9.42	9.68	9.89	10.15	23.57	-13.42		
106T	53			11.44	11.58	11.89	12.03	23.57	-11.54		
	54			11.40	11.57	11.85	12.02	23.57	-11.55		
	56			11.25	11.40	11.70	11.85	23.57	-11.72		
242T	61			12.14	12.52	12.58	12.96	23.57	-10.61		
	62			12.16	12.53	12.60	12.97	23.57	-10.60		
SU	-			13.24	13.34	13.34	13.44	23.57	-10.13		
High	5670			26T	0	7.68	7.67	8.17	8.16	23.64	-15.47
					9	7.66	7.79	8.15	8.28	23.64	-15.36
		17	7.26		7.84	7.75	8.33	23.64	-15.31		
		52T	37	10.14	9.72	10.61	10.19	23.64	-13.03		
			41	9.86	9.75	10.33	10.22	23.64	-13.31		
			44	9.79	9.69	10.26	10.16	23.64	-13.38		
		106T	53	11.51	11.68	11.96	12.13	23.64	-11.51		
			54	11.41	11.66	11.86	12.11	23.64	-11.53		
			56	11.29	11.51	11.74	11.96	23.64	-11.68		
		242T	61	12.21	12.57	12.65	13.01	23.64	-10.63		
			62	12.16	12.60	12.60	13.04	23.64	-10.60		
		SU	-	13.14	13.47	13.24	13.57	23.64	-10.07		

Channel	Frequency [MHz]	Tones	RU offset	Antenna 1 Meas Power [dBm]	Antenna 2 Meas Power [dBm]	Antenna 1 Corr'd Power [dBm]	Antenna 2 Corr'd Power [dBm]	Power Limit [dBm]	Power Margin [dB]
Stradle	5710	26T	0	7.73	8.05	8.22	8.54	23.74	-15.20
			9	7.89	8.39	8.38	8.88	23.74	-14.86
		52T	37	10.17	10.08	10.64	10.55	23.74	-13.10
			41	10.09	10.21	10.56	10.68	23.74	-13.06
		106T	53	11.49	11.64	11.94	12.09	23.74	-11.65
			54	11.53	11.89	11.98	12.34	23.74	-11.40
		242T	61	11.76	11.91	12.63	13.08	23.74	-10.66

Actual RBW	Ref. Bandwidth	Corr'd factor
100 kHz	1000 kHz	10.00 dB

Calculation of PPSD result
 Corr'd PPSD [dBm] = Meas PPSD [dBm] + Duty CF [dB] + Corr'd factor [dB]

PPSD Results

Channel	Frequency [MHz]	Tones	RU offset	Antenna 1	Antenna 2	Antenna 1	Antenna 2	PSD Limit [dBm]	Power Margin [dB]
				Meas PPSD [dBm]	Meas PPSD [dBm]	Corr'd PPSD [dBm]	Corr'd PPSD [dBm]		
Low	5510	26T	0	-4.05	-4.13	6.44	6.36	11.00	-4.56
			9	-4.22	-4.08	6.27	6.41	11.00	-4.59
			17	-4.39	-3.43	6.10	7.06	11.00	-3.94
		52T	37	-4.77	-4.90	5.70	5.58	11.00	-5.30
			41	-4.88	-5.45	5.59	5.02	11.00	-5.41
			44	-5.51	-5.26	4.97	5.21	11.00	-5.79
		106T	53	-6.67	-6.29	3.78	4.16	11.00	-6.84
			54	-6.78	-6.65	3.67	3.80	11.00	-7.20
			56	-6.83	-6.46	3.62	3.99	11.00	-7.01
		242T	61	-9.39	-8.97	1.05	1.47	11.00	-9.53
			62	-8.92	-8.78	1.52	1.66	11.00	-9.34
		SU	-	-10.89	-10.95	-0.79	-0.85	11.00	-11.79
		Mid	5590	26T	0	-4.05	-3.64	6.44	6.85
9	-4.02				-4.42	6.47	6.08	11.00	-4.53
17	-4.37				-4.75	6.12	5.74	11.00	-4.88
52T	37			-4.82	-4.99	5.65	5.48	11.00	-5.35
	41			-4.84	-5.17	5.63	5.30	11.00	-5.37
	44			-5.39	-4.76	5.08	5.71	11.00	-5.29
106T	53			-6.54	-6.39	3.91	4.07	11.00	-6.94
	54			-6.74	-6.48	3.71	3.97	11.00	-7.03
	56			-6.93	-6.87	3.52	3.59	11.00	-7.42
242T	61			-9.38	-8.90	1.06	1.54	11.00	-9.46
	62			-9.02	-9.01	1.42	1.43	11.00	-9.57
SU	-			-10.90	-10.91	-0.80	-0.81	11.00	-11.80
High	5670			26T	0	-4.08	-4.18	6.41	6.31
		9	-4.01		-4.11	6.48	6.38	11.00	-4.52
		17	-4.04		-3.37	6.45	7.12	11.00	-3.88
		52T	37	-4.71	-4.79	5.76	5.68	11.00	-5.24
			41	-4.94	-5.34	5.53	5.13	11.00	-5.47
			44	-5.21	-5.00	5.26	5.47	11.00	-5.53
		106T	53	-6.56	-6.32	3.89	4.13	11.00	-6.87
			54	-6.79	-6.42	3.66	4.04	11.00	-6.97
			56	-6.90	-6.45	3.55	4.00	11.00	-7.00
		242T	61	-9.16	-8.70	1.28	1.74	11.00	-9.26
			62	-8.90	-8.90	1.55	1.54	11.00	-9.46
		SU	-	-10.45	-10.91	-0.35	-0.81	11.00	-11.35
		Stradle	5710	26T	0	-4.47	-4.61	6.02	5.88
9	-4.98				-4.19	5.51	6.30	11.00	-4.70
52T	37			-4.96	-5.98	5.51	4.50	11.00	-5.49
	41			-5.35	-5.49	5.13	4.98	11.00	-5.88
106T	53			-6.71	-6.81	3.74	3.65	11.00	-7.26
	54			-6.89	-6.78	3.56	3.67	11.00	-7.33
242T	61			-9.68	-9.29	0.76	1.15	11.00	-9.85

10.2.9. 802.11ax HE80 1TX MODE IN THE 5.5 GHz BAND

Bandwidth and Antenna Gain

Channel	Frequency [MHz]	Min 26 dB BW [MHz]	Min 99% BW [MHz]	Directional Gain for Power [dBi]
Low	5530	18.42	N/A	-3.78
High	5610	17.77	N/A	-3.78
Straddle	5690	18.05	N/A	-3.78

Limits

Channel	Frequency [MHz]	FCC Power Limit [dBm]	IC Power Limit [dBm]	FCC PPSD Limit [dBm]
Low	5530	23.65	N/A	11.00
High	5610	23.50	N/A	11.00
Straddle	5690	23.56	N/A	11.00

Included in Calculations of Corr'd Power & PPSD				
Duty Cycle CF [dB]	HE80	26T	0.50	dB
		52T	0.48	dB
		106T	0.45	dB
		242T	0.44	dB
		484T	0.43	dB
		SU	0.10	dB

Calculation of Output Power result

Corr'd Power [dBm] = Meas Power [dBm] + Duty CF [dB]

Output Power Results

Channel	Frequency [MHz]	Tones	RU offset	Antenna 1 Meas Power [dBm]	Antenna 2 Meas Power [dBm]	Antenna 1 Corr'd Power [dBm]	Antenna 2 Corr'd Power [dBm]	Power Limit [dBm]	Power Margin [dB]		
Low	5530	26T	0	7.72	7.81	8.22	8.31	23.65	-15.34		
			18	7.83	7.95	8.33	8.45	23.65	-15.20		
			36	6.96	7.78	7.46	8.28	23.65	-15.37		
		52T	37	10.16	10.02	10.64	10.50	23.65	-13.01		
			45	9.93	9.88	10.41	10.36	23.65	-13.24		
			52	9.03	9.46	9.51	9.94	23.65	-13.71		
		106T	53	11.28	11.25	11.73	11.70	23.65	-11.92		
			57	11.54	11.58	11.99	12.03	23.65	-11.62		
			60	10.97	11.05	11.42	11.50	23.65	-12.15		
		242T	61	11.58	11.90	12.02	12.34	23.65	-11.31		
			62	11.80	12.13	12.24	12.57	23.65	-11.08		
			64	11.57	11.84	12.01	12.28	23.65	-11.37		
		484T	65	12.00	12.64	12.43	13.07	23.65	-10.58		
			66	12.05	12.66	12.48	13.09	23.65	-10.56		
		SU	-	13.00	13.43	13.10	13.53	23.65	-10.12		
		High	5610	26T	0	7.92	7.81	8.42	8.31	23.50	-15.08
					18	7.94	7.85	8.44	8.35	23.50	-15.06
					36	7.02	7.71	7.52	8.21	23.50	-15.29
52T	37			9.73	9.85	10.21	10.33	23.50	-13.17		
	45			9.68	9.70	10.16	10.18	23.50	-13.32		
	52			10.02	9.28	10.50	9.76	23.50	-13.00		
106T	53			11.14	11.23	11.59	11.68	23.50	-11.82		
	57			11.38	11.41	11.83	11.86	23.50	-11.64		
	60			10.83	11.01	11.28	11.46	23.50	-12.04		
242T	61			11.86	11.79	12.30	12.23	23.50	-11.20		
	62			12.09	11.97	12.53	12.41	23.50	-10.97		
	64			11.80	11.76	12.24	12.20	23.50	-11.26		
484T	65			12.40	12.53	12.83	12.96	23.50	-10.54		
	66			12.32	12.55	12.75	12.98	23.50	-10.52		
SU	-			12.87	13.37	12.97	13.47	23.50	-10.03		

Channel	Frequency [MHz]	Tones	RU offset	Antenna 1 Meas Power [dBm]	Antenna 2 Meas Power [dBm]	Antenna 1 Corr'd Power [dBm]	Antenna 2 Corr'd Power [dBm]	Power Limit [dBm]	Power Margin [dB]
Straddle	5690	26T	0	7.70	7.96	8.20	8.46	23.56	-15.10
			18	7.68	7.62	8.18	8.12	23.56	-15.38
		52T	37	9.90	9.82	10.38	10.30	23.56	-13.18
			45	9.87	10.16	10.35	10.64	23.56	-12.92
		106T	53	11.03	11.23	11.48	11.68	23.56	-11.88
			57	11.35	11.53	11.80	11.98	23.56	-11.58
		242T	61	11.76	11.87	12.20	12.31	23.56	-11.25
			62	11.99	12.04	12.43	12.48	23.56	-11.08
		484T	65	12.23	12.59	12.66	13.02	23.56	-10.54

Actual RBW	Ref. Bandwidth	Corr'd factor
100 kHz	1000 kHz	10.00 dB

Calculation of PPSD result

Corr'd PPSD [dBm] = Meas PPSD [dBm] + Duty CF [dB] + Corr'd factor [dB]

PPSD Results

Channel	Frequency [MHz]	Tones	RU offset	Antenna 1	Antenna 2	Antenna 1	Antenna 2	PSD Limit [dBm]	Power Margin [dB]
				Meas PPSD [dBm]	Meas PPSD [dBm]	Corr'd PPSD [dBm]	Corr'd PPSD [dBm]		
Low	5530	26T	0	-3.68	-4.74	6.82	5.76	11.00	-4.18
			18	-4.60	-4.90	5.90	5.60	11.00	-5.10
			36	-4.27	-4.35	6.23	6.15	11.00	-4.77
		52T	37	-4.93	-4.94	5.55	5.54	11.00	-5.45
			45	-4.90	-5.13	5.58	5.36	11.00	-5.42
			52	-6.08	-5.61	4.40	4.87	11.00	-6.13
		106T	53	-6.28	-7.12	4.17	3.33	11.00	-6.83
			57	-6.13	-7.04	4.32	3.41	11.00	-6.68
			60	-6.85	-6.93	3.61	3.52	11.00	-7.40
		242T	61	-10.01	-9.70	0.43	0.74	11.00	-10.26
			62	-10.05	-9.23	0.39	1.21	11.00	-9.79
			64	-10.52	-10.09	-0.08	0.35	11.00	-10.65
		484T	65	-12.18	-11.97	-1.75	-1.54	11.00	-12.54
			66	-11.87	-11.19	-1.44	-0.76	11.00	-11.76
		SU	-	-14.55	-13.69	-4.45	-3.59	11.00	-14.59
		High	5610	26T	0	-3.40	-4.43	7.10	6.07
18	-4.15				-5.07	6.35	5.43	11.00	-4.65
36	-4.57				-5.39	5.94	5.11	11.00	-5.07
52T	37			-4.51	-4.74	5.97	5.74	11.00	-5.03
	45			-5.17	-5.41	5.31	5.07	11.00	-5.69
	52			-4.65	-5.39	5.83	5.10	11.00	-5.17
106T	53			-6.66	-7.14	3.79	3.31	11.00	-7.21
	57			-6.15	-6.88	4.31	3.57	11.00	-6.70
	60			-7.07	-7.04	3.38	3.41	11.00	-7.59
242T	61			-9.17	-9.46	1.27	0.98	11.00	-9.73
	62			-9.52	-9.65	0.92	0.79	11.00	-10.08
	64			-9.14	-9.81	1.30	0.63	11.00	-9.70
484T	65			-12.17	-12.03	-1.74	-1.60	11.00	-12.60
	66			-11.49	-11.45	-1.06	-1.02	11.00	-12.02
SU	-			-14.73	-13.96	-4.63	-3.86	11.00	-14.86
Straddle	5690			26T	0	-4.51	-4.04	5.99	6.46
		18	-4.08		-4.13	6.42	6.37	11.00	-4.58
		52T	37	-5.30	-5.52	5.18	4.96	11.00	-5.82
			45	-5.10	-5.45	5.38	5.03	11.00	-5.62
		106T	53	-6.81	-6.89	3.64	3.56	11.00	-7.36
			57	-6.53	-6.54	3.92	3.91	11.00	-7.08
		242T	61	-9.54	-9.94	0.90	0.50	11.00	-10.10
			62	-9.90	-9.70	0.54	0.74	11.00	-10.26
		484T	65	-11.97	-11.82	-1.54	-1.39	11.00	-12.39

10.2.10. 802.11ax HE20 1TX MODE IN THE 5.8 GHz BAND

Limits

Channel	Frequency [MHz]	FCC Power Limit [dBm]	IC Power Limit [dBm]	FCC PPSD Limit [dBm]
Stradle	5720	30.00	30.00	30.00
Low	5745	30.00	30.00	30.00
Mid	5785	30.00	30.00	30.00
High	5825	30.00	30.00	30.00

Included in Calculations of Corr'd Power & PPSD				
Duty Cycle CF [dB]	HE20	26T	0.50	dB
		52T	0.46	dB
		106T	0.45	dB
		SU	0.11	dB

Calculation of Output Power result
 Corr'd Power [dBm] = Meas Power [dBm] + Duty CF [dB]

Output Power Results

Channel	Frequency [MHz]	Tones	RU offset	Antenna 1 Meas Power [dBm]	Antenna 2 Meas Power [dBm]	Antenna 1 Corr'd Power [dBm]	Antenna 2 Corr'd Power [dBm]	Power Limit [dBm]	Power Margin [dB]		
Stradle	5720	26T	8	7.05	7.97	7.55	8.47	30.00	-21.53		
		52T	40	8.86	10.03	9.32	10.49	30.00	-19.51		
Low	5745	26T	0	7.44	8.25	7.94	8.75	30.00	-21.25		
			4	7.92	8.29	8.42	8.79	30.00	-21.21		
		52T	8	7.55	8.08	8.05	8.58	30.00	-21.42		
			37	9.38	10.11	9.84	10.57	30.00	-19.43		
		106T	38	9.43	10.23	9.89	10.69	30.00	-19.31		
			40	9.12	9.93	9.58	10.39	30.00	-19.61		
		SU	53	11.57	12.13	12.02	12.58	30.00	-17.42		
			54	11.37	11.95	11.82	12.40	30.00	-17.60		
		Mid	5785	26T	-	15.61	16.37	15.72	16.48	30.00	-13.52
					0	7.47	8.27	7.97	8.77	30.00	-21.23
4	7.69				8.45	8.19	8.95	30.00	-21.05		
52T	8			7.33	8.08	7.83	8.58	30.00	-21.42		
	37			8.82	10.05	9.28	10.51	30.00	-19.49		
	38			8.96	10.26	9.42	10.72	30.00	-19.28		
106T	40			8.64	10.00	9.10	10.46	30.00	-19.54		
	53			11.50	12.08	11.95	12.53	30.00	-17.47		
SU	54			11.36	11.91	11.81	12.36	30.00	-17.64		
	-			15.67	16.33	15.78	16.44	30.00	-13.56		
High	5825			26T	0	7.10	8.36	7.60	8.86	30.00	-21.14
					4	7.75	8.48	8.25	8.98	30.00	-21.02
		8	7.43		7.81	7.93	8.31	30.00	-21.69		
		52T	37	8.92	9.79	9.38	10.25	30.00	-19.75		
			38	9.15	9.98	9.61	10.44	30.00	-19.56		
			40	8.79	9.70	9.25	10.16	30.00	-19.84		
		106T	53	11.33	11.90	11.78	12.35	30.00	-17.65		
			54	11.29	11.77	11.74	12.22	30.00	-17.78		
		SU	-	15.53	16.23	15.64	16.34	30.00	-13.66		

Actual RBW	Ref. Bandwidth	Corr'd factor
100 kHz	500 kHz	6.99 dB

Calculation of PPSD result

Corr'd PPSD [dBm] = Meas PPSD [dBm] + Duty CF [dB] + Corr'd factor [dB]

PPSD Results

Channel	Frequency [MHz]	Tones	RU offset	Antenna 1 Meas PPSD [dBm]	Antenna 2 Meas PPSD [dBm]	Antenna 1 Corr'd PPSD [dBm]	Antenna 2 Corr'd PPSD [dBm]	PSD Limit [dBm]	Power Margin [dB]
Stradle	5720	26T	0	-4.53	-4.33	2.96	7.09	30.00	-22.91
		52T	4	-6.53	-5.18	0.96	2.70	30.00	-27.30
Low	5745	26T	0	-4.84	-3.77	2.65	3.16	11.00	-7.84
			4	-4.42	-3.66	3.07	2.31	11.00	-7.93
			8	-4.75	-4.40	2.74	7.44	11.00	-3.56
		52T	37	-5.97	-4.96	1.48	7.10	11.00	-3.90
			38	-5.81	-4.81	1.64	3.73	11.00	-7.28
			40	-5.68	-5.43	1.78	3.83	11.00	-7.17
			53	-6.80	-6.14	0.64	3.09	11.00	-7.91
		106T	54	-6.85	-6.43	0.59	2.49	11.00	-8.51
			SU	-	-5.72	-5.43	1.38	2.64	11.00
		Mid	5785	26T	0	-4.76	-4.80	2.73	2.02
4	-4.50				-4.35	2.99	1.30	11.00	-8.01
8	-4.81				-4.98	2.68	1.01	11.00	-8.32
52T	37			-6.16	-5.43	1.29	1.67	11.00	-9.33
	38			-5.60	-4.93	1.85	2.69	11.00	-8.31
	40			-6.79	-5.25	0.66	3.14	11.00	-7.86
106T	53			-6.63	-6.37	0.81	2.51	11.00	-8.49
	54			-6.76	-6.62	0.68	2.02	11.00	-8.98
SU	-			-6.14	-5.58	0.96	2.52	11.00	-8.48
High	5825			26T	0	-5.09	-4.27	2.40	2.20
		4	-5.06		-4.02	2.43	1.07	11.00	-8.57
		8	-5.38		-4.54	2.12	0.82	11.00	-8.89
		52T	37	-6.09	-5.50	1.36	1.52	11.00	-9.48
			38	-6.26	-5.41	1.19	3.23	11.00	-7.78
			40	-6.15	-5.71	1.30	3.48	11.00	-7.53
		106T	53	-7.09	-6.82	0.35	2.95	11.00	-8.05
			54	-7.30	-6.43	0.14	1.96	11.00	-9.05
		SU	-	-6.39	-5.51	0.72	2.04	11.00	-8.96

10.2.11. 802.11ax HE40 1TX MODE IN THE 5.8 GHz BAND

Limits

Channel	Frequency	FCC Power Limit	IC Power Limit	FCC PPSD Limit
	[MHz]	[dBm]	[dBm]	[dBm]
Straddle	5710	30.00	30.00	30.00
Low	5755	30.00	30.00	30.00
High	5795	30.00	30.00	30.00

Included in Calculations of Corr'd Power & PPSD				
Duty Cycle CF [dB]	HE40	26T	0.49	dB
		52T	0.47	dB
		106T	0.45	dB
		242T	0.44	dB
		SU	0.10	dB

Calculation of Output Power result
 Corr'd Power [dBm] = Meas Power [dBm] + Duty CF [dB]

Output Power Results

Channel	Frequency	Tones	RU offset	Antenna 1 Meas Power	Antenna 2 Meas Power	Antenna 1 Corr'd Power	Antenna 2 Corr'd Power	Power Limit	Power Margin
	[MHz]			[dBm]	[dBm]	[dBm]	[dBm]	[dBm]	[dB]
Straddle	5710	26T	17	7.67	8.35	8.16	8.84	30.00	-21.16
		52T	44	9.75	10.31	10.22	10.78	30.00	-19.22
Low	5755	26T	0	7.71	7.72	8.20	8.21	30.00	-21.79
			9	7.92	7.97	8.41	8.46	30.00	-21.54
		37	17	7.64	7.95	8.13	8.44	30.00	-21.56
			37	9.70	10.05	10.17	10.52	30.00	-19.48
			41	9.61	10.15	10.08	10.62	30.00	-19.38
		52T	44	9.69	10.20	10.16	10.67	30.00	-19.33
			53	11.50	11.96	11.95	12.41	30.00	-17.59
			54	11.56	11.88	12.01	12.33	30.00	-17.67
		106T	56	11.41	11.83	11.86	12.28	30.00	-17.72
			61	12.30	12.70	12.74	13.14	30.00	-16.86
			62	12.28	12.69	12.72	13.13	30.00	-16.87
		242T	62	12.28	12.69	12.72	13.13	30.00	-16.87
SU	-	13.32	13.53	13.42	13.63	30.00	-16.37		
High	5795	26T	0	7.28	7.84	7.77	8.33	30.00	-21.67
			9	7.90	8.34	8.39	8.83	30.00	-21.17
			17	7.15	8.02	7.64	8.51	30.00	-21.49
		37	37	9.71	9.69	10.18	10.16	30.00	-19.82
			41	10.03	10.16	10.50	10.63	30.00	-19.37
			44	9.33	9.71	9.80	10.18	30.00	-19.82
		52T	53	11.29	11.64	11.74	12.09	30.00	-17.91
			54	11.60	11.83	12.05	12.28	30.00	-17.72
			56	11.15	11.50	11.60	11.95	30.00	-18.05
		106T	61	12.14	12.49	12.58	12.93	30.00	-17.07
			62	12.16	12.56	12.60	13.00	30.00	-17.00
		242T	62	12.16	12.56	12.60	13.00	30.00	-17.00
		SU	-	13.30	13.43	13.40	13.53	30.00	-16.47

Actual RBW	Ref. Bandwidth	Corr'd factor
100 kHz	500 kHz	6.99 dB

Calculation of PPSD result

Corr'd PPSD [dBm] = Meas PPSD [dBm] + Duty CF [dB] + Corr'd factor [dB]

PPSD Results

Channel	Frequency [MHz]	Tones	RU offset	Antenna 1 Meas PPSD [dBm]	Antenna 2 Meas PPSD [dBm]	Antenna 1 Corr'd PPSD [dBm]	Antenna 2 Corr'd PPSD [dBm]	PSD Limit [dBm]	Power Margin [dB]		
Straddle	5710	26T	17	-4.44	-4.27	3.05	3.21	30.00	-26.79		
		52T	44	-5.55	-4.95	1.94	2.53	30.00	-27.47		
Low	5755	26T	0	-4.53	-4.78	2.95	2.70	30.00	-27.05		
			9	-4.75	-4.65	2.73	2.83	30.00	-27.17		
			17	-4.42	-4.57	3.06	2.91	30.00	-26.94		
		52T	37	-5.31	-5.32	2.15	2.14	30.00	-27.85		
			41	-5.44	-5.49	2.02	1.97	30.00	-27.98		
			44	-5.07	-5.20	2.39	2.26	30.00	-27.61		
		106T	53	-6.52	-6.37	0.92	1.07	30.00	-28.93		
			54	-6.79	-6.41	0.65	1.03	30.00	-28.97		
			56	-6.50	-6.48	0.94	0.96	30.00	-29.04		
		242T	61	-9.57	-9.01	-2.14	-1.58	30.00	-31.58		
			62	-9.01	-8.90	-1.58	-1.47	30.00	-31.47		
		SU	-	-10.76	-11.06	-3.67	-3.97	30.00	-33.67		
		High	5795	26T	0	-4.63	-4.66	2.85	2.82	30.00	-27.15
					9	-4.36	-4.17	3.12	3.31	30.00	-26.69
17	-5.31				-4.03	2.17	3.45	30.00	-26.55		
52T	37			-5.41	-5.86	2.05	1.60	30.00	-27.95		
	41			-4.99	-5.70	2.47	1.76	30.00	-27.53		
	44			-6.03	-5.45	1.43	2.01	30.00	-27.99		
106T	53			-6.97	-6.85	0.47	0.59	30.00	-29.41		
	54			-6.80	-6.62	0.65	0.82	30.00	-29.18		
	56			-7.03	-6.77	0.41	0.67	30.00	-29.33		
242T	61			-9.45	-9.23	-2.02	-1.80	30.00	-31.80		
	62			-9.30	-9.27	-1.87	-1.84	30.00	-31.84		
SU	-			-11.19	-11.33	-4.10	-4.24	30.00	-34.10		

10.2.12. 802.11ax HE80 1TX MODE IN THE 5.8 GHz BAND

Limits

Channel	Frequency	FCC Power Limit	IC Power Limit	FCC PPSD Limit
	[MHz]	[dBm]	[dBm]	[dBm]
Straddle	5690	30.00	30.00	30.00
Mid	5775	30.00	30.00	30.00

Included in Calculations of Corr'd Power & PPSD				
Duty Cycle CF [dB]	HE80	26T	0.50	dB
		52T	0.48	dB
		106T	0.45	dB
		242T	0.44	dB
		484T	0.43	dB
		SU	0.10	dB

Calculation of Output Power result

Corr'd Power [dBm] = Meas Power [dBm] + Duty CF [dB]

Output Power Results

Channel	Frequency	Tones	RU offset	Antenna 1 Meas Power	Antenna 2 Meas Power	Antenna 1 Corr'd Power	Antenna 2 Corr'd Power	Power Limit	Power Margin	
	[MHz]			[dBm]	[dBm]	[dBm]	[dBm]	[dBm]	[dB]	
Straddle	5690	26T	36	7.42	7.52	7.92	8.02	30.00	-21.98	
		52T	52	10.05	9.54	10.53	10.04	30.00	-19.47	
Mid	5775	26T	0	7.91	7.83	8.41	8.33	30.00	-21.59	
			18	7.78	8.00	8.28	8.50	30.00	-21.50	
		52T	36	8.06	8.05	8.56	8.55	30.00	-21.44	
			37	9.54	9.61	10.02	10.11	30.00	-19.89	
			45	9.74	9.72	10.22	10.22	30.00	-19.78	
		106T	52	10.21	10.05	10.69	10.55	30.00	-19.31	
			53	11.00	11.20	11.45	11.70	30.00	-18.30	
			57	11.36	11.53	11.81	12.03	30.00	-17.97	
			60	11.01	11.08	11.46	11.58	30.00	-18.42	
		242T	61	11.88	11.96	12.32	12.46	30.00	-17.54	
			62	12.08	12.26	12.52	12.76	30.00	-17.24	
			64	11.85	12.01	12.29	12.51	30.00	-17.49	
		484T	65	12.30	12.48	12.73	12.98	30.00	-17.02	
			66	12.38	12.58	12.81	13.08	30.00	-16.92	
		SU	-	-	12.86	12.98	12.96	13.48	30.00	-16.52

Actual RBW	Ref. Bandwidth	Corr'd factor
100 kHz	500 kHz	6.99 dB

Calculation of PPSD result

Corr'd PPSD [dBm]
 = Meas PPSD [dBm] + Duty CF [dB] + Corr'd factor [dB]

PPSD Results

Channel	Frequency [MHz]	Tones	RU offset	Antenna 1 Meas PPSD [dBm]	Antenna 2 Meas PPSD [dBm]	Antenna 1 Corr'd PPSD [dBm]	Antenna 2 Corr'd PPSD [dBm]	PSD Limit [dBm]	Power Margin [dB]
Straddle	5690	26T	36	-3.53	-3.89	3.96	3.60	30.00	-26.04
		52T	52	-4.45	-5.61	3.04	1.88	30.00	-26.96
Mid	5775	26T	0	-5.08	-4.44	2.41	3.05	30.00	-26.95
			18	-4.24	-5.45	3.25	2.05	30.00	-26.75
			36	-3.96	-4.50	3.54	2.99	30.00	-26.47
		52T	37	-5.36	-5.47	2.11	2.00	30.00	-27.89
			45	-5.65	-5.43	1.82	2.04	30.00	-27.96
			52	-5.07	-5.70	2.41	1.77	30.00	-27.60
		106T	53	-7.19	-6.70	0.25	0.74	30.00	-29.26
			57	-7.21	-6.88	0.23	0.56	30.00	-29.44
			60	-7.31	-7.69	0.13	-0.25	30.00	-29.87
		242T	61	-9.68	-9.64	-2.25	-2.21	30.00	-32.21
			62	-9.62	-9.79	-2.19	-2.36	30.00	-32.19
			64	-9.79	-9.91	-2.36	-2.48	30.00	-32.36
		484T	65	-12.24	-11.99	-4.82	-4.57	30.00	-34.57
			66	-12.16	-12.23	-4.74	-4.81	30.00	-34.74
		SU	-	-15.06	-14.19	-7.97	-7.10	30.00	-37.10

10.2.13. 802.11ax HE20 1TX MODE IN THE STRADDLE CHANNEL

Bandwidth and Antenna Gain

Channel	Frequency [MHz]	Min 26 dB BW [MHz]	Min 99% BW [MHz]	Directional Gain for Power [dBi]
UNII-2C	5720	15.25	N/A	-3.78
UNII-3		5.65	N/A	-3.94

Limits

Channel	Frequency [MHz]	FCC Power Limit [dBm]	IC Power Limit [dBm]	FCC PPSD Limit [dBm]
UNII-2C	5720	22.83	N/A	11.00
UNII-3		30.00	N/A	30.00

Included in Calculations of Corr'd Power & PPSD				
Duty Cycle CF [dB]	HE20	106T	0.45	dB
		SU	0.11	dB

Calculation of Output Power result

Corr'd Power [dBm] = Meas Power [dBm] + Duty CF [dB]

Output Power Results

Portion	Frequency [MHz]	Tones	RU offset	Antenna 1 Meas Power [dBm]	Antenna 2 Meas Power [dBm]	Antenna 1 Corr'd Power [dBm]	Antenna 2 Corr'd Power [dBm]	Power Limit [dBm]	Power Margin [dB]
UNII-2C	5720	106T	54	8.07	8.36	8.52	8.81	22.83	-14.02
		SU	-	13.74	14.15	13.85	14.26	22.83	-8.57
UNII-3		106T	54	8.61	8.96	9.06	9.41	30.00	-20.59
		SU	-	8.34	8.91	8.45	9.02	30.00	-20.98

Band	Actual RBW	Ref. Bandwidth	Corr'd factor
UNII-2C	100 kHz	1000 kHz	10.00 dB
UNII-3	100 kHz	500 kHz	6.99 dB

Calculation of PPSD result

Corr'd PPSD [dBm] = Meas PPSD [dBm] + Duty CF [dB] + Corr'd factor [dB]

PPSD Results

Channel	Frequency [MHz]	Tones	RU offset	Antenna 1 Meas PPSD [dBm]	Antenna 2 Meas PPSD [dBm]	Antenna 1 Corr'd PPSD [dBm]	Antenna 2 Corr'd PPSD [dBm]	PSD Limit [dBm]	Power Margin [dB]
UNII-2C	5720	106T	54	-7.16	-6.49	3.29	3.96	11.00	-7.04
		SU	-	-6.65	-6.05	3.46	4.06	11.00	-6.94
UNII-3		106T	54	-7.20	-8.09	0.24	-0.65	30.00	-29.76
		SU	-	-7.08	-6.74	0.03	0.36	30.00	-29.64

10.2.14. 802.11ax HE40 1TX MODE IN THE STRADDLE CHANNEL

Bandwidth and Antenna Gain

Channel	Frequency [MHz]	Min 26 dB BW [MHz]	Min 99% BW [MHz]	Directional Gain for Power [dBi]
UNII-2C	5710	15.79	N/A	-3.78
UNII-3		4.98	N/A	-3.94

Limits

Channel	Frequency [MHz]	FCC Power Limit [dBm]	IC Power Limit [dBm]	FCC PPSD Limit [dBm]
UNII-2C	5710	22.98	N/A	11.00
UNII-3		30.00	N/A	30.00

Included in Calculations of Corr'd Power & PPSD				
Duty Cycle CF [dB]	HE40	106T	0.45	dB
		242T	0.44	dB
		SU	0.10	dB

Calculation of Outpu Power result

Corr'd Power [dBm] = Meas Power [dBm] + Duty CF [dB]
 * The below Measure Powers is already added the Duty CF.

Output Power Results

Portion	Frequency [MHz]	Tones	RU offset	Antenna 1 Meas Power [dBm]	Antenna 2 Meas Power [dBm]	Antenna 1 Corr'd Power [dBm]	Antenna 2 Corr'd Power [dBm]	Power Limit [dBm]	Power Margin [dB]
UNII-2C	5710	106T	56	8.69	8.78	9.14	9.23	22.98	-13.75
		242T	62	11.01	11.67	11.45	12.11	22.98	-10.87
		SU	-	12.83	13.14	12.93	13.24	22.98	-9.74
UNII-3		106T	56	7.92	8.00	8.37	8.45	30.00	-21.55
		242T	62	4.60	5.07	5.04	5.51	30.00	-24.49
		SU	-	2.71	3.11	2.81	3.21	30.00	-26.79

Band	Actual RBW	Ref. Bandwidth	Corr'd factor
UNII-2C	100 kHz	1000 kHz	10.00 dB
UNII-3	100 kHz	500 kHz	6.99 dB

Calculation of PPSD result

Corr'd PPSD [dBm] = Meas PPSD [dBm] + Duty CF [dB] + Corr'd factor [dB]

PPSD Results

Channel	Frequency [MHz]	Tones	RU offset	Antenna 1 Meas PPSD [dBm]	Antenna 2 Meas PPSD [dBm]	Antenna 1 Corr'd PPSD [dBm]	Antenna 2 Corr'd PPSD [dBm]	PSD Limit [dBm]	Power Margin [dB]
UNII-2C	5710	106T	56	-6.93	-6.84	3.52	3.61	11.00	-7.39
		242T	62	-9.11	-9.11	1.33	1.34	11.00	-9.67
		SU	-	-11.06	-11.35	-0.96	-1.25	11.00	-11.96
UNII-3		106T	56	-7.03	-6.86	0.41	0.58	30.00	-29.42
		242T	62	-10.03	-9.72	-2.60	-2.29	30.00	-32.29
		SU	-	-12.09	-12.22	-5.00	-5.13	30.00	-35.00

10.2.15. 802.11ax HE80 1TX MODE IN THE STRADDLE CHANNEL

Bandwidth and Antenna Gain

Channel	Frequency [MHz]	Min 26 dB BW [MHz]	Min 99% BW [MHz]	Directional Gain for Power [dBi]
UNII-2C	5690	35.00	N/A	-3.78
UNII-3		-35.00	N/A	-3.94

Limits

Channel	Frequency [MHz]	FCC Power Limit [dBm]	IC Power Limit [dBm]	FCC PPSD Limit [dBm]
UNII-2C	5690	24.00	N/A	11.00
UNII-3		30.00	N/A	30.00

Included in Calculations of Corr'd Power & PPSD				
Duty Cycle CF [dB]	HE40	106T	0.45	dB
		242T	0.44	dB
		484T	0.43	dB
		SU	0.10	dB

Calculation of Outpu Power result

Corr'd Power [dBm] = Meas Power [dBm] + Duty CF [dB]

Output Power Results

Portion	Frequency [MHz]	Tones	RU offset	Antenna 1 Meas Power [dBm]	Antenna 2 Meas Power [dBm]	Antenna 1 Corr'd Power [dBm]	Antenna 2 Corr'd Power [dBm]	Power Limit [dBm]	Power Margin [dB]
UNII-2C	5690	106T	60	8.05	8.23	8.50	8.68	24.00	-15.32
		242T	64	10.91	10.65	11.35	11.09	24.00	-12.65
		484T	66	11.94	11.96	12.37	12.39	24.00	-11.61
		SU	-	12.43	13.04	12.53	13.14	24.00	-10.86
UNII-3		106T	60	7.50	7.39	7.95	7.84	30.00	-22.05
		242T	64	4.42	4.26	4.86	4.70	30.00	-25.14
		484T	66	1.25	1.10	1.68	1.53	30.00	-28.32
		SU	-	-1.96	-1.35	-1.86	-1.25	30.00	-31.25

Band	Actual RBW	Ref. Bandwidth	Corr'd factor
UNII-2C	100 kHz	1000 kHz	10.00 dB
UNII-3	100 kHz	500 kHz	6.99 dB

Calculation of PPSD result

Corr'd PPSD [dBm] = Meas PPSD [dBm] + Duty CF [dB] + Corr'd factor [dB]

PPSD Results

Channel	Frequency [MHz]	Tones	RU offset	Antenna 1 Meas PPSD [dBm]	Antenna 2 Meas PPSD [dBm]	Antenna 1 Corr'd PPSD [dBm]	Antenna 2 Corr'd PPSD [dBm]	PSD Limit [dBm]	Power Margin [dB]
UNII-2C	5690	106T	60	-7.11	-7.35	3.34	3.10	11.00	-7.66
		242T	64	-9.56	-9.79	0.88	0.65	11.00	-10.12
		484T	66	-11.56	-11.39	-1.13	-0.96	11.00	-11.96
		SU	-	-14.54	-13.80	-4.44	-3.70	11.00	-14.70
UNII-3		106T	60	-6.86	-7.45	0.58	-0.01	30.00	-29.42
		242T	64	-10.43	-10.42	-3.00	-2.99	30.00	-32.99
		484T	66	-13.22	-13.25	-5.80	-5.83	30.00	-35.80
		SU	-	-16.88	-16.12	-9.79	-9.03	30.00	-39.03

10.2.16. 802.11ax HE20 2TX CDD MODE IN THE 5.2 GHz BAND

Bandwidth and Antenna Gain

Channel	Frequency [MHz]	Min 26 dB BW [MHz]	Min 99% BW [MHz]	Directional Gain for Power [dBi]
Low	5180	18.17	N/A	-4.82
Mid	5200	18.20	N/A	-4.82
High	5240	18.00	N/A	-4.82

Limits

Channel	Frequency [MHz]	FCC Power Limit [dBm]	IC Power Limit [dBm]	FCC PPSD Limit [dBm]
Low	5180	23.59	N/A	11.00
Mid	5200	23.60	N/A	11.00
High	5240	23.55	N/A	11.00

Included in Calculations of Corr'd Power & PPSD				
Duty Cycle CF [dB]	HE20	26T	0.46	dB
		52T	0.45	dB
		106T	0.44	dB
		SU	0.21	dB

Calculation of Output Power result

Sum PW = Antenna1_Meas Power [mW] + Antenna2_Meas Power [mW]
 Total Corr'd Power [dBm] = Sum PW [dBm] + Duty CF [dB]

Output Power Results

Channel	Frequency [MHz]	Tones	RU offset	Antenna 1 Meas Power [dBm]	Antenna 2 Meas Power [dBm]	Total Corr'd Power [dBm]	Power Limit [dBm]	Power Margin [dB]
Low	5180	26T	0	4.64	4.35	7.97	23.59	-15.62
			4	5.05	4.43	8.22	23.59	-15.37
			8	4.58	4.05	7.79	23.59	-15.80
		52T	37	6.06	6.17	9.58	23.59	-14.01
			38	6.76	6.73	10.21	23.59	-13.38
			40	6.65	6.17	9.88	23.59	-13.71
		106T	53	8.66	8.37	11.97	23.59	-11.62
			54	8.85	8.22	12.02	23.59	-11.57
		SU	-	13.44	13.08	16.48	23.59	-7.11
		Mid	5200	26T	0	4.35	4.18	7.74
4	4.71				4.42	8.04	23.60	-15.56
8	4.23				4.03	7.60	23.60	-16.00
52T	37			6.40	5.80	9.57	23.60	-14.03
	38			6.77	6.49	10.09	23.60	-13.51
	40			6.26	6.03	9.61	23.60	-13.99
106T	53			8.61	8.38	11.95	23.60	-11.65
	54			8.42	8.14	11.75	23.60	-11.85
SU	-			13.32	13.02	16.39	23.60	-7.21
High	5240			26T	0	4.62	4.13	7.85
		4	4.75		4.32	8.01	23.55	-15.54
		8	4.01		3.96	7.46	23.55	-16.09
		52T	37	6.26	6.28	9.73	23.55	-13.82
			38	6.43	6.45	9.90	23.55	-13.65
			40	6.06	6.09	9.54	23.55	-14.01
		106T	53	8.95	8.57	12.21	23.55	-11.34
			54	8.80	8.40	12.07	23.55	-11.48
		SU	-	13.33	13.06	16.42	23.55	-7.13

Actual RBW	Ref. Bandwidth	Corr'd factor
100 kHz	1000 kHz	10.00 dB

Calculation of PPSD result
 Sum PW = Antenna1_Meas PPSD [mW] + Antenna2_Meas PPSD [mW]
 Total Corr'd Power [dBm]
 = Sum PW [dBm] + Duty CF [dB] + Corr'd factor [dB]

PPSD Results

Channel	Frequency [MHz]	Tones	RU offset	Antenna 1 Meas PPSD [dBm]	Antenna 2 Meas PPSD [dBm]	Total Corr'd PPSD [dBm]	PSD Limit [dBm]	Power Margin [dB]
Low	5180	26T	0	-8.55	-8.94	4.73	11.00	-6.27
			4	-7.89	-8.77	5.16	11.00	-5.84
			8	-8.11	-8.34	5.25	11.00	-5.75
		52T	37	-8.95	-9.70	4.15	11.00	-6.85
			38	-8.83	-8.79	4.65	11.00	-6.35
			40	-8.90	-9.45	4.30	11.00	-6.70
		106T	53	-9.84	-10.01	3.53	11.00	-7.47
			54	-9.65	-9.16	4.06	11.00	-6.94
		SU	-	-8.37	-8.73	4.67	11.00	-6.33
		Mid	5200	26T	0	-8.47	-8.34	5.07
4	-8.37				-8.29	5.14	11.00	-5.86
8	-8.29				-8.46	5.10	11.00	-5.90
52T	37			-9.37	-8.71	4.43	11.00	-6.57
	38			-8.95	-9.44	4.28	11.00	-6.72
	40			-8.97	-9.78	4.11	11.00	-6.89
106T	53			-9.52	-10.29	3.56	11.00	-7.44
	54			-8.92	-9.67	4.17	11.00	-6.83
SU	-			-8.25	-8.38	4.90	11.00	-6.10
High	5240			26T	0	-7.99	-8.62	5.18
		4	-7.89		-8.34	5.36	11.00	-5.64
		8	-8.16		-8.44	5.18	11.00	-5.82
		52T	37	-8.61	-9.23	4.55	11.00	-6.45
			38	-8.68	-9.17	4.54	11.00	-6.46
			40	-9.30	-9.05	4.28	11.00	-6.72
		106T	53	-10.05	-9.45	3.71	11.00	-7.29
			54	-9.59	-10.24	3.55	11.00	-7.45
		SU	-	-8.45	-8.80	4.60	11.00	-6.40

10.2.17. 802.11ax HE40 2TX CDD MODE IN THE 5.2 GHz BAND

Bandwidth and Antenna Gain

Channel	Frequency [MHz]	Min 26 dB BW [MHz]	Min 99% BW [MHz]	Directional Gain for Power [dBi]
Low	5190	19.30	N/A	-4.82
High	5230	18.68	N/A	-4.82

Limits

Channel	Frequency [MHz]	FCC Power Limit [dBm]	IC Power Limit [dBm]	FCC PPSD Limit [dBm]
Low	5190	23.86	N/A	11.00
High	5230	23.71	N/A	11.00

Included in Calculations of Corr'd Power & PPSD				
Duty Cycle CF [dB]	HE40	26T	0.46	dB
		52T	0.45	dB
		106T	0.45	dB
		242T	0.43	dB
		SU	0.19	dB

Calculation of Output Power result

Sum PW = Antenna1_Meas Power [mW] + Antenna2_Meas Power [mW]
 Total Corr'd Power [dBm] = Sum PW [dBm] + Duty CF [dB]

Output Power Results

Channel	Frequency [MHz]	Tones	RU offset	Antenna 1 Meas Power [dBm]	Antenna 2 Meas Power [dBm]	Total Corr'd Power [dBm]	Power Limit [dBm]	Power Margin [dB]
Low	5190	26T	0	5.15	4.36	8.24	23.86	-15.62
			9	4.85	4.06	7.94	23.86	-15.92
			17	4.50	4.42	7.93	23.86	-15.93
		52T	37	6.75	6.33	10.01	23.86	-13.85
			41	7.04	6.85	10.41	23.86	-13.45
			44	7.02	6.94	10.44	23.86	-13.42
		106T	53	8.95	8.20	12.05	23.86	-11.81
			54	8.85	8.07	11.94	23.86	-11.92
			56	8.78	8.03	11.88	23.86	-11.98
		242T	61	9.97	9.68	13.27	23.86	-10.59
			62	10.05	9.41	13.18	23.86	-10.68
		SU	-	13.43	13.23	16.53	23.86	-7.33
		High	5230	26T	0	4.74	4.36	8.02
9	4.46				4.19	7.80	23.86	-16.06
17	4.43				4.17	7.77	23.86	-16.09
52T	37			7.23	6.87	10.51	23.86	-13.35
	41			6.80	6.36	10.05	23.86	-13.81
	44			7.03	6.67	10.31	23.86	-13.55
106T	53			9.07	8.59	12.30	23.86	-11.56
	54			8.83	8.39	12.08	23.86	-11.78
	56			8.73	8.35	12.00	23.86	-11.86
242T	61			10.19	9.61	13.35	23.86	-10.51
	62			10.03	9.58	13.25	23.86	-10.61
SU	-			13.39	13.16	16.48	23.86	-7.38

Actual RBW	Ref. Bandwidth	Corr'd factor
100 kHz	1000 kHz	10.00 dB

Calculation of PPSD result
 Sum PW = Antenna1_Meas PPSD [mW] + Antenna2_Meas PPSD [mW]
 Total Corr'd Power [dBm]
 = Sum PW [dBm] + Duty CF [dB] + Corr'd factor [dB]

PPSD Results

Channel	Frequency [MHz]	Tones	RU offset	Antenna 1 Meas PPSD [dBm]	Antenna 2 Meas PPSD [dBm]	Total Corr'd PPSD [dBm]	PSD Limit [dBm]	Power Margin [dB]		
Low	5190	26T	0	-7.84	-8.42	5.37	11.00	-5.63		
			9	-7.90	-8.53	5.29	11.00	-5.71		
			17	-7.14	-8.10	5.90	11.00	-5.10		
		52T	37	-8.01	-8.70	5.12	11.00	-5.88		
			41	-8.36	-8.94	4.82	11.00	-6.18		
			44	-7.95	-8.92	5.05	11.00	-5.95		
		106T	53	-9.24	-9.72	3.99	11.00	-7.01		
			54	-8.71	-9.22	4.50	11.00	-6.50		
			56	-9.32	-10.50	3.59	11.00	-7.41		
		242T	61	-11.50	-12.16	1.62	11.00	-9.38		
			62	-11.11	-11.95	1.93	11.00	-9.07		
		SU	-	-11.32	-11.51	1.79	11.00	-9.21		
		High	5230	26T	0	-7.15	-8.14	5.87	11.00	-5.13
					9	-8.18	-8.33	5.23	11.00	-5.77
17	-7.74				-7.72	5.76	11.00	-5.24		
52T	37			-8.22	-8.69	5.02	11.00	-5.98		
	41			-8.66	-9.03	4.62	11.00	-6.38		
	44			-7.74	-8.49	5.36	11.00	-5.64		
106T	53			-9.23	-9.51	4.10	11.00	-6.90		
	54			-9.28	-9.55	4.05	11.00	-6.95		
	56			-9.64	-9.39	3.95	11.00	-7.05		
242T	61			-11.51	-11.97	1.70	11.00	-9.30		
	62			-11.41	-12.23	1.64	11.00	-9.36		
SU	-			-11.09	-11.39	1.96	11.00	-9.04		

10.2.18. 802.11ax HE80 2TX CDD MODE IN THE 5.2 GHz BAND

Bandwidth and Antenna Gain

Channel	Frequency [MHz]	Min 26 dB BW [MHz]	Min 99% BW [MHz]	Directional Gain for Power [dBi]
Mid	5210	19.83	N/A	-4.82

Limits

Channel	Frequency [MHz]	FCC Power Limit [dBm]	IC Power Limit [dBm]	FCC PPSD Limit [dBm]
Mid	5210	23.97	N/A	11.00

Included in Calculations of Corr'd Power & PPSD				
Duty Cycle CF [dB]	HE40	26T	0.37	dB
		52T	0.46	dB
		106T	0.45	dB
		242T	0.44	dB
		484T	0.12	dB
		SU	0.21	dB

Calculation of Output Power result

Sum PW = Antenna1_Meas Power [mW] + Antenna2_Meas Power [mW]
 Total Corr'd Power [dBm] = Sum PW [dBm] + Duty CF [dB]

Output Power Results

Channel	Frequency [MHz]	Tones	RU offset	Antenna 1 Meas Power [dBm]	Antenna 2 Meas Power [dBm]	Total Corr'd Power [dBm]	Power Limit [dBm]	Power Margin [dB]
Mid	5210	26T	0	4.69	4.72	8.09	23.97	-15.88
			18	5.05	4.74	8.28	23.97	-15.69
			36	4.23	4.64	7.82	23.97	-16.15
		52T	37	6.44	6.46	9.92	23.97	-14.05
			45	6.73	6.35	10.01	23.97	-13.96
			52	6.34	6.55	9.92	23.97	-14.05
		106T	53	8.57	8.68	12.09	23.97	-11.88
			57	8.26	8.03	11.61	23.97	-12.36
			60	7.56	8.09	11.29	23.97	-12.68
		242T	61	9.04	8.82	12.38	23.97	-11.59
			62	8.46	8.56	11.96	23.97	-12.01
			64	8.59	8.48	11.99	23.97	-11.98
		484T	65	9.40	9.31	12.49	23.97	-11.48
			66	9.46	9.18	12.45	23.97	-11.52
		SU	-	12.97	13.11	16.26	23.97	-7.71

Actual RBW	Ref. Bandwidth	Corr'd factor
100 kHz	1000 kHz	10.00 dB

Calculation of PPSD result
 Sum PW = Antenna1_Meas PPSD [mW] + Antenna2_Meas PPSD [mW]
 Total Corr'd Power [dBm]
 = Sum PW [dBm] + Duty CF [dB] + Corr'd factor [dB]

PPSD Results

Channel	Frequency [MHz]	Tones	RU offset	Antenna 1 Meas PPSD [dBm]	Antenna 2 Meas PPSD [dBm]	Total Corr'd PPSD [dBm]	PSD Limit [dBm]	Power Margin [dB]	
Mid	5210	26T	0	-8.02	-8.04	5.35	11.00	-5.65	
			18	-8.52	-7.46	5.42	11.00	-5.58	
			36	-8.64	-7.32	5.45	11.00	-5.55	
		52T	37	-9.83	-9.05	4.05	11.00	-6.95	
			45	-9.02	-8.80	4.56	11.00	-6.44	
			52	-9.20	-8.74	4.50	11.00	-6.50	
		106T	53	-10.15	-9.83	3.48	11.00	-7.52	
			57	-10.65	-9.39	3.49	11.00	-7.51	
			60	-10.79	-9.95	3.11	11.00	-7.89	
		242T	61	-13.81	-13.45	-0.17	11.00	-11.17	
			62	-13.40	-13.01	0.25	11.00	-10.75	
			64	-13.73	-13.08	0.06	11.00	-10.94	
		484T	65	-15.44	-15.58	-2.38	11.00	-13.38	
			66	-15.11	-15.09	-1.97	11.00	-12.97	
		SU	-	-	-14.64	-14.35	-1.27	11.00	-12.27

10.2.19. 802.11ax HE20 2TX CDD MODE IN THE 5.3 GHz BAND

Bandwidth and Antenna Gain

Channel	Frequency [MHz]	Min 26 dB BW [MHz]	Min 99% BW [MHz]	Directional Gain for Power [dBi]
Low	5260	17.00	N/A	-4.29
Mid	5300	17.92	N/A	-4.29
High	5320	18.88	N/A	-4.29

Limits

Channel	Frequency [MHz]	FCC Power Limit [dBm]	IC Power Limit [dBm]	FCC PPSD Limit [dBm]
Low	5260	23.30	N/A	11.00
Mid	5300	23.53	N/A	11.00
High	5320	23.76	N/A	11.00

Included in Calculations of Corr'd Power & PPSD				
Duty Cycle CF [dB]	HE20	26T	0.46	dB
		52T	0.45	dB
		106T	0.44	dB
		SU	0.21	dB

Calculation of Output Power result

Sum PW = Antenna1_Meas Power [mW] + Antenna2_Meas Power [mW]
 Total Corr'd Power [dBm] = Sum PW [dBm] + Duty CF [dB]

Output Power Results

Channel	Frequency [MHz]	Tones	RU offset	Antenna 1 Meas Power [dBm]	Antenna 2 Meas Power [dBm]	Total Corr'd Power [dBm]	Power Limit [dBm]	Power Margin [dB]
Low	5260	26T	0	4.55	4.06	7.78	23.30	-15.52
			4	4.61	4.75	8.15	23.30	-15.15
			8	4.20	4.45	7.80	23.30	-15.50
		52T	37	6.61	6.06	9.80	23.30	-13.50
			38	6.75	6.26	9.97	23.30	-13.33
			40	6.38	5.94	9.63	23.30	-13.67
		106T	53	8.98	8.66	12.27	23.30	-11.03
			54	8.75	8.72	12.19	23.30	-11.11
		SU	-	13.28	12.94	16.33	23.30	-6.97
		Mid	5300	26T	0	4.80	4.16	7.96
4	4.81				4.12	7.95	23.53	-15.58
8	4.33				3.75	7.52	23.53	-16.01
52T	37			6.56	6.04	9.77	23.53	-13.76
	38			6.86	6.39	10.09	23.53	-13.44
	40			6.59	5.97	9.75	23.53	-13.78
106T	53			9.32	8.74	12.49	23.53	-11.04
	54			9.19	8.72	12.41	23.53	-11.12
SU	-			13.24	12.91	16.30	23.53	-7.23
High	5320			26T	0	4.93	4.28	8.09
		4	4.97		4.13	8.04	23.76	-15.72
		8	4.59		4.16	7.85	23.76	-15.91
		52T	37	6.86	6.47	10.13	23.76	-13.63
			38	6.81	6.46	10.10	23.76	-13.66
			40	6.43	6.17	9.76	23.76	-14.00
		106T	53	8.97	8.42	12.15	23.76	-11.61
			54	8.94	8.47	12.16	23.76	-11.60
		SU	-	13.19	12.94	16.29	23.76	-7.47

Actual RBW	Ref. Bandwidth	Corr'd factor
100 kHz	1000 kHz	10.00 dB

Calculation of PPSD result

Sum PW [mW] = Antenna1_Meas PPSD [mW] + Antenna2_Meas PPSD [mW]
 Total Corr'd Power [dBm]
 = Sum PW [dBm] + Duty CF [dB] + Corr'd factor [dB]

PPSD Results

Channel	Frequency [MHz]	Tones	RU offset	Antenna 1 Meas PPSD [dBm]	Antenna 2 Meas PPSD [dBm]	Total Corr'd PPSD [dBm]	PSD Limit [dBm]	Power Margin [dB]
Low	5260	26T	0	-8.32	-8.93	4.86	11.00	-6.14
			4	-8.10	-7.84	5.50	11.00	-5.50
			8	-8.10	-8.54	5.16	11.00	-5.84
		52T	37	-8.42	-9.25	4.64	11.00	-6.36
			38	-8.30	-9.10	4.78	11.00	-6.22
			40	-8.80	-9.26	4.43	11.00	-6.57
		106T	53	-9.70	-9.43	3.89	11.00	-7.11
			54	-9.74	-9.63	3.77	11.00	-7.23
		SU	-	-8.51	-8.74	4.59	11.00	-6.41
		Mid	5300	26T	0	-7.83	-8.03	5.54
4	-8.03				-8.22	5.35	11.00	-5.65
8	-8.31				-8.03	5.30	11.00	-5.70
52T	37			-8.57	-9.08	4.64	11.00	-6.36
	38			-8.52	-8.76	4.82	11.00	-6.18
	40			-8.76	-8.68	4.74	11.00	-6.26
106T	53			-9.07	-9.59	4.13	11.00	-6.87
	54			-9.36	-9.45	4.05	11.00	-6.95
SU	-			-8.77	-8.65	4.51	11.00	-6.49
High	5320			26T	0	-7.96	-8.11	5.44
		4	-7.40		-8.04	5.76	11.00	-5.24
		8	-7.89		-8.35	5.36	11.00	-5.64
		52T	37	-8.35	-8.85	4.87	11.00	-6.13
			38	-8.56	-8.85	4.76	11.00	-6.24
			40	-8.58	-8.76	4.79	11.00	-6.21
		106T	53	-9.52	-9.69	3.84	11.00	-7.16
			54	-9.70	-9.51	3.85	11.00	-7.15
		SU	-	-8.51	-8.48	4.73	11.00	-6.27

10.2.20. 802.11ax HE40 2TX CDD MODE IN THE 5.3 GHz BAND

Bandwidth and Antenna Gain

Channel	Frequency [MHz]	Min 26 dB BW [MHz]	Min 99% BW [MHz]	Directional Gain for Power [dBi]
Low	5270	19.49	N/A	-4.29
High	5310	19.22	N/A	-4.29

Limits

Channel	Frequency [MHz]	FCC Power Limit [dBm]	IC Power Limit [dBm]	FCC PPSD Limit [dBm]
Low	5270	23.90	N/A	11.00
High	5310	23.84	N/A	11.00

Included in Calculations of Corr'd Power & PPSD				
Duty Cycle CF [dB]	HE40	26T	0.46	dB
		52T	0.45	dB
		106T	0.45	dB
		242T	0.43	dB
		SU	0.19	dB

Calculation of Output Power result

Sum PW = Antenna1_Meas Power [mW] + Antenna2_Meas Power [mW]
 Total Corr'd Power [dBm] = Sum PW [dBm] + Duty CF [dB]

Output Power Results

Channel	Frequency [MHz]	Tones	RU offset	Antenna 1 Meas Power [dBm]	Antenna 2 Meas Power [dBm]	Total Corr'd Power [dBm]	Power Limit [dBm]	Power Margin [dB]		
Low	5270	26T	0	4.99	4.60	8.27	23.90	-15.63		
			9	4.76	4.40	8.05	23.90	-15.85		
			17	4.46	4.24	7.82	23.90	-16.08		
		52T	37	7.16	6.82	10.45	23.90	-13.45		
			41	7.07	6.15	10.09	23.90	-13.81		
			44	6.71	6.50	10.07	23.90	-13.83		
		106T	53	9.09	8.69	12.35	23.90	-11.55		
			54	8.97	8.71	12.30	23.90	-11.60		
			56	8.56	8.43	11.96	23.90	-11.94		
		242T	61	10.27	9.52	13.35	23.90	-10.55		
			62	9.99	9.73	13.30	23.90	-10.60		
		SU	-	13.29	13.04	16.37	23.90	-7.53		
		High	5310	26T	0	5.14	4.64	8.37	23.90	-15.53
					9	4.96	4.49	8.20	23.90	-15.70
17	4.75				4.34	8.02	23.90	-15.88		
52T	37			6.43	6.65	10.00	23.90	-13.90		
	41			6.87	6.39	10.10	23.90	-13.80		
	44			6.56	6.13	9.81	23.90	-14.09		
106T	53			9.15	8.65	12.37	23.90	-11.53		
	54			9.19	8.71	12.42	23.90	-11.48		
	56			8.76	8.25	11.97	23.90	-11.93		
242T	61			10.26	9.62	13.39	23.90	-10.51		
	62			10.05	9.43	13.19	23.90	-10.71		
SU	-			13.23	13.05	16.34	23.90	-7.56		

Actual RBW	Ref. Bandwidth	Corr'd factor
100 kHz	1000 kHz	10.00 dB

Calculation of PPSD result
 Sum PW = Antenna1_Meas PPSD [mW] + Antenna2_Meas PPSD [mW]
 Total Corr'd Power [dBm]
 = Sum PW [dBm] + Duty CF [dB] + Corr'd factor [dB]

PPSD Results

Channel	Frequency [MHz]	Tones	RU offset	Antenna 1 Meas PPSD [dBm]	Antenna 2 Meas PPSD [dBm]	Total Corr'd PPSD [dBm]	PSD Limit [dBm]	Power Margin [dB]		
Low	5270	26T	0	-7.30	-7.47	5.37	11.00	-5.63		
			9	-7.28	-7.89	5.29	11.00	-5.71		
			17	-7.48	-7.96	5.90	11.00	-5.10		
		52T	37	-7.66	-7.61	5.12	11.00	-5.88		
			41	-7.99	-8.50	4.82	11.00	-6.18		
			44	-8.39	-8.53	5.05	11.00	-5.95		
		106T	53	-9.41	-9.14	3.99	11.00	-7.01		
			54	-9.20	-9.49	4.50	11.00	-6.50		
			56	-9.66	-9.37	3.59	11.00	-7.41		
		242T	61	-11.14	-10.98	1.62	11.00	-9.38		
			62	-11.07	-10.98	1.93	11.00	-9.07		
		SU	-	-11.15	-11.20	1.79	11.00	-9.21		
		High	5310	26T	0	-6.82	-7.38	5.87	11.00	-5.13
					9	-7.53	-7.85	5.23	11.00	-5.77
17	-7.52				-7.68	5.76	11.00	-5.24		
52T	37			-7.85	-8.43	5.02	11.00	-5.98		
	41			-8.03	-8.46	4.62	11.00	-6.38		
	44			-8.62	-8.33	5.36	11.00	-5.64		
106T	53			-8.98	-9.01	4.10	11.00	-6.90		
	54			-9.09	-9.38	4.05	11.00	-6.95		
	56			-9.69	-9.49	3.95	11.00	-7.05		
242T	61			-11.81	-10.94	1.70	11.00	-9.30		
	62			-11.40	-11.70	1.64	11.00	-9.36		
SU	-			-11.30	-11.48	1.96	11.00	-9.04		

10.2.21. 802.11ax HE80 2TX CDD MODE IN THE 5.3 GHz BAND

Bandwidth and Antenna Gain

Channel	Frequency [MHz]	Min 26 dB BW [MHz]	Min 99% BW [MHz]	Directional Gain for Power [dBi]
Mid	5290	20.66	N/A	-4.29

Limits

Channel	Frequency [MHz]	FCC Power Limit [dBm]	IC Power Limit [dBm]	FCC PPSD Limit [dBm]
Mid	5290	24.00	N/A	11.00

Included in Calculations of Corr'd Power & PPSD				
Duty Cycle CF [dB]	HE80	26T	0.37	dB
		52T	0.46	dB
		106T	0.45	dB
		242T	0.44	dB
		484T	0.12	dB
		SU	0.21	dB

Calculation of Outpu Power result
 Sum PW = Antenna1_Meas Power [mW] + Antenna2_Meas Power [mW]
 Total Corr'd Power [dBm] = Sum PW [dBm] + Duty CF [dB]

Output Power Results

Channel	Frequency [MHz]	Tones	RU offset	Antenna 1 Meas Power [dBm]	Antenna 2 Meas Power [dBm]	Total Corr'd Power [dBm]	Power Limit [dBm]	Power Margin [dB]
Mid	5290	26T	0	4.74	4.86	8.18	24.00	-15.82
			18	4.87	4.64	8.14	24.00	-15.86
			36	4.38	4.69	7.92	24.00	-16.08
		52T	37	6.14	6.57	9.83	24.00	-14.17
			45	7.12	6.88	10.47	24.00	-13.53
			52	6.05	6.42	9.71	24.00	-14.29
		106T	53	8.50	8.59	12.01	24.00	-11.99
			57	7.97	8.36	11.63	24.00	-12.37
			60	7.93	8.30	11.58	24.00	-12.42
		242T	61	8.91	8.84	12.33	24.00	-11.67
			62	8.97	8.72	12.30	24.00	-11.70
			64	8.47	8.24	11.81	24.00	-12.19
		484T	65	9.30	9.56	12.56	24.00	-11.44
			66	9.55	9.58	12.70	24.00	-11.30
		SU	-	12.83	12.94	16.11	24.00	-7.89

Actual RBW	Ref. Bandwidth	Corr'd factor
100 kHz	1000 kHz	10.00 dB

Calculation of PPSD result
 Sum PW = Antenna1_Meas PPSD [mW] + Antenna2_Meas PPSD [mW]
 Total Corr'd Power [dBm]
 = Sum PW [dBm] + Duty CF [dB] + Corr'd factor [dB]

PPSD Results

Channel	Frequency [MHz]	Tones	RU offset	Antenna 1 Meas PPSD [dBm]	Antenna 2 Meas PPSD [dBm]	Total Corr'd PPSD [dBm]	PSD Limit [dBm]	Power Margin [dB]
Low	5290	26T	0	-7.64	-7.27	5.93	11.00	-5.07
			18	-7.95	-7.23	5.80	11.00	-5.20
			36	-7.64	-6.88	6.13	11.00	-4.87
		52T	37	-8.81	-8.47	4.84	11.00	-6.16
			45	-8.93	-7.72	5.19	11.00	-5.81
			52	-9.06	-8.13	4.90	11.00	-6.10
		106T	53	-10.61	-10.12	3.10	11.00	-7.90
			57	-10.68	-9.66	3.32	11.00	-7.68
			60	-10.38	-9.78	3.39	11.00	-7.61
		242T	61	-13.23	-12.03	0.86	11.00	-10.14
			62	-13.48	-12.59	0.44	11.00	-10.56
			64	-13.80	-12.50	0.35	11.00	-10.65
		484T	65	-15.43	-14.72	-1.93	11.00	-12.93
			66	-14.19	-14.56	-1.24	11.00	-12.24
		SU	-	-14.75	-14.36	-1.33	11.00	-12.33

10.2.22. 802.11ax HE20 2TX CDD MODE IN THE 5.5 GHz BAND

Bandwidth and Antenna Gain

Channel	Frequency [MHz]	Min 26 dB BW [MHz]	Min 99% BW [MHz]	Directional Gain for Power [dBi]
Low	5500	17.10	N/A	-3.78
Mid	5580	17.38	N/A	-3.78
High	5700	18.88	N/A	-3.78
Stradle	5720	17.50	N/A	-3.78

Limits

Channel	Frequency [MHz]	FCC Power Limit [dBm]	IC Power Limit [dBm]	FCC PPSD Limit [dBm]
Low	5500	23.33	N/A	11.00
Mid	5580	23.40	N/A	11.00
High	5700	23.76	N/A	11.00
Stradle	5720	23.43	N/A	11.00

Included in Calculations of Corr'd Power & PPSD				
Duty Cycle CF [dB]	HE20	26T	0.46	dB
		52T	0.45	dB
		106T	0.44	dB
		SU	0.21	dB

Calculation of Outpu Power result
 Sum PW = Antenna1_Meas Power [mW] + Antenna2_Meas Power [mW]
 Total Corr'd Power [dBm] = Sum PW [dBm] + Duty CF [dB]

Output Power Results

Channel	Frequency [MHz]	Tones	RU offset	Antenna 1 Meas Power [dBm]	Antenna 2 Meas Power [dBm]	Total Corr'd Power [dBm]	Power Limit [dBm]	Power Margin [dB]
Low	5500	26T	0	4.79	4.62	8.18	23.33	-15.15
			4	4.75	4.71	8.20	23.33	-15.13
			8	4.42	4.33	7.85	23.33	-15.48
		52T	37	6.51	6.46	9.95	23.33	-13.38
			38	6.45	6.41	9.89	23.33	-13.44
			40	6.20	6.20	9.66	23.33	-13.67
		106T	53	8.82	8.78	12.25	23.33	-11.08
			54	8.67	8.64	12.11	23.33	-11.22
		SU	-	14.49	14.87	17.90	23.33	-5.43
		Mid	5580	26T	0	4.35	4.18	7.74
4	4.34				4.27	7.78	23.40	-15.62
8	4.09				3.92	7.48	23.40	-15.92
52T	37			6.60	6.41	9.97	23.40	-13.43
	38			6.17	6.39	9.74	23.40	-13.66
	40			6.38	6.20	9.75	23.40	-13.65
106T	53			8.58	8.52	12.00	23.40	-11.40
	54			8.32	8.27	11.75	23.40	-11.65
SU	-			14.39	14.68	17.76	23.40	-5.64
High	5700			26T	0	4.54	4.66	8.07
		4	4.67		4.83	8.22	23.76	-15.54
		8	4.25		4.34	7.77	23.76	-15.99
		52T	37	6.83	6.81	10.28	23.76	-13.48
			38	6.34	6.26	9.76	23.76	-14.00
			40	6.06	6.64	9.82	23.76	-13.94
		106T	53	8.62	8.88	12.20	23.76	-11.56
			54	8.64	8.92	12.23	23.76	-11.53
		SU	-	14.27	14.80	17.76	23.76	-6.00

Channel	Frequency [MHz]	Tones	RU offset	Antenna 1 Meas Power [dBm]	Antenna 2 Meas Power [dBm]	Total Corr'd Power [dBm]	Power Limit [dBm]	Power Margin [dB]
Straddle	5720	26T	0	4.24	5.02	7.87	23.43	-15.56
			4	4.42	5.17	8.04	23.43	-15.39
			8	4.60	5.34	8.21	23.43	-15.22
		52T	37	6.70	7.06	10.12	23.43	-13.31
			38	6.74	7.02	10.12	23.43	-13.31
106T	53	8.98	9.25	12.35	23.43	-11.08		

Actual RBW	Ref. Bandwidth	Corr'd factor
100 kHz	1000 kHz	10.00 dB

Calculation of PPSD result
 Sum PW = Antenna1_Meas PPSD [mW] + Antenna2_Meas PPSD [mW]
 Total Corr'd Power [dBm]
 = Sum PW [dBm] + Duty CF [dB] + Corr'd factor [dB]

PPSD Results

Channel	Frequency [MHz]	Tones	RU offset	Antenna 1 Meas PPSD [dBm]	Antenna 2 Meas PPSD [dBm]	Total Corr'd PPSD [dBm]	PSD Limit [dBm]	Power Margin [dB]
Low	5500	26T	0	-7.96	-8.17	5.41	11.00	-5.59
			4	-7.70	-7.46	5.89	11.00	-5.11
			8	-8.52	-8.12	5.15	11.00	-5.85
		52T	37	-8.77	-8.56	4.79	11.00	-6.21
			38	-8.55	-8.72	4.83	11.00	-6.17
			40	-8.67	-8.61	4.82	11.00	-6.18
		106T	53	-9.58	-9.62	3.85	11.00	-7.15
			54	-9.78	-9.59	3.77	11.00	-7.23
		SU	-	-7.51	-7.24	5.85	11.00	-5.15
		Mid	5580	26T	0	-8.45	-7.86	5.33
4	-8.06				-8.10	5.39	11.00	-5.61
8	-8.00				-8.09	5.43	11.00	-5.57
52T	37			-8.81	-9.09	4.51	11.00	-6.49
	38			-8.90	-8.30	4.87	11.00	-6.13
	40			-8.85	-8.96	4.56	11.00	-6.44
106T	53			-9.95	-9.54	3.71	11.00	-7.29
	54			-10.09	-9.69	3.57	11.00	-7.43
SU	-			-7.55	-6.71	6.11	11.00	-4.89
High	5700			26T	0	-7.83	-7.41	5.86
		4	-7.68		-7.20	6.04	11.00	-4.96
		8	-8.11		-7.74	5.55	11.00	-5.45
		52T	37	-9.23	-8.20	4.77	11.00	-6.23
			38	-8.65	-8.39	4.94	11.00	-6.06
			40	-9.29	-8.70	4.48	11.00	-6.52
		106T	53	-9.57	-9.19	4.08	11.00	-6.92
			54	-9.61	-9.11	4.10	11.00	-6.90
		SU	-	-7.50	-6.36	6.33	11.00	-4.67
		Straddle	5720	26T	0	-9.09	-8.26	4.82
4	-8.00				-7.95	5.49	11.00	-5.51
52T	37			-9.42	-9.43	4.04	11.00	-6.96
	38			-8.71	-8.33	4.95	11.00	-6.05
106T	53			-10.25	-9.49	3.60	11.00	-7.40

10.2.23. 802.11ax HE40 2TX CDD MODE IN THE 5.5 GHz BAND

Bandwidth and Antenna Gain

Channel	Frequency [MHz]	Min 26 dB BW [MHz]	Min 99% BW [MHz]	Directional Gain for Power [dBi]
Low	5510	17.63	N/A	-3.78
Mid	5590	18.07	N/A	-3.78
High	5670	18.36	N/A	-3.78
Stradle	5710	18.78	N/A	-3.78

Limits

Channel	Frequency [MHz]	FCC Power Limit [dBm]	IC Power Limit [dBm]	FCC PPSD Limit [dBm]
Low	5510	23.46	N/A	11.00
Mid	5590	23.57	N/A	11.00
High	5670	23.64	N/A	11.00
Stradle	5710	23.74	N/A	11.00

Included in Calculations of Corr'd Power & PPSD				
Duty Cycle CF [dB]	HE40	26T	0.46	dB
		52T	0.45	dB
		106T	0.45	dB
		242T	0.43	dB
		SU	0.19	dB

Calculation of Output Power result
 Sum PW = Antenna1_Meas Power [mW] + Antenna2_Meas Power [mW]
 Total Corr'd Power [dBm] = Sum PW [dBm] + Duty CF [dB]

Output Power Results

Channel	Frequency [MHz]	Tones	RU offset	Antenna 1 Meas Power [dBm]	Antenna 2 Meas Power [dBm]	Total Corr'd Power [dBm]	Power Limit [dBm]	Power Margin [dB]		
Low	5510	26T	0	5.10	4.81	8.43	23.46	-15.03		
			9	4.73	4.45	8.06	23.46	-15.40		
			17	4.43	4.15	7.76	23.46	-15.70		
		52T	37	6.60	6.36	9.94	23.46	-13.52		
			41	6.59	6.42	9.97	23.46	-13.49		
			44	6.16	6.27	9.68	23.46	-13.78		
		106T	53	8.66	8.76	12.17	23.46	-11.29		
			54	8.91	9.05	12.44	23.46	-11.02		
			56	8.39	8.82	12.07	23.46	-11.39		
		242T	61	9.72	9.74	13.17	23.46	-10.29		
			62	9.37	9.52	12.89	23.46	-10.57		
		SU	-	13.01	13.52	16.47	23.46	-6.99		
		Mid	5590	26T	0	4.56	4.81	8.16	23.57	-15.41
					9	4.19	4.42	7.78	23.57	-15.79
17	4.44				4.16	7.77	23.57	-15.80		
52T	37			6.71	6.36	10.00	23.57	-13.57		
	41			6.16	6.35	9.72	23.57	-13.85		
	44			6.00	6.14	9.53	23.57	-14.04		
106T	53			8.98	8.67	12.29	23.57	-11.28		
	54			8.90	8.62	12.22	23.57	-11.35		
	56			8.43	8.18	11.77	23.57	-11.80		
242T	61			9.98	9.64	13.25	23.57	-10.32		
	62			9.38	9.47	12.87	23.57	-10.70		
SU	-			12.82	13.26	16.25	23.57	-7.32		
High	5670			26T	0	5.24	4.78	8.49	23.64	-15.15
					9	4.76	4.20	7.96	23.64	-15.68
		17	4.43		4.09	7.73	23.64	-15.91		
		52T	37	6.77	6.28	9.99	23.64	-13.65		
			41	6.25	6.71	9.95	23.64	-13.69		
			44	6.07	6.43	9.71	23.64	-13.93		
		106T	53	8.96	8.99	12.44	23.64	-11.20		
			54	8.98	9.07	12.49	23.64	-11.15		
			56	8.07	8.61	11.81	23.64	-11.83		
		242T	61	10.09	9.59	13.29	23.64	-10.35		
			62	9.80	9.25	12.97	23.64	-10.67		
		SU	-	12.82	13.22	16.22	23.64	-7.42		

Channel	Frequency [MHz]	Tones	RU offset	Antenna 1 Meas Power [dBm]	Antenna 2 Meas Power [dBm]	Total Corr'd Power [dBm]	Power Limit [dBm]	Power Margin [dB]
Stradle	5710	26T	0	4.80	5.23	8.49	23.74	-15.25
			9	4.44	4.80	8.09	23.74	-15.65
		52T	37	6.94	6.73	10.30	23.74	-13.44
			41	7.03	6.83	10.39	23.74	-13.35
		106T	53	9.16	9.17	12.63	23.74	-11.11
			54	9.14	8.95	12.51	23.74	-11.23
		242T	61	9.73	9.97	13.29	23.74	-10.45

Actual RBW	Ref. Bandwidth	Corr'd factor
100 kHz	1000 kHz	10.00 dB

Calculation of PPSD result
 Sum PW = Antenna1_Meas PPSD [mW] + Antenna2_Meas PPSD [mW]
 Total Corr'd Power [dBm]
 = Sum PW [dBm] + Duty CF [dB] + Corr'd factor [dB]

PPSD Results

Channel	Frequency [MHz]	Tones	RU offset	Antenna 1 Meas PPSD [dBm]	Antenna 2 Meas PPSD [dBm]	Total Corr'd PPSD [dBm]	PSD Limit [dBm]	Power Margin [dB]		
Low	5510	26T	0	-7.05	-7.45	6.25	11.00	-4.75		
			9	-7.87	-7.55	5.79	11.00	-5.21		
			17	-7.93	-8.14	5.45	11.00	-5.55		
		52T	37	-8.58	-8.31	5.02	11.00	-5.98		
			41	-8.93	-8.56	4.72	11.00	-6.28		
			44	-8.58	-8.26	5.05	11.00	-5.95		
		106T	53	-9.11	-9.06	4.37	11.00	-6.63		
			54	-9.67	-9.44	3.91	11.00	-7.09		
			56	-9.93	-9.53	3.74	11.00	-7.26		
		242T	61	-11.37	-11.66	1.93	11.00	-9.07		
			62	-11.59	-11.67	1.81	11.00	-9.19		
		SU	-	-11.46	-11.12	1.91	11.00	-9.09		
		Mid	5590	26T	0	-7.11	-7.72	6.09	11.00	-4.91
					9	-7.52	-8.02	5.73	11.00	-5.27
17	-8.11				-8.02	5.43	11.00	-5.57		
52T	37			-8.68	-8.28	4.98	11.00	-6.02		
	41			-8.44	-9.05	4.72	11.00	-6.28		
	44			-9.05	-8.15	4.88	11.00	-6.12		
106T	53			-9.23	-8.85	4.42	11.00	-6.58		
	54			-9.54	-9.47	3.96	11.00	-7.04		
	56			-9.74	-9.08	4.06	11.00	-6.94		
242T	61			-10.86	-11.36	2.34	11.00	-8.66		
	62			-11.51	-11.52	1.93	11.00	-9.07		
SU	-			-11.30	-11.15	1.97	11.00	-9.03		
High	5670			26T	0	-7.32	-7.28	6.19	11.00	-4.81
					9	-7.55	-7.63	5.90	11.00	-5.10
		17	-7.52		-7.36	6.05	11.00	-4.95		
		52T	37	-8.24	-7.93	5.38	11.00	-5.62		
			41	-8.53	-8.50	4.94	11.00	-6.06		
			44	-8.41	-8.11	5.20	11.00	-5.80		
		106T	53	-9.07	-9.36	4.25	11.00	-6.75		
			54	-9.26	-9.04	4.31	11.00	-6.69		
			56	-9.67	-9.36	3.95	11.00	-7.05		
		242T	61	-11.30	-11.17	2.20	11.00	-8.80		
			62	-11.48	-11.14	2.13	11.00	-8.87		
		SU	-	-11.46	-11.26	1.85	11.00	-9.15		
		Stradle	5710	26T	0	-7.92	-8.05	5.50	11.00	-5.50
					9	-7.95	-7.75	5.64	11.00	-5.36
52T	37			-9.13	-8.69	4.56	11.00	-6.44		
	41			-8.92	-9.38	4.32	11.00	-6.68		
106T	53			-9.83	-9.47	3.82	11.00	-7.18		
	54			-9.43	-9.19	4.16	11.00	-6.84		
242T	61			-11.43	-11.92	1.77	11.00	-9.23		

10.2.24. 802.11ax HE80 2TX CDD MODE IN THE 5.5 GHz BAND

Bandwidth and Antenna Gain

Channel	Frequency [MHz]	Min 26 dB BW [MHz]	Min 99% BW [MHz]	Directional Gain for Power [dBi]
Low	5530	18.42	N/A	-3.78
High	5610	17.77	N/A	-3.78
Straddle	5690	18.05	N/A	-3.78

Limits

Channel	Frequency [MHz]	FCC Power Limit [dBm]	IC Power Limit [dBm]	FCC PPSD Limit [dBm]
Low	5530	23.65	N/A	11.00
High	5610	23.50	N/A	11.00
Straddle	5690	23.56	N/A	11.00

Included in Calculations of Corr'd Power & PPSD				
Duty Cycle CF [dB]	HE80	26T	0.37	dB
		52T	0.46	dB
		106T	0.45	dB
		242T	0.44	dB
		484T	0.12	dB
		SU	0.21	dB

Calculation of Output Power result
 Sum PW = Antenna1_Meas Power [mW] + Antenna2_Meas Power [mW]
 Total Corr'd Power [dBm] = Sum PW [dBm] + Duty CF [dB]

Output Power Results

Channel	Frequency [MHz]	Tones	RU offset	Antenna 1 Meas Power [dBm]	Antenna 2 Meas Power [dBm]	Total Corr'd Power [dBm]	Power Limit [dBm]	Power Margin [dB]		
Low	5530	26T	0	4.66	5.12	8.28	23.65	-15.37		
			18	4.35	4.89	8.01	23.65	-15.64		
			36	4.36	4.34	7.73	23.65	-15.92		
		52T	37	6.11	6.95	10.02	23.65	-13.63		
			45	6.54	6.57	10.03	23.65	-13.62		
			52	6.34	7.04	10.17	23.65	-13.48		
		106T	53	8.01	8.06	11.50	23.65	-12.15		
			57	7.91	7.97	11.40	23.65	-12.25		
			60	7.65	7.84	11.21	23.65	-12.44		
		242T	61	9.12	9.13	12.58	23.65	-11.07		
			62	9.20	9.19	12.65	23.65	-11.00		
			64	8.38	8.39	11.84	23.65	-11.81		
		484T	65	9.64	9.66	12.78	23.65	-10.87		
			66	9.53	9.54	12.67	23.65	-10.98		
			SU	-	12.76	13.29	16.25	23.65	-7.40	
		High	5610	26T	0	4.56	4.85	8.09	23.50	-15.41
					18	4.42	4.75	7.97	23.50	-15.53
					36	4.12	4.31	7.60	23.50	-15.90
52T	37			6.18	6.82	9.98	23.50	-13.52		
	45			6.57	7.15	10.34	23.50	-13.16		
	52			6.40	6.96	10.16	23.50	-13.34		
106T	53			8.31	8.51	11.87	23.50	-11.63		
	57			7.70	8.15	11.39	23.50	-12.11		
	60			7.65	7.86	11.22	23.50	-12.28		
242T	61			9.04	9.05	12.50	23.50	-11.00		
	62			8.76	9.04	12.35	23.50	-11.15		
	64			8.19	8.38	11.74	23.50	-11.76		
484T	65			9.43	9.61	12.65	23.50	-10.85		
	66			9.04	9.35	12.33	23.50	-11.17		
	SU			-	12.67	13.18	16.15	23.50	-7.35	

Channel	Frequency [MHz]	Tones	RU offset	Antenna 1 Meas Power [dBm]	Antenna 2 Meas Power [dBm]	Total Corr'd Power [dBm]	Power Limit [dBm]	Power Margin [dB]
Straddle	5690	26T	0	4.84	5.27	8.44	23.56	-15.12
			18	4.58	5.29	8.33	23.56	-15.23
		52T	37	6.06	7.00	10.03	23.56	-13.53
			45	6.24	7.13	10.18	23.56	-13.38
		106T	53	7.97	8.16	11.53	23.56	-12.03
			57	7.73	8.35	11.43	23.56	-12.13
		242T	61	7.76	8.08	12.10	23.56	-11.46
			62	8.48	8.81	12.21	23.56	-11.35
		484T	65	8.91	9.25	12.75	23.56	-10.81

Actual RBW	Ref. Bandwidth	Corr'd factor
100 kHz	1000 kHz	10.00 dB

Calculation of PPSD result
 Sum PW = Antenna1_Meas PPSD [mW] + Antenna2_Meas PPSD [mW]
 Total Corr'd Power [dBm]
 = Sum PW [dBm] + Duty CF [dB] + Corr'd factor [dB]

PPSD Results

Channel	Frequency [MHz]	Tones	RU offset	Antenna 1 Meas PPSD [dBm]	Antenna 2 Meas PPSD [dBm]	Total Corr'd PPSD [dBm]	PSD Limit [dBm]	Power Margin [dB]
Low	5530	26T	0	-7.39	-7.25	6.06	11.00	-4.94
			18	-7.06	-7.37	6.17	11.00	-4.83
			36	-7.53	-7.75	5.75	11.00	-5.25
		52T	37	-8.89	-8.02	5.04	11.00	-5.96
			45	-8.65	-8.04	5.14	11.00	-5.86
			52	-8.62	-8.06	5.14	11.00	-5.86
		106T	53	-10.07	-9.54	3.67	11.00	-7.33
			57	-10.78	-10.11	3.03	11.00	-7.97
			60	-10.38	-9.45	3.57	11.00	-7.43
		242T	61	-13.11	-12.57	0.62	11.00	-10.38
			62	-13.10	-12.52	0.65	11.00	-10.35
			64	-13.71	-12.76	0.24	11.00	-10.76
		484T	65	-14.82	-14.15	-1.34	11.00	-12.34
			66	-14.43	-14.19	-1.18	11.00	-12.18
		SU	-	-14.64	-13.65	-0.90	11.00	-11.90
		High	5610	26T	0	-7.84	-7.29	5.83
18	-7.28				-7.40	6.04	11.00	-4.96
36	-7.88				-7.58	5.65	11.00	-5.35
52T	37			-8.43	-7.60	5.47	11.00	-5.53
	45			-8.18	-8.05	5.36	11.00	-5.64
	52			-8.49	-8.14	5.16	11.00	-5.84
106T	53			-9.68	-9.42	3.91	11.00	-7.09
	57			-10.22	-10.44	3.13	11.00	-7.87
	60			-9.98	-10.28	3.33	11.00	-7.67
242T	61			-12.37	-12.28	1.12	11.00	-9.88
	62			-12.62	-12.33	0.98	11.00	-10.02
	64			-13.41	-12.70	0.41	11.00	-10.59
484T	65			-15.04	-14.22	-1.48	11.00	-12.48
	66			-14.92	-14.54	-1.60	11.00	-12.60
SU	-			-14.51	-14.06	-1.06	11.00	-12.06
Straddle	5690			26T	0	-8.28	-7.49	5.52
		18	-7.47		-7.60	5.85	11.00	-5.15
		52T	37	-9.13	-9.47	4.18	11.00	-6.82
			45	-8.22	-8.49	5.12	11.00	-5.88
		106T	53	-10.94	-9.77	3.14	11.00	-7.86
			57	-9.86	-9.68	3.69	11.00	-7.31
		242T	61	-12.83	-13.05	0.51	11.00	-10.49
			62	-12.76	-12.79	0.68	11.00	-10.32
		484T	65	-15.58	-15.08	-2.19	11.00	-13.19

10.2.25. 802.11ax HE20 2TX CDD MODE IN THE 5.8 GHz BAND

Limits

Channel	Frequency	FCC Power Limit	IC Power Limit	FCC PPSD Limit
	[MHz]	[dBm]	[dBm]	[dBm]
Stradle	5720	30.00	30.00	30.00
Low	5745	30.00	30.00	30.00
Mid	5785	30.00	30.00	30.00
High	5825	30.00	30.00	30.00

Included in Calculations of Corr'd Power & PPSD				
Duty Cycle CF [dB]	HE20	26T	0.46	dB
		52T	0.45	dB
		106T	0.44	dB
		SU	0.21	dB

Calculation of Outpu Power result
 Sum PW = Antenna1_Meas Power [mW] + Antenna2_Meas Power [mW]
 Total Corr'd Power [dBm] = Sum PW [dBm] + Duty CF [dB]

Output Power Results

Channel	Frequency	Tones	RU offset	Antenna 1 Meas Power	Antenna 2 Meas Power	Total Corr'd Power	Power Limit	Power Margin
	[MHz]			[dBm]	[dBm]	[dBm]	[dBm]	[dB]
Stradle	5720	26T	8	3.94	4.31	7.60	30.00	-22.40
		52T	40	6.16	6.08	9.58	30.00	-20.42
Low	5745	26T	0	4.64	4.77	8.18	30.00	-21.82
			4	4.73	4.79	8.23	30.00	-21.77
			8	4.34	4.51	7.90	30.00	-22.10
		52T	37	6.47	6.36	9.88	30.00	-20.12
			38	6.51	6.85	10.14	30.00	-19.86
			40	6.20	6.11	9.62	30.00	-20.38
		106T	53	8.58	9.09	12.29	30.00	-17.71
			54	8.44	9.07	12.22	30.00	-17.78
		SU	-	15.48	16.30	19.13	30.00	-10.87
		Mid	5785	26T	0	4.32	4.79	8.03
4	4.61				4.50	8.03	30.00	-21.97
8	4.14				4.02	7.55	30.00	-22.45
52T	37			6.72	7.01	10.33	30.00	-19.67
	38			6.86	6.72	10.25	30.00	-19.75
	40			6.39	6.67	9.99	30.00	-20.01
106T	53			8.57	9.12	12.30	30.00	-17.70
	54			8.62	9.26	12.40	30.00	-17.60
SU	-			15.50	16.17	19.07	30.00	-10.93
High	5825			26T	0	4.64	4.61	8.10
		4	4.75		4.77	8.23	30.00	-21.77
		8	4.40		4.43	7.89	30.00	-22.11
		52T	37	6.83	6.26	10.01	30.00	-19.99
			38	7.03	6.96	10.46	30.00	-19.54
			40	6.31	6.26	9.75	30.00	-20.25
		106T	53	7.88	8.35	11.57	30.00	-18.43
			54	8.40	8.62	11.96	30.00	-18.04
		SU	-	15.52	16.08	19.03	30.00	-10.97

Actual RBW	Ref. Bandwidth	Corr'd factor
100 kHz	500 kHz	6.99 dB

Calculation of PPSD result
 Sum PW = Antenna1_Meas PPSD [mW] + Antenna2_Meas PPSD [mW]
 Total Corr'd Power [dBm]
 = Sum PW [dBm] + Duty CF [dB] + Corr'd factor [dB]

PPSD Results

Channel	Frequency [MHz]	Tones	RU offset	Antenna 1 Meas PPSD [dBm]	Antenna 2 Meas PPSD [dBm]	Total Corr'd PPSD [dBm]	PSD Limit [dBm]	Power Margin [dB]
Stradle	5720	26T	0	-8.56	-8.18	2.09	30.00	-27.91
		52T	4	-8.94	-8.52	1.73	30.00	-28.27
Low	5745	26T	0	-7.83	-7.99	2.55	11.00	-8.45
			4	-7.68	-8.05	2.60	11.00	-8.40
			8	-7.87	-8.56	2.26	11.00	-8.74
		52T	37	-8.77	-8.40	1.87	11.00	-9.13
			38	-8.58	-8.59	1.87	11.00	-9.13
			40	-9.73	-8.99	1.10	11.00	-9.90
		106T	53	-9.48	-9.03	1.19	11.00	-9.81
			54	-9.55	-9.34	1.00	11.00	-10.00
		SU	-	-6.12	-5.09	4.64	11.00	-6.36
		Mid	5785	26T	0	-8.29	-7.58	2.54
4	-8.06				-7.27	2.82	11.00	-8.18
8	-8.54				-8.34	2.03	11.00	-8.97
52T	37			-9.10	-9.21	1.30	11.00	-9.70
	38			-8.76	-8.32	1.92	11.00	-9.08
	40			-9.46	-8.86	1.30	11.00	-9.70
106T	53			-10.07	-9.26	0.80	11.00	-10.20
	54			-9.40	-10.03	0.74	11.00	-10.26
SU	-			-6.22	-5.89	4.16	11.00	-6.84
High	5825			26T	0	-8.32	-7.96	2.32
		4	-7.57		-7.60	2.88	11.00	-8.12
		8	-8.25		-8.10	2.28	11.00	-8.72
		52T	37	-9.10	-9.12	1.34	11.00	-9.66
			38	-8.64	-8.66	1.80	11.00	-9.20
			40	-8.73	-9.01	1.58	11.00	-9.42
		106T	53	-10.07	-9.83	0.49	11.00	-10.51
			54	-10.12	-9.74	0.52	11.00	-10.48
		SU	-	-6.49	-5.59	4.19	11.00	-6.81

10.2.26. 802.11ax HE40 2TX CDD MODE IN THE 5.8 GHz BAND

Limits

Channel	Frequency	FCC Power Limit	IC Power Limit	FCC PPSD Limit
	[MHz]	[dBm]	[dBm]	[dBm]
Straddle	5710	30.00	30.00	30.00
Low	5755	30.00	30.00	30.00
High	5795	30.00	30.00	30.00

Included in Calculations of Corr'd Power & PPSD				
Duty Cycle CF [dB]	HE40	26T	0.46	dB
		52T	0.45	dB
		106T	0.45	dB
		242T	0.43	dB
		SU	0.19	dB

Calculation of Output Power result
 Sum PW = Antenna1_Meas Power [mW] + Antenna2_Meas Power [mW]
 Total Corr'd Power [dBm] = Sum PW [dBm] + Duty CF [dB]

Output Power Results

Channel	Frequency	Tones	RU offset	Antenna 1 Meas Power	Antenna 2 Meas Power	Total Corr'd Power	Power Limit	Power Margin		
	[MHz]			[dBm]	[dBm]	[dBm]	[dBm]	[dB]		
Straddle	5710	26T	17	4.16	4.79	7.96	30.00	-22.04		
		52T	44	6.84	7.05	10.41	30.00	-19.59		
Low	5755	26T	0	4.83	5.27	8.53	30.00	-21.47		
			9	4.56	5.00	8.26	30.00	-21.74		
			17	4.36	4.91	8.11	30.00	-21.89		
		52T	37	6.85	6.89	10.33	30.00	-19.67		
			41	7.01	6.98	10.46	30.00	-19.54		
			44	6.97	7.15	10.52	30.00	-19.48		
		106T	53	9.15	8.98	12.53	30.00	-17.47		
			54	8.97	9.01	12.45	30.00	-17.55		
		242T	56	8.79	8.72	12.22	30.00	-17.78		
			61	10.09	9.95	13.46	30.00	-16.54		
		SU	62	9.49	9.77	13.07	30.00	-16.93		
		SU	-	12.95	13.32	16.34	30.00	-13.66		
		High	5795	26T	0	4.85	4.80	8.30	30.00	-21.70
					9	5.05	5.01	8.50	30.00	-21.50
17	4.35				4.46	7.88	30.00	-22.12		
52T	37			6.43	6.44	9.90	30.00	-20.10		
	41			6.90	6.85	10.34	30.00	-19.66		
	44			6.44	6.84	10.10	30.00	-19.90		
106T	53			8.74	9.05	12.36	30.00	-17.64		
	54			8.41	8.44	11.89	30.00	-18.11		
242T	56			8.37	8.38	11.84	30.00	-18.16		
	61			10.02	10.24	13.57	30.00	-16.43		
SU	62			9.67	9.99	13.27	30.00	-16.73		
SU	-			12.84	13.33	16.29	30.00	-13.71		

Actual RBW	Ref. Bandwidth	Corr'd factor
100 kHz	500 kHz	6.99 dB

Calculation of PPSD result
 Sum PW = Antenna1_Meas PPSD [mW] + Antenna2_Meas PPSD [mW]
 Total Corr'd Power [dBm]
 = Sum PW [dBm] + Duty CF [dB] + Corr'd factor [dB]

PPSD Results

Channel	Frequency [MHz]	Tones	RU offset	Antenna 1 Meas PPSD [dBm]	Antenna 2 Meas PPSD [dBm]	Total Corr'd PPSD [dBm]	PSD Limit [dBm]	Power Margin [dB]		
Straddle	5710	26T	17	-7.87	-7.81	2.64	30.00	-27.36		
		52T	44	-8.47	-9.02	1.74	30.00	-28.26		
Low	5755	26T	0	-6.98	-6.77	3.61	30.00	-26.39		
			9	-7.68	-7.24	3.03	30.00	-26.97		
			17	-7.38	-7.04	3.28	30.00	-26.72		
		52T	37	-8.61	-8.84	1.73	30.00	-28.27		
			41	-8.86	-8.30	1.88	30.00	-28.12		
			44	-8.52	-7.53	2.46	30.00	-27.54		
		106T	53	-9.12	-9.34	1.22	30.00	-28.78		
			54	-9.44	-8.99	1.24	30.00	-28.76		
			56	-9.58	-9.76	0.78	30.00	-29.22		
		242T	61	-11.66	-11.55	-1.17	30.00	-31.17		
			62	-11.74	-11.63	-1.25	30.00	-31.25		
		SU	-	-11.66	-11.51	-1.39	30.00	-31.39		
		High	5795	26T	0	-7.58	-7.26	3.06	30.00	-26.94
					9	-7.92	-7.72	2.66	30.00	-27.34
17	-8.17				-7.65	2.58	30.00	-27.42		
52T	37			-9.28	-8.55	1.55	30.00	-28.45		
	41			-8.75	-8.37	1.90	30.00	-28.10		
	44			-9.19	-8.74	1.49	30.00	-28.51		
106T	53			-9.66	-9.46	0.89	30.00	-29.11		
	54			-9.81	-9.57	0.76	30.00	-29.24		
	56			-10.08	-9.65	0.60	30.00	-29.40		
242T	61			-11.60	-11.25	-0.99	30.00	-30.99		
	62			-11.80	-11.38	-1.16	30.00	-31.16		
SU	-			-11.76	-11.31	-1.34	30.00	-31.34		

10.2.27. 802.11ax HE80 2TX CDD MODE IN THE 5.8 GHz BAND

Limits

Channel	Frequency	FCC Power Limit	IC Power Limit	FCC PPSD Limit
	[MHz]	[dBm]	[dBm]	[dBm]
Straddle	5690	30.00	30.00	30.00
Mid	5775	30.00	30.00	30.00

Included in Calculations of Corr'd Power & PPSD				
Duty Cycle CF [dB]	HE80	26T	0.37	dB
		52T	0.46	dB
		106T	0.45	dB
		242T	0.44	dB
		484T	0.12	dB
		SU	0.21	dB

Calculation of Outpu Power result
 Sum PW = Antenna1_Meas Power [mW] + Antenna2_Meas Power [mW]
 Total Corr'd Power [dBm] = Sum PW [dBm] + Duty CF [dB]

Output Power Results

Channel	Frequency	Tones	RU offset	Antenna 1 Meas Power	Antenna 2 Meas Power	Total Corr'd Power	Power Limit	Power Margin	
	[MHz]			[dBm]	[dBm]	[dBm]	[dBm]	[dB]	
Straddle	5690	26T	36	4.25	4.96	8.00	30.00	-22.00	
		52T	52	6.38	6.80	10.07	30.00	-19.93	
Mid	5775	26T	0	4.27	5.33	8.21	30.00	-21.79	
			18	4.22	5.14	8.08	30.00	-21.92	
			36	4.47	5.38	8.33	30.00	-21.67	
		52T	37	5.89	6.86	9.87	30.00	-20.13	
			45	6.55	6.85	10.17	30.00	-19.83	
			52	6.51	7.43	10.46	30.00	-19.54	
		106T	53	7.26	7.87	11.04	30.00	-18.96	
			57	7.61	8.07	11.31	30.00	-18.69	
			60	7.77	8.70	11.72	30.00	-18.28	
		242T	61	8.36	8.92	12.10	30.00	-17.90	
			62	8.28	8.96	12.08	30.00	-17.92	
			64	8.78	8.80	12.24	30.00	-17.76	
		484T	65	9.50	9.62	12.69	30.00	-17.31	
			66	9.43	9.67	12.68	30.00	-17.32	
		SU	-	-	12.79	13.16	16.20	30.00	-13.80

Actual RBW	Ref. Bandwidth	Corr'd factor
100 kHz	500 kHz	6.99 dB

Calculation of PPSD result
 Sum PW = Antenna1_Meas PPSD [mW] + Antenna2_Meas PPSD [mW]
 Total Corr'd Power [dBm]
 = Sum PW [dBm] + Duty CF [dB] + Corr'd factor [dB]

PPSD Results

Channel	Frequency [MHz]	Tones	RU offset	Antenna 1 Meas PPSD [dBm]	Antenna 2 Meas PPSD [dBm]	Total Corr'd PPSD [dBm]	PSD Limit [dBm]	Power Margin [dB]
Straddle	5690	26T	36	-7.48	-7.68	2.79	30.00	-27.21
		52T	52	-8.46	-8.05	2.12	30.00	-27.88
Mid	5775	26T	0	-8.12	-7.17	2.75	30.00	-27.25
			18	-8.37	-7.92	2.23	30.00	-27.77
			36	-8.29	-7.21	2.66	30.00	-27.34
		52T	37	-9.10	-8.01	1.94	30.00	-28.06
			45	-9.38	-8.80	1.38	30.00	-28.62
			52	-8.37	-8.54	2.01	30.00	-27.99
		106T	53	-10.30	-9.73	0.44	30.00	-29.56
			57	-10.60	-10.14	0.09	30.00	-29.91
			60	-10.00	-10.32	0.29	30.00	-29.71
		242T	61	-13.29	-12.91	-2.66	30.00	-32.66
			62	-13.12	-13.14	-2.69	30.00	-32.69
			64	-13.46	-13.61	-3.09	30.00	-33.09
		484T	65	-14.96	-14.99	-4.85	30.00	-34.85
			66	-14.94	-14.55	-4.62	30.00	-34.62
		SU	-	-	-15.08	-14.35	-4.49	30.00

10.2.28. 802.11ax HE20 2TX CDD MODE IN THE STRADDLE CHANNEL

Bandwidth and Antenna Gain

Channel	Frequency [MHz]	Min 26 dB BW [MHz]	Min 99% BW [MHz]	Directional Gain for Power [dBi]
UNII-2C	5720	15.25	N/A	-3.78
UNII-3		5.65	N/A	-3.94

Limits

Channel	Frequency [MHz]	FCC Power Limit [dBm]	IC Power Limit [dBm]	FCC PPSD Limit [dBm]
UNII-2C	5720	22.83	N/A	11.00
UNII-3		30.00	N/A	30.00

Included in Calculations of Corr'd Power & PPSD				
Duty Cycle CF [dB]	HE20	106T	0.44	dB
		SU	0.21	dB

Calculation of Output Power result
 Sum PW = Antenna1_Meas Power [mW] + Antenna2_Meas Power [mW]
 Total Corr'd Power [dBm] = Sum PW [dBm] + Duty CF [dB]

Output Power Results

Portion	Frequency [MHz]	Tones	RU offset	Antenna 1 Meas Power [dBm]	Antenna 2 Meas Power [dBm]	Total Corr'd Power [dBm]	Power Limit [dBm]	Power Margin [dB]
UNII-2C	5720	106T	54	5.36	4.83	8.55	22.83	-14.28
		SU	-	12.93	13.57	16.48	22.83	-6.35
UNII-3		106T	54	6.27	5.52	9.36	30.00	-20.64
		SU	-	7.56	8.39	11.21	30.00	-18.79

Band	Actual RBW	Ref. Bandwidth	Corr'd factor
UNII-2C	100 kHz	1000 kHz	10.00 dB
UNII-3	100 kHz	500 kHz	6.99 dB

Calculation of PPSD result
 Sum PW = Antenna1_Meas PPSD [mW] + Antenna2_Meas PPSD [mW]
 Total Corr'd Power [dBm]
 = Sum PW [dBm] + Duty CF [dB] + Corr'd factor [dB]

PPSD Results

Channel	Frequency [MHz]	Tones	RU offset	Antenna 1 Meas PPSD [dBm]	Antenna 2 Meas PPSD [dBm]	Total Corr'd PPSD [dBm]	PSD Limit [dBm]	Power Margin [dB]
UNII-2C	5720	106T	54	-10.23	-9.20	3.77	11.00	-7.23
		SU	-	-7.54	-6.63	6.16	11.00	-4.84
UNII-3		106T	54	-10.34	-9.58	0.50	30.00	-29.50
		SU	-	-7.78	-7.09	2.79	30.00	-27.21

10.2.29. 802.11ax HE40 2TX CDD MODE IN THE STRADDLE CHANNEL

Bandwidth and Antenna Gain

Channel	Frequency [MHz]	Min 26 dB BW [MHz]	Min 99% BW [MHz]	Directional Gain for Power [dBi]
UNII-2C	5710	15.79	N/A	-3.78
UNII-3		4.98	N/A	-3.94

Limits

Channel	Frequency [MHz]	FCC Power Limit [dBm]	IC Power Limit [dBm]	FCC PPSD Limit [dBm]
UNII-2C	5710	22.98	N/A	11.00
UNII-3		30.00	N/A	30.00

Included in Calculations of Corr'd Power & PPSD				
Duty Cycle CF [dB]	HE40	106T	0.45	dB
		242T	0.43	dB
		SU	0.19	dB

Calculation of Output Power result
 Sum PW = Antenna1_Meas Power [mW] + Antenna2_Meas Power [mW]
 Total Corr'd Power [dBm] = Sum PW [dBm] + Duty CF [dB]

Output Power Results

Portion	Frequency [MHz]	Tones	RU offset	Antenna 1 Meas Power [dBm]	Antenna 2 Meas Power [dBm]	Total Corr'd Power [dBm]	Power Limit [dBm]	Power Margin [dB]
UNII-2C	5710	106T	56	6.27	5.69	9.45	22.98	-13.53
		242T	62	8.36	8.47	11.86	22.98	-11.12
		SU	-	12.42	12.81	15.82	22.98	-7.16
UNII-3		106T	56	5.24	4.95	8.56	30.00	-21.44
		242T	62	1.90	2.02	5.40	30.00	-24.60
		SU	-	2.28	2.68	5.68	30.00	-24.32

Band	Actual RBW	Ref. Bandwidth	Corr'd factor
UNII-2C	100 kHz	1000 kHz	10.00 dB
UNII-3	100 kHz	500 kHz	6.99 dB

Calculation of PPSD result
 Sum PW = Antenna1_Meas PPSD [mW] + Antenna2_Meas PPSD [mW]
 Total Corr'd Power [dBm]
 = Sum PW [dBm] + Duty CF [dB] + Corr'd factor [dB]

PPSD Results

Channel	Frequency [MHz]	Tones	RU offset	Antenna 1 Meas PPSD [dBm]	Antenna 2 Meas PPSD [dBm]	Total Corr'd PPSD [dBm]	PSD Limit [dBm]	Power Margin [dB]
UNII-2C	5710	106T	56	-9.48	-9.56	3.94	11.00	-7.06
		242T	62	-11.49	-11.49	1.95	11.00	-9.05
		SU	-	-11.52	-11.60	1.64	11.00	-9.36
UNII-3		106T	56	-9.66	-9.84	0.70	30.00	-29.30
		242T	62	-12.47	-12.46	-2.03	30.00	-32.03
		SU	-	-12.43	-11.94	-1.99	30.00	-31.99

10.2.30. 802.11ax HE80 2TX CDD MODE IN THE STRADDLE CHANNEL

Bandwidth and Antenna Gain

Channel	Frequency [MHz]	Min 26 dB BW [MHz]	Min 99% BW [MHz]	Directional Gain for Power [dBi]
UNII-2C	5690	35.00	N/A	-3.78
UNII-3		-35.00	N/A	-3.94

Limits

Channel	Frequency [MHz]	FCC Power Limit [dBm]	IC Power Limit [dBm]	FCC PPSD Limit [dBm]
UNII-2C	5690	24.00	N/A	11.00
UNII-3		30.00	N/A	30.00

Included in Calculations of Corr'd Power & PPSD				
Duty Cycle CF [dB]	HE40	106T	0.45	dB
		242T	0.44	dB
		484T	0.12	dB
		SU	0.21	dB

Calculation of Output Power result
 Sum PW = Antenna1_Meas Power [mW] + Antenna2_Meas Power [mW]
 Total Corr'd Power [dBm] = Sum PW [dBm] + Duty CF [dB]

Output Power Results

Portion	Frequency [MHz]	Tones	RU offset	Antenna 1 Meas Power [dBm]	Antenna 2 Meas Power [dBm]	Total Corr'd Power [dBm]	Power Limit [dBm]	Power Margin [dB]
UNII-2C	5690	106T	60	5.14	5.24	8.65	24.00	-15.35
		242T	64	6.91	7.45	10.64	24.00	-13.36
		484T	66	8.88	8.64	11.89	24.00	-12.11
		SU	-	12.36	12.81	15.81	24.00	-8.19
UNII-3		106T	60	4.24	4.49	7.82	30.00	-22.18
		242T	64	0.58	0.88	4.18	30.00	-25.82
		484T	66	-1.79	-2.10	1.19	30.00	-28.81
		SU	-	-2.01	-1.60	1.42	30.00	-28.58

Band	Actual RBW	Ref. Bandwidth	Corr'd factor
UNII-2C	100 kHz	1000 kHz	10.00 dB
UNII-3	100 kHz	500 kHz	6.99 dB

Calculation of PPSD result
 Sum PW = Antenna1_Meas PPSD [mW] + Antenna2_Meas PPSD [mW]
 Total Corr'd Power [dBm]
 = Sum PW [dBm] + Duty CF [dB] + Corr'd factor [dB]

PPSD Results

Channel	Frequency [MHz]	Tones	RU offset	Antenna 1 Meas PPSD [dBm]	Antenna 2 Meas PPSD [dBm]	Total Corr'd PPSD [dBm]	PSD Limit [dBm]	Power Margin [dB]
UNII-2C	5690	106T	60	-9.90	-9.71	3.66	11.00	-7.34
		242T	64	-12.98	-13.40	0.27	11.00	-10.73
		484T	66	-14.71	-14.36	-1.40	11.00	-12.40
		SU	-	-14.64	-13.81	-0.98	11.00	-11.98
UNII-3		106T	60	-10.58	-10.34	-0.01	30.00	-30.01
		242T	64	-13.79	-14.73	-3.80	30.00	-33.80
		484T	66	-16.52	-16.72	-6.50	30.00	-36.50
		SU	-	-16.99	-16.34	-6.44	30.00	-36.44

11. TRANSMITTER ABOVE 1 GHz

LIMITS

FCC §15.205 and §15.209

Limits for radiated disturbance of an intentional radiator		
Frequency range (MHz)	Limits (µV/m)	Measurement Distance (m)
0.009 – 0.490	2400 / F (kHz)	300
0.490 – 1.705	24000 / F (kHz)	30
1.705 – 30.0	30	30
30 – 88	100**	3
88 - 216	150**	3
216 – 960	200**	3
Above 960	500	3

** Except as provided in paragraph (g), fundamental emissions from intentional radiators operating under this section shall not be located in the frequency bands 54-72 MHz, 76-88 MHz, 174-216 MHz or 470-806 MHz. However, operation within these frequency bands is permitted under other sections of this part, e.g. §§ 15.231 and 15.241.

FCC §15.407 (b)

(b) Undesirable emission limits. Except as shown in paragraph (b)(7) of this section, the maximum emissions outside of the frequency bands of operation shall be attenuated in accordance with the following limits:

- (1) For transmitters operating in the 5.15-5.25 GHz band: All emissions outside of the 5.15-5.35 GHz band shall not exceed an e.i.r.p. of -27 dBm/MHz.
- (2) For transmitters operating in the 5.25-5.35 GHz band: All emissions outside of the 5.15-5.35 GHz band shall not exceed an e.i.r.p. of -27 dBm/MHz.
- (3) For transmitters operating in the 5.47-5.725 GHz band: All emissions outside of the 5.47-5.725 GHz band shall not exceed an e.i.r.p. of -27 dBm/MHz.
- (4) For transmitters operating in the 5.725-5.85 GHz band:
 - (i) All emissions shall be limited to a level of -27 dBm/MHz at 75 MHz or more above or below the band edge increasing linearly to 10 dBm/MHz at 25 MHz above or below the band edge, and from 25 MHz above or below the band edge increasing linearly to a level of 15.6 dBm/MHz at 5 MHz above or below the band edge, and from 5 MHz above or below the band edge increasing linearly to a level of 27 dBm/MHz at the band edge.
- (5) The emission measurements shall be performed using a minimum resolution bandwidth of 1 MHz. A lower resolution bandwidth may be employed near the band edge, when necessary, provided the measured energy is integrated to show the total power over 1 MHz.

- (6) Unwanted emissions below 1 GHz must comply with the general field strength limits set forth in §15.209. Further, any U-NII devices using an AC power line are required to comply also with the conducted limits set forth in §15.207.
- (7) The provisions of §15.205 apply to intentional radiators operating under this section.
- (8) When measuring the emission limits, the nominal carrier frequency shall be adjusted as close to the upper and lower frequency band edges as the design of the equipment permits.

Note

- Limit translation to field strength level (FCC §15.407)

$$E[\text{dBuV/m}] = \text{EIRP}[\text{dBm}] + 95.2 = -27\text{dBm} + 95.2 = 68.2\text{dBuV/m}$$

$$E[\text{dBuV/m}] = \text{EIRP}[\text{dBm}] + 95.2 = -17\text{dBm} + 95.2 = 78.2\text{dBuV/m}$$

TEST PROCEDURE

The EUT is placed on a non-conducting table 80 cm above the ground plane for below 1GHz and 150 cm for above 1GHz. The antenna to EUT distance is 3 meters. The EUT is configured in accordance with ANSI C63.10. The EUT is set to transmit in a continuous mode.

For measurements below 1 GHz the resolution bandwidth is set to 100 kHz for peak detection measurements or 120 kHz for quasi-peak detection measurements. Peak detection is used unless otherwise noted as quasi-peak.

Reference to KDB 789033 D02 v02r01 UNII part G) 6) c) Method AD:

For measurements above 1 GHz the resolution bandwidth is set to 1 MHz; the video bandwidth is set to 3 MHz for peak measurements and add duty cycle factor to the reading offset for average measurements.

Pre-scans to detect harmonic and spurious emissions, the resolution bandwidth is set to 1 MHz; the video bandwidth is set to 30 KHz for peak measurements.

The spectrum from 1GHz to 40 GHz is investigated with the transmitter set to the lowest, middle, and highest channels in each applicable band.

(From 30MHz to 1GHz, test was performed with the EUT set to transmit at the channel with highest output power)

The frequency range of interest is monitored at a fixed antenna height and EUT azimuth. The EUT is rotated through 360 degrees to maximize emissions received. The antenna is scanned from 1 to 4 meters above the ground plane to further maximize the emission. Measurements are made with the antenna polarized in both the vertical and the horizontal positions.

Note : Emission was pre-scanned from 9KHz to 30MHz; No emissions were detected which was at least 20dB below the specification limit (consider distance correction factor).
Per FCC part 15.31(o), test results were not reported.

Although these tests were performed other than open area test site, adequate comparison measurements were confirmed against 30 m open are test site.
Therefore sufficient tests were made to demonstrate that the alternative site produces results that correlate with the one of tests made in an open field based on KDB 414788.

11.1. 5.2 GHz_1TX

11.1.1.TX Above 1GHz 802.11ax MODE IN THE 5.2GHz BAND RESTRICTED BANDEDGE (LOW CHANNEL)

HE20 SU mode (ANT_1)

HORIZONTAL PEAK AND AVERAGE PLOT

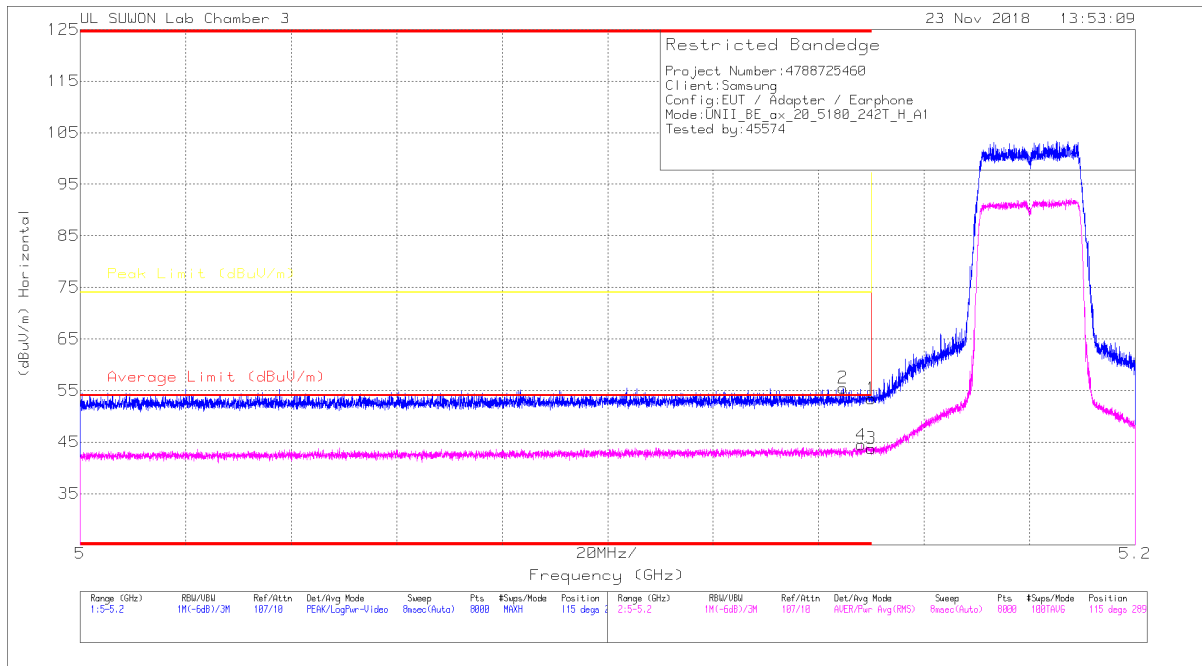

HORIZONTAL DATA

Trace Markers

Marker	Frequency (GHz)	Meter Reading (dBuV)	Det	3117_00209599	10dB[dB]	DC Corr (dB)	Corrected Reading (dBuV/m)	Average Limit (dBuV/m)	Margin (dB)	Peak Limit (dBuV/m)	PK Margin (dB)	Azimuth (Degs)	Height (cm)	Polarity
1	* 5.15	38.01	Pk		34.4	-19	53.41	-	-	74	-20.59	115	289	H
2	* 5.145	40.2	Pk		34.4	-19.1	55.5	-	-	74	-18.5	115	289	H
3	* 5.15	28.67	RMS		34.4	-19.4	43.78	54	-10.22	-	-	115	289	H
4	* 5.148	29.35	RMS		34.4	-19.4	44.46	54	-9.54	-	-	115	289	H

* - indicates frequency in CFR47 Pt 15 / IC RSS-Restricted Band

Pk - Peak detector

RMS - RMS detection

VERTICAL PEAK AND AVERAGE PLOT

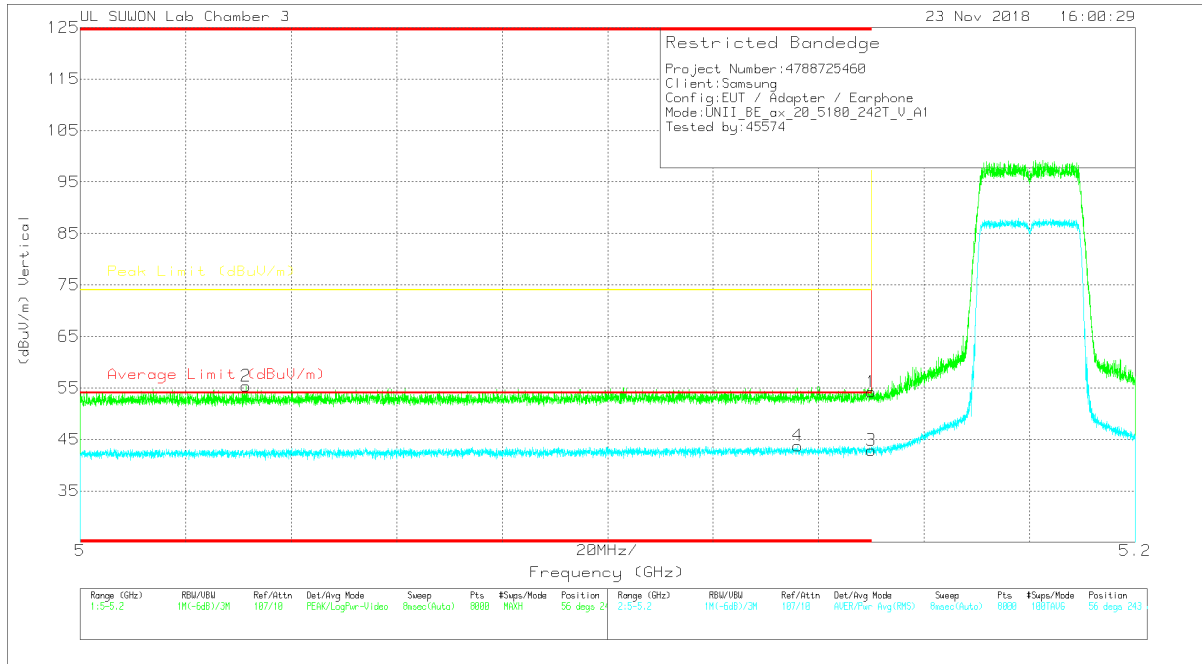

VERTICAL DATA

Trace Markers

Marker	Frequency (GHz)	Meter Reading (dBuV)	Det	3117_00209959	10dB(dB)	DC Corr (dB)	Corrected Reading (dBuV/m)	Average Limit (dBuV/m)	Margin (dB)	Peak Limit (dBuV/m)	PK Margin (dB)	Asimuth (Degs)	Height (cm)	Polarity
1	* 5.15	38.82	Pk	34.4	-19	0	54.22	-	-	74	-19.78	56	243	V
2	* 5.032	40.25	Pk	34.3	-19.2	0	55.35	-	-	74	-18.65	56	243	V
3	* 5.15	27.78	RMS	34.4	-19.4	.11	42.89	54	-11.11	-	-	56	243	V
4	* 5.136	28.66	RMS	34.4	-19.4	.11	43.77	54	-10.23	-	-	56	243	V

* - indicates frequency in CFR47 Pt 15 / IC RSS-Restricted Band

Pk - Peak detector

RMS - RMS detection

HE20 SU mode (ANT_2)

HORIZONTAL PEAK AND AVERAGE PLOT

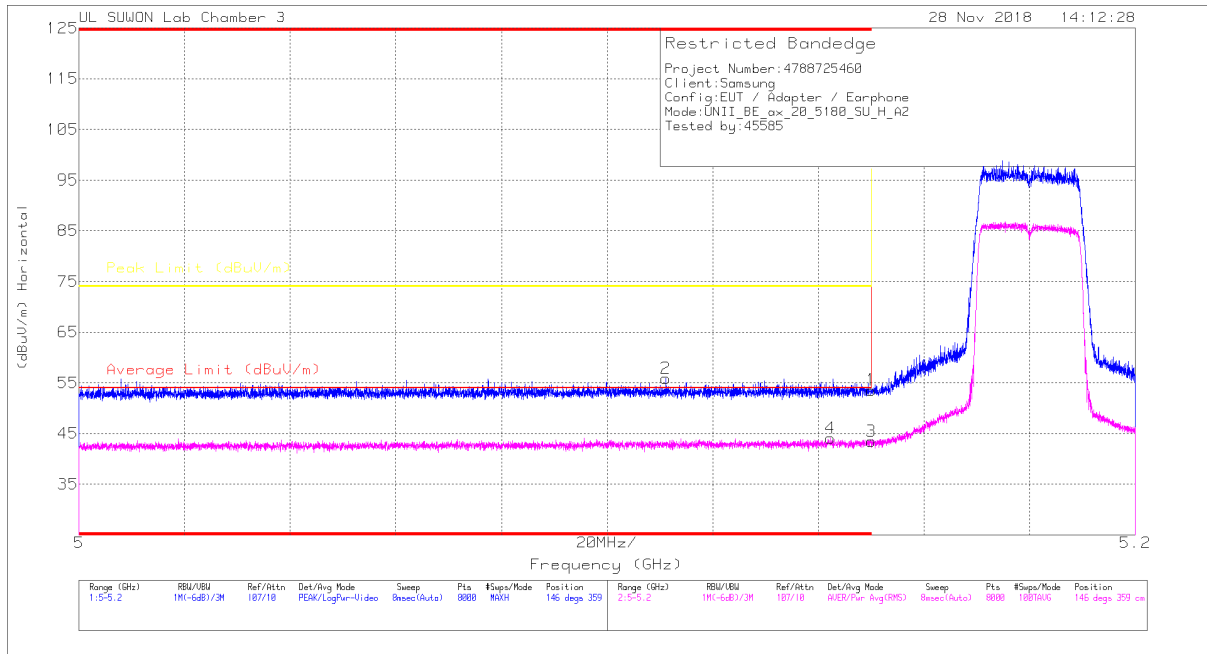

HORIZONTAL DATA

Trace Markers

Marker	Frequency (GHz)	Meter Reading (dBuV)	Det	3117_00205959	10dB(dB)	DC Corr (dB)	Corrected Reading (dBuV/m)	Average Limit (dBuV/m)	Margin (dB)	Peak Limit (dBuV/m)	PK Margin (dB)	Asimuth (Degs)	Height (cm)	Polarity
1	* 5.15	38.18	Pk		34.4	-19	53.58	-	-	74	-20.42	146	359	H
2	* 5.111	40.54	Pk		34.4	-19.1	55.84	-	-	74	-18.16	146	359	H
3	* 5.15	28.34	RMS		34.4	-19.4	43.45	54	-10.55	-	-	146	359	H
4	* 5.142	29.01	RMS		34.4	-19.4	44.12	54	-9.88	-	-	146	359	H

* - indicates frequency in CFR47 Pt 15 / IC RSS-Restricted Band

Pk - Peak detector

RMS - RMS detection

VERTICAL PEAK AND AVERAGE PLOT

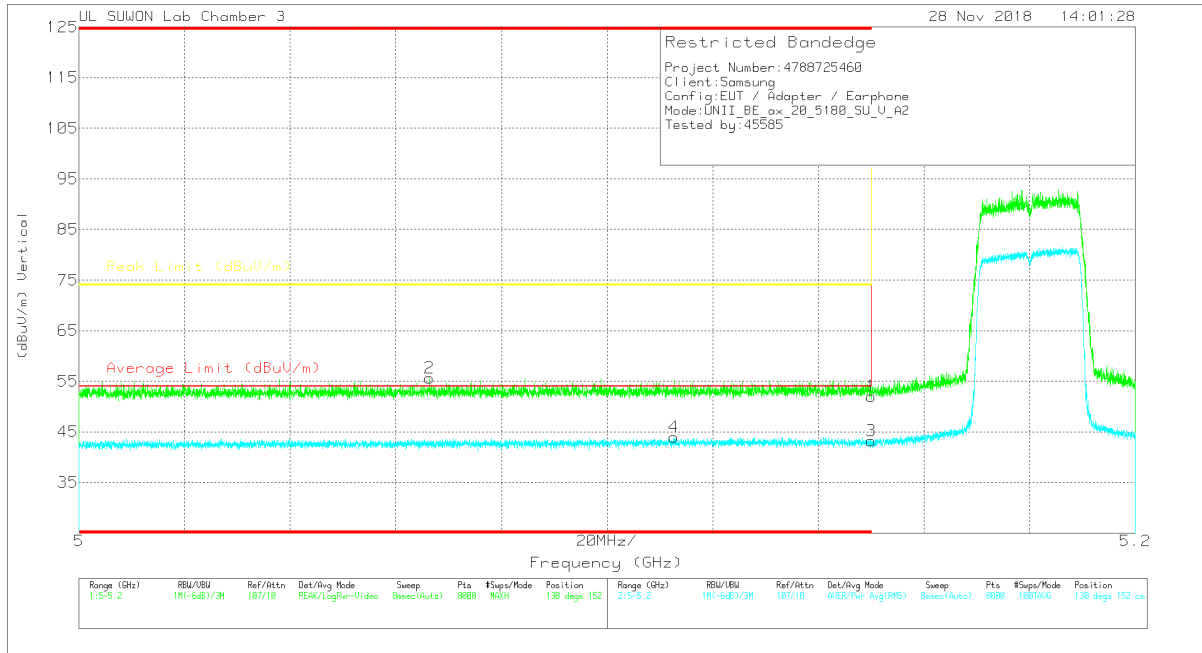

VERTICAL DATA

Trace Markers

Marker	Frequency (GHz)	Meter Reading (dBuV)	Det	3117_00209599	10dB(dB)	DC Corr (dB)	Corrected Reading (dBuV/m)	Average Limit (dBuV/m)	Margin (dB)	Peak Limit (dBuV/m)	PK Margin (dB)	Azimuth (Degs)	Height (cm)	Polarity
1	* 5.15	36.66	PK	34.4	-19	0	52.06	-	-	74	-21.94	130	152	V
2	* 5.066	40.48	PK	34.3	-19.1	0	55.68	-	-	74	-18.32	130	152	V
3	* 5.15	28.15	RMS	34.4	-19.4	.11	43.26	54	-10.74	-	-	130	152	V
4	* 5.113	28.96	RMS	34.4	-19.5	.11	43.97	54	-10.03	-	-	130	152	V

* - indicates frequency in CFR47 Pt 15 / IC RSS-Restricted Band

PK - Peak detector

RMS - RMS detection

HE40 SU mode (ANT_1)

HORIZONTAL PEAK AND AVERAGE PLOT

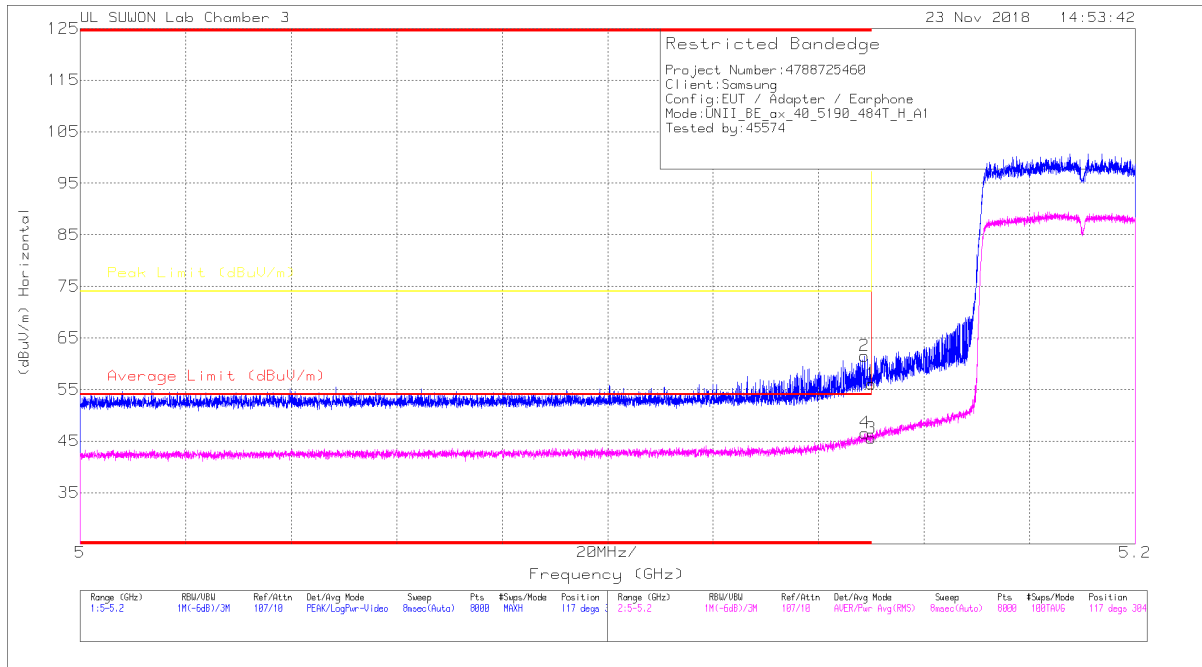

HORIZONTAL DATA

Trace Markers

Marker	Frequency (GHz)	Meter Reading (dBu)	Det	3117_00205959	10dB(dB)	DC Corr (dB)	Corrected Reading (dBu/m)	Average Limit (dBu/m)	Margin (dB)	Peak Limit (dBu/m)	PK Margin (dB)	Azimuth (Degs)	Height (cm)	Polarity
1	* 5.15	40.71	Pk	34.4	-19	0	56.11	-	-	74	-17.89	117	304	H
2	* 5.149	46.21	Pk	34.4	-19.1	0	61.51	-	-	74	-12.49	117	304	H
3	* 5.15	30.44	RMS	34.4	-19.4	.1	45.54	54	-8.46	-	-	117	304	H
4	* 5.149	31.48	RMS	34.4	-19.4	.1	46.58	54	-7.42	-	-	117	304	H

* - indicates frequency in CFR47 Pt 15 / IC RSS-Restricted Band

Pk - Peak detector

RMS - RMS detection

VERTICAL PEAK AND AVERAGE PLOT

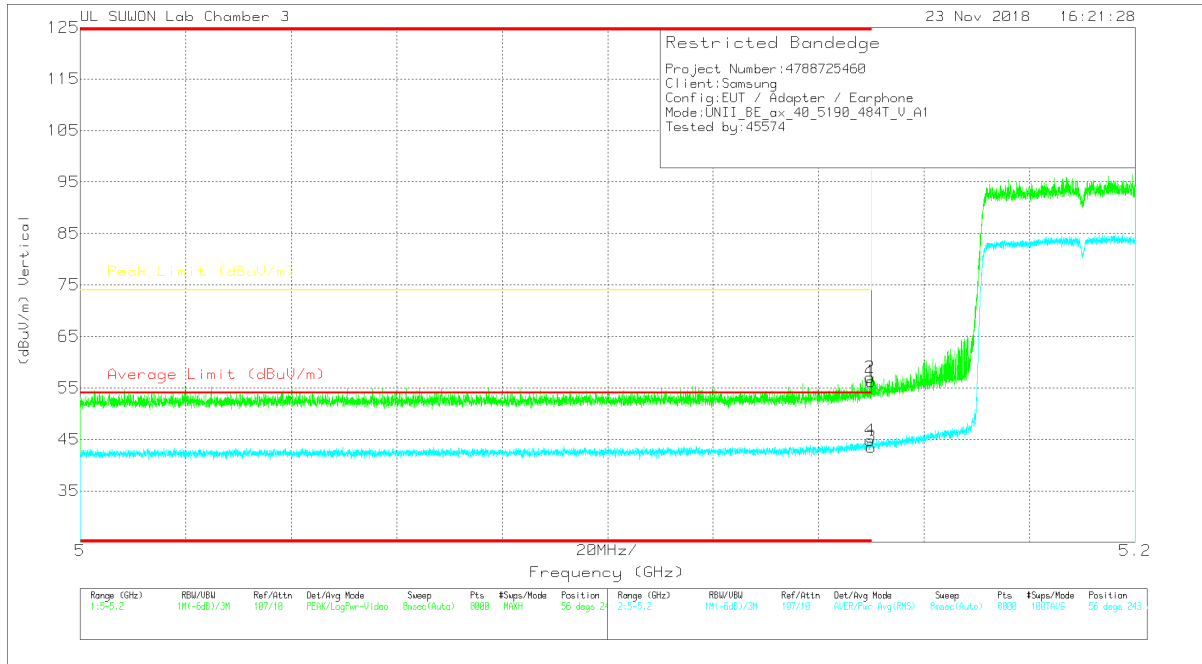

VERTICAL DATA

Trace Markers

Marker	Frequency (GHz)	Meter Reading (dBuV)	Det	3117_00209959	10dB(dB)	DC Corr (dB)	Corrected Reading (dBuV/m)	Average Limit (dBuV/m)	Margin (dB)	Peak Limit (dBuV/m)	PK Margin (dB)	Asimuth (Degs)	Height (cm)	Polarity
1	* 5.15	40.86	Pk	34.4	-19	0	56.26	-	-	74	-17.74	56	243	V
2	* 5.15	41.64	Pk	34.4	-19	0	57.04	-	-	74	-16.96	56	243	V
3	* 5.15	28.43	RMS	34.4	-19.4	.1	43.53	54	-10.47	-	-	56	243	V
4	* 5.15	29.72	RMS	34.4	-19.4	.1	44.82	54	-9.18	-	-	56	243	V

* - indicates frequency in CFR47 Pt 15 / IC RSS-Restricted Band

Pk - Peak detector

RMS - RMS detection

HE40 SU mode (ANT_2)

HORIZONTAL PEAK AND AVERAGE PLOT

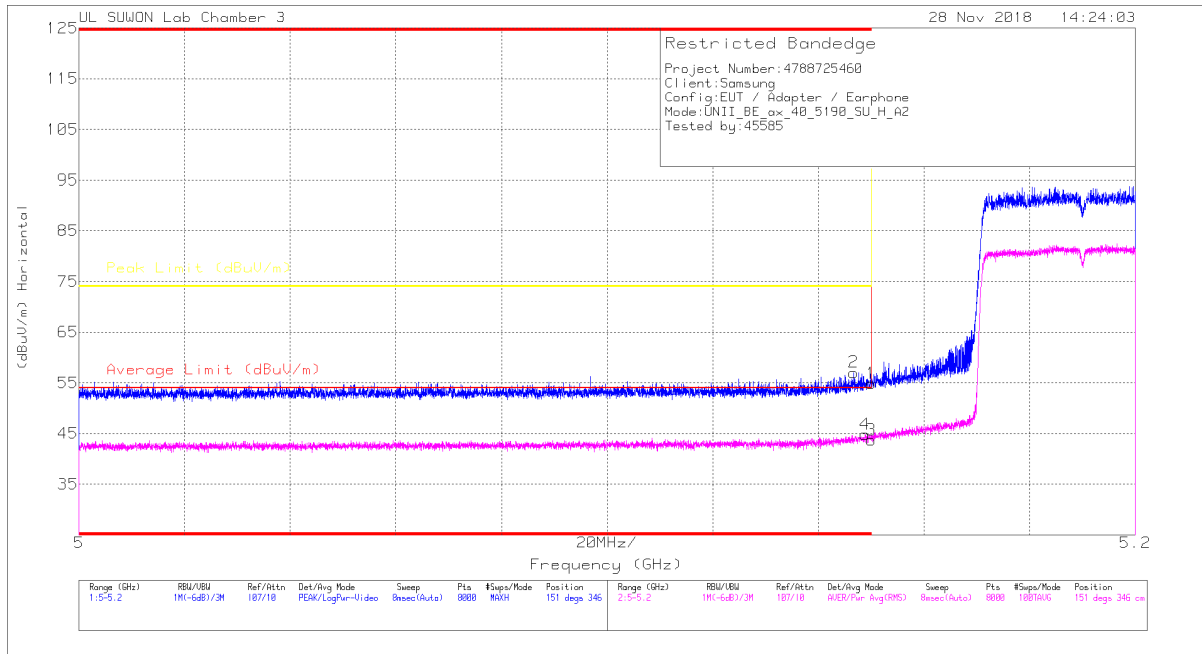

HORIZONTAL DATA

Trace Markers

Marker	Frequency (GHz)	Meter Reading (dBuV)	Det	3117_00205959	10dB(dB)	DC Corr (dB)	Corrected Reading (dBuV/m)	Average Limit (dBuV/m)	Margin (dB)	Peak Limit (dBuV/m)	PK Margin (dB)	Asimuth (Degs)	Height (cm)	Polarity
1	* 5.15	39.43	Pk		34.4	-19	54.83	-	-	74	-19.17	151	346	H
2	* 5.147	41.76	Pk		34.4	-19.1	57.06	-	-	74	-16.94	151	346	H
3	* 5.15	28.64	RMS		34.4	-19.4	43.74	54	-10.24	-	-	151	346	H
4	* 5.149	29.68	RMS		34.4	-19.4	44.78	54	-9.2	-	-	151	346	H

* - indicates frequency in CFR47 Pt 15 / IC RSS-Restricted Band

Pk - Peak detector

RMS - RMS detection

VERTICAL PEAK AND AVERAGE PLOT

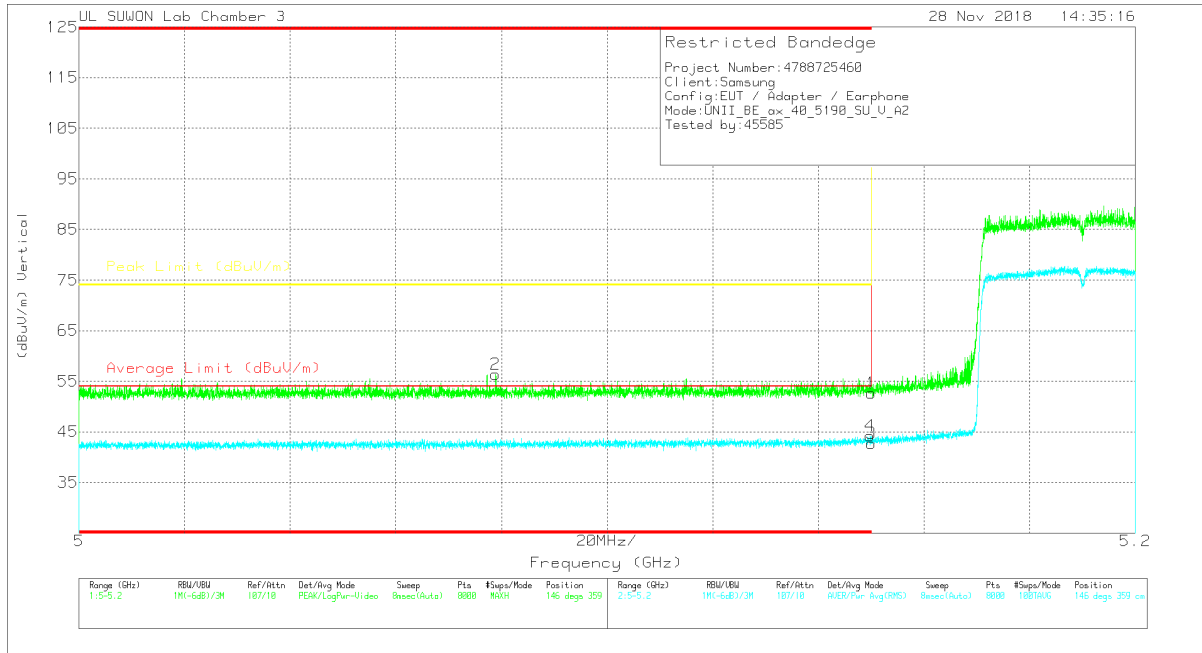

VERTICAL DATA

Trace Markers

Marker	Frequency (GHz)	Meter Reading (dBuV)	Det	3117_00209599	10dB(dB)	DC Corr (dB)	Corrected Reading (dBuV/m)	Average Limit (dBuV/m)	Margin (dB)	Peak Limit (dBuV/m)	PK Margin (dB)	Azimuth (Degs)	Height (cm)	Polarity
1	* 5.15	37.28	PK	34.4	-19	0	52.68	-	-	74	-21.32	146	359	V
2	* 5.079	41.17	PK	34.3	-19.1	0	56.37	-	-	74	-17.63	146	359	V
3	* 5.15	27.64	RMS	34.4	-19.4	.1	42.74	54	-11.26	-	-	146	359	V
4	* 5.15	29.06	RMS	34.4	-19.4	.1	44.16	54	-9.84	-	-	146	359	V

* - indicates frequency in CFR47 Pt 15 / IC RSS-Restricted Band

Pk - Peak detector

RMS - RMS detection

HE80 SU mode (ANT_1)

HORIZONTAL PEAK AND AVERAGE PLOT

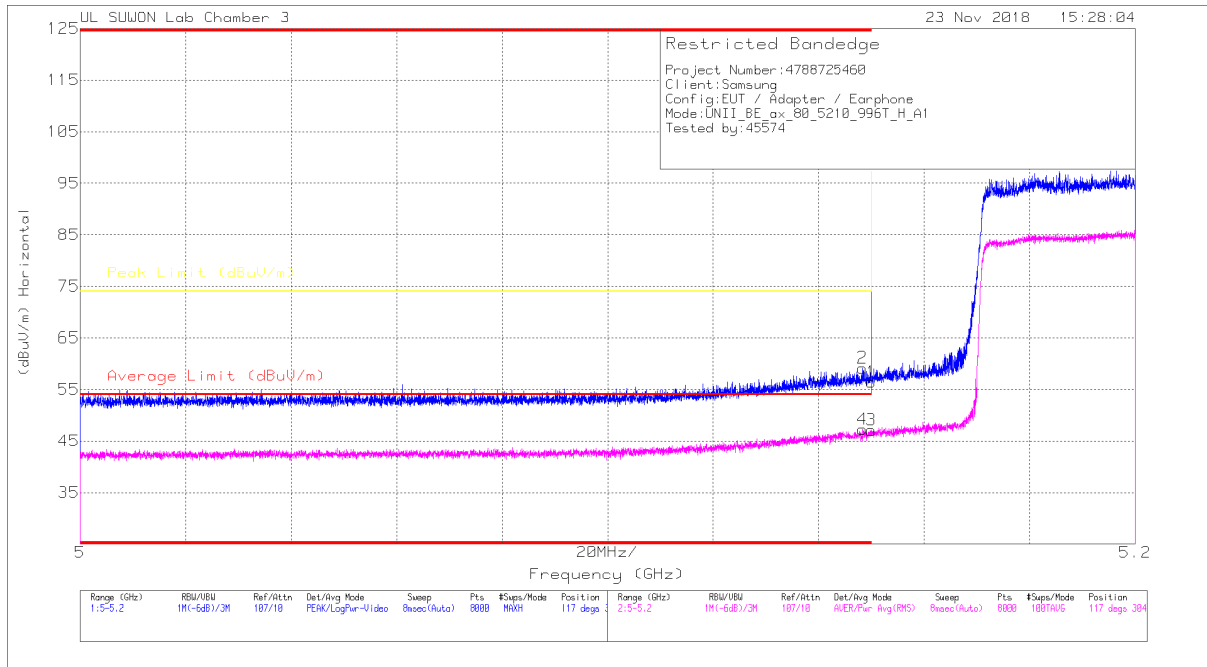

HORIZONTAL DATA

Trace Markers

Marker	Frequency (GHz)	Meter Reading (dBu)	Det	3117_00205959	10dB(dB)	DC Corr (dB)	Corrected Reading (dBu/m)	Average Limit (dBu/m)	Margin (dB)	Peak Limit (dBu/m)	PK Margin (dB)	Azimuth (Degs)	Height (cm)	Polarity
1	* 5.15	41.01	Pk	34.4	-19	0	56.41	-	-	74	-17.59	117	304	H
2	* 5.148	43.85	Pk	34.4	-19.1	0	59.15	-	-	74	-14.85	117	304	H
3	* 5.15	32.01	RMS	34.4	-19.4	.1	47.11	54	-6.89	-	-	117	304	H
4	* 5.148	32.16	RMS	34.4	-19.4	.1	47.26	54	-6.74	-	-	117	304	H

* - indicates frequency in CFR47 Pt 15 / IC RSS-Restricted Band

Pk - Peak detector

RMS - RMS detection

VERTICAL PEAK AND AVERAGE PLOT

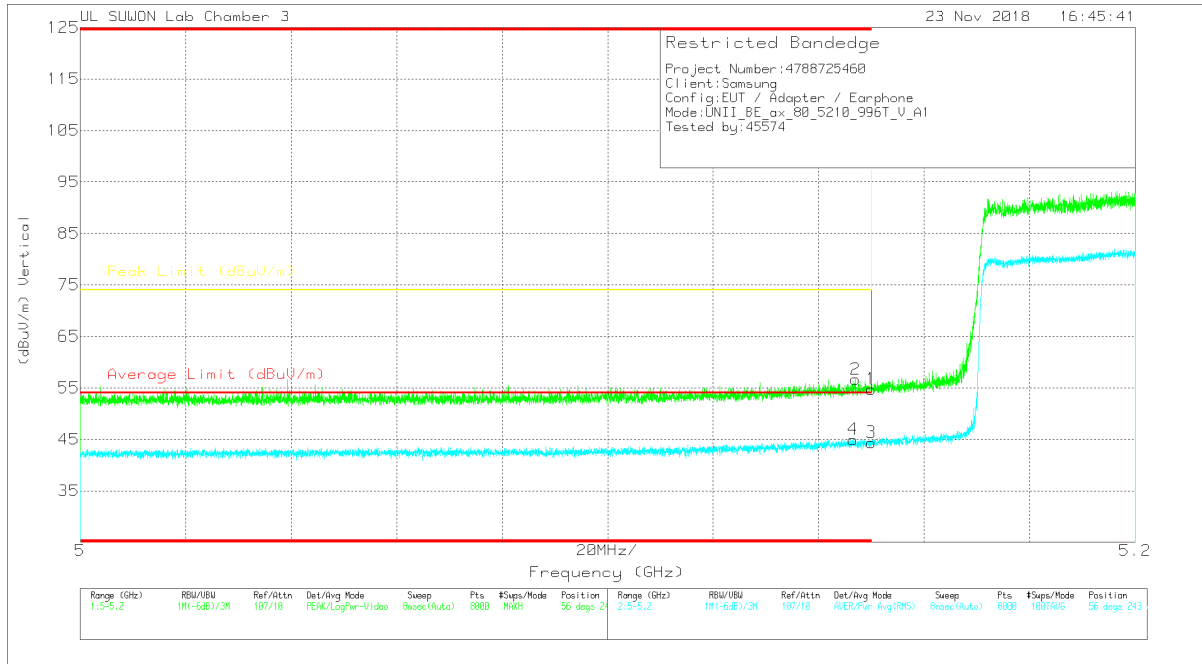

VERTICAL DATA

Trace Markers

Marker	Frequency (GHz)	Meter Reading (dBuV)	Det	3117_00209959	10dB(dB)	DC Corr (dB)	Corrected Reading (dBuV/m)	Average Limit (dBuV/m)	Margin (dB)	Peak Limit (dBuV/m)	PK Margin (dB)	Azimuth (Degs)	Height (cm)	Polarity
1	* 5.15	39.37	Pk	34.4	-19	0	54.77	-	-	74	-19.23	56	243	V
2	* 5.147	41.36	Pk	34.4	-19.1	0	56.66	-	-	74	-17.34	56	243	V
3	* 5.15	29.28	RMS	34.4	-19.4	.1	44.38	54	-9.62	-	-	56	243	V
4	* 5.147	29.9	RMS	34.4	-19.4	.1	45	54	-9	-	-	56	243	V

* - indicates frequency in CFR47 Pt 15 / IC RSS-Restricted Band

Pk - Peak detector

RMS - RMS detection

HE80 SU mode (ANT_2)

HORIZONTAL PEAK AND AVERAGE PLOT

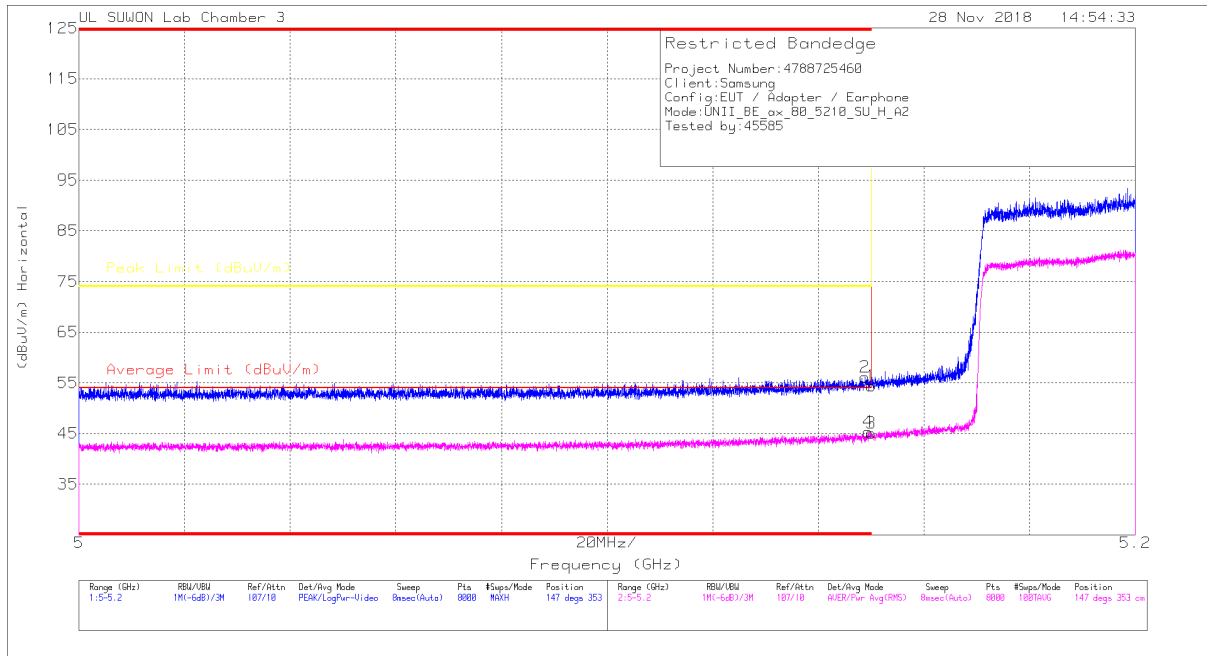

HORIZONTAL DATA

Trace Markers

Marker	Frequency (GHz)	Meter Reading (dBuV)	Det	3117_00205959	10dB(dB)	DC Corr (dB)	Corrected Reading (dBuV/m)	Average Limit (dBuV/m)	Margin (dB)	Peak Limit (dBuV/m)	PK Margin (dB)	Azimuth (Degs)	Height (cm)	Polarity
1	* 5.15	38.95	Pk		34.4	-19	54.35	-	-	74	-19.65	147	353	H
2	* 5.149	40.78	Pk		34.4	-19.1	56.08	-	-	74	-17.92	147	353	H
3	* 5.15	30.01	RMS		34.4	-19.4	45.11	54	-8.89	-	-	147	353	H
4	* 5.149	30.2	RMS		34.4	-19.4	45.3	54	-8.7	-	-	147	353	H

* - indicates frequency in CFR47 Pt 15 / IC RSS-Restricted Band

Pk - Peak detector

RMS - RMS detection

VERTICAL PEAK AND AVERAGE PLOT

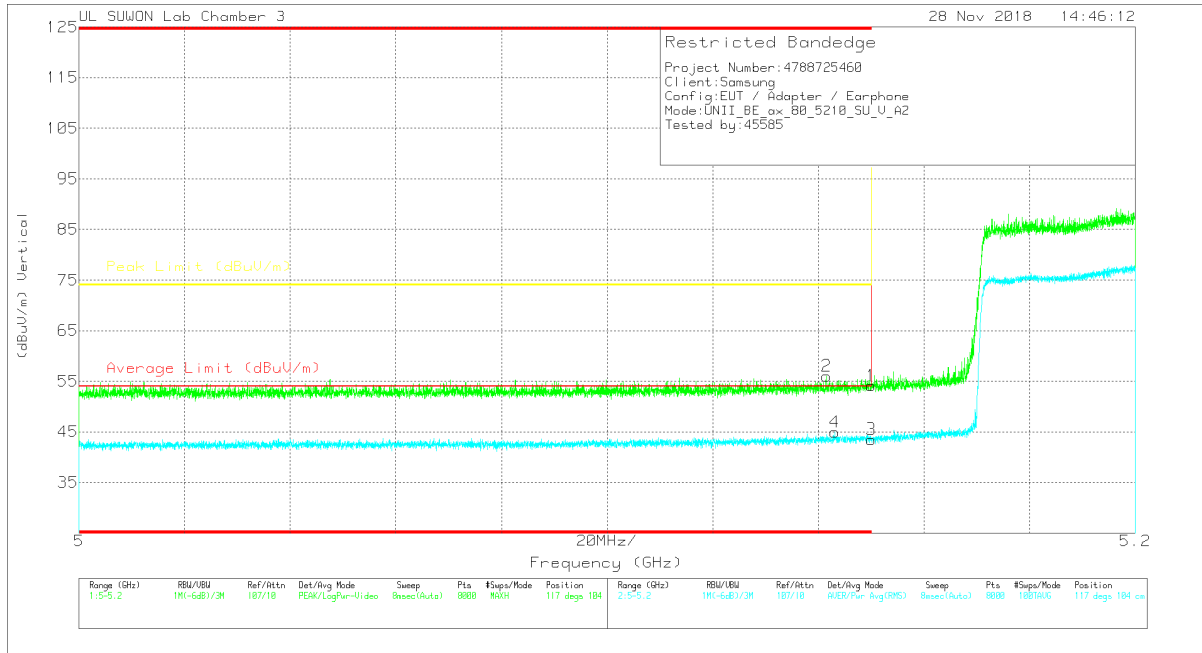

VERTICAL DATA

Trace Markers

Marker	Frequency (GHz)	Meter Reading (dBuV)	Det	3117_00209599	10dB(dB)	DC Corr (dB)	Corrected Reading (dBuV/m)	Average Limit (dBuV/m)	Margin (dB)	Peak Limit (dBuV/m)	PK Margin (dB)	Azimuth (Degs)	Height (cm)	Polarity
1	* 5.15	38.75	Pk	34.4	-19	0	54.15	-	-	74	-19.85	117	104	V
2	* 5.142	40.76	Pk	34.4	-19.1	0	56.06	-	-	74	-17.94	117	104	V
3	* 5.15	28.42	RMS	34.4	-19.4	.1	43.52	54	-10.48	-	-	117	104	V
4	* 5.143	29.88	RMS	34.4	-19.4	.1	44.98	54	-9.02	-	-	117	104	V

* - indicates frequency in CFR47 Pt 15 / IC RSS-Restricted Band

Pk - Peak detector

RMS - RMS detection

106T RU mode (ANT_1 / HE40 / RU offset 53)

HORIZONTAL PEAK AND AVERAGE PLOT

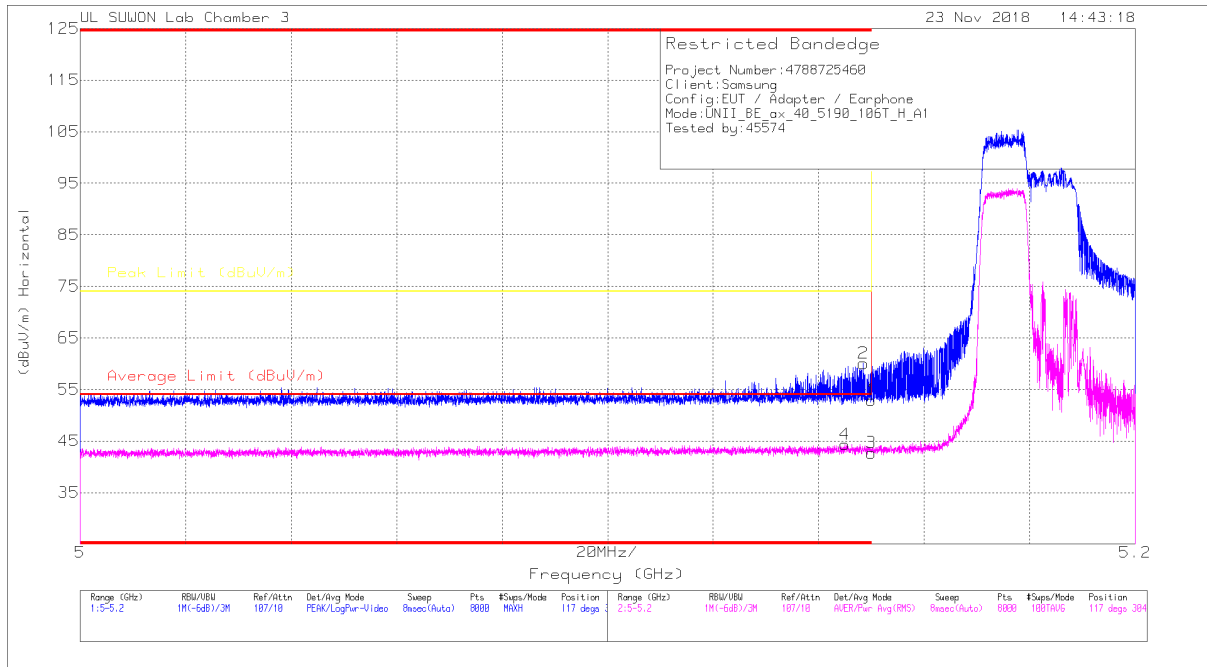

HORIZONTAL DATA

Trace Markers

Marker	Frequency (GHz)	Meter Reading (dBu)	Det	3117_00205959	10dB(dB)	DC Corr (dB)	Corrected Reading (dBu/m)	Average Limit (dBu/m)	Margin (dB)	Peak Limit (dBu/m)	PK Margin (dB)	Azimuth (Degs)	Height (cm)	Polarity
1	* 5.15	37.51	Pk	34.4	-19	0	52.91	-	-	74	-21.09	117	304	H
2	* 5.148	44.75	Pk	34.4	-19.1	0	60.05	-	-	74	-13.95	117	304	H
3	* 5.15	27.25	RMS	34.4	-19.4	45	42.7	54	-11.3	-	-	117	304	H
4	* 5.145	28.9	RMS	34.4	-19.4	45	44.35	54	-9.65	-	-	117	304	H

* - indicates frequency in CFR47 Pt 15 / IC RSS-Restricted Band

Pk - Peak detector

RMS - RMS detection

VERTICAL PEAK AND AVERAGE PLOT

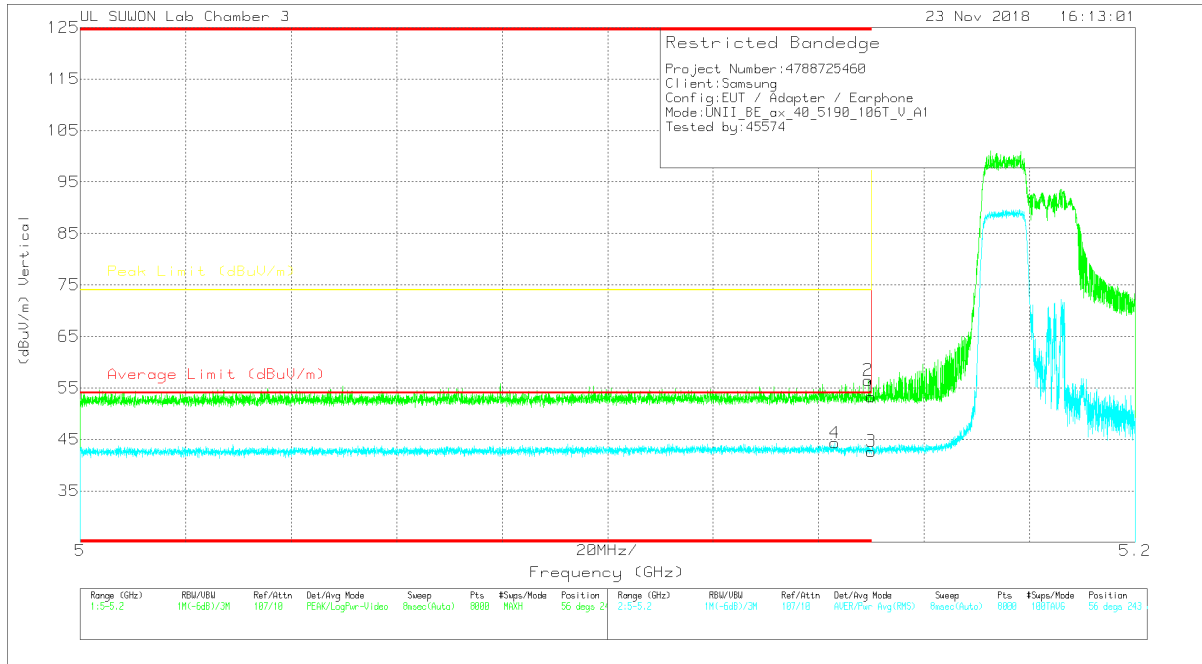

VERTICAL DATA

Trace Markers

Marker	Frequency (GHz)	Meter Reading (dBuV)	Det	3117_00209959	10dB(dB)	DC Corr (dB)	Corrected Reading (dBuV/m)	Average Limit (dBuV/m)	Margin (dB)	Peak Limit (dBuV/m)	PK Margin (dB)	Asimuth (Degs)	Height (cm)	Polarity
1	* 5.15	37.84	Pk	34.4	-19	0	53.24	-	-	74	-20.76	56	243	V
2	* 5.149	41.08	Pk	34.4	-19	0	56.48	-	-	74	-17.52	56	243	V
3	* 5.15	27.23	RMS	34.4	-19.4	-45	42.68	54	-11.32	-	-	56	243	V
4	* 5.143	28.9	RMS	34.4	-19.4	-45	44.35	54	-9.65	-	-	56	243	V

* - indicates frequency in CFR47 Pt 15 / IC RSS-Restricted Band

Pk - Peak detector

RMS - RMS detection

106T RU mode (ANT_2 / HE20 / RU offset 53)

HORIZONTAL PEAK AND AVERAGE PLOT

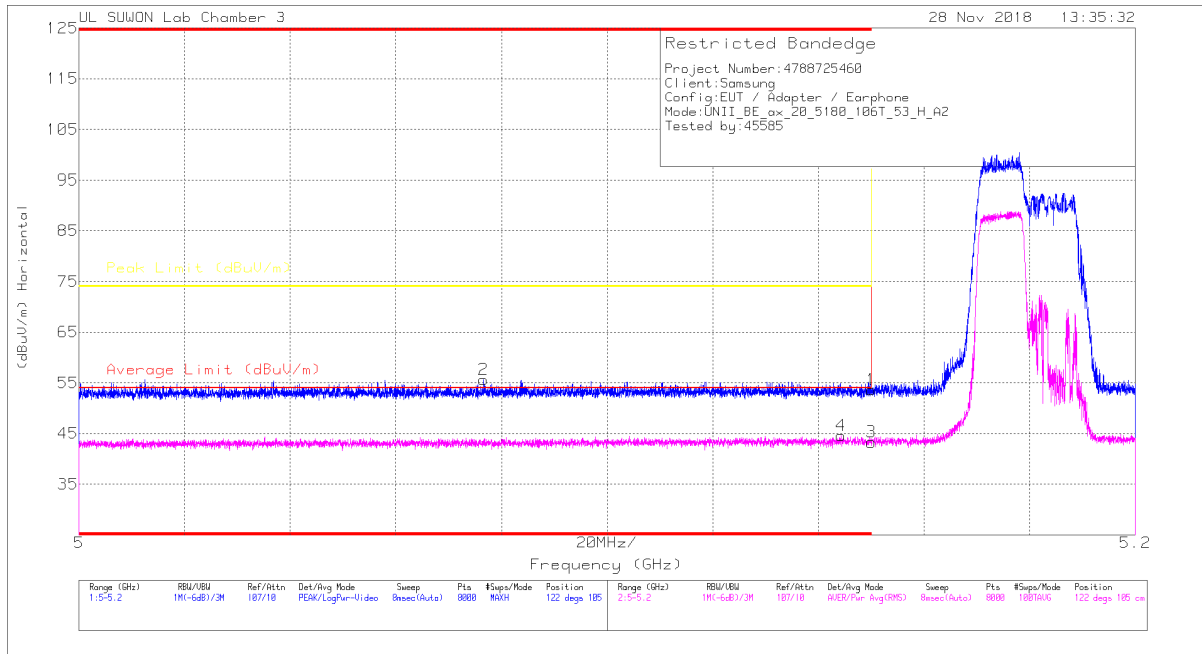

HORIZONTAL DATA

Trace Markers

Marker	Frequency (GHz)	Meter Reading (dBuV)	Det	3117_00205959	10dB(dB)	DC Corr (dB)	Corrected Reading (dBuV/m)	Average Limit (dBuV/m)	Margin (dB)	Peak Limit (dBuV/m)	PK Margin (dB)	Asimuth (Degs)	Height (cm)	Polarity
1	* 5.15	38.23	Pk	34.4	-19	0	53.63	-	-	74	-20.37	122	105	H
2	* 5.077	40.41	Pk	34.3	-19.1	0	55.61	-	-	74	-18.39	122	105	H
3	* 5.15	27.83	RMS	34.4	-19.4	.45	43.28	54	-10.72	-	-	122	105	H
4	* 5.144	29.15	RMS	34.4	-19.4	.45	44.6	54	-9.4	-	-	122	105	H

* - indicates frequency in CFR47 Pt 15 / IC RSS-Restricted Band

Pk - Peak detector

RMS - RMS detection

VERTICAL PEAK AND AVERAGE PLOT

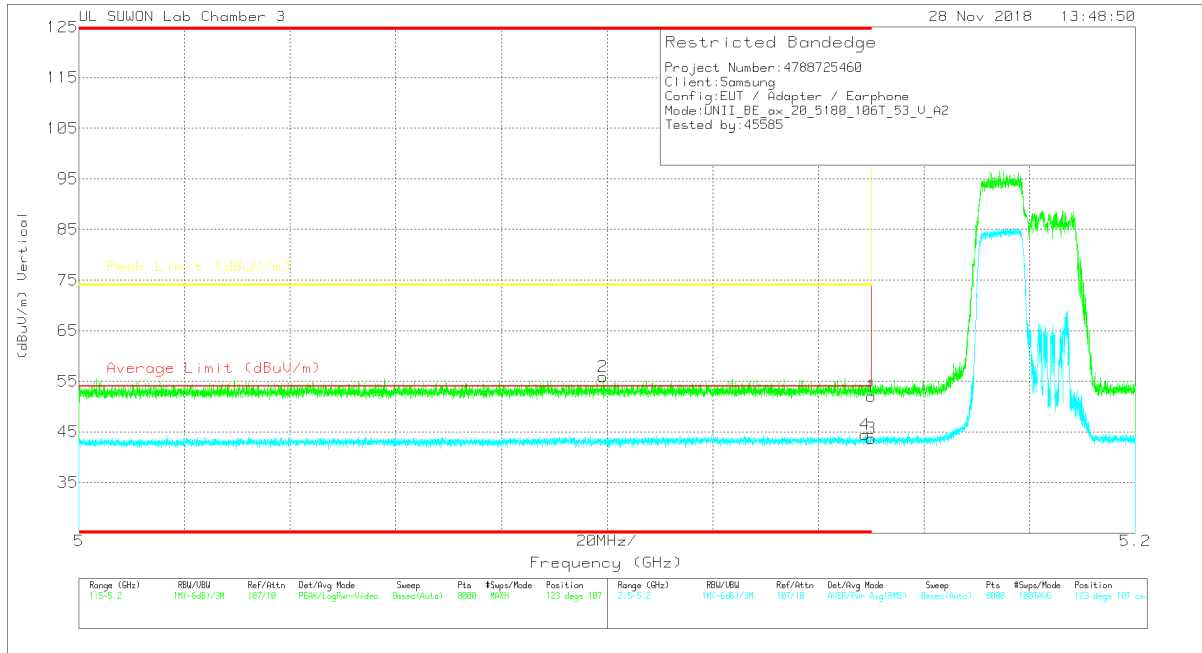

VERTICAL DATA

Trace Markers

Marker	Frequency (GHz)	Meter Reading (dBuV)	Det	3117_00209599	10dB(dB)	DC Corr (dB)	Corrected Reading (dBuV/m)	Average Limit (dBuV/m)	Margin (dB)	Peak Limit (dBuV/m)	PK Margin (dB)	Azimuth (Degs)	Height (cm)	Polarity
1	* 5.15	36.62	Pk	34.4	-19	0	52.02	-	-	74	-21.98	123	107	V
2	* 5.099	40.43	Pk	34.4	-19	0	55.83	-	-	74	-18.17	123	107	V
3	* 5.15	28.3	RMS	34.4	-19.4	.45	43.75	54	-10.25	-	-	123	107	V
4	* 5.149	28.97	RMS	34.4	-19.4	.45	44.42	54	-9.58	-	-	123	107	V

* - indicates frequency in CFR47 Pt 15 / IC RSS-Restricted Band

Pk - Peak detector

RMS - RMS detection

52T RU mode (ANT_1 / HE40 / RU offset 37)

HORIZONTAL PEAK AND AVERAGE PLOT

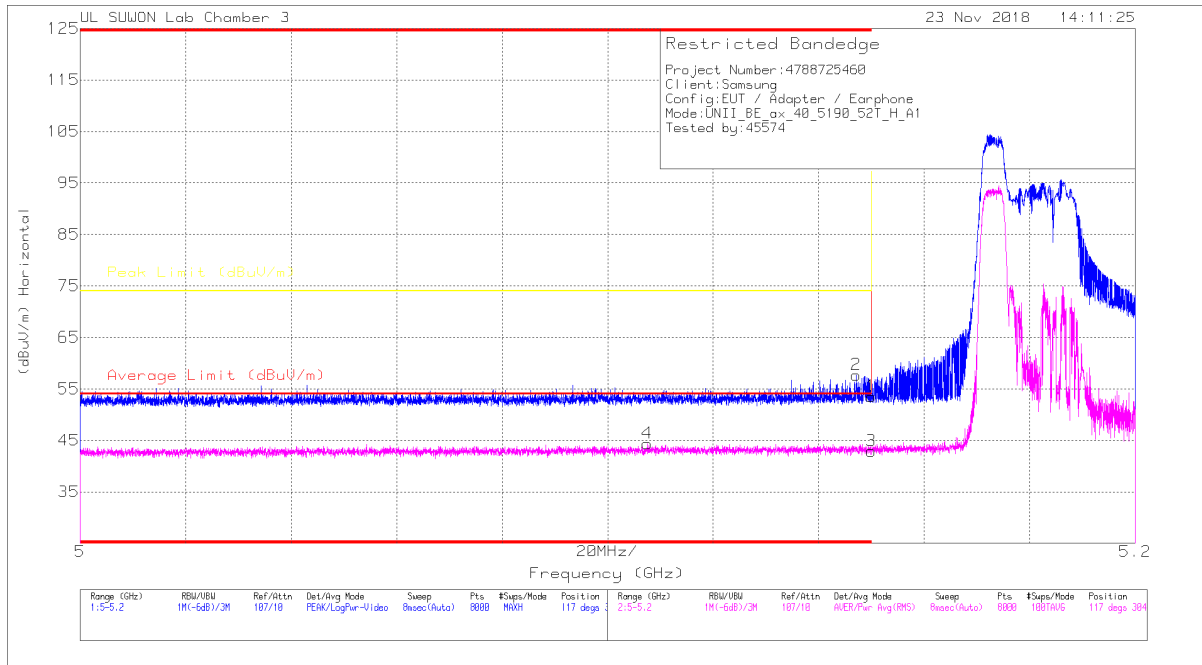

HORIZONTAL DATA

Trace Markers

Marker	Frequency (GHz)	Meter Reading (dBuV)	Det	3117_00205959	10dB[dB]	DC Corr (dB)	Corrected Reading (dBuV/m)	Average Limit (dBuV/m)	Margin (dB)	Peak Limit (dBuV/m)	PK Margin (dB)	Azimuth (Degs)	Height (cm)	Polarity
1	* 5.15	38.14	Pk	34.4	-19	0	53.54	-	-	74	-20.46	117	304	H
2	* 5.147	42.42	Pk	34.4	-19.1	0	57.72	-	-	74	-16.28	117	304	H
3	* 5.15	27.48	RMS	34.4	-19.4	.47	42.95	54	-11.05	-	-	117	304	H
4	* 5.108	29.03	RMS	34.4	-19.5	.47	44.4	54	-9.6	-	-	117	304	H

* - indicates frequency in CFR47 Pt 15 / IC RSS-Restricted Band

Pk - Peak detector

RMS - RMS detection

VERTICAL PEAK AND AVERAGE PLOT

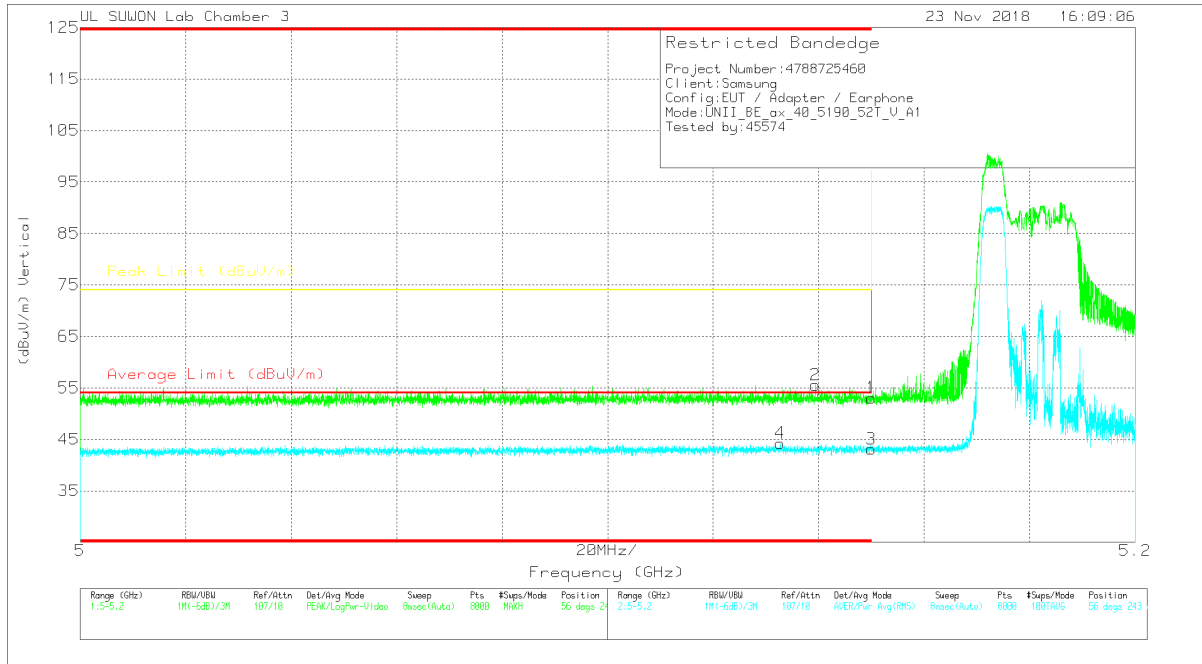

VERTICAL DATA

Trace Markers

Marker	Frequency (GHz)	Meter Reading (dBuV)	Det	3117_0020959	10dB(dB)	DC Corr (dB)	Corrected Reading (dBuV/m)	Average Limit (dBuV/m)	Margin (dB)	Peak Limit (dBuV/m)	PK Margin (dB)	Azimuth (Degs)	Height (cm)	Polarity
1	* 5.15	37.67	Pk	34.4	-19	0	53.07	-	-	74	-20.93	56	243	V
2	* 5.139	40.14	Pk	34.4	-19	0	55.54	-	-	74	-18.46	56	243	V
3	* 5.15	27.63	RMS	34.4	-19.4	.47	43.1	54	-10.9	-	-	56	243	V
4	* 5.133	28.77	RMS	34.4	-19.4	.47	44.24	54	-9.76	-	-	56	243	V

* - indicates frequency in CFR47 Pt 15 / IC RSS-Restricted Band

Pk - Peak detector

RMS - RMS detection

52T RU mode (ANT_2 / HE80 / RU offset 37)

HORIZONTAL PEAK AND AVERAGE PLOT

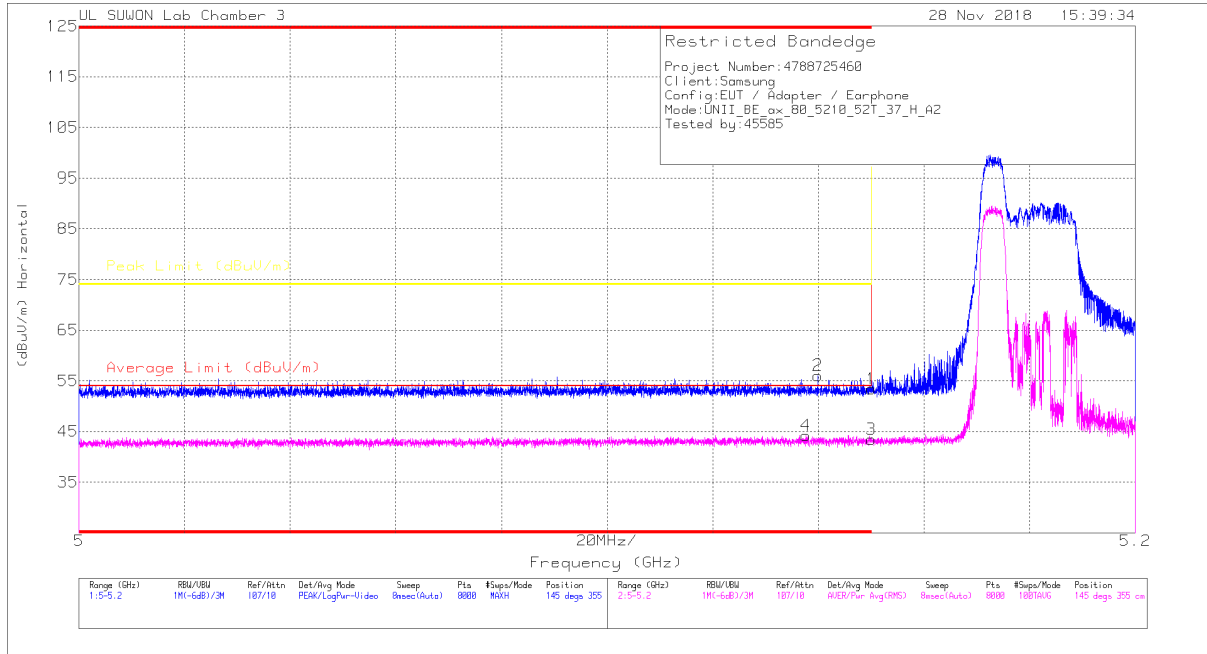

HORIZONTAL DATA

Trace Markers

Marker	Frequency (GHz)	Meter Reading (dBuV)	Det	3117_00205959	10dB(dB)	DC Corr (dB)	Corrected Reading (dBuV/m)	Average Limit (dBuV/m)	Margin (dB)	Peak Limit (dBuV/m)	PK Margin (dB)	Asimuth (Degs)	Height (cm)	Polarity
1	* 5.15	37.98	Pk	34.4	-19	0	53.38	-	-	74	-20.62	145	355	H
2	* 5.14	40.76	Pk	34.4	-19.1	0	56.06	-	-	74	-17.94	145	355	H
3	* 5.15	28	RMS	34.4	-19.4	.48	43.48	54	-10.52	-	-	145	355	H
4	* 5.138	28.78	RMS	34.4	-19.4	.48	44.26	54	-9.74	-	-	145	355	H

* - indicates frequency in CFR47 Pt 15 / IC RSS-Restricted Band

Pk - Peak detector

RMS - RMS detection

VERTICAL PEAK AND AVERAGE PLOT

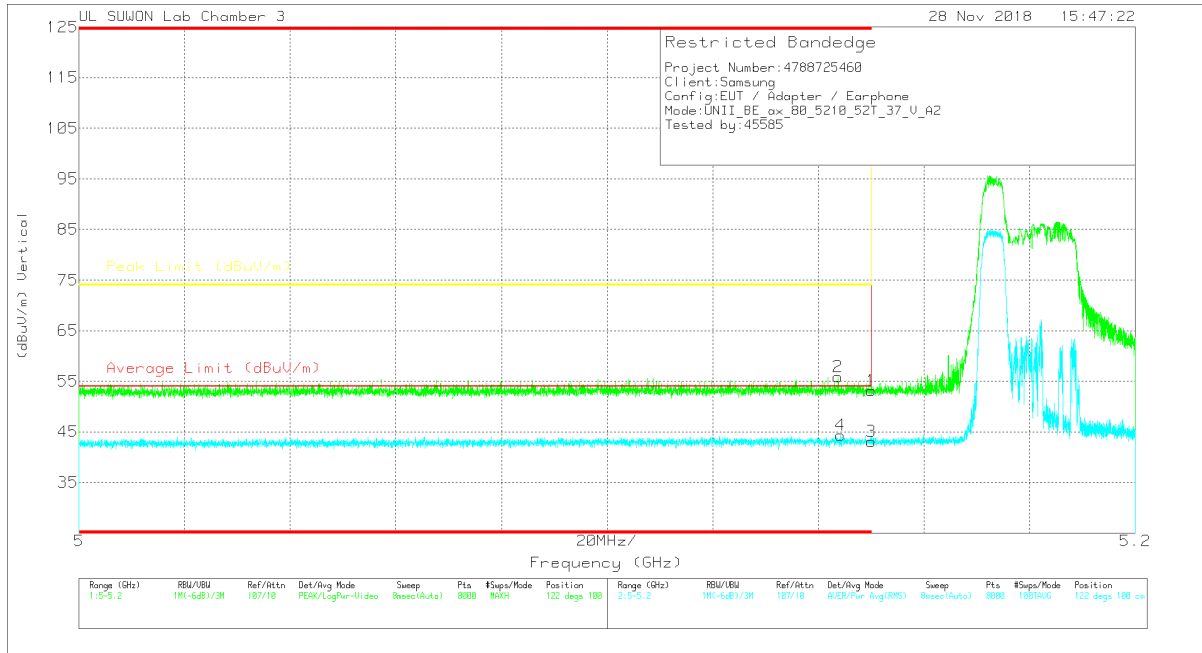

VERTICAL DATA

Trace Markers

Marker	Frequency (GHz)	Meter Reading (dBuV)	Det	3117_00209599	10dB(dB)	DC Corr (dB)	Corrected Reading (dBuV/m)	Average Limit (dBuV/m)	Margin (dB)	Peak Limit (dBuV/m)	PK Margin (dB)	Azimuth (Degs)	Height (cm)	Polarity
1	* 5.15	37.78	Pk	34.4	-19	0	53.18	-	-	74	-20.82	122	100	V
2	* 5.144	40.55	Pk	34.4	-19.1	0	55.85	-	-	74	-18.15	122	100	V
3	* 5.15	27.58	RMS	34.4	-19.4	.48	43.06	54	-10.94	-	-	122	100	V
4	* 5.144	28.83	RMS	34.4	-19.4	.48	44.31	54	-9.69	-	-	122	100	V

* - indicates frequency in CFR47 Pt 15 / IC RSS-Restricted Band

Pk - Peak detector

RMS - RMS detection

26T RU mode (ANT_1 / HE40 / RU offset 0)

HORIZONTAL PEAK AND AVERAGE PLOT

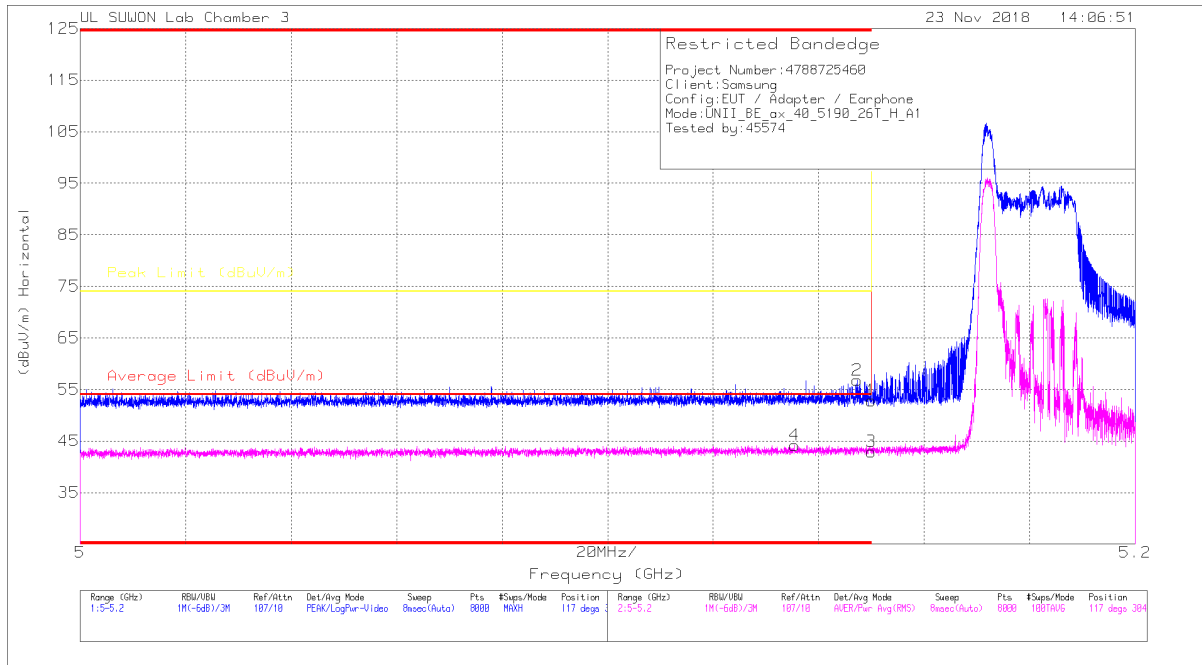

HORIZONTAL DATA

Trace Markers

Marker	Frequency (GHz)	Meter Reading (dBuV)	Det	3117_00209599	10dB(dB)	DC Corr (dB)	Corrected Reading (dBuV/m)	Average Limit (dBuV/m)	Margin (dB)	Peak Limit (dBuV/m)	PK Margin (dB)	Azimuth (Degs)	Height (cm)	Polarity
1	* 5.15	37.44	Pk	34.4	-19	0	52.84	-	-	74	-21.16	117	304	H
2	* 5.147	41.47	Pk	34.4	-19.1	0	56.77	-	-	74	-17.23	117	304	H
3	* 5.15	27.45	RMS	34.4	-19.4	.49	42.94	54	-11.06	-	-	117	304	H
4	* 5.135	28.68	RMS	34.4	-19.4	.49	44.17	54	-9.83	-	-	117	304	H

* - indicates frequency in CFR47 Pt 15 / IC RSS-Restricted Band

Pk - Peak detector

RMS - RMS detection

VERTICAL PEAK AND AVERAGE PLOT

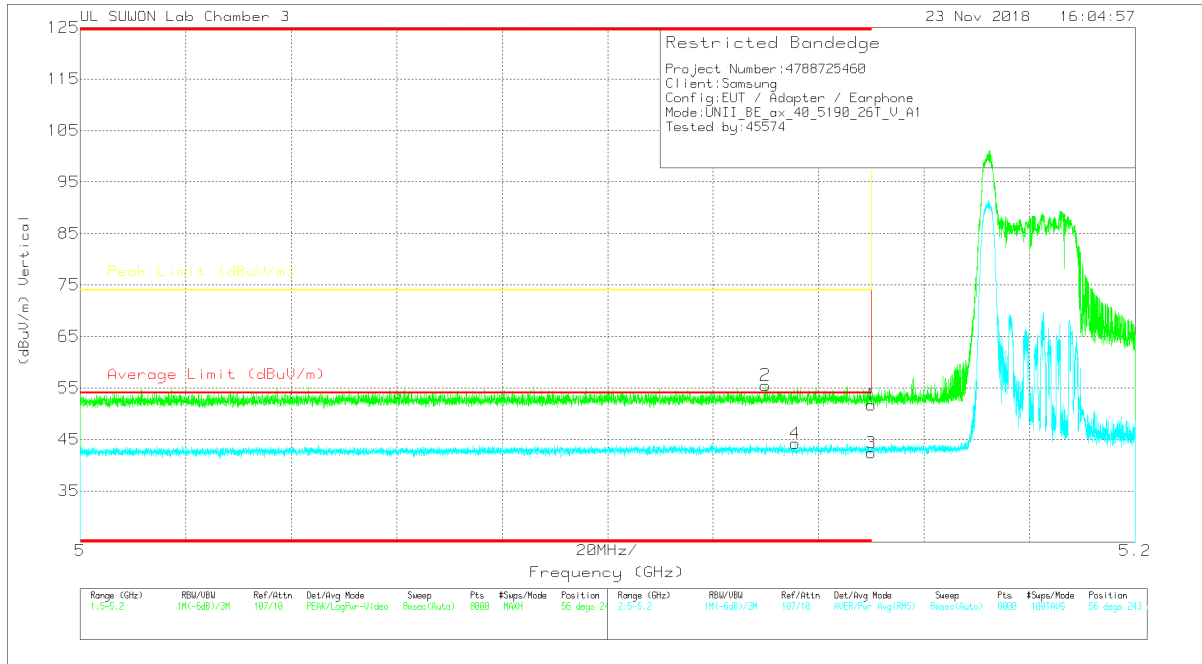

VERTICAL DATA

Trace Markers

Marker	Frequency (GHz)	Meter Reading (dBuV)	Det	3117_0020959	10dB(dB)	DC Corr (dB)	Corrected Reading (dBuV/m)	Average Limit (dBuV/m)	Margin (dB)	Peak Limit (dBuV/m)	PK Margin (dB)	Asimuth (Degs)	Height (cm)	Polarity
1	* 5.15	36.3	Pk	34.4	-19	0	51.7	-	-	74	-22.3	56	243	V
2	* 5.13	40.1	Pk	34.4	-19	0	55.5	-	-	74	-18.5	56	243	V
3	* 5.15	26.9	RMS	34.4	-19.4	-49	42.39	54	-11.61	-	-	56	243	V
4	* 5.136	28.73	RMS	34.4	-19.4	-49	44.22	54	-9.78	-	-	56	243	V

* - indicates frequency in CFR47 Pt 15 / IC RSS-Restricted Band
 Pk - Peak detector
 RMS - RMS detection

26T RU mode (ANT_2 / HE80 / RU offset 0)

HORIZONTAL PEAK AND AVERAGE PLOT

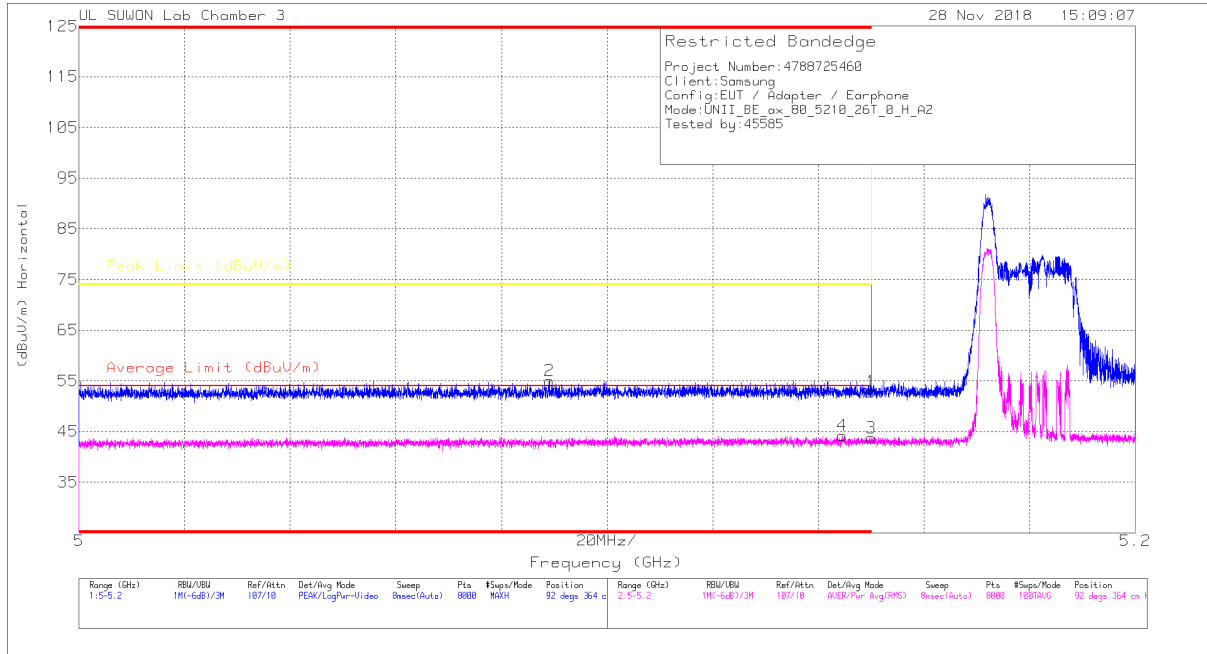

HORIZONTAL DATA

Trace Markers

Marker	Frequency (GHz)	Meter Reading (dBuV)	Det	3117_00205959	10dB(dB)	DC Corr (dB)	Corrected Reading (dBuV/m)	Average Limit (dBuV/m)	Margin (dB)	Peak Limit (dBuV/m)	PK Margin (dB)	Asimuth (Degs)	Height (cm)	Polarity
1	* 5.15	37.44	Pk	34.4	-19	0	52.84	-	-	74	-21.16	92	364	H
2	* 5.089	39.86	Pk	34.3	-19.1	0	55.06	-	-	74	-18.94	92	364	H
3	* 5.15	28.39	RMS	34.4	-19.4	.5	43.89	54	-10.11	-	-	92	364	H
4	* 5.144	28.81	RMS	34.4	-19.4	.5	44.31	54	-9.69	-	-	92	364	H

* - indicates frequency in CFR47 Pt 15 / IC RSS-Restricted Band

Pk - Peak detector

RMS - RMS detection

VERTICAL PEAK AND AVERAGE PLOT

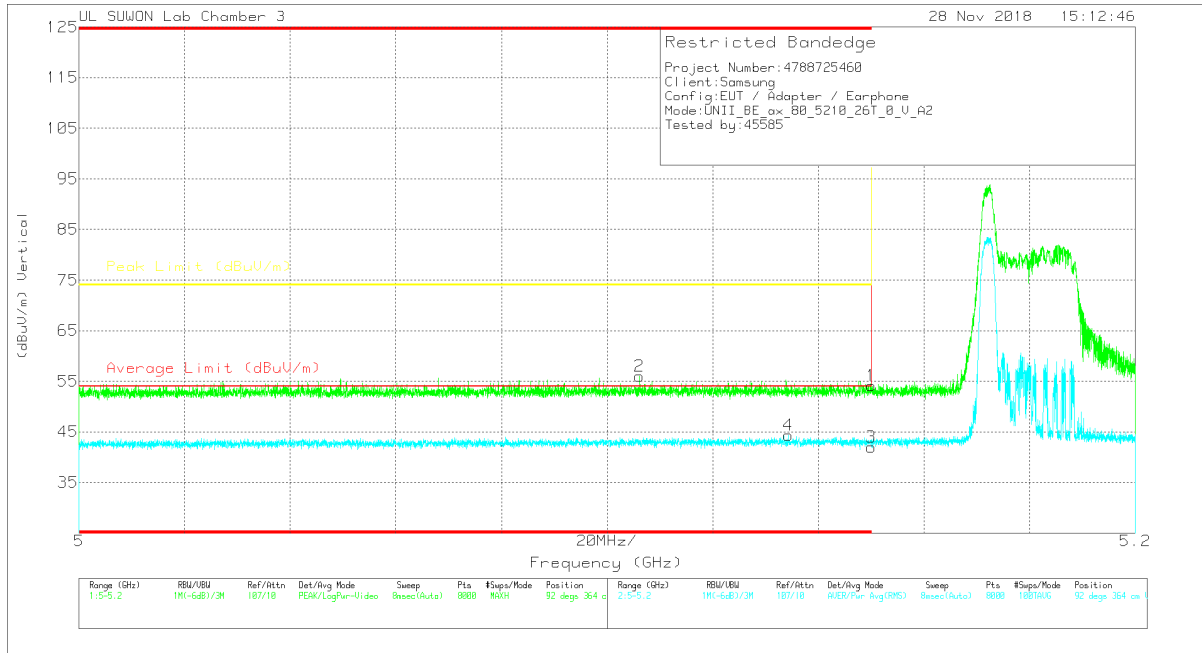

VERTICAL DATA

Trace Markers

Marker	Frequency (GHz)	Meter Reading (dBuV)	Det	3117_00209599	10dB(dB)	DC Corr (dB)	Corrected Reading (dBuV/m)	Average Limit (dBuV/m)	Margin (dB)	Peak Limit (dBuV/m)	PK Margin (dB)	Azimuth (Degs)	Height (cm)	Polarity
1	* 5.15	38.78	PK	34.4	-19	0	54.18	-	-	74	-19.82	92	364	V
2	* 5.106	40.67	PK	34.4	-19.1	0	55.97	-	-	74	-18.03	92	364	V
3	* 5.15	26.57	RMS	34.4	-19.4	.5	42.07	54	-11.93	-	-	92	364	V
4	* 5.134	28.95	RMS	34.4	-19.4	.5	44.45	54	-9.55	-	-	92	364	V

* - indicates frequency in CFR47 Pt 15 / IC RSS-Restricted Band

PK - Peak detector

RMS - RMS detection

HARMONICS AND SPURIOUS EMISSIONS

HE20 SU mode (ANT_1)

LOW CHANNEL HORIZONTAL

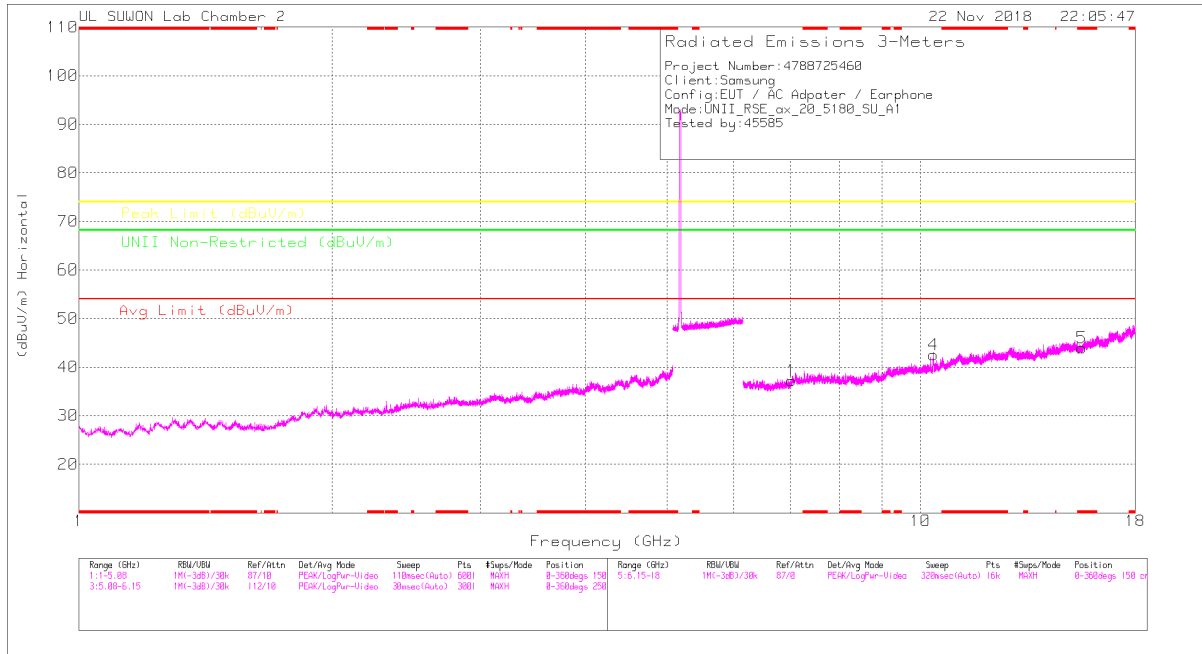

LOW CHANNEL VERTICAL

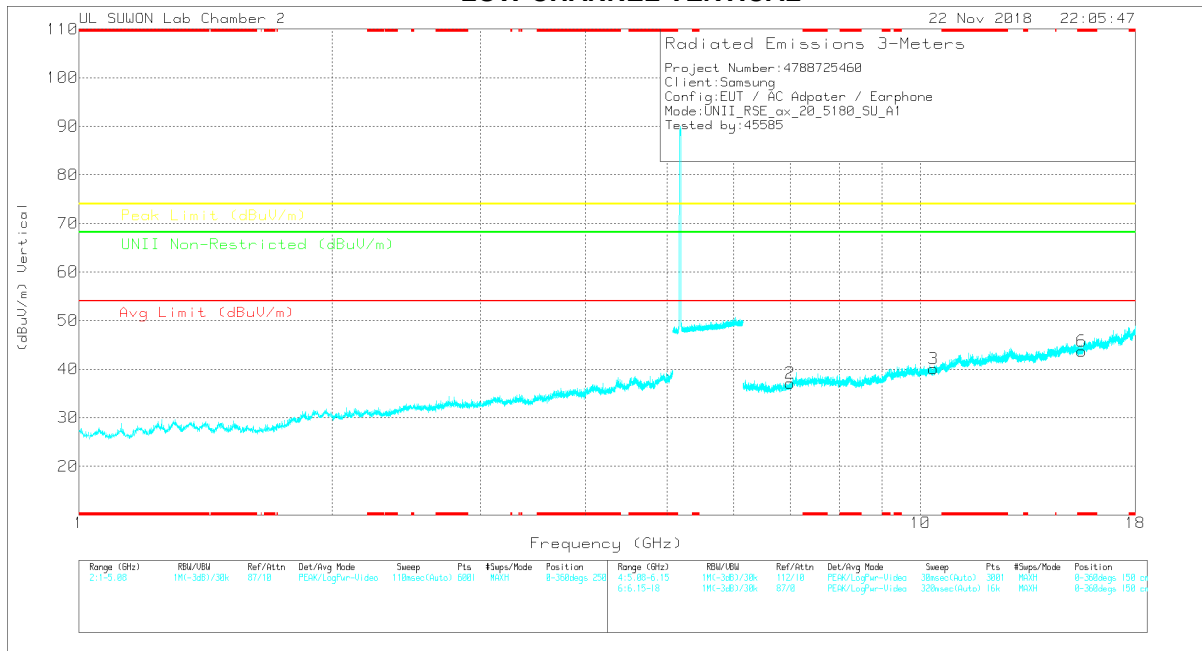

Note: Emission was scanned up to 40GHz; No emissions were detected above the noise floor which was at least 20dB below the specification limit.

LOW CHANNEL DATA

Trace Markers

Marker	Frequency (GHz)	Meter Reading (dBuV)	Det	3117_00168724	6GHz_HP[dB]	DC Corr (dB)	Corrected Reading (dBuV/m)	Avg Limit (dBuV/m)	Margin (dB)	Peak Limit (dBuV/m)	Margin (dB)	UNII Non-Restricted (dBuV/m)	Margin (dB)	Azimuth (Degs)	Height (cm)	Polarity
1	7.024	26.69	PK	35.9	-25.4	0	37.19	-	-	-	-	68.2	-31.01	0-360	150	H
4	10.362	26.17	PK	37.5	-21.1	0	42.57	-	-	-	-	68.2	-25.63	0-360	250	H
5	* 15.542	23.73	PK	39.9	-19.7	0	43.93	-	-	74	-30.07	-	-	0-360	250	H
2	7.001	26.98	PK	35.8	-25.7	0	37.08	-	-	-	-	68.2	-31.12	0-360	250	V
3	10.359	23.55	PK	37.5	-21	0	40.05	-	-	-	-	68.2	-28.15	0-360	150	V
6	* 15.541	23.5	PK	39.9	-19.7	0	43.7	-	-	74	-30.3	-	-	0-360	150	V

* - indicates frequency in CFR47 Pt 15 / IC RSS-Restricted Band
 PK – Peak Detector

Radiated Emissions

Frequency (GHz)	Meter Reading (dBuV)	Det	3117_00168724	6GHz_HP[dB]	DC Corr (dB)	Corrected Reading (dBuV/m)	Avg Limit (dBuV/m)	Margin (dB)	Peak Limit (dBuV/m)	Margin (dB)	UNII Non-Restricted (dBuV/m)	Margin (dB)	Azimuth (Degs)	Height (cm)	Polarity
10.361	38.38	PK-U	37.5	-21	0	54.89	-	-	-	-	68.2	-13.31	194	250	H
10.364	34.41	PK-U	37.6	-21	0	51.01	-	-	-	-	68.2	-17.19	178	236	V

* - indicates frequency in CFR47 Pt 15 / IC RSS-Restricted Band
 PK-U - U-NII: Maximum Peak

MID CHANNEL HORIZONTAL

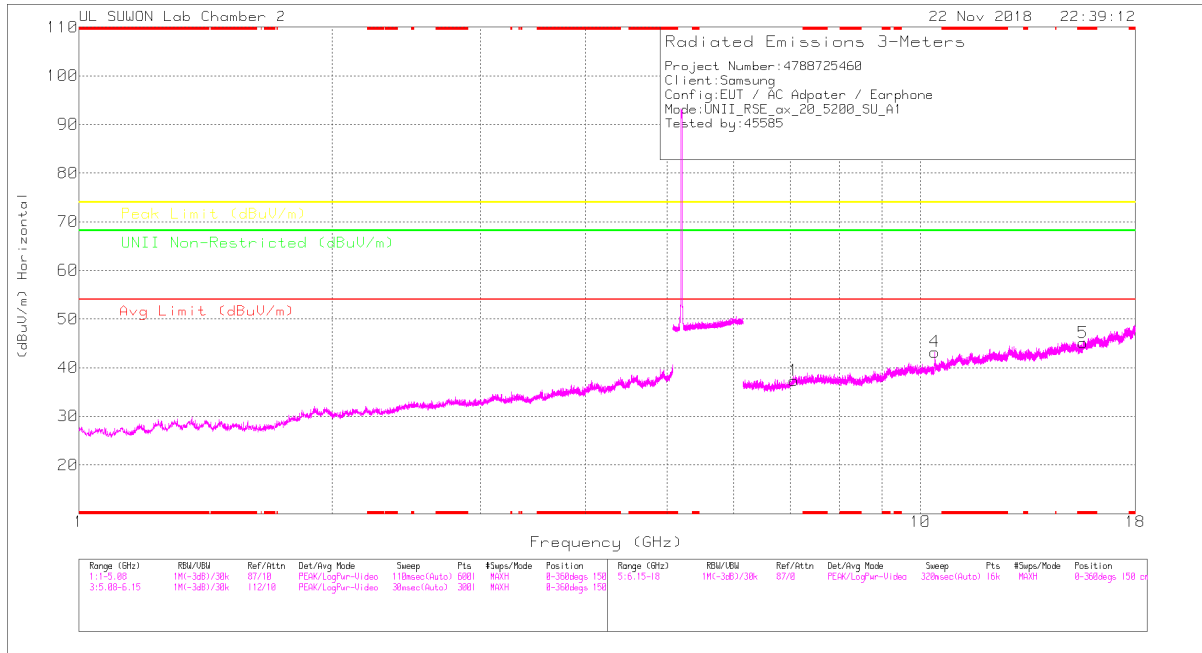

MID CHANNEL VERTICAL

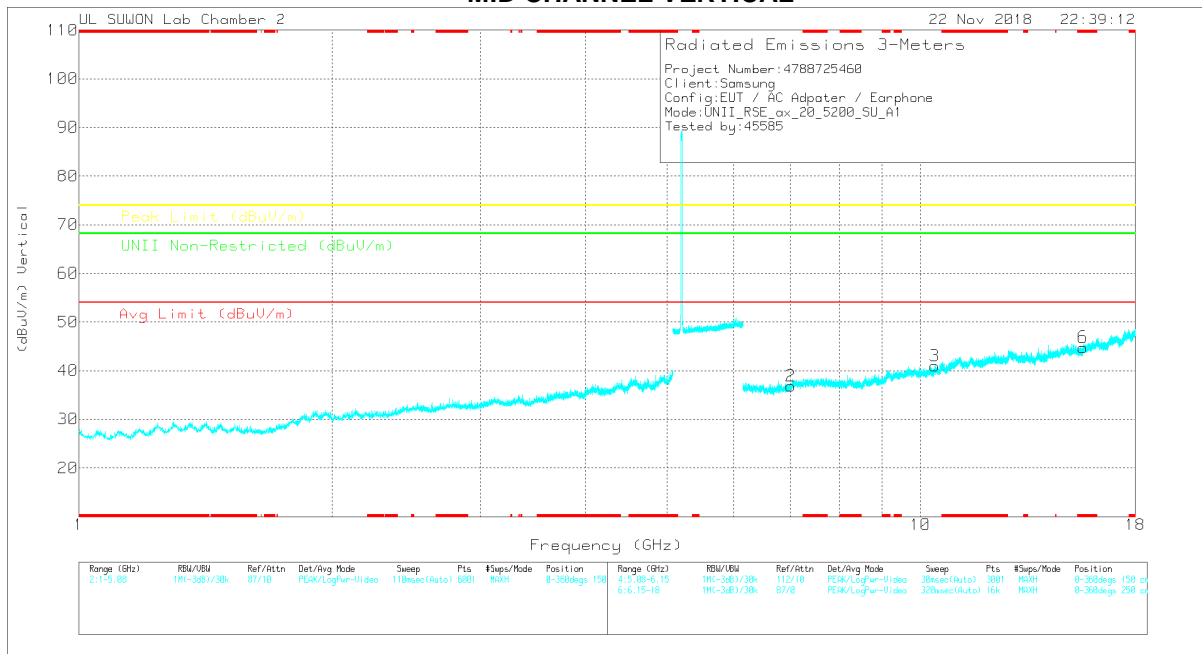

Note: Emission was scanned up to 40GHz; No emissions were detected above the noise floor which was at least 20dB below the specification limit.

MID CHANNEL DATA

Trace Markers

Marker	Frequency (GHz)	Meter Reading (dBuV)	Det	3117_00188724	6GHz_HF(dB)	DC Corr (dB)	Corrected Reading (dBuV/m)	Ag Limit (dBuV/m)	Margin (dB)	Peak Limit (dBuV/m)	Margin (dB)	UNII Non-Restricted (dBuV/m)	Margin (dB)	Asimuth (Degs)	Height (cm)	Polarity
1	7.078	25.5	PK	35.9	-24	0	37.4	-	-	-	-	68.2	-30.8	0-360	250	H
4	10.402	26.54	PK	37.6	-20.9	0	43.24	-	-	-	-	68.2	-24.96	0-360	250	H
5	* 15.603	24.96	PK	40	-19.8	0	45.16	-	-	74	-28.84	-	-	0-360	250	H
2	7.011	26.59	PK	35.8	-25.6	0	36.79	-	-	-	-	68.2	-31.41	0-360	250	V
3	10.401	24.39	PK	37.6	-21	0	40.99	-	-	-	-	68.2	-27.21	0-360	250	V
6	* 15.601	24.59	PK	40	-19.8	0	44.79	-	-	74	-29.21	-	-	0-360	150	V

* - indicates frequency in CFR47 Pt 15 / IC RSS-Restricted Band
 PK – Peak Detector

Radiated Emissions

Frequency (GHz)	Meter Reading (dBuV)	Det	3117_00188724	6GHz_HF(dB)	DC Corr (dB)	Corrected Reading (dBuV/m)	Ag Limit (dBuV/m)	Margin (dB)	Peak Limit (dBuV/m)	Margin (dB)	UNII Non-Restricted (dBuV/m)	Margin (dB)	Asimuth (Degs)	Height (cm)	Polarity
10.398	38.2	PK-U	37.6	-20.9	0	54.9	-	-	-	-	68.2	-13.3	101	246	H
10.423	34.01	PK-U	37.6	-20.9	0	50.71	-	-	-	-	68.2	-17.49	186	232	V

* - indicates frequency in CFR47 Pt 15 / IC RSS-Restricted Band
 PK-U - U-NII: Maximum Peak

HIGH CHANNEL HORIZONTAL

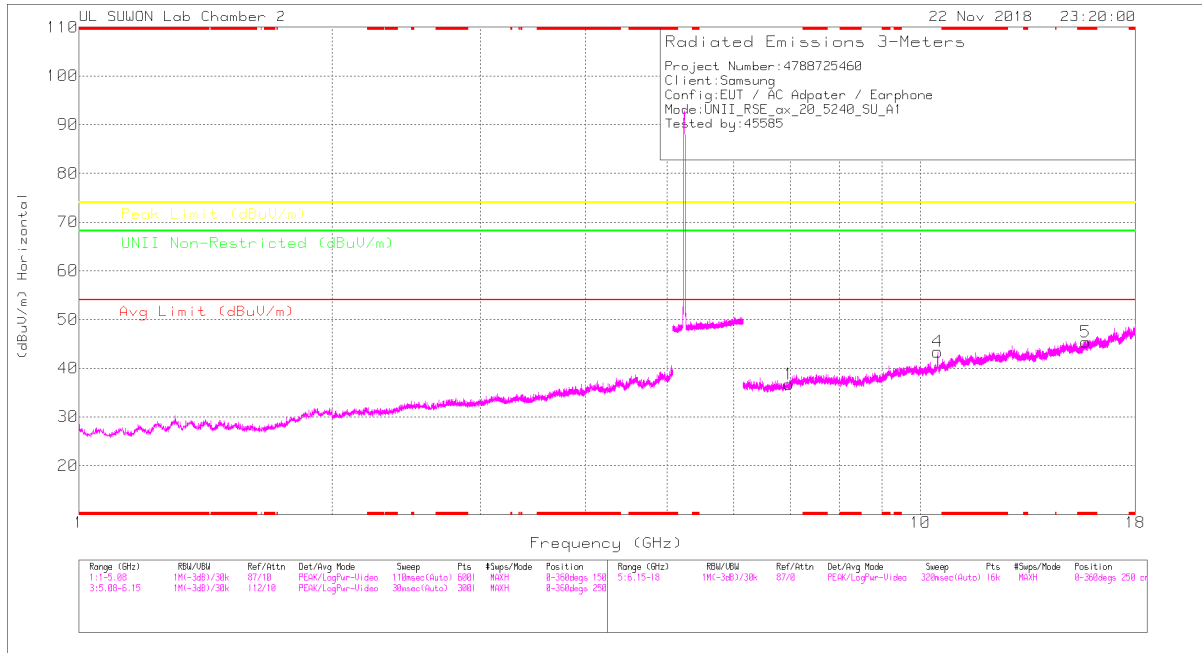

HIGH CHANNEL VERTICAL

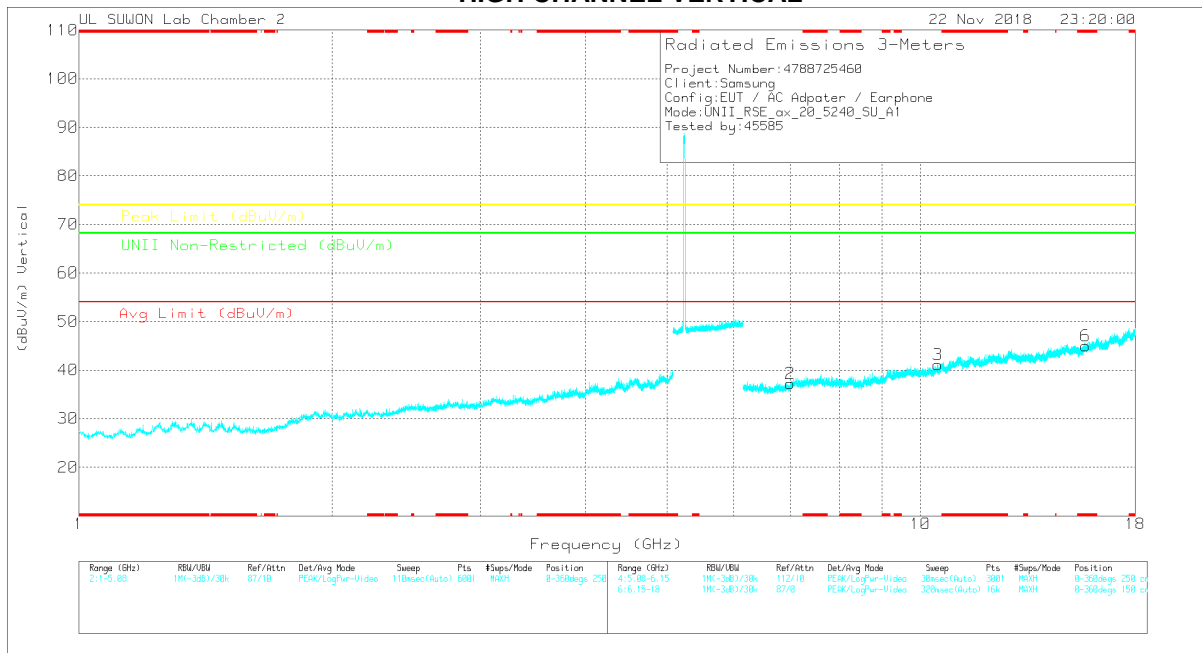

Note: Emission was scanned up to 40GHz; No emissions were detected above the noise floor which was at least 20dB below the specification limit.

HIGH CHANNEL DATA

Trace Markers

Marker	Frequency (GHz)	Meter Reading (dBuV)	Det	3117_0018724	6GHz_H(F)(dB)	DC Corr (dB)	Corrected Reading (dBuV/m)	Avg Limit (dBuV/m)	Margin (dB)	Peak Limit (dBuV/m)	Margin (dB)	Limit Non-Restricted (dBuV/m)	Margin (dB)	Azimuth (Degs)	Height (cm)	Polarity
1	6.982	26.63	PK	35.8	-25.7	0	36.73	-	-	-	-	68.2	-31.47	0-360	150	H
4	10.479	26.47	PK	37.7	-20.8	0	43.37	-	-	-	-	68.2	-24.83	0-360	250	H
5	* 15.718	24.83	PK	40.2	-19.6	0	45.43	-	-	74	-28.57	-	-	0-360	150	H
2	7.005	26.99	PK	35.8	-25.6	0	37.19	-	-	-	-	68.2	-31.01	0-360	150	V
3	10.482	24.27	PK	37.7	-20.9	0	41.07	-	-	-	-	68.2	-27.13	0-360	250	V
6	* 15.721	24.34	PK	40.2	-19.6	0	44.94	-	-	74	-29.06	-	-	0-360	150	V

* - indicates frequency in CFR47 Pt 15 / IC RSS-Restricted Band
 PK – Peak Detector

Radiated Emissions

Frequency (GHz)	Meter Reading (dBuV)	Det	3117_0018724	6GHz_H(F)(dB)	DC Corr (dB)	Corrected Reading (dBuV/m)	Avg Limit (dBuV/m)	Margin (dB)	Peak Limit (dBuV/m)	Margin (dB)	Limit Non-Restricted (dBuV/m)	Margin (dB)	Azimuth (Degs)	Height (cm)	Polarity
10.479	38.92	PK-U	37.7	-20.8	0	55.82	-	-	-	-	68.2	-12.38	100	249	H
10.478	35.46	PK-U	37.7	-20.8	0	52.36	-	-	-	-	68.2	-15.84	173	224	V

* - indicates frequency in CFR47 Pt 15 / IC RSS-Restricted Band
 PK-U - U-NII: Maximum Peak

HE20 SU mode (ANT_2)

LOW CHANNEL HORIZONTAL

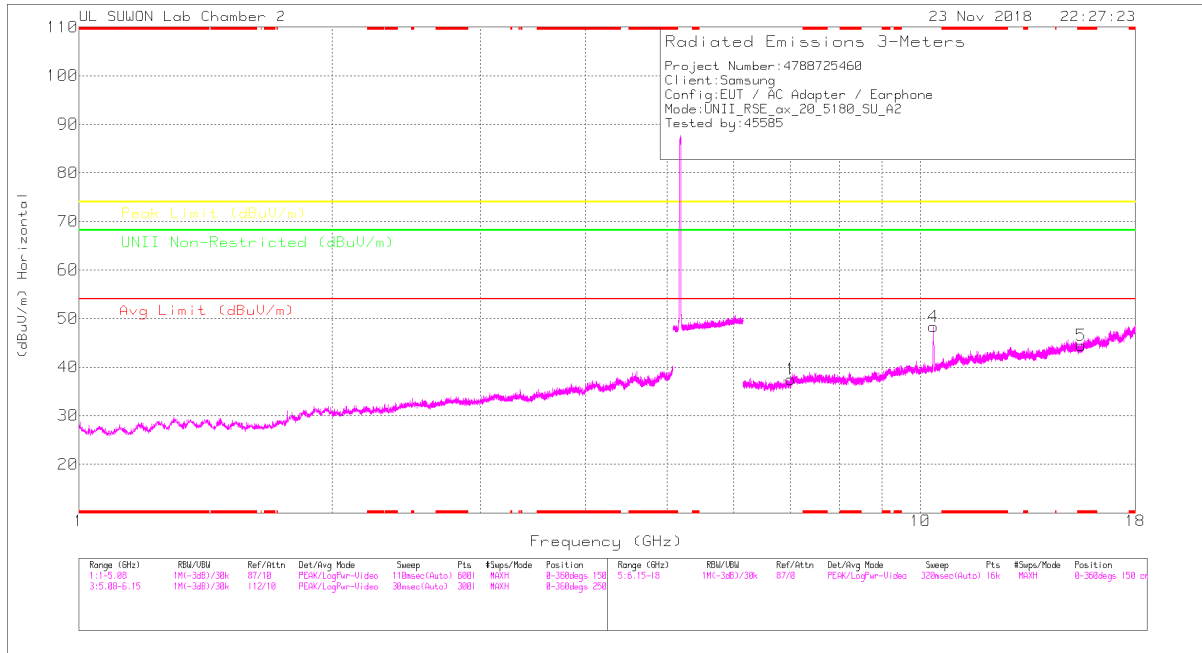

LOW CHANNEL VERTICAL

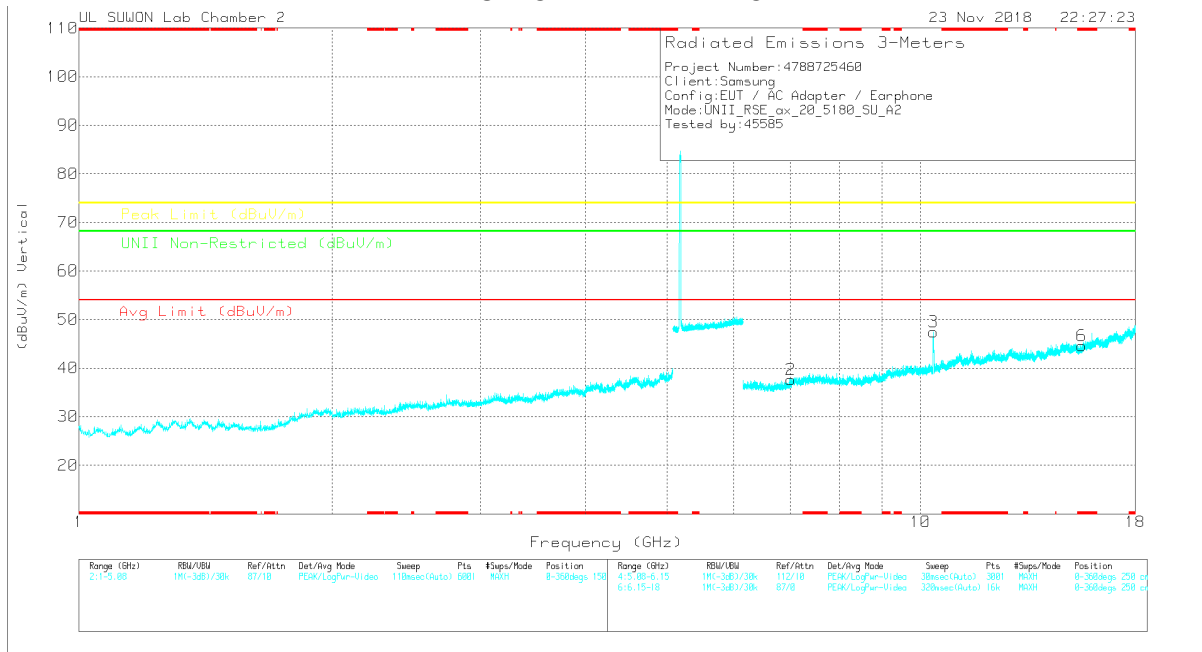

Note: Emission was scanned up to 40GHz; No emissions were detected above the noise floor which was at least 20dB below the specification limit.

LOW CHANNEL DATA

Trace Markers

Marker	Frequency (GHz)	Meter Reading (dBuV)	Det	3117_0018724	6GHz_HF(dB)	DC Corr (dB)	Corrected Reading (dBuV/m)	Avg Limit (dBuV/m)	Margin (dB)	Peak Limit (dBuV/m)	Margin (dB)	UNI Non-Restricted (dBuV/m)	Margin (dB)	Azimuth (Degs)	Height (cm)	Polarity
1	7.011	27.31	PK	35.8	-25.6	0	37.51	-	-	-	-	68.2	-30.69	0-360	250	H
4	10.365	31.89	PK	37.6	-21.1	0	48.39	-	-	-	-	68.2	-19.81	0-360	250	H
5	* 15.534	24.11	PK	39.9	-19.6	0	44.41	-	-	74	-29.59	-	-	0-360	250	H
2	7.016	27.2	PK	35.8	-25.4	0	37.6	-	-	-	-	68.2	-30.6	0-360	150	V
3	10.361	30.97	PK	37.5	-21	0	47.47	-	-	-	-	68.2	-20.73	0-360	250	V
6	* 15.54	24.46	PK	39.9	-19.8	0	44.56	-	-	74	-29.44	-	-	0-360	250	V

* - indicates frequency in CFR47 Pt 15 / IC RSS-Restricted Band
 PK – Peak Detector

Radiated Emissions

Frequency (GHz)	Meter Reading (dBuV)	Det	3117_0018724	6GHz_HF(dB)	DC Corr (dB)	Corrected Reading (dBuV/m)	Avg Limit (dBuV/m)	Margin (dB)	Peak Limit (dBuV/m)	Margin (dB)	UNI Non-Restricted (dBuV/m)	Margin (dB)	Azimuth (Degs)	Height (cm)	Polarity
10.359	44.87	PK-U	37.5	-21	0	61.37	-	-	-	-	68.2	-6.83	103	132	H
10.359	44.07	PK-U	37.5	-21	0	60.57	-	-	-	-	68.2	-7.63	217	248	V

* - indicates frequency in CFR47 Pt 15 / IC RSS-Restricted Band
 PK-U - U-NII: Maximum Peak

MID CHANNEL HORIZONTAL

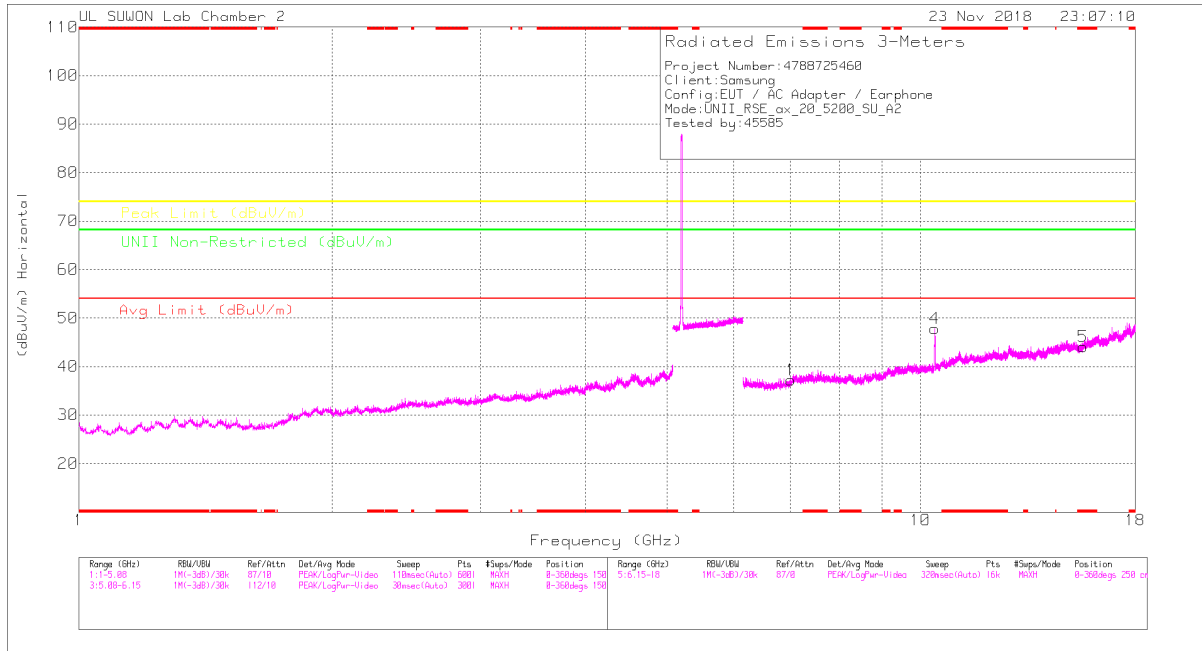

MID CHANNEL VERTICAL

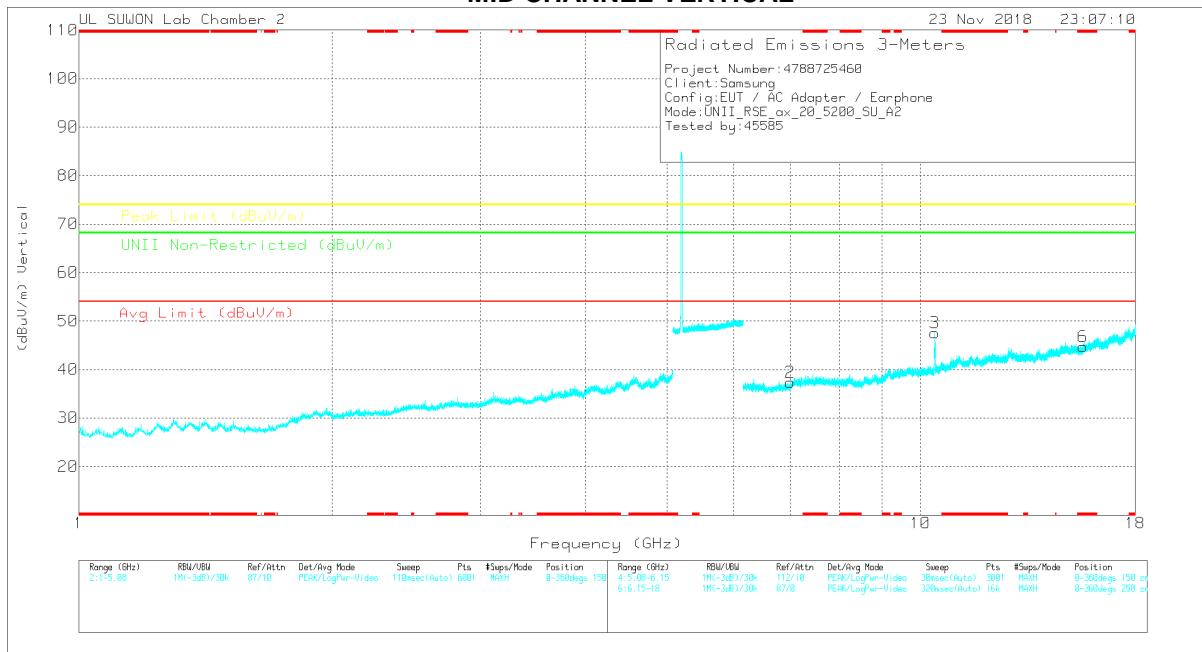

Note: Emission was scanned up to 40GHz; No emissions were detected above the noise floor which was at least 20dB below the specification limit.

MID CHANNEL DATA

Trace Markers

Marker	Frequency (GHz)	Meter Reading (dBuV)	Det	3117_00168724	6GHz_HF(dB)	DC Corr (dB)	Corrected Reading (dBuV/m)	Ag Limit (dBuV/m)	Margin (dB)	Peak Limit (dBuV/m)	Margin (dB)	UNII Non-Restricted (dBuV/m)	Margin (dB)	Asimuth (Degs)	Height (cm)	Polarity
1	7.016	26.81	PK	35.8	-25.4	0	37.21	-	-	-	-	68.2	-30.99	0-360	150	H
4	10.399	31.14	PK	37.6	-20.9	0	47.84	-	-	-	-	68.2	-20.36	0-360	250	H
5	* 15.601	23.84	PK	40	-19.8	0	44.04	-	-	74	-29.96	-	-	0-360	250	H
2	7.002	27.17	PK	35.8	-25.6	0	37.37	-	-	-	-	68.2	-30.83	0-360	150	V
3	10.399	30.84	PK	37.6	-20.9	0	47.54	-	-	-	-	68.2	-20.66	0-360	250	V
6	* 15.601	24.51	PK	40	-19.8	0	44.71	-	-	74	-29.29	-	-	0-360	250	V

* - indicates frequency in CFR47 Pt 15 / IC RSS-Restricted Band
 PK – Peak Detector

Radiated Emissions

Frequency (GHz)	Meter Reading (dBuV)	Det	3117_00168724	6GHz_HF(dB)	DC Corr (dB)	Corrected Reading (dBuV/m)	Ag Limit (dBuV/m)	Margin (dB)	Peak Limit (dBuV/m)	Margin (dB)	UNII Non-Restricted (dBuV/m)	Margin (dB)	Asimuth (Degs)	Height (cm)	Polarity
10.398	44.16	PK-U	37.6	-20.9	0	60.86	-	-	-	-	68.2	-7.34	224	102	H
10.399	44.31	PK-U	37.6	-20.9	0	61.01	-	-	-	-	68.2	-7.19	216	237	V

* - indicates frequency in CFR47 Pt 15 / IC RSS-Restricted Band
 PK-U - U-NII: Maximum Peak

HIGH CHANNEL HORIZONTAL

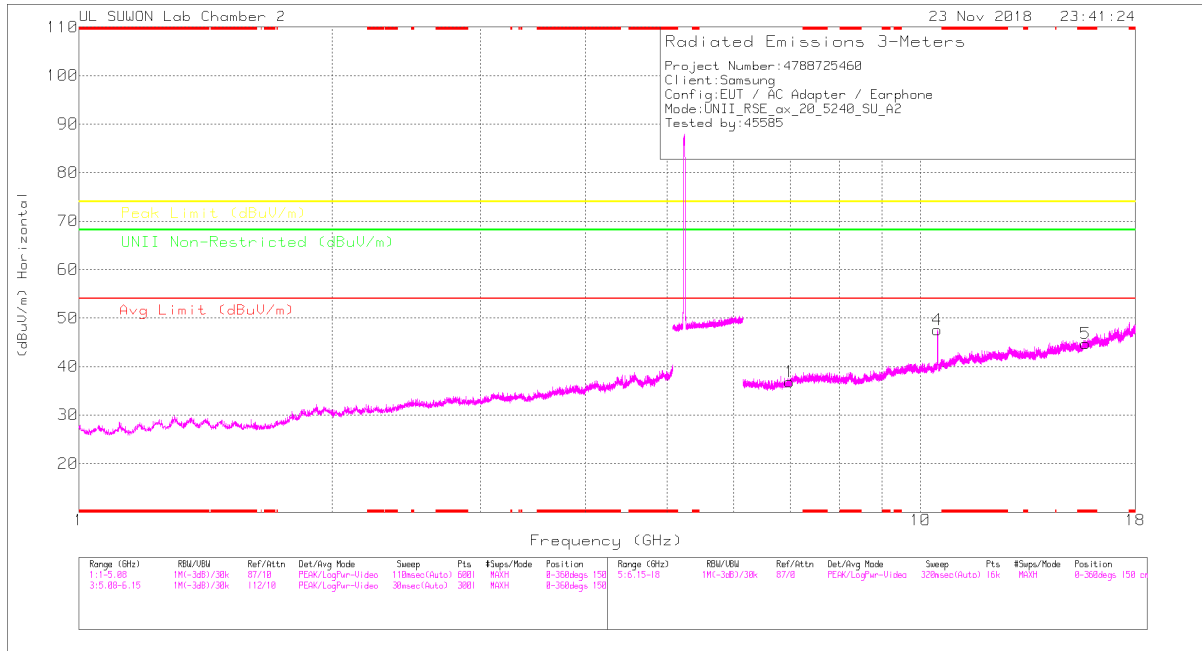

HIGH CHANNEL VERTICAL

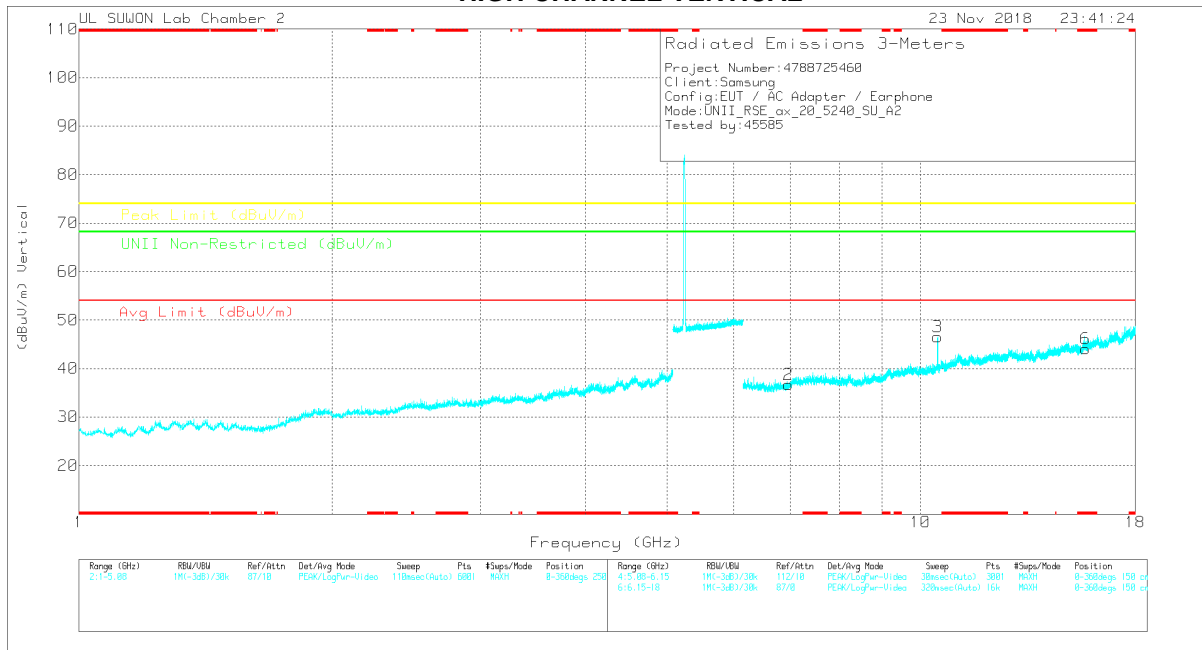

Note: Emission was scanned up to 40GHz; No emissions were detected above the noise floor which was at least 20dB below the specification limit.

HIGH CHANNEL DATA

Trace Markers

Marker	Frequency (GHz)	Meter Reading (dBuV)	Det	3117_00188724	6GHz_H(F)(dB)	DC Corr (dB)	Corrected Reading (dBuV/m)	Aug Limit (dBuV/m)	Margin (dB)	Peak Limit (dBuV/m)	Margin (dB)	UNI Non-Restricted (dBuV/m)	Margin (dB)	Azimuth (Degs)	Height (cm)	Polarity
1	6.993	26.71	PK	35.8	-25.7	0	36.81	-	-	-	-	68.2	-31.39	0-360	150	H
4	10.478	30.62	PK	37.7	-20.8	0	47.52	-	-	-	-	68.2	-20.68	0-360	250	H
5	* 15.72	24.02	PK	40.2	-19.5	0	44.72	-	-	74	-29.28	-	-	0-360	150	H
2	6.963	26.42	PK	35.8	-25.5	0	36.72	-	-	-	-	68.2	-31.48	0-360	250	V
3	10.479	29.63	PK	37.7	-20.8	0	46.53	-	-	-	-	68.2	-21.67	0-360	250	V
6	* 15.72	23.32	PK	40.2	-19.5	0	44.02	-	-	74	-29.98	-	-	0-360	250	V

* - indicates frequency in CFR47 Pt 15 / IC RSS-Restricted Band
 PK – Peak Detector

Radiated Emissions

Frequency (GHz)	Meter Reading (dBuV)	Det	3117_00188724	6GHz_H(F)(dB)	DC Corr (dB)	Corrected Reading (dBuV/m)	Aug Limit (dBuV/m)	Margin (dB)	Peak Limit (dBuV/m)	Margin (dB)	UNI Non-Restricted (dBuV/m)	Margin (dB)	Azimuth (Degs)	Height (cm)	Polarity
10.476	43.68	PK-U	37.7	-20.7	0	60.68	-	-	-	-	68.2	-7.52	228	100	H
10.473	41.6	PK-U	37.7	-20.8	0	58.5	-	-	-	-	68.2	-9.7	222	239	V

* - indicates frequency in CFR47 Pt 15 / IC RSS-Restricted Band
 PK-U - U-NII: Maximum Peak

HE40 SU mode (ANT_1)

LOW CHANNEL HORIZONTAL

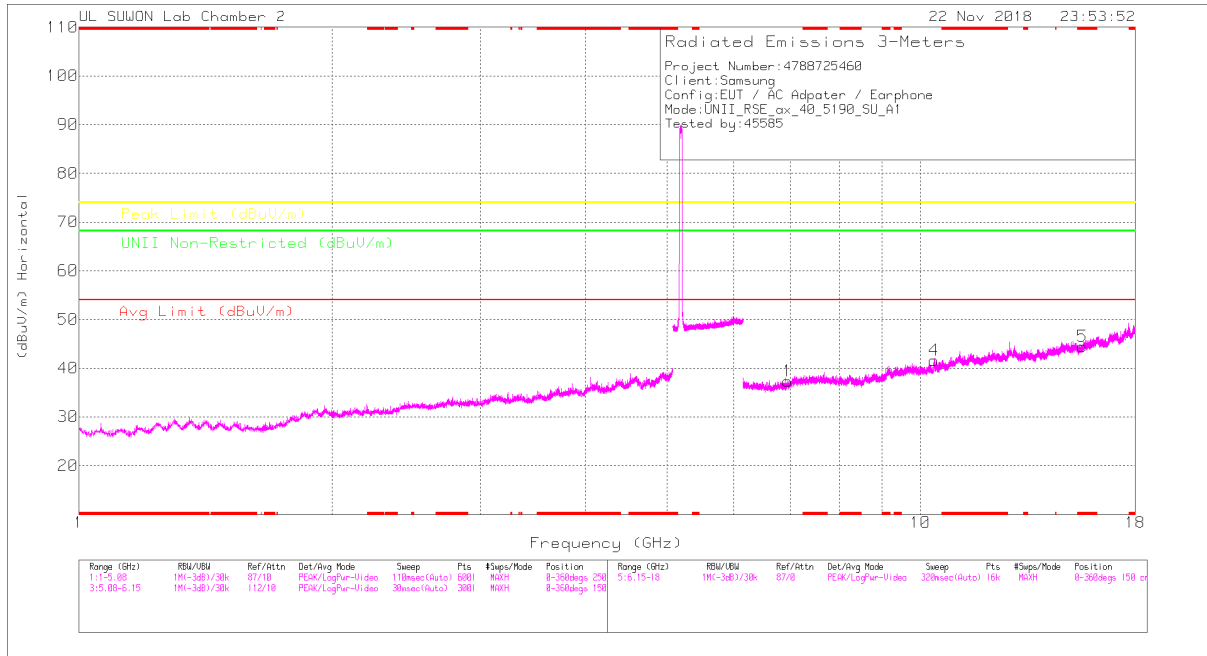

LOW CHANNEL VERTICAL

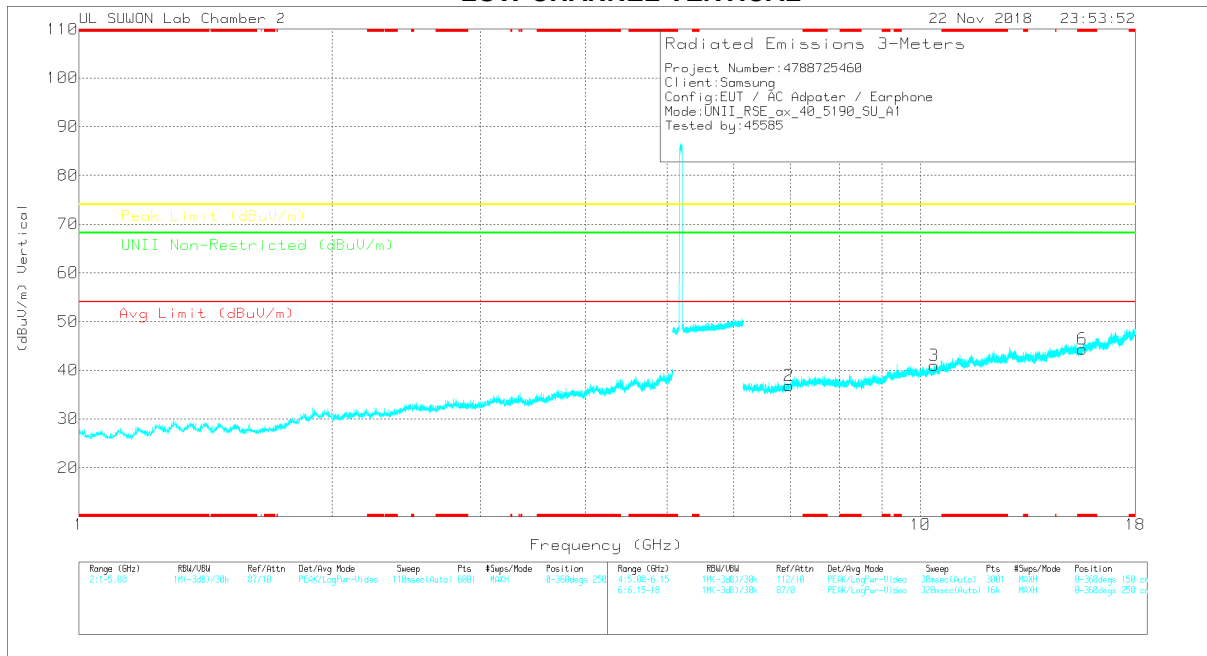

Note: Emission was scanned up to 40GHz; No emissions were detected above the noise floor which was at least 20dB below the specification limit.

LOW CHANNEL DATA

Trace Markers

Marker	Frequency (GHz)	Meter Reading (dBuV)	Det	3117_0018724	6GHz_H(F)(dB)	DC Corr (dB)	Corrected Reading (dBuV/m)	Avg Limit (dBuV/m)	Margin (dB)	Peak Limit (dBuV/m)	Margin (dB)	Limit Non-Restricted (dBuV/m)	Margin (dB)	Azimuth (Degs)	Height (cm)	Polarity
1	6.955	27.03	PK	35.8	-25.5	0	37.33	-	-	-	-	68.2	-30.87	0-360	150	H
4	10.379	24.97	PK	37.6	-21	0	41.57	-	-	-	-	68.2	-26.63	0-360	250	H
5	* 15.573	24.31	PK	40	-19.8	0	44.51	-	-	74	-29.49	-	-	0-360	250	H
2	6.977	26.76	PK	35.8	-25.7	0	36.86	-	-	-	-	68.2	-31.34	0-360	250	V
3	10.379	24.4	PK	37.6	-21	0	41	-	-	-	-	68.2	-27.2	0-360	150	V
6	* 15.569	24	PK	40	-19.7	0	44.3	-	-	74	-29.7	-	-	0-360	150	V

* - indicates frequency in CFR47 Pt 15 / IC RSS-Restricted Band
 PK – Peak Detector

Radiated Emissions

Frequency (GHz)	Meter Reading (dBuV)	Det	3117_0018724	6GHz_H(F)(dB)	DC Corr (dB)	Corrected Reading (dBuV/m)	Avg Limit (dBuV/m)	Margin (dB)	Peak Limit (dBuV/m)	Margin (dB)	Limit Non-Restricted (dBuV/m)	Margin (dB)	Azimuth (Degs)	Height (cm)	Polarity
10.38	35.41	PK-U	37.6	-21	0	52.01	-	-	-	-	68.2	-16.19	99	247	H
10.399	34.43	PK-U	37.6	-20.9	0	51.13	-	-	-	-	68.2	-17.07	182	214	V

* - indicates frequency in CFR47 Pt 15 / IC RSS-Restricted Band
 PK-U - U-NII: Maximum Peak

HIGH CHANNEL HORIZONTAL

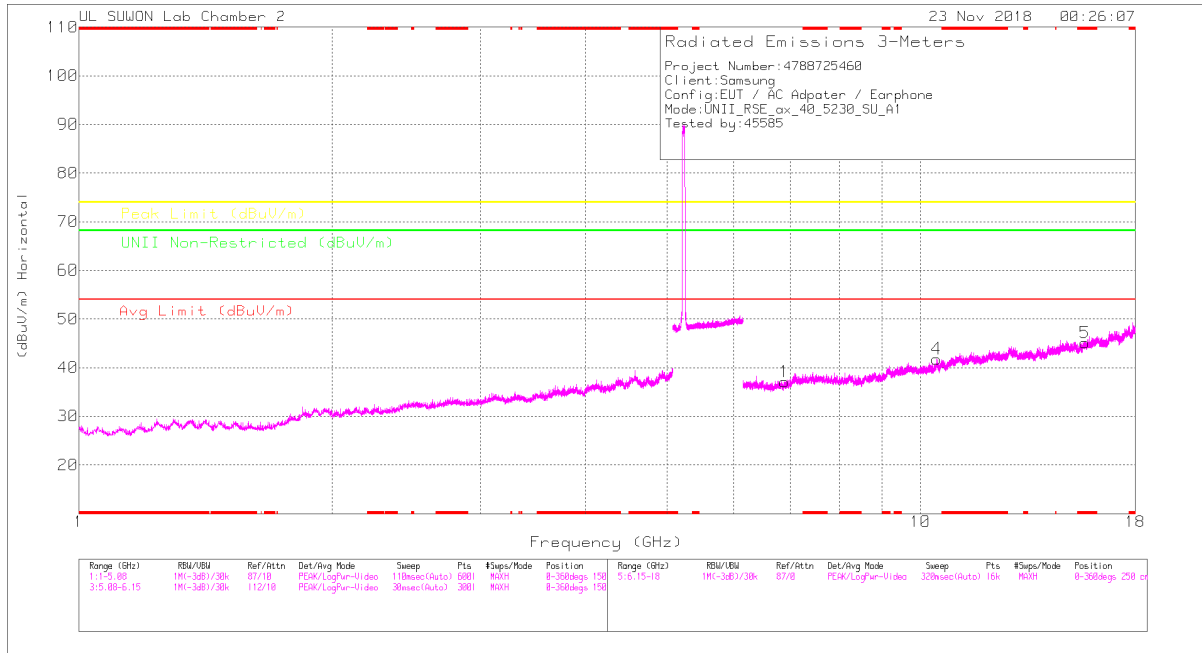

HIGH CHANNEL VERTICAL

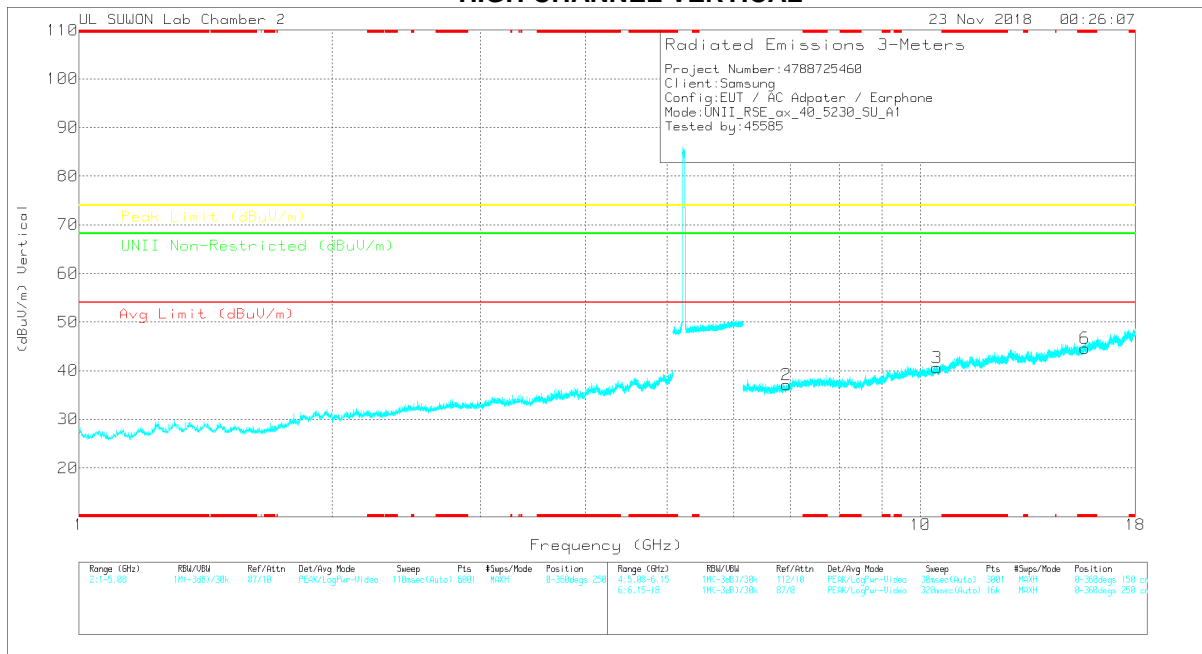

Note: Emission was scanned up to 40GHz; No emissions were detected above the noise floor which was at least 20dB below the specification limit.

HIGH CHANNEL DATA

Trace Markers

Marker	Frequency (GHz)	Major Reading (dBuV)	Det	3117_00188724	66Hz_HR(dB)	DC Corr (dB)	Corrected Reading (dBuV/m)	Avg Limit (dBuV/m)	Margin (dB)	Peak Limit (dBuV/m)	Margin (dB)	Limit Non-Restricted (dBuV/m)	Margin (dB)	Altitude (Degs)	Height (cm)	Polarity
1	6.893	26.49	PK	35.7	-25.1	0	37.09	-	-	-	-	68.2	-31.11	0-360	250	H
4	10.458	24.91	PK	37.6	-20.7	0	41.81	-	-	-	-	68.2	-26.39	0-360	250	H
5	* 15.689	24.7	PK	40.2	-19.8	0	45.1	-	-	74	-28.9	-	-	0-360	150	H
2	6.929	26.75	PK	35.7	-25.3	0	37.15	-	-	-	-	68.2	-31.05	0-360	150	V
3	10.461	23.68	PK	37.6	-20.7	0	40.58	-	-	-	-	68.2	-27.62	0-360	250	V
6	* 15.691	24.19	PK	40.2	-19.8	0	44.59	-	-	74	-29.41	-	-	0-360	150	V

* - indicates frequency in CFR47 Pt 15 / IC RSS-Restricted Band
 PK – Peak Detector

Note: Only peak measurement was performed. Because peak measurement result of unwanted emission is less than average limit (54dBuV/m).

HE40 SU mode (ANT_2)

LOW CHANNEL HORIZONTAL

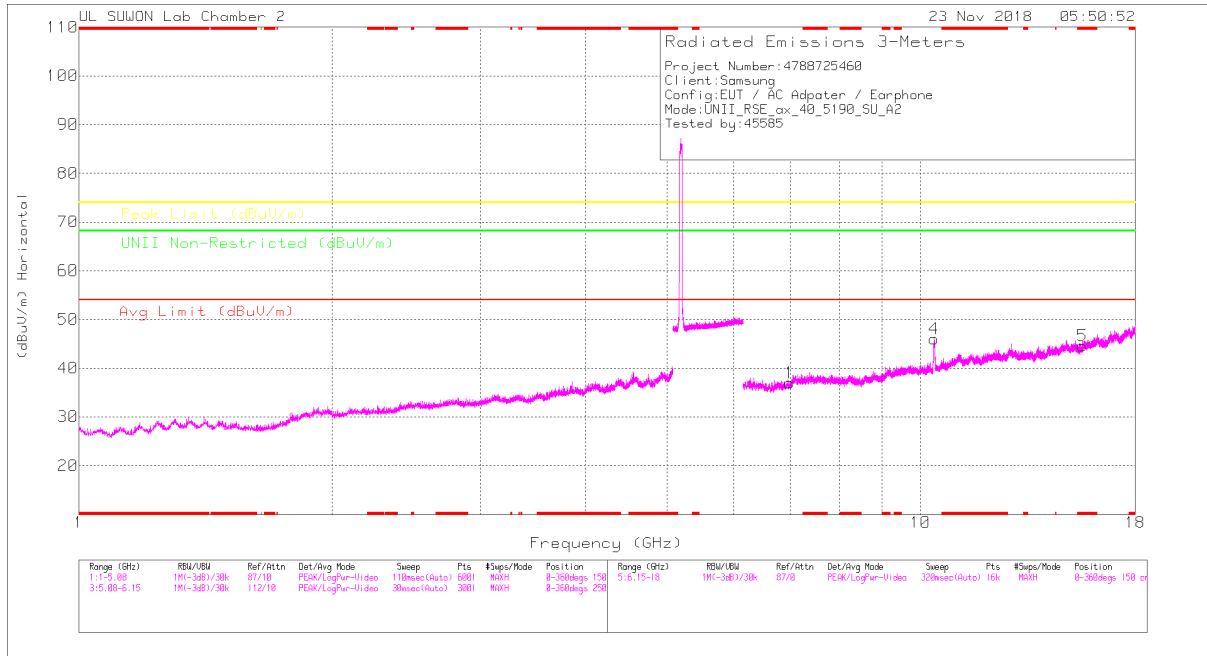

LOW CHANNEL VERTICAL

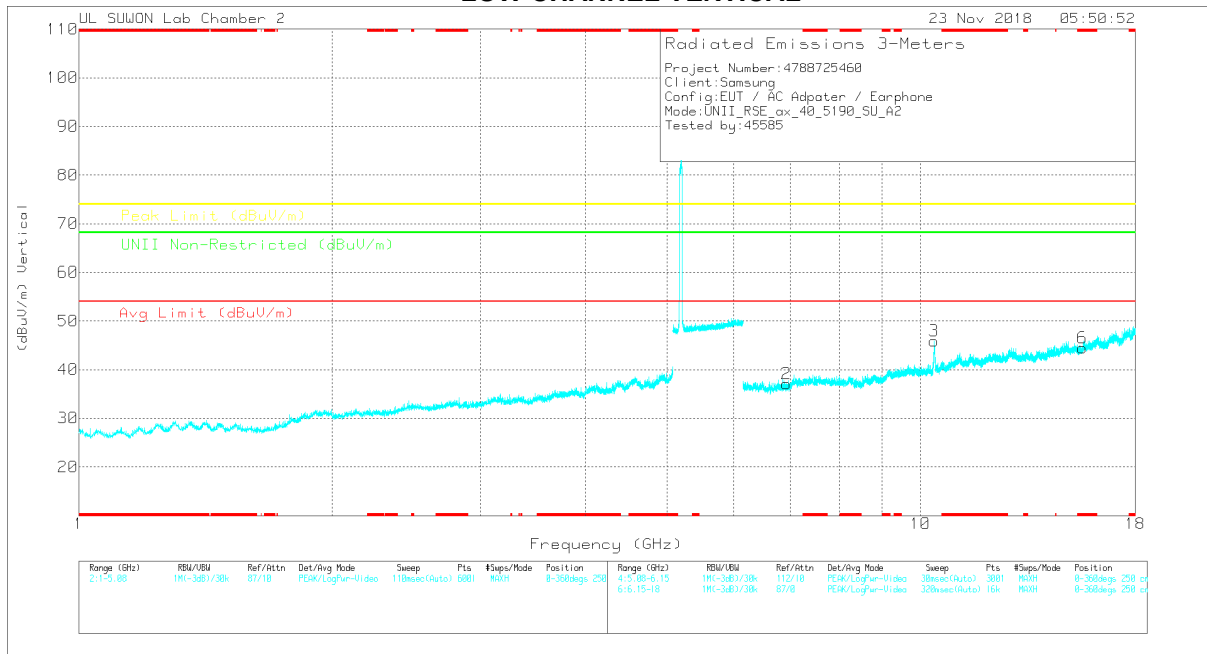

Note: Emission was scanned up to 40GHz; No emissions were detected above the noise floor which was at least 20dB below the specification limit.

LOW CHANNEL DATA

Trace Markers

Marker	Frequency (GHz)	Meter Reading (dBuV)	Det	3117_0018724	6GHz_H(F)(dB)	DC Corr (dB)	Corrected Reading (dBuV/m)	Ag Limit (dBuV/m)	Margin (dB)	Peak Limit (dBuV/m)	Margin (dB)	UNI Non-Restricted (dBuV/m)	Margin (dB)	Azimuth (Degs)	Height (cm)	Polarity
1	6.99	26.9	PK	35.8	-25.7	0	37	-	-	-	-	68.2	-31.2	0-360	150	H
4	10.383	29.42	PK	37.6	-21	0	46.02	-	-	-	-	68.2	-22.18	0-360	150	H
5	* 15.571	24.3	PK	40	-19.7	0	44.6	-	-	74	-29.4	-	-	0-360	250	H
2	6.933	26.75	PK	35.7	-25.3	0	37.15	-	-	-	-	68.2	-31.05	0-360	150	V
3	10.381	29.24	PK	37.6	-21	0	45.84	-	-	-	-	68.2	-22.36	0-360	250	V
6	* 15.573	24.21	PK	40	-19.8	0	44.41	-	-	74	-29.59	-	-	0-360	150	V

* - indicates frequency in CFR47 Pt 15 / IC RSS-Restricted Band
 PK – Peak Detector

Radiated Emissions

Frequency (GHz)	Meter Reading (dBuV)	Det	3117_0018724	6GHz_H(F)(dB)	DC Corr (dB)	Corrected Reading (dBuV/m)	Ag Limit (dBuV/m)	Margin (dB)	Peak Limit (dBuV/m)	Margin (dB)	UNI Non-Restricted (dBuV/m)	Margin (dB)	Azimuth (Degs)	Height (cm)	Polarity
10.378	42.49	PK-U	37.6	-21	0	59.09	-	-	-	-	68.2	-9.11	101	100	H
10.378	42.41	PK-U	37.6	-21	0	59.01	-	-	-	-	68.2	-9.19	215	238	V

* - indicates frequency in CFR47 Pt 15 / IC RSS-Restricted Band
 PK-U - U-NII: Maximum Peak

HIGH CHANNEL HORIZONTAL

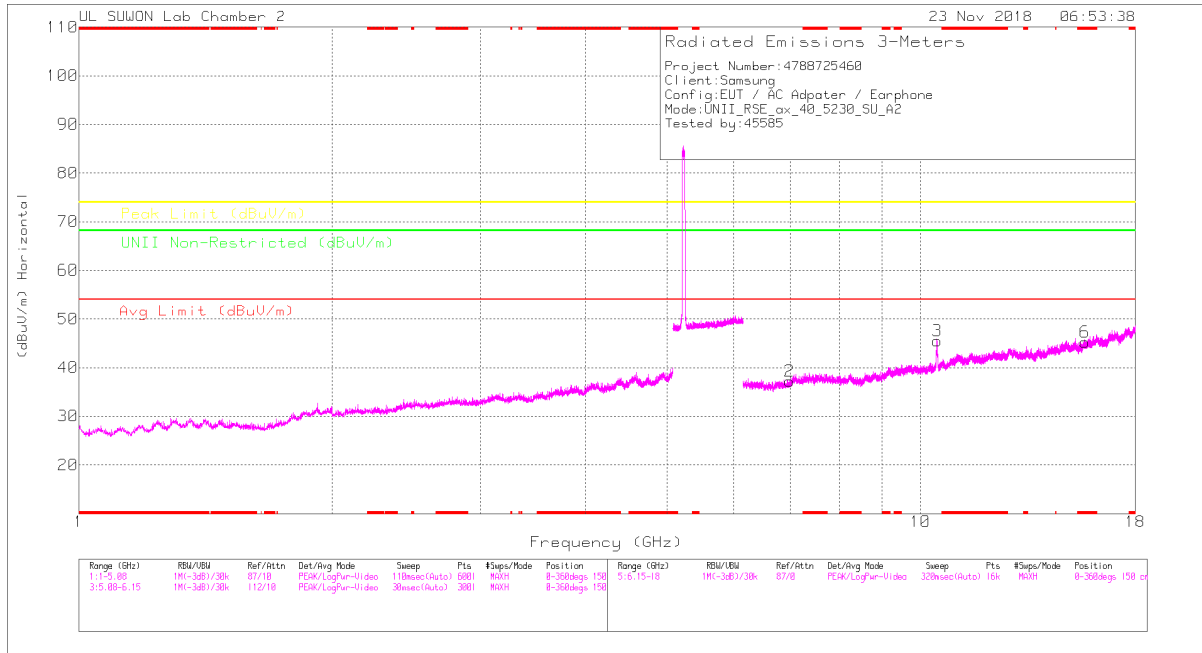

HIGH CHANNEL VERTICAL

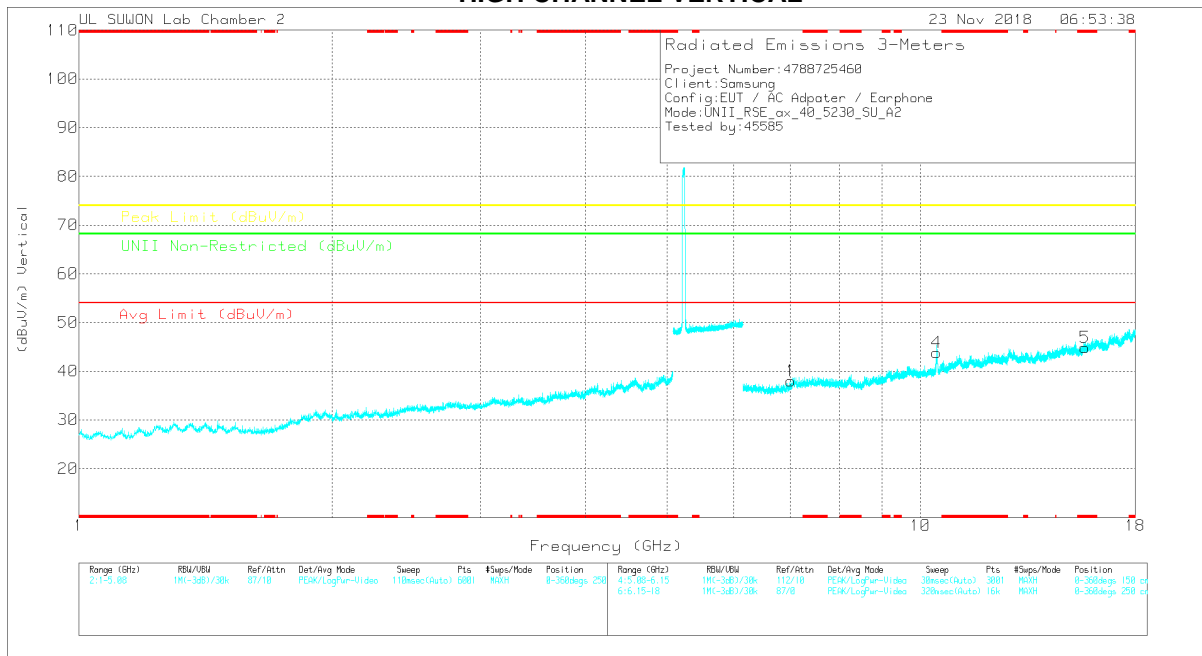

Note: Emission was scanned up to 40GHz; No emissions were detected above the noise floor which was at least 20dB below the specification limit.

HIGH CHANNEL DATA

Trace Markers

Marker	Frequency (GHz)	Meter Reading (dBuV)	Det	3117_0018724	6GHz_H(F)(dB)	DC Corr (dB)	Corrected Reading (dBuV/m)	Avg Limit (dBuV/m)	Margin (dB)	Peak Limit (dBuV/m)	Margin (dB)	Limit Non-Restricted (dBuV/m)	Margin (dB)	Azimuth (Degs)	Height (cm)	Polarity
2	6.986	27.23	PK	35.8	-25.8	0	37.23	-	-	-	-	68.2	-30.97	0-360	250	H
3	10.463	28.59	PK	37.6	-20.7	0	45.49	-	-	-	-	68.2	-22.71	0-360	250	H
6	* 15.691	24.87	PK	40.2	-19.8	0	45.27	-	-	74	-28.73	-	-	0-360	150	H
1	7.016	27.55	PK	35.8	-25.4	0	37.95	-	-	-	-	68.2	-30.25	0-360	150	V
4	10.454	26.87	PK	37.6	-20.7	0	43.77	-	-	-	-	68.2	-24.43	0-360	250	V
5	* 15.693	24.4	PK	40.2	-19.8	0	44.8	-	-	74	-29.2	-	-	0-360	250	V

* - indicates frequency in CFR47 Pt 15 / IC RSS-Restricted Band
 PK – Peak Detector

Radiated Emissions

Frequency (GHz)	Meter Reading (dBuV)	Det	3117_0018724	6GHz_H(F)(dB)	DC Corr (dB)	Corrected Reading (dBuV/m)	Avg Limit (dBuV/m)	Margin (dB)	Peak Limit (dBuV/m)	Margin (dB)	Limit Non-Restricted (dBuV/m)	Margin (dB)	Azimuth (Degs)	Height (cm)	Polarity
10.458	42.34	PK-U	37.6	-20.7	0	59.24	-	-	-	-	68.2	-8.96	230	100	H
10.459	40.21	PK-U	37.6	-20.7	0	57.11	-	-	-	-	68.2	-11.09	225	262	V

* - indicates frequency in CFR47 Pt 15 / IC RSS-Restricted Band
 PK-U - U-NII: Maximum Peak

HE80 SU mode (ANT_1)

MID CHANNEL HORIZONTAL

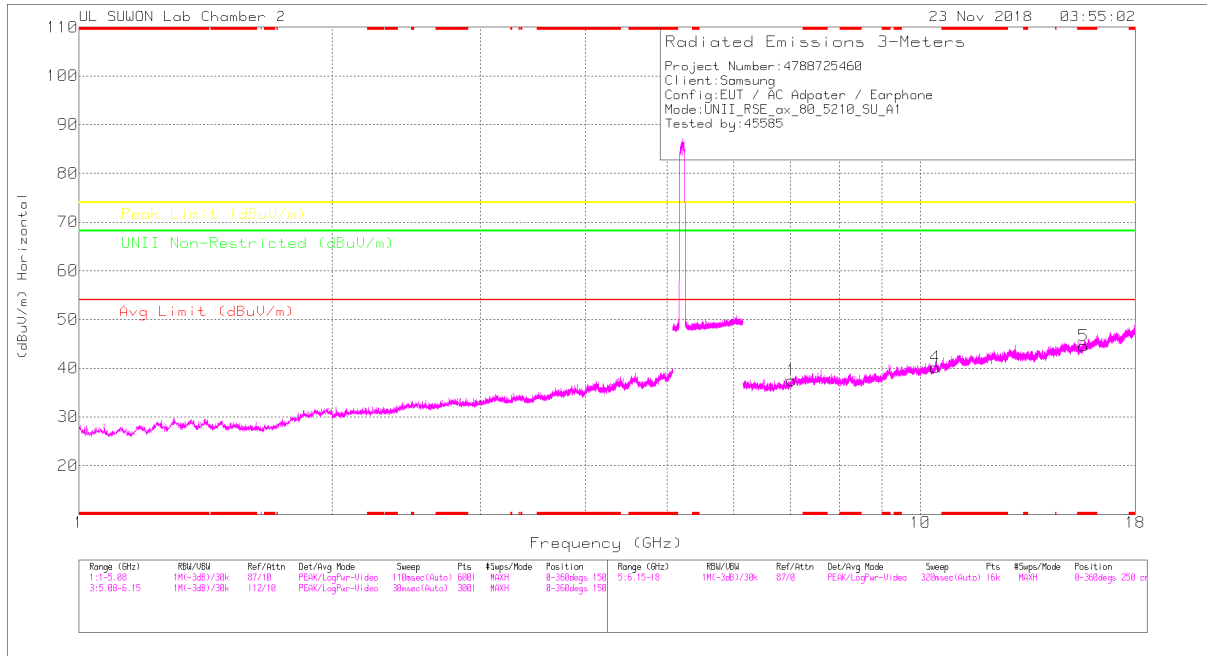

MID CHANNEL VERTICAL

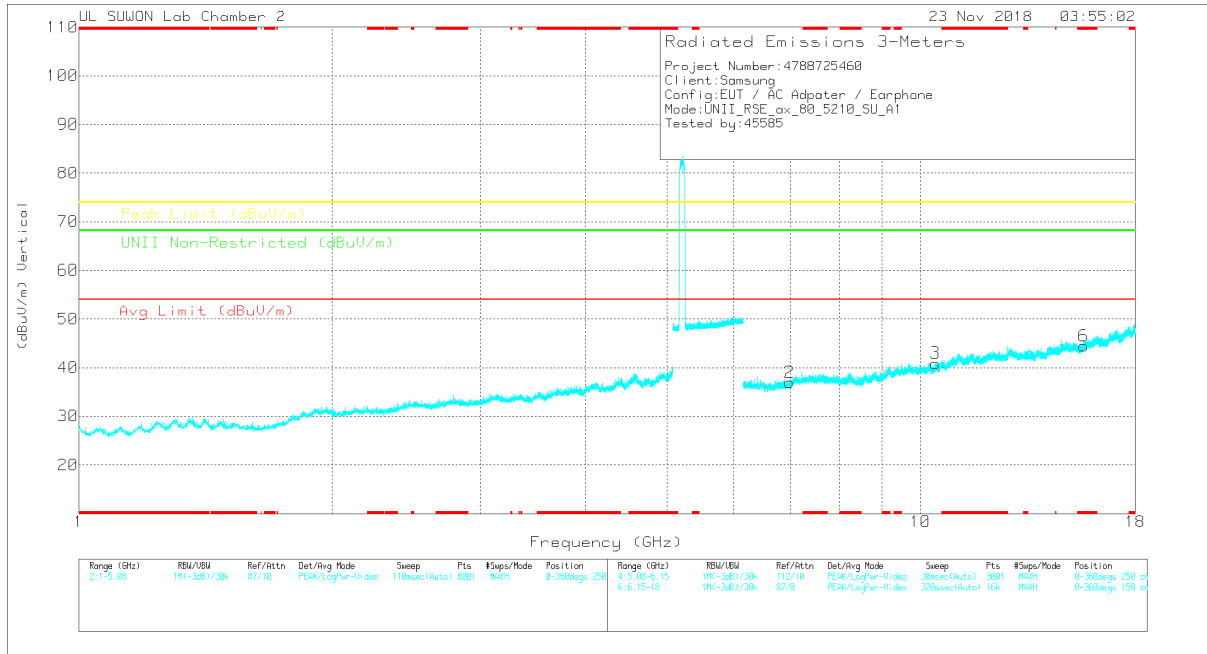

Note: Emission was scanned up to 40GHz; No emissions were detected above the noise floor which was at least 20dB below the specification limit.

MID CHANNEL DATA

Trace Markers

Marker	Frequency (GHz)	Major Reading (dBuV)	Det	3117_00188724	66Hz_HR(dB)	DC Corr (dB)	Corrected Reading (dBuV/m)	Avg Limit (dBuV/m)	Margin (dB)	Peak Limit (dBuV/m)	Margin (dB)	Unit Non-Restricted (dBuV/m)	Margin (dB)	Altitude (Degs)	Height (cm)	Polarity
1	7.025	26.83	PK	35.9	-25.3	0	37.43	-	-	-	-	68.2	-30.77	0-360	150	H
4	10.414	23.47	PK	37.6	-20.9	0	40.17	-	-	-	-	68.2	-28.03	0-360	250	H
5	* 15.631	24.42	PK	40.1	-19.9	0	44.62	-	-	74	-29.38	-	-	0-360	150	H
2	6.994	26.81	PK	35.8	-25.7	0	36.91	-	-	-	-	68.2	-31.29	0-360	250	V
3	10.415	24.21	PK	37.6	-20.9	0	40.91	-	-	-	-	68.2	-27.29	0-360	150	V
6	* 15.631	24.26	PK	40.1	-19.9	0	44.46	-	-	74	-29.54	-	-	0-360	250	V

* - indicates frequency in CFR47 Pt 15 / IC RSS-Restricted Band
 PK – Peak Detector

Note: Only peak measurement was performed. Because peak measurement result of unwanted emission is less than average limit (54dBuV/m).

HE80 SU mode (ANT_2)

MID CHANNEL HORIZONTAL

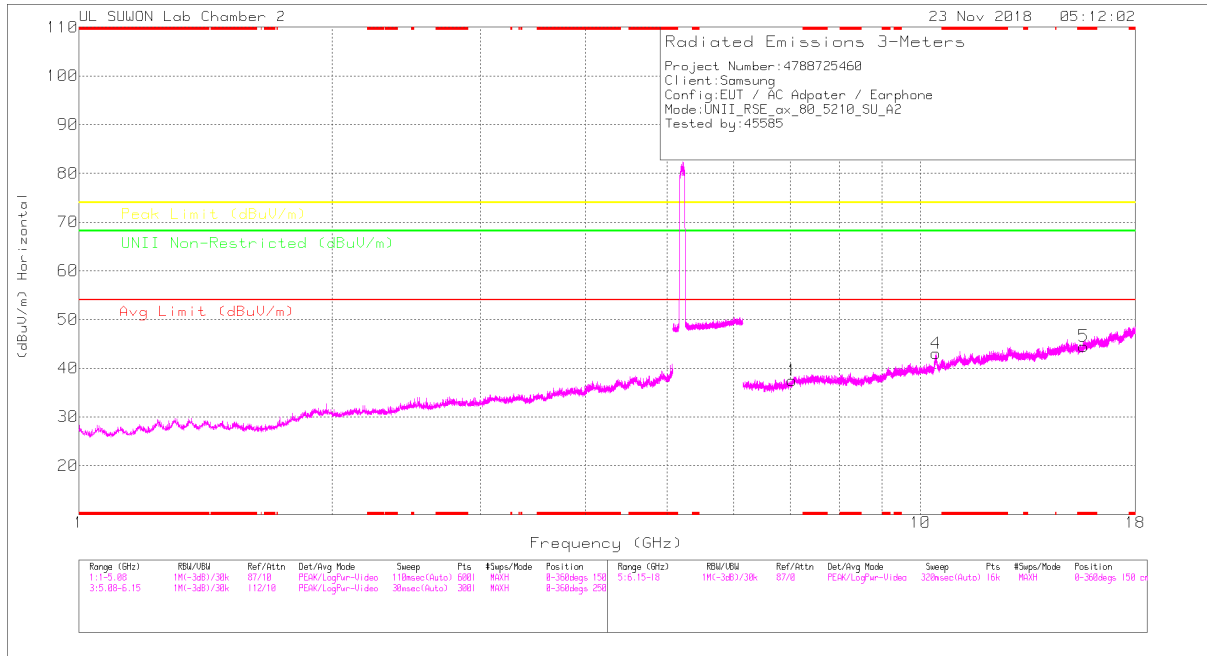

MID CHANNEL VERTICAL

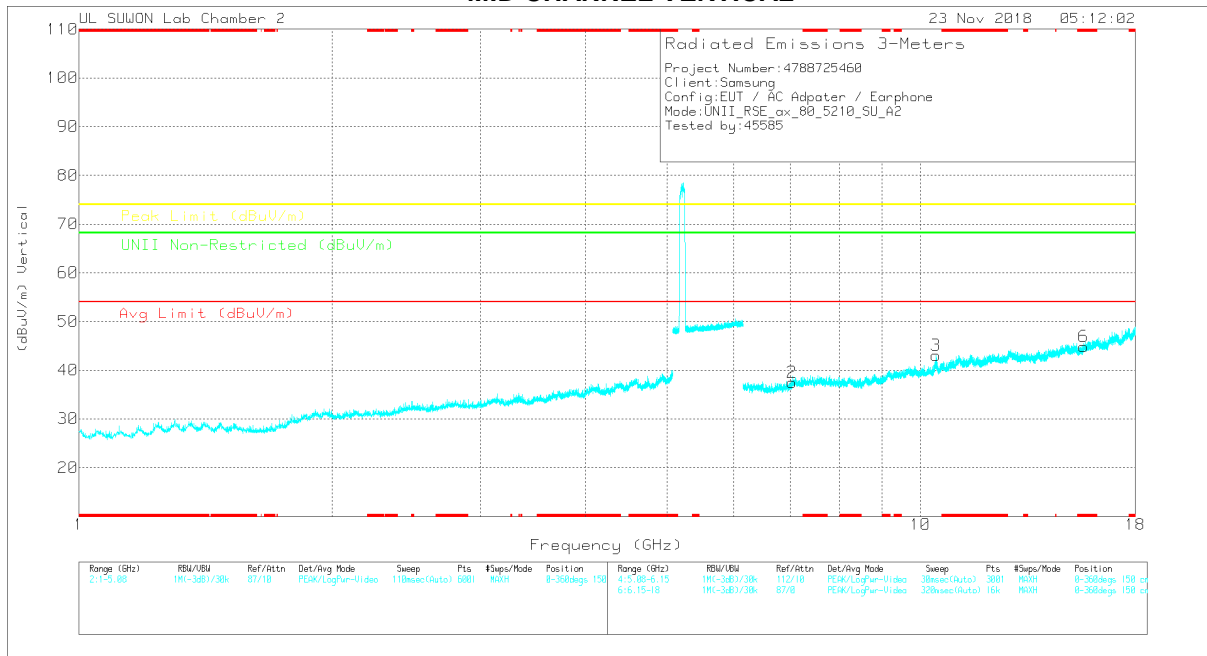

Note: Emission was scanned up to 40GHz; No emissions were detected above the noise floor which was at least 20dB below the specification limit.

MID CHANNEL DATA

Trace Markers

Marker	Frequency (GHz)	Meter Reading (dBuV)	Det	3117_0018724	6GHz_HF(dB)	DC Corr (dB)	Corrected Reading (dBuV/m)	Avg Limit (dBuV/m)	Margin (dB)	Peak Limit (dBuV/m)	Margin (dB)	Limit Non-Restricted (dBuV/m)	Margin (dB)	Azimuth (Degs)	Height (cm)	Polarity
1	7.041	26.5	PK	35.9	-24.9	0	37.5	-	-	-	-	68.2	-30.7	0-360	250	H
4	10.431	26.25	PK	37.6	-20.8	0	43.05	-	-	-	-	68.2	-25.15	0-360	250	H
5	* 15.629	24.23	PK	40.1	-19.8	0	44.53	-	-	74	-29.47	-	-	0-360	150	H
2	7.039	26.53	PK	35.9	-24.9	0	37.53	-	-	-	-	68.2	-30.67	0-360	150	V
3	10.434	26.39	PK	37.6	-20.9	0	43.09	-	-	-	-	68.2	-25.11	0-360	250	V
6	* 15.629	24.53	PK	40.1	-19.8	0	44.83	-	-	74	-29.17	-	-	0-360	150	V

* - indicates frequency in CFR47 Pt 15 / IC RSS-Restricted Band
 PK – Peak Detector

Radiated Emissions

Frequency (GHz)	Meter Reading (dBuV)	Det	3117_0018724	6GHz_HF(dB)	DC Corr (dB)	Corrected Reading (dBuV/m)	Avg Limit (dBuV/m)	Margin (dB)	Peak Limit (dBuV/m)	Margin (dB)	Limit Non-Restricted (dBuV/m)	Margin (dB)	Azimuth (Degs)	Height (cm)	Polarity
10.432	38.98	PK-U	37.6	-20.8	0	55.78	-	-	-	-	68.2	-12.42	105	100	H
10.416	36.55	PK-U	37.6	-20.9	0	53.25	-	-	-	-	68.2	-14.95	219	248	V

* - indicates frequency in CFR47 Pt 15 / IC RSS-Restricted Band
 PK-U - U-NII: Maximum Peak

HE20 RU mode (ANT_1 / 26T / Low: 4, Mid: 0, High: 4)

LOW CHANNEL HORIZONTAL

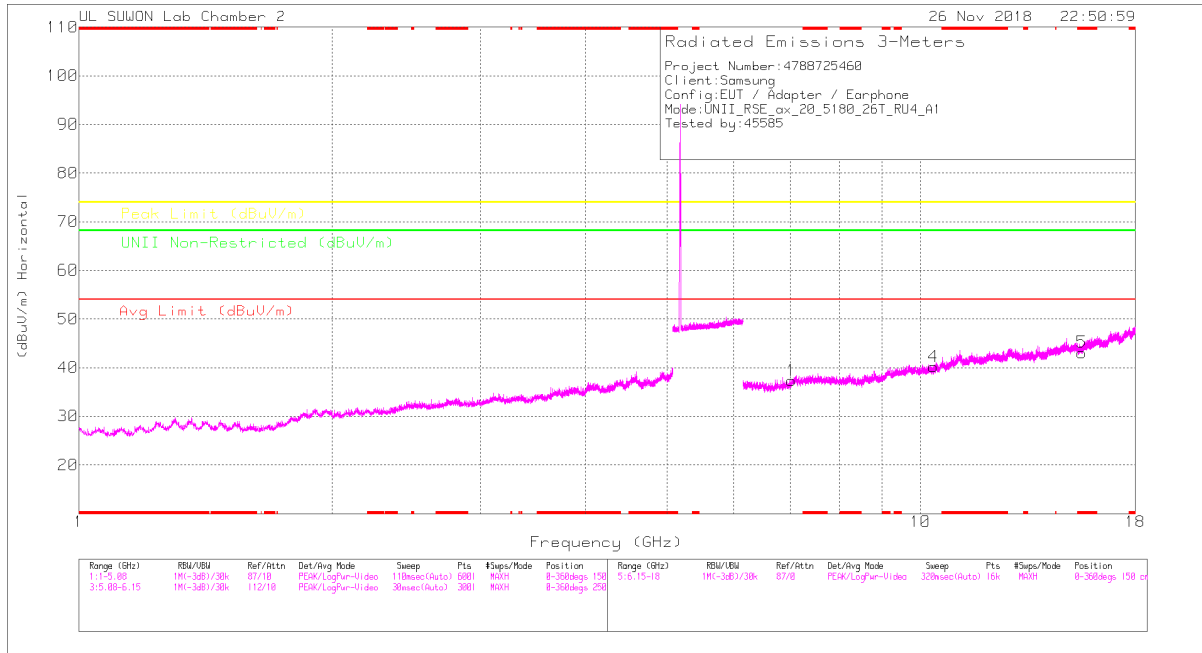

LOW CHANNEL VERTICAL

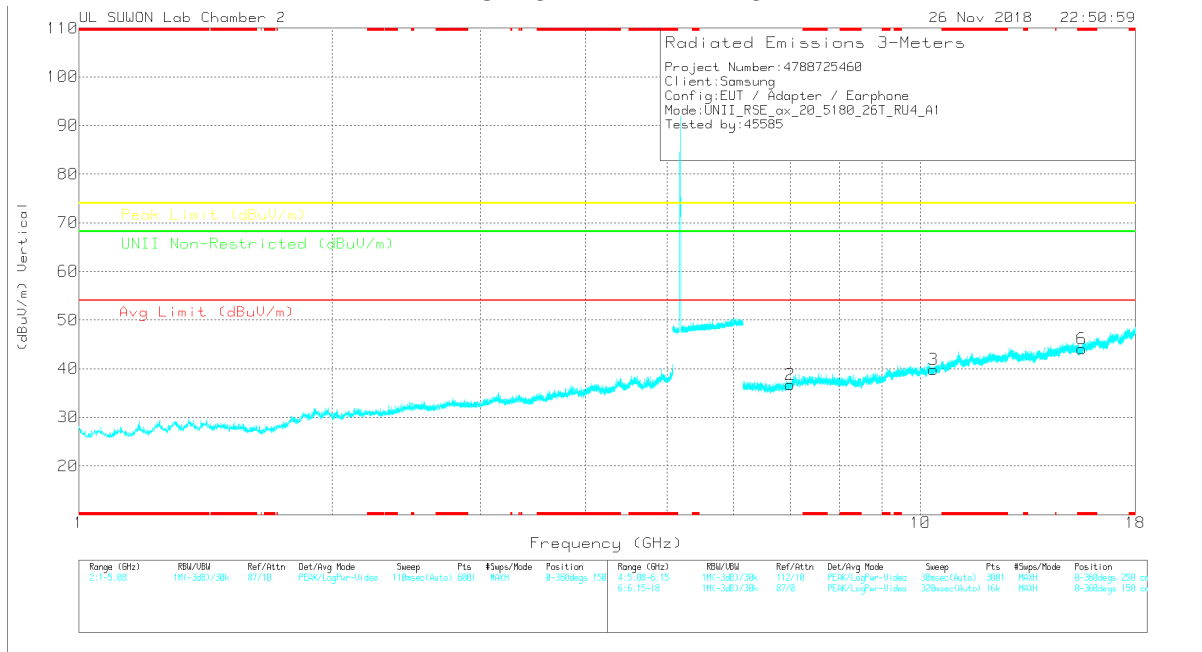

Note: Emission was scanned up to 40GHz; No emissions were detected above the noise floor which was at least 20dB below the specification limit.

LOW CHANNEL DATA

Trace Markers

Marker	Frequency (GHz)	Major Reading (dBuV)	Det	3117_00188724	66Hz_HR(dB)	DC Corr (dB)	Corrected Reading (dBuV/m)	Avg Limit (dBuV/m)	Margin (dB)	Peak Limit (dBuV/m)	Margin (dB)	Unit Non-Restricted (dBuV/m)	Margin (dB)	Altitude (Degs)	Height (cm)	Polarity
1	7.024	26.81	PK	35.9	-25.4	0	37.31	-	-	-	-	68.2	-30.89	0-360	150	H
4	10.36	23.72	PK	37.5	-21	0	40.22	-	-	-	-	68.2	-27.98	0-360	150	H
5	* 15.541	22.91	PK	39.9	-19.7	0	43.11	-	-	74	-30.89	-	-	0-360	250	H
2	7.005	26.51	PK	35.8	-25.6	0	36.71	-	-	-	-	68.2	-31.49	0-360	250	V
3	10.359	23.37	PK	37.5	-21	0	39.87	-	-	-	-	68.2	-28.33	0-360	250	V
6	* 15.541	23.89	PK	39.9	-19.7	0	44.09	-	-	74	-29.91	-	-	0-360	150	V

* - indicates frequency in CFR47 Pt 15 / IC RSS-Restricted Band
 PK – Peak Detector

Note: Only peak measurement was performed. Because peak measurement result of unwanted emission is less than average limit (54dBuV/m).

MID CHANNEL HORIZONTAL

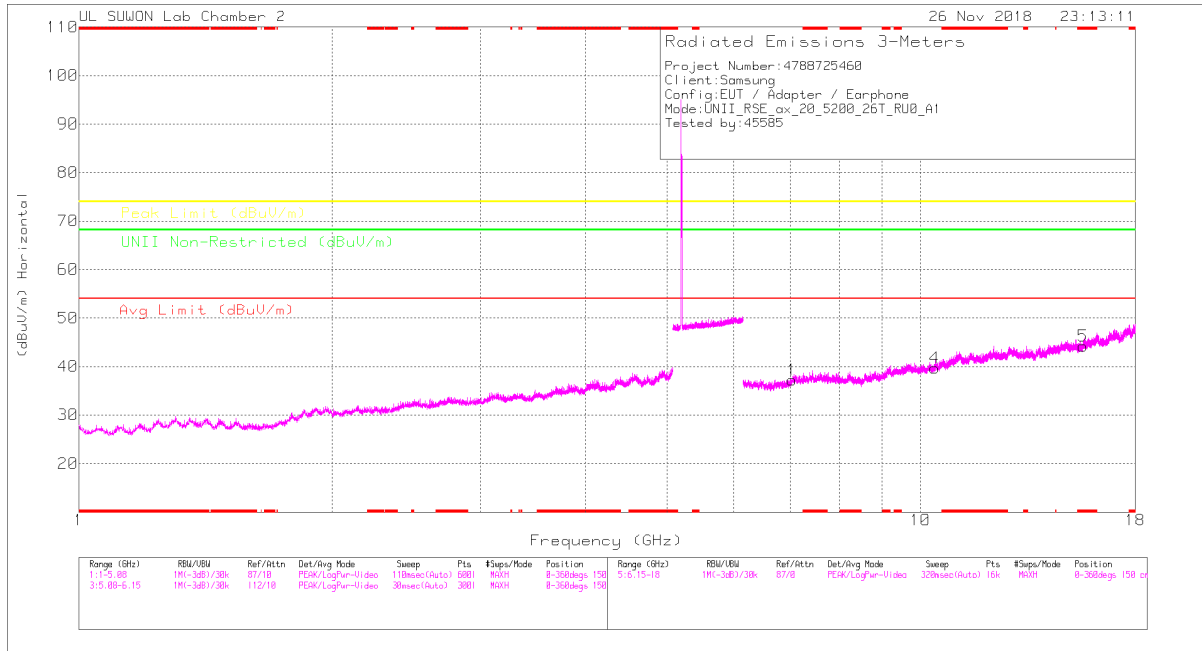

MID CHANNEL VERTICAL

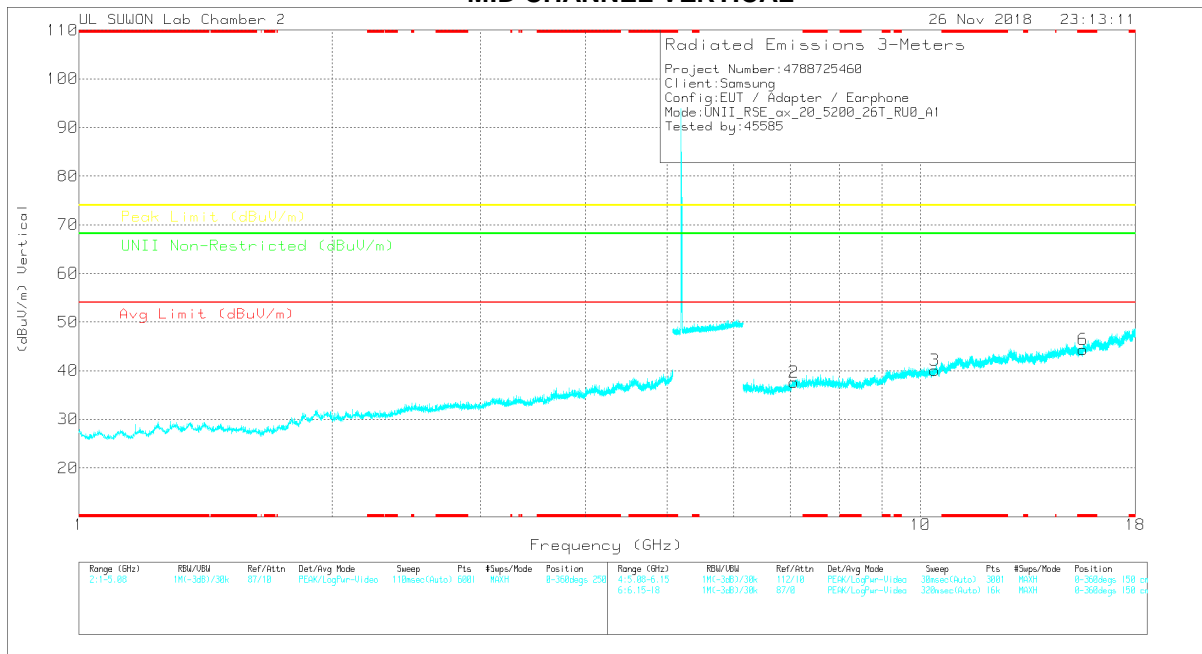

Note: Emission was scanned up to 40GHz; No emissions were detected above the noise floor which was at least 20dB below the specification limit.

MID CHANNEL DATA

Trace Markers

Marker	Frequency (GHz)	Meter Reading (dBuV)	Det	3117_00188724	6GHz_HF[dB]	DC Corr (dB)	Corrected Reading (dBuV/m)	Avg Limit (dBuV/m)	Margin (dB)	Peak Limit (dBuV/m)	Margin (dB)	UNII Non-Restricted (dBuV/m)	Margin (dB)	Asimuth (Degs)	Height (cm)	Polarity
1	7.034	26.36	PK	35.9	-25	0	37.26	-	-	-	-	68.2	-30.94	0-360	250	H
4	10.4	23.13	PK	37.6	-21	0	39.73	-	-	-	-	68.2	-28.47	0-360	250	H
5	* 15.602	23.96	PK	40	-19.8	0	44.16	-	-	74	-29.84	-	-	0-360	250	H
2	7.071	25.72	PK	35.9	-24	0	37.62	-	-	-	-	68.2	-30.58	0-360	150	V
3	10.4	23.42	PK	37.6	-21	0	40.02	-	-	-	-	68.2	-28.18	0-360	250	V
6	* 15.601	24.17	PK	40	-19.8	0	44.37	-	-	74	-29.63	-	-	0-360	150	V

* - indicates frequency in CFR47 Pt 15 / IC RSS-Restricted Band

PK – Peak Detector

Note: Only peak measurement was performed. Because peak measurement result of unwanted emission is less than average limit (54dBuV/m).

HIGH CHANNEL HORIZONTAL

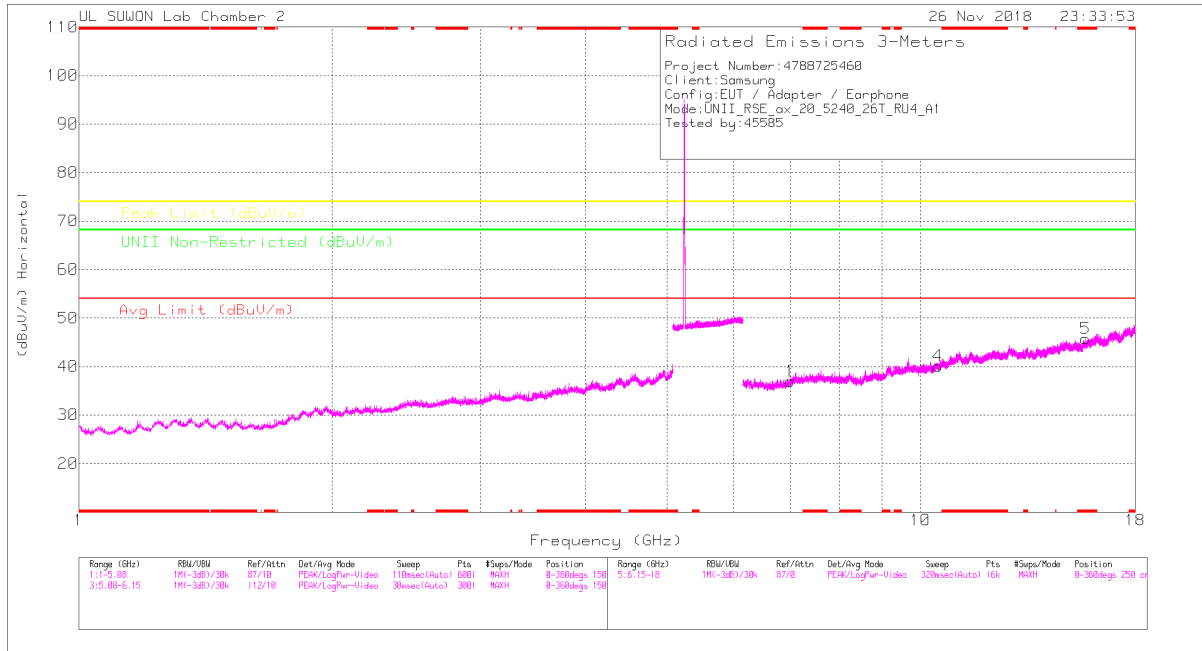

HIGH CHANNEL VERTICAL

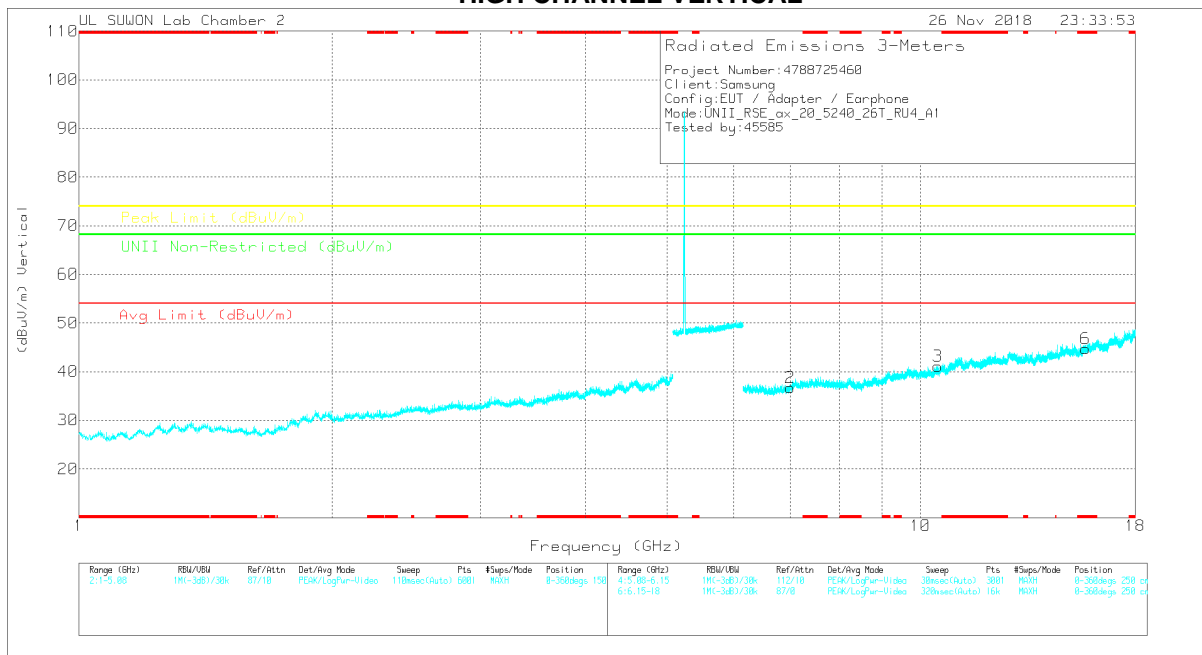

Note: Emission was scanned up to 40GHz; No emissions were detected above the noise floor which was at least 20dB below the specification limit.

HIGH CHANNEL DATA

Trace Markers

Marker	Frequency (GHz)	Marker Reading (dBuV)	Det	3117_00188724	66Hz_HR(dB)	DC Corr (dB)	Corrected Reading (dBuV/m)	Avg Limit (dBuV/m)	Margin (dB)	Peak Limit (dBuV/m)	Margin (dB)	Limit Non-Restricted (dBuV/m)	Margin (dB)	Altitude (Degs)	Height (cm)	Polarity
1	7.001	26.87	PK	35.8	-25.7	0	36.97	-	-	-	-	68.2	-31.23	0-360	250	H
4	10.481	23.23	PK	37.7	-20.8	0	40.13	-	-	-	-	68.2	-28.07	0-360	250	H
5	* 15.722	25.11	PK	40.2	-19.6	0	45.71	-	-	74	-28.29	-	-	0-360	150	H
2	6.999	26.66	PK	35.8	-25.7	0	36.76	-	-	-	-	68.2	-31.44	0-360	150	V
3	10.479	24.18	PK	37.7	-20.8	0	41.08	-	-	-	-	68.2	-27.12	0-360	250	V
6	* 15.72	23.97	PK	40.2	-19.5	0	44.67	-	-	74	-29.33	-	-	0-360	150	V

* - indicates frequency in CFR47 Pt 15 / IC RSS-Restricted Band
 PK – Peak Detector

Note: Only peak measurement was performed. Because peak measurement result of unwanted emission is less than average limit (54dBuV/m).

HE20 RU mode (ANT_2 / 26T / Low: 4, Mid: 0, High: 8)

LOW CHANNEL HORIZONTAL

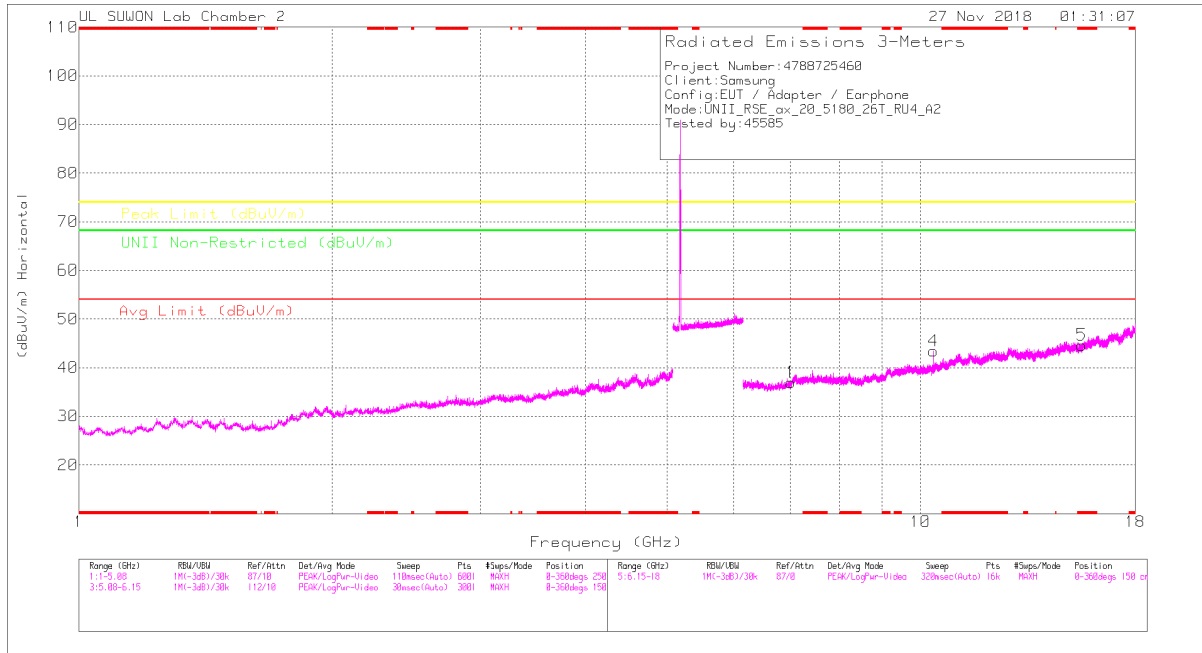

LOW CHANNEL VERTICAL

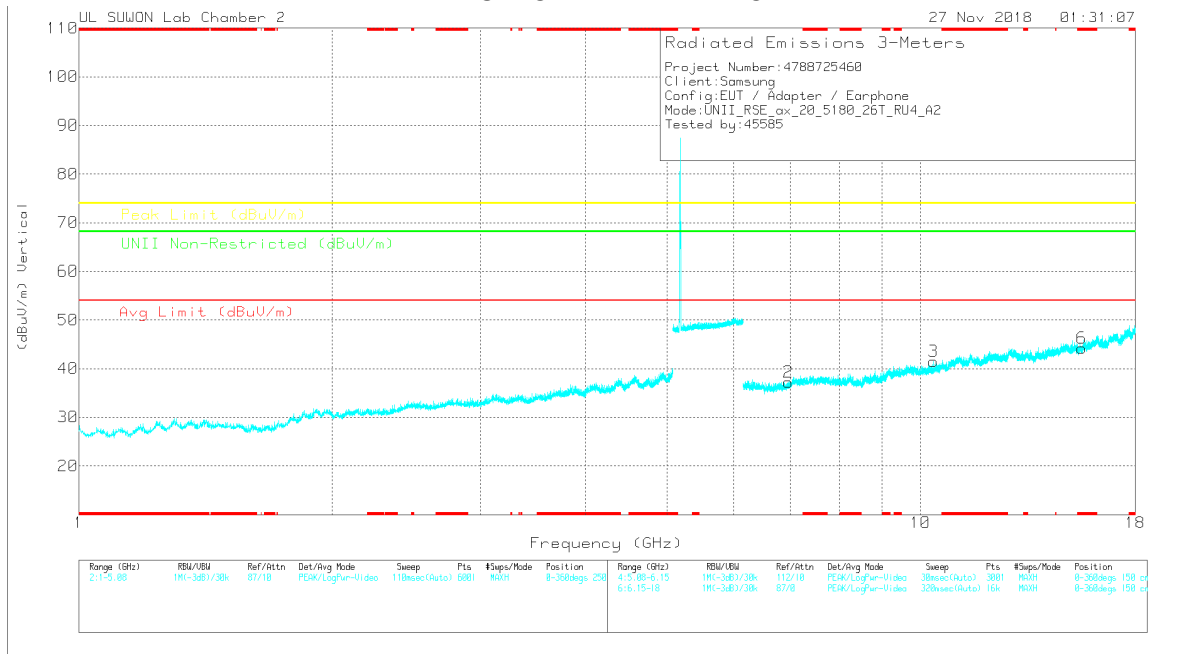

Note: Emission was scanned up to 40GHz; No emissions were detected above the noise floor which was at least 20dB below the specification limit.

LOW CHANNEL DATA

Trace Markers

Marker	Frequency (GHz)	Meter Reading (dBuV)	Det	3117_0018724	6GHz_HF(dB)	DC Corr (dB)	Corrected Reading (dBuV/m)	Ag Limit (dBuV/m)	Margin (dB)	Peak Limit (dBuV/m)	Margin (dB)	UNI Non-Restricted (dBuV/m)	Margin (dB)	Asimuth (Degs)	Height (cm)	Polarity
1	7.011	26.81	PK	35.8	-25.6	0	37.01	-	-	-	-	68.2	-31.19	0-360	150	H
4	10.359	26.99	PK	37.5	-21	0	43.49	-	-	-	-	68.2	-24.71	0-360	250	H
5	* 15.543	24.46	PK	39.9	-19.7	0	44.66	-	-	74	-29.34	-	-	0-360	250	H
2	6.966	26.88	PK	35.8	-25.5	0	37.18	-	-	-	-	68.2	-31.02	0-360	150	V
3	10.36	24.96	PK	37.5	-21	0	41.46	-	-	-	-	68.2	-26.74	0-360	250	V
6	* 15.539	24.12	PK	39.9	-19.8	0	44.22	-	-	74	-29.78	-	-	0-360	250	V

* - indicates frequency in CFR47 Pt 15 / IC RSS-Restricted Band
 PK – Peak Detector

Radiated Emissions

Frequency (GHz)	Meter Reading (dBuV)	Det	3117_0018724	6GHz_HF(dB)	DC Corr (dB)	Corrected Reading (dBuV/m)	Ag Limit (dBuV/m)	Margin (dB)	Peak Limit (dBuV/m)	Margin (dB)	UNI Non-Restricted (dBuV/m)	Margin (dB)	Asimuth (Degs)	Height (cm)	Polarity
10.36	44.22	PK-U	37.5	-21	0	60.72	-	-	-	-	68.2	-7.48	218	108	H
10.359	43.67	PK-U	37.5	-21	0	60.17	-	-	-	-	68.2	-8.03	220	241	V

* - indicates frequency in CFR47 Pt 15 / IC RSS-Restricted Band
 PK-U - U-NII: Maximum Peak

MID CHANNEL HORIZONTAL

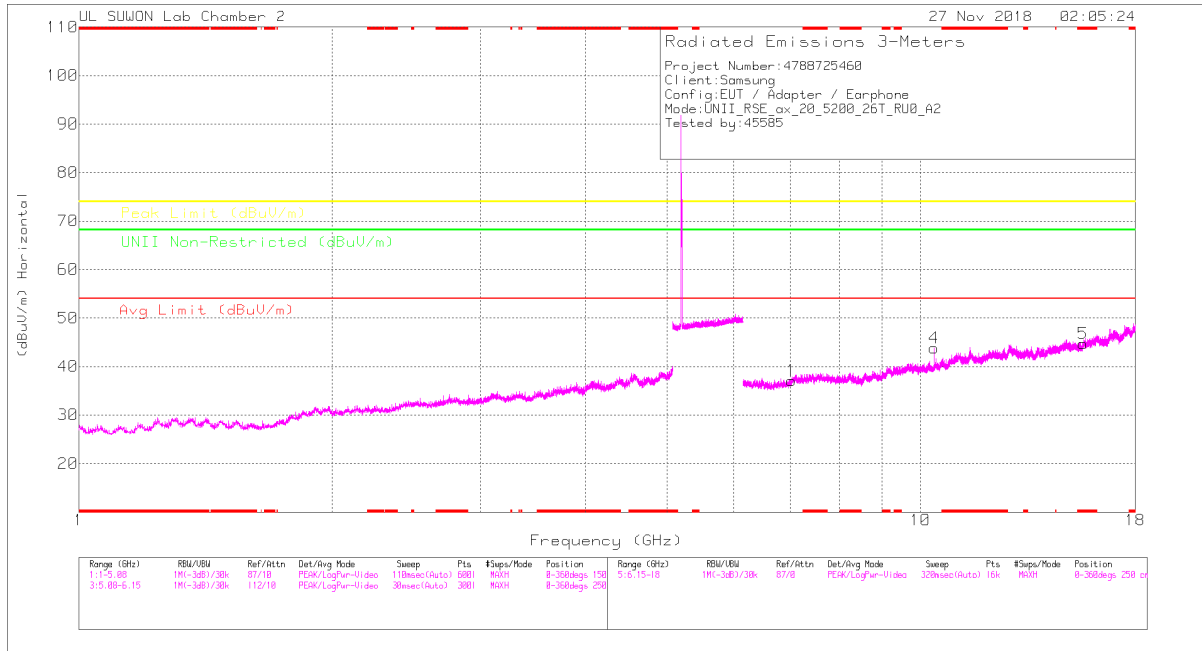

MID CHANNEL VERTICAL

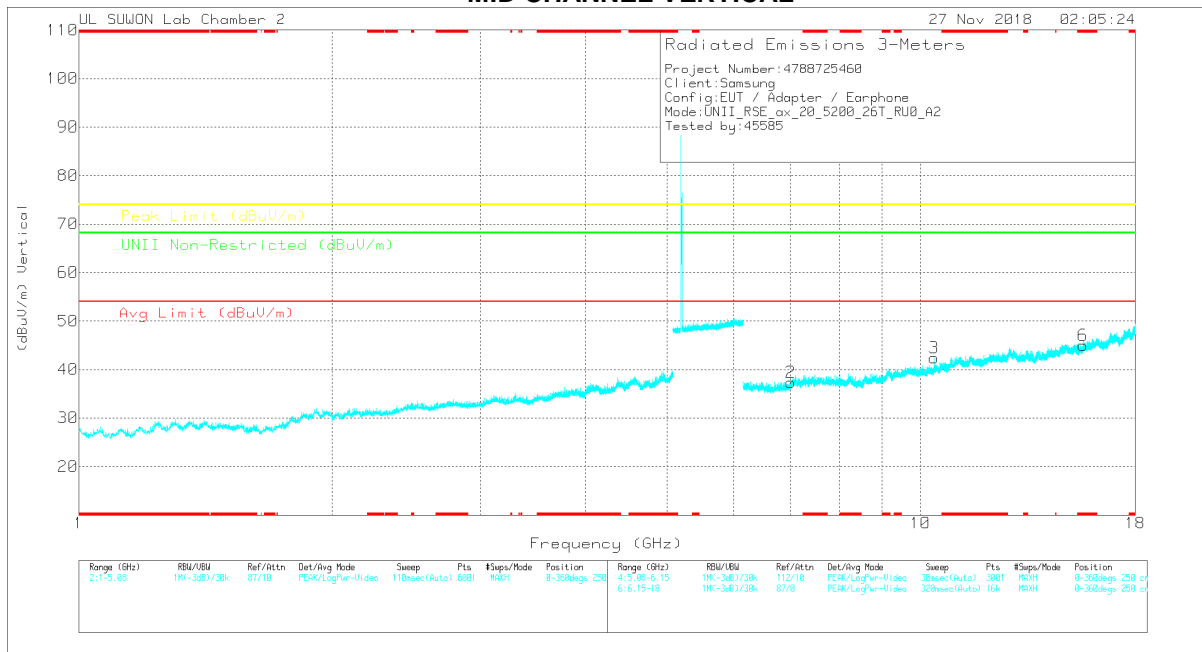

Note: Emission was scanned up to 40GHz; No emissions were detected above the noise floor which was at least 20dB below the specification limit.

MID CHANNEL DATA

Trace Markers

Marker	Frequency (GHz)	Meter Reading (dBuV)	Det	3117_00168724	6GHz_HF[dB]	DC Corr (dB)	Corrected Reading (dBuV/m)	Avg Limit (dBuV/m)	Margin (dB)	Peak Limit (dBuV/m)	Margin (dB)	UNII Non-Restricted (dBuV/m)	Margin (dB)	Asimuth (Degs)	Height (cm)	Polarity
1	7.028	26.35	PK	35.9	-25.2	0	37.05	-	-	-	-	68.2	-31.15	0-360	250	H
4	10.383	27.17	PK	37.6	-21	0	43.77	-	-	-	-	68.2	-24.43	0-360	150	H
5	* 15.6	24.54	PK	40	-19.8	0	44.74	-	-	74	-29.26	-	-	0-360	150	H
2	7.016	27.01	PK	35.8	-25.5	0	37.31	-	-	-	-	68.2	-30.89	0-360	250	V
3	10.383	25.84	PK	37.6	-21	0	42.44	-	-	-	-	68.2	-25.76	0-360	250	V
6	* 15.6	24.76	PK	40	-19.8	0	44.96	-	-	74	-29.04	-	-	0-360	150	V

* - indicates frequency in CFR47 Pt 15 / IC RSS-Restricted Band
 PK – Peak Detector

Radiated Emissions

Frequency (GHz)	Meter Reading (dBuV)	Det	3117_00168724	6GHz_HF[dB]	DC Corr (dB)	Corrected Reading (dBuV/m)	Avg Limit (dBuV/m)	Margin (dB)	Peak Limit (dBuV/m)	Margin (dB)	UNII Non-Restricted (dBuV/m)	Margin (dB)	Asimuth (Degs)	Height (cm)	Polarity
10.383	46.46	PK-U	37.6	-21	0	63.06	-	-	-	-	68.2	-5.14	230	226	H
10.383	45.69	PK-U	37.6	-21	0	62.29	-	-	-	-	68.2	-5.91	220	241	V

* - indicates frequency in CFR47 Pt 15 / IC RSS-Restricted Band
 PK-U - U-NII: Maximum Peak

HIGH CHANNEL HORIZONTAL

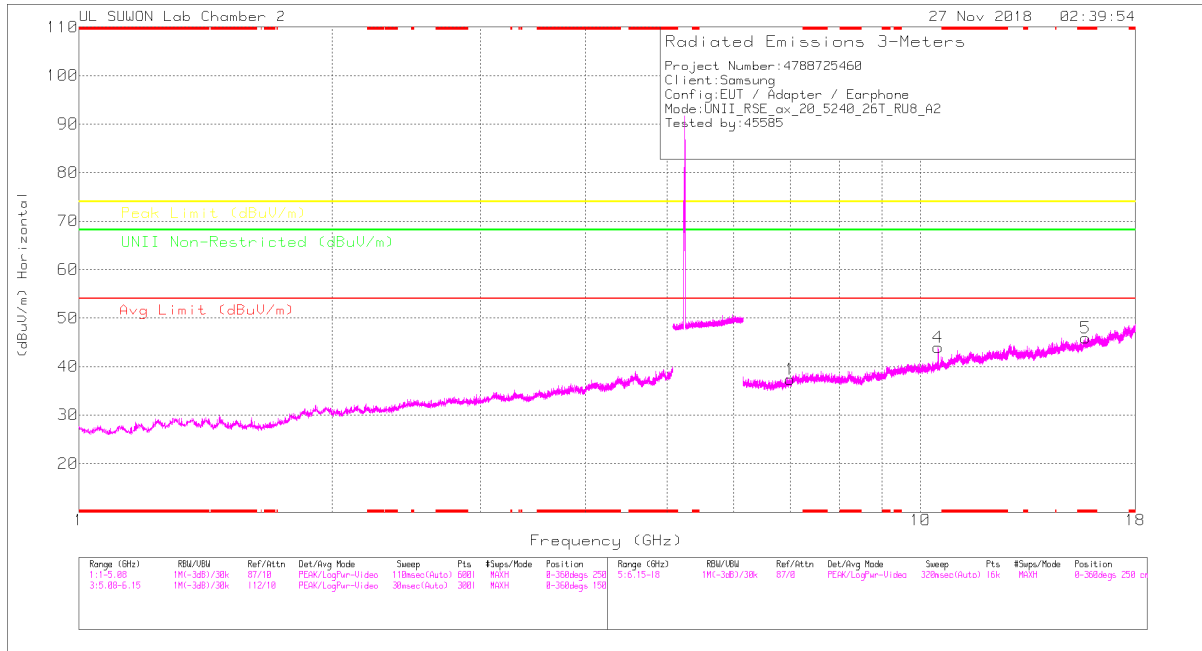

HIGH CHANNEL VERTICAL

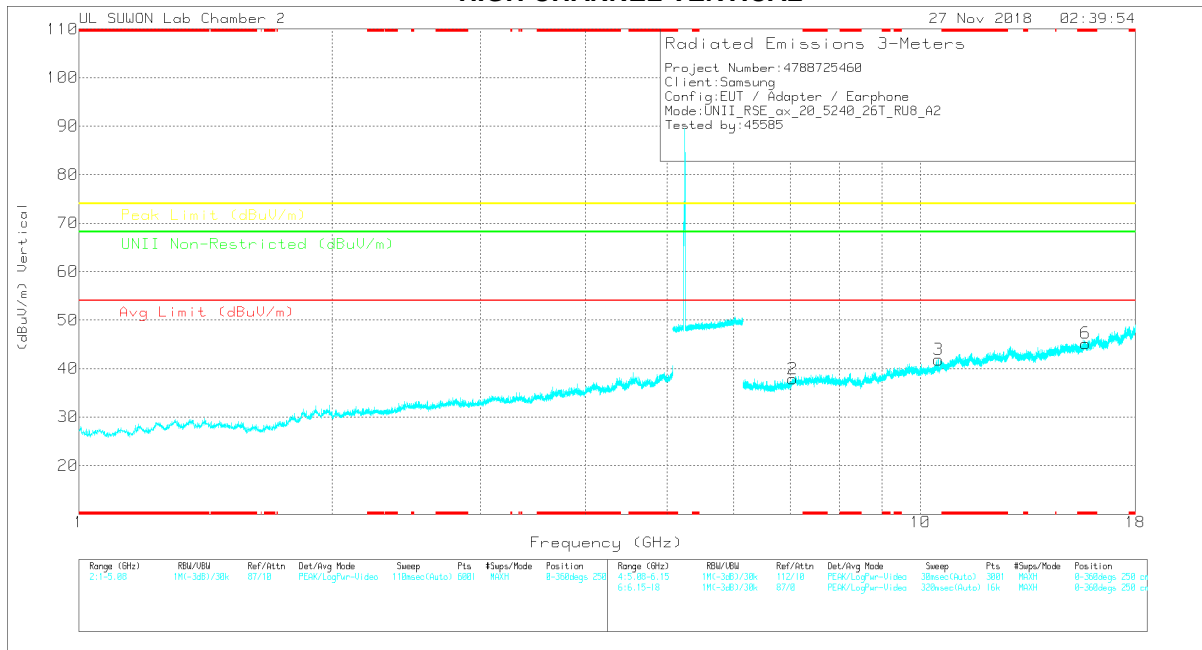

Note: Emission was scanned up to 40GHz; No emissions were detected above the noise floor which was at least 20dB below the specification limit.

HIGH CHANNEL DATA

Trace Markers

Marker	Frequency (GHz)	Meter Reading (dBuV)	Det	3117_0018724	6GHz_HF(dB)	DC Corr (dB)	Corrected Reading (dBuV/m)	Avg Limit (dBuV/m)	Margin (dB)	Peak Limit (dBuV/m)	Margin (dB)	Limit Non-Restricted (dBuV/m)	Margin (dB)	Azimuth (Degs)	Height (cm)	Polarity
1	7.002	27.19	PK	35.8	-25.6	0	37.39	-	-	-	-	68.2	-30.81	0-360	250	H
4	10.496	27	PK	37.7	-20.8	0	43.9	-	-	-	-	68.2	-24.3	0-360	150	H
5	* 15.72	25.2	PK	40.2	-19.5	0	45.9	-	-	74	-28.1	-	-	0-360	150	H
2	7.047	26.68	PK	35.9	-24.7	0	37.88	-	-	-	-	68.2	-30.32	0-360	150	V
3	10.497	24.92	PK	37.7	-20.8	0	41.82	-	-	-	-	68.2	-26.38	0-360	250	V
6	* 15.722	24.58	PK	40.2	-19.6	0	45.18	-	-	74	-28.82	-	-	0-360	150	V

* - indicates frequency in CFR47 Pt 15 / IC RSS-Restricted Band
 PK – Peak Detector

Radiated Emissions

Frequency (GHz)	Meter Reading (dBuV)	Det	3117_0018724	6GHz_HF(dB)	DC Corr (dB)	Corrected Reading (dBuV/m)	Avg Limit (dBuV/m)	Margin (dB)	Peak Limit (dBuV/m)	Margin (dB)	Limit Non-Restricted (dBuV/m)	Margin (dB)	Azimuth (Degs)	Height (cm)	Polarity
10.497	47.38	PK-U	37.7	-20.8	0	64.28	-	-	-	-	68.2	-3.92	226	100	H
10.497	46.54	PK-U	37.7	-20.8	0	63.44	-	-	-	-	68.2	-4.76	218	279	V

* - indicates frequency in CFR47 Pt 15 / IC RSS-Restricted Band
 PK-U - U-NII: Maximum Peak

HE40 RU mode (ANT_1 / 26T / Low: 17, High: 0)

LOW CHANNEL HORIZONTAL

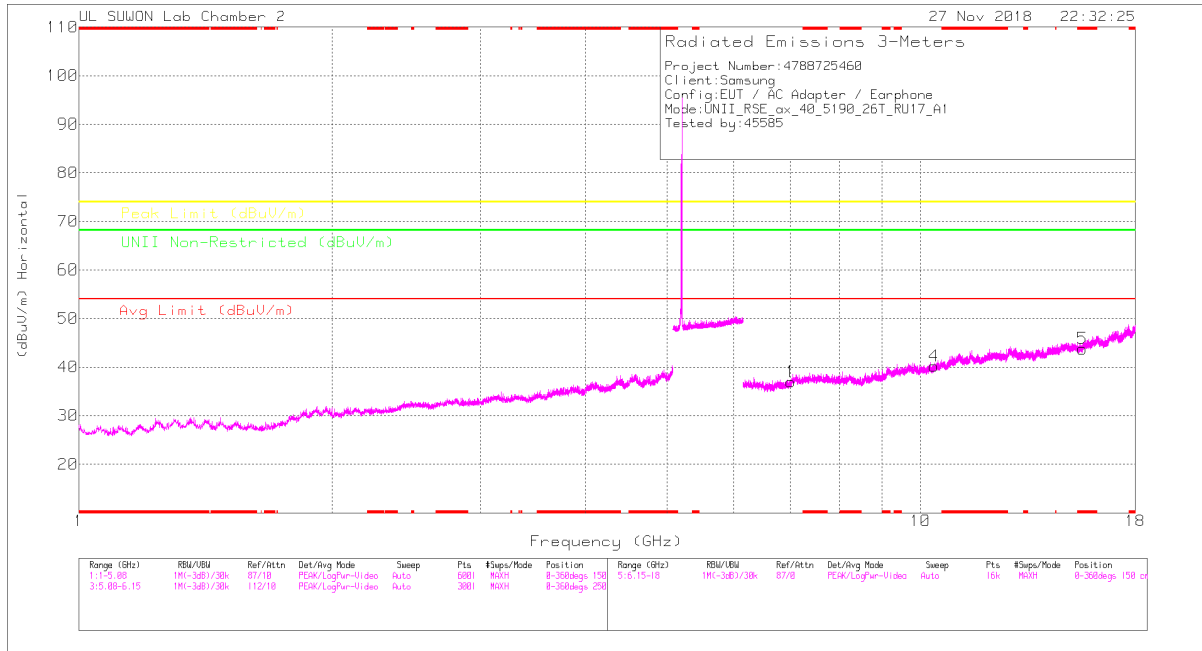

LOW CHANNEL VERTICAL

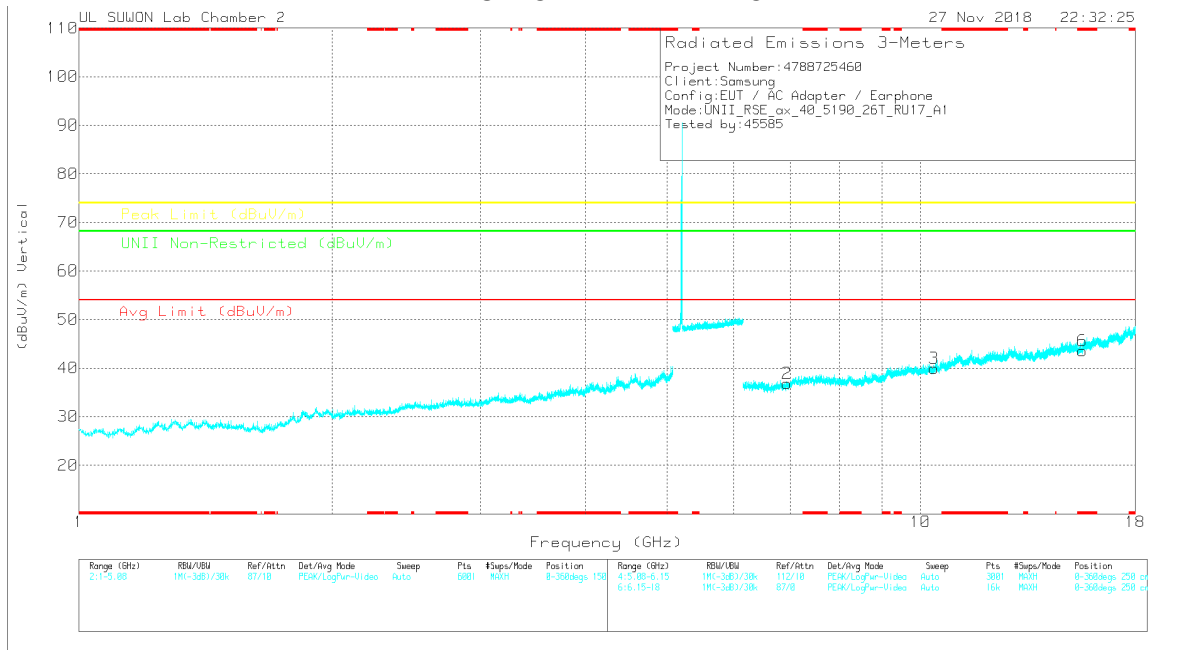

Note: Emission was scanned up to 40GHz; No emissions were detected above the noise floor which was at least 20dB below the specification limit.

LOW CHANNEL DATA

Trace Markers

Marker	Frequency (GHz)	Major Reading (dBuV)	Det	3117_00188724	66Hz_HR(dB)	DC Corr (dB)	Corrected Reading (dBuV/m)	Avg Limit (dBuV/m)	Margin (dB)	Peak Limit (dBuV/m)	Margin (dB)	Limit Non-Restricted (dBuV/m)	Margin (dB)	Altitude (Degs)	Height (cm)	Polarity
1	7.015	26.61	PK	35.8	-25.5	0	36.91	-	-	-	-	68.2	-31.29	0-360	250	H
4	10.381	23.56	PK	37.6	-21	0	40.16	-	-	-	-	68.2	-28.04	0-360	150	H
5	* 15.571	23.46	PK	40	-19.7	0	43.76	-	-	74	-30.24	-	-	0-360	250	H
2	6.944	26.49	PK	35.7	-25.3	0	36.89	-	-	-	-	68.2	-31.31	0-360	150	V
3	10.381	23.29	PK	37.6	-21	0	39.89	-	-	-	-	68.2	-28.31	0-360	150	V
6	* 15.571	23.29	PK	40	-19.7	0	43.59	-	-	74	-30.41	-	-	0-360	250	V

* - indicates frequency in CFR47 Pt 15 / IC RSS-Restricted Band

PK – Peak Detector

Note: Only peak measurement was performed. Because peak measurement result of unwanted emission is less than average limit (54dBuV/m).

HIGH CHANNEL HORIZONTAL

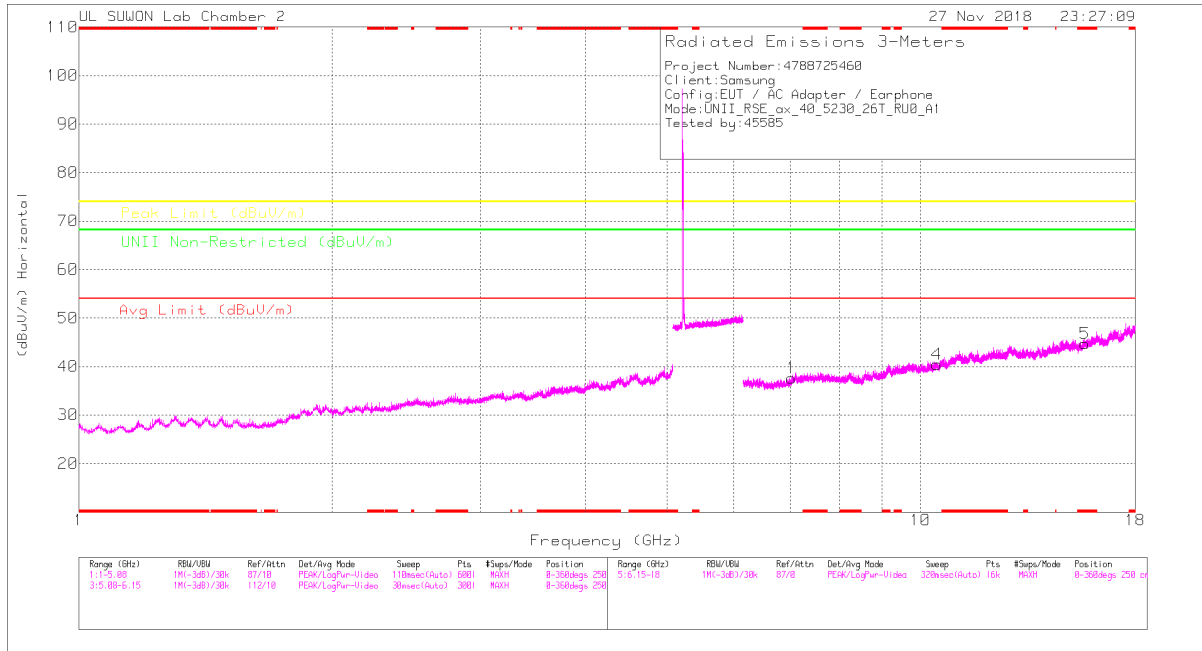

HIGH CHANNEL VERTICAL

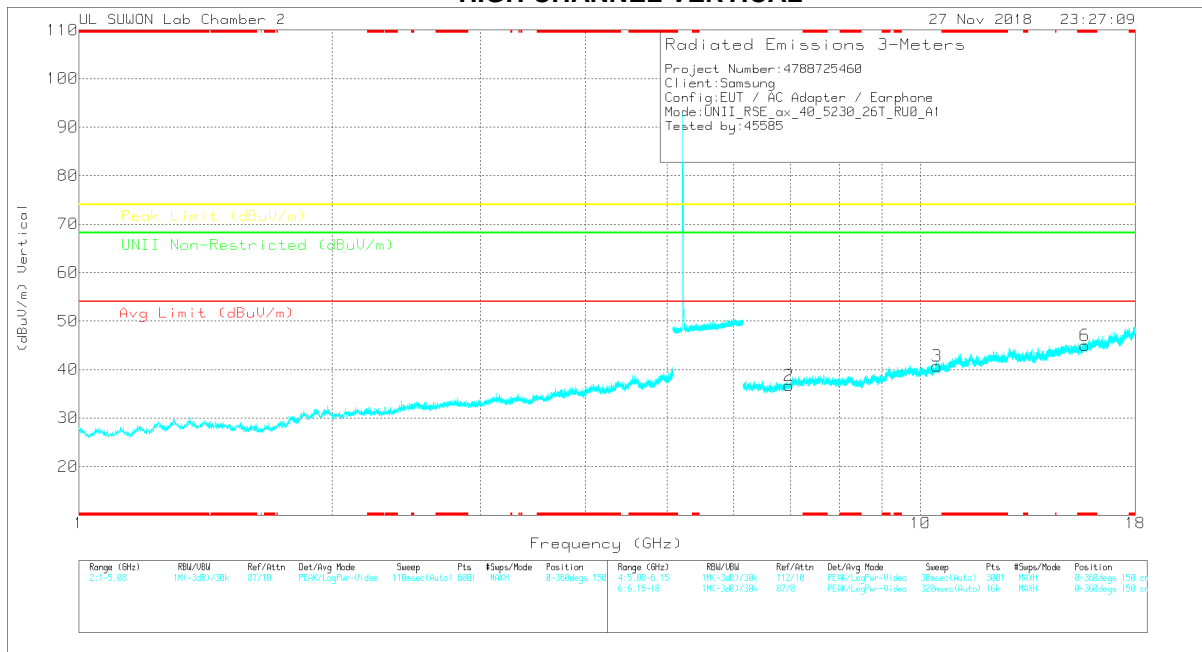

Note: Emission was scanned up to 40GHz; No emissions were detected above the noise floor which was at least 20dB below the specification limit.

HIGH CHANNEL DATA

Trace Markers

Marker	Frequency (GHz)	Marker Reading (dBuV)	Det	3117_00168724	66GHz_HP[dB]	DC Corr (dB)	Corrected Reading (dBuV/m)	Aug Limit (dBuV/m)	Margin (dB)	Peak Limit (dBuV/m)	Margin (dB)	Unit Non-Restricted (dBuV/m)	Margin (dB)	Azimuth (Degs)	Height (cm)	Polarity
1	7.024	27.08	PK	35.9	-25.4	0	37.58	-	-	-	-	68.2	-30.62	0-360	150	H
4	10.461	23.6	PK	37.6	-20.7	0	40.5	-	-	-	-	68.2	-27.7	0-360	250	H
5	* 15.69	24.32	PK	40.2	-19.8	0	44.72	-	-	74	-29.28	-	-	0-360	250	H
2	6.982	26.65	PK	35.8	-25.7	0	36.75	-	-	-	-	68.2	-31.45	0-360	250	V
3	10.461	23.83	PK	37.6	-20.7	0	40.73	-	-	-	-	68.2	-27.47	0-360	150	V
6	* 15.69	24.64	PK	40.2	-19.8	0	45.04	-	-	74	-28.96	-	-	0-360	150	V

* - indicates frequency in CFR47 Pt 15 / IC RSS-Restricted Band

PK – Peak Detector

Note: Only peak measurement was performed. Because peak measurement result of unwanted emission is less than average limit (54dBuV/m).

HE40 RU mode (ANT_2 / 26T / Low: 17, High: 17)

LOW CHANNEL HORIZONTAL

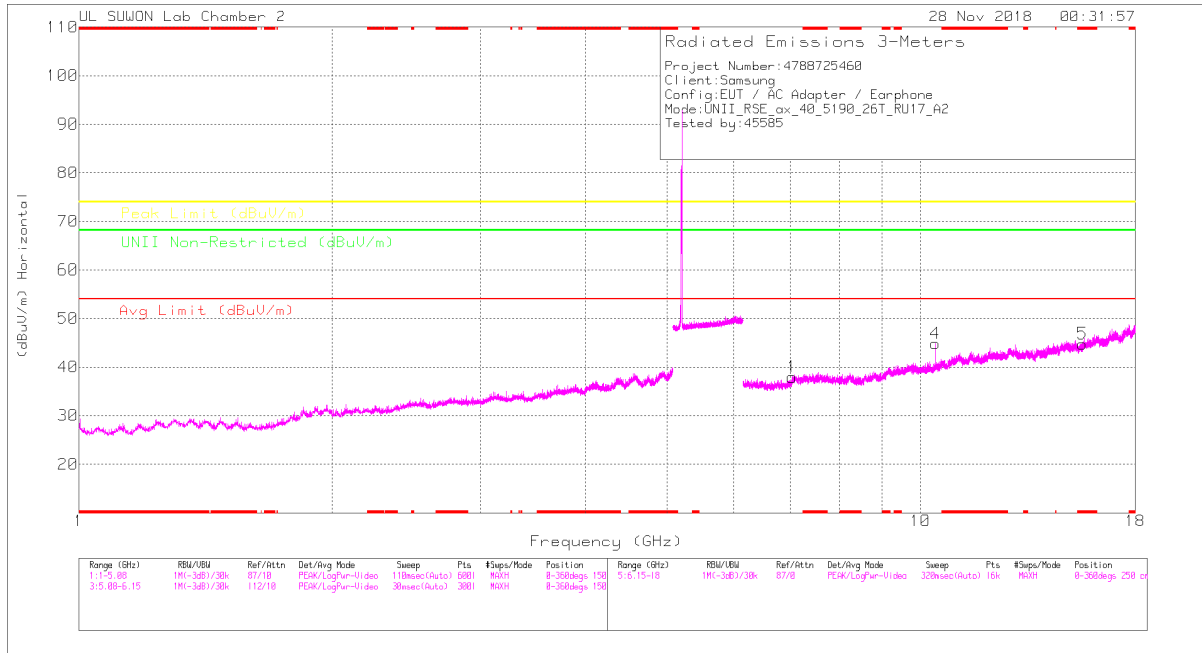

LOW CHANNEL VERTICAL

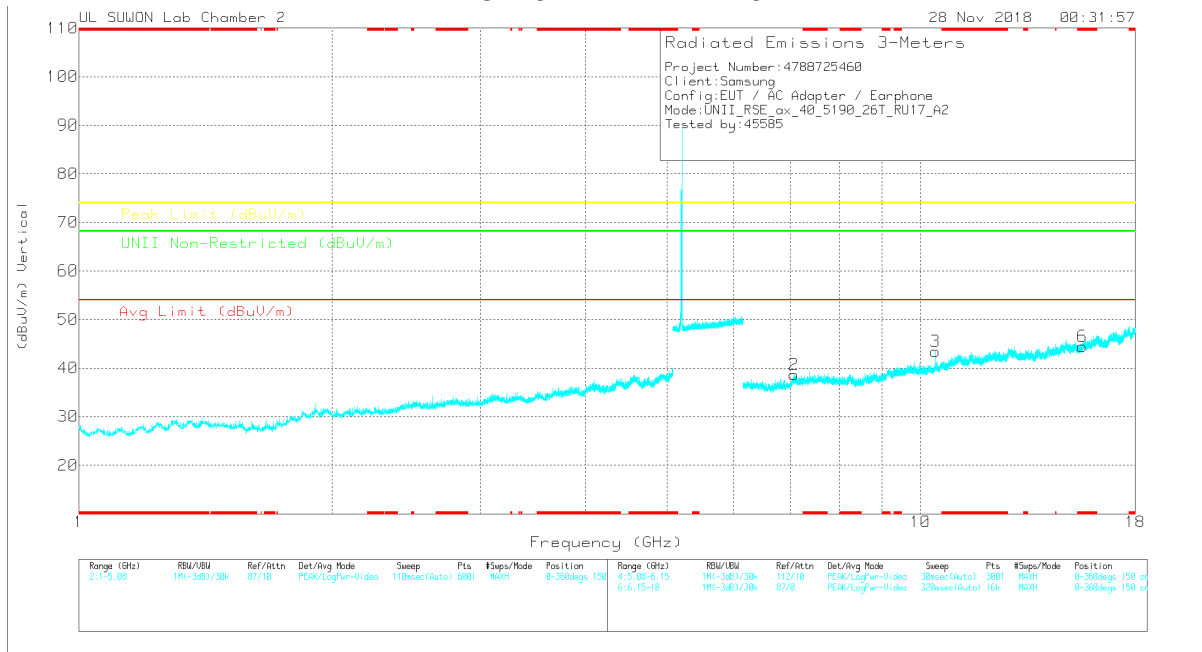

Note: Emission was scanned up to 40GHz; No emissions were detected above the noise floor which was at least 20dB below the specification limit.

LOW CHANNEL DATA

Trace Markers

Marker	Frequency (GHz)	Meter Reading (dBuV)	Det	3117_0018724	6GHz_H(F)(dB)	DC Corr (dB)	Corrected Reading (dBuV/m)	Avg Limit (dBuV/m)	Margin (dB)	Peak Limit (dBuV/m)	Margin (dB)	Limit Non-Restricted (dBuV/m)	Margin (dB)	Azimuth (Degs)	Height (cm)	Polarity
1	7.035	27.04	PK	35.9	-25	0	37.94	-	-	-	-	68.2	-30.26	0-360	150	H
4	10.415	28.12	PK	37.6	-20.9	0	44.82	-	-	-	-	68.2	-23.38	0-360	150	H
5	* 15.571	24.49	PK	40	-19.7	0	44.79	-	-	74	-29.21	-	-	0-360	150	H
2	7.076	26.76	PK	35.9	-24	0	38.66	-	-	-	-	68.2	-29.54	0-360	250	V
3	10.415	26.79	PK	37.6	-20.9	0	43.49	-	-	-	-	68.2	-24.71	0-360	250	V
6	* 15.572	24.21	PK	40	-19.8	0	44.41	-	-	74	-29.59	-	-	0-360	250	V

* - indicates frequency in CFR47 Pt 15 / IC RSS-Restricted Band
 PK – Peak Detector

Radiated Emissions

Frequency (GHz)	Meter Reading (dBuV)	Det	3117_0018724	6GHz_H(F)(dB)	DC Corr (dB)	Corrected Reading (dBuV/m)	Avg Limit (dBuV/m)	Margin (dB)	Peak Limit (dBuV/m)	Margin (dB)	Limit Non-Restricted (dBuV/m)	Margin (dB)	Azimuth (Degs)	Height (cm)	Polarity
10.415	47.96	PK-U	37.6	-20.9	0	64.66	-	-	-	-	68.2	-3.54	105	100	H
10.416	46.38	PK-U	37.6	-20.9	0	63.08	-	-	-	-	68.2	-5.12	216	233	V

* - indicates frequency in CFR47 Pt 15 / IC RSS-Restricted Band
 PK-U - U-NII: Maximum Peak

HIGH CHANNEL HORIZONTAL

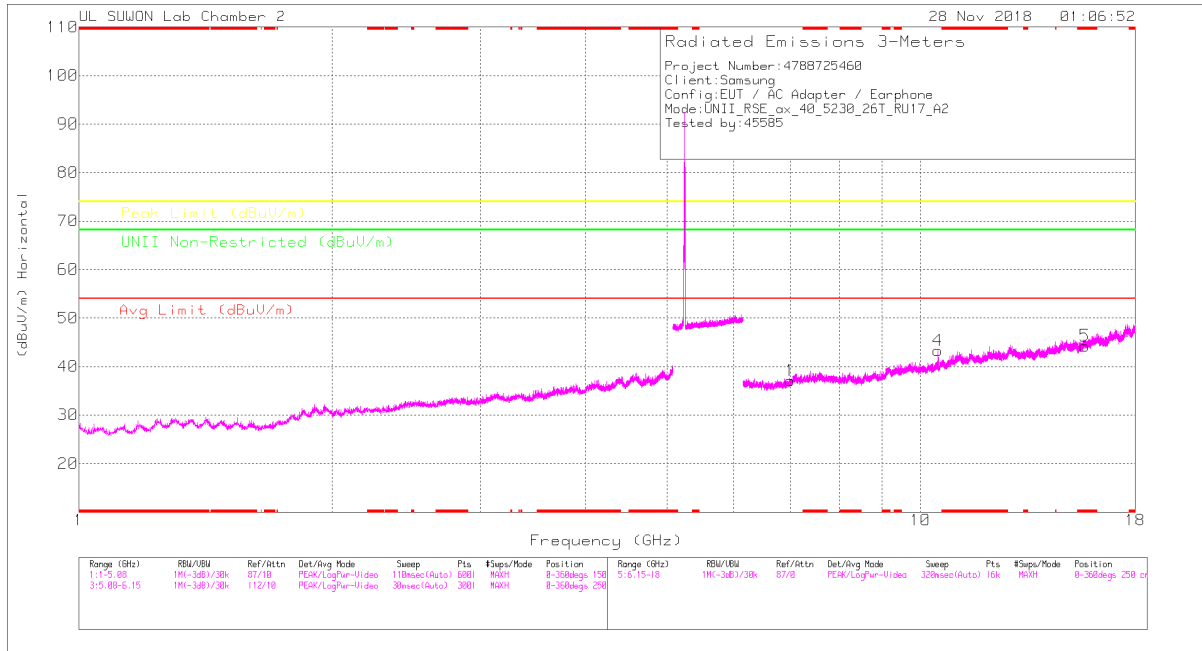

HIGH CHANNEL VERTICAL

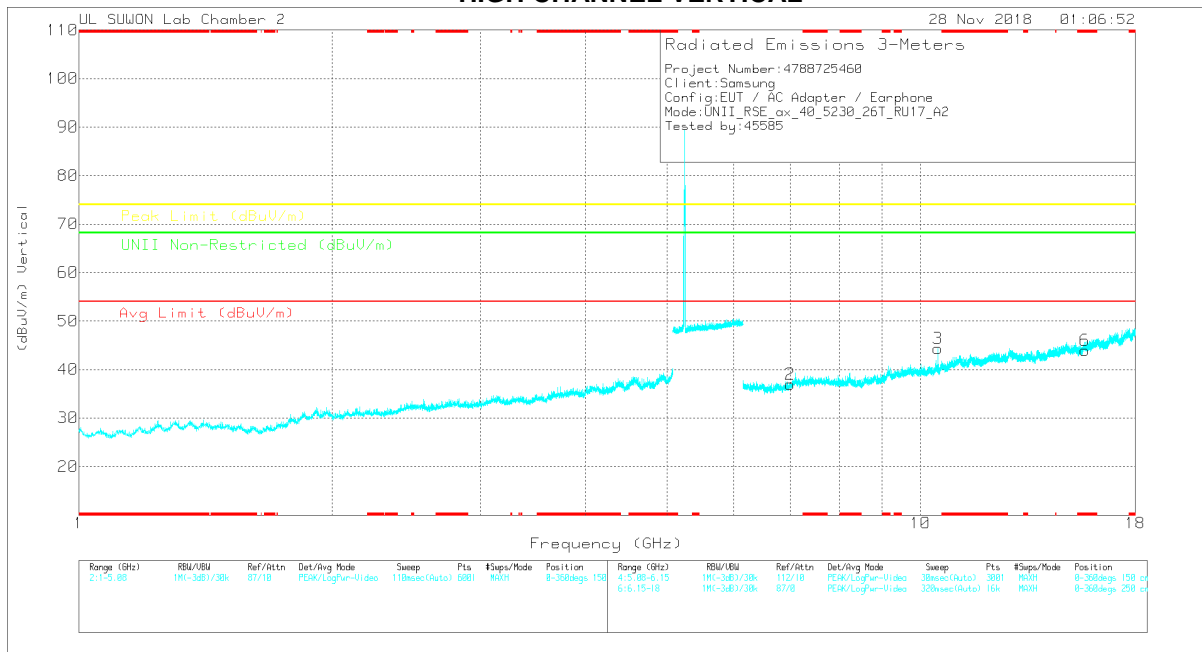

Note: Emission was scanned up to 40GHz; No emissions were detected above the noise floor which was at least 20dB below the specification limit.

HIGH CHANNEL DATA

Trace Markers

Marker	Frequency (GHz)	Meter Reading (dBuV)	Det	3117_00188724	6GHz_H(F)(dB)	DC Corr (dB)	Corrected Reading (dBuV/m)	Aug Limit (dBuV/m)	Margin (dB)	Peak Limit (dBuV/m)	Margin (dB)	UNI Non-Restricted (dBuV/m)	Margin (dB)	Azimuth (Degs)	Height (cm)	Polarity
1	7.005	26.85	PK	35.8	-25.6	0	37.05	-	-	-	-	68.2	-31.15	0-360	150	H
4	10.495	26.41	PK	37.7	-20.8	0	43.31	-	-	-	-	68.2	-24.89	0-360	150	H
5	* 15.69	23.87	PK	40.2	-19.8	0	44.27	-	-	74	-29.73	-	-	0-360	250	H
2	6.998	26.81	PK	35.8	-25.7	0	36.91	-	-	-	-	68.2	-31.29	0-360	150	V
3	10.496	27.42	PK	37.7	-20.8	0	44.32	-	-	-	-	68.2	-23.88	0-360	250	V
6	* 15.69	23.57	PK	40.2	-19.8	0	43.97	-	-	74	-30.03	-	-	0-360	150	V

* - indicates frequency in CFR47 Pt 15 / IC RSS-Restricted Band
 PK – Peak Detector

Radiated Emissions

Frequency (GHz)	Meter Reading (dBuV)	Det	3117_00188724	6GHz_H(F)(dB)	DC Corr (dB)	Corrected Reading (dBuV/m)	Aug Limit (dBuV/m)	Margin (dB)	Peak Limit (dBuV/m)	Margin (dB)	UNI Non-Restricted (dBuV/m)	Margin (dB)	Azimuth (Degs)	Height (cm)	Polarity
10.495	47.45	PK-U	37.7	-20.8	0	64.35	-	-	-	-	68.2	-3.85	223	100	H
10.495	45.75	PK-U	37.7	-20.8	0	62.65	-	-	-	-	68.2	-5.55	215	234	V

* - indicates frequency in CFR47 Pt 15 / IC RSS-Restricted Band
 PK-U - U-NII: Maximum Peak

HE80 RU mode (ANT_1 / 26T / Mid: 0)

MID CHANNEL HORIZONTAL

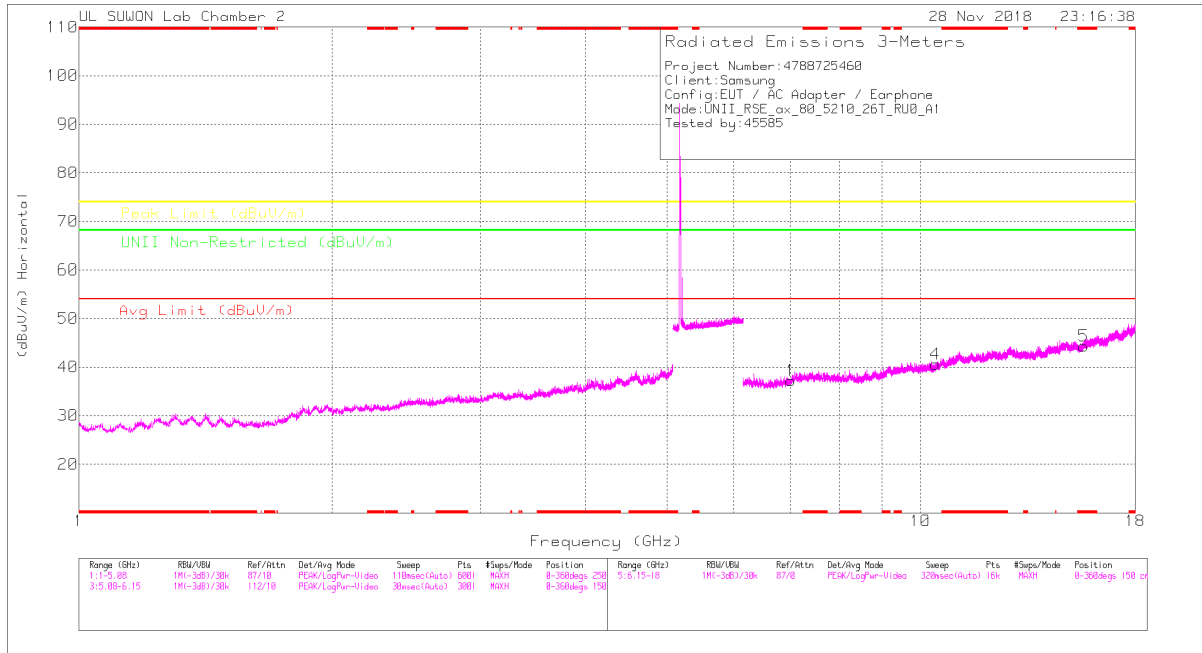

MID CHANNEL VERTICAL

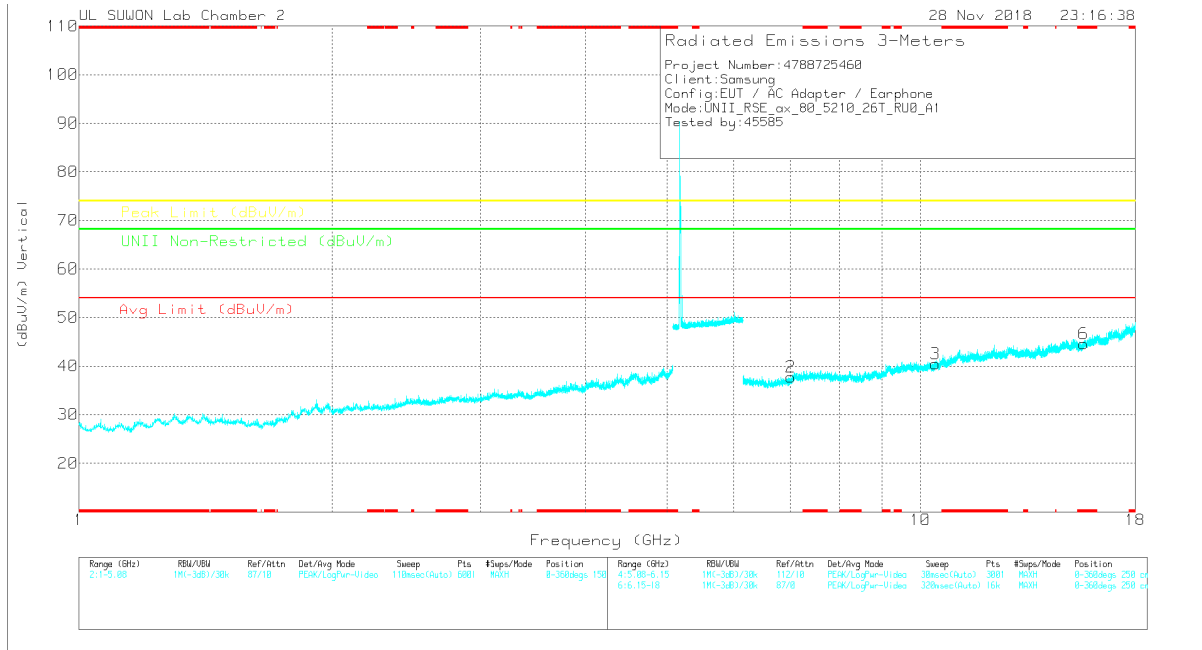

Note: Emission was scanned up to 40GHz; No emissions were detected above the noise floor which was at least 20dB below the specification limit.

MID CHANNEL DATA

Trace Markers

Marker	Frequency (GHz)	Marker Reading (dBuV)	Det	3117_00168724	66GHz_HP[dB]	DC Corr (dB)	Corrected Reading (dBuV/m)	Avg Limit (dBuV/m)	Margin (dB)	Peak Limit (dBuV/m)	Margin (dB)	Unit Non-Restricted (dBuV/m)	Margin (dB)	Azimuth (Degs)	Height (cm)	Polarity
1	7.01	26.89	PK	35.8	-25.5	0	37.19	-	-	-	-	68.2	-31.01	0-360	150	H
4	10.42	23.83	PK	37.6	-20.9	0	40.53	-	-	-	-	68.2	-27.67	0-360	150	H
5	* 15.63	23.98	PK	40.1	-19.8	0	44.28	-	-	74	-29.72	-	-	0-360	250	H
2	7.013	27.4	PK	35.8	-25.5	0	37.7	-	-	-	-	68.2	-30.5	0-360	150	V
3	10.421	23.76	PK	37.6	-20.9	0	40.46	-	-	-	-	68.2	-27.74	0-360	150	V
6	* 15.63	24.33	PK	40.1	-19.8	0	44.63	-	-	74	-29.37	-	-	0-360	250	V

* - indicates frequency in CFR47 Pt 15 / IC RSS-Restricted Band
 PK – Peak Detector

Note: Only peak measurement was performed. Because peak measurement result of unwanted emission is less than average limit (54dBuV/m).

HE80 RU mode (ANT_2 / 26T / Mid: 36)

MID CHANNEL HORIZONTAL

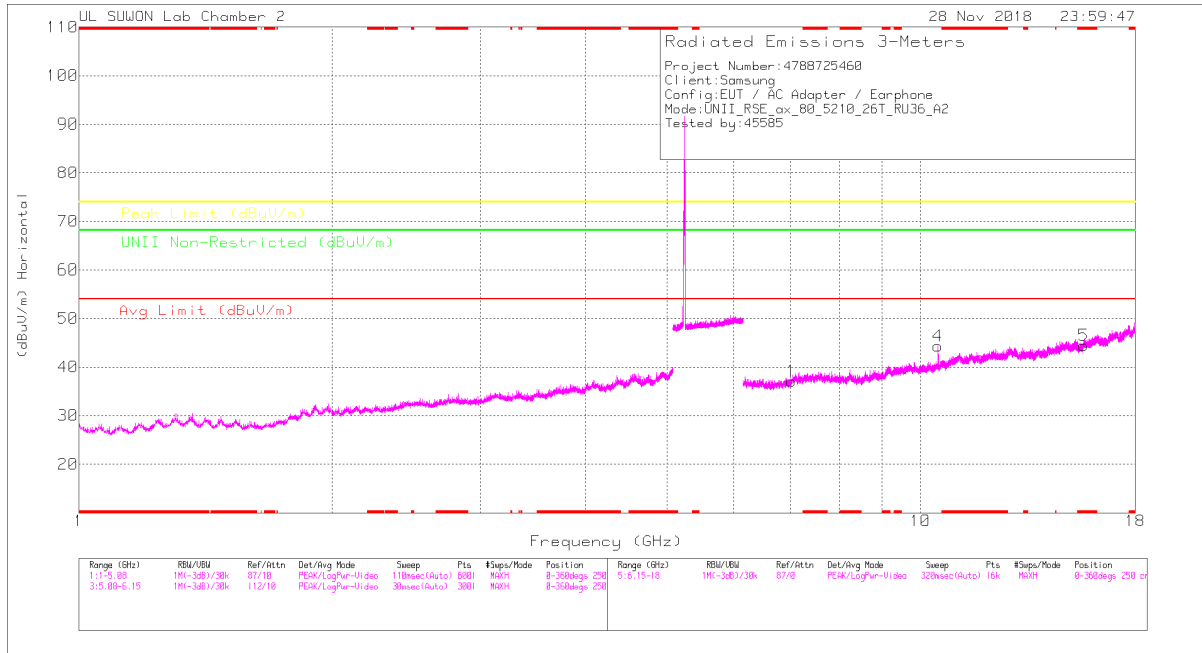

MID CHANNEL VERTICAL

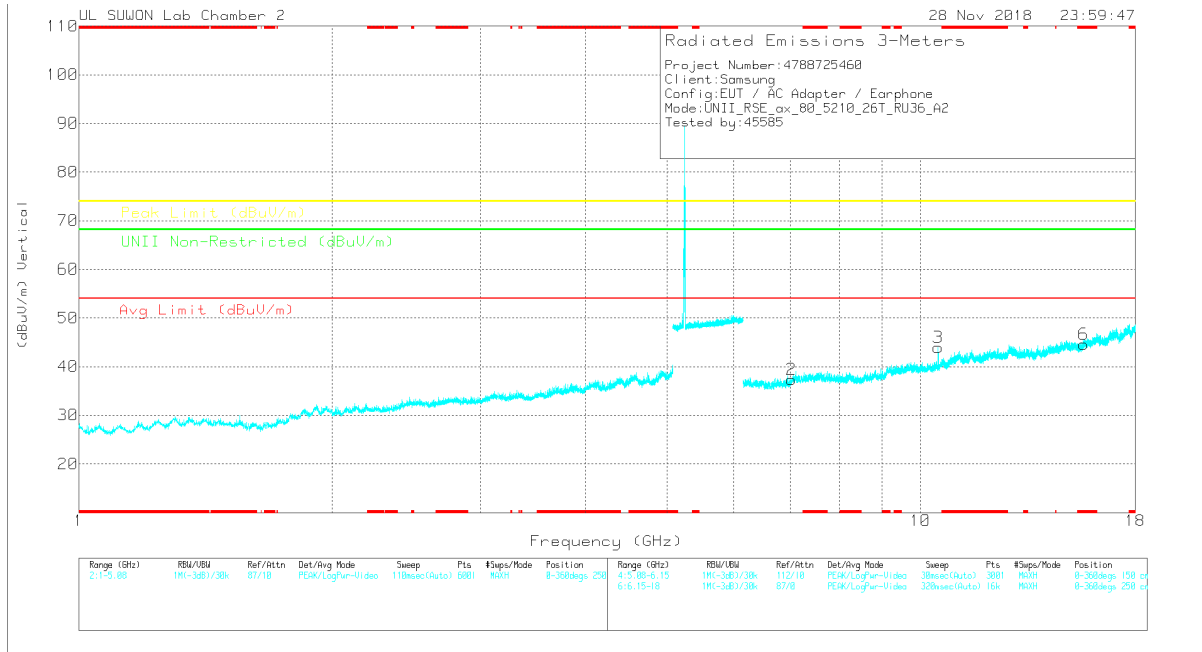

Note: Emission was scanned up to 40GHz; No emissions were detected above the noise floor which was at least 20dB below the specification limit.

MID CHANNEL DATA

Trace Markers

Marker	Frequency (GHz)	Meter Reading (dBuV)	Det	3117_00168724	6GHz_HF(dB)	DC Corr (dB)	Corrected Reading (dBuV/m)	Aug Limit (dBuV/m)	Margin (dB)	Peak Limit (dBuV/m)	Margin (dB)	UNII Non-Restricted (dBuV/m)	Margin (dB)	Asimuth (Degs)	Height (cm)	Polarity
1	7.024	26.57	PK	35.9	-25.4	0	37.07	-	-	-	-	68.2	-31.13	0-360	250	H
4	10.496	27.46	PK	37.7	-20.8	0	44.36	-	-	-	-	68.2	-23.84	0-360	150	H
5	* 15.63	24.21	PK	40.1	-19.8	0	44.51	-	-	74	-29.49	-	-	0-360	150	H
2	7.025	26.79	PK	35.9	-25.3	0	37.39	-	-	-	-	68.2	-30.81	0-360	150	V
3	10.496	27.09	PK	37.7	-20.8	0	43.99	-	-	-	-	68.2	-24.21	0-360	250	V
6	* 15.63	24.24	PK	40.1	-19.8	0	44.54	-	-	74	-29.46	-	-	0-360	250	V

* - indicates frequency in CFR47 Pt 15 / IC RSS-Restricted Band
 PK – Peak Detector

Radiated Emissions

Frequency (GHz)	Meter Reading (dBuV)	Det	3117_00168724	6GHz_HF(dB)	DC Corr (dB)	Corrected Reading (dBuV/m)	Aug Limit (dBuV/m)	Margin (dB)	Peak Limit (dBuV/m)	Margin (dB)	UNII Non-Restricted (dBuV/m)	Margin (dB)	Asimuth (Degs)	Height (cm)	Polarity
10.495	47.7	PK-U	37.7	-20.8	0	64.6	-	-	-	-	68.2	-3.6	219	264	V
10.496	46.42	PK-U	37.7	-20.8	0	63.32	-	-	-	-	68.2	-4.88	226	135	H

* - indicates frequency in CFR47 Pt 15 / IC RSS-Restricted Band
 PK-U - U-NII: Maximum Peak

11.2. 5.3 GHz_1TX

11.2.1.TX ABOVE 1GHz 802.11ax MODE IN THE 5.3GHz BAND

RESTRICTED BANDEDGE (HIGH CHANNEL)

HE20 SU mode (ANT_1)

HORIZONTAL PEAK AND AVERAGE PLOT

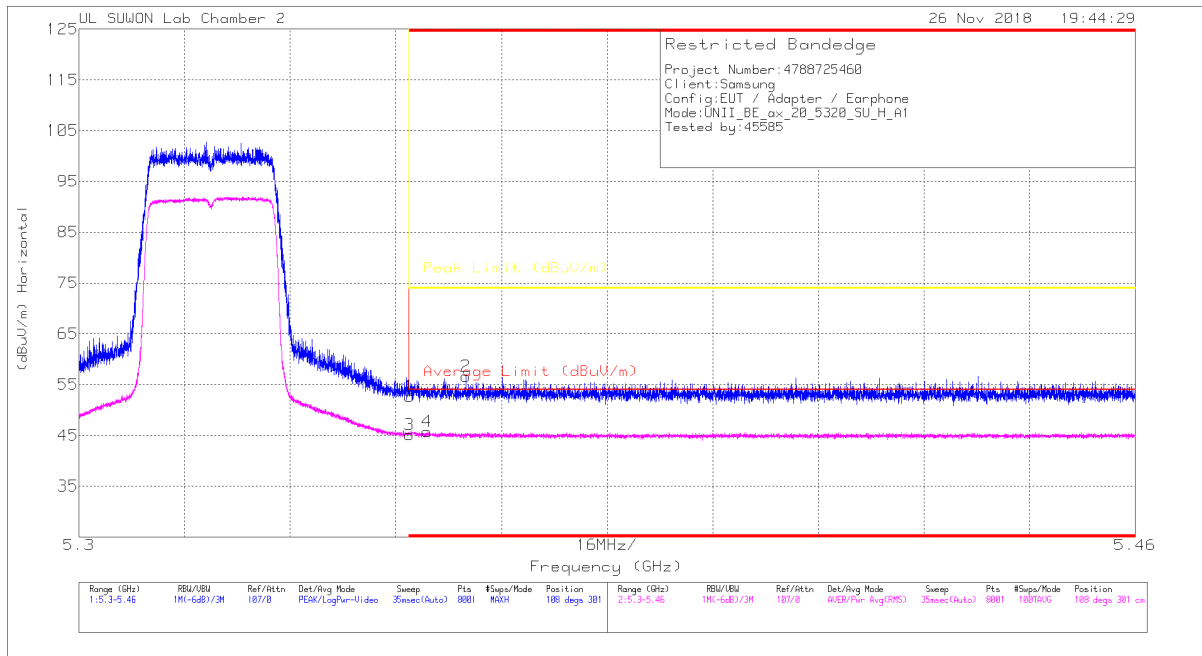

HORIZONTAL DATA

Trace Markers

Marker	Frequency (GHz)	Meter Reading (dBuV)	Det	3117_00168724	10dB(dB)	DC Corr (dB)	Corrected Reading (dBuV/m)	Average Limit (dBuV/m)	Margin (dB)	Peak Limit (dBuV/m)	PK Margin (dB)	Azimuth (Degs)	Height (cm)	Polarity
1	* 5.35	36.33	PK	34.5	-18.1	0	52.73	-	-	74	-21.27	108	301	H
2	* 5.359	40.26	PK	34.5	-18.1	0	56.66	-	-	74	-17.34	108	301	H
3	* 5.35	27.55	RMS	34.5	-17.1	.11	45.06	54	-8.94	-	-	108	301	H
4	* 5.353	28.18	RMS	34.5	-17.1	.11	45.69	54	-8.31	-	-	108	301	H

* - indicates frequency in CFR47 Pt 15 / IC RSS-Restricted Band

PK - Peak detector

RMS - RMS detection

VERTICAL PEAK AND AVERAGE PLOT

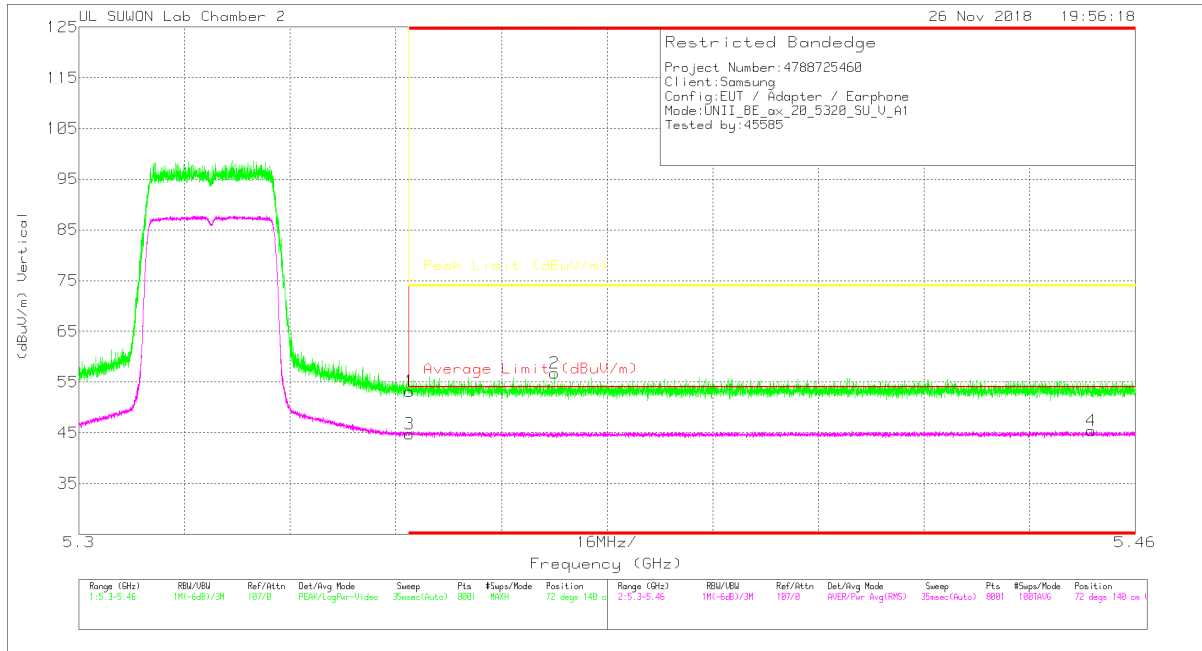

VERTICAL DATA

Trace Markers

Marker	Frequency (GHz)	Meter Reading (dBuV)	Det	3117_00168724	10dB(dB)	DC Corr (dB)	Corrected Reading (dBuV/m)	Average Limit (dBuV/m)	Margin (dB)	Peak Limit (dBuV/m)	PK Margin (dB)	Azimuth (Degs)	Height (cm)	Polarity
1	* 5.35	36.81	Pk	34.5	-18.1	0	53.21	-	-	74	-20.79	72	140	V
2	* 5.372	40.38	Pk	34.5	-18.1	0	56.78	-	-	74	-17.22	72	140	V
3	* 5.35	27.3	RMS	34.5	-17.1	.11	44.81	54	-9.19	-	-	72	140	V
4	* 5.453	27.61	RMS	34.6	-16.9	.11	45.42	54	-8.58	-	-	72	140	V

* - indicates frequency in CFR47 Pt 15 / IC RSS-Restricted Band

Pk - Peak detector

RMS - RMS detection

HE20 SU mode (ANT_2)

HORIZONTAL PEAK AND AVERAGE PLOT

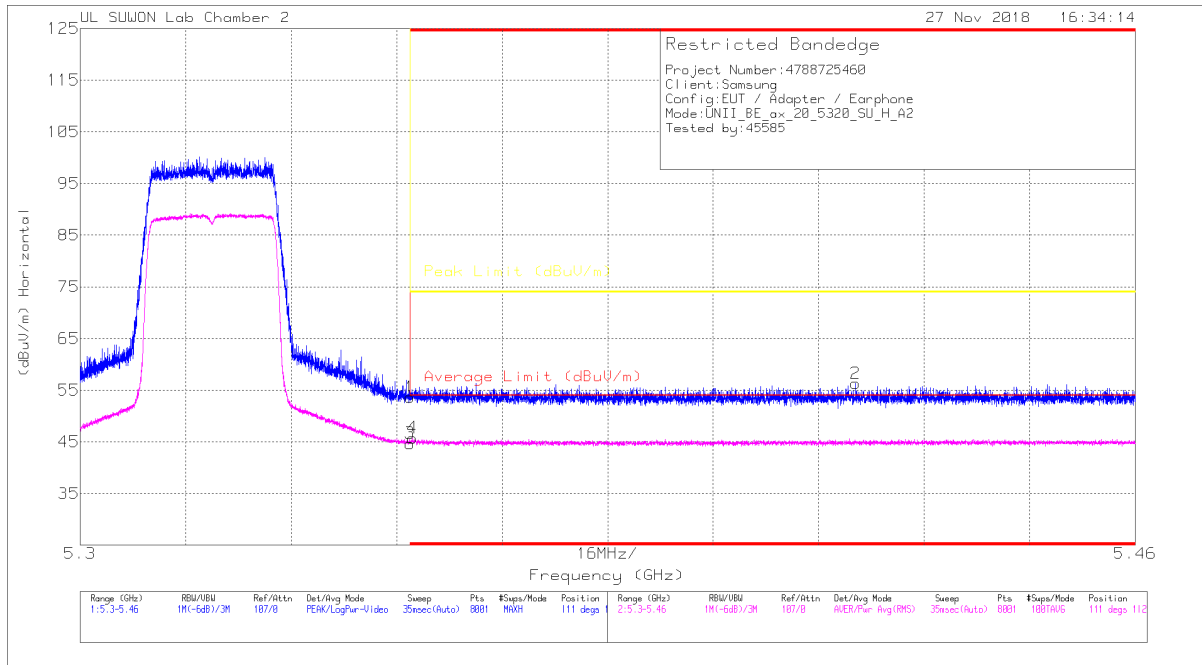

HORIZONTAL DATA

Trace Markers

Marker	Frequency (GHz)	Meter Reading (dBuV)	Det	3117_00168724	10dB(dB)	DC Corr (dB)	Corrected Reading (dBuV/m)	Average Limit (dBuV/m)	Margin (dB)	Peak Limit (dBuV/m)	PK Margin (dB)	Azimuth (Degs)	Height (cm)	Polarity
1	* 5.35	37.23	Pk	34.5	-18.1	0	53.63	-	-	74	-20.37	111	112	H
2	* 5.418	40.03	Pk	34.5	-18.2	0	56.33	-	-	74	-17.67	111	112	H
3	* 5.35	27.18	RMS	34.5	-17.1	.11	44.69	54	-9.31	-	-	111	112	H
4	* 5.35	28.24	RMS	34.5	-17.1	.11	45.75	54	-8.25	-	-	111	112	H

* - indicates frequency in CFR47 Pt 15 / IC RSS-Restricted Band

Pk - Peak detector

RMS - RMS detection

VERTICAL PEAK AND AVERAGE PLOT

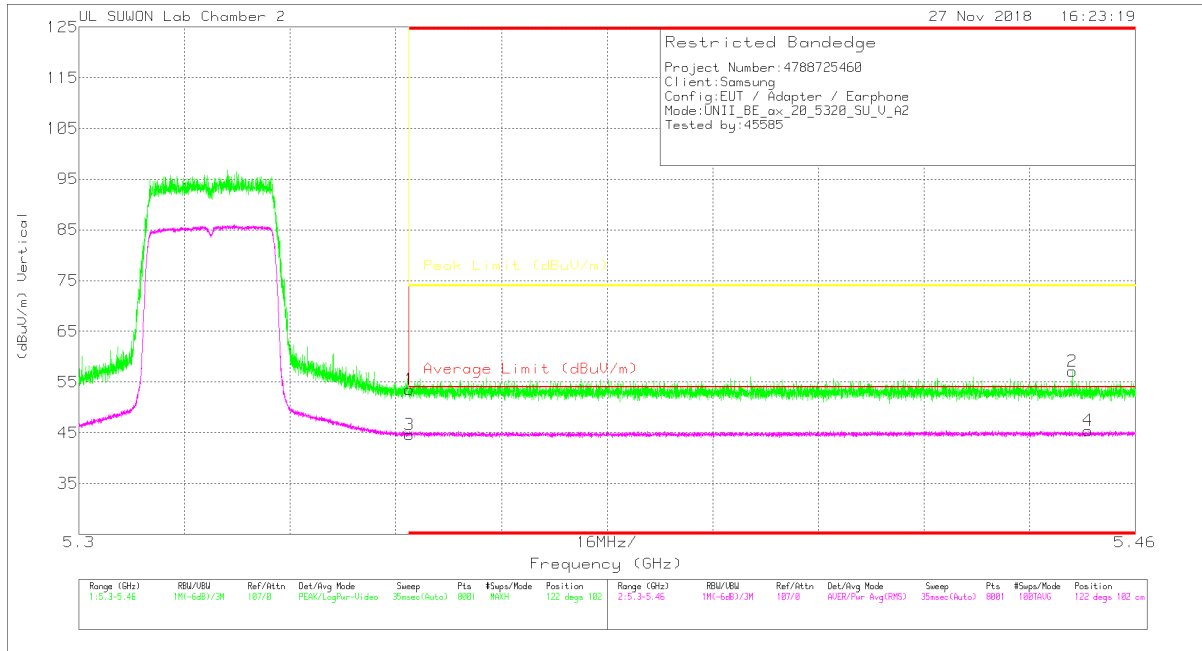

VERTICAL DATA

Trace Markers

Marker	Frequency (GHz)	Meter Reading (dBuV)	Det	3117_00168724	10dB(dB)	DC Corr (dB)	Corrected Reading (dBuV/m)	Average Limit (dBuV/m)	Margin (dB)	Peak Limit (dBuV/m)	PK Margin (dB)	Azimuth (Degs)	Height (cm)	Polarity
1	* 5.35	37.19	Pk	34.5	-18.1	0	53.59	-	-	74	-20.41	122	102	V
2	* 5.451	40.66	Pk	34.6	-18.1	0	57.16	-	-	74	-16.84	122	102	V
3	* 5.35	27.13	RMS	34.5	-17.1	.11	44.64	54	-9.36	-	-	122	102	V
4	* 5.453	27.63	RMS	34.6	-16.9	.11	45.44	54	-8.56	-	-	122	102	V

* - indicates frequency in CFR47 Pt 15 / IC RSS-Restricted Band

Pk - Peak detector

RMS - RMS detection

HE40 SU mode (ANT_1)

HORIZONTAL PEAK AND AVERAGE PLOT

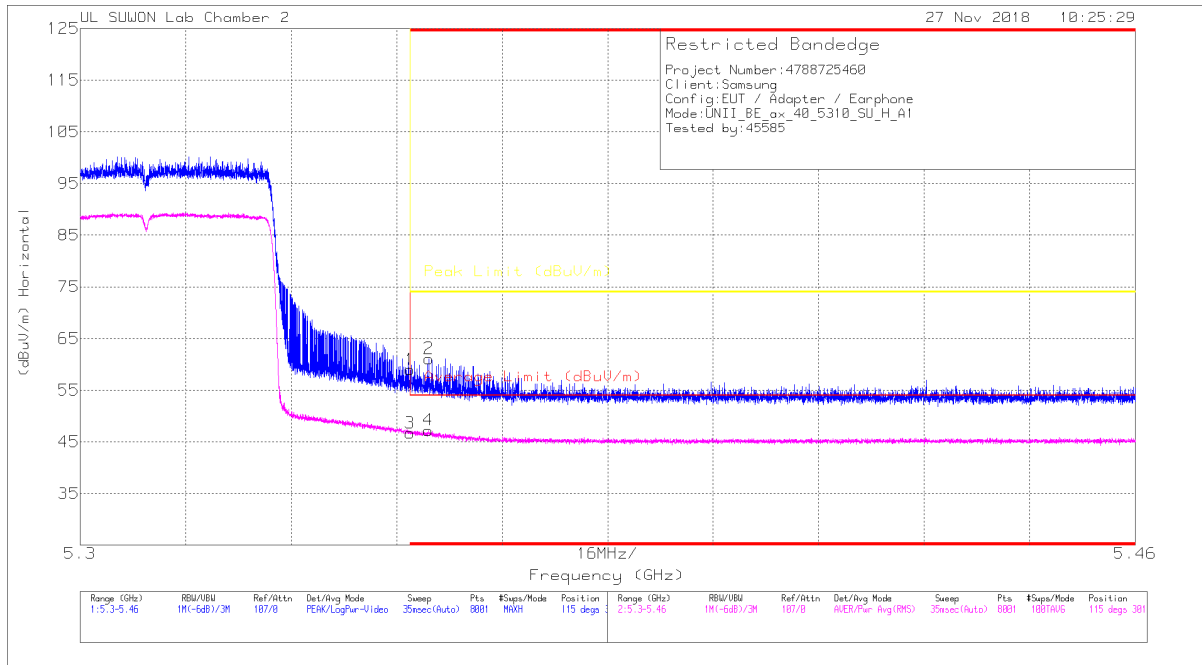

HORIZONTAL DATA

Trace Markers

Marker	Frequency (GHz)	Meter Reading (dBuV)	Det	3117_D0168724	10dB(dB)	DC Corr (dB)	Corrected Reading (dBuV/m)	Average Limit (dBuV/m)	Margin (dB)	Peak Limit (dBuV/m)	PK Margin (dB)	Azimuth (Degs)	Height (cm)	Polarity
1	* 5.35	42.57	Pk	34.5	-18.1	0	58.97	-	-	74	-15.03	115	301	H
2	* 5.353	44.71	Pk	34.5	-18.1	0	61.11	-	-	74	-12.89	115	301	H
3	* 5.35	28.85	RMS	34.5	-17.1	.1	46.35	54	-7.65	-	-	115	301	H
4	* 5.353	29.43	RMS	34.5	-17.1	.1	46.93	54	-7.07	-	-	115	301	H

* - indicates frequency in CFR47 Pt 15 / IC RSS-Restricted Band

Pk - Peak detector

RMS - RMS detection

VERTICAL PEAK AND AVERAGE PLOT

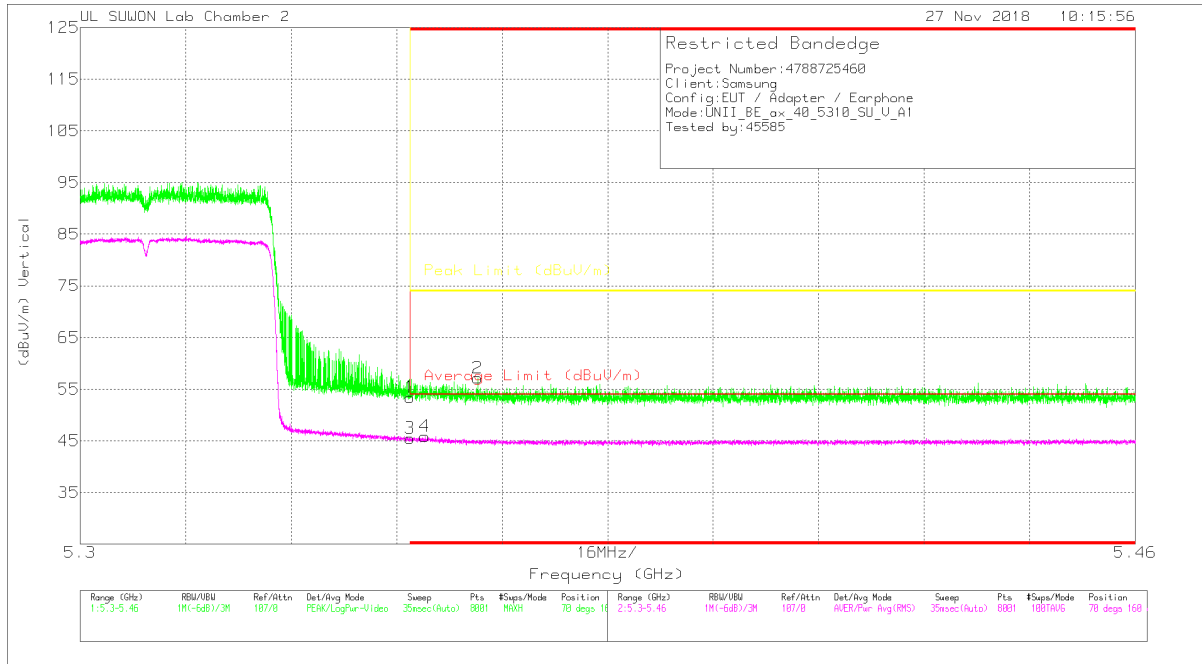

VERTICAL DATA

Trace Markers

Marker	Frequency (GHz)	Meter Reading (dBuV)	Det	3117_00168724	10dB(dB)	DC Corr (dB)	Corrected Reading (dBuV/m)	Average Limit (dBuV/m)	Margin (dB)	Peak Limit (dBuV/m)	PK Margin (dB)	Azimuth (Degs)	Height (cm)	Polarity
1	* 5.35	37.04	Pk		34.5	-18.1	0	53.44	-	74	-20.56	70	160	V
2	* 5.36	40.78	Pk		34.5	-18.1	0	57.18	-	74	-16.82	70	160	V
3	* 5.35	28.02	RMS		34.5	-17.1	.1	45.52	54	-8.48	-	70	160	V
4	* 5.352	28.38	RMS		34.5	-17.1	.1	45.88	54	-8.12	-	70	160	V

* - indicates frequency in CFR47 Pt 15 / IC RSS-Restricted Band

Pk - Peak detector

RMS - RMS detection

HE40 SU mode (ANT_2)

HORIZONTAL PEAK AND AVERAGE PLOT

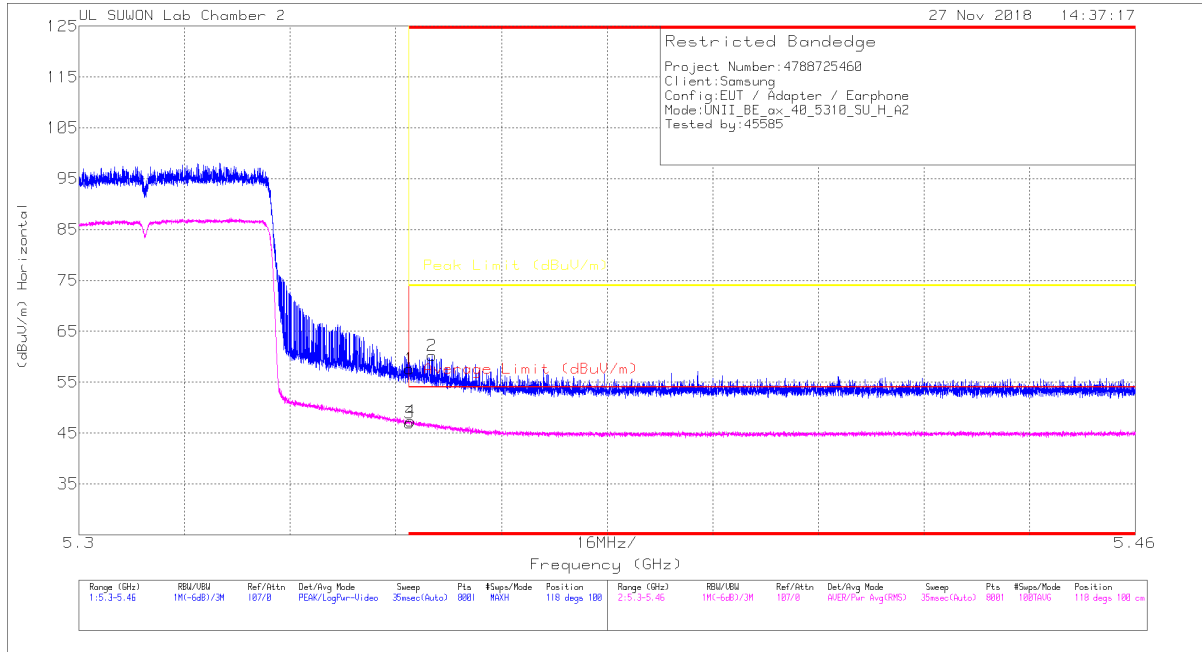

HORIZONTAL DATA

Trace Markers

Marker	Frequency (GHz)	Meter Reading (dBuV)	Det	3117_00168724	10dB(dB)	DC Corr (dB)	Corrected Reading (dBuV/m)	Average Limit (dBuV/m)	Margin (dB)	Peak Limit (dBuV/m)	PK Margin (dB)	Azimuth (Degs)	Height (cm)	Polarity
1	* 5.35	41.21	Pk	34.5	-18.1	0	57.61	-	-	74	-16.39	118	100	H
2	* 5.354	43.81	Pk	34.5	-18.1	0	60.21	-	-	74	-13.79	118	100	H
3	* 5.35	29.49	RMS	34.5	-17.1	.1	46.99	54	-7.01	-	-	118	100	H
4	* 5.35	29.88	RMS	34.5	-17.1	.1	47.38	54	-6.62	-	-	118	100	H

* - indicates frequency in CFR47 Pt 15 / IC RSS-Restricted Band

Pk - Peak detector

RMS - RMS detection

VERTICAL PEAK AND AVERAGE PLOT

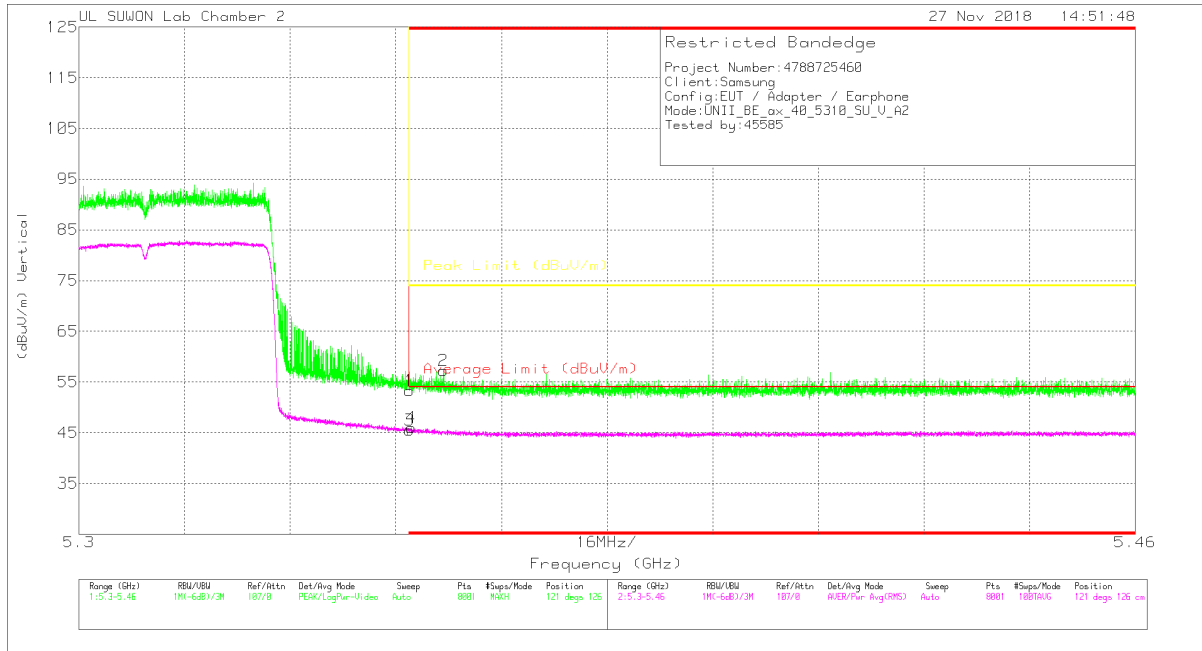

VERTICAL DATA

Trace Markers

Marker	Frequency (GHz)	Meter Reading (dBuV)	Det	3117_00168724	10dB(dB)	DC Corr (dB)	Corrected Reading (dBuV/m)	Average Limit (dBuV/m)	Margin (dB)	Peak Limit (dBuV/m)	PK Margin (dB)	Azimuth (Degs)	Height (cm)	Polarity
1	* 5.35	36.95	PK	34.5	-18.1	0	53.35	-	-	74	-20.65	121	126	V
2	* 5.355	40.82	PK	34.5	-18.1	0	57.22	-	-	74	-16.78	121	126	V
3	* 5.35	27.99	RMS	34.5	-17.1	.1	45.49	54	-8.51	-	-	121	126	V
4	* 5.35	28.49	RMS	34.5	-17.1	.1	45.99	54	-8.01	-	-	121	126	V

* - indicates frequency in CFR47 Pt 15 / IC RSS-Restricted Band

PK - Peak detector

RMS - RMS detection

HE80 SU mode (ANT_1)

HORIZONTAL PEAK AND AVERAGE PLOT

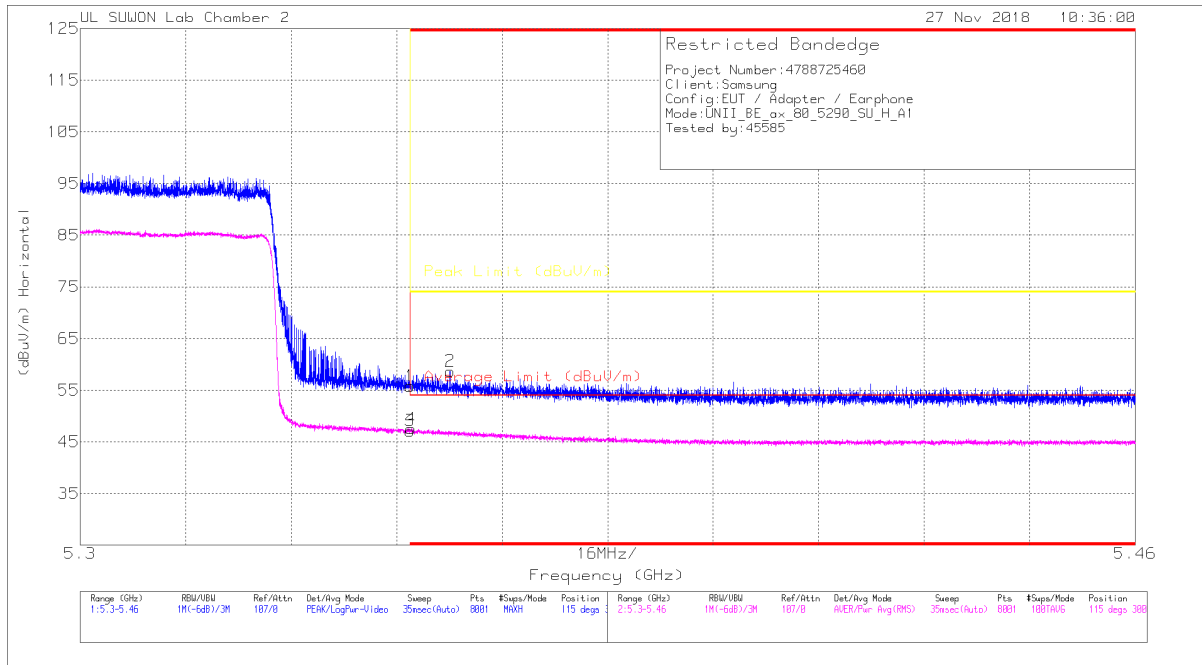

HORIZONTAL DATA

Trace Markers

Marker	Frequency (GHz)	Meter Reading (dBuV)	Det	3117_D0168724	10dB(dB)	DC Corr (dB)	Corrected Reading (dBuV/m)	Average Limit (dBuV/m)	Margin (dB)	Peak Limit (dBuV/m)	PK Margin (dB)	Azimuth (Degs)	Height (cm)	Polarity
1	* 5.35	39.4	Pk	34.5	-18.1	0	55.8	-	-	74	-18.2	115	300	H
2	* 5.356	42.28	Pk	34.5	-18.1	0	58.68	-	-	74	-15.32	115	300	H
3	* 5.35	29.63	RMS	34.5	-17.1	.1	47.13	54	-6.87	-	-	115	300	H
4	* 5.35	30.05	RMS	34.5	-17.1	.1	47.55	54	-6.45	-	-	115	300	H

* - indicates frequency in CFR47 Pt 15 / IC RSS-Restricted Band

Pk - Peak detector

RMS - RMS detection

VERTICAL PEAK AND AVERAGE PLOT

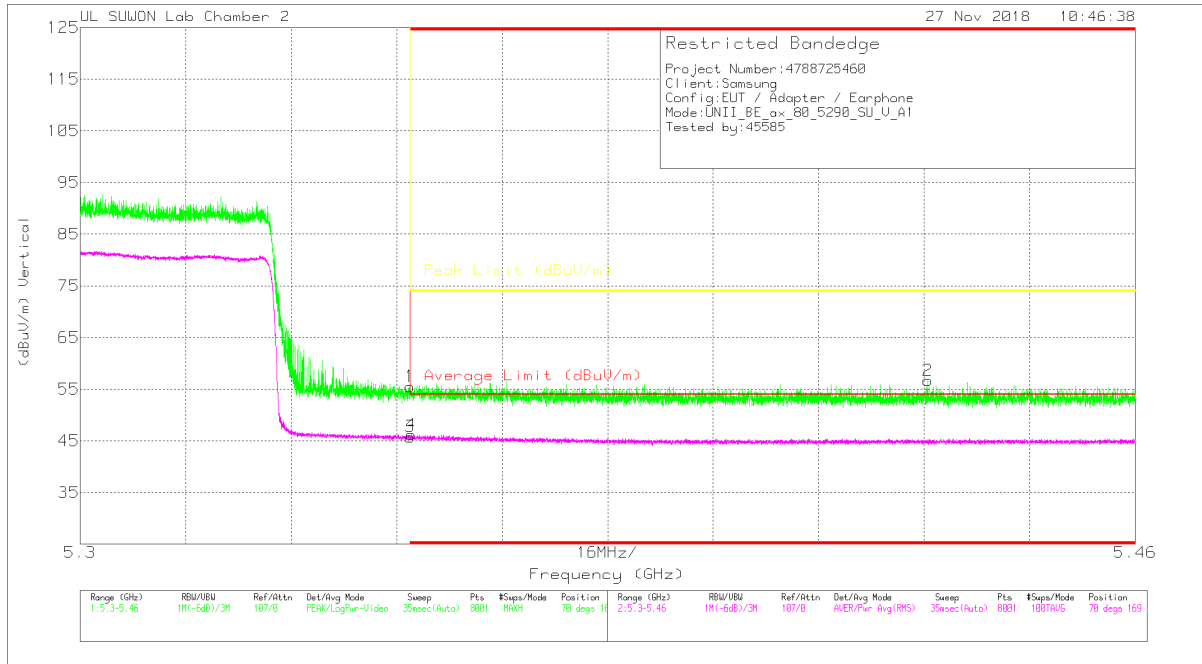

VERTICAL DATA

Trace Markers

Marker	Frequency (GHz)	Meter Reading (dBuV)	Det	3117_00168724	10dB(dB)	DC Corr (dB)	Corrected Reading (dBuV/m)	Average Limit (dBuV/m)	Margin (dB)	Peak Limit (dBuV/m)	PK Margin (dB)	Azimuth (Degs)	Height (cm)	Polarity
1	* 5.35	39.1	Pk	34.5	-18.1	0	55.5	-	-	74	-18.5	70	169	V
2	* 5.429	40.28	Pk	34.5	-18.1	0	56.68	-	-	74	-17.32	70	169	V
3	* 5.35	28.25	RMS	34.5	-17.1	.1	45.75	54	-8.25	-	-	70	169	V
4	* 5.35	28.67	RMS	34.5	-17.1	.1	46.17	54	-7.83	-	-	70	169	V

* - indicates frequency in CFR47 Pt 15 / IC RSS-Restricted Band

Pk - Peak detector

RMS - RMS detection

HE80 SU mode (ANT_2)

HORIZONTAL PEAK AND AVERAGE PLOT

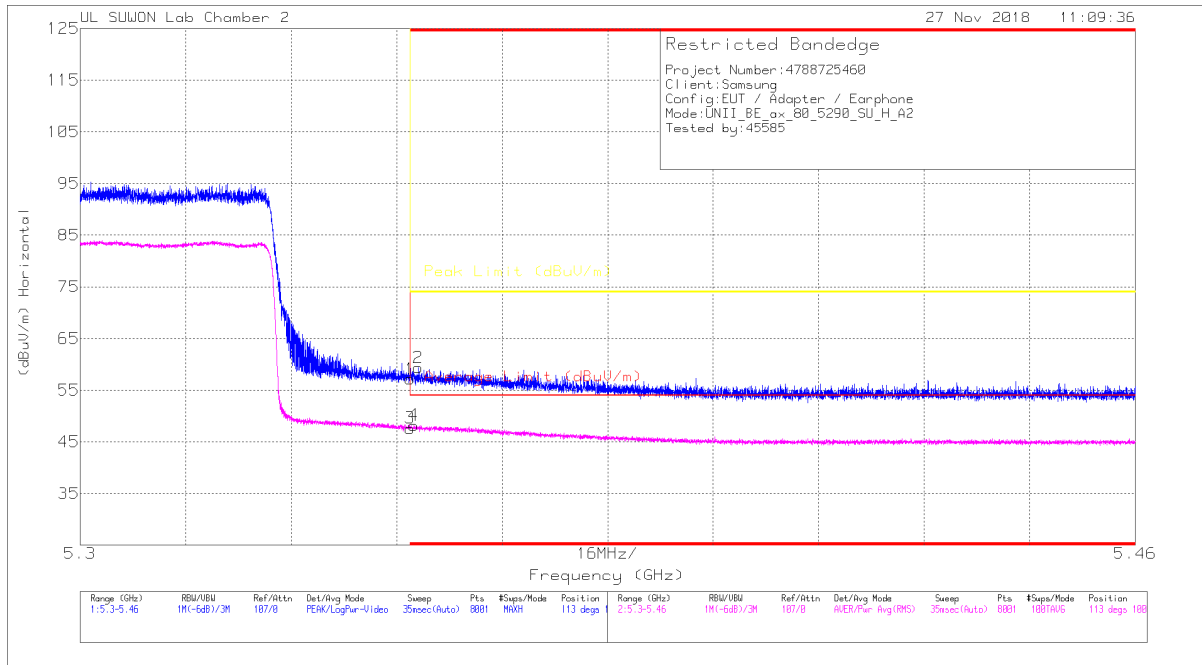

HORIZONTAL DATA

Trace Markers

Marker	Frequency (GHz)	Meter Reading (dBuV)	Det	3117_D0168724	10dB(dB)	DC Corr (dB)	Corrected Reading (dBuV/m)	Average Limit (dBuV/m)	Margin (dB)	Peak Limit (dBuV/m)	PK Margin (dB)	Azimuth (Degs)	Height (cm)	Polarity
1	* 5.35	40.79	Pk	34.5	-18.1	0	57.19	-	-	74	-16.81	113	100	H
2	* 5.351	42.94	Pk	34.5	-18.1	0	59.34	-	-	74	-14.66	113	100	H
3	* 5.35	30.07	RMS	34.5	-17.1	.1	47.57	54	-6.43	-	-	113	100	H
4	* 5.351	30.65	RMS	34.5	-17.1	.1	48.15	54	-5.85	-	-	113	100	H

* - indicates frequency in CFR47 Pt 15 / IC RSS-Restricted Band

Pk - Peak detector

RMS - RMS detection

VERTICAL PEAK AND AVERAGE PLOT

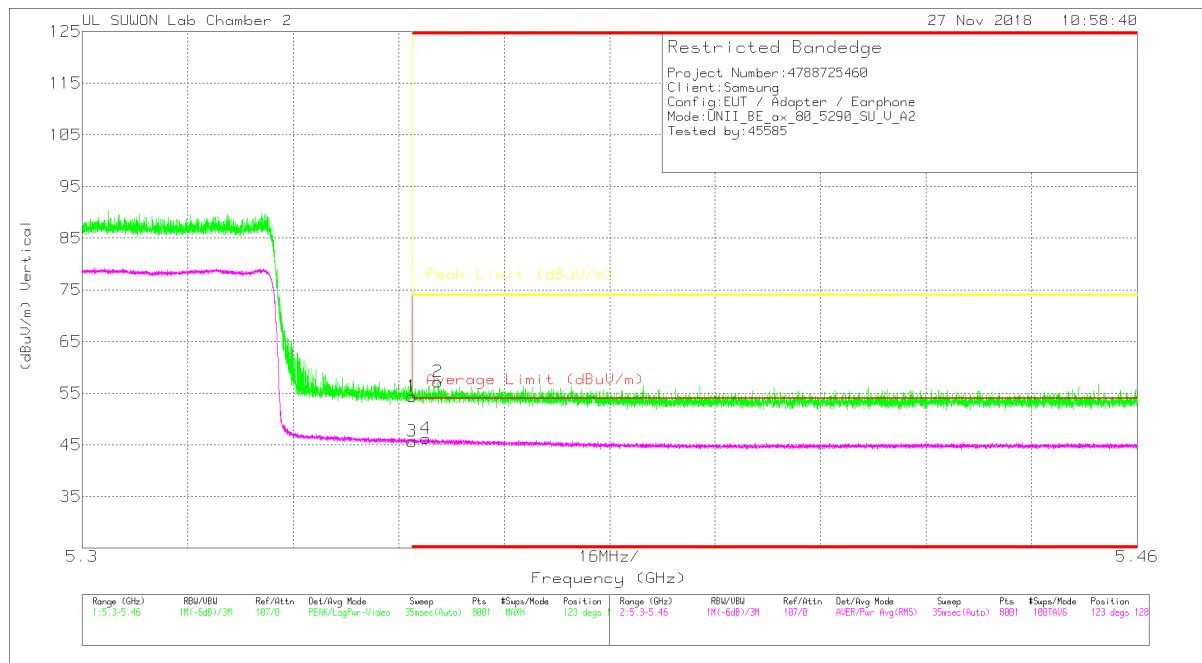

VERTICAL DATA

Trace Markers

Marker	Frequency (GHz)	Meter Reading (dBuV)	Det	3117_00168724	10dB(dB)	DC Corr (dB)	Corrected Reading (dBuV/m)	Average Limit (dBuV/m)	Margin (dB)	Peak Limit (dBuV/m)	PK Margin (dB)	Azimuth (Degs)	Height (cm)	Polarity
1	* 5.35	38.01	Pk		-18.1	0	54.41	-	-	74	-19.59	123	128	V
2	* 5.354	40.84	Pk		-18.1	0	57.24	-	-	74	-16.76	123	128	V
3	* 5.35	28.14	RMS		-17.1	.1	45.64	54	-8.36	-	-	123	128	V
4	* 5.352	28.71	RMS		-17.1	.1	46.21	54	-7.79	-	-	123	128	V

* - indicates frequency in CFR47 Pt 15 / IC RSS-Restricted Band

Pk - Peak detector

RMS - RMS detection

106T RU mode (ANT_1 / HE20 / RU offset 54)

HORIZONTAL PEAK AND AVERAGE PLOT

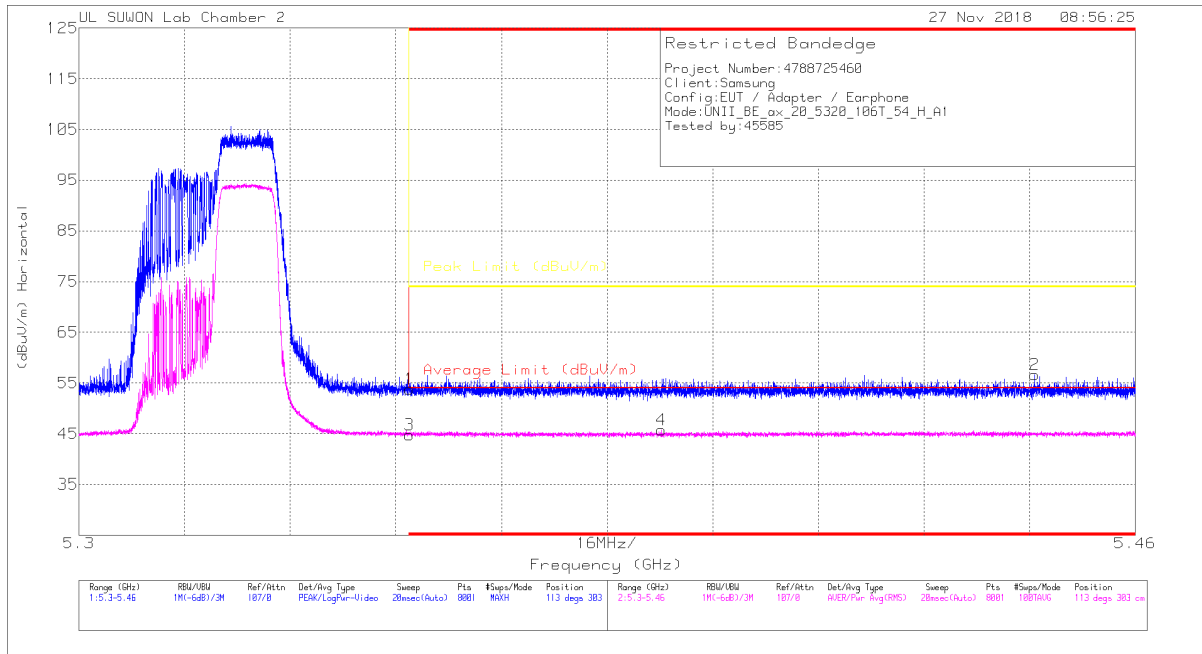

HORIZONTAL DATA

Trace Markers

Marker	Frequency (GHz)	Meter Reading (dBuV)	Det	3117_00168724	10dB(dB)	DC Corr (dB)	Corrected Reading (dBuV/m)	Average Limit (dBuV/m)	Margin (dB)	Peak Limit (dBuV/m)	PK Margin (dB)	Azimuth (Degs)	Height (cm)	Polarity
1	* 5.35	37.39	Pk	34.5	-18.1	0	53.79	-	-	74	-20.21	113	303	H
2	* 5.445	40.35	Pk	34.5	-18.2	0	56.65	-	-	74	-17.35	113	303	H
3	* 5.35	27.23	RMS	34.5	-17.1	.45	45.10	54	-8.92	-	-	113	303	H
4	* 5.388	28.1	RMS	34.5	-17	.45	46.05	54	-7.95	-	-	113	303	H

* - indicates frequency in CFR47 Pt 15 / IC RSS-Restricted Band

Pk - Peak detector

RMS - RMS detection

VERTICAL PEAK AND AVERAGE PLOT

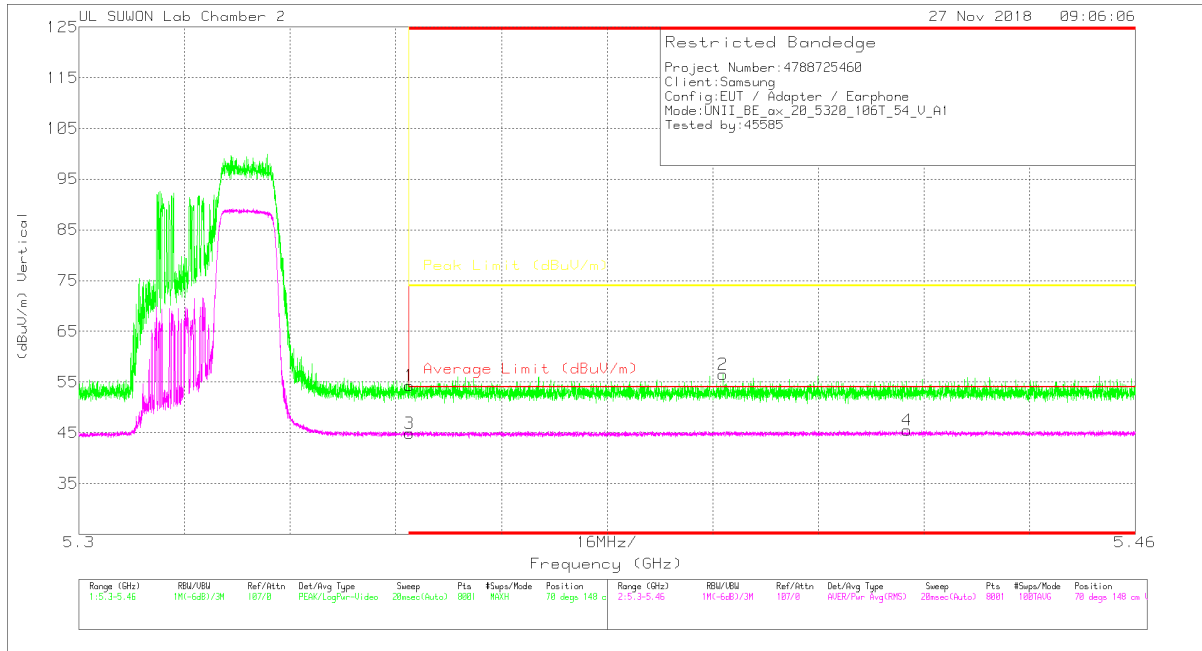

VERTICAL DATA

Trace Markers

Marker	Frequency (GHz)	Meter Reading (dBuV)	Det	3117_00168724	10dB(dB)	DC Corr (dB)	Corrected Reading (dBuV/m)	Average Limit (dBuV/m)	Margin (dB)	Peak Limit (dBuV/m)	PK Margin (dB)	Altitude (Degs)	Height (cm)	Polarity
1	* 5.35	37.93	Pk	34.5	-18.1	0	54.33	-	-	74	-19.67	70	148	V
2	* 5.398	40.11	Pk	34.5	-18.1	0	56.51	-	-	74	-17.49	70	148	V
3	* 5.35	27.36	RMS	34.5	-17.1	.45	45.21	54	-8.79	-	-	70	148	V
4	* 5.425	27.91	RMS	34.5	-17	.45	45.86	54	-8.14	-	-	70	148	V

* - indicates frequency in CFR47 Pt 15 / IC RSS-Restricted Band

Pk - Peak detector

RMS - RMS detection

106T RU mode (ANT_2 / HE20 / RU offset 54)

HORIZONTAL PEAK AND AVERAGE PLOT

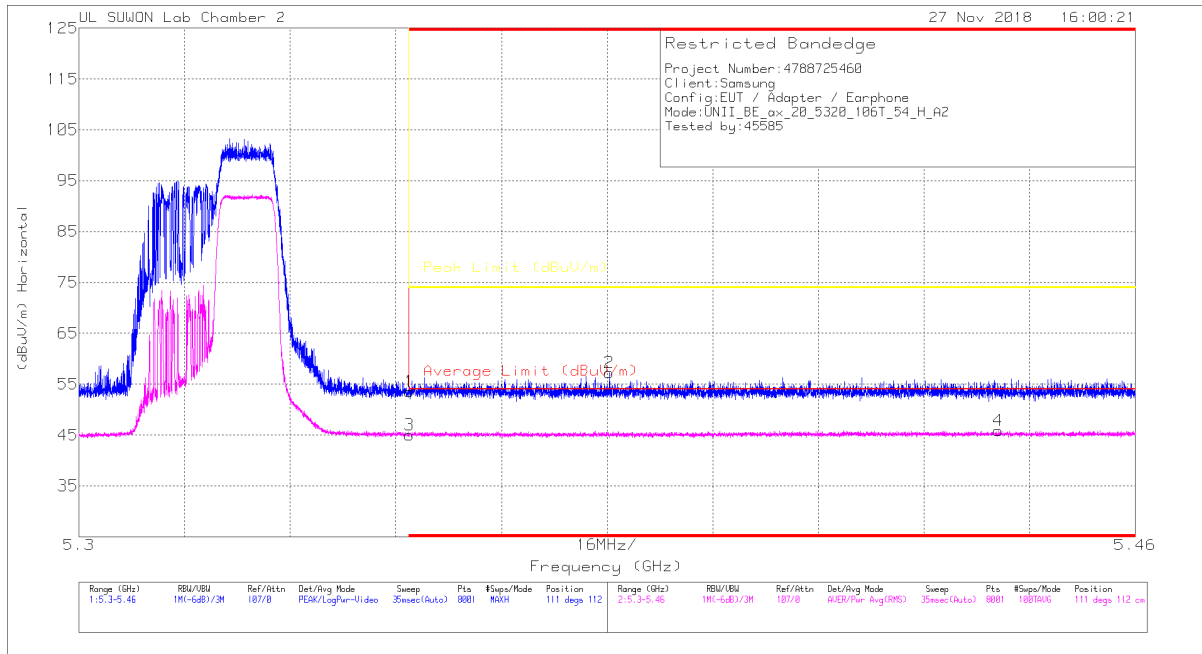

HORIZONTAL DATA

Trace Markers

Marker	Frequency (GHz)	Meter Reading (dBuV)	Det	3117_00168724	10dB(dB)	DC Corr (dB)	Corrected Reading (dBuV/m)	Average Limit (dBuV/m)	Margin (dB)	Peak Limit (dBuV/m)	PK Margin (dB)	Azimuth (Degs)	Height (cm)	Polarity
1	* 5.35	37.15	Pk	34.5	-18.1	0	53.55	-	-	74	-20.45	111	112	H
2	* 5.38	41	Pk	34.5	-18.2	0	57.3	-	-	74	-16.7	111	112	H
3	* 5.35	27.13	RMS	34.5	-17.1	.45	44.98	54	-9.02	-	-	111	112	H
4	* 5.439	27.98	RMS	34.5	-17	.45	45.93	54	-8.07	-	-	111	112	H

* - indicates frequency in CFR47 Pt 15 / IC RSS-Restricted Band

Pk - Peak detector

RMS - RMS detection

VERTICAL PEAK AND AVERAGE PLOT

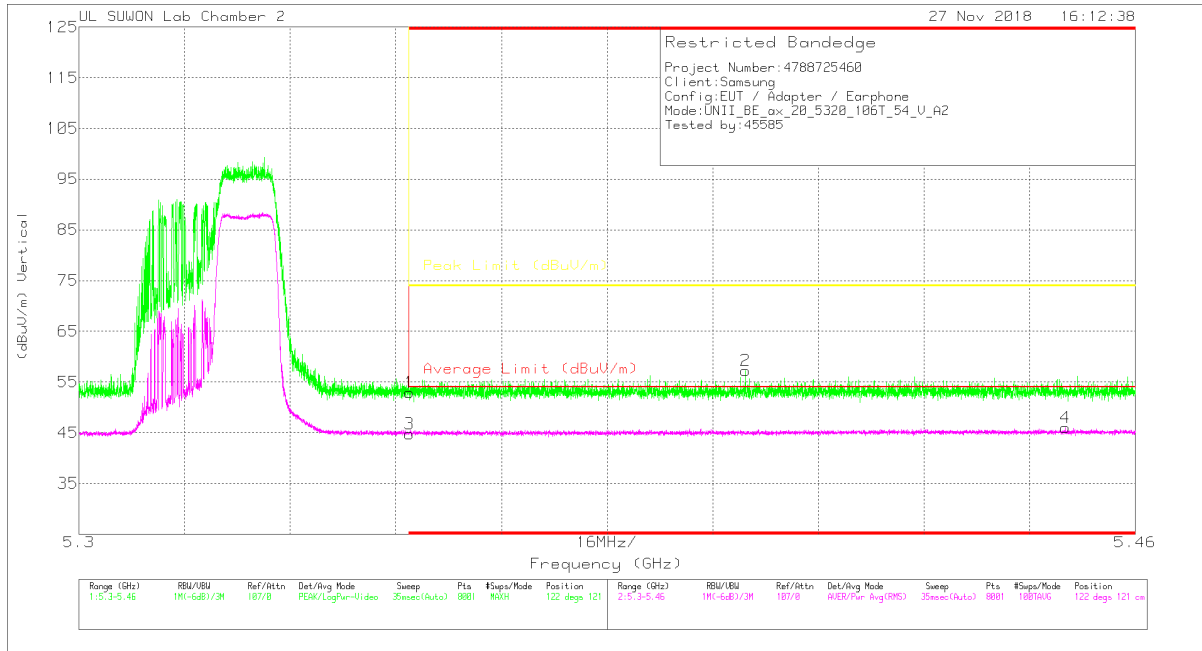

VERTICAL DATA

Trace Markers

Marker	Frequency (GHz)	Meter Reading (dBuV)	Det	3117_00168724	10dB(dB)	DC Corr (dB)	Corrected Reading (dBuV/m)	Average Limit (dBuV/m)	Margin (dB)	Peak Limit (dBuV/m)	PK Margin (dB)	Azimuth (Degs)	Height (cm)	Polarity
1	* 5.35	36.48	PK	34.5	-18.1	0	52.88	-	-	74	-21.12	122	121	V
2	* 5.401	40.91	PK	34.5	-18.2	0	57.21	-	-	74	-16.79	122	121	V
3	* 5.35	26.96	RMS	34.5	-17.1	.45	44.81	54	-9.19	-	-	122	121	V
4	* 5.449	27.9	RMS	34.5	-16.9	.45	45.95	54	-8.05	-	-	122	121	V

* - indicates frequency in CFR47 Pt 15 / IC RSS-Restricted Band

PK - Peak detector

RMS - RMS detection

52T RU mode (ANT_1 / HE40 / RU offset 44)

HORIZONTAL PEAK AND AVERAGE PLOT

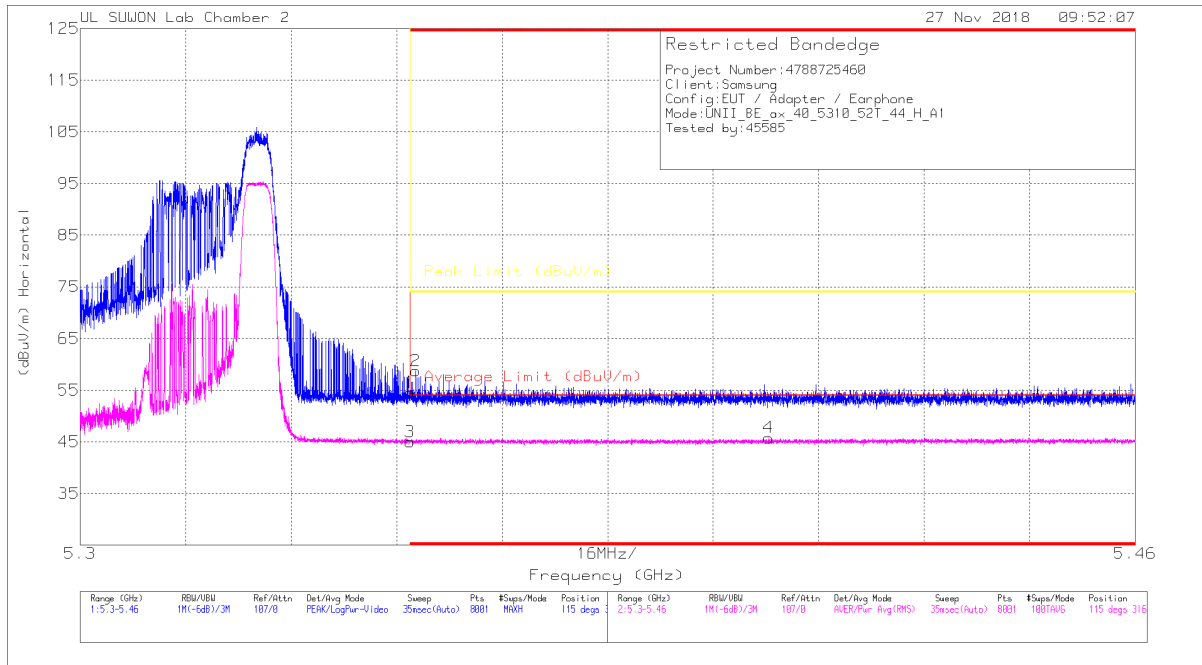

HORIZONTAL DATA

Trace Markers

Marker	Frequency (GHz)	Meter Reading (dBuV)	Det	3117_00168724	10dB(dB)	DC Corr (dB)	Corrected Reading (dBuV/m)	Average Limit (dBuV/m)	Margin (dB)	Peak Limit (dBuV/m)	PK Margin (dB)	Azimuth (Degs)	Height (cm)	Polarity
1	* 5.35	38.13	PK	34.5	-18.1	0	54.53	-	-	74	-19.47	115	316	H
2	* 5.351	42.33	PK	34.5	-18.1	0	58.73	-	-	74	-15.27	115	316	H
3	* 5.35	27.11	RMS	34.5	-17.1	.47	44.98	54	-9.02	-	-	115	316	H
4	* 5.404	27.83	RMS	34.5	-17	.47	45.8	54	-8.2	-	-	115	316	H

* - indicates frequency in CFR47 Pt 15 / IC RSS-Restricted Band

Pk - Peak detector

RMS - RMS detection

VERTICAL PEAK AND AVERAGE PLOT

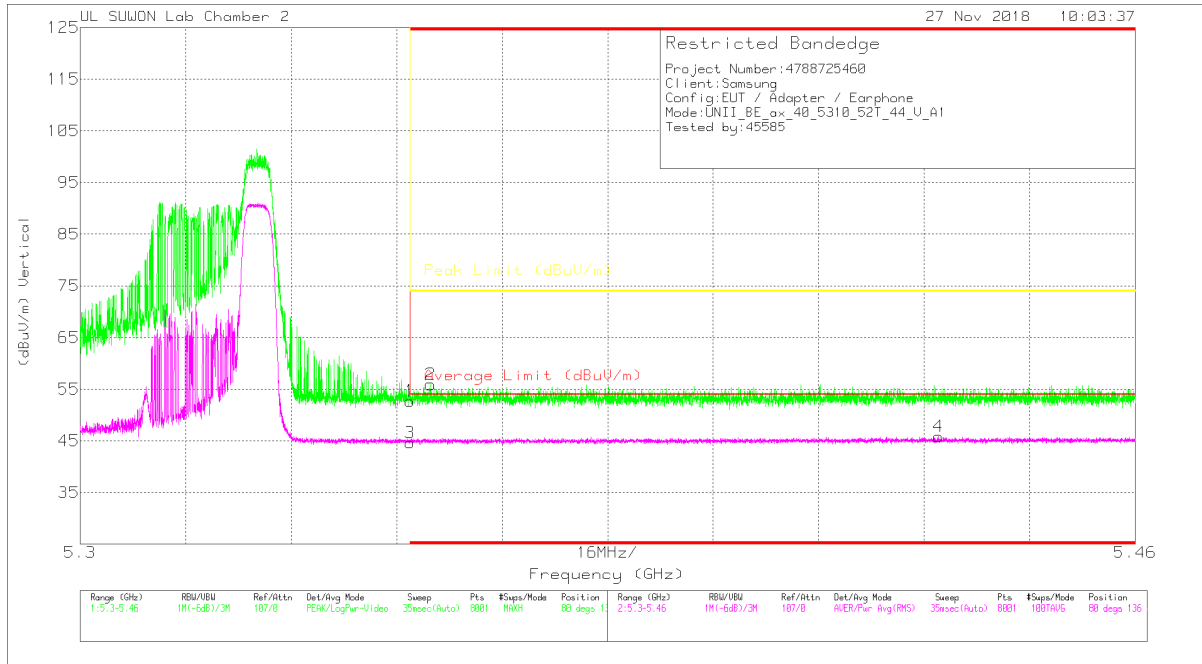

VERTICAL DATA

Trace Markers

Marker	Frequency (GHz)	Meter Reading (dBuV)	Det	3117_00168724	10dB(dB)	DC Corr (dB)	Corrected Reading (dBuV/m)	Average Limit (dBuV/m)	Margin (dB)	Peak Limit (dBuV/m)	PK Margin (dB)	Azimuth (Degs)	Height (cm)	Polarity
1	* 5.35	36.3	Pk	34.5	-18.1	0	52.7	-	-	74	-21.3	80	136	V
2	* 5.353	39.52	Pk	34.5	-18.1	0	55.92	-	-	74	-18.08	80	136	V
3	* 5.35	26.76	RMS	34.5	-17.1	.47	44.63	54	-9.37	-	-	80	136	V
4	* 5.43	27.87	RMS	34.5	-17	.47	45.84	54	-8.16	-	-	80	136	V

* - indicates frequency in CFR47 Pt 15 / IC RSS-Restricted Band

Pk - Peak detector

RMS - RMS detection

52T RU mode (ANT_2 / HE40 / RU offset 44)

HORIZONTAL PEAK AND AVERAGE PLOT

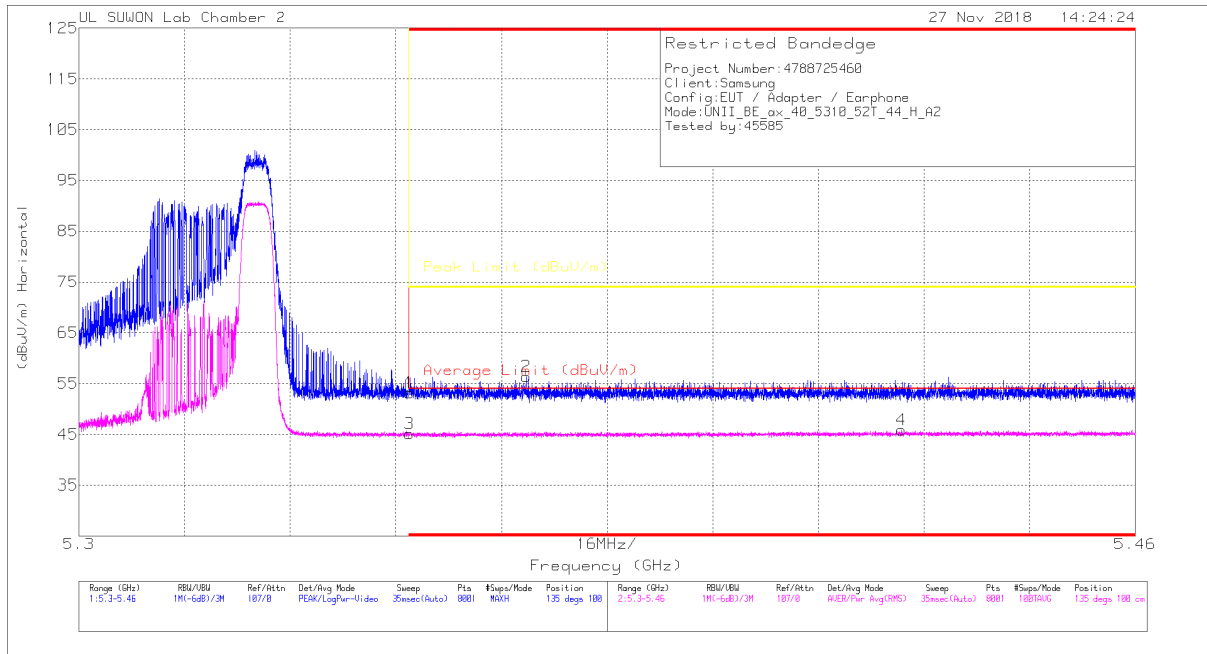

HORIZONTAL DATA

Trace Markers

Marker	Frequency (GHz)	Meter Reading (dBuV)	Det	3117_00168724	10dB(dB)	DC Corr (dB)	Corrected Reading (dBuV/m)	Average Limit (dBuV/m)	Margin (dB)	Peak Limit (dBuV/m)	PK Margin (dB)	Azimuth (Degs)	Height (cm)	Polarity
1	* 5.35	36.81	Pk	34.5	-18.1	0	53.21	-	-	74	-20.79	135	100	H
2	* 5.368	39.94	Pk	34.5	-18.1	0	56.34	-	-	74	-17.66	135	100	H
3	* 5.35	27.23	RMS	34.5	-17.1	.47	45.1	54	-8.9	-	-	135	100	H
4	* 5.425	27.89	RMS	34.5	-17	.47	45.86	54	-8.14	-	-	135	100	H

* - indicates frequency in CFR47 Pt 15 / IC RSS-Restricted Band

Pk - Peak detector

RMS - RMS detection

VERTICAL PEAK AND AVERAGE PLOT

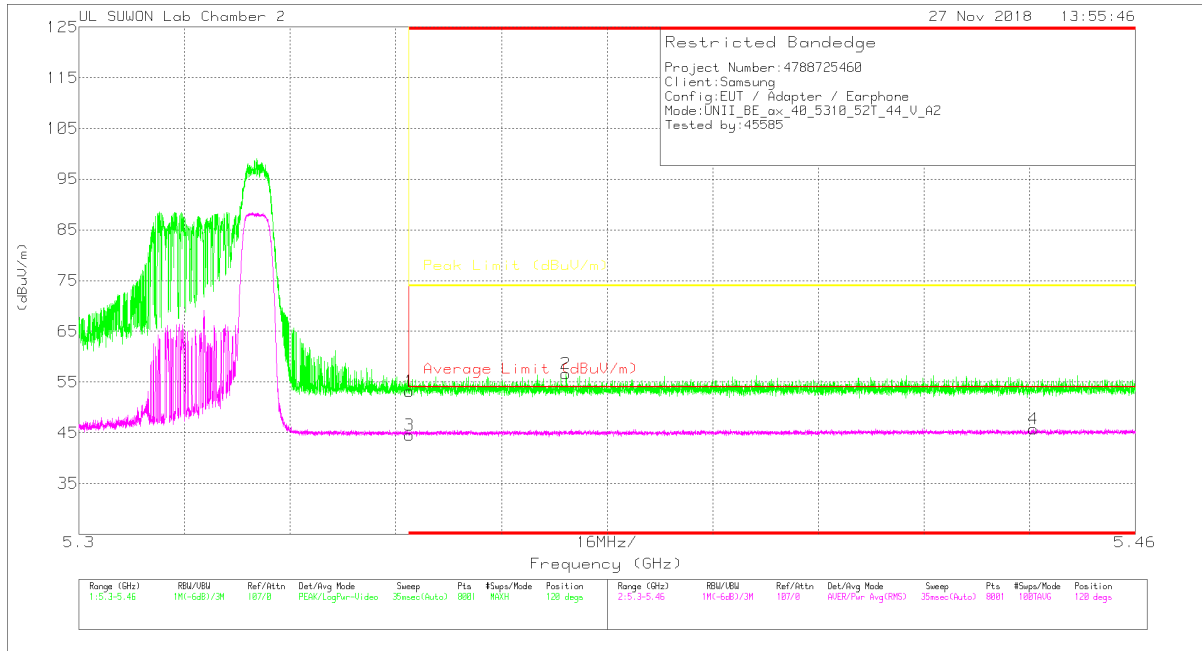

VERTICAL DATA

Trace Markers

Marker	Frequency (GHz)	Meter Reading (dBuV)	Det	3117_00168724	10dB(dB)	DC Corr (dB)	Corrected Reading (dBuV/m)	Average Limit (dBuV/m)	Margin (dB)	Peak Limit (dBuV/m)	PK Margin (dB)	Azimuth (Degs)
1	* 5.35	36.8	Pk		-18.1	0	53.2	-	-	74	-20.8	120
2	* 5.374	40.23	Pk		-18.1	0	56.63	-	-	74	-17.37	120
3	* 5.35	26.59	RMS		-17.1	.47	44.46	54	-9.54	-	-	120
4	* 5.445	27.67	RMS		-16.9	.47	45.74	54	-8.26	-	-	120

* - indicates frequency in CFR47 Pt 15 / IC RSS-Restricted Band

Pk - Peak detector

RMS - RMS detection

26T RU mode (ANT_1 / HE40 / RU offset 17)

HORIZONTAL PEAK AND AVERAGE PLOT

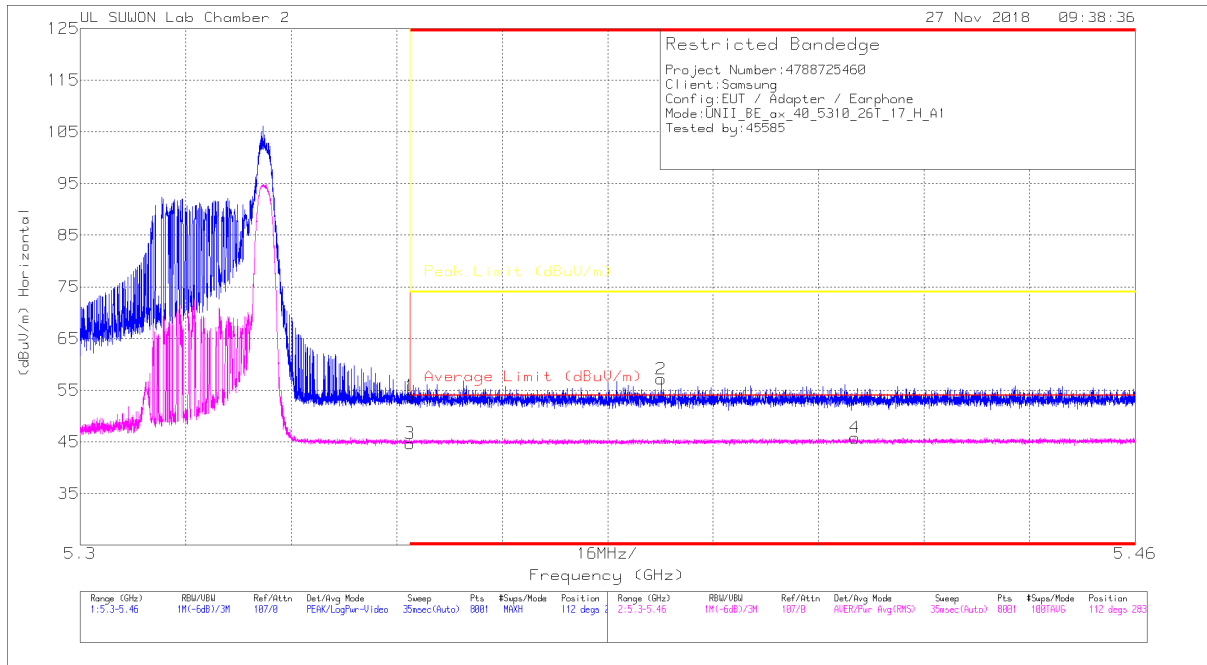

HORIZONTAL DATA

Trace Markers

Marker	Frequency (GHz)	Meter Reading (dBu)	Det	3117_00168724	10dB(dB)	DC Corr (dB)	Corrected Reading (dBu/m)	Average Limit (dBu/m)	Margin (dB)	Peak Limit (dBu/m)	PK Margin (dB)	Azimuth (Degs)	Height (cm)	Polarity
1	* 5.35	37.51	Pk	34.5	-18.1	0	53.91	-	-	74	-20.09	112	283	H
2	* 5.388	40.77	Pk	34.5	-18.1	0	57.17	-	-	74	-16.83	112	283	H
3	* 5.35	26.79	RMS	34.5	-17.1	49	44.68	54	-9.32	-	-	112	283	H
4	* 5.417	27.83	RMS	34.5	-17	49	45.82	54	-8.18	-	-	112	283	H

* - indicates frequency in CFR47 Pt 15 / IC RSS-Restricted Band

Pk - Peak detector

RMS - RMS detection

VERTICAL PEAK AND AVERAGE PLOT

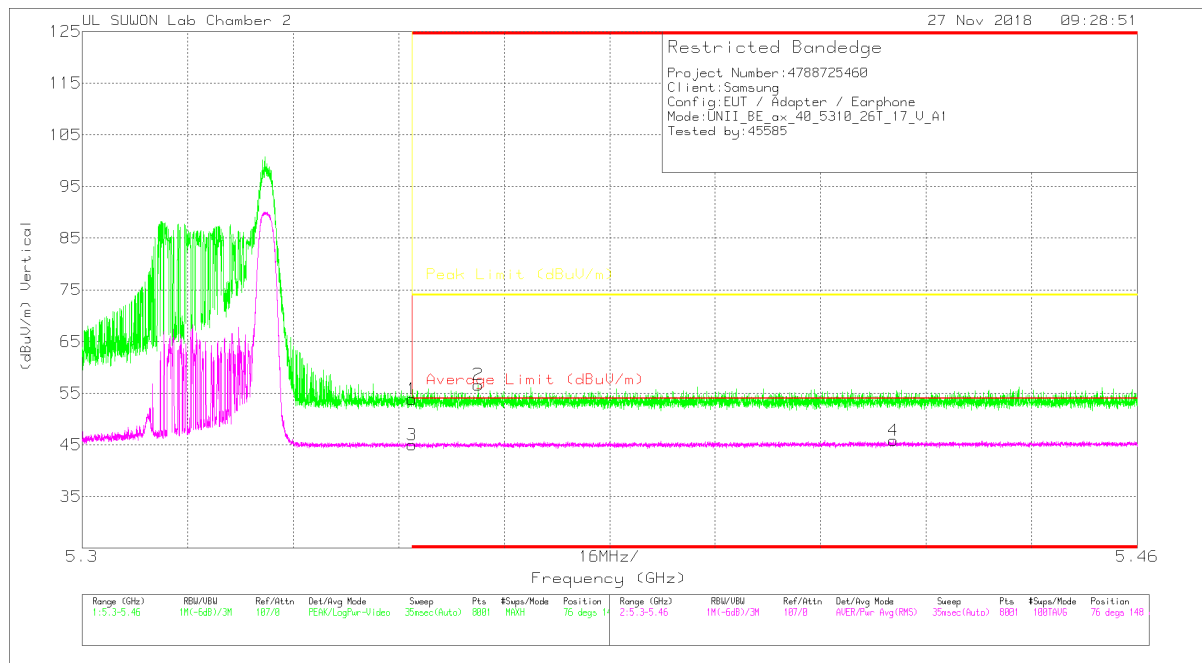

VERTICAL DATA

Trace Markers

Marker	Frequency (GHz)	Meter Reading (dBuV)	Det	3117_00168724	10dB(dB)	DC Corr (dB)	Corrected Reading (dBuV/m)	Average Limit (dBuV/m)	Margin (dB)	Peak Limit (dBuV/m)	PK Margin (dB)	Azimuth (Degs)	Height (cm)	Polarity
1	* 5.35	37.45	Pk		34.5	-18.1	53.85	-	-	74	-20.15	76	148	V
2	* 5.36	40.23	Pk		34.5	-18.1	56.63	-	-	74	-17.37	76	148	V
3	* 5.35	27.12	RMS		34.5	-17.1	45.01	54	-8.99	-	-	76	148	V
4	* 5.423	27.86	RMS		34.5	-17	45.85	54	-8.15	-	-	76	148	V

* - indicates frequency in CFR47 Pt 15 / IC RSS-Restricted Band

Pk - Peak detector

RMS - RMS detection

26T RU mode (ANT_2 / HE40 / RU offset 17)

HORIZONTAL PEAK AND AVERAGE PLOT

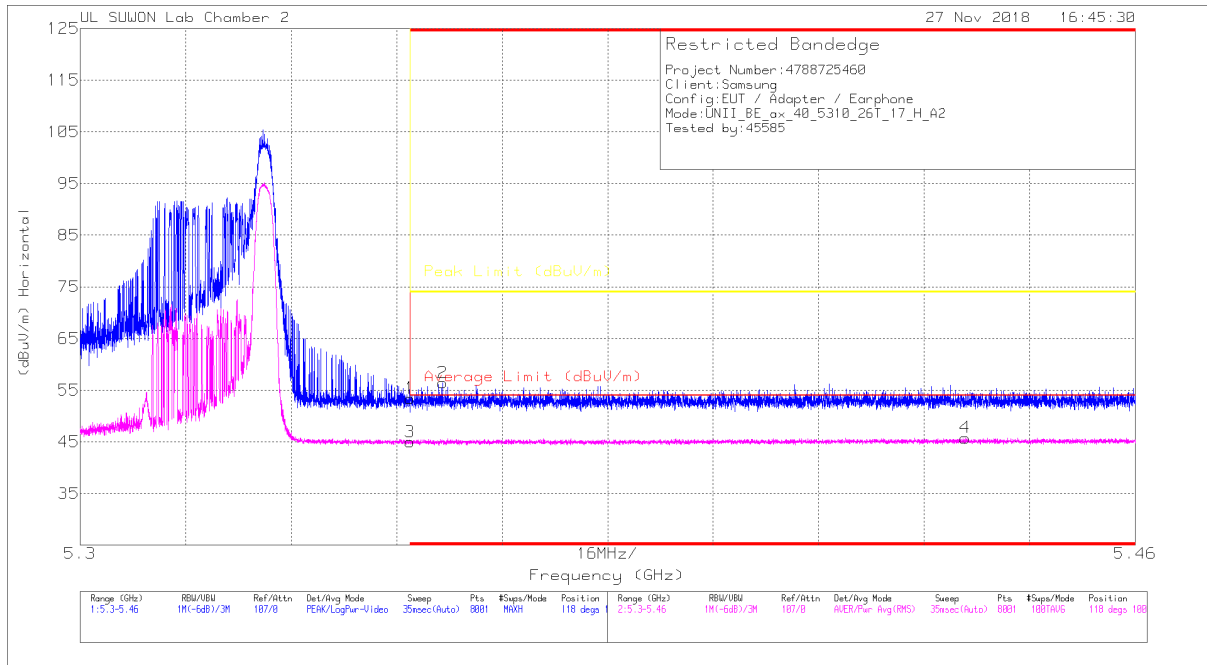

HORIZONTAL DATA

Trace Markers

Marker	Frequency (GHz)	Meter Reading (dBuV)	Det	3117_D0168724	10dB(dB)	DC Corr (dB)	Corrected Reading (dBuV/m)	Average Limit (dBuV/m)	Margin (dB)	Peak Limit (dBuV/m)	PK Margin (dB)	Azimuth (Degs)	Height (cm)	Polarity
1	* 5.35	37.04	Pk	34.5	-18.1	0	53.44	-	-	74	-20.56	118	100	H
2	* 5.355	40.06	Pk	34.5	-18.1	0	56.46	-	-	74	-17.54	118	100	H
3	* 5.35	27.11	RMS	34.5	-17.1	49	45	54	-9	-	-	118	100	H
4	* 5.434	27.8	RMS	34.5	-17	49	45.79	54	-8.21	-	-	118	100	H

* - indicates frequency in CFR47 Pt 15 / IC RSS-Restricted Band

Pk - Peak detector

RMS - RMS detection

VERTICAL PEAK AND AVERAGE PLOT

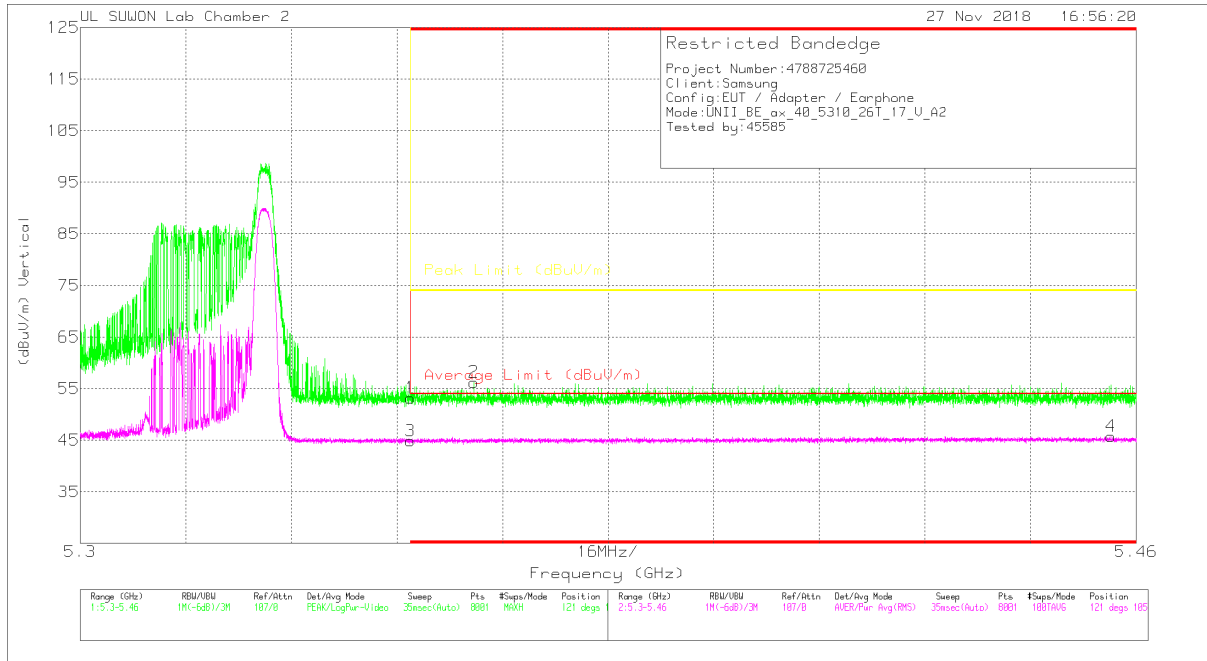

VERTICAL DATA

Trace Markers

Marker	Frequency (GHz)	Meter Reading (dBuV)	Det	3117_00168724	10dB(dB)	DC Corr (dB)	Corrected Reading (dBuV/m)	Average Limit (dBuV/m)	Margin (dB)	Peak Limit (dBuV/m)	PK Margin (dB)	Azimuth (Degs)	Height (cm)	Polarity
1	* 5.35	36.8	Pk	34.5	-18.1	0	53.2	-	-	74	-20.8	121	105	V
2	* 5.36	39.84	Pk	34.5	-18.1	0	56.24	-	-	74	-17.76	121	105	V
3	* 5.35	26.99	RMS	34.5	-17.1	49	44.88	54	-9.12	-	-	121	105	V
4	* 5.456	27.56	RMS	34.6	-16.9	49	45.75	54	-8.25	-	-	121	105	V

* - indicates frequency in CFR47 Pt 15 / IC RSS-Restricted Band

Pk - Peak detector

RMS - RMS detection

HARMONICS AND SPURIOUS EMISSIONS

HE20 SU mode (ANT_1)

LOW CHANNEL HORIZONTAL

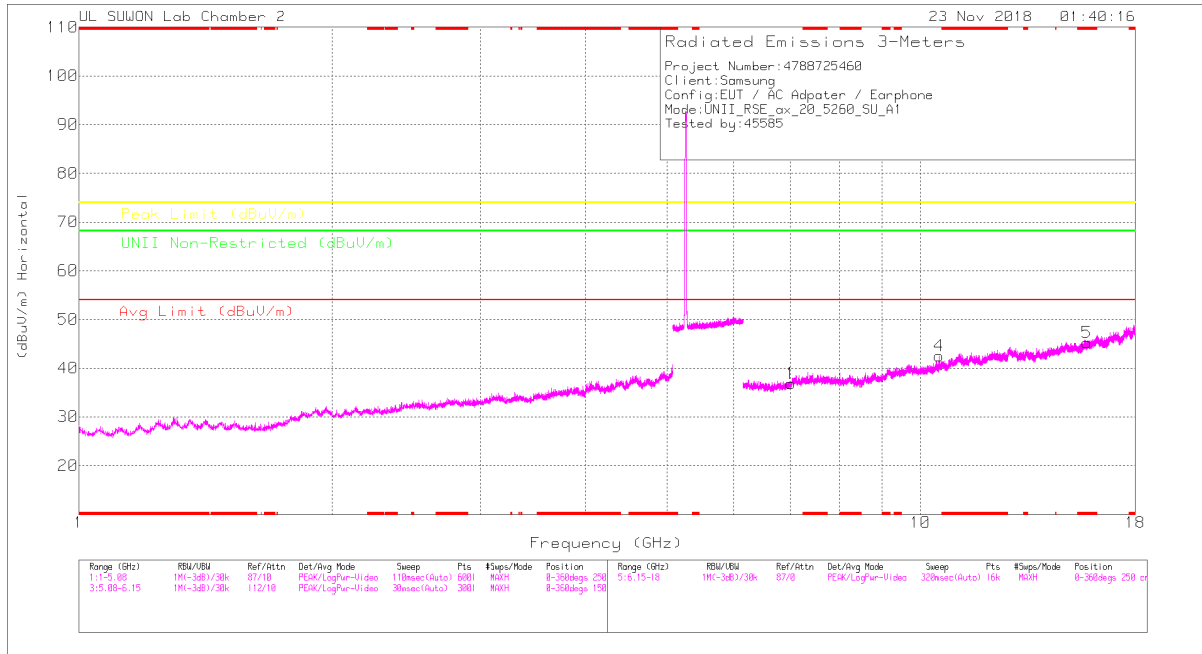

LOW CHANNEL VERTICAL

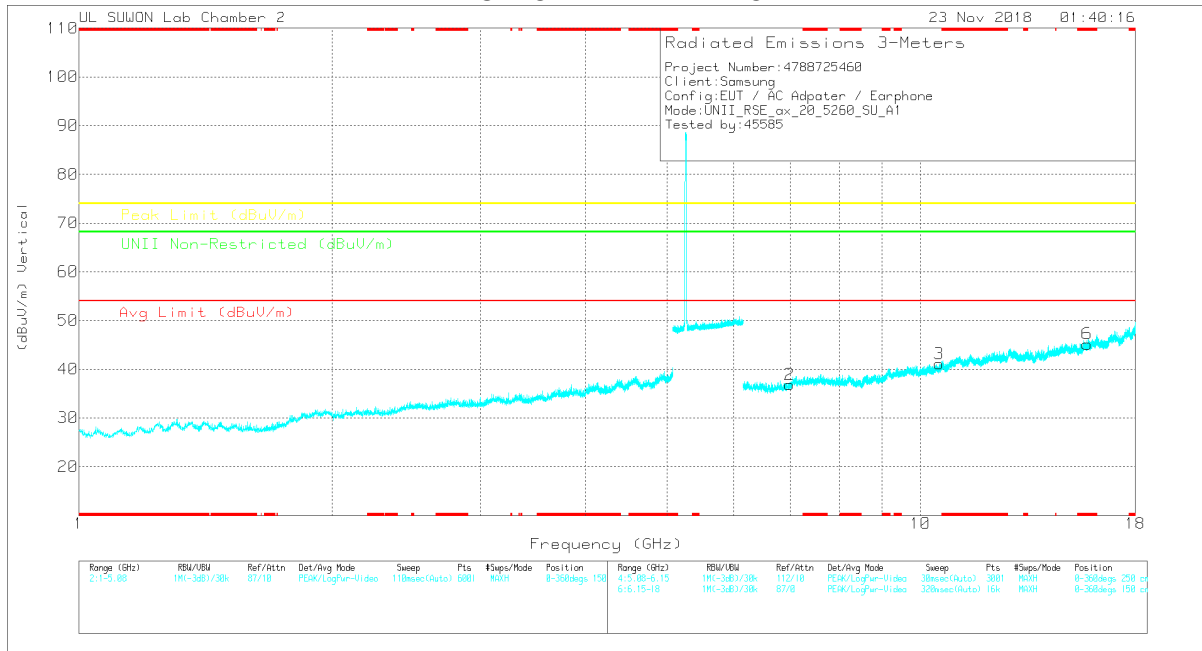

Note: Emission was scanned up to 40GHz; No emissions were detected above the noise floor which was at least 20dB below the specification limit.

LOW CHANNEL DATA

Trace Markers

Marker	Frequency (GHz)	Meter Reading (dBuV)	Det	3117_00168724	6GHz_HF(dB)	DC Corr (dB)	Corrected Reading (dBuV/m)	Avg Limit (dBuV/m)	Margin (dB)	Peak Limit (dBuV/m)	Margin (dB)	UNII Non-Restricted (dBuV/m)	Margin (dB)	Asimuth (Degs)	Height (cm)	Polarity
1	7.014	26.59	PK	35.8	-25.5	0	36.89	-	-	-	-	68.2	-31.31	0-360	150	H
4	10.522	25.67	PK	37.7	-20.8	0	42.57	-	-	-	-	68.2	-25.63	0-360	250	H
5	* 15.776	25	PK	40.3	-20	0	45.3	-	-	74	-28.7	-	-	0-360	150	H
2	6.993	26.69	PK	35.8	-25.7	0	36.79	-	-	-	-	68.2	-31.41	0-360	250	V
3	10.52	24.06	PK	37.7	-20.7	0	41.06	-	-	-	-	68.2	-27.14	0-360	250	V
6	* 15.778	24.88	PK	40.3	-20	0	45.18	-	-	74	-28.82	-	-	0-360	250	V

* - indicates frequency in CFR47 Pt 15 / IC RSS-Restricted Band
 PK – Peak Detector

Radiated Emissions

Frequency (GHz)	Meter Reading (dBuV)	Det	3117_00168724	6GHz_HF(dB)	DC Corr (dB)	Corrected Reading (dBuV/m)	Avg Limit (dBuV/m)	Margin (dB)	Peak Limit (dBuV/m)	Margin (dB)	UNII Non-Restricted (dBuV/m)	Margin (dB)	Asimuth (Degs)	Height (cm)	Polarity
10.521	37.56	PK-U	37.7	-20.7	0	54.56	-	-	-	-	68.2	-13.64	100	247	H
10.52	36.17	PK-U	37.7	-20.7	0	53.17	-	-	-	-	68.2	-15.03	173	221	V

* - indicates frequency in CFR47 Pt 15 / IC RSS-Restricted Band
 PK-U - U-NII: Maximum Peak

MID CHANNEL HORIZONTAL

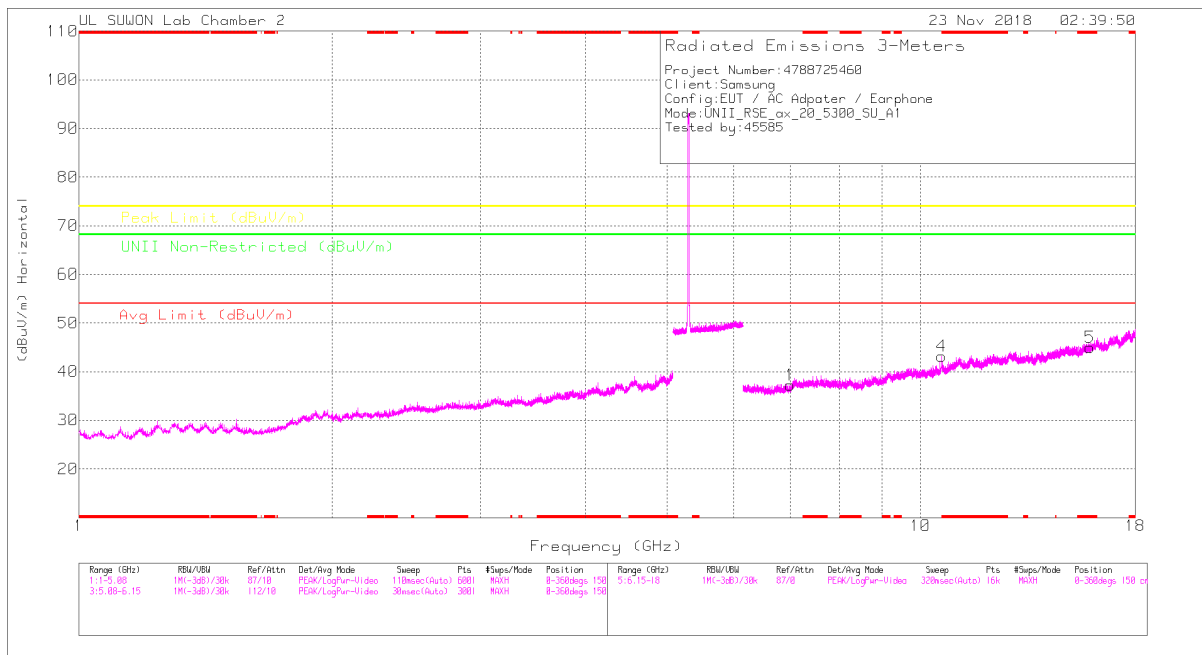

MID CHANNEL VERTICAL

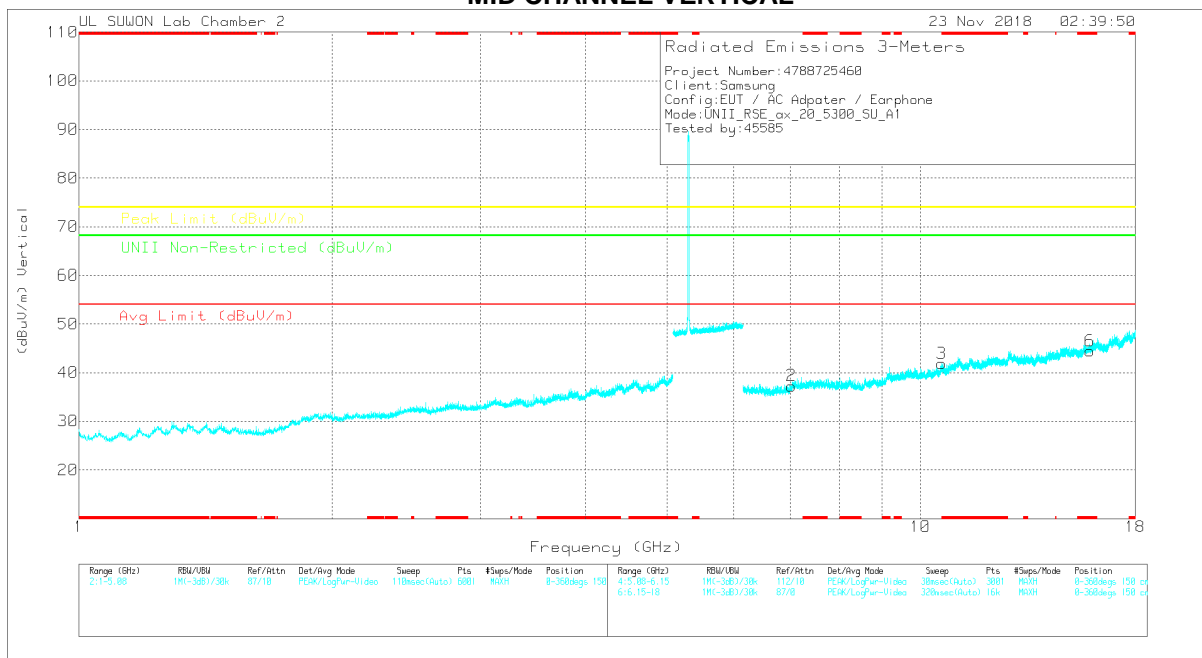

Note: Emission was scanned up to 40GHz; No emissions were detected above the noise floor which was at least 20dB below the specification limit.

MID CHANNEL DATA

Trace Markers

Marker	Frequency (GHz)	Meter Reading (dBuV)	Det	3117_00168724	6GHz_HF[dB]	DC Corr (dB)	Corrected Reading (dBuV/m)	Avg Limit (dBuV/m)	Margin (dB)	Peak Limit (dBuV/m)	Margin (dB)	UNII Non-Restricted (dBuV/m)	Margin (dB)	Asimuth (Degs)	Height (cm)	Polarity
1	7.004	27.09	PK	35.8	-25.7	0	37.19	-	-	-	-	68.2	-31.01	0-360	150	H
4	10.599	25.09	PK	37.8	-19.7	0	43.19	-	-	-	-	68.2	-25.01	0-360	150	H
5	* 15.901	24	PK	40.5	-19.5	0	45	-	-	74	-29	-	-	0-360	250	H
2	7.026	26.69	PK	35.9	-25.3	0	37.29	-	-	-	-	68.2	-30.91	0-360	250	V
3	10.599	23.83	PK	37.8	-19.7	0	41.93	-	-	-	-	68.2	-26.27	0-360	250	V
6	* 15.901	23.47	PK	40.5	-19.5	0	44.47	-	-	74	-29.53	-	-	0-360	250	V

* - indicates frequency in CFR47 Pt 15 / IC RSS-Restricted Band

PK – Peak Detector

Radiated Emissions

Frequency (GHz)	Meter Reading (dBuV)	Det	3117_00168724	6GHz_HF[dB]	DC Corr (dB)	Corrected Reading (dBuV/m)	Avg Limit (dBuV/m)	Margin (dB)	Peak Limit (dBuV/m)	Margin (dB)	UNII Non-Restricted (dBuV/m)	Margin (dB)	Asimuth (Degs)	Height (cm)	Polarity
* 10.61	38.15	PK-U	37.8	-19.6	0	56.35	-	-	74	-17.65	-	-	105	115	H
* 10.6	24.41	ADR	37.8	-19.7	.11	42.62	54	-11.38	-	-	-	-	105	115	H
* 10.602	35.85	PK-U	37.8	-19.7	0	53.95	-	-	74	-20.05	-	-	173	231	V
* 10.6	22.6	ADR	37.8	-19.7	.11	40.81	54	-13.19	-	-	-	-	173	231	V

* - indicates frequency in CFR47 Pt 15 / IC RSS-Restricted Band

PK-U - U-NII: Maximum Peak

ADR - U-NII AD primary method, RMS average