

LOW CHANNEL HORIZONTAL

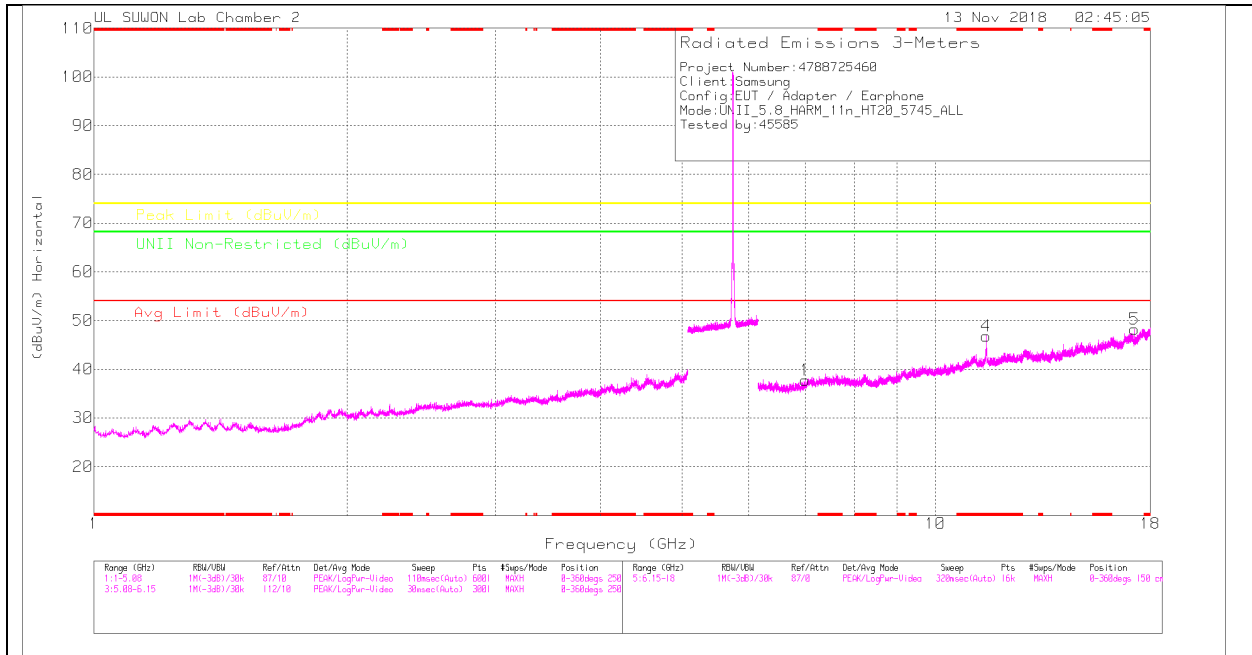

LOW CHANNEL VERTICAL

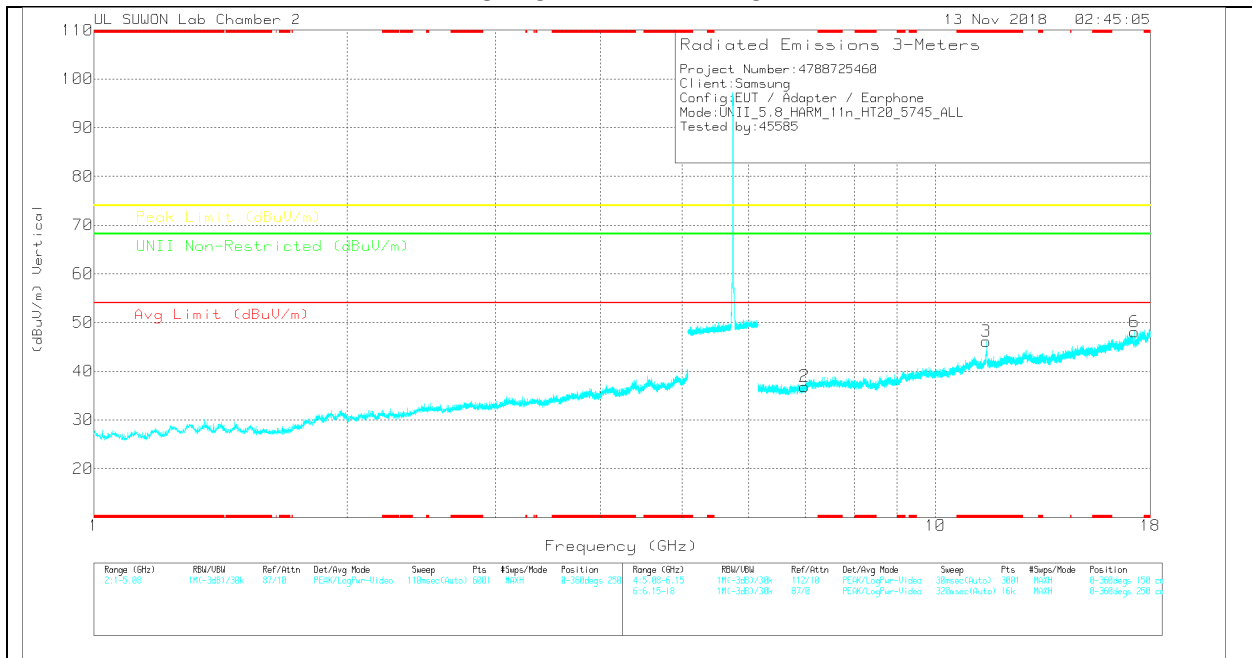

Note: Emission was scanned up to 40GHz; No emissions were detected above the noise floor which was at least 20dB below the specification limit.

LOW CHANNEL DATA

Trace Markers

Marker	Frequency (GHz)	Meter Reading (dBuV)	Det	3117_00168724	6GHz_HF[dB]	DC Corr (dB)	Corrected Reading (dBuV/m)	Avg Limit (dBuV/m)	Margin (dB)	Peak Limit (dBuV/m)	Margin (dB)	LNII Non-Restricted (dBuV/m)	Margin (dB)	Asimuth (Degs)	Height (cm)	Polarity
1	7.004	27.62	PK	35.8	-25.7	0	37.72	-	-	-	-	68.2	-30.48	0-360	150	H
4	* 11.485	28.51	PK	38.3	-20	0	45.81	-	-	74	-27.19	-	-	0-360	250	H
5	17.238	25.68	PK	41.3	-18.8	0	48.18	-	-	-	-	68.2	-20.02	0-360	250	H
2	6.991	26.9	PK	35.8	-25.8	0	36.9	-	-	-	-	68.2	-31.3	0-360	150	V
3	* 11.489	27.9	PK	38.3	-20	0	46.2	-	-	74	-27.8	-	-	0-360	250	V
6	17.235	25.48	PK	41.3	-18.7	0	48.08	-	-	-	-	68.2	-20.12	0-360	250	V

* - indicates frequency in CFR47 Pt 15 / IC RSS-Restricted Band

PK – Peak Detector

Radiated Emissions

Frequency (GHz)	Meter Reading (dBuV)	Det	3117_00168724	6GHz_HF[dB]	DC Corr (dB)	Corrected Reading (dBuV/m)	Avg Limit (dBuV/m)	Margin (dB)	Peak Limit (dBuV/m)	Margin (dB)	LNII Non-Restricted (dBuV/m)	Margin (dB)	Asimuth (Degs)	Height (cm)	Polarity
* 11.482	38.4	PK-U	38.3	-20	0	56.7	-	-	74	-17.3	-	-	198	230	H
* 11.49	26.63	ADR	38.3	-19.9	0	45.03	54	-8.97	-	-	-	-	198	230	H
* 11.484	39.42	PK-U	38.3	-20	0	57.72	-	-	74	-16.28	-	-	121	102	V
* 11.492	26.59	ADR	38.3	-20	0	44.89	54	-9.11	-	-	-	-	121	102	V
17.237	38.41	PK-U	41.3	-18.8	0	60.91	-	-	-	-	68.2	-7.29	214	201	V
17.247	37.22	PK-U	41.3	-18.7	0	59.82	-	-	-	-	68.2	-8.38	96	109	H

* - indicates frequency in CFR47 Pt 15 / IC RSS-Restricted Band

PK-U - U-NII: Maximum Peak

ADR - U-NII AD primary method, RMS average

MID CHANNEL HORIZONTAL

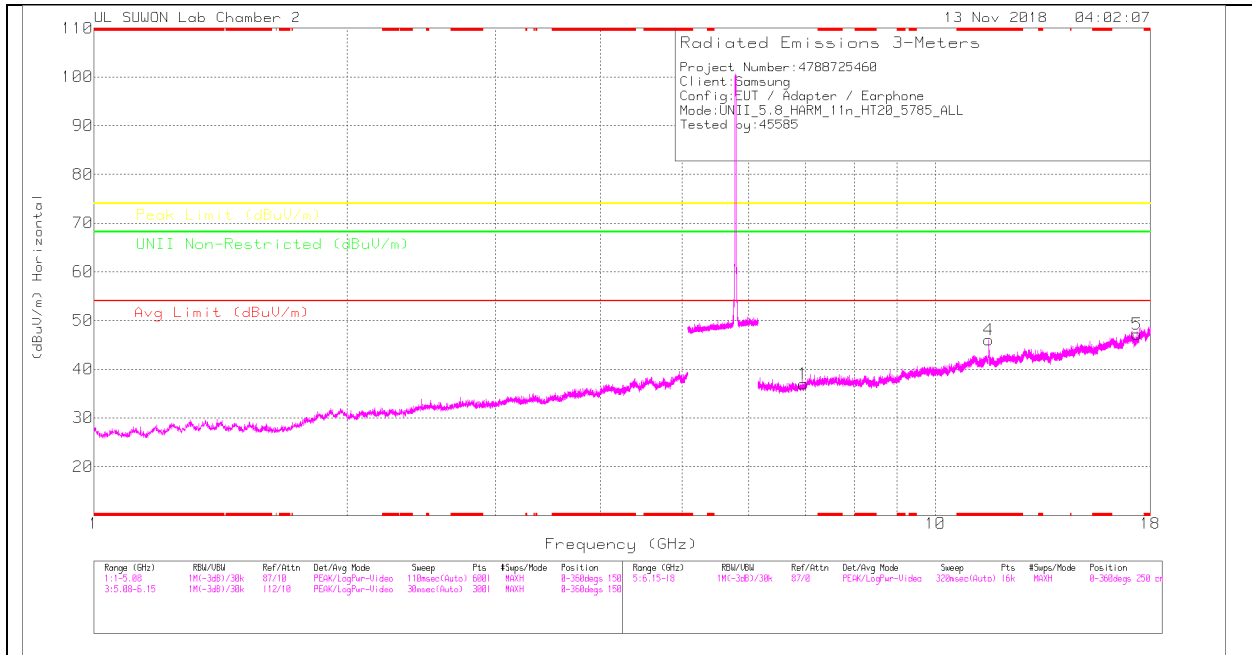

MID CHANNEL VERTICAL

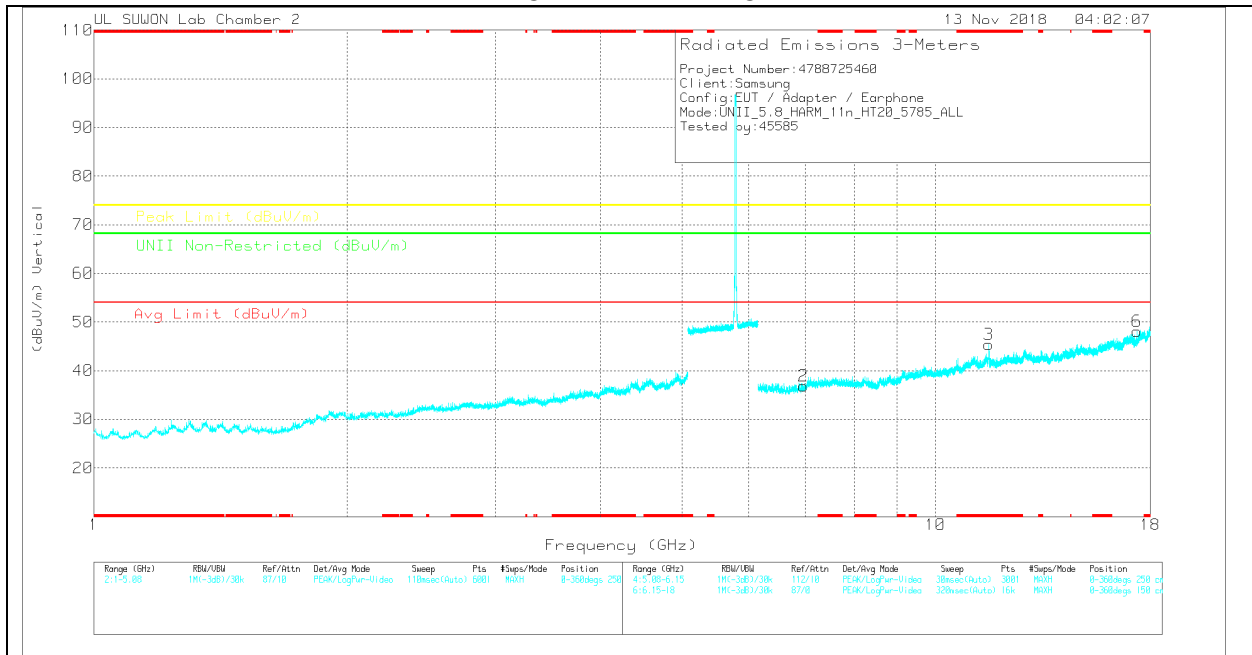

Note: Emission was scanned up to 40GHz; No emissions were detected above the noise floor which was at least 20dB below the specification limit.

MID CHANNEL DATA

Trace Markers

Marker	Frequency (GHz)	Meter Reading (dBuV)	Det	3117_00168724	6GHz_HF(dB)	DC Corr (dB)	Corrected Reading (dBuV/m)	Avg Limit (dBuV/m)	Margin (dB)	Peak Limit (dBuV/m)	Margin (dB)	UNII Non-Restricted (dBuV/m)	Margin (dB)	Azimuth (Degs)	Height (cm)	Polarity
1	6.969	26.71	PK	35.8	-25.6	0	36.91	-	-	-	-	68.2	-31.29	0-360	150	H
4	* 11.57	27.7	PK	38.4	-20.1	0	46	-	-	74	-28	-	-	0-360	150	H
5	17.358	24.65	PK	41.3	-18.8	0	47.15	-	-	-	-	68.2	-21.05	0-360	250	H
2	6.962	26.65	PK	35.8	-25.6	0	36.86	-	-	-	-	68.2	-31.34	0-360	250	V
3	* 11.57	27.02	PK	38.4	-20.1	0	45.32	-	-	74	-28.68	-	-	0-360	250	V
6	17.357	25.63	PK	41.3	-18.8	0	48.13	-	-	-	-	68.2	-20.07	0-360	250	V

* - indicates frequency in CFR47 Pt 15 / IC RSS-Restricted Band
 PK – Peak Detector

Radiated Emissions

Frequency (GHz)	Meter Reading (dBuV)	Det	3117_00168724	6GHz_HF(dB)	DC Corr (dB)	Corrected Reading (dBuV/m)	Avg Limit (dBuV/m)	Margin (dB)	Peak Limit (dBuV/m)	Margin (dB)	UNII Non-Restricted (dBuV/m)	Margin (dB)	Azimuth (Degs)	Height (cm)	Polarity
* 11.565	37.92	PK-U	38.4	-19.9	0	56.42	-	-	74	-17.58	-	-	102	325	H
* 11.57	25.57	ADR	38.4	-20	0	43.97	54	-10.03	-	-	-	-	102	325	H
* 11.57	38.95	PK-U	38.4	-20.1	0	57.25	-	-	74	-16.75	-	-	122	114	V
* 11.569	26.68	ADR	38.4	-20	0	45.08	54	-8.92	-	-	-	-	122	114	V
17.357	37.87	PK-U	41.3	-18.8	0	60.37	-	-	-	-	68.2	-7.83	212	192	V
17.365	36.97	PK-U	41.3	-18.8	0	59.37	-	-	-	-	68.2	-8.83	90	123	H

* - indicates frequency in CFR47 Pt 15 / IC RSS-Restricted Band
 PK-U - U-NII: Maximum Peak
 ADR - U-NII AD primary method, RMS average

HIGH CHANNEL HORIZONTAL

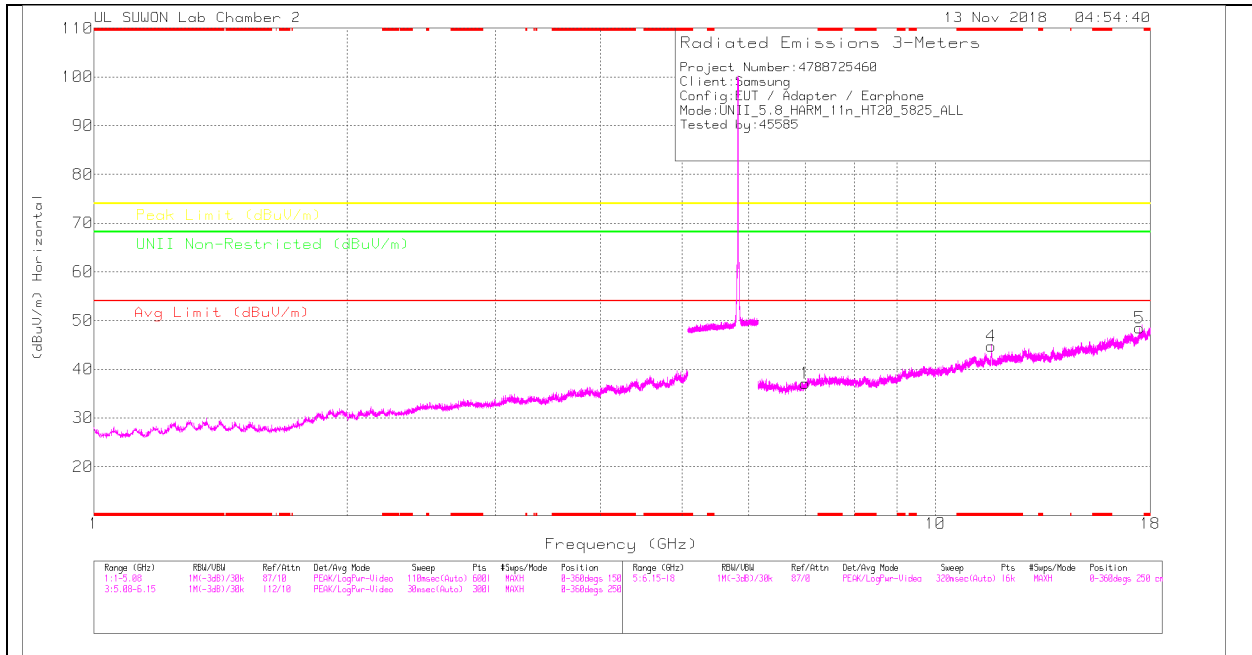

HIGH CHANNEL VERTICAL

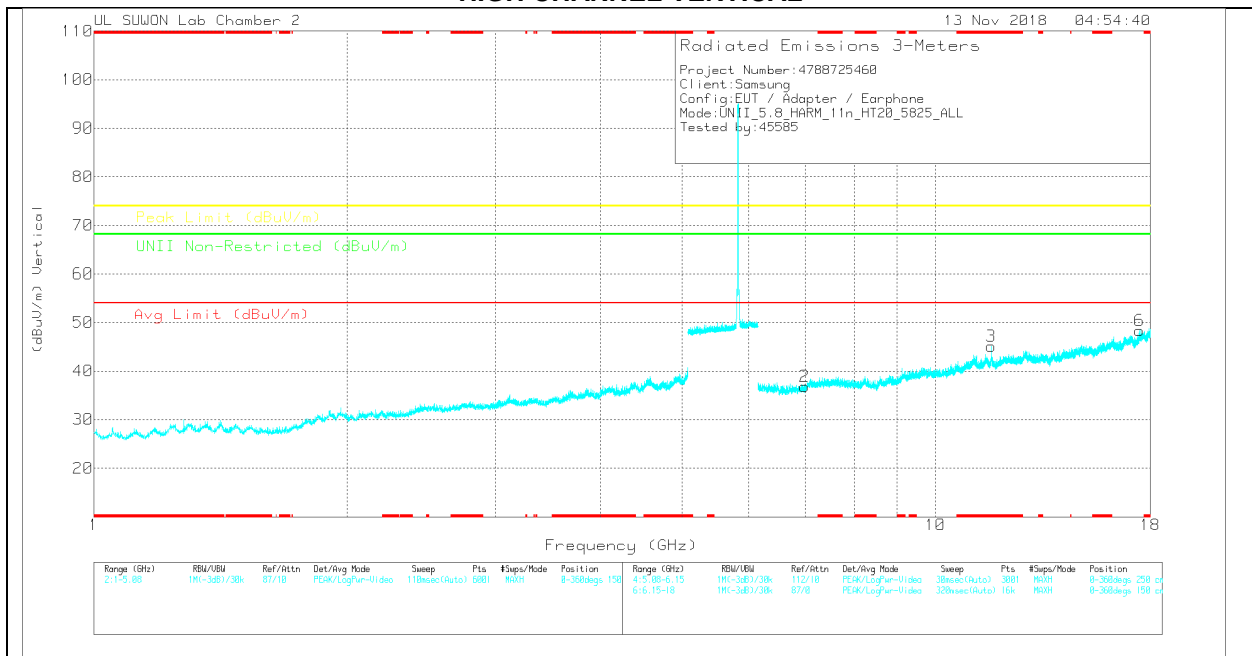

Note: Emission was scanned up to 40GHz; No emissions were detected above the noise floor which was at least 20dB below the specification limit.

HIGH CHANNEL DATA

Trace Markers

Marker	Frequency (GHz)	Meter Reading (dBuV)	Det	3117_00168724	6GHz_HP[dB]	DC Corr (dB)	Corrected Reading (dBuV/m)	Avg Limit (dBuV/m)	Margin (dB)	Peak Limit (dBuV/m)	Margin (dB)	UNII Non-Restricted (dBuV/m)	Margin (dB)	Asimuth (Degs)	Height (cm)	Polarity
1	7.005	26.85	PK	35.8	-25.6	0	37.05	-	-	-	-	68.2	-31.15	0-360	150	H
4	*11.652	26.34	PK	38.4	-20	0	44.74	-	-	74	-29.26	-	-	0-360	250	H
5	17.483	25.24	PK	41.4	-18.2	0	48.44	-	-	-	-	68.2	-19.76	0-360	150	H
2	6.988	26.7	PK	35.8	-25.7	0	36.8	-	-	-	-	68.2	-31.4	0-360	150	V
3	*11.656	26.59	PK	38.4	-19.9	0	45.09	-	-	74	-28.91	-	-	0-360	250	V
6	17.465	25.26	PK	41.4	-18.3	0	48.36	-	-	-	-	68.2	-19.84	0-360	250	V

* - indicates frequency in CFR47 Pt 15 / IC RSS-Restricted Band

PK – Peak Detector

Radiated Emissions

Frequency (GHz)	Meter Reading (dBuV)	Det	3117_00168724	6GHz_HP[dB]	DC Corr (dB)	Corrected Reading (dBuV/m)	Avg Limit (dBuV/m)	Margin (dB)	Peak Limit (dBuV/m)	Margin (dB)	UNII Non-Restricted (dBuV/m)	Margin (dB)	Asimuth (Degs)	Height (cm)	Polarity
*11.644	37.72	PK-U	38.4	-20	0	56.12	-	-	74	-17.88	-	-	125	118	H
*11.651	25.61	ADR	38.4	-20	0	44.01	54	-9.99	-	-	-	-	125	118	H
*11.644	37.05	PK-U	38.4	-20	0	55.45	-	-	74	-18.55	-	-	126	396	V
*11.65	25.26	ADR	38.4	-20	0	43.66	54	-10.34	-	-	-	-	126	396	V
17.475	35.16	PK-U	41.4	-18.2	0	58.36	-	-	-	-	68.2	-9.84	179	100	V
17.47	36.4	PK-U	41.4	-18.3	0	59.5	-	-	-	-	68.2	-8.7	159	202	H

* - indicates frequency in CFR47 Pt 15 / IC RSS-Restricted Band

PK-U - U-NII: Maximum Peak

ADR - U-NII AD primary method, RMS average

11.4.5.TX ABOVE 1GHz 802.11n HT20 1Tx ANT1 IN THE 5.8GHz BAND BANDEDGE (LOW CHANNEL)

HORIZONTAL PEAK PLOT

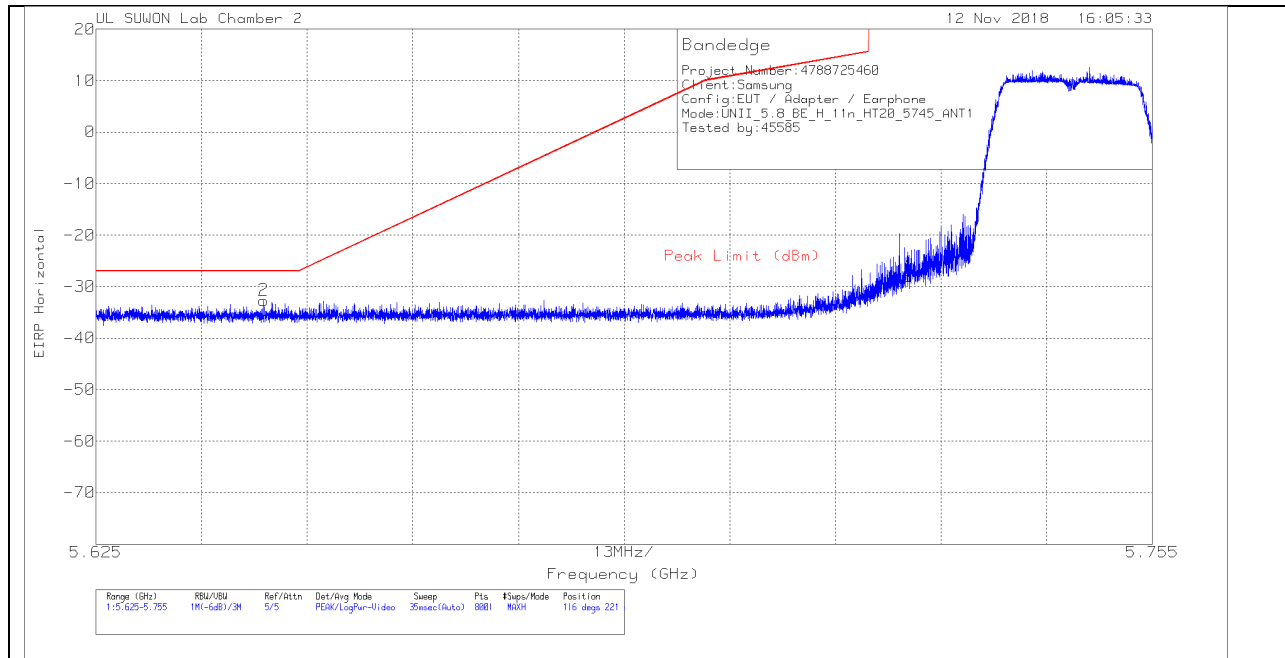

HORIZONTAL DATA

Trace Markers

Marker	Frequency (GHz)	Meter Reading (dBm)	Det	170531_3117[00 168724]	Path_2_10dB	Conversion Factor (dB)	DC Corr (dB)	Corrected Reading EIRP	Peak Limit (dBm)	PK Margin (dB)	Azimuth (Degs)	Height (cm)	Polarity
1	5.725	-58.75	Pk	34.5	-15.6	11.8	0	-28.05	26.97	-55.02	116	221	H
2	5.646	-63.14	Pk	34.4	-15.7	11.8	0	-32.64	-27	-5.64	116	221	H

Pk - Peak detector

VERTICAL PEAK PLOT

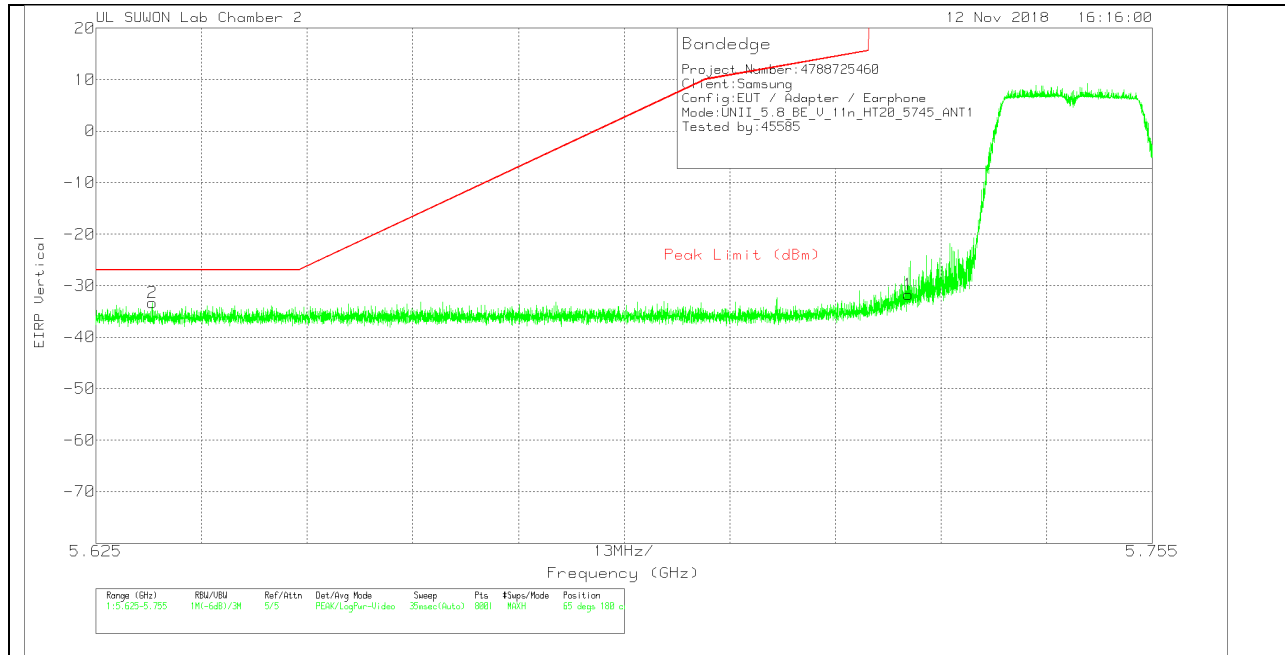

VERTICAL DATA

Trace Markers

Marker	Frequency (GHz)	Meter Reading (dBm)	Det	170531_3117[00 168724]	Path_2_10dB	Conversion Factor (dB)	DC Corr (dB)	Corrected Reading EIRP	Peak Limit (dBm)	PK Margin (dB)	Azimuth (Degs)	Height (cm)	Polarity
1	5.725	-62.4	Pk	34.5	-15.6	11.8	0	-31.7	26.97	-58.67	65	180	V
2	5.632	-63.81	Pk	34.4	-15.7	11.8	0	-33.31	-27	-6.31	65	180	V

Pk - Peak detector

BANDEDGE (HIGH CHANNEL)

HORIZONTAL PEAK AND AVERAGE PLOT

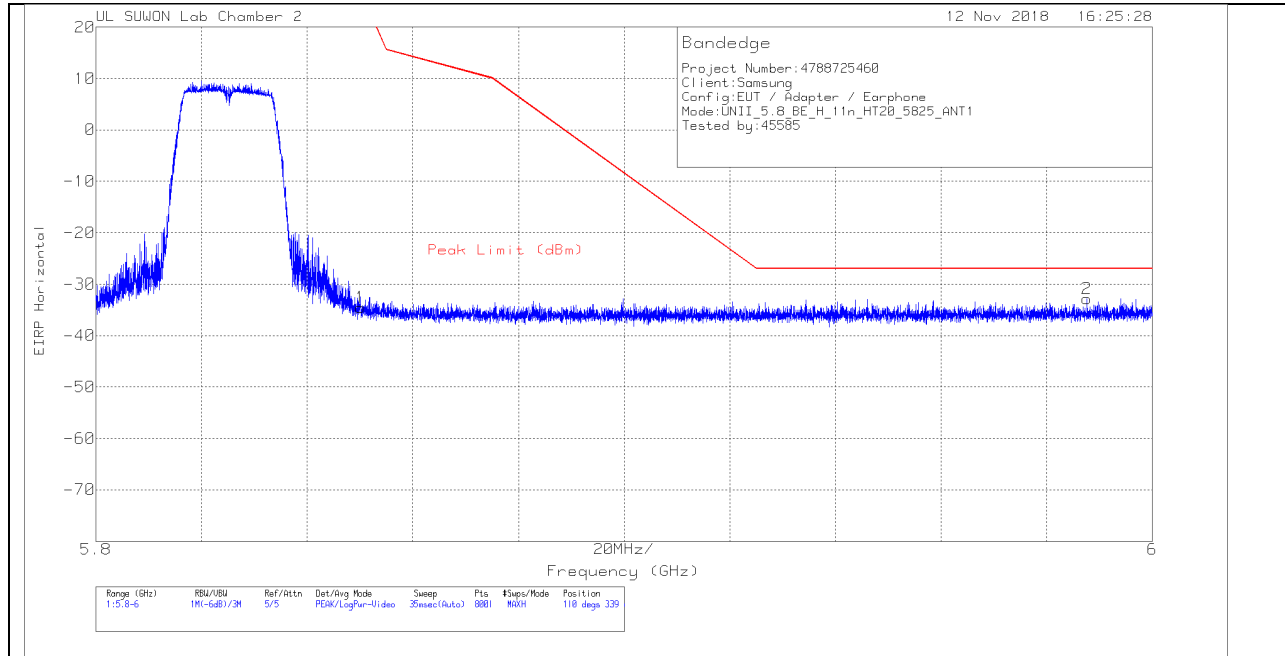

HORIZONTAL DATA

Trace Markers

Marker	Frequency (GHz)	Meter Reading (dBm)	Det	170531_3117[00 168724]	Path_2_10dB	Conversion Factor (dB)	DC Corr (dB)	Corrected Reading EIRP	Peak Limit (dBm)	PK Margin (dB)	Azimuth (Degs)	Height (cm)	Polarity
1	5.85	-65.36	Pk	34.5	-15.5	11.8	0	-34.56	26.94	-61.5	110	339	H
2	5.988	-64.01	Pk	34.8	-15.4	11.8	0	-32.81	-27	-5.81	110	339	H

Pk - Peak detector

VERTICAL PEAK PLOT

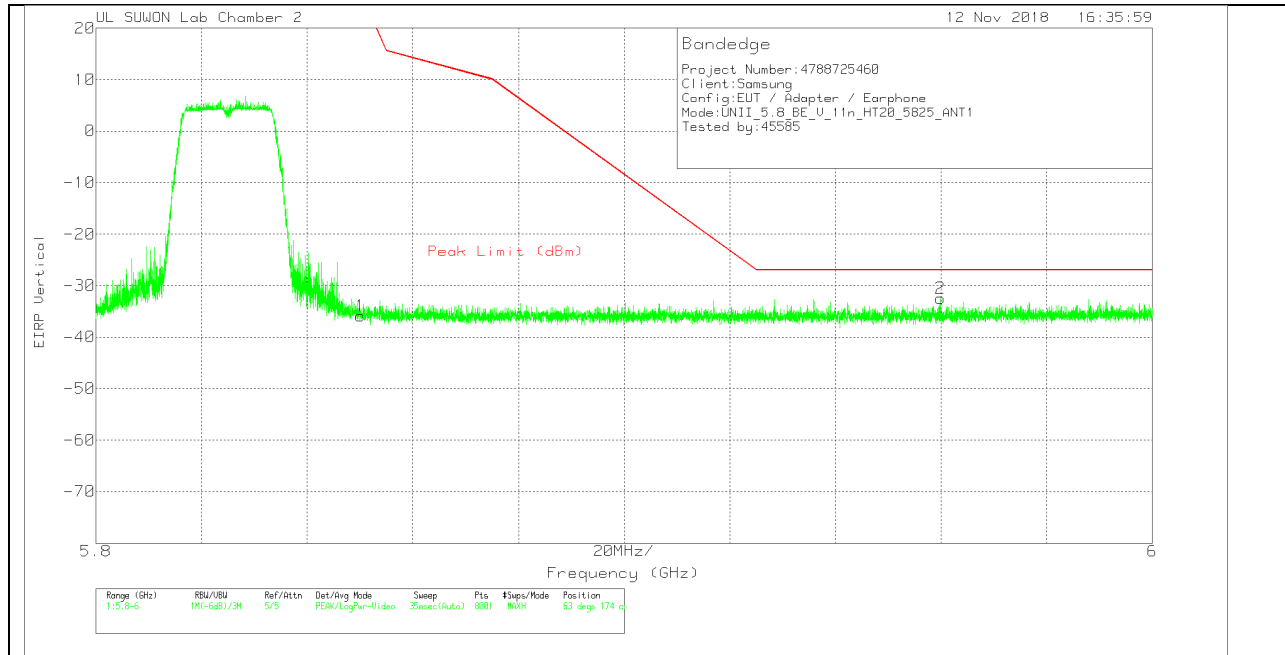

VERTICAL DATA

Trace Markers

Marker	Frequency (GHz)	Meter Reading (dBm)	Det	170531_3117[00 168724]	Path_2_10dB	Conversion Factor (dB)	DC Corr (dB)	Corrected Reading EIRP	Peak Limit (dBm)	PK Margin (dB)	Azimuth (Degs)	Height (cm)	Polarity
1	5.85	-66.65	Pk	34.5	-15.5	11.8	0	-35.85	26.94	-62.79	63	174	V
2	5.96	-63.5	Pk	34.6	-15.4	11.8	0	-32.5	-27	-5.5	63	174	V

Pk - Peak detector

LOW CHANNEL HORIZONTAL

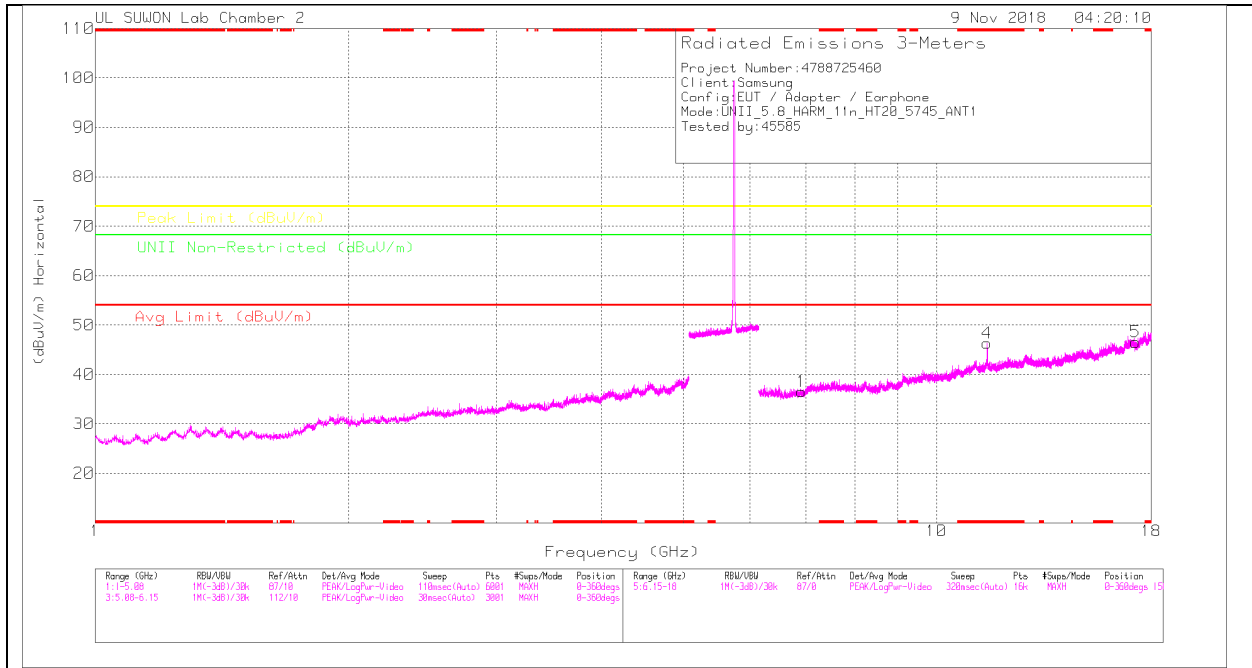

LOW CHANNEL VERTICAL

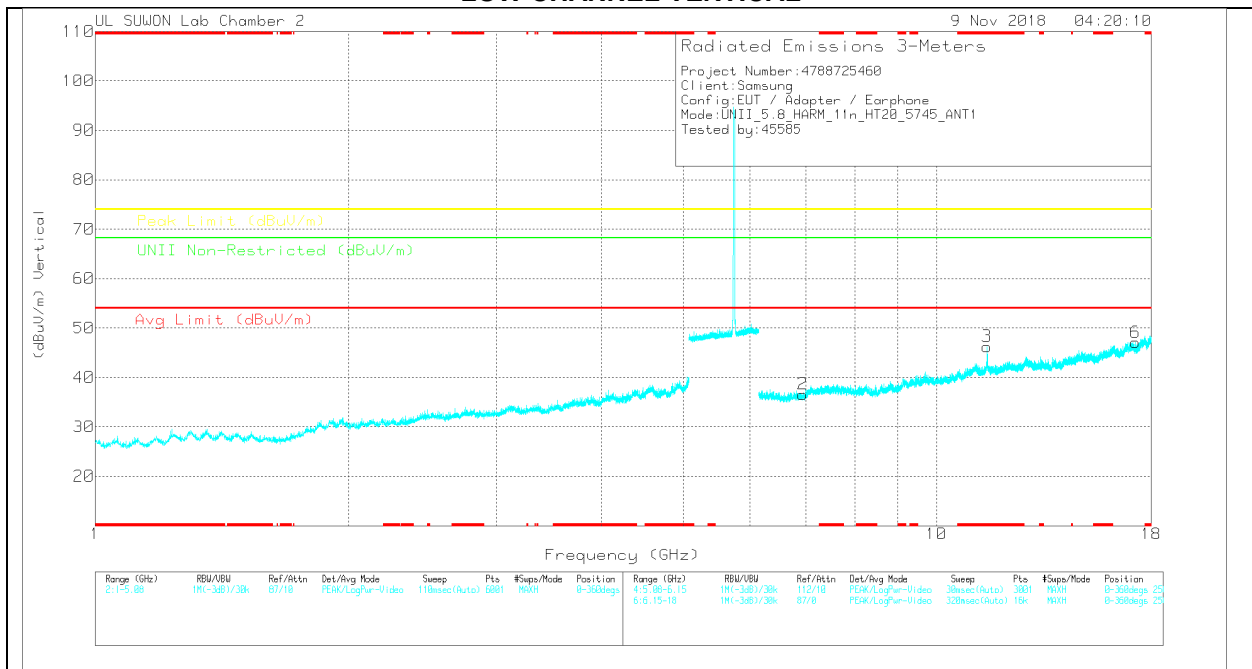

Note: Emission was scanned up to 40GHz; No emissions were detected above the noise floor which was at least 20dB below the specification limit.

LOW CHANNEL DATA

Trace Markers

Marker	Frequency (GHz)	Meter Reading (dBuV)	Det	3117_00108724	6GHz_HF[dB]	DC Corr (dB)	Corrected Reading (dBuV/m)	Avg Limit (dBuV/m)	Margin (dB)	Peak Limit (dBuV/m)	Margin (dB)	LNII Non-Restricted (dBuV/m)	Margin (dB)	Asimuth (Degs)	Height (cm)	Polarity
1	6.914	26.13	PK	35.7	-25.3	0	36.53	-	-	-	-	68.2	-31.67	0-360	150	H
4	* 11.49	27.91	PK	38.3	-19.9	0	46.31	-	-	74	-27.69	-	-	0-360	250	H
5	17.236	23.95	PK	41.3	-18.7	0	46.55	-	-	-	-	68.2	-21.65	0-360	250	H
2	6.933	26.2	PK	35.7	-25.3	0	36.6	-	-	-	-	68.2	-31.6	0-360	150	V
3	* 11.487	27.96	PK	38.3	-20	0	46.26	-	-	74	-27.74	-	-	0-360	250	V
6	17.234	24.48	PK	41.3	-18.7	0	47.08	-	-	-	-	68.2	-21.12	0-360	250	V

* - indicates frequency in CFR47 Pt 15 / IC RSS-Restricted Band

PK – Peak Detector

Radiated Emissions

Frequency (GHz)	Meter Reading (dBuV)	Det	3117_00168724	6GHz_HF[dB]	DC Corr (dB)	Corrected Reading (dBuV/m)	Avg Limit (dBuV/m)	Margin (dB)	Peak Limit (dBuV/m)	Margin (dB)	LNII Non-Restricted (dBuV/m)	Margin (dB)	Asimuth (Degs)	Height (cm)	Polarity
* 11.49	38.44	PK-U	38.3	-19.9	0	56.84	-	-	74	-17.16	-	-	95	111	H
* 11.488	25.76	ADR	38.3	-20	0	44.06	54	-9.94	-	-	-	-	95	111	H
* 11.495	38.32	PK-U	38.3	-19.9	0	56.72	-	-	74	-17.28	-	-	139	391	V
* 11.49	25.93	ADR	38.3	-19.9	0	44.33	54	-9.67	-	-	-	-	139	391	V

* - indicates frequency in CFR47 Pt 15 / IC RSS-Restricted Band

PK-U - U-NII: Maximum Peak

ADR - U-NII AD primary method, RMS average

MID CHANNEL HORIZONTAL

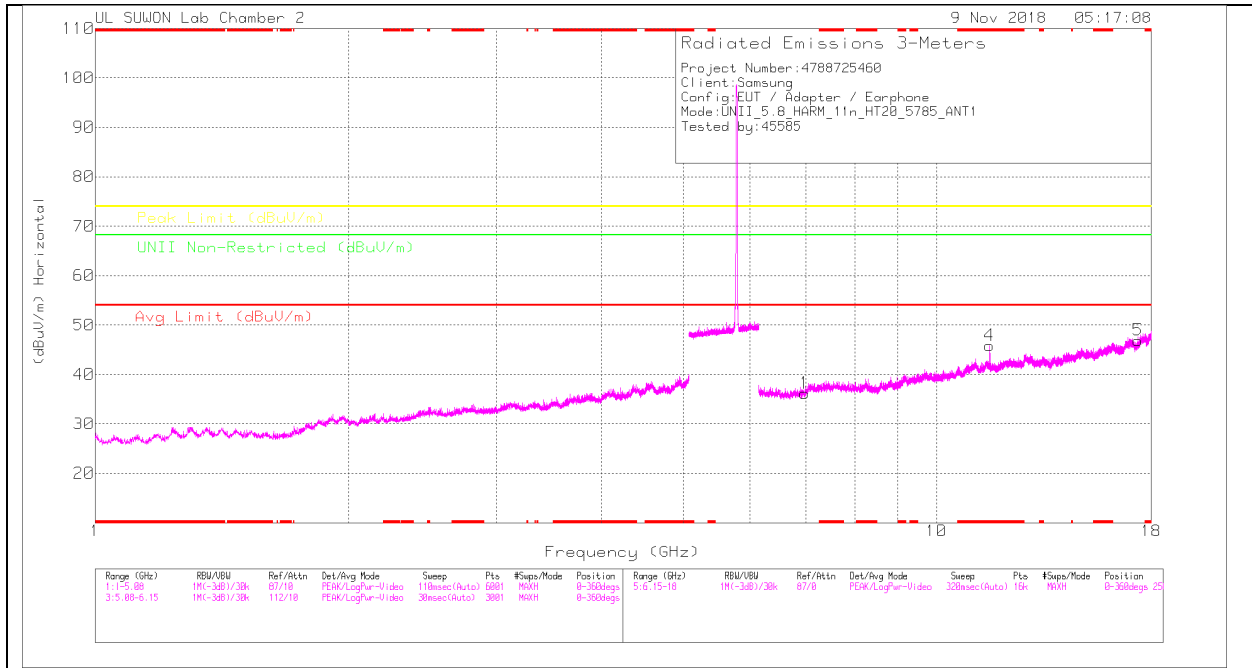

MID CHANNEL VERTICAL

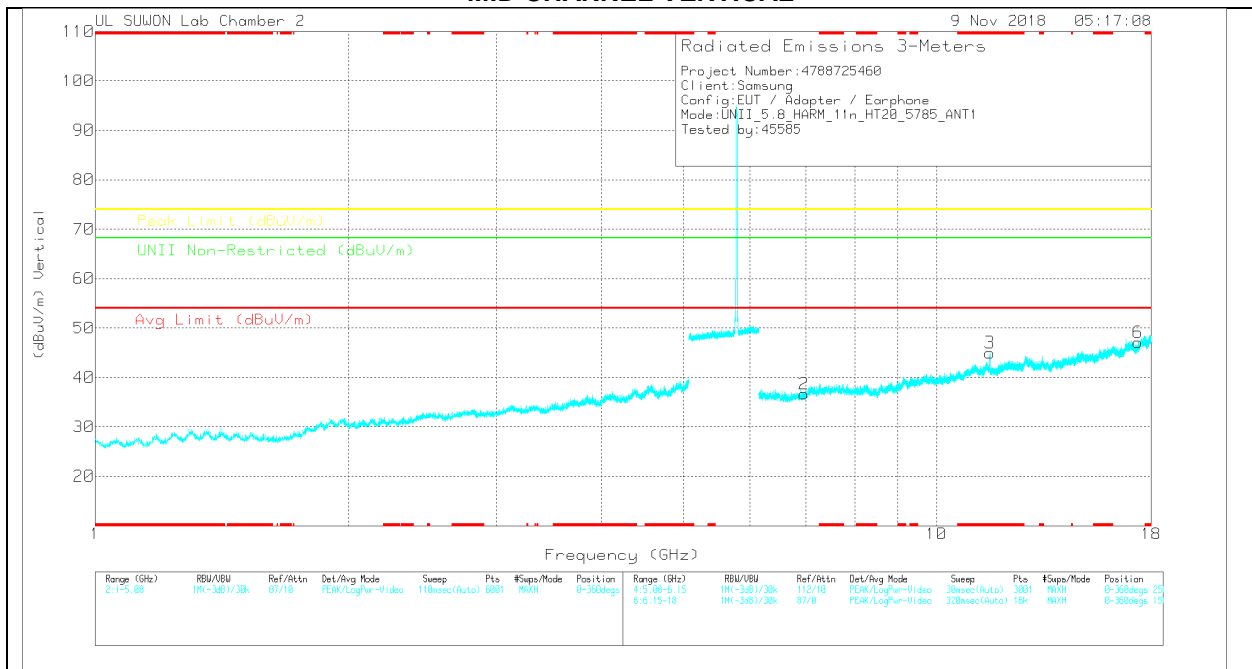

Note: Emission was scanned up to 40GHz; No emissions were detected above the noise floor which was at least 20dB below the specification limit.

MID CHANNEL DATA

Trace Markers

Marker	Frequency (GHz)	Meter Reading (dBuV)	Det	3117_00168724	6GHz_HF[dB]	DC Corr (dB)	Corrected Reading (dBuV/m)	Avg Limit (dBuV/m)	Margin (dB)	Peak Limit (dBuV/m)	Margin (dB)	LNII Non-Restricted (dBuV/m)	Margin (dB)	Azimuth (Degs)	Height (cm)	Polarity
1	6.974	26.01	PK	35.8	-25.6	0	36.21	-	-	-	-	68.2	-31.99	0-360	150	H
4	* 11.571	27.47	PK	38.4	-20	0	45.87	-	-	74	-28.13	-	-	0-360	250	H
5	17.353	24.41	PK	41.3	-18.8	0	46.91	-	-	-	-	68.2	-21.29	0-360	250	H
2	6.957	26.35	PK	35.8	-25.5	0	36.65	-	-	-	-	68.2	-31.55	0-360	150	V
3	* 11.573	26.57	PK	38.4	-20	0	44.97	-	-	74	-29.03	-	-	0-360	250	V
6	17.353	24.61	PK	41.3	-18.8	0	47.11	-	-	-	-	68.2	-21.09	0-360	150	V

* - indicates frequency in CFR47 Pt 15 / IC RSS-Restricted Band
 PK – Peak Detector

Radiated Emissions

Frequency (GHz)	Meter Reading (dBuV)	Det	3117_00168724	6GHz_HF[dB]	DC Corr (dB)	Corrected Reading (dBuV/m)	Avg Limit (dBuV/m)	Margin (dB)	Peak Limit (dBuV/m)	Margin (dB)	LNII Non-Restricted (dBuV/m)	Margin (dB)	Azimuth (Degs)	Height (cm)	Polarity
* 11.569	37.19	PK-U	38.4	-20	0	55.59	-	-	74	-18.41	-	-	195	128	H
* 11.569	25.08	ADR	38.4	-20	0	43.48	54	-10.52	-	-	-	-	195	128	H
* 11.57	38.14	PK-U	38.4	-20	0	56.54	-	-	74	-17.46	-	-	145	347	V
* 11.57	25.66	ADR	38.4	-20.1	0	43.96	54	-10.04	-	-	-	-	145	347	V

* - indicates frequency in CFR47 Pt 15 / IC RSS-Restricted Band
 PK-U - U-NII: Maximum Peak
 ADR - U-NII AD primary method, RMS average

HIGH CHANNEL HORIZONTAL

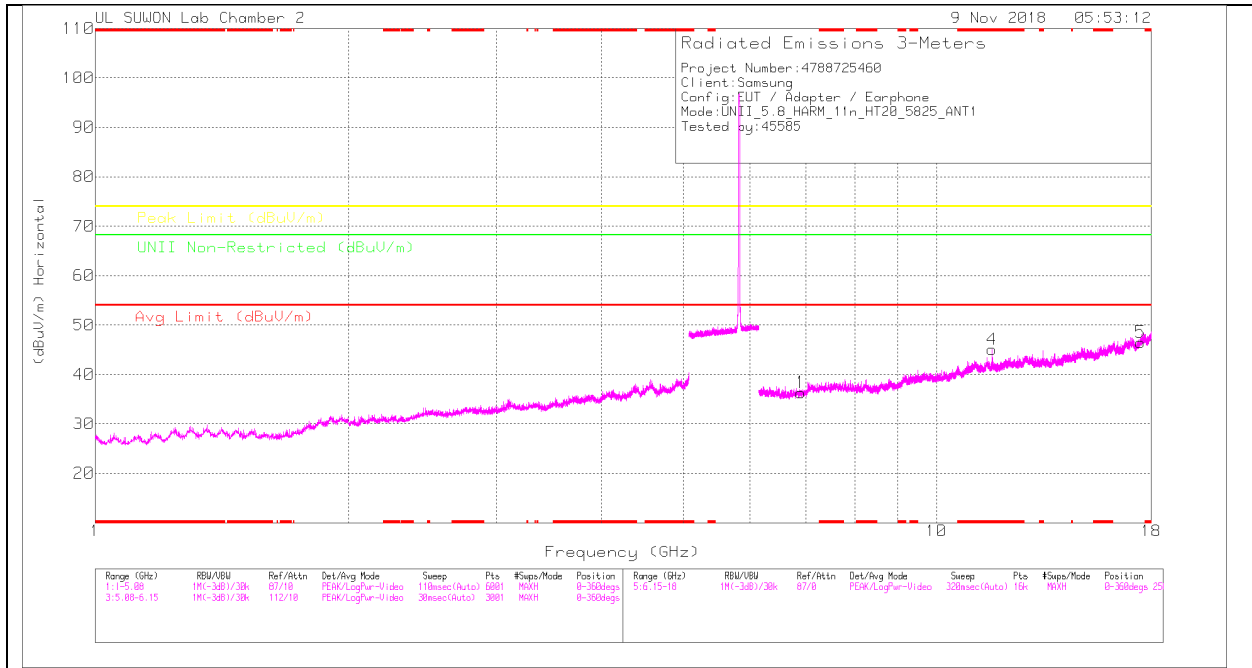

HIGH CHANNEL VERTICAL

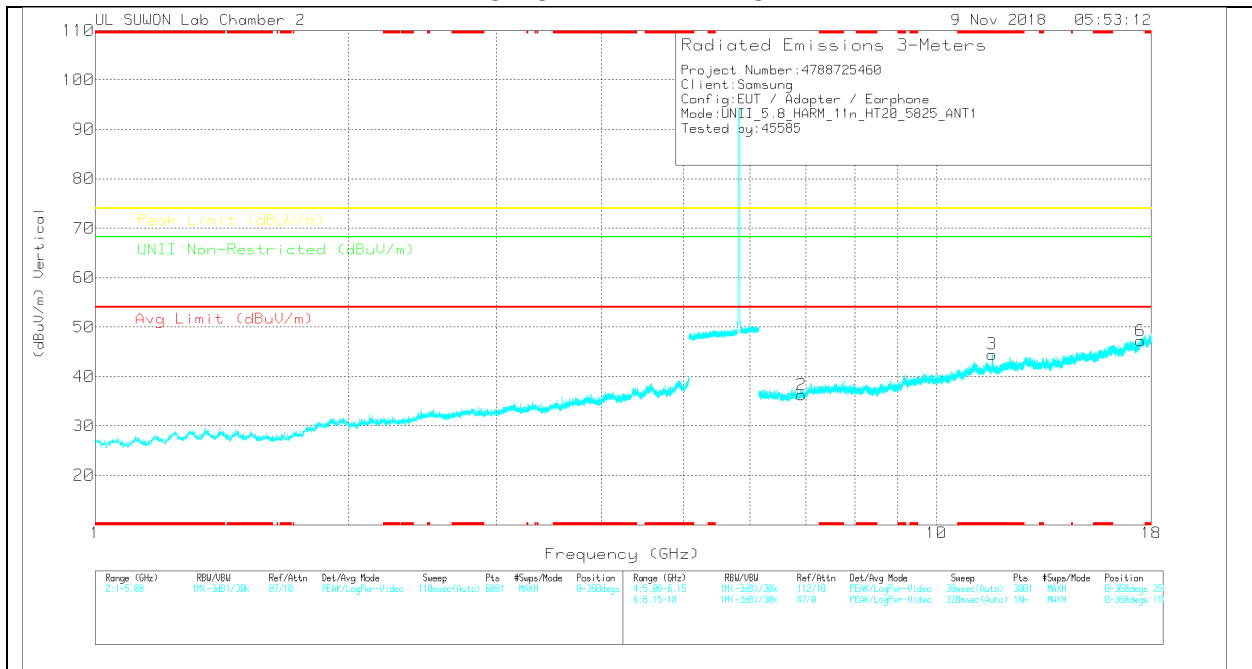

Note: Emission was scanned up to 40GHz; No emissions were detected above the noise floor which was at least 20dB below the specification limit.

HIGH CHANNEL DATA

Trace Markers

Marker	Frequency (GHz)	Meter Reading (dBuV)	Det	3117_00108724	6GHz_HF[dB]	DC Corr (dB)	Corrected Reading (dBuV/m)	Avg Limit (dBuV/m)	Margin (dB)	Peak Limit (dBuV/m)	Margin (dB)	LNII Non-Restricted (dBuV/m)	Margin (dB)	Asimuth (Degs)	Height (cm)	Polarity
1	6.902	25.74	PK	35.7	-25.1	0	35.34	-	-	-	-	68.2	-31.86	0-360	150	H
4	* 11.65	26.65	PK	38.4	-20	0	45.05	-	-	74	-28.95	-	-	0-360	150	H
5	17.476	23.3	PK	41.4	-18.2	0	46.5	-	-	-	-	68.2	-31.7	0-360	250	H
2	6.91	25.78	PK	35.7	-25.2	0	35.28	-	-	-	-	68.2	-31.92	0-360	150	V
3	* 11.646	26	PK	38.4	-19.9	0	44.5	-	-	74	-29.5	-	-	0-360	250	V
6	17.476	24.02	PK	41.4	-18.2	0	47.22	-	-	-	-	68.2	-20.98	0-360	150	V

* - indicates frequency in CFR47 Pt 15 / IC RSS-Restricted Band

PK – Peak Detector

Radiated Emissions

Frequency (GHz)	Meter Reading (dBuV)	Det	3117_00168724	6GHz_HF[dB]	DC Corr (dB)	Corrected Reading (dBuV/m)	Avg Limit (dBuV/m)	Margin (dB)	Peak Limit (dBuV/m)	Margin (dB)	LNII Non-Restricted (dBuV/m)	Margin (dB)	Asimuth (Degs)	Height (cm)	Polarity	
* 11.643	39.32	PK-U	38.4	-20	0	57.72	-	-	74	-16.28	-	-	-	127	100	H
* 11.65	25.97	ADR	38.4	-20	0	44.37	54	-9.63	-	-	-	-	-	127	100	H
* 11.648	37.85	PK-U	38.4	-20	0	56.25	-	-	74	-17.75	-	-	-	142	361	V
* 11.65	25.95	ADR	38.4	-20	0	44.35	54	-9.65	-	-	-	-	-	142	361	V

* - indicates frequency in CFR47 Pt 15 / IC RSS-Restricted Band

PK-U - U-NII: Maximum Peak

ADR - U-NII AD primary method, RMS average

11.4.6.TX ABOVE 1GHz 802.11n HT20 1Tx ANT2 IN THE 5.8GHz BAND BANDEDGE (LOW CHANNEL)

HORIZONTAL PEAK PLOT

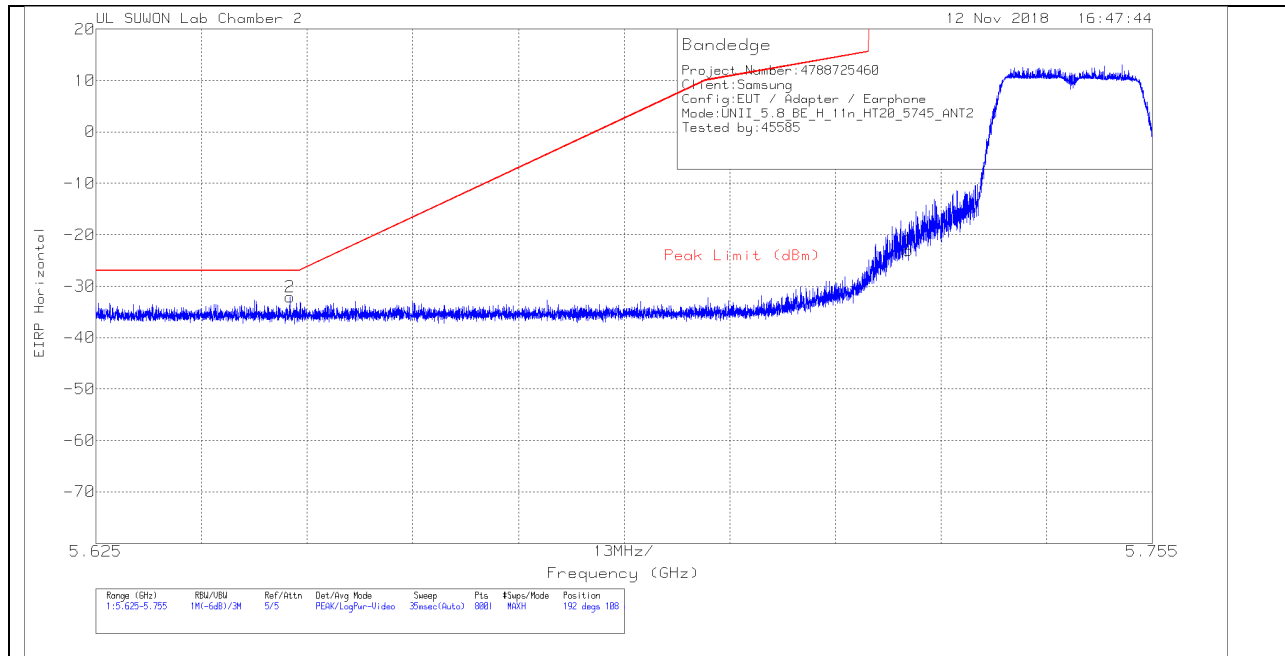

HORIZONTAL DATA

Trace Markers

Marker	Frequency (GHz)	Meter Reading (dBm)	Det	170531_3117[00 168724]	Path_2_10dB	Conversion Factor (dB)	DC Corr (dB)	Corrected Reading EIRP	Peak Limit (dBm)	PK Margin (dB)	Azimuth (Degs)	Height (cm)	Polarity
1	5.725	-53.68	Pk	34.5	-15.6	11.8	0	-22.98	26.97	-49.95	192	108	H
2	5.649	-62.61	Pk	34.4	-15.7	11.8	0	-32.11	-27	-5.11	192	108	H

Pk - Peak detector

VERTICAL PEAK PLOT

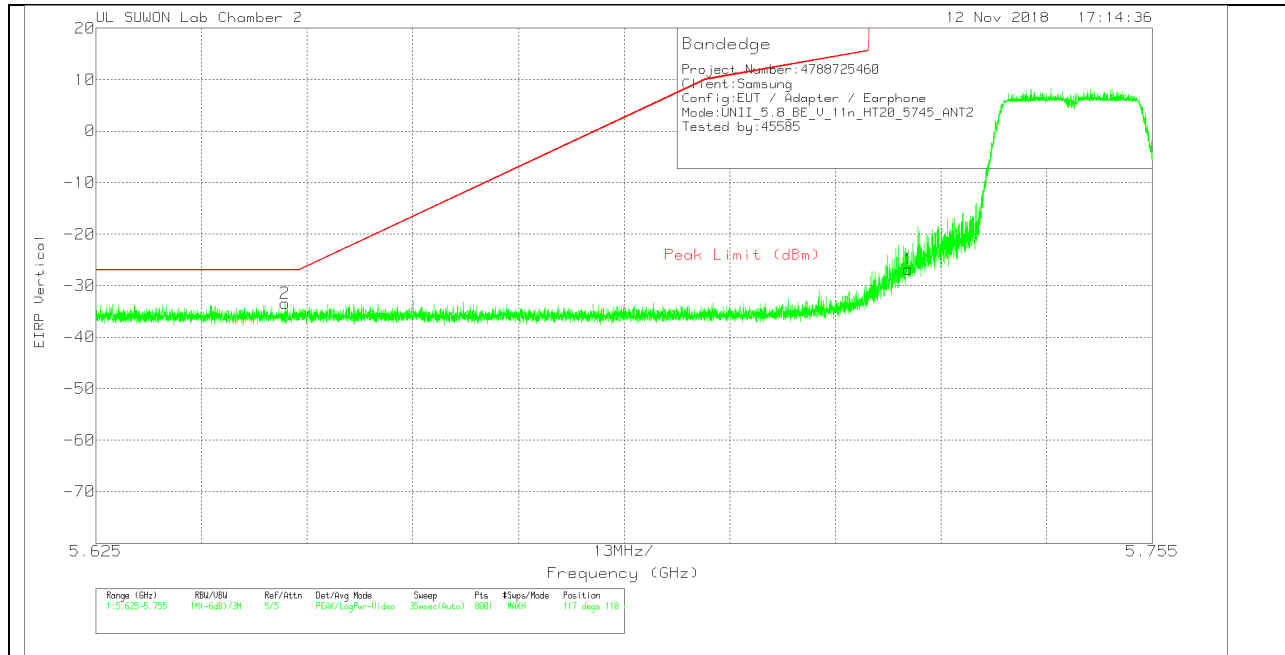

VERTICAL DATA

Trace Markers

Marker	Frequency (GHz)	Meter Reading (dBm)	Det	170531_3117[00 168724]	Path_2_10dB	Conversion Factor (dB)	DC Corr (dB)	Corrected Reading EIRP	Peak Limit (dBm)	PK Margin (dB)	Azimuth (Degs)	Height (cm)	Polarity
1	5.725	-57.55	Pk	34.5	-15.6	11.8	0	-26.85	26.97	-53.82	117	110	V
2	5.648	-63.89	Pk	34.4	-15.7	11.8	0	-33.39	-27	-6.39	117	110	V

Pk - Peak detector

BANDEDGE (HIGH CHANNEL)

HORIZONTAL PEAK AND AVERAGE PLOT

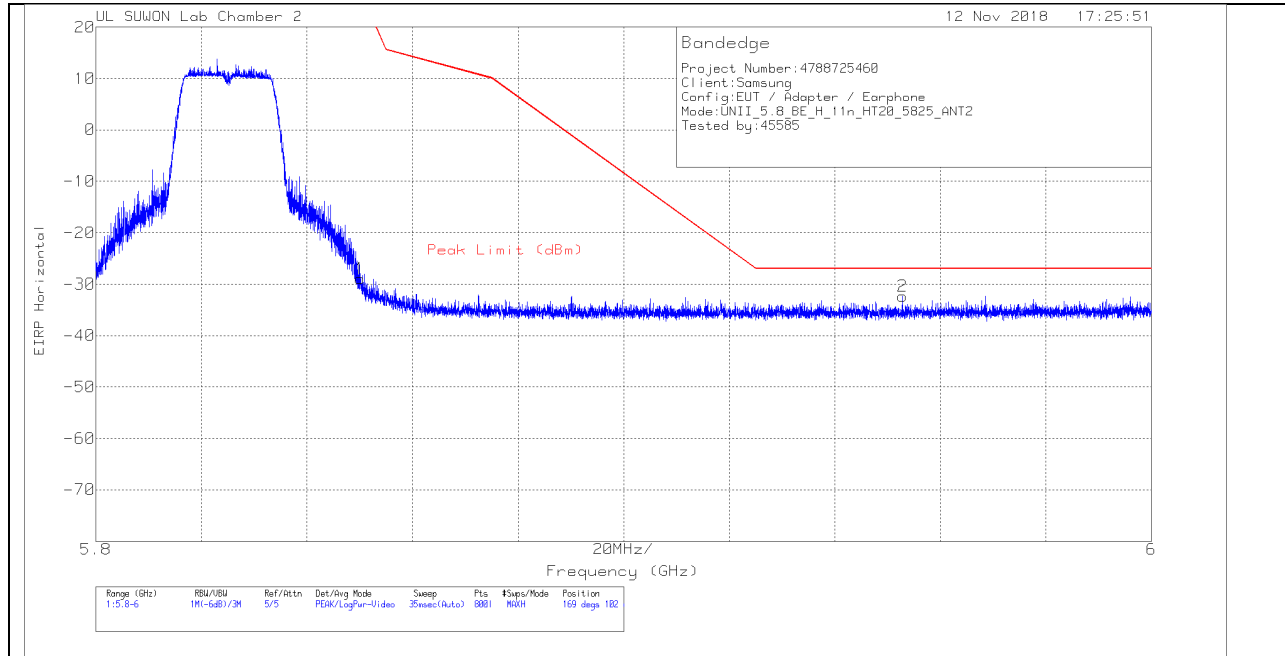

HORIZONTAL DATA

Trace Markers

Marker	Frequency (GHz)	Meter Reading (dBm)	Det	170531_3117[00168724]	Path_2_10dB	Conversion Factor (dB)	DC Corr (dB)	Corrected Reading EIRP	Peak Limit (dBm)	PK Margin (dB)	Azimuth (Degs)	Height (cm)	Polarity
1	5.85	-59.66	Pk	34.5	-15.5	11.8	0	-28.86	26.94	-55.8	169	102	H
2	5.953	-63.18	Pk	34.6	-15.5	11.8	0	-32.28	-27	-5.28	169	102	H

Pk - Peak detector

VERTICAL PEAK PLOT

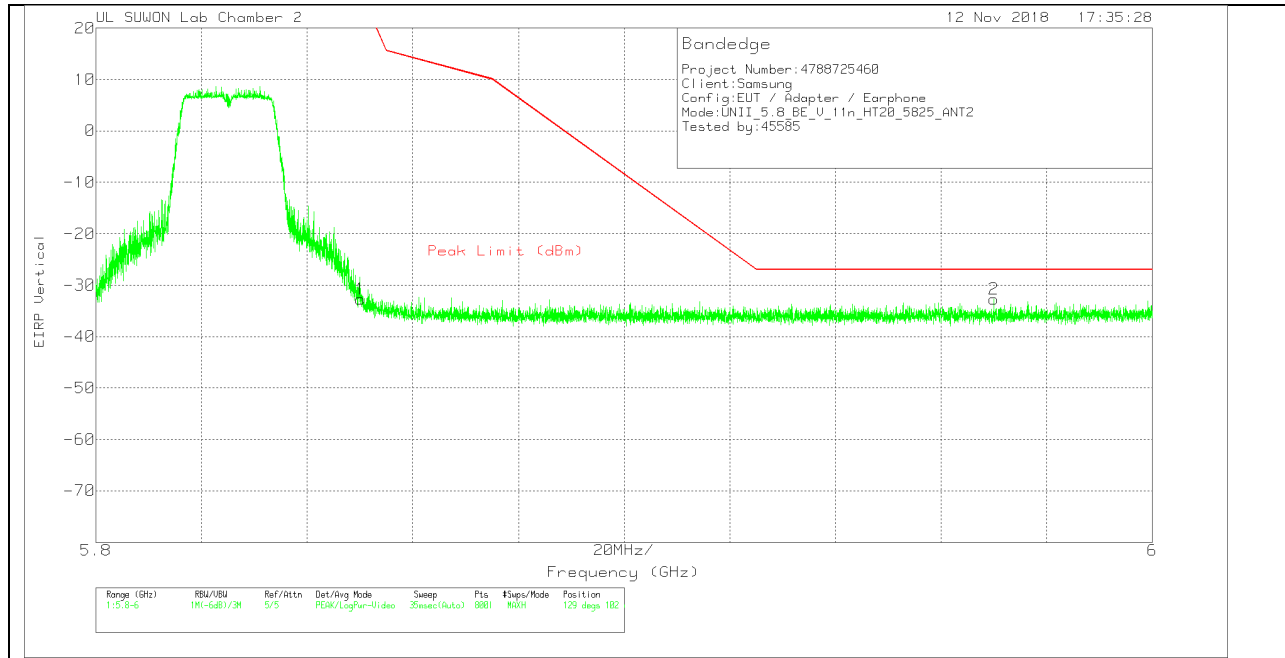

VERTICAL DATA

Trace Markers

Marker	Frequency (GHz)	Meter Reading (dBm)	Det	170531_3117[00 168724]	Path_2_10dB	Conversion Factor (dB)	DC Corr (dB)	Corrected Reading EIRP	Peak Limit (dBm)	PK Margin (dB)	Azimuth (Degs)	Height (cm)	Polarity
1	5.85	-63.45	Pk	34.5	-15.5	11.8	0	-32.65	26.94	-59.59	129	102	V
2	5.97	-63.83	Pk	34.7	-15.4	11.8	0	-32.73	-27	-5.73	129	102	V

Pk - Peak detector

LOW CHANNEL HORIZONTAL

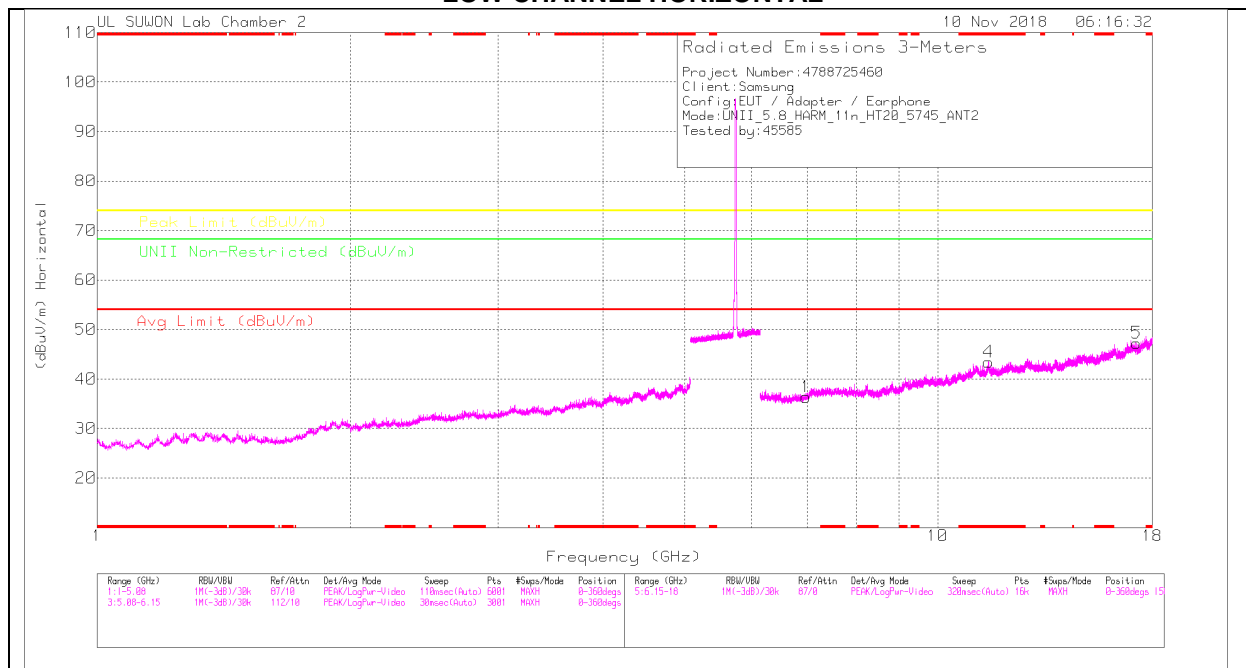

LOW CHANNEL VERTICAL

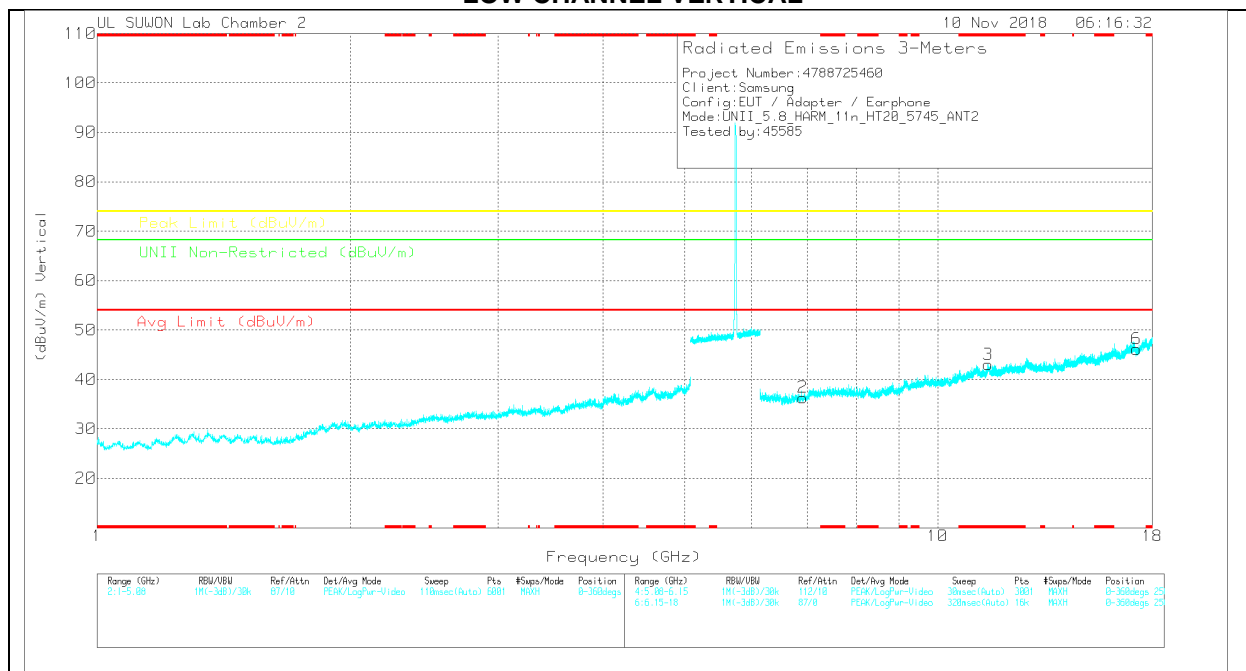

Note: Emission was scanned up to 40GHz; No emissions were detected above the noise floor which was at least 20dB below the specification limit.

LOW CHANNEL DATA

Trace Markers

Marker	Frequency (GHz)	Meter Reading (dBµV)	Det	3117_00108724	GHz_HF[dB]	DC Corr (dB)	Corrected Reading (dBµV/m)	Avg Limit (dBµV/m)	Margin (dB)	Peak Limit (dBµV/m)	Margin (dB)	LNB Non-Restricted (dBµV/m)	Margin (dB)	Azimuth (Degs)	Height (cm)	Polarity
1	6.973	26.17	PK	35.8	-25.6	0	36.37	-	-	-	-	68.2	-31.83	0-360	150	H
4	*11.494	25.04	PK	38.3	-19.9	0	43.44	-	-	74	-30.56	-	-	0-360	250	H
5	17.239	24.78	PK	41.3	-18.8	0	47.28	-	-	-	-	68.2	-20.92	0-360	250	H
2	6.912	25.85	PK	35.7	-25.2	0	36.35	-	-	-	-	68.2	-31.85	0-360	250	V
3	*11.49	24.62	PK	38.3	-19.9	0	43.02	-	-	74	-30.98	-	-	0-360	250	V
6	17.236	23.57	PK	41.3	-18.7	0	46.17	-	-	-	-	68.2	-22.03	0-360	150	V

* - indicates frequency in CFR47 Pt 15 / IC RSS-Restricted Band
 PK – Peak Detector

Note: Only peak measurement was performed. Because peak measurement result of unwanted emission is less than average limit (54dBuV/m).

MID CHANNEL HORIZONTAL

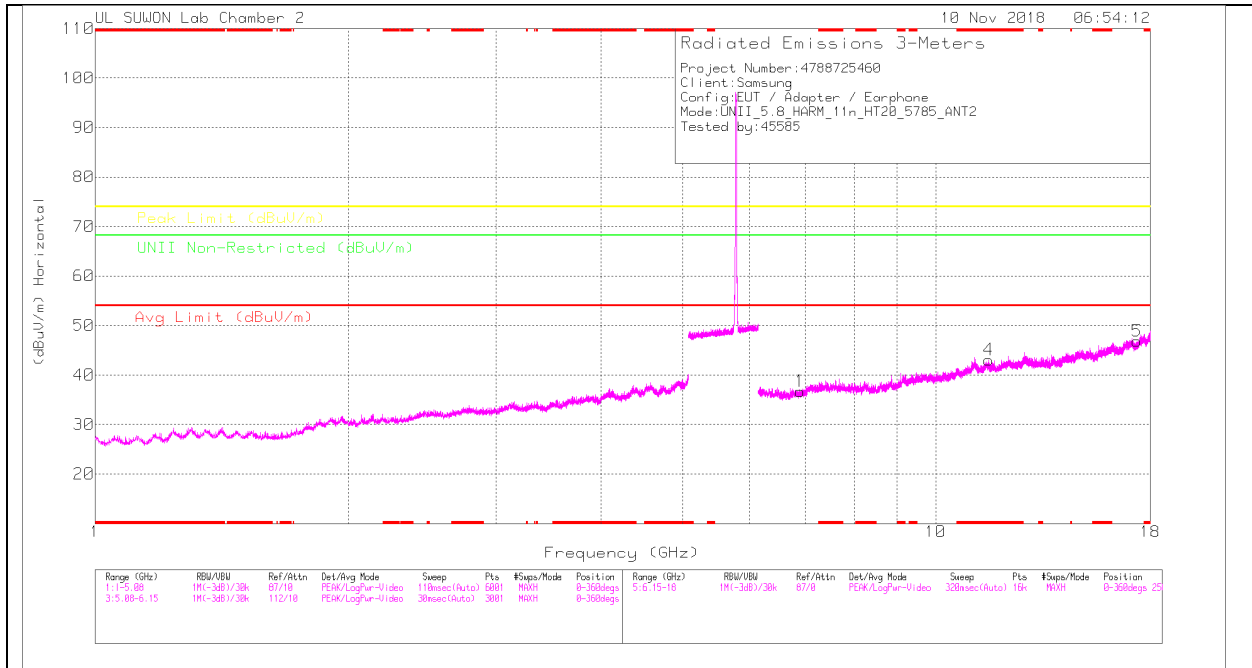

MID CHANNEL VERTICAL

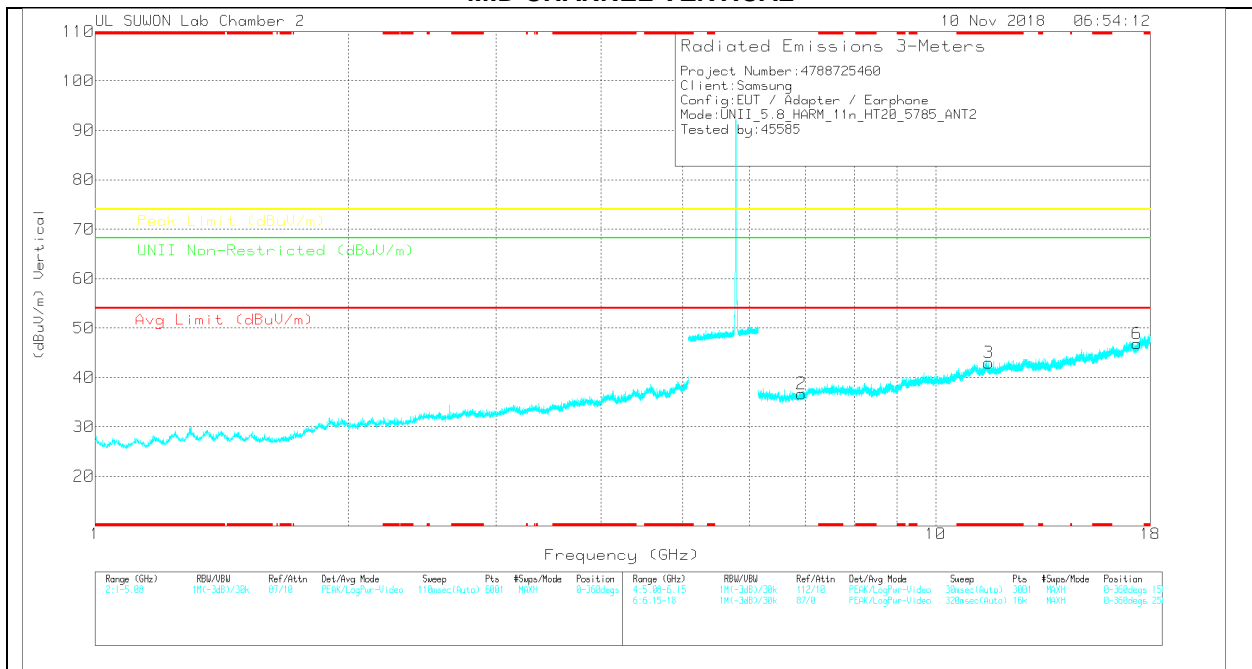

Note: Emission was scanned up to 40GHz; No emissions were detected above the noise floor which was at least 20dB below the specification limit.

MID CHANNEL DATA

Trace Markers

Marker	Frequency (GHz)	Meter Reading (dBuV)	Det	3117_00108724	GHz_HF[dB]	DC Corr (dB)	Corrected Reading (dBuV/m)	Avg Limit (dBuV/m)	Margin (dB)	Peak Limit (dBuV/m)	Margin (dB)	LN3 Non-Restricted (dBuV/m)	Margin (dB)	Azimuth (Degs)	Height (cm)	Polarity
1	6.897	26.12	PK	35.7	-25.1	0	36.72	-	-	-	-	68.2	-31.48	0-360	250	H
4	*11.57	24.66	PK	38.4	-20	0	43.06	-	-	74	-30.94	-	-	0-360	250	H
5	17.356	24.42	PK	41.3	-18.9	0	46.82	-	-	-	-	68.2	-21.38	0-360	250	H
2	6.927	26.31	PK	35.7	-25.3	0	36.71	-	-	-	-	68.2	-31.49	0-360	150	V
3	*11.571	24.58	PK	38.4	-20	0	42.98	-	-	74	-31.02	-	-	0-360	250	V
6	17.354	24.32	PK	41.3	-18.8	0	46.82	-	-	-	-	68.2	-21.38	0-360	250	V

* - indicates frequency in CFR47 Pt 15 / IC RSS-Restricted Band

PK – Peak Detector

Note: Only peak measurement was performed. Because peak measurement result of unwanted emission is less than average limit (54dBuV/m).

HIGH CHANNEL HORIZONTAL

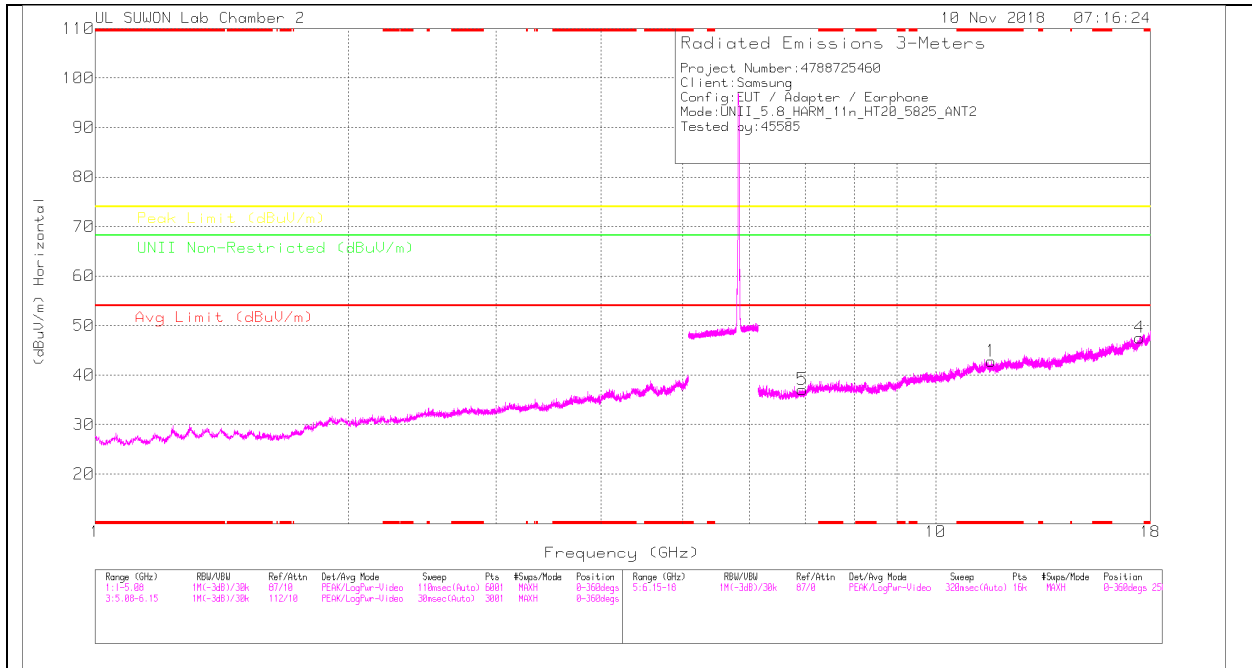

HIGH CHANNEL VERTICAL

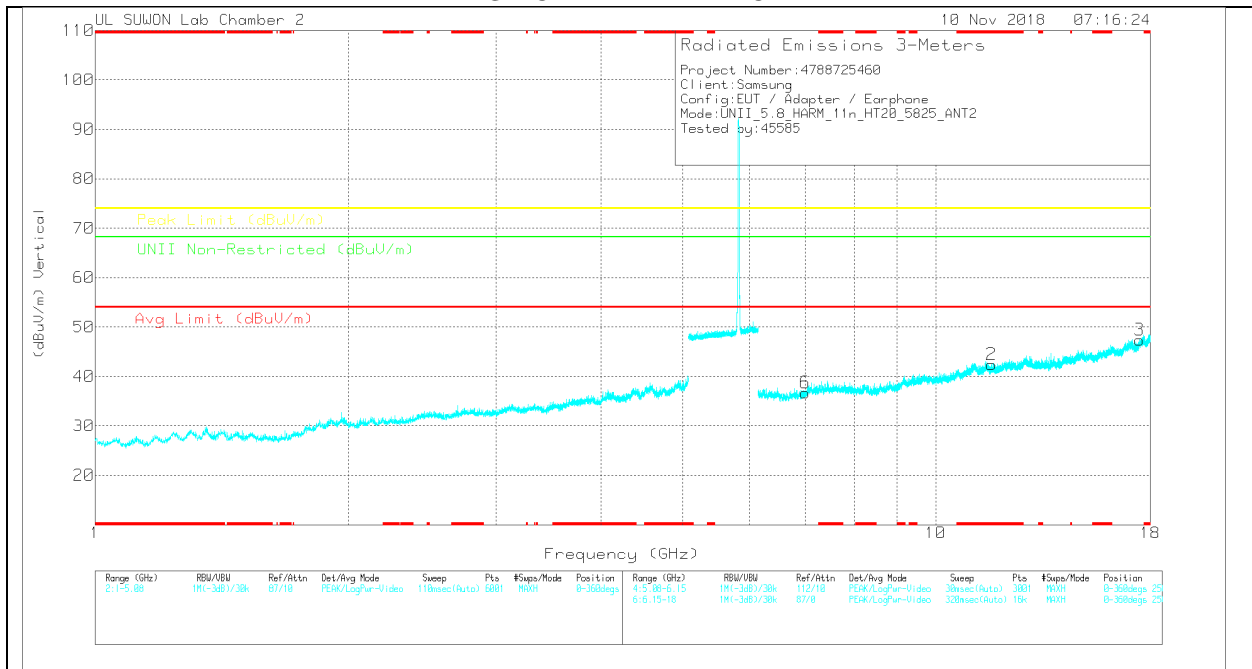

Note: Emission was scanned up to 40GHz; No emissions were detected above the noise floor which was at least 20dB below the specification limit.

HIGH CHANNEL DATA

Trace Markers

Marker	Frequency (GHz)	Meter Reading (dBµV)	Det	3117_00108724	GHz_HF[dB]	DC Corr (dB)	Corrected Reading (dBµV/m)	Avg Limit (dBµV/m)	Margin (dB)	Peak Limit (dBµV/m)	Margin (dB)	LNI Non-Restricted (dBµV/m)	Margin (dB)	Azimuth (Degs)	Height (cm)	Polarity
1	* 11.65	24.41	PK	38.4	-20	0	42.83	-	-	74	-31.19	-	-	0-360	250	H
4	17.475	24.35	PK	41.4	-18.2	0	47.55	-	-	-	-	68.2	-20.65	0-360	250	H
5	6.941	26.78	PK	35.7	-25.4	0	37.08	-	-	-	-	68.2	-31.12	0-360	150	H
2	* 11.652	24.03	PK	38.4	-20	0	42.43	-	-	74	-31.57	-	-	0-360	150	V
3	17.476	24.19	PK	41.4	-18.2	0	47.39	-	-	-	-	68.2	-20.81	0-360	250	V
6	6.998	26.61	PK	35.8	-25.7	0	36.71	-	-	-	-	68.2	-31.49	0-360	250	V

* - indicates frequency in CFR47 Pt 15 / IC RSS-Restricted Band
 PK – Peak Detector

Note: Only peak measurement was performed. Because peak measurement result of unwanted emission is less than average limit (54dBuV/m).

11.4.7. TX ABOVE 1GHz 802.11n HT40 2Tx CDD MODE IN THE 5.8GHz BAND BANDEDGE (LOW CHANNEL)

HORIZONTAL PEAK PLOT

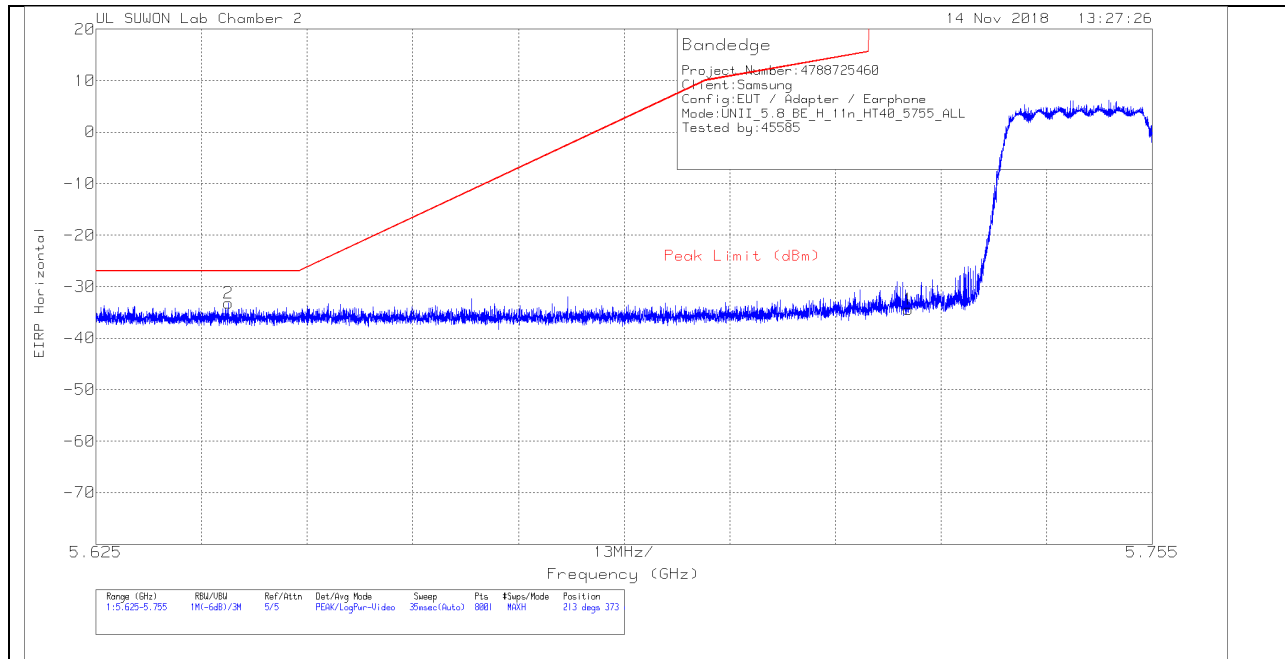

HORIZONTAL DATA

Trace Markers

Marker	Frequency (GHz)	Meter Reading (dBm)	Det	170531_3117[00 168724]	Path_2_10dB	Conversion Factor (dB)	DC Corr (dB)	Corrected Reading EIRP	Peak Limit (dBm)	PK Margin (dB)	Azimuth (Degs)	Height (cm)	Polarity
1	5.725	-65.06	Pk	34.5	-15.6	11.8	0	-34.36	26.97	-61.33	213	373	H
2	5.641	-63.72	Pk	34.4	-15.7	11.8	0	-33.22	-27	-6.22	213	373	H

Pk - Peak detector

VERTICAL PEAK PLOT

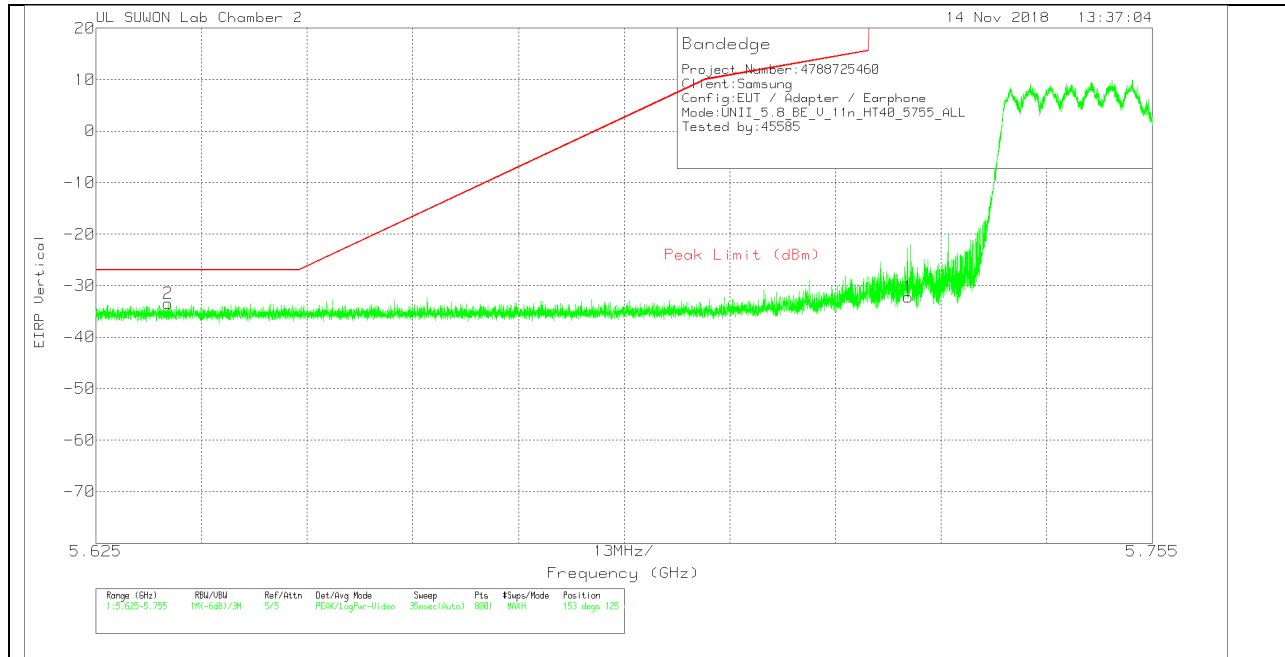

VERTICAL DATA

Trace Markers

Marker	Frequency (GHz)	Meter Reading (dBm)	Det	170531_3117[00 168724]	Path_2_10dB	Conversion Factor (dB)	DC Corr (dB)	Corrected Reading EIRP	Peak Limit (dBm)	PK Margin (dB)	Azimuth (Degs)	Height (cm)	Polarity
1	5.725	-62.95	Pk	34.5	-15.6	11.8	0	-32.25	26.97	-59.22	153	125	V
2	5.634	-63.99	Pk	34.4	-15.7	11.8	0	-33.49	-27	-6.49	153	125	V

Pk - Peak detector

BANDEDGE (HIGH CHANNEL)

HORIZONTAL PEAK PLOT

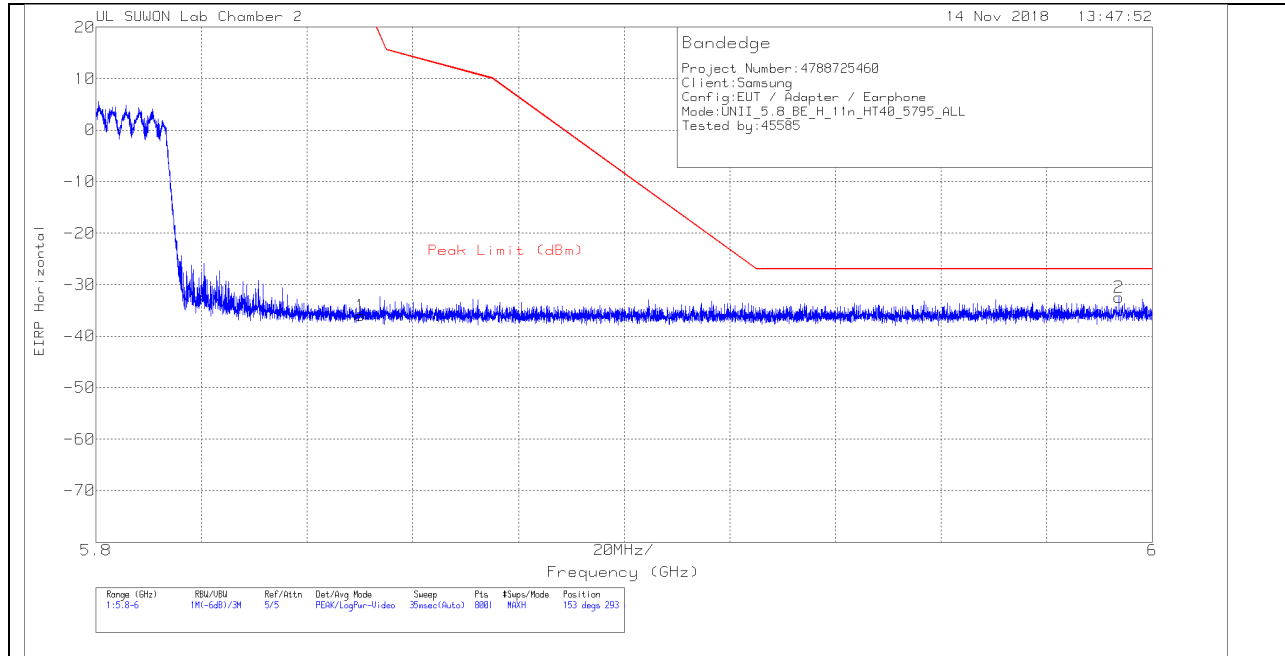

HORIZONTAL DATA

Trace Markers

Marker	Frequency (GHz)	Meter Reading (dBm)	Det	170531_3117[00 168724]	Path_2_10dB	Conversion Factor (dB)	DC Corr (dB)	Corrected Reading EIRP	Peak Limit (dBm)	PK Margin (dB)	Azimuth (Degs)	Height (cm)	Polarity
1	5.85	-66.77	Pk	34.5	-15.5	11.8	0	-35.97	26.94	-62.91	153	293	H
2	5.994	-63.68	Pk	34.8	-15.4	11.8	0	-32.48	-27	-5.48	153	293	H

Pk - Peak detector

VERTICAL PEAK PLOT

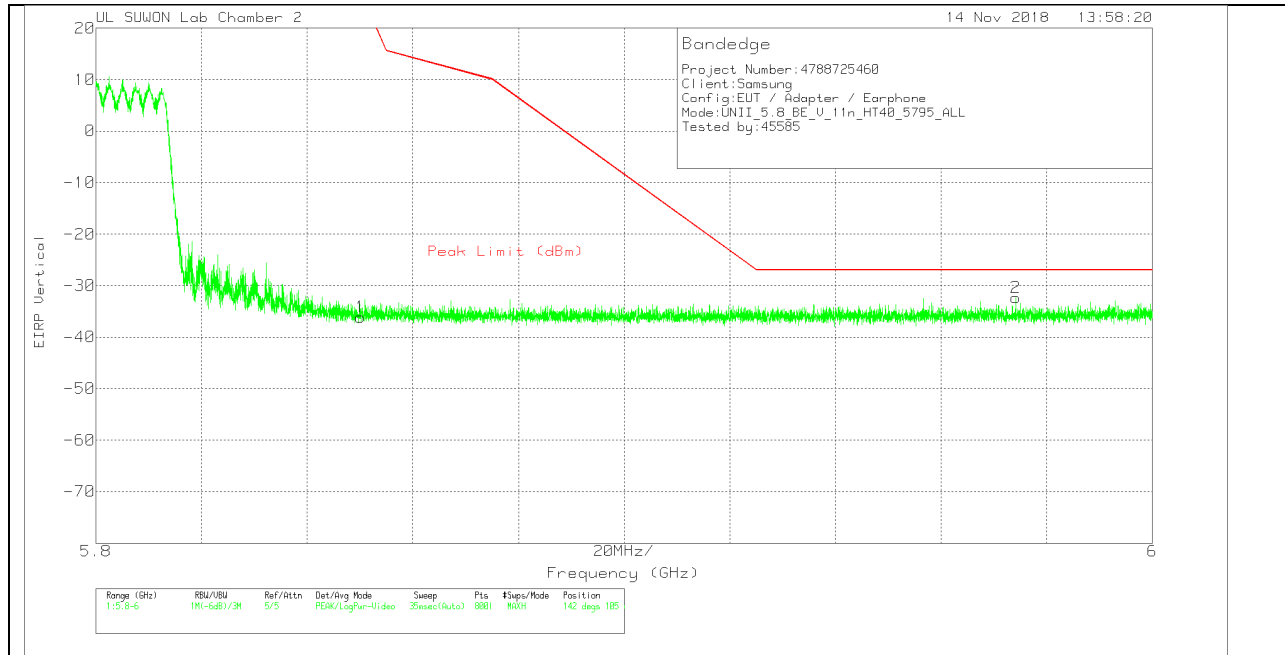

VERTICAL DATA

Trace Markers

Marker	Frequency (GHz)	Meter Reading (dBm)	Det	170531_3117[00 168724]	Path_2_10dB	Conversion Factor (dB)	DC Corr (dB)	Corrected Reading EIRP	Peak Limit (dBm)	PK Margin (dB)	Azimuth (Degs)	Height (cm)	Polarity
1	5.85	-66.98	Pk	34.5	-15.5	11.8	0	-36.18	26.94	-63.12	142	105	V
2	5.974	-63.44	Pk	34.7	-15.4	11.8	0	-32.34	-27	-5.34	142	105	V

Pk - Peak detector

LOW CHANNEL HORIZONTAL

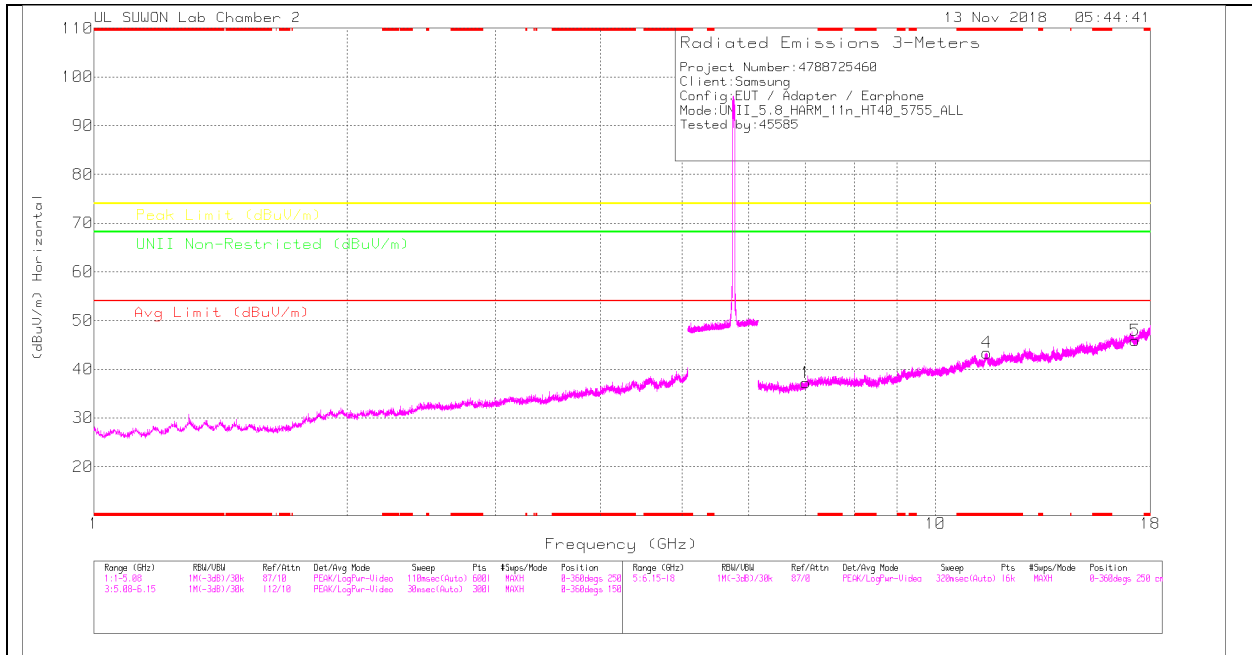

LOW CHANNEL VERTICAL

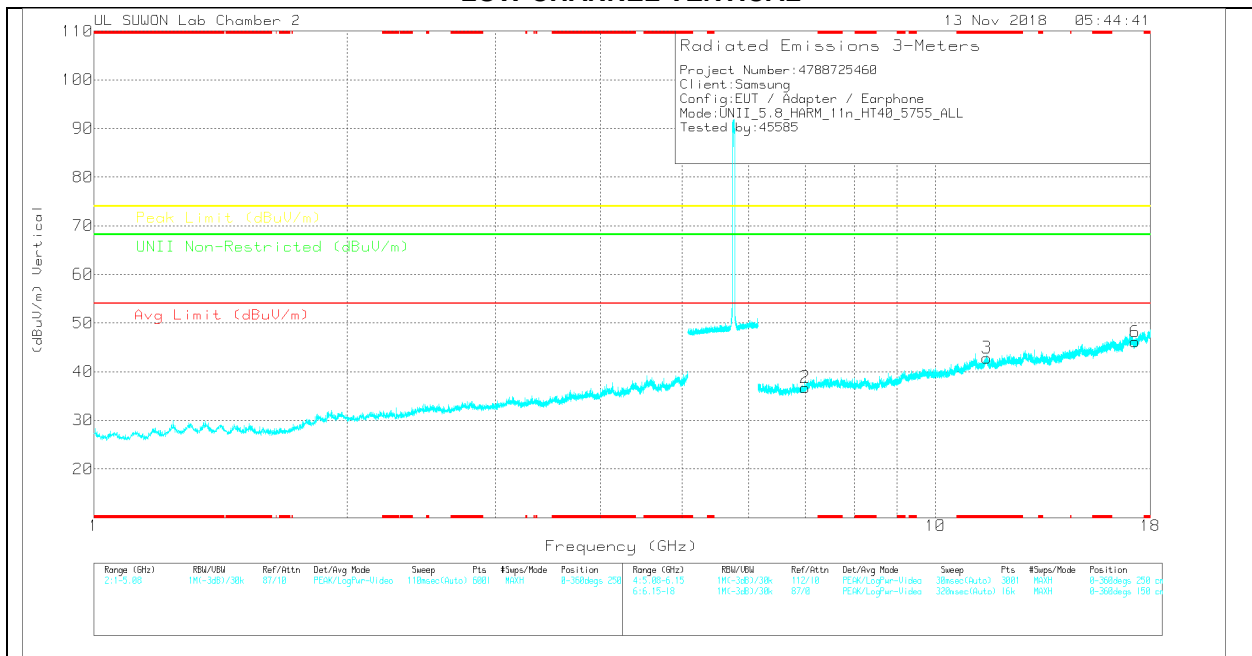

Note: Emission was scanned up to 40GHz; No emissions were detected above the noise floor which was at least 20dB below the specification limit.

LOW CHANNEL DATA

Trace Markers

Marker	Frequency (GHz)	Meter Reading (dBm)	Det	3117_00108724	GHz_HF[dB]	DC Corr (dB)	Corrected Reading (dBuV/m)	Avg Limit (dBuV/m)	Margin (dB)	Peak Limit (dBuV/m)	Margin (dB)	LNB Non-Restricted (dBuV/m)	Margin (dB)	Azimuth (Degs)	Height (cm)	Polarity
1	7.012	26.97	PK	35.8	-25.5	0	37.27	-	-	-	-	68.2	-30.93	0-360	250	H
4	*11.509	24.97	PK	38.3	-19.9	0	43.37	-	-	74	-30.63	-	-	0-360	250	H
5	17.266	23.41	PK	41.3	-18.8	0	45.91	-	-	-	-	68.2	-22.29	0-360	150	H
2	7.001	26.67	PK	35.8	-25.7	0	36.77	-	-	-	-	68.2	-31.43	0-360	150	V
3	*11.507	24.45	PK	38.3	-19.9	0	42.85	-	-	74	-31.15	-	-	0-360	250	V
6	17.268	23.75	PK	41.3	-18.9	0	46.15	-	-	-	-	68.2	-22.05	0-360	250	V

* - indicates frequency in CFR47 Pt 15 / IC RSS-Restricted Band
 PK – Peak Detector

Note: Only peak measurement was performed. Because peak measurement result of unwanted emission is less than average limit (54dBuV/m).

HIGH CHANNEL HORIZONTAL

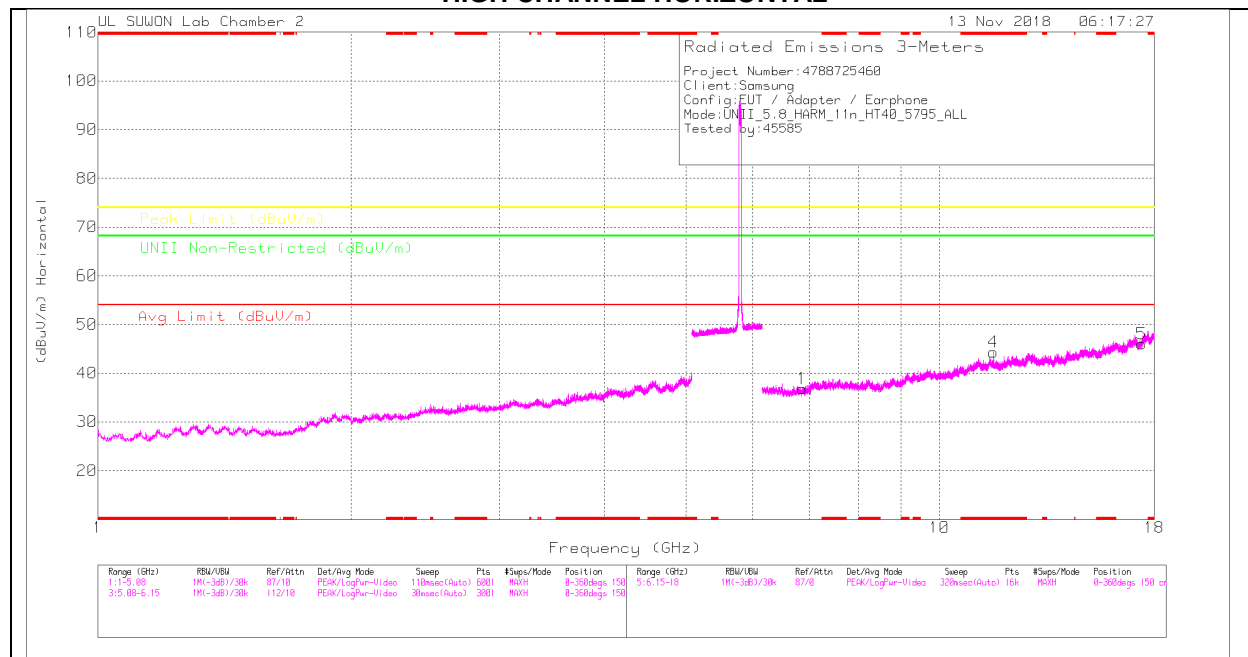

HIGH CHANNEL VERTICAL

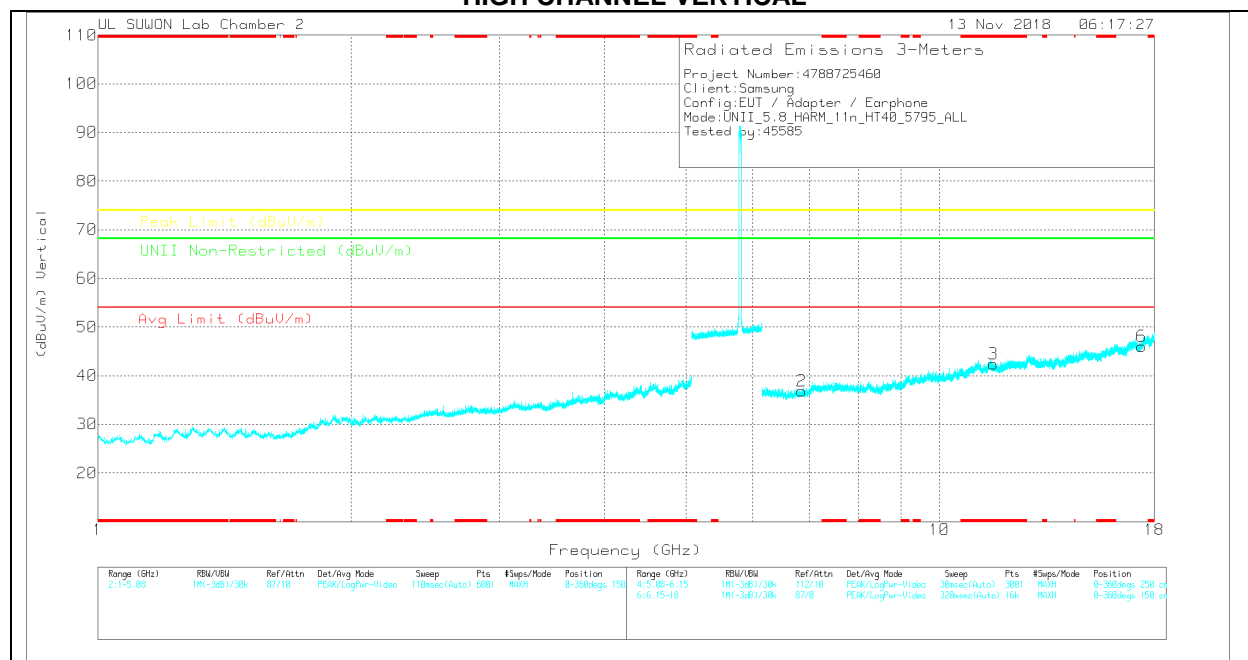

Note: Emission was scanned up to 40GHz; No emissions were detected above the noise floor which was at least 20dB below the specification limit.

HIGH CHANNEL DATA

Trace Markers

Marker	Frequency (GHz)	Meter Reading (dBµV)	Det	3117_00108724	GHz_HF[dB]	DC Corr (dB)	Corrected Reading (dBµV/m)	Avg Limit (dBµV/m)	Margin (dB)	Peak Limit (dBµV/m)	Margin (dB)	LNI Non-Restricted (dBµV/m)	Margin (dB)	Azimuth (Degs)	Height (cm)	Polarity
1	6.874	26.31	PK	35.6	-25.1	0	36.81	-	-	-	-	68.2	-31.39	0-360	150	H
4	*11.589	26.16	PK	38.4	-20.2	0	44.36	-	-	74	-29.64	-	-	0-360	250	H
5	17.386	23.43	PK	41.4	-18.8	0	46.03	-	-	-	-	68.2	-22.17	0-360	250	H
2	6.862	26.18	PK	35.6	-25	0	36.78	-	-	-	-	68.2	-31.42	0-360	150	V
3	*11.587	24.24	PK	38.4	-20.2	0	42.44	-	-	74	-31.56	-	-	0-360	250	V
6	17.387	23.26	PK	41.4	-18.7	0	45.96	-	-	-	-	68.2	-22.24	0-360	250	V

* - indicates frequency in CFR47 Pt 15 / IC RSS-Restricted Band

PK – Peak Detector

Note: Only peak measurement was performed. Because peak measurement result of unwanted emission is less than average limit (54dBuV/m).

11.4.8.TX ABOVE 1GHz 802.11n HT40 1Tx ANT1 IN THE 5.8GHz BAND BANDEDGE (LOW CHANNEL)

HORIZONTAL PEAK PLOT

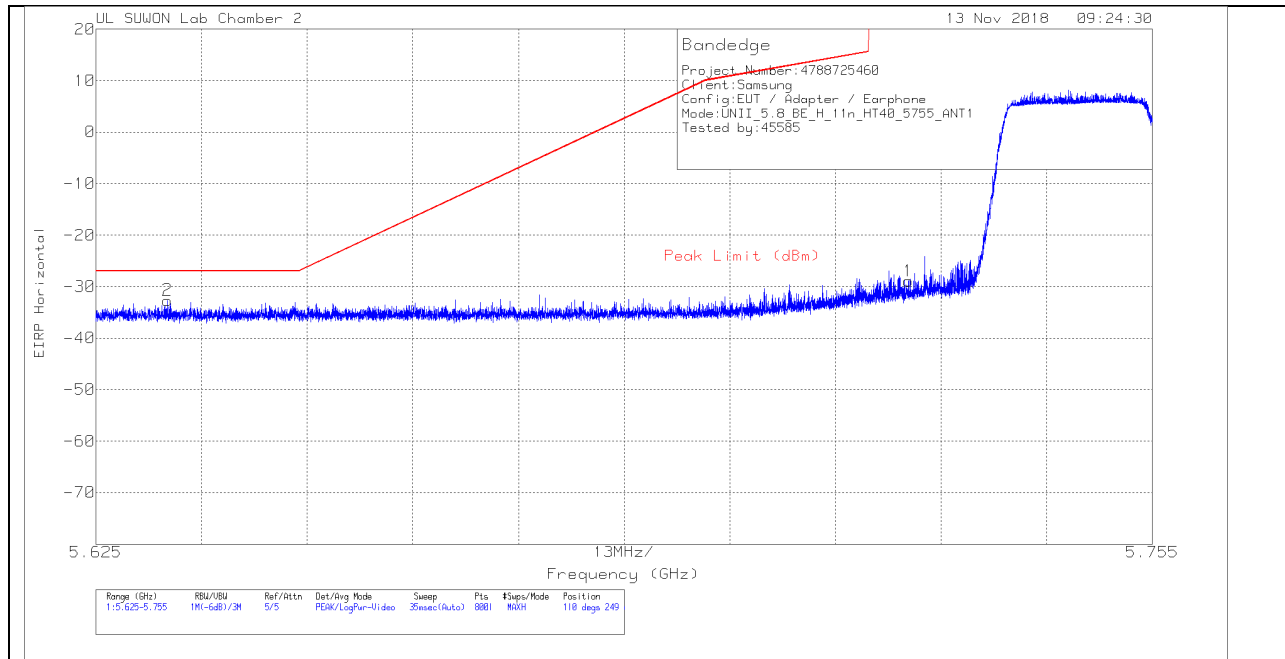

HORIZONTAL DATA

Trace Markers

Marker	Frequency (GHz)	Meter Reading (dBm)	Det	170531_3117[00 168724]	Path_2_10dB	Conversion Factor (dB)	DC Corr (dB)	Corrected Reading EIRP	Peak Limit (dBm)	PK Margin (dB)	Azimuth (Degs)	Height (cm)	Polarity
1	5.725	-59.61	Pk	34.5	-15.6	11.8	0	-28.91	26.97	-55.88	110	249	H
2	5.634	-63.14	Pk	34.4	-15.7	11.8	0	-32.64	-27	-5.64	110	249	H

Pk - Peak detector

VERTICAL PEAK PLOT

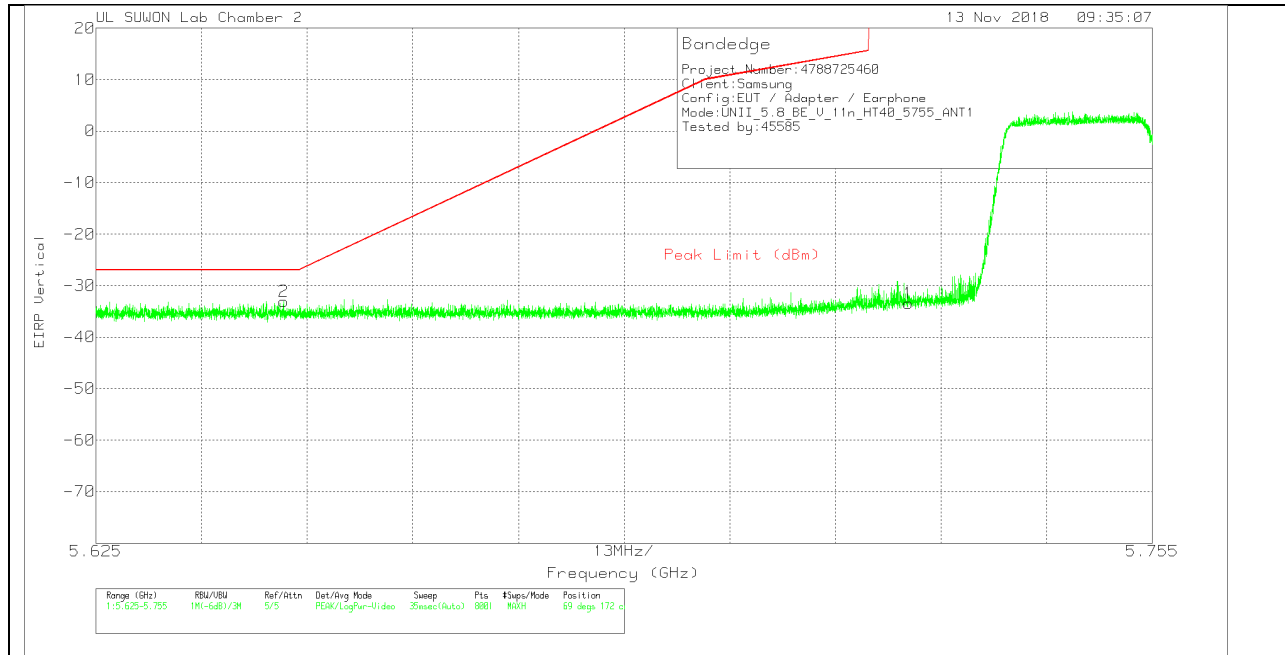

VERTICAL DATA

Trace Markers

Marker	Frequency (GHz)	Meter Reading (dBm)	Det	170531_3117[00 168724]	Path_2_10dB	Conversion Factor (dB)	DC Corr (dB)	Corrected Reading EIRP	Peak Limit (dBm)	PK Margin (dB)	Azimuth (Degs)	Height (cm)	Polarity
1	5.725	-64.19	Pk	34.5	-15.6	11.8	0	-33.49	26.97	-60.46	69	172	V
2	5.648	-63.55	Pk	34.4	-15.7	11.8	0	-33.05	-27	-6.05	69	172	V

Pk - Peak detector

BANDEDGE (HIGH CHANNEL)

HORIZONTAL PEAK PLOT

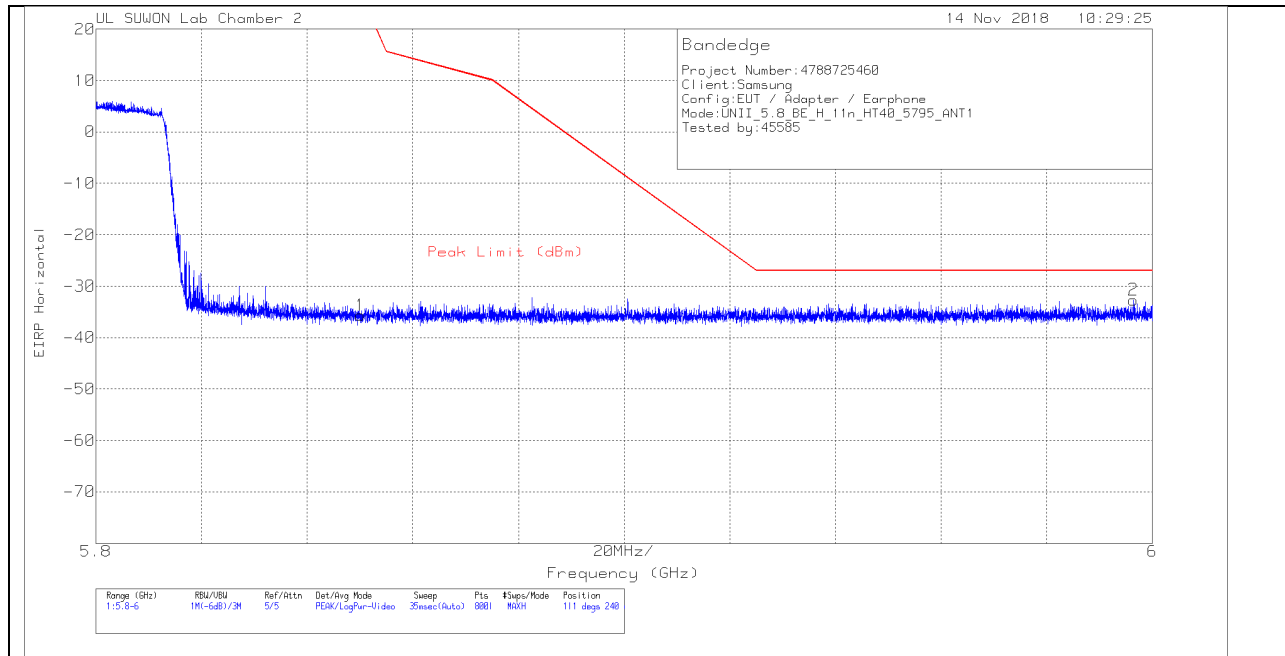

HORIZONTAL DATA

Trace Markers

Marker	Frequency (GHz)	Meter Reading (dBm)	Det	170531_3117[00 168724]	Path_2_10dB	Conversion Factor (dB)	DC Corr (dB)	Corrected Reading EIRP	Peak Limit (dBm)	PK Margin (dB)	Azimuth (Degs)	Height (cm)	Polarity
1	5.85	-66.43	Pk	34.5	-15.5	11.8	0	-35.63	26.94	-62.57	111	240	H
2	5.996	-63.84	Pk	34.8	-15.4	11.8	0	-32.64	-27	-5.64	111	240	H

Pk - Peak detector

VERTICAL PEAK PLOT

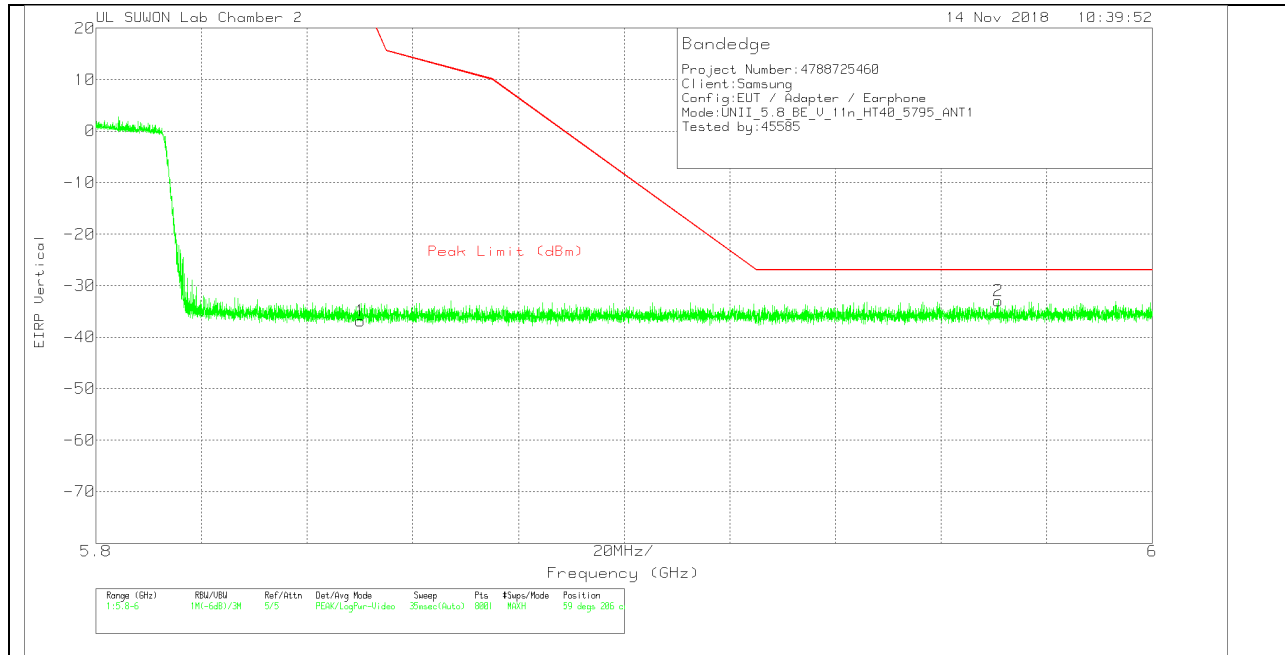

VERTICAL DATA

Trace Markers

Marker	Frequency (GHz)	Meter Reading (dBm)	Det	170531_3117[00 168724]	Path_2_10dB	Conversion Factor (dB)	DC Corr (dB)	Corrected Reading EIRP	Peak Limit (dBm)	PK Margin (dB)	Azimuth (Degs)	Height (cm)	Polarity
1	5.85	-67.67	Pk	34.5	-15.5	11.8	0	-36.87	26.94	-63.81	59	206	V
2	5.971	-64.07	Pk	34.7	-15.4	11.8	0	-32.97	-27	-5.97	59	206	V

Pk - Peak detector

LOW CHANNEL HORIZONTAL

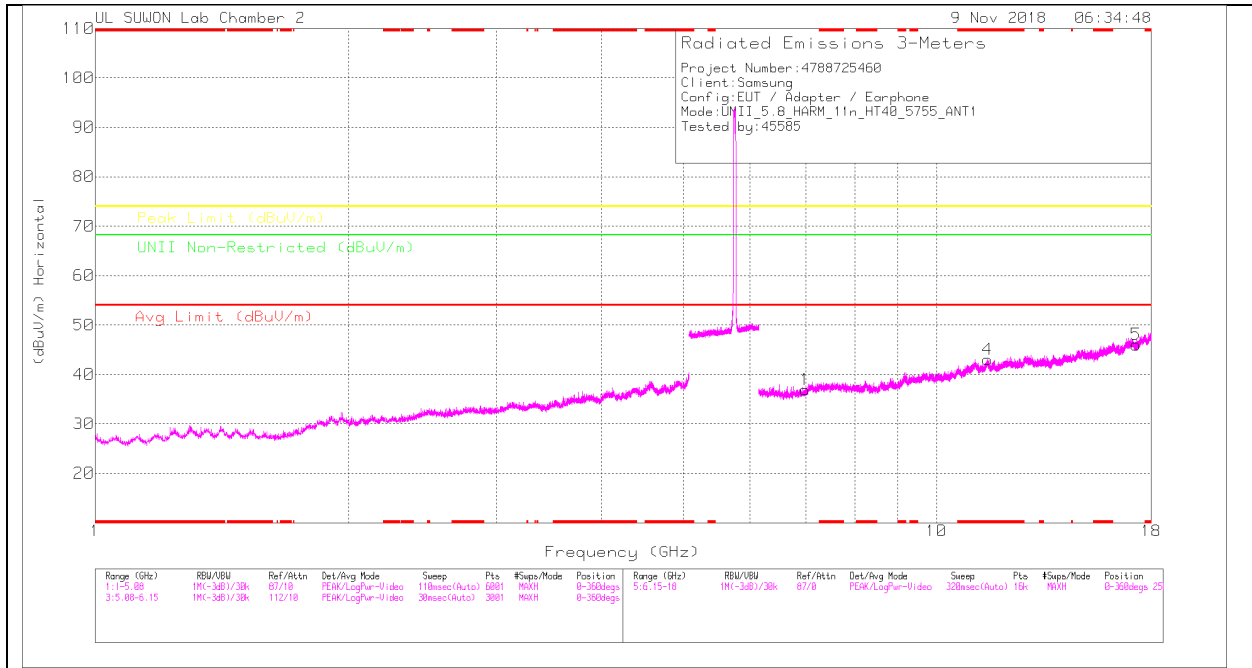

LOW CHANNEL VERTICAL

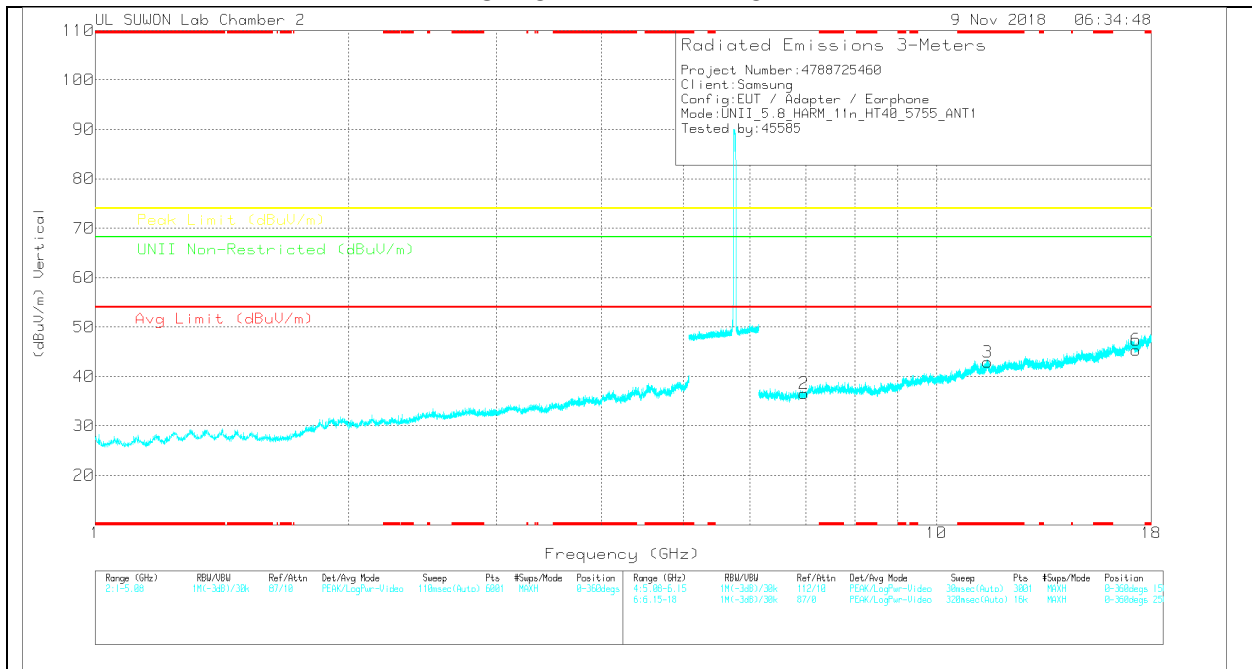

Note: Emission was scanned up to 40GHz; No emissions were detected above the noise floor which was at least 20dB below the specification limit.

LOW CHANNEL DATA

Trace Markers

Marker	Frequency (GHz)	Meter Reading (dBuV)	Det	3117_00108724	6GHz_HPF(dB)	DC Corr (dB)	Corrected Reading (dBuV/m)	Avg Limit (dBuV/m)	Margin (dB)	Peak Limit (dBuV/m)	Margin (dB)	LN0 Non-Restricted (dBuV/m)	Margin (dB)	Azimuth (Degs)	Height (cm)	Polarity
1	6.982	26.83	PK	35.8	-25.7	0	36.93	-	-	-	-	68.2	-31.27	0-360	250	H
4	*11.51	24.61	PK	38.3	-19.9	0	43.01	-	-	74	-30.99	-	-	0-360	150	H
5	17.265	23.53	PK	41.3	-18.8	0	46.03	-	-	-	-	68.2	-22.17	0-360	150	H
2	6.961	26.26	PK	35.8	-25.5	0	36.56	-	-	-	-	68.2	-31.64	0-360	150	V
3	*11.51	24.48	PK	38.3	-19.9	0	42.88	-	-	74	-31.12	-	-	0-360	250	V
6	17.266	22.86	PK	41.3	-18.8	0	45.36	-	-	-	-	68.2	-22.84	0-360	250	V

* - indicates frequency in CFR47 Pt 15 / IC RSS-Restricted Band
 PK – Peak Detector

Note: Only peak measurement was performed. Because peak measurement result of unwanted emission is less than average limit (54dBuV/m).

HIGH CHANNEL HORIZONTAL

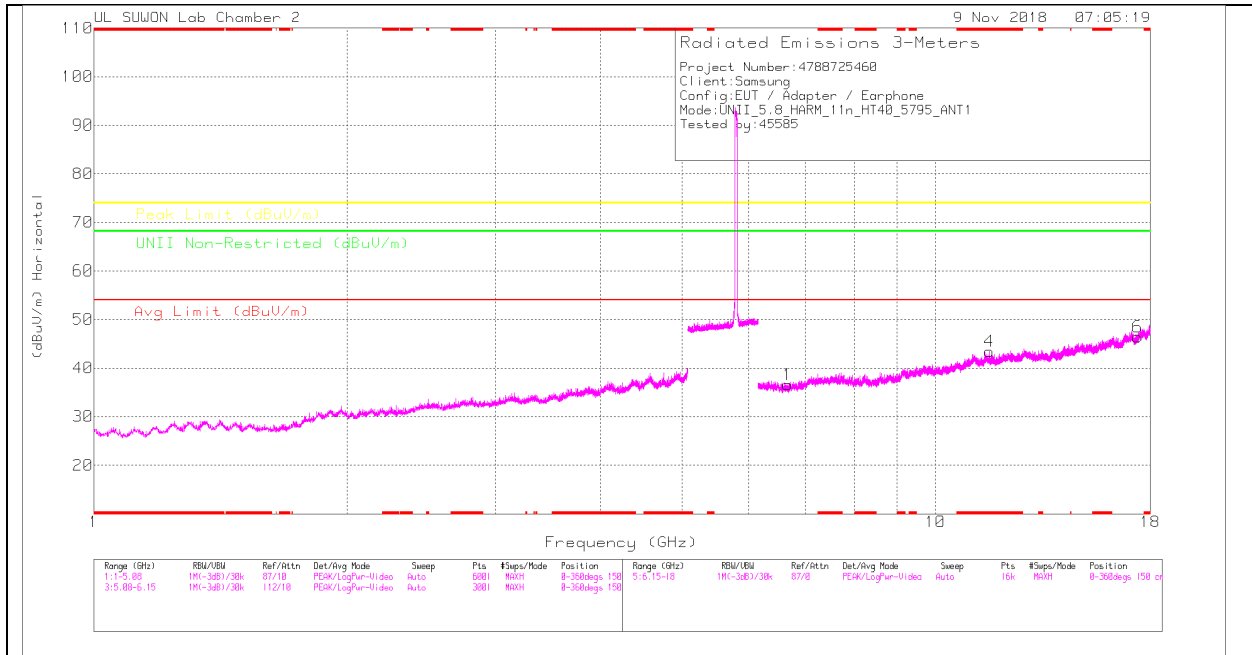

HIGH CHANNEL VERTICAL

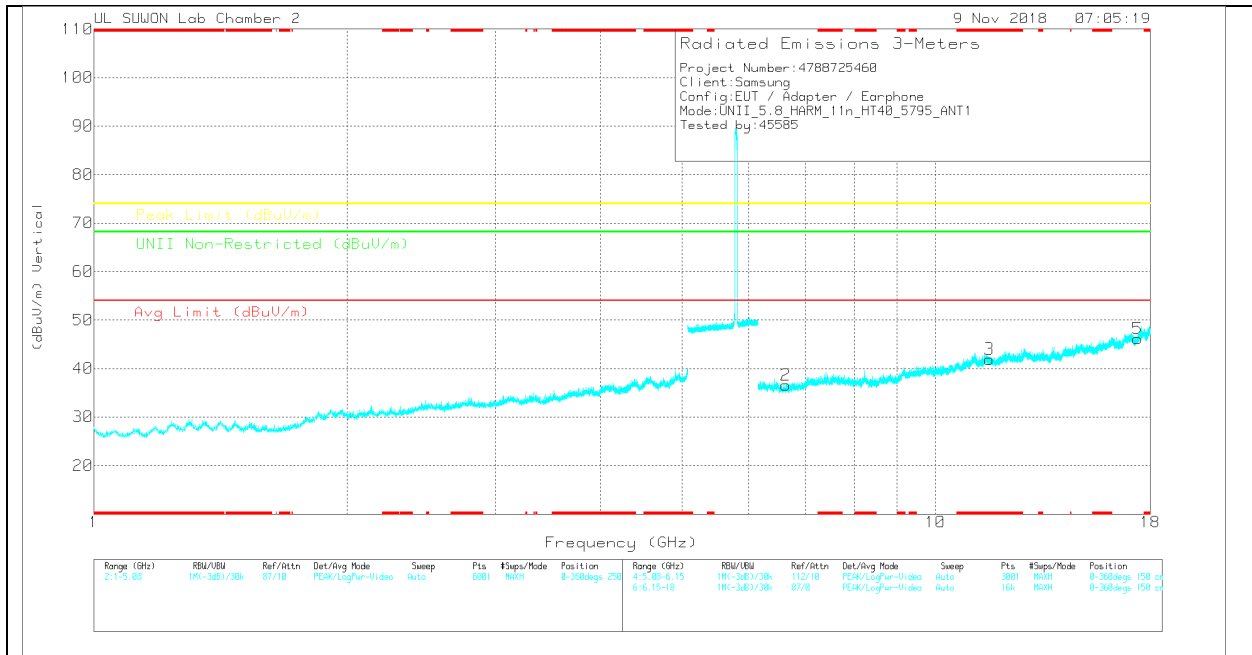

Note: Emission was scanned up to 40GHz; No emissions were detected above the noise floor which was at least 20dB below the specification limit.

HIGH CHANNEL DATA

Trace Markers

Marker	Frequency (GHz)	Marker Reading (dBuV)	Det	3117_00168724	60Hz_HR(dB)	DC Corr (dB)	Corrected Reading (dBuV/m)	Avg Limit (dBuV/m)	Margin (dB)	Peak Limit (dBuV/m)	Margin (dB)	Limit Non-Restricted (dBuV/m)	Margin (dB)	Azimuth (Degs)	Height (cm)	Polarity
1	6.669	26.92	PK	35.4	-25.8	0	36.52	-	-	-	-	68.2	-31.68	0-360	150	H
4	*11.591	25.18	PK	38.4	-20.2	0	43.38	-	-	74	-30.62	-	-	0-360	250	H
6	17.385	23.8	PK	41.4	-18.8	0	46.4	-	-	-	-	68.2	-21.8	0-360	250	H
2	6.642	26.85	PK	35.4	-25.7	0	36.55	-	-	-	-	68.2	-31.65	0-360	150	V
3	*11.59	23.74	PK	38.4	-20.2	0	41.94	-	-	74	-32.06	-	-	0-360	150	V
5	17.382	23.59	PK	41.4	-18.9	0	46.09	-	-	-	-	68.2	-22.11	0-360	150	V

* - indicates frequency in CFR47 Pt 15 / IC RSS-Restricted Band
 PK – Peak Detector

Note: Only peak measurement was performed. Because peak measurement result of unwanted emission is less than average limit (54dBuV/m).

11.4.9.TX ABOVE 1GHz 802.11n HT40 1Tx ANT2 IN THE 5.8GHz BAND BANDEDGE (LOW CHANNEL)

HORIZONTAL PEAK PLOT

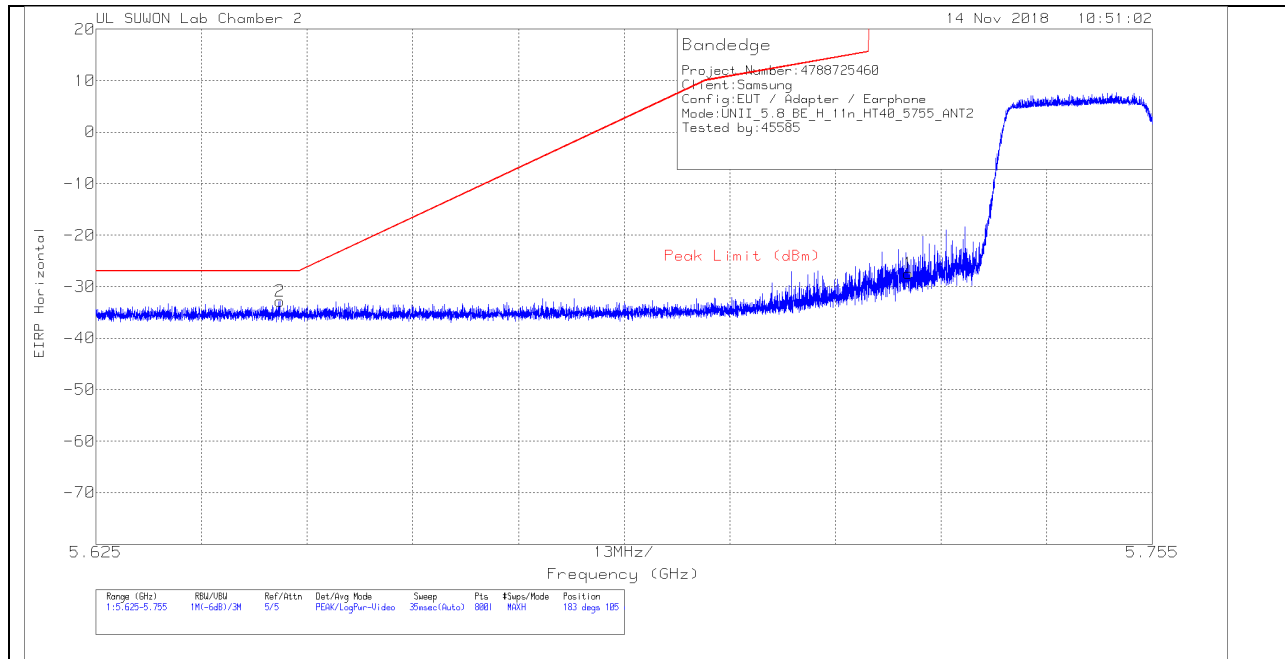

HORIZONTAL DATA

Trace Markers

Marker	Frequency (GHz)	Meter Reading (dBm)	Det	170531_3117[00 168724]	Path_2_10dB	Conversion Factor (dB)	DC Corr (dB)	Corrected Reading EIRP	Peak Limit (dBm)	PK Margin (dB)	Azimuth (Degs)	Height (cm)	Polarity
1	5.725	-58.13	Pk	34.5	-15.6	11.8	0	-27.43	26.97	-54.4	183	105	H
2	5.648	-63.28	Pk	34.4	-15.7	11.8	0	-32.78	-27	-5.78	183	105	H

Pk - Peak detector

VERTICAL PEAK PLOT

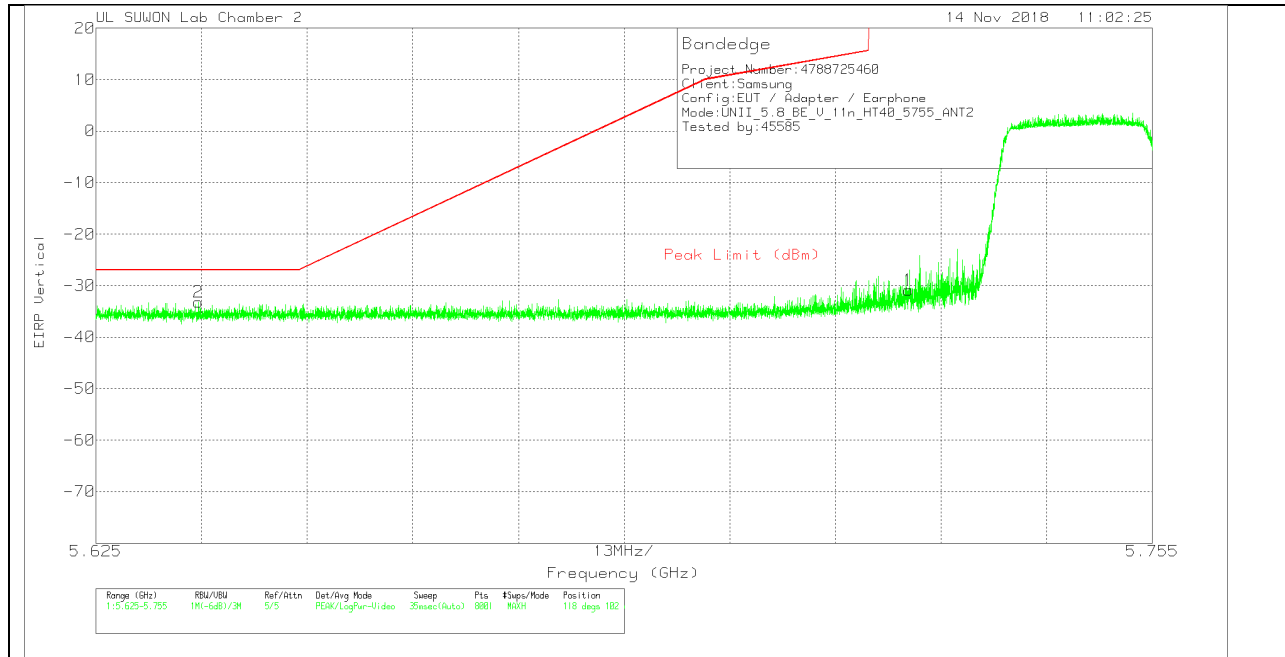

VERTICAL DATA

Trace Markers

Marker	Frequency (GHz)	Meter Reading (dBm)	Det	170531_3117[00 168724]	Path_2_10dB	Conversion Factor (dB)	DC Corr (dB)	Corrected Reading EIRP	Peak Limit (dBm)	PK Margin (dB)	Azimuth (Degs)	Height (cm)	Polarity
1	5.725	-61.57	Pk	34.5	-15.6	11.8	0	-30.87	26.97	-57.84	118	102	V
2	5.638	-63.65	Pk	34.4	-15.7	11.8	0	-33.15	-27	-6.15	118	102	V

Pk - Peak detector

BANDEDGE (HIGH CHANNEL)

HORIZONTAL PEAK PLOT

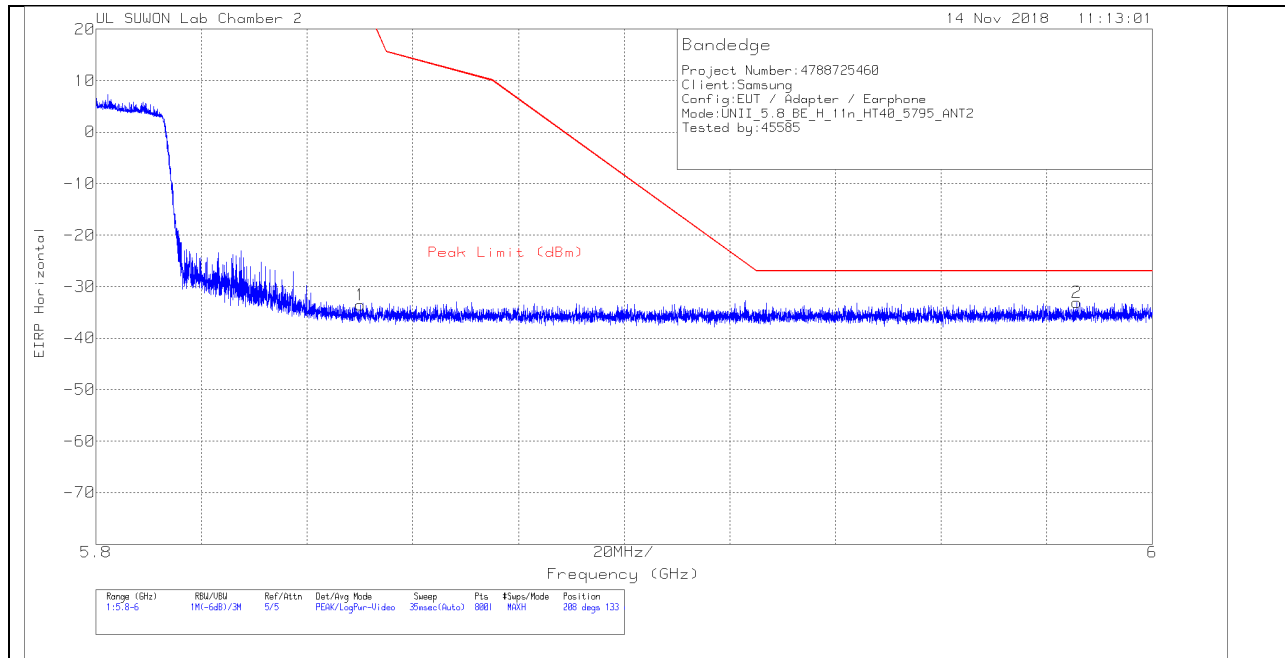

HORIZONTAL DATA

Trace Markers

Marker	Frequency (GHz)	Meter Reading (dBm)	Det	170531_3117[00168724]	Path_2_10dB	Conversion Factor (dB)	DC Corr (dB)	Corrected Reading EIRP	Peak Limit (dBm)	PK Margin (dB)	Azimuth (Degs)	Height (cm)	Polarity
1	5.85	-64.36	Pk	34.5	-15.5	11.8	0	-33.56	26.94	-60.5	208	133	H
2	5.986	-64.22	Pk	34.7	-15.4	11.8	0	-33.12	-27	-6.12	208	133	H

Pk - Peak detector

VERTICAL PEAK PLOT

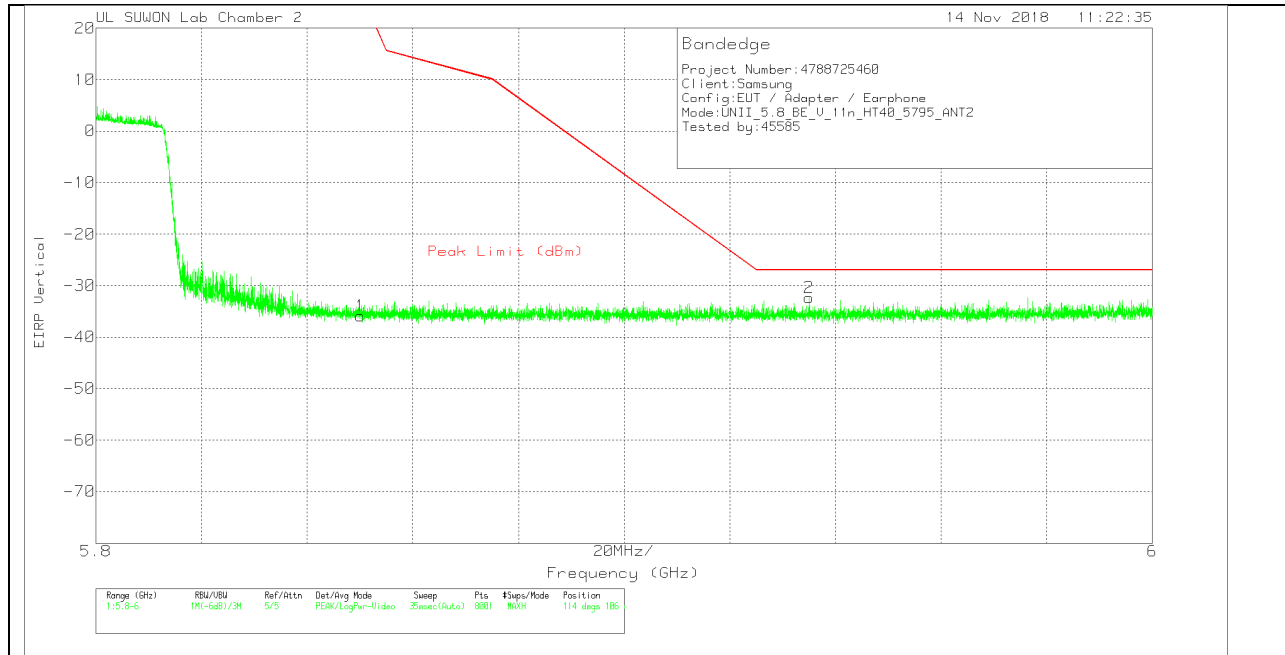

VERTICAL DATA

Trace Markers

Marker	Frequency (GHz)	Meter Reading (dBm)	Det	170531_3117[00 168724]	Path_2_10dB	Conversion Factor (dB)	DC Corr (dB)	Corrected Reading EIRP	Peak Limit (dBm)	PK Margin (dB)	Azimuth (Degs)	Height (cm)	Polarity
1	5.85	-66.65	Pk	34.5	-15.5	11.8	0	-35.85	26.94	-62.79	114	106	V
2	5.935	-63.24	Pk	34.6	-15.5	11.8	0	-32.34	-27	-5.34	114	106	V

Pk - Peak detector

LOW CHANNEL HORIZONTAL

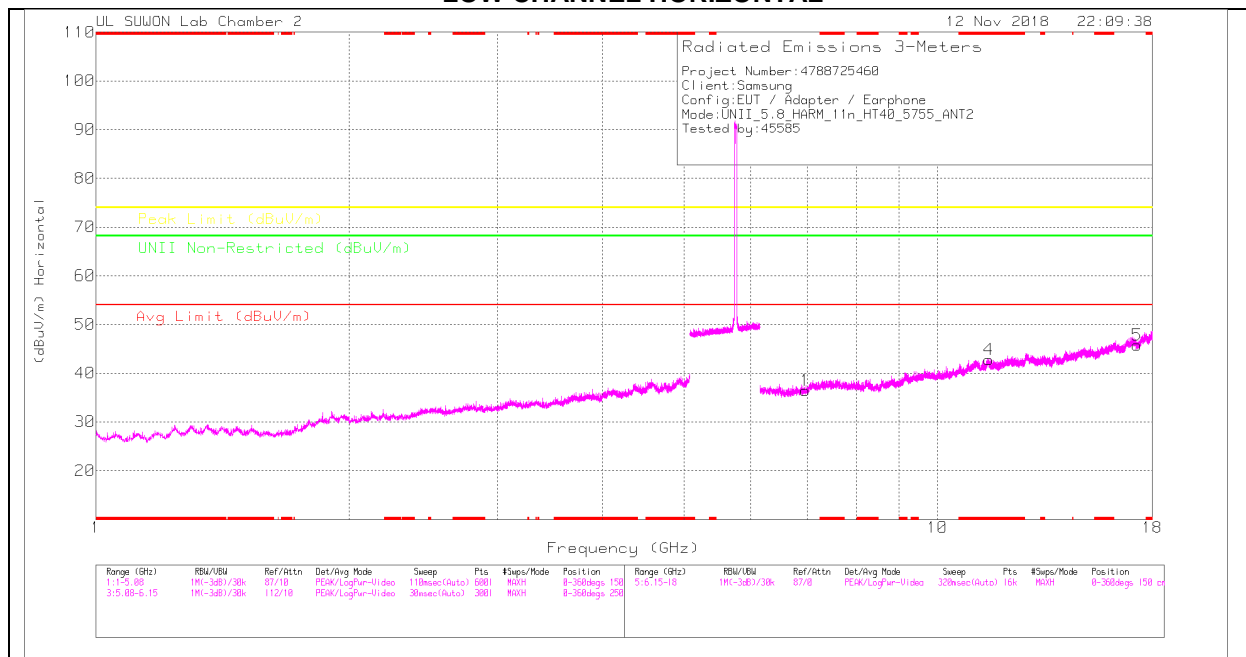

LOW CHANNEL VERTICAL

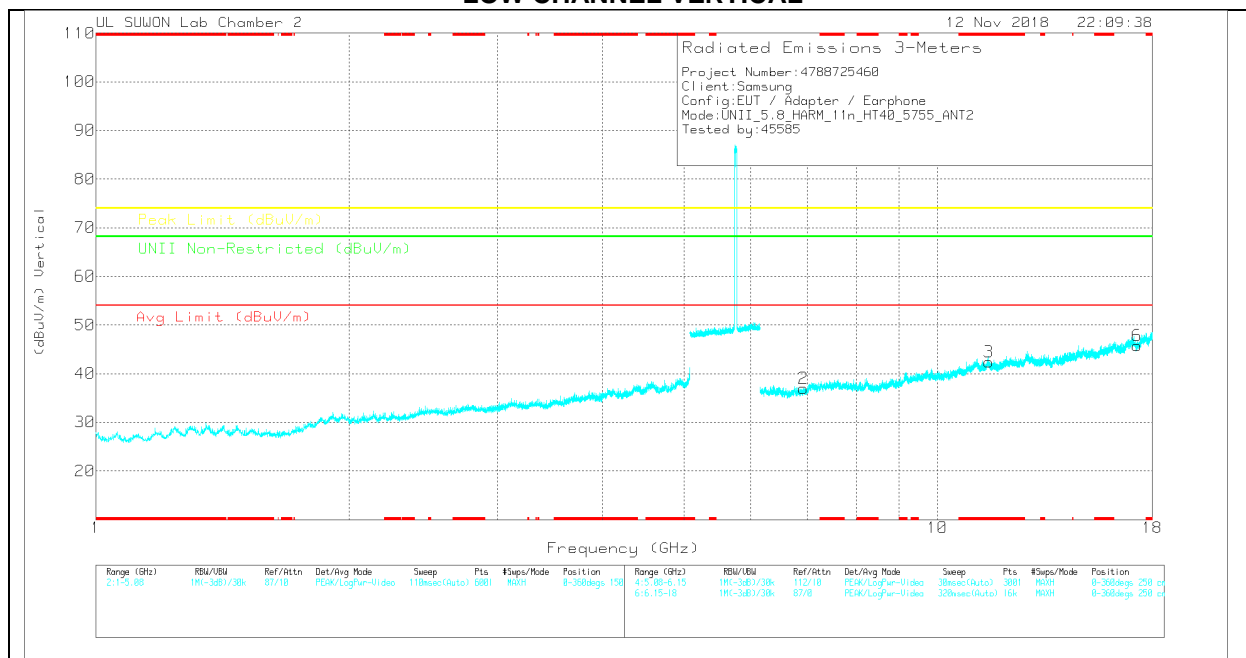

Note: Emission was scanned up to 40GHz; No emissions were detected above the noise floor which was at least 20dB below the specification limit.

LOW CHANNEL DATA

Trace Markers

Marker	Frequency (GHz)	Meter Reading (dBµV)	Det	3117_00108724	GHz_HF[dB]	DC Corr (dB)	Corrected Reading (dBµV/m)	Avg Limit (dBµV/m)	Margin (dB)	Peak Limit (dBµV/m)	Margin (dB)	LNB Non-Restricted (dBµV/m)	Margin (dB)	Azimuth (Degs)	Height (cm)	Polarity
1	6.962	26.3	PK	35.8	-25.6	0	36.5	-	-	-	-	68.2	-31.7	0-360	250	H
4	*11.508	24.44	PK	38.3	-19.9	0	42.84	-	-	74	-31.16	-	-	0-360	150	H
5	17.266	23.27	PK	41.3	-18.8	0	45.77	-	-	-	-	68.2	-22.43	0-360	150	H
2	6.938	26.53	PK	35.7	-25.3	0	36.93	-	-	-	-	68.2	-31.27	0-360	250	V
3	*11.509	24	PK	38.3	-19.9	0	42.4	-	-	74	-31.6	-	-	0-360	150	V
6	17.265	23.29	PK	41.3	-18.8	0	45.79	-	-	-	-	68.2	-22.41	0-360	150	V

* - indicates frequency in CFR47 Pt 15 / IC RSS-Restricted Band
 PK – Peak Detector

Note: Only peak measurement was performed. Because peak measurement result of unwanted emission is less than average limit (54dBuV/m).

HIGH CHANNEL HORIZONTAL

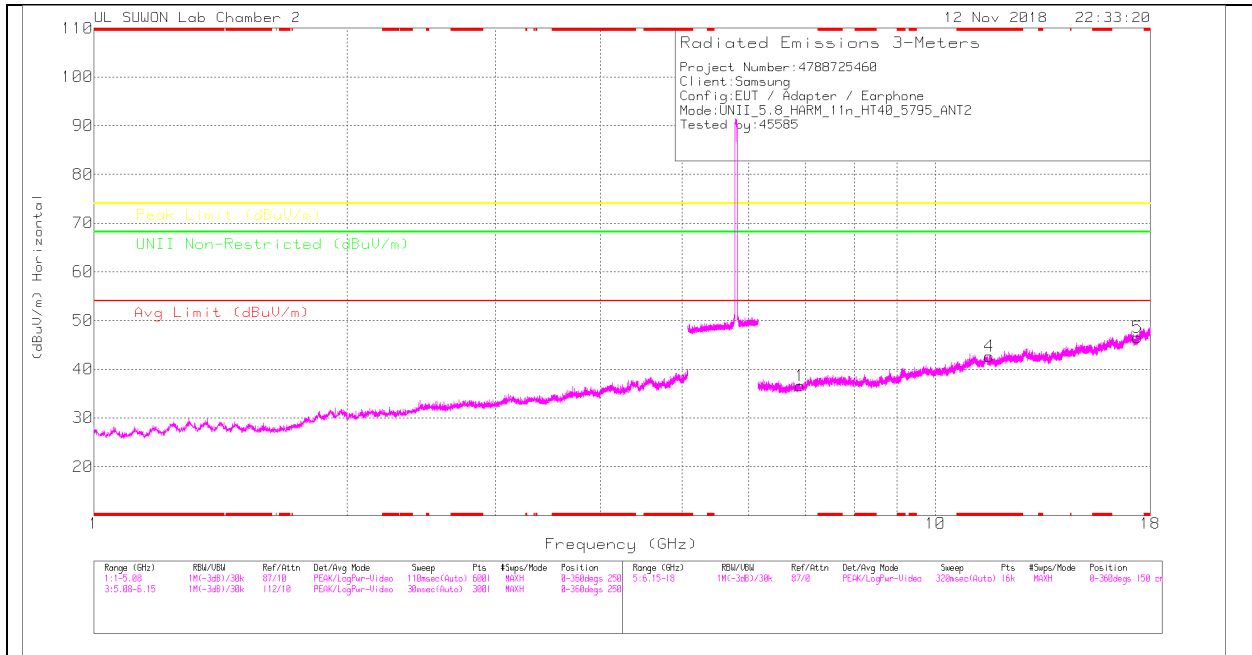

HIGH CHANNEL VERTICAL

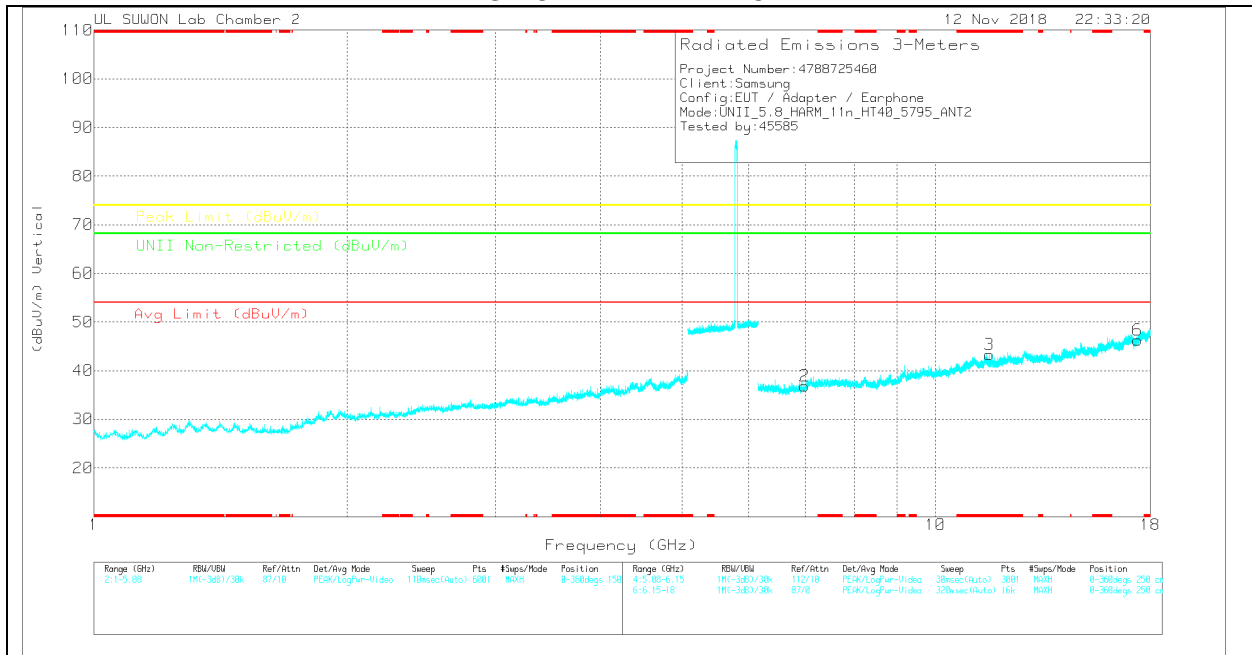

Note: Emission was scanned up to 40GHz; No emissions were detected above the noise floor which was at least 20dB below the specification limit.

HIGH CHANNEL DATA

Trace Markers

Marker	Frequency (GHz)	Meter Reading (dBµV)	Det	3117_00108724	GHz_HF[dB]	DC Corr (dB)	Corrected Reading (dBµV/m)	Avg Limit (dBµV/m)	Margin (dB)	Peak Limit (dBµV/m)	Margin (dB)	LNI Non-Restricted (dBµV/m)	Margin (dB)	Azimuth (Degs)	Height (cm)	Polarity
1	6.904	26.06	PK	35.7	-25.2	0	36.56	-	-	-	-	68.2	-31.64	0-360	250	H
4	*11.591	24.43	PK	38.4	-20.2	0	42.63	-	-	74	-31.37	-	-	0-360	150	H
5	17.382	23.93	PK	41.4	-18.8	0	46.53	-	-	-	-	68.2	-21.67	0-360	150	H
2	6.991	26.87	PK	35.8	-25.8	0	36.87	-	-	-	-	68.2	-31.33	0-360	250	V
3	*11.59	25.05	PK	38.4	-20.2	0	43.25	-	-	74	-30.75	-	-	0-360	250	V
6	17.388	23.64	PK	41.4	-18.8	0	46.24	-	-	-	-	68.2	-21.96	0-360	250	V

* - indicates frequency in CFR47 Pt 15 / IC RSS-Restricted Band

PK – Peak Detector

Note: Only peak measurement was performed. Because peak measurement result of unwanted emission is less than average limit (54dBuV/m).

11.4.10.TX ABOVE 1GHz 802.11ac VHT80 2Tx CDD MODE IN THE 5.8GHz BAND BANDEDGE (Lower side)

HORIZONTAL PEAK PLOT

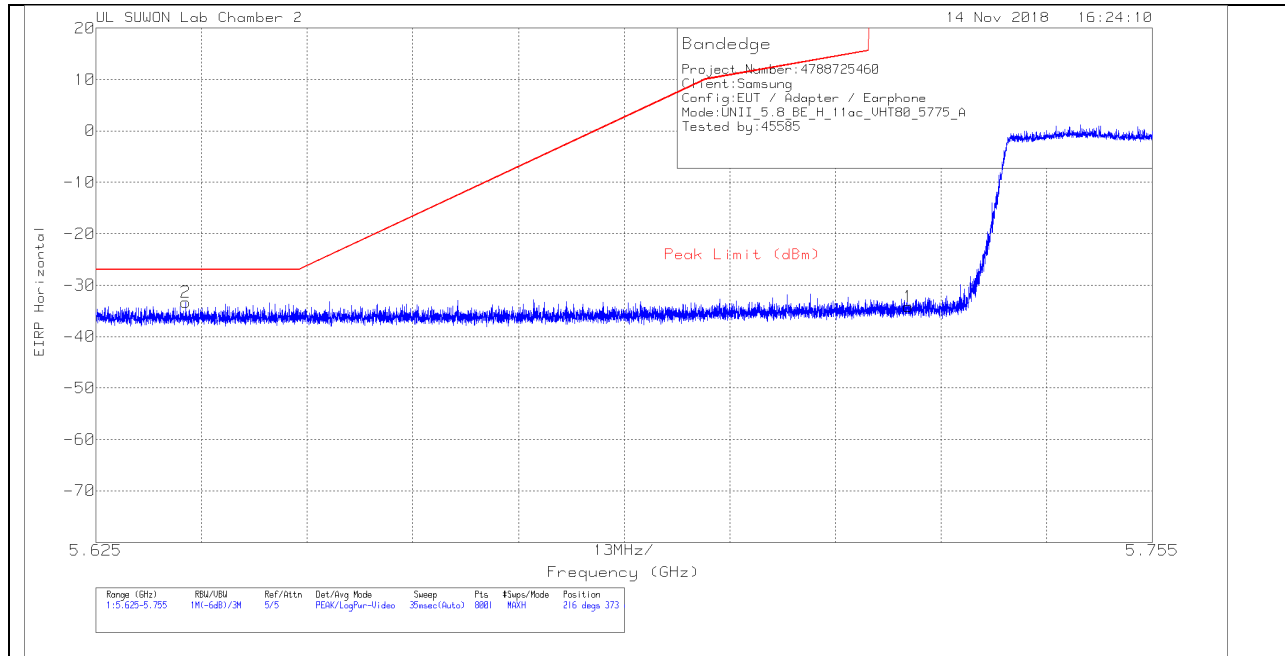

HORIZONTAL DATA

Trace Markers

Marker	Frequency (GHz)	Meter Reading (dBm)	Det	170531_3117[00 168724]	Path_2_10dB	Conversion Factor (dB)	DC Corr (dB)	Corrected Reading EIRP	Peak Limit (dBm)	PK Margin (dB)	Azimuth (Degs)	Height (cm)	Polarity
1	5.725	-64.84	Pk	34.5	-15.6	11.8	0	-34.14	26.97	-61.11	216	373	H
2	5.636	-63.86	Pk	34.4	-15.7	11.8	0	-33.36	-27	-6.36	216	373	H

Pk - Peak detector

VERTICAL PEAK PLOT

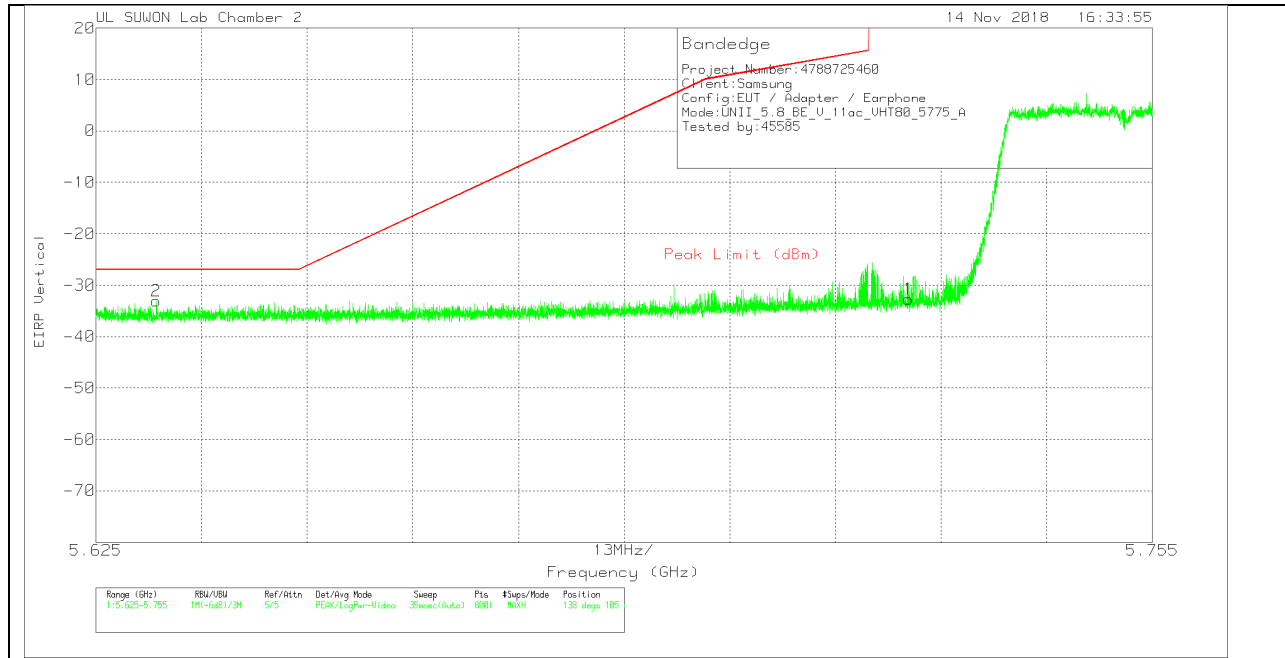

VERTICAL DATA

Trace Markers

Marker	Frequency (GHz)	Meter Reading (dBm)	Det	170531_3117[00 168724]	Path_2_10dB	Conversion Factor (dB)	DC Corr (dB)	Corrected Reading EIRP	Peak Limit (dBm)	PK Margin (dB)	Azimuth (Degs)	Height (cm)	Polarity
1	5.725	-63.44	Pk	34.5	-15.6	11.8	0	-32.74	26.97	-59.71	138	105	V
2	5.632	-63.54	Pk	34.4	-15.7	11.8	0	-33.04	-27	-6.04	138	105	V

Pk - Peak detector

BANDEDGE (Upper side)

HORIZONTAL PEAK PLOT

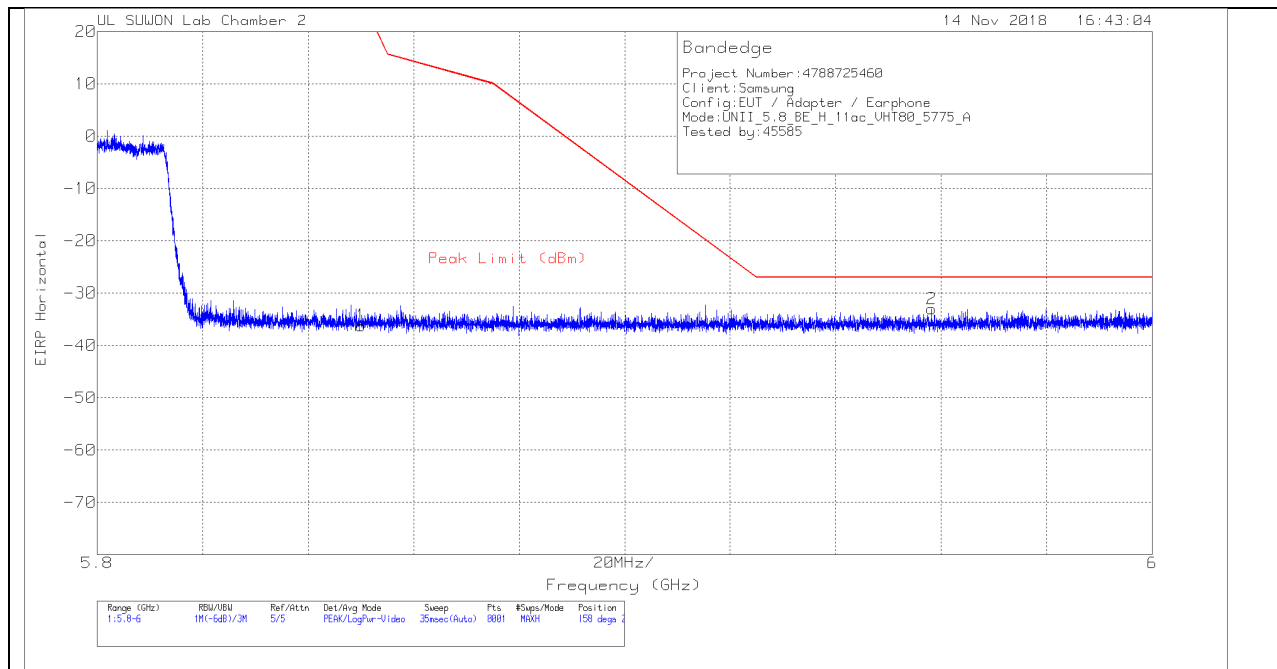

HORIZONTAL DATA

Trace Markers

Marker	Frequency (GHz)	Meter Reading (dBm)	Det	170531_3117[00 168724]	Path_2_10dB	Conversion Factor (dB)	DC Corr (dB)	Corrected Reading EIRP	Peak Limit (dBm)	PK Margin (dB)	Azimuth (Degs)	Height (cm)	Polarity
1	5.85	-67	Pk	34.5	-15.5	11.8	0	-36.2	26.94	-63.14	158	250	H
2	5.958	-63.92	Pk	34.6	-15.5	11.8	0	-33.02	-27	-6.02	158	250	H

Pk - Peak detector

VERTICAL PEAK PLOT

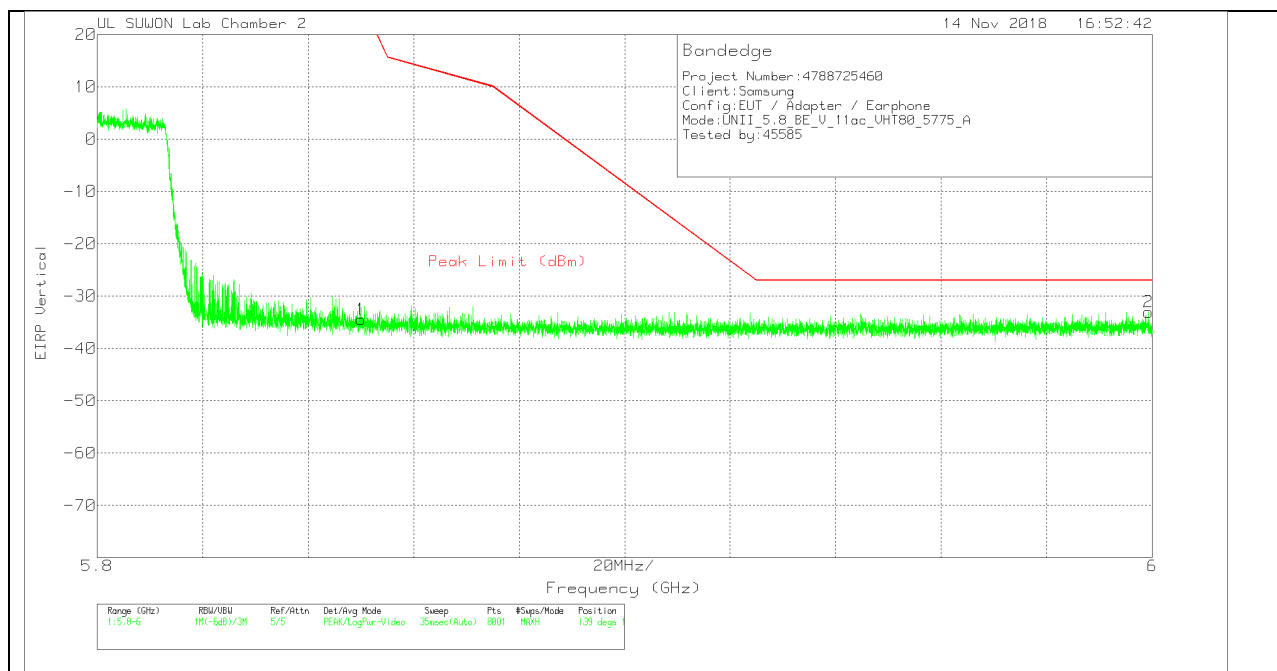

VERTICAL DATA

Trace Markers

Marker	Frequency (GHz)	Meter Reading (dBm)	Det	170531_3117[00 168724]	Path_2_10dB	Conversion Factor (dB)	DC Corr (dB)	Corrected Reading EIRP	Peak Limit (dBm)	PK Margin (dB)	Azimuth (Degs)	Height (cm)	Polarity
1	5.85	-65.24	Pk	34.5	-15.5	11.8	0	-34.44	26.94	-61.38	139	106	V
2	5.999	-64.25	Pk	34.8	-15.4	11.8	0	-33.05	-27	-6.05	139	106	V

Pk - Peak detector

MID CHANNEL HORIZONTAL

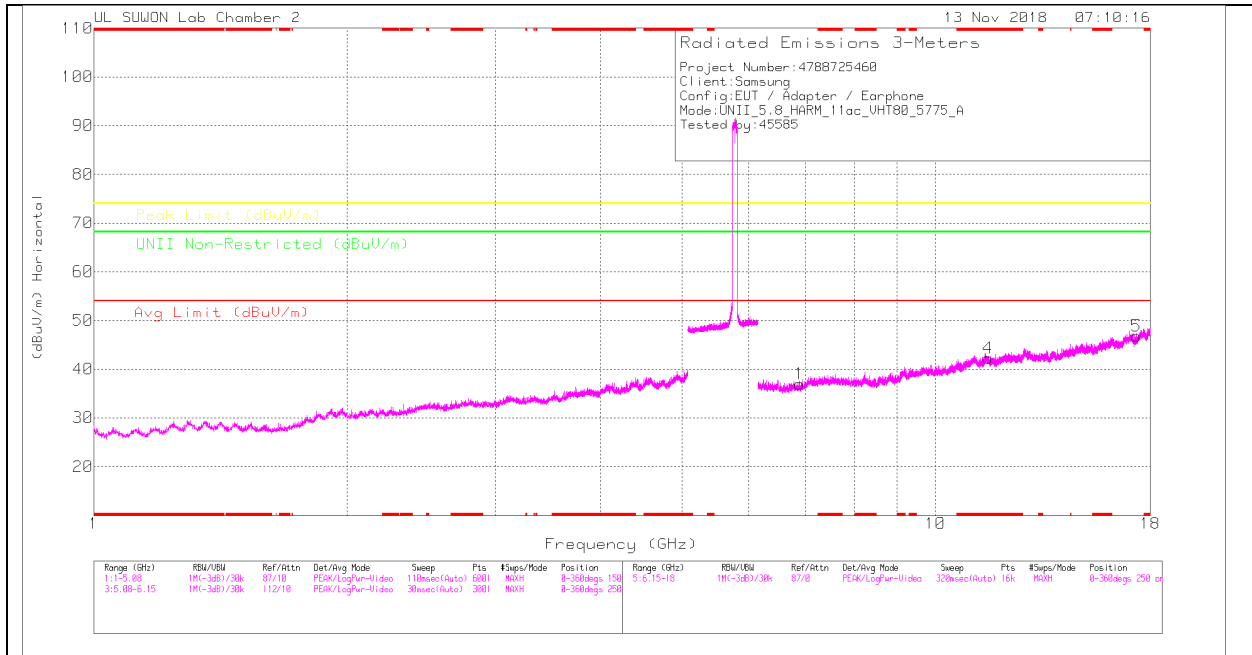

MID CHANNEL VERTICAL

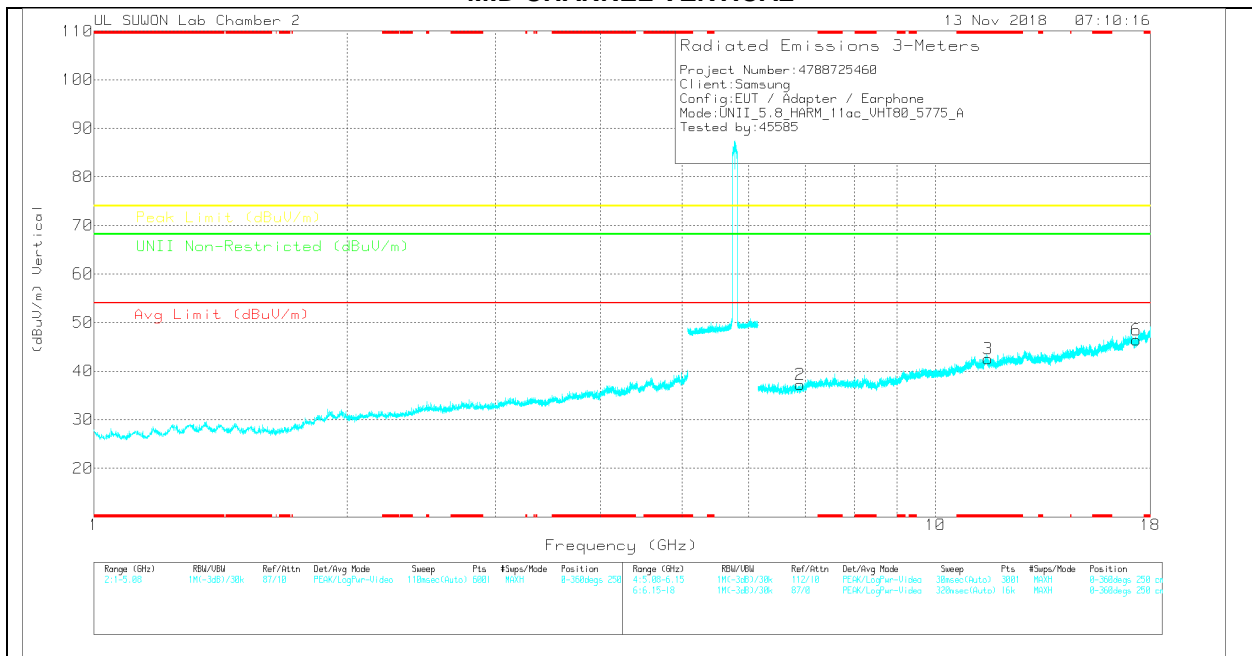

Note: Emission was scanned up to 40GHz; No emissions were detected above the noise floor which was at least 20dB below the specification limit.

MID CHANNEL DATA

Trace Markers

Marker	Frequency (GHz)	Meter Reading (dBμV)	Det	3117_00108724	GHz_HF[dB]	DC Corr (dB)	Corrected Reading (dBμV/m)	Avg Limit (dBμV/m)	Margin (dB)	Peak Limit (dBμV/m)	Margin (dB)	LNI Non-Restricted (dBμV/m)	Margin (dB)	Azimuth (Degs)	Height (cm)	Polarity
1	6.897	26.42	PK	35.7	-25.1	0	37.02	-	-	-	-	68.2	-31.18	0-360	150	H
4	*11.551	23.83	PK	38.3	-19.9	0	42.23	-	-	74	-31.77	-	-	0-360	250	H
5	17.325	24.41	PK	41.3	-18.9	0	46.81	-	-	-	-	68.2	-21.39	0-360	150	H
2	6.908	26.61	PK	35.7	-25.1	0	37.21	-	-	-	-	68.2	-30.99	0-360	250	V
3	*11.551	24.15	PK	38.3	-19.9	0	42.55	-	-	74	-31.45	-	-	0-360	150	V
6	17.328	24.05	PK	41.3	-18.9	0	46.45	-	-	-	-	68.2	-21.75	0-360	150	V

* - indicates frequency in CFR47 Pt 15 / IC RSS-Restricted Band
 PK – Peak Detector

Note: Only peak measurement was performed. Because peak measurement result of unwanted emission is less than average limit (54dBuV/m).

11.4.11. TX ABOVE 1GHz 802.11ac VHT80 1Tx ANT1 IN THE 5.8GHz BAND BANDEDGE (Lower side)

HORIZONTAL PEAK PLOT

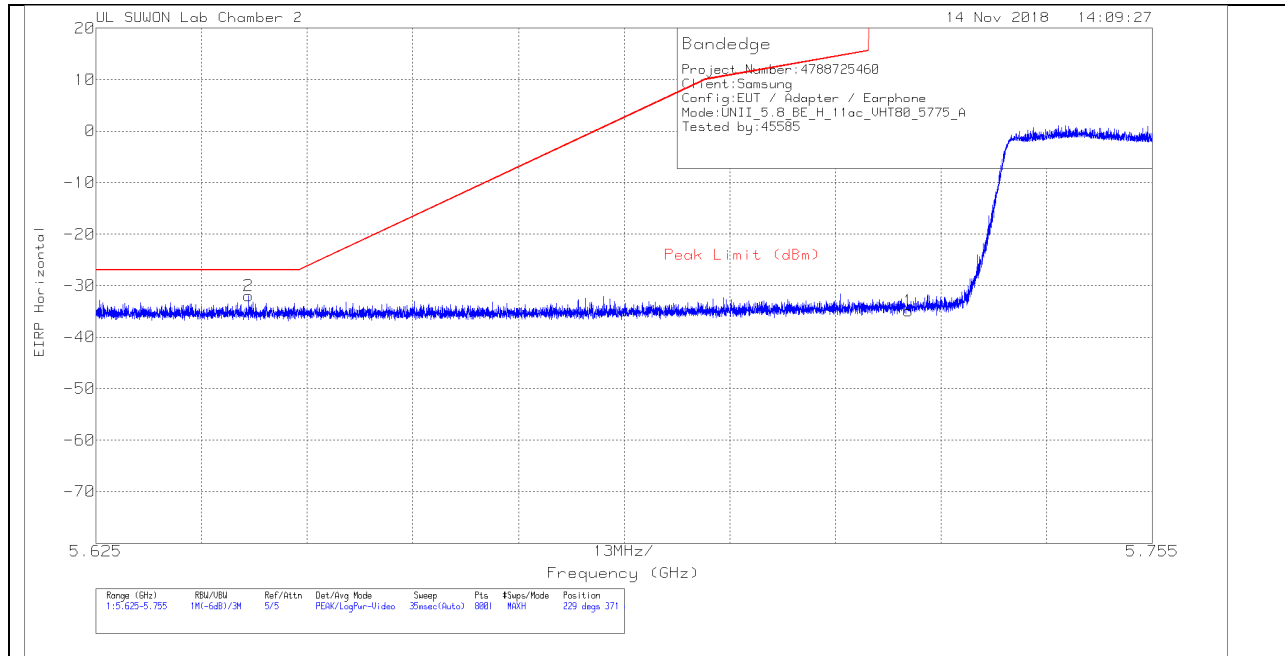

HORIZONTAL DATA

Trace Markers

Marker	Frequency (GHz)	Meter Reading (dBm)	Det	170531_3117[00 168724]	Path_2_10dB	Conversion Factor (dB)	DC Corr (dB)	Corrected Reading EIRP	Peak Limit (dBm)	PK Margin (dB)	Azimuth (Degs)	Height (cm)	Polarity
1	5.725	-65.55	Pk	34.5	-15.6	11.8	0	-34.85	26.97	-61.82	229	371	H
2	5.644	-62.46	Pk	34.4	-15.7	11.8	0	-31.96	-27	-4.96	229	371	H

Pk - Peak detector

VERTICAL PEAK PLOT

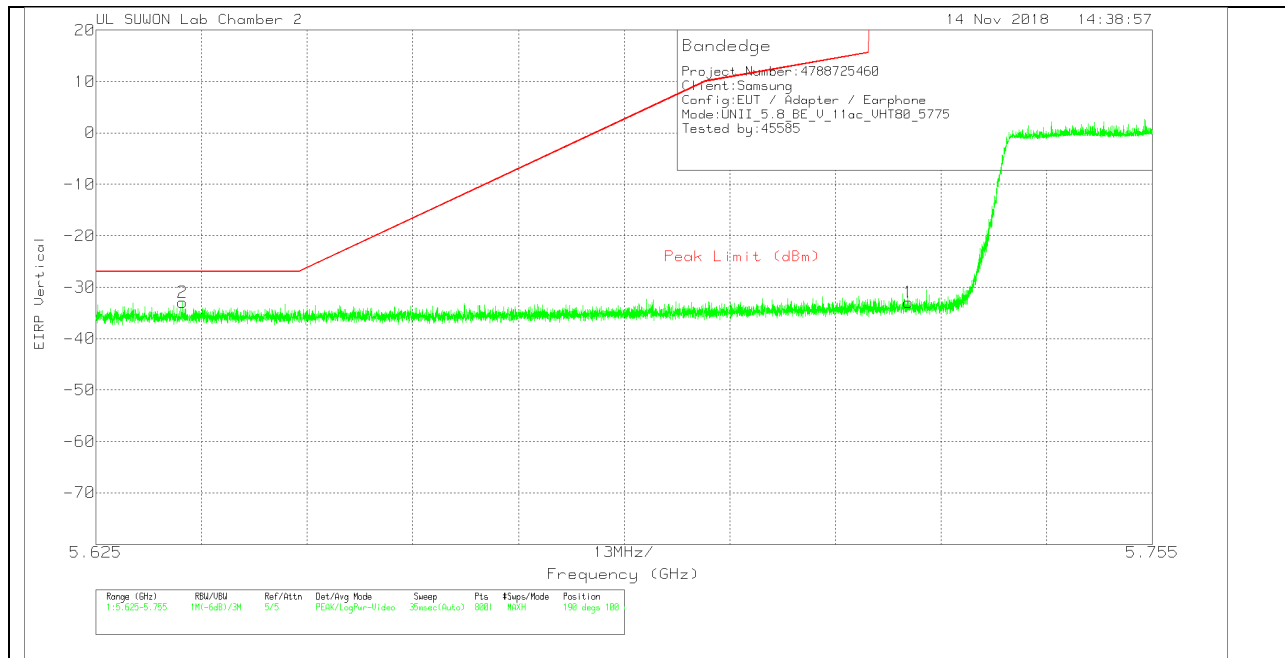

VERTICAL DATA

Trace Markers

Marker	Frequency (GHz)	Meter Reading (dBm)	Det	170531_3117[00 168724]	Path_2_10dB	Conversion Factor (dB)	DC Corr (dB)	Corrected Reading EIRP	Peak Limit (dBm)	PK Margin (dB)	Azimuth (Degs)	Height (cm)	Polarity
1	5.725	-63.61	Pk	34.5	-15.6	11.8	0	-32.91	26.97	-59.88	190	100	V
2	5.636	-63.4	Pk	34.4	-15.7	11.8	0	-32.9	-27	-5.9	190	100	V

Pk - Peak detector

BANDEDGE (Upper side)

HORIZONTAL PEAK PLOT

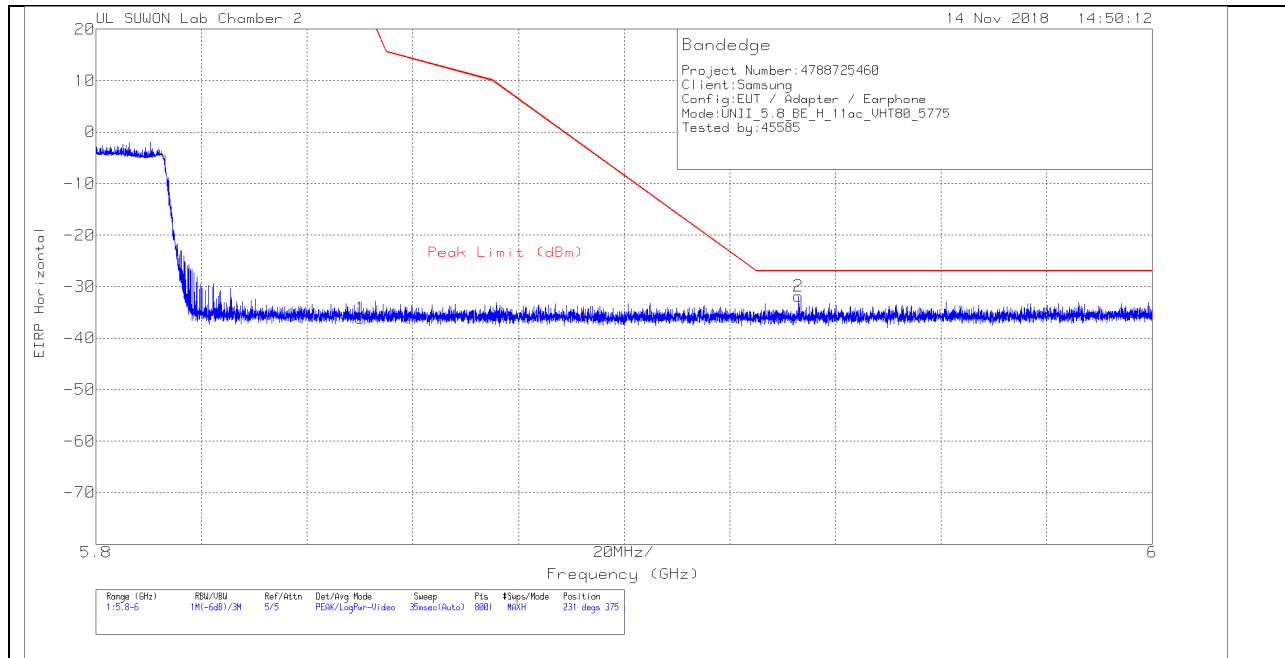

HORIZONTAL DATA

Trace Markers

Marker	Frequency (GHz)	Meter Reading (dBm)	Det	170531_3117[00168724]	Path_2_10dB	Conversion Factor (dB)	DC Corr (dB)	Corrected Reading EIRP	Peak Limit (dBm)	PK Margin (dB)	Azimuth (Degs)	Height (cm)	Polarity
1	5.85	-66.98	Pk	34.5	-15.5	11.8	0	-36.18	26.94	-63.12	231	375	H
2	5.933	-62.77	Pk	34.6	-15.5	11.8	0	-31.87	-27	-4.87	231	375	H

Pk - Peak detector

VERTICAL PEAK PLOT

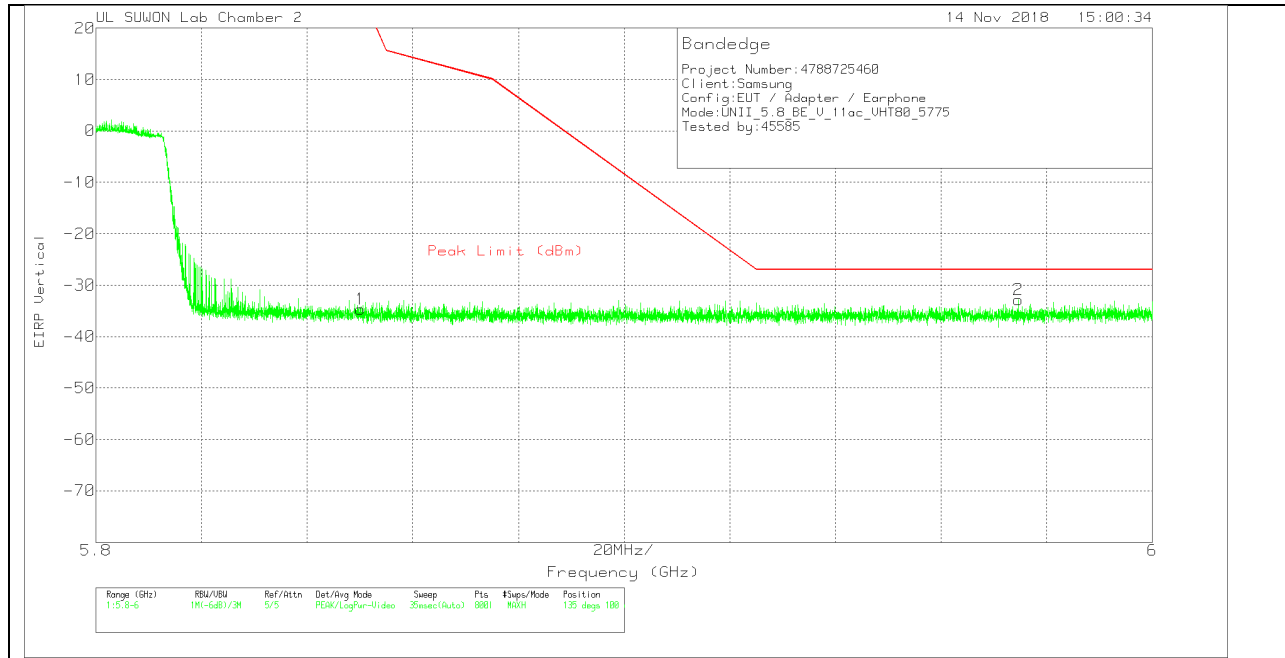

VERTICAL DATA

Trace Markers

Marker	Frequency (GHz)	Meter Reading (dBm)	Det	170531_3117[00 168724]	Path_2_10dB	Conversion Factor (dB)	DC Corr (dB)	Corrected Reading EIRP	Peak Limit (dBm)	PK Margin (dB)	Azimuth (Degs)	Height (cm)	Polarity
1	5.85	-65.5	Pk	34.5	-15.5	11.8	0	-34.7	26.94	-61.64	135	100	V
2	5.975	-63.94	Pk	34.7	-15.4	11.8	0	-32.84	-27	-5.84	135	100	V

Pk - Peak detector

MID CHANNEL HORIZONTAL

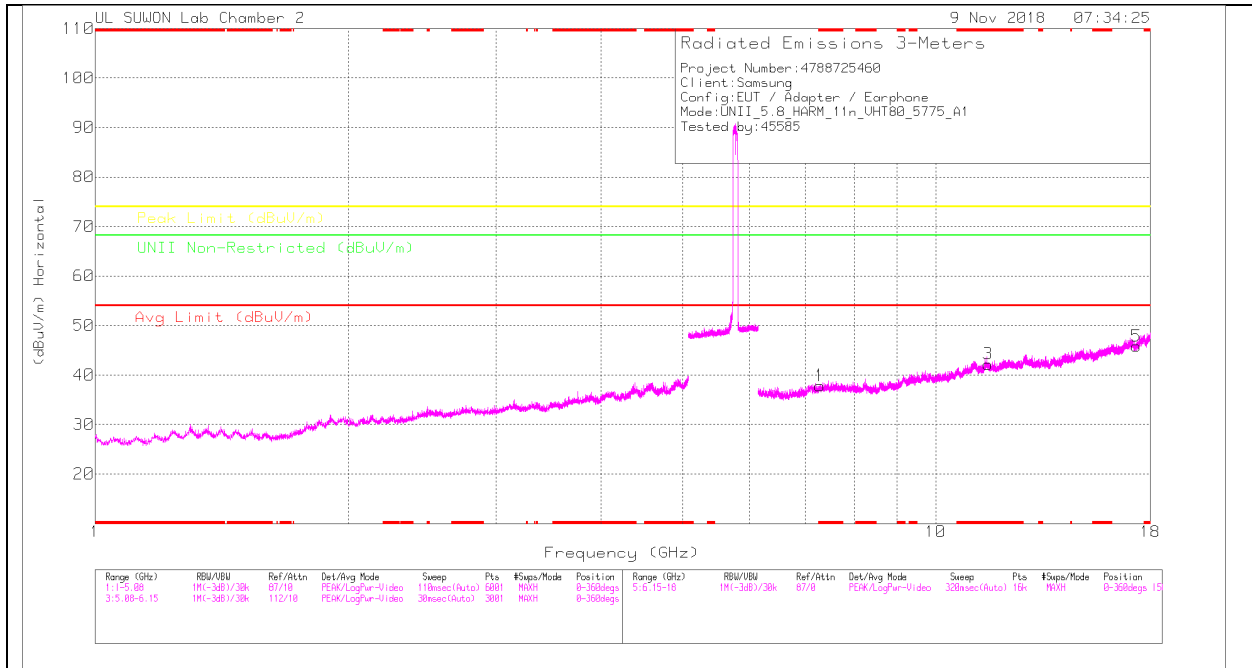

MID CHANNEL VERTICAL

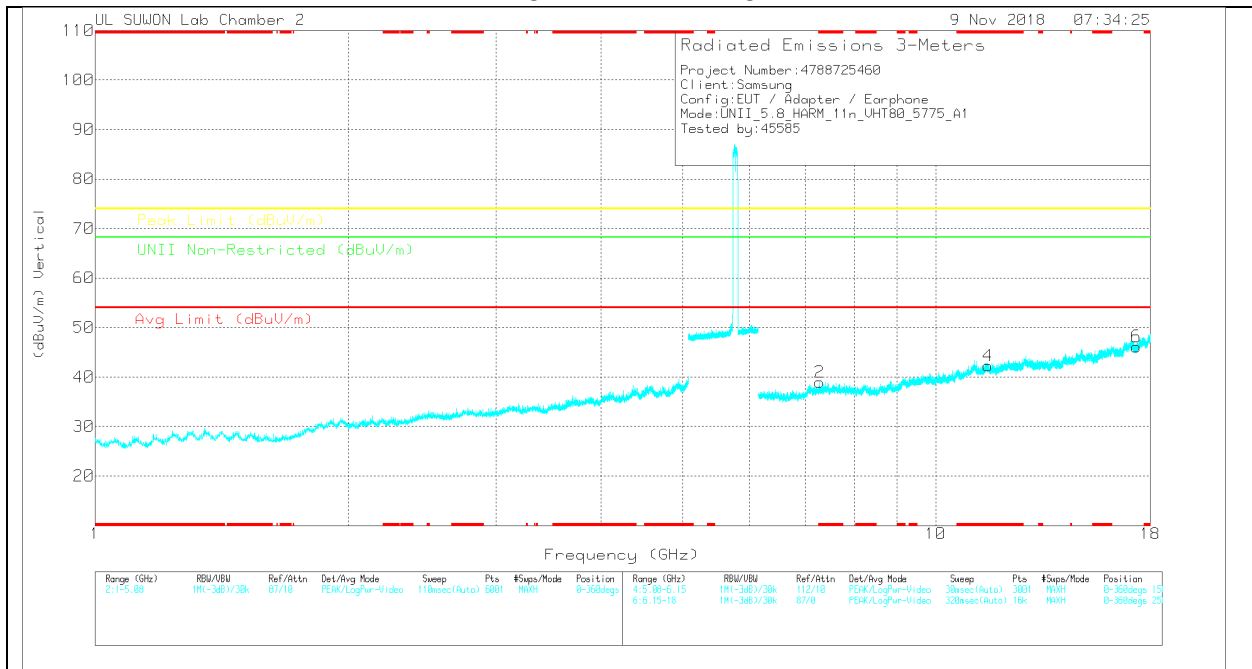

Note: Emission was scanned up to 40GHz; No emissions were detected above the noise floor which was at least 20dB below the specification limit.

MID CHANNEL DATA

Trace Markers

Marker	Frequency (GHz)	Meter Reading (dBuV)	Det	3117_00108724	6GHz_HPF(dB)	DC Corr (dB)	Corrected Reading (dBuV/m)	Avd Limit (dBuV/m)	Margin (dB)	Peak Limit (dBuV/m)	Margin (dB)	LN0 Non-Restricted (dBuV/m)	Margin (dB)	Asimuth (Degs)	Height (cm)	Polarity
1	*7.284	26.83	PK	36.2	-25.2	0	37.83	-	-	74	-36.17	-	-	0-360	150	H
3	*11.55	23.7	PK	38.3	-19.8	0	42.2	-	-	74	-31.8	-	-	0-360	250	H
5	17.324	23.42	PK	41.3	-18.9	0	45.82	-	-	-	-	68.2	-22.38	0-360	250	H
2	*7.282	27.96	PK	36.2	-25.2	0	38.96	-	-	74	-35.04	-	-	0-360	250	V
4	*11.55	23.77	PK	38.3	-19.8	0	42.27	-	-	74	-31.73	-	-	0-360	250	V
6	17.326	23.82	PK	41.3	-19	0	46.12	-	-	-	-	68.2	-22.08	0-360	150	V

* - indicates frequency in CFR47 Pt 15 / IC RSS-Restricted Band
 PK – Peak Detector

Note: Only peak measurement was performed. Because peak measurement result of unwanted emission is less than average limit (54dBuV/m).

11.4.12. TX ABOVE 1GHz 802.11ac VHT80 1Tx ANT2 IN THE 5.8GHz BAND BANDEDGE (Lower side)

HORIZONTAL PEAK PLOT

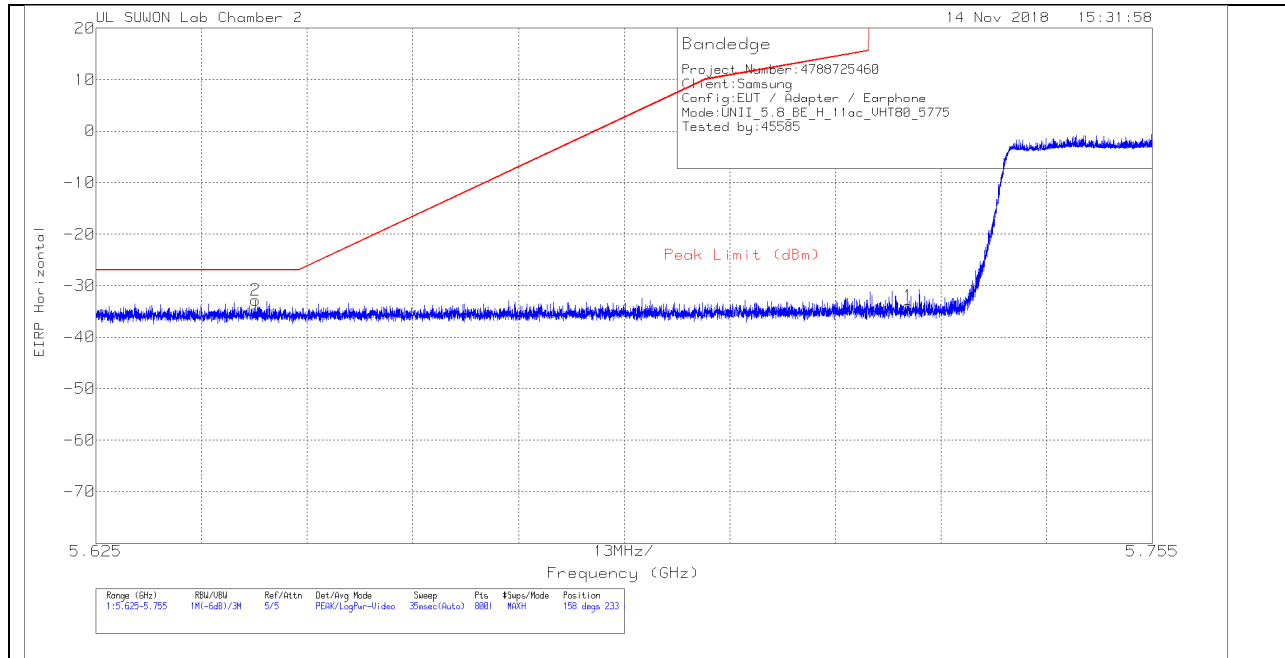

HORIZONTAL DATA

Trace Markers

Marker	Frequency (GHz)	Meter Reading (dBm)	Det	170531_3117[00 168724]	Path_2_10dB	Conversion Factor (dB)	DC Corr (dB)	Corrected Reading EIRP	Peak Limit (dBm)	PK Margin (dB)	Azimuth (Degs)	Height (cm)	Polarity
1	5.725	-64.58	Pk	34.5	-15.6	11.8	0	-33.88	26.97	-60.85	158	233	H
2	5.645	-63.31	Pk	34.4	-15.7	11.8	0	-32.81	-27	-5.81	158	233	H

Pk - Peak detector

VERTICAL PEAK PLOT

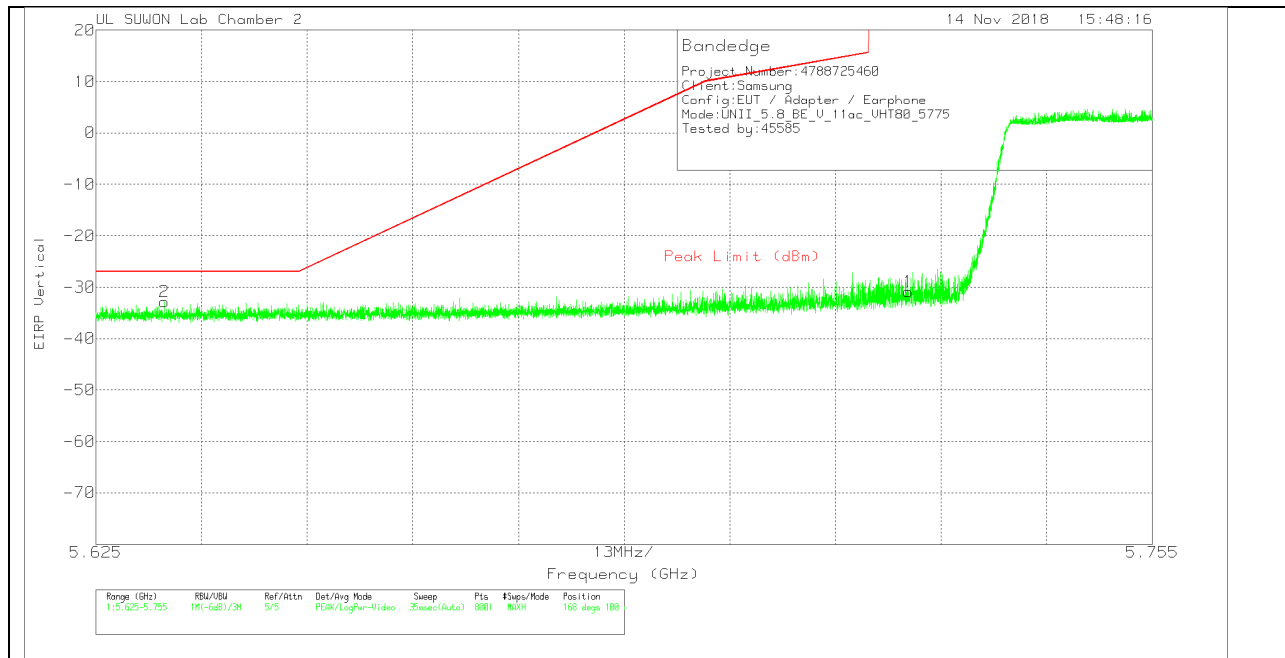

VERTICAL DATA

Trace Markers

Marker	Frequency (GHz)	Meter Reading (dBm)	Det	170531_3117[00 168724]	Path_2_10dB	Conversion Factor (dB)	DC Corr (dB)	Corrected Reading EIRP	Peak Limit (dBm)	PK Margin (dB)	Azimuth (Degs)	Height (cm)	Polarity
1	5.725	-61.51	Pk	34.5	-15.6	11.8	0	-30.81	26.97	-57.78	168	100	V
2	5.633	-63.31	Pk	34.4	-15.7	11.8	0	-32.81	-27	-5.81	168	100	V

Pk - Peak detector

BANDEDGE (Upper side)

HORIZONTAL PEAK PLOT

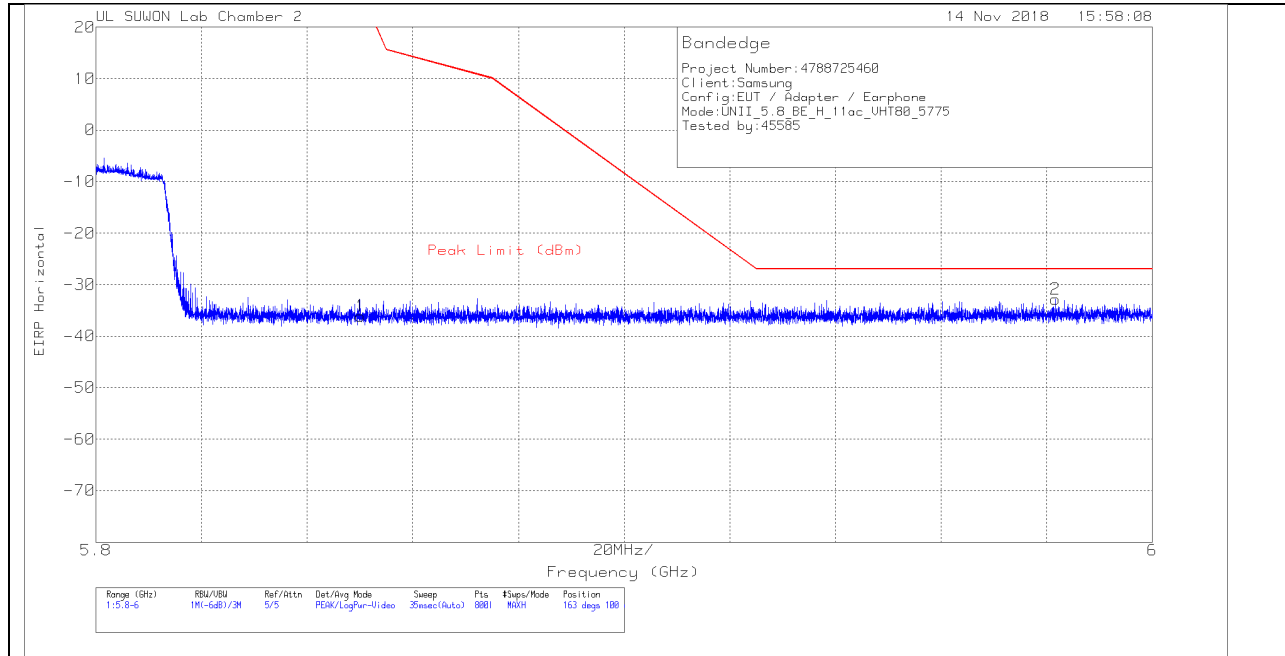

HORIZONTAL DATA

Trace Markers

Marker	Frequency (GHz)	Meter Reading (dBm)	Det	170531_3117[00 168724]	Path_2_10dB	Conversion Factor (dB)	DC Corr (dB)	Corrected Reading EIRP	Peak Limit (dBm)	PK Margin (dB)	Azimuth (Degs)	Height (cm)	Polarity
1	5.85	-66.87	Pk	34.5	-15.5	11.8	0	-36.07	26.94	-63.01	163	100	H
2	5.982	-63.97	Pk	34.7	-15.4	11.8	0	-32.87	-27	-5.87	163	100	H

Pk - Peak detector

VERTICAL PEAK PLOT

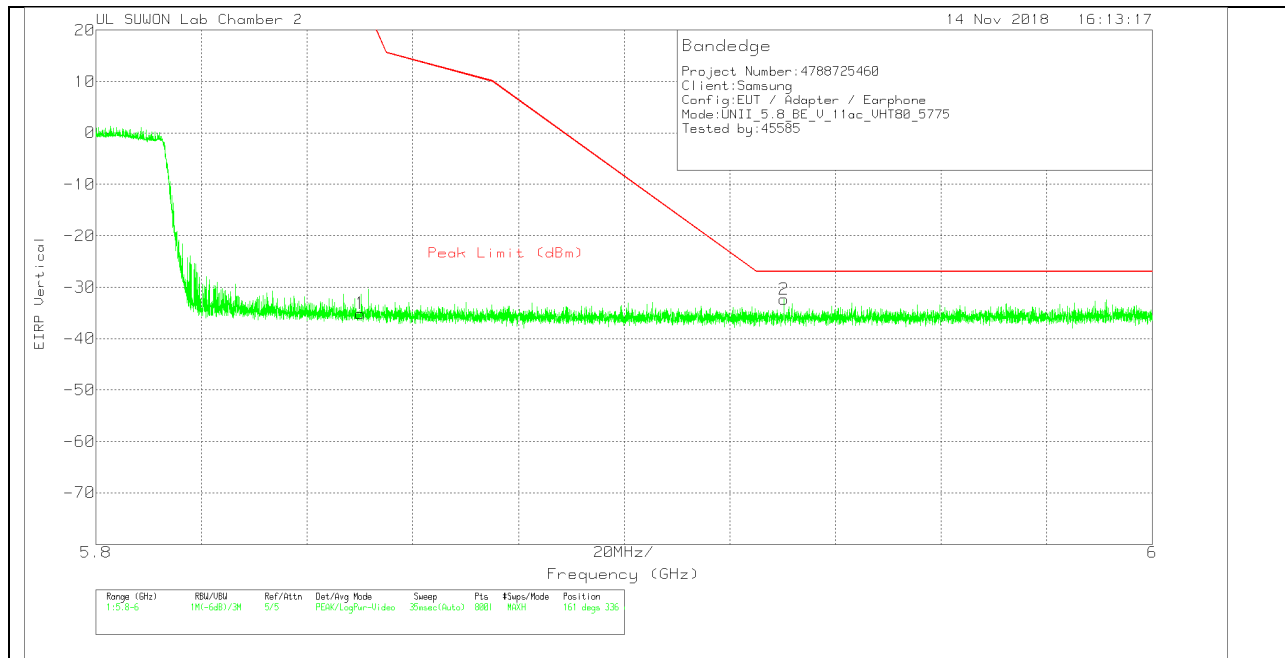

VERTICAL DATA

Trace Markers

Marker	Frequency (GHz)	Meter Reading (dBm)	Det	170531_3117[00 168724]	Path_2_10dB	Conversion Factor (dB)	DC Corr (dB)	Corrected Reading EIRP	Peak Limit (dBm)	PK Margin (dB)	Azimuth (Degs)	Height (cm)	Polarity
1	5.85	-65.89	Pk	34.5	-15.5	11.8	0	-35.09	26.94	-62.03	161	336	V
2	5.93	-63.19	Pk	34.6	-15.5	11.8	0	-32.29	-27	-5.29	161	336	V

Pk - Peak detector

MID CHANNEL HORIZONTAL

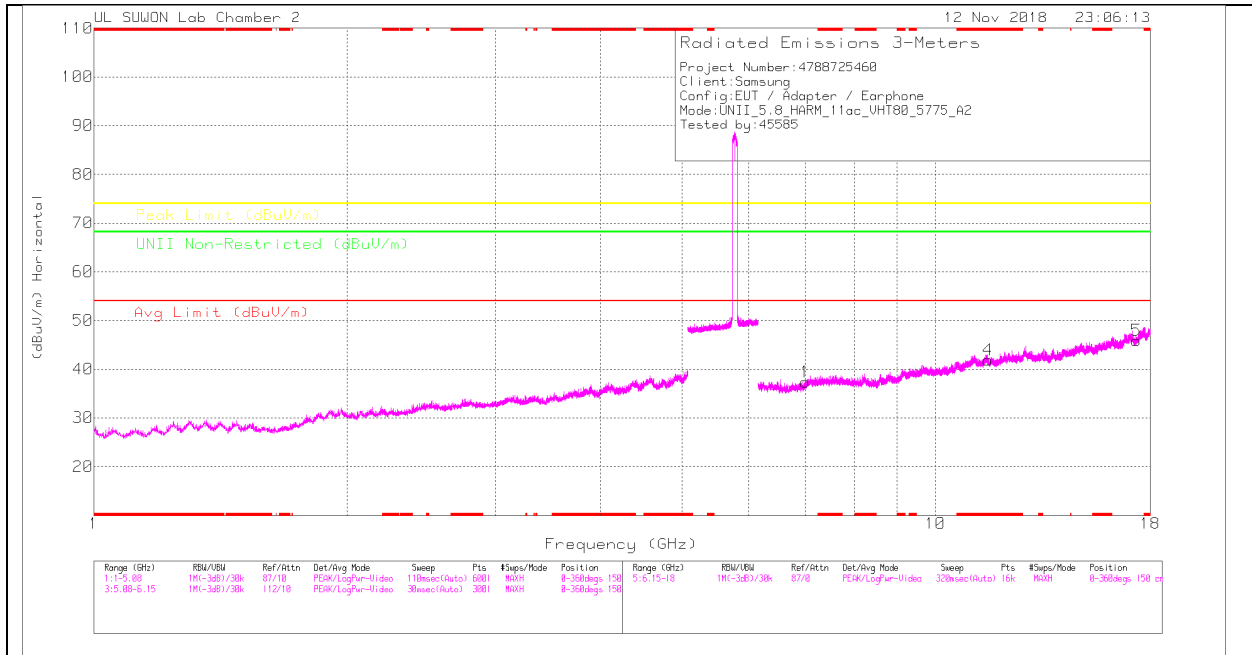

MID CHANNEL VERTICAL

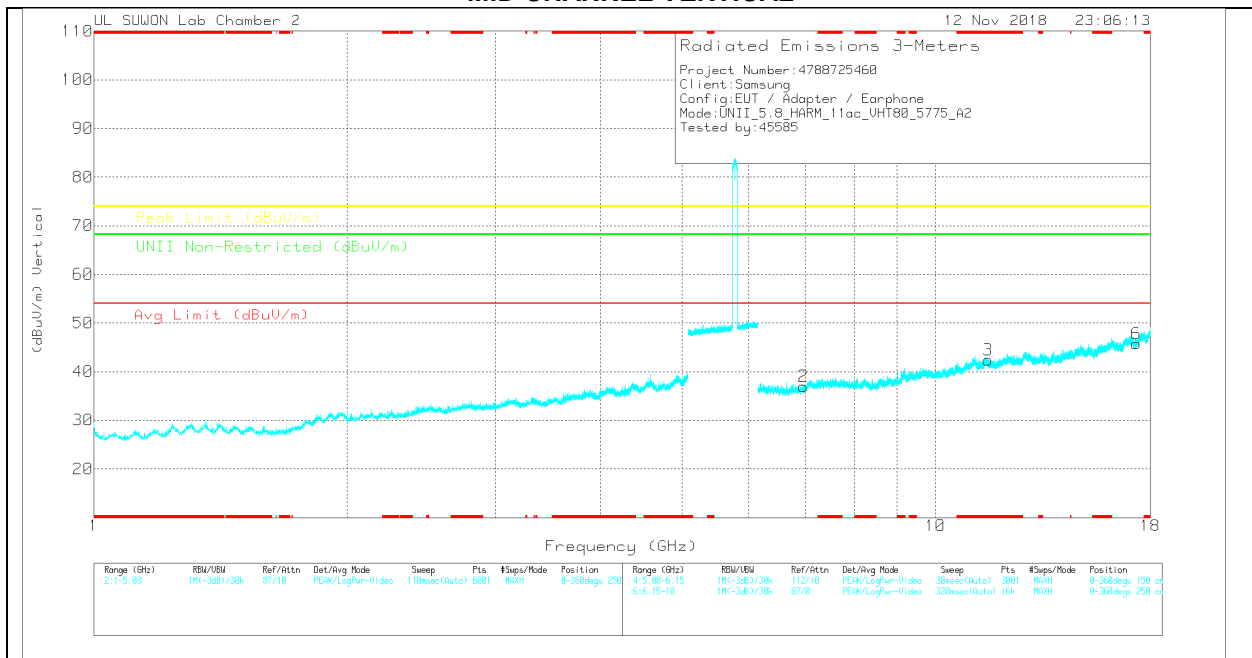

Note: Emission was scanned up to 40GHz; No emissions were detected above the noise floor which was at least 20dB below the specification limit.

MID CHANNEL DATA

Trace Markers

Marker	Frequency (GHz)	Meter Reading (dBµV)	Det	3117_00108724	GHz_HF[dB]	DC Corr (dB)	Corrected Reading (dBµV/m)	Avg Limit (dBµV/m)	Margin (dB)	Peak Limit (dBµV/m)	Margin (dB)	LNI Non-Restricted (dBµV/m)	Margin (dB)	Azimuth (Degs)	Height (cm)	Polarity
1	7.002	27.16	PK	35.8	-25.6	0	37.36	-	-	-	-	68.2	-30.84	0-360	250	H
4	*11.549	23.51	PK	38.3	-19.9	0	41.91	-	-	74	-32.09	-	-	0-360	150	H
5	17.326	23.64	PK	41.3	-19	0	45.94	-	-	-	-	68.2	-22.26	0-360	150	H
2	6.963	26.68	PK	35.8	-25.5	0	36.98	-	-	-	-	68.2	-31.72	0-360	150	V
3	*11.552	23.96	PK	38.3	-19.9	0	42.36	-	-	74	-31.64	-	-	0-360	150	V
6	17.325	23.32	PK	41.3	-18.9	0	45.72	-	-	-	-	68.2	-22.48	0-360	150	V

* - indicates frequency in CFR47 Pt 15 / IC RSS-Restricted Band

PK – Peak Detector

Note: Only peak measurement was performed. Because peak measurement result of unwanted emission is less than average limit (54dBuV/m).

11.5. Spurious Emissions for Simultaneous Transmission

Simultaneous TX Condition (RSDB)

	# TX	5GHz WIFI [dBm]		2.4GHz WIFI [dBm]	
		Ant1	Ant2	Ant1	Ant2
2.4 GHz + 5 GHz RSDB Only	2	A	-	-	B
	2	-	A	B	-
	2	A	-	B	-
	2	-	A	-	B
2.4 GHz + 5 GHz RSDB & MIMO	3	A	A	B	-
	3	A	A	-	B
	3	A	-	B	B
	3	-	A	B	B
2.4 GHz + 5 GHz RSDB MIMO	4	A	A	B	B

Simultaneous TX Condition Bluetooth with 5GHz WIFI (Not RSDB)

	# TX	5GHz WIFI		2.4GHz BT
		ANT1	ANT2	ANT1
2.4GHz BT+5GHz WIFI (Not RSDB)	2	A	-	B
	2	-	A	B
	3	A	A	B

11.5.1. Worst test case condition

Target power of 802.11a and 802.11n HT20 mode in each UNII band are different and therefore, the lowest margin condition among the channels and modes were selected for test. No significant emission detected and emission levels were lower than stand-alone condition.

Also 4 Tx condition(Test case 4) can cover other RSDB and MIMO condition. So test lab. conducted the test on the condition of 1 Tx for each antenna, 4Tx MIMO antenna condition and 2Tx MIMO(5GHz) with Bluetooth condition(Test case 5) like below.

Test case 1

	ANTENNA 1 - 2.4GHz	ANTENNA 2 - 5GHz
Mode	802.11 b mode	802.11 a mode
Channel	1	60
Frequency	2412 MHz	5300 MHz
Data Rate	1 Mbps	6 Mbps

Test case 2

	ANTENNA 1 - 5GHz	ANTENNA 2 - 2.4GHz
Mode	802.11 a mode	802.11 b mode
Channel	100	6
Frequency	5500 MHz	2437 MHz
Data Rate	6 Mbps	1 Mbps

Test case 3

	ANTENNA 1 - 2.4GHz	ANTENNA 2 - 5GHz
Mode	802.11 ax HE20 mode	802.11 ax HE40 mode
Channel	6	54
Frequency	2437 MHz	5270 MHz
Tone / RU	26T / 4	26T / 17
Data Rate	MCS 0	MCS 0

Test case 4

	MIMO - 2.4GHz	MIMO - 5GHz
Mode	802.11 n HT20 mode	802.11 a mode
Channel	6	64
Frequency	2437 MHz	5320 MHz
Data Rate	MCS 0	6 Mbps

Test case 5

	ANTENNA 1 Bluetooth	MIMO - 5GHz
Mode	GFSK	802.11 a mode
Channel	41	64
Frequency	2441 MHz	5320 MHz
Data Rate	1 Mbps	6 Mbps

(This test case can cover ANT1(Bluetooth) + ANT1(5GHz UNII) and ANT1(Bluetooth) + ANT2(5GHz UNII) combination)

RESULTS

11.5.2. Test case 1

Spurious emission for Simultaneous Transmission

802.11b mode 1 CHANNEL + 802.11a mode 60 CHANNEL HORIZONTAL

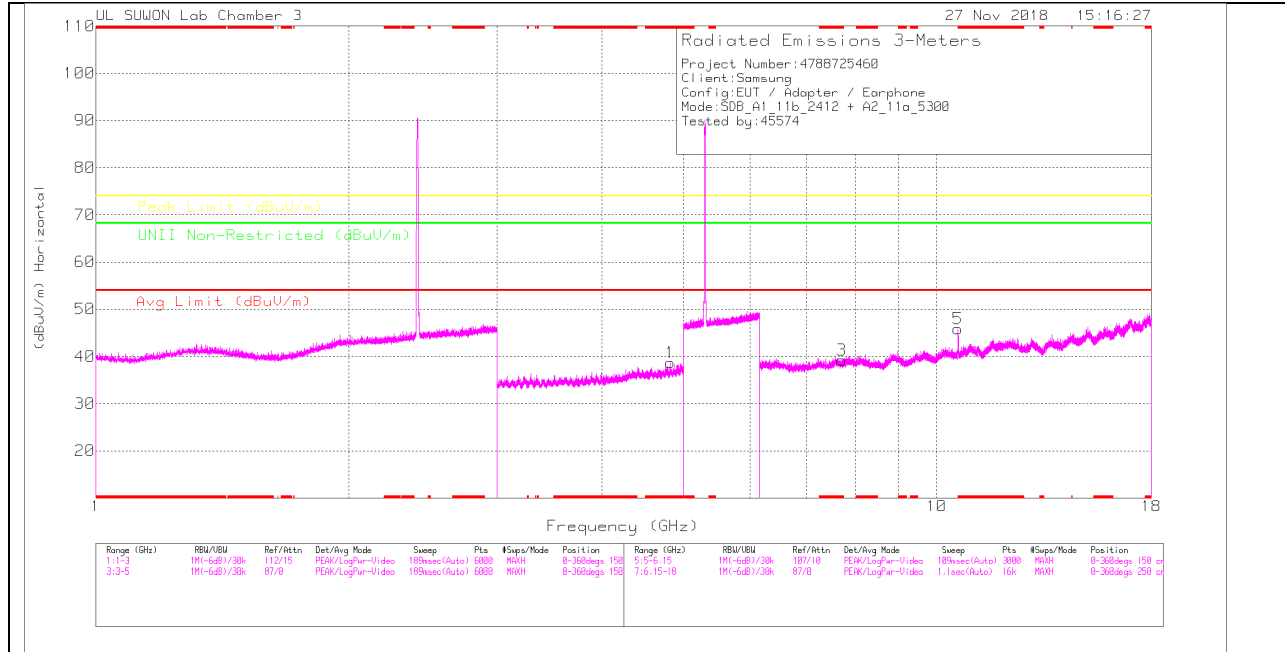

802.11b mode 1 CHANNEL + 802.11a mode 60 CHANNEL VERTICAL

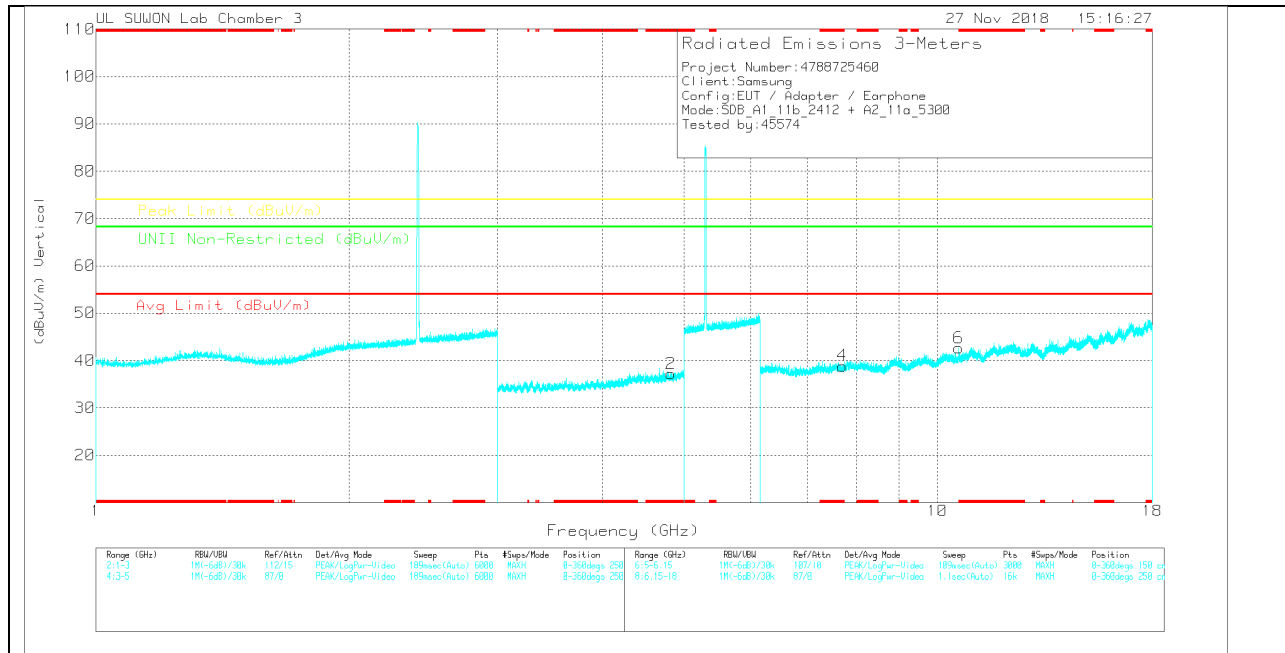

802.11b mode 1 CHANNEL + 802.11a mode 60 CHANNEL DATA

Trace Markers

Marker	Frequency (GHz)	Meter Reading (dBuV)	Det	3117_00209599	5GHz_rF5[dB]	D15_Noise	DC Corr (dB)	Corrected Reading (dBuV/m)	Avg Limit (dBuV/m)	Margin (dB)	Peak Limit (dBuV/m)	Margin (dB)	Limit Non-Restricted (dBuV/m)	Margin (dB)	Azimuth (Degs)	Height (cm)	Polarity
1	* 4.824	32.54	PK	34.2	-28.5	.4	0	38.64	-	-	74	-35.36	-	-	0-360	250	H
2	* 4.825	31.08	PK	34.2	-28.5	.4	0	37.18	-	-	74	-36.82	-	-	0-360	250	V

Marker	Frequency (GHz)	Meter Reading (dBuV)	Det	3117_00209599	6GHz_HF1[dB]	DC Corr (dB)	Corrected Reading (dBuV/m)	Avg Limit (dBuV/m)	Margin (dB)	Peak Limit (dBuV/m)	Margin (dB)	Limit Non-Restricted (dBuV/m)	Margin (dB)	Azimuth (Degs)	Height (cm)	Polarity
3	* 7.713	26.79	PK	35.9	-23.5	0	39.19	-	-	74	-34.81	-	-	0-360	250	H
5	10.598	27.34	PK	37.8	-19.3	0	45.84	-	-	-	-	68.2	-22.36	0-360	250	H
4	* 7.714	26.48	PK	35.9	-23.5	0	38.88	-	-	74	-35.12	-	-	0-360	250	V
6	10.596	24.13	PK	37.8	-19.3	0	42.63	-	-	-	-	68.2	-25.57	0-360	250	V

* - indicates frequency in CFR47 Pt 15 / IC RSS-Restricted Band
 PK – Peak Detector

Radiated Emissions

Frequency (GHz)	Meter Reading (dBuV)	Det	3117_00209599	6GHz_HF1[dB]	DC Corr (dB)	Corrected Reading (dBuV/m)	Avg Limit (dBuV/m)	Margin (dB)	Peak Limit (dBuV/m)	Margin (dB)	Limit Non-Restricted (dBuV/m)	Margin (dB)	Azimuth (Degs)	Height (cm)	Polarity
* 10.603	35.87	PK-U	37.8	-19.3	0	54.37	-	-	74	-19.63	-	-	233	256	H
* 10.603	24.62	ADR	37.8	-19.3	0	43.12	54	-10.88	-	-	-	-	233	256	H
* 10.6	32.19	PK-U	37.8	-19.3	0	50.69	-	-	74	-23.31	-	-	192	363	V
* 10.601	22.51	ADR	37.8	-19.3	0	41.01	54	-12.99	-	-	-	-	192	363	V

* - indicates frequency in CFR47 Pt 15 / IC RSS-Restricted Band
 PK-U - U-NII: Maximum Peak
 ADR - U-NII AD primary method, RMS average

11.5.3. Test case 2

Spurious emission for Simultaneous Transmission

802.11a mode 100 CHANNEL + 802.11b mode 6 CHANNEL HORIZONTAL

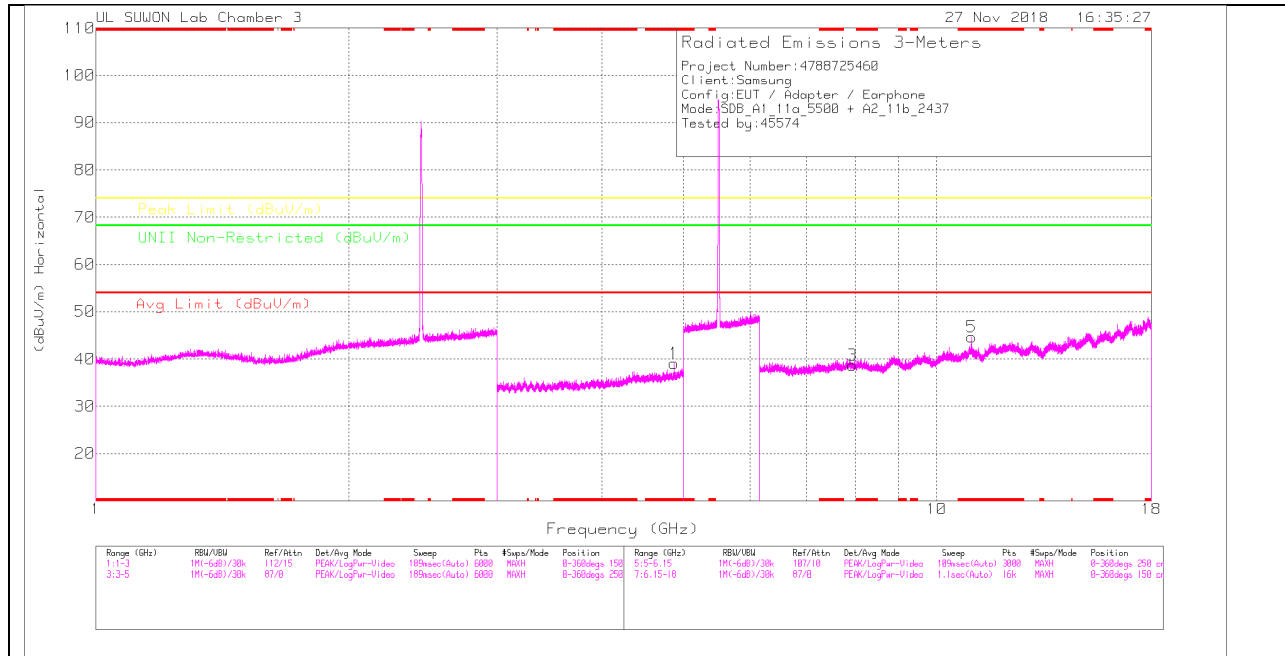

802.11a mode 100 CHANNEL + 802.11b mode 6 CHANNEL VERTICAL

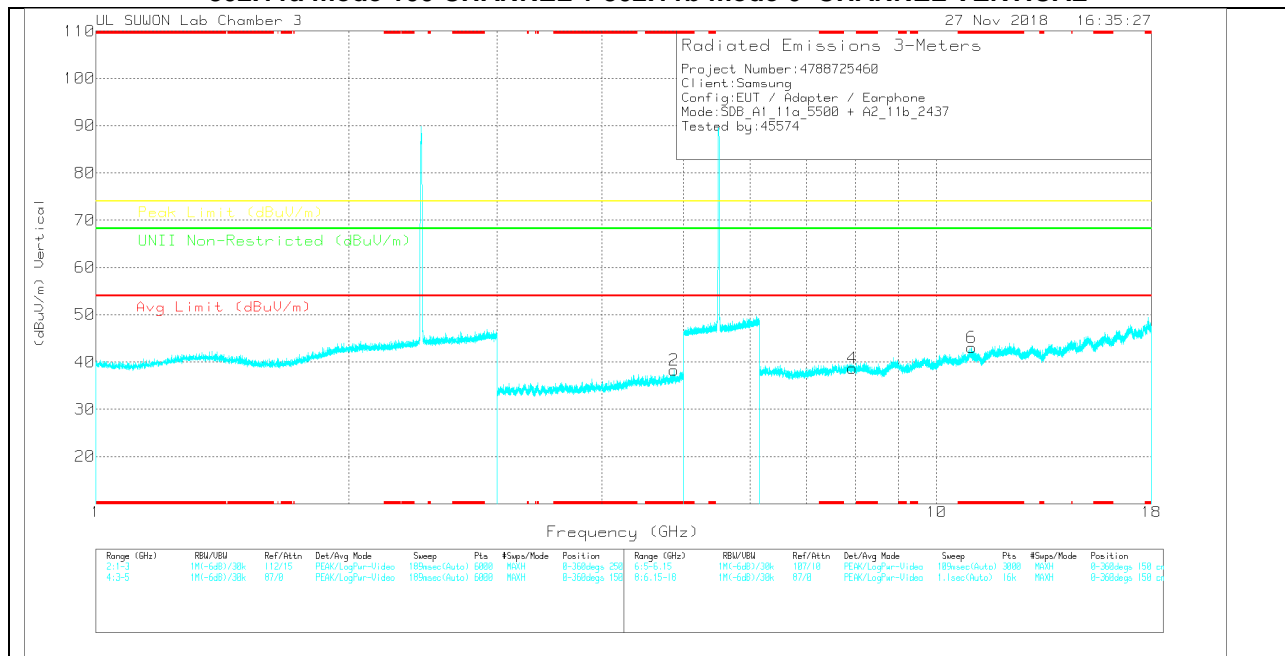

802.11a mode 100 CHANNEL + 802.11b mode 6 CHANNEL DATA

Trace Markers

Marker	Frequency (GHz)	Meter Reading (dBuV)	Det	3117_0020959	5GHz_LF(dB)	DTS_Noise	DC Corr (dB)	Corrected Reading (dBuV/m)	Avg Limit (dBuV/m)	Margin (dB)	Peak Limit (dBuV/m)	Margin (dB)	UNII Non-Restricted (dBuV/m)	Margin (dB)	Azimuth (Degs)	Height (cm)	Polarity
1	* 4.874	32.95	PK	34.2	-28.5	.4	0	39.05	-	-	74	-34.95	-	-	0-360	250	H
2	* 4.875	32.12	PK	34.2	-28.4	.4	0	38.32	-	-	74	-35.68	-	-	0-360	150	V

Marker	Frequency (GHz)	Meter Reading (dBuV)	Det	3117_0020959	6GHz_HF(dB)	DC Corr (dB)	Corrected Reading (dBuV/m)	Avg Limit (dBuV/m)	Margin (dB)	Peak Limit (dBuV/m)	Margin (dB)	UNII Non-Restricted (dBuV/m)	Margin (dB)	Azimuth (Degs)	Height (cm)	Polarity
3	7.939	25.29	PK	36	-22.6	0	38.69	-	-	-	-	68.2	-29.51	0-360	150	H
5	* 11.002	25.88	PK	38.2	-19.4	0	44.68	-	-	74	-29.32	-	-	0-360	250	H
4	7.939	25.26	PK	36	-22.6	0	38.66	-	-	-	-	68.2	-29.54	0-360	150	V
6	* 11.004	24.33	PK	38.2	-19.5	0	43.03	-	-	74	-30.97	-	-	0-360	250	V

* - indicates frequency in CFR47 Pt 15 / IC RSS-Restricted Band
 PK – Peak Detector

Radiated Emissions

Frequency (GHz)	Meter Reading (dBuV)	Det	3117_0020959	5GHz_LF(dB)	DTS_Noise	DC Corr (dB)	Corrected Reading (dBuV/m)	Avg Limit (dBuV/m)	Margin (dB)	Peak Limit (dBuV/m)	Margin (dB)	UNII Non-Restricted (dBuV/m)	Margin (dB)	Azimuth (Degs)	Height (cm)	Polarity
* 4.874	38.01	PK2	34.2	-28.5	.4	0	44.11	-	-	74	-29.89	-	-	126	100	H
* 4.874	31.92	MAV1	34.2	-28.5	.4	0	38.02	54	-15.98	-	-	-	-	126	100	H

* - indicates frequency in CFR47 Pt 15 / IC RSS-Restricted Band
 PK2 - KDB558074 Method: Maximum Peak
 MAV1 - KDB558074 Option 1 Maximum RMS Average

Frequency (GHz)	Meter Reading (dBuV)	Det	3117_0020959	6GHz_HF(dB)	DC Corr (dB)	Corrected Reading (dBuV/m)	Avg Limit (dBuV/m)	Margin (dB)	Peak Limit (dBuV/m)	Margin (dB)	UNII Non-Restricted (dBuV/m)	Margin (dB)	Azimuth (Degs)	Height (cm)	Polarity	
* 11	24.26	ADR	38.2	-19.5	0	42.96	54	-11.04	-	-	-	-	-	112	305	H
* 11.002	32.85	PK-U	38.2	-19.4	0	51.65	-	-	74	-22.35	-	-	-	112	305	H

* - indicates frequency in CFR47 Pt 15 / IC RSS-Restricted Band
 PK-U - U-NII: Maximum Peak
 ADR - U-NII AD primary method, RMS average

11.5.4. Test case 3

Spurious emission for Simultaneous Transmission

802.11ax HE20 mode 6 + 802.11ax HE40 mode 54 CHANNEL HORIZONTAL

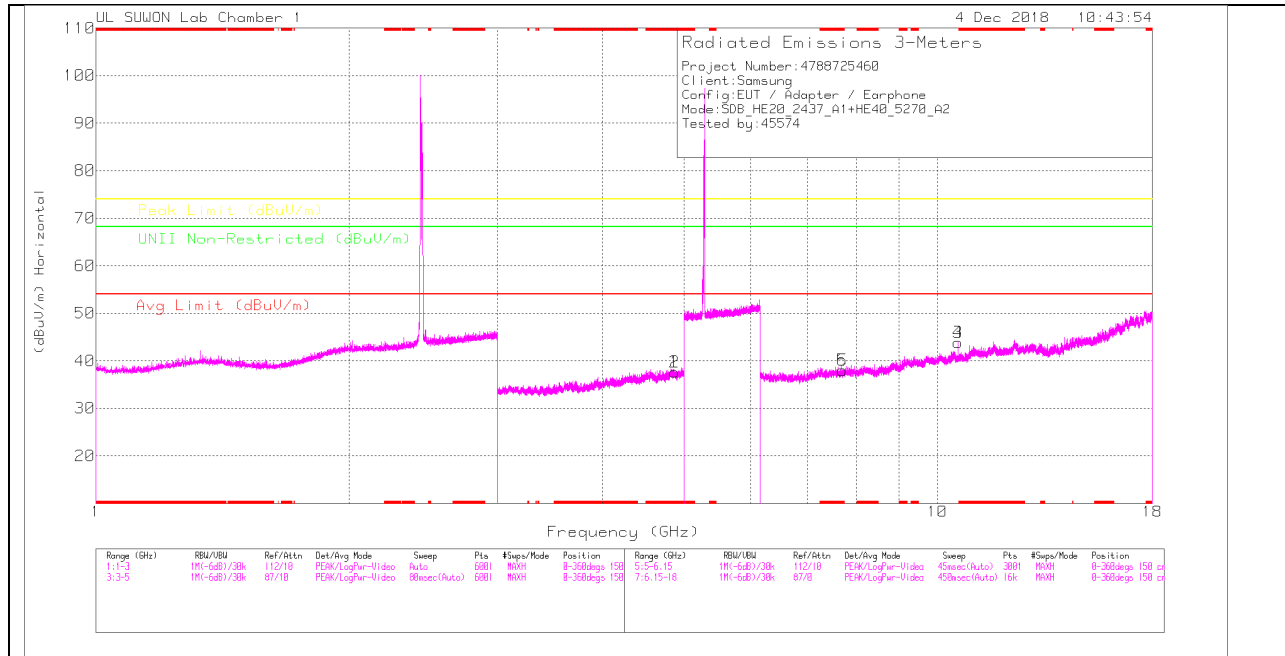

802.11ax HE20 mode 6 + 802.11ax HE40 mode 54 CHANNEL VERTICAL

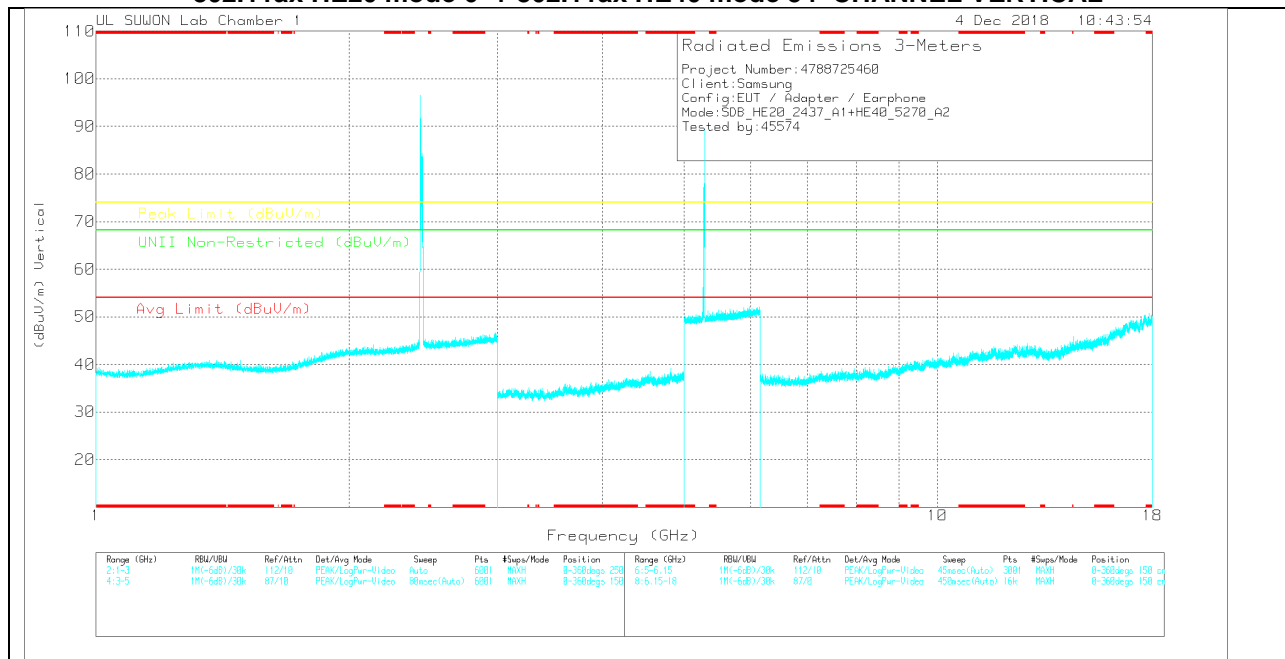

802.11ax HE20 mode 6 + 802.11ax HE40 mode 54 CHANNEL DATA

Trace Markers

Marker	Frequency (GHz)	Meter Reading (dBuV)	Det	3117_00168717	5GHz_HF1(dB)	DC Corr (dB)	Corrected Reading (dBuV/m)	Avg Limit (dBuV/m)	Margin (dB)	Peak Limit (dBuV/m)	Margin (dB)	Limit Non-Restricted (dBuV/m)	Margin (dB)	Azimuth (Degs)	Height (cm)	Polarity	
1	* 4.873	33.09	PK	34.2	-30.1	.4	0	37.59	-	-	74	-36.41	-	-	0-360	150	H
2	* 4.873	33.09	PK	34.2	-30.1	.4	0	37.59	-	-	74	-36.41	-	-	0-360	150	H

Marker	Frequency (GHz)	Meter Reading (dBuV)	Det	3117_00168717	5GHz_HF1(dB)	DC Corr (dB)	Corrected Reading (dBuV/m)	Avg Limit (dBuV/m)	Margin (dB)	Peak Limit (dBuV/m)	Margin (dB)	Limit Non-Restricted (dBuV/m)	Margin (dB)	Azimuth (Degs)	Height (cm)	Polarity
3	10.575	28.81	PK	37.8	-22.7	0	43.91	-	-	-	-	68.2	-24.29	0-360	250	H
4	10.575	28.81	PK	37.8	-22.7	0	43.91	-	-	-	-	68.2	-24.29	0-360	250	H
5	* 7.704	28.78	PK	35.9	-26.7	0	37.98	-	-	74	-36.02	-	-	0-360	250	H
6	* 7.704	28.78	PK	35.9	-26.7	0	37.98	-	-	74	-36.02	-	-	0-360	250	H

* - indicates frequency in CFR47 Pt 15 / IC RSS-Restricted Band
 PK – Peak Detector

Radiated Emissions

Frequency (GHz)	Meter Reading (dBuV)	Det	3117_00168717	5GHz_HF1(dB)	DC Corr (dB)	Corrected Reading (dBuV/m)	Avg Limit (dBuV/m)	Margin (dB)	Peak Limit (dBuV/m)	Margin (dB)	Limit Non-Restricted (dBuV/m)	Margin (dB)	Azimuth (Degs)	Height (cm)	Polarity
10.575	43.56	PK-U	37.8	-22.7	0	58.66	-	-	-	-	68.2	-9.54	101	108	H
10.576	40.49	PK-U	37.8	-22.7	0	55.59	-	-	-	-	68.2	-12.61	218	335	V

* - indicates frequency in CFR47 Pt 15 / IC RSS-Restricted Band
 PK-U - U-NII: Maximum Peak

11.5.5. Test case 4

Spurious emission for Simultaneous Transmission

802.11n HT20 mode 6 CHANNEL + 802.11a mode 64 CHANNEL HORIZONTAL

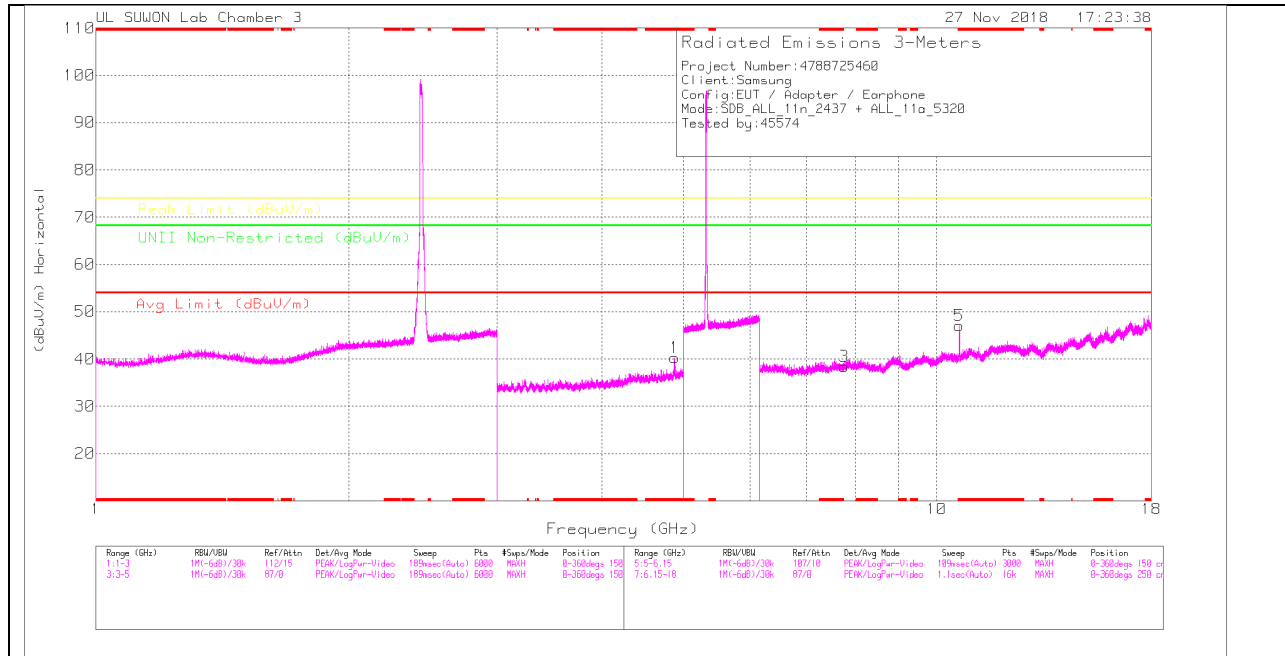

802.11n HT20 mode 6 CHANNEL + 802.11a mode 64 CHANNEL VERTICAL

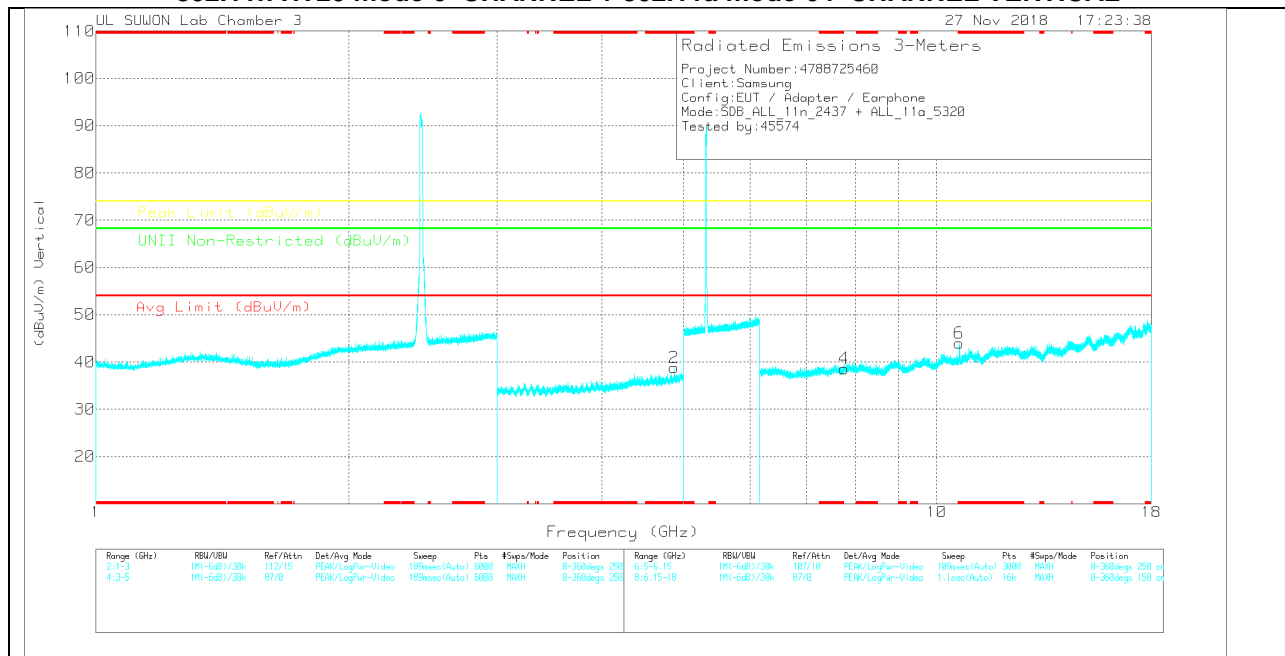

802.11n HT20 mode 6 CHANNEL + 802.11a mode 64 CHANNEL DATA

Trace Markers

Marker	Frequency (GHz)	Meter Reading (dBuV)	Det	3117_0020959	5GHz_LF(dB)	DTS_Noise	DC Corr (dB)	Corrected Reading (dBuV/m)	Avg Limit (dBuV/m)	Margin (dB)	Peak Limit (dBuV/m)	Margin (dB)	UNII Non-Restricted (dBuV/m)	Margin (dB)	Azimuth (Degs)	Height (cm)	Polarity
1	* 4.877	34.11	PK	34.2	-28.4	.4	0	40.31	-	-	74	-33.69	-	-	0-360	150	H
2	* 4.874	32.75	PK	34.2	-28.5	.4	0	38.85	-	-	74	-35.15	-	-	0-360	150	V

Marker	Frequency (GHz)	Meter Reading (dBuV)	Det	3117_0020959	6GHz_HF(dB)	DC Corr (dB)	Corrected Reading (dBuV/m)	Avg Limit (dBuV/m)	Margin (dB)	Peak Limit (dBuV/m)	Margin (dB)	UNII Non-Restricted (dBuV/m)	Margin (dB)	Azimuth (Degs)	Height (cm)	Polarity
3	7.757	25.64	PK	35.9	-23.1	0	38.44	-	-	-	-	68.2	-29.76	0-360	150	H
5	* 10.636	28.5	PK	37.8	-19.2	0	47.1	-	-	74	-26.9	-	-	0-360	250	H
4	7.757	25.81	PK	35.9	-23.1	0	38.61	-	-	-	-	68.2	-29.59	0-360	150	V
6	* 10.641	25.49	PK	37.8	-19.3	0	43.99	-	-	74	-30.01	-	-	0-360	250	V

* - indicates frequency in CFR47 Pt 15 / IC RSS-Restricted Band
 PK – Peak Detector

Radiated Emissions

Frequency (GHz)	Meter Reading (dBuV)	Det	3117_0020959	5GHz_LF(dB)	DTS_Noise	DC Corr (dB)	Corrected Reading (dBuV/m)	Avg Limit (dBuV/m)	Margin (dB)	Peak Limit (dBuV/m)	Margin (dB)	UNII Non-Restricted (dBuV/m)	Margin (dB)	Azimuth (Degs)	Height (cm)	Polarity
* 4.876	40.36	PK2	34.2	-28.5	.4	0	46.46	-	-	74	-27.54	-	-	127	100	H
* 4.878	29.82	MAv1	34.2	-28.4	.4	0	36.02	54	-17.98	-	-	-	-	127	100	H

* - indicates frequency in CFR47 Pt 15 / IC RSS-Restricted Band
 PK2 - KDB558074 Method: Maximum Peak
 MAV1 - KDB558074 Option 1 Maximum RMS Average

Frequency (GHz)	Meter Reading (dBuV)	Det	3117_0020959	6GHz_HF(dB)	DC Corr (dB)	Corrected Reading (dBuV/m)	Avg Limit (dBuV/m)	Margin (dB)	Peak Limit (dBuV/m)	Margin (dB)	UNII Non-Restricted (dBuV/m)	Margin (dB)	Azimuth (Degs)	Height (cm)	Polarity
* 10.641	27.37	ADR	37.8	-19.2	0	45.97	54	-8.03	-	-	-	-	232	254	H
* 10.638	22.45	ADR	37.8	-19.3	0	40.95	54	-13.05	-	-	-	-	190	360	V
* 10.641	35.63	PK-U	37.8	-19.2	0	54.23	-	-	74	-19.77	-	-	232	254	H
* 10.633	31.99	PK-U	37.8	-19.2	0	50.59	-	-	74	-23.41	-	-	190	360	V

* - indicates frequency in CFR47 Pt 15 / IC RSS-Restricted Band
 PK-U - U-NII: Maximum Peak
 ADR - U-NII AD primary method, RMS average

11.5.6. Test case 5

Spurious emission for Simultaneous Transmission

BLUETOOTH GFSK 41 CHANNEL + 802.11a mode 64 CHANNEL HORIZONTAL

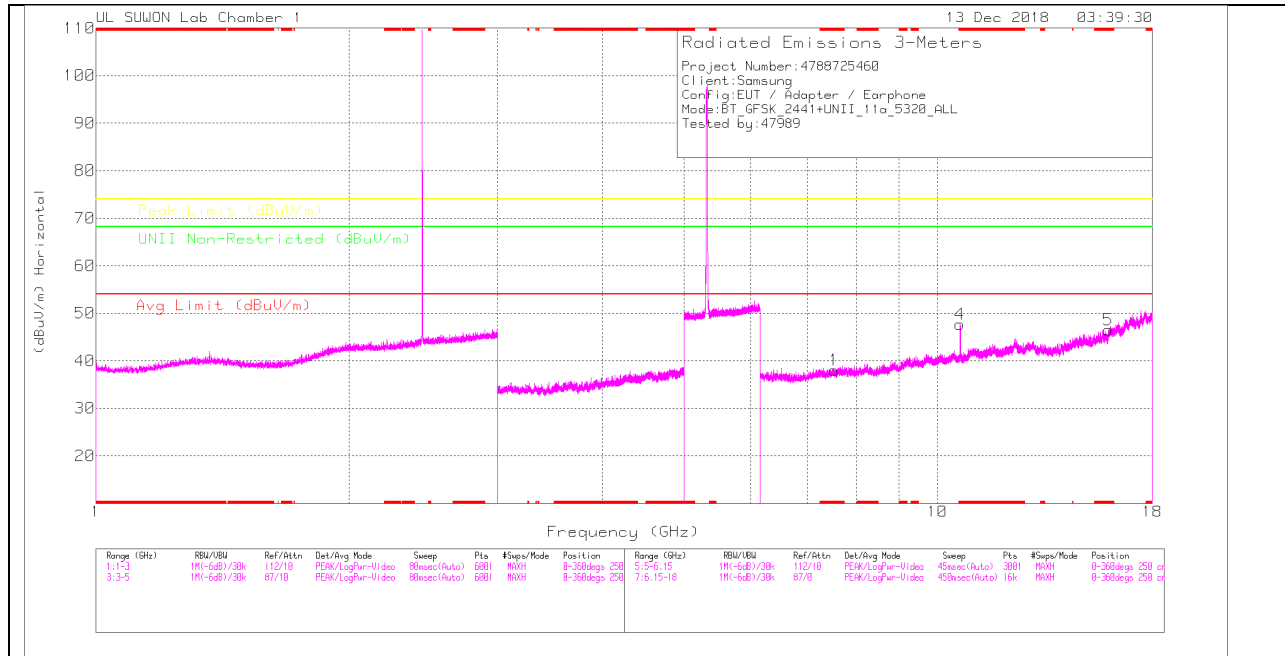

BLUETOOTH GFSK 41 CHANNEL + 802.11a mode 64 CHANNEL VERTICAL

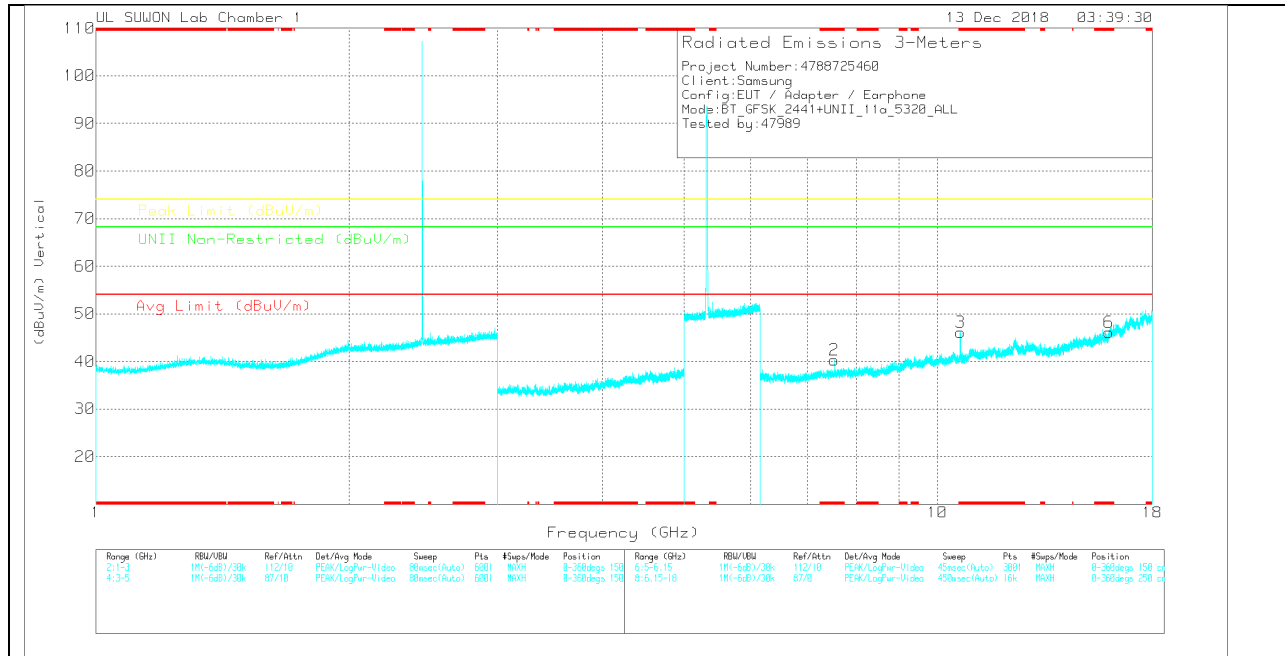

802.11n HT20 mode 6 CHANNEL + 802.11a mode 64 CHANNEL DATA

Trace Markers

Marker	Frequency (GHz)	Meter Reading (dBuV)	Det	3117_00168717	6GHz_HF[dB]	DC Corr (dB)	Corrected Reading (dBuV/m)	Avg Limit (dBuV/m)	Margin (dB)	Peak Limit (dBuV/m)	Margin (dB)	UNII Non-Restricted (dBuV/m)	Margin (dB)	Azimuth (Degs)	Height (cm)	Polarity
1	* 7.544	28.89	PK	35.8	-26.6	0	38.09	-	-	74	-35.91	-	-	0-360	150	H
4	* 10.639	32	PK	37.8	-22.1	0	47.7	-	-	74	-26.3	-	-	0-360	150	H
5	* 15.955	26.67	PK	40.7	-20.9	0	46.47	-	-	74	-27.53	-	-	0-360	250	H
2	* 7.543	31.04	PK	35.8	-26.6	0	40.24	-	-	74	-33.76	-	-	0-360	150	V
3	* 10.643	30.36	PK	37.8	-22.1	0	46.06	-	-	74	-27.94	-	-	0-360	250	V
6	* 15.977	25.97	PK	40.7	-20.6	0	46.07	-	-	74	-27.93	-	-	0-360	250	V

* - indicates frequency in CFR47 Pt 15 / IC RSS-Restricted Band
 PK – Peak detector

Radiated Emissions

Frequency (GHz)	Meter Reading (dBuV)	Det	3117_00168717	6GHz_HF[dB]	DC Corr (dB)	Corrected Reading (dBuV/m)	Avg Limit (dBuV/m)	Margin (dB)	Peak Limit (dBuV/m)	Margin (dB)	UNII Non-Restricted (dBuV/m)	Margin (dB)	Azimuth (Degs)	Height (cm)	Polarity
* 10.639	42.75	PK-U	37.8	-22.1	0	58.45	-	-	74	-15.55	-	-	198	220	H
* 10.64	30.58	ADR	37.8	-22.1	0	46.28	54	-7.72	-	-	-	-	198	220	H
* 10.646	40.43	PK-U	37.8	-22.1	0	56.13	-	-	74	-17.87	-	-	212	270	V
* 10.64	28.1	ADR	37.8	-22.1	0	43.8	54	-10.2	-	-	-	-	212	270	V

* - indicates frequency in CFR47 Pt 15 / IC RSS-Restricted Band
 PK-U - U-NII: Maximum Peak
 ADR - U-NII AD primary method, RMS average

12. WORST-CASE BELOW 1 GHz

SPURIOUS EMISSIONS 30 TO 1000 MHz (WORST-CASE CONFIGURATION, HORIZONTAL)

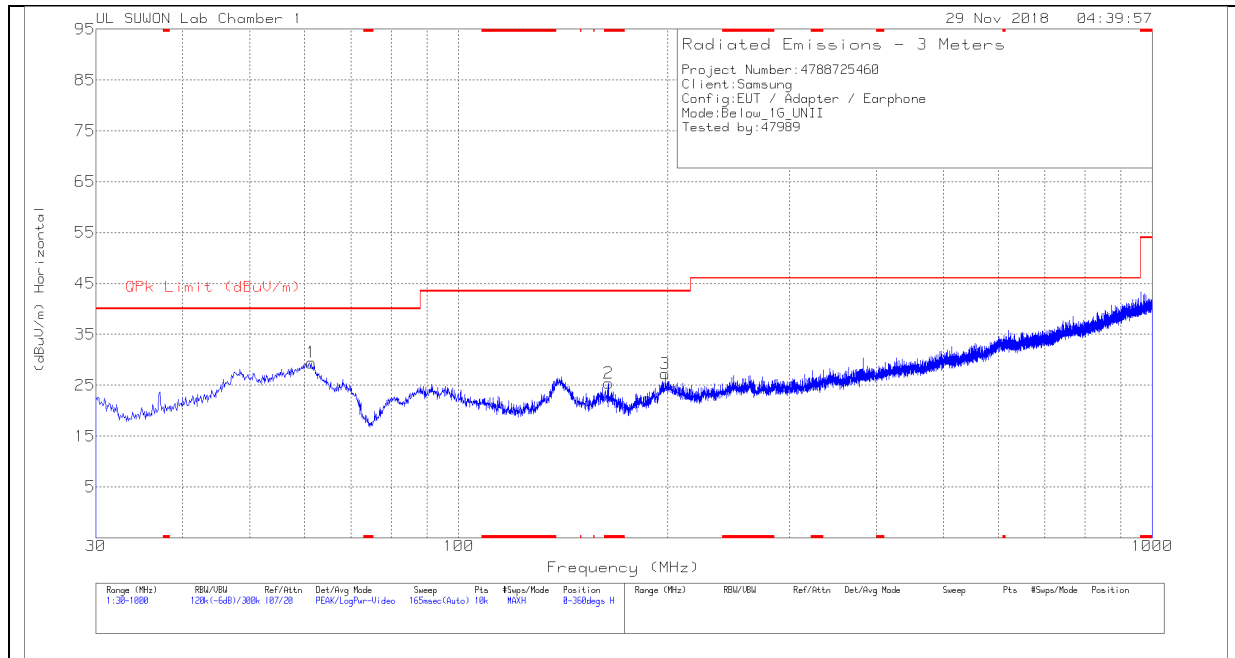

SPURIOUS EMISSIONS 30 TO 1000 MHz (WORST-CASE CONFIGURATION, VERTICAL)

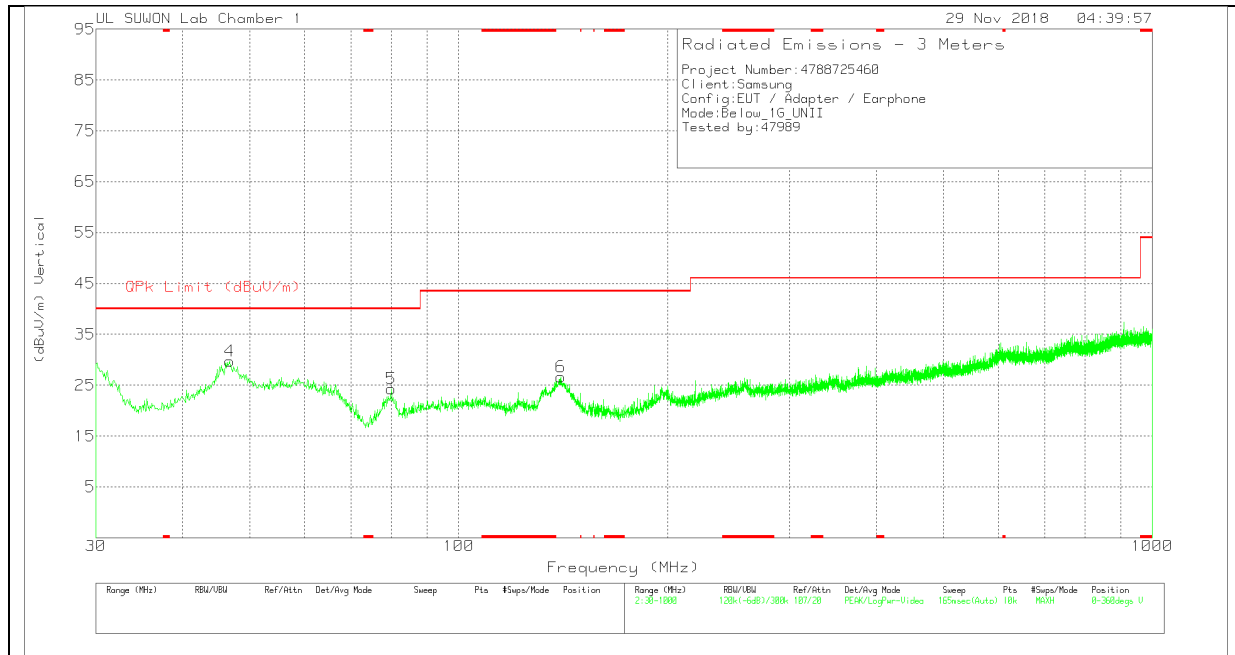

Below 1G Data

Trace Markers

Marker	Frequency (MHz)	Meter Reading (dBuV)	Det	VULB9163_750	Below_1G[dB]	Corrected Reading (dBuV/m)	QPk Limit (dBuV/m)	Margin (dB)	Azimuth (Degs)	Height (cm)	Polarity
1	61.331	41.42	Pk	18.3	-30.3	29.42	40	-10.58	0-360	400	H
2	* 164.442	39.52	Pk	14.8	-28.9	25.42	43.52	-18.1	0-360	200	H
3	198.586	37.88	Pk	18	-28.6	27.28	43.52	-16.24	0-360	200	H
4	46.781	40.58	Pk	19.8	-30.6	29.78	40	-10.22	0-360	100	V
5	79.955	41.63	Pk	12.6	-30	24.23	40	-15.77	0-360	100	V
6	140.289	41.73	Pk	14.1	-29.2	26.63	43.52	-16.89	0-360	100	V

* - indicates frequency in CFR47 Pt 15 / IC RSS-Restricted Band

Pk - Peak detector

13. AC POWER LINE CONDUCTED EMISSIONS

LIMITS

FCC §15.207 (a)
IC RSS-GEN Clause 8.8

Frequency of Emission (MHz)	Conducted Limit (dBuV)	
	Quasi-peak	Average
0.15-0.5	66 to 56 [*]	56 to 46 [*]
0.5-5	56	46
5-30	60	50

^{*}Decreases with the logarithm of the frequency.

TEST PROCEDURE

The EUT is placed on a non-conducting table 40 cm from the vertical ground plane and 80 cm above the horizontal ground plane. The EUT is configured in accordance with ANSI C63.10.

The receiver is set to a resolution bandwidth of 9 kHz. Peak detection is used unless otherwise noted as quasi-peak or average.

Line conducted data is recorded for both NEUTRAL and HOT lines.

RESULTS

6 WORST EMISSIONS

LINE 1 PLOT

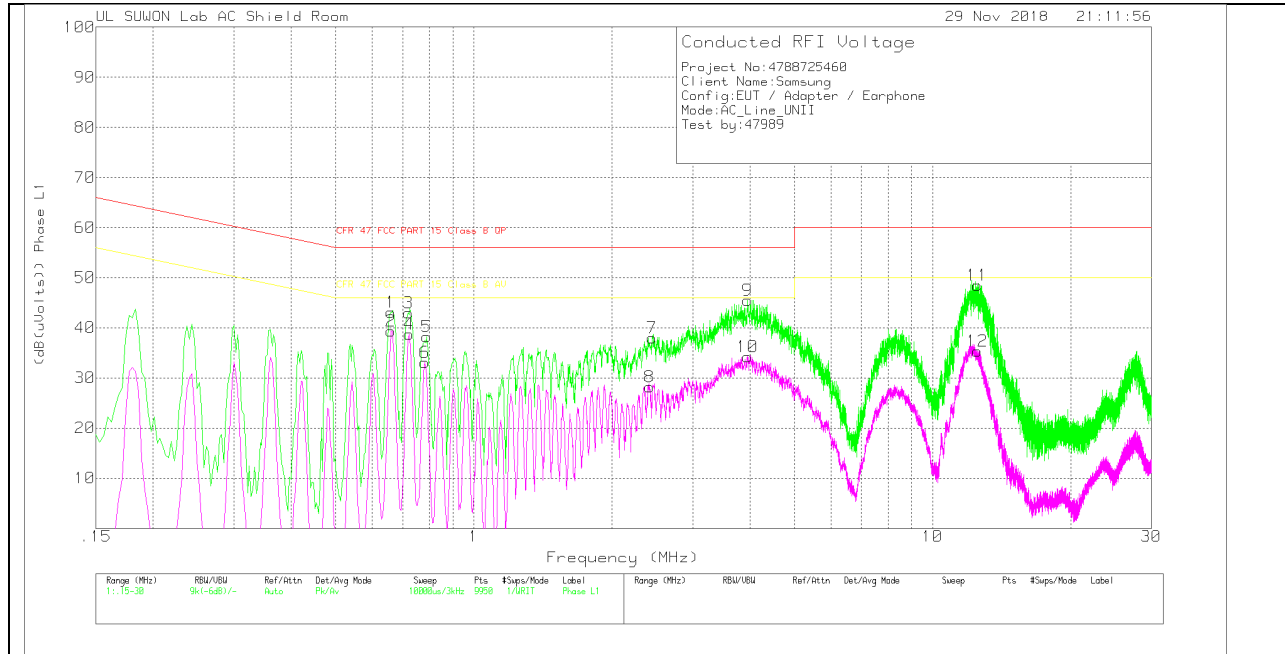

LINE 1 RESULTS

Trace Markers

Range 1: Phase L1 .15 - 30MHz

Marker	Frequency (MHz)	Meter Reading (dBuV)	Det	ENV216_10183 6_With ex-cord_L1	CABLELOSS(dB)	Corrected Reading (dB(uVolts))	CFR 47 FCC PART 15 Class B QP	Margin (dB)	CFR 47 FCC PART 15 Class B AV	Margin (dB)
1	.66	33.04	Pk	9.9	.2	43.14	56	-12.86	-	-
2	.66	29.23	Av	9.9	.2	39.33	-	-	46	-6.67
3	.72	32.88	Pk	9.9	.2	42.98	56	-13.02	-	-
4	.723	28.69	Av	9.9	.2	38.79	-	-	46	-7.21
5	.789	28.1	Pk	9.9	.2	38.2	56	-17.8	-	-
6	.783	23.05	Av	9.9	.2	33.15	-	-	46	-12.85
7	2.448	27.72	Pk	10	.3	38.02	56	-17.98	-	-
8	2.418	17.89	Av	10	.3	28.19	-	-	46	-17.81
9	3.954	35.43	Pk	9.8	.3	45.53	56	-10.47	-	-
10	3.948	24.15	Av	9.8	.3	34.25	-	-	46	-11.75
11	12.513	38.12	Pk	10.1	.3	48.52	60	-11.48	-	-
12	12.54	24.97	Av	10.1	.3	35.37	-	-	50	-14.63

Pk - Peak detector

Av - Average detection

LINE 2 PLOT

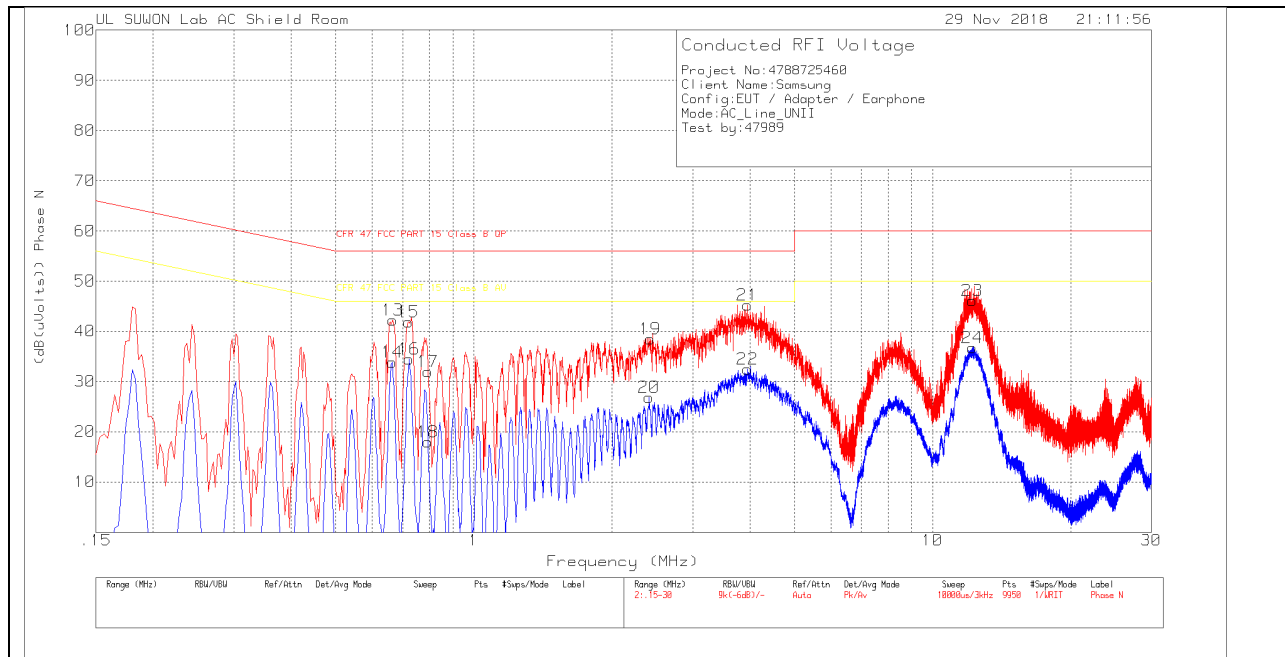

LINE 2 RESULTS

Trace Markers

Range 2: Phase N .15 - 30MHz

Marker	Frequency (MHz)	Meter Reading (dBuV)	Det	ENV216_10183 6_With ex-cord_N	CABLELOSS(dB)	Corrected Reading (dB(uVolts))	CFR 47 FCC PART 15 Class B QP	Margin (dB)	CFR 47 FCC PART 15 Class B AV	Margin (dB)
13	.666	32.14	Pk	9.9	.2	42.24	56	-13.76	-	-
14	.663	23.7	Av	9.9	.2	33.8	-	-	46	-12.2
15	.72	31.79	Pk	9.9	.2	41.89	56	-14.11	-	-
16	.723	24.38	Av	9.9	.2	34.48	-	-	46	-11.52
17	.795	22.01	Pk	9.8	.2	32.01	56	-23.99	-	-
18	.795	7.94	Av	9.8	.2	17.94	-	-	46	-28.06
19	2.421	28.5	Pk	9.7	.3	38.5	56	-17.5	-	-
20	2.409	16.81	Av	9.7	.3	26.81	-	-	46	-19.19
21	3.954	35.09	Pk	9.8	.3	45.19	56	-10.81	-	-
22	3.954	22.43	Av	9.8	.3	32.53	-	-	46	-13.47
23	12.219	35.7	Pk	10.1	.3	46.1	60	-13.9	-	-
24	12.204	26.33	Av	10.1	.3	36.73	-	-	50	-13.27

Pk - Peak detector

Av - Average detection

14. DYNAMIC FREQUENCY SELECTION

14.1. OVERVIEW

14.1.1. LIMITS

FCC

§15.407 (h), FCC KDB 905462 D02 “COMPLIANCE MEASUREMENT PROCEDURES FOR UNLICENSED-NATIONAL INFORMATION INFRASTRUCTURE DEVICES OPERATING IN THE 5250-5350 MHz AND 5470-5725 MHz BANDS INCORPORATING DYNAMIC FREQUENCY SELECTION” and KDB 905462 D03 “U-NII CLIENT DEVICES WITHOUT RADAR DETECTION CAPABILITY”.

Table 1: Applicability of DFS requirements prior to use of a channel

Requirement	Operational Mode		
	Master	Client (without radar detection)	Client (with radar detection)
Non-Occupancy Period	Yes	Not required	Yes
DFS Detection Threshold	Yes	Not required	Yes
Channel Availability Check Time	Yes	Not required	Not required
U-NII Detection Bandwidth	Yes	Not required	Yes

Table 2: Applicability of DFS requirements during normal operation

Requirement	Operational Mode		
	Master	Client (without DFS)	Client (with DFS)
DFS Detection Threshold	Yes	Not required	Yes
Channel Closing Transmission Time	Yes	Yes	Yes
Channel Move Time	Yes	Yes	Yes
U-NII Detection Bandwidth	Yes	Not required	Yes

Additional requirements for devices with multiple bandwidth modes	Master Device or Client with Radar DFS	Client (without DFS)
U-NII Detection Bandwidth and Statistical Performance Check	All BW modes must be tested	Not required
Channel Move Time and Channel Closing Transmission Time	Test using widest BW mode available	Test using the widest BW mode available for the link
All other tests	Any single BW mode	Not required
<p>Note: Frequencies selected for statistical performance check (Section 7.8.4) should include several frequencies within the radar detection bandwidth and frequencies near the edge of the radar detection bandwidth. For 802.11 devices it is suggested to select frequencies in all 20 MHz channel blocks and a null frequency between the bonded 20 MHz channel blocks.</p>		

Table 3: Interference Threshold values, Master or Client incorporating In-Service Monitoring

Maximum Transmit Power	Value (see notes)
E.I.R.P. \geq 200 mill watt	-64 dBm
E.I.R.P. < 200 mill watt and power spectral density < 10 dBm/MHz	-62 dBm
E.I.R.P. < 200 mill watt that do not meet power spectral density requirement	-64 dBm
<p>Note 1: This is the level at the input of the receiver assuming a 0 dBi receive antenna Note 2: Throughout these test procedures an additional 1 dB has been added to the amplitude of the test transmission waveforms to account for variations in measurement equipment. This will ensure that the test signal is at or above the detection threshold level to trigger a DFS response. Note 3: E.I.R.P. is based on the highest antenna gain. For MIMO devices refer to KDB publication 662911 D01.</p>	

Table 4: DFS Response requirement values

Parameter	Value
<i>Non-occupancy period</i>	30 minutes
<i>Channel Availability Check Time</i>	60 seconds
<i>Channel Move Time</i>	10 seconds (See Note 1)
<i>Channel Closing Transmission Time</i>	200 milliseconds + approx. 60 milliseconds over remaining 10 second period. (See Notes 1 and 2)
<i>U-NII Detection Bandwidth</i>	Minimum 100% of the U-NII 99% transmission power bandwidth. (See Note 3)
<p>Note 1: <i>Channel Move Time</i> and the <i>Channel Closing Transmission Time</i> should be performed with Radar Type 0. The measurement timing begins at the end of the Radar Type 0 burst. Note 2: The <i>Channel Closing Transmission Time</i> is comprised of 200 milliseconds starting at the beginning of the <i>Channel Move Time</i> plus any additional intermittent control signals required to facilitate a <i>Channel</i> move (an aggregate of 60 milliseconds) during the remainder of the 10 second period. The aggregate duration of control signals will not count quiet periods in between transmissions. Note 3: During the <i>U-NII Detection Bandwidth</i> detection test, radar type 0 should be used. For each frequency step the minimum percentage of detection is 90 percent. Measurements are performed with no data traffic.</p>	

Table 5 – Short Pulse Radar Test Waveforms

Radar Type	Pulse Width (usec)	PRI (usec)	Pulses	Minimum Percentage of Successful Detection	Minimum Trials
0	1	1428	18	See Note 1	See Note 1
1	1	Test A: 15 unique PRI values randomly selected from the list of 23 PRI values in table 5a	Roundup: $\{(1/360) \times (19 \times 10^6 \text{ PRI}_{\text{usec}})\}$	60%	30
		Test B: 15 unique PRI values randomly selected within the range of 518-3066 usec. With a minimum increment of 1 usec, excluding PRI values selected in Test A			
2	1-5	150-230	23-29	60%	30
3	6-10	200-500	16-18	60%	30
4	11-20	200-500	12-16	60%	30
Aggregate (Radar Types 1-4)				80%	120
Note 1: Short Pulse Radar Type 0 should be used for the <i>Detection Bandwidth</i> test, <i>Channel Move Time</i> , and <i>Channel Closing Time</i> tests.					

Table 6 – Long Pulse Radar Test Signal

Radar Waveform Type	Pulse Width (µsec)	Chirp Width (MHz)	PRI (µsec)	Pulses per Burst	Number of Bursts	Minimum Percentage of Successful Detection	Minimum Trials
5	50-100	5-20	1000-2000	1-3	8-20	80%	30

Table 7 – Frequency Hopping Radar Test Signal

Radar Waveform Type	Pulse Width (µsec)	PRI (µsec)	Pulses per Hop	Hopping Rate (kHz)	Hopping Sequence Length (msec)	Minimum Percentage of Successful Detection	Minimum Trials
6	1	333	9	0.333	300	70%	30

14.1.1. TEST AND MEASUREMENT SYSTEM

CONDUCTED METHOD SYSTEM BLOCK DIAGRAM

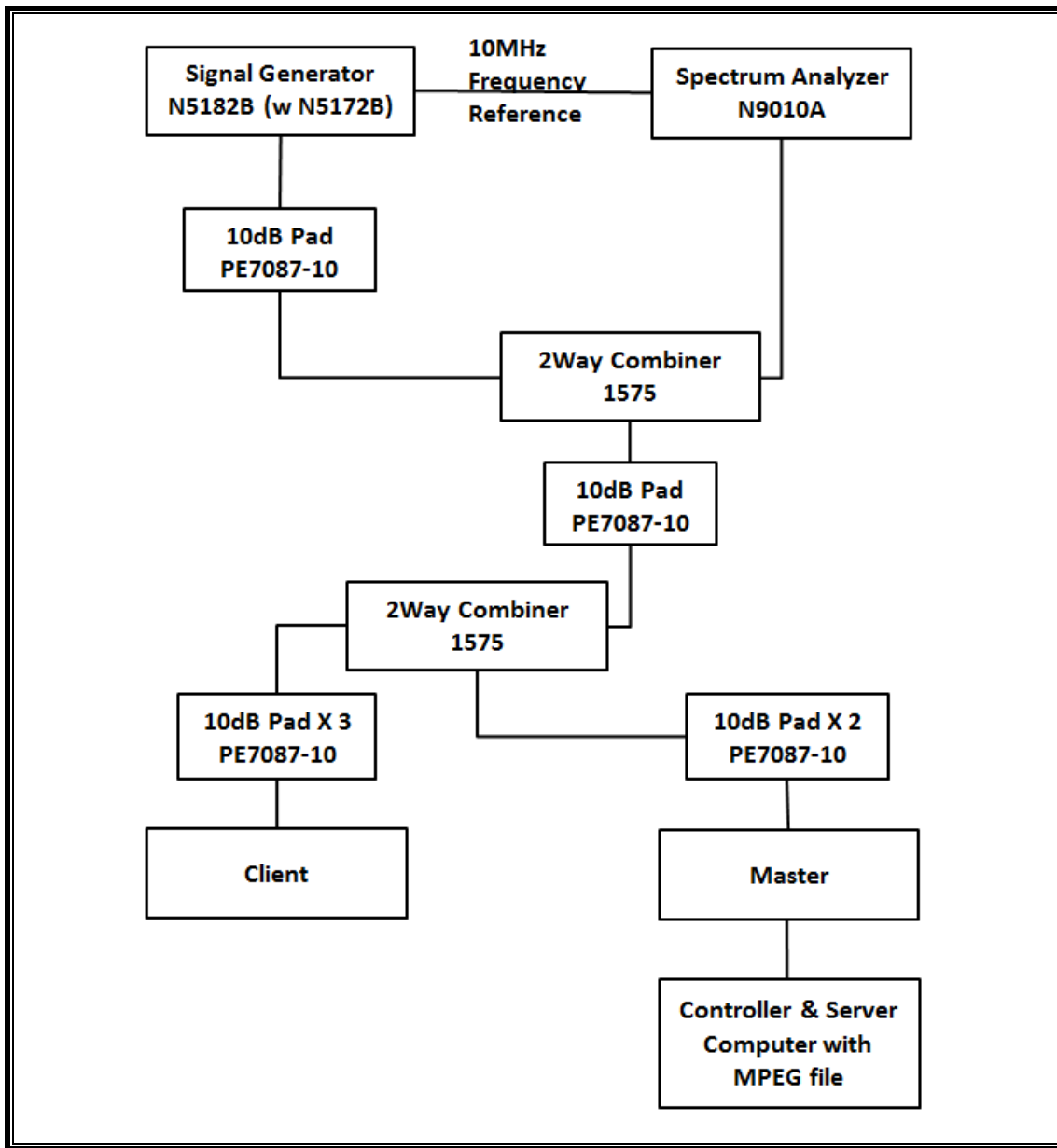

SYSTEM OVERVIEW

The short pulse and long pulse signal generating system utilizes the Keysite Signal Studio for Pulse Building as N5172B. The Vector Signal Generator has been validated by the NTIA. The hopping signal generating system utilizes the CCS simulated hopping method and system, which has been validated by the DoD, FCC and NTIA. The software selects waveform parameters from within the bounds of the signal type on a random basis using uniform distribution.

The short pulse types 1, 2, 3 and 4, and the long pulse type 5 parameters are randomized at run-time.

The hopping type 6 pulse parameters are fixed while the hopping sequence is based on the August 2005 NTIA Hopping Frequency List. The initial starting point randomized at run-time and each subsequent starting point is incremented by 475. Each frequency in the 100-length segment is compared to the boundaries of the EUT Detection Bandwidth and the software creates a hopping burst pattern in accordance with Section 7.4.1.3 Method #2 Simulated Frequency Hopping Radar Waveform Generating Subsystem of KDB 905462 D02. The frequency of the signal generator is incremented in 1 MHz steps from F_L to F_H for each successive trial. This incremental sequence is repeated as required to generate a minimum of 30 total trials and to maintain a uniform frequency distribution over the entire Detection Bandwidth.

The signal monitoring equipment consists of a spectrum analyzer. The aggregate ON time is calculated by multiplying the number of bins above a threshold during a particular observation period by the dwell time per bin, with the analyzer set to peak detection and max hold.

SYSTEM CALIBRATION

A 50-ohm load is connected in place of the spectrum analyzer, and the spectrum analyzer is connected to a horn antenna via a coaxial cable, with the reference level offset set to (horn antenna gain – coaxial cable loss). The signal generator is set to CW mode. The amplitude of the signal generator is adjusted to yield a level of –64 dBm as measured on the spectrum analyzer.

Without changing any of the instrument settings, the spectrum analyzer is reconnected to the Common port of the Spectrum Analyzer Combiner/Divider. The Reference Level Offset of the spectrum analyzer is adjusted so that the displayed amplitude of the signal is –64 dBm.

The spectrum analyzer displays the level of the signal generator as received at the antenna ports of the Master Device. The interference detection threshold may be varied from the calibrated value of –64 dBm and the spectrum analyzer will still indicate the level as received by the Master Device.

ADJUSTMENT OF DISPLAYED TRAFFIC LEVEL

A link is established between the Master and Slave and the distance between the units is adjusted as needed to provide a suitable received level at the Master and Slave devices. The video test file is streamed to generate WLAN traffic. The monitoring antenna is adjusted so that the WLAN traffic level, as displayed on the spectrum analyzer, is at lower amplitude than the radar detection threshold.

TEST AND MEASUREMENT EQUIPMENT

The following test and measurement equipment was utilized for the DFS tests documented in this report:

TEST EQUIPMENT LIST				
Description	Manufacturer	Model	S/N	Next Cal Due
Spectrum Analyzer, 7 GHz	Agilent / HP	N9010A	MY54200580	08-07-19
Vector Signal Generator, 6GHz	Agilent / HP	N5182B	MY53051241	08-07-19

14.1.2. SETUP OF EUT

CONDUCTED METHOD EUT TEST SETUP

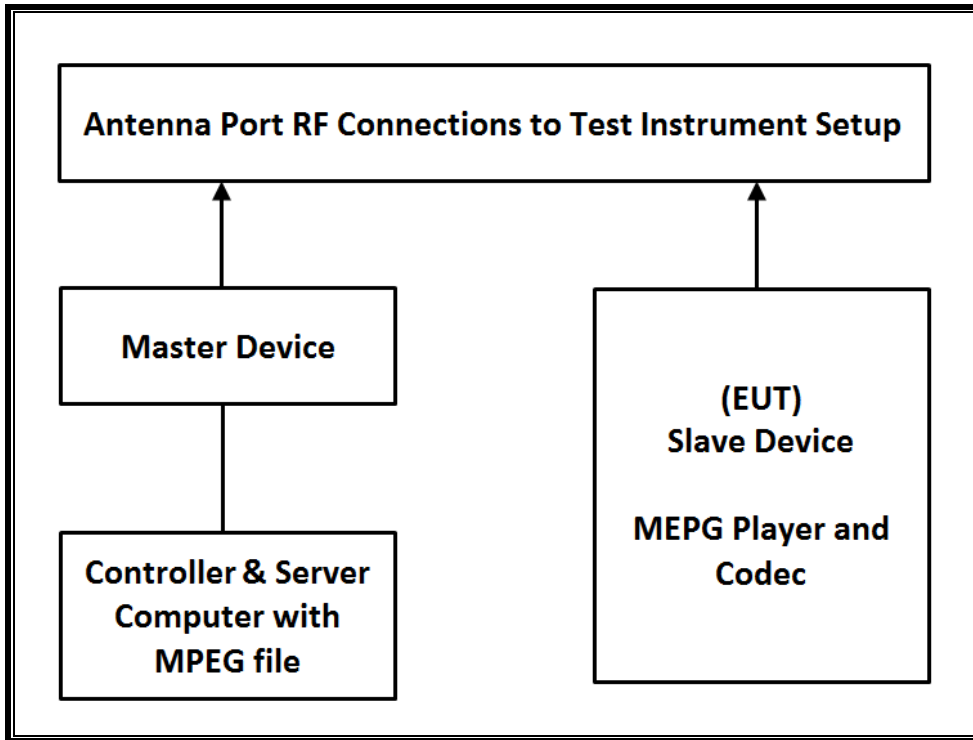

SUPPORT EQUIPMENT

The following support equipment was utilized for the DFS tests documented in this report:

PERIPHERAL SUPPORT EQUIPMENT LIST				
Description	Manufacturer	Model	Serial Number	FCC ID
Wireless Access Point	Cisco	AIR-CAP3702E-A-K9	FTX182276QX	LDK102087
Notebook PC (Controller/Server)	HP	HP EliteDesk 800 G1 TWR	CZC4125J25	DoC

14.1.3. DESCRIPTION OF EUT

The EUT operates over the 5250-5350 MHz and 5470-5725 MHz ranges.

The EUT is a Slave Device without Radar Detection.

The highest power level within these bands is 17.55 dBm in the 5250-5350 MHz band and 18.47 dBm in the 5470-5725 MHz band.

The antenna assembly utilized two antenna.

Gain of antenna 1 : -7.4 dBi for UNII 2A and -7.1 dBi for UNII 2C.

Gain of antenna 2 : -7.2 dBi for UNII 2A and -6.5 dBi for UNII 2C.

The rated output power of the Master unit is > 23dBm (EIRP). Therefore the required interference threshold level is -64 dBm. After correction for procedural adjustments, the required conducted threshold at the antenna port is $-64 + 1 = -63$ dBm.

The calibrated radiated DFS Detection Threshold level is set to -64 dBm. The tested level is lower than the required level hence it provides a margin to the limit.

The EUT uses one transmitter/receiver chain connected to an antenna to perform radiated tests.

WLAN traffic that meets or exceeds the minimum required loading was generated by transferring a data stream from the controller/server PC to the EUT using iPerf version 2.0.5 software package.

TPC is not required since the maximum EIRP is less than 500 mW (27 dBm).

The EUT utilizes the 802.11ac architecture. Three nominal channel bandwidths are implemented: 20 MHz, 40 MHz and 80 MHz.

The software installed in the access point is 12.4(25d)JA1.

UNIFORM CHANNEL SPREADING

This requirement is not applicable to Slave radio devices.

OVERVIEW OF MASTER DEVICE WITH RESPECT TO §15.407 (h) REQUIREMENTS

The Master Device is a Cisco Access Point, FCC ID: LDK102087. The minimum antenna gain for the Master Device is 6 dBi.

The rated output power of the Master unit is > 23dBm (EIRP). Therefore the required interference threshold level is -64 dBm. After correction for procedural adjustments, the required radiated threshold at the antenna port is $-64 + 1 = -63$ dBm.

The calibrated radiated DFS Detection Threshold level is set to -64 dBm. The tested level is lower than the required level hence it provides a margin to the limit.

14.2. RESULTS FOR 20 MHz BANDWIDTH

14.2.1. TEST CHANNEL

All tests were performed at a channel center frequency of 5500 MHz.

14.2.2. RADAR WAVEFORM AND TRAFFIC

RADAR WAVEFORM

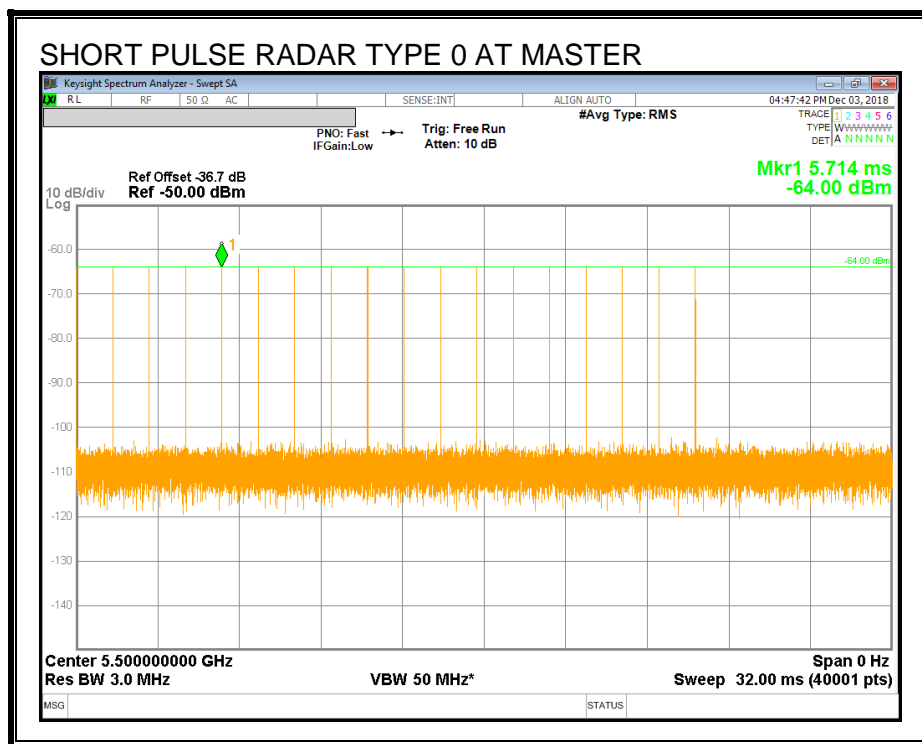

TRAFFIC

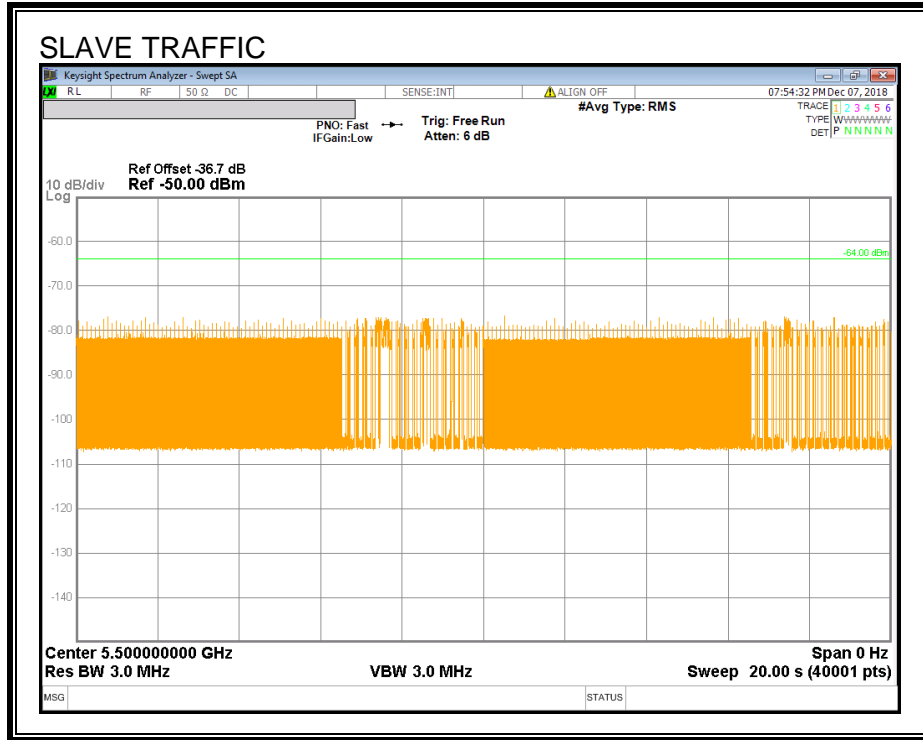

14.2.3. OVERLAPPING CHANNEL TESTS

RESULTS

These tests are not applicable.

14.2.4. MOVE AND CLOSING TIME

REPORTING NOTES

The reference marker is set at the end of last radar pulse.

The delta marker is set at the end of the last WLAN transmission following the radar pulse. This delta is the channel move time.

The aggregate channel closing transmission time is calculated as follows:

Aggregate Transmission Time =
(Number of analyzer bins showing transmission) * (dwell time per bin)

The observation period over which the aggregate time is calculated begins at (Reference Marker + 200 msec) and ends no earlier than (Reference Marker + 10 sec).

RESULTS

Channel Move Time (sec)	Limit (sec)
0.782	10

Aggregate Channel Closing Transmission Time (msec)	Limit (msec)
4.125	60

NON-OCCUPANCY PERIOD

RESULTS

No EUT transmissions were observed on the test channel during the 10-minute observation time.

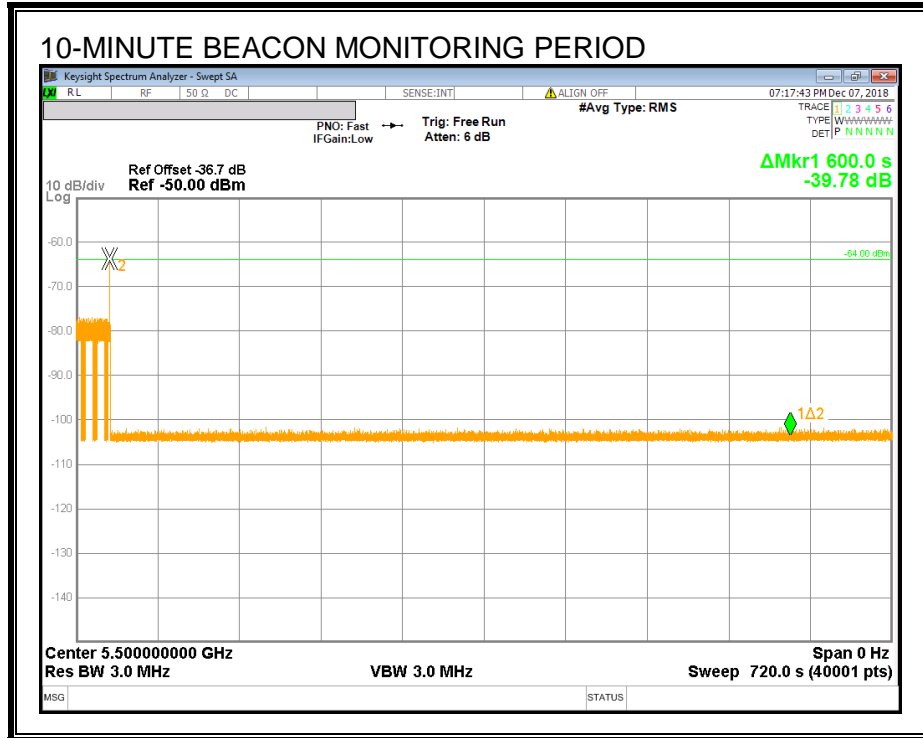

14.3. RESULTS FOR 40 MHz BANDWIDTH

14.3.1. TEST CHANNEL

All tests were performed at a channel center frequency of 5510 MHz.

14.3.2. RADAR WAVEFORM AND TRAFFIC

RADAR WAVEFORM

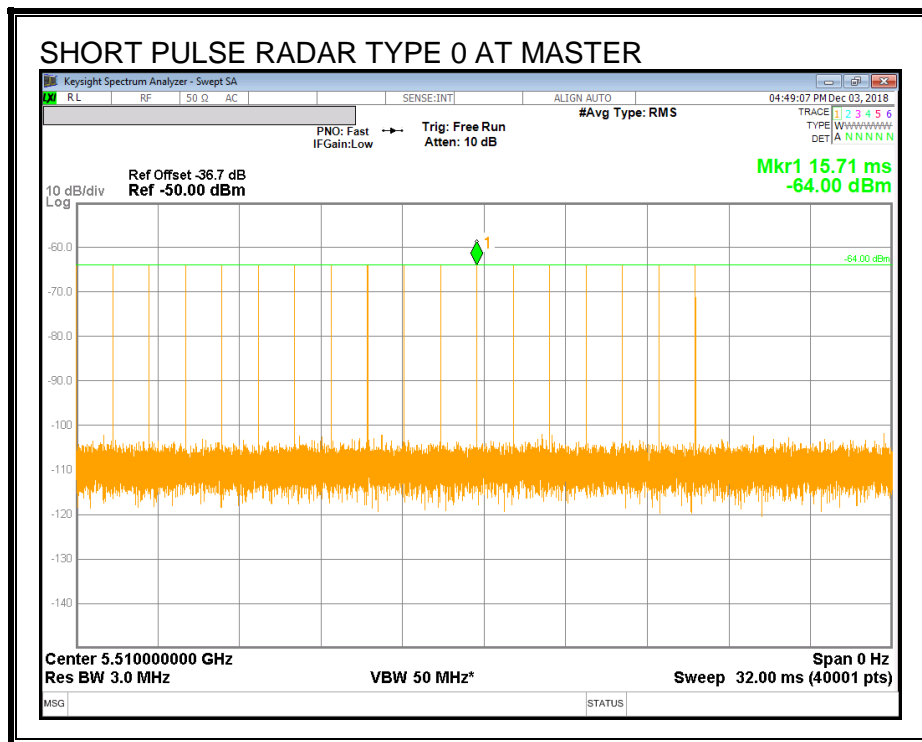

TRAFFIC

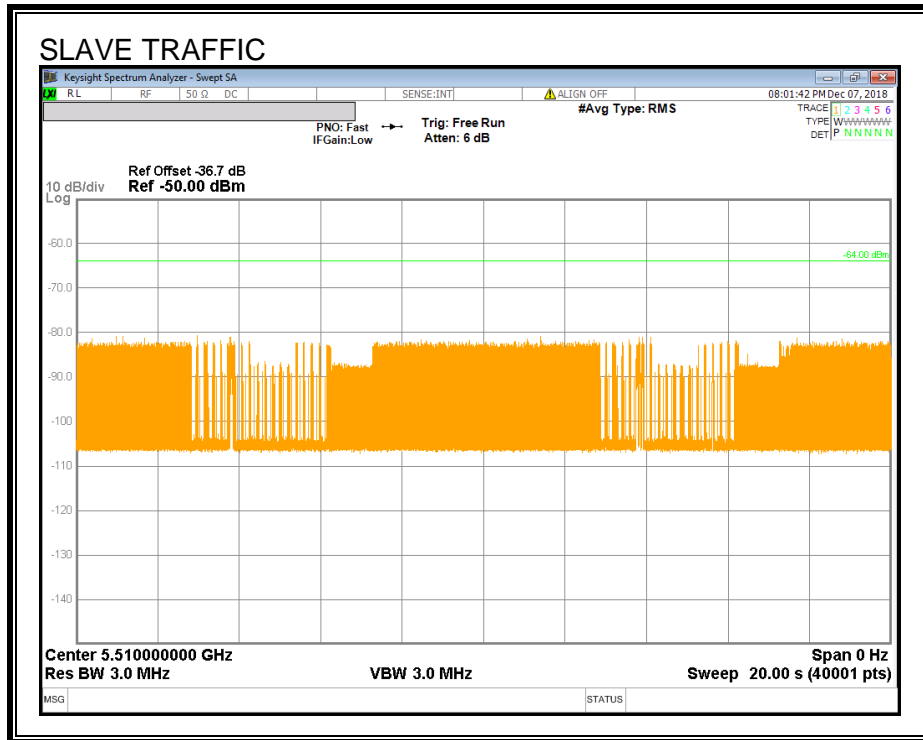

14.3.3. OVERLAPPING CHANNEL TESTS

RESULTS

These tests are not applicable.

14.3.4. MOVE AND CLOSING TIME

REPORTING NOTES

The reference marker is set at the end of last radar pulse.

The delta marker is set at the end of the last WLAN transmission following the radar pulse. This delta is the channel move time.

The aggregate channel closing transmission time is calculated as follows:

Aggregate Transmission Time =
(Number of analyzer bins showing transmission) * (dwell time per bin)

The observation period over which the aggregate time is calculated begins at (Reference Marker + 200 msec) and ends no earlier than (Reference Marker + 10 sec).

RESULTS

Channel Move Time (sec)	Limit (sec)
0.730	10

Aggregate Channel Closing Transmission Time (msec)	Limit (msec)
1.875	60

MOVE TIME & CHANNEL CLOSING TIME

AGGREGATE CHANNEL CLOSING TRANSMISSION TIME

No transmissions are observed during the aggregate monitoring period.

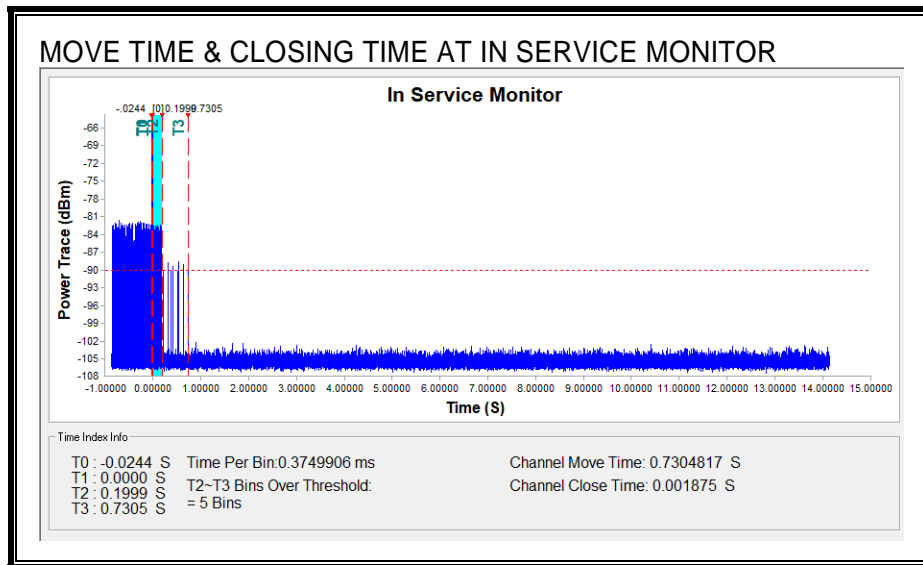
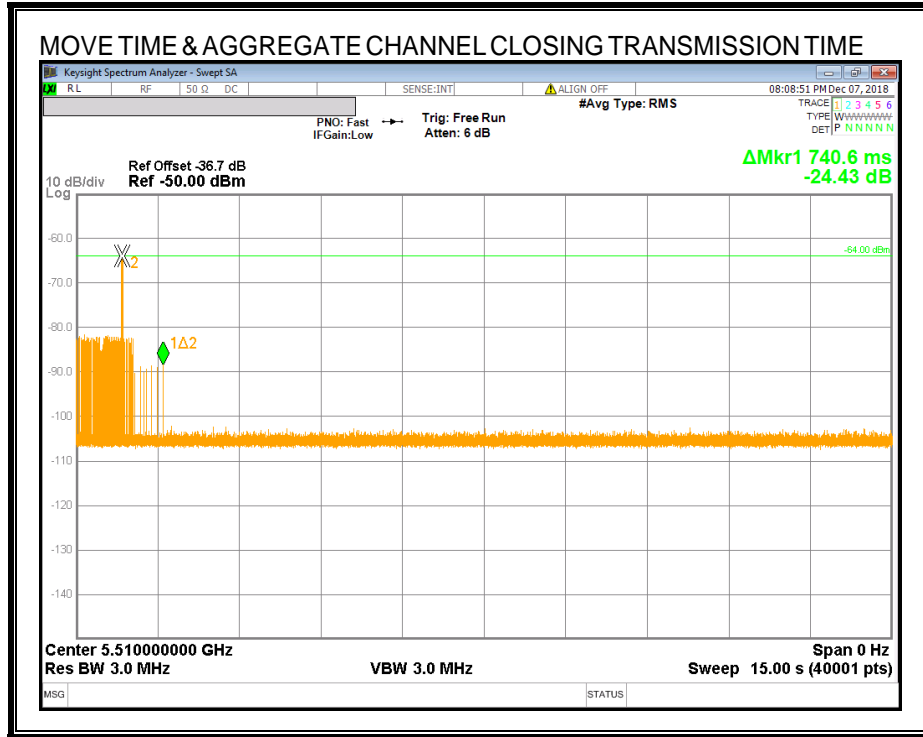

NON-OCCUPANCY PERIOD

RESULTS

No EUT transmissions were observed on the test channel during the 10-minute observation time.

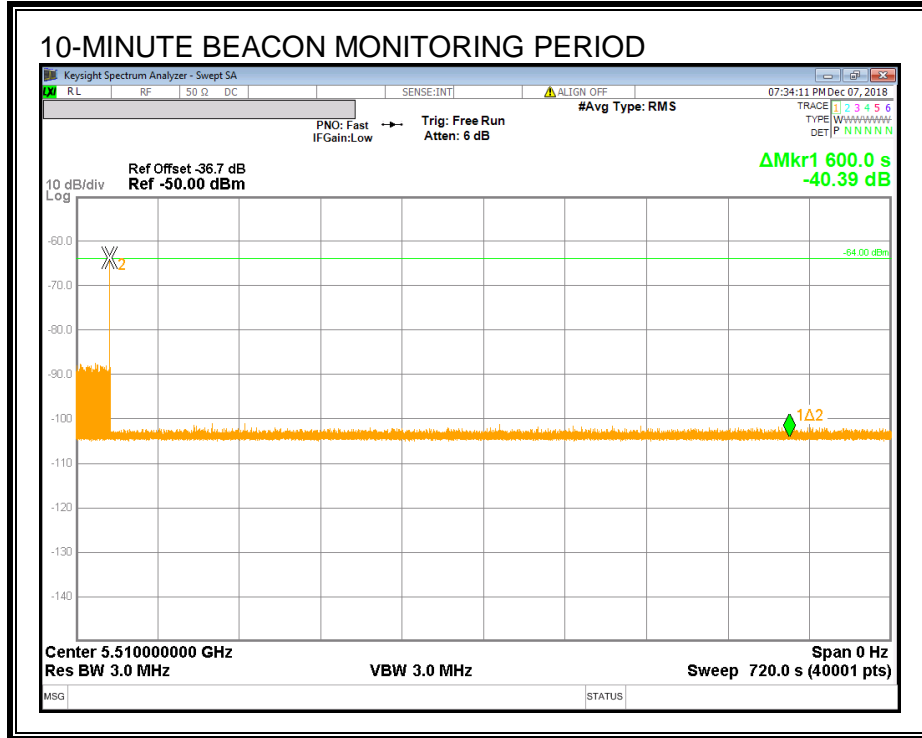

14.4. RESULTS FOR 80 MHz BANDWIDTH

14.4.1. TEST CHANNEL

All tests were performed at a channel center frequency of 5530 MHz.

14.4.2. RADAR WAVEFORM AND TRAFFIC

RADAR WAVEFORM

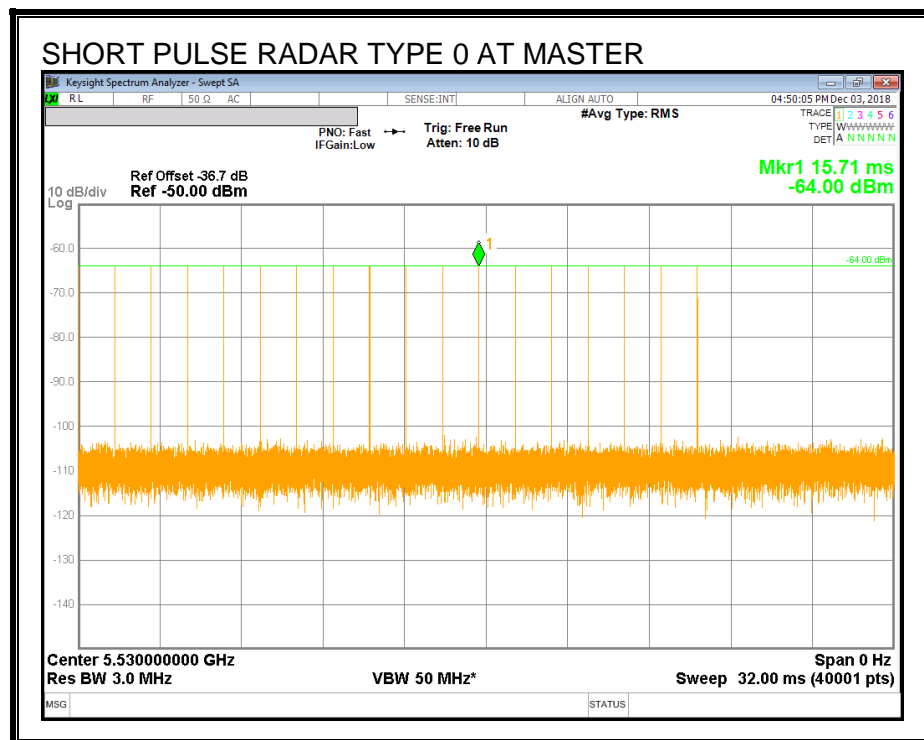

TRAFFIC

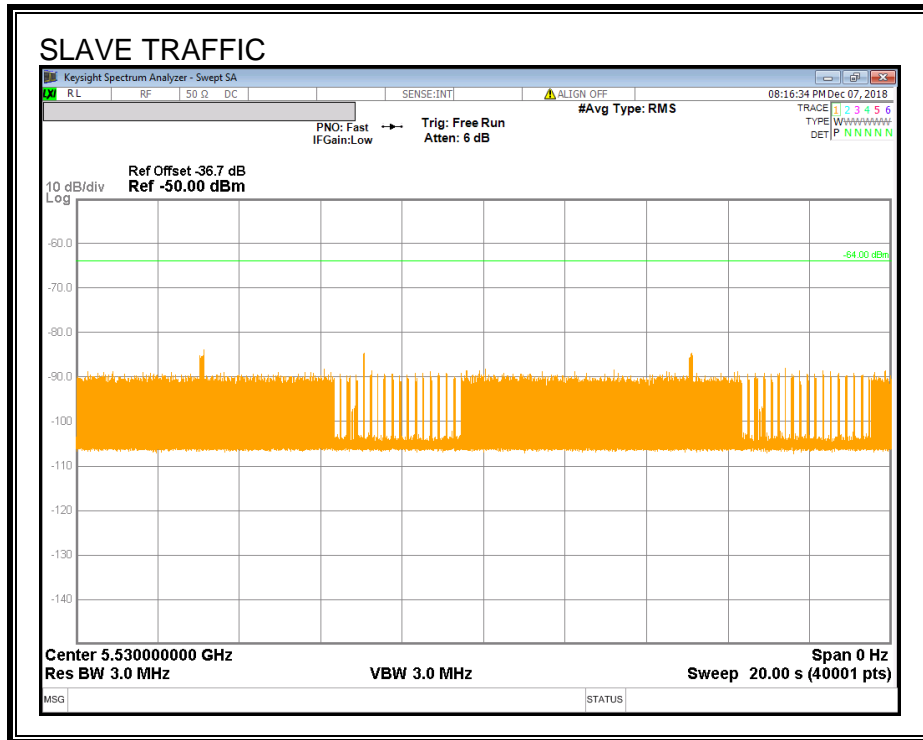

14.4.3. OVERLAPPING CHANNEL TESTS

RESULTS

These tests are not applicable.

14.4.4. MOVE AND CLOSING TIME

REPORTING NOTES

The reference marker is set at the end of last radar pulse.

The delta marker is set at the end of the last WLAN transmission following the radar pulse. This delta is the channel move time.

The aggregate channel closing transmission time is calculated as follows:

Aggregate Transmission Time =
(Number of analyzer bins showing transmission) * (dwell time per bin)

The observation period over which the aggregate time is calculated begins at (Reference Marker + 200 msec) and ends no earlier than (Reference Marker + 10 sec).

RESULTS

Channel Move Time (sec)	Limit (sec)
0.720	10

Aggregate Channel Closing Transmission Time (msec)	Limit (msec)
5.625	60

NON-OCCUPANCY PERIOD

RESULTS

No EUT transmissions were observed on the test channel during the 10-minute observation time.

