



FCC CFR47 PART 22 SUBPART H  
FCC CFR47 PART 24 SUBPART E  
FCC CFR47 PART 27 SUBPART F  
FCC CFR47 PART 27 SUBPART H  
FCC CFR47 PART 27 SUBPART L  
FCC CFR47 PART 27 SUBPART M  
FCC CFR47 PART 90 SUBPART S

**WWAN**

**CERTIFICATION TEST REPORT**

**FOR**

**GSM/WCDMA/LTE Phone + BT/BLE, DTS/UNII a/b/g/n/ac/ax, ANT+, NFC and WPT**

**MODEL NUMBER : SM-G973F/DS, SM-G973F, SM-G973X**

**FCC ID: A3LSMG973F**

**REPORT NUMBER: 4788725460-E1V2**

**ISSUE DATE: DEC 26, 2018**

*Prepared for*

**SAMSUNG ELECTRONICS CO., LTD.  
129 SAMSUNG-RO, YEONGTONG-GU, SUWON-SI,  
GYEONGGI-DO, 16677, KOREA**

*Prepared by*

**UL Korea, Ltd.**

**26th floor, 152, Teheran-ro, Gangnam-gu Seoul, 06236, Korea**

**Suwon Test Site: UL Korea, Ltd. Suwon Laboratory**

**218 Maeyeong-ro, Yeongtong-gu,**

**Suwon-si, Gyeonggi-do, 16675, Korea**

**TEL: (031) 337-9902**

**FAX: (031) 213-5433**



**ACCREDITED\***

Testing  
Laboratory

**TL-637**

Revision History

<u>Rev.</u>	<u>Issue Date</u>	<u>Revisions</u>	<u>Revised By</u>
V1	12/20/18	Initial issue	Junwhan Lee
V2	12/26/18	Updated to address TCB's question	Junwhan Lee

## TABLE OF CONTENTS

<b>1. ATTESTATION OF TEST RESULTS .....</b>	<b>5</b>
<b>2. TEST METHODOLOGY .....</b>	<b>6</b>
<b>3. FACILITIES AND ACCREDITATION .....</b>	<b>6</b>
<b>4. CALIBRATION AND UNCERTAINTY .....</b>	<b>7</b>
4.1. <i>MEASURING INSTRUMENT CALIBRATION.....</i>	<i>7</i>
4.2. <i>SAMPLE CALCULATION.....</i>	<i>7</i>
4.3. <i>MEASUREMENT UNCERTAINTY .....</i>	<i>7</i>
<b>5. EQUIPMENT UNDER TEST .....</b>	<b>8</b>
5.1. <i>DESCRIPTION OF EUT.....</i>	<i>8</i>
5.2. <i>MAXIMUM OUTPUT POWER.....</i>	<i>8</i>
5.3. <i>DESCRIPTION OF AVAILABLE ANTENNAS .....</i>	<i>16</i>
5.4. <i>WORST-CASE ORIENTATION.....</i>	<i>17</i>
5.5. <i>DESCRIPTION OF TEST SETUP.....</i>	<i>19</i>
<b>6. TEST AND MEASUREMENT EQUIPMENT .....</b>	<b>21</b>
<b>7. SUMMARY TABLE.....</b>	<b>22</b>
<b>8. PEAK TO AVERAGE RATIO .....</b>	<b>23</b>
8.1. <i>CONDUCTED PEAK TO AVERAGE RESULT.....</i>	<i>24</i>
<b>9. LIMITS AND CONDUCTED RESULTS .....</b>	<b>41</b>
9.1. <i>OCCUPIED BANDWIDTH.....</i>	<i>41</i>
9.1.1. <i>OCCUPIED BANDWIDTH RESULTS .....</i>	<i>42</i>
9.2. <i>BAND EDGE EMISSIONS .....</i>	<i>98</i>
9.2.1. <i>BAND EDGE RESULT.....</i>	<i>101</i>
9.2.2. <i>EMISSION MASK RESULT .....</i>	<i>145</i>
9.3. <i>OUT OF BAND EMISSIONS.....</i>	<i>159</i>
9.3.1. <i>OUT OF BAND EMISSIONS RESULT.....</i>	<i>161</i>
9.4. <i>FREQUENCY STABILITY.....</i>	<i>176</i>
9.4.1. <i>FREQUENCY STABILITY RESULTS .....</i>	<i>177</i>
<b>10. RADIATED TEST RESULTS .....</b>	<b>185</b>
10.1. <i>RADIATED POWER (ERP &amp; EIRP).....</i>	<i>185</i>
10.1.1. <i>ERP/EIRP Results.....</i>	<i>186</i>
10.1.2. <i>ERP/EIRP DATA .....</i>	<i>197</i>
10.2. <i>FIELD STRENGTH OF SPURIOUS RADIATION.....</i>	<i>253</i>
10.2.1. <i>SPURIOUS RADIATION PLOTS.....</i>	<i>255</i>

---

11. **Appendix A: SETUP PHOTOS .....271**

**Appendix B : Part 15B test report for cellular receiver mode was issued separately.**

# 1. ATTESTATION OF TEST RESULTS

**COMPANY NAME:** SAMSUNG ELECTRONICS CO., LTD.

**EUT DESCRIPTION:** GSM/WCDMA/LTE Phone + BT/BLE, DTS/UNII a/b/g/n/ac/ax, ANT+, NFC and WPT

**MODEL NUMBER:** SM-G973F/DS, SM-G973F, SM-G973X

**SERIAL NUMBER:** R38K806534T (CONDUCTED)  
R38KA0BE04H, R38KA0BE5CF, R38KA0BE3PA, R38K8065W1D (RADIATED);

**DATE TESTED:** OCT 18, 2018 - DEC 19, 2018;

APPLICABLE STANDARDS	
STANDARD	TEST RESULTS
FCC PART 22H, 24E, 27H, 27L, 27F and 27M	Pass

UL Korea, Ltd. tested the above equipment in accordance with the requirements set forth in the above standards. All indications of Pass/Fail in this report are opinions expressed by UL Korea, Ltd. based on interpretations and/or observations of test results. Measurement Uncertainties were not taken into account and are published for informational purposes only. The test results show that the equipment tested is capable of demonstrating compliance with the requirements as documented in this report.

**Note:** The results documented in this report apply only to the tested sample, under the conditions and modes of operation as described herein. This document may not be altered or revised in any way unless done so by UL Korea, Ltd. and all revisions are duly noted in the revisions section. Any alteration of this document not carried out by UL Korea, Ltd. will constitute fraud and shall nullify the document. This report must not be used by the client to claim product certification, approval, or endorsement by IAS, any agency of the Federal Government, or any agency of any government.

Approved & Released For  
UL Korea, Ltd. By:



SungGil Park  
Suwon Lab Engineer  
UL Korea, Ltd.

Tested By:



Junwhan Lee  
Suwon Lab Engineer  
UL Korea, Ltd.

## 2. TEST METHODOLOGY

The tests documented in this report were performed in accordance with following methods.

1. FCC CFR 47 Part 2.
2. FCC CFR 47 Part15.
3. FCC CFR 47 Part 22.
4. FCC CFR 47 Part 24.
5. FCC CFR 47 Part 27.
6. FCC CFR 47 Part 90.
7. ANSI TIA-603-E, 2016
8. ANSI C63.4 : 2014
9. KDB 971168 D01 Power Meas License Digital Systems v03r01

## 3. FACILITIES AND ACCREDITATION

The test sites and measurement facilities used to collect data are located at 218 Maeyeong-ro, Yeongtong-gu, Suwon-si, Gyeonggi-do, 16675, Korea. Line conducted emissions are measured only at the 218 address. The following table identifies which facilities were utilized for radiated emission measurements documented in this report. Specific facilities are also identified in the test results sections.

218 Maeyeong-ro	
<input checked="" type="checkbox"/>	Chamber 1
<input checked="" type="checkbox"/>	Chamber 2
<input type="checkbox"/>	Chamber 3

UL Korea, Ltd. is accredited by IAS, Laboratory Code TL-637. The full scope of accreditation can be viewed at <http://www.iasonline.org/PDF/TL/TL-637.pdf>.

## 4. CALIBRATION AND UNCERTAINTY

### 4.1. MEASURING INSTRUMENT CALIBRATION

The measuring equipment utilized to perform the tests documented in this report has been calibrated in accordance with the manufacturer's recommendations, and is traceable to recognized national standards.

### 4.2. SAMPLE CALCULATION

Where relevant, the following sample calculation is provided:

$EIRP = \text{PSA reading with EUT worst orientation (dBm)} + \text{Path loss (dB)} - \text{cable loss (between the SG and substitution antenna)} + \text{Substitution Antenna Factor (dBi)}$

$ERP = \text{PSA reading with EUT worst orientation (dBm)} + \text{Path loss (dB)} - \text{cable loss (between the SG and substitution antenna)}$

(Path loss = Signal generator output – PSA reading with substitution antenna)

### 4.3. MEASUREMENT UNCERTAINTY

Where relevant, the following measurement uncertainty levels have been estimated for tests performed on the apparatus:

PARAMETER	UNCERTAINTY
Conducted Disturbance, 0.15 to 30 MHz	2.32 dB
Radiated Disturbance, Below 1GHz	3.86 dB
Radiated Disturbance, Above 1 GHz	5.97 dB

Uncertainty figures are valid to a confidence level of 95%.

## 5. EQUIPMENT UNDER TEST

### 5.1. DESCRIPTION OF EUT

The EUT is a GSM/WCDMA/LTE Phone + BT/BLE, DTS/UNII a/b/g/n/ac/ax, ANT+, NFC and WPT. This test report addresses the WWAN operational mode.

### 5.2. MAXIMUM OUTPUT POWER

The transmitter has a maximum average radiated ERP / EIRP output powers as follows:

#### **GSM**

FCC Part 22/24				
Band	Frequency Range	Modulation	Radiated	
	[MHz]		Avg [dBm]	Avg [mW]
GSM850	824~849	GPRS	28.02	633.87
		EGPRS	23.81	240.44
GSM1900	1850~1910	GPRS	28.62	727.78
		EGPRS	27.22	527.23

#### **WCDMA**

FCC Part 22/24				
Band	Frequency Range	Modulation	Radiated	
	[MHz]		Avg [dBm]	Avg [mW]
Band 5	824~849	REL99	<b>19.07</b>	<b>80.72</b>
		HSDPA	18.26	66.99
Band 4	1710~1755	REL99	<b>24.32</b>	<b>270.40</b>
		HSDPA	23.95	248.31
Band 2	1850~1910	REL99	<b>22.22</b>	<b>166.72</b>
		HSDPA	21.42	138.68



**LTE Band 2**

FCC Part 24					
Band	Frequency Range [MHz]	BandWidth [MHz]	Modulation	Radiated	
				Avg [dBm]	Avg [mW]
Band 2	1850 ~ 1910	20	QPSK	<b>23.41</b>	<b>219.28</b>
			16QAM	<b>21.96</b>	<b>157.04</b>
		15	QPSK	22.98	198.61
			16QAM	21.40	138.04
		10	QPSK	23.08	203.24
			16QAM	21.74	149.28
		5	QPSK	22.94	196.79
			16QAM	21.48	140.60
		3	QPSK	22.87	193.64
			16QAM	21.40	138.04
		1.4	QPSK	23.16	207.01
			16QAM	21.67	146.89

**LTE Band 4**

FCC Part 27					
Band	Frequency Range [MHz]	BandWidth [MHz]	Modulation	Radiated	
				Avg [dBm]	Avg [mW]
Band 4	1710 ~ 1755	20	QPSK	22.28	169.04
			16QAM	<b>20.81</b>	<b>120.50</b>
		15	QPSK	22.24	167.49
			16QAM	20.59	114.55
		10	QPSK	21.96	157.04
			16QAM	20.26	106.17
		5	QPSK	<b>22.43</b>	<b>174.98</b>
			16QAM	20.50	112.20
		3	QPSK	22.39	173.38
			16QAM	20.58	114.29
		1.4	QPSK	22.32	170.61
			16QAM	20.72	118.03

**LTE Band 5**

FCC Part 22					
Band	Frequency Range [MHz]	BandWidth [MHz]	Modulation	Radiated	
				Avg [dBm]	Avg [mW]
Band 5	824 ~ 849	10	QPSK	19.66	92.47
			16QAM	17.21	52.60
		5	QPSK	20.08	101.86
			16QAM	17.45	55.59
		3	QPSK	19.91	97.95
			16QAM	17.27	53.33
		1.4	QPSK	<b>20.22</b>	<b>105.20</b>
			16QAM	<b>17.47</b>	<b>55.85</b>

**LTE Band 7**

FCC Part 27					
Band	Frequency Range [MHz]	BandWidth [MHz]	Modulation	Radiated	
				Avg [dBm]	Avg [mW]
Band 7	2500-2570	20	QPSK	<b>23.12</b>	<b>205.12</b>
			16QAM	<b>21.11</b>	<b>129.12</b>
		15	QPSK	22.77	189.23
			16QAM	20.68	116.95
		10	QPSK	23.05	201.84
			16QAM	21.09	128.53
		5	QPSK	22.85	192.75
			16QAM	20.71	117.76

**LTE Band 12**

FCC Part 27					
Band	Frequency Range [MHz]	BandWidth [MHz]	Modulation	Radiated	
				Avg [dBm]	Avg [mW]
Band 12	699 ~ 716	10	QPSK	<b>16.23</b>	<b>41.98</b>
			16QAM	13.72	23.55
		5	QPSK	16.01	39.90
			16QAM	<b>14.03</b>	<b>25.29</b>
		3	QPSK	16.09	40.64
			16QAM	14.02	25.23
		1.4	QPSK	<b>16.23</b>	<b>41.98</b>
			16QAM	13.94	24.77

**LTE Band 17**

LTE Band 17 (Frequency range: 704-716 MHz) is covered by LTE Band 12 (Frequency range: 699-716 MHz) due to overlapping frequency range, same maximum tune-up limit and same channel bandwidth.

**LTE Band 13**

FCC Part 27					
Band	Frequency Range [MHz]	BandWidth [MHz]	Modulation	Radiated	
				Avg [dBm]	Avg [mW]
Band 13	777 ~ 787	10	QPSK	18.71	74.30
			16QAM	16.50	44.67
		5	QPSK	<b>19.61</b>	<b>91.41</b>
			16QAM	<b>17.63</b>	<b>57.94</b>

**LTE Band 25**

FCC Part 24					
Band	Frequency Range [MHz]	BandWidth [MHz]	Modulation	Radiated	
				Avg [dBm]	Avg [mW]
Band 25	1850 ~ 1915	20	QPSK	21.87	153.82
			16QAM	20.87	122.18
		15	QPSK	21.99	158.12
			16QAM	20.90	123.03
		10	QPSK	21.94	156.31
			16QAM	<b>20.93</b>	<b>123.88</b>
		5	QPSK	21.72	148.59
			16QAM	20.68	116.95
		3	QPSK	<b>22.07</b>	<b>161.06</b>
			16QAM	20.89	122.74
		1.4	QPSK	21.85	153.11
			16QAM	20.27	106.41

**LTE Band 26 (Part90)**

Band	Frequency Range [MHz]	BandWidth [MHz]	Modulation Peak	Radiated	
				Avg [dBm]	Avg [mW]
Band 26	814 ~ 824	15	QPSK	<b>17.92</b>	<b>61.94</b>
			16QAM	<b>16.53</b>	<b>44.98</b>
		10	QPSK	16.89	48.87
			16QAM	15.28	33.73
		5	QPSK	17.18	52.24
			16QAM	15.75	37.58
		3	QPSK	17.74	59.43
			16QAM	16.01	39.90
		1.4	QPSK	17.84	60.81
			16QAM	15.91	38.99

**LTE Band 26 (Part22)**

Band	Frequency Range [MHz]	BandWidth [MHz]	Modulation Peak	Radiated	
				Avg [dBm]	Avg [mW]
Band 26	824 ~ 849	15	QPSK	<b>20.75</b>	<b>118.85</b>
			16QAM	<b>19.28</b>	<b>84.72</b>
		10	QPSK	18.86	76.91
			16QAM	17.14	51.76
		5	QPSK	19.01	79.62
			16QAM	17.17	52.12
		3	QPSK	19.07	80.72
			16QAM	17.31	53.83
		1.4	QPSK	18.89	77.45
			16QAM	17.20	52.48

**LTE Band 41**

FCC Part 27					
Band	Frequency Range [MHz]	BandWidth [MHz]	Modulation	Radiated	
				Avg [dBm]	Avg [mW]
Band 41	2496 - 2690	20	QPSK	23.19	208.45
			16QAM	<b>22.20</b>	<b>165.96</b>
		15	QPSK	<b>24.13</b>	<b>258.82</b>
			16QAM	22.00	158.49
		10	QPSK	22.65	184.08
			16QAM	21.49	140.93
		5	QPSK	22.96	197.70
			16QAM	21.83	152.41

**LTE Band 38[Single carrier]**

LTE Band 38[Single carrier] (Frequency range: 2570-2620 MHz) is covered by LTE Band 41 (Frequency range: 2496-2690 MHz) due to overlapping frequency range, same maximum tune-up limit and same channel bandwidth.

**LTE Band 66**

FCC Part 27					
Band	Frequency Range [MHz]	BandWidth [MHz]	Modulation	Radiated	
				Avg [dBm]	Avg [mW]
Band 66	1710 ~ 1780	20	QPSK	24.82	303.39
			16QAM	22.88	194.09
		15	QPSK	24.36	272.90
			16QAM	<b>24.02</b>	<b>252.35</b>
		10	QPSK	24.78	300.61
			16QAM	22.80	190.55
		5	QPSK	<b>25.34</b>	<b>341.98</b>
			16QAM	22.87	193.64
		3	QPSK	24.82	303.39
			16QAM	23.46	221.82
		1.4	QPSK	24.54	284.45
			16QAM	22.62	182.81

### 5.3. DESCRIPTION OF AVAILABLE ANTENNAS

The radio utilizes a internal antenna for the [List the bands supported] with a maximum peak gain as follow:

Frequency (MHz)	Peak Gain (dBi)
WCDMA Band 2 / LTE Band 2 / LTE Band 25 1850 ~ 1910 MHz	-5.39
WCDMA Band 4 / LTE Band 4 / LTE Band 66 1710 ~ 1755 MHz	-4.53
WCDMA Band 5 / LTE Band 5 / LTE Band 26 814 ~ 849 MHz	-2.74
LTE Band 7 2500 ~ 2570 MHz	-4.18
LTE Band 12 / LTE Band 17 699 ~ 716 MHz	-2.21
LTE Band 41 2496 ~ 2690 MHz	-4.18
LTE Band 13 777 ~ 787 MHz	-5.06
LTE Band 38 2570 ~ 2620 MHz	-4.24



## 5.4. WORST-CASE ORIENTATION

Following modes should be considered as worst-case scenario for all other measurements.

- GSM GPRS/EGPRS
- UMTS REL 99/HSDPA

For all LTE Bands, the worst-case scenario for all measurements is based on the average conducted output power measurement investigation results. Output power measurements were measured on QPSK, 16QAM and 64QAM modulations. It was found that QPSK and 16QAM results were worst case. All testing was performed using QPSK and 16QAM modulations to represent the worst case. However, the out of band emissions and spurious radiation were only performed on bandwidth and RB offset(with RB size 1) with the highest power in QPSK.

Highest power setting for each bands				
LTE Band	Frequency (MHz)	Bandwidth (MHz)	RB size	RB offset
2	1860.0	20	1	0
	1880.0		1	0
	1900.0		1	0
4	1711.5	15	1	37
	1732.5		1	37
	1753.5		1	37
5	825.5	3	1	8
	836.5		1	8
	847.5		1	0
7	2502.5	5	1	12
	2535.0		1	24
	2567.5		1	12
12	700.5	3	1	8
	707.5		1	8
	714.5		1	0
13	779.5	5	1	12
	782.0		1	24
	784.5		1	12
25	1851.5	3	1	8
	1882.5		1	8
	1913.5		1	8
26	815.5	3	1	8
	831.5		1	8
	847.5		1	8
41	2503.5	15	1	0
	2593.0		1	0
	2682.5		1	0
66	1717.5	15	1	37
	1745.0		1	37
	1772.5		1	37

**- ERP/EIRP**

For GSM850 / WCDMA B4 / LTE B12 / LTE B41, the fundamental of the EUT was investigated in three orthogonal orientations X, Y and Z it was determined that X orientation was worst-case orientation.

For GSM1900 / WCDMA B2 / LTE B2 / LTE B25 / LTE B66, the fundamental of the EUT was investigated in three orthogonal orientations X, Y and Z it was determined that Y orientation was worst-case orientation.

For WCDMA B5 / LTE B4 / LTE B5 / LTE B7 / LTE B13 / LTE B26, the fundamental of the EUT was investigated in three orthogonal orientations X, Y and Z it was determined that Z orientation was worst-case orientation.

**- Radiated spurious emissions**

For GSM850 / WCDMA B4, the spurious emissions was investigated in three orthogonal orientations X, Y and Z it was determined that X orientation was worst-case orientation.

For GSM1900 / WCDMA B2 / LTE B2 / LTE B5 / LTE B7 / LTE B12 / LTE B13 / LTE B25 / LTE B26 / LTE B66, the spurious emissions was investigated in three orthogonal orientations X, Y and Z it was determined that Y orientation was worst-case orientation.

For WCDMA B5 / LTE B4 / LTE B41, the spurious emissions was investigated in three orthogonal orientations X, Y and Z it was determined that Z orientation was worst-case orientation.

Note : All radiated spurious tests were performed connected with earphone and charger for evaluation of worst case mode.(For erp/eirp tests, the EUT didn't connected with earphone and charger)

**For check the Part15B receiver mode(Appendix B):**

For GSM850, the spurious emissions was investigated in three orthogonal orientations X, Y and Z it was determined that X orientation was worst-case orientation.

For LTE B5 / LTE B12 / LTE B13 / LTE B26, the spurious emissions was investigated in three orthogonal orientations X, Y and Z it was determined that Y orientation was worst-case orientation.

For WCDMA B5, the spurious emissions was investigated in three orthogonal orientations X, Y and Z it was determined that Z orientation was worst-case orientation.

## 5.5. DESCRIPTION OF TEST SETUP

### SUPPORT EQUIPMENT

Support Equipment List				
Description	Manufacturer	Model	Serial Number	FCC ID
Charger	SAMSUNG	EP-TA200	R37KB5B03T1SE3	N/A
Data Cable	SAMSUNG	EP-DG970BBE	N/A	N/A
Earphone	SAMSUNG	EO-IG955	N/A	N/A

### I/O CABLE

I/O Cable List						
Cable No	Port	# of identical ports	Connector Type	Cable Type	Cable Length (m)	Remarks
1	DC Power	1	C Type	Shielded	1.1m	N/A
2	Audio	2	Mini-Jack	Unshielded	1.2m	N/A

### TEST SETUP

The EUT is continuously communicated to the call box during the tests.

**SETUP DIAGRAM FOR TESTS (CONDUCTED TEST SETUP)**

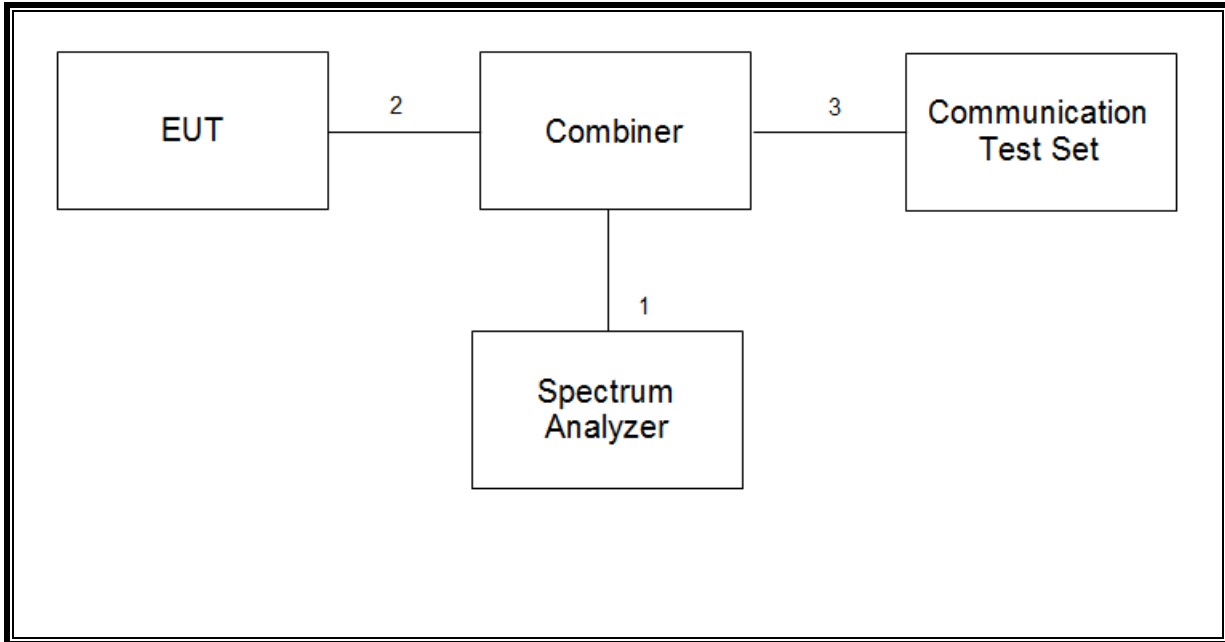

**SETUP DIAGRAM FOR TESTS (RADIATED TEST SETUP)**

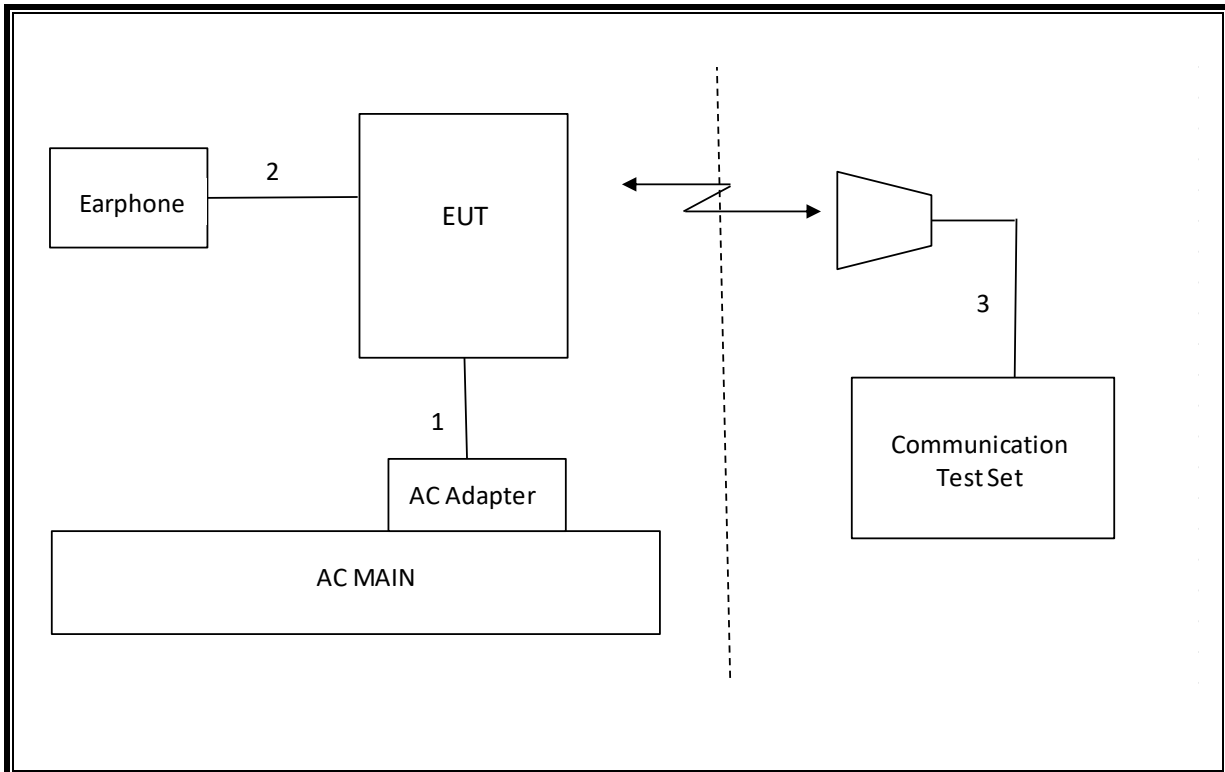

## 6. TEST AND MEASUREMENT EQUIPMENT

The following test and measurement equipment was utilized for the tests documented in this report:

Test Equipment List				
Description	Manufacturer	Model	S/N	Cal Due
Antenna, Tuned Dipole 400~1000 MHz	ETS	3121D DB4	00164753	06-30-19
Antenna, Horn, 40 GHz	ETS	3116C	00166155	12-04-19
Preamplifier	ETS	3116C-PA	00168841	08-09-19
Antenna, Horn, 40 GHz	ETS	3116C	00168645	12-04-19
Antenna, Bilog, 30MHz-1GHz	SCHWARZBECK	VULB9163	750	08-04-20
Antenna, Bilog, 30MHz-1GHz	SCHWARZBECK	VULB9163	845	08-04-20
Antenna, Bilog, 30MHz-1GHz	SCHWARZBECK	VULB9163	749	08-04-20
Antenna, Horn, 18 GHz	ETS	3115	00167211	08-04-20
Antenna, Horn, 18 GHz	ETS	3115	00161451	08-04-20
Antenna, Horn, 18 GHz	ETS	3117	00168724	08-04-20
Antenna, Horn, 18 GHz	ETS	3117	00205959	08-04-20
Antenna, Horn, 18 GHz	ETS	3117	00168717	08-04-20
Combiner	WEINSCHTEL	1575	2152	08-08-19
Communications Test Set	R&S	CMW500	115331	08-07-19
DC Power Supply	Agilent / HP	E3640A	MY54226395	08-06-19
Preamplifier, 1000 MHz	Sonoma	310N	341282	08-07-19
Preamplifier, 1000 MHz	Sonoma	310N	370599	08-06-19
Preamplifier, 1000 MHz	Sonoma	310N	351741	08-07-19
Preamplifier, 18 GHz	Miteq	AFS42-00101800-25-S-42	1876511	08-07-19
Preamplifier, 18 GHz	Miteq	AFS42-00101800-25-S-42	2029169	08-07-19
Preamplifier, 18 GHz	Miteq	AFS42-00101800-25-S-42	1896138	08-07-19
Spectrum Analyzer, 44 GHz	Agilent / HP	N9030A	MY54490312	08-06-19
EMI Test Receive, 40 GHz	R&S	ESU40	100439	08-06-19
EMI Test Receive, 40 GHz	R&S	ESU40	100457	08-06-19
EMI Test Receive, 44 GHz	R&S	ESW40	101590	08-06-19
High Pass Filter 1.2GHz	Micro-Tronics	HPM50108-02	G005	08-08-19
High Pass Filter 1.2GHz	Micro-Tronics	HPM50108-02	G006	08-08-19
High Pass Filter 2.8GHz	Micro-Tronics	HPM50111-02	010	08-08-19
High Pass Filter 2.8GHz	Micro-Tronics	HPM50111-02	011	08-08-19
High Pass Filter 4GHz	Micro-Tronics	HPM50118-02	G001	08-08-19
High Pass Filter 4GHz	Micro-Tronics	HPM50118-02	G002	08-08-19
Attenuator	PASTERNAK	PE7087-10	A009	08-08-19
Attenuator	PASTERNAK	PE7087-10	A001	08-08-19
Attenuator	PASTERNAK	PE7087-10	A008	08-08-19
Attenuator	PASTERNAK	PE7087-10	2	08-07-19
Attenuator	PASTERNAK	PE7395-10	A011	08-08-19
Antenna, Loop, 9kHz-30MHz	R&S	HFH2-Z2	100418	10-26-19
Temperature Chamber	ESPEC	SH-642	93001109	08-06-19
UL Software				
Description	Manufacturer	Model	Version	
Antenna port test software	UL	CLT	Ver 2.5	

## 7. SUMMARY TABLE

FCC Part Section	Test Description	Test Limit	Test Condition	Test Result
2.1049	Occupied Band width (99%)	N/A	Conducted	Pass
22.917(a) 24.238(a) 27.53(c),(g),(h) 90.691	Band Edge / Conducted Spurious Emission	-13dBm		Pass
27.53(m)	Conducted Spurious Emission	-25 dBm		Pass
27.53(m)	Emission mask	Section 9.2.2		Pass
2.1046	Conducted output power	N/A		See the RF exposure test report. (4788725460-S1 FCC Report SAR)
22.355 24.235 27.54 90.213	Frequency Stability	2.5PPM		Pass
22.913(a)(5)	Effective Radiated Power	38.5 dBm	Radiated	Pass
27.50(c)(10) 27.50(b)(10)		34.77 dBm		Pass
90.635(b)		34.77 dBm		Pass
24.232(c) 27.50(h)(2)	Equivalent Isotropic Radiated Power	33dBm		Pass
27.50(d)(4)		30dBm		Pass
22.917(a) 24.238(a) 27.53 (c),(g),(h) 90.691	Radiated Spurious Emission	-13dBm		Pass
27.53 (m)		-25dBm		Pass

## 8. PEAK TO AVERAGE RATIO

### Test Procedure

Per KDB 971168 D01 Power Meas License Digital Systems v03r01;

The transmitter output was connected to a CMW500 Test Set and configured to operate at maximum power. The PAR were measured on the Spectrum Analyzer.

### Test Spec

In addition, when the transmitter power is measured in terms of average value, the peak-to-average ratio of the power shall not exceed 13 dB.

## RESULTS

## 8.1. CONDUCTED PEAK TO AVERAGE RESULT

### GSM

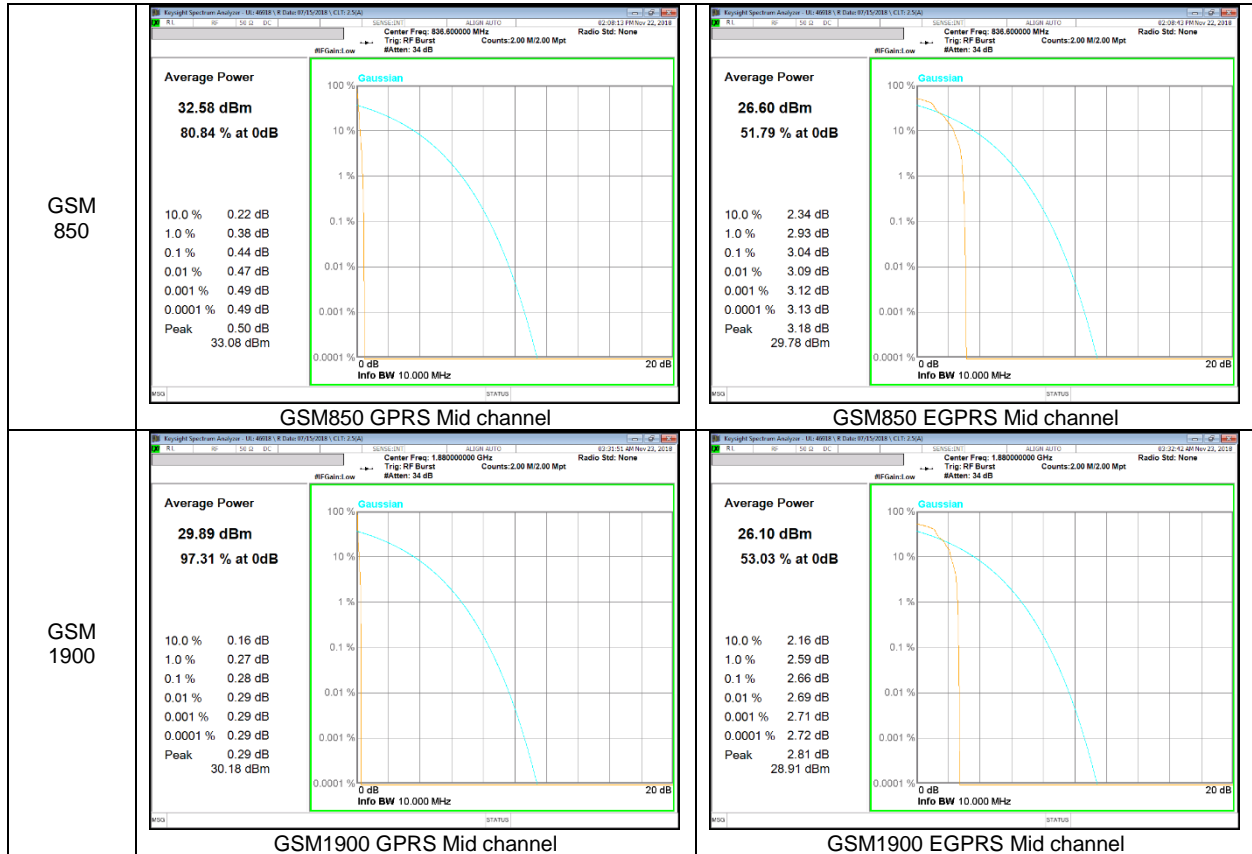



**WCDMA**

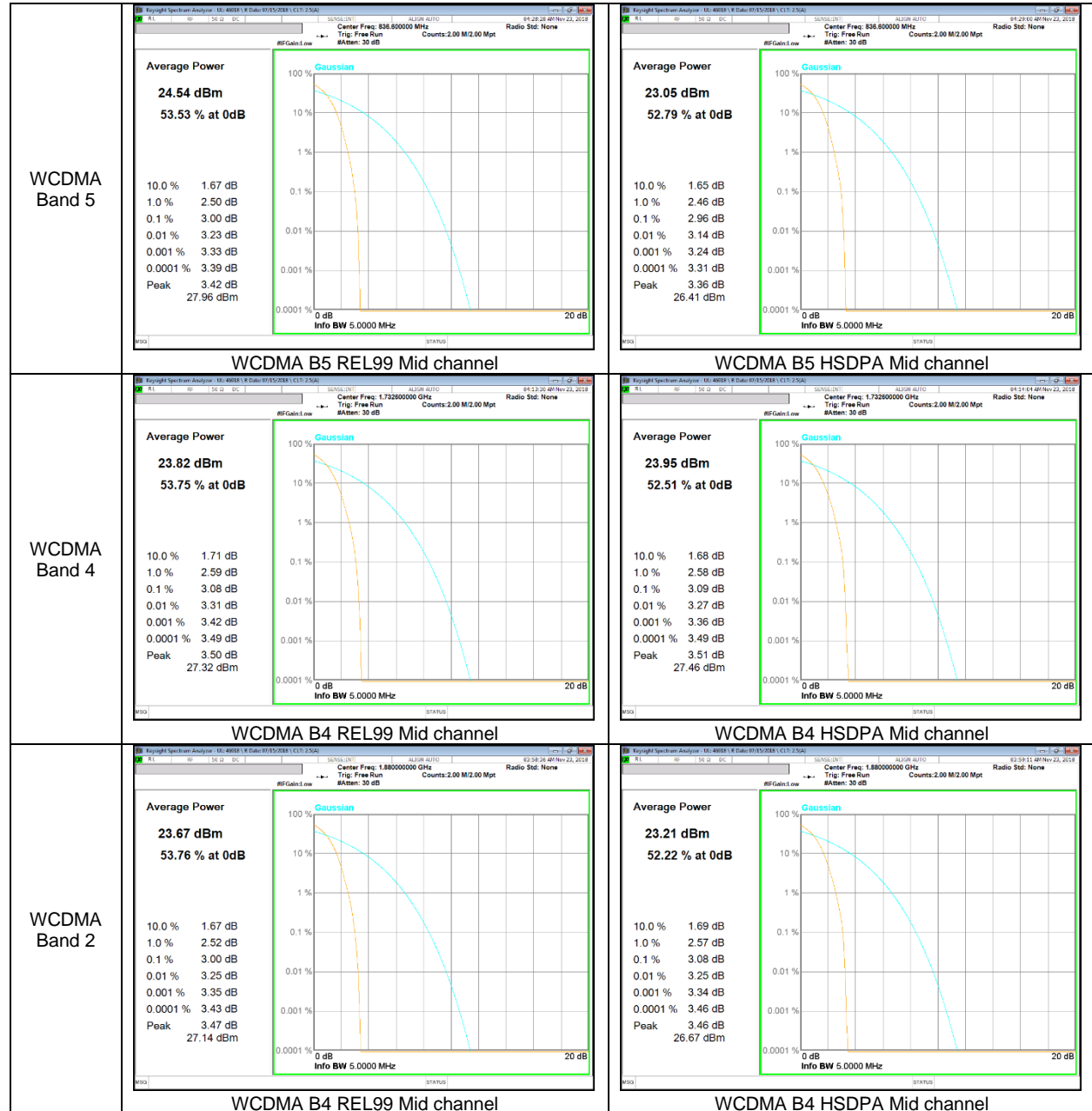

**LTE Band 2**

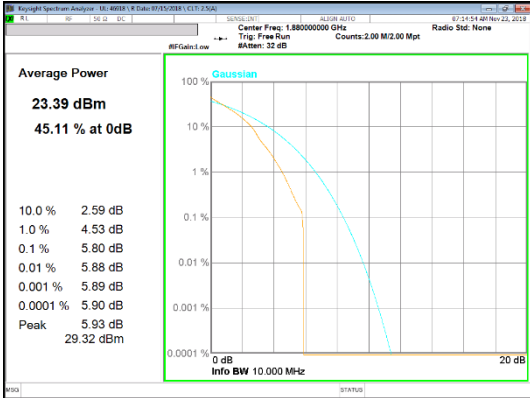
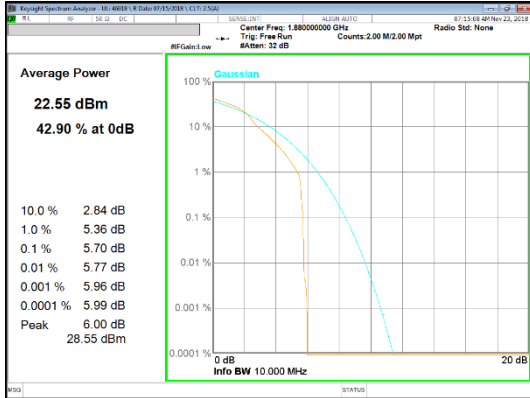
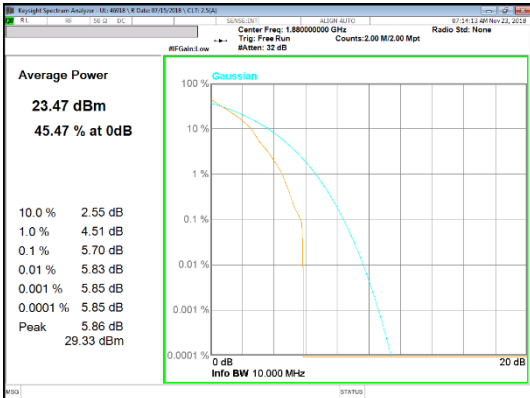
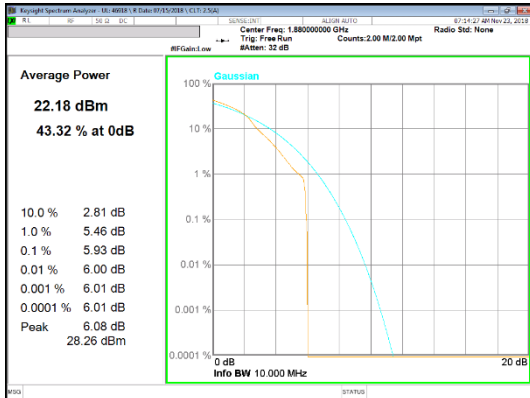
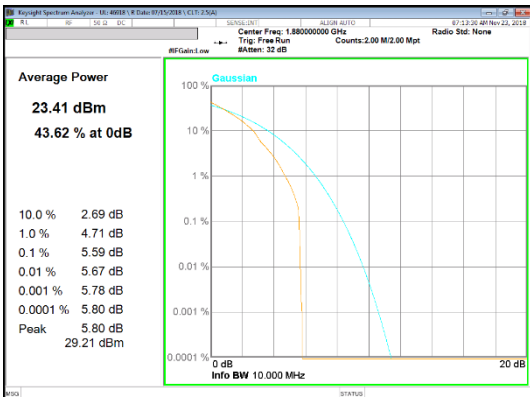
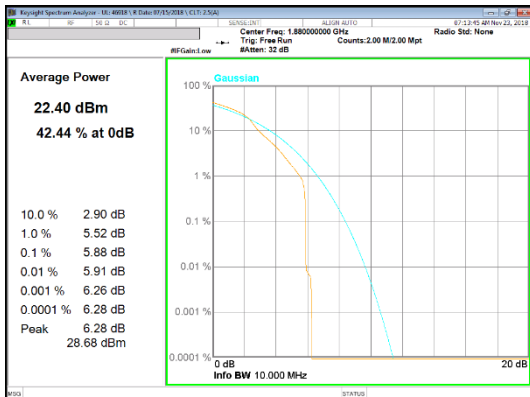
<p>LTE Band 2 20 MHz</p>	 <p>Average Power <b>23.39 dBm</b> 45.11 % at 0dB</p> <p>10.0 % 2.59 dB 1.0 % 4.53 dB 0.1 % 5.80 dB 0.01 % 5.88 dB 0.001 % 5.89 dB 0.0001 % 5.90 dB Peak 5.93 dB 29.32 dBm</p> <p>Info BW 10.000 MHz</p> <p>LTE B2 20MHz QPSK Mid channel</p>	 <p>Average Power <b>22.55 dBm</b> 42.90 % at 0dB</p> <p>10.0 % 2.84 dB 1.0 % 5.36 dB 0.1 % 5.70 dB 0.01 % 5.77 dB 0.001 % 5.96 dB 0.0001 % 5.99 dB Peak 6.00 dB 28.55 dBm</p> <p>Info BW 10.000 MHz</p> <p>LTE B2 20MHz 16QAM Mid channel</p>
<p>LTE Band 2 15 MHz</p>	 <p>Average Power <b>23.47 dBm</b> 45.47 % at 0dB</p> <p>10.0 % 2.55 dB 1.0 % 4.51 dB 0.1 % 5.70 dB 0.01 % 5.83 dB 0.001 % 5.85 dB 0.0001 % 5.85 dB Peak 5.86 dB 29.33 dBm</p> <p>Info BW 10.000 MHz</p> <p>LTE B2 15MHz QPSK Mid channel</p>	 <p>Average Power <b>22.18 dBm</b> 43.32 % at 0dB</p> <p>10.0 % 2.81 dB 1.0 % 5.46 dB 0.1 % 5.93 dB 0.01 % 6.00 dB 0.001 % 6.01 dB 0.0001 % 6.01 dB Peak 6.08 dB 28.26 dBm</p> <p>Info BW 10.000 MHz</p> <p>LTE B2 15MHz 16QAM Mid channel</p>
<p>LTE Band 2 10 MHz</p>	 <p>Average Power <b>23.41 dBm</b> 43.62 % at 0dB</p> <p>10.0 % 2.69 dB 1.0 % 4.71 dB 0.1 % 5.59 dB 0.01 % 5.67 dB 0.001 % 5.78 dB 0.0001 % 5.80 dB Peak 5.80 dB 29.21 dBm</p> <p>Info BW 10.000 MHz</p> <p>LTE B2 10MHz QPSK Mid channel</p>	 <p>Average Power <b>22.40 dBm</b> 42.44 % at 0dB</p> <p>10.0 % 2.90 dB 1.0 % 5.52 dB 0.1 % 5.88 dB 0.01 % 5.91 dB 0.001 % 6.26 dB 0.0001 % 6.28 dB Peak 6.28 dB 28.68 dBm</p> <p>Info BW 10.000 MHz</p> <p>LTE B2 10MHz 16QAM Mid channel</p>

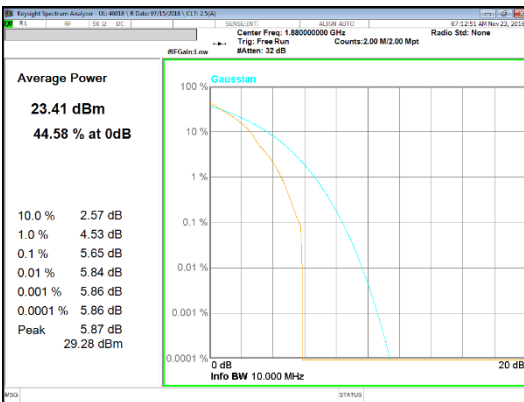
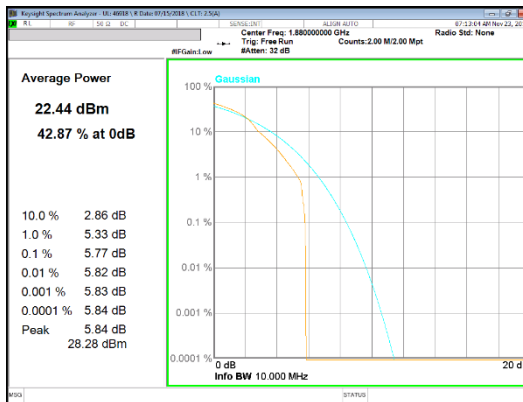
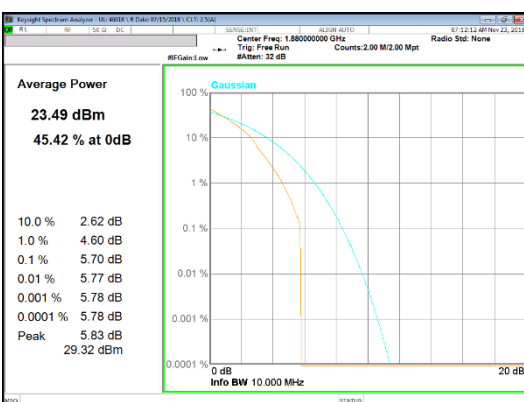
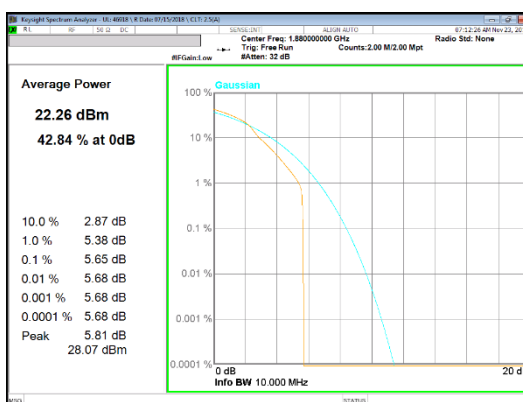
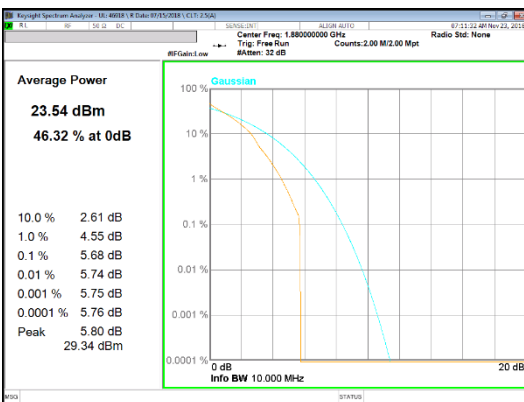
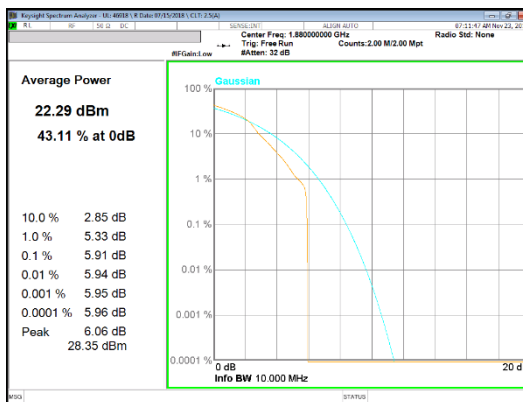
<p>LTE Band 2 5 MHz</p>	 <p><b>Average Power</b> 23.41 dBm 44.58 % at 0dB</p> <table border="1"> <tr><td>10.0 %</td><td>2.57 dB</td></tr> <tr><td>1.0 %</td><td>4.53 dB</td></tr> <tr><td>0.1 %</td><td>5.65 dB</td></tr> <tr><td>0.01 %</td><td>5.84 dB</td></tr> <tr><td>0.001 %</td><td>5.86 dB</td></tr> <tr><td>0.0001 %</td><td>5.86 dB</td></tr> <tr><td>Peak</td><td>5.87 dB</td></tr> <tr><td></td><td>29.28 dBm</td></tr> </table> <p>LTE B2 5MHz QPSK Mid channel</p>	10.0 %	2.57 dB	1.0 %	4.53 dB	0.1 %	5.65 dB	0.01 %	5.84 dB	0.001 %	5.86 dB	0.0001 %	5.86 dB	Peak	5.87 dB		29.28 dBm	 <p><b>Average Power</b> 22.44 dBm 42.87 % at 0dB</p> <table border="1"> <tr><td>10.0 %</td><td>2.86 dB</td></tr> <tr><td>1.0 %</td><td>5.33 dB</td></tr> <tr><td>0.1 %</td><td>5.77 dB</td></tr> <tr><td>0.01 %</td><td>5.82 dB</td></tr> <tr><td>0.001 %</td><td>5.83 dB</td></tr> <tr><td>0.0001 %</td><td>5.84 dB</td></tr> <tr><td>Peak</td><td>5.84 dB</td></tr> <tr><td></td><td>28.28 dBm</td></tr> </table> <p>LTE B2 5MHz 16QAM Mid channel</p>	10.0 %	2.86 dB	1.0 %	5.33 dB	0.1 %	5.77 dB	0.01 %	5.82 dB	0.001 %	5.83 dB	0.0001 %	5.84 dB	Peak	5.84 dB		28.28 dBm
10.0 %	2.57 dB																																	
1.0 %	4.53 dB																																	
0.1 %	5.65 dB																																	
0.01 %	5.84 dB																																	
0.001 %	5.86 dB																																	
0.0001 %	5.86 dB																																	
Peak	5.87 dB																																	
	29.28 dBm																																	
10.0 %	2.86 dB																																	
1.0 %	5.33 dB																																	
0.1 %	5.77 dB																																	
0.01 %	5.82 dB																																	
0.001 %	5.83 dB																																	
0.0001 %	5.84 dB																																	
Peak	5.84 dB																																	
	28.28 dBm																																	
<p>LTE Band 2 3 MHz</p>	 <p><b>Average Power</b> 23.49 dBm 45.42 % at 0dB</p> <table border="1"> <tr><td>10.0 %</td><td>2.62 dB</td></tr> <tr><td>1.0 %</td><td>4.60 dB</td></tr> <tr><td>0.1 %</td><td>5.70 dB</td></tr> <tr><td>0.01 %</td><td>5.77 dB</td></tr> <tr><td>0.001 %</td><td>5.78 dB</td></tr> <tr><td>0.0001 %</td><td>5.78 dB</td></tr> <tr><td>Peak</td><td>5.83 dB</td></tr> <tr><td></td><td>29.32 dBm</td></tr> </table> <p>LTE B2 3MHz QPSK Mid channel</p>	10.0 %	2.62 dB	1.0 %	4.60 dB	0.1 %	5.70 dB	0.01 %	5.77 dB	0.001 %	5.78 dB	0.0001 %	5.78 dB	Peak	5.83 dB		29.32 dBm	 <p><b>Average Power</b> 22.26 dBm 42.84 % at 0dB</p> <table border="1"> <tr><td>10.0 %</td><td>2.87 dB</td></tr> <tr><td>1.0 %</td><td>5.38 dB</td></tr> <tr><td>0.1 %</td><td>5.65 dB</td></tr> <tr><td>0.01 %</td><td>5.68 dB</td></tr> <tr><td>0.001 %</td><td>5.68 dB</td></tr> <tr><td>0.0001 %</td><td>5.68 dB</td></tr> <tr><td>Peak</td><td>5.81 dB</td></tr> <tr><td></td><td>28.07 dBm</td></tr> </table> <p>LTE B2 3MHz 16QAM Mid channel</p>	10.0 %	2.87 dB	1.0 %	5.38 dB	0.1 %	5.65 dB	0.01 %	5.68 dB	0.001 %	5.68 dB	0.0001 %	5.68 dB	Peak	5.81 dB		28.07 dBm
10.0 %	2.62 dB																																	
1.0 %	4.60 dB																																	
0.1 %	5.70 dB																																	
0.01 %	5.77 dB																																	
0.001 %	5.78 dB																																	
0.0001 %	5.78 dB																																	
Peak	5.83 dB																																	
	29.32 dBm																																	
10.0 %	2.87 dB																																	
1.0 %	5.38 dB																																	
0.1 %	5.65 dB																																	
0.01 %	5.68 dB																																	
0.001 %	5.68 dB																																	
0.0001 %	5.68 dB																																	
Peak	5.81 dB																																	
	28.07 dBm																																	
<p>LTE Band 2 1.4 MHz</p>	 <p><b>Average Power</b> 23.54 dBm 46.32 % at 0dB</p> <table border="1"> <tr><td>10.0 %</td><td>2.61 dB</td></tr> <tr><td>1.0 %</td><td>4.55 dB</td></tr> <tr><td>0.1 %</td><td>5.68 dB</td></tr> <tr><td>0.01 %</td><td>5.74 dB</td></tr> <tr><td>0.001 %</td><td>5.75 dB</td></tr> <tr><td>0.0001 %</td><td>5.76 dB</td></tr> <tr><td>Peak</td><td>5.80 dB</td></tr> <tr><td></td><td>29.34 dBm</td></tr> </table> <p>LTE B2 1.4MHz QPSK Mid channel</p>	10.0 %	2.61 dB	1.0 %	4.55 dB	0.1 %	5.68 dB	0.01 %	5.74 dB	0.001 %	5.75 dB	0.0001 %	5.76 dB	Peak	5.80 dB		29.34 dBm	 <p><b>Average Power</b> 22.29 dBm 43.11 % at 0dB</p> <table border="1"> <tr><td>10.0 %</td><td>2.85 dB</td></tr> <tr><td>1.0 %</td><td>5.33 dB</td></tr> <tr><td>0.1 %</td><td>5.91 dB</td></tr> <tr><td>0.01 %</td><td>5.94 dB</td></tr> <tr><td>0.001 %</td><td>5.95 dB</td></tr> <tr><td>0.0001 %</td><td>5.96 dB</td></tr> <tr><td>Peak</td><td>6.06 dB</td></tr> <tr><td></td><td>28.35 dBm</td></tr> </table> <p>LTE B2 1.4MHz 16QAM Mid channel</p>	10.0 %	2.85 dB	1.0 %	5.33 dB	0.1 %	5.91 dB	0.01 %	5.94 dB	0.001 %	5.95 dB	0.0001 %	5.96 dB	Peak	6.06 dB		28.35 dBm
10.0 %	2.61 dB																																	
1.0 %	4.55 dB																																	
0.1 %	5.68 dB																																	
0.01 %	5.74 dB																																	
0.001 %	5.75 dB																																	
0.0001 %	5.76 dB																																	
Peak	5.80 dB																																	
	29.34 dBm																																	
10.0 %	2.85 dB																																	
1.0 %	5.33 dB																																	
0.1 %	5.91 dB																																	
0.01 %	5.94 dB																																	
0.001 %	5.95 dB																																	
0.0001 %	5.96 dB																																	
Peak	6.06 dB																																	
	28.35 dBm																																	

**LTE Band 4**

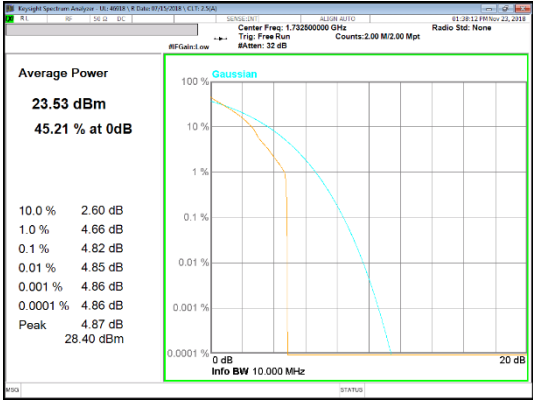
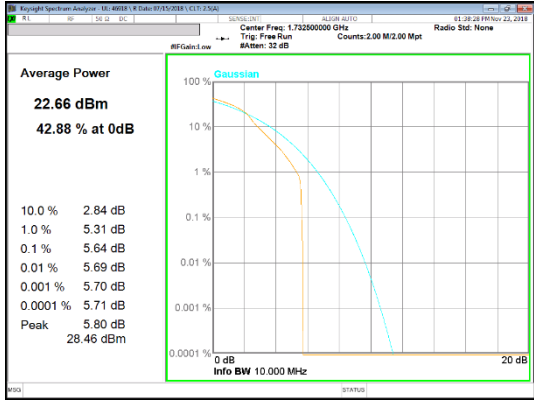
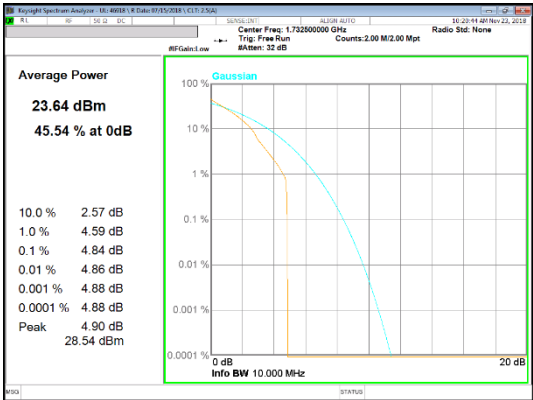
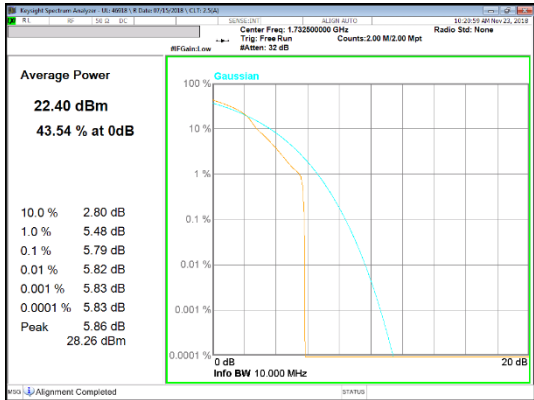
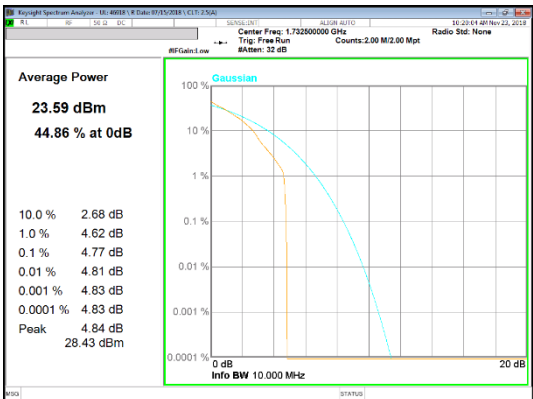
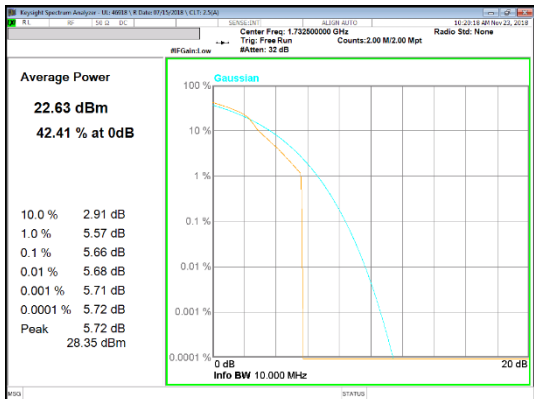
<p>LTE Band 4 20 MHz</p>	 <p>Average Power <b>23.53 dBm</b> 45.21 % at 0dB</p> <p>10.0 % 2.60 dB 1.0 % 4.66 dB 0.1 % 4.82 dB 0.01 % 4.85 dB 0.001 % 4.86 dB 0.0001 % 4.86 dB Peak 4.87 dB 28.40 dBm</p> <p>LTE B4 20MHz QPSK Mid channel</p>	 <p>Average Power <b>22.66 dBm</b> 42.88 % at 0dB</p> <p>10.0 % 2.84 dB 1.0 % 5.31 dB 0.1 % 5.64 dB 0.01 % 5.69 dB 0.001 % 5.70 dB 0.0001 % 5.71 dB Peak 5.80 dB 28.46 dBm</p> <p>LTE B4 20MHz 16QAM Mid channel</p>
<p>LTE Band 4 15 MHz</p>	 <p>Average Power <b>23.64 dBm</b> 45.54 % at 0dB</p> <p>10.0 % 2.57 dB 1.0 % 4.59 dB 0.1 % 4.84 dB 0.01 % 4.86 dB 0.001 % 4.88 dB 0.0001 % 4.88 dB Peak 4.90 dB 28.54 dBm</p> <p>LTE B4 15MHz QPSK Mid channel</p>	 <p>Average Power <b>22.40 dBm</b> 43.54 % at 0dB</p> <p>10.0 % 2.80 dB 1.0 % 5.48 dB 0.1 % 5.79 dB 0.01 % 5.82 dB 0.001 % 5.83 dB 0.0001 % 5.83 dB Peak 5.86 dB 28.26 dBm</p> <p>LTE B4 15MHz 16QAM Mid channel</p>
<p>LTE Band 4 10 MHz</p>	 <p>Average Power <b>23.59 dBm</b> 44.86 % at 0dB</p> <p>10.0 % 2.68 dB 1.0 % 4.62 dB 0.1 % 4.77 dB 0.01 % 4.81 dB 0.001 % 4.83 dB 0.0001 % 4.83 dB Peak 4.84 dB 28.43 dBm</p> <p>LTE B4 10MHz QPSK Mid channel</p>	 <p>Average Power <b>22.63 dBm</b> 42.41 % at 0dB</p> <p>10.0 % 2.91 dB 1.0 % 5.57 dB 0.1 % 5.66 dB 0.01 % 5.68 dB 0.001 % 5.71 dB 0.0001 % 5.72 dB Peak 5.72 dB 28.35 dBm</p> <p>LTE B4 10MHz 16QAM Mid channel</p>

<p>LTE Band 4 5 MHz</p>	<p>Average Power  <b>23.81 dBm</b>  <b>46.00 % at 0dB</b></p> <p>10.0 % 2.57 dB              1.0 % 4.52 dB              0.1 % 4.62 dB              0.01 % 4.64 dB              0.001 % 4.65 dB              0.0001 % 4.65 dB              Peak 4.66 dB              28.47 dBm</p> <p>LTE B4 5MHz QPSK Mid channel</p>	<p>Average Power  <b>22.44 dBm</b>  <b>43.42 % at 0dB</b></p> <p>10.0 % 2.79 dB              1.0 % 5.25 dB              0.1 % 5.56 dB              0.01 % 5.59 dB              0.001 % 5.60 dB              0.0001 % 5.60 dB              Peak 5.67 dB              28.11 dBm</p> <p>LTE B4 5MHz 16QAM Mid channel</p>
<p>LTE Band 4 3 MHz</p>	<p>Average Power  <b>23.64 dBm</b>  <b>46.36 % at 0dB</b></p> <p>10.0 % 2.60 dB              1.0 % 4.64 dB              0.1 % 4.78 dB              0.01 % 4.81 dB              0.001 % 4.82 dB              0.0001 % 4.82 dB              Peak 4.86 dB              28.50 dBm</p> <p>LTE B4 3MHz QPSK Mid channel</p>	<p>Average Power  <b>22.43 dBm</b>  <b>43.01 % at 0dB</b></p> <p>10.0 % 2.86 dB              1.0 % 5.39 dB              0.1 % 5.68 dB              0.01 % 5.71 dB              0.001 % 5.72 dB              0.0001 % 5.73 dB              Peak 5.75 dB              28.18 dBm</p> <p>LTE B4 3MHz 16QAM Mid channel</p>
<p>LTE Band 4 1.4 MHz</p>	<p>Average Power  <b>23.74 dBm</b>  <b>46.69 % at 0dB</b></p> <p>10.0 % 2.59 dB              1.0 % 4.56 dB              0.1 % 4.68 dB              0.01 % 4.71 dB              0.001 % 4.72 dB              0.0001 % 4.72 dB              Peak 4.96 dB              28.70 dBm</p> <p>LTE B4 1.4MHz QPSK Mid channel</p>	<p>Average Power  <b>22.58 dBm</b>  <b>43.47 % at 0dB</b></p> <p>10.0 % 2.81 dB              1.0 % 5.37 dB              0.1 % 5.84 dB              0.01 % 5.86 dB              0.001 % 5.87 dB              0.0001 % 5.88 dB              Peak 5.88 dB              28.46 dBm</p> <p>LTE B4 1.4MHz 16QAM Mid channel</p>

**LTE Band 5**

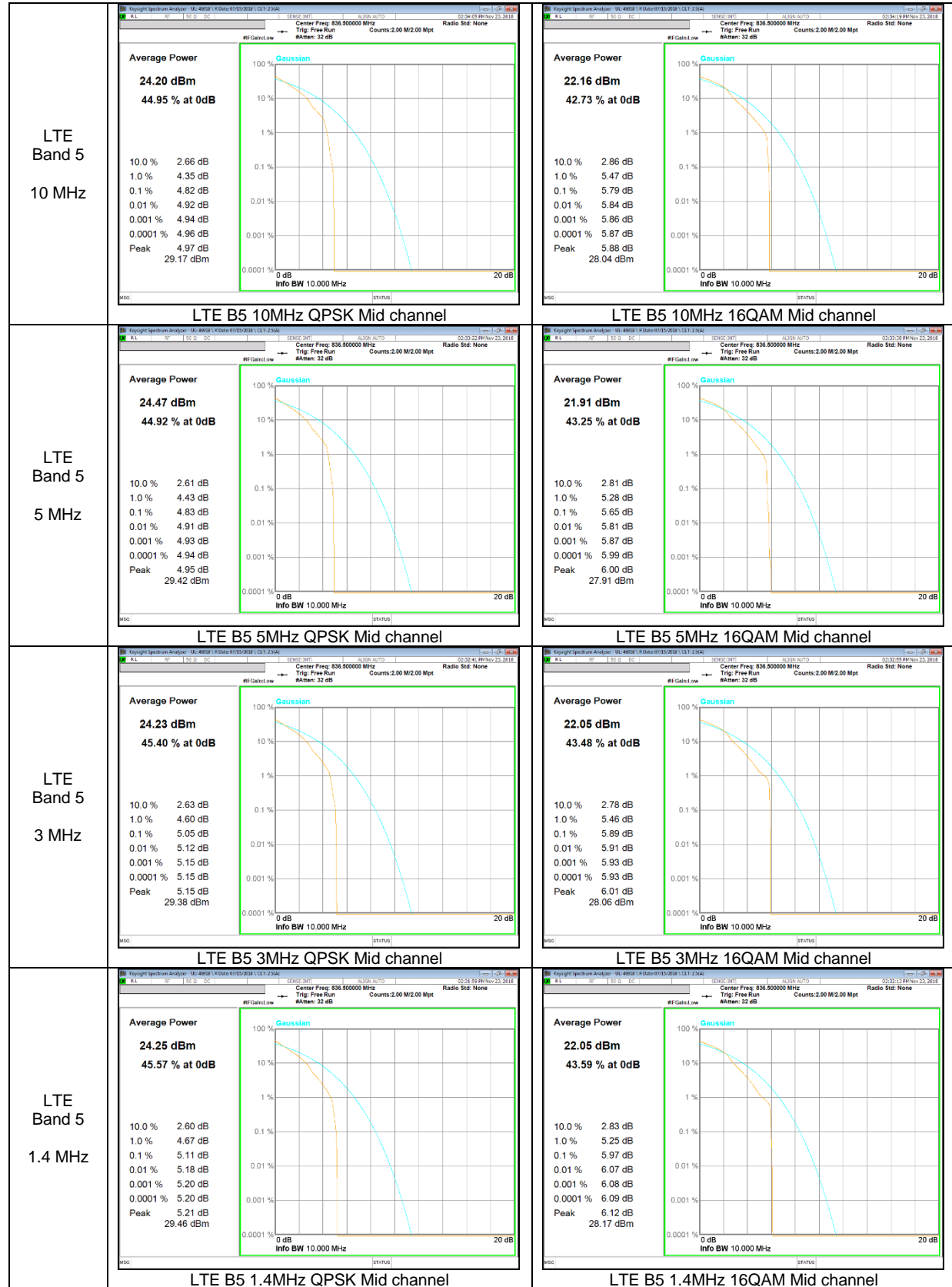

**LTE Band 7**

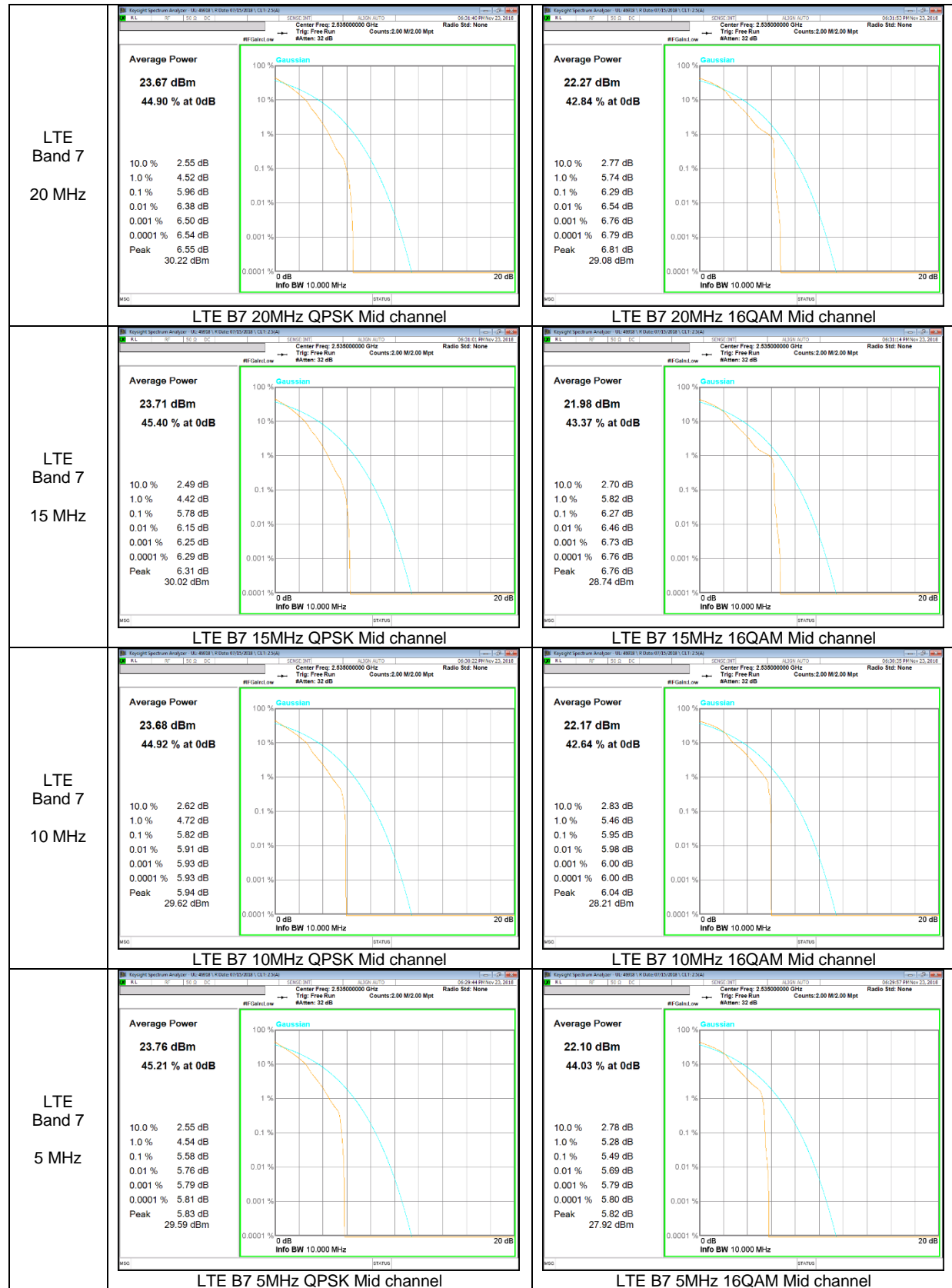

**LTE Band 12**

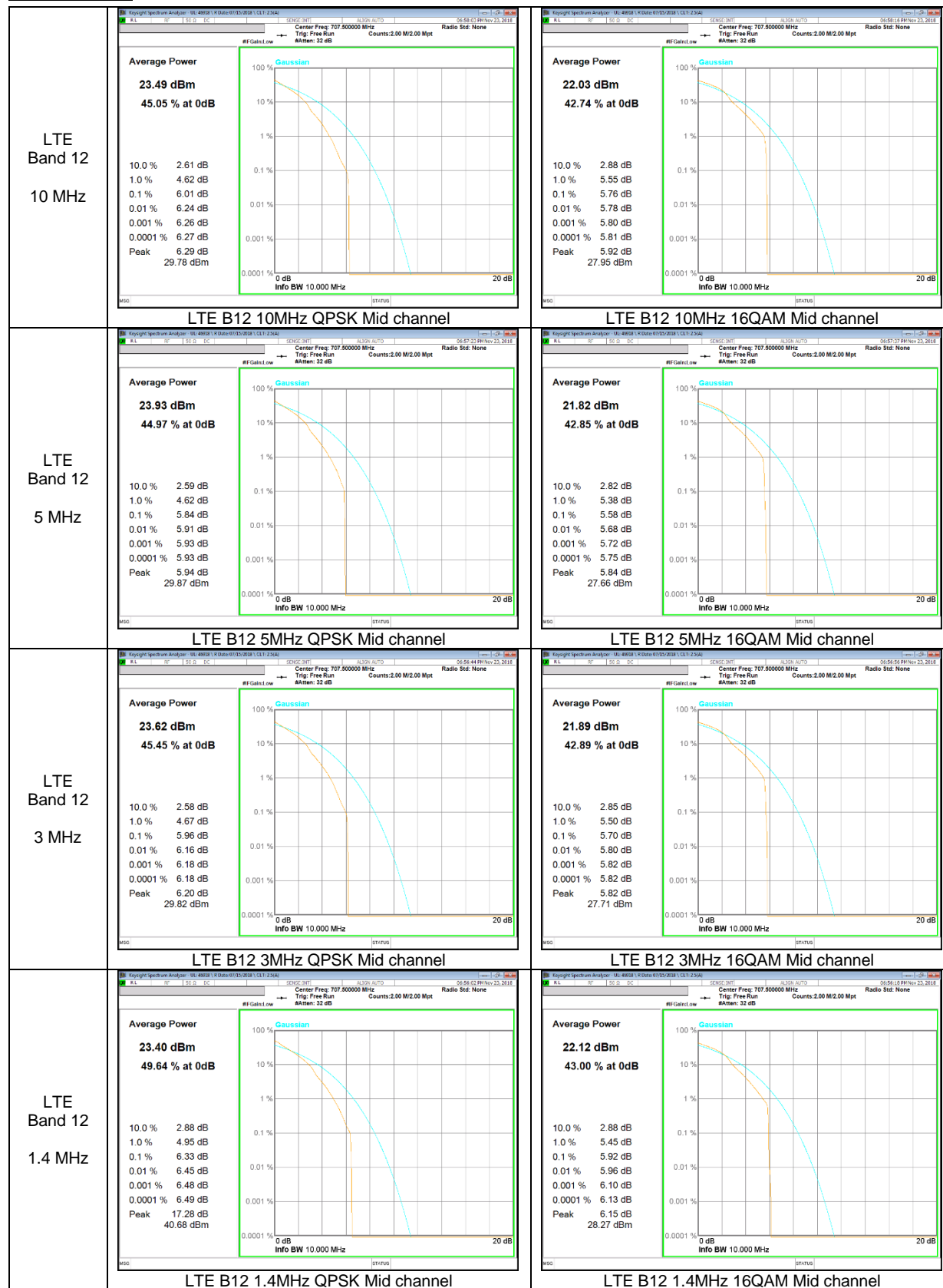



**LTE Band 13**

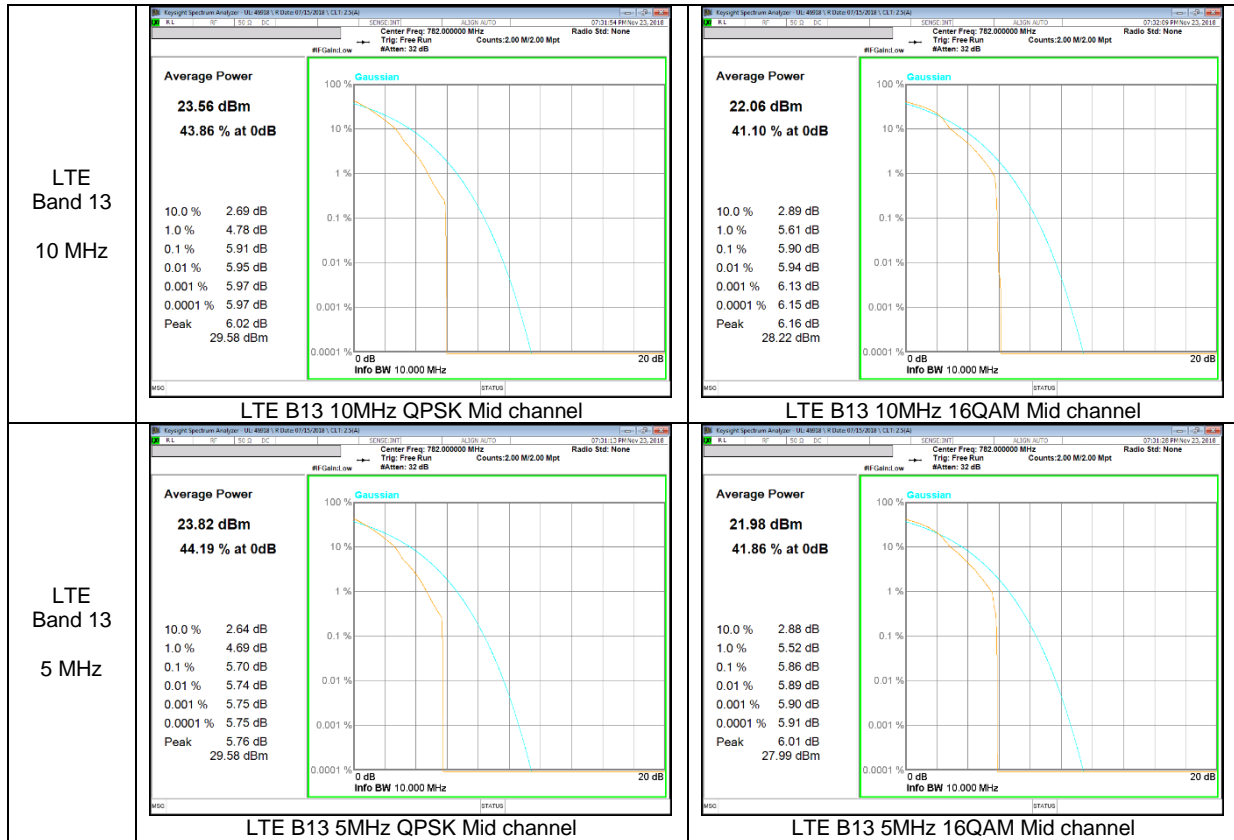

**LTE Band 25**

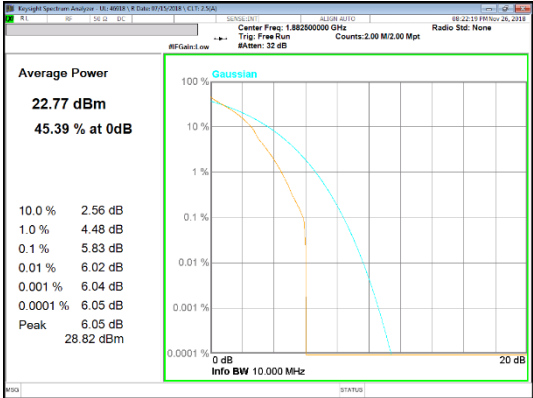
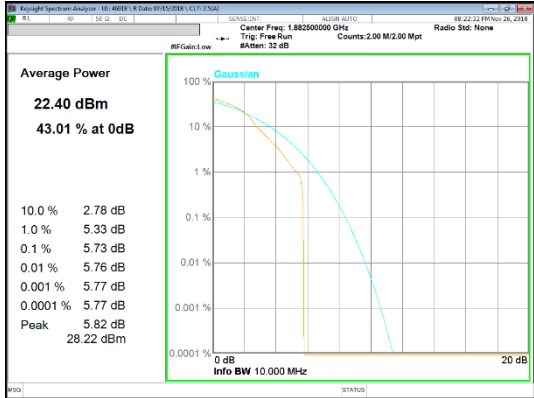
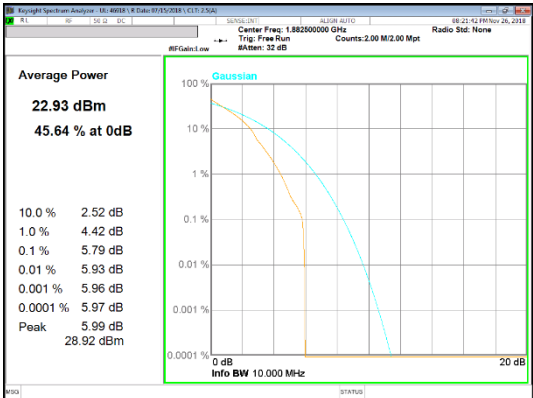
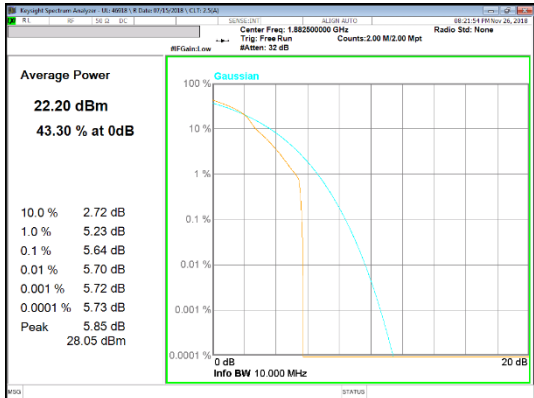
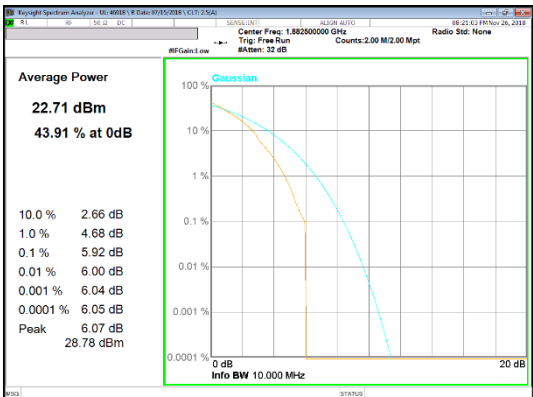
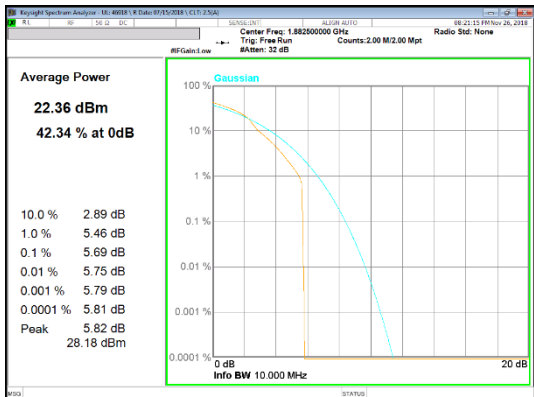
<p>LTE Band 25 20 MHz</p>	 <p>Average Power <b>22.77 dBm</b> 45.39 % at 0dB</p> <p>10.0 % 2.56 dB 1.0 % 4.48 dB 0.1 % 5.83 dB 0.01 % 6.02 dB 0.001 % 6.04 dB 0.0001 % 6.05 dB Peak 6.05 dB 28.82 dBm</p> <p>Info BW 10.000 MHz</p>	 <p>Average Power <b>22.40 dBm</b> 43.01 % at 0dB</p> <p>10.0 % 2.78 dB 1.0 % 5.33 dB 0.1 % 5.73 dB 0.01 % 5.76 dB 0.001 % 5.77 dB 0.0001 % 5.77 dB Peak 5.82 dB 28.22 dBm</p> <p>Info BW 10.000 MHz</p>
<p>LTE Band 25 15 MHz</p>	 <p>Average Power <b>22.93 dBm</b> 45.64 % at 0dB</p> <p>10.0 % 2.52 dB 1.0 % 4.42 dB 0.1 % 5.79 dB 0.01 % 5.93 dB 0.001 % 5.96 dB 0.0001 % 5.97 dB Peak 5.99 dB 28.92 dBm</p> <p>Info BW 10.000 MHz</p>	 <p>Average Power <b>22.20 dBm</b> 43.30 % at 0dB</p> <p>10.0 % 2.72 dB 1.0 % 5.23 dB 0.1 % 5.64 dB 0.01 % 5.70 dB 0.001 % 5.72 dB 0.0001 % 5.73 dB Peak 5.85 dB 28.05 dBm</p> <p>Info BW 10.000 MHz</p>
<p>LTE Band 25 10 MHz</p>	 <p>Average Power <b>22.71 dBm</b> 43.91 % at 0dB</p> <p>10.0 % 2.66 dB 1.0 % 4.68 dB 0.1 % 5.92 dB 0.01 % 6.00 dB 0.001 % 6.04 dB 0.0001 % 6.05 dB Peak 6.07 dB 28.78 dBm</p> <p>Info BW 10.000 MHz</p>	 <p>Average Power <b>22.36 dBm</b> 42.34 % at 0dB</p> <p>10.0 % 2.89 dB 1.0 % 5.46 dB 0.1 % 5.69 dB 0.01 % 5.75 dB 0.001 % 5.79 dB 0.0001 % 5.81 dB Peak 5.82 dB 28.18 dBm</p> <p>Info BW 10.000 MHz</p>

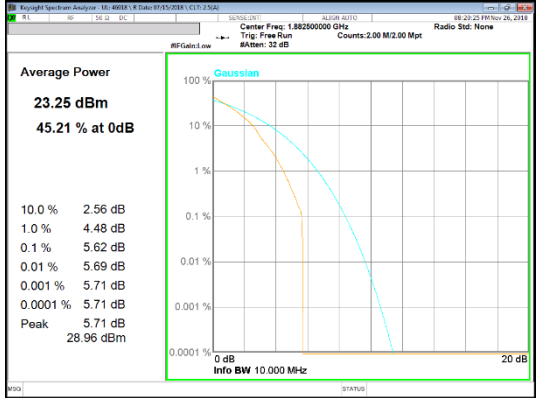
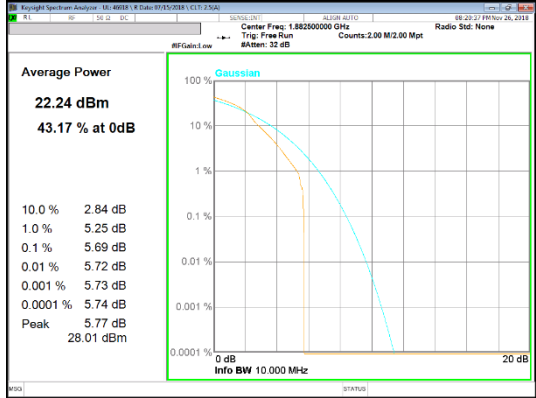
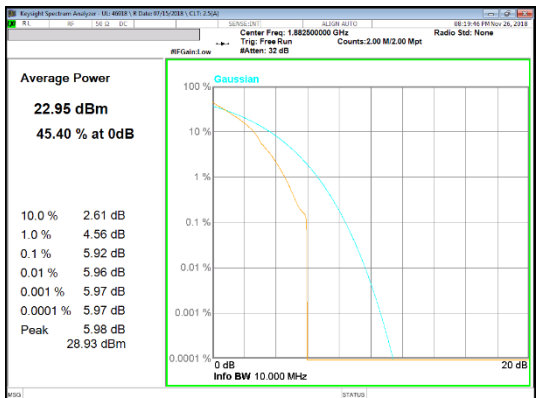
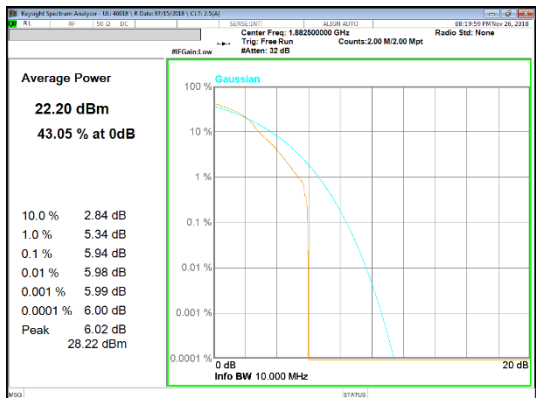
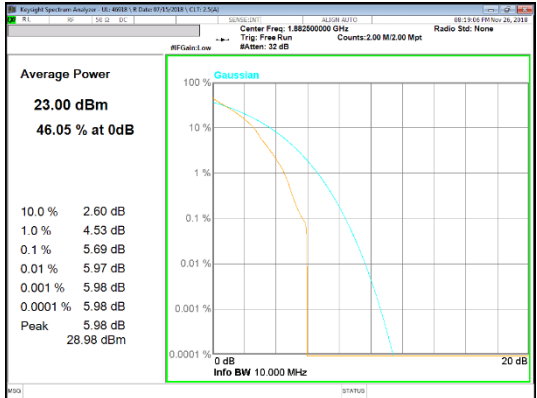
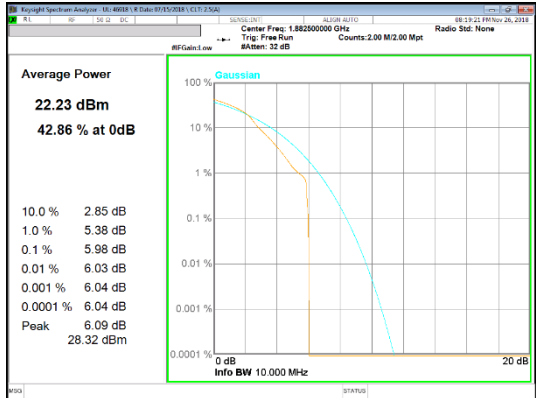
<p>LTE Band 25 5 MHz</p>	 <p>Average Power <b>23.25 dBm</b> <b>45.21 % at 0dB</b></p> <table border="1"> <tr><td>10.0 %</td><td>2.56 dB</td></tr> <tr><td>1.0 %</td><td>4.48 dB</td></tr> <tr><td>0.1 %</td><td>5.62 dB</td></tr> <tr><td>0.01 %</td><td>5.69 dB</td></tr> <tr><td>0.001 %</td><td>5.71 dB</td></tr> <tr><td>0.0001 %</td><td>5.71 dB</td></tr> <tr><td>Peak</td><td>5.71 dB</td></tr> <tr><td>Peak</td><td>28.96 dBm</td></tr> </table> <p>LTE B25 5MHz QPSK Mid channel</p>	10.0 %	2.56 dB	1.0 %	4.48 dB	0.1 %	5.62 dB	0.01 %	5.69 dB	0.001 %	5.71 dB	0.0001 %	5.71 dB	Peak	5.71 dB	Peak	28.96 dBm	 <p>Average Power <b>22.24 dBm</b> <b>43.17 % at 0dB</b></p> <table border="1"> <tr><td>10.0 %</td><td>2.84 dB</td></tr> <tr><td>1.0 %</td><td>5.25 dB</td></tr> <tr><td>0.1 %</td><td>5.69 dB</td></tr> <tr><td>0.01 %</td><td>5.72 dB</td></tr> <tr><td>0.001 %</td><td>5.73 dB</td></tr> <tr><td>0.0001 %</td><td>5.74 dB</td></tr> <tr><td>Peak</td><td>5.77 dB</td></tr> <tr><td>Peak</td><td>28.01 dBm</td></tr> </table> <p>LTE B25 5MHz 16QAM Mid channel</p>	10.0 %	2.84 dB	1.0 %	5.25 dB	0.1 %	5.69 dB	0.01 %	5.72 dB	0.001 %	5.73 dB	0.0001 %	5.74 dB	Peak	5.77 dB	Peak	28.01 dBm
10.0 %	2.56 dB																																	
1.0 %	4.48 dB																																	
0.1 %	5.62 dB																																	
0.01 %	5.69 dB																																	
0.001 %	5.71 dB																																	
0.0001 %	5.71 dB																																	
Peak	5.71 dB																																	
Peak	28.96 dBm																																	
10.0 %	2.84 dB																																	
1.0 %	5.25 dB																																	
0.1 %	5.69 dB																																	
0.01 %	5.72 dB																																	
0.001 %	5.73 dB																																	
0.0001 %	5.74 dB																																	
Peak	5.77 dB																																	
Peak	28.01 dBm																																	
<p>LTE Band 25 3 MHz</p>	 <p>Average Power <b>22.95 dBm</b> <b>45.40 % at 0dB</b></p> <table border="1"> <tr><td>10.0 %</td><td>2.61 dB</td></tr> <tr><td>1.0 %</td><td>4.56 dB</td></tr> <tr><td>0.1 %</td><td>5.92 dB</td></tr> <tr><td>0.01 %</td><td>5.96 dB</td></tr> <tr><td>0.001 %</td><td>5.97 dB</td></tr> <tr><td>0.0001 %</td><td>5.97 dB</td></tr> <tr><td>Peak</td><td>5.98 dB</td></tr> <tr><td>Peak</td><td>28.93 dBm</td></tr> </table> <p>LTE B25 3MHz QPSK Mid channel</p>	10.0 %	2.61 dB	1.0 %	4.56 dB	0.1 %	5.92 dB	0.01 %	5.96 dB	0.001 %	5.97 dB	0.0001 %	5.97 dB	Peak	5.98 dB	Peak	28.93 dBm	 <p>Average Power <b>22.20 dBm</b> <b>43.05 % at 0dB</b></p> <table border="1"> <tr><td>10.0 %</td><td>2.84 dB</td></tr> <tr><td>1.0 %</td><td>5.34 dB</td></tr> <tr><td>0.1 %</td><td>5.94 dB</td></tr> <tr><td>0.01 %</td><td>5.98 dB</td></tr> <tr><td>0.001 %</td><td>5.99 dB</td></tr> <tr><td>0.0001 %</td><td>6.00 dB</td></tr> <tr><td>Peak</td><td>6.02 dB</td></tr> <tr><td>Peak</td><td>28.22 dBm</td></tr> </table> <p>LTE B25 3MHz 16QAM Mid channel</p>	10.0 %	2.84 dB	1.0 %	5.34 dB	0.1 %	5.94 dB	0.01 %	5.98 dB	0.001 %	5.99 dB	0.0001 %	6.00 dB	Peak	6.02 dB	Peak	28.22 dBm
10.0 %	2.61 dB																																	
1.0 %	4.56 dB																																	
0.1 %	5.92 dB																																	
0.01 %	5.96 dB																																	
0.001 %	5.97 dB																																	
0.0001 %	5.97 dB																																	
Peak	5.98 dB																																	
Peak	28.93 dBm																																	
10.0 %	2.84 dB																																	
1.0 %	5.34 dB																																	
0.1 %	5.94 dB																																	
0.01 %	5.98 dB																																	
0.001 %	5.99 dB																																	
0.0001 %	6.00 dB																																	
Peak	6.02 dB																																	
Peak	28.22 dBm																																	
<p>LTE Band 25 1.4 MHz</p>	 <p>Average Power <b>23.00 dBm</b> <b>46.05 % at 0dB</b></p> <table border="1"> <tr><td>10.0 %</td><td>2.60 dB</td></tr> <tr><td>1.0 %</td><td>4.53 dB</td></tr> <tr><td>0.1 %</td><td>5.69 dB</td></tr> <tr><td>0.01 %</td><td>5.97 dB</td></tr> <tr><td>0.001 %</td><td>5.98 dB</td></tr> <tr><td>0.0001 %</td><td>5.98 dB</td></tr> <tr><td>Peak</td><td>5.98 dB</td></tr> <tr><td>Peak</td><td>28.98 dBm</td></tr> </table> <p>LTE B25 1.4MHz QPSK Mid channel</p>	10.0 %	2.60 dB	1.0 %	4.53 dB	0.1 %	5.69 dB	0.01 %	5.97 dB	0.001 %	5.98 dB	0.0001 %	5.98 dB	Peak	5.98 dB	Peak	28.98 dBm	 <p>Average Power <b>22.23 dBm</b> <b>42.86 % at 0dB</b></p> <table border="1"> <tr><td>10.0 %</td><td>2.85 dB</td></tr> <tr><td>1.0 %</td><td>5.38 dB</td></tr> <tr><td>0.1 %</td><td>5.98 dB</td></tr> <tr><td>0.01 %</td><td>6.03 dB</td></tr> <tr><td>0.001 %</td><td>6.04 dB</td></tr> <tr><td>0.0001 %</td><td>6.04 dB</td></tr> <tr><td>Peak</td><td>6.09 dB</td></tr> <tr><td>Peak</td><td>28.32 dBm</td></tr> </table> <p>LTE B25 1.4MHz 16QAM Mid channel</p>	10.0 %	2.85 dB	1.0 %	5.38 dB	0.1 %	5.98 dB	0.01 %	6.03 dB	0.001 %	6.04 dB	0.0001 %	6.04 dB	Peak	6.09 dB	Peak	28.32 dBm
10.0 %	2.60 dB																																	
1.0 %	4.53 dB																																	
0.1 %	5.69 dB																																	
0.01 %	5.97 dB																																	
0.001 %	5.98 dB																																	
0.0001 %	5.98 dB																																	
Peak	5.98 dB																																	
Peak	28.98 dBm																																	
10.0 %	2.85 dB																																	
1.0 %	5.38 dB																																	
0.1 %	5.98 dB																																	
0.01 %	6.03 dB																																	
0.001 %	6.04 dB																																	
0.0001 %	6.04 dB																																	
Peak	6.09 dB																																	
Peak	28.32 dBm																																	

**LTE Band 26**

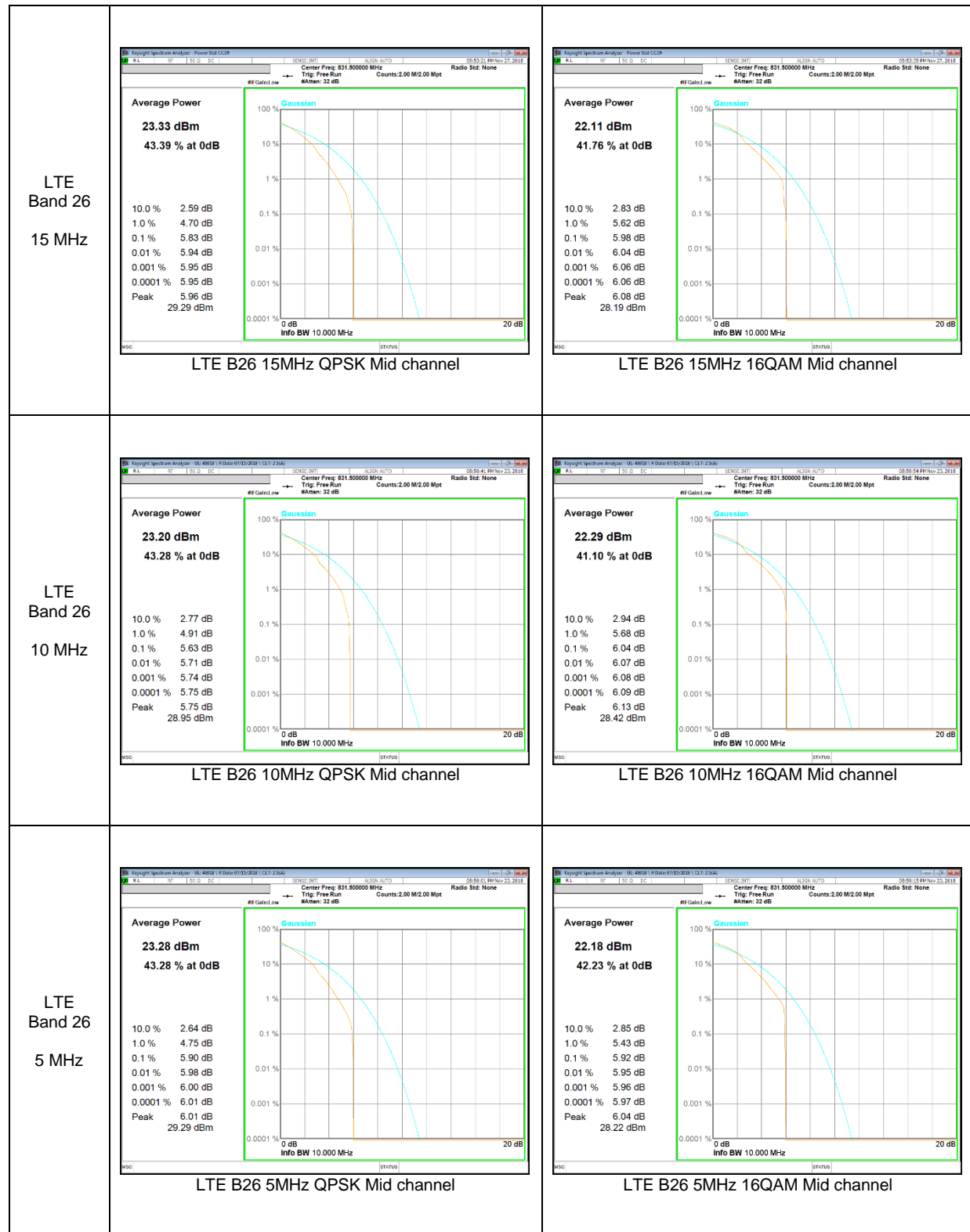

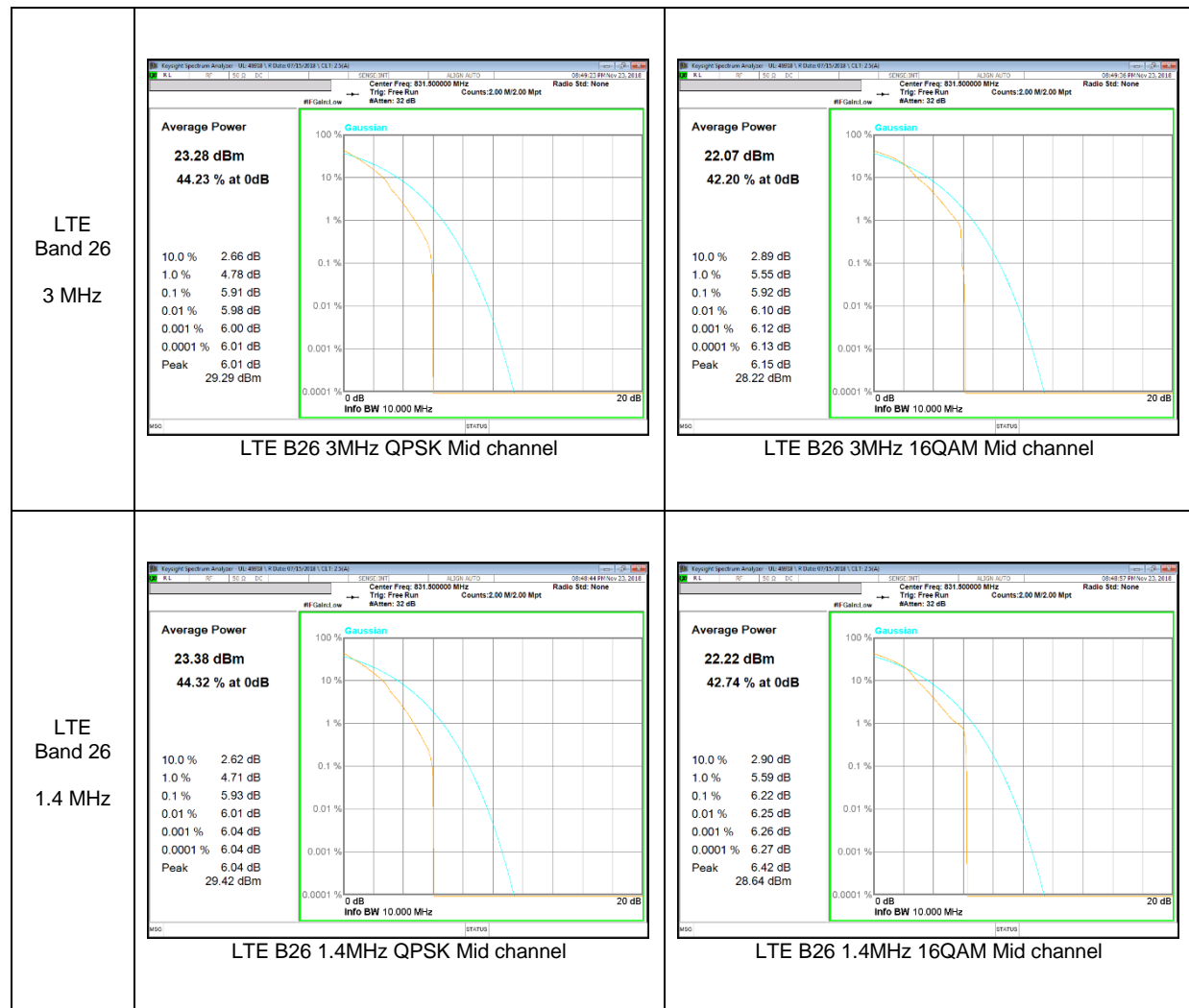

**LTE Band 41**

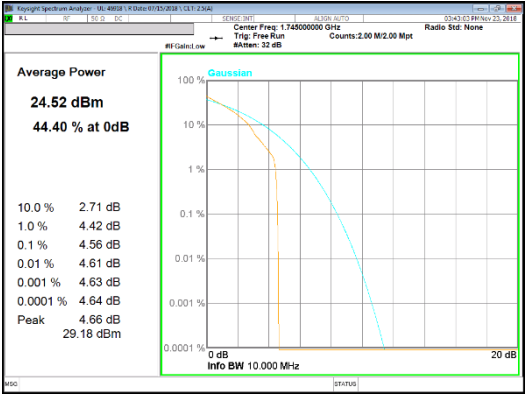
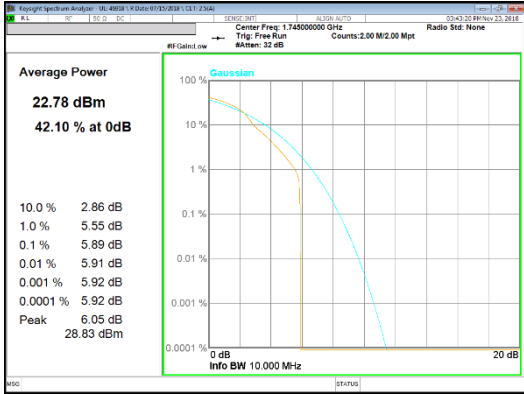
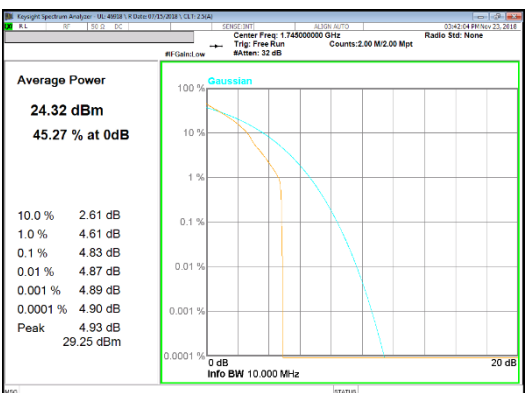
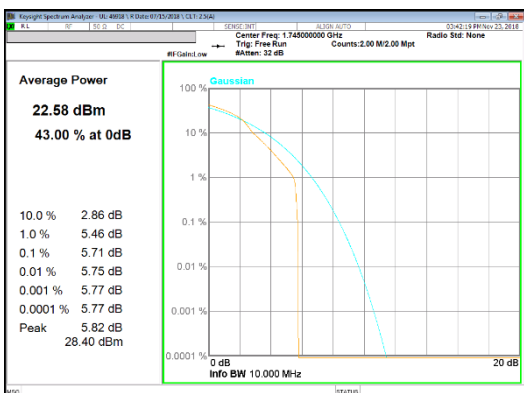
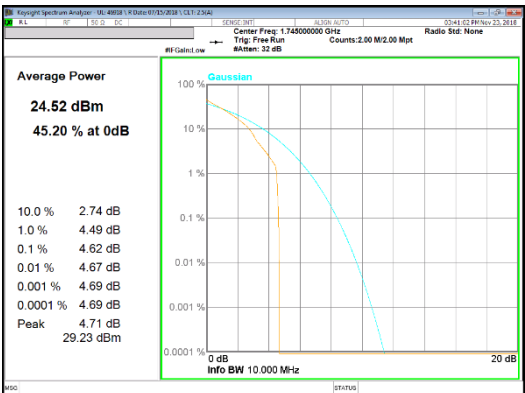
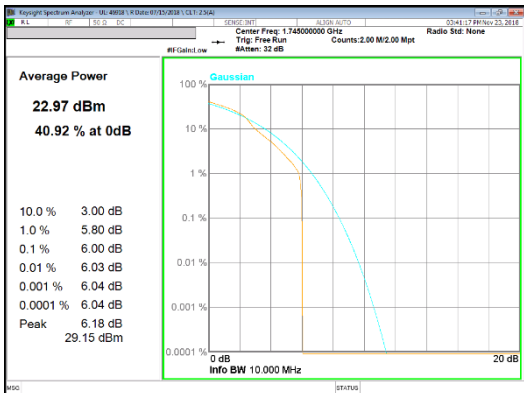

**LTE Band 66**

<p>LTE Band 66 20 MHz</p>	 <p>Average Power <b>24.52 dBm</b> 44.40 % at 0dB</p> <p>10.0 % 2.71 dB 1.0 % 4.42 dB 0.1 % 4.56 dB 0.01 % 4.61 dB 0.001 % 4.63 dB 0.0001 % 4.64 dB Peak 4.66 dB 29.18 dBm</p> <p>LTE B66 20MHz QPSK Mid channel</p>	 <p>Average Power <b>22.78 dBm</b> 42.10 % at 0dB</p> <p>10.0 % 2.86 dB 1.0 % 5.55 dB 0.1 % 5.89 dB 0.01 % 5.91 dB 0.001 % 5.92 dB 0.0001 % 5.92 dB Peak 6.05 dB 28.83 dBm</p> <p>LTE B66 20MHz 16QAM Mid channel</p>
<p>LTE Band 66 15 MHz</p>	 <p>Average Power <b>24.32 dBm</b> 45.27 % at 0dB</p> <p>10.0 % 2.61 dB 1.0 % 4.61 dB 0.1 % 4.83 dB 0.01 % 4.87 dB 0.001 % 4.89 dB 0.0001 % 4.90 dB Peak 4.93 dB 29.25 dBm</p> <p>LTE B66 15MHz QPSK Mid channel</p>	 <p>Average Power <b>22.58 dBm</b> 43.00 % at 0dB</p> <p>10.0 % 2.86 dB 1.0 % 5.46 dB 0.1 % 5.71 dB 0.01 % 5.75 dB 0.001 % 5.77 dB 0.0001 % 5.77 dB Peak 5.82 dB 28.40 dBm</p> <p>LTE B66 15MHz 16QAM Mid channel</p>
<p>LTE Band 66 10 MHz</p>	 <p>Average Power <b>24.52 dBm</b> 45.20 % at 0dB</p> <p>10.0 % 2.74 dB 1.0 % 4.49 dB 0.1 % 4.62 dB 0.01 % 4.67 dB 0.001 % 4.69 dB 0.0001 % 4.69 dB Peak 4.71 dB 29.23 dBm</p> <p>LTE B66 10MHz QPSK Mid channel</p>	 <p>Average Power <b>22.97 dBm</b> 40.92 % at 0dB</p> <p>10.0 % 3.00 dB 1.0 % 5.80 dB 0.1 % 6.00 dB 0.01 % 6.03 dB 0.001 % 6.04 dB 0.0001 % 6.04 dB Peak 6.18 dB 29.15 dBm</p> <p>LTE B66 10MHz 16QAM Mid channel</p>

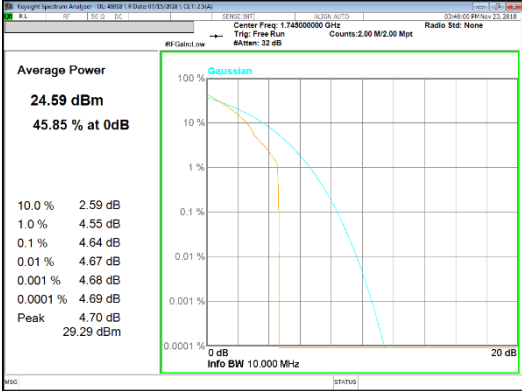
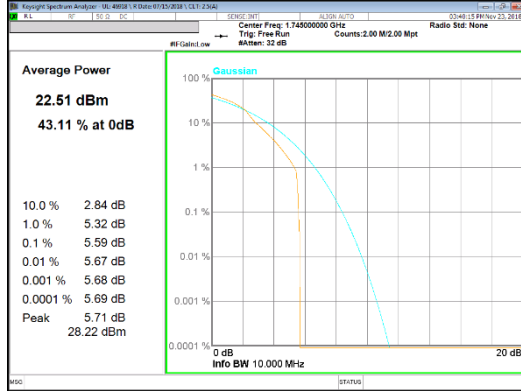
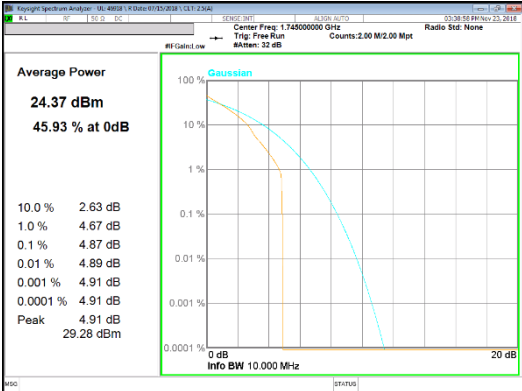
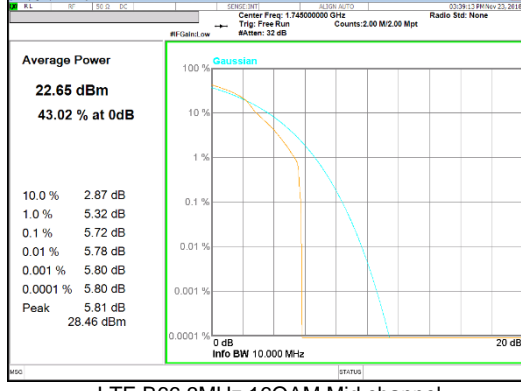
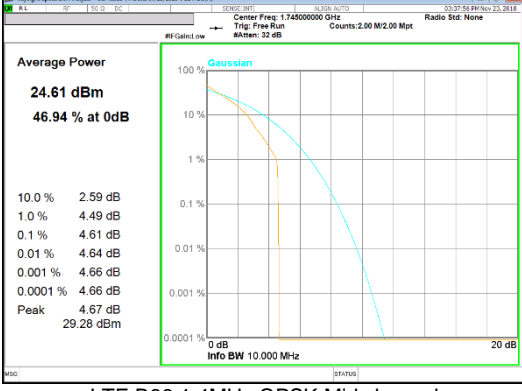
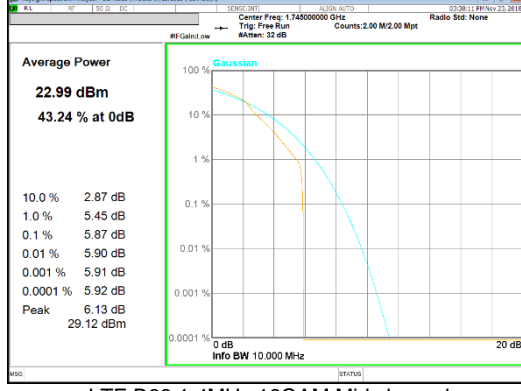
<p>LTE Band 66 5 MHz</p>	 <p><b>Average Power</b> 24.59 dBm 45.85 % at 0dB</p> <table border="1"> <tr><td>10.0 %</td><td>2.59 dB</td></tr> <tr><td>1.0 %</td><td>4.55 dB</td></tr> <tr><td>0.1 %</td><td>4.64 dB</td></tr> <tr><td>0.01 %</td><td>4.67 dB</td></tr> <tr><td>0.001 %</td><td>4.68 dB</td></tr> <tr><td>0.0001 %</td><td>4.69 dB</td></tr> <tr><td>Peak</td><td>4.70 dB</td></tr> <tr><td>Peak</td><td>29.29 dBm</td></tr> </table> <p>LTE B66 5MHz QPSK Mid channel</p>	10.0 %	2.59 dB	1.0 %	4.55 dB	0.1 %	4.64 dB	0.01 %	4.67 dB	0.001 %	4.68 dB	0.0001 %	4.69 dB	Peak	4.70 dB	Peak	29.29 dBm	 <p><b>Average Power</b> 22.51 dBm 43.11 % at 0dB</p> <table border="1"> <tr><td>10.0 %</td><td>2.84 dB</td></tr> <tr><td>1.0 %</td><td>5.32 dB</td></tr> <tr><td>0.1 %</td><td>5.59 dB</td></tr> <tr><td>0.01 %</td><td>5.67 dB</td></tr> <tr><td>0.001 %</td><td>5.68 dB</td></tr> <tr><td>0.0001 %</td><td>5.69 dB</td></tr> <tr><td>Peak</td><td>5.71 dB</td></tr> <tr><td>Peak</td><td>28.22 dBm</td></tr> </table> <p>LTE B66 5MHz 16QAM Mid channel</p>	10.0 %	2.84 dB	1.0 %	5.32 dB	0.1 %	5.59 dB	0.01 %	5.67 dB	0.001 %	5.68 dB	0.0001 %	5.69 dB	Peak	5.71 dB	Peak	28.22 dBm
10.0 %	2.59 dB																																	
1.0 %	4.55 dB																																	
0.1 %	4.64 dB																																	
0.01 %	4.67 dB																																	
0.001 %	4.68 dB																																	
0.0001 %	4.69 dB																																	
Peak	4.70 dB																																	
Peak	29.29 dBm																																	
10.0 %	2.84 dB																																	
1.0 %	5.32 dB																																	
0.1 %	5.59 dB																																	
0.01 %	5.67 dB																																	
0.001 %	5.68 dB																																	
0.0001 %	5.69 dB																																	
Peak	5.71 dB																																	
Peak	28.22 dBm																																	
<p>LTE Band 66 3 MHz</p>	 <p><b>Average Power</b> 24.37 dBm 45.93 % at 0dB</p> <table border="1"> <tr><td>10.0 %</td><td>2.63 dB</td></tr> <tr><td>1.0 %</td><td>4.67 dB</td></tr> <tr><td>0.1 %</td><td>4.87 dB</td></tr> <tr><td>0.01 %</td><td>4.89 dB</td></tr> <tr><td>0.001 %</td><td>4.91 dB</td></tr> <tr><td>0.0001 %</td><td>4.91 dB</td></tr> <tr><td>Peak</td><td>4.91 dB</td></tr> <tr><td>Peak</td><td>29.28 dBm</td></tr> </table> <p>LTE B66 3MHz QPSK Mid channel</p>	10.0 %	2.63 dB	1.0 %	4.67 dB	0.1 %	4.87 dB	0.01 %	4.89 dB	0.001 %	4.91 dB	0.0001 %	4.91 dB	Peak	4.91 dB	Peak	29.28 dBm	 <p><b>Average Power</b> 22.65 dBm 43.02 % at 0dB</p> <table border="1"> <tr><td>10.0 %</td><td>2.87 dB</td></tr> <tr><td>1.0 %</td><td>5.32 dB</td></tr> <tr><td>0.1 %</td><td>5.72 dB</td></tr> <tr><td>0.01 %</td><td>5.78 dB</td></tr> <tr><td>0.001 %</td><td>5.80 dB</td></tr> <tr><td>0.0001 %</td><td>5.80 dB</td></tr> <tr><td>Peak</td><td>5.81 dB</td></tr> <tr><td>Peak</td><td>28.46 dBm</td></tr> </table> <p>LTE B66 3MHz 16QAM Mid channel</p>	10.0 %	2.87 dB	1.0 %	5.32 dB	0.1 %	5.72 dB	0.01 %	5.78 dB	0.001 %	5.80 dB	0.0001 %	5.80 dB	Peak	5.81 dB	Peak	28.46 dBm
10.0 %	2.63 dB																																	
1.0 %	4.67 dB																																	
0.1 %	4.87 dB																																	
0.01 %	4.89 dB																																	
0.001 %	4.91 dB																																	
0.0001 %	4.91 dB																																	
Peak	4.91 dB																																	
Peak	29.28 dBm																																	
10.0 %	2.87 dB																																	
1.0 %	5.32 dB																																	
0.1 %	5.72 dB																																	
0.01 %	5.78 dB																																	
0.001 %	5.80 dB																																	
0.0001 %	5.80 dB																																	
Peak	5.81 dB																																	
Peak	28.46 dBm																																	
<p>LTE Band 66 1.4 MHz</p>	 <p><b>Average Power</b> 24.61 dBm 46.94 % at 0dB</p> <table border="1"> <tr><td>10.0 %</td><td>2.59 dB</td></tr> <tr><td>1.0 %</td><td>4.49 dB</td></tr> <tr><td>0.1 %</td><td>4.61 dB</td></tr> <tr><td>0.01 %</td><td>4.64 dB</td></tr> <tr><td>0.001 %</td><td>4.66 dB</td></tr> <tr><td>0.0001 %</td><td>4.66 dB</td></tr> <tr><td>Peak</td><td>4.67 dB</td></tr> <tr><td>Peak</td><td>29.28 dBm</td></tr> </table> <p>LTE B66 1.4MHz QPSK Mid channel</p>	10.0 %	2.59 dB	1.0 %	4.49 dB	0.1 %	4.61 dB	0.01 %	4.64 dB	0.001 %	4.66 dB	0.0001 %	4.66 dB	Peak	4.67 dB	Peak	29.28 dBm	 <p><b>Average Power</b> 22.99 dBm 43.24 % at 0dB</p> <table border="1"> <tr><td>10.0 %</td><td>2.87 dB</td></tr> <tr><td>1.0 %</td><td>5.45 dB</td></tr> <tr><td>0.1 %</td><td>5.87 dB</td></tr> <tr><td>0.01 %</td><td>5.90 dB</td></tr> <tr><td>0.001 %</td><td>5.91 dB</td></tr> <tr><td>0.0001 %</td><td>5.92 dB</td></tr> <tr><td>Peak</td><td>6.13 dB</td></tr> <tr><td>Peak</td><td>29.12 dBm</td></tr> </table> <p>LTE B66 1.4MHz 16QAM Mid channel</p>	10.0 %	2.87 dB	1.0 %	5.45 dB	0.1 %	5.87 dB	0.01 %	5.90 dB	0.001 %	5.91 dB	0.0001 %	5.92 dB	Peak	6.13 dB	Peak	29.12 dBm
10.0 %	2.59 dB																																	
1.0 %	4.49 dB																																	
0.1 %	4.61 dB																																	
0.01 %	4.64 dB																																	
0.001 %	4.66 dB																																	
0.0001 %	4.66 dB																																	
Peak	4.67 dB																																	
Peak	29.28 dBm																																	
10.0 %	2.87 dB																																	
1.0 %	5.45 dB																																	
0.1 %	5.87 dB																																	
0.01 %	5.90 dB																																	
0.001 %	5.91 dB																																	
0.0001 %	5.92 dB																																	
Peak	6.13 dB																																	
Peak	29.12 dBm																																	



### **LTE Band 17**

LTE Band 17 (Frequency range: 704-716 MHz) is covered by LTE Band 12 (Frequency range: 699-716 MHz) due to overlapping frequency range, same maximum tune-up limit and same channel bandwidth.

### **LTE Band 38[Single carrier]**

LTE Band 38[Single carrier] (Frequency range: 2570-2620 MHz) is covered by LTE Band 41 (Frequency range: 2496-2690 MHz) due to overlapping frequency range, same maximum tune-up limit and same channel bandwidth.

## **9. LIMITS AND CONDUCTED RESULTS**

### **9.1. OCCUPIED BANDWIDTH**

#### **RULE PART(S)**

FCC: §2.1049

#### **LIMITS**

For reporting purposes only

#### **TEST PROCEDURE**

The transmitter output was connected to a calibrated coaxial cable and coupler, the other end of which was connected to a spectrum analyzer. The occupied bandwidth was measured with the spectrum analyzer at the low, middle and high channel in each band. The -26dB bandwidth was also measured and recorded.

(KDB 971168 D01 Power Meas License Digital Systems v03r01)

#### **RESULTS**

See the following pages.