



FCC CFR47 PART 27 SUBPART M

WWAN Uplink Carrier Aggregation

CERTIFICATION TEST REPORT

FOR

GSM/WCDMA/LTE Phone + BT/BLE, DTS/UNII a/b/g/n/ac/ax, ANT+, NFC and WPT

MODEL NUMBER : SM-G973F/DS, SM-G973F, SM-G973X

FCC ID: A3LSMG973F

REPORT NUMBER: 4788725460-E11V2

ISSUE DATE: DEC 31, 2018

Prepared for

**SAMSUNG ELECTRONICS CO., LTD.
129 SAMSUNG-RO, YEONGTONG-GU, SUWON-SI,
GYEONGGI-DO, 16677, KOREA**

Prepared by

UL Korea, Ltd.

26th floor, 152, Teheran-ro, Gangnam-gu Seoul, 06236, Korea

Suwon Test Site: UL Korea, Ltd. Suwon Laboratory

**218 Maeyeong-ro, Yeongtong-gu,
Suwon-si, Gyeonggi-do, 16675, Korea**

TEL: (031) 337-9902

FAX: (031) 213-5433



ACCREDITED*

Testing
Laboratory

TL-637

Revision History

<u>Rev.</u>	<u>Issue Date</u>	<u>Revisions</u>	<u>Revised By</u>
V1	12/27/18	Initial issue	Junwhan Lee
V2	12/31/18	Updated to address TCB's question	Junwhan Lee

TABLE OF CONTENTS

1. ATTESTATION OF TEST RESULTS	4
2. TEST METHODOLOGY	5
3. FACILITIES AND ACCREDITATION	5
4. CALIBRATION AND UNCERTAINTY	5
4.1. <i>MEASURING INSTRUMENT CALIBRATION.....</i>	<i>5</i>
4.2. <i>SAMPLE CALCULATION.....</i>	<i>5</i>
4.3. <i>MEASUREMENT UNCERTAINTY</i>	<i>6</i>
5. EQUIPMENT UNDER TEST	7
5.1. <i>DESCRIPTION OF EUT.....</i>	<i>7</i>
5.2. <i>MAXIMUM OUTPUT POWER.....</i>	<i>7</i>
5.3. <i>RF OUTPUT POWER VERIFICATION (CONDUCTED AND EIRP).....</i>	<i>9</i>
5.4. <i>DESCRIPTION OF AVAILABLE ANTENNAS</i>	<i>13</i>
5.5. <i>WORST-CASE ORIENTATION.....</i>	<i>14</i>
5.6. <i>DESCRIPTION OF TEST SETUP.....</i>	<i>14</i>
6. TEST AND MEASUREMENT EQUIPMENT	16
7. SUMMARY TABLE.....	17
7. LIMITS AND CONDUCTED RESULTS	18
7.1. <i>OCCUPIED BANDWIDTH.....</i>	<i>18</i>
7.1.1. <i>OCCUPIED BANDWIDTH RESULTS</i>	<i>19</i>
7.2. <i>EMISSION MASK</i>	<i>22</i>
7.3. <i>OUT OF BAND EMISSIONS.....</i>	<i>41</i>
7.3.1. <i>OUT OF BAND EMISSIONS RESULT.....</i>	<i>42</i>
8. RADIATED TEST RESULTS.....	44
8.1. <i>FIELD STRENGTH OF SPURIOUS RADIATION.....</i>	<i>44</i>
8.1.1. <i>SPURIOUS RADIATION PLOTS</i>	<i>45</i>
9. Appendix A: SETUP PHOTOS.....	47

1. ATTESTATION OF TEST RESULTS

COMPANY NAME: SAMSUNG ELECTRONICS CO., LTD.

EUT DESCRIPTION: GSM/WCDMA/LTE Phone + BT/BLE, DTS/UNII a/b/g/n/ac/ax, ANT+, NFC and WPT

MODEL NUMBER: SM-G973F/DS, SM-G973F, SM-G973X

SERIAL NUMBER: R38K806534T (CONDUCTED)
R38K8065W2V (RADIATED);

DATE TESTED: DEC 20, 2018 - DEC 27, 2018;

APPLICABLE STANDARDS	
STANDARD	TEST RESULTS
FCC PART 27M	Pass

UL Korea, Ltd. tested the above equipment in accordance with the requirements set forth in the above standards. All indications of Pass/Fail in this report are opinions expressed by UL Korea, Ltd. based on interpretations and/or observations of test results. Measurement Uncertainties were not taken into account and are published for informational purposes only. The test results show that the equipment tested is capable of demonstrating compliance with the requirements as documented in this report.

Note: The results documented in this report apply only to the tested sample, under the conditions and modes of operation as described herein. This document may not be altered or revised in any way unless done so by UL Korea, Ltd. and all revisions are duly noted in the revisions section. Any alteration of this document not carried out by UL Korea, Ltd. will constitute fraud and shall nullify the document. This report must not be used by the client to claim product certification, approval, or endorsement by IAS, any agency of the Federal Government, or any agency of any government.

Approved & Released For
UL Korea, Ltd. By:



SungGil Park
Suwon Lab Engineer
UL Korea, Ltd.

Tested By:



Junwhan Lee
Suwon Lab Engineer
UL Korea, Ltd.

2. TEST METHODOLOGY

The tests documented in this report were performed in accordance with following methods.

1. FCC CFR 47 Part 2.
2. FCC CFR 47 Part 27.
3. ANSI TIA-603-E, 2016
4. KDB 971168 D01 Power Meas License Digital Systems v03r01

3. FACILITIES AND ACCREDITATION

The test sites and measurement facilities used to collect data are located at 218 Maeyeong-ro, Yeongtong-gu, Suwon-si, Gyeonggi-do, 16675, Korea. Line conducted emissions are measured only at the 218 address. The following table identifies which facilities were utilized for radiated emission measurements documented in this report. Specific facilities are also identified in the test results sections.

218 Maeyeong-ro	
<input checked="" type="checkbox"/>	Chamber 1
<input checked="" type="checkbox"/>	Chamber 2
<input type="checkbox"/>	Chamber 3

UL Korea, Ltd. is accredited by IAS, Laboratory Code TL-637. The full scope of accreditation can be viewed at <http://www.iasonline.org/PDF/TL/TL-637.pdf>.

4. CALIBRATION AND UNCERTAINTY

4.1. MEASURING INSTRUMENT CALIBRATION

The measuring equipment utilized to perform the tests documented in this report has been calibrated in accordance with the manufacturer's recommendations, and is traceable to recognized national standards.

4.2. SAMPLE CALCULATION

Where relevant, the following sample calculation is provided:

EIRP = PSA reading with EUT worst orientation (dBm) + Path loss (dB) – cable loss(between the SG and substitution antenna) + Substitution Antenna Factor (dBi)

ERP = PSA reading with EUT worst orientation (dBm) + Path loss (dB) – cable loss(between the SG and substitution antenna)

(Path loss = Signal generator output – PSA reading with substitution antenna)

4.3. MEASUREMENT UNCERTAINTY

Where relevant, the following measurement uncertainty levels have been estimated for tests performed on the apparatus:

PARAMETER	UNCERTAINTY
Conducted Disturbance, 0.15 to 30 MHz	2.32 dB
Radiated Disturbance, Below 1GHz	3.86 dB
Radiated Disturbance, Above 1 GHz	5.97 dB

Uncertainty figures are valid to a confidence level of 95%.

5. EQUIPMENT UNDER TEST

5.1. DESCRIPTION OF EUT

The EUT is a GSM/WCDMA/LTE Phone + BT/BLE, DTS/UNII a/b/g/n/ac/ax, ANT+, NFC and WPT. This test report addresses the WWAN Uplink Carrier Aggregation operational mode.

5.2. MAXIMUM OUTPUT POWER

The transmitter has a maximum average radiated EIRP output powers as follows:

LTE Band 7C (Uplink CA)

Part 27				OUTPUT POWER		
EIRP Limit (dBm)		33.00		EIRP Average (dBm)		Margin (dB)
Antenna Gain (dBi)		-4.18		Conducted Average (dBm)	mW	
Bandwidth (MHz)	Frequency Range (MHz)	Modulation	Conducted Average (dBm)	dBm	mW	Margin (dB)
15+10	2500-2570	QPSK	22.98	18.80	75.86	-14.20
		16QAM	22.20	18.02	63.39	-14.98
		64QAM	20.01	15.83	38.28	-17.17
10+20		QPSK	23.24	19.06	80.54	-13.94
		16QAM	22.36	18.18	65.77	-14.82
		64QAM	20.29	16.11	40.83	-16.89
15+15		QPSK	23.05	18.87	77.09	-14.13
		16QAM	22.03	17.85	60.95	-15.15
		64QAM	20.08	15.90	38.90	-17.10
20+10		QPSK	22.84	18.66	73.45	-14.34
		16QAM	21.98	17.80	60.26	-15.20
		64QAM	19.76	15.58	36.14	-17.42
15+20		QPSK	23.18	19.00	79.43	-14.00
		16QAM	22.31	18.13	65.01	-14.87
		64QAM	20.04	15.86	38.55	-17.14
20+15	QPSK	22.94	18.76	75.16	-14.24	
	16QAM	21.89	17.71	59.02	-15.29	
	64QAM	19.78	15.60	36.31	-17.40	
20+20	QPSK	22.99	18.81	76.03	-14.19	
	16QAM	22.16	17.98	62.81	-15.02	
	64QAM	19.89	15.71	37.24	-17.29	

LTE Band 38C (Uplink CA)

Part 27						
EIRP Limit (dBm)		33.00				
Antenna Gain (dBi)		-4.24				
Bandwidth (MHz)	Frequency Range (MHz)	Modulation	OUTPUT POWER			
			Conducted Average (dBm)	EIRP Average (dBm)		Margin (dB)
				dBm	mW	
15+15	2570-2620	QPSK	23.18	19.00	79.43	-14.00
		16QAM	22.38	18.20	66.07	-14.80
		64QAM	20.23	16.05	40.27	-16.95
20+20		QPSK	23.20	19.02	79.80	-13.98
		16QAM	22.35	18.17	65.61	-14.83
		64QAM	20.28	16.10	40.74	-16.90

5.3. RF OUTPUT POWER VERIFICATION (CONDUCTED AND EIRP)

RULE PART(S)

FCC: §2.1046, §27.50

EIRP LIMIT

FCC: §27.50(h)

(h) The following power limits shall apply in the BRS and EBS:

(2) Mobile and other user stations. Mobile stations are limited to 2.0 watts EIRP. All user stations are limited to 2.0 watts transmitter output power.

TEST PROCEDURE

TIA-603-E Clause 2.2.17

KDB 971168 Section 5.6

$ERP/EIRP = P_{Meas} + GT - LC$

where: ERP/EIRP = effective or equivalent radiated power, respectively (expressed in the same units as P_{Meas} , typically dBW or dBm);

P_{Meas} = measured transmitter output power or PSD, in dBm or dBW;

GT = gain of the transmitting antenna, in dBd (ERP) or dBi (EIRP);

LC = signal attenuation in the connecting cable between the transmitter and antenna, in dB.

RESULTS

EUT includes different power levels for head use configuration and body use configuration and the below tables contain the highest of all configurations average conducted and ERP/EIRP output powers as follows:

OUTPUT POWER FOR LTE BAND 7C (15.0MHz + 10.0MHz)

Antenna Gain (dBi)		-4.18								
Bandwidth	PCC Frequency (MHz)	SCC1 Frequency (MHz)	PCC RB	PCC RB	SCC1 RB	SCC1 RB	Conducted Average (dBm)			
			Size	Offset	Size	Offset	QPSK	16QAM	64QAM	
15MHz / 10MHz	2507.5	2519.5	1	74	1	0	22.98	22.20	20.01	
			1	0	1	49	15.13	15.19	15.24	
			75	0	50	0	21.22	19.94	19.93	
	2527.5	2539.5	1	74	1	0	22.41	21.68	19.59	
			1	0	1	49	14.17	14.25	14.32	
			75	0	50	0	20.56	19.31	19.29	
	2552.5	2564.5	1	74	1	0	22.64	21.68	19.79	
			1	0	1	49	14.15	13.99	14.25	
			75	0	50	0	20.68	19.48	19.47	

OUTPUT POWER FOR LTE BAND 7C (10.0MHz + 20.0MHz)

Antenna Gain (dBi)		-4.18								
Bandwidth	PCC Frequency (MHz)	SCC1 Frequency (MHz)	PCC RB	PCC RB	SCC1 RB	SCC1 RB	Conducted Average (dBm)			
			Size	Offset	Size	Offset	QPSK	16QAM	64QAM	
10MHz / 20MHz	2505.5	2519.9	1	49	1	0	23.24	22.36	20.29	
			1	0	1	99	15.25	15.15	15.21	
			50	0	100	0	21.16	19.99	19.97	
	2525.6	2540.0	1	49	1	0	22.84	22.02	19.94	
			1	0	1	99	14.15	14.22	14.19	
			50	0	100	0	20.51	19.27	19.26	
	2545.6	2560.0	1	49	1	0	22.92	22.17	19.53	
			1	0	1	99	14.02	14.03	13.89	
			50	0	100	0	20.61	19.38	19.40	

OUTPUT POWER FOR LTE BAND 7C (15.0MHz + 15.0MHz)

Antenna Gain (dBi)		-4.18								
Bandwidth	PCC Frequency (MHz)	SCC1 Frequency (MHz)	PCC RB	PCC RB	SCC1 RB	SCC1 RB	Conducted Average (dBm)			
			Size	Offset	Size	Offset	QPSK	16QAM	64QAM	
15MHz / 15MHz	2507.5	2522.5	1	74	1	0	23.05	22.03	20.08	
			1	0	1	74	15.20	15.08	15.21	
			75	0	75	0	21.25	20.03	20.04	
	2527.5	2542.5	1	74	1	0	22.62	21.77	19.61	
			1	0	1	74	14.12	14.11	14.19	
			75	0	75	0	20.48	19.31	19.27	
	2547.5	2562.5	1	74	1	0	22.70	21.95	19.84	
			1	0	1	74	13.98	14.04	14.13	
			75	0	75	0	20.65	19.45	19.46	

OUTPUT POWER FOR LTE BAND 7C (20.0MHz + 10.0MHz)

Antenna Gain (dBi)		-4.18								
Bandwidth	PCC Frequency (MHz)	SCC1 Frequency (MHz)	PCC RB	PCC RB	SCC1 RB	SCC1 RB	Conducted Average (dBm)			
			Size	Offset	Size	Offset	QPSK	16QAM	64QAM	
20MHz / 10MHz	2510.0	2524.4	1	99	1	0	22.84	21.98	19.62	
			1	0	1	49	15.05	14.98	14.86	
			100	0	50	0	20.91	19.77	19.76	
	2530.1	2544.5	1	99	1	0	22.60	21.48	19.39	
			1	0	1	49	14.19	13.93	14.09	
			100	0	50	0	20.33	19.12	19.11	
	2550.1	2564.5	1	99	1	0	22.58	21.74	19.61	
			1	0	1	49	14.03	14.06	13.96	
			100	0	50	0	20.47	19.27	19.24	

OUTPUT POWER FOR LTE BAND 7C (15.0MHz + 20.0MHz)

Antenna Gain (dBi)	-4.18								
Bandwidth	PCC Frequency (MHz)	SCC1 Frequency (MHz)	PCC RB	PCC RB	SCC1 RB	SCC1 RB	Conducted Average (dBm)		
			Size	Offset	Size	Offset	QPSK	16QAM	64QAM
15MHz / 20MHz	2507.8	2524.9	1	74	1	0	23.18	22.31	20.04
			1	0	1	99	15.12	15.04	15.09
			75	0	100	0	21.23	20.06	20.00
	2525.30	2542.40	1	74	1	0	22.67	21.92	19.87
			1	0	1	99	14.13	14.19	14.31
			75	0	100	0	20.56	19.38	19.32
	2542.9	2560.0	1	74	1	0	22.76	21.80	19.85
			1	0	1	99	13.94	13.78	14.07
			75	0	100	0	20.61	19.41	19.39

OUTPUT POWER FOR LTE BAND 7C (20.0MHz + 15.0MHz)

Antenna Gain (dBi)	-4.18								
Bandwidth	PCC Frequency (MHz)	SCC1 Frequency (MHz)	PCC RB	PCC RB	SCC1 RB	SCC1 RB	Conducted Average (dBm)		
			Size	Offset	Size	Offset	QPSK	16QAM	64QAM
20MHz / 15MHz	2510.0	2527.1	1	99	1	0	22.94	21.89	19.57
			1	0	1	74	15.11	14.89	14.80
			100	0	75	0	20.98	19.75	19.78
	2527.6	2544.7	1	99	1	0	22.48	21.61	19.52
			1	0	1	74	14.18	14.14	14.15
			100	0	75	0	20.32	19.16	19.10
	2545.1	2562.2	1	99	1	0	22.57	21.63	19.29
			1	0	1	74	13.96	13.84	13.74
			100	0	75	0	20.45	19.21	19.20

OUTPUT POWER FOR LTE BAND 7C (20.0MHz + 20.0MHz)

Antenna Gain (dBi)	-4.18								
Bandwidth	PCC Frequency (MHz)	SCC1 Frequency (MHz)	PCC RB	PCC RB	SCC1 RB	SCC1 RB	Conducted Average (dBm)		
			Size	Offset	Size	Offset	QPSK	16QAM	64QAM
20MHz / 20MHz	2510.0	2529.8	1	99	1	0	22.99	22.16	19.89
			1	0	1	99	15.07	14.97	14.87
			100	0	100	0	21.03	19.82	19.77
	2525.1	2544.9	1	99	1	0	22.62	21.69	19.38
			1	0	1	99	14.13	14.02	14.01
			100	0	100	0	20.41	19.20	19.19
	2540.2	2560.0	1	99	1	0	22.60	21.69	19.66
			1	0	1	99	13.83	13.81	13.84
			100	0	100	0	20.32	19.13	19.09

OUTPUT POWER FOR LTE BAND 38C (15.0MHz + 15.0MHz)

Antenna Gain (dBi)	-4.24									
Bandwidth	PCC Frequency (MHz)	SCC1 Frequency (MHz)	PCC RB	PCC RB	SCC1 RB	SCC1 RB	Conducted Average (dBm)			
			Size	Offset	Size	Offset	QPSK	16QAM	64QAM	
15MHz / 15MHz	2577.5	2592.5	1	74	1	0	23.18	22.15	20.11	
			1	0	1	74	15.44	15.30	15.25	
			75	0	75	0	21.31	20.16	20.13	
	2587.5	2602.5	1	74	1	0	23.14	22.31	20.05	
			1	0	1	74	15.35	15.51	15.36	
			75	0	75	0	21.38	20.24	20.22	
	2597.5	2612.5	1	74	1	0	23.15	22.38	20.10	
			1	0	1	74	15.35	15.51	15.23	
			75	0	75	0	21.39	20.24	20.23	

OUTPUT POWER FOR LTE BAND 38C (20.0MHz + 20.0MHz)

Antenna Gain (dBi)	-4.24									
Bandwidth	PCC Frequency (MHz)	SCC1 Frequency (MHz)	PCC RB	PCC RB	SCC1 RB	SCC1 RB	Conducted Average (dBm)			
			Size	Offset	Size	Offset	QPSK	16QAM	64QAM	
20MHz / 20MHz	2580.0	2599.8	1	99	1	0	23.20	22.35	20.28	
			1	0	1	99	15.51	15.46	15.42	
			100	0	100	0	20.76	19.68	19.63	
	2585.1	2604.9	1	99	1	0	23.04	22.24	19.94	
			1	0	1	99	15.49	15.45	15.37	
			100	0	100	0	21.31	20.14	20.12	
	2590.2	2610.0	1	99	1	0	23.12	22.23	20.20	
			1	0	1	99	15.52	15.37	15.32	
			100	0	100	0	21.34	20.24	20.18	

5.4. DESCRIPTION OF AVAILABLE ANTENNAS

The radio utilizes a internal antenna for the [List the bands supported] with a maximum peak gain as follow:

Frequency (MHz)	Peak Gain (dBi)
LTE Band 38 2570 ~ 2620 MHz	-4.24
LTE Band 7 2500 ~ 2570 MHz	-4.18

5.5. WORST-CASE ORIENTATION

The worst-case scenario for all measurements is based on the average conducted output power measurement investigation results. Output power measurements were measured on QPSK, 16QAM and 64QAM modulations. It was found that QPSK and 16QAM results were worst case. All testing was performed using QPSK and 16QAM modulations to represent the worst case. However, the out of band emissions and spurious radiation were only performed on bandwidth and RB offset(with RB size 1) with the highest power in QPSK.

Highest power setting for each bands					
LTE Band	Component Carrier	Frequency (MHz)	Bandwidth (MHz)	RB size	RB offset
7 (Uplink CA)	PCC	2505.5	10	1	49
	SCC	2519.9	20	1	0
38 (Uplink CA)	PCC	2580.0	20	1	99
	SCC	2599.8	20	1	0

- Radiated spurious emissions

For LTE CA_7C, LTE CA_38C the spurious emissions was investigated in three orthogonal orientations X, Y and Z it was determined that Z orientation was worst-case orientation.

Note : All radiated spurious tests were performed connected with earphone and charger for evaluation of worst case mode.

5.6. DESCRIPTION OF TEST SETUP

SUPPORT EQUIPMENT

Support Equipment List				
Description	Manufacturer	Model	Serial Number	FCC ID
Charger	SAMSUNG	EP-TA200	R37KB5B03T1SE3	N/A
Data Cable	SAMSUNG	EP-DG970BBE	N/A	N/A
Earphone	SAMSUNG	EO-IG955	N/A	N/A

I/O CABLE

I/O Cable List						
Cable No	Port	# of identical ports	Connector Type	Cable Type	Cable Length (m)	Remarks
1	DC Power	1	C Type	Shielded	1.1m	N/A
2	Audio	2	Mini-Jack	Unshielded	1.2m	N/A

TEST SETUP

The EUT is continuously communicated to the call box during the tests.

SETUP DIAGRAM FOR TESTS (CONDUCTED TEST SETUP)

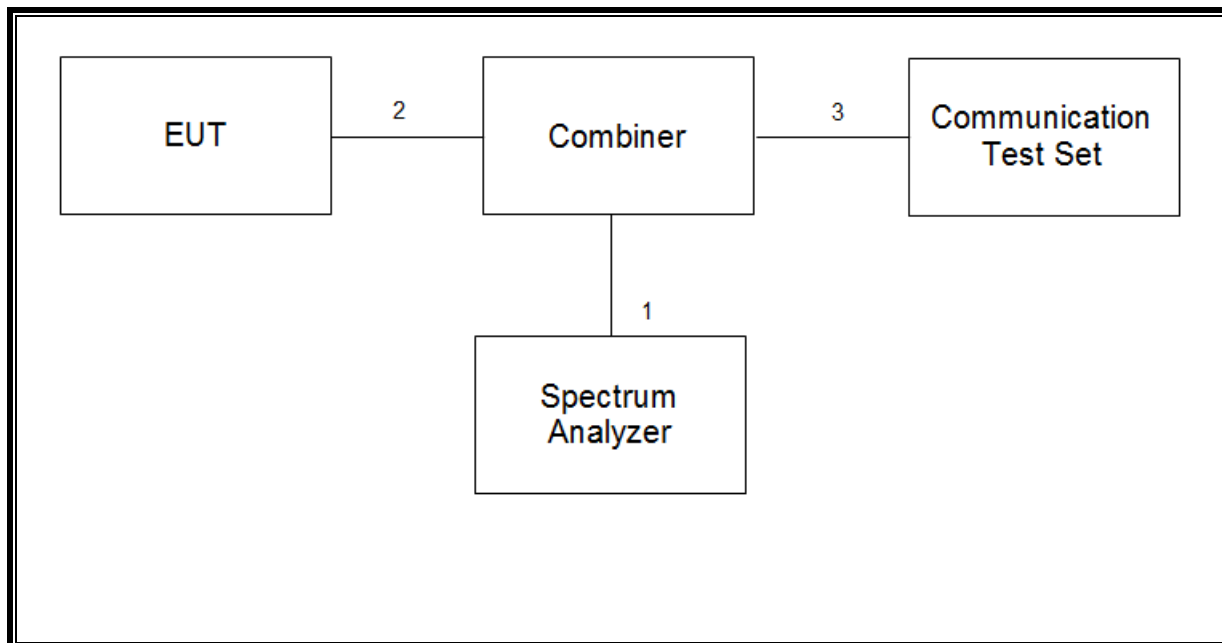

SETUP DIAGRAM FOR TESTS (RADIATED TEST SETUP)

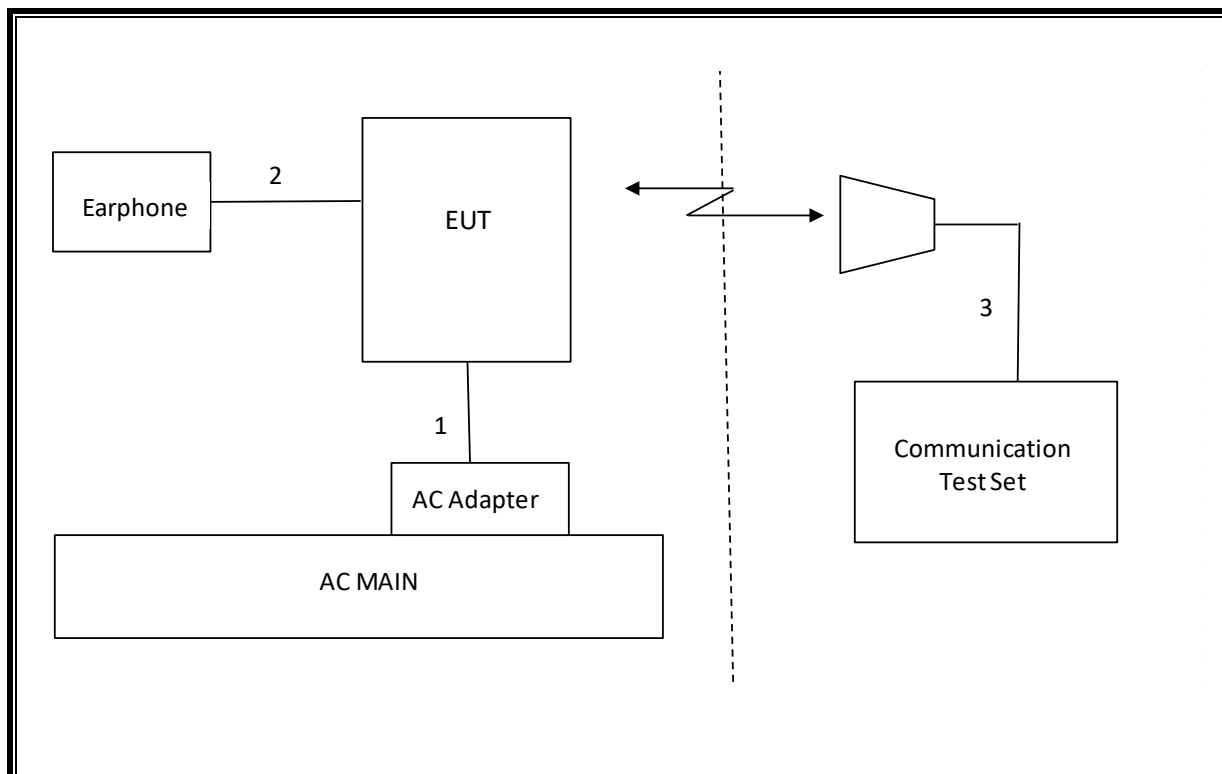

6. TEST AND MEASUREMENT EQUIPMENT

The following test and measurement equipment was utilized for the tests documented in this report:

Test Equipment List				
Description	Manufacturer	Model	S/N	Cal Due
Antenna, Tuned Dipole 400~1000 MHz	ETS	3121D DB4	00164753	06-30-19
Antenna, Horn, 40 GHz	ETS	3116C	00166155	12-04-19
Preamplifier	ETS	3116C-PA	00168841	08-09-19
Antenna, Horn, 40 GHz	ETS	3116C	00168645	12-04-19
Antenna, Bilog, 30MHz-1GHz	SCHWARZBECK	VULB9163	750	08-04-20
Antenna, Bilog, 30MHz-1GHz	SCHWARZBECK	VULB9163	845	08-04-20
Antenna, Bilog, 30MHz-1GHz	SCHWARZBECK	VULB9163	749	08-04-20
Antenna, Horn, 18 GHz	ETS	3115	00167211	08-04-20
Antenna, Horn, 18 GHz	ETS	3115	00161451	08-04-20
Antenna, Horn, 18 GHz	ETS	3117	00168724	08-04-20
Antenna, Horn, 18 GHz	ETS	3117	00205959	08-04-20
Antenna, Horn, 18 GHz	ETS	3117	00168717	08-04-20
Combiner	WEINSCHTEL	1575	2152	08-08-19
Communications Test Set	R&S	CMW500	115331	08-07-19
DC Power Supply	Agilent / HP	E3640A	MY54226395	08-06-19
Preamplifier, 1000 MHz	Sonoma	310N	341282	08-07-19
Preamplifier, 1000 MHz	Sonoma	310N	370599	08-06-19
Preamplifier, 1000 MHz	Sonoma	310N	351741	08-07-19
Preamplifier, 18 GHz	Miteq	AFS42-00101800-25-S-42	1876511	08-07-19
Preamplifier, 18 GHz	Miteq	AFS42-00101800-25-S-42	2029169	08-07-19
Preamplifier, 18 GHz	Miteq	AFS42-00101800-25-S-42	1896138	08-07-19
Spectrum Analyzer, 44 GHz	Agilent / HP	N9030A	MY54490312	08-06-19
EMI Test Receive, 40 GHz	R&S	ESU40	100439	08-06-19
EMI Test Receive, 40 GHz	R&S	ESU40	100457	08-06-19
EMI Test Receive, 44 GHz	R&S	ESW40	101590	08-06-19
High Pass Filter 1.2GHz	Micro-Tronics	HPM50108-02	G005	08-08-19
High Pass Filter 1.2GHz	Micro-Tronics	HPM50108-02	G006	08-08-19
High Pass Filter 2.8GHz	Micro-Tronics	HPM50111-02	010	08-08-19
High Pass Filter 2.8GHz	Micro-Tronics	HPM50111-02	011	08-08-19
High Pass Filter 4GHz	Micro-Tronics	HPM50118-02	G001	08-08-19
High Pass Filter 4GHz	Micro-Tronics	HPM50118-02	G002	08-08-19
Attenuator	PASTERNAK	PE7087-10	A009	08-08-19
Attenuator	PASTERNAK	PE7087-10	A001	08-08-19
Attenuator	PASTERNAK	PE7087-10	A008	08-08-19
Attenuator	PASTERNAK	PE7087-10	2	08-07-19
Attenuator	PASTERNAK	PE7395-10	A011	08-08-19
Antenna, Loop, 9kHz-30MHz	R&S	HFH2-Z2	100418	10-26-19
Temperature Chamber	ESPEC	SH-642	93001109	08-06-19
UL Software				
Description	Manufacturer	Model	Version	
Antenna port test software	UL	CLT	Ver 2.5	

7. SUMMARY TABLE

FCC Part Section	Test Description	Test Limit	Test Condition	Test Result
2.1049	Occupied Band width (99%)	N/A	Conducted	Pass
27.53(m)	Conducted Spurious Emission	-25 dBm		Pass
27.53(m)	Emission mask	Section 7.2		Pass
2.1046	Conducted output power	N/A		Pass
27.50(h)(2)	Equivalent Isotropic Radiated Power	33dBm	Radiated	Pass
27.53 (m)	Radiated Spurious Emission	-25dBm		Pass

7. LIMITS AND CONDUCTED RESULTS

7.1. OCCUPIED BANDWIDTH

RULE PART(S)

FCC: §2.1049

LIMITS

For reporting purposes only

TEST PROCEDURE

The transmitter output was connected to a calibrated coaxial cable and coupler, the other end of which was connected to a spectrum analyzer. The occupied bandwidth was measured with the spectrum analyzer at the low, middle and high channel in each band. The -26dB bandwidth was also measured and recorded.

(KDB 971168 D01 Power Meas License Digital Systems v03r01)

RESULTS

See the following pages.

7.1.1. OCCUPIED BANDWIDTH RESULTS

LTE Band 7C (UL CA)

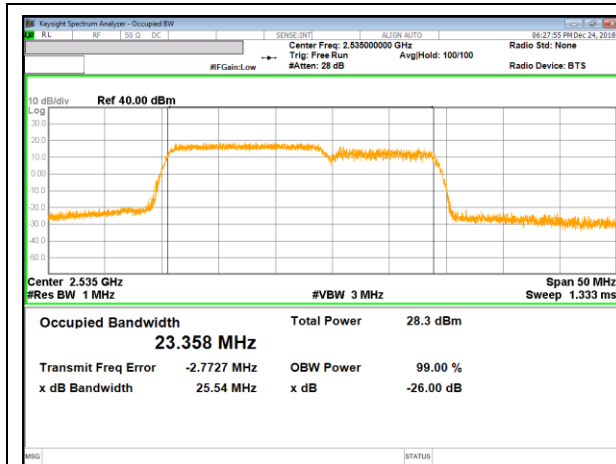

LTE B7 15MHz + 10MHz QPSK RB75-0 + RB50-0

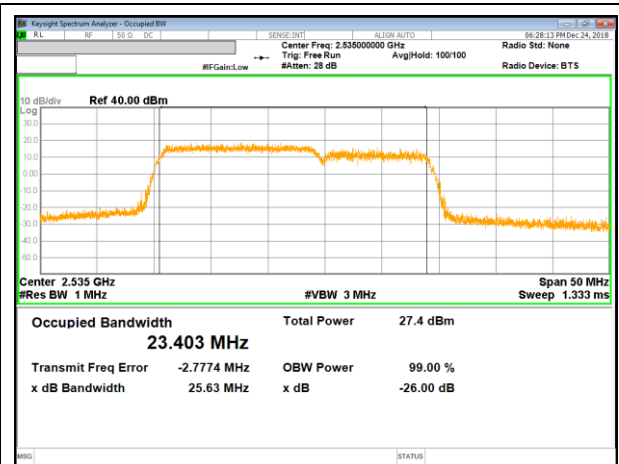

LTE B7 15MHz + 10MHz 16QAM RB75-0 + RB50-0

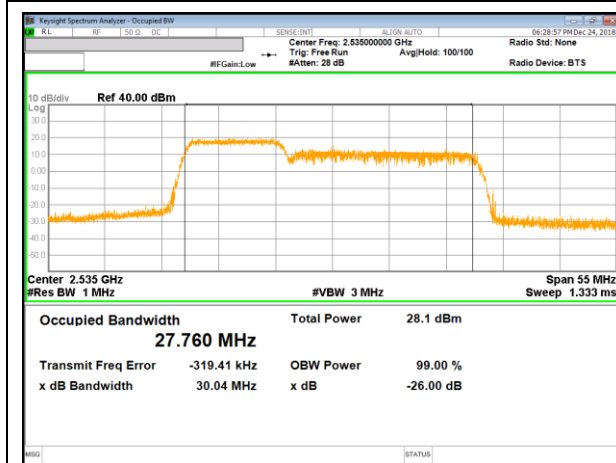

LTE B7 10MHz + 20MHz QPSK RB50-0 + RB100-0

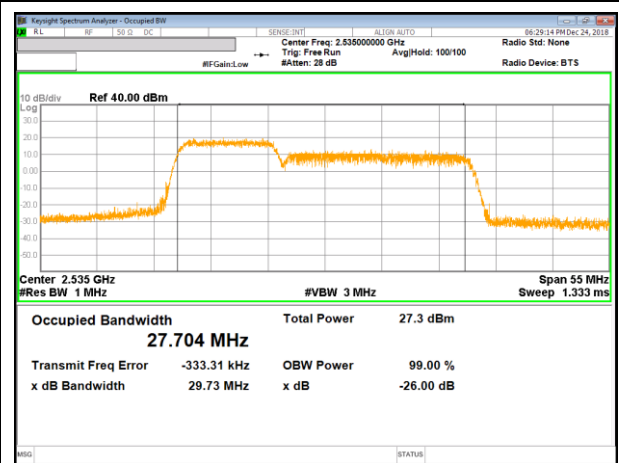

LTE B7 10MHz + 20MHz 16QAM RB50-0 + RB100-0

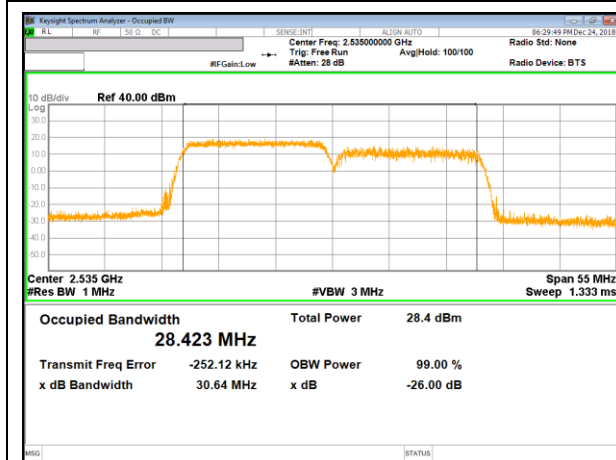

LTE B7 15MHz + 15MHz QPSK RB75-0 + RB75-0

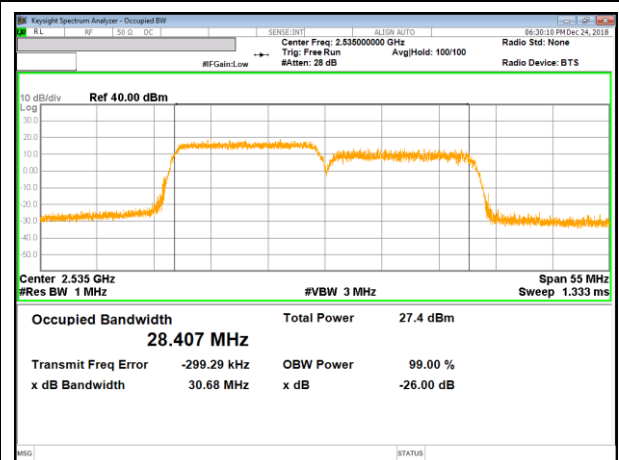

LTE B7 15MHz + 15MHz 16QAM RB75-0 + RB75-0

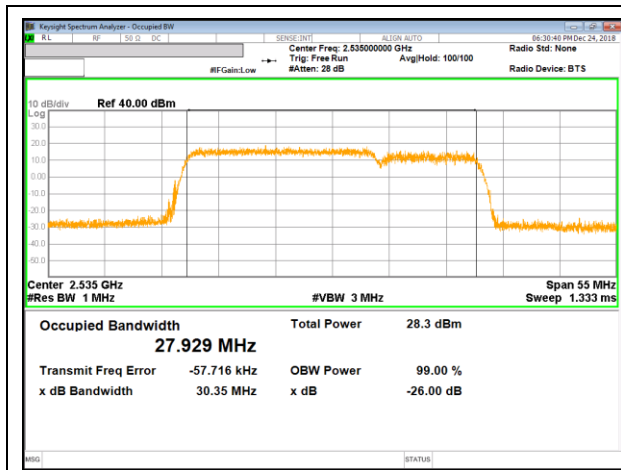

LTE B7 20MHz + 10MHz QPSK RB100-0 + RB50-0

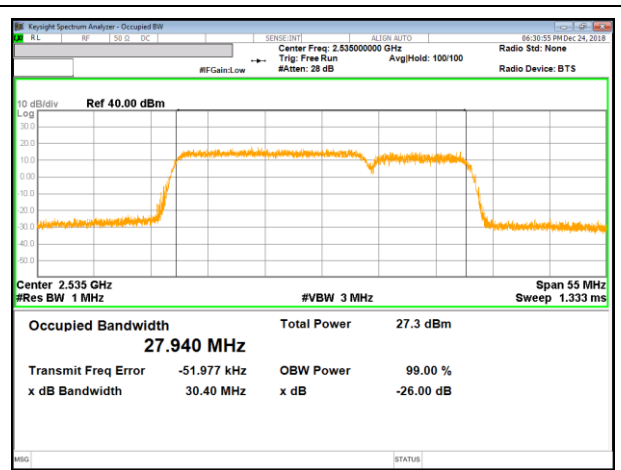

LTE B7 20MHz + 10MHz 16QAM RB100-0 + RB50-0

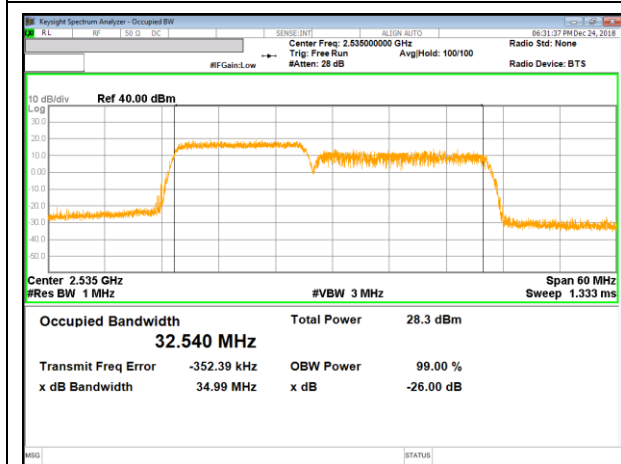

LTE B7 15MHz + 20MHz QPSK RB75-0 + RB100-0

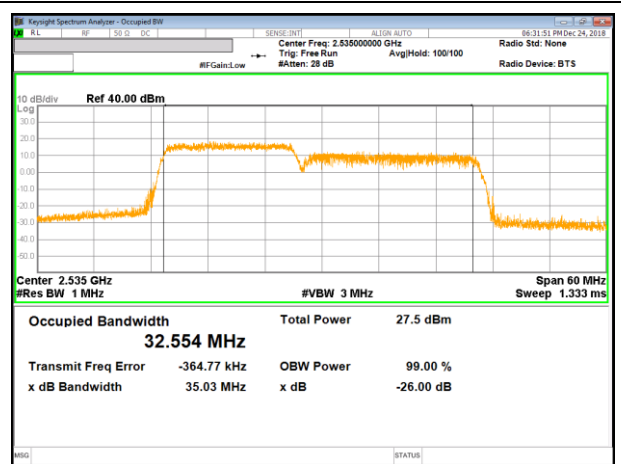

LTE B7 15MHz + 20MHz 16QAM RB75-0 + RB100-0

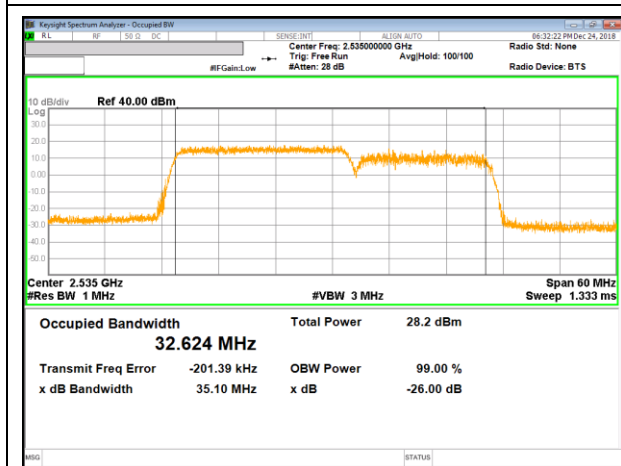

LTE B77 20MHz + 15MHz QPSK RB100-0 + RB75-0

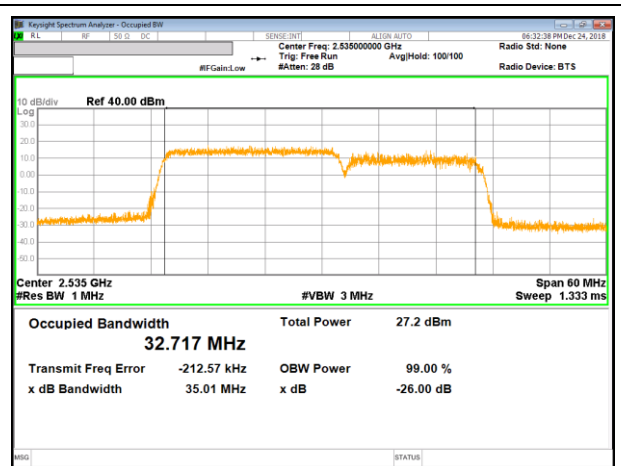

LTE B7 20MHz + 15MHz 16QAM RB100-0 + RB75-0

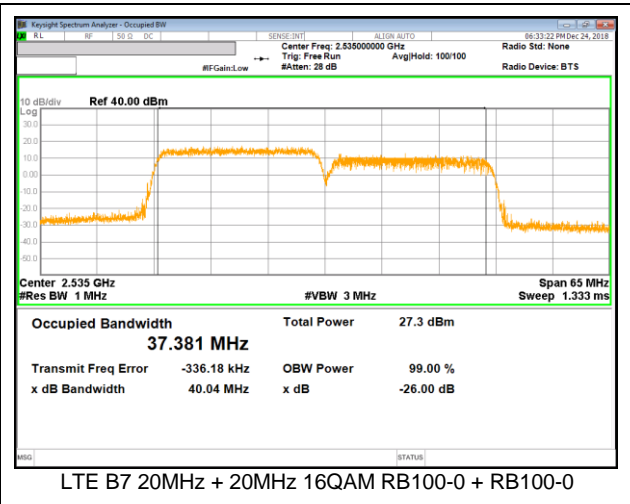
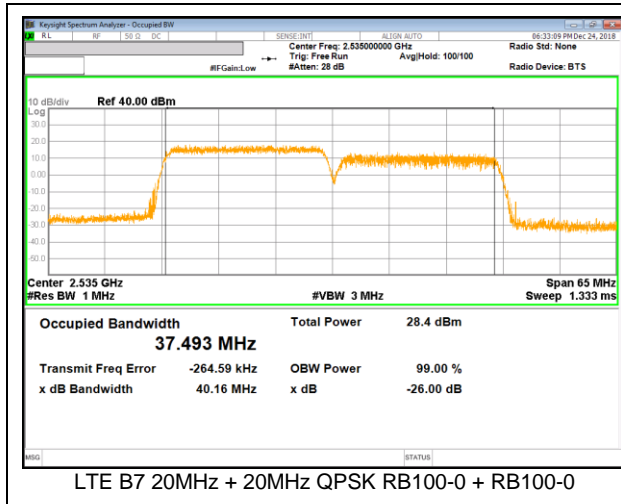

LTE Band 38C (UL CA)

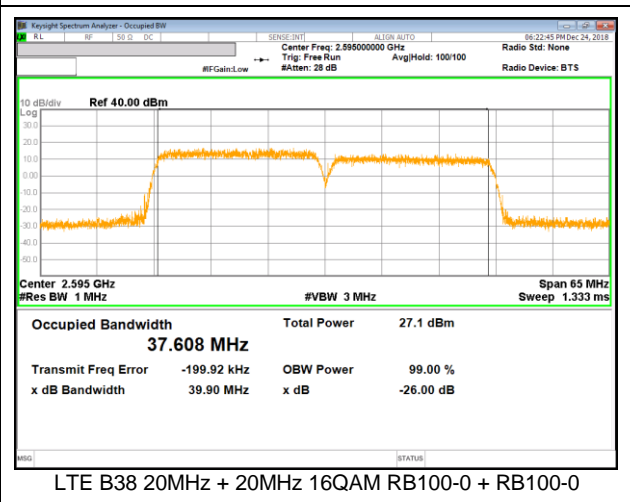
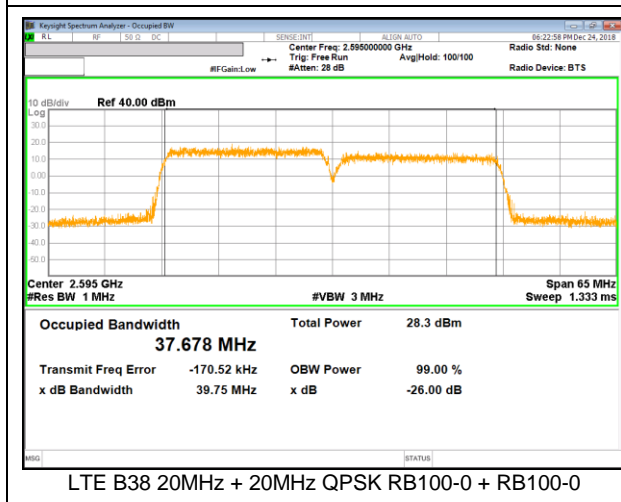
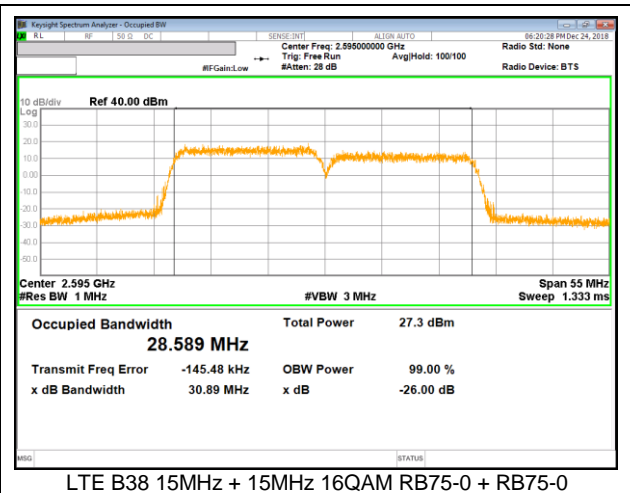
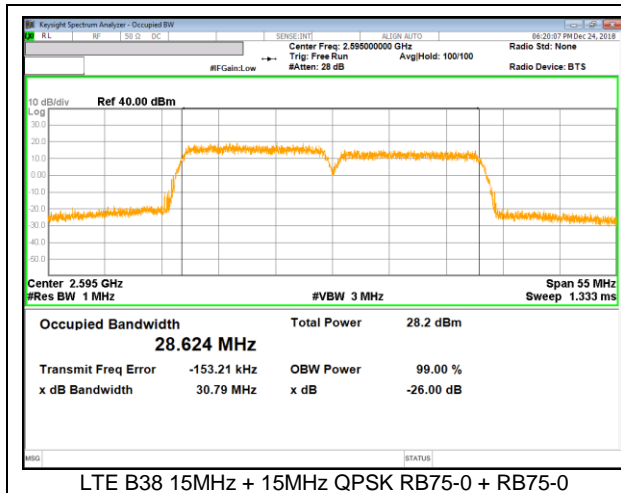

7.2. EMISSION MASK

RULE PART(S)

FCC: §27. 53

LIMITS

The power of any emission outside of the authorized operating frequency ranges must be attenuated below the transmitting power (P) by a factor of at least $43 + 10 \log (P)$ dB.

(m) (4) For mobile digital stations, the attenuation factor shall be not less than $40 + 10 \log (P)$ dB on all frequencies between the channel edge and 5 megahertz from the channel edge, $43 + 10 \log (P)$ dB on all frequencies between 5 megahertz and X megahertz from the channel edge, and $55 + 10 \log (P)$ dB on all frequencies more than X megahertz from the channel edge, where X is the greater of 6 megahertz or the actual emission bandwidth as defined in paragraph (m)(6) of this section. In addition, the attenuation factor shall not be less than $43 + 10 \log (P)$ dB on all frequencies between 2490.5 MHz and 2496 MHz and $55 + 10 \log (P)$ dB at or below 2490.5 MHz. Mobile Satellite Service licensees operating on frequencies below 2495 MHz may also submit a documented interference complaint against BRS licensees operating on channel BRS Channel 1 on the same terms and conditions as adjacent channel BRS or EBS licensees.

TEST PROCEDURE

Per KDB 971168 D01 Power Meas License Digital Systems v03r01

The transmitter output was connected to a CMW500 Test Set and configured to operate at maximum power. The band edge emissions were measured at the required operating frequencies in each band on the Spectrum Analyzer.

NOTE1

LTE Band 38 - Duty cycle correction factor(2.22dB) already applied on the plot.

RESULTS

See the following pages.

LTE Band 7C(UL CA)

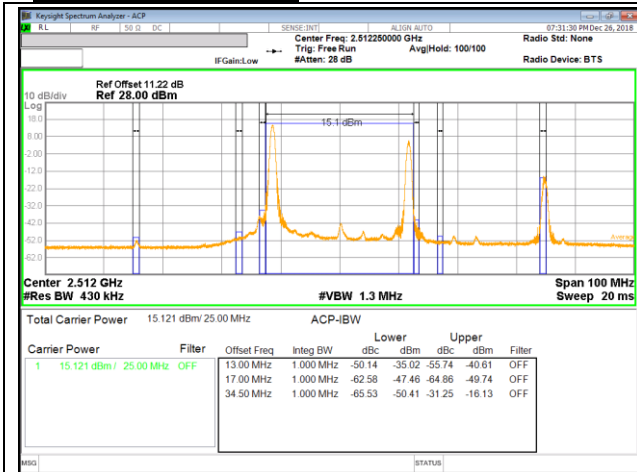

LTE B7 15MHz + 10MHz QPSK Low Ch RB1-0 + RB1-49

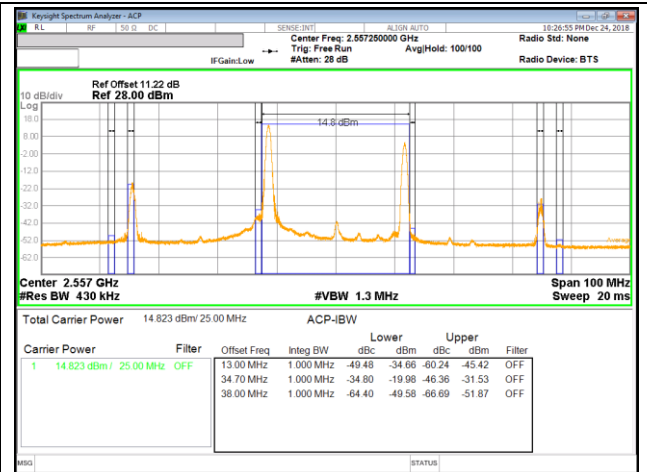

LTE B7 15MHz + 10MHz QPSK High Ch RB1-0 + RB1-49

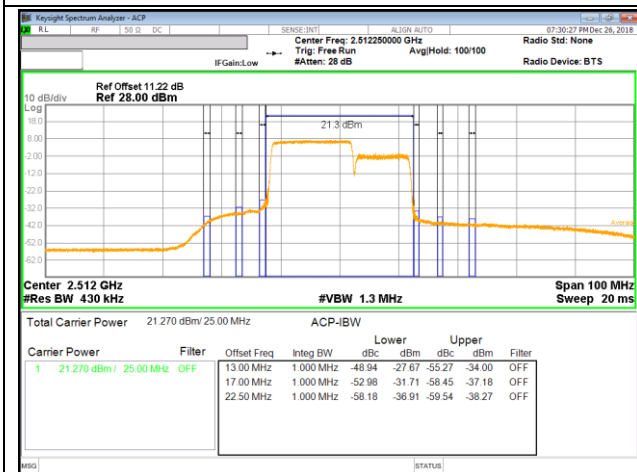

LTE B7 15MHz + 10MHz QPSK Low Ch RB75-0 + RB50-0

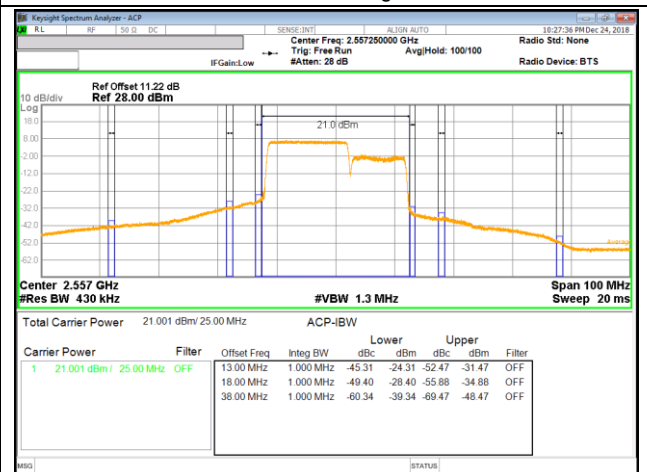

LTE B7 15MHz + 10MHz QPSK High Ch RB75-0 + RB50-0

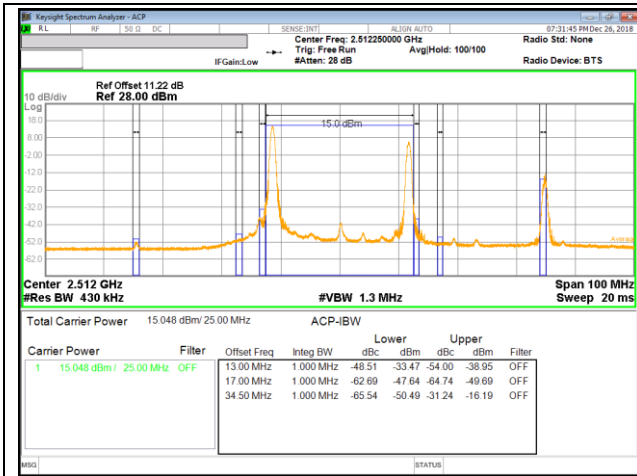

LTE B7 15MHz + 10MHz 16QAM Low Ch RB1-0 + RB1-49

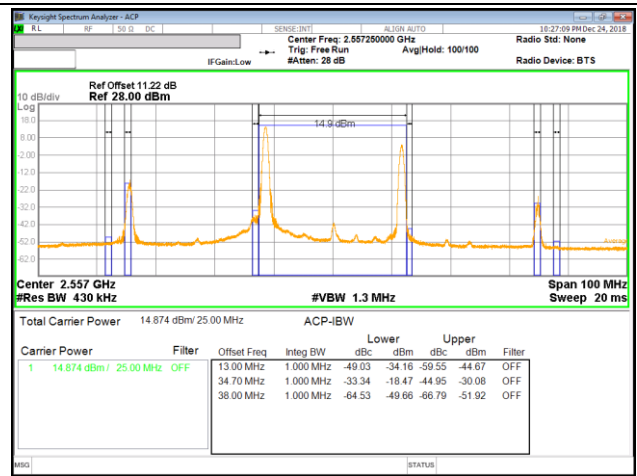

LTE B7 15MHz + 10MHz 16QAM High Ch RB1-0 + RB1-49

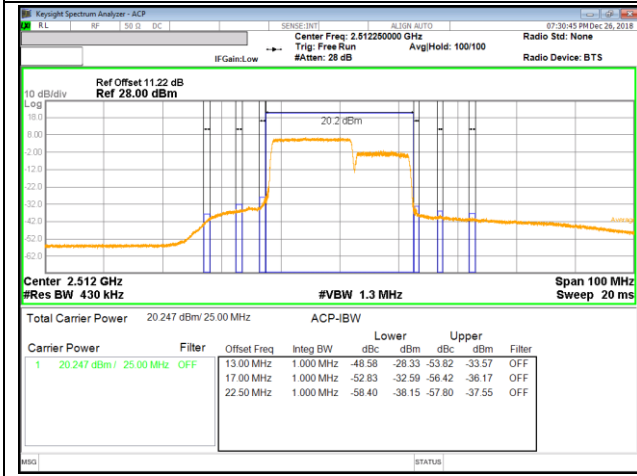

LTE B7 15MHz + 10MHz 16QAM Low Ch RB75-0 + RB50-0

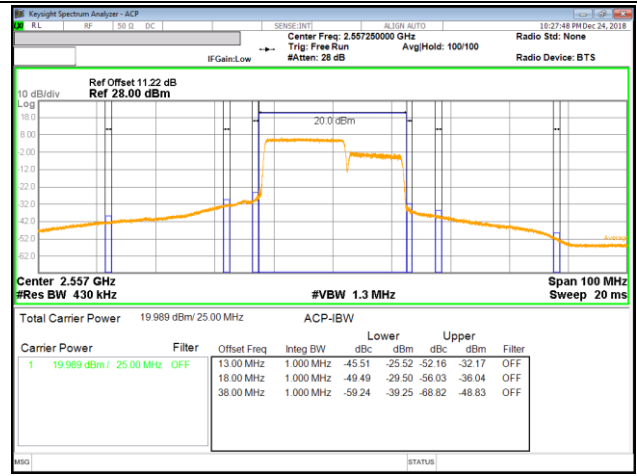

LTE B7 15MHz + 10MHz 16QAM High Ch RB75-0 + RB50-0

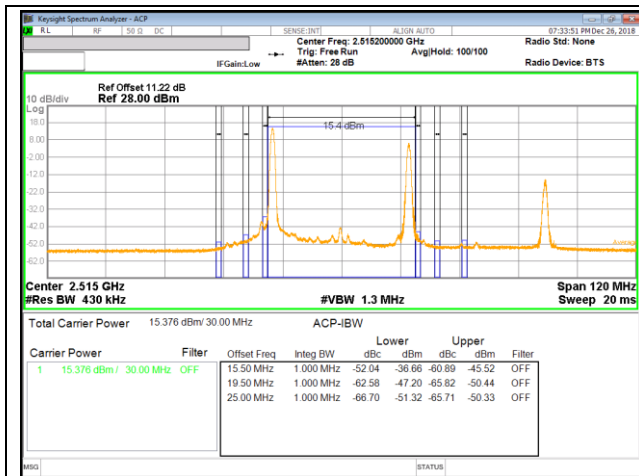

LTE B7 10MHz + 20MHz QPSK Low Ch RB1-0 + RB1-99

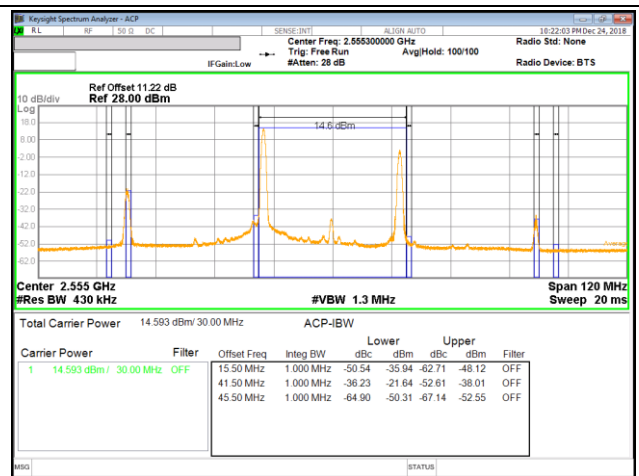

LTE B7 10MHz + 20MHz QPSK High Ch RB1-0 + RB1-99

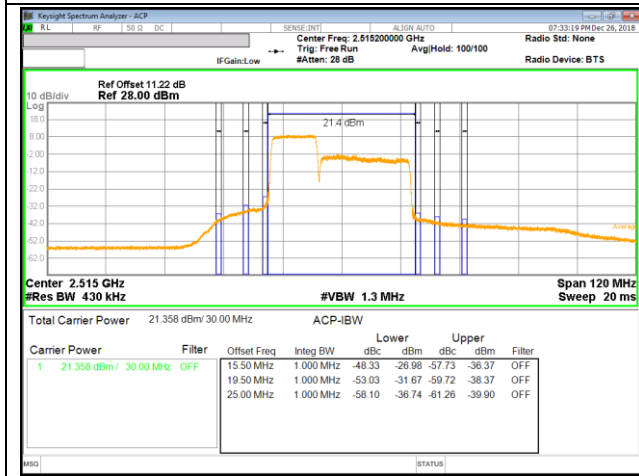

LTE B7 10MHz + 20MHz QPSK Low Ch RB50-0 + RB100-0

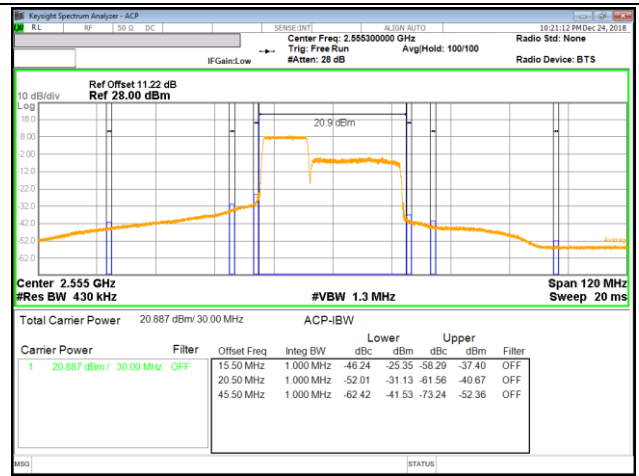

LTE B7 10MHz + 20MHz QPSK High Ch RB50-0 + RB100-0

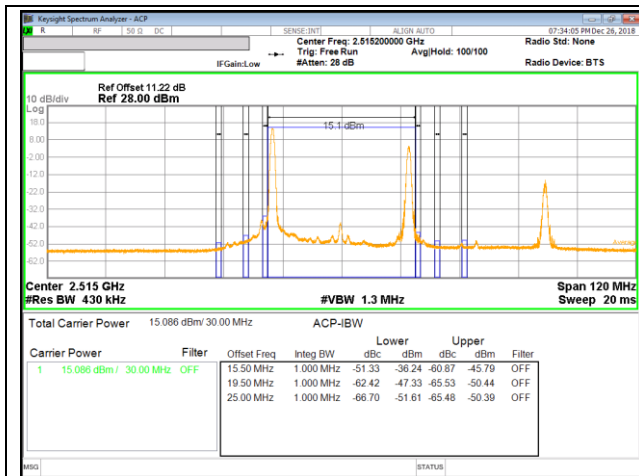

LTE B7 10MHz + 20MHz 16QAM Low Ch RB1-0 + RB1-99

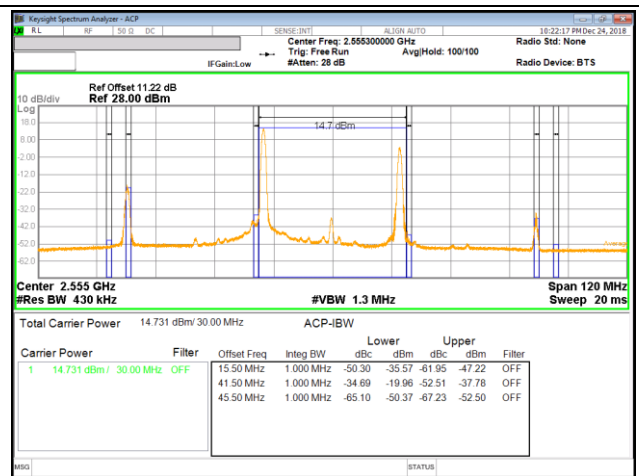

LTE B7 10MHz + 20MHz 16QAM High Ch RB1-0 + RB1-99

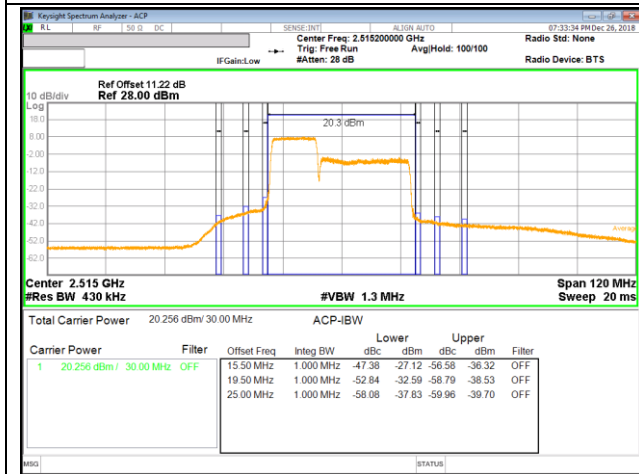

LTE B7 10MHz + 20MHz 16QAM Low Ch RB50-0 + RB100-0

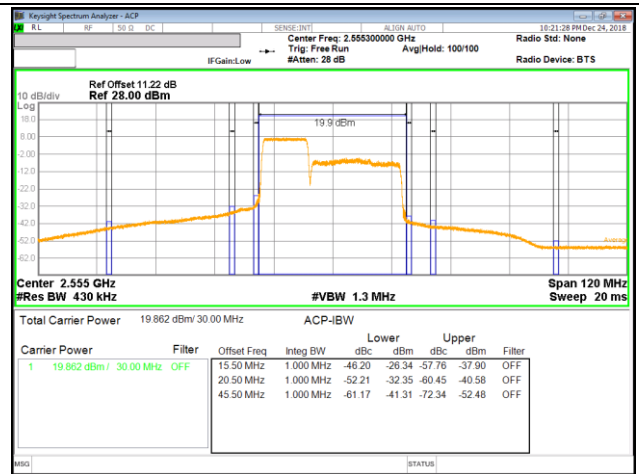

LTE B7 10MHz + 20MHz 16QAM High Ch RB50-0 + RB100-0

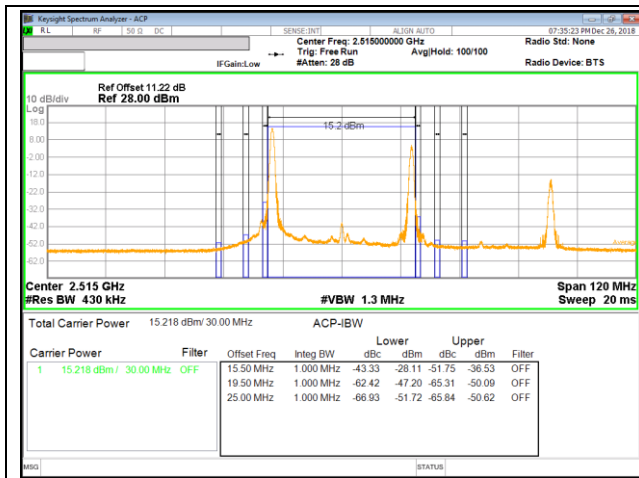

LTE B7 15MHz + 15MHz QPSK Low Ch RB1-0 + RB1-74

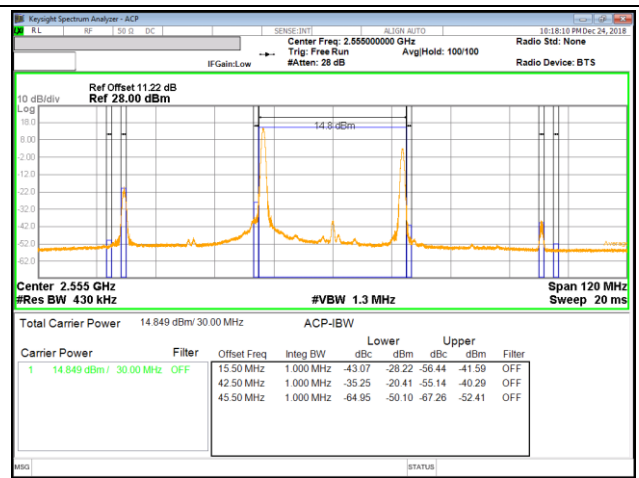

LTE B7 15MHz + 15MHz QPSK High Ch RB1-0 + RB1-74

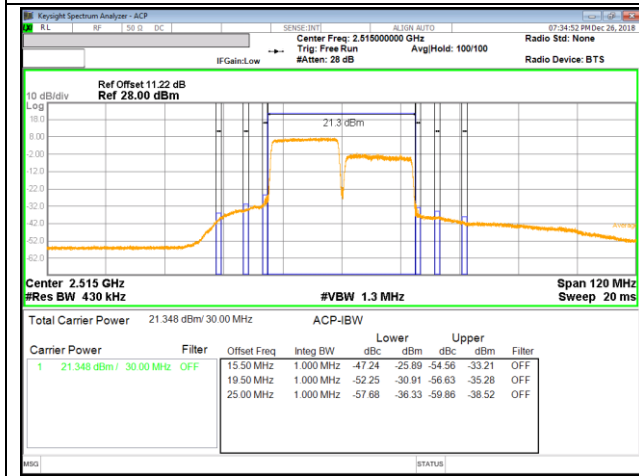

LTE B7 15MHz + 15MHz QPSK Low Ch RB75-0 + RB75-0

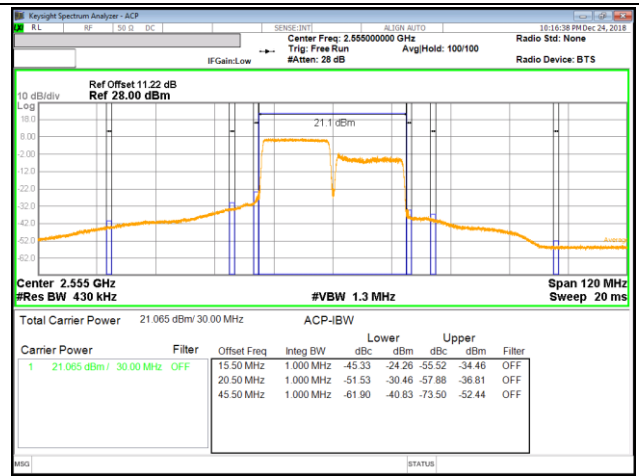

LTE B7 15MHz + 15MHz QPSK High Ch RB75-0 + RB75-0

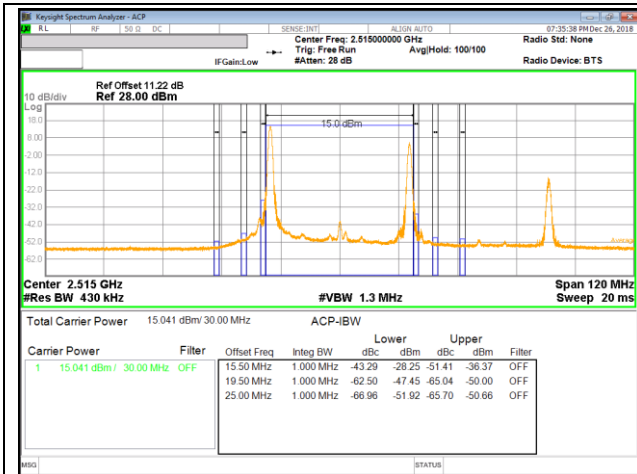

LTE B7 15MHz + 15MHz 16QAM Low Ch RB1-0 + RB1-74

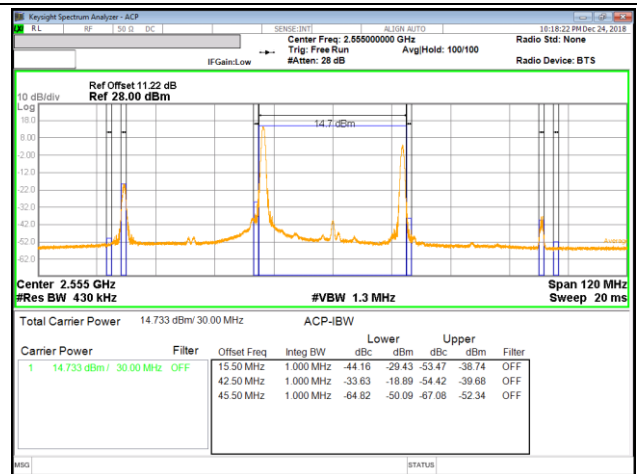

LTE B7 15MHz + 15MHz 16QAM High Ch RB1-0 + RB1-74

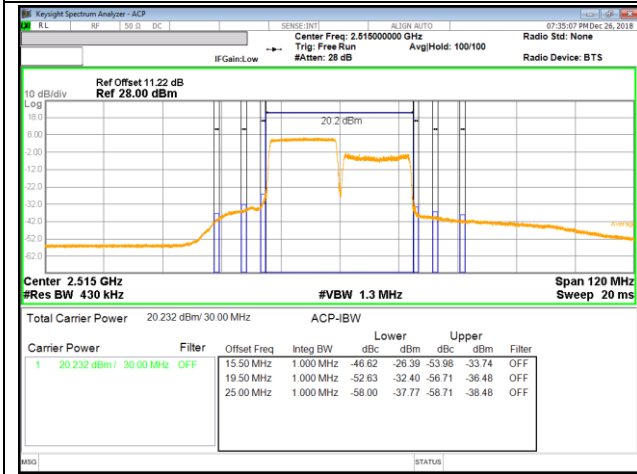

LTE B7 15MHz + 15MHz 16QAM Low Ch RB75-0 + RB75-0

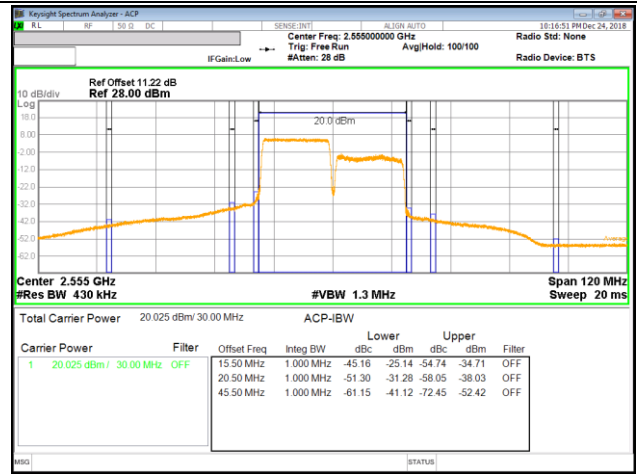

LTE B7 15MHz + 15MHz 16QAM High Ch RB75-0 + RB75-0

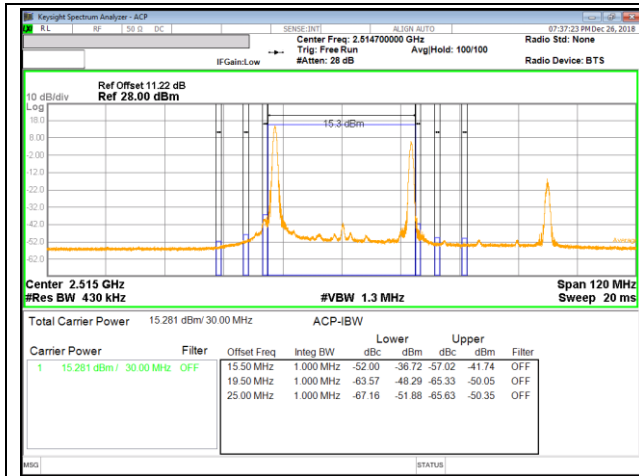

LTE B7 20MHz + 10MHz QPSK Low Ch RB1-0 + RB1-49

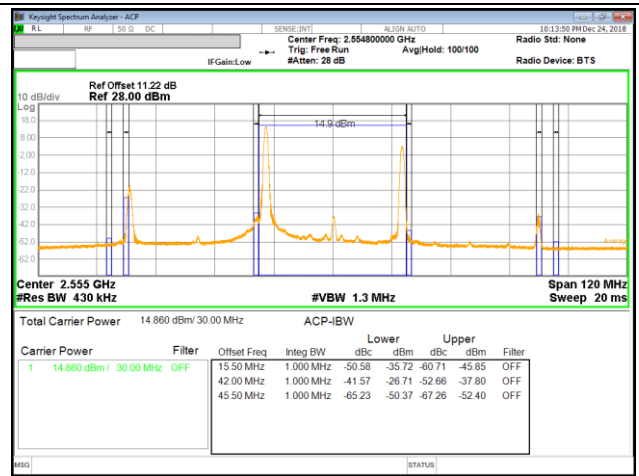

LTE B7 20MHz + 10MHz QPSK High Ch RB1-0 + RB1-49

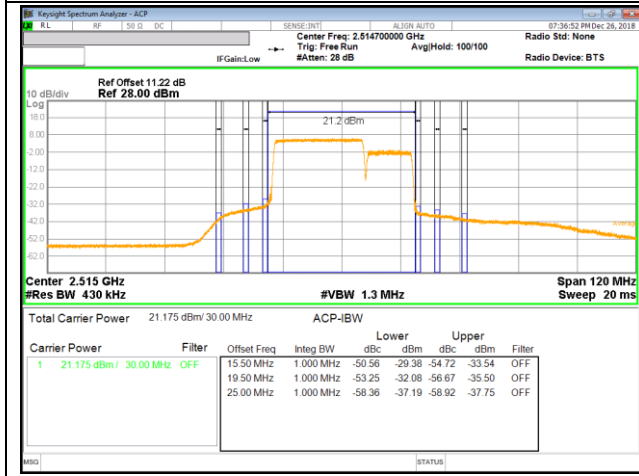

LTE B7 20MHz + 10MHz QPSK Low Ch RB100-0 + RB50-0

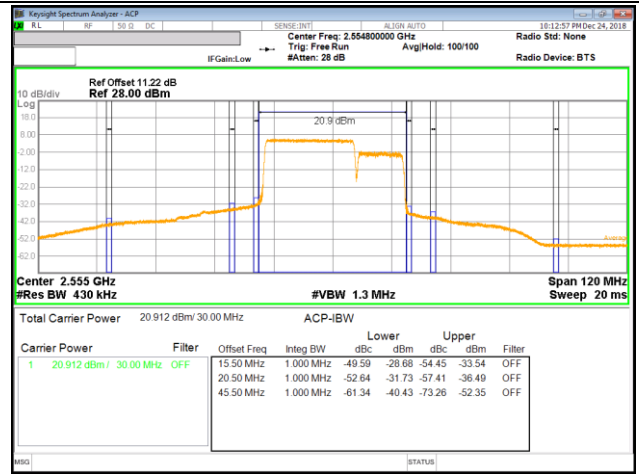

LTE B7 20MHz + 10MHz QPSK High Ch RB100-0 + RB50-0

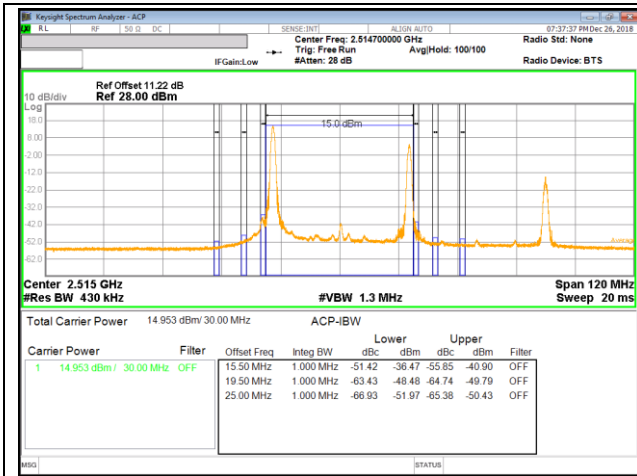

LTE B7 20MHz + 10MHz 16QAM Low Ch RB1-0 + RB1-49

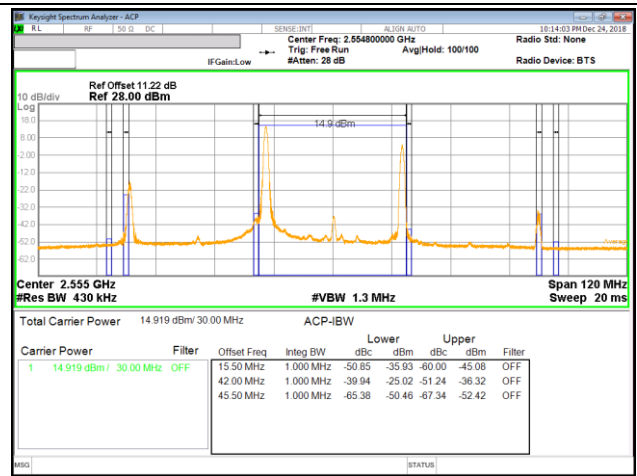

LTE B7 20MHz + 10MHz 16QAM High Ch RB1-0 + RB1-49

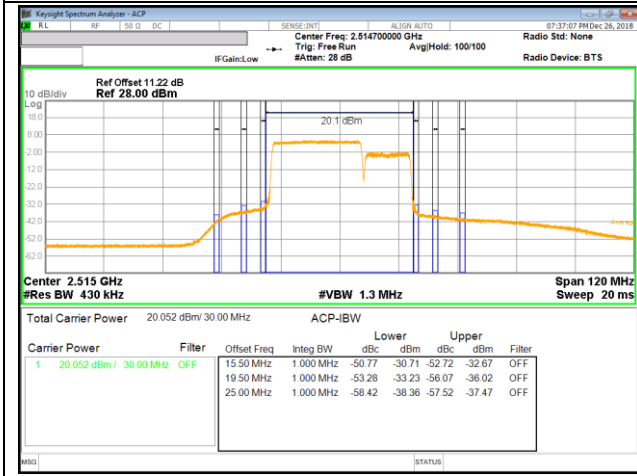

LTE B7 20MHz + 10MHz 16QAM Low Ch RB100-0 + RB50-0

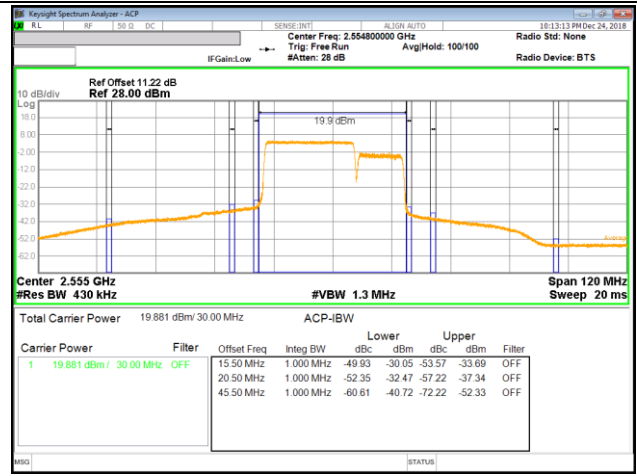

LTE B7 20MHz + 10MHz 16QAM High Ch RB100-0 + RB50-0

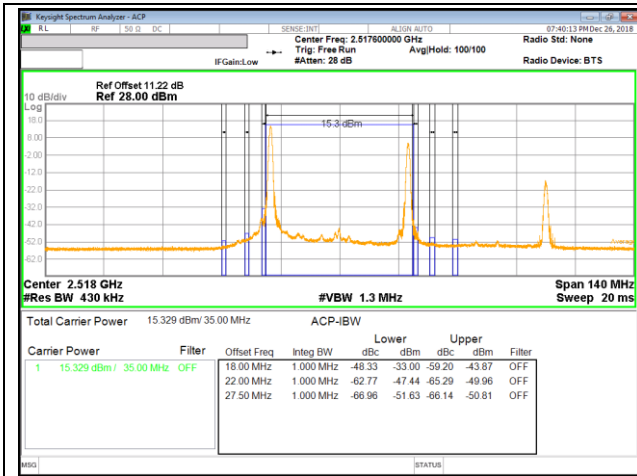

LTE B7 15MHz + 20MHz QPSK Low Ch RB1-0 + RB1-99

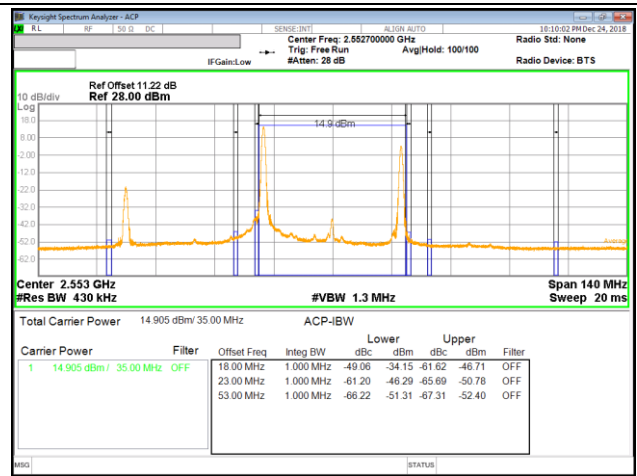

LTE B7 15MHz + 20MHz QPSK High Ch RB1-0 + RB1-99

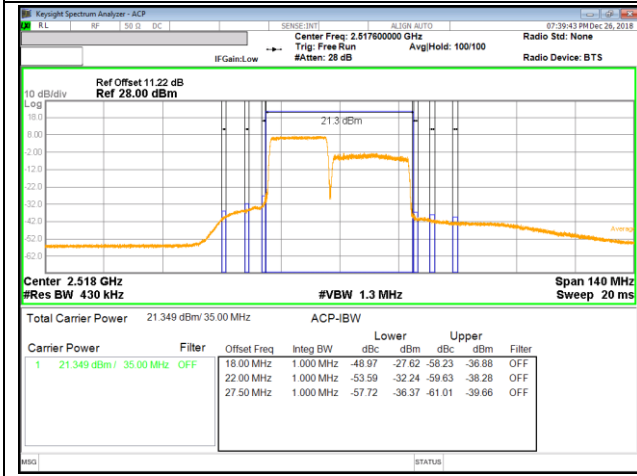

LTE B7 15MHz + 20MHz QPSK Low Ch RB75-0 + RB100-0

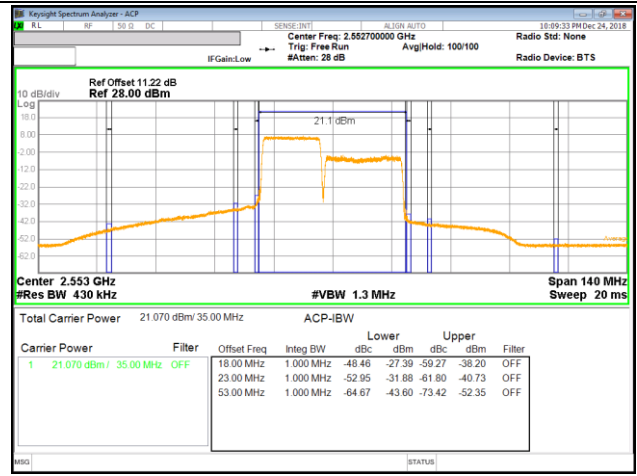

LTE B7 15MHz + 20MHz QPSK High Ch RB75-0 + RB100-0

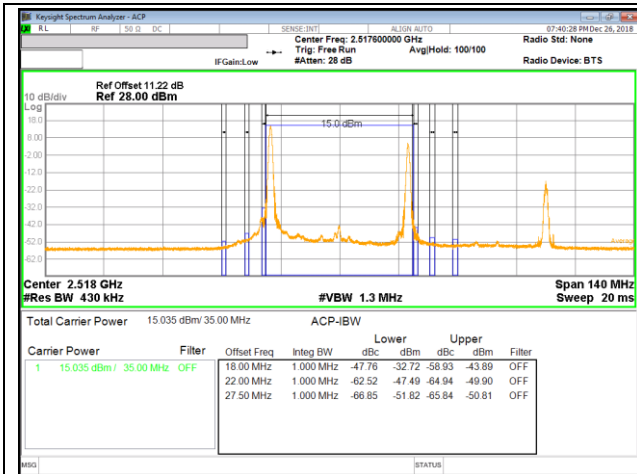

LTE B7 15MHz + 20MHz 16QAM Low Ch RB1-0 + RB1-99

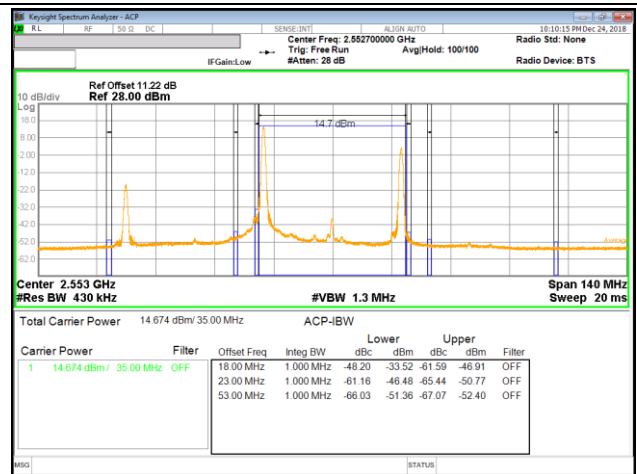

LTE B7 15MHz + 20MHz 16QAM High Ch RB1-0 + RB1-99

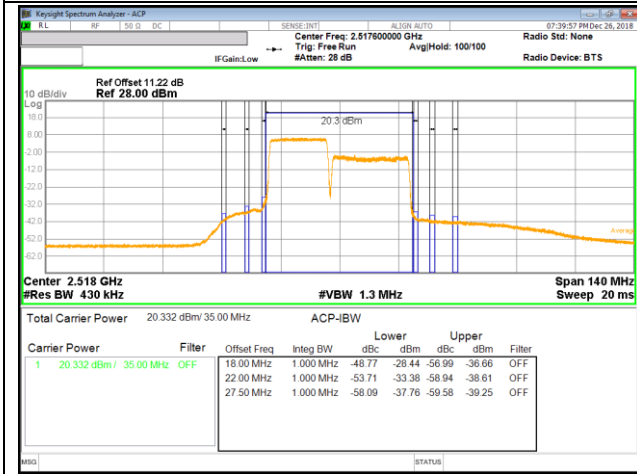

LTE B7 15MHz + 20MHz 16QAM Low Ch RB75-0 + RB100-0

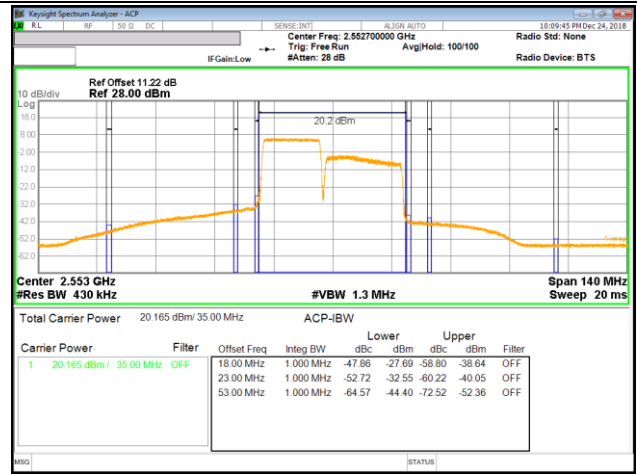

LTE B7 15MHz + 20MHz 16QAM High Ch RB75-0 + RB100-0

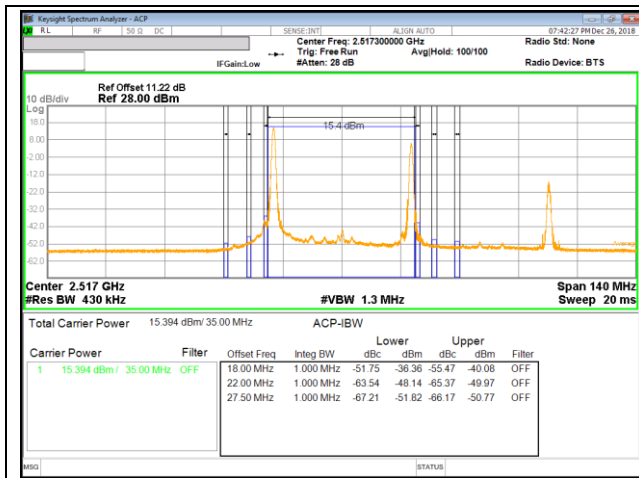

LTE B7 20MHz + 15MHz QPSK Low Ch RB1-0 + RB1-74

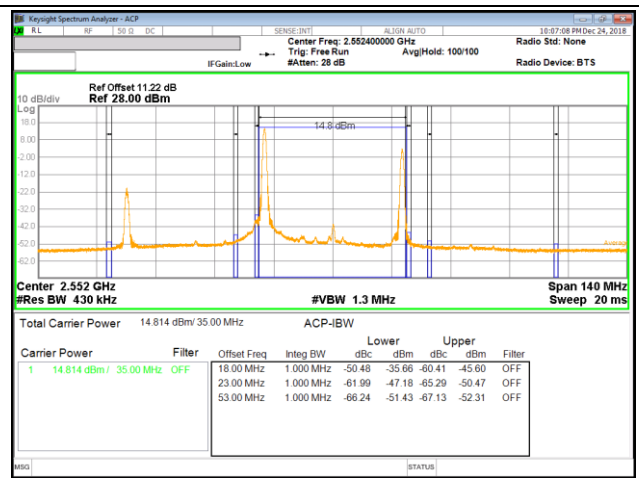

LTE B7 20MHz + 15MHz QPSK High Ch RB1-0 + RB1-74

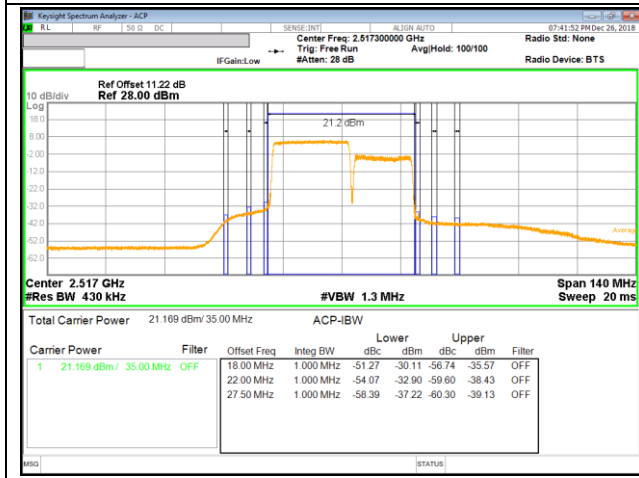

LTE B7 20MHz + 15MHz QPSK Low Ch RB100-0 + RB75-0

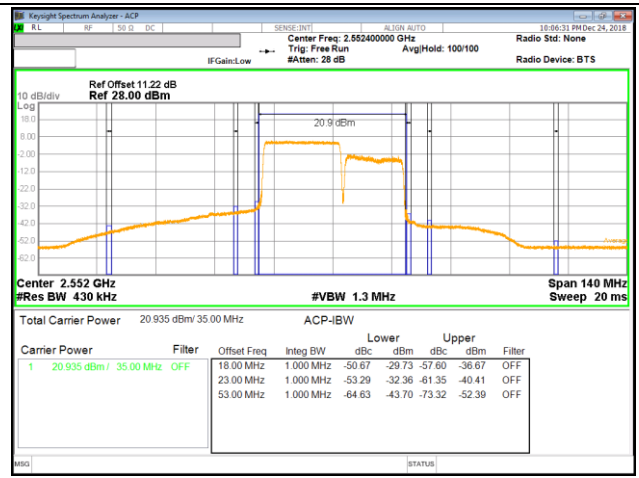

LTE B7 20MHz + 15MHz QPSK High Ch RB100-0 + RB75-0

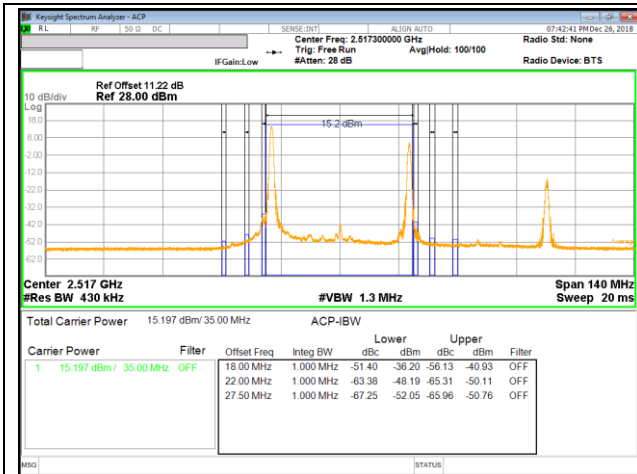

LTE B7 20MHz + 15MHz 16QAM Low Ch RB1-0 + RB1-74

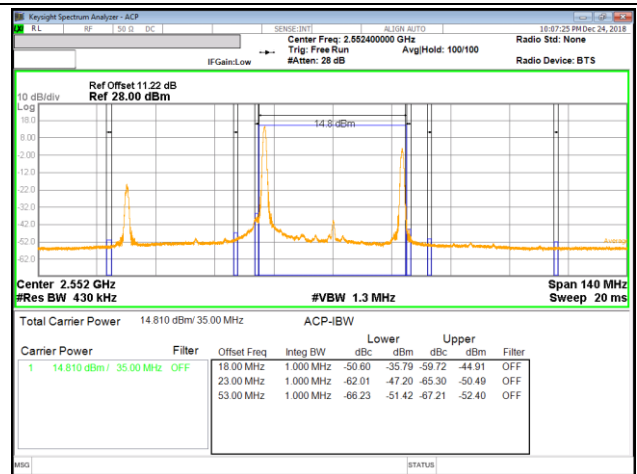

LTE B7 20MHz + 15MHz 16QAM High Ch RB1-0 + RB1-74

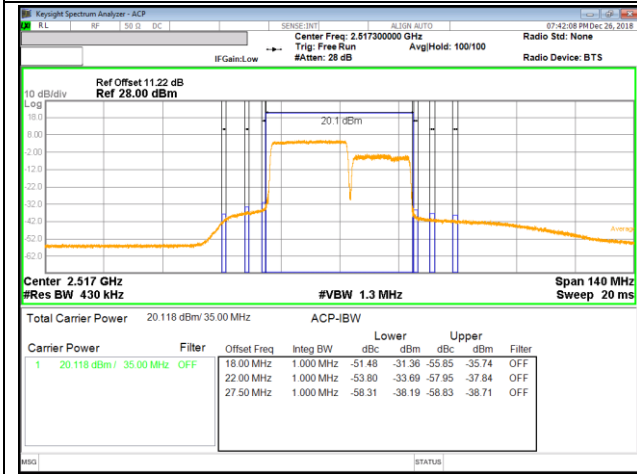

LTE B7 20MHz + 15MHz 16QAM Low Ch RB100-0 + RB75-0

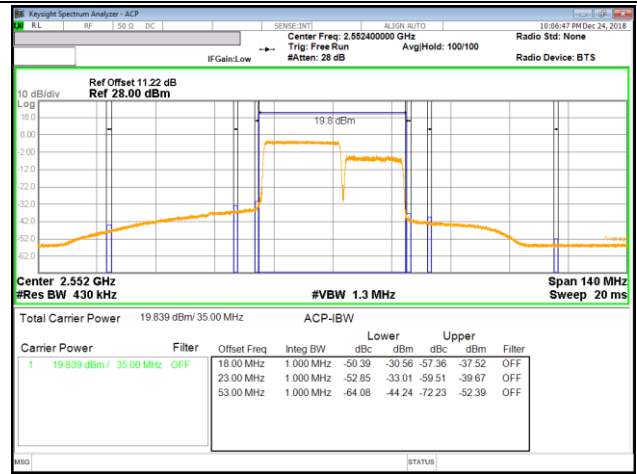

LTE B7 20MHz + 15MHz 16QAM High Ch RB100-0 + RB75-0

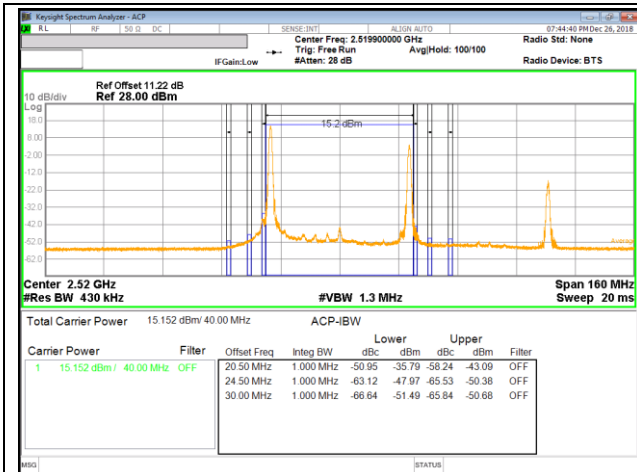

LTE B7 20MHz + 20MHz QPSK Low Ch RB1-0 + RB1-99

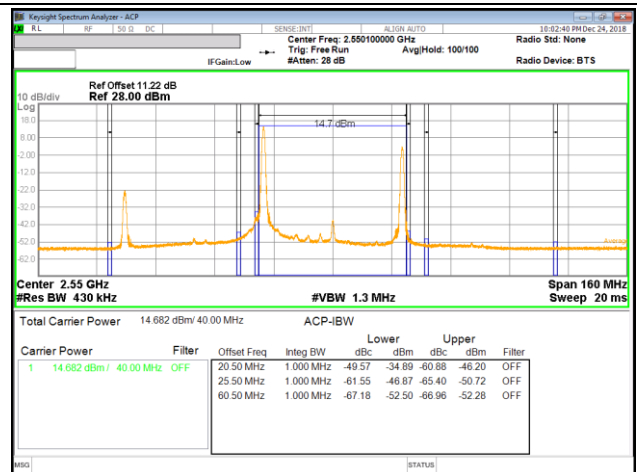

LTE B7 20MHz + 20MHz QPSK High Ch RB1-0 + RB1-99

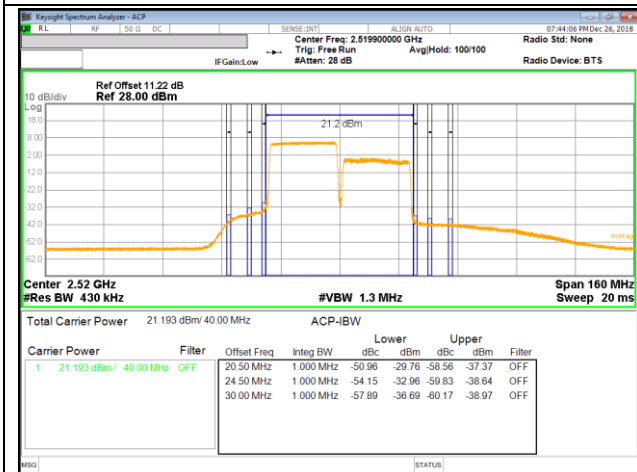

LTE B7 20MHz + 20MHz QPSK Low Ch RB100-0 + RB100-0

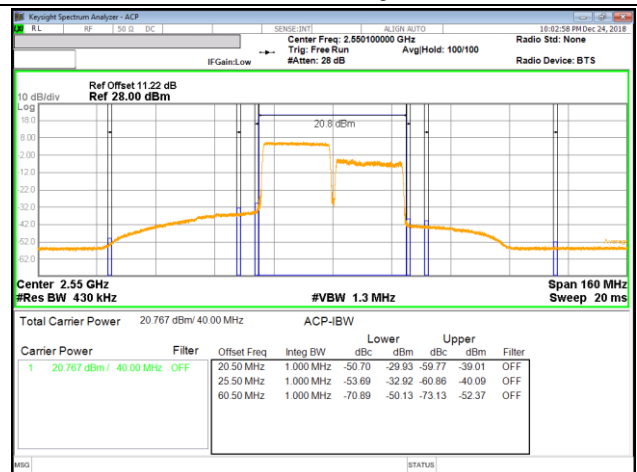

LTE B7 20MHz + 20MHz QPSK High Ch RB100-0 + RB100-0