



**FCC CFR47 PART 15 SUBPART C**

**DTS Wireless LAN**

**CERTIFICATION TEST REPORT**

**FOR**

**GSM/WCDMA/LTE Phone + BT/BLE, DTS/UNII a/b/g/n/ac/ax, ANT+, NFC and WPT**

**MODEL NUMBER : SM-G973F/DS, SM-G973F, SM-G973X**

**FCC ID: A3LSMG973F**

**REPORT NUMBER: 4788725460-E2V2**

**ISSUE DATE: DEC 24, 2018**

*Prepared for*  
**SAMSUNG ELECTRONICS CO., LTD.**  
**129 SAMSUNG-RO, YEONGTONG-GU, SUWON-SI,**  
**GYEONGGI-DO, 16677, KOREA**

*Prepared by*  
**UL Korea, Ltd.**  
**26th floor, 152, Teheran-ro, Gangnam-gu Seoul, 06236, Korea**

**Suwon Test Site: UL Korea, Ltd. Suwon Laboratory**  
**218 Maeyeong-ro, Yeongtong-gu,**  
**Suwon-si, Gyeonggi-do, 16675, Korea**  
**TEL: (031) 337-9902**  
**FAX: (031) 213-5433**



Testing  
Laboratory

**TL-637**

Revision History

<u>Rev.</u>	<u>Issue Date</u>	<u>Revisions</u>	<u>Revised By</u>
V1	12/20/18	Initial issue	Hoonpyo Lee
V2	12/24/18	Updated to address TCB's question	Hoonpyo Lee

## TABLE OF CONTENTS

<b>1. ATTESTATION OF TEST RESULTS .....</b>	<b>5</b>
<b>2. TEST METHODOLOGY .....</b>	<b>6</b>
<b>3. FACILITIES AND ACCREDITATION .....</b>	<b>6</b>
<b>4. CALIBRATION AND UNCERTAINTY .....</b>	<b>6</b>
4.1. <i>MEASURING INSTRUMENT CALIBRATION.....</i>	6
4.2. <i>SAMPLE CALCULATION.....</i>	6
4.3. <i>MEASUREMENT UNCERTAINTY.....</i>	7
<b>5. EQUIPMENT UNDER TEST .....</b>	<b>8</b>
5.1. <i>DESCRIPTION OF EUT.....</i>	8
5.2. <i>MAXIMUM OUTPUT POWER.....</i>	9
5.3. <i>DESCRIPTION OF AVAILABLE ANTENNAS .....</i>	9
5.4. <i>TESTED CHANNELS LIST.....</i>	10
5.5. <i>WORST-CASE CONFIGURATION AND MODE .....</i>	10
5.6. <i>DESCRIPTION OF TEST SETUP.....</i>	11
<b>6. TEST AND MEASUREMENT EQUIPMENT .....</b>	<b>13</b>
<b>7. REFERENCE MEASUREMENT RESULTS.....</b>	<b>14</b>
7.1. <i>ON TIME AND DUTY CYCLE RESULTS.....</i>	14
<b>8. MEASUREMENT METHODS .....</b>	<b>15</b>
<b>9. SUMMARY TABLE .....</b>	<b>16</b>
<b>10. ANTENNA PORT TEST RESULTS .....</b>	<b>17</b>
10.1. <i>6 dB BANDWIDTH.....</i>	17
10.1.1. <i>802.11b MODE IN THE 2.4 GHz BAND.....</i>	18
10.1.2. <i>802.11g MODE IN THE 2.4 GHz BAND.....</i>	18
10.1.3. <i>802.11n HT20 MODE IN THE 2.4 GHz BAND.....</i>	19
10.1.4. <i>6 dB BANDWIDTH PLOTS.....</i>	20
10.2. <i>OUTPUT POWER.....</i>	26
10.2.1. <i>1TX_TEST RESULTS .....</i>	27
10.2.2. <i>2TX_TEST RESULTS .....</i>	28
10.3. <i>PSD.....</i>	29
10.3.1. <i>TEST RESULTS.....</i>	30
10.3.2. <i>PSD PLOTS .....</i>	31
10.4. <i>OUT-OF-BAND EMISSIONS .....</i>	37
10.4.1. <i>802.11b MODE IN THE 2.4 GHz BAND.....</i>	38
10.4.2. <i>802.11g MODE IN THE 2.4 GHz BAND.....</i>	46

10.4.3. 802.11n HT20 MODE IN THE 2.4 GHz BAND .....56

**11. RADIATED TEST RESULTS .....66**

11.1. LIMITS AND PROCEDURE .....66

11.2. TRANSMITTER ABOVE 1 GHz .....68

11.2.1. TX ABOVE 1 GHz 802.11b MODE IN THE 2.4 GHz BAND ANTENNA1 .....68

11.2.2. TX ABOVE 1 GHz 802.11b MODE IN THE 2.4 GHz BAND ANTENNA2 .....82

11.2.3. TX ABOVE 1 GHz 802.11g MODE IN THE 2.4 GHz BAND ANTENNA1 .....96

11.2.4. TX ABOVE 1 GHz 802.11g MODE IN THE 2.4 GHz BAND ANTENNA2 .....112

11.2.5. TX ABOVE 1 GHz 802.11n HT20 MODE IN THE 2.4 GHz BAND ANTENNA1 128

11.2.6. TX ABOVE 1 GHz 802.11n HT20 MODE IN THE 2.4 GHz BAND ANTENNA2 144

11.2.7. TX ABOVE 1 GHz 802.11g 2TX CDD MODE IN THE 2.4 GHz BAND .....160

11.2.8. TX ABOVE 1 GHz 802.11n HT20 2TX CDD MODE IN THE 2.4 GHz BAND ....176

11.3. WORST-CASE BELOW 1 GHz..... 192

**12. AC POWER LINE CONDUCTED EMISSIONS .....194**

**13. SETUP PHOTOS .....199**

# 1. ATTESTATION OF TEST RESULTS

**COMPANY NAME:** SAMSUNG ELECTRONICS CO., LTD.

**EUT DESCRIPTION:** GSM/WCDMA/LTE Phone + BT/BLE, DTS/UNII a/b/g/n/ac/ax, ANT+, NFC and WPT

**MODEL NUMBER:** SM-G973F/DS, SM-G973F, SM-G973X

**SERIAL NUMBER:** R38KA0BE04H,R38KA0BE5CF (RADIATED);  
R38KA0BCW8E (CONDUCTED)

**DATE TESTED:** NOV 06, 2018 - NOV 29, 2018

APPLICABLE STANDARDS	
STANDARD	TEST RESULTS
CFR 47 Part 15 Subpart C	Pass

UL Korea, Ltd. tested the above equipment in accordance with the requirements set forth in the above standards. All indications of Pass/Fail in this report are opinions expressed by UL Korea, Ltd. based on interpretations and/or observations of test results. Measurement Uncertainties were not taken into account and are published for informational purposes only. The test results show that the equipment tested is capable of demonstrating compliance with the requirements as documented in this report.

**Note:** The results documented in this report apply only to the tested sample, under the conditions and modes of operation as described herein. This document may not be altered or revised in any way unless done so by UL Korea, Ltd. and all revisions are duly noted in the revisions section. Any alteration of this document not carried out by UL Korea, Ltd. will constitute fraud and shall nullify the document. This report must not be used by the client to claim product certification, approval, or endorsement by IAS, any agency of the Federal Government, or any agency of any government.

Approved & Released For  
UL Korea, Ltd. By:



SungGil Park  
Suwon Lab Engineer  
UL Korea, Ltd.

Tested By:



Hoonpyo Lee  
Suwon Lab Engineer  
UL Korea, Ltd.

## 2. TEST METHODOLOGY

The tests documented in this report were performed in accordance with following methods.

1. FCC CFR 47 Part 2.
2. FCC CFR 47 Part 15.
3. KDB 558074 D01 15.247 Meas Guidance v05.
4. ANSI C63.10-2013.
5. KDB 662911 D01 v02r01

## 3. FACILITIES AND ACCREDITATION

The test sites and measurement facilities used to collect data are located at 218 Maeyeong-ro, Yeongtong-gu, Suwon-si, Gyeonggi-do, 16675, Korea. Line conducted emissions are measured only at the 218 address. The following table identifies which facilities were utilized for radiated emission measurements documented in this report. Specific facilities are also identified in the test results sections.

218 Maeyeong-ro	
<input checked="" type="checkbox"/>	Chamber 1
<input checked="" type="checkbox"/>	Chamber 2
<input type="checkbox"/>	Chamber 3

UL Korea, Ltd. is accredited by IAS, Laboratory Code TL-637. The full scope of accreditation can be viewed at <http://www.iasonline.org/PDF/TL/TL-637.pdf>.

## 4. CALIBRATION AND UNCERTAINTY

### 4.1. MEASURING INSTRUMENT CALIBRATION

The measuring equipment utilized to perform the tests documented in this report has been calibrated in accordance with the manufacturer's recommendations, and is traceable to recognized national standards.

### 4.2. SAMPLE CALCULATION

Where relevant, the following sample calculation is provided:

$$\begin{aligned} \text{Field Strength (dBuV/m)} &= \text{Measured Voltage (dBuV)} + \text{Antenna Factor (dB/m)} + \\ &\text{Cable Loss (dB)} - \text{Preamp Gain (dB)} \\ 36.5 \text{ dBuV} + 18.7 \text{ dB/m} + 0.6 \text{ dB} - 26.9 \text{ dB} &= 28.9 \text{ dBuV/m} \end{aligned}$$

### 4.3. MEASUREMENT UNCERTAINTY

Where relevant, the following measurement uncertainty levels have been estimated for tests performed on the apparatus:

PARAMETER	UNCERTAINTY
Conducted Disturbance, 0.15 to 30 MHz	2.32 dB
Radiated Disturbance, Below 1GHz	3.86 dB
Radiated Disturbance, Above 1 GHz	5.97 dB

Uncertainty figures are valid to a confidence level of 95%.

## 5. EQUIPMENT UNDER TEST

### 5.1. DESCRIPTION OF EUT

The EUT is a GSM/WCDMA/LTE Phone + BT/BLE, DTS/UNII a/b/g/n/ac/ax, ANT+, NFC and WPT. This test report addresses the DTS (WLAN) operational mode.

#### WiFi MIMO Condition

Frequency	Mode	Antenna 1	Antenna 2
2.4GHz	802.11g	TX / RX	TX / RX
	802.11g MIMO	TX / RX	TX / RX
	802.11n	TX / RX	TX / RX
	802.11n MIMO	TX / RX	TX / RX
	802.11ax	TX / RX	TX / RX
	802.11ax MIMO	TX / RX	TX / RX
5 GHz	802.11a	TX / RX	TX / RX
	802.11a MIMO	TX / RX	TX / RX
	802.11n	TX / RX	TX / RX
	802.11n MIMO	TX / RX	TX / RX
	802.11ac	TX / RX	TX / RX
	802.11ac MIMO	TX / RX	TX / RX
	802.11ax	TX / RX	TX / RX
	802.11ax MIMO	TX / RX	TX / RX



**Simultaneous TX Condition (RSDB)**

	# TX	5GHz WIFI [dBm]		2.4GHz WIFI [dBm]	
		Ant1	Ant2	Ant1	Ant2
2.4 GHz + 5 GHz RSDB Only	2	A	-	-	B
	2	-	A	B	-
	2	A	-	B	-
	2	-	A	-	B
2.4 GHz + 5 GHz RSDB & MIMO	3	A	A	B	-
	3	A	A	-	B
	3	A	-	B	B
	3	-	A	B	B
2.4 GHz + 5 GHz RSDB MIMO	4	A	A	B	B

**Simultaneous TX Condition Bluetooth with 5GHz WIFI (Not RSDB)**

	# TX	5GHz WIFI		2.4GHz BT
		ANT1	ANT2	ANT1
2.4GHz BT+5GHz WIFI (Not RSDB)	2	A	-	B
	2	-	A	B
	3	A	A	B

Spurious Emissions for Simultaneous Transmission were reported on the UNII test report(4788725460-E4) section 11.5.

**5.2. MAXIMUM OUTPUT POWER**

The transmitter has a maximum total conducted average output power as follows:

Frequency Range [MHz]	Mode	Output Power [dBm]		Output Power [mW]	
		Antenna1	Antenna2	Antenna1	Antenna2
2412 - 2472	802.11b SISO	18.24	<b>18.80</b>	66.68	<b>75.86</b>
	802.11g SISO	15.97	15.74	39.54	37.50
	802.11g MIMO	<b>18.86</b>		<b>76.91</b>	
	802.11n HT20 SISO	15.91	15.73	38.99	37.41
	802.11n HT20 MIMO	18.83		76.38	

**5.3. DESCRIPTION OF AVAILABLE ANTENNAS**

The radio utilizes an internal antennas, with antenna1's maximum gain of -5.0 dBi and antenna2's maximum gain of -5.7 dBi ..

### 5.4. TESTED CHANNELS LIST

802.11b mode	CHANNEL	Frequency (MHz)
LOW	1	2412
MID	6	2437
HIGH	11	2462
REDUCTION HIGH 1	12	2467
REDUCTION HIGH 2	13	2472

802.11g/n mode	CHANNEL	Frequency (MHz)
LOW	1	2412
MID	6	2437
HIGH	10	2457
REDUCTION HIGH 1	11	2462
REDUCTION HIGH 2	12	2467
REDUCTION HIGH 3	13	2472

### 5.5. WORST-CASE CONFIGURATION AND MODE

Radiated emission below 1GHz and power line conducted emission were performed with the EUT set to transmit at the channel with highest output power as worst-case scenario.

Radiated emission above 1GHz was performed with the EUT set to transmit low/mid/High Channels.

For SISO, the fundamental of the EUT was investigated in three orthogonal orientations X, Y and Z it was determined that X orientation was worst-case orientation; therefore, all final radiated testing was performed with the EUT in X orientation.

For MIMO, the fundamental of the EUT was investigated in three orthogonal orientations X, Y and Z it was determined that Y orientation was worst-case orientation; therefore, all final radiated testing was performed with the EUT in Y orientation.

Based on the baseline scan, the worst-case data rates were:

802.11b mode: 1 Mbps  
 802.11g mode: 6 Mbps  
 802.11n HT20 mode: MCS0

Note : All radiated and power line conducted tests were performed connected with earphone and charger for evaluation of worst case mode.

## 5.6. DESCRIPTION OF TEST SETUP

### SUPPORT EQUIPMENT

Support Equipment List				
Description	Manufacturer	Model	Serial Number	FCC ID
Charger	SAMSUNG	EP-TA200	R37KB5B03T1SE3	N/A
Data Cable	SAMSUNG	EP-DG970BBE	N/A	N/A
Earphone	SAMSUNG	EO-IG955	N/A	N/A

### I/O CABLE

I/O Cable List						
Cable No	Port	# of identical ports	Connector Type	Cable Type	Cable Length (m)	Remarks
1	DC Power	1	C Type	Shielded	1.1m	N/A
2	Audio	2	Mini-Jack	Unshielded	1.2m	N/A

### TEST SETUP

The EUT is a stand-alone unit during the tests.  
 Test software in hidden menu exercised the EUT to enable DTS mode.

**SETUP DIAGRAM FOR TESTS (CONDUCTED TEST SETUP)**

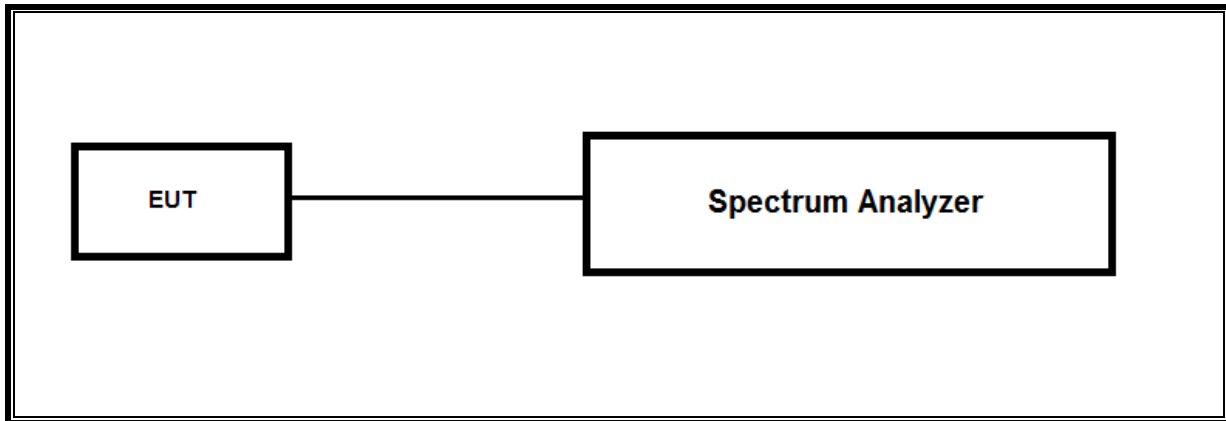

**SETUP DIAGRAM FOR TESTS (RADIATED TEST SETUP)**

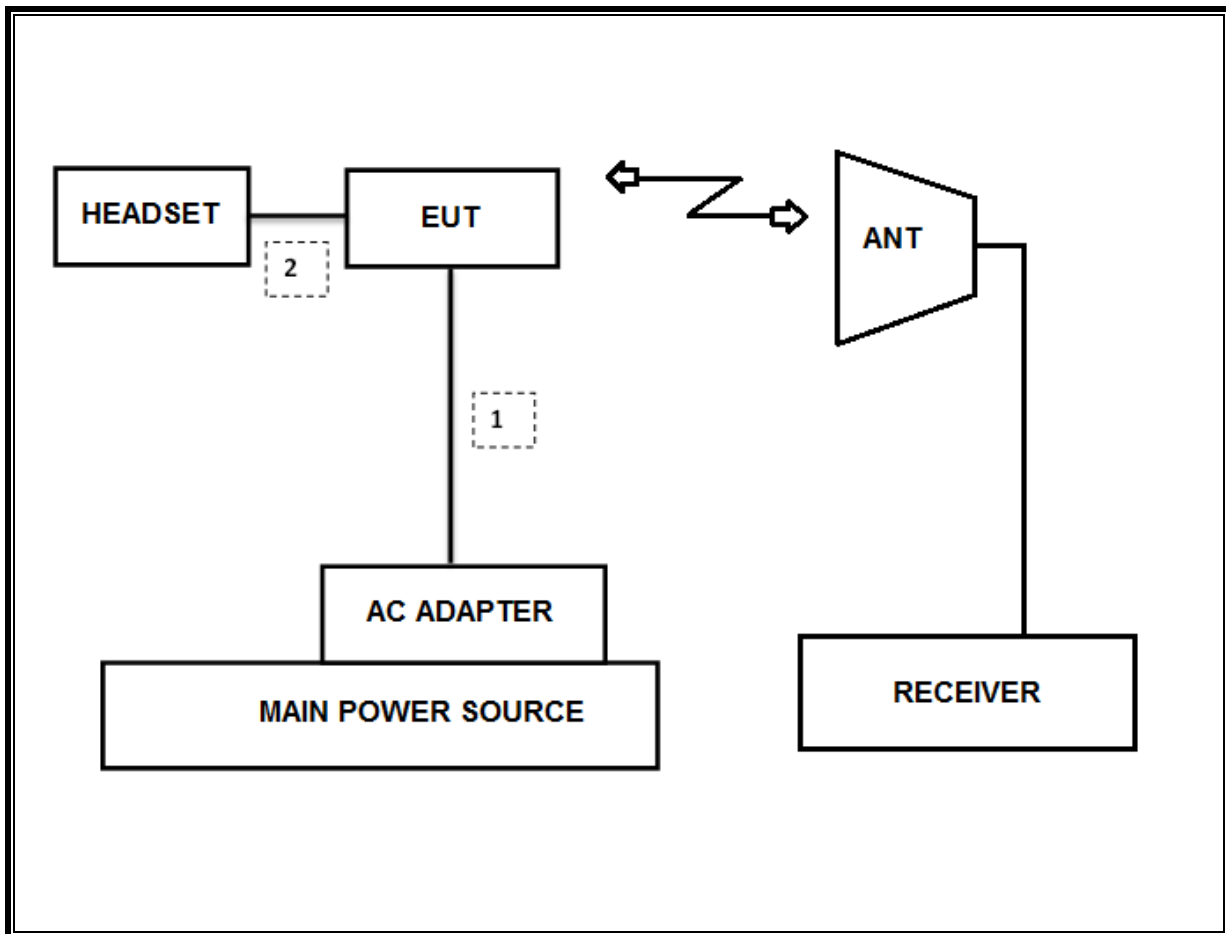

## 6. TEST AND MEASUREMENT EQUIPMENT

The following test and measurement equipment was utilized for the tests documented in this report:

Test Equipment List				
Description	Manufacturer	Model	S/N	Cal Due
Antenna, Bilog, 30MHz-1GHz	SCHWARZBECK	VULB9163	750	08-04-20
Antenna, Bilog, 30MHz-1GHz	SCHWARZBECK	VULB9163	749	08-04-20
Antenna, Bilog, 30MHz-1GHz	SCHWARZBECK	VULB9163	845	08-04-20
Antenna, Horn, 18 GHz	ETS	3115	00167211	08-04-20
Antenna, Horn, 18 GHz	ETS	3115	00161451	08-04-20
Antenna, Horn, 18 GHz	ETS	3117	00168724	08-04-20
Antenna, Horn, 18 GHz	ETS	3117	00168717	08-04-20
Antenna, Horn, 18 GHz	ETS	3117	00205959	08-04-20
Antenna, Horn, 40 GHz	ETS	3116C	00166155	12-04-19
Antenna, Horn, 40 GHz	ETS	3116C	00168645	12-04-19
Antenna, Horn, 40 GHz	ETS	3116C-PA	00168841	08-09-19
Preamplifier, 1000 MHz	Sonoma	310N	341282	08-07-19
Preamplifier, 1000 MHz	Sonoma	310N	351741	08-07-19
Preamplifier, 1000 MHz	Sonoma	310N	370599	08-06-19
Preamplifier, 18 GHz	Miteq	AFS42-00101800-25-S-42	1876511	08-07-19
Preamplifier, 18 GHz	Miteq	AFS42-00101800-25-S-42	1896138	08-07-19
Preamplifier, 18 GHz	Miteq	AFS42-00101800-25-S-42	2029169	08-07-19
Spectrum Analyzer, 44 GHz	Agilent / HP	N9030A	MY54170614	08-07-19
Spectrum Analyzer, 44 GHz	Agilent / HP	N9030A	MY54490312	08-06-19
Spectrum Analyzer, 43.5 GHz	R&S	FSW43	104089	08-06-19
Average Power Sensor	Agilent / HP	U2000	MY54270007	08-07-19
Attenuator	PASTERNAK	PE7087-10	A001	08-08-19
Attenuator	PASTERNAK	PE7087-10	A008	08-08-19
Attenuator	PASTERNAK	PE7004-10	2	08-07-19
Attenuator	PASTERNAK	PE7087-10	A009	08-08-19
EMI Test Receive, 40 GHz	R&S	ESU40	100439	08-06-19
EMI Test Receive, 40 GHz	R&S	ESU40	100457	08-06-19
EMI Test Receive, 44 GHz	R&S	ESW44	101590	08-06-19
EMI Test Receive, 3 GHz	R&S	ESR3	101832	08-06-19
Low Pass Filter 5GHz	Micro-Tronics	LPS17541	009	08-07-19
Low Pass Filter 5GHz	Micro-Tronics	LPS17541	015	08-07-19
Low Pass Filter 5GHz	Micro-Tronics	LPS17541	020	08-06-19
High Pass Filter 3GHz	Micro-Tronics	HPM17543	010	08-07-19
High Pass Filter 3GHz	Micro-Tronics	HPM17543	015	08-07-19
High Pass Filter 3GHz	Micro-Tronics	HPM17543	020	08-06-19
High Pass Filter 6GHz	Micro-Tronics	HPS17542	009	08-07-19
High Pass Filter 6GHz	Micro-Tronics	HPS17542	016	08-07-19
High Pass Filter 6GHz	Micro-Tronics	HPS17542	021	08-06-19
Antenna, Loop, 9kHz-30MHz	R&S	HFH2-Z2	100418	10-26-19
LISN	R&S	ENV-216	101837	08-09-19
UL Software				
Description	Manufacturer	Model	Version	
Radiated software	UL	UL EMC	Ver 9.5	
AC Line Conducted software	UL	UL EMC	Ver 9.5	

## 7. REFERENCE MEASUREMENT RESULTS

### 7.1. ON TIME AND DUTY CYCLE RESULTS

#### LIMITS

None; for reporting purposes only.

Mode	On Time [mS]	Period [mS]	Duty Cycle X [linear]	Duty Cycle X [%]	Duty Cycle Correction Factor [dB]	1/T Minimum VBW [kHz]
802.11b	32.950	33.050	0.997	99.7	0.00	0.010
802.11g	5.484	5.584	0.982	98.2	0.00	0.010
802.11n HT20	5.079	5.182	0.980	98.0	0.00	0.010

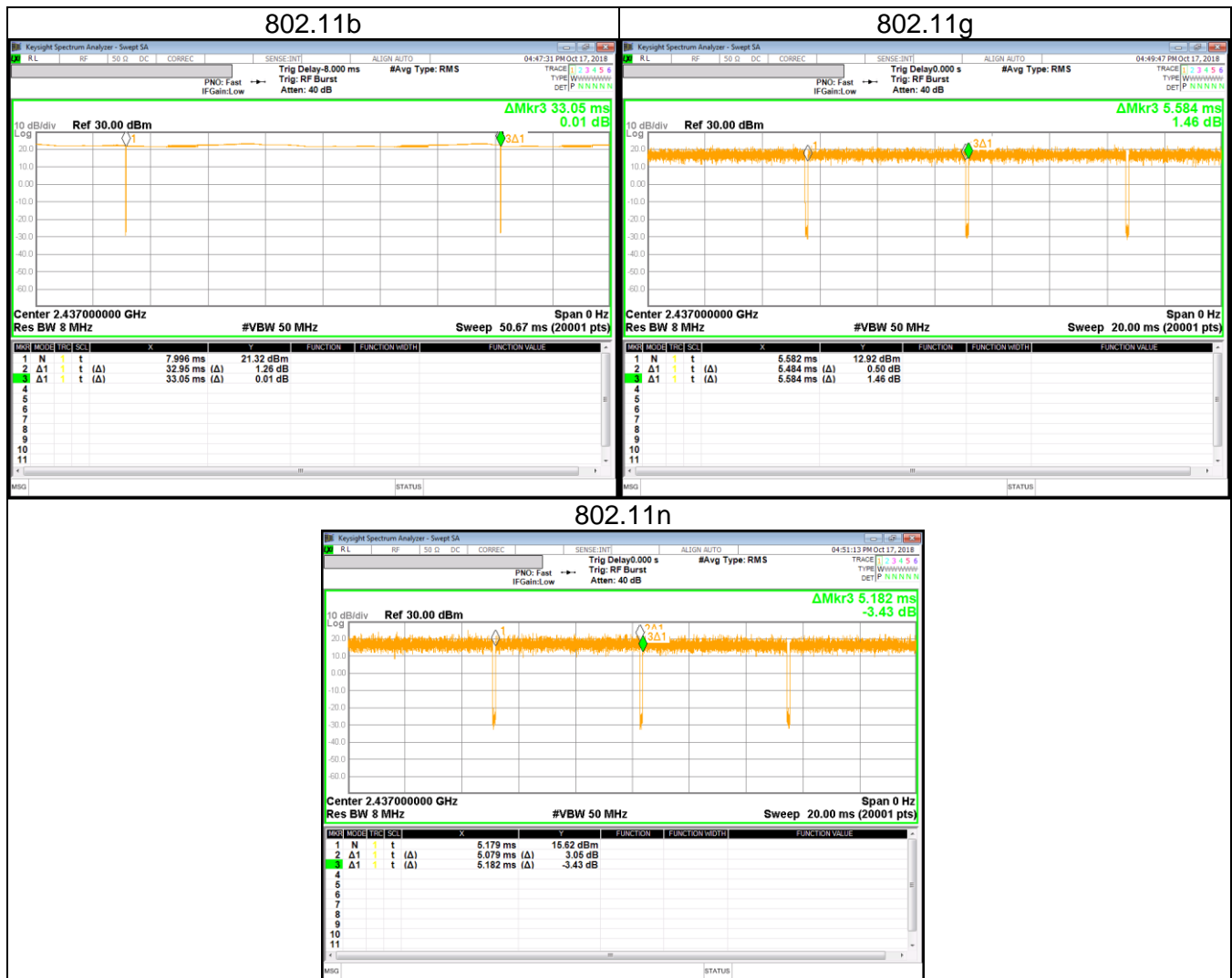

## 8. MEASUREMENT METHODS

6 dB BW : KDB 558074 D01 v05, Section 8.2.

OUTPUT POWER : KDB 558074 D01 v05, Section 8.3.2.3.

POWER SPECTRAL DENSITY : KDB 558074 D01 v05, Section 8.4.

Out-of-band EMISSIONS (Conducted) : KDB 558074 D01 v05, Section 8.5, 8.7.

Out-of-band EMISSIONS IN NON-RESTRICTED BANDS: KDB 558074 D01 v05, Section 8.5.

Out-of-band EMISSIONS IN RESTRICTED BANDS : KDB 558074 D01 v05, Section 8.6.

AC Power Line Conducted Emission : ANSI C63.10-2013, Section 6.2.

## 9. SUMMARY TABLE

FCC Part Section	Test Description	Test Limit	Test Condition	Test Result
15.247 (a)(2)	Occupied Band width (6dB)	>500KHz	Conducted	Pass
2.1051, 15.247 (d)	Band Edge / Conducted Spurious Emission	-30dBc		Pass
15.247 (b)(3)	TX conducted output power	<30dBm		Pass
15.247 (e)	PSD	<8dBm		Pass
15.207 (a)	AC Power Line conducted emissions	Section 10	Power Line conducted	Pass
15.205, 15.209	Radiated Spurious Emission	< 54dBuV/m	Radiated	Pass



## 10. ANTENNA PORT TEST RESULTS

### 10.1. 6 dB BANDWIDTH

#### LIMITS

FCC §15.247 (a) (2)

The minimum 6 dB bandwidth shall be at least 500 kHz.

#### TEST PROCEDURE

Reference to KDB 558074 D01 15.247 Meas Guidance: The transmitter output is connected to a spectrum analyzer with the RBW set to 100KHz, the VBW  $\geq 3 \times$  RBW, peak detector and max hold.

**RESULTS**

**10.1.1. 802.11b MODE IN THE 2.4 GHz BAND**

ANTENNA	Channel	Frequency [MHz]	6 dB Bandwidth [MHz]	Minimum Limit [MHz]
1	Low	2412	7.544	0.5
	Mid	2437	7.556	0.5
	High	2462	7.061	0.5
	11	2467	8.019	0.5
	12	2472	7.556	0.5
	Worst			<b>7.061</b>
2	Low	2412	7.564	0.5
	Mid	2437	7.090	0.5
	High	2462	7.082	0.5
	11	2467	7.546	0.5
	12	2472	7.565	0.5
	Worst			<b>7.082</b>

**10.1.2. 802.11g MODE IN THE 2.4 GHz BAND**

ANTENNA	Channel	Frequency [MHz]	6 dB Bandwidth [MHz]	Minimum Limit [MHz]
1	Low	2412	16.350	0.5
	Mid	2437	16.350	0.5
	High	2457	16.360	0.5
	11	2462	16.340	0.5
	12	2467	16.360	0.5
	13	2472	16.360	0.5
	Worst			<b>16.340</b>
2	Low	2412	16.360	0.5
	Mid	2437	16.350	0.5
	High	2457	16.350	0.5
	11	2462	16.330	0.5
	12	2467	16.340	0.5
	13	2472	16.090	0.5
	Worst			<b>16.090</b>

10.1.3. **802.11n HT20 MODE IN THE 2.4 GHz BAND**

ANTENNA	Channel	Frequency [MHz]	6 dB Bandwidth [MHz]	Minimum Limit [MHz]
1	Low	2412	17.590	0.5
	Mid	2437	17.570	0.5
	High	2457	17.600	0.5
	11	2462	17.580	0.5
	12	2467	17.580	0.5
	13	2472	17.590	0.5
	Worst			<b>17.570</b>
2	Low	2412	17.590	0.5
	Mid	2437	17.580	0.5
	High	2457	17.580	0.5
	11	2462	17.580	0.5
	12	2467	17.330	0.5
	13	2472	16.940	0.5
	Worst			<b>16.940</b>

### 10.1.4. 6 dB BANDWIDTH PLOTS



### 1TX\_ANTENNA 2

#### 11b Mode Low

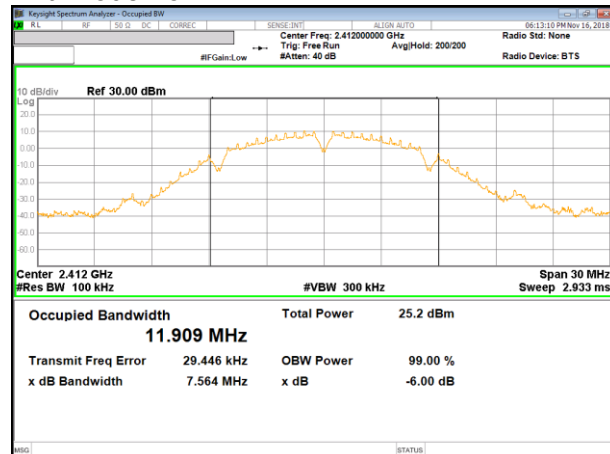

#### 11b Mode Mid

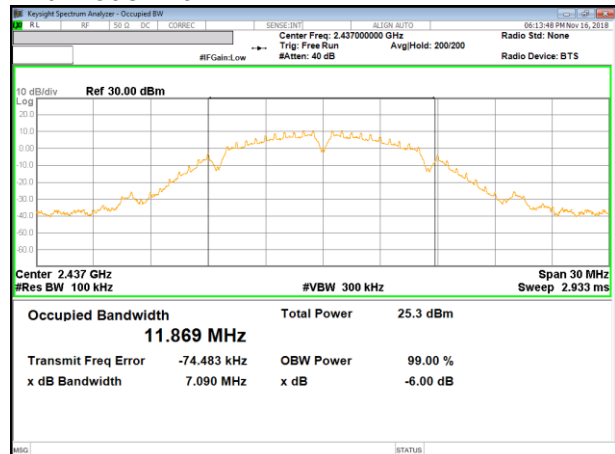

#### 11b Mode High

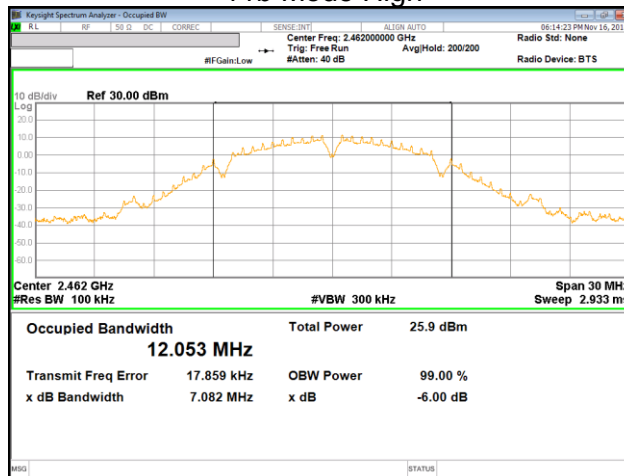

#### 11b Mode 12 CH

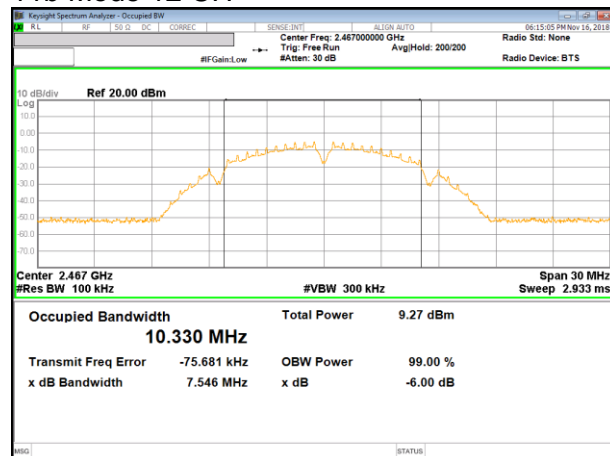

#### 11b Mode 13 CH

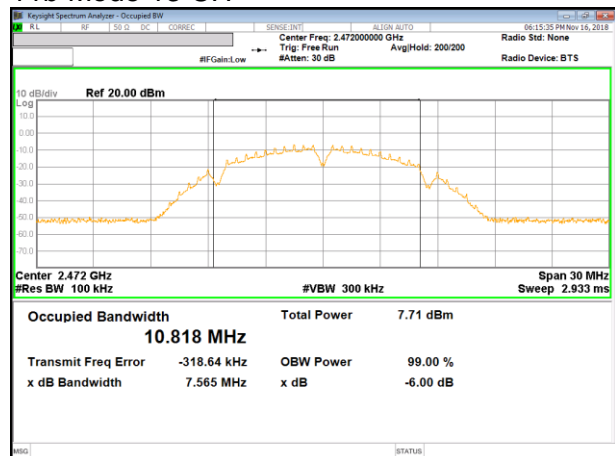

### 1TX\_ANTENNA 1

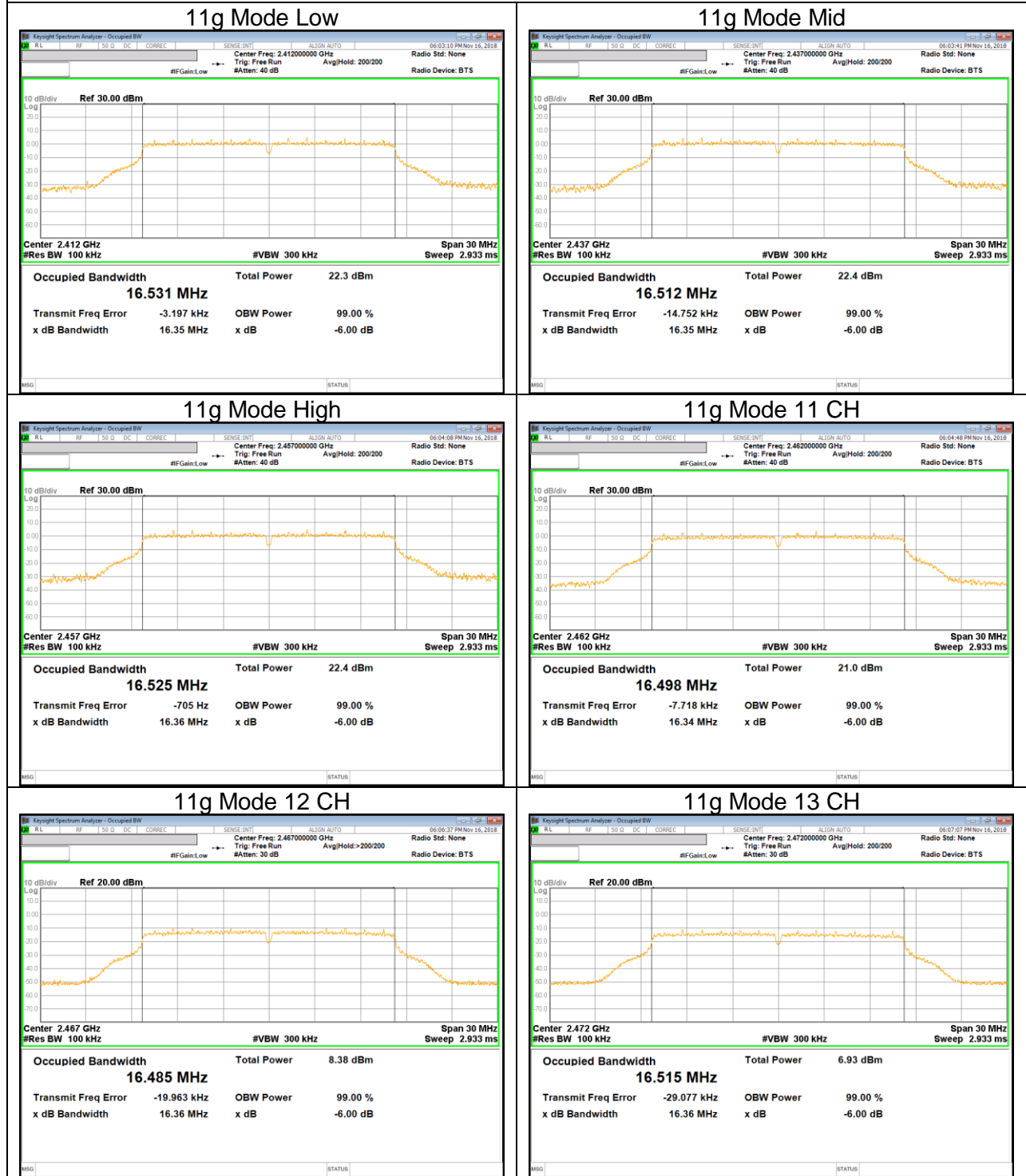

1TX\_ANTENNA 2

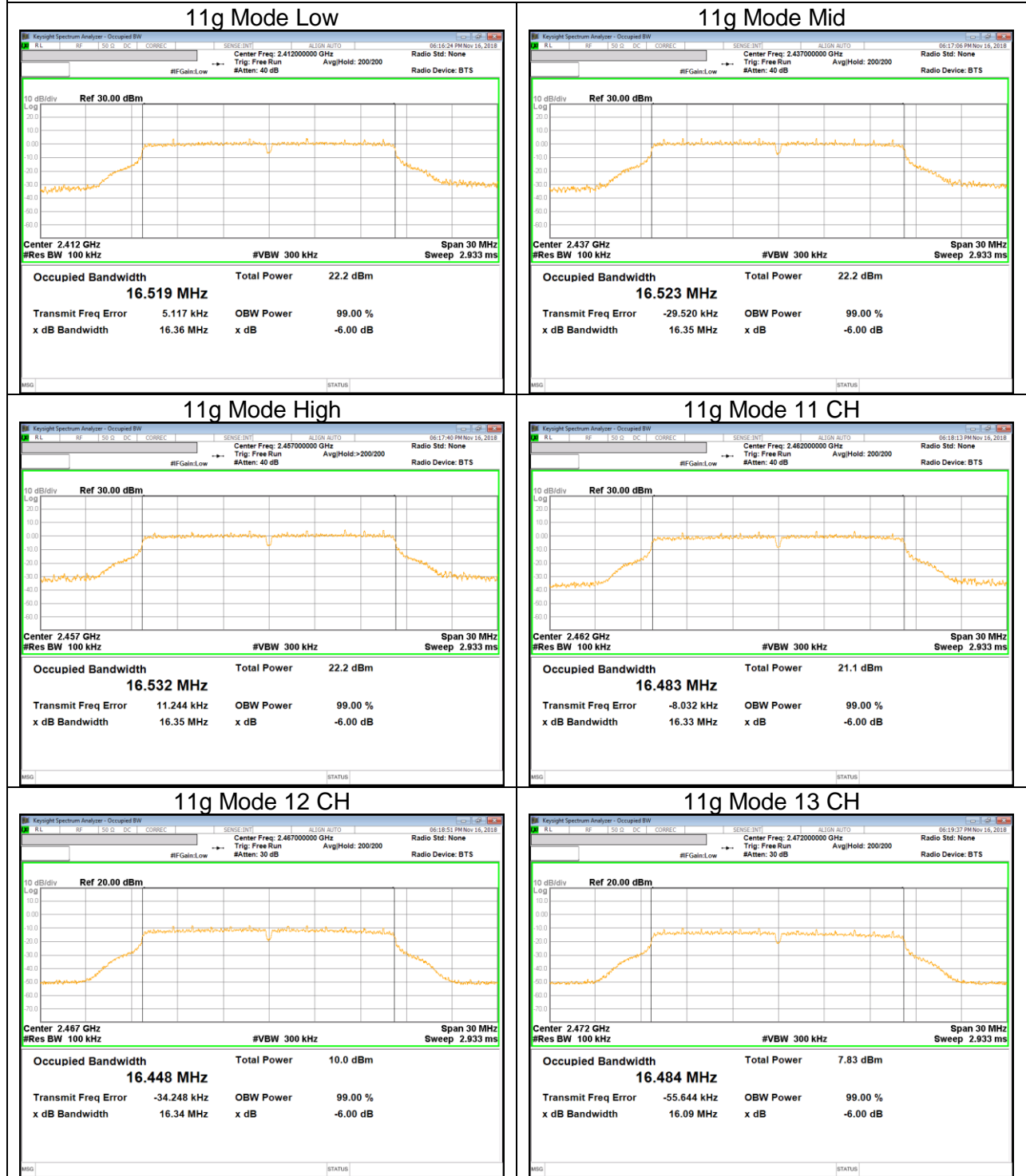

1TX\_ANTENNA 1

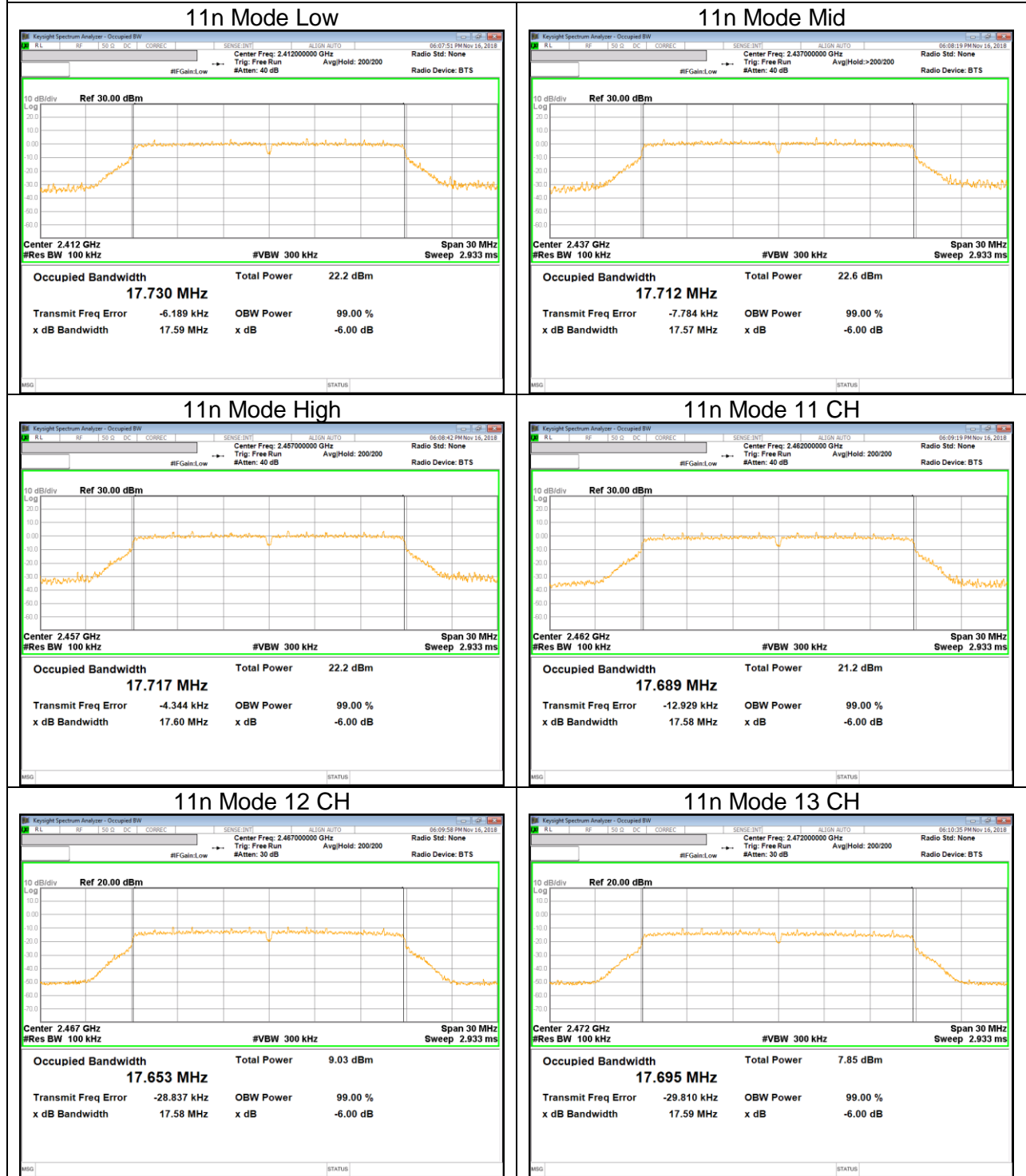



1TX\_ANTENNA 2

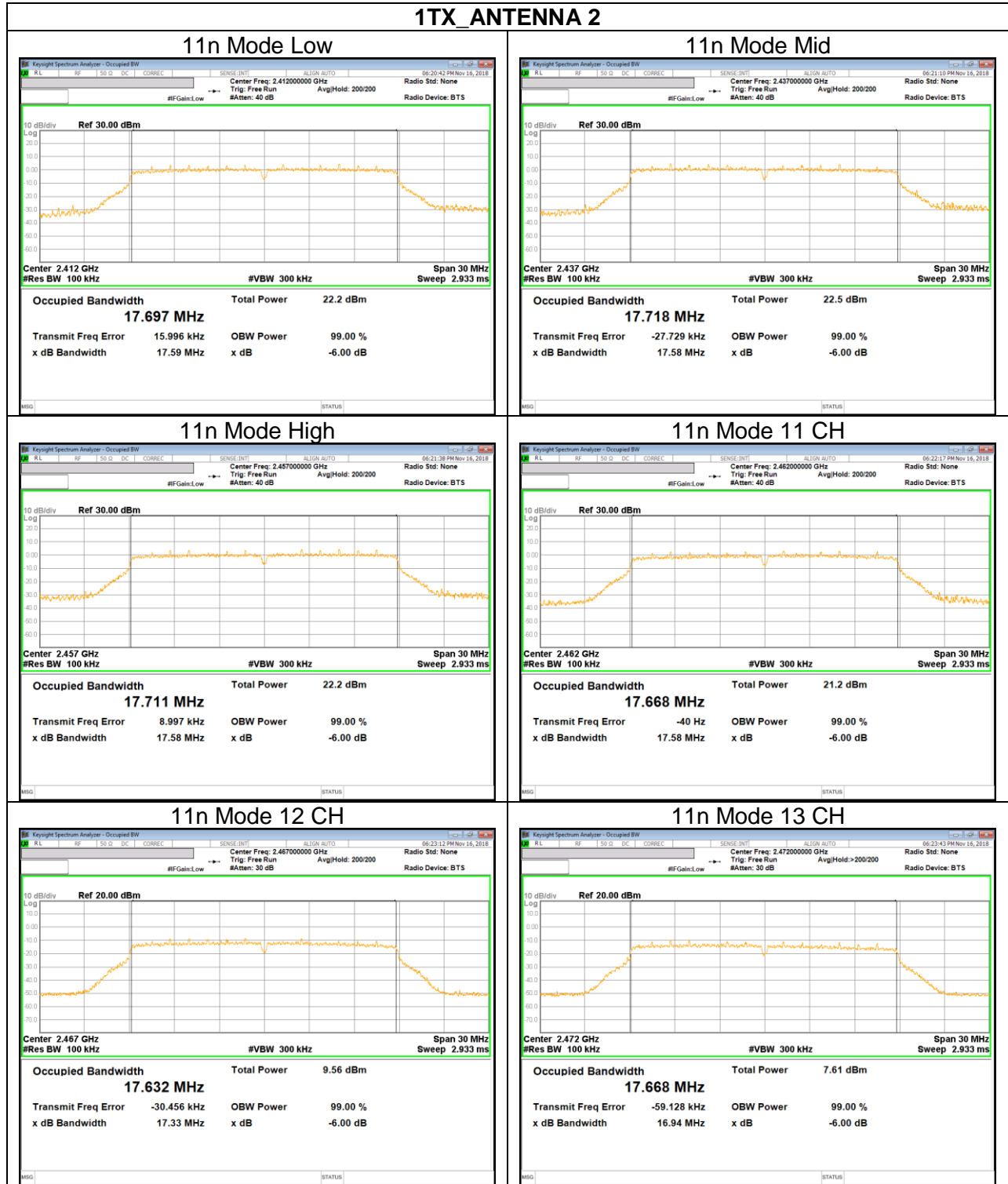

## 10.2. OUTPUT POWER

### LIMITS

FCC §15.247

For systems using digital modulation in the 902–928 MHz, 2400–2483.5 MHz, and 5725–5850 MHz bands: 1 Watt, based on the use of antennas with directional gains that do not exceed 6 dBi. If transmitting antennas of directional gain greater than 6 dBi are used, the conducted output power from the intentional radiator shall be reduced by the amount in dB that the directional gain of the antenna exceeds 6 dBi.

### TEST PROCEDURE

The transmitter output is connected to a power meter.

The cable assembly insertion loss was entered as an offset in the power meter to allow for direct reading of power.

Output power measurement was performed utilizing the 8.3.2.3 under KDB558074 D01 15.247 Meas Guidance.

Duty cycle correction factor is not added to the average output power results for duty cycle factor > 98%. (All mode)

### DIRECTIONAL ANTENNA GAIN

The TX chains are correlated and the antenna gain is unequal among the chains.  
The directional gain is:

Frequency Band [MHz]	Antenna1 Gain [dBi]	Antenna2 Gain [dBi]	Correlated Chains Directional Gain [dBi]
2400 ~ 2483.5	-5.00	-5.70	-2.33

- IEEE 802.11b Mode is not supported MIMO operation. So can't transmit on two antennas as the same time.

**RESULTS**

**10.2.1. 1TX\_TEST RESULTS**

**Limits**

Frequency Range [MHz]	Directional Gain ANTENNA1 [dBi]	Directional Gain ANTENNA2 [dBi]	FCC Power Limit [dBm]	Max Power [dBm]
2412 - 2472	-5.00	-5.70	30.00	30.00

Included in Calculations of Corr'd Power			
Duty Cycle CF [dB]	b	0.00	dB
	g	0.00	dB
	n	0.00	dB

**Calculation of Output Power result**

Corr'd Power [dBm] = Meas Power [dBm] + Duty CF [dB]

**Output Power Results**

Mode	Channel	Frequency [MHz]	Antenna 1 Meas Power [dBm]	Antenna 2 Meas Power [dBm]	Antenna 1 Corr'd Power [dBm]	Antenna 2 Corr'd Power [dBm]	Power Limit [dBm]	Power Margin [dB]
802.11b	Low	2412	18.24	18.32	18.24	18.32	30.00	-11.68
	Mid	2437	18.19	18.27	18.19	18.27	30.00	-11.73
	High	2462	17.62	18.80	17.62	18.80	30.00	-11.20
	12	2467	2.51	2.52	2.51	2.52	30.00	-27.48
	13	2472	0.65	0.84	0.65	0.84	30.00	-29.16
Worst Case					18.24	18.80	30.00	-11.20

**Output Power Results**

Mode	Channel	Frequency [MHz]	Antenna 1 Meas Power [dBm]	Antenna 2 Meas Power [dBm]	Antenna 1 Corr'd Power [dBm]	Antenna 2 Corr'd Power [dBm]	Power Limit [dBm]	Power Margin [dB]
802.11g	Low	2412	15.65	15.74	15.65	15.74	30.00	-14.26
	Mid	2437	15.97	15.70	15.97	15.70	30.00	-14.03
	High	2457	15.47	15.51	15.47	15.51	30.00	-14.49
	11	2462	14.34	14.49	14.34	14.49	30.00	-15.51
	12	2467	3.01	2.97	3.01	2.97	30.00	-26.99
	13	2472	0.92	1.43	0.92	1.43	30.00	-28.57
Worst Case					15.97	15.74	30.00	-14.03

**Output Power Results**

Mode	Channel	Frequency [MHz]	Antenna 1 Meas Power [dBm]	Antenna 2 Meas Power [dBm]	Antenna 1 Corr'd Power [dBm]	Antenna 2 Corr'd Power [dBm]	Power Limit [dBm]	Power Margin [dB]
802.11n	Low	2412	15.42	15.69	15.42	15.69	30.00	-14.31
	Mid	2437	15.91	15.73	15.91	15.73	30.00	-14.09
	High	2457	15.31	15.31	15.31	15.31	30.00	-14.69
	11	2462	14.29	14.45	14.29	14.45	30.00	-15.55
	12	2467	3.13	2.92	3.13	2.92	30.00	-26.87
	13	2472	1.27	1.15	1.27	1.15	30.00	-28.73
Worst Case					15.91	15.73	30.00	-14.09

### 10.2.2. 2TX\_TEST RESULTS

Limits

Frequency Range [MHz]	Correlated Chains Directional Gain [dBi]	FCC Power Limit [dBm]	Max Power [dBm]
2412 - 2472	-2.33	30.00	30

Included in Calculations of Corr'd Power			
Duty Cycle CF [dB]	g	0.00	dB
	n	0.00	dB

Calculation of Output Power result

Sum PW  
 = ANTENNA1\_Meas Power [mW] + ANTENNA2\_Meas Power [mW]  
 Total Corr'd Power [dBm]  
 = Sum PW [dBm] + Duty CF [dB]

Output Power Results

Mode	Channel	Frequency [MHz]	Antenna 1 Meas Power [dBm]	Antenna 2 Meas Power [dBm]	Total Corr'd Power [dBm]	Power Limit [dBm]	Power Margin [dB]
802.11g	Low	2412	15.60	15.24	18.43	30.00	-11.57
	Mid	2437	15.99	15.70	<b>18.86</b>	30.00	<b>-11.14</b>
	High	2457	15.89	15.65	18.78	30.00	-11.22
	11	2462	14.93	14.48	17.72	30.00	-12.28
	12	2467	2.76	2.62	5.70	30.00	-24.30
	13	2472	1.21	1.12	4.18	30.00	-25.82
Worst Case					<b>18.86</b>	30.00	<b>-11.14</b>

Mode	Channel	Frequency [MHz]	Antenna 1 Meas Power [dBm]	Antenna 2 Meas Power [dBm]	Total Corr'd Power [dBm]	Power Limit [dBm]	Power Margin [dB]
802.11n	Low	2412	15.50	15.21	18.37	<b>30.00</b>	-11.63
	Mid	2437	15.97	15.67	<b>18.83</b>	<b>30.00</b>	<b>-11.17</b>
	High	2457	15.90	15.53	18.73	<b>30.00</b>	-11.27
	11	2462	14.80	14.51	17.67	<b>30.00</b>	-12.33
	12	2467	2.85	3.15	6.01	<b>30.00</b>	-23.99
	13	2472	1.48	1.47	4.49	<b>30.00</b>	-25.51
Worst Case					<b>18.83</b>	30.00	<b>-11.17</b>

### **10.3. PSD**

#### **LIMITS**

FCC §15.247

The power spectral density conducted from the transmitter to the antenna shall not be greater than 8 dBm in any 3 kHz band during any time interval of continuous transmission.

#### **TEST PROCEDURE**

Power Spectral Density was performed utilizing the section 8.4 under KDB558074 D01 15.247 Meas Guidance.

**RESULTS**

**10.3.1. TEST RESULTS**

Included in Calculations of Corr'd Power			
Duty Cycle CF [dB]	b	0.00	dB
	g	0.00	dB
	n	0.00	dB

**Calculation of Output Power result**

- 1TX  
 $\text{Corr'd PSD [dBm]} = \text{Meas PSD [dBm]} + \text{Duty CF [dB]}$
- 2TX  
 $\text{Sum PSD} = \text{Ant1\_Meas PSD [mW]} + \text{Ant1\_Meas PSD [mW]}$   
 $\text{Total Corr'd PSD [dBm]} = \text{Sum PW [dBm]} + \text{Duty CF [dB]}$

**PSD Results**

Mode	Channel	Frequency [MHz]	Antenna 1	Antenna 2	Antenna 1	Antenna 2	PSD Limit [dBm/3kHz]	PSD Margin [dB]
			Meas PSD [dBm/3kHz]	Meas PSD [dBm/3kHz]	Corr'd PSD [dBm/3kHz]	Corr'd PSD [dBm/3kHz]		
802.11b	Low	2412	-12.09	-13.00	<b>-12.09</b>	-13.00	8.00	-20.09
	Mid	2437	-12.63	-12.72	-12.63	-12.72	8.00	-20.63
	High	2462	-13.53	-11.94	-13.53	<b>-11.94</b>	8.00	<b>-19.94</b>
	12	2467	-28.27	-27.24	-28.27	-27.24	8.00	-35.24
	13	2472	-30.12	-29.69	-30.12	-29.69	8.00	-37.69
Worst Case					-12.09	<b>-11.94</b>	8.00	<b>-19.94</b>

**PSD Results**

Mode	Channel	Frequency [MHz]	Antenna 1	Antenna 2	Total	PSD Limit [dBm/3kHz]	PSD Margin [dB]
			Meas PSD [dBm/3kHz]	Meas PSD [dBm/3kHz]	Corr'd PSD [dBm/3kHz]		
802.11g	Low	2412	-17.07	-16.27	-13.64	8.00	-21.64
	Mid	2437	-15.72	-16.85	<b>-13.24</b>	8.00	<b>-21.24</b>
	High	2457	-17.25	-16.24	-13.70	8.00	-21.70
	11	2462	-18.23	-17.50	-14.84	8.00	-22.84
	12	2467	-28.93	-29.02	-25.96	8.00	-33.96
	13	2472	-32.29	-30.46	-28.27	8.00	-36.27
Worst Case					<b>-13.24</b>	8.00	<b>-21.24</b>

**PSD Results**

Mode	Channel	Frequency [MHz]	Antenna 1	Antenna 2	Total	PSD Limit [dBm/3kHz]	PSD Margin [dB]
			Meas PSD [dBm/3kHz]	Meas PSD [dBm/3kHz]	Corr'd PSD [dBm/3kHz]		
802.11n	Low	2412	-19.01	-18.73	-15.86	8.00	-23.86
	Mid	2437	-18.23	-18.34	<b>-15.28</b>	8.00	<b>-23.28</b>
	High	2457	-18.98	-18.96	-15.96	8.00	-23.96
	11	2462	-19.95	-19.73	-16.83	8.00	-24.83
	12	2467	-31.52	-31.05	-28.26	8.00	-36.26
	13	2472	-32.97	-33.16	-30.05	8.00	-38.05
Worst Case					<b>-15.28</b>	8.00	<b>-23.28</b>

### 10.3.2. PSD PLOTS

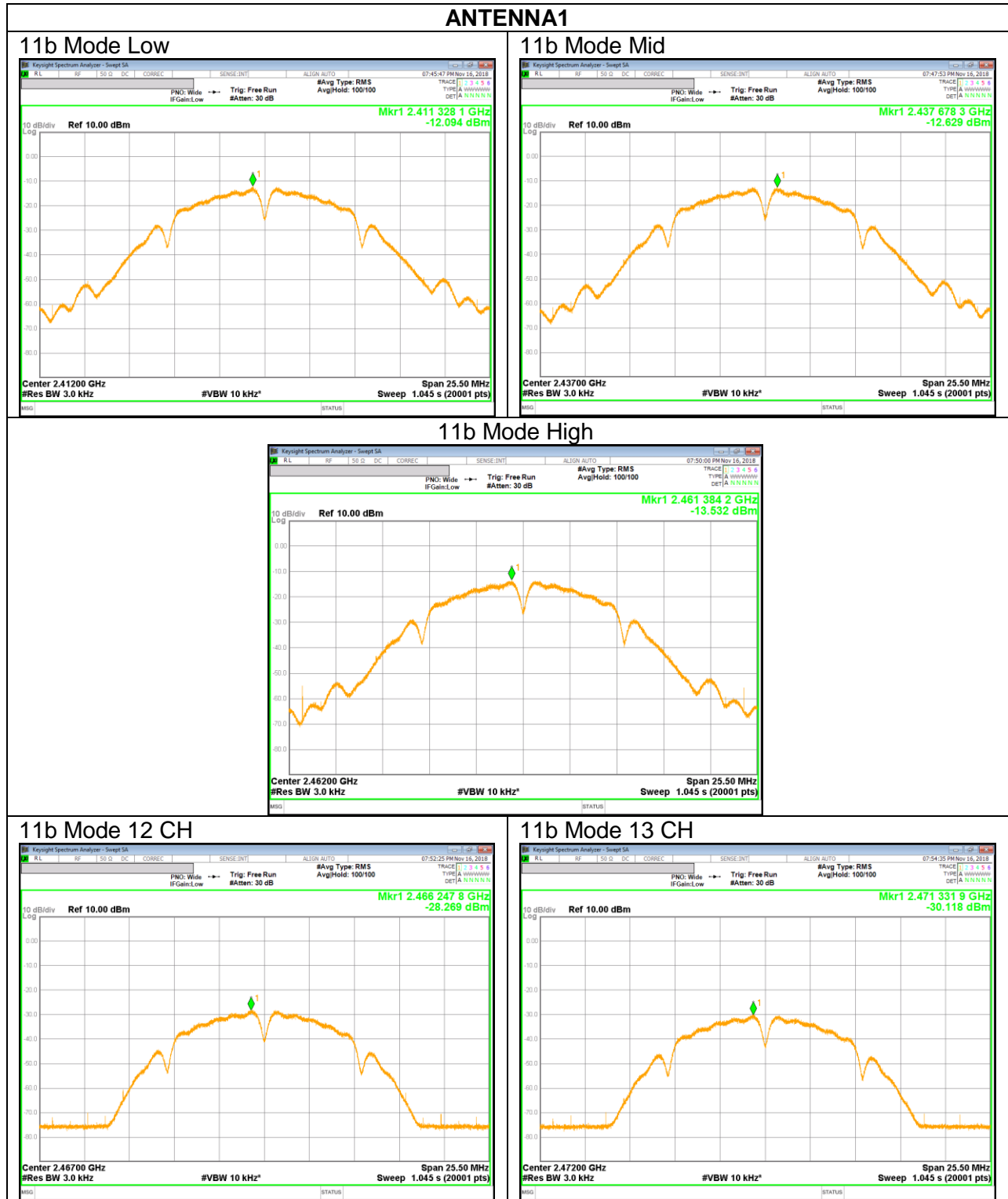

ANTENNA 2

11b Mode Low

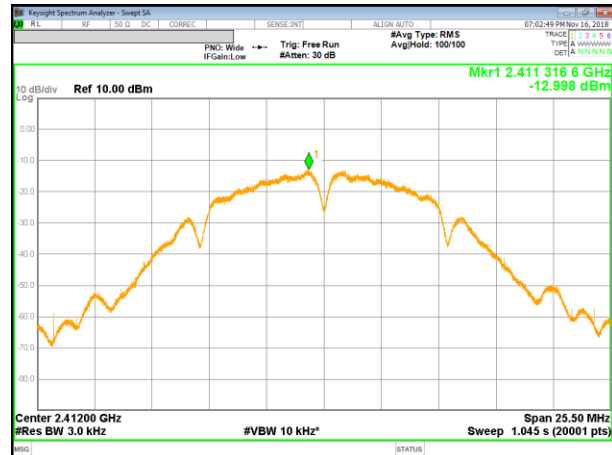

11b Mode Mid

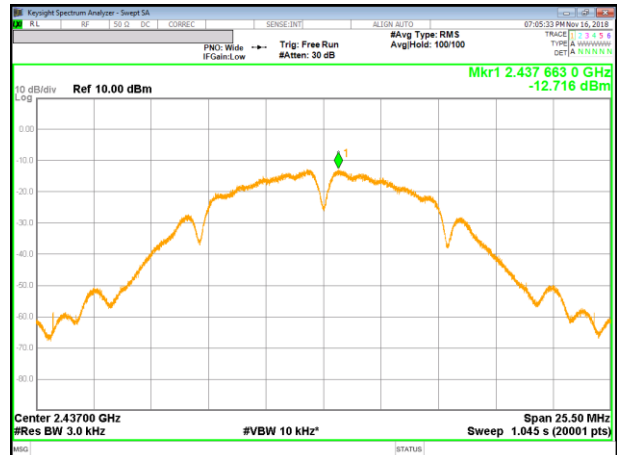

11b Mode High



11b Mode 12 CH

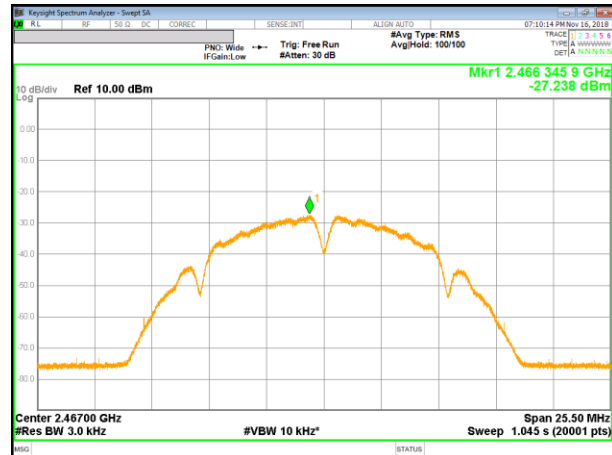

11b Mode 13 CH

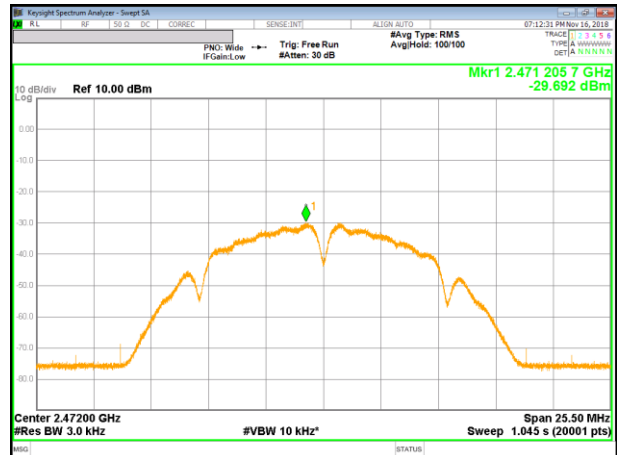



ANTENNA 1

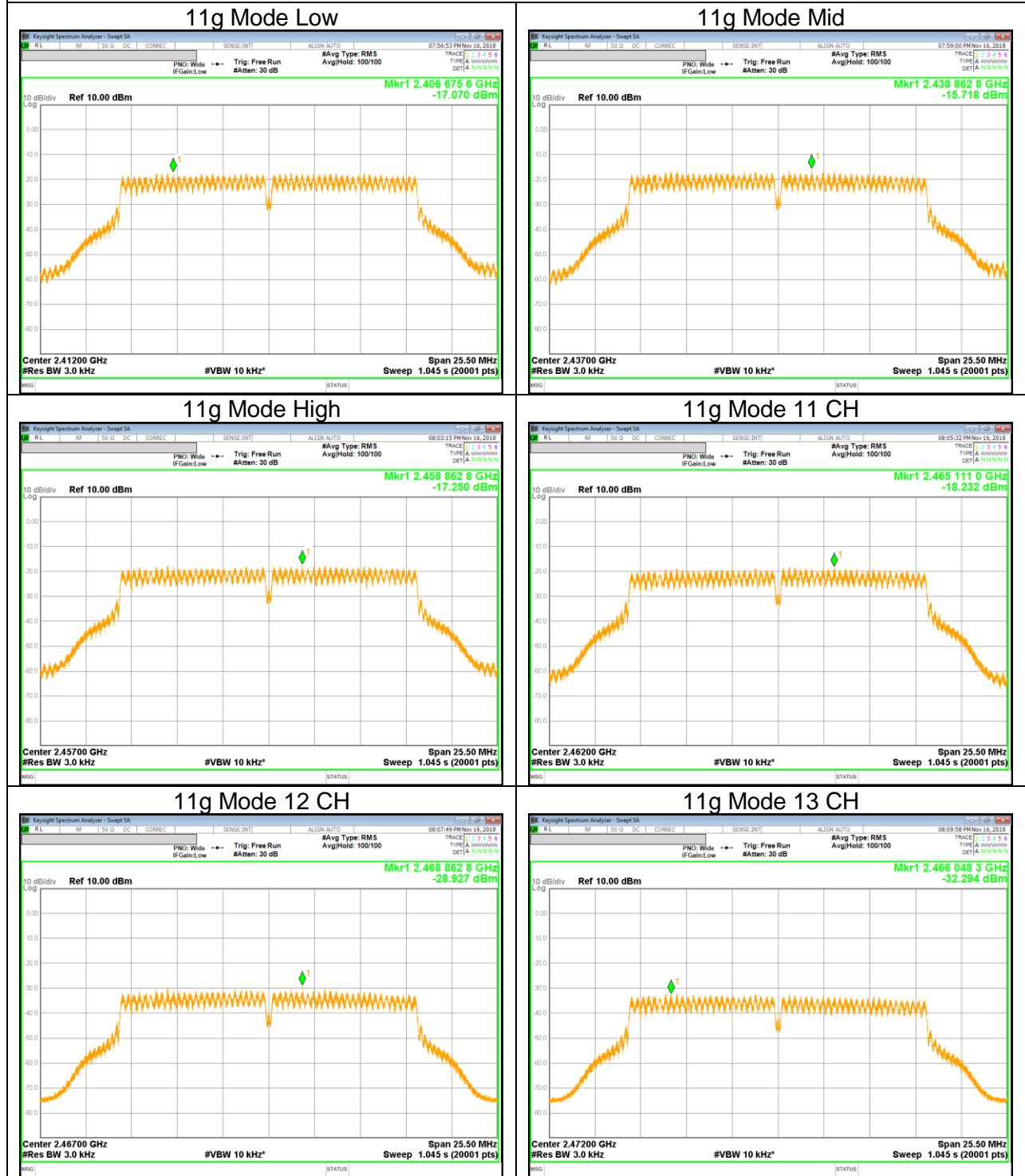

ANTENNA 2

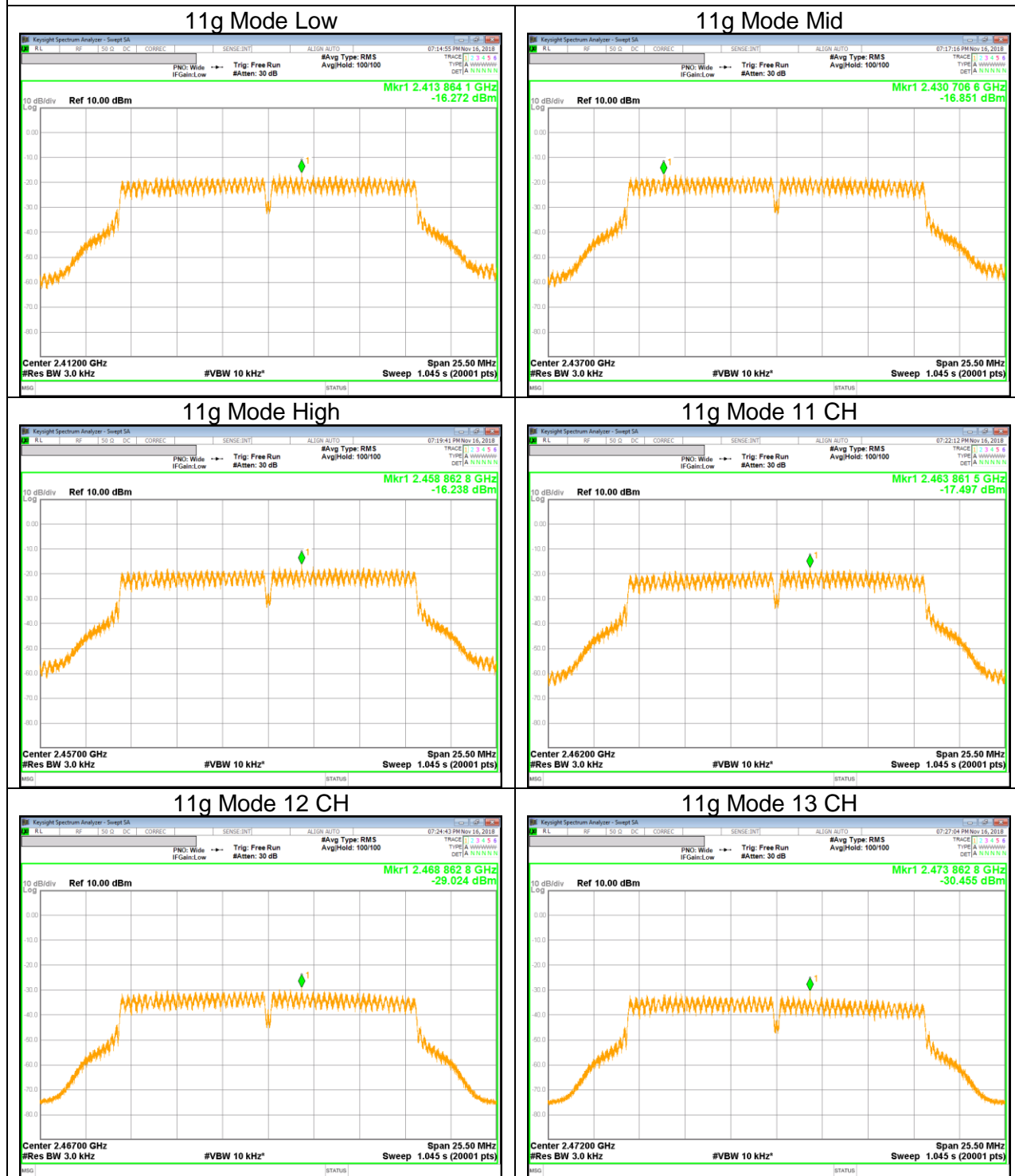

### ANTENNA 1

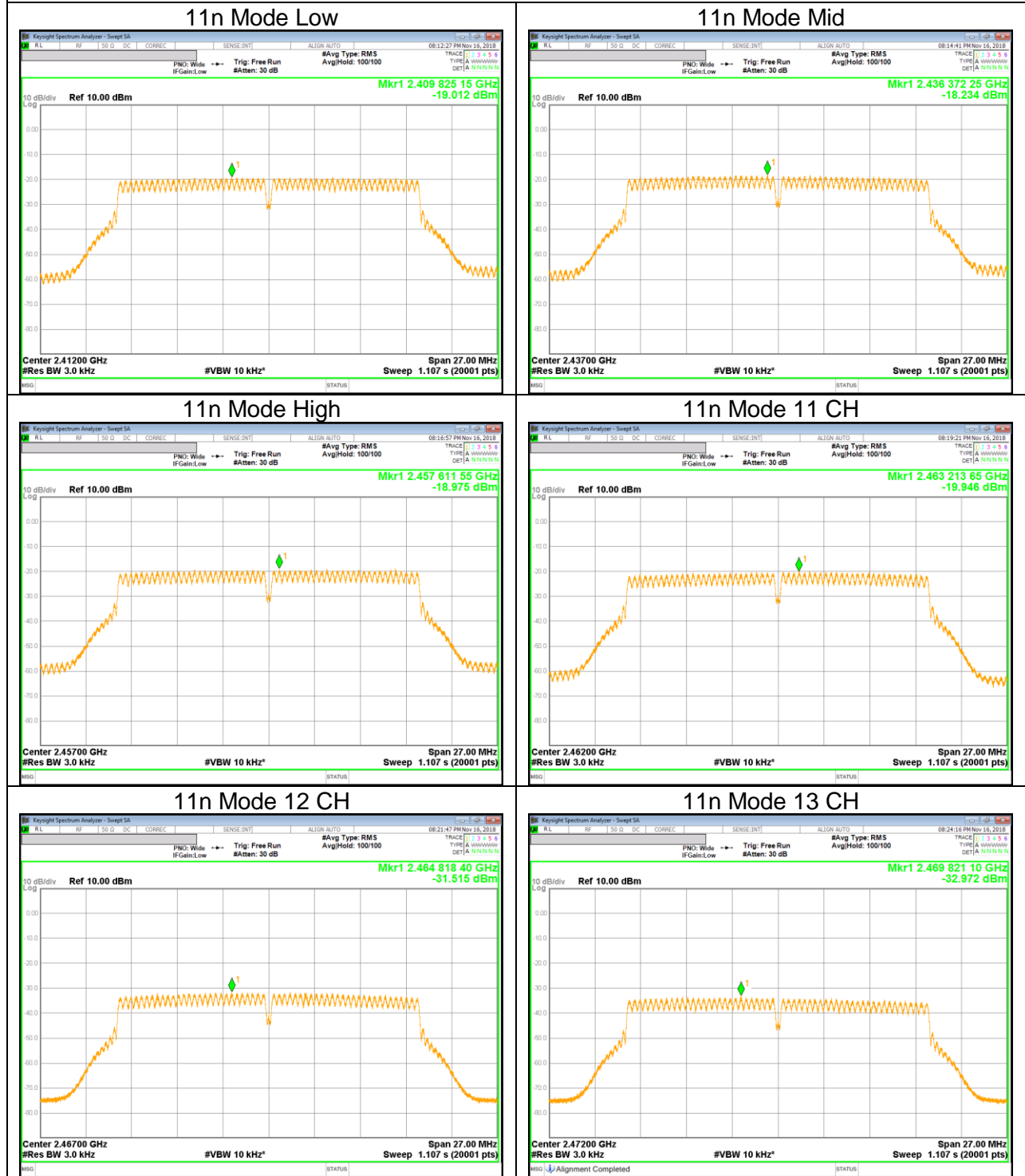

### ANTENNA 2

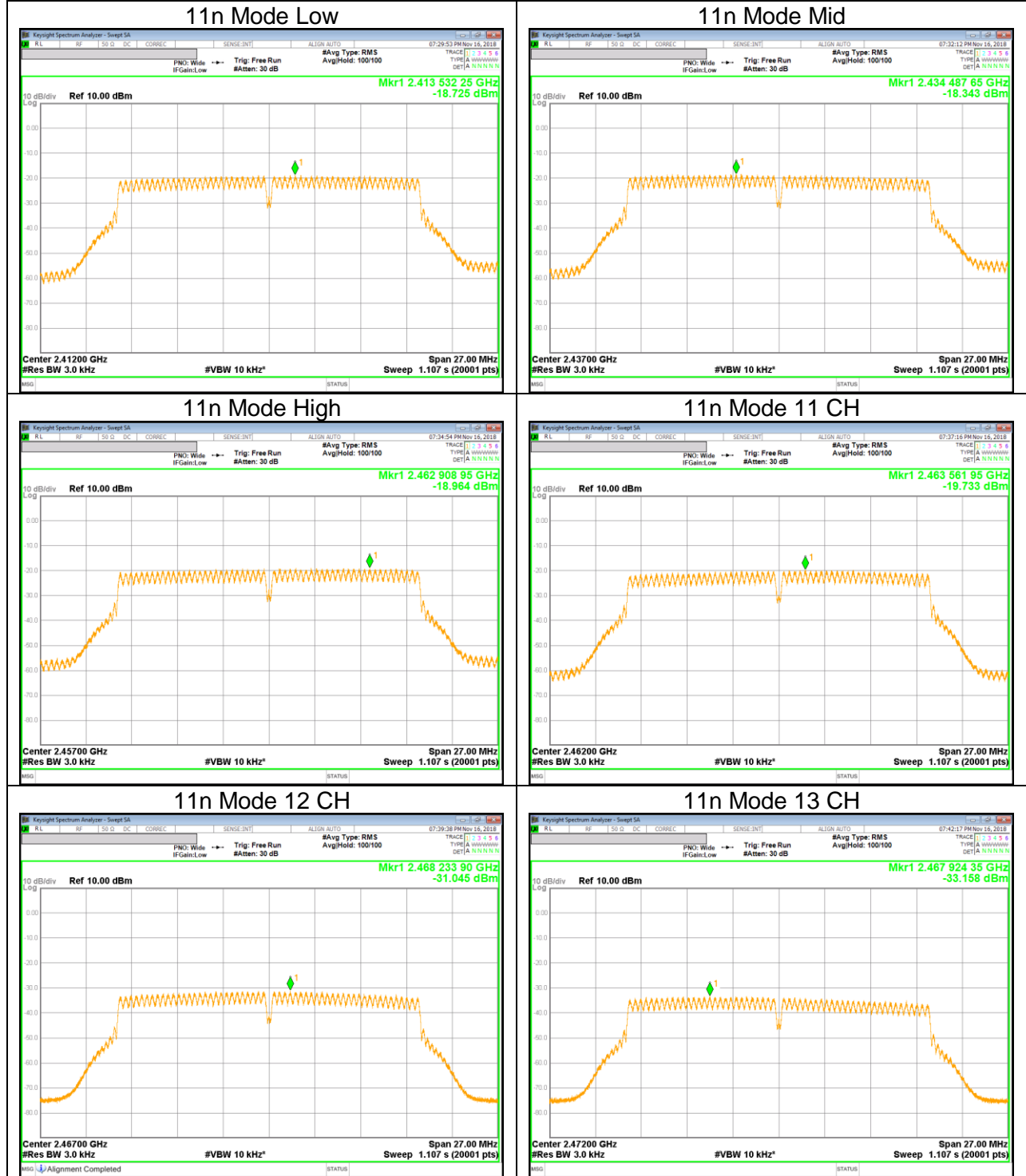

## 10.4. OUT-OF-BAND EMISSIONS

### LIMITS

FCC §15.247 (d)

In any 100 kHz bandwidth outside the frequency band in which the spread spectrum or digitally modulated intentional radiator is operating, the radio frequency power that is produced by the intentional radiator shall be at least 20 dB below that in the 100 kHz bandwidth within the band that contains the highest level of the desired power, based on either an RF conducted or a radiated measurement, provided the transmitter demonstrates compliance with the peak conducted power limits. If the transmitter complies with the conducted power limits based on the use of RMS averaging over a time interval, as permitted under paragraph (b)(3) of this section, the attenuation required under this paragraph shall be 30 dB instead of 20 dB. Attenuation below the general limits specified in §15.209(a) is not required.

### TEST PROCEDURE

The transmitter output is connected to a spectrum analyzer with RBW = 100 kHz, VBW = 300 kHz, peak detector, and max hold. Measurements utilizing these settings are made of the in-band reference level, bandedge, out-of-band emissions (where measurements to the general radiated limits will not be made)

**RESULTS**

**10.4.1. 802.11b MODE IN THE 2.4 GHz BAND**

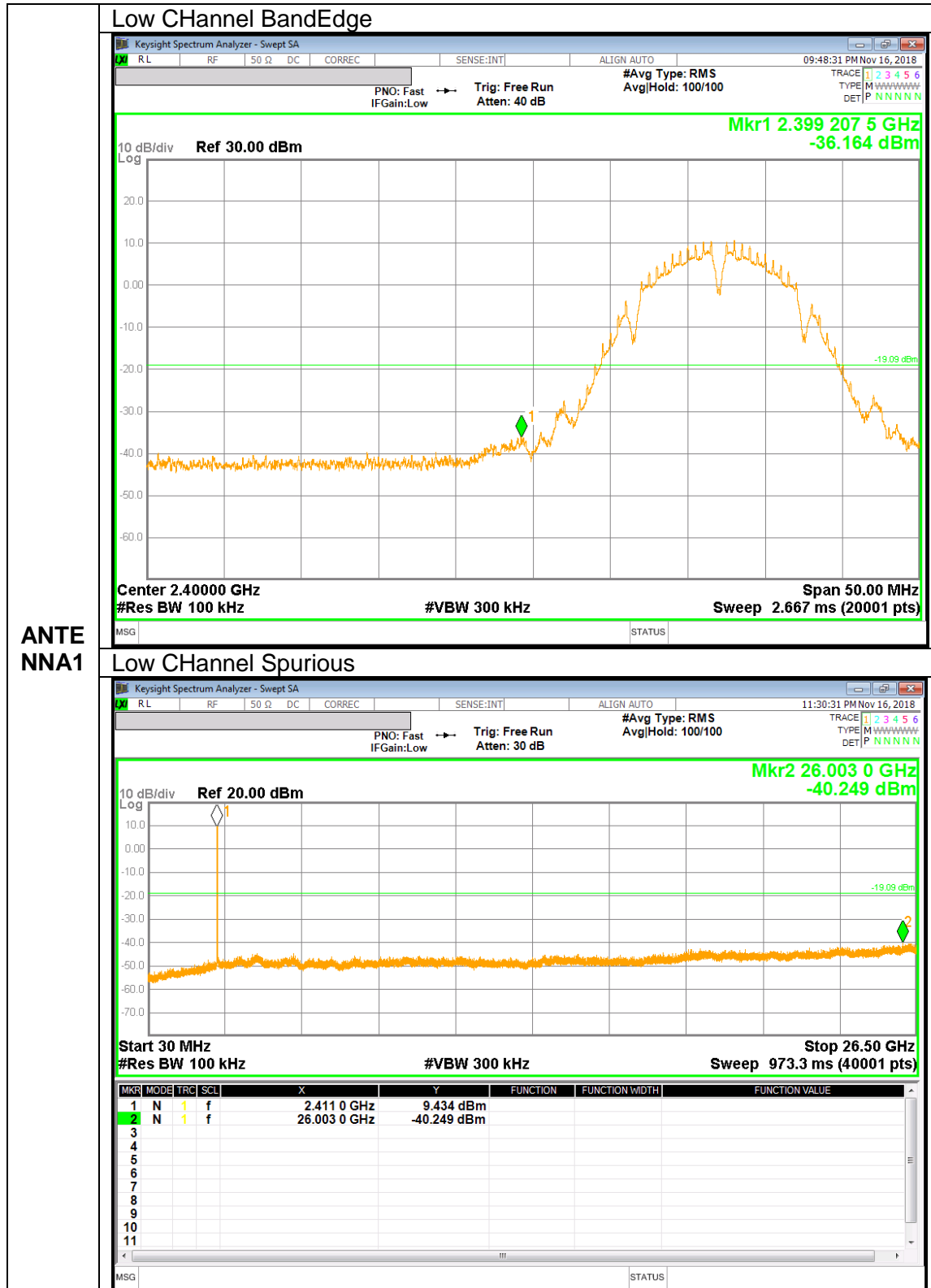

ANTE  
NNA1

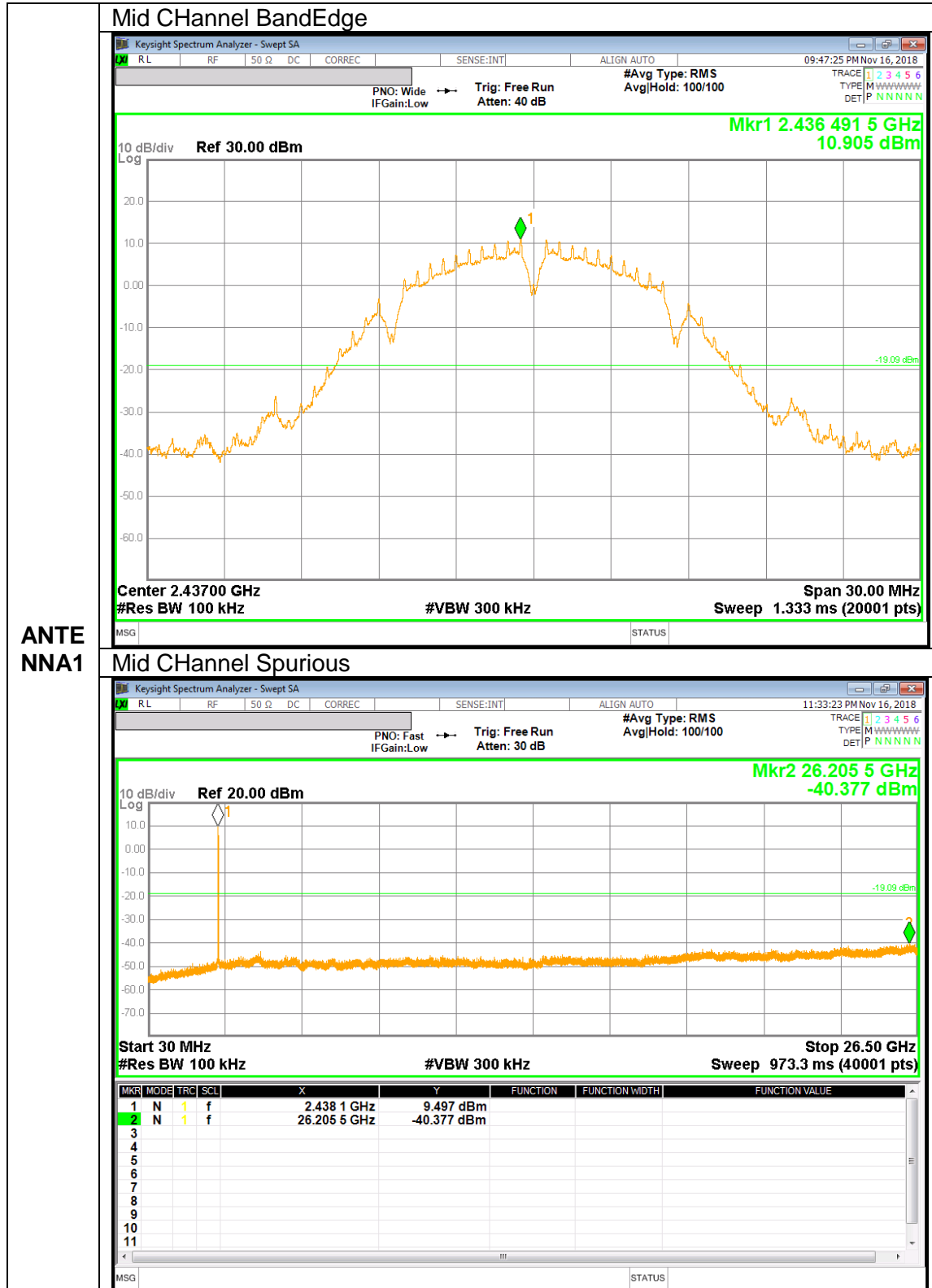

ANTE  
 NNA1

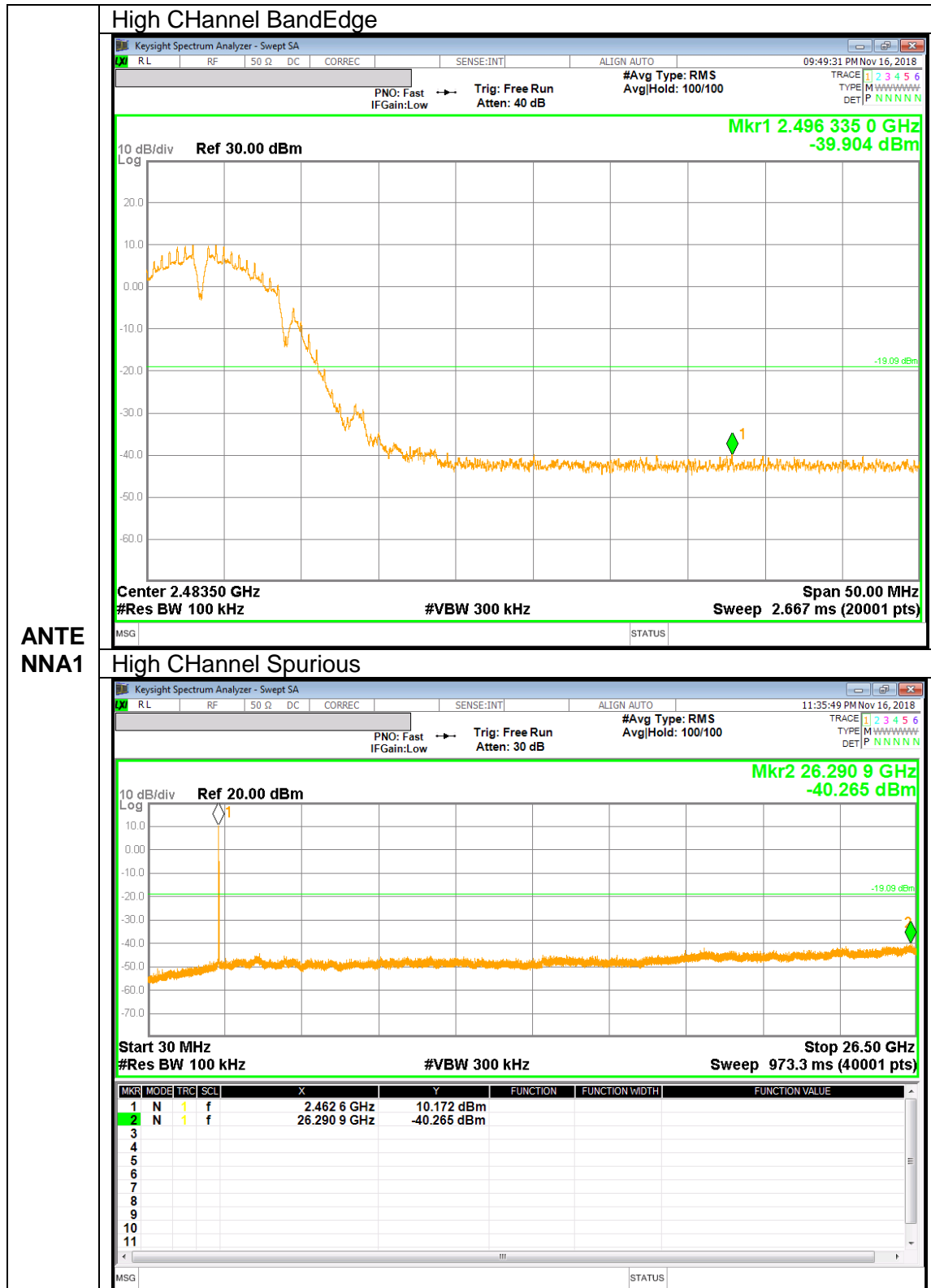

ANTE  
 NNA1



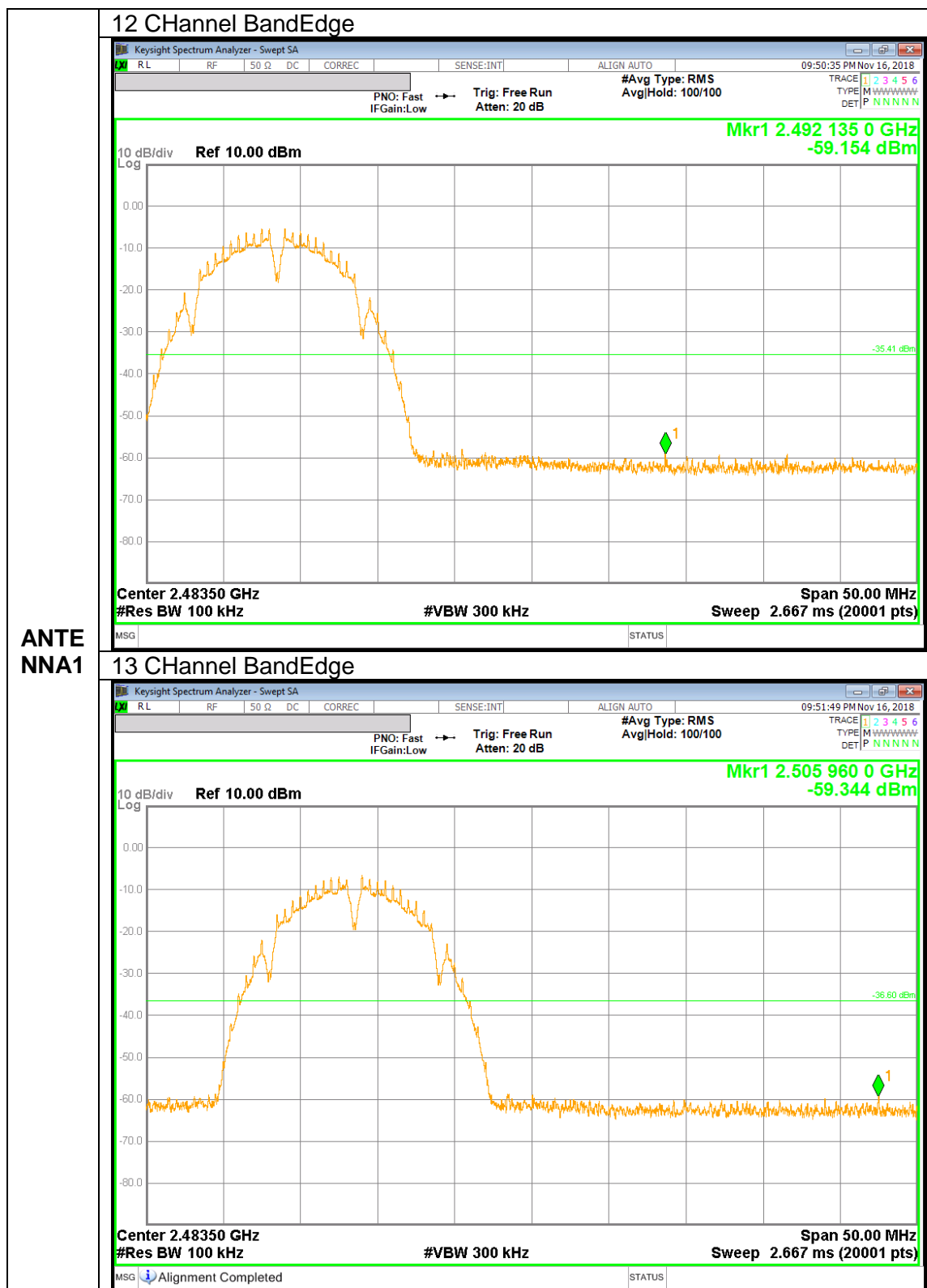

ANTE  
NNA1

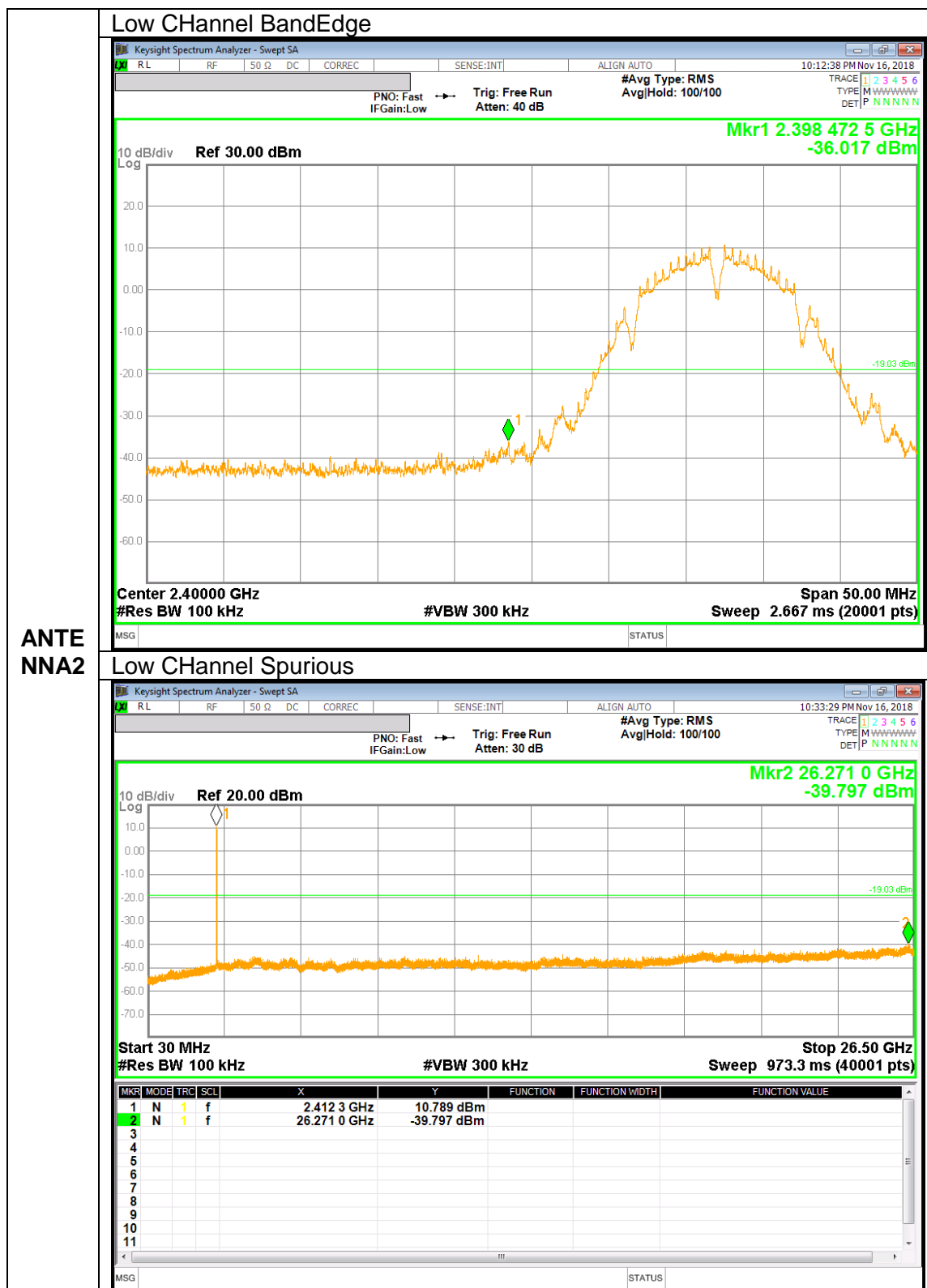

ANTE  
 NNA2

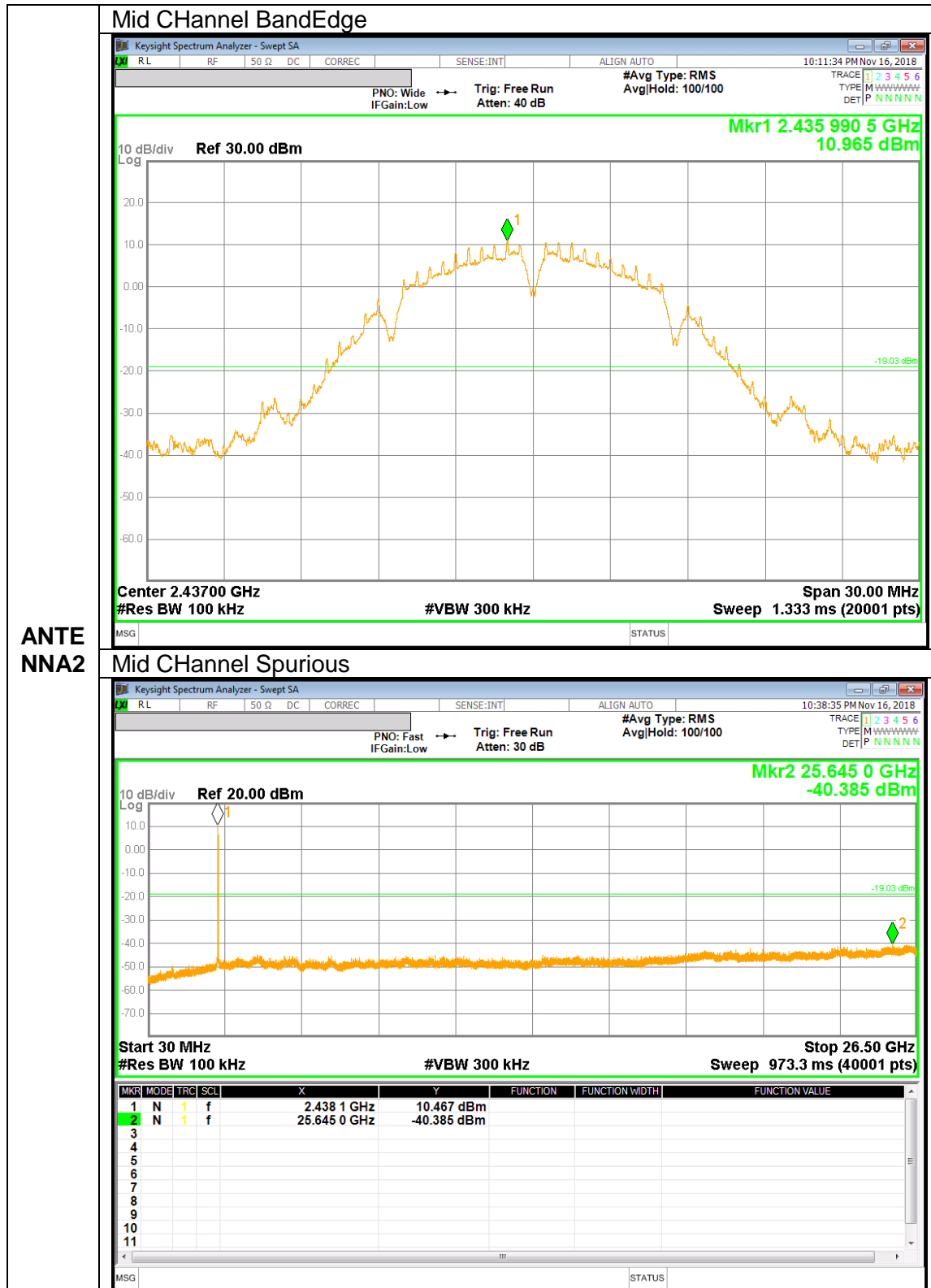

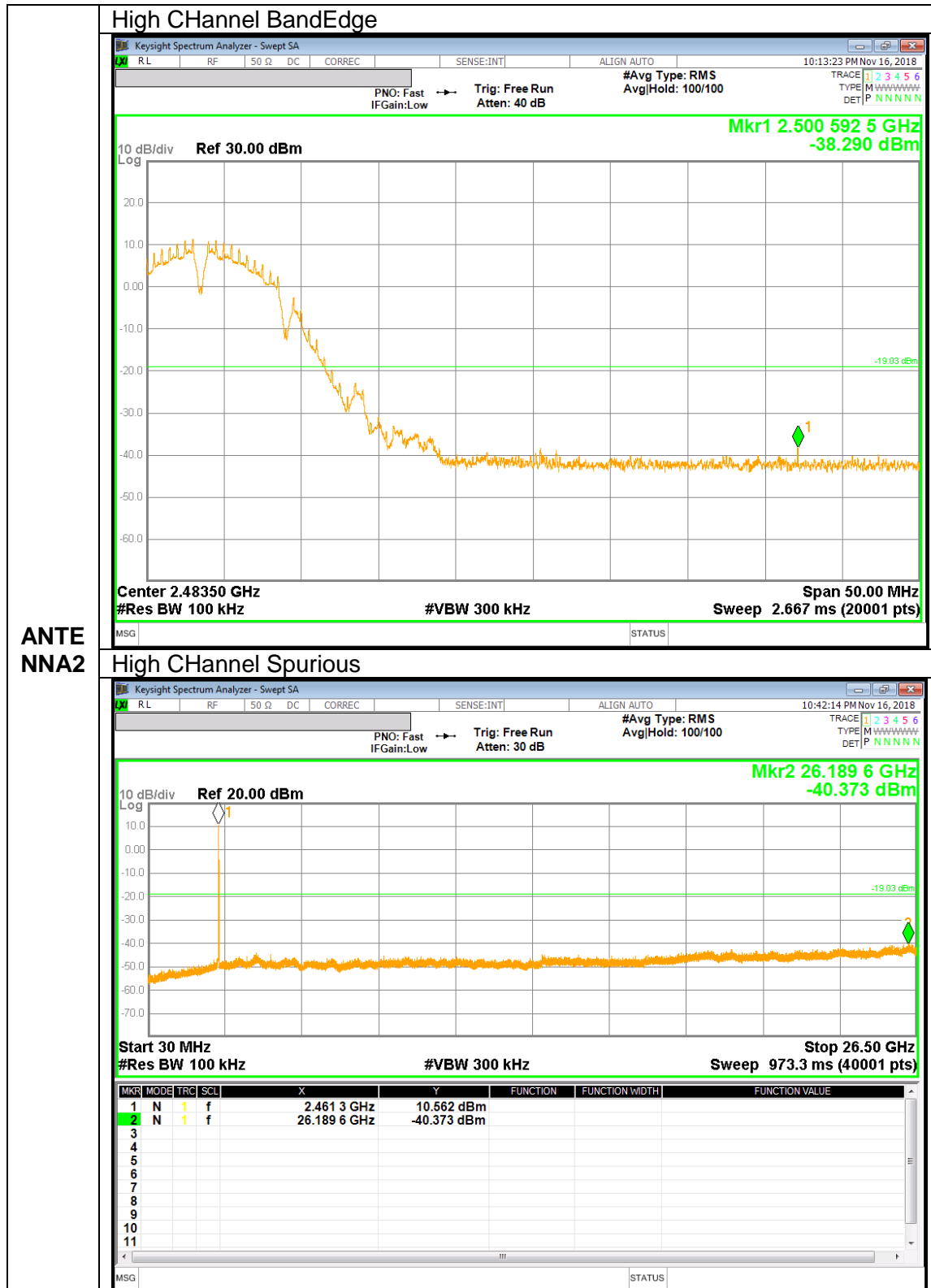

ANTE  
 NNA2

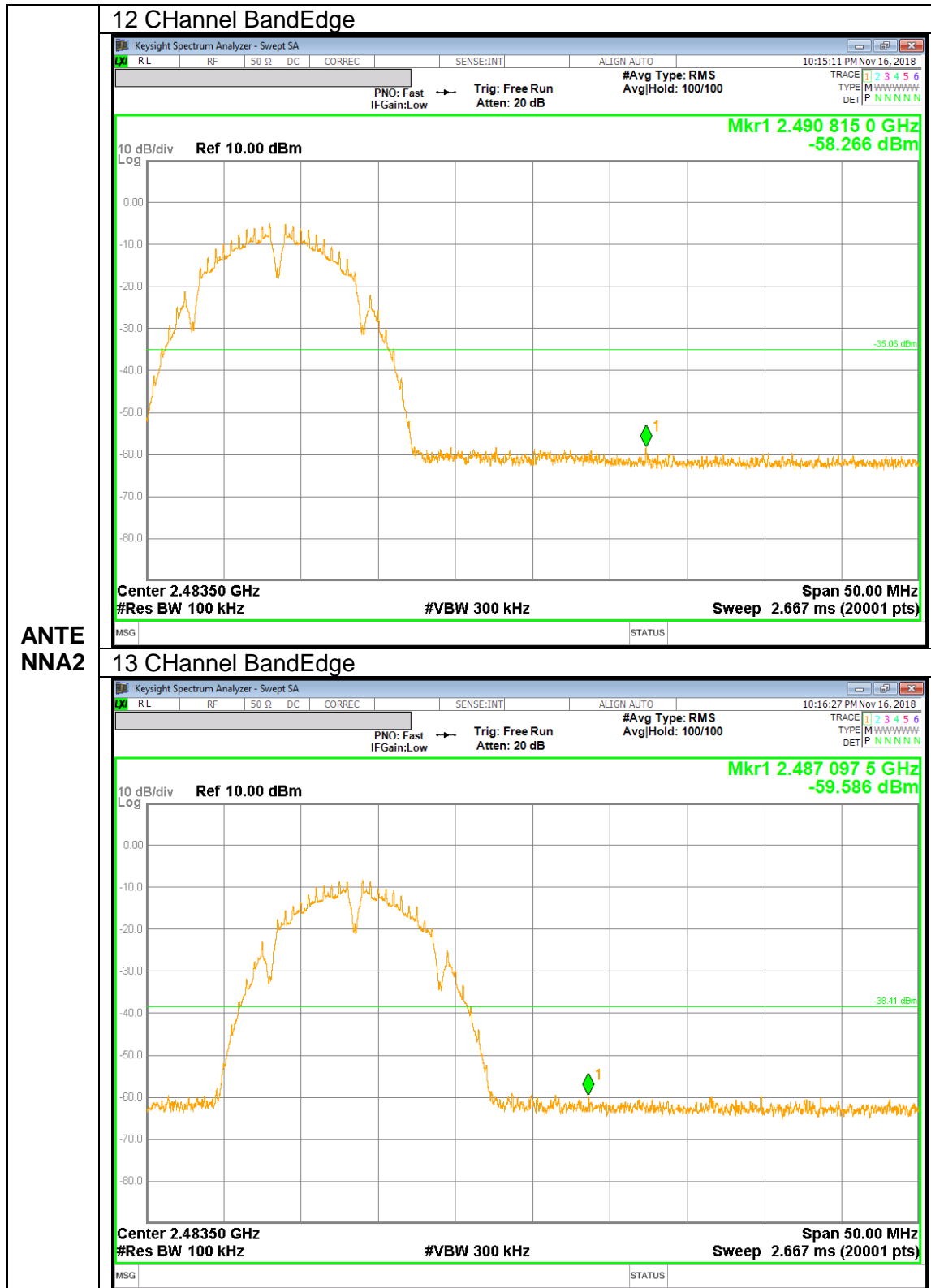

ANTE  
NNA2

10.4.2. 802.11g MODE IN THE 2.4 GHz BAND

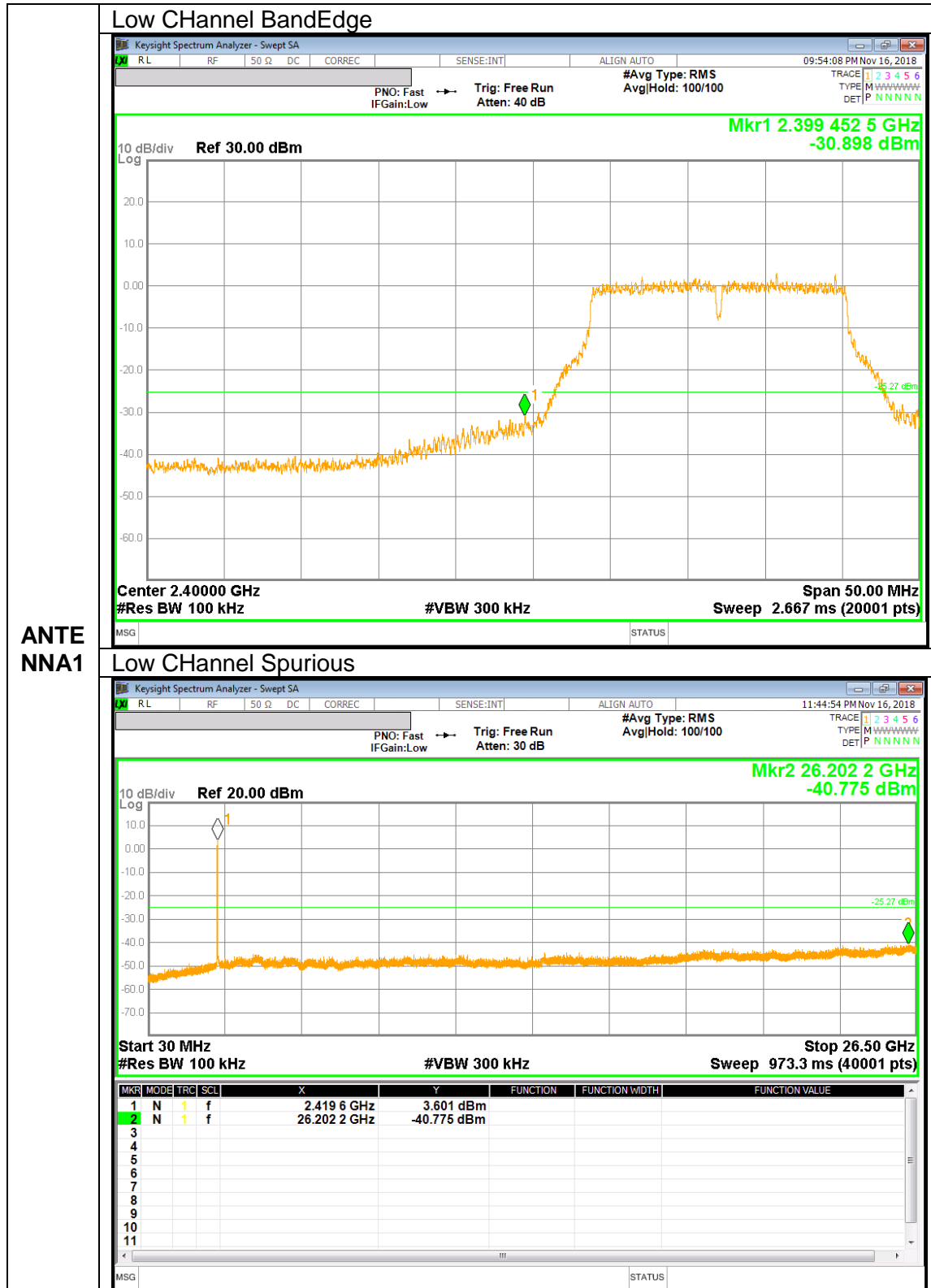

ANTE  
 NNA1