



# CERTIFICATION TEST REPORT

**Report Number. :** 12563993-E1V3

**Applicant :** Samsung Electronics Co., Ltd.  
129 Samsung-Ro, Yeongtong-Gu,  
Suwon-Si, Gyeonggi-Do, 16677, Korea

**Model :** SM-G970N

**FCC ID :** A3LSMG970KOR

**EUT Description :** GSM/WCDMA/LTE Phone with BT, DTS/UNII a/b/g/n/ac/11ax HE 20/40/80,  
ANT+ and NFC.

**Test Standard(s) :** FCC CFR47 PART 22 SUBPART H  
FCC CFR47 PART 24 SUBPART E  
FCC CFR47 PART 27 SUBPART F, H, L, and M  
FCC CFR47 PART 90 SUBPART S

**Date Of Issue:**  
JANUARY 29, 2019

**Prepared by:**  
UL Verification Services Inc.  
47173 Benicia Street  
Fremont, CA 94538 U.S.A.  
TEL: (510) 771-1000  
FAX: (510) 661-0888



NVLAP Lab code: 200065-0

Revision History

<u>Rev.</u>	<u>Issue Date</u>	<u>Revisions</u>	<u>Revised By</u>
V1	1/24/2019	Initial Review	--
V2	1/28/2019	Updated Section 2.1, 2.2, add 2.4 section and 11	Dan Corona
V3	1/29/2019	Updated Page 11	Dan Corona

## TABLE OF CONTENTS

<b>TABLE OF CONTENTS</b> .....	<b>3</b>
<b>1. ATTESTATION OF TEST RESULTS</b> .....	<b>8</b>
<b>2. INTRODUCTION OF TEST DATA REUSE</b> .....	<b>9</b>
2.1. INTRODUCTION.....	9
2.2. DIFFERENCE .....	9
2.3. SPOT CHECK VERIFICATION RESULTS SUMMARY .....	9
2.4. REFERENCE DETAIL.....	24
<b>3. TEST METHODOLOGY</b> .....	<b>25</b>
<b>4. FACILITIES AND ACCREDITATION</b> .....	<b>25</b>
<b>5. CALIBRATION AND UNCERTAINTY</b> .....	<b>26</b>
5.1. MEASURING INSTRUMENT CALIBRATION .....	26
5.2. SAMPLE CALCULATION.....	26
5.3. MEASUREMENT UNCERTAINTY .....	26
<b>6. EQUIPMENT UNDER TEST</b> .....	<b>27</b>
6.1. DESCRIPTION OF EUT.....	27
6.2. MAXIMUM OUTPUT POWER.....	27
6.3. SOFTWARE AND FIRMWARE .....	35
6.4. MAXIMUM ANTENNA GAIN .....	35
6.5. WORST-CASE CONFIGURATION AND MODE .....	36
6.6. DESCRIPTION OF TEST SETUP.....	37
<b>7. TEST AND MEASUREMENT EQUIPMENT</b> .....	<b>40</b>
<b>8. RF OUTPUT POWER VERIFICATION</b> .....	<b>41</b>
8.1. GSM .....	41
8.1.1. GSM850 .....	42
8.1.2. GSM1900 .....	42
8.2. WCDMA .....	43
8.2.1. WCDMA BAND5 .....	47
8.2.2. WCDMA BAND2 .....	48
8.2.3. WCDMA BAND4 .....	49
8.3. LTE.....	50
8.3.1. LTE 2.....	52

8.3.2.	LTE 4.....	55
8.3.3.	LTE 5.....	58
8.3.4.	LTE 12.....	60
8.3.5.	LTE 13.....	62
8.3.6.	LTE 17.....	63
8.3.7.	LTE 25.....	64
8.3.8.	LTE 26 (FCC PART 90S).....	67
8.3.9.	LTE 26 (FCC PART 22) .....	70
8.3.10.	LTE 41 (FCC) .....	73
8.3.11.	LTE 66.....	75
<b>9.</b>	<b>CONDUCTED TEST RESULTS.....</b>	<b>78</b>
9.1.	OCCUPIED BANDWIDTH.....	78
9.1.1.	GSM.....	84
9.1.2.	WCDMA .....	85
9.1.3.	LTE BAND 2.....	86
9.1.4.	LTE BAND 4.....	88
9.1.5.	LTE BAND 5.....	90
9.1.6.	LTE BAND 12.....	92
9.1.7.	LTE BAND 13.....	94
9.1.8.	LTE BAND 17.....	95
9.1.9.	LTE BAND 25.....	96
9.1.10.	LTE BAND 26 (FCC PART 90S) .....	98
9.1.11.	LTE BAND 26 (FCC PART 22).....	100
9.1.12.	LTE BAND 41 .....	102
9.1.13.	LTE BAND 66.....	104
9.2.	BAND EDGE AND EMISSION MASK.....	106
9.2.1.	GSM850 .....	108
9.2.2.	GSM1900 .....	109
9.2.3.	WCDMA BAND5 .....	110
9.2.4.	WCDMA BAND2 .....	111
9.2.5.	WCDMA BAND4 .....	112
9.2.6.	LTE BAND 2 BANDEDGE .....	113
9.2.7.	LTE BAND 4 BANDEDGE .....	125
9.2.8.	LTE BAND 5 BANDEDGE .....	137
9.2.9.	LTE BAND 12 BANDEDGE .....	145

9.2.10.	LTE BAND 13 BANDEDGE .....	153
9.2.11.	LTE BAND 17 BANDEDGE .....	157
9.2.12.	LTE BAND 25 BANDEDGE .....	161
9.2.13.	LTE BAND 26 EMISSION MASK (FCC PART 90S) .....	173
9.2.14.	LTE BAND 26 BANDEDGE (FCC PART 22) .....	181
9.2.15.	LTE BAND 41 ADJACENT CHANNEL POWER .....	191
9.2.16.	LTE BAND 66 BANDEDGE .....	199
9.3.	OUT OF BAND EMISSIONS .....	207
9.3.1.	GSM850 .....	208
9.3.2.	GSM1900 .....	210
9.3.3.	WCDMA BAND5 .....	212
9.3.4.	WCDMA BAND2 .....	214
9.3.5.	WCDMA BAND4 .....	216
9.3.6.	LTE BAND 2.....	218
9.3.7.	LTE BAND 4.....	224
9.3.8.	LTE BAND 5.....	230
9.3.9.	LTE BAND 12.....	234
9.3.10.	LTE BAND 13.....	238
9.3.11.	LTE BAND 17 .....	240
9.3.12.	LTE BAND 25 .....	242
9.3.13.	LTE BAND 26 .....	248
9.3.14.	LTE BAND 41 .....	253
9.3.15.	LTE BAND 66.....	257
9.4.	FREQUENCY STABILITY .....	263
9.4.1.	GSM.....	264
9.4.2.	WCDMA .....	266
9.4.3.	LTE BAND 2.....	269
9.4.4.	LTE BAND 4.....	270
9.4.5.	LTE BAND 5.....	271
9.4.6.	LTE BAND 12.....	272
9.4.7.	LTE BAND 13.....	273
9.4.8.	LTE BAND 17.....	274
9.4.9.	LTE BAND 25.....	275
9.4.10.	LTE BAND 26(FCC PART 90S) .....	276
9.4.11.	LTE BAND 26(FCC PART 22).....	277

9.4.12.	LTE BAND 41 .....	278
9.4.13.	LTE BAND 66 .....	279
9.5.	PEAK TO AVERAGE RATIO .....	280
9.5.1.	GSM .....	281
9.5.2.	WCDMA .....	282
9.5.3.	LTE BAND 2.....	283
9.5.4.	LTE BAND 4.....	285
9.5.5.	LTE BAND 5.....	287
9.5.6.	LTE BAND 12.....	289
9.5.7.	LTE BAND 13.....	291
9.5.8.	LTE BAND 17.....	292
9.5.9.	LTE BAND 25.....	293
9.5.10.	LTE BAND 26 (FCC PART 90S) .....	295
9.5.11.	LTE BAND 26 (FCC PART 22).....	297
9.5.12.	LTE BAND 41 .....	299
9.5.13.	LTE BAND 66 .....	301
<b>10.</b>	<b>RADIATED TEST RESULTS .....</b>	<b>303</b>
10.1.	EFFECTIVE RADIATED POWER ERP/EIRP .....	303
10.1.1.	GSM .....	311
10.1.2.	WCDMA.....	312
10.1.3.	LTE Band 2.....	313
10.1.4.	LTE Band 4.....	313
10.1.5.	LTE Band 5.....	314
10.1.6.	LTE Band 12.....	314
10.1.7.	LTE Band 13.....	315
10.1.8.	LTE Band 17.....	315
10.1.9.	LTE Band 25.....	316
10.1.10.	LTE Band 26 (FCC PART 90S) .....	317
10.1.11.	LTE Band 26 (FCC PART 22) .....	317
10.1.12.	LTE Band 41 .....	318
10.1.13.	LTE Band 66.....	318
10.2.	FIELD STRENGTH OF SPURIOUS RADIATION .....	319
10.2.1.	GSM .....	320
10.2.2.	WCDMA.....	324
10.2.3.	LTE BAND 2 .....	330

10.2.4.	LTE BAND 4 .....	332
10.2.5.	LTE BAND 5 .....	334
10.2.6.	LTE BAND 12 .....	336
10.2.7.	LTE BAND 13 .....	338
10.2.8.	LTE BAND 17 .....	340
10.2.9.	LTE BAND 25 .....	342
10.2.10.	LTE BAND 26 Part 90S .....	344
10.2.11.	LTE BAND 26 Part 22 .....	346
10.2.12.	LTE BAND 41 .....	348
10.2.13.	LTE BAND 66 .....	350
<b>11.</b>	<b>APPENDIX A: PRE-SCAN DATA FOR 15B RECEIVER MODE.....</b>	<b>352</b>
11.1.	LTE Band 12 .....	352
11.1.1.	BELOW 1GHz .....	352
11.1.2.	ABOVE 1GHz .....	354
11.2.	LTE Band 13 .....	356
11.2.1.	BELOW 1GHz .....	356
11.2.2.	ABOVE 1GHz .....	358
11.3.	LTE Band 26 .....	360
11.3.1.	BELOW 1GHz .....	360
11.3.2.	ABOVE 1GHz .....	362
<b>12.</b>	<b>SETUP PHOTOS.....</b>	<b>364</b>
12.1.1.	SMG-970F (Original) .....	364
12.1.2.	SMG-970N (Spot Check).....	366



# 1. ATTESTATION OF TEST RESULTS

Applicant Name and Address	SAMSUNG ELECTRONICS CO., LTD. 129 SAMSUNG-RO, YEONGTONG-GU, SUWON-SI, GYEONGGI-DO, 16677, KOREA
Model	SM-G970N
FCC ID	A3LSMG970KOR
EUT Description	GSM/WCDMA/LTE PHONE WITH BT, DTS/UNII A/B/G/N/AC/11AX HE 20/40/80, ANT+ AND NFC.
Serial Number	R38KA0H4BJF (CONDUCTED)R38B05BDYN (RADIATED) (Original) R39KBOAHYMF (RADIATED) (Spot Check)
Date Tested	Oct. 25, 2018 to Jan 22, 2019 (Original) Dec. 10 to 31, 2018 (Spot Check) Jan 28, 2019 (RX Appendix)
Applicable Standards	FCC CFR 47 PART 22H, 24E, 27F,H,L,M and 90S
Test Results	Complies

UL Verification Services Inc. tested the above equipment in accordance with the requirements set forth in the above standards. The test results show that the equipment tested is capable of demonstrating compliance with the requirements as documented in this report.

The results documented in this report apply only to the tested sample, under the conditions and modes of operation as described herein. It is the manufacturer's responsibility to assure that additional production units of this model are manufactured with identical electrical and mechanical components. All samples tested were in good operating condition throughout the entire test program. Measurement Uncertainties are published for informational purposes only and were not taken into account unless noted otherwise.

This document may not be altered or revised in any way unless done so by UL Verification Services Inc. and all revisions are duly noted in the revisions section. Any alteration of this document not carried out by UL Verification Services Inc. will constitute fraud and shall nullify the document. This report must not be used by the client to claim product certification, approval, or endorsement by NVLAP, NIST, any agency of the Federal Government, or any agency of the U.S. government.

Approved & Released For UL Verification Services Inc. By:  	Reviewed By:  
Dan Corona Operations Leader Consumer Technology Division UL Verification Services Inc.	Steven Tran Project Engineer Consumer Technology Division UL Verification Services Inc.



## **2. INTRODUCTION OF TEST DATA REUSE**

### **2.1. INTRODUCTION**

According to the manufacturer, FCC ID: A3LSMG970F and FCC ID: A3LSMG970KOR licensed radio is electrically identical. The FCC ID: A3LSMG970F test data shall remain representative of FCC ID: A3LSMG970KOR.

The applicant takes full responsibility that the test data as referenced in this section represents compliance for this FCC ID.

### **2.2. DIFFERENCE**

Difference between A3LSMG970F and A3LSMG970KOR:

Samsung Electronics Co. Ltd. hereby declares that the difference between A3LSMG970F and A3LSMG970KOR are the following: LTE Band 7 and Band 38 not supported and LTE UL CA not supported.

After confirming through preliminary radiated emissions that the performance of the FCC ID: A3LSMG970F remains representative of FCC ID: A3LSMG970KOR. The test data of FCC ID: A3LSMG970F being submitted for this application to cover WWAN features.

### **2.3. SPOT CHECK VERIFICATION RESULTS SUMMARY**

Spot check verification has been done on device A3LSMG970KOR for radiated harmonic spurious. The data from the application has been verified through appropriate spot checks to demonstrate compliance for this device as shown in the summary below.

Comparison of two models, upper deviation is within 3dB range and all tests are under FCC Technical Limits.

**SPOT CHECK DATA**

A3LSMG970KOR SPOT CHECK RESULTS							
Technology	Mode	Test Item	Channel	Measured	A3LSMG970F	A3LSMG970KOR	Delta (dB)
				Frequency	Peak (dBm)	Peak (dBm)	
GSM	GPRS 850	RSE	High	2.546GHz	-57.7	-60.5	-2.8
	GPRS 1900	RSE	High	7.591GHz	-50.55	-55.9	-5.35
	EGPRS 850	RSE	High	2.546GHz	-53.25	-56.4	-3.15
	EGPRS 1900	RSE	High	7.63GHz	-49.53	-51.99	-2.46
WCDMA	REL99 B5	RSE	Low	3.307GHz	-59.42	-57.64	1.78
	REL99 B4	RSE	Mid	5.261GHz	-56.61	-57.39	-0.78
	REL99 B2	RSE	High	7.626GHz	-51.26	-56.41	-5.15
	HSDPA B5	RSE	Low	3.308GHz	-59.33	-59.43	-0.1
	HSDPA B4	RSE	Mid	6.928GHz	-56.53	-58.22	-1.69
	HSDPA B2	RSE	High	7.631GHz	-55.55	-53.72	1.83

A3LSMG970KOR SPOT CHECK RESULTS							
Technology	Mode	Test Item	Channel	Measured	A3LSMG970F	A3LSMG970KOR	Delta (dB)
				Frequency	Peak (dBm)	Peak (dBm)	
LTE 2	QPSK @ highest BW	RSE	High	7.565GHz	-47.86	-56.76	-8.9
	16QAM @ highest BW	RSE	High	7.565GHz	-48.15	-55.26	-7.11
LTE 4	QPSK @ 20MHz BW	RSE	High	5.197GHz	-40.11	-57.51	-17.4
	16QAM @ 20MHz BW	RSE			-56.27	-58.71	-2.44
LTE 5	QPSK @ highest BW	RSE	Low	3.292GHz	-55.47	-58.82	-3.35
	16QAM @ highest BW	RSE	High	3.355GHz	-55.56	-59.83	-4.27
LTE 12	QPSK @ highest BW	RSE	High	8.185GHz	-48.23	-53.47	-5.24
	16QAM @ highest BW	RSE	High	6.437GHz	-48.59	-59.79	-11.2
LTE 13	QPSK @ highest BW	RSE	Low	3.051GHz	-54.43	-59.73	-5.3
	16QAM @ highest BW	RSE			-54.46	-57.78	-3.32
LTE 17	QPSK @ highest BW	RSE	Mid	1.411GHz	-54.21	-65.67	-11.46
	16QAM @ highest BW	RSE	Low	2.834GHz	-54.99	-60.73	-5.74
LTE 25	QPSK @ highest BW	RSE	Low	5.551GHz	-41.35	-54.32	-12.97
	16QAM @ highest BW	RSE			-42.73	-54.08	-11.35
LTE 26 (Part 90S)	QPSK @ highest BW	RSE	Low	3.261GHz	-56.97	-58.39	-1.42
	16QAM @ highest BW	RSE	Low	3.257GHz	-55.92	-56.3	-0.38
LTE 26 (Part 22)	QPSK @ highest BW	RSE	Low	3.275GHz	-55.73	-60.76	-5.03
	16QAM @ highest BW	RSE	High	2.524GHz	-54.71	-60.11	-5.4

A3LSMG970KOR SPOT CHECK RESULTS							
Technology	Mode	Test Item	Channel	Measured	A3LSMG970F	A3LSMG970KOR	Delta (dB)
				Frequency	Peak (dBm)	Peak (dBm)	
LTE 41	QPSK @ highest BW	RSE	Mid	10.354GHz	-47.5	-50.53	-3.03
	16QAM @ highest BW	RSE			-41.87	-52.37	-10.5
LTE 66	QPSK @ highest BW	RSE	Mid	10.416GHz	-45.15	-52.15	-7
	16QAM @ highest BW	RSE	Mid	10.416GHz	-44.67	-53.22	-8.55

**HARMONICS AND SPURIOUS EMISSIONS**

**GSM**

Company:	Samsung
Project #:	12563993
Date:	12/13/18
Test Engineer:	19498
Configuration:	EUT+ Support Equipment
Mode:	GPRS 850 High Channel
Chamber #:	Chamber B

Marker	Frequency (GHz)	Meter Reading (dBm)	Det	AFT863 (dB/m)	Amp/Cbl (dB)	Amp/Cbl (dB)	Corrected Reading (dBm)	Limit	PK Margin (dB)	Azimuth (Degs)	Height (cm)	Polarity
848.8 MHz												
1	2.546	-68.65	Pk	32.7	-32	8.9	-59.05	-13	-46.05	0-360	149	V
2	2.547	-70.4	Pk	32.7	-32	9.2	-60.5	-13	-47.5	0-360	149	H

Company:	Samsung
Project #:	12563993
Date:	01/04/19
Test Engineer:	19480
Configuration:	EUT+ Support Equipment
Mode:	GPRS 1900 High Channel
Chamber #:	Chamber B

Marker	Frequency (GHz)	Meter Reading (dBm)	Det	AFT863 (dB/m)	Amp/Cbl (dB)	Amp/Cbl (dB)	Corrected Reading (dBm)	Limit	PK Margin (dB)	Azimuth (Degs)	Height (cm)	Polarity
1909.8 MHz												
1	7.591	-71.19	Pk	36.3	-27.1	7.1	-54.89	-13	-41.89	0-360	149	H
2	7.591	-72	Pk	36.3	-27.1	6.9	-55.9	-13	-42.9	0-360	149	V

Company:	Samsung
Project #:	12563993
Date:	12/14/18
Test Engineer:	16069
Configuration:	EUT+ Support Equipment
Mode:	EGPRS 850 High Channel
Chamber #:	Chamber A

Marker	Frequency (GHz)	Meter Reading (dBm)	Det	AFT345 (dB/m)	Amp/Cbl (dB)	Amp/Cbl (dB)	Corrected Reading (dBm)	Limit	PK Margin (dB)	Azimuth (Degs)	Height (cm)	Polarity
848.8 MHz												
1	2.541	-70.2	Pk	32.3	-30.4	11.9	-56.4	-13	-43.4	0-360	149	H
2	2.545	-71.24	Pk	32.2	-30.4	11.7	-57.74	-13	-44.74	0-360	149	V

Company:	Samsung
Project #:	12563993
Date:	01/04/19
Test Engineer:	19480
Configuration:	EUT+ Support Equipment
Mode:	EGPRS 1900 High Channel
Chamber #:	Chamber B

Marker	Frequency (GHz)	Meter Reading (dBm)	Det	AFT863 (dB/m)	Amp/Cbl (dB)	Amp/Cbl (dB)	Corrected Reading (dBm)	Limit	PK Margin (dB)	Azimuth (Degs)	Height (cm)	Polarity
1909.8 MHz												
1	7.63	-68.79	Pk	36.4	-27	7.4	-51.99	-13	-38.99	0-360	149	H
2	7.63	-69.56	Pk	36.4	-27	7.4	-52.76	-13	-39.76	0-360	149	V

**WCDMA**

Company:	Samsung
Project #:	12563993
Date:	01/05/19
Test Engineer:	19480
Configuration:	EUT+ Support Equipment
Mode:	REL 99 B5 Low Channel
Chamber #:	Chamber B

Marker	Frequency (GHz)	Meter Reading (dBm)	Det	AFT863 (dB/m)	Amp/Cbl (dB)	Amp/Cbl (dB)	Corrected Reading (dBm)	Limit	PK Margin (dB)	Azimuth (Degs)	Height (cm)	Polarity
826.4 MHz												
1	3.307	-69.24	Pk	32.9	-30.9	9.6	-57.64	-13	-44.64	0-360	149	H
2	3.307	-70.93	Pk	32.9	-30.9	9.9	-59.03	-13	-46.03	0-360	149	V

Company:	Samsung
Project #:	12563993
Date:	01/04/19
Test Engineer:	19480
Configuration:	EUT+ Support Equipment
Mode:	REL 99 B4 High Channel
Chamber #:	Chamber B

Marker	Frequency (GHz)	Meter Reading (dBm)	Det	AFT863 (dB/m)	Amp/Cbl (dB)	Amp/Cbl (dB)	Corrected Reading (dBm)	Limit	Margin (dB)	Azimuth (Degs)	Height (cm)	Polarity
1752.6 MHz												
1	5.261	-71.09	Pk	34.8	-29.7	8.6	-57.39	-13	-44.39	0-360	149	H
2	5.261	-70.7	Pk	34.8	-29.7	8.7	-56.9	-13	-43.9	0-360	149	V

Company:	Samsung
Project #:	12563993
Date:	01/04/19
Test Engineer:	19480
Configuration:	EUT+ Support Equipment
Mode:	REL 99 B2 High Channel
Chamber #:	Chamber B

Marker	Frequency (GHz)	Meter Reading (dBm)	Det	AFT863 (dB/m)	Amp/Cbl (dB)	Amp/Cbl (dB)	Corrected Reading (dBm)	Limit	Margin (dB)	Azimuth (Degs)	Height (cm)	Polarity
1907.6 MHz												
1	7.626	-74.69	Pk	36.4	-27	7.4	-57.89	-13	-44.89	0-360	149	H
2	7.626	-73.21	Pk	36.4	-27	7.4	-56.41	-13	-43.41	0-360	149	V

Company:	Samsung
Project #:	12563993
Date:	01/05/19
Test Engineer:	19480
Configuration:	EUT+ Support Equipment
Mode:	HSDPA B5 Low Channel
Chamber #:	Chamber B

Marker	Frequency (GHz)	Meter Reading (dBm)	Det	AFT863 (dB/m)	Amp/Cbl (dB)	Amp/Cbl (dB)	Corrected Reading (dBm)	Limit	PK Margin (dB)	Azimuth (Degs)	Height (cm)	Polarity
826.4 MHz												
1	3.308	-70.46	Pk	32.9	-30.9	9.6	-58.86	-13	-45.86	0-360	149	H
2	3.308	-71.33	Pk	32.9	-30.9	9.9	-59.43	-13	-46.43	0-360	149	V

Company:	Samsung
Project #:	12563993
Date:	01/04/19
Test Engineer:	19480
Configuration:	EUT+ Support Equipment
Mode:	HSDPA B4 Mid Channel
Chamber #:	Chamber B

Marker	Frequency (GHz)	Meter Reading (dBm)	Det	AFT863 (dB/m)	Amp/Cbl (dB)	Amp/Cbl (dB)	Corrected Reading (dBm)	Limit	Margin (dB)	Azimuth (Degs)	Height (cm)	Polarity
1732.6 MHz												
1	6.928	-72.92	Pk	35.8	-27.9	6.8	-58.22	-13	-45.22	0-360	149	H
2	6.928	-72.27	Pk	35.8	-27.9	6.9	-57.47	-13	-44.47	0-360	149	V

Company:	Samsung
Project #:	12563993
Date:	01/04/19
Test Engineer:	19480
Configuration:	EUT+ Support Equipment
Mode:	HSDPA B2 High Channel
Chamber #:	Chamber B

Marker	Frequency (GHz)	Meter Reading (dBm)	Det	AFT863 (dB/m)	Amp/Cbl (dB)	Amp/Cbl (dB)	Corrected Reading (dBm)	Limit	Margin (dB)	Azimuth (Degs)	Height (cm)	Polarity
1907.6 MHz												
1	7.631	-70.52	Pk	36.4	-27	7.4	-53.72	-13	-40.72	0-360	149	H
2	7.631	-69.89	Pk	36.4	-27	7.4	-53.09	-13	-40.09	0-360	149	V

**LTE BAND 2**

Company:	Samsung
Project #:	12563993
Date:	01/04/19
Test Engineer:	19480
Configuration:	EUT+ Support Equipment
Mode:	LTE 2 QPSK 20MHz High Channel
Chamber #:	Chamber B

Marker	Frequency (GHz)	Meter Reading (dBm)	Det	AFT863 (dB/m)	Amp/Cbl (dB)	Amp/Cbl (dB)	Corrected Reading (dBm)	LTE Limit	Margin (dB)	Azimuth (Degs)	Height (cm)	Polarity
1900 MHz												
1	7.565	-71.19	Pk	36.3	-27.4	7.4	-54.89	-13	-41.89	0-360	149	H
2	7.565	-73.06	Pk	36.3	-27.4	7.4	-56.76	-13	-43.76	0-360	149	V



Company:	Samsung
Project #:	12563993
Date:	01/04/19
Test Engineer:	19480
Configuration:	EUT+ Support Equipment
Mode:	LTE 2 16QAM 20MHz High Channel
Chamber #:	Chamber B

Marker	Frequency (GHz)	Meter Reading (dBm)	Det	AF T863 (dB/m)	Amp/Cbl (dB)	Amp/Cbl (dB)	Corrected Reading (dBm)	LTE Limit	Margin (dB)	Azimuth (Degs)	Height (cm)	Polarity
1900 MHz												
1	7.565	-72.45	Pk	36.3	-27.4	7.4	-56.15	-13	-43.15	0-360	149	H
2	7.565	-71.56	Pk	36.3	-27.4	7.4	-55.26	-13	-42.26	0-360	149	V

**LTE BAND 4**

Company:	Samsung
Project #:	12563993
Date:	12/14/18
Test Engineer:	19498
Configuration:	EUT+ Support Equipment
Mode:	LTE 4 QPSK 20MHz High Channel
Chamber #:	Chamber B

Marker	Frequency (MHz)	Meter Reading (dBm)	Det	AF T863 (dB/m)	Amp/Cbl (dB)	Amp/Cbl (dB)	Corrected Reading (dBm)	Limit	Margin (dB)	Azimuth (Degs)	Height (cm)	Polarity
1745 MHz												
1	5.199	-70.49	Pk	34.7	-29.8	9.3	-56.29	-13	-43.29	0-360	149	H
2	5.2	-71.71	Pk	34.7	-29.8	9.3	-57.51	-13	-44.51	0-360	149	V

Company:	Samsung
Project #:	12563993
Date:	12/14/18
Test Engineer:	19498
Configuration:	EUT+ Support Equipment
Mode:	LTE 4 16QAM 20MHz High Channel
Chamber #:	Chamber B

Marker	Frequency (MHz)	Meter Reading (dBm)	Det	AF T863 (dB/m)	Amp/Cbl (dB)	Amp/Cbl (dB)	Corrected Reading (dBm)	Limit	Margin (dB)	Azimuth (Degs)	Height (cm)	Polarity
1745 MHz												
1	5.198	-71.87	Pk	34.7	-29.8	9.3	-57.67	-13	-44.67	0-360	149	H
2	5.198	-72.81	Pk	34.7	-29.8	9.2	-58.71	-13	-45.71	0-360	149	V

**LTE BAND 5**

Company:	Samsung
Project #:	12563993
Date:	01/07/19
Test Engineer:	19480
Configuration:	EUT+ Support Equipment
Mode:	LTE 5 QPSK 10MHz Low Channel
Chamber #:	Chamber B

Marker	Frequency (GHz)	Meter Reading (dBm)	Det	AFT863 (dB/m)	Amp/Cbl (dB)	Amp/Cbl (dB)	Corrected Reading (dBm)	LTE Limit	Margin (dB)	Azimuth (Degs)	Height (cm)	Polarity
829 MHz												
1	3.292	-71.63	Pk	32.9	-31.2	9.7	-60.23	-13	-47.23	0-360	149	H
2	3.292	-70.32	Pk	32.9	-31.1	9.7	-58.82	-13	-45.82	0-360	149	V

Company:	Samsung
Project #:	12563993
Date:	01/07/19
Test Engineer:	19480
Configuration:	EUT+ Support Equipment
Mode:	LTE 5 16QAM 10MHz High Channel
Chamber #:	Chamber B

Marker	Frequency (GHz)	Meter Reading (dBm)	Det	AFT863 (dB/m)	Amp/Cbl (dB)	Amp/Cbl (dB)	Corrected Reading (dBm)	LTE Limit	Margin (dB)	Azimuth (Degs)	Height (cm)	Polarity
844 MHz												
1	3.355	-70.49	Pk	32.9	-30.8	9.5	-58.89	-13	-45.89	0-360	149	H
2	3.355	-71.83	Pk	32.9	-30.8	9.9	-59.83	-13	-46.83	0-360	149	V

**LTE BAND 12**

Company:	Samsung
Project #:	12563993
Date:	01/07/19
Test Engineer:	19480
Configuration:	EUT+ Support Equipment
Mode:	LTE 12 QPSK 10MHz High Channel
Chamber #:	Chamber B

Marker	Frequency (MHz)	Meter Reading (dBm)	Det	AFT863 (dB/m)	Amp/Cbl (dB)	Amp/Cbl (dB)	Corrected Reading (dBm)	Limit	Margin (dB)	Azimuth (Degs)	Height (cm)	Polarity
711 MHz												
1	8.185	-73.1	Pk	36.5	-26.1	7.7	-55	-13	-42	0-360	149	H
2	8.185	-71.67	Pk	36.5	-26.1	7.8	-53.47	-13	-40.47	0-360	149	V

Company:	Samsung
Project #:	12563993
Date:	01/07/19
Test Engineer:	19480
Configuration:	EUT+ Support Equipment
Mode:	LTE 12 16QAM 10MHz High Channel
Chamber #:	Chamber B

Marker	Frequency (MHz)	Meter Reading (dBm)	Det	AFT863 (dB/m)	Amp/Cbl (dB)	Amp/Cbl (dB)	Corrected Reading (dBm)	Limit	Margin (dB)	Azimuth (Degs)	Height (cm)	Polarity
711 MHz												
1	6.437	-72.64	Pk	35.7	-28.8	6.7	-59.04	-13	-46.04	0-360	149	H
2	6.437	-73.69	Pk	35.7	-28.8	7	-59.79	-13	-46.79	0-360	149	V

**LTE BAND 13**

Company:	Samsung
Project #:	12563993
Date:	12/14/18
Test Engineer:	19498
Configuration:	EUT+ Support Equipment
Mode:	LTE 13 QPSK 5MHz Low Channel
Chamber #:	Chamber B

Marker	Frequency (MHz)	Meter Reading (dBm)	Det	AFT863 (dB/m)	Amp/Cbl (dB)	Amp/Cbl (dB)	Corrected Reading (dBm)	Limit	Margin (dB)	Azimuth (Degs)	Height (cm)	Polarity
779.5 MHz												
1	3.051	-70.37	Pk	33	-31.8	9.7	-59.47	-13	-46.47	0-360	149	H
2	3.051	-70.33	Pk	33	-31.8	9.4	-59.73	-13	-46.73	0-360	149	V

Company:	Samsung
Project #:	12563993
Date:	12/14/18
Test Engineer:	19498
Configuration:	EUT+ Support Equipment
Mode:	LTE 13 16QAM 5MHz Low Channel
Chamber #:	Chamber B

Marker	Frequency (MHz)	Meter Reading (dBm)	Det	AFT863 (dB/m)	Amp/Cbl (dB)	Amp/Cbl (dB)	Corrected Reading (dBm)	Limit	Margin (dB)	Azimuth (Degs)	Height (cm)	Polarity
779.5 MHz												
2	3.052	-69.38	Pk	32.9	-31	9.7	-57.78	-13	-44.78	0-360	149	V
1	3.053	-70.26	Pk	32.9	-31	9.7	-58.66	-13	-45.66	0-360	149	H

**LTE BAND 17**

Company:	Samsung
Project #:	12563993
Date:	01/07/19
Test Engineer:	19480
Configuration:	EUT+ Support Equipment
Mode:	LTE 17 QPSK 10MHz Mid Channel
Chamber #:	Chamber B

Marker	Frequency (MHz)	Meter Reading (dBm)	Det	AF T863 (dB/m)	Amp/Cbl (dB)	Amp/Cbl (dB)	Corrected Reading (dBm)	Limit	Margin (dB)	Azimuth (Degs)	Height (cm)	Polarity
710 MHz												
1	1.411	-69.25	Pk	28.4	-33.7	10.4	-64.15	-13	-51.15	0-360	149	H
2	1.411	-69.87	Pk	28.4	-33.7	9.5	-65.67	-13	-52.67	0-360	149	V

Company:	Samsung
Project #:	12563993
Date:	01/07/19
Test Engineer:	19480
Configuration:	EUT+ Support Equipment
Mode:	LTE 17 16QAM 10MHz Low Channel
Chamber #:	Chamber B

Marker	Frequency (MHz)	Meter Reading (dBm)	Det	AF T863 (dB/m)	Amp/Cbl (dB)	Amp/Cbl (dB)	Corrected Reading (dBm)	Limit	Margin (dB)	Azimuth (Degs)	Height (cm)	Polarity
709MHz												
1	2.834	-71.82	Pk	32.5	-31.9	9.5	-61.72	-13	-48.72	0-360	149	H
2	2.834	-70.63	Pk	32.5	-31.9	9.3	-60.73	-13	-47.73	0-360	149	V

**LTE BAND 25**

Company:	Samsung
Project #:	12563993
Date:	12/14/18
Test Engineer:	19498
Configuration:	EUT+ Support Equipment
Mode:	LTE 25 QPSK 1.4MHz Low Channel
Chamber #:	Chamber B

Marker	Frequency (MHz)	Meter Reading (dBm)	Det	AF T863 (dB/m)	Amp/Cbl (dB)	Amp/Cbl (dB)	Corrected Reading (dBm)	Limit	Margin (dB)	Azimuth (Degs)	Height (cm)	Polarity
1882.5MHz												
1	5.552	-69.02	Pk	35.4	-29.6	8.9	-54.32	-13	-41.32	0-360	149	H
2	5.552	-69.91	Pk	35.4	-29.6	9	-55.11	-13	-42.11	0-360	149	V

Company:	Samsung
Project #:	12563993
Date:	12/14/18
Test Engineer:	19498
Configuration:	EUT+ Support Equipment
Mode:	LTE 25 16QAM 1.4MHz Low Channel
Chamber #:	Chamber B

Marker	Frequency (MHz)	Meter Reading (dBm)	Det	AFT863 (dB/m)	Amp/Cbl (dB)	Amp/Cbl (dB)	Corrected Reading (dBm)	Limit	Margin (dB)	Azimuth (Degs)	Height (cm)	Polarity
1882.5MHz												
2	5.551	-69.45	Pk	35.4	-29.7	8.8	-54.95	-13	-41.95	0-360	149	V
1	5.552	-68.98	Pk	35.4	-29.6	9.1	-54.08	-13	-41.08	0-360	149	H

**LTE BAND 26 (FCC Part 90S)**

Company:	Samsung
Project #:	12563993
Date:	01/24/19
Test Engineer:	19480
Configuration:	EUT+ Support Equipment
Mode:	LTE 26 QPSK 15MHz Low Channel
Chamber #:	Chamber B

Marker	Frequency (MHz)	Meter Reading (dBm)	Det	AFT863 (dB/m)	Amp/Cbl (dB)	Amp/Cbl (dB)	Corrected Reading (dBm)	Limit	Margin (dB)	Azimuth (Degs)	Height (cm)	Polarity
821.5MHz												
1	3.261	-70.89	Pk	33	-30.9	10.4	-58.39	-13	-45.39	0-360	149	H
2	3.261	-72.41	Pk	33	-30.9	9.9	-60.41	-13	-47.41	0-360	149	V

Company:	Samsung
Project #:	12563993
Date:	01/24/19
Test Engineer:	19480
Configuration:	EUT+ Support Equipment
Mode:	LTE 26 16QAM 15MHz Low Channel
Chamber #:	Chamber B

Marker	Frequency (MHz)	Meter Reading (dBm)	Det	AFT863 (dB/m)	Amp/Cbl (dB)	Amp/Cbl (dB)	Corrected Reading (dBm)	Limit	Margin (dB)	Azimuth (Degs)	Height (cm)	Polarity
821.5MHz												
1	3.257	-68.6	Pk	33	-31	10.3	-56.3	-13	-43.3	0-360	149	H
2	3.257	-70.68	Pk	33	-31.1	9.8	-58.98	-13	-45.98	0-360	149	V

**LTE BAND 26 (FCC Part 22)**

Company:	Samsung
Project #:	12563993
Date:	01/07/19
Test Engineer:	19480
Configuration:	EUT+ Support Equipment
Mode:	LTE 26 QPSK 15MHz Low Channel
Chamber #:	Chamber B

Marker	Frequency (MHz)	Meter Reading (dBm)	Det	AFT863 (dB/m)	Amp/Cbl (dB)	Amp/Cbl (dB)	Corrected Reading (dBm)	Limit	Margin (dB)	Azimuth (Degs)	Height (cm)	Polarity
831.5MHz												
1	3.275	-71.29	Pk	33	-31.3	10	-59.59	-13	-46.59	0-360	149	H
2	3.275	-71.66	Pk	33	-31.3	9.2	-60.76	-13	-47.76	0-360	149	V

Company:	Samsung
Project #:	12563993
Date:	01/07/19
Test Engineer:	19480
Configuration:	EUT+ Support Equipment
Mode:	LTE 26 16QAM 15MHz High Channel
Chamber #:	Chamber B

Marker	Frequency (MHz)	Meter Reading (dBm)	Det	AFT863 (dB/m)	Amp/Cbl (dB)	Amp/Cbl (dB)	Corrected Reading (dBm)	Limit	Margin (dB)	Azimuth (Degs)	Height (cm)	Polarity
841.5MHz												
1	2.524	-69.91	Pk	32.7	-32.1	9.2	-60.11	-13	-47.11	0-360	149	H
2	2.524	-69.96	Pk	32.7	-32.1	9.4	-59.96	-13	-46.96	0-360	149	V

**LTE BAND 41**

Company:	Samsung
Project #:	12563993
Date:	12/14/18
Test Engineer:	19498
Configuration:	EUT+ Support Equipment
Mode:	LTE 41 QPSK 10MHz Mid Channel
Chamber #:	Chamber B

Marker	Frequency (MHz)	Meter Reading (dBm)	Det	AFT863 (dB/m)	Amp/Cbl (dB)	Amp/Cbl (dB)	Corrected Reading (dBm)	Limit	Margin (dB)	Azimuth (Degs)	Height (cm)	Polarity
2593MHz												
2	10.354	-72.43	Pk	37.8	-22.9	7	-50.53	-25	-25.53	0-360	149	V
1	10.356	-74.3	Pk	37.8	-22.8	7.1	-52.2	-25	-27.2	0-360	149	H

Company:	Samsung
Project #:	12563993
Date:	12/14/18
Test Engineer:	19498
Configuration:	EUT+ Support Equipment
Mode:	LTE 41 16QAM 10MHz Mid Channel
Chamber #:	Chamber B

Marker	Frequency (MHz)	Meter Reading (dBm)	Det	AFT863 (dB/m)	Amp/Cbl (dB)	Amp/Cbl (dB)	Corrected Reading (dBm)	Limit	Margin (dB)	Azimuth (Degs)	Height (cm)	Polarity
2593MHz												
1	10.354	-74.54	Pk	37.8	-22.9	7	-52.64	-25	-27.64	0-360	149	H
2	10.354	-74.27	Pk	37.8	-22.9	7	-52.37	-25	-27.37	0-360	149	V

**LTE BAND 66**

Company:	Samsung
Project #:	125637993
Date:	01/04/19
Test Engineer:	19480
Configuration:	EUT+ Support Equipment
Mode:	LTE 66 QPSK 20MHz Mid Channel
Chamber #:	Chamber B

Marker	Frequency (MHz)	Meter Reading (dBm)	Det	AFT863 (dB/m)	Amp/Cbl (dB)	Amp/Cbl (dB)	Corrected Reading (dBm)	Limit	Margin (dB)	Azimuth (Degs)	Height (cm)	Polarity
1745 MHz												
1	10.416	-74.15	Pk	37.9	-23.1	7.2	-52.15	-13	-39.15	0-360	149	H
2	10.416	-75.23	Pk	37.9	-23.1	7.2	-53.23	-13	-40.23	0-360	149	V

Company:	Samsung
Project #:	12563993
Date:	01/04/19
Test Engineer:	19480
Configuration:	EUT+ Support Equipment
Mode:	LTE 66 16QAM 20MHz Mid Channel
Chamber #:	Chamber B

Marker	Frequency (MHz)	Meter Reading (dBm)	Det	AFT863 (dB/m)	Amp/Cbl (dB)	Amp/Cbl (dB)	Corrected Reading (dBm)	Limit	Margin (dB)	Azimuth (Degs)	Height (cm)	Polarity
1745 MHz												
1	10.416	-75.22	Pk	37.9	-23.1	7.2	-53.22	-13	-40.22	0-360	149	H
2	10.416	-73.76	Pk	37.9	-23.1	7.2	-51.76	-13	-38.76	0-360	149	V

## 2.4. REFERENCE DETAIL

Reference application that contains the reused reference data.

Equipment Class	Reference FCC ID	Type Grant/ Permissive Change	Reference Application	Folder Test/RF Exposure	Report Title/Section
PCE	A3LSMG970F	Grant	12563734-E1V6	Test	FCC Report WWAN / All sections except Appendix A
DSS	A3LSMG970F	Grant	12563734-E2V2	Test	FCC Report BT / All sections
DTS	A3LSMG970F	Grant	12563734-E3V3	Test	FCC Report BLE / All sections
			12563734-E4V4		FCC Report DTS WLAN / All sections
NII	A3LSMG970F	Grant	12563734-E5V3	Test	FCC Report UNII WLAN / All sections except DFS
DXX	A3LSMG970F	Grant	12563734-E7V3	Test	FCC Report ANT+ / All sections
			12563734-E8V3	Test	FCC Report NFC / All sections
DCD	A3LSMG970F	Grant	12563734-E9V3	Test	FCC Report Wireless Charging / All sections



### 3. TEST METHODOLOGY

The tests documented in this report were performed in accordance with ANSI C63.26:2015, ANSI C63.4:2014, TIA-603-E, FCC CFR 47 Part 2, Part 22, Part 24, Part 27, Part 90, FCC KDB 971168 D01 v3r1.

### 4. FACILITIES AND ACCREDITATION

The test sites and measurement facilities used to collect data are located at 47173 and 47266 Benicia Street, and 47658 Kato Road, Fremont, California, USA. Line conducted emissions are measured only at the 47173 address. The following table identifies which facilities were utilized for radiated emission measurements documented in this report. Specific facilities are also identified in the test results sections.

47173 Benicia Street	47266 Benicia Street	47658 Kato Rd
<input checked="" type="checkbox"/> Chamber A (ISED:2324B-1)	<input type="checkbox"/> Chamber D (ISED:22541-1)	<input type="checkbox"/> Chamber I (ISED:2324A-5)
<input checked="" type="checkbox"/> Chamber B (ISED:2324B-2)	<input type="checkbox"/> Chamber E (ISED:22541-2)	<input type="checkbox"/> Chamber J (ISED:2324A-6)
<input type="checkbox"/> Chamber C (ISED:2324B-3)	<input type="checkbox"/> Chamber F (ISED:22541-3)	<input type="checkbox"/> Chamber K (ISED:2324A-1)
	<input type="checkbox"/> Chamber G (ISED:22541-4)	<input type="checkbox"/> Chamber L (ISED:2324A-3)
	<input type="checkbox"/> Chamber H (ISED:22541-5)	

The above test sites and facilities are covered under FCC Test Firm Registration # 208313. Chambers above are covered under Industry Canada company address and respective code

UL Verification Services Inc. is accredited by NVLAP, Laboratory Code 200065-0

## 5. CALIBRATION AND UNCERTAINTY

### 5.1. MEASURING INSTRUMENT CALIBRATION

The measuring equipment utilized to perform the tests documented in this report has been calibrated in accordance with the manufacturer's recommendations, and is traceable to recognized national standards.

### 5.2. SAMPLE CALCULATION

#### RADIATED EMISSIONS

Where relevant, the following sample calculation is provided:

$$\text{Field Strength (dBuV/m)} = \text{Measured Voltage (dBuV)} + \text{Antenna Factor (dB/m)} + \text{Cable Loss (dB)} - \text{Preamp Gain (dB)}$$
$$36.5 \text{ dBuV} + 18.7 \text{ dB/m} + 0.6 \text{ dB} - 26.9 \text{ dB} = 28.9 \text{ dBuV/m}$$

#### MAINS CONDUCTED EMISSIONS

Where relevant, the following sample calculation is provided:

$$\text{Final Voltage (dBuV)} = \text{Measured Voltage (dBuV)} + \text{Cable Loss (dB)} + \text{Limiter Factor (dB)} + \text{LISN Insertion Loss.}$$
$$36.5 \text{ dBuV} + 0 \text{ dB} + 10.1 \text{ dB} + 0 \text{ dB} = 46.6 \text{ dBuV}$$

### 5.3. MEASUREMENT UNCERTAINTY

Where relevant, the following measurement uncertainty levels have been estimated for tests performed on the apparatus:

PARAMETER	UNCERTAINTY
Worst Case Conducted Disturbance, 9KHz to 0.15 MHz	3.84 dB
Worst Case Conducted Disturbance, 0.15 to 30 MHz	3.65 dB
Worst Case Radiated Disturbance, 9KHz to 30 MHz	3.15 dB
Worst Case Radiated Disturbance, 30 to 1000 MHz	5.36 dB
Worst Case Radiated Disturbance, 1000 to 18000 MHz	4.32 dB
Worst Case Radiated Disturbance, 18000 to 26000 MHz	4.45 dB
Worst Case Radiated Disturbance, 26000 to 40000 MHz	5.24 dB

Uncertainty figures are valid to a confidence level of 95%.

## 6. EQUIPMENT UNDER TEST

### 6.1. DESCRIPTION OF EUT

The EUT is a GSM/WCDMA/LTE phone with BT, DTS/UNII a/b/g/n/ac/11ax HE 20/40/80, ANT+ and NFC.

### 6.2. MAXIMUM OUTPUT POWER

#### ERP/EIRP LIMIT

FCC: §2.1046, §22.913, §24.232, §27.50, §90.635

#### EIRP/ERP TEST PROCEDURE

ANSI C63.26:2015/ TIA-603-E Clause 2.2.17

KDB 971168 D01Section 5.6

KDB 412172 D01

$ERP/EIRP = P_{Meas} + GT - LC$

where: ERP/EIRP = effective or equivalent radiated power, respectively (expressed in the same units as P<sub>Meas</sub>, typically dBW or dBm);

P<sub>Meas</sub> = measured transmitter output power or PSD, in dBm or dBW;

GT = gain of the transmitting antenna, in dBd (ERP) or dBi (EIRP);

LC = signal attenuation in the connecting cable between the transmitter and antenna, in dB.

For devices utilizing multiple antennas, KDB 662911 provides guidance for determining the effective array transmit antenna gain term to be used in the above equation.

The transmitter has a maximum average conducted and ERP / EIRP output powers as follows:

**GSM MODES**

<b>Part 22 850MHz</b>								
Frequency range (MHz)	Modulation	Conducted (Average) (dBm)	Antenna Gain (dBi)	Limit (W)	ERP		99% BW (kHz)	Emission Designator
					(dBm)	(W)		
824.2-848.8	GPRS	33.6	-1.32	7.0	30.13	1.030	245.77	246KGXW
	EGPRS	26.7			23.23	0.210	244.6	245KG7W
<b>Part 24 1900MHz</b>								
Frequency range (MHz)	Modulation	Conducted (Average) (dBm)	Antenna Gain (dBi)	Limit (W)	EIRP		99% BW (kHz)	Emission Designator
					(dBm)	(W)		
1850.2-1909.8	GPRS	30.5	-0.30	2.0	30.20	1.047	241.31	241KGXW
	EGPRS	25.7			25.40	0.347	232.14	232KG7W

**WCDMA MODE**

<b>Part 22 Band 5</b>								
Frequency range (MHz)	Modulation	Conducted (Average) (dBm)	Antenna Gain (dBi)	Limit (W)	ERP		99% BW (kHz)	Emission Designator
					(dBm)	(W)		
826.4-846.6	REL 99	24.9	-1.32	7.0	21.43	0.139	4160	4M16F9W
	HSDPA	23.5			20.03	0.101	4180	4M18F9W
<b>Part 24 Band 2</b>								
Frequency range (MHz)	Modulation	Conducted (Average) (dBm)	Antenna Gain (dBi)	Limit (W)	ERP		99% BW (kHz)	Emission Designator
					(dBm)	(W)		
1852.4-1907.6	REL 99	24.5	-0.30	2.0	24.20	0.263	4150	4M15F9W
	HSDPA	23.9			23.60	0.229	4170	4M17F9W
<b>Part 27 Band 4</b>								
Frequency range (MHz)	Modulation	Conducted (Average) (dBm)	Antenna Gain (dBi)	Limit (W)	EIRP		99% BW (kHz)	Emission Designator
					(dBm)	(W)		
1712.4-1752.6	REL 99	24.3	0.60	1.0	24.90	0.309	4160	4M16F9W
	HSDPA	24.4			25.00	0.316	4180	4M18F9W

**LTE BAND 2**

Part 24								
EIRP Limit (W)		2.00						
Antenna Gain (dBi)		-0.30						
Bandwidth (MHz)	Modulation	Low Frequency (MHz)	Upper Frequency (MHz)	Conducted Average (dBm)	EIRP Average (dBm)	EIRP Average (W)	99% BW (kHz)	Emission Designator
1.4	QPSK	1850.7	1909.3	24.2	23.90	0.245	1090	1M09G7W
	16QAM			22.4	22.10	0.162	1090	1M09D7W
	64QAM			21.1	20.80	0.120		
3.0	QPSK	1851.5	1908.5	24.4	24.10	0.257	2690	2M69G7W
	16QAM			22.8	22.50	0.178	2690	2M69D7W
	64QAM			21.7	21.40	0.138		
5.0	QPSK	1852.5	1907.5	24.3	24.00	0.251	4500	4M50G7W
	16QAM			22.9	22.60	0.182	4510	4M51D7W
	64QAM			21.7	21.40	0.138		
10.0	QPSK	1855.0	1905.0	24.4	24.10	0.257	8970	8M97G7W
	16QAM			22.7	22.40	0.174	8970	8M97D7W
	64QAM			21.7	21.40	0.138		
15.0	QPSK	1857.5	1902.5	24.5	24.20	0.263	13440	13M4G7W
	16QAM			22.7	22.40	0.174	13420	13M4D7W
	64QAM			21.6	21.30	0.135		
20.0	QPSK	1860.0	1900.0	24.4	24.10	0.257	17880	17M9G7W
	16QAM			22.8	22.50	0.178	17870	17M9D7W
	64QAM			21.6	21.30	0.135		

**LTE BAND 4**

Part 27								
EIRP Limit (W)		1.00						
Antenna Gain (dBi)		0.60						
Bandwidth (MHz)	Modulation	Low Frequency (MHz)	Upper Frequency (MHz)	Conducted Average (dBm)	EIRP Average (dBm)	EIRP Average (W)	99% BW (kHz)	Emission Designator
1.4	QPSK	1710.7	1754.3	24.2	24.80	0.302	1080	1M08G7W
	16QAM			22.4	23.00	0.200	1090	1M09D7W
	64QAM			21.3	21.90	0.155		
3.0	QPSK	1711.5	1753.5	24.4	25.00	0.316	2680	2M68G7W
	16QAM			22.8	23.40	0.219	2680	2M68D7W
	64QAM			21.6	22.20	0.166		
5.0	QPSK	1712.5	1752.5	24.3	24.90	0.309	4500	4M50G7W
	16QAM			22.5	23.10	0.204	4510	4M51D7W
	64QAM			21.3	21.90	0.155		
10.0	QPSK	1715.0	1750.0	24.2	24.80	0.302	8960	8M96G7W
	16QAM			22.4	23.00	0.200	8970	8M97D7W
	64QAM			21.4	22.00	0.158		
15.0	QPSK	1717.5	1747.5	24.4	25.00	0.316	13410	13M4G7W
	16QAM			22.5	23.10	0.204	13370	13M4D7W
	64QAM			21.5	22.10	0.162		
20.0	QPSK	1720.0	1745.0	24.2	24.80	0.302	17860	17M9G7W
	16QAM			22.6	23.20	0.209	17870	17M9D7W
	64QAM			21.6	22.20	0.166		

**LTE BAND 5**

Part 22H								
ERP Limit (W)		7.00						
Antenna Gain (dBi)		-1.32						
Bandwidth (MHz)	Modulation	Low Frequency (MHz)	Upper Frequency (MHz)	Conducted Average (dBm)	ERP Average (dBm)	ERP Average (W)	99% BW (kHz)	Emission Designator
1.4	QPSK	824.7	848.3	24.8	21.33	0.136	1080	1M08G7W
	16QAM			22.7	19.23	0.084	1090	1M09D7W
	64QAM			21.6	18.13	0.065		
3.0	QPSK	825.5	847.5	25.0	21.53	0.142	2680	2M68G7W
	16QAM			22.9	19.43	0.088	2690	2M69D7W
	64QAM			21.8	18.33	0.068		
5.0	QPSK	826.5	846.5	24.8	21.33	0.136	4510	4M51G7W
	16QAM			22.7	19.23	0.084	4520	4M52D7W
	64QAM			21.7	18.23	0.067		
10.0	QPSK	829.0	844.0	24.7	21.23	0.133	8950	8M95G7W
	16QAM			22.3	18.83	0.076	8940	8M94D7W
	64QAM			21.4	17.93	0.062		

**LTE BAND 12**

Part 27								
ERP Limit (W)		3.00						
Antenna Gain (dBi)		-2.15						
Bandwidth (MHz)	Modulation	Low Frequency (MHz)	Upper Frequency (MHz)	Conducted Average (dBm)	ERP Average (dBm)	ERP Average (W)	99% BW (kHz)	Emission Designator
1.4	QPSK	699.7	715.3	24.1	19.80	0.095	1080	1M08G7W
	16QAM			22.6	18.30	0.068	1090	1M09D7W
	64QAM			21.4	17.10	0.051		
3.0	QPSK	700.5	714.5	24.3	20.00	0.100	2680	2M68G7W
	16QAM			22.7	18.40	0.069	2690	2M69D7W
	64QAM			21.4	17.10	0.051		
5.0	QPSK	701.5	713.5	24.1	19.80	0.095	4520	4M52G7W
	16QAM			22.5	18.20	0.066	4490	4M49D7W
	64QAM			21.4	17.10	0.051		
10.0	QPSK	704.0	711.0	24.1	19.80	0.095	8970	8M97G7W
	16QAM			22.3	18.00	0.063	8950	8M95D7W
	64QAM			21.5	17.20	0.052		

**LTE BAND 13**

Part 27								
ERP Limit (W)		3.00						
Antenna Gain (dBi)		-4.60						
Bandwidth (MHz)	Modulation	Low Frequency (MHz)	Upper Frequency (MHz)	Conducted Average (dBm)	ERP Average (dBm)	ERP Average (W)	99% BW (kHz)	Emission Designator
5.0	QPSK	779.5	784.5	24.8	18.05	0.064	4510	4M51G7W
	16QAM			22.7	15.95	0.039	4510	4M51D7W
	64QAM			21.8	15.05	0.032		
10.0	QPSK	782.0	782.0	24.7	17.95	0.062	8940	8M94G7W
	16QAM			22.5	15.75	0.038	8940	8M94D7W
	64QAM			21.5	14.75	0.030		

**LTE BAND 17**

Part 27								
ERP Limit (W)		3.00						
Antenna Gain (dBi)		-2.15						
Bandwidth (MHz)	Modulation	Low Frequency (MHz)	Upper Frequency (MHz)	Conducted Average (dBm)	ERP Average (dBm)	ERP Average (W)	99% BW (kHz)	Emission Designator
5.0	QPSK	706.5	713.5	24.1	19.80	0.095	4510	4M51G7W
	16QAM			22.4	18.10	0.065	4500	4M50D7W
	64QAM			21.4	17.10	0.051		
10.0	QPSK	709.0	711.0	24.1	19.80	0.095	8950	8M95G7W
	16QAM			22.6	18.30	0.068	8930	8M93D7W
	64QAM			21.5	17.20	0.052		

**LTE BAND 25**

Part 24								
EIRP Limit (W)		2.00						
Antenna Gain (dBi)		-0.30						
Bandwidth (MHz)	Modulation	Low Frequency (MHz)	Upper Frequency (MHz)	Conducted Average (dBm)	EIRP Average (dBm)	EIRP Average (W)	99% BW (kHz)	Emission Designator
1.4	QPSK	1850.7	1914.3	24.4	24.10	0.257	1090	1M09G7W
	16QAM			22.7	22.40	0.174	1090	1M09D7W
	64QAM			21.5	21.20	0.132		
3.0	QPSK	1851.5	1913.5	24.7	24.40	0.275	2690	2M69G7W
	16QAM			22.7	22.40	0.174	2690	2M69D7W
	64QAM			21.8	21.50	0.141		
5.0	QPSK	1852.5	1912.5	24.4	24.10	0.257	4520	4M52G7W
	16QAM			23.1	22.80	0.191	4500	4M50D7W
	64QAM			21.6	21.30	0.135		
10.0	QPSK	1855.0	1910.0	24.5	24.20	0.263	8970	8M97G7W
	16QAM			22.6	22.30	0.170	8980	8M98D7W
	64QAM			21.7	21.40	0.138		
15.0	QPSK	1857.5	1907.5	24.6	24.30	0.269	13410	13M4G7W
	16QAM			22.9	22.60	0.182	13420	13M4D7W
	64QAM			21.7	21.40	0.138		
20.0	QPSK	1860.0	1905.0	24.6	24.30	0.269	17900	17M9G7W
	16QAM			23.1	22.80	0.191	17860	17M9D7W
	64QAM			21.9	21.60	0.145		

**LTE BAND 26 (FCC Part 90S)**

Part 90S								
ERP Limit (W)		100.00						
Antenna Gain (dBi)		-2.11						
Bandwidth (MHz)	Modulation	Low Frequency (MHz)	Upper Frequency (MHz)	Conducted Average (dBm)	ERP Average (dBm)	ERP Average (W)	99% BW (kHz)	Emission Designator
1.4	QPSK	814.7	823.3	24.5	20.24	0.106	1080	1M08G7W
	16QAM			22.5	18.24	0.067	1090	1M09D7W
	64QAM			21.7	17.44	0.055		
3.0	QPSK	815.5	822.5	24.5	20.24	0.106	2690	2M69G7W
	16QAM			22.9	18.64	0.073	2690	2M69D7W
	64QAM			21.7	17.44	0.055		
5.0	QPSK	816.5	821.5	24.4	20.14	0.103	4510	4M51G7W
	16QAM			22.8	18.54	0.071	4510	4M51D7W
	64QAM			21.8	17.54	0.057		
10.0	QPSK	819.0	819.0	24.4	20.14	0.103	8940	8M94G7W
	16QAM			22.7	18.44	0.070	8950	8M95D7W
	64QAM			21.6	17.34	0.054		
15.0	QPSK	821.5	821.5	24.4	20.14	0.103	13420	13M4G7W
	16QAM			22.8	18.54	0.071	13450	13M5D7W
	64QAM			21.4	17.14	0.052		



**LTE BAND 26 (FCC Part 22)**

Part 22								
ERP Limit (W)		7.00						
Antenna Gain (dBi)		-1.32						
Bandwidth (MHz)	Modulation	Low Frequency (MHz)	Upper Frequency (MHz)	Conducted Average (dBm)	ERP Average (dBm)	ERP Average (W)	99% BW (kHz)	Emission Designator
1.4	QPSK	824.7	848.3	24.3	20.83	0.121	1090	1M09G7W
	16QAM			22.5	19.03	0.080	1080	1M08D7W
	64QAM			21.8	18.33	0.068		
3.0	QPSK	825.5	847.5	24.5	21.03	0.127	2680	2M68G7W
	16QAM			22.9	19.43	0.088	2690	2M69D7W
	64QAM			21.7	18.23	0.067		
5.0	QPSK	826.5	846.5	24.2	20.73	0.118	4500	4M50G7W
	16QAM			22.8	19.33	0.086	4500	4M50D7W
	64QAM			21.6	18.13	0.065		
10.0	QPSK	829.0	844.0	24.3	20.83	0.121	8960	8M96G7W
	16QAM			22.4	18.93	0.078	8980	8M98D7W
	64QAM			21.5	18.03	0.064		
15.0	QPSK	831.5	841.5	24.5	21.03	0.127	13380	13M4G7W
	16QAM			22.7	19.23	0.084	13420	13M4D7W
	64QAM			21.7	18.23	0.067		

**LTE BAND 41**

Part 27								
EIRP Limit (W)		2.00						
Antenna Gain (dBi)		2.21						
Bandwidth (MHz)	Modulation	Low Frequency (MHz)	Upper Frequency (MHz)	Conducted Average (dBm)	EIRP Average (dBm)	EIRP Average (W)	99% BW (kHz)	Emission Designator
5.0	QPSK	2498.5	2687.5	23.7	25.91	0.390	4510	4M51G7W
	16QAM			21.7	23.91	0.246	4500	4M50D7W
	64QAM			21.7	23.91	0.246		
10.0	QPSK	2501.0	2685.0	23.7	25.91	0.390	8980	8M98G7W
	16QAM			22.0	24.21	0.264	8970	8M97D7W
	64QAM			20.9	23.11	0.205		
15.0	QPSK	2503.5	2682.5	23.8	26.01	0.399	13450	13M5G7W
	16QAM			22.0	24.21	0.264	13450	13M5D7W
	64QAM			21.0	23.21	0.209		
20.0	QPSK	2506.0	2680.0	23.9	26.11	0.408	17910	17M9G7W
	16QAM			22.0	24.21	0.264	17910	17M9D7W
	64QAM			21.2	23.41	0.219		

**LTE BAND 66**

Part 27								
EIRP Limit (W)		1.00						
Antenna Gain (dBi)		0.60						
Bandwidth (MHz)	Modulation	Low Frequency (MHz)	Upper Frequency (MHz)	Conducted Average (dBm)	EIRP Average (dBm)	EIRP Average (W)	99% BW (kHz)	Emission Designator
1.4	QPSK	1710.7	1779.3	24.1	24.70	0.295	1090	1M09G7W
	16QAM			22.5	23.10	0.204	1080	1M08D7W
	64QAM			22.3	22.90	0.195		
3.0	QPSK	1711.5	1778.5	24.3	24.90	0.309	2690	2M69G7W
	16QAM			22.5	23.10	0.204	2690	2M69D7W
	64QAM			22.5	23.10	0.204		
5.0	QPSK	1712.5	1777.5	24.2	24.80	0.302	4500	4M50G7W
	16QAM			22.6	23.20	0.209	4520	4M52D7W
	64QAM			21.5	22.10	0.162		
10.0	QPSK	1715.0	1775.0	24.1	24.70	0.295	8950	8M95G7W
	16QAM			22.3	22.90	0.195	8960	8M96D7W
	64QAM			21.4	22.00	0.158		
15.0	QPSK	1717.5	1772.5	24.3	24.90	0.309	13380	13M4G7W
	16QAM			22.6	23.20	0.209	13400	13M4D7W
	64QAM			21.6	22.20	0.166		
20.0	QPSK	1720.0	1770.0	24.2	24.80	0.302	17890	17M9G7W
	16QAM			22.6	23.20	0.209	17880	17M9D7W
	64QAM			21.7	22.30	0.170		

### 6.3. SOFTWARE AND FIRMWARE

The EUT firmware installed during testing was G970N.001

### 6.4. MAXIMUM ANTENNA GAIN

Please see table below:

LTE Bands	Antenna Gain (dBi)
GSM850, 824-849MHz	-1.32
GSM1900, 1850-1910MHz	-0.30
WCDMA Band 2, 1850-1910 MHz	-0.30
WCDMA Band 4, 1710-1755 MHz	0.60
WCDMA Band 5, 824-849 MHz	-1.32
LTE BAND 2, 1850 - 1910 MHz	-0.30
LTE BAND 4, 1710 - 1755 MHz	0.60
LTE BAND 5, 824 - 849 MHz	-1.32
LTE BAND 12, 699 - 716 MHz	-2.15
LTE BAND 13, 777 - 787 MHz	-4.60
LTE BAND 17, 704 - 716 MHz	-2.15
LTE BAND 25, 1850 - 1915 MHz	-0.30
LTE BAND 26 (FCC PART 22), 824 - 849 MHz	-1.32
LTE BAND 26 (FCC PART 90S), 814 - 824 MHz	-2.11
LTE BAND 41 (FCC), 2496 - 2690 MHz	2.21
LTE BAND 66, 1710 - 1780 MHz	0.60

## 6.5. WORST-CASE CONFIGURATION AND MODE

The EUT supports LTE Bands of:

Band 2, Band 4, Band 5, Band 12, Band 13, Band 17, Band 25, Band 26, Band 41 and Band 66.

The worst-case scenario for all measurements is based on the average conducted output power measurement investigation results. Output power measurements were measured on QPSK, 16QAM, and 64QAM modulations. All testing was performed using QPSK, and 16QAM modulations to represent the worst case.

The fundamental of the EUT was investigated in three orthogonal orientations X, Y, & Z, and it was determined that Y-Axis for 1880MHz, Z-Axis for 800MHz, and X-Axis for 2500MHz with AC/DC Adapter and headset was worst-case orientation.

All radios that can be transmitted simultaneously have been evaluated for radiated for all possible combinations of transmission and found to be in compliance.

### **For check the Part15B receiver mode (Appendix A):**

LTE Band 26 (Frequency range: 859-894 MHz) cover GSM850, WCDMA B5, and LTE Band 5 due to overlapping frequency range. The middle channel was set to test and spurious emissions was investigated in three orthogonal orientations X, Y and Z it was determined that Z orientation was worst-case orientation

For LTE B12 , the middle channel was set to test and the spurious emissions was investigated in three orthogonal orientations X, Y and Z it was determined that Z orientation was worst-case orientation.

For LTE B13 , the middle channel was set to test and the spurious emissions was investigated in three orthogonal orientations X, Y and Z it was determined that Z orientation was worst-case orientation.

In addition, LTE Band 17 (Frequency range: 734-746 MHz) is covered by LTE Band 12 (Frequency range: 729-746 MHz) due to overlapping frequency range, same maximum tune-up limit and same channel bandwidth.

## 6.6. DESCRIPTION OF TEST SETUP

### SUPPORT EQUIPMENT

Support Equipment List				
Description	Manufacturer	Model	Serial Number	FCC ID
AC Adapter	Samsung	EP-TA300	R3KB5B01S1SE3	N/A
USB Data Cable	Samsung	N/A	N/A	N/A
Earphone	Samsung	N/A	N/A	N/A

### I/O CABLES (RF Conducted Test)

I/O Cable List						
Cable No	Port	# of identical ports	Connector Type	Cable Type	Cable Length (m)	Remarks
1	RF Out	1	Spectrum Analyzer	Shielded	None	NA
2	Antenna Port	1	EUT	Shielded	0.1m	NA
3	RF In/Out	1	Communication Test Set	Shielded	1m	NA

### I/O CABLES (RF Radiated Test)

I/O Cable List						
Cable No	Port	# of identic	Connector Type	Cable Type	Cable Length	Remarks
1	USB	1	AC Adapter	Un-shielded	1.2m	No
2	Earphone	1	USB	Un-shielded	1m	No
3	RF In/out	1	Communication Test Set	Un-shielded	2m	No

### TEST SETUP

The EUT is continuously communicated to the call box during the tests

**CONDUCTED TEST SETUP DIAGRAM**

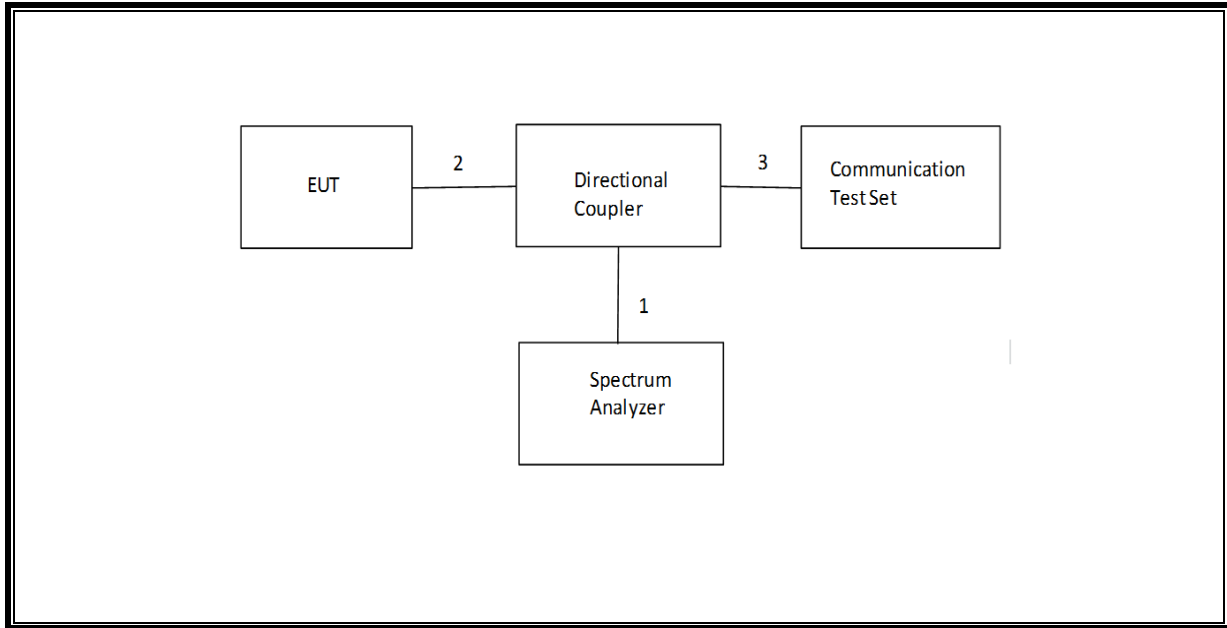

**RADIATED TEST SETUP DIAGRAM**

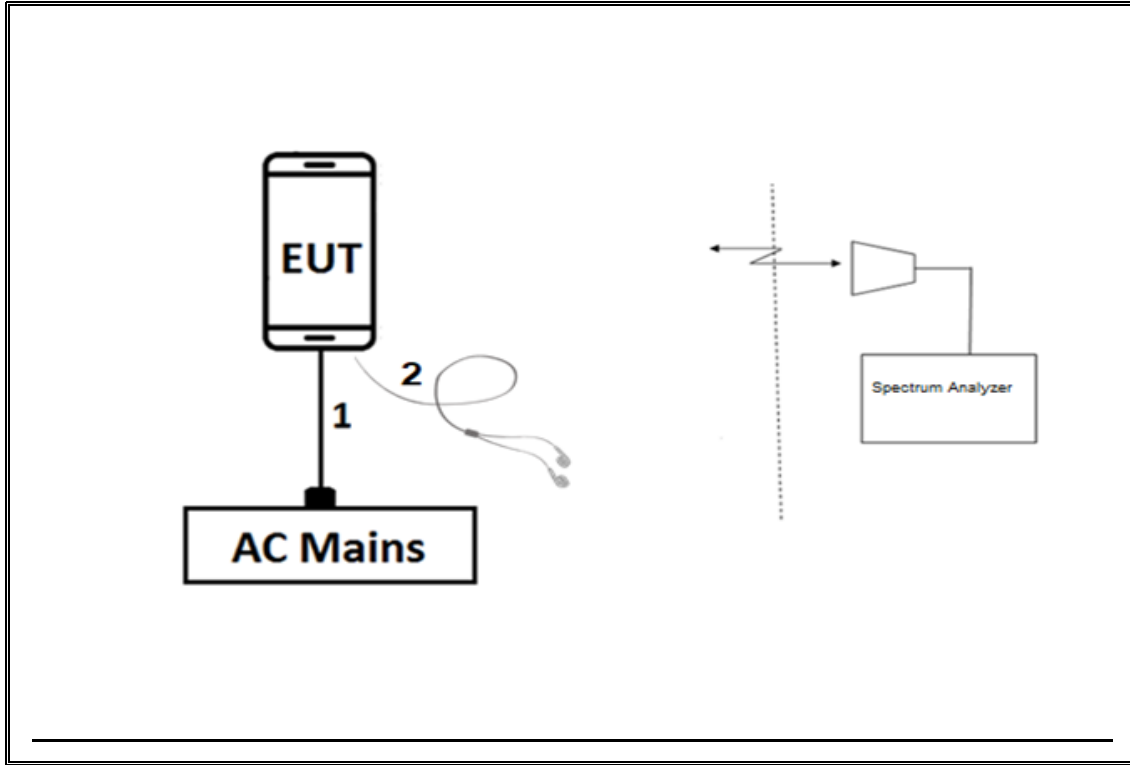

## 7. TEST AND MEASUREMENT EQUIPMENT

The following test and measurement equipment was utilized for the tests documented in this report:

TEST EQUIPMENT LIST					
Description	Manufacturer	Model	ID Num	Cal Due	Last Cal
Highpass Filter, 2.7 GHz	Micro-Circuits	H2G518G6	T772	07/05/19	07/05/18
Highpass Filter, 1 GHz	Micro-Tronics	HPM18129	T889	02/21/19	02/21/18
Highpass Filter, 1.5 GHz	Micro-Tronics	HPM50114	T1852	07/16/19	07/16/18
Highpass Filter, 4GHz	Micro-Tronics	HPM13351	T1241	07/19/19	07/19/18
Antenna, Horn 1-18GHz	ETS-Lindgren	3117	T345	04/25/19	04/25/18
Antenna, Horn 1-18GHz	ETS-Lindgren	3117	T863	06/21/19	06/21/18
Antenna, Horn 18 - 26.5 GHz	ARA	MWH-1826/B	T477	06/16/2019	06/16/2018
RF Amplifier	MITEQ	AFS42-00101800-25-S-42	T1165	06/12/19	06/12/18
RF Amplifier	MITEQ	AFS42-00101800-25-S-42	T493	04/03/19	04/03/18
Directional Coupler	Mini-Circuits	ZUDC10-183+	T1136	06/18/19	06/18/18
Wideband Communication Test Set, Call Box	R&S	CMW500	T972	05/29/19	05/29/18
Wideband Communication Test Set, Call Box	R&S	CMW500	T1872	02/15/19	02/15/18
Wideband Communication Test Set, Call Box	R&S	CMW500	T949	02/21/19	02/21/18
Chamber, Environmental	Thermotron	SE-600-10-10	T80	02/22/19	02/22/18
Spectrum Analyzer	Agilent (Keysight) Technologies	E4446A	T146	07/18/19	07/18/18
Spectrum Analyzer	Agilent	CCS01178-1C	T200	09/11/19	09/11/18
Spectrum Analyzer, PXA, 3Hz to 44GHz	Agilent (Keysight) Technologies	N9030A	T1450	02/05/19	02/05/18
Spectrum Analyzer, PXA, 3Hz to 44GHz	Agilent (Keysight) Technologies	N9030A	T1466	04/16/19	04/16/18
Spectrum Analyzer, PXA, 3Hz to 44GHz	Agilent (Keysight) Technologies	N9030A	T1454	01/08/19	01/08/18
DC power supply, 8 V @ 3 A or 15 V @ 2 A	Agilent / HP	E3610A	None	CNR	CNR
DC power supply 15V	Spresen	XT15-4	T463	CNR	CNR

UL AUTOMATION SOFTWARE			
CLT Software	UL	UL RF	Ver 7.6, November 11, 2017
Power Measurement Software	UL	UL RF	Ver 2.2, June 2017

### NOTES:

1. Equipment listed above that calibrated during the testing period was set for test after the calibration.
2. Equipment listed above that has a calibration due date during the testing period, the testing is completed before equipment expiration date.