



**HAC T-COIL SIGNAL TEST REPORT**

**FCC 47 CFR § 20.19  
ANSI C63.19-2011**

*For*

**GSM/WCDMA/LTE phone with BT, DTS/UNII a/b/g/n/ac/11ax HE 20/40/80, ANT+ and NFC**

**FCC ID: A3LSMG970F  
Model Name: SM-G970F/DS, SM-G970F**

**Report Number: 12563734-S2V6  
Issue Date: 2/14/2019**

*Prepared for*

**Samsung Electronics Co., Ltd.  
129 Samsung-Ro, Yeongtong-Gu,  
Suwon-Si, Gyeonggi-Do, 16677, Korea**

*Prepared by*

**UL VERIFICATION SERVICES INC.  
47173 BENICIA STREET  
FREMONT, CA 94538, U.S.A.  
TEL: (510) 771-1000  
FAX: (510) 661-0888**



NVLAP LAB CODE 200065-0



**Revision History**

Rev.	Date	Revisions	Revised By
V1	1/3/2019	Initial Issue	--
V2	1/10/2019	Updated §4.1., §9.1.1., §9.4., §9.5., and Appendix C	Nathan Sousa
V3	1/16/2019	Updated §4.1., §9.4., § 9.5., Appendix C, and Appendix D	Nathan Sousa
V4	1/17/2019	Updated §9.3. and Appendix B	Nathan Sousa
V5	1/22/2019	Updated §6., §9.1., §9.1.1., §9.2., §9.4., and Appendix C	Nathan Sousa
V6	1/22/2019	Updated per FCC's feedback	Nathan Sousa

## Table of Contents

<b>1. Attestation of Test Results</b> .....	<b>4</b>
<b>2. Test Methodology</b> .....	<b>5</b>
<b>3. Facilities and Accreditation</b> .....	<b>5</b>
<b>4. Calibration and Uncertainty</b> .....	<b>5</b>
4.1. <i>Measuring Instrument Calibration</i> .....	5
4.2. <i>Measurement Uncertainty</i> .....	6
<b>5. Test Procedures for all Technologies</b> .....	<b>7</b>
5.1. <i>Over the Top (OTT)</i> .....	9
<b>6. Audio Level and Gain Measurements</b> .....	<b>10</b>
<b>7. T-coil Measurement Criteria</b> .....	<b>12</b>
7.1. <i>Frequency Response</i> .....	12
7.2. <i>Signal to Noise</i> .....	13
<b>8. Device Under Test</b> .....	<b>14</b>
8.1. <i>Air Interfaces and Operating Mode</i> .....	14
<b>9. HAC (T-coil) Test Results</b> .....	<b>15</b>
9.1. <i>Codec Bit-rate Investigation</i> .....	15
9.1.1. <i>OTT Codec Bit-rate Investigation</i> .....	17
9.2. <i>Air Interface Investigation</i> .....	18
9.3. <i>HAC (T-coil) Test Results</i> .....	23
9.4. <i>OTT HAC (T-coil) Results</i> .....	24
9.5. <i>Worst Case T-Coil Test Plot</i> .....	25
<b>Appendix</b> .....	<b>26</b>
<i>Appendix A: T-Coil Setup Photo</i> .....	26
<i>Appendix B: T-Coil Test Plots</i> .....	26
<i>Appendix C: T-Coil Test Plots (OTT)</i> .....	26
<i>Appendix D: T-Coil Probe Certificates</i> .....	26
<i>Appendix E: Adjusted Gain Procedure</i> .....	26

### 1. Attestation of Test Results

Applicant Name	Samsung Electronics Co., Ltd.	
FCC ID	A3LSMG970F	
Model Name	SM-G970F/DS, SM-G970F	
Applicable Standards	FCC 47 CFR § 20.19 ANSI C63.19-2011	
HAC Rating	T3	
Date Tested	11/13/2018 to 12/24/2018; 1/15/2019 to 1/22/2019; 2/13/2019 to 2/14/2019	
Test Results	Pass	
<p>UL Verification Services Inc. tested the above equipment in accordance with the requirements set forth in the above standards. All indications of Pass/Fail in this report are opinions expressed by UL Verification Services Inc. based on interpretations and/or observations of test results. Measurement Uncertainties were not taken into account and are published for informational purposes only. The test results show that the equipment tested is capable of demonstrating compliance with the requirements as documented in this report.</p> <p><b>Note:</b> The results documented in this report apply only to the tested sample, under the conditions and modes of operation as described herein. This document may not be altered or revised in any way unless done so by UL Verification Services Inc. and all revisions are duly noted in the revisions section. Any alteration of this document not carried out by UL Verification Services Inc. will constitute fraud and shall nullify the document. This report must not be used by the client to claim product certification, approval, or endorsement by NVLAP, NIST, any agency of the Federal Government, or any agency of any government (NIST Handbook 150, Annex A). This report is written to support regulatory compliance of the applicable standards stated above.</p>		
Approved & Released By:	Prepared By:	
		
Dave Weaver Operations Leader UL Verification Services Inc.	Lance Fleischer Laboratory Engineer UL Verification Services Inc.	

## 2. Test Methodology

The tests documented in this report were performed in accordance with ANSI C63.19-2011 Methods of Measurement of Compatibility between Wireless Communications Devices and Hearing Aids and FCC published procedure KDB 285076 D01 HAC Guidance v05  
KDB 285076 D02 T-Coil testing for CMRS IP v03  
KDB 285076 D03 HAC FAQ v01  
TCB workshop updates

## 3. Facilities and Accreditation

The test sites and measurement facilities used to collect data are located at

47173 Benicia Street	47266 Benicia Street
SAR Lab C	SAR Lab 2

UL Verification Services Inc. is accredited by NVLAP, Laboratory Code 200065-0.

The test sites and measurement facilities used to collect data were also located at

Suwon
SAR 2 Room (HAC)

UL Korea, Ltd., is accredited by IAS, Laboratory Code TL-637. The full scope of the accreditation can be viewed at <http://www.iasonline.org/PDF/TL/TL-637.pdf>.

## 4. Calibration and Uncertainty

### 4.1. Measuring Instrument Calibration

The measuring equipment used to perform the tests documented in this report has been calibrated in accordance with the manufacturers' recommendations and is traceable to recognized national standards.

Name of Equipment	Manufacturer	Type/Model	Serial No.	Cal. Due Date
ABM Probe**	SPEAG	AM1DV3	3083	1/15/2019
ABM Probe	SPEAG	AM1DV3	3092	7/10/2019
Data Acquisition Electronics	SPEAG	DAE4	1472	3/8/2019
Radio Communication Tester	R & S	CMW 500	125236	3/28/2019
DAC	Sound Devices	USBPre 2	HB11173410003	N/A
AP	Cisco	AIR-CAP3702I-A-K9	FCW1925NNPJ	N/A
Series Wireless Controller	Cisco	WLAN 2500 Series Controller	PSZ1901CMV	N/A
Network Hub	Linksys	NH1005	R8730G403203	N/A
Switch	Netgear	ProSafe Plus Switch	29B9273A50BF5	N/A
Support Device	Samsung	SM-G891A	R38H90K96HA	N/A
ABM Probe*	SPEAG	AM1DV3	3137	11/20/2019
Data Acquisition Electronics*	SPEAG	DAE4	1447	03/15/2019
Radio Communication Tester*	R & S	CMW 500	150314	08/09/2019

#### Note(s):

\*: Denotes the equipment used by UL Korea. Data measured by UL Korea, herein, will also be noted.

\*\* : Denotes that the equipment was not used outside of its calibration date.

## 4.2. Measurement Uncertainty

### Measurement Uncertainty for Audio Band Magnetic Measurement

Error Description	Uncertainty values ( $\pm\%$ )	Probe Dist.	Div.	$c_i$		Std. Unc.	
				ABM1	ABM2	ABM1 ( $\pm\%$ )	ABM2 ( $\pm\%$ )
<b>Probe Sensitivity</b>							
Reference level	3.0	N	1	1	1	3.0	3.0
AMCC geometry	0.4	R	$\sqrt{3}$	1	1	0.2	0.2
AMCC current	1.0	R	$\sqrt{3}$	1	1	0.6	0.6
Probe positioning during calibration	0.1	R	$\sqrt{3}$	1	1	0.1	0.1
Noise contribution	0.7	R	$\sqrt{3}$	0.0143	1	0.0	0.4
Frequency slope	5.9	R	$\sqrt{3}$	0.1	1.00	0.3	3.5
<b>Probe System</b>							
Repeatability / drift	1.0	R	$\sqrt{3}$	1	1	0.6	0.6
Linearity / Dynamic range	0.6	R	$\sqrt{3}$	1	1	0.4	0.4
Acoustic noise	1.0	R	$\sqrt{3}$	0.1	1	0.1	0.6
Probe angle	2.3	R	$\sqrt{3}$	1	1	1.4	1.4
Spectral processing	0.9	R	$\sqrt{3}$	1	1	0.5	0.5
Integration time	0.6	N	1	1	5	0.6	3.0
Field disturbance	0.2	R	$\sqrt{3}$	1	1	0.1	0.1
<b>Test Signal</b>							
Reference signal spectral response	0.6	R	$\sqrt{3}$	0	1	0.0	0.4
<b>Positioning</b>							
Probe positioning	1.9	R	$\sqrt{3}$	1	1	1.1	1.1
Phantom positioning	0.9	R	$\sqrt{3}$	1	1	0.5	0.5
EUT positioning	1.9	R	$\sqrt{3}$	1	1	1.1	1.1
<b>External Contributions</b>							
RF interference	0.0	R	$\sqrt{3}$	1	0.3	0.0	0.0
Test signal variation	2.0	R	$\sqrt{3}$	1	1	1.2	1.2
<b>Combined Std. Uncertainty (ABM field)</b>						4.1	6.1
<b>Expanded Std. Uncertainty (%)</b>						8.1	12.3
Notes for table							
1. N - Normal							
2. R - Rectangular							
3. Div. - Divisor used to obtain standard uncertainty							

## 5. Test Procedures for all Technologies

ANSI C63.19-2011, Section 7

This document describes the procedures used to measure the ABM (T-Coil) performance of the WD. In addition to measuring the absolute signal levels, the A-weighted magnitude of the unintended signal shall also be determined. In order to assure that the required signal quality is measured, the measurement of the intended signal and the measurement of the unintended signal must be made at the same location for all measurement positions. In addition, the RF field strength at each measurement location must be at or below that required for the assigned category. Measurements shall not include undesired properties from the WD's RF field; therefore, use of a coaxial connection to a base station simulator or non-radiating load may be necessary. However, even then with a coaxial connection to a base station simulator or non-radiating load there may still be RF leakage from the WD, which may interfere with the desired measurement. Pre-measurement checks should be made to avoid this possibility. All measurements shall be done with the WD operating on battery power with an appropriate normal speech audio signal input level given in Table 7.1. If the device display can be turned off during a phone call then that may be done during the measurement as well.

Measurements shall be performed at two locations specified in A.3, with the correct probe orientation for a particular location, in a multistage sequence by first measuring the field intensity of the desired T-Coil signal (ABM1) that is useful to a hearing aid T-Coil. The undesired magnetic components (ABM2) must be measured at the same location as the desired ABM or T-Coil signal (ABM1), and the ratio of desired to undesired ABM signals must be calculated. For the perpendicular field location, only the ABM1 frequency response shall be determined in a third measurement stage. The flow chart in Figure 7.3 illustrates this three-stage, two orientation process.

The following steps summarize the basic test flow for determining ABM1<sup>1</sup> and ABM2<sup>2</sup>. These steps assume that a sine wave or narrowband 1/3 octave signal can be used for the measurement of ABM1.

- a. A validation of the test setup and instrumentation may be performed using a TMFS or Helmholtz coil. Measure the emissions and confirm that they are within the specified tolerance.
- b. Position the WD in the test setup and connect the WD RF connector to a base station simulator or a non-radiating load as shown in Figure 7.1 or Figure 7.2. Confirm that equipment that requires calibration has been calibrated, and that the noise level meets the requirements given in 7.3.1.
- c. The drive level to the WD is set such that the reference input level specified in Table 7.1 is input to the base station simulator (or manufacturer's test mode equivalent) in the 1 kHz, 1/3 octave band. This drive level shall be used for the T-Coil signal test (ABM1) at  $f = 1$  kHz. Either a sine wave at 1025 Hz or a voice-like signal, band-limited to the 1 kHz 1/3 octave, as defined in 7.4.2, shall be used for the reference audio signal. If interference is found at 1025 Hz an alternative nearby reference audio signal frequency may be used.<sup>46</sup> The same drive level will be used for the ABM1 frequency response measurements at each 1/3 octave band center frequency. The WD volume control may be set at any level up to maximum, provided that a signal at any frequency at maximum modulation would not result in clipping or signal overload.
- d. Determine the magnetic measurement locations for the WD device (A.3), if not already specified by the manufacturer, as described in 7.4.4.1.1 and 7.4.4.2.

---

<sup>1</sup> **Audio Band Magnetic signal - desired (ABM1):** Measured quantity of the desired magnetic signal

<sup>2</sup> **Audio Band Magnetic signal - undesired (ABM2):** Measured quantity of the undesired magnetic signal, such as interference from battery current and similar non-signal elements.

- e. At each measurement location, measure and record the desired T-Coil magnetic signals (ABM1 at  $f_i$ ) as described in 7.4.4.2 in each individual ISO 266-1975 R10 standard 1/3 octave band. The desired audio band input frequency ( $f_i$ ) shall be centered in each 1/3 octave band maintaining the same drive level as determined in item c) and the reading taken for that band.

Equivalent methods of determining the frequency response may also be employed, such as fast Fourier transform (FFT) analysis using noise excitation or input–output comparison using simulated speech. The full-band integrated or half-band integrated probe output, as specified in D.9, may be used, as long as the appropriate calibration curve is applied to the measured result, so as to yield an accurate measurement of the field magnitude. (The resulting measurement shall be an accurate measurement in dB A/m.)

All measurements of the desired signal shall be shown to be of the desired signal and not of an undesired signal. This may be shown by turning the desired signal ON and OFF with the probe measuring the same location. If the scanning method is used the scans shall show that all measurement points selected for the ABM1 measurement meet the ambient and test system noise criteria in 7.3.1.

- f. At the measurement location for each orientation, measure and record the undesired broadband audio magnetic signal (ABM2) as specified in 7.4.4.4 with no audio signal applied (or digital zero applied, if appropriate) using A-weighting and the half-band integrator. Calculate the ratio of the desired to undesired signal strength (i.e., signal quality).
- g. Obtain the data from the postprocessor, SEMCAD, and determine the category that properly classifies the signal quality based on Table 8.5.

Test Setup Diagram

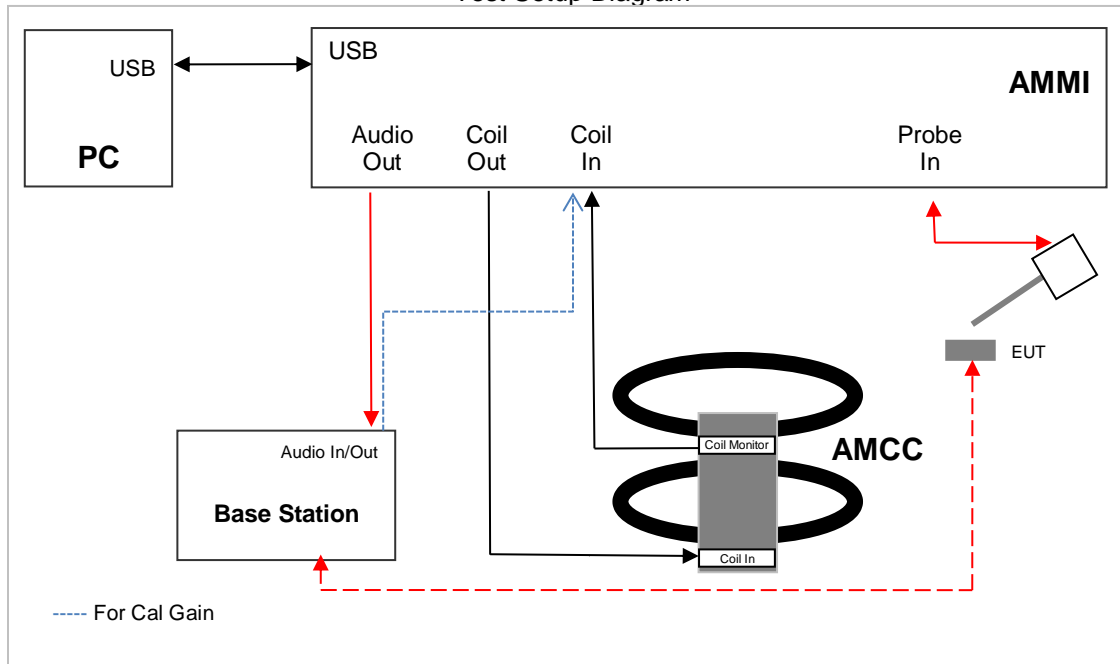



### 5.1. Over the Top (OTT)

The test procedure for OTT testing is identical to the section above, except for how the signal is sent to the DUT, as outlined in the diagram below.

The AMMI is connected to an external ADC (Analog to Digital Converter) and the ADC is connected to the support device via USB. The support device is connected to the Internet via Wi-Fi and the DUT is connected to the mobile base station via the technology under test. Using the DUT's OTT application, a VoIP call is established with the support device. The test signal is sent from the DASY PC to the AMMI, from the AMMI to the ADC, from the ADC to the support device, and finally to the DUT. To exercise the license antenna, the DUT was simultaneously connected to an external AP and to a mobile base station. This is essentially the manufacturer's test mode method (C63.19 2011 §7.3.3) but with the audio wired signal injection replaced by the Wi-Fi connection.

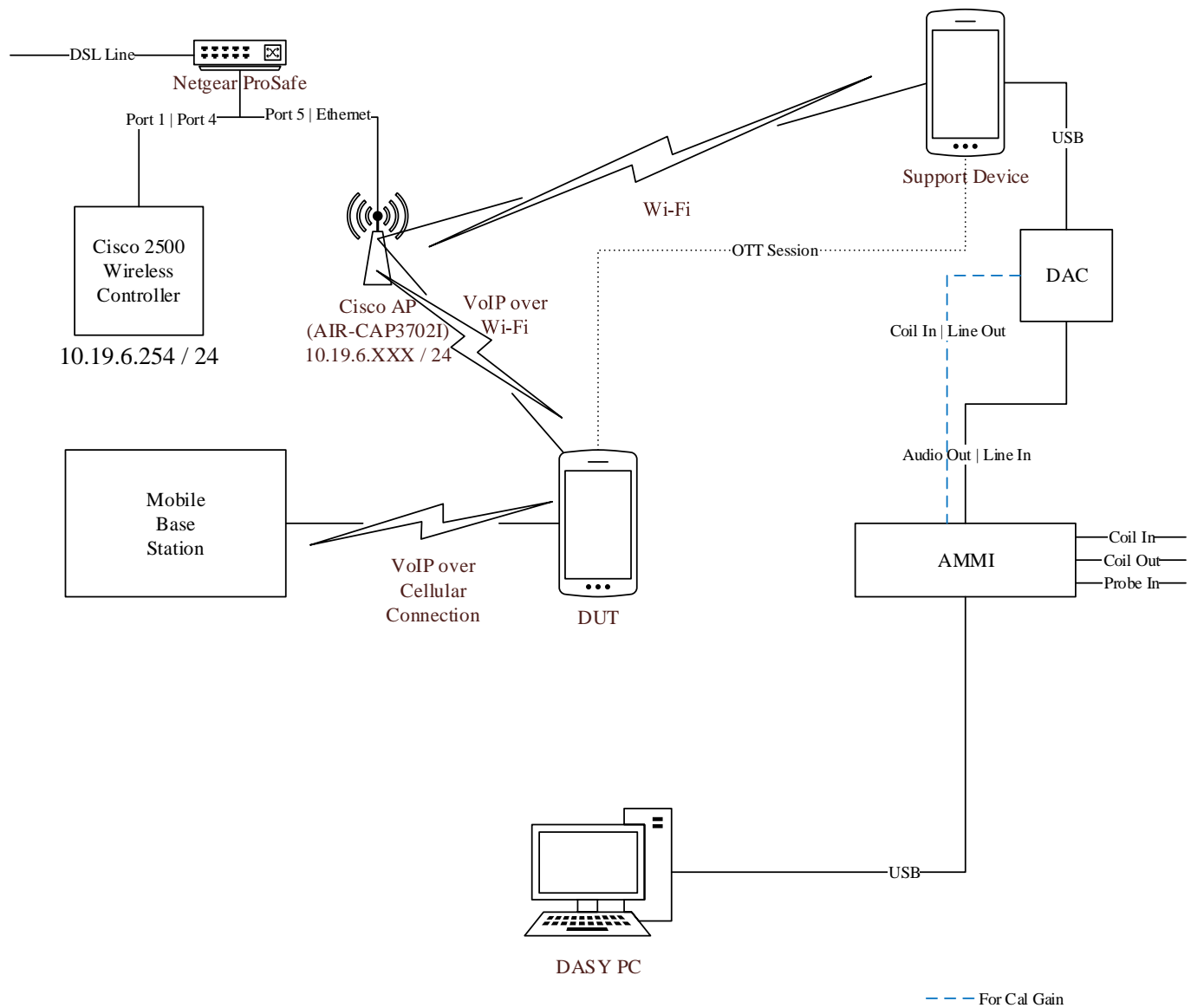

## 6. Audio Level and Gain Measurements

### W-CDMA/GSM/VoLTE

The adjusted gain was calculated using Speag's *TN-LK-05042018-D-T-Coil\_Levels* document. First, the output of AMMI is determined in a closed loop, then, using the CMW500's input sensitivity, the adjusted gain required for testing can then be calculated. The adjusted linear gain used within this report is as follows:

Signal type	Difference to 1 kHz sine [dB]	Audio level [dBm0]	Gain [dB]	Gain (linear)
1 kHz sine	0.00	-16.00	14.88	5.55
1.025 kHz sine	0.00	-16.00	14.88	5.55
Voice 1 kHz	-12.73	-16.00	27.61	24.02
Voice 300-3kHz	-18.58	-16.00	33.46	47.10

The following software/firmware was used to simulate the VoLTE server for testing:

Firmware	License Keys	Software Name
V3.2.70 for LTE	KS500 KA100	LTE FDD R8 SIG BASIC IP APPL ENABLING IPv4
V3.2.30 for Audio	KA150 KAA20 KM050	IP APPL ENABLING IPv4 IP APPL IMS BASIC DATA APPL MEAS

### VoWi-Fi

The adjusted gain was calculated using Speag's *TN-LK-05042018-D-T-Coil\_Levels* document. First, the output of AMMI is determined in a closed loop, then, using the CMW500's input sensitivity, the adjusted gain required for testing can then be calculated. The adjusted linear gain used within this report is as follows:

Signal type	Difference to 1 kHz sine [dB]	Audio level [dBm0]	Gain [dB]	Gain (linear)
1 kHz sine	0.00	-20.00	10.88	3.50
1.025 kHz sine	0.00	-20.00	10.88	3.50
Voice 1 kHz	-12.73	-20.00	23.61	15.15
Voice 300-3kHz	-18.58	-20.00	29.46	29.72

Firmware	License Keys	Software Name
V3.7.30 for WLAN	KS650 KS651 KA100	WLAN A/B/G SIG BASIC WLAN N SIG BASIC IP APPL ENABLING IPv4
V3.7.20 for Audio	KA150 KAA20 KM050 KS104	IP APPL ENABLING IPv6 IP APPL IMS BASIC DATA APPL MEAS EVS SPEECH CODEC

**Over the Top (OTT)**

For HSPA, LTE, and Wi-Fi, the linear gain levels listed below were used. The results below are based on a reference input level of -20 dBm0. Granted, the C63.19-2011 interpretation for T-coil audio levels for LTE states that an input reference level of -16 dBm0 should be used, we, the test lab, opted for -20 dBm0 for LTE due to it being a more conservative input reference level.

The adjusted gain measurements are based on an external Analogue to Digital Converter (ADC), where the signal is sent from the AMMI to the ADC, then to the DUT.

To calibrate the ADC, three .wav audio files (sine wave, 1 kHz voice, and 300 Hz to 3 kHz voice) were sent from the DASY5 PC to the AMMI, then to the ADC. The Helmholtz resonator measures the field strength, which represents the AMMI to ADC input sensitivity. After determining the input sensitivity, the adjusted linear gain values can then be calculated.

**HSPA/LTE/Wi-Fi**

Signal type	Difference to 1 kHz sine [dB]	Audio level [dBm0]	Gain [dB]	Gain (linear)
1 kHz sine	0.00	-20.00	12.61	4.27
1.025 kHz sine	0.00	-20.00	12.61	4.27
Voice 1 kHz	-12.73	-20.00	25.34	18.49
Voice 300-3kHz	-18.58	-20.00	31.19	36.27

## 7. T-coil Measurement Criteria

### 7.1. Frequency Response

The frequency response of the axial component of the magnetic field, measured in 1/3 octave bands, shall follow the response curve, over the frequency range 300 Hz to 3000 Hz.

Figure 8.1 and Figure 8.2 provide the boundaries for the specified frequency. These response curves are for true field strength measurements of the T-Coil signal. Thus the 6 dB/octave probe response has been corrected from the raw readings.

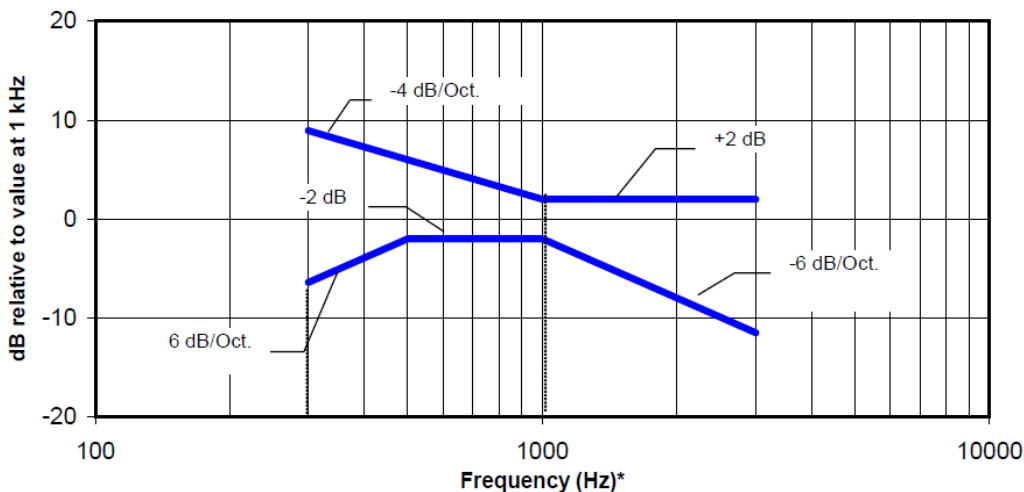

NOTE—The frequency response is between 300 Hz and 3000 Hz.

**Figure 8.1—Magnetic field frequency response for WDs with field strength  $\leq -15$  dB (A/m) at 1 kHz**

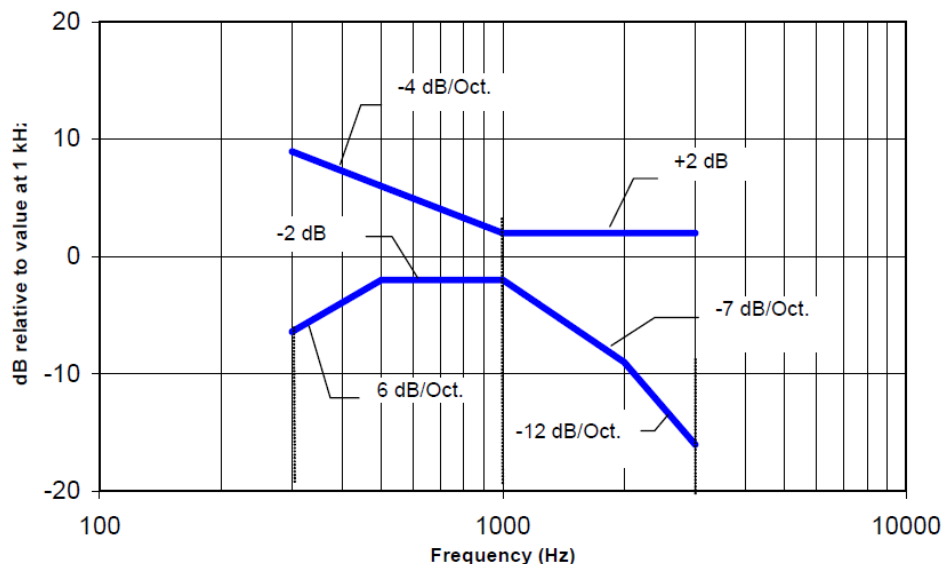

NOTE—The frequency response is between 300 Hz and 3000 Hz.

**Figure 8.2—Magnetic field frequency response for WDs with a field that exceeds  $-15$  dB(A/m) at 1 kHz**

## 7.2. Signal to Noise

This specifies the signal-to-noise quality requirement for the intended T-Coil signal from a WD. The worst signal to noise of the two T-Coil signal measurements, as determined in Clause 7, shall be used to determine the T-Coil mode category per Table 8.5.

Only the RF immunity of the hearing aid is measured in T-Coil mode. It is assumed that a hearing aid can have no immunity to an interference signal in the audio band, which is the intended reception band for this mode. So, the only criterion that can be measured is the RF immunity in T-Coil Mode. This is measured using the same procedure as for the audio coupling mode and at the same levels as specified in 6.4.

**Table 8.5—T-Coil signal-to-noise categories**

Category	Telephone parameters WD signal quality [(signal + noise)-to-noise ratio in decibels]
Category T1	0 dB to 10 dB
Category T2	10 dB to 20 dB
Category T3	20 dB to 30 dB
Category T4	>30 dB

Measurement locations and reference plane to be used for the T-coil measurements

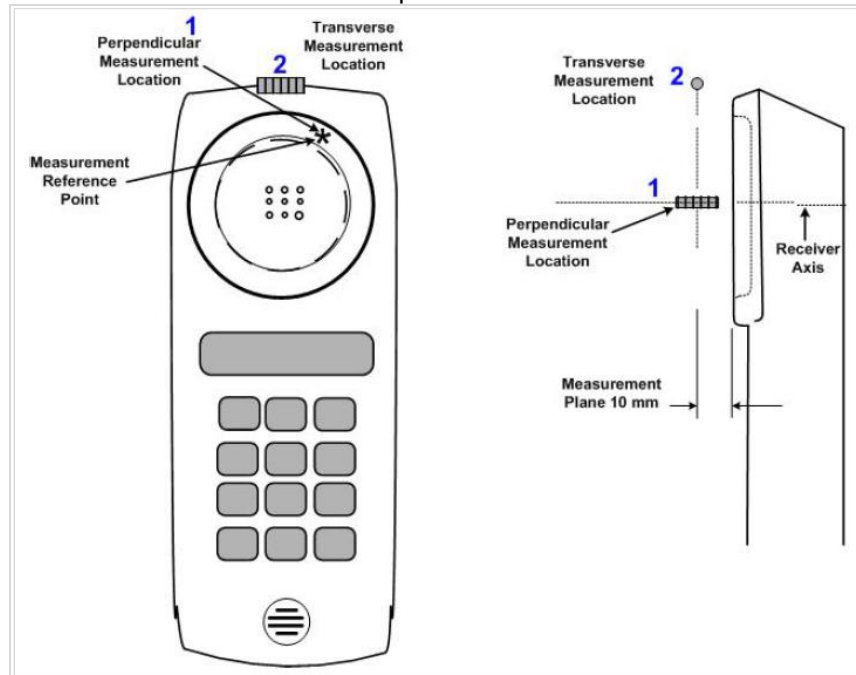

### 8. Device Under Test

Normal operation	Held to head		
Back Cover	The Back Cover is not removable		
Test sample information	<b>S/N</b>	<b>IMEI</b>	<b>Notes</b>
	R38KA0H49PP	352249/10/026305/9	HAC Radiated Unit
	R38KB0M86SF	352248/10/033544/6	HAC Radiated Unit (UL Korea)
	RF8KC29P8KB	354889/10/001256/4	HAC Radiated Unit (UL Korea)
	RF8KC29RRSF	354889/10/002962/6	HAC Radiated Unit (UL Korea)

### 8.1. Air Interfaces and Operating Mode

Air Interface	Bands (MHz)	Type	C63.19 Tested	Simultaneous Transmitter	OTT Testing Required? Name of Voice Service <sup>1</sup>	Power Reduction	Audio Codecs Evaluated
GSM	850	VO	Yes	Wi-Fi, BT	CMRS	NA	EFR
	1900					No	
	GPRS/EDGE	DT	No	Wi-Fi, BT	No	NA	N/A
W-CDMA (UMTS)	850	VO	Yes	Wi-Fi, BT	CMRS	NA	AMR-NB & AMR-WB
	1700						
	1900	VD	Yes	Wi-Fi, BT	Google Duo	NA	OPUS
LTE - FDD	700 (B12/13/17)	VD	Yes	Wi-Fi, BT	Google Duo & VoLTE	NA	AMR-NB, AMR-WB, EVS, and OPUS
	850 (B5/26)						
	1700 (B4/66)						
	1900 (B2/25)						
	2600 (B7)						
LTE - TDD	2500 (B38/41)	VD	Yes	Wi-Fi, BT	Google Duo & VoLTE	NA	AMR-NB, AMR-WB, EVS, and OPUS
Wi-Fi	2450	VD	Yes	WWAN	Google Duo & Wi-Fi calling	NA	AMR-NB, AMR-WB, EVS, and OPUS
	5200 (U-NII-1)			WWAN, BT			
	5300 (U-NII-2A)						
	5500 (U-NII-2C)						
	5800 (U-NII-3)						
BT	2450	DT	NA	WWAN, Wi-Fi (5 GHz bands)	NA	NA	N/A
Type VO: Legacy Cellular Voice Service DT: Digital Transport only (no voice) VD: IP Voice Service over Digital Transport CMRS: Commercial Mobile Radio Service			Note: 1. For protocols not listed in Table 7.1 of ANSI C63.19-2011 or the ANSI C63.19-2011 VoLTE interpretation, the average speech level of -20 dBm0 was used				

## 9. HAC (T-coil) Test Results

### 9.1. Codec Bit-rate Investigation

An investigation between the various bit-rate configurations (Low/Mid/High bit rates for Narrowband, Wideband, and EVS) are documented (ABM1, ABM2, SNNR, frequency response) to determine the worst-case bit-rate for each voice service type. The tables below compare the varying bit-rate configurations.

W-CDMA Bit-rate Investigation								
Codec State	NB AMR (kbit/s)			WB AMR (kbit/s)			Orientation	Band/ BandWidth/ Channel
	4.75	7.4	12.2	6.6	15.85	23.85		
ABM1 (dB/m)	4.30	4.61	4.93	2.64	3.69	4.02	z (Axial)	W-CDMA BIV Ch. 1413
ABM2 (dBA/m)	-40.97	-40.37	-40.69	-41.04	-40.90	-40.63		
S+N/N (dB)	47.48	47.08	46.89	46.13	45.94	45.93		
Freq. Resposne (dB)	2.00	1.66	1.74	1.32	1.04	1.09		
ABM1 (dB/m)	-4.49	-3.83	-3.86	-5.53	5.08	-5.02	y (Transversal)	
ABM2 (dBA/m)	-44.97	-44.45	-44.37	-42.93	-43.89	-43.79		
S+N/N (dB)	43.08	43.19	43.88	<b>41.68</b>	42.20	42.87		

**Note:**

AMR-WB 6.6 kbit/s is the worst case bit rate for W-CDMA.

VoLTE Bit-rate Investigation											
Codec State	AMR-NB (kbit/s)			AMR-WB (kbit/s)			EVS (kbit/s)			Orientation	Band/ BandWidth/ Channel
	4.75	7.4	12.2	6.6	15.85	23.85	5.9	9.6	24.4		
ABM1 (dB/m)	7.45	7.46	7.57	4.37	5.33	5.49	5.11	6.04	7.29	z (Axial)	LTE Band 25 CH. 26365 20 MHz BW
ABM2 (dBA/m)	-27.20	-21.83	-37.16	-22.38	-26.63	-31.71	-30.21	-30.17	-29.75		
S+N/N (dB)	50.02	50.09	49.72	47.00	48.13	48.16	46.29	47.07	49.02		
Freq. Resposne (dB)	1.40	1.67	1.87	1.63	1.11	1.06	1.64	1.63	2.00	y (Transversal)	
ABM1 (dB/m)	-1.11	-1.38	-0.86	-4.12	-3.10	-3.15	-3.38	-2.48	-1.08		
ABM2 (dBA/m)	-33.96	-20.22	-38.98	-30.80	-37.28	-34.53	-33.22	-33.48	-32.13		
S+N/N (dB)	44.96	43.06	45.70	43.04	44.11	44.19	<b>42.68</b>	44.05	45.06	z (Axial)	LTE Band 41 CH. 40620 20 MHz BW
ABM1 (dB/m)	7.43	7.32	8.30	5.80	2.75	3.59	5.29	5.95	6.33		
ABM2 (dBA/m)	-39.94	-39.65	-39.13	-16.71	-20.54	-25.44	-15.71	-18.26	-18.88		
S+N/N (dB)	50.61	50.32	51.34	43.41	44.44	45.52	45.55	47.45	48.18	y (Transversal)	
Freq. Resposne (dB)	1.24	2.00	1.83	1.77	1.05	1.13	2.00	2.00	2.00		
ABM1 (dB/m)	-1.51	-1.04	-0.92	-6.39	-5.55	-4.83	-3.85	-1.00	-1.11		
ABM2 (dBA/m)	-42.78	-43.92	-38.61	-22.82	-25.25	-42.77	-19.87	-22.70	-23.34	y (Transversal)	
S+N/N (dB)	45.65	46.08	46.24	<b>37.30</b>	39.52	41.84	39.03	42.80	42.92		

**Note:**

EVS 5.9 kbit/s and AMR-WB 6.6 kbit/s are the worst case bit-rates for LTE-FDD and LTE-TDD respectively.

VoWi-Fi Bit-rate Investigation											
Codec State	AMR-NB (kbit/s)			AMR-WB (kbit/s)			EVS (kbit/s)			Orientation	Band/ BandWidth/ Channel
	4.75	7.4	12.2	6.6	15.85	23.85	5.9	9.6	24.4		
ABM1 (dB/m)	0.21	1.57	1.91	-1.06	0.11	0.41	1.34	2.16	1.72	z (Axial)	802.11b Ch. 6 DSSS 1 Mbps (ANT 1)
ABM2 (dBA/m)	-21.84	-24.95	-27.61	-27.76	-27.05	-26.68	-34.33	-34.40	-34.11		
S+N/N (dB)	39.14	40.51	40.99	38.31	39.27	39.79	40.18	41.74	40.97		
Freq. Resposne (dB)	1.57	1.73	2.00	1.37	1.02	1.35	1.54	1.48	1.71		
ABM1 (dB/m)	-8.94	-7.30	-6.56	-9.85	-8.09	-7.96	-16.89	-6.83	-6.25	y (Transversal)	802.11a Ch. 36 BPSK 6 Mbps (ANT 1)
ABM2 (dBA/m)	-30.63	-31.01	-30.81	-30.79	-30.12	-30.11	-37.85	-38.31	-38.29		
S+N/N (dB)	34.53	35.97	36.82	33.42	35.08	35.38	<b>27.24</b>	37.51	37.98		
ABM1 (dB/m)	0.66	2.32	1.90	3.94	0.40	1.37	-9.54	2.66	3.07	z (Axial)	802.11a Ch. 36 BPSK 6 Mbps (ANT 1)
ABM2 (dBA/m)	-35.46	-28.70	-27.82	-28.28	-35.59	-30.29	-35.88	-35.24	-35.36		
S+N/N (dB)	39.50	43.79	40.79	45.22	39.09	39.52	29.57	40.91	41.63		
Freq. Resposne (dB)	1.72	2.00	1.80	2.00	1.13	1.11	1.35	1.69	1.66	y (Transversal)	802.11a Ch. 36 BPSK 6 Mbps (ANT 1)
ABM1 (dB/m)	-6.37	-5.94	-6.36	-4.46	-7.64	-7.02	-17.99	-6.48	-6.27		
ABM2 (dBA/m)	-38.18	-30.98	-40.02	-31.48	-39.38	-37.54	-39.98	-39.57	-39.82		
S+N/N (dB)	37.69	38.75	37.74	40.80	36.77	36.52	<b>26.59</b>	37.36	37.67	z (Axial)	802.11a Ch. 36 BPSK 6 Mbps (ANT 2)
ABM1 (dB/m)							1.70				
ABM2 (dBA/m)							-19.24				
S+N/N (dB)							43.54				
Freq. Resposne (dB)							2.00			y (Transversal)	802.11a Ch. 36 BPSK 6 Mbps (ANT 2)
ABM1 (dB/m)							-5.95				
ABM2 (dBA/m)							-27.17				
S+N/N (dB)							<b>39.45</b>				

**Note:**

EVS 5.9 kbit/s was the worst case bit-rates for 802.11b and 802.11a. The secondary antenna was investigated to determine which antenna yields a worse SNNR. The worst case codec and bit-rate from Antenna 1 was used to determine Antenna 2's exclusion. Since Antenna 2 yielded a better SNNR than Antenna 1, all subsequent measurements were measured using Antenna 1.



### 9.1.1. OTT Codec Bit-rate Investigation

Mode:	Channel, Frequency, & RB	Bandwidth/ Data Rate	Antenna	Orientation	ABM1 dB(A/m)	ABM2 dB(A/m)	Ambient Noise dB(A/m)	Freq. Response (dB)	ABM SNR (dB)	T-Rating
W-CDMA Band IV HSPA Google Duo @ 6 kbps	1513 1752.6 MHz	N/A	N/A	z (Axial)	-3.47	-32.52	-39.85	1.73	36.02	T4
				y (Transverse)	-11.28	-36.33	-44.56		32.76	T4
W-CDMA Band IV HSPA Google Duo @ 35 kbps	1513 1752.6 MHz	N/A	N/A	z (Axial)	-3.88	-32.59	-39.85	1.57	36.04	T4
				y (Transverse)	-11.82	-36.42	-44.56		<b>32.49</b>	T4
W-CDMA Band IV HSPA Google Duo @ 64 kbps	1513 1752.6 MHz	N/A	N/A	z (Axial)	-3.48	-32.77	-39.85	1.68	36.34	T4
				y (Transverse)	-11.57	-36.63	-44.56		32.82	T4
LTE Band 25 QPSK Google Duo @ 6 kbps	26365 1882.5 MHz	20 MHz	N/A	z (Axial)	-3.48	-32.77	-39.85	1.68	36.34	T4
				y (Transverse)	-11.57	-36.63	-44.56		32.82	T4
LTE Band 25 QPSK Google Duo @ 35 kbps	26365 1882.5 MHz	20 MHz	N/A	z (Axial)	-4.01	-31.08	-39.85	1.68	35.74	T4
				y (Transverse)	-11.70	-31.46	-44.56		32.52	T4
LTE Band 25 QPSK Google Duo @ 64 kbps	26365 1882.5 MHz	20 MHz	N/A	z (Axial)	-4.02	-32.80	-39.85	1.59	35.66	T4
				y (Transverse)	-11.90	-36.60	-44.56		<b>32.46</b>	T4
LTE Band 41 QPSK Google Duo @ 6 kbps	40620 2593 MHz	20 MHz	N/A	z (Axial)	-3.84	-32.87	-39.85	1.66	35.67	T4
				y (Transverse)	-12.00	-36.72	-44.56		<b>32.34</b>	T4
LTE Band 41 QPSK Google Duo @ 35 kbps	40620 2593 MHz	20 MHz	N/A	z (Axial)	-3.95	-32.75	-39.85	1.89	35.43	T4
				y (Transverse)	-11.64	-36.86	-44.56		32.56	T4
LTE Band 41 QPSK Google Duo @ 64 kbps	40620 2593 MHz	20 MHz	N/A	z (Axial)	-3.99	-32.85	-39.85	1.66	35.29	T4
				y (Transverse)	-11.63	-36.68	-44.56		32.41	T4
802.11b Google Duo @ 6 kbps	6 2437 MHz	DSSS 1 Mbps	ANT1	z (Axial)	-4.69	-20.47	-39.56	1.66	32.84	T4
				y (Transverse)	-13.79	-27.21	-44.56		28.47	T3
802.11b Google Duo @ 35 kbps	6 2437 MHz	DSSS 1 Mbps	ANT1	z (Axial)	-3.50	-23.38	-39.56	1.67	34.38	T4
				y (Transverse)	-13.61	-27.76	-44.56		28.33	T3
802.11b Google Duo @ 64 kbps	6 2437 MHz	DSSS 1 Mbps	ANT1	z (Axial)	-3.81	-23.05	-39.56	1.61	34.23	T4
				y (Transverse)	-14.16	-28.28	-44.56		<b>28.25</b>	T3
802.11a Google Duo @ 6 kbps	36 5180 MHz	BPSK 6 Mbps	ANT1	z (Axial)	-4.78	-31.30	-39.56	1.72	33.54	T4
				y (Transverse)	-13.16	-34.08	-44.56		30.32	T4
802.11a Google Duo @ 35 kbps	36 5180 MHz	BPSK 6 Mbps	ANT1	z (Axial)	-4.13	-29.96	-39.56	1.47	34.07	T4
				y (Transverse)	-12.29	-33.34	-44.56		31.00	T4
802.11a Google Duo @ 64 kbps	36 5180 MHz	BPSK 6 Mbps	ANT1	z (Axial)	-7.83	-30.67	-39.56	1.81	30.30	T4
				y (Transverse)	-15.97	-33.92	-44.56		<b>27.54</b>	T3

#### Note:

A bit-rate investigation was performed on the pre-installed VoIP application to determine the worst case bit-rate:

1. For W-CDMA, it is observed that 35 kbit/s is the worst case
2. For LTE-FDD, it is observed that 64 kbit/s is the worst case
3. For LTE-TDD, it is observed that 6 kbit/s is the worst case
4. For 802.11b, it is observed that 64 kbit/s is the worst case
5. For 802.11a, it is observed that 64 kbit/s is the worst case

For the remaining technologies that were not tested within this investigation, the technologies that were tested, and whose bit-rate was determined to be the worst case, was leveraged for the subsequent measurements.

### 9.2. Air Interface Investigation

Using the worst-case bit-rate found in §9.1, a limited set of bands/channels/bandwidths were then tested to confirm that there is no effect to the T-rating when changing the band/channel/bandwidth. This was limited to W-CDMA, VoLTE, and VoWi-Fi.

W-CDMA Air Interface Investigation									
Mode:	Channel and Frequency	Bandwidth (if applicable)	Orientation	ABM1 dB(A/m)	ABM2 dB(A/m)	Ambient Noise dB(A/m)	Freq. Response (dB)	ABM SNR (dB)	T-Rating
W-CDMA Band IV Voice Wideband AMR Codec: 6.6 kbit/s	1312 1712.4 MHz	N/A	z (Axial)	2.70	-40.80	-43.18	1.40	45.12	T4
			y (Transverse)	-5.33	-43.81	-47.14		41.84	T4
	1413 1732.6 MHz	N/A	z (Axial)	2.64	-41.04	-43.18	1.32	46.13	T4
			y (Transverse)	-5.53	-42.93	-47.14		<b>41.68</b>	T4
	1513 1752.6 MHz	N/A	z (Axial)	2.61	-40.68	-43.18	1.05	44.64	T4
			y (Transverse)	-5.43	-43.46	-47.14		41.84	T4

**Note:**

Middle channel yielded a lower SNNR when compared to the Low and High channels. All subsequent testing for W-CDMA was performed on their respective Middle channel.

VoLTE Air Interface Investigation											
Mode:	Channel and Frequency	Bandwidth (if applicable)	RB Allocation		Orientation	ABM1 dB(A/m)	ABM2 dB(A/m)	Ambient Noise dB(A/m)	Freq. Response (dB)	ABM SNR (dB)	T-Rating
LTE Band 25 QPSK EVS Codec: 5.9 kbit/s	26140 1860 MHz	20 MHz	1	49	z (Axial)	5.85	-34.87	-42.98	2.00	48.52	T4
					y (Transverse)	-2.26	-36.37	-46.93		44.49	T4
	26365 1882.5 MHz	20 MHz	1	0	z (Axial)	3.16	-30.55	-50.92	2.00	51.35	T4
					y (Transverse)	-2.63	-33.92	-50.96		45.46	T4
			1	49	z (Axial)	5.11	-30.21	-42.98	1.64	46.29	T4
					y (Transverse)	-3.38	-33.22	-46.93		<b>42.68</b>	T4
			1	99	z (Axial)	3.12	-29.10	-50.92	2.00	52.61	T4
					y (Transverse)	-2.65	-32.22	-50.96		46.73	T4
			50	0	z (Axial)	6.35	-28.66	-50.92	1.78	52.92	T4
					y (Transverse)	-2.82	-35.94	-50.96		46.86	T4
			50	24	z (Axial)	6.11	-30.43	-50.92	2.00	52.84	T4
					y (Transverse)	-2.44	-35.73	-50.96		47.60	T4
			50	49	z (Axial)	1.79	-29.88	-50.90	2.00	51.90	T4
					y (Transverse)	-5.04	-26.03	-50.93		45.71	T4
			100	0	z (Axial)	0.76	-32.56	-50.90	2.00	47.37	T4
					y (Transverse)	-2.94	-29.25	-50.93		47.13	T4
26590 1905 MHz	20 MHz	1	49	z (Axial)	5.75	-39.53	-42.98	2.00	48.03	T4	
				y (Transverse)	-2.01	-38.49	-46.93		44.76	T4	
LTE Band 25 16QAM EVS Codec: 5.9 kbit/s	26365 1882.5 MHz	20 MHz	1	49	z (Axial)	5.02	-40.18	-42.98	2.00	47.99	T4
					y (Transverse)	-2.97	-44.44	-46.93		44.46	T4
LTE Band 26 QPSK EVS Codec: 5.9 kbit/s	26865 831.5 MHz	15 MHz	1	37	z (Axial)	6.47	-40.66	-42.98	2.00	49.67	T4
					y (Transverse)	-2.49	-44.37	-46.93		44.57	T4
LTE Band 12 QPSK EVS Codec: 5.9 kbit/s	23095 707.5 MHz	10 MHz	1	25	z (Axial)	4.64	-35.15	-43.01	2.00	48.10	T4
					y (Transverse)	-2.48	-44.88	-46.93		44.66	T4

**Note:**  
 For LTE-FDD Band 25, Middle channel 1/49 RB combination yielded a lower SNNR when compared to its respective Low and High channels. All subsequent testing for LTE-FDD bands were performed on their respective Middle channel and 1/50% RB combination.

VoLTE Air Interface Investigation											
Mode:	Channel and Frequency	Bandwidth (if applicable)	RB Allocation		Orientation	ABM1 dB(A/m)	ABM2 dB(A/m)	Ambient Noise dB(A/m)	Freq. Response (dB)	ABM SNR (dB)	T-Rating
LTE Band 41 QPSK Voice Wideband AMR Codec: 6.6 kbit/s	39750 2506 MHz	20 MHz	1	49	z (Axial)	7.54	-39.64	-43.01	2.00	50.61	T4
					y (Transverse)	-0.43	-44.23	-46.93		46.91	T4
	40185 2549.5 MHz	20 MHz	1	49	z (Axial)	7.65	-40.00	-43.01	2.00	50.98	T4
					y (Transverse)	-0.33	-44.49	-46.93		46.62	T4
	40620 2593 MHz	20 MHz	1	0	z (Axial)	3.95	-16.88	-50.92	2.00	51.22	T4
					y (Transverse)	-4.76	-21.60	-50.96		43.42	T4
			1	49	z (Axial)	5.80	-16.71	-40.34	1.77	43.41	T4
					y (Transverse)	-6.39	-22.82	-47.05		<b>37.30</b>	T4
			1	99	z (Axial)	4.00	-16.79	-50.92	1.96	51.08	T4
					y (Transverse)	-4.56	-21.30	-50.96		43.42	T4
			50	0	z (Axial)	5.42	-18.45	-50.92	1.92	52.28	T4
					y (Transverse)	-4.12	-23.21	-50.96		44.51	T4
			50	24	z (Axial)	4.35	-15.25	-50.92	2.00	52.23	T4
					y (Transverse)	-2.21	-23.19	-50.96		44.96	T4
	50	49	z (Axial)	5.01	-18.54	-50.92	2.00	52.55	T4		
			y (Transverse)	-4.29	-23.23	-50.96		44.30	T4		
	100	0	z (Axial)	5.52	-18.18	-50.92	2.00	52.42	T4		
			y (Transverse)	-4.23	-23.05	-50.96		44.32	T4		
41055 2636.5 MHz	20 MHz	1	49	z (Axial)	7.34	-39.93	-43.01	2.00	50.38	T4	
				y (Transverse)	-0.20	-44.82	-46.93		46.74	T4	
41490 2680 MHz	20 MHz	1	49	z (Axial)	7.71	-38.96	-43.01	2.00	49.67	T4	
				y (Transverse)	-0.79	-44.24	-46.93		46.23	T4	
LTE Band 41 QPSK Voice Wideband AMR Codec: 6.6 kbit/s	40620 2593 MHz	15 MHz	1	37	z (Axial)	7.52	-39.63	-43.01	1.89	50.11	T4
					y (Transverse)	-0.90	-44.16	-46.93		45.72	T4
	40620 2593 MHz	10 MHz	1	25	z (Axial)	7.58	-39.69	-43.01	2.00	49.77	T4
					y (Transverse)	-0.29	-44.40	-46.93		46.57	T4
LTE Band 41 16QAM Voice Wideband AMR Codec: 6.6 kbit/s	40620 2593 MHz	20 MHz	1	49	z (Axial)	7.42	-40.23	-43.01	1.68	50.11	T4
					y (Transverse)	-0.79	-44.26	-46.93		45.76	T4

**Note:**  
 For LTE-TDD Band 41, Middle channel 1/49 RB combination yielded a lower SNNR when compared to its respective Low and High channels. All subsequent testing for LTE-TDD was performed on its respective Middle channel and the 1/49 RB combination.

VoWi-Fi Air Interface Investigation												
Mode:	Channel and Frequency	Modulation	Data Rate	Antenna	Orientation	ABM1 dB(A/m)	ABM2 dB(A/m)	Ambient Noise dB(A/m)	Freq. Response (dB)	ABM SNR (dB)	T-Rating	
802.11b EVS 5.9 kbit/s	6 2437 MHz	CCK	5.5 Mbps	ANT1	z (Axial)	1.97	-26.48	-32.54	1.48	44.18	T4	
					y (Transverse)	-5.90	-30.27	-32.66		38.87	T4	
802.11b EVS 5.9 kbit/s	6 2437 MHz	CCK	11 Mbps	ANT1	z (Axial)	3.06	-27.63	-32.54	1.49	43.83	T4	
					y (Transverse)	-4.91	-29.42	-32.66		39.11	T4	
802.11n HT20 EVS 5.9 kbit/s	6 2437 MHz	MCS0	6.5 Mbps	ANT1	z (Axial)	1.58	-28.77	-32.54	1.69	43.79	T4	
					y (Transverse)	-5.02	-33.68	-32.66		40.89	T4	
802.11a EVS 5.9 kbit/s	36 5180 MHz	QPSK	18 Mbps	ANT1	z (Axial)	1.87	-32.47	-42.33	2.00	44.06	T4	
					y (Transverse)	-5.55	-33.15	-46.57		40.24	T4	
802.11a EVS 5.9 kbit/s	36 5180 MHz	64QAM	54 Mbps	ANT1	z (Axial)	0.90	-30.60	-42.33	2.00	43.04	T4	
					y (Transverse)	-6.07	-33.90	-46.57		40.18	T4	
802.11n 20 MHz EVS 5.9 kbit/s	36 5180 MHz	MCS0	6.5 Mbps	ANT1	z (Axial)	4.24	-36.39	-42.33	2.00	46.05	T4	
					y (Transverse)	-5.39	-40.06	-46.57		40.13	T4	
802.11n 20 MHz EVS 5.9 kbit/s	36 5180 MHz	MCS3	26 Mbps	ANT1	z (Axial)	1.79	-36.63	-42.33	2.00	43.29	T4	
					y (Transverse)	-6.26	-38.40	-46.57		40.02	T4	
802.11n 20 MHz EVS 5.9 kbit/s	36 5180 MHz	MCS7	65 Mbps	ANT1	z (Axial)	1.68	-37.15	-42.33	1.40	43.37	T4	
					y (Transverse)	-4.52	-41.74	-46.57		41.58	T4	
802.11n 40 MHz EVS 5.9 kbit/s	38 5190 MHz	MCS0	13.5 Mbps	ANT1	z (Axial)	1.32	-36.15	-42.33	2.00	43.12	T4	
					y (Transverse)	-6.73	-40.35	-46.57		39.88	T4	
802.11n 40 MHz EVS 5.9 kbit/s	38 5190 MHz	MCS3	54 Mbps	ANT1	z (Axial)	1.93	-37.80	-42.33	2.00	43.34	T4	
					y (Transverse)	-4.80	-41.13	-46.57		41.92	T4	
802.11n 40 MHz EVS 5.9 kbit/s	38 5190 MHz	MCS7	135 Mbps	ANT1	z (Axial)	2.45	-36.53	-42.33	1.72	44.13	T4	
					y (Transverse)	-6.55	-41.97	-46.57		40.12	T4	
802.11ac 20 MHz EVS 5.9 kbit/s	36 5180 MHz	MCS0	6.5 Mbps	ANT1	z (Axial)	1.24	-26.91	-51.22	1.64	50.62	T4	
					y (Transverse)	-8.43	-31.40	-51.26		41.07	T4	
802.11ac 20 MHz EVS 5.9 kbit/s	36 5180 MHz	MCS4	39 Mbps	ANT1	z (Axial)	1.09	-18.53	-51.22	2.00	51.31	T4	
					y (Transverse)	-7.99	-32.35	-51.26		41.35	T4	
802.11ac 20 MHz EVS 5.9 kbit/s	36 5180 MHz	MCS8	78 Mbps	ANT1	z (Axial)	1.92	-20.26	-51.22	1.62	52.17	T4	
					y (Transverse)	-5.99	-18.62	-51.26		42.15	T4	
802.11ac 40 MHz EVS 5.9 kbit/s	38 5190 MHz	MCS0	13.5 Mbps	ANT1	z (Axial)	0.22	-22.12	-51.22	1.74	49.51	T4	
					y (Transverse)	-9.65	-25.35	-51.26		39.19	T4	
802.11ac 40 MHz EVS 5.9 kbit/s	38 5190 MHz	MCS5	108 Mbps	ANT1	z (Axial)	0.38	-24.45	-51.22	1.95	50.16	T4	
					y (Transverse)	-7.95	-22.91	-51.26		40.63	T4	
802.11ac 40 MHz EVS 5.9 kbit/s	38 5190 MHz	MCS9	180 Mbps	ANT1	z (Axial)	0.52	-22.81	-51.22	2.00	50.44	T4	
					y (Transverse)	-9.52	-26.97	-51.26		38.80	T4	
802.11ac 80 MHz EVS 5.9 kbit/s	42 5210 MHz	MCS0	13.5 Mbps	ANT1	z (Axial)	0.11	-24.34	-51.22	1.44	49.77	T4	
					y (Transverse)	-7.65	-25.82	-51.26		40.67	T4	
802.11ac 80 MHz EVS 5.9 kbit/s	42 5210 MHz	MCS5	108 Mbps	ANT1	z (Axial)	-0.18	-22.32	-51.22	2.00	49.41	T4	
					y (Transverse)	-8.16	-26.37	-51.26		40.06	T4	
802.11ac 80 MHz EVS 5.9 kbit/s	42 5210 MHz	MCS9	180 Mbps	ANT1	z (Axial)	-0.73	-28.35	-51.19	1.29	49.40	T4	
					y (Transverse)	-6.49	-32.13	-51.25		42.61	T4	

VoWi-Fi Air Interface Investigation											
Mode:	Channel and Frequency	Modulation	Data Rate	Antenna	Orientation	ABM1 dB(A/m)	ABM2 dB(A/m)	Ambient Noise dB(A/m)	Freq. Response (dB)	ABM SNR (dB)	T-Rating
802.11ax 20 MHz EVS 5.9 kbit/s	36 5180 MHz	MCS0	8.6 Mbps	ANT1	z (Axial)	4.23	-22.04	-51.26	1.50	47.94	T4
					y (Transverse)	-5.15	-25.87	-51.27		38.98	T4
802.11ax 20 MHz EVS 5.9 kbit/s	36 5180 MHz	MCS6	77 Mbps	ANT1	z (Axial)	1.33	-22.63	-51.26	1.70	50.92	T4
					y (Transverse)	-7.69	-28.08	-51.27		39.02	T4
802.11ax 20 MHz EVS 5.9 kbit/s	36 5180 MHz	MCS11	143 Mbps	ANT1	z (Axial)	-0.94	-23.23	-51.26	1.90	48.85	T4
					y (Transverse)	-10.08	-26.94	-51.27		39.26	T4
802.11ax 40 MHz EVS 5.9 kbit/s	38 5190 MHz	MCS0	17.2 Mbps	ANT1	z (Axial)	-0.52	-24.82	-51.22	1.13	49.44	T4
					y (Transverse)	-7.39	-21.87	-51.26		41.61	T4
802.11ax 40 MHz EVS 5.9 kbit/s	38 5190 MHz	MCS6	155 Mbps	ANT1	z (Axial)	1.12	-27.97	-51.22	1.27	49.90	T4
					y (Transverse)	-5.98	-30.04	-51.26		42.83	T4
802.11ax 40 MHz EVS 5.9 kbit/s	38 5190 MHz	MCS11	287 Mbps	ANT1	z (Axial)	0.55	-26.93	-51.22	1.35	50.14	T4
					y (Transverse)	-6.73	-28.04	-51.26		42.55	T4
802.11ax 80 MHz EVS 5.9 kbit/s	42 5210 MHz	MCS0	36 Mbps	ANT1	z (Axial)	-0.11	-22.01	-51.22	2.00	49.33	T4
					y (Transverse)	-4.69	-25.43	-51.26		42.82	T4
802.11ax 80 MHz EVS 5.9 kbit/s	42 5210 MHz	MCS6	324 Mbps	ANT1	z (Axial)	-1.29	-23.09	-51.22	1.92	47.55	T4
					y (Transverse)	-8.52	-29.84	-51.26		39.91	T4
802.11ax 80 MHz EVS 5.9 kbit/s	42 5210 MHz	MCS11	600 Mbps	ANT1	z (Axial)	-0.43	-25.51	-51.22	1.79	48.51	T4
					y (Transverse)	-8.00	-29.09	-51.26		39.68	T4

**Note(s):**

1. The highlighted results are the worst case IEEE mode when not compared to 802.11a. Since 802.11a was the worst case, all subsequent testing was performed using 802.11a at BPSK as its data rate.
2. As for the 2.4 GHz spectrum, 802.11b was only investigated since 802.11g/n share the same modulation as 802.11a/ac/ax. To confirm the worst case, 802.11b was tested using varying data rates. It has been determined that 802.11b DSSS at 1 Mbps was the worst case.
3. 802.11ac/ax 20, 40, and 80 MHz bandwidths were performed in UL Korea.

### 9.3. HAC (T-coil) Test Results

Mode:	Channel and Frequency	Bandwidth (if applicable)	Orientation	ABM1 dB(A/m)	ABM2 dB(A/m)	Ambient Noise dB(A/m)	Freq. Response (dB)	ABM SNR (dB)	T-Rating	Plot Page #
GSM 850 Voice Coder Speechcodec Low	190 836.6 MHz	N/A	z (Axial)	3.05	1.65	-43.18	1.60	36.62	T4	1 - 3
			y (Transverse)	-4.92	-3.37	-47.14		32.06	T4	
GSM 1900 Voice Coder Speechcodec Low	661 1880 MHz	N/A	z (Axial)	2.94	-5.05	-43.18	1.66	40.10	T4	4 - 6
			y (Transverse)	-4.91	-8.86	-47.14		38.65	T4	
W-CDMA Band II Voice Wideband AMR Codec: 6.6 kbit/s	9400 1880.6 MHz	N/A	z (Axial)	-0.27	-32.93	-43.05	1.11	42.88	T4	7 - 9
			y (Transverse)	-9.15	-37.19	-47.11		38.15	T4	
W-CDMA Band IV Voice Wideband AMR Codec: 6.6 kbit/s	1413 1732.6 MHz	N/A	z (Axial)	2.64	-41.04	-43.18	1.32	46.13	T4	10 - 12
			y (Transverse)	-5.53	-42.93	-47.14		41.68	T4	
W-CDMA Band V Voice Wideband AMR Codec: 6.6 kbit/s	4183 836.6 MHz	N/A	z (Axial)	-0.43	-33.50	-43.05	1.20	42.73	T4	13 - 15
			y (Transverse)	-8.90	-37.05	-47.11		37.72	T4	
LTE Band 7 QPSK EVS Codec: 5.9 kbit/s	21100 2535 MHz	20 MHz	z (Axial)	5.67	-40.30	-43.01	2.00	48.68	T4	16 - 18
			y (Transverse)	-1.89	-43.36	-43.93		45.05	T4	
LTE Band 12 QPSK EVS Codec: 5.9 kbit/s	23095 707.5 MHz	10 MHz	z (Axial)	4.64	-35.15	-43.01	2.00	48.10	T4	19 - 21
			y (Transverse)	-2.48	-44.88	-43.93		44.66	T4	
LTE Band 25 QPSK EVS Codec: 5.9 kbit/s	26365 1882.5 MHz	20 MHz	z (Axial)	5.11	-30.21	-42.68	1.64	46.29	T4	22 - 24
			y (Transverse)	-3.38	-33.22	-46.93		42.68	T4	
LTE Band 26 QPSK EVS Codec: 5.9 kbit/s	26865 831.5 MHz	15 MHz	z (Axial)	6.47	-40.66	-42.98	2.00	49.67	T4	25 - 27
			y (Transverse)	-2.49	-44.37	-46.93		44.57	T4	
LTE Band 41 QPSK Voice Wideband AMR Codec: 6.6 kbit/s	40620 2593 MHz	20 MHz	z (Axial)	5.80	-16.71	-40.34	1.77	43.41	T4	28 - 30
			y (Transverse)	-6.39	-22.82	-47.05		37.30	T4	
802.11b EVS 5.9 kbit/s	6 2437 MHz	20 MHz DSSS 1 Mbps	z (Axial)	1.34	-34.33	-32.53	1.54	40.18	T4	31 - 33
			y (Transverse)	-16.89	-37.85	-32.73		27.24	T3	
802.11a EVS 5.9 kbit/s	36 5180 MHz	20 MHz BPSK 6 Mbps	z (Axial)	-9.54	-35.88	-32.53	1.35	29.57	T3	34 - 36
			y (Transverse)	-17.99	-39.98	-32.73		<b>26.59</b>	T3	
802.11a EVS 5.9 kbit/s	52 5260 MHz	20 MHz BPSK 6 Mbps	z (Axial)	2.10	-36.07	-42.69	1.86	44.23	T4	37 - 39
			y (Transverse)	-5.20	-40.39	-47.27		41.57	T4	
802.11a EVS 5.9 kbit/s	100 5500 MHz	20 MHz BPSK 6 Mbps	z (Axial)	2.89	-36.63	-42.69	2.00	44.27	T4	40 - 42
			y (Transverse)	-4.06	-40.53	-47.27		42.87	T4	
802.11a EVS 5.9 kbit/s	149 5745 MHz	20 MHz BPSK 6 Mbps	z (Axial)	3.84	-36.80	-42.69	2.00	45.77	T4	43 - 45
			y (Transverse)	-5.94	-37.86	-47.27		40.45	T4	

#### Note:

The radial longitudinal (x axis) measurements are no longer required per ANSI C63.19

### 9.4. OTT HAC (T-coil) Results

Mode:	Channel and Frequency	Bandwidth/ Data Rate	Antenna	Orientation	ABM1 dB(A/m)	ABM2 dB(A/m)	Ambient Noise dB(A/m)	Freq. Response (dB)	ABM SNR (dB)	T-Rating	Plot Page #
W-CDMA Band II HSPA Google Duo @ 64 kbps	9538 1907.6 MHz	N/A	N/A	z (Axial)	-3.87	-32.10	-39.89	1.52	35.09	T4	1 - 3
				y (Transverse)	-11.70	-36.27	-44.55		31.96	T4	
W-CDMA Band IV HSPA Google Duo @ 64 kbps	1513 1752.6 MHz	N/A	N/A	z (Axial)	-3.88	-32.59	-39.85	1.57	36.04	T4	4 - 6
				y (Transverse)	-11.82	-36.42	-44.56		32.49	T4	
W-CDMA Band V HSPA Google Duo @ 64 kbps	4233 846.6 MHz	N/A	N/A	z (Axial)	-3.65	-31.79	-39.89	1.59	35.42	T4	7 - 9
				y (Transverse)	-11.27	-36.43	-44.55		32.44	T4	
LTE Band 25 QPSK Google Duo @ 64 kbps	26365 1882.5 MHz	20 MHz	N/A	z (Axial)	-4.02	-32.80	-39.85	1.59	35.66	T4	10 - 12
				y (Transverse)	-11.90	-36.60	-44.56		32.46	T4	
LTE Band 41 QPSK Google Duo @ 6 kbps	40620 2593 MHz	20 MHz	N/A	z (Axial)	-3.84	-32.87	-39.85	1.66	35.67	T4	13 - 15
				y (Transverse)	-12.00	-36.72	-44.56		32.34	T4	
802.11b Google Duo @ 64 kbps	6 2437 MHz	DSSS 1 Mbps	ANT1	z (Axial)	-3.81	-23.05	-39.56	1.61	34.23	T4	16 - 18
				y (Transverse)	-14.16	-28.28	-44.56		28.25	T3	
802.11a Google Duo @ 6 kbps	36 5200 MHz	BPSK 6 Mbps	ANT1	z (Axial)	-7.83	-30.67	-39.56	1.81	30.30	T4	19 - 21
				y (Transverse)	-15.97	-33.92	-44.56		27.54	T3	
802.11a Google Duo @ 64 kbps	52 5260 MHz	BPSK 6 Mbps	ANT1	z (Axial)	-3.88	-30.73	-39.89	1.53	35.13	T4	22 - 24
				y (Transverse)	-11.64	-34.24	-44.55		31.97	T4	
802.11a Google Duo @ 64 kbps	100 5500 MHz	BPSK 6 Mbps	ANT1	z (Axial)	-3.65	-31.75	-39.89	1.63	35.42	T4	25 - 27
				y (Transverse)	-11.48	-34.43	-44.55		32.28	T4	
802.11a Google Duo @ 64 kbps	149 5745 MHz	BPSK 6 Mbps	ANT1	z (Axial)	-3.76	-31.50	-39.89	1.69	35.44	T4	28 - 30
				y (Transverse)	-11.69	-34.03	-44.55		32.24	T4	

**Note:**

The radial longitudinal (x axis) measurements are no longer required per ANSI C63.19



### 9.5. Worst Case T-Coil Test Plot

Test Laboratory: UL Verification Services Inc. SAR Lab C

Date: 2/14/2019

#### 802.11a

Communication System: UID 0, @IEEE 802.11a/n/ac 5 GHz Band (0); Frequency: 5180 MHz; Duty Cycle: 1:1

Phantom section: TCoil Section

DASY5 Configuration:

- Probe: AM1DV3 - 3092; ; Calibrated: 7/10/2018
- Sensor-Surface: 0mm (Fix Surface)
- Electronics: DAE4 Sn1472; Calibrated: 3/8/2018
- Phantom: HAC Test Arch with AMCC; Type: SD HAC P01 BB
- Measurement SW: DASY52, Version 52.8 (7);SEMCAD X Version 14.6.10 (7164)

#### T-Coil scan (scan for ANSI C63.19 2011 compliance)/802.11a Ch. 36 BPSK 6 Mbps EVS 5.9 kbps/y (transversal) 4.2mm 50 x 50/ABM Interpolated SNR(x,y,z) (121x121x1):

Interpolated grid: dx=1.000 mm, dy=1.000 mm

Signal Type: Audio File (.wav) 48k\_voice\_1kHz\_1s.wav

Output Gain: 15.15

Measure Window Start: 300ms

Measure Window Length: 1000ms

BWC applied: 0.16 dB

Device Reference Point: 0, 0, -6.3 mm

#### Cursor:

ABM1/ABM2 = 26.59 dB

ABM1 comp = -17.99 dBA/m

BWC Factor = 0.16 dB

Location: 4.2, 12.1, 3.7 mm

ABM2 = -39.98 dBA/m

Location: 16.7, -16.7, 3.7 mm

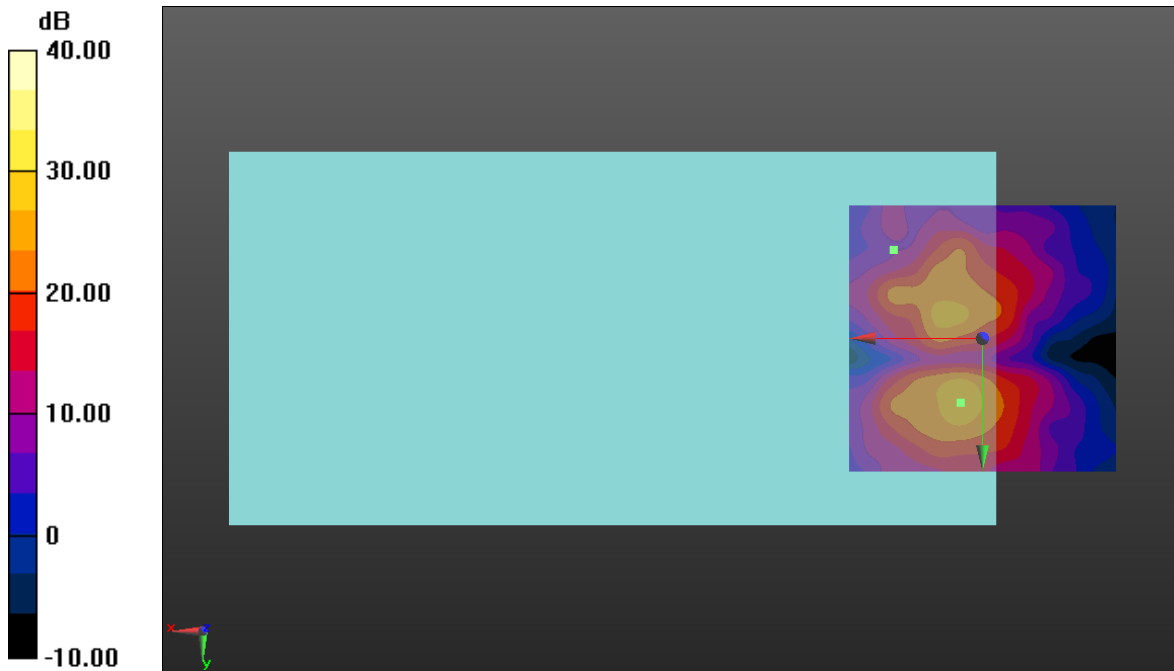

0 dB = 1.000 = 0.00 dB

## **Appendix**

**Refer to separated files for the following appendixes**

**Appendix A: T-Coil Setup Photo**

**Appendix B: T-Coil Test Plots**

**Appendix C: T-Coil Test Plots (OTT)**

**Appendix D: T-Coil Probe Certificates**

**Appendix E: Adjusted Gain Procedure**

**END OF REPORT**