



Accredited by the Swiss Accreditation Service (SAS)  
The Swiss Accreditation Service is one of the signatories to the EA  
Multilateral Agreement for the recognition of calibration certificates

Accreditation No.: **SCS 0108**

Client **PC Test**

Certificate No: **EX3-7410\_Jul17**

## CALIBRATION CERTIFICATE

Object: **EX3DV4 - SN:7410**

Calibration procedure(s): **QA CAL-01.v9, QA CAL-23.v5, QA CAL-25.v6  
Calibration procedure for dosimetric E-field probes**

Calibration date: **July 17, 2017**

*BN ✓  
8/3/2017*

This calibration certificate documents the traceability to national standards, which realize the physical units of measurements (SI).  
The measurements and the uncertainties with confidence probability are given on the following pages and are part of the certificate.

All calibrations have been conducted in the closed laboratory facility: environment temperature (22 ± 3)°C and humidity < 70%.

Calibration Equipment used (M&TE critical for calibration)

Primary Standards	ID	Cal Date (Certificate No.)	Scheduled Calibration
Power meter NRP	SN: 104778	04-Apr-17 (No. 217-02521/02522)	Apr-18
Power sensor NRP-Z91	SN: 103244	04-Apr-17 (No. 217-02521)	Apr-18
Power sensor NRP-Z91	SN: 103245	04-Apr-17 (No. 217-02525)	Apr-18
Reference 20 dB Attenuator	SN: S5277 (20x)	07-Apr-17 (No. 217-02528)	Apr-18
Reference Probe ES3DV2	SN: 3013	31-Dec-16 (No. ES3-3013_Dec16)	Dec-17
DAE4	SN: 660	7-Dec-16 (No. DAE4-660_Dec16)	Dec-17
Secondary Standards	ID	Check Date (in house)	Scheduled Check
Power meter E4419B	SN: GB41293874	06-Apr-16 (in house check Jun-16)	In house check: Jun-18
Power sensor E4412A	SN: MY41498087	06-Apr-16 (in house check Jun-16)	In house check: Jun-18
Power sensor E4412A	SN: 000110210	06-Apr-16 (in house check Jun-16)	In house check: Jun-18
RF generator HP 8648C	SN: US3642U01700	04-Aug-99 (in house check Jun-16)	In house check: Jun-18
Network Analyzer HP 8753E	SN: US37390585	18-Oct-01 (in house check Oct-16)	In house check: Oct-17

Calibrated by:	Name <b>Jeton Kastrati</b>	Function <b>Laboratory Technician</b>	Signature 
Approved by:	Name <b>Katja Pokovic</b>	Function <b>Technical Manager</b>	

Issued: July 17, 2017

This calibration certificate shall not be reproduced except in full without written approval of the laboratory.



Accredited by the Swiss Accreditation Service (SAS)

The Swiss Accreditation Service is one of the signatories to the EA  
Multilateral Agreement for the recognition of calibration certificates

Accreditation No.: **SCS 0108**

**Glossary:**

TSL	tissue simulating liquid
NORM <sub>x,y,z</sub>	sensitivity in free space
ConvF	sensitivity in TSL / NORM <sub>x,y,z</sub>
DCP	diode compression point
CF	crest factor (1/duty_cycle) of the RF signal
A, B, C, D	modulation dependent linearization parameters
Polarization $\varphi$	$\varphi$ rotation around probe axis
Polarization $\vartheta$	$\vartheta$ rotation around an axis that is in the plane normal to probe axis (at measurement center), i.e., $\vartheta = 0$ is normal to probe axis
Connector Angle	information used in DASY system to align probe sensor X to the robot coordinate system

**Calibration is Performed According to the Following Standards:**

- a) IEEE Std 1528-2013, "IEEE Recommended Practice for Determining the Peak Spatial-Averaged Specific Absorption Rate (SAR) in the Human Head from Wireless Communications Devices: Measurement Techniques", June 2013
- b) IEC 62209-1, "Measurement procedure for the assessment of Specific Absorption Rate (SAR) from hand-held and body-mounted devices used next to the ear (frequency range of 300 MHz to 6 GHz)", July 2016
- c) IEC 62209-2, "Procedure to determine the Specific Absorption Rate (SAR) for wireless communication devices used in close proximity to the human body (frequency range of 30 MHz to 6 GHz)", March 2010
- d) KDB 865664, "SAR Measurement Requirements for 100 MHz to 6 GHz"

**Methods Applied and Interpretation of Parameters:**

- **NORM<sub>x,y,z</sub>**: Assessed for E-field polarization  $\vartheta = 0$  ( $f \leq 900$  MHz in TEM-cell;  $f > 1800$  MHz: R22 waveguide). NORM<sub>x,y,z</sub> are only intermediate values, i.e., the uncertainties of NORM<sub>x,y,z</sub> does not affect the E<sup>2</sup>-field uncertainty inside TSL (see below ConvF).
- **NORM(f)<sub>x,y,z</sub>** = NORM<sub>x,y,z</sub> \* frequency\_response (see Frequency Response Chart). This linearization is implemented in DASY4 software versions later than 4.2. The uncertainty of the frequency response is included in the stated uncertainty of ConvF.
- **DCP<sub>x,y,z</sub>**: DCP are numerical linearization parameters assessed based on the data of power sweep with CW signal (no uncertainty required). DCP does not depend on frequency nor media.
- **PAR**: PAR is the Peak to Average Ratio that is not calibrated but determined based on the signal characteristics
- **A<sub>x,y,z</sub>; B<sub>x,y,z</sub>; C<sub>x,y,z</sub>; D<sub>x,y,z</sub>; VR<sub>x,y,z</sub>**: A, B, C, D are numerical linearization parameters assessed based on the data of power sweep for specific modulation signal. The parameters do not depend on frequency nor media. VR is the maximum calibration range expressed in RMS voltage across the diode.
- **ConvF and Boundary Effect Parameters**: Assessed in flat phantom using E-field (or Temperature Transfer Standard for  $f \leq 800$  MHz) and inside waveguide using analytical field distributions based on power measurements for  $f > 800$  MHz. The same setups are used for assessment of the parameters applied for boundary compensation (alpha, depth) of which typical uncertainty values are given. These parameters are used in DASY4 software to improve probe accuracy close to the boundary. The sensitivity in TSL corresponds to NORM<sub>x,y,z</sub> \* ConvF whereby the uncertainty corresponds to that given for ConvF. A frequency dependent ConvF is used in DASY version 4.4 and higher which allows extending the validity from  $\pm 50$  MHz to  $\pm 100$  MHz.
- **Spherical isotropy (3D deviation from isotropy)**: in a field of low gradients realized using a flat phantom exposed by a patch antenna.
- **Sensor Offset**: The sensor offset corresponds to the offset of virtual measurement center from the probe tip (on probe axis). No tolerance required.
- **Connector Angle**: The angle is assessed using the information gained by determining the NORM<sub>x</sub> (no uncertainty required).

# Probe EX3DV4

## SN:7410

Manufactured: November 24, 2015  
Calibrated: July 17, 2017

Calibrated for DASY/EASY Systems  
(Note: non-compatible with DASY2 system!)

## DASY/EASY - Parameters of Probe: EX3DV4 - SN:7410

### Basic Calibration Parameters

	Sensor X	Sensor Y	Sensor Z	Unc (k=2)
Norm ( $\mu\text{V}/(\text{V}/\text{m})^{2.5}$ ) <sup>A</sup>	0.40	0.46	0.43	$\pm 10.1 \%$
DCP (mV) <sup>B</sup>	95.4	94.7	91.2	

### Modulation Calibration Parameters

UID	Communication System Name		A dB	B dB $\sqrt{\mu\text{V}}$	C	D dB	VR mV	Unc <sup>E</sup> (k=2)
0	CW	X	0.0	0.0	1.0	0.00	130.7	$\pm 3.5 \%$
		Y	0.0	0.0	1.0		146.7	
		Z	0.0	0.0	1.0		132.5	

Note: For details on UID parameters see Appendix.

### Sensor Model Parameters

	C1 fF	C2 fF	$\alpha$ $\text{V}^{-1}$	T1 $\text{ms}\cdot\text{V}^{-2}$	T2 $\text{ms}\cdot\text{V}^{-1}$	T3 ms	T4 $\text{V}^{-2}$	T5 $\text{V}^{-1}$	T6
X	41.43	313.6	36.54	8.525	0.381	5.024	0.000	0.467	1.003
Y	41.67	315.5	36.57	10.32	0.000	5.055	0.334	0.426	1.004
Z	51.58	393.9	37.05	11.42	0.427	5.066	0.000	0.561	1.006

The reported uncertainty of measurement is stated as the standard uncertainty of measurement multiplied by the coverage factor  $k=2$ , which for a normal distribution corresponds to a coverage probability of approximately 95%.

<sup>A</sup> The uncertainties of Norm X,Y,Z do not affect the  $E^2$ -field uncertainty inside TSL (see Pages 5 and 6).

<sup>B</sup> Numerical linearization parameter: uncertainty not required.

<sup>E</sup> Uncertainty is determined using the max. deviation from linear response applying rectangular distribution and is expressed for the square of the field value.

## DASY/EASY - Parameters of Probe: EX3DV4 - SN:7410

### Calibration Parameter Determined in Head Tissue Simulating Media

f (MHz) <sup>C</sup>	Relative Permittivity <sup>F</sup>	Conductivity (S/m) <sup>F</sup>	ConvF X	ConvF Y	ConvF Z	Alpha <sup>G</sup>	Depth <sup>G</sup> (mm)	Unc (k=2)
750	41.9	0.89	10.60	10.60	10.60	0.53	0.80	± 12.0 %
835	41.5	0.90	10.08	10.08	10.08	0.41	0.98	± 12.0 %
1750	40.1	1.37	8.66	8.66	8.66	0.41	0.82	± 12.0 %
1900	40.0	1.40	8.37	8.37	8.37	0.28	1.19	± 12.0 %
2300	39.5	1.67	8.02	8.02	8.02	0.35	0.80	± 12.0 %
2450	39.2	1.80	7.68	7.68	7.68	0.33	0.89	± 12.0 %
2600	39.0	1.96	7.42	7.42	7.42	0.40	0.80	± 12.0 %

<sup>C</sup> Frequency validity above 300 MHz of ± 100 MHz only applies for DASY v4.4 and higher (see Page 2), else it is restricted to ± 50 MHz. The uncertainty is the RSS of the ConvF uncertainty at calibration frequency and the uncertainty for the indicated frequency band. Frequency validity below 300 MHz is ± 10, 25, 40, 50 and 70 MHz for ConvF assessments at 30, 64, 128, 150 and 220 MHz respectively. Above 5 GHz frequency validity can be extended to ± 110 MHz.

<sup>F</sup> At frequencies below 3 GHz, the validity of tissue parameters ( $\epsilon$  and  $\sigma$ ) can be relaxed to ± 10% if liquid compensation formula is applied to measured SAR values. At frequencies above 3 GHz, the validity of tissue parameters ( $\epsilon$  and  $\sigma$ ) is restricted to ± 5%. The uncertainty is the RSS of the ConvF uncertainty for indicated target tissue parameters.

<sup>G</sup> Alpha/Depth are determined during calibration. SPEAG warrants that the remaining deviation due to the boundary effect after compensation is always less than ± 1% for frequencies below 3 GHz and below ± 2% for frequencies between 3-6 GHz at any distance larger than half the probe tip diameter from the boundary.

## DASY/EASY - Parameters of Probe: EX3DV4 - SN:7410

### Calibration Parameter Determined in Body Tissue Simulating Media

f (MHz) <sup>C</sup>	Relative Permittivity <sup>F</sup>	Conductivity (S/m) <sup>F</sup>	ConvF X	ConvF Y	ConvF Z	Alpha <sup>G</sup>	Depth <sup>G</sup> (mm)	Unc (k=2)
750	55.5	0.96	10.19	10.19	10.19	0.33	1.02	± 12.0 %
835	55.2	0.97	9.95	9.95	9.95	0.50	0.80	± 12.0 %
1750	53.4	1.49	8.32	8.32	8.32	0.39	0.86	± 12.0 %
1900	53.3	1.52	7.98	7.98	7.98	0.44	0.86	± 12.0 %
2300	52.9	1.81	7.85	7.85	7.85	0.44	0.84	± 12.0 %
2450	52.7	1.95	7.69	7.69	7.69	0.37	0.89	± 12.0 %
2600	52.5	2.16	7.43	7.43	7.43	0.28	0.99	± 12.0 %

<sup>C</sup> Frequency validity above 300 MHz of ± 100 MHz only applies for DASY v4.4 and higher (see Page 2), else it is restricted to ± 50 MHz. The uncertainty is the RSS of the ConvF uncertainty at calibration frequency and the uncertainty for the indicated frequency band. Frequency validity below 300 MHz is ± 10, 25, 40, 50 and 70 MHz for ConvF assessments at 30, 64, 128, 150 and 220 MHz respectively. Above 5 GHz frequency validity can be extended to ± 110 MHz.

<sup>F</sup> At frequencies below 3 GHz, the validity of tissue parameters ( $\epsilon$  and  $\sigma$ ) can be relaxed to ± 10% if liquid compensation formula is applied to measured SAR values. At frequencies above 3 GHz, the validity of tissue parameters ( $\epsilon$  and  $\sigma$ ) is restricted to ± 5%. The uncertainty is the RSS of the ConvF uncertainty for indicated target tissue parameters.

<sup>G</sup> Alpha/Depth are determined during calibration. SPEAG warrants that the remaining deviation due to the boundary effect after compensation is always less than ± 1% for frequencies below 3 GHz and below ± 2% for frequencies between 3-6 GHz at any distance larger than half the probe tip diameter from the boundary.

### Frequency Response of E-Field (TEM-Cell:ifi110 EXX, Waveguide: R22)

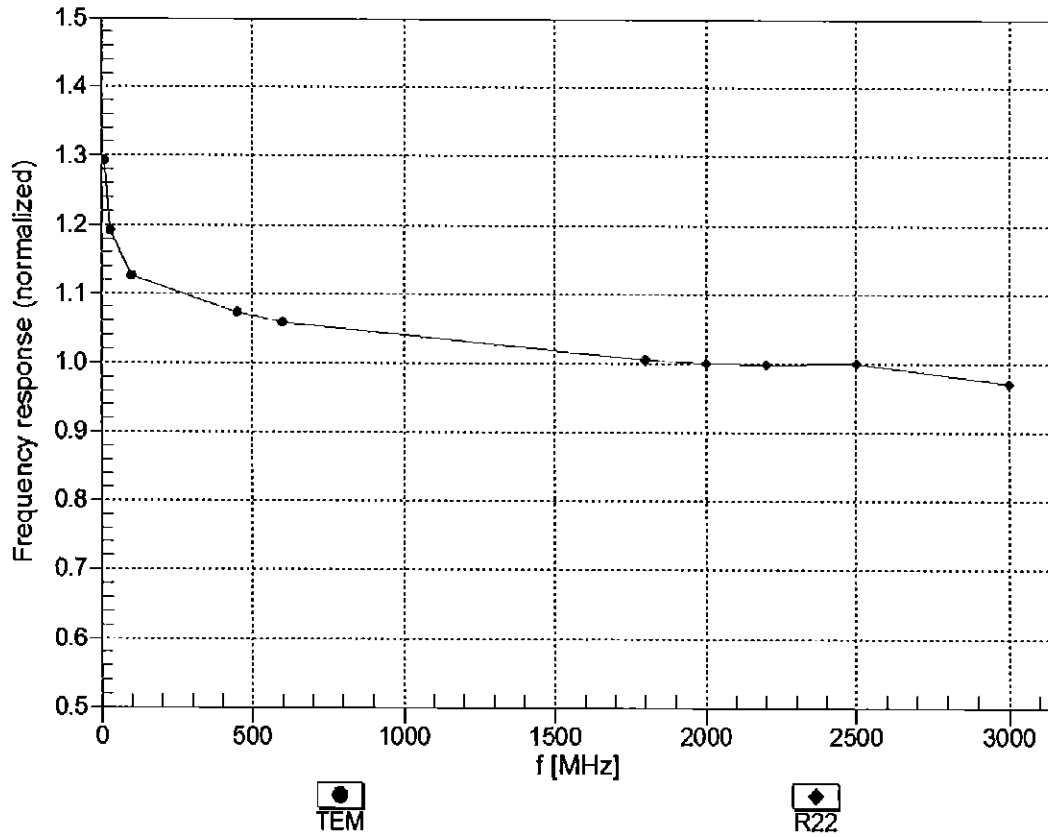

Uncertainty of Frequency Response of E-field:  $\pm 6.3\%$  (k=2)

### Receiving Pattern ( $\phi$ ), $\theta = 0^\circ$

f=600 MHz,TEM

f=1800 MHz,R22

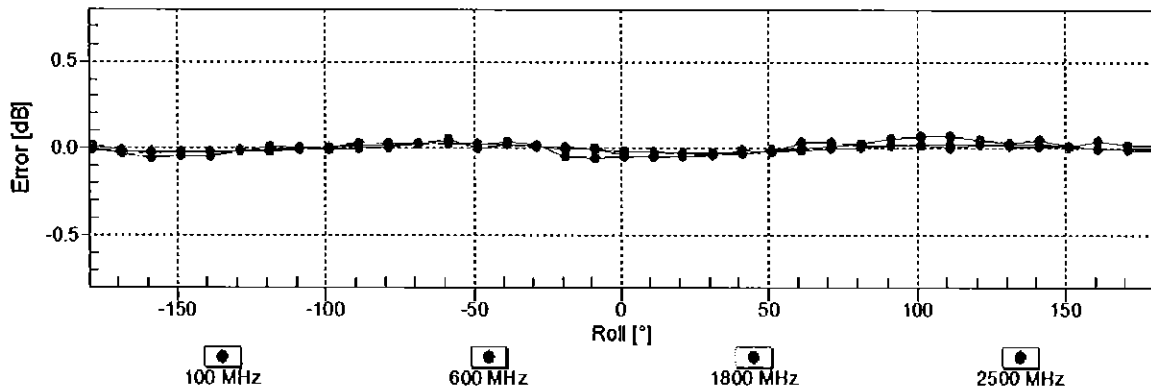
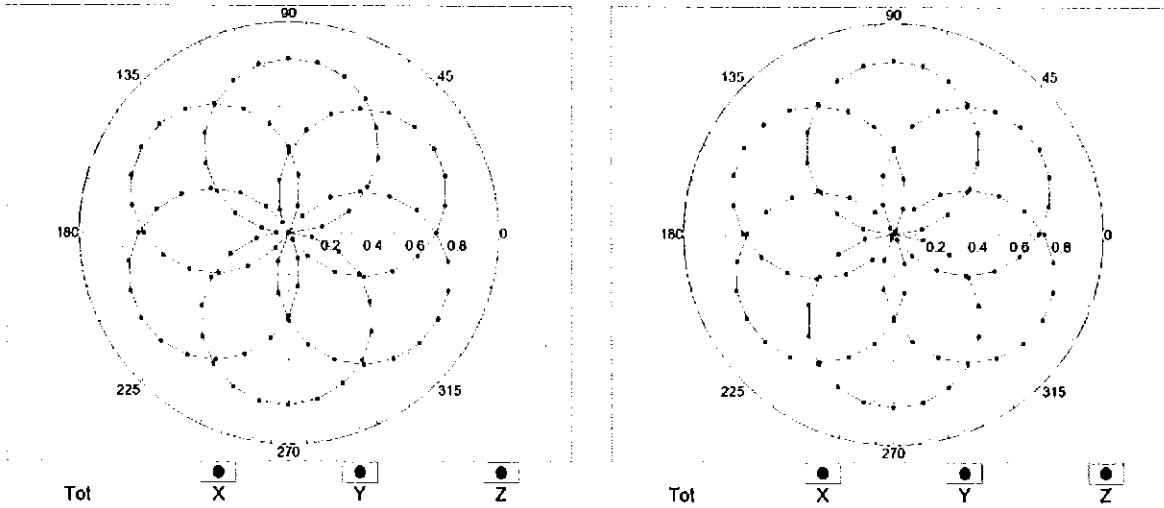

Uncertainty of Axial Isotropy Assessment:  $\pm 0.5\%$  ( $k=2$ )



### Dynamic Range $f(SAR_{head})$ (TEM cell, $f_{eval}=1900$ MHz)

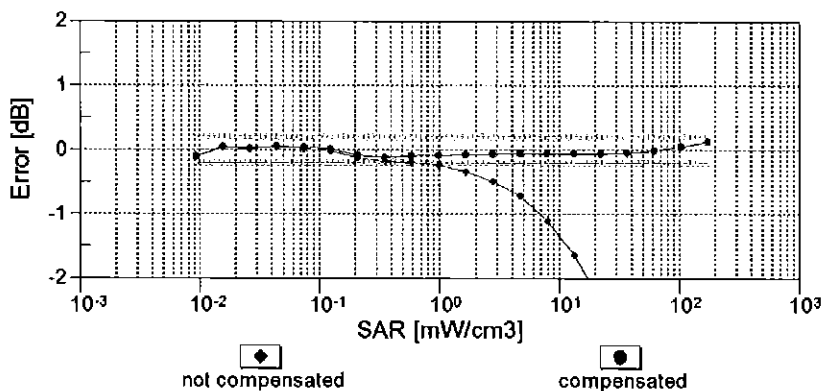
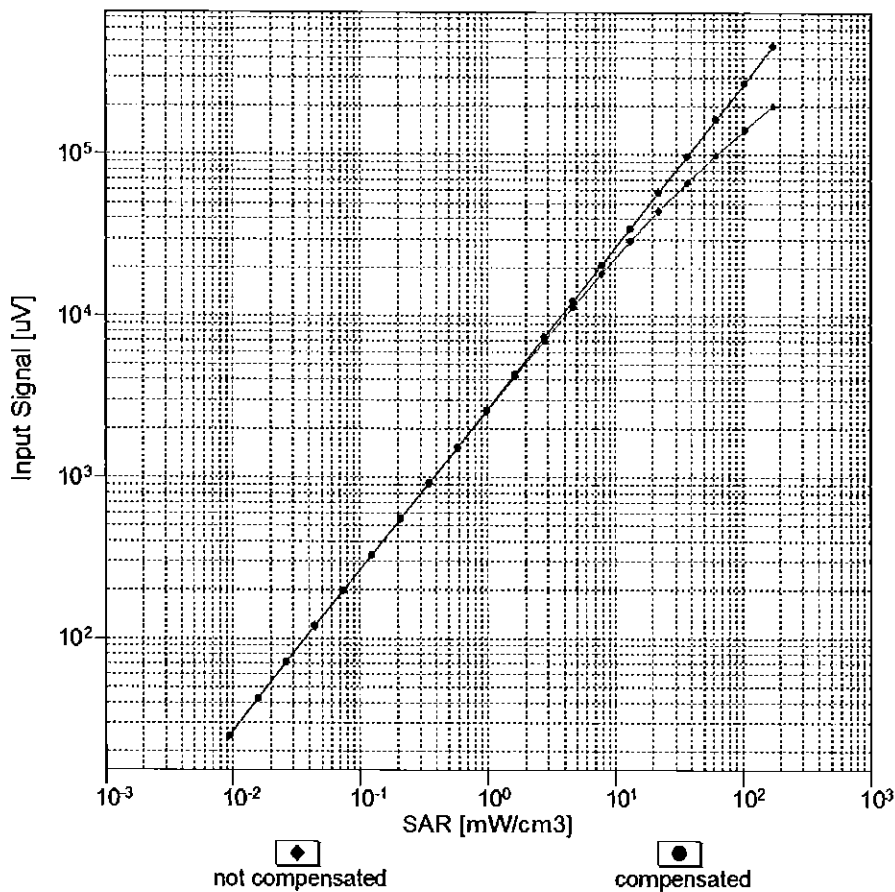

Uncertainty of Linearity Assessment:  $\pm 0.6\%$  ( $k=2$ )

## Conversion Factor Assessment

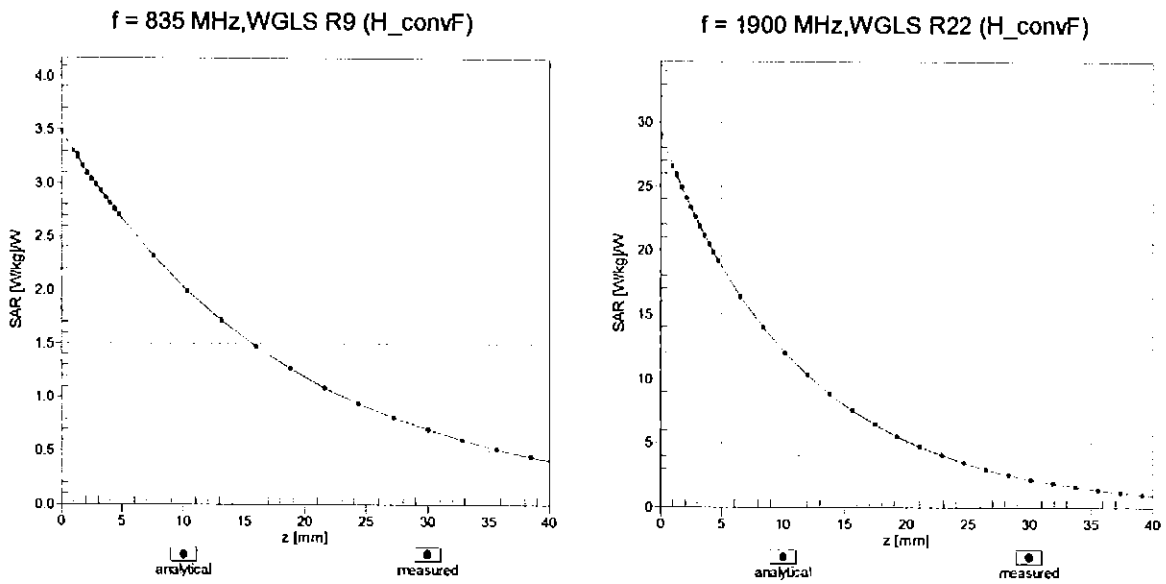

## Deviation from Isotropy in Liquid Error ( $\phi, \vartheta$ ), f = 900 MHz

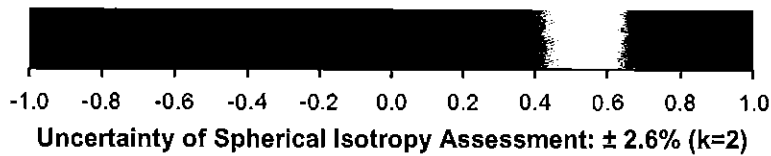
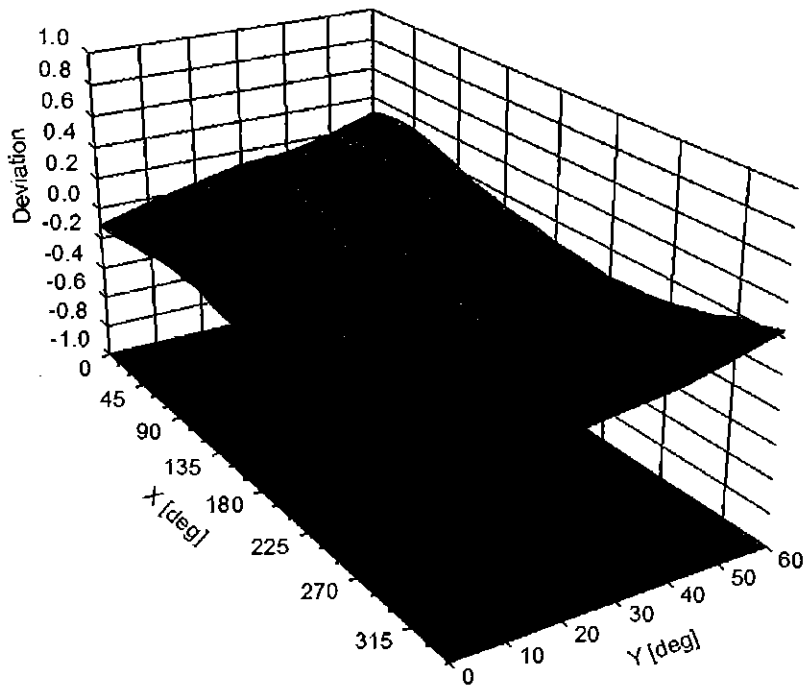

Uncertainty of Spherical Isotropy Assessment:  $\pm 2.6\%$  (k=2)

**DASY/EASY - Parameters of Probe: EX3DV4 - SN:7410****Other Probe Parameters**

Sensor Arrangement	Triangular
Connector Angle (°)	1.2
Mechanical Surface Detection Mode	enabled
Optical Surface Detection Mode	disabled
Probe Overall Length	337 mm
Probe Body Diameter	10 mm
Tip Length	9 mm
Tip Diameter	2.5 mm
Probe Tip to Sensor X Calibration Point	1 mm
Probe Tip to Sensor Y Calibration Point	1 mm
Probe Tip to Sensor Z Calibration Point	1 mm
Recommended Measurement Distance from Surface	1.4 mm

## Appendix: Modulation Calibration Parameters

UID	Communication System Name		A dB	B dB $\sqrt{\mu}$ V	C	D dB	VR mV	Max Unc <sup>E</sup> (k=2)
0	CW	X	0.00	0.00	1.00	0.00	130.7	$\pm 3.5\%$
		Y	0.00	0.00	1.00		146.7	
		Z	0.00	0.00	1.00		132.5	
10010- CAA	SAR Validation (Square, 100ms, 10ms)	X	2.07	65.38	9.86	10.00	20.0	$\pm 9.6\%$
		Y	1.71	64.71	9.07		20.0	
		Z	3.44	71.14	12.92		20.0	
10011- CAB	UMTS-FDD (WCDMA)	X	1.05	67.82	15.62	0.00	150.0	$\pm 9.6\%$
		Y	1.11	68.91	16.28		150.0	
		Z	1.02	66.59	14.94		150.0	
10012- CAB	IEEE 802.11b WiFi 2.4 GHz (DSSS, 1 Mbps)	X	1.16	63.70	15.28	0.41	150.0	$\pm 9.6\%$
		Y	1.18	64.10	15.65		150.0	
		Z	1.17	63.41	15.09		150.0	
10013- CAB	IEEE 802.11g WiFi 2.4 GHz (DSSS-OFDM, 6 Mbps)	X	4.78	66.61	17.05	1.46	150.0	$\pm 9.6\%$
		Y	4.80	66.74	17.21		150.0	
		Z	4.93	66.52	17.11		150.0	
10021- DAC	GSM-FDD (TDMA, GMSK)	X	100.00	111.37	25.72	9.39	50.0	$\pm 9.6\%$
		Y	100.00	111.58	25.35		50.0	
		Z	100.00	117.02	28.59		50.0	
10023- DAC	GPRS-FDD (TDMA, GMSK, TN 0)	X	100.00	110.83	25.53	9.57	50.0	$\pm 9.6\%$
		Y	1707.76	142.54	31.32		50.0	
		Z	100.00	116.46	28.39		50.0	
10024- DAC	GPRS-FDD (TDMA, GMSK, TN 0-1)	X	100.00	111.84	24.81	6.56	60.0	$\pm 9.6\%$
		Y	100.00	114.48	25.68		60.0	
		Z	100.00	118.35	28.09		60.0	
10025- DAC	EDGE-FDD (TDMA, 8PSK, TN 0)	X	3.46	65.17	23.20	12.57	50.0	$\pm 9.6\%$
		Y	5.27	82.06	33.95		50.0	
		Z	3.61	65.78	23.81		50.0	
10026- DAC	EDGE-FDD (TDMA, 8PSK, TN 0-1)	X	6.19	83.69	29.67	9.56	60.0	$\pm 9.6\%$
		Y	7.27	90.43	33.46		60.0	
		Z	7.46	87.49	31.34		60.0	
10027- DAC	GPRS-FDD (TDMA, GMSK, TN 0-1-2)	X	100.00	114.23	25.06	4.80	80.0	$\pm 9.6\%$
		Y	100.00	119.65	27.19		80.0	
		Z	100.00	121.09	28.48		80.0	
10028- DAC	GPRS-FDD (TDMA, GMSK, TN 0-1-2-3)	X	100.00	118.39	26.12	3.55	100.0	$\pm 9.6\%$
		Y	100.00	127.35	29.74		100.0	
		Z	100.00	125.00	29.42		100.0	
10029- DAC	EDGE-FDD (TDMA, 8PSK, TN 0-1-2)	X	4.31	75.70	25.15	7.80	80.0	$\pm 9.6\%$
		Y	4.62	78.76	27.21		80.0	
		Z	5.10	78.80	26.60		80.0	
10030- CAA	IEEE 802.15.1 Bluetooth (GFSK, DH1)	X	100.00	110.42	23.70	5.30	70.0	$\pm 9.6\%$
		Y	100.00	113.76	24.95		70.0	
		Z	100.00	117.44	27.22		70.0	
10031- CAA	IEEE 802.15.1 Bluetooth (GFSK, DH3)	X	100.00	118.50	24.77	1.88	100.0	$\pm 9.6\%$
		Y	100.00	132.66	30.37		100.0	
		Z	100.00	126.29	28.44		100.0	

10032-CAA	IEEE 802.15.1 Bluetooth (GFSK, DH5)	X	100.00	133.47	29.67	1.17	100.0	± 9.6 %
		Y	100.00	157.48	38.89		100.0	
		Z	100.00	136.04	31.29		100.0	
10033-CAA	IEEE 802.15.1 Bluetooth (PI/4-DQPSK, DH1)	X	8.66	91.15	24.16	5.30	70.0	± 9.6 %
		Y	61.92	124.81	33.89		70.0	
		Z	18.44	105.53	29.79		70.0	
10034-CAA	IEEE 802.15.1 Bluetooth (PI/4-DQPSK, DH3)	X	2.66	76.47	17.66	1.88	100.0	± 9.6 %
		Y	4.91	85.76	21.28		100.0	
		Z	3.14	79.12	19.77		100.0	
10035-CAA	IEEE 802.15.1 Bluetooth (PI/4-DQPSK, DH5)	X	1.87	72.76	15.96	1.17	100.0	± 9.6 %
		Y	2.71	78.22	18.36		100.0	
		Z	2.01	73.50	17.25		100.0	
10036-CAA	IEEE 802.15.1 Bluetooth (8-DPSK, DH1)	X	12.89	97.56	26.18	5.30	70.0	± 9.6 %
		Y	100.00	133.04	35.90		70.0	
		Z	33.52	115.95	32.67		70.0	
10037-CAA	IEEE 802.15.1 Bluetooth (8-DPSK, DH3)	X	2.40	75.20	17.16	1.88	100.0	± 9.6 %
		Y	4.17	83.65	20.57		100.0	
		Z	2.91	78.15	19.38		100.0	
10038-CAA	IEEE 802.15.1 Bluetooth (8-DPSK, DH5)	X	1.89	73.11	16.24	1.17	100.0	± 9.6 %
		Y	2.73	78.67	18.67		100.0	
		Z	2.03	73.85	17.51		100.0	
10039-CAB	CDMA2000 (1xRTT, RC1)	X	1.93	73.30	15.79	0.00	150.0	± 9.6 %
		Y	2.16	74.82	16.50		150.0	
		Z	1.82	71.39	15.74		150.0	
10042-CAB	IS-54 / IS-136 FDD (TDMA/FDM, PI/4-DQPSK, Halfrate)	X	100.00	108.18	23.51	7.78	50.0	± 9.6 %
		Y	100.00	108.75	23.44		50.0	
		Z	100.00	113.77	26.32		50.0	
10044-CAA	IS-91/EIA/TIA-553 FDD (FDMA, FM)	X	0.00	97.63	1.20	0.00	150.0	± 9.6 %
		Y	0.00	97.90	0.75		150.0	
		Z	0.00	95.09	2.63		150.0	
10048-CAA	DECT (TDD, TDMA/FDM, GFSK, Full Slot, 24)	X	29.38	92.85	22.01	13.80	25.0	± 9.6 %
		Y	100.00	106.19	24.33		25.0	
		Z	100.00	113.54	28.60		25.0	
10049-CAA	DECT (TDD, TDMA/FDM, GFSK, Double Slot, 12)	X	92.32	108.50	25.07	10.79	40.0	± 9.6 %
		Y	100.00	108.13	24.14		40.0	
		Z	100.00	114.66	27.93		40.0	
10056-CAA	UMTS-TDD (TD-SCDMA, 1.28 Mcps)	X	28.80	103.53	27.62	9.03	50.0	± 9.6 %
		Y	100.00	125.87	33.73		50.0	
		Z	90.56	125.80	34.77		50.0	
10058-DAC	EDGE-FDD (TDMA, 8PSK, TN 0-1-2-3)	X	3.55	72.15	22.79	6.55	100.0	± 9.6 %
		Y	3.72	74.09	24.21		100.0	
		Z	4.11	74.59	23.97		100.0	
10059-CAB	IEEE 802.11b WiFi 2.4 GHz (DSSS, 2 Mbps)	X	1.17	64.52	15.76	0.61	110.0	± 9.6 %
		Y	1.20	65.09	16.25		110.0	
		Z	1.19	64.38	15.68		110.0	
10060-CAB	IEEE 802.11b WiFi 2.4 GHz (DSSS, 5.5 Mbps)	X	5.38	97.28	26.54	1.30	110.0	± 9.6 %
		Y	94.12	145.74	39.06		110.0	
		Z	7.25	100.99	27.69		110.0	

10061-CAB	IEEE 802.11b WiFi 2.4 GHz (DSSS, 11 Mbps)	X	2.03	75.84	20.79	2.04	110.0	± 9.6 %
		Y	2.53	80.86	23.32		110.0	
		Z	2.46	78.49	22.05		110.0	
10062-CAB	IEEE 802.11a/h WiFi 5 GHz (OFDM, 6 Mbps)	X	4.60	66.68	16.54	0.49	100.0	± 9.6 %
		Y	4.62	66.77	16.65		100.0	
		Z	4.74	66.54	16.54		100.0	
10063-CAB	IEEE 802.11a/h WiFi 5 GHz (OFDM, 9 Mbps)	X	4.61	66.74	16.62	0.72	100.0	± 9.6 %
		Y	4.63	66.85	16.75		100.0	
		Z	4.75	66.63	16.64		100.0	
10064-CAB	IEEE 802.11a/h WiFi 5 GHz (OFDM, 12 Mbps)	X	4.88	66.97	16.83	0.86	100.0	± 9.6 %
		Y	4.90	67.08	16.96		100.0	
		Z	5.06	66.93	16.89		100.0	
10065-CAB	IEEE 802.11a/h WiFi 5 GHz (OFDM, 18 Mbps)	X	4.74	66.82	16.90	1.21	100.0	± 9.6 %
		Y	4.76	66.95	17.05		100.0	
		Z	4.91	66.81	16.98		100.0	
10066-CAB	IEEE 802.11a/h WiFi 5 GHz (OFDM, 24 Mbps)	X	4.74	66.80	17.04	1.46	100.0	± 9.6 %
		Y	4.77	66.94	17.21		100.0	
		Z	4.93	66.83	17.15		100.0	
10067-CAB	IEEE 802.11a/h WiFi 5 GHz (OFDM, 36 Mbps)	X	5.03	66.98	17.46	2.04	100.0	± 9.6 %
		Y	5.05	67.14	17.66		100.0	
		Z	5.21	66.94	17.57		100.0	
10068-CAB	IEEE 802.11a/h WiFi 5 GHz (OFDM, 48 Mbps)	X	5.05	66.91	17.63	2.55	100.0	± 9.6 %
		Y	5.07	67.08	17.84		100.0	
		Z	5.27	67.04	17.82		100.0	
10069-CAB	IEEE 802.11a/h WiFi 5 GHz (OFDM, 54 Mbps)	X	5.12	66.93	17.81	2.67	100.0	± 9.6 %
		Y	5.15	67.10	18.04		100.0	
		Z	5.34	66.99	17.99		100.0	
10071-CAB	IEEE 802.11g WiFi 2.4 GHz (DSSS/OFDM, 9 Mbps)	X	4.86	66.65	17.32	1.99	100.0	± 9.6 %
		Y	4.89	66.79	17.50		100.0	
		Z	5.01	66.60	17.41		100.0	
10072-CAB	IEEE 802.11g WiFi 2.4 GHz (DSSS/OFDM, 12 Mbps)	X	4.82	66.89	17.50	2.30	100.0	± 9.6 %
		Y	4.84	67.05	17.70		100.0	
		Z	4.99	66.92	17.63		100.0	
10073-CAB	IEEE 802.11g WiFi 2.4 GHz (DSSS/OFDM, 18 Mbps)	X	4.86	67.00	17.79	2.83	100.0	± 9.6 %
		Y	4.89	67.17	18.02		100.0	
		Z	5.04	67.03	17.94		100.0	
10074-CAB	IEEE 802.11g WiFi 2.4 GHz (DSSS/OFDM, 24 Mbps)	X	4.85	66.87	17.91	3.30	100.0	± 9.6 %
		Y	4.86	67.04	18.15		100.0	
		Z	5.01	66.88	18.08		100.0	
10075-CAB	IEEE 802.11g WiFi 2.4 GHz (DSSS/OFDM, 36 Mbps)	X	4.86	66.89	18.16	3.82	90.0	± 9.6 %
		Y	4.87	67.06	18.42		90.0	
		Z	5.04	67.00	18.40		90.0	
10076-CAB	IEEE 802.11g WiFi 2.4 GHz (DSSS/OFDM, 48 Mbps)	X	4.88	66.70	18.29	4.15	90.0	± 9.6 %
		Y	4.89	66.85	18.55		90.0	
		Z	5.03	66.71	18.47		90.0	
10077-CAB	IEEE 802.11g WiFi 2.4 GHz (DSSS/OFDM, 54 Mbps)	X	4.91	66.76	18.38	4.30	90.0	± 9.6 %
		Y	4.91	66.91	18.65		90.0	
		Z	5.05	66.76	18.56		90.0	

10081-CAB	CDMA2000 (1xRTT, RC3)	X	0.83	66.43	12.40	0.00	150.0	± 9.6 %
		Y	0.90	67.46	13.02		150.0	
		Z	0.87	65.72	12.74		150.0	
10082-CAB	IS-54 / IS-136 FDD (TDMA/FDM, PI/4-DQPSK, Fullrate)	X	0.60	60.00	4.03	4.77	80.0	± 9.6 %
		Y	1.74	63.67	4.99		80.0	
		Z	0.50	57.10	2.51		80.0	
10090-DAC	GPRS-FDD (TDMA, GMSK, TN 0-4)	X	100.00	111.84	24.82	6.56	60.0	± 9.6 %
		Y	100.00	114.47	25.69		60.0	
		Z	100.00	118.36	28.12		60.0	
10097-CAB	UMTS-FDD (HSDPA)	X	1.87	68.36	15.98	0.00	150.0	± 9.6 %
		Y	1.92	68.79	16.27		150.0	
		Z	1.83	67.16	15.53		150.0	
10098-CAB	UMTS-FDD (HSUPA, Subtest 2)	X	1.83	68.30	15.96	0.00	150.0	± 9.6 %
		Y	1.88	68.76	16.25		150.0	
		Z	1.79	67.10	15.49		150.0	
10099-DAC	EDGE-FDD (TDMA, 8PSK, TN 0-4)	X	6.23	83.81	29.72	9.56	60.0	± 9.6 %
		Y	7.34	90.66	33.54		60.0	
		Z	7.51	87.64	31.39		60.0	
10100-CAC	LTE-FDD (SC-FDMA, 100% RB, 20 MHz, QPSK)	X	3.10	70.42	16.91	0.00	150.0	± 9.6 %
		Y	3.17	70.79	17.14		150.0	
		Z	3.14	69.95	16.56		150.0	
10101-CAC	LTE-FDD (SC-FDMA, 100% RB, 20 MHz, 16-QAM)	X	3.21	67.53	16.05	0.00	150.0	± 9.6 %
		Y	3.24	67.71	16.18		150.0	
		Z	3.28	67.33	15.89		150.0	
10102-CAC	LTE-FDD (SC-FDMA, 100% RB, 20 MHz, 64-QAM)	X	3.31	67.53	16.15	0.00	150.0	± 9.6 %
		Y	3.34	67.67	16.26		150.0	
		Z	3.39	67.31	16.00		150.0	
10103-CAC	LTE-TDD (SC-FDMA, 100% RB, 20 MHz, QPSK)	X	5.23	73.47	19.72	3.98	65.0	± 9.6 %
		Y	5.84	75.95	21.01		65.0	
		Z	5.88	74.83	20.39		65.0	
10104-CAC	LTE-TDD (SC-FDMA, 100% RB, 20 MHz, 16-QAM)	X	5.46	71.98	19.77	3.98	65.0	± 9.6 %
		Y	5.63	73.01	20.49		65.0	
		Z	6.00	73.07	20.39		65.0	
10105-CAC	LTE-TDD (SC-FDMA, 100% RB, 20 MHz, 64-QAM)	X	5.42	71.61	19.91	3.98	65.0	± 9.6 %
		Y	5.43	72.06	20.36		65.0	
		Z	5.47	71.05	19.77		65.0	
10108-CAD	LTE-FDD (SC-FDMA, 100% RB, 10 MHz, QPSK)	X	2.70	69.72	16.76	0.00	150.0	± 9.6 %
		Y	2.76	70.10	16.99		150.0	
		Z	2.75	69.19	16.39		150.0	
10109-CAD	LTE-FDD (SC-FDMA, 100% RB, 10 MHz, 16-QAM)	X	2.86	67.48	15.96	0.00	150.0	± 9.6 %
		Y	2.89	67.67	16.11		150.0	
		Z	2.94	67.16	15.80		150.0	
10110-CAD	LTE-FDD (SC-FDMA, 100% RB, 5 MHz, QPSK)	X	2.18	68.93	16.34	0.00	150.0	± 9.6 %
		Y	2.24	69.40	16.63		150.0	
		Z	2.24	68.24	15.99		150.0	
10111-CAD	LTE-FDD (SC-FDMA, 100% RB, 5 MHz, 16-QAM)	X	2.61	68.71	16.36	0.00	150.0	± 9.6 %
		Y	2.63	68.84	16.47		150.0	
		Z	2.65	67.91	16.10		150.0	

10112-CAD	LTE-FDD (SC-FDMA, 100% RB, 10 MHz, 64-QAM)	X	2.99	67.52	16.03	0.00	150.0	± 9.6 %
		Y	3.01	67.67	16.15		150.0	
		Z	3.06	67.16	15.86		150.0	
10113-CAD	LTE-FDD (SC-FDMA, 100% RB, 5 MHz, 64-QAM)	X	2.77	68.89	16.50	0.00	150.0	± 9.6 %
		Y	2.78	68.97	16.58		150.0	
		Z	2.81	68.06	16.24		150.0	
10114-CAB	IEEE 802.11n (HT Greenfield, 13.5 Mbps, BPSK)	X	5.09	67.23	16.55	0.00	150.0	± 9.6 %
		Y	5.10	67.28	16.60		150.0	
		Z	5.19	67.11	16.46		150.0	
10115-CAB	IEEE 802.11n (HT Greenfield, 81 Mbps, 16-QAM)	X	5.34	67.29	16.58	0.00	150.0	± 9.6 %
		Y	5.35	67.33	16.63		150.0	
		Z	5.51	67.33	16.58		150.0	
10116-CAB	IEEE 802.11n (HT Greenfield, 135 Mbps, 64-QAM)	X	5.18	67.42	16.57	0.00	150.0	± 9.6 %
		Y	5.19	67.47	16.62		150.0	
		Z	5.30	67.34	16.50		150.0	
10117-CAB	IEEE 802.11n (HT Mixed, 13.5 Mbps, BPSK)	X	5.06	67.11	16.50	0.00	150.0	± 9.6 %
		Y	5.07	67.16	16.56		150.0	
		Z	5.16	66.99	16.42		150.0	
10118-CAB	IEEE 802.11n (HT Mixed, 81 Mbps, 16-QAM)	X	5.42	67.49	16.69	0.00	150.0	± 9.6 %
		Y	5.44	67.54	16.74		150.0	
		Z	5.60	67.55	16.70		150.0	
10119-CAB	IEEE 802.11n (HT Mixed, 135 Mbps, 64-QAM)	X	5.16	67.38	16.56	0.00	150.0	± 9.6 %
		Y	5.17	67.43	16.62		150.0	
		Z	5.27	67.27	16.48		150.0	
10140-CAC	LTE-FDD (SC-FDMA, 100% RB, 15 MHz, 16-QAM)	X	3.34	67.53	16.06	0.00	150.0	± 9.6 %
		Y	3.37	67.68	16.18		150.0	
		Z	3.42	67.31	15.91		150.0	
10141-CAC	LTE-FDD (SC-FDMA, 100% RB, 15 MHz, 64-QAM)	X	3.47	67.67	16.25	0.00	150.0	± 9.6 %
		Y	3.49	67.79	16.35		150.0	
		Z	3.55	67.42	16.09		150.0	
10142-CAD	LTE-FDD (SC-FDMA, 100% RB, 3 MHz, QPSK)	X	1.97	69.09	15.95	0.00	150.0	± 9.6 %
		Y	2.03	69.63	16.28		150.0	
		Z	2.02	68.20	15.69		150.0	
10143-CAD	LTE-FDD (SC-FDMA, 100% RB, 3 MHz, 16-QAM)	X	2.49	69.65	15.98	0.00	150.0	± 9.6 %
		Y	2.52	69.83	16.12		150.0	
		Z	2.51	68.62	15.86		150.0	
10144-CAD	LTE-FDD (SC-FDMA, 100% RB, 3 MHz, 64-QAM)	X	2.16	66.67	13.99	0.00	150.0	± 9.6 %
		Y	2.21	66.99	14.22		150.0	
		Z	2.30	66.43	14.30		150.0	
10145-CAD	LTE-FDD (SC-FDMA, 100% RB, 1.4 MHz, QPSK)	X	1.07	64.11	10.67	0.00	150.0	± 9.6 %
		Y	1.11	64.57	11.01		150.0	
		Z	1.31	65.51	12.40		150.0	
10146-CAD	LTE-FDD (SC-FDMA, 100% RB, 1.4 MHz, 16-QAM)	X	1.34	62.65	9.02	0.00	150.0	± 9.6 %
		Y	1.43	63.27	9.42		150.0	
		Z	2.01	66.35	12.18		150.0	
10147-CAD	LTE-FDD (SC-FDMA, 100% RB, 1.4 MHz, 64-QAM)	X	1.45	63.47	9.57	0.00	150.0	± 9.6 %
		Y	1.57	64.27	10.06		150.0	
		Z	2.34	68.34	13.28		150.0	



10149-CAC	LTE-FDD (SC-FDMA, 50% RB, 20 MHz, 16-QAM)	X	2.87	67.55	16.01	0.00	150.0	± 9.6 %
		Y	2.90	67.73	16.15		150.0	
		Z	2.95	67.22	15.84		150.0	
10150-CAC	LTE-FDD (SC-FDMA, 50% RB, 20 MHz, 64-QAM)	X	3.00	67.58	16.08	0.00	150.0	± 9.6 %
		Y	3.02	67.73	16.20		150.0	
		Z	3.07	67.21	15.90		150.0	
10151-CAC	LTE-TDD (SC-FDMA, 50% RB, 20 MHz, QPSK)	X	5.65	76.57	21.08	3.98	65.0	± 9.6 %
		Y	6.17	78.83	22.29		65.0	
		Z	6.35	77.82	21.74		65.0	
10152-CAC	LTE-TDD (SC-FDMA, 50% RB, 20 MHz, 16-QAM)	X	4.98	71.84	19.37	3.98	65.0	± 9.6 %
		Y	5.18	73.09	20.20		65.0	
		Z	5.53	73.00	20.11		65.0	
10153-CAC	LTE-TDD (SC-FDMA, 50% RB, 20 MHz, 64-QAM)	X	5.35	72.93	20.23	3.98	65.0	± 9.6 %
		Y	5.53	74.06	20.99		65.0	
		Z	5.88	73.94	20.90		65.0	
10154-CAD	LTE-FDD (SC-FDMA, 50% RB, 10 MHz, QPSK)	X	2.24	69.40	16.63	0.00	150.0	± 9.6 %
		Y	2.29	69.81	16.88		150.0	
		Z	2.29	68.69	16.27		150.0	
10155-CAD	LTE-FDD (SC-FDMA, 50% RB, 10 MHz, 16-QAM)	X	2.62	68.74	16.38	0.00	150.0	± 9.6 %
		Y	2.64	68.87	16.49		150.0	
		Z	2.65	67.91	16.11		150.0	
10156-CAD	LTE-FDD (SC-FDMA, 50% RB, 5 MHz, QPSK)	X	1.81	69.21	15.68	0.00	150.0	± 9.6 %
		Y	1.88	69.80	16.04		150.0	
		Z	1.87	68.31	15.53		150.0	
10157-CAD	LTE-FDD (SC-FDMA, 50% RB, 5 MHz, 16-QAM)	X	2.01	67.27	13.98	0.00	150.0	± 9.6 %
		Y	2.06	67.66	14.24		150.0	
		Z	2.13	67.00	14.37		150.0	
10158-CAD	LTE-FDD (SC-FDMA, 50% RB, 10 MHz, 64-QAM)	X	2.78	68.97	16.55	0.00	150.0	± 9.6 %
		Y	2.79	69.05	16.63		150.0	
		Z	2.81	68.12	16.28		150.0	
10159-CAD	LTE-FDD (SC-FDMA, 50% RB, 5 MHz, 64-QAM)	X	2.12	67.76	14.27	0.00	150.0	± 9.6 %
		Y	2.17	68.10	14.50		150.0	
		Z	2.25	67.49	14.68		150.0	
10160-CAC	LTE-FDD (SC-FDMA, 50% RB, 15 MHz, QPSK)	X	2.73	68.96	16.55	0.00	150.0	± 9.6 %
		Y	2.78	69.27	16.76		150.0	
		Z	2.78	68.34	16.22		150.0	
10161-CAC	LTE-FDD (SC-FDMA, 50% RB, 15 MHz, 16-QAM)	X	2.89	67.56	16.00	0.00	150.0	± 9.6 %
		Y	2.92	67.72	16.12		150.0	
		Z	2.97	67.14	15.84		150.0	
10162-CAC	LTE-FDD (SC-FDMA, 50% RB, 15 MHz, 64-QAM)	X	3.00	67.76	16.13	0.00	150.0	± 9.6 %
		Y	3.03	67.89	16.24		150.0	
		Z	3.08	67.27	15.94		150.0	
10166-CAD	LTE-FDD (SC-FDMA, 50% RB, 1.4 MHz, QPSK)	X	3.29	68.55	18.62	3.01	150.0	± 9.6 %
		Y	3.39	69.14	19.00		150.0	
		Z	3.56	68.77	18.74		150.0	
10167-CAD	LTE-FDD (SC-FDMA, 50% RB, 1.4 MHz, 16-QAM)	X	3.85	70.83	18.84	3.01	150.0	± 9.6 %
		Y	4.06	71.87	19.39		150.0	
		Z	4.27	71.19	19.04		150.0	

10168-CAD	LTE-FDD (SC-FDMA, 50% RB, 1.4 MHz, 64-QAM)	X	4.31	73.34	20.36	3.01	150.0	± 9.6 %
		Y	4.51	74.19	20.77		150.0	
		Z	4.72	73.40	20.38		150.0	
10169-CAC	LTE-FDD (SC-FDMA, 1 RB, 20 MHz, QPSK)	X	2.65	67.07	17.95	3.01	150.0	± 9.6 %
		Y	2.76	67.90	18.46		150.0	
		Z	2.95	68.18	18.47		150.0	
10170-CAC	LTE-FDD (SC-FDMA, 1 RB, 20 MHz, 16-QAM)	X	3.35	71.83	19.98	3.01	150.0	± 9.6 %
		Y	3.58	73.08	20.56		150.0	
		Z	3.90	73.37	20.58		150.0	
10171-AAC	LTE-FDD (SC-FDMA, 1 RB, 20 MHz, 64-QAM)	X	2.80	68.11	17.24	3.01	150.0	± 9.6 %
		Y	3.01	69.49	17.99		150.0	
		Z	3.23	69.44	17.85		150.0	
10172-CAC	LTE-TDD (SC-FDMA, 1 RB, 20 MHz, QPSK)	X	3.65	76.31	22.99	6.02	65.0	± 9.6 %
		Y	5.48	85.89	27.40		65.0	
		Z	5.55	83.03	25.87		65.0	
10173-CAC	LTE-TDD (SC-FDMA, 1 RB, 20 MHz, 16-QAM)	X	6.66	85.15	24.55	6.02	65.0	± 9.6 %
		Y	10.56	95.03	28.43		65.0	
		Z	12.26	94.72	28.10		65.0	
10174-CAC	LTE-TDD (SC-FDMA, 1 RB, 20 MHz, 64-QAM)	X	4.93	79.32	21.92	6.02	65.0	± 9.6 %
		Y	8.98	90.91	26.48		65.0	
		Z	8.81	87.78	25.30		65.0	
10175-CAD	LTE-FDD (SC-FDMA, 1 RB, 10 MHz, QPSK)	X	2.62	66.79	17.70	3.01	150.0	± 9.6 %
		Y	2.73	67.64	18.24		150.0	
		Z	2.91	67.87	18.21		150.0	
10176-CAD	LTE-FDD (SC-FDMA, 1 RB, 10 MHz, 16-QAM)	X	3.35	71.86	19.99	3.01	150.0	± 9.6 %
		Y	3.58	73.10	20.58		150.0	
		Z	3.90	73.39	20.59		150.0	
10177-CAF	LTE-FDD (SC-FDMA, 1 RB, 5 MHz, QPSK)	X	2.64	66.92	17.79	3.01	150.0	± 9.6 %
		Y	2.75	67.76	18.31		150.0	
		Z	2.94	68.03	18.32		150.0	
10178-CAD	LTE-FDD (SC-FDMA, 1 RB, 5 MHz, 16-QAM)	X	3.33	71.68	19.88	3.01	150.0	± 9.6 %
		Y	3.56	72.95	20.49		150.0	
		Z	3.86	73.15	20.45		150.0	
10179-CAD	LTE-FDD (SC-FDMA, 1 RB, 10 MHz, 64-QAM)	X	3.04	69.83	18.46	3.01	150.0	± 9.6 %
		Y	3.27	71.21	19.16		150.0	
		Z	3.53	71.24	19.06		150.0	
10180-CAD	LTE-FDD (SC-FDMA, 1 RB, 5 MHz, 64-QAM)	X	2.79	68.06	17.20	3.01	150.0	± 9.6 %
		Y	3.00	69.44	17.95		150.0	
		Z	3.23	69.37	17.80		150.0	
10181-CAC	LTE-FDD (SC-FDMA, 1 RB, 15 MHz, QPSK)	X	2.64	66.91	17.79	3.01	150.0	± 9.6 %
		Y	2.74	67.75	18.31		150.0	
		Z	2.93	68.01	18.31		150.0	
10182-CAC	LTE-FDD (SC-FDMA, 1 RB, 15 MHz, 16-QAM)	X	3.32	71.66	19.87	3.01	150.0	± 9.6 %
		Y	3.55	72.93	20.48		150.0	
		Z	3.85	73.13	20.44		150.0	
10183-AAB	LTE-FDD (SC-FDMA, 1 RB, 15 MHz, 64-QAM)	X	2.79	68.04	17.19	3.01	150.0	± 9.6 %
		Y	3.00	69.42	17.94		150.0	
		Z	3.22	69.35	17.79		150.0	

10184-CAD	LTE-FDD (SC-FDMA, 1 RB, 3 MHz, QPSK)	X	2.65	66.95	17.81	3.01	150.0	± 9.6 %
		Y	2.75	67.79	18.33		150.0	
		Z	2.95	68.05	18.33		150.0	
10185-CAD	LTE-FDD (SC-FDMA, 1 RB, 3 MHz, 16-QAM)	X	3.34	71.72	19.91	3.01	150.0	± 9.6 %
		Y	3.57	72.99	20.51		150.0	
		Z	3.87	73.20	20.48		150.0	
10186-AAD	LTE-FDD (SC-FDMA, 1 RB, 3 MHz, 64-QAM)	X	2.80	68.09	17.22	3.01	150.0	± 9.6 %
		Y	3.01	69.48	17.97		150.0	
		Z	3.23	69.41	17.82		150.0	
10187-CAD	LTE-FDD (SC-FDMA, 1 RB, 1.4 MHz, QPSK)	X	2.66	67.00	17.88	3.01	150.0	± 9.6 %
		Y	2.76	67.84	18.40		150.0	
		Z	2.95	68.09	18.39		150.0	
10188-CAD	LTE-FDD (SC-FDMA, 1 RB, 1.4 MHz, 16-QAM)	X	3.43	72.31	20.28	3.01	150.0	± 9.6 %
		Y	3.66	73.53	20.84		150.0	
		Z	4.00	73.86	20.87		150.0	
10189-AAD	LTE-FDD (SC-FDMA, 1 RB, 1.4 MHz, 64-QAM)	X	2.85	68.45	17.48	3.01	150.0	± 9.6 %
		Y	3.07	69.84	18.22		150.0	
		Z	3.30	69.81	18.09		150.0	
10193-CAB	IEEE 802.11n (HT Greenfield, 6.5 Mbps, BPSK)	X	4.48	66.73	16.24	0.00	150.0	± 9.6 %
		Y	4.49	66.78	16.30		150.0	
		Z	4.58	66.49	16.16		150.0	
10194-CAB	IEEE 802.11n (HT Greenfield, 39 Mbps, 16-QAM)	X	4.63	67.01	16.37	0.00	150.0	± 9.6 %
		Y	4.65	67.06	16.43		150.0	
		Z	4.76	66.82	16.28		150.0	
10195-CAB	IEEE 802.11n (HT Greenfield, 65 Mbps, 64-QAM)	X	4.67	67.04	16.38	0.00	150.0	± 9.6 %
		Y	4.69	67.09	16.44		150.0	
		Z	4.80	66.85	16.30		150.0	
10196-CAB	IEEE 802.11n (HT Mixed, 6.5 Mbps, BPSK)	X	4.47	66.77	16.24	0.00	150.0	± 9.6 %
		Y	4.48	66.82	16.30		150.0	
		Z	4.59	66.56	16.19		150.0	
10197-CAB	IEEE 802.11n (HT Mixed, 39 Mbps, 16-QAM)	X	4.64	67.02	16.38	0.00	150.0	± 9.6 %
		Y	4.66	67.08	16.44		150.0	
		Z	4.78	66.84	16.30		150.0	
10198-CAB	IEEE 802.11n (HT Mixed, 65 Mbps, 64-QAM)	X	4.67	67.05	16.39	0.00	150.0	± 9.6 %
		Y	4.68	67.10	16.45		150.0	
		Z	4.81	66.86	16.31		150.0	
10219-CAB	IEEE 802.11n (HT Mixed, 7.2 Mbps, BPSK)	X	4.42	66.79	16.21	0.00	150.0	± 9.6 %
		Y	4.44	66.84	16.27		150.0	
		Z	4.54	66.57	16.15		150.0	
10220-CAB	IEEE 802.11n (HT Mixed, 43.3 Mbps, 16-QAM)	X	4.64	66.99	16.36	0.00	150.0	± 9.6 %
		Y	4.65	67.04	16.42		150.0	
		Z	4.77	66.82	16.29		150.0	
10221-CAB	IEEE 802.11n (HT Mixed, 72.2 Mbps, 64-QAM)	X	4.68	66.98	16.38	0.00	150.0	± 9.6 %
		Y	4.69	67.03	16.44		150.0	
		Z	4.81	66.80	16.30		150.0	
10222-CAB	IEEE 802.11n (HT Mixed, 15 Mbps, BPSK)	X	5.03	67.11	16.49	0.00	150.0	± 9.6 %
		Y	5.04	67.15	16.55		150.0	
		Z	5.14	67.00	16.41		150.0	

10223-CAB	IEEE 802.11n (HT Mixed, 90 Mbps, 16-QAM)	X	5.33	67.33	16.62	0.00	150.0	± 9.6 %
		Y	5.34	67.38	16.68		150.0	
		Z	5.45	67.21	16.54		150.0	
10224-CAB	IEEE 802.11n (HT Mixed, 150 Mbps, 64-QAM)	X	5.07	67.22	16.48	0.00	150.0	± 9.6 %
		Y	5.09	67.26	16.53		150.0	
		Z	5.18	67.11	16.40		150.0	
10225-CAB	UMTS-FDD (HSPA+)	X	2.76	66.33	15.32	0.00	150.0	± 9.6 %
		Y	2.78	66.46	15.44		150.0	
		Z	2.85	65.93	15.34		150.0	
10226-CAA	LTE-TDD (SC-FDMA, 1 RB, 1.4 MHz, 16-QAM)	X	7.05	86.26	25.03	6.02	65.0	± 9.6 %
		Y	11.33	96.43	28.97		65.0	
		Z	13.18	96.17	28.66		65.0	
10227-CAA	LTE-TDD (SC-FDMA, 1 RB, 1.4 MHz, 64-QAM)	X	7.07	85.23	24.04	6.02	65.0	± 9.6 %
		Y	11.45	95.09	27.83		65.0	
		Z	12.76	94.16	27.40		65.0	
10228-CAA	LTE-TDD (SC-FDMA, 1 RB, 1.4 MHz, QPSK)	X	4.84	82.15	25.37	6.02	65.0	± 9.6 %
		Y	6.17	88.64	28.46		65.0	
		Z	7.76	90.12	28.51		65.0	
10229-CAB	LTE-TDD (SC-FDMA, 1 RB, 3 MHz, 16-QAM)	X	6.71	85.26	24.59	6.02	65.0	± 9.6 %
		Y	10.65	95.13	28.47		65.0	
		Z	12.36	94.84	28.14		65.0	
10230-CAB	LTE-TDD (SC-FDMA, 1 RB, 3 MHz, 64-QAM)	X	6.68	84.20	23.61	6.02	65.0	± 9.6 %
		Y	10.65	93.73	27.33		65.0	
		Z	11.94	92.89	26.92		65.0	
10231-CAB	LTE-TDD (SC-FDMA, 1 RB, 3 MHz, QPSK)	X	4.67	81.40	24.99	6.02	65.0	± 9.6 %
		Y	5.94	87.77	28.07		65.0	
		Z	7.43	89.17	28.10		65.0	
10232-CAC	LTE-TDD (SC-FDMA, 1 RB, 5 MHz, 16-QAM)	X	6.69	85.24	24.58	6.02	65.0	± 9.6 %
		Y	10.63	95.12	28.47		65.0	
		Z	12.34	94.82	28.14		65.0	
10233-CAC	LTE-TDD (SC-FDMA, 1 RB, 5 MHz, 64-QAM)	X	6.66	84.17	23.60	6.02	65.0	± 9.6 %
		Y	10.62	93.69	27.32		65.0	
		Z	11.91	92.86	26.91		65.0	
10234-CAC	LTE-TDD (SC-FDMA, 1 RB, 5 MHz, QPSK)	X	4.54	80.75	24.63	6.02	65.0	± 9.6 %
		Y	5.76	87.05	27.69		65.0	
		Z	7.17	88.32	27.68		65.0	
10235-CAC	LTE-TDD (SC-FDMA, 1 RB, 10 MHz, 16-QAM)	X	6.69	85.26	24.59	6.02	65.0	± 9.6 %
		Y	10.64	95.16	28.48		65.0	
		Z	12.35	94.85	28.15		65.0	
10236-CAC	LTE-TDD (SC-FDMA, 1 RB, 10 MHz, 64-QAM)	X	6.73	84.30	23.64	6.02	65.0	± 9.6 %
		Y	10.78	93.91	27.38		65.0	
		Z	12.05	93.03	26.96		65.0	
10237-CAC	LTE-TDD (SC-FDMA, 1 RB, 10 MHz, QPSK)	X	4.67	81.42	25.00	6.02	65.0	± 9.6 %
		Y	5.94	87.83	28.10		65.0	
		Z	7.43	89.21	28.12		65.0	
10238-CAC	LTE-TDD (SC-FDMA, 1 RB, 15 MHz, 16-QAM)	X	6.68	85.21	24.57	6.02	65.0	± 9.6 %
		Y	10.60	95.09	28.46		65.0	
		Z	12.31	94.79	28.13		65.0	

10239-CAC	LTE-TDD (SC-FDMA, 1 RB, 15 MHz, 64-QAM)	X	6.64	84.13	23.58	6.02	65.0	± 9.6 %
		Y	10.57	93.64	27.30		65.0	
		Z	11.87	92.82	26.90		65.0	
10240-CAC	LTE-TDD (SC-FDMA, 1 RB, 15 MHz, QPSK)	X	4.66	81.38	24.99	6.02	65.0	± 9.6 %
		Y	5.92	87.78	28.08		65.0	
		Z	7.41	89.16	28.10		65.0	
10241-CAA	LTE-TDD (SC-FDMA, 50% RB, 1.4 MHz, 16-QAM)	X	6.49	77.69	23.88	6.98	65.0	± 9.6 %
		Y	7.06	80.22	25.34		65.0	
		Z	7.33	78.75	24.61		65.0	
10242-CAA	LTE-TDD (SC-FDMA, 50% RB, 1.4 MHz, 64-QAM)	X	5.69	74.96	22.63	6.98	65.0	± 9.6 %
		Y	6.72	79.20	24.84		65.0	
		Z	6.48	76.10	23.39		65.0	
10243-CAA	LTE-TDD (SC-FDMA, 50% RB, 1.4 MHz, QPSK)	X	5.22	73.93	23.04	6.98	65.0	± 9.6 %
		Y	5.37	75.23	24.06		65.0	
		Z	5.30	72.76	22.72		65.0	
10244-CAB	LTE-TDD (SC-FDMA, 50% RB, 3 MHz, 16-QAM)	X	4.03	70.70	15.63	3.98	65.0	± 9.6 %
		Y	4.63	73.27	17.01		65.0	
		Z	5.80	76.12	19.17		65.0	
10245-CAB	LTE-TDD (SC-FDMA, 50% RB, 3 MHz, 64-QAM)	X	3.94	70.12	15.32	3.98	65.0	± 9.6 %
		Y	4.47	72.48	16.60		65.0	
		Z	5.67	75.49	18.85		65.0	
10246-CAB	LTE-TDD (SC-FDMA, 50% RB, 3 MHz, QPSK)	X	4.17	75.16	18.15	3.98	65.0	± 9.6 %
		Y	5.29	79.64	20.23		65.0	
		Z	5.81	80.17	21.10		65.0	
10247-CAC	LTE-TDD (SC-FDMA, 50% RB, 5 MHz, 16-QAM)	X	4.10	71.58	17.29	3.98	65.0	± 9.6 %
		Y	4.43	73.43	18.37		65.0	
		Z	4.92	74.07	19.21		65.0	
10248-CAC	LTE-TDD (SC-FDMA, 50% RB, 5 MHz, 64-QAM)	X	4.07	70.96	16.98	3.98	65.0	± 9.6 %
		Y	4.37	72.65	17.99		65.0	
		Z	4.90	73.42	18.88		65.0	
10249-CAC	LTE-TDD (SC-FDMA, 50% RB, 5 MHz, QPSK)	X	5.33	79.24	20.92	3.98	65.0	± 9.6 %
		Y	6.73	84.01	23.05		65.0	
		Z	6.62	82.34	22.76		65.0	
10250-CAC	LTE-TDD (SC-FDMA, 50% RB, 10 MHz, 16-QAM)	X	4.99	74.32	20.40	3.98	65.0	± 9.6 %
		Y	5.24	75.79	21.30		65.0	
		Z	5.59	75.60	21.35		65.0	
10251-CAC	LTE-TDD (SC-FDMA, 50% RB, 10 MHz, 64-QAM)	X	4.75	72.14	19.02	3.98	65.0	± 9.6 %
		Y	4.99	73.56	19.92		65.0	
		Z	5.35	73.44	20.02		65.0	
10252-CAC	LTE-TDD (SC-FDMA, 50% RB, 10 MHz, QPSK)	X	5.62	79.05	22.01	3.98	65.0	± 9.6 %
		Y	6.48	82.42	23.65		65.0	
		Z	6.49	80.72	22.96		65.0	
10253-CAC	LTE-TDD (SC-FDMA, 50% RB, 15 MHz, 16-QAM)	X	4.91	71.43	19.12	3.98	65.0	± 9.6 %
		Y	5.09	72.60	19.93		65.0	
		Z	5.40	72.41	19.86		65.0	
10254-CAC	LTE-TDD (SC-FDMA, 50% RB, 15 MHz, 64-QAM)	X	5.23	72.40	19.88	3.98	65.0	± 9.6 %
		Y	5.41	73.49	20.63		65.0	
		Z	5.73	73.30	20.57		65.0	

10255-CAC	LTE-TDD (SC-FDMA, 50% RB, 15 MHz, QPSK)	X	5.37	75.82	20.95	3.98	65.0	± 9.6 %
		Y	5.81	77.90	22.11		65.0	
		Z	5.98	76.90	21.60		65.0	
10256-CAA	LTE-TDD (SC-FDMA, 100% RB, 1.4 MHz, 16-QAM)	X	2.95	66.44	12.43	3.98	65.0	± 9.6 %
		Y	3.25	68.14	13.47		65.0	
		Z	4.63	72.57	16.66		65.0	
10257-CAA	LTE-TDD (SC-FDMA, 100% RB, 1.4 MHz, 64-QAM)	X	2.90	65.89	12.05	3.98	65.0	± 9.6 %
		Y	3.14	67.36	12.98		65.0	
		Z	4.49	71.73	16.18		65.0	
10258-CAA	LTE-TDD (SC-FDMA, 100% RB, 1.4 MHz, QPSK)	X	2.90	69.51	14.64	3.98	65.0	± 9.6 %
		Y	3.44	72.54	16.25		65.0	
		Z	4.52	75.89	18.60		65.0	
10259-CAB	LTE-TDD (SC-FDMA, 100% RB, 3 MHz, 16-QAM)	X	4.46	72.72	18.47	3.98	65.0	± 9.6 %
		Y	4.78	74.47	19.50		65.0	
		Z	5.19	74.62	19.97		65.0	
10260-CAB	LTE-TDD (SC-FDMA, 100% RB, 3 MHz, 64-QAM)	X	4.49	72.43	18.33	3.98	65.0	± 9.6 %
		Y	4.79	74.08	19.32		65.0	
		Z	5.22	74.34	19.84		65.0	
10261-CAB	LTE-TDD (SC-FDMA, 100% RB, 3 MHz, QPSK)	X	5.17	78.27	21.02	3.98	65.0	± 9.6 %
		Y	6.16	82.12	22.85		65.0	
		Z	6.14	80.53	22.44		65.0	
10262-CAC	LTE-TDD (SC-FDMA, 100% RB, 5 MHz, 16-QAM)	X	4.98	74.25	20.35	3.98	65.0	± 9.6 %
		Y	5.23	75.73	21.26		65.0	
		Z	5.58	75.55	21.31		65.0	
10263-CAC	LTE-TDD (SC-FDMA, 100% RB, 5 MHz, 64-QAM)	X	4.74	72.12	19.01	3.98	65.0	± 9.6 %
		Y	4.98	73.53	19.91		65.0	
		Z	5.34	73.42	20.01		65.0	
10264-CAC	LTE-TDD (SC-FDMA, 100% RB, 5 MHz, QPSK)	X	5.56	78.83	21.90	3.98	65.0	± 9.6 %
		Y	6.41	82.18	23.54		65.0	
		Z	6.42	80.51	22.86		65.0	
10265-CAC	LTE-TDD (SC-FDMA, 100% RB, 10 MHz, 16-QAM)	X	4.98	71.84	19.37	3.98	65.0	± 9.6 %
		Y	5.18	73.09	20.20		65.0	
		Z	5.53	73.00	20.12		65.0	
10266-CAC	LTE-TDD (SC-FDMA, 100% RB, 10 MHz, 64-QAM)	X	5.34	72.91	20.22	3.98	65.0	± 9.6 %
		Y	5.53	74.04	20.98		65.0	
		Z	5.88	73.92	20.89		65.0	
10267-CAC	LTE-TDD (SC-FDMA, 100% RB, 10 MHz, QPSK)	X	5.64	76.53	21.06	3.98	65.0	± 9.6 %
		Y	6.16	78.78	22.27		65.0	
		Z	6.34	77.78	21.72		65.0	
10268-CAC	LTE-TDD (SC-FDMA, 100% RB, 15 MHz, 16-QAM)	X	5.63	71.94	19.85	3.98	65.0	± 9.6 %
		Y	5.78	72.88	20.51		65.0	
		Z	6.14	72.88	20.41		65.0	
10269-CAC	LTE-TDD (SC-FDMA, 100% RB, 15 MHz, 64-QAM)	X	5.64	71.57	19.72	3.98	65.0	± 9.6 %
		Y	5.77	72.45	20.36		65.0	
		Z	6.12	72.44	20.27		65.0	
10270-CAC	LTE-TDD (SC-FDMA, 100% RB, 15 MHz, QPSK)	X	5.66	74.09	20.17	3.98	65.0	± 9.6 %
		Y	5.94	75.48	21.01		65.0	
		Z	6.22	75.05	20.69		65.0	

10274-CAB	UMTS-FDD (HSUPA, Subtest 5, 3GPP Rel8.10)	X	2.58	66.84	15.32	0.00	150.0	± 9.6 %
		Y	2.61	67.05	15.49		150.0	
		Z	2.61	66.19	15.19		150.0	
10275-CAB	UMTS-FDD (HSUPA, Subtest 5, 3GPP Rel8.4)	X	1.62	68.33	15.81	0.00	150.0	± 9.6 %
		Y	1.68	69.01	16.23		150.0	
		Z	1.61	67.33	15.34		150.0	
10277-CAA	PHS (QPSK)	X	1.71	60.26	5.85	9.03	50.0	± 9.6 %
		Y	1.46	60.00	5.35		50.0	
		Z	2.08	61.87	7.57		50.0	
10278-CAA	PHS (QPSK, BW 884MHz, Rolloff 0.5)	X	3.48	68.77	13.21	9.03	50.0	± 9.6 %
		Y	3.86	71.42	14.38		50.0	
		Z	7.61	81.06	19.61		50.0	
10279-CAA	PHS (QPSK, BW 884MHz, Rolloff 0.38)	X	3.59	69.09	13.42	9.03	50.0	± 9.6 %
		Y	4.03	71.88	14.65		50.0	
		Z	7.80	81.31	19.76		50.0	
10290-AAB	CDMA2000, RC1, SO55, Full Rate	X	1.38	68.75	13.54	0.00	150.0	± 9.6 %
		Y	1.49	69.81	14.11		150.0	
		Z	1.48	68.40	14.11		150.0	
10291-AAB	CDMA2000, RC3, SO55, Full Rate	X	0.81	66.18	12.25	0.00	150.0	± 9.6 %
		Y	0.88	67.15	12.85		150.0	
		Z	0.85	65.51	12.62		150.0	
10292-AAB	CDMA2000, RC3, SO32, Full Rate	X	1.25	72.63	15.60	0.00	150.0	± 9.6 %
		Y	1.48	75.02	16.70		150.0	
		Z	1.05	69.24	14.85		150.0	
10293-AAB	CDMA2000, RC3, SO3, Full Rate	X	3.55	87.18	21.36	0.00	150.0	± 9.6 %
		Y	4.57	90.90	22.67		150.0	
		Z	1.55	74.98	17.80		150.0	
10295-AAB	CDMA2000, RC1, SO3, 1/8th Rate 25 fr.	X	10.90	87.79	24.10	9.03	50.0	± 9.6 %
		Y	17.38	97.96	27.91		50.0	
		Z	9.27	86.92	25.25		50.0	
10297-AAB	LTE-FDD (SC-FDMA, 50% RB, 20 MHz, QPSK)	X	2.71	69.84	16.83	0.00	150.0	± 9.6 %
		Y	2.77	70.21	17.06		150.0	
		Z	2.77	69.29	16.46		150.0	
10298-AAC	LTE-FDD (SC-FDMA, 50% RB, 3 MHz, QPSK)	X	1.47	67.49	13.62	0.00	150.0	± 9.6 %
		Y	1.54	68.13	14.02		150.0	
		Z	1.61	67.49	14.26		150.0	
10299-AAC	LTE-FDD (SC-FDMA, 50% RB, 3 MHz, 16-QAM)	X	1.91	66.04	11.93	0.00	150.0	± 9.6 %
		Y	2.08	67.06	12.49		150.0	
		Z	2.55	68.88	14.29		150.0	
10300-AAC	LTE-FDD (SC-FDMA, 50% RB, 3 MHz, 64-QAM)	X	1.52	62.84	9.56	0.00	150.0	± 9.6 %
		Y	1.60	63.32	9.89		150.0	
		Z	2.01	64.97	11.67		150.0	
10301-AAA	IEEE 802.16e WiMAX (29:18, 5ms, 10MHz, QPSK, PUSC)	X	4.49	64.94	17.15	4.17	50.0	± 9.6 %
		Y	4.51	65.12	17.33		50.0	
		Z	4.77	65.09	17.35		50.0	
10302-AAA	IEEE 802.16e WiMAX (29:18, 5ms, 10MHz, QPSK, PUSC, 3 CTRL symbols)	X	4.98	65.58	17.87	4.96	50.0	± 9.6 %
		Y	5.02	65.83	18.08		50.0	
		Z	5.23	65.61	18.00		50.0	

10303-AAA	IEEE 802.16e WiMAX (31:15, 5ms, 10MHz, 64QAM, PUSC)	X	4.72	65.17	17.66	4.96	50.0	± 9.6 %
		Y	4.76	65.39	17.86		50.0	
		Z	4.98	65.24	17.83		50.0	
10304-AAA	IEEE 802.16e WiMAX (29:18, 5ms, 10MHz, 64QAM, PUSC)	X	4.56	65.16	17.23	4.17	50.0	± 9.6 %
		Y	4.60	65.38	17.42		50.0	
		Z	4.79	65.14	17.34		50.0	
10305-AAA	IEEE 802.16e WiMAX (31:15, 10ms, 10MHz, 64QAM, PUSC, 15 symbols)	X	4.06	66.26	18.68	6.02	35.0	± 9.6 %
		Y	3.98	66.05	18.73		35.0	
		Z	4.32	66.47	19.19		35.0	
10306-AAA	IEEE 802.16e WiMAX (29:18, 10ms, 10MHz, 64QAM, PUSC, 18 symbols)	X	4.43	65.65	18.52	6.02	35.0	± 9.6 %
		Y	4.40	65.62	18.63		35.0	
		Z	4.69	65.80	18.88		35.0	
10307-AAA	IEEE 802.16e WiMAX (29:18, 10ms, 10MHz, QPSK, PUSC, 18 symbols)	X	4.31	65.69	18.43	6.02	35.0	± 9.6 %
		Y	4.27	65.62	18.52		35.0	
		Z	4.59	65.95	18.85		35.0	
10308-AAA	IEEE 802.16e WiMAX (29:18, 10ms, 10MHz, 16QAM, PUSC)	X	4.28	65.86	18.56	6.02	35.0	± 9.6 %
		Y	4.24	65.78	18.65		35.0	
		Z	4.55	66.08	18.95		35.0	
10309-AAA	IEEE 802.16e WiMAX (29:18, 10ms, 10MHz, 16QAM, AMC 2x3, 18 symbols)	X	4.47	65.79	18.63	6.02	35.0	± 9.6 %
		Y	4.44	65.78	18.76		35.0	
		Z	4.75	66.03	19.03		35.0	
10310-AAA	IEEE 802.16e WiMAX (29:18, 10ms, 10MHz, QPSK, AMC 2x3, 18 symbols)	X	4.38	65.69	18.49	6.02	35.0	± 9.6 %
		Y	4.34	65.63	18.59		35.0	
		Z	4.64	65.84	18.85		35.0	
10311-AAB	LTE-FDD (SC-FDMA, 100% RB, 15 MHz, QPSK)	X	3.08	69.08	16.47	0.00	150.0	± 9.6 %
		Y	3.14	69.40	16.66		150.0	
		Z	3.12	68.62	16.13		150.0	
10313-AAA	iDEN 1:3	X	2.89	72.65	16.29	6.99	70.0	± 9.6 %
		Y	4.19	78.79	18.89		70.0	
		Z	4.02	76.71	18.18		70.0	
10314-AAA	iDEN 1:6	X	5.30	83.78	23.47	10.00	30.0	± 9.6 %
		Y	6.55	89.94	26.15		30.0	
		Z	6.97	88.50	25.50		30.0	
10315-AAB	IEEE 802.11b WiFi 2.4 GHz (DSSS, 1 Mbps, 96pc duty cycle)	X	1.08	63.77	15.30	0.17	150.0	± 9.6 %
		Y	1.10	64.11	15.62		150.0	
		Z	1.08	63.32	14.99		150.0	
10316-AAB	IEEE 802.11g WiFi 2.4 GHz (ERP-OFDM, 6 Mbps, 96pc duty cycle)	X	4.51	66.68	16.32	0.17	150.0	± 9.6 %
		Y	4.53	66.78	16.42		150.0	
		Z	4.64	66.54	16.30		150.0	
10317-AAB	IEEE 802.11a WiFi 5 GHz (OFDM, 6 Mbps, 96pc duty cycle)	X	4.51	66.68	16.32	0.17	150.0	± 9.6 %
		Y	4.53	66.78	16.42		150.0	
		Z	4.64	66.54	16.30		150.0	
10400-AAC	IEEE 802.11ac WiFi (20MHz, 64-QAM, 99pc duty cycle)	X	4.61	67.03	16.35	0.00	150.0	± 9.6 %
		Y	4.63	67.11	16.42		150.0	
		Z	4.76	66.86	16.27		150.0	
10401-AAC	IEEE 802.11ac WiFi (40MHz, 64-QAM, 99pc duty cycle)	X	5.34	67.18	16.51	0.00	150.0	± 9.6 %
		Y	5.36	67.26	16.59		150.0	
		Z	5.46	67.09	16.45		150.0	



10402-AAC	IEEE 802.11ac WiFi (80MHz, 64-QAM, 99pc duty cycle)	X	5.59	67.45	16.52	0.00	150.0	± 9.6 %
		Y	5.60	67.49	16.57		150.0	
		Z	5.71	67.42	16.48		150.0	
10403-AAB	CDMA2000 (1xEV-DO, Rev. 0)	X	1.38	68.75	13.54	0.00	115.0	± 9.6 %
		Y	1.49	69.81	14.11		115.0	
		Z	1.48	68.40	14.11		115.0	
10404-AAB	CDMA2000 (1xEV-DO, Rev. A)	X	1.38	68.75	13.54	0.00	115.0	± 9.6 %
		Y	1.49	69.81	14.11		115.0	
		Z	1.48	68.40	14.11		115.0	
10406-AAB	CDMA2000, RC3, SO32, SCH0, Full Rate	X	17.35	99.43	24.90	0.00	100.0	± 9.6 %
		Y	63.25	115.82	28.80		100.0	
		Z	11.61	93.88	24.12		100.0	
10410-AAB	LTE-TDD (SC-FDMA, 1 RB, 10 MHz, QPSK, UL Subframe=2,3,4,7,8,9)	X	8.36	91.25	22.62	3.23	80.0	± 9.6 %
		Y	100.00	127.16	32.13		80.0	
		Z	100.00	125.70	32.09		80.0	
10415-AAA	IEEE 802.11b WiFi 2.4 GHz (DSSS, 1 Mbps, 99pc duty cycle)	X	1.03	63.22	14.88	0.00	150.0	± 9.6 %
		Y	1.04	63.49	15.13		150.0	
		Z	1.02	62.64	14.46		150.0	
10416-AAA	IEEE 802.11g WiFi 2.4 GHz (ERP-OFDM, 6 Mbps, 99pc duty cycle)	X	4.48	66.75	16.31	0.00	150.0	± 9.6 %
		Y	4.49	66.81	16.37		150.0	
		Z	4.59	66.53	16.22		150.0	
10417-AAA	IEEE 802.11a/h WiFi 5 GHz (OFDM, 6 Mbps, 99pc duty cycle)	X	4.48	66.75	16.31	0.00	150.0	± 9.6 %
		Y	4.49	66.81	16.37		150.0	
		Z	4.59	66.53	16.22		150.0	
10418-AAA	IEEE 802.11g WiFi 2.4 GHz (DSSS-OFDM, 6 Mbps, 99pc duty cycle, Long preamble)	X	4.47	66.94	16.35	0.00	150.0	± 9.6 %
		Y	4.48	67.00	16.41		150.0	
		Z	4.58	66.68	16.24		150.0	
10419-AAA	IEEE 802.11g WiFi 2.4 GHz (DSSS-OFDM, 6 Mbps, 99pc duty cycle, Short preamble)	X	4.49	66.88	16.34	0.00	150.0	± 9.6 %
		Y	4.50	66.93	16.40		150.0	
		Z	4.60	66.63	16.24		150.0	
10422-AAA	IEEE 802.11n (HT Greenfield, 7.2 Mbps, BPSK)	X	4.60	66.86	16.35	0.00	150.0	± 9.6 %
		Y	4.61	66.91	16.41		150.0	
		Z	4.72	66.64	16.26		150.0	
10423-AAA	IEEE 802.11n (HT Greenfield, 43.3 Mbps, 16-QAM)	X	4.74	67.14	16.45	0.00	150.0	± 9.6 %
		Y	4.76	67.20	16.51		150.0	
		Z	4.89	66.97	16.38		150.0	
10424-AAA	IEEE 802.11n (HT Greenfield, 72.2 Mbps, 64-QAM)	X	4.67	67.10	16.43	0.00	150.0	± 9.6 %
		Y	4.68	67.15	16.49		150.0	
		Z	4.81	66.91	16.35		150.0	
10425-AAA	IEEE 802.11n (HT Greenfield, 15 Mbps, BPSK)	X	5.29	67.34	16.60	0.00	150.0	± 9.6 %
		Y	5.30	67.39	16.66		150.0	
		Z	5.42	67.29	16.55		150.0	
10426-AAA	IEEE 802.11n (HT Greenfield, 90 Mbps, 16-QAM)	X	5.31	67.43	16.64	0.00	150.0	± 9.6 %
		Y	5.32	67.48	16.70		150.0	
		Z	5.43	67.30	16.56		150.0	

10427-AAA	IEEE 802.11n (HT Greenfield, 150 Mbps, 64-QAM)	X	5.30	67.32	16.58	0.00	150.0	± 9.6 %
		Y	5.31	67.37	16.64		150.0	
		Z	5.44	67.28	16.54		150.0	
10430-AAA	LTE-FDD (OFDMA, 5 MHz, E-TM 3.1)	X	4.41	72.30	18.78	0.00	150.0	± 9.6 %
		Y	4.28	71.61	18.44		150.0	
		Z	4.35	70.84	18.35		150.0	
10431-AAA	LTE-FDD (OFDMA, 10 MHz, E-TM 3.1)	X	4.12	67.35	16.27	0.00	150.0	± 9.6 %
		Y	4.14	67.43	16.34		150.0	
		Z	4.27	67.06	16.22		150.0	
10432-AAA	LTE-FDD (OFDMA, 15 MHz, E-TM 3.1)	X	4.43	67.18	16.37	0.00	150.0	± 9.6 %
		Y	4.45	67.24	16.44		150.0	
		Z	4.58	66.95	16.29		150.0	
10433-AAA	LTE-FDD (OFDMA, 20 MHz, E-TM 3.1)	X	4.69	67.13	16.45	0.00	150.0	± 9.6 %
		Y	4.70	67.18	16.51		150.0	
		Z	4.82	66.95	16.37		150.0	
10434-AAA	W-CDMA (BS Test Model 1, 64 DPCH)	X	4.58	73.43	18.77	0.00	150.0	± 9.6 %
		Y	4.41	72.61	18.39		150.0	
		Z	4.46	71.72	18.35		150.0	
10435-AAB	LTE-TDD (SC-FDMA, 1 RB, 20 MHz, QPSK, UL Subframe=2,3,4,7,8,9)	X	7.84	90.24	22.26	3.23	80.0	± 9.6 %
		Y	100.00	126.90	32.00		80.0	
		Z	100.00	125.48	31.98		80.0	
10447-AAA	LTE-FDD (OFDMA, 5 MHz, E-TM 3.1, Clipping 44%)	X	3.40	67.35	15.41	0.00	150.0	± 9.6 %
		Y	3.42	67.47	15.52		150.0	
		Z	3.56	67.03	15.56		150.0	
10448-AAA	LTE-FDD (OFDMA, 10 MHz, E-TM 3.1, Clipping 44%)	X	3.98	67.14	16.14	0.00	150.0	± 9.6 %
		Y	4.00	67.22	16.21		150.0	
		Z	4.11	66.83	16.08		150.0	
10449-AAA	LTE-FDD (OFDMA, 15 MHz, E-TM 3.1, Clipping 44%)	X	4.26	67.02	16.27	0.00	150.0	± 9.6 %
		Y	4.28	67.08	16.34		150.0	
		Z	4.38	66.77	16.19		150.0	
10450-AAA	LTE-FDD (OFDMA, 20 MHz, E-TM 3.1, Clipping 44%)	X	4.47	66.91	16.31	0.00	150.0	± 9.6 %
		Y	4.48	66.96	16.37		150.0	
		Z	4.58	66.71	16.22		150.0	
10451-AAA	W-CDMA (BS Test Model 1, 64 DPCH, Clipping 44%)	X	3.25	67.38	14.88	0.00	150.0	± 9.6 %
		Y	3.28	67.53	15.01		150.0	
		Z	3.46	67.22	15.21		150.0	
10456-AAA	IEEE 802.11ac WiFi (160MHz, 64-QAM, 99pc duty cycle)	X	6.22	67.99	16.81	0.00	150.0	± 9.6 %
		Y	6.22	68.02	16.86		150.0	
		Z	6.28	67.84	16.71		150.0	
10457-AAA	UMTS-FDD (DC-HSDPA)	X	3.78	65.43	16.02	0.00	150.0	± 9.6 %
		Y	3.79	65.48	16.08		150.0	
		Z	3.83	65.16	15.92		150.0	
10458-AAA	CDMA2000 (1xEV-DO, Rev. B, 2 carriers)	X	3.02	66.44	14.01	0.00	150.0	± 9.6 %
		Y	3.06	66.64	14.18		150.0	
		Z	3.28	66.54	14.63		150.0	
10459-AAA	CDMA2000 (1xEV-DO, Rev. B, 3 carriers)	X	4.18	65.23	15.36	0.00	150.0	± 9.6 %
		Y	4.18	65.21	15.41		150.0	
		Z	4.47	65.25	15.75		150.0	

10460-AAA	UMTS-FDD (WCDMA, AMR)	X	0.93	68.87	16.62	0.00	150.0	± 9.6 %
		Y	1.00	70.16	17.38		150.0	
		Z	0.88	67.06	15.60		150.0	
10461-AAA	LTE-TDD (SC-FDMA, 1 RB, 1.4 MHz, QPSK, UL Subframe=2,3,4,7,8,9)	X	4.32	84.19	21.37	3.29	80.0	± 9.6 %
		Y	46.98	120.39	31.74		80.0	
		Z	70.92	123.84	32.55		80.0	
10462-AAA	LTE-TDD (SC-FDMA, 1 RB, 1.4 MHz, 16-QAM, UL Subframe=2,3,4,7,8,9)	X	0.93	61.17	8.92	3.23	80.0	± 9.6 %
		Y	1.50	66.22	11.48		80.0	
		Z	4.18	75.74	15.77		80.0	
10463-AAA	LTE-TDD (SC-FDMA, 1 RB, 1.4 MHz, 64-QAM, UL Subframe=2,3,4,7,8,9)	X	0.83	60.00	7.74	3.23	80.0	± 9.6 %
		Y	0.90	60.95	8.47		80.0	
		Z	1.89	66.55	11.77		80.0	
10464-AAA	LTE-TDD (SC-FDMA, 1 RB, 3 MHz, QPSK, UL Subframe=2,3,4,7,8,9)	X	3.27	79.79	19.27	3.23	80.0	± 9.6 %
		Y	44.63	117.13	30.10		80.0	
		Z	63.16	119.86	30.88		80.0	
10465-AAA	LTE-TDD (SC-FDMA, 1 RB, 3 MHz, 16-QAM, UL Subframe=2,3,4,7,8,9)	X	0.88	60.65	8.58	3.23	80.0	± 9.6 %
		Y	1.28	64.64	10.73		80.0	
		Z	2.98	72.01	14.38		80.0	
10466-AAA	LTE-TDD (SC-FDMA, 1 RB, 3 MHz, 64-QAM, UL Subframe=2,3,4,7,8,9)	X	0.83	60.00	7.69	3.23	80.0	± 9.6 %
		Y	0.85	60.44	8.16		80.0	
		Z	1.66	65.17	11.12		80.0	
10467-AAB	LTE-TDD (SC-FDMA, 1 RB, 5 MHz, QPSK, UL Subframe=2,3,4,7,8,9)	X	3.54	80.96	19.70	3.23	80.0	± 9.6 %
		Y	60.93	121.68	31.18		80.0	
		Z	84.88	124.19	31.89		80.0	
10468-AAB	LTE-TDD (SC-FDMA, 1 RB, 5 MHz, 16-QAM, UL Subframe=2,3,4,7,8,9)	X	0.89	60.80	8.68	3.23	80.0	± 9.6 %
		Y	1.33	65.06	10.94		80.0	
		Z	3.21	72.86	14.71		80.0	
10469-AAB	LTE-TDD (SC-FDMA, 1 RB, 5 MHz, 64-QAM, UL Subframe=2,3,4,7,8,9)	X	0.83	60.00	7.69	3.23	80.0	± 9.6 %
		Y	0.85	60.46	8.17		80.0	
		Z	1.66	65.20	11.14		80.0	
10470-AAB	LTE-TDD (SC-FDMA, 1 RB, 10 MHz, QPSK, UL Subframe=2,3,4,7,8,9)	X	3.54	80.99	19.71	3.23	80.0	± 9.6 %
		Y	63.11	122.20	31.29		80.0	
		Z	86.48	124.48	31.95		80.0	
10471-AAB	LTE-TDD (SC-FDMA, 1 RB, 10 MHz, 16-QAM, UL Subframe=2,3,4,7,8,9)	X	0.88	60.76	8.65	3.23	80.0	± 9.6 %
		Y	1.32	64.98	10.89		80.0	
		Z	3.18	72.76	14.66		80.0	
10472-AAB	LTE-TDD (SC-FDMA, 1 RB, 10 MHz, 64-QAM, UL Subframe=2,3,4,7,8,9)	X	0.83	60.00	7.68	3.23	80.0	± 9.6 %
		Y	0.84	60.42	8.13		80.0	
		Z	1.65	65.15	11.10		80.0	
10473-AAB	LTE-TDD (SC-FDMA, 1 RB, 15 MHz, QPSK, UL Subframe=2,3,4,7,8,9)	X	3.52	80.93	19.68	3.23	80.0	± 9.6 %
		Y	62.71	122.07	31.26		80.0	
		Z	85.93	124.36	31.91		80.0	
10474-AAB	LTE-TDD (SC-FDMA, 1 RB, 15 MHz, 16-QAM, UL Subframe=2,3,4,7,8,9)	X	0.88	60.74	8.64	3.23	80.0	± 9.6 %
		Y	1.31	64.94	10.87		80.0	
		Z	3.15	72.67	14.63		80.0	
10475-AAB	LTE-TDD (SC-FDMA, 1 RB, 15 MHz, 64-QAM, UL Subframe=2,3,4,7,8,9)	X	0.83	60.00	7.68	3.23	80.0	± 9.6 %
		Y	0.84	60.40	8.12		80.0	
		Z	1.64	65.11	11.08		80.0	

10477-AAB	LTE-TDD (SC-FDMA, 1 RB, 20 MHz, 16-QAM, UL Subframe=2,3,4,7,8,9)	X	0.87	60.61	8.55	3.23	80.0	± 9.6 %
		Y	1.27	64.59	10.69		80.0	
		Z	2.97	71.99	14.36		80.0	
10478-AAB	LTE-TDD (SC-FDMA, 1 RB, 20 MHz, 64-QAM, UL Subframe=2,3,4,7,8,9)	X	0.83	60.00	7.67	3.23	80.0	± 9.6 %
		Y	0.84	60.37	8.09		80.0	
		Z	1.63	65.04	11.04		80.0	
10479-AAA	LTE-TDD (SC-FDMA, 50% RB, 1.4 MHz, QPSK, UL Subframe=2,3,4,7,8,9)	X	4.53	79.52	20.39	3.23	80.0	± 9.6 %
		Y	7.80	88.47	23.78		80.0	
		Z	5.78	82.49	22.28		80.0	
10480-AAA	LTE-TDD (SC-FDMA, 50% RB, 1.4 MHz, 16-QAM, UL Subframe=2,3,4,7,8,9)	X	3.53	72.09	15.68	3.23	80.0	± 9.6 %
		Y	6.36	79.96	18.76		80.0	
		Z	6.52	79.72	19.55		80.0	
10481-AAA	LTE-TDD (SC-FDMA, 50% RB, 1.4 MHz, 64-QAM, UL Subframe=2,3,4,7,8,9)	X	2.81	68.83	13.98	3.23	80.0	± 9.6 %
		Y	4.53	74.98	16.60		80.0	
		Z	5.48	76.73	18.13		80.0	
10482-AAA	LTE-TDD (SC-FDMA, 50% RB, 3 MHz, QPSK, UL Subframe=2,3,4,7,8,9)	X	2.20	68.90	15.09	2.23	80.0	± 9.6 %
		Y	2.93	73.22	17.16		80.0	
		Z	2.97	72.34	17.43		80.0	
10483-AAA	LTE-TDD (SC-FDMA, 50% RB, 3 MHz, 16-QAM, UL Subframe=2,3,4,7,8,9)	X	2.35	65.97	12.90	2.23	80.0	± 9.6 %
		Y	3.02	69.40	14.64		80.0	
		Z	4.23	73.30	17.24		80.0	
10484-AAA	LTE-TDD (SC-FDMA, 50% RB, 3 MHz, 64-QAM, UL Subframe=2,3,4,7,8,9)	X	2.28	65.32	12.60	2.23	80.0	± 9.6 %
		Y	2.83	68.32	14.18		80.0	
		Z	3.99	72.23	16.81		80.0	
10485-AAB	LTE-TDD (SC-FDMA, 50% RB, 5 MHz, QPSK, UL Subframe=2,3,4,7,8,9)	X	2.68	71.36	17.35	2.23	80.0	± 9.6 %
		Y	3.27	74.89	19.08		80.0	
		Z	3.17	72.95	18.56		80.0	
10486-AAB	LTE-TDD (SC-FDMA, 50% RB, 5 MHz, 16-QAM, UL Subframe=2,3,4,7,8,9)	X	2.64	67.61	15.00	2.23	80.0	± 9.6 %
		Y	2.99	69.69	16.14		80.0	
		Z	3.15	69.34	16.51		80.0	
10487-AAB	LTE-TDD (SC-FDMA, 50% RB, 5 MHz, 64-QAM, UL Subframe=2,3,4,7,8,9)	X	2.64	67.21	14.79	2.23	80.0	± 9.6 %
		Y	2.96	69.13	15.87		80.0	
		Z	3.15	68.96	16.33		80.0	
10488-AAB	LTE-TDD (SC-FDMA, 50% RB, 10 MHz, QPSK, UL Subframe=2,3,4,7,8,9)	X	3.00	70.76	18.02	2.23	80.0	± 9.6 %
		Y	3.34	72.92	19.20		80.0	
		Z	3.42	71.88	18.69		80.0	
10489-AAB	LTE-TDD (SC-FDMA, 50% RB, 10 MHz, 16-QAM, UL Subframe=2,3,4,7,8,9)	X	3.07	67.95	16.69	2.23	80.0	± 9.6 %
		Y	3.24	69.09	17.42		80.0	
		Z	3.37	68.53	17.27		80.0	
10490-AAB	LTE-TDD (SC-FDMA, 50% RB, 10 MHz, 64-QAM, UL Subframe=2,3,4,7,8,9)	X	3.16	67.82	16.63	2.23	80.0	± 9.6 %
		Y	3.32	68.90	17.33		80.0	
		Z	3.47	68.38	17.21		80.0	
10491-AAB	LTE-TDD (SC-FDMA, 50% RB, 15 MHz, QPSK, UL Subframe=2,3,4,7,8,9)	X	3.29	69.57	17.67	2.23	80.0	± 9.6 %
		Y	3.53	71.04	18.54		80.0	
		Z	3.67	70.46	18.17		80.0	
10492-AAB	LTE-TDD (SC-FDMA, 50% RB, 15 MHz, 16-QAM, UL Subframe=2,3,4,7,8,9)	X	3.43	67.31	16.78	2.23	80.0	± 9.6 %
		Y	3.55	68.11	17.34		80.0	
		Z	3.72	67.80	17.20		80.0	

10493-AAB	LTE-TDD (SC-FDMA, 50% RB, 15 MHz, 64-QAM, UL Subframe=2,3,4,7,8,9)	X	3.50	67.21	16.74	2.23	80.0	± 9.6 %
		Y	3.62	67.97	17.27		80.0	
		Z	3.79	67.69	17.16		80.0	
10494-AAB	LTE-TDD (SC-FDMA, 50% RB, 20 MHz, QPSK, UL Subframe=2,3,4,7,8,9)	X	3.52	70.87	18.10	2.23	80.0	± 9.6 %
		Y	3.84	72.64	19.08		80.0	
		Z	3.98	72.03	18.67		80.0	
10495-AAB	LTE-TDD (SC-FDMA, 50% RB, 20 MHz, 16-QAM, UL Subframe=2,3,4,7,8,9)	X	3.45	67.59	16.97	2.23	80.0	± 9.6 %
		Y	3.58	68.42	17.54		80.0	
		Z	3.75	68.20	17.40		80.0	
10496-AAB	LTE-TDD (SC-FDMA, 50% RB, 20 MHz, 64-QAM, UL Subframe=2,3,4,7,8,9)	X	3.54	67.39	16.91	2.23	80.0	± 9.6 %
		Y	3.65	68.15	17.44		80.0	
		Z	3.83	67.94	17.32		80.0	
10497-AAA	LTE-TDD (SC-FDMA, 100% RB, 1.4 MHz, QPSK, UL Subframe=2,3,4,7,8,9)	X	1.43	63.58	11.40	2.23	80.0	± 9.6 %
		Y	1.80	66.67	13.09		80.0	
		Z	2.27	68.74	14.99		80.0	
10498-AAA	LTE-TDD (SC-FDMA, 100% RB, 1.4 MHz, 16-QAM, UL Subframe=2,3,4,7,8,9)	X	1.24	60.00	8.33	2.23	80.0	± 9.6 %
		Y	1.23	60.00	8.51		80.0	
		Z	1.81	63.14	11.27		80.0	
10499-AAA	LTE-TDD (SC-FDMA, 100% RB, 1.4 MHz, 64-QAM, UL Subframe=2,3,4,7,8,9)	X	1.26	60.00	8.18	2.23	80.0	± 9.6 %
		Y	1.24	60.00	8.34		80.0	
		Z	1.76	62.56	10.83		80.0	
10500-AAA	LTE-TDD (SC-FDMA, 100% RB, 3 MHz, QPSK, UL Subframe=2,3,4,7,8,9)	X	2.78	70.93	17.56	2.23	80.0	± 9.6 %
		Y	3.23	73.75	19.01		80.0	
		Z	3.21	72.13	18.47		80.0	
10501-AAA	LTE-TDD (SC-FDMA, 100% RB, 3 MHz, 16-QAM, UL Subframe=2,3,4,7,8,9)	X	2.86	67.97	15.75	2.23	80.0	± 9.6 %
		Y	3.13	69.65	16.71		80.0	
		Z	3.25	69.01	16.80		80.0	
10502-AAA	LTE-TDD (SC-FDMA, 100% RB, 3 MHz, 64-QAM, UL Subframe=2,3,4,7,8,9)	X	2.90	67.83	15.61	2.23	80.0	± 9.6 %
		Y	3.18	69.45	16.55		80.0	
		Z	3.31	68.90	16.69		80.0	
10503-AAB	LTE-TDD (SC-FDMA, 100% RB, 5 MHz, QPSK, UL Subframe=2,3,4,7,8,9)	X	2.96	70.56	17.92	2.23	80.0	± 9.6 %
		Y	3.29	72.71	19.10		80.0	
		Z	3.38	71.68	18.59		80.0	
10504-AAB	LTE-TDD (SC-FDMA, 100% RB, 5 MHz, 16-QAM, UL Subframe=2,3,4,7,8,9)	X	3.05	67.84	16.62	2.23	80.0	± 9.6 %
		Y	3.22	69.00	17.36		80.0	
		Z	3.35	68.44	17.21		80.0	
10505-AAB	LTE-TDD (SC-FDMA, 100% RB, 5 MHz, 64-QAM, UL Subframe=2,3,4,7,8,9)	X	3.14	67.73	16.57	2.23	80.0	± 9.6 %
		Y	3.31	68.81	17.27		80.0	
		Z	3.45	68.28	17.16		80.0	
10506-AAB	LTE-TDD (SC-FDMA, 100% RB, 10 MHz, QPSK, UL Subframe=2,3,4,7,8,9)	X	3.49	70.73	18.03	2.23	80.0	± 9.6 %
		Y	3.81	72.49	19.00		80.0	
		Z	3.95	71.88	18.59		80.0	
10507-AAB	LTE-TDD (SC-FDMA, 100% RB, 10 MHz, 16-QAM, UL Subframe=2,3,4,7,8,9)	X	3.44	67.53	16.93	2.23	80.0	± 9.6 %
		Y	3.56	68.36	17.50		80.0	
		Z	3.73	68.13	17.36		80.0	

10508-AAB	LTE-TDD (SC-FDMA, 100% RB, 10 MHz, 64-QAM, UL Subframe=2,3,4,7,8,9)	X	3.53	67.32	16.87	2.23	80.0	± 9.6 %
		Y	3.64	68.08	17.40		80.0	
		Z	3.82	67.87	17.27		80.0	
10509-AAB	LTE-TDD (SC-FDMA, 100% RB, 15 MHz, QPSK, UL Subframe=2,3,4,7,8,9)	X	3.90	69.82	17.65	2.23	80.0	± 9.6 %
		Y	4.14	71.06	18.38		80.0	
		Z	4.30	70.72	18.09		80.0	
10510-AAB	LTE-TDD (SC-FDMA, 100% RB, 15 MHz, 16-QAM, UL Subframe=2,3,4,7,8,9)	X	3.92	67.34	16.97	2.23	80.0	± 9.6 %
		Y	4.03	67.99	17.44		80.0	
		Z	4.22	67.93	17.34		80.0	
10511-AAB	LTE-TDD (SC-FDMA, 100% RB, 15 MHz, 64-QAM, UL Subframe=2,3,4,7,8,9)	X	3.99	67.15	16.93	2.23	80.0	± 9.6 %
		Y	4.09	67.75	17.36		80.0	
		Z	4.28	67.68	17.27		80.0	
10512-AAB	LTE-TDD (SC-FDMA, 100% RB, 20 MHz, QPSK, UL Subframe=2,3,4,7,8,9)	X	4.00	71.09	18.05	2.23	80.0	± 9.6 %
		Y	4.33	72.71	18.93		80.0	
		Z	4.49	72.31	18.60		80.0	
10513-AAB	LTE-TDD (SC-FDMA, 100% RB, 20 MHz, 16-QAM, UL Subframe=2,3,4,7,8,9)	X	3.80	67.50	17.05	2.23	80.0	± 9.6 %
		Y	3.92	68.21	17.54		80.0	
		Z	4.11	68.20	17.45		80.0	
10514-AAB	LTE-TDD (SC-FDMA, 100% RB, 20 MHz, 64-QAM, UL Subframe=2,3,4,7,8,9)	X	3.85	67.16	16.95	2.23	80.0	± 9.6 %
		Y	3.95	67.80	17.41		80.0	
		Z	4.13	67.78	17.32		80.0	
10515-AAA	IEEE 802.11b WiFi 2.4 GHz (DSSS, 2 Mbps, 99pc duty cycle)	X	0.99	63.41	14.95	0.00	150.0	± 9.6 %
		Y	1.00	63.71	15.22		150.0	
		Z	0.98	62.80	14.50		150.0	
10516-AAA	IEEE 802.11b WiFi 2.4 GHz (DSSS, 5.5 Mbps, 99pc duty cycle)	X	0.63	71.18	17.99	0.00	150.0	± 9.6 %
		Y	0.75	74.25	19.60		150.0	
		Z	0.56	68.07	16.15		150.0	
10517-AAA	IEEE 802.11b WiFi 2.4 GHz (DSSS, 11 Mbps, 99pc duty cycle)	X	0.84	65.39	15.66	0.00	150.0	± 9.6 %
		Y	0.87	66.03	16.14		150.0	
		Z	0.82	64.43	14.97		150.0	
10518-AAA	IEEE 802.11a/h WiFi 5 GHz (OFDM, 9 Mbps, 99pc duty cycle)	X	4.47	66.84	16.30	0.00	150.0	± 9.6 %
		Y	4.48	66.90	16.36		150.0	
		Z	4.58	66.60	16.20		150.0	
10519-AAA	IEEE 802.11a/h WiFi 5 GHz (OFDM, 12 Mbps, 99pc duty cycle)	X	4.63	67.03	16.39	0.00	150.0	± 9.6 %
		Y	4.64	67.09	16.46		150.0	
		Z	4.77	66.85	16.33		150.0	
10520-AAA	IEEE 802.11a/h WiFi 5 GHz (OFDM, 18 Mbps, 99pc duty cycle)	X	4.49	66.98	16.32	0.00	150.0	± 9.6 %
		Y	4.50	67.04	16.38		150.0	
		Z	4.62	66.81	16.25		150.0	
10521-AAA	IEEE 802.11a/h WiFi 5 GHz (OFDM, 24 Mbps, 99pc duty cycle)	X	4.42	66.97	16.30	0.00	150.0	± 9.6 %
		Y	4.43	67.03	16.37		150.0	
		Z	4.55	66.80	16.23		150.0	
10522-AAA	IEEE 802.11a/h WiFi 5 GHz (OFDM, 36 Mbps, 99pc duty cycle)	X	4.48	67.10	16.40	0.00	150.0	± 9.6 %
		Y	4.49	67.16	16.47		150.0	
		Z	4.61	66.88	16.31		150.0	

10523-AAA	IEEE 802.11a/h WiFi 5 GHz (OFDM, 48 Mbps, 99pc duty cycle)	X	4.38	67.02	16.28	0.00	150.0	± 9.6 %
		Y	4.40	67.08	16.35		150.0	
		Z	4.49	66.74	16.15		150.0	
10524-AAA	IEEE 802.11a/h WiFi 5 GHz (OFDM, 54 Mbps, 99pc duty cycle)	X	4.42	67.02	16.37	0.00	150.0	± 9.6 %
		Y	4.44	67.08	16.44		150.0	
		Z	4.56	66.80	16.28		150.0	
10525-AAA	IEEE 802.11ac WiFi (20MHz, MCS0, 99pc duty cycle)	X	4.44	66.11	15.98	0.00	150.0	± 9.6 %
		Y	4.45	66.16	16.04		150.0	
		Z	4.54	65.84	15.87		150.0	
10526-AAA	IEEE 802.11ac WiFi (20MHz, MCS1, 99pc duty cycle)	X	4.58	66.42	16.11	0.00	150.0	± 9.6 %
		Y	4.59	66.48	16.17		150.0	
		Z	4.71	66.22	16.01		150.0	
10527-AAA	IEEE 802.11ac WiFi (20MHz, MCS2, 99pc duty cycle)	X	4.51	66.39	16.05	0.00	150.0	± 9.6 %
		Y	4.52	66.45	16.12		150.0	
		Z	4.63	66.17	15.95		150.0	
10528-AAA	IEEE 802.11ac WiFi (20MHz, MCS3, 99pc duty cycle)	X	4.52	66.40	16.08	0.00	150.0	± 9.6 %
		Y	4.54	66.46	16.15		150.0	
		Z	4.65	66.19	15.99		150.0	
10529-AAA	IEEE 802.11ac WiFi (20MHz, MCS4, 99pc duty cycle)	X	4.52	66.40	16.08	0.00	150.0	± 9.6 %
		Y	4.54	66.46	16.15		150.0	
		Z	4.65	66.19	15.99		150.0	
10531-AAA	IEEE 802.11ac WiFi (20MHz, MCS6, 99pc duty cycle)	X	4.50	66.46	16.08	0.00	150.0	± 9.6 %
		Y	4.51	66.53	16.14		150.0	
		Z	4.64	66.30	16.00		150.0	
10532-AAA	IEEE 802.11ac WiFi (20MHz, MCS7, 99pc duty cycle)	X	4.37	66.32	16.01	0.00	150.0	± 9.6 %
		Y	4.39	66.39	16.08		150.0	
		Z	4.50	66.15	15.93		150.0	
10533-AAA	IEEE 802.11ac WiFi (20MHz, MCS8, 99pc duty cycle)	X	4.53	66.48	16.08	0.00	150.0	± 9.6 %
		Y	4.54	66.54	16.15		150.0	
		Z	4.66	66.23	15.97		150.0	
10534-AAA	IEEE 802.11ac WiFi (40MHz, MCS0, 99pc duty cycle)	X	5.07	66.45	16.14	0.00	150.0	± 9.6 %
		Y	5.09	66.50	16.19		150.0	
		Z	5.19	66.33	16.06		150.0	
10535-AAA	IEEE 802.11ac WiFi (40MHz, MCS1, 99pc duty cycle)	X	5.13	66.62	16.22	0.00	150.0	± 9.6 %
		Y	5.14	66.67	16.27		150.0	
		Z	5.25	66.51	16.14		150.0	
10536-AAA	IEEE 802.11ac WiFi (40MHz, MCS2, 99pc duty cycle)	X	5.01	66.59	16.19	0.00	150.0	± 9.6 %
		Y	5.03	66.64	16.24		150.0	
		Z	5.12	66.45	16.09		150.0	
10537-AAA	IEEE 802.11ac WiFi (40MHz, MCS3, 99pc duty cycle)	X	5.07	66.55	16.17	0.00	150.0	± 9.6 %
		Y	5.08	66.59	16.22		150.0	
		Z	5.18	66.42	16.08		150.0	
10538-AAA	IEEE 802.11ac WiFi (40MHz, MCS4, 99pc duty cycle)	X	5.14	66.54	16.20	0.00	150.0	± 9.6 %
		Y	5.15	66.59	16.25		150.0	
		Z	5.27	66.46	16.14		150.0	
10540-AAA	IEEE 802.11ac WiFi (40MHz, MCS6, 99pc duty cycle)	X	5.07	66.52	16.21	0.00	150.0	± 9.6 %
		Y	5.08	66.57	16.26		150.0	
		Z	5.20	66.47	16.16		150.0	

10541-AAA	IIEEE 802.11ac WiFi (40MHz, MCS7, 99pc duty cycle)	X	5.05	66.41	16.14	0.00	150.0	± 9.6 %
		Y	5.06	66.46	16.20		150.0	
		Z	5.17	66.33	16.08		150.0	
10542-AAA	IIEEE 802.11ac WiFi (40MHz, MCS8, 99pc duty cycle)	X	5.21	66.51	16.21	0.00	150.0	± 9.6 %
		Y	5.22	66.55	16.26		150.0	
		Z	5.33	66.41	16.13		150.0	
10543-AAA	IIEEE 802.11ac WiFi (40MHz, MCS9, 99pc duty cycle)	X	5.27	66.52	16.24	0.00	150.0	± 9.6 %
		Y	5.28	66.56	16.29		150.0	
		Z	5.41	66.45	16.18		150.0	
10544-AAA	IIEEE 802.11ac WiFi (80MHz, MCS0, 99pc duty cycle)	X	5.40	66.53	16.13	0.00	150.0	± 9.6 %
		Y	5.42	66.58	16.18		150.0	
		Z	5.49	66.45	16.06		150.0	
10545-AAA	IIEEE 802.11ac WiFi (80MHz, MCS1, 99pc duty cycle)	X	5.59	66.98	16.30	0.00	150.0	± 9.6 %
		Y	5.60	67.03	16.36		150.0	
		Z	5.69	66.88	16.22		150.0	
10546-AAA	IIEEE 802.11ac WiFi (80MHz, MCS2, 99pc duty cycle)	X	5.45	66.68	16.17	0.00	150.0	± 9.6 %
		Y	5.46	66.73	16.22		150.0	
		Z	5.56	66.67	16.13		150.0	
10547-AAA	IIEEE 802.11ac WiFi (80MHz, MCS3, 99pc duty cycle)	X	5.52	66.76	16.20	0.00	150.0	± 9.6 %
		Y	5.53	66.80	16.25		150.0	
		Z	5.63	66.71	16.14		150.0	
10548-AAA	IIEEE 802.11ac WiFi (80MHz, MCS4, 99pc duty cycle)	X	5.72	67.56	16.57	0.00	150.0	± 9.6 %
		Y	5.74	67.62	16.64		150.0	
		Z	5.92	67.73	16.62		150.0	
10550-AAA	IIEEE 802.11ac WiFi (80MHz, MCS6, 99pc duty cycle)	X	5.50	66.81	16.24	0.00	150.0	± 9.6 %
		Y	5.51	66.85	16.30		150.0	
		Z	5.59	66.68	16.14		150.0	
10551-AAA	IIEEE 802.11ac WiFi (80MHz, MCS7, 99pc duty cycle)	X	5.47	66.72	16.16	0.00	150.0	± 9.6 %
		Y	5.48	66.77	16.22		150.0	
		Z	5.59	66.72	16.13		150.0	
10552-AAA	IIEEE 802.11ac WiFi (80MHz, MCS8, 99pc duty cycle)	X	5.41	66.62	16.12	0.00	150.0	± 9.6 %
		Y	5.42	66.66	16.16		150.0	
		Z	5.50	66.51	16.03		150.0	
10553-AAA	IIEEE 802.11ac WiFi (80MHz, MCS9, 99pc duty cycle)	X	5.48	66.60	16.14	0.00	150.0	± 9.6 %
		Y	5.49	66.65	16.19		150.0	
		Z	5.59	66.56	16.08		150.0	
10554-AAA	IIEEE 1602.11ac WiFi (160MHz, MCS0, 99pc duty cycle)	X	5.82	66.88	16.21	0.00	150.0	± 9.6 %
		Y	5.83	66.92	16.26		150.0	
		Z	5.90	66.82	16.15		150.0	
10555-AAA	IIEEE 1602.11ac WiFi (160MHz, MCS1, 99pc duty cycle)	X	5.94	67.15	16.33	0.00	150.0	± 9.6 %
		Y	5.95	67.20	16.38		150.0	
		Z	6.03	67.13	16.28		150.0	
10556-AAA	IIEEE 1602.11ac WiFi (160MHz, MCS2, 99pc duty cycle)	X	5.96	67.23	16.36	0.00	150.0	± 9.6 %
		Y	5.98	67.27	16.41		150.0	
		Z	6.05	67.17	16.30		150.0	
10557-AAA	IIEEE 1602.11ac WiFi (160MHz, MCS3, 99pc duty cycle)	X	5.92	67.10	16.31	0.00	150.0	± 9.6 %
		Y	5.93	67.14	16.36		150.0	
		Z	6.02	67.08	16.27		150.0	



10558-AAA	IEEE 1602.11ac WiFi (160MHz, MCS4, 99pc duty cycle)	X	5.96	67.24	16.39	0.00	150.0	± 9.6 %
		Y	5.97	67.29	16.45		150.0	
		Z	6.07	67.25	16.37		150.0	
10560-AAA	IEEE 1602.11ac WiFi (160MHz, MCS6, 99pc duty cycle)	X	5.95	67.10	16.36	0.00	150.0	± 9.6 %
		Y	5.97	67.14	16.41		150.0	
		Z	6.06	67.09	16.33		150.0	
10561-AAA	IEEE 1602.11ac WiFi (160MHz, MCS7, 99pc duty cycle)	X	5.89	67.09	16.39	0.00	150.0	± 9.6 %
		Y	5.90	67.14	16.45		150.0	
		Z	5.99	67.06	16.35		150.0	
10562-AAA	IEEE 1602.11ac WiFi (160MHz, MCS8, 99pc duty cycle)	X	5.97	67.34	16.52	0.00	150.0	± 9.6 %
		Y	5.98	67.39	16.57		150.0	
		Z	6.12	67.47	16.55		150.0	
10563-AAA	IEEE 1602.11ac WiFi (160MHz, MCS9, 99pc duty cycle)	X	6.05	67.24	16.43	0.00	150.0	± 9.6 %
		Y	6.06	67.29	16.49		150.0	
		Z	6.41	67.91	16.73		150.0	
10564-AAA	IEEE 802.11g WiFi 2.4 GHz (DSSS-OFDM, 9 Mbps, 99pc duty cycle)	X	4.78	66.85	16.41	0.46	150.0	± 9.6 %
		Y	4.80	66.93	16.49		150.0	
		Z	4.91	66.67	16.35		150.0	
10565-AAA	IEEE 802.11g WiFi 2.4 GHz (DSSS-OFDM, 12 Mbps, 99pc duty cycle)	X	4.99	67.29	16.74	0.46	150.0	± 9.6 %
		Y	5.01	67.35	16.80		150.0	
		Z	5.14	67.15	16.69		150.0	
10566-AAA	IEEE 802.11g WiFi 2.4 GHz (DSSS-OFDM, 18 Mbps, 99pc duty cycle)	X	4.83	67.11	16.54	0.46	150.0	± 9.6 %
		Y	4.84	67.18	16.62		150.0	
		Z	4.98	66.99	16.50		150.0	
10567-AAA	IEEE 802.11g WiFi 2.4 GHz (DSSS-OFDM, 24 Mbps, 99pc duty cycle)	X	4.87	67.55	16.94	0.46	150.0	± 9.6 %
		Y	4.87	67.57	16.98		150.0	
		Z	5.01	67.40	16.87		150.0	
10568-AAA	IEEE 802.11g WiFi 2.4 GHz (DSSS-OFDM, 36 Mbps, 99pc duty cycle)	X	4.73	66.85	16.28	0.46	150.0	± 9.6 %
		Y	4.75	66.97	16.39		150.0	
		Z	4.88	66.73	16.25		150.0	
10569-AAA	IEEE 802.11g WiFi 2.4 GHz (DSSS-OFDM, 48 Mbps, 99pc duty cycle)	X	4.84	67.72	17.05	0.46	150.0	± 9.6 %
		Y	4.85	67.73	17.08		150.0	
		Z	4.96	67.48	16.93		150.0	
10570-AAA	IEEE 802.11g WiFi 2.4 GHz (DSSS-OFDM, 54 Mbps, 99pc duty cycle)	X	4.86	67.53	16.95	0.46	150.0	± 9.6 %
		Y	4.87	67.55	16.99		150.0	
		Z	5.00	67.32	16.86		150.0	
10571-AAA	IEEE 802.11b WiFi 2.4 GHz (DSSS, 1 Mbps, 90pc duty cycle)	X	1.13	63.98	15.42	0.46	130.0	± 9.6 %
		Y	1.15	64.46	15.85		130.0	
		Z	1.15	63.75	15.28		130.0	
10572-AAA	IEEE 802.11b WiFi 2.4 GHz (DSSS, 2 Mbps, 90pc duty cycle)	X	1.14	64.53	15.78	0.46	130.0	± 9.6 %
		Y	1.16	65.03	16.22		130.0	
		Z	1.16	64.27	15.61		130.0	
10573-AAA	IEEE 802.11b WiFi 2.4 GHz (DSSS, 5.5 Mbps, 90pc duty cycle)	X	1.37	80.51	21.92	0.46	130.0	± 9.6 %
		Y	2.18	89.24	25.44		130.0	
		Z	1.24	77.68	20.60		130.0	
10574-AAA	IEEE 802.11b WiFi 2.4 GHz (DSSS, 11 Mbps, 90pc duty cycle)	X	1.21	70.03	18.74	0.46	130.0	± 9.6 %
		Y	1.26	70.93	19.36		130.0	
		Z	1.21	69.23	18.24		130.0	

10575-AAA	IEEE 802.11g WiFi 2.4 GHz (DSSS-OFDM, 6 Mbps, 90pc duty cycle)	X	4.55	66.59	16.41	0.46	130.0	± 9.6 %
		Y	4.57	66.69	16.52		130.0	
		Z	4.69	66.45	16.40		130.0	
10576-AAA	IEEE 802.11g WiFi 2.4 GHz (DSSS-OFDM, 9 Mbps, 90pc duty cycle)	X	4.58	66.78	16.50	0.46	130.0	± 9.6 %
		Y	4.60	66.87	16.60		130.0	
		Z	4.71	66.62	16.47		130.0	
10577-AAA	IEEE 802.11g WiFi 2.4 GHz (DSSS-OFDM, 12 Mbps, 90pc duty cycle)	X	4.76	67.04	16.65	0.46	130.0	± 9.6 %
		Y	4.78	67.12	16.75		130.0	
		Z	4.92	66.93	16.65		130.0	
10578-AAA	IEEE 802.11g WiFi 2.4 GHz (DSSS-OFDM, 18 Mbps, 90pc duty cycle)	X	4.67	67.21	16.78	0.46	130.0	± 9.6 %
		Y	4.68	67.27	16.85		130.0	
		Z	4.82	67.09	16.76		130.0	
10579-AAA	IEEE 802.11g WiFi 2.4 GHz (DSSS-OFDM, 24 Mbps, 90pc duty cycle)	X	4.41	66.37	16.00	0.46	130.0	± 9.6 %
		Y	4.44	66.52	16.15		130.0	
		Z	4.58	66.34	16.04		130.0	
10580-AAA	IEEE 802.11g WiFi 2.4 GHz (DSSS-OFDM, 36 Mbps, 90pc duty cycle)	X	4.45	66.43	16.02	0.46	130.0	± 9.6 %
		Y	4.49	66.59	16.18		130.0	
		Z	4.62	66.36	16.05		130.0	
10581-AAA	IEEE 802.11g WiFi 2.4 GHz (DSSS-OFDM, 48 Mbps, 90pc duty cycle)	X	4.57	67.26	16.72	0.46	130.0	± 9.6 %
		Y	4.58	67.33	16.82		130.0	
		Z	4.71	67.12	16.69		130.0	
10582-AAA	IEEE 802.11g WiFi 2.4 GHz (DSSS-OFDM, 54 Mbps, 90pc duty cycle)	X	4.34	66.11	15.76	0.46	130.0	± 9.6 %
		Y	4.38	66.30	15.94		130.0	
		Z	4.52	66.09	15.82		130.0	
10583-AAA	IEEE 802.11a/h WiFi 5 GHz (OFDM, 6 Mbps, 90pc duty cycle)	X	4.55	66.59	16.41	0.46	130.0	± 9.6 %
		Y	4.57	66.69	16.52		130.0	
		Z	4.69	66.45	16.40		130.0	
10584-AAA	IEEE 802.11a/h WiFi 5 GHz (OFDM, 9 Mbps, 90pc duty cycle)	X	4.58	66.78	16.50	0.46	130.0	± 9.6 %
		Y	4.60	66.87	16.60		130.0	
		Z	4.71	66.62	16.47		130.0	
10585-AAA	IEEE 802.11a/h WiFi 5 GHz (OFDM, 12 Mbps, 90pc duty cycle)	X	4.76	67.04	16.65	0.46	130.0	± 9.6 %
		Y	4.78	67.12	16.75		130.0	
		Z	4.92	66.93	16.65		130.0	
10586-AAA	IEEE 802.11a/h WiFi 5 GHz (OFDM, 18 Mbps, 90pc duty cycle)	X	4.67	67.21	16.78	0.46	130.0	± 9.6 %
		Y	4.68	67.27	16.85		130.0	
		Z	4.82	67.09	16.76		130.0	
10587-AAA	IEEE 802.11a/h WiFi 5 GHz (OFDM, 24 Mbps, 90pc duty cycle)	X	4.41	66.37	16.00	0.46	130.0	± 9.6 %
		Y	4.44	66.52	16.15		130.0	
		Z	4.58	66.34	16.04		130.0	
10588-AAA	IEEE 802.11a/h WiFi 5 GHz (OFDM, 36 Mbps, 90pc duty cycle)	X	4.45	66.43	16.02	0.46	130.0	± 9.6 %
		Y	4.49	66.59	16.18		130.0	
		Z	4.62	66.36	16.05		130.0	
10589-AAA	IEEE 802.11a/h WiFi 5 GHz (OFDM, 48 Mbps, 90pc duty cycle)	X	4.57	67.26	16.72	0.46	130.0	± 9.6 %
		Y	4.58	67.33	16.82		130.0	
		Z	4.71	67.12	16.69		130.0	
10590-AAA	IEEE 802.11a/h WiFi 5 GHz (OFDM, 54 Mbps, 90pc duty cycle)	X	4.34	66.11	15.76	0.46	130.0	± 9.6 %
		Y	4.38	66.30	15.94		130.0	
		Z	4.52	66.09	15.82		130.0	

10591-AAA	IEEE 802.11n (HT Mixed, 20MHz, MCS0, 90pc duty cycle)	X	4.71	66.67	16.53	0.46	130.0	± 9.6 %
		Y	4.73	66.75	16.62		130.0	
		Z	4.84	66.53	16.51		130.0	
10592-AAA	IEEE 802.11n (HT Mixed, 20MHz, MCS1, 90pc duty cycle)	X	4.84	66.99	16.66	0.46	130.0	± 9.6 %
		Y	4.86	67.07	16.75		130.0	
		Z	5.00	66.87	16.64		130.0	
10593-AAA	IEEE 802.11n (HT Mixed, 20MHz, MCS2, 90pc duty cycle)	X	4.76	66.86	16.52	0.46	130.0	± 9.6 %
		Y	4.78	66.96	16.62		130.0	
		Z	4.92	66.77	16.52		130.0	
10594-AAA	IEEE 802.11n (HT Mixed, 20MHz, MCS3, 90pc duty cycle)	X	4.82	67.05	16.69	0.46	130.0	± 9.6 %
		Y	4.84	67.13	16.78		130.0	
		Z	4.97	66.94	16.68		130.0	
10595-AAA	IEEE 802.11n (HT Mixed, 20MHz, MCS4, 90pc duty cycle)	X	4.78	67.01	16.59	0.46	130.0	± 9.6 %
		Y	4.80	67.10	16.69		130.0	
		Z	4.94	66.89	16.57		130.0	
10596-AAA	IEEE 802.11n (HT Mixed, 20MHz, MCS5, 90pc duty cycle)	X	4.71	66.98	16.58	0.46	130.0	± 9.6 %
		Y	4.73	67.08	16.69		130.0	
		Z	4.87	66.88	16.57		130.0	
10597-AAA	IEEE 802.11n (HT Mixed, 20MHz, MCS6, 90pc duty cycle)	X	4.66	66.85	16.44	0.46	130.0	± 9.6 %
		Y	4.69	66.96	16.56		130.0	
		Z	4.82	66.78	16.45		130.0	
10598-AAA	IEEE 802.11n (HT Mixed, 20MHz, MCS7, 90pc duty cycle)	X	4.65	67.11	16.73	0.46	130.0	± 9.6 %
		Y	4.67	67.18	16.81		130.0	
		Z	4.81	67.03	16.73		130.0	
10599-AAA	IEEE 802.11n (HT Mixed, 40MHz, MCS0, 90pc duty cycle)	X	5.39	67.16	16.75	0.46	130.0	± 9.6 %
		Y	5.40	67.23	16.84		130.0	
		Z	5.52	67.11	16.73		130.0	
10600-AAA	IEEE 802.11n (HT Mixed, 40MHz, MCS1, 90pc duty cycle)	X	5.51	67.57	16.93	0.46	130.0	± 9.6 %
		Y	5.53	67.67	17.03		130.0	
		Z	5.67	67.58	16.94		130.0	
10601-AAA	IEEE 802.11n (HT Mixed, 40MHz, MCS2, 90pc duty cycle)	X	5.40	67.32	16.82	0.46	130.0	± 9.6 %
		Y	5.42	67.41	16.92		130.0	
		Z	5.55	67.30	16.82		130.0	
10602-AAA	IEEE 802.11n (HT Mixed, 40MHz, MCS3, 90pc duty cycle)	X	5.53	67.48	16.82	0.46	130.0	± 9.6 %
		Y	5.55	67.58	16.92		130.0	
		Z	5.64	67.31	16.73		130.0	
10603-AAA	IEEE 802.11n (HT Mixed, 40MHz, MCS4, 90pc duty cycle)	X	5.60	67.77	17.10	0.46	130.0	± 9.6 %
		Y	5.62	67.84	17.19		130.0	
		Z	5.72	67.63	17.03		130.0	
10604-AAA	IEEE 802.11n (HT Mixed, 40MHz, MCS5, 90pc duty cycle)	X	5.48	67.44	16.92	0.46	130.0	± 9.6 %
		Y	5.50	67.51	17.01		130.0	
		Z	5.52	67.07	16.74		130.0	
10605-AAA	IEEE 802.11n (HT Mixed, 40MHz, MCS6, 90pc duty cycle)	X	5.51	67.48	16.93	0.46	130.0	± 9.6 %
		Y	5.53	67.59	17.04		130.0	
		Z	5.64	67.42	16.91		130.0	
10606-AAA	IEEE 802.11n (HT Mixed, 40MHz, MCS7, 90pc duty cycle)	X	5.24	66.77	16.43	0.46	130.0	± 9.6 %
		Y	5.27	66.88	16.54		130.0	
		Z	5.39	66.79	16.45		130.0	

10607-AAA	IEEE 802.11ac WiFi (20MHz, MCS0, 90pc duty cycle)	X	4.56	66.02	16.17	0.46	130.0	± 9.6 %
		Y	4.58	66.11	16.27		130.0	
		Z	4.68	65.84	16.13		130.0	
10608-AAA	IEEE 802.11ac WiFi (20MHz, MCS1, 90pc duty cycle)	X	4.71	66.38	16.33	0.46	130.0	± 9.6 %
		Y	4.74	66.48	16.43		130.0	
		Z	4.87	66.25	16.30		130.0	
10609-AAA	IEEE 802.11ac WiFi (20MHz, MCS2, 90pc duty cycle)	X	4.60	66.21	16.15	0.46	130.0	± 9.6 %
		Y	4.63	66.32	16.26		130.0	
		Z	4.75	66.09	16.13		130.0	
10610-AAA	IEEE 802.11ac WiFi (20MHz, MCS3, 90pc duty cycle)	X	4.66	66.38	16.32	0.46	130.0	± 9.6 %
		Y	4.68	66.48	16.42		130.0	
		Z	4.81	66.25	16.30		130.0	
10611-AAA	IEEE 802.11ac WiFi (20MHz, MCS4, 90pc duty cycle)	X	4.57	66.17	16.16	0.46	130.0	± 9.6 %
		Y	4.59	66.28	16.27		130.0	
		Z	4.72	66.06	16.14		130.0	
10612-AAA	IEEE 802.11ac WiFi (20MHz, MCS5, 90pc duty cycle)	X	4.57	66.31	16.20	0.46	130.0	± 9.6 %
		Y	4.59	66.44	16.32		130.0	
		Z	4.73	66.20	16.18		130.0	
10613-AAA	IEEE 802.11ac WiFi (20MHz, MCS6, 90pc duty cycle)	X	4.56	66.14	16.05	0.46	130.0	± 9.6 %
		Y	4.59	66.27	16.18		130.0	
		Z	4.73	66.09	16.06		130.0	
10614-AAA	IEEE 802.11ac WiFi (20MHz, MCS7, 90pc duty cycle)	X	4.53	66.39	16.32	0.46	130.0	± 9.6 %
		Y	4.55	66.47	16.42		130.0	
		Z	4.68	66.29	16.31		130.0	
10615-AAA	IEEE 802.11ac WiFi (20MHz, MCS8, 90pc duty cycle)	X	4.56	65.98	15.91	0.46	130.0	± 9.6 %
		Y	4.59	66.13	16.05		130.0	
		Z	4.72	65.87	15.91		130.0	
10616-AAA	IEEE 802.11ac WiFi (40MHz, MCS0, 90pc duty cycle)	X	5.20	66.41	16.36	0.46	130.0	± 9.6 %
		Y	5.22	66.48	16.45		130.0	
		Z	5.34	66.37	16.34		130.0	
10617-AAA	IEEE 802.11ac WiFi (40MHz, MCS1, 90pc duty cycle)	X	5.27	66.60	16.43	0.46	130.0	± 9.6 %
		Y	5.29	66.69	16.53		130.0	
		Z	5.41	66.54	16.40		130.0	
10618-AAA	IEEE 802.11ac WiFi (40MHz, MCS2, 90pc duty cycle)	X	5.17	66.64	16.47	0.46	130.0	± 9.6 %
		Y	5.19	66.72	16.55		130.0	
		Z	5.29	66.54	16.42		130.0	
10619-AAA	IEEE 802.11ac WiFi (40MHz, MCS3, 90pc duty cycle)	X	5.17	66.40	16.28	0.46	130.0	± 9.6 %
		Y	5.19	66.49	16.38		130.0	
		Z	5.31	66.37	16.27		130.0	
10620-AAA	IEEE 802.11ac WiFi (40MHz, MCS4, 90pc duty cycle)	X	5.25	66.42	16.34	0.46	130.0	± 9.6 %
		Y	5.27	66.52	16.44		130.0	
		Z	5.40	66.41	16.34		130.0	
10621-AAA	IEEE 802.11ac WiFi (40MHz, MCS5, 90pc duty cycle)	X	5.27	66.59	16.55	0.46	130.0	± 9.6 %
		Y	5.28	66.65	16.62		130.0	
		Z	5.40	66.53	16.52		130.0	
10622-AAA	IEEE 802.11ac WiFi (40MHz, MCS6, 90pc duty cycle)	X	5.27	66.70	16.60	0.46	130.0	± 9.6 %
		Y	5.28	66.78	16.68		130.0	
		Z	5.41	66.70	16.60		130.0	

10623-AAA	IEEE 802.11ac WiFi (40MHz, MCS7, 90pc duty cycle)	X	5.14	66.21	16.21	0.46	130.0	± 9.6 %
		Y	5.16	66.31	16.32		130.0	
		Z	5.28	66.20	16.22		130.0	
10624-AAA	IEEE 802.11ac WiFi (40MHz, MCS8, 90pc duty cycle)	X	5.34	66.45	16.40	0.46	130.0	± 9.6 %
		Y	5.36	66.54	16.49		130.0	
		Z	5.48	66.42	16.39		130.0	
10625-AAA	IEEE 802.11ac WiFi (40MHz, MCS9, 90pc duty cycle)	X	5.55	66.97	16.72	0.46	130.0	± 9.6 %
		Y	5.57	67.07	16.81		130.0	
		Z	5.88	67.48	16.97		130.0	
10626-AAA	IEEE 802.11ac WiFi (80MHz, MCS0, 90pc duty cycle)	X	5.53	66.46	16.32	0.46	130.0	± 9.6 %
		Y	5.54	66.54	16.40		130.0	
		Z	5.63	66.43	16.30		130.0	
10627-AAA	IEEE 802.11ac WiFi (80MHz, MCS1, 90pc duty cycle)	X	5.77	67.07	16.59	0.46	130.0	± 9.6 %
		Y	5.79	67.16	16.68		130.0	
		Z	5.88	67.02	16.56		130.0	
10628-AAA	IEEE 802.11ac WiFi (80MHz, MCS2, 90pc duty cycle)	X	5.53	66.46	16.22	0.46	130.0	± 9.6 %
		Y	5.55	66.56	16.32		130.0	
		Z	5.67	66.54	16.25		130.0	
10629-AAA	IEEE 802.11ac WiFi (80MHz, MCS3, 90pc duty cycle)	X	5.62	66.57	16.27	0.46	130.0	± 9.6 %
		Y	5.64	66.67	16.37		130.0	
		Z	5.76	66.64	16.29		130.0	
10630-AAA	IEEE 802.11ac WiFi (80MHz, MCS4, 90pc duty cycle)	X	5.96	67.80	16.88	0.46	130.0	± 9.6 %
		Y	5.98	67.92	17.00		130.0	
		Z	6.25	68.26	17.09		130.0	
10631-AAA	IEEE 802.11ac WiFi (80MHz, MCS5, 90pc duty cycle)	X	5.89	67.74	17.06	0.46	130.0	± 9.6 %
		Y	5.91	67.78	17.11		130.0	
		Z	6.11	67.97	17.16		130.0	
10632-AAA	IEEE 802.11ac WiFi (80MHz, MCS6, 90pc duty cycle)	X	5.75	67.20	16.81	0.46	130.0	± 9.6 %
		Y	5.76	67.24	16.86		130.0	
		Z	5.85	67.08	16.73		130.0	
10633-AAA	IEEE 802.11ac WiFi (80MHz, MCS7, 90pc duty cycle)	X	5.60	66.69	16.37	0.46	130.0	± 9.6 %
		Y	5.62	66.77	16.45		130.0	
		Z	5.73	66.69	16.36		130.0	
10634-AAA	IEEE 802.11ac WiFi (80MHz, MCS8, 90pc duty cycle)	X	5.58	66.71	16.44	0.46	130.0	± 9.6 %
		Y	5.60	66.78	16.51		130.0	
		Z	5.72	66.73	16.44		130.0	
10635-AAA	IEEE 802.11ac WiFi (80MHz, MCS9, 90pc duty cycle)	X	5.44	65.95	15.77	0.46	130.0	± 9.6 %
		Y	5.47	66.09	15.91		130.0	
		Z	5.60	66.05	15.82		130.0	
10636-AAA	IEEE 1602.11ac WiFi (160MHz, MCS0, 90pc duty cycle)	X	5.96	66.83	16.41	0.46	130.0	± 9.6 %
		Y	5.97	66.90	16.49		130.0	
		Z	6.05	66.82	16.40		130.0	
10637-AAA	IEEE 1602.11ac WiFi (160MHz, MCS1, 90pc duty cycle)	X	6.10	67.19	16.58	0.46	130.0	± 9.6 %
		Y	6.12	67.27	16.66		130.0	
		Z	6.21	67.21	16.58		130.0	
10638-AAA	IEEE 1602.11ac WiFi (160MHz, MCS2, 90pc duty cycle)	X	6.10	67.17	16.54	0.46	130.0	± 9.6 %
		Y	6.12	67.25	16.63		130.0	
		Z	6.21	67.17	16.54		130.0	

10639-AAA	IEEE 1602.11ac WiFi (160MHz, MCS3, 90pc duty cycle)	X	6.07	67.09	16.55	0.46	130.0	± 9.6 %
		Y	6.09	67.17	16.63		130.0	
		Z	6.19	67.14	16.56		130.0	
10640-AAA	IEEE 1602.11ac WiFi (160MHz, MCS4, 90pc duty cycle)	X	6.06	67.06	16.47	0.46	130.0	± 9.6 %
		Y	6.08	67.16	16.57		130.0	
		Z	6.19	67.15	16.51		130.0	
10641-AAA	IEEE 1602.11ac WiFi (160MHz, MCS5, 90pc duty cycle)	X	6.13	67.06	16.49	0.46	130.0	± 9.6 %
		Y	6.15	67.15	16.59		130.0	
		Z	6.23	67.02	16.46		130.0	
10642-AAA	IEEE 1602.11ac WiFi (160MHz, MCS6, 90pc duty cycle)	X	6.16	67.29	16.78	0.46	130.0	± 9.6 %
		Y	6.17	67.34	16.84		130.0	
		Z	6.28	67.31	16.78		130.0	
10643-AAA	IEEE 1602.11ac WiFi (160MHz, MCS7, 90pc duty cycle)	X	6.00	66.97	16.51	0.46	130.0	± 9.6 %
		Y	6.02	67.06	16.61		130.0	
		Z	6.11	66.97	16.50		130.0	
10644-AAA	IEEE 1602.11ac WiFi (160MHz, MCS8, 90pc duty cycle)	X	6.09	67.26	16.67	0.46	130.0	± 9.6 %
		Y	6.12	67.36	16.77		130.0	
		Z	6.29	67.52	16.80		130.0	
10645-AAA	IEEE 1602.11ac WiFi (160MHz, MCS9, 90pc duty cycle)	X	6.23	67.33	16.67	0.46	130.0	± 9.6 %
		Y	6.26	67.42	16.77		130.0	
		Z	6.72	68.38	17.18		130.0	
10646-AAC	LTE-TDD (SC-FDMA, 1 RB, 5 MHz, QPSK, UL Subframe=2,7)	X	7.97	91.85	31.39	9.30	60.0	± 9.6 %
		Y	11.74	104.28	36.86		60.0	
		Z	11.88	99.49	34.28		60.0	
10647-AAB	LTE-TDD (SC-FDMA, 1 RB, 20 MHz, QPSK, UL Subframe=2,7)	X	7.13	89.84	30.79	9.30	60.0	± 9.6 %
		Y	9.93	100.75	35.82		60.0	
		Z	10.62	97.47	33.72		60.0	
10648-AAA	CDMA2000 (1x Advanced)	X	0.64	63.39	10.24	0.00	150.0	± 9.6 %
		Y	0.67	63.88	10.62		150.0	
		Z	0.72	63.48	11.02		150.0	

<sup>E</sup> Uncertainty is determined using the max. deviation from linear response applying rectangular distribution and is expressed for the square of the field value.



Accredited by the Swiss Accreditation Service (SAS)  
The Swiss Accreditation Service is one of the signatories to the EA  
Multilateral Agreement for the recognition of calibration certificates

Accreditation No.: **SCS 0108**

Client **PC Test**

Certificate No: **ES3-3319\_Mar17**

**CALIBRATION CERTIFICATE**

Object **ES3DV3 - SN:3319**

Calibration procedure(s) **QA CAL-01.v9, QA CAL-23.v5, QA CAL-25.v6  
Calibration procedure for dosimetric E-field probes**

*BN ✓  
03-27-2017*

Calibration date: **March 14, 2017**

This calibration certificate documents the traceability to national standards, which realize the physical units of measurements (SI).  
The measurements and the uncertainties with confidence probability are given on the following pages and are part of the certificate.

All calibrations have been conducted in the closed laboratory facility: environment temperature (22 ± 3)°C and humidity < 70%.

Calibration Equipment used (M&TE critical for calibration)

Primary Standards	ID	Cal Date (Certificate No.)	Scheduled Calibration
Power meter NRP	SN: 104778	06-Apr-16 (No. 217-02288/02289)	Apr-17
Power sensor NRP-Z91	SN: 103244	06-Apr-16 (No. 217-02288)	Apr-17
Power sensor NRP-Z91	SN: 103245	06-Apr-16 (No. 217-02289)	Apr-17
Reference 20 dB Attenuator	SN: S5277 (20x)	05-Apr-16 (No. 217-02293)	Apr-17
Reference Probe ES3DV2	SN: 3013	31-Dec-16 (No. ES3-3013_Dec16)	Dec-17
DAE4	SN: 660	7-Dec-16 (No. DAE4-660_Dec16)	Dec-17
Secondary Standards	ID	Check Date (in house)	Scheduled Check
Power meter E4419B	SN: GB41293874	06-Apr-16 (in house check Jun-16)	In house check: Jun-18
Power sensor E4412A	SN: MY41498087	06-Apr-16 (in house check Jun-16)	In house check: Jun-18
Power sensor E4412A	SN: 000110210	06-Apr-16 (in house check Jun-16)	In house check: Jun-18
RF generator HP 8648C	SN: US3642U01700	04-Aug-99 (in house check Jun-16)	In house check: Jun-18
Network Analyzer HP 8753E	SN: US37390585	18-Oct-01 (in house check Oct-16)	In house check: Oct-17

Calibrated by:	Name <b>Jeton Kastrati</b>	Function <b>Laboratory Technician</b>	Signature 
Approved by:	Name <b>Katja Pokovic</b>	Function <b>Technical Manager</b>	Signature 

Issued: March 16, 2017

This calibration certificate shall not be reproduced except in full without written approval of the laboratory.



Accredited by the Swiss Accreditation Service (SAS)

Accreditation No.: **SCS 0108**

The Swiss Accreditation Service is one of the signatories to the EA  
Multilateral Agreement for the recognition of calibration certificates

**Glossary:**

TSL	tissue simulating liquid
NORM <sub>x,y,z</sub>	sensitivity in free space
ConvF	sensitivity in TSL / NORM <sub>x,y,z</sub>
DCP	diode compression point
CF	crest factor (1/duty_cycle) of the RF signal
A, B, C, D	modulation dependent linearization parameters
Polarization φ	φ rotation around probe axis
Polarization θ	θ rotation around an axis that is in the plane normal to probe axis (at measurement center), i.e., θ = 0 is normal to probe axis
Connector Angle	information used in DASY system to align probe sensor X to the robot coordinate system

**Calibration is Performed According to the Following Standards:**

- a) IEEE Std 1528-2013, "IEEE Recommended Practice for Determining the Peak Spatial-Averaged Specific Absorption Rate (SAR) in the Human Head from Wireless Communications Devices: Measurement Techniques", June 2013
- b) IEC 62209-1, "Procedure to measure the Specific Absorption Rate (SAR) for hand-held devices used in close proximity to the ear (frequency range of 300 MHz to 3 GHz)", February 2005
- c) IEC 62209-2, "Procedure to determine the Specific Absorption Rate (SAR) for wireless communication devices used in close proximity to the human body (frequency range of 30 MHz to 6 GHz)", March 2010
- d) KDB 865664, "SAR Measurement Requirements for 100 MHz to 6 GHz"

**Methods Applied and Interpretation of Parameters:**

- *NORM<sub>x,y,z</sub>*: Assessed for E-field polarization θ = 0 (f ≤ 900 MHz in TEM-cell; f > 1800 MHz: R22 waveguide). *NORM<sub>x,y,z</sub>* are only intermediate values, i.e., the uncertainties of *NORM<sub>x,y,z</sub>* does not affect the E<sup>2</sup>-field uncertainty inside TSL (see below *ConvF*).
- *NORM(f)<sub>x,y,z</sub>* = *NORM<sub>x,y,z</sub>* \* *frequency\_response* (see Frequency Response Chart). This linearization is implemented in DASY4 software versions later than 4.2. The uncertainty of the frequency response is included in the stated uncertainty of *ConvF*.
- *DCP<sub>x,y,z</sub>*: DCP are numerical linearization parameters assessed based on the data of power sweep with CW signal (no uncertainty required). DCP does not depend on frequency nor media.
- *PAR*: PAR is the Peak to Average Ratio that is not calibrated but determined based on the signal characteristics
- *A<sub>x,y,z</sub>*; *B<sub>x,y,z</sub>*; *C<sub>x,y,z</sub>*; *D<sub>x,y,z</sub>*; *VR<sub>x,y,z</sub>*; *A, B, C, D* are numerical linearization parameters assessed based on the data of power sweep for specific modulation signal. The parameters do not depend on frequency nor media. *VR* is the maximum calibration range expressed in RMS voltage across the diode.
- *ConvF* and *Boundary Effect Parameters*: Assessed in flat phantom using E-field (or Temperature Transfer Standard for f ≤ 800 MHz) and inside waveguide using analytical field distributions based on power measurements for f > 800 MHz. The same setups are used for assessment of the parameters applied for boundary compensation (alpha, depth) of which typical uncertainty values are given. These parameters are used in DASY4 software to improve probe accuracy close to the boundary. The sensitivity in TSL corresponds to *NORM<sub>x,y,z</sub>* \* *ConvF* whereby the uncertainty corresponds to that given for *ConvF*. A frequency dependent *ConvF* is used in DASY version 4.4 and higher which allows extending the validity from ± 50 MHz to ± 100 MHz.
- *Spherical isotropy (3D deviation from isotropy)*: in a field of low gradients realized using a flat phantom exposed by a patch antenna.
- *Sensor Offset*: The sensor offset corresponds to the offset of virtual measurement center from the probe tip (on probe axis). No tolerance required.
- *Connector Angle*: The angle is assessed using the information gained by determining the *NORM<sub>x</sub>* (no uncertainty required).



# Probe ES3DV3

## SN:3319

Manufactured: January 10, 2012  
Calibrated: March 14, 2017

Calibrated for DASY/EASY Systems  
(Note: non-compatible with DASY2 system!)

## DASY/EASY - Parameters of Probe: ES3DV3 - SN:3319

### Basic Calibration Parameters

	Sensor X	Sensor Y	Sensor Z	Unc (k=2)
Norm ( $\mu\text{V}/(\text{V}/\text{m})^2$ ) <sup>A</sup>	1.07	1.07	1.12	$\pm 10.1 \%$
DCP (mV) <sup>B</sup>	102.5	101.2	103.5	

### Modulation Calibration Parameters

UID	Communication System Name		A dB	B dB $\sqrt{\mu\text{V}}$	C	D dB	VR mV	Unc <sup>E</sup> (k=2)
0	CW	X	0.0	0.0	1.0	0.00	199.3	$\pm 3.5 \%$
		Y	0.0	0.0	1.0		195.9	
		Z	0.0	0.0	1.0		195.7	

Note: For details on UID parameters see Appendix.

### Sensor Model Parameters

	C1 fF	C2 fF	$\alpha$ $\text{V}^{-1}$	T1 $\text{ms}\cdot\text{V}^{-2}$	T2 $\text{ms}\cdot\text{V}^{-1}$	T3 ms	T4 $\text{V}^{-2}$	T5 $\text{V}^{-1}$	T6
X	70.81	508.1	35.61	29.87	3.768	5.1	0.566	0.571	1.012
Y	67.78	484.5	35.24	29.79	3.269	5.1	1.181	0.458	1.009
Z	70.95	506.9	35.21	30.32	4.051	5.1	1.117	0.534	1.012

The reported uncertainty of measurement is stated as the standard uncertainty of measurement multiplied by the coverage factor  $k=2$ , which for a normal distribution corresponds to a coverage probability of approximately 95%.

<sup>A</sup> The uncertainties of Norm X,Y,Z do not affect the  $E^2$ -field uncertainty inside TSL (see Pages 5 and 6).

<sup>B</sup> Numerical linearization parameter: uncertainty not required.

<sup>E</sup> Uncertainty is determined using the max. deviation from linear response applying rectangular distribution and is expressed for the square of the field value.

## DASY/EASY - Parameters of Probe: ES3DV3 - SN:3319

### Calibration Parameter Determined in Head Tissue Simulating Media

f (MHz) <sup>C</sup>	Relative Permittivity <sup>F</sup>	Conductivity (S/m) <sup>F</sup>	ConvF X	ConvF Y	ConvF Z	Alpha <sup>G</sup>	Depth <sup>G</sup> (mm)	Unc (k=2)
750	41.9	0.89	6.76	6.76	6.76	0.52	1.48	± 12.0 %
835	41.5	0.90	6.46	6.46	6.46	0.59	1.35	± 12.0 %
1750	40.1	1.37	5.38	5.38	5.38	0.57	1.39	± 12.0 %
1900	40.0	1.40	5.20	5.20	5.20	0.80	1.13	± 12.0 %
2300	39.5	1.67	4.86	4.86	4.86	0.48	1.60	± 12.0 %
2450	39.2	1.80	4.60	4.60	4.60	0.76	1.23	± 12.0 %
2600	39.0	1.96	4.41	4.41	4.41	0.80	1.27	± 12.0 %

<sup>C</sup> Frequency validity above 300 MHz of ± 100 MHz only applies for DASY v4.4 and higher (see Page 2), else it is restricted to ± 50 MHz. The uncertainty is the RSS of the ConvF uncertainty at calibration frequency and the uncertainty for the indicated frequency band. Frequency validity below 300 MHz is ± 10, 25, 40, 50 and 70 MHz for ConvF assessments at 30, 64, 128, 150 and 220 MHz respectively. Above 5 GHz frequency validity can be extended to ± 110 MHz.

<sup>F</sup> At frequencies below 3 GHz, the validity of tissue parameters ( $\epsilon$  and  $\sigma$ ) can be relaxed to ± 10% if liquid compensation formula is applied to measured SAR values. At frequencies above 3 GHz, the validity of tissue parameters ( $\epsilon$  and  $\sigma$ ) is restricted to ± 5%. The uncertainty is the RSS of the ConvF uncertainty for indicated target tissue parameters.

<sup>G</sup> Alpha/Depth are determined during calibration. SPEAG warrants that the remaining deviation due to the boundary effect after compensation is always less than ± 1% for frequencies below 3 GHz and below ± 2% for frequencies between 3-6 GHz at any distance larger than half the probe tip diameter from the boundary.

## DASY/EASY - Parameters of Probe: ES3DV3 - SN:3319

### Calibration Parameter Determined in Body Tissue Simulating Media

f (MHz) <sup>C</sup>	Relative Permittivity <sup>F</sup>	Conductivity (S/m) <sup>F</sup>	ConvF X	ConvF Y	ConvF Z	Alpha <sup>G</sup>	Depth <sup>G</sup> (mm)	Unc (k=2)
750	55.5	0.96	6.37	6.37	6.37	0.80	1.19	± 12.0 %
835	55.2	0.97	6.29	6.29	6.29	0.80	1.17	± 12.0 %
1750	53.4	1.49	5.07	5.07	5.07	0.57	1.50	± 12.0 %
1900	53.3	1.52	4.88	4.88	4.88	0.80	1.24	± 12.0 %
2300	52.9	1.81	4.62	4.62	4.62	0.80	1.21	± 12.0 %
2450	52.7	1.95	4.42	4.42	4.42	0.80	1.25	± 12.0 %
2600	52.5	2.16	4.18	4.18	4.18	0.80	1.25	± 12.0 %

<sup>C</sup> Frequency validity above 300 MHz of ± 100 MHz only applies for DASY v4.4 and higher (see Page 2), else it is restricted to ± 50 MHz. The uncertainty is the RSS of the ConvF uncertainty at calibration frequency and the uncertainty for the indicated frequency band. Frequency validity below 300 MHz is ± 10, 25, 40, 50 and 70 MHz for ConvF assessments at 30, 64, 128, 150 and 220 MHz respectively. Above 5 GHz frequency validity can be extended to ± 110 MHz.

<sup>F</sup> At frequencies below 3 GHz, the validity of tissue parameters ( $\epsilon$  and  $\sigma$ ) can be relaxed to ± 10% if liquid compensation formula is applied to measured SAR values. At frequencies above 3 GHz, the validity of tissue parameters ( $\epsilon$  and  $\sigma$ ) is restricted to ± 5%. The uncertainty is the RSS of the ConvF uncertainty for indicated target tissue parameters.

<sup>G</sup> Alpha/Depth are determined during calibration. SPEAG warrants that the remaining deviation due to the boundary effect after compensation is always less than ± 1% for frequencies below 3 GHz and below ± 2% for frequencies between 3-6 GHz at any distance larger than half the probe tip diameter from the boundary.

# Frequency Response of E-Field

(TEM-Cell:ifi110 EXX, Waveguide: R22)

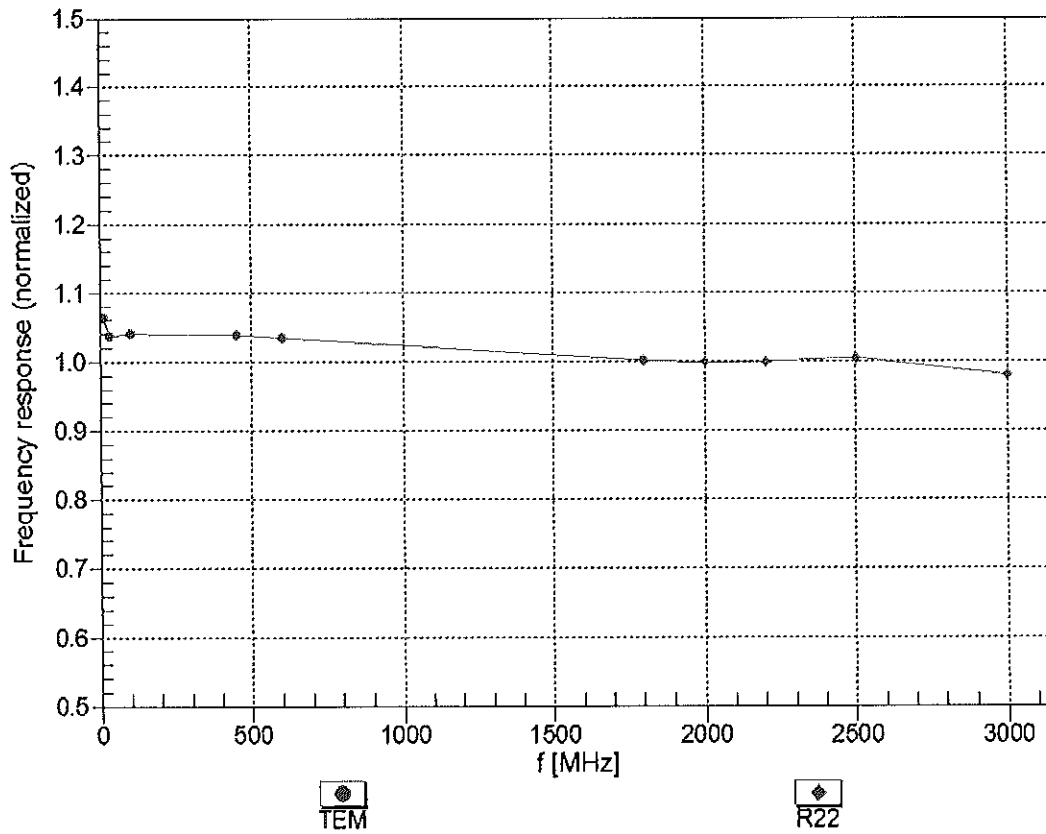

Uncertainty of Frequency Response of E-field:  $\pm 6.3\%$  (k=2)

## Receiving Pattern ( $\phi$ ), $\vartheta = 0^\circ$

f=600 MHz, TEM

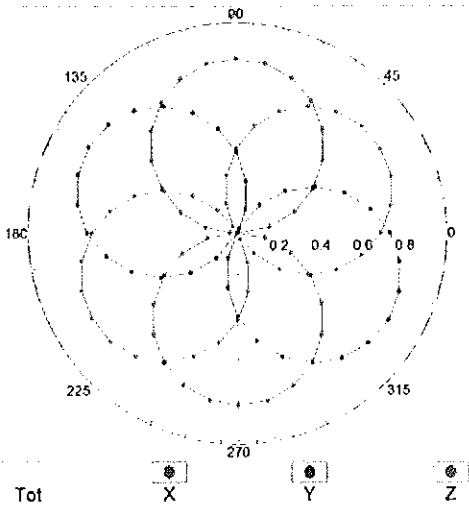

f=1800 MHz, R22

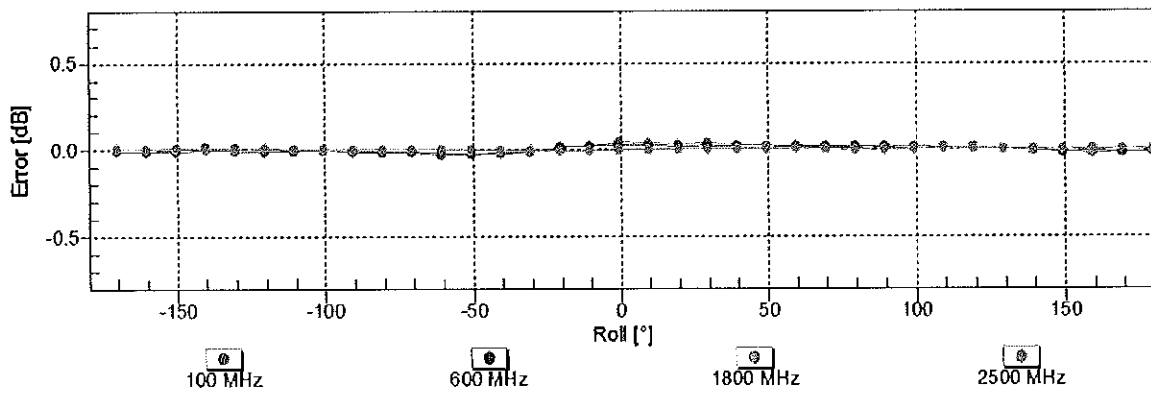
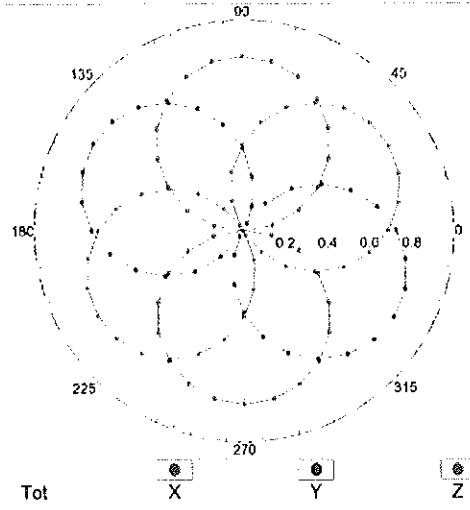

Uncertainty of Axial Isotropy Assessment:  $\pm 0.5\%$  (k=2)

### Dynamic Range f(SAR<sub>head</sub>) (TEM cell , f<sub>eval</sub>= 1900 MHz)

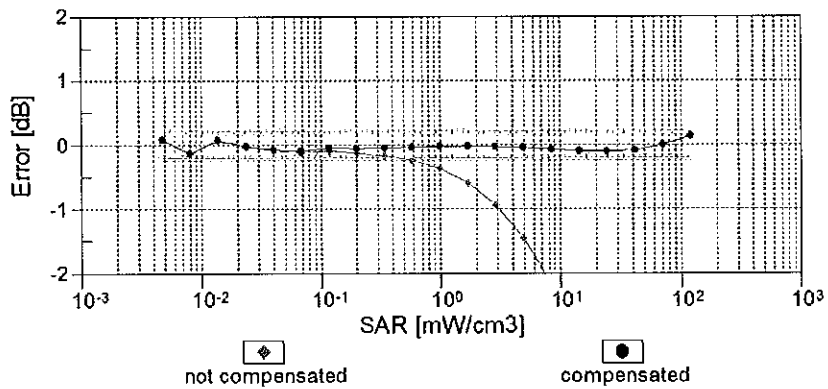
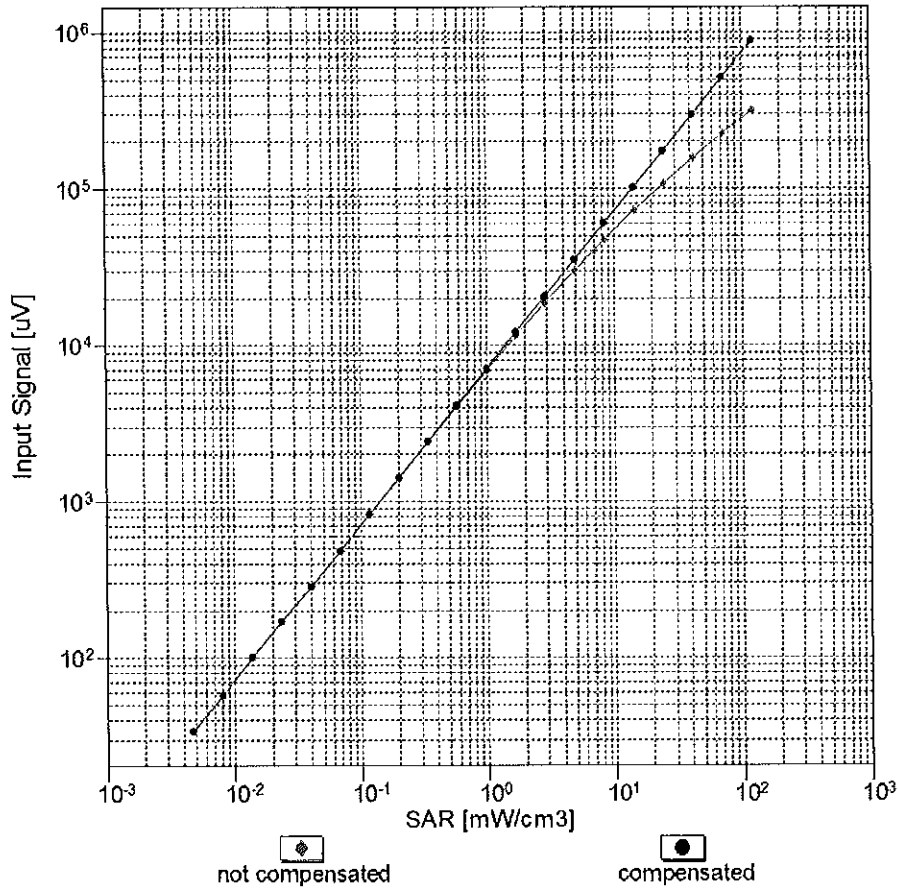

Uncertainty of Linearity Assessment: ± 0.6% (k=2)

# Conversion Factor Assessment

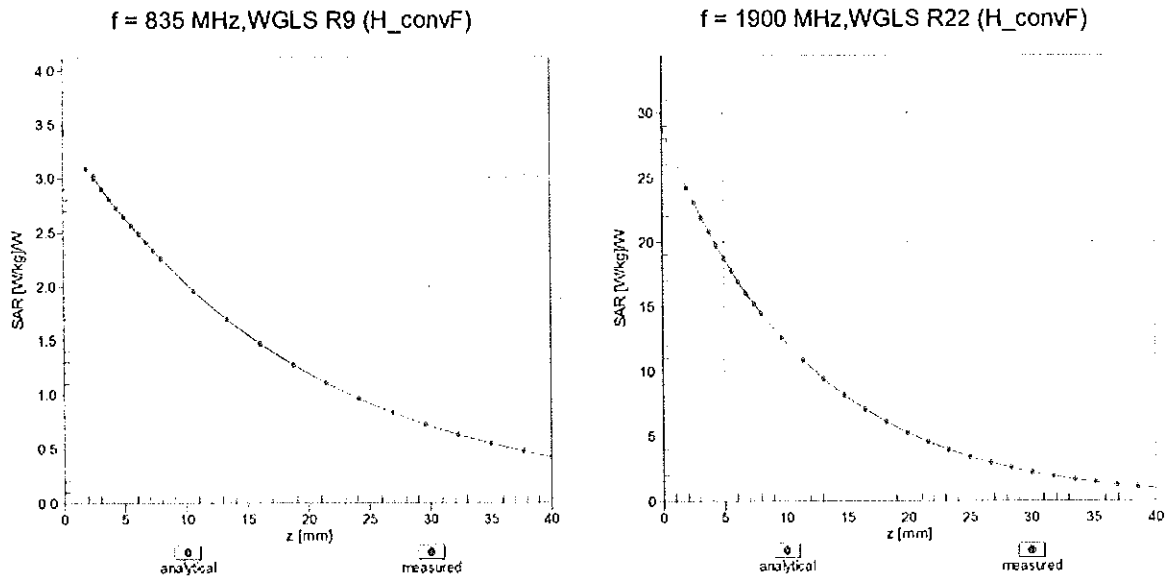

## Deviation from Isotropy in Liquid Error ( $\phi, \theta$ ), f = 900 MHz

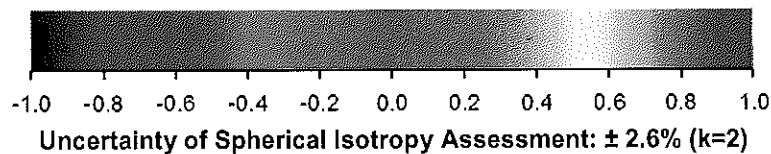
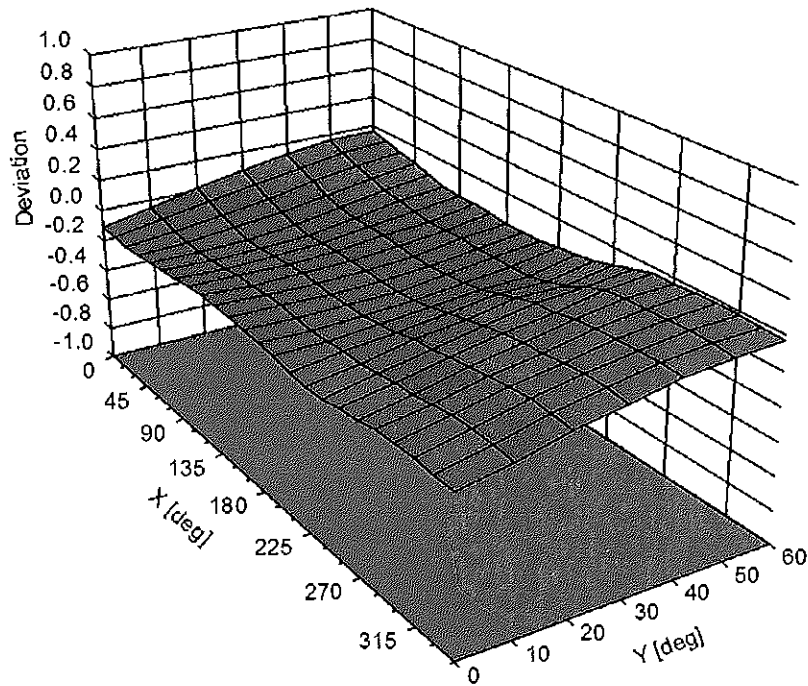



**DASY/EASY - Parameters of Probe: ES3DV3 - SN:3319****Other Probe Parameters**

Sensor Arrangement	Triangular
Connector Angle (°)	59.3
Mechanical Surface Detection Mode	enabled
Optical Surface Detection Mode	disabled
Probe Overall Length	337 mm
Probe Body Diameter	10 mm
Tip Length	10 mm
Tip Diameter	4 mm
Probe Tip to Sensor X Calibration Point	2 mm
Probe Tip to Sensor Y Calibration Point	2 mm
Probe Tip to Sensor Z Calibration Point	2 mm
Recommended Measurement Distance from Surface	3 mm

**Appendix: Modulation Calibration Parameters**

UID	Communication System Name		A dB	B dB $\sqrt{\mu}$ V	C	D dB	VR mV	Max Unc <sup>E</sup> (k=2)
0	CW	X	0.00	0.00	1.00	0.00	199.3	± 3.5 %
		Y	0.00	0.00	1.00		195.9	
		Z	0.00	0.00	1.00		195.7	
10010- CAA	SAR Validation (Square, 100ms, 10ms)	X	9.85	81.84	20.91	10.00	25.0	± 9.6 %
		Y	10.35	82.84	20.96		25.0	
		Z	9.24	80.45	20.49		25.0	
10011- CAB	UMTS-FDD (WCDMA)	X	1.42	72.72	18.48	0.00	150.0	± 9.6 %
		Y	1.15	68.46	16.03		150.0	
		Z	1.19	69.33	16.47		150.0	
10012- CAB	IEEE 802.11b WiFi 2.4 GHz (DSSS, 1 Mbps)	X	1.41	66.60	17.14	0.41	150.0	± 9.6 %
		Y	1.35	65.41	16.14		150.0	
		Z	1.37	65.70	16.31		150.0	
10013- CAB	IEEE 802.11g WiFi 2.4 GHz (DSSS-OFDM, 6 Mbps)	X	5.30	67.44	17.71	1.46	150.0	± 9.6 %
		Y	5.25	67.26	17.48		150.0	
		Z	5.29	67.34	17.54		150.0	
10021- DAC	GSM-FDD (TDMA, GMSK)	X	15.55	91.05	25.81	9.39	50.0	± 9.6 %
		Y	21.52	97.05	27.50		50.0	
		Z	13.40	88.00	24.84		50.0	
10023- DAC	GPRS-FDD (TDMA, GMSK, TN 0)	X	14.67	89.87	25.47	9.57	50.0	± 9.6 %
		Y	19.36	95.07	26.93		50.0	
		Z	12.87	87.11	24.58		50.0	
10024- DAC	GPRS-FDD (TDMA, GMSK, TN 0-1)	X	72.67	116.69	31.50	6.56	60.0	± 9.6 %
		Y	100.00	120.97	32.15		60.0	
		Z	31.96	103.34	28.02		60.0	
10025- DAC	EDGE-FDD (TDMA, 8PSK, TN 0)	X	17.81	101.87	38.70	12.57	50.0	± 9.6 %
		Y	13.13	92.90	34.83		50.0	
		Z	14.72	95.03	35.71		50.0	
10026- DAC	EDGE-FDD (TDMA, 8PSK, TN 0-1)	X	18.31	99.96	34.53	9.56	60.0	± 9.6 %
		Y	16.31	97.17	33.33		60.0	
		Z	16.55	96.65	33.14		60.0	
10027- DAC	GPRS-FDD (TDMA, GMSK, TN 0-1-2)	X	100.00	120.78	31.24	4.80	80.0	± 9.6 %
		Y	100.00	119.86	30.63		80.0	
		Z	100.00	120.27	31.10		80.0	
10028- DAC	GPRS-FDD (TDMA, GMSK, TN 0-1-2-3)	X	100.00	121.31	30.58	3.55	100.0	± 9.6 %
		Y	100.00	120.10	29.87		100.0	
		Z	100.00	120.31	30.21		100.0	
10029- DAC	EDGE-FDD (TDMA, 8PSK, TN 0-1-2)	X	13.74	94.06	31.43	7.80	80.0	± 9.6 %
		Y	12.10	91.11	30.13		80.0	
		Z	12.69	91.48	30.26		80.0	
10030- CAA	IEEE 802.15.1 Bluetooth (GFSK, DH1)	X	100.00	120.44	31.46	5.30	70.0	± 9.6 %
		Y	100.00	119.51	30.84		70.0	
		Z	86.39	117.92	30.89		70.0	
10031- CAA	IEEE 802.15.1 Bluetooth (GFSK, DH3)	X	100.00	124.75	30.39	1.88	100.0	± 9.6 %
		Y	100.00	122.04	29.08		100.0	
		Z	100.00	122.19	29.33		100.0	

10032-CAA	IEEE 802.15.1 Bluetooth (GFSK, DH5)	X	100.00	132.42	32.41	1.17	100.0	± 9.6 %
		Y	100.00	127.37	30.18		100.0	
		Z	100.00	127.22	30.26		100.0	
10033-CAA	IEEE 802.15.1 Bluetooth (PI/4-DQPSK, DH1)	X	16.06	95.52	27.18	5.30	70.0	± 9.6 %
		Y	16.39	95.85	27.05		70.0	
		Z	12.53	90.50	25.41		70.0	
10034-CAA	IEEE 802.15.1 Bluetooth (PI/4-DQPSK, DH3)	X	10.70	94.04	25.42	1.88	100.0	± 9.6 %
		Y	7.71	88.38	23.29		100.0	
		Z	7.05	86.80	22.76		100.0	
10035-CAA	IEEE 802.15.1 Bluetooth (PI/4-DQPSK, DH5)	X	6.38	88.03	23.33	1.17	100.0	± 9.6 %
		Y	4.42	81.78	20.80		100.0	
		Z	4.44	81.54	20.78		100.0	
10036-CAA	IEEE 802.15.1 Bluetooth (8-DPSK, DH1)	X	18.54	98.19	28.07	5.30	70.0	± 9.6 %
		Y	19.46	98.99	28.08		70.0	
		Z	13.96	92.52	26.13		70.0	
10037-CAA	IEEE 802.15.1 Bluetooth (8-DPSK, DH3)	X	10.52	93.81	25.31	1.88	100.0	± 9.6 %
		Y	7.46	87.90	23.09		100.0	
		Z	6.91	86.34	22.63		100.0	
10038-CAA	IEEE 802.15.1 Bluetooth (8-DPSK, DH5)	X	6.72	89.10	23.77	1.17	100.0	± 9.6 %
		Y	4.58	82.55	21.16		100.0	
		Z	4.59	82.28	21.12		100.0	
10039-CAB	CDMA2000 (1xRTT, RC1)	X	2.88	78.08	19.66	0.00	150.0	± 9.6 %
		Y	2.19	73.41	17.38		150.0	
		Z	2.24	73.69	17.58		150.0	
10042-CAB	IS-54 / IS-136 FDD (TDMA/FDM, PI/4-DQPSK, Halfrate)	X	29.89	101.32	27.42	7.78	50.0	± 9.6 %
		Y	57.75	111.39	29.82		50.0	
		Z	20.04	94.63	25.49		50.0	
10044-CAA	IS-91/EIA/TIA-553 FDD (FDMA, FM)	X	0.01	60.00	29147.00	0.00	150.0	± 9.6 %
		Y	0.01	96.41	0.53		150.0	
		Z	0.00	108.36	0.61		150.0	
10048-CAA	DECT (TDD, TDMA/FDM, GFSK, Full Slot, 24)	X	10.82	81.42	24.20	13.80	25.0	± 9.6 %
		Y	12.01	84.16	25.00		25.0	
		Z	10.45	80.25	23.85		25.0	
10049-CAA	DECT (TDD, TDMA/FDM, GFSK, Double Slot, 12)	X	12.11	85.56	24.37	10.79	40.0	± 9.6 %
		Y	14.10	88.79	25.27		40.0	
		Z	11.33	83.90	23.85		40.0	
10056-CAA	UMTS-TDD (TD-SCDMA, 1.28 Mcps)	X	12.14	85.93	24.81	9.03	50.0	± 9.6 %
		Y	12.75	87.19	25.07		50.0	
		Z	11.32	84.12	24.10		50.0	
10058-DAC	EDGE-FDD (TDMA, 8PSK, TN 0-1-2-3)	X	10.68	89.49	29.10	6.55	100.0	± 9.6 %
		Y	9.42	86.65	27.81		100.0	
		Z	10.05	87.45	28.09		100.0	
10059-CAB	IEEE 802.11b WiFi 2.4 GHz (DSSS, 2 Mbps)	X	1.65	69.30	18.41	0.61	110.0	± 9.6 %
		Y	1.54	67.66	17.23		110.0	
		Z	1.58	68.07	17.43		110.0	
10060-CAB	IEEE 802.11b WiFi 2.4 GHz (DSSS, 5.5 Mbps)	X	100.00	134.53	35.47	1.30	110.0	± 9.6 %
		Y	100.00	132.25	34.36		110.0	
		Z	100.00	131.68	34.21		110.0	

10061-CAB	IEEE 802.11b WiFi 2.4 GHz (DSSS, 11 Mbps)	X	15.72	103.92	29.80	2.04	110.0	± 9.6 %
		Y	9.78	95.24	26.89		110.0	
		Z	9.50	94.05	26.46		110.0	
10062-CAB	IEEE 802.11a/h WiFi 5 GHz (OFDM, 6 Mbps)	X	5.02	67.22	17.01	0.49	100.0	± 9.6 %
		Y	4.97	67.04	16.79		100.0	
		Z	5.00	67.08	16.82		100.0	
10063-CAB	IEEE 802.11a/h WiFi 5 GHz (OFDM, 9 Mbps)	X	5.07	67.40	17.16	0.72	100.0	± 9.6 %
		Y	5.02	67.21	16.94		100.0	
		Z	5.04	67.26	16.97		100.0	
10064-CAB	IEEE 802.11a/h WiFi 5 GHz (OFDM, 12 Mbps)	X	5.43	67.77	17.43	0.86	100.0	± 9.6 %
		Y	5.38	67.58	17.21		100.0	
		Z	5.41	67.64	17.25		100.0	
10065-CAB	IEEE 802.11a/h WiFi 5 GHz (OFDM, 18 Mbps)	X	5.34	67.82	17.61	1.21	100.0	± 9.6 %
		Y	5.28	67.62	17.38		100.0	
		Z	5.32	67.69	17.43		100.0	
10066-CAB	IEEE 802.11a/h WiFi 5 GHz (OFDM, 24 Mbps)	X	5.40	67.98	17.85	1.46	100.0	± 9.6 %
		Y	5.34	67.76	17.61		100.0	
		Z	5.39	67.85	17.67		100.0	
10067-CAB	IEEE 802.11a/h WiFi 5 GHz (OFDM, 36 Mbps)	X	5.73	68.10	18.30	2.04	100.0	± 9.6 %
		Y	5.66	67.87	18.05		100.0	
		Z	5.72	68.01	18.13		100.0	
10068-CAB	IEEE 802.11a/h WiFi 5 GHz (OFDM, 48 Mbps)	X	5.90	68.56	18.70	2.55	100.0	± 9.6 %
		Y	5.82	68.29	18.44		100.0	
		Z	5.90	68.48	18.54		100.0	
10069-CAB	IEEE 802.11a/h WiFi 5 GHz (OFDM, 54 Mbps)	X	5.97	68.43	18.86	2.67	100.0	± 9.6 %
		Y	5.89	68.17	18.59		100.0	
		Z	5.97	68.35	18.70		100.0	
10071-CAB	IEEE 802.11g WiFi 2.4 GHz (DSSS/OFDM, 9 Mbps)	X	5.46	67.71	18.10	1.99	100.0	± 9.6 %
		Y	5.40	67.50	17.87		100.0	
		Z	5.45	67.61	17.94		100.0	
10072-CAB	IEEE 802.11g WiFi 2.4 GHz (DSSS/OFDM, 12 Mbps)	X	5.55	68.34	18.45	2.30	100.0	± 9.6 %
		Y	5.48	68.10	18.20		100.0	
		Z	5.55	68.24	18.28		100.0	
10073-CAB	IEEE 802.11g WiFi 2.4 GHz (DSSS/OFDM, 18 Mbps)	X	5.71	68.73	18.89	2.83	100.0	± 9.6 %
		Y	5.63	68.45	18.63		100.0	
		Z	5.71	68.65	18.73		100.0	
10074-CAB	IEEE 802.11g WiFi 2.4 GHz (DSSS/OFDM, 24 Mbps)	X	5.76	68.86	19.19	3.30	100.0	± 9.6 %
		Y	5.67	68.55	18.90		100.0	
		Z	5.77	68.80	19.03		100.0	
10075-CAB	IEEE 802.11g WiFi 2.4 GHz (DSSS/OFDM, 36 Mbps)	X	5.97	69.51	19.77	3.82	90.0	± 9.6 %
		Y	5.85	69.11	19.43		90.0	
		Z	5.99	69.45	19.61		90.0	
10076-CAB	IEEE 802.11g WiFi 2.4 GHz (DSSS/OFDM, 48 Mbps)	X	5.96	69.27	19.86	4.15	90.0	± 9.6 %
		Y	5.85	68.87	19.52		90.0	
		Z	5.99	69.24	19.72		90.0	
10077-CAB	IEEE 802.11g WiFi 2.4 GHz (DSSS/OFDM, 54 Mbps)	X	6.00	69.37	19.97	4.30	90.0	± 9.6 %
		Y	5.89	68.96	19.62		90.0	
		Z	6.03	69.34	19.83		90.0	

10081-CAB	CDMA2000 (1xRTT, RC3)	X	1.41	72.76	17.31	0.00	150.0	± 9.6 %
		Y	1.06	67.92	14.61		150.0	
		Z	1.11	68.62	15.03		150.0	
10082-CAB	IS-54 / IS-136 FDD (TDMA/FDM, PI/4-DQPSK, Fullrate)	X	2.74	66.09	10.68	4.77	80.0	± 9.6 %
		Y	2.51	65.26	10.02		80.0	
		Z	2.76	65.88	10.66		80.0	
10090-DAC	GPRS-FDD (TDMA, GMSK, TN 0-4)	X	68.83	115.90	31.34	6.56	60.0	± 9.6 %
		Y	100.00	121.06	32.22		60.0	
		Z	31.05	102.92	27.93		60.0	
10097-CAB	UMTS-FDD (HSDPA)	X	2.05	69.35	17.13	0.00	150.0	± 9.6 %
		Y	1.92	67.86	16.10		150.0	
		Z	1.93	68.06	16.23		150.0	
10098-CAB	UMTS-FDD (HSUPA, Subtest 2)	X	2.02	69.37	17.13	0.00	150.0	± 9.6 %
		Y	1.88	67.83	16.06		150.0	
		Z	1.90	68.05	16.21		150.0	
10099-DAC	EDGE-FDD (TDMA, 8PSK, TN 0-4)	X	18.22	99.79	34.47	9.56	60.0	± 9.6 %
		Y	16.25	97.06	33.29		60.0	
		Z	16.47	96.50	33.09		60.0	
10100-CAC	LTE-FDD (SC-FDMA, 100% RB, 20 MHz, QPSK)	X	3.71	72.76	17.93	0.00	150.0	± 9.6 %
		Y	3.41	71.21	17.05		150.0	
		Z	3.48	71.52	17.17		150.0	
10101-CAC	LTE-FDD (SC-FDMA, 100% RB, 20 MHz, 16-QAM)	X	3.57	68.80	16.73	0.00	150.0	± 9.6 %
		Y	3.46	68.11	16.22		150.0	
		Z	3.49	68.27	16.30		150.0	
10102-CAC	LTE-FDD (SC-FDMA, 100% RB, 20 MHz, 64-QAM)	X	3.66	68.61	16.75	0.00	150.0	± 9.6 %
		Y	3.56	68.02	16.30		150.0	
		Z	3.58	68.13	16.36		150.0	
10103-CAC	LTE-TDD (SC-FDMA, 100% RB, 20 MHz, QPSK)	X	8.88	78.01	21.33	3.98	65.0	± 9.6 %
		Y	8.67	77.74	21.13		65.0	
		Z	8.55	77.02	20.81		65.0	
10104-CAC	LTE-TDD (SC-FDMA, 100% RB, 20 MHz, 16-QAM)	X	8.93	77.00	21.79	3.98	65.0	± 9.6 %
		Y	8.73	76.65	21.51		65.0	
		Z	8.82	76.47	21.44		65.0	
10105-CAC	LTE-TDD (SC-FDMA, 100% RB, 20 MHz, 64-QAM)	X	7.98	74.72	21.06	3.98	65.0	± 9.6 %
		Y	8.03	74.96	21.06		65.0	
		Z	7.61	73.51	20.40		65.0	
10108-CAD	LTE-FDD (SC-FDMA, 100% RB, 10 MHz, QPSK)	X	3.27	71.88	17.76	0.00	150.0	± 9.6 %
		Y	3.02	70.38	16.87		150.0	
		Z	3.08	70.66	16.99		150.0	
10109-CAD	LTE-FDD (SC-FDMA, 100% RB, 10 MHz, 16-QAM)	X	3.25	68.64	16.73	0.00	150.0	± 9.6 %
		Y	3.13	67.91	16.18		150.0	
		Z	3.16	68.05	16.25		150.0	
10110-CAD	LTE-FDD (SC-FDMA, 100% RB, 5 MHz, QPSK)	X	2.71	70.99	17.56	0.00	150.0	± 9.6 %
		Y	2.49	69.37	16.56		150.0	
		Z	2.54	69.69	16.72		150.0	
10111-CAD	LTE-FDD (SC-FDMA, 100% RB, 5 MHz, 16-QAM)	X	2.94	69.24	17.11	0.00	150.0	± 9.6 %
		Y	2.83	68.45	16.51		150.0	
		Z	2.85	68.47	16.54		150.0	

10112-CAD	LTE-FDD (SC-FDMA, 100% RB, 10 MHz, 64-QAM)	X	3.35	68.45	16.70	0.00	150.0	± 9.6 %
		Y	3.25	67.82	16.20		150.0	
		Z	3.28	67.92	16.26		150.0	
10113-CAD	LTE-FDD (SC-FDMA, 100% RB, 5 MHz, 64-QAM)	X	3.09	69.18	17.14	0.00	150.0	± 9.6 %
		Y	2.99	68.50	16.60		150.0	
		Z	3.00	68.49	16.61		150.0	
10114-CAB	IEEE 802.11n (HT Greenfield, 13.5 Mbps, BPSK)	X	5.36	67.61	16.76	0.00	150.0	± 9.6 %
		Y	5.31	67.41	16.53		150.0	
		Z	5.33	67.45	16.56		150.0	
10115-CAB	IEEE 802.11n (HT Greenfield, 81 Mbps, 16-QAM)	X	5.78	68.00	16.95	0.00	150.0	± 9.6 %
		Y	5.71	67.76	16.71		150.0	
		Z	5.74	67.85	16.76		150.0	
10116-CAB	IEEE 802.11n (HT Greenfield, 135 Mbps, 64-QAM)	X	5.50	67.87	16.80	0.00	150.0	± 9.6 %
		Y	5.45	67.67	16.59		150.0	
		Z	5.46	67.70	16.60		150.0	
10117-CAB	IEEE 802.11n (HT Mixed, 13.5 Mbps, BPSK)	X	5.37	67.63	16.79	0.00	150.0	± 9.6 %
		Y	5.32	67.44	16.57		150.0	
		Z	5.33	67.46	16.59		150.0	
10118-CAB	IEEE 802.11n (HT Mixed, 81 Mbps, 16-QAM)	X	5.80	67.97	16.94	0.00	150.0	± 9.6 %
		Y	5.75	67.80	16.74		150.0	
		Z	5.76	67.82	16.75		150.0	
10119-CAB	IEEE 802.11n (HT Mixed, 135 Mbps, 64-QAM)	X	5.47	67.83	16.80	0.00	150.0	± 9.6 %
		Y	5.42	67.63	16.58		150.0	
		Z	5.43	67.65	16.60		150.0	
10140-CAC	LTE-FDD (SC-FDMA, 100% RB, 15 MHz, 16-QAM)	X	3.71	68.61	16.68	0.00	150.0	± 9.6 %
		Y	3.61	68.02	16.22		150.0	
		Z	3.64	68.14	16.28		150.0	
10141-CAC	LTE-FDD (SC-FDMA, 100% RB, 15 MHz, 64-QAM)	X	3.82	68.57	16.77	0.00	150.0	± 9.6 %
		Y	3.73	68.05	16.36		150.0	
		Z	3.75	68.13	16.40		150.0	
10142-CAD	LTE-FDD (SC-FDMA, 100% RB, 3 MHz, QPSK)	X	2.49	71.10	17.54	0.00	150.0	± 9.6 %
		Y	2.27	69.32	16.43		150.0	
		Z	2.31	69.61	16.60		150.0	
10143-CAD	LTE-FDD (SC-FDMA, 100% RB, 3 MHz, 16-QAM)	X	2.87	70.15	17.21	0.00	150.0	± 9.6 %
		Y	2.72	69.17	16.50		150.0	
		Z	2.73	69.14	16.52		150.0	
10144-CAD	LTE-FDD (SC-FDMA, 100% RB, 3 MHz, 64-QAM)	X	2.68	68.25	15.88	0.00	150.0	± 9.6 %
		Y	2.54	67.28	15.14		150.0	
		Z	2.58	67.43	15.28		150.0	
10145-CAD	LTE-FDD (SC-FDMA, 100% RB, 1.4 MHz, QPSK)	X	1.97	70.87	16.37	0.00	150.0	± 9.6 %
		Y	1.68	68.25	14.76		150.0	
		Z	1.73	68.59	15.05		150.0	
10146-CAD	LTE-FDD (SC-FDMA, 100% RB, 1.4 MHz, 16-QAM)	X	4.75	78.42	19.14	0.00	150.0	± 9.6 %
		Y	3.83	74.52	16.97		150.0	
		Z	4.41	76.61	18.14		150.0	
10147-CAD	LTE-FDD (SC-FDMA, 100% RB, 1.4 MHz, 64-QAM)	X	6.27	82.79	20.95	0.00	150.0	± 9.6 %
		Y	5.05	78.64	18.78		150.0	
		Z	5.67	80.46	19.79		150.0	

10149-CAC	LTE-FDD (SC-FDMA, 50% RB, 20 MHz, 16-QAM)	X	3.26	68.70	16.77	0.00	150.0	± 9.6 %
		Y	3.14	67.97	16.22		150.0	
		Z	3.17	68.10	16.29		150.0	
10150-CAC	LTE-FDD (SC-FDMA, 50% RB, 20 MHz, 64-QAM)	X	3.36	68.50	16.73	0.00	150.0	± 9.6 %
		Y	3.26	67.87	16.24		150.0	
		Z	3.28	67.96	16.30		150.0	
10151-CAC	LTE-TDD (SC-FDMA, 50% RB, 20 MHz, QPSK)	X	9.26	79.92	22.22	3.98	65.0	± 9.6 %
		Y	9.15	79.84	22.08		65.0	
		Z	8.96	78.94	21.70		65.0	
10152-CAC	LTE-TDD (SC-FDMA, 50% RB, 20 MHz, 16-QAM)	X	8.60	77.27	21.75	3.98	65.0	± 9.6 %
		Y	8.35	76.82	21.41		65.0	
		Z	8.46	76.64	21.35		65.0	
10153-CAC	LTE-TDD (SC-FDMA, 50% RB, 20 MHz, 64-QAM)	X	8.88	77.79	22.28	3.98	65.0	± 9.6 %
		Y	8.70	77.50	22.02		65.0	
		Z	8.75	77.18	21.89		65.0	
10154-CAD	LTE-FDD (SC-FDMA, 50% RB, 10 MHz, QPSK)	X	2.78	71.52	17.87	0.00	150.0	± 9.6 %
		Y	2.56	69.90	16.88		150.0	
		Z	2.60	70.17	17.01		150.0	
10155-CAD	LTE-FDD (SC-FDMA, 50% RB, 10 MHz, 16-QAM)	X	2.94	69.23	17.11	0.00	150.0	± 9.6 %
		Y	2.83	68.44	16.51		150.0	
		Z	2.85	68.47	16.54		150.0	
10156-CAD	LTE-FDD (SC-FDMA, 50% RB, 5 MHz, QPSK)	X	2.40	71.71	17.74	0.00	150.0	± 9.6 %
		Y	2.14	69.64	16.49		150.0	
		Z	2.19	69.95	16.67		150.0	
10157-CAD	LTE-FDD (SC-FDMA, 50% RB, 5 MHz, 16-QAM)	X	2.56	69.20	16.24	0.00	150.0	± 9.6 %
		Y	2.39	67.98	15.37		150.0	
		Z	2.42	68.11	15.51		150.0	
10158-CAD	LTE-FDD (SC-FDMA, 50% RB, 10 MHz, 64-QAM)	X	3.10	69.22	17.17	0.00	150.0	± 9.6 %
		Y	2.99	68.55	16.64		150.0	
		Z	3.00	68.53	16.65		150.0	
10159-CAD	LTE-FDD (SC-FDMA, 50% RB, 5 MHz, 64-QAM)	X	2.68	69.58	16.50	0.00	150.0	± 9.6 %
		Y	2.51	68.44	15.68		150.0	
		Z	2.54	68.50	15.78		150.0	
10160-CAC	LTE-FDD (SC-FDMA, 50% RB, 15 MHz, QPSK)	X	3.14	70.23	17.31	0.00	150.0	± 9.6 %
		Y	2.97	69.12	16.58		150.0	
		Z	3.01	69.30	16.67		150.0	
10161-CAC	LTE-FDD (SC-FDMA, 50% RB, 15 MHz, 16-QAM)	X	3.25	68.37	16.69	0.00	150.0	± 9.6 %
		Y	3.15	67.75	16.20		150.0	
		Z	3.17	67.82	16.25		150.0	
10162-CAC	LTE-FDD (SC-FDMA, 50% RB, 15 MHz, 64-QAM)	X	3.35	68.34	16.71	0.00	150.0	± 9.6 %
		Y	3.25	67.77	16.24		150.0	
		Z	3.27	67.82	16.29		150.0	
10166-CAD	LTE-FDD (SC-FDMA, 50% RB, 1.4 MHz, QPSK)	X	4.16	70.95	20.14	3.01	150.0	± 9.6 %
		Y	4.09	70.57	19.65		150.0	
		Z	4.23	71.07	20.00		150.0	
10167-CAD	LTE-FDD (SC-FDMA, 50% RB, 1.4 MHz, 16-QAM)	X	5.42	74.49	20.88	3.01	150.0	± 9.6 %
		Y	5.38	74.26	20.45		150.0	
		Z	5.66	74.92	20.85		150.0	

10168-CAD	LTE-FDD (SC-FDMA, 50% RB, 1.4 MHz, 64-QAM)	X	5.88	76.24	21.91	3.01	150.0	± 9.6 %
		Y	5.94	76.40	21.68		150.0	
		Z	6.16	76.77	21.92		150.0	
10169-CAC	LTE-FDD (SC-FDMA, 1 RB, 20 MHz, QPSK)	X	4.00	73.62	21.32	3.01	150.0	± 9.6 %
		Y	3.90	72.96	20.64		150.0	
		Z	4.22	74.22	21.31		150.0	
10170-CAC	LTE-FDD (SC-FDMA, 1 RB, 20 MHz, 16-QAM)	X	6.31	81.51	24.09	3.01	150.0	± 9.6 %
		Y	6.48	81.75	23.78		150.0	
		Z	7.05	82.86	24.27		150.0	
10171-AAC	LTE-FDD (SC-FDMA, 1 RB, 20 MHz, 64-QAM)	X	5.08	76.75	21.32	3.01	150.0	± 9.6 %
		Y	4.94	75.94	20.54		150.0	
		Z	5.51	77.53	21.31		150.0	
10172-CAC	LTE-TDD (SC-FDMA, 1 RB, 20 MHz, QPSK)	X	28.35	107.78	33.34	6.02	65.0	± 9.6 %
		Y	28.59	107.61	32.92		65.0	
		Z	27.19	105.85	32.47		65.0	
10173-CAC	LTE-TDD (SC-FDMA, 1 RB, 20 MHz, 16-QAM)	X	29.50	104.02	30.66	6.02	65.0	± 9.6 %
		Y	34.69	106.60	31.03		65.0	
		Z	27.86	101.98	29.79		65.0	
10174-CAC	LTE-TDD (SC-FDMA, 1 RB, 20 MHz, 64-QAM)	X	23.87	98.93	28.69	6.02	65.0	± 9.6 %
		Y	26.66	100.64	28.84		65.0	
		Z	22.60	97.09	27.89		65.0	
10175-CAD	LTE-FDD (SC-FDMA, 1 RB, 10 MHz, QPSK)	X	3.94	73.23	21.05	3.01	150.0	± 9.6 %
		Y	3.83	72.52	20.34		150.0	
		Z	4.15	73.80	21.02		150.0	
10176-CAD	LTE-FDD (SC-FDMA, 1 RB, 10 MHz, 16-QAM)	X	6.32	81.53	24.10	3.01	150.0	± 9.6 %
		Y	6.49	81.78	23.79		150.0	
		Z	7.06	82.89	24.28		150.0	
10177-CAF	LTE-FDD (SC-FDMA, 1 RB, 5 MHz, QPSK)	X	3.98	73.42	21.16	3.01	150.0	± 9.6 %
		Y	3.88	72.74	20.47		150.0	
		Z	4.19	74.00	21.14		150.0	
10178-CAD	LTE-FDD (SC-FDMA, 1 RB, 5 MHz, 16-QAM)	X	6.20	81.16	23.93	3.01	150.0	± 9.6 %
		Y	6.35	81.32	23.59		150.0	
		Z	6.91	82.48	24.09		150.0	
10179-CAD	LTE-FDD (SC-FDMA, 1 RB, 10 MHz, 64-QAM)	X	5.64	78.94	22.55	3.01	150.0	± 9.6 %
		Y	5.60	78.53	21.96		150.0	
		Z	6.18	79.93	22.60		150.0	
10180-CAD	LTE-FDD (SC-FDMA, 1 RB, 5 MHz, 64-QAM)	X	5.06	76.62	21.25	3.01	150.0	± 9.6 %
		Y	4.91	75.79	20.46		150.0	
		Z	5.47	77.39	21.24		150.0	
10181-CAC	LTE-FDD (SC-FDMA, 1 RB, 15 MHz, QPSK)	X	3.98	73.40	21.15	3.01	150.0	± 9.6 %
		Y	3.87	72.72	20.46		150.0	
		Z	4.18	73.98	21.13		150.0	
10182-CAC	LTE-FDD (SC-FDMA, 1 RB, 15 MHz, 16-QAM)	X	6.19	81.13	23.92	3.01	150.0	± 9.6 %
		Y	6.34	81.29	23.57		150.0	
		Z	6.90	82.45	24.08		150.0	
10183-AAB	LTE-FDD (SC-FDMA, 1 RB, 15 MHz, 64-QAM)	X	5.05	76.59	21.24	3.01	150.0	± 9.6 %
		Y	4.90	75.76	20.45		150.0	
		Z	5.46	77.36	21.23		150.0	



10184-CAD	LTE-FDD (SC-FDMA, 1 RB, 3 MHz, QPSK)	X	3.99	73.45	21.17	3.01	150.0	± 9.6 %
		Y	3.89	72.78	20.49		150.0	
		Z	4.20	74.03	21.16		150.0	
10185-CAD	LTE-FDD (SC-FDMA, 1 RB, 3 MHz, 16-QAM)	X	6.23	81.21	23.95	3.01	150.0	± 9.6 %
		Y	6.37	81.39	23.62		150.0	
		Z	6.94	82.53	24.12		150.0	
10186-AAD	LTE-FDD (SC-FDMA, 1 RB, 3 MHz, 64-QAM)	X	5.08	76.67	21.27	3.01	150.0	± 9.6 %
		Y	4.93	75.84	20.48		150.0	
		Z	5.49	77.44	21.26		150.0	
10187-CAD	LTE-FDD (SC-FDMA, 1 RB, 1.4 MHz, QPSK)	X	4.00	73.48	21.22	3.01	150.0	± 9.6 %
		Y	3.89	72.80	20.53		150.0	
		Z	4.21	74.07	21.20		150.0	
10188-CAD	LTE-FDD (SC-FDMA, 1 RB, 1.4 MHz, 16-QAM)	X	6.48	82.07	24.38	3.01	150.0	± 9.6 %
		Y	6.71	82.45	24.13		150.0	
		Z	7.27	83.49	24.57		150.0	
10189-AAD	LTE-FDD (SC-FDMA, 1 RB, 1.4 MHz, 64-QAM)	X	5.21	77.21	21.58	3.01	150.0	± 9.6 %
		Y	5.09	76.46	20.83		150.0	
		Z	5.66	78.03	21.58		150.0	
10193-CAB	IEEE 802.11n (HT Greenfield, 6.5 Mbps, BPSK)	X	4.79	66.98	16.56	0.00	150.0	± 9.6 %
		Y	4.74	66.79	16.32		150.0	
		Z	4.76	66.81	16.35		150.0	
10194-CAB	IEEE 802.11n (HT Greenfield, 39 Mbps, 16-QAM)	X	5.00	67.38	16.67	0.00	150.0	± 9.6 %
		Y	4.95	67.18	16.43		150.0	
		Z	4.97	67.21	16.46		150.0	
10195-CAB	IEEE 802.11n (HT Greenfield, 65 Mbps, 64-QAM)	X	5.04	67.38	16.66	0.00	150.0	± 9.6 %
		Y	4.99	67.18	16.43		150.0	
		Z	5.00	67.20	16.45		150.0	
10196-CAB	IEEE 802.11n (HT Mixed, 6.5 Mbps, BPSK)	X	4.82	67.11	16.60	0.00	150.0	± 9.6 %
		Y	4.77	66.91	16.36		150.0	
		Z	4.78	66.93	16.39		150.0	
10197-CAB	IEEE 802.11n (HT Mixed, 39 Mbps, 16-QAM)	X	5.02	67.40	16.67	0.00	150.0	± 9.6 %
		Y	4.97	67.20	16.44		150.0	
		Z	4.98	67.22	16.46		150.0	
10198-CAB	IEEE 802.11n (HT Mixed, 65 Mbps, 64-QAM)	X	5.05	67.39	16.67	0.00	150.0	± 9.6 %
		Y	5.00	67.20	16.44		150.0	
		Z	5.01	67.21	16.46		150.0	
10219-CAB	IEEE 802.11n (HT Mixed, 7.2 Mbps, BPSK)	X	4.77	67.13	16.58	0.00	150.0	± 9.6 %
		Y	4.72	66.92	16.33		150.0	
		Z	4.73	66.95	16.36		150.0	
10220-CAB	IEEE 802.11n (HT Mixed, 43.3 Mbps, 16-QAM)	X	5.02	67.40	16.68	0.00	150.0	± 9.6 %
		Y	4.97	67.20	16.44		150.0	
		Z	4.99	67.23	16.47		150.0	
10221-CAB	IEEE 802.11n (HT Mixed, 72.2 Mbps, 64-QAM)	X	5.05	67.33	16.66	0.00	150.0	± 9.6 %
		Y	5.00	67.13	16.44		150.0	
		Z	5.02	67.15	16.46		150.0	
10222-CAB	IEEE 802.11n (HT Mixed, 15 Mbps, BPSK)	X	5.36	67.67	16.80	0.00	150.0	± 9.6 %
		Y	5.31	67.46	16.57		150.0	
		Z	5.32	67.50	16.60		150.0	

10223-CAB	IEEE 802.11n (HT Mixed, 90 Mbps, 16-QAM)	X	5.75	68.00	16.98	0.00	150.0	± 9.6 %
		Y	5.70	67.82	16.77		150.0	
		Z	5.71	67.82	16.78		150.0	
10224-CAB	IEEE 802.11n (HT Mixed, 150 Mbps, 64-QAM)	X	5.42	67.80	16.78	0.00	150.0	± 9.6 %
		Y	5.36	67.58	16.55		150.0	
		Z	5.38	67.63	16.58		150.0	
10225-CAB	UMTS-FDD (HSPA+)	X	3.07	66.80	16.19	0.00	150.0	± 9.6 %
		Y	3.00	66.35	15.75		150.0	
		Z	3.01	66.39	15.81		150.0	
10226-CAA	LTE-TDD (SC-FDMA, 1 RB, 1.4 MHz, 16-QAM)	X	30.74	104.89	30.99	6.02	65.0	± 9.6 %
		Y	36.94	107.88	31.47		65.0	
		Z	29.00	102.81	30.11		65.0	
10227-CAA	LTE-TDD (SC-FDMA, 1 RB, 1.4 MHz, 64-QAM)	X	24.57	99.58	28.97	6.02	65.0	± 9.6 %
		Y	28.65	102.05	29.35		65.0	
		Z	23.52	97.91	28.22		65.0	
10228-CAA	LTE-TDD (SC-FDMA, 1 RB, 1.4 MHz, QPSK)	X	30.31	109.61	33.99	6.02	65.0	± 9.6 %
		Y	29.44	108.70	33.37		65.0	
		Z	27.38	106.50	32.79		65.0	
10229-CAB	LTE-TDD (SC-FDMA, 1 RB, 3 MHz, 16-QAM)	X	29.49	104.00	30.66	6.02	65.0	± 9.6 %
		Y	34.74	106.61	31.04		65.0	
		Z	27.87	101.97	29.80		65.0	
10230-CAB	LTE-TDD (SC-FDMA, 1 RB, 3 MHz, 64-QAM)	X	23.73	98.88	28.69	6.02	65.0	± 9.6 %
		Y	27.25	101.06	28.99		65.0	
		Z	22.75	97.24	27.95		65.0	
10231-CAB	LTE-TDD (SC-FDMA, 1 RB, 3 MHz, QPSK)	X	29.15	108.72	33.67	6.02	65.0	± 9.6 %
		Y	27.96	107.57	32.97		65.0	
		Z	26.38	105.67	32.48		65.0	
10232-CAC	LTE-TDD (SC-FDMA, 1 RB, 5 MHz, 16-QAM)	X	29.48	104.00	30.66	6.02	65.0	± 9.6 %
		Y	34.72	106.61	31.04		65.0	
		Z	27.86	101.97	29.80		65.0	
10233-CAC	LTE-TDD (SC-FDMA, 1 RB, 5 MHz, 64-QAM)	X	23.75	98.91	28.70	6.02	65.0	± 9.6 %
		Y	27.26	101.08	28.99		65.0	
		Z	22.77	97.26	27.96		65.0	
10234-CAC	LTE-TDD (SC-FDMA, 1 RB, 5 MHz, QPSK)	X	27.90	107.69	33.28	6.02	65.0	± 9.6 %
		Y	26.50	106.35	32.52		65.0	
		Z	25.32	104.71	32.10		65.0	
10235-CAC	LTE-TDD (SC-FDMA, 1 RB, 10 MHz, 16-QAM)	X	29.56	104.06	30.68	6.02	65.0	± 9.6 %
		Y	34.83	106.68	31.06		65.0	
		Z	27.92	102.02	29.81		65.0	
10236-CAC	LTE-TDD (SC-FDMA, 1 RB, 10 MHz, 64-QAM)	X	23.93	99.02	28.74	6.02	65.0	± 9.6 %
		Y	27.48	101.20	29.02		65.0	
		Z	22.92	97.36	27.99		65.0	
10237-CAC	LTE-TDD (SC-FDMA, 1 RB, 10 MHz, QPSK)	X	29.43	108.94	33.73	6.02	65.0	± 9.6 %
		Y	28.18	107.75	33.02		65.0	
		Z	26.59	105.85	32.53		65.0	
10238-CAC	LTE-TDD (SC-FDMA, 1 RB, 15 MHz, 16-QAM)	X	29.51	104.02	30.67	6.02	65.0	± 9.6 %
		Y	34.75	106.63	31.04		65.0	
		Z	27.87	101.98	29.80		65.0	

10239-CAC	LTE-TDD (SC-FDMA, 1 RB, 15 MHz, 64-QAM)	X	23.77	98.93	28.71	6.02	65.0	± 9.6 %
		Y	27.27	101.10	29.00		65.0	
		Z	22.78	97.29	27.97		65.0	
10240-CAC	LTE-TDD (SC-FDMA, 1 RB, 15 MHz, QPSK)	X	29.33	108.88	33.71	6.02	65.0	± 9.6 %
		Y	28.09	107.69	33.00		65.0	
		Z	26.51	105.80	32.51		65.0	
10241-CAA	LTE-TDD (SC-FDMA, 50% RB, 1.4 MHz, 16-QAM)	X	12.97	86.83	27.84	6.98	65.0	± 9.6 %
		Y	12.74	86.49	27.42		65.0	
		Z	13.39	87.03	27.74		65.0	
10242-CAA	LTE-TDD (SC-FDMA, 50% RB, 1.4 MHz, 64-QAM)	X	11.77	84.58	26.87	6.98	65.0	± 9.6 %
		Y	12.19	85.46	26.94		65.0	
		Z	12.90	86.14	27.32		65.0	
10243-CAA	LTE-TDD (SC-FDMA, 50% RB, 1.4 MHz, QPSK)	X	9.86	82.57	26.93	6.98	65.0	± 9.6 %
		Y	9.88	82.69	26.70		65.0	
		Z	10.64	83.89	27.31		65.0	
10244-CAB	LTE-TDD (SC-FDMA, 50% RB, 3 MHz, 16-QAM)	X	10.27	81.73	22.33	3.98	65.0	± 9.6 %
		Y	10.27	81.67	21.99		65.0	
		Z	10.19	81.13	21.98		65.0	
10245-CAB	LTE-TDD (SC-FDMA, 50% RB, 3 MHz, 64-QAM)	X	10.17	81.33	22.14	3.98	65.0	± 9.6 %
		Y	10.15	81.24	21.78		65.0	
		Z	10.11	80.77	21.80		65.0	
10246-CAB	LTE-TDD (SC-FDMA, 50% RB, 3 MHz, QPSK)	X	9.71	83.45	22.80	3.98	65.0	± 9.6 %
		Y	9.49	83.12	22.47		65.0	
		Z	8.94	81.57	21.97		65.0	
10247-CAC	LTE-TDD (SC-FDMA, 50% RB, 5 MHz, 16-QAM)	X	8.20	78.33	21.34	3.98	65.0	± 9.6 %
		Y	8.00	78.01	21.02		65.0	
		Z	7.96	77.44	20.86		65.0	
10248-CAC	LTE-TDD (SC-FDMA, 50% RB, 5 MHz, 64-QAM)	X	8.23	77.94	21.17	3.98	65.0	± 9.6 %
		Y	8.00	77.54	20.82		65.0	
		Z	8.02	77.11	20.72		65.0	
10249-CAC	LTE-TDD (SC-FDMA, 50% RB, 5 MHz, QPSK)	X	10.15	84.14	23.49	3.98	65.0	± 9.6 %
		Y	9.98	83.94	23.24		65.0	
		Z	9.39	82.30	22.67		65.0	
10250-CAC	LTE-TDD (SC-FDMA, 50% RB, 10 MHz, 16-QAM)	X	8.79	79.35	22.70	3.98	65.0	± 9.6 %
		Y	8.63	79.16	22.48		65.0	
		Z	8.57	78.51	22.22		65.0	
10251-CAC	LTE-TDD (SC-FDMA, 50% RB, 10 MHz, 64-QAM)	X	8.44	77.55	21.73	3.98	65.0	± 9.6 %
		Y	8.21	77.13	21.40		65.0	
		Z	8.29	76.85	21.32		65.0	
10252-CAC	LTE-TDD (SC-FDMA, 50% RB, 10 MHz, QPSK)	X	9.81	82.69	23.38	3.98	65.0	± 9.6 %
		Y	9.69	82.59	23.21		65.0	
		Z	9.29	81.25	22.69		65.0	
10253-CAC	LTE-TDD (SC-FDMA, 50% RB, 15 MHz, 16-QAM)	X	8.37	76.69	21.57	3.98	65.0	± 9.6 %
		Y	8.14	76.24	21.23		65.0	
		Z	8.26	76.10	21.20		65.0	
10254-CAC	LTE-TDD (SC-FDMA, 50% RB, 15 MHz, 64-QAM)	X	8.69	77.25	22.08	3.98	65.0	± 9.6 %
		Y	8.50	76.93	21.80		65.0	
		Z	8.58	76.68	21.71		65.0	

10255-CAC	LTE-TDD (SC-FDMA, 50% RB, 15 MHz, QPSK)	X	9.00	79.61	22.34	3.98	65.0	± 9.6 %
		Y	8.85	79.45	22.16		65.0	
		Z	8.73	78.67	21.83		65.0	
10256-CAA	LTE-TDD (SC-FDMA, 100% RB, 1.4 MHz, 16-QAM)	X	9.74	80.69	21.31	3.98	65.0	± 9.6 %
		Y	9.59	80.32	20.81		65.0	
		Z	9.63	80.04	20.95		65.0	
10257-CAA	LTE-TDD (SC-FDMA, 100% RB, 1.4 MHz, 64-QAM)	X	9.62	80.13	21.03	3.98	65.0	± 9.6 %
		Y	9.43	79.69	20.50		65.0	
		Z	9.55	79.55	20.70		65.0	
10258-CAA	LTE-TDD (SC-FDMA, 100% RB, 1.4 MHz, QPSK)	X	9.09	82.16	21.89	3.98	65.0	± 9.6 %
		Y	8.77	81.62	21.46		65.0	
		Z	8.39	80.38	21.12		65.0	
10259-CAB	LTE-TDD (SC-FDMA, 100% RB, 3 MHz, 16-QAM)	X	8.43	78.63	21.79	3.98	65.0	± 9.6 %
		Y	8.23	78.33	21.49		65.0	
		Z	8.20	77.76	21.31		65.0	
10260-CAB	LTE-TDD (SC-FDMA, 100% RB, 3 MHz, 64-QAM)	X	8.46	78.42	21.72	3.98	65.0	± 9.6 %
		Y	8.27	78.12	21.43		65.0	
		Z	8.26	77.59	21.26		65.0	
10261-CAB	LTE-TDD (SC-FDMA, 100% RB, 3 MHz, QPSK)	X	9.72	83.07	23.32	3.98	65.0	± 9.6 %
		Y	9.52	82.82	23.06		65.0	
		Z	9.11	81.46	22.57		65.0	
10262-CAC	LTE-TDD (SC-FDMA, 100% RB, 5 MHz, 16-QAM)	X	8.78	79.33	22.68	3.98	65.0	± 9.6 %
		Y	8.62	79.12	22.45		65.0	
		Z	8.57	78.49	22.19		65.0	
10263-CAC	LTE-TDD (SC-FDMA, 100% RB, 5 MHz, 64-QAM)	X	8.44	77.55	21.74	3.98	65.0	± 9.6 %
		Y	8.21	77.13	21.40		65.0	
		Z	8.29	76.86	21.32		65.0	
10264-CAC	LTE-TDD (SC-FDMA, 100% RB, 5 MHz, QPSK)	X	9.77	82.59	23.33	3.98	65.0	± 9.6 %
		Y	9.63	82.47	23.15		65.0	
		Z	9.25	81.16	22.64		65.0	
10265-CAC	LTE-TDD (SC-FDMA, 100% RB, 10 MHz, 16-QAM)	X	8.59	77.27	21.75	3.98	65.0	± 9.6 %
		Y	8.35	76.82	21.41		65.0	
		Z	8.46	76.64	21.35		65.0	
10266-CAC	LTE-TDD (SC-FDMA, 100% RB, 10 MHz, 64-QAM)	X	8.88	77.79	22.27	3.98	65.0	± 9.6 %
		Y	8.70	77.49	22.01		65.0	
		Z	8.76	77.18	21.88		65.0	
10267-CAC	LTE-TDD (SC-FDMA, 100% RB, 10 MHz, QPSK)	X	9.25	79.89	22.21	3.98	65.0	± 9.6 %
		Y	9.14	79.81	22.06		65.0	
		Z	8.95	78.92	21.69		65.0	
10268-CAC	LTE-TDD (SC-FDMA, 100% RB, 15 MHz, 16-QAM)	X	8.99	76.65	21.78	3.98	65.0	± 9.6 %
		Y	8.81	76.35	21.53		65.0	
		Z	8.91	76.18	21.46		65.0	
10269-CAC	LTE-TDD (SC-FDMA, 100% RB, 15 MHz, 64-QAM)	X	8.91	76.26	21.70	3.98	65.0	± 9.6 %
		Y	8.73	75.96	21.44		65.0	
		Z	8.84	75.83	21.39		65.0	
10270-CAC	LTE-TDD (SC-FDMA, 100% RB, 15 MHz, QPSK)	X	8.90	77.57	21.40	3.98	65.0	± 9.6 %
		Y	8.79	77.49	21.27		65.0	
		Z	8.75	76.94	21.02		65.0	

10274-CAB	UMTS-FDD (HSUPA, Subtest 5, 3GPP Rel8.10)	X	2.78	67.12	16.09	0.00	150.0	± 9.6 %
		Y	2.71	66.52	15.56		150.0	
		Z	2.72	66.59	15.63		150.0	
10275-CAB	UMTS-FDD (HSUPA, Subtest 5, 3GPP Rel8.4)	X	1.98	70.91	17.52	0.00	150.0	± 9.6 %
		Y	1.76	68.59	16.10		150.0	
		Z	1.80	69.04	16.33		150.0	
10277-CAA	PHS (QPSK)	X	6.79	72.27	16.39	9.03	50.0	± 9.6 %
		Y	6.45	71.67	15.76		50.0	
		Z	6.90	72.24	16.49		50.0	
10278-CAA	PHS (QPSK, BW 884MHz, Rolloff 0.5)	X	10.13	81.40	22.32	9.03	50.0	± 9.6 %
		Y	10.29	81.97	22.29		50.0	
		Z	9.77	80.32	21.92		50.0	
10279-CAA	PHS (QPSK, BW 884MHz, Rolloff 0.38)	X	10.33	81.63	22.41	9.03	50.0	± 9.6 %
		Y	10.47	82.16	22.36		50.0	
		Z	9.96	80.55	22.00		50.0	
10290-AAB	CDMA2000, RC1, SO55, Full Rate	X	2.27	74.32	17.90	0.00	150.0	± 9.6 %
		Y	1.81	70.49	15.86		150.0	
		Z	1.87	70.91	16.13		150.0	
10291-AAB	CDMA2000, RC3, SO55, Full Rate	X	1.36	72.30	17.10	0.00	150.0	± 9.6 %
		Y	1.04	67.63	14.46		150.0	
		Z	1.08	68.31	14.87		150.0	
10292-AAB	CDMA2000, RC3, SO32, Full Rate	X	1.99	79.46	20.52	0.00	150.0	± 9.6 %
		Y	1.29	71.82	16.85		150.0	
		Z	1.35	72.59	17.26		150.0	
10293-AAB	CDMA2000, RC3, SO3, Full Rate	X	3.14	87.23	23.85	0.00	150.0	± 9.6 %
		Y	1.79	77.07	19.53		150.0	
		Z	1.82	77.43	19.74		150.0	
10295-AAB	CDMA2000, RC1, SO3, 1/8th Rate 25 fr.	X	10.44	82.93	24.52	9.03	50.0	± 9.6 %
		Y	10.27	82.91	24.32		50.0	
		Z	10.06	81.64	23.93		50.0	
10297-AAB	LTE-FDD (SC-FDMA, 50% RB, 20 MHz, QPSK)	X	3.29	71.99	17.83	0.00	150.0	± 9.6 %
		Y	3.04	70.48	16.94		150.0	
		Z	3.09	70.76	17.06		150.0	
10298-AAC	LTE-FDD (SC-FDMA, 50% RB, 3 MHz, QPSK)	X	2.22	71.79	17.28	0.00	150.0	± 9.6 %
		Y	1.94	69.36	15.82		150.0	
		Z	1.98	69.66	16.04		150.0	
10299-AAC	LTE-FDD (SC-FDMA, 50% RB, 3 MHz, 16-QAM)	X	4.69	77.67	19.45	0.00	150.0	± 9.6 %
		Y	4.12	75.07	17.83		150.0	
		Z	4.54	76.51	18.69		150.0	
10300-AAC	LTE-FDD (SC-FDMA, 50% RB, 3 MHz, 64-QAM)	X	3.41	71.70	16.24	0.00	150.0	± 9.6 %
		Y	3.02	69.50	14.72		150.0	
		Z	3.36	70.96	15.66		150.0	
10301-AAA	IEEE 802.16e WiMAX (29:18, 5ms, 10MHz, QPSK, PUSC)	X	6.06	68.71	19.27	4.17	80.0	± 9.6 %
		Y	5.82	67.97	18.75		80.0	
		Z	6.19	69.17	19.41		80.0	
10302-AAA	IEEE 802.16e WiMAX (29:18, 5ms, 10MHz, QPSK, PUSC, 3 CTRL symbols)	X	6.72	70.11	20.48	4.96	80.0	± 9.6 %
		Y	6.33	68.61	19.48		80.0	
		Z	6.73	69.98	20.27		80.0	

10303-AAA	IEEE 802.16e WiMAX (31:15, 5ms, 10MHz, 64QAM, PUSC)	X	6.65	70.48	20.70	4.96	80.0	± 9.6 %
		Y	6.20	68.74	19.57		80.0	
		Z	6.66	70.35	20.48		80.0	
10304-AAA	IEEE 802.16e WiMAX (29:18, 5ms, 10MHz, 64QAM, PUSC)	X	6.16	69.37	19.66	4.17	80.0	± 9.6 %
		Y	5.81	67.99	18.75		80.0	
		Z	6.16	69.23	19.45		80.0	
10305-AAA	IEEE 802.16e WiMAX (31:15, 10ms, 10MHz, 64QAM, PUSC, 15 symbols)	X	9.30	81.07	26.04	6.02	50.0	± 9.6 %
		Y	8.89	81.17	26.15		50.0	
		Z	9.30	80.60	25.61		50.0	
10306-AAA	IEEE 802.16e WiMAX (29:18, 10ms, 10MHz, 64QAM, PUSC, 18 symbols)	X	7.60	74.94	23.58	6.02	50.0	± 9.6 %
		Y	6.58	71.27	21.48		50.0	
		Z	7.65	74.77	23.31		50.0	
10307-AAA	IEEE 802.16e WiMAX (29:18, 10ms, 10MHz, QPSK, PUSC, 18 symbols)	X	7.89	76.12	23.89	6.02	50.0	± 9.6 %
		Y	6.67	71.96	21.62		50.0	
		Z	7.93	75.88	23.59		50.0	
10308-AAA	IEEE 802.16e WiMAX (29:18, 10ms, 10MHz, 16QAM, PUSC)	X	8.03	76.77	24.18	6.02	50.0	± 9.6 %
		Y	6.71	72.32	21.80		50.0	
		Z	8.07	76.51	23.87		50.0	
10309-AAA	IEEE 802.16e WiMAX (29:18, 10ms, 10MHz, 16QAM, AMC 2x3, 18 symbols)	X	7.75	75.30	23.75	6.02	50.0	± 9.6 %
		Y	6.70	71.56	21.63		50.0	
		Z	7.79	75.10	23.47		50.0	
10310-AAA	IEEE 802.16e WiMAX (29:18, 10ms, 10MHz, QPSK, AMC 2x3, 18 symbols)	X	7.67	75.32	23.64	6.02	50.0	± 9.6 %
		Y	6.59	71.48	21.48		50.0	
		Z	7.72	75.12	23.36		50.0	
10311-AAB	LTE-FDD (SC-FDMA, 100% RB, 15 MHz, QPSK)	X	3.65	71.15	17.38	0.00	150.0	± 9.6 %
		Y	3.40	69.80	16.59		150.0	
		Z	3.45	70.04	16.69		150.0	
10313-AAA	IDEN 1:3	X	8.19	79.62	19.75	6.99	70.0	± 9.6 %
		Y	7.93	79.22	19.41		70.0	
		Z	7.49	77.80	19.02		70.0	
10314-AAA	IDEN 1:6	X	9.48	83.29	23.38	10.00	30.0	± 9.6 %
		Y	9.95	84.52	23.69		30.0	
		Z	8.48	80.77	22.38		30.0	
10315-AAB	IEEE 802.11b WiFi 2.4 GHz (DSSS, 1 Mbps, 96pc duty cycle)	X	1.25	66.08	16.91	0.17	150.0	± 9.6 %
		Y	1.20	64.89	15.87		150.0	
		Z	1.21	65.13	16.03		150.0	
10316-AAB	IEEE 802.11g WiFi 2.4 GHz (ERP-OFDM, 6 Mbps, 96pc duty cycle)	X	4.90	67.19	16.76	0.17	150.0	± 9.6 %
		Y	4.85	66.99	16.52		150.0	
		Z	4.87	67.02	16.55		150.0	
10317-AAB	IEEE 802.11a WiFi 5 GHz (OFDM, 6 Mbps, 96pc duty cycle)	X	4.90	67.19	16.76	0.17	150.0	± 9.6 %
		Y	4.85	66.99	16.52		150.0	
		Z	4.87	67.02	16.55		150.0	
10400-AAC	IEEE 802.11ac WiFi (20MHz, 64-QAM, 99pc duty cycle)	X	5.03	67.46	16.67	0.00	150.0	± 9.6 %
		Y	4.97	67.23	16.42		150.0	
		Z	4.99	67.27	16.45		150.0	
10401-AAC	IEEE 802.11ac WiFi (40MHz, 64-QAM, 99pc duty cycle)	X	5.60	67.40	16.67	0.00	150.0	± 9.6 %
		Y	5.56	67.25	16.46		150.0	
		Z	5.57	67.25	16.48		150.0	

10402-AAC	IEEE 802.11ac WiFi (80MHz, 64-QAM, 99pc duty cycle)	X	5.93	68.04	16.82	0.00	150.0	± 9.6 %
		Y	5.88	67.87	16.62		150.0	
		Z	5.89	67.90	16.63		150.0	
10403-AAB	CDMA2000 (1xEV-DO, Rev. 0)	X	2.27	74.32	17.90	0.00	115.0	± 9.6 %
		Y	1.81	70.49	15.86		115.0	
		Z	1.87	70.91	16.13		115.0	
10404-AAB	CDMA2000 (1xEV-DO, Rev. A)	X	2.27	74.32	17.90	0.00	115.0	± 9.6 %
		Y	1.81	70.49	15.86		115.0	
		Z	1.87	70.91	16.13		115.0	
10406-AAB	CDMA2000, RC3, SO32, SCH0, Full Rate	X	100.00	127.40	33.82	0.00	100.0	± 9.6 %
		Y	100.00	122.61	31.43		100.0	
		Z	100.00	123.45	32.03		100.0	
10410-AAB	LTE-TDD (SC-FDMA, 1 RB, 10 MHz, QPSK, UL Subframe=2,3,4,7,8,9)	X	100.00	121.97	31.96	3.23	80.0	± 9.6 %
		Y	100.00	119.93	30.78		80.0	
		Z	100.00	120.31	31.22		80.0	
10415-AAA	IEEE 802.11b WiFi 2.4 GHz (DSSS, 1 Mbps, 99pc duty cycle)	X	1.07	64.27	15.93	0.00	150.0	± 9.6 %
		Y	1.04	63.30	14.96		150.0	
		Z	1.04	63.46	15.09		150.0	
10416-AAA	IEEE 802.11g WiFi 2.4 GHz (ERP-OFDM, 6 Mbps, 99pc duty cycle)	X	4.79	67.01	16.59	0.00	150.0	± 9.6 %
		Y	4.74	66.82	16.35		150.0	
		Z	4.76	66.83	16.37		150.0	
10417-AAA	IEEE 802.11a/h WiFi 5 GHz (OFDM, 6 Mbps, 99pc duty cycle)	X	4.79	67.01	16.59	0.00	150.0	± 9.6 %
		Y	4.74	66.82	16.35		150.0	
		Z	4.76	66.83	16.37		150.0	
10418-AAA	IEEE 802.11g WiFi 2.4 GHz (DSSS-OFDM, 6 Mbps, 99pc duty cycle, Long preamble)	X	4.77	67.15	16.59	0.00	150.0	± 9.6 %
		Y	4.73	66.95	16.35		150.0	
		Z	4.74	66.96	16.37		150.0	
10419-AAA	IEEE 802.11g WiFi 2.4 GHz (DSSS-OFDM, 6 Mbps, 99pc duty cycle, Short preamble)	X	4.80	67.11	16.60	0.00	150.0	± 9.6 %
		Y	4.75	66.92	16.36		150.0	
		Z	4.76	66.93	16.38		150.0	
10422-AAA	IEEE 802.11n (HT Greenfield, 7.2 Mbps, BPSK)	X	4.93	67.11	16.61	0.00	150.0	± 9.6 %
		Y	4.88	66.93	16.38		150.0	
		Z	4.90	66.94	16.40		150.0	
10423-AAA	IEEE 802.11n (HT Greenfield, 43.3 Mbps, 16-QAM)	X	5.16	67.53	16.76	0.00	150.0	± 9.6 %
		Y	5.10	67.33	16.53		150.0	
		Z	5.12	67.36	16.55		150.0	
10424-AAA	IEEE 802.11n (HT Greenfield, 72.2 Mbps, 64-QAM)	X	5.06	67.46	16.72	0.00	150.0	± 9.6 %
		Y	5.01	67.26	16.49		150.0	
		Z	5.02	67.28	16.51		150.0	
10425-AAA	IEEE 802.11n (HT Greenfield, 15 Mbps, BPSK)	X	5.63	67.84	16.88	0.00	150.0	± 9.6 %
		Y	5.58	67.63	16.65		150.0	
		Z	5.59	67.66	16.67		150.0	
10426-AAA	IEEE 802.11n (HT Greenfield, 90 Mbps, 16-QAM)	X	5.65	67.87	16.88	0.00	150.0	± 9.6 %
		Y	5.59	67.67	16.66		150.0	
		Z	5.60	67.69	16.68		150.0	

10427-AAA	IEEE 802.11n (HT Greenfield, 150 Mbps, 64-QAM)	X	5.67	67.88	16.88	0.00	150.0	± 9.6 %
		Y	5.61	67.68	16.67		150.0	
		Z	5.63	67.72	16.69		150.0	
10430-AAA	LTE-FDD (OFDMA, 5 MHz, E-TM 3.1)	X	4.49	70.32	18.41	0.00	150.0	± 9.6 %
		Y	4.47	70.35	18.30		150.0	
		Z	4.43	69.94	18.10		150.0	
10431-AAA	LTE-FDD (OFDMA, 10 MHz, E-TM 3.1)	X	4.57	67.64	16.73	0.00	150.0	± 9.6 %
		Y	4.50	67.37	16.44		150.0	
		Z	4.52	67.40	16.48		150.0	
10432-AAA	LTE-FDD (OFDMA, 15 MHz, E-TM 3.1)	X	4.84	67.52	16.72	0.00	150.0	± 9.6 %
		Y	4.78	67.30	16.46		150.0	
		Z	4.81	67.32	16.49		150.0	
10433-AAA	LTE-FDD (OFDMA, 20 MHz, E-TM 3.1)	X	5.08	67.52	16.75	0.00	150.0	± 9.6 %
		Y	5.02	67.32	16.52		150.0	
		Z	5.04	67.34	16.54		150.0	
10434-AAA	W-CDMA (BS Test Model 1, 64 DPCH)	X	4.58	71.00	18.44	0.00	150.0	± 9.6 %
		Y	4.56	71.04	18.32		150.0	
		Z	4.50	70.55	18.09		150.0	
10435-AAB	LTE-TDD (SC-FDMA, 1 RB, 20 MHz, QPSK, UL Subframe=2,3,4,7,8,9)	X	100.00	121.83	31.89	3.23	80.0	± 9.6 %
		Y	100.00	119.78	30.72		80.0	
		Z	100.00	120.18	31.16		80.0	
10447-AAA	LTE-FDD (OFDMA, 5 MHz, E-TM 3.1, Clipping 44%)	X	3.91	67.81	16.42	0.00	150.0	± 9.6 %
		Y	3.82	67.43	16.03		150.0	
		Z	3.85	67.45	16.10		150.0	
10448-AAA	LTE-FDD (OFDMA, 10 MHz, E-TM 3.1, Clipping 44%)	X	4.37	67.41	16.59	0.00	150.0	± 9.6 %
		Y	4.31	67.14	16.30		150.0	
		Z	4.33	67.16	16.33		150.0	
10449-AAA	LTE-FDD (OFDMA, 15 MHz, E-TM 3.1, Clipping 44%)	X	4.61	67.35	16.62	0.00	150.0	± 9.6 %
		Y	4.56	67.11	16.36		150.0	
		Z	4.57	67.13	16.39		150.0	
10450-AAA	LTE-FDD (OFDMA, 20 MHz, E-TM 3.1, Clipping 44%)	X	4.78	67.27	16.62	0.00	150.0	± 9.6 %
		Y	4.73	67.06	16.37		150.0	
		Z	4.75	67.08	16.40		150.0	
10451-AAA	W-CDMA (BS Test Model 1, 64 DPCH, Clipping 44%)	X	3.87	68.19	16.26	0.00	150.0	± 9.6 %
		Y	3.76	67.74	15.84		150.0	
		Z	3.80	67.77	15.91		150.0	
10456-AAA	IEEE 802.11ac WiFi (160MHz, 64-QAM, 99pc duty cycle)	X	6.48	68.45	17.03	0.00	150.0	± 9.6 %
		Y	6.43	68.27	16.83		150.0	
		Z	6.44	68.31	16.86		150.0	
10457-AAA	UMTS-FDD (DC-HSDPA)	X	3.93	65.66	16.35	0.00	150.0	± 9.6 %
		Y	3.90	65.46	16.09		150.0	
		Z	3.90	65.49	16.13		150.0	
10458-AAA	CDMA2000 (1xEV-DO, Rev. B, 2 carriers)	X	3.65	67.27	15.76	0.00	150.0	± 9.6 %
		Y	3.56	66.88	15.33		150.0	
		Z	3.59	66.88	15.43		150.0	
10459-AAA	CDMA2000 (1xEV-DO, Rev. B, 3 carriers)	X	4.75	65.30	16.25	0.00	150.0	± 9.6 %
		Y	4.56	64.61	15.72		150.0	
		Z	4.62	64.74	15.85		150.0	



10460-AAA	UMTS-FDD (WCDMA, AMR)	X	1.26	74.40	19.85	0.00	150.0	± 9.6 %
		Y	0.98	69.11	16.84		150.0	
		Z	1.02	70.09	17.34		150.0	
10461-AAA	LTE-TDD (SC-FDMA, 1 RB, 1.4 MHz, QPSK, UL Subframe=2,3,4,7,8,9)	X	100.00	124.67	33.28	3.29	80.0	± 9.6 %
		Y	100.00	122.71	32.15		80.0	
		Z	100.00	122.52	32.32		80.0	
10462-AAA	LTE-TDD (SC-FDMA, 1 RB, 1.4 MHz, 16-QAM, UL Subframe=2,3,4,7,8,9)	X	100.00	112.53	27.42	3.23	80.0	± 9.6 %
		Y	100.00	109.84	25.94		80.0	
		Z	100.00	110.74	26.63		80.0	
10463-AAA	LTE-TDD (SC-FDMA, 1 RB, 1.4 MHz, 64-QAM, UL Subframe=2,3,4,7,8,9)	X	100.00	110.09	26.24	3.23	80.0	± 9.6 %
		Y	100.00	107.30	24.71		80.0	
		Z	100.00	108.46	25.52		80.0	
10464-AAA	LTE-TDD (SC-FDMA, 1 RB, 3 MHz, QPSK, UL Subframe=2,3,4,7,8,9)	X	100.00	123.17	32.44	3.23	80.0	± 9.6 %
		Y	100.00	121.02	31.22		80.0	
		Z	100.00	121.02	31.48		80.0	
10465-AAA	LTE-TDD (SC-FDMA, 1 RB, 3 MHz, 16-QAM, UL Subframe=2,3,4,7,8,9)	X	100.00	112.13	27.22	3.23	80.0	± 9.6 %
		Y	100.00	109.39	25.71		80.0	
		Z	100.00	110.36	26.43		80.0	
10466-AAA	LTE-TDD (SC-FDMA, 1 RB, 3 MHz, 64-QAM, UL Subframe=2,3,4,7,8,9)	X	100.00	109.70	26.05	3.23	80.0	± 9.6 %
		Y	100.00	106.88	24.51		80.0	
		Z	100.00	108.09	25.34		80.0	
10467-AAB	LTE-TDD (SC-FDMA, 1 RB, 5 MHz, QPSK, UL Subframe=2,3,4,7,8,9)	X	100.00	123.35	32.52	3.23	80.0	± 9.6 %
		Y	100.00	121.21	31.30		80.0	
		Z	100.00	121.18	31.55		80.0	
10468-AAB	LTE-TDD (SC-FDMA, 1 RB, 5 MHz, 16-QAM, UL Subframe=2,3,4,7,8,9)	X	100.00	112.26	27.27	3.23	80.0	± 9.6 %
		Y	100.00	109.52	25.77		80.0	
		Z	100.00	110.48	26.49		80.0	
10469-AAB	LTE-TDD (SC-FDMA, 1 RB, 5 MHz, 64-QAM, UL Subframe=2,3,4,7,8,9)	X	100.00	109.71	26.05	3.23	80.0	± 9.6 %
		Y	100.00	106.88	24.50		80.0	
		Z	100.00	108.10	25.34		80.0	
10470-AAB	LTE-TDD (SC-FDMA, 1 RB, 10 MHz, QPSK, UL Subframe=2,3,4,7,8,9)	X	100.00	123.38	32.53	3.23	80.0	± 9.6 %
		Y	100.00	121.23	31.30		80.0	
		Z	100.00	121.21	31.55		80.0	
10471-AAB	LTE-TDD (SC-FDMA, 1 RB, 10 MHz, 16-QAM, UL Subframe=2,3,4,7,8,9)	X	100.00	112.22	27.25	3.23	80.0	± 9.6 %
		Y	100.00	109.48	25.75		80.0	
		Z	100.00	110.44	26.46		80.0	
10472-AAB	LTE-TDD (SC-FDMA, 1 RB, 10 MHz, 64-QAM, UL Subframe=2,3,4,7,8,9)	X	100.00	109.68	26.03	3.23	80.0	± 9.6 %
		Y	100.00	106.84	24.48		80.0	
		Z	100.00	108.06	25.32		80.0	
10473-AAB	LTE-TDD (SC-FDMA, 1 RB, 15 MHz, QPSK, UL Subframe=2,3,4,7,8,9)	X	100.00	123.36	32.52	3.23	80.0	± 9.6 %
		Y	100.00	121.21	31.29		80.0	
		Z	100.00	121.18	31.54		80.0	
10474-AAB	LTE-TDD (SC-FDMA, 1 RB, 15 MHz, 16-QAM, UL Subframe=2,3,4,7,8,9)	X	100.00	112.23	27.26	3.23	80.0	± 9.6 %
		Y	100.00	109.49	25.75		80.0	
		Z	100.00	110.45	26.47		80.0	
10475-AAB	LTE-TDD (SC-FDMA, 1 RB, 15 MHz, 64-QAM, UL Subframe=2,3,4,7,8,9)	X	100.00	109.69	26.03	3.23	80.0	± 9.6 %
		Y	100.00	106.85	24.48		80.0	
		Z	100.00	108.07	25.32		80.0	

10477-AAB	LTE-TDD (SC-FDMA, 1 RB, 20 MHz, 16-QAM, UL Subframe=2,3,4,7,8,9)	X	100.00	112.10	27.19	3.23	80.0	± 9.6 %
		Y	100.00	109.35	25.68		80.0	
		Z	100.00	110.33	26.40		80.0	
10478-AAB	LTE-TDD (SC-FDMA, 1 RB, 20 MHz, 64-QAM, UL Subframe=2,3,4,7,8,9)	X	100.00	109.65	26.01	3.23	80.0	± 9.6 %
		Y	100.00	106.81	24.47		80.0	
		Z	100.00	108.04	25.30		80.0	
10479-AAA	LTE-TDD (SC-FDMA, 50% RB, 1.4 MHz, QPSK, UL Subframe=2,3,4,7,8,9)	X	14.38	94.20	26.88	3.23	80.0	± 9.6 %
		Y	12.62	91.51	25.59		80.0	
		Z	11.98	90.33	25.40		80.0	
10480-AAA	LTE-TDD (SC-FDMA, 50% RB, 1.4 MHz, 16-QAM, UL Subframe=2,3,4,7,8,9)	X	16.92	91.85	24.70	3.23	80.0	± 9.6 %
		Y	16.07	90.43	23.78		80.0	
		Z	14.43	88.66	23.48		80.0	
10481-AAA	LTE-TDD (SC-FDMA, 50% RB, 1.4 MHz, 64-QAM, UL Subframe=2,3,4,7,8,9)	X	15.52	89.82	23.79	3.23	80.0	± 9.6 %
		Y	14.42	88.14	22.78		80.0	
		Z	13.29	86.80	22.62		80.0	
10482-AAA	LTE-TDD (SC-FDMA, 50% RB, 3 MHz, QPSK, UL Subframe=2,3,4,7,8,9)	X	7.56	82.70	21.88	2.23	80.0	± 9.6 %
		Y	6.34	79.89	20.64		80.0	
		Z	6.13	78.95	20.35		80.0	
10483-AAA	LTE-TDD (SC-FDMA, 50% RB, 3 MHz, 16-QAM, UL Subframe=2,3,4,7,8,9)	X	10.42	84.68	22.62	2.23	80.0	± 9.6 %
		Y	9.52	82.90	21.60		80.0	
		Z	9.24	82.26	21.60		80.0	
10484-AAA	LTE-TDD (SC-FDMA, 50% RB, 3 MHz, 64-QAM, UL Subframe=2,3,4,7,8,9)	X	9.76	83.43	22.21	2.23	80.0	± 9.6 %
		Y	8.92	81.70	21.20		80.0	
		Z	8.78	81.26	21.26		80.0	
10485-AAB	LTE-TDD (SC-FDMA, 50% RB, 5 MHz, QPSK, UL Subframe=2,3,4,7,8,9)	X	7.43	82.48	22.31	2.23	80.0	± 9.6 %
		Y	6.34	79.89	21.17		80.0	
		Z	6.26	79.21	20.92		80.0	
10486-AAB	LTE-TDD (SC-FDMA, 50% RB, 5 MHz, 16-QAM, UL Subframe=2,3,4,7,8,9)	X	5.54	75.02	19.37	2.23	80.0	± 9.6 %
		Y	5.16	73.91	18.72		80.0	
		Z	5.15	73.47	18.58		80.0	
10487-AAB	LTE-TDD (SC-FDMA, 50% RB, 5 MHz, 64-QAM, UL Subframe=2,3,4,7,8,9)	X	5.49	74.50	19.17	2.23	80.0	± 9.6 %
		Y	5.13	73.46	18.54		80.0	
		Z	5.13	73.07	18.42		80.0	
10488-AAB	LTE-TDD (SC-FDMA, 50% RB, 10 MHz, QPSK, UL Subframe=2,3,4,7,8,9)	X	6.90	79.78	21.64	2.23	80.0	± 9.6 %
		Y	6.14	77.86	20.75		80.0	
		Z	6.18	77.51	20.58		80.0	
10489-AAB	LTE-TDD (SC-FDMA, 50% RB, 10 MHz, 16-QAM, UL Subframe=2,3,4,7,8,9)	X	5.38	73.43	19.44	2.23	80.0	± 9.6 %
		Y	5.09	72.55	18.91		80.0	
		Z	5.16	72.40	18.83		80.0	
10490-AAB	LTE-TDD (SC-FDMA, 50% RB, 10 MHz, 64-QAM, UL Subframe=2,3,4,7,8,9)	X	5.41	72.95	19.27	2.23	80.0	± 9.6 %
		Y	5.14	72.16	18.78		80.0	
		Z	5.21	72.02	18.71		80.0	
10491-AAB	LTE-TDD (SC-FDMA, 50% RB, 15 MHz, QPSK, UL Subframe=2,3,4,7,8,9)	X	6.32	76.48	20.47	2.23	80.0	± 9.6 %
		Y	5.85	75.21	19.82		80.0	
		Z	5.92	75.01	19.70		80.0	
10492-AAB	LTE-TDD (SC-FDMA, 50% RB, 15 MHz, 16-QAM, UL Subframe=2,3,4,7,8,9)	X	5.50	72.00	19.03	2.23	80.0	± 9.6 %
		Y	5.27	71.31	18.59		80.0	
		Z	5.36	71.28	18.56		80.0	

10493-AAB	LTE-TDD (SC-FDMA, 50% RB, 15 MHz, 64-QAM, UL Subframe=2,3,4,7,8,9)	X	5.54	71.72	18.94	2.23	80.0	± 9.6 %
		Y	5.32	71.08	18.52		80.0	
		Z	5.41	71.05	18.49		80.0	
10494-AAB	LTE-TDD (SC-FDMA, 50% RB, 20 MHz, QPSK, UL Subframe=2,3,4,7,8,9)	X	7.25	78.81	21.14	2.23	80.0	± 9.6 %
		Y	6.59	77.27	20.41		80.0	
		Z	6.62	76.95	20.25		80.0	
10495-AAB	LTE-TDD (SC-FDMA, 50% RB, 20 MHz, 16-QAM, UL Subframe=2,3,4,7,8,9)	X	5.65	72.70	19.29	2.23	80.0	± 9.6 %
		Y	5.39	71.95	18.83		80.0	
		Z	5.48	71.90	18.78		80.0	
10496-AAB	LTE-TDD (SC-FDMA, 50% RB, 20 MHz, 64-QAM, UL Subframe=2,3,4,7,8,9)	X	5.64	72.15	19.11	2.23	80.0	± 9.6 %
		Y	5.41	71.48	18.68		80.0	
		Z	5.50	71.45	18.64		80.0	
10497-AAA	LTE-TDD (SC-FDMA, 100% RB, 1.4 MHz, QPSK, UL Subframe=2,3,4,7,8,9)	X	6.62	80.74	20.69	2.23	80.0	± 9.6 %
		Y	5.48	77.81	19.35		80.0	
		Z	5.31	76.98	19.14		80.0	
10498-AAA	LTE-TDD (SC-FDMA, 100% RB, 1.4 MHz, 16-QAM, UL Subframe=2,3,4,7,8,9)	X	4.90	73.48	17.22	2.23	80.0	± 9.6 %
		Y	4.27	71.53	16.16		80.0	
		Z	4.35	71.46	16.28		80.0	
10499-AAA	LTE-TDD (SC-FDMA, 100% RB, 1.4 MHz, 64-QAM, UL Subframe=2,3,4,7,8,9)	X	4.83	72.93	16.89	2.23	80.0	± 9.6 %
		Y	4.21	71.00	15.82		80.0	
		Z	4.31	71.03	15.99		80.0	
10500-AAA	LTE-TDD (SC-FDMA, 100% RB, 3 MHz, QPSK, UL Subframe=2,3,4,7,8,9)	X	6.85	80.51	21.77	2.23	80.0	± 9.6 %
		Y	6.00	78.35	20.77		80.0	
		Z	6.00	77.87	20.57		80.0	
10501-AAA	LTE-TDD (SC-FDMA, 100% RB, 3 MHz, 16-QAM, UL Subframe=2,3,4,7,8,9)	X	5.43	74.16	19.30	2.23	80.0	± 9.6 %
		Y	5.10	73.18	18.71		80.0	
		Z	5.13	72.87	18.60		80.0	
10502-AAA	LTE-TDD (SC-FDMA, 100% RB, 3 MHz, 64-QAM, UL Subframe=2,3,4,7,8,9)	X	5.44	73.80	19.13	2.23	80.0	± 9.6 %
		Y	5.13	72.89	18.57		80.0	
		Z	5.15	72.59	18.46		80.0	
10503-AAB	LTE-TDD (SC-FDMA, 100% RB, 5 MHz, QPSK, UL Subframe=2,3,4,7,8,9)	X	6.81	79.57	21.56	2.23	80.0	± 9.6 %
		Y	6.06	77.64	20.66		80.0	
		Z	6.11	77.33	20.51		80.0	
10504-AAB	LTE-TDD (SC-FDMA, 100% RB, 5 MHz, 16-QAM, UL Subframe=2,3,4,7,8,9)	X	5.36	73.36	19.40	2.23	80.0	± 9.6 %
		Y	5.07	72.47	18.86		80.0	
		Z	5.14	72.33	18.79		80.0	
10505-AAB	LTE-TDD (SC-FDMA, 100% RB, 5 MHz, 64-QAM, UL Subframe=2,3,4,7,8,9)	X	5.38	72.87	19.23	2.23	80.0	± 9.6 %
		Y	5.11	72.07	18.73		80.0	
		Z	5.19	71.95	18.67		80.0	
10506-AAB	LTE-TDD (SC-FDMA, 100% RB, 10 MHz, QPSK, UL Subframe=2,3,4,7,8,9)	X	7.19	78.66	21.07	2.23	80.0	± 9.6 %
		Y	6.54	77.11	20.34		80.0	
		Z	6.57	76.81	20.18		80.0	
10507-AAB	LTE-TDD (SC-FDMA, 100% RB, 10 MHz, 16-QAM, UL Subframe=2,3,4,7,8,9)	X	5.63	72.64	19.26	2.23	80.0	± 9.6 %
		Y	5.37	71.89	18.79		80.0	
		Z	5.46	71.85	18.75		80.0	

10508-AAB	LTE-TDD (SC-FDMA, 100% RB, 10 MHz, 64-QAM, UL Subframe=2,3,4,7,8,9)	X	5.63	72.09	19.07	2.23	80.0	± 9.6 %
		Y	5.39	71.41	18.64		80.0	
		Z	5.49	71.39	18.61		80.0	
10509-AAB	LTE-TDD (SC-FDMA, 100% RB, 15 MHz, QPSK, UL Subframe=2,3,4,7,8,9)	X	6.80	75.80	19.99	2.23	80.0	± 9.6 %
		Y	6.40	74.81	19.47		80.0	
		Z	6.44	74.60	19.35		80.0	
10510-AAB	LTE-TDD (SC-FDMA, 100% RB, 15 MHz, 16-QAM, UL Subframe=2,3,4,7,8,9)	X	6.00	71.87	18.97	2.23	80.0	± 9.6 %
		Y	5.78	71.27	18.59		80.0	
		Z	5.87	71.27	18.56		80.0	
10511-AAB	LTE-TDD (SC-FDMA, 100% RB, 15 MHz, 64-QAM, UL Subframe=2,3,4,7,8,9)	X	5.98	71.43	18.84	2.23	80.0	± 9.6 %
		Y	5.78	70.88	18.48		80.0	
		Z	5.87	70.89	18.46		80.0	
10512-AAB	LTE-TDD (SC-FDMA, 100% RB, 20 MHz, QPSK, UL Subframe=2,3,4,7,8,9)	X	7.65	78.39	20.81	2.23	80.0	± 9.6 %
		Y	7.04	77.04	20.17		80.0	
		Z	7.05	76.73	20.01		80.0	
10513-AAB	LTE-TDD (SC-FDMA, 100% RB, 20 MHz, 16-QAM, UL Subframe=2,3,4,7,8,9)	X	5.99	72.54	19.22	2.23	80.0	± 9.6 %
		Y	5.74	71.83	18.79		80.0	
		Z	5.84	71.84	18.77		80.0	
10514-AAB	LTE-TDD (SC-FDMA, 100% RB, 20 MHz, 64-QAM, UL Subframe=2,3,4,7,8,9)	X	5.89	71.84	19.00	2.23	80.0	± 9.6 %
		Y	5.67	71.22	18.61		80.0	
		Z	5.77	71.23	18.59		80.0	
10515-AAA	IEEE 802.11b WiFi 2.4 GHz (DSSS, 2 Mbps, 99pc duty cycle)	X	1.04	64.60	16.09	0.00	150.0	± 9.6 %
		Y	1.01	63.51	15.03		150.0	
		Z	1.00	63.69	15.18		150.0	
10516-AAA	IEEE 802.11b WiFi 2.4 GHz (DSSS, 5.5 Mbps, 99pc duty cycle)	X	1.58	89.32	26.18	0.00	150.0	± 9.6 %
		Y	0.68	71.98	18.30		150.0	
		Z	0.78	74.89	19.62		150.0	
10517-AAA	IEEE 802.11b WiFi 2.4 GHz (DSSS, 11 Mbps, 99pc duty cycle)	X	0.96	68.28	17.72	0.00	150.0	± 9.6 %
		Y	0.87	65.73	15.83		150.0	
		Z	0.88	66.23	16.14		150.0	
10518-AAA	IEEE 802.11a/h WiFi 5 GHz (OFDM, 9 Mbps, 99pc duty cycle)	X	4.79	67.10	16.58	0.00	150.0	± 9.6 %
		Y	4.74	66.90	16.34		150.0	
		Z	4.76	66.92	16.36		150.0	
10519-AAA	IEEE 802.11a/h WiFi 5 GHz (OFDM, 12 Mbps, 99pc duty cycle)	X	5.03	67.42	16.72	0.00	150.0	± 9.6 %
		Y	4.98	67.22	16.49		150.0	
		Z	5.00	67.24	16.51		150.0	
10520-AAA	IEEE 802.11a/h WiFi 5 GHz (OFDM, 18 Mbps, 99pc duty cycle)	X	4.88	67.42	16.66	0.00	150.0	± 9.6 %
		Y	4.82	67.20	16.42		150.0	
		Z	4.84	67.23	16.44		150.0	
10521-AAA	IEEE 802.11a/h WiFi 5 GHz (OFDM, 24 Mbps, 99pc duty cycle)	X	4.81	67.44	16.66	0.00	150.0	± 9.6 %
		Y	4.75	67.21	16.40		150.0	
		Z	4.77	67.24	16.43		150.0	
10522-AAA	IEEE 802.11a/h WiFi 5 GHz (OFDM, 36 Mbps, 99pc duty cycle)	X	4.84	67.34	16.65	0.00	150.0	± 9.6 %
		Y	4.79	67.14	16.41		150.0	
		Z	4.81	67.14	16.43		150.0	

10523-AAA	IEEE 802.11a/h WiFi 5 GHz (OFDM, 48 Mbps, 99pc duty cycle)	X	4.72	67.29	16.53	0.00	150.0	± 9.6 %
		Y	4.66	67.07	16.29		150.0	
		Z	4.68	67.09	16.31		150.0	
10524-AAA	IEEE 802.11a/h WiFi 5 GHz (OFDM, 54 Mbps, 99pc duty cycle)	X	4.80	67.32	16.65	0.00	150.0	± 9.6 %
		Y	4.75	67.12	16.41		150.0	
		Z	4.77	67.13	16.43		150.0	
10525-AAA	IEEE 802.11ac WiFi (20MHz, MCS0, 99pc duty cycle)	X	4.74	66.35	16.23	0.00	150.0	± 9.6 %
		Y	4.69	66.14	16.00		150.0	
		Z	4.71	66.16	16.01		150.0	
10526-AAA	IEEE 802.11ac WiFi (20MHz, MCS1, 99pc duty cycle)	X	4.97	66.77	16.38	0.00	150.0	± 9.6 %
		Y	4.91	66.56	16.14		150.0	
		Z	4.92	66.58	16.16		150.0	
10527-AAA	IEEE 802.11ac WiFi (20MHz, MCS2, 99pc duty cycle)	X	4.88	66.77	16.35	0.00	150.0	± 9.6 %
		Y	4.82	66.54	16.10		150.0	
		Z	4.84	66.57	16.13		150.0	
10528-AAA	IEEE 802.11ac WiFi (20MHz, MCS3, 99pc duty cycle)	X	4.90	66.79	16.38	0.00	150.0	± 9.6 %
		Y	4.84	66.56	16.14		150.0	
		Z	4.86	66.59	16.16		150.0	
10529-AAA	IEEE 802.11ac WiFi (20MHz, MCS4, 99pc duty cycle)	X	4.90	66.79	16.38	0.00	150.0	± 9.6 %
		Y	4.84	66.56	16.14		150.0	
		Z	4.86	66.59	16.16		150.0	
10531-AAA	IEEE 802.11ac WiFi (20MHz, MCS6, 99pc duty cycle)	X	4.93	66.97	16.42	0.00	150.0	± 9.6 %
		Y	4.86	66.72	16.17		150.0	
		Z	4.88	66.75	16.19		150.0	
10532-AAA	IEEE 802.11ac WiFi (20MHz, MCS7, 99pc duty cycle)	X	4.77	66.86	16.39	0.00	150.0	± 9.6 %
		Y	4.71	66.60	16.12		150.0	
		Z	4.73	66.64	16.15		150.0	
10533-AAA	IEEE 802.11ac WiFi (20MHz, MCS8, 99pc duty cycle)	X	4.92	66.80	16.36	0.00	150.0	± 9.6 %
		Y	4.86	66.58	16.11		150.0	
		Z	4.87	66.60	16.13		150.0	
10534-AAA	IEEE 802.11ac WiFi (40MHz, MCS0, 99pc duty cycle)	X	5.41	66.95	16.41	0.00	150.0	± 9.6 %
		Y	5.35	66.75	16.19		150.0	
		Z	5.37	66.78	16.21		150.0	
10535-AAA	IEEE 802.11ac WiFi (40MHz, MCS1, 99pc duty cycle)	X	5.48	67.09	16.46	0.00	150.0	± 9.6 %
		Y	5.43	66.89	16.25		150.0	
		Z	5.44	66.92	16.26		150.0	
10536-AAA	IEEE 802.11ac WiFi (40MHz, MCS2, 99pc duty cycle)	X	5.35	67.09	16.45	0.00	150.0	± 9.6 %
		Y	5.29	66.87	16.23		150.0	
		Z	5.30	66.90	16.24		150.0	
10537-AAA	IEEE 802.11ac WiFi (40MHz, MCS3, 99pc duty cycle)	X	5.41	67.05	16.43	0.00	150.0	± 9.6 %
		Y	5.36	66.85	16.22		150.0	
		Z	5.37	66.87	16.23		150.0	
10538-AAA	IEEE 802.11ac WiFi (40MHz, MCS4, 99pc duty cycle)	X	5.54	67.15	16.52	0.00	150.0	± 9.6 %
		Y	5.48	66.94	16.30		150.0	
		Z	5.50	66.97	16.32		150.0	
10540-AAA	IEEE 802.11ac WiFi (40MHz, MCS6, 99pc duty cycle)	X	5.43	67.07	16.50	0.00	150.0	± 9.6 %
		Y	5.37	66.86	16.28		150.0	
		Z	5.38	66.89	16.29		150.0	

10541-AAA	IEEE 802.11ac WiFi (40MHz, MCS7, 99pc duty cycle)	X	5.42	67.03	16.48	0.00	150.0	± 9.6 %
		Y	5.36	66.81	16.25		150.0	
		Z	5.38	66.86	16.28		150.0	
10542-AAA	IEEE 802.11ac WiFi (40MHz, MCS8, 99pc duty cycle)	X	5.56	67.00	16.48	0.00	150.0	± 9.6 %
		Y	5.50	66.81	16.26		150.0	
		Z	5.52	66.84	16.28		150.0	
10543-AAA	IEEE 802.11ac WiFi (40MHz, MCS9, 99pc duty cycle)	X	5.65	67.02	16.49	0.00	150.0	± 9.6 %
		Y	5.60	66.83	16.28		150.0	
		Z	5.62	66.87	16.31		150.0	
10544-AAA	IEEE 802.11ac WiFi (80MHz, MCS0, 99pc duty cycle)	X	5.67	67.03	16.38	0.00	150.0	± 9.6 %
		Y	5.62	66.85	16.18		150.0	
		Z	5.63	66.88	16.19		150.0	
10545-AAA	IEEE 802.11ac WiFi (80MHz, MCS1, 99pc duty cycle)	X	5.89	67.44	16.51	0.00	150.0	± 9.6 %
		Y	5.84	67.25	16.31		150.0	
		Z	5.84	67.26	16.32		150.0	
10546-AAA	IEEE 802.11ac WiFi (80MHz, MCS2, 99pc duty cycle)	X	5.78	67.35	16.50	0.00	150.0	± 9.6 %
		Y	5.73	67.16	16.29		150.0	
		Z	5.74	67.19	16.30		150.0	
10547-AAA	IEEE 802.11ac WiFi (80MHz, MCS3, 99pc duty cycle)	X	5.88	67.44	16.53	0.00	150.0	± 9.6 %
		Y	5.82	67.23	16.31		150.0	
		Z	5.84	67.28	16.34		150.0	
10548-AAA	IEEE 802.11ac WiFi (80MHz, MCS4, 99pc duty cycle)	X	6.24	68.68	17.12	0.00	150.0	± 9.6 %
		Y	6.15	68.36	16.84		150.0	
		Z	6.16	68.38	16.86		150.0	
10550-AAA	IEEE 802.11ac WiFi (80MHz, MCS6, 99pc duty cycle)	X	5.80	67.28	16.46	0.00	150.0	± 9.6 %
		Y	5.75	67.09	16.26		150.0	
		Z	5.76	67.12	16.27		150.0	
10551-AAA	IEEE 802.11ac WiFi (80MHz, MCS7, 99pc duty cycle)	X	5.83	67.43	16.50	0.00	150.0	± 9.6 %
		Y	5.77	67.22	16.29		150.0	
		Z	5.78	67.25	16.30		150.0	
10552-AAA	IEEE 802.11ac WiFi (80MHz, MCS8, 99pc duty cycle)	X	5.72	67.16	16.39	0.00	150.0	± 9.6 %
		Y	5.67	66.97	16.18		150.0	
		Z	5.68	67.00	16.20		150.0	
10553-AAA	IEEE 802.11ac WiFi (80MHz, MCS9, 99pc duty cycle)	X	5.81	67.18	16.42	0.00	150.0	± 9.6 %
		Y	5.76	67.00	16.22		150.0	
		Z	5.77	67.03	16.23		150.0	
10554-AAA	IEEE 1602.11ac WiFi (160MHz, MCS0, 99pc duty cycle)	X	6.07	67.41	16.47	0.00	150.0	± 9.6 %
		Y	6.02	67.24	16.28		150.0	
		Z	6.02	67.27	16.29		150.0	
10555-AAA	IEEE 1602.11ac WiFi (160MHz, MCS1, 99pc duty cycle)	X	6.25	67.82	16.64	0.00	150.0	± 9.6 %
		Y	6.19	67.62	16.43		150.0	
		Z	6.20	67.66	16.46		150.0	
10556-AAA	IEEE 1602.11ac WiFi (160MHz, MCS2, 99pc duty cycle)	X	6.24	67.77	16.61	0.00	150.0	± 9.6 %
		Y	6.19	67.59	16.41		150.0	
		Z	6.19	67.61	16.43		150.0	
10557-AAA	IEEE 1602.11ac WiFi (160MHz, MCS3, 99pc duty cycle)	X	6.24	67.78	16.64	0.00	150.0	± 9.6 %
		Y	6.18	67.59	16.43		150.0	
		Z	6.19	67.62	16.45		150.0	

10558-AAA	IEEE 1602.11ac WiFi (160MHz, MCS4, 99pc duty cycle)	X	6.31	68.00	16.76	0.00	150.0	± 9.6 %
		Y	6.25	67.79	16.55		150.0	
		Z	6.26	67.82	16.57		150.0	
10560-AAA	IEEE 1602.11ac WiFi (160MHz, MCS6, 99pc duty cycle)	X	6.30	67.81	16.70	0.00	150.0	± 9.6 %
		Y	6.24	67.61	16.50		150.0	
		Z	6.26	67.66	16.52		150.0	
10561-AAA	IEEE 1602.11ac WiFi (160MHz, MCS7, 99pc duty cycle)	X	6.20	67.76	16.72	0.00	150.0	± 9.6 %
		Y	6.15	67.55	16.51		150.0	
		Z	6.16	67.60	16.53		150.0	
10562-AAA	IEEE 1602.11ac WiFi (160MHz, MCS8, 99pc duty cycle)	X	6.39	68.33	17.01	0.00	150.0	± 9.6 %
		Y	6.32	68.08	16.77		150.0	
		Z	6.34	68.13	16.81		150.0	
10563-AAA	IEEE 1602.11ac WiFi (160MHz, MCS9, 99pc duty cycle)	X	6.65	68.60	17.09	0.00	150.0	± 9.6 %
		Y	6.59	68.41	16.88		150.0	
		Z	6.58	68.40	16.88		150.0	
10564-AAA	IEEE 802.11g WiFi 2.4 GHz (DSSS-OFDM, 9 Mbps, 99pc duty cycle)	X	5.14	67.24	16.77	0.46	150.0	± 9.6 %
		Y	5.09	67.04	16.53		150.0	
		Z	5.10	67.08	16.57		150.0	
10565-AAA	IEEE 802.11g WiFi 2.4 GHz (DSSS-OFDM, 12 Mbps, 99pc duty cycle)	X	5.42	67.73	17.08	0.46	150.0	± 9.6 %
		Y	5.36	67.55	16.86		150.0	
		Z	5.38	67.58	16.89		150.0	
10566-AAA	IEEE 802.11g WiFi 2.4 GHz (DSSS-OFDM, 18 Mbps, 99pc duty cycle)	X	5.25	67.63	16.93	0.46	150.0	± 9.6 %
		Y	5.19	67.42	16.69		150.0	
		Z	5.21	67.47	16.73		150.0	
10567-AAA	IEEE 802.11g WiFi 2.4 GHz (DSSS-OFDM, 24 Mbps, 99pc duty cycle)	X	5.27	67.98	17.24	0.46	150.0	± 9.6 %
		Y	5.22	67.81	17.03		150.0	
		Z	5.23	67.81	17.03		150.0	
10568-AAA	IEEE 802.11g WiFi 2.4 GHz (DSSS-OFDM, 36 Mbps, 99pc duty cycle)	X	5.15	67.34	16.68	0.46	150.0	± 9.6 %
		Y	5.09	67.11	16.43		150.0	
		Z	5.12	67.17	16.48		150.0	
10569-AAA	IEEE 802.11g WiFi 2.4 GHz (DSSS-OFDM, 48 Mbps, 99pc duty cycle)	X	5.20	67.97	17.24	0.46	150.0	± 9.6 %
		Y	5.15	67.81	17.04		150.0	
		Z	5.16	67.80	17.04		150.0	
10570-AAA	IEEE 802.11g WiFi 2.4 GHz (DSSS-OFDM, 54 Mbps, 99pc duty cycle)	X	5.25	67.80	17.18	0.46	150.0	± 9.6 %
		Y	5.20	67.64	16.98		150.0	
		Z	5.21	67.63	16.98		150.0	
10571-AAA	IEEE 802.11b WiFi 2.4 GHz (DSSS, 1 Mbps, 90pc duty cycle)	X	1.47	67.75	17.68	0.46	130.0	± 9.6 %
		Y	1.40	66.34	16.57		130.0	
		Z	1.42	66.69	16.76		130.0	
10572-AAA	IEEE 802.11b WiFi 2.4 GHz (DSSS, 2 Mbps, 90pc duty cycle)	X	1.51	68.57	18.12	0.46	130.0	± 9.6 %
		Y	1.43	67.03	16.96		130.0	
		Z	1.45	67.37	17.14		130.0	
10573-AAA	IEEE 802.11b WiFi 2.4 GHz (DSSS, 5.5 Mbps, 90pc duty cycle)	X	100.00	149.09	40.35	0.46	130.0	± 9.6 %
		Y	5.48	98.07	27.02		130.0	
		Z	8.77	105.39	29.04		130.0	
10574-AAA	IEEE 802.11b WiFi 2.4 GHz (DSSS, 11 Mbps, 90pc duty cycle)	X	2.10	78.38	22.53	0.46	130.0	± 9.6 %
		Y	1.75	74.27	20.33		130.0	
		Z	1.81	74.78	20.52		130.0	

10575-AAA	IEEE 802.11g WiFi 2.4 GHz (DSSS-OFDM, 6 Mbps, 90pc duty cycle)	X	4.95	67.11	16.87	0.46	130.0	± 9.6 %
		Y	4.91	66.91	16.63		130.0	
		Z	4.93	66.95	16.67		130.0	
10576-AAA	IEEE 802.11g WiFi 2.4 GHz (DSSS-OFDM, 9 Mbps, 90pc duty cycle)	X	4.98	67.26	16.93	0.46	130.0	± 9.6 %
		Y	4.93	67.07	16.70		130.0	
		Z	4.95	67.11	16.73		130.0	
10577-AAA	IEEE 802.11g WiFi 2.4 GHz (DSSS-OFDM, 12 Mbps, 90pc duty cycle)	X	5.23	67.61	17.11	0.46	130.0	± 9.6 %
		Y	5.18	67.42	16.88		130.0	
		Z	5.21	67.46	16.91		130.0	
10578-AAA	IEEE 802.11g WiFi 2.4 GHz (DSSS-OFDM, 18 Mbps, 90pc duty cycle)	X	5.13	67.79	17.20	0.46	130.0	± 9.6 %
		Y	5.07	67.60	16.98		130.0	
		Z	5.10	67.62	17.00		130.0	
10579-AAA	IEEE 802.11g WiFi 2.4 GHz (DSSS-OFDM, 24 Mbps, 90pc duty cycle)	X	4.92	67.26	16.64	0.46	130.0	± 9.6 %
		Y	4.85	66.98	16.35		130.0	
		Z	4.89	67.08	16.43		130.0	
10580-AAA	IEEE 802.11g WiFi 2.4 GHz (DSSS-OFDM, 36 Mbps, 90pc duty cycle)	X	4.96	67.18	16.62	0.46	130.0	± 9.6 %
		Y	4.89	66.92	16.33		130.0	
		Z	4.93	67.01	16.41		130.0	
10581-AAA	IEEE 802.11g WiFi 2.4 GHz (DSSS-OFDM, 48 Mbps, 90pc duty cycle)	X	5.04	67.92	17.18	0.46	130.0	± 9.6 %
		Y	4.98	67.70	16.95		130.0	
		Z	5.01	67.74	16.97		130.0	
10582-AAA	IEEE 802.11g WiFi 2.4 GHz (DSSS-OFDM, 54 Mbps, 90pc duty cycle)	X	4.88	67.01	16.45	0.46	130.0	± 9.6 %
		Y	4.81	66.72	16.14		130.0	
		Z	4.85	66.84	16.24		130.0	
10583-AAA	IEEE 802.11a/h WiFi 5 GHz (OFDM, 6 Mbps, 90pc duty cycle)	X	4.95	67.11	16.87	0.46	130.0	± 9.6 %
		Y	4.91	66.91	16.63		130.0	
		Z	4.93	66.95	16.67		130.0	
10584-AAA	IEEE 802.11a/h WiFi 5 GHz (OFDM, 9 Mbps, 90pc duty cycle)	X	4.98	67.26	16.93	0.46	130.0	± 9.6 %
		Y	4.93	67.07	16.70		130.0	
		Z	4.95	67.11	16.73		130.0	
10585-AAA	IEEE 802.11a/h WiFi 5 GHz (OFDM, 12 Mbps, 90pc duty cycle)	X	5.23	67.61	17.11	0.46	130.0	± 9.6 %
		Y	5.18	67.42	16.88		130.0	
		Z	5.21	67.46	16.91		130.0	
10586-AAA	IEEE 802.11a/h WiFi 5 GHz (OFDM, 18 Mbps, 90pc duty cycle)	X	5.13	67.79	17.20	0.46	130.0	± 9.6 %
		Y	5.07	67.60	16.98		130.0	
		Z	5.10	67.62	17.00		130.0	
10587-AAA	IEEE 802.11a/h WiFi 5 GHz (OFDM, 24 Mbps, 90pc duty cycle)	X	4.92	67.26	16.64	0.46	130.0	± 9.6 %
		Y	4.85	66.98	16.35		130.0	
		Z	4.89	67.08	16.43		130.0	
10588-AAA	IEEE 802.11a/h WiFi 5 GHz (OFDM, 36 Mbps, 90pc duty cycle)	X	4.96	67.18	16.62	0.46	130.0	± 9.6 %
		Y	4.89	66.92	16.33		130.0	
		Z	4.93	67.01	16.41		130.0	
10589-AAA	IEEE 802.11a/h WiFi 5 GHz (OFDM, 48 Mbps, 90pc duty cycle)	X	5.04	67.92	17.18	0.46	130.0	± 9.6 %
		Y	4.98	67.70	16.95		130.0	
		Z	5.01	67.74	16.97		130.0	
10590-AAA	IEEE 802.11a/h WiFi 5 GHz (OFDM, 54 Mbps, 90pc duty cycle)	X	4.88	67.01	16.45	0.46	130.0	± 9.6 %
		Y	4.81	66.72	16.14		130.0	
		Z	4.85	66.84	16.24		130.0	



10591-AAA	IEEE 802.11n (HT Mixed, 20MHz, MCS0, 90pc duty cycle)	X	5.10	67.15	16.94	0.46	130.0	± 9.6 %
		Y	5.06	66.97	16.72		130.0	
		Z	5.07	67.00	16.75		130.0	
10592-AAA	IEEE 802.11n (HT Mixed, 20MHz, MCS1, 90pc duty cycle)	X	5.29	67.50	17.06	0.46	130.0	± 9.6 %
		Y	5.24	67.32	16.84		130.0	
		Z	5.26	67.35	16.87		130.0	
10593-AAA	IEEE 802.11n (HT Mixed, 20MHz, MCS2, 90pc duty cycle)	X	5.23	67.49	16.99	0.46	130.0	± 9.6 %
		Y	5.17	67.29	16.76		130.0	
		Z	5.20	67.34	16.80		130.0	
10594-AAA	IEEE 802.11n (HT Mixed, 20MHz, MCS3, 90pc duty cycle)	X	5.27	67.61	17.11	0.46	130.0	± 9.6 %
		Y	5.22	67.43	16.89		130.0	
		Z	5.25	67.46	16.92		130.0	
10595-AAA	IEEE 802.11n (HT Mixed, 20MHz, MCS4, 90pc duty cycle)	X	5.26	67.62	17.04	0.46	130.0	± 9.6 %
		Y	5.20	67.41	16.81		130.0	
		Z	5.23	67.46	16.84		130.0	
10596-AAA	IEEE 802.11n (HT Mixed, 20MHz, MCS5, 90pc duty cycle)	X	5.19	67.61	17.04	0.46	130.0	± 9.6 %
		Y	5.14	67.40	16.80		130.0	
		Z	5.17	67.44	16.84		130.0	
10597-AAA	IEEE 802.11n (HT Mixed, 20MHz, MCS6, 90pc duty cycle)	X	5.15	67.57	16.97	0.46	130.0	± 9.6 %
		Y	5.09	67.35	16.72		130.0	
		Z	5.12	67.41	16.76		130.0	
10598-AAA	IEEE 802.11n (HT Mixed, 20MHz, MCS7, 90pc duty cycle)	X	5.13	67.83	17.22	0.46	130.0	± 9.6 %
		Y	5.07	67.62	16.99		130.0	
		Z	5.10	67.66	17.02		130.0	
10599-AAA	IEEE 802.11n (HT Mixed, 40MHz, MCS0, 90pc duty cycle)	X	5.77	67.78	17.12	0.46	130.0	± 9.6 %
		Y	5.72	67.60	16.91		130.0	
		Z	5.74	67.64	16.94		130.0	
10600-AAA	IEEE 802.11n (HT Mixed, 40MHz, MCS1, 90pc duty cycle)	X	6.05	68.62	17.52	0.46	130.0	± 9.6 %
		Y	5.98	68.34	17.26		130.0	
		Z	6.00	68.41	17.31		130.0	
10601-AAA	IEEE 802.11n (HT Mixed, 40MHz, MCS2, 90pc duty cycle)	X	5.86	68.09	17.27	0.46	130.0	± 9.6 %
		Y	5.80	67.88	17.04		130.0	
		Z	5.82	67.93	17.07		130.0	
10602-AAA	IEEE 802.11n (HT Mixed, 40MHz, MCS3, 90pc duty cycle)	X	5.98	68.19	17.24	0.46	130.0	± 9.6 %
		Y	5.90	67.93	16.99		130.0	
		Z	5.94	68.03	17.05		130.0	
10603-AAA	IEEE 802.11n (HT Mixed, 40MHz, MCS4, 90pc duty cycle)	X	6.09	68.56	17.54	0.46	130.0	± 9.6 %
		Y	6.02	68.33	17.31		130.0	
		Z	6.05	68.40	17.35		130.0	
10604-AAA	IEEE 802.11n (HT Mixed, 40MHz, MCS5, 90pc duty cycle)	X	5.79	67.78	17.15	0.46	130.0	± 9.6 %
		Y	5.74	67.59	16.93		130.0	
		Z	5.76	67.64	16.97		130.0	
10605-AAA	IEEE 802.11n (HT Mixed, 40MHz, MCS6, 90pc duty cycle)	X	5.91	68.09	17.31	0.46	130.0	± 9.6 %
		Y	5.85	67.88	17.08		130.0	
		Z	5.87	67.94	17.12		130.0	
10606-AAA	IEEE 802.11n (HT Mixed, 40MHz, MCS7, 90pc duty cycle)	X	5.67	67.56	16.92	0.46	130.0	± 9.6 %
		Y	5.62	67.36	16.69		130.0	
		Z	5.63	67.40	16.73		130.0	

10607-AAA	IEEE 802.11ac WiFi (20MHz, MCS0, 90pc duty cycle)	X	4.93	66.44	16.55	0.46	130.0	± 9.6 %
		Y	4.88	66.25	16.33		130.0	
		Z	4.90	66.28	16.35		130.0	
10608-AAA	IEEE 802.11ac WiFi (20MHz, MCS1, 90pc duty cycle)	X	5.16	66.88	16.71	0.46	130.0	± 9.6 %
		Y	5.11	66.69	16.49		130.0	
		Z	5.13	66.71	16.51		130.0	
10609-AAA	IEEE 802.11ac WiFi (20MHz, MCS2, 90pc duty cycle)	X	5.05	66.80	16.60	0.46	130.0	± 9.6 %
		Y	4.99	66.58	16.36		130.0	
		Z	5.02	66.62	16.39		130.0	
10610-AAA	IEEE 802.11ac WiFi (20MHz, MCS3, 90pc duty cycle)	X	5.11	66.94	16.74	0.46	130.0	± 9.6 %
		Y	5.05	66.74	16.51		130.0	
		Z	5.07	66.77	16.54		130.0	
10611-AAA	IEEE 802.11ac WiFi (20MHz, MCS4, 90pc duty cycle)	X	5.04	66.82	16.63	0.46	130.0	± 9.6 %
		Y	4.98	66.59	16.39		130.0	
		Z	5.01	66.64	16.42		130.0	
10612-AAA	IEEE 802.11ac WiFi (20MHz, MCS5, 90pc duty cycle)	X	5.06	66.96	16.66	0.46	130.0	± 9.6 %
		Y	4.99	66.72	16.41		130.0	
		Z	5.02	66.77	16.45		130.0	
10613-AAA	IEEE 802.11ac WiFi (20MHz, MCS6, 90pc duty cycle)	X	5.08	66.91	16.58	0.46	130.0	± 9.6 %
		Y	5.01	66.66	16.32		130.0	
		Z	5.04	66.72	16.37		130.0	
10614-AAA	IEEE 802.11ac WiFi (20MHz, MCS7, 90pc duty cycle)	X	5.00	67.09	16.80	0.46	130.0	± 9.6 %
		Y	4.94	66.86	16.56		130.0	
		Z	4.96	66.90	16.59		130.0	
10615-AAA	IEEE 802.11ac WiFi (20MHz, MCS8, 90pc duty cycle)	X	5.04	66.62	16.41	0.46	130.0	± 9.6 %
		Y	4.98	66.38	16.15		130.0	
		Z	5.01	66.45	16.20		130.0	
10616-AAA	IEEE 802.11ac WiFi (40MHz, MCS0, 90pc duty cycle)	X	5.59	67.05	16.74	0.46	130.0	± 9.6 %
		Y	5.54	66.86	16.53		130.0	
		Z	5.56	66.89	16.55		130.0	
10617-AAA	IEEE 802.11ac WiFi (40MHz, MCS1, 90pc duty cycle)	X	5.66	67.16	16.76	0.46	130.0	± 9.6 %
		Y	5.60	66.97	16.55		130.0	
		Z	5.62	67.01	16.57		130.0	
10618-AAA	IEEE 802.11ac WiFi (40MHz, MCS2, 90pc duty cycle)	X	5.55	67.23	16.82	0.46	130.0	± 9.6 %
		Y	5.50	67.04	16.61		130.0	
		Z	5.51	67.07	16.62		130.0	
10619-AAA	IEEE 802.11ac WiFi (40MHz, MCS3, 90pc duty cycle)	X	5.57	67.04	16.66	0.46	130.0	± 9.6 %
		Y	5.51	66.84	16.44		130.0	
		Z	5.53	66.88	16.47		130.0	
10620-AAA	IEEE 802.11ac WiFi (40MHz, MCS4, 90pc duty cycle)	X	5.71	67.21	16.79	0.46	130.0	± 9.6 %
		Y	5.65	66.99	16.56		130.0	
		Z	5.67	67.05	16.60		130.0	
10621-AAA	IEEE 802.11ac WiFi (40MHz, MCS5, 90pc duty cycle)	X	5.67	67.21	16.90	0.46	130.0	± 9.6 %
		Y	5.61	67.05	16.70		130.0	
		Z	5.63	67.07	16.71		130.0	
10622-AAA	IEEE 802.11ac WiFi (40MHz, MCS6, 90pc duty cycle)	X	5.66	67.33	16.95	0.46	130.0	± 9.6 %
		Y	5.61	67.14	16.74		130.0	
		Z	5.63	67.17	16.76		130.0	

10623-AAA	IEEE 802.11ac WiFi (40MHz, MCS7, 90pc duty cycle)	X	5.58	67.03	16.70	0.46	130.0	± 9.6 %
		Y	5.51	66.79	16.46		130.0	
		Z	5.54	66.88	16.51		130.0	
10624-AAA	IEEE 802.11ac WiFi (40MHz, MCS8, 90pc duty cycle)	X	5.74	67.07	16.77	0.46	130.0	± 9.6 %
		Y	5.68	66.89	16.57		130.0	
		Z	5.70	66.92	16.59		130.0	
10625-AAA	IEEE 802.11ac WiFi (40MHz, MCS9, 90pc duty cycle)	X	6.12	68.00	17.28	0.46	130.0	± 9.6 %
		Y	6.07	67.85	17.09		130.0	
		Z	6.06	67.78	17.06		130.0	
10626-AAA	IEEE 802.11ac WiFi (80MHz, MCS0, 90pc duty cycle)	X	5.83	67.05	16.65	0.46	130.0	± 9.6 %
		Y	5.78	66.88	16.46		130.0	
		Z	5.79	66.91	16.47		130.0	
10627-AAA	IEEE 802.11ac WiFi (80MHz, MCS1, 90pc duty cycle)	X	6.10	67.59	16.86	0.46	130.0	± 9.6 %
		Y	6.05	67.42	16.67		130.0	
		Z	6.05	67.42	16.67		130.0	
10628-AAA	IEEE 802.11ac WiFi (80MHz, MCS2, 90pc duty cycle)	X	5.92	67.28	16.66	0.46	130.0	± 9.6 %
		Y	5.86	67.08	16.45		130.0	
		Z	5.88	67.13	16.48		130.0	
10629-AAA	IEEE 802.11ac WiFi (80MHz, MCS3, 90pc duty cycle)	X	6.03	67.42	16.72	0.46	130.0	± 9.6 %
		Y	5.97	67.19	16.49		130.0	
		Z	5.99	67.27	16.54		130.0	
10630-AAA	IEEE 802.11ac WiFi (80MHz, MCS4, 90pc duty cycle)	X	6.68	69.49	17.76	0.46	130.0	± 9.6 %
		Y	6.56	69.10	17.44		130.0	
		Z	6.58	69.15	17.48		130.0	
10631-AAA	IEEE 802.11ac WiFi (80MHz, MCS5, 90pc duty cycle)	X	6.50	69.03	17.69	0.46	130.0	± 9.6 %
		Y	6.41	68.76	17.46		130.0	
		Z	6.44	68.80	17.47		130.0	
10632-AAA	IEEE 802.11ac WiFi (80MHz, MCS6, 90pc duty cycle)	X	6.08	67.69	17.04	0.46	130.0	± 9.6 %
		Y	6.03	67.54	16.87		130.0	
		Z	6.05	67.55	16.87		130.0	
10633-AAA	IEEE 802.11ac WiFi (80MHz, MCS7, 90pc duty cycle)	X	6.06	67.65	16.87	0.46	130.0	± 9.6 %
		Y	5.99	67.42	16.64		130.0	
		Z	6.01	67.48	16.68		130.0	
10634-AAA	IEEE 802.11ac WiFi (80MHz, MCS8, 90pc duty cycle)	X	6.02	67.58	16.89	0.46	130.0	± 9.6 %
		Y	5.96	67.38	16.68		130.0	
		Z	5.98	67.43	16.71		130.0	
10635-AAA	IEEE 802.11ac WiFi (80MHz, MCS9, 90pc duty cycle)	X	5.89	66.92	16.32	0.46	130.0	± 9.6 %
		Y	5.83	66.68	16.08		130.0	
		Z	5.86	66.78	16.14		130.0	
10636-AAA	IEEE 1602.11ac WiFi (160MHz, MCS0, 90pc duty cycle)	X	6.23	67.45	16.75	0.46	130.0	± 9.6 %
		Y	6.19	67.29	16.56		130.0	
		Z	6.20	67.31	16.57		130.0	
10637-AAA	IEEE 1602.11ac WiFi (160MHz, MCS1, 90pc duty cycle)	X	6.44	67.93	16.96	0.46	130.0	± 9.6 %
		Y	6.38	67.73	16.75		130.0	
		Z	6.40	67.78	16.78		130.0	
10638-AAA	IEEE 1602.11ac WiFi (160MHz, MCS2, 90pc duty cycle)	X	6.41	67.82	16.88	0.46	130.0	± 9.6 %
		Y	6.36	67.64	16.69		130.0	
		Z	6.37	67.67	16.71		130.0	

10639-AAA	IEEE 1602.11ac WiFi (160MHz, MCS3, 90pc duty cycle)	X	6.43	67.88	16.96	0.46	130.0	± 9.6 %
		Y	6.38	67.70	16.77		130.0	
		Z	6.39	67.74	16.79		130.0	
10640-AAA	IEEE 1602.11ac WiFi (160MHz, MCS4, 90pc duty cycle)	X	6.48	68.03	16.99	0.46	130.0	± 9.6 %
		Y	6.42	67.80	16.76		130.0	
		Z	6.43	67.86	16.80		130.0	
10641-AAA	IEEE 1602.11ac WiFi (160MHz, MCS5, 90pc duty cycle)	X	6.45	67.69	16.83	0.46	130.0	± 9.6 %
		Y	6.39	67.49	16.62		130.0	
		Z	6.41	67.55	16.66		130.0	
10642-AAA	IEEE 1602.11ac WiFi (160MHz, MCS6, 90pc duty cycle)	X	6.53	68.02	17.15	0.46	130.0	± 9.6 %
		Y	6.47	67.85	16.96		130.0	
		Z	6.49	67.89	16.98		130.0	
10643-AAA	IEEE 1602.11ac WiFi (160MHz, MCS7, 90pc duty cycle)	X	6.36	67.74	16.93	0.46	130.0	± 9.6 %
		Y	6.30	67.53	16.71		130.0	
		Z	6.31	67.59	16.75		130.0	
10644-AAA	IEEE 1602.11ac WiFi (160MHz, MCS8, 90pc duty cycle)	X	6.64	68.58	17.37	0.46	130.0	± 9.6 %
		Y	6.55	68.29	17.12		130.0	
		Z	6.58	68.38	17.17		130.0	
10645-AAA	IEEE 1602.11ac WiFi (160MHz, MCS9, 90pc duty cycle)	X	6.88	68.81	17.43	0.46	130.0	± 9.6 %
		Y	6.82	68.61	17.21		130.0	
		Z	6.82	68.61	17.22		130.0	
10646-AAC	LTE-TDD (SC-FDMA, 1 RB, 5 MHz, QPSK, UL Subframe=2,7)	X	25.26	106.71	35.56	9.30	60.0	± 9.6 %
		Y	24.21	105.83	35.01		60.0	
		Z	22.77	103.47	34.30		60.0	
10647-AAB	LTE-TDD (SC-FDMA, 1 RB, 20 MHz, QPSK, UL Subframe=2,7)	X	26.48	108.55	36.25	9.30	60.0	± 9.6 %
		Y	24.67	107.00	35.49		60.0	
		Z	23.62	105.03	34.91		60.0	
10648-AAA	CDMA2000 (1x Advanced)	X	1.07	68.58	14.85	0.00	150.0	± 9.6 %
		Y	0.88	65.28	12.75		150.0	
		Z	0.91	65.79	13.10		150.0	

<sup>F</sup> Uncertainty is determined using the max. deviation from linear response applying rectangular distribution and is expressed for the square of the field value.



Accredited by the Swiss Accreditation Service (SAS)  
The Swiss Accreditation Service is one of the signatories to the EA  
Multilateral Agreement for the recognition of calibration certificates

Accreditation No.: **SCS 0108**

Client **PC Test**

Certificate No: **EX3-3914\_Feb17**

**CALIBRATION CERTIFICATE**

Object: **EX3DV4 - SN:3914**

Calibration procedure(s): **QA CAL-01.v9, QA CAL-12.v9, QA CAL-14.v4, QA CAL-23.v5,  
QA CAL-25.v6  
Calibration procedure for dosimetric E-field probes**

Calibration date: **February 13, 2017**

*BN ✓  
03-01-2017*

This calibration certificate documents the traceability to national standards, which realize the physical units of measurements (SI).  
The measurements and the uncertainties with confidence probability are given on the following pages and are part of the certificate.

All calibrations have been conducted in the closed laboratory facility: environment temperature (22 ± 3)°C and humidity < 70%.

Calibration Equipment used (M&TE critical for calibration)

Primary Standards	ID	Cal Date (Certificate No.)	Scheduled Calibration
Power meter NRP	SN: 104778	06-Apr-16 (No. 217-02288/02289)	Apr-17
Power sensor NRP-Z91	SN: 103244	06-Apr-16 (No. 217-02288)	Apr-17
Power sensor NRP-Z91	SN: 103245	06-Apr-16 (No. 217-02289)	Apr-17
Reference 20 dB Attenuator	SN: S5277 (20x)	05-Apr-16 (No. 217-02293)	Apr-17
Reference Probe ES3DV2	SN: 3013	31-Dec-16 (No. ES3-3013_Dec16)	Dec-17
DAE4	SN: 660	7-Dec-16 (No. DAE4-660_Dec16)	Dec-17
Secondary Standards	ID	Check Date (in house)	Scheduled Check
Power meter E4419B	SN: GB41293874	06-Apr-16 (in house check Jun-16)	In house check: Jun-18
Power sensor E4412A	SN: MY41498087	06-Apr-16 (in house check Jun-16)	In house check: Jun-18
Power sensor E4412A	SN: 000110210	06-Apr-16 (in house check Jun-16)	In house check: Jun-18
RF generator HP 8648C	SN: US3642U01700	04-Aug-99 (in house check Jun-16)	In house check: Jun-18
Network Analyzer HP 8753E	SN: US37390585	18-Oct-01 (in house check Oct-16)	In house check: Oct-17

Calibrated by:	Name <b>Jeton Kastrati</b>	Function <b>Laboratory Technician</b>	Signature 
Approved by:	Name <b>Katja Pokovic</b>	Function <b>Technical Manager</b>	Signature 

Issued: February 13, 2017

This calibration certificate shall not be reproduced except in full without written approval of the laboratory.



Accredited by the Swiss Accreditation Service (SAS)

Accreditation No.: **SCS 0108**

The Swiss Accreditation Service is one of the signatories to the EA Multilateral Agreement for the recognition of calibration certificates

**Glossary:**

TSL	tissue simulating liquid
NORM <sub>x,y,z</sub>	sensitivity in free space
ConvF	sensitivity in TSL / NORM <sub>x,y,z</sub>
DCP	diode compression point
CF	crest factor (1/duty_cycle) of the RF signal
A, B, C, D	modulation dependent linearization parameters
Polarization $\varphi$	$\varphi$ rotation around probe axis
Polarization $\vartheta$	$\vartheta$ rotation around an axis that is in the plane normal to probe axis (at measurement center), i.e., $\vartheta = 0$ is normal to probe axis
Connector Angle	information used in DASY system to align probe sensor X to the robot coordinate system

**Calibration is Performed According to the Following Standards:**

- a) IEEE Std 1528-2013, "IEEE Recommended Practice for Determining the Peak Spatial-Averaged Specific Absorption Rate (SAR) in the Human Head from Wireless Communications Devices: Measurement Techniques", June 2013
- b) IEC 62209-1, "Procedure to measure the Specific Absorption Rate (SAR) for hand-held devices used in close proximity to the ear (frequency range of 300 MHz to 3 GHz)", February 2005
- c) IEC 62209-2, "Procedure to determine the Specific Absorption Rate (SAR) for wireless communication devices used in close proximity to the human body (frequency range of 30 MHz to 6 GHz)", March 2010
- d) KDB 865664, "SAR Measurement Requirements for 100 MHz to 6 GHz"

**Methods Applied and Interpretation of Parameters:**

- **NORM<sub>x,y,z</sub>**: Assessed for E-field polarization  $\vartheta = 0$  ( $f \leq 900$  MHz in TEM-cell;  $f > 1800$  MHz: R22 waveguide). NORM<sub>x,y,z</sub> are only intermediate values, i.e., the uncertainties of NORM<sub>x,y,z</sub> does not affect the E<sup>2</sup>-field uncertainty inside TSL (see below ConvF).
- **NORM(f)<sub>x,y,z</sub> = NORM<sub>x,y,z</sub> \* frequency\_response** (see Frequency Response Chart). This linearization is implemented in DASY4 software versions later than 4.2. The uncertainty of the frequency response is included in the stated uncertainty of ConvF.
- **DCP<sub>x,y,z</sub>**: DCP are numerical linearization parameters assessed based on the data of power sweep with CW signal (no uncertainty required). DCP does not depend on frequency nor media.
- **PAR**: PAR is the Peak to Average Ratio that is not calibrated but determined based on the signal characteristics
- **A<sub>x,y,z</sub>; B<sub>x,y,z</sub>; C<sub>x,y,z</sub>; D<sub>x,y,z</sub>; VR<sub>x,y,z</sub>; A, B, C, D** are numerical linearization parameters assessed based on the data of power sweep for specific modulation signal. The parameters do not depend on frequency nor media. VR is the maximum calibration range expressed in RMS voltage across the diode.
- **ConvF and Boundary Effect Parameters**: Assessed in flat phantom using E-field (or Temperature Transfer Standard for  $f \leq 800$  MHz) and inside waveguide using analytical field distributions based on power measurements for  $f > 800$  MHz. The same setups are used for assessment of the parameters applied for boundary compensation (alpha, depth) of which typical uncertainty values are given. These parameters are used in DASY4 software to improve probe accuracy close to the boundary. The sensitivity in TSL corresponds to NORM<sub>x,y,z</sub> \* ConvF whereby the uncertainty corresponds to that given for ConvF. A frequency dependent ConvF is used in DASY version 4.4 and higher which allows extending the validity from  $\pm 50$  MHz to  $\pm 100$  MHz.
- **Spherical isotropy (3D deviation from isotropy)**: in a field of low gradients realized using a flat phantom exposed by a patch antenna.
- **Sensor Offset**: The sensor offset corresponds to the offset of virtual measurement center from the probe tip (on probe axis). No tolerance required.
- **Connector Angle**: The angle is assessed using the information gained by determining the NORM<sub>x</sub> (no uncertainty required).

# Probe EX3DV4

## SN:3914

Manufactured: December 18, 2012  
Calibrated: February 13, 2017

Calibrated for DASY/EASY Systems  
(Note: non-compatible with DASY2 system!)

## DASY/EASY - Parameters of Probe: EX3DV4 - SN:3914

### Basic Calibration Parameters

	Sensor X	Sensor Y	Sensor Z	Unc (k=2)
Norm ( $\mu\text{V}/(\text{V}/\text{m})^2$ ) <sup>A</sup>	0.46	0.41	0.44	$\pm 10.1 \%$
DCP (mV) <sup>B</sup>	98.6	102.5	103.7	

### Modulation Calibration Parameters

UID	Communication System Name		A dB	B dB $\sqrt{\mu\text{V}}$	C	D dB	VR mV	Unc <sup>E</sup> (k=2)
0	CW	X	0.0	0.0	1.0	0.00	156.6	$\pm 3.3 \%$
		Y	0.0	0.0	1.0		139.0	
		Z	0.0	0.0	1.0		149.0	

Note: For details on UID parameters see Appendix.

### Sensor Model Parameters

	C1 fF	C2 fF	$\alpha$ V <sup>-1</sup>	T1 ms.V <sup>-2</sup>	T2 ms.V <sup>-1</sup>	T3 ms	T4 V <sup>-2</sup>	T5 V <sup>-1</sup>	T6
X	46.19	344.3	35.58	12.88	0.995	4.971	0.985	0.325	1.004
Y	48.34	356	34.87	12.19	1.102	4.961	0.683	0.315	1.003
Z	44.31	328.7	35.26	10.14	1.122	4.975	1.527	0.227	1.005

The reported uncertainty of measurement is stated as the standard uncertainty of measurement multiplied by the coverage factor k=2, which for a normal distribution corresponds to a coverage probability of approximately 95%.

<sup>A</sup> The uncertainties of Norm X,Y,Z do not affect the E<sup>2</sup>-field uncertainty inside TSL (see Pages 5 and 6).

<sup>B</sup> Numerical linearization parameter: uncertainty not required.

<sup>E</sup> Uncertainty is determined using the max. deviation from linear response applying rectangular distribution and is expressed for the square of the field value.



## DASY/EASY - Parameters of Probe: EX3DV4 - SN:3914

### Calibration Parameter Determined in Head Tissue Simulating Media

f (MHz) <sup>C</sup>	Relative Permittivity <sup>F</sup>	Conductivity (S/m) <sup>F</sup>	ConvF X	ConvF Y	ConvF Z	Alpha <sup>G</sup>	Depth <sup>G</sup> (mm)	Unc (k=2)
6	55.5	0.75	21.32	21.32	21.32	0.00	1.00	± 13.3 %
13	55.5	0.75	17.87	17.87	17.87	0.00	1.00	± 13.3 %
5250	35.9	4.71	5.49	5.49	5.49	0.30	1.80	± 13.1 %
5600	35.5	5.07	4.94	4.94	4.94	0.40	1.80	± 13.1 %
5750	35.4	5.22	4.91	4.91	4.91	0.40	1.80	± 13.1 %

<sup>C</sup> Frequency validity above 300 MHz of ± 100 MHz only applies for DASY v4.4 and higher (see Page 2), else it is restricted to ± 50 MHz. The uncertainty is the RSS of the ConvF uncertainty at calibration frequency and the uncertainty for the indicated frequency band. Frequency validity below 300 MHz is ± 10, 25, 40, 50 and 70 MHz for ConvF assessments at 30, 64, 128, 150 and 220 MHz respectively. Above 5 GHz frequency validity can be extended to ± 110 MHz.

<sup>F</sup> At frequencies below 3 GHz, the validity of tissue parameters ( $\epsilon$  and  $\sigma$ ) can be relaxed to ± 10% if liquid compensation formula is applied to measured SAR values. At frequencies above 3 GHz, the validity of tissue parameters ( $\epsilon$  and  $\sigma$ ) is restricted to ± 5%. The uncertainty is the RSS of the ConvF uncertainty for indicated target tissue parameters.

<sup>G</sup> Alpha/Depth are determined during calibration. SPEAG warrants that the remaining deviation due to the boundary effect after compensation is always less than ± 1% for frequencies below 3 GHz and below ± 2% for frequencies between 3-6 GHz at any distance larger than half the probe tip diameter from the boundary.

## DASY/EASY - Parameters of Probe: EX3DV4 - SN:3914

### Calibration Parameter Determined in Body Tissue Simulating Media

f (MHz) <sup>C</sup>	Relative Permittivity <sup>F</sup>	Conductivity (S/m) <sup>F</sup>	ConvF X	ConvF Y	ConvF Z	Alpha <sup>G</sup>	Depth <sup>G</sup> (mm)	Unc (k=2)
750	55.5	0.96	9.98	9.98	9.98	0.45	0.88	± 12.0 %
835	55.2	0.97	9.73	9.73	9.73	0.40	0.88	± 12.0 %
1750	53.4	1.49	8.01	8.01	8.01	0.32	1.02	± 12.0 %
1900	53.3	1.52	7.75	7.75	7.75	0.34	0.95	± 12.0 %
2300	52.9	1.81	7.56	7.56	7.56	0.44	0.80	± 12.0 %
2450	52.7	1.95	7.45	7.45	7.45	0.35	0.90	± 12.0 %
2600	52.5	2.16	7.24	7.24	7.24	0.29	0.95	± 12.0 %
5250	48.9	5.36	4.78	4.78	4.78	0.40	1.90	± 13.1 %
5600	48.5	5.77	4.07	4.07	4.07	0.45	1.90	± 13.1 %
5750	48.3	5.94	4.15	4.15	4.15	0.50	1.90	± 13.1 %

<sup>C</sup> Frequency validity above 300 MHz of ± 100 MHz only applies for DASY v4.4 and higher (see Page 2), else it is restricted to ± 50 MHz. The uncertainty is the RSS of the ConvF uncertainty at calibration frequency and the uncertainty for the indicated frequency band. Frequency validity below 300 MHz is ± 10, 25, 40, 50 and 70 MHz for ConvF assessments at 30, 64, 128, 150 and 220 MHz respectively. Above 5 GHz frequency validity can be extended to ± 110 MHz.

<sup>F</sup> At frequencies below 3 GHz, the validity of tissue parameters ( $\epsilon$  and  $\sigma$ ) can be relaxed to ± 10% if liquid compensation formula is applied to measured SAR values. At frequencies above 3 GHz, the validity of tissue parameters ( $\epsilon$  and  $\sigma$ ) is restricted to ± 5%. The uncertainty is the RSS of the ConvF uncertainty for indicated target tissue parameters.

<sup>G</sup> Alpha/Depth are determined during calibration. SPEAG warrants that the remaining deviation due to the boundary effect after compensation is always less than ± 1% for frequencies below 3 GHz and below ± 2% for frequencies between 3-6 GHz at any distance larger than half the probe tip diameter from the boundary.

### Frequency Response of E-Field (TEM-Cell:ifi110 EXX, Waveguide: R22)

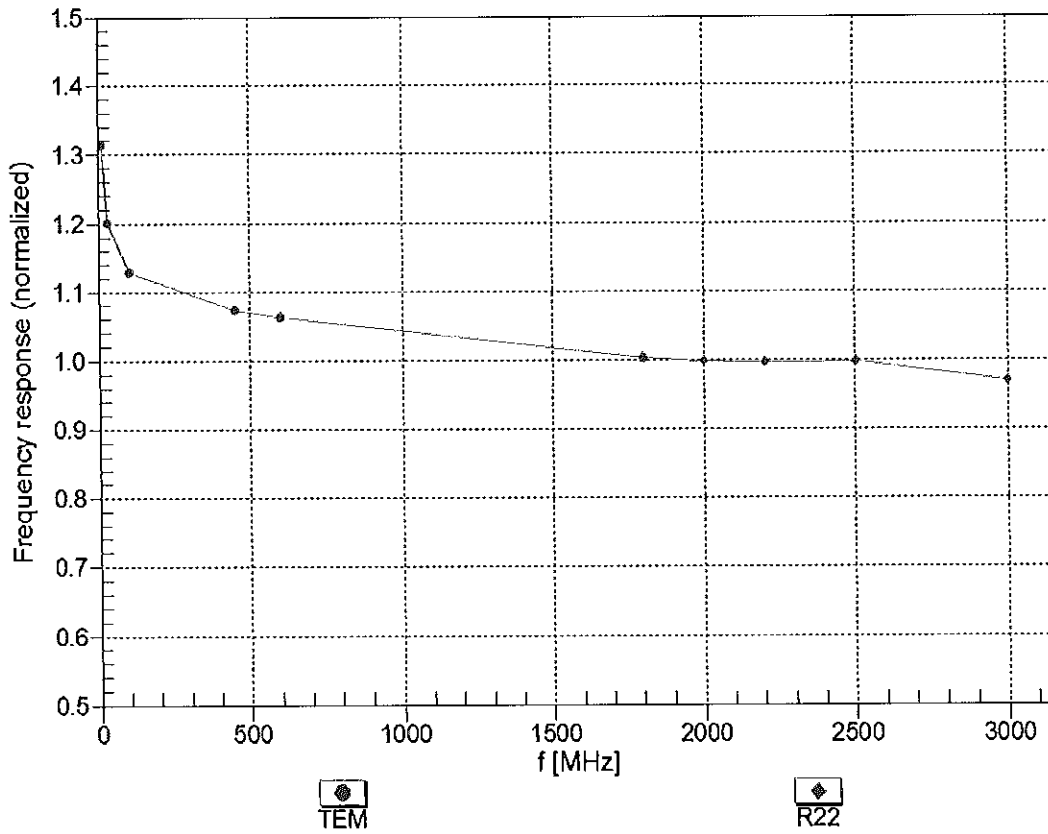

Uncertainty of Frequency Response of E-field:  $\pm 6.3\%$  (k=2)

### Receiving Pattern ( $\phi$ ), $\theta = 0^\circ$

f=600 MHz,TEM

f=1800 MHz,R22

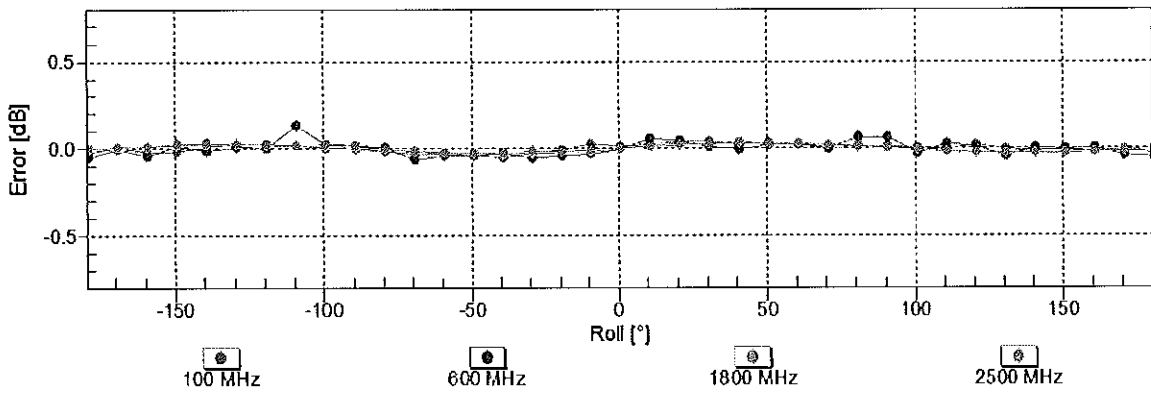
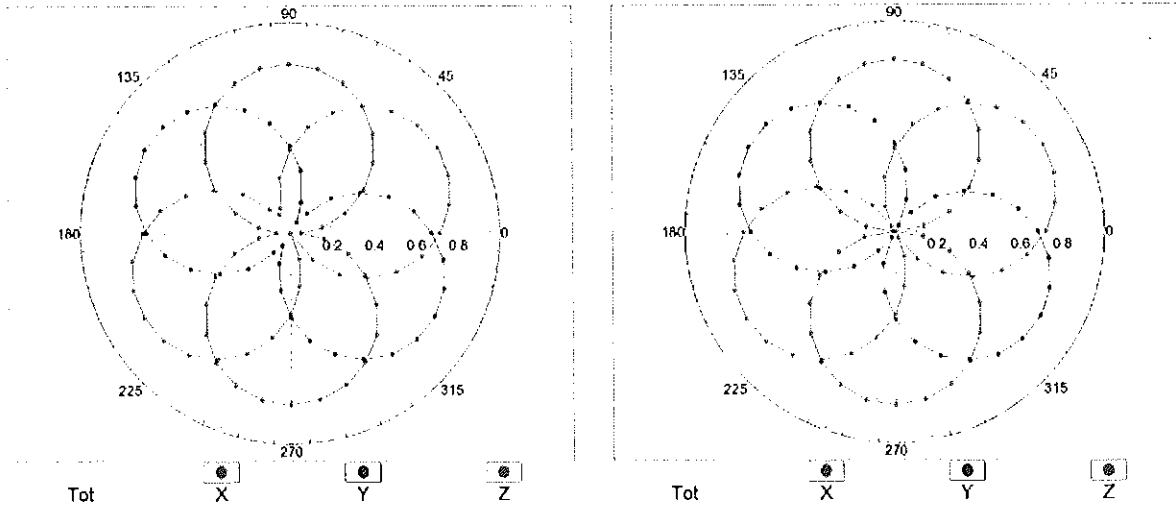

Uncertainty of Axial Isotropy Assessment:  $\pm 0.5\%$  (k=2)

### Dynamic Range $f(SAR_{head})$ (TEM cell, $f_{eval}= 1900$ MHz)

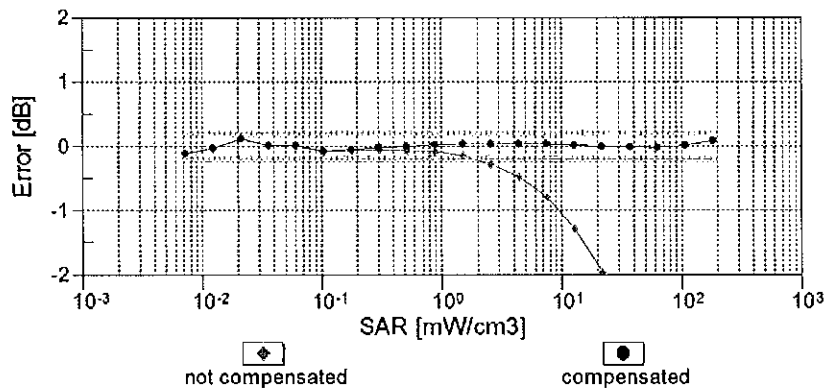
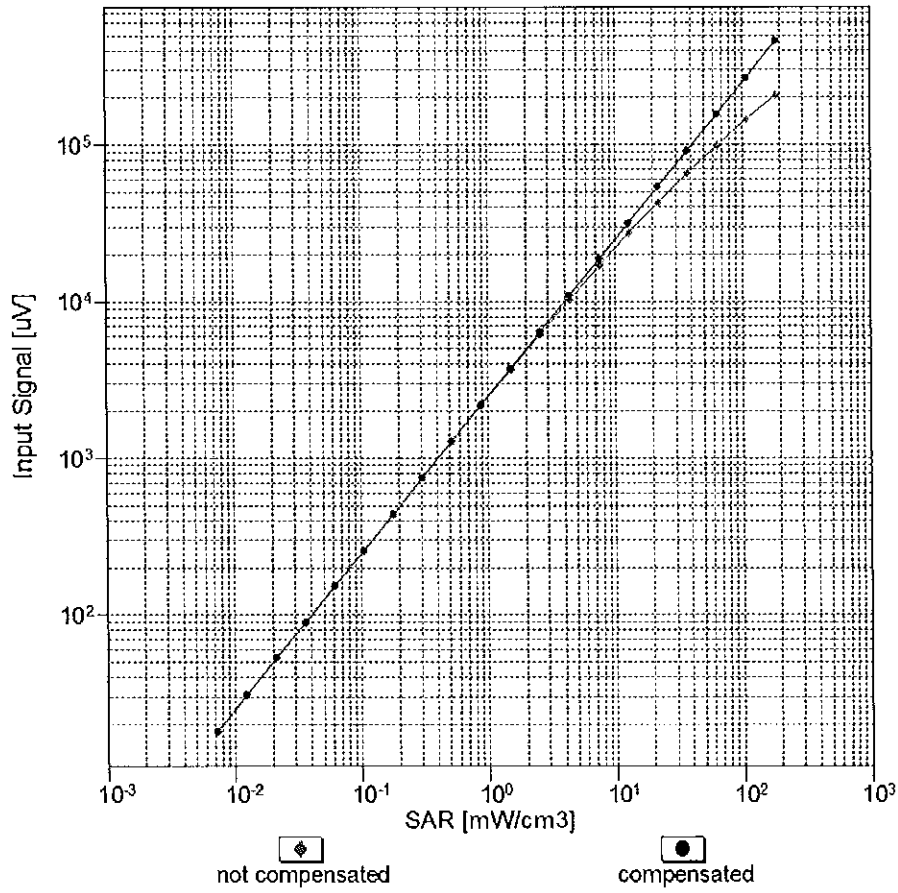

Uncertainty of Linearity Assessment:  $\pm 0.6\%$  ( $k=2$ )

# Conversion Factor Assessment

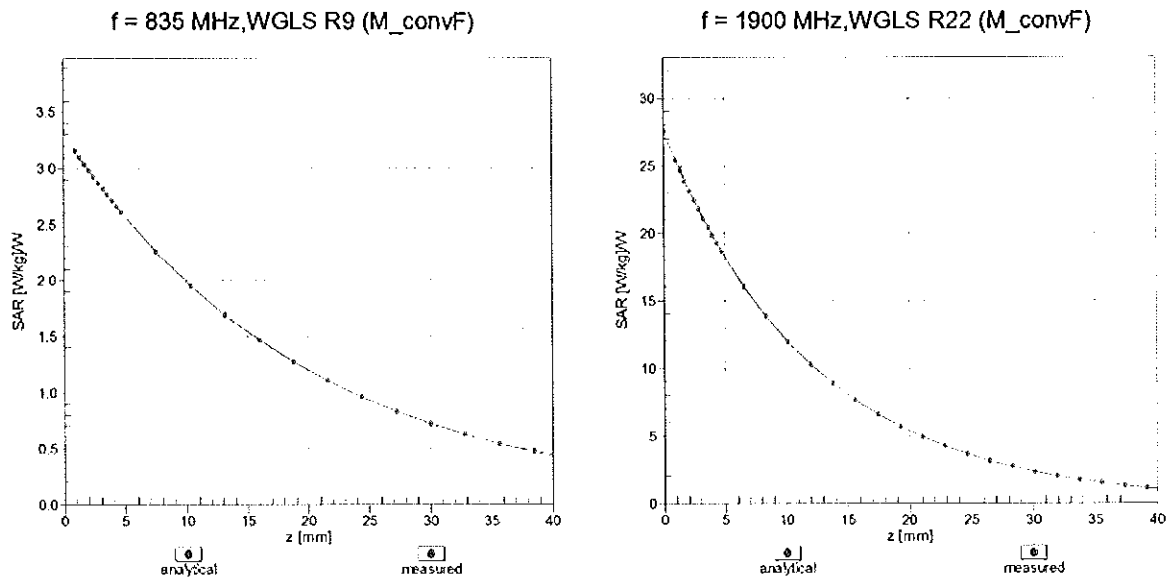

## Deviation from Isotropy in Liquid Error ( $\phi, \vartheta$ ), f = 900 MHz

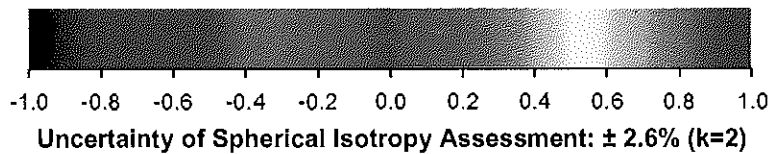
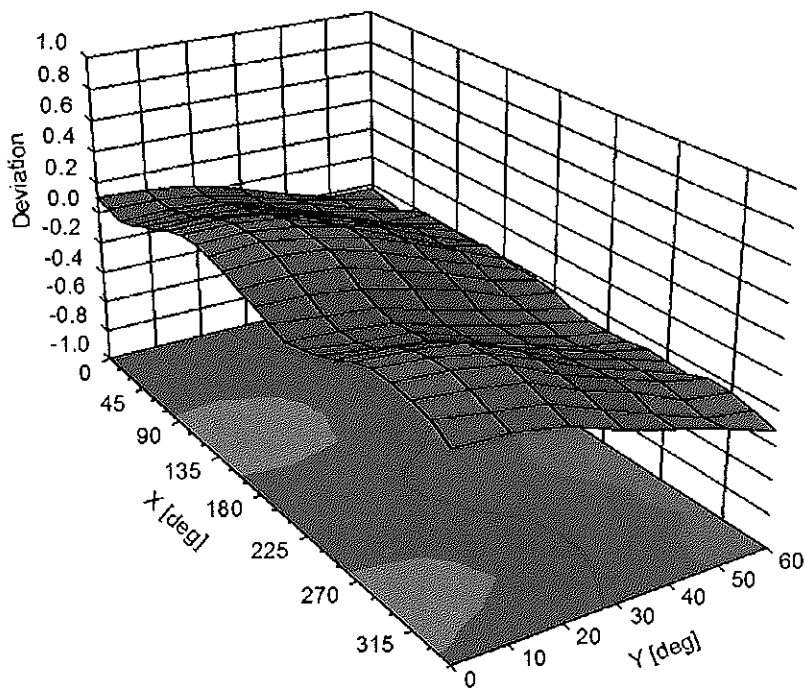

## DASY/EASY - Parameters of Probe: EX3DV4 - SN:3914

### Other Probe Parameters

Sensor Arrangement	Triangular
Connector Angle (°)	130.8
Mechanical Surface Detection Mode	enabled
Optical Surface Detection Mode	disabled
Probe Overall Length	337 mm
Probe Body Diameter	10 mm
Tip Length	9 mm
Tip Diameter	2.5 mm
Probe Tip to Sensor X Calibration Point	1 mm
Probe Tip to Sensor Y Calibration Point	1 mm
Probe Tip to Sensor Z Calibration Point	1 mm
Recommended Measurement Distance from Surface	1.4 mm

**Appendix: Modulation Calibration Parameters**

UID	Communication System Name		A dB	B dB $\sqrt{\mu V}$	C	D dB	VR mV	Max Unc <sup>E</sup> (k=2)
0	CW	X	0.00	0.00	1.00	0.00	156.6	± 3.3 %
		Y	0.00	0.00	1.00		139.0	
		Z	0.00	0.00	1.00		149.0	
10010- CAA	SAR Validation (Square, 100ms, 10ms)	X	2.67	66.07	10.73	10.00	20.0	± 9.6 %
		Y	2.77	66.16	10.84		20.0	
		Z	3.01	67.22	11.52		20.0	
10011- CAB	UMTS-FDD (WCDMA)	X	1.07	68.17	15.86	0.00	150.0	± 9.6 %
		Y	1.14	69.43	16.60		150.0	
		Z	1.05	67.81	15.63		150.0	
10012- CAB	IEEE 802.11b WiFi 2.4 GHz (DSSS, 1 Mbps)	X	1.18	63.94	15.29	0.41	150.0	± 9.6 %
		Y	1.19	64.27	15.54		150.0	
		Z	1.17	63.79	15.16		150.0	
10013- CAB	IEEE 802.11g WiFi 2.4 GHz (DSSS-OFDM, 6 Mbps)	X	4.82	66.52	16.88	1.46	150.0	± 9.6 %
		Y	4.84	66.55	16.88		150.0	
		Z	4.80	66.54	16.86		150.0	
10021- DAC	GSM-FDD (TDMA, GMSK)	X	10.62	83.12	18.62	9.39	50.0	± 9.6 %
		Y	8.33	79.79	17.55		50.0	
		Z	13.42	86.52	20.09		50.0	
10023- DAC	GPRS-FDD (TDMA, GMSK, TN 0)	X	8.76	80.53	17.78	9.57	50.0	± 9.6 %
		Y	7.40	78.13	16.99		50.0	
		Z	10.55	83.20	19.04		50.0	
10024- DAC	GPRS-FDD (TDMA, GMSK, TN 0-1)	X	21.17	91.31	19.68	6.56	60.0	± 9.6 %
		Y	12.07	85.13	17.96		60.0	
		Z	52.32	102.57	22.98		60.0	
10025- DAC	EDGE-FDD (TDMA, 8PSK, TN 0)	X	4.95	72.82	26.24	12.57	50.0	± 9.6 %
		Y	7.53	84.57	31.77		50.0	
		Z	4.80	71.26	25.29		50.0	
10026- DAC	EDGE-FDD (TDMA, 8PSK, TN 0-1)	X	8.84	88.73	30.42	9.56	60.0	± 9.6 %
		Y	10.05	91.59	31.44		60.0	
		Z	8.11	86.61	29.62		60.0	
10027- DAC	GPRS-FDD (TDMA, GMSK, TN 0-1-2)	X	100.00	106.86	22.53	4.80	80.0	± 9.6 %
		Y	100.00	106.55	22.42		80.0	
		Z	100.00	109.38	23.65		80.0	
10028- DAC	GPRS-FDD (TDMA, GMSK, TN 0-1-2-3)	X	100.00	107.35	22.11	3.55	100.0	± 9.6 %
		Y	100.00	107.02	21.99		100.0	
		Z	100.00	110.40	23.40		100.0	
10029- DAC	EDGE-FDD (TDMA, 8PSK, TN 0-1-2)	X	5.77	79.87	25.94	7.80	80.0	± 9.6 %
		Y	6.21	81.41	26.54		80.0	
		Z	5.35	78.22	25.29		80.0	
10030- CAA	IEEE 802.15.1 Bluetooth (GFSK, DH1)	X	13.42	86.20	17.57	5.30	70.0	± 9.6 %
		Y	9.31	82.44	16.50		70.0	
		Z	29.70	95.60	20.46		70.0	
10031- CAA	IEEE 802.15.1 Bluetooth (GFSK, DH3)	X	100.00	106.43	20.54	1.88	100.0	± 9.6 %
		Y	100.00	106.56	20.60		100.0	
		Z	100.00	109.99	21.95		100.0	



10032-CAA	IEEE 802.15.1 Bluetooth (GFSK, DH5)	X	100.00	112.98	22.39	1.17	100.0	± 9.6 %
		Y	100.00	114.09	22.82		100.0	
		Z	100.00	117.75	24.22		100.0	
10033-CAA	IEEE 802.15.1 Bluetooth (PI/4-DQPSK, DH1)	X	5.28	79.65	19.49	5.30	70.0	± 9.6 %
		Y	5.39	79.85	19.61		70.0	
		Z	4.87	78.68	19.23		70.0	
10034-CAA	IEEE 802.15.1 Bluetooth (PI/4-DQPSK, DH3)	X	2.39	73.05	16.10	1.88	100.0	± 9.6 %
		Y	2.51	73.86	16.59		100.0	
		Z	2.22	72.28	15.77		100.0	
10035-CAA	IEEE 802.15.1 Bluetooth (PI/4-DQPSK, DH5)	X	1.86	71.23	15.30	1.17	100.0	± 9.6 %
		Y	1.97	72.22	15.90		100.0	
		Z	1.74	70.56	14.96		100.0	
10036-CAA	IEEE 802.15.1 Bluetooth (8-DPSK, DH1)	X	6.16	82.06	20.41	5.30	70.0	± 9.6 %
		Y	6.25	82.19	20.50		70.0	
		Z	5.60	80.92	20.11		70.0	
10037-CAA	IEEE 802.15.1 Bluetooth (8-DPSK, DH3)	X	2.26	72.39	15.80	1.88	100.0	± 9.6 %
		Y	2.37	73.21	16.30		100.0	
		Z	2.09	71.60	15.47		100.0	
10038-CAA	IEEE 802.15.1 Bluetooth (8-DPSK, DH5)	X	1.87	71.57	15.55	1.17	100.0	± 9.6 %
		Y	2.00	72.59	16.17		100.0	
		Z	1.75	70.84	15.19		100.0	
10039-CAB	CDMA2000 (1xRTT, RC1)	X	2.22	74.99	16.99	0.00	150.0	± 9.6 %
		Y	2.65	77.61	18.26		150.0	
		Z	2.08	74.23	16.52		150.0	
10042-CAB	IS-54 / IS-136 FDD (TDMA/FDM, PI/4-DQPSK, Halfrate)	X	7.56	79.14	16.13	7.78	50.0	± 9.6 %
		Y	6.34	77.01	15.44		50.0	
		Z	11.33	84.23	18.10		50.0	
10044-CAA	IS-91/EIA/TIA-553 FDD (FDMA, FM)	X	0.00	97.59	0.84	0.00	150.0	± 9.6 %
		Y	0.00	98.99	0.04		150.0	
		Z	0.00	96.10	0.72		150.0	
10048-CAA	DECT (TDD, TDMA/FDM, GFSK, Full Slot, 24)	X	6.44	73.35	16.60	13.80	25.0	± 9.6 %
		Y	6.16	72.26	16.24		25.0	
		Z	7.34	74.65	17.41		25.0	
10049-CAA	DECT (TDD, TDMA/FDM, GFSK, Double Slot, 12)	X	6.68	76.08	16.45	10.79	40.0	± 9.6 %
		Y	6.26	74.90	16.07		40.0	
		Z	7.59	77.73	17.40		40.0	
10056-CAA	UMTS-TDD (TD-SCDMA, 1.28 Mcps)	X	8.65	81.91	20.55	9.03	50.0	± 9.6 %
		Y	8.47	81.27	20.33		50.0	
		Z	8.59	81.70	20.58		50.0	
10058-DAC	EDGE-FDD (TDMA, 8PSK, TN 0-1-2-3)	X	4.50	75.41	23.42	6.55	100.0	± 9.6 %
		Y	4.71	76.39	23.81		100.0	
		Z	4.21	74.08	22.88		100.0	
10059-CAB	IEEE 802.11b WiFi 2.4 GHz (DSSS, 2 Mbps)	X	1.22	64.88	15.72	0.61	110.0	± 9.6 %
		Y	1.23	65.26	15.98		110.0	
		Z	1.20	64.63	15.56		110.0	
10060-CAB	IEEE 802.11b WiFi 2.4 GHz (DSSS, 5.5 Mbps)	X	5.20	91.89	23.64	1.30	110.0	± 9.6 %
		Y	8.22	98.67	25.63		110.0	
		Z	3.57	87.17	22.39		110.0	

10061-CAB	IEEE 802.11b WiFi 2.4 GHz (DSSS, 11 Mbps)	X	2.42	76.11	19.87	2.04	110.0	± 9.6 %
		Y	2.58	77.18	20.29		110.0	
		Z	2.18	74.61	19.37		110.0	
10062-CAB	IEEE 802.11a/h WiFi 5 GHz (OFDM, 6 Mbps)	X	4.65	66.63	16.45	0.49	100.0	± 9.6 %
		Y	4.67	66.69	16.47		100.0	
		Z	4.63	66.64	16.42		100.0	
10063-CAB	IEEE 802.11a/h WiFi 5 GHz (OFDM, 9 Mbps)	X	4.66	66.68	16.51	0.72	100.0	± 9.6 %
		Y	4.68	66.74	16.53		100.0	
		Z	4.63	66.69	16.48		100.0	
10064-CAB	IEEE 802.11a/h WiFi 5 GHz (OFDM, 12 Mbps)	X	4.94	66.91	16.71	0.86	100.0	± 9.6 %
		Y	4.96	66.98	16.73		100.0	
		Z	4.91	66.92	16.68		100.0	
10065-CAB	IEEE 802.11a/h WiFi 5 GHz (OFDM, 18 Mbps)	X	4.80	66.77	16.76	1.21	100.0	± 9.6 %
		Y	4.82	66.84	16.78		100.0	
		Z	4.77	66.77	16.73		100.0	
10066-CAB	IEEE 802.11a/h WiFi 5 GHz (OFDM, 24 Mbps)	X	4.81	66.75	16.88	1.46	100.0	± 9.6 %
		Y	4.83	66.82	16.89		100.0	
		Z	4.78	66.75	16.85		100.0	
10067-CAB	IEEE 802.11a/h WiFi 5 GHz (OFDM, 36 Mbps)	X	5.09	66.88	17.26	2.04	100.0	± 9.6 %
		Y	5.11	66.92	17.27		100.0	
		Z	5.07	66.91	17.25		100.0	
10068-CAB	IEEE 802.11a/h WiFi 5 GHz (OFDM, 48 Mbps)	X	5.13	66.89	17.43	2.55	100.0	± 9.6 %
		Y	5.16	66.96	17.45		100.0	
		Z	5.10	66.89	17.41		100.0	
10069-CAB	IEEE 802.11a/h WiFi 5 GHz (OFDM, 54 Mbps)	X	5.21	66.88	17.61	2.67	100.0	± 9.6 %
		Y	5.23	66.94	17.62		100.0	
		Z	5.18	66.90	17.59		100.0	
10071-CAB	IEEE 802.11g WiFi 2.4 GHz (DSSS/OFDM, 9 Mbps)	X	4.91	66.56	17.12	1.99	100.0	± 9.6 %
		Y	4.92	66.60	17.13		100.0	
		Z	4.89	66.58	17.10		100.0	
10072-CAB	IEEE 802.11g WiFi 2.4 GHz (DSSS/OFDM, 12 Mbps)	X	4.88	66.83	17.29	2.30	100.0	± 9.6 %
		Y	4.90	66.89	17.30		100.0	
		Z	4.86	66.85	17.27		100.0	
10073-CAB	IEEE 802.11g WiFi 2.4 GHz (DSSS/OFDM, 18 Mbps)	X	4.94	66.95	17.56	2.83	100.0	± 9.6 %
		Y	4.95	67.01	17.56		100.0	
		Z	4.92	66.98	17.54		100.0	
10074-CAB	IEEE 802.11g WiFi 2.4 GHz (DSSS/OFDM, 24 Mbps)	X	4.92	66.84	17.68	3.30	100.0	± 9.6 %
		Y	4.94	66.89	17.68		100.0	
		Z	4.91	66.87	17.66		100.0	
10075-CAB	IEEE 802.11g WiFi 2.4 GHz (DSSS/OFDM, 36 Mbps)	X	4.96	66.95	17.95	3.82	90.0	± 9.6 %
		Y	4.99	67.03	17.97		90.0	
		Z	4.95	66.97	17.93		90.0	
10076-CAB	IEEE 802.11g WiFi 2.4 GHz (DSSS/OFDM, 48 Mbps)	X	4.98	66.76	18.06	4.15	90.0	± 9.6 %
		Y	5.00	66.82	18.07		90.0	
		Z	4.98	66.79	18.06		90.0	
10077-CAB	IEEE 802.11g WiFi 2.4 GHz (DSSS/OFDM, 54 Mbps)	X	5.01	66.82	18.15	4.30	90.0	± 9.6 %
		Y	5.02	66.89	18.16		90.0	
		Z	5.01	66.87	18.15		90.0	

10081-CAB	CDMA2000 (1xRTT, RC3)	X	0.92	67.41	13.37	0.00	150.0	± 9.6 %
		Y	1.03	69.09	14.44		150.0	
		Z	0.88	66.94	12.99		150.0	
10082-CAB	IS-54 / IS-136 FDD (TDMA/FDM, PI/4-DQPSK, Fullrate)	X	0.63	57.80	3.24	4.77	80.0	± 9.6 %
		Y	0.66	58.21	3.60		80.0	
		Z	0.62	57.96	3.46		80.0	
10090-DAC	GPRS-FDD (TDMA, GMSK, TN 0-4)	X	20.08	90.74	19.54	6.56	60.0	± 9.6 %
		Y	11.65	84.73	17.86		60.0	
		Z	47.95	101.61	22.77		60.0	
10097-CAB	UMTS-FDD (HSDPA)	X	1.89	68.37	16.12	0.00	150.0	± 9.6 %
		Y	1.94	68.91	16.47		150.0	
		Z	1.87	68.28	16.00		150.0	
10098-CAB	UMTS-FDD (HSUPA, Subtest 2)	X	1.85	68.32	16.09	0.00	150.0	± 9.6 %
		Y	1.90	68.87	16.45		150.0	
		Z	1.83	68.22	15.96		150.0	
10099-DAC	EDGE-FDD (TDMA, 8PSK, TN 0-4)	X	8.88	88.80	30.43	9.56	60.0	± 9.6 %
		Y	10.09	91.64	31.45		60.0	
		Z	8.15	86.66	29.63		60.0	
10100-CAC	LTE-FDD (SC-FDMA, 100% RB, 20 MHz, QPSK)	X	3.20	70.80	17.02	0.00	150.0	± 9.6 %
		Y	3.31	71.44	17.31		150.0	
		Z	3.15	70.62	16.92		150.0	
10101-CAC	LTE-FDD (SC-FDMA, 100% RB, 20 MHz, 16-QAM)	X	3.26	67.72	16.10	0.00	150.0	± 9.6 %
		Y	3.31	68.03	16.26		150.0	
		Z	3.23	67.65	16.04		150.0	
10102-CAC	LTE-FDD (SC-FDMA, 100% RB, 20 MHz, 64-QAM)	X	3.37	67.70	16.20	0.00	150.0	± 9.6 %
		Y	3.41	67.97	16.34		150.0	
		Z	3.34	67.64	16.14		150.0	
10103-CAC	LTE-TDD (SC-FDMA, 100% RB, 20 MHz, QPSK)	X	6.10	74.42	19.52	3.98	65.0	± 9.6 %
		Y	5.87	73.66	19.14		65.0	
		Z	5.74	73.57	19.22		65.0	
10104-CAC	LTE-TDD (SC-FDMA, 100% RB, 20 MHz, 16-QAM)	X	6.15	72.80	19.65	3.98	65.0	± 9.6 %
		Y	6.23	72.96	19.68		65.0	
		Z	5.94	72.31	19.46		65.0	
10105-CAC	LTE-TDD (SC-FDMA, 100% RB, 20 MHz, 64-QAM)	X	5.87	71.80	19.52	3.98	65.0	± 9.6 %
		Y	5.67	71.06	19.13		65.0	
		Z	5.56	70.91	19.13		65.0	
10108-CAD	LTE-FDD (SC-FDMA, 100% RB, 10 MHz, QPSK)	X	2.79	70.03	16.86	0.00	150.0	± 9.6 %
		Y	2.88	70.63	17.15		150.0	
		Z	2.74	69.86	16.75		150.0	
10109-CAD	LTE-FDD (SC-FDMA, 100% RB, 10 MHz, 16-QAM)	X	2.92	67.64	16.04	0.00	150.0	± 9.6 %
		Y	2.97	67.95	16.22		150.0	
		Z	2.89	67.57	15.96		150.0	
10110-CAD	LTE-FDD (SC-FDMA, 100% RB, 5 MHz, QPSK)	X	2.26	69.17	16.48	0.00	150.0	± 9.6 %
		Y	2.35	69.78	16.82		150.0	
		Z	2.22	68.99	16.35		150.0	
10111-CAD	LTE-FDD (SC-FDMA, 100% RB, 5 MHz, 16-QAM)	X	2.67	68.78	16.48	0.00	150.0	± 9.6 %
		Y	2.73	69.09	16.70		150.0	
		Z	2.65	68.73	16.39		150.0	

10112-CAD	LTE-FDD (SC-FDMA, 100% RB, 10 MHz, 64-QAM)	X	3.05	67.64	16.10	0.00	150.0	± 9.6 %
		Y	3.10	67.91	16.26		150.0	
		Z	3.02	67.58	16.03		150.0	
10113-CAD	LTE-FDD (SC-FDMA, 100% RB, 5 MHz, 64-QAM)	X	2.83	68.92	16.61	0.00	150.0	± 9.6 %
		Y	2.88	69.19	16.80		150.0	
		Z	2.80	68.89	16.53		150.0	
10114-CAB	IEEE 802.11n (HT Greenfield, 13.5 Mbps, BPSK)	X	5.14	67.30	16.52	0.00	150.0	± 9.6 %
		Y	5.15	67.37	16.54		150.0	
		Z	5.11	67.28	16.49		150.0	
10115-CAB	IEEE 802.11n (HT Greenfield, 81 Mbps, 16-QAM)	X	5.41	67.39	16.58	0.00	150.0	± 9.6 %
		Y	5.44	67.49	16.61		150.0	
		Z	5.37	67.35	16.53		150.0	
10116-CAB	IEEE 802.11n (HT Greenfield, 135 Mbps, 64-QAM)	X	5.23	67.48	16.54	0.00	150.0	± 9.6 %
		Y	5.25	67.56	16.57		150.0	
		Z	5.20	67.46	16.50		150.0	
10117-CAB	IEEE 802.11n (HT Mixed, 13.5 Mbps, BPSK)	X	5.10	67.15	16.47	0.00	150.0	± 9.6 %
		Y	5.12	67.24	16.50		150.0	
		Z	5.07	67.14	16.44		150.0	
10118-CAB	IEEE 802.11n (HT Mixed, 81 Mbps, 16-QAM)	X	5.49	67.59	16.68	0.00	150.0	± 9.6 %
		Y	5.52	67.68	16.71		150.0	
		Z	5.45	67.53	16.63		150.0	
10119-CAB	IEEE 802.11n (HT Mixed, 135 Mbps, 64-QAM)	X	5.21	67.43	16.53	0.00	150.0	± 9.6 %
		Y	5.22	67.50	16.55		150.0	
		Z	5.18	67.41	16.49		150.0	
10140-CAC	LTE-FDD (SC-FDMA, 100% RB, 15 MHz, 16-QAM)	X	3.40	67.70	16.11	0.00	150.0	± 9.6 %
		Y	3.45	67.97	16.25		150.0	
		Z	3.37	67.64	16.05		150.0	
10141-CAC	LTE-FDD (SC-FDMA, 100% RB, 15 MHz, 64-QAM)	X	3.53	67.82	16.29	0.00	150.0	± 9.6 %
		Y	3.57	68.05	16.41		150.0	
		Z	3.50	67.77	16.23		150.0	
10142-CAD	LTE-FDD (SC-FDMA, 100% RB, 3 MHz, QPSK)	X	2.05	69.36	16.22	0.00	150.0	± 9.6 %
		Y	2.15	70.07	16.65		150.0	
		Z	2.01	69.16	16.05		150.0	
10143-CAD	LTE-FDD (SC-FDMA, 100% RB, 3 MHz, 16-QAM)	X	2.58	69.85	16.32	0.00	150.0	± 9.6 %
		Y	2.67	70.31	16.66		150.0	
		Z	2.55	69.76	16.17		150.0	
10144-CAD	LTE-FDD (SC-FDMA, 100% RB, 3 MHz, 64-QAM)	X	2.27	67.04	14.44	0.00	150.0	± 9.6 %
		Y	2.35	67.51	14.81		150.0	
		Z	2.23	66.89	14.26		150.0	
10145-CAD	LTE-FDD (SC-FDMA, 100% RB, 1.4 MHz, QPSK)	X	1.27	65.89	12.21	0.00	150.0	± 9.6 %
		Y	1.42	67.33	13.21		150.0	
		Z	1.20	65.32	11.71		150.0	
10146-CAD	LTE-FDD (SC-FDMA, 100% RB, 1.4 MHz, 16-QAM)	X	1.76	65.12	10.79	0.00	150.0	± 9.6 %
		Y	1.85	65.98	11.50		150.0	
		Z	1.79	65.33	10.70		150.0	
10147-CAD	LTE-FDD (SC-FDMA, 100% RB, 1.4 MHz, 64-QAM)	X	2.02	66.77	11.72	0.00	150.0	± 9.6 %
		Y	2.20	68.07	12.63		150.0	
		Z	2.10	67.13	11.69		150.0	

10149-CAC	LTE-FDD (SC-FDMA, 50% RB, 20 MHz, 16-QAM)	X	2.93	67.71	16.09	0.00	150.0	± 9.6 %
		Y	2.98	68.02	16.27		150.0	
		Z	2.90	67.64	16.02		150.0	
10150-CAC	LTE-FDD (SC-FDMA, 50% RB, 20 MHz, 64-QAM)	X	3.06	67.71	16.14	0.00	150.0	± 9.6 %
		Y	3.10	67.97	16.30		150.0	
		Z	3.03	67.65	16.07		150.0	
10151-CAC	LTE-TDD (SC-FDMA, 50% RB, 20 MHz, QPSK)	X	6.20	76.14	20.26	3.98	65.0	± 9.6 %
		Y	6.27	76.18	20.22		65.0	
		Z	5.93	75.60	20.10		65.0	
10152-CAC	LTE-TDD (SC-FDMA, 50% RB, 20 MHz, 16-QAM)	X	5.64	72.55	19.21	3.98	65.0	± 9.6 %
		Y	5.73	72.74	19.28		65.0	
		Z	5.43	72.04	19.00		65.0	
10153-CAC	LTE-TDD (SC-FDMA, 50% RB, 20 MHz, 64-QAM)	X	6.03	73.59	20.04	3.98	65.0	± 9.6 %
		Y	6.10	73.69	20.06		65.0	
		Z	5.81	73.08	19.84		65.0	
10154-CAD	LTE-FDD (SC-FDMA, 50% RB, 10 MHz, QPSK)	X	2.32	69.68	16.78	0.00	150.0	± 9.6 %
		Y	2.41	70.30	17.13		150.0	
		Z	2.28	69.49	16.65		150.0	
10155-CAD	LTE-FDD (SC-FDMA, 50% RB, 10 MHz, 16-QAM)	X	2.68	68.79	16.50	0.00	150.0	± 9.6 %
		Y	2.73	69.11	16.71		150.0	
		Z	2.65	68.75	16.41		150.0	
10156-CAD	LTE-FDD (SC-FDMA, 50% RB, 5 MHz, QPSK)	X	1.92	69.63	16.09	0.00	150.0	± 9.6 %
		Y	2.03	70.50	16.63		150.0	
		Z	1.87	69.37	15.88		150.0	
10157-CAD	LTE-FDD (SC-FDMA, 50% RB, 5 MHz, 16-QAM)	X	2.14	67.82	14.58	0.00	150.0	± 9.6 %
		Y	2.24	68.46	15.06		150.0	
		Z	2.09	67.62	14.35		150.0	
10158-CAD	LTE-FDD (SC-FDMA, 50% RB, 10 MHz, 64-QAM)	X	2.84	69.00	16.66	0.00	150.0	± 9.6 %
		Y	2.89	69.26	16.85		150.0	
		Z	2.81	68.97	16.58		150.0	
10159-CAD	LTE-FDD (SC-FDMA, 50% RB, 5 MHz, 64-QAM)	X	2.26	68.38	14.91	0.00	150.0	± 9.6 %
		Y	2.37	69.05	15.40		150.0	
		Z	2.21	68.17	14.68		150.0	
10160-CAC	LTE-FDD (SC-FDMA, 50% RB, 15 MHz, QPSK)	X	2.78	69.02	16.58	0.00	150.0	± 9.6 %
		Y	2.84	69.39	16.78		150.0	
		Z	2.74	68.91	16.49		150.0	
10161-CAC	LTE-FDD (SC-FDMA, 50% RB, 15 MHz, 16-QAM)	X	2.96	67.68	16.09	0.00	150.0	± 9.6 %
		Y	3.00	67.95	16.25		150.0	
		Z	2.93	67.62	16.01		150.0	
10162-CAC	LTE-FDD (SC-FDMA, 50% RB, 15 MHz, 64-QAM)	X	3.07	67.83	16.20	0.00	150.0	± 9.6 %
		Y	3.11	68.07	16.35		150.0	
		Z	3.04	67.79	16.13		150.0	
10166-CAD	LTE-FDD (SC-FDMA, 50% RB, 1.4 MHz, QPSK)	X	3.52	69.42	18.97	3.01	150.0	± 9.6 %
		Y	3.48	69.21	18.88		150.0	
		Z	3.58	69.99	19.29		150.0	
10167-CAD	LTE-FDD (SC-FDMA, 50% RB, 1.4 MHz, 16-QAM)	X	4.35	72.55	19.50	3.01	150.0	± 9.6 %
		Y	4.23	72.10	19.35		150.0	
		Z	4.57	73.71	20.03		150.0	

10168-CAD	LTE-FDD (SC-FDMA, 50% RB, 1.4 MHz, 64-QAM)	X	4.95	75.33	21.09	3.01	150.0	± 9.6 %
		Y	4.74	74.55	20.78		150.0	
		Z	5.31	76.94	21.79		150.0	
10169-CAC	LTE-FDD (SC-FDMA, 1 RB, 20 MHz, QPSK)	X	2.92	68.92	18.76	3.01	150.0	± 9.6 %
		Y	2.83	68.61	18.65		150.0	
		Z	3.02	69.75	19.20		150.0	
10170-CAC	LTE-FDD (SC-FDMA, 1 RB, 20 MHz, 16-QAM)	X	4.20	75.93	21.56	3.01	150.0	± 9.6 %
		Y	3.90	74.95	21.22		150.0	
		Z	4.73	78.44	22.61		150.0	
10171-AAC	LTE-FDD (SC-FDMA, 1 RB, 20 MHz, 64-QAM)	X	3.29	70.86	18.34	3.01	150.0	± 9.6 %
		Y	3.14	70.43	18.23		150.0	
		Z	3.53	72.31	18.98		150.0	
10172-CAC	LTE-TDD (SC-FDMA, 1 RB, 20 MHz, QPSK)	X	6.18	83.60	24.73	6.02	65.0	± 9.6 %
		Y	5.31	80.83	23.64		65.0	
		Z	5.59	82.35	24.48		65.0	
10173-CAC	LTE-TDD (SC-FDMA, 1 RB, 20 MHz, 16-QAM)	X	9.66	88.05	24.34	6.02	65.0	± 9.6 %
		Y	9.20	87.15	23.96		65.0	
		Z	11.03	90.93	25.45		65.0	
10174-CAC	LTE-TDD (SC-FDMA, 1 RB, 20 MHz, 64-QAM)	X	7.49	83.02	22.12	6.02	65.0	± 9.6 %
		Y	6.16	79.95	20.98		65.0	
		Z	7.52	83.81	22.58		65.0	
10175-CAD	LTE-FDD (SC-FDMA, 1 RB, 10 MHz, QPSK)	X	2.88	68.56	18.48	3.01	150.0	± 9.6 %
		Y	2.79	68.29	18.39		150.0	
		Z	2.97	69.36	18.91		150.0	
10176-CAD	LTE-FDD (SC-FDMA, 1 RB, 10 MHz, 16-QAM)	X	4.20	75.96	21.58	3.01	150.0	± 9.6 %
		Y	3.90	74.98	21.23		150.0	
		Z	4.74	78.47	22.62		150.0	
10177-CAF	LTE-FDD (SC-FDMA, 1 RB, 5 MHz, QPSK)	X	2.90	68.74	18.59	3.01	150.0	± 9.6 %
		Y	2.82	68.45	18.49		150.0	
		Z	3.00	69.54	19.02		150.0	
10178-CAD	LTE-FDD (SC-FDMA, 1 RB, 5 MHz, 16-QAM)	X	4.15	75.68	21.43	3.01	150.0	± 9.6 %
		Y	3.86	74.72	21.10		150.0	
		Z	4.66	78.13	22.46		150.0	
10179-CAD	LTE-FDD (SC-FDMA, 1 RB, 10 MHz, 64-QAM)	X	3.69	73.16	19.77	3.01	150.0	± 9.6 %
		Y	3.48	72.54	19.57		150.0	
		Z	4.04	75.08	20.59		150.0	
10180-CAD	LTE-FDD (SC-FDMA, 1 RB, 5 MHz, 64-QAM)	X	3.28	70.77	18.28	3.01	150.0	± 9.6 %
		Y	3.13	70.35	18.17		150.0	
		Z	3.52	72.21	18.92		150.0	
10181-CAC	LTE-FDD (SC-FDMA, 1 RB, 15 MHz, QPSK)	X	2.90	68.71	18.58	3.01	150.0	± 9.6 %
		Y	2.81	68.43	18.49		150.0	
		Z	2.99	69.52	19.01		150.0	
10182-CAC	LTE-FDD (SC-FDMA, 1 RB, 15 MHz, 16-QAM)	X	4.14	75.65	21.42	3.01	150.0	± 9.6 %
		Y	3.85	74.70	21.08		150.0	
		Z	4.65	78.10	22.45		150.0	
10183-AAB	LTE-FDD (SC-FDMA, 1 RB, 15 MHz, 64-QAM)	X	3.28	70.75	18.27	3.01	150.0	± 9.6 %
		Y	3.12	70.33	18.16		150.0	
		Z	3.51	72.19	18.91		150.0	

10184-CAD	LTE-FDD (SC-FDMA, 1 RB, 3 MHz, QPSK)	X	2.91	68.76	18.61	3.01	150.0	± 9.6 %
		Y	2.82	68.48	18.51		150.0	
		Z	3.00	69.57	19.04		150.0	
10185-CAD	LTE-FDD (SC-FDMA, 1 RB, 3 MHz, 16-QAM)	X	4.16	75.74	21.46	3.01	150.0	± 9.6 %
		Y	3.87	74.78	21.12		150.0	
		Z	4.68	78.20	22.50		150.0	
10186-AAD	LTE-FDD (SC-FDMA, 1 RB, 3 MHz, 64-QAM)	X	3.29	70.82	18.30	3.01	150.0	± 9.6 %
		Y	3.14	70.40	18.20		150.0	
		Z	3.53	72.27	18.95		150.0	
10187-CAD	LTE-FDD (SC-FDMA, 1 RB, 1.4 MHz, QPSK)	X	2.92	68.82	18.67	3.01	150.0	± 9.6 %
		Y	2.83	68.53	18.57		150.0	
		Z	3.01	69.64	19.11		150.0	
10188-CAD	LTE-FDD (SC-FDMA, 1 RB, 1.4 MHz, 16-QAM)	X	4.34	76.58	21.92	3.01	150.0	± 9.6 %
		Y	4.01	75.52	21.54		150.0	
		Z	4.92	79.24	23.02		150.0	
10189-AAD	LTE-FDD (SC-FDMA, 1 RB, 1.4 MHz, 64-QAM)	X	3.38	71.31	18.62	3.01	150.0	± 9.6 %
		Y	3.21	70.86	18.50		150.0	
		Z	3.64	72.84	19.29		150.0	
10193-CAB	IEEE 802.11n (HT Greenfield, 6.5 Mbps, BPSK)	X	4.53	66.74	16.24	0.00	150.0	± 9.6 %
		Y	4.55	66.82	16.28		150.0	
		Z	4.50	66.75	16.20		150.0	
10194-CAB	IEEE 802.11n (HT Greenfield, 39 Mbps, 16-QAM)	X	4.70	67.04	16.36	0.00	150.0	± 9.6 %
		Y	4.73	67.14	16.40		150.0	
		Z	4.67	67.04	16.32		150.0	
10195-CAB	IEEE 802.11n (HT Greenfield, 65 Mbps, 64-QAM)	X	4.74	67.07	16.38	0.00	150.0	± 9.6 %
		Y	4.77	67.16	16.42		150.0	
		Z	4.71	67.07	16.34		150.0	
10196-CAB	IEEE 802.11n (HT Mixed, 6.5 Mbps, BPSK)	X	4.53	66.80	16.25	0.00	150.0	± 9.6 %
		Y	4.56	66.89	16.30		150.0	
		Z	4.50	66.80	16.21		150.0	
10197-CAB	IEEE 802.11n (HT Mixed, 39 Mbps, 16-QAM)	X	4.71	67.06	16.37	0.00	150.0	± 9.6 %
		Y	4.74	67.16	16.41		150.0	
		Z	4.68	67.06	16.33		150.0	
10198-CAB	IEEE 802.11n (HT Mixed, 65 Mbps, 64-QAM)	X	4.74	67.09	16.39	0.00	150.0	± 9.6 %
		Y	4.77	67.18	16.43		150.0	
		Z	4.71	67.09	16.35		150.0	
10219-CAB	IEEE 802.11n (HT Mixed, 7.2 Mbps, BPSK)	X	4.48	66.81	16.22	0.00	150.0	± 9.6 %
		Y	4.51	66.91	16.27		150.0	
		Z	4.45	66.82	16.18		150.0	
10220-CAB	IEEE 802.11n (HT Mixed, 43.3 Mbps, 16-QAM)	X	4.70	67.03	16.36	0.00	150.0	± 9.6 %
		Y	4.73	67.13	16.40		150.0	
		Z	4.67	67.03	16.32		150.0	
10221-CAB	IEEE 802.11n (HT Mixed, 72.2 Mbps, 64-QAM)	X	4.75	67.02	16.37	0.00	150.0	± 9.6 %
		Y	4.78	67.11	16.41		150.0	
		Z	4.72	67.01	16.33		150.0	
10222-CAB	IEEE 802.11n (HT Mixed, 15 Mbps, BPSK)	X	5.07	67.16	16.47	0.00	150.0	± 9.6 %
		Y	5.09	67.26	16.50		150.0	
		Z	5.05	67.15	16.43		150.0	

10223-CAB	IEEE 802.11n (HT Mixed, 90 Mbps, 16-QAM)	X	5.37	67.36	16.58	0.00	150.0	± 9.6 %
		Y	5.39	67.42	16.59		150.0	
		Z	5.35	67.37	16.56		150.0	
10224-CAB	IEEE 802.11n (HT Mixed, 150 Mbps, 64-QAM)	X	5.12	67.28	16.45	0.00	150.0	± 9.6 %
		Y	5.14	67.37	16.48		150.0	
		Z	5.09	67.26	16.42		150.0	
10225-CAB	UMTS-FDD (HSPA+)	X	2.82	66.40	15.48	0.00	150.0	± 9.6 %
		Y	2.86	66.59	15.66		150.0	
		Z	2.79	66.37	15.39		150.0	
10226-CAA	LTE-TDD (SC-FDMA, 1 RB, 1.4 MHz, 16-QAM)	X	10.34	89.28	24.84	6.02	65.0	± 9.6 %
		Y	9.78	88.26	24.43		65.0	
		Z	11.95	92.40	26.02		65.0	
10227-CAA	LTE-TDD (SC-FDMA, 1 RB, 1.4 MHz, 64-QAM)	X	9.45	86.56	23.34	6.02	65.0	± 9.6 %
		Y	8.84	85.37	22.86		65.0	
		Z	10.93	89.56	24.47		65.0	
10228-CAA	LTE-TDD (SC-FDMA, 1 RB, 1.4 MHz, QPSK)	X	7.32	86.94	25.98	6.02	65.0	± 9.6 %
		Y	7.51	87.27	26.00		65.0	
		Z	7.20	87.24	26.30		65.0	
10229-CAB	LTE-TDD (SC-FDMA, 1 RB, 3 MHz, 16-QAM)	X	9.74	88.16	24.39	6.02	65.0	± 9.6 %
		Y	9.28	87.26	24.01		65.0	
		Z	11.13	91.06	25.50		65.0	
10230-CAB	LTE-TDD (SC-FDMA, 1 RB, 3 MHz, 64-QAM)	X	8.91	85.54	22.92	6.02	65.0	± 9.6 %
		Y	8.39	84.47	22.48		65.0	
		Z	10.18	88.33	24.00		65.0	
10231-CAB	LTE-TDD (SC-FDMA, 1 RB, 3 MHz, QPSK)	X	7.00	86.05	25.58	6.02	65.0	± 9.6 %
		Y	7.21	86.43	25.62		65.0	
		Z	6.88	86.32	25.89		65.0	
10232-CAC	LTE-TDD (SC-FDMA, 1 RB, 5 MHz, 16-QAM)	X	9.72	88.14	24.38	6.02	65.0	± 9.6 %
		Y	9.26	87.24	24.00		65.0	
		Z	11.11	91.04	25.49		65.0	
10233-CAC	LTE-TDD (SC-FDMA, 1 RB, 5 MHz, 64-QAM)	X	8.89	85.52	22.92	6.02	65.0	± 9.6 %
		Y	8.37	84.45	22.47		65.0	
		Z	10.16	88.31	23.99		65.0	
10234-CAC	LTE-TDD (SC-FDMA, 1 RB, 5 MHz, QPSK)	X	6.73	85.20	25.16	6.02	65.0	± 9.6 %
		Y	6.94	85.61	25.22		65.0	
		Z	6.62	85.46	25.47		65.0	
10235-CAC	LTE-TDD (SC-FDMA, 1 RB, 10 MHz, 16-QAM)	X	9.73	88.16	24.39	6.02	65.0	± 9.6 %
		Y	9.26	87.26	24.01		65.0	
		Z	11.12	91.07	25.50		65.0	
10236-CAC	LTE-TDD (SC-FDMA, 1 RB, 10 MHz, 64-QAM)	X	8.97	85.63	22.95	6.02	65.0	± 9.6 %
		Y	8.44	84.56	22.50		65.0	
		Z	10.26	88.43	24.03		65.0	
10237-CAC	LTE-TDD (SC-FDMA, 1 RB, 10 MHz, QPSK)	X	7.00	86.09	25.59	6.02	65.0	± 9.6 %
		Y	7.21	86.48	25.64		65.0	
		Z	6.88	86.35	25.91		65.0	
10238-CAC	LTE-TDD (SC-FDMA, 1 RB, 15 MHz, 16-QAM)	X	9.70	88.11	24.37	6.02	65.0	± 9.6 %
		Y	9.24	87.21	23.99		65.0	
		Z	11.08	91.01	25.48		65.0	



10239-CAC	LTE-TDD (SC-FDMA, 1 RB, 15 MHz, 64-QAM)	X	8.86	85.49	22.91	6.02	65.0	± 9.6 %
		Y	8.34	84.42	22.46		65.0	
		Z	10.12	88.27	23.98		65.0	
10240-CAC	LTE-TDD (SC-FDMA, 1 RB, 15 MHz, QPSK)	X	6.98	86.05	25.58	6.02	65.0	± 9.6 %
		Y	7.19	86.44	25.63		65.0	
		Z	6.87	86.32	25.89		65.0	
10241-CAA	LTE-TDD (SC-FDMA, 50% RB, 1.4 MHz, 16-QAM)	X	7.66	79.41	24.04	6.98	65.0	± 9.6 %
		Y	7.53	78.99	23.87		65.0	
		Z	7.72	79.98	24.35		65.0	
10242-CAA	LTE-TDD (SC-FDMA, 50% RB, 1.4 MHz, 64-QAM)	X	7.08	77.85	23.32	6.98	65.0	± 9.6 %
		Y	6.56	76.18	22.61		65.0	
		Z	6.82	77.47	23.23		65.0	
10243-CAA	LTE-TDD (SC-FDMA, 50% RB, 1.4 MHz, QPSK)	X	5.72	74.40	22.72	6.98	65.0	± 9.6 %
		Y	5.45	73.28	22.19		65.0	
		Z	5.52	73.92	22.57		65.0	
10244-CAB	LTE-TDD (SC-FDMA, 50% RB, 3 MHz, 16-QAM)	X	4.75	71.39	15.87	3.98	65.0	± 9.6 %
		Y	4.77	71.48	16.03		65.0	
		Z	4.72	71.54	15.92		65.0	
10245-CAB	LTE-TDD (SC-FDMA, 50% RB, 3 MHz, 64-QAM)	X	4.68	70.96	15.63	3.98	65.0	± 9.6 %
		Y	4.72	71.09	15.82		65.0	
		Z	4.64	71.06	15.66		65.0	
10246-CAB	LTE-TDD (SC-FDMA, 50% RB, 3 MHz, QPSK)	X	4.46	73.85	17.32	3.98	65.0	± 9.6 %
		Y	4.61	74.27	17.59		65.0	
		Z	4.17	73.10	17.00		65.0	
10247-CAC	LTE-TDD (SC-FDMA, 50% RB, 5 MHz, 16-QAM)	X	4.62	71.66	17.10	3.98	65.0	± 9.6 %
		Y	4.72	71.92	17.30		65.0	
		Z	4.41	71.11	16.82		65.0	
10248-CAC	LTE-TDD (SC-FDMA, 50% RB, 5 MHz, 64-QAM)	X	4.64	71.26	16.91	3.98	65.0	± 9.6 %
		Y	4.75	71.55	17.13		65.0	
		Z	4.42	70.71	16.63		65.0	
10249-CAC	LTE-TDD (SC-FDMA, 50% RB, 5 MHz, QPSK)	X	5.55	77.29	19.64	3.98	65.0	± 9.6 %
		Y	5.67	77.48	19.75		65.0	
		Z	5.19	76.50	19.35		65.0	
10250-CAC	LTE-TDD (SC-FDMA, 50% RB, 10 MHz, 16-QAM)	X	5.62	74.57	20.02	3.98	65.0	± 9.6 %
		Y	5.69	74.63	20.05		65.0	
		Z	5.39	73.98	19.78		65.0	
10251-CAC	LTE-TDD (SC-FDMA, 50% RB, 10 MHz, 64-QAM)	X	5.39	72.65	18.85	3.98	65.0	± 9.6 %
		Y	5.48	72.84	18.95		65.0	
		Z	5.18	72.13	18.61		65.0	
10252-CAC	LTE-TDD (SC-FDMA, 50% RB, 10 MHz, QPSK)	X	6.13	78.05	20.93	3.98	65.0	± 9.6 %
		Y	6.21	78.10	20.92		65.0	
		Z	5.78	77.32	20.70		65.0	
10253-CAC	LTE-TDD (SC-FDMA, 50% RB, 15 MHz, 16-QAM)	X	5.54	72.10	19.00	3.98	65.0	± 9.6 %
		Y	5.62	72.26	19.07		65.0	
		Z	5.35	71.63	18.79		65.0	
10254-CAC	LTE-TDD (SC-FDMA, 50% RB, 15 MHz, 64-QAM)	X	5.89	73.05	19.74	3.98	65.0	± 9.6 %
		Y	5.96	73.15	19.77		65.0	
		Z	5.69	72.56	19.53		65.0	

10255-CAC	LTE-TDD (SC-FDMA, 50% RB, 15 MHz, QPSK)	X	5.96	75.63	20.26	3.98	65.0	± 9.6 %
		Y	6.03	75.68	20.24		65.0	
		Z	5.70	75.08	20.08		65.0	
10256-CAA	LTE-TDD (SC-FDMA, 100% RB, 1.4 MHz, 16-QAM)	X	3.65	67.68	13.12	3.98	65.0	± 9.6 %
		Y	3.72	67.99	13.43		65.0	
		Z	3.58	67.63	13.06		65.0	
10257-CAA	LTE-TDD (SC-FDMA, 100% RB, 1.4 MHz, 64-QAM)	X	3.61	67.24	12.83	3.98	65.0	± 9.6 %
		Y	3.69	67.57	13.15		65.0	
		Z	3.52	67.14	12.74		65.0	
10258-CAA	LTE-TDD (SC-FDMA, 100% RB, 1.4 MHz, QPSK)	X	3.39	69.66	14.64	3.98	65.0	± 9.6 %
		Y	3.55	70.26	15.05		65.0	
		Z	3.18	68.99	14.30		65.0	
10259-CAB	LTE-TDD (SC-FDMA, 100% RB, 3 MHz, 16-QAM)	X	5.01	72.76	18.17	3.98	65.0	± 9.6 %
		Y	5.10	72.95	18.31		65.0	
		Z	4.79	72.21	17.91		65.0	
10260-CAB	LTE-TDD (SC-FDMA, 100% RB, 3 MHz, 64-QAM)	X	5.05	72.57	18.09	3.98	65.0	± 9.6 %
		Y	5.14	72.76	18.24		65.0	
		Z	4.83	72.02	17.83		65.0	
10261-CAB	LTE-TDD (SC-FDMA, 100% RB, 3 MHz, QPSK)	X	5.55	76.95	19.93	3.98	65.0	± 9.6 %
		Y	5.66	77.10	20.01		65.0	
		Z	5.23	76.20	19.66		65.0	
10262-CAC	LTE-TDD (SC-FDMA, 100% RB, 5 MHz, 16-QAM)	X	5.61	74.51	19.98	3.98	65.0	± 9.6 %
		Y	5.68	74.58	20.01		65.0	
		Z	5.37	73.92	19.73		65.0	
10263-CAC	LTE-TDD (SC-FDMA, 100% RB, 5 MHz, 64-QAM)	X	5.38	72.63	18.84	3.98	65.0	± 9.6 %
		Y	5.47	72.82	18.95		65.0	
		Z	5.17	72.10	18.61		65.0	
10264-CAC	LTE-TDD (SC-FDMA, 100% RB, 5 MHz, QPSK)	X	6.07	77.87	20.84	3.98	65.0	± 9.6 %
		Y	6.16	77.94	20.84		65.0	
		Z	5.73	77.15	20.61		65.0	
10265-CAC	LTE-TDD (SC-FDMA, 100% RB, 10 MHz, 16-QAM)	X	5.64	72.55	19.22	3.98	65.0	± 9.6 %
		Y	5.73	72.74	19.29		65.0	
		Z	5.43	72.04	19.01		65.0	
10266-CAC	LTE-TDD (SC-FDMA, 100% RB, 10 MHz, 64-QAM)	X	6.02	73.57	20.03	3.98	65.0	± 9.6 %
		Y	6.09	73.68	20.05		65.0	
		Z	5.81	73.06	19.83		65.0	
10267-CAC	LTE-TDD (SC-FDMA, 100% RB, 10 MHz, QPSK)	X	6.19	76.11	20.24	3.98	65.0	± 9.6 %
		Y	6.26	76.15	20.20		65.0	
		Z	5.92	75.57	20.08		65.0	
10268-CAC	LTE-TDD (SC-FDMA, 100% RB, 15 MHz, 16-QAM)	X	6.31	72.74	19.74	3.98	65.0	± 9.6 %
		Y	6.38	72.86	19.76		65.0	
		Z	6.11	72.28	19.56		65.0	
10269-CAC	LTE-TDD (SC-FDMA, 100% RB, 15 MHz, 64-QAM)	X	6.31	72.40	19.66	3.98	65.0	± 9.6 %
		Y	6.37	72.52	19.68		65.0	
		Z	6.11	71.95	19.47		65.0	
10270-CAC	LTE-TDD (SC-FDMA, 100% RB, 15 MHz, QPSK)	X	6.25	74.19	19.65	3.98	65.0	± 9.6 %
		Y	6.30	74.22	19.60		65.0	
		Z	6.03	73.76	19.52		65.0	

10274-CAB	UMTS-FDD (HSUPA, Subtest 5, 3GPP Rel8.10)	X	2.62	66.83	15.44	0.00	150.0	± 9.6 %
		Y	2.65	67.06	15.64		150.0	
		Z	2.60	66.81	15.36		150.0	
10275-CAB	UMTS-FDD (HSUPA, Subtest 5, 3GPP Rel8.4)	X	1.66	68.56	15.99	0.00	150.0	± 9.6 %
		Y	1.74	69.37	16.47		150.0	
		Z	1.63	68.35	15.83		150.0	
10277-CAA	PHS (QPSK)	X	2.45	61.81	7.48	9.03	50.0	± 9.6 %
		Y	2.59	62.16	7.82		50.0	
		Z	2.54	62.07	7.75		50.0	
10278-CAA	PHS (QPSK, BW 884MHz, Rolloff 0.5)	X	4.03	68.72	13.51	9.03	50.0	± 9.6 %
		Y	4.22	69.17	13.84		50.0	
		Z	4.10	68.73	13.58		50.0	
10279-CAA	PHS (QPSK, BW 884MHz, Rolloff 0.38)	X	4.13	68.96	13.67	9.03	50.0	± 9.6 %
		Y	4.33	69.41	14.00		50.0	
		Z	4.19	68.95	13.73		50.0	
10290-AAB	CDMA2000, RC1, SO55, Full Rate	X	1.59	70.25	14.71	0.00	150.0	± 9.6 %
		Y	1.82	72.15	15.78		150.0	
		Z	1.50	69.65	14.28		150.0	
10291-AAB	CDMA2000, RC3, SO55, Full Rate	X	0.90	67.12	13.22	0.00	150.0	± 9.6 %
		Y	1.00	68.73	14.25		150.0	
		Z	0.86	66.67	12.84		150.0	
10292-AAB	CDMA2000, RC3, SO32, Full Rate	X	1.36	73.82	16.65	0.00	150.0	± 9.6 %
		Y	1.71	77.26	18.32		150.0	
		Z	1.28	73.01	16.14		150.0	
10293-AAB	CDMA2000, RC3, SO3, Full Rate	X	3.29	86.77	21.89	0.00	150.0	± 9.6 %
		Y	4.71	92.66	24.11		150.0	
		Z	3.08	85.69	21.33		150.0	
10295-AAB	CDMA2000, RC1, SO3, 1/8th Rate 25 fr.	X	7.29	78.77	20.59	9.03	50.0	± 9.6 %
		Y	7.06	78.09	20.40		50.0	
		Z	7.48	78.90	20.60		50.0	
10297-AAB	LTE-FDD (SC-FDMA, 50% RB, 20 MHz, QPSK)	X	2.80	70.15	16.93	0.00	150.0	± 9.6 %
		Y	2.90	70.75	17.22		150.0	
		Z	2.76	69.98	16.83		150.0	
10298-AAC	LTE-FDD (SC-FDMA, 50% RB, 3 MHz, QPSK)	X	1.64	68.64	14.60	0.00	150.0	± 9.6 %
		Y	1.79	69.89	15.40		150.0	
		Z	1.57	68.20	14.24		150.0	
10299-AAC	LTE-FDD (SC-FDMA, 50% RB, 3 MHz, 16-QAM)	X	2.47	68.83	13.61	0.00	150.0	± 9.6 %
		Y	2.54	69.43	14.13		150.0	
		Z	2.67	69.79	13.88		150.0	
10300-AAC	LTE-FDD (SC-FDMA, 50% RB, 3 MHz, 64-QAM)	X	1.84	64.47	10.78	0.00	150.0	± 9.6 %
		Y	1.87	64.82	11.18		150.0	
		Z	1.87	64.71	10.75		150.0	
10301-AAA	IEEE 802.16e WiMAX (29:18, 5ms, 10MHz, QPSK, PUSC)	X	4.69	65.44	17.46	4.17	50.0	± 9.6 %
		Y	4.63	65.10	17.32		50.0	
		Z	4.65	65.38	17.36		50.0	
10302-AAA	IEEE 802.16e WiMAX (29:18, 5ms, 10MHz, QPSK, PUSC, 3 CTRL symbols)	X	5.12	65.81	18.03	4.96	50.0	± 9.6 %
		Y	5.16	65.97	18.16		50.0	
		Z	5.12	65.91	18.02		50.0	

10303-AAA	IEEE 802.16e WiMAX (31:15, 5ms, 10MHz, 64QAM, PUSC)	X	4.87	65.45	17.87	4.96	50.0	± 9.6 %
		Y	4.92	65.62	18.01		50.0	
		Z	4.87	65.57	17.85		50.0	
10304-AAA	IEEE 802.16e WiMAX (29:18, 5ms, 10MHz, 64QAM, PUSC)	X	4.68	65.35	17.39	4.17	50.0	± 9.6 %
		Y	4.72	65.48	17.50		50.0	
		Z	4.68	65.45	17.37		50.0	
10305-AAA	IEEE 802.16e WiMAX (31:15, 10ms, 10MHz, 64QAM, PUSC, 15 symbols)	X	4.39	67.43	19.46	6.02	35.0	± 9.6 %
		Y	4.48	67.81	19.80		35.0	
		Z	4.49	68.01	19.61		35.0	
10306-AAA	IEEE 802.16e WiMAX (29:18, 10ms, 10MHz, 64QAM, PUSC, 18 symbols)	X	4.67	66.30	18.98	6.02	35.0	± 9.6 %
		Y	4.73	66.54	19.21		35.0	
		Z	4.72	66.69	19.08		35.0	
10307-AAA	IEEE 802.16e WiMAX (29:18, 10ms, 10MHz, QPSK, PUSC, 18 symbols)	X	4.58	66.51	18.97	6.02	35.0	± 9.6 %
		Y	4.65	66.79	19.23		35.0	
		Z	4.64	66.91	19.08		35.0	
10308-AAA	IEEE 802.16e WiMAX (29:18, 10ms, 10MHz, 16QAM, PUSC)	X	4.56	66.71	19.12	6.02	35.0	± 9.6 %
		Y	4.63	67.02	19.38		35.0	
		Z	4.62	67.14	19.23		35.0	
10309-AAA	IEEE 802.16e WiMAX (29:18, 10ms, 10MHz, 16QAM, AMC 2x3, 18 symbols)	X	4.72	66.48	19.11	6.02	35.0	± 9.6 %
		Y	4.79	66.75	19.35		35.0	
		Z	4.77	66.86	19.21		35.0	
10310-AAA	IEEE 802.16e WiMAX (29:18, 10ms, 10MHz, QPSK, AMC 2x3, 18 symbols)	X	4.62	66.39	18.97	6.02	35.0	± 9.6 %
		Y	4.69	66.63	19.20		35.0	
		Z	4.68	66.79	19.08		35.0	
10311-AAB	LTE-FDD (SC-FDMA, 100% RB, 15 MHz, QPSK)	X	3.17	69.43	16.56	0.00	150.0	± 9.6 %
		Y	3.28	70.00	16.83		150.0	
		Z	3.13	69.27	16.47		150.0	
10313-AAA	IDEN 1:3	X	3.04	69.90	14.46	6.99	70.0	± 9.6 %
		Y	3.00	69.58	14.26		70.0	
		Z	2.91	69.76	14.60		70.0	
10314-AAA	IDEN 1:6	X	4.05	75.03	19.23	10.00	30.0	± 9.6 %
		Y	3.94	74.12	18.73		30.0	
		Z	4.12	75.22	19.44		30.0	
10315-AAB	IEEE 802.11b WiFi 2.4 GHz (DSSS, 1 Mbps, 96pc duty cycle)	X	1.10	63.97	15.35	0.17	150.0	± 9.6 %
		Y	1.11	64.32	15.62		150.0	
		Z	1.09	63.83	15.22		150.0	
10316-AAB	IEEE 802.11g WiFi 2.4 GHz (ERP-OFDM, 6 Mbps, 96pc duty cycle)	X	4.56	66.66	16.26	0.17	150.0	± 9.6 %
		Y	4.58	66.74	16.29		150.0	
		Z	4.53	66.67	16.22		150.0	
10317-AAB	IEEE 802.11a WiFi 5 GHz (OFDM, 6 Mbps, 96pc duty cycle)	X	4.56	66.66	16.26	0.17	150.0	± 9.6 %
		Y	4.58	66.74	16.29		150.0	
		Z	4.53	66.67	16.22		150.0	
10400-AAC	IEEE 802.11ac WiFi (20MHz, 64-QAM, 99pc duty cycle)	X	4.68	67.08	16.34	0.00	150.0	± 9.6 %
		Y	4.72	67.18	16.39		150.0	
		Z	4.65	67.07	16.30		150.0	
10401-AAC	IEEE 802.11ac WiFi (40MHz, 64-QAM, 99pc duty cycle)	X	5.39	67.23	16.48	0.00	150.0	± 9.6 %
		Y	5.40	67.28	16.50		150.0	
		Z	5.35	67.18	16.43		150.0	

10402-AAC	IEEE 802.11ac WiFi (80MHz, 64-QAM, 99pc duty cycle)	X	5.64	67.54	16.50	0.00	150.0	± 9.6 %
		Y	5.66	67.64	16.53		150.0	
		Z	5.61	67.52	16.47		150.0	
10403-AAB	CDMA2000 (1xEV-DO, Rev. 0)	X	1.59	70.25	14.71	0.00	115.0	± 9.6 %
		Y	1.82	72.15	15.78		115.0	
		Z	1.50	69.65	14.28		115.0	
10404-AAB	CDMA2000 (1xEV-DO, Rev. A)	X	1.59	70.25	14.71	0.00	115.0	± 9.6 %
		Y	1.82	72.15	15.78		115.0	
		Z	1.50	69.65	14.28		115.0	
10406-AAB	CDMA2000, RC3, SO32, SCH0, Full Rate	X	100.00	119.40	29.12	0.00	100.0	± 9.6 %
		Y	100.00	122.00	30.20		100.0	
		Z	100.00	117.27	28.11		100.0	
10410-AAB	LTE-TDD (SC-FDMA, 1 RB, 10 MHz, QPSK, UL Subframe=2,3,4,7,8,9)	X	7.12	84.42	19.31	3.23	80.0	± 9.6 %
		Y	6.26	82.81	18.74		80.0	
		Z	11.96	91.59	21.64		80.0	
10415-AAA	IEEE 802.11b WiFi 2.4 GHz (DSSS, 1 Mbps, 99pc duty cycle)	X	1.03	63.32	14.96	0.00	150.0	± 9.6 %
		Y	1.04	63.68	15.26		150.0	
		Z	1.03	63.25	14.86		150.0	
10416-AAA	IEEE 802.11g WiFi 2.4 GHz (ERP-OFDM, 6 Mbps, 99pc duty cycle)	X	4.53	66.77	16.30	0.00	150.0	± 9.6 %
		Y	4.56	66.86	16.35		150.0	
		Z	4.51	66.78	16.27		150.0	
10417-AAA	IEEE 802.11a/h WiFi 5 GHz (OFDM, 6 Mbps, 99pc duty cycle)	X	4.53	66.77	16.30	0.00	150.0	± 9.6 %
		Y	4.56	66.86	16.35		150.0	
		Z	4.51	66.78	16.27		150.0	
10418-AAA	IEEE 802.11g WiFi 2.4 GHz (DSSS-OFDM, 6 Mbps, 99pc duty cycle, Long preamble)	X	4.52	66.95	16.33	0.00	150.0	± 9.6 %
		Y	4.55	67.03	16.37		150.0	
		Z	4.50	66.95	16.30		150.0	
10419-AAA	IEEE 802.11g WiFi 2.4 GHz (DSSS-OFDM, 6 Mbps, 99pc duty cycle, Short preamble)	X	4.54	66.89	16.33	0.00	150.0	± 9.6 %
		Y	4.57	66.97	16.37		150.0	
		Z	4.52	66.90	16.30		150.0	
10422-AAA	IEEE 802.11n (HT Greenfield, 7.2 Mbps, BPSK)	X	4.66	66.88	16.34	0.00	150.0	± 9.6 %
		Y	4.68	66.96	16.38		150.0	
		Z	4.63	66.88	16.30		150.0	
10423-AAA	IEEE 802.11n (HT Greenfield, 43.3 Mbps, 16-QAM)	X	4.82	67.18	16.45	0.00	150.0	± 9.6 %
		Y	4.85	67.27	16.49		150.0	
		Z	4.78	67.18	16.41		150.0	
10424-AAA	IEEE 802.11n (HT Greenfield, 72.2 Mbps, 64-QAM)	X	4.74	67.14	16.42	0.00	150.0	± 9.6 %
		Y	4.77	67.23	16.47		150.0	
		Z	4.71	67.13	16.39		150.0	
10425-AAA	IEEE 802.11n (HT Greenfield, 15 Mbps, BPSK)	X	5.34	67.39	16.57	0.00	150.0	± 9.6 %
		Y	5.35	67.47	16.59		150.0	
		Z	5.30	67.36	16.53		150.0	
10426-AAA	IEEE 802.11n (HT Greenfield, 90 Mbps, 16-QAM)	X	5.35	67.44	16.59	0.00	150.0	± 9.6 %
		Y	5.36	67.49	16.60		150.0	
		Z	5.32	67.42	16.56		150.0	

10427-AAA	IEEE 802.11n (HT Greenfield, 150 Mbps, 64-QAM)	X	5.36	67.40	16.57	0.00	150.0	± 9.6 %
		Y	5.37	67.48	16.59		150.0	
		Z	5.32	67.37	16.53		150.0	
10430-AAA	LTE-FDD (OFDMA, 5 MHz, E-TM 3.1)	X	4.43	71.93	18.75	0.00	150.0	± 9.6 %
		Y	4.42	71.71	18.69		150.0	
		Z	4.43	72.11	18.76		150.0	
10431-AAA	LTE-FDD (OFDMA, 10 MHz, E-TM 3.1)	X	4.21	67.37	16.31	0.00	150.0	± 9.6 %
		Y	4.25	67.48	16.39		150.0	
		Z	4.17	67.37	16.26		150.0	
10432-AAA	LTE-FDD (OFDMA, 15 MHz, E-TM 3.1)	X	4.51	67.21	16.38	0.00	150.0	± 9.6 %
		Y	4.54	67.31	16.43		150.0	
		Z	4.47	67.21	16.34		150.0	
10433-AAA	LTE-FDD (OFDMA, 20 MHz, E-TM 3.1)	X	4.75	67.17	16.44	0.00	150.0	± 9.6 %
		Y	4.79	67.27	16.49		150.0	
		Z	4.72	67.17	16.41		150.0	
10434-AAA	W-CDMA (BS Test Model 1, 64 DPCH)	X	4.61	73.06	18.81	0.00	150.0	± 9.6 %
		Y	4.59	72.83	18.78		150.0	
		Z	4.61	73.27	18.81		150.0	
10435-AAB	LTE-TDD (SC-FDMA, 1 RB, 20 MHz, QPSK, UL Subframe=2,3,4,7,8,9)	X	6.74	83.64	19.02	3.23	80.0	± 9.6 %
		Y	5.96	82.09	18.46		80.0	
		Z	10.99	90.40	21.25		80.0	
10447-AAA	LTE-FDD (OFDMA, 5 MHz, E-TM 3.1, Clipping 44%)	X	3.51	67.45	15.64	0.00	150.0	± 9.6 %
		Y	3.57	67.65	15.82		150.0	
		Z	3.46	67.42	15.53		150.0	
10448-AAA	LTE-FDD (OFDMA, 10 MHz, E-TM 3.1, Clipping 44%)	X	4.05	67.16	16.18	0.00	150.0	± 9.6 %
		Y	4.09	67.27	16.26		150.0	
		Z	4.02	67.16	16.13		150.0	
10449-AAA	LTE-FDD (OFDMA, 15 MHz, E-TM 3.1, Clipping 44%)	X	4.33	67.05	16.28	0.00	150.0	± 9.6 %
		Y	4.36	67.15	16.34		150.0	
		Z	4.30	67.04	16.24		150.0	
10450-AAA	LTE-FDD (OFDMA, 20 MHz, E-TM 3.1, Clipping 44%)	X	4.52	66.95	16.30	0.00	150.0	± 9.6 %
		Y	4.55	67.05	16.35		150.0	
		Z	4.50	66.95	16.27		150.0	
10451-AAA	W-CDMA (BS Test Model 1, 64 DPCH, Clipping 44%)	X	3.39	67.63	15.23	0.00	150.0	± 9.6 %
		Y	3.47	67.90	15.48		150.0	
		Z	3.34	67.55	15.09		150.0	
10456-AAA	IEEE 802.11ac WiFi (160MHz, 64-QAM, 99pc duty cycle)	X	6.21	67.93	16.72	0.00	150.0	± 9.6 %
		Y	6.21	67.99	16.72		150.0	
		Z	6.19	67.92	16.69		150.0	
10457-AAA	UMTS-FDD (DC-HSDPA)	X	3.80	65.42	16.01	0.00	150.0	± 9.6 %
		Y	3.81	65.50	16.06		150.0	
		Z	3.79	65.44	15.98		150.0	
10458-AAA	CDMA2000 (1xEV-DO, Rev. B, 2 carriers)	X	3.19	66.85	14.54	0.00	150.0	± 9.6 %
		Y	3.28	67.17	14.85		150.0	
		Z	3.13	66.73	14.35		150.0	
10459-AAA	CDMA2000 (1xEV-DO, Rev. B, 3 carriers)	X	4.26	65.09	15.50	0.00	150.0	± 9.6 %
		Y	4.45	65.72	15.90		150.0	
		Z	4.15	64.82	15.27		150.0	

10460-AAA	UMTS-FDD (WCDMA, AMR)	X	0.95	69.24	16.88	0.00	150.0	± 9.6 %
		Y	1.02	70.79	17.77		150.0	
		Z	0.93	68.79	16.59		150.0	
10461-AAA	LTE-TDD (SC-FDMA, 1 RB, 1.4 MHz, QPSK, UL Subframe=2,3,4,7,8,9)	X	3.16	76.40	17.59	3.29	80.0	± 9.6 %
		Y	3.00	75.64	17.23		80.0	
		Z	4.60	82.00	19.74		80.0	
10462-AAA	LTE-TDD (SC-FDMA, 1 RB, 1.4 MHz, 16-QAM, UL Subframe=2,3,4,7,8,9)	X	0.95	60.00	7.73	3.23	80.0	± 9.6 %
		Y	0.93	60.00	7.68		80.0	
		Z	0.93	60.16	7.81		80.0	
10463-AAA	LTE-TDD (SC-FDMA, 1 RB, 1.4 MHz, 64-QAM, UL Subframe=2,3,4,7,8,9)	X	0.96	60.00	7.25	3.23	80.0	± 9.6 %
		Y	0.96	60.00	7.20		80.0	
		Z	0.93	60.00	7.22		80.0	
10464-AAA	LTE-TDD (SC-FDMA, 1 RB, 3 MHz, QPSK, UL Subframe=2,3,4,7,8,9)	X	2.40	72.59	15.64	3.23	80.0	± 9.6 %
		Y	2.28	71.93	15.30		80.0	
		Z	3.30	77.16	17.51		80.0	
10465-AAA	LTE-TDD (SC-FDMA, 1 RB, 3 MHz, 16-QAM, UL Subframe=2,3,4,7,8,9)	X	0.94	60.00	7.67	3.23	80.0	± 9.6 %
		Y	0.93	60.00	7.61		80.0	
		Z	0.91	60.00	7.66		80.0	
10466-AAA	LTE-TDD (SC-FDMA, 1 RB, 3 MHz, 64-QAM, UL Subframe=2,3,4,7,8,9)	X	0.97	60.00	7.21	3.23	80.0	± 9.6 %
		Y	0.96	60.00	7.15		80.0	
		Z	0.93	60.00	7.18		80.0	
10467-AAB	LTE-TDD (SC-FDMA, 1 RB, 5 MHz, QPSK, UL Subframe=2,3,4,7,8,9)	X	2.51	73.23	15.91	3.23	80.0	± 9.6 %
		Y	2.39	72.52	15.56		80.0	
		Z	3.54	78.13	17.88		80.0	
10468-AAB	LTE-TDD (SC-FDMA, 1 RB, 5 MHz, 16-QAM, UL Subframe=2,3,4,7,8,9)	X	0.94	60.00	7.68	3.23	80.0	± 9.6 %
		Y	0.93	60.00	7.62		80.0	
		Z	0.91	60.00	7.68		80.0	
10469-AAB	LTE-TDD (SC-FDMA, 1 RB, 5 MHz, 64-QAM, UL Subframe=2,3,4,7,8,9)	X	0.97	60.00	7.20	3.23	80.0	± 9.6 %
		Y	0.96	60.00	7.15		80.0	
		Z	0.93	60.00	7.18		80.0	
10470-AAB	LTE-TDD (SC-FDMA, 1 RB, 10 MHz, QPSK, UL Subframe=2,3,4,7,8,9)	X	2.50	73.21	15.89	3.23	80.0	± 9.6 %
		Y	2.37	72.50	15.54		80.0	
		Z	3.54	78.12	17.87		80.0	
10471-AAB	LTE-TDD (SC-FDMA, 1 RB, 10 MHz, 16-QAM, UL Subframe=2,3,4,7,8,9)	X	0.94	60.00	7.67	3.23	80.0	± 9.6 %
		Y	0.93	60.00	7.61		80.0	
		Z	0.91	60.00	7.66		80.0	
10472-AAB	LTE-TDD (SC-FDMA, 1 RB, 10 MHz, 64-QAM, UL Subframe=2,3,4,7,8,9)	X	0.96	60.00	7.19	3.23	80.0	± 9.6 %
		Y	0.96	60.00	7.14		80.0	
		Z	0.93	60.00	7.16		80.0	
10473-AAB	LTE-TDD (SC-FDMA, 1 RB, 15 MHz, QPSK, UL Subframe=2,3,4,7,8,9)	X	2.50	73.17	15.87	3.23	80.0	± 9.6 %
		Y	2.37	72.47	15.52		80.0	
		Z	3.52	78.07	17.84		80.0	
10474-AAB	LTE-TDD (SC-FDMA, 1 RB, 15 MHz, 16-QAM, UL Subframe=2,3,4,7,8,9)	X	0.94	60.00	7.67	3.23	80.0	± 9.6 %
		Y	0.93	60.00	7.61		80.0	
		Z	0.91	60.00	7.66		80.0	
10475-AAB	LTE-TDD (SC-FDMA, 1 RB, 15 MHz, 64-QAM, UL Subframe=2,3,4,7,8,9)	X	0.96	60.00	7.19	3.23	80.0	± 9.6 %
		Y	0.95	60.00	7.14		80.0	
		Z	0.93	60.00	7.16		80.0	

10477-AAB	LTE-TDD (SC-FDMA, 1 RB, 20 MHz, 16-QAM, UL Subframe=2,3,4,7,8,9)	X	0.94	60.00	7.65	3.23	80.0	± 9.6 %
		Y	0.93	60.00	7.59		80.0	
		Z	0.91	60.00	7.64		80.0	
10478-AAB	LTE-TDD (SC-FDMA, 1 RB, 20 MHz, 64-QAM, UL Subframe=2,3,4,7,8,9)	X	0.96	60.00	7.18	3.23	80.0	± 9.6 %
		Y	0.96	60.00	7.13		80.0	
		Z	0.93	60.00	7.15		80.0	
10479-AAA	LTE-TDD (SC-FDMA, 50% RB, 1.4 MHz, QPSK, UL Subframe=2,3,4,7,8,9)	X	3.82	75.02	18.32	3.23	80.0	± 9.6 %
		Y	3.62	74.21	18.05		80.0	
		Z	4.46	77.72	19.42		80.0	
10480-AAA	LTE-TDD (SC-FDMA, 50% RB, 1.4 MHz, 16-QAM, UL Subframe=2,3,4,7,8,9)	X	3.25	69.58	14.47	3.23	80.0	± 9.6 %
		Y	3.17	69.32	14.47		80.0	
		Z	3.70	71.50	15.22		80.0	
10481-AAA	LTE-TDD (SC-FDMA, 50% RB, 1.4 MHz, 64-QAM, UL Subframe=2,3,4,7,8,9)	X	2.76	67.27	13.16	3.23	80.0	± 9.6 %
		Y	2.74	67.18	13.23		80.0	
		Z	3.01	68.58	13.68		80.0	
10482-AAA	LTE-TDD (SC-FDMA, 50% RB, 3 MHz, QPSK, UL Subframe=2,3,4,7,8,9)	X	2.20	67.37	14.31	2.23	80.0	± 9.6 %
		Y	2.35	68.14	14.78		80.0	
		Z	2.08	66.84	14.02		80.0	
10483-AAA	LTE-TDD (SC-FDMA, 50% RB, 3 MHz, 16-QAM, UL Subframe=2,3,4,7,8,9)	X	2.64	66.33	13.17	2.23	80.0	± 9.6 %
		Y	2.72	66.71	13.49		80.0	
		Z	2.71	66.89	13.39		80.0	
10484-AAA	LTE-TDD (SC-FDMA, 50% RB, 3 MHz, 64-QAM, UL Subframe=2,3,4,7,8,9)	X	2.59	65.86	12.96	2.23	80.0	± 9.6 %
		Y	2.68	66.27	13.30		80.0	
		Z	2.63	66.32	13.14		80.0	
10485-AAB	LTE-TDD (SC-FDMA, 50% RB, 5 MHz, QPSK, UL Subframe=2,3,4,7,8,9)	X	2.65	69.52	16.23	2.23	80.0	± 9.6 %
		Y	2.77	70.09	16.54		80.0	
		Z	2.52	69.04	16.02		80.0	
10486-AAB	LTE-TDD (SC-FDMA, 50% RB, 5 MHz, 16-QAM, UL Subframe=2,3,4,7,8,9)	X	2.73	66.83	14.56	2.23	80.0	± 9.6 %
		Y	2.83	67.27	14.87		80.0	
		Z	2.62	66.49	14.35		80.0	
10487-AAB	LTE-TDD (SC-FDMA, 50% RB, 5 MHz, 64-QAM, UL Subframe=2,3,4,7,8,9)	X	2.75	66.57	14.44	2.23	80.0	± 9.6 %
		Y	2.85	67.00	14.75		80.0	
		Z	2.64	66.24	14.22		80.0	
10488-AAB	LTE-TDD (SC-FDMA, 50% RB, 10 MHz, QPSK, UL Subframe=2,3,4,7,8,9)	X	3.11	69.87	17.17	2.23	80.0	± 9.6 %
		Y	3.21	70.31	17.35		80.0	
		Z	2.98	69.45	17.00		80.0	
10489-AAB	LTE-TDD (SC-FDMA, 50% RB, 10 MHz, 16-QAM, UL Subframe=2,3,4,7,8,9)	X	3.21	67.51	16.20	2.23	80.0	± 9.6 %
		Y	3.27	67.74	16.32		80.0	
		Z	3.12	67.26	16.07		80.0	
10490-AAB	LTE-TDD (SC-FDMA, 50% RB, 10 MHz, 64-QAM, UL Subframe=2,3,4,7,8,9)	X	3.31	67.44	16.19	2.23	80.0	± 9.6 %
		Y	3.37	67.66	16.31		80.0	
		Z	3.22	67.20	16.06		80.0	
10491-AAB	LTE-TDD (SC-FDMA, 50% RB, 15 MHz, QPSK, UL Subframe=2,3,4,7,8,9)	X	3.45	69.12	17.04	2.23	80.0	± 9.6 %
		Y	3.54	69.47	17.16		80.0	
		Z	3.34	68.78	16.91		80.0	
10492-AAB	LTE-TDD (SC-FDMA, 50% RB, 15 MHz, 16-QAM, UL Subframe=2,3,4,7,8,9)	X	3.61	67.20	16.42	2.23	80.0	± 9.6 %
		Y	3.67	67.39	16.51		80.0	
		Z	3.53	66.97	16.31		80.0	



10493-AAB	LTE-TDD (SC-FDMA, 50% RB, 15 MHz, 64-QAM, UL Subframe=2,3,4,7,8,9)	X	3.68	67.13	16.41	2.23	80.0	± 9.6 %
		Y	3.74	67.31	16.49		80.0	
		Z	3.60	66.91	16.30		80.0	
10494-AAB	LTE-TDD (SC-FDMA, 50% RB, 20 MHz, QPSK, UL Subframe=2,3,4,7,8,9)	X	3.65	70.25	17.36	2.23	80.0	± 9.6 %
		Y	3.77	70.66	17.50		80.0	
		Z	3.52	69.86	17.23		80.0	
10495-AAB	LTE-TDD (SC-FDMA, 50% RB, 20 MHz, 16-QAM, UL Subframe=2,3,4,7,8,9)	X	3.63	67.51	16.59	2.23	80.0	± 9.6 %
		Y	3.69	67.72	16.68		80.0	
		Z	3.55	67.26	16.48		80.0	
10496-AAB	LTE-TDD (SC-FDMA, 50% RB, 20 MHz, 64-QAM, UL Subframe=2,3,4,7,8,9)	X	3.72	67.34	16.57	2.23	80.0	± 9.6 %
		Y	3.78	67.53	16.64		80.0	
		Z	3.64	67.11	16.46		80.0	
10497-AAA	LTE-TDD (SC-FDMA, 100% RB, 1.4 MHz, QPSK, UL Subframe=2,3,4,7,8,9)	X	1.59	63.52	11.51	2.23	80.0	± 9.6 %
		Y	1.71	64.33	12.09		80.0	
		Z	1.49	63.03	11.17		80.0	
10498-AAA	LTE-TDD (SC-FDMA, 100% RB, 1.4 MHz, 16-QAM, UL Subframe=2,3,4,7,8,9)	X	1.40	60.13	8.74	2.23	80.0	± 9.6 %
		Y	1.50	60.76	9.30		80.0	
		Z	1.35	60.00	8.54		80.0	
10499-AAA	LTE-TDD (SC-FDMA, 100% RB, 1.4 MHz, 64-QAM, UL Subframe=2,3,4,7,8,9)	X	1.40	60.00	8.54	2.23	80.0	± 9.6 %
		Y	1.47	60.38	8.96		80.0	
		Z	1.37	60.00	8.41		80.0	
10500-AAA	LTE-TDD (SC-FDMA, 100% RB, 3 MHz, QPSK, UL Subframe=2,3,4,7,8,9)	X	2.81	69.52	16.57	2.23	80.0	± 9.6 %
		Y	2.92	70.00	16.81		80.0	
		Z	2.69	69.09	16.38		80.0	
10501-AAA	LTE-TDD (SC-FDMA, 100% RB, 3 MHz, 16-QAM, UL Subframe=2,3,4,7,8,9)	X	2.95	67.23	15.25	2.23	80.0	± 9.6 %
		Y	3.03	67.55	15.48		80.0	
		Z	2.85	66.94	15.08		80.0	
10502-AAA	LTE-TDD (SC-FDMA, 100% RB, 3 MHz, 64-QAM, UL Subframe=2,3,4,7,8,9)	X	3.01	67.14	15.16	2.23	80.0	± 9.6 %
		Y	3.09	67.47	15.39		80.0	
		Z	2.91	66.86	14.98		80.0	
10503-AAB	LTE-TDD (SC-FDMA, 100% RB, 5 MHz, QPSK, UL Subframe=2,3,4,7,8,9)	X	3.07	69.70	17.08	2.23	80.0	± 9.6 %
		Y	3.18	70.14	17.26		80.0	
		Z	2.95	69.28	16.91		80.0	
10504-AAB	LTE-TDD (SC-FDMA, 100% RB, 5 MHz, 16-QAM, UL Subframe=2,3,4,7,8,9)	X	3.19	67.42	16.14	2.23	80.0	± 9.6 %
		Y	3.25	67.66	16.27		80.0	
		Z	3.11	67.17	16.01		80.0	
10505-AAB	LTE-TDD (SC-FDMA, 100% RB, 5 MHz, 64-QAM, UL Subframe=2,3,4,7,8,9)	X	3.29	67.35	16.13	2.23	80.0	± 9.6 %
		Y	3.35	67.57	16.26		80.0	
		Z	3.20	67.11	16.00		80.0	
10506-AAB	LTE-TDD (SC-FDMA, 100% RB, 10 MHz, QPSK, UL Subframe=2,3,4,7,8,9)	X	3.63	70.12	17.29	2.23	80.0	± 9.6 %
		Y	3.74	70.54	17.44		80.0	
		Z	3.50	69.73	17.16		80.0	
10507-AAB	LTE-TDD (SC-FDMA, 100% RB, 10 MHz, 16-QAM, UL Subframe=2,3,4,7,8,9)	X	3.62	67.45	16.55	2.23	80.0	± 9.6 %
		Y	3.67	67.66	16.64		80.0	
		Z	3.53	67.20	16.44		80.0	

10508-AAB	LTE-TDD (SC-FDMA, 100% RB, 10 MHz, 64-QAM, UL Subframe=2,3,4,7,8,9)	X	3.71	67.28	16.52	2.23	80.0	± 9.6 %
		Y	3.77	67.47	16.60		80.0	
		Z	3.63	67.04	16.41		80.0	
10509-AAB	LTE-TDD (SC-FDMA, 100% RB, 15 MHz, QPSK, UL Subframe=2,3,4,7,8,9)	X	4.06	69.48	17.08	2.23	80.0	± 9.6 %
		Y	4.15	69.80	17.17		80.0	
		Z	3.94	69.18	16.98		80.0	
10510-AAB	LTE-TDD (SC-FDMA, 100% RB, 15 MHz, 16-QAM, UL Subframe=2,3,4,7,8,9)	X	4.13	67.43	16.69	2.23	80.0	± 9.6 %
		Y	4.18	67.63	16.75		80.0	
		Z	4.04	67.20	16.59		80.0	
10511-AAB	LTE-TDD (SC-FDMA, 100% RB, 15 MHz, 64-QAM, UL Subframe=2,3,4,7,8,9)	X	4.20	67.25	16.66	2.23	80.0	± 9.6 %
		Y	4.25	67.43	16.72		80.0	
		Z	4.11	67.04	16.57		80.0	
10512-AAB	LTE-TDD (SC-FDMA, 100% RB, 20 MHz, QPSK, UL Subframe=2,3,4,7,8,9)	X	4.13	70.56	17.37	2.23	80.0	± 9.6 %
		Y	4.25	70.98	17.50		80.0	
		Z	4.00	70.21	17.25		80.0	
10513-AAB	LTE-TDD (SC-FDMA, 100% RB, 20 MHz, 16-QAM, UL Subframe=2,3,4,7,8,9)	X	4.00	67.59	16.74	2.23	80.0	± 9.6 %
		Y	4.06	67.82	16.82		80.0	
		Z	3.91	67.34	16.64		80.0	
10514-AAB	LTE-TDD (SC-FDMA, 100% RB, 20 MHz, 64-QAM, UL Subframe=2,3,4,7,8,9)	X	4.05	67.28	16.67	2.23	80.0	± 9.6 %
		Y	4.10	67.48	16.74		80.0	
		Z	3.96	67.05	16.57		80.0	
10515-AAA	IEEE 802.11b WiFi 2.4 GHz (DSSS, 2 Mbps, 99pc duty cycle)	X	0.99	63.52	15.04	0.00	150.0	± 9.6 %
		Y	1.00	63.92	15.36		150.0	
		Z	0.99	63.44	14.93		150.0	
10516-AAA	IEEE 802.11b WiFi 2.4 GHz (DSSS, 5.5 Mbps, 99pc duty cycle)	X	0.65	71.87	18.40	0.00	150.0	± 9.6 %
		Y	0.77	75.38	20.23		150.0	
		Z	0.62	70.84	17.85		150.0	
10517-AAA	IEEE 802.11b WiFi 2.4 GHz (DSSS, 11 Mbps, 99pc duty cycle)	X	0.85	65.63	15.82	0.00	150.0	± 9.6 %
		Y	0.87	66.42	16.38		150.0	
		Z	0.84	65.40	15.63		150.0	
10518-AAA	IEEE 802.11a/h WiFi 5 GHz (OFDM, 9 Mbps, 99pc duty cycle)	X	4.52	66.86	16.29	0.00	150.0	± 9.6 %
		Y	4.55	66.94	16.33		150.0	
		Z	4.50	66.86	16.25		150.0	
10519-AAA	IEEE 802.11a/h WiFi 5 GHz (OFDM, 12 Mbps, 99pc duty cycle)	X	4.70	67.07	16.39	0.00	150.0	± 9.6 %
		Y	4.73	67.16	16.44		150.0	
		Z	4.67	67.07	16.35		150.0	
10520-AAA	IEEE 802.11a/h WiFi 5 GHz (OFDM, 18 Mbps, 99pc duty cycle)	X	4.55	67.03	16.32	0.00	150.0	± 9.6 %
		Y	4.59	67.14	16.37		150.0	
		Z	4.52	67.02	16.28		150.0	
10521-AAA	IEEE 802.11a/h WiFi 5 GHz (OFDM, 24 Mbps, 99pc duty cycle)	X	4.49	67.03	16.31	0.00	150.0	± 9.6 %
		Y	4.52	67.14	16.36		150.0	
		Z	4.46	67.02	16.27		150.0	
10522-AAA	IEEE 802.11a/h WiFi 5 GHz (OFDM, 36 Mbps, 99pc duty cycle)	X	4.55	67.14	16.40	0.00	150.0	± 9.6 %
		Y	4.58	67.23	16.45		150.0	
		Z	4.52	67.13	16.36		150.0	

10523-AAA	IEEE 802.11a/h WiFi 5 GHz (OFDM, 48 Mbps, 99pc duty cycle)	X	4.44	67.02	16.26	0.00	150.0	± 9.6 %
		Y	4.47	67.12	16.31		150.0	
		Z	4.41	67.03	16.23		150.0	
10524-AAA	IEEE 802.11a/h WiFi 5 GHz (OFDM, 54 Mbps, 99pc duty cycle)	X	4.49	67.05	16.37	0.00	150.0	± 9.6 %
		Y	4.52	67.14	16.41		150.0	
		Z	4.46	67.05	16.33		150.0	
10525-AAA	IEEE 802.11ac WiFi (20MHz, MCS0, 99pc duty cycle)	X	4.49	66.12	15.97	0.00	150.0	± 9.6 %
		Y	4.51	66.21	16.02		150.0	
		Z	4.46	66.13	15.94		150.0	
10526-AAA	IEEE 802.11ac WiFi (20MHz, MCS1, 99pc duty cycle)	X	4.65	66.47	16.11	0.00	150.0	± 9.6 %
		Y	4.68	66.57	16.15		150.0	
		Z	4.62	66.46	16.07		150.0	
10527-AAA	IEEE 802.11ac WiFi (20MHz, MCS2, 99pc duty cycle)	X	4.57	66.44	16.05	0.00	150.0	± 9.6 %
		Y	4.61	66.54	16.10		150.0	
		Z	4.54	66.43	16.01		150.0	
10528-AAA	IEEE 802.11ac WiFi (20MHz, MCS3, 99pc duty cycle)	X	4.59	66.45	16.08	0.00	150.0	± 9.6 %
		Y	4.62	66.56	16.13		150.0	
		Z	4.56	66.44	16.04		150.0	
10529-AAA	IEEE 802.11ac WiFi (20MHz, MCS4, 99pc duty cycle)	X	4.59	66.45	16.08	0.00	150.0	± 9.6 %
		Y	4.62	66.56	16.13		150.0	
		Z	4.56	66.44	16.04		150.0	
10531-AAA	IEEE 802.11ac WiFi (20MHz, MCS6, 99pc duty cycle)	X	4.57	66.54	16.09	0.00	150.0	± 9.6 %
		Y	4.61	66.66	16.15		150.0	
		Z	4.54	66.52	16.05		150.0	
10532-AAA	IEEE 802.11ac WiFi (20MHz, MCS7, 99pc duty cycle)	X	4.44	66.40	16.03	0.00	150.0	± 9.6 %
		Y	4.47	66.53	16.09		150.0	
		Z	4.41	66.38	15.98		150.0	
10533-AAA	IEEE 802.11ac WiFi (20MHz, MCS8, 99pc duty cycle)	X	4.60	66.51	16.08	0.00	150.0	± 9.6 %
		Y	4.63	66.61	16.13		150.0	
		Z	4.57	66.51	16.04		150.0	
10534-AAA	IEEE 802.11ac WiFi (40MHz, MCS0, 99pc duty cycle)	X	5.12	66.51	16.12	0.00	150.0	± 9.6 %
		Y	5.14	66.61	16.16		150.0	
		Z	5.10	66.50	16.09		150.0	
10535-AAA	IEEE 802.11ac WiFi (40MHz, MCS1, 99pc duty cycle)	X	5.19	66.69	16.20	0.00	150.0	± 9.6 %
		Y	5.21	66.78	16.23		150.0	
		Z	5.16	66.67	16.17		150.0	
10536-AAA	IEEE 802.11ac WiFi (40MHz, MCS2, 99pc duty cycle)	X	5.06	66.65	16.16	0.00	150.0	± 9.6 %
		Y	5.08	66.75	16.20		150.0	
		Z	5.03	66.64	16.13		150.0	
10537-AAA	IEEE 802.11ac WiFi (40MHz, MCS3, 99pc duty cycle)	X	5.12	66.61	16.15	0.00	150.0	± 9.6 %
		Y	5.14	66.71	16.18		150.0	
		Z	5.09	66.59	16.11		150.0	
10538-AAA	IEEE 802.11ac WiFi (40MHz, MCS4, 99pc duty cycle)	X	5.20	66.61	16.19	0.00	150.0	± 9.6 %
		Y	5.23	66.72	16.22		150.0	
		Z	5.17	66.59	16.15		150.0	
10540-AAA	IEEE 802.11ac WiFi (40MHz, MCS6, 99pc duty cycle)	X	5.13	66.62	16.21	0.00	150.0	± 9.6 %
		Y	5.16	66.73	16.24		150.0	
		Z	5.10	66.59	16.16		150.0	

10541-AAA	IEEE 802.11ac WiFi (40MHz, MCS7, 99pc duty cycle)	X	5.11	66.51	16.14	0.00	150.0	± 9.6 %
		Y	5.13	66.61	16.18		150.0	
		Z	5.08	66.49	16.10		150.0	
10542-AAA	IEEE 802.11ac WiFi (40MHz, MCS8, 99pc duty cycle)	X	5.26	66.57	16.19	0.00	150.0	± 9.6 %
		Y	5.29	66.67	16.22		150.0	
		Z	5.23	66.56	16.15		150.0	
10543-AAA	IEEE 802.11ac WiFi (40MHz, MCS9, 99pc duty cycle)	X	5.33	66.59	16.22	0.00	150.0	± 9.6 %
		Y	5.36	66.69	16.25		150.0	
		Z	5.30	66.57	16.18		150.0	
10544-AAA	IEEE 802.11ac WiFi (80MHz, MCS0, 99pc duty cycle)	X	5.44	66.62	16.11	0.00	150.0	± 9.6 %
		Y	5.45	66.72	16.14		150.0	
		Z	5.42	66.60	16.08		150.0	
10545-AAA	IEEE 802.11ac WiFi (80MHz, MCS1, 99pc duty cycle)	X	5.62	67.02	16.26	0.00	150.0	± 9.6 %
		Y	5.64	67.09	16.28		150.0	
		Z	5.59	66.99	16.23		150.0	
10546-AAA	IEEE 802.11ac WiFi (80MHz, MCS2, 99pc duty cycle)	X	5.50	66.80	16.17	0.00	150.0	± 9.6 %
		Y	5.52	66.92	16.21		150.0	
		Z	5.47	66.77	16.13		150.0	
10547-AAA	IEEE 802.11ac WiFi (80MHz, MCS3, 99pc duty cycle)	X	5.57	66.85	16.18	0.00	150.0	± 9.6 %
		Y	5.59	66.95	16.21		150.0	
		Z	5.54	66.82	16.15		150.0	
10548-AAA	IEEE 802.11ac WiFi (80MHz, MCS4, 99pc duty cycle)	X	5.78	67.66	16.56	0.00	150.0	± 9.6 %
		Y	5.79	67.74	16.58		150.0	
		Z	5.73	67.57	16.50		150.0	
10550-AAA	IEEE 802.11ac WiFi (80MHz, MCS6, 99pc duty cycle)	X	5.53	66.84	16.20	0.00	150.0	± 9.6 %
		Y	5.54	66.93	16.22		150.0	
		Z	5.50	66.82	16.17		150.0	
10551-AAA	IEEE 802.11ac WiFi (80MHz, MCS7, 99pc duty cycle)	X	5.53	66.87	16.18	0.00	150.0	± 9.6 %
		Y	5.55	66.98	16.21		150.0	
		Z	5.50	66.83	16.13		150.0	
10552-AAA	IEEE 802.11ac WiFi (80MHz, MCS8, 99pc duty cycle)	X	5.45	66.69	16.10	0.00	150.0	± 9.6 %
		Y	5.47	66.80	16.13		150.0	
		Z	5.43	66.69	16.07		150.0	
10553-AAA	IEEE 802.11ac WiFi (80MHz, MCS9, 99pc duty cycle)	X	5.53	66.71	16.13	0.00	150.0	± 9.6 %
		Y	5.55	66.82	16.17		150.0	
		Z	5.50	66.69	16.10		150.0	
10554-AAA	IEEE 1602.11ac WiFi (160MHz, MCS0, 99pc duty cycle)	X	5.85	66.97	16.19	0.00	150.0	± 9.6 %
		Y	5.86	67.06	16.22		150.0	
		Z	5.83	66.95	16.16		150.0	
10555-AAA	IEEE 1602.11ac WiFi (160MHz, MCS1, 99pc duty cycle)	X	5.97	67.25	16.31	0.00	150.0	± 9.6 %
		Y	5.98	67.34	16.33		150.0	
		Z	5.94	67.22	16.27		150.0	
10556-AAA	IEEE 1602.11ac WiFi (160MHz, MCS2, 99pc duty cycle)	X	5.99	67.30	16.33	0.00	150.0	± 9.6 %
		Y	6.00	67.39	16.35		150.0	
		Z	5.96	67.27	16.29		150.0	
10557-AAA	IEEE 1602.11ac WiFi (160MHz, MCS3, 99pc duty cycle)	X	5.95	67.20	16.30	0.00	150.0	± 9.6 %
		Y	5.97	67.30	16.33		150.0	
		Z	5.93	67.17	16.26		150.0	

10558-AAA	IEEE 1602.11ac WiFi (160MHz, MCS4, 99pc duty cycle)	X	6.00	67.35	16.39	0.00	150.0	± 9.6 %
		Y	6.01	67.46	16.42		150.0	
		Z	5.97	67.32	16.35		150.0	
10560-AAA	IEEE 1602.11ac WiFi (160MHz, MCS6, 99pc duty cycle)	X	6.00	67.21	16.36	0.00	150.0	± 9.6 %
		Y	6.01	67.32	16.39		150.0	
		Z	5.97	67.18	16.32		150.0	
10561-AAA	IEEE 1602.11ac WiFi (160MHz, MCS7, 99pc duty cycle)	X	5.92	67.18	16.38	0.00	150.0	± 9.6 %
		Y	5.93	67.28	16.40		150.0	
		Z	5.89	67.15	16.34		150.0	
10562-AAA	IEEE 1602.11ac WiFi (160MHz, MCS8, 99pc duty cycle)	X	6.03	67.51	16.54	0.00	150.0	± 9.6 %
		Y	6.05	67.63	16.58		150.0	
		Z	5.99	67.45	16.49		150.0	
10563-AAA	IEEE 1602.11ac WiFi (160MHz, MCS9, 99pc duty cycle)	X	6.16	67.54	16.51	0.00	150.0	± 9.6 %
		Y	6.24	67.80	16.62		150.0	
		Z	6.09	67.38	16.42		150.0	
10564-AAA	IEEE 802.11g WiFi 2.4 GHz (DSSS-OFDM, 9 Mbps, 99pc duty cycle)	X	4.84	66.87	16.39	0.46	150.0	± 9.6 %
		Y	4.86	66.95	16.43		150.0	
		Z	4.81	66.87	16.35		150.0	
10565-AAA	IEEE 802.11g WiFi 2.4 GHz (DSSS-OFDM, 12 Mbps, 99pc duty cycle)	X	5.06	67.32	16.72	0.46	150.0	± 9.6 %
		Y	5.09	67.40	16.76		150.0	
		Z	5.03	67.32	16.69		150.0	
10566-AAA	IEEE 802.11g WiFi 2.4 GHz (DSSS-OFDM, 18 Mbps, 99pc duty cycle)	X	4.90	67.15	16.53	0.46	150.0	± 9.6 %
		Y	4.93	67.25	16.57		150.0	
		Z	4.86	67.14	16.49		150.0	
10567-AAA	IEEE 802.11g WiFi 2.4 GHz (DSSS-OFDM, 24 Mbps, 99pc duty cycle)	X	4.93	67.58	16.91	0.46	150.0	± 9.6 %
		Y	4.96	67.66	16.94		150.0	
		Z	4.90	67.58	16.88		150.0	
10568-AAA	IEEE 802.11g WiFi 2.4 GHz (DSSS-OFDM, 36 Mbps, 99pc duty cycle)	X	4.80	66.88	16.26	0.46	150.0	± 9.6 %
		Y	4.83	66.98	16.31		150.0	
		Z	4.77	66.87	16.22		150.0	
10569-AAA	IEEE 802.11g WiFi 2.4 GHz (DSSS-OFDM, 48 Mbps, 99pc duty cycle)	X	4.89	67.70	16.99	0.46	150.0	± 9.6 %
		Y	4.92	67.76	17.00		150.0	
		Z	4.87	67.71	16.96		150.0	
10570-AAA	IEEE 802.11g WiFi 2.4 GHz (DSSS-OFDM, 54 Mbps, 99pc duty cycle)	X	4.92	67.54	16.91	0.46	150.0	± 9.6 %
		Y	4.95	67.61	16.94		150.0	
		Z	4.89	67.54	16.89		150.0	
10571-AAA	IEEE 802.11b WiFi 2.4 GHz (DSSS, 1 Mbps, 90pc duty cycle)	X	1.16	64.28	15.41	0.46	130.0	± 9.6 %
		Y	1.17	64.64	15.67		130.0	
		Z	1.15	64.08	15.27		130.0	
10572-AAA	IEEE 802.11b WiFi 2.4 GHz (DSSS, 2 Mbps, 90pc duty cycle)	X	1.18	64.84	15.77	0.46	130.0	± 9.6 %
		Y	1.19	65.22	16.04		130.0	
		Z	1.16	64.62	15.61		130.0	
10573-AAA	IEEE 802.11b WiFi 2.4 GHz (DSSS, 5.5 Mbps, 90pc duty cycle)	X	1.62	81.69	21.81	0.46	130.0	± 9.6 %
		Y	2.21	87.31	23.95		130.0	
		Z	1.35	78.93	20.83		130.0	
10574-AAA	IEEE 802.11b WiFi 2.4 GHz (DSSS, 11 Mbps, 90pc duty cycle)	X	1.28	70.51	18.69	0.46	130.0	± 9.6 %
		Y	1.33	71.36	19.17		130.0	
		Z	1.24	69.92	18.40		130.0	

10575-AAA	IEEE 802.11g WiFi 2.4 GHz (DSSS-OFDM, 6 Mbps, 90pc duty cycle)	X	4.60	66.56	16.34	0.46	130.0	± 9.6 %
		Y	4.63	66.64	16.38		130.0	
		Z	4.58	66.57	16.31		130.0	
10576-AAA	IEEE 802.11g WiFi 2.4 GHz (DSSS-OFDM, 9 Mbps, 90pc duty cycle)	X	4.63	66.74	16.42	0.46	130.0	± 9.6 %
		Y	4.65	66.81	16.45		130.0	
		Z	4.61	66.75	16.39		130.0	
10577-AAA	IEEE 802.11g WiFi 2.4 GHz (DSSS-OFDM, 12 Mbps, 90pc duty cycle)	X	4.82	67.02	16.59	0.46	130.0	± 9.6 %
		Y	4.85	67.10	16.62		130.0	
		Z	4.79	67.02	16.55		130.0	
10578-AAA	IEEE 802.11g WiFi 2.4 GHz (DSSS-OFDM, 18 Mbps, 90pc duty cycle)	X	4.73	67.20	16.71	0.46	130.0	± 9.6 %
		Y	4.75	67.27	16.73		130.0	
		Z	4.70	67.20	16.68		130.0	
10579-AAA	IEEE 802.11g WiFi 2.4 GHz (DSSS-OFDM, 24 Mbps, 90pc duty cycle)	X	4.48	66.39	15.95	0.46	130.0	± 9.6 %
		Y	4.51	66.51	16.01		130.0	
		Z	4.45	66.37	15.90		130.0	
10580-AAA	IEEE 802.11g WiFi 2.4 GHz (DSSS-OFDM, 36 Mbps, 90pc duty cycle)	X	4.52	66.43	15.97	0.46	130.0	± 9.6 %
		Y	4.55	66.54	16.03		130.0	
		Z	4.49	66.42	15.93		130.0	
10581-AAA	IEEE 802.11g WiFi 2.4 GHz (DSSS-OFDM, 48 Mbps, 90pc duty cycle)	X	4.62	67.23	16.64	0.46	130.0	± 9.6 %
		Y	4.65	67.31	16.67		130.0	
		Z	4.60	67.23	16.61		130.0	
10582-AAA	IEEE 802.11g WiFi 2.4 GHz (DSSS-OFDM, 54 Mbps, 90pc duty cycle)	X	4.41	66.13	15.72	0.46	130.0	± 9.6 %
		Y	4.45	66.25	15.79		130.0	
		Z	4.38	66.11	15.67		130.0	
10583-AAA	IEEE 802.11a/h WiFi 5 GHz (OFDM, 6 Mbps, 90pc duty cycle)	X	4.60	66.56	16.34	0.46	130.0	± 9.6 %
		Y	4.63	66.64	16.38		130.0	
		Z	4.58	66.57	16.31		130.0	
10584-AAA	IEEE 802.11a/h WiFi 5 GHz (OFDM, 9 Mbps, 90pc duty cycle)	X	4.63	66.74	16.42	0.46	130.0	± 9.6 %
		Y	4.65	66.81	16.45		130.0	
		Z	4.61	66.75	16.39		130.0	
10585-AAA	IEEE 802.11a/h WiFi 5 GHz (OFDM, 12 Mbps, 90pc duty cycle)	X	4.82	67.02	16.59	0.46	130.0	± 9.6 %
		Y	4.85	67.10	16.62		130.0	
		Z	4.79	67.02	16.55		130.0	
10586-AAA	IEEE 802.11a/h WiFi 5 GHz (OFDM, 18 Mbps, 90pc duty cycle)	X	4.73	67.20	16.71	0.46	130.0	± 9.6 %
		Y	4.75	67.27	16.73		130.0	
		Z	4.70	67.20	16.68		130.0	
10587-AAA	IEEE 802.11a/h WiFi 5 GHz (OFDM, 24 Mbps, 90pc duty cycle)	X	4.48	66.39	15.95	0.46	130.0	± 9.6 %
		Y	4.51	66.51	16.01		130.0	
		Z	4.45	66.37	15.90		130.0	
10588-AAA	IEEE 802.11a/h WiFi 5 GHz (OFDM, 36 Mbps, 90pc duty cycle)	X	4.52	66.43	15.97	0.46	130.0	± 9.6 %
		Y	4.55	66.54	16.03		130.0	
		Z	4.49	66.42	15.93		130.0	
10589-AAA	IEEE 802.11a/h WiFi 5 GHz (OFDM, 48 Mbps, 90pc duty cycle)	X	4.62	67.23	16.64	0.46	130.0	± 9.6 %
		Y	4.65	67.31	16.67		130.0	
		Z	4.60	67.23	16.61		130.0	
10590-AAA	IEEE 802.11a/h WiFi 5 GHz (OFDM, 54 Mbps, 90pc duty cycle)	X	4.41	66.13	15.72	0.46	130.0	± 9.6 %
		Y	4.45	66.25	15.79		130.0	
		Z	4.38	66.11	15.67		130.0	

10591-AAA	IEEE 802.11n (HT Mixed, 20MHz, MCS0, 90pc duty cycle)	X	4.76	66.64	16.46	0.46	130.0	± 9.6 %
		Y	4.78	66.70	16.48		130.0	
		Z	4.73	66.65	16.43		130.0	
10592-AAA	IEEE 802.11n (HT Mixed, 20MHz, MCS1, 90pc duty cycle)	X	4.90	66.97	16.59	0.46	130.0	± 9.6 %
		Y	4.93	67.04	16.61		130.0	
		Z	4.87	66.97	16.56		130.0	
10593-AAA	IEEE 802.11n (HT Mixed, 20MHz, MCS2, 90pc duty cycle)	X	4.82	66.86	16.45	0.46	130.0	± 9.6 %
		Y	4.85	66.94	16.49		130.0	
		Z	4.79	66.85	16.42		130.0	
10594-AAA	IEEE 802.11n (HT Mixed, 20MHz, MCS3, 90pc duty cycle)	X	4.88	67.04	16.62	0.46	130.0	± 9.6 %
		Y	4.90	67.11	16.65		130.0	
		Z	4.85	67.04	16.59		130.0	
10595-AAA	IEEE 802.11n (HT Mixed, 20MHz, MCS4, 90pc duty cycle)	X	4.84	66.98	16.51	0.46	130.0	± 9.6 %
		Y	4.87	67.06	16.54		130.0	
		Z	4.81	66.98	16.48		130.0	
10596-AAA	IEEE 802.11n (HT Mixed, 20MHz, MCS5, 90pc duty cycle)	X	4.78	66.97	16.51	0.46	130.0	± 9.6 %
		Y	4.81	67.05	16.54		130.0	
		Z	4.75	66.96	16.47		130.0	
10597-AAA	IEEE 802.11n (HT Mixed, 20MHz, MCS6, 90pc duty cycle)	X	4.73	66.86	16.38	0.46	130.0	± 9.6 %
		Y	4.76	66.95	16.42		130.0	
		Z	4.69	66.85	16.34		130.0	
10598-AAA	IEEE 802.11n (HT Mixed, 20MHz, MCS7, 90pc duty cycle)	X	4.71	67.12	16.66	0.46	130.0	± 9.6 %
		Y	4.74	67.20	16.70		130.0	
		Z	4.69	67.11	16.63		130.0	
10599-AAA	IEEE 802.11n (HT Mixed, 40MHz, MCS0, 90pc duty cycle)	X	5.42	67.13	16.65	0.46	130.0	± 9.6 %
		Y	5.44	67.22	16.67		130.0	
		Z	5.39	67.11	16.62		130.0	
10600-AAA	IEEE 802.11n (HT Mixed, 40MHz, MCS1, 90pc duty cycle)	X	5.54	67.51	16.81	0.46	130.0	± 9.6 %
		Y	5.55	67.54	16.80		130.0	
		Z	5.50	67.46	16.76		130.0	
10601-AAA	IEEE 802.11n (HT Mixed, 40MHz, MCS2, 90pc duty cycle)	X	5.44	67.29	16.72	0.46	130.0	± 9.6 %
		Y	5.45	67.35	16.73		130.0	
		Z	5.40	67.27	16.68		130.0	
10602-AAA	IEEE 802.11n (HT Mixed, 40MHz, MCS3, 90pc duty cycle)	X	5.54	67.36	16.67	0.46	130.0	± 9.6 %
		Y	5.55	67.38	16.66		130.0	
		Z	5.52	67.38	16.65		130.0	
10603-AAA	IEEE 802.11n (HT Mixed, 40MHz, MCS4, 90pc duty cycle)	X	5.61	67.63	16.94	0.46	130.0	± 9.6 %
		Y	5.62	67.67	16.94		130.0	
		Z	5.58	67.64	16.92		130.0	
10604-AAA	IEEE 802.11n (HT Mixed, 40MHz, MCS5, 90pc duty cycle)	X	5.46	67.22	16.72	0.46	130.0	± 9.6 %
		Y	5.45	67.21	16.69		130.0	
		Z	5.45	67.27	16.72		130.0	
10605-AAA	IEEE 802.11n (HT Mixed, 40MHz, MCS6, 90pc duty cycle)	X	5.53	67.42	16.82	0.46	130.0	± 9.6 %
		Y	5.54	67.45	16.81		130.0	
		Z	5.50	67.41	16.78		130.0	
10606-AAA	IEEE 802.11n (HT Mixed, 40MHz, MCS7, 90pc duty cycle)	X	5.27	66.74	16.33	0.46	130.0	± 9.6 %
		Y	5.30	66.85	16.37		130.0	
		Z	5.24	66.71	16.29		130.0	

10607-AAA	IEEE 802.11ac WiFi (20MHz, MCS0, 90pc duty cycle)	X	4.60	65.96	16.09	0.46	130.0	± 9.6 %
		Y	4.62	66.04	16.12		130.0	
		Z	4.57	65.98	16.06		130.0	
10608-AAA	IEEE 802.11ac WiFi (20MHz, MCS1, 90pc duty cycle)	X	4.77	66.35	16.25	0.46	130.0	± 9.6 %
		Y	4.80	66.43	16.28		130.0	
		Z	4.74	66.36	16.22		130.0	
10609-AAA	IEEE 802.11ac WiFi (20MHz, MCS2, 90pc duty cycle)	X	4.66	66.18	16.07	0.46	130.0	± 9.6 %
		Y	4.69	66.28	16.12		130.0	
		Z	4.63	66.18	16.04		130.0	
10610-AAA	IEEE 802.11ac WiFi (20MHz, MCS3, 90pc duty cycle)	X	4.71	66.35	16.24	0.46	130.0	± 9.6 %
		Y	4.74	66.44	16.28		130.0	
		Z	4.68	66.36	16.21		130.0	
10611-AAA	IEEE 802.11ac WiFi (20MHz, MCS4, 90pc duty cycle)	X	4.63	66.15	16.08	0.46	130.0	± 9.6 %
		Y	4.66	66.24	16.12		130.0	
		Z	4.60	66.15	16.05		130.0	
10612-AAA	IEEE 802.11ac WiFi (20MHz, MCS5, 90pc duty cycle)	X	4.63	66.27	16.11	0.46	130.0	± 9.6 %
		Y	4.66	66.38	16.15		130.0	
		Z	4.59	66.27	16.08		130.0	
10613-AAA	IEEE 802.11ac WiFi (20MHz, MCS6, 90pc duty cycle)	X	4.63	66.15	15.99	0.46	130.0	± 9.6 %
		Y	4.66	66.26	16.04		130.0	
		Z	4.59	66.13	15.95		130.0	
10614-AAA	IEEE 802.11ac WiFi (20MHz, MCS7, 90pc duty cycle)	X	4.58	66.38	16.25	0.46	130.0	± 9.6 %
		Y	4.61	66.48	16.29		130.0	
		Z	4.56	66.37	16.22		130.0	
10615-AAA	IEEE 802.11ac WiFi (20MHz, MCS8, 90pc duty cycle)	X	4.62	65.95	15.84	0.46	130.0	± 9.6 %
		Y	4.65	66.05	15.89		130.0	
		Z	4.59	65.95	15.80		130.0	
10616-AAA	IEEE 802.11ac WiFi (40MHz, MCS0, 90pc duty cycle)	X	5.24	66.41	16.28	0.46	130.0	± 9.6 %
		Y	5.26	66.49	16.30		130.0	
		Z	5.21	66.40	16.25		130.0	
10617-AAA	IEEE 802.11ac WiFi (40MHz, MCS1, 90pc duty cycle)	X	5.31	66.58	16.34	0.46	130.0	± 9.6 %
		Y	5.32	66.64	16.34		130.0	
		Z	5.28	66.57	16.31		130.0	
10618-AAA	IEEE 802.11ac WiFi (40MHz, MCS2, 90pc duty cycle)	X	5.20	66.60	16.36	0.46	130.0	± 9.6 %
		Y	5.21	66.67	16.38		130.0	
		Z	5.17	66.60	16.34		130.0	
10619-AAA	IEEE 802.11ac WiFi (40MHz, MCS3, 90pc duty cycle)	X	5.20	66.38	16.18	0.46	130.0	± 9.6 %
		Y	5.22	66.46	16.20		130.0	
		Z	5.18	66.37	16.15		130.0	
10620-AAA	IEEE 802.11ac WiFi (40MHz, MCS4, 90pc duty cycle)	X	5.29	66.42	16.25	0.46	130.0	± 9.6 %
		Y	5.31	66.50	16.28		130.0	
		Z	5.26	66.40	16.22		130.0	
10621-AAA	IEEE 802.11ac WiFi (40MHz, MCS5, 90pc duty cycle)	X	5.31	66.59	16.47	0.46	130.0	± 9.6 %
		Y	5.32	66.66	16.47		130.0	
		Z	5.28	66.59	16.44		130.0	
10622-AAA	IEEE 802.11ac WiFi (40MHz, MCS6, 90pc duty cycle)	X	5.31	66.74	16.53	0.46	130.0	± 9.6 %
		Y	5.33	66.80	16.54		130.0	
		Z	5.29	66.75	16.51		130.0	



10623-AAA	IEEE 802.11ac WiFi (40MHz, MCS7, 90pc duty cycle)	X	5.19	66.24	16.15	0.46	130.0	± 9.6 %
		Y	5.21	66.33	16.17		130.0	
		Z	5.16	66.23	16.11		130.0	
10624-AAA	IEEE 802.11ac WiFi (40MHz, MCS8, 90pc duty cycle)	X	5.38	66.45	16.32	0.46	130.0	± 9.6 %
		Y	5.40	66.52	16.33		130.0	
		Z	5.35	66.44	16.29		130.0	
10625-AAA	IEEE 802.11ac WiFi (40MHz, MCS9, 90pc duty cycle)	X	5.69	67.26	16.78	0.46	130.0	± 9.6 %
		Y	5.73	67.39	16.82		130.0	
		Z	5.62	67.15	16.69		130.0	
10626-AAA	IEEE 802.11ac WiFi (80MHz, MCS0, 90pc duty cycle)	X	5.54	66.47	16.24	0.46	130.0	± 9.6 %
		Y	5.55	66.55	16.25		130.0	
		Z	5.52	66.47	16.21		130.0	
10627-AAA	IEEE 802.11ac WiFi (80MHz, MCS1, 90pc duty cycle)	X	5.77	67.01	16.47	0.46	130.0	± 9.6 %
		Y	5.77	67.06	16.46		130.0	
		Z	5.74	66.99	16.44		130.0	
10628-AAA	IEEE 802.11ac WiFi (80MHz, MCS2, 90pc duty cycle)	X	5.56	66.51	16.15	0.46	130.0	± 9.6 %
		Y	5.58	66.61	16.18		130.0	
		Z	5.53	66.48	16.12		130.0	
10629-AAA	IEEE 802.11ac WiFi (80MHz, MCS3, 90pc duty cycle)	X	5.63	66.57	16.17	0.46	130.0	± 9.6 %
		Y	5.65	66.66	16.19		130.0	
		Z	5.61	66.55	16.14		130.0	
10630-AAA	IEEE 802.11ac WiFi (80MHz, MCS4, 90pc duty cycle)	X	6.00	67.86	16.82	0.46	130.0	± 9.6 %
		Y	6.01	67.93	16.83		130.0	
		Z	5.94	67.73	16.73		130.0	
10631-AAA	IEEE 802.11ac WiFi (80MHz, MCS5, 90pc duty cycle)	X	5.95	67.83	17.01	0.46	130.0	± 9.6 %
		Y	5.97	67.92	17.02		130.0	
		Z	5.91	67.77	16.96		130.0	
10632-AAA	IEEE 802.11ac WiFi (80MHz, MCS6, 90pc duty cycle)	X	5.75	67.12	16.67	0.46	130.0	± 9.6 %
		Y	5.75	67.15	16.65		130.0	
		Z	5.73	67.12	16.65		130.0	
10633-AAA	IEEE 802.11ac WiFi (80MHz, MCS7, 90pc duty cycle)	X	5.63	66.72	16.29	0.46	130.0	± 9.6 %
		Y	5.65	66.81	16.31		130.0	
		Z	5.61	66.70	16.26		130.0	
10634-AAA	IEEE 802.11ac WiFi (80MHz, MCS8, 90pc duty cycle)	X	5.62	66.75	16.37	0.46	130.0	± 9.6 %
		Y	5.64	66.85	16.39		130.0	
		Z	5.59	66.74	16.34		130.0	
10635-AAA	IEEE 802.11ac WiFi (80MHz, MCS9, 90pc duty cycle)	X	5.48	66.01	15.71	0.46	130.0	± 9.6 %
		Y	5.51	66.14	15.76		130.0	
		Z	5.45	65.98	15.67		130.0	
10636-AAA	IEEE 1602.11ac WiFi (160MHz, MCS0, 90pc duty cycle)	X	5.96	66.83	16.32	0.46	130.0	± 9.6 %
		Y	5.96	66.90	16.33		130.0	
		Z	5.94	66.82	16.30		130.0	
10637-AAA	IEEE 1602.11ac WiFi (160MHz, MCS1, 90pc duty cycle)	X	6.11	67.19	16.49	0.46	130.0	± 9.6 %
		Y	6.11	67.25	16.49		130.0	
		Z	6.08	67.17	16.46		130.0	
10638-AAA	IEEE 1602.11ac WiFi (160MHz, MCS2, 90pc duty cycle)	X	6.11	67.17	16.45	0.46	130.0	± 9.6 %
		Y	6.11	67.25	16.46		130.0	
		Z	6.08	67.16	16.42		130.0	

10639-AAA	IEEE 1602.11ac WiFi (160MHz, MCS3, 90pc duty cycle)	X	6.08	67.12	16.47	0.46	130.0	± 9.6 %
		Y	6.09	67.20	16.48		130.0	
		Z	6.06	67.10	16.44		130.0	
10640-AAA	IEEE 1602.11ac WiFi (160MHz, MCS4, 90pc duty cycle)	X	6.08	67.10	16.40	0.46	130.0	± 9.6 %
		Y	6.09	67.19	16.42		130.0	
		Z	6.05	67.07	16.36		130.0	
10641-AAA	IEEE 1602.11ac WiFi (160MHz, MCS5, 90pc duty cycle)	X	6.13	67.03	16.39	0.46	130.0	± 9.6 %
		Y	6.13	67.10	16.39		130.0	
		Z	6.11	67.02	16.36		130.0	
10642-AAA	IEEE 1602.11ac WiFi (160MHz, MCS6, 90pc duty cycle)	X	6.18	67.31	16.70	0.46	130.0	± 9.6 %
		Y	6.19	67.39	16.71		130.0	
		Z	6.15	67.29	16.67		130.0	
10643-AAA	IEEE 1602.11ac WiFi (160MHz, MCS7, 90pc duty cycle)	X	6.01	66.96	16.42	0.46	130.0	± 9.6 %
		Y	6.01	67.04	16.43		130.0	
		Z	5.98	66.94	16.38		130.0	
10644-AAA	IEEE 1602.11ac WiFi (160MHz, MCS8, 90pc duty cycle)	X	6.14	67.38	16.65	0.46	130.0	± 9.6 %
		Y	6.16	67.50	16.68		130.0	
		Z	6.11	67.32	16.59		130.0	
10645-AAA	IEEE 1602.11ac WiFi (160MHz, MCS9, 90pc duty cycle)	X	6.34	67.58	16.70	0.46	130.0	± 9.6 %
		Y	6.43	67.90	16.84		130.0	
		Z	6.25	67.39	16.59		130.0	
10646-AAC	LTE-TDD (SC-FDMA, 1 RB, 5 MHz, QPSK, UL Subframe=2,7)	X	12.03	96.53	31.61	9.30	60.0	± 9.6 %
		Y	13.68	98.80	32.22		60.0	
		Z	11.35	95.67	31.51		60.0	
10647-AAB	LTE-TDD (SC-FDMA, 1 RB, 20 MHz, QPSK, UL Subframe=2,7)	X	10.87	95.02	31.23	9.30	60.0	± 9.6 %
		Y	12.42	97.44	31.90		60.0	
		Z	10.19	94.02	31.08		60.0	
10648-AAA	CDMA2000 (1x Advanced)	X	0.71	64.17	11.16	0.00	150.0	± 9.6 %
		Y	0.76	65.11	11.91		150.0	
		Z	0.68	63.86	10.84		150.0	

<sup>E</sup> Uncertainty is determined using the max. deviation from linear response applying rectangular distribution and is expressed for the square of the field value.



Accredited by the Swiss Accreditation Service (SAS)  
The Swiss Accreditation Service is one of the signatories to the EA  
Multilateral Agreement for the recognition of calibration certificates

Accreditation No.: **SCS 0108**

Client **PC Test**

Certificate No: **ES3-3209\_Mar17**

## CALIBRATION CERTIFICATE

Object **ES3DV3 - SN:3209**

Calibration procedure(s) **QA CAL-01.v9, QA CAL-23.v5, QA CAL-25.v6  
Calibration procedure for dosimetric E-field probes**

*BNW  
03-27-2017*

Calibration date: **March 14, 2017**

This calibration certificate documents the traceability to national standards, which realize the physical units of measurements (SI).  
The measurements and the uncertainties with confidence probability are given on the following pages and are part of the certificate.

All calibrations have been conducted in the closed laboratory facility: environment temperature (22 ± 3)°C and humidity < 70%.

Calibration Equipment used (M&TE critical for calibration)

Primary Standards	ID	Cal Date (Certificate No.)	Scheduled Calibration
Power meter NRP	SN: 104778	06-Apr-16 (No. 217-02288/02289)	Apr-17
Power sensor NRP-Z91	SN: 103244	06-Apr-16 (No. 217-02288)	Apr-17
Power sensor NRP-Z91	SN: 103245	06-Apr-16 (No. 217-02289)	Apr-17
Reference 20 dB Attenuator	SN: S5277 (20x)	05-Apr-16 (No. 217-02293)	Apr-17
Reference Probe ES3DV2	SN: 3013	31-Dec-16 (No. ES3-3013_Dec16)	Dec-17
DAE4	SN: 660	7-Dec-16 (No. DAE4-660_Dec16)	Dec-17
Secondary Standards	ID	Check Date (in house)	Scheduled Check
Power meter E4419B	SN: GB41293874	06-Apr-16 (in house check Jun-16)	In house check: Jun-18
Power sensor E4412A	SN: MY41498087	06-Apr-16 (in house check Jun-16)	In house check: Jun-18
Power sensor E4412A	SN: 000110210	06-Apr-16 (in house check Jun-16)	In house check: Jun-18
RF generator HP 8648C	SN: US3642U01700	04-Aug-99 (in house check Jun-16)	In house check: Jun-18
Network Analyzer HP 8753E	SN: US37390585	18-Oct-01 (in house check Oct-16)	In house check: Oct-17

	Name	Function	Signature
Calibrated by:	Jeton Kastrati	Laboratory Technician	
Approved by:	Katja Pokovic	Technical Manager	
			Issued: March 16, 2017
This calibration certificate shall not be reproduced except in full without written approval of the laboratory.			



Accredited by the Swiss Accreditation Service (SAS)

Accreditation No.: **SCS 0108**

The Swiss Accreditation Service is one of the signatories to the EA Multilateral Agreement for the recognition of calibration certificates

**Glossary:**

TSL	tissue simulating liquid
NORM <sub>x,y,z</sub>	sensitivity in free space
ConvF	sensitivity in TSL / NORM <sub>x,y,z</sub>
DCP	diode compression point
CF	crest factor (1/duty_cycle) of the RF signal
A, B, C, D	modulation dependent linearization parameters
Polarization $\phi$	$\phi$ rotation around probe axis
Polarization $\vartheta$	$\vartheta$ rotation around an axis that is in the plane normal to probe axis (at measurement center), i.e., $\vartheta = 0$ is normal to probe axis
Connector Angle	information used in DASY system to align probe sensor X to the robot coordinate system

**Calibration is Performed According to the Following Standards:**

- a) IEEE Std 1528-2013, "IEEE Recommended Practice for Determining the Peak Spatial-Averaged Specific Absorption Rate (SAR) in the Human Head from Wireless Communications Devices: Measurement Techniques", June 2013
- b) IEC 62209-1, "Procedure to measure the Specific Absorption Rate (SAR) for hand-held devices used in close proximity to the ear (frequency range of 300 MHz to 3 GHz)", February 2005
- c) IEC 62209-2, "Procedure to determine the Specific Absorption Rate (SAR) for wireless communication devices used in close proximity to the human body (frequency range of 30 MHz to 6 GHz)", March 2010
- d) KDB 865664, "SAR Measurement Requirements for 100 MHz to 6 GHz"

**Methods Applied and Interpretation of Parameters:**

- *NORM<sub>x,y,z</sub>*: Assessed for E-field polarization  $\vartheta = 0$  ( $f \leq 900$  MHz in TEM-cell;  $f > 1800$  MHz: R22 waveguide). *NORM<sub>x,y,z</sub>* are only intermediate values, i.e., the uncertainties of *NORM<sub>x,y,z</sub>* does not affect the  $E^2$ -field uncertainty inside TSL (see below *ConvF*).
- *NORM(f)<sub>x,y,z</sub>* = *NORM<sub>x,y,z</sub>* \* *frequency\_response* (see Frequency Response Chart). This linearization is implemented in DASY4 software versions later than 4.2. The uncertainty of the frequency response is included in the stated uncertainty of *ConvF*.
- *DCP<sub>x,y,z</sub>*: DCP are numerical linearization parameters assessed based on the data of power sweep with CW signal (no uncertainty required). DCP does not depend on frequency nor media.
- *PAR*: PAR is the Peak to Average Ratio that is not calibrated but determined based on the signal characteristics
- *A<sub>x,y,z</sub>*; *B<sub>x,y,z</sub>*; *C<sub>x,y,z</sub>*; *D<sub>x,y,z</sub>*; *VR<sub>x,y,z</sub>*; *A, B, C, D* are numerical linearization parameters assessed based on the data of power sweep for specific modulation signal. The parameters do not depend on frequency nor media. *VR* is the maximum calibration range expressed in RMS voltage across the diode.
- *ConvF* and *Boundary Effect Parameters*: Assessed in flat phantom using E-field (or Temperature Transfer Standard for  $f \leq 800$  MHz) and inside waveguide using analytical field distributions based on power measurements for  $f > 800$  MHz. The same setups are used for assessment of the parameters applied for boundary compensation (alpha, depth) of which typical uncertainty values are given. These parameters are used in DASY4 software to improve probe accuracy close to the boundary. The sensitivity in TSL corresponds to *NORM<sub>x,y,z</sub>* \* *ConvF* whereby the uncertainty corresponds to that given for *ConvF*. A frequency dependent *ConvF* is used in DASY version 4.4 and higher which allows extending the validity from  $\pm 50$  MHz to  $\pm 100$  MHz.
- *Spherical isotropy (3D deviation from isotropy)*: in a field of low gradients realized using a flat phantom exposed by a patch antenna.
- *Sensor Offset*: The sensor offset corresponds to the offset of virtual measurement center from the probe tip (on probe axis). No tolerance required.
- *Connector Angle*: The angle is assessed using the information gained by determining the *NORM<sub>x</sub>* (no uncertainty required).

# Probe ES3DV3

## SN:3209

Manufactured: October 14, 2008  
Calibrated: March 14, 2017

Calibrated for DASY/EASY Systems  
(Note: non-compatible with DASY2 system!)

## DASY/EASY - Parameters of Probe: ES3DV3 - SN:3209

### Basic Calibration Parameters

	Sensor X	Sensor Y	Sensor Z	Unc (k=2)
Norm ( $\mu\text{V}/(\text{V}/\text{m})^2$ ) <sup>A</sup>	1.31	1.28	1.10	$\pm 10.1 \%$
DCP (mV) <sup>B</sup>	98.7	100.9	101.0	

### Modulation Calibration Parameters

UID	Communication System Name		A dB	B dB $\sqrt{\mu\text{V}}$	C	D dB	VR mV	Unc <sup>E</sup> (k=2)
0	CW	X	0.0	0.0	1.0	0.00	185.7	$\pm 3.5 \%$
		Y	0.0	0.0	1.0		188.4	
		Z	0.0	0.0	1.0		174.0	

Note: For details on UID parameters see Appendix.

### Sensor Model Parameters

	C1 fF	C2 fF	$\alpha$ $\text{V}^{-1}$	T1 $\text{ms}\cdot\text{V}^{-2}$	T2 $\text{ms}\cdot\text{V}^{-1}$	T3 ms	T4 $\text{V}^{-2}$	T5 $\text{V}^{-1}$	T6
X	55.02	400.2	36.4	24.81	1.139	5.1	1.332	0.294	1.012
Y	53.76	389.5	36.01	25.47	1.401	5.1	1.486	0.333	1.011
Z	54.22	392	35.92	24.25	1.184	5.1	1.305	0.356	1.012

The reported uncertainty of measurement is stated as the standard uncertainty of measurement multiplied by the coverage factor  $k=2$ , which for a normal distribution corresponds to a coverage probability of approximately 95%.

<sup>A</sup> The uncertainties of Norm X,Y,Z do not affect the  $E^2$ -field uncertainty inside TSL (see Pages 5 and 6).

<sup>B</sup> Numerical linearization parameter: uncertainty not required.

<sup>E</sup> Uncertainty is determined using the max. deviation from linear response applying rectangular distribution and is expressed for the square of the field value.

## DASY/EASY - Parameters of Probe: ES3DV3 - SN:3209

### Calibration Parameter Determined in Head Tissue Simulating Media

f (MHz) <sup>C</sup>	Relative Permittivity <sup>F</sup>	Conductivity (S/m) <sup>F</sup>	ConvF X	ConvF Y	ConvF Z	Alpha <sup>G</sup>	Depth <sup>G</sup> (mm)	Unc (k=2)
750	41.9	0.89	6.76	6.76	6.76	0.80	1.17	± 12.0 %
835	41.5	0.90	6.36	6.36	6.36	0.63	1.31	± 12.0 %
1750	40.1	1.37	5.50	5.50	5.50	0.74	1.16	± 12.0 %
1900	40.0	1.40	5.31	5.31	5.31	0.63	1.30	± 12.0 %
2300	39.5	1.67	4.92	4.92	4.92	0.80	1.20	± 12.0 %
2450	39.2	1.80	4.72	4.72	4.72	0.71	1.33	± 12.0 %
2600	39.0	1.96	4.53	4.53	4.53	0.69	1.37	± 12.0 %

<sup>C</sup> Frequency validity above 300 MHz of ± 100 MHz only applies for DASY v4.4 and higher (see Page 2), else it is restricted to ± 50 MHz. The uncertainty is the RSS of the ConvF uncertainty at calibration frequency and the uncertainty for the indicated frequency band. Frequency validity below 300 MHz is ± 10, 25, 40, 50 and 70 MHz for ConvF assessments at 30, 64, 128, 150 and 220 MHz respectively. Above 5 GHz frequency validity can be extended to ± 110 MHz.

<sup>F</sup> At frequencies below 3 GHz, the validity of tissue parameters ( $\epsilon$  and  $\sigma$ ) can be relaxed to ± 10% if liquid compensation formula is applied to measured SAR values. At frequencies above 3 GHz, the validity of tissue parameters ( $\epsilon$  and  $\sigma$ ) is restricted to ± 5%. The uncertainty is the RSS of the ConvF uncertainty for indicated target tissue parameters.

<sup>G</sup> Alpha/Depth are determined during calibration. SPEAG warrants that the remaining deviation due to the boundary effect after compensation is always less than ± 1% for frequencies below 3 GHz and below ± 2% for frequencies between 3-6 GHz at any distance larger than half the probe tip diameter from the boundary.

## DASY/EASY - Parameters of Probe: ES3DV3 - SN:3209

### Calibration Parameter Determined in Body Tissue Simulating Media

f (MHz) <sup>C</sup>	Relative Permittivity <sup>F</sup>	Conductivity (S/m) <sup>F</sup>	ConvF X	ConvF Y	ConvF Z	Alpha <sup>G</sup>	Depth <sup>G</sup> (mm)	Unc (k=2)
750	55.5	0.96	6.44	6.44	6.44	0.80	1.17	± 12.0 %
835	55.2	0.97	6.36	6.36	6.36	0.80	1.20	± 12.0 %
1750	53.4	1.49	5.13	5.13	5.13	0.51	1.53	± 12.0 %
1900	53.3	1.52	4.93	4.93	4.93	0.50	1.59	± 12.0 %
2300	52.9	1.81	4.62	4.62	4.62	0.80	1.24	± 12.0 %
2450	52.7	1.95	4.48	4.48	4.48	0.80	1.24	± 12.0 %
2600	52.5	2.16	4.26	4.26	4.26	0.80	1.20	± 12.0 %

<sup>C</sup> Frequency validity above 300 MHz of ± 100 MHz only applies for DASY v4.4 and higher (see Page 2), else it is restricted to ± 50 MHz. The uncertainty is the RSS of the ConvF uncertainty at calibration frequency and the uncertainty for the indicated frequency band. Frequency validity below 300 MHz is ± 10, 25, 40, 50 and 70 MHz for ConvF assessments at 30, 64, 128, 150 and 220 MHz respectively. Above 5 GHz frequency validity can be extended to ± 110 MHz.

<sup>F</sup> At frequencies below 3 GHz, the validity of tissue parameters ( $\epsilon$  and  $\sigma$ ) can be relaxed to ± 10% if liquid compensation formula is applied to measured SAR values. At frequencies above 3 GHz, the validity of tissue parameters ( $\epsilon$  and  $\sigma$ ) is restricted to ± 5%. The uncertainty is the RSS of the ConvF uncertainty for indicated target tissue parameters.

<sup>G</sup> Alpha/Depth are determined during calibration. SPEAG warrants that the remaining deviation due to the boundary effect after compensation is always less than ± 1% for frequencies below 3 GHz and below ± 2% for frequencies between 3-6 GHz at any distance larger than half the probe tip diameter from the boundary.



# Frequency Response of E-Field

(TEM-Cell:ifi110 EXX, Waveguide: R22)

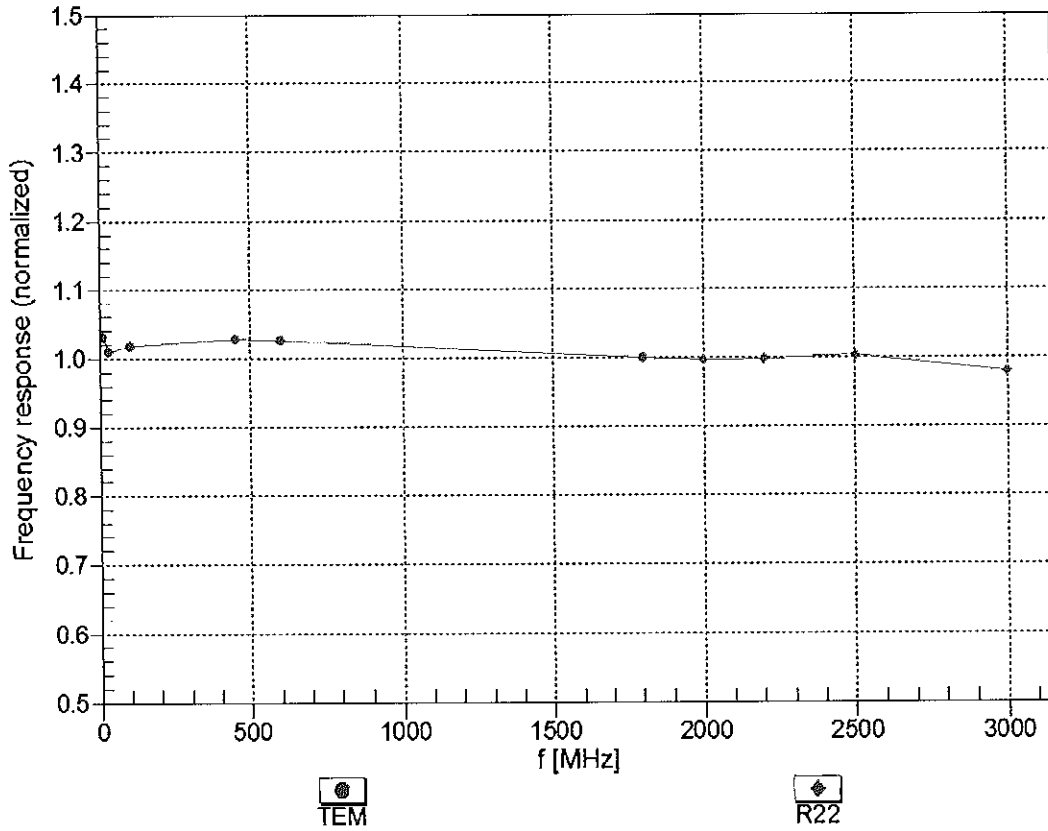

Uncertainty of Frequency Response of E-field:  $\pm 6.3\%$  (k=2)

### Receiving Pattern ( $\phi$ ), $\vartheta = 0^\circ$

f=600 MHz, TEM

f=1800 MHz, R22

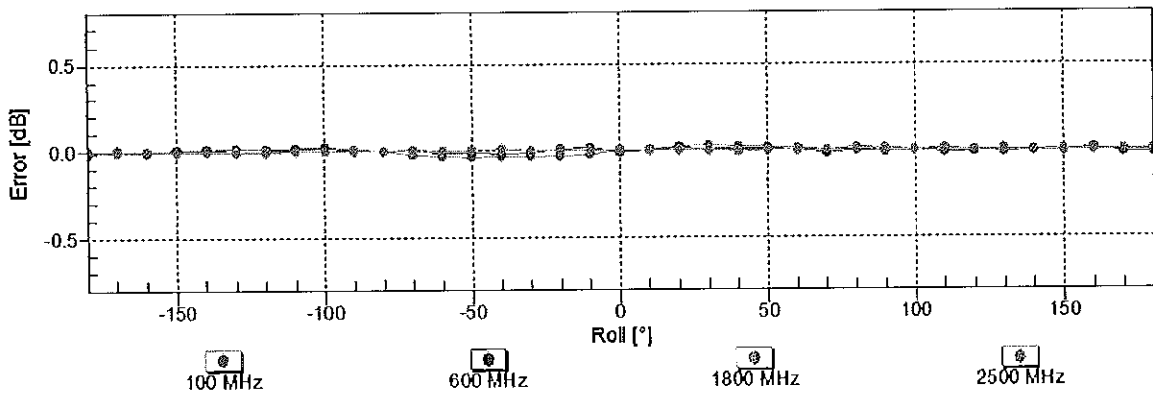
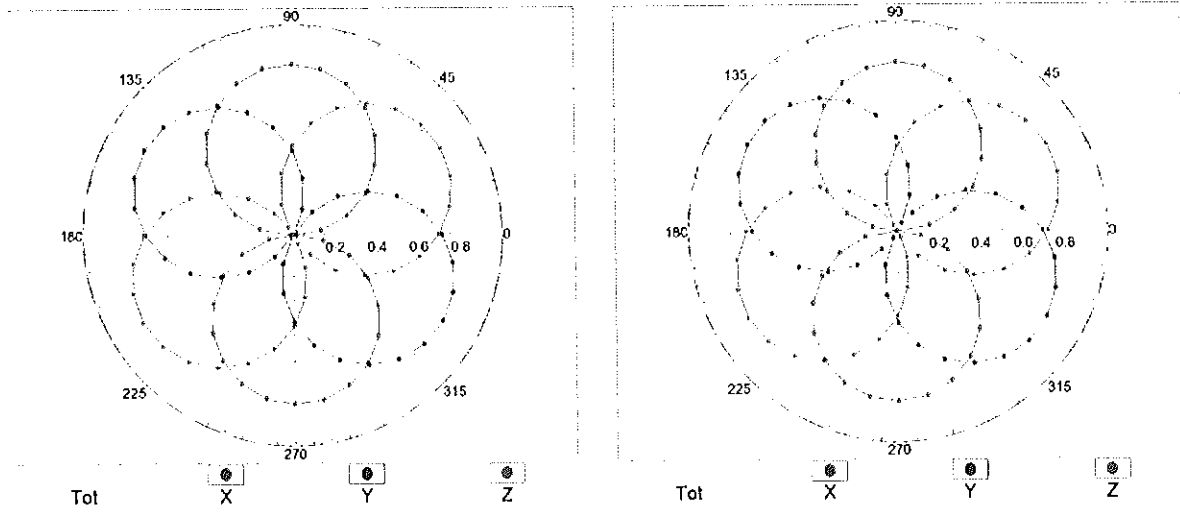

Uncertainty of Axial Isotropy Assessment:  $\pm 0.5\%$  ( $k=2$ )

### Dynamic Range f(SAR<sub>head</sub>) (TEM cell , f<sub>eval</sub>= 1900 MHz)

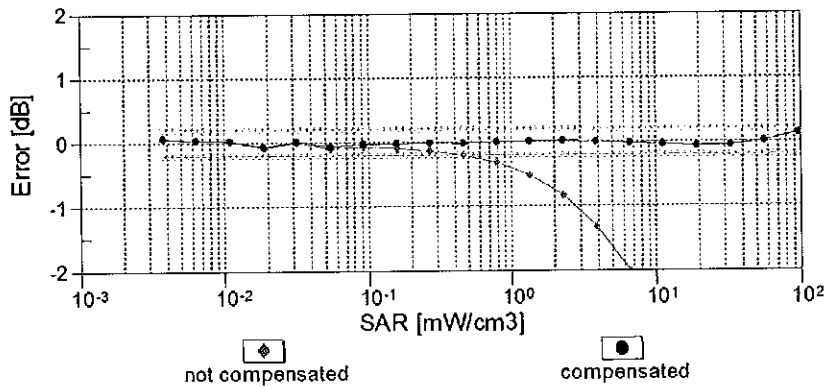
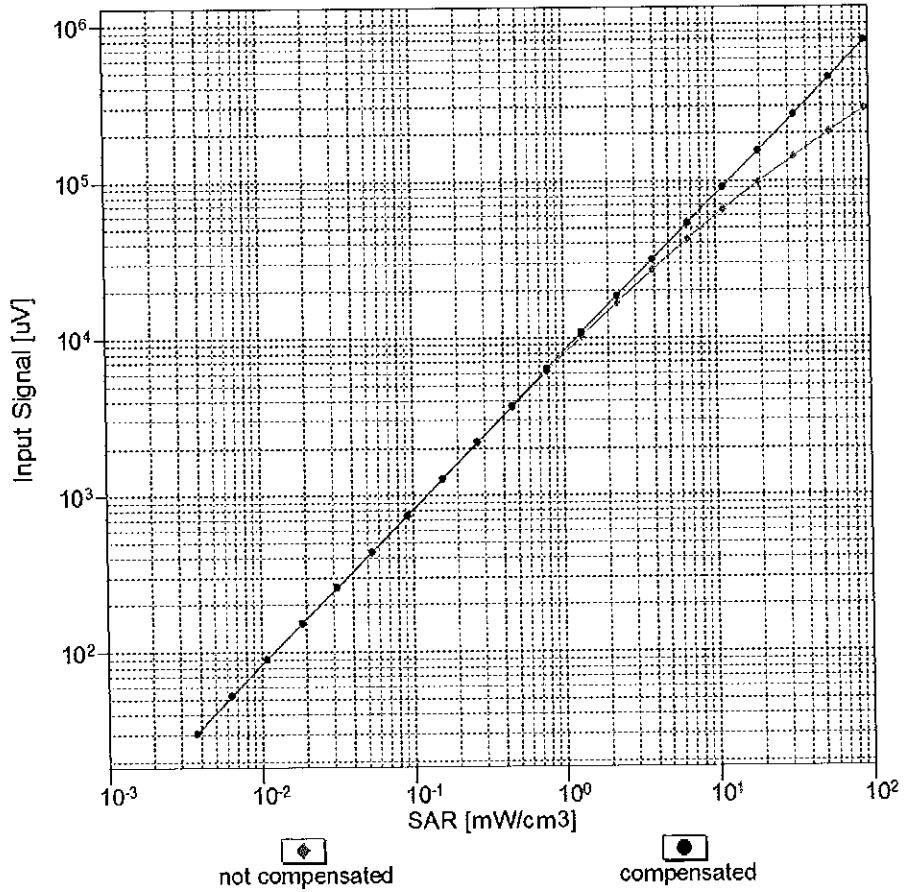

Uncertainty of Linearity Assessment: ± 0.6% (k=2)

# Conversion Factor Assessment

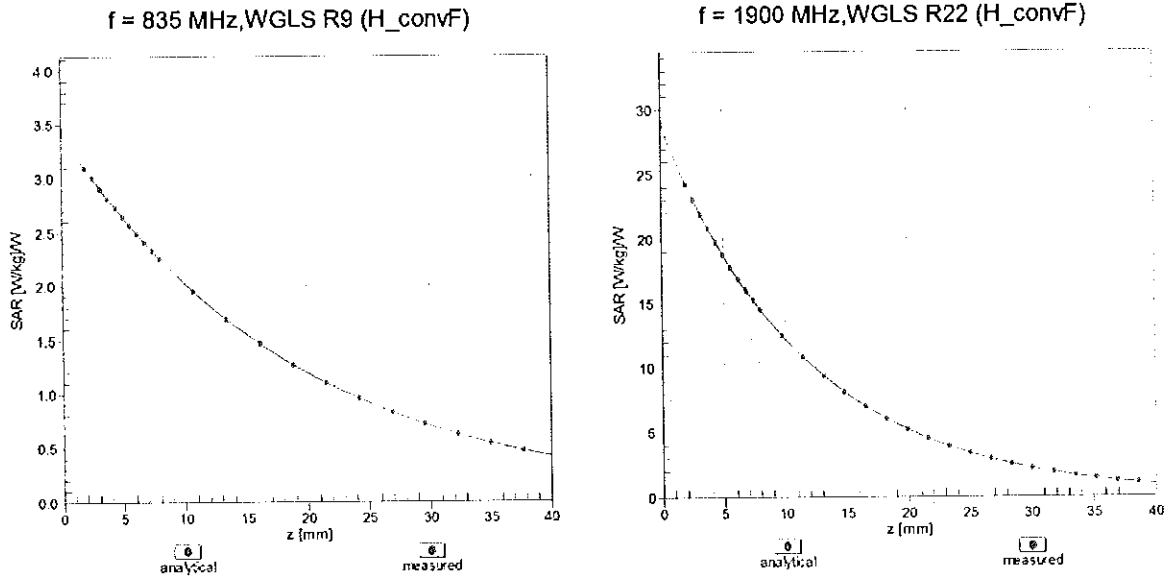

## Deviation from Isotropy in Liquid Error ( $\phi, \theta$ ), f = 900 MHz

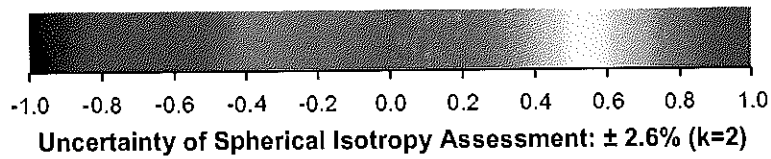
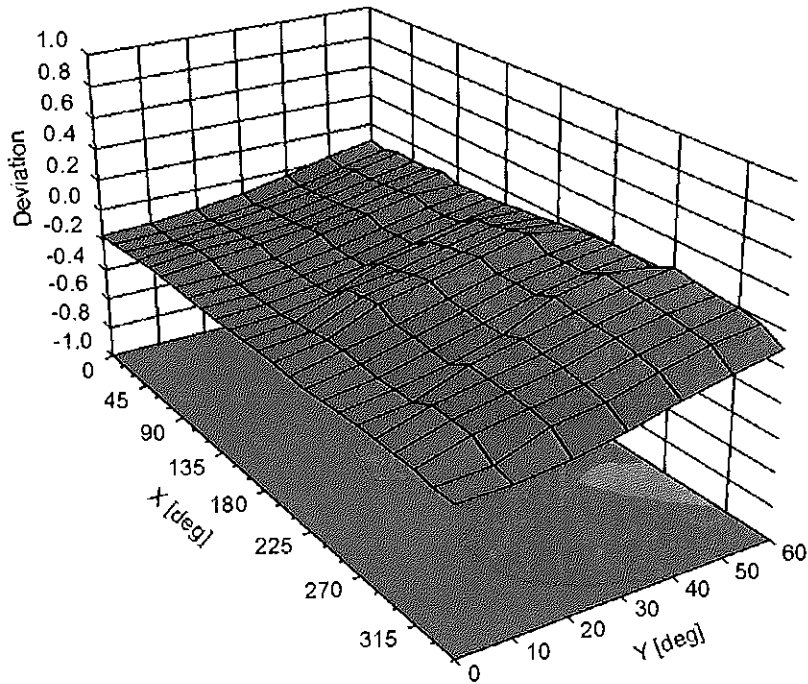

**DASY/EASY - Parameters of Probe: ES3DV3 - SN:3209****Other Probe Parameters**

Sensor Arrangement	Triangular
Connector Angle (°)	-39.9
Mechanical Surface Detection Mode	enabled
Optical Surface Detection Mode	disabled
Probe Overall Length	337 mm
Probe Body Diameter	10 mm
Tip Length	10 mm
Tip Diameter	4 mm
Probe Tip to Sensor X Calibration Point	2 mm
Probe Tip to Sensor Y Calibration Point	2 mm
Probe Tip to Sensor Z Calibration Point	2 mm
Recommended Measurement Distance from Surface	3 mm

**Appendix: Modulation Calibration Parameters**

UID	Communication System Name		A dB	B dB $\sqrt{\mu V}$	C	D dB	VR mV	Max Unc <sup>E</sup> (k=2)
0	CW	X	0.00	0.00	1.00	0.00	185.7	± 3.5 %
		Y	0.00	0.00	1.00		188.4	
		Z	0.00	0.00	1.00		174.0	
10010- CAA	SAR Validation (Square, 100ms, 10ms)	X	16.56	89.85	21.07	10.00	25.0	± 9.6 %
		Y	14.18	87.91	20.84		25.0	
		Z	16.46	89.94	21.19		25.0	
10011- CAB	UMTS-FDD (WCDMA)	X	1.31	71.34	17.73	0.00	150.0	± 9.6 %
		Y	1.07	67.38	15.30		150.0	
		Z	1.14	68.61	16.10		150.0	
10012- CAB	IEEE 802.11b WiFi 2.4 GHz (DSSS, 1 Mbps)	X	1.33	65.77	16.71	0.41	150.0	± 9.6 %
		Y	1.28	64.69	15.69		150.0	
		Z	1.29	65.03	16.02		150.0	
10013- CAB	IEEE 802.11g WiFi 2.4 GHz (DSSS-OFDM, 6 Mbps)	X	5.11	67.29	17.66	1.46	150.0	± 9.6 %
		Y	5.08	67.12	17.41		150.0	
		Z	5.08	67.16	17.48		150.0	
10021- DAC	GSM-FDD (TDMA, GMSK)	X	100.00	120.30	31.44	9.39	50.0	± 9.6 %
		Y	100.00	121.02	32.06		50.0	
		Z	100.00	120.74	31.69		50.0	
10023- DAC	GPRS-FDD (TDMA, GMSK, TN 0)	X	100.00	120.21	31.45	9.57	50.0	± 9.6 %
		Y	100.00	120.94	32.08		50.0	
		Z	100.00	120.65	31.69		50.0	
10024- DAC	GPRS-FDD (TDMA, GMSK, TN 0-1)	X	100.00	118.31	29.49	6.56	60.0	± 9.6 %
		Y	100.00	118.38	29.74		60.0	
		Z	100.00	118.51	29.61		60.0	
10025- DAC	EDGE-FDD (TDMA, 8PSK, TN 0)	X	79.79	164.11	61.22	12.57	50.0	± 9.6 %
		Y	21.03	115.56	45.00		50.0	
		Z	21.02	118.33	46.74		50.0	
10026- DAC	EDGE-FDD (TDMA, 8PSK, TN 0-1)	X	56.10	137.19	47.52	9.56	60.0	± 9.6 %
		Y	22.58	110.81	38.90		60.0	
		Z	30.67	120.33	42.31		60.0	
10027- DAC	GPRS-FDD (TDMA, GMSK, TN 0-1-2)	X	100.00	118.60	28.85	4.80	80.0	± 9.6 %
		Y	100.00	117.96	28.73		80.0	
		Z	100.00	118.50	28.81		80.0	
10028- DAC	GPRS-FDD (TDMA, GMSK, TN 0-1-2-3)	X	100.00	120.37	28.91	3.55	100.0	± 9.6 %
		Y	100.00	118.79	28.36		100.0	
		Z	100.00	119.82	28.67		100.0	
10029- DAC	EDGE-FDD (TDMA, 8PSK, TN 0-1-2)	X	18.11	107.13	37.13	7.80	80.0	± 9.6 %
		Y	12.22	95.66	32.56		80.0	
		Z	13.69	99.54	34.27		80.0	
10030- CAA	IEEE 802.15.1 Bluetooth (GFSK, DH1)	X	100.00	117.23	28.52	5.30	70.0	± 9.6 %
		Y	100.00	116.90	28.56		70.0	
		Z	100.00	117.22	28.54		70.0	
10031- CAA	IEEE 802.15.1 Bluetooth (GFSK, DH3)	X	100.00	124.45	29.19	1.88	100.0	± 9.6 %
		Y	100.00	120.00	27.42		100.0	
		Z	100.00	122.22	28.25		100.0	

10032-CAA	IEEE 802.15.1 Bluetooth (GFSK, DH5)	X	100.00	134.81	32.39	1.17	100.0	± 9.6 %
		Y	100.00	125.40	28.63		100.0	
		Z	100.00	129.61	30.26		100.0	
10033-CAA	IEEE 802.15.1 Bluetooth (PI/4-DQPSK, DH1)	X	100.00	129.27	35.65	5.30	70.0	± 9.6 %
		Y	49.54	115.99	32.11		70.0	
		Z	90.11	126.99	34.97		70.0	
10034-CAA	IEEE 802.15.1 Bluetooth (PI/4-DQPSK, DH3)	X	16.84	102.10	27.13	1.88	100.0	± 9.6 %
		Y	7.82	89.20	22.87		100.0	
		Z	9.48	92.81	24.19		100.0	
10035-CAA	IEEE 802.15.1 Bluetooth (PI/4-DQPSK, DH5)	X	6.67	89.65	23.23	1.17	100.0	± 9.6 %
		Y	3.84	80.35	19.62		100.0	
		Z	4.40	82.90	20.73		100.0	
10036-CAA	IEEE 802.15.1 Bluetooth (8-DPSK, DH1)	X	100.00	129.52	35.77	5.30	70.0	± 9.6 %
		Y	85.34	125.22	34.45		70.0	
		Z	100.00	128.99	35.51		70.0	
10037-CAA	IEEE 802.15.1 Bluetooth (8-DPSK, DH3)	X	15.79	101.19	26.84	1.88	100.0	± 9.6 %
		Y	7.32	88.29	22.54		100.0	
		Z	8.88	91.91	23.88		100.0	
10038-CAA	IEEE 802.15.1 Bluetooth (8-DPSK, DH5)	X	6.96	90.64	23.66	1.17	100.0	± 9.6 %
		Y	3.95	81.00	19.95		100.0	
		Z	4.52	83.60	21.07		100.0	
10039-CAB	CDMA2000 (1xRTT, RC1)	X	2.68	77.46	18.66	0.00	150.0	± 9.6 %
		Y	1.87	71.76	15.92		150.0	
		Z	2.09	73.47	16.81		150.0	
10042-CAB	IS-54 / IS-136 FDD (TDMA/FDM, PI/4-DQPSK, Halfrate)	X	100.00	116.28	28.75	7.78	50.0	± 9.6 %
		Y	100.00	116.68	29.16		50.0	
		Z	100.00	116.58	28.91		50.0	
10044-CAA	IS-91/EIA/TIA-553 FDD (FDMA, FM)	X	0.01	103.03	6.46	0.00	150.0	± 9.6 %
		Y	0.01	95.61	0.65		150.0	
		Z	0.02	122.64	11.17		150.0	
10048-CAA	DECT (TDD, TDMA/FDM, GFSK, Full Slot, 24)	X	100.00	122.27	33.78	13.80	25.0	± 9.6 %
		Y	88.36	120.80	33.95		25.0	
		Z	100.00	122.70	34.06		25.0	
10049-CAA	DECT (TDD, TDMA/FDM, GFSK, Double Slot, 12)	X	100.00	120.46	31.88	10.79	40.0	± 9.6 %
		Y	100.00	121.38	32.63		40.0	
		Z	100.00	120.92	32.14		40.0	
10056-CAA	UMTS-TDD (TD-SCDMA, 1.28 Mcps)	X	64.71	119.17	33.88	9.03	50.0	± 9.6 %
		Y	31.81	105.88	30.24		50.0	
		Z	48.79	114.06	32.52		50.0	
10058-DAC	EDGE-FDD (TDMA, 8PSK, TN 0-1-2-3)	X	10.31	93.78	31.68	6.55	100.0	± 9.6 %
		Y	8.35	87.44	28.76		100.0	
		Z	8.74	89.37	29.77		100.0	
10059-CAB	IEEE 802.11b WiFi 2.4 GHz (DSSS, 2 Mbps)	X	1.47	67.98	17.85	0.61	110.0	± 9.6 %
		Y	1.41	66.57	16.67		110.0	
		Z	1.42	66.96	17.03		110.0	
10060-CAB	IEEE 802.11b WiFi 2.4 GHz (DSSS, 5.5 Mbps)	X	100.00	138.63	36.70	1.30	110.0	± 9.6 %
		Y	100.00	134.16	34.76		110.0	
		Z	100.00	136.34	35.67		110.0	

10061-CAB	IEEE 802.11b WiFi 2.4 GHz (DSSS, 11 Mbps)	X	21.25	113.68	33.06	2.04	110.0	± 9.6 %
		Y	8.67	95.89	27.33		110.0	
		Z	10.38	100.06	28.88		110.0	
10062-CAB	IEEE 802.11a/h WiFi 5 GHz (OFDM, 6 Mbps)	X	4.87	67.16	16.99	0.49	100.0	± 9.6 %
		Y	4.83	66.94	16.72		100.0	
		Z	4.84	67.02	16.80		100.0	
10063-CAB	IEEE 802.11a/h WiFi 5 GHz (OFDM, 9 Mbps)	X	4.90	67.29	17.12	0.72	100.0	± 9.6 %
		Y	4.86	67.08	16.85		100.0	
		Z	4.87	67.15	16.93		100.0	
10064-CAB	IEEE 802.11a/h WiFi 5 GHz (OFDM, 12 Mbps)	X	5.22	67.61	17.38	0.86	100.0	± 9.6 %
		Y	5.17	67.40	17.11		100.0	
		Z	5.19	67.47	17.19		100.0	
10065-CAB	IEEE 802.11a/h WiFi 5 GHz (OFDM, 18 Mbps)	X	5.10	67.59	17.53	1.21	100.0	± 9.6 %
		Y	5.06	67.39	17.27		100.0	
		Z	5.07	67.45	17.34		100.0	
10066-CAB	IEEE 802.11a/h WiFi 5 GHz (OFDM, 24 Mbps)	X	5.14	67.68	17.74	1.46	100.0	± 9.6 %
		Y	5.10	67.48	17.48		100.0	
		Z	5.11	67.54	17.56		100.0	
10067-CAB	IEEE 802.11a/h WiFi 5 GHz (OFDM, 36 Mbps)	X	5.44	67.85	18.21	2.04	100.0	± 9.6 %
		Y	5.41	67.66	17.95		100.0	
		Z	5.41	67.71	18.02		100.0	
10068-CAB	IEEE 802.11a/h WiFi 5 GHz (OFDM, 48 Mbps)	X	5.54	68.11	18.56	2.55	100.0	± 9.6 %
		Y	5.51	67.91	18.28		100.0	
		Z	5.51	67.95	18.36		100.0	
10069-CAB	IEEE 802.11a/h WiFi 5 GHz (OFDM, 54 Mbps)	X	5.62	68.08	18.75	2.67	100.0	± 9.6 %
		Y	5.59	67.88	18.46		100.0	
		Z	5.59	67.92	18.55		100.0	
10071-CAB	IEEE 802.11g WiFi 2.4 GHz (DSSS/OFDM, 9 Mbps)	X	5.23	67.47	18.03	1.99	100.0	± 9.6 %
		Y	5.20	67.30	17.78		100.0	
		Z	5.20	67.34	17.85		100.0	
10072-CAB	IEEE 802.11g WiFi 2.4 GHz (DSSS/OFDM, 12 Mbps)	X	5.25	67.96	18.33	2.30	100.0	± 9.6 %
		Y	5.23	67.77	18.07		100.0	
		Z	5.22	67.81	18.14		100.0	
10073-CAB	IEEE 802.11g WiFi 2.4 GHz (DSSS/OFDM, 18 Mbps)	X	5.35	68.24	18.74	2.83	100.0	± 9.6 %
		Y	5.33	68.06	18.47		100.0	
		Z	5.32	68.08	18.54		100.0	
10074-CAB	IEEE 802.11g WiFi 2.4 GHz (DSSS/OFDM, 24 Mbps)	X	5.35	68.21	18.96	3.30	100.0	± 9.6 %
		Y	5.34	68.06	18.69		100.0	
		Z	5.32	68.06	18.76		100.0	
10075-CAB	IEEE 802.11g WiFi 2.4 GHz (DSSS/OFDM, 36 Mbps)	X	5.45	68.57	19.42	3.82	90.0	± 9.6 %
		Y	5.44	68.40	19.14		90.0	
		Z	5.42	68.40	19.20		90.0	
10076-CAB	IEEE 802.11g WiFi 2.4 GHz (DSSS/OFDM, 48 Mbps)	X	5.44	68.33	19.53	4.15	90.0	± 9.6 %
		Y	5.45	68.18	19.25		90.0	
		Z	5.42	68.16	19.32		90.0	
10077-CAB	IEEE 802.11g WiFi 2.4 GHz (DSSS/OFDM, 54 Mbps)	X	5.47	68.40	19.63	4.30	90.0	± 9.6 %
		Y	5.48	68.26	19.35		90.0	
		Z	5.45	68.24	19.42		90.0	



10081-CAB	CDMA2000 (1xRTT, RC3)	X	1.23	71.08	15.82	0.00	150.0	± 9.6 %
		Y	0.91	66.28	13.04		150.0	
		Z	0.99	67.64	13.91		150.0	
10082-CAB	IS-54 / IS-136 FDD (TDMA/FDM, PI/4-DQPSK, Fullrate)	X	1.44	62.24	7.11	4.77	80.0	± 9.6 %
		Y	1.55	62.44	7.40		80.0	
		Z	1.44	62.17	7.10		80.0	
10090-DAC	GPRS-FDD (TDMA, GMSK, TN 0-4)	X	100.00	118.36	29.54	6.56	60.0	± 9.6 %
		Y	100.00	118.45	29.79		60.0	
		Z	100.00	118.56	29.65		60.0	
10097-CAB	UMTS-FDD (HSDPA)	X	2.01	69.10	16.79	0.00	150.0	± 9.6 %
		Y	1.86	67.49	15.67		150.0	
		Z	1.91	68.05	16.06		150.0	
10098-CAB	UMTS-FDD (HSUPA, Subtest 2)	X	1.98	69.12	16.80	0.00	150.0	± 9.6 %
		Y	1.82	67.46	15.64		150.0	
		Z	1.87	68.03	16.04		150.0	
10099-DAC	EDGE-FDD (TDMA, 8PSK, TN 0-4)	X	56.10	137.12	47.49	9.56	60.0	± 9.6 %
		Y	22.61	110.79	38.89		60.0	
		Z	30.74	120.33	42.30		60.0	
10100-CAC	LTE-FDD (SC-FDMA, 100% RB, 20 MHz, QPSK)	X	3.46	71.82	17.60	0.00	150.0	± 9.6 %
		Y	3.20	70.34	16.69		150.0	
		Z	3.29	70.87	17.01		150.0	
10101-CAC	LTE-FDD (SC-FDMA, 100% RB, 20 MHz, 16-QAM)	X	3.44	68.35	16.55	0.00	150.0	± 9.6 %
		Y	3.33	67.66	16.01		150.0	
		Z	3.37	67.92	16.20		150.0	
10102-CAC	LTE-FDD (SC-FDMA, 100% RB, 20 MHz, 64-QAM)	X	3.53	68.21	16.59	0.00	150.0	± 9.6 %
		Y	3.43	67.60	16.09		150.0	
		Z	3.46	67.83	16.26		150.0	
10103-CAC	LTE-TDD (SC-FDMA, 100% RB, 20 MHz, QPSK)	X	8.71	80.18	22.43	3.98	65.0	± 9.6 %
		Y	8.63	79.54	22.01		65.0	
		Z	8.72	80.06	22.29		65.0	
10104-CAC	LTE-TDD (SC-FDMA, 100% RB, 20 MHz, 16-QAM)	X	8.41	78.26	22.59	3.98	65.0	± 9.6 %
		Y	8.16	77.17	21.90		65.0	
		Z	8.16	77.51	22.15		65.0	
10105-CAC	LTE-TDD (SC-FDMA, 100% RB, 20 MHz, 64-QAM)	X	7.75	76.58	22.19	3.98	65.0	± 9.6 %
		Y	7.29	74.89	21.22		65.0	
		Z	7.40	75.53	21.60		65.0	
10108-CAD	LTE-FDD (SC-FDMA, 100% RB, 10 MHz, QPSK)	X	3.04	71.09	17.48	0.00	150.0	± 9.6 %
		Y	2.81	69.59	16.53		150.0	
		Z	2.89	70.12	16.86		150.0	
10109-CAD	LTE-FDD (SC-FDMA, 100% RB, 10 MHz, 16-QAM)	X	3.10	68.24	16.51	0.00	150.0	± 9.6 %
		Y	2.98	67.47	15.91		150.0	
		Z	3.02	67.76	16.12		150.0	
10110-CAD	LTE-FDD (SC-FDMA, 100% RB, 5 MHz, QPSK)	X	2.51	70.39	17.27	0.00	150.0	± 9.6 %
		Y	2.30	68.71	16.17		150.0	
		Z	2.37	69.29	16.55		150.0	
10111-CAD	LTE-FDD (SC-FDMA, 100% RB, 5 MHz, 16-QAM)	X	2.80	68.98	16.82	0.00	150.0	± 9.6 %
		Y	2.67	68.08	16.14		150.0	
		Z	2.72	68.39	16.37		150.0	

10112-CAD	LTE-FDD (SC-FDMA, 100% RB, 10 MHz, 64-QAM)	X	3.21	68.13	16.51	0.00	150.0	± 9.6 %
		Y	3.11	67.44	15.96		150.0	
		Z	3.14	67.70	16.15		150.0	
10113-CAD	LTE-FDD (SC-FDMA, 100% RB, 5 MHz, 64-QAM)	X	2.94	69.00	16.88	0.00	150.0	± 9.6 %
		Y	2.83	68.20	16.26		150.0	
		Z	2.87	68.48	16.47		150.0	
10114-CAB	IEEE 802.11n (HT Greenfield, 13.5 Mbps, BPSK)	X	5.29	67.60	16.80	0.00	150.0	± 9.6 %
		Y	5.23	67.37	16.54		150.0	
		Z	5.25	67.46	16.62		150.0	
10115-CAB	IEEE 802.11n (HT Greenfield, 81 Mbps, 16-QAM)	X	5.64	67.91	16.97	0.00	150.0	± 9.6 %
		Y	5.58	67.65	16.70		150.0	
		Z	5.60	67.75	16.78		150.0	
10116-CAB	IEEE 802.11n (HT Greenfield, 135 Mbps, 64-QAM)	X	5.42	67.88	16.87	0.00	150.0	± 9.6 %
		Y	5.35	67.63	16.60		150.0	
		Z	5.37	67.72	16.68		150.0	
10117-CAB	IEEE 802.11n (HT Mixed, 13.5 Mbps, BPSK)	X	5.27	67.51	16.78	0.00	150.0	± 9.6 %
		Y	5.21	67.27	16.51		150.0	
		Z	5.23	67.37	16.60		150.0	
10118-CAB	IEEE 802.11n (HT Mixed, 81 Mbps, 16-QAM)	X	5.75	68.18	17.12	0.00	150.0	± 9.6 %
		Y	5.68	67.91	16.83		150.0	
		Z	5.70	68.00	16.92		150.0	
10119-CAB	IEEE 802.11n (HT Mixed, 135 Mbps, 64-QAM)	X	5.39	67.82	16.85	0.00	150.0	± 9.6 %
		Y	5.33	67.57	16.58		150.0	
		Z	5.35	67.66	16.66		150.0	
10140-CAC	LTE-FDD (SC-FDMA, 100% RB, 15 MHz, 16-QAM)	X	3.57	68.23	16.51	0.00	150.0	± 9.6 %
		Y	3.47	67.61	16.01		150.0	
		Z	3.51	67.84	16.19		150.0	
10141-CAC	LTE-FDD (SC-FDMA, 100% RB, 15 MHz, 64-QAM)	X	3.69	68.24	16.63	0.00	150.0	± 9.6 %
		Y	3.59	67.69	16.17		150.0	
		Z	3.63	67.89	16.33		150.0	
10142-CAD	LTE-FDD (SC-FDMA, 100% RB, 3 MHz, QPSK)	X	2.30	70.61	17.13	0.00	150.0	± 9.6 %
		Y	2.07	68.65	15.88		150.0	
		Z	2.15	69.31	16.31		150.0	
10143-CAD	LTE-FDD (SC-FDMA, 100% RB, 3 MHz, 16-QAM)	X	2.70	69.93	16.73	0.00	150.0	± 9.6 %
		Y	2.53	68.73	15.89		150.0	
		Z	2.59	69.14	16.18		150.0	
10144-CAD	LTE-FDD (SC-FDMA, 100% RB, 3 MHz, 64-QAM)	X	2.50	67.93	15.31	0.00	150.0	± 9.6 %
		Y	2.35	66.79	14.47		150.0	
		Z	2.40	67.20	14.77		150.0	
10145-CAD	LTE-FDD (SC-FDMA, 100% RB, 1.4 MHz, QPSK)	X	1.61	68.59	14.32	0.00	150.0	± 9.6 %
		Y	1.36	65.99	12.68		150.0	
		Z	1.44	66.83	13.25		150.0	
10146-CAD	LTE-FDD (SC-FDMA, 100% RB, 1.4 MHz, 16-QAM)	X	4.12	76.15	17.00	0.00	150.0	± 9.6 %
		Y	3.13	71.87	14.86		150.0	
		Z	3.61	74.04	16.00		150.0	
10147-CAD	LTE-FDD (SC-FDMA, 100% RB, 1.4 MHz, 64-QAM)	X	5.91	81.17	19.01	0.00	150.0	± 9.6 %
		Y	4.21	75.86	16.64		150.0	
		Z	5.05	78.62	17.93		150.0	

10149-CAC	LTE-FDD (SC-FDMA, 50% RB, 20 MHz, 16-QAM)	X	3.10	68.30	16.55	0.00	150.0	± 9.6 %
		Y	2.99	67.53	15.95		150.0	
		Z	3.03	67.81	16.16		150.0	
10150-CAC	LTE-FDD (SC-FDMA, 50% RB, 20 MHz, 64-QAM)	X	3.22	68.17	16.55	0.00	150.0	± 9.6 %
		Y	3.11	67.49	16.00		150.0	
		Z	3.15	67.74	16.19		150.0	
10151-CAC	LTE-TDD (SC-FDMA, 50% RB, 20 MHz, QPSK)	X	9.92	84.00	24.01	3.98	65.0	± 9.6 %
		Y	9.28	82.23	23.13		65.0	
		Z	9.42	82.88	23.47		65.0	
10152-CAC	LTE-TDD (SC-FDMA, 50% RB, 20 MHz, 16-QAM)	X	8.12	78.81	22.58	3.98	65.0	± 9.6 %
		Y	7.79	77.46	21.77		65.0	
		Z	7.82	77.90	22.06		65.0	
10153-CAC	LTE-TDD (SC-FDMA, 50% RB, 20 MHz, 64-QAM)	X	8.47	79.51	23.20	3.98	65.0	± 9.6 %
		Y	8.19	78.31	22.47		65.0	
		Z	8.19	78.67	22.72		65.0	
10154-CAD	LTE-FDD (SC-FDMA, 50% RB, 10 MHz, QPSK)	X	2.56	70.77	17.50	0.00	150.0	± 9.6 %
		Y	2.35	69.09	16.42		150.0	
		Z	2.42	69.67	16.79		150.0	
10155-CAD	LTE-FDD (SC-FDMA, 50% RB, 10 MHz, 16-QAM)	X	2.80	68.99	16.83	0.00	150.0	± 9.6 %
		Y	2.68	68.09	16.15		150.0	
		Z	2.72	68.40	16.38		150.0	
10156-CAD	LTE-FDD (SC-FDMA, 50% RB, 5 MHz, QPSK)	X	2.18	71.04	17.14	0.00	150.0	± 9.6 %
		Y	1.92	68.76	15.73		150.0	
		Z	2.01	69.52	16.21		150.0	
10157-CAD	LTE-FDD (SC-FDMA, 50% RB, 5 MHz, 16-QAM)	X	2.37	68.82	15.55	0.00	150.0	± 9.6 %
		Y	2.18	67.35	14.55		150.0	
		Z	2.25	67.86	14.90		150.0	
10158-CAD	LTE-FDD (SC-FDMA, 50% RB, 10 MHz, 64-QAM)	X	2.95	69.05	16.92	0.00	150.0	± 9.6 %
		Y	2.83	68.25	16.30		150.0	
		Z	2.87	68.52	16.51		150.0	
10159-CAD	LTE-FDD (SC-FDMA, 50% RB, 5 MHz, 64-QAM)	X	2.48	69.16	15.77	0.00	150.0	± 9.6 %
		Y	2.29	67.76	14.81		150.0	
		Z	2.35	68.25	15.15		150.0	
10160-CAC	LTE-FDD (SC-FDMA, 50% RB, 15 MHz, QPSK)	X	3.02	70.00	17.21	0.00	150.0	± 9.6 %
		Y	2.84	68.79	16.39		150.0	
		Z	2.90	69.20	16.66		150.0	
10161-CAC	LTE-FDD (SC-FDMA, 50% RB, 15 MHz, 16-QAM)	X	3.11	68.10	16.49	0.00	150.0	± 9.6 %
		Y	3.01	67.41	15.93		150.0	
		Z	3.04	67.66	16.12		150.0	
10162-CAC	LTE-FDD (SC-FDMA, 50% RB, 15 MHz, 64-QAM)	X	3.22	68.18	16.56	0.00	150.0	± 9.6 %
		Y	3.11	67.53	16.02		150.0	
		Z	3.15	67.77	16.21		150.0	
10166-CAD	LTE-FDD (SC-FDMA, 50% RB, 1.4 MHz, QPSK)	X	4.01	71.57	20.55	3.01	150.0	± 9.6 %
		Y	3.96	70.99	19.97		150.0	
		Z	4.00	71.24	20.22		150.0	
10167-CAD	LTE-FDD (SC-FDMA, 50% RB, 1.4 MHz, 16-QAM)	X	5.34	76.03	21.61	3.01	150.0	± 9.6 %
		Y	5.24	75.14	20.90		150.0	
		Z	5.29	75.43	21.17		150.0	

10168-CAD	LTE-FDD (SC-FDMA, 50% RB, 1.4 MHz, 64-QAM)	X	5.92	78.26	22.84	3.01	150.0	± 9.6 %
		Y	5.88	77.64	22.28		150.0	
		Z	5.88	77.74	22.45		150.0	
10169-CAC	LTE-FDD (SC-FDMA, 1 RB, 20 MHz, QPSK)	X	3.56	72.83	21.25	3.01	150.0	± 9.6 %
		Y	3.54	72.03	20.47		150.0	
		Z	3.57	72.33	20.78		150.0	
10170-CAC	LTE-FDD (SC-FDMA, 1 RB, 20 MHz, 16-QAM)	X	5.89	82.52	24.81	3.01	150.0	± 9.6 %
		Y	5.80	81.18	23.85		150.0	
		Z	5.77	81.27	24.06		150.0	
10171-AAC	LTE-FDD (SC-FDMA, 1 RB, 20 MHz, 64-QAM)	X	4.66	77.30	21.81	3.01	150.0	± 9.6 %
		Y	4.48	75.56	20.63		150.0	
		Z	4.56	76.10	21.06		150.0	
10172-CAC	LTE-TDD (SC-FDMA, 1 RB, 20 MHz, QPSK)	X	100.00	142.02	43.67	6.02	65.0	± 9.6 %
		Y	29.14	113.86	35.69		65.0	
		Z	42.14	122.72	38.48		65.0	
10173-CAC	LTE-TDD (SC-FDMA, 1 RB, 20 MHz, 16-QAM)	X	100.00	131.99	38.44	6.02	65.0	± 9.6 %
		Y	100.00	129.98	37.53		65.0	
		Z	100.00	131.24	38.14		65.0	
10174-CAC	LTE-TDD (SC-FDMA, 1 RB, 20 MHz, 64-QAM)	X	100.00	130.14	37.45	6.02	65.0	± 9.6 %
		Y	100.00	127.86	36.41		65.0	
		Z	91.70	127.77	36.74		65.0	
10175-CAD	LTE-FDD (SC-FDMA, 1 RB, 10 MHz, QPSK)	X	3.52	72.50	21.01	3.01	150.0	± 9.6 %
		Y	3.49	71.66	20.21		150.0	
		Z	3.53	71.99	20.53		150.0	
10176-CAD	LTE-FDD (SC-FDMA, 1 RB, 10 MHz, 16-QAM)	X	5.90	82.55	24.82	3.01	150.0	± 9.6 %
		Y	5.81	81.21	23.86		150.0	
		Z	5.78	81.30	24.07		150.0	
10177-CAF	LTE-FDD (SC-FDMA, 1 RB, 5 MHz, QPSK)	X	3.55	72.66	21.10	3.01	150.0	± 9.6 %
		Y	3.52	71.84	20.31		150.0	
		Z	3.56	72.16	20.62		150.0	
10178-CAD	LTE-FDD (SC-FDMA, 1 RB, 5 MHz, 16-QAM)	X	5.82	82.23	24.68	3.01	150.0	± 9.6 %
		Y	5.72	80.87	23.70		150.0	
		Z	5.70	80.99	23.93		150.0	
10179-CAD	LTE-FDD (SC-FDMA, 1 RB, 10 MHz, 64-QAM)	X	5.25	79.82	23.19	3.01	150.0	± 9.6 %
		Y	5.07	78.18	22.08		150.0	
		Z	5.12	78.56	22.43		150.0	
10180-CAD	LTE-FDD (SC-FDMA, 1 RB, 5 MHz, 64-QAM)	X	4.65	77.21	21.76	3.01	150.0	± 9.6 %
		Y	4.46	75.45	20.57		150.0	
		Z	4.54	76.00	21.00		150.0	
10181-CAC	LTE-FDD (SC-FDMA, 1 RB, 15 MHz, QPSK)	X	3.55	72.65	21.10	3.01	150.0	± 9.6 %
		Y	3.51	71.82	20.30		150.0	
		Z	3.55	72.14	20.62		150.0	
10182-CAC	LTE-FDD (SC-FDMA, 1 RB, 15 MHz, 16-QAM)	X	5.81	82.20	24.67	3.01	150.0	± 9.6 %
		Y	5.71	80.84	23.69		150.0	
		Z	5.69	80.96	23.92		150.0	
10183-AAB	LTE-FDD (SC-FDMA, 1 RB, 15 MHz, 64-QAM)	X	4.64	77.18	21.74	3.01	150.0	± 9.6 %
		Y	4.45	75.42	20.56		150.0	
		Z	4.53	75.97	20.99		150.0	

10184-CAD	LTE-FDD (SC-FDMA, 1 RB, 3 MHz, QPSK)	X	3.56	72.69	21.12	3.01	150.0	± 9.6 %
		Y	3.53	71.87	20.33		150.0	
		Z	3.57	72.19	20.64		150.0	
10185-CAD	LTE-FDD (SC-FDMA, 1 RB, 3 MHz, 16-QAM)	X	5.84	82.29	24.71	3.01	150.0	± 9.6 %
		Y	5.74	80.94	23.73		150.0	
		Z	5.72	81.05	23.96		150.0	
10186-AAD	LTE-FDD (SC-FDMA, 1 RB, 3 MHz, 64-QAM)	X	4.67	77.27	21.78	3.01	150.0	± 9.6 %
		Y	4.47	75.51	20.59		150.0	
		Z	4.56	76.06	21.03		150.0	
10187-CAD	LTE-FDD (SC-FDMA, 1 RB, 1.4 MHz, QPSK)	X	3.57	72.74	21.18	3.01	150.0	± 9.6 %
		Y	3.54	71.92	20.39		150.0	
		Z	3.58	72.24	20.70		150.0	
10188-CAD	LTE-FDD (SC-FDMA, 1 RB, 1.4 MHz, 16-QAM)	X	6.08	83.16	25.13	3.01	150.0	± 9.6 %
		Y	6.00	81.87	24.19		150.0	
		Z	5.95	81.90	24.38		150.0	
10189-AAD	LTE-FDD (SC-FDMA, 1 RB, 1.4 MHz, 64-QAM)	X	4.80	77.83	22.09	3.01	150.0	± 9.6 %
		Y	4.61	76.08	20.92		150.0	
		Z	4.69	76.60	21.33		150.0	
10193-CAB	IEEE 802.11n (HT Greenfield, 6.5 Mbps, BPSK)	X	4.68	66.98	16.53	0.00	150.0	± 9.6 %
		Y	4.62	66.73	16.24		150.0	
		Z	4.64	66.83	16.34		150.0	
10194-CAB	IEEE 802.11n (HT Greenfield, 39 Mbps, 16-QAM)	X	4.86	67.32	16.65	0.00	150.0	± 9.6 %
		Y	4.81	67.07	16.37		150.0	
		Z	4.83	67.17	16.46		150.0	
10195-CAB	IEEE 802.11n (HT Greenfield, 65 Mbps, 64-QAM)	X	4.91	67.35	16.66	0.00	150.0	± 9.6 %
		Y	4.85	67.10	16.38		150.0	
		Z	4.87	67.20	16.47		150.0	
10196-CAB	IEEE 802.11n (HT Mixed, 6.5 Mbps, BPSK)	X	4.69	67.06	16.56	0.00	150.0	± 9.6 %
		Y	4.63	66.81	16.27		150.0	
		Z	4.65	66.91	16.37		150.0	
10197-CAB	IEEE 802.11n (HT Mixed, 39 Mbps, 16-QAM)	X	4.88	67.35	16.66	0.00	150.0	± 9.6 %
		Y	4.82	67.09	16.38		150.0	
		Z	4.84	67.19	16.47		150.0	
10198-CAB	IEEE 802.11n (HT Mixed, 65 Mbps, 64-QAM)	X	4.91	67.37	16.68	0.00	150.0	± 9.6 %
		Y	4.85	67.12	16.39		150.0	
		Z	4.87	67.22	16.49		150.0	
10219-CAB	IEEE 802.11n (HT Mixed, 7.2 Mbps, BPSK)	X	4.64	67.08	16.52	0.00	150.0	± 9.6 %
		Y	4.58	66.82	16.23		150.0	
		Z	4.60	66.92	16.33		150.0	
10220-CAB	IEEE 802.11n (HT Mixed, 43.3 Mbps, 16-QAM)	X	4.88	67.33	16.66	0.00	150.0	± 9.6 %
		Y	4.82	67.07	16.37		150.0	
		Z	4.84	67.17	16.47		150.0	
10221-CAB	IEEE 802.11n (HT Mixed, 72.2 Mbps, 64-QAM)	X	4.92	67.29	16.66	0.00	150.0	± 9.6 %
		Y	4.86	67.05	16.38		150.0	
		Z	4.88	67.14	16.47		150.0	
10222-CAB	IEEE 802.11n (HT Mixed, 15 Mbps, BPSK)	X	5.24	67.52	16.77	0.00	150.0	± 9.6 %
		Y	5.18	67.28	16.51		150.0	
		Z	5.21	67.38	16.59		150.0	

10223-CAB	IEEE 802.11n (HT Mixed, 90 Mbps, 16-QAM)	X	5.57	67.76	16.92	0.00	150.0	± 9.6 %
		Y	5.51	67.51	16.65		150.0	
		Z	5.53	67.60	16.73		150.0	
10224-CAB	IEEE 802.11n (HT Mixed, 150 Mbps, 64-QAM)	X	5.29	67.62	16.75	0.00	150.0	± 9.6 %
		Y	5.23	67.38	16.48		150.0	
		Z	5.25	67.47	16.57		150.0	
10225-CAB	UMTS-FDD (HSPA+)	X	2.96	66.72	15.94	0.00	150.0	± 9.6 %
		Y	2.88	66.18	15.44		150.0	
		Z	2.91	66.38	15.61		150.0	
10226-CAA	LTE-TDD (SC-FDMA, 1 RB, 1.4 MHz, 16-QAM)	X	100.00	132.19	38.58	6.02	65.0	± 9.6 %
		Y	100.00	130.20	37.67		65.0	
		Z	100.00	131.44	38.27		65.0	
10227-CAA	LTE-TDD (SC-FDMA, 1 RB, 1.4 MHz, 64-QAM)	X	100.00	129.74	37.30	6.02	65.0	± 9.6 %
		Y	100.00	127.95	36.49		65.0	
		Z	100.00	129.11	37.05		65.0	
10228-CAA	LTE-TDD (SC-FDMA, 1 RB, 1.4 MHz, QPSK)	X	100.00	141.90	43.60	6.02	65.0	± 9.6 %
		Y	64.28	130.08	40.04		65.0	
		Z	94.90	139.78	42.86		65.0	
10229-CAB	LTE-TDD (SC-FDMA, 1 RB, 3 MHz, 16-QAM)	X	100.00	131.97	38.44	6.02	65.0	± 9.6 %
		Y	100.00	129.97	37.54		65.0	
		Z	100.00	131.22	38.14		65.0	
10230-CAB	LTE-TDD (SC-FDMA, 1 RB, 3 MHz, 64-QAM)	X	100.00	129.60	37.20	6.02	65.0	± 9.6 %
		Y	100.00	127.79	36.39		65.0	
		Z	100.00	128.96	36.95		65.0	
10231-CAB	LTE-TDD (SC-FDMA, 1 RB, 3 MHz, QPSK)	X	100.00	141.75	43.50	6.02	65.0	± 9.6 %
		Y	57.85	127.76	39.37		65.0	
		Z	84.57	137.19	42.14		65.0	
10232-CAC	LTE-TDD (SC-FDMA, 1 RB, 5 MHz, 16-QAM)	X	100.00	131.99	38.45	6.02	65.0	± 9.6 %
		Y	100.00	129.98	37.54		65.0	
		Z	100.00	131.24	38.14		65.0	
10233-CAC	LTE-TDD (SC-FDMA, 1 RB, 5 MHz, 64-QAM)	X	100.00	129.61	37.21	6.02	65.0	± 9.6 %
		Y	100.00	127.81	36.39		65.0	
		Z	100.00	128.97	36.95		65.0	
10234-CAC	LTE-TDD (SC-FDMA, 1 RB, 5 MHz, QPSK)	X	100.00	141.44	43.31	6.02	65.0	± 9.6 %
		Y	52.53	125.50	38.67		65.0	
		Z	75.93	134.62	41.39		65.0	
10235-CAC	LTE-TDD (SC-FDMA, 1 RB, 10 MHz, 16-QAM)	X	100.00	132.00	38.45	6.02	65.0	± 9.6 %
		Y	100.00	130.00	37.54		65.0	
		Z	100.00	131.25	38.15		65.0	
10236-CAC	LTE-TDD (SC-FDMA, 1 RB, 10 MHz, 64-QAM)	X	100.00	129.56	37.18	6.02	65.0	± 9.6 %
		Y	100.00	127.76	36.37		65.0	
		Z	100.00	128.92	36.93		65.0	
10237-CAC	LTE-TDD (SC-FDMA, 1 RB, 10 MHz, QPSK)	X	100.00	141.78	43.50	6.02	65.0	± 9.6 %
		Y	58.86	128.14	39.47		65.0	
		Z	86.67	137.73	42.28		65.0	
10238-CAC	LTE-TDD (SC-FDMA, 1 RB, 15 MHz, 16-QAM)	X	100.00	132.00	38.45	6.02	65.0	± 9.6 %
		Y	100.00	129.99	37.54		65.0	
		Z	100.00	131.25	38.14		65.0	

10239-CAC	LTE-TDD (SC-FDMA, 1 RB, 15 MHz, 64-QAM)	X	100.00	129.64	37.21	6.02	65.0	± 9.6 %
		Y	100.00	127.83	36.40		65.0	
		Z	100.00	129.00	36.96		65.0	
10240-CAC	LTE-TDD (SC-FDMA, 1 RB, 15 MHz, QPSK)	X	100.00	141.80	43.51	6.02	65.0	± 9.6 %
		Y	58.51	128.03	39.44		65.0	
		Z	86.02	137.59	42.24		65.0	
10241-CAA	LTE-TDD (SC-FDMA, 50% RB, 1.4 MHz, 16-QAM)	X	13.65	92.13	30.26	6.98	65.0	± 9.6 %
		Y	12.73	89.47	28.84		65.0	
		Z	12.83	90.19	29.33		65.0	
10242-CAA	LTE-TDD (SC-FDMA, 50% RB, 1.4 MHz, 64-QAM)	X	11.56	88.33	28.75	6.98	65.0	± 9.6 %
		Y	12.17	88.47	28.39		65.0	
		Z	10.55	85.79	27.57		65.0	
10243-CAA	LTE-TDD (SC-FDMA, 50% RB, 1.4 MHz, QPSK)	X	8.75	83.84	28.04	6.98	65.0	± 9.6 %
		Y	9.16	83.97	27.64		65.0	
		Z	8.20	81.83	26.97		65.0	
10244-CAB	LTE-TDD (SC-FDMA, 50% RB, 3 MHz, 16-QAM)	X	11.15	85.22	22.92	3.98	65.0	± 9.6 %
		Y	10.49	83.51	22.06		65.0	
		Z	10.74	84.39	22.53		65.0	
10245-CAB	LTE-TDD (SC-FDMA, 50% RB, 3 MHz, 64-QAM)	X	10.71	84.28	22.53	3.98	65.0	± 9.6 %
		Y	10.12	82.65	21.69		65.0	
		Z	10.34	83.48	22.15		65.0	
10246-CAB	LTE-TDD (SC-FDMA, 50% RB, 3 MHz, QPSK)	X	11.99	89.44	24.35	3.98	65.0	± 9.6 %
		Y	10.01	85.73	22.85		65.0	
		Z	10.59	87.16	23.46		65.0	
10247-CAC	LTE-TDD (SC-FDMA, 50% RB, 5 MHz, 16-QAM)	X	7.78	79.88	21.56	3.98	65.0	± 9.6 %
		Y	7.39	78.44	20.77		65.0	
		Z	7.42	78.92	21.06		65.0	
10248-CAC	LTE-TDD (SC-FDMA, 50% RB, 5 MHz, 64-QAM)	X	7.68	79.17	21.27	3.98	65.0	± 9.6 %
		Y	7.29	77.74	20.47		65.0	
		Z	7.33	78.22	20.77		65.0	
10249-CAC	LTE-TDD (SC-FDMA, 50% RB, 5 MHz, QPSK)	X	13.65	92.24	26.09	3.98	65.0	± 9.6 %
		Y	11.34	88.25	24.50		65.0	
		Z	12.01	89.77	25.14		65.0	
10250-CAC	LTE-TDD (SC-FDMA, 50% RB, 10 MHz, 16-QAM)	X	8.65	81.91	23.79	3.98	65.0	± 9.6 %
		Y	8.26	80.45	22.98		65.0	
		Z	8.27	80.90	23.26		65.0	
10251-CAC	LTE-TDD (SC-FDMA, 50% RB, 10 MHz, 64-QAM)	X	8.08	79.43	22.51	3.98	65.0	± 9.6 %
		Y	7.71	78.00	21.68		65.0	
		Z	7.74	78.46	21.99		65.0	
10252-CAC	LTE-TDD (SC-FDMA, 50% RB, 10 MHz, QPSK)	X	11.90	89.42	25.97	3.98	65.0	± 9.6 %
		Y	10.50	86.42	24.67		65.0	
		Z	10.87	87.52	25.18		65.0	
10253-CAC	LTE-TDD (SC-FDMA, 50% RB, 15 MHz, 16-QAM)	X	7.84	78.03	22.28	3.98	65.0	± 9.6 %
		Y	7.57	76.80	21.51		65.0	
		Z	7.57	77.19	21.79		65.0	
10254-CAC	LTE-TDD (SC-FDMA, 50% RB, 15 MHz, 64-QAM)	X	8.21	78.77	22.87	3.98	65.0	± 9.6 %
		Y	7.97	77.64	22.16		65.0	
		Z	7.95	77.97	22.41		65.0	

10255-CAC	LTE-TDD (SC-FDMA, 50% RB, 15 MHz, QPSK)	X	9.44	83.41	24.04	3.98	65.0	± 9.6 %
		Y	8.86	81.64	23.14		65.0	
		Z	8.96	82.26	23.48		65.0	
10256-CAA	LTE-TDD (SC-FDMA, 100% RB, 1.4 MHz, 16-QAM)	X	9.33	81.69	20.68	3.98	65.0	± 9.6 %
		Y	8.73	79.97	19.81		65.0	
		Z	9.01	80.96	20.33		65.0	
10257-CAA	LTE-TDD (SC-FDMA, 100% RB, 1.4 MHz, 64-QAM)	X	8.80	80.36	20.09	3.98	65.0	± 9.6 %
		Y	8.27	78.77	19.26		65.0	
		Z	8.51	79.68	19.75		65.0	
10258-CAA	LTE-TDD (SC-FDMA, 100% RB, 1.4 MHz, QPSK)	X	9.10	84.22	21.80	3.98	65.0	± 9.6 %
		Y	7.87	81.28	20.53		65.0	
		Z	8.20	82.41	21.04		65.0	
10259-CAB	LTE-TDD (SC-FDMA, 100% RB, 3 MHz, 16-QAM)	X	8.13	80.62	22.35	3.98	65.0	± 9.6 %
		Y	7.73	79.15	21.54		65.0	
		Z	7.76	79.63	21.84		65.0	
10260-CAB	LTE-TDD (SC-FDMA, 100% RB, 3 MHz, 64-QAM)	X	8.07	80.16	22.18	3.98	65.0	± 9.6 %
		Y	7.70	78.77	21.40		65.0	
		Z	7.73	79.22	21.69		65.0	
10261-CAB	LTE-TDD (SC-FDMA, 100% RB, 3 MHz, QPSK)	X	11.98	89.88	25.68	3.98	65.0	± 9.6 %
		Y	10.32	86.47	24.25		65.0	
		Z	10.77	87.74	24.81		65.0	
10262-CAC	LTE-TDD (SC-FDMA, 100% RB, 5 MHz, 16-QAM)	X	8.64	81.87	23.76	3.98	65.0	± 9.6 %
		Y	8.25	80.40	22.94		65.0	
		Z	8.26	80.85	23.23		65.0	
10263-CAC	LTE-TDD (SC-FDMA, 100% RB, 5 MHz, 64-QAM)	X	8.06	79.41	22.51	3.98	65.0	± 9.6 %
		Y	7.70	77.98	21.68		65.0	
		Z	7.73	78.44	21.98		65.0	
10264-CAC	LTE-TDD (SC-FDMA, 100% RB, 5 MHz, QPSK)	X	11.79	89.22	25.88	3.98	65.0	± 9.6 %
		Y	10.40	86.22	24.58		65.0	
		Z	10.77	87.33	25.09		65.0	
10265-CAC	LTE-TDD (SC-FDMA, 100% RB, 10 MHz, 16-QAM)	X	8.12	78.81	22.58	3.98	65.0	± 9.6 %
		Y	7.79	77.46	21.77		65.0	
		Z	7.81	77.90	22.07		65.0	
10266-CAC	LTE-TDD (SC-FDMA, 100% RB, 10 MHz, 64-QAM)	X	8.47	79.50	23.19	3.98	65.0	± 9.6 %
		Y	8.19	78.30	22.46		65.0	
		Z	8.19	78.66	22.72		65.0	
10267-CAC	LTE-TDD (SC-FDMA, 100% RB, 10 MHz, QPSK)	X	9.89	83.95	23.99	3.98	65.0	± 9.6 %
		Y	9.26	82.18	23.11		65.0	
		Z	9.39	82.83	23.45		65.0	
10268-CAC	LTE-TDD (SC-FDMA, 100% RB, 15 MHz, 16-QAM)	X	8.44	77.80	22.53	3.98	65.0	± 9.6 %
		Y	8.24	76.84	21.89		65.0	
		Z	8.22	77.13	22.11		65.0	
10269-CAC	LTE-TDD (SC-FDMA, 100% RB, 15 MHz, 64-QAM)	X	8.33	77.26	22.37	3.98	65.0	± 9.6 %
		Y	8.15	76.36	21.76		65.0	
		Z	8.12	76.62	21.97		65.0	
10270-CAC	LTE-TDD (SC-FDMA, 100% RB, 15 MHz, QPSK)	X	8.75	79.75	22.52	3.98	65.0	± 9.6 %
		Y	8.49	78.72	21.92		65.0	
		Z	8.50	79.07	22.14		65.0	



10274-CAB	UMTS-FDD (HSUPA, Subtest 5, 3GPP Rel8.10)	X	2.73	67.18	15.92	0.00	150.0	± 9.6 %
		Y	2.64	66.46	15.31		150.0	
		Z	2.68	66.73	15.52		150.0	
10275-CAB	UMTS-FDD (HSUPA, Subtest 5, 3GPP Rel8.4)	X	1.87	70.21	17.08	0.00	150.0	± 9.6 %
		Y	1.66	67.87	15.58		150.0	
		Z	1.73	68.66	16.09		150.0	
10277-CAA	PHS (QPSK)	X	3.84	66.56	11.27	9.03	50.0	± 9.6 %
		Y	4.12	66.98	11.68		50.0	
		Z	3.85	66.55	11.29		50.0	
10278-CAA	PHS (QPSK, BW 884MHz, Rolloff 0.5)	X	11.65	86.02	22.30	9.03	50.0	± 9.6 %
		Y	10.21	83.31	21.39		50.0	
		Z	10.96	84.97	21.93		50.0	
10279-CAA	PHS (QPSK, BW 884MHz, Rolloff 0.38)	X	11.92	86.31	22.44	9.03	50.0	± 9.6 %
		Y	10.38	83.50	21.49		50.0	
		Z	11.18	85.20	22.04		50.0	
10290-AAB	CDMA2000, RC1, SO55, Full Rate	X	2.05	73.37	16.75	0.00	150.0	± 9.6 %
		Y	1.54	68.94	14.39		150.0	
		Z	1.68	70.29	15.17		150.0	
10291-AAB	CDMA2000, RC3, SO55, Full Rate	X	1.19	70.69	15.63	0.00	150.0	± 9.6 %
		Y	0.89	66.06	12.92		150.0	
		Z	0.97	67.37	13.76		150.0	
10292-AAB	CDMA2000, RC3, SO32, Full Rate	X	1.82	77.98	19.13	0.00	150.0	± 9.6 %
		Y	1.09	69.78	15.12		150.0	
		Z	1.26	72.00	16.33		150.0	
10293-AAB	CDMA2000, RC3, SO3, Full Rate	X	3.13	86.75	22.80	0.00	150.0	± 9.6 %
		Y	1.53	74.84	17.78		150.0	
		Z	1.85	77.92	19.23		150.0	
10295-AAB	CDMA2000, RC1, SO3, 1/8th Rate 25 fr.	X	16.24	95.47	28.50	9.03	50.0	± 9.6 %
		Y	13.39	90.69	26.64		50.0	
		Z	14.20	92.62	27.44		50.0	
10297-AAB	LTE-FDD (SC-FDMA, 50% RB, 20 MHz, QPSK)	X	3.05	71.18	17.54	0.00	150.0	± 9.6 %
		Y	2.82	69.68	16.59		150.0	
		Z	2.90	70.21	16.92		150.0	
10298-AAC	LTE-FDD (SC-FDMA, 50% RB, 3 MHz, QPSK)	X	1.96	70.66	16.14	0.00	150.0	± 9.6 %
		Y	1.66	67.94	14.50		150.0	
		Z	1.76	68.83	15.06		150.0	
10299-AAC	LTE-FDD (SC-FDMA, 50% RB, 3 MHz, 16-QAM)	X	4.77	78.24	18.75	0.00	150.0	± 9.6 %
		Y	3.92	74.76	16.99		150.0	
		Z	4.32	76.42	17.88		150.0	
10300-AAC	LTE-FDD (SC-FDMA, 50% RB, 3 MHz, 64-QAM)	X	3.00	70.52	14.82	0.00	150.0	± 9.6 %
		Y	2.63	68.29	13.44		150.0	
		Z	2.81	69.37	14.14		150.0	
10301-AAA	IEEE 802.16e WiMAX (29:18, 5ms, 10MHz, QPSK, PUSC)	X	5.51	68.11	19.09	4.17	80.0	± 9.6 %
		Y	5.33	67.16	18.33		80.0	
		Z	5.40	67.58	18.66		80.0	
10302-AAA	IEEE 802.16e WiMAX (29:18, 5ms, 10MHz, QPSK, PUSC, 3 CTRL symbols)	X	5.91	68.43	19.68	4.96	80.0	± 9.6 %
		Y	5.80	67.70	19.02		80.0	
		Z	5.81	67.92	19.25		80.0	

10303-AAA	IEEE 802.16e WiMAX (31:15, 5ms, 10MHz, 64QAM, PUSC)	X	5.70	68.33	19.67	4.96	80.0	± 9.6 %
		Y	5.59	67.57	18.98		80.0	
		Z	5.60	67.78	19.21		80.0	
10304-AAA	IEEE 802.16e WiMAX (29:18, 5ms, 10MHz, 64QAM, PUSC)	X	5.41	67.77	18.89	4.17	80.0	± 9.6 %
		Y	5.31	67.11	18.28		80.0	
		Z	5.33	67.30	18.48		80.0	
10305-AAA	IEEE 802.16e WiMAX (31:15, 10ms, 10MHz, 64QAM, PUSC, 15 symbols)	X	6.16	75.00	23.87	6.02	50.0	± 9.6 %
		Y	6.03	73.79	22.78		50.0	
		Z	5.90	73.64	22.94		50.0	
10306-AAA	IEEE 802.16e WiMAX (29:18, 10ms, 10MHz, 64QAM, PUSC, 18 symbols)	X	5.76	70.24	21.37	6.02	50.0	± 9.6 %
		Y	5.59	69.03	20.35		50.0	
		Z	5.60	69.33	20.68		50.0	
10307-AAA	IEEE 802.16e WiMAX (29:18, 10ms, 10MHz, QPSK, PUSC, 18 symbols)	X	5.75	70.76	21.47	6.02	50.0	± 9.6 %
		Y	5.78	71.13	21.51		50.0	
		Z	5.57	69.74	20.73		50.0	
10308-AAA	IEEE 802.16e WiMAX (29:18, 10ms, 10MHz, 16QAM, PUSC)	X	5.77	71.12	21.68	6.02	50.0	± 9.6 %
		Y	5.80	71.54	21.74		50.0	
		Z	5.57	70.05	20.90		50.0	
10309-AAA	IEEE 802.16e WiMAX (29:18, 10ms, 10MHz, 16QAM, AMC 2x3, 18 symbols)	X	5.87	70.63	21.59	6.02	50.0	± 9.6 %
		Y	5.68	69.33	20.52		50.0	
		Z	5.69	69.66	20.87		50.0	
10310-AAA	IEEE 802.16e WiMAX (29:18, 10ms, 10MHz, QPSK, AMC 2x3, 18 symbols)	X	5.74	70.42	21.38	6.02	50.0	± 9.6 %
		Y	5.56	69.17	20.34		50.0	
		Z	5.57	69.47	20.67		50.0	
10311-AAB	LTE-FDD (SC-FDMA, 100% RB, 15 MHz, QPSK)	X	3.41	70.28	17.06	0.00	150.0	± 9.6 %
		Y	3.18	68.96	16.24		150.0	
		Z	3.26	69.44	16.53		150.0	
10313-AAA	iDEN 1:3	X	11.93	87.85	22.00	6.99	70.0	± 9.6 %
		Y	8.95	83.03	20.34		70.0	
		Z	9.92	85.08	21.06		70.0	
10314-AAA	iDEN 1:6	X	19.66	101.09	29.03	10.00	30.0	± 9.6 %
		Y	13.64	93.68	26.63		30.0	
		Z	14.94	96.21	27.54		30.0	
10315-AAB	IEEE 802.11b WiFi 2.4 GHz (DSSS, 1 Mbps, 96pc duty cycle)	X	1.20	65.36	16.48	0.17	150.0	± 9.6 %
		Y	1.15	64.26	15.42		150.0	
		Z	1.17	64.62	15.77		150.0	
10316-AAB	IEEE 802.11g WiFi 2.4 GHz (ERP-OFDM, 6 Mbps, 96pc duty cycle)	X	4.76	67.14	16.74	0.17	150.0	± 9.6 %
		Y	4.71	66.90	16.45		150.0	
		Z	4.73	66.99	16.55		150.0	
10317-AAB	IEEE 802.11a WiFi 5 GHz (OFDM, 6 Mbps, 96pc duty cycle)	X	4.76	67.14	16.74	0.17	150.0	± 9.6 %
		Y	4.71	66.90	16.45		150.0	
		Z	4.73	66.99	16.55		150.0	
10400-AAC	IEEE 802.11ac WiFi (20MHz, 64-QAM, 99pc duty cycle)	X	4.87	67.43	16.68	0.00	150.0	± 9.6 %
		Y	4.81	67.14	16.37		150.0	
		Z	4.83	67.26	16.47		150.0	
10401-AAC	IEEE 802.11ac WiFi (40MHz, 64-QAM, 99pc duty cycle)	X	5.57	67.64	16.85	0.00	150.0	± 9.6 %
		Y	5.51	67.40	16.57		150.0	
		Z	5.53	67.48	16.66		150.0	

10402-AAC	IEEE 802.11ac WiFi (80MHz, 64-QAM, 99pc duty cycle)	X	5.83	67.94	16.82	0.00	150.0	± 9.6 %
		Y	5.77	67.71	16.58		150.0	
		Z	5.79	67.80	16.65		150.0	
10403-AAB	CDMA2000 (1xEV-DO, Rev. 0)	X	2.05	73.37	16.75	0.00	115.0	± 9.6 %
		Y	1.54	68.94	14.39		115.0	
		Z	1.68	70.29	15.17		115.0	
10404-AAB	CDMA2000 (1xEV-DO, Rev. A)	X	2.05	73.37	16.75	0.00	115.0	± 9.6 %
		Y	1.54	68.94	14.39		115.0	
		Z	1.68	70.29	15.17		115.0	
10406-AAB	CDMA2000, RC3, SO32, SCH0, Full Rate	X	100.00	124.58	31.94	0.00	100.0	± 9.6 %
		Y	100.00	121.04	30.37		100.0	
		Z	100.00	123.01	31.32		100.0	
10410-AAB	LTE-TDD (SC-FDMA, 1 RB, 10 MHz, QPSK, UL Subframe=2,3,4,7,8,9)	X	100.00	125.25	32.53	3.23	80.0	± 9.6 %
		Y	100.00	122.76	31.43		80.0	
		Z	100.00	124.49	32.22		80.0	
10415-AAA	IEEE 802.11b WiFi 2.4 GHz (DSSS, 1 Mbps, 99pc duty cycle)	X	1.07	64.01	15.66	0.00	150.0	± 9.6 %
		Y	1.03	63.00	14.62		150.0	
		Z	1.05	63.37	14.98		150.0	
10416-AAA	IEEE 802.11g WiFi 2.4 GHz (ERP-OFDM, 6 Mbps, 99pc duty cycle)	X	4.68	67.03	16.59	0.00	150.0	± 9.6 %
		Y	4.63	66.78	16.30		150.0	
		Z	4.65	66.88	16.40		150.0	
10417-AAA	IEEE 802.11a/n WiFi 5 GHz (OFDM, 6 Mbps, 99pc duty cycle)	X	4.68	67.03	16.59	0.00	150.0	± 9.6 %
		Y	4.63	66.78	16.30		150.0	
		Z	4.65	66.88	16.40		150.0	
10418-AAA	IEEE 802.11g WiFi 2.4 GHz (DSSS-OFDM, 6 Mbps, 99pc duty cycle, Long preamble)	X	4.67	67.18	16.60	0.00	150.0	± 9.6 %
		Y	4.61	66.92	16.31		150.0	
		Z	4.64	67.02	16.41		150.0	
10419-AAA	IEEE 802.11g WiFi 2.4 GHz (DSSS-OFDM, 6 Mbps, 99pc duty cycle, Short preamble)	X	4.69	67.13	16.61	0.00	150.0	± 9.6 %
		Y	4.64	66.87	16.32		150.0	
		Z	4.66	66.98	16.42		150.0	
10422-AAA	IEEE 802.11n (HT Greenfield, 7.2 Mbps, BPSK)	X	4.82	67.13	16.62	0.00	150.0	± 9.6 %
		Y	4.76	66.89	16.34		150.0	
		Z	4.78	66.98	16.43		150.0	
10423-AAA	IEEE 802.11n (HT Greenfield, 43.3 Mbps, 16-QAM)	X	5.00	67.48	16.75	0.00	150.0	± 9.6 %
		Y	4.94	67.23	16.47		150.0	
		Z	4.96	67.33	16.56		150.0	
10424-AAA	IEEE 802.11n (HT Greenfield, 72.2 Mbps, 64-QAM)	X	4.92	67.43	16.72	0.00	150.0	± 9.6 %
		Y	4.86	67.17	16.43		150.0	
		Z	4.88	67.27	16.53		150.0	
10425-AAA	IEEE 802.11n (HT Greenfield, 15 Mbps, BPSK)	X	5.54	67.85	16.94	0.00	150.0	± 9.6 %
		Y	5.48	67.60	16.67		150.0	
		Z	5.50	67.69	16.75		150.0	
10426-AAA	IEEE 802.11n (HT Greenfield, 90 Mbps, 16-QAM)	X	5.55	67.86	16.94	0.00	150.0	± 9.6 %
		Y	5.48	67.61	16.67		150.0	
		Z	5.50	67.70	16.75		150.0	

10427-AAA	IEEE 802.11n (HT Greenfield, 150 Mbps, 64-QAM)	X	5.55	67.81	16.91	0.00	150.0	± 9.6 %
		Y	5.49	67.57	16.65		150.0	
		Z	5.51	67.66	16.73		150.0	
10430-AAA	LTE-FDD (OFDMA, 5 MHz, E-TM 3.1)	X	4.30	70.44	18.21	0.00	150.0	± 9.6 %
		Y	4.27	70.38	18.04		150.0	
		Z	4.27	70.33	18.05		150.0	
10431-AAA	LTE-FDD (OFDMA, 10 MHz, E-TM 3.1)	X	4.40	67.65	16.65	0.00	150.0	± 9.6 %
		Y	4.32	67.31	16.31		150.0	
		Z	4.35	67.44	16.43		150.0	
10432-AAA	LTE-FDD (OFDMA, 15 MHz, E-TM 3.1)	X	4.69	67.49	16.69	0.00	150.0	± 9.6 %
		Y	4.62	67.20	16.38		150.0	
		Z	4.65	67.32	16.48		150.0	
10433-AAA	LTE-FDD (OFDMA, 20 MHz, E-TM 3.1)	X	4.93	67.46	16.74	0.00	150.0	± 9.6 %
		Y	4.87	67.20	16.45		150.0	
		Z	4.89	67.31	16.55		150.0	
10434-AAA	W-CDMA (BS Test Model 1, 64 DPCH)	X	4.38	71.21	18.18	0.00	150.0	± 9.6 %
		Y	4.35	71.12	17.99		150.0	
		Z	4.34	71.07	18.01		150.0	
10435-AAB	LTE-TDD (SC-FDMA, 1 RB, 20 MHz, QPSK, UL Subframe=2,3,4,7,8,9)	X	100.00	125.05	32.43	3.23	80.0	± 9.6 %
		Y	100.00	122.57	31.34		80.0	
		Z	100.00	124.29	32.13		80.0	
10447-AAA	LTE-FDD (OFDMA, 5 MHz, E-TM 3.1, Clipping 44%)	X	3.71	67.79	16.12	0.00	150.0	± 9.6 %
		Y	3.61	67.29	15.67		150.0	
		Z	3.65	67.48	15.83		150.0	
10448-AAA	LTE-FDD (OFDMA, 10 MHz, E-TM 3.1, Clipping 44%)	X	4.22	67.42	16.51	0.00	150.0	± 9.6 %
		Y	4.15	67.08	16.17		150.0	
		Z	4.18	67.21	16.28		150.0	
10449-AAA	LTE-FDD (OFDMA, 15 MHz, E-TM 3.1, Clipping 44%)	X	4.49	67.31	16.58	0.00	150.0	± 9.6 %
		Y	4.42	67.02	16.27		150.0	
		Z	4.45	67.13	16.38		150.0	
10450-AAA	LTE-FDD (OFDMA, 20 MHz, E-TM 3.1, Clipping 44%)	X	4.67	67.22	16.59	0.00	150.0	± 9.6 %
		Y	4.62	66.95	16.30		150.0	
		Z	4.64	67.06	16.40		150.0	
10451-AAA	W-CDMA (BS Test Model 1, 64 DPCH, Clipping 44%)	X	3.63	68.08	15.83	0.00	150.0	± 9.6 %
		Y	3.51	67.49	15.33		150.0	
		Z	3.56	67.71	15.51		150.0	
10456-AAA	IEEE 802.11ac WiFi (160MHz, 64-QAM, 99pc duty cycle)	X	6.40	68.36	17.05	0.00	150.0	± 9.6 %
		Y	6.34	68.15	16.82		150.0	
		Z	6.36	68.22	16.89		150.0	
10457-AAA	UMTS-FDD (DC-HSDPA)	X	3.89	65.64	16.31	0.00	150.0	± 9.6 %
		Y	3.85	65.40	16.01		150.0	
		Z	3.87	65.50	16.11		150.0	
10458-AAA	CDMA2000 (1xEV-DO, Rev. B, 2 carriers)	X	3.46	67.50	15.35	0.00	150.0	± 9.6 %
		Y	3.34	66.87	14.80		150.0	
		Z	3.39	67.11	15.01		150.0	
10459-AAA	CDMA2000 (1xEV-DO, Rev. B, 3 carriers)	X	4.52	65.47	16.05	0.00	150.0	± 9.6 %
		Y	4.52	65.47	15.86		150.0	
		Z	4.43	65.14	15.75		150.0	

10460-AAA	UMTS-FDD (WCDMA, AMR)	X	1.17	72.68	18.90	0.00	150.0	± 9.6 %
		Y	0.92	67.87	15.98		150.0	
		Z	0.99	69.33	16.91		150.0	
10461-AAA	LTE-TDD (SC-FDMA, 1 RB, 1.4 MHz, QPSK, UL Subframe=2,3,4,7,8,9)	X	100.00	132.17	35.74	3.29	80.0	± 9.6 %
		Y	100.00	128.42	34.08		80.0	
		Z	100.00	130.59	35.07		80.0	
10462-AAA	LTE-TDD (SC-FDMA, 1 RB, 1.4 MHz, 16-QAM, UL Subframe=2,3,4,7,8,9)	X	100.00	113.31	26.72	3.23	80.0	± 9.6 %
		Y	100.00	110.59	25.58		80.0	
		Z	100.00	112.57	26.48		80.0	
10463-AAA	LTE-TDD (SC-FDMA, 1 RB, 1.4 MHz, 64-QAM, UL Subframe=2,3,4,7,8,9)	X	100.00	109.35	24.86	3.23	80.0	± 9.6 %
		Y	100.00	106.97	23.86		80.0	
		Z	100.00	108.85	24.71		80.0	
10464-AAA	LTE-TDD (SC-FDMA, 1 RB, 3 MHz, QPSK, UL Subframe=2,3,4,7,8,9)	X	100.00	130.18	34.63	3.23	80.0	± 9.6 %
		Y	100.00	126.36	32.95		80.0	
		Z	100.00	128.62	33.98		80.0	
10465-AAA	LTE-TDD (SC-FDMA, 1 RB, 3 MHz, 16-QAM, UL Subframe=2,3,4,7,8,9)	X	100.00	112.71	26.43	3.23	80.0	± 9.6 %
		Y	100.00	110.00	25.29		80.0	
		Z	100.00	111.98	26.19		80.0	
10466-AAA	LTE-TDD (SC-FDMA, 1 RB, 3 MHz, 64-QAM, UL Subframe=2,3,4,7,8,9)	X	100.00	108.78	24.59	3.23	80.0	± 9.6 %
		Y	100.00	106.43	23.61		80.0	
		Z	100.00	108.29	24.45		80.0	
10467-AAB	LTE-TDD (SC-FDMA, 1 RB, 5 MHz, QPSK, UL Subframe=2,3,4,7,8,9)	X	100.00	130.44	34.75	3.23	80.0	± 9.6 %
		Y	100.00	126.60	33.07		80.0	
		Z	100.00	128.86	34.09		80.0	
10468-AAB	LTE-TDD (SC-FDMA, 1 RB, 5 MHz, 16-QAM, UL Subframe=2,3,4,7,8,9)	X	100.00	112.91	26.52	3.23	80.0	± 9.6 %
		Y	100.00	110.19	25.38		80.0	
		Z	100.00	112.17	26.28		80.0	
10469-AAB	LTE-TDD (SC-FDMA, 1 RB, 5 MHz, 64-QAM, UL Subframe=2,3,4,7,8,9)	X	100.00	108.81	24.59	3.23	80.0	± 9.6 %
		Y	100.00	106.45	23.61		80.0	
		Z	100.00	108.32	24.46		80.0	
10470-AAB	LTE-TDD (SC-FDMA, 1 RB, 10 MHz, QPSK, UL Subframe=2,3,4,7,8,9)	X	100.00	130.49	34.76	3.23	80.0	± 9.6 %
		Y	100.00	126.64	33.07		80.0	
		Z	100.00	128.91	34.11		80.0	
10471-AAB	LTE-TDD (SC-FDMA, 1 RB, 10 MHz, 16-QAM, UL Subframe=2,3,4,7,8,9)	X	100.00	112.85	26.49	3.23	80.0	± 9.6 %
		Y	100.00	110.13	25.35		80.0	
		Z	100.00	112.12	26.25		80.0	
10472-AAB	LTE-TDD (SC-FDMA, 1 RB, 10 MHz, 64-QAM, UL Subframe=2,3,4,7,8,9)	X	100.00	108.74	24.56	3.23	80.0	± 9.6 %
		Y	100.00	106.39	23.57		80.0	
		Z	100.00	108.26	24.42		80.0	
10473-AAB	LTE-TDD (SC-FDMA, 1 RB, 15 MHz, QPSK, UL Subframe=2,3,4,7,8,9)	X	100.00	130.46	34.75	3.23	80.0	± 9.6 %
		Y	100.00	126.61	33.06		80.0	
		Z	100.00	128.88	34.09		80.0	
10474-AAB	LTE-TDD (SC-FDMA, 1 RB, 15 MHz, 16-QAM, UL Subframe=2,3,4,7,8,9)	X	100.00	112.87	26.49	3.23	80.0	± 9.6 %
		Y	100.00	110.14	25.35		80.0	
		Z	100.00	112.13	26.25		80.0	
10475-AAB	LTE-TDD (SC-FDMA, 1 RB, 15 MHz, 64-QAM, UL Subframe=2,3,4,7,8,9)	X	100.00	108.76	24.57	3.23	80.0	± 9.6 %
		Y	100.00	106.40	23.58		80.0	
		Z	100.00	108.28	24.43		80.0	

10477-AAB	LTE-TDD (SC-FDMA, 1 RB, 20 MHz, 16-QAM, UL Subframe=2,3,4,7,8,9)	X	100.00	112.67	26.40	3.23	80.0	± 9.6 %
		Y	100.00	109.96	25.26		80.0	
		Z	100.00	111.94	26.16		80.0	
10478-AAB	LTE-TDD (SC-FDMA, 1 RB, 20 MHz, 64-QAM, UL Subframe=2,3,4,7,8,9)	X	100.00	108.69	24.54	3.23	80.0	± 9.6 %
		Y	100.00	106.34	23.55		80.0	
		Z	100.00	108.21	24.40		80.0	
10479-AAA	LTE-TDD (SC-FDMA, 50% RB, 1.4 MHz, QPSK, UL Subframe=2,3,4,7,8,9)	X	40.01	113.99	32.23	3.23	80.0	± 9.6 %
		Y	25.66	104.98	29.34		80.0	
		Z	28.59	107.69	30.37		80.0	
10480-AAA	LTE-TDD (SC-FDMA, 50% RB, 1.4 MHz, 16-QAM, UL Subframe=2,3,4,7,8,9)	X	65.50	112.78	29.57	3.23	80.0	± 9.6 %
		Y	38.67	103.69	26.87		80.0	
		Z	45.46	106.90	27.97		80.0	
10481-AAA	LTE-TDD (SC-FDMA, 50% RB, 1.4 MHz, 64-QAM, UL Subframe=2,3,4,7,8,9)	X	43.66	105.54	27.32	3.23	80.0	± 9.6 %
		Y	27.51	97.77	24.89		80.0	
		Z	32.53	100.89	25.98		80.0	
10482-AAA	LTE-TDD (SC-FDMA, 50% RB, 3 MHz, QPSK, UL Subframe=2,3,4,7,8,9)	X	7.07	83.64	21.75	2.23	80.0	± 9.6 %
		Y	5.28	78.63	19.68		80.0	
		Z	5.64	80.01	20.31		80.0	
10483-AAA	LTE-TDD (SC-FDMA, 50% RB, 3 MHz, 16-QAM, UL Subframe=2,3,4,7,8,9)	X	12.44	88.49	23.12	2.23	80.0	± 9.6 %
		Y	10.70	85.40	21.78		80.0	
		Z	11.46	86.94	22.49		80.0	
10484-AAA	LTE-TDD (SC-FDMA, 50% RB, 3 MHz, 64-QAM, UL Subframe=2,3,4,7,8,9)	X	10.60	85.91	22.30	2.23	80.0	± 9.6 %
		Y	9.30	83.19	21.06		80.0	
		Z	9.88	84.56	21.72		80.0	
10485-AAB	LTE-TDD (SC-FDMA, 50% RB, 5 MHz, QPSK, UL Subframe=2,3,4,7,8,9)	X	6.73	83.37	22.54	2.23	80.0	± 9.6 %
		Y	5.38	79.13	20.71		80.0	
		Z	5.62	80.23	21.24		80.0	
10486-AAB	LTE-TDD (SC-FDMA, 50% RB, 5 MHz, 16-QAM, UL Subframe=2,3,4,7,8,9)	X	4.83	74.76	18.90	2.23	80.0	± 9.6 %
		Y	4.43	72.99	17.93		80.0	
		Z	4.49	73.45	18.22		80.0	
10487-AAB	LTE-TDD (SC-FDMA, 50% RB, 5 MHz, 64-QAM, UL Subframe=2,3,4,7,8,9)	X	4.73	74.06	18.61	2.23	80.0	± 9.6 %
		Y	4.38	72.45	17.70		80.0	
		Z	4.42	72.86	17.97		80.0	
10488-AAB	LTE-TDD (SC-FDMA, 50% RB, 10 MHz, QPSK, UL Subframe=2,3,4,7,8,9)	X	5.94	79.74	21.83	2.23	80.0	± 9.6 %
		Y	5.18	76.93	20.48		80.0	
		Z	5.31	77.65	20.88		80.0	
10489-AAB	LTE-TDD (SC-FDMA, 50% RB, 10 MHz, 16-QAM, UL Subframe=2,3,4,7,8,9)	X	4.65	72.93	19.25	2.23	80.0	± 9.6 %
		Y	4.44	71.79	18.53		80.0	
		Z	4.45	72.03	18.73		80.0	
10490-AAB	LTE-TDD (SC-FDMA, 50% RB, 10 MHz, 64-QAM, UL Subframe=2,3,4,7,8,9)	X	4.70	72.53	19.10	2.23	80.0	± 9.6 %
		Y	4.51	71.49	18.42		80.0	
		Z	4.51	71.71	18.61		80.0	
10491-AAB	LTE-TDD (SC-FDMA, 50% RB, 15 MHz, QPSK, UL Subframe=2,3,4,7,8,9)	X	5.47	76.11	20.55	2.23	80.0	± 9.6 %
		Y	5.05	74.35	19.60		80.0	
		Z	5.11	74.80	19.88		80.0	
10492-AAB	LTE-TDD (SC-FDMA, 50% RB, 15 MHz, 16-QAM, UL Subframe=2,3,4,7,8,9)	X	4.82	71.43	18.89	2.23	80.0	± 9.6 %
		Y	4.68	70.61	18.31		80.0	
		Z	4.67	70.78	18.47		80.0	

10493-AAB	LTE-TDD (SC-FDMA, 50% RB, 15 MHz, 64-QAM, UL Subframe=2,3,4,7,8,9)	X	4.87	71.19	18.80	2.23	80.0	± 9.6 %
		Y	4.73	70.41	18.24		80.0	
		Z	4.72	70.57	18.39		80.0	
10494-AAB	LTE-TDD (SC-FDMA, 50% RB, 20 MHz, QPSK, UL Subframe=2,3,4,7,8,9)	X	6.24	78.41	21.24	2.23	80.0	± 9.6 %
		Y	5.62	76.22	20.16		80.0	
		Z	5.73	76.81	20.48		80.0	
10495-AAB	LTE-TDD (SC-FDMA, 50% RB, 20 MHz, 16-QAM, UL Subframe=2,3,4,7,8,9)	X	4.91	72.01	19.14	2.23	80.0	± 9.6 %
		Y	4.75	71.11	18.53		80.0	
		Z	4.74	71.30	18.69		80.0	
10496-AAB	LTE-TDD (SC-FDMA, 50% RB, 20 MHz, 64-QAM, UL Subframe=2,3,4,7,8,9)	X	4.93	71.51	18.96	2.23	80.0	± 9.6 %
		Y	4.79	70.71	18.40		80.0	
		Z	4.78	70.87	18.55		80.0	
10497-AAA	LTE-TDD (SC-FDMA, 100% RB, 1.4 MHz, QPSK, UL Subframe=2,3,4,7,8,9)	X	5.37	79.10	19.27	2.23	80.0	± 9.6 %
		Y	4.01	74.46	17.26		80.0	
		Z	4.32	75.84	17.92		80.0	
10498-AAA	LTE-TDD (SC-FDMA, 100% RB, 1.4 MHz, 16-QAM, UL Subframe=2,3,4,7,8,9)	X	3.20	69.04	14.31	2.23	80.0	± 9.6 %
		Y	2.73	66.72	13.06		80.0	
		Z	2.85	67.49	13.50		80.0	
10499-AAA	LTE-TDD (SC-FDMA, 100% RB, 1.4 MHz, 64-QAM, UL Subframe=2,3,4,7,8,9)	X	3.04	68.09	13.76	2.23	80.0	± 9.6 %
		Y	2.62	65.95	12.57		80.0	
		Z	2.73	66.66	12.99		80.0	
10500-AAA	LTE-TDD (SC-FDMA, 100% RB, 3 MHz, QPSK, UL Subframe=2,3,4,7,8,9)	X	6.09	81.07	21.99	2.23	80.0	± 9.6 %
		Y	5.13	77.67	20.43		80.0	
		Z	5.29	78.55	20.89		80.0	
10501-AAA	LTE-TDD (SC-FDMA, 100% RB, 3 MHz, 16-QAM, UL Subframe=2,3,4,7,8,9)	X	4.73	73.89	18.97	2.23	80.0	± 9.6 %
		Y	4.43	72.44	18.13		80.0	
		Z	4.46	72.79	18.37		80.0	
10502-AAA	LTE-TDD (SC-FDMA, 100% RB, 3 MHz, 64-QAM, UL Subframe=2,3,4,7,8,9)	X	4.76	73.56	18.78	2.23	80.0	± 9.6 %
		Y	4.47	72.19	17.97		80.0	
		Z	4.49	72.52	18.21		80.0	
10503-AAB	LTE-TDD (SC-FDMA, 100% RB, 5 MHz, QPSK, UL Subframe=2,3,4,7,8,9)	X	5.85	79.51	21.73	2.23	80.0	± 9.6 %
		Y	5.11	76.71	20.38		80.0	
		Z	5.24	77.44	20.78		80.0	
10504-AAB	LTE-TDD (SC-FDMA, 100% RB, 5 MHz, 16-QAM, UL Subframe=2,3,4,7,8,9)	X	4.63	72.85	19.20	2.23	80.0	± 9.6 %
		Y	4.42	71.70	18.48		80.0	
		Z	4.43	71.95	18.68		80.0	
10505-AAB	LTE-TDD (SC-FDMA, 100% RB, 5 MHz, 64-QAM, UL Subframe=2,3,4,7,8,9)	X	4.68	72.44	19.05	2.23	80.0	± 9.6 %
		Y	4.49	71.39	18.37		80.0	
		Z	4.49	71.62	18.56		80.0	
10506-AAB	LTE-TDD (SC-FDMA, 100% RB, 10 MHz, QPSK, UL Subframe=2,3,4,7,8,9)	X	6.19	78.25	21.17	2.23	80.0	± 9.6 %
		Y	5.58	76.07	20.08		80.0	
		Z	5.68	76.66	20.41		80.0	
10507-AAB	LTE-TDD (SC-FDMA, 100% RB, 10 MHz, 16-QAM, UL Subframe=2,3,4,7,8,9)	X	4.89	71.95	19.11	2.23	80.0	± 9.6 %
		Y	4.73	71.04	18.50		80.0	
		Z	4.73	71.24	18.66		80.0	

10508-AAB	LTE-TDD (SC-FDMA, 100% RB, 10 MHz, 64-QAM, UL Subframe=2,3,4,7,8,9)	X	4.92	71.45	18.93	2.23	80.0	± 9.6 %
		Y	4.78	70.64	18.36		80.0	
		Z	4.77	70.80	18.51		80.0	
10509-AAB	LTE-TDD (SC-FDMA, 100% RB, 15 MHz, QPSK, UL Subframe=2,3,4,7,8,9)	X	5.95	75.24	19.99	2.23	80.0	± 9.6 %
		Y	5.60	73.90	19.24		80.0	
		Z	5.65	74.26	19.47		80.0	
10510-AAB	LTE-TDD (SC-FDMA, 100% RB, 15 MHz, 16-QAM, UL Subframe=2,3,4,7,8,9)	X	5.29	71.15	18.83	2.23	80.0	± 9.6 %
		Y	5.16	70.46	18.33		80.0	
		Z	5.15	70.61	18.47		80.0	
10511-AAB	LTE-TDD (SC-FDMA, 100% RB, 15 MHz, 64-QAM, UL Subframe=2,3,4,7,8,9)	X	5.30	70.75	18.70	2.23	80.0	± 9.6 %
		Y	5.19	70.12	18.23		80.0	
		Z	5.17	70.25	18.36		80.0	
10512-AAB	LTE-TDD (SC-FDMA, 100% RB, 20 MHz, QPSK, UL Subframe=2,3,4,7,8,9)	X	6.65	77.81	20.82	2.23	80.0	± 9.6 %
		Y	6.08	75.94	19.88		80.0	
		Z	6.18	76.48	20.17		80.0	
10513-AAB	LTE-TDD (SC-FDMA, 100% RB, 20 MHz, 16-QAM, UL Subframe=2,3,4,7,8,9)	X	5.24	71.68	19.04	2.23	80.0	± 9.6 %
		Y	5.09	70.89	18.50		80.0	
		Z	5.08	71.06	18.65		80.0	
10514-AAB	LTE-TDD (SC-FDMA, 100% RB, 20 MHz, 64-QAM, UL Subframe=2,3,4,7,8,9)	X	5.18	71.04	18.83	2.23	80.0	± 9.6 %
		Y	5.06	70.34	18.33		80.0	
		Z	5.05	70.49	18.47		80.0	
10515-AAA	IEEE 802.11b WiFi 2.4 GHz (DSSS, 2 Mbps, 99pc duty cycle)	X	1.04	64.30	15.79	0.00	150.0	± 9.6 %
		Y	1.00	63.17	14.68		150.0	
		Z	1.01	63.58	15.06		150.0	
10516-AAA	IEEE 802.11b WiFi 2.4 GHz (DSSS, 5.5 Mbps, 99pc duty cycle)	X	1.17	82.68	23.48	0.00	150.0	± 9.6 %
		Y	0.61	69.65	16.88		150.0	
		Z	0.72	72.79	18.69		150.0	
10517-AAA	IEEE 802.11b WiFi 2.4 GHz (DSSS, 11 Mbps, 99pc duty cycle)	X	0.94	67.44	17.14	0.00	150.0	± 9.6 %
		Y	0.85	65.01	15.25		150.0	
		Z	0.88	65.81	15.88		150.0	
10518-AAA	IEEE 802.11a/h WiFi 5 GHz (OFDM, 9 Mbps, 99pc duty cycle)	X	4.68	67.10	16.57	0.00	150.0	± 9.6 %
		Y	4.62	66.85	16.28		150.0	
		Z	4.64	66.95	16.38		150.0	
10519-AAA	IEEE 802.11a/h WiFi 5 GHz (OFDM, 12 Mbps, 99pc duty cycle)	X	4.88	67.37	16.70	0.00	150.0	± 9.6 %
		Y	4.82	67.11	16.42		150.0	
		Z	4.84	67.21	16.51		150.0	
10520-AAA	IEEE 802.11a/h WiFi 5 GHz (OFDM, 18 Mbps, 99pc duty cycle)	X	4.73	67.35	16.63	0.00	150.0	± 9.6 %
		Y	4.67	67.07	16.33		150.0	
		Z	4.69	67.18	16.43		150.0	
10521-AAA	IEEE 802.11a/h WiFi 5 GHz (OFDM, 24 Mbps, 99pc duty cycle)	X	4.66	67.35	16.62	0.00	150.0	± 9.6 %
		Y	4.60	67.06	16.32		150.0	
		Z	4.62	67.17	16.42		150.0	
10522-AAA	IEEE 802.11a/h WiFi 5 GHz (OFDM, 36 Mbps, 99pc duty cycle)	X	4.72	67.40	16.69	0.00	150.0	± 9.6 %
		Y	4.66	67.13	16.39		150.0	
		Z	4.68	67.24	16.49		150.0	



10523-AAA	IEEE 802.11a/h WiFi 5 GHz (OFDM, 48 Mbps, 99pc duty cycle)	X	4.59	67.26	16.53	0.00	150.0	± 9.6 %
		Y	4.53	66.98	16.23		150.0	
		Z	4.55	67.09	16.33		150.0	
10524-AAA	IEEE 802.11a/h WiFi 5 GHz (OFDM, 54 Mbps, 99pc duty cycle)	X	4.66	67.34	16.66	0.00	150.0	± 9.6 %
		Y	4.60	67.06	16.36		150.0	
		Z	4.63	67.17	16.46		150.0	
10525-AAA	IEEE 802.11ac WiFi (20MHz, MCS0, 99pc duty cycle)	X	4.64	66.35	16.23	0.00	150.0	± 9.6 %
		Y	4.58	66.08	15.94		150.0	
		Z	4.60	66.19	16.04		150.0	
10526-AAA	IEEE 802.11ac WiFi (20MHz, MCS1, 99pc duty cycle)	X	4.82	66.75	16.38	0.00	150.0	± 9.6 %
		Y	4.76	66.47	16.09		150.0	
		Z	4.78	66.58	16.19		150.0	
10527-AAA	IEEE 802.11ac WiFi (20MHz, MCS2, 99pc duty cycle)	X	4.74	66.71	16.33	0.00	150.0	± 9.6 %
		Y	4.68	66.42	16.03		150.0	
		Z	4.70	66.54	16.13		150.0	
10528-AAA	IEEE 802.11ac WiFi (20MHz, MCS3, 99pc duty cycle)	X	4.76	66.73	16.36	0.00	150.0	± 9.6 %
		Y	4.69	66.44	16.07		150.0	
		Z	4.72	66.56	16.17		150.0	
10529-AAA	IEEE 802.11ac WiFi (20MHz, MCS4, 99pc duty cycle)	X	4.76	66.73	16.36	0.00	150.0	± 9.6 %
		Y	4.69	66.44	16.07		150.0	
		Z	4.72	66.56	16.17		150.0	
10531-AAA	IEEE 802.11ac WiFi (20MHz, MCS6, 99pc duty cycle)	X	4.76	66.87	16.39	0.00	150.0	± 9.6 %
		Y	4.69	66.56	16.08		150.0	
		Z	4.72	66.68	16.19		150.0	
10532-AAA	IEEE 802.11ac WiFi (20MHz, MCS7, 99pc duty cycle)	X	4.62	66.72	16.33	0.00	150.0	± 9.6 %
		Y	4.55	66.41	16.02		150.0	
		Z	4.57	66.53	16.12		150.0	
10533-AAA	IEEE 802.11ac WiFi (20MHz, MCS8, 99pc duty cycle)	X	4.77	66.77	16.35	0.00	150.0	± 9.6 %
		Y	4.70	66.48	16.05		150.0	
		Z	4.73	66.80	16.15		150.0	
10534-AAA	IEEE 802.11ac WiFi (40MHz, MCS0, 99pc duty cycle)	X	5.29	66.84	16.41	0.00	150.0	± 9.6 %
		Y	5.23	66.60	16.14		150.0	
		Z	5.25	66.69	16.23		150.0	
10535-AAA	IEEE 802.11ac WiFi (40MHz, MCS1, 99pc duty cycle)	X	5.37	67.02	16.49	0.00	150.0	± 9.6 %
		Y	5.30	66.78	16.22		150.0	
		Z	5.32	66.87	16.31		150.0	
10536-AAA	IEEE 802.11ac WiFi (40MHz, MCS2, 99pc duty cycle)	X	5.23	66.97	16.44	0.00	150.0	± 9.6 %
		Y	5.17	66.72	16.17		150.0	
		Z	5.19	66.82	16.26		150.0	
10537-AAA	IEEE 802.11ac WiFi (40MHz, MCS3, 99pc duty cycle)	X	5.29	66.95	16.43	0.00	150.0	± 9.6 %
		Y	5.23	66.69	16.17		150.0	
		Z	5.25	66.79	16.25		150.0	
10538-AAA	IEEE 802.11ac WiFi (40MHz, MCS4, 99pc duty cycle)	X	5.39	66.99	16.50	0.00	150.0	± 9.6 %
		Y	5.33	66.74	16.23		150.0	
		Z	5.35	66.84	16.31		150.0	
10540-AAA	IEEE 802.11ac WiFi (40MHz, MCS6, 99pc duty cycle)	X	5.32	66.99	16.51	0.00	150.0	± 9.6 %
		Y	5.25	66.74	16.24		150.0	
		Z	5.27	66.83	16.33		150.0	

10541-AAA	IEEE 802.11ac WiFi (40MHz, MCS7, 99pc duty cycle)	X	5.28	66.83	16.43	0.00	150.0	± 9.6 %
		Y	5.22	66.59	16.16		150.0	
		Z	5.24	66.69	16.25		150.0	
10542-AAA	IEEE 802.11ac WiFi (40MHz, MCS8, 99pc duty cycle)	X	5.44	66.91	16.48	0.00	150.0	± 9.6 %
		Y	5.38	66.68	16.22		150.0	
		Z	5.40	66.77	16.30		150.0	
10543-AAA	IEEE 802.11ac WiFi (40MHz, MCS9, 99pc duty cycle)	X	5.53	66.97	16.53	0.00	150.0	± 9.6 %
		Y	5.47	66.73	16.27		150.0	
		Z	5.49	66.82	16.35		150.0	
10544-AAA	IEEE 802.11ac WiFi (80MHz, MCS0, 99pc duty cycle)	X	5.59	66.91	16.37	0.00	150.0	± 9.6 %
		Y	5.53	66.70	16.13		150.0	
		Z	5.55	66.79	16.21		150.0	
10545-AAA	IEEE 802.11ac WiFi (80MHz, MCS1, 99pc duty cycle)	X	5.82	67.42	16.57	0.00	150.0	± 9.6 %
		Y	5.75	67.17	16.32		150.0	
		Z	5.77	67.26	16.40		150.0	
10546-AAA	IEEE 802.11ac WiFi (80MHz, MCS2, 99pc duty cycle)	X	5.68	67.19	16.48	0.00	150.0	± 9.6 %
		Y	5.61	66.95	16.22		150.0	
		Z	5.64	67.05	16.30		150.0	
10547-AAA	IEEE 802.11ac WiFi (80MHz, MCS3, 99pc duty cycle)	X	5.77	67.28	16.51	0.00	150.0	± 9.6 %
		Y	5.70	67.03	16.25		150.0	
		Z	5.72	67.12	16.33		150.0	
10548-AAA	IEEE 802.11ac WiFi (80MHz, MCS4, 99pc duty cycle)	X	6.16	68.66	17.18	0.00	150.0	± 9.6 %
		Y	6.05	68.25	16.83		150.0	
		Z	6.07	68.36	16.93		150.0	
10550-AAA	IEEE 802.11ac WiFi (80MHz, MCS6, 99pc duty cycle)	X	5.70	67.18	16.48	0.00	150.0	± 9.6 %
		Y	5.64	66.95	16.23		150.0	
		Z	5.66	67.04	16.31		150.0	
10551-AAA	IEEE 802.11ac WiFi (80MHz, MCS7, 99pc duty cycle)	X	5.70	67.20	16.45	0.00	150.0	± 9.6 %
		Y	5.64	66.98	16.21		150.0	
		Z	5.66	67.07	16.28		150.0	
10552-AAA	IEEE 802.11ac WiFi (80MHz, MCS8, 99pc duty cycle)	X	5.60	66.97	16.34	0.00	150.0	± 9.6 %
		Y	5.55	66.76	16.11		150.0	
		Z	5.57	66.85	16.18		150.0	
10553-AAA	IEEE 802.11ac WiFi (80MHz, MCS9, 99pc duty cycle)	X	5.69	67.02	16.40	0.00	150.0	± 9.6 %
		Y	5.64	66.81	16.16		150.0	
		Z	5.66	66.90	16.24		150.0	
10554-AAA	IEEE 1602.11ac WiFi (160MHz, MCS0, 99pc duty cycle)	X	6.00	67.29	16.47	0.00	150.0	± 9.6 %
		Y	5.95	67.09	16.23		150.0	
		Z	5.96	67.17	16.31		150.0	
10555-AAA	IEEE 1602.11ac WiFi (160MHz, MCS1, 99pc duty cycle)	X	6.15	67.65	16.62	0.00	150.0	± 9.6 %
		Y	6.09	67.42	16.38		150.0	
		Z	6.11	67.51	16.45		150.0	
10556-AAA	IEEE 1602.11ac WiFi (160MHz, MCS2, 99pc duty cycle)	X	6.17	67.68	16.63	0.00	150.0	± 9.6 %
		Y	6.11	67.45	16.39		150.0	
		Z	6.13	67.54	16.46		150.0	
10557-AAA	IEEE 1602.11ac WiFi (160MHz, MCS3, 99pc duty cycle)	X	6.14	67.59	16.60	0.00	150.0	± 9.6 %
		Y	6.07	67.36	16.36		150.0	
		Z	6.09	67.45	16.44		150.0	

10558-AAA	IEEE 1602.11ac WiFi (160MHz, MCS4, 99pc duty cycle)	X	6.20	67.79	16.72	0.00	150.0	± 9.6 %
		Y	6.13	67.55	16.47		150.0	
		Z	6.15	67.64	16.55		150.0	
10560-AAA	IEEE 1602.11ac WiFi (160MHz, MCS6, 99pc duty cycle)	X	6.18	67.59	16.66	0.00	150.0	± 9.6 %
		Y	6.11	67.37	16.42		150.0	
		Z	6.14	67.46	16.49		150.0	
10561-AAA	IEEE 1602.11ac WiFi (160MHz, MCS7, 99pc duty cycle)	X	6.10	67.58	16.69	0.00	150.0	± 9.6 %
		Y	6.04	67.35	16.45		150.0	
		Z	6.06	67.44	16.52		150.0	
10562-AAA	IEEE 1602.11ac WiFi (160MHz, MCS8, 99pc duty cycle)	X	6.27	68.10	16.96	0.00	150.0	± 9.6 %
		Y	6.19	67.81	16.68		150.0	
		Z	6.21	67.92	16.77		150.0	
10563-AAA	IEEE 1602.11ac WiFi (160MHz, MCS9, 99pc duty cycle)	X	6.68	68.88	17.30	0.00	150.0	± 9.6 %
		Y	6.56	68.48	16.97		150.0	
		Z	6.59	68.61	17.07		150.0	
10564-AAA	IEEE 802.11g WiFi 2.4 GHz (DSSS-OFDM, 9 Mbps, 99pc duty cycle)	X	5.02	67.23	16.76	0.46	150.0	± 9.6 %
		Y	4.96	66.98	16.48		150.0	
		Z	4.98	67.08	16.57		150.0	
10565-AAA	IEEE 802.11g WiFi 2.4 GHz (DSSS-OFDM, 12 Mbps, 99pc duty cycle)	X	5.26	67.67	17.06	0.46	150.0	± 9.6 %
		Y	5.20	67.43	16.79		150.0	
		Z	5.22	67.52	16.88		150.0	
10566-AAA	IEEE 802.11g WiFi 2.4 GHz (DSSS-OFDM, 18 Mbps, 99pc duty cycle)	X	5.09	67.55	16.90	0.46	150.0	± 9.6 %
		Y	5.03	67.29	16.62		150.0	
		Z	5.05	67.39	16.71		150.0	
10567-AAA	IEEE 802.11g WiFi 2.4 GHz (DSSS-OFDM, 24 Mbps, 99pc duty cycle)	X	5.11	67.86	17.20	0.46	150.0	± 9.6 %
		Y	5.05	67.64	16.94		150.0	
		Z	5.07	67.72	17.02		150.0	
10568-AAA	IEEE 802.11g WiFi 2.4 GHz (DSSS-OFDM, 36 Mbps, 99pc duty cycle)	X	5.02	67.38	16.73	0.46	150.0	± 9.6 %
		Y	4.95	67.09	16.41		150.0	
		Z	4.98	67.21	16.52		150.0	
10569-AAA	IEEE 802.11g WiFi 2.4 GHz (DSSS-OFDM, 48 Mbps, 99pc duty cycle)	X	5.05	67.90	17.23	0.46	150.0	± 9.6 %
		Y	5.00	67.70	16.99		150.0	
		Z	5.02	67.78	17.06		150.0	
10570-AAA	IEEE 802.11g WiFi 2.4 GHz (DSSS-OFDM, 54 Mbps, 99pc duty cycle)	X	5.10	67.80	17.20	0.46	150.0	± 9.6 %
		Y	5.05	67.57	16.93		150.0	
		Z	5.07	67.66	17.02		150.0	
10571-AAA	IEEE 802.11b WiFi 2.4 GHz (DSSS, 1 Mbps, 90pc duty cycle)	X	1.35	66.69	17.17	0.46	130.0	± 9.6 %
		Y	1.30	65.45	16.06		130.0	
		Z	1.31	65.81	16.41		130.0	
10572-AAA	IEEE 802.11b WiFi 2.4 GHz (DSSS, 2 Mbps, 90pc duty cycle)	X	1.38	67.41	17.59	0.46	130.0	± 9.6 %
		Y	1.32	66.05	16.42		130.0	
		Z	1.33	66.44	16.78		130.0	
10573-AAA	IEEE 802.11b WiFi 2.4 GHz (DSSS, 5.5 Mbps, 90pc duty cycle)	X	100.00	151.66	41.18	0.46	130.0	± 9.6 %
		Y	3.17	90.18	24.53		130.0	
		Z	5.56	100.47	28.08		130.0	
10574-AAA	IEEE 802.11b WiFi 2.4 GHz (DSSS, 11 Mbps, 90pc duty cycle)	X	1.74	75.66	21.49	0.46	130.0	± 9.6 %
		Y	1.50	72.10	19.33		130.0	
		Z	1.55	73.02	19.95		130.0	

10575-AAA	IEEE 802.11g WiFi 2.4 GHz (DSSS-OFDM, 6 Mbps, 90pc duty cycle)	X	4.81	67.07	16.85	0.46	130.0	± 9.6 %
		Y	4.77	66.83	16.57		130.0	
		Z	4.78	66.92	16.66		130.0	
10576-AAA	IEEE 802.11g WiFi 2.4 GHz (DSSS-OFDM, 9 Mbps, 90pc duty cycle)	X	4.84	67.21	16.90	0.46	130.0	± 9.6 %
		Y	4.79	66.98	16.63		130.0	
		Z	4.81	67.07	16.71		130.0	
10577-AAA	IEEE 802.11g WiFi 2.4 GHz (DSSS-OFDM, 12 Mbps, 90pc duty cycle)	X	5.05	67.51	17.07	0.46	130.0	± 9.6 %
		Y	5.00	67.28	16.80		130.0	
		Z	5.02	67.37	16.88		130.0	
10578-AAA	IEEE 802.11g WiFi 2.4 GHz (DSSS-OFDM, 18 Mbps, 90pc duty cycle)	X	4.95	67.65	17.15	0.46	130.0	± 9.6 %
		Y	4.90	67.43	16.89		130.0	
		Z	4.91	67.51	16.97		130.0	
10579-AAA	IEEE 802.11g WiFi 2.4 GHz (DSSS-OFDM, 24 Mbps, 90pc duty cycle)	X	4.73	67.10	16.58	0.46	130.0	± 9.6 %
		Y	4.67	66.80	16.26		130.0	
		Z	4.70	66.92	16.37		130.0	
10580-AAA	IEEE 802.11g WiFi 2.4 GHz (DSSS-OFDM, 36 Mbps, 90pc duty cycle)	X	4.79	67.13	16.61	0.46	130.0	± 9.6 %
		Y	4.72	66.82	16.27		130.0	
		Z	4.74	66.95	16.39		130.0	
10581-AAA	IEEE 802.11g WiFi 2.4 GHz (DSSS-OFDM, 48 Mbps, 90pc duty cycle)	X	4.85	67.72	17.11	0.46	130.0	± 9.6 %
		Y	4.80	67.49	16.84		130.0	
		Z	4.81	67.57	16.92		130.0	
10582-AAA	IEEE 802.11g WiFi 2.4 GHz (DSSS-OFDM, 54 Mbps, 90pc duty cycle)	X	4.69	66.92	16.42	0.46	130.0	± 9.6 %
		Y	4.62	66.58	16.06		130.0	
		Z	4.65	66.72	16.19		130.0	
10583-AAA	IEEE 802.11a/h WiFi 5 GHz (OFDM, 6 Mbps, 90pc duty cycle)	X	4.81	67.07	16.85	0.46	130.0	± 9.6 %
		Y	4.77	66.83	16.57		130.0	
		Z	4.78	66.92	16.66		130.0	
10584-AAA	IEEE 802.11a/h WiFi 5 GHz (OFDM, 9 Mbps, 90pc duty cycle)	X	4.84	67.21	16.90	0.46	130.0	± 9.6 %
		Y	4.79	66.98	16.63		130.0	
		Z	4.81	67.07	16.71		130.0	
10585-AAA	IEEE 802.11a/h WiFi 5 GHz (OFDM, 12 Mbps, 90pc duty cycle)	X	5.05	67.51	17.07	0.46	130.0	± 9.6 %
		Y	5.00	67.28	16.80		130.0	
		Z	5.02	67.37	16.88		130.0	
10586-AAA	IEEE 802.11a/h WiFi 5 GHz (OFDM, 18 Mbps, 90pc duty cycle)	X	4.95	67.65	17.15	0.46	130.0	± 9.6 %
		Y	4.90	67.43	16.89		130.0	
		Z	4.91	67.51	16.97		130.0	
10587-AAA	IEEE 802.11a/h WiFi 5 GHz (OFDM, 24 Mbps, 90pc duty cycle)	X	4.73	67.10	16.58	0.46	130.0	± 9.6 %
		Y	4.67	66.80	16.26		130.0	
		Z	4.70	66.92	16.37		130.0	
10588-AAA	IEEE 802.11a/h WiFi 5 GHz (OFDM, 36 Mbps, 90pc duty cycle)	X	4.79	67.13	16.61	0.46	130.0	± 9.6 %
		Y	4.72	66.82	16.27		130.0	
		Z	4.74	66.95	16.39		130.0	
10589-AAA	IEEE 802.11a/h WiFi 5 GHz (OFDM, 48 Mbps, 90pc duty cycle)	X	4.85	67.72	17.11	0.46	130.0	± 9.6 %
		Y	4.80	67.49	16.84		130.0	
		Z	4.81	67.57	16.92		130.0	
10590-AAA	IEEE 802.11a/h WiFi 5 GHz (OFDM, 54 Mbps, 90pc duty cycle)	X	4.69	66.92	16.42	0.46	130.0	± 9.6 %
		Y	4.62	66.58	16.06		130.0	
		Z	4.65	66.72	16.19		130.0	

10591-AAA	IEEE 802.11n (HT Mixed, 20MHz, MCS0, 90pc duty cycle)	X	4.96	67.09	16.93	0.46	130.0	± 9.6 %
		Y	4.92	66.88	16.66		130.0	
		Z	4.93	66.96	16.75		130.0	
10592-AAA	IEEE 802.11n (HT Mixed, 20MHz, MCS1, 90pc duty cycle)	X	5.13	67.44	17.05	0.46	130.0	± 9.6 %
		Y	5.08	67.22	16.79		130.0	
		Z	5.09	67.30	16.87		130.0	
10593-AAA	IEEE 802.11n (HT Mixed, 20MHz, MCS2, 90pc duty cycle)	X	5.05	67.38	16.96	0.46	130.0	± 9.6 %
		Y	5.00	67.15	16.69		130.0	
		Z	5.02	67.24	16.77		130.0	
10594-AAA	IEEE 802.11n (HT Mixed, 20MHz, MCS3, 90pc duty cycle)	X	5.10	67.52	17.09	0.46	130.0	± 9.6 %
		Y	5.05	67.30	16.83		130.0	
		Z	5.07	67.38	16.91		130.0	
10595-AAA	IEEE 802.11n (HT Mixed, 20MHz, MCS4, 90pc duty cycle)	X	5.08	67.50	17.01	0.46	130.0	± 9.6 %
		Y	5.02	67.26	16.73		130.0	
		Z	5.04	67.35	16.82		130.0	
10596-AAA	IEEE 802.11n (HT Mixed, 20MHz, MCS5, 90pc duty cycle)	X	5.02	67.52	17.02	0.46	130.0	± 9.6 %
		Y	4.96	67.27	16.74		130.0	
		Z	4.98	67.36	16.83		130.0	
10597-AAA	IEEE 802.11n (HT Mixed, 20MHz, MCS6, 90pc duty cycle)	X	4.97	67.44	16.92	0.46	130.0	± 9.6 %
		Y	4.91	67.18	16.63		130.0	
		Z	4.93	67.28	16.72		130.0	
10598-AAA	IEEE 802.11n (HT Mixed, 20MHz, MCS7, 90pc duty cycle)	X	4.94	67.63	17.14	0.46	130.0	± 9.6 %
		Y	4.89	67.40	16.88		130.0	
		Z	4.91	67.48	16.96		130.0	
10599-AAA	IEEE 802.11n (HT Mixed, 40MHz, MCS0, 90pc duty cycle)	X	5.64	67.68	17.14	0.46	130.0	± 9.6 %
		Y	5.59	67.47	16.88		130.0	
		Z	5.61	67.54	16.96		130.0	
10600-AAA	IEEE 802.11n (HT Mixed, 40MHz, MCS1, 90pc duty cycle)	X	5.87	68.41	17.49	0.46	130.0	± 9.6 %
		Y	5.79	68.09	17.17		130.0	
		Z	5.81	68.18	17.26		130.0	
10601-AAA	IEEE 802.11n (HT Mixed, 40MHz, MCS2, 90pc duty cycle)	X	5.71	67.98	17.28	0.46	130.0	± 9.6 %
		Y	5.65	67.72	17.00		130.0	
		Z	5.66	67.81	17.08		130.0	
10602-AAA	IEEE 802.11n (HT Mixed, 40MHz, MCS3, 90pc duty cycle)	X	5.79	67.98	17.21	0.46	130.0	± 9.6 %
		Y	5.73	67.73	16.93		130.0	
		Z	5.75	67.82	17.01		130.0	
10603-AAA	IEEE 802.11n (HT Mixed, 40MHz, MCS4, 90pc duty cycle)	X	5.87	68.25	17.46	0.46	130.0	± 9.6 %
		Y	5.81	68.01	17.19		130.0	
		Z	5.83	68.09	17.27		130.0	
10604-AAA	IEEE 802.11n (HT Mixed, 40MHz, MCS5, 90pc duty cycle)	X	5.65	67.64	17.14	0.46	130.0	± 9.6 %
		Y	5.60	67.42	16.89		130.0	
		Z	5.61	67.50	16.96		130.0	
10605-AAA	IEEE 802.11n (HT Mixed, 40MHz, MCS6, 90pc duty cycle)	X	5.80	68.11	17.39	0.46	130.0	± 9.6 %
		Y	5.73	67.85	17.10		130.0	
		Z	5.75	67.93	17.19		130.0	
10606-AAA	IEEE 802.11n (HT Mixed, 40MHz, MCS7, 90pc duty cycle)	X	5.53	67.43	16.92	0.46	130.0	± 9.6 %
		Y	5.48	67.20	16.64		130.0	
		Z	5.50	67.29	16.73		130.0	

10607-AAA	IEEE 802.11ac WiFi (20MHz, MCS0, 90pc duty cycle)	X	4.80	66.40	16.54	0.46	130.0	± 9.6 %
		Y	4.75	66.17	16.27		130.0	
		Z	4.76	66.26	16.35		130.0	
10608-AAA	IEEE 802.11ac WiFi (20MHz, MCS1, 90pc duty cycle)	X	5.00	66.83	16.71	0.46	130.0	± 9.6 %
		Y	4.94	66.59	16.44		130.0	
		Z	4.96	66.68	16.52		130.0	
10609-AAA	IEEE 802.11ac WiFi (20MHz, MCS2, 90pc duty cycle)	X	4.89	66.71	16.57	0.46	130.0	± 9.6 %
		Y	4.83	66.45	16.28		130.0	
		Z	4.85	66.55	16.38		130.0	
10610-AAA	IEEE 802.11ac WiFi (20MHz, MCS3, 90pc duty cycle)	X	4.94	66.85	16.71	0.46	130.0	± 9.6 %
		Y	4.88	66.60	16.44		130.0	
		Z	4.90	66.69	16.53		130.0	
10611-AAA	IEEE 802.11ac WiFi (20MHz, MCS4, 90pc duty cycle)	X	4.86	66.68	16.58	0.46	130.0	± 9.6 %
		Y	4.80	66.42	16.30		130.0	
		Z	4.82	66.52	16.39		130.0	
10612-AAA	IEEE 802.11ac WiFi (20MHz, MCS5, 90pc duty cycle)	X	4.88	66.87	16.65	0.46	130.0	± 9.6 %
		Y	4.82	66.59	16.35		130.0	
		Z	4.84	66.69	16.44		130.0	
10613-AAA	IEEE 802.11ac WiFi (20MHz, MCS6, 90pc duty cycle)	X	4.89	66.78	16.55	0.46	130.0	± 9.6 %
		Y	4.82	66.49	16.24		130.0	
		Z	4.85	66.60	16.34		130.0	
10614-AAA	IEEE 802.11ac WiFi (20MHz, MCS7, 90pc duty cycle)	X	4.81	66.89	16.73	0.46	130.0	± 9.6 %
		Y	4.75	66.64	16.45		130.0	
		Z	4.77	66.73	16.54		130.0	
10615-AAA	IEEE 802.11ac WiFi (20MHz, MCS8, 90pc duty cycle)	X	4.87	66.56	16.40	0.46	130.0	± 9.6 %
		Y	4.81	66.27	16.09		130.0	
		Z	4.83	66.38	16.19		130.0	
10616-AAA	IEEE 802.11ac WiFi (40MHz, MCS0, 90pc duty cycle)	X	5.46	66.92	16.73	0.46	130.0	± 9.6 %
		Y	5.41	66.70	16.48		130.0	
		Z	5.43	66.79	16.56		130.0	
10617-AAA	IEEE 802.11ac WiFi (40MHz, MCS1, 90pc duty cycle)	X	5.54	67.11	16.80	0.46	130.0	± 9.6 %
		Y	5.48	66.88	16.54		130.0	
		Z	5.50	66.96	16.62		130.0	
10618-AAA	IEEE 802.11ac WiFi (40MHz, MCS2, 90pc duty cycle)	X	5.42	67.11	16.81	0.46	130.0	± 9.6 %
		Y	5.36	66.88	16.56		130.0	
		Z	5.38	66.97	16.63		130.0	
10619-AAA	IEEE 802.11ac WiFi (40MHz, MCS3, 90pc duty cycle)	X	5.45	66.98	16.69	0.46	130.0	± 9.6 %
		Y	5.39	66.74	16.43		130.0	
		Z	5.41	66.83	16.51		130.0	
10620-AAA	IEEE 802.11ac WiFi (40MHz, MCS4, 90pc duty cycle)	X	5.55	67.03	16.77	0.46	130.0	± 9.6 %
		Y	5.49	66.78	16.50		130.0	
		Z	5.51	66.88	16.58		130.0	
10621-AAA	IEEE 802.11ac WiFi (40MHz, MCS5, 90pc duty cycle)	X	5.51	67.03	16.86	0.46	130.0	± 9.6 %
		Y	5.46	66.84	16.63		130.0	
		Z	5.48	66.91	16.70		130.0	
10622-AAA	IEEE 802.11ac WiFi (40MHz, MCS6, 90pc duty cycle)	X	5.54	67.25	16.97	0.46	130.0	± 9.6 %
		Y	5.49	67.04	16.73		130.0	
		Z	5.50	67.11	16.80		130.0	

10623-AAA	IEEE 802.11ac WiFi (40MHz, MCS7, 90pc duty cycle)	X	5.41	66.79	16.63	0.46	130.0	± 9.6 %
		Y	5.36	66.56	16.37		130.0	
		Z	5.38	66.65	16.45		130.0	
10624-AAA	IEEE 802.11ac WiFi (40MHz, MCS8, 90pc duty cycle)	X	5.62	67.00	16.79	0.46	130.0	± 9.6 %
		Y	5.56	66.77	16.54		130.0	
		Z	5.58	66.86	16.62		130.0	
10625-AAA	IEEE 802.11ac WiFi (40MHz, MCS9, 90pc duty cycle)	X	6.10	68.33	17.51	0.46	130.0	± 9.6 %
		Y	6.00	67.98	17.19		130.0	
		Z	6.02	68.08	17.28		130.0	
10626-AAA	IEEE 802.11ac WiFi (80MHz, MCS0, 90pc duty cycle)	X	5.74	66.93	16.65	0.46	130.0	± 9.6 %
		Y	5.69	66.74	16.43		130.0	
		Z	5.71	66.82	16.50		130.0	
10627-AAA	IEEE 802.11ac WiFi (80MHz, MCS1, 90pc duty cycle)	X	6.03	67.63	16.96	0.46	130.0	± 9.6 %
		Y	5.97	67.40	16.71		130.0	
		Z	5.98	67.48	16.79		130.0	
10628-AAA	IEEE 802.11ac WiFi (80MHz, MCS2, 90pc duty cycle)	X	5.81	67.14	16.66	0.46	130.0	± 9.6 %
		Y	5.75	66.90	16.41		130.0	
		Z	5.77	67.00	16.49		130.0	
10629-AAA	IEEE 802.11ac WiFi (80MHz, MCS3, 90pc duty cycle)	X	5.89	67.21	16.69	0.46	130.0	± 9.6 %
		Y	5.84	67.00	16.45		130.0	
		Z	5.85	67.08	16.52		130.0	
10630-AAA	IEEE 802.11ac WiFi (80MHz, MCS4, 90pc duty cycle)	X	6.58	69.47	17.83	0.46	130.0	± 9.6 %
		Y	6.44	68.97	17.43		130.0	
		Z	6.47	69.10	17.53		130.0	
10631-AAA	IEEE 802.11ac WiFi (80MHz, MCS5, 90pc duty cycle)	X	6.29	68.65	17.58	0.46	130.0	± 9.6 %
		Y	6.21	68.38	17.32		130.0	
		Z	6.23	68.46	17.39		130.0	
10632-AAA	IEEE 802.11ac WiFi (80MHz, MCS6, 90pc duty cycle)	X	5.97	67.59	17.06	0.46	130.0	± 9.6 %
		Y	5.92	67.40	16.84		130.0	
		Z	5.93	67.46	16.90		130.0	
10633-AAA	IEEE 802.11ac WiFi (80MHz, MCS7, 90pc duty cycle)	X	5.86	67.25	16.74	0.46	130.0	± 9.6 %
		Y	5.80	67.03	16.49		130.0	
		Z	5.82	67.11	16.57		130.0	
10634-AAA	IEEE 802.11ac WiFi (80MHz, MCS8, 90pc duty cycle)	X	5.83	67.23	16.78	0.46	130.0	± 9.6 %
		Y	5.78	67.04	16.55		130.0	
		Z	5.80	67.11	16.62		130.0	
10635-AAA	IEEE 802.11ac WiFi (80MHz, MCS9, 90pc duty cycle)	X	5.74	66.71	16.29	0.46	130.0	± 9.6 %
		Y	5.68	66.44	16.01		130.0	
		Z	5.70	66.56	16.11		130.0	
10636-AAA	IEEE 1602.11ac WiFi (160MHz, MCS0, 90pc duty cycle)	X	6.17	67.34	16.76	0.46	130.0	± 9.6 %
		Y	6.11	67.15	16.53		130.0	
		Z	6.13	67.22	16.60		130.0	
10637-AAA	IEEE 1602.11ac WiFi (160MHz, MCS1, 90pc duty cycle)	X	6.35	67.79	16.97	0.46	130.0	± 9.6 %
		Y	6.29	67.57	16.73		130.0	
		Z	6.30	67.65	16.80		130.0	
10638-AAA	IEEE 1602.11ac WiFi (160MHz, MCS2, 90pc duty cycle)	X	6.35	67.77	16.94	0.46	130.0	± 9.6 %
		Y	6.29	67.54	16.69		130.0	
		Z	6.30	67.62	16.76		130.0	

10639-AAA	IIEEE 1602.11ac WiFi (160MHz, MCS3, 90pc duty cycle)	X	6.32	67.69	16.93	0.46	130.0	± 9.6 %
		Y	6.26	67.48	16.70		130.0	
		Z	6.28	67.56	16.77		130.0	
10640-AAA	IIEEE 1602.11ac WiFi (160MHz, MCS4, 90pc duty cycle)	X	6.35	67.80	16.94	0.46	130.0	± 9.6 %
		Y	6.28	67.54	16.68		130.0	
		Z	6.30	67.64	16.76		130.0	
10641-AAA	IIEEE 1602.11ac WiFi (160MHz, MCS5, 90pc duty cycle)	X	6.36	67.58	16.85	0.46	130.0	± 9.6 %
		Y	6.30	67.37	16.61		130.0	
		Z	6.32	67.45	16.69		130.0	
10642-AAA	IIEEE 1602.11ac WiFi (160MHz, MCS6, 90pc duty cycle)	X	6.40	67.80	17.11	0.46	130.0	± 9.6 %
		Y	6.34	67.61	16.89		130.0	
		Z	6.36	67.68	16.96		130.0	
10643-AAA	IIEEE 1602.11ac WiFi (160MHz, MCS7, 90pc duty cycle)	X	6.25	67.58	16.92	0.46	130.0	± 9.6 %
		Y	6.19	67.34	16.66		130.0	
		Z	6.21	67.43	16.74		130.0	
10644-AAA	IIEEE 1602.11ac WiFi (160MHz, MCS8, 90pc duty cycle)	X	6.47	68.26	17.28	0.46	130.0	± 9.6 %
		Y	6.39	67.96	16.99		130.0	
		Z	6.42	68.06	17.08		130.0	
10645-AAA	IIEEE 1602.11ac WiFi (160MHz, MCS9, 90pc duty cycle)	X	7.06	69.52	17.87	0.46	130.0	± 9.6 %
		Y	6.93	69.10	17.52		130.0	
		Z	6.96	69.22	17.62		130.0	
10646-AAC	LTE-TDD (SC-FDMA, 1 RB, 5 MHz, QPSK, UL Subframe=2,7)	X	100.00	148.85	48.77	9.30	60.0	± 9.6 %
		Y	80.54	141.06	46.17		60.0	
		Z	100.00	148.08	48.38		60.0	
10647-AAB	LTE-TDD (SC-FDMA, 1 RB, 20 MHz, QPSK, UL Subframe=2,7)	X	100.00	150.12	49.32	9.30	60.0	± 9.6 %
		Y	73.97	140.10	46.12		60.0	
		Z	100.00	149.31	48.92		60.0	
10648-AAA	CDMA2000 (1x Advanced)	X	0.92	66.97	13.32	0.00	150.0	± 9.6 %
		Y	0.75	63.96	11.29		150.0	
		Z	0.80	64.80	11.93		150.0	

<sup>E</sup> Uncertainty is determined using the max. deviation from linear response applying rectangular distribution and is expressed for the square of the field value.





Accredited by the Swiss Accreditation Service (SAS)  
The Swiss Accreditation Service is one of the signatories to the EA  
Multilateral Agreement for the recognition of calibration certificates

Accreditation No.: **SCS 0108**

Client **PC Test**

Certificate No: **ES3-3213\_Feb17**

**CALIBRATION CERTIFICATE**

Object **ES3DV3 - SN:3213**

Calibration procedure(s) **QA CAL-01.v9, QA CAL-23.v5, QA CAL-25.v6  
Calibration procedure for dosimetric E-field probes**

Calibration date: **February 10, 2017**

This calibration certificate documents the traceability to national standards, which realize the physical units of measurements (SI).  
The measurements and the uncertainties with confidence probability are given on the following pages and are part of the certificate.

All calibrations have been conducted in the closed laboratory facility: environment temperature (22 ± 3)°C and humidity < 70%.

Calibration Equipment used (M&TE critical for calibration)

*Bny  
03-01-2017*

Primary Standards	ID	Cal Date (Certificate No.)	Scheduled Calibration
Power meter NRP	SN: 104778	06-Apr-16 (No. 217-02288/02289)	Apr-17
Power sensor NRP-Z91	SN: 103244	06-Apr-16 (No. 217-02288)	Apr-17
Power sensor NRP-Z91	SN: 103245	06-Apr-16 (No. 217-02289)	Apr-17
Reference 20 dB Attenuator	SN: S5277 (20x)	05-Apr-16 (No. 217-02293)	Apr-17
Reference Probe ES3DV2	SN: 3013	31-Dec-16 (No. ES3-3013_Dec16)	Dec-17
DAE4	SN: 660	7-Dec-16 (No. DAE4-660_Dec16)	Dec-17
Secondary Standards	ID	Check Date (in house)	Scheduled Check
Power meter E4419B	SN: GB41293874	06-Apr-16 (in house check Jun-16)	In house check: Jun-18
Power sensor E4412A	SN: MY41498087	06-Apr-16 (in house check Jun-16)	In house check: Jun-18
Power sensor E4412A	SN: 000110210	06-Apr-16 (in house check Jun-16)	In house check: Jun-18
RF generator HP 8648C	SN: US3642U01700	04-Aug-99 (in house check Jun-16)	In house check: Jun-18
Network Analyzer HP 8753E	SN: US37390585	18-Oct-01 (in house check Oct-16)	In house check: Oct-17

Calibrated by: **Claudio Leubler** (Name) **Laboratory Technician** (Function) *[Signature]* (Signature)

Approved by: **Katja Pokovic** (Name) **Technical Manager** (Function) *[Signature]* (Signature)

Issued: February 13, 2017

This calibration certificate shall not be reproduced except in full without written approval of the laboratory.



Accredited by the Swiss Accreditation Service (SAS)  
The Swiss Accreditation Service is one of the signatories to the EA  
Multilateral Agreement for the recognition of calibration certificates

Accreditation No.: **SCS 0108**

**Glossary:**

TSL	tissue simulating liquid
NORM <sub>x,y,z</sub>	sensitivity in free space
ConvF	sensitivity in TSL / NORM <sub>x,y,z</sub>
DCP	diode compression point
CF	crest factor (1/duty_cycle) of the RF signal
A, B, C, D	modulation dependent linearization parameters
Polarization $\phi$	$\phi$ rotation around probe axis
Polarization $\vartheta$	$\vartheta$ rotation around an axis that is in the plane normal to probe axis (at measurement center), i.e., $\vartheta = 0$ is normal to probe axis
Connector Angle	information used in DASY system to align probe sensor X to the robot coordinate system

**Calibration is Performed According to the Following Standards:**

- a) IEEE Std 1528-2013, "IEEE Recommended Practice for Determining the Peak Spatial-Averaged Specific Absorption Rate (SAR) in the Human Head from Wireless Communications Devices: Measurement Techniques", June 2013
- b) IEC 62209-1, "Procedure to measure the Specific Absorption Rate (SAR) for hand-held devices used in close proximity to the ear (frequency range of 300 MHz to 3 GHz)", February 2005
- c) IEC 62209-2, "Procedure to determine the Specific Absorption Rate (SAR) for wireless communication devices used in close proximity to the human body (frequency range of 30 MHz to 6 GHz)", March 2010
- d) KDB 865664, "SAR Measurement Requirements for 100 MHz to 6 GHz"

**Methods Applied and Interpretation of Parameters:**

- *NORM<sub>x,y,z</sub>*: Assessed for E-field polarization  $\vartheta = 0$  ( $f \leq 900$  MHz in TEM-cell;  $f > 1800$  MHz: R22 waveguide). *NORM<sub>x,y,z</sub>* are only intermediate values, i.e., the uncertainties of *NORM<sub>x,y,z</sub>* does not affect the  $E^2$ -field uncertainty inside TSL (see below *ConvF*).
- *NORM(f)<sub>x,y,z</sub>* = *NORM<sub>x,y,z</sub>* \* *frequency\_response* (see Frequency Response Chart). This linearization is implemented in DASY4 software versions later than 4.2. The uncertainty of the frequency response is included in the stated uncertainty of *ConvF*.
- *DCP<sub>x,y,z</sub>*: DCP are numerical linearization parameters assessed based on the data of power sweep with CW signal (no uncertainty required). DCP does not depend on frequency nor media.
- *PAR*: PAR is the Peak to Average Ratio that is not calibrated but determined based on the signal characteristics
- *A<sub>x,y,z</sub>*; *B<sub>x,y,z</sub>*; *C<sub>x,y,z</sub>*; *D<sub>x,y,z</sub>*; *VR<sub>x,y,z</sub>*: *A, B, C, D* are numerical linearization parameters assessed based on the data of power sweep for specific modulation signal. The parameters do not depend on frequency nor media. *VR* is the maximum calibration range expressed in RMS voltage across the diode.
- *ConvF and Boundary Effect Parameters*: Assessed in flat phantom using E-field (or Temperature Transfer Standard for  $f \leq 800$  MHz) and inside waveguide using analytical field distributions based on power measurements for  $f > 800$  MHz. The same setups are used for assessment of the parameters applied for boundary compensation (alpha, depth) of which typical uncertainty values are given. These parameters are used in DASY4 software to improve probe accuracy close to the boundary. The sensitivity in TSL corresponds to *NORM<sub>x,y,z</sub>* \* *ConvF* whereby the uncertainty corresponds to that given for *ConvF*. A frequency dependent *ConvF* is used in DASY version 4.4 and higher which allows extending the validity from  $\pm 50$  MHz to  $\pm 100$  MHz.
- *Spherical isotropy (3D deviation from isotropy)*: in a field of low gradients realized using a flat phantom exposed by a patch antenna.
- *Sensor Offset*: The sensor offset corresponds to the offset of virtual measurement center from the probe tip (on probe axis). No tolerance required.
- *Connector Angle*: The angle is assessed using the information gained by determining the *NORM<sub>x</sub>* (no uncertainty required).

# Probe ES3DV3

## SN:3213

Manufactured: October 14, 2008  
Calibrated: February 10, 2017

Calibrated for DASY/EASY Systems  
(Note: non-compatible with DASY2 system!)

## DASY/EASY - Parameters of Probe: ES3DV3 - SN:3213

### Basic Calibration Parameters

	Sensor X	Sensor Y	Sensor Z	Unc (k=2)
Norm ( $\mu\text{V}/(\text{V}/\text{m})^2$ ) <sup>A</sup>	1.44	1.32	1.29	$\pm 10.1 \%$
DCP (mV) <sup>B</sup>	101.3	102.3	101.6	

### Modulation Calibration Parameters

UID	Communication System Name		A dB	B dB $\sqrt{\mu\text{V}}$	C	D dB	VR mV	Unc <sup>E</sup> (k=2)
0	CW	X	0.0	0.0	1.0	0.00	228.2	$\pm 3.5 \%$
		Y	0.0	0.0	1.0		230.0	
		Z	0.0	0.0	1.0		221.7	

Note: For details on UID parameters see Appendix.

### Sensor Model Parameters

	C1 fF	C2 fF	$\alpha$ $\text{V}^{-1}$	T1 $\text{ms}\cdot\text{V}^{-2}$	T2 $\text{ms}\cdot\text{V}^{-1}$	T3 ms	T4 $\text{V}^{-2}$	T5 $\text{V}^{-1}$	T6
X	56.23	407.2	35.93	28.85	2.251	5.1	1.129	0.439	1.012
Y	55.47	400.7	35.87	28.65	2.277	5.1	1.321	0.386	1.013
Z	51.67	374.7	36	28.45	2.103	5.1	0.358	0.504	1.009

The reported uncertainty of measurement is stated as the standard uncertainty of measurement multiplied by the coverage factor  $k=2$ , which for a normal distribution corresponds to a coverage probability of approximately 95%.

<sup>A</sup> The uncertainties of Norm X,Y,Z do not affect the  $E^2$ -field uncertainty inside TSL (see Pages 5 and 6).

<sup>B</sup> Numerical linearization parameter: uncertainty not required.

<sup>E</sup> Uncertainty is determined using the max. deviation from linear response applying rectangular distribution and is expressed for the square of the field value.

## DASY/EASY - Parameters of Probe: ES3DV3 - SN:3213

### Calibration Parameter Determined in Head Tissue Simulating Media

f (MHz) <sup>C</sup>	Relative Permittivity <sup>F</sup>	Conductivity (S/m) <sup>F</sup>	ConvF X	ConvF Y	ConvF Z	Alpha <sup>G</sup>	Depth <sup>G</sup> (mm)	Unc (k=2)
750	41.9	0.89	6.85	6.85	6.85	0.80	1.18	± 12.0 %
835	41.5	0.90	6.49	6.49	6.49	0.49	1.52	± 12.0 %
1750	40.1	1.37	5.49	5.49	5.49	0.60	1.35	± 12.0 %
1900	40.0	1.40	5.29	5.29	5.29	0.68	1.27	± 12.0 %
2300	39.5	1.67	4.95	4.95	4.95	0.70	1.28	± 12.0 %
2450	39.2	1.80	4.70	4.70	4.70	0.80	1.24	± 12.0 %
2600	39.0	1.96	4.52	4.52	4.52	0.78	1.28	± 12.0 %

<sup>C</sup> Frequency validity above 300 MHz of ± 100 MHz only applies for DASY v4.4 and higher (see Page 2), else it is restricted to ± 50 MHz. The uncertainty is the RSS of the ConvF uncertainty at calibration frequency and the uncertainty for the indicated frequency band. Frequency validity below 300 MHz is ± 10, 25, 40, 50 and 70 MHz for ConvF assessments at 30, 64, 128, 150 and 220 MHz respectively. Above 5 GHz frequency validity can be extended to ± 110 MHz.

<sup>F</sup> At frequencies below 3 GHz, the validity of tissue parameters ( $\epsilon$  and  $\sigma$ ) can be relaxed to ± 10% if liquid compensation formula is applied to measured SAR values. At frequencies above 3 GHz, the validity of tissue parameters ( $\epsilon$  and  $\sigma$ ) is restricted to ± 5%. The uncertainty is the RSS of the ConvF uncertainty for indicated target tissue parameters.

<sup>G</sup> Alpha/Depth are determined during calibration. SPEAG warrants that the remaining deviation due to the boundary effect after compensation is always less than ± 1% for frequencies below 3 GHz and below ± 2% for frequencies between 3-6 GHz at any distance larger than half the probe tip diameter from the boundary.

## DASY/EASY - Parameters of Probe: ES3DV3 - SN:3213

### Calibration Parameter Determined in Body Tissue Simulating Media

f (MHz) <sup>C</sup>	Relative Permittivity <sup>F</sup>	Conductivity (S/m) <sup>F</sup>	ConvF X	ConvF Y	ConvF Z	Alpha <sup>G</sup>	Depth <sup>G</sup> (mm)	Unc (k=2)
750	55.5	0.96	6.38	6.38	6.38	0.60	1.31	± 12.0 %
835	55.2	0.97	6.28	6.28	6.28	0.80	1.20	± 12.0 %
1750	53.4	1.49	5.09	5.09	5.09	0.66	1.33	± 12.0 %
1900	53.3	1.52	4.94	4.94	4.94	0.40	1.85	± 12.0 %
2300	52.9	1.81	4.69	4.69	4.69	0.80	1.24	± 12.0 %
2450	52.7	1.95	4.53	4.53	4.53	0.72	1.28	± 12.0 %
2600	52.5	2.16	4.32	4.32	4.32	0.80	1.20	± 12.0 %

<sup>C</sup> Frequency validity above 300 MHz of ± 100 MHz only applies for DASY v4.4 and higher (see Page 2), else it is restricted to ± 50 MHz. The uncertainty is the RSS of the ConvF uncertainty at calibration frequency and the uncertainty for the indicated frequency band. Frequency validity below 300 MHz is ± 10, 25, 40, 50 and 70 MHz for ConvF assessments at 30, 64, 128, 150 and 220 MHz respectively. Above 5 GHz frequency validity can be extended to ± 110 MHz.

<sup>F</sup> At frequencies below 3 GHz, the validity of tissue parameters ( $\epsilon$  and  $\sigma$ ) can be relaxed to ± 10% if liquid compensation formula is applied to measured SAR values. At frequencies above 3 GHz, the validity of tissue parameters ( $\epsilon$  and  $\sigma$ ) is restricted to ± 5%. The uncertainty is the RSS of the ConvF uncertainty for indicated target tissue parameters.

<sup>G</sup> Alpha/Depth are determined during calibration. SPEAG warrants that the remaining deviation due to the boundary effect after compensation is always less than ± 1% for frequencies below 3 GHz and below ± 2% for frequencies between 3-6 GHz at any distance larger than half the probe tip diameter from the boundary.

### Frequency Response of E-Field (TEM-Cell:ifi110 EXX, Waveguide: R22)

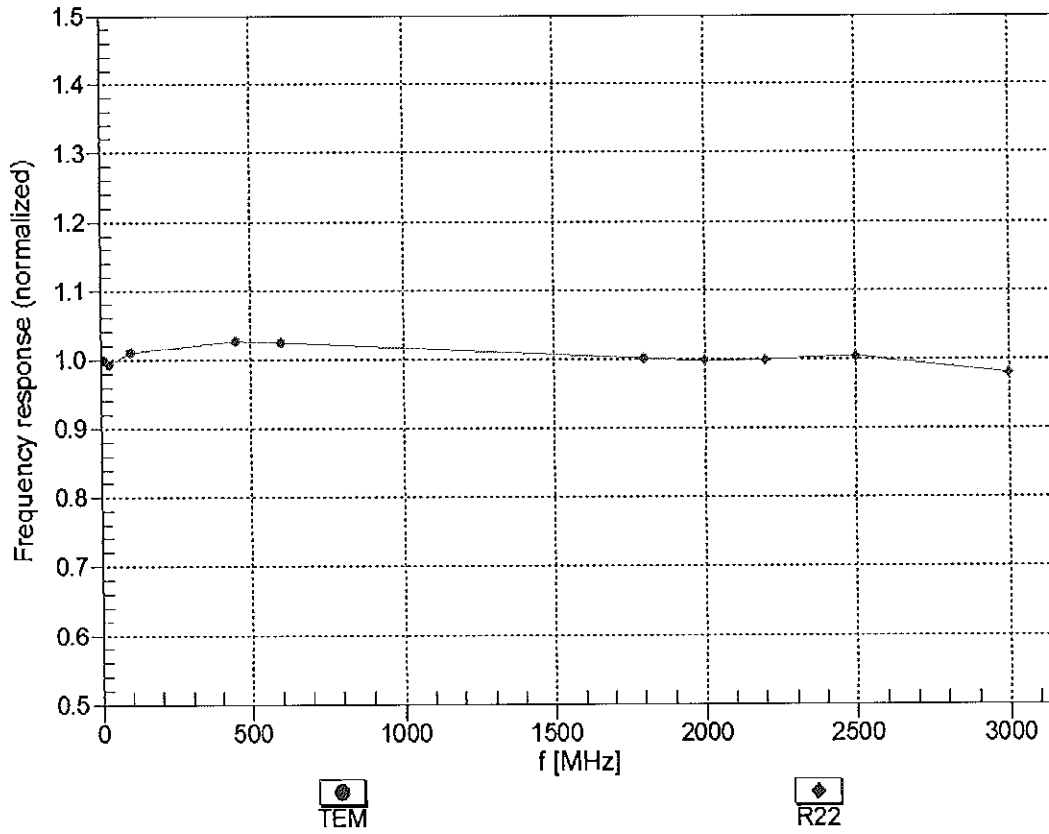

Uncertainty of Frequency Response of E-field:  $\pm 6.3\%$  (k=2)

### Receiving Pattern ( $\phi$ ), $\vartheta = 0^\circ$

f=600 MHz, TEM

f=1800 MHz, R22

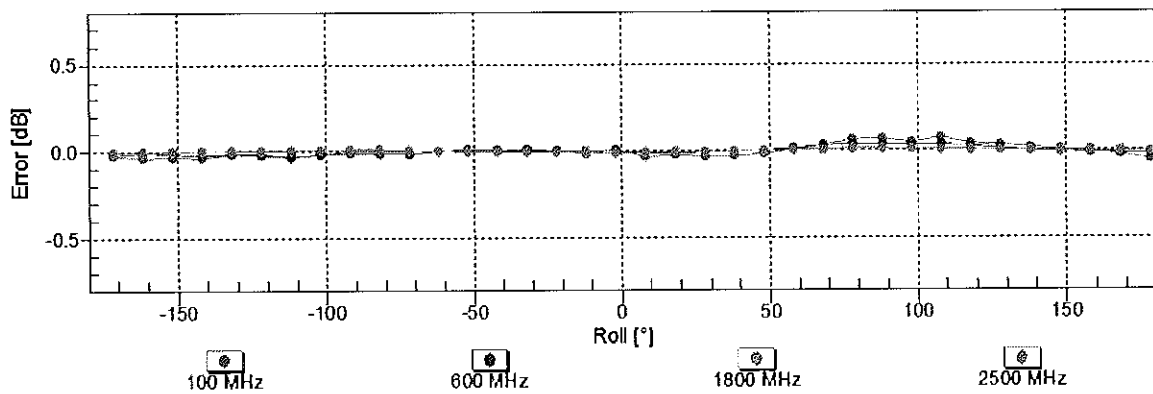
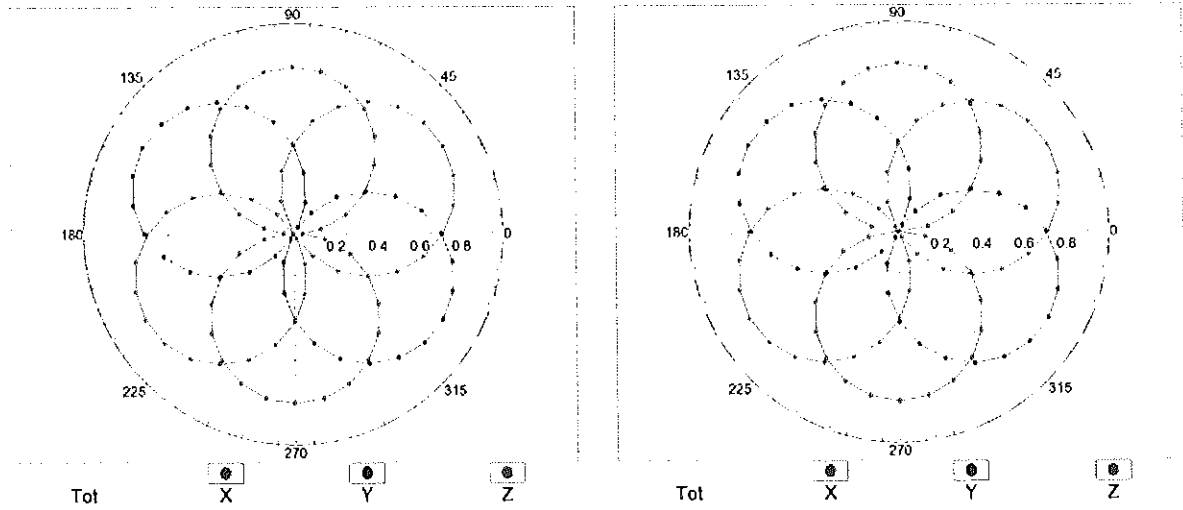

Uncertainty of Axial Isotropy Assessment:  $\pm 0.5\%$  ( $k=2$ )



### Dynamic Range $f(\text{SAR}_{\text{head}})$ (TEM cell , $f_{\text{eval}} = 1900 \text{ MHz}$ )

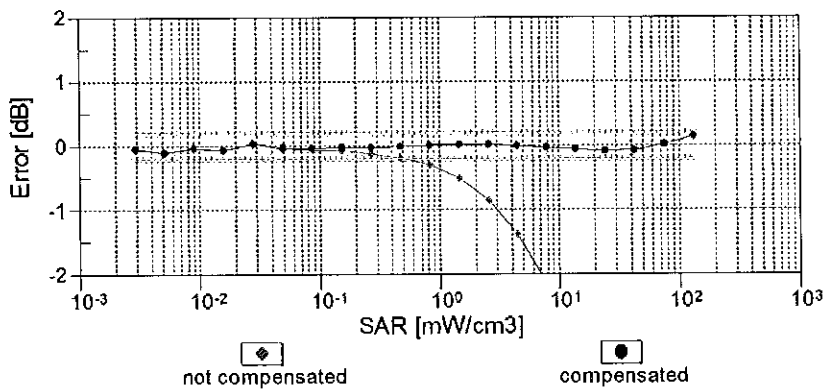
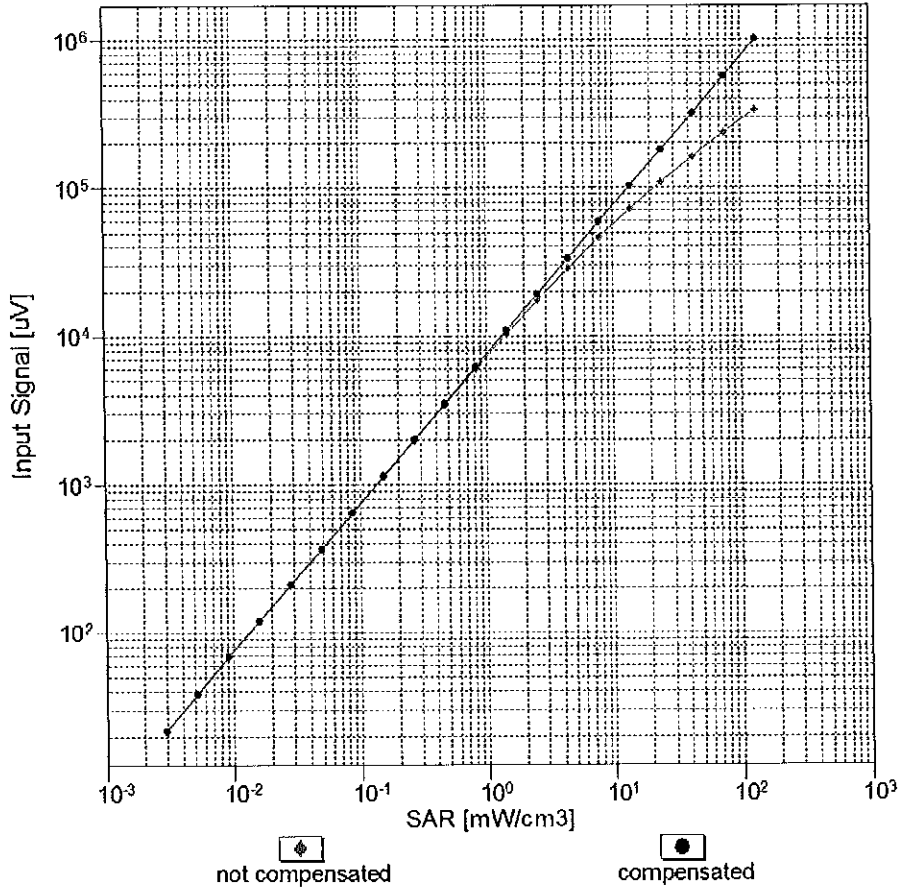

Uncertainty of Linearity Assessment:  $\pm 0.6\%$  (k=2)

# Conversion Factor Assessment

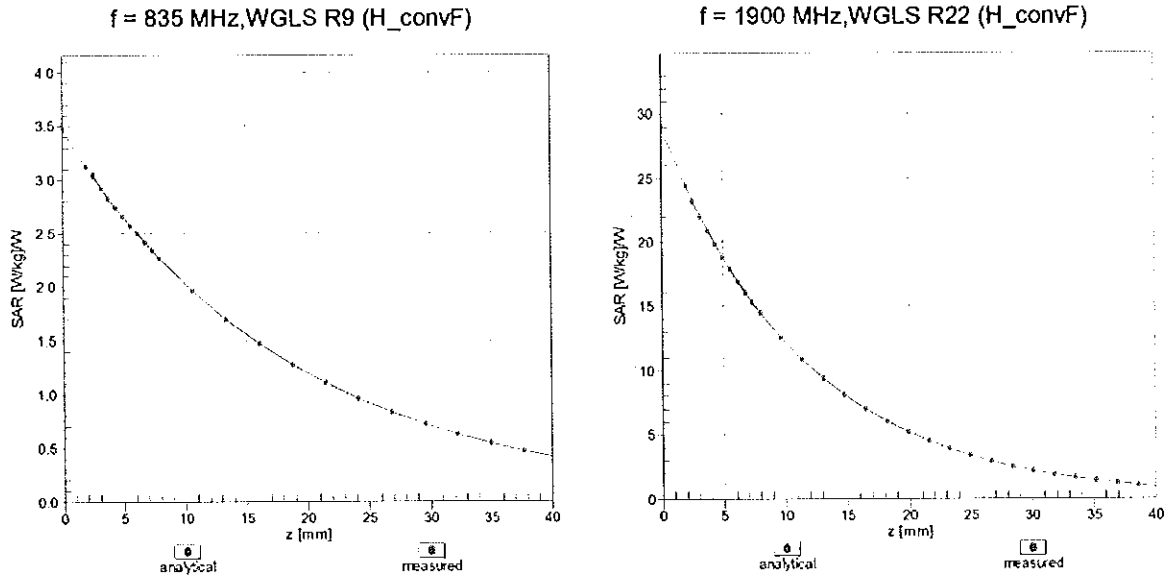

## Deviation from Isotropy in Liquid Error ( $\phi, \vartheta$ ), f = 900 MHz

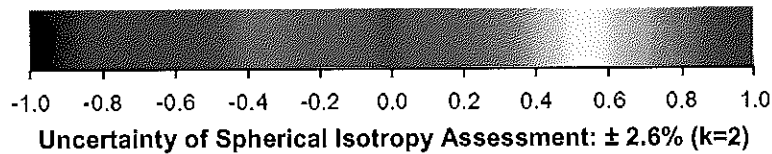
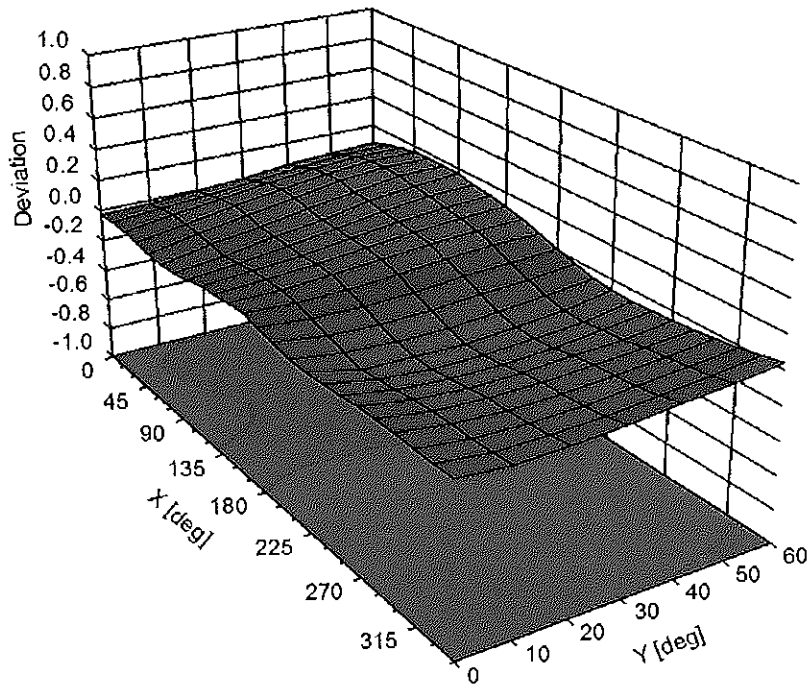

**DASY/EASY - Parameters of Probe: ES3DV3 - SN:3213****Other Probe Parameters**

Sensor Arrangement	Triangular
Connector Angle (°)	98.2
Mechanical Surface Detection Mode	enabled
Optical Surface Detection Mode	disabled
Probe Overall Length	337 mm
Probe Body Diameter	10 mm
Tip Length	10 mm
Tip Diameter	4 mm
Probe Tip to Sensor X Calibration Point	2 mm
Probe Tip to Sensor Y Calibration Point	2 mm
Probe Tip to Sensor Z Calibration Point	2 mm
Recommended Measurement Distance from Surface	3 mm

**Appendix: Modulation Calibration Parameters**

UID	Communication System Name		A dB	B dB $\sqrt{\mu V}$	C	D dB	VR mV	Max Unc <sup>E</sup> (k=2)
0	CW	X	0.00	0.00	1.00	0.00	228.2	± 3.5 %
		Y	0.00	0.00	1.00		230.0	
		Z	0.00	0.00	1.00		221.7	
10010- CAA	SAR Validation (Square, 100ms, 10ms)	X	11.07	84.26	20.62	10.00	25.0	± 9.6 %
		Y	10.49	83.36	20.27		25.0	
		Z	11.03	84.22	20.43		25.0	
10011- CAB	UMTS-FDD (WCDMA)	X	1.04	66.65	14.82	0.00	150.0	± 9.6 %
		Y	1.16	69.13	16.33		150.0	
		Z	1.01	66.30	14.54		150.0	
10012- CAB	IEEE 802.11b WiFi 2.4 GHz (DSSS, 1 Mbps)	X	1.30	64.60	15.49	0.41	150.0	± 9.6 %
		Y	1.33	65.49	16.22		150.0	
		Z	1.28	64.47	15.36		150.0	
10013- CAB	IEEE 802.11g WiFi 2.4 GHz (DSSS-OFDM, 6 Mbps)	X	5.14	67.15	17.39	1.46	150.0	± 9.6 %
		Y	5.14	67.35	17.57		150.0	
		Z	5.09	67.17	17.37		150.0	
10021- DAC	GSM-FDD (TDMA, GMSK)	X	62.94	114.81	31.61	9.39	50.0	± 9.6 %
		Y	41.95	107.82	29.66		50.0	
		Z	94.76	121.25	33.03		50.0	
10023- DAC	GPRS-FDD (TDMA, GMSK, TN 0)	X	46.50	109.76	30.33	9.57	50.0	± 9.6 %
		Y	33.70	104.15	28.69		50.0	
		Z	62.69	114.46	31.37		50.0	
10024- DAC	GPRS-FDD (TDMA, GMSK, TN 0-1)	X	100.00	119.19	30.75	6.56	60.0	± 9.6 %
		Y	100.00	118.97	30.64		60.0	
		Z	100.00	118.83	30.48		60.0	
10025- DAC	EDGE-FDD (TDMA, 8PSK, TN 0)	X	18.95	107.68	41.29	12.57	50.0	± 9.6 %
		Y	31.91	124.81	47.58		50.0	
		Z	17.05	104.98	40.36		50.0	
10026- DAC	EDGE-FDD (TDMA, 8PSK, TN 0-1)	X	20.29	105.23	36.57	9.56	60.0	± 9.6 %
		Y	28.92	114.92	39.99		60.0	
		Z	20.11	105.49	36.71		60.0	
10027- DAC	GPRS-FDD (TDMA, GMSK, TN 0-1-2)	X	100.00	118.17	29.38	4.80	80.0	± 9.6 %
		Y	100.00	118.12	29.34		80.0	
		Z	100.00	117.81	29.12		80.0	
10028- DAC	GPRS-FDD (TDMA, GMSK, TN 0-1-2-3)	X	100.00	118.40	28.68	3.55	100.0	± 9.6 %
		Y	100.00	118.60	28.76		100.0	
		Z	100.00	118.00	28.41		100.0	
10029- DAC	EDGE-FDD (TDMA, 8PSK, TN 0-1-2)	X	12.78	94.46	31.72	7.80	80.0	± 9.6 %
		Y	16.27	100.85	34.22		80.0	
		Z	12.37	94.11	31.64		80.0	
10030- CAA	IEEE 802.15.1 Bluetooth (GFSK, DH1)	X	100.00	117.61	29.45	5.30	70.0	± 9.6 %
		Y	100.00	117.52	29.40		70.0	
		Z	100.00	117.17	29.14		70.0	
10031- CAA	IEEE 802.15.1 Bluetooth (GFSK, DH3)	X	100.00	119.11	27.47	1.88	100.0	± 9.6 %
		Y	100.00	120.30	27.96		100.0	
		Z	100.00	118.27	27.02		100.0	

10032-CAA	IEEE 802.15.1 Bluetooth (GFSK, DH5)	X	100.00	123.13	28.10	1.17	100.0	± 9.6 %
		Y	100.00	125.86	29.19		100.0	
		Z	100.00	121.81	27.46		100.0	
10033-CAA	IEEE 802.15.1 Bluetooth (PI/4-DQPSK, DH1)	X	19.81	99.27	27.58	5.30	70.0	± 9.6 %
		Y	23.75	102.32	28.48		70.0	
		Z	20.10	99.19	27.31		70.0	
10034-CAA	IEEE 802.15.1 Bluetooth (PI/4-DQPSK, DH3)	X	6.18	84.61	21.36	1.88	100.0	± 9.6 %
		Y	8.74	90.01	23.19		100.0	
		Z	6.07	84.02	20.83		100.0	
10035-CAA	IEEE 802.15.1 Bluetooth (PI/4-DQPSK, DH5)	X	3.50	78.04	18.75	1.17	100.0	± 9.6 %
		Y	4.77	82.88	20.59		100.0	
		Z	3.40	77.42	18.19		100.0	
10036-CAA	IEEE 802.15.1 Bluetooth (8-DPSK, DH1)	X	25.06	103.36	28.83	5.30	70.0	± 9.6 %
		Y	30.48	106.66	29.76		70.0	
		Z	25.78	103.46	28.61		70.0	
10037-CAA	IEEE 802.15.1 Bluetooth (8-DPSK, DH3)	X	5.91	84.02	21.13	1.88	100.0	± 9.6 %
		Y	8.37	89.43	22.97		100.0	
		Z	5.74	83.28	20.55		100.0	
10038-CAA	IEEE 802.15.1 Bluetooth (8-DPSK, DH5)	X	3.58	78.59	19.05	1.17	100.0	± 9.6 %
		Y	4.93	83.62	20.94		100.0	
		Z	3.47	77.94	18.48		100.0	
10039-CAB	CDMA2000 (1xRTT, RC1)	X	1.75	70.49	15.41	0.00	150.0	± 9.6 %
		Y	2.11	73.63	16.88		150.0	
		Z	1.63	69.80	14.78		150.0	
10042-CAB	IS-54 / IS-136 FDD (TDMA/FDM, PI/4-DQPSK, Halfrate)	X	100.00	117.99	30.44	7.78	50.0	± 9.6 %
		Y	100.00	117.70	30.30		50.0	
		Z	100.00	117.57	30.13		50.0	
10044-CAA	IS-91/EIA/TIA-553 FDD (FDMA, FM)	X	0.01	92.86	0.28	0.00	150.0	± 9.6 %
		Y	0.00	128.30	10.22		150.0	
		Z	0.01	91.94	0.27		150.0	
10048-CAA	DECT (TDD, TDMA/FDM, GFSK, Full Slot, 24)	X	16.43	91.36	26.72	13.80	25.0	± 9.6 %
		Y	14.26	88.55	25.69		25.0	
		Z	18.21	93.36	27.20		25.0	
10049-CAA	DECT (TDD, TDMA/FDM, GFSK, Double Slot, 12)	X	21.81	96.95	27.09	10.79	40.0	± 9.6 %
		Y	18.36	93.74	25.99		40.0	
		Z	24.94	99.20	27.59		40.0	
10056-CAA	UMTS-TDD (TD-SCDMA, 1.28 Mcps)	X	16.12	92.43	26.40	9.03	50.0	± 9.6 %
		Y	16.40	92.69	26.46		50.0	
		Z	16.84	93.23	26.48		50.0	
10058-DAC	EDGE-FDD (TDMA, 8PSK, TN 0-1-2-3)	X	9.13	87.64	28.49	6.55	100.0	± 9.6 %
		Y	10.85	92.11	30.40		100.0	
		Z	8.80	87.14	28.33		100.0	
10059-CAB	IEEE 802.11b WiFi 2.4 GHz (DSSS, 2 Mbps)	X	1.45	66.53	16.46	0.61	110.0	± 9.6 %
		Y	1.51	67.75	17.33		110.0	
		Z	1.43	66.36	16.31		110.0	
10060-CAB	IEEE 802.11b WiFi 2.4 GHz (DSSS, 5.5 Mbps)	X	71.32	126.43	32.69	1.30	110.0	± 9.6 %
		Y	100.00	133.00	34.47		110.0	
		Z	56.46	122.77	31.74		110.0	

10061-CAB	IEEE 802.11b WiFi 2.4 GHz (DSSS, 11 Mbps)	X	7.70	91.83	25.70	2.04	110.0	± 9.6 %
		Y	12.85	101.15	28.77		110.0	
		Z	7.42	91.30	25.47		110.0	
10062-CAB	IEEE 802.11a/h WiFi 5 GHz (OFDM, 6 Mbps)	X	4.86	66.91	16.67	0.49	100.0	± 9.6 %
		Y	4.87	67.10	16.85		100.0	
		Z	4.81	66.91	16.64		100.0	
10063-CAB	IEEE 802.11a/h WiFi 5 GHz (OFDM, 9 Mbps)	X	4.90	67.06	16.81	0.72	100.0	± 9.6 %
		Y	4.91	67.26	16.99		100.0	
		Z	4.85	67.06	16.78		100.0	
10064-CAB	IEEE 802.11a/h WiFi 5 GHz (OFDM, 12 Mbps)	X	5.22	67.40	17.08	0.86	100.0	± 9.6 %
		Y	5.23	67.59	17.25		100.0	
		Z	5.16	67.38	17.04		100.0	
10065-CAB	IEEE 802.11a/h WiFi 5 GHz (OFDM, 18 Mbps)	X	5.12	67.42	17.25	1.21	100.0	± 9.6 %
		Y	5.13	67.61	17.43		100.0	
		Z	5.06	67.40	17.21		100.0	
10066-CAB	IEEE 802.11a/h WiFi 5 GHz (OFDM, 24 Mbps)	X	5.18	67.55	17.48	1.46	100.0	± 9.6 %
		Y	5.19	67.76	17.66		100.0	
		Z	5.11	67.52	17.44		100.0	
10067-CAB	IEEE 802.11a/h WiFi 5 GHz (OFDM, 36 Mbps)	X	5.50	67.74	17.95	2.04	100.0	± 9.6 %
		Y	5.51	67.96	18.15		100.0	
		Z	5.44	67.76	17.93		100.0	
10068-CAB	IEEE 802.11a/h WiFi 5 GHz (OFDM, 48 Mbps)	X	5.63	68.06	18.32	2.55	100.0	± 9.6 %
		Y	5.64	68.30	18.53		100.0	
		Z	5.56	68.03	18.28		100.0	
10069-CAB	IEEE 802.11a/h WiFi 5 GHz (OFDM, 54 Mbps)	X	5.71	68.03	18.50	2.67	100.0	± 9.6 %
		Y	5.72	68.29	18.74		100.0	
		Z	5.64	68.03	18.48		100.0	
10071-CAB	IEEE 802.11g WiFi 2.4 GHz (DSSS/OFDM, 9 Mbps)	X	5.28	67.38	17.78	1.99	100.0	± 9.6 %
		Y	5.29	67.59	17.97		100.0	
		Z	5.23	67.40	17.76		100.0	
10072-CAB	IEEE 802.11g WiFi 2.4 GHz (DSSS/OFDM, 12 Mbps)	X	5.33	67.91	18.09	2.30	100.0	± 9.6 %
		Y	5.34	68.14	18.30		100.0	
		Z	5.28	67.91	18.07		100.0	
10073-CAB	IEEE 802.11g WiFi 2.4 GHz (DSSS/OFDM, 18 Mbps)	X	5.46	68.24	18.51	2.83	100.0	± 9.6 %
		Y	5.48	68.51	18.74		100.0	
		Z	5.40	68.25	18.50		100.0	
10074-CAB	IEEE 802.11g WiFi 2.4 GHz (DSSS/OFDM, 24 Mbps)	X	5.49	68.30	18.76	3.30	100.0	± 9.6 %
		Y	5.51	68.58	19.00		100.0	
		Z	5.44	68.31	18.74		100.0	
10075-CAB	IEEE 802.11g WiFi 2.4 GHz (DSSS/OFDM, 36 Mbps)	X	5.63	68.74	19.25	3.82	90.0	± 9.6 %
		Y	5.66	69.06	19.51		90.0	
		Z	5.57	68.71	19.21		90.0	
10076-CAB	IEEE 802.11g WiFi 2.4 GHz (DSSS/OFDM, 48 Mbps)	X	5.64	68.56	19.38	4.15	90.0	± 9.6 %
		Y	5.68	68.89	19.66		90.0	
		Z	5.60	68.57	19.36		90.0	
10077-CAB	IEEE 802.11g WiFi 2.4 GHz (DSSS/OFDM, 54 Mbps)	X	5.68	68.64	19.49	4.30	90.0	± 9.6 %
		Y	5.71	68.99	19.77		90.0	
		Z	5.64	68.66	19.47		90.0	

10081-CAB	CDMA2000 (1xRTT, RC3)	X	0.88	65.55	12.70	0.00	150.0	± 9.6 %
		Y	1.01	67.94	14.05		150.0	
		Z	0.82	64.98	12.07		150.0	
10082-CAB	IS-54 / IS-136 FDD (TDMA/FDM, PI/4-DQPSK, Fullrate)	X	2.05	63.91	8.77	4.77	80.0	± 9.6 %
		Y	2.06	64.02	8.81		80.0	
		Z	1.95	63.58	8.48		80.0	
10090-DAC	GPRS-FDD (TDMA, GMSK, TN 0-4)	X	100.00	119.26	30.80	6.56	60.0	± 9.6 %
		Y	100.00	119.04	30.70		60.0	
		Z	100.00	118.90	30.53		60.0	
10097-CAB	UMTS-FDD (HSDPA)	X	1.83	67.01	15.38	0.00	150.0	± 9.6 %
		Y	1.91	68.15	16.11		150.0	
		Z	1.80	66.92	15.21		150.0	
10098-CAB	UMTS-FDD (HSUPA, Subtest 2)	X	1.79	66.97	15.34	0.00	150.0	± 9.6 %
		Y	1.88	68.14	16.10		150.0	
		Z	1.76	66.87	15.18		150.0	
10099-DAC	EDGE-FDD (TDMA, 8PSK, TN 0-4)	X	20.23	105.10	36.53	9.56	60.0	± 9.6 %
		Y	28.70	114.68	39.91		60.0	
		Z	20.06	105.38	36.67		60.0	
10100-CAC	LTE-FDD (SC-FDMA, 100% RB, 20 MHz, QPSK)	X	3.16	69.99	16.45	0.00	150.0	± 9.6 %
		Y	3.31	71.03	17.06		150.0	
		Z	3.09	69.73	16.33		150.0	
10101-CAC	LTE-FDD (SC-FDMA, 100% RB, 20 MHz, 16-QAM)	X	3.32	67.51	15.87	0.00	150.0	± 9.6 %
		Y	3.38	68.00	16.23		150.0	
		Z	3.27	67.36	15.78		150.0	
10102-CAC	LTE-FDD (SC-FDMA, 100% RB, 20 MHz, 64-QAM)	X	3.43	67.46	15.96	0.00	150.0	± 9.6 %
		Y	3.47	67.89	16.28		150.0	
		Z	3.37	67.33	15.88		150.0	
10103-CAC	LTE-TDD (SC-FDMA, 100% RB, 20 MHz, QPSK)	X	8.65	78.54	21.48	3.98	65.0	± 9.6 %
		Y	8.85	79.12	21.77		65.0	
		Z	8.48	78.45	21.46		65.0	
10104-CAC	LTE-TDD (SC-FDMA, 100% RB, 20 MHz, 16-QAM)	X	8.46	76.91	21.67	3.98	65.0	± 9.6 %
		Y	8.66	77.60	22.06		65.0	
		Z	8.34	76.89	21.66		65.0	
10105-CAC	LTE-TDD (SC-FDMA, 100% RB, 20 MHz, 64-QAM)	X	7.58	74.70	20.99	3.98	65.0	± 9.6 %
		Y	7.79	75.45	21.40		65.0	
		Z	7.31	74.25	20.79		65.0	
10108-CAD	LTE-FDD (SC-FDMA, 100% RB, 10 MHz, QPSK)	X	2.79	69.24	16.28	0.00	150.0	± 9.6 %
		Y	2.91	70.28	16.91		150.0	
		Z	2.71	69.00	16.16		150.0	
10109-CAD	LTE-FDD (SC-FDMA, 100% RB, 10 MHz, 16-QAM)	X	2.98	67.28	15.76	0.00	150.0	± 9.6 %
		Y	3.03	67.83	16.15		150.0	
		Z	2.92	67.15	15.65		150.0	
10110-CAD	LTE-FDD (SC-FDMA, 100% RB, 5 MHz, QPSK)	X	2.28	68.31	15.91	0.00	150.0	± 9.6 %
		Y	2.39	69.47	16.63		150.0	
		Z	2.21	68.09	15.75		150.0	
10111-CAD	LTE-FDD (SC-FDMA, 100% RB, 5 MHz, 16-QAM)	X	2.66	67.75	15.94	0.00	150.0	± 9.6 %
		Y	2.72	68.40	16.37		150.0	
		Z	2.60	67.66	15.80		150.0	

10112-CAD	LTE-FDD (SC-FDMA, 100% RB, 10 MHz, 64-QAM)	X	3.11	67.26	15.82	0.00	150.0	± 9.6 %
		Y	3.15	67.75	16.17		150.0	
		Z	3.05	67.15	15.72		150.0	
10113-CAD	LTE-FDD (SC-FDMA, 100% RB, 5 MHz, 64-QAM)	X	2.82	67.88	16.07	0.00	150.0	± 9.6 %
		Y	2.87	68.46	16.46		150.0	
		Z	2.76	67.81	15.94		150.0	
10114-CAB	IEEE 802.11n (HT Greenfield, 13.5 Mbps, BPSK)	X	5.24	67.28	16.46	0.00	150.0	± 9.6 %
		Y	5.25	67.46	16.63		150.0	
		Z	5.20	67.29	16.46		150.0	
10115-CAB	IEEE 802.11n (HT Greenfield, 81 Mbps, 16-QAM)	X	5.61	67.64	16.65	0.00	150.0	± 9.6 %
		Y	5.61	67.79	16.81		150.0	
		Z	5.52	67.52	16.58		150.0	
10116-CAB	IEEE 802.11n (HT Greenfield, 135 Mbps, 64-QAM)	X	5.36	67.55	16.52	0.00	150.0	± 9.6 %
		Y	5.37	67.74	16.69		150.0	
		Z	5.32	67.53	16.51		150.0	
10117-CAB	IEEE 802.11n (HT Mixed, 13.5 Mbps, BPSK)	X	5.22	67.23	16.45	0.00	150.0	± 9.6 %
		Y	5.23	67.39	16.61		150.0	
		Z	5.17	67.16	16.41		150.0	
10118-CAB	IEEE 802.11n (HT Mixed, 81 Mbps, 16-QAM)	X	5.69	67.85	16.77	0.00	150.0	± 9.6 %
		Y	5.70	68.02	16.93		150.0	
		Z	5.63	67.79	16.73		150.0	
10119-CAB	IEEE 802.11n (HT Mixed, 135 Mbps, 64-QAM)	X	5.34	67.49	16.51	0.00	150.0	± 9.6 %
		Y	5.35	67.67	16.67		150.0	
		Z	5.29	67.47	16.49		150.0	
10140-CAC	LTE-FDD (SC-FDMA, 100% RB, 15 MHz, 16-QAM)	X	3.47	67.47	15.89	0.00	150.0	± 9.6 %
		Y	3.51	67.91	16.21		150.0	
		Z	3.41	67.34	15.80		150.0	
10141-CAC	LTE-FDD (SC-FDMA, 100% RB, 15 MHz, 64-QAM)	X	3.59	67.54	16.05	0.00	150.0	± 9.6 %
		Y	3.63	67.94	16.35		150.0	
		Z	3.53	67.43	15.97		150.0	
10142-CAD	LTE-FDD (SC-FDMA, 100% RB, 3 MHz, QPSK)	X	2.05	68.16	15.60	0.00	150.0	± 9.6 %
		Y	2.17	69.48	16.39		150.0	
		Z	1.97	67.92	15.36		150.0	
10143-CAD	LTE-FDD (SC-FDMA, 100% RB, 3 MHz, 16-QAM)	X	2.51	68.28	15.68	0.00	150.0	± 9.6 %
		Y	2.59	69.11	16.17		150.0	
		Z	2.43	68.15	15.43		150.0	
10144-CAD	LTE-FDD (SC-FDMA, 100% RB, 3 MHz, 64-QAM)	X	2.35	66.54	14.37	0.00	150.0	± 9.6 %
		Y	2.42	67.28	14.84		150.0	
		Z	2.27	66.32	14.07		150.0	
10145-CAD	LTE-FDD (SC-FDMA, 100% RB, 1.4 MHz, QPSK)	X	1.37	65.72	12.66	0.00	150.0	± 9.6 %
		Y	1.46	66.99	13.37		150.0	
		Z	1.25	64.89	11.82		150.0	
10146-CAD	LTE-FDD (SC-FDMA, 100% RB, 1.4 MHz, 16-QAM)	X	3.11	71.69	15.06	0.00	150.0	± 9.6 %
		Y	3.87	74.93	16.48		150.0	
		Z	2.20	67.57	12.72		150.0	
10147-CAD	LTE-FDD (SC-FDMA, 100% RB, 1.4 MHz, 64-QAM)	X	3.99	75.14	16.65	0.00	150.0	± 9.6 %
		Y	5.26	79.21	18.27		150.0	
		Z	2.59	69.69	13.85		150.0	



10149-CAC	LTE-FDD (SC-FDMA, 50% RB, 20 MHz, 16-QAM)	X	2.99	67.34	15.80	0.00	150.0	± 9.6 %
		Y	3.04	67.88	16.19		150.0	
		Z	2.93	67.20	15.70		150.0	
10150-CAC	LTE-FDD (SC-FDMA, 50% RB, 20 MHz, 64-QAM)	X	3.11	67.30	15.85	0.00	150.0	± 9.6 %
		Y	3.16	67.79	16.21		150.0	
		Z	3.05	67.19	15.76		150.0	
10151-CAC	LTE-TDD (SC-FDMA, 50% RB, 20 MHz, QPSK)	X	9.14	80.78	22.44	3.98	65.0	± 9.6 %
		Y	9.49	81.66	22.85		65.0	
		Z	9.14	81.08	22.55		65.0	
10152-CAC	LTE-TDD (SC-FDMA, 50% RB, 20 MHz, 16-QAM)	X	8.08	77.12	21.52	3.98	65.0	± 9.6 %
		Y	8.33	77.95	21.96		65.0	
		Z	7.95	77.09	21.46		65.0	
10153-CAC	LTE-TDD (SC-FDMA, 50% RB, 20 MHz, 64-QAM)	X	8.46	77.89	22.17	3.98	65.0	± 9.6 %
		Y	8.68	78.63	22.56		65.0	
		Z	8.36	77.94	22.15		65.0	
10154-CAD	LTE-FDD (SC-FDMA, 50% RB, 10 MHz, QPSK)	X	2.33	68.67	16.15	0.00	150.0	± 9.6 %
		Y	2.44	69.83	16.86		150.0	
		Z	2.25	68.43	15.98		150.0	
10155-CAD	LTE-FDD (SC-FDMA, 50% RB, 10 MHz, 16-QAM)	X	2.66	67.76	15.95	0.00	150.0	± 9.6 %
		Y	2.72	68.41	16.38		150.0	
		Z	2.60	67.68	15.82		150.0	
10156-CAD	LTE-FDD (SC-FDMA, 50% RB, 5 MHz, QPSK)	X	1.90	68.21	15.44	0.00	150.0	± 9.6 %
		Y	2.03	69.70	16.30		150.0	
		Z	1.81	67.89	15.12		150.0	
10157-CAD	LTE-FDD (SC-FDMA, 50% RB, 5 MHz, 16-QAM)	X	2.18	67.00	14.41	0.00	150.0	± 9.6 %
		Y	2.26	67.93	14.96		150.0	
		Z	2.09	66.73	14.04		150.0	
10158-CAD	LTE-FDD (SC-FDMA, 50% RB, 10 MHz, 64-QAM)	X	2.82	67.92	16.11	0.00	150.0	± 9.6 %
		Y	2.87	68.51	16.50		150.0	
		Z	2.76	67.86	15.98		150.0	
10159-CAD	LTE-FDD (SC-FDMA, 50% RB, 5 MHz, 64-QAM)	X	2.28	67.39	14.67	0.00	150.0	± 9.6 %
		Y	2.36	68.28	15.19		150.0	
		Z	2.18	67.11	14.29		150.0	
10160-CAC	LTE-FDD (SC-FDMA, 50% RB, 15 MHz, QPSK)	X	2.82	68.45	16.16	0.00	150.0	± 9.6 %
		Y	2.91	69.30	16.70		150.0	
		Z	2.76	68.35	16.07		150.0	
10161-CAC	LTE-FDD (SC-FDMA, 50% RB, 15 MHz, 16-QAM)	X	3.01	67.20	15.78	0.00	150.0	± 9.6 %
		Y	3.05	67.71	16.14		150.0	
		Z	2.95	67.10	15.68		150.0	
10162-CAC	LTE-FDD (SC-FDMA, 50% RB, 15 MHz, 64-QAM)	X	3.11	67.31	15.88	0.00	150.0	± 9.6 %
		Y	3.16	67.80	16.23		150.0	
		Z	3.06	67.24	15.78		150.0	
10166-CAD	LTE-FDD (SC-FDMA, 50% RB, 1.4 MHz, QPSK)	X	3.96	70.63	19.76	3.01	150.0	± 9.6 %
		Y	4.08	71.58	20.41		150.0	
		Z	3.69	69.63	19.19		150.0	
10167-CAD	LTE-FDD (SC-FDMA, 50% RB, 1.4 MHz, 16-QAM)	X	5.16	74.36	20.54	3.01	150.0	± 9.6 %
		Y	5.47	75.92	21.41		150.0	
		Z	4.54	72.52	19.67		150.0	

10168-CAD	LTE-FDD (SC-FDMA, 50% RB, 1.4 MHz, 64-QAM)	X	5.71	76.55	21.79	3.01	150.0	± 9.6 %
		Y	6.04	78.08	22.60		150.0	
		Z	4.98	74.53	20.87		150.0	
10169-CAC	LTE-FDD (SC-FDMA, 1 RB, 20 MHz, QPSK)	X	3.56	71.66	20.23	3.01	150.0	± 9.6 %
		Y	3.72	73.10	21.16		150.0	
		Z	3.12	69.36	19.09		150.0	
10170-CAC	LTE-FDD (SC-FDMA, 1 RB, 20 MHz, 16-QAM)	X	5.50	79.49	23.11	3.01	150.0	± 9.6 %
		Y	6.14	82.25	24.43		150.0	
		Z	4.23	74.96	21.26		150.0	
10171-AAC	LTE-FDD (SC-FDMA, 1 RB, 20 MHz, 64-QAM)	X	4.39	74.63	20.21	3.01	150.0	± 9.6 %
		Y	4.87	77.16	21.52		150.0	
		Z	3.55	71.26	18.74		150.0	
10172-CAC	LTE-TDD (SC-FDMA, 1 RB, 20 MHz, QPSK)	X	36.90	115.61	35.71	6.02	65.0	± 9.6 %
		Y	89.16	134.58	40.97		65.0	
		Z	21.04	105.02	32.65		65.0	
10173-CAC	LTE-TDD (SC-FDMA, 1 RB, 20 MHz, 16-QAM)	X	54.93	117.26	34.23	6.02	65.0	± 9.6 %
		Y	100.00	128.92	37.35		65.0	
		Z	30.85	107.44	31.57		65.0	
10174-CAC	LTE-TDD (SC-FDMA, 1 RB, 20 MHz, 64-QAM)	X	39.60	109.76	31.68	6.02	65.0	± 9.6 %
		Y	70.95	120.74	34.73		65.0	
		Z	23.48	101.22	29.25		65.0	
10175-CAD	LTE-FDD (SC-FDMA, 1 RB, 10 MHz, QPSK)	X	3.51	71.32	19.98	3.01	150.0	± 9.6 %
		Y	3.68	72.77	20.92		150.0	
		Z	3.08	69.09	18.87		150.0	
10176-CAD	LTE-FDD (SC-FDMA, 1 RB, 10 MHz, 16-QAM)	X	5.51	79.52	23.12	3.01	150.0	± 9.6 %
		Y	6.15	82.28	24.44		150.0	
		Z	4.23	74.98	21.27		150.0	
10177-CAF	LTE-FDD (SC-FDMA, 1 RB, 5 MHz, QPSK)	X	3.54	71.49	20.08	3.01	150.0	± 9.6 %
		Y	3.71	72.93	21.01		150.0	
		Z	3.11	69.22	18.95		150.0	
10178-CAD	LTE-FDD (SC-FDMA, 1 RB, 5 MHz, 16-QAM)	X	5.43	79.21	22.98	3.01	150.0	± 9.6 %
		Y	6.06	81.97	24.30		150.0	
		Z	4.19	74.78	21.16		150.0	
10179-CAD	LTE-FDD (SC-FDMA, 1 RB, 10 MHz, 64-QAM)	X	4.90	76.90	21.51	3.01	150.0	± 9.6 %
		Y	5.47	79.59	22.84		150.0	
		Z	3.86	73.02	19.88		150.0	
10180-CAD	LTE-FDD (SC-FDMA, 1 RB, 5 MHz, 64-QAM)	X	4.38	74.54	20.15	3.01	150.0	± 9.6 %
		Y	4.86	77.07	21.46		150.0	
		Z	3.54	71.20	18.69		150.0	
10181-CAC	LTE-FDD (SC-FDMA, 1 RB, 15 MHz, QPSK)	X	3.54	71.47	20.07	3.01	150.0	± 9.6 %
		Y	3.70	72.91	21.00		150.0	
		Z	3.10	69.21	18.95		150.0	
10182-CAC	LTE-FDD (SC-FDMA, 1 RB, 15 MHz, 16-QAM)	X	5.42	79.19	22.97	3.01	150.0	± 9.6 %
		Y	6.05	81.94	24.29		150.0	
		Z	4.19	74.76	21.15		150.0	
10183-AAB	LTE-FDD (SC-FDMA, 1 RB, 15 MHz, 64-QAM)	X	4.37	74.51	20.14	3.01	150.0	± 9.6 %
		Y	4.85	77.04	21.45		150.0	
		Z	3.53	71.17	18.68		150.0	

10184-CAD	LTE-FDD (SC-FDMA, 1 RB, 3 MHz, QPSK)	X	3.55	71.52	20.09	3.01	150.0	± 9.6 %
		Y	3.72	72.96	21.02		150.0	
		Z	3.11	69.25	18.97		150.0	
10185-CAD	LTE-FDD (SC-FDMA, 1 RB, 3 MHz, 16-QAM)	X	5.45	79.27	23.00	3.01	150.0	± 9.6 %
		Y	6.09	82.03	24.33		150.0	
		Z	4.20	74.82	21.19		150.0	
10186-AAD	LTE-FDD (SC-FDMA, 1 RB, 3 MHz, 64-QAM)	X	4.39	74.59	20.17	3.01	150.0	± 9.6 %
		Y	4.88	77.13	21.49		150.0	
		Z	3.55	71.24	18.71		150.0	
10187-CAD	LTE-FDD (SC-FDMA, 1 RB, 1.4 MHz, QPSK)	X	3.56	71.57	20.15	3.01	150.0	± 9.6 %
		Y	3.73	73.01	21.08		150.0	
		Z	3.12	69.30	19.03		150.0	
10188-CAD	LTE-FDD (SC-FDMA, 1 RB, 1.4 MHz, 16-QAM)	X	5.67	80.08	23.42	3.01	150.0	± 9.6 %
		Y	6.33	82.86	24.73		150.0	
		Z	4.33	75.42	21.53		150.0	
10189-AAD	LTE-FDD (SC-FDMA, 1 RB, 1.4 MHz, 64-QAM)	X	4.51	75.09	20.47	3.01	150.0	± 9.6 %
		Y	5.01	77.67	21.79		150.0	
		Z	3.62	71.63	18.97		150.0	
10193-CAB	IEEE 802.11n (HT Greenfield, 6.5 Mbps, BPSK)	X	4.64	66.65	16.17	0.00	150.0	± 9.6 %
		Y	4.65	66.84	16.35		150.0	
		Z	4.59	66.64	16.13		150.0	
10194-CAB	IEEE 802.11n (HT Greenfield, 39 Mbps, 16-QAM)	X	4.82	67.00	16.30	0.00	150.0	± 9.6 %
		Y	4.83	67.19	16.48		150.0	
		Z	4.76	66.96	16.26		150.0	
10195-CAB	IEEE 802.11n (HT Greenfield, 65 Mbps, 64-QAM)	X	4.87	67.02	16.31	0.00	150.0	± 9.6 %
		Y	4.87	67.22	16.49		150.0	
		Z	4.81	67.00	16.28		150.0	
10196-CAB	IEEE 802.11n (HT Mixed, 6.5 Mbps, BPSK)	X	4.65	66.74	16.20	0.00	150.0	± 9.6 %
		Y	4.66	66.93	16.38		150.0	
		Z	4.59	66.71	16.15		150.0	
10197-CAB	IEEE 802.11n (HT Mixed, 39 Mbps, 16-QAM)	X	4.84	67.02	16.31	0.00	150.0	± 9.6 %
		Y	4.85	67.22	16.49		150.0	
		Z	4.78	66.99	16.27		150.0	
10198-CAB	IEEE 802.11n (HT Mixed, 65 Mbps, 64-QAM)	X	4.87	67.04	16.32	0.00	150.0	± 9.6 %
		Y	4.88	67.24	16.50		150.0	
		Z	4.81	67.01	16.29		150.0	
10219-CAB	IEEE 802.11n (HT Mixed, 7.2 Mbps, BPSK)	X	4.60	66.74	16.16	0.00	150.0	± 9.6 %
		Y	4.61	66.94	16.34		150.0	
		Z	4.54	66.71	16.11		150.0	
10220-CAB	IEEE 802.11n (HT Mixed, 43.3 Mbps, 16-QAM)	X	4.84	67.00	16.31	0.00	150.0	± 9.6 %
		Y	4.84	67.20	16.48		150.0	
		Z	4.77	66.96	16.26		150.0	
10221-CAB	IEEE 802.11n (HT Mixed, 72.2 Mbps, 64-QAM)	X	4.88	66.97	16.31	0.00	150.0	± 9.6 %
		Y	4.89	67.16	16.49		150.0	
		Z	4.82	66.95	16.28		150.0	
10222-CAB	IEEE 802.11n (HT Mixed, 15 Mbps, BPSK)	X	5.20	67.24	16.45	0.00	150.0	± 9.6 %
		Y	5.21	67.41	16.61		150.0	
		Z	5.15	67.17	16.40		150.0	

10223-CAB	IEEE 802.11n (HT Mixed, 90 Mbps, 16-QAM)	X	5.54	67.51	16.61	0.00	150.0	± 9.6 %
		Y	5.54	67.65	16.76		150.0	
		Z	5.46	67.41	16.55		150.0	
10224-CAB	IEEE 802.11n (HT Mixed, 150 Mbps, 64-QAM)	X	5.24	67.33	16.42	0.00	150.0	± 9.6 %
		Y	5.25	67.50	16.58		150.0	
		Z	5.19	67.27	16.38		150.0	
10225-CAB	UMTS-FDD (HSPA+)	X	2.89	66.01	15.34	0.00	150.0	± 9.6 %
		Y	2.91	66.41	15.64		150.0	
		Z	2.83	65.96	15.20		150.0	
10226-CAA	LTE-TDD (SC-FDMA, 1 RB, 1.4 MHz, 16-QAM)	X	60.00	119.05	34.79	6.02	65.0	± 9.6 %
		Y	100.00	129.10	37.47		65.0	
		Z	33.08	108.86	32.05		65.0	
10227-CAA	LTE-TDD (SC-FDMA, 1 RB, 1.4 MHz, 64-QAM)	X	44.36	111.89	32.33	6.02	65.0	± 9.6 %
		Y	77.77	122.52	35.25		65.0	
		Z	27.85	104.26	30.19		65.0	
10228-CAA	LTE-TDD (SC-FDMA, 1 RB, 1.4 MHz, QPSK)	X	40.71	118.07	36.50	6.02	65.0	± 9.6 %
		Y	92.59	135.95	41.44		65.0	
		Z	26.22	109.78	34.13		65.0	
10229-CAB	LTE-TDD (SC-FDMA, 1 RB, 3 MHz, 16-QAM)	X	54.96	117.26	34.24	6.02	65.0	± 9.6 %
		Y	100.00	128.91	37.35		65.0	
		Z	30.93	107.47	31.58		65.0	
10230-CAB	LTE-TDD (SC-FDMA, 1 RB, 3 MHz, 64-QAM)	X	41.37	110.53	31.89	6.02	65.0	± 9.6 %
		Y	71.92	120.98	34.79		65.0	
		Z	26.25	103.12	29.80		65.0	
10231-CAB	LTE-TDD (SC-FDMA, 1 RB, 3 MHz, QPSK)	X	37.97	116.54	36.00	6.02	65.0	± 9.6 %
		Y	84.76	133.97	40.88		65.0	
		Z	24.71	108.49	33.69		65.0	
10232-CAC	LTE-TDD (SC-FDMA, 1 RB, 5 MHz, 16-QAM)	X	54.99	117.28	34.24	6.02	65.0	± 9.6 %
		Y	100.00	128.92	37.35		65.0	
		Z	30.92	107.48	31.58		65.0	
10233-CAC	LTE-TDD (SC-FDMA, 1 RB, 5 MHz, 64-QAM)	X	41.40	110.55	31.90	6.02	65.0	± 9.6 %
		Y	72.14	121.04	34.81		65.0	
		Z	26.24	103.13	29.80		65.0	
10234-CAC	LTE-TDD (SC-FDMA, 1 RB, 5 MHz, QPSK)	X	35.49	114.97	35.47	6.02	65.0	± 9.6 %
		Y	77.34	131.82	40.23		65.0	
		Z	23.39	107.20	33.21		65.0	
10235-CAC	LTE-TDD (SC-FDMA, 1 RB, 10 MHz, 16-QAM)	X	55.28	117.39	34.27	6.02	65.0	± 9.6 %
		Y	100.00	128.93	37.36		65.0	
		Z	31.03	107.56	31.61		65.0	
10236-CAC	LTE-TDD (SC-FDMA, 1 RB, 10 MHz, 64-QAM)	X	41.91	110.74	31.95	6.02	65.0	± 9.6 %
		Y	73.33	121.30	34.87		65.0	
		Z	26.52	103.28	29.84		65.0	
10237-CAC	LTE-TDD (SC-FDMA, 1 RB, 10 MHz, QPSK)	X	38.41	116.80	36.08	6.02	65.0	± 9.6 %
		Y	86.80	134.49	41.01		65.0	
		Z	24.91	108.68	33.74		65.0	
10238-CAC	LTE-TDD (SC-FDMA, 1 RB, 15 MHz, 16-QAM)	X	55.05	117.31	34.25	6.02	65.0	± 9.6 %
		Y	100.00	128.93	37.35		65.0	
		Z	30.91	107.49	31.58		65.0	

10239-CAC	LTE-TDD (SC-FDMA, 1 RB, 15 MHz, 64-QAM)	X	41.42	110.58	31.91	6.02	65.0	± 9.6 %
		Y	72.33	121.11	34.83		65.0	
		Z	26.22	103.13	29.80		65.0	
10240-CAC	LTE-TDD (SC-FDMA, 1 RB, 15 MHz, QPSK)	X	38.25	116.72	36.05	6.02	65.0	± 9.6 %
		Y	86.28	134.37	40.98		65.0	
		Z	24.82	108.62	33.73		65.0	
10241-CAA	LTE-TDD (SC-FDMA, 50% RB, 1.4 MHz, 16-QAM)	X	12.92	88.42	28.30	6.98	65.0	± 9.6 %
		Y	14.47	91.50	29.64		65.0	
		Z	11.71	86.68	27.54		65.0	
10242-CAA	LTE-TDD (SC-FDMA, 50% RB, 1.4 MHz, 64-QAM)	X	12.30	87.28	27.78	6.98	65.0	± 9.6 %
		Y	13.91	90.55	29.21		65.0	
		Z	10.78	84.84	26.74		65.0	
10243-CAA	LTE-TDD (SC-FDMA, 50% RB, 1.4 MHz, QPSK)	X	9.57	83.58	27.27	6.98	65.0	± 9.6 %
		Y	10.70	86.76	28.80		65.0	
		Z	8.63	81.57	26.33		65.0	
10244-CAB	LTE-TDD (SC-FDMA, 50% RB, 3 MHz, 16-QAM)	X	9.97	81.73	21.53	3.98	65.0	± 9.6 %
		Y	10.43	82.64	21.91		65.0	
		Z	8.76	79.58	20.36		65.0	
10245-CAB	LTE-TDD (SC-FDMA, 50% RB, 3 MHz, 64-QAM)	X	9.75	81.12	21.26	3.98	65.0	± 9.6 %
		Y	10.17	81.97	21.61		65.0	
		Z	8.56	78.97	20.07		65.0	
10246-CAB	LTE-TDD (SC-FDMA, 50% RB, 3 MHz, QPSK)	X	9.14	83.08	21.95	3.98	65.0	± 9.6 %
		Y	9.72	84.22	22.38		65.0	
		Z	8.89	82.67	21.56		65.0	
10247-CAC	LTE-TDD (SC-FDMA, 50% RB, 5 MHz, 16-QAM)	X	7.53	77.68	20.47	3.98	65.0	± 9.6 %
		Y	7.73	78.28	20.74		65.0	
		Z	7.33	77.37	20.13		65.0	
10248-CAC	LTE-TDD (SC-FDMA, 50% RB, 5 MHz, 64-QAM)	X	7.50	77.17	20.25	3.98	65.0	± 9.6 %
		Y	7.71	77.80	20.54		65.0	
		Z	7.27	76.81	19.89		65.0	
10249-CAC	LTE-TDD (SC-FDMA, 50% RB, 5 MHz, QPSK)	X	10.17	85.08	23.35	3.98	65.0	± 9.6 %
		Y	10.94	86.52	23.90		65.0	
		Z	10.18	85.27	23.26		65.0	
10250-CAC	LTE-TDD (SC-FDMA, 50% RB, 10 MHz, 16-QAM)	X	8.40	79.60	22.53	3.98	65.0	± 9.6 %
		Y	8.67	80.38	22.90		65.0	
		Z	8.32	79.67	22.46		65.0	
10251-CAC	LTE-TDD (SC-FDMA, 50% RB, 10 MHz, 64-QAM)	X	7.96	77.51	21.40	3.98	65.0	± 9.6 %
		Y	8.23	78.35	21.83		65.0	
		Z	7.84	77.49	21.29		65.0	
10252-CAC	LTE-TDD (SC-FDMA, 50% RB, 10 MHz, QPSK)	X	9.91	84.03	23.67	3.98	65.0	± 9.6 %
		Y	10.54	85.36	24.22		65.0	
		Z	9.99	84.47	23.78		65.0	
10253-CAC	LTE-TDD (SC-FDMA, 50% RB, 15 MHz, 16-QAM)	X	7.87	76.54	21.30	3.98	65.0	± 9.6 %
		Y	8.11	77.33	21.72		65.0	
		Z	7.77	76.53	21.24		65.0	
10254-CAC	LTE-TDD (SC-FDMA, 50% RB, 15 MHz, 64-QAM)	X	8.25	77.30	21.90	3.98	65.0	± 9.6 %
		Y	8.47	78.02	22.29		65.0	
		Z	8.16	77.35	21.86		65.0	

10255-CAC	LTE-TDD (SC-FDMA, 50% RB, 15 MHz, QPSK)	X	8.82	80.37	22.51	3.98	65.0	± 9.6 %
		Y	9.18	81.32	22.95		65.0	
		Z	8.82	80.67	22.60		65.0	
10256-CAA	LTE-TDD (SC-FDMA, 100% RB, 1.4 MHz, 16-QAM)	X	8.67	79.06	19.69	3.98	65.0	± 9.6 %
		Y	9.00	79.76	19.98		65.0	
		Z	7.35	76.40	18.22		65.0	
10257-CAA	LTE-TDD (SC-FDMA, 100% RB, 1.4 MHz, 64-QAM)	X	8.39	78.18	19.27	3.98	65.0	± 9.6 %
		Y	8.67	78.82	19.53		65.0	
		Z	7.11	75.57	17.80		65.0	
10258-CAA	LTE-TDD (SC-FDMA, 100% RB, 1.4 MHz, QPSK)	X	7.67	79.80	20.11	3.98	65.0	± 9.6 %
		Y	7.97	80.50	20.36		65.0	
		Z	7.13	78.64	19.35		65.0	
10259-CAB	LTE-TDD (SC-FDMA, 100% RB, 3 MHz, 16-QAM)	X	7.87	78.36	21.19	3.98	65.0	± 9.6 %
		Y	8.11	79.04	21.50		65.0	
		Z	7.72	78.21	20.96		65.0	
10260-CAB	LTE-TDD (SC-FDMA, 100% RB, 3 MHz, 64-QAM)	X	7.88	78.07	21.09	3.98	65.0	± 9.6 %
		Y	8.10	78.72	21.39		65.0	
		Z	7.71	77.89	20.85		65.0	
10261-CAB	LTE-TDD (SC-FDMA, 100% RB, 3 MHz, QPSK)	X	9.63	83.94	23.25	3.98	65.0	± 9.6 %
		Y	10.30	85.33	23.81		65.0	
		Z	9.64	84.17	23.22		65.0	
10262-CAC	LTE-TDD (SC-FDMA, 100% RB, 5 MHz, 16-QAM)	X	8.39	79.56	22.49	3.98	65.0	± 9.6 %
		Y	8.66	80.34	22.86		65.0	
		Z	8.31	79.62	22.42		65.0	
10263-CAC	LTE-TDD (SC-FDMA, 100% RB, 5 MHz, 64-QAM)	X	7.95	77.50	21.40	3.98	65.0	± 9.6 %
		Y	8.22	78.34	21.82		65.0	
		Z	7.83	77.47	21.29		65.0	
10264-CAC	LTE-TDD (SC-FDMA, 100% RB, 5 MHz, QPSK)	X	9.83	83.88	23.59	3.98	65.0	± 9.6 %
		Y	10.46	85.22	24.15		65.0	
		Z	9.91	84.30	23.70		65.0	
10265-CAC	LTE-TDD (SC-FDMA, 100% RB, 10 MHz, 16-QAM)	X	8.08	77.12	21.52	3.98	65.0	± 9.6 %
		Y	8.33	77.96	21.96		65.0	
		Z	7.95	77.09	21.47		65.0	
10266-CAC	LTE-TDD (SC-FDMA, 100% RB, 10 MHz, 64-QAM)	X	8.45	77.88	22.16	3.98	65.0	± 9.6 %
		Y	8.68	78.62	22.55		65.0	
		Z	8.36	77.93	22.14		65.0	
10267-CAC	LTE-TDD (SC-FDMA, 100% RB, 10 MHz, QPSK)	X	9.12	80.75	22.43	3.98	65.0	± 9.6 %
		Y	9.47	81.62	22.84		65.0	
		Z	9.12	81.04	22.54		65.0	
10268-CAC	LTE-TDD (SC-FDMA, 100% RB, 15 MHz, 16-QAM)	X	8.54	76.63	21.68	3.98	65.0	± 9.6 %
		Y	8.73	77.26	22.04		65.0	
		Z	8.44	76.63	21.67		65.0	
10269-CAC	LTE-TDD (SC-FDMA, 100% RB, 15 MHz, 64-QAM)	X	8.47	76.21	21.58	3.98	65.0	± 9.6 %
		Y	8.64	76.83	21.94		65.0	
		Z	8.37	76.22	21.56		65.0	
10270-CAC	LTE-TDD (SC-FDMA, 100% RB, 15 MHz, QPSK)	X	8.62	78.00	21.50	3.98	65.0	± 9.6 %
		Y	8.81	78.56	21.80		65.0	
		Z	8.57	78.16	21.57		65.0	

10274-CAB	UMTS-FDD (HSUPA, Subtest 5, 3GPP Rel8.10)	X	2.63	66.22	15.16	0.00	150.0	± 9.6 %
		Y	2.68	66.76	15.56		150.0	
		Z	2.60	66.20	15.05		150.0	
10275-CAB	UMTS-FDD (HSUPA, Subtest 5, 3GPP Rel8.4)	X	1.63	67.34	15.24	0.00	150.0	± 9.6 %
		Y	1.75	68.91	16.21		150.0	
		Z	1.59	67.10	15.04		150.0	
10277-CAA	PHS (QPSK)	X	5.23	69.17	13.58	9.03	50.0	± 9.6 %
		Y	5.23	69.14	13.54		50.0	
		Z	4.94	68.42	12.95		50.0	
10278-CAA	PHS (QPSK, BW 884MHz, Rolloff 0.5)	X	9.44	80.92	21.03	9.03	50.0	± 9.6 %
		Y	9.27	80.52	20.82		50.0	
		Z	8.80	79.60	20.21		50.0	
10279-CAA	PHS (QPSK, BW 884MHz, Rolloff 0.38)	X	9.60	81.11	21.12	9.03	50.0	± 9.6 %
		Y	9.45	80.75	20.93		50.0	
		Z	8.93	79.76	20.30		50.0	
10290-AAB	CDMA2000, RC1, SO55, Full Rate	X	1.49	68.14	14.07	0.00	150.0	± 9.6 %
		Y	1.71	70.53	15.29		150.0	
		Z	1.38	67.47	13.43		150.0	
10291-AAB	CDMA2000, RC3, SO55, Full Rate	X	0.87	65.35	12.59	0.00	150.0	± 9.6 %
		Y	0.98	67.67	13.90		150.0	
		Z	0.81	64.81	11.96		150.0	
10292-AAB	CDMA2000, RC3, SO32, Full Rate	X	1.01	68.28	14.43	0.00	150.0	± 9.6 %
		Y	1.28	72.37	16.47		150.0	
		Z	0.94	67.61	13.77		150.0	
10293-AAB	CDMA2000, RC3, SO3, Full Rate	X	1.31	72.09	16.62	0.00	150.0	± 9.6 %
		Y	1.86	78.07	19.28		150.0	
		Z	1.24	71.48	16.00		150.0	
10295-AAB	CDMA2000, RC1, SO3, 1/8th Rate 25 fr.	X	11.68	86.43	25.21	9.03	50.0	± 9.6 %
		Y	12.34	87.51	25.61		50.0	
		Z	12.30	87.31	25.27		50.0	
10297-AAB	LTE-FDD (SC-FDMA, 50% RB, 20 MHz, QPSK)	X	2.80	69.32	16.34	0.00	150.0	± 9.6 %
		Y	2.92	70.37	16.97		150.0	
		Z	2.72	69.08	16.22		150.0	
10298-AAC	LTE-FDD (SC-FDMA, 50% RB, 3 MHz, QPSK)	X	1.65	67.43	14.29	0.00	150.0	± 9.6 %
		Y	1.78	69.00	15.16		150.0	
		Z	1.54	66.87	13.72		150.0	
10299-AAC	LTE-FDD (SC-FDMA, 50% RB, 3 MHz, 16-QAM)	X	3.71	73.80	16.79	0.00	150.0	± 9.6 %
		Y	4.50	76.98	18.19		150.0	
		Z	2.80	70.24	14.88		150.0	
10300-AAC	LTE-FDD (SC-FDMA, 50% RB, 3 MHz, 64-QAM)	X	2.66	68.22	13.61	0.00	150.0	± 9.6 %
		Y	2.97	70.07	14.57		150.0	
		Z	2.16	65.95	12.13		150.0	
10301-AAA	IEEE 802.16e WiMAX (29:18, 5ms, 10MHz, QPSK, PUSC)	X	5.56	67.67	18.53	4.17	80.0	± 9.6 %
		Y	5.78	68.72	19.18		80.0	
		Z	5.51	67.68	18.44		80.0	
10302-AAA	IEEE 802.16e WiMAX (29:18, 5ms, 10MHz, QPSK, PUSC, 3 CTRL symbols)	X	6.08	68.43	19.36	4.96	80.0	± 9.6 %
		Y	6.31	69.64	20.14		80.0	
		Z	6.00	68.40	19.26		80.0	

10303-AAA	IEEE 802.16e WiMAX (31:15, 5ms, 10MHz, 64QAM, PUSC)	X	5.91	68.44	19.38	4.96	80.0	± 9.6 %
		Y	6.17	69.77	20.23		80.0	
		Z	5.83	68.37	19.25		80.0	
10304-AAA	IEEE 802.16e WiMAX (29:18, 5ms, 10MHz, 64QAM, PUSC)	X	5.57	67.76	18.57	4.17	80.0	± 9.6 %
		Y	5.77	68.85	19.27		80.0	
		Z	5.49	67.73	18.47		80.0	
10305-AAA	IEEE 802.16e WiMAX (31:15, 10ms, 10MHz, 64QAM, PUSC, 15 symbols)	X	7.72	78.82	24.99	6.02	50.0	± 9.6 %
		Y	9.80	85.05	27.90		50.0	
		Z	7.68	78.78	24.73		50.0	
10306-AAA	IEEE 802.16e WiMAX (29:18, 10ms, 10MHz, 64QAM, PUSC, 18 symbols)	X	6.19	70.81	21.17	6.02	50.0	± 9.6 %
		Y	6.78	73.45	22.69		50.0	
		Z	6.09	70.68	20.96		50.0	
10307-AAA	IEEE 802.16e WiMAX (29:18, 10ms, 10MHz, QPSK, PUSC, 18 symbols)	X	6.23	71.39	21.28	6.02	50.0	± 9.6 %
		Y	6.93	74.34	22.91		50.0	
		Z	6.66	74.17	22.78		50.0	
10308-AAA	IEEE 802.16e WiMAX (29:18, 10ms, 10MHz, 16QAM, PUSC)	X	6.84	74.87	23.29	6.02	50.0	± 9.6 %
		Y	7.04	74.94	23.20		50.0	
		Z	6.77	74.83	23.10		50.0	
10309-AAA	IEEE 802.16e WiMAX (29:18, 10ms, 10MHz, 16QAM, AMC 2x3, 18 symbols)	X	6.29	71.13	21.36	6.02	50.0	± 9.6 %
		Y	6.92	73.87	22.92		50.0	
		Z	6.18	70.98	21.13		50.0	
10310-AAA	IEEE 802.16e WiMAX (29:18, 10ms, 10MHz, QPSK, AMC 2x3, 18 symbols)	X	6.19	71.01	21.18	6.02	50.0	± 9.6 %
		Y	6.82	73.78	22.75		50.0	
		Z	6.55	73.55	22.58		50.0	
10311-AAB	LTE-FDD (SC-FDMA, 100% RB, 15 MHz, QPSK)	X	3.15	68.64	16.01	0.00	150.0	± 9.6 %
		Y	3.28	69.57	16.56		150.0	
		Z	3.07	68.40	15.89		150.0	
10313-AAA	iDEN 1:3	X	7.93	80.00	19.43	6.99	70.0	± 9.6 %
		Y	8.50	81.06	19.83		70.0	
		Z	7.91	80.08	19.40		70.0	
10314-AAA	iDEN 1:6	X	10.36	86.77	24.35	10.00	30.0	± 9.6 %
		Y	11.09	87.90	24.72		30.0	
		Z	10.57	87.37	24.52		30.0	
10315-AAB	IEEE 802.11b WiFi 2.4 GHz (DSSS, 1 Mbps, 96pc duty cycle)	X	1.16	64.08	15.18	0.17	150.0	± 9.6 %
		Y	1.19	64.95	15.92		150.0	
		Z	1.15	63.96	15.05		150.0	
10316-AAB	IEEE 802.11g WiFi 2.4 GHz (ERP-OFDM, 6 Mbps, 96pc duty cycle)	X	4.74	66.85	16.40	0.17	150.0	± 9.6 %
		Y	4.75	67.05	16.58		150.0	
		Z	4.69	66.84	16.36		150.0	
10317-AAB	IEEE 802.11a WiFi 5 GHz (OFDM, 6 Mbps, 96pc duty cycle)	X	4.74	66.85	16.40	0.17	150.0	± 9.6 %
		Y	4.75	67.05	16.58		150.0	
		Z	4.69	66.84	16.36		150.0	
10400-AAC	IEEE 802.11ac WiFi (20MHz, 64-QAM, 99pc duty cycle)	X	4.83	67.07	16.30	0.00	150.0	± 9.6 %
		Y	4.84	67.29	16.50		150.0	
		Z	4.76	67.04	16.26		150.0	
10401-AAC	IEEE 802.11ac WiFi (40MHz, 64-QAM, 99pc duty cycle)	X	5.51	67.29	16.49	0.00	150.0	± 9.6 %
		Y	5.53	67.49	16.67		150.0	
		Z	5.49	67.36	16.51		150.0	



10402-AAC	IEEE 802.11ac WiFi (80MHz, 64-QAM, 99pc duty cycle)	X	5.79	67.69	16.53	0.00	150.0	± 9.6 %
		Y	5.79	67.83	16.67		150.0	
		Z	5.72	67.60	16.48		150.0	
10403-AAB	CDMA2000 (1xEV-DO, Rev. 0)	X	1.49	68.14	14.07	0.00	115.0	± 9.6 %
		Y	1.71	70.53	15.29		115.0	
		Z	1.38	67.47	13.43		115.0	
10404-AAB	CDMA2000 (1xEV-DO, Rev. A)	X	1.49	68.14	14.07	0.00	115.0	± 9.6 %
		Y	1.71	70.53	15.29		115.0	
		Z	1.38	67.47	13.43		115.0	
10406-AAB	CDMA2000, RC3, SO32, SCH0, Full Rate	X	100.00	122.23	31.08	0.00	100.0	± 9.6 %
		Y	100.00	122.94	31.38		100.0	
		Z	21.98	102.39	26.35		100.0	
10410-AAB	LTE-TDD (SC-FDMA, 1 RB, 10 MHz, QPSK, UL Subframe=2,3,4,7,8,9)	X	100.00	121.68	31.26	3.23	80.0	± 9.6 %
		Y	100.00	122.54	31.65		80.0	
		Z	100.00	121.97	31.19		80.0	
10415-AAA	IEEE 802.11b WiFi 2.4 GHz (DSSS, 1 Mbps, 99pc duty cycle)	X	1.03	62.73	14.35	0.00	150.0	± 9.6 %
		Y	1.04	63.46	15.05		150.0	
		Z	1.02	62.64	14.23		150.0	
10416-AAA	IEEE 802.11g WiFi 2.4 GHz (ERP-OFDM, 6 Mbps, 99pc duty cycle)	X	4.64	66.69	16.23	0.00	150.0	± 9.6 %
		Y	4.65	66.89	16.41		150.0	
		Z	4.59	66.68	16.20		150.0	
10417-AAA	IEEE 802.11a/h WiFi 5 GHz (OFDM, 6 Mbps, 99pc duty cycle)	X	4.64	66.69	16.23	0.00	150.0	± 9.6 %
		Y	4.65	66.89	16.41		150.0	
		Z	4.59	66.68	16.20		150.0	
10418-AAA	IEEE 802.11g WiFi 2.4 GHz (DSSS-OFDM, 6 Mbps, 99pc duty cycle, Long preamble)	X	4.63	66.83	16.23	0.00	150.0	± 9.6 %
		Y	4.64	67.04	16.42		150.0	
		Z	4.58	66.82	16.21		150.0	
10419-AAA	IEEE 802.11g WiFi 2.4 GHz (DSSS-OFDM, 6 Mbps, 99pc duty cycle, Short preamble)	X	4.65	66.79	16.24	0.00	150.0	± 9.6 %
		Y	4.66	66.99	16.43		150.0	
		Z	4.60	66.78	16.21		150.0	
10422-AAA	IEEE 802.11n (HT Greenfield, 7.2 Mbps, BPSK)	X	4.78	66.81	16.27	0.00	150.0	± 9.6 %
		Y	4.78	67.00	16.45		150.0	
		Z	4.72	66.79	16.24		150.0	
10423-AAA	IEEE 802.11n (HT Greenfield, 43.3 Mbps, 16-QAM)	X	4.96	67.16	16.40	0.00	150.0	± 9.6 %
		Y	4.97	67.35	16.58		150.0	
		Z	4.89	67.12	16.36		150.0	
10424-AAA	IEEE 802.11n (HT Greenfield, 72.2 Mbps, 64-QAM)	X	4.88	67.10	16.36	0.00	150.0	± 9.6 %
		Y	4.88	67.30	16.54		150.0	
		Z	4.81	67.07	16.33		150.0	
10425-AAA	IEEE 802.11n (HT Greenfield, 15 Mbps, BPSK)	X	5.49	67.52	16.59	0.00	150.0	± 9.6 %
		Y	5.50	67.70	16.76		150.0	
		Z	5.44	67.51	16.58		150.0	
10426-AAA	IEEE 802.11n (HT Greenfield, 90 Mbps, 16-QAM)	X	5.49	67.54	16.59	0.00	150.0	± 9.6 %
		Y	5.50	67.71	16.76		150.0	
		Z	5.45	67.53	16.59		150.0	

10427-AAA	IEEE 802.11n (HT Greenfield, 150 Mbps, 64-QAM)	X	5.50	67.50	16.57	0.00	150.0	± 9.6 %
		Y	5.51	67.67	16.73		150.0	
		Z	5.45	67.48	16.56		150.0	
10430-AAA	LTE-FDD (OFDMA, 5 MHz, E-TM 3.1)	X	4.25	70.00	17.85	0.00	150.0	± 9.6 %
		Y	4.23	70.09	17.93		150.0	
		Z	4.19	70.14	17.80		150.0	
10431-AAA	LTE-FDD (OFDMA, 10 MHz, E-TM 3.1)	X	4.34	67.20	16.23	0.00	150.0	± 9.6 %
		Y	4.36	67.46	16.45		150.0	
		Z	4.27	67.18	16.16		150.0	
10432-AAA	LTE-FDD (OFDMA, 15 MHz, E-TM 3.1)	X	4.64	67.12	16.31	0.00	150.0	± 9.6 %
		Y	4.65	67.34	16.50		150.0	
		Z	4.57	67.09	16.26		150.0	
10433-AAA	LTE-FDD (OFDMA, 20 MHz, E-TM 3.1)	X	4.89	67.13	16.38	0.00	150.0	± 9.6 %
		Y	4.90	67.33	16.56		150.0	
		Z	4.82	67.10	16.34		150.0	
10434-AAA	W-CDMA (BS Test Model 1, 64 DPCH)	X	4.31	70.67	17.79	0.00	150.0	± 9.6 %
		Y	4.30	70.79	17.87		150.0	
		Z	4.25	70.82	17.71		150.0	
10435-AAB	LTE-TDD (SC-FDMA, 1 RB, 20 MHz, QPSK, UL Subframe=2,3,4,7,8,9)	X	100.00	121.51	31.18	3.23	80.0	± 9.6 %
		Y	100.00	122.37	31.57		80.0	
		Z	100.00	121.79	31.11		80.0	
10447-AAA	LTE-FDD (OFDMA, 5 MHz, E-TM 3.1, Clipping 44%)	X	3.63	67.13	15.60	0.00	150.0	± 9.6 %
		Y	3.66	67.50	15.86		150.0	
		Z	3.54	67.07	15.44		150.0	
10448-AAA	LTE-FDD (OFDMA, 10 MHz, E-TM 3.1, Clipping 44%)	X	4.17	66.96	16.08	0.00	150.0	± 9.6 %
		Y	4.19	67.23	16.30		150.0	
		Z	4.10	66.94	16.02		150.0	
10449-AAA	LTE-FDD (OFDMA, 15 MHz, E-TM 3.1, Clipping 44%)	X	4.44	66.92	16.19	0.00	150.0	± 9.6 %
		Y	4.45	67.15	16.39		150.0	
		Z	4.38	66.90	16.14		150.0	
10450-AAA	LTE-FDD (OFDMA, 20 MHz, E-TM 3.1, Clipping 44%)	X	4.63	66.87	16.23	0.00	150.0	± 9.6 %
		Y	4.64	67.08	16.41		150.0	
		Z	4.58	66.85	16.19		150.0	
10451-AAA	W-CDMA (BS Test Model 1, 64 DPCH, Clipping 44%)	X	3.53	67.33	15.28	0.00	150.0	± 9.6 %
		Y	3.57	67.74	15.55		150.0	
		Z	3.43	67.21	15.05		150.0	
10456-AAA	IEEE 802.11ac WiFi (160MHz, 64-QAM, 99pc duty cycle)	X	6.35	68.11	16.76	0.00	150.0	± 9.6 %
		Y	6.36	68.24	16.90		150.0	
		Z	6.31	68.06	16.74		150.0	
10457-AAA	UMTS-FDD (DC-HSDPA)	X	3.86	65.32	15.94	0.00	150.0	± 9.6 %
		Y	3.86	65.52	16.13		150.0	
		Z	3.83	65.31	15.89		150.0	
10458-AAA	CDMA2000 (1xEV-DO, Rev. B, 2 carriers)	X	3.37	66.71	14.79	0.00	150.0	± 9.6 %
		Y	3.41	67.16	15.08		150.0	
		Z	3.26	66.61	14.51		150.0	
10459-AAA	CDMA2000 (1xEV-DO, Rev. B, 3 carriers)	X	4.52	65.23	15.77	0.00	150.0	± 9.6 %
		Y	4.60	65.75	16.11		150.0	
		Z	4.38	65.07	15.54		150.0	

10460-AAA	UMTS-FDD (WCDMA, AMR)	X	0.89	66.92	15.35	0.00	150.0	± 9.6 %
		Y	1.01	69.93	17.18		150.0	
		Z	0.86	66.57	15.06		150.0	
10461-AAA	LTE-TDD (SC-FDMA, 1 RB, 1.4 MHz, QPSK, UL Subframe=2,3,4,7,8,9)	X	100.00	125.62	33.15	3.29	80.0	± 9.6 %
		Y	100.00	127.39	33.94		80.0	
		Z	100.00	125.16	32.74		80.0	
10462-AAA	LTE-TDD (SC-FDMA, 1 RB, 1.4 MHz, 16-QAM, UL Subframe=2,3,4,7,8,9)	X	100.00	110.62	25.96	3.23	80.0	± 9.6 %
		Y	100.00	111.65	26.39		80.0	
		Z	84.76	108.06	25.05		80.0	
10463-AAA	LTE-TDD (SC-FDMA, 1 RB, 1.4 MHz, 64-QAM, UL Subframe=2,3,4,7,8,9)	X	100.00	107.62	24.51	3.23	80.0	± 9.6 %
		Y	100.00	108.53	24.89		80.0	
		Z	14.33	86.37	18.99		80.0	
10464-AAA	LTE-TDD (SC-FDMA, 1 RB, 3 MHz, QPSK, UL Subframe=2,3,4,7,8,9)	X	100.00	123.78	32.14	3.23	80.0	± 9.6 %
		Y	100.00	125.58	32.94		80.0	
		Z	100.00	123.19	31.67		80.0	
10465-AAA	LTE-TDD (SC-FDMA, 1 RB, 3 MHz, 16-QAM, UL Subframe=2,3,4,7,8,9)	X	100.00	110.13	25.71	3.23	80.0	± 9.6 %
		Y	100.00	111.18	26.15		80.0	
		Z	35.58	97.99	22.58		80.0	
10466-AAA	LTE-TDD (SC-FDMA, 1 RB, 3 MHz, 64-QAM, UL Subframe=2,3,4,7,8,9)	X	95.39	106.65	24.18	3.23	80.0	± 9.6 %
		Y	100.00	108.07	24.67		80.0	
		Z	9.21	81.47	17.50		80.0	
10467-AAB	LTE-TDD (SC-FDMA, 1 RB, 5 MHz, QPSK, UL Subframe=2,3,4,7,8,9)	X	100.00	123.99	32.23	3.23	80.0	± 9.6 %
		Y	100.00	125.80	33.04		80.0	
		Z	100.00	123.41	31.77		80.0	
10468-AAB	LTE-TDD (SC-FDMA, 1 RB, 5 MHz, 16-QAM, UL Subframe=2,3,4,7,8,9)	X	100.00	110.29	25.79	3.23	80.0	± 9.6 %
		Y	100.00	111.34	26.23		80.0	
		Z	43.78	100.42	23.20		80.0	
10469-AAB	LTE-TDD (SC-FDMA, 1 RB, 5 MHz, 64-QAM, UL Subframe=2,3,4,7,8,9)	X	99.99	107.17	24.29	3.23	80.0	± 9.6 %
		Y	100.00	108.09	24.67		80.0	
		Z	9.38	81.68	17.56		80.0	
10470-AAB	LTE-TDD (SC-FDMA, 1 RB, 10 MHz, QPSK, UL Subframe=2,3,4,7,8,9)	X	100.00	124.02	32.24	3.23	80.0	± 9.6 %
		Y	100.00	125.83	33.05		80.0	
		Z	100.00	123.44	31.77		80.0	
10471-AAB	LTE-TDD (SC-FDMA, 1 RB, 10 MHz, 16-QAM, UL Subframe=2,3,4,7,8,9)	X	100.00	110.24	25.76	3.23	80.0	± 9.6 %
		Y	100.00	111.29	26.20		80.0	
		Z	43.76	100.38	23.18		80.0	
10472-AAB	LTE-TDD (SC-FDMA, 1 RB, 10 MHz, 64-QAM, UL Subframe=2,3,4,7,8,9)	X	100.00	107.12	24.26	3.23	80.0	± 9.6 %
		Y	100.00	108.04	24.64		80.0	
		Z	9.36	81.64	17.53		80.0	
10473-AAB	LTE-TDD (SC-FDMA, 1 RB, 15 MHz, QPSK, UL Subframe=2,3,4,7,8,9)	X	100.00	123.99	32.23	3.23	80.0	± 9.6 %
		Y	100.00	125.81	33.03		80.0	
		Z	100.00	123.41	31.76		80.0	
10474-AAB	LTE-TDD (SC-FDMA, 1 RB, 15 MHz, 16-QAM, UL Subframe=2,3,4,7,8,9)	X	100.00	110.25	25.76	3.23	80.0	± 9.6 %
		Y	100.00	111.30	26.20		80.0	
		Z	42.90	100.17	23.13		80.0	
10475-AAB	LTE-TDD (SC-FDMA, 1 RB, 15 MHz, 64-QAM, UL Subframe=2,3,4,7,8,9)	X	99.25	107.05	24.25	3.23	80.0	± 9.6 %
		Y	100.00	108.06	24.65		80.0	
		Z	9.24	81.52	17.50		80.0	

10477-AAB	LTE-TDD (SC-FDMA, 1 RB, 20 MHz, 16-QAM, UL Subframe=2,3,4,7,8,9)	X	100.00	110.09	25.68	3.23	80.0	± 9.6 %
		Y	100.00	111.14	26.12		80.0	
		Z	37.23	98.47	22.68		80.0	
10478-AAB	LTE-TDD (SC-FDMA, 1 RB, 20 MHz, 64-QAM, UL Subframe=2,3,4,7,8,9)	X	95.92	106.64	24.15	3.23	80.0	± 9.6 %
		Y	100.00	108.00	24.62		80.0	
		Z	9.13	81.36	17.44		80.0	
10479-AAA	LTE-TDD (SC-FDMA, 50% RB, 1.4 MHz, QPSK, UL Subframe=2,3,4,7,8,9)	X	15.99	96.17	26.79	3.23	80.0	± 9.6 %
		Y	25.94	104.65	29.40		80.0	
		Z	12.83	92.51	25.34		80.0	
10480-AAA	LTE-TDD (SC-FDMA, 50% RB, 1.4 MHz, 16-QAM, UL Subframe=2,3,4,7,8,9)	X	19.48	93.48	24.25	3.23	80.0	± 9.6 %
		Y	30.64	100.38	26.28		80.0	
		Z	12.85	87.46	22.08		80.0	
10481-AAA	LTE-TDD (SC-FDMA, 50% RB, 1.4 MHz, 64-QAM, UL Subframe=2,3,4,7,8,9)	X	16.00	89.85	22.83	3.23	80.0	± 9.6 %
		Y	23.58	95.63	24.59		80.0	
		Z	10.55	84.00	20.64		80.0	
10482-AAA	LTE-TDD (SC-FDMA, 50% RB, 3 MHz, QPSK, UL Subframe=2,3,4,7,8,9)	X	5.04	76.94	19.04	2.23	80.0	± 9.6 %
		Y	6.02	79.79	20.13		80.0	
		Z	4.78	76.30	18.55		80.0	
10483-AAA	LTE-TDD (SC-FDMA, 50% RB, 3 MHz, 16-QAM, UL Subframe=2,3,4,7,8,9)	X	9.12	82.48	20.94	2.23	80.0	± 9.6 %
		Y	10.77	85.20	21.94		80.0	
		Z	6.99	78.47	19.09		80.0	
10484-AAA	LTE-TDD (SC-FDMA, 50% RB, 3 MHz, 64-QAM, UL Subframe=2,3,4,7,8,9)	X	8.29	80.89	20.40	2.23	80.0	± 9.6 %
		Y	9.58	83.28	21.31		80.0	
		Z	6.43	77.10	18.60		80.0	
10485-AAB	LTE-TDD (SC-FDMA, 50% RB, 5 MHz, QPSK, UL Subframe=2,3,4,7,8,9)	X	5.28	77.72	20.08	2.23	80.0	± 9.6 %
		Y	6.19	80.50	21.18		80.0	
		Z	5.13	77.51	19.85		80.0	
10486-AAB	LTE-TDD (SC-FDMA, 50% RB, 5 MHz, 16-QAM, UL Subframe=2,3,4,7,8,9)	X	4.51	72.42	17.68	2.23	80.0	± 9.6 %
		Y	4.81	73.61	18.21		80.0	
		Z	4.36	72.13	17.34		80.0	
10487-AAB	LTE-TDD (SC-FDMA, 50% RB, 5 MHz, 64-QAM, UL Subframe=2,3,4,7,8,9)	X	4.47	71.97	17.49	2.23	80.0	± 9.6 %
		Y	4.74	73.05	17.98		80.0	
		Z	4.32	71.65	17.14		80.0	
10488-AAB	LTE-TDD (SC-FDMA, 50% RB, 10 MHz, QPSK, UL Subframe=2,3,4,7,8,9)	X	5.28	76.23	20.05	2.23	80.0	± 9.6 %
		Y	5.88	78.28	20.95		80.0	
		Z	5.13	76.06	19.94		80.0	
10489-AAB	LTE-TDD (SC-FDMA, 50% RB, 10 MHz, 16-QAM, UL Subframe=2,3,4,7,8,9)	X	4.61	71.60	18.35	2.23	80.0	± 9.6 %
		Y	4.82	72.56	18.83		80.0	
		Z	4.51	71.52	18.23		80.0	
10490-AAB	LTE-TDD (SC-FDMA, 50% RB, 10 MHz, 64-QAM, UL Subframe=2,3,4,7,8,9)	X	4.69	71.33	18.26	2.23	80.0	± 9.6 %
		Y	4.87	72.22	18.72		80.0	
		Z	4.59	71.26	18.14		80.0	
10491-AAB	LTE-TDD (SC-FDMA, 50% RB, 15 MHz, QPSK, UL Subframe=2,3,4,7,8,9)	X	5.21	74.00	19.31	2.23	80.0	± 9.6 %
		Y	5.57	75.36	19.96		80.0	
		Z	5.08	73.85	19.24		80.0	
10492-AAB	LTE-TDD (SC-FDMA, 50% RB, 15 MHz, 16-QAM, UL Subframe=2,3,4,7,8,9)	X	4.87	70.59	18.20	2.23	80.0	± 9.6 %
		Y	5.02	71.33	18.60		80.0	
		Z	4.77	70.51	18.12		80.0	

10493-AAB	LTE-TDD (SC-FDMA, 50% RB, 15 MHz, 64-QAM, UL Subframe=2,3,4,7,8,9)	X	4.93	70.41	18.14	2.23	80.0	± 9.6 %
		Y	5.07	71.11	18.53		80.0	
		Z	4.83	70.34	18.06		80.0	
10494-AAB	LTE-TDD (SC-FDMA, 50% RB, 20 MHz, QPSK, UL Subframe=2,3,4,7,8,9)	X	5.74	75.68	19.79	2.23	80.0	± 9.6 %
		Y	6.23	77.26	20.51		80.0	
		Z	5.57	75.46	19.70		80.0	
10495-AAB	LTE-TDD (SC-FDMA, 50% RB, 20 MHz, 16-QAM, UL Subframe=2,3,4,7,8,9)	X	4.94	71.08	18.40	2.23	80.0	± 9.6 %
		Y	5.11	71.86	18.83		80.0	
		Z	4.84	70.96	18.32		80.0	
10496-AAB	LTE-TDD (SC-FDMA, 50% RB, 20 MHz, 64-QAM, UL Subframe=2,3,4,7,8,9)	X	4.99	70.71	18.29	2.23	80.0	± 9.6 %
		Y	5.14	71.42	18.69		80.0	
		Z	4.89	70.61	18.21		80.0	
10497-AAA	LTE-TDD (SC-FDMA, 100% RB, 1.4 MHz, QPSK, UL Subframe=2,3,4,7,8,9)	X	3.95	73.39	16.94	2.23	80.0	± 9.6 %
		Y	4.59	75.63	17.82		80.0	
		Z	3.56	72.03	16.04		80.0	
10498-AAA	LTE-TDD (SC-FDMA, 100% RB, 1.4 MHz, 16-QAM, UL Subframe=2,3,4,7,8,9)	X	2.99	67.14	13.42	2.23	80.0	± 9.6 %
		Y	3.17	68.04	13.81		80.0	
		Z	2.58	65.48	12.27		80.0	
10499-AAA	LTE-TDD (SC-FDMA, 100% RB, 1.4 MHz, 64-QAM, UL Subframe=2,3,4,7,8,9)	X	2.90	66.50	13.01	2.23	80.0	± 9.6 %
		Y	3.06	67.30	13.36		80.0	
		Z	2.49	64.82	11.82		80.0	
10500-AAA	LTE-TDD (SC-FDMA, 100% RB, 3 MHz, QPSK, UL Subframe=2,3,4,7,8,9)	X	5.14	76.64	19.91	2.23	80.0	± 9.6 %
		Y	5.86	79.02	20.91		80.0	
		Z	5.00	76.51	19.75		80.0	
10501-AAA	LTE-TDD (SC-FDMA, 100% RB, 3 MHz, 16-QAM, UL Subframe=2,3,4,7,8,9)	X	4.55	72.03	17.90	2.23	80.0	± 9.6 %
		Y	4.80	73.10	18.41		80.0	
		Z	4.43	71.87	17.67		80.0	
10502-AAA	LTE-TDD (SC-FDMA, 100% RB, 3 MHz, 64-QAM, UL Subframe=2,3,4,7,8,9)	X	4.59	71.80	17.77	2.23	80.0	± 9.6 %
		Y	4.83	72.81	18.25		80.0	
		Z	4.47	71.64	17.53		80.0	
10503-AAB	LTE-TDD (SC-FDMA, 100% RB, 5 MHz, QPSK, UL Subframe=2,3,4,7,8,9)	X	5.22	76.03	19.96	2.23	80.0	± 9.6 %
		Y	5.81	78.08	20.86		80.0	
		Z	5.07	75.86	19.85		80.0	
10504-AAB	LTE-TDD (SC-FDMA, 100% RB, 5 MHz, 16-QAM, UL Subframe=2,3,4,7,8,9)	X	4.59	71.52	18.30	2.23	80.0	± 9.6 %
		Y	4.80	72.48	18.79		80.0	
		Z	4.49	71.43	18.18		80.0	
10505-AAB	LTE-TDD (SC-FDMA, 100% RB, 5 MHz, 64-QAM, UL Subframe=2,3,4,7,8,9)	X	4.66	71.24	18.21	2.23	80.0	± 9.6 %
		Y	4.85	72.13	18.67		80.0	
		Z	4.56	71.17	18.09		80.0	
10506-AAB	LTE-TDD (SC-FDMA, 100% RB, 10 MHz, QPSK, UL Subframe=2,3,4,7,8,9)	X	5.69	75.54	19.72	2.23	80.0	± 9.6 %
		Y	6.18	77.12	20.44		80.0	
		Z	5.52	75.31	19.63		80.0	
10507-AAB	LTE-TDD (SC-FDMA, 100% RB, 10 MHz, 16-QAM, UL Subframe=2,3,4,7,8,9)	X	4.93	71.03	18.37	2.23	80.0	± 9.6 %
		Y	5.09	71.81	18.80		80.0	
		Z	4.82	70.90	18.29		80.0	

10508-AAB	LTE-TDD (SC-FDMA, 100% RB, 10 MHz, 64-QAM, UL Subframe=2,3,4,7,8,9)	X	4.98	70.65	18.25	2.23	80.0	± 9.6 %
		Y	5.12	71.36	18.65		80.0	
		Z	4.87	70.54	18.17		80.0	
10509-AAB	LTE-TDD (SC-FDMA, 100% RB, 15 MHz, QPSK, UL Subframe=2,3,4,7,8,9)	X	5.75	73.61	18.99	2.23	80.0	± 9.6 %
		Y	6.04	74.62	19.49		80.0	
		Z	5.61	73.42	18.92		80.0	
10510-AAB	LTE-TDD (SC-FDMA, 100% RB, 15 MHz, 16-QAM, UL Subframe=2,3,4,7,8,9)	X	5.37	70.52	18.25	2.23	80.0	± 9.6 %
		Y	5.50	71.12	18.60		80.0	
		Z	5.26	70.38	18.18		80.0	
10511-AAB	LTE-TDD (SC-FDMA, 100% RB, 15 MHz, 64-QAM, UL Subframe=2,3,4,7,8,9)	X	5.39	70.20	18.16	2.23	80.0	± 9.6 %
		Y	5.51	70.76	18.50		80.0	
		Z	5.29	70.08	18.10		80.0	
10512-AAB	LTE-TDD (SC-FDMA, 100% RB, 20 MHz, QPSK, UL Subframe=2,3,4,7,8,9)	X	6.17	75.45	19.55	2.23	80.0	± 9.6 %
		Y	6.61	76.77	20.16		80.0	
		Z	5.99	75.18	19.45		80.0	
10513-AAB	LTE-TDD (SC-FDMA, 100% RB, 20 MHz, 16-QAM, UL Subframe=2,3,4,7,8,9)	X	5.29	70.93	18.40	2.23	80.0	± 9.6 %
		Y	5.44	71.61	18.78		80.0	
		Z	5.18	70.76	18.31		80.0	
10514-AAB	LTE-TDD (SC-FDMA, 100% RB, 20 MHz, 64-QAM, UL Subframe=2,3,4,7,8,9)	X	5.26	70.42	18.25	2.23	80.0	± 9.6 %
		Y	5.39	71.03	18.61		80.0	
		Z	5.16	70.27	18.17		80.0	
10515-AAA	IEEE 802.11b WiFi 2.4 GHz (DSSS, 2 Mbps, 99pc duty cycle)	X	0.99	62.88	14.39	0.00	150.0	± 9.6 %
		Y	1.01	63.69	15.14		150.0	
		Z	0.98	62.78	14.25		150.0	
10516-AAA	IEEE 802.11b WiFi 2.4 GHz (DSSS, 5.5 Mbps, 99pc duty cycle)	X	0.57	67.90	15.77	0.00	150.0	± 9.6 %
		Y	0.79	74.76	19.51		150.0	
		Z	0.54	67.33	15.34		150.0	
10517-AAA	IEEE 802.11b WiFi 2.4 GHz (DSSS, 11 Mbps, 99pc duty cycle)	X	0.83	64.48	14.80	0.00	150.0	± 9.6 %
		Y	0.88	66.11	16.05		150.0	
		Z	0.82	64.26	14.59		150.0	
10518-AAA	IEEE 802.11a/h WiFi 5 GHz (OFDM, 9 Mbps, 99pc duty cycle)	X	4.64	66.76	16.21	0.00	150.0	± 9.6 %
		Y	4.64	66.97	16.39		150.0	
		Z	4.58	66.75	16.17		150.0	
10519-AAA	IEEE 802.11a/h WiFi 5 GHz (OFDM, 12 Mbps, 99pc duty cycle)	X	4.84	67.04	16.35	0.00	150.0	± 9.6 %
		Y	4.85	67.24	16.53		150.0	
		Z	4.77	67.00	16.30		150.0	
10520-AAA	IEEE 802.11a/h WiFi 5 GHz (OFDM, 18 Mbps, 99pc duty cycle)	X	4.69	67.00	16.26	0.00	150.0	± 9.6 %
		Y	4.70	67.20	16.45		150.0	
		Z	4.62	66.95	16.22		150.0	
10521-AAA	IEEE 802.11a/h WiFi 5 GHz (OFDM, 24 Mbps, 99pc duty cycle)	X	4.62	66.99	16.24	0.00	150.0	± 9.6 %
		Y	4.63	67.20	16.43		150.0	
		Z	4.55	66.94	16.20		150.0	
10522-AAA	IEEE 802.11a/h WiFi 5 GHz (OFDM, 36 Mbps, 99pc duty cycle)	X	4.67	67.03	16.31	0.00	150.0	± 9.6 %
		Y	4.69	67.25	16.50		150.0	
		Z	4.61	67.03	16.28		150.0	

10523-AAA	IEEE 802.11a/h WiFi 5 GHz (OFDM, 48 Mbps, 99pc duty cycle)	X	4.55	66.89	16.15	0.00	150.0	± 9.6 %
		Y	4.56	67.11	16.34		150.0	
		Z	4.49	66.88	16.12		150.0	
10524-AAA	IEEE 802.11a/h WiFi 5 GHz (OFDM, 54 Mbps, 99pc duty cycle)	X	4.62	66.97	16.28	0.00	150.0	± 9.6 %
		Y	4.63	67.19	16.48		150.0	
		Z	4.56	66.95	16.25		150.0	
10525-AAA	IEEE 802.11ac WiFi (20MHz, MCS0, 99pc duty cycle)	X	4.59	65.99	15.86	0.00	150.0	± 9.6 %
		Y	4.60	66.20	16.05		150.0	
		Z	4.54	65.98	15.83		150.0	
10526-AAA	IEEE 802.11ac WiFi (20MHz, MCS1, 99pc duty cycle)	X	4.77	66.38	16.01	0.00	150.0	± 9.6 %
		Y	4.79	66.60	16.20		150.0	
		Z	4.71	66.35	15.98		150.0	
10527-AAA	IEEE 802.11ac WiFi (20MHz, MCS2, 99pc duty cycle)	X	4.69	66.34	15.95	0.00	150.0	± 9.6 %
		Y	4.71	66.56	16.15		150.0	
		Z	4.63	66.30	15.91		150.0	
10528-AAA	IEEE 802.11ac WiFi (20MHz, MCS3, 99pc duty cycle)	X	4.71	66.36	15.99	0.00	150.0	± 9.6 %
		Y	4.72	66.58	16.18		150.0	
		Z	4.65	66.32	15.95		150.0	
10529-AAA	IEEE 802.11ac WiFi (20MHz, MCS4, 99pc duty cycle)	X	4.71	66.36	15.99	0.00	150.0	± 9.6 %
		Y	4.72	66.58	16.18		150.0	
		Z	4.65	66.32	15.95		150.0	
10531-AAA	IEEE 802.11ac WiFi (20MHz, MCS6, 99pc duty cycle)	X	4.71	66.48	16.01	0.00	150.0	± 9.6 %
		Y	4.73	66.71	16.20		150.0	
		Z	4.64	66.43	15.96		150.0	
10532-AAA	IEEE 802.11ac WiFi (20MHz, MCS7, 99pc duty cycle)	X	4.56	66.33	15.94	0.00	150.0	± 9.6 %
		Y	4.58	66.56	16.14		150.0	
		Z	4.50	66.27	15.89		150.0	
10533-AAA	IEEE 802.11ac WiFi (20MHz, MCS8, 99pc duty cycle)	X	4.72	66.39	15.97	0.00	150.0	± 9.6 %
		Y	4.73	66.61	16.16		150.0	
		Z	4.65	66.36	15.93		150.0	
10534-AAA	IEEE 802.11ac WiFi (40MHz, MCS0, 99pc duty cycle)	X	5.24	66.54	16.07	0.00	150.0	± 9.6 %
		Y	5.25	66.71	16.24		150.0	
		Z	5.19	66.49	16.04		150.0	
10535-AAA	IEEE 802.11ac WiFi (40MHz, MCS1, 99pc duty cycle)	X	5.31	66.70	16.14	0.00	150.0	± 9.6 %
		Y	5.33	66.88	16.31		150.0	
		Z	5.26	66.68	16.13		150.0	
10536-AAA	IEEE 802.11ac WiFi (40MHz, MCS2, 99pc duty cycle)	X	5.18	66.65	16.10	0.00	150.0	± 9.6 %
		Y	5.19	66.84	16.27		150.0	
		Z	5.12	66.60	16.07		150.0	
10537-AAA	IEEE 802.11ac WiFi (40MHz, MCS3, 99pc duty cycle)	X	5.24	66.63	16.10	0.00	150.0	± 9.6 %
		Y	5.25	66.81	16.26		150.0	
		Z	5.19	66.58	16.06		150.0	
10538-AAA	IEEE 802.11ac WiFi (40MHz, MCS4, 99pc duty cycle)	X	5.35	66.69	16.17	0.00	150.0	± 9.6 %
		Y	5.36	66.87	16.33		150.0	
		Z	5.28	66.62	16.12		150.0	
10540-AAA	IEEE 802.11ac WiFi (40MHz, MCS6, 99pc duty cycle)	X	5.26	66.66	16.17	0.00	150.0	± 9.6 %
		Y	5.27	66.85	16.34		150.0	
		Z	5.21	66.63	16.14		150.0	

10541-AAA	IEEE 802.11ac WiFi (40MHz, MCS7, 99pc duty cycle)	X	5.23	66.53	16.10	0.00	150.0	± 9.6 %
		Y	5.24	66.71	16.26		150.0	
		Z	5.18	66.49	16.06		150.0	
10542-AAA	IEEE 802.11ac WiFi (40MHz, MCS8, 99pc duty cycle)	X	5.39	66.62	16.16	0.00	150.0	± 9.6 %
		Y	5.40	66.79	16.32		150.0	
		Z	5.34	66.57	16.12		150.0	
10543-AAA	IEEE 802.11ac WiFi (40MHz, MCS9, 99pc duty cycle)	X	5.48	66.66	16.19	0.00	150.0	± 9.6 %
		Y	5.49	66.83	16.36		150.0	
		Z	5.42	66.63	16.18		150.0	
10544-AAA	IEEE 802.11ac WiFi (80MHz, MCS0, 99pc duty cycle)	X	5.54	66.65	16.07	0.00	150.0	± 9.6 %
		Y	5.55	66.80	16.22		150.0	
		Z	5.50	66.61	16.04		150.0	
10545-AAA	IEEE 802.11ac WiFi (80MHz, MCS1, 99pc duty cycle)	X	5.76	67.11	16.24	0.00	150.0	± 9.6 %
		Y	5.77	67.28	16.40		150.0	
		Z	5.71	67.07	16.23		150.0	
10546-AAA	IEEE 802.11ac WiFi (80MHz, MCS2, 99pc duty cycle)	X	5.63	66.91	16.16	0.00	150.0	± 9.6 %
		Y	5.64	67.07	16.32		150.0	
		Z	5.57	66.84	16.12		150.0	
10547-AAA	IEEE 802.11ac WiFi (80MHz, MCS3, 99pc duty cycle)	X	5.72	67.00	16.20	0.00	150.0	± 9.6 %
		Y	5.72	67.16	16.35		150.0	
		Z	5.65	66.88	16.14		150.0	
10548-AAA	IEEE 802.11ac WiFi (80MHz, MCS4, 99pc duty cycle)	X	6.07	68.22	16.78	0.00	150.0	± 9.6 %
		Y	6.08	68.42	16.96		150.0	
		Z	5.98	68.06	16.70		150.0	
10550-AAA	IEEE 802.11ac WiFi (80MHz, MCS6, 99pc duty cycle)	X	5.65	66.89	16.16	0.00	150.0	± 9.6 %
		Y	5.66	67.05	16.31		150.0	
		Z	5.60	66.86	16.14		150.0	
10551-AAA	IEEE 802.11ac WiFi (80MHz, MCS7, 99pc duty cycle)	X	5.65	66.93	16.14	0.00	150.0	± 9.6 %
		Y	5.66	67.09	16.29		150.0	
		Z	5.60	66.87	16.11		150.0	
10552-AAA	IEEE 802.11ac WiFi (80MHz, MCS8, 99pc duty cycle)	X	5.56	66.71	16.04	0.00	150.0	± 9.6 %
		Y	5.57	66.86	16.19		150.0	
		Z	5.51	66.66	16.01		150.0	
10553-AAA	IEEE 802.11ac WiFi (80MHz, MCS9, 99pc duty cycle)	X	5.65	66.77	16.10	0.00	150.0	± 9.6 %
		Y	5.66	66.92	16.25		150.0	
		Z	5.60	66.70	16.07		150.0	
10554-AAA	IEEE 1602.11ac WiFi (160MHz, MCS0, 99pc duty cycle)	X	5.95	67.04	16.18	0.00	150.0	± 9.6 %
		Y	5.96	67.19	16.31		150.0	
		Z	5.91	66.99	16.15		150.0	
10555-AAA	IEEE 1602.11ac WiFi (160MHz, MCS1, 99pc duty cycle)	X	6.09	67.37	16.32	0.00	150.0	± 9.6 %
		Y	6.11	67.53	16.46		150.0	
		Z	6.05	67.32	16.29		150.0	
10556-AAA	IEEE 1602.11ac WiFi (160MHz, MCS2, 99pc duty cycle)	X	6.11	67.40	16.33	0.00	150.0	± 9.6 %
		Y	6.12	67.56	16.47		150.0	
		Z	6.07	67.36	16.30		150.0	
10557-AAA	IEEE 1602.11ac WiFi (160MHz, MCS3, 99pc duty cycle)	X	6.08	67.33	16.31	0.00	150.0	± 9.6 %
		Y	6.09	67.48	16.45		150.0	
		Z	6.03	67.26	16.27		150.0	



10558-AAA	IEEE 1602.11ac WiFi (160MHz, MCS4, 99pc duty cycle)	X	6.14	67.52	16.42	0.00	150.0	± 9.6 %
		Y	6.15	67.67	16.56		150.0	
		Z	6.09	67.43	16.37		150.0	
10560-AAA	IEEE 1602.11ac WiFi (160MHz, MCS6, 99pc duty cycle)	X	6.13	67.34	16.37	0.00	150.0	± 9.6 %
		Y	6.14	67.49	16.51		150.0	
		Z	6.07	67.26	16.33		150.0	
10561-AAA	IEEE 1602.11ac WiFi (160MHz, MCS7, 99pc duty cycle)	X	6.05	67.31	16.39	0.00	150.0	± 9.6 %
		Y	6.06	67.47	16.54		150.0	
		Z	6.00	67.24	16.36		150.0	
10562-AAA	IEEE 1602.11ac WiFi (160MHz, MCS8, 99pc duty cycle)	X	6.21	67.80	16.64	0.00	150.0	± 9.6 %
		Y	6.22	67.97	16.79		150.0	
		Z	6.14	67.67	16.57		150.0	
10563-AAA	IEEE 1602.11ac WiFi (160MHz, MCS9, 99pc duty cycle)	X	6.60	68.52	16.95	0.00	150.0	± 9.6 %
		Y	6.61	68.70	17.11		150.0	
		Z	6.44	68.18	16.78		150.0	
10564-AAA	IEEE 802.11g WiFi 2.4 GHz (DSSS-OFDM, 9 Mbps, 99pc duty cycle)	X	4.98	66.92	16.42	0.46	150.0	± 9.6 %
		Y	4.99	67.12	16.60		150.0	
		Z	4.93	66.90	16.38		150.0	
10565-AAA	IEEE 802.11g WiFi 2.4 GHz (DSSS-OFDM, 12 Mbps, 99pc duty cycle)	X	5.22	67.37	16.73	0.46	150.0	± 9.6 %
		Y	5.23	67.55	16.90		150.0	
		Z	5.16	67.34	16.69		150.0	
10566-AAA	IEEE 802.11g WiFi 2.4 GHz (DSSS-OFDM, 18 Mbps, 99pc duty cycle)	X	5.06	67.23	16.56	0.46	150.0	± 9.6 %
		Y	5.06	67.43	16.74		150.0	
		Z	4.99	67.19	16.51		150.0	
10567-AAA	IEEE 802.11g WiFi 2.4 GHz (DSSS-OFDM, 24 Mbps, 99pc duty cycle)	X	5.08	67.57	16.87	0.46	150.0	± 9.6 %
		Y	5.08	67.74	17.03		150.0	
		Z	5.01	67.53	16.84		150.0	
10568-AAA	IEEE 802.11g WiFi 2.4 GHz (DSSS-OFDM, 36 Mbps, 99pc duty cycle)	X	4.98	67.03	16.35	0.46	150.0	± 9.6 %
		Y	4.99	67.26	16.56		150.0	
		Z	4.91	67.01	16.31		150.0	
10569-AAA	IEEE 802.11g WiFi 2.4 GHz (DSSS-OFDM, 48 Mbps, 99pc duty cycle)	X	5.02	67.62	16.91	0.46	150.0	± 9.6 %
		Y	5.03	67.78	17.06		150.0	
		Z	4.97	67.61	16.89		150.0	
10570-AAA	IEEE 802.11g WiFi 2.4 GHz (DSSS-OFDM, 54 Mbps, 99pc duty cycle)	X	5.07	67.49	16.86	0.46	150.0	± 9.6 %
		Y	5.07	67.68	17.03		150.0	
		Z	5.00	67.48	16.83		150.0	
10571-AAA	IEEE 802.11b WiFi 2.4 GHz (DSSS, 1 Mbps, 90pc duty cycle)	X	1.33	65.38	15.85	0.46	130.0	± 9.6 %
		Y	1.37	66.42	16.66		130.0	
		Z	1.31	65.23	15.71		130.0	
10572-AAA	IEEE 802.11b WiFi 2.4 GHz (DSSS, 2 Mbps, 90pc duty cycle)	X	1.35	65.94	16.19	0.46	130.0	± 9.6 %
		Y	1.40	67.08	17.03		130.0	
		Z	1.33	65.79	16.04		130.0	
10573-AAA	IEEE 802.11b WiFi 2.4 GHz (DSSS, 5.5 Mbps, 90pc duty cycle)	X	2.45	84.59	22.30	0.46	130.0	± 9.6 %
		Y	10.53	109.30	30.18		130.0	
		Z	2.23	83.07	21.66		130.0	
10574-AAA	IEEE 802.11b WiFi 2.4 GHz (DSSS, 11 Mbps, 90pc duty cycle)	X	1.51	71.42	18.78	0.46	130.0	± 9.6 %
		Y	1.69	74.14	20.31		130.0	
		Z	1.47	71.09	18.56		130.0	

10575-AAA	IEEE 802.11g WiFi 2.4 GHz (DSSS-OFDM, 6 Mbps, 90pc duty cycle)	X	4.80	66.79	16.52	0.46	130.0	± 9.6 %
		Y	4.80	66.99	16.70		130.0	
		Z	4.74	66.78	16.48		130.0	
10576-AAA	IEEE 802.11g WiFi 2.4 GHz (DSSS-OFDM, 9 Mbps, 90pc duty cycle)	X	4.82	66.93	16.57	0.46	130.0	± 9.6 %
		Y	4.83	67.13	16.75		130.0	
		Z	4.77	66.93	16.54		130.0	
10577-AAA	IEEE 802.11g WiFi 2.4 GHz (DSSS-OFDM, 12 Mbps, 90pc duty cycle)	X	5.04	67.25	16.75	0.46	130.0	± 9.6 %
		Y	5.04	67.43	16.92		130.0	
		Z	4.97	67.22	16.71		130.0	
10578-AAA	IEEE 802.11g WiFi 2.4 GHz (DSSS-OFDM, 18 Mbps, 90pc duty cycle)	X	4.93	67.39	16.83	0.46	130.0	± 9.6 %
		Y	4.93	67.57	17.00		130.0	
		Z	4.87	67.36	16.79		130.0	
10579-AAA	IEEE 802.11g WiFi 2.4 GHz (DSSS-OFDM, 24 Mbps, 90pc duty cycle)	X	4.71	66.78	16.21	0.46	130.0	± 9.6 %
		Y	4.73	67.02	16.43		130.0	
		Z	4.65	66.73	16.16		130.0	
10580-AAA	IEEE 802.11g WiFi 2.4 GHz (DSSS-OFDM, 36 Mbps, 90pc duty cycle)	X	4.76	66.79	16.23	0.46	130.0	± 9.6 %
		Y	4.77	67.05	16.45		130.0	
		Z	4.69	66.76	16.18		130.0	
10581-AAA	IEEE 802.11g WiFi 2.4 GHz (DSSS-OFDM, 48 Mbps, 90pc duty cycle)	X	4.83	67.44	16.78	0.46	130.0	± 9.6 %
		Y	4.84	67.63	16.95		130.0	
		Z	4.77	67.41	16.74		130.0	
10582-AAA	IEEE 802.11g WiFi 2.4 GHz (DSSS-OFDM, 54 Mbps, 90pc duty cycle)	X	4.66	66.56	16.03	0.46	130.0	± 9.6 %
		Y	4.68	66.83	16.26		130.0	
		Z	4.59	66.51	15.97		130.0	
10583-AAA	IEEE 802.11a/h WiFi 5 GHz (OFDM, 6 Mbps, 90pc duty cycle)	X	4.80	66.79	16.52	0.46	130.0	± 9.6 %
		Y	4.80	66.99	16.70		130.0	
		Z	4.74	66.78	16.48		130.0	
10584-AAA	IEEE 802.11a/h WiFi 5 GHz (OFDM, 9 Mbps, 90pc duty cycle)	X	4.82	66.93	16.57	0.46	130.0	± 9.6 %
		Y	4.83	67.13	16.75		130.0	
		Z	4.77	66.93	16.54		130.0	
10585-AAA	IEEE 802.11a/h WiFi 5 GHz (OFDM, 12 Mbps, 90pc duty cycle)	X	5.04	67.25	16.75	0.46	130.0	± 9.6 %
		Y	5.04	67.43	16.92		130.0	
		Z	4.97	67.22	16.71		130.0	
10586-AAA	IEEE 802.11a/h WiFi 5 GHz (OFDM, 18 Mbps, 90pc duty cycle)	X	4.93	67.39	16.83	0.46	130.0	± 9.6 %
		Y	4.93	67.57	17.00		130.0	
		Z	4.87	67.36	16.79		130.0	
10587-AAA	IEEE 802.11a/h WiFi 5 GHz (OFDM, 24 Mbps, 90pc duty cycle)	X	4.71	66.78	16.21	0.46	130.0	± 9.6 %
		Y	4.73	67.02	16.43		130.0	
		Z	4.65	66.73	16.16		130.0	
10588-AAA	IEEE 802.11a/h WiFi 5 GHz (OFDM, 36 Mbps, 90pc duty cycle)	X	4.76	66.79	16.23	0.46	130.0	± 9.6 %
		Y	4.77	67.05	16.45		130.0	
		Z	4.69	66.76	16.18		130.0	
10589-AAA	IEEE 802.11a/h WiFi 5 GHz (OFDM, 48 Mbps, 90pc duty cycle)	X	4.83	67.44	16.78	0.46	130.0	± 9.6 %
		Y	4.84	67.63	16.95		130.0	
		Z	4.77	67.41	16.74		130.0	
10590-AAA	IEEE 802.11a/h WiFi 5 GHz (OFDM, 54 Mbps, 90pc duty cycle)	X	4.66	66.56	16.03	0.46	130.0	± 9.6 %
		Y	4.68	66.83	16.26		130.0	
		Z	4.59	66.51	15.97		130.0	

10591-AAA	IEEE 802.11n (HT Mixed, 20MHz, MCS0, 90pc duty cycle)	X	4.94	66.84	16.61	0.46	130.0	± 9.6 %
		Y	4.95	67.02	16.78		130.0	
		Z	4.89	66.83	16.58		130.0	
10592-AAA	IEEE 802.11n (HT Mixed, 20MHz, MCS1, 90pc duty cycle)	X	5.11	67.18	16.74	0.46	130.0	± 9.6 %
		Y	5.11	67.36	16.91		130.0	
		Z	5.05	67.16	16.71		130.0	
10593-AAA	IEEE 802.11n (HT Mixed, 20MHz, MCS2, 90pc duty cycle)	X	5.04	67.12	16.64	0.46	130.0	± 9.6 %
		Y	5.04	67.31	16.81		130.0	
		Z	4.97	67.08	16.60		130.0	
10594-AAA	IEEE 802.11n (HT Mixed, 20MHz, MCS3, 90pc duty cycle)	X	5.09	67.26	16.77	0.46	130.0	± 9.6 %
		Y	5.09	67.44	16.95		130.0	
		Z	5.02	67.24	16.74		130.0	
10595-AAA	IEEE 802.11n (HT Mixed, 20MHz, MCS4, 90pc duty cycle)	X	5.06	67.23	16.68	0.46	130.0	± 9.6 %
		Y	5.07	67.42	16.86		130.0	
		Z	4.99	67.20	16.64		130.0	
10596-AAA	IEEE 802.11n (HT Mixed, 20MHz, MCS5, 90pc duty cycle)	X	5.00	67.23	16.68	0.46	130.0	± 9.6 %
		Y	5.01	67.44	16.87		130.0	
		Z	4.93	67.20	16.65		130.0	
10597-AAA	IEEE 802.11n (HT Mixed, 20MHz, MCS6, 90pc duty cycle)	X	4.95	67.15	16.58	0.46	130.0	± 9.6 %
		Y	4.96	67.36	16.77		130.0	
		Z	4.88	67.11	16.54		130.0	
10598-AAA	IEEE 802.11n (HT Mixed, 20MHz, MCS7, 90pc duty cycle)	X	4.92	67.37	16.82	0.46	130.0	± 9.6 %
		Y	4.93	67.55	16.99		130.0	
		Z	4.86	67.32	16.78		130.0	
10599-AAA	IEEE 802.11n (HT Mixed, 40MHz, MCS0, 90pc duty cycle)	X	5.62	67.44	16.83	0.46	130.0	± 9.6 %
		Y	5.62	67.59	16.99		130.0	
		Z	5.57	67.41	16.81		130.0	
10600-AAA	IEEE 802.11n (HT Mixed, 40MHz, MCS1, 90pc duty cycle)	X	5.83	68.08	17.13	0.46	130.0	± 9.6 %
		Y	5.83	68.26	17.31		130.0	
		Z	5.75	67.98	17.08		130.0	
10601-AAA	IEEE 802.11n (HT Mixed, 40MHz, MCS2, 90pc duty cycle)	X	5.67	67.70	16.95	0.46	130.0	± 9.6 %
		Y	5.68	67.87	17.12		130.0	
		Z	5.61	67.65	16.92		130.0	
10602-AAA	IEEE 802.11n (HT Mixed, 40MHz, MCS3, 90pc duty cycle)	X	5.76	67.70	16.88	0.46	130.0	± 9.6 %
		Y	5.77	67.88	17.05		130.0	
		Z	5.71	67.69	16.87		130.0	
10603-AAA	IEEE 802.11n (HT Mixed, 40MHz, MCS4, 90pc duty cycle)	X	5.83	67.96	17.13	0.46	130.0	± 9.6 %
		Y	5.84	68.14	17.30		130.0	
		Z	5.78	67.93	17.11		130.0	
10604-AAA	IEEE 802.11n (HT Mixed, 40MHz, MCS5, 90pc duty cycle)	X	5.62	67.40	16.84	0.46	130.0	± 9.6 %
		Y	5.63	67.56	17.00		130.0	
		Z	5.57	67.37	16.81		130.0	
10605-AAA	IEEE 802.11n (HT Mixed, 40MHz, MCS6, 90pc duty cycle)	X	5.75	67.79	17.04	0.46	130.0	± 9.6 %
		Y	5.76	67.98	17.22		130.0	
		Z	5.71	67.80	17.04		130.0	
10606-AAA	IEEE 802.11n (HT Mixed, 40MHz, MCS7, 90pc duty cycle)	X	5.50	67.17	16.59	0.46	130.0	± 9.6 %
		Y	5.51	67.36	16.78		130.0	
		Z	5.45	67.15	16.57		130.0	

10607-AAA	IEEE 802.11ac WiFi (20MHz, MCS0, 90pc duty cycle)	X	4.77	66.11	16.20	0.46	130.0	± 9.6 %
		Y	4.78	66.31	16.38		130.0	
		Z	4.72	66.10	16.17		130.0	
10608-AAA	IEEE 802.11ac WiFi (20MHz, MCS1, 90pc duty cycle)	X	4.97	66.53	16.37	0.46	130.0	± 9.6 %
		Y	4.98	66.73	16.55		130.0	
		Z	4.91	66.51	16.34		130.0	
10609-AAA	IEEE 802.11ac WiFi (20MHz, MCS2, 90pc duty cycle)	X	4.86	66.39	16.22	0.46	130.0	± 9.6 %
		Y	4.87	66.61	16.41		130.0	
		Z	4.80	66.37	16.19		130.0	
10610-AAA	IEEE 802.11ac WiFi (20MHz, MCS3, 90pc duty cycle)	X	4.91	66.54	16.37	0.46	130.0	± 9.6 %
		Y	4.92	66.75	16.55		130.0	
		Z	4.85	66.52	16.34		130.0	
10611-AAA	IEEE 802.11ac WiFi (20MHz, MCS4, 90pc duty cycle)	X	4.83	66.37	16.24	0.46	130.0	± 9.6 %
		Y	4.84	66.58	16.42		130.0	
		Z	4.77	66.34	16.20		130.0	
10612-AAA	IEEE 802.11ac WiFi (20MHz, MCS5, 90pc duty cycle)	X	4.85	66.53	16.28	0.46	130.0	± 9.6 %
		Y	4.86	66.77	16.48		130.0	
		Z	4.78	66.50	16.25		130.0	
10613-AAA	IEEE 802.11ac WiFi (20MHz, MCS6, 90pc duty cycle)	X	4.86	66.45	16.19	0.46	130.0	± 9.6 %
		Y	4.87	66.68	16.39		130.0	
		Z	4.79	66.40	16.14		130.0	
10614-AAA	IEEE 802.11ac WiFi (20MHz, MCS7, 90pc duty cycle)	X	4.79	66.59	16.39	0.46	130.0	± 9.6 %
		Y	4.80	66.80	16.57		130.0	
		Z	4.72	66.55	16.34		130.0	
10615-AAA	IEEE 802.11ac WiFi (20MHz, MCS8, 90pc duty cycle)	X	4.84	66.22	16.03	0.46	130.0	± 9.6 %
		Y	4.85	66.46	16.24		130.0	
		Z	4.77	66.19	15.99		130.0	
10616-AAA	IEEE 802.11ac WiFi (40MHz, MCS0, 90pc duty cycle)	X	5.43	66.66	16.42	0.46	130.0	± 9.6 %
		Y	5.44	66.83	16.58		130.0	
		Z	5.38	66.62	16.39		130.0	
10617-AAA	IEEE 802.11ac WiFi (40MHz, MCS1, 90pc duty cycle)	X	5.49	66.80	16.46	0.46	130.0	± 9.6 %
		Y	5.50	66.99	16.63		130.0	
		Z	5.45	66.83	16.47		130.0	
10618-AAA	IEEE 802.11ac WiFi (40MHz, MCS2, 90pc duty cycle)	X	5.38	66.84	16.49	0.46	130.0	± 9.6 %
		Y	5.39	67.01	16.65		130.0	
		Z	5.33	66.80	16.47		130.0	
10619-AAA	IEEE 802.11ac WiFi (40MHz, MCS3, 90pc duty cycle)	X	5.41	66.69	16.36	0.46	130.0	± 9.6 %
		Y	5.42	66.88	16.53		130.0	
		Z	5.36	66.66	16.34		130.0	
10620-AAA	IEEE 802.11ac WiFi (40MHz, MCS4, 90pc duty cycle)	X	5.51	66.76	16.45	0.46	130.0	± 9.6 %
		Y	5.52	66.94	16.61		130.0	
		Z	5.45	66.69	16.40		130.0	
10621-AAA	IEEE 802.11ac WiFi (40MHz, MCS5, 90pc duty cycle)	X	5.49	66.80	16.57	0.46	130.0	± 9.6 %
		Y	5.49	66.95	16.72		130.0	
		Z	5.43	66.76	16.55		130.0	
10622-AAA	IEEE 802.11ac WiFi (40MHz, MCS6, 90pc duty cycle)	X	5.50	66.97	16.65	0.46	130.0	± 9.6 %
		Y	5.51	67.14	16.81		130.0	
		Z	5.46	66.96	16.64		130.0	

10623-AAA	IEEE 802.11ac WiFi (40MHz, MCS7, 90pc duty cycle)	X	5.38	66.52	16.31	0.46	130.0	± 9.6 %
		Y	5.39	66.70	16.48		130.0	
		Z	5.33	66.49	16.29		130.0	
10624-AAA	IEEE 802.11ac WiFi (40MHz, MCS8, 90pc duty cycle)	X	5.58	66.73	16.48	0.46	130.0	± 9.6 %
		Y	5.59	66.90	16.64		130.0	
		Z	5.52	66.69	16.46		130.0	
10625-AAA	IEEE 802.11ac WiFi (40MHz, MCS9, 90pc duty cycle)	X	6.03	67.94	17.14	0.46	130.0	± 9.6 %
		Y	6.04	68.15	17.32		130.0	
		Z	5.94	67.84	17.08		130.0	
10626-AAA	IEEE 802.11ac WiFi (80MHz, MCS0, 90pc duty cycle)	X	5.70	66.70	16.37	0.46	130.0	± 9.6 %
		Y	5.71	66.85	16.51		130.0	
		Z	5.66	66.67	16.35		130.0	
10627-AAA	IEEE 802.11ac WiFi (80MHz, MCS1, 90pc duty cycle)	X	5.98	67.34	16.65	0.46	130.0	± 9.6 %
		Y	5.99	67.51	16.80		130.0	
		Z	5.93	67.32	16.64		130.0	
10628-AAA	IEEE 802.11ac WiFi (80MHz, MCS2, 90pc duty cycle)	X	5.76	66.88	16.35	0.46	130.0	± 9.6 %
		Y	5.78	67.04	16.51		130.0	
		Z	5.72	66.82	16.32		130.0	
10629-AAA	IEEE 802.11ac WiFi (80MHz, MCS3, 90pc duty cycle)	X	5.85	66.94	16.38	0.46	130.0	± 9.6 %
		Y	5.86	67.11	16.54		130.0	
		Z	5.81	66.93	16.37		130.0	
10630-AAA	IEEE 802.11ac WiFi (80MHz, MCS4, 90pc duty cycle)	X	6.47	68.96	17.39	0.46	130.0	± 9.6 %
		Y	6.50	69.20	17.59		130.0	
		Z	6.37	68.78	17.30		130.0	
10631-AAA	IEEE 802.11ac WiFi (80MHz, MCS5, 90pc duty cycle)	X	6.25	68.39	17.28	0.46	130.0	± 9.6 %
		Y	6.25	68.53	17.42		130.0	
		Z	6.15	68.22	17.20		130.0	
10632-AAA	IEEE 802.11ac WiFi (80MHz, MCS6, 90pc duty cycle)	X	5.93	67.33	16.77	0.46	130.0	± 9.6 %
		Y	5.93	67.47	16.90		130.0	
		Z	5.89	67.32	16.77		130.0	
10633-AAA	IEEE 802.11ac WiFi (80MHz, MCS7, 90pc duty cycle)	X	5.83	67.02	16.45	0.46	130.0	± 9.6 %
		Y	5.83	67.17	16.59		130.0	
		Z	5.76	66.93	16.40		130.0	
10634-AAA	IEEE 802.11ac WiFi (80MHz, MCS8, 90pc duty cycle)	X	5.80	67.01	16.50	0.46	130.0	± 9.6 %
		Y	5.81	67.15	16.64		130.0	
		Z	5.75	66.94	16.47		130.0	
10635-AAA	IEEE 802.11ac WiFi (80MHz, MCS9, 90pc duty cycle)	X	5.71	66.44	15.97	0.46	130.0	± 9.6 %
		Y	5.72	66.63	16.15		130.0	
		Z	5.64	66.35	15.92		130.0	
10636-AAA	IEEE 1602.11ac WiFi (160MHz, MCS0, 90pc duty cycle)	X	6.12	67.11	16.48	0.46	130.0	± 9.6 %
		Y	6.13	67.25	16.62		130.0	
		Z	6.09	67.07	16.46		130.0	
10637-AAA	IEEE 1602.11ac WiFi (160MHz, MCS1, 90pc duty cycle)	X	6.30	67.52	16.67	0.46	130.0	± 9.6 %
		Y	6.31	67.68	16.81		130.0	
		Z	6.26	67.49	16.65		130.0	
10638-AAA	IEEE 1602.11ac WiFi (160MHz, MCS2, 90pc duty cycle)	X	6.30	67.50	16.63	0.46	130.0	± 9.6 %
		Y	6.31	67.65	16.78		130.0	
		Z	6.26	67.46	16.61		130.0	

10639-AAA	IEEE 1602.11ac WiFi (160MHz, MCS3, 90pc duty cycle)	X	6.28	67.46	16.65	0.46	130.0	± 9.6 %
		Y	6.28	67.59	16.79		130.0	
		Z	6.23	67.38	16.62		130.0	
10640-AAA	IEEE 1602.11ac WiFi (160MHz, MCS4, 90pc duty cycle)	X	6.30	67.54	16.64	0.46	130.0	± 9.6 %
		Y	6.31	67.70	16.79		130.0	
		Z	6.24	67.43	16.59		130.0	
10641-AAA	IEEE 1602.11ac WiFi (160MHz, MCS5, 90pc duty cycle)	X	6.31	67.32	16.55	0.46	130.0	± 9.6 %
		Y	6.32	67.48	16.70		130.0	
		Z	6.28	67.31	16.54		130.0	
10642-AAA	IEEE 1602.11ac WiFi (160MHz, MCS6, 90pc duty cycle)	X	6.36	67.59	16.84	0.46	130.0	± 9.6 %
		Y	6.36	67.71	16.97		130.0	
		Z	6.31	67.52	16.81		130.0	
10643-AAA	IEEE 1602.11ac WiFi (160MHz, MCS7, 90pc duty cycle)	X	6.20	67.31	16.61	0.46	130.0	± 9.6 %
		Y	6.21	67.47	16.77		130.0	
		Z	6.16	67.26	16.58		130.0	
10644-AAA	IEEE 1602.11ac WiFi (160MHz, MCS8, 90pc duty cycle)	X	6.42	67.97	16.97	0.46	130.0	± 9.6 %
		Y	6.43	68.15	17.13		130.0	
		Z	6.34	67.82	16.88		130.0	
10645-AAA	IEEE 1602.11ac WiFi (160MHz, MCS9, 90pc duty cycle)	X	6.93	69.02	17.44	0.46	130.0	± 9.6 %
		Y	6.97	69.27	17.65		130.0	
		Z	6.82	68.81	17.34		130.0	
10646-AAC	LTE-TDD (SC-FDMA, 1 RB, 5 MHz, QPSK, UL Subframe=2,7)	X	47.20	124.94	41.34	9.30	60.0	± 9.6 %
		Y	100.00	143.87	46.72		60.0	
		Z	42.87	123.31	40.85		60.0	
10647-AAB	LTE-TDD (SC-FDMA, 1 RB, 20 MHz, QPSK, UL Subframe=2,7)	X	47.80	126.16	41.84	9.30	60.0	± 9.6 %
		Y	100.00	144.94	47.17		60.0	
		Z	42.80	124.20	41.27		60.0	
10648-AAA	CDMA2000 (1x Advanced)	X	0.75	63.57	11.13	0.00	150.0	± 9.6 %
		Y	0.80	64.99	12.02		150.0	
		Z	0.70	63.11	10.54		150.0	

<sup>E</sup> Uncertainty is determined using the max. deviation from linear response applying rectangular distribution and is expressed for the square of the field value.



Accredited by the Swiss Accreditation Service (SAS)  
The Swiss Accreditation Service is one of the signatories to the EA  
Multilateral Agreement for the recognition of calibration certificates

Accreditation No.: **SCS 0108**

Client **PC Test**

Certificate No: **EX3-7308\_Aug17**

**CALIBRATION CERTIFICATE**

Object: **EX3DV4 - SN:7308**

Calibration procedure(s): **QA CAL-01.v9, QA CAL-14.v4, QA CAL-23.v5, QA CAL-25.v6  
Calibration procedure for dosimetric E-field probes**

*PM ✓  
8/27/17*

Calibration date: **August 16, 2017**

This calibration certificate documents the traceability to national standards, which realize the physical units of measurements (SI).  
The measurements and the uncertainties with confidence probability are given on the following pages and are part of the certificate.

All calibrations have been conducted in the closed laboratory facility: environment temperature (22 ± 3)°C and humidity < 70%.

Calibration Equipment used (M&TE critical for calibration)

Primary Standards	ID	Cal Date (Certificate No.)	Scheduled Calibration
Power meter NRP	SN: 104778	04-Apr-17 (No. 217-02521/02522)	Apr-18
Power sensor NRP-Z91	SN: 103244	04-Apr-17 (No. 217-02521)	Apr-18
Power sensor NRP-Z91	SN: 103245	04-Apr-17 (No. 217-02525)	Apr-18
Reference 20 dB Attenuator	SN: S5277 (20x)	07-Apr-17 (No. 217-02528)	Apr-18
Reference Probe ES3DV2	SN: 3013	31-Dec-16 (No. ES3-3013_Dec16)	Dec-17
DAE4	SN: 660	7-Dec-16 (No. DAE4-660_Dec16)	Dec-17
Secondary Standards	ID	Check Date (in house)	Scheduled Check
Power meter E4419B	SN: GB41293874	06-Apr-16 (in house check Jun-16)	In house check: Jun-18
Power sensor E4412A	SN: MY41498087	06-Apr-16 (in house check Jun-16)	In house check: Jun-18
Power sensor E4412A	SN: 000110210	06-Apr-16 (in house check Jun-16)	In house check: Jun-18
RF generator HP 8648C	SN: US3642U01700	04-Aug-99 (in house check Jun-16)	In house check: Jun-18
Network Analyzer HP 8753E	SN: US37390585	18-Oct-01 (in house check Oct-16)	In house check: Oct-17

Calibrated by:	Name <b>Leif Klysnar</b>	Function <b>Laboratory Technician</b>	Signature <i>Leif Klysnar</i>
Approved by:	Name <b>Katja Pokovic</b>	Function <b>Technical Manager</b>	Signature <i>Katja Pokovic</i>

Issued: August 16, 2017

This calibration certificate shall not be reproduced except in full without written approval of the laboratory.



Accredited by the Swiss Accreditation Service (SAS)

Accreditation No.: **SCS 0108**

The Swiss Accreditation Service is one of the signatories to the EA  
Multilateral Agreement for the recognition of calibration certificates

**Glossary:**

TSL	tissue simulating liquid
NORM <sub>x,y,z</sub>	sensitivity in free space
ConvF	sensitivity in TSL / NORM <sub>x,y,z</sub>
DCP	diode compression point
CF	crest factor (1/duty_cycle) of the RF signal
A, B, C, D	modulation dependent linearization parameters
Polarization $\varphi$	$\varphi$ rotation around probe axis
Polarization $\vartheta$	$\vartheta$ rotation around an axis that is in the plane normal to probe axis (at measurement center), i.e., $\vartheta = 0$ is normal to probe axis
Connector Angle	information used in DASY system to align probe sensor X to the robot coordinate system

**Calibration is Performed According to the Following Standards:**

- a) IEEE Std 1528-2013, "IEEE Recommended Practice for Determining the Peak Spatial-Averaged Specific Absorption Rate (SAR) in the Human Head from Wireless Communications Devices: Measurement Techniques", June 2013
- b) IEC 62209-1, "Measurement procedure for the assessment of Specific Absorption Rate (SAR) from hand-held and body-mounted devices used next to the ear (frequency range of 300 MHz to 6 GHz)", July 2016
- c) IEC 62209-2, "Procedure to determine the Specific Absorption Rate (SAR) for wireless communication devices used in close proximity to the human body (frequency range of 30 MHz to 6 GHz)", March 2010
- d) KDB 865664, "SAR Measurement Requirements for 100 MHz to 6 GHz"

**Methods Applied and Interpretation of Parameters:**

- *NORM<sub>x,y,z</sub>*: Assessed for E-field polarization  $\vartheta = 0$  ( $f \leq 900$  MHz in TEM-cell;  $f > 1800$  MHz: R22 waveguide). *NORM<sub>x,y,z</sub>* are only intermediate values, i.e., the uncertainties of *NORM<sub>x,y,z</sub>* does not affect the  $E^2$ -field uncertainty inside TSL (see below *ConvF*).
- *NORM(f)<sub>x,y,z</sub> = NORM<sub>x,y,z</sub> \* frequency\_response* (see Frequency Response Chart). This linearization is implemented in DASY4 software versions later than 4.2. The uncertainty of the frequency response is included in the stated uncertainty of *ConvF*.
- *DCP<sub>x,y,z</sub>*: DCP are numerical linearization parameters assessed based on the data of power sweep with CW signal (no uncertainty required). DCP does not depend on frequency nor media.
- *PAR*: PAR is the Peak to Average Ratio that is not calibrated but determined based on the signal characteristics
- *A<sub>x,y,z</sub>; B<sub>x,y,z</sub>; C<sub>x,y,z</sub>; D<sub>x,y,z</sub>; VR<sub>x,y,z</sub>; A, B, C, D* are numerical linearization parameters assessed based on the data of power sweep for specific modulation signal. The parameters do not depend on frequency nor media. VR is the maximum calibration range expressed in RMS voltage across the diode.
- *ConvF and Boundary Effect Parameters*: Assessed in flat phantom using E-field (or Temperature Transfer Standard for  $f \leq 800$  MHz) and inside waveguide using analytical field distributions based on power measurements for  $f > 800$  MHz. The same setups are used for assessment of the parameters applied for boundary compensation (alpha, depth) of which typical uncertainty values are given. These parameters are used in DASY4 software to improve probe accuracy close to the boundary. The sensitivity in TSL corresponds to *NORM<sub>x,y,z</sub> \* ConvF* whereby the uncertainty corresponds to that given for *ConvF*. A frequency dependent *ConvF* is used in DASY version 4.4 and higher which allows extending the validity from  $\pm 50$  MHz to  $\pm 100$  MHz.
- *Spherical isotropy (3D deviation from isotropy)*: in a field of low gradients realized using a flat phantom exposed by a patch antenna.
- *Sensor Offset*: The sensor offset corresponds to the offset of virtual measurement center from the probe tip (on probe axis). No tolerance required.
- *Connector Angle*: The angle is assessed using the information gained by determining the *NORM<sub>x</sub>* (no uncertainty required).



# Probe EX3DV4

## SN:7308

Manufactured: March 11, 2014  
Calibrated: August 16, 2017

Calibrated for DASY/EASY Systems  
(Note: non-compatible with DASY2 system!)

## DASY/EASY - Parameters of Probe: EX3DV4 - SN:7308

### Basic Calibration Parameters

	Sensor X	Sensor Y	Sensor Z	Unc (k=2)
Norm ( $\mu\text{V}/(\text{V}/\text{m})^2$ ) <sup>A</sup>	0.49	0.60	0.44	$\pm 10.1 \%$
DCP (mV) <sup>B</sup>	97.0	91.7	98.5	

### Modulation Calibration Parameters

UID	Communication System Name		A dB	B dB $\sqrt{\mu\text{V}}$	C	D dB	VR mV	Unc <sup>E</sup> (k=2)
0	CW	X	0.0	0.0	1.0	0.00	134.5	$\pm 3.3 \%$
		Y	0.0	0.0	1.0		130.8	
		Z	0.0	0.0	1.0		149.9	

Note: For details on UID parameters see Appendix.

### Sensor Model Parameters

	C1 fF	C2 fF	$\alpha$ V <sup>-1</sup>	T1 ms.V <sup>-2</sup>	T2 ms.V <sup>-1</sup>	T3 ms	T4 V <sup>-2</sup>	T5 V <sup>-1</sup>	T6
X	46.65	351.1	36.16	14.68	0.000	5.088	0.834	0.399	1.005
Y	52.88	402.1	36.74	19.55	0.309	5.100	0.477	0.605	1.007
Z	36.70	273.3	35.48	9.322	0.000	5.034	0.373	0.314	1.002

The reported uncertainty of measurement is stated as the standard uncertainty of measurement multiplied by the coverage factor k=2, which for a normal distribution corresponds to a coverage probability of approximately 95%.

<sup>A</sup> The uncertainties of Norm X,Y,Z do not affect the E<sup>2</sup>-field uncertainty inside TSL (see Pages 5 and 6).

<sup>B</sup> Numerical linearization parameter: uncertainty not required.

<sup>E</sup> Uncertainty is determined using the max. deviation from linear response applying rectangular distribution and is expressed for the square of the field value.

## DASY/EASY - Parameters of Probe: EX3DV4 - SN:7308

### Calibration Parameter Determined in Head Tissue Simulating Media

f (MHz) <sup>C</sup>	Relative Permittivity <sup>F</sup>	Conductivity (S/m) <sup>F</sup>	ConvF X	ConvF Y	ConvF Z	Alpha <sup>G</sup>	Depth <sup>G</sup> (mm)	Unc (k=2)
5250	35.9	4.71	5.25	5.25	5.25	0.35	1.80	± 13.1 %
5600	35.5	5.07	4.83	4.83	4.83	0.40	1.80	± 13.1 %
5750	35.4	5.22	5.11	5.11	5.11	0.40	1.80	± 13.1 %

<sup>C</sup> Frequency validity above 300 MHz of ± 100 MHz only applies for DASY v4.4 and higher (see Page 2), else it is restricted to ± 50 MHz. The uncertainty is the RSS of the ConvF uncertainty at calibration frequency and the uncertainty for the indicated frequency band. Frequency validity below 300 MHz is ± 10, 25, 40, 50 and 70 MHz for ConvF assessments at 30, 64, 128, 150 and 220 MHz respectively. Above 5 GHz frequency validity can be extended to ± 110 MHz.

<sup>F</sup> At frequencies below 3 GHz, the validity of tissue parameters ( $\epsilon$  and  $\sigma$ ) can be relaxed to ± 10% if liquid compensation formula is applied to measured SAR values. At frequencies above 3 GHz, the validity of tissue parameters ( $\epsilon$  and  $\sigma$ ) is restricted to ± 5%. The uncertainty is the RSS of the ConvF uncertainty for indicated target tissue parameters.

<sup>G</sup> Alpha/Depth are determined during calibration. SPEAG warrants that the remaining deviation due to the boundary effect after compensation is always less than ± 1% for frequencies below 3 GHz and below ± 2% for frequencies between 3-6 GHz at any distance larger than half the probe tip diameter from the boundary.

## DASY/EASY - Parameters of Probe: EX3DV4 - SN:7308

### Calibration Parameter Determined in Body Tissue Simulating Media

f (MHz) <sup>C</sup>	Relative Permittivity <sup>F</sup>	Conductivity (S/m) <sup>F</sup>	ConvF X	ConvF Y	ConvF Z	Alpha <sup>G</sup>	Depth <sup>G</sup> (mm)	Unc (k=2)
750	55.5	0.96	10.39	10.39	10.39	0.54	0.85	± 12.0 %
835	55.2	0.97	10.21	10.21	10.21	0.47	0.84	± 12.0 %
1750	53.4	1.49	8.24	8.24	8.24	0.41	0.84	± 12.0 %
1900	53.3	1.52	7.96	7.96	7.96	0.37	0.80	± 12.0 %
2300	52.9	1.81	7.77	7.77	7.77	0.39	0.86	± 12.0 %
2450	52.7	1.95	7.66	7.66	7.66	0.35	0.85	± 12.0 %
2600	52.5	2.16	7.46	7.46	7.46	0.31	0.95	± 12.0 %
5250	48.9	5.36	4.84	4.84	4.84	0.35	1.90	± 13.1 %
5600	48.5	5.77	4.23	4.23	4.23	0.40	1.90	± 13.1 %
5750	48.3	5.94	4.50	4.50	4.50	0.40	1.90	± 13.1 %

<sup>C</sup> Frequency validity above 300 MHz of ± 100 MHz only applies for DASY v4.4 and higher (see Page 2), else it is restricted to ± 50 MHz. The uncertainty is the RSS of the ConvF uncertainty at calibration frequency and the uncertainty for the indicated frequency band. Frequency validity below 300 MHz is ± 10, 25, 40, 50 and 70 MHz for ConvF assessments at 30, 64, 128, 150 and 220 MHz respectively. Above 5 GHz frequency validity can be extended to ± 110 MHz.

<sup>F</sup> At frequencies below 3 GHz, the validity of tissue parameters ( $\epsilon$  and  $\sigma$ ) can be relaxed to ± 10% if liquid compensation formula is applied to measured SAR values. At frequencies above 3 GHz, the validity of tissue parameters ( $\epsilon$  and  $\sigma$ ) is restricted to ± 5%. The uncertainty is the RSS of the ConvF uncertainty for indicated target tissue parameters.

<sup>G</sup> Alpha/Depth are determined during calibration. SPEAG warrants that the remaining deviation due to the boundary effect after compensation is always less than ± 1% for frequencies below 3 GHz and below ± 2% for frequencies between 3-6 GHz at any distance larger than half the probe tip diameter from the boundary.

### Frequency Response of E-Field (TEM-Cell:ifi110 EXX, Waveguide: R22)

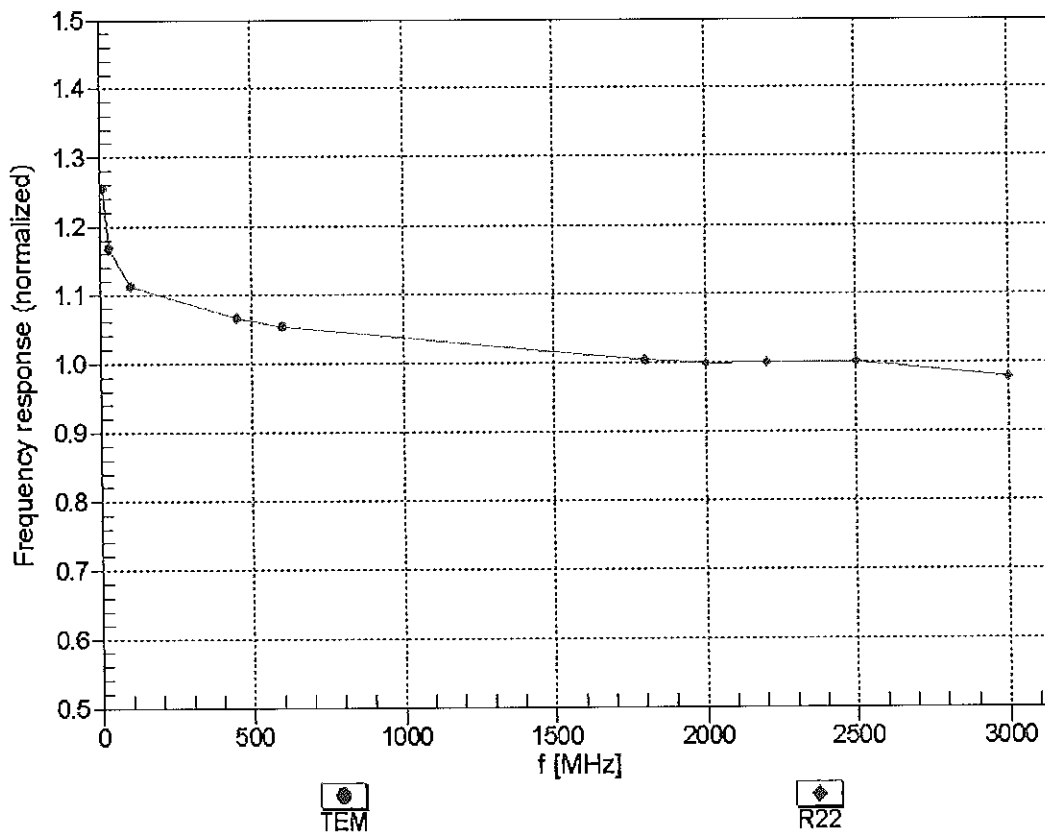

Uncertainty of Frequency Response of E-field:  $\pm 6.3\%$  (k=2)

### Receiving Pattern ( $\phi$ ), $\theta = 0^\circ$

f=600 MHz,TEM

f=1800 MHz,R22

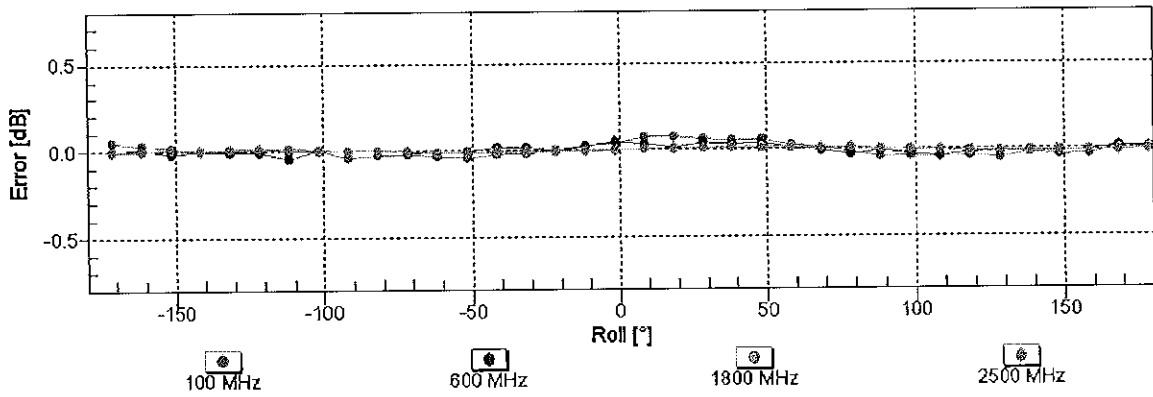
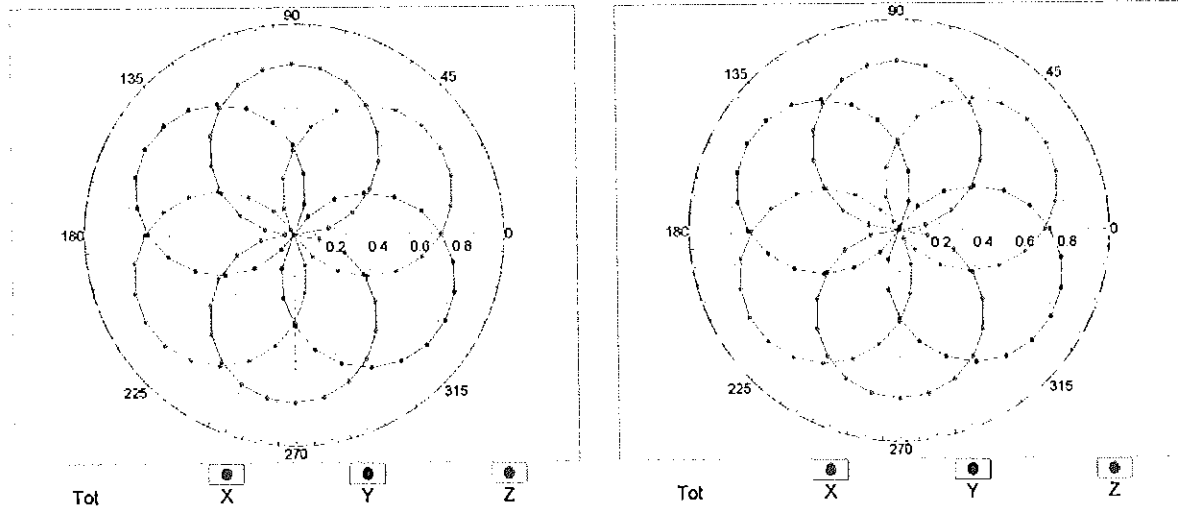

Uncertainty of Axial Isotropy Assessment:  $\pm 0.5\%$  (k=2)

### Dynamic Range $f(SAR_{head})$ (TEM cell , $f_{eval} = 1900$ MHz)

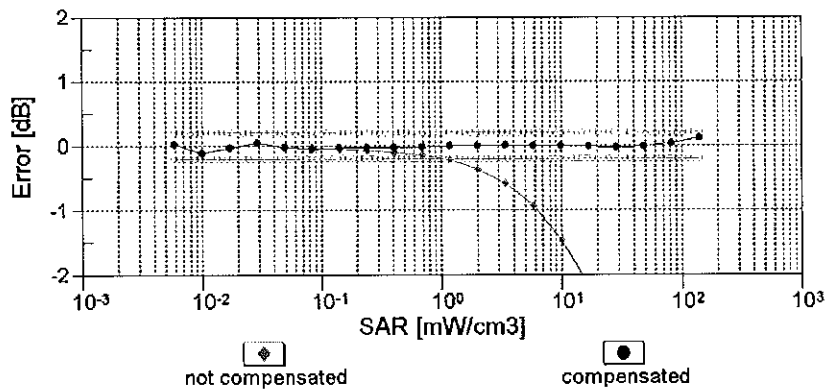
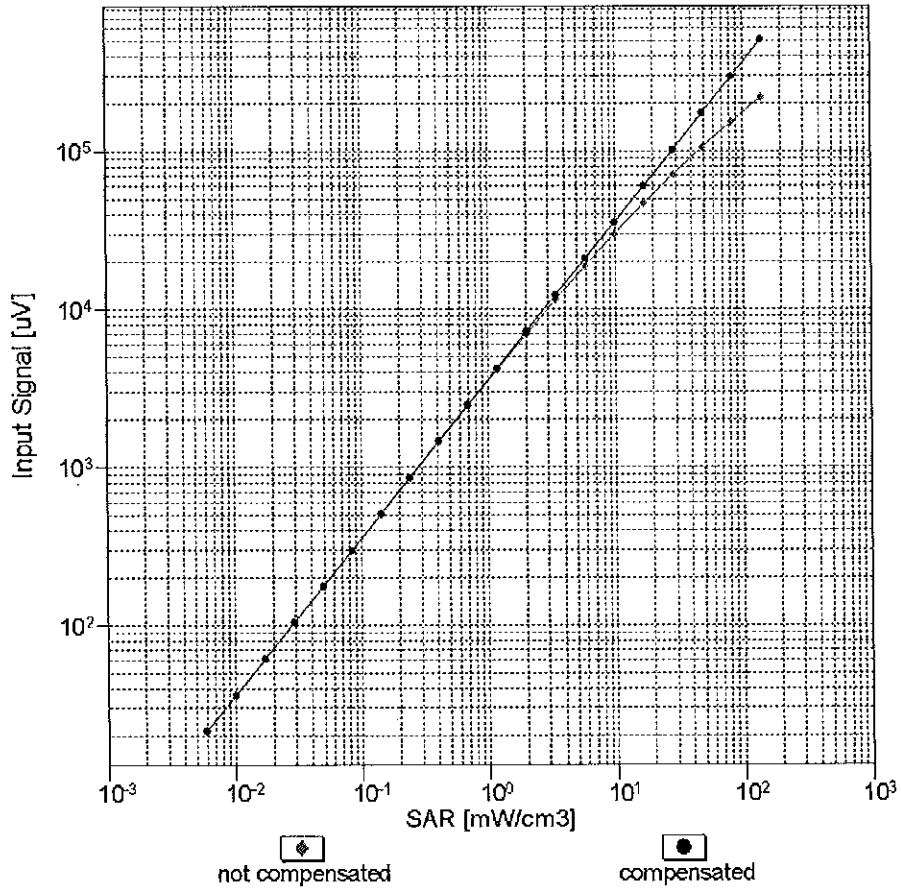

Uncertainty of Linearity Assessment:  $\pm 0.6\%$  (k=2)

## Conversion Factor Assessment

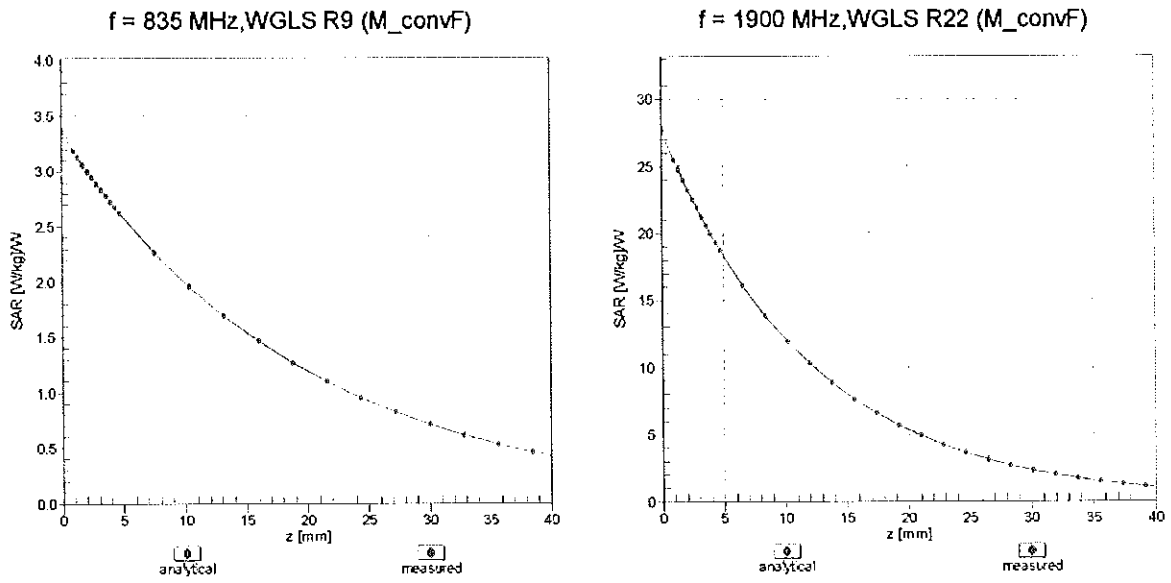

## Deviation from Isotropy in Liquid Error ( $\phi, \theta$ ), f = 900 MHz

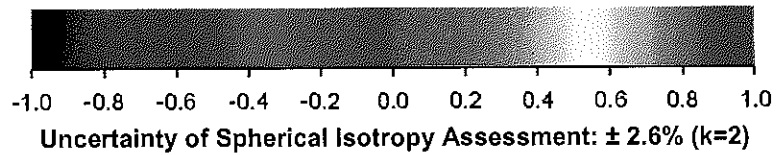
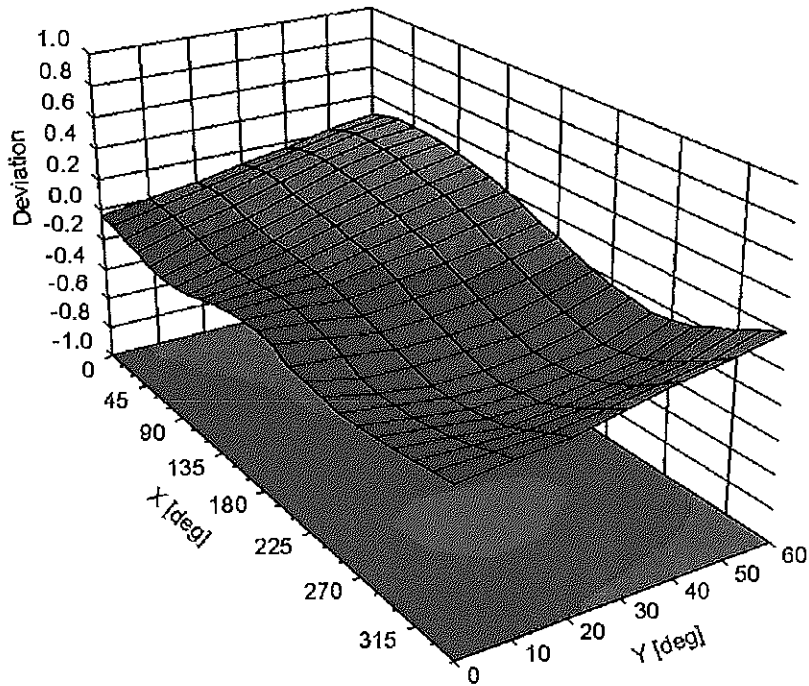



**DASY/EASY - Parameters of Probe: EX3DV4 - SN:7308****Other Probe Parameters**

Sensor Arrangement	Triangular
Connector Angle (°)	108.4
Mechanical Surface Detection Mode	enabled
Optical Surface Detection Mode	disabled
Probe Overall Length	337 mm
Probe Body Diameter	10 mm
Tip Length	9 mm
Tip Diameter	2.5 mm
Probe Tip to Sensor X Calibration Point	1 mm
Probe Tip to Sensor Y Calibration Point	1 mm
Probe Tip to Sensor Z Calibration Point	1 mm
Recommended Measurement Distance from Surface	1.4 mm

**Appendix: Modulation Calibration Parameters**

UID	Communication System Name		A dB	B dB $\sqrt{\mu V}$	C	D dB	VR mV	Max Unc <sup>E</sup> (k=2)
0	CW	X	0.00	0.00	1.00	0.00	134.5	$\pm 3.3\%$
		Y	0.00	0.00	1.00		130.8	
		Z	0.00	0.00	1.00		149.9	
10010- CAA	SAR Validation (Square, 100ms, 10ms)	X	2.82	69.38	11.47	10.00	20.0	$\pm 9.6\%$
		Y	8.85	81.60	16.75		20.0	
		Z	1.57	63.55	8.34		20.0	
10011- CAB	UMTS-FDD (WCDMA)	X	1.10	68.34	15.94	0.00	150.0	$\pm 9.6\%$
		Y	1.03	66.61	14.91		150.0	
		Z	1.05	68.21	15.74		150.0	
10012- CAB	IEEE 802.11b WiFi 2.4 GHz (DSSS, 1 Mbps)	X	1.19	64.20	15.65	0.41	150.0	$\pm 9.6\%$
		Y	1.20	63.83	15.29		150.0	
		Z	1.16	63.91	15.33		150.0	
10013- CAB	IEEE 802.11g WiFi 2.4 GHz (DSSS-OFDM, 6 Mbps)	X	4.89	66.77	17.26	1.46	150.0	$\pm 9.6\%$
		Y	4.97	66.66	17.21		150.0	
		Z	4.71	66.76	17.06		150.0	
10021- DAC	GSM-FDD (TDMA, GMSK)	X	100.00	115.21	27.27	9.39	50.0	$\pm 9.6\%$
		Y	100.00	118.99	29.62		50.0	
		Z	100.00	108.16	23.75		50.0	
10023- DAC	GPRS-FDD (TDMA, GMSK, TN 0)	X	100.00	114.49	26.98	9.57	50.0	$\pm 9.6\%$
		Y	100.00	118.59	29.46		50.0	
		Z	100.00	107.44	23.48		50.0	
10024- DAC	GPRS-FDD (TDMA, GMSK, TN 0-1)	X	100.00	117.36	27.41	6.56	60.0	$\pm 9.6\%$
		Y	100.00	118.20	28.43		60.0	
		Z	100.00	109.72	23.49		60.0	
10025- DAC	EDGE-FDD (TDMA, 8PSK, TN 0)	X	9.43	102.43	43.37	12.57	50.0	$\pm 9.6\%$
		Y	5.76	81.81	33.21		50.0	
		Z	6.64	89.92	37.39		50.0	
10026- DAC	EDGE-FDD (TDMA, 8PSK, TN 0-1)	X	12.23	103.58	38.33	9.56	60.0	$\pm 9.6\%$
		Y	13.89	103.56	37.54		60.0	
		Z	6.87	89.09	32.73		60.0	
10027- DAC	GPRS-FDD (TDMA, GMSK, TN 0-1-2)	X	100.00	121.12	28.38	4.80	80.0	$\pm 9.6\%$
		Y	100.00	119.35	28.26		80.0	
		Z	100.00	113.58	24.47		80.0	
10028- DAC	GPRS-FDD (TDMA, GMSK, TN 0-1-2-3)	X	100.00	126.40	29.97	3.55	100.0	$\pm 9.6\%$
		Y	100.00	121.68	28.61		100.0	
		Z	100.00	119.83	26.46		100.0	
10029- DAC	EDGE-FDD (TDMA, 8PSK, TN 0-1-2)	X	6.36	85.88	30.18	7.80	80.0	$\pm 9.6\%$
		Y	7.77	88.44	30.64		80.0	
		Z	4.37	77.58	26.51		80.0	
10030- CAA	IEEE 802.15.1 Bluetooth (GFSK, DH1)	X	100.00	116.71	26.74	5.30	70.0	$\pm 9.6\%$
		Y	100.00	116.86	27.45		70.0	
		Z	100.00	108.46	22.53		70.0	
10031- CAA	IEEE 802.15.1 Bluetooth (GFSK, DH3)	X	100.00	130.68	30.26	1.88	100.0	$\pm 9.6\%$
		Y	100.00	122.76	27.68		100.0	
		Z	100.00	121.33	25.72		100.0	

10032-CAA	IEEE 802.15.1 Bluetooth (GFSK, DH5)	X	100.00	146.47	35.43	1.17	100.0	± 9.6 %
		Y	100.00	130.05	29.64		100.0	
		Z	100.00	142.38	32.95		100.0	
10033-CAA	IEEE 802.15.1 Bluetooth (PI/4-DQPSK, DH1)	X	100.00	133.81	36.67	5.30	70.0	± 9.6 %
		Y	100.00	132.56	36.57		70.0	
		Z	18.79	102.95	27.19		70.0	
10034-CAA	IEEE 802.15.1 Bluetooth (PI/4-DQPSK, DH3)	X	7.76	92.37	23.91	1.88	100.0	± 9.6 %
		Y	6.00	87.65	22.68		100.0	
		Z	3.22	78.87	18.00		100.0	
10035-CAA	IEEE 802.15.1 Bluetooth (PI/4-DQPSK, DH5)	X	3.37	81.04	19.87	1.17	100.0	± 9.6 %
		Y	2.89	77.85	18.94		100.0	
		Z	2.06	74.00	15.93		100.0	
10036-CAA	IEEE 802.15.1 Bluetooth (8-DPSK, DH1)	X	100.00	134.35	36.91	5.30	70.0	± 9.6 %
		Y	100.00	133.01	36.79		70.0	
		Z	38.41	113.99	30.14		70.0	
10037-CAA	IEEE 802.15.1 Bluetooth (8-DPSK, DH3)	X	6.72	90.40	23.29	1.88	100.0	± 9.6 %
		Y	5.52	86.51	22.28		100.0	
		Z	2.77	77.09	17.35		100.0	
10038-CAA	IEEE 802.15.1 Bluetooth (8-DPSK, DH5)	X	3.40	81.53	20.18	1.17	100.0	± 9.6 %
		Y	2.93	78.34	19.24		100.0	
		Z	2.07	74.35	16.21		100.0	
10039-CAB	CDMA2000 (1xRTT, RC1)	X	2.05	73.74	16.48	0.00	150.0	± 9.6 %
		Y	1.78	70.97	15.59		150.0	
		Z	1.68	71.87	14.68		150.0	
10042-CAB	IS-54 / IS-136 FDD (TDMA/FDM, PI/4-DQPSK, Halfrate)	X	100.00	111.92	25.18	7.78	50.0	± 9.6 %
		Y	100.00	114.62	26.97		50.0	
		Z	100.00	105.38	21.87		50.0	
10044-CAA	IS-91/EIA/TIA-553 FDD (FDMA, FM)	X	0.00	97.13	0.41	0.00	150.0	± 9.6 %
		Y	0.00	93.19	1.28		150.0	
		Z	0.01	94.96	0.54		150.0	
10048-CAA	DECT (TDD, TDMA/FDM, GFSK, Full Slot, 24)	X	100.00	111.98	26.96	13.80	25.0	± 9.6 %
		Y	100.00	121.05	31.60		25.0	
		Z	34.07	91.91	20.28		25.0	
10049-CAA	DECT (TDD, TDMA/FDM, GFSK, Double Slot, 12)	X	1284.72	142.21	32.21	10.79	40.0	± 9.6 %
		Y	100.00	117.51	29.18		40.0	
		Z	145.96	109.32	23.74		40.0	
10056-CAA	UMTS-TDD (TD-SCDMA, 1.28 Mcps)	X	100.00	128.20	35.15	9.03	50.0	± 9.6 %
		Y	100.00	128.83	35.96		50.0	
		Z	100.00	122.10	31.77		50.0	
10058-DAC	EDGE-FDD (TDMA, 8PSK, TN 0-1-2-3)	X	4.71	78.88	26.31	6.55	100.0	± 9.6 %
		Y	5.67	81.33	26.92		100.0	
		Z	3.54	73.15	23.60		100.0	
10059-CAB	IEEE 802.11b WiFi 2.4 GHz (DSSS, 2 Mbps)	X	1.24	65.47	16.42	0.61	110.0	± 9.6 %
		Y	1.27	65.23	16.10		110.0	
		Z	1.17	64.77	15.84		110.0	
10060-CAB	IEEE 802.11b WiFi 2.4 GHz (DSSS, 5.5 Mbps)	X	100.00	144.38	38.50	1.30	110.0	± 9.6 %
		Y	100.00	138.88	36.40		110.0	
		Z	13.09	112.30	30.84		110.0	

10061-CAB	IEEE 802.11b WiFi 2.4 GHz (DSSS, 11 Mbps)	X	4.05	88.33	25.97	2.04	110.0	± 9.6 %
		Y	4.75	88.86	25.68		110.0	
		Z	2.16	77.73	21.68		110.0	
10062-CAB	IEEE 802.11a/h WiFi 5 GHz (OFDM, 6 Mbps)	X	4.69	66.76	16.65	0.49	100.0	± 9.6 %
		Y	4.76	66.60	16.58		100.0	
		Z	4.53	66.78	16.51		100.0	
10063-CAB	IEEE 802.11a/h WiFi 5 GHz (OFDM, 9 Mbps)	X	4.71	66.86	16.76	0.72	100.0	± 9.6 %
		Y	4.78	66.72	16.70		100.0	
		Z	4.54	66.86	16.60		100.0	
10064-CAB	IEEE 802.11a/h WiFi 5 GHz (OFDM, 12 Mbps)	X	4.99	67.12	16.99	0.86	100.0	± 9.6 %
		Y	5.09	67.02	16.95		100.0	
		Z	4.78	67.06	16.80		100.0	
10065-CAB	IEEE 802.11a/h WiFi 5 GHz (OFDM, 18 Mbps)	X	4.86	67.02	17.11	1.21	100.0	± 9.6 %
		Y	4.96	66.95	17.08		100.0	
		Z	4.65	66.90	16.87		100.0	
10066-CAB	IEEE 802.11a/h WiFi 5 GHz (OFDM, 24 Mbps)	X	4.88	67.05	17.29	1.46	100.0	± 9.6 %
		Y	4.99	66.99	17.27		100.0	
		Z	4.65	66.88	17.02		100.0	
10067-CAB	IEEE 802.11a/h WiFi 5 GHz (OFDM, 36 Mbps)	X	5.16	67.22	17.75	2.04	100.0	± 9.6 %
		Y	5.27	67.12	17.71		100.0	
		Z	4.93	67.13	17.49		100.0	
10068-CAB	IEEE 802.11a/h WiFi 5 GHz (OFDM, 48 Mbps)	X	5.20	67.26	17.98	2.55	100.0	± 9.6 %
		Y	5.34	67.28	18.00		100.0	
		Z	4.95	67.02	17.64		100.0	
10069-CAB	IEEE 802.11a/h WiFi 5 GHz (OFDM, 54 Mbps)	X	5.28	67.26	18.18	2.67	100.0	± 9.6 %
		Y	5.42	67.23	18.17		100.0	
		Z	5.02	67.05	17.83		100.0	
10071-CAB	IEEE 802.11g WiFi 2.4 GHz (DSSS/OFDM, 9 Mbps)	X	4.98	66.86	17.58	1.99	100.0	± 9.6 %
		Y	5.07	66.77	17.55		100.0	
		Z	4.79	66.80	17.35		100.0	
10072-CAB	IEEE 802.11g WiFi 2.4 GHz (DSSS/OFDM, 12 Mbps)	X	4.95	67.19	17.81	2.30	100.0	± 9.6 %
		Y	5.06	67.16	17.80		100.0	
		Z	4.74	67.03	17.53		100.0	
10073-CAB	IEEE 802.11g WiFi 2.4 GHz (DSSS/OFDM, 18 Mbps)	X	5.00	67.34	18.16	2.83	100.0	± 9.6 %
		Y	5.12	67.33	18.16		100.0	
		Z	4.79	67.17	17.85		100.0	
10074-CAB	IEEE 802.11g WiFi 2.4 GHz (DSSS/OFDM, 24 Mbps)	X	4.97	67.20	18.31	3.30	100.0	± 9.6 %
		Y	5.10	67.22	18.33		100.0	
		Z	4.78	67.07	17.99		100.0	
10075-CAB	IEEE 802.11g WiFi 2.4 GHz (DSSS/OFDM, 36 Mbps)	X	5.00	67.30	18.63	3.82	90.0	± 9.6 %
		Y	5.15	67.40	18.70		90.0	
		Z	4.78	67.05	18.23		90.0	
10076-CAB	IEEE 802.11g WiFi 2.4 GHz (DSSS/OFDM, 48 Mbps)	X	5.00	67.05	18.74	4.15	90.0	± 9.6 %
		Y	5.14	67.12	18.78		90.0	
		Z	4.81	66.90	18.39		90.0	
10077-CAB	IEEE 802.11g WiFi 2.4 GHz (DSSS/OFDM, 54 Mbps)	X	5.02	67.11	18.84	4.30	90.0	± 9.6 %
		Y	5.16	67.16	18.87		90.0	
		Z	4.84	66.97	18.50		90.0	

10081-CAB	CDMA2000 (1xRTT, RC3)	X	0.91	67.10	13.23	0.00	150.0	± 9.6 %
		Y	0.87	65.55	12.69		150.0	
		Z	0.76	65.80	11.60		150.0	
10082-CAB	IS-54 / IS-136 FDD (TDMA/FDM, PI/4-DQPSK, Fullrate)	X	0.67	60.00	4.34	4.77	80.0	± 9.6 %
		Y	0.83	60.00	4.98		80.0	
		Z	1.32	62.68	4.53		80.0	
10090-DAC	GPRS-FDD (TDMA, GMSK, TN 0-4)	X	100.00	117.37	27.43	6.56	60.0	± 9.6 %
		Y	100.00	118.23	28.46		60.0	
		Z	100.00	109.70	23.50		60.0	
10097-CAB	UMTS-FDD (HSDPA)	X	1.89	68.18	16.03	0.00	150.0	± 9.6 %
		Y	1.82	67.06	15.47		150.0	
		Z	1.87	68.73	15.97		150.0	
10098-CAB	UMTS-FDD (HSUPA, Subtest 2)	X	1.85	68.15	16.01	0.00	150.0	± 9.6 %
		Y	1.78	67.01	15.43		150.0	
		Z	1.83	68.68	15.95		150.0	
10099-DAC	EDGE-FDD (TDMA, 8PSK, TN 0-4)	X	12.41	103.93	38.44	9.56	60.0	± 9.6 %
		Y	14.05	103.81	37.62		60.0	
		Z	6.94	89.30	32.81		60.0	
10100-CAD	LTE-FDD (SC-FDMA, 100% RB, 20 MHz, QPSK)	X	3.20	70.68	16.98	0.00	150.0	± 9.6 %
		Y	3.15	69.96	16.53		150.0	
		Z	3.05	70.44	16.91		150.0	
10101-CAD	LTE-FDD (SC-FDMA, 100% RB, 20 MHz, 16-QAM)	X	3.27	67.67	16.10	0.00	150.0	± 9.6 %
		Y	3.29	67.34	15.87		150.0	
		Z	3.15	67.56	16.02		150.0	
10102-CAD	LTE-FDD (SC-FDMA, 100% RB, 20 MHz, 64-QAM)	X	3.37	67.61	16.17	0.00	150.0	± 9.6 %
		Y	3.39	67.30	15.96		150.0	
		Z	3.26	67.54	16.10		150.0	
10103-CAD	LTE-TDD (SC-FDMA, 100% RB, 20 MHz, QPSK)	X	6.70	77.76	21.71	3.98	65.0	± 9.6 %
		Y	7.25	78.01	21.66		65.0	
		Z	5.31	74.49	20.24		65.0	
10104-CAD	LTE-TDD (SC-FDMA, 100% RB, 20 MHz, 16-QAM)	X	6.39	74.88	21.30	3.98	65.0	± 9.6 %
		Y	7.01	75.63	21.49		65.0	
		Z	5.41	72.53	20.08		65.0	
10105-CAD	LTE-TDD (SC-FDMA, 100% RB, 20 MHz, 64-QAM)	X	5.93	73.22	20.87	3.98	65.0	± 9.6 %
		Y	6.37	73.62	20.93		65.0	
		Z	4.98	70.66	19.52		65.0	
10108-CAE	LTE-FDD (SC-FDMA, 100% RB, 10 MHz, QPSK)	X	2.79	69.92	16.81	0.00	150.0	± 9.6 %
		Y	2.76	69.17	16.35		150.0	
		Z	2.63	69.76	16.75		150.0	
10109-CAE	LTE-FDD (SC-FDMA, 100% RB, 10 MHz, 16-QAM)	X	2.93	67.55	16.01	0.00	150.0	± 9.6 %
		Y	2.94	67.14	15.76		150.0	
		Z	2.80	67.54	15.90		150.0	
10110-CAE	LTE-FDD (SC-FDMA, 100% RB, 5 MHz, QPSK)	X	2.27	69.10	16.46	0.00	150.0	± 9.6 %
		Y	2.25	68.23	15.96		150.0	
		Z	2.13	69.06	16.32		150.0	
10111-CAE	LTE-FDD (SC-FDMA, 100% RB, 5 MHz, 16-QAM)	X	2.65	68.45	16.32	0.00	150.0	± 9.6 %
		Y	2.64	67.76	16.00		150.0	
		Z	2.55	68.78	16.20		150.0	

10112-CAE	LTE-FDD (SC-FDMA, 100% RB, 10 MHz, 64-QAM)	X	3.05	67.53	16.06	0.00	150.0	± 9.6 %
		Y	3.07	67.13	15.82		150.0	
		Z	2.92	67.58	15.97		150.0	
10113-CAE	LTE-FDD (SC-FDMA, 100% RB, 5 MHz, 64-QAM)	X	2.80	68.56	16.43	0.00	150.0	± 9.6 %
		Y	2.80	67.90	16.13		150.0	
		Z	2.69	68.93	16.32		150.0	
10114-CAB	IEEE 802.11n (HT Greenfield, 13.5 Mbps, BPSK)	X	5.15	67.26	16.54	0.00	150.0	± 9.6 %
		Y	5.19	67.08	16.42		150.0	
		Z	4.99	67.20	16.47		150.0	
10115-CAB	IEEE 802.11n (HT Greenfield, 81 Mbps, 16-QAM)	X	5.43	67.37	16.60	0.00	150.0	± 9.6 %
		Y	5.52	67.34	16.56		150.0	
		Z	5.24	67.27	16.51		150.0	
10116-CAB	IEEE 802.11n (HT Greenfield, 135 Mbps, 64-QAM)	X	5.24	67.44	16.56	0.00	150.0	± 9.6 %
		Y	5.30	67.32	16.46		150.0	
		Z	5.08	67.39	16.50		150.0	
10117-CAB	IEEE 802.11n (HT Mixed, 13.5 Mbps, BPSK)	X	5.11	67.11	16.48	0.00	150.0	± 9.6 %
		Y	5.16	66.99	16.39		150.0	
		Z	4.99	67.15	16.47		150.0	
10118-CAB	IEEE 802.11n (HT Mixed, 81 Mbps, 16-QAM)	X	5.51	67.58	16.71	0.00	150.0	± 9.6 %
		Y	5.61	67.54	16.67		150.0	
		Z	5.31	67.44	16.61		150.0	
10119-CAB	IEEE 802.11n (HT Mixed, 135 Mbps, 64-QAM)	X	5.22	67.40	16.54	0.00	150.0	± 9.6 %
		Y	5.27	67.25	16.44		150.0	
		Z	5.07	67.38	16.51		150.0	
10140-CAD	LTE-FDD (SC-FDMA, 100% RB, 15 MHz, 16-QAM)	X	3.41	67.63	16.10	0.00	150.0	± 9.6 %
		Y	3.43	67.31	15.88		150.0	
		Z	3.28	67.57	16.02		150.0	
10141-CAD	LTE-FDD (SC-FDMA, 100% RB, 15 MHz, 64-QAM)	X	3.53	67.71	16.25	0.00	150.0	± 9.6 %
		Y	3.55	67.40	16.05		150.0	
		Z	3.40	67.71	16.20		150.0	
10142-CAD	LTE-FDD (SC-FDMA, 100% RB, 3 MHz, QPSK)	X	2.05	69.21	16.15	0.00	150.0	± 9.6 %
		Y	2.02	68.14	15.65		150.0	
		Z	1.90	69.18	15.79		150.0	
10143-CAD	LTE-FDD (SC-FDMA, 100% RB, 3 MHz, 16-QAM)	X	2.53	69.32	16.06	0.00	150.0	± 9.6 %
		Y	2.50	68.40	15.76		150.0	
		Z	2.39	69.52	15.59		150.0	
10144-CAD	LTE-FDD (SC-FDMA, 100% RB, 3 MHz, 64-QAM)	X	2.28	66.94	14.41	0.00	150.0	± 9.6 %
		Y	2.31	66.41	14.31		150.0	
		Z	2.06	66.49	13.57		150.0	
10145-CAE	LTE-FDD (SC-FDMA, 100% RB, 1.4 MHz, QPSK)	X	1.26	65.57	12.06	0.00	150.0	± 9.6 %
		Y	1.33	65.51	12.47		150.0	
		Z	0.90	62.72	9.31		150.0	
10146-CAE	LTE-FDD (SC-FDMA, 100% RB, 1.4 MHz, 16-QAM)	X	1.87	65.71	11.26	0.00	150.0	± 9.6 %
		Y	2.34	67.84	13.03		150.0	
		Z	1.05	60.97	7.27		150.0	
10147-CAE	LTE-FDD (SC-FDMA, 100% RB, 1.4 MHz, 64-QAM)	X	2.17	67.47	12.23	0.00	150.0	± 9.6 %
		Y	2.79	70.16	14.23		150.0	
		Z	1.11	61.38	7.60		150.0	

10149-CAD	LTE-FDD (SC-FDMA, 50% RB, 20 MHz, 16-QAM)	X	2.93	67.61	16.06	0.00	150.0	± 9.6 %
		Y	2.95	67.20	15.81		150.0	
		Z	2.81	67.60	15.95		150.0	
10150-CAD	LTE-FDD (SC-FDMA, 50% RB, 20 MHz, 64-QAM)	X	3.06	67.58	16.10	0.00	150.0	± 9.6 %
		Y	3.08	67.18	15.86		150.0	
		Z	2.93	67.64	16.01		150.0	
10151-CAD	LTE-TDD (SC-FDMA, 50% RB, 20 MHz, QPSK)	X	7.47	81.50	23.31	3.98	65.0	± 9.6 %
		Y	8.13	81.64	23.19		65.0	
		Z	5.82	78.02	21.74		65.0	
10152-CAD	LTE-TDD (SC-FDMA, 50% RB, 20 MHz, 16-QAM)	X	5.96	75.09	21.13	3.98	65.0	± 9.6 %
		Y	6.59	75.82	21.34		65.0	
		Z	4.95	72.53	19.69		65.0	
10153-CAD	LTE-TDD (SC-FDMA, 50% RB, 20 MHz, 64-QAM)	X	6.33	76.00	21.87	3.98	65.0	± 9.6 %
		Y	6.98	76.72	22.08		65.0	
		Z	5.31	73.57	20.52		65.0	
10154-CAE	LTE-FDD (SC-FDMA, 50% RB, 10 MHz, QPSK)	X	2.32	69.50	16.70	0.00	150.0	± 9.6 %
		Y	2.30	68.63	16.21		150.0	
		Z	2.17	69.43	16.55		150.0	
10155-CAE	LTE-FDD (SC-FDMA, 50% RB, 10 MHz, 16-QAM)	X	2.65	68.47	16.34	0.00	150.0	± 9.6 %
		Y	2.64	67.77	16.01		150.0	
		Z	2.55	68.82	16.23		150.0	
10156-CAE	LTE-FDD (SC-FDMA, 50% RB, 5 MHz, QPSK)	X	1.90	69.38	15.98	0.00	150.0	± 9.6 %
		Y	1.87	68.22	15.49		150.0	
		Z	1.73	69.10	15.35		150.0	
10157-CAE	LTE-FDD (SC-FDMA, 50% RB, 5 MHz, 16-QAM)	X	2.13	67.61	14.49	0.00	150.0	± 9.6 %
		Y	2.14	66.94	14.37		150.0	
		Z	1.88	66.88	13.39		150.0	
10158-CAE	LTE-FDD (SC-FDMA, 50% RB, 10 MHz, 64-QAM)	X	2.80	68.62	16.48	0.00	150.0	± 9.6 %
		Y	2.80	67.95	16.18		150.0	
		Z	2.70	69.02	16.37		150.0	
10159-CAE	LTE-FDD (SC-FDMA, 50% RB, 5 MHz, 64-QAM)	X	2.24	68.05	14.76	0.00	150.0	± 9.6 %
		Y	2.25	67.38	14.65		150.0	
		Z	1.97	67.26	13.62		150.0	
10160-CAD	LTE-FDD (SC-FDMA, 50% RB, 15 MHz, QPSK)	X	2.79	68.96	16.56	0.00	150.0	± 9.6 %
		Y	2.78	68.29	16.16		150.0	
		Z	2.67	69.03	16.52		150.0	
10161-CAD	LTE-FDD (SC-FDMA, 50% RB, 15 MHz, 16-QAM)	X	2.95	67.54	16.03	0.00	150.0	± 9.6 %
		Y	2.97	67.10	15.79		150.0	
		Z	2.82	67.63	15.91		150.0	
10162-CAD	LTE-FDD (SC-FDMA, 50% RB, 15 MHz, 64-QAM)	X	3.06	67.69	16.14	0.00	150.0	± 9.6 %
		Y	3.08	67.22	15.89		150.0	
		Z	2.94	67.84	16.05		150.0	
10166-CAE	LTE-FDD (SC-FDMA, 50% RB, 1.4 MHz, QPSK)	X	3.60	69.71	19.22	3.01	150.0	± 9.6 %
		Y	3.76	69.53	19.10		150.0	
		Z	3.14	68.43	18.52		150.0	
10167-CAE	LTE-FDD (SC-FDMA, 50% RB, 1.4 MHz, 16-QAM)	X	4.49	72.92	19.79	3.01	150.0	± 9.6 %
		Y	4.71	72.48	19.58		150.0	
		Z	3.64	70.88	18.81		150.0	

10168-CAE	LTE-FDD (SC-FDMA, 50% RB, 1.4 MHz, 64-QAM)	X	4.99	75.19	21.10	3.01	150.0	± 9.6 %
		Y	5.19	74.57	20.82		150.0	
		Z	4.03	73.14	20.19		150.0	
10169-CAD	LTE-FDD (SC-FDMA, 1 RB, 20 MHz, QPSK)	X	3.02	69.31	19.06	3.01	150.0	± 9.6 %
		Y	3.27	69.70	19.15		150.0	
		Z	2.51	66.78	17.76		150.0	
10170-CAD	LTE-FDD (SC-FDMA, 1 RB, 20 MHz, 16-QAM)	X	4.24	75.66	21.52	3.01	150.0	± 9.6 %
		Y	4.60	75.59	21.37		150.0	
		Z	3.08	71.28	19.66		150.0	
10171-AAD	LTE-FDD (SC-FDMA, 1 RB, 20 MHz, 64-QAM)	X	3.48	71.52	18.79	3.01	150.0	± 9.6 %
		Y	3.80	71.54	18.73		150.0	
		Z	2.62	68.04	17.18		150.0	
10172-CAD	LTE-TDD (SC-FDMA, 1 RB, 20 MHz, QPSK)	X	9.86	97.03	31.31	6.02	65.0	± 9.6 %
		Y	11.94	97.60	31.03		65.0	
		Z	3.49	77.54	23.86		65.0	
10173-CAD	LTE-TDD (SC-FDMA, 1 RB, 20 MHz, 16-QAM)	X	35.90	116.24	34.55	6.02	65.0	± 9.6 %
		Y	33.36	111.72	33.12		65.0	
		Z	6.56	87.15	25.45		65.0	
10174-CAD	LTE-TDD (SC-FDMA, 1 RB, 20 MHz, 64-QAM)	X	21.48	105.16	30.85	6.02	65.0	± 9.6 %
		Y	20.65	101.59	29.68		65.0	
		Z	4.70	80.63	22.56		65.0	
10175-CAE	LTE-FDD (SC-FDMA, 1 RB, 10 MHz, QPSK)	X	2.98	69.02	18.83	3.01	150.0	± 9.6 %
		Y	3.23	69.39	18.90		150.0	
		Z	2.49	66.55	17.55		150.0	
10176-CAE	LTE-FDD (SC-FDMA, 1 RB, 10 MHz, 16-QAM)	X	4.24	75.68	21.53	3.01	150.0	± 9.6 %
		Y	4.61	75.61	21.38		150.0	
		Z	3.09	71.30	19.67		150.0	
10177-CAG	LTE-FDD (SC-FDMA, 1 RB, 5 MHz, QPSK)	X	3.01	69.16	18.92	3.01	150.0	± 9.6 %
		Y	3.26	69.54	19.00		150.0	
		Z	2.50	66.65	17.62		150.0	
10178-CAE	LTE-FDD (SC-FDMA, 1 RB, 5 MHz, 16-QAM)	X	4.21	75.48	21.42	3.01	150.0	± 9.6 %
		Y	4.56	75.38	21.26		150.0	
		Z	3.07	71.19	19.60		150.0	
10179-CAE	LTE-FDD (SC-FDMA, 1 RB, 10 MHz, 64-QAM)	X	3.83	73.49	20.03	3.01	150.0	± 9.6 %
		Y	4.16	73.42	19.91		150.0	
		Z	2.83	69.59	18.31		150.0	
10180-CAE	LTE-FDD (SC-FDMA, 1 RB, 5 MHz, 64-QAM)	X	3.47	71.46	18.75	3.01	150.0	± 9.6 %
		Y	3.79	71.47	18.68		150.0	
		Z	2.62	68.01	17.15		150.0	
10181-CAD	LTE-FDD (SC-FDMA, 1 RB, 15 MHz, QPSK)	X	3.00	69.14	18.91	3.01	150.0	± 9.6 %
		Y	3.26	69.52	18.99		150.0	
		Z	2.50	66.64	17.62		150.0	
10182-CAD	LTE-FDD (SC-FDMA, 1 RB, 15 MHz, 16-QAM)	X	4.20	75.46	21.41	3.01	150.0	± 9.6 %
		Y	4.55	75.36	21.25		150.0	
		Z	3.07	71.17	19.59		150.0	
10183-AAC	LTE-FDD (SC-FDMA, 1 RB, 15 MHz, 64-QAM)	X	3.46	71.44	18.74	3.01	150.0	± 9.6 %
		Y	3.78	71.45	18.67		150.0	
		Z	2.62	68.00	17.14		150.0	



10184-CAD	LTE-FDD (SC-FDMA, 1 RB, 3 MHz, QPSK)	X	3.01	69.18	18.93	3.01	150.0	± 9.6 %
		Y	3.27	69.56	19.01		150.0	
		Z	2.51	66.67	17.63		150.0	
10185-CAD	LTE-FDD (SC-FDMA, 1 RB, 3 MHz, 16-QAM)	X	4.22	75.53	21.45	3.01	150.0	± 9.6 %
		Y	4.57	75.42	21.28		150.0	
		Z	3.08	71.23	19.63		150.0	
10186-AAD	LTE-FDD (SC-FDMA, 1 RB, 3 MHz, 64-QAM)	X	3.48	71.51	18.77	3.01	150.0	± 9.6 %
		Y	3.80	71.51	18.70		150.0	
		Z	2.63	68.05	17.17		150.0	
10187-CAE	LTE-FDD (SC-FDMA, 1 RB, 1.4 MHz, QPSK)	X	3.02	69.24	19.00	3.01	150.0	± 9.6 %
		Y	3.28	69.61	19.07		150.0	
		Z	2.52	66.73	17.71		150.0	
10188-CAE	LTE-FDD (SC-FDMA, 1 RB, 1.4 MHz, 16-QAM)	X	4.35	76.17	21.80	3.01	150.0	± 9.6 %
		Y	4.72	76.08	21.65		150.0	
		Z	3.15	71.69	19.93		150.0	
10189-AAE	LTE-FDD (SC-FDMA, 1 RB, 1.4 MHz, 64-QAM)	X	3.56	71.93	19.04	3.01	150.0	± 9.6 %
		Y	3.88	71.93	18.97		150.0	
		Z	2.67	68.37	17.41		150.0	
10193-CAB	IEEE 802.11n (HT Greenfield, 6.5 Mbps, BPSK)	X	4.54	66.68	16.24	0.00	150.0	± 9.6 %
		Y	4.59	66.47	16.13		150.0	
		Z	4.40	66.85	16.19		150.0	
10194-CAB	IEEE 802.11n (HT Greenfield, 39 Mbps, 16-QAM)	X	4.70	66.99	16.36	0.00	150.0	± 9.6 %
		Y	4.77	66.80	16.26		150.0	
		Z	4.55	67.09	16.33		150.0	
10195-CAB	IEEE 802.11n (HT Greenfield, 65 Mbps, 64-QAM)	X	4.74	67.02	16.38	0.00	150.0	± 9.6 %
		Y	4.81	66.83	16.27		150.0	
		Z	4.58	67.11	16.34		150.0	
10196-CAB	IEEE 802.11n (HT Mixed, 6.5 Mbps, BPSK)	X	4.54	66.74	16.25	0.00	150.0	± 9.6 %
		Y	4.60	66.55	16.16		150.0	
		Z	4.39	66.85	16.19		150.0	
10197-CAB	IEEE 802.11n (HT Mixed, 39 Mbps, 16-QAM)	X	4.72	67.01	16.37	0.00	150.0	± 9.6 %
		Y	4.78	66.83	16.27		150.0	
		Z	4.56	67.10	16.33		150.0	
10198-CAB	IEEE 802.11n (HT Mixed, 65 Mbps, 64-QAM)	X	4.75	67.04	16.39	0.00	150.0	± 9.6 %
		Y	4.81	66.85	16.28		150.0	
		Z	4.58	67.11	16.34		150.0	
10219-CAB	IEEE 802.11n (HT Mixed, 7.2 Mbps, BPSK)	X	4.49	66.76	16.22	0.00	150.0	± 9.6 %
		Y	4.55	66.56	16.12		150.0	
		Z	4.34	66.89	16.16		150.0	
10220-CAB	IEEE 802.11n (HT Mixed, 43.3 Mbps, 16-QAM)	X	4.71	66.98	16.36	0.00	150.0	± 9.6 %
		Y	4.78	66.81	16.26		150.0	
		Z	4.55	67.06	16.32		150.0	
10221-CAB	IEEE 802.11n (HT Mixed, 72.2 Mbps, 64-QAM)	X	4.75	66.96	16.37	0.00	150.0	± 9.6 %
		Y	4.82	66.78	16.27		150.0	
		Z	4.59	67.05	16.33		150.0	
10222-CAB	IEEE 802.11n (HT Mixed, 15 Mbps, BPSK)	X	5.08	67.12	16.48	0.00	150.0	± 9.6 %
		Y	5.14	67.00	16.39		150.0	
		Z	4.96	67.13	16.45		150.0	

10223-CAB	IEEE 802.11n (HT Mixed, 90 Mbps, 16-QAM)	X	5.38	67.33	16.60	0.00	150.0	± 9.6 %
		Y	5.45	67.20	16.51		150.0	
		Z	5.23	67.33	16.56		150.0	
10224-CAB	IEEE 802.11n (HT Mixed, 150 Mbps, 64-QAM)	X	5.13	67.23	16.46	0.00	150.0	± 9.6 %
		Y	5.19	67.11	16.37		150.0	
		Z	4.99	67.25	16.44		150.0	
10225-CAB	UMTS-FDD (HSPA+)	X	2.82	66.29	15.44	0.00	150.0	± 9.6 %
		Y	2.85	65.89	15.31		150.0	
		Z	2.69	66.42	15.13		150.0	
10226-CAA	LTE-TDD (SC-FDMA, 1 RB, 1.4 MHz, 16-QAM)	X	40.58	118.73	35.31	6.02	65.0	± 9.6 %
		Y	36.88	113.76	33.77		65.0	
		Z	6.94	88.26	25.92		65.0	
10227-CAA	LTE-TDD (SC-FDMA, 1 RB, 1.4 MHz, 64-QAM)	X	36.33	114.29	33.35	6.02	65.0	± 9.6 %
		Y	31.30	108.87	31.78		65.0	
		Z	6.95	87.06	24.80		65.0	
10228-CAA	LTE-TDD (SC-FDMA, 1 RB, 1.4 MHz, QPSK)	X	13.65	104.05	33.59	6.02	65.0	± 9.6 %
		Y	18.81	107.23	34.08		65.0	
		Z	4.50	82.80	25.97		65.0	
10229-CAB	LTE-TDD (SC-FDMA, 1 RB, 3 MHz, 16-QAM)	X	36.18	116.36	34.59	6.02	65.0	± 9.6 %
		Y	33.58	111.82	33.15		65.0	
		Z	6.61	87.25	25.49		65.0	
10230-CAB	LTE-TDD (SC-FDMA, 1 RB, 3 MHz, 64-QAM)	X	32.38	112.10	32.69	6.02	65.0	± 9.6 %
		Y	28.70	107.19	31.24		65.0	
		Z	6.54	85.97	24.36		65.0	
10231-CAB	LTE-TDD (SC-FDMA, 1 RB, 3 MHz, QPSK)	X	12.84	102.68	33.09	6.02	65.0	± 9.6 %
		Y	17.62	105.78	33.56		65.0	
		Z	4.35	82.09	25.62		65.0	
10232-CAD	LTE-TDD (SC-FDMA, 1 RB, 5 MHz, 16-QAM)	X	36.15	116.36	34.59	6.02	65.0	± 9.6 %
		Y	33.55	111.82	33.15		65.0	
		Z	6.59	87.23	25.48		65.0	
10233-CAD	LTE-TDD (SC-FDMA, 1 RB, 5 MHz, 64-QAM)	X	32.28	112.07	32.68	6.02	65.0	± 9.6 %
		Y	28.65	107.18	31.24		65.0	
		Z	6.52	85.93	24.35		65.0	
10234-CAD	LTE-TDD (SC-FDMA, 1 RB, 5 MHz, QPSK)	X	12.22	101.47	32.58	6.02	65.0	± 9.6 %
		Y	16.65	104.42	33.04		65.0	
		Z	4.24	81.51	25.28		65.0	
10235-CAD	LTE-TDD (SC-FDMA, 1 RB, 10 MHz, 16-QAM)	X	36.31	116.46	34.62	6.02	65.0	± 9.6 %
		Y	33.66	111.90	33.18		65.0	
		Z	6.60	87.26	25.49		65.0	
10236-CAD	LTE-TDD (SC-FDMA, 1 RB, 10 MHz, 64-QAM)	X	33.06	112.44	32.77	6.02	65.0	± 9.6 %
		Y	29.12	107.43	31.30		65.0	
		Z	6.60	86.11	24.40		65.0	
10237-CAD	LTE-TDD (SC-FDMA, 1 RB, 10 MHz, QPSK)	X	12.90	102.82	33.13	6.02	65.0	± 9.6 %
		Y	17.72	105.93	33.61		65.0	
		Z	4.35	82.12	25.64		65.0	
10238-CAD	LTE-TDD (SC-FDMA, 1 RB, 15 MHz, 16-QAM)	X	36.09	116.34	34.59	6.02	65.0	± 9.6 %
		Y	33.52	111.82	33.15		65.0	
		Z	6.58	87.20	25.47		65.0	

10239-CAD	LTE-TDD (SC-FDMA, 1 RB, 15 MHz, 64-QAM)	X	32.17	112.03	32.67	6.02	65.0	± 9.6 %
		Y	28.59	107.16	31.23		65.0	
		Z	6.49	85.89	24.34		65.0	
10240-CAD	LTE-TDD (SC-FDMA, 1 RB, 15 MHz, QPSK)	X	12.85	102.75	33.11	6.02	65.0	± 9.6 %
		Y	17.65	105.86	33.59		65.0	
		Z	4.34	82.09	25.63		65.0	
10241-CAA	LTE-TDD (SC-FDMA, 50% RB, 1.4 MHz, 16-QAM)	X	8.52	83.40	26.72	6.98	65.0	± 9.6 %
		Y	9.34	83.46	26.63		65.0	
		Z	6.49	79.39	24.77		65.0	
10242-CAA	LTE-TDD (SC-FDMA, 50% RB, 1.4 MHz, 64-QAM)	X	7.72	81.29	25.79	6.98	65.0	± 9.6 %
		Y	8.22	80.66	25.42		65.0	
		Z	5.72	76.85	23.63		65.0	
10243-CAA	LTE-TDD (SC-FDMA, 50% RB, 1.4 MHz, QPSK)	X	5.95	76.72	24.82	6.98	65.0	± 9.6 %
		Y	6.41	76.67	24.65		65.0	
		Z	4.75	73.34	22.98		65.0	
10244-CAB	LTE-TDD (SC-FDMA, 50% RB, 3 MHz, 16-QAM)	X	6.67	78.45	19.67	3.98	65.0	± 9.6 %
		Y	8.20	80.91	21.14		65.0	
		Z	3.50	69.23	14.35		65.0	
10245-CAB	LTE-TDD (SC-FDMA, 50% RB, 3 MHz, 64-QAM)	X	6.39	77.48	19.23	3.98	65.0	± 9.6 %
		Y	7.92	80.07	20.76		65.0	
		Z	3.42	68.65	14.03		65.0	
10246-CAB	LTE-TDD (SC-FDMA, 50% RB, 3 MHz, QPSK)	X	8.15	85.97	22.95	3.98	65.0	± 9.6 %
		Y	9.24	86.80	23.49		65.0	
		Z	4.03	75.23	17.77		65.0	
10247-CAD	LTE-TDD (SC-FDMA, 50% RB, 5 MHz, 16-QAM)	X	5.50	76.42	20.00	3.98	65.0	± 9.6 %
		Y	6.26	77.49	20.66		65.0	
		Z	3.95	71.61	16.94		65.0	
10248-CAD	LTE-TDD (SC-FDMA, 50% RB, 5 MHz, 64-QAM)	X	5.40	75.54	19.60	3.98	65.0	± 9.6 %
		Y	6.16	76.66	20.28		65.0	
		Z	3.89	70.88	16.59		65.0	
10249-CAD	LTE-TDD (SC-FDMA, 50% RB, 5 MHz, QPSK)	X	9.66	89.43	25.19	3.98	65.0	± 9.6 %
		Y	10.35	89.11	25.13		65.0	
		Z	5.64	80.91	21.33		65.0	
10250-CAD	LTE-TDD (SC-FDMA, 50% RB, 10 MHz, 16-QAM)	X	6.21	78.20	22.44	3.98	65.0	± 9.6 %
		Y	6.93	79.00	22.73		65.0	
		Z	4.95	74.96	20.57		65.0	
10251-CAD	LTE-TDD (SC-FDMA, 50% RB, 10 MHz, 64-QAM)	X	5.85	75.76	21.03	3.98	65.0	± 9.6 %
		Y	6.49	76.44	21.31		65.0	
		Z	4.69	72.73	19.17		65.0	
10252-CAD	LTE-TDD (SC-FDMA, 50% RB, 10 MHz, QPSK)	X	8.41	86.24	25.10	3.98	65.0	± 9.6 %
		Y	9.13	86.11	24.91		65.0	
		Z	5.95	81.04	22.79		65.0	
10253-CAD	LTE-TDD (SC-FDMA, 50% RB, 15 MHz, 16-QAM)	X	5.81	74.45	20.83	3.98	65.0	± 9.6 %
		Y	6.39	75.11	21.05		65.0	
		Z	4.88	72.13	19.42		65.0	
10254-CAD	LTE-TDD (SC-FDMA, 50% RB, 15 MHz, 64-QAM)	X	6.16	75.32	21.51	3.98	65.0	± 9.6 %
		Y	6.77	75.99	21.73		65.0	
		Z	5.19	73.05	20.14		65.0	

10255-CAD	LTE-TDD (SC-FDMA, 50% RB, 15 MHz, QPSK)	X	6.96	80.42	23.12	3.98	65.0	± 9.6 %
		Y	7.59	80.64	23.06		65.0	
		Z	5.51	77.21	21.58		65.0	
10256-CAA	LTE-TDD (SC-FDMA, 100% RB, 1.4 MHz, 16-QAM)	X	4.89	73.41	16.49	3.98	65.0	± 9.6 %
		Y	6.68	77.30	18.76		65.0	
		Z	2.46	64.75	10.88		65.0	
10257-CAA	LTE-TDD (SC-FDMA, 100% RB, 1.4 MHz, 64-QAM)	X	4.63	72.26	15.89	3.98	65.0	± 9.6 %
		Y	6.35	76.13	18.19		65.0	
		Z	2.42	64.27	10.52		65.0	
10258-CAA	LTE-TDD (SC-FDMA, 100% RB, 1.4 MHz, QPSK)	X	5.50	79.01	19.45	3.98	65.0	± 9.6 %
		Y	7.01	81.77	20.90		65.0	
		Z	2.56	68.30	13.54		65.0	
10259-CAB	LTE-TDD (SC-FDMA, 100% RB, 3 MHz, 16-QAM)	X	5.80	77.14	20.90	3.98	65.0	± 9.6 %
		Y	6.53	78.01	21.38		65.0	
		Z	4.38	73.08	18.36		65.0	
10260-CAB	LTE-TDD (SC-FDMA, 100% RB, 3 MHz, 64-QAM)	X	5.78	76.67	20.70	3.98	65.0	± 9.6 %
		Y	6.51	77.60	21.22		65.0	
		Z	4.39	72.73	18.19		65.0	
10261-CAB	LTE-TDD (SC-FDMA, 100% RB, 3 MHz, QPSK)	X	8.27	86.47	24.62	3.98	65.0	± 9.6 %
		Y	9.00	86.40	24.57		65.0	
		Z	5.46	80.05	21.57		65.0	
10262-CAD	LTE-TDD (SC-FDMA, 100% RB, 5 MHz, 16-QAM)	X	6.19	78.15	22.39	3.98	65.0	± 9.6 %
		Y	6.92	78.95	22.69		65.0	
		Z	4.94	74.88	20.51		65.0	
10263-CAD	LTE-TDD (SC-FDMA, 100% RB, 5 MHz, 64-QAM)	X	5.84	75.72	21.02	3.98	65.0	± 9.6 %
		Y	6.48	76.42	21.31		65.0	
		Z	4.68	72.71	19.16		65.0	
10264-CAD	LTE-TDD (SC-FDMA, 100% RB, 5 MHz, QPSK)	X	8.30	85.98	24.99	3.98	65.0	± 9.6 %
		Y	9.03	85.88	24.80		65.0	
		Z	5.88	80.81	22.67		65.0	
10265-CAD	LTE-TDD (SC-FDMA, 100% RB, 10 MHz, 16-QAM)	X	5.96	75.09	21.13	3.98	65.0	± 9.6 %
		Y	6.59	75.82	21.35		65.0	
		Z	4.95	72.53	19.70		65.0	
10266-CAD	LTE-TDD (SC-FDMA, 100% RB, 10 MHz, 64-QAM)	X	6.33	75.99	21.86	3.98	65.0	± 9.6 %
		Y	6.97	76.70	22.07		65.0	
		Z	5.31	73.56	20.51		65.0	
10267-CAD	LTE-TDD (SC-FDMA, 100% RB, 10 MHz, QPSK)	X	7.45	81.44	23.28	3.98	65.0	± 9.6 %
		Y	8.11	81.58	23.17		65.0	
		Z	5.81	77.97	21.72		65.0	
10268-CAD	LTE-TDD (SC-FDMA, 100% RB, 15 MHz, 16-QAM)	X	6.50	74.59	21.27	3.98	65.0	± 9.6 %
		Y	7.11	75.29	21.47		65.0	
		Z	5.58	72.49	20.14		65.0	
10269-CAD	LTE-TDD (SC-FDMA, 100% RB, 15 MHz, 64-QAM)	X	6.45	74.07	21.10	3.98	65.0	± 9.6 %
		Y	7.04	74.76	21.30		65.0	
		Z	5.59	72.11	20.01		65.0	
10270-CAD	LTE-TDD (SC-FDMA, 100% RB, 15 MHz, QPSK)	X	6.83	77.38	21.77	3.98	65.0	± 9.6 %
		Y	7.44	77.78	21.79		65.0	
		Z	5.71	75.01	20.64		65.0	

10274-CAB	UMTS-FDD (HSUPA, Subtest 5, 3GPP Rel8.10)	X	2.62	66.75	15.42	0.00	150.0	± 9.6 %
		Y	2.61	66.15	15.17		150.0	
		Z	2.54	67.07	15.23		150.0	
10275-CAB	UMTS-FDD (HSUPA, Subtest 5, 3GPP Rel8.4)	X	1.67	68.55	15.99	0.00	150.0	± 9.6 %
		Y	1.61	67.31	15.31		150.0	
		Z	1.61	68.63	15.84		150.0	
10277-CAA	PHS (QPSK)	X	1.74	60.91	6.37	9.03	50.0	± 9.6 %
		Y	2.31	62.75	8.24		50.0	
		Z	1.34	59.32	4.61		50.0	
10278-CAA	PHS (QPSK, BW 884MHz, Rolloff 0.5)	X	9.23	83.71	19.86	9.03	50.0	± 9.6 %
		Y	16.13	92.59	23.80		50.0	
		Z	2.80	66.68	11.50		50.0	
10279-CAA	PHS (QPSK, BW 884MHz, Rolloff 0.38)	X	9.55	84.14	20.09	9.03	50.0	± 9.6 %
		Y	16.22	92.62	23.87		50.0	
		Z	2.90	67.01	11.74		50.0	
10290-AAB	CDMA2000, RC1, SO55, Full Rate	X	1.55	69.78	14.51	0.00	150.0	± 9.6 %
		Y	1.48	68.23	14.09		150.0	
		Z	1.19	67.52	12.47		150.0	
10291-AAB	CDMA2000, RC3, SO55, Full Rate	X	0.89	66.83	13.08	0.00	150.0	± 9.6 %
		Y	0.85	65.35	12.57		150.0	
		Z	0.74	65.55	11.46		150.0	
10292-AAB	CDMA2000, RC3, SO32, Full Rate	X	1.27	72.61	16.13	0.00	150.0	± 9.6 %
		Y	1.03	68.80	14.67		150.0	
		Z	1.20	72.32	14.93		150.0	
10293-AAB	CDMA2000, RC3, SO3, Full Rate	X	2.34	81.60	20.09	0.00	150.0	± 9.6 %
		Y	1.43	73.64	17.27		150.0	
		Z	3.93	87.90	20.92		150.0	
10295-AAB	CDMA2000, RC1, SO3, 1/8th Rate 25 fr.	X	16.32	98.49	29.02	9.03	50.0	± 9.6 %
		Y	11.98	92.39	27.58		50.0	
		Z	18.77	96.90	26.52		50.0	
10297-AAC	LTE-FDD (SC-FDMA, 50% RB, 20 MHz, QPSK)	X	2.80	70.02	16.88	0.00	150.0	± 9.6 %
		Y	2.77	69.27	16.41		150.0	
		Z	2.65	69.87	16.82		150.0	
10298-AAC	LTE-FDD (SC-FDMA, 50% RB, 3 MHz, QPSK)	X	1.62	68.28	14.44	0.00	150.0	± 9.6 %
		Y	1.62	67.40	14.26		150.0	
		Z	1.32	66.56	12.71		150.0	
10299-AAC	LTE-FDD (SC-FDMA, 50% RB, 3 MHz, 16-QAM)	X	2.59	69.34	14.00	0.00	150.0	± 9.6 %
		Y	2.92	70.30	15.01		150.0	
		Z	1.54	64.05	10.22		150.0	
10300-AAC	LTE-FDD (SC-FDMA, 50% RB, 3 MHz, 64-QAM)	X	1.92	64.86	11.14	0.00	150.0	± 9.6 %
		Y	2.24	65.95	12.27		150.0	
		Z	1.26	61.60	8.20		150.0	
10301-AAA	IEEE 802.16e WiMAX (29:18, 5ms, 10MHz, QPSK, PUSC)	X	4.85	66.06	17.86	4.17	50.0	± 9.6 %
		Y	4.97	65.84	17.76		50.0	
		Z	4.42	65.27	17.23		50.0	
10302-AAA	IEEE 802.16e WiMAX (29:18, 5ms, 10MHz, QPSK, PUSC, 3 CTRL symbols)	X	5.22	66.19	18.31	4.96	50.0	± 9.6 %
		Y	5.38	66.17	18.31		50.0	
		Z	4.86	65.76	17.88		50.0	

10303-AAA	IEEE 802.16e WiMAX (31:15, 5ms, 10MHz, 64QAM, PUSC)	X	4.96	65.79	18.13	4.96	50.0	± 9.6 %
		Y	5.14	65.84	18.17		50.0	
		Z	4.61	65.34	17.65		50.0	
10304-AAA	IEEE 802.16e WiMAX (29:18, 5ms, 10MHz, 64QAM, PUSC)	X	4.78	65.69	17.62	4.17	50.0	± 9.6 %
		Y	4.94	65.66	17.62		50.0	
		Z	4.45	65.35	17.22		50.0	
10305-AAA	IEEE 802.16e WiMAX (31:15, 10ms, 10MHz, 64QAM, PUSC, 15 symbols)	X	4.24	66.91	19.40	6.02	35.0	± 9.6 %
		Y	4.54	67.57	19.86		35.0	
		Z	3.84	65.89	18.29		35.0	
10306-AAA	IEEE 802.16e WiMAX (29:18, 10ms, 10MHz, 64QAM, PUSC, 18 symbols)	X	4.62	66.22	19.11	6.02	35.0	± 9.6 %
		Y	4.86	66.59	19.39		35.0	
		Z	4.26	65.53	18.31		35.0	
10307-AAA	IEEE 802.16e WiMAX (29:18, 10ms, 10MHz, QPSK, PUSC, 18 symbols)	X	4.50	66.31	19.05	6.02	35.0	± 9.6 %
		Y	4.77	66.81	19.39		35.0	
		Z	4.12	65.47	18.17		35.0	
10308-AAA	IEEE 802.16e WiMAX (29:18, 10ms, 10MHz, 16QAM, PUSC)	X	4.47	66.49	19.18	6.02	35.0	± 9.6 %
		Y	4.73	66.98	19.51		35.0	
		Z	4.09	65.63	18.30		35.0	
10309-AAA	IEEE 802.16e WiMAX (29:18, 10ms, 10MHz, 16QAM, AMC 2x3, 18 symbols)	X	4.68	66.45	19.27	6.02	35.0	± 9.6 %
		Y	4.93	66.86	19.56		35.0	
		Z	4.28	65.63	18.41		35.0	
10310-AAA	IEEE 802.16e WiMAX (29:18, 10ms, 10MHz, QPSK, AMC 2x3, 18 symbols)	X	4.56	66.25	19.08	6.02	35.0	± 9.6 %
		Y	4.81	66.65	19.36		35.0	
		Z	4.20	65.54	18.28		35.0	
10311-AAC	LTE-FDD (SC-FDMA, 100% RB, 15 MHz, QPSK)	X	3.16	69.26	16.50	0.00	150.0	± 9.6 %
		Y	3.13	68.60	16.08		150.0	
		Z	3.01	69.09	16.45		150.0	
10313-AAA	IDEN 1:3	X	8.00	86.23	21.34	6.99	70.0	± 9.6 %
		Y	8.53	85.21	20.95		70.0	
		Z	3.31	75.28	17.31		70.0	
10314-AAA	IDEN 1:6	X	12.68	100.31	29.33	10.00	30.0	± 9.6 %
		Y	13.31	98.73	28.67		30.0	
		Z	5.19	85.23	24.17		30.0	
10315-AAB	IEEE 802.11b WiFi 2.4 GHz (DSSS, 1 Mbps, 96pc duty cycle)	X	1.10	64.07	15.53	0.17	150.0	± 9.6 %
		Y	1.10	63.56	15.08		150.0	
		Z	1.08	63.95	15.31		150.0	
10316-AAB	IEEE 802.11g WiFi 2.4 GHz (ERP-OFDM, 6 Mbps, 96pc duty cycle)	X	4.59	66.75	16.41	0.17	150.0	± 9.6 %
		Y	4.66	66.58	16.32		150.0	
		Z	4.43	66.78	16.29		150.0	
10317-AAB	IEEE 802.11a WiFi 5 GHz (OFDM, 6 Mbps, 96pc duty cycle)	X	4.59	66.75	16.41	0.17	150.0	± 9.6 %
		Y	4.66	66.58	16.32		150.0	
		Z	4.43	66.78	16.29		150.0	
10400-AAC	IEEE 802.11ac WiFi (20MHz, 64-QAM, 99pc duty cycle)	X	4.69	67.06	16.37	0.00	150.0	± 9.6 %
		Y	4.77	66.86	16.25		150.0	
		Z	4.51	67.11	16.31		150.0	
10401-AAC	IEEE 802.11ac WiFi (40MHz, 64-QAM, 99pc duty cycle)	X	5.41	67.26	16.54	0.00	150.0	± 9.6 %
		Y	5.45	67.06	16.42		150.0	
		Z	5.18	66.94	16.33		150.0	

10402-AAC	IEEE 802.11ac WiFi (80MHz, 64-QAM, 99pc duty cycle)	X	5.65	67.49	16.51	0.00	150.0	± 9.6 %
		Y	5.72	67.43	16.45		150.0	
		Z	5.51	67.47	16.48		150.0	
10403-AAB	CDMA2000 (1xEV-DO, Rev. 0)	X	1.55	69.78	14.51	0.00	115.0	± 9.6 %
		Y	1.48	68.23	14.09		115.0	
		Z	1.19	67.52	12.47		115.0	
10404-AAB	CDMA2000 (1xEV-DO, Rev. A)	X	1.55	69.78	14.51	0.00	115.0	± 9.6 %
		Y	1.48	68.23	14.09		115.0	
		Z	1.19	67.52	12.47		115.0	
10406-AAB	CDMA2000, RC3, SO32, SCH0, Full Rate	X	100.00	120.41	29.76	0.00	100.0	± 9.6 %
		Y	19.72	99.25	25.38		100.0	
		Z	22.86	100.95	24.14		100.0	
10410-AAC	LTE-TDD (SC-FDMA, 1 RB, 10 MHz, QPSK, UL Subframe=2,3,4,7,8,9)	X	100.00	125.71	31.88	3.23	80.0	± 9.6 %
		Y	100.00	124.16	31.78		80.0	
		Z	8.15	91.76	22.46		80.0	
10415-AAA	IEEE 802.11b WiFi 2.4 GHz (DSSS, 1 Mbps, 99pc duty cycle)	X	1.03	63.26	14.92	0.00	150.0	± 9.6 %
		Y	1.02	62.63	14.41		150.0	
		Z	1.03	63.39	14.88		150.0	
10416-AAA	IEEE 802.11g WiFi 2.4 GHz (ERP-OFDM, 6 Mbps, 99pc duty cycle)	X	4.54	66.72	16.31	0.00	150.0	± 9.6 %
		Y	4.59	66.51	16.19		150.0	
		Z	4.40	66.84	16.26		150.0	
10417-AAA	IEEE 802.11a/h WiFi 5 GHz (OFDM, 6 Mbps, 99pc duty cycle)	X	4.54	66.72	16.31	0.00	150.0	± 9.6 %
		Y	4.59	66.51	16.19		150.0	
		Z	4.40	66.84	16.26		150.0	
10418-AAA	IEEE 802.11g WiFi 2.4 GHz (DSSS-OFDM, 6 Mbps, 99pc duty cycle, Long preamble)	X	4.53	66.89	16.33	0.00	150.0	± 9.6 %
		Y	4.58	66.66	16.20		150.0	
		Z	4.40	67.05	16.32		150.0	
10419-AAA	IEEE 802.11g WiFi 2.4 GHz (DSSS-OFDM, 6 Mbps, 99pc duty cycle, Short preamble)	X	4.55	66.83	16.33	0.00	150.0	± 9.6 %
		Y	4.60	66.61	16.21		150.0	
		Z	4.41	66.98	16.30		150.0	
10422-AAA	IEEE 802.11n (HT Greenfield, 7.2 Mbps, BPSK)	X	4.66	66.83	16.34	0.00	150.0	± 9.6 %
		Y	4.72	66.62	16.23		150.0	
		Z	4.52	66.95	16.31		150.0	
10423-AAA	IEEE 802.11n (HT Greenfield, 43.3 Mbps, 16-QAM)	X	4.82	67.13	16.45	0.00	150.0	± 9.6 %
		Y	4.90	66.96	16.35		150.0	
		Z	4.65	67.21	16.40		150.0	
10424-AAA	IEEE 802.11n (HT Greenfield, 72.2 Mbps, 64-QAM)	X	4.75	67.09	16.43	0.00	150.0	± 9.6 %
		Y	4.82	66.90	16.32		150.0	
		Z	4.58	67.17	16.38		150.0	
10425-AAA	IEEE 802.11n (HT Greenfield, 15 Mbps, BPSK)	X	5.35	67.37	16.60	0.00	150.0	± 9.6 %
		Y	5.42	67.27	16.52		150.0	
		Z	5.19	67.35	16.55		150.0	
10426-AAA	IEEE 802.11n (HT Greenfield, 90 Mbps, 16-QAM)	X	5.36	67.42	16.62	0.00	150.0	± 9.6 %
		Y	5.42	67.27	16.52		150.0	
		Z	5.21	67.42	16.58		150.0	

10427-AAA	IEEE 802.11n (HT Greenfield, 150 Mbps, 64-QAM)	X	5.37	67.38	16.60	0.00	150.0	± 9.6 %
		Y	5.43	67.25	16.50		150.0	
		Z	5.18	67.23	16.48		150.0	
10430-AAB	LTE-FDD (OFDMA, 5 MHz, E-TM 3.1)	X	4.24	70.83	18.17	0.00	150.0	± 9.6 %
		Y	4.26	70.25	18.02		150.0	
		Z	4.20	71.89	18.27		150.0	
10431-AAB	LTE-FDD (OFDMA, 10 MHz, E-TM 3.1)	X	4.21	67.30	16.30	0.00	150.0	± 9.6 %
		Y	4.28	67.03	16.19		150.0	
		Z	4.03	67.45	16.18		150.0	
10432-AAB	LTE-FDD (OFDMA, 15 MHz, E-TM 3.1)	X	4.51	67.15	16.38	0.00	150.0	± 9.6 %
		Y	4.58	66.93	16.27		150.0	
		Z	4.34	67.27	16.32		150.0	
10433-AAB	LTE-FDD (OFDMA, 20 MHz, E-TM 3.1)	X	4.76	67.12	16.45	0.00	150.0	± 9.6 %
		Y	4.83	66.94	16.34		150.0	
		Z	4.59	67.20	16.40		150.0	
10434-AAA	W-CDMA (BS Test Model 1, 64 DPCH)	X	4.34	71.72	18.14	0.00	150.0	± 9.6 %
		Y	4.35	71.03	17.99		150.0	
		Z	4.31	72.81	18.12		150.0	
10435-AAC	LTE-TDD (SC-FDMA, 1 RB, 20 MHz, QPSK, UL Subframe=2,3,4,7,8,9)	X	100.00	125.48	31.77	3.23	80.0	± 9.6 %
		Y	100.00	123.97	31.69		80.0	
		Z	7.63	90.76	22.11		80.0	
10447-AAB	LTE-FDD (OFDMA, 5 MHz, E-TM 3.1, Clipping 44%)	X	3.51	67.35	15.60	0.00	150.0	± 9.6 %
		Y	3.58	66.99	15.55		150.0	
		Z	3.28	67.36	15.16		150.0	
10448-AAB	LTE-FDD (OFDMA, 10 MHz, E-TM 3.1, Clipping 44%)	X	4.06	67.09	16.17	0.00	150.0	± 9.6 %
		Y	4.12	66.80	16.05		150.0	
		Z	3.89	67.25	16.05		150.0	
10449-AAB	LTE-FDD (OFDMA, 15 MHz, E-TM 3.1, Clipping 44%)	X	4.33	66.98	16.28	0.00	150.0	± 9.6 %
		Y	4.39	66.75	16.16		150.0	
		Z	4.18	67.10	16.22		150.0	
10450-AAB	LTE-FDD (OFDMA, 20 MHz, E-TM 3.1, Clipping 44%)	X	4.53	66.89	16.30	0.00	150.0	± 9.6 %
		Y	4.58	66.69	16.19		150.0	
		Z	4.39	66.98	16.26		150.0	
10451-AAA	W-CDMA (BS Test Model 1, 64 DPCH, Clipping 44%)	X	3.39	67.51	15.20	0.00	150.0	± 9.6 %
		Y	3.48	67.19	15.21		150.0	
		Z	3.10	67.22	14.48		150.0	
10456-AAA	IEEE 802.11ac WiFi (160MHz, 64-QAM, 99pc duty cycle)	X	6.22	67.91	16.74	0.00	150.0	± 9.6 %
		Y	6.28	67.83	16.68		150.0	
		Z	6.11	67.90	16.72		150.0	
10457-AAA	UMTS-FDD (DC-HSDPA)	X	3.80	65.37	16.02	0.00	150.0	± 9.6 %
		Y	3.83	65.15	15.90		150.0	
		Z	3.74	65.57	15.99		150.0	
10458-AAA	CDMA2000 (1xEV-DO, Rev. B, 2 carriers)	X	3.21	66.83	14.57	0.00	150.0	± 9.6 %
		Y	3.31	66.55	14.68		150.0	
		Z	2.82	66.01	13.39		150.0	
10459-AAA	CDMA2000 (1xEV-DO, Rev. B, 3 carriers)	X	4.29	65.14	15.57	0.00	150.0	± 9.6 %
		Y	4.36	64.71	15.51		150.0	
		Z	4.04	65.27	15.07		150.0	



10460-AAA	UMTS-FDD (WCDMA, AMR)	X	0.96	69.26	16.86	0.00	150.0	± 9.6 %
		Y	0.88	67.02	15.53		150.0	
		Z	0.94	69.35	16.76		150.0	
10461-AAA	LTE-TDD (SC-FDMA, 1 RB, 1.4 MHz, QPSK, UL Subframe=2,3,4,7,8,9)	X	100.00	131.25	34.47	3.29	80.0	± 9.6 %
		Y	100.00	128.59	33.89		80.0	
		Z	3.16	81.29	20.28		80.0	
10462-AAA	LTE-TDD (SC-FDMA, 1 RB, 1.4 MHz, 16-QAM, UL Subframe=2,3,4,7,8,9)	X	18.15	90.54	19.55	3.23	80.0	± 9.6 %
		Y	100.00	110.06	25.23		80.0	
		Z	0.71	60.00	7.72		80.0	
10463-AAA	LTE-TDD (SC-FDMA, 1 RB, 1.4 MHz, 64-QAM, UL Subframe=2,3,4,7,8,9)	X	2.32	68.92	12.27	3.23	80.0	± 9.6 %
		Y	12.78	85.50	18.46		80.0	
		Z	0.72	60.00	7.06		80.0	
10464-AAA	LTE-TDD (SC-FDMA, 1 RB, 3 MHz, QPSK, UL Subframe=2,3,4,7,8,9)	X	100.00	128.50	33.02	3.23	80.0	± 9.6 %
		Y	100.00	126.31	32.66		80.0	
		Z	2.43	77.27	18.20		80.0	
10465-AAA	LTE-TDD (SC-FDMA, 1 RB, 3 MHz, 16-QAM, UL Subframe=2,3,4,7,8,9)	X	7.48	81.44	16.98	3.23	80.0	± 9.6 %
		Y	53.06	102.63	23.42		80.0	
		Z	0.71	60.00	7.65		80.0	
10466-AAA	LTE-TDD (SC-FDMA, 1 RB, 3 MHz, 64-QAM, UL Subframe=2,3,4,7,8,9)	X	1.86	66.75	11.37	3.23	80.0	± 9.6 %
		Y	7.10	79.26	16.56		80.0	
		Z	0.72	60.00	7.01		80.0	
10467-AAC	LTE-TDD (SC-FDMA, 1 RB, 5 MHz, QPSK, UL Subframe=2,3,4,7,8,9)	X	100.00	128.82	33.16	3.23	80.0	± 9.6 %
		Y	100.00	126.57	32.78		80.0	
		Z	2.60	78.29	18.60		80.0	
10468-AAC	LTE-TDD (SC-FDMA, 1 RB, 5 MHz, 16-QAM, UL Subframe=2,3,4,7,8,9)	X	9.21	83.60	17.62	3.23	80.0	± 9.6 %
		Y	76.07	106.68	24.37		80.0	
		Z	0.70	60.00	7.67		80.0	
10469-AAC	LTE-TDD (SC-FDMA, 1 RB, 5 MHz, 64-QAM, UL Subframe=2,3,4,7,8,9)	X	1.87	66.82	11.40	3.23	80.0	± 9.6 %
		Y	7.22	79.45	16.62		80.0	
		Z	0.72	60.00	7.01		80.0	
10470-AAC	LTE-TDD (SC-FDMA, 1 RB, 10 MHz, QPSK, UL Subframe=2,3,4,7,8,9)	X	100.00	128.87	33.17	3.23	80.0	± 9.6 %
		Y	100.00	126.61	32.79		80.0	
		Z	2.61	78.33	18.61		80.0	
10471-AAC	LTE-TDD (SC-FDMA, 1 RB, 10 MHz, 16-QAM, UL Subframe=2,3,4,7,8,9)	X	9.03	83.37	17.54	3.23	80.0	± 9.6 %
		Y	75.72	106.57	24.32		80.0	
		Z	0.70	60.00	7.66		80.0	
10472-AAC	LTE-TDD (SC-FDMA, 1 RB, 10 MHz, 64-QAM, UL Subframe=2,3,4,7,8,9)	X	1.85	66.72	11.34	3.23	80.0	± 9.6 %
		Y	7.17	79.36	16.58		80.0	
		Z	0.72	60.00	6.99		80.0	
10473-AAC	LTE-TDD (SC-FDMA, 1 RB, 15 MHz, QPSK, UL Subframe=2,3,4,7,8,9)	X	100.00	128.83	33.15	3.23	80.0	± 9.6 %
		Y	100.00	126.57	32.77		80.0	
		Z	2.60	78.28	18.59		80.0	
10474-AAC	LTE-TDD (SC-FDMA, 1 RB, 15 MHz, 16-QAM, UL Subframe=2,3,4,7,8,9)	X	8.86	83.19	17.49	3.23	80.0	± 9.6 %
		Y	73.20	106.22	24.25		80.0	
		Z	0.70	60.00	7.66		80.0	
10475-AAC	LTE-TDD (SC-FDMA, 1 RB, 15 MHz, 64-QAM, UL Subframe=2,3,4,7,8,9)	X	1.84	66.67	11.33	3.23	80.0	± 9.6 %
		Y	7.07	79.22	16.54		80.0	
		Z	0.72	60.00	6.99		80.0	

10477-AAC	LTE-TDD (SC-FDMA, 1 RB, 20 MHz, 16-QAM, UL Subframe=2,3,4,7,8,9)	X	7.55	81.52	16.98	3.23	80.0	± 9.6 %
		Y	56.45	103.26	23.54		80.0	
		Z	0.70	60.00	7.63		80.0	
10478-AAC	LTE-TDD (SC-FDMA, 1 RB, 20 MHz, 64-QAM, UL Subframe=2,3,4,7,8,9)	X	1.82	66.56	11.27	3.23	80.0	± 9.6 %
		Y	6.95	79.03	16.47		80.0	
		Z	0.72	60.00	6.98		80.0	
10479-AAA	LTE-TDD (SC-FDMA, 50% RB, 1.4 MHz, QPSK, UL Subframe=2,3,4,7,8,9)	X	10.99	93.23	25.61	3.23	80.0	± 9.6 %
		Y	9.79	90.18	24.96		80.0	
		Z	4.54	80.48	20.41		80.0	
10480-AAA	LTE-TDD (SC-FDMA, 50% RB, 1.4 MHz, 16-QAM, UL Subframe=2,3,4,7,8,9)	X	12.16	88.23	21.88	3.23	80.0	± 9.6 %
		Y	11.98	87.55	22.28		80.0	
		Z	2.88	70.37	14.48		80.0	
10481-AAA	LTE-TDD (SC-FDMA, 50% RB, 1.4 MHz, 64-QAM, UL Subframe=2,3,4,7,8,9)	X	8.71	82.91	19.80	3.23	80.0	± 9.6 %
		Y	9.82	84.02	20.80		80.0	
		Z	2.18	66.77	12.57		80.0	
10482-AAA	LTE-TDD (SC-FDMA, 50% RB, 3 MHz, QPSK, UL Subframe=2,3,4,7,8,9)	X	4.05	77.33	19.19	2.23	80.0	± 9.6 %
		Y	4.17	76.68	19.19		80.0	
		Z	2.07	68.66	14.58		80.0	
10483-AAA	LTE-TDD (SC-FDMA, 50% RB, 3 MHz, 16-QAM, UL Subframe=2,3,4,7,8,9)	X	4.93	75.57	17.70	2.23	80.0	± 9.6 %
		Y	6.34	78.50	19.36		80.0	
		Z	1.80	63.38	11.04		80.0	
10484-AAA	LTE-TDD (SC-FDMA, 50% RB, 3 MHz, 64-QAM, UL Subframe=2,3,4,7,8,9)	X	4.47	74.01	17.11	2.23	80.0	± 9.6 %
		Y	5.79	76.98	18.82		80.0	
		Z	1.76	62.89	10.79		80.0	
10485-AAC	LTE-TDD (SC-FDMA, 50% RB, 5 MHz, QPSK, UL Subframe=2,3,4,7,8,9)	X	4.05	77.49	20.34	2.23	80.0	± 9.6 %
		Y	4.20	76.76	20.09		80.0	
		Z	2.71	72.24	17.50		80.0	
10486-AAC	LTE-TDD (SC-FDMA, 50% RB, 5 MHz, 16-QAM, UL Subframe=2,3,4,7,8,9)	X	3.54	71.63	17.34	2.23	80.0	± 9.6 %
		Y	3.76	71.58	17.54		80.0	
		Z	2.51	67.51	14.60		80.0	
10487-AAC	LTE-TDD (SC-FDMA, 50% RB, 5 MHz, 64-QAM, UL Subframe=2,3,4,7,8,9)	X	3.49	71.03	17.07	2.23	80.0	± 9.6 %
		Y	3.74	71.08	17.31		80.0	
		Z	2.49	67.04	14.35		80.0	
10488-AAC	LTE-TDD (SC-FDMA, 50% RB, 10 MHz, QPSK, UL Subframe=2,3,4,7,8,9)	X	3.92	74.84	20.03	2.23	80.0	± 9.6 %
		Y	4.21	74.77	19.87		80.0	
		Z	2.99	71.49	18.31		80.0	
10489-AAC	LTE-TDD (SC-FDMA, 50% RB, 10 MHz, 16-QAM, UL Subframe=2,3,4,7,8,9)	X	3.58	70.14	18.01	2.23	80.0	± 9.6 %
		Y	3.82	70.22	18.04		80.0	
		Z	3.03	68.36	16.75		80.0	
10490-AAC	LTE-TDD (SC-FDMA, 50% RB, 10 MHz, 64-QAM, UL Subframe=2,3,4,7,8,9)	X	3.66	69.89	17.90	2.23	80.0	± 9.6 %
		Y	3.90	69.97	17.95		80.0	
		Z	3.10	68.21	16.67		80.0	
10491-AAC	LTE-TDD (SC-FDMA, 50% RB, 15 MHz, QPSK, UL Subframe=2,3,4,7,8,9)	X	4.00	72.50	19.16	2.23	80.0	± 9.6 %
		Y	4.28	72.62	19.08		80.0	
		Z	3.25	70.05	17.90		80.0	
10492-AAC	LTE-TDD (SC-FDMA, 50% RB, 15 MHz, 16-QAM, UL Subframe=2,3,4,7,8,9)	X	3.86	68.99	17.79	2.23	80.0	± 9.6 %
		Y	4.11	69.18	17.85		80.0	
		Z	3.37	67.61	16.86		80.0	

10493-AAC	LTE-TDD (SC-FDMA, 50% RB, 15 MHz, 64-QAM, UL Subframe=2,3,4,7,8,9)	X	3.92	68.82	17.72	2.23	80.0	± 9.6 %
		Y	4.17	69.02	17.78		80.0	
		Z	3.43	67.50	16.80		80.0	
10494-AAC	LTE-TDD (SC-FDMA, 50% RB, 20 MHz, QPSK, UL Subframe=2,3,4,7,8,9)	X	4.43	74.41	19.78	2.23	80.0	± 9.6 %
		Y	4.75	74.52	19.68		80.0	
		Z	3.49	71.39	18.37		80.0	
10495-AAC	LTE-TDD (SC-FDMA, 50% RB, 20 MHz, 16-QAM, UL Subframe=2,3,4,7,8,9)	X	3.90	69.39	18.01	2.23	80.0	± 9.6 %
		Y	4.16	69.65	18.06		80.0	
		Z	3.39	67.86	17.06		80.0	
10496-AAC	LTE-TDD (SC-FDMA, 50% RB, 20 MHz, 64-QAM, UL Subframe=2,3,4,7,8,9)	X	3.97	69.05	17.88	2.23	80.0	± 9.6 %
		Y	4.22	69.30	17.94		80.0	
		Z	3.47	67.65	16.99		80.0	
10497-AAA	LTE-TDD (SC-FDMA, 100% RB, 1.4 MHz, QPSK, UL Subframe=2,3,4,7,8,9)	X	2.87	72.14	16.05	2.23	80.0	± 9.6 %
		Y	3.23	72.92	16.83		80.0	
		Z	1.19	62.14	10.12		80.0	
10498-AAA	LTE-TDD (SC-FDMA, 100% RB, 1.4 MHz, 16-QAM, UL Subframe=2,3,4,7,8,9)	X	1.73	63.11	10.85	2.23	80.0	± 9.6 %
		Y	2.27	65.45	12.56		80.0	
		Z	1.15	60.00	7.68		80.0	
10499-AAA	LTE-TDD (SC-FDMA, 100% RB, 1.4 MHz, 64-QAM, UL Subframe=2,3,4,7,8,9)	X	1.65	62.30	10.28	2.23	80.0	± 9.6 %
		Y	2.18	64.69	12.05		80.0	
		Z	1.17	60.00	7.51		80.0	
10500-AAA	LTE-TDD (SC-FDMA, 100% RB, 3 MHz, QPSK, UL Subframe=2,3,4,7,8,9)	X	3.87	75.87	20.03	2.23	80.0	± 9.6 %
		Y	4.07	75.40	19.81		80.0	
		Z	2.80	71.83	17.80		80.0	
10501-AAA	LTE-TDD (SC-FDMA, 100% RB, 3 MHz, 16-QAM, UL Subframe=2,3,4,7,8,9)	X	3.57	71.05	17.60	2.23	80.0	± 9.6 %
		Y	3.78	70.97	17.70		80.0	
		Z	2.79	68.23	15.59		80.0	
10502-AAA	LTE-TDD (SC-FDMA, 100% RB, 3 MHz, 64-QAM, UL Subframe=2,3,4,7,8,9)	X	3.61	70.84	17.44	2.23	80.0	± 9.6 %
		Y	3.84	70.79	17.56		80.0	
		Z	2.82	68.03	15.41		80.0	
10503-AAC	LTE-TDD (SC-FDMA, 100% RB, 5 MHz, QPSK, UL Subframe=2,3,4,7,8,9)	X	3.87	74.62	19.92	2.23	80.0	± 9.6 %
		Y	4.15	74.55	19.77		80.0	
		Z	2.95	71.29	18.21		80.0	
10504-AAC	LTE-TDD (SC-FDMA, 100% RB, 5 MHz, 16-QAM, UL Subframe=2,3,4,7,8,9)	X	3.57	70.04	17.95	2.23	80.0	± 9.6 %
		Y	3.80	70.13	17.99		80.0	
		Z	3.01	68.26	16.69		80.0	
10505-AAC	LTE-TDD (SC-FDMA, 100% RB, 5 MHz, 64-QAM, UL Subframe=2,3,4,7,8,9)	X	3.64	69.79	17.85	2.23	80.0	± 9.6 %
		Y	3.88	69.88	17.89		80.0	
		Z	3.09	68.12	16.62		80.0	
10506-AAC	LTE-TDD (SC-FDMA, 100% RB, 10 MHz, QPSK, UL Subframe=2,3,4,7,8,9)	X	4.39	74.26	19.71	2.23	80.0	± 9.6 %
		Y	4.71	74.37	19.61		80.0	
		Z	3.46	71.26	18.30		80.0	
10507-AAC	LTE-TDD (SC-FDMA, 100% RB, 10 MHz, 16-QAM, UL Subframe=2,3,4,7,8,9)	X	3.89	69.33	17.97	2.23	80.0	± 9.6 %
		Y	4.14	69.59	18.03		80.0	
		Z	3.38	67.80	17.02		80.0	

10508-AAC	LTE-TDD (SC-FDMA, 100% RB, 10 MHz, 64-QAM, UL Subframe=2,3,4,7,8,9)	X	3.95	68.98	17.84	2.23	80.0	± 9.6 %
		Y	4.21	69.23	17.90		80.0	
		Z	3.46	67.59	16.95		80.0	
10509-AAC	LTE-TDD (SC-FDMA, 100% RB, 15 MHz, QPSK, UL Subframe=2,3,4,7,8,9)	X	4.62	72.40	18.91	2.23	80.0	± 9.6 %
		Y	4.92	72.59	18.86		80.0	
		Z	3.86	70.20	17.85		80.0	
10510-AAC	LTE-TDD (SC-FDMA, 100% RB, 15 MHz, 16-QAM, UL Subframe=2,3,4,7,8,9)	X	4.34	68.87	17.84	2.23	80.0	± 9.6 %
		Y	4.61	69.18	17.91		80.0	
		Z	3.85	67.53	17.06		80.0	
10511-AAC	LTE-TDD (SC-FDMA, 100% RB, 15 MHz, 64-QAM, UL Subframe=2,3,4,7,8,9)	X	4.39	68.57	17.74	2.23	80.0	± 9.6 %
		Y	4.65	68.86	17.81		80.0	
		Z	3.92	67.35	17.00		80.0	
10512-AAC	LTE-TDD (SC-FDMA, 100% RB, 20 MHz, QPSK, UL Subframe=2,3,4,7,8,9)	X	4.95	74.43	19.59	2.23	80.0	± 9.6 %
		Y	5.29	74.60	19.52		80.0	
		Z	3.97	71.52	18.28		80.0	
10513-AAC	LTE-TDD (SC-FDMA, 100% RB, 20 MHz, 16-QAM, UL Subframe=2,3,4,7,8,9)	X	4.24	69.19	17.98	2.23	80.0	± 9.6 %
		Y	4.52	69.55	18.06		80.0	
		Z	3.73	67.67	17.13		80.0	
10514-AAC	LTE-TDD (SC-FDMA, 100% RB, 20 MHz, 64-QAM, UL Subframe=2,3,4,7,8,9)	X	4.25	68.69	17.82	2.23	80.0	± 9.6 %
		Y	4.51	69.03	17.90		80.0	
		Z	3.78	67.33	17.02		80.0	
10515-AAA	IEEE 802.11b WiFi 2.4 GHz (DSSS, 2 Mbps, 99pc duty cycle)	X	0.99	63.46	15.00	0.00	150.0	± 9.6 %
		Y	0.98	62.78	14.45		150.0	
		Z	0.99	63.59	14.96		150.0	
10516-AAA	IEEE 802.11b WiFi 2.4 GHz (DSSS, 5.5 Mbps, 99pc duty cycle)	X	0.69	72.54	18.63	0.00	150.0	± 9.6 %
		Y	0.56	68.11	16.08		150.0	
		Z	0.67	72.15	18.45		150.0	
10517-AAA	IEEE 802.11b WiFi 2.4 GHz (DSSS, 11 Mbps, 99pc duty cycle)	X	0.85	65.62	15.80	0.00	150.0	± 9.6 %
		Y	0.82	64.42	14.91		150.0	
		Z	0.84	65.62	15.72		150.0	
10518-AAA	IEEE 802.11a/h WiFi 5 GHz (OFDM, 9 Mbps, 99pc duty cycle)	X	4.53	66.80	16.29	0.00	150.0	± 9.6 %
		Y	4.59	66.58	16.17		150.0	
		Z	4.39	66.94	16.26		150.0	
10519-AAA	IEEE 802.11a/h WiFi 5 GHz (OFDM, 12 Mbps, 99pc duty cycle)	X	4.71	67.02	16.40	0.00	150.0	± 9.6 %
		Y	4.78	66.84	16.30		150.0	
		Z	4.54	67.11	16.34		150.0	
10520-AAA	IEEE 802.11a/h WiFi 5 GHz (OFDM, 18 Mbps, 99pc duty cycle)	X	4.56	66.98	16.32	0.00	150.0	± 9.6 %
		Y	4.63	66.80	16.22		150.0	
		Z	4.40	67.05	16.26		150.0	
10521-AAA	IEEE 802.11a/h WiFi 5 GHz (OFDM, 24 Mbps, 99pc duty cycle)	X	4.49	66.97	16.31	0.00	150.0	± 9.6 %
		Y	4.56	66.79	16.20		150.0	
		Z	4.33	67.02	16.25		150.0	
10522-AAA	IEEE 802.11a/h WiFi 5 GHz (OFDM, 36 Mbps, 99pc duty cycle)	X	4.56	67.08	16.40	0.00	150.0	± 9.6 %
		Y	4.62	66.86	16.28		150.0	
		Z	4.38	67.14	16.34		150.0	

10523-AAA	IEEE 802.11a/h WiFi 5 GHz (OFDM, 48 Mbps, 99pc duty cycle)	X	4.44	66.96	16.26	0.00	150.0	± 9.6 %
		Y	4.50	66.72	16.12		150.0	
		Z	4.31	67.14	16.26		150.0	
10524-AAA	IEEE 802.11a/h WiFi 5 GHz (OFDM, 54 Mbps, 99pc duty cycle)	X	4.50	67.00	16.37	0.00	150.0	± 9.6 %
		Y	4.57	66.78	16.25		150.0	
		Z	4.33	67.10	16.33		150.0	
10525-AAA	IEEE 802.11ac WiFi (20MHz, MCS0, 99pc duty cycle)	X	4.49	66.06	15.96	0.00	150.0	± 9.6 %
		Y	4.54	65.82	15.83		150.0	
		Z	4.36	66.21	15.95		150.0	
10526-AAA	IEEE 802.11ac WiFi (20MHz, MCS1, 99pc duty cycle)	X	4.65	66.41	16.10	0.00	150.0	± 9.6 %
		Y	4.72	66.20	15.98		150.0	
		Z	4.49	66.49	16.07		150.0	
10527-AAA	IEEE 802.11ac WiFi (20MHz, MCS2, 99pc duty cycle)	X	4.58	66.37	16.05	0.00	150.0	± 9.6 %
		Y	4.64	66.16	15.92		150.0	
		Z	4.42	66.47	16.01		150.0	
10528-AAA	IEEE 802.11ac WiFi (20MHz, MCS3, 99pc duty cycle)	X	4.59	66.39	16.08	0.00	150.0	± 9.6 %
		Y	4.65	66.18	15.96		150.0	
		Z	4.43	66.48	16.04		150.0	
10529-AAA	IEEE 802.11ac WiFi (20MHz, MCS4, 99pc duty cycle)	X	4.59	66.39	16.08	0.00	150.0	± 9.6 %
		Y	4.65	66.18	15.96		150.0	
		Z	4.43	66.48	16.04		150.0	
10531-AAA	IEEE 802.11ac WiFi (20MHz, MCS6, 99pc duty cycle)	X	4.58	66.48	16.09	0.00	150.0	± 9.6 %
		Y	4.65	66.29	15.97		150.0	
		Z	4.40	66.51	16.02		150.0	
10532-AAA	IEEE 802.11ac WiFi (20MHz, MCS7, 99pc duty cycle)	X	4.44	66.34	16.02	0.00	150.0	± 9.6 %
		Y	4.51	66.14	15.90		150.0	
		Z	4.28	66.37	15.96		150.0	
10533-AAA	IEEE 802.11ac WiFi (20MHz, MCS8, 99pc duty cycle)	X	4.60	66.44	16.07	0.00	150.0	± 9.6 %
		Y	4.66	66.22	15.94		150.0	
		Z	4.44	66.56	16.05		150.0	
10534-AAA	IEEE 802.11ac WiFi (40MHz, MCS0, 99pc duty cycle)	X	5.13	66.46	16.12	0.00	150.0	± 9.6 %
		Y	5.19	66.32	16.03		150.0	
		Z	4.99	66.46	16.09		150.0	
10535-AAA	IEEE 802.11ac WiFi (40MHz, MCS1, 99pc duty cycle)	X	5.20	66.64	16.21	0.00	150.0	± 9.6 %
		Y	5.25	66.49	16.10		150.0	
		Z	5.03	66.59	16.15		150.0	
10536-AAA	IEEE 802.11ac WiFi (40MHz, MCS2, 99pc duty cycle)	X	5.07	66.60	16.17	0.00	150.0	± 9.6 %
		Y	5.12	66.44	16.06		150.0	
		Z	4.92	66.60	16.13		150.0	
10537-AAA	IEEE 802.11ac WiFi (40MHz, MCS3, 99pc duty cycle)	X	5.12	66.56	16.15	0.00	150.0	± 9.6 %
		Y	5.18	66.41	16.05		150.0	
		Z	4.98	66.58	16.13		150.0	
10538-AAA	IEEE 802.11ac WiFi (40MHz, MCS4, 99pc duty cycle)	X	5.21	66.56	16.19	0.00	150.0	± 9.6 %
		Y	5.28	66.45	16.11		150.0	
		Z	5.05	66.54	16.15		150.0	
10540-AAA	IEEE 802.11ac WiFi (40MHz, MCS6, 99pc duty cycle)	X	5.14	66.58	16.22	0.00	150.0	± 9.6 %
		Y	5.20	66.45	16.12		150.0	
		Z	4.98	66.51	16.15		150.0	

10541-AAA	IEEE 802.11ac WiFi (40MHz, MCS7, 99pc duty cycle)	X	5.12	66.46	16.14	0.00	150.0	± 9.6 %
		Y	5.18	66.32	16.05		150.0	
		Z	4.96	66.43	16.09		150.0	
10542-AAA	IEEE 802.11ac WiFi (40MHz, MCS8, 99pc duty cycle)	X	5.27	66.53	16.19	0.00	150.0	± 9.6 %
		Y	5.33	66.40	16.10		150.0	
		Z	5.12	66.52	16.15		150.0	
10543-AAA	IEEE 802.11ac WiFi (40MHz, MCS9, 99pc duty cycle)	X	5.34	66.55	16.23	0.00	150.0	± 9.6 %
		Y	5.41	66.44	16.14		150.0	
		Z	5.19	66.58	16.21		150.0	
10544-AAA	IEEE 802.11ac WiFi (80MHz, MCS0, 99pc duty cycle)	X	5.45	66.57	16.12	0.00	150.0	± 9.6 %
		Y	5.49	66.44	16.03		150.0	
		Z	5.33	66.54	16.08		150.0	
10545-AAA	IEEE 802.11ac WiFi (80MHz, MCS1, 99pc duty cycle)	X	5.64	66.98	16.28	0.00	150.0	± 9.6 %
		Y	5.69	66.86	16.18		150.0	
		Z	5.50	66.96	16.25		150.0	
10546-AAA	IEEE 802.11ac WiFi (80MHz, MCS2, 99pc duty cycle)	X	5.50	66.75	16.18	0.00	150.0	± 9.6 %
		Y	5.56	66.68	16.11		150.0	
		Z	5.36	66.66	16.11		150.0	
10547-AAA	IEEE 802.11ac WiFi (80MHz, MCS3, 99pc duty cycle)	X	5.57	66.80	16.19	0.00	150.0	± 9.6 %
		Y	5.64	66.72	16.12		150.0	
		Z	5.44	66.76	16.16		150.0	
10548-AAA	IEEE 802.11ac WiFi (80MHz, MCS4, 99pc duty cycle)	X	5.80	67.67	16.61	0.00	150.0	± 9.6 %
		Y	5.91	67.72	16.59		150.0	
		Z	5.58	67.38	16.44		150.0	
10550-AAA	IEEE 802.11ac WiFi (80MHz, MCS6, 99pc duty cycle)	X	5.54	66.80	16.21	0.00	150.0	± 9.6 %
		Y	5.59	66.67	16.11		150.0	
		Z	5.42	66.83	16.21		150.0	
10551-AAA	IEEE 802.11ac WiFi (80MHz, MCS7, 99pc duty cycle)	X	5.54	66.82	16.18	0.00	150.0	± 9.6 %
		Y	5.59	66.72	16.10		150.0	
		Z	5.36	66.63	16.07		150.0	
10552-AAA	IEEE 802.11ac WiFi (80MHz, MCS8, 99pc duty cycle)	X	5.46	66.64	16.10	0.00	150.0	± 9.6 %
		Y	5.51	66.51	16.00		150.0	
		Z	5.34	66.66	16.08		150.0	
10553-AAA	IEEE 802.11ac WiFi (80MHz, MCS9, 99pc duty cycle)	X	5.54	66.66	16.14	0.00	150.0	± 9.6 %
		Y	5.59	66.56	16.06		150.0	
		Z	5.39	66.61	16.09		150.0	
10554-AAB	IEEE 802.11ac WiFi (160MHz, MCS0, 99pc duty cycle)	X	5.86	66.92	16.20	0.00	150.0	± 9.6 %
		Y	5.89	66.81	16.12		150.0	
		Z	5.75	66.87	16.15		150.0	
10555-AAB	IEEE 802.11ac WiFi (160MHz, MCS1, 99pc duty cycle)	X	5.98	67.22	16.33	0.00	150.0	± 9.6 %
		Y	6.03	67.12	16.25		150.0	
		Z	5.84	67.10	16.25		150.0	
10556-AAB	IEEE 802.11ac WiFi (160MHz, MCS2, 99pc duty cycle)	X	6.00	67.27	16.35	0.00	150.0	± 9.6 %
		Y	6.05	67.16	16.27		150.0	
		Z	5.88	67.20	16.30		150.0	
10557-AAB	IEEE 802.11ac WiFi (160MHz, MCS3, 99pc duty cycle)	X	5.96	67.16	16.31	0.00	150.0	± 9.6 %
		Y	6.02	67.08	16.25		150.0	
		Z	5.84	67.08	16.25		150.0	

10558-AAB	IEEE 802.11ac WiFi (160MHz, MCS4, 99pc duty cycle)	X	6.01	67.32	16.41	0.00	150.0	± 9.6 %
		Y	6.07	67.25	16.34		150.0	
		Z	5.85	67.15	16.31		150.0	
10560-AAB	IEEE 802.11ac WiFi (160MHz, MCS6, 99pc duty cycle)	X	6.01	67.17	16.37	0.00	150.0	± 9.6 %
		Y	6.06	67.10	16.31		150.0	
		Z	5.87	67.07	16.30		150.0	
10561-AAB	IEEE 802.11ac WiFi (160MHz, MCS7, 99pc duty cycle)	X	5.93	67.15	16.40	0.00	150.0	± 9.6 %
		Y	5.98	67.06	16.32		150.0	
		Z	5.80	67.05	16.32		150.0	
10562-AAB	IEEE 802.11ac WiFi (160MHz, MCS8, 99pc duty cycle)	X	6.04	67.49	16.57	0.00	150.0	± 9.6 %
		Y	6.12	67.48	16.53		150.0	
		Z	5.85	67.23	16.41		150.0	
10563-AAB	IEEE 802.11ac WiFi (160MHz, MCS9, 99pc duty cycle)	X	6.18	67.55	16.56	0.00	150.0	± 9.6 %
		Y	6.43	68.00	16.75		150.0	
		Z	5.95	67.17	16.35		150.0	
10564-AAA	IEEE 802.11g WiFi 2.4 GHz (DSSS-OFDM, 9 Mbps, 99pc duty cycle)	X	4.86	66.88	16.45	0.46	150.0	± 9.6 %
		Y	4.92	66.69	16.36		150.0	
		Z	4.71	66.96	16.39		150.0	
10565-AAA	IEEE 802.11g WiFi 2.4 GHz (DSSS-OFDM, 12 Mbps, 99pc duty cycle)	X	5.08	67.30	16.76	0.46	150.0	± 9.6 %
		Y	5.16	67.15	16.67		150.0	
		Z	4.90	67.36	16.69		150.0	
10566-AAA	IEEE 802.11g WiFi 2.4 GHz (DSSS-OFDM, 18 Mbps, 99pc duty cycle)	X	4.91	67.15	16.58	0.46	150.0	± 9.6 %
		Y	4.99	67.00	16.50		150.0	
		Z	4.74	67.18	16.50		150.0	
10567-AAA	IEEE 802.11g WiFi 2.4 GHz (DSSS-OFDM, 24 Mbps, 99pc duty cycle)	X	4.94	67.52	16.92	0.46	150.0	± 9.6 %
		Y	5.01	67.38	16.84		150.0	
		Z	4.77	67.57	16.87		150.0	
10568-AAA	IEEE 802.11g WiFi 2.4 GHz (DSSS-OFDM, 36 Mbps, 99pc duty cycle)	X	4.83	66.96	16.38	0.46	150.0	± 9.6 %
		Y	4.90	66.77	16.27		150.0	
		Z	4.63	66.92	16.25		150.0	
10569-AAA	IEEE 802.11g WiFi 2.4 GHz (DSSS-OFDM, 48 Mbps, 99pc duty cycle)	X	4.90	67.63	17.00	0.46	150.0	± 9.6 %
		Y	4.96	67.44	16.88		150.0	
		Z	4.75	67.78	17.00		150.0	
10570-AAA	IEEE 802.11g WiFi 2.4 GHz (DSSS-OFDM, 54 Mbps, 99pc duty cycle)	X	4.93	67.48	16.92	0.46	150.0	± 9.6 %
		Y	5.00	67.29	16.82		150.0	
		Z	4.76	67.58	16.89		150.0	
10571-AAA	IEEE 802.11b WiFi 2.4 GHz (DSSS, 1 Mbps, 90pc duty cycle)	X	1.18	64.69	15.93	0.46	130.0	± 9.6 %
		Y	1.20	64.37	15.58		130.0	
		Z	1.13	64.22	15.49		130.0	
10572-AAA	IEEE 802.11b WiFi 2.4 GHz (DSSS, 2 Mbps, 90pc duty cycle)	X	1.19	65.27	16.29	0.46	130.0	± 9.6 %
		Y	1.21	64.91	15.92		130.0	
		Z	1.14	64.74	15.83		130.0	
10573-AAA	IEEE 802.11b WiFi 2.4 GHz (DSSS, 5.5 Mbps, 90pc duty cycle)	X	2.77	92.16	26.12	0.46	130.0	± 9.6 %
		Y	1.86	83.27	22.47		130.0	
		Z	1.57	83.20	23.00		130.0	
10574-AAA	IEEE 802.11b WiFi 2.4 GHz (DSSS, 11 Mbps, 90pc duty cycle)	X	1.31	71.26	19.39	0.46	130.0	± 9.6 %
		Y	1.31	70.26	18.63		130.0	
		Z	1.20	70.00	18.67		130.0	

10575-AAA	IEEE 802.11g WiFi 2.4 GHz (DSSS-OFDM, 6 Mbps, 90pc duty cycle)	X	4.64	66.67	16.51	0.46	130.0	± 9.6 %
		Y	4.71	66.50	16.43		130.0	
		Z	4.47	66.69	16.39		130.0	
10576-AAA	IEEE 802.11g WiFi 2.4 GHz (DSSS-OFDM, 9 Mbps, 90pc duty cycle)	X	4.66	66.83	16.58	0.46	130.0	± 9.6 %
		Y	4.73	66.66	16.49		130.0	
		Z	4.50	66.89	16.47		130.0	
10577-AAA	IEEE 802.11g WiFi 2.4 GHz (DSSS-OFDM, 12 Mbps, 90pc duty cycle)	X	4.86	67.11	16.74	0.46	130.0	± 9.6 %
		Y	4.94	66.97	16.66		130.0	
		Z	4.67	67.12	16.61		130.0	
10578-AAA	IEEE 802.11g WiFi 2.4 GHz (DSSS-OFDM, 18 Mbps, 90pc duty cycle)	X	4.76	67.25	16.83	0.46	130.0	± 9.6 %
		Y	4.84	67.12	16.76		130.0	
		Z	4.57	67.26	16.72		130.0	
10579-AAA	IEEE 802.11g WiFi 2.4 GHz (DSSS-OFDM, 24 Mbps, 90pc duty cycle)	X	4.52	66.57	16.17	0.46	130.0	± 9.6 %
		Y	4.61	66.44	16.10		130.0	
		Z	4.33	66.48	15.99		130.0	
10580-AAA	IEEE 802.11g WiFi 2.4 GHz (DSSS-OFDM, 36 Mbps, 90pc duty cycle)	X	4.57	66.63	16.21	0.46	130.0	± 9.6 %
		Y	4.66	66.47	16.12		130.0	
		Z	4.36	66.53	16.01		130.0	
10581-AAA	IEEE 802.11g WiFi 2.4 GHz (DSSS-OFDM, 48 Mbps, 90pc duty cycle)	X	4.65	67.30	16.78	0.46	130.0	± 9.6 %
		Y	4.73	67.15	16.70		130.0	
		Z	4.48	67.34	16.69		130.0	
10582-AAA	IEEE 802.11g WiFi 2.4 GHz (DSSS-OFDM, 54 Mbps, 90pc duty cycle)	X	4.47	66.35	15.97	0.46	130.0	± 9.6 %
		Y	4.56	66.21	15.89		130.0	
		Z	4.26	66.25	15.78		130.0	
10583-AAA	IEEE 802.11a/h WiFi 5 GHz (OFDM, 6 Mbps, 90pc duty cycle)	X	4.64	66.67	16.51	0.46	130.0	± 9.6 %
		Y	4.71	66.50	16.43		130.0	
		Z	4.47	66.69	16.39		130.0	
10584-AAA	IEEE 802.11a/h WiFi 5 GHz (OFDM, 9 Mbps, 90pc duty cycle)	X	4.66	66.83	16.58	0.46	130.0	± 9.6 %
		Y	4.73	66.66	16.49		130.0	
		Z	4.50	66.89	16.47		130.0	
10585-AAA	IEEE 802.11a/h WiFi 5 GHz (OFDM, 12 Mbps, 90pc duty cycle)	X	4.86	67.11	16.74	0.46	130.0	± 9.6 %
		Y	4.94	66.97	16.66		130.0	
		Z	4.67	67.12	16.61		130.0	
10586-AAA	IEEE 802.11a/h WiFi 5 GHz (OFDM, 18 Mbps, 90pc duty cycle)	X	4.76	67.25	16.83	0.46	130.0	± 9.6 %
		Y	4.84	67.12	16.76		130.0	
		Z	4.57	67.26	16.72		130.0	
10587-AAA	IEEE 802.11a/h WiFi 5 GHz (OFDM, 24 Mbps, 90pc duty cycle)	X	4.52	66.57	16.17	0.46	130.0	± 9.6 %
		Y	4.61	66.44	16.10		130.0	
		Z	4.33	66.48	15.99		130.0	
10588-AAA	IEEE 802.11a/h WiFi 5 GHz (OFDM, 36 Mbps, 90pc duty cycle)	X	4.57	66.63	16.21	0.46	130.0	± 9.6 %
		Y	4.66	66.47	16.12		130.0	
		Z	4.36	66.53	16.01		130.0	
10589-AAA	IEEE 802.11a/h WiFi 5 GHz (OFDM, 48 Mbps, 90pc duty cycle)	X	4.65	67.30	16.78	0.46	130.0	± 9.6 %
		Y	4.73	67.15	16.70		130.0	
		Z	4.48	67.34	16.69		130.0	
10590-AAA	IEEE 802.11a/h WiFi 5 GHz (OFDM, 54 Mbps, 90pc duty cycle)	X	4.47	66.35	15.97	0.46	130.0	± 9.6 %
		Y	4.56	66.21	15.89		130.0	
		Z	4.26	66.25	15.78		130.0	



10591-AAA	IEEE 802.11n (HT Mixed, 20MHz, MCS0, 90pc duty cycle)	X	4.79	66.72	16.61	0.46	130.0	± 9.6 %
		Y	4.86	66.57	16.53		130.0	
		Z	4.63	66.78	16.50		130.0	
10592-AAA	IEEE 802.11n (HT Mixed, 20MHz, MCS1, 90pc duty cycle)	X	4.94	67.05	16.74	0.46	130.0	± 9.6 %
		Y	5.02	66.91	16.66		130.0	
		Z	4.75	67.07	16.63		130.0	
10593-AAA	IEEE 802.11n (HT Mixed, 20MHz, MCS2, 90pc duty cycle)	X	4.86	66.96	16.62	0.46	130.0	± 9.6 %
		Y	4.94	66.83	16.55		130.0	
		Z	4.67	66.95	16.49		130.0	
10594-AAA	IEEE 802.11n (HT Mixed, 20MHz, MCS3, 90pc duty cycle)	X	4.91	67.12	16.77	0.46	130.0	± 9.6 %
		Y	5.00	66.98	16.70		130.0	
		Z	4.72	67.12	16.65		130.0	
10595-AAA	IEEE 802.11n (HT Mixed, 20MHz, MCS4, 90pc duty cycle)	X	4.88	67.08	16.67	0.46	130.0	± 9.6 %
		Y	4.96	66.94	16.59		130.0	
		Z	4.69	67.10	16.56		130.0	
10596-AAA	IEEE 802.11n (HT Mixed, 20MHz, MCS5, 90pc duty cycle)	X	4.82	67.08	16.68	0.46	130.0	± 9.6 %
		Y	4.90	66.94	16.60		130.0	
		Z	4.62	67.07	16.55		130.0	
10597-AAA	IEEE 802.11n (HT Mixed, 20MHz, MCS6, 90pc duty cycle)	X	4.77	66.98	16.56	0.46	130.0	± 9.6 %
		Y	4.85	66.85	16.49		130.0	
		Z	4.57	66.94	16.41		130.0	
10598-AAA	IEEE 802.11n (HT Mixed, 20MHz, MCS7, 90pc duty cycle)	X	4.75	67.19	16.80	0.46	130.0	± 9.6 %
		Y	4.83	67.08	16.74		130.0	
		Z	4.56	67.16	16.67		130.0	
10599-AAA	IEEE 802.11n (HT Mixed, 40MHz, MCS0, 90pc duty cycle)	X	5.46	67.23	16.81	0.46	130.0	± 9.6 %
		Y	5.53	67.13	16.74		130.0	
		Z	5.31	67.22	16.74		130.0	
10600-AAA	IEEE 802.11n (HT Mixed, 40MHz, MCS1, 90pc duty cycle)	X	5.59	67.67	17.00	0.46	130.0	± 9.6 %
		Y	5.69	67.62	16.95		130.0	
		Z	5.40	67.56	16.88		130.0	
10601-AAA	IEEE 802.11n (HT Mixed, 40MHz, MCS2, 90pc duty cycle)	X	5.48	67.41	16.88	0.46	130.0	± 9.6 %
		Y	5.56	67.33	16.83		130.0	
		Z	5.31	67.36	16.79		130.0	
10602-AAA	IEEE 802.11n (HT Mixed, 40MHz, MCS3, 90pc duty cycle)	X	5.59	67.49	16.85	0.46	130.0	± 9.6 %
		Y	5.65	67.34	16.75		130.0	
		Z	5.41	67.42	16.75		130.0	
10603-AAA	IEEE 802.11n (HT Mixed, 40MHz, MCS4, 90pc duty cycle)	X	5.65	67.74	17.10	0.46	130.0	± 9.6 %
		Y	5.74	67.66	17.04		130.0	
		Z	5.48	67.71	17.02		130.0	
10604-AAA	IEEE 802.11n (HT Mixed, 40MHz, MCS5, 90pc duty cycle)	X	5.49	67.31	16.87	0.46	130.0	± 9.6 %
		Y	5.53	67.10	16.74		130.0	
		Z	5.37	67.37	16.83		130.0	
10605-AAA	IEEE 802.11n (HT Mixed, 40MHz, MCS6, 90pc duty cycle)	X	5.58	67.57	17.01	0.46	130.0	± 9.6 %
		Y	5.65	67.44	16.92		130.0	
		Z	5.40	67.46	16.88		130.0	
10606-AAA	IEEE 802.11n (HT Mixed, 40MHz, MCS7, 90pc duty cycle)	X	5.32	66.88	16.52	0.46	130.0	± 9.6 %
		Y	5.42	66.88	16.50		130.0	
		Z	5.18	66.90	16.45		130.0	

10607-AAA	IEEE 802.11ac WiFi (20MHz, MCS0, 90pc duty cycle)	X	4.63	66.06	16.24	0.46	130.0	± 9.6 %
		Y	4.69	65.87	16.14		130.0	
		Z	4.48	66.14	16.16		130.0	
10608-AAA	IEEE 802.11ac WiFi (20MHz, MCS1, 90pc duty cycle)	X	4.81	66.46	16.41	0.46	130.0	± 9.6 %
		Y	4.89	66.28	16.31		130.0	
		Z	4.62	66.47	16.30		130.0	
10609-AAA	IEEE 802.11ac WiFi (20MHz, MCS2, 90pc duty cycle)	X	4.70	66.31	16.25	0.46	130.0	± 9.6 %
		Y	4.78	66.14	16.15		130.0	
		Z	4.52	66.31	16.13		130.0	
10610-AAA	IEEE 802.11ac WiFi (20MHz, MCS3, 90pc duty cycle)	X	4.75	66.46	16.40	0.46	130.0	± 9.6 %
		Y	4.83	66.29	16.31		130.0	
		Z	4.57	66.47	16.29		130.0	
10611-AAA	IEEE 802.11ac WiFi (20MHz, MCS4, 90pc duty cycle)	X	4.67	66.27	16.25	0.46	130.0	± 9.6 %
		Y	4.74	66.11	16.17		130.0	
		Z	4.48	66.27	16.14		130.0	
10612-AAA	IEEE 802.11ac WiFi (20MHz, MCS5, 90pc duty cycle)	X	4.68	66.43	16.31	0.46	130.0	± 9.6 %
		Y	4.76	66.26	16.21		130.0	
		Z	4.47	66.40	16.18		130.0	
10613-AAA	IEEE 802.11ac WiFi (20MHz, MCS6, 90pc duty cycle)	X	4.68	66.30	16.19	0.46	130.0	± 9.6 %
		Y	4.76	66.16	16.10		130.0	
		Z	4.47	66.22	16.03		130.0	
10614-AAA	IEEE 802.11ac WiFi (20MHz, MCS7, 90pc duty cycle)	X	4.62	66.47	16.40	0.46	130.0	± 9.6 %
		Y	4.70	66.33	16.32		130.0	
		Z	4.44	66.44	16.27		130.0	
10615-AAA	IEEE 802.11ac WiFi (20MHz, MCS8, 90pc duty cycle)	X	4.67	66.12	16.05	0.46	130.0	± 9.6 %
		Y	4.75	65.95	15.95		130.0	
		Z	4.48	66.11	15.92		130.0	
10616-AAA	IEEE 802.11ac WiFi (40MHz, MCS0, 90pc duty cycle)	X	5.28	66.50	16.42	0.46	130.0	± 9.6 %
		Y	5.35	66.40	16.35		130.0	
		Z	5.12	66.44	16.33		130.0	
10617-AAA	IEEE 802.11ac WiFi (40MHz, MCS1, 90pc duty cycle)	X	5.35	66.70	16.50	0.46	130.0	± 9.6 %
		Y	5.42	66.55	16.40		130.0	
		Z	5.16	66.57	16.37		130.0	
10618-AAA	IEEE 802.11ac WiFi (40MHz, MCS2, 90pc duty cycle)	X	5.24	66.70	16.51	0.46	130.0	± 9.6 %
		Y	5.30	66.57	16.42		130.0	
		Z	5.08	66.64	16.42		130.0	
10619-AAA	IEEE 802.11ac WiFi (40MHz, MCS3, 90pc duty cycle)	X	5.25	66.50	16.35	0.46	130.0	± 9.6 %
		Y	5.33	66.41	16.28		130.0	
		Z	5.09	66.45	16.26		130.0	
10620-AAA	IEEE 802.11ac WiFi (40MHz, MCS4, 90pc duty cycle)	X	5.34	66.53	16.41	0.46	130.0	± 9.6 %
		Y	5.42	66.46	16.35		130.0	
		Z	5.16	66.45	16.31		130.0	
10621-AAA	IEEE 802.11ac WiFi (40MHz, MCS5, 90pc duty cycle)	X	5.34	66.65	16.59	0.46	130.0	± 9.6 %
		Y	5.41	66.55	16.51		130.0	
		Z	5.17	66.56	16.48		130.0	
10622-AAA	IEEE 802.11ac WiFi (40MHz, MCS6, 90pc duty cycle)	X	5.35	66.81	16.66	0.46	130.0	± 9.6 %
		Y	5.42	66.71	16.59		130.0	
		Z	5.16	66.65	16.52		130.0	

10623-AAA	IEEE 802.11ac WiFi (40MHz, MCS7, 90pc duty cycle)	X	5.23	66.36	16.32	0.46	130.0	± 9.6 %
		Y	5.30	66.25	16.24		130.0	
		Z	5.05	66.22	16.17		130.0	
10624-AAA	IEEE 802.11ac WiFi (40MHz, MCS8, 90pc duty cycle)	X	5.42	66.55	16.47	0.46	130.0	± 9.6 %
		Y	5.50	66.45	16.40		130.0	
		Z	5.25	66.47	16.36		130.0	
10625-AAA	IEEE 802.11ac WiFi (40MHz, MCS9, 90pc duty cycle)	X	5.75	67.41	16.95	0.46	130.0	± 9.6 %
		Y	5.89	67.51	16.98		130.0	
		Z	5.34	66.63	16.50		130.0	
10626-AAA	IEEE 802.11ac WiFi (80MHz, MCS0, 90pc duty cycle)	X	5.59	66.56	16.38	0.46	130.0	± 9.6 %
		Y	5.64	66.46	16.31		130.0	
		Z	5.45	66.47	16.28		130.0	
10627-AAA	IEEE 802.11ac WiFi (80MHz, MCS1, 90pc duty cycle)	X	5.82	67.13	16.63	0.46	130.0	± 9.6 %
		Y	5.88	67.03	16.55		130.0	
		Z	5.67	67.05	16.54		130.0	
10628-AAA	IEEE 802.11ac WiFi (80MHz, MCS2, 90pc duty cycle)	X	5.61	66.64	16.32	0.46	130.0	± 9.6 %
		Y	5.68	66.59	16.27		130.0	
		Z	5.44	66.46	16.18		130.0	
10629-AAA	IEEE 802.11ac WiFi (80MHz, MCS3, 90pc duty cycle)	X	5.69	66.69	16.34	0.46	130.0	± 9.6 %
		Y	5.78	66.69	16.31		130.0	
		Z	5.54	66.62	16.26		130.0	
10630-AAA	IEEE 802.11ac WiFi (80MHz, MCS4, 90pc duty cycle)	X	6.09	68.10	17.05	0.46	130.0	± 9.6 %
		Y	6.25	68.29	17.11		130.0	
		Z	5.78	67.54	16.72		130.0	
10631-AAA	IEEE 802.11ac WiFi (80MHz, MCS5, 90pc duty cycle)	X	5.99	67.90	17.13	0.46	130.0	± 9.6 %
		Y	6.12	67.99	17.15		130.0	
		Z	5.75	67.56	16.92		130.0	
10632-AAA	IEEE 802.11ac WiFi (80MHz, MCS6, 90pc duty cycle)	X	5.79	67.18	16.78	0.46	130.0	± 9.6 %
		Y	5.85	67.07	16.70		130.0	
		Z	5.67	67.21	16.76		130.0	
10633-AAA	IEEE 802.11ac WiFi (80MHz, MCS7, 90pc duty cycle)	X	5.68	66.80	16.43	0.46	130.0	± 9.6 %
		Y	5.74	66.74	16.37		130.0	
		Z	5.48	66.57	16.27		130.0	
10634-AAA	IEEE 802.11ac WiFi (80MHz, MCS8, 90pc duty cycle)	X	5.66	66.82	16.49	0.46	130.0	± 9.6 %
		Y	5.73	66.76	16.44		130.0	
		Z	5.50	66.72	16.40		130.0	
10635-AAA	IEEE 802.11ac WiFi (80MHz, MCS9, 90pc duty cycle)	X	5.54	66.19	15.93	0.46	130.0	± 9.6 %
		Y	5.62	66.14	15.87		130.0	
		Z	5.36	66.00	15.77		130.0	
10636-AAB	IEEE 802.11ac WiFi (160MHz, MCS0, 90pc duty cycle)	X	6.00	66.92	16.46	0.46	130.0	± 9.6 %
		Y	6.05	66.85	16.41		130.0	
		Z	5.88	66.82	16.36		130.0	
10637-AAB	IEEE 802.11ac WiFi (160MHz, MCS1, 90pc duty cycle)	X	6.16	67.31	16.64	0.46	130.0	± 9.6 %
		Y	6.21	67.23	16.58		130.0	
		Z	6.00	67.12	16.50		130.0	
10638-AAB	IEEE 802.11ac WiFi (160MHz, MCS2, 90pc duty cycle)	X	6.16	67.28	16.60	0.46	130.0	± 9.6 %
		Y	6.21	67.20	16.54		130.0	
		Z	6.02	67.18	16.51		130.0	

10639-AAB	IEEE 802.11ac WiFi (160MHz, MCS3, 90pc duty cycle)	X	6.13	67.21	16.61	0.46	130.0	± 9.6 %
		Y	6.20	67.17	16.57		130.0	
		Z	5.98	67.06	16.49		130.0	
10640-AAB	IEEE 802.11ac WiFi (160MHz, MCS4, 90pc duty cycle)	X	6.13	67.23	16.57	0.46	130.0	± 9.6 %
		Y	6.21	67.21	16.53		130.0	
		Z	5.95	66.98	16.40		130.0	
10641-AAB	IEEE 802.11ac WiFi (160MHz, MCS5, 90pc duty cycle)	X	6.19	67.17	16.55	0.46	130.0	± 9.6 %
		Y	6.24	67.06	16.48		130.0	
		Z	6.04	67.04	16.44		130.0	
10642-AAB	IEEE 802.11ac WiFi (160MHz, MCS6, 90pc duty cycle)	X	6.22	67.37	16.82	0.46	130.0	± 9.6 %
		Y	6.28	67.33	16.77		130.0	
		Z	6.06	67.23	16.70		130.0	
10643-AAB	IEEE 802.11ac WiFi (160MHz, MCS7, 90pc duty cycle)	X	6.06	67.09	16.58	0.46	130.0	± 9.6 %
		Y	6.12	67.02	16.52		130.0	
		Z	5.91	66.93	16.45		130.0	
10644-AAB	IEEE 802.11ac WiFi (160MHz, MCS8, 90pc duty cycle)	X	6.20	67.52	16.82	0.46	130.0	± 9.6 %
		Y	6.31	67.59	16.83		130.0	
		Z	5.97	67.13	16.57		130.0	
10645-AAB	IEEE 802.11ac WiFi (160MHz, MCS9, 90pc duty cycle)	X	6.41	67.77	16.91	0.46	130.0	± 9.6 %
		Y	6.76	68.49	17.23		130.0	
		Z	6.10	67.18	16.56		130.0	
10646-AAD	LTE-TDD (SC-FDMA, 1 RB, 5 MHz, QPSK, UL Subframe=2,7)	X	32.54	128.38	44.23	9.30	60.0	± 9.6 %
		Y	33.21	124.21	42.28		60.0	
		Z	8.58	97.27	34.21		60.0	
10647-AAC	LTE-TDD (SC-FDMA, 1 RB, 20 MHz, QPSK, UL Subframe=2,7)	X	24.86	122.50	42.74	9.30	60.0	± 9.6 %
		Y	27.83	120.75	41.46		60.0	
		Z	7.33	94.04	33.20		60.0	
10648-AAA	CDMA2000 (1x Advanced)	X	0.71	63.99	11.07	0.00	150.0	± 9.6 %
		Y	0.72	63.38	11.01		150.0	
		Z	0.57	62.72	9.40		150.0	
10652-AAB	LTE-TDD (OFDMA, 5 MHz, E-TM 3.1, Clipping 44%)	X	3.64	67.29	16.91	2.23	80.0	± 9.6 %
		Y	3.79	67.25	16.93		80.0	
		Z	3.31	66.63	16.20		80.0	
10653-AAB	LTE-TDD (OFDMA, 10 MHz, E-TM 3.1, Clipping 44%)	X	4.13	66.44	16.95	2.23	80.0	± 9.6 %
		Y	4.30	66.53	16.99		80.0	
		Z	3.84	65.89	16.44		80.0	
10654-AAB	LTE-TDD (OFDMA, 15 MHz, E-TM 3.1, Clipping 44%)	X	4.11	66.04	16.93	2.23	80.0	± 9.6 %
		Y	4.26	66.17	16.97		80.0	
		Z	3.86	65.50	16.46		80.0	
10655-AAB	LTE-TDD (OFDMA, 20 MHz, E-TM 3.1, Clipping 44%)	X	4.17	66.02	16.96	2.23	80.0	± 9.6 %
		Y	4.32	66.18	17.01		80.0	
		Z	3.93	65.42	16.50		80.0	

<sup>E</sup> Uncertainty is determined using the max. deviation from linear response applying rectangular distribution and is expressed for the square of the field value.

## APPENDIX D: SAR TISSUE SPECIFICATIONS

Measurement Procedure for Tissue verification:

- 1) The network analyzer and probe system was configured and calibrated.
- 2) The probe was immersed in the tissue. The tissue was placed in a nonmetallic container. Trapped air bubbles beneath the flange were minimized by placing the probe at a slight angle.
- 3) The complex admittance with respect to the probe aperture was measured
- 4) The complex relative permittivity  $\epsilon'$  can be calculated from the below equation (Pournaropoulos and Misra):

$$Y = \frac{j2\omega\epsilon_r\epsilon_0}{[\ln(b/a)]^2} \int_a^b \int_a^b \int_0^\pi \cos\phi' \frac{\exp[-j\omega r(\mu_0\epsilon_r'\epsilon_0)^{1/2}]}{r} d\phi' d\rho' d\rho$$

where Y is the admittance of the probe in contact with the sample, the primed and unprimed coordinates refer to source and observation points, respectively,  $r^2 = \rho^2 + \rho'^2 - 2\rho\rho' \cos\phi'$ ,  $\omega$  is the angular frequency, and  $j = \sqrt{-1}$ .

**Table D-I**  
**Composition of the Tissue Equivalent Matter**

Frequency (MHz)	750	750	835	835	1750	1750	1900	1900	2450	2450	5200-5800	5200-5800
Tissue	Head	Body	Head	Body	Head	Body	Head	Body	Head	Body	Head	Body
Ingredients (% by weight)												
Bactericide			0.1	0.1								
DGBE					47	31	44.92	29.44		26.7		
HEC			1	1								
NaCl	See page 2-3	See page 2	1.45	0.94	0.4	0.2	0.18	0.39	See page 4	0.1	See page 5	
Sucrose			57	44.9								
Polysorbate (Tween) 80												20
Water			40.45	53.06	52.6	68.8	54.9	70.17		73.2		80

<b>FCC ID:</b> A3LSMG960U	<b>PCTEST</b> <small>PROFESSIONAL COMMUNICATIONS TESTING, INC.</small>	<b>SAR EVALUATION REPORT</b>		<b>Approved by:</b> Quality Manager
<b>Test Dates:</b> 11/03/17 - 12/07/17	<b>DUT Type:</b> Portable Handset			APPENDIX D: Page 1 of 5

## 2 Composition / Information on ingredients

The Item is composed of the following ingredients:

H <sub>2</sub> O	Water, 35 – 58%
Sucrose	Sugar, white, refined, 40 – 60%
NaCl	Sodium Chloride, 0 – 6%
Hydroxyethyl-cellulose	Medium Viscosity (CAS# 9004-62-0), <0.3%
Preventol-D7	Preservative: aqueous preparation, (CAS# 55965-84-9), containing 5-chloro-2-methyl-3(2H)-isothiazolone and 2-methyl-3(2H)-isothiazolone, 0.1 – 0.7%

Relevant for safety; Refer to the respective Safety Data Sheet\*.

**Figure D-1  
Composition of 750 MHz Head and Body Tissue Equivalent Matter**

**Note:** 750MHz liquid recipes are proprietary SPEAG. Since the composition is approximate to the actual liquids utilized, the manufacturer tissue-equivalent liquid data sheets are provided below.

### Measurement Certificate / Material Test

Item Name	Body Tissue Simulating Liquid (MSL750V2)
Product No.	SL AAM 075 AA (Batch: 150518-2)
Manufacturer	SPEAG

#### Measurement Method

TSL dielectric parameters measured using calibrated DAK probe.

#### Setup Validation

Validation results were within  $\pm 2.5\%$  towards the target values of Methanol.

#### Target Parameters

Target parameters as defined in the IEEE 1528 and IEC 62209 compliance standards.

#### Test Condition

Ambient	Environment temperatur (22 $\pm$ 3) $^{\circ}$ C and humidity < 70%.
TSL Temperature	22 $^{\circ}$ C
Test Date	20-Apr-16
Operator	WM



#### Additional Information

TSL Density	1.212 g/cm <sup>3</sup>
TSL Heat capacity	3.006 kJ/(kg $\cdot$ K)

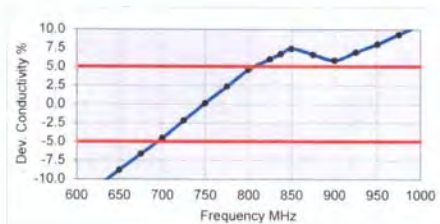
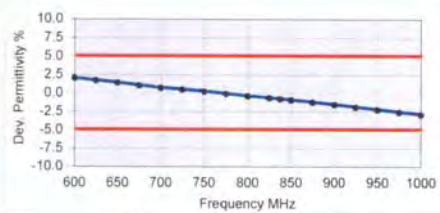
f [MHz]	Measured			Target			Diff. to Target [%]	
	e'	e''	sigma	eps	sigma	$\Delta$ -eps	$\Delta$ -sigma	
600	57.2	24.76	0.83	56.1	0.95	2.0	-13.2	
625	57.0	24.43	0.85	56.0	0.95	1.7	-11.0	
650	56.7	24.11	0.87	55.9	0.96	1.4	-8.8	
675	56.4	23.82	0.89	55.8	0.96	1.1	-6.6	
700	56.1	23.53	0.92	55.7	0.96	0.7	-4.5	
725	55.9	23.32	0.94	55.6	0.96	0.5	-2.2	
<b>750</b>	<b>55.7</b>	<b>23.12</b>	<b>0.96</b>	<b>55.5</b>	<b>0.96</b>	<b>0.2</b>	<b>0.1</b>	
775	55.4	22.93	0.99	55.4	0.97	-0.1	2.4	
800	55.1	22.73	1.01	55.3	0.97	-0.4	4.6	
825	54.9	22.59	1.04	55.2	0.98	-0.7	6.0	
838	54.8	22.52	1.05	55.2	0.98	-0.8	6.7	
850	54.6	22.45	1.06	55.2	0.99	-0.9	7.4	
875	54.4	22.32	1.09	55.1	1.02	-1.2	6.6	
900	54.1	22.19	1.11	55.0	1.05	-1.6	5.8	
925	53.9	22.09	1.14	55.0	1.06	-1.9	6.9	
950	53.7	21.98	1.16	54.9	1.08	-2.2	8.0	
975	53.5	21.91	1.19	54.9	1.09	-2.6	9.3	
1000	53.2	21.83	1.21	54.8	1.10	-2.9	10.6	



**Figure D-2  
750MHz Body Tissue Equivalent Matter**

<b>FCC ID:</b> A3LSMG960U		<b>SAR EVALUATION REPORT</b>		<b>Approved by:</b> Quality Manager
<b>Test Dates:</b> 11/03/17 - 12/07/17	<b>DUT Type:</b> Portable Handset			<b>APPENDIX D:</b> Page 2 of 5

## Measurement Certificate / Material Test

Item Name	Head Tissue Simulating Liquid (HSL750V2)
Product No.	SL AAH 075 AB (Batch: 160322-2)
Manufacturer	SPEAG

### Measurement Method

TSL dielectric parameters measured using calibrated DAK probe.

### Setup Validation

Validation results were within  $\pm 2.5\%$  towards the target values of Methanol.

### Target Parameters

Target parameters as defined in the IEEE 1528 and IEC 62209 compliance standards.

### Test Condition

Ambient	Environment temperatur ( $22 \pm 3$ )°C and humidity < 70%.
TSL Temperature	22°C
Test Date	23-Mar-16
Operator	WM



### Additional Information

TSL Density	1.284 g/cm <sup>3</sup>
TSL Heat-capacity	2.701 kJ/(kg*K)

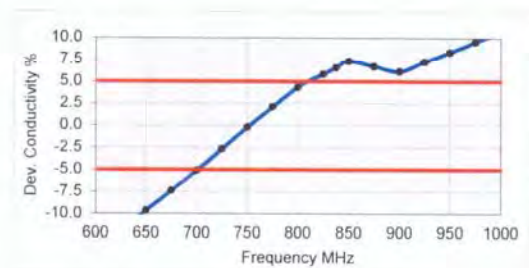
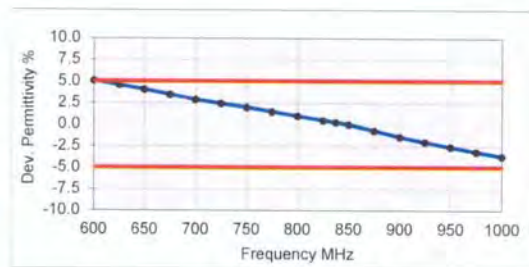
f [MHz]	Measured			Target		Diff. to Target [%]	
	e'	e''	sigma	eps	sigma	$\Delta$ -eps	$\Delta$ -sigma
600	44.9	22.60	0.75	42.7	0.88	5.1	-14.4
625	44.5	22.37	0.78	42.6	0.88	4.5	-12.0
650	44.2	22.13	0.80	42.5	0.89	4.0	-9.6
675	43.8	21.90	0.82	42.3	0.89	3.4	-7.4
700	43.4	21.67	0.84	42.2	0.89	2.8	-5.1
725	43.1	21.52	0.87	42.1	0.89	2.4	-2.6
750	42.8	21.37	0.89	41.9	0.89	2.0	-0.2
775	42.4	21.21	0.91	41.8	0.90	1.5	2.1
800	42.1	21.04	0.94	41.7	0.90	0.9	4.4
825	41.8	20.92	0.96	41.6	0.91	0.5	5.9
838	41.6	20.86	0.97	41.5	0.91	0.2	6.6
850	41.5	20.79	0.98	41.5	0.92	0.0	7.3
875	41.2	20.68	1.01	41.5	0.94	-0.7	6.7
900	40.9	20.56	1.03	41.5	0.97	-1.5	6.1
925	40.6	20.48	1.05	41.5	0.98	-2.0	7.3
950	40.3	20.39	1.08	41.4	0.99	-2.6	8.3
975	40.1	20.29	1.10	41.4	1.00	-3.2	9.5
1000	39.8	20.20	1.12	41.3	1.01	-3.7	10.7



**Figure D-3**  
**750MHz Head Tissue Equivalent Matter**

FCC ID: A3LSMG960U		SAR EVALUATION REPORT		Approved by: Quality Manager
Test Dates: 11/03/17 - 12/07/17	DUT Type: Portable Handset			APPENDIX D: Page 3 of 5

### 3 Composition / Information on ingredients

The Item is composed of the following ingredients:

Water	50 – 73 %	
Non-ionic detergents	25 – 50 %	polyoxyethylenesorbitan monolaurate
NaCl	0 – 2 %	
Preservative	0.05 – 0.1%	Preventol-D7

Safety relevant ingredients:

CAS-No. 55965-84-9	< 0.1 %	aqueous preparation, containing 5-chloro-2-methyl-3(2H)-isothiazolone and 2-methyl-3(2H)-isothiazolone
CAS-No. 9005-64-5	<50 %	polyoxyethylenesorbitan monolaurate

According to international guidelines, the product is not a dangerous mixture and therefore not required to be marked by symbols.

**Figure D-4**  
**Composition of 2.4 GHz Head Tissue Equivalent Matter**

**Note:** 2.4 GHz head liquid recipes are proprietary SPEAG. Since the composition is approximate to the actual liquids utilized, the manufacturer tissue-equivalent liquid data sheets are provided below.

#### Measurement Certificate / Material Test

Item Name	Head Tissue Simulating Liquid (HBBL1900-3800V3)		
Product No.	SL AAH 196 AB (Batch: 160330-1)		
Manufacturer	SPEAG		
<b>Measurement Method</b>			
TSL dielectric parameters measured using calibrated DAK probe.			
<b>Setup Validation</b>			
Validation results were within $\pm 2.5\%$ towards the target values of Methanol.			
<b>Target Parameters</b>			
Target parameters as defined in the IEEE 1528 and IEC 62209 compliance standards.			
<b>Test Condition</b>			
Ambient	Environment temperatur (22 $\pm$ 3) $^{\circ}$ C and humidity < 70%		
TSL Temperature	22 $^{\circ}$ C		
Test Date	30-Mar-16		
Operator	WM		

#### Additional Information

TSL Density 1.054 g/cm $^3$							
TSL Heat-capacity 3.389 kJ/(kg $\cdot$ K)							
Measured	Target		Diff to Target (%)				
f (MHz)	$\epsilon'$	$\epsilon''$	eps	sigma	$\delta$ -eps	$\delta$ -sigma	
1900	40.7	12.3	1.3	40.0	1.4	1.7	-6.9
1950	40.5	12.5	1.4	40.0	1.4	1.2	-3.3
2000	40.3	12.6	1.4	40.0	1.4	0.8	0.1
2050	40.1	12.7	1.5	39.9	1.4	0.6	0.5
2100	39.9	12.9	1.5	39.8	1.5	0.3	0.9
2150	39.8	13.0	1.6	39.7	1.5	0.1	1.2
2200	39.6	13.1	1.6	39.6	1.6	-0.2	1.7
2250	39.4	13.2	1.7	39.6	1.6	-0.3	2.0
2300	39.2	13.3	1.7	39.5	1.7	-0.6	2.4
2350	39.1	13.5	1.8	39.4	1.7	-0.8	2.9
2400	38.9	13.6	1.8	39.3	1.8	-1.0	3.4
2450	38.7	13.7	1.9	39.2	1.8	-1.2	4.0
2500	38.5	13.8	1.9	39.1	1.9	-1.5	3.9
2550	38.3	13.9	2.0	39.1	1.9	-1.9	3.5
2600	38.2	14.1	2.0	39.0	2.0	-2.2	3.9
2650	37.9	14.2	2.1	38.9	2.0	-2.6	3.8
2700	37.8	14.3	2.2	38.9	2.1	-2.8	3.9
2750	37.5	14.4	2.2	38.8	2.1	-3.3	3.6
2800	37.4	14.5	2.3	38.8	2.2	-3.6	3.6
2850	37.2	14.6	2.3	38.7	2.2	-3.9	3.7
2900	37.0	14.7	2.4	38.6	2.3	-4.1	3.8
2950	36.8	14.8	2.4	38.6	2.3	-4.5	3.7
3000	36.6	14.9	2.5	38.5	2.4	-4.8	3.6
3050	36.4	15.0	2.5	38.4	2.5	-5.2	3.8
3100	36.2	15.1	2.6	38.4	2.5	-5.6	3.8
3150	36.1	15.2	2.7	38.3	2.6	-5.9	4.0
3200	35.9	15.2	2.7	38.3	2.6	-6.2	3.9
3250	35.7	15.3	2.8	38.2	2.7	-6.6	4.1
3300	35.5	15.3	2.8	38.2	2.7	-6.9	4.0
3350	35.4	15.4	2.9	38.1	2.8	-7.2	4.2
3400	35.2	15.5	2.9	38.0	2.8	-7.5	4.1
3450	35.0	15.5	3.0	38.0	2.9	-7.8	4.2
3500	34.9	15.6	3.0	37.9	2.9	-8.1	4.2
3550	34.7	15.6	3.1	37.9	3.0	-8.4	4.2
3600	34.5	15.7	3.1	37.8	3.0	-8.7	4.4
3650	34.4	15.8	3.2	37.8	3.1	-9.0	4.3
3700	34.2	15.8	3.3	37.7	3.1	-9.3	4.5
3750	34.1	15.9	3.3	37.6	3.2	-9.5	4.4
3800	33.9	15.9	3.4	37.6	3.2	-9.8	4.7
3850	33.7	16.0	3.4	37.5	3.3	-10.1	4.7

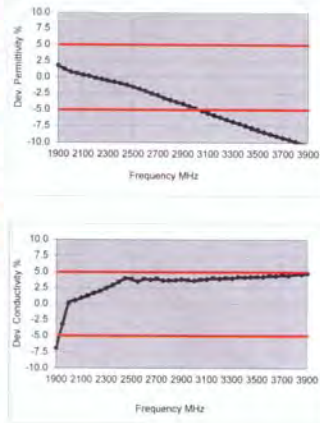

**Figure D-5**  
**2.4 GHz Head Tissue Equivalent Matter**

FCC ID: A3LSMG960U		SAR EVALUATION REPORT		Approved by: Quality Manager
Test Dates: 11/03/17 - 12/07/17	DUT Type: Portable Handset			APPENDIX D: Page 4 of 5



## 2 Composition / Information on ingredients

The Item is composed of the following ingredients:

Water	50 – 65%
Mineral oil	10 – 30%
Emulsifiers	8 – 25%
Sodium salt	0 – 1.5%

**Figure D-6**

### Composition of 5 GHz Head Tissue Equivalent Matter

**Note:** 5GHz head liquid recipes are proprietary SPEAG. Since the composition is approximate to the actual liquids utilized, the manufacturer tissue-equivalent liquid data sheets are provided below.

#### Measurement Certificate / Material Test

Item Name	Head Tissue Simulating Liquid (HBBL3500-5800V5)
Product No.	SL AAH 502 AG (Batch: 160331-2)
Manufacturer	SPEAG
<b>Measurement Method</b>	
TSL dielectric parameters measured using calibrated DAK probe.	
<b>Setup Validation</b>	
Validation results were within $\pm 2.5\%$ towards the target values of Methanol.	
<b>Target Parameters</b>	
Target parameters as defined in the IEEE 1528 and IEC 62209 compliance standards.	
<b>Test Condition</b>	
Ambient	Environment temperatur ( $22 \pm 3$ )°C and humidity < 70%
TSL Temperature	22°C
Test Date	4-Apr-16
Operator	WM
<b>Additional Information</b>	
TSL Density	0.985 g/cm <sup>3</sup>
TSL Heat-capacity	3.383 kJ/(kg*K)

f (MHz)	Measured			Target		Diff.to Target [%]	
	e'	e''	sigma	eps	sigma	Δ-eps	Δ-sigma
3400	39.0	15.12	2.86	38.0	2.81	2.5	1.8
<b>3500</b>	<b>38.8</b>	<b>15.09</b>	<b>2.94</b>	<b>37.9</b>	<b>2.91</b>	<b>2.3</b>	<b>0.9</b>
3600	38.7	15.08	3.02	37.8	3.02	2.3	0.2
<b>3700</b>	<b>38.6</b>	<b>15.08</b>	<b>3.10</b>	<b>37.7</b>	<b>3.12</b>	<b>2.4</b>	<b>-0.6</b>
3800	38.4	15.07	3.19	37.6	3.22	2.2	-0.9
3900	38.3	15.09	3.27	37.5	3.32	2.2	-1.6
4000	38.2	15.10	3.36	37.4	3.43	2.3	-1.9
4100	38.1	15.13	3.45	37.2	3.53	2.3	-2.2
4200	38.0	15.18	3.55	37.1	3.63	2.3	-2.2
4300	37.8	15.22	3.64	37.0	3.73	2.1	-2.5
4400	37.7	15.29	3.74	36.9	3.84	2.2	-2.5
4500	37.6	15.34	3.84	36.8	3.94	2.2	-2.5
4600	37.4	15.41	3.94	36.7	4.04	2.0	-2.5
4700	37.3	15.47	4.05	36.6	4.14	2.0	-2.2
4800	37.1	15.53	4.15	36.4	4.25	1.8	-2.2
4850	37.1	15.57	4.20	36.4	4.30	2.0	-2.2
4900	37.0	15.60	4.25	36.3	4.35	1.8	-2.2
4950	36.9	15.62	4.30	36.3	4.40	1.7	-2.2
5000	36.8	15.66	4.35	36.2	4.45	1.6	-2.2
5050	36.8	15.68	4.40	36.2	4.50	1.8	-2.2
5100	36.7	15.73	4.46	36.1	4.55	1.7	-2.0
5150	36.6	15.75	4.51	36.0	4.60	1.5	-2.0
<b>5200</b>	<b>36.5</b>	<b>15.78</b>	<b>4.57</b>	<b>36.0</b>	<b>4.66</b>	<b>1.4</b>	<b>-1.8</b>
5250	36.4	15.80	4.62	35.9	4.71	1.3	-1.8
5300	36.4	15.84	4.67	35.9	4.76	1.5	-1.8
5350	36.3	15.85	4.72	35.8	4.81	1.4	-1.8
5400	36.2	15.88	4.77	35.8	4.86	1.2	-1.9
5450	36.2	15.90	4.82	35.7	4.91	1.4	-1.9
<b>5500</b>	<b>36.1</b>	<b>15.91</b>	<b>4.87</b>	<b>35.6</b>	<b>4.96</b>	<b>1.3</b>	<b>-1.9</b>
5550	36.0	15.95	4.93	35.6	5.01	1.2	-1.7
5600	35.9	15.99	4.98	35.5	5.07	1.0	-1.7
5650	35.9	16.02	5.04	35.5	5.12	1.2	-1.5
5700	35.8	16.05	5.09	35.4	5.17	1.1	-1.5
5750	35.7	16.09	5.15	35.4	5.22	1.0	-1.3
<b>5800</b>	<b>35.7</b>	<b>16.10</b>	<b>5.20</b>	<b>35.3</b>	<b>5.27</b>	<b>1.1</b>	<b>-1.3</b>
5850	35.6	16.14	5.25	35.3	5.34	0.8	-1.6
5900	35.5	16.15	5.30	35.3	5.40	0.6	-1.9

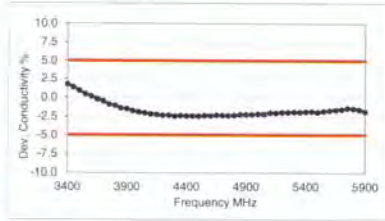
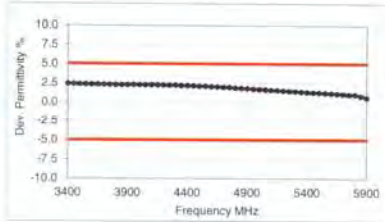

**Figure D-7**  
5GHz Head Tissue Equivalent Matter

FCC ID: A3LSMG960U		SAR EVALUATION REPORT		Approved by: Quality Manager
Test Dates: 11/03/17 - 12/07/17	DUT Type: Portable Handset			APPENDIX D: Page 5 of 5

## APPENDIX E: SAR SYSTEM VALIDATION



Per FCC KDB Publication 865664 D02v01r02, SAR system validation status should be documented to confirm measurement accuracy. The SAR systems (including SAR probes, system components and software versions) used for this device were validated against its performance specifications prior to the SAR measurements. Reference dipoles were used with the required tissue- equivalent media for system validation, according to the procedures outlined in FCC KDB Publication 865664 D01v01r04 and IEEE 1528-2013. Since SAR probe calibrations are frequency dependent, each probe calibration point was validated at a frequency within the valid frequency range of the probe calibration point, using the system that normally operates with the probe for routine SAR measurements and according to the required tissue-equivalent media.

A tabulated summary of the system validation status including the validation date(s), measurement frequencies, SAR probes and tissue dielectric parameters has been included.

**Table E-1**  
**SAR System Validation Summary**

SAR SYSTEM #	FREQ. [MHz]	DATE	PROBE SN	PROBE TYPE	PROBE CAL. POINT		COND.	PERM.	CW VALIDATION			MOD. VALIDATION		
							(σ)	(εr)	SENSITIVITY	PROBE LINEARITY	PROBE ISOTROPY	MOD. TYPE	DUTY FACTOR	PAR
G	750	8/30/2017	3332	ES3DV3	750	Head	0.911	43.081	PASS	PASS	PASS	N/A	N/A	N/A
D	750	11/17/2017	3318	ES3DV3	750	Head	0.908	42.271	PASS	PASS	PASS	N/A	N/A	N/A
K	835	5/2/2017	7406	EX3DV4	835	Head	0.896	40.478	PASS	PASS	PASS	GMSK	PASS	N/A
H	835	8/31/2017	7410	EX3DV4	835	Head	0.919	43.248	PASS	PASS	PASS	GMSK	PASS	N/A
E	1750	4/18/2017	3319	ES3DV3	1750	Head	1.373	39.389	PASS	PASS	PASS	N/A	N/A	N/A
G	1900	8/31/2017	3332	ES3DV3	1900	Head	1.457	40.398	PASS	PASS	PASS	GMSK	PASS	N/A
E	2300	4/3/2017	3319	ES3DV3	2300	Head	1.695	39.552	PASS	PASS	PASS	N/A	N/A	N/A
E	2450	4/3/2017	3319	ES3DV3	2450	Head	1.869	38.994	PASS	PASS	PASS	OFDM/TDD	PASS	PASS
E	2600	4/3/2017	3319	ES3DV3	2600	Head	2.038	38.360	PASS	PASS	PASS	TDD	PASS	N/A
H	5250	6/10/2017	3914	EX3DV4	5250	Head	4.580	35.029	PASS	PASS	PASS	OFDM	N/A	PASS
H	5600	6/10/2017	3914	EX3DV4	5600	Head	4.940	34.501	PASS	PASS	PASS	OFDM	N/A	PASS
H	5750	6/10/2017	3914	EX3DV4	5750	Head	5.103	34.300	PASS	PASS	PASS	OFDM	N/A	PASS
D	750	11/6/2017	3318	ES3DV3	750	Body	0.961	54.445	PASS	PASS	PASS	N/A	N/A	N/A
K	835	5/2/2017	7406	EX3DV4	835	Body	0.966	53.380	PASS	PASS	PASS	GMSK	PASS	N/A
J	835	6/19/2017	3209	ES3DV3	835	Body	1.004	53.490	PASS	PASS	PASS	GMSK	PASS	N/A
J	1750	6/5/2017	3209	ES3DV3	1750	Body	1.474	51.981	PASS	PASS	PASS	N/A	N/A	N/A
H	1900	9/5/2017	7410	EX3DV4	1900	Body	1.580	52.546	PASS	PASS	PASS	GMSK	PASS	N/A
J	1900	6/15/2017	3209	ES3DV3	1900	Body	1.552	52.203	PASS	PASS	PASS	GMSK	PASS	N/A
I	2300	5/10/2017	3213	ES3DV3	2300	Body	1.792	52.487	PASS	PASS	PASS	N/A	N/A	N/A
I	2450	5/10/2017	3213	ES3DV3	2450	Body	2.003	51.944	PASS	PASS	PASS	OFDM/TDD	PASS	PASS
I	2600	5/10/2017	3213	ES3DV3	2600	Body	2.207	51.200	PASS	PASS	PASS	TDD	PASS	N/A
D	5250	10/24/2017	7308	EX3DV4	5250	Body	5.405	48.529	PASS	PASS	PASS	OFDM	N/A	PASS
D	5600	10/24/2017	7308	EX3DV4	5600	Body	5.910	47.818	PASS	PASS	PASS	OFDM	N/A	PASS
D	5750	10/24/2017	7308	EX3DV4	5750	Body	6.135	47.546	PASS	PASS	PASS	OFDM	N/A	PASS

NOTE: While the probes have been calibrated for both CW and modulated signals, all measurements were performed using communication systems calibrated for CW signals only. Modulations in the table above represent test configurations for which the measurement system has been validated per FCC KDB Publication 865664 D01v01r04 for scenarios when CW probe calibrations are used with other signal types. SAR systems were validated for modulated signals with a periodic duty cycle, such as GMSK, or with a high peak to average ratio (>5 dB), such as OFDM according to FCC KDB Publication 865664 D01v01r04.

<b>FCC ID:</b> A3LSMG960U		<b>SAR EVALUATION REPORT</b>		<b>Approved by:</b> Quality Manager
<b>Test Dates:</b> 11/03/17 - 12/07/17	<b>DUT Type:</b> Portable Handset	APPENDIX E: Page 1 of 1		

## APPENDIX G: POWER REDUCTION VERIFICATION

Per the May 2017 TCBC Workshop Notes, demonstration of proper functioning of the power reduction mechanisms is required to support the corresponding SAR configurations. The verification process was divided into two parts: (1) evaluation of output power levels for individual or multiple triggering mechanisms and (2) evaluation of the triggering distances for proximity-based sensors.

### 1.1 Power Verification Procedure



The power verification was performed according to the following procedure:

1. A base station simulator was used to establish a conducted RF connection and the output power was monitored. The power measurements were confirmed to be within expected tolerances for all states before and after a power reduction mechanism was triggered.
2. Step 1 was repeated for all relevant modes and frequency bands for the mechanism being investigated.
3. Steps 1 and 2 were repeated for all individual power reduction mechanisms and combinations thereof. For the combination cases, one mechanism was switched to a 'triggered' state at a time; powers were confirmed to be within tolerances after each additional mechanism was activated.

### 1.2 Distance Verification Procedure

The distance verification procedure was performed according to the following procedure:



1. A base station simulator was used to establish an RF connection and to monitor the power levels. The device being tested was placed below the relevant section of the phantom with the relevant side or edge of the device facing toward the phantom.
2. The device was moved toward and away from the phantom to determine the distance at which the mechanism triggers and the output power is reduced, per KDB Publication 616217 D04v01r02 and FCC Guidance. Each applicable test position was evaluated. The distances were confirmed to be the same or larger (more conservative) than the minimum distances provided by the manufacturer.
3. Steps 1 and 2 were repeated for all relevant frequency bands.
4. Steps 1 through 3 were repeated for all distance-based power reduction mechanisms.

FCC ID: A3LSMG960U	 <b>PCTEST</b> ENGINEERING LABORATORY, INC.	SAR EVALUATION REPORT		Reviewed by: Quality Manager
Test Dates: 11/03/17 – 12/07/17	DUT Type: Portable Handset			APPENDIX G: Page 1 of 3

### 1.3 Main Antenna Verification Summary

**Table G-1  
Power Measurement Verification for Main Antenna**

Mechanism(s)	Mode/Band	Conducted Power (dBm)	
		Un-triggered (Max)	Mechanism #1 (Reduced)
Hotspot On	GSM1900	29.59	27.07
Hotspot On	UMTS B4	24.63	20.48
Hotspot On	UMTS B2	24.52	20.45
Hotspot On	CDMA BC1	24.22	20.11
Hotspot On	LTE FDD B4	23.90	20.48
Hotspot On	LTE FDD B66	24.98	20.32
Hotspot On	LTE FDD B2	24.29	19.80
Hotspot On	LTE FDD B25	24.22	20.13
Hotspot On	LTE FDD B30 Ant B	24.24	21.23
Hotspot On	LTE FDD B30 Ant A	24.09	21.07
Hotspot On	LTE FDD B7 Ant B	23.61	21.13
Hotspot On	LTE FDD B7 Ant A	22.97	20.44
Hotspot On	LTE TDD B41 PC3	24.23	23.19
Hotspot On	LTE TDD B41 PC2	26.63	22.89

FCC ID: A3LSMG960U	 <b>PCTEST</b> ENGINEERING LABORATORY, INC.	<b>SAR EVALUATION REPORT</b>		<b>Reviewed by:</b> Quality Manager
<b>Test Dates:</b> 11/03/17 – 12/07/17	<b>DUT Type:</b> Portable Handset		<b>APPENDIX G:</b> Page 2 of 3	

## 1.4 WIFI Verification Summary



**Table G-2**  
**Power Measurement Verification WIFI**

Mechanism(s)	Mode/Band	Conducted Power (dBm)	
		Un-triggered (Max)	Mechanism #1 (Reduced)
Held-to-Ear	802.11b	19.85	15.39
Held-to-Ear	802.11g	17.26	15.23
Held-to-Ear	802.11n (2.4GHz)	16.82	15.04
Held-to-Ear	802.11a	17.52	13.2
Held-to-Ear	802.11n (5GHz, 20MHz BW)	16.52	12.07
Held-to-Ear	802.11ac (20MHz BW)	16.54	13.47
Held-to-Ear	802.11n (5GHz, 40MHz BW)	17.33	13.43
Held-to-Ear	802.11ac (40MHz BW)	16.10	13.49

**Note: 802.11 ac was not measured due to equipment limitation.**

**Table G-3**  
**Distance Measurement Verification for WIFI**

Mechanism(s)	Test Condition	Mode/Band	Distance Measurements (mm)		Minimum Distance from Manufacturer (mm)
			Moving Toward	Moving Away	
Held-to-Ear	Head - Right Cheek	2.4 GHz	75	>95	60
Held-to-Ear	Head - Right Cheek	5 GHz	75	>95	60
Held-to-Ear	Head - Left Cheek	2.4 GHz	71	>95	60
Held-to-Ear	Head - Left Cheek	5 GHz	71	>95	60

FCC ID: A3LSMG960U	 <b>PCTEST</b> ENGINEERING LABORATORY, INC.	<b>SAR EVALUATION REPORT</b>		<b>Reviewed by:</b> Quality Manager
<b>Test Dates:</b> 11/03/17 – 12/07/17	<b>DUT Type:</b> Portable Handset		APPENDIX G: Page 3 of 3	

# APPENDIX H: DOWNLINK LTE CA TEST EXCLUSION

SAR test exclusion for LTE downlink Carrier Aggregation is determined by power measurements according to the number of component carriers (CCs) supported by the product implementation. Per FCC Guidance, the following test reduction methodology was applied to determine the combinations required for conducted power measurements.

## LTE DLCA Test Reduction Methodology:

- The supported combinations were arranged by the number of component carriers in columns.
- Any limitations on the PCC or SCC for each combination were identified alongside the combination (e.g. CA\_2A-2A-4A-12A, but B12 can only be configured as a SCC).
- Power measurements were performed for "supersets" (LTE CA combinations with multiple components carriers) and any "subsets" (LTE CA combinations with fewer component carriers) that were not completely covered by the supersets.
- Only subsets that have the exact same components as a superset were excluded for measurement.
- When there were certain restrictions on component carriers that existed in the superset that were not applied for the subset, the subset configuration was additionally evaluated.
- Both inter-band and intra-band downlink carrier aggregation scenarios were considered.
- Downlink CA combinations for SISO and 4x4 Downlink MIMO operations were measured independently, per May 2017 TCBC Workshop notes.

Table 1 – Example of Exclusion Table for SISO Configurations

Index	2CC	Restriction	Completely Covered by Measurement Superset	Index	3CC	Restriction	Completely Covered by Measurement Superset	Index	4CC	Restriction	Completely Covered by Measurement Superset	Index	5CC	Restriction	Completely Covered by Measurement Superset
RCC #1	CA 2C		SCC #4	RCC #1	CA 2A-2A-4A		ACC #1	RCC #1	CA 2A-2A-4A-5A		No	RCC #1	CA 2A-5B-66A-66A		No
RCC #2	CA 2A-5A		SCC #1	RCC #2	CA 2A-5A-5A		ACC #1	RCC #2	CA 2A-5A-12A	B12 SCC Only	No	RCC #2	CA 2A-5B-66A-66A		No
RCC #3	CA 2A-12A (1)		SCC #3	RCC #3	CA 2A-2A-12A		No	RCC #3	CA 2A-2A-5A-30A		No	RCC #3	CA 2A-5B-66A-66A		No
RCC #4	CA 2A-13A		SCC #9	RCC #4	CA 2C-66A		No	RCC #4	CA 2A-2A-66A		No	RCC #4	CA 2A-5B-66A-66A		No
RCC #5	CA 2A-13A		No	RCC #5	CA 2A-2A-71A		No	RCC #5	CA 2A-5B-30A		SCC #1	RCC #5	CA 2A-5B-66A-66A		No
RCC #6	CA 2A-30A		SCC #14	RCC #6	CA 2A-4A-4A		No	RCC #6	CA 2A-5B-66A		SCC #9	RCC #6	CA 2A-5B-66A-66A		No
RCC #7	CA 2A-66A		SCC #1	RCC #7	CA 2A-4A-5A		ACC #1	RCC #7	CA 5B-30A-66A		SCC #1	RCC #7	CA 5B-30A-66A-66A		No
RCC #8	CA 2A-71A		SCC #10	RCC #8	CA 2A-4A-11A		No	RCC #8	CA 5B-66A-66A		SCC #9	RCC #8	CA 5A-30A-66A-66A		No
RCC #9	CA 4A-4A		SCC #6	RCC #9	CA 2A-4A-11A		No	RCC #9	CA 5A-30A-66A-66A		No	RCC #9	CA 5A-30A-66A-66A		No
RCC #10	CA 4A-5A (1)		ACC #1	RCC #10	CA 2A-4A-71A		No	RCC #10	CA 41E		No	RCC #10	CA 41E		No
RCC #11	CA 4A-12A (1)		SCC #8	RCC #11	CA 2A-5B		ACC #1								
RCC #12	CA 4A-13A		SCC #9	RCC #12	CA 2A-7A-12A		No								
RCC #13	CA 4A-17A	B17 SCC Only	No	RCC #13	CA 2A-12B		No								
RCC #14	CA 5B		SCC #3	RCC #14	CA 2A-12B-30A		No								
RCC #15	CA 5A-25A		No	RCC #15	CA 4A-4A-5A		No								
RCC #16	CA 7C		No	RCC #16	CA 5B-30A		SCC #1								
RCC #17	CA 7A-7A (1)		No	RCC #17	CA 5B-66A		SCC #2								
RCC #18	CA 7A-12A		SCC #12	RCC #18	CA 5B-30A-66A		ACC #9								
RCC #19	CA 13B		SCC #13	RCC #19	CA 13A-66C		No								
RCC #20	CA 13B-25A		No	RCC #20	CA 30A-66A-66A		ACC #9								
RCC #21	CA 13B-30A		SCC #14	RCC #21	CA 41E		No								
RCC #22	CA 41A-41A (1)		No	RCC #22	CA 41A-41C		No								
RCC #23			No	RCC #23	CA 66D		No								
RCC #24			No	RCC #24	CA 66A-66C		No								

Table 2 – Example of Exclusion Table for 4x4 Downlink MIMO Configurations

Index	2CC	Restriction	Completely Covered by Measurement Superset	Index	3CC	Restriction	Completely Covered by Measurement Superset	Index	4CC	Restriction	Completely Covered by Measurement Superset
RCC #M1	CA [2C]		SCC #M8	RCC #M1	CA [2A]-2A-4A		No	RCC #M1	CA [2A]-5B-66A		No
RCC #M2	CA [2A]-2A		SCC #M1	RCC #M2	CA [2A]-2A-5A		No	RCC #M2	CA [2A]-5B-166A		No
RCC #M3	CA [2A]-2A (1)		No	RCC #M3	CA [2A]-2A-12A		No	RCC #M3	CA [2A]-5B-66B		No
RCC #M4	CA [2A]-4A (2)		SCC #M1	RCC #M4	CA [2A]-2A-13A		No	RCC #M4	CA [2A]-5A-166B		No
RCC #M5	CA [2A]-4A (1) (2)		No	RCC #M5	CA [2A]-2A-30A		No	RCC #M5	CA [2A]-5A-66C		No
RCC #M6	CA [2A]-5A		ACC #M3	RCC #M6	CA [2C]-66A		No	RCC #M6	CA [2A]-5A-166C		No
RCC #M7	CA [2A]-12A (1)		SCC #M3	RCC #M7	CA [2C]-66C		No				
RCC #M8	CA [2A]-13A		SCC #M4	RCC #M8	CA [2C]-166A		No				
RCC #M9	CA [2A]-17A		No	RCC #M9	CA [2A]-2A-66A		No				
RCC #M10	CA [2A]-25A (2)	B29 SCC Only	SCC #M12	RCC #M10	CA [2A]-2A-166A		No				
RCC #M11	CA [2A]-30A		SCC #M5	RCC #M11	CA [2A]-2A-71A		No				
RCC #M12	CA [2A]-66A		ACC #M1	RCC #M12	CA [2A]-4A-25A	B29 SCC Only	No				
RCC #M13	CA [2A]-66A (1)		ACC #M2	RCC #M13	CA [2A]-4A-71A		No				
RCC #M14	CA [2A]-66A (2)		No	RCC #M14	CA [2A]-5B		ACC #M1				
RCC #M15	CA [2A]-71A		SCC #M11	RCC #M15	CA [2A]-5A-66A		No				
RCC #M16	CA 3A-166A		SCC #M16	RCC #M16	CA [2A]-5A-166A		No				
RCC #M17	CA 12A-166A (1)		SCC #M17	RCC #M17	CA [2A]-12A-166A		No				
RCC #M18	CA 13A-166A		SCC #M19	RCC #M18	CA [2A]-13A-66A		No				
RCC #M19	CA 30A-166A		SCC #M20	RCC #M19	CA [2A]-13A-166A		No				
RCC #M20	CA [66B]		ACC #M4	RCC #M20	CA [2A]-30A-166A		No				
RCC #M21	CA [66C]		ACC #M6	RCC #M21	CA [2A]-66B		ACC #M3				
RCC #M22	CA [66A]-66A		SCC #M28	RCC #M22	CA [2A]-66B		ACC #M4				
RCC #M23	CA [66A]-166A		No	RCC #M23	CA [2A]-166B		No				
				RCC #M24	CA [2A]-66C		ACC #M5				
				RCC #M25	CA [2A]-166C		ACC #M6				
				RCC #M26	CA [2A]-166C		No				
				RCC #M27	CA [2A]-66A-66A		No				
				RCC #M28	CA [2A]-166A-66A		No				
				RCC #M29	CA [2A]-66A-71A		No				

Note: [CC] indicates component carrier with 4x4 DL MIMO antenna configuration

FCC ID: A3LSMG960U	 PCTEST PROBATION LABORATORY, INC.	SAR EVALUATION REPORT	Reviewed by: Quality Manager
Test Dates: 11/03/17 – 12/07/17	DUT Type: Portable Handset		APPENDIX H Page 1 of 1

# APPENDIX I: CONDUCTED POWERS FOR 4X4 DL MIMO

This device supports downlink 4x4 MIMO operations for LTE Bands 2, 4, 25, 7, 30, 41 and 66 only. Uplink transmission is limited to a single output stream. Power measurements were performed with downlink 4x4 MIMO active for the configuration with highest measured maximum conducted power with 4x4 downlink MIMO inactive measured among the channel bandwidth, modulation, and RB combinations in each frequency band.

Per May 2017 TCB Workshop Notes, SAR for downlink 4x4 MIMO was not needed since the maximum average output power in 4x4 downlink MIMO mode was not > 0.25 dB higher than the maximum output power with downlink 4x4 MIMO inactive. When carrier aggregation is applicable, power measurements were performed with the downlink carrier aggregation and 4x4 DL MIMO active for the configuration with highest measured maximum conducted power with downlink carrier aggregation inactive measured among the channel bandwidth, modulation, and RB combinations in each frequency band.

Note: Per FCC guidance LTE B12 SISO powers were used to select measurement configurations for LTE Band 17, LTE Band 66 SISO powers were used to select measurement configurations for LTE Band 4, and LTE B25 SISO powers were used to select measurement configurations for LTE Band 2.

## I.1 Single Carrier 4x4 Downlink MIMO

**Table I-1  
Additional Maximum Output Powers**



LTE Band	Bandwidth [MHz]	Channel	Frequency [MHz]	Modulation	RB Size	RB Offset	4x4 DL MIMO Tx. Power [dBm]	Single Antenna Tx. Power [dBm]
4	15	20325	1747.5	QPSK	1	0	24.40	24.38
66	15	132597	1772.5	QPSK	1	0	24.36	24.38
2	20	18700	1860	QPSK	1	0	24.28	24.29
25	20	26140	1860	QPSK	1	0	24.25	24.29
7 AntB	15	21375	2562.5	QPSK	1	0	23.71	23.65
30 AntB	10	27710	2310	QPSK	1	0	24.48	24.50
41	15	40185	2549.5	QPSK	1	0	24.00	24.08
41 PC2	15	40185	2549.5	QPSK	1	0	27.10	27.06

**Table I-2  
Additional Hotspot Reduced Output Powers**

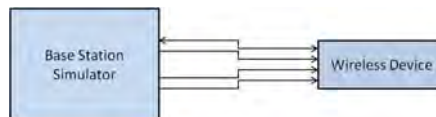
LTE Band	Bandwidth [MHz]	Channel	Frequency [MHz]	Modulation	RB Size	RB Offset	4x4 DL MIMO Tx. Power [dBm]	Single Antenna Tx. Power [dBm]
4	20	20300	1745	16QAM	1	0	20.49	20.50
66	20	132322	1745	16QAM	1	0	20.50	20.50
2	20	18700	1860	16QAM	1	0	20.48	20.50
25	20	26140	1860	16QAM	1	0	20.50	20.50
7 Ant B	20	21350	2560	64QAM	1	0	21.00	21.03
30 Ant B	10	27710	2310	64QAM	1	0	21.32	21.26
41	20	40185	2549.5	QPSK	1	0	23.50	23.50
41 PC2	20	39750	2506	16QAM	1	0	23.49	23.50



**Figure I-1  
Power Measurement Setup**

FCC ID: A3LSMG960U	 PCTEST ENGINEERING LABORATORY, INC.	SAR EVALUATION REPORT		Approved by: Quality Manager
Test Dates: 11/03/17 – 12/07/17	DUT Type: Portable Handset		APPENDIX I: Page 1 of 19	

## 1.2 Carrier Aggregation Scenarios with 2 Component Carriers with 4x4 Downlink MIMO

### 1.2.1 LTE Band 17

Table I-3  
Additional Maximum Output Powers – 2 Component Carriers

Combination	PCC										SCC				Power		
	PCC Band	PCC Bandwidth [MHz]	PCC (UL) Channel	PCC (UL) Frequency [MHz]	Modulation	PCC UL RB	PCC UL RB Offset	PCC (DL) Channel	PCC (DL) Frequency [MHz]	DL Ant. Config.	SCC Band	SCC Bandwidth [MHz]	SCC (DL) Channel	SCC (DL) Frequency [MHz]	DL Ant. Config.	LTE Tx Power with DL CA Enabled (dBm)	LTE Single Carrier Tx Power (dBm)
CA_2A-17A	LTE B17	5	23755	706.5	QPSK	1	0	5755	736.5	2x2 MIMO	LTE B2	10	900	1960	4x4 MIMO	24.62	24.67

### 1.2.2 LTE Band 26

Table I-4  
Additional Maximum Output Powers – 2 Component Carriers

Combination	PCC										SCC				Power		
	PCC Band	PCC Bandwidth [MHz]	PCC (UL) Channel	PCC (UL) Frequency [MHz]	Modulation	PCC UL RB	PCC UL RB Offset	PCC (DL) Channel	PCC (DL) Frequency [MHz]	DL Ant. Config.	SCC Band	SCC Bandwidth [MHz]	SCC (DL) Channel	SCC (DL) Frequency [MHz]	DL Ant. Config.	LTE Tx Power with DL CA Enabled (dBm)	LTE Single Carrier Tx Power (dBm)
CA_26A-41A	LTE B26	5	27015	846.5	QPSK	1	12	9015	891.5	2x2 MIMO	LTE B41	20	40620	2593	4x4 MIMO	24.29	24.54

### 1.2.3 LTE Band 66

Table I-5  
Additional Maximum Output Powers – 2 Component Carriers

Combination	PCC										SCC				Power		
	PCC Band	PCC Bandwidth [MHz]	PCC (UL) Channel	PCC (UL) Frequency [MHz]	Modulation	PCC UL RB	PCC UL RB Offset	PCC (DL) Channel	PCC (DL) Frequency [MHz]	DL Ant. Config.	SCC Band	SCC Bandwidth [MHz]	SCC (DL) Channel	SCC (DL) Frequency [MHz]	DL Ant. Config.	LTE Tx Power with DL CA Enabled (dBm)	LTE Single Carrier Tx Power (dBm)
CA_2A-66A	LTE B66	15	132597	1772.5	QPSK	1	0	67061	2172.5	4x4 MIMO	LTE B2	20	900	1960	4x4 MIMO	24.40	24.38
CA_66A-66A	LTE B66	15	132597	1772.5	QPSK	1	0	67061	2172.5	4x4 MIMO	LTE B66	20	66536	2120	4x4 MIMO	24.36	24.38

Table I-6  
Additional Hotspot Reduced Output Powers – 2 Component Carriers

Combination	PCC										SCC				Power		
	PCC Band	PCC Bandwidth [MHz]	PCC (UL) Channel	PCC (UL) Frequency [MHz]	Modulation	PCC UL RB	PCC UL RB Offset	PCC (DL) Channel	PCC (DL) Frequency [MHz]	DL Ant. Config.	SCC Band	SCC Bandwidth [MHz]	SCC (DL) Channel	SCC (DL) Frequency [MHz]	DL Ant. Config.	LTE Tx Power with DL CA Enabled (dBm)	LTE Single Carrier Tx Power (dBm)
CA_2A-66A	LTE B66	20	132322	1745	16QAM	1	0	66796	2145	4x4 MIMO	LTE B2	20	900	1960	4x4 MIMO	20.48	20.50
CA_66A-66A	LTE B66	20	132322	1745	16QAM	1	0	66796	2145	4x4 MIMO	LTE B66	20	67236	2190	4x4 MIMO	20.50	20.50



### 1.2.4 LTE Band 4

Table I-7  
Additional Maximum Output Powers – 2 Component Carriers

Combination	PCC										SCC				Power		
	PCC Band	PCC Bandwidth [MHz]	PCC (UL) Channel	PCC (UL) Frequency [MHz]	Modulation	PCC UL RB	PCC UL RB Offset	PCC (DL) Channel	PCC (DL) Frequency [MHz]	DL Ant. Config.	SCC Band	SCC Bandwidth [MHz]	SCC (DL) Channel	SCC (DL) Frequency [MHz]	DL Ant. Config.	LTE Tx Power with DL CA Enabled (dBm)	LTE Single Carrier Tx Power (dBm)
CA_2A-4A (2)	LTE B4	15	20325	1747.5	QPSK	1	0	2325	2147.5	4x4 MIMO	LTE B2	20	900	1960	4x4 MIMO	24.44	24.38
CA_4A-4A	LTE B4	15	20325	1747.5	QPSK	1	0	2325	2147.5	4x4 MIMO	LTE B4	20	2050	2120	4x4 MIMO	24.42	24.38
CA_4A-17A	LTE B4	10	20300	1745	QPSK	1	0	2300	2145	4x4 MIMO	LTE B17	10	5790	740	2x2 MIMO	24.36	24.37

Table I-8  
Additional Hotspot Reduced Output Powers – 2 Component Carriers

Combination	PCC										SCC				Power		
	PCC Band	PCC Bandwidth [MHz]	PCC (UL) Channel	PCC (UL) Frequency [MHz]	Modulation	PCC UL RB	PCC UL RB Offset	PCC (DL) Channel	PCC (DL) Frequency [MHz]	DL Ant. Config.	SCC Band	SCC Bandwidth [MHz]	SCC (DL) Channel	SCC (DL) Frequency [MHz]	DL Ant. Config.	LTE Tx Power with DL CA Enabled (dBm)	LTE Single Carrier Tx Power (dBm)
CA_2A-4A (2)	LTE B4	20	20300	1745	16QAM	1	0	2300	2145	4x4 MIMO	LTE B2	20	900	1960	4x4 MIMO	20.42	20.50
CA_4A-4A	LTE B4	20	20300	1745	16QAM	1	0	2300	2145	4x4 MIMO	LTE B4	20	2050	2120	4x4 MIMO	20.44	20.50
CA_4A-17A	LTE B4	10	20000	1745	64QAM	1	25	2000	2115	4x4 MIMO	LTE B17	10	5790	740	2x2 MIMO	20.38	20.42

FCC ID: A3LSMG960U	 PCTEST ENGINEERING LABORATORY, INC.	SAR EVALUATION REPORT		Approved by: Quality Manager
Test Dates: 11/03/17 – 12/07/17	DUT Type: Portable Handset		APPENDIX I: Page 2 of 19	



## 1.2.5 LTE Band 25

Table I-9  
Additional Maximum Output Powers – 2 Component Carriers

Combination	PCC										SCC				Power		
	PCC Band	PCC Bandwidth [MHz]	PCC (UL) Channel	PCC (UL) Frequency [MHz]	Modulation	PCC UL# RB	PCC UL RB Offset	PCC (DL) Channel	PCC (DL) Frequency [MHz]	DL Ant. Config.	SCC Band	SCC Bandwidth [MHz]	SCC (DL) Channel	SCC (DL) Frequency [MHz]	DL Ant. Config.	LTE Tx Power with DL CA Enabled (dBm)	LTE Single Carrier Tx Power (dBm)
CA_25A-25A (1)	LTE B25	20	26140	1860	QPSK	1	0	8140	1940	4x4 MIMO	LTE B25	20	8590	1985	4x4 MIMO	24.33	24.29
CA_25A-41A	LTE B25	20	26140	1860	QPSK	1	0	8140	1940	4x4 MIMO	LTE B41	20	40620	2593	2x2 MIMO	23.72	24.29
CA_25A-41A	LTE B25	20	26140	1860	QPSK	1	0	8140	1940	2x2 MIMO	LTE B41	20	40620	2593	4x4 MIMO	23.69	24.29

Table I-10  
Additional Hotspot Reduced Output Powers – 2 Component Carriers

Combination	PCC										SCC				Power		
	PCC Band	PCC Bandwidth [MHz]	PCC (UL) Channel	PCC (UL) Frequency [MHz]	Modulation	PCC UL# RB	PCC UL RB Offset	PCC (DL) Channel	PCC (DL) Frequency [MHz]	DL Ant. Config.	SCC Band	SCC Bandwidth [MHz]	SCC (DL) Channel	SCC (DL) Frequency [MHz]	DL Ant. Config.	LTE Tx Power with DL CA Enabled (dBm)	LTE Single Carrier Tx Power (dBm)
CA_25A-25A (1)	LTE B25	20	26140	1860	16QAM	1	0	8140	1940	4x4 MIMO	LTE B25	20	8590	1985	4x4 MIMO	20.45	20.50
CA_25A-41A	LTE B25	20	26140	1860	16QAM	1	0	8140	1940	4x4 MIMO	LTE B41	20	40620	2593	2x2 MIMO	19.96	20.50
CA_25A-41A	LTE B25	20	26140	1860	16QAM	1	0	8140	1940	2x2 MIMO	LTE B41	20	40620	2593	4x4 MIMO	20.06	20.50

## 1.2.6 LTE Band 2

Table I-11  
Additional Maximum Output Powers – 2 Component Carriers

Combination	PCC										SCC				Power		
	PCC Band	PCC Bandwidth [MHz]	PCC (UL) Channel	PCC (UL) Frequency [MHz]	Modulation	PCC UL# RB	PCC UL RB Offset	PCC (DL) Channel	PCC (DL) Frequency [MHz]	DL Ant. Config.	SCC Band	SCC Bandwidth [MHz]	SCC (DL) Channel	SCC (DL) Frequency [MHz]	DL Ant. Config.	LTE Tx Power with DL CA Enabled (dBm)	LTE Single Carrier Tx Power (dBm)
CA_2A-2A	LTE B2	20	18700	1860	QPSK	1	0	700	1940	4x4 MIMO	LTE B2	20	1100	1980	4x4 MIMO	24.29	24.29
CA_2A-4A (2)	LTE B2	20	18700	1860	QPSK	1	0	700	1940	4x4 MIMO	LTE B4	20	2175	2132.5	4x4 MIMO	24.32	24.29
CA_2A-17A	LTE B2	10	18650	1855	QPSK	1	0	650	1935	4x4 MIMO	LTE B17	10	5790	740	2x2 MIMO	24.02	24.14
CA_2A-30A	LTE B2	20	18700	1860	QPSK	1	0	700	1940	4x4 MIMO	LTE B30	10	9820	2355	4x4 MIMO	24.15	24.29
CA_2A-66A	LTE B2	20	18700	1860	QPSK	1	0	700	1940	4x4 MIMO	LTE B66	20	66786	2145	4x4 MIMO	24.28	24.29

Table I-12  
Additional Hotspot Reduced Output Powers – 2 Component Carriers

Combination	PCC										SCC				Power		
	PCC Band	PCC Bandwidth [MHz]	PCC (UL) Channel	PCC (UL) Frequency [MHz]	Modulation	PCC UL# RB	PCC UL RB Offset	PCC (DL) Channel	PCC (DL) Frequency [MHz]	DL Ant. Config.	SCC Band	SCC Bandwidth [MHz]	SCC (DL) Channel	SCC (DL) Frequency [MHz]	DL Ant. Config.	LTE Tx Power with DL CA Enabled (dBm)	LTE Single Carrier Tx Power (dBm)
CA_2A-2A	LTE B2	20	18700	1860	16QAM	1	0	700	1940	4x4 MIMO	LTE B2	20	1100	1980	4x4 MIMO	20.48	20.50
CA_2A-4A (2)	LTE B2	20	18700	1860	16QAM	1	0	700	1940	4x4 MIMO	LTE B4	20	2175	2132.5	4x4 MIMO	20.49	20.50
CA_2A-17A	LTE B2	10	18625	1852.5	16QAM	1	0	625	1922.5	4x4 MIMO	LTE B17	10	5790	740	2x2 MIMO	20.30	20.48
CA_2A-30A	LTE B2	20	18700	1860	16QAM	1	0	700	1940	4x4 MIMO	LTE B30	10	9820	2355	4x4 MIMO	20.32	20.50
CA_2A-66A	LTE B2	20	18700	1860	16QAM	1	0	700	1940	4x4 MIMO	LTE B66	20	66786	2145	4x4 MIMO	20.50	20.50



## 1.2.7 LTE Band 30 Antenna A

Table I-13  
Additional Maximum Output Powers – 2 Component Carriers

Combination	PCC										SCC				Power		
	PCC Band	PCC Bandwidth [MHz]	PCC (UL) Channel	PCC (UL) Frequency [MHz]	Modulation	PCC UL# RB	PCC UL RB Offset	PCC (DL) Channel	PCC (DL) Frequency [MHz]	DL Ant. Config.	SCC Band	SCC Bandwidth [MHz]	SCC (DL) Channel	SCC (DL) Frequency [MHz]	DL Ant. Config.	LTE Tx Power with DL CA Enabled (dBm)	LTE Ant. A Tx Power (dBm)
CA_2A-30A	LTE B30 AntA	10	27710	2310	QPSK	1	0	9820	2355	4x4 MIMO	LTE B2	20	900	1960	4x4 MIMO	24.38	24.41

Table I-14  
Additional Hotspot Reduced Output Powers – 2 Component Carriers

Combination	PCC										SCC				Power		
	PCC Band	PCC Bandwidth [MHz]	PCC (UL) Channel	PCC (UL) Frequency [MHz]	Modulation	PCC UL# RB	PCC UL RB Offset	PCC (DL) Channel	PCC (DL) Frequency [MHz]	DL Ant. Config.	SCC Band	SCC Bandwidth [MHz]	SCC (DL) Channel	SCC (DL) Frequency [MHz]	DL Ant. Config.	LTE Tx Power with DL CA Enabled (dBm)	LTE Ant. A Tx Power (dBm)
CA_2A-30A	LTE B30 AntA	10	27710	2310	16QAM	1	0	9820	2355	4x4 MIMO	LTE B2	20	900	1960	4x4 MIMO	21.10	21.39

FCC ID: A3LSMG960U	 PCTEST Engineering Laboratory, Inc.	SAR EVALUATION REPORT		Approved by: Quality Manager
Test Dates: 11/03/17 – 12/07/17	DUT Type: Portable Handset		APPENDIX I: Page 3 of 19	

## 1.2.8 LTE Band 7 Antenna B

Table I-15  
Additional Maximum Output Powers – 2 Component Carriers

Combination	PCC										SCC				Power		
	PCC Band	PCC Bandwidth [MHz]	PCC (UL) Channel	PCC (UL) Frequency [MHz]	Modulation	PCC UL# RB	PCC UL RB Offset	PCC (DL) Channel	PCC (DL) Frequency [MHz]	DL Ant. Config.	SCC Band	SCC Bandwidth [MHz]	SCC (DL) Channel	SCC (DL) Frequency [MHz]	DL Ant. Config.	LTE Tx Power with DL CA Enabled (dBm)	LTE Single Carrier Tx Power (dBm)
CA_7C	LTE B7	15	21375	2562.5	QPSK	1	0	3375	2682.5	4x4 MIMO	LTE B7	20	3204	2665.4	4x4 MIMO	23.54	23.65
CA_7A-7A (1)	LTE B7	15	21375	2562.5	QPSK	1	0	3375	2682.5	4x4 MIMO	LTE B7	20	2850	2630	2x2 MIMO	23.61	23.65
CA_7A-7A (1)	LTE B7	15	21375	2562.5	QPSK	1	0	3375	2682.5	2x2 MIMO	LTE B7	20	2850	2630	4x4 MIMO	23.68	23.65
CA_7A-7A (1)	LTE B7	15	21375	2562.5	QPSK	1	0	3375	2682.5	4x4 MIMO	LTE B7	20	2850	2630	4x4 MIMO	23.66	23.65

Table I-16  
Additional Hotspot Reduced Output Powers – 2 Component Carriers

Combination	PCC										SCC				Power		
	PCC Band	PCC Bandwidth [MHz]	PCC (UL) Channel	PCC (UL) Frequency [MHz]	Modulation	PCC UL# RB	PCC UL RB Offset	PCC (DL) Channel	PCC (DL) Frequency [MHz]	DL Ant. Config.	SCC Band	SCC Bandwidth [MHz]	SCC (DL) Channel	SCC (DL) Frequency [MHz]	DL Ant. Config.	LTE Tx Power with DL CA Enabled (dBm)	LTE Single Carrier Tx Power (dBm)
CA_7C	LTE B7	20	21350	2560	64QAM	1	0	3350	2680	4x4 MIMO	LTE B7	20	3152	2660.2	4x4 MIMO	20.87	21.03
CA_7A-7A (1)	LTE B7	20	21350	2560	64QAM	1	0	3350	2680	4x4 MIMO	LTE B7	20	2850	2630	2x2 MIMO	21.00	21.03
CA_7A-7A (1)	LTE B7	20	21350	2560	64QAM	1	0	3350	2680	2x2 MIMO	LTE B7	20	2850	2630	4x4 MIMO	20.91	21.03
CA_7A-7A (1)	LTE B7	20	21350	2560	64QAM	1	0	3350	2680	4x4 MIMO	LTE B7	20	2850	2630	4x4 MIMO	20.93	21.03

## 1.2.9 LTE Band 41 PC3

Table I-17  
Additional Maximum Output Powers – 2 Component Carriers

Combination	PCC										SCC				Power		
	PCC Band	PCC Bandwidth [MHz]	PCC (UL) Channel	PCC (UL) Frequency [MHz]	Modulation	PCC UL# RB	PCC UL RB Offset	PCC (DL) Channel	PCC (DL) Frequency [MHz]	DL Ant. Config.	SCC Band	SCC Bandwidth [MHz]	SCC (DL) Channel	SCC (DL) Frequency [MHz]	DL Ant. Config.	LTE Tx Power with DL CA Enabled (dBm)	LTE Single Carrier Tx Power (dBm)
CA_41A-41A (1)	LTE B41	15	40185	2549.5	QPSK	1	0	40185	2549.5	4x4 MIMO	LTE B41	20	41490	2680	2x2 MIMO	24.06	24.08
CA_41A-41A (1)	LTE B41	15	40185	2549.5	QPSK	1	0	40185	2549.5	2x2 MIMO	LTE B41	20	41490	2680	4x4 MIMO	24.09	24.08
CA_41A-41A (1)	LTE B41	15	40185	2549.5	QPSK	1	0	40185	2549.5	4x4 MIMO	LTE B41	20	41490	2680	4x4 MIMO	24.05	24.08

Table I-18  
Additional Hotspot Reduced Output Powers – 2 Component Carriers

Combination	PCC										SCC				Power		
	PCC Band	PCC Bandwidth [MHz]	PCC (UL) Channel	PCC (UL) Frequency [MHz]	Modulation	PCC UL# RB	PCC UL RB Offset	PCC (DL) Channel	PCC (DL) Frequency [MHz]	DL Ant. Config.	SCC Band	SCC Bandwidth [MHz]	SCC (DL) Channel	SCC (DL) Frequency [MHz]	DL Ant. Config.	LTE Tx Power with DL CA Enabled (dBm)	LTE Single Carrier Tx Power (dBm)
CA_41A-41A (1)	LTE B41	20	40185	2549.5	QPSK	1	0	40185	2549.5	4x4 MIMO	LTE B41	20	41490	2680	2x2 MIMO	23.44	23.50
CA_41A-41A (1)	LTE B41	20	40185	2549.5	QPSK	1	0	40185	2549.5	2x2 MIMO	LTE B41	20	41490	2680	4x4 MIMO	23.49	23.50
CA_41A-41A (1)	LTE B41	20	40185	2549.5	QPSK	1	0	40185	2549.5	4x4 MIMO	LTE B41	20	41490	2680	4x4 MIMO	23.48	23.50

## 1.2.10 LTE Band 41 PC2

Table I-19  
Additional Maximum Output Powers – 2 Component Carriers

Combination	PCC										SCC				Power		
	PCC Band	PCC Bandwidth [MHz]	PCC (UL) Channel	PCC (UL) Frequency [MHz]	Modulation	PCC UL# RB	PCC UL RB Offset	PCC (DL) Channel	PCC (DL) Frequency [MHz]	DL Ant. Config.	SCC Band	SCC Bandwidth [MHz]	SCC (DL) Channel	SCC (DL) Frequency [MHz]	DL Ant. Config.	LTE Tx Power with DL CA Enabled (dBm)	LTE Single Carrier Tx Power (dBm)
CA_41A-41A (1)	LTE B41 PC2	15	40185	2549.5	QPSK	1	0	40185	2549.5	4x4 MIMO	LTE B41 PC2	20	41490	2680	2x2 MIMO	27.18	27.06
CA_41A-41A (1)	LTE B41 PC2	15	40185	2549.5	QPSK	1	0	40185	2549.5	2x2 MIMO	LTE B41 PC2	20	41490	2680	4x4 MIMO	27.10	27.06
CA_41A-41A (1)	LTE B41 PC2	15	40185	2549.5	QPSK	1	0	40185	2549.5	4x4 MIMO	LTE B41 PC2	20	41490	2680	4x4 MIMO	27.17	27.06

Table I-20  
Additional Hotspot Reduced Output Powers – 2 Component Carriers

Combination	PCC										SCC				Power		
	PCC Band	PCC Bandwidth [MHz]	PCC (UL) Channel	PCC (UL) Frequency [MHz]	Modulation	PCC UL# RB	PCC UL RB Offset	PCC (DL) Channel	PCC (DL) Frequency [MHz]	DL Ant. Config.	SCC Band	SCC Bandwidth [MHz]	SCC (DL) Channel	SCC (DL) Frequency [MHz]	DL Ant. Config.	LTE Tx Power with DL CA Enabled (dBm)	LTE Single Carrier Tx Power (dBm)
CA_41A-41A (1)	LTE B41 PC2	20	39750	2506	16QAM	1	0	39750	2506	4x4 MIMO	LTE B41 PC2	20	41490	2680	2x2 MIMO	23.38	23.50
CA_41A-41A (1)	LTE B41 PC2	20	39750	2506	16QAM	1	0	39750	2506	2x2 MIMO	LTE B41 PC2	20	41490	2680	4x4 MIMO	23.40	23.50
CA_41A-41A (1)	LTE B41 PC2	20	39750	2506	16QAM	1	0	39750	2506	4x4 MIMO	LTE B41 PC2	20	41490	2680	4x4 MIMO	23.38	23.50

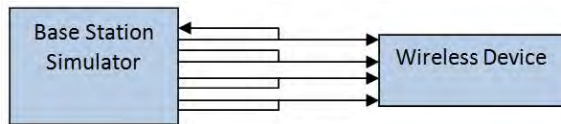

Figure I-2  
Power Measurement Setup

FCC ID: A3LSMG960U	PCTEST ENGINEERING LABORATORY, INC.	SAR EVALUATION REPORT		Approved by: Quality Manager
Test Dates: 11/03/17 – 12/07/17	DUT Type: Portable Handset	APPENDIX I: Page 4 of 19		

# I.3 Carrier Aggregation Scenarios with 3 Component Carriers with 4x4 Downlink MIMO

## 1.3.1 LTE Band 71

Table I-21  
Additional Maximum Output Powers – 3 Component Carriers

Combination	PCC Band	PCC Bandwidth [MHz]	PCC (UL) Channel	PCC (UL) Frequency [MHz]	Modulation	PCC			SCC 1				SCC 2				Power					
						PCC UL RB	PCC UL RB Offset	PCC (DL) Channel	PCC (DL) Frequency [MHz]	DL Ant. Config.	SCC Band	SCC Bandwidth [MHz]	SCC (DL) Channel	SCC (DL) Frequency [MHz]	DL Ant. Config.	SCC Band	SCC Bandwidth [MHz]	SCC (DL) Channel	SCC (DL) Frequency [MHz]	DL Ant. Config.	LTE Tx Power with DC CA Enabled [dBm]	LTE Single Carrier Tx Power [dBm]
CA 2A-2A-71A	LTE B71	20	13297	680.5	QPSK	1	0	68761	634.5	2x2 MIMO	LTE B72	20	900	1960	4x4 MIMO	LTE B72	20	700	1940	2x2 MIMO	24.77	24.81
CA 2A-4A-71A	LTE B71	20	13297	680.5	QPSK	1	0	68761	634.5	2x2 MIMO	LTE B72	20	900	1960	4x4 MIMO	LTE B72	20	2175	2132.5	2x2 MIMO	24.84	24.81
CA 2A-6A-71A	LTE B71	20	13297	680.5	QPSK	1	0	68761	634.5	2x2 MIMO	LTE B72	20	900	1960	4x4 MIMO	LTE B72	20	2175	2132.5	2x2 MIMO	24.81	24.81
CA 2A-6A-71A	LTE B71	20	13297	680.5	QPSK	1	0	68761	634.5	2x2 MIMO	LTE B72	20	900	1960	4x4 MIMO	LTE B66	20	66786	2145	2x2 MIMO	24.81	24.81
CA 4A-4A-71A	LTE B71	20	13297	680.5	QPSK	1	0	68761	634.5	2x2 MIMO	LTE B72	20	900	1960	4x4 MIMO	LTE B66	20	66786	2145	2x2 MIMO	24.78	24.81
CA 4A-4A-71A	LTE B71	20	13297	680.5	QPSK	1	0	68761	634.5	2x2 MIMO	LTE B72	20	2175	2132.5	4x4 MIMO	LTE B66	20	2150	2150	2x2 MIMO	24.77	24.81
CA 6A-71A	LTE B71	20	13297	680.5	QPSK	1	0	68761	634.5	2x2 MIMO	LTE B66	20	66786	2145	4x4 MIMO	LTE B66	20	66984	2164.8	4x4 MIMO	24.76	24.81
CA 6A-6A-71A	LTE B71	20	13297	680.5	QPSK	1	0	68761	634.5	2x2 MIMO	LTE B66	20	66786	2145	4x4 MIMO	LTE B66	20	67236	2190	2x2 MIMO	24.76	24.81

## 1.3.2 LTE Band 12

Table I-22  
Additional Maximum Output Powers – 3 Component Carriers

Combination	PCC Band	PCC Bandwidth [MHz]	PCC (UL) Channel	PCC (UL) Frequency [MHz]	Modulation	PCC			SCC 1				SCC 2				Power					
						PCC UL RB	PCC UL RB Offset	PCC (DL) Channel	PCC (DL) Frequency [MHz]	DL Ant. Config.	SCC Band	SCC Bandwidth [MHz]	SCC (DL) Channel	SCC (DL) Frequency [MHz]	DL Ant. Config.	SCC Band	SCC Bandwidth [MHz]	SCC (DL) Channel	SCC (DL) Frequency [MHz]	DL Ant. Config.	LTE Tx Power with DC CA Enabled [dBm]	LTE Single Carrier Tx Power [dBm]
CA 2A-2A-12A	LTE B12	5	23035	701.5	QPSK	1	0	5035	731.5	2x2 MIMO	LTE B2	20	900	1960	4x4 MIMO	LTE B2	20	700	1940	2x2 MIMO	24.65	24.67
CA 2A-4A-12A	LTE B12	5	23035	701.5	QPSK	1	0	5035	731.5	2x2 MIMO	LTE B2	20	900	1960	4x4 MIMO	LTE B4	20	2175	2132.5	2x2 MIMO	24.61	24.67
CA 2A-6A-12A	LTE B12	5	23035	701.5	QPSK	1	0	5035	731.5	2x2 MIMO	LTE B2	20	900	1960	4x4 MIMO	LTE B4	20	2175	2132.5	2x2 MIMO	24.68	24.67
CA 2A-7A-12A	LTE B12	5	23035	701.5	QPSK	1	0	5035	731.5	2x2 MIMO	LTE B2	20	900	1960	4x4 MIMO	LTE B7	20	3100	2655	2x2 MIMO	24.66	24.67
CA 2A-12A-12A	LTE B12	5	23035	701.5	QPSK	1	0	5035	731.5	2x2 MIMO	LTE B2	20	900	1960	4x4 MIMO	LTE B7	20	3100	2655	2x2 MIMO	24.65	24.67
CA 2A-12A-30A	LTE B12	5	23035	701.5	QPSK	1	0	5035	731.5	2x2 MIMO	LTE B2	20	900	1960	4x4 MIMO	LTE B30	10	9820	2355	2x2 MIMO	24.69	24.67
CA 2A-12A-30A	LTE B12	5	23035	701.5	QPSK	1	0	5035	731.5	2x2 MIMO	LTE B2	20	900	1960	4x4 MIMO	LTE B30	10	9820	2355	4x4 MIMO	24.63	24.67
CA 2A-12A-66A	LTE B12	5	23035	701.5	QPSK	1	0	5035	731.5	2x2 MIMO	LTE B2	20	900	1960	4x4 MIMO	LTE B66	20	66786	2145	2x2 MIMO	24.71	24.67
CA 2A-12A-66A	LTE B12	5	23035	701.5	QPSK	1	0	5035	731.5	2x2 MIMO	LTE B2	20	900	1960	4x4 MIMO	LTE B66	20	66786	2145	4x4 MIMO	24.66	24.67
CA 4A-4A-12A	LTE B12	5	23035	701.5	QPSK	1	0	5035	731.5	2x2 MIMO	LTE B4	20	2175	2132.5	4x4 MIMO	LTE B4	10	2350	2190	2x2 MIMO	24.56	24.67
CA 12A-66A	LTE B12	5	23035	701.5	QPSK	1	0	5035	731.5	2x2 MIMO	LTE B66	20	66786	2145	4x4 MIMO	LTE B66	20	66984	2164.8	4x4 MIMO	24.81	24.67
CA 12A-66A-66A	LTE B12	5	23035	701.5	QPSK	1	0	5035	731.5	2x2 MIMO	LTE B66	20	66786	2145	4x4 MIMO	LTE B66	20	67236	2190	2x2 MIMO	24.64	24.67

## 1.3.3 LTE Band 13

Table I-23  
Additional Maximum Output Powers – 3 Component Carriers

Combination	PCC Band	PCC Bandwidth [MHz]	PCC (UL) Channel	PCC (UL) Frequency [MHz]	Modulation	PCC			SCC 1				SCC 2				Power					
						PCC UL RB	PCC UL RB Offset	PCC (DL) Channel	PCC (DL) Frequency [MHz]	DL Ant. Config.	SCC Band	SCC Bandwidth [MHz]	SCC (DL) Channel	SCC (DL) Frequency [MHz]	DL Ant. Config.	SCC Band	SCC Bandwidth [MHz]	SCC (DL) Channel	SCC (DL) Frequency [MHz]	DL Ant. Config.	LTE Tx Power with DC CA Enabled [dBm]	LTE Single Carrier Tx Power [dBm]
CA 2A-2A-13A	LTE B13	10	23280	782	QPSK	1	0	5280	751	2x2 MIMO	LTE B2	20	900	1960	4x4 MIMO	LTE B2	20	700	1940	2x2 MIMO	24.67	24.67
CA 2A-4A-13A	LTE B13	10	23280	782	QPSK	1	0	5280	751	2x2 MIMO	LTE B2	20	900	1960	4x4 MIMO	LTE B4	20	2175	2132.5	2x2 MIMO	24.5	24.58
CA 2A-6A-13A	LTE B13	10	23280	782	QPSK	1	0	5280	751	2x2 MIMO	LTE B2	20	900	1960	4x4 MIMO	LTE B4	20	2175	2132.5	2x2 MIMO	24.63	24.58
CA 2A-13A-66A	LTE B13	10	23280	782	QPSK	1	0	5280	751	2x2 MIMO	LTE B2	20	900	1960	4x4 MIMO	LTE B66	20	66786	2145	2x2 MIMO	24.57	24.58
CA 2A-13A-66A	LTE B13	10	23280	782	QPSK	1	0	5280	751	2x2 MIMO	LTE B2	20	900	1960	4x4 MIMO	LTE B66	20	66786	2145	4x4 MIMO	24.61	24.58
CA 4A-4A-13A	LTE B13	10	23280	782	QPSK	1	0	5280	751	2x2 MIMO	LTE B4	20	2175	2132.5	4x4 MIMO	LTE B4	10	2350	2190	2x2 MIMO	24.57	24.58
CA 50A-66A-66A	LTE B13	10	23280	782	QPSK	1	0	5280	751	2x2 MIMO	LTE B66	20	66786	2145	4x4 MIMO	LTE B66	20	67236	2190	2x2 MIMO	24.48	24.58

## 1.3.4 LTE Band 26

Table I-24  
Additional Maximum Output Powers – 3 Component Carriers

Combination	PCC Band	PCC Bandwidth [MHz]	PCC (UL) Channel	PCC (UL) Frequency [MHz]	Modulation	PCC			SCC 1				SCC 2				Power					
						PCC UL RB	PCC UL RB Offset	PCC (DL) Channel	PCC (DL) Frequency [MHz]	DL Ant. Config.	SCC Band	SCC Bandwidth [MHz]	SCC (DL) Channel	SCC (DL) Frequency [MHz]	DL Ant. Config.	SCC Band	SCC Bandwidth [MHz]	SCC (DL) Channel	SCC (DL) Frequency [MHz]	DL Ant. Config.	LTE Tx Power with DC CA Enabled [dBm]	LTE Single Carrier Tx Power [dBm]
CA 2A-2A-26A	LTE B26	5	27025	866.5	QPSK	1	7	9025	866.5	2x2 MIMO	LTE B26	20	8960	1962.5	4x4 MIMO	LTE B26	20	8080	1986	2x2 MIMO	24.56	24.62
CA 50A-40C	LTE B26	5	27025	866.5	QPSK	1	12	9025	866.5	2x2 MIMO	LTE B41	20	40420	2593	4x4 MIMO	LTE B41	20	40422	2573.2	4x4 MIMO	24.23	24.54

## 1.3.5 LTE Band 5

Table I-25  
Additional Maximum Output Powers – 3 Component Carriers

Combination	PCC Band	PCC Bandwidth [MHz]	PCC (UL) Channel	PCC (UL) Frequency [MHz]	Modulation	PCC			SCC 1				SCC 2				Power					
						PCC UL RB	PCC UL RB Offset	PCC (DL) Channel	PCC (DL) Frequency [MHz]	DL Ant. Config.	SCC Band	SCC Bandwidth [MHz]	SCC (DL) Channel	SCC (DL) Frequency [MHz]	DL Ant. Config.	SCC Band	SCC Bandwidth [MHz]	SCC (DL) Channel	SCC (DL) Frequency [MHz]	DL Ant. Config.	LTE Tx Power with DC CA Enabled [dBm]	LTE Single Carrier Tx Power [dBm]
CA 2A-2A-5A	LTE B5	5	20225	836.5	QPSK	1	0	2525	881.5	2x2 MIMO	LTE B2	20	900	1960	4x4 MIMO	LTE B2	20	700	1940	2x2 MIMO	24.35	24.33
CA 2A-4A-5A	LTE B5	5	20225	836.5	QPSK	1	0	2525	881.5	2x2 MIMO	LTE B2	20	900	1960	4x4 MIMO	LTE B4	20	2175	2132.5	2x2 MIMO	24.43	24.33
CA 2A-6A-5A	LTE B5	5	20225	836.5	QPSK	1	0	2525	881.5	2x2 MIMO	LTE B2	20	900	1960	4x4 MIMO	LTE B4	20	2175	2132.5	4x4 MIMO	24.26	24.33
CA 2A-5A-10A	LTE B5	5	20225	836.5	QPSK	1	0	2525	881.5	2x2 MIMO	LTE B2	20	900	1960	4x4 MIMO	LTE B10	10	9920	2355	2x2 MIMO	24.32	24.33
CA 2A-5A-10A	LTE B5	5	20225	836.5	QPSK	1	0	2525	881.5	2x2 MIMO	LTE B2	20	900	1960	4x4 MIMO	LTE B10	10	9920	2355	4x4 MIMO	24.29	24.33
CA 2A-5A-66A	LTE B5	5	20225	836.5	QPSK	1	0	2525	881.5	2x2 MIMO	LTE B2	20	900	1960	4x4 MIMO	LTE B66	20	66786	2145	2x2 MIMO	24.4	24.33
CA 2A-5A-66A	LTE B5	5	20225	836.5	QPSK	1	0	2525	881.5	2x2 MIMO	LTE B2	20	900	1960	4x4 MIMO	LTE B66	20	66786	2145	4x4 MIMO	24.32	24.33
CA 4A-4A-5A	LTE B5	5	20225	836.5	QPSK	1	0	2525	881.5	2x2 MIMO	LTE B4	20	2175	2132.5	4x4 MIMO	LTE B4	10	2350	2190	2x2 MIMO	24.33	24.33
CA 4A-5A-30A	LTE B5	5	20225	836.5	QPSK	1	0	2525	881.5	2x2 MIMO	LTE B4	20	2175	2132.5	4x4 MIMO	LTE B30	10	9920	2355	4x4 MIMO	24.35	24.33
CA 5A-30A-66A	LTE B5	5	20225	836.5	QPSK	1	0	2525	881.5	2x2 MIMO	LTE B30	10	9920	2355	4x4 MIMO	LTE B66	20	66786	2145	2x2 MIMO	24.31	24.33
CA 5A-30A-66A	LTE B5	5	20225	836.5	QPSK	1	0	2525	881.5	2x2 MIMO	LTE B30	10	9920	2355	4x4 MIMO	LTE B66	20	66786	2145	4x4 MIMO	24.26	24.33
CA 5A-66A-66A	LTE B5	5	20225	836.5	QPSK	1	0	2525	881.5	2x2 MIMO	LTE B66	20	66786	2145	4x4 MIMO	LTE B66	20	67236	2190	2x2 MIMO	24.31	24.33

# 1.3.6 LTE Band 66

## Table I-26

### Additional Maximum Output Powers – 3 Component Carriers

Combination	PCC Band	PCC Bandwidth [MHz]	PCC (UL) Channel	PCC (UL) Frequency [MHz]	Modulation	PCC UL RB	PCC UL RB Offset	PCC (DL) Channel	PCC (DL) Frequency [MHz]	DL Ant. Config.	SCC 1			SCC 2			Power					
											SCC Band	SCC Bandwidth [MHz]	SCC (DL) Channel	SCC (DL) Frequency [MHz]	DL Ant. Config.	SCC Band	SCC Bandwidth [MHz]	SCC (DL) Channel	SCC (DL) Frequency [MHz]	DL Ant. Config.	LTE Tx Power with DL CA Enabled (dBm)	LTE Single Carrier Tx Power (dBm)
CA_2C_66A	LTE B66	15	132597	1772.5	QPSK	1	0	67061	2127.5	2x2 MIMO	LTE B2	20	900	1960	4x4 MIMO	LTE B2	20	702	1940.2	4x4 MIMO	24.34	24.38
CA_2C_66B	LTE B66	15	132597	1772.5	QPSK	1	0	67061	2127.5	4x4 MIMO	LTE B2	20	900	1960	2x2 MIMO	LTE B2	20	702	1940.2	2x2 MIMO	24.4	24.38
CA_2A_2A_66A	LTE B66	15	132597	1772.5	QPSK	1	0	67061	2127.5	4x4 MIMO	LTE B2	20	900	1960	4x4 MIMO	LTE B2	20	702	1940.2	2x2 MIMO	24.35	24.38
CA_2A_2A_66B	LTE B66	15	132597	1772.5	QPSK	1	0	67061	2127.5	2x2 MIMO	LTE B2	20	900	1960	4x4 MIMO	LTE B2	20	700	1940	2x2 MIMO	24.43	24.38
CA_2A_2A_66C	LTE B66	15	132597	1772.5	QPSK	1	0	67061	2127.5	4x4 MIMO	LTE B2	20	900	1960	2x2 MIMO	LTE B2	20	700	1940	2x2 MIMO	24.44	24.38
CA_2A_2A_66D	LTE B66	15	132597	1772.5	QPSK	1	0	67061	2127.5	4x4 MIMO	LTE B2	20	900	1960	2x2 MIMO	LTE B5	10	2525	881.5	2x2 MIMO	24.35	24.38
CA_2A_13A_66A	LTE B66	15	132597	1772.5	QPSK	1	0	67061	2127.5	2x2 MIMO	LTE B2	20	900	1960	4x4 MIMO	LTE B12	10	5095	737.5	2x2 MIMO	24.38	24.38
CA_2A_13A_66B	LTE B66	15	132597	1772.5	QPSK	1	0	67061	2127.5	4x4 MIMO	LTE B2	20	900	1960	2x2 MIMO	LTE B13	10	5230	751	2x2 MIMO	24.38	24.38
CA_2A_13A_66C	LTE B66	15	132597	1772.5	QPSK	1	0	67061	2127.5	2x2 MIMO	LTE B2	20	900	1960	4x4 MIMO	LTE B11	10	5230	751	2x2 MIMO	24.38	24.38
CA_2A_13A_66D	LTE B66	15	132597	1772.5	QPSK	1	0	67061	2127.5	4x4 MIMO	LTE B2	20	900	1960	2x2 MIMO	LTE B13	10	5230	751	2x2 MIMO	24.47	24.38
CA_2A_30A_66A	LTE B66	15	132597	1772.5	QPSK	1	0	67061	2127.5	2x2 MIMO	LTE B2	20	900	1960	4x4 MIMO	LTE B13	10	9820	2355	2x2 MIMO	24.38	24.38
CA_2A_30A_66B	LTE B66	15	132597	1772.5	QPSK	1	0	67061	2127.5	4x4 MIMO	LTE B2	20	900	1960	2x2 MIMO	LTE B30	10	9820	2355	2x2 MIMO	24.46	24.38
CA_2A_66A	LTE B66	15	132597	1772.5	QPSK	1	0	67061	2127.5	4x4 MIMO	LTE B66	5	66908	2163.2	4x4 MIMO	LTE B2	20	900	1960	4x4 MIMO	24.35	24.38
CA_2A_66B	LTE B66	15	132597	1772.5	QPSK	1	0	67061	2127.5	2x2 MIMO	LTE B66	20	66908	2163.2	4x4 MIMO	LTE B2	20	900	1960	4x4 MIMO	24.4	24.38
CA_2A_66A_66A	LTE B66	15	132597	1772.5	QPSK	1	0	67061	2127.5	2x2 MIMO	LTE B66	20	66536	2120	2x2 MIMO	LTE B2	20	900	1960	4x4 MIMO	24.34	24.38
CA_2A_66A_66B	LTE B66	15	132597	1772.5	QPSK	1	0	67061	2127.5	4x4 MIMO	LTE B66	20	66536	2120	2x2 MIMO	LTE B2	20	900	1960	2x2 MIMO	24.47	24.38
CA_2A_66A_66C	LTE B66	15	132597	1772.5	QPSK	1	0	67061	2127.5	2x2 MIMO	LTE B66	20	66536	2120	4x4 MIMO	LTE B5	10	2525	881.5	2x2 MIMO	24.35	24.38
CA_2A_66A_66D	LTE B66	15	132597	1772.5	QPSK	1	0	67061	2127.5	4x4 MIMO	LTE B66	20	66536	2120	4x4 MIMO	LTE B71	20	68761	634.5	2x2 MIMO	24.37	24.38
CA_2A_66A_66E	LTE B66	15	132597	1772.5	QPSK	1	0	67061	2127.5	4x4 MIMO	LTE B2	20	900	1960	2x2 MIMO	LTE B71	20	68761	634.5	2x2 MIMO	24.45	24.38
CA_2A_66A_66F	LTE B66	15	132597	1772.5	QPSK	1	0	67061	2127.5	2x2 MIMO	LTE B66	20	66536	2120	4x4 MIMO	LTE B5	10	2525	881.5	2x2 MIMO	24.36	24.38
CA_2A_66A_66G	LTE B66	15	132597	1772.5	QPSK	1	0	67061	2127.5	4x4 MIMO	LTE B66	20	66536	2120	4x4 MIMO	LTE B30	10	9820	2355	2x2 MIMO	24.4	24.38
CA_2A_66A_66H	LTE B66	15	132597	1772.5	QPSK	1	0	67061	2127.5	2x2 MIMO	LTE B66	20	66536	2120	4x4 MIMO	LTE B12	10	5095	737.5	2x2 MIMO	24.38	24.38
CA_2A_66A_66I	LTE B66	15	132597	1772.5	QPSK	1	0	67061	2127.5	4x4 MIMO	LTE B66	20	66536	2120	2x2 MIMO	LTE B12	10	5095	737.5	2x2 MIMO	24.33	24.38
CA_2A_66A_66J	LTE B66	15	132597	1772.5	QPSK	1	0	67061	2127.5	2x2 MIMO	LTE B66	20	66536	2120	4x4 MIMO	LTE B13	10	5230	751	2x2 MIMO	24.39	24.38
CA_2A_66A_66K	LTE B66	15	132597	1772.5	QPSK	1	0	67061	2127.5	4x4 MIMO	LTE B66	20	66536	2120	4x4 MIMO	LTE B11	10	5230	751	2x2 MIMO	24.35	24.38
CA_2A_66A_66L	LTE B66	15	132597	1772.5	QPSK	1	0	67061	2127.5	2x2 MIMO	LTE B66	20	66536	2120	4x4 MIMO	LTE B30	10	9820	2355	2x2 MIMO	24.38	24.38
CA_2A_66A_66M	LTE B66	15	132597	1772.5	QPSK	1	0	67061	2127.5	4x4 MIMO	LTE B66	20	66536	2120	4x4 MIMO	LTE B30	10	9820	2355	2x2 MIMO	24.38	24.38
CA_2A_66A_66N	LTE B66	15	132597	1772.5	QPSK	1	0	67061	2127.5	2x2 MIMO	LTE B66	20	66536	2120	4x4 MIMO	LTE B30	10	9820	2355	2x2 MIMO	24.38	24.38
CA_2A_66A_66O	LTE B66	15	132597	1772.5	QPSK	1	0	67061	2127.5	4x4 MIMO	LTE B66	20	66536	2120	4x4 MIMO	LTE B71	20	68761	634.5	2x2 MIMO	24.37	24.38
CA_2A_66A_66P	LTE B66	15	132597	1772.5	QPSK	1	0	67061	2127.5	2x2 MIMO	LTE B66	20	66536	2120	4x4 MIMO	LTE B71	20	68761	634.5	2x2 MIMO	24.43	24.38
CA_2A_66A_66Q	LTE B66	15	132597	1772.5	QPSK	1	0	67061	2127.5	4x4 MIMO	LTE B66	20	66536	2120	4x4 MIMO	LTE B71	20	68761	634.5	2x2 MIMO	24.33	24.38

## Table I-27

### Additional Hotspot Output Powers – 3 Component Carriers

Combination	PCC Band	PCC Bandwidth [MHz]	PCC (UL) Channel	PCC (UL) Frequency [MHz]	Modulation	PCC UL RB	PCC UL RB Offset	PCC (DL) Channel	PCC (DL) Frequency [MHz]	DL Ant. Config.	SCC 1			SCC 2			Power					
											SCC Band	SCC Bandwidth [MHz]	SCC (DL) Channel	SCC (DL) Frequency [MHz]	DL Ant. Config.	SCC Band	SCC Bandwidth [MHz]	SCC (DL) Channel	SCC (DL) Frequency [MHz]	DL Ant. Config.	LTE Tx Power with DL CA Enabled (dBm)	LTE Single Carrier Tx Power (dBm)
CA_2C_66A	LTE B66	20	132322	1745	16QAM	1	0	66786	2145	2x2 MIMO	LTE B2	20	900	1960	4x4 MIMO	LTE B2	20	702	1940.2	4x4 MIMO	20.21	20.50
CA_2C_66B	LTE B66	20	132322	1745	16QAM	1	0	66786	2145	4x4 MIMO	LTE B2	20	900	1960	2x2 MIMO	LTE B2	20	702	1940.2	2x2 MIMO	20.21	20.50
CA_2A_2A_66A	LTE B66	20	132322	1745	16QAM	1	0	66786	2145	4x4 MIMO	LTE B2	20	900	1960	4x4 MIMO	LTE B2	20	700	1940.2	2x2 MIMO	20.27	20.50
CA_2A_2A_66B	LTE B66	20	132322	1745	16QAM	1	0	66786	2145	4x4 MIMO	LTE B2	20	900	1960	2x2 MIMO	LTE B2	20	700	1940	2x2 MIMO	20.23	20.50
CA_2A_2A_66C	LTE B66	20	132322	1745	16QAM	1	0	66786	2145	2x2 MIMO	LTE B2	20	900	1960	4x4 MIMO	LTE B5	10	2525	881.5	2x2 MIMO	20.13	20.50
CA_2A_2A_66D	LTE B66	20	132322	1745	16QAM	1	0	66786	2145	4x4 MIMO	LTE B2	20	900	1960	4x4 MIMO	LTE B5	10	2525	881.5	2x2 MIMO	20.13	20.50
CA_2A_13A_66A	LTE B66	20	132322	1745	16QAM	1	0	66786	2145	2x2 MIMO	LTE B2	20	900	1960	4x4 MIMO	LTE B12	10	5230	751	2x2 MIMO	20.13	20.50
CA_2A_13A_66B	LTE B66	20	132322	1745	16QAM	1	0	66786	2145	4x4 MIMO	LTE B2	20	900	1960	2x2 MIMO	LTE B13	10	5230	751	2x2 MIMO	20.20	20.50
CA_2A_13A_66C	LTE B66	20	132322	1745	16QAM	1	0	66786	2145	2x2 MIMO	LTE B2	20	900	1960	4x4 MIMO	LTE B11	10	5230	751	2x2 MIMO	20.13	20.50
CA_2A_13A_66D	LTE B66	20	132322	1745	16QAM	1	0	66786	2145	4x4 MIMO	LTE B2	20	900	1960	2x2 MIMO	LTE B13	10	5230	751	2x2 MIMO	20.27	20.50
CA_2A_30A_66A	LTE B66	20	132322	1745	16QAM	1	0	66786	2145	2x2 MIMO	LTE B2	20	900	1960	4x4 MIMO	LTE B13	10	9820	2355	2x2 MIMO	20.17	20.50
CA_2A_66A	LTE B66	15	132047	1717.5	64QAM	1	0	66511	2117.5	4x4 MIMO	LTE B66	5	66668	2126.8	4x4 MIMO	LTE B2	20	900	1960	4x4 MIMO	20.20	20.47
CA_2A_66B	LTE B66	20	132322	1745	16QAM	1	0	66786	2145	4x4 MIMO	LTE B66	20	66588	2125.2	4x4 MIMO	LTE B2	20	900	1960	4x4 MIMO	20.13	20.50
CA_2A_66A_66A	LTE B66	20	132322	1745	16QAM	1	0	66786	2145	2x2 MIMO	LTE B66	20	67736	2190	2x2 MIMO	LTE B2	20	900	1960	4x4 MIMO	20.17	20.50
CA_2A_66A_66B	LTE B66	20	132322	1745	16QAM	1	0	66786	2145	4x4 MIMO	LTE B66	20	67736	2190	2x2 MIMO	LTE B2	20	900	1960	2x2 MIMO	20.20	20.50
CA_2A_66A_66C	LTE B66	20	132322	1745	16QAM	1	0	66786	2145	2x2 MIMO	LTE B66	20	67736	2190	4x4 MIMO	LTE B5	10	2525	881.5	2x2 MIMO	20.13	20.50
CA_2A																						

1.3.7

LTE Band 4

Table I-28
Additional Maximum Output Powers - 3 Component Carriers

Table with 24 columns: Combination, PCC Band, PCC Bandwidth, PCC (UL) Channel, PCC (UL) Frequency, Modulation, PCC UL RB, PCC UL RB Offset, PCC (DL) Channel, PCC (DL) Frequency, DL Ant. Config., SCC Band, SCC Bandwidth, SCC (DL) Channel, SCC (DL) Frequency, DL Ant. Config., SCC Band, SCC Bandwidth, SCC (DL) Channel, SCC (DL) Frequency, DL Ant. Config., LTE Tx Power with DL CA Enabled (dBm), LTE Single Carrier Tx Power (dBm)

Table I-29
Additional Hotspot Output Powers - 3 Component Carriers

Table with 24 columns: Combination, PCC Band, PCC Bandwidth, PCC (UL) Channel, PCC (UL) Frequency, Modulation, PCC UL RB, PCC UL RB Offset, PCC (DL) Channel, PCC (DL) Frequency, DL Ant. Config., SCC Band, SCC Bandwidth, SCC (DL) Channel, SCC (DL) Frequency, DL Ant. Config., SCC Band, SCC Bandwidth, SCC (DL) Channel, SCC (DL) Frequency, DL Ant. Config., LTE Tx Power with DL CA Enabled (dBm), LTE Single Carrier Tx Power (dBm)

FCC ID: A3LSMG960U



SAR EVALUATION REPORT



Approved by:
Quality Manager

Test Dates:
11/03/17 - 12/07/17

DUT Type:
Portable Handset

APPENDIX I:
Page 7 of 19



# 1.3.8 LTE Band 25

## Table I-30 Additional Maximum Output Powers – 3 Component Carriers

Combination	PCC Band	PCC Bandwidth [MHz]	PCC (UL) Channel	PCC (UL) Frequency [MHz]	Modulation	PCC						SCC 1				SCC 2				Power		
						PCC UL RB	PCC UL RB Offset	PCC (DL) Channel	PCC (DL) Frequency [MHz]	DL Ant. Config.	SCC Band	SCC Bandwidth [MHz]	SCC (DL) Channel	SCC (DL) Frequency [MHz]	DL Ant. Config.	SCC Band	SCC Bandwidth [MHz]	SCC (DL) Channel	SCC (DL) Frequency [MHz]	DL Ant. Config.	LTE Tx Power with DL CA Enabled [dBm]	LTE Single Carrier Tx Power [dBm]
CA 25A-25A-26A	LTE B25	20	26340	1860	QPSK	1	0	8140	1940	4x4 MIMO	LTE B25	20	8590	1985	2x2 MIMO	LTE B26	5	8865	876.5	2x2 MIMO	24.29	24.29
CA 25A-25A-26A	LTE B25	20	26140	1860	QPSK	1	0	8140	1940	2x2 MIMO	LTE B25	20	8590	1985	4x4 MIMO	LTE B26	5	8865	876.5	2x2 MIMO	24.34	24.29
CA 25A-41C	LTE B25	20	26340	1860	QPSK	1	0	8140	1940	4x4 MIMO	LTE B41	20	40620	2593	2x2 MIMO	LTE B41	20	40422	2573.2	2x2 MIMO	23.77	24.29
CA 25A-41C	LTE B25	20	26140	1860	QPSK	1	0	8140	1940	2x2 MIMO	LTE B41	20	40620	2593	4x4 MIMO	LTE B41	20	40422	2573.2	4x4 MIMO	23.8	24.29

## Table I-31 Additional Hotspot Output Powers – 3 Component Carriers

Combination	PCC Band	PCC Bandwidth [MHz]	PCC (UL) Channel	PCC (UL) Frequency [MHz]	Modulation	PCC						SCC 1				SCC 2				Power		
						PCC UL RB	PCC UL RB Offset	PCC (DL) Channel	PCC (DL) Frequency [MHz]	DL Ant. Config.	SCC Band	SCC Bandwidth [MHz]	SCC (DL) Channel	SCC (DL) Frequency [MHz]	DL Ant. Config.	SCC Band	SCC Bandwidth [MHz]	SCC (DL) Channel	SCC (DL) Frequency [MHz]	DL Ant. Config.	LTE Tx Power with DL CA Enabled [dBm]	LTE Single Carrier Tx Power [dBm]
CA 25A-25A-26A	LTE B25	20	26340	1860	16QAM	1	0	8140	1940	4x4 MIMO	LTE B25	20	8590	1985	2x2 MIMO	LTE B26	5	8865	876.5	2x2 MIMO	20.47	20.50
CA 25A-25A-26A	LTE B25	20	26140	1860	16QAM	1	0	8140	1940	2x2 MIMO	LTE B25	20	8590	1985	4x4 MIMO	LTE B26	5	8865	876.5	2x2 MIMO	20.49	20.50
CA 25A-41C	LTE B25	20	26340	1860	16QAM	1	0	8140	1940	4x4 MIMO	LTE B41	20	40620	2593	2x2 MIMO	LTE B41	20	40422	2573.2	2x2 MIMO	19.98	20.50
CA 25A-41C	LTE B25	20	26140	1860	16QAM	1	0	8140	1940	2x2 MIMO	LTE B41	20	40620	2593	4x4 MIMO	LTE B41	20	40422	2573.2	4x4 MIMO	19.97	20.50

FCC ID: A3LSMG960U	 PCTEST ENGINEERING LABORATORY, INC.	SAR EVALUATION REPORT		Approved by: Quality Manager
Test Dates: 11/03/17 – 12/07/17	DUT Type: Portable Handset	APPENDIX I: Page 8 of 19		

1.3.9

LTE Band 2

Table I-32  
Additional Maximum Output Powers – 3 Component Carriers

Combination	PCC										SCC 1				SCC 2				Power			
	PCC Band	PCC Bandwidth (MHz)	PCC (UL) Channel	PCC (DL) Frequency (MHz)	Modulation	PCC UL RB	PCC UL RB Offset	PCC (DL) Channel	PCC (DL) Frequency (MHz)	DL Ant. Config.	SCC Band	SCC Bandwidth (MHz)	SCC (DL) Channel	SCC (DL) Frequency (MHz)	DL Ant. Config.	SCC Band	SCC Bandwidth (MHz)	SCC (DL) Channel		SCC (DL) Frequency (MHz)	DL Ant. Config.	LTE Tx Power with DL CA Enabled (dBm)
CA 26-2A-4A	LTE B2	20	18700	1860	QPSK	1	0	700	1840	4x4 MIMO	LTE B2	20	1100	1980	2x2 MIMO	LTE B4	20	2175	2132.5	2x2 MIMO	24.25	24.25
CA 26-2A-4A	LTE B2	20	18700	1860	QPSK	1	0	700	1840	2x2 MIMO	LTE B2	20	1100	1980	4x4 MIMO	LTE B4	20	2175	2132.5	2x2 MIMO	24.31	24.25
CA 26-2A-5A	LTE B2	20	18700	1860	QPSK	1	0	700	1840	2x2 MIMO	LTE B2	20	1100	1980	2x2 MIMO	LTE B4	20	2175	2132.5	4x4 MIMO	24.25	24.25
CA 26-2A-5A	LTE B2	20	18700	1860	QPSK	1	0	700	1840	4x4 MIMO	LTE B2	20	1100	1980	2x2 MIMO	LTE B4	20	2175	2132.5	2x2 MIMO	24.31	24.25
CA 26-2A-5A	LTE B2	20	18700	1860	QPSK	1	0	700	1840	2x2 MIMO	LTE B2	20	1100	1980	4x4 MIMO	LTE B4	20	2175	2132.5	2x2 MIMO	24.25	24.25
CA 26-2A-12A	LTE B2	20	18700	1860	QPSK	1	0	700	1840	4x4 MIMO	LTE B2	20	1100	1980	2x2 MIMO	LTE B4	20	2175	2132.5	4x4 MIMO	24.25	24.25
CA 26-2A-12A	LTE B2	20	18700	1860	QPSK	1	0	700	1840	2x2 MIMO	LTE B2	20	1100	1980	4x4 MIMO	LTE B4	20	2175	2132.5	2x2 MIMO	24.31	24.25
CA 26-2A-13A	LTE B2	20	18700	1860	QPSK	1	0	700	1840	4x4 MIMO	LTE B2	20	1100	1980	2x2 MIMO	LTE B4	20	2175	2132.5	4x4 MIMO	24.25	24.25
CA 26-2A-13A	LTE B2	20	18700	1860	QPSK	1	0	700	1840	2x2 MIMO	LTE B2	20	1100	1980	4x4 MIMO	LTE B4	20	2175	2132.5	2x2 MIMO	24.31	24.25
CA 26-2A-30A	LTE B2	20	18700	1860	QPSK	1	0	700	1840	4x4 MIMO	LTE B2	20	1100	1980	2x2 MIMO	LTE B4	20	2175	2132.5	4x4 MIMO	24.25	24.25
CA 26-2A-30A	LTE B2	20	18700	1860	QPSK	1	0	700	1840	2x2 MIMO	LTE B2	20	1100	1980	4x4 MIMO	LTE B4	20	2175	2132.5	2x2 MIMO	24.31	24.25
CA 26-2A-30A	LTE B2	20	18700	1860	QPSK	1	0	700	1840	4x4 MIMO	LTE B2	20	1100	1980	2x2 MIMO	LTE B4	20	2175	2132.5	4x4 MIMO	24.25	24.25
CA 2C-66A	LTE B2	20	18700	1860	QPSK	1	0	700	1840	4x4 MIMO	LTE B2	20	808	1950.8	2x2 MIMO	LTE B66	20	66786	2145	4x4 MIMO	24.26	24.25
CA 2C-66A	LTE B2	20	18700	1860	QPSK	1	0	700	1840	2x2 MIMO	LTE B2	20	808	1950.8	4x4 MIMO	LTE B66	20	66786	2145	4x4 MIMO	24.26	24.25
CA 26-2A-66A	LTE B2	20	18700	1860	QPSK	1	0	700	1840	4x4 MIMO	LTE B2	20	1100	1980	2x2 MIMO	LTE B66	20	66786	2145	4x4 MIMO	24.27	24.25
CA 26-2A-66A	LTE B2	20	18700	1860	QPSK	1	0	700	1840	2x2 MIMO	LTE B2	20	1100	1980	4x4 MIMO	LTE B66	20	66786	2145	4x4 MIMO	24.24	24.25
CA 26-2A-66A	LTE B2	20	18700	1860	QPSK	1	0	700	1840	4x4 MIMO	LTE B2	20	1100	1980	2x2 MIMO	LTE B66	20	66786	2145	4x4 MIMO	24.29	24.25
CA 26-2A-71A	LTE B2	20	18700	1860	QPSK	1	0	700	1840	4x4 MIMO	LTE B2	20	1100	1980	2x2 MIMO	LTE B71	20	68761	634.5	2x2 MIMO	24.31	24.25
CA 26-2A-71A	LTE B2	20	18700	1860	QPSK	1	0	700	1840	2x2 MIMO	LTE B2	20	1100	1980	4x4 MIMO	LTE B71	20	68761	634.5	2x2 MIMO	24.25	24.25
CA 26-2A-71A	LTE B2	20	18700	1860	QPSK	1	0	700	1840	4x4 MIMO	LTE B2	20	2175	2132.5	4x4 MIMO	LTE B4	10	2350	2150	2x2 MIMO	24.31	24.25
CA 26-4A-5A	LTE B2	20	18700	1860	QPSK	1	0	700	1840	4x4 MIMO	LTE B4	20	2175	2132.5	2x2 MIMO	LTE B5	10	2525	881.5	2x2 MIMO	24.24	24.25
CA 26-4A-5A	LTE B2	20	18700	1860	QPSK	1	0	700	1840	2x2 MIMO	LTE B4	20	2175	2132.5	4x4 MIMO	LTE B5	10	2525	881.5	2x2 MIMO	24.29	24.25
CA 26-4A-7A	LTE B2	20	18700	1860	QPSK	1	0	700	1840	4x4 MIMO	LTE B4	20	2175	2132.5	2x2 MIMO	LTE B7	20	3100	2655	2x2 MIMO	24.39	24.25
CA 26-4A-7A	LTE B2	20	18700	1860	QPSK	1	0	700	1840	2x2 MIMO	LTE B4	20	2175	2132.5	4x4 MIMO	LTE B7	20	3100	2655	2x2 MIMO	24.34	24.25
CA 26-4A-7A	LTE B2	20	18700	1860	QPSK	1	0	700	1840	4x4 MIMO	LTE B4	20	2175	2132.5	2x2 MIMO	LTE B7	20	3100	2655	4x4 MIMO	24.31	24.25
CA 26-4A-12A	LTE B2	20	18700	1860	QPSK	1	0	700	1840	4x4 MIMO	LTE B4	20	2175	2132.5	2x2 MIMO	LTE B12	10	5095	737.5	2x2 MIMO	24.35	24.25
CA 26-4A-12A	LTE B2	20	18700	1860	QPSK	1	0	700	1840	2x2 MIMO	LTE B4	20	2175	2132.5	4x4 MIMO	LTE B12	10	5095	737.5	2x2 MIMO	24.35	24.25
CA 26-4A-12A	LTE B2	20	18700	1860	QPSK	1	0	700	1840	4x4 MIMO	LTE B4	20	2175	2132.5	2x2 MIMO	LTE B12	10	5095	737.5	4x4 MIMO	24.27	24.25
CA 26-4A-13A	LTE B2	20	18700	1860	QPSK	1	0	700	1840	4x4 MIMO	LTE B4	20	2175	2132.5	2x2 MIMO	LTE B13	10	5230	751	2x2 MIMO	24.38	24.25
CA 26-4A-13A	LTE B2	20	18700	1860	QPSK	1	0	700	1840	2x2 MIMO	LTE B4	20	2175	2132.5	4x4 MIMO	LTE B13	10	5230	751	2x2 MIMO	24.28	24.25
CA 26-4A-13A	LTE B2	20	18700	1860	QPSK	1	0	700	1840	4x4 MIMO	LTE B4	20	2175	2132.5	2x2 MIMO	LTE B13	10	5230	751	4x4 MIMO	24.37	24.25
CA 26-4A-30A	LTE B2	20	18700	1860	QPSK	1	0	700	1840	4x4 MIMO	LTE B4	20	2175	2132.5	2x2 MIMO	LTE B30	10	9715	722.5	2x2 MIMO	24.29	24.25
CA 26-4A-30A	LTE B2	20	18700	1860	QPSK	1	0	700	1840	2x2 MIMO	LTE B4	20	2175	2132.5	4x4 MIMO	LTE B30	10	9715	722.5	4x4 MIMO	24.35	24.25
CA 26-4A-30A	LTE B2	20	18700	1860	QPSK	1	0	700	1840	4x4 MIMO	LTE B4	20	2175	2132.5	2x2 MIMO	LTE B30	10	9715	722.5	2x2 MIMO	24.31	24.25
CA 26-4A-71A	LTE B2	20	18700	1860	QPSK	1	0	700	1840	4x4 MIMO	LTE B4	20	2175	2132.5	4x4 MIMO	LTE B71	20	68761	634.5	2x2 MIMO	24.33	24.25
CA 26-4A-71A	LTE B2	20	18700	1860	QPSK	1	0	700	1840	2x2 MIMO	LTE B4	20	2175	2132.5	2x2 MIMO	LTE B71	20	68761	634.5	4x4 MIMO	24.31	24.25
CA 26-5A-30A	LTE B2	20	18700	1860	QPSK	1	0	700	1840	2x2 MIMO	LTE B5	10	2525	881.5	2x2 MIMO	LTE B30	10	9820	2355	2x2 MIMO	24.31	24.25
CA 26-5A-30A	LTE B2	20	18700	1860	QPSK	1	0	700	1840	4x4 MIMO	LTE B5	10	2525	881.5	2x2 MIMO	LTE B30	10	9820	2355	4x4 MIMO	24.3	24.25
CA 26-5A-66A	LTE B2	20	18700	1860	QPSK	1	0	700	1840	4x4 MIMO	LTE B5	10	2525	881.5	2x2 MIMO	LTE B66	20	66786	2145	2x2 MIMO	24.26	24.25
CA 26-5A-66A	LTE B2	20	18700	1860	QPSK	1	0	700	1840	2x2 MIMO	LTE B5	10	2525	881.5	4x4 MIMO	LTE B66	20	66786	2145	4x4 MIMO	24.27	24.25
CA 26-7A-12A	LTE B2	20	18700	1860	QPSK	1	0	700	1840	4x4 MIMO	LTE B7	20	3100	2655	4x4 MIMO	LTE B7	20	2850	2630	2x2 MIMO	24.33	24.25
CA 26-7A-12A	LTE B2	20	18700	1860	QPSK	1	0	700	1840	2x2 MIMO	LTE B7	20	3100	2655	2x2 MIMO	LTE B12	10	5095	737.5	2x2 MIMO	24.27	24.25
CA 26-7A-12A	LTE B2	20	18700	1860	QPSK	1	0	700	1840	4x4 MIMO	LTE B7	20	3100	2655	4x4 MIMO	LTE B12	10	5095	737.5	2x2 MIMO	24.31	24.25
CA 26-12A-30A	LTE B2	20	18700	1860	QPSK	1	0	700	1840	4x4 MIMO	LTE B12	10	5095	737.5	2x2 MIMO	LTE B30	10	9820	2355	2x2 MIMO	24.34	24.25
CA 26-12A-30A	LTE B2	20	18700	1860	QPSK	1	0	700	1840	2x2 MIMO	LTE B12	10	5095	737.5	4x4 MIMO	LTE B30	10	9820	2355	4x4 MIMO	24.34	24.25
CA 26-12A-30A	LTE B2	20	18700	1860	QPSK	1	0	700	1840	4x4 MIMO	LTE B12	10	5095	737.5	2x2 MIMO	LTE B66	20	66786	2145	4x4 MIMO	24.26	24.25
CA 26-13A-66A	LTE B2	20	18700	1860	QPSK	1	0	700	1840	4x4 MIMO	LTE B13	10	5230	751	2x2 MIMO	LTE B66	20	66786	2145	2x2 MIMO	24.26	24.25
CA 26-13A-66A	LTE B2	20	18700	1860	QPSK	1	0	700	1840	2x2 MIMO	LTE B13	10	5230	751	4x4 MIMO	LTE B66	20	66786	2145	4x4 MIMO	24.26	24.25
CA 26-29A-30A	LTE B2	20	18700	1860	QPSK	1	0	700	1840	4x4 MIMO	LTE B20	10	9715	722.5	2x2 MIMO	LTE B30	10	9820	2355	2x2 MIMO	24.29	24.25
CA 26-29A-30A	LTE B2	20	18700	1860	QPSK	1	0	700	1840	2x2 MIMO	LTE B20	10	9715	722.5	4x4 MIMO	LTE B30	10	9820	2355	4x4 MIMO	24.31	24.25
CA 26-29A-30A	LTE B2	20	18700	1860	QPSK	1	0	700	1840	4x4 MIMO	LTE B20	10	9715	722.5	2x2 MIMO	LTE B66	20	66786	2145	2x2 MIMO	24.32	24.25
CA 26-30A-66A	LTE B2	20	18700	1860	QPSK	1	0	700	1840	4x4 MIMO	LTE B20	10	9715	722.5	4x4 MIMO	LTE B66	20	66786	2145	4x4 MIMO	24.29	24.25
CA 26-30A-66A	LTE B2	20	18700	1860	QPSK	1	0	700	1840	2x2 MIMO	LTE B20	10	9715	722.5	2x2 MIMO	LTE B66	20	66786	2145	4x4 MIMO	24.28	24.25
CA 26-30A-66A	LTE B2	20	18700	1860	QPSK	1	0	700	1840	4x4 MIMO	LTE B20	10	9715	722.5	2x2 MIMO	LTE B66	20	66786	2145	2x2 MIMO	24.26	24.25
CA 26-66A-66A	LTE B2	20	18700	1860	QPSK	1	0	700	1840	4x4 MIMO	LTE B66	20	66786	2145	4x4 MIMO	LTE B66	20	66786	2145	2x2 MIMO	24.29	24.25
CA 26-66A-66A	LTE B2	20	18700	1860	QPSK	1	0	700	1840	2x2 MIMO	LTE B66	20	66786	2145	2x2 MIMO	LTE B71	20	68761	634.5	2x2 MIMO	24.26	24.25
CA 26-66A-71A	LTE B2	20	18700	1860	QPSK	1	0	700														





## 1.3.10 LTE Band 30 Antenna A

### Table I-34 Additional Maximum Output Powers – 3 Component Carriers

Combination	PCC Band	PCC Bandwidth [MHz]	PCC [DL] Channel	PCC [UL] Frequency [MHz]	Modulation	PCC UL RB	PCC UL RB Offset	PCC [DL] Channel	PCC [DL] Frequency [MHz]	DL Ant. Config.	SCC 1			SCC 2			Power					
											SCC Band	SCC Bandwidth [MHz]	SCC [DL] Channel	SCC [DL] Frequency [MHz]	DL Ant. Config.	SCC Band	SCC Bandwidth [MHz]	SCC [DL] Channel	SCC [DL] Frequency [MHz]	DL Ant. Config.	LTE Tx Power with DL CA Enabled (dBm)	LTE Ant. A Tx Power (dBm)
CA 2A-2A-30A	LTE B30 AHA	10	27710	2310	QPSK	1	0	9820	2355	2x2 MIMO	LTE B2	20	900	1960	4x4 MIMO	LTE B2	20	700	1940	2x2 MIMO	24.48	24.41
CA 2A-2A-30A	LTE B30 AHA	10	27710	2310	QPSK	1	0	9820	2355	4x4 MIMO	LTE B2	20	900	1960	2x2 MIMO	LTE B2	20	700	1940	2x2 MIMO	24.48	24.41
CA 2A-4A-30A	LTE B30 AHA	10	27710	2310	QPSK	1	0	9820	2355	4x4 MIMO	LTE B2	20	900	1960	2x2 MIMO	LTE B4	20	2175	2132.5	2x2 MIMO	24.48	24.41
CA 2A-5A-30A	LTE B30 AHA	10	27710	2310	QPSK	1	0	9820	2355	4x4 MIMO	LTE B2	20	900	1960	4x4 MIMO	LTE B5	10	2525	2132.5	2x2 MIMO	24.47	24.41
CA 2A-5A-30A	LTE B30 AHA	10	27710	2310	QPSK	1	0	9820	2355	4x4 MIMO	LTE B2	20	900	1960	4x4 MIMO	LTE B5	10	2525	2132.5	2x2 MIMO	24.47	24.41
CA 2A-12A-30A	LTE B30 AHA	10	27710	2310	QPSK	1	0	9820	2355	2x2 MIMO	LTE B2	20	900	1960	4x4 MIMO	LTE B12	10	5095	737.5	2x2 MIMO	24.48	24.41
CA 2A-29A-30A	LTE B30 AHA	10	27710	2310	QPSK	1	0	9820	2355	2x2 MIMO	LTE B2	20	900	1960	4x4 MIMO	LTE B29	10	9715	722.5	2x2 MIMO	24.45	24.41
CA 2A-30A-66A	LTE B30 AHA	10	27710	2310	QPSK	1	0	9820	2355	4x4 MIMO	LTE B2	20	900	1960	4x4 MIMO	LTE B66	20	66786	2145	2x2 MIMO	24.46	24.41
CA 2A-30A-66A	LTE B30 AHA	10	27710	2310	QPSK	1	0	9820	2355	2x2 MIMO	LTE B2	20	900	1960	2x2 MIMO	LTE B66	20	66786	2145	4x4 MIMO	24.47	24.41
CA 4A-29A-30A	LTE B30 AHA	10	27710	2310	QPSK	1	0	9820	2355	4x4 MIMO	LTE B4	20	2175	2132.5	2x2 MIMO	LTE B5	10	2525	881.5	2x2 MIMO	24.49	24.41
CA 4A-29A-30A	LTE B30 AHA	10	27710	2310	QPSK	1	0	9820	2355	4x4 MIMO	LTE B4	20	2175	2132.5	2x2 MIMO	LTE B29	10	9715	722.5	2x2 MIMO	24.45	24.41
CA 4A-30A-66A	LTE B30 AHA	10	27710	2310	QPSK	1	0	9820	2355	4x4 MIMO	LTE B5	10	2525	881.5	2x2 MIMO	LTE B66	20	66786	2145	2x2 MIMO	24.46	24.41
CA 4A-30A-66A	LTE B30 AHA	10	27710	2310	QPSK	1	0	9820	2355	4x4 MIMO	LTE B5	10	2525	881.5	2x2 MIMO	LTE B66	20	66786	2145	4x4 MIMO	24.45	24.41
CA 12A-30A-66A	LTE B30 AHA	10	27710	2310	QPSK	1	0	9820	2355	2x2 MIMO	LTE B12	10	5095	737.5	2x2 MIMO	LTE B66	20	66786	2145	4x4 MIMO	24.48	24.41
CA 12A-30A-66A	LTE B30 AHA	10	27710	2310	QPSK	1	0	9820	2355	2x2 MIMO	LTE B12	10	5095	737.5	2x2 MIMO	LTE B66	20	66786	2145	2x2 MIMO	24.48	24.41
CA 30A-66A-66A	LTE B30 AHA	10	27710	2310	QPSK	1	0	9820	2355	2x2 MIMO	LTE B66	20	66786	2145	2x2 MIMO	LTE B66	20	66786	2145	2x2 MIMO	24.43	24.41
CA 30A-66A-66A	LTE B30 AHA	10	27710	2310	QPSK	1	0	9820	2355	2x2 MIMO	LTE B66	20	66786	2145	2x2 MIMO	LTE B66	20	66786	2145	2x2 MIMO	24.43	24.41

### Table I-35 Additional Hotspot Output Powers – 3 Component Carriers

Combination	PCC Band	PCC Bandwidth [MHz]	PCC [DL] Channel	PCC [UL] Frequency [MHz]	Modulation	PCC UL RB	PCC UL RB Offset	PCC [DL] Channel	PCC [DL] Frequency [MHz]	DL Ant. Config.	SCC 1			SCC 2			Power					
											SCC Band	SCC Bandwidth [MHz]	SCC [DL] Channel	SCC [DL] Frequency [MHz]	DL Ant. Config.	SCC Band	SCC Bandwidth [MHz]	SCC [DL] Channel	SCC [DL] Frequency [MHz]	DL Ant. Config.	LTE Tx Power with DL CA Enabled (dBm)	LTE Ant. A Tx Power (dBm)
CA 2A-2A-30A	LTE B30 AHA	10	27710	2310	16QAM	1	0	9820	2355	2x2 MIMO	LTE B2	20	900	1960	4x4 MIMO	LTE B2	20	700	1940	2x2 MIMO	21.37	21.39
CA 2A-2A-30A	LTE B30 AHA	10	27710	2310	16QAM	1	0	9820	2355	4x4 MIMO	LTE B2	20	900	1960	2x2 MIMO	LTE B2	20	700	1940	2x2 MIMO	21.37	21.39
CA 2A-4A-30A	LTE B30 AHA	10	27710	2310	16QAM	1	0	9820	2355	4x4 MIMO	LTE B2	20	900	1960	2x2 MIMO	LTE B4	20	2175	2132.5	2x2 MIMO	21.37	21.39
CA 2A-5A-30A	LTE B30 AHA	10	27710	2310	16QAM	1	0	9820	2355	4x4 MIMO	LTE B2	20	900	1960	4x4 MIMO	LTE B5	10	2525	881.5	2x2 MIMO	21.38	21.39
CA 2A-5A-30A	LTE B30 AHA	10	27710	2310	16QAM	1	0	9820	2355	4x4 MIMO	LTE B2	20	900	1960	4x4 MIMO	LTE B5	10	2525	881.5	2x2 MIMO	21.38	21.39
CA 2A-12A-30A	LTE B30 AHA	10	27710	2310	16QAM	1	0	9820	2355	2x2 MIMO	LTE B2	20	900	1960	4x4 MIMO	LTE B12	10	5095	737.5	2x2 MIMO	21.39	21.39
CA 2A-29A-30A	LTE B30 AHA	10	27710	2310	16QAM	1	0	9820	2355	2x2 MIMO	LTE B2	20	900	1960	4x4 MIMO	LTE B29	10	9715	722.5	2x2 MIMO	21.37	21.39
CA 2A-30A-66A	LTE B30 AHA	10	27710	2310	16QAM	1	0	9820	2355	4x4 MIMO	LTE B2	20	900	1960	4x4 MIMO	LTE B66	20	66786	2145	2x2 MIMO	21.40	21.39
CA 2A-30A-66A	LTE B30 AHA	10	27710	2310	16QAM	1	0	9820	2355	2x2 MIMO	LTE B2	20	900	1960	2x2 MIMO	LTE B66	20	66786	2145	4x4 MIMO	21.37	21.39
CA 4A-29A-30A	LTE B30 AHA	10	27710	2310	16QAM	1	0	9820	2355	4x4 MIMO	LTE B4	20	2175	2132.5	2x2 MIMO	LTE B5	10	2525	881.5	2x2 MIMO	21.37	21.39
CA 4A-29A-30A	LTE B30 AHA	10	27710	2310	16QAM	1	0	9820	2355	4x4 MIMO	LTE B4	20	2175	2132.5	2x2 MIMO	LTE B29	10	9715	722.5	2x2 MIMO	21.36	21.39
CA 4A-30A-66A	LTE B30 AHA	10	27710	2310	16QAM	1	0	9820	2355	4x4 MIMO	LTE B5	10	2525	881.5	2x2 MIMO	LTE B66	20	66786	2145	2x2 MIMO	21.38	21.39
CA 4A-30A-66A	LTE B30 AHA	10	27710	2310	16QAM	1	0	9820	2355	4x4 MIMO	LTE B5	10	2525	881.5	2x2 MIMO	LTE B66	20	66786	2145	4x4 MIMO	21.38	21.39
CA 12A-30A-66A	LTE B30 AHA	10	27710	2310	16QAM	1	0	9820	2355	2x2 MIMO	LTE B12	10	5095	737.5	2x2 MIMO	LTE B66	20	66786	2145	2x2 MIMO	21.41	21.39
CA 12A-30A-66A	LTE B30 AHA	10	27710	2310	16QAM	1	0	9820	2355	2x2 MIMO	LTE B12	10	5095	737.5	2x2 MIMO	LTE B66	20	66786	2145	2x2 MIMO	21.41	21.39
CA 30A-66A-66A	LTE B30 AHA	10	27710	2310	16QAM	1	0	9820	2355	2x2 MIMO	LTE B66	20	66786	2145	2x2 MIMO	LTE B66	20	66786	2145	2x2 MIMO	21.36	21.39
CA 30A-66A-66A	LTE B30 AHA	10	27710	2310	16QAM	1	0	9820	2355	2x2 MIMO	LTE B66	20	66786	2145	2x2 MIMO	LTE B66	20	66786	2145	2x2 MIMO	21.36	21.39

## 1.3.11 LTE Band 7 Antenna A

### Table I-36 Additional Maximum Output Powers – 3 Component Carriers

Combination	PCC Band	PCC Bandwidth [MHz]	PCC [DL] Channel	PCC [UL] Frequency [MHz]	Modulation	PCC UL RB	PCC UL RB Offset	PCC [DL] Channel	PCC [DL] Frequency [MHz]	DL Ant. Config.	SCC 1			SCC 2			Power					
											SCC Band	SCC Bandwidth [MHz]	SCC [DL] Channel	SCC [DL] Frequency [MHz]	DL Ant. Config.	SCC Band	SCC Bandwidth [MHz]	SCC [DL] Channel	SCC [DL] Frequency [MHz]	DL Ant. Config.	LTE Tx Power with DL CA Enabled (dBm)	LTE Ant. A Tx Power (dBm)
CA 2A-4A-7A	LTE B7 AHA	20	21350	2560	QPSK	1	99	3350	2680	2x2 MIMO	LTE B2	20	900	1960	4x4 MIMO	LTE B4	20	2175	2132.5	2x2 MIMO	23.37	23.39
CA 2A-4A-7A	LTE B7 AHA	20	21350	2560	QPSK	1	99	3350	2680	4x4 MIMO	LTE B2	20	900	1960	2x2 MIMO	LTE B4	20	2175	2132.5	2x2 MIMO	23.37	23.39
CA 2A-7A-7A	LTE B7 AHA	20	21350	2560	QPSK	1	99	3350	2680	2x2 MIMO	LTE B7	20	2850	2630	2x2 MIMO	LTE B2	20	900	1960	4x4 MIMO	21.4	21.39
CA 2A-7A-7A	LTE B7 AHA	20	21350	2560	QPSK	1	99	3350	2680	4x4 MIMO	LTE B7	20	2850	2630	2x2 MIMO	LTE B2	20	900	1960	4x4 MIMO	21.38	21.39
CA 2A-7A-7A	LTE B7 AHA	20	21350	2560	QPSK	1	99	3350	2680	2x2 MIMO	LTE B7	20	2850	2630	4x4 MIMO	LTE B2	20	900	1960	2x2 MIMO	21.36	21.39
CA 2A-7A-12A	LTE B7 AHA	20	21350	2560	QPSK	1	99	3350	2680	2x2 MIMO	LTE B2	20	900	1960	4x4 MIMO	LTE B12	10	5095	737.5	2x2 MIMO	21.37	21.39
CA 2A-7A-12A	LTE B7 AHA	20	21350	2560	QPSK	1	99	3350	2680	4x4 MIMO	LTE B2	20	900	1960	2x2 MIMO	LTE B12	10	5095	737.5	2x2 MIMO	21.41	21.39
CA 4A-7A-7A	LTE B7 AHA	20	21350	2560	QPSK	1	99	3350	2680	2x2 MIMO	LTE B7	20	2850	2630	2x2 MIMO	LTE B4	20	2175	2132.5	4x4 MIMO	21.38	21.39
CA 4A-7A-7A	LTE B7 AHA	20	21350	2560	QPSK	1	99	3350	2680	4x4 MIMO	LTE B7	20	2850	2630	2x2 MIMO	LTE B4	20	2175	2132.5	2x2 MIMO	21.33	21.39
CA 4A-7A-7A	LTE B7 AHA	20	21350	2560	QPSK	1	99	3350	2680	2x2 MIMO	LTE B7	20	2850	2630	4x4 MIMO	LTE B4	20	2175	2132.5	2x2 MIMO	21.37	21.39
CA 4A-7A-12A	LTE B7 AHA	20	21350	2560	QPSK	1	99	3350	2680	2x2 MIMO	LTE B4	20	2175	2132.5	4x4 MIMO	LTE B12	10	5095	737.5	2x2 MIMO	21.38	21.39
CA 4A-7A-12A	LTE B7 AHA	20	21350	2560	QPSK	1	99	3350	2680	4x4 MIMO	LTE B4	20										

### 1.3.12 LTE Band 41 PC3

Table I-38  
Additional Maximum Output Powers – 3 Component Carriers

Combination	PCC										SCC1				SCC2				Power			
	PCC Band	PCC Bandwidth [MHz]	PCC [UL] Channel	PCC [DL] Frequency [MHz]	Modulation	PCC UL RB	PCC UL RB Offset	PCC [DL] Channel	PCC [DL] Frequency [MHz]	DL Ant. Config.	SCC Band	SCC Bandwidth [MHz]	SCC [DL] Channel	SCC [DL] Frequency [MHz]	DL Ant. Config.	SCC Band	SCC Bandwidth [MHz]	SCC [DL] Channel	SCC [DL] Frequency [MHz]	DL Ant. Config.	LTE Tx Power with DL CA Enabled [dBm]	LTE Single Carrier Tx Power [dBm]
CA_41D	LTE B41	15	40185	2549.5	QPSK	1	0	40185	2549.5	4x4 MIMO	LTE B41	20	40356	2569.6	4x4 MIMO	LTE B41	20	40554	2589.4	4x4 MIMO	24.07	24.08
CA_41A_41C	LTE B41	15	40185	2549.5	QPSK	1	0	40185	2549.5	4x4 MIMO	LTE B41	20	41292	2660.2	2x2 MIMO	LTE B41	20	41490	2680	2x2 MIMO	24.03	24.08
CA_41C_41A	LTE B41	15	40185	2549.5	QPSK	1	0	40185	2549.5	2x2 MIMO	LTE B41	20	40356	2569.6	4x4 MIMO	LTE B41	20	41490	2680	4x4 MIMO	24.04	24.08
CA_41A_41C	LTE B41	15	40185	2549.5	QPSK	1	0	40185	2549.5	2x2 MIMO	LTE B41	20	41292	2660.2	4x4 MIMO	LTE B41	20	41490	2680	4x4 MIMO	24.06	24.08
CA_41C_41A	LTE B41	15	40185	2549.5	QPSK	1	0	40185	2549.5	4x4 MIMO	LTE B41	20	40356	2569.6	4x4 MIMO	LTE B41	20	41490	2680	4x4 MIMO	24.07	24.08
CA_41A_41C	LTE B41	15	40185	2549.5	QPSK	1	0	40185	2549.5	4x4 MIMO	LTE B41	20	41292	2660.2	4x4 MIMO	LTE B41	20	41490	2680	4x4 MIMO	24.04	24.08
CA_41C_41A	LTE B41	15	40185	2549.5	QPSK	1	0	40185	2549.5	4x4 MIMO	LTE B41	20	40356	2569.6	4x4 MIMO	LTE B41	20	41490	2680	4x4 MIMO	24.03	24.08

Table I-39  
Additional Hotspot Output Powers – 3 Component Carriers

Combination	PCC										SCC1				SCC2				Power			
	PCC Band	PCC Bandwidth [MHz]	PCC [UL] Channel	PCC [DL] Frequency [MHz]	Modulation	PCC UL RB	PCC UL RB Offset	PCC [DL] Channel	PCC [DL] Frequency [MHz]	DL Ant. Config.	SCC Band	SCC Bandwidth [MHz]	SCC [DL] Channel	SCC [DL] Frequency [MHz]	DL Ant. Config.	SCC Band	SCC Bandwidth [MHz]	SCC [DL] Channel	SCC [DL] Frequency [MHz]	DL Ant. Config.	LTE Tx Power with DL CA Enabled [dBm]	LTE Single Carrier Tx Power [dBm]
CA_41D	LTE B41	20	40185	2549.5	QPSK	1	0	40185	2549.5	4x4 MIMO	LTE B41	20	40393	2569.3	4x4 MIMO	LTE B41	20	40581	2589.1	4x4 MIMO	23.47	23.50
CA_41A_41C	LTE B41	20	40185	2549.5	QPSK	1	0	40185	2549.5	4x4 MIMO	LTE B41	20	41292	2660.2	2x2 MIMO	LTE B41	20	41490	2680	2x2 MIMO	23.45	23.50
CA_41C_41A	LTE B41	20	40185	2549.5	QPSK	1	0	40185	2549.5	2x2 MIMO	LTE B41	20	40393	2569.3	2x2 MIMO	LTE B41	20	40581	2589.1	4x4 MIMO	23.47	23.50
CA_41A_41C	LTE B41	20	40185	2549.5	QPSK	1	0	40185	2549.5	2x2 MIMO	LTE B41	20	41292	2660.2	4x4 MIMO	LTE B41	20	41490	2680	4x4 MIMO	23.42	23.50
CA_41C_41A	LTE B41	20	40185	2549.5	QPSK	1	0	40185	2549.5	4x4 MIMO	LTE B41	20	40393	2569.3	4x4 MIMO	LTE B41	20	40581	2589.1	4x4 MIMO	23.46	23.50
CA_41A_41C	LTE B41	20	40185	2549.5	QPSK	1	0	40185	2549.5	4x4 MIMO	LTE B41	20	41292	2660.2	4x4 MIMO	LTE B41	20	41490	2680	4x4 MIMO	23.46	23.50
CA_41C_41A	LTE B41	20	40185	2549.5	QPSK	1	0	40185	2549.5	4x4 MIMO	LTE B41	20	40393	2569.3	4x4 MIMO	LTE B41	20	41490	2680	4x4 MIMO	23.48	23.50

### 1.3.13 LTE Band 41 PC2

Table I-40  
Additional Maximum Output Powers – 3 Component Carriers

Combination	PCC										SCC1				SCC2				Power			
	PCC Band	PCC Bandwidth [MHz]	PCC [UL] Channel	PCC [DL] Frequency [MHz]	Modulation	PCC UL RB	PCC UL RB Offset	PCC [DL] Channel	PCC [DL] Frequency [MHz]	DL Ant. Config.	SCC Band	SCC Bandwidth [MHz]	SCC [DL] Channel	SCC [DL] Frequency [MHz]	DL Ant. Config.	SCC Band	SCC Bandwidth [MHz]	SCC [DL] Channel	SCC [DL] Frequency [MHz]	DL Ant. Config.	LTE Tx Power with DL CA Enabled [dBm]	LTE Single Carrier Tx Power [dBm]
CA_41D	LTE B41 PC2	15	40185	2549.5	QPSK	1	0	40185	2549.5	4x4 MIMO	LTE B41 PC2	20	40356	2569.6	4x4 MIMO	LTE B41 PC2	20	40554	2589.4	4x4 MIMO	27.05	27.06
CA_41A_41C	LTE B41 PC2	15	40185	2549.5	QPSK	1	0	40185	2549.5	4x4 MIMO	LTE B41 PC2	20	41292	2660.2	2x2 MIMO	LTE B41 PC2	20	41490	2680	2x2 MIMO	27.04	27.06
CA_41C_41A	LTE B41 PC2	15	40185	2549.5	QPSK	1	0	40185	2549.5	2x2 MIMO	LTE B41 PC2	20	40356	2569.6	2x2 MIMO	LTE B41 PC2	20	41490	2680	4x4 MIMO	27.07	27.06
CA_41A_41C	LTE B41 PC2	15	40185	2549.5	QPSK	1	0	40185	2549.5	2x2 MIMO	LTE B41 PC2	20	41292	2660.2	4x4 MIMO	LTE B41 PC2	20	41490	2680	4x4 MIMO	27.07	27.06
CA_41C_41A	LTE B41 PC2	15	40185	2549.5	QPSK	1	0	40185	2549.5	4x4 MIMO	LTE B41 PC2	20	40356	2569.6	4x4 MIMO	LTE B41 PC2	20	41490	2680	4x4 MIMO	27.06	27.06
CA_41A_41C	LTE B41 PC2	15	40185	2549.5	QPSK	1	0	40185	2549.5	4x4 MIMO	LTE B41 PC2	20	41292	2660.2	4x4 MIMO	LTE B41 PC2	20	41490	2680	4x4 MIMO	27.06	27.06
CA_41C_41A	LTE B41 PC2	15	40185	2549.5	QPSK	1	0	40185	2549.5	4x4 MIMO	LTE B41 PC2	20	40356	2569.6	4x4 MIMO	LTE B41 PC2	20	41490	2680	4x4 MIMO	27.03	27.06

Table I-41  
Additional Hotspot Output Powers – 3 Component Carriers

Combination	PCC										SCC1				SCC2				Power			
	PCC Band	PCC Bandwidth [MHz]	PCC [UL] Channel	PCC [DL] Frequency [MHz]	Modulation	PCC UL RB	PCC UL RB Offset	PCC [DL] Channel	PCC [DL] Frequency [MHz]	DL Ant. Config.	SCC Band	SCC Bandwidth [MHz]	SCC [DL] Channel	SCC [DL] Frequency [MHz]	DL Ant. Config.	SCC Band	SCC Bandwidth [MHz]	SCC [DL] Channel	SCC [DL] Frequency [MHz]	DL Ant. Config.	LTE Tx Power with DL CA Enabled [dBm]	LTE Single Carrier Tx Power [dBm]
CA_41D	LTE B41 PC2	20	39750	2506	16QAM	1	0	39750	2506	4x4 MIMO	LTE B41 PC2	20	39848	2525.8	4x4 MIMO	LTE B41 PC2	20	40146	2545.6	4x4 MIMO	23.45	23.50
CA_41A_41C	LTE B41 PC2	20	39750	2506	16QAM	1	0	39750	2506	4x4 MIMO	LTE B41 PC2	20	41292	2660.2	2x2 MIMO	LTE B41 PC2	20	41490	2680	2x2 MIMO	23.37	23.50
CA_41C_41A	LTE B41 PC2	20	39750	2506	16QAM	1	0	39750	2506	2x2 MIMO	LTE B41 PC2	20	39848	2525.8	2x2 MIMO	LTE B41 PC2	20	41490	2680	4x4 MIMO	23.48	23.50
CA_41A_41C	LTE B41 PC2	20	39750	2506	16QAM	1	0	39750	2506	2x2 MIMO	LTE B41 PC2	20	41292	2660.2	4x4 MIMO	LTE B41 PC2	20	41490	2680	4x4 MIMO	23.40	23.50
CA_41C_41A	LTE B41 PC2	20	39750	2506	16QAM	1	0	39750	2506	4x4 MIMO	LTE B41 PC2	20	39848	2525.8	4x4 MIMO	LTE B41 PC2	20	41490	2680	4x4 MIMO	23.41	23.50
CA_41A_41C	LTE B41 PC2	20	39750	2506	16QAM	1	0	39750	2506	4x4 MIMO	LTE B41 PC2	20	41292	2660.2	4x4 MIMO	LTE B41 PC2	20	41490	2680	4x4 MIMO	23.44	23.50
CA_41C_41A	LTE B41 PC2	20	39750	2506	16QAM	1	0	39750	2506	4x4 MIMO	LTE B41 PC2	20	39848	2525.8	4x4 MIMO	LTE B41 PC2	20	41490	2680	4x4 MIMO	23.43	23.50

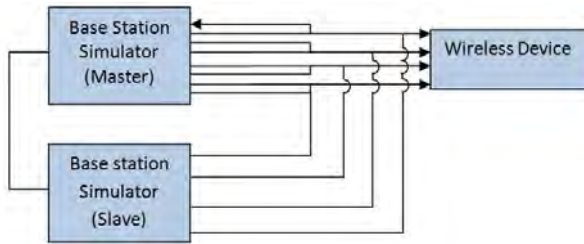

Figure I-3  
Power Measurement Setup

# 1.4 Carrier Aggregation Scenarios with 4 Component Carriers with 4x4 Downlink MIMO

## 1.4.1 LTE Band 13

Table I-42  
Additional Maximum Output Powers – 4 Component Carriers

Combination	PCC Band	PCC BW [MHz]	PCC [UL] Ch.	PCC				SCC 1				SCC 2				SCC 3				LTE Tx Power with DL CA Enabled [dBm]	LTE Single Carrier Tx Power [dBm]											
				PCC [DL] Freq. [MHz]	Mult.	PCC UL RB	PCC UL RB Offset	PCC [DL] Ch.	PCC [DL] Freq. [MHz]	DL Ant. Config.	SCC Band	SCC BW [MHz]	SCC [DL] Ch.	SCC [DL] Freq. [MHz]	DL Ant. Config.	SCC Band	SCC BW [MHz]	SCC [DL] Ch.	SCC [DL] Freq. [MHz]			DL Ant. Config.	SCC Band	SCC BW [MHz]	SCC [DL] Ch.	SCC [DL] Freq. [MHz]	DL Ant. Config.					
CA 2A-5B-6A	11E 85	5	20075	818.5	QPSK	1	0	2745	881.5	2x2 MIMO	11E 85	5	20075	818.5	QPSK	1	0	2745	881.5	2x2 MIMO	11E 85	5	20075	818.5	QPSK	1	0	2745	881.5	2x2 MIMO	24.18	24.18
CA 2A-5B-6A	11E 85	5	20075	818.5	QPSK	1	0	2745	881.5	2x2 MIMO	11E 85	5	20075	818.5	QPSK	1	0	2745	881.5	2x2 MIMO	11E 85	5	20075	818.5	QPSK	1	0	2745	881.5	2x2 MIMO	24.18	24.18
CA 2A-5B-6A	11E 85	5	20075	818.5	QPSK	1	0	2745	881.5	2x2 MIMO	11E 85	5	20075	818.5	QPSK	1	0	2745	881.5	2x2 MIMO	11E 85	5	20075	818.5	QPSK	1	0	2745	881.5	2x2 MIMO	24.18	24.18

## 1.4.2 LTE Band 5

Table I-43  
Additional Maximum Output Powers – 4 Component Carriers

Combination	PCC Band	PCC BW [MHz]	PCC [UL] Ch.	PCC				SCC 1				SCC 2				SCC 3				LTE Tx Power with DL CA Enabled [dBm]	LTE Single Carrier Tx Power [dBm]											
				PCC [DL] Freq. [MHz]	Mult.	PCC UL RB	PCC UL RB Offset	PCC [DL] Ch.	PCC [DL] Freq. [MHz]	DL Ant. Config.	SCC Band	SCC BW [MHz]	SCC [DL] Ch.	SCC [DL] Freq. [MHz]	DL Ant. Config.	SCC Band	SCC BW [MHz]	SCC [DL] Ch.	SCC [DL] Freq. [MHz]			DL Ant. Config.	SCC Band	SCC BW [MHz]	SCC [DL] Ch.	SCC [DL] Freq. [MHz]	DL Ant. Config.					
CA 2A-5B-6A	11E 85	5	20075	818.5	QPSK	1	0	2745	881.5	2x2 MIMO	11E 85	5	20075	818.5	QPSK	1	0	2745	881.5	2x2 MIMO	11E 85	5	20075	818.5	QPSK	1	0	2745	881.5	2x2 MIMO	24.18	24.18
CA 2A-5B-6A	11E 85	5	20075	818.5	QPSK	1	0	2745	881.5	2x2 MIMO	11E 85	5	20075	818.5	QPSK	1	0	2745	881.5	2x2 MIMO	11E 85	5	20075	818.5	QPSK	1	0	2745	881.5	2x2 MIMO	24.18	24.18
CA 2A-5B-6A	11E 85	5	20075	818.5	QPSK	1	0	2745	881.5	2x2 MIMO	11E 85	5	20075	818.5	QPSK	1	0	2745	881.5	2x2 MIMO	11E 85	5	20075	818.5	QPSK	1	0	2745	881.5	2x2 MIMO	24.18	24.18

## 1.4.3 LTE Band 66

Table I-44  
Additional Maximum Output Powers – 4 Component Carriers

Combination	PCC Band	PCC BW [MHz]	PCC [UL] Ch.	PCC				SCC 1				SCC 2				SCC 3				LTE Tx Power with DL CA Enabled [dBm]	LTE Single Carrier Tx Power [dBm]											
				PCC [DL] Freq. [MHz]	Mult.	PCC UL RB	PCC UL RB Offset	PCC [DL] Ch.	PCC [DL] Freq. [MHz]	DL Ant. Config.	SCC Band	SCC BW [MHz]	SCC [DL] Ch.	SCC [DL] Freq. [MHz]	DL Ant. Config.	SCC Band	SCC BW [MHz]	SCC [DL] Ch.	SCC [DL] Freq. [MHz]			DL Ant. Config.	SCC Band	SCC BW [MHz]	SCC [DL] Ch.	SCC [DL] Freq. [MHz]	DL Ant. Config.					
CA 2A-5B-6A	11E 85	5	20075	818.5	QPSK	1	0	2745	881.5	2x2 MIMO	11E 85	5	20075	818.5	QPSK	1	0	2745	881.5	2x2 MIMO	11E 85	5	20075	818.5	QPSK	1	0	2745	881.5	2x2 MIMO	24.18	24.18
CA 2A-5B-6A	11E 85	5	20075	818.5	QPSK	1	0	2745	881.5	2x2 MIMO	11E 85	5	20075	818.5	QPSK	1	0	2745	881.5	2x2 MIMO	11E 85	5	20075	818.5	QPSK	1	0	2745	881.5	2x2 MIMO	24.18	24.18
CA 2A-5B-6A	11E 85	5	20075	818.5	QPSK	1	0	2745	881.5	2x2 MIMO	11E 85	5	20075	818.5	QPSK	1	0	2745	881.5	2x2 MIMO	11E 85	5	20075	818.5	QPSK	1	0	2745	881.5	2x2 MIMO	24.18	24.18

Table I-45  
Additional Hotspot Output Powers – 4 Component Carriers

Combination	PCC Band	PCC BW [MHz]	PCC [UL] Ch.	PCC				SCC 1				SCC 2				SCC 3				LTE Tx Power with DL CA Enabled [dBm]	LTE Single Carrier Tx Power [dBm]											
				PCC [DL] Freq. [MHz]	Mult.	PCC UL RB	PCC UL RB Offset	PCC [DL] Ch.	PCC [DL] Freq. [MHz]	DL Ant. Config.	SCC Band	SCC BW [MHz]	SCC [DL] Ch.	SCC [DL] Freq. [MHz]	DL Ant. Config.	SCC Band	SCC BW [MHz]	SCC [DL] Ch.	SCC [DL] Freq. [MHz]			DL Ant. Config.	SCC Band	SCC BW [MHz]	SCC [DL] Ch.	SCC [DL] Freq. [MHz]	DL Ant. Config.					
CA 2A-5B-6A	11E 85	5	20075	818.5	QPSK	1	0	2745	881.5	2x2 MIMO	11E 85	5	20075	818.5	QPSK	1	0	2745	881.5	2x2 MIMO	11E 85	5	20075	818.5	QPSK	1	0	2745	881.5	2x2 MIMO	24.18	24.18
CA 2A-5B-6A	11E 85	5	20075	818.5	QPSK	1	0	2745	881.5	2x2 MIMO	11E 85	5	20075	818.5	QPSK	1	0	2745	881.5	2x2 MIMO	11E 85	5	20075	818.5	QPSK	1	0	2745	881.5	2x2 MIMO	24.18	24.18
CA 2A-5B-6A	11E 85	5	20075	818.5	QPSK	1	0	2745	881.5	2x2 MIMO	11E 85	5	20075	818.5	QPSK	1	0	2745	881.5	2x2 MIMO	11E 85	5	20075	818.5	QPSK	1	0	2745	881.5	2x2 MIMO	24.18	24.18

## 1.4.4 LTE Band 4

Table I-46  
Additional Maximum Output Powers – 4 Component Carriers

Combination	PCC Band	PCC BW [MHz]	PCC [UL] Ch.	PCC				SCC 1				SCC 2				SCC 3				LTE Tx Power with DL CA Enabled [dBm]	LTE Single Carrier Tx Power [dBm]											
				PCC [DL] Freq. [MHz]	Mult.	PCC UL RB	PCC UL RB Offset	PCC [DL] Ch.	PCC [DL] Freq. [MHz]	DL Ant. Config.	SCC Band	SCC BW [MHz]	SCC [DL] Ch.	SCC [DL] Freq. [MHz]	DL Ant. Config.	SCC Band	SCC BW [MHz]	SCC [DL] Ch.	SCC [DL] Freq. [MHz]			DL Ant. Config.	SCC Band	SCC BW [MHz]	SCC [DL] Ch.	SCC [DL] Freq. [MHz]	DL Ant. Config.					
CA 2A-4A-7C	11E 84	5	20020	1347.5	QPSK	1	0	2200	2147.5	2x2 MIMO	11E 84	5	20020	1347.5	QPSK	1	0	2200	2147.5	2x2 MIMO	11E 84	5	20020	1347.5	QPSK	1	0	2200	2147.5	2x2 MIMO	24.18	24.18

Table I-47  
Additional Hotspot Output Powers – 4 Component Carriers

Combination	PCC Band	PCC BW [MHz]	PCC [UL] Ch.	PCC				SCC 1				SCC 2				SCC 3				LTE Tx Power with DL CA Enabled [dBm]	LTE Single Carrier Tx Power [dBm]											
				PCC [DL] Freq. [MHz]	Mult.	PCC UL RB	PCC UL RB Offset	PCC [DL] Ch.	PCC [DL] Freq. [MHz]	DL Ant. Config.	SCC Band	SCC BW [MHz]	SCC [DL] Ch.	SCC [DL] Freq. [MHz]	DL Ant. Config.	SCC Band	SCC BW [MHz]	SCC [DL] Ch.	SCC [DL] Freq. [MHz]			DL Ant. Config.	SCC Band	SCC BW [MHz]	SCC [DL] Ch.	SCC [DL] Freq. [MHz]	DL Ant. Config.					
CA 2A-4A-7C	11E 84	5	20020	1347.5	QPSK	1	0	2200	2147.5	2x2 MIMO	11E 84	5	20020	1347.5	QPSK	1	0	2200	2147.5	2x2 MIMO	11E 84	5	20020	1347.5	QPSK	1	0	2200	2147.5	2x2 MIMO	24.18	24.18

FCC ID: A3LSMG960U		SAR EVALUATION REPORT		Approved by: Quality Manager
Test Dates: 11/03/17 – 12/07/17	DUT Type: Portable Handset		APPENDIX I: Page 13 of 19	

## 1.4.5 LTE Band 25

Table I-48  
Additional Maximum Output Powers – 4 Component Carriers

Combination	PCC										SCC 1				SCC 2				SCC 3				Power				
	PCC Band	PCC BW [MHz]	PCC [UL] Ch.	PCC [DL] Freq. [MHz]	Mod.	PCC UL RB	PCC UL RB Offset	PCC [DL] Ch.	PCC [DL] Freq. [MHz]	DL Ant. Config.	SCC Band	SCC BW [MHz]	SCC [DL] Ch.	SCC [DL] Freq. [MHz]	DL Ant. Config.	SCC Band	SCC BW [MHz]	SCC [DL] Ch.	SCC [DL] Freq. [MHz]	DL Ant. Config.	SCC Band	SCC BW [MHz]	SCC [DL] Ch.	SCC [DL] Freq. [MHz]	DL Ant. Config.	LTE Tx Power with DL CA Enabled [dBm]	LTE Single Carrier Tx Power [dBm]
CA_25A-420	LTE B25	20	20	2040	QPSK	1	0	2040	2040	4x4 MIMO	LTE B41	20	40020	2073.2	2x2 MIMO	LTE B41	20	40020	2103.2	2x2 MIMO	LTE B41	20	40020	2103.2	2x2 MIMO	23.2	23.2

Table I-49  
Additional Hotspot Output Powers – 4 Component Carriers

Combination	PCC										SCC 1				SCC 2				SCC 3				Power				
	PCC Band	PCC BW [MHz]	PCC [UL] Ch.	PCC [DL] Freq. [MHz]	Mod.	PCC UL RB	PCC UL RB Offset	PCC [DL] Ch.	PCC [DL] Freq. [MHz]	DL Ant. Config.	SCC Band	SCC BW [MHz]	SCC [DL] Ch.	SCC [DL] Freq. [MHz]	DL Ant. Config.	SCC Band	SCC BW [MHz]	SCC [DL] Ch.	SCC [DL] Freq. [MHz]	DL Ant. Config.	SCC Band	SCC BW [MHz]	SCC [DL] Ch.	SCC [DL] Freq. [MHz]	DL Ant. Config.	LTE Tx Power with DL CA Enabled [dBm]	LTE Single Carrier Tx Power [dBm]
CA_25A-420	LTE B25	20	20	2040	QPSK	1	0	2040	2040	4x4 MIMO	LTE B41	20	40020	2073.2	2x2 MIMO	LTE B41	20	40020	2103.2	2x2 MIMO	LTE B41	20	40020	2103.2	2x2 MIMO	23.2	23.2

## 1.4.6 LTE Band 2

Table I-50  
Additional Maximum Output Powers – 4 Component Carriers

Combination	PCC										SCC 1				SCC 2				SCC 3				Power				
	PCC Band	PCC BW [MHz]	PCC [UL] Ch.	PCC [DL] Freq. [MHz]	Mod.	PCC UL RB	PCC UL RB Offset	PCC [DL] Ch.	PCC [DL] Freq. [MHz]	DL Ant. Config.	SCC Band	SCC BW [MHz]	SCC [DL] Ch.	SCC [DL] Freq. [MHz]	DL Ant. Config.	SCC Band	SCC BW [MHz]	SCC [DL] Ch.	SCC [DL] Freq. [MHz]	DL Ant. Config.	SCC Band	SCC BW [MHz]	SCC [DL] Ch.	SCC [DL] Freq. [MHz]	DL Ant. Config.	LTE Tx Power with DL CA Enabled [dBm]	LTE Single Carrier Tx Power [dBm]
CA_25A-56A	LTE B2	20	18700	1880	QPSK	1	0	700	1880	2x2 MIMO	LTE B41	20	2175	2133.4	2x2 MIMO	LTE B7	20	2175	2103.2	4x4 MIMO	LTE B7	20	2175	2103.2	4x4 MIMO	23.2	23.2

Table I-51  
Additional Hotspot Output Powers – 4 Component Carriers

Combination	PCC										SCC 1				SCC 2				SCC 3				Power				
	PCC Band	PCC BW [MHz]	PCC [UL] Ch.	PCC [DL] Freq. [MHz]	Mod.	PCC UL RB	PCC UL RB Offset	PCC [DL] Ch.	PCC [DL] Freq. [MHz]	DL Ant. Config.	SCC Band	SCC BW [MHz]	SCC [DL] Ch.	SCC [DL] Freq. [MHz]	DL Ant. Config.	SCC Band	SCC BW [MHz]	SCC [DL] Ch.	SCC [DL] Freq. [MHz]	DL Ant. Config.	SCC Band	SCC BW [MHz]	SCC [DL] Ch.	SCC [DL] Freq. [MHz]	DL Ant. Config.	LTE Tx Power with DL CA Enabled [dBm]	LTE Single Carrier Tx Power [dBm]
CA_25A-56A	LTE B2	20	18700	1880	QPSK	1	0	700	1880	2x2 MIMO	LTE B41	20	2175	2133.4	2x2 MIMO	LTE B7	20	2175	2103.2	4x4 MIMO	LTE B7	20	2175	2103.2	4x4 MIMO	23.2	23.2

## 1.4.7 LTE Band 7 Antenna A

Table I-52  
Additional Maximum Output Powers – 4 Component Carriers

Combination	PCC										SCC 1				SCC 2				SCC 3				Power				
	PCC Band	PCC BW [MHz]	PCC [UL] Ch.	PCC [DL] Freq. [MHz]	Mod.	PCC UL RB	PCC UL RB Offset	PCC [DL] Ch.	PCC [DL] Freq. [MHz]	DL Ant. Config.	SCC Band	SCC BW [MHz]	SCC [DL] Ch.	SCC [DL] Freq. [MHz]	DL Ant. Config.	SCC Band	SCC BW [MHz]	SCC [DL] Ch.	SCC [DL] Freq. [MHz]	DL Ant. Config.	SCC Band	SCC BW [MHz]	SCC [DL] Ch.	SCC [DL] Freq. [MHz]	DL Ant. Config.	LTE Tx Power with DL CA Enabled [dBm]	LTE Ant. A Tx Power [dBm]
CA_25A-7A	LTE B7 Antenna A	20	31300	2980	QPSK	1	0	31300	2980	4x4 MIMO	LTE B7	20	31320	2980.2	4x4 MIMO	LTE B7	20	31320	2980.2	4x4 MIMO	LTE B7	20	31320	2980.2	4x4 MIMO	23.2	23.2

Table I-53  
Additional Hotspot Output Powers – 4 Component Carriers

Combination	PCC										SCC 1				SCC 2				SCC 3				Power				
	PCC Band	PCC BW [MHz]	PCC [UL] Ch.	PCC [DL] Freq. [MHz]	Mod.	PCC UL RB	PCC UL RB Offset	PCC [DL] Ch.	PCC [DL] Freq. [MHz]	DL Ant. Config.	SCC Band	SCC BW [MHz]	SCC [DL] Ch.	SCC [DL] Freq. [MHz]	DL Ant. Config.	SCC Band	SCC BW [MHz]	SCC [DL] Ch.	SCC [DL] Freq. [MHz]	DL Ant. Config.	SCC Band	SCC BW [MHz]	SCC [DL] Ch.	SCC [DL] Freq. [MHz]	DL Ant. Config.	LTE Tx Power with DL CA Enabled [dBm]	LTE Ant. A Tx Power [dBm]
CA_25A-7A	LTE B7 Antenna A	20	31300	2980	QPSK	1	0	31300	2980	4x4 MIMO	LTE B7	20	31320	2980.2	4x4 MIMO	LTE B7	20	31320	2980.2	4x4 MIMO	LTE B7	20	31320	2980.2	4x4 MIMO	23.2	23.2

## 1.4.8 LTE Band 41 PC3

Table I-54  
Additional Maximum Output Powers – 4 Component Carriers

Combination	PCC										SCC 1				SCC 2				SCC 3				Power									
	PCC Band	PCC BW [MHz]	PCC [DL] Ch.	PCC [UL] Freq. [MHz]	Mod.	PCC USA RB	PCC UL RB Offset	PCC [DL] Ch.	PCC [DL] Freq. [MHz]	DL Ant. Config.	SCC Band	SCC BW [MHz]	SCC [DL] Ch.	SCC [DL] Freq. [MHz]	DL Ant. Config.	SCC Band	SCC BW [MHz]	SCC [DL] Ch.	SCC [DL] Freq. [MHz]	DL Ant. Config.	SCC Band	SCC BW [MHz]	SCC [DL] Ch.	SCC [DL] Freq. [MHz]	DL Ant. Config.	SCC Band	SCC BW [MHz]	SCC [DL] Ch.	SCC [DL] Freq. [MHz]	DL Ant. Config.	LTE Tx Power with DL CA Enabled [dBm]	LTE Single Carrier Tx Power [dBm]
CA_41C-41C	LTE B41	15	40180	2149.5	QPSK	1	0	40180	2149.5	4x4 MIMO	LTE B41	20	40180	2149.5	4x4 MIMO	LTE B41	20	41202	2660.2	4x4 MIMO	LTE B41	20	41202	2660.2	4x4 MIMO	LTE B41	20	41202	2660.2	4x4 MIMO	24.00	23.00
CA_41C-41C	LTE B41	15	40180	2149.5	QPSK	1	0	40180	2149.5	2x2 MIMO	LTE B41	20	40180	2149.5	2x2 MIMO	LTE B41	20	41202	2660.2	2x2 MIMO	LTE B41	20	41202	2660.2	2x2 MIMO	LTE B41	20	41202	2660.2	2x2 MIMO	21.40	21.00

Table I-55  
Additional Hotspot Output Powers – 4 Component Carriers

Combination	PCC										SCC 1				SCC 2				SCC 3				Power									
	PCC Band	PCC BW [MHz]	PCC [DL] Ch.	PCC [UL] Freq. [MHz]	Mod.	PCC USA RB	PCC UL RB Offset	PCC [DL] Ch.	PCC [DL] Freq. [MHz]	DL Ant. Config.	SCC Band	SCC BW [MHz]	SCC [DL] Ch.	SCC [DL] Freq. [MHz]	DL Ant. Config.	SCC Band	SCC BW [MHz]	SCC [DL] Ch.	SCC [DL] Freq. [MHz]	DL Ant. Config.	SCC Band	SCC BW [MHz]	SCC [DL] Ch.	SCC [DL] Freq. [MHz]	DL Ant. Config.	SCC Band	SCC BW [MHz]	SCC [DL] Ch.	SCC [DL] Freq. [MHz]	DL Ant. Config.	LTE Tx Power with DL CA Enabled [dBm]	LTE Single Carrier Tx Power [dBm]
CA_41C-41C	LTE B41	20	40180	2149.5	QPSK	1	0	40180	2149.5	4x4 MIMO	LTE B41	20	40180	2149.5	4x4 MIMO	LTE B41	20	41202	2660.2	4x4 MIMO	LTE B41	20	41202	2660.2	4x4 MIMO	LTE B41	20	41202	2660.2	4x4 MIMO	26.00	23.00
CA_41C-41C	LTE B41	20	40180	2149.5	QPSK	1	0	40180	2149.5	2x2 MIMO	LTE B41	20	40180	2149.5	2x2 MIMO	LTE B41	20	41202	2660.2	2x2 MIMO	LTE B41	20	41202	2660.2	2x2 MIMO	LTE B41	20	41202	2660.2	2x2 MIMO	23.40	23.00

## 1.4.9 LTE Band 41 PC2

Table I-56  
Additional Maximum Output Powers – 4 Component Carriers

Combination	PCC										SCC 1				SCC 2				SCC 3				Power									
	PCC Band	PCC BW [MHz]	PCC [DL] Ch.	PCC [UL] Freq. [MHz]	Mod.	PCC USA RB	PCC UL RB Offset	PCC [DL] Ch.	PCC [DL] Freq. [MHz]	DL Ant. Config.	SCC Band	SCC BW [MHz]	SCC [DL] Ch.	SCC [DL] Freq. [MHz]	DL Ant. Config.	SCC Band	SCC BW [MHz]	SCC [DL] Ch.	SCC [DL] Freq. [MHz]	DL Ant. Config.	SCC Band	SCC BW [MHz]	SCC [DL] Ch.	SCC [DL] Freq. [MHz]	DL Ant. Config.	SCC Band	SCC BW [MHz]	SCC [DL] Ch.	SCC [DL] Freq. [MHz]	DL Ant. Config.	LTE Tx Power with DL CA Enabled [dBm]	LTE Single Carrier Tx Power [dBm]
CA_41C-41C	LTE B41 PC2	15	40180	2149.5	QPSK	1	0	40180	2149.5	4x4 MIMO	LTE B41 PC2	20	40180	2149.5	4x4 MIMO	LTE B41 PC2	20	41202	2660.2	4x4 MIMO	LTE B41 PC2	20	41202	2660.2	4x4 MIMO	LTE B41 PC2	20	41202	2660.2	4x4 MIMO	24.00	23.00
CA_41C-41C	LTE B41 PC2	15	40180	2149.5	QPSK	1	0	40180	2149.5	2x2 MIMO	LTE B41 PC2	20	40180	2149.5	2x2 MIMO	LTE B41 PC2	20	41202	2660.2	2x2 MIMO	LTE B41 PC2	20	41202	2660.2	2x2 MIMO	LTE B41 PC2	20	41202	2660.2	2x2 MIMO	21.40	23.00

Table I-57  
Additional Hotspot Output Powers – 4 Component Carriers

Combination	PCC										SCC 1				SCC 2				SCC 3				Power									
	PCC Band	PCC BW [MHz]	PCC [DL] Ch.	PCC [UL] Freq. [MHz]	Mod.	PCC USA RB	PCC UL RB Offset	PCC [DL] Ch.	PCC [DL] Freq. [MHz]	DL Ant. Config.	SCC Band	SCC BW [MHz]	SCC [DL] Ch.	SCC [DL] Freq. [MHz]	DL Ant. Config.	SCC Band	SCC BW [MHz]	SCC [DL] Ch.	SCC [DL] Freq. [MHz]	DL Ant. Config.	SCC Band	SCC BW [MHz]	SCC [DL] Ch.	SCC [DL] Freq. [MHz]	DL Ant. Config.	SCC Band	SCC BW [MHz]	SCC [DL] Ch.	SCC [DL] Freq. [MHz]	DL Ant. Config.	LTE Tx Power with DL CA Enabled [dBm]	LTE Single Carrier Tx Power [dBm]
CA_41C-41C	LTE B41 PC2	20	39750	2506	16QAM	1	0	39750	2506	4x4 MIMO	LTE B41 PC2	20	39750	2506	4x4 MIMO	LTE B41 PC2	20	41202	2660.2	4x4 MIMO	LTE B41 PC2	20	41202	2660.2	4x4 MIMO	LTE B41 PC2	20	41202	2660.2	4x4 MIMO	26.00	23.00
CA_41C-41C	LTE B41 PC2	20	39750	2506	16QAM	1	0	39750	2506	2x2 MIMO	LTE B41 PC2	20	39750	2506	2x2 MIMO	LTE B41 PC2	20	41202	2660.2	2x2 MIMO	LTE B41 PC2	20	41202	2660.2	2x2 MIMO	LTE B41 PC2	20	41202	2660.2	2x2 MIMO	23.40	23.00

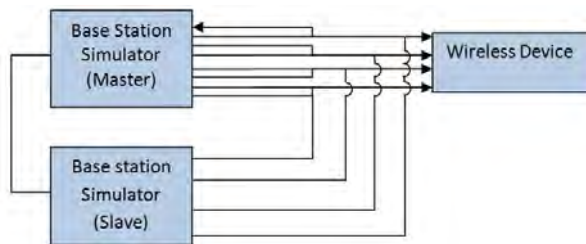

Figure I-4  
Power Measurement Setup

FCC ID: A3LSMG960U	PCTEST ENGINEERING LABORATORY, INC.	SAR EVALUATION REPORT		Approved by: Quality Manager
Test Dates: 11/03/17 – 12/07/17	DUT Type: Portable Handset	APPENDIX I: Page 15 of 19		

# 1.5 Downlink 4X4 MIMO LAA Additional Conducted Powers

**Table I-58**  
**Additional Maximum Output Powers- 2 Component Carriers**

Combination	PCC										SCC					Power	
	PCC Band	PCC Bandwidth [MHz]	PCC (UL) Channel	PCC (UL) Frequency [MHz]	Modulation	PCC UL RB	PCC UL RB Offset	PCC (DL) Channel	PCC (DL) Frequency [MHz]	DL Ant. Config.	SCC Band	SCC Bandwidth [MHz]	SCC (DL) Channel	SCC (DL) Frequency [MHz]	DL Ant. Config.	LTE Tx Power with DL CA Enabled (dBm)	LTE Single Carrier Tx Power (dBm)
CA_7A-46,A	LTE B7	15	21375	2562.5	QPSK	1	0	3375	2682.5	4x4 MIMO	LTE B46 <sub>s</sub>	20	47290	5200	2x2 MIMO	23.65	23.65
CA_7A-46 <sub>s</sub> A	LTE B7	15	21375	2562.5	QPSK	1	0	3375	2682.5	4x4 MIMO	LTE B46 <sub>s</sub>	20	48290	5300	2x2 MIMO	23.65	23.65
CA_7A-46,A	LTE B7	15	21375	2562.5	QPSK	1	0	3375	2682.5	4x4 MIMO	LTE B46 <sub>s</sub>	20	51290	5600	2x2 MIMO	23.62	23.65
CA_7A-46 <sub>s</sub> A	LTE B7	15	21375	2562.5	QPSK	1	0	3375	2682.5	4x4 MIMO	LTE B46 <sub>s</sub>	20	53140	5785	2x2 MIMO	23.64	23.65

**Table I-59**  
**Additional Maximum Output Powers- 3 Component Carriers**

Combination	PCC Band	PCC Bandwidth [MHz]	PCC (UL) Channel	PCC (UL) Frequency [MHz]	Modulation	PCC UL RB	PCC UL RB Offset	PCC (DL) Channel	PCC (DL) Frequency [MHz]	DL Ant. Config.	SCC					Power						
											SCC Band	SCC Bandwidth [MHz]	SCC (DL) Channel	SCC (DL) Frequency [MHz]	DL Ant. Config.	SCC Band	SCC Bandwidth [MHz]	SCC (DL) Channel	SCC (DL) Frequency [MHz]	DL Ant. Config.	LTE Tx Power with DL CA Enabled (dBm)	LTE Single Carrier Tx Power (dBm)
CA_2A-46,A-46 <sub>s</sub> A	LTE B2	20	18700	1860	QPSK	1	0	700	1940	4x4 MIMO	LTE B46 <sub>s</sub>	20	47090	5180	2x2 MIMO	LTE B46 <sub>s</sub>	20	53540	5825	2x2 MIMO	24.32	24.29
CA_2A-46,A-66A	LTE B2	20	18700	1860	QPSK	1	0	700	1940	4x4 MIMO	LTE B46 <sub>s</sub>	20	47290	5200	2x2 MIMO	LTE B66	20	66786	2145	2x2 MIMO	24.31	24.29
CA_2A-46,A-66A	LTE B2	20	18700	1860	QPSK	1	0	700	1940	4x4 MIMO	LTE B46 <sub>s</sub>	20	48290	5300	2x2 MIMO	LTE B66	20	66786	2145	2x2 MIMO	24.32	24.29
CA_2A-46,A-66A	LTE B2	20	18700	1860	QPSK	1	0	700	1940	4x4 MIMO	LTE B46 <sub>s</sub>	20	51290	5600	2x2 MIMO	LTE B66	20	66786	2145	2x2 MIMO	24.32	24.29
CA_2A-46,A-66A	LTE B2	20	18700	1860	QPSK	1	0	700	1940	4x4 MIMO	LTE B46 <sub>s</sub>	20	53140	5785	2x2 MIMO	LTE B66	20	66786	2145	2x2 MIMO	24.32	24.29
CA_2A-46,A-66A	LTE B2	20	18700	1860	QPSK	1	0	700	1940	2x2 MIMO	LTE B46 <sub>s</sub>	20	47290	5200	2x2 MIMO	LTE B66	20	66786	2145	4x4 MIMO	24.30	24.29
CA_2A-46,A-66A	LTE B2	20	18700	1860	QPSK	1	0	700	1940	2x2 MIMO	LTE B46 <sub>s</sub>	20	48290	5300	2x2 MIMO	LTE B66	20	66786	2145	4x4 MIMO	24.29	24.29
CA_2A-46,A-66A	LTE B2	20	18700	1860	QPSK	1	0	700	1940	2x2 MIMO	LTE B46 <sub>s</sub>	20	51290	5600	2x2 MIMO	LTE B66	20	66786	2145	4x4 MIMO	24.30	24.29
CA_2A-46,A-66A	LTE B2	20	18700	1860	QPSK	1	0	700	1940	2x2 MIMO	LTE B46 <sub>s</sub>	20	53140	5785	2x2 MIMO	LTE B66	20	66786	2145	4x4 MIMO	24.34	24.29
CA_4A-46,A-46 <sub>s</sub> A	LTE B4	15	20225	1747.5	QPSK	1	0	2325	2147.5	4x4 MIMO	LTE B46 <sub>s</sub>	20	47090	5180	2x2 MIMO	LTE B46 <sub>s</sub>	20	53540	5825	2x2 MIMO	24.30	24.38
CA_2A-46,A-66A	LTE B66	15	132597	1772.5	QPSK	1	0	67061	2172.5	4x4 MIMO	LTE B2	20	900	1960	2x2 MIMO	LTE B46 <sub>s</sub>	20	47290	5200	2x2 MIMO	24.25	24.38
CA_2A-46,A-66A	LTE B66	15	132597	1772.5	QPSK	1	0	67061	2172.5	4x4 MIMO	LTE B2	20	900	1960	2x2 MIMO	LTE B46 <sub>s</sub>	20	48290	5300	2x2 MIMO	24.36	24.38
CA_2A-46,A-66A	LTE B66	15	132597	1772.5	QPSK	1	0	67061	2172.5	4x4 MIMO	LTE B2	20	900	1960	2x2 MIMO	LTE B46 <sub>s</sub>	20	51290	5600	2x2 MIMO	24.34	24.38
CA_2A-46,A-66A	LTE B66	15	132597	1772.5	QPSK	1	0	67061	2172.5	4x4 MIMO	LTE B2	20	900	1960	2x2 MIMO	LTE B46 <sub>s</sub>	20	53140	5785	2x2 MIMO	24.33	24.38
CA_2A-46,A-66A	LTE B66	15	132597	1772.5	QPSK	1	0	67061	2172.5	2x2 MIMO	LTE B2	20	900	1960	4x4 MIMO	LTE B46 <sub>s</sub>	20	47290	5200	2x2 MIMO	24.36	24.38
CA_2A-46,A-66A	LTE B66	15	132597	1772.5	QPSK	1	0	67061	2172.5	2x2 MIMO	LTE B2	20	900	1960	4x4 MIMO	LTE B46 <sub>s</sub>	20	48290	5300	2x2 MIMO	24.36	24.38
CA_2A-46,A-66A	LTE B66	15	132597	1772.5	QPSK	1	0	67061	2172.5	2x2 MIMO	LTE B2	20	900	1960	4x4 MIMO	LTE B46 <sub>s</sub>	20	51290	5600	2x2 MIMO	24.37	24.38
CA_2A-46,A-66A	LTE B66	15	132597	1772.5	QPSK	1	0	67061	2172.5	2x2 MIMO	LTE B2	20	900	1960	4x4 MIMO	LTE B46 <sub>s</sub>	20	53140	5785	2x2 MIMO	24.32	24.38
CA_46A-46 <sub>s</sub> A-66A	LTE B66	15	132597	1772.5	QPSK	1	0	67061	2172.5	4x4 MIMO	LTE B46 <sub>s</sub>	20	47090	5180	2x2 MIMO	LTE B46 <sub>s</sub>	20	53540	5825	2x2 MIMO	24.27	24.38
CA_7A-46,C	LTE B7	15	21375	2562.5	QPSK	1	0	3375	2682.5	4x4 MIMO	LTE B46 <sub>s</sub>	20	47290	5200	2x2 MIMO	LTE B46 <sub>s</sub>	20	47488	5319.8	2x2 MIMO	23.64	23.65
CA_7A-46,C	LTE B7	15	21375	2562.5	QPSK	1	0	3375	2682.5	4x4 MIMO	LTE B46 <sub>s</sub>	20	48290	5300	2x2 MIMO	LTE B46 <sub>s</sub>	20	48488	5319.8	2x2 MIMO	23.65	23.65
CA_7A-46,C	LTE B7	15	21375	2562.5	QPSK	1	0	3375	2682.5	4x4 MIMO	LTE B46 <sub>s</sub>	20	51290	5600	2x2 MIMO	LTE B46 <sub>s</sub>	20	51488	5619.8	2x2 MIMO	23.66	23.65
CA_7A-46,C	LTE B7	15	21375	2562.5	QPSK	1	0	3375	2682.5	4x4 MIMO	LTE B46 <sub>s</sub>	20	53140	5785	2x2 MIMO	LTE B46 <sub>s</sub>	20	53338	5804.8	2x2 MIMO	23.63	23.65

## Table I-60 Additional Maximum Output Powers- 4 Component Carriers

Combination	PCC Band	PCC BW [MHz]	PCC (UL) Channel	PCC (UL) Freq. [MHz]	Modulation	PCC UL RB	PCC UL RB Offset	PCC (DL) Channel	PCC (DL) Freq. [MHz]	DL Ant. Config.	SCC Band			DL Ant. Config.	SCC Band			DL Ant. Config.	LTE Tx Power with DL CA Enabled (dBm)	LTE Single Carrier Tx Power (dBm)		
											SCC Band	SCC BW [MHz]	SCC (DL) Channel		SCC (DL) Freq. [MHz]	DL Ant. Config.	SCC Band				SCC BW [MHz]	SCC (DL) Channel
CA 2A-46_D	LTE B2	20	18700	1860	QPSK	1	0	700	1940	4x4 MIMO	LTE B46	20	47290	5200	2x2 MIMO	LTE B46	20	47488	5219.8	2x2 MIMO	24.31	24.29
CA 2A-46_D	LTE B2	20	18700	1860	QPSK	1	0	700	1940	4x4 MIMO	LTE B46	20	48290	5300	2x2 MIMO	LTE B46	20	48488	5319.8	2x2 MIMO	24.29	24.29
CA 2A-46_D	LTE B2	20	18700	1860	QPSK	1	0	700	1940	4x4 MIMO	LTE B46	20	51290	5600	2x2 MIMO	LTE B46	20	51488	5619.8	2x2 MIMO	24.30	24.29
CA 2A-46_D	LTE B2	20	18700	1860	QPSK	1	0	700	1940	4x4 MIMO	LTE B46	20	53140	5785	2x2 MIMO	LTE B46	20	53338	5804.8	2x2 MIMO	24.32	24.29
CA 2A-46_A-46_C	LTE B2	20	18700	1860	QPSK	1	0	700	1940	4x4 MIMO	LTE B46	20	47090	5180	2x2 MIMO	LTE B46	20	47340	5625	2x2 MIMO	24.33	24.29
CA 2A-46_C-66A	LTE B2	20	18700	1860	QPSK	1	0	700	1940	4x4 MIMO	LTE B46	20	47290	5200	2x2 MIMO	LTE B46	20	47488	5219.8	2x2 MIMO	24.32	24.29
CA 2A-46_C-66A	LTE B2	20	18700	1860	QPSK	1	0	700	1940	4x4 MIMO	LTE B46	20	48290	5300	2x2 MIMO	LTE B46	20	48488	5319.8	2x2 MIMO	24.30	24.29
CA 2A-46_C-66A	LTE B2	20	18700	1860	QPSK	1	0	700	1940	4x4 MIMO	LTE B46	20	51290	5600	2x2 MIMO	LTE B46	20	51488	5619.8	2x2 MIMO	24.32	24.29
CA 2A-46_C-66A	LTE B2	20	18700	1860	QPSK	1	0	700	1940	4x4 MIMO	LTE B46	20	53140	5785	2x2 MIMO	LTE B46	20	53338	5804.8	2x2 MIMO	24.35	24.29
CA 2A-46_C-66A	LTE B2	20	18700	1860	QPSK	1	0	700	1940	2x2 MIMO	LTE B46	20	47290	5200	2x2 MIMO	LTE B46	20	47488	5219.8	2x2 MIMO	24.32	24.29
CA 2A-46_C-66A	LTE B2	20	18700	1860	QPSK	1	0	700	1940	2x2 MIMO	LTE B46	20	48290	5300	2x2 MIMO	LTE B46	20	48488	5319.8	2x2 MIMO	24.31	24.29
CA 2A-46_C-66A	LTE B2	20	18700	1860	QPSK	1	0	700	1940	2x2 MIMO	LTE B46	20	51290	5600	2x2 MIMO	LTE B46	20	51488	5619.8	2x2 MIMO	24.33	24.29
CA 2A-46_C-66A	LTE B2	20	18700	1860	QPSK	1	0	700	1940	2x2 MIMO	LTE B46	20	53140	5785	2x2 MIMO	LTE B46	20	53338	5804.8	2x2 MIMO	24.35	24.29
CA 4A-46_D	LTE B4	15	20325	1947.5	QPSK	1	0	3325	2147.5	4x4 MIMO	LTE B46	20	47290	5200	2x2 MIMO	LTE B46	20	47488	5219.8	2x2 MIMO	24.33	24.38
CA 4A-46_D	LTE B4	15	20325	1947.5	QPSK	1	0	3325	2147.5	4x4 MIMO	LTE B46	20	48290	5300	2x2 MIMO	LTE B46	20	48488	5319.8	2x2 MIMO	24.34	24.38
CA 4A-46_D	LTE B4	15	20325	1947.5	QPSK	1	0	3325	2147.5	4x4 MIMO	LTE B46	20	51290	5600	2x2 MIMO	LTE B46	20	51488	5619.8	2x2 MIMO	24.34	24.38
CA 4A-46_A-46_C	LTE B4	15	20325	1947.5	QPSK	1	0	3325	2147.5	4x4 MIMO	LTE B46	20	47090	5180	2x2 MIMO	LTE B46	20	47340	5625	2x2 MIMO	24.40	24.38
CA 2A-46_C-66A	LTE B66	15	132597	1372.5	QPSK	1	0	67063	2172.5	4x4 MIMO	LTE B2	20	900	1960	2x2 MIMO	LTE B46	20	47290	5200	2x2 MIMO	24.33	24.38
CA 2A-46_C-66A	LTE B66	15	132597	1372.5	QPSK	1	0	67063	2172.5	4x4 MIMO	LTE B2	20	900	1960	2x2 MIMO	LTE B46	20	48290	5300	2x2 MIMO	24.35	24.38
CA 2A-46_C-66A	LTE B66	15	132597	1372.5	QPSK	1	0	67063	2172.5	4x4 MIMO	LTE B2	20	900	1960	2x2 MIMO	LTE B46	20	51290	5600	2x2 MIMO	24.34	24.38
CA 2A-46_C-66A	LTE B66	15	132597	1372.5	QPSK	1	0	67063	2172.5	4x4 MIMO	LTE B2	20	900	1960	2x2 MIMO	LTE B46	20	53140	5785	2x2 MIMO	24.36	24.38
CA 2A-46_C-66A	LTE B66	15	132597	1372.5	QPSK	1	0	67063	2172.5	4x4 MIMO	LTE B2	20	900	1960	2x2 MIMO	LTE B46	20	47290	5200	2x2 MIMO	24.33	24.38
CA 2A-46_C-66A	LTE B66	15	132597	1372.5	QPSK	1	0	67063	2172.5	4x4 MIMO	LTE B2	20	900	1960	2x2 MIMO	LTE B46	20	48290	5300	2x2 MIMO	24.35	24.38
CA 2A-46_C-66A	LTE B66	15	132597	1372.5	QPSK	1	0	67063	2172.5	4x4 MIMO	LTE B2	20	900	1960	2x2 MIMO	LTE B46	20	51290	5600	2x2 MIMO	24.34	24.38
CA 2A-46_C-66A	LTE B66	15	132597	1372.5	QPSK	1	0	67063	2172.5	4x4 MIMO	LTE B2	20	900	1960	2x2 MIMO	LTE B46	20	53140	5785	2x2 MIMO	24.36	24.38
CA 46_D-66A	LTE B66	15	132597	1372.5	QPSK	1	0	67063	2172.5	4x4 MIMO	LTE B46	20	47290	5200	2x2 MIMO	LTE B46	20	47488	5219.8	2x2 MIMO	24.33	24.38
CA 46_D-66A	LTE B66	15	132597	1372.5	QPSK	1	0	67063	2172.5	4x4 MIMO	LTE B46	20	48290	5300	2x2 MIMO	LTE B46	20	48488	5319.8	2x2 MIMO	24.34	24.38
CA 46_D-66A	LTE B66	15	132597	1372.5	QPSK	1	0	67063	2172.5	4x4 MIMO	LTE B46	20	51290	5600	2x2 MIMO	LTE B46	20	51488	5619.8	2x2 MIMO	24.35	24.38
CA 46_D-66A	LTE B66	15	132597	1372.5	QPSK	1	0	67063	2172.5	4x4 MIMO	LTE B46	20	53140	5785	2x2 MIMO	LTE B46	20	53338	5804.8	2x2 MIMO	24.37	24.38
CA 46_A-46_C-66A	LTE B66	15	132597	1372.5	QPSK	1	0	67063	2172.5	4x4 MIMO	LTE B46	20	47090	5180	2x2 MIMO	LTE B46	20	47340	5625	2x2 MIMO	24.32	24.38
CA 7A-46_D	LTE B7	20	21375	2562.5	QPSK	1	0	3375	2682.5	4x4 MIMO	LTE B46	20	47290	5200	2x2 MIMO	LTE B46	20	47488	5219.8	2x2 MIMO	23.63	23.65
CA 7A-46_D	LTE B7	20	21375	2562.5	QPSK	1	0	3375	2682.5	4x4 MIMO	LTE B46	20	48290	5300	2x2 MIMO	LTE B46	20	48488	5319.8	2x2 MIMO	23.66	23.65
CA 7A-46_D	LTE B7	20	21375	2562.5	QPSK	1	0	3375	2682.5	4x4 MIMO	LTE B46	20	51290	5600	2x2 MIMO	LTE B46	20	51488	5619.8	2x2 MIMO	23.63	23.65
CA 7A-46_D	LTE B7	20	21375	2562.5	QPSK	1	0	3375	2682.5	4x4 MIMO	LTE B46	20	53140	5785	2x2 MIMO	LTE B46	20	53338	5804.8	2x2 MIMO	23.66	23.65

## Table I-61 Additional Hotspot Reduced Output Powers- 2 Component Carriers

Combination	PCC Band	PCC Bandwidth [MHz]	PCC (UL) Channel	PCC (UL) Frequency [MHz]	Modulation	PCC UL RB	PCC UL RB Offset	PCC (DL) Channel	PCC (DL) Frequency [MHz]	DL Ant. Config.	SCC			DL Ant. Config.	LTE Tx Power with DL CA Enabled (dBm)	LTE Single Carrier Tx Power (dBm)	
											SCC Band	SCC Bandwidth [MHz]	SCC (DL) Channel				
CA 7A-46_A	LTE B7	20	21350	2560	64QAM	1	0	3350	2680	4x4 MIMO	LTE B46	20	47290	5200	2x2 MIMO	20.87	21.03
CA 7A-46_A	LTE B7	20	21350	2560	64QAM	1	0	3350	2680	4x4 MIMO	LTE B46	20	48290	5300	2x2 MIMO	20.86	21.03
CA 7A-46_A	LTE B7	20	21350	2560	64QAM	1	0	3350	2680	4x4 MIMO	LTE B46	20	51290	5600	2x2 MIMO	20.87	21.03
CA 7A-46_A	LTE B7	20	21350	2560	64QAM	1	0	3350	2680	4x4 MIMO	LTE B46	20	53140	5785	2x2 MIMO	20.89	21.03

## Table I-62 Additional Hotspot Reduced Output Powers- 3 Component Carriers

Combination	PCC Band	PCC Bandwidth [MHz]	PCC (UL) Channel	PCC (UL) Frequency [MHz]	Modulation	PCC UL RB	PCC UL RB Offset	PCC (DL) Channel	PCC (DL) Frequency [MHz]	DL Ant. Config.	SCC 1			SCC 2			DL Ant. Config.	LTE Tx Power with DL CA Enabled (dBm)	LTE Single Carrier Tx Power (dBm)			
											SCC Band	SCC Bandwidth [MHz]	SCC (DL) Channel	SCC (DL) Frequency [MHz]	DL Ant. Config.	SCC Band				SCC Bandwidth [MHz]	SCC (DL) Channel	SCC (DL) Frequency [MHz]
CA 2A-46_A-46_A	LTE B2	20	18700	1860	16QAM	1	0	700	1940	4x4 MIMO	LTE B46	20	47090	5180	2x2 MIMO	LTE B46	20	53540	5825	2x2 MIMO	20.40	20.50
CA 2A-46_A-66A	LTE B2	20	18700	1860	16QAM	1	0	700	1940	4x4 MIMO	LTE B46	20	47290	5200	2x2 MIMO	LTE B46	20	66786	2145	2x2 MIMO	20.46	20.50
CA 2A-46_A-66A	LTE B2	20	18700	1860	16QAM	1	0	700	1940	4x4 MIMO	LTE B46	20	48290	5300	2x2 MIMO	LTE B66	20	66786	2145	2x2 MIMO	20.42	20.50
CA 2A-46_A-66A	LTE B2	20	18700	1860	16QAM	1	0	700	1940	4x4 MIMO	LTE B46	20	51290	5600	2x2 MIMO	LTE B66	20	66786	2145	2x2 MIMO	20.43	20.50
CA 2A-46_A-66A	LTE B2	20	18700	1860	16QAM	1	0	700	1940	4x4 MIMO	LTE B46	20	53140	5785	2x2 MIMO	LTE B66	20	66786	2145	2x2 MIMO	20.44	20.50
CA 2A-46_A-66A	LTE B2	20	18700	1860	16QAM	1	0	700	1940	2x2 MIMO	LTE B46	20	47290	5200	2x2 MIMO	LTE B66	20	66786	2145	4x4 MIMO	20.39	20.50
CA 2A-46_A-66A	LTE B2	20	18700	1860	16QAM	1	0	700	1940	2x2 MIMO	LTE B46	20	48290	5300	2x2 MIMO	LTE B66	20	66786	2145	4x4 MIMO	20.42	20.50
CA 2A-46_A-66A	LTE B2	20	18700	1860	16QAM	1	0	700	1940	2x2 MIMO	LTE B46	20	51290	5600	2x2 MIMO	LTE B66	20	66786	2145	4x4 MIMO	20.41	20.50
CA 2A-46_A-66A	LTE B2	20	18700	1860	16QAM	1	0	700	1940	2x2 MIMO	LTE B46	20	53140	5785	2x2 MIMO	LTE B66	20	66786	2145	4x4 MIMO		

**Table I-63  
Additional Hotspot Reduced Output Powers- 4 Component Carriers**

Combination	PCC Band	PCC BW [MHz]	PCC [UL] Channel	PCC				SCC1				SCC2				SCC3				Power							
				PCC [DL] Freq [MHz]	Modulation	PCC UL RB	PCC UL RB Offset	PCC [DL] Channel	PCC [DL] Freq [MHz]	DL Ant. Config.	SCC Band	SCC BW [MHz]	SCC [DL] Channel	SCC [DL] Freq [MHz]	DL Ant. Config.	SCC Band	SCC BW [MHz]	SCC [DL] Channel	SCC [DL] Freq [MHz]	DL Ant. Config.	SCC Band	SCC BW [MHz]	SCC [DL] Channel	SCC [DL] Freq [MHz]	DL Ant. Config.	LTE Tx Power with DL CA Enabled [dBm]	LTE Single Carrier Tx Power [dBm]
CA 2A-46-D	LTE B2	20	18700	1860	16QAM	1	0	700	1940	4x4 MIMO	LTE B46	20	47290	5200	2x2 MIMO	LTE B46	20	47488	5219.8	2x2 MIMO	LTE B46	20	47092	5180.2	2x2 MIMO	20.49	20.50
CA 2A-46-D	LTE B2	20	18700	1860	16QAM	1	0	700	1940	4x4 MIMO	LTE B46	20	48290	5300	2x2 MIMO	LTE B46	20	48488	5319.8	2x2 MIMO	LTE B46	20	48092	5280.2	2x2 MIMO	20.50	20.50
CA 2A-46-D	LTE B2	20	18700	1860	16QAM	1	0	700	1940	4x4 MIMO	LTE B46	20	51290	5600	2x2 MIMO	LTE B46	20	51488	5619.8	2x2 MIMO	LTE B46	20	51092	5580.2	2x2 MIMO	20.49	20.50
CA 2A-46-D	LTE B2	20	18700	1860	16QAM	1	0	700	1940	4x4 MIMO	LTE B46	20	53140	5785	2x2 MIMO	LTE B46	20	53338	5804.8	2x2 MIMO	LTE B46	20	52942	5765.2	2x2 MIMO	20.48	20.50
CA 2A-46A,46E-C	LTE B2	20	18700	1860	16QAM	1	0	700	1940	4x4 MIMO	LTE B46	20	47050	5180	2x2 MIMO	LTE B46	20	47488	5219.8	2x2 MIMO	LTE B46	20	47092	5180.2	2x2 MIMO	20.49	20.50
CA 2A-46C-66A	LTE B2	20	18700	1860	16QAM	1	0	700	1940	4x4 MIMO	LTE B46	20	47290	5200	2x2 MIMO	LTE B46	20	47488	5219.8	2x2 MIMO	LTE B66	20	46786	2145	2x2 MIMO	20.45	20.50
CA 2A-46C-66A	LTE B2	20	18700	1860	16QAM	1	0	700	1940	4x4 MIMO	LTE B46	20	48290	5300	2x2 MIMO	LTE B46	20	48488	5319.8	2x2 MIMO	LTE B66	20	46786	2145	2x2 MIMO	20.49	20.50
CA 2A-46C-66A	LTE B2	20	18700	1860	16QAM	1	0	700	1940	4x4 MIMO	LTE B46	20	51290	5600	2x2 MIMO	LTE B46	20	51488	5619.8	2x2 MIMO	LTE B66	20	46786	2145	2x2 MIMO	20.47	20.50
CA 2A-46C-66A	LTE B2	20	18700	1860	16QAM	1	0	700	1940	4x4 MIMO	LTE B46	20	53140	5785	2x2 MIMO	LTE B46	20	53338	5804.8	2x2 MIMO	LTE B66	20	46786	2145	2x2 MIMO	20.45	20.50
CA 2A-46C-66A	LTE B2	20	18700	1860	16QAM	1	0	700	1940	2x2 MIMO	LTE B46	20	47290	5200	2x2 MIMO	LTE B46	20	47488	5219.8	2x2 MIMO	LTE B66	20	46786	2145	4x4 MIMO	20.44	20.50
CA 2A-46C-66A	LTE B2	20	18700	1860	16QAM	1	0	700	1940	2x2 MIMO	LTE B46	20	48290	5300	2x2 MIMO	LTE B46	20	48488	5319.8	2x2 MIMO	LTE B66	20	46786	2145	4x4 MIMO	20.43	20.50
CA 2A-46C-66A	LTE B2	20	18700	1860	16QAM	1	0	700	1940	2x2 MIMO	LTE B46	20	51290	5600	2x2 MIMO	LTE B46	20	51488	5619.8	2x2 MIMO	LTE B66	20	46786	2145	4x4 MIMO	20.44	20.50
CA 2A-46C-66A	LTE B2	20	18700	1860	16QAM	1	0	700	1940	2x2 MIMO	LTE B46	20	53140	5785	2x2 MIMO	LTE B46	20	53338	5804.8	2x2 MIMO	LTE B66	20	46786	2145	4x4 MIMO	20.41	20.50
CA 4A-46-D	LTE B4	20	20300	1745	16QAM	1	0	2300	2145	4x4 MIMO	LTE B46	20	47290	5200	2x2 MIMO	LTE B46	20	47488	5219.8	2x2 MIMO	LTE B46	20	47092	5180.2	2x2 MIMO	20.26	20.50
CA 4A-46-D	LTE B4	20	20300	1745	16QAM	1	0	2300	2145	4x4 MIMO	LTE B46	20	48290	5300	2x2 MIMO	LTE B46	20	48488	5319.8	2x2 MIMO	LTE B46	20	48092	5280.2	2x2 MIMO	20.27	20.50
CA 4A-46-D	LTE B4	20	20300	1745	16QAM	1	0	2300	2145	4x4 MIMO	LTE B46	20	51290	5600	2x2 MIMO	LTE B46	20	51488	5619.8	2x2 MIMO	LTE B46	20	51092	5580.2	2x2 MIMO	20.25	20.50
CA 4A-46-D	LTE B4	20	20300	1745	16QAM	1	0	2300	2145	4x4 MIMO	LTE B46	20	53140	5785	2x2 MIMO	LTE B46	20	53338	5804.8	2x2 MIMO	LTE B46	20	52942	5765.2	2x2 MIMO	20.28	20.50
CA 4A-46A,46E-C	LTE B4	20	20300	1745	16QAM	1	0	2300	2145	4x4 MIMO	LTE B46	20	47050	5180	2x2 MIMO	LTE B46	20	47488	5219.8	2x2 MIMO	LTE B46	20	47092	5180.2	2x2 MIMO	20.25	20.50
CA 2A-46C-66A	LTE B66	20	132322	1745	16QAM	1	0	66786	2145	4x4 MIMO	LTE B2	20	900	1960	2x2 MIMO	LTE B46	20	47290	5200	2x2 MIMO	LTE B46	20	47488	5219.8	2x2 MIMO	20.39	20.50
CA 2A-46C-66A	LTE B66	20	132322	1745	16QAM	1	0	66786	2145	4x4 MIMO	LTE B2	20	900	1960	2x2 MIMO	LTE B46	20	48290	5300	2x2 MIMO	LTE B46	20	48488	5319.8	2x2 MIMO	20.37	20.50
CA 2A-46C-66A	LTE B66	20	132322	1745	16QAM	1	0	66786	2145	4x4 MIMO	LTE B2	20	900	1960	2x2 MIMO	LTE B46	20	51290	5600	2x2 MIMO	LTE B46	20	51488	5619.8	2x2 MIMO	20.38	20.50
CA 2A-46C-66A	LTE B66	20	132322	1745	16QAM	1	0	66786	2145	4x4 MIMO	LTE B2	20	900	1960	2x2 MIMO	LTE B46	20	53140	5785	2x2 MIMO	LTE B46	20	53338	5804.8	2x2 MIMO	20.40	20.50
CA 2A-46C-66A	LTE B66	20	132322	1745	16QAM	1	0	66786	2145	2x2 MIMO	LTE B2	20	900	1960	4x4 MIMO	LTE B46	20	47290	5200	2x2 MIMO	LTE B46	20	47488	5219.8	2x2 MIMO	20.35	20.50
CA 2A-46C-66A	LTE B66	20	132322	1745	16QAM	1	0	66786	2145	2x2 MIMO	LTE B2	20	900	1960	4x4 MIMO	LTE B46	20	48290	5300	2x2 MIMO	LTE B46	20	48488	5319.8	2x2 MIMO	20.33	20.50
CA 2A-46C-66A	LTE B66	20	132322	1745	16QAM	1	0	66786	2145	2x2 MIMO	LTE B2	20	900	1960	4x4 MIMO	LTE B46	20	51290	5600	2x2 MIMO	LTE B46	20	51488	5619.8	2x2 MIMO	20.36	20.50
CA 2A-46C-66A	LTE B66	20	132322	1745	16QAM	1	0	66786	2145	2x2 MIMO	LTE B2	20	900	1960	4x4 MIMO	LTE B46	20	53140	5785	2x2 MIMO	LTE B46	20	53338	5804.8	2x2 MIMO	20.33	20.50
CA 46-D-66A	LTE B66	20	132322	1745	16QAM	1	0	66786	2145	4x4 MIMO	LTE B46	20	47290	5200	2x2 MIMO	LTE B46	20	47488	5219.8	2x2 MIMO	LTE B46	20	47092	5180.2	2x2 MIMO	20.31	20.50
CA 46-D-66A	LTE B66	20	132322	1745	16QAM	1	0	66786	2145	4x4 MIMO	LTE B46	20	48290	5300	2x2 MIMO	LTE B46	20	48488	5319.8	2x2 MIMO	LTE B46	20	48092	5280.2	2x2 MIMO	20.29	20.50
CA 46-D-66A	LTE B66	20	132322	1745	16QAM	1	0	66786	2145	4x4 MIMO	LTE B46	20	51290	5600	2x2 MIMO	LTE B46	20	51488	5619.8	2x2 MIMO	LTE B46	20	51092	5580.2	2x2 MIMO	20.28	20.50
CA 46-D-66A	LTE B66	20	132322	1745	16QAM	1	0	66786	2145	4x4 MIMO	LTE B46	20	53140	5785	2x2 MIMO	LTE B46	20	53338	5804.8	2x2 MIMO	LTE B46	20	52942	5765.2	2x2 MIMO	20.23	20.50
CA 46A,46C-66A	LTE B66	20	132322	1745	16QAM	1	0	66786	2145	4x4 MIMO	LTE B46	20	47050	5180	2x2 MIMO	LTE B46	20	47488	5219.8	2x2 MIMO	LTE B46	20	47092	5180.2	2x2 MIMO	20.26	20.50
CA 7A-46-D	LTE B7	20	23350	2650	64QAM	1	0	3350	2680	4x4 MIMO	LTE B46	20	47290	5200	2x2 MIMO	LTE B46	20	47488	5219.8	2x2 MIMO	LTE B46	20	47092	5180.2	2x2 MIMO	21.05	21.03
CA 7A-46-D	LTE B7	20	23350	2650	64QAM	1	0	3350	2680	4x4 MIMO	LTE B46	20	48290	5300	2x2 MIMO	LTE B46	20	48488	5319.8	2x2 MIMO	LTE B46	20	48092	5280.2	2x2 MIMO	21.05	21.03
CA 7A-46-D	LTE B7	20	23350	2650	64QAM	1	0	3350	2680	4x4 MIMO	LTE B46	20	51290	5600	2x2 MIMO	LTE B46	20	51488	5619.8	2x2 MIMO	LTE B46	20	51092	5580.2	2x2 MIMO	21.00	21.03
CA 7A-46-D	LTE B7	20	23350	2650	64QAM	1	0	3350	2680	4x4 MIMO	LTE B46	20	53140	5785	2x2 MIMO	LTE B46	20	53338	5804.8	2x2 MIMO	LTE B46	20	52942	5765.2	2x2 MIMO	21.00	21.03

This device supports LAA with downlink carrier aggregation only. All uplink communications and acknowledgements on the PCC remain identical to specifications when downlink carrier aggregation is inactive.



For those combinations required by FCC Guidance, power measurements were performed with downlink carrier aggregation active for the configuration with highest measured maximum conducted power with downlink carrier aggregation inactive measured among the channel bandwidth, modulation, and RB combinations in each frequency band.

The PCC uplink channel was selected based on section C)3)b)ii) of KBD 941225 D05 V01r02. The downlink PCC channel was paired with the selected PCC uplink channel according to normal configurations without carrier aggregation per 3GPP requirements. The SCC downlink channels were selected near the middle of their transmission bands. For contiguous intra-band carriers, the downlink channel spacing between the component carriers was set to multiple of 300 kHz less than the nominal channel spacing defined in section 5.4.1A of 3GPP TS 36.521. For LAA operations, each Band 46 sub-band was evaluated independently due to the wide downlink bandwidth.

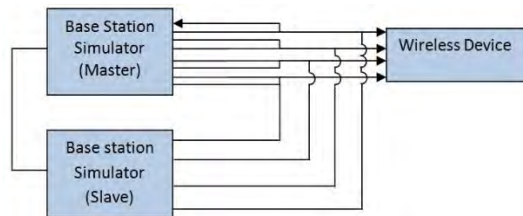
Per FCC KDB Publication 941225 D05Av01r02, no SAR measurements are required for carrier aggregation configurations when the average output power with downlink only carrier aggregation active is not more than 0.25 dB higher than the average output power with downlink only carrier aggregation inactive.



**Figure I-5  
Power Measurement Setup for LAA 4X4 MIMO**

<b>FCC ID:</b> A3LSMG960U	 <b>PCTEST</b> <small>PROFESSIONAL COMMUNICATIONS TESTING</small>	<b>SAR EVALUATION REPORT</b>		<b>Approved by:</b> Quality Manager
<b>Test Dates:</b> 11/03/17 – 12/07/17	<b>DUT Type:</b> Portable Handset	<b>APPENDIX I:</b> Page 18 of 19		



# I.6 LTE CA\_41C Uplink Carrier Aggregation

**Table I-64  
Additional Maximum Output Powers- 2 Component Carriers**

Combination	PCC									SCC						Power		Target Power (dBm)	
	PCC Band	PCC Bandwidth [MHz]	PCC (UL/DL) Channel	PCC (UL/DL) Frequency [MHz]	Modulation	PCC UL# RB	PCC UL RB Offset	DL Ant. Config.	SCC Band	SCC Bandwidth [MHz]	SCC (UL/DL) Channel	SCC (UL/DL) Frequency [MHz]	Modulation	SCC UL# RB	SCC UL RB Offset	DL Ant. Config.	CA_41C ULCA Tx. Power with 4x4 DL MIMO enabled (dBm)		CA_41C ULCA Tx. Power (dBm)
CA_41C	LTE B41	20	40185	2549.5	QPSK	1	0	4x4 MIMO	LTE B41	20	39987	2529.7	QPSK	1	99	4x4 MIMO	23.89	23.88	24.0

**Table I-65  
Additional Maximum Output Powers LTE CA\_41C Uplink Carrier Aggregation with Three Component Carrier Aggregation on the Downlink -**

Combination	PCC									SCC1						SCC2						Power		Target Power (dBm)
	PCC Band	PCC Bandwidth [MHz]	PCC (UL/DL) Channel	PCC (UL/DL) Frequency [MHz]	Modulation	PCC UL# RB	PCC UL RB Offset	DL Ant. Config.	SCC Band	SCC Bandwidth [MHz]	SCC (UL/DL) Channel	SCC (UL/DL) Frequency [MHz]	Modulation	SCC UL# RB	SCC UL RB Offset	DL Ant. Config.	SCC Band	SCC Bandwidth [MHz]	SCC (DL) Channel	SCC (DL) Frequency [MHz]	DL Ant. Config.	CA_41C ULCA Tx. Power with 4x4 DL MIMO enabled (dBm)	CA_41C ULCA Tx. Power (dBm)	
CA_41D	LTE B41	20	40185	2549.5	QPSK	1	0	4x4 MIMO	LTE B41	20	39987	2529.7	QPSK	1	99	4x4 MIMO	LTE B41	20	40383	2569.3	4x4 MIMO	23.86	23.88	24.0
CA_41C-41A	LTE B41	20	40185	2549.5	QPSK	1	0	2x2 MIMO	LTE B41	20	39987	2529.7	QPSK	1	99	2x2 MIMO	LTE B41	20	41490	2680	4x4 MIMO	23.90	23.88	24.0
CA_41C-41A	LTE B41	20	40185	2549.5	QPSK	1	0	4x4 MIMO	LTE B41	20	39987	2529.7	QPSK	1	99	4x4 MIMO	LTE B41	20	41490	2680	2x2 MIMO	23.87	23.88	24.0
CA_41C-41A	LTE B41	20	40185	2549.5	QPSK	1	0	4x4 MIMO	LTE B41	20	39987	2529.7	QPSK	1	99	4x4 MIMO	LTE B41	20	41490	2680	4x4 MIMO	23.88	23.88	24.0

**Table I-66  
Additional Maximum Output Powers LTE CA\_41C Uplink Carrier Aggregation with Four Component Carrier Aggregation on the Downlink**

Combination	PCC									SCC1						SCC2						SCC3						Power		Target Power (dBm)
	PCC Band	PCC Bandwidth [MHz]	PCC (UL/DL) Channel	PCC (UL/DL) Frequency [MHz]	Modulation	PCC UL# RB	PCC UL RB Offset	DL Ant. Config.	SCC Band	SCC Bandwidth [MHz]	SCC (UL/DL) Channel	SCC (UL/DL) Frequency [MHz]	Modulation	SCC UL# RB	SCC UL RB Offset	DL Ant. Config.	SCC Band	SCC Bandwidth [MHz]	SCC (DL) Channel	SCC (DL) Frequency [MHz]	DL Ant. Config.	SCC Band	SCC Bandwidth [MHz]	SCC (DL) Channel	SCC (DL) Frequency [MHz]	DL Ant. Config.	CA_41C ULCA Tx. Power with 4x4 DL MIMO enabled (dBm)	CA_41C ULCA Tx. Power (dBm)		
CA_41C-41C	LTE B41	20	40185	2549.5	QPSK	1	0	4x4 MIMO	LTE B41	20	39987	2529.7	QPSK	1	99	4x4 MIMO	LTE B41	20	41292	2660.2	2x2 MIMO	LTE B41	20	41490	2680	2x2 MIMO	23.88	23.88	24.0	
CA_41C-41C	LTE B41	20	40185	2549.5	QPSK	1	0	2x2 MIMO	LTE B41	20	39987	2529.7	QPSK	1	99	2x2 MIMO	LTE B41	20	41292	2660.2	4x4 MIMO	LTE B41	20	41490	2680	4x4 MIMO	23.88	23.88	24.0	

**Table I-67  
Additional Hotspot Reduced Output Powers- 2 Component Carriers**

Combination	PCC									SCC						Power		Target Power (dBm)	
	PCC Band	PCC Bandwidth [MHz]	PCC (UL/DL) Channel	PCC (UL/DL) Frequency [MHz]	Modulation	PCC UL# RB	PCC UL RB Offset	DL Ant. Config.	SCC Band	SCC Bandwidth [MHz]	SCC (UL/DL) Channel	SCC (UL/DL) Frequency [MHz]	Modulation	SCC UL# RB	SCC UL RB Offset	DL Ant. Config.	CA_41C ULCA Tx. Power with 4x4 DL MIMO enabled (dBm)		CA_41C ULCA Tx. Power (dBm)
CA_41C	LTE B41	20	40185	2549.5	QPSK	1	0	4x4 MIMO	LTE B41	20	39987	2529.7	QPSK	1	99	4x4 MIMO	23.40	23.35	23.0

**Table I-68  
Additional Hotspot Reduced Output Powers LTE CA\_41C Uplink Carrier Aggregation with Three Component Carrier Aggregation on the Downlink -**

Combination	PCC									SCC1						SCC2						Power		Target Power (dBm)
	PCC Band	PCC Bandwidth [MHz]	PCC (UL/DL) Channel	PCC (UL/DL) Frequency [MHz]	Modulation	PCC UL# RB	PCC UL RB Offset	DL Ant. Config.	SCC Band	SCC Bandwidth [MHz]	SCC (UL/DL) Channel	SCC (UL/DL) Frequency [MHz]	Modulation	SCC UL# RB	SCC UL RB Offset	DL Ant. Config.	SCC Band	SCC Bandwidth [MHz]	SCC (DL) Channel	SCC (DL) Frequency [MHz]	DL Ant. Config.	CA_41C ULCA Tx. Power with 4x4 DL MIMO enabled (dBm)	CA_41C ULCA Tx. Power (dBm)	
CA_41D	LTE B41	20	40185	2549.5	QPSK	1	0	4x4 MIMO	LTE B41	20	39987	2529.7	QPSK	1	99	4x4 MIMO	LTE B41	20	40383	2569.3	4x4 MIMO	23.37	23.35	23.0
CA_41C-41A	LTE B41	20	40185	2549.5	QPSK	1	0	2x2 MIMO	LTE B41	20	39987	2529.7	QPSK	1	99	2x2 MIMO	LTE B41	20	41490	2680	4x4 MIMO	23.36	23.35	23.0
CA_41C-41A	LTE B41	20	40185	2549.5	QPSK	1	0	4x4 MIMO	LTE B41	20	39987	2529.7	QPSK	1	99	4x4 MIMO	LTE B41	20	41490	2680	2x2 MIMO	23.38	23.35	23.0
CA_41C-41A	LTE B41	20	40185	2549.5	QPSK	1	0	4x4 MIMO	LTE B41	20	39987	2529.7	QPSK	1	99	4x4 MIMO	LTE B41	20	41490	2680	4x4 MIMO	23.37	23.35	23.0

**Table I-69  
Additional Hotspot Reduced Output Powers LTE CA\_41C Uplink Carrier Aggregation with Four Component Carrier Aggregation on the Downlink**

Combination	PCC									SCC1						SCC2						SCC3						Power		Target Power (dBm)
	PCC Band	PCC Bandwidth [MHz]	PCC (UL/DL) Channel	PCC (UL/DL) Frequency [MHz]	Modulation	PCC UL# RB	PCC UL RB Offset	DL Ant. Config.	SCC Band	SCC Bandwidth [MHz]	SCC (UL/DL) Channel	SCC (UL/DL) Frequency [MHz]	Modulation	SCC UL# RB	SCC UL RB Offset	DL Ant. Config.	SCC Band	SCC Bandwidth [MHz]	SCC (DL) Channel	SCC (DL) Frequency [MHz]	DL Ant. Config.	SCC Band	SCC Bandwidth [MHz]	SCC (DL) Channel	SCC (DL) Frequency [MHz]	DL Ant. Config.	CA_41C ULCA Tx. Power with 4x4 DL MIMO enabled (dBm)	CA_41C ULCA Tx. Power (dBm)		
CA_41C-41C	LTE B41	20	40185	2549.5	QPSK	1	0	4x4 MIMO	LTE B41	20	39987	2529.7	QPSK	1	99	4x4 MIMO	LTE B41	20	41292	2660.2	2x2 MIMO	LTE B41	20	41490	2680	2x2 MIMO	23.41	23.35	23.0	
CA_41C-41C	LTE B41	20	40185	2549.5	QPSK	1	0	2x2 MIMO	LTE B41	20	39987	2529.7	QPSK	1	99	2x2 MIMO	LTE B41	20	41292	2660.2	4x4 MIMO	LTE B41	20	41490	2680	4x4 MIMO	23.40	23.35	23.0	

FCC ID: A3LSMG960U		SAR EVALUATION REPORT		Approved by: Quality Manager
Test Dates: 11/03/17 – 12/07/17	DUT Type: Portable Handset	APPENDIX I: Page 19 of 19		