



# PCTEST ENGINEERING LABORATORY, INC.

7185 Oakland Mills Road, Columbia, MD 21046 USA  
Tel. +1.410.290.6652 / Fax +1.410.290.6654  
http://www.pctestlab.com



## SAR EVALUATION REPORT

**Applicant Name:**  
Samsung Electronics Co., Ltd.  
129, Samsung-ro, Maetan dong,  
Yeongtong-gu, Suwon-si  
Gyeonggi-do, 16677, Korea

**Date of Testing:**  
03/06/17 - 03/20/17  
**Test Site/Location:**  
PCTEST Lab, Columbia, MD, USA  
**Document Serial No.:**  
1M1703100103-01.A3L

**FCC ID:** A3LSMG950N

**APPLICANT:** SAMSUNG ELECTRONICS CO., LTD.

**DUT Type:** Portable Handset  
**Application Type:** Class II Permissive Change  
**FCC Rule Part(s):** CFR §2.1093  
**Model:** SM-G950N  
**Original Grant Date:** 03/10/2017  
**Permissive Change(s):** See FCC Change Document

Equipment Class	Band & Mode	Tx Frequency	SAR		
			1 gm Head (W/kg)	1 gm Body-Worn (W/kg)	1 gm Hotspot (W/kg)
PCE	GSM/GPRS/EDGE 1900	1850.20 - 1909.80 MHz	0.10	0.43	0.96
PCE	UMTS 850	826.40 - 846.60 MHz	0.23	0.30	0.37
PCE	UMTS 1900	1852.4 - 1907.6 MHz	0.14	0.46	0.66
PCE	LTE Band 12	699.7 - 715.3 MHz	< 0.1	0.12	0.17
PCE	LTE Band 17	706.5 - 713.5 MHz	N/A	N/A	N/A
PCE	LTE Band 13	779.5 - 784.5 MHz	0.13	0.26	0.32
PCE	LTE Band 26 (Cell)	814.7 - 848.3 MHz	0.17	0.23	0.36
PCE	LTE Band 5 (Cell)	824.7 - 848.3 MHz	0.20	0.26	0.52
PCE	LTE Band 4 (AWS)	1710.7 - 1754.3 MHz	0.21	0.43	0.45
PCE	LTE Band 25 (PCS)	1850.7 - 1914.3 MHz	0.20	0.43	0.35
PCE	LTE Band 2 (PCS)	1850.7 - 1909.3 MHz	N/A	N/A	N/A
PCE	LTE Band 41	2498.5 - 2687.5 MHz	< 0.1	0.10	0.25
DTS	2.4 GHz WLAN	2412 - 2462 MHz	0.60	0.10	0.25
Nil	U-NII-1	5180 - 5240 MHz	N/A	N/A	N/A
Nil	U-NII-2A	5260 - 5320 MHz	0.31	0.17	N/A
Nil	U-NII-2C	5500 - 5720 MHz	0.11	0.13	N/A
Nil	U-NII-3	5745 - 5825 MHz	0.18	0.24	0.35
DSS/DTS	Bluetooth	2402 - 2480 MHz	< 0.1	< 0.1	< 0.1
<b>Simultaneous SAR per KDB 690783 D01v01r03:</b>			1.25	1.09	1.59

This wireless portable device has been shown to be capable of compliance for localized specific absorption rate (SAR) for uncontrolled environment/general population exposure limits specified in ANSI/IEEE C95.1-1992 and has been tested in accordance with the measurement procedures specified in Section 1.8 of this report; for North American frequency bands only.

I attest to the accuracy of data. All measurements reported herein were performed by me or were made under my supervision and are correct to the best of my knowledge and belief. I assume full responsibility for the completeness of these measurements and vouch for the qualifications of all persons taking them. Test results reported herein relate only to the item(s) tested.

Randy Ortanez  
President



The SAR Tick is an initiative of the Mobile Manufacturers Forum (MMF). While a product may be considered eligible, use of the SAR Tick logo requires an agreement with the MMF. Further details can be obtained by emailing: sartick@mmfai.info.

<b>FCC ID:</b> A3LSMG950N		<b>SAR EVALUATION REPORT</b>		<b>Approved by:</b> Quality Manager
<b>Document S/N:</b> 1M1703100103-01.A3L	<b>Test Dates:</b> 03/06/17 - 03/20/17	<b>DUT Type:</b> Portable Handset	Page 1 of 91	

# T A B L E O F C O N T E N T S

1	DEVICE UNDER TEST .....	3
2	LTE INFORMATION .....	12
3	INTRODUCTION .....	13
4	DOSIMETRIC ASSESSMENT .....	14
5	DEFINITION OF REFERENCE POINTS .....	15
6	TEST CONFIGURATION POSITIONS .....	16
7	RF EXPOSURE LIMITS .....	19
8	FCC MEASUREMENT PROCEDURES.....	20
9	RF CONDUCTED POWERS.....	25
10	SYSTEM VERIFICATION.....	60
11	SAR DATA SUMMARY .....	62
12	FCC MULTI-TX AND ANTENNA SAR CONSIDERATIONS.....	77
13	SAR MEASUREMENT VARIABILITY .....	84
14	ADDITIONAL TESTING PER FCC GUIDANCE .....	85
15	EQUIPMENT LIST.....	87
16	MEASUREMENT UNCERTAINTIES.....	87
17	CONCLUSION.....	89
18	REFERENCES .....	90
APPENDIX A:	SAR TEST PLOTS	
APPENDIX B:	SAR DIPOLE VERIFICATION PLOTS	
APPENDIX C:	PROBE AND DIPOLE CALIBRATION CERTIFICATES	
APPENDIX D:	SAR TISSUE SPECIFICATIONS	
APPENDIX E:	SAR SYSTEM VALIDATION	
APPENDIX F:	DUT ANTENNA DIAGRAM & SAR TEST SETUP PHOTOGRAPHS	

FCC ID: A3LSMG950N		<b>SAR EVALUATION REPORT</b>		<b>Approved by:</b> Quality Manager
<b>Document S/N:</b> 1M1703100103-01.A3L	<b>Test Dates:</b> 03/06/17 - 03/20/17	<b>DUT Type:</b> Portable Handset	Page 2 of 91	

# 1 DEVICE UNDER TEST



## 1.1 Device Overview

Band & Mode	Operating Modes	Tx Frequency
UMTS 850	Voice/Data	826.40 - 846.60 MHz
GSM/GPRS/EDGE 1900	Voice/Data	1850.20 - 1909.80 MHz
UMTS 1900	Voice/Data	1852.4 - 1907.6 MHz
LTE Band 12	Data	699.7 - 715.3 MHz
LTE Band 17	Data	706.5 - 713.5 MHz
LTE Band 13	Data	779.5 - 784.5 MHz
LTE Band 5 (Cell)	Data	824.7 - 848.3 MHz
LTE Band 26 (Cell)	Data	814.7 - 848.3 MHz
LTE Band 4 (AWS)	Data	1710.7 - 1754.3 MHz
LTE Band 25 (PCS)	Data	1850.7 - 1914.3 MHz
LTE Band 2 (PCS)	Data	1850.7 - 1909.3 MHz
LTE Band 41	Data	2498.5 - 2687.5 MHz
2.4 GHz WLAN	Data	2412 - 2462 MHz
U-NII-1	Data	5180 - 5240 MHz
U-NII-2A	Data	5260 - 5320 MHz
U-NII-2C	Data	5500 - 5720 MHz
U-NII-3	Data	5745 - 5825 MHz
Bluetooth	Data	2402 - 2480 MHz
NFC	Data	13.56 MHz
ANT+	Data	2402 - 2480 MHz
MST	Data	555 Hz - 8.33 kHz

## 1.2 Power Reduction for SAR

This device utilizes a single step power reduction mechanism for SAR compliance under portable hotspot conditions for some wireless modes and bands. All hotspot SAR evaluations for this device were performed at the maximum allowed output power when hotspot is enabled. Detailed descriptions of the power reduction mechanism are included in the operational description.

This device uses an independent fixed level power reduction mechanism for WLAN operations during voice or VoIP held to ear scenarios. Per FCC Guidance, the held-to-ear exposure conditions were evaluated at reduced power according to the head SAR positions described in IEEE 1528-2013. Detailed descriptions of the power reduction mechanism are included in the operational description.

FCC ID: A3LSMG950N		SAR EVALUATION REPORT		Approved by: Quality Manager
Document S/N: 1M1703100103-01.A3L	Test Dates: 03/06/17 - 03/20/17	DUT Type: Portable Handset	Page 3 of 91	

### 1.3 Nominal and Maximum Output Power Specifications



This device operates using the following maximum and nominal output power specifications. SAR values were scaled to the maximum allowed power to determine compliance per KDB Publication 447498 D01v06.

#### 1.3.1 Maximum Power

Mode / Band		Voice (dBm)	Burst Average GMSK (dBm)				Burst Average 8-PSK (dBm)			
		1 TX Slot	1 TX Slots	2 TX Slots	3 TX Slots	4 TX Slots	1 TX Slots	2 TX Slots	3 TX Slots	4 TX Slots
GSM/GPRS/EDGE 1900	Maximum	30.5	30.5	28.5	27.0	26.0	26.0	24.0	23.0	22.0
	Nominal	30.0	30.0	28.0	26.5	25.5	25.5	23.5	22.5	21.5

Mode / Band		Modulated Average (dBm)		
		3GPP WCDMA	3GPP HSDPA	3GPP HSUPA
UMTS Band 5 (850 MHz)	Maximum	23.5	23.5	23.0
	Nominal	23.0	23.0	22.5
UMTS Band 2 (1900 MHz)	Maximum	23.5	23.5	23.0
	Nominal	23.0	23.0	22.5

Mode / Band		Modulated Average (dBm)
LTE Band 12	Maximum	23.5
	Nominal	23.0
LTE Band 17	Maximum	23.5
	Nominal	23.0
LTE Band 13	Maximum	23.5
	Nominal	23.0
LTE Band 5 (Cell) Ant A	Maximum	24.5
	Nominal	24.0
LTE Band 5 (Cell) Ant C	Maximum	23.5
	Nominal	23.0
LTE Band 26 (Cell)	Maximum	23.5
	Nominal	23.0
LTE Band 4 (AWS)	Maximum	23.5
	Nominal	23.0
LTE Band 25 (PCS)	Maximum	23.5
	Nominal	23.0
LTE Band 2 (PCS)	Maximum	23.5
	Nominal	23.0
LTE Band 41	Maximum	24.0
	Nominal	23.5



FCC ID: A3LSMG950N		SAR EVALUATION REPORT		Approved by: Quality Manager
Document S/N: 1M1703100103-01.A3L	Test Dates: 03/06/17 - 03/20/17	DUT Type: Portable Handset		Page 4 of 91

Mode / Band		Modulated Average - Single Tx Chain (dBm)
IEEE 802.11b (2.4 GHz)	Maximum	19.5
	Nominal	19.0
IEEE 802.11g (2.4 GHz)	Maximum	17.5
	Nominal	17.0
IEEE 802.11n (2.4 GHz)	Maximum	15.5
	Nominal	15.0
Bluetooth (1 Mbps)	Maximum	16.5
	Nominal	16.0
Bluetooth (EDR)	Maximum	10.5
	Nominal	10.0
Bluetooth LE	Maximum	9.5
	Nominal	9.0
Bluetooth LE (2 Mbps, v5.0)	Maximum	9.5
	Nominal	9.0

Mode / Band		Modulated Average - MIMO (dBm)
IEEE 802.11g (2.4 GHz)	Maximum	20.5
	Nominal	20.0
IEEE 802.11n (2.4 GHz)	Maximum	18.5
	Nominal	18.0

Mode / Band		Modulated Average - Single Tx Chain (dBm)		
		20 MHz Bandwidth	40 MHz Bandwidth	80 MHz Bandwidth
IEEE 802.11a (5 GHz)	Maximum	16.5		
	Nominal	16.0		
IEEE 802.11n (5 GHz)	Maximum	16.5	15.5	
	Nominal	16.0	15.0	
IEEE 802.11ac (5 GHz)	Maximum	16.5	15.5	14.5
	Nominal	16.0	15.0	14.0

Mode / Band		Modulated Average - MIMO (dBm)		
		20 MHz Bandwidth	40 MHz Bandwidth	80 MHz Bandwidth
IEEE 802.11a (5 GHz)	Maximum	19.5		
	Nominal	19.0		
IEEE 802.11n (5 GHz)	Maximum	19.5	18.5	
	Nominal	19.0	18.0	
IEEE 802.11ac (5 GHz)	Maximum	19.5	18.5	17.5
	Nominal	19.0	18.0	17.0

FCC ID: A3LSMG950N		<b>SAR EVALUATION REPORT</b>		Approved by: Quality Manager
Document S/N: 1M1703100103-01.A3L	Test Dates: 03/06/17 - 03/20/17	DUT Type: Portable Handset		Page 5 of 91

### 1.3.2 Maximum Output Powers During Operations with Simultaneous 2.4 GHz and 5 GHz WLAN



	# Tx	5 GHz WiFi [dBm]		2.4 GHz WiFi [dBm]		802.11 Modes
		Ant1	Ant2	Ant1	Ant2	
2.4 GHz + 5 GHz RSDB Only	2	A	-	-	B	2.4 GHz: b,g,n 5 GHz: a,n,ac
	2	-	A	B	-	
	2	A	-	B	-	
	2	-	A	-	B	
2.4 GHz + 5 GHz RSDB & MIMO	3	A	A	B	-	2.4 GHz: b, g, n 5 GHz: n, ac, a (CDD +STBC only)
	3	A	A	-	B	
	3	A	-	B	B	2.4 GHz: n, g (CDD +STBC only) 5 GHz: a, n, ac
	3	-	A	B	B	
2.4 GHz + 5 GHz RSDB MIMO	4	A	A	B	B	2.4 GHz: n, g (CDD +STBC only) 5 GHz: n, ac, a (CDD +STBC only)

A = 11.0, B=11.0  
(Upper Tolerance: target+0.5 dB)

### 1.3.3 Reduced Power

Mode / Band		Modulated Average (dBm)		
		3GPP WCDMA	3GPP HSDPA	3GPP HSUPA
UMTS Band 5 (850 MHz)	Maximum	22.5	22.5	22.0
	Nominal	22.0	22.0	21.5
UMTS Band 2 (1900 MHz)	Maximum	19.5	19.5	19.5
	Nominal	19.0	19.0	19.0

Mode / Band		Modulated Average (dBm)
LTE Band 12	Maximum	22.5
	Nominal	22.0
LTE Band 17	Maximum	22.5
	Nominal	22.0
LTE Band 13	Maximum	22.5
	Nominal	22.0
LTE Band 4 (AWS)	Maximum	20.5
	Nominal	20.0
LTE Band 25 (PCS)	Maximum	20.5
	Nominal	20.0
LTE Band 2 (PCS)	Maximum	20.5
	Nominal	20.0



FCC ID: A3LSMG950N		SAR EVALUATION REPORT		Approved by: Quality Manager
Document S/N: 1M1703100103-01.A3L	Test Dates: 03/06/17 - 03/20/17	DUT Type: Portable Handset		Page 6 of 91

Mode / Band		Modulated Average - Single Tx Chain (dBm)
IEEE 802.11b (2.4 GHz)	Maximum	16.5
	Nominal	16.0
IEEE 802.11g (2.4 GHz)	Maximum	16.5
	Nominal	16.0
IEEE 802.11n (2.4 GHz)	Maximum	15.5
	Nominal	15.0

Mode / Band		Modulated Average - MIMO (dBm)
IEEE 802.11g (2.4 GHz)	Maximum	19.5
	Nominal	19.0
IEEE 802.11n (2.4 GHz)	Maximum	18.5
	Nominal	18.0

Mode / Band		Modulated Average - Single Tx Chain (dBm)		
		20 MHz Bandwidth	40 MHz Bandwidth	80 MHz Bandwidth
IEEE 802.11a (5 GHz)	Maximum	14.5		
	Nominal	14.0		
IEEE 802.11n (5 GHz)	Maximum	14.5	14.5	
	Nominal	14.0	14.0	
IEEE 802.11ac (5 GHz)	Maximum	14.5	14.5	14.5
	Nominal	14.0	14.0	14.0

Mode / Band		Modulated Average - MIMO (dBm)		
		20 MHz Bandwidth	40 MHz Bandwidth	80 MHz Bandwidth
IEEE 802.11a (5 GHz)	Maximum	17.5		
	Nominal	17.0		
IEEE 802.11n (5 GHz)	Maximum	17.5	17.5	
	Nominal	17.0	17.0	
IEEE 802.11ac (5 GHz)	Maximum	17.5	17.5	17.5
	Nominal	17.0	17.0	17.0

FCC ID: A3LSMG950N		SAR EVALUATION REPORT		Approved by: Quality Manager
Document S/N: 1M1703100103-01.A3L	Test Dates: 03/06/17 - 03/20/17	DUT Type: Portable Handset		Page 7 of 91

## 1.4 DUT Antenna Locations

The overall dimensions of this device are > 9 x 5 cm. The overall diagonal dimension of the device is ≤160 mm and the diagonal display is ≤150 mm. A diagram showing the location of the device antennas can be found in Appendix F.

**Table 1-1  
Device Edges/Sides for SAR Testing**

Mode	Back	Front	Top	Bottom	Right	Left
UMTS 850	Yes	Yes	No	Yes	Yes	Yes
GPRS 1900	Yes	Yes	No	Yes	Yes	Yes
UMTS 1900	Yes	Yes	No	Yes	Yes	Yes
LTE Band 12	Yes	Yes	No	Yes	Yes	Yes
LTE Band 13	Yes	Yes	No	Yes	Yes	Yes
LTE Band 5 (Cell) Ant A	Yes	Yes	No	Yes	Yes	Yes
LTE Band 5 (Cell) Ant C	Yes	Yes	Yes	No	Yes	Yes
LTE Band 26 (Cell)	Yes	Yes	No	Yes	Yes	Yes
LTE Band 4 (AWS)	Yes	Yes	No	Yes	Yes	Yes
LTE Band 25 (PCS)	Yes	Yes	No	Yes	Yes	Yes
LTE Band 41	Yes	Yes	No	Yes	Yes	Yes
2.4 GHz WLAN Ant 1	Yes	Yes	Yes	No	No	Yes
2.4 GHz WLAN Ant 2	Yes	Yes	Yes	No	No	Yes
Bluetooth	Yes	Yes	Yes	No	No	Yes
5 GHz WLAN Ant 1	Yes	Yes	Yes	No	No	Yes
5 GHz WLAN Ant 2	Yes	Yes	Yes	No	No	Yes



Note: Particular DUT edges were not required to be evaluated for wireless router SAR if the edges were greater than 2.5 cm from the transmitting antenna according to FCC KDB Publication 941225 D06v02r01 Section III. The distances between the transmit antennas and the edges of the device are included in the filing. When wireless router mode is enabled, U-NII-1, U-NII-2A, U-NII-2C operations are disabled. Therefore, U-NII-1, U-NII-2A, U-NII-2C operations are not considered in this section. Right edge tests were additionally performed for some modes per manufacturer request.

## 1.5 Near Field Communications (NFC) Antenna

This DUT has NFC operations. The NFC antenna is integrated into the device for this model. Therefore, all SAR tests were performed with the device which already incorporates the NFC antenna. A diagram showing the location of the NFC antenna can be found in Appendix F.

## 1.6 Simultaneous Transmission Capabilities

According to FCC KDB Publication 447498 D01v06, transmitters are considered to be transmitting simultaneously when there is overlapping transmission, with the exception of transmissions during network hand-offs with maximum hand-off duration less than 30 seconds. Possible transmission paths for the DUT are shown in Figure 1-1 and are color-coded to indicate communication modes which share the same path. Modes which share the same transmission path cannot transmit simultaneously with one another.

FCC ID: A3LSMG950N		SAR EVALUATION REPORT		Approved by: Quality Manager
Document S/N: 1M1703100103-01.A3L	Test Dates: 03/06/17 - 03/20/17	DUT Type: Portable Handset	Page 8 of 91	

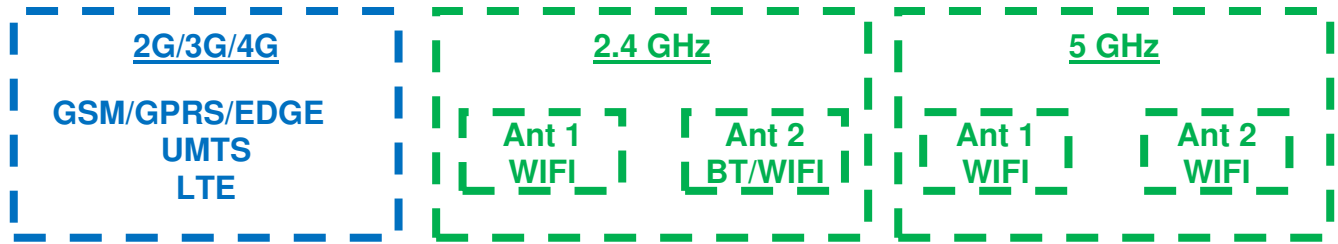

**Figure 1-1**  
**Simultaneous Transmission Paths**

This device contains multiple transmitters that may operate simultaneously, and therefore requires a simultaneous transmission analysis according to FCC KDB Publication 447498 D01v06 4.3.2 procedures.

**Table 1-2**  
**Simultaneous Transmission Scenarios**

No.	Capable Transmit Configuration	Head	Body-Worn Accessory	Wireless Router	Notes
1	GSM voice + 2.4 GHz Wi-Fi	Yes	Yes	N/A	
2	GSM voice + 5 GHz Wi-Fi	Yes	Yes	N/A	
3	GSM voice + 2.4 GHz Wi-Fi + 5 GHz Wi-Fi	Yes	Yes	N/A	
4	GSM voice + 2.4 GHz Bluetooth	Yes <sup>^</sup>	Yes	N/A	<sup>^</sup> BT Tethering applications are considered.
5	GSM voice + 2.4 GHz Wi-Fi MIMO	Yes	Yes	N/A	
6	GSM voice + 5 GHz Wi-Fi MIMO	Yes	Yes	N/A	
7	GSM voice + 2.4 GHz Wi-Fi MIMO + 5 GHz Wi-Fi MIMO	Yes	Yes	N/A	
8	UMTS + 2.4 GHz Wi-Fi	Yes	Yes	Yes	
9	UMTS + 5 GHz Wi-Fi	Yes	Yes	Yes	
10	UMTS + 2.4 GHz Wi-Fi + 5 GHz Wi-Fi	Yes	Yes	Yes	
11	UMTS + 2.4 GHz Bluetooth	Yes <sup>^</sup>	Yes	Yes <sup>^</sup>	<sup>^</sup> BT Tethering applications are considered.
12	UMTS + 2.4 GHz Wi-Fi MIMO	Yes	Yes	Yes	
13	UMTS + 5 GHz Wi-Fi MIMO	Yes	Yes	Yes	
14	UMTS + 2.4 GHz Wi-Fi MIMO + 5 GHz Wi-Fi MIMO	Yes	Yes	Yes	
15	LTE + 2.4 GHz Wi-Fi	Yes*	Yes*	Yes	*-Pre-installed VOIP applications are considered.
16	LTE + 5 GHz Wi-Fi	Yes*	Yes*	Yes	*-Pre-installed VOIP applications are considered.
17	LTE + 2.4 GHz Wi-Fi + 5 GHz Wi-Fi	Yes*	Yes*	Yes	*-Pre-installed VOIP applications are considered.
18	LTE + 2.4 GHz Bluetooth	Yes <sup>^</sup> *	Yes*	Yes <sup>^</sup>	*-Pre-installed VOIP applications are considered. <sup>^</sup> BT Tethering applications are considered.
19	LTE + 2.4 GHz Wi-Fi MIMO	Yes*	Yes*	Yes	*-Pre-installed VOIP applications are considered.
20	LTE + 5 GHz Wi-Fi MIMO	Yes*	Yes*	Yes	*-Pre-installed VOIP applications are considered.
21	LTE + 2.4 GHz Wi-Fi MIMO + 5 GHz Wi-Fi MIMO	Yes*	Yes*	Yes	*-Pre-installed VOIP applications are considered.
22	GPRS/EDGE + 2.4 GHz Wi-Fi	N/A	N/A	Yes	
23	GPRS/EDGE + 5 GHz Wi-Fi	N/A	N/A	Yes	
24	GPRS/EDGE + 2.4 GHz Wi-Fi + 5 GHz Wi-Fi	N/A	N/A	Yes	
25	GPRS/EDGE + 2.4 GHz Bluetooth	N/A	N/A	Yes <sup>^</sup>	<sup>^</sup> BT Tethering applications are considered.
26	GPRS/EDGE + 2.4 GHz Wi-Fi MIMO	N/A	N/A	Yes	
27	GPRS/EDGE + 5 GHz Wi-Fi MIMO	N/A	N/A	Yes	
28	GPRS/EDGE + 2.4 GHz Wi-Fi MIMO + 5 GHz Wi-Fi MIMO	N/A	N/A	Yes	

1. All licensed modes share the same antenna path and cannot transmit simultaneously.
2. When the user utilizes multiple services in UMTS 3G mode it uses multi-Radio Access Bearer or multi-RAB. The power control is based on a physical control channel (Dedicated Physical Control Channel [DPCCH]) and power control will be adjusted to meet the needs of both services. Therefore, the UMTS+WLAN scenario also represents the UMTS Voice/DATA + WLAN Hotspot scenario.
3. Per the manufacturer, WIFI Direct is not expected to be used in conjunction with a held-to-ear or body-worn accessory voice call. Therefore, there are no simultaneous transmission scenarios involving WIFI direct beyond that listed in the above table.
4. 5 GHz Wireless Router is only supported for the U-NII-3 by S/W, therefore U-NII-1, U-NII2A, and U-NII2C were not evaluated for wireless router conditions.
5. This device supports 2x2 MIMO Tx for WLAN 802.11a/g/n/ac. Each WLAN antenna can transmit independently or together when operating with MIMO.
6. Antenna A and Antenna C operate in a switched condition only and cannot transmit simultaneously. Transmission from Antenna C is disabled when the device is in a held-to-ear use condition.
7. This device supports Bluetooth tethering for EDR packet only.

FCC ID: A3LSMG950N		SAR EVALUATION REPORT			Approved by: Quality Manager
Document S/N: 1M1703100103-01.A3L	Test Dates: 03/06/17 - 03/20/17	DUT Type: Portable Handset		Page 9 of 91	

## 1.7 Miscellaneous SAR Test Considerations

### (A) WIFI/BT

Since U-NII-1 and U-NII-2A bands have the same maximum output power and the highest reported SAR for U-NII-2A is less than 1.2 W/kg, SAR is not required for U-NII-1 band according to FCC KDB Publication 248227 D01v02r02.

Since Wireless Router operations are not allowed by the chipset firmware using U-NII-1, U-NII-2A & U-NII-2C WIFI, only 2.4 GHz and U-NII-3 WIFI Hotspot SAR tests and combinations are considered for SAR with respect to Wireless Router configurations according to FCC KDB 941225 D06v02r01.

This device supports IEEE 802.11ac with the following features:

- a) Up to 80 MHz Bandwidth only
- b) No aggregate channel configurations
- c) 2 Tx antenna output
- d) 256 QAM is supported
- e) TDWR and Band gap channels are supported

### (B) Licensed Transmitter(s)

GSM/GPRS/EDGE DTM is not supported for US bands. Therefore, the GSM Voice modes in this report do not transmit simultaneously with GPRS/EDGE Data.

This device is only capable of QPSK HSUPA in the uplink. Therefore, no additional SAR tests are required beyond that described for devices with HSUPA in KDB 941225 D01v03r01.



LTE SAR for the higher modulations and lower bandwidths were not tested since the maximum average output power of all required channels and configurations was not more than 0.5 dB higher than the highest bandwidth; and the reported LTE SAR for the highest bandwidth was less than 1.45 W/kg for all configurations according to FCC KDB 941225 D05v02r04.

LTE Band 5 Ant C is disabled for all held to ear scenarios. Therefore SAR was only assessed for body-worn accessory and wireless router conditions

LTE with 64QAM in the uplink is permanently disabled for US Operations.

This device supports both LTE Band 12 and LTE Band 17. Since the supported frequency span for LTE Band 17 falls completely within the supported frequency span for LTE Band 12, both LTE bands have the same target power, and both LTE bands share the same transmission path, SAR was only assessed for LTE Band 12.

This device supports both LTE Band 2 and LTE Band 25. Since the supported frequency span for LTE Band 2 falls completely within the supported frequency span for LTE Band 25, both LTE bands have the same target power, and both LTE bands share the same transmission path, SAR was only assessed for LTE Band 25.

FCC ID: A3LSMG950N		SAR EVALUATION REPORT		Approved by: Quality Manager
Document S/N: 1M1703100103-01.A3L	Test Dates: 03/06/17 - 03/20/17	DUT Type: Portable Handset		Page 10 of 91



## 1.8 Guidance Applied

- IEEE 1528-2013
- FCC KDB Publication 941225 D01v03r01, D05v02r04, D05Av01r02, D06v02r01 (2G/3G/4G and Hotspot)
- FCC KDB Publication 248227 D01v02r02 (SAR Considerations for 802.11 Devices)
- FCC KDB Publication 447498 D01v06 (General SAR Guidance)
- FCC KDB Publication 865664 D01v01r04, D02v01r02 (SAR Measurements up to 6 GHz)
- October 2013 TCB Workshop Notes (GPRS Testing Considerations)

## 1.9 Device Serial Numbers

Several samples with identical hardware were used to support SAR testing. The manufacturer has confirmed that the device(s) tested have the same physical, mechanical and thermal characteristics and are within operational tolerances expected for production units.



	Head Serial Number	Body-Worn Serial Number	Hotspot Serial Number
GSM/GPRS/EDGE 1900	E3D05	E3D11	E3D11
UMTS 850	E3D05	E3D12	E3D12
UMTS 1900	E3D05	E3D11	E3D11
LTE Band 12	E3D02	E3D11	E3D11
LTE Band 13	E3D02	E3D11	E3D11
LTE Band 26 (Cell)	E3D05	E3D12	E3D12
LTE Band 5 (Cell) Ant A	E3D05	E3D12	E3D12
LTE Band 5 (Cell) Ant C	-	E3D02	E3D02
LTE Band 4 (AWS)	E3D11	E3D11	E3D11
LTE Band 25 (PCS)	E3D05	E3D11	E3D11
LTE Band 41	E3D11	E3D02	E3D02
2.4 GHz WLAN	E3D11	E3D11	E3D11
5 GHz WLAN	E3D12	E3D02	E3D02
Bluetooth	E3D02	E3D11	E3D11

FCC ID: A3LSMG950N		SAR EVALUATION REPORT		Approved by: Quality Manager
Document S/N: 1M1703100103-01.A3L	Test Dates: 03/06/17 - 03/20/17	DUT Type: Portable Handset	Page 11 of 91	

# 2

# LTE INFORMATION

LTE Information					
<b>FCC ID</b>	<b>A3LSMG950N</b>				
Form Factor	Portable Handset				
Frequency Range of each LTE transmission band	LTE Band 12 (699.7 - 715.3 MHz) LTE Band 17 (706.5 - 713.5 MHz) LTE Band 13 (779.5 - 784.5 MHz) LTE Band 5 (Cell) (824.7 - 848.3 MHz) LTE Band 26 (Cell) (814.7 - 848.3 MHz) LTE Band 4 (AWS) (1710.7 - 1754.3 MHz) LTE Band 25 (PCS) (1850.7 - 1914.3 MHz) LTE Band 2 (PCS) (1850.7 - 1909.3 MHz) LTE Band 41 (2498.5 - 2687.5 MHz)				
Channel Bandwidths	LTE Band 12: 1.4 MHz, 3 MHz, 5 MHz, 10 MHz LTE Band 17: 5 MHz, 10 MHz LTE Band 13: 5 MHz, 10 MHz LTE Band 5 (Cell): 1.4 MHz, 3 MHz, 5 MHz, 10 MHz LTE Band 26 (Cell): 1.4 MHz, 3 MHz, 5 MHz, 10 MHz, 15 MHz LTE Band 4 (AWS): 1.4 MHz, 3 MHz, 5 MHz, 10 MHz, 15 MHz, 20 MHz LTE Band 25 (PCS): 1.4 MHz, 3 MHz, 5 MHz, 10 MHz, 15 MHz, 20 MHz LTE Band 2 (PCS): 1.4 MHz, 3 MHz, 5 MHz, 10 MHz, 15 MHz, 20 MHz LTE Band 41: 5 MHz, 10 MHz, 15 MHz, 20 MHz				
Channel Numbers and Frequencies (MHz)	Low	Low-Mid	Mid	Mid-High	High
LTE Band 12: 1.4 MHz	699.7 (23017)		707.5 (23095)		715.3 (23173)
LTE Band 12: 3 MHz	700.5 (23025)		707.5 (23095)		714.5 (23165)
LTE Band 12: 5 MHz	701.5 (23035)		707.5 (23095)		713.5 (23155)
LTE Band 12: 10 MHz	704 (23060)		707.5 (23095)		711 (23130)
LTE Band 17: 5 MHz	706.5 (23755)		710 (23790)		713.5 (23825)
LTE Band 17: 10 MHz	709 (23780)		710 (23790)		711 (23800)
LTE Band 13: 5 MHz	779.5 (23205)		782 (23230)		784.5 (23255)
LTE Band 13: 10 MHz	N/A		782 (23230)		N/A
LTE Band 5 (Cell): 1.4 MHz	824.7 (20407)		836.5 (20525)		848.3 (20643)
LTE Band 5 (Cell): 3 MHz	825.5 (20415)		836.5 (20525)		847.5 (20635)
LTE Band 5 (Cell): 5 MHz	826.5 (20425)		836.5 (20525)		846.5 (20625)
LTE Band 5 (Cell): 10 MHz	829 (20450)		836.5 (20525)		844 (20600)
LTE Band 26 (Cell): 1.4 MHz	814.7 (26697)		831.5 (26865)		848.3 (27033)
LTE Band 26 (Cell): 3 MHz	815.5 (26705)		831.5 (26865)		847.5 (27025)
LTE Band 26 (Cell): 5 MHz	816.5 (26715)		831.5 (26865)		846.5 (27015)
LTE Band 26 (Cell): 10 MHz	819 (26740)		831.5 (26865)		844 (26990)
LTE Band 26 (Cell): 15 MHz	821.5 (26765)		831.5 (26865)		841.5 (26965)
LTE Band 4 (AWS): 1.4 MHz	1710.7 (19957)		1732.5 (20175)		1754.3 (20393)
LTE Band 4 (AWS): 3 MHz	1711.5 (19965)		1732.5 (20175)		1753.5 (20385)
LTE Band 4 (AWS): 5 MHz	1712.5 (19975)		1732.5 (20175)		1752.5 (20375)
LTE Band 4 (AWS): 10 MHz	1715 (20000)		1732.5 (20175)		1750 (20350)
LTE Band 4 (AWS): 15 MHz	1717.5 (20025)		1732.5 (20175)		1747.5 (20325)
LTE Band 4 (AWS): 20 MHz	1720 (20050)		1732.5 (20175)		1745 (20300)
LTE Band 25 (PCS): 1.4 MHz	1850.7 (26047)		1882.5 (26365)		1914.3 (26683)
LTE Band 25 (PCS): 3 MHz	1851.5 (26055)		1882.5 (26365)		1913.5 (26675)
LTE Band 25 (PCS): 5 MHz	1852.5 (26065)		1882.5 (26365)		1912.5 (26665)
LTE Band 25 (PCS): 10 MHz	1855 (26090)		1882.5 (26365)		1910 (26640)
LTE Band 25 (PCS): 15 MHz	1857.5 (26115)		1882.5 (26365)		1907.5 (26615)
LTE Band 25 (PCS): 20 MHz	1860 (26140)		1882.5 (26365)		1905 (26590)
LTE Band 2 (PCS): 1.4 MHz	1850.7 (18607)		1880 (18900)		1909.3 (19193)
LTE Band 2 (PCS): 3 MHz	1851.5 (18615)		1880 (18900)		1908.5 (19185)
LTE Band 2 (PCS): 5 MHz	1852.5 (18625)		1880 (18900)		1907.5 (19175)
LTE Band 2 (PCS): 10 MHz	1855 (18650)		1880 (18900)		1905 (19150)
LTE Band 2 (PCS): 15 MHz	1857.5 (18675)		1880 (18900)		1902.5 (19125)
LTE Band 2 (PCS): 20 MHz	1860 (18700)		1880 (18900)		1900 (19100)
LTE Band 41: 5 MHz	2506 (39750)	2549.5 (40185)	2593 (40620)	2636.5 (41055)	2680 (41490)
LTE Band 41: 10 MHz	2506 (39750)	2549.5 (40185)	2593 (40620)	2636.5 (41055)	2680 (41490)
LTE Band 41: 15 MHz	2506 (39750)	2549.5 (40185)	2593 (40620)	2636.5 (41055)	2680 (41490)
LTE Band 41: 20 MHz	2506 (39750)	2549.5 (40185)	2593 (40620)	2636.5 (41055)	2680 (41490)
UE Category	6				
DL UE Category	16				
UL UE Category	5				
Modulations Supported in UL	QPSK, 16QAM				
LTE MPR Permanently implemented per 3GPP TS 36.101 section 6.2.3-6.2.5? (manufacturer attestation to be provided)	YES				
A-MPR (Additional MPR) disabled for SAR Testing?	YES				
LTE Release 12 Additional Information	This device does not support full CA features on 3GPP Release 12. All uplink communications are identical to the Release 8 Specifications. Uplink communications are done on the PCC. The following LTE Release 12 Features are not supported: Carrier Aggregation, Relay, HetNet, Enhanced MIMO, eCIC, WIFI Offloading, MDH, eMBMS, Cross-Carrier Scheduling, Enhanced SC-FDMA.				

<b>FCC ID:</b> A3LSMG950N		<b>SAR EVALUATION REPORT</b>		<b>Approved by:</b> Quality Manager
<b>Document S/N:</b> 1M1703100103-01.A3L	<b>Test Dates:</b> 03/06/17 - 03/20/17	<b>DUT Type:</b> Portable Handset	Page 12 of 91	

## 3 INTRODUCTION

The FCC and Innovation, Science, and Economic Development Canada have adopted the guidelines for evaluating the environmental effects of radio frequency (RF) radiation in ET Docket 93-62 on Aug. 6, 1996 and Health Canada Safety Code 6 to protect the public and workers from the potential hazards of RF emissions due to FCC-regulated portable devices. [1]

The safety limits used for the environmental evaluation measurements are based on the criteria published by the American National Standards Institute (ANSI) for localized specific absorption rate (SAR) in IEEE/ANSI C95.1-1992 Standard for Safety Levels with Respect to Human Exposure to Radio Frequency Electromagnetic Fields, 3 kHz to 300 GHz [3] and Health Canada RF Exposure Guidelines Safety Code 6 [22]. The measurement procedure described in IEEE/ANSI C95.3-2002 Recommended Practice for the Measurement of Potentially Hazardous Electromagnetic Fields - RF and Microwave [4] is used for guidance in measuring the Specific Absorption Rate (SAR) due to the RF radiation exposure from the Equipment Under Test (EUT). These criteria for SAR evaluation are similar to those recommended by the International Committee for Non-Ionizing Radiation Protection (ICNIRP) in Biological Effects and Exposure Criteria for Radiofrequency Electromagnetic Fields,” Report No. Vol 74. SAR is a measure of the rate of energy absorption due to exposure to an RF transmitting source. SAR values have been related to threshold levels for potential biological hazards.

### 3.1 SAR Definition

Specific Absorption Rate is defined as the time derivative (rate) of the incremental energy (dU) absorbed by (dissipated in) an incremental mass (dm) contained in a volume element (dV) of a given density ( $\rho$ ). It is also defined as the rate of RF energy absorption per unit mass at a point in an absorbing body (see Equation 3-1).

**Equation 3-1**  
**SAR Mathematical Equation**

$$SAR = \frac{d}{dt} \left( \frac{dU}{dm} \right) = \frac{d}{dt} \left( \frac{dU}{\rho dv} \right)$$



SAR is expressed in units of Watts per Kilogram (W/kg).

$$SAR = \frac{\sigma \cdot E^2}{\rho}$$

where:

- $\sigma$  = conductivity of the tissue-simulating material (S/m)
- $\rho$  = mass density of the tissue-simulating material (kg/m<sup>3</sup>)
- E = Total RMS electric field strength (V/m)

NOTE: The primary factors that control rate of energy absorption were found to be the wavelength of the incident field in relation to the dimensions and geometry of the irradiated organism, the orientation of the organism in relation to the polarity of field vectors, the presence of reflecting surfaces, and whether conductive contact is made by the organism with a ground plane.[6]

FCC ID: A3LSMG950N		SAR EVALUATION REPORT		Approved by: Quality Manager
Document S/N: 1M1703100103-01.A3L	Test Dates: 03/06/17 - 03/20/17	DUT Type: Portable Handset	Page 13 of 91	

# 4 DOSIMETRIC ASSESSMENT

## 4.1 Measurement Procedure

The evaluation was performed using the following procedure compliant to FCC KDB Publication 865664 D01v01r04 and IEEE 1528-2013:

1. The SAR distribution at the exposed side of the head or body was measured at a distance no greater than 5.0 mm from the inner surface of the shell. The area covered the entire dimension of the device-head and body interface and the horizontal grid resolution was determined per FCC KDB Publication 865664 D01v01r04 (See Table 4-1) and IEEE 1528-2013.
2. The point SAR measurement was taken at the maximum SAR region determined from Step 1 to enable the monitoring of SAR fluctuations/drifts during the 1g/10g cube evaluation. SAR at this fixed point was measured and used as a reference value.
3. Based on the area scan data, the peak of the region with maximum SAR was determined by spline interpolation. Around this point, a volume was assessed according to the measurement resolution and volume size requirements of FCC KDB Publication 865664 D01v01r04 (See Table 4-1) and IEEE 1528-2013. On the basis of this data set, the spatial peak SAR value was evaluated with the following procedure (see references or the DASYS manual online for more details):
  - a. SAR values at the inner surface of the phantom are extrapolated from the measured values along the line away from the surface with spacing no greater than that in Table 4-1. The extrapolation was based on a least-squares algorithm. A polynomial of the fourth order was calculated through the points in the z-axis (normal to the phantom shell).
  - b. After the maximum interpolated values were calculated between the points in the cube, the SAR was averaged over the spatial volume (1g or 10g) using a 3D-Spline interpolation algorithm. The 3D-spline is composed of three one-dimensional splines with the “Not a knot” condition (in x, y, and z directions). The volume was then integrated with the trapezoidal algorithm. One thousand points (10 x 10 x 10) were obtained through interpolation, in order to calculate the averaged SAR.
  - c. All neighboring volumes were evaluated until no neighboring volume with a higher average value was found.
4. The SAR reference value, at the same location as step 2, was re-measured after the zoom scan was complete to calculate the SAR drift. If the drift deviated by more than 5%, the SAR test and drift measurements were repeated.

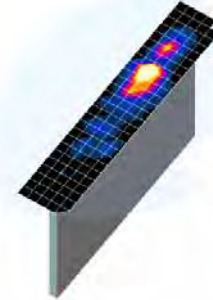



**Figure 4-1  
Sample SAR Area  
Scan**

**Table 4-1  
Area and Zoom Scan Resolutions per FCC KDB Publication 865664 D01v01r04\***

Frequency	Maximum Area Scan Resolution (mm) ( $\Delta x_{area}, \Delta y_{area}$ )	Maximum Zoom Scan Resolution (mm) ( $\Delta x_{zoom}, \Delta y_{zoom}$ )	Maximum Zoom Scan Spatial Resolution (mm)			Minimum Zoom Scan Volume (mm) (x,y,z)
			Uniform Grid	Graded Grid		
			$\Delta z_{zoom}(n)$	$\Delta z_{zoom}(1)^*$	$\Delta z_{zoom}(n>1)^*$	
≤ 2 GHz	≤ 15	≤ 8	≤ 5	≤ 4	≤ 1.5* $\Delta z_{zoom}(n-1)$	≥ 30
2-3 GHz	≤ 12	≤ 5	≤ 5	≤ 4	≤ 1.5* $\Delta z_{zoom}(n-1)$	≥ 30
3-4 GHz	≤ 12	≤ 5	≤ 4	≤ 3	≤ 1.5* $\Delta z_{zoom}(n-1)$	≥ 28
4-5 GHz	≤ 10	≤ 4	≤ 3	≤ 2.5	≤ 1.5* $\Delta z_{zoom}(n-1)$	≥ 25
5-6 GHz	≤ 10	≤ 4	≤ 2	≤ 2	≤ 1.5* $\Delta z_{zoom}(n-1)$	≥ 22

\*Also compliant to IEEE 1528-2013 Table 6

<b>FCC ID:</b> A3LSMG950N		<b>SAR EVALUATION REPORT</b>		<b>Approved by:</b> Quality Manager
<b>Document S/N:</b> 1M1703100103-01.A3L	<b>Test Dates:</b> 03/06/17 - 03/20/17	<b>DUT Type:</b> Portable Handset	Page 14 of 91	

# 5 DEFINITION OF REFERENCE POINTS

## 5.1 EAR REFERENCE POINT

Figure 5-2 shows the front, back and side views of the SAM Twin Phantom. The point “M” is the reference point for the center of the mouth, “LE” is the left ear reference point (ERP), and “RE” is the right ERP. The ERP is 15mm posterior to the entrance to the ear canal (EEC) along the B-M line (Back-Mouth), as shown in Figure 5-1. The plane passing through the two ear canals and M is defined as the Reference Plane. The line N-F (Neck-Front), also called the Reference Pivoting Line, is not perpendicular to the reference plane (see Figure 5-1). Line B-M is perpendicular to the N-F line. Both N-F and B-M lines are marked on the external phantom shell to facilitate handset positioning [5].

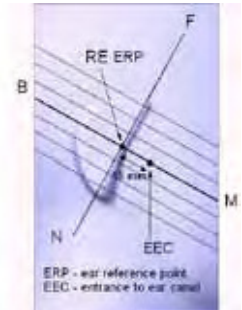

Close-Up Side view of ERP

## 5.2 HANDSET REFERENCE POINTS

Two imaginary lines on the handset were established: the vertical centerline and the horizontal line. The test device was placed in a normal operating position with the acoustic output located along the “vertical centerline” on the front of the device aligned to the “ear reference point” (See Figure 5-3). The acoustic output was then located at the same level as the center of the ear reference point. The test device was positioned so that the “vertical centerline” was bisecting the front surface of the handset at its top and bottom edges, positioning the “ear reference point” on the outer surface of the both the left and right head phantoms on the ear reference point.



Figure 5-2  
Front, back and side view of SAM Twin Phantom

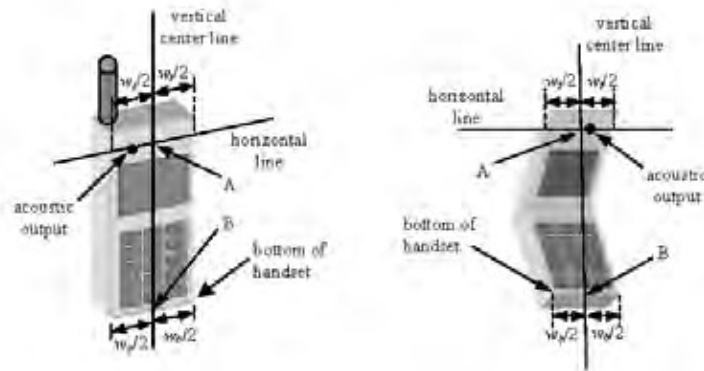

Figure 5-3  
Handset Vertical Center & Horizontal Line Reference Points

FCC ID: A3LSMG950N		SAR EVALUATION REPORT		Approved by: Quality Manager
Document S/N: 1M1703100103-01.A3L	Test Dates: 03/06/17 - 03/20/17	DUT Type: Portable Handset		Page 15 of 91

## 6 TEST CONFIGURATION POSITIONS

### 6.1 Device Holder

The device holder is made out of low-loss POM material having the following dielectric parameters: relative permittivity  $\epsilon = 3$  and loss tangent  $\delta = 0.02$ .

### 6.2 Positioning for Cheek

1. The test device was positioned with the device close to the surface of the phantom such that point A is on the (virtual) extension of the line passing through points RE and LE on the phantom (see Figure 6-1), such that the plane defined by the vertical center line and the horizontal line of the phone is approximately parallel to the sagittal plane of the phantom.





Figure 6-1 Front, Side and Top View of Cheek Position

2. The handset was translated towards the phantom along the line passing through RE & LE until the handset touches the pinna.
3. While maintaining the handset in this plane, the handset was rotated around the LE-RE line until the vertical centerline was in the reference plane.
4. The phone was then rotated around the vertical centerline until the phone (horizontal line) was symmetrical with respect to the line NF.
5. While maintaining the vertical centerline in the reference plane, keeping point A on the line passing through RE and LE, and maintaining the device contact with the ear, the device was rotated about the NF line until any point on the handset made contact with a phantom point below the ear (cheek) (See Figure 6-2).

### 6.3 Positioning for Ear / 15° Tilt

With the test device aligned in the “Cheek Position”:

1. While maintaining the orientation of the phone, the phone was retracted parallel to the reference plane far enough to enable a rotation of the phone by 15 degrees.
2. The phone was then rotated around the horizontal line by 15 degrees.
3. While maintaining the orientation of the phone, the phone was moved parallel to the reference plane until any part of the handset touched the head. (In this position, point A was located on the line RE-LE). The tilted position is obtained when the contact is on the pinna. If the contact was at any location other than the pinna, the angle of the phone would then be reduced. In this situation, the tilted position was obtained when any part of the phone was in contact of the ear as well as a second part of the phone was in contact with the head (see Figure 6-2).

FCC ID: A3LSMG950N		SAR EVALUATION REPORT		Approved by: Quality Manager
Document S/N: 1M1703100103-01.A3L	Test Dates: 03/06/17 - 03/20/17	DUT Type: Portable Handset		Page 16 of 91



**Figure 6-2 Front, Side and Top View of Ear/15° Tilt Position**

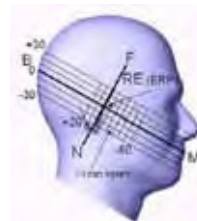

**Figure 6-3 Side view w/ relevant markings**

### 6.4 SAR Evaluations near the Mouth/Jaw Regions of the SAM Phantom

Antennas located near the bottom of a phone may require SAR measurements around the mouth and jaw regions of the SAM head phantom. This typically applies to clam-shell style phones that are generally longer in the unfolded normal use positions or to certain older style long rectangular phones. Per IEEE 1528-2013, a rotated SAM phantom is necessary to allow probe access to such regions. Both SAM heads of the TwinSAM-Chin20 are rotated 20 degrees around the NF line. Each head can be removed from the table for emptying and cleaning.

Under these circumstances, the following procedures apply, adopted from the FCC guidance on SAR handsets document FCC KDB Publication 648474 D04v01r03. The SAR required in these regions of SAM should be measured using a flat phantom. The phone should be positioned with a separation distance of 4 mm between the ear reference point (ERP) and the outer surface of the flat phantom shell. While maintaining this distance at the ERP location, the low (bottom) edge of the phone should be lowered from the phantom to establish the same separation distance between the peak SAR location identified by the truncated partial SAR distribution measured with the SAM phantom. The distance from the peak SAR location to the phone is determined by the straight line passing perpendicularly through the phantom surface. When it is not feasible to maintain 4 mm separation at the ERP while also establishing the required separation at the peak SAR location, the top edge of the phone will be allowed to touch the phantom with a separation < 4 mm at the ERP. The phone should not be tilted to the left or right while placed in this inclined position to the flat phantom.

### 6.5 Body-Worn Accessory Configurations

Body-worn operating configurations are tested with the belt-clips and holsters attached to the device and positioned against a flat phantom in a normal use configuration (see Figure 6-4). Per FCC KDB Publication 648474 D04v01r03, Body-worn accessory exposure is typically related to voice mode operations when handsets are carried in body-worn accessories. The body-worn accessory procedures in FCC KDB Publication 447498 D01v06 should be used to test for body-worn accessory SAR compliance, without a headset connected to it. This enables the test results for such configuration to be compatible with that required for hotspot mode when the body-worn accessory test separation distance is greater than or equal to that required for hotspot mode, when applicable. When the reported SAR for a body-worn accessory, measured without a headset connected to the handset, is > 1.2 W/kg, the highest reported SAR configuration for that wireless mode and frequency band should be repeated for that body-worn accessory with a headset attached to the handset.

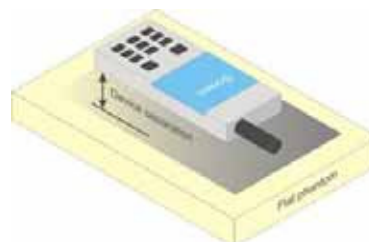

**Figure 6-4 Sample Body-Worn Diagram**

Accessories for Body-worn operation configurations are divided into two categories: those that do not contain metallic components and those that do contain metallic components. When multiple accessories that do not contain metallic components are supplied with the device, the device is tested with only the accessory that

FCC ID: A3LSMG950N		SAR EVALUATION REPORT		Approved by: Quality Manager
Document S/N: 1M1703100103-01.A3L	Test Dates: 03/06/17 - 03/20/17	DUT Type: Portable Handset		Page 17 of 91

dictates the closest spacing to the body. Then multiple accessories that contain metallic components are tested with the device with each accessory. If multiple accessories share an identical metallic component (i.e. the same metallic belt-clip used with different holsters with no other metallic components) only the accessory that dictates the closest spacing to the body is tested.

Body-worn accessories may not always be supplied or available as options for some devices intended to be authorized for body-worn use. In this case, a test configuration with a separation distance between the back of the device and the flat phantom is used. Test position spacing was documented. Transmitters that are designed to operate in front of a person’s face, as in push-to-talk configurations, are tested for SAR compliance with the front of the device positioned to face the flat phantom in head fluid. For devices that are carried next to the body such as a shoulder, waist or chest-worn transmitters, SAR compliance is tested with the accessories, including headsets and microphones, attached to the device and positioned against a flat phantom in a normal use configuration.

## 6.6 Extremity Exposure Configurations



Devices that are designed or intended for use on extremities or mainly operated in extremity only exposure conditions; i.e., hands, wrists, feet and ankles, may require extremity SAR evaluation. When the device also operates in close proximity to the user’s body, SAR compliance for the body is also required. The 1-g body and 10-g extremity SAR Exclusion Thresholds found in KDB Publication 447498 D01v06 should be applied to determine SAR test requirements.

Per KDB Publication 447498 D01v06, Cell phones (handsets) are not normally designed to be used on extremities or operated in extremity only exposure conditions. The maximum output power levels of handsets generally do not require extremity SAR testing to show compliance. Therefore, extremity SAR was not evaluated for this device.

## 6.7 Wireless Router Configurations

Some battery-operated handsets have the capability to transmit and receive user data through simultaneous transmission of WIFI simultaneously with a separate licensed transmitter. The FCC has provided guidance in FCC KDB Publication 941225 D06v02r01 where SAR test considerations for handsets ( $L \times W \geq 9 \text{ cm} \times 5 \text{ cm}$ ) are based on a composite test separation distance of 10 mm from the front, back and edges of the device containing transmitting antennas within 2.5 cm of their edges, determined from general mixed use conditions for this type of devices. Since the hotspot SAR results may overlap with the body-worn accessory SAR requirements, the more conservative configurations can be considered, thus excluding some body-worn accessory SAR tests.

When the user enables the personal wireless router functions for the handset, actual operations include simultaneous transmission of both the WIFI transmitter and another licensed transmitter. Both transmitters often do not transmit at the same transmitting frequency and thus cannot be evaluated for SAR under actual use conditions due to the limitations of the SAR assessment probes. Therefore, SAR must be evaluated for each frequency transmission and mode separately and spatially summed with the WIFI transmitter according to FCC KDB Publication 447498 D01v06 procedures. The “Portable Hotspot” feature on the handset was NOT activated during SAR assessments, to ensure the SAR measurements were evaluated for a single transmission frequency RF signal at a time.

FCC ID: A3LSMG950N		SAR EVALUATION REPORT		Approved by: Quality Manager
Document S/N: 1M1703100103-01.A3L	Test Dates: 03/06/17 - 03/20/17	DUT Type: Portable Handset	Page 18 of 91	

# 7 RF EXPOSURE LIMITS

## 7.1 Uncontrolled Environment

UNCONTROLLED ENVIRONMENTS are defined as locations where there is the exposure of individuals who have no knowledge or control of their exposure. The general population/uncontrolled exposure limits are applicable to situations in which the general public may be exposed or in which persons who are exposed as a consequence of their employment may not be made fully aware of the potential for exposure or cannot exercise control over their exposure. Members of the general public would come under this category when exposure is not employment-related; for example, in the case of a wireless transmitter that exposes persons in its vicinity.



## 7.2 Controlled Environment

CONTROLLED ENVIRONMENTS are defined as locations where there is exposure that may be incurred by persons who are aware of the potential for exposure, (i.e. as a result of employment or occupation). In general, occupational/controlled exposure limits are applicable to situations in which persons are exposed as a consequence of their employment, who have been made fully aware of the potential for exposure and can exercise control over their exposure. This exposure category is also applicable when the exposure is of a transient nature due to incidental passage through a location where the exposure levels may be higher than the general population/uncontrolled limits, but the exposed person is fully aware of the potential for exposure and can exercise control over his or her exposure by leaving the area or by some other appropriate means.

**Table 7-1  
SAR Human Exposure Specified in ANSI/IEEE C95.1-1992 and Health Canada Safety Code 6**

HUMAN EXPOSURE LIMITS		
	UNCONTROLLED ENVIRONMENT <i>General Population</i> (W/kg) or (mW/g)	CONTROLLED ENVIRONMENT <i>Occupational</i> (W/kg) or (mW/g)
<b>Peak Spatial Average SAR</b> Head	1.6	8.0
<b>Whole Body SAR</b>	0.08	0.4
<b>Peak Spatial Average SAR</b> Hands, Feet, Ankle, Wrists, etc.	4.0	20

1. The Spatial Peak value of the SAR averaged over any 1 gram of tissue (defined as a tissue volume in the shape of a cube) and over the appropriate averaging time.
2. The Spatial Average value of the SAR averaged over the whole body.
3. The Spatial Peak value of the SAR averaged over any 10 grams of tissue (defined as a tissue volume in the shape of a cube) and over the appropriate averaging time.

FCC ID: A3LSMG950N		SAR EVALUATION REPORT		Approved by: Quality Manager
Document S/N: 1M1703100103-01.A3L	Test Dates: 03/06/17 - 03/20/17	DUT Type: Portable Handset	Page 19 of 91	

## 8 FCC MEASUREMENT PROCEDURES



Power measurements for licensed transmitters are performed using a base station simulator under digital average power.

### 8.1 Measured and Reported SAR

Per FCC KDB Publication 447498 D01v06, when SAR is not measured at the maximum power level allowed for production units, the results must be scaled to the maximum tune-up tolerance limit according to the power applied to the individual channels tested to determine compliance. For simultaneous transmission, the measured aggregate SAR must be scaled according to the sum of the differences between the maximum tune-up tolerance and actual power used to test each transmitter. When SAR is measured at or scaled to the maximum tune-up tolerance limit, the results are referred to as *reported* SAR. The highest *reported* SAR results are identified on the grant of equipment authorization according to procedures in KDB 690783 D01v01r03.

### 8.2 3G SAR Test Reduction Procedure

In FCC KDB Publication 941225 D01v03r01, certain transmission modes within a frequency band and wireless mode evaluated for SAR are defined as primary modes. The equivalent modes considered for SAR test reduction are denoted as secondary modes. When the maximum output power including tune-up tolerance specified for production units in a secondary mode is

FCC ID: A3LSMG950N		SAR EVALUATION REPORT		Approved by: Quality Manager
Document S/N: 1M1703100103-01.A3L	Test Dates: 03/06/17 - 03/20/17	DUT Type: Portable Handset	Page 20 of 91	

## 8.4.2 Head SAR Measurements

SAR for next to the ear head exposure is measured using a 12.2 kbps RMC with TPC bits configured to all “1’s”. The 3G SAR test reduction procedure is applied to AMR configurations with 12.2 kbps RMC as the primary mode. Otherwise, SAR is measured for 12.2 kbps AMR in 3.4 kbps SRB (signaling radio bearer) using the highest reported SAR configuration in 12.2 kbps RMC for head exposure.

## 8.4.3 Body SAR Measurements

SAR for body exposure configurations is measured using the 12.2 kbps RMC with the TPC bits all “1s”. The 3G SAR test reduction procedure is applied to other spreading codes and multiple DPDCH<sub>n</sub> configurations supported by the handset with 12.2 kbps RMC as the primary mode. Otherwise, SAR is measured using an applicable RMC configuration with the corresponding spreading code or DPDCH<sub>n</sub>, for the highest reported SAR configuration in 12.2 kbps RMC.

## 8.4.4 SAR Measurements with Rel 5 HSDPA

The 3G SAR test reduction procedure is applied to HSDPA body configurations with 12.2 kbps RMC as the primary mode. Otherwise, Body SAR for HSDPA is measured using an FRC with H-Set 1 in Sub-test 1 and a 12.2 kbps RMC configured in Test Loop Mode 1, for the highest reported SAR configuration in 12.2 kbps RMC without HSDPA. Handsets with both HSDPA and HSUPA are tested according to Release 6 HSPA test procedures.

## 8.4.5 SAR Measurements with Rel 6 HSUPA

The 3G SAR test reduction procedure is applied to HSPA (HSUPA/HSDPA with RMC) body configurations with 12.2 kbps RMC as the primary mode. Otherwise, Body SAR for HSPA is measured with E-DCH Sub-test 5, using H-Set 1 and QPSK for FRC and a 12.2 kbps RMC configured in Test Loop Mode 1 and power control algorithm 2, according to the highest reported body SAR configuration in 12.2 kbps RMC without HSPA.

When VOIP applies to head exposure, the 3G SAR test reduction procedure is applied with 12.2 kbps RMC as the primary mode; otherwise, the same HSPA configuration used for body SAR measurements are applied to head exposure testing.

## 8.5 SAR Measurement Conditions for LTE



LTE modes are tested according to FCC KDB 941225 D05v02r04 publication. Establishing connections with base station simulators ensure a consistent means for testing SAR and are recommended for evaluating SAR [4]. The R&S CMW500 or Anritsu MT8820C simulators are used for LTE output power measurements and SAR testing. Closed loop power control was used so the UE transmits with maximum output power during SAR testing. SAR tests were performed with the same number of RB and RB offsets transmitting on all TTI frames (maximum TTI).

### 8.5.1 Spectrum Plots for RB Configurations

A properly configured base station simulator was used for SAR tests and power measurements. Therefore, spectrum plots for RB configurations were not required to be included in this report.

### 8.5.2 MPR

MPR is permanently implemented for this device by the manufacturer. The specific manufacturer target MPR is indicated alongside the SAR results. MPR is enabled for this device, according to 3GPP TS36.101 Section 6.2.3 – 6.2.5 under Table 6.2.3-1.

FCC ID: A3LSMG950N		SAR EVALUATION REPORT		Approved by: Quality Manager
Document S/N: 1M1703100103-01.A3L	Test Dates: 03/06/17 - 03/20/17	DUT Type: Portable Handset		Page 21 of 91

### 8.5.3 A-MPR

A-MPR (Additional MPR) has been disabled for all SAR tests by setting NS=01 on the base station simulator.

### 8.5.4 Required RB Size and RB Offsets for SAR Testing

According to FCC KDB 941225 D05v02r04:

- a. Per Section 5.2.1, SAR is required for QPSK 1 RB Allocation for the largest bandwidth
  - i. The required channel and offset combination with the highest maximum output power is required for SAR.
  - ii. When the reported SAR is  $\leq 0.8$  W/kg, testing of the remaining RB offset configurations and required test channels is not required. Otherwise, SAR is required for the remaining required test channels using the RB offset configuration with highest output power for that channel.
  - iii. When the reported SAR for a required test channel is  $> 1.45$  W/kg, SAR is required for all RB offset configurations for that channel.
- b. Per Section 5.2.2, SAR is required for 50% RB allocation using the largest bandwidth following the same procedures outlined in Section 5.2.1.
- c. Per Section 5.2.3, QPSK SAR is not required for the 100% allocation when the highest maximum output power for the 100% allocation is less than the highest maximum output power of the 1 RB and 50% RB allocations and the reported SAR for the 1 RB and 50% RB allocations is  $< 0.8$  W/kg.
- d. Per Section 5.2.4 and 5.3, SAR tests for higher order modulations and lower bandwidths configurations are not required when the conducted power of the required test configurations determined by Sections 5.2.1 through 5.2.3 is less than or equal to  $\frac{1}{2}$  dB higher than the equivalent configuration using QPSK modulation and when the QPSK SAR for those configurations is  $< 1.45$  W/kg.

### 8.5.5 TDD

LTE TDD testing is performed using the SAR test guidance provided in FCC KDB 941225 D05v02r04. TDD is tested at the highest duty factor using UL-DL configuration 0 with special subframe configuration 6 and applying the FDD LTE procedures in KDB 941225 D05v02r04. SAR testing is performed using the extended cyclic prefix listed in 3GPP TS 36.211 Section 4.



## 8.6 SAR Testing with 802.11 Transmitters

The normal network operating configurations of 802.11 transmitters are not suitable for SAR measurements. Unpredictable fluctuations in network traffic and antenna diversity conditions can introduce undesirable variations in SAR results. The SAR for these devices should be measured using chipset based test mode software to ensure the results are consistent and reliable. See KDB Publication 248227 D01v02r02 for more details.

### 8.6.1 General Device Setup

Chipset based test mode software is hardware dependent and generally varies among manufacturers. The device operating parameters established in test mode for SAR measurements must be identical to those programmed in production units, including output power levels, amplifier gain settings and other RF performance tuning parameters.

A periodic duty factor is required for current generation SAR systems to measure SAR. When 802.11 frame gaps are accounted for in the transmission, a maximum transmission duty factor of 92 - 96% is typically achievable in most test mode configurations. A minimum transmission duty factor of 85% is required to avoid certain hardware and device implementation issues related to wide range SAR scaling.

FCC ID: A3LSMG950N		SAR EVALUATION REPORT		Approved by: Quality Manager
Document S/N: 1M1703100103-01.A3L	Test Dates: 03/06/17 - 03/20/17	DUT Type: Portable Handset		Page 22 of 91

The reported SAR is scaled to 100% transmission duty factor to determine compliance at the maximum tune-up tolerance limit.

### 8.6.2 U-NII-1 and U-NII-2A

For devices that operate in both U-NII-1 and U-NII-2A bands, when the same maximum output power is specified for both bands, SAR measurement using OFDM SAR test procedures is not required for U-NII-1 unless the highest reported SAR for U-NII-2A is > 1.2 W/kg. When different maximum output powers are specified for the bands, SAR measurement for the U-NII band with the lower maximum output power is not required unless the highest reported SAR for the U-NII band with the higher maximum output power, adjusted by the ratio of lower to higher specified maximum output power for the two bands, is > 1.2 W/kg.

### 8.6.3 U-NII-2C and U-NII-3

The frequency range covered by U-NII-2C and U-NII-3 is 380 MHz (5.47 – 5.85 GHz), which requires a minimum of at least two SAR probe calibration frequency points to support SAR measurements. When Terminal Doppler Weather Radar (TDWR) restriction applies, the channels at 5.60 – 5.65 GHz in U-NII-2C band must be disabled with acceptable mechanisms and documented in the equipment certification. Unless band gap channels are permanently disabled, SAR must be considered for these channels. Each band is tested independently according to the normally required OFDM SAR measurement and probe calibration frequency points requirements.

### 8.6.4 Initial Test Position Procedure

For exposure conditions with multiple test positions, such as handset operating next to the ear, devices with hotspot mode or UMPC mini-tablet, procedures for initial test position can be applied. Using the transmission mode determined by the DSSS procedure or initial test configuration, area scans are measured for all positions in an exposure condition. The test position with the highest extrapolated (peak) SAR is used as the initial test position. When reported SAR for the initial test position is ≤ 0.4 W/kg, no additional testing for the remaining test positions is required. Otherwise, SAR is evaluated at the subsequent highest peak SAR positions until the reported SAR result is ≤ 0.8 W/kg or all test positions are measured.

### 8.6.5 2.4 GHz SAR Test Requirements



SAR is measured for 2.4 GHz 802.11b DSSS using either the fixed test position or, when applicable, the initial test position procedure. SAR test reduction is determined according to the following:

- 1) When the reported SAR of the highest measured maximum output power channel for the exposure configuration is ≤ 0.8 W/kg, no further SAR testing is required for 802.11b DSSS in that exposure configuration.
- 2) When the reported SAR is > 0.8 W/kg, SAR is required for that position using the next highest measured output power channel. When any reported SAR is > 1.2 W/kg, SAR is required for the third channel; i.e., all channels require testing.

2.4 GHz 802.11 g/n OFDM are additionally evaluated for SAR if the highest reported SAR for 802.11b, adjusted by the ratio of the OFDM to DSSS specified maximum output power, is >1.2 W/kg. When SAR is required for OFDM modes in 2.4 GHz band, the Initial Test Configuration Procedures should be followed.

### 8.6.6 OFDM Transmission Mode and SAR Test Channel Selection

When the same maximum output power was specified for multiple OFDM transmission mode configurations in a frequency band or aggregated band, SAR is measured using the configuration with the largest channel bandwidth, lowest order modulation and lowest data rate. When the maximum output power of a channel is the same for equivalent OFDM configurations; for example, 802.11a, 802.11n and 802.11ac or 802.11g and 802.11n with the same channel bandwidth, modulation and data rate etc., the

FCC ID: A3LSMG950N		SAR EVALUATION REPORT		Approved by: Quality Manager
Document S/N: 1M1703100103-01.A3L	Test Dates: 03/06/17 - 03/20/17	DUT Type: Portable Handset	Page 23 of 91	

lower order 802.11 mode i.e., 802.11a, then 802.11n and 802.11ac or 802.11g then 802.11n, is used for SAR measurement. When the maximum output power are the same for multiple test channels, either according to the default or additional power measurement requirements, SAR is measured using the channel closest to the middle of the frequency band or aggregated band. When there are multiple channels with the same maximum output power, SAR is measured using the higher number channel.

### 8.6.7 Initial Test Configuration Procedure

For OFDM, an initial test configuration is determined for each frequency band and aggregated band, according to the transmission mode with the highest maximum output power specified for SAR measurements. When the same maximum output power is specified for multiple OFDM transmission mode configurations in a frequency band or aggregated band, SAR is measured using the configuration(s) with the largest channel bandwidth, lowest order modulation, lowest data rate and lowest order IEEE 802.11 mode. The channel of the transmission mode with the highest average RF output conducted power will be the initial test configuration.



When the reported SAR is  $\leq 0.8$  W/kg, no additional measurements on other test channels are required. Otherwise, SAR is evaluated using the subsequent highest average RF output channel until the reported SAR result is  $\leq 1.2$  W/kg or all channels are measured. When there are multiple untested channels having the same subsequent highest average RF output power, the channel with higher frequency from the lowest 802.11 mode is considered for SAR measurements (See Section 8.6.6).

### 8.6.8 Subsequent Test Configuration Procedures

For OFDM configurations in each frequency band and aggregated band, SAR is evaluated for initial test configuration using the fixed test position or the initial test position procedure. When the highest reported SAR (for the initial test configuration), adjusted by the ratio of the specified maximum output power of the subsequent test configuration to initial test configuration, is  $\leq 1.2$  W/kg, no additional SAR tests for the subsequent test configurations are required.

### 8.6.9 MIMO SAR considerations

Per KDB Publication 248227 D01v02r02, the simultaneous SAR provisions in KDB Publication 447498 D01v06 should be applied to determine simultaneous transmission SAR test exclusion for WIFI MIMO. If the sum of 1g single transmission chain SAR measurements is  $< 1.6$  W/kg, no additional SAR measurements for MIMO are required. Alternatively, SAR for MIMO can be measured with all antennas transmitting simultaneously at the specified maximum output power of MIMO operation.

FCC ID: A3LSMG950N		SAR EVALUATION REPORT		Approved by: Quality Manager
Document S/N: 1M1703100103-01.A3L	Test Dates: 03/06/17 - 03/20/17	DUT Type: Portable Handset	Page 24 of 91	

# 9 RF CONDUCTED POWERS

## 9.1 GSM Conducted Powers

**Table 9-1  
Maximum Conducted Powers**

Maximum Burst-Averaged Output Power										
Band	Channel	Voice	GPRS/EDGE Data (GMSK)				EDGE Data (8-PSK)			
		GSM [dBm] CS (1 Slot)	GPRS [dBm] 1 Tx Slot	GPRS [dBm] 2 Tx Slot	GPRS [dBm] 3 Tx Slot	GPRS [dBm] 4 Tx Slot	EDGE [dBm] 1 Tx Slot	EDGE [dBm] 2 Tx Slot	EDGE [dBm] 3 Tx Slot	EDGE [dBm] 4 Tx Slot
GSM 1900	512	29.69	29.71	27.63	26.02	<b>24.90</b>	25.10	22.82	21.62	20.64
	661	29.75	29.77	27.80	26.04	<b>24.89</b>	25.09	22.79	21.77	20.61
	810	29.95	29.94	27.93	26.42	<b>24.94</b>	25.22	22.72	21.84	20.78
Calculated Maximum Frame-Averaged Output Power										
Band	Channel	Voice	GPRS/EDGE Data (GMSK)				EDGE Data (8-PSK)			
		GSM [dBm] CS (1 Slot)	GPRS [dBm] 1 Tx Slot	GPRS [dBm] 2 Tx Slot	GPRS [dBm] 3 Tx Slot	GPRS [dBm] 4 Tx Slot	EDGE [dBm] 1 Tx Slot	EDGE [dBm] 2 Tx Slot	EDGE [dBm] 3 Tx Slot	EDGE [dBm] 4 Tx Slot
GSM 1900	512	20.66	20.68	21.61	21.76	<b>21.89</b>	16.07	16.80	17.36	17.63
	661	20.72	20.74	21.78	21.78	<b>21.88</b>	16.06	16.77	17.51	17.60
	810	20.92	20.91	21.91	22.16	<b>21.93</b>	16.19	16.70	17.58	17.77
GSM 1900	Frame Avg.Targets:	20.97	20.97	21.98	22.24	<b>22.49</b>	16.47	17.48	18.24	18.49

Note:

- Both burst-averaged and calculated frame-averaged powers are included. Frame-averaged power was calculated from the measured burst-averaged power by converting the slot powers into linear units and calculating the energy over 8 timeslots.
- GPRS/EDGE (GMSK) output powers were measured with coding scheme setting of 1 (CS1) on the base station simulator. CS1 was configured to measure GPRS output power measurements and SAR to ensure GMSK modulation in the signal. Our Investigation has shown that CS1 - CS4 settings do not have any impact on the output levels or modulation in the GPRS modes.
- EDGE (8-PSK) output powers were measured with MCS7 on the base station simulator. MCS7 coding scheme was used to measure the output powers for EDGE since investigation has shown that choosing MCS7 coding scheme will ensure 8-PSK modulation. It has been shown that MCS levels that produce 8PSK modulation do not have an impact on output power.

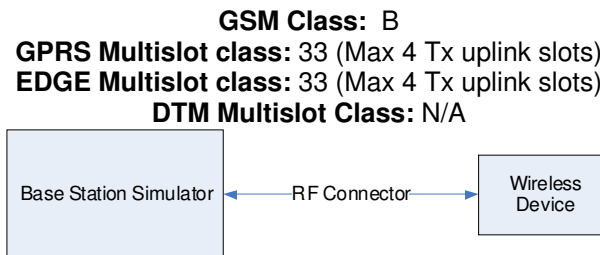

**Figure 9-1  
Power Measurement Setup**

FCC ID: A3LSMG950N		SAR EVALUATION REPORT		Approved by: Quality Manager
Document S/N: 1M1703100103-01.A3L	Test Dates: 03/06/17 - 03/20/17	DUT Type: Portable Handset	Page 25 of 91	

## 9.2 UMTS Conducted Powers

**Table 9-2**  
**Maximum Conducted Powers**

3GPP Release Version	Mode	3GPP 34.121 Subtest	Cellular Band [dBm]			PCS Band [dBm]			3GPP MPR [dB]
			4132	4183	4233	9262	9400	9538	
99	WCDMA	12.2 kbps RMC	23.05	23.06	22.91	22.41	22.35	22.56	-
99		12.2 kbps AMR	23.04	22.85	22.88	22.35	22.31	22.54	-
6	HSDPA	Subtest 1	23.29	23.03	23.00	22.54	22.27	22.46	0
6		Subtest 2	23.28	23.05	23.08	22.53	22.44	22.66	0
6		Subtest 3	22.52	22.26	22.23	22.34	22.23	22.37	0.5
6		Subtest 4	21.65	21.42	21.41	22.31	22.18	22.42	0.5
6	HSUPA	Subtest 1	20.68	20.43	20.41	19.79	19.73	19.87	0
6		Subtest 2	19.28	19.05	19.02	19.38	19.20	19.00	2
6		Subtest 3	22.43	22.23	22.24	21.83	21.72	21.88	1
6		Subtest 4	19.15	19.01	19.00	19.85	19.72	19.26	2
6		Subtest 5	23.00	22.88	22.89	22.49	22.36	22.61	0

**Table 9-3**  
**Reduced Conducted Powers**

3GPP Release Version	Mode	3GPP 34.121 Subtest	Cellular Band [dBm]			PCS Band [dBm]			3GPP MPR [dB]
			4132	4183	4233	9262	9400	9538	
99	WCDMA	12.2 kbps RMC	22.10	21.92	21.94	19.46	19.32	19.49	-
99		12.2 kbps AMR	22.02	21.84	21.88	19.42	19.37	19.48	-
6	HSDPA	Subtest 1	22.23	22.09	22.10	19.13	19.40	19.50	0
6		Subtest 2	22.28	22.15	22.16	19.45	19.39	19.49	0
6		Subtest 3	22.41	22.23	22.19	19.46	19.38	19.50	0.5
6		Subtest 4	21.76	21.51	21.49	19.42	19.37	19.49	0.5
6	HSUPA	Subtest 1	20.64	20.40	20.41	18.61	18.48	17.76	0
6		Subtest 2	19.18	18.90	18.91	18.71	18.61	18.80	2
6		Subtest 3	21.70	21.47	21.51	18.76	18.52	18.74	1
6		Subtest 4	19.19	18.88	18.86	18.24	18.09	18.29	2
6		Subtest 5	22.00	21.95	21.92	19.46	19.31	19.50	0

This device does not support DC-HSDPA.

It is expected by the manufacturer that MPR for some HSPA subtests may be up to 2 dB more than specified by 3GPP, but also as low as 0 dB according to the chipset implementation in this model.



**Figure 9-2**  
**Power Measurement Setup**

FCC ID: A3LSMG950N		SAR EVALUATION REPORT		Approved by: Quality Manager
Document S/N: 1M1703100103-01.A3L	Test Dates: 03/06/17 - 03/20/17	DUT Type: Portable Handset		Page 26 of 91

## 9.3 LTE Conducted Powers

### 9.3.1 LTE Band 12



**Table 9-4**  
**Maximum LTE Band 12 Conducted Powers - 10 MHz Bandwidth**

LTE Band 12 10 MHz Bandwidth					
Modulation	RB Size	RB Offset	Mid Channel	MPR Allowed per 3GPP [dB]	MPR [dB]
			23095 (707.5 MHz)		
			Conducted Power [dBm]		
QPSK	1	0	22.86	0	0
	1	25	22.76		0
	1	49	22.75		0
	25	0	21.88	0-1	1
	25	12	21.85		1
	25	25	21.90		1
	50	0	21.87		1
16QAM	1	0	21.58	0-1	1
	1	25	21.62		1
	1	49	21.61		1
	25	0	20.94	0-2	2
	25	12	20.93		2
	25	25	20.96		2
	50	0	20.64		2

Note: LTE Band 12 at 10 MHz bandwidth does not support three non-overlapping channels. Per KDB Publication 941225 D05v02, when a device supports overlapping channel assignment in a channel bandwidth configuration, the middle channel of the group of overlapping channels should be selected for testing.

**Table 9-5**  
**Maximum LTE Band 12 Conducted Powers - 5 MHz Bandwidth**

LTE Band 12 5 MHz Bandwidth							
Modulation	RB Size	RB Offset	Low Channel	Mid Channel	High Channel	MPR Allowed per 3GPP [dB]	MPR [dB]
			23035 (701.5 MHz)	23095 (707.5 MHz)	23155 (713.5 MHz)		
			Conducted Power [dBm]				
QPSK	1	0	22.66	22.85	22.81	0	0
	1	12	22.63	22.80	22.74		0
	1	24	22.65	22.84	22.77		0
	12	0	21.76	21.79	21.76	0-1	1
	12	6	21.79	21.74	21.70		1
	12	13	21.74	21.73	21.67		1
	25	0	21.73	21.74	21.60		1
16QAM	1	0	21.92	21.77	21.61	0-1	1
	1	12	21.98	21.71	21.65		1
	1	24	22.00	21.69	21.51		1
	12	0	20.92	20.85	20.72	0-2	2
	12	6	20.90	20.98	20.60		2
	12	13	20.94	20.89	20.64		2
	25	0	20.89	20.87	20.71		2



FCC ID: A3LSMG950N		<b>SAR EVALUATION REPORT</b>		<b>Approved by:</b> Quality Manager
<b>Document S/N:</b> 1M1703100103-01.A3L	<b>Test Dates:</b> 03/06/17 - 03/20/17	<b>DUT Type:</b> Portable Handset	Page 27 of 91	

**Table 9-6**  
**Maximum LTE Band 12 Conducted Powers - 3 MHz Bandwidth**

LTE Band 12 3 MHz Bandwidth							
Modulation	RB Size	RB Offset	Low Channel	Mid Channel	High Channel	MPR Allowed per 3GPP [dB]	MPR [dB]
			23025 (700.5 MHz)	23095 (707.5 MHz)	23165 (714.5 MHz)		
			Conducted Power [dBm]				
QPSK	1	0	22.60	22.55	22.72	0	0
	1	7	22.57	22.59	22.70		0
	1	14	22.55	22.56	22.67		0
	8	0	21.61	21.51	21.60	0-1	1
	8	4	21.57	21.54	21.58		1
	8	7	21.53	21.51	21.60		1
	15	0	21.52	21.55	21.58		1
16QAM	1	0	21.56	21.78	21.69	0-1	1
	1	7	21.57	21.79	21.65		1
	1	14	21.55	21.69	21.61		1
	8	0	20.76	20.67	20.68	0-2	2
	8	4	20.81	20.69	20.66		2
	8	7	20.77	20.73	20.64		2
	15	0	20.69	20.70	20.68		2

**Table 9-7**  
**Maximum LTE Band 12 Conducted Powers -1.4 MHz Bandwidth**

LTE Band 12 1.4 MHz Bandwidth							
Modulation	RB Size	RB Offset	Low Channel	Mid Channel	High Channel	MPR Allowed per 3GPP [dB]	MPR [dB]
			23017 (699.7 MHz)	23095 (707.5 MHz)	23173 (715.3 MHz)		
			Conducted Power [dBm]				
QPSK	1	0	22.68	22.77	22.70	0	0
	1	2	22.71	22.79	22.68		0
	1	5	22.64	22.74	22.69		0
	3	0	22.71	22.68	22.67		0
	3	2	22.70	22.70	22.68		0
	3	3	22.72	22.65	22.63		0
	6	0	21.64	21.57	21.60	0-1	1
16QAM	1	0	21.66	21.55	21.46	0-1	1
	1	2	21.67	21.53	21.44		1
	1	5	21.71	21.60	21.47		1
	3	0	21.69	21.76	21.65		1
	3	2	21.63	21.70	21.62		1
	3	3	21.66	21.69	21.63		1
	6	0	20.80	20.82	20.63	0-2	2

FCC ID: A3LSMG950N	 <b>SAR EVALUATION REPORT</b> 	Approved by: Quality Manager
Document S/N: 1M1703100103-01.A3L	Test Dates: 03/06/17 - 03/20/17	DUT Type: Portable Handset
		Page 28 of 91



**Table 9-8**  
**Reduced LTE Band 12 Conducted Powers - 10 MHz Bandwidth**

LTE Band 12 10 MHz Bandwidth					
Modulation	RB Size	RB Offset	Mid Channel	MPR Allowed per 3GPP [dB]	MPR [dB]
			23095 (707.5 MHz)		
			Conducted Power [dBm]		
QPSK	1	0	21.76	0	0
	1	25	<b>21.80</b>		0
	1	49	21.72		0
	25	0	21.80	0-1	0
	25	12	21.76		0
	25	25	<b>21.88</b>		0
	50	0	21.79		0
16QAM	1	0	21.59	0-1	0
	1	25	21.61		0
	1	49	21.67		0
	25	0	20.86	0-2	1
	25	12	20.83		1
	25	25	20.81		1
	50	0	20.86		1

Note: LTE Band 12 at 10 MHz bandwidth does not support three non-overlapping channels. Per KDB Publication 941225 D05v02, when a device supports overlapping channel assignment in a channel bandwidth configuration, the middle channel of the group of overlapping channels should be selected for testing.

**Table 9-9**  
**Reduced LTE Band 12 Conducted Powers - 5 MHz Bandwidth**

LTE Band 12 5 MHz Bandwidth							
Modulation	RB Size	RB Offset	Low Channel	Mid Channel	High Channel	MPR Allowed per 3GPP [dB]	MPR [dB]
			23035 (701.5 MHz)	23095 (707.5 MHz)	23155 (713.5 MHz)		
			Conducted Power [dBm]				
QPSK	1	0	21.77	21.93	21.76	0	0
	1	12	21.76	21.80	21.82		0
	1	24	21.87	21.72	21.82		0
	12	0	21.80	21.91	21.92	0-1	0
	12	6	21.62	21.72	21.70		0
	12	13	21.94	21.90	21.85		0
	25	0	21.79	21.85	21.73		0
16QAM	1	0	21.56	21.59	21.66	0-1	0
	1	12	21.46	21.62	21.57		0
	1	24	21.70	21.54	21.67		0
	12	0	20.87	20.91	20.85	0-2	1
	12	6	20.92	20.83	20.67		1
	12	13	20.77	20.83	20.94		1
	25	0	20.98	20.79	20.92		1



FCC ID: A3LSMG950N		<b>SAR EVALUATION REPORT</b>		<b>Approved by:</b> Quality Manager
<b>Document S/N:</b> 1M1703100103-01.A3L	<b>Test Dates:</b> 03/06/17 - 03/20/17	<b>DUT Type:</b> Portable Handset		Page 29 of 91

**Table 9-10**  
**Reduced LTE Band 12 Conducted Powers - 3 MHz Bandwidth**

LTE Band 12 3 MHz Bandwidth							
Modulation	RB Size	RB Offset	Low Channel	Mid Channel	High Channel	MPR Allowed per 3GPP [dB]	MPR [dB]
			23025 (700.5 MHz)	23095 (707.5 MHz)	23165 (714.5 MHz)		
			Conducted Power [dBm]				
QPSK	1	0	21.76	21.79	21.69	0	0
	1	7	21.77	21.71	21.77		0
	1	14	21.85	21.65	21.84		0
	8	0	21.91	21.85	21.82	0-1	0
	8	4	21.64	21.64	21.92		0
	8	7	21.95	21.91	21.93		0
	15	0	21.85	21.85	21.65		0
16QAM	1	0	21.53	21.48	21.70	0-1	0
	1	7	21.48	21.55	21.61		0
	1	14	21.55	21.56	21.65		0
	8	0	20.84	20.88	20.72	0-2	1
	8	4	20.84	20.72	20.79		1
	8	7	20.78	20.88	20.83		1
	15	0	20.71	20.75	20.95		1

**Table 9-11**  
**Reduced LTE Band 12 Conducted Powers -1.4 MHz Bandwidth**

LTE Band 12 1.4 MHz Bandwidth							
Modulation	RB Size	RB Offset	Low Channel	Mid Channel	High Channel	MPR Allowed per 3GPP [dB]	MPR [dB]
			23017 (699.7 MHz)	23095 (707.5 MHz)	23173 (715.3 MHz)		
			Conducted Power [dBm]				
QPSK	1	0	21.84	21.89	21.93	0	0
	1	2	21.52	21.70	21.70		0
	1	5	21.74	21.76	21.78		0
	3	0	21.87	21.88	21.80		0
	3	2	21.82	21.86	21.90		0
	3	3	21.78	21.79	21.80	0	
	6	0	21.87	21.88	21.82	0-1	0
16QAM	1	0	21.95	21.88	21.83	0-1	0
	1	2	21.87	21.89	22.00		0
	1	5	21.97	21.82	21.96		0
	3	0	21.73	21.70	21.54		0
	3	2	21.67	21.69	21.75		0
	3	3	21.80	21.86	21.87	0	
	6	0	21.00	20.99	20.91	0-2	1

FCC ID: A3LSMG950N		<b>SAR EVALUATION REPORT</b>		<b>Approved by:</b> Quality Manager
<b>Document S/N:</b> 1M1703100103-01.A3L	<b>Test Dates:</b> 03/06/17 - 03/20/17	<b>DUT Type:</b> Portable Handset	Page 30 of 91	

### 9.3.2 LTE Band 13



**Table 9-12**  
**Maximum LTE Band 13 Conducted Powers - 10 MHz Bandwidth**

LTE Band 13 10 MHz Bandwidth					
Modulation	RB Size	RB Offset	Mid Channel	MPR Allowed per 3GPP [dB]	MPR [dB]
			23230 (782.0 MHz)		
			Conducted Power [dBm]		
QPSK	1	0	23.30	0	0
	1	25	23.23		0
	1	49	23.26		0
	25	0	22.32	0-1	1
	25	12	22.26		1
	25	25	22.26		1
	50	0	22.29		1
16QAM	1	0	22.29	0-1	1
	1	25	22.10		1
	1	49	22.13		1
	25	0	21.12	0-2	2
	25	12	21.12		2
	25	25	21.13		2
	50	0	21.19		2

**Table 9-13**  
**Maximum LTE Band 13 Conducted Powers - 5 MHz Bandwidth**

LTE Band 13 5 MHz Bandwidth					
Modulation	RB Size	RB Offset	Mid Channel	MPR Allowed per 3GPP [dB]	MPR [dB]
			23230 (782.0 MHz)		
			Conducted Power [dBm]		
QPSK	1	0	23.04	0	0
	1	12	23.02		0
	1	24	23.07		0
	12	0	22.18	0-1	1
	12	6	22.11		1
	12	13	22.13		1
	25	0	22.08		1
16QAM	1	0	22.10	0-1	1
	1	12	22.08		1
	1	24	22.08		1
	12	0	21.02	0-2	2
	12	6	21.14		2
	12	13	21.07		2
	25	0	21.17		2

Note: LTE Band 13 at 5 MHz bandwidth does not support three non-overlapping channels. Per KDB Publication 941225 D05v02, when a device supports overlapping channel assignment in a channel bandwidth configuration, the middle channel of the group of overlapping channels should be selected for testing.

FCC ID: A3LSMG950N		SAR EVALUATION REPORT		Approved by: Quality Manager
Document S/N: 1M1703100103-01.A3L	Test Dates: 03/06/17 - 03/20/17	DUT Type: Portable Handset		Page 31 of 91



**Table 9-14**  
**Reduced LTE Band 13 Conducted Powers - 10 MHz Bandwidth**

LTE Band 13 10 MHz Bandwidth					
Modulation	RB Size	RB Offset	Mid Channel	MPR Allowed per 3GPP [dB]	MPR [dB]
			23230 (782.0 MHz)		
			Conducted Power [dBm]		
QPSK	1	0	22.09	0	0
	1	25	22.03		0
	1	49	22.00		0
	25	0	22.10	0-1	0
	25	12	22.06		0
	25	25	22.07		0
16QAM	50	0	22.08	0-1	0
	1	0	22.07		0
	1	25	22.02		0
	1	49	21.99	0-2	0
	25	0	21.06		1
	25	12	21.00		1
	25	25	20.96	1	
	50	0	21.05	1	

**Table 9-15**  
**Reduced LTE Band 13 Conducted Powers - 5 MHz Bandwidth**

LTE Band 13 5 MHz Bandwidth					
Modulation	RB Size	RB Offset	Mid Channel	MPR Allowed per 3GPP [dB]	MPR [dB]
			23230 (782.0 MHz)		
			Conducted Power [dBm]		
QPSK	1	0	22.04	0	0
	1	12	22.05		0
	1	24	22.14		0
	12	0	22.05	0-1	0
	12	6	22.15		0
	12	13	22.06		0
16QAM	25	0	22.14	0-1	0
	1	0	22.07		0
	1	12	21.97		0
	1	24	21.91	0-2	0
	12	0	21.00		1
	12	6	21.06		1
	12	13	20.80	1	
	25	0	21.04	1	

Note: LTE Band 13 at 5 MHz bandwidth does not support three non-overlapping channels. Per KDB Publication 941225 D05v02, when a device supports overlapping channel assignment in a channel bandwidth configuration, the middle channel of the group of overlapping channels should be selected for testing.

FCC ID: A3LSMG950N		<b>SAR EVALUATION REPORT</b>		<b>Approved by:</b> Quality Manager
<b>Document S/N:</b> 1M1703100103-01.A3L	<b>Test Dates:</b> 03/06/17 - 03/20/17	<b>DUT Type:</b> Portable Handset		Page 32 of 91

### 9.3.3 LTE Band 5 (Cell)



**Table 9-16**  
**Maximum LTE Band 5 (Cell) Conducted Powers - 10 MHz Bandwidth – Ant A**

LTE Band 5 (Cell) 10 MHz Bandwidth					
Modulation	RB Size	RB Offset	Mid Channel	MPR Allowed per 3GPP [dB]	MPR [dB]
			20525 (836.5 MHz)		
			Conducted Power [dBm]		
QPSK	1	0	24.40	0	0
	1	25	24.32		0
	1	49	24.33		0
	25	0	23.32	0-1	1
	25	12	23.33		1
	25	25	23.29		1
	50	0	23.31		1
16QAM	1	0	23.25	0-1	1
	1	25	23.28		1
	1	49	23.27		1
	25	0	22.19	0-2	2
	25	12	22.14		2
	25	25	22.14		2
	50	0	22.16		2

Note: LTE Band 5 (Cell) at 10 MHz bandwidth does not support three non-overlapping channels. Per KDB Publication 941225 D05v02, when a device supports overlapping channel assignment in a channel bandwidth configuration, the middle channel of the group of overlapping channels should be selected for testing.

**Table 9-17**  
**Maximum LTE Band 5 (Cell) Conducted Powers - 5 MHz Bandwidth – Ant A**

LTE Band 5 (Cell) 5 MHz Bandwidth							
Modulation	RB Size	RB Offset	Low Channel	Mid Channel	High Channel	MPR Allowed per 3GPP [dB]	MPR [dB]
			20425 (826.5 MHz)	20525 (836.5 MHz)	20625 (846.5 MHz)		
			Conducted Power [dBm]				
QPSK	1	0	24.45	24.30	24.22	0	0
	1	12	24.36	24.22	24.17		0
	1	24	24.39	24.26	24.18		0
	12	0	23.33	23.35	23.10	0-1	1
	12	6	23.29	23.28	23.09		1
	12	13	23.31	23.25	23.09		1
	25	0	23.34	23.24	23.09		1
16QAM	1	0	23.40	23.34	23.21	0-1	1
	1	12	23.50	23.44	23.08		1
	1	24	23.44	23.43	23.07		1
	12	0	22.31	22.16	22.06	0-2	2
	12	6	22.21	22.28	22.06		2
	12	13	22.22	22.15	22.12		2
	25	0	22.18	22.26	22.11		2



FCC ID: A3LSMG950N		<b>SAR EVALUATION REPORT</b>		<b>Approved by:</b> Quality Manager
<b>Document S/N:</b> 1M1703100103-01.A3L	<b>Test Dates:</b> 03/06/17 - 03/20/17	<b>DUT Type:</b> Portable Handset	Page 33 of 91	

**Table 9-18**  
**Maximum LTE Band 5 (Cell) Conducted Powers - 3 MHz Bandwidth – Ant A**

LTE Band 5 (Cell) 3 MHz Bandwidth							
Modulation	RB Size	RB Offset	Low Channel	Mid Channel	High Channel	MPR Allowed per 3GPP [dB]	MPR [dB]
			20415 (825.5 MHz)	20525 (836.5 MHz)	20635 (847.5 MHz)		
			Conducted Power [dBm]				
QPSK	1	0	24.41	24.33	24.27	0	0
	1	7	24.46	24.21	24.15		0
	1	14	24.30	24.09	24.13		0
	8	0	23.34	23.32	23.05	0-1	1
	8	4	23.31	23.15	23.08		1
	8	7	23.42	23.25	23.13		1
	15	0	23.43	23.18	23.07		1
16QAM	1	0	23.43	23.16	23.24	0-1	1
	1	7	23.41	23.50	23.20		1
	1	14	23.47	23.47	23.04		1
	8	0	22.30	22.13	21.91	0-2	2
	8	4	22.15	22.42	22.11		2
	8	7	22.24	22.22	22.27		2
	15	0	22.11	22.09	22.14		2

**Table 9-19**  
**Maximum LTE Band 5 (Cell) Conducted Powers -1.4 MHz Bandwidth – Ant A**

LTE Band 5 (Cell) 1.4 MHz Bandwidth							
Modulation	RB Size	RB Offset	Low Channel	Mid Channel	High Channel	MPR Allowed per 3GPP [dB]	MPR [dB]
			20407 (824.7 MHz)	20525 (836.5 MHz)	20643 (848.3 MHz)		
			Conducted Power [dBm]				
QPSK	1	0	24.50	24.41	24.26	0	0
	1	2	24.47	24.26	24.15		0
	1	5	24.27	24.20	24.20		0
	3	0	24.30	24.31	24.17		0
	3	2	24.29	24.39	24.13		0
	3	3	24.25	24.25	24.12	0	
	6	0	23.26	23.20	23.24	0-1	1
16QAM	1	0	23.40	23.27	23.22	0-1	1
	1	2	23.50	23.40	23.00		1
	1	5	23.46	23.50	22.96		1
	3	0	23.43	23.12	23.00		1
	3	2	23.15	23.31	23.18		1
	3	3	23.12	23.22	23.24		1
	6	0	22.17	22.28	22.12	0-2	2

FCC ID: A3LSMG950N	 <b>SAR EVALUATION REPORT</b> 	Approved by: Quality Manager
Document S/N: 1M1703100103-01.A3L	Test Dates: 03/06/17 - 03/20/17	DUT Type: Portable Handset
		Page 34 of 91



**Table 9-20**  
**Maximum LTE Band 5 (Cell) Conducted Powers - 10 MHz Bandwidth - Ant C**

LTE Band 5 (Cell) 10 MHz Bandwidth					
Modulation	RB Size	RB Offset	Mid Channel	MPR Allowed per 3GPP [dB]	MPR [dB]
			20525 (836.5 MHz)		
			Conducted Power [dBm]		
QPSK	1	0	22.48	0	0
	1	25	22.38		0
	1	49	22.41		0
	25	0	21.30	0-1	1
	25	12	21.28		1
	25	25	21.33		1
	50	0	21.29		1
16QAM	1	0	21.37	0-1	1
	1	25	21.35		1
	1	49	21.30		1
	25	0	20.30	0-2	2
	25	12	20.25		2
	25	25	20.25		2
	50	0	20.35		2

Note: LTE Band 5 (Cell) at 10 MHz bandwidth does not support three non-overlapping channels. Per KDB Publication 941225 D05v02, when a device supports overlapping channel assignment in a channel bandwidth configuration, the middle channel of the group of overlapping channels should be selected for testing.

**Table 9-21**  
**Maximum LTE Band 5 (Cell) Conducted Powers - 5 MHz Bandwidth - Ant C**

LTE Band 5 (Cell) 5 MHz Bandwidth							
Modulation	RB Size	RB Offset	Low Channel	Mid Channel	High Channel	MPR Allowed per 3GPP [dB]	MPR [dB]
			20425 (826.5 MHz)	20525 (836.5 MHz)	20625 (846.5 MHz)		
			Conducted Power [dBm]				
QPSK	1	0	22.56	22.57	22.48	0	0
	1	12	22.25	22.48	22.38		0
	1	24	22.49	22.41	22.54		0
	12	0	21.31	21.18	21.31	0-1	1
	12	6	21.36	21.42	21.22		1
	12	13	21.31	21.31	21.20		1
	25	0	21.19	21.14	21.08		1
16QAM	1	0	21.50	21.30	21.27	0-1	1
	1	12	21.25	21.44	21.29		1
	1	24	21.41	21.25	21.40		1
	12	0	20.30	20.42	20.43	0-2	2
	12	6	20.23	20.38	20.35		2
	12	13	20.21	20.31	20.37		2
	25	0	20.49	20.36	20.31		2



FCC ID: A3LSMG950N		<b>SAR EVALUATION REPORT</b>		<b>Approved by:</b> Quality Manager
<b>Document S/N:</b> 1M1703100103-01.A3L	<b>Test Dates:</b> 03/06/17 - 03/20/17	<b>DUT Type:</b> Portable Handset	Page 35 of 91	

**Table 9-22**  
**Maximum LTE Band 5 (Cell) Conducted Powers - 3 MHz Bandwidth – Ant C**

LTE Band 5 (Cell) 3 MHz Bandwidth							
Modulation	RB Size	RB Offset	Low Channel	Mid Channel	High Channel	MPR Allowed per 3GPP [dB]	MPR [dB]
			20415 (825.5 MHz)	20525 (836.5 MHz)	20635 (847.5 MHz)		
			Conducted Power [dBm]				
QPSK	1	0	22.33	22.61	22.56	0	0
	1	7	22.44	22.37	22.18		0
	1	14	22.52	22.45	22.41		0
	8	0	21.16	21.18	21.35	0-1	1
	8	4	21.29	21.36	21.45		1
	8	7	21.36	21.30	21.32		1
	15	0	21.33	21.20	21.36		1
16QAM	1	0	21.26	21.32	21.28	0-1	1
	1	7	21.44	21.39	21.17		1
	1	14	21.24	21.18	21.41		1
	8	0	20.33	20.21	20.29	0-2	2
	8	4	20.27	20.24	20.31		2
	8	7	20.09	20.35	20.38		2
	15	0	20.44	20.13	20.48		2

**Table 9-23**  
**Maximum LTE Band 5 (Cell) Conducted Powers -1.4 MHz Bandwidth - Ant C**

LTE Band 5 (Cell) 1.4 MHz Bandwidth							
Modulation	RB Size	RB Offset	Low Channel	Mid Channel	High Channel	MPR Allowed per 3GPP [dB]	MPR [dB]
			20407 (824.7 MHz)	20525 (836.5 MHz)	20643 (848.3 MHz)		
			Conducted Power [dBm]				
QPSK	1	0	22.64	22.58	22.50	0	0
	1	2	22.46	22.33	22.41		0
	1	5	22.29	22.62	22.48		0
	3	0	22.35	22.28	22.28		0
	3	2	22.25	22.24	22.40		0
	3	3	22.25	22.38	22.35	0	
	6	0	21.21	21.27	21.27	0-1	1
16QAM	1	0	21.57	21.28	21.38	0-1	1
	1	2	21.48	21.40	21.47		1
	1	5	21.45	21.30	21.10		1
	3	0	21.30	21.37	21.20		1
	3	2	21.07	21.28	21.14		1
	3	3	21.16	21.18	21.38		1
	6	0	20.33	20.29	20.29	0-2	2

FCC ID: A3LSMG950N	 <b>SAR EVALUATION REPORT</b> 	Approved by: Quality Manager
Document S/N: 1M1703100103-01.A3L	Test Dates: 03/06/17 - 03/20/17	DUT Type: Portable Handset
		Page 36 of 91

### 9.3.4 LTE Band 26 (Cell)



**Table 9-24**  
**Maximum LTE Band 26 (Cell) Conducted Powers - 15 MHz Bandwidth**

LTE Band 26 (Cell) 15 MHz Bandwidth					
Modulation	RB Size	RB Offset	Mid Channel	MPR Allowed per 3GPP [dB]	MPR [dB]
			26865 (831.5 MHz) Conducted Power [dBm]		
QPSK	1	0	23.40	0	0
	1	36	23.47		0
	1	74	23.33		0
	36	0	22.48	0-1	1
	36	18	22.46		1
	36	37	22.43		1
	75	0	22.47		1
16QAM	1	0	22.40	0-1	1
	1	36	22.34		1
	1	74	22.19		1
	36	0	21.50	0-2	2
	36	18	21.45		2
	36	37	21.43		2
	75	0	21.48		2

Note: LTE Band 26 (Cell) at 15 MHz bandwidth does not support three non-overlapping channels. Per KDB Publication 941225 D05v02, when a device supports overlapping channel assignment in a channel bandwidth configuration, the middle channel of the group of overlapping channels should be selected for testing.

**Table 9-25**  
**Maximum LTE Band 26 (Cell) Conducted Powers - 10 MHz Bandwidth**

LTE Band 26 (Cell) 10 MHz Bandwidth							
Modulation	RB Size	RB Offset	Low Channel	Mid Channel	High Channel	MPR Allowed per 3GPP [dB]	MPR [dB]
			26740 (819.0 MHz)	26865 (831.5 MHz)	26990 (844.0 MHz)		
QPSK	1	0	23.37	23.42	23.30	0	0
	1	25	23.30	23.33	23.23		0
	1	49	23.28	23.29	23.14		0
	25	0	22.25	22.33	22.25	0-1	1
	25	12	22.26	22.35	22.15		1
	25	25	22.13	22.37	22.16		1
	50	0	22.30	22.34	22.17		1
16QAM	1	0	22.49	22.50	22.15	0-1	1
	1	25	22.43	22.44	22.00		1
	1	49	22.40	22.46	21.97		1
	25	0	21.26	21.36	21.21	0-2	2
	25	12	21.23	21.37	21.22		2
	25	25	21.13	21.35	21.20		2
	50	0	21.20	21.36	21.13		2



FCC ID: A3LSMG950N		<b>SAR EVALUATION REPORT</b>		<b>Approved by:</b> Quality Manager
Document S/N: 1M1703100103-01.A3L	Test Dates: 03/06/17 - 03/20/17	DUT Type: Portable Handset		Page 37 of 91

**Table 9-26**  
**Maximum LTE Band 26 (Cell) Conducted Powers - 5 MHz Bandwidth**

LTE Band 26 (Cell) 5 MHz Bandwidth							
Modulation	RB Size	RB Offset	Low Channel	Mid Channel	High Channel	MPR Allowed per 3GPP [dB]	MPR [dB]
			26715 (816.5 MHz)	26865 (831.5 MHz)	27015 (846.5 MHz)		
			Conducted Power [dBm]				
QPSK	1	0	23.42	23.48	23.25	0	0
	1	12	23.25	23.33	23.36		0
	1	24	23.22	23.18	23.08		0
	12	0	22.21	22.42	22.13	0-1	1
	12	6	22.32	22.25	22.19		1
	12	13	22.17	22.38	22.18		1
	25	0	22.47	22.35	22.21		1
16QAM	1	0	22.37	22.47	22.19	0-1	1
	1	12	22.45	22.33	22.01		1
	1	24	22.31	22.50	21.99		1
	12	0	21.44	21.40	21.27	0-2	2
	12	6	21.27	21.38	21.06		2
	12	13	21.19	21.29	21.25		2
	25	0	21.02	21.28	21.01		2



**Table 9-27**  
**Maximum LTE Band 26 (Cell) Conducted Powers - 3 MHz Bandwidth**

LTE Band 26 (Cell) 3 MHz Bandwidth							
Modulation	RB Size	RB Offset	Low Channel	Mid Channel	High Channel	MPR Allowed per 3GPP [dB]	MPR [dB]
			26705 (815.5 MHz)	26865 (831.5 MHz)	27025 (847.5 MHz)		
			Conducted Power [dBm]				
QPSK	1	0	23.31	23.26	23.14	0	0
	1	7	23.21	23.36	23.21		0
	1	14	23.26	23.25	23.21		0
	8	0	22.43	22.31	22.21	0-1	1
	8	4	22.19	22.32	22.12		1
	8	7	22.17	22.50	22.17		1
	15	0	22.35	22.30	22.10		1
16QAM	1	0	22.46	22.50	22.32	0-1	1
	1	7	22.47	22.42	21.90		1
	1	14	22.33	22.41	21.93		1
	8	0	21.27	21.46	21.24	0-2	2
	8	4	21.13	21.41	21.12		2
	8	7	21.13	21.38	21.10		2
	15	0	21.20	21.50	21.22		2

FCC ID: A3LSMG950N		<b>SAR EVALUATION REPORT</b>		<b>Approved by:</b> Quality Manager
<b>Document S/N:</b> 1M1703100103-01.A3L	<b>Test Dates:</b> 03/06/17 - 03/20/17	<b>DUT Type:</b> Portable Handset	Page 38 of 91	

**Table 9-28**  
**Maximum LTE Band 26 (Cell) Conducted Powers -1.4 MHz Bandwidth**

LTE Band 26 (Cell) 1.4 MHz Bandwidth							
Modulation	RB Size	RB Offset	Low Channel	Mid Channel	High Channel	MPR Allowed per 3GPP [dB]	MPR [dB]
			26697 (814.7 MHz)	26865 (831.5 MHz)	27033 (848.3 MHz)		
			Conducted Power [dBm]				
QPSK	1	0	23.20	23.46	23.26	0	0
	1	2	23.42	23.41	23.25		0
	1	5	23.32	23.26	23.08		0
	3	0	23.23	23.41	23.24		0
	3	2	23.11	23.25	23.17		0
	3	3	23.13	23.50	23.24		0
16QAM	6	0	22.35	22.27	22.29	0-1	1
	1	0	22.50	22.50	22.03	0-1	1
	1	2	22.49	22.50	22.08		1
	1	5	22.38	22.37	21.96		1
	3	0	22.33	22.37	22.23		1
	3	2	22.24	22.40	22.34		1
	3	3	22.16	22.27	22.23		1
	6	0	21.18	21.32	20.97	0-2	2

FCC ID: A3LSMG950N		<b>SAR EVALUATION REPORT</b>		<b>Approved by:</b> Quality Manager
<b>Document S/N:</b> 1M1703100103-01.A3L	<b>Test Dates:</b> 03/06/17 - 03/20/17	<b>DUT Type:</b> Portable Handset	Page 39 of 91	

### 9.3.5 LTE Band 4 (AWS)



**Table 9-29**  
**Maximum LTE Band 4 (AWS) Conducted Powers - 20 MHz Bandwidth**

LTE Band 4 (AWS) 20 MHz Bandwidth						
Modulation	RB Size	RB Offset	Mid Channel	MPR Allowed per 3GPP [dB]	MPR [dB]	
			20175 (1732.5 MHz) Conducted Power [dBm]			
QPSK	1	0	22.95	0	0	
	1	50	22.87		0	
	1	99	22.82		0	
	QPSK	50	0	22.05	0-1	1
		50	25	22.06		1
		50	50	22.03		1
		100	0	22.04		1
16QAM	1	0	22.02	0-1	1	
	1	50	21.81		1	
	1	99	21.88		1	
	16QAM	50	0	21.23	0-2	2
		50	25	21.17		2
		50	50	21.20		2
		100	0	21.23		2

Note: LTE Band 4 (AWS) at 20 MHz bandwidth does not support three non-overlapping channels. Per KDB Publication 941225 D05v02, when a device supports overlapping channel assignment in a channel bandwidth configuration, the middle channel of the group of overlapping channels should be selected for testing.

**Table 9-30**  
**Maximum LTE Band 4 (AWS) Conducted Powers - 15 MHz Bandwidth**

LTE Band 4 (AWS) 15 MHz Bandwidth								
Modulation	RB Size	RB Offset	Low Channel	Mid Channel	High Channel	MPR Allowed per 3GPP [dB]	MPR [dB]	
			20025 (1717.5 MHz) Conducted Power [dBm]	20175 (1732.5 MHz)	20325 (1747.5 MHz)			
QPSK	1	0	23.16	23.04	23.15	0	0	
	1	36	22.99	23.00	22.90		0	
	1	74	23.18	23.06	23.08		0	
	QPSK	36	0	21.87	21.88	21.78	0-1	1
		36	18	22.03	21.90	22.04		1
		36	37	21.81	21.93	21.92		1
		75	0	21.84	21.95	21.95		1
16QAM	1	0	22.28	22.06	22.07	0-1	1	
	1	36	22.21	22.11	22.17		1	
	1	74	21.99	22.10	22.05		1	
	16QAM	36	0	21.24	21.06	21.06	0-2	2
		36	18	20.99	21.00	21.03		2
		36	37	21.06	21.06	21.22		2
		75	0	20.98	21.03	21.10		2



FCC ID: A3LSMG950N		<b>SAR EVALUATION REPORT</b>		<b>Approved by:</b> Quality Manager
<b>Document S/N:</b> 1M1703100103-01.A3L	<b>Test Dates:</b> 03/06/17 - 03/20/17	<b>DUT Type:</b> Portable Handset	Page 40 of 91	

**Table 9-31**  
**Maximum LTE Band 4 (AWS) Conducted Powers - 10 MHz Bandwidth**

LTE Band 4 (AWS) 10 MHz Bandwidth							
Modulation	RB Size	RB Offset	Low Channel	Mid Channel	High Channel	MPR Allowed per 3GPP [dB]	MPR [dB]
			20000 (1715.0 MHz)	20175 (1732.5 MHz)	20350 (1750.0 MHz)		
			Conducted Power [dBm]				
QPSK	1	0	23.00	23.00	22.93	0	0
	1	25	22.79	22.96	22.97		0
	1	49	23.02	22.94	23.14		0
	25	0	22.06	22.06	22.18	0-1	1
	25	12	21.94	21.95	22.08		1
	25	25	21.96	21.96	22.06		1
	50	0	21.92	22.03	22.05		1
16QAM	1	0	21.94	21.90	21.75	0-1	1
	1	25	22.00	22.06	22.14		1
	1	49	22.05	22.10	22.25		1
	25	0	21.13	21.06	21.09	0-2	2
	25	12	21.04	21.00	21.11		2
	25	25	20.89	21.00	21.08		2
	50	0	21.06	21.06	20.94		2

**Table 9-32**  
**Maximum LTE Band 4 (AWS) Conducted Powers - 5 MHz Bandwidth**

LTE Band 4 (AWS) 5 MHz Bandwidth							
Modulation	RB Size	RB Offset	Low Channel	Mid Channel	High Channel	MPR Allowed per 3GPP [dB]	MPR [dB]
			19975 (1712.5 MHz)	20175 (1732.5 MHz)	20375 (1752.5 MHz)		
			Conducted Power [dBm]				
QPSK	1	0	23.22	23.08	23.20	0	0
	1	12	23.04	23.00	22.94		0
	1	24	23.02	23.06	23.26		0
	12	0	21.93	21.96	21.92	0-1	1
	12	6	21.99	21.99	22.13		1
	12	13	22.09	21.95	22.17		1
	25	0	22.03	21.95	21.83		1
16QAM	1	0	21.95	22.00	22.10	0-1	1
	1	12	21.99	22.06	21.93		1
	1	24	21.97	22.10	22.08		1
	12	0	21.14	21.06	21.00	0-2	2
	12	6	20.95	20.95	20.98		2
	12	13	21.02	20.99	21.02		2
	25	0	21.11	21.00	21.01		2



FCC ID: A3LSMG950N	 <b>SAR EVALUATION REPORT</b> 	Approved by: Quality Manager
Document S/N: 1M1703100103-01.A3L	Test Dates: 03/06/17 - 03/20/17	DUT Type: Portable Handset
		Page 41 of 91

**Table 9-33**  
**Maximum LTE Band 4 (AWS) Conducted Powers - 3 MHz Bandwidth**

LTE Band 4 (AWS) 3 MHz Bandwidth							
Modulation	RB Size	RB Offset	Low Channel	Mid Channel	High Channel	MPR Allowed per 3GPP [dB]	MPR [dB]
			19965 (1711.5 MHz)	20175 (1732.5 MHz)	20385 (1753.5 MHz)		
			Conducted Power [dBm]				
QPSK	1	0	22.98	22.93	22.83	0	0
	1	7	23.02	22.86	22.96		0
	1	14	22.90	22.90	23.00		0
	8	0	21.95	21.93	21.88	0-1	1
	8	4	21.87	22.01	22.06		1
	8	7	21.94	21.95	21.96		1
	15	0	22.10	21.96	21.98		1
16QAM	1	0	22.08	22.05	22.13	0-1	1
	1	7	21.90	22.00	22.00		1
	1	14	21.99	22.03	21.99		1
	8	0	21.08	21.03	21.11	0-2	2
	8	4	20.96	20.99	21.02		2
	8	7	21.07	20.94	21.03		2
	15	0	21.14	21.20	21.37		2

**Table 9-34**  
**Maximum LTE Band 4 (AWS) Conducted Powers - 1.4 MHz Bandwidth**

LTE Band 4 (AWS) 1.4 MHz Bandwidth							
Modulation	RB Size	RB Offset	Low Channel	Mid Channel	High Channel	MPR Allowed per 3GPP [dB]	MPR [dB]
			19957 (1710.7 MHz)	20175 (1732.5 MHz)	20393 (1754.3 MHz)		
			Conducted Power [dBm]				
QPSK	1	0	23.02	23.04	22.91	0	0
	1	2	23.00	22.91	23.09		0
	1	5	23.07	22.93	23.00		0
	3	0	22.93	22.90	23.06		0
	3	2	23.13	22.94	23.08		0
	3	3	23.15	22.99	23.19		0
	6	0	21.86	21.98	22.15	0-1	1
16QAM	1	0	22.11	22.07	22.09	0-1	1
	1	2	22.06	21.88	21.73		1
	1	5	21.93	21.90	21.95		1
	3	0	22.14	21.95	21.95		1
	3	2	22.01	21.96	21.96		1
	3	3	21.83	21.95	22.06		1
	6	0	21.08	21.10	21.12	0-2	2

FCC ID: A3LSMG950N	 <b>SAR EVALUATION REPORT</b> 	Approved by: Quality Manager
Document S/N: 1M1703100103-01.A3L	Test Dates: 03/06/17 - 03/20/17	DUT Type: Portable Handset
		Page 42 of 91



**Table 9-35**  
**Reduced LTE Band 4 (AWS) Conducted Powers - 20 MHz Bandwidth**

LTE Band 4 (AWS) 20 MHz Bandwidth					
Modulation	RB Size	RB Offset	Mid Channel	MPR Allowed per 3GPP [dB]	MPR [dB]
			20175 (1732.5 MHz)		
			Conducted Power [dBm]		
QPSK	1	0	20.20	0	0
	1	50	20.21		0
	1	99	20.15		0
	50	0	20.24	0-1	0
	50	25	20.17		0
	50	50	20.16		0
	100	0	20.20		0
16QAM	1	0	20.45	0-1	0
	1	50	20.41		0
	1	99	20.45		0
	50	0	20.33	0-2	0
	50	25	20.38		0
	50	50	20.40		0
	100	0	20.36		0

Note: LTE Band 4 (AWS) at 20 MHz bandwidth does not support three non-overlapping channels. Per KDB Publication 941225 D05v02, when a device supports overlapping channel assignment in a channel bandwidth configuration, the middle channel of the group of overlapping channels should be selected for testing.

**Table 9-36**  
**Reduced LTE Band 4 (AWS) Conducted Powers - 15 MHz Bandwidth**

LTE Band 4 (AWS) 15 MHz Bandwidth							
Modulation	RB Size	RB Offset	Low Channel	Mid Channel	High Channel	MPR Allowed per 3GPP [dB]	MPR [dB]
			20025 (1717.5 MHz)	20175 (1732.5 MHz)	20325 (1747.5 MHz)		
			Conducted Power [dBm]				
QPSK	1	0	20.30	20.26	20.22	0	0
	1	36	20.20	20.09	20.24		0
	1	74	20.06	20.05	20.34		0
	36	0	20.35	20.27	20.23	0-1	0
	36	18	20.25	20.06	20.06		0
	36	37	20.22	20.20	20.10		0
	75	0	20.14	20.16	20.14		0
16QAM	1	0	20.42	20.50	20.44	0-1	0
	1	36	20.23	20.44	20.46		0
	1	74	20.47	20.44	20.41		0
	36	0	20.36	20.22	20.27	0-2	0
	36	18	20.44	20.36	20.38		0
	36	37	20.34	20.39	20.40		0
	75	0	20.44	20.38	20.19		0



FCC ID: A3LSMG950N		<b>SAR EVALUATION REPORT</b>		<b>Approved by:</b> Quality Manager
<b>Document S/N:</b> 1M1703100103-01.A3L	<b>Test Dates:</b> 03/06/17 - 03/20/17	<b>DUT Type:</b> Portable Handset		Page 43 of 91

**Table 9-37**  
**Reduced LTE Band 4 (AWS) Conducted Powers - 10 MHz Bandwidth**

LTE Band 4 (AWS) 10 MHz Bandwidth							
Modulation	RB Size	RB Offset	Low Channel	Mid Channel	High Channel	MPR Allowed per 3GPP [dB]	MPR [dB]
			20000 (1715.0 MHz)	20175 (1732.5 MHz)	20350 (1750.0 MHz)		
			Conducted Power [dBm]				
QPSK	1	0	20.20	20.17	20.13	0	0
	1	25	20.25	20.28	20.21		0
	1	49	20.01	20.19	20.23		0
	25	0	20.29	20.26	20.12	0-1	0
	25	12	20.17	20.20	20.12		0
	25	25	20.31	20.07	20.16		0
	50	0	20.12	20.33	20.23		0
16QAM	1	0	20.29	20.44	20.46	0-1	0
	1	25	20.41	20.33	20.44		0
	1	49	20.40	20.50	20.50		0
	25	0	20.41	20.36	20.23	0-2	0
	25	12	20.47	20.40	20.46		0
	25	25	20.47	20.41	20.50		0
	50	0	20.44	20.40	20.38		0

**Table 9-38**  
**Reduced LTE Band 4 (AWS) Conducted Powers - 5 MHz Bandwidth**

LTE Band 4 (AWS) 5 MHz Bandwidth							
Modulation	RB Size	RB Offset	Low Channel	Mid Channel	High Channel	MPR Allowed per 3GPP [dB]	MPR [dB]
			19975 (1712.5 MHz)	20175 (1732.5 MHz)	20375 (1752.5 MHz)		
			Conducted Power [dBm]				
QPSK	1	0	20.29	20.25	20.25	0	0
	1	12	20.23	20.22	20.25		0
	1	24	20.17	20.04	20.04		0
	12	0	20.21	20.26	20.23	0-1	0
	12	6	20.33	20.16	20.15		0
	12	13	20.06	20.08	20.31		0
	25	0	20.24	20.24	20.25		0
16QAM	1	0	20.50	20.37	20.47	0-1	0
	1	12	20.28	20.50	20.26		0
	1	24	20.34	20.35	20.50		0
	12	0	20.30	20.42	20.36	0-2	0
	12	6	20.43	20.29	20.45		0
	12	13	20.42	20.50	20.35		0
	25	0	20.43	20.42	20.38		0



FCC ID: A3LSMG950N	 <b>SAR EVALUATION REPORT</b> 	Approved by: Quality Manager
Document S/N: 1M1703100103-01.A3L	Test Dates: 03/06/17 - 03/20/17	DUT Type: Portable Handset
		Page 44 of 91

**Table 9-39**  
**Reduced LTE Band 4 (AWS) Conducted Powers - 3 MHz Bandwidth**

LTE Band 4 (AWS) 3 MHz Bandwidth							
Modulation	RB Size	RB Offset	Low Channel	Mid Channel	High Channel	MPR Allowed per 3GPP [dB]	MPR [dB]
			19965 (1711.5 MHz)	20175 (1732.5 MHz)	20385 (1753.5 MHz)		
			Conducted Power [dBm]				
QPSK	1	0	20.26	20.22	20.20	0	0
	1	7	20.23	20.06	20.34		0
	1	14	20.26	20.07	20.12		0
	8	0	20.33	20.14	20.16	0-1	0
	8	4	20.16	20.16	20.17		0
	8	7	20.24	20.11	20.07		0
	15	0	20.13	20.19	20.32		0
16QAM	1	0	20.48	20.50	20.33	0-1	0
	1	7	20.36	20.35	20.38		0
	1	14	20.41	20.35	20.42		0
	8	0	20.30	20.31	20.25	0-2	0
	8	4	20.34	20.38	20.40		0
	8	7	20.27	20.39	20.45		0
	15	0	20.34	20.42	20.28		0

**Table 9-40**  
**Reduced LTE Band 4 (AWS) Conducted Powers -1.4 MHz Bandwidth**

LTE Band 4 (AWS) 1.4 MHz Bandwidth							
Modulation	RB Size	RB Offset	Low Channel	Mid Channel	High Channel	MPR Allowed per 3GPP [dB]	MPR [dB]
			19957 (1710.7 MHz)	20175 (1732.5 MHz)	20393 (1754.3 MHz)		
			Conducted Power [dBm]				
QPSK	1	0	20.19	20.29	20.15	0	0
	1	2	20.13	20.17	20.28		0
	1	5	20.07	20.12	20.13		0
	3	0	20.44	20.16	20.37		0
	3	2	20.15	20.21	20.24		0
	3	3	20.18	20.12	20.19		0
	6	0	20.32	20.28	20.18	0-1	0
16QAM	1	0	20.50	20.49	20.48	0-1	0
	1	2	20.30	20.46	20.32		0
	1	5	20.43	20.35	20.45		0
	3	0	20.45	20.33	20.28		0
	3	2	20.29	20.41	20.44		0
	3	3	20.33	20.50	20.30		0
	6	0	20.30	20.28	20.27	0-2	0

FCC ID: A3LSMG950N	 <b>SAR EVALUATION REPORT</b> 	Approved by: Quality Manager
Document S/N: 1M1703100103-01.A3L	Test Dates: 03/06/17 - 03/20/17	DUT Type: Portable Handset
		Page 45 of 91



### 9.3.6 LTE Band 25 (PCS)

**Table 9-41**  
**Maximum LTE Band 25 (PCS) Conducted Powers - 20 MHz Bandwidth**

LTE Band 25 (PCS) 20 MHz Bandwidth							
Modulation	RB Size	RB Offset	Low Channel	Mid Channel	High Channel	MPR Allowed per 3GPP [dB]	MPR [dB]
			26140 (1860.0 MHz)	26365 (1882.5 MHz)	26590 (1905.0 MHz)		
			Conducted Power [dBm]				
QPSK	1	0	22.31	22.67	22.74	0	0
	1	50	22.23	22.65	22.75		0
	1	99	22.23	22.65	22.77		0
	50	0	21.45	21.71	21.95	0-1	1
	50	25	21.42	21.70	21.88		1
	50	50	21.44	21.59	21.92		1
16QAM	100	0	21.40	21.66	21.93	0-1	1
	1	0	21.21	21.43	22.00		1
	1	50	21.13	21.31	21.86		1
	1	99	21.00	21.31	21.79	0-2	1
	50	0	20.46	20.75	20.94		2
	50	25	20.45	20.70	20.93		2
	50	50	20.40	20.62	20.90		2
100	0	20.46	20.60	20.87	2		

**Table 9-42**  
**Maximum LTE Band 25 (PCS) Conducted Powers - 15 MHz Bandwidth**

LTE Band 25 (PCS) 15 MHz Bandwidth							
Modulation	RB Size	RB Offset	Low Channel	Mid Channel	High Channel	MPR Allowed per 3GPP [dB]	MPR [dB]
			26115 (1857.5 MHz)	26365 (1882.5 MHz)	26615 (1907.5 MHz)		
			Conducted Power [dBm]				
QPSK	1	0	22.64	22.68	22.64	0	0
	1	36	22.64	22.55	22.47		0
	1	74	22.65	22.50	22.37		0
	36	0	21.71	21.61	21.75	0-1	1
	36	18	21.47	21.57	21.56		1
	36	37	21.50	21.53	21.47		1
	75	0	21.71	21.59	21.70		1
16QAM	1	0	21.95	21.77	21.79	0-1	1
	1	36	21.69	21.66	21.78		1
	1	74	21.62	21.62	21.69		1
	36	0	20.70	20.75	20.77	0-2	2
	36	18	20.57	20.56	20.62		2
	36	37	20.56	20.56	20.64		2
	75	0	20.64	20.61	20.71		2



FCC ID: A3LSMG950N		<b>SAR EVALUATION REPORT</b>		<b>Approved by:</b> Quality Manager
<b>Document S/N:</b> 1M1703100103-01.A3L	<b>Test Dates:</b> 03/06/17 - 03/20/17	<b>DUT Type:</b> Portable Handset	Page 46 of 91	

**Table 9-43**  
**Maximum LTE Band 25 (PCS) Conducted Powers - 10 MHz Bandwidth**

LTE Band 25 (PCS) 10 MHz Bandwidth								
Modulation	RB Size	RB Offset	Low Channel	Mid Channel	High Channel	MPR Allowed per 3GPP [dB]	MPR [dB]	
			26090 (1855.0 MHz)	26365 (1882.5 MHz)	26640 (1910.0 MHz)			
			Conducted Power [dBm]					
QPSK	1	0	22.52	22.57	22.63	0	0	
	1	25	22.59	22.53	22.73		0	
	1	49	22.51	22.49	22.58		0	
	25	0	21.37	21.44	21.34	0-1	1	
	25	12	21.66	21.60	21.71		1	
	25	25	21.53	21.51	21.66		1	
16QAM	50	0	21.66	21.52	21.64	0-1	1	
	1	0	21.73	21.67	21.76		0-1	1
	1	25	21.70	21.56	21.58			1
	1	49	21.63	21.57	21.69	0-2		1
	25	0	20.47	20.62	20.76		2	
	25	12	20.75	20.63	20.72		2	
	25	25	20.46	20.50	20.55		2	
50	0	20.57	20.53	20.68	2			

**Table 9-44**  
**Maximum LTE Band 25 (PCS) Conducted Powers - 5 MHz Bandwidth**

LTE Band 25 (PCS) 5 MHz Bandwidth								
Modulation	RB Size	RB Offset	Low Channel	Mid Channel	High Channel	MPR Allowed per 3GPP [dB]	MPR [dB]	
			26065 (1852.5 MHz)	26365 (1882.5 MHz)	26665 (1912.5 MHz)			
			Conducted Power [dBm]					
QPSK	1	0	22.44	22.54	22.48	0	0	
	1	12	22.48	22.48	22.47		0	
	1	24	22.44	22.52	22.53		0	
	12	0	21.72	21.52	21.50	0-1	1	
	12	6	21.47	21.48	21.40		1	
	12	13	21.51	21.49	21.69		1	
16QAM	25	0	21.52	21.47	21.43	0-1	1	
	1	0	21.95	21.79	21.98		0-1	1
	1	12	21.78	21.74	21.91			1
	1	24	21.73	21.66	21.67	0-2		1
	12	0	20.57	20.46	20.32		2	
	12	6	20.65	20.59	20.64		2	
	12	13	20.54	20.49	20.56		2	
25	0	20.49	20.51	20.37	2			



FCC ID: A3LSMG950N		<b>SAR EVALUATION REPORT</b>		<b>Approved by:</b> Quality Manager
<b>Document S/N:</b> 1M1703100103-01.A3L	<b>Test Dates:</b> 03/06/17 - 03/20/17	<b>DUT Type:</b> Portable Handset	Page 47 of 91	

**Table 9-45**  
**Maximum LTE Band 25 (PCS) Conducted Powers - 3 MHz Bandwidth**

LTE Band 25 (PCS) 3 MHz Bandwidth								
Modulation	RB Size	RB Offset	Low Channel	Mid Channel	High Channel	MPR Allowed per 3GPP [dB]	MPR [dB]	
			26055 (1851.5 MHz)	26365 (1882.5 MHz)	26675 (1913.5 MHz)			
			Conducted Power [dBm]					
QPSK	1	0	22.35	22.35	22.48	0	0	
	1	7	22.51	22.56	22.65		0	
	1	14	22.30	22.35	22.35		0	
	8	0	21.50	21.47	21.53	0-1	1	
	8	4	21.58	21.44	21.46		1	
	8	7	21.46	21.43	21.44		1	
16QAM	15	0	21.56	21.50	21.46	0-1	1	
	1	0	21.77	21.75	21.94		0-1	1
	1	7	21.69	21.80	21.83			1
	1	14	21.67	21.79	21.65	0-2		1
	8	0	20.52	20.53	20.64		2	
	8	4	20.51	20.46	20.27		2	
	8	7	20.77	20.55	20.55		2	
15	0	20.75	20.51	20.49	2			

**Table 9-46**  
**Maximum LTE Band 25 (PCS) Conducted Powers -1.4 MHz Bandwidth**

LTE Band 25 (PCS) 1.4 MHz Bandwidth							
Modulation	RB Size	RB Offset	Low Channel	Mid Channel	High Channel	MPR Allowed per 3GPP [dB]	MPR [dB]
			26047 (1850.7 MHz)	26365 (1882.5 MHz)	26683 (1914.3 MHz)		
			Conducted Power [dBm]				
QPSK	1	0	22.48	22.48	22.60	0	0
	1	2	22.41	22.40	22.28		0
	1	5	22.43	22.55	22.65		0
	3	0	22.44	22.50	22.55		0
	3	2	22.91	22.70	22.57		0
	3	3	22.71	22.61	22.52		0
	6	0	21.69	21.51	21.55	0-1	1
16QAM	1	0	21.58	21.63	21.67	0-1	1
	1	2	21.79	21.75	21.77		1
	1	5	21.60	21.51	21.58		1
	3	0	21.58	21.43	21.47		1
	3	2	21.42	21.44	21.39		1
	3	3	21.37	21.50	21.44		1
	6	0	20.65	20.52	20.61	0-2	2



FCC ID: A3LSMG950N	 <b>PCTEST</b>	<b>SAR EVALUATION REPORT</b>		<b>Approved by:</b> Quality Manager
<b>Document S/N:</b> 1M1703100103-01.A3L	<b>Test Dates:</b> 03/06/17 - 03/20/17	<b>DUT Type:</b> Portable Handset		Page 48 of 91

**Table 9-47**  
**Reduced LTE Band 25 (PCS) Conducted Powers - 20 MHz Bandwidth**

LTE Band 25 (PCS) 20 MHz Bandwidth							
Modulation	RB Size	RB Offset	Low Channel	Mid Channel	High Channel	MPR Allowed per 3GPP [dB]	MPR [dB]
			26140 (1860.0 MHz)	26365 (1882.5 MHz)	26590 (1905.0 MHz)		
			Conducted Power [dBm]				
QPSK	1	0	19.65	19.91	20.05	0	0
	1	50	19.55	19.86	20.04		0
	1	99	19.57	19.91	19.90		0
	50	0	19.57	19.90	20.15	0-1	0
	50	25	19.65	19.90	20.13		0
	50	50	19.69	19.80	20.07		0
	100	0	19.67	19.89	20.03		0
16QAM	1	0	19.63	19.94	20.26	0-1	0
	1	50	19.54	19.81	20.27		0
	1	99	19.60	19.86	20.20		0
	50	0	19.62	19.92	20.15	0-2	0
	50	25	19.64	20.00	20.20		0
	50	50	19.60	19.91	20.19		0
	100	0	19.67	19.94	20.21		0

**Table 9-48**  
**Reduced LTE Band 25 (PCS) Conducted Powers - 15 MHz Bandwidth**

LTE Band 25 (PCS) 15 MHz Bandwidth							
Modulation	RB Size	RB Offset	Low Channel	Mid Channel	High Channel	MPR Allowed per 3GPP [dB]	MPR [dB]
			26115 (1857.5 MHz)	26365 (1882.5 MHz)	26615 (1907.5 MHz)		
			Conducted Power [dBm]				
QPSK	1	0	19.63	19.91	20.07	0	0
	1	36	19.50	19.91	19.91		0
	1	74	19.53	19.83	19.87		0
	36	0	19.62	19.98	20.07	0-1	0
	36	18	19.66	19.97	20.16		0
	36	37	19.78	19.83	20.14		0
	75	0	19.55	19.87	20.17		0
16QAM	1	0	19.60	19.94	20.26	0-1	0
	1	36	19.67	19.82	20.27		0
	1	74	19.54	19.81	20.22		0
	36	0	19.63	20.02	20.15	0-2	0
	36	18	19.54	20.07	20.23		0
	36	37	19.57	19.93	20.22		0
	75	0	19.81	19.99	20.14		0



FCC ID: A3LSMG950N		<b>SAR EVALUATION REPORT</b>		<b>Approved by:</b> Quality Manager
<b>Document S/N:</b> 1M1703100103-01.A3L	<b>Test Dates:</b> 03/06/17 - 03/20/17	<b>DUT Type:</b> Portable Handset		Page 49 of 91

**Table 9-49**  
**Reduced LTE Band 25 (PCS) Conducted Powers - 10 MHz Bandwidth**

LTE Band 25 (PCS) 10 MHz Bandwidth							
Modulation	RB Size	RB Offset	Low Channel	Mid Channel	High Channel	MPR Allowed per 3GPP [dB]	MPR [dB]
			26090 (1855.0 MHz)	26365 (1882.5 MHz)	26640 (1910.0 MHz)		
			Conducted Power [dBm]				
QPSK	1	0	19.59	19.94	19.95	0	0
	1	25	19.52	19.87	20.12		0
	1	49	19.55	19.95	19.74		0
	25	0	19.61	19.87	20.07	0-1	0
	25	12	19.72	19.82	20.17		0
	25	25	19.77	19.77	19.96		0
16QAM	50	0	19.86	19.89	20.01	0-1	0
	1	0	19.64	19.98	20.17		0
	1	25	19.51	19.96	20.22		0
	1	49	19.46	19.86	20.13	0-2	0
	25	0	19.57	19.74	20.20		0
	25	12	19.78	20.11	20.23		0
	25	25	19.48	19.93	20.21	0	
	50	0	19.56	19.96	20.35	0	

**Table 9-50**  
**Reduced LTE Band 25 (PCS) Conducted Powers - 5 MHz Bandwidth**

LTE Band 25 (PCS) 5 MHz Bandwidth							
Modulation	RB Size	RB Offset	Low Channel	Mid Channel	High Channel	MPR Allowed per 3GPP [dB]	MPR [dB]
			26065 (1852.5 MHz)	26365 (1882.5 MHz)	26665 (1912.5 MHz)		
			Conducted Power [dBm]				
QPSK	1	0	19.75	19.98	20.15	0	0
	1	12	19.46	19.73	20.02		0
	1	24	19.48	19.85	19.90		0
	12	0	19.70	19.79	20.05	0-1	0
	12	6	19.62	19.84	20.28		0
	12	13	19.67	19.68	19.89		0
16QAM	25	0	19.73	19.72	20.05	0-1	0
	1	0	19.61	19.89	20.23		0
	1	12	19.45	19.94	20.16		0
	1	24	19.56	19.75	20.24	0-2	0
	12	0	19.55	19.86	19.98		0
	12	6	19.64	20.07	20.04		0
	12	13	19.49	20.04	20.33	0	
	25	0	19.72	19.84	20.22	0	



FCC ID: A3LSMG950N		<b>SAR EVALUATION REPORT</b>		<b>Approved by:</b> Quality Manager
<b>Document S/N:</b> 1M1703100103-01.A3L	<b>Test Dates:</b> 03/06/17 - 03/20/17	<b>DUT Type:</b> Portable Handset		Page 50 of 91

**Table 9-51**  
**Reduced LTE Band 25 (PCS) Conducted Powers - 3 MHz Bandwidth**

LTE Band 25 (PCS) 3 MHz Bandwidth							
Modulation	RB Size	RB Offset	Low Channel	Mid Channel	High Channel	MPR Allowed per 3GPP [dB]	MPR [dB]
			26055 (1851.5 MHz)	26365 (1882.5 MHz)	26675 (1913.5 MHz)		
			Conducted Power [dBm]				
QPSK	1	0	19.55	19.88	20.03	0	0
	1	7	19.49	19.82	20.10		0
	1	14	19.72	19.94	19.86		0
	8	0	19.57	19.87	20.17	0-1	0
	8	4	19.56	19.83	20.25		0
	8	7	19.63	19.87	20.08		0
16QAM	15	0	19.79	19.94	19.96	0-1	0
	1	0	19.74	19.95	20.17		0
	1	7	19.58	19.71	20.26		0
	1	14	19.62	19.87	20.29	0-2	0
	8	0	19.67	19.94	20.18		0
	8	4	19.80	19.96	20.29		0
	8	7	19.54	19.80	20.18	0	
	15	0	19.67	19.94	20.30	0	

**Table 9-52**  
**Reduced LTE Band 25 (PCS) Conducted Powers -1.4 MHz Bandwidth**

LTE Band 25 (PCS) 1.4 MHz Bandwidth							
Modulation	RB Size	RB Offset	Low Channel	Mid Channel	High Channel	MPR Allowed per 3GPP [dB]	MPR [dB]
			26047 (1850.7 MHz)	26365 (1882.5 MHz)	26683 (1914.3 MHz)		
			Conducted Power [dBm]				
QPSK	1	0	19.77	19.83	19.98	0	0
	1	2	19.60	19.95	19.99		0
	1	5	19.60	20.03	19.86		0
	3	0	19.51	19.92	20.27		0
	3	2	19.66	19.83	20.15		0
	3	3	19.61	19.74	20.14		0
	6	0	19.76	19.81	20.09	0-1	0
16QAM	1	0	19.43	19.85	20.22	0-1	0
	1	2	19.62	19.77	20.42		0
	1	5	19.72	19.82	20.13		0
	3	0	19.63	19.86	20.09		0
	3	2	19.48	20.17	20.21		0
	3	3	19.51	19.95	20.24		0
	6	0	19.69	19.90	20.29	0-2	0

FCC ID: A3LSMG950N	 <b>PCTEST</b>	<b>SAR EVALUATION REPORT</b>		<b>Approved by:</b> Quality Manager
<b>Document S/N:</b> 1M1703100103-01.A3L	<b>Test Dates:</b> 03/06/17 - 03/20/17	<b>DUT Type:</b> Portable Handset		Page 51 of 91



### 9.3.7 LTE Band 41

**Table 9-53  
Maximum LTE Band 41 Conducted Powers - 20 MHz Bandwidth**

LTE Band 41 20 MHz Bandwidth									
Modulation	RB Size	RB Offset	Low Channel	Low-Mid Channel	Mid Channel	Mid-High Channel	High Channel	MPR Allowed per 3GPP [dB]	MPR [dB]
			39750 (2506.0 MHz)	40185 (2549.5 MHz)	40620 (2593.0 MHz)	41055 (2636.5 MHz)	41490 (2680.0 MHz)		
			Conducted Power [dBm]						
QPSK	1	0	23.94	23.61	23.50	23.56	23.94	0	0
	1	50	23.99	23.84	23.75	23.61	24.00		0
	1	99	23.99	23.79	23.74	23.62	23.96		0
	50	0	22.99	22.80	22.90	22.80	22.96	0-1	1
	50	25	22.97	22.76	22.91	22.81	22.94		1
	50	50	23.00	22.80	22.88	22.80	22.98		1
16QAM	100	0	22.99	22.78	22.90	22.79	22.97	0-1	1
	1	0	22.90	22.39	22.55	22.61	22.99		1
	1	50	22.95	22.43	22.85	22.65	22.98		1
	1	99	22.93	22.50	22.81	22.62	22.93	0-2	1
	50	0	22.00	21.82	21.83	21.82	21.97		2
	50	25	22.00	21.79	21.95	21.80	22.00		2
50	50	21.99	21.86	21.92	21.90	21.99	2		
100	0	22.00	21.89	21.99	21.86	21.98	2		

**Table 9-54  
Maximum LTE Band 41 Conducted Powers - 15 MHz Bandwidth**

LTE Band 41 15 MHz Bandwidth										
Modulation	RB Size	RB Offset	Low Channel	Low-Mid Channel	Mid Channel	Mid-High Channel	High Channel	MPR Allowed per 3GPP [dB]	MPR [dB]	
			39750 (2506.0 MHz)	40185 (2549.5 MHz)	40620 (2593.0 MHz)	41055 (2636.5 MHz)	41490 (2680.0 MHz)			
			Conducted Power [dBm]							
QPSK	1	0	23.92	23.62	23.69	23.52	23.80	0	0	
	1	36	23.87	23.70	23.60	23.40	23.77		0	
	1	74	23.95	23.67	23.58	23.34	23.71		0	
	36	0	22.99	22.70	22.64	22.53	22.85	0-1	1	
	36	18	23.00	22.60	22.58	22.46	22.78		1	
	36	37	22.95	22.64	22.56	22.45	22.77		1	
16QAM	75	0	22.90	22.66	22.61	22.50	22.71	0-1	1	
	1	0	22.91	22.80	22.60	22.60	22.90		0-1	1
	1	36	22.86	22.64	22.43	22.51	22.78			1
	1	74	22.94	22.66	22.41	22.55	22.72	0-2		1
	36	0	22.00	21.70	21.71	21.51	21.85		2	
	36	18	21.95	21.73	21.68	21.55	21.90		2	
36	37	21.90	21.71	21.73	21.60	21.84	2			
75	0	21.88	21.63	21.59	21.53	21.85	2			



FCC ID: A3LSMG950N		<b>SAR EVALUATION REPORT</b>		<b>Approved by:</b> Quality Manager
Document S/N: 1M1703100103-01.A3L	Test Dates: 03/06/17 - 03/20/17	DUT Type: Portable Handset	Page 52 of 91	

**Table 9-55**  
**Maximum LTE Band 41 Conducted Powers - 10 MHz Bandwidth**

LTE Band 41 10 MHz Bandwidth									
Modulation	RB Size	RB Offset	Low Channel	Low-Mid Channel	Mid Channel	Mid-High Channel	High Channel	MPR Allowed per 3GPP [dB]	MPR [dB]
			39750 (2506.0 MHz)	40185 (2549.5 MHz)	40620 (2593.0 MHz)	41055 (2636.5 MHz)	41490 (2680.0 MHz)		
			Conducted Power [dBm]						
QPSK	1	0	24.00	23.66	23.85	23.67	23.72	0	0
	1	25	23.82	23.68	23.70	23.38	23.91		0
	1	49	24.00	23.70	23.49	23.51	23.69		0
	25	0	23.00	22.55	22.66	22.62	22.80	0-1	1
	25	12	23.00	22.60	22.60	22.55	22.70		1
	25	25	22.97	22.54	22.44	22.43	22.60		1
50	0	22.75	22.64	22.70	22.48	22.75	1		
16QAM	1	0	22.82	22.86	22.62	22.74	22.91	0-1	1
	1	25	22.74	22.73	22.44	22.36	22.74		1
	1	49	22.98	22.67	22.36	22.49	22.74		1
	25	0	22.00	21.57	21.78	21.47	21.77	0-2	2
	25	12	21.87	21.78	21.72	21.47	21.88		2
	25	25	22.00	21.71	21.76	21.71	21.94		2
50	0	21.93	21.79	21.60	21.53	21.98	2		

**Table 9-56**  
**Maximum LTE Band 41 Conducted Powers - 5 MHz Bandwidth**

LTE Band 41 5 MHz Bandwidth									
Modulation	RB Size	RB Offset	Low Channel	Low-Mid Channel	Mid Channel	Mid-High Channel	High Channel	MPR Allowed per 3GPP [dB]	MPR [dB]
			39750 (2506.0 MHz)	40185 (2549.5 MHz)	40620 (2593.0 MHz)	41055 (2636.5 MHz)	41490 (2680.0 MHz)		
			Conducted Power [dBm]						
QPSK	1	0	23.97	23.58	23.83	23.54	23.90	0	0
	1	12	23.83	23.82	23.58	23.44	23.77		0
	1	24	23.93	23.55	23.70	23.25	23.69		0
	12	0	22.94	22.77	22.68	22.50	22.91	0-1	1
	12	6	23.00	22.63	22.56	22.47	22.72		1
	12	13	22.92	22.73	22.61	22.55	22.74		1
25	0	22.60	22.52	22.52	22.52	22.61	1		
16QAM	1	0	22.83	22.81	22.54	22.77	22.81	0-1	1
	1	12	22.89	22.73	22.51	22.38	22.76		1
	1	24	23.00	22.60	22.43	22.42	22.70		1
	12	0	21.83	21.68	21.67	21.42	21.96	0-2	2
	12	6	21.98	21.77	21.63	21.45	21.71		2
	12	13	21.76	21.74	21.82	21.55	21.92		2
25	0	21.91	21.52	21.57	21.61	21.92	2		

FCC ID: A3LSMG950N		<b>SAR EVALUATION REPORT</b>		<b>Approved by:</b> Quality Manager
<b>Document S/N:</b> 1M1703100103-01.A3L	<b>Test Dates:</b> 03/06/17 - 03/20/17	<b>DUT Type:</b> Portable Handset	Page 53 of 91	

## 9.4 WLAN Conducted Powers

**Table 9-57**  
2.4 GHz WLAN Maximum Average RF Power – Antenna 1



Freq [MHz]	Channel	2.4GHz Conducted Power [dBm]	
		IEEE Transmission Mode	
		802.11b	802.11g
2412	1	18.63	16.92
2437	6	19.21	17.14
2462	11	18.98	17.12

**Table 9-58**  
2.4 GHz WLAN Maximum Average RF Power – Antenna 2

Freq [MHz]	Channel	2.4GHz Conducted Power [dBm]	
		IEEE Transmission Mode	
		802.11b	802.11g
2412	1	18.82	16.93
2437	6	19.44	17.32
2462	11	19.27	17.17

**Table 9-59**  
5 GHz WLAN Maximum Average RF Power – Antenna 1

Freq [MHz]	Channel	5GHz (20MHz) Conducted Power [dBm]		
		IEEE Transmission Mode		
		802.11a	802.11n	802.11ac
5180	36	16.13	16.06	16.15
5200	40	16.22	16.00	16.23
5220	44	16.28	16.03	16.25
5240	48	16.30	16.03	16.24
5260	52	16.05	16.06	15.94
5280	56	16.04	15.98	16.00
5300	60	16.10	16.03	16.12
5320	64	16.00	16.02	16.03
5500	100	16.10	15.92	15.97
5600	120	16.20	16.01	16.13
5620	124	16.08	16.06	16.09
5720	144	16.13	16.11	16.15
5745	149	16.00	15.89	15.99
5785	157	15.96	15.93	15.99
5825	165	16.05	16.00	16.05



FCC ID: A3LSMG950N		SAR EVALUATION REPORT		Approved by: Quality Manager
Document S/N: 1M1703100103-01.A3L	Test Dates: 03/06/17 - 03/20/17	DUT Type: Portable Handset		Page 54 of 91

**Table 9-60**  
**5 GHz WLAN Maximum Average RF Power – Antenna 2**

Freq [MHz]	Channel	5GHz (20MHz) Conducted Power [dBm]		
		IEEE Transmission Mode		
		802.11a	802.11n	802.11ac
5180	36	15.51	15.87	15.77
5200	40	15.68	15.96	15.70
5220	44	15.82	16.12	15.94
5240	48	15.97	15.99	16.14
5260	52	15.88	16.27	15.75
5280	56	15.95	16.18	15.95
5300	60	15.88	16.03	16.09
5320	64	16.09	16.22	16.19
5500	100	15.96	15.84	15.97
5600	120	15.81	15.73	15.85
5620	124	15.71	15.75	15.74
5720	144	15.44	15.55	15.81
5745	149	15.82	15.96	15.78
5785	157	15.88	15.91	15.82
5825	165	15.63	15.82	15.92

**Table 9-61**  
**Maximum Output Powers During Operations**  
**with Simultaneous 2.4 GHz 802.11n and 5 GHz 802.11ac (80MHz) WLAN**

Freq [MHz]	Channel	2.4GHz Conducted Power [dBm]	
		ANT1	ANT2
2412	1	10.89	11.13
2437	6	11.48	10.44
2462	11	11.14	10.37
Freq [MHz]	Channel	5GHz (80MHz) Conducted Power [dBm]	
		ANT1	ANT2
5210	42	11.32	11.01
5290	58	11.31	11.02
5530	106	11.09	11.06
5610	122	11.18	11.05
5690	138	11.27	11.05
5775	155	11.15	11.29

FCC ID: A3LSMG950N		<b>SAR EVALUATION REPORT</b>		<b>Approved by:</b> Quality Manager
<b>Document S/N:</b> 1M1703100103-01.A3L	<b>Test Dates:</b> 03/06/17 - 03/20/17	<b>DUT Type:</b> Portable Handset	Page 55 of 91	

**Table 9-62**  
**2.4 GHz WLAN Reduced Average RF Power – Antenna 1**



Freq [MHz]	Channel	2.4GHz Conducted Power [dBm]	
		IEEE Transmission Mode	
		802.11b	802.11g
2412	1	16.02	15.95
2437	6	16.33	16.04
2462	11	16.49	16.11

**Table 9-63**  
**2.4 GHz WLAN Reduced Average RF Power – Antenna 2**

Freq [MHz]	Channel	2.4GHz Conducted Power [dBm]	
		IEEE Transmission Mode	
		802.11b	802.11g
2412	1	15.92	15.88
2437	6	16.11	16.14
2462	11	16.04	16.00

**Table 9-64**  
**5 GHz WLAN Reduced Average RF Power – Antenna 1**

5GHz (80MHz) Conducted Power [dBm]		
Freq [MHz]	Channel	IEEE Transmission Mode
		802.11ac
5210	42	14.27
5290	58	14.20
5530	106	14.13
5610	122	14.15
5690	138	14.20
5775	155	14.02



FCC ID: A3LSMG950N		<b>SAR EVALUATION REPORT</b>		<b>Approved by:</b> Quality Manager
<b>Document S/N:</b> 1M1703100103-01.A3L	<b>Test Dates:</b> 03/06/17 - 03/20/17	<b>DUT Type:</b> Portable Handset	Page 56 of 91	

**Table 9-65**  
**5 GHz WLAN Reduced Average RF Power – Antenna 2**

Justification for test configurations for WLAN per KDB Publication 248227 D01v02r02:

- Power measurements were performed for the transmission mode configuration with the highest maximum output power specified for production units.
- For transmission modes with the same maximum output power specification, powers were measured for the largest channel bandwidth, lowest order modulation and lowest data rate.
- For transmission modes with identical maximum specified output power, channel bandwidth, modulation and data rates, power measurements were required for all identical configurations.
- For each transmission mode configuration, powers were measured for the highest and lowest channels; and at the mid-band channel(s) when there were at least 3 channels supported. For configurations with multiple mid-band channels, due to an even number of channels, both channels were measured.
- The bolded data rate and channel above were tested for SAR.

**Figure 9-3**

FCC ID: A3LSMG950N		<b>SAR EVALUATION REPORT</b>		<b>Approved by:</b> Quality Manager
<b>Document S/N:</b> 1M1703100103-01.A3L	<b>Test Dates:</b> 03/06/17 - 03/20/17	<b>DUT Type:</b> Portable Handset	Page 57 of 91	

## 9.5 Bluetooth Conducted Powers

Table 9-66  
Bluetooth Average RF Power

Frequency [MHz]	Data Rate [Mbps]	Channel No.	Avg Conducted Power	
			[dBm]	[mW]
2402	1.0	0	15.19	33.045
2441	1.0	39	<b>16.09</b>	40.682
2480	1.0	78	14.89	30.853
2402	2.0	0	9.48	8.861
2441	2.0	39	<b>10.02</b>	10.037
2480	2.0	78	9.14	8.206
2402	3.0	0	9.72	9.379
2441	3.0	39	10.20	10.476
2480	3.0	78	8.76	7.515

Note: The bolded data rate and channel above were tested for SAR.





Figure 9-5  
Bluetooth Transmission Plot

FCC ID: A3LSMG950N		SAR EVALUATION REPORT		Approved by: Quality Manager
Document S/N: 1M1703100103-01.A3L	Test Dates: 03/06/17 - 03/20/17	DUT Type: Portable Handset		Page 58 of 91

**Equation 9-1**  
**Bluetooth Duty Cycle Calculation**

$$Duty\ Cycle = Pulse\ \frac{Width}{Period} * 100\% = \frac{2.880ms}{3.760ms} * 100\% = 76.6\%$$

**Figure 9-6**

FCC ID: A3LSMG950N	 <b>SAR EVALUATION REPORT</b> 		<b>Approved by:</b> Quality Manager
Document S/N: 1M1703100103-01.A3L	Test Dates: 03/06/17 - 03/20/17	DUT Type: Portable Handset	Page 59 of 91



# 10 SYSTEM VERIFICATION

## 10.1 Tissue Verification

**Table 10-1  
Measured Tissue Properties**

Calibrated for Tests Performed on:	Tissue Type	Tissue Temp During Calibration (°C)	Measured Frequency (MHz)	Measured Conductivity, $\sigma$ (S/m)	Measured Dielectric Constant, $\epsilon$	TARGET Conductivity, $\sigma$ (S/m)	TARGET Dielectric Constant, $\epsilon$	% dev $\sigma$	% dev $\epsilon$
3/16/2017	750H	21.3	700	0.849	41.108	0.889	42.201	-4.50%	-2.59%
			710	0.859	40.934	0.890	42.149	-3.48%	-2.88%
			740	0.890	40.520	0.893	41.994	-0.34%	-3.51%
			755	0.905	40.329	0.894	41.916	1.23%	-3.79%
			770	0.918	40.144	0.895	41.838	2.57%	-4.05%
			785	0.930	39.919	0.896	41.760	3.79%	-4.41%
3/8/2017	835H	21.2	820	0.885	41.877	0.899	41.578	-1.56%	0.72%
			835	0.901	41.700	0.900	41.500	0.11%	0.48%
			850	0.915	41.506	0.916	41.500	-0.11%	0.01%
3/13/2017	1750H	21.5	1710	1.341	39.176	1.348	40.142	-0.52%	-2.41%
			1750	1.381	39.006	1.371	40.079	0.73%	-2.68%
			1790	1.419	38.812	1.394	40.016	1.79%	-3.01%
3/13/2017	1900H	22.8	1850	1.389	40.155	1.400	40.000	-0.79%	0.39%
			1880	1.421	40.086	1.400	40.000	1.50%	0.21%
			1910	1.451	39.954	1.400	40.000	3.64%	-0.11%
3/6/2017	2450H	21.9	2400	1.795	38.923	1.756	39.289	2.22%	-0.93%
			2450	1.856	38.730	1.800	39.200	3.11%	-1.20%
			2500	1.910	38.538	1.855	39.136	2.96%	-1.53%
			2550	1.965	38.340	1.909	39.073	2.93%	-1.88%
			2600	2.022	38.139	1.964	39.009	2.95%	-2.23%
			2650	2.082	37.968	2.018	38.945	3.17%	-2.51%
			2700	2.136	37.768	2.073	38.882	3.04%	-2.87%
3/9/2017	2450H	23.2	2400	1.818	37.901	1.756	39.289	3.53%	-3.53%
			2450	1.871	37.716	1.800	39.200	3.94%	-3.79%
			2500	1.929	37.527	1.855	39.136	3.99%	-4.11%
			5240	4.776	35.747	4.696	35.940	1.70%	-0.54%
03/13/2017	5200H-5800H	21.5	5260	4.776	35.722	4.717	35.917	1.25%	-0.54%
			5280	4.795	35.783	4.737	35.894	1.22%	-0.31%
			5300	4.816	35.706	4.758	35.871	1.22%	-0.46%
			5600	5.144	35.182	5.065	35.529	1.56%	-0.98%
			5620	5.181	35.187	5.086	35.506	1.87%	-0.90%
			5680	5.227	35.049	5.147	35.437	1.55%	-1.09%
			5700	5.241	35.065	5.168	35.414	1.41%	-0.99%
			5745	5.275	35.041	5.214	35.363	1.17%	-0.91%
			5765	5.327	34.910	5.234	35.340	1.78%	-1.22%
			5785	5.335	34.956	5.255	35.317	1.52%	-1.02%
			700	0.913	57.053	0.959	55.726	-4.80%	2.38%
3/7/2017	750B	21.3	710	0.922	56.967	0.960	55.687	-3.96%	2.30%
			740	0.948	56.862	0.963	55.570	-1.56%	1.97%
			755	0.959	56.500	0.964	55.512	-0.52%	1.78%
			770	0.973	56.339	0.965	55.453	0.83%	1.60%
			785	0.989	56.202	0.966	55.395	2.38%	1.46%
			820	0.971	53.682	0.969	55.258	0.21%	-2.85%
3/8/2017	835B	24.1	835	0.986	53.550	0.970	55.200	1.65%	-2.99%
			850	1.000	53.400	0.988	55.154	1.21%	-3.18%
			1710	1.409	51.321	1.463	53.537	-3.69%	-4.14%
3/6/2017	1750B	20.7	1750	1.467	51.204	1.488	53.432	-1.41%	-4.17%
			1790	1.507	51.080	1.514	53.326	-0.46%	-4.21%
			1850	1.480	52.341	1.520	53.300	-2.63%	-1.80%
3/7/2017	1900B	22.4	1880	1.516	52.299	1.520	53.300	-0.26%	-1.88%
			1910	1.555	52.215	1.520	53.300	2.30%	-2.04%
			2400	1.966	53.059	1.902	52.767	3.36%	0.55%
3/9/2017	2450B	22.1	2450	2.033	52.897	1.950	52.700	4.26%	0.37%
			2500	2.105	52.657	2.021	52.636	4.16%	0.04%
			2550	2.177	52.494	2.092	52.573	4.06%	-0.15%
			2600	2.247	52.247	2.163	52.509	3.88%	-0.50%
			2650	2.324	52.070	2.234	52.445	4.03%	-0.72%
			2700	2.392	51.848	2.305	52.382	3.77%	-1.02%
			5240	5.520	47.071	5.346	48.960	3.25%	-3.86%
03/20/2017	5200B-5800B	20.8	5260	5.528	47.004	5.369	48.933	2.96%	-3.94%
			5300	5.596	46.959	5.416	48.879	3.32%	-3.93%
			5320	5.632	46.957	5.439	48.851	3.55%	-3.88%
			5500	5.844	46.679	5.650	48.607	3.43%	-3.97%
			5600	6.009	46.520	5.766	48.471	4.21%	-4.03%
			5745	6.198	46.289	5.936	48.275	4.41%	-4.11%
			5765	6.219	46.283	5.959	48.248	4.36%	-4.07%
			5785	6.232	46.219	5.982	48.220	4.18%	-4.15%
			5825	6.308	46.089	6.029	48.166	4.63%	-4.31%

The above measured tissue parameters were used in the DASY software. The DASY software was used to perform interpolation to determine the dielectric parameters at the SAR test device frequencies (per KDB Publication 865664 D01v01r04 and IEEE 1528-2013 6.6.1.2). The tissue parameters listed in the SAR test plots may slightly differ from the table above due to significant digit rounding in the software.

FCC ID: A3LSMG950N		<b>SAR EVALUATION REPORT</b>		<b>Approved by:</b> Quality Manager
<b>Document S/N:</b> 1M1703100103-01.A3L	<b>Test Dates:</b> 03/06/17 - 03/20/17	<b>DUT Type:</b> Portable Handset		Page 60 of 91

## 10.2 Test System Verification

Prior to SAR assessment, the system is verified to  $\pm 10\%$  of the SAR measurement on the reference dipole at the time of calibration by the calibration facility. Full system validation status and result summary can be found in Appendix E.

**Table 10-2  
System Verification Results**

System Verification TARGET & MEASURED												
SAR System #	Tissue Frequency (MHz)	Tissue Type	Date:	Amb. Temp (°C)	Liquid Temp (°C)	Input Power (W)	Dipole SN	Probe SN	Measured SAR <sub>1g</sub> (W/kg)	1 W Target SAR <sub>1g</sub> (W/kg)	1 W Normalized SAR <sub>1g</sub> (W/kg)	Deviation <sub>1g</sub> (%)
G	750	HEAD	03/16/2017	21.1	21.3	0.200	1161	3287	1.580	8.170	7.900	-3.30%
K	835	HEAD	03/08/2017	23.5	21.2	0.200	4d047	7409	1.790	9.130	8.950	-1.97%
I	1750	HEAD	03/13/2017	22.5	21.5	0.100	1008	3213	3.630	36.700	36.300	-1.09%
H	1900	HEAD	03/13/2017	21.8	22.3	0.100	5d149	3318	3.960	40.100	39.600	-1.25%
G	2450	HEAD	03/06/2017	23.6	20.8	0.100	797	3287	5.320	52.100	53.200	2.11%
G	2450	HEAD	03/09/2017	20.9	22.1	0.100	797	3287	5.480	52.100	54.800	5.18%
G	2600	HEAD	03/06/2017	23.6	20.8	0.100	1126	3287	5.910	56.300	59.100	4.97%
J	5250	HEAD	03/13/2017	20.2	19.9	0.050	1120	3914	3.930	83.200	78.600	-5.53%
J	5600	HEAD	03/13/2017	20.2	19.9	0.050	1120	3914	3.970	85.800	79.400	-7.46%
J	5750	HEAD	03/13/2017	20.2	19.9	0.050	1120	3914	4.050	81.800	81.000	-0.98%
I	750	BODY	03/07/2017	24.5	23.0	0.200	1003	3213	1.740	8.790	8.700	-1.02%
H	835	BODY	03/08/2017	24.5	24.1	0.200	4d047	3318	1.960	9.570	9.800	2.40%
I	1750	BODY	03/06/2017	21.5	20.7	0.100	1008	3213	3.660	37.300	36.600	-1.88%
J	1900	BODY	03/07/2017	23.2	21.9	0.100	5d149	3334	4.060	39.900	40.600	1.75%
E	2450	BODY	03/09/2017	24.0	22.1	0.100	981	7406	4.960	50.800	49.600	-2.36%
E	2600	BODY	03/09/2017	24.0	22.1	0.100	1071	7406	5.700	54.200	57.000	5.17%
K	5250	BODY	03/20/2017	23.1	21.0	0.050	1237	7308	3.680	74.800	73.600	-1.60%
K	5600	BODY	03/20/2017	23.1	21.0	0.050	1237	7308	4.060	77.000	81.200	5.45%
K	5750	BODY	03/20/2017	23.1	21.0	0.050	1237	7308	3.530	75.400	70.600	-6.37%

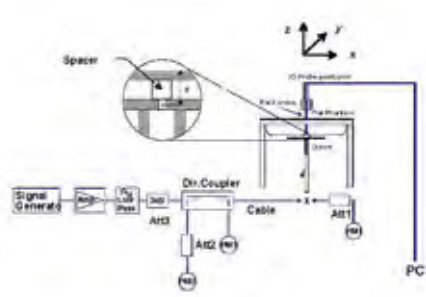

**Figure 10-1  
System Verification Setup Diagram**



**Figure 10-2  
System Verification Setup Photo**

FCC ID: A3LSMG950N		SAR EVALUATION REPORT		Approved by: Quality Manager
Document S/N: 1M1703100103-01.A3L	Test Dates: 03/06/17 - 03/20/17	DUT Type: Portable Handset		Page 61 of 91

# 11 SAR DATA SUMMARY

## 11.1 Standalone Head SAR Data

**Table 11-1  
GSM 1900 Head SAR**



MEASUREMENT RESULTS														
FREQUENCY		Mode/Band	Service	Maximum Allowed Power [dBm]	Conducted Power [dBm]	Power Drift [dB]	Side	Test Position	Device Serial Number	Duty Cycle	SAR (1g)	Scaling Factor	Reported SAR (1g)	Plot #
MHz	Ch.										(W/kg)		(W/kg)	
1880.00	661	GSM 1900	GSM	30.5	29.75	0.10	Right	Cheek	E3D05	1:8.3	0.067	1.189	0.080	
1880.00	661	GSM 1900	GSM	30.5	29.75	0.18	Right	Tilt	E3D05	1:8.3	0.025	1.189	0.030	
1880.00	661	GSM 1900	GSM	30.5	29.75	0.09	Left	Cheek	E3D05	1:8.3	0.086	1.189	0.102	A1
1880.00	661	GSM 1900	GSM	30.5	29.75	0.21	Left	Tilt	E3D05	1:8.3	0.016	1.189	0.019	
ANSI / IEEE C95.1 1992 - SAFETY LIMIT Spatial Peak Uncontrolled Exposure/General Population							Head 1.6 W/kg (mW/g) averaged over 1 gram							

**Table 11-2  
UMTS 850 Head SAR**

MEASUREMENT RESULTS															
FREQUENCY		Mode/Band	Service	Maximum Allowed Power [dBm]	Conducted Power [dBm]	Power Drift [dB]	Side	Test Position	Device Serial Number	Antenna State	Duty Cycle	SAR (1g)	Scaling Factor	Reported SAR (1g)	Plot #
MHz	Ch.											(W/kg)		(W/kg)	
836.60	4183	UMTS 850	RMC	23.5	23.06	-0.13	Right	Cheek	E3D05	7	1:1	0.203	1.107	0.225	A2
836.60	4183	UMTS 850	RMC	23.5	23.06	0.07	Right	Tilt	E3D05	7	1:1	0.071	1.107	0.079	
836.60	4183	UMTS 850	RMC	23.5	23.06	0.11	Left	Cheek	E3D05	7	1:1	0.143	1.107	0.158	
836.60	4183	UMTS 850	RMC	23.5	23.06	0.17	Left	Tilt	E3D05	7	1:1	0.069	1.107	0.076	
ANSI / IEEE C95.1 1992 - SAFETY LIMIT Spatial Peak Uncontrolled Exposure/General Population							Head 1.6 W/kg (mW/g) averaged over 1 gram								

**Table 11-3  
UMTS 1900 Head SAR**

MEASUREMENT RESULTS														
FREQUENCY		Mode/Band	Service	Maximum Allowed Power [dBm]	Conducted Power [dBm]	Power Drift [dB]	Side	Test Position	Device Serial Number	Duty Cycle	SAR (1g)	Scaling Factor	Reported SAR (1g)	Plot #
MHz	Ch.										(W/kg)		(W/kg)	
1880.00	9400	UMTS 1900	RMC	23.5	22.35	0.03	Right	Cheek	E3D05	1:1	0.084	1.303	0.109	
1880.00	9400	UMTS 1900	RMC	23.5	22.35	0.15	Right	Tilt	E3D05	1:1	0.036	1.303	0.047	
1880.00	9400	UMTS 1900	RMC	23.5	22.35	0.02	Left	Cheek	E3D05	1:1	0.107	1.303	0.139	A3
1880.00	9400	UMTS 1900	RMC	23.5	22.35	0.17	Left	Tilt	E3D05	1:1	0.024	1.303	0.031	
ANSI / IEEE C95.1 1992 - SAFETY LIMIT Spatial Peak Uncontrolled Exposure/General Population							Head 1.6 W/kg (mW/g) averaged over 1 gram							

FCC ID: A3LSMG950N		<b>SAR EVALUATION REPORT</b>		<b>Approved by:</b> Quality Manager
<b>Document S/N:</b> 1M1703100103-01.A3L	<b>Test Dates:</b> 03/06/17 - 03/20/17	<b>DUT Type:</b> Portable Handset	Page 62 of 91	

**Table 11-4  
LTE Band 12 Head SAR**



MEASUREMENT RESULTS																			
FREQUENCY		Mode	Bandwidth [MHz]	Maximum Allowed Power [dBm]	Conducted Power [dBm]	Power Drift [dB]	MPR [dB]	Side	Test Position	Modulation	RB Size	RB Offset	Device Serial Number	Duty Cycle	SAR (1g)	Scaling Factor	Reported SAR (1g)	Plot #	
MHz	Ch.														(W/kg)		(W/kg)		
707.50	23095	Mid	LTE Band 12	10	23.5	22.86	-0.06	0	Right	Cheek	QPSK	1	0	E3D02	1:1	0.048	1.159	0.056	A4
707.50	23095	Mid	LTE Band 12	10	22.5	21.90	0.01	1	Right	Cheek	QPSK	25	25	E3D02	1:1	0.037	1.148	0.042	
707.50	23095	Mid	LTE Band 12	10	23.5	22.86	0.06	0	Right	Tilt	QPSK	1	0	E3D02	1:1	0.032	1.159	0.037	
707.50	23095	Mid	LTE Band 12	10	22.5	21.90	0.12	1	Right	Tilt	QPSK	25	25	E3D02	1:1	0.024	1.148	0.028	
707.50	23095	Mid	LTE Band 12	10	23.5	22.86	0.13	0	Left	Cheek	QPSK	1	0	E3D02	1:1	0.037	1.159	0.043	
707.50	23095	Mid	LTE Band 12	10	22.5	21.90	0.12	1	Left	Cheek	QPSK	25	25	E3D02	1:1	0.026	1.148	0.030	
707.50	23095	Mid	LTE Band 12	10	23.5	22.86	0.10	0	Left	Tilt	QPSK	1	0	E3D02	1:1	0.035	1.159	0.041	
707.50	23095	Mid	LTE Band 12	10	22.5	21.90	0.00	1	Left	Tilt	QPSK	25	25	E3D02	1:1	0.027	1.148	0.031	
ANSI / IEEE C95.1 1992 - SAFETY LIMIT Spatial Peak Uncontrolled Exposure/General Population										Head 1.6 W/kg (mW/g) averaged over 1 gram									

**Table 11-5  
LTE Band 13 Head SAR**

MEASUREMENT RESULTS																			
FREQUENCY		Mode	Bandwidth [MHz]	Maximum Allowed Power [dBm]	Conducted Power [dBm]	Power Drift [dB]	MPR [dB]	Side	Test Position	Modulation	RB Size	RB Offset	Device Serial Number	Duty Cycle	SAR (1g)	Scaling Factor	Reported SAR (1g)	Plot #	
MHz	Ch.														(W/kg)		(W/kg)		
782.00	23230	Mid	LTE Band 13	10	23.5	23.30	0.17	0	Right	Cheek	QPSK	1	0	E3D02	1:1	0.122	1.047	0.128	A5
782.00	23230	Mid	LTE Band 13	10	22.5	22.32	0.03	1	Right	Cheek	QPSK	25	0	E3D02	1:1	0.089	1.042	0.093	
782.00	23230	Mid	LTE Band 13	10	23.5	23.30	0.13	0	Right	Tilt	QPSK	1	0	E3D02	1:1	0.075	1.047	0.079	
782.00	23230	Mid	LTE Band 13	10	22.5	22.32	0.07	1	Right	Tilt	QPSK	25	0	E3D02	1:1	0.052	1.042	0.054	
782.00	23230	Mid	LTE Band 13	10	23.5	23.30	0.07	0	Left	Cheek	QPSK	1	0	E3D02	1:1	0.109	1.047	0.114	
782.00	23230	Mid	LTE Band 13	10	22.5	22.32	0.20	1	Left	Cheek	QPSK	25	0	E3D02	1:1	0.072	1.042	0.075	
782.00	23230	Mid	LTE Band 13	10	23.5	23.30	0.20	0	Left	Tilt	QPSK	1	0	E3D02	1:1	0.094	1.047	0.098	
782.00	23230	Mid	LTE Band 13	10	22.5	22.32	0.07	1	Left	Tilt	QPSK	25	0	E3D02	1:1	0.069	1.042	0.072	
ANSI / IEEE C95.1 1992 - SAFETY LIMIT Spatial Peak Uncontrolled Exposure/General Population										Head 1.6 W/kg (mW/g) averaged over 1 gram									

**Table 11-6  
LTE Band 26 (Cell) Head SAR**

MEASUREMENT RESULTS																			
FREQUENCY		Mode	Bandwidth [MHz]	Maximum Allowed Power [dBm]	Conducted Power [dBm]	Power Drift [dB]	MPR [dB]	Side	Test Position	Modulation	RB Size	RB Offset	Device Serial Number	Duty Cycle	SAR (1g)	Scaling Factor	Reported SAR (1g)	Plot #	
MHz	Ch.														(W/kg)		(W/kg)		
831.50	26865	Mid	LTE Band 26 (Cell)	15	23.5	23.47	-0.09	0	Right	Cheek	QPSK	1	36	E3D05	1:1	0.169	1.007	0.170	A6
831.50	26865	Mid	LTE Band 26 (Cell)	15	22.5	22.48	0.06	1	Right	Cheek	QPSK	36	0	E3D05	1:1	0.124	1.005	0.125	
831.50	26865	Mid	LTE Band 26 (Cell)	15	23.5	23.47	0.07	0	Right	Tilt	QPSK	1	36	E3D05	1:1	0.053	1.007	0.053	
831.50	26865	Mid	LTE Band 26 (Cell)	15	22.5	22.48	0.10	1	Right	Tilt	QPSK	36	0	E3D05	1:1	0.046	1.005	0.046	
831.50	26865	Mid	LTE Band 26 (Cell)	15	23.5	23.47	-0.06	0	Left	Cheek	QPSK	1	36	E3D05	1:1	0.110	1.007	0.111	
831.50	26865	Mid	LTE Band 26 (Cell)	15	22.5	22.48	0.10	1	Left	Cheek	QPSK	36	0	E3D05	1:1	0.087	1.005	0.087	
831.50	26865	Mid	LTE Band 26 (Cell)	15	23.5	23.47	0.15	0	Left	Tilt	QPSK	1	36	E3D05	1:1	0.063	1.007	0.063	
831.50	26865	Mid	LTE Band 26 (Cell)	15	22.5	22.48	0.11	1	Left	Tilt	QPSK	36	0	E3D05	1:1	0.056	1.005	0.056	
ANSI / IEEE C95.1 1992 - SAFETY LIMIT Spatial Peak Uncontrolled Exposure/General Population										Head 1.6 W/kg (mW/g) averaged over 1 gram									

FCC ID: A3LSMG950N		<b>SAR EVALUATION REPORT</b>		<b>Approved by:</b> Quality Manager
Document S/N: 1M1703100103-01.A3L	Test Dates: 03/06/17 - 03/20/17	DUT Type: Portable Handset	Page 63 of 91	

**Table 11-7  
LTE Band 5 (Cell) Head SAR**



MEASUREMENT RESULTS																					
FREQUENCY		Mode	Bandwidth [MHz]	Maximum Allowed Power [dBm]	Conducted Power [dBm]	Power Drift [dB]	MPR [dB]	Side	Test Position	Antenna Config.	Antenna State	Modulation	RB Size	RB Offset	Device Serial Number	Duty Cycle	SAR (1g)	Scaling Factor	Reported SAR (1g)	Plot #	
MHz	Ch.																(W/kg)		(W/kg)		
836.50	20525	Mid	LTE Band 5 (Cell)	10	24.5	24.40	-0.07	0	Right	Cheek	Ant A	7	QPSK	1	0	E3D05	1:1	0.193	1.023	0.197	A7
836.50	20525	Mid	LTE Band 5 (Cell)	10	23.5	23.33	-0.12	1	Right	Cheek	Ant A	7	QPSK	25	12	E3D05	1:1	0.170	1.040	0.177	
836.50	20525	Mid	LTE Band 5 (Cell)	10	24.5	24.40	-0.05	0	Right	Tilt	Ant A	7	QPSK	1	0	E3D05	1:1	0.058	1.023	0.059	
836.50	20525	Mid	LTE Band 5 (Cell)	10	23.5	23.33	-0.07	1	Right	Tilt	Ant A	7	QPSK	25	12	E3D05	1:1	0.045	1.040	0.047	
836.50	20525	Mid	LTE Band 5 (Cell)	10	24.5	24.40	-0.17	0	Left	Cheek	Ant A	7	QPSK	1	0	E3D05	1:1	0.141	1.023	0.144	
836.50	20525	Mid	LTE Band 5 (Cell)	10	23.5	23.33	-0.01	1	Left	Cheek	Ant A	7	QPSK	25	12	E3D05	1:1	0.124	1.040	0.129	
836.50	20525	Mid	LTE Band 5 (Cell)	10	24.5	24.40	-0.06	0	Left	Tilt	Ant A	7	QPSK	1	0	E3D05	1:1	0.074	1.023	0.076	
836.50	20525	Mid	LTE Band 5 (Cell)	10	23.5	23.33	-0.00	1	Left	Tilt	Ant A	7	QPSK	25	12	E3D05	1:1	0.055	1.040	0.057	
ANSI / IEEE C95.1 1992 - SAFETY LIMIT Spatial Peak Uncontrolled Exposure/General Population												Head 1.6 W/kg (mW/g) averaged over 1 gram									

**Table 11-8  
LTE Band 4 (AWS) Head SAR**

MEASUREMENT RESULTS																			
FREQUENCY		Mode	Bandwidth [MHz]	Maximum Allowed Power [dBm]	Conducted Power [dBm]	Power Drift [dB]	MPR [dB]	Side	Test Position	Modulation	RB Size	RB Offset	Device Serial Number	Duty Cycle	SAR (1g)	Scaling Factor	Reported SAR (1g)	Plot #	
MHz	Ch.														(W/kg)		(W/kg)		
1732.50	20175	Mid	LTE Band 4 (AWS)	20	23.5	22.95	0.02	0	Right	Cheek	QPSK	1	0	E3D11	1:1	0.132	1.135	0.150	
1732.50	20175	Mid	LTE Band 4 (AWS)	20	22.5	22.06	0.09	1	Right	Cheek	QPSK	50	25	E3D11	1:1	0.113	1.107	0.125	
1732.50	20175	Mid	LTE Band 4 (AWS)	20	23.5	22.95	0.09	0	Right	Tilt	QPSK	1	0	E3D11	1:1	0.074	1.135	0.084	
1732.50	20175	Mid	LTE Band 4 (AWS)	20	22.5	22.06	0.03	1	Right	Tilt	QPSK	50	25	E3D11	1:1	0.059	1.107	0.065	
1732.50	20175	Mid	LTE Band 4 (AWS)	20	23.5	22.95	0.03	0	Left	Cheek	QPSK	1	0	E3D11	1:1	0.182	1.135	0.207	A8
1732.50	20175	Mid	LTE Band 4 (AWS)	20	22.5	22.06	-0.01	1	Left	Cheek	QPSK	50	25	E3D11	1:1	0.158	1.107	0.175	
1732.50	20175	Mid	LTE Band 4 (AWS)	20	23.5	22.95	0.16	0	Left	Tilt	QPSK	1	0	E3D11	1:1	0.088	1.135	0.100	
1732.50	20175	Mid	LTE Band 4 (AWS)	20	22.5	22.06	-0.09	1	Left	Tilt	QPSK	50	25	E3D11	1:1	0.067	1.107	0.074	
ANSI / IEEE C95.1 1992 - SAFETY LIMIT Spatial Peak Uncontrolled Exposure/General Population												Head 1.6 W/kg (mW/g) averaged over 1 gram							

**Table 11-9  
LTE Band 25 (PCS) Head SAR**

MEASUREMENT RESULTS																			
FREQUENCY		Mode	Bandwidth [MHz]	Maximum Allowed Power [dBm]	Conducted Power [dBm]	Power Drift [dB]	MPR [dB]	Side	Test Position	Modulation	RB Size	RB Offset	Device Serial Number	Duty Cycle	SAR (1g)	Scaling Factor	Reported SAR (1g)	Plot #	
MHz	Ch.														(W/kg)		(W/kg)		
1905.00	26590	High	LTE Band 25 (PCS)	20	23.5	22.77	0.02	0	Right	Cheek	QPSK	1	99	E3D05	1:1	0.111	1.183	0.131	
1905.00	26590	High	LTE Band 25 (PCS)	20	22.5	21.95	0.03	1	Right	Cheek	QPSK	50	0	E3D05	1:1	0.092	1.135	0.104	
1905.00	26590	High	LTE Band 25 (PCS)	20	23.5	22.77	0.07	0	Right	Tilt	QPSK	1	99	E3D05	1:1	0.069	1.183	0.082	
1905.00	26590	High	LTE Band 25 (PCS)	20	22.5	21.95	0.04	1	Right	Tilt	QPSK	50	0	E3D05	1:1	0.049	1.135	0.056	
1905.00	26590	High	LTE Band 25 (PCS)	20	23.5	22.77	0.03	0	Left	Cheek	QPSK	1	99	E3D05	1:1	0.171	1.183	0.202	A9
1905.00	26590	High	LTE Band 25 (PCS)	20	22.5	21.95	-0.03	1	Left	Cheek	QPSK	50	0	E3D05	1:1	0.129	1.135	0.146	
1905.00	26590	High	LTE Band 25 (PCS)	20	23.5	22.77	-0.04	0	Left	Tilt	QPSK	1	99	E3D05	1:1	0.056	1.183	0.066	
1905.00	26590	High	LTE Band 25 (PCS)	20	22.5	21.95	0.18	1	Left	Tilt	QPSK	50	0	E3D05	1:1	0.037	1.135	0.042	
ANSI / IEEE C95.1 1992 - SAFETY LIMIT Spatial Peak Uncontrolled Exposure/General Population												Head 1.6 W/kg (mW/g) averaged over 1 gram							

FCC ID: A3LSMG950N		<b>SAR EVALUATION REPORT</b>		<b>Approved by:</b> Quality Manager
Document S/N: 1M1703100103-01.A3L	Test Dates: 03/06/17 - 03/20/17	DUT Type: Portable Handset	Page 64 of 91	

**Table 11-10  
LTE Band 41 Head SAR**

MEASUREMENT RESULTS																		
FREQUENCY		Mode	Bandwidth [MHz]	Maximum Allowed Power [dBm]	Conducted Power [dBm]	Power Drift [dB]	MPR [dB]	Side	Test Position	Modulation	RB Size	RB Offset	Device Serial Number	Duty Cycle	SAR (1g)	Scaling Factor	Reported SAR (1g)	Plot #
MHz	Ch.														(W/kg)		(W/kg)	
2680.00	41490	High	LTE Band 41	20	24.0	24.00	0.19	0	Right	Cheek	QPSK	1	50	E3D11	1:1.58	1.000	0.009	
2506.00	39750	Low	LTE Band 41	20	23.0	23.00	0.13	1	Right	Cheek	QPSK	50	50	E3D11	1:1.58	1.000	0.015	
2680.00	41490	High	LTE Band 41	20	24.0	24.00	0.20	0	Right	Tilt	QPSK	1	50	E3D11	1:1.58	1.000	0.011	
2506.00	39750	Low	LTE Band 41	20	23.0	23.00	0.18	1	Right	Tilt	QPSK	50	50	E3D11	1:1.58	1.000	0.016	
2680.00	41490	High	LTE Band 41	20	24.0	24.00	0.11	0	Left	Cheek	QPSK	1	50	E3D11	1:1.58	1.000	0.022	
2506.00	39750	Low	LTE Band 41	20	23.0	23.00	0.15	1	Left	Cheek	QPSK	50	50	E3D11	1:1.58	1.000	0.028	A10
2680.00	41490	High	LTE Band 41	20	24.0	24.00	0.17	0	Left	Tilt	QPSK	1	50	E3D11	1:1.58	1.000	0.005	
2506.00	39750	Low	LTE Band 41	20	23.0	23.00	0.17	1	Left	Tilt	QPSK	50	50	E3D11	1:1.58	1.000	0.009	
ANSI / IEEE C95.1 1992 - SAFETY LIMIT Spatial Peak Uncontrolled Exposure/General Population										Head 1.6 W/kg (mW/g) averaged over 1 gram								



**Table 11-11  
DTS Head SAR**

MEASUREMENT RESULTS																			
FREQUENCY		Mode	Service	Bandwidth [MHz]	Maximum Allowed Power [dBm]	Conducted Power [dBm]	Power Drift [dB]	Side	Test Position	Antenna Config.	Device Serial Number	Data Rate (Mbps)	Duty Cycle (%)	Peak SAR of Area Scan	SAR (1g)	Scaling Factor (Power)	Scaling Factor (Duty Cycle)	Reported SAR (1g)	Plot #
MHz	Ch.													(W/kg)	(W/kg)			(W/kg)	
2462	11	802.11b	DSSS	22	16.5	16.49	0.03	Right	Cheek	1	E3D11	1	99.0	0.556	0.416	1.002	1.010	0.421	
2462	11	802.11b	DSSS	22	16.5	16.49	0.01	Right	Tilt	1	E3D11	1	99.0	0.512	0.327	1.002	1.010	0.331	
2462	11	802.11b	DSSS	22	16.5	16.49	-0.07	Left	Cheek	1	E3D11	1	99.0	0.169	-	1.002	1.010	-	
2462	11	802.11b	DSSS	22	16.5	16.49	0.13	Left	Tilt	1	E3D11	1	99.0	0.202	-	1.002	1.010	-	
2437	6	802.11b	DSSS	22	16.5	16.11	0.21	Right	Cheek	2	E3D11	1	99.3	0.524	0.547	1.094	1.007	0.603	A11
2437	6	802.11b	DSSS	22	16.5	16.11	0.21	Right	Tilt	2	E3D11	1	99.3	0.412	0.322	1.094	1.007	0.355	
2437	6	802.11b	DSSS	22	16.5	16.11	0.20	Left	Cheek	2	E3D11	1	99.3	0.326	-	1.094	1.007	-	
2437	6	802.11b	DSSS	22	16.5	16.11	-0.01	Left	Tilt	2	E3D11	1	99.3	0.172	-	1.094	1.007	-	
ANSI / IEEE C95.1 1992 - SAFETY LIMIT Spatial Peak Uncontrolled Exposure/General Population										Head 1.6 W/kg (mW/g) averaged over 1 gram									

**Table 11-12  
DTS Head SAR for Conditions with Simultaneous 2.4 GHz and 5 GHz WLAN**



MEASUREMENT RESULTS																				
FREQUENCY		Mode	Service	Bandwidth [MHz]	Maximum Allowed Power Per Antenna [dBm]	Ant 1 Conducted Power [dBm]	Ant 2 Conducted Power [dBm]	Power Drift [dB]	Side	Test Position	Antenna Config.	Device Serial Number	Data Rate (Mbps)	Duty Cycle (%)	Peak SAR of Area Scan	SAR (1g)	Scaling Factor (Power)	Scaling Factor (Duty Cycle)	Reported SAR (1g)	Plot #
MHz	Ch.														(W/kg)	(W/kg)			(W/kg)	
2412	1	802.11n	OFDM	20	11.5	10.89	11.13	-0.12	Right	Cheek	MIMO	E3D11	13	98.2	0.334	0.281	1.151	1.018	0.329	
2412	1	802.11n	OFDM	20	11.5	10.89	11.13	0.16	Right	Tilt	MIMO	E3D11	13	98.2	0.247	-	1.151	1.018	-	
2412	1	802.11n	OFDM	20	11.5	10.89	11.13	-0.17	Left	Cheek	MIMO	E3D11	13	98.2	0.115	-	1.151	1.018	-	
2412	1	802.11n	OFDM	20	11.5	10.89	11.13	-0.20	Left	Tilt	MIMO	E3D11	13	98.2	0.100	-	1.151	1.018	-	
ANSI / IEEE C95.1 1992 - SAFETY LIMIT Spatial Peak Uncontrolled Exposure/General Population										Head 1.6 W/kg (mW/g) averaged over 1 gram										

Note: DTS MIMO was additionally evaluated at the maximum allowed output power during operations with Simultaneous 2.4 GHz and 5 GHz WLAN. 5 GHz WLAN was not transmitting during the above evaluations.

FCC ID: A3LSMG950N		<b>SAR EVALUATION REPORT</b>		<b>Approved by:</b> Quality Manager
Document S/N: 1M1703100103-01.A3L	Test Dates: 03/06/17 - 03/20/17	DUT Type: Portable Handset	Page 65 of 91	

**Table 11-13  
NII Head SAR**

**Table 11-14**

FCC ID: A3LSMG950N		SAR EVALUATION REPORT		<b>Approved by:</b> Quality Manager
<b>Document S/N:</b> 1M1703100103-01.A3L	<b>Test Dates:</b> 03/06/17 - 03/20/17	<b>DUT Type:</b> Portable Handset	Page 66 of 91	

**Table 11-15  
DSS Head SAR**

MEASUREMENT RESULTS																
FREQUENCY		Mode	Service	Maximum Allowed Power [dBm]	Conducted Power [dBm]	Power Drift [dB]	Side	Test Position	Device Serial Number	Data Rate (Mbps)	Duty Cycle (%)	SAR (1g)	Scaling Factor (Power)	Scaling Factor (Duty Cycle)	Reported SAR (1g)	Plot #
MHz	Ch.											(W/kg)			(W/kg)	
2441	39	Bluetooth	FHSS	10.5	10.02	-0.15	Right	Cheek	E3D02	2	76.6	0.033	1.117	1.306	0.048	A13
2441	39	Bluetooth	FHSS	10.5	10.02	0.05	Right	Tilt	E3D02	2	76.6	0.022	1.117	1.306	0.032	
2441	39	Bluetooth	FHSS	10.5	10.02	0.15	Left	Cheek	E3D02	2	76.6	0.015	1.117	1.306	0.022	
2441	39	Bluetooth	FHSS	10.5	10.02	0.17	Left	Tilt	E3D02	2	76.6	0.011	1.117	1.306	0.016	
ANSI / IEEE C95.1 1992 - SAFETY LIMIT Spatial Peak Uncontrolled Exposure/General Population								Body 1.6 W/kg (mW/g) averaged over 1 gram								



**11.2 Standalone Body-Worn SAR Data**

**Table 11-16  
GSM/UMTS Body-Worn SAR Data**

MEASUREMENT RESULTS																
FREQUENCY		Mode	Service	Maximum Allowed Power [dBm]	Conducted Power [dBm]	Power Drift [dB]	Spacing	Antenna State	Device Serial Number	# of Time Slots	Duty Cycle	Side	SAR (1g)	Scaling Factor	Reported SAR (1g)	Plot #
MHz	Ch.												(W/kg)		(W/kg)	
1880.00	661	GSM 1900	GSM	30.5	29.75	-0.05	15 mm	N/A	E3D11	1	1:8.3	back	0.365	1.189	0.434	A14
836.60	4183	UMTS 850	RMC	23.5	23.06	0.00	15 mm	7	E3D12	N/A	1:1	back	0.269	1.107	0.298	A16
1880.00	9400	UMTS 1900	RMC	23.5	22.35	-0.06	15 mm	N/A	E3D11	N/A	1:1	back	0.350	1.303	0.456	A18
ANSI / IEEE C95.1 1992 - SAFETY LIMIT Spatial Peak Uncontrolled Exposure/General Population								Body 1.6 W/kg (mW/g) averaged over 1 gram								

**Table 11-17  
LTE Body-Worn SAR**

MEASUREMENT RESULTS																					
FREQUENCY		Mode	Bandwidth [MHz]	Maximum Allowed Power [dBm]	Conducted Power [dBm]	Power Drift [dB]	MPR [dB]	Antenna Config.	Antenna State	Device Serial Number	Modulation	RB Size	RB Offset	Spacing	Side	Duty Cycle	SAR (1g)	Scaling Factor	Reported SAR (1g)	Plot #	
MHz	Ch.																(W/kg)		(W/kg)		
707.50	23095	Mid	LTE Band 12	10	23.5	22.86	0.01	0	N/A	N/A	E3D11	QPSK	1	0	15 mm	back	1:1	0.102	1.159	0.118	A20
707.50	23095	Mid	LTE Band 12	10	22.5	21.90	-0.03	1	N/A	N/A	E3D11	QPSK	25	25	15 mm	back	1:1	0.079	1.148	0.091	
782.00	23230	Mid	LTE Band 13	10	23.5	23.30	-0.13	0	N/A	N/A	E3D11	QPSK	1	0	15 mm	back	1:1	0.244	1.047	0.255	A22
782.00	23230	Mid	LTE Band 13	10	22.5	22.32	0.08	1	N/A	N/A	E3D11	QPSK	25	0	15 mm	back	1:1	0.185	1.042	0.193	
831.50	26865	Mid	LTE Band 26 (Cell)	15	23.5	23.47	0.00	0	N/A	N/A	E3D12	QPSK	1	36	15 mm	back	1:1	0.226	1.007	0.228	A24
831.50	26865	Mid	LTE Band 26 (Cell)	15	22.5	22.48	0.00	1	N/A	N/A	E3D12	QPSK	36	0	15 mm	back	1:1	0.172	1.005	0.173	
836.50	20525	Mid	LTE Band 5 (Cell)	10	24.5	24.40	0.00	0	Ant A	7	E3D12	QPSK	1	0	15 mm	back	1:1	0.257	1.023	0.263	A26
836.50	20525	Mid	LTE Band 5 (Cell)	10	23.5	23.33	0.03	1	Ant A	7	E3D12	QPSK	25	12	15 mm	back	1:1	0.207	1.040	0.215	
836.50	20525	Mid	LTE Band 5 (Cell)	10	23.5	22.48	0.04	0	Ant C	N/A	E3D02	QPSK	1	0	15 mm	back	1:1	0.141	1.265	0.178	
836.50	20525	Mid	LTE Band 5 (Cell)	10	22.5	21.33	-0.01	1	Ant C	N/A	E3D02	QPSK	25	25	15 mm	back	1:1	0.113	1.309	0.148	
1732.50	20175	Mid	LTE Band 4 (AWS)	20	23.5	22.95	0.00	0	N/A	N/A	E3D11	QPSK	1	0	15 mm	back	1:1	0.377	1.135	0.428	A28
1732.50	20175	Mid	LTE Band 4 (AWS)	20	22.5	22.06	-0.06	1	N/A	N/A	E3D11	QPSK	50	25	15 mm	back	1:1	0.314	1.107	0.348	
1905.00	26590	High	LTE Band 25 (PCS)	20	23.5	22.77	-0.06	0	N/A	N/A	E3D11	QPSK	1	99	15 mm	back	1:1	0.360	1.183	0.426	A30
1905.00	26590	High	LTE Band 25 (PCS)	20	22.5	21.95	-0.02	1	N/A	N/A	E3D11	QPSK	50	0	15 mm	back	1:1	0.273	1.135	0.310	
2680.00	41490	High	LTE Band 41	20	24.0	24.00	0.21	0	N/A	N/A	E3D02	QPSK	1	50	15 mm	back	1:1.58	0.083	1.000	0.083	
2506.00	39750	Low	LTE Band 41	20	23.0	23.00	0.04	1	N/A	N/A	E3D02	QPSK	50	50	15 mm	back	1:1.58	0.096	1.000	0.096	A32
ANSI / IEEE C95.1 1992 - SAFETY LIMIT Spatial Peak Uncontrolled Exposure/General Population								Body 1.6 W/kg (mW/g) averaged over 1 gram													

FCC ID: A3LSMG950N		<b>SAR EVALUATION REPORT</b>		<b>Approved by:</b> Quality Manager
<b>Document S/N:</b> 1M1703100103-01.A3L	<b>Test Dates:</b> 03/06/17 - 03/20/17	<b>DUT Type:</b> Portable Handset	Page 67 of 91	

**Table 11-18  
DTS Body-Worn SAR**



MEASUREMENT RESULTS																			
FREQUENCY		Mode	Service	Bandwidth [MHz]	Maximum Allowed Power [dBm]	Conducted Power [dBm]	Power Drift [dB]	Spacing	Antenna Config.	Device Serial Number	Data Rate (Mbps)	Side	Duty Cycle (%)	Peak SAR of Area Scan	SAR (1g)	Scaling Factor (Power)	Scaling Factor (Duty Cycle)	Reported SAR (1g)	Plot #
MHz	Ch.													(W/kg)	(W/kg)			(W/kg)	
2437	6	802.11b	DSSS	22	19.5	19.21	-0.19	15 mm	1	E3D11	1	back	99.0	0.135	0.092	1.069	1.010	0.099	A34
2437	6	802.11b	DSSS	22	19.5	19.44	-0.16	15 mm	2	E3D11	1	back	99.3	0.112	0.069	1.014	1.007	0.070	
ANSI / IEEE C95.1 1992 - SAFETY LIMIT Spatial Peak Uncontrolled Exposure/General Population								Body 1.6 W/kg (mW/g) averaged over 1 gram											

**Table 11-19  
NII Body-Worn SAR**

MEASUREMENT RESULTS																			
FREQUENCY		Mode	Service	Bandwidth [MHz]	Maximum Allowed Power [dBm]	Conducted Power [dBm]	Power Drift [dB]	Spacing	Antenna Config.	Device Serial Number	Data Rate (Mbps)	Side	Duty Cycle (%)	Peak SAR of Area Scan	SAR (1g)	Scaling Factor (Power)	Scaling Factor (Duty Cycle)	Reported SAR (1g)	Plot #
MHz	Ch.													(W/kg)	(W/kg)			(W/kg)	
5300	60	802.11a	OFDM	20	16.5	16.10	-0.10	15 mm	1	E3D02	6	back	99.2	0.234	0.114	1.096	1.008	0.126	
5320	64	802.11a	OFDM	20	16.5	16.09	-0.04	15 mm	2	E3D02	6	back	99.0	0.304	0.157	1.099	1.010	0.174	
5600	120	802.11a	OFDM	20	16.5	16.20	0.15	15 mm	1	E3D02	6	back	99.2	0.206	0.097	1.072	1.008	0.105	
5500	100	802.11a	OFDM	20	16.5	15.96	-0.12	15 mm	2	E3D02	6	back	99.0	0.210	0.116	1.132	1.010	0.133	
5825	165	802.11a	OFDM	20	16.5	16.05	0.14	15 mm	1	E3D02	6	back	99.2	0.517	0.211	1.109	1.008	0.236	A36
5785	157	802.11a	OFDM	20	16.5	15.88	0.06	15 mm	2	E3D02	6	back	99.0	0.444	0.192	1.153	1.010	0.224	
ANSI / IEEE C95.1 1992 - SAFETY LIMIT Spatial Peak Uncontrolled Exposure/General Population								Body 1.6 W/kg (mW/g) averaged over 1 gram											

**Table 11-20  
DSS Body-Worn SAR**

MEASUREMENT RESULTS																
FREQUENCY		Mode	Service	Maximum Allowed Power [dBm]	Conducted Power [dBm]	Power Drift [dB]	Spacing	Device Serial Number	Data Rate (Mbps)	Side	Duty Cycle (%)	SAR (1g)	Scaling Factor (Power)	Scaling Factor (Duty Cycle)	Reported SAR (1g)	Plot #
MHz	Ch.											(W/kg)			(W/kg)	
2441	39	Bluetooth	FHSS	16.5	16.09	0.20	15 mm	E3D11	1	back	76.6	0.026	1.098	1.306	0.037	A38
ANSI / IEEE C95.1 1992 - SAFETY LIMIT Spatial Peak Uncontrolled Exposure/General Population								Body 1.6 W/kg (mW/g) averaged over 1 gram								

FCC ID: A3LSMG950N		<b>SAR EVALUATION REPORT</b>		<b>Approved by:</b> Quality Manager
Document S/N: 1M1703100103-01.A3L	Test Dates: 03/06/17 - 03/20/17	DUT Type: Portable Handset	Page 68 of 91	



## 11.3 Standalone Hotspot SAR Data

**Table 11-21  
GPRS/UMTS Hotspot SAR Data**

MEASUREMENT RESULTS																
FREQUENCY		Mode	Service	Maximum Allowed Power [dBm]	Conducted Power [dBm]	Power Drift [dB]	Spacing	Antenna State	Device Serial Number	# of GPRS Slots	Duty Cycle	Side	SAR (1g) (W/kg)	Scaling Factor	Reported SAR (1g) (W/kg)	Plot #
MHz	Ch.															
1880.00	661	GSM 1900	GPRS	26.0	24.89	-0.11	10 mm	N/A	E3D11	4	1:2.076	back	0.512	1.291	0.661	
1880.00	661	GSM 1900	GPRS	26.0	24.89	-0.09	10 mm	N/A	E3D11	4	1:2.076	front	0.401	1.291	0.518	
1850.20	512	GSM 1900	GPRS	26.0	24.90	0.01	10 mm	N/A	E3D11	4	1:2.076	bottom	0.748	1.288	0.963	A15
1880.00	661	GSM 1900	GPRS	26.0	24.89	-0.05	10 mm	N/A	E3D11	4	1:2.076	bottom	0.676	1.291	0.873	
1909.80	810	GSM 1900	GPRS	26.0	24.94	-0.09	10 mm	N/A	E3D11	4	1:2.076	bottom	0.638	1.276	0.814	
1880.00	661	GSM 1900	GPRS	26.0	24.89	0.07	10 mm	N/A	E3D11	4	1:2.076	right	0.073	1.291	0.094	
1880.00	661	GSM 1900	GPRS	26.0	24.89	0.02	10 mm	N/A	E3D11	4	1:2.076	left	0.137	1.291	0.177	
836.60	4183	UMTS 850	RMC	22.5	21.92	-0.04	10 mm	7	E3D12	N/A	1:1	back	0.322	1.143	0.368	A17
836.60	4183	UMTS 850	RMC	22.5	21.92	-0.04	10 mm	7	E3D12	N/A	1:1	front	0.285	1.143	0.326	
836.60	4183	UMTS 850	RMC	22.5	21.92	0.00	10 mm	7	E3D12	N/A	1:1	bottom	0.161	1.143	0.184	
836.60	4183	UMTS 850	RMC	22.5	21.92	-0.02	10 mm	7	E3D12	N/A	1:1	right	0.201	1.143	0.230	
836.60	4183	UMTS 850	RMC	22.5	21.92	0.03	10 mm	7	E3D12	N/A	1:1	left	0.065	1.143	0.074	
1880.00	9400	UMTS 1900	RMC	19.5	19.32	0.00	10 mm	N/A	E3D11	N/A	1:1	back	0.609	1.042	0.635	
1880.00	9400	UMTS 1900	RMC	19.5	19.32	-0.06	10 mm	N/A	E3D11	N/A	1:1	front	0.450	1.042	0.469	
1880.00	9400	UMTS 1900	RMC	19.5	19.32	-0.01	10 mm	N/A	E3D11	N/A	1:1	bottom	0.631	1.042	0.658	A19
1880.00	9400	UMTS 1900	RMC	19.5	19.32	-0.03	10 mm	N/A	E3D11	N/A	1:1	right	0.072	1.042	0.075	
1880.00	9400	UMTS 1900	RMC	19.5	19.32	-0.06	10 mm	N/A	E3D11	N/A	1:1	left	0.130	1.042	0.135	
ANSI / IEEE C95.1 1992 - SAFETY LIMIT Spatial Peak Uncontrolled Exposure/General Population							Body 1.6 W/kg (mW/g) averaged over 1 gram									

**Table 11-22  
LTE Band 12 Hotspot SAR**

MEASUREMENT RESULTS																		
FREQUENCY		Mode	Bandwidth [MHz]	Maximum Allowed Power [dBm]	Conducted Power [dBm]	Power Drift [dB]	MPR [dB]	Device Serial Number	Modulation	RB Size	RB Offset	Spacing	Side	Duty Cycle	SAR (1g) (W/kg)	Scaling Factor	Reported SAR (1g) (W/kg)	Plot #
MHz	Ch.																	
707.50	23095	Mid	LTE Band 12	10	21.80	-0.06	0	E3D11	QPSK	1	25	10 mm	back	1:1	0.147	1.175	0.173	A21
707.50	23095	Mid	LTE Band 12	10	21.88	-0.07	0	E3D11	QPSK	25	25	10 mm	back	1:1	0.146	1.153	0.168	
707.50	23095	Mid	LTE Band 12	10	21.80	-0.01	0	E3D11	QPSK	1	25	10 mm	front	1:1	0.098	1.175	0.115	
707.50	23095	Mid	LTE Band 12	10	21.88	0.08	0	E3D11	QPSK	25	25	10 mm	front	1:1	0.097	1.153	0.112	
707.50	23095	Mid	LTE Band 12	10	21.80	-0.05	0	E3D11	QPSK	1	25	10 mm	bottom	1:1	0.064	1.175	0.075	
707.50	23095	Mid	LTE Band 12	10	21.88	0.03	0	E3D11	QPSK	25	25	10 mm	bottom	1:1	0.062	1.153	0.071	
707.50	23095	Mid	LTE Band 12	10	21.80	0.01	0	E3D11	QPSK	1	25	10 mm	right	1:1	0.074	1.175	0.087	
707.50	23095	Mid	LTE Band 12	10	21.88	0.12	0	E3D11	QPSK	25	25	10 mm	right	1:1	0.077	1.153	0.089	
707.50	23095	Mid	LTE Band 12	10	21.80	0.05	0	E3D11	QPSK	1	25	10 mm	left	1:1	0.032	1.175	0.038	
707.50	23095	Mid	LTE Band 12	10	21.88	-0.10	0	E3D11	QPSK	25	25	10 mm	left	1:1	0.032	1.153	0.037	
ANSI / IEEE C95.1 1992 - SAFETY LIMIT Spatial Peak Uncontrolled Exposure/General Population							Body 1.6 W/kg (mW/g) averaged over 1 gram											



FCC ID: A3LSMG950N		<b>SAR EVALUATION REPORT</b>		<b>Approved by:</b> Quality Manager
<b>Document S/N:</b> 1M1703100103-01.A3L	<b>Test Dates:</b> 03/06/17 - 03/20/17	<b>DUT Type:</b> Portable Handset	Page 69 of 91	

**Table 11-23  
LTE Band 13 Hotspot SAR**

MEASUREMENT RESULTS																			
FREQUENCY		Mode	Bandwidth [MHz]	Maximum Allowed Power [dBm]	Conducted Power [dBm]	Power Drift [dB]	MPR [dB]	Device Serial Number	Modulation	RB Size	RB Offset	Spacing	Side	Duty Cycle	SAR (1g)	Scaling Factor	Reported SAR (1g)	Plot #	
MHz	Ch.														(W/kg)		(W/kg)		
782.00	23230	Mid	LTE Band 13	10	22.5	22.09	0.02	0	E3D11	QPSK	1	0	10 mm	back	1:1	0.292	1.099	0.321	A23
782.00	23230	Mid	LTE Band 13	10	22.5	22.10	0.02	0	E3D11	QPSK	25	0	10 mm	back	1:1	0.285	1.096	0.312	
782.00	23230	Mid	LTE Band 13	10	22.5	22.09	0.04	0	E3D11	QPSK	1	0	10 mm	front	1:1	0.239	1.099	0.263	
782.00	23230	Mid	LTE Band 13	10	22.5	22.10	0.06	0	E3D11	QPSK	25	0	10 mm	front	1:1	0.231	1.096	0.253	
782.00	23230	Mid	LTE Band 13	10	22.5	22.09	0.00	0	E3D11	QPSK	1	0	10 mm	bottom	1:1	0.140	1.099	0.154	
782.00	23230	Mid	LTE Band 13	10	22.5	22.10	-0.06	0	E3D11	QPSK	25	0	10 mm	bottom	1:1	0.136	1.096	0.149	
782.00	23230	Mid	LTE Band 13	10	22.5	22.09	0.07	0	E3D11	QPSK	1	0	10 mm	right	1:1	0.220	1.099	0.242	
782.00	23230	Mid	LTE Band 13	10	22.5	22.10	-0.02	0	E3D11	QPSK	25	0	10 mm	right	1:1	0.213	1.096	0.233	
782.00	23230	Mid	LTE Band 13	10	22.5	22.09	0.01	0	E3D11	QPSK	1	0	10 mm	left	1:1	0.095	1.099	0.104	
782.00	23230	Mid	LTE Band 13	10	22.5	22.10	0.02	0	E3D11	QPSK	25	0	10 mm	left	1:1	0.077	1.096	0.084	
ANSI / IEEE C95.1 1992 - SAFETY LIMIT Spatial Peak Uncontrolled Exposure/General Population										Body 1.6 W/kg (mW/g) averaged over 1 gram									

**Table 11-24  
LTE Band 26 (Cell) Hotspot SAR**

MEASUREMENT RESULTS																			
FREQUENCY		Mode	Bandwidth [MHz]	Maximum Allowed Power [dBm]	Conducted Power [dBm]	Power Drift [dB]	MPR [dB]	Device Serial Number	Modulation	RB Size	RB Offset	Spacing	Side	Duty Cycle	SAR (1g)	Scaling Factor	Reported SAR (1g)	Plot #	
MHz	Ch.														(W/kg)		(W/kg)		
831.50	26865	Mid	LTE Band 26 (Cell)	15	23.5	23.47	-0.01	0	E3D12	QPSK	1	36	10 mm	back	1:1	0.359	1.007	0.362	A25
831.50	26865	Mid	LTE Band 26 (Cell)	15	22.5	22.48	0.12	1	E3D12	QPSK	36	0	10 mm	back	1:1	0.277	1.005	0.278	
831.50	26865	Mid	LTE Band 26 (Cell)	15	23.5	23.47	-0.08	0	E3D12	QPSK	1	36	10 mm	front	1:1	0.313	1.007	0.315	
831.50	26865	Mid	LTE Band 26 (Cell)	15	22.5	22.48	0.05	1	E3D12	QPSK	36	0	10 mm	front	1:1	0.237	1.005	0.238	
831.50	26865	Mid	LTE Band 26 (Cell)	15	23.5	23.47	-0.06	0	E3D12	QPSK	1	36	10 mm	bottom	1:1	0.202	1.007	0.203	
831.50	26865	Mid	LTE Band 26 (Cell)	15	22.5	22.48	-0.04	1	E3D12	QPSK	36	0	10 mm	bottom	1:1	0.166	1.005	0.167	
831.50	26865	Mid	LTE Band 26 (Cell)	15	23.5	23.47	0.02	0	E3D12	QPSK	1	36	10 mm	right	1:1	0.237	1.007	0.239	
831.50	26865	Mid	LTE Band 26 (Cell)	15	22.5	22.48	-0.01	1	E3D12	QPSK	36	0	10 mm	right	1:1	0.190	1.005	0.191	
831.50	26865	Mid	LTE Band 26 (Cell)	15	23.5	23.47	0.11	0	E3D12	QPSK	1	36	10 mm	left	1:1	0.054	1.007	0.054	
831.50	26865	Mid	LTE Band 26 (Cell)	15	22.5	22.48	0.11	1	E3D12	QPSK	36	0	10 mm	left	1:1	0.041	1.005	0.041	
ANSI / IEEE C95.1 1992 - SAFETY LIMIT Spatial Peak Uncontrolled Exposure/General Population										Body 1.6 W/kg (mW/g) averaged over 1 gram									



FCC ID: A3LSMG950N		<b>SAR EVALUATION REPORT</b>		<b>Approved by:</b> Quality Manager
<b>Document S/N:</b> 1M1703100103-01.A3L	<b>Test Dates:</b> 03/06/17 - 03/20/17	<b>DUT Type:</b> Portable Handset	Page 70 of 91	

**Table 11-25  
LTE Band 5 (Cell) Hotspot SAR**

MEASUREMENT RESULTS																					
FREQUENCY		Mode	Bandwidth [MHz]	Maximum Allowed Power [dBm]	Conducted Power [dBm]	Power Drift [dB]	MPR [dB]	Antenna Config.	Antenna State	Device Serial Number	Modulation	RB Size	RB Offset	Spacing	Side	Duty Cycle	SAR(1g)	Scaling Factor	Reported SAR	Plot #	
MHz	Ch.																(W/kg)		(W/kg)		
836.50	20525	Mid	LTE Band 5 (Cell)	10	24.5	24.40	0.05	0	Ant A	7	E3D12	QPSK	1	0	10 mm	back	1:1	0.508	1.023	0.520	A27
836.50	20525	Mid	LTE Band 5 (Cell)	10	23.5	23.33	0.12	1	Ant A	7	E3D12	QPSK	25	12	10 mm	back	1:1	0.371	1.040	0.386	
836.50	20525	Mid	LTE Band 5 (Cell)	10	24.5	24.40	0.02	0	Ant A	7	E3D12	QPSK	1	0	10 mm	front	1:1	0.445	1.023	0.455	
836.50	20525	Mid	LTE Band 5 (Cell)	10	23.5	23.33	-0.03	1	Ant A	7	E3D12	QPSK	25	12	10 mm	front	1:1	0.276	1.040	0.287	
836.50	20525	Mid	LTE Band 5 (Cell)	10	24.5	24.40	-0.05	0	Ant A	7	E3D12	QPSK	1	0	10 mm	bottom	1:1	0.218	1.023	0.223	
836.50	20525	Mid	LTE Band 5 (Cell)	10	23.5	23.33	-0.01	1	Ant A	7	E3D12	QPSK	25	12	10 mm	bottom	1:1	0.182	1.040	0.189	
836.50	20525	Mid	LTE Band 5 (Cell)	10	24.5	24.40	-0.09	0	Ant A	7	E3D12	QPSK	1	0	10 mm	right	1:1	0.249	1.023	0.255	
836.50	20525	Mid	LTE Band 5 (Cell)	10	23.5	23.33	0.01	1	Ant A	7	E3D12	QPSK	25	12	10 mm	right	1:1	0.206	1.040	0.214	
836.50	20525	Mid	LTE Band 5 (Cell)	10	24.5	24.40	0.03	0	Ant A	7	E3D12	QPSK	1	0	10 mm	left	1:1	0.065	1.023	0.066	
836.50	20525	Mid	LTE Band 5 (Cell)	10	23.5	23.33	0.08	1	Ant A	7	E3D12	QPSK	25	12	10 mm	left	1:1	0.069	1.040	0.072	
836.50	20525	Mid	LTE Band 5 (Cell)	10	23.5	22.48	-0.12	0	Ant C	N/A	E3D02	QPSK	1	0	10 mm	back	1:1	0.206	1.265	0.261	
836.50	20525	Mid	LTE Band 5 (Cell)	10	22.5	21.33	0.03	1	Ant C	N/A	E3D02	QPSK	25	25	10 mm	back	1:1	0.166	1.309	0.217	
836.50	20525	Mid	LTE Band 5 (Cell)	10	23.5	22.48	0.00	0	Ant C	N/A	E3D02	QPSK	1	0	10 mm	front	1:1	0.221	1.265	0.280	
836.50	20525	Mid	LTE Band 5 (Cell)	10	22.5	21.33	0.03	1	Ant C	N/A	E3D02	QPSK	25	25	10 mm	front	1:1	0.179	1.309	0.234	
836.50	20525	Mid	LTE Band 5 (Cell)	10	23.5	22.48	-0.01	0	Ant C	N/A	E3D02	QPSK	1	0	10 mm	top	1:1	0.130	1.265	0.164	
836.50	20525	Mid	LTE Band 5 (Cell)	10	22.5	21.33	-0.06	1	Ant C	N/A	E3D02	QPSK	25	25	10 mm	top	1:1	0.094	1.309	0.123	
836.50	20525	Mid	LTE Band 5 (Cell)	10	23.5	22.48	0.08	0	Ant C	N/A	E3D02	QPSK	1	0	10 mm	right	1:1	0.037	1.265	0.047	
836.50	20525	Mid	LTE Band 5 (Cell)	10	22.5	21.33	0.11	1	Ant C	N/A	E3D02	QPSK	25	25	10 mm	right	1:1	0.032	1.309	0.042	
836.50	20525	Mid	LTE Band 5 (Cell)	10	23.5	22.48	-0.02	0	Ant C	N/A	E3D02	QPSK	1	0	10 mm	left	1:1	0.181	1.265	0.229	
836.50	20525	Mid	LTE Band 5 (Cell)	10	22.5	21.33	0.00	1	Ant C	N/A	E3D02	QPSK	25	25	10 mm	left	1:1	0.144	1.309	0.188	
ANSI / IEEE C95.1 1992 - SAFETY LIMIT										Body											
Spatial Peak										1.6 W/kg (mW/g)											
Uncontrolled Exposure/General Population										averaged over 1 gram											

**Table 11-26  
LTE Band 4 (AWS) Hotspot SAR**

MEASUREMENT RESULTS																			
FREQUENCY		Mode	Bandwidth [MHz]	Maximum Allowed Power [dBm]	Conducted Power [dBm]	Power Drift [dB]	MPR [dB]	Device Serial Number	Modulation	RB Size	RB Offset	Spacing	Side	Duty Cycle	SAR(1g)	Scaling Factor	Reported SAR	Plot #	
MHz	Ch.														(W/kg)		(W/kg)		
1732.50	20175	Mid	LTE Band 4 (AWS)	20	20.5	20.21	0.00	0	E3D11	QPSK	1	50	10 mm	back	1:1	0.305	1.069	0.326	
1732.50	20175	Mid	LTE Band 4 (AWS)	20	20.5	20.24	-0.13	0	E3D11	QPSK	50	0	10 mm	back	1:1	0.316	1.062	0.336	
1732.50	20175	Mid	LTE Band 4 (AWS)	20	20.5	20.21	-0.06	0	E3D11	QPSK	1	50	10 mm	front	1:1	0.275	1.069	0.294	
1732.50	20175	Mid	LTE Band 4 (AWS)	20	20.5	20.24	-0.02	0	E3D11	QPSK	50	0	10 mm	front	1:1	0.275	1.062	0.292	
1732.50	20175	Mid	LTE Band 4 (AWS)	20	20.5	20.21	0.06	0	E3D11	QPSK	1	50	10 mm	bottom	1:1	0.423	1.069	0.452	
1732.50	20175	Mid	LTE Band 4 (AWS)	20	20.5	20.24	0.00	0	E3D11	QPSK	50	0	10 mm	bottom	1:1	0.424	1.062	0.450	A29
1732.50	20175	Mid	LTE Band 4 (AWS)	20	20.5	20.21	-0.07	0	E3D11	QPSK	1	50	10 mm	right	1:1	0.045	1.069	0.048	
1732.50	20175	Mid	LTE Band 4 (AWS)	20	20.5	20.24	-0.01	0	E3D11	QPSK	50	0	10 mm	right	1:1	0.044	1.062	0.047	
1732.50	20175	Mid	LTE Band 4 (AWS)	20	20.5	20.21	0.05	0	E3D11	QPSK	1	50	10 mm	left	1:1	0.151	1.069	0.161	
1732.50	20175	Mid	LTE Band 4 (AWS)	20	20.5	20.24	-0.11	0	E3D11	QPSK	50	0	10 mm	left	1:1	0.156	1.062	0.166	
ANSI / IEEE C95.1 1992 - SAFETY LIMIT										Body									
Spatial Peak										1.6 W/kg (mW/g)									
Uncontrolled Exposure/General Population										averaged over 1 gram									



FCC ID: A3LSMG950N		<b>SAR EVALUATION REPORT</b>		<b>Approved by:</b> Quality Manager
Document S/N: 1M1703100103-01.A3L	Test Dates: 03/06/17 - 03/20/17	DUT Type: Portable Handset	Page 71 of 91	

**Table 11-27  
LTE Band 25 (PCS) Hotspot SAR**

MEASUREMENT RESULTS																			
FREQUENCY		Mode	Bandwidth [MHz]	Maximum Allowed Power [dBm]	Conducted Power [dBm]	Power Drift [dB]	MPR [dB]	Device Serial Number	Modulation	RB Size	RB Offset	Spacing	Side	Duty Cycle	SAR (1g)	Scaling Factor	Reported SAR (1g)	Plot #	
MHz	Ch.														(W/kg)		(W/kg)		
1905.00	26590	High	LTE Band 25 (PCS)	20	20.5	20.05	0.04	0	E3D11	QPSK	1	0	10 mm	back	1:1	0.283	1.109	0.314	
1905.00	26590	High	LTE Band 25 (PCS)	20	20.5	20.15	-0.03	0	E3D11	QPSK	50	0	10 mm	back	1:1	0.300	1.084	0.325	
1905.00	26590	High	LTE Band 25 (PCS)	20	20.5	20.05	0.01	0	E3D11	QPSK	1	0	10 mm	front	1:1	0.225	1.109	0.250	
1905.00	26590	High	LTE Band 25 (PCS)	20	20.5	20.15	-0.03	0	E3D11	QPSK	50	0	10 mm	front	1:1	0.235	1.084	0.255	
1905.00	26590	High	LTE Band 25 (PCS)	20	20.5	20.05	-0.03	0	E3D11	QPSK	1	0	10 mm	bottom	1:1	0.299	1.109	0.332	
1905.00	26590	High	LTE Band 25 (PCS)	20	20.5	20.15	-0.07	0	E3D11	QPSK	50	0	10 mm	bottom	1:1	0.322	1.084	0.349	A31
1905.00	26590	High	LTE Band 25 (PCS)	20	20.5	20.05	0.11	0	E3D11	QPSK	1	0	10 mm	right	1:1	0.026	1.109	0.029	
1905.00	26590	High	LTE Band 25 (PCS)	20	20.5	20.15	0.19	0	E3D11	QPSK	50	0	10 mm	right	1:1	0.027	1.084	0.029	
1905.00	26590	High	LTE Band 25 (PCS)	20	20.5	20.05	-0.02	0	E3D11	QPSK	1	0	10 mm	left	1:1	0.104	1.109	0.115	
1905.00	26590	High	LTE Band 25 (PCS)	20	20.5	20.15	-0.05	0	E3D11	QPSK	50	0	10 mm	left	1:1	0.111	1.084	0.120	
ANSI / IEEE C95.1 1992 - SAFETY LIMIT Spatial Peak Uncontrolled Exposure/General Population								Body 1.6 W/kg (mW/g) averaged over 1 gram											



**Table 11-28  
LTE Band 41 Hotspot SAR**

MEASUREMENT RESULTS																			
FREQUENCY		Mode	Bandwidth [MHz]	Maximum Allowed Power [dBm]	Conducted Power [dBm]	Power Drift [dB]	MPR [dB]	Device Serial Number	Modulation	RB Size	RB Offset	Spacing	Side	Duty Cycle	SAR (1g)	Scaling Factor	Reported SAR (1g)	Plot #	
MHz	Ch.														(W/kg)		(W/kg)		
2680.00	41490	High	LTE Band 41	20	24.0	24.00	0.04	0	E3D02	QPSK	1	50	10 mm	back	1:1.58	0.208	1.000	0.208	
2506.00	39750	Low	LTE Band 41	20	23.0	23.00	0.08	1	E3D02	QPSK	50	50	10 mm	back	1:1.58	0.248	1.000	0.248	A33
2680.00	41490	High	LTE Band 41	20	24.0	24.00	0.00	0	E3D02	QPSK	1	50	10 mm	front	1:1.58	0.215	1.000	0.215	
2506.00	39750	Low	LTE Band 41	20	23.0	23.00	0.12	1	E3D02	QPSK	50	50	10 mm	front	1:1.58	0.193	1.000	0.193	
2680.00	41490	High	LTE Band 41	20	24.0	24.00	0.05	0	E3D02	QPSK	1	50	10 mm	bottom	1:1.58	0.050	1.000	0.050	
2506.00	39750	Low	LTE Band 41	20	23.0	23.00	-0.08	1	E3D02	QPSK	50	50	10 mm	bottom	1:1.58	0.146	1.000	0.146	
2680.00	41490	High	LTE Band 41	20	24.0	24.00	-0.12	0	E3D02	QPSK	1	50	10 mm	right	1:1.58	0.008	1.000	0.008	
2506.00	39750	Low	LTE Band 41	20	23.0	23.00	-0.11	1	E3D02	QPSK	50	50	10 mm	right	1:1.58	0.041	1.000	0.041	
2680.00	41490	High	LTE Band 41	20	24.0	24.00	0.16	0	E3D02	QPSK	1	50	10 mm	left	1:1.58	0.111	1.000	0.111	
2506.00	39750	Low	LTE Band 41	20	23.0	23.00	0.05	1	E3D02	QPSK	50	50	10 mm	left	1:1.58	0.101	1.000	0.101	
ANSI / IEEE C95.1 1992 - SAFETY LIMIT Spatial Peak Uncontrolled Exposure/General Population								Body 1.6 W/kg (mW/g) averaged over 1 gram											

FCC ID: A3LSMG950N		<b>SAR EVALUATION REPORT</b>		<b>Approved by:</b> Quality Manager
<b>Document S/N:</b> 1M1703100103-01.A3L	<b>Test Dates:</b> 03/06/17 - 03/20/17	<b>DUT Type:</b> Portable Handset	Page 72 of 91	

**Table 11-29  
WLAN Hotspot SAR**

**Table 11-30**

FCC ID: A3LSMG950N	 <b>SAR EVALUATION REPORT</b> 		<b>Approved by:</b> Quality Manager
Document S/N: 1M1703100103-01.A3L	Test Dates: 03/06/17 - 03/20/17	DUT Type: Portable Handset	Page 73 of 91

**Table 11-31  
DSS Hotspot SAR**

MEASUREMENT RESULTS																
FREQUENCY		Mode	Service	Maximum Allowed Power [dBm]	Conducted Power [dBm]	Power Drift [dB]	Spacing	Device Serial Number	Data Rate (Mbps)	Side	Duty Cycle (%)	SAR (1g)	Scaling Factor (Power)	Scaling Factor (Duty Cycle)	Reported SAR (1g)	Plot #
MHz	Ch.											(W/kg)			(W/kg)	
2441	39	Bluetooth	FHSS	10.5	10.02	0.21	10 mm	E3D11	2	back	76.6	0.008	1.117	1.306	0.012	A39
2441	39	Bluetooth	FHSS	10.5	10.02	0.12	10 mm	E3D11	2	front	76.6	0.007	1.117	1.306	0.010	
2441	39	Bluetooth	FHSS	10.5	10.02	0.14	10 mm	E3D11	2	top	76.6	0.004	1.117	1.306	0.006	
2441	39	Bluetooth	FHSS	10.5	10.02	0.14	10 mm	E3D11	2	left	76.6	0.005	1.117	1.306	0.007	
ANSI / IEEE C95.1 1992 - SAFETY LIMIT Spatial Peak Uncontrolled Exposure/General Population							Body 1.6 W/kg (mW/g) averaged over 1 gram									



### 11.4 SAR Test Notes

General Notes:

- The test data reported are the worst-case SAR values according to test procedures specified in IEEE 1528-2013, and FCC KDB Publication 447498 D01v06.
- Batteries are fully charged at the beginning of the SAR measurements.
- Liquid tissue depth was at least 15.0 cm for all frequencies.
- The manufacturer has confirmed that the device(s) tested have the same physical, mechanical and thermal characteristics and are within operational tolerances expected for production units.
- SAR results were scaled to the maximum allowed power to demonstrate compliance per FCC KDB Publication 447498 D01v06.
- Device was tested using a fixed spacing for body-worn accessory testing. A separation distance of 15 mm was considered because the manufacturer has determined that there will be body-worn accessories available in the marketplace for users to support this separation distance.
- Per FCC KDB Publication 648474 D04v01r03, body-worn SAR was evaluated without a headset connected to the device. Since the standalone reported body-worn SAR was  $\leq 1.2$  W/kg, no additional body-worn SAR evaluations using a headset cable were required.
- Per FCC KDB 865664 D01v01r04, variability SAR tests were not performed because the measured SAR results for a frequency band were less than 0.8 W/kg. Please see Section 13 for more information.
- During SAR Testing for the Wireless Router conditions per FCC KDB Publication 941225 D06v02r01, the actual Portable Hotspot operation (with actual simultaneous transmission of a transmitter with WIFI) was not activated (See Section 6.7 for more details).
- This device utilizes power reduction for some wireless modes and technologies, as outlined in Section 1.3. The maximum output power allowed for each transmitter and exposure condition was evaluated for SAR compliance based on expected use conditions and simultaneous transmission scenarios.
- This device supports dynamic antenna tuning for some bands. Per FCC Guidance, SAR was measured according to the normally required SAR measurement configurations with tuner active. The auto-tune state determined by the device was verified before and after each SAR measurement and is listed in tables above. Please see Section 14 for supplemental data.

GSM Test Notes:

- Body-Worn accessory testing is typically associated with voice operations. Therefore, GSM voice was evaluated for body-worn SAR.
- Justification for reduced test configurations per KDB Publication 941225 D01v03r01 and October 2013 TCB Workshop Notes: The source-based frame-averaged output power was evaluated for all GPRS/EDGE slot configurations. The configuration with the highest target frame averaged output power was evaluated for hotspot SAR. When the maximum frame-averaged powers are equivalent across two or more slots (within 0.25 dB), the configuration with the most number of time slots was tested.
- Per FCC KDB Publication 447498 D01v06, if the reported (scaled) SAR measured at the middle channel or highest output power channel for each test configuration is  $\leq 0.8$  W/kg then testing at the other

FCC ID: A3LSMG950N		SAR EVALUATION REPORT		Approved by: Quality Manager
Document S/N: 1M1703100103-01.A3L	Test Dates: 03/06/17 - 03/20/17	DUT Type: Portable Handset	Page 74 of 91	

channels is not required for such test configuration(s). When the maximum output power variation across the required test channels is  $> \frac{1}{2}$  dB, instead of the middle channel, the highest output power channel was used.

**UMTS Notes:**



1. UMTS mode in was tested under RMC 12.2 kbps with HSPA Inactive per KDB Publication 941225 D01v03r01. AMR and HSPA SAR was not required per the 3G Test Reduction Procedure in KDB Publication 941225 D01v03r01.
2. Per FCC KDB Publication 447498 D01v06, if the reported (scaled) SAR measured at the middle channel or highest output power channel for each test configuration is  $\leq 0.8$  W/kg then testing at the other channels is not required for such test configuration(s). When the maximum output power variation across the required test channels is  $> \frac{1}{2}$  dB, instead of the middle channel, the highest output power channel was used.

**LTE Notes:**

1. LTE Considerations: LTE test configurations are determined according to SAR Evaluation Considerations for LTE Devices in FCC KDB Publication 941225 D05v02r04. The general test procedures used for testing can be found in Section 8.5.4.
2. MPR is permanently implemented for this device by the manufacturer. The specific manufacturer target MPR is indicated alongside the SAR results. MPR is enabled for this device, according to 3GPP TS36.101 Section 6.2.3 – 6.2.5 under Table 6.2.3-1.
3. A-MPR was disabled for all SAR tests by setting NS=01 on the base station simulator. SAR tests were performed with the same number of RB and RB offsets transmitting on all TTI frames (maximum TTI).
4. Per FCC KDB Publication 447498 D01v06, when the reported (scaled) for LTE Band 41 SAR measured at the highest output power channel in a given a test configuration was  $> 0.6$  W/kg, testing at the other channels was required for such test configurations.
5. TDD LTE was tested per the guidance provided in FCC KDB Publication 941225 D05v02r04. Testing was performed using UL-DL configuration 0 with 6 UL subframes and 2 S subframes using extended cyclic prefix only and special subframe configuration 6. SAR tests were performed at maximum output power and worst-case transmission duty factor in extended cyclic prefix. Per 3GPP 36.211 Section 4, the duty factor for special subframe configuration 6 using extended cyclic prefix is 0.633.

**WLAN Notes:**



1. For held-to-ear and hotspot operations, the initial test position procedures were applied. The test position with the highest extrapolated peak SAR will be used as the initial test position. When reported SAR for the initial test position is  $\leq 0.4$  W/kg, no additional testing for the remaining test positions was required. Otherwise, SAR is evaluated at the subsequent highest peak SAR positions until the reported SAR result is  $\leq 0.8$  W/kg or all test positions are measured.
2. Justification for test configurations for WLAN per KDB Publication 248227 D01v02r02 for 2.4 GHz WIFI single transmission chain operations, the highest measured maximum output power channel for DSSS was selected for SAR measurement. SAR for OFDM modes (2.4 GHz 802.11g/n) was not required due to the maximum allowed powers and the highest reported DSSS SAR. See Section 8.6.5 for more information.
3. Justification for test configurations for WLAN per KDB Publication 248227 D01v02r02 for 5 GHz WIFI single transmission chain operations, the initial test configuration was selected according to the transmission mode with the highest maximum allowed powers. Other transmission modes were not investigated since the highest reported SAR for initial test configuration adjusted by the ratio of maximum output powers is less than 1.2 W/kg. See Section 8.6.6 for more information.
4. Per KDB Publication 248227 D01v02r02, SAR for MIMO was evaluated by following the simultaneous SAR provisions from KDB Publication 447498 D01v06 by either evaluating the sum of the 1g SAR values of each antenna transmitting independently or making a SAR measurement with both antennas transmitting simultaneously. Please see Section 12 for complete analysis.

FCC ID: A3LSMG950N		<b>SAR EVALUATION REPORT</b>		<b>Approved by:</b> Quality Manager
<b>Document S/N:</b> 1M1703100103-01.A3L	<b>Test Dates:</b> 03/06/17 - 03/20/17	<b>DUT Type:</b> Portable Handset	Page 75 of 91	

5. When the maximum reported 1g averaged SAR is  $\leq 0.8$  W/kg, SAR testing on additional channels was not required. Otherwise, SAR for the next highest output power channel was required until the reported SAR result was  $\leq 1.20$  W/kg or all test channels were measured.
6. The device was configured to transmit continuously at the required data rate, channel bandwidth and signal modulation, using the highest transmission duty factor supported by the test mode tools. The reported SAR was scaled to the 100% transmission duty factor to determine compliance. Procedures used to measure the duty factor are identical to that in the associated EMC test reports.

**Bluetooth Notes:**

1. Bluetooth SAR was measured with the device connected to a call box with hopping disabled with DH5 operation and Tx Tests test mode type. Per October 2016 TCB Workshop Notes, the reported SAR was scaled to the 100% transmission duty factor to determine compliance. See Section 9.5 for the time-domain plot and calculation for the duty factor of the device.
2. Head and Hotspot Bluetooth SAR were evaluated for BT EDR tethering applications.

FCC ID: A3LSMG950N	 <b>SAR EVALUATION REPORT</b> 		<b>Approved by:</b> Quality Manager
Document S/N: 1M1703100103-01.A3L	Test Dates: 03/06/17 - 03/20/17	DUT Type: Portable Handset	Page 76 of 91

# 12 FCC MULTI-TX AND ANTENNA SAR CONSIDERATIONS

## 12.1 Introduction

The following procedures adopted from FCC KDB Publication 447498 D01v06 are applicable to devices with built-in unlicensed transmitters such as 802.11 and Bluetooth devices which may simultaneously transmit with the licensed transmitter.



## 12.2 Simultaneous Transmission Procedures

This device contains transmitters that may operate simultaneously. Therefore simultaneous transmission analysis is required. Per FCC KDB Publication 447498 D01v06 4.3.2 and IEEE 1528-2013 Section 6.3.4.1.2, simultaneous transmission SAR test exclusion may be applied when the sum of the 1-g SAR for all the simultaneous transmitting antennas in a specific a physical test configuration is  $\leq 1.6$  W/kg. The different test positions in an exposure condition may be considered collectively to determine SAR test exclusion according to the sum of 1-g SAR.

## 12.3 Head SAR Simultaneous Transmission Analysis



**Table 12-1**  
**Simultaneous Transmission Scenario with 2.4 GHz WLAN (Held to Ear)**

Exposure Condition	Mode	2G/3G/4G SAR (W/kg)	2.4 GHz WLAN Ant 1 SAR (W/kg)	2.4 GHz WLAN Ant 2 SAR (W/kg)	$\Sigma$ SAR (W/kg)		
		1	2	3	1+2	1+3	1+2+3
Head SAR	GSM 1900	0.102	0.421	0.603	0.523	0.705	1.126
	UMTS 850	0.225	0.421	0.603	0.646	0.828	<b>1.249</b>
	UMTS 1900	0.139	0.421	0.603	0.560	0.742	1.163
	LTE Band 12	0.056	0.421	0.603	0.477	0.659	1.080
	LTE Band 13	0.128	0.421	0.603	0.549	0.731	1.152
	LTE Band 26 (Cell)	0.170	0.421	0.603	0.591	0.773	1.194
	LTE Band 5 (Cell)	0.197	0.421	0.603	0.618	0.800	1.221
	LTE Band 4 (AWS)	0.207	0.421	0.603	0.628	0.810	1.231
	LTE Band 25 (PCS)	0.202	0.421	0.603	0.623	0.805	1.226
	LTE Band 41	0.028	0.421	0.603	0.449	0.631	1.052

FCC ID: A3LSMG950N		<b>SAR EVALUATION REPORT</b>		<b>Approved by:</b> Quality Manager
<b>Document S/N:</b> 1M1703100103-01.A3L	<b>Test Dates:</b> 03/06/17 - 03/20/17	<b>DUT Type:</b> Portable Handset	Page 77 of 91	

**Table 12-2**  
**Simultaneous Transmission Scenario with 5 GHz WLAN (Held to Ear)**

**Table 12-3**

FCC ID: A3LSMG950N	 <b>SAR EVALUATION REPORT</b> 		<b>Approved by:</b> Quality Manager
Document S/N: 1M1703100103-01.A3L	Test Dates: 03/06/17 - 03/20/17	DUT Type: Portable Handset	Page 78 of 91



**Table 12-4**  
**Simultaneous Transmission Scenario with Bluetooth (Held to Ear)**

Exposure Condition	Mode	2G/3G/4G SAR (W/kg)	Bluetooth SAR (W/kg)	Σ SAR (W/kg)
		1	2	1+2
Head SAR	GSM 1900	0.102	0.048	0.150
	UMTS 850	0.225	0.048	<b>0.273</b>
	UMTS 1900	0.139	0.048	0.187
	LTE Band 12	0.056	0.048	0.104
	LTE Band 13	0.128	0.048	0.176
	LTE Band 26 (Cell)	0.170	0.048	0.218
	LTE Band 5 (Cell)	0.197	0.048	0.245
	LTE Band 4 (AWS)	0.207	0.048	0.255
	LTE Band 25 (PCS)	0.202	0.048	0.250
	LTE Band 41	0.028	0.048	0.076

## 12.4 Body-Worn Simultaneous Transmission Analysis

**Table 12-5**  
**Simultaneous Transmission Scenario with 2.4 GHz WLAN (Body-Worn at 1.5 cm)**

Exposure Condition	Mode	2G/3G/4G SAR (W/kg)	2.4 GHz WLAN Ant 1 SAR (W/kg)	2.4 GHz WLAN Ant 2 SAR (W/kg)	Σ SAR (W/kg)		
		1	2	3	1+2	1+3	1+2+3
Body-Worn	GSM 1900	0.434	0.099	0.070	0.533	0.504	0.603
	UMTS 850	0.298	0.099	0.070	0.397	0.368	0.467
	UMTS 1900	0.456	0.099	0.070	0.555	0.526	<b>0.625</b>
	LTE Band 12	0.118	0.099	0.070	0.217	0.188	0.287
	LTE Band 13	0.255	0.099	0.070	0.354	0.325	0.424
	LTE Band 26 (Cell)	0.228	0.099	0.070	0.327	0.298	0.397
	LTE Band 5 (Cell)	0.263	0.099	0.070	0.362	0.333	0.432
	LTE Band 4 (AWS)	0.428	0.099	0.070	0.527	0.498	0.597
	LTE Band 25 (PCS)	0.426	0.099	0.070	0.525	0.496	0.595
	LTE Band 41	0.096	0.099	0.070	0.195	0.166	0.265



FCC ID: A3LSMG950N	 <b>SAR EVALUATION REPORT</b> 	Approved by: Quality Manager
Document S/N: 1M1703100103-01.A3L	Test Dates: 03/06/17 - 03/20/17	DUT Type: Portable Handset
		Page 79 of 91

**Table 12-6**  
**Simultaneous Transmission Scenario with 5 GHz WLAN (Body-Worn at 1.5 cm)**

Exposure Condition	Mode	2G/3G/4G SAR (W/kg)	5 GHz WLAN Ant 1 SAR (W/kg)	5 GHz WLAN Ant 2 SAR (W/kg)	Σ SAR (W/kg)		
		1	2	3	1+2	1+3	1+2+3
Body-Worn	GSM 1900	0.434	0.236	0.224	0.670	0.658	0.894
	UMTS 850	0.298	0.236	0.224	0.534	0.522	0.758
	UMTS 1900	0.456	0.236	0.224	0.692	0.680	<b>0.916</b>
	LTE Band 12	0.118	0.236	0.224	0.354	0.342	0.578
	LTE Band 13	0.255	0.236	0.224	0.491	0.479	0.715
	LTE Band 26 (Cell)	0.228	0.236	0.224	0.464	0.452	0.688
	LTE Band 5 (Cell)	0.263	0.236	0.224	0.499	0.487	0.723
	LTE Band 4 (AWS)	0.428	0.236	0.224	0.664	0.652	0.888
	LTE Band 25 (PCS)	0.426	0.236	0.224	0.662	0.650	0.886
	LTE Band 41	0.096	0.236	0.224	0.332	0.320	0.556

**Table 12-7**  
**Simultaneous Transmission Scenario with 2.4 GHz WLAN Ant 1 & 2, 5GHz WLAN Ant 1 & 2 (Body-Worn at 1.5 cm)**

Exposure Condition	Mode	2G/3G/4G SAR (W/kg)	2.4 GHz WLAN Ant 1 SAR (W/kg)	2.4 GHz WLAN Ant 2 SAR (W/kg)	5 GHz WLAN Ant 1 SAR (W/kg)	5 GHz WLAN Ant 2 SAR (W/kg)	Σ SAR (W/kg)
		1	2	3	4	5	1+2+3+4+5
Body-Worn	GSM 1900	0.434	0.099	0.070	0.236	0.224	1.063
	UMTS 850	0.298	0.099	0.070	0.236	0.224	0.927
	UMTS 1900	0.456	0.099	0.070	0.236	0.224	<b>1.085</b>
	LTE Band 12	0.118	0.099	0.070	0.236	0.224	0.747
	LTE Band 13	0.255	0.099	0.070	0.236	0.224	0.884
	LTE Band 26 (Cell)	0.228	0.099	0.070	0.236	0.224	0.857
	LTE Band 5 (Cell)	0.263	0.099	0.070	0.236	0.224	0.892
	LTE Band 4 (AWS)	0.428	0.099	0.070	0.236	0.224	1.057
	LTE Band 25 (PCS)	0.426	0.099	0.070	0.236	0.224	1.055
	LTE Band 41	0.096	0.099	0.070	0.236	0.224	0.725

FCC ID: A3LSMG950N	 <b>SAR EVALUATION REPORT</b> 	Approved by: Quality Manager
Document S/N: 1M1703100103-01.A3L	Test Dates: 03/06/17 - 03/20/17	DUT Type: Portable Handset
		Page 80 of 91



**Table 12-8**  
**Simultaneous Transmission Scenario with Bluetooth (Body-Worn at 1.5 cm)**

Exposure Condition	Mode	2G/3G/4G SAR (W/kg)	Bluetooth SAR (W/kg)	Σ SAR (W/kg)
		1	2	1+2
Body-Worn	GSM 1900	0.434	0.037	0.471
	UMTS 850	0.298	0.037	0.335
	UMTS 1900	0.456	0.037	<b>0.493</b>
	LTE Band 12	0.118	0.037	0.155
	LTE Band 13	0.255	0.037	0.292
	LTE Band 26 (Cell)	0.228	0.037	0.265
	LTE Band 5 (Cell)	0.263	0.037	0.300
	LTE Band 4 (AWS)	0.428	0.037	0.465
	LTE Band 25 (PCS)	0.426	0.037	0.463
	LTE Band 41	0.096	0.037	0.133

## 12.5 Hotspot SAR Simultaneous Transmission Analysis



**Table 12-9**  
**Simultaneous Transmission Scenario 2.4 GHz WLAN (Hotspot at 1.0 cm)**

Exposure Condition	Mode	2G/3G/4G SAR (W/kg)	2.4 GHz WLAN Ant 1 SAR (W/kg)	2.4 GHz WLAN Ant 2 SAR (W/kg)	Σ SAR (W/kg)		
		1	2	3	1+2	1+3	1+2+3
Hotspot SAR	GPRS 1900	0.963	0.252	0.207	1.215	1.170	<b>1.422</b>
	UMTS 850	0.368	0.252	0.207	0.620	0.575	0.827
	UMTS 1900	0.658	0.252	0.207	0.910	0.865	1.117
	LTE Band 12	0.173	0.252	0.207	0.425	0.380	0.632
	LTE Band 13	0.321	0.252	0.207	0.573	0.528	0.780
	LTE Band 26 (Cell)	0.362	0.252	0.207	0.614	0.569	0.821
	LTE Band 5 (Cell)	0.520	0.252	0.207	0.772	0.727	0.979
	LTE Band 4 (AWS)	0.452	0.252	0.207	0.704	0.659	0.911
	LTE Band 25 (PCS)	0.349	0.252	0.207	0.601	0.556	0.808
	LTE Band 41	0.248	0.252	0.207	0.500	0.455	0.707

FCC ID: A3LSMG950N	 <b>SAR EVALUATION REPORT</b> 	Approved by: Quality Manager
Document S/N: 1M1703100103-01.A3L	Test Dates: 03/06/17 - 03/20/17	DUT Type: Portable Handset
		Page 81 of 91

**Table 12-10**  
**Simultaneous Transmission Scenario with 5 GHz WLAN (Hotspot at 1.0 cm)**

**Table 12-11**



FCC ID: A3LSMG950N	 <b>SAR EVALUATION REPORT</b> 		<b>Approved by:</b> Quality Manager
Document S/N: 1M1703100103-01.A3L	Test Dates: 03/06/17 - 03/20/17	DUT Type: Portable Handset	Page 82 of 91

**Table 12-12**  
**Simultaneous Transmission Scenario with Bluetooth (Hotspot at 1.0 cm)**

Exposure Condition	Mode	2G/3G/4G SAR (W/kg)	Bluetooth SAR (W/kg)	Σ SAR (W/kg)
		1	2	1+2
Hotspot SAR	GPRS 1900	0.963	0.012	<b>0.975</b>
	UMTS 850	0.368	0.012	0.380
	UMTS 1900	0.658	0.012	0.670
	LTE Band 12	0.173	0.012	0.185
	LTE Band 13	0.321	0.012	0.333
	LTE Band 26 (Cell)	0.362	0.012	0.374
	LTE Band 5 (Cell)	0.520	0.012	0.532
	LTE Band 4 (AWS)	0.452	0.012	0.464
	LTE Band 25 (PCS)	0.349	0.012	0.361
	LTE Band 41	0.248	0.012	0.260

## 12.6 Simultaneous Transmission Conclusion

The above numerical summed SAR results for all the worst-case simultaneous transmission conditions were below the SAR limit. Therefore, the above analysis is sufficient to determine that simultaneous transmission cases will not exceed the SAR limit and therefore no measured volumetric simultaneous SAR summation is required per FCC KDB Publication 447498 D01v06 and IEEE 1528-2013 Section 6.3.4.1.2.

FCC ID: A3LSMG950N		<b>SAR EVALUATION REPORT</b>		<b>Approved by:</b> Quality Manager
<b>Document S/N:</b> 1M1703100103-01.A3L	<b>Test Dates:</b> 03/06/17 - 03/20/17	<b>DUT Type:</b> Portable Handset	Page 83 of 91	



## 13 SAR MEASUREMENT VARIABILITY

### 13.1 Measurement Variability

Per FCC KDB Publication 865664 D01v01r04, SAR measurement variability was not assessed for each frequency band since all measured SAR values are  $< 0.80$  W/kg for 1g SAR

### 13.2 Measurement Uncertainty

The measured SAR was  $< 1.5$  W/kg for all frequency bands. Therefore, per KDB Publication 865664 D01v01r04, the extended measurement uncertainty analysis per IEEE 1528-2013 was not required.

FCC ID: A3LSMG950N		SAR EVALUATION REPORT		Approved by: Quality Manager
Document S/N: 1M1703100103-01.A3L	Test Dates: 03/06/17 - 03/20/17	DUT Type: Portable Handset		Page 84 of 91

# 14 ADDITIONAL TESTING PER FCC GUIDANCE

## 14.1 Tuner Testing



The following test procedures were followed to demonstrate that the SAR results in Section 11 represented the appropriate SAR test conditions. For bands with dynamic tuning implemented, SAR was measured according to the required FCC SAR test procedures with the dynamic tuner active to allow the device to automatically tune to the antenna state for the respective RF exposure test configurations. Additional single point SAR time-sweep measurements were evaluated for other tuner states to determine that the other tuner configurations would result in equivalent or lower SAR values. The additional tuner hardware has no influence to the antenna characteristics, other than impedance matching.

To evaluate all of the tuner states, the 25 tuner states were divided evenly among band, mode and exposure combinations so that at least one single point SAR measurement was measured among the configurations. Single point time-sweep measurements were performed at the peak SAR location determined by the zoom scan of the configuration with the highest reported SAR for each combination. While inserting and removing the USB cable between single point SAR measurements, the device was ensured to capture the same physical point SAR that generated the highest SAR. The SAR probe remained stationary at the same position throughout the entire series of single point measurements for each combination.

The operational description contains more information about the design and implementation of the dynamic antenna tuning.



**Table 14-1  
Supplemental Head SAR Data**

Supplemental Head SAR Data			
LTE Band 5 Ant A		UMTS 850 Ant A	
QPSK, 10MHz Bandwidth, 1 RB, 0 RB Offset		RMC	
Test Position	Right Cheek	Test Position	Right Cheek
Frequency (MHz)	836.5	Frequency (MHz)	836.6
Channel	20525	Channel	4183
Measured 1g SAR (W/kg)	0.193	Measured 1g SAR (W/kg)	0.203
Average Value of Time Sweep (W/kg)		Average Value of Time Sweep (W/kg)	
Auto-tune (State 7)	0.236	Auto-tune (State 7)	0.232
Default (State 7)	0.239	Default (State 7)	0.221
State 3	0.256	State 2	0.211
State 7	0.239	State 4	0.217
State 11	0.132	State 8	0.215
State 15	0.239	State 12	0.142
State 17	0.221	State 16	0.221
State 21	0.174	State 20	0.089
State 23	0.240	State 24	0.220

FCC ID: A3LSMG950N		<b>SAR EVALUATION REPORT</b>		<b>Approved by:</b> Quality Manager
<b>Document S/N:</b> 1M1703100103-01.A3L	<b>Test Dates:</b> 03/06/17 - 03/20/17	<b>DUT Type:</b> Portable Handset	Page 85 of 91	

**Table 14-2  
Supplemental Body SAR Data**

Supplemental Body SAR Data			
LTE Band 5 Ant A		UMTS 850 Ant A	
QPSK, 10MHz Bandwidth, 1 RB, 0 RB Offset		RMC	
Test Position	Back Side	Test Position	Back Side
Spacing	10 mm	Spacing	10 mm
Frequency (MHz)	836.5	Frequency (MHz)	836.6
Channel	20525	Channel	4183
Measured 1g SAR (W/kg)	0.508	Measured 1g SAR (W/kg)	0.322
Average Value of Time Sweep (W/kg)		Average Value of Time Sweep (W/kg)	
Auto-tune (State 7)	0.599	Auto-tune (State 7)	0.557
Default (State 7)	0.597	Default (State 7)	0.533
State 1	0.603	State 2	0.447
State 5	0.604	State 6	0.500
State 9	0.597	State 10	0.421
State 13	0.342	State 12	0.361
State 19	0.457	State 14	0.498
State 21	0.434	State 18	0.339
State 25	0.561	State 22	0.278



FCC ID: A3LSMG950N		<b>SAR EVALUATION REPORT</b>		<b>Approved by:</b> Quality Manager
<b>Document S/N:</b> 1M1703100103-01.A3L	<b>Test Dates:</b> 03/06/17 - 03/20/17	<b>DUT Type:</b> Portable Handset	Page 86 of 91	

# 15 EQUIPMENT LIST

Manufacturer	Model	Description	Cal Date	Cal Interval	Cal Due	Serial Number
Agilent	8753ES	S-Parameter Network Analyzer	6/28/2016	Annual	6/28/2017	MY40000670
Agilent	8753ES	S-Parameter Vector Network Analyzer	8/19/2016	Annual	8/19/2017	MY40003841
Agilent	E5515C	Wireless Communications Test Set	1/8/2015	Triennial	1/8/2018	GB43163447
Agilent	E5515C	8960 Series 10 Wireless Communications Test Set	10/5/2016	Annual	10/5/2017	GB42230325
Agilent	E5515C	Wireless Communications Test Set	12/12/2016	Annual	12/12/2017	GB44400860
Agilent	N4010A	Wireless Connectivity Test Set	N/A	N/A	N/A	GB44450273
Agilent	N5182A	MXG Vector Signal Generator	10/27/2016	Annual	10/27/2017	MY47420603
Agilent	N9020A	MXA Signal Analyzer	10/28/2016	Annual	10/28/2017	US46470561
Amplifier Research	15S1G6	Amplifier	CBT	N/A	CBT	433971
Anritsu	MA24106A	USB Power Sensor	3/28/2016	Annual	3/28/2017	1344554
Anritsu	MA24106A	USB Power Sensor	6/2/2016	Annual	6/2/2017	1231538
Anritsu	MA2411B	Pulse Power Sensor	2/10/2017	Annual	2/10/2018	1207364
Anritsu	MA2411B	Pulse Power Sensor	2/10/2017	Annual	2/10/2018	1339018
Anritsu	ML2495A	Power Meter	10/16/2015	Biennial	10/16/2017	941001
Anritsu	MT8820C	Radio Communication Analyzer	12/8/2016	Annual	12/8/2017	6201300731
COMTech	AR85729-5	Solid State Amplifier	CBT	N/A	CBT	M155A00-009
Control Company	4352	Ultra Long Stem Thermometer	3/8/2016	Biennial	3/8/2018	160261701
Keysight	772D	Dual Directional Coupler	CBT	N/A	CBT	MY52180215
MCL	BW-N6W5+	6dB Attenuator	CBT	N/A	CBT	1139
MiniCircuits	SLP-2400+	Low Pass Filter	CBT	N/A	CBT	R8979500903
MiniCircuits	VLF-6000+	Low Pass Filter	CBT	N/A	CBT	N/A
Mini-Circuits	BW-N20W5	Power Attenuator	CBT	N/A	CBT	1226
Mini-Circuits	BW-N20W5+	DC to 18 GHz Precision Fixed 20dB Attenuator	CBT	N/A	CBT	N/A
Mini-Circuits	NLP-1200+	Low Pass Filter DC to 1000 MHz	CBT	N/A	CBT	N/A
Mini-Circuits	NLP-2950+	Low Pass Filter DC to 2700 MHz	CBT	N/A	CBT	N/A
Mitutoyo	CD-6°CSX	Digital Caliper	3/2/2016	Biennial	3/2/2018	13264162
Narda	4014C-6	4 - 8 GHz SMA 6dB Directional Coupler	CBT	N/A	CBT	N/A
Narda	4772-3	Attenuator (3dB)	CBT	N/A	CBT	9406
Pasternack	NC-100	Torque Wrench	5/21/2015	Biennial	5/21/2017	N/A
Pasternack	PE2208-6	Bidirectional Coupler	CBT	N/A	CBT	N/A
Pasternack	PE2209-10	Bidirectional Coupler	CBT	N/A	CBT	N/A
Rohde & Schwarz	CMU200	Base Station Simulator	12/12/2016	Annual	12/12/2017	833855/0010
Rohde & Schwarz	CMW500	Radio Communication Tester	3/25/2016	Annual	3/25/2017	128633
Seekonk	NC-100	Torque Wrench	11/6/2015	Biennial	11/6/2017	N/A
Seekonk	NC-100	Torque Wrench 5/16", 8" lbs	3/2/2016	Biennial	3/2/2018	N/A
Seekonk	NC-100	Torque Wrench (8" lb)	8/30/2016	Biennial	8/30/2018	N/A
SPEAG	D1765V2	1765 MHz SAR Dipole	5/11/2016	Annual	5/11/2017	1008
SPEAG	D1900V2	1900 MHz SAR Dipole	7/15/2016	Annual	7/15/2017	5d149
SPEAG	D2450V2	2450 MHz SAR Dipole	7/25/2016	Annual	7/25/2017	981
SPEAG	D2450V2	2450 MHz SAR Dipole	9/13/2016	Annual	9/13/2017	797
SPEAG	D2600V2	2600 MHz SAR Dipole	7/25/2016	Annual	7/25/2017	1126
SPEAG	D2600V2	2600 MHz SAR Dipole	9/13/2016	Annual	9/13/2017	1071
SPEAG	D5GHzV2	5 GHz SAR Dipole	8/2/2016	Annual	8/2/2017	1237
SPEAG	D5GHzV2	5 GHz SAR Dipole	2/13/2017	Annual	2/13/2018	1120
SPEAG	D750V3	750 MHz SAR Dipole	7/13/2016	Annual	7/13/2017	1161
SPEAG	D750V3	750 MHz SAR Dipole	1/11/2017	Annual	1/11/2018	1003
SPEAG	D835V2	835 MHz SAR Dipole	7/13/2016	Annual	7/13/2017	4d047
SPEAG	DAE4	Dasy Data Acquisition Electronics	4/14/2016	Annual	4/14/2017	1407
SPEAG	DAE4	Dasy Data Acquisition Electronics	5/11/2016	Annual	5/11/2017	859
SPEAG	DAE4	Dasy Data Acquisition Electronics	9/14/2016	Annual	9/14/2017	1408
SPEAG	DAE4	Dasy Data Acquisition Electronics	11/11/2016	Annual	11/11/2017	1334
SPEAG	DAE4	Dasy Data Acquisition Electronics	2/9/2017	Annual	2/9/2018	665
SPEAG	DAE4	Dasy Data Acquisition Electronics	2/9/2017	Annual	2/9/2018	1272
SPEAG	DAK-3.5	Dielectric Assessment Kit	5/10/2016	Annual	5/10/2017	1070
SPEAG	E53DV3	SAR Probe	9/19/2016	Annual	9/19/2017	3287
SPEAG	E53DV3	SAR Probe	11/15/2016	Annual	11/15/2017	3334
SPEAG	E53DV3	SAR Probe	2/10/2017	Annual	2/10/2018	3213
SPEAG	E53DV3	SAR Probe	2/10/2017	Annual	2/10/2018	3318
SPEAG	EX3DV4	SAR Probe	4/19/2016	Annual	4/19/2017	7406
SPEAG	EX3DV4	SAR Probe	5/17/2016	Annual	5/17/2017	7409
SPEAG	EX3DV4	SAR Probe	7/21/2016	Annual	7/21/2017	7308
SPEAG	EX3DV4	SAR Probe	2/13/2017	Annual	2/13/2018	3914



**Notes:**

- CBT (Calibrated Before Testing). Prior to testing, the measurement paths containing a cable, amplifier, attenuator, coupler or filter were connected to a calibrated source (i.e. a signal generator) to determine the losses of the measurement path. The power meter offset was then adjusted to compensate for the measurement system losses. This level offset is stored within the power meter before measurements are made. This calibration verification procedure applies to the system verification and output power measurements. The calibrated reading is then taken directly from the power meter after compensation of the losses for all final power measurements.
- Each equipment item was used solely within its respective calibration period.

FCC ID: A3LSMG950N		<b>SAR EVALUATION REPORT</b>		<b>Approved by:</b> Quality Manager
<b>Document S/N:</b> 1M1703100103-01.A3L	<b>Test Dates:</b> 03/06/17 - 03/20/17	<b>DUT Type:</b> Portable Handset	Page 87 of 91	

# 16 MEASUREMENT UNCERTAINTIES

a	c	d	e= f(d,k)	f	g	h = c x f/e	i = c x g/e	k
Uncertainty Component	Tol. (± %)	Prob. Dist.	Div.	c <sub>i</sub> 1gm	c <sub>i</sub> 10 gms	1gm u <sub>i</sub> (± %)	10gms u <sub>i</sub> (± %)	v <sub>i</sub>
<b>Measurement System</b>								
Probe Calibration	6.55	N	1	1.0	1.0	6.6	6.6	∞
Axial Isotropy	0.25	N	1	0.7	0.7	0.2	0.2	∞
Hemishperical Isotropy	1.3	N	1	0.7	0.7	0.9	0.9	∞
Boundary Effect	2.0	R	1.73	1.0	1.0	1.2	1.2	∞
Linearity	0.3	N	1	1.0	1.0	0.3	0.3	∞
System Detection Limits	0.25	R	1.73	1.0	1.0	0.1	0.1	∞
Readout Electronics	0.3	N	1	1.0	1.0	0.3	0.3	∞
Response Time	0.8	R	1.73	1.0	1.0	0.5	0.5	∞
Integration Time	2.6	R	1.73	1.0	1.0	1.5	1.5	∞
RF Ambient Conditions - Noise	3.0	R	1.73	1.0	1.0	1.7	1.7	∞
RF Ambient Conditions - Reflections	3.0	R	1.73	1.0	1.0	1.7	1.7	∞
Probe Positioner Mechanical Tolerance	0.4	R	1.73	1.0	1.0	0.2	0.2	∞
Probe Positioning w/ respect to Phantom	6.7	R	1.73	1.0	1.0	3.9	3.9	∞
Extrapolation, Interpolation & Integration algorithms for Max. SAR Evaluation	4.0	R	1.73	1.0	1.0	2.3	2.3	∞
<b>Test Sample Related</b>								
Test Sample Positioning	2.7	N	1	1.0	1.0	2.7	2.7	35
Device Holder Uncertainty	1.67	N	1	1.0	1.0	1.7	1.7	5
Output Power Variation - SAR drift measurement	5.0	R	1.73	1.0	1.0	2.9	2.9	∞
SAR Scaling	0.0	R	1.73	1.0	1.0	0.0	0.0	∞
<b>Phantom &amp; Tissue Parameters</b>								
Phantom Uncertainty (Shape & Thickness tolerances)	7.6	R	1.73	1.0	1.0	4.4	4.4	∞
Liquid Conductivity - measurement uncertainty	4.2	N	1	0.78	0.71	3.3	3.0	10
Liquid Permittivity - measurement uncertainty	4.1	N	1	0.23	0.26	1.0	1.1	10
Liquid Conductivity - Temperature Uncertainty	3.4	R	1.73	0.78	0.71	1.5	1.4	∞
Liquid Permittivity - Temperature Uncertainty	0.6	R	1.73	0.23	0.26	0.1	0.1	∞
Liquid Conductivity - deviation from target values	5.0	R	1.73	0.64	0.43	1.8	1.2	∞
Liquid Permittivity - deviation from target values	5.0	R	1.73	0.60	0.49	1.7	1.4	∞
<b>Combined Standard Uncertainty (k=1)</b>	RSS					11.5	11.3	60
<b>Expanded Uncertainty</b> (95% CONFIDENCELEVEL)	k=2					23.0	22.6	



FCC ID: A3LSMG950N		<b>SAR EVALUATION REPORT</b>		<b>Approved by:</b> Quality Manager
<b>Document S/N:</b> 1M1703100103-01.A3L	<b>Test Dates:</b> 03/06/17 - 03/20/17	<b>DUT Type:</b> Portable Handset	Page 88 of 91	

# 17 CONCLUSION

## 17.1 Measurement Conclusion



The SAR evaluation indicates that the EUT complies with the RF radiation exposure limits of the FCC and Innovation, Science, and Economic Development Canada, with respect to all parameters subject to this test. These measurements were taken to simulate the RF effects of RF exposure under worst-case conditions. Precise laboratory measures were taken to assure repeatability of the tests. The results and statements relate only to the item(s) tested.

Please note that the absorption and distribution of electromagnetic energy in the body are very complex phenomena that depend on the mass, shape, and size of the body, the orientation of the body with respect to the field vectors, and the electrical properties of both the body and the environment. Other variables that may play a substantial role in possible biological effects are those that characterize the environment (e.g. ambient temperature, air velocity, relative humidity, and body insulation) and those that characterize the individual (e.g. age, gender, activity level, debilitation, or disease). Because various factors may interact with one another to vary the specific biological outcome of an exposure to electromagnetic fields, any protection guide should consider maximal amplification of biological effects as a result of field-body interactions, environmental conditions, and physiological variables. [3]



FCC ID: A3LSMG950N		SAR EVALUATION REPORT		Approved by: Quality Manager
Document S/N: 1M1703100103-01.A3L	Test Dates: 03/06/17 - 03/20/17	DUT Type: Portable Handset		Page 89 of 91

## 18 REFERENCES

- [1] Federal Communications Commission, ET Docket 93-62, Guidelines for Evaluating the Environmental Effects of Radiofrequency Radiation, Aug. 1996.
- [2] ANSI/IEEE C95.1-2005, American National Standard safety levels with respect to human exposure to radio frequency electromagnetic fields, 3kHz to 300GHz, New York: IEEE, 2006.
- [3] ANSI/IEEE C95.1-1992, American National Standard safety levels with respect to human exposure to radio frequency electromagnetic fields, 3kHz to 300GHz, New York: IEEE, Sept. 1992.
- [4] ANSI/IEEE C95.3-2002, IEEE Recommended Practice for the Measurement of Potentially Hazardous Electromagnetic Fields - RF and Microwave, New York: IEEE, December 2002.
- [5] IEEE Standards Coordinating Committee 39 –Standards Coordinating Committee 34 – IEEE Std. 1528-2013, IEEE Recommended Practice for Determining the Peak Spatial-Average Specific Absorption Rate (SAR) in the Human Head from Wireless Communications Devices: Measurement Techniques.
- [6] NCRP, National Council on Radiation Protection and Measurements, Biological Effects and Exposure Criteria for RadioFrequency Electromagnetic Fields, NCRP Report No. 86, 1986. Reprinted Feb. 1995.
- [7] T. Schmid, O. Egger, N. Kuster, Automated E-field scanning system for dosimetric assessments, IEEE Transaction on Microwave Theory and Techniques, vol. 44, Jan. 1996, pp. 105-113.
- [8] K. Pokovic, T. Schmid, N. Kuster, Robust setup for precise calibration of E-field probes in tissue simulating liquids at mobile communications frequencies, ICECOM97, Oct. 1997, pp. 1 -124.
- [9] K. Pokovic, T. Schmid, and N. Kuster, E-field Probe with improved isotropy in brain simulating liquids, Proceedings of the ELMAR, Zadar, Croatia, June 23-25, 1996, pp. 172-175.
- [10] Schmid & Partner Engineering AG, Application Note: Data Storage and Evaluation, June 1998, p2.
- [11] V. Hombach, K. Meier, M. Burkhardt, E. Kuhn, N. Kuster, The Dependence of EM Energy Absorption upon Human Modeling at 900 MHz, IEEE Transaction on Microwave Theory and Techniques, vol. 44 no. 10, Oct. 1996, pp. 1865-1873.
- [12] N. Kuster and Q. Balzano, Energy absorption mechanism by biological bodies in the near field of dipole antennas above 300MHz, IEEE Transaction on Vehicular Technology, vol. 41, no. 1, Feb. 1992, pp. 17-23.
- [13] G. Hartsgrove, A. Kraszewski, A. Surowiec, Simulated Biological Materials for Electromagnetic Radiation Absorption Studies, University of Ottawa, Bioelectromagnetics, Canada: 1987, pp. 29-36.
- [14] Q. Balzano, O. Garay, T. Manning Jr., Electromagnetic Energy Exposure of Simulated Users of Portable Cellular Telephones, IEEE Transactions on Vehicular Technology, vol. 44, no.3, Aug. 1995.
- [15] W. Gander, Computermathematick, Birkhaeuser, Basel, 1992.
- [16] W.H. Press, S.A. Teukolsky, W.T. Vetterling, and B.P. Flannery, Numerical Recipes in C, The Art of Scientific Computing, Second edition, Cambridge University Press, 1992.
- [17] N. Kuster, R. Kastle, T. Schmid, Dosimetric evaluation of mobile communications equipment with known precision, IEEE Transaction on Communications, vol. E80-B, no. 5, May 1997, pp. 645-652.

FCC ID: A3LSMG950N		SAR EVALUATION REPORT		Approved by: Quality Manager
Document S/N: 1M1703100103-01.A3L	Test Dates: 03/06/17 - 03/20/17	DUT Type: Portable Handset		Page 90 of 91

- [18] CENELEC CLC/SC111B, European Prestandard (prENV 50166-2), Human Exposure to Electromagnetic Fields High-frequency: 10kHz-300GHz, Jan. 1995.
- [19] Prof. Dr. Niels Kuster, ETH, Eidgenössische Technische Hochschule Zürich, Dosimetric Evaluation of the Cellular Phone.
- [20] IEC 62209-1, Human exposure to radio frequency fields from hand-held and body-mounted wireless communication devices - Human models, instrumentation, and procedures - Part 1: Procedure to determine the specific absorption rate (SAR) for hand-held devices used in close proximity to the ear (frequency range of 300 MHz to 3 GHz), Feb. 2005.
- [21] Innovation, Science, Economic Development Canada RSS-102 Radio Frequency Exposure Compliance of Radiocommunication Apparatus (All Frequency Bands) Issue 5, March 2015.
- [22] Health Canada Safety Code 6 Limits of Human Exposure to Radio Frequency Electromagnetic Fields in the Frequency Range from 3 kHz – 300 GHz, 2015
- [23] FCC SAR Test Procedures for 2G-3G Devices, Mobile Hotspot and UMPC Devices KDB Publications 941225, D01-D07
- [24] SAR Measurement Guidance for IEEE 802.11 Transmitters, KDB Publication 248227 D01
- [25] FCC SAR Considerations for Handsets with Multiple Transmitters and Antennas, KDB Publications 648474 D03-D04
- [26] FCC SAR Evaluation Considerations for Laptop, Notebook, Netbook and Tablet Computers, FCC KDB Publication 616217 D04
- [27] FCC SAR Measurement and Reporting Requirements for 100MHz – 6 GHz, KDB Publications 865664 D01-D02
- [28] FCC General RF Exposure Guidance and SAR Procedures for Dongles, KDB Publication 447498, D01-D02
- [29] Anexo à Resolução No. 533, de 10 de Setembro de 2009.
- [30] IEC 62209-2, Human exposure to radio frequency fields from hand-held and body-mounted wireless communication devices - Human models, instrumentation, and procedures - Part 2: Procedure to determine the specific absorption rate (SAR) for wireless communication devices used in close proximity to the human body (frequency range of 30 MHz to 6 GHz), Mar. 2010.

<b>FCC ID:</b> A3LSMG950N		<b>SAR EVALUATION REPORT</b>		<b>Approved by:</b> Quality Manager
<b>Document S/N:</b> 1M1703100103-01.A3L	<b>Test Dates:</b> 03/06/17 - 03/20/17	<b>DUT Type:</b> Portable Handset	Page 91 of 91	

## APPENDIX A: SAR TEST DATA

# PCTEST ENGINEERING LABORATORY, INC.

**DUT: A3LSMG950N; Type: Portable Handset; Serial: E3D05**

Communication System: UID 0, GSM; Frequency: 1880 MHz; Duty Cycle: 1:8.3  
Medium: 1900 Head; Medium parameters used:  
 $f = 1880 \text{ MHz}$ ;  $\sigma = 1.421 \text{ S/m}$ ;  $\epsilon_r = 40.086$ ;  $\rho = 1000 \text{ kg/m}^3$   
Phantom section: Left Section

Test Date: 03-13-2017; Ambient Temp: 21.8°C; Tissue Temp: 22.3°C

Probe: ES3DV3 - SN3318; ConvF(5.31, 5.31, 5.31); Calibrated: 2/10/2017;  
Sensor-Surface: 3mm (Mechanical Surface Detection)  
Electronics: DAE4 Sn665; Calibrated: 2/9/2017  
Phantom: SAM with CRP (Left); Type: SAM; Serial: 1715  
Measurement SW: DASY52, Version 52.8 (8); SEMCAD X Version 14.6.10 (7331)

**Mode: GSM 1900, Left Head, Cheek, Mid.ch**

**Area Scan (9x14x1):** Measurement grid: dx=15mm, dy=15mm

**Zoom Scan (5x5x7)/Cube 0:** Measurement grid: dx=8mm, dy=8mm, dz=5mm

Reference Value = 8.191 V/m; Power Drift = 0.09 dB

Peak SAR (extrapolated) = 0.134 W/kg

**SAR(1 g) = 0.086 W/kg**

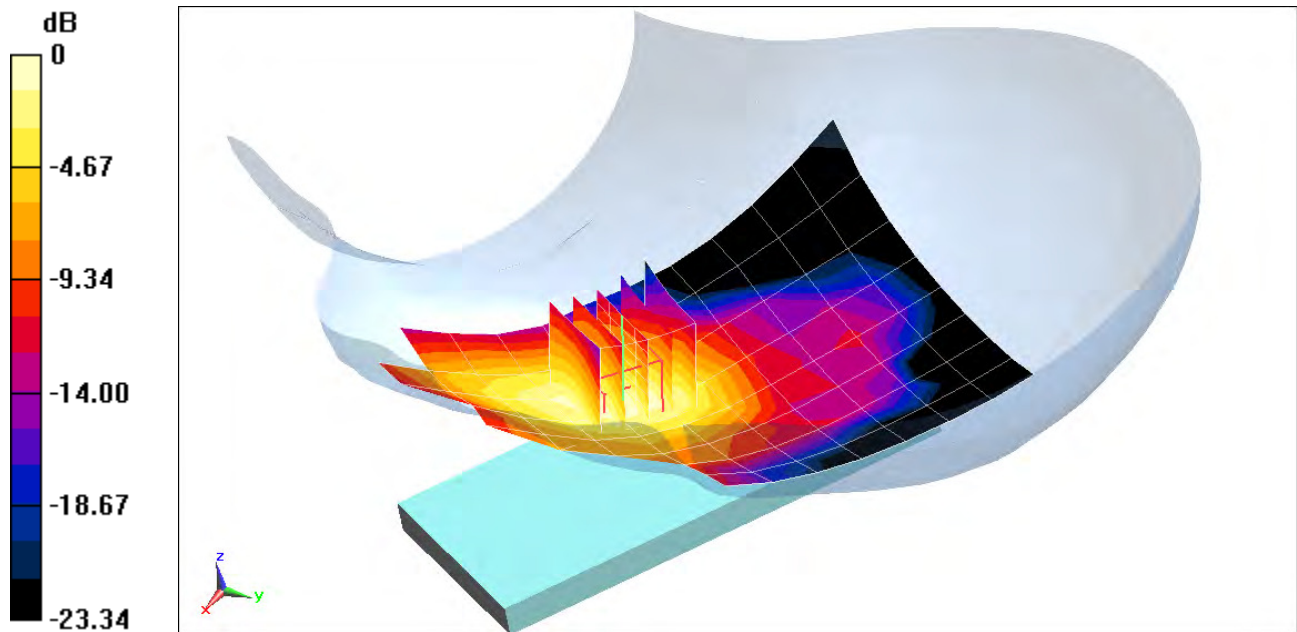

0 dB = 0.101 W/kg = -9.96 dBW/kg

# PCTEST ENGINEERING LABORATORY, INC.

**DUT: A3LSMG950N; Type: Portable Handset; Serial: E3D05**

Communication System: UID 0, UMTS; Frequency: 836.6 MHz; Duty Cycle: 1:1  
Medium: 835 Head; Medium parameters used (interpolated):  
 $f = 836.6 \text{ MHz}$ ;  $\sigma = 0.902 \text{ S/m}$ ;  $\epsilon_r = 41.679$ ;  $\rho = 1000 \text{ kg/m}^3$   
Phantom section: Right Section

Test Date: 03-08-2017; Ambient Temp: 23.5°C; Tissue Temp: 21.2°C

Probe: EX3DV4 - SN7409; ConvF(10.04, 10.04, 10.04); Calibrated: 5/17/2016;  
Sensor-Surface: 1.4mm (Mechanical Surface Detection)  
Electronics: DAE4 Sn859; Calibrated: 5/11/2016  
Phantom: SAM Right; Type: QD000P40CD; Serial: TP:7535  
Measurement SW: DASY52, Version 52.8 (8); SEMCAD X Version 14.6.10 (7331)

**Mode: UMTS 850, Right Head, Cheek, Mid.ch**

**Area Scan (9x15x1):** Measurement grid: dx=15mm, dy=15mm

**Zoom Scan (5x5x7)/Cube 0:** Measurement grid: dx=8mm, dy=8mm, dz=5mm

Reference Value = 15.45 V/m; Power Drift = -0.13 dB

Peak SAR (extrapolated) = 0.257 W/kg

**SAR(1 g) = 0.203 W/kg**

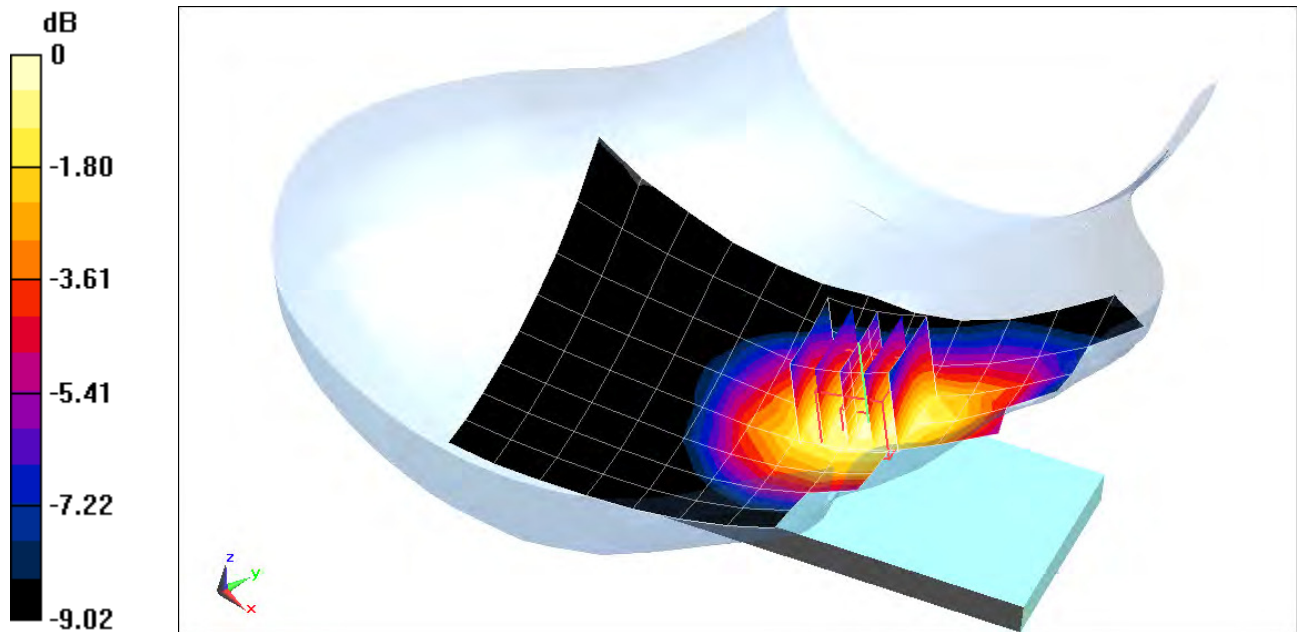

0 dB = 0.239 W/kg = -6.22 dBW/kg

# PCTEST ENGINEERING LABORATORY, INC.

**DUT: A3LSMG950N; Type: Portable Handset; Serial: E3D05**

Communication System: UID 0, UMTS; Frequency: 1880 MHz; Duty Cycle: 1:1  
Medium: 1900 Head; Medium parameters used:  
 $f = 1880 \text{ MHz}$ ;  $\sigma = 1.421 \text{ S/m}$ ;  $\epsilon_r = 40.086$ ;  $\rho = 1000 \text{ kg/m}^3$   
Phantom section: Left Section

Test Date: 03-13-2017; Ambient Temp: 21.8°C; Tissue Temp: 22.3°C

Probe: ES3DV3 - SN3318; ConvF(5.31, 5.31, 5.31); Calibrated: 2/10/2017;  
Sensor-Surface: 3mm (Mechanical Surface Detection)  
Electronics: DAE4 Sn665; Calibrated: 2/9/2017  
Phantom: SAM with CRP (Left); Type: SAM; Serial: 1715  
Measurement SW: DASY52, Version 52.8 (8); SEMCAD X Version 14.6.10 (7331)

**Mode: UMTS 1900, Left Head, Cheek, Mid.ch**

**Area Scan (9x15x1):** Measurement grid: dx=15mm, dy=15mm

**Zoom Scan (5x5x7)/Cube 0:** Measurement grid: dx=8mm, dy=8mm, dz=5mm

Reference Value = 9.203 V/m; Power Drift = 0.02 dB

Peak SAR (extrapolated) = 0.162 W/kg

**SAR(1 g) = 0.107 W/kg**

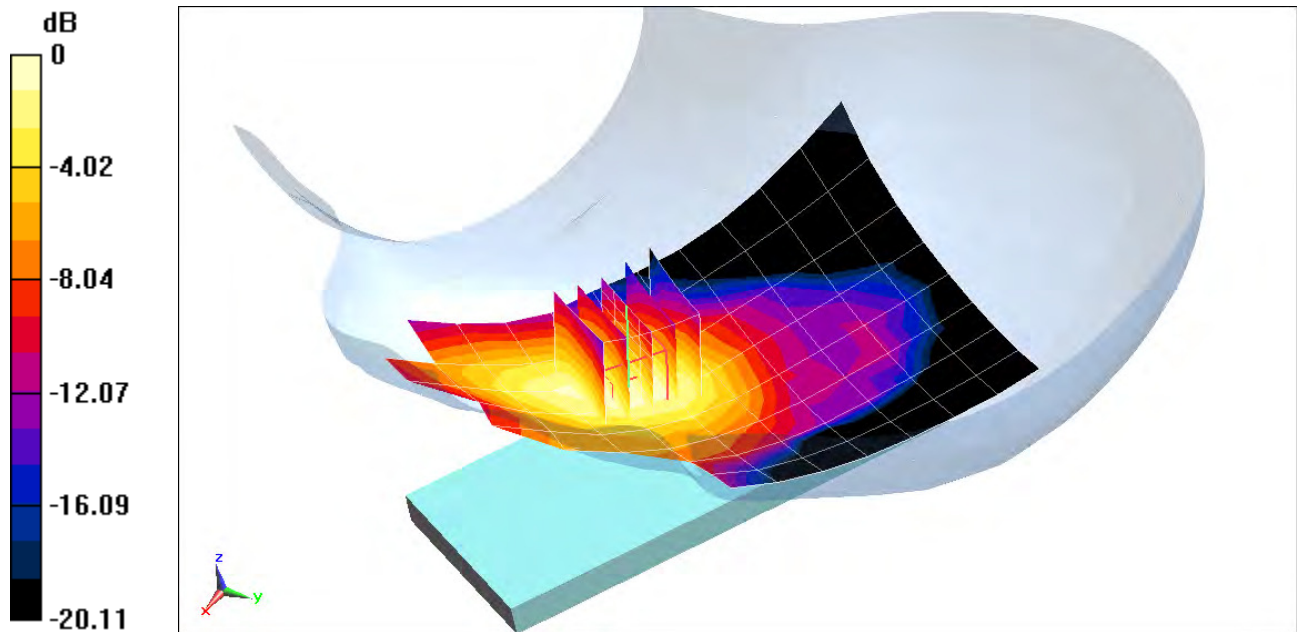

0 dB = 0.125 W/kg = -9.03 dBW/kg

# PCTEST ENGINEERING LABORATORY, INC.

**DUT: A3LSMG950N; Type: Portable Handset; Serial: E3D02**

Communication System: UID 0, LTE Band 12; Frequency: 707.5 MHz; Duty Cycle: 1:1  
Medium: 750 Head; Medium parameters used (interpolated):  
 $f = 707.5 \text{ MHz}$ ;  $\sigma = 0.856 \text{ S/m}$ ;  $\epsilon_r = 40.977$ ;  $\rho = 1000 \text{ kg/m}^3$   
Phantom section: Right Section

Test Date: 03-16-2017; Ambient Temp: 21.1°C; Tissue Temp: 21.3°C

Probe: ES3DV3 - SN3287; ConvF(6.96, 6.96, 6.96); Calibrated: 9/19/2016;  
Sensor-Surface: 3mm (Mechanical Surface Detection)  
Electronics: DAE4 Sn1408; Calibrated: 9/14/2016  
Phantom: SAM Left; Type: QD000P40CA; Serial: TP:82355  
Measurement SW: DASY52, Version 52.8 (8); SEMCAD X Version 14.6.10 (7331)

**Mode: LTE Band 12, Right Head, Cheek, Mid.ch**  
**10 MHz Bandwidth, QPSK, 1 RB, 0 RB Offset**

**Area Scan (9x14x1):** Measurement grid:  $dx=15\text{mm}$ ,  $dy=15\text{mm}$   
**Zoom Scan (5x5x7)/Cube 0:** Measurement grid:  $dx=8\text{mm}$ ,  $dy=8\text{mm}$ ,  $dz=5\text{mm}$   
Reference Value = 8.068 V/m; Power Drift = -0.06 dB  
Peak SAR (extrapolated) = 0.0620 W/kg  
**SAR(1 g) = 0.048 W/kg**

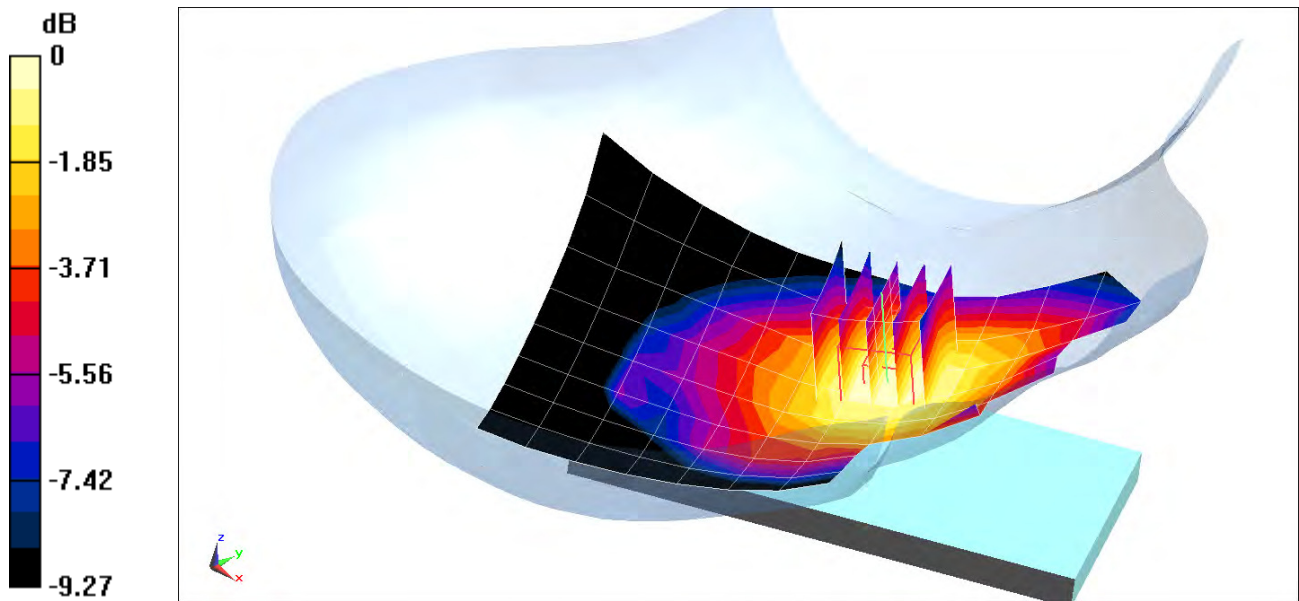

# PCTEST ENGINEERING LABORATORY, INC.

**DUT: A3LSMG950N; Type: Portable Handset; Serial: E3D02**

Communication System: UID 0, LTE Band 13; Frequency: 782 MHz; Duty Cycle: 1:1  
Medium: 750 Head; Medium parameters used (interpolated):  
 $f = 782 \text{ MHz}$ ;  $\sigma = 0.928 \text{ S/m}$ ;  $\epsilon_r = 39.964$ ;  $\rho = 1000 \text{ kg/m}^3$   
Phantom section: Right Section

Test Date: 03-16-2017; Ambient Temp: 21.1°C; Tissue Temp: 21.3°C

Probe: ES3DV3 - SN3287; ConvF(6.96, 6.96, 6.96); Calibrated: 9/19/2016;  
Sensor-Surface: 3mm (Mechanical Surface Detection)  
Electronics: DAE4 Sn1408; Calibrated: 9/14/2016  
Phantom: SAM Left; Type: QD000P40CA; Serial: TP:82355  
Measurement SW: DASY52, Version 52.8 (8); SEMCAD X Version 14.6.10 (7331)

**Mode: LTE Band 13, Right Head, Cheek, Mid.ch**  
**10 MHz Bandwidth, QPSK, 1 RB, 0 RB Offset**

**Area Scan (9x13x1):** Measurement grid:  $dx=15\text{mm}$ ,  $dy=15\text{mm}$   
**Zoom Scan (5x5x7)/Cube 0:** Measurement grid:  $dx=8\text{mm}$ ,  $dy=8\text{mm}$ ,  $dz=5\text{mm}$   
Reference Value = 12.12 V/m; Power Drift = 0.17 dB  
Peak SAR (extrapolated) = 0.159 W/kg  
**SAR(1 g) = 0.122 W/kg**

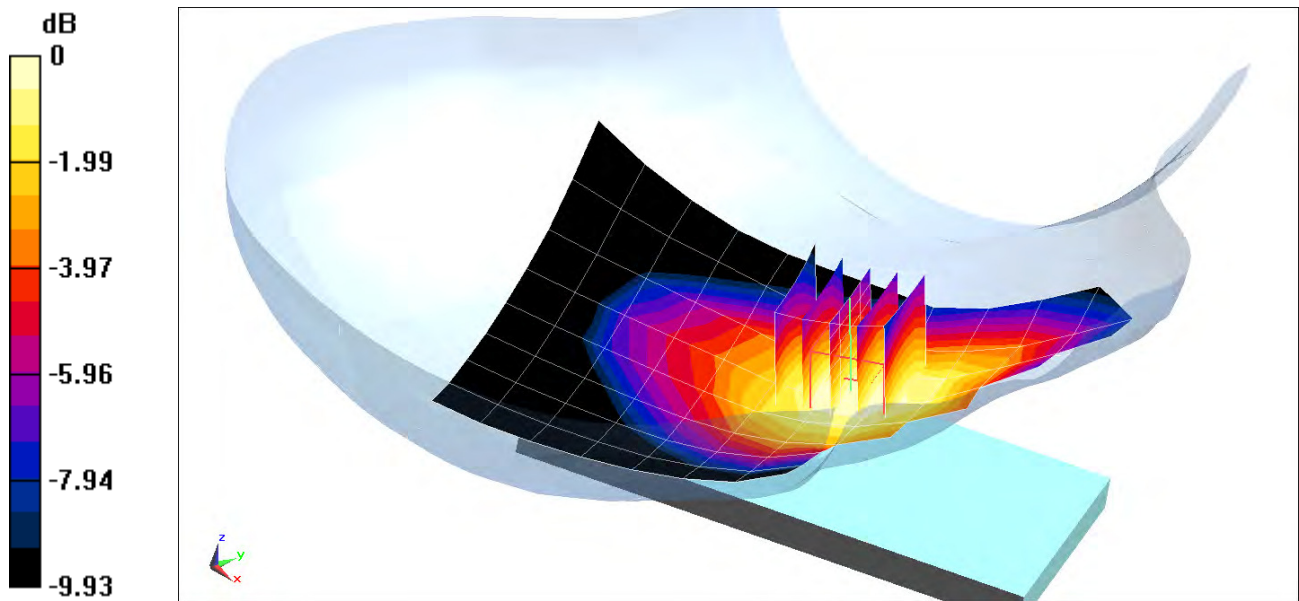

0 dB = 0.134 W/kg = -8.73 dBW/kg

# PCTEST ENGINEERING LABORATORY, INC.

**DUT: A3LSMG950N; Type: Portable Handset; Serial: E3D05**

Communication System: UID 0, LTE Band 26; Frequency: 831.5 MHz; Duty Cycle: 1:1  
Medium: 835 Head; Medium parameters used (interpolated):  
 $f = 831.5 \text{ MHz}$ ;  $\sigma = 0.897 \text{ S/m}$ ;  $\epsilon_r = 41.741$ ;  $\rho = 1000 \text{ kg/m}^3$   
Phantom section: Right Section

Test Date: 03-08-2017; Ambient Temp: 23.5°C; Tissue Temp: 21.2°C

Probe: EX3DV4 - SN7409; ConvF(10.04, 10.04, 10.04); Calibrated: 5/17/2016;  
Sensor-Surface: 1.4mm (Mechanical Surface Detection)  
Electronics: DAE4 Sn859; Calibrated: 5/11/2016  
Phantom: SAM Right; Type: QD000P40CD; Serial: TP:7535  
Measurement SW: DASY52, Version 52.8 (8); SEMCAD X Version 14.6.10 (7331)

**Mode: LTE Band 26 (Cell.), Right Head, Cheek, Mid.ch**  
**15 MHz Bandwidth, QPSK, 1 RB, 36 RB Offset**

**Area Scan (9x15x1):** Measurement grid:  $dx=15\text{mm}$ ,  $dy=15\text{mm}$   
**Zoom Scan (6x6x7)/Cube 0:** Measurement grid:  $dx=8\text{mm}$ ,  $dy=8\text{mm}$ ,  $dz=5\text{mm}$   
Reference Value = 14.10 V/m; Power Drift = -0.09 dB  
Peak SAR (extrapolated) = 0.216 W/kg  
**SAR(1 g) = 0.169 W/kg**

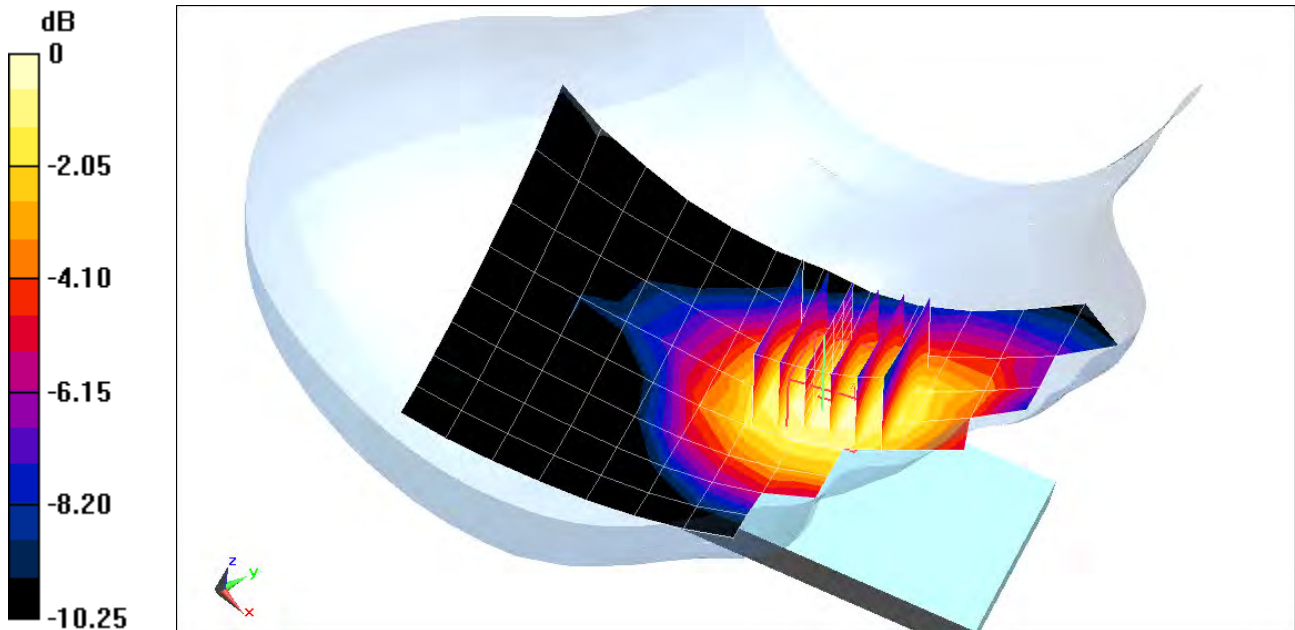

# PCTEST ENGINEERING LABORATORY, INC.

**DUT: A3LSMG950N; Type: Portable Handset; Serial: E3D05**

Communication System: UID 0, LTE Band 5 (Cell.); Frequency: 836.5 MHz; Duty Cycle: 1:1  
Medium: 835 Head; Medium parameters used (interpolated):  
 $f = 836.5 \text{ MHz}$ ;  $\sigma = 0.902 \text{ S/m}$ ;  $\epsilon_r = 41.681$ ;  $\rho = 1000 \text{ kg/m}^3$   
Phantom section: Right Section

Test Date: 03-08-2017; Ambient Temp: 23.5°C; Tissue Temp: 21.2°C

Probe: EX3DV4 - SN7409; ConvF(10.04, 10.04, 10.04); Calibrated: 5/17/2016;  
Sensor-Surface: 1.4mm (Mechanical Surface Detection)  
Electronics: DAE4 Sn859; Calibrated: 5/11/2016  
Phantom: SAM Right; Type: QD000P40CD; Serial: TP:7535  
Measurement SW: DASY52, Version 52.8 (8); SEMCAD X Version 14.6.10 (7331)

**Mode: LTE Band 5 (Cell.), Right Head, Cheek, Mid.ch**  
**10 MHz Bandwidth, QPSK, 1 RB, 0 RB Offset**

**Area Scan (9x15x1):** Measurement grid:  $dx=15\text{mm}$ ,  $dy=15\text{mm}$   
**Zoom Scan (5x5x7)/Cube 0:** Measurement grid:  $dx=8\text{mm}$ ,  $dy=8\text{mm}$ ,  $dz=5\text{mm}$   
Reference Value = 15.37 V/m; Power Drift = 0.07 dB  
Peak SAR (extrapolated) = 0.244 W/kg  
**SAR(1 g) = 0.193 W/kg**

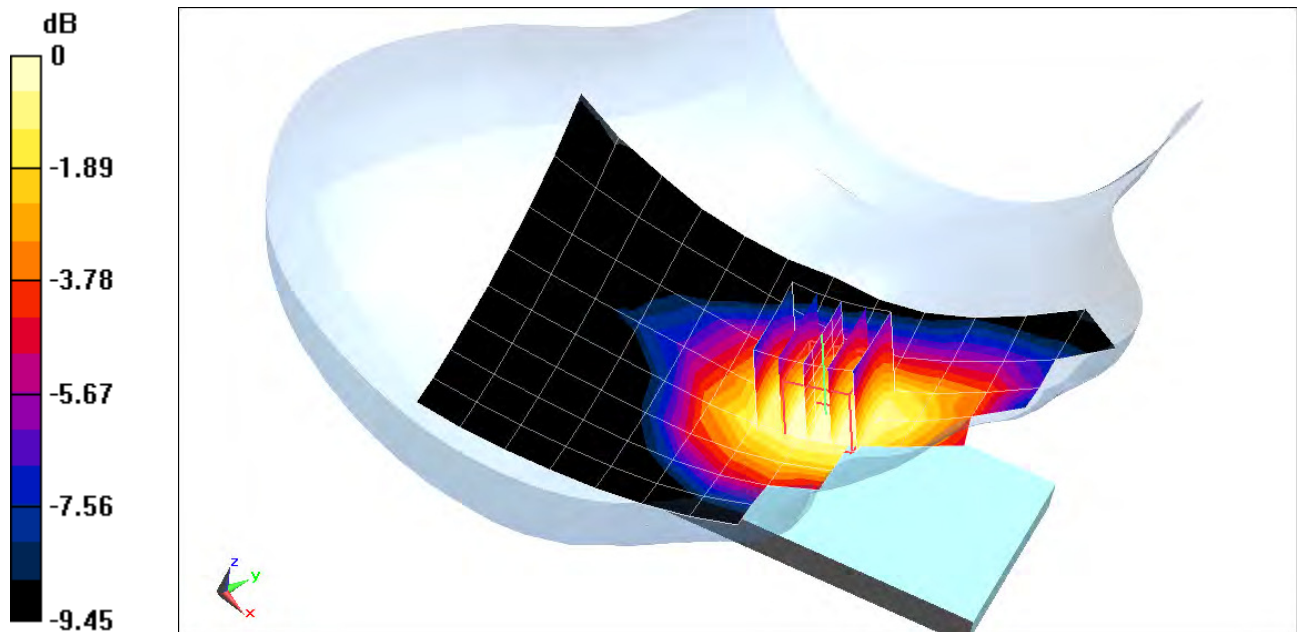

0 dB = 0.225 W/kg = -6.48 dBW/kg

# PCTEST ENGINEERING LABORATORY, INC.

**DUT: A3LSMG950N; Type: Portable Handset; Serial: E3D11**

Communication System: UID 0, LTE Band 4 (AWS); Frequency: 1732.5 MHz; Duty Cycle: 1:1  
Medium: 1750 Head; Medium parameters used (interpolated):  
 $f = 1732.5 \text{ MHz}$ ;  $\sigma = 1.364 \text{ S/m}$ ;  $\epsilon_r = 39.08$ ;  $\rho = 1000 \text{ kg/m}^3$   
Phantom section: Left Section

Test Date: 03-13-2017; Ambient Temp: 22.5°C; Tissue Temp: 21.5°C

Probe: ES3DV3 - SN3213; ConvF(5.49, 5.49, 5.49); Calibrated: 2/10/2017;  
Sensor-Surface: 3mm (Mechanical Surface Detection)  
Electronics: DAE4 Sn1272; Calibrated: 2/9/2017  
Phantom: SAM Front; Type: QD000P40CD; Serial: TP:1758  
Measurement SW: DASY52, Version 52.8 (8); SEMCAD X Version 14.6.10 (7331)

**Mode: LTE Band 4 (AWS), Left Head, Cheek, Mid.ch**  
**20 MHz Bandwidth, QPSK, 1 RB, 0 RB Offset**

**Area Scan (9x15x1):** Measurement grid:  $dx=15\text{mm}$ ,  $dy=15\text{mm}$   
**Zoom Scan (5x5x7)/Cube 0:** Measurement grid:  $dx=8\text{mm}$ ,  $dy=8\text{mm}$ ,  $dz=5\text{mm}$   
Reference Value = 12.95 V/m; Power Drift = 0.03 dB  
Peak SAR (extrapolated) = 0.276 W/kg  
**SAR(1 g) = 0.182 W/kg**

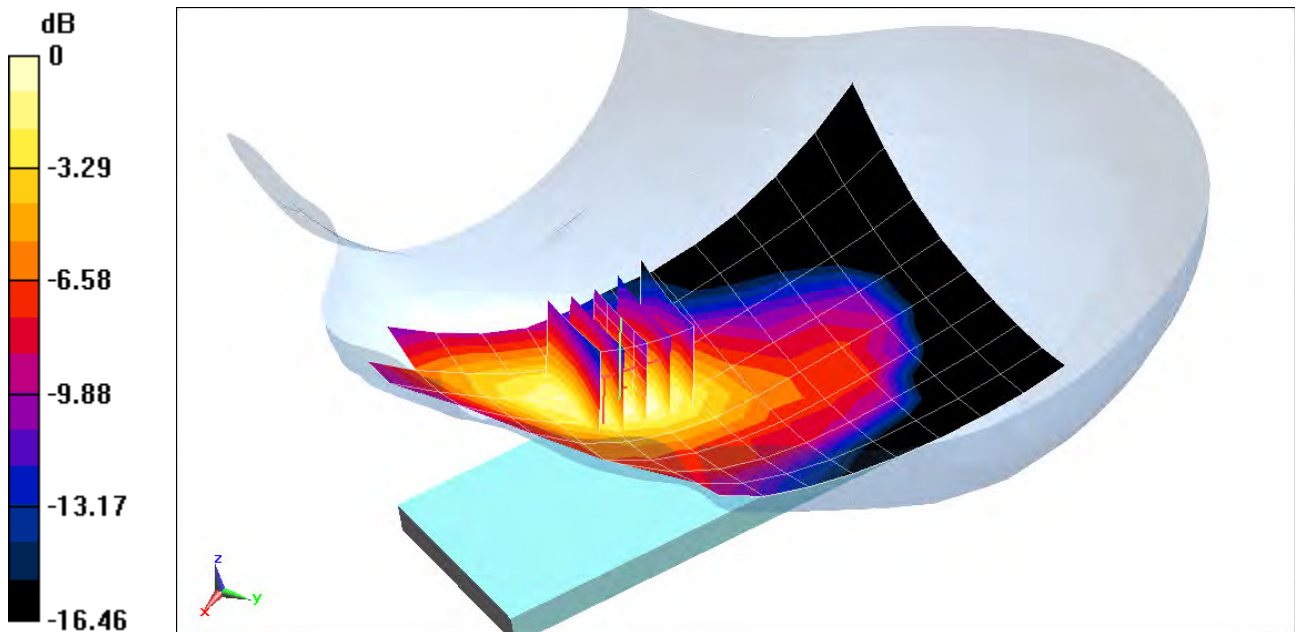

0 dB = 0.214 W/kg = -6.70 dBW/kg

# PCTEST ENGINEERING LABORATORY, INC.

**DUT: A3LSMG950N; Type: Portable Handset; Serial: E3D05**

Communication System: UID 0, LTE Band 25 (PCS); Frequency: 1905 MHz; Duty Cycle: 1:1  
Medium: 1900 Head; Medium parameters used (interpolated):  
 $f = 1905 \text{ MHz}$ ;  $\sigma = 1.446 \text{ S/m}$ ;  $\epsilon_r = 39.976$ ;  $\rho = 1000 \text{ kg/m}^3$   
Phantom section: Left Section

Test Date: 03-13-2017; Ambient Temp: 21.8°C; Tissue Temp: 22.3°C

Probe: ES3DV3 - SN3318; ConvF(5.31, 5.31, 5.31); Calibrated: 2/10/2017;  
Sensor-Surface: 3mm (Mechanical Surface Detection)  
Electronics: DAE4 Sn665; Calibrated: 2/9/2017  
Phantom: SAM with CRP (Left); Type: SAM; Serial: 1715  
Measurement SW: DASY52, Version 52.8 (8); SEMCAD X Version 14.6.10 (7331)

**Mode: LTE Band 25 (PCS), Left Head, Cheek, High.ch**  
**20 MHz Bandwidth, QPSK, 1 RB, 99 RB Offset**

**Area Scan (7x14x1):** Measurement grid: dx=15mm, dy=15mm  
**Zoom Scan (5x5x7)/Cube 0:** Measurement grid: dx=8mm, dy=8mm, dz=5mm  
Reference Value = 12.16 V/m; Power Drift = 0.03 dB  
Peak SAR (extrapolated) = 0.270 W/kg  
**SAR(1 g) = 0.171 W/kg**

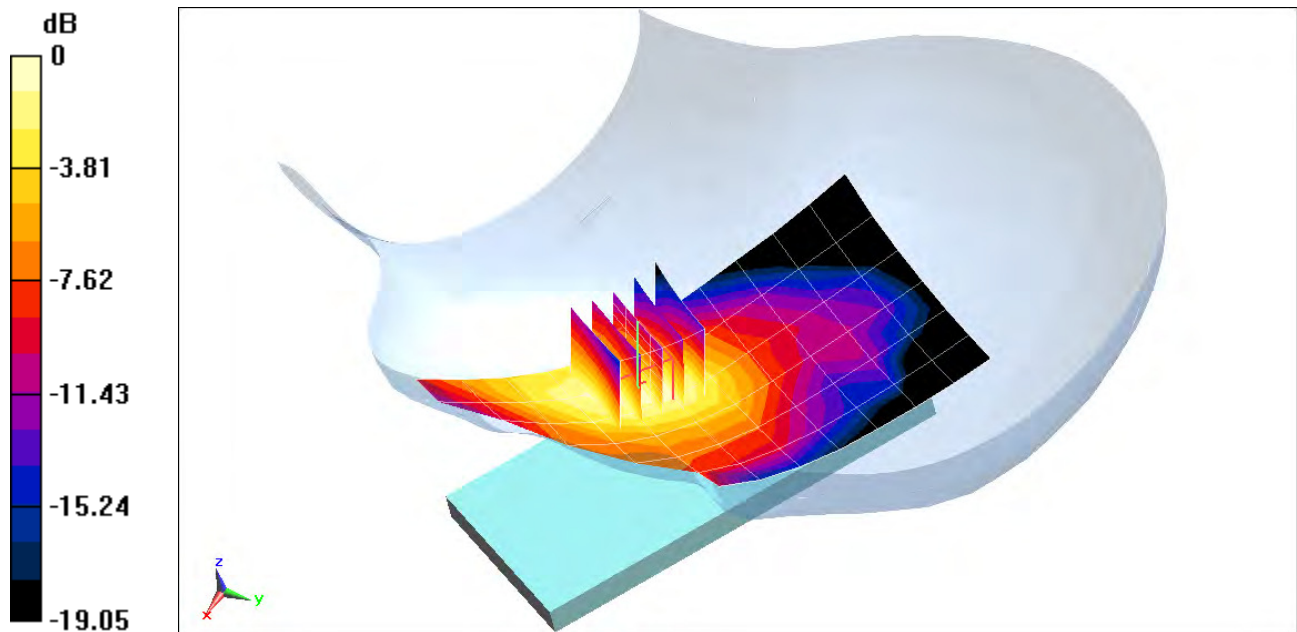

0 dB = 0.204 W/kg = -6.90 dBW/kg

# PCTEST ENGINEERING LABORATORY, INC.

**DUT: A3LSMG950N; Type: Portable Handset; Serial: E3D11**

Communication System: UID 0, LTE Band 41; Frequency: 2506 MHz; Duty Cycle: 1:1.58  
Medium: 2450 Head; Medium parameters used (interpolated):  
 $f = 2506 \text{ MHz}$ ;  $\sigma = 1.917 \text{ S/m}$ ;  $\epsilon_r = 38.514$ ;  $\rho = 1000 \text{ kg/m}^3$   
Phantom section: Left Section

Test Date: 03-06-2017; Ambient Temp: 23.6°C; Tissue Temp: 20.8°C

Probe: ES3DV3 - SN3287; ConvF(4.54, 4.54, 4.54); Calibrated: 9/19/2016;  
Sensor-Surface: 3mm (Mechanical Surface Detection)  
Electronics: DAE4 Sn1408; Calibrated: 9/14/2016  
Phantom: SAM Front; Type: SAM; Serial: 1686  
Measurement SW: DASY52, Version 52.8 (8); SEMCAD X Version 14.6.10 (7331)

**Mode: LTE Band 41, Left Head, Cheek, Low.ch, QPSK**  
**20 MHz Bandwidth, 50 RB, 50 RB Offset**

**Area Scan (10x17x1):** Measurement grid:  $dx=12\text{mm}$ ,  $dy=12\text{mm}$   
**Zoom Scan (8x8x7)/Cube 0:** Measurement grid:  $dx=5\text{mm}$ ,  $dy=5\text{mm}$ ,  $dz=5\text{mm}$   
Reference Value = 4.459 V/m; Power Drift = 0.15 dB  
Peak SAR (extrapolated) = 0.0510 W/kg  
**SAR(1 g) = 0.028 W/kg**

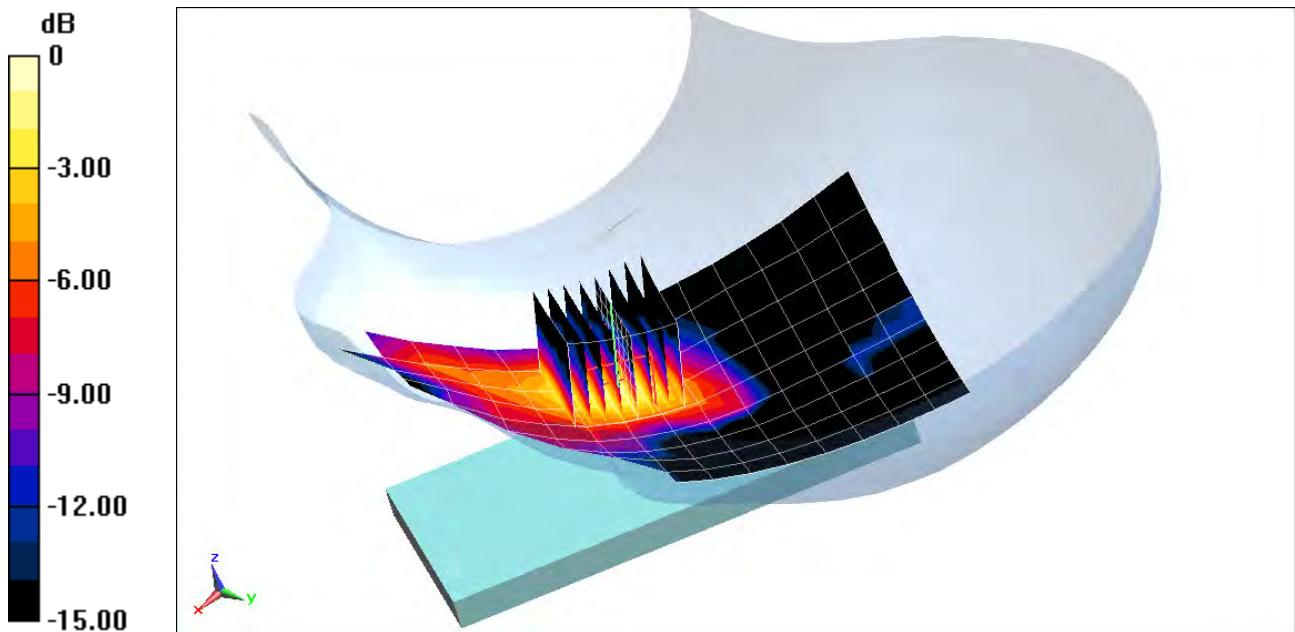

0 dB = 0.0347 W/kg = -14.60 dBW/kg

# PCTEST ENGINEERING LABORATORY, INC.

**DUT: A3LSMG950N; Type: Portable Handset; Serial: E3D11**

Communication System: UID 0, IEEE 802.11b; Frequency: 2437 MHz; Duty Cycle: 1:1  
Medium: 2450 Head; Medium parameters used (interpolated):  
 $f = 2437 \text{ MHz}$ ;  $\sigma = 1.84 \text{ S/m}$ ;  $\epsilon_r = 38.78$ ;  $\rho = 1000 \text{ kg/m}^3$   
Phantom section: Right Section

Test Date: 03-06-2017; Ambient Temp: 23.6°C; Tissue Temp: 20.8°C

Probe: ES3DV3 - SN3287; ConvF(4.54, 4.54, 4.54); Calibrated: 9/19/2016;  
Sensor-Surface: 3mm (Mechanical Surface Detection)  
Electronics: DAE4 Sn1408; Calibrated: 9/14/2016  
Phantom: SAM Front; Type: SAM; Serial: 1686  
Measurement SW: DASY52, Version 52.8 (8); SEMCAD X Version 14.6.10 (7331)

**Mode: IEEE 802.11b, Antenna 2, 22 MHz Bandwidth, Right Head, Cheek, Ch 6, 1 Mbps**

**Area Scan (11x18x1):** Measurement grid: dx=12mm, dy=12mm  
**Zoom Scan (7x8x7)/Cube 0:** Measurement grid: dx=5mm, dy=5mm, dz=5mm  
Reference Value = 18.41 V/m; Power Drift = 0.21 dB  
Peak SAR (extrapolated) = 1.21 W/kg  
**SAR(1 g) = 0.547 W/kg**

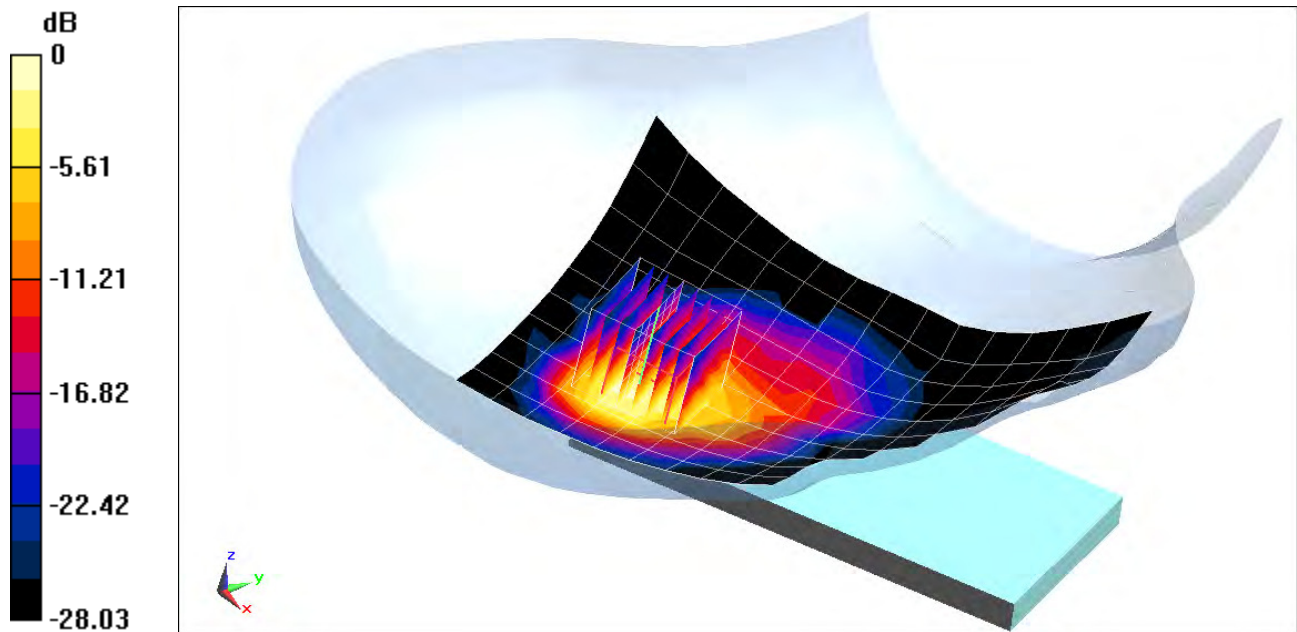

0 dB = 0.727 W/kg = -1.38 dBW/kg

# PCTEST ENGINEERING LABORATORY, INC.

**DUT: A3LSMG950N; Type: Portable Handset; Serial: E3D12**

Communication System: UID 0, 802.11ac 5.2-5.8 GHz Band; Frequency: 5290 MHz; Duty Cycle: 1:1  
Medium: 5GHz Head; Medium parameters used (interpolated):  
 $f = 5290 \text{ MHz}$ ;  $\sigma = 4.806 \text{ S/m}$ ;  $\epsilon_r = 35.745$ ;  $\rho = 1000 \text{ kg/m}^3$   
Phantom section: Right Section

Test Date: 03-13-2017; Ambient Temp: 20.2°C; Tissue Temp: 19.9°C

Probe: EX3DV4 - SN3914; ConvF(5.49, 5.49, 5.49); Calibrated: 2/13/2017;

Sensor-Surface: 1.4mm (Mechanical Surface Detection)

Electronics: DAE4 Sn1334; Calibrated: 11/11/2016

Phantom: SAM with CRP v4.0; Type: QD000P40CD; Serial: TP:1800

Measurement SW: DASY52, Version 52.8 (8); SEMCAD X Version 14.6.10 (7331)

**Mode: IEEE 802.11ac, Antenna 2, U-NII-2A, 80 MHz Bandwidth  
Right Head, Tilt, Ch 58, 29.3 Mbps**

**Area Scan (13x22x1):** Measurement grid: dx=10mm, dy=10mm

**Zoom Scan (8x8x7)/Cube 0:** Measurement grid: dx=4mm, dy=4mm, dz=1.4mm; Graded Ratio: 1.4

Reference Value = 6.814 V/m; Power Drift = 0.18 dB

Peak SAR (extrapolated) = 1.31 W/kg

**SAR(1 g) = 0.279 W/kg**

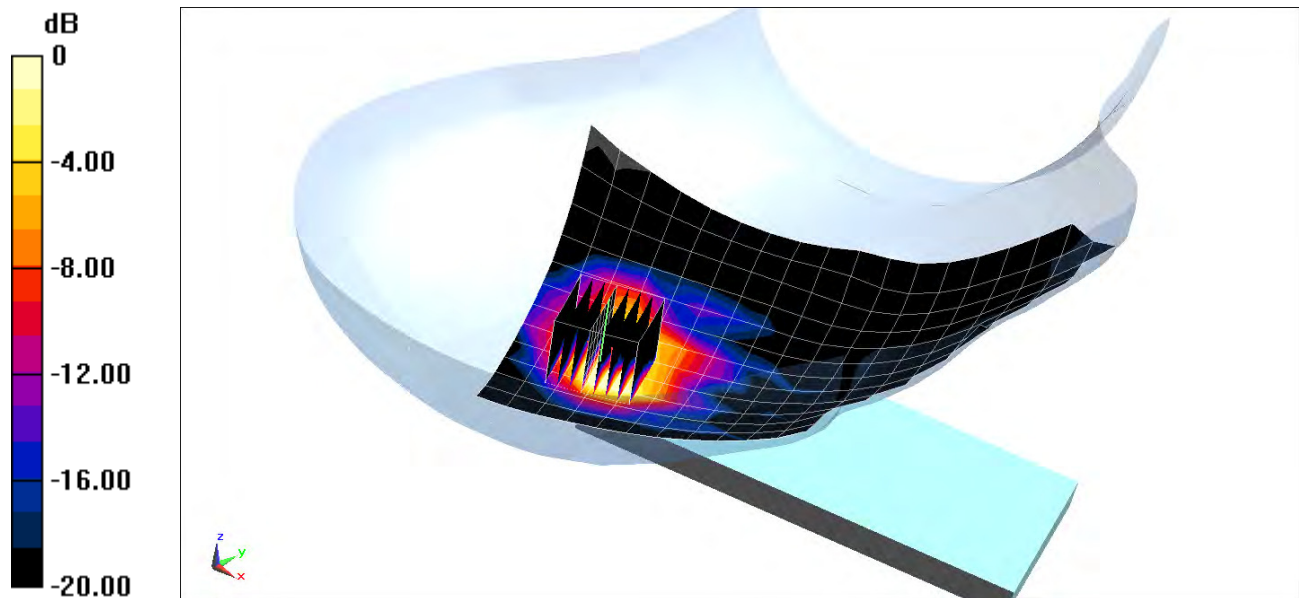

0 dB = 0.756 W/kg = -1.21 dBW/kg

# PCTEST ENGINEERING LABORATORY, INC.

**DUT: A3LSMG950N; Type: Portable Handset; Serial: E3D02**

Communication System: UID 0, Bluetooth; Frequency: 2441 MHz; Duty Cycle: 1:1.306

Medium: 2450 Head; Medium parameters used (interpolated):

$f = 2441 \text{ MHz}$ ;  $\sigma = 1.861 \text{ S/m}$ ;  $\epsilon_r = 37.749$ ;  $\rho = 1000 \text{ kg/m}^3$

Phantom section: Right Section

Test Date: 03-09-2017; Ambient Temp: 20.9°C; Tissue Temp: 22.1°C

Probe: ES3DV3 - SN3287; ConvF(4.54, 4.54, 4.54); Calibrated: 9/19/2016;

Sensor-Surface: 3mm (Mechanical Surface Detection)

Electronics: DAE4 Sn1408; Calibrated: 9/14/2016

Phantom: SAM Front; Type: SAM; Serial: 1686

Measurement SW: DASY52, Version 52.8 (8); SEMCAD X Version 14.6.10 (7331)

**Mode: Bluetooth, Right Head, Cheek, Ch 39, 2Mbps**

**Area Scan (10x16x1):** Measurement grid: dx=12mm, dy=12mm

**Zoom Scan (11x9x7)/Cube 0:** Measurement grid: dx=5mm, dy=5mm, dz=5mm

Reference Value = 1.978 V/m; Power Drift = -0.15 dB

Peak SAR (extrapolated) = 0.0900 W/kg

**SAR(1 g) = 0.033 W/kg**

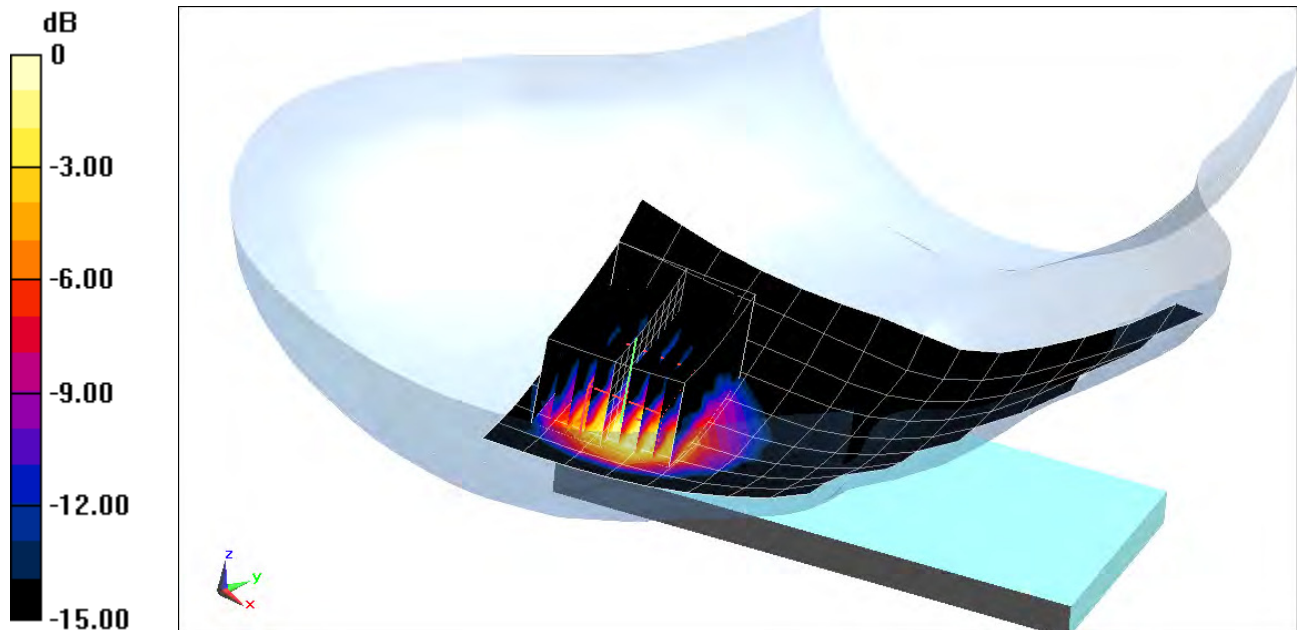

0 dB = 0.0471 W/kg = -13.27 dBW/kg

# PCTEST ENGINEERING LABORATORY, INC.

**DUT: A3LSMG950N; Type: Portable Handset; Serial: E3D11**

Communication System: UID 0, GSM; Frequency: 1880 MHz; Duty Cycle: 1:8.3  
Medium: 1900 Body; Medium parameters used:  
 $f = 1880 \text{ MHz}$ ;  $\sigma = 1.516 \text{ S/m}$ ;  $\epsilon_r = 52.299$ ;  $\rho = 1000 \text{ kg/m}^3$   
Phantom section: Flat Section; Space: 1.5 cm

Test Date: 03-07-2017; Ambient Temp: 23.2°C; Tissue Temp: 21.9°C

Probe: ES3DV3 - SN3334; ConvF(4.91, 4.91, 4.91); Calibrated: 11/15/2016;  
Sensor-Surface: 3mm (Mechanical Surface Detection)  
Electronics: DAE4 Sn1334; Calibrated: 11/11/2016

Phantom: SAM with CRP v4.0 Left; Type: QD000P40CD; Serial: TP:1692  
Measurement SW: DASY52, Version 52.8 (8); SEMCAD X Version 14.6.10 (7331)

**Mode: GSM 1900, Body SAR, Back side, Mid.ch**

**Area Scan (9x15x1):** Measurement grid:  $dx=15\text{mm}$ ,  $dy=15\text{mm}$

**Zoom Scan (5x5x7)/Cube 0:** Measurement grid:  $dx=8\text{mm}$ ,  $dy=8\text{mm}$ ,  $dz=5\text{mm}$

Reference Value = 16.57 V/m; Power Drift = -0.05 dB

Peak SAR (extrapolated) = 0.582 W/kg

**SAR(1 g) = 0.365 W/kg**

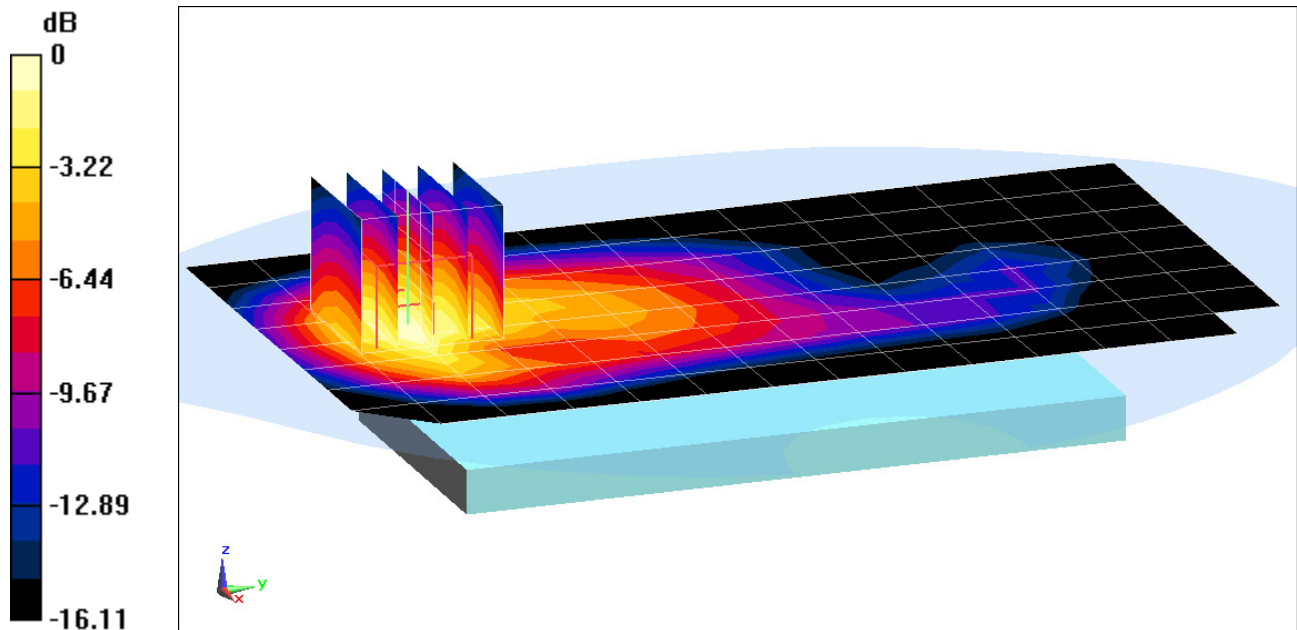

0 dB = 0.433 W/kg = -3.64 dBW/kg

# PCTEST ENGINEERING LABORATORY, INC.

**DUT: A3LSMG950N; Type: Portable Handset; Serial: E3D11**

Communication System: UID 0, GSM GPRS; 4 Tx slots; Frequency: 1850.2 MHz; Duty Cycle: 1:2.076  
Medium: 1900 Body; Medium parameters used (interpolated):  
 $f = 1850.2 \text{ MHz}$ ;  $\sigma = 1.48 \text{ S/m}$ ;  $\epsilon_r = 52.341$ ;  $\rho = 1000 \text{ kg/m}^3$   
Phantom section: Flat Section; Space: 1.0 cm

Test Date: 03-07-2017; Ambient Temp: 23.2°C; Tissue Temp: 21.9°C

Probe: ES3DV3 - SN3334; ConvF(4.91, 4.91, 4.91); Calibrated: 11/15/2016;  
Sensor-Surface: 3mm (Mechanical Surface Detection)  
Electronics: DAE4 Sn1334; Calibrated: 11/11/2016

Phantom: SAM with CRP v4.0 Left; Type: QD000P40CD; Serial: TP:1692  
Measurement SW: DASY52, Version 52.8 (8); SEMCAD X Version 14.6.10 (7331)

**Mode: GPRS 1900, Body SAR, Bottom Edge, Low.ch, 4 Tx Slots**

**Area Scan (10x7x1):** Measurement grid:  $dx=5\text{mm}$ ,  $dy=15\text{mm}$

**Zoom Scan (5x5x7)/Cube 0:** Measurement grid:  $dx=8\text{mm}$ ,  $dy=8\text{mm}$ ,  $dz=5\text{mm}$

Reference Value = 24.35 V/m; Power Drift = 0.01 dB

Peak SAR (extrapolated) = 1.24 W/kg

**SAR(1 g) = 0.748 W/kg**

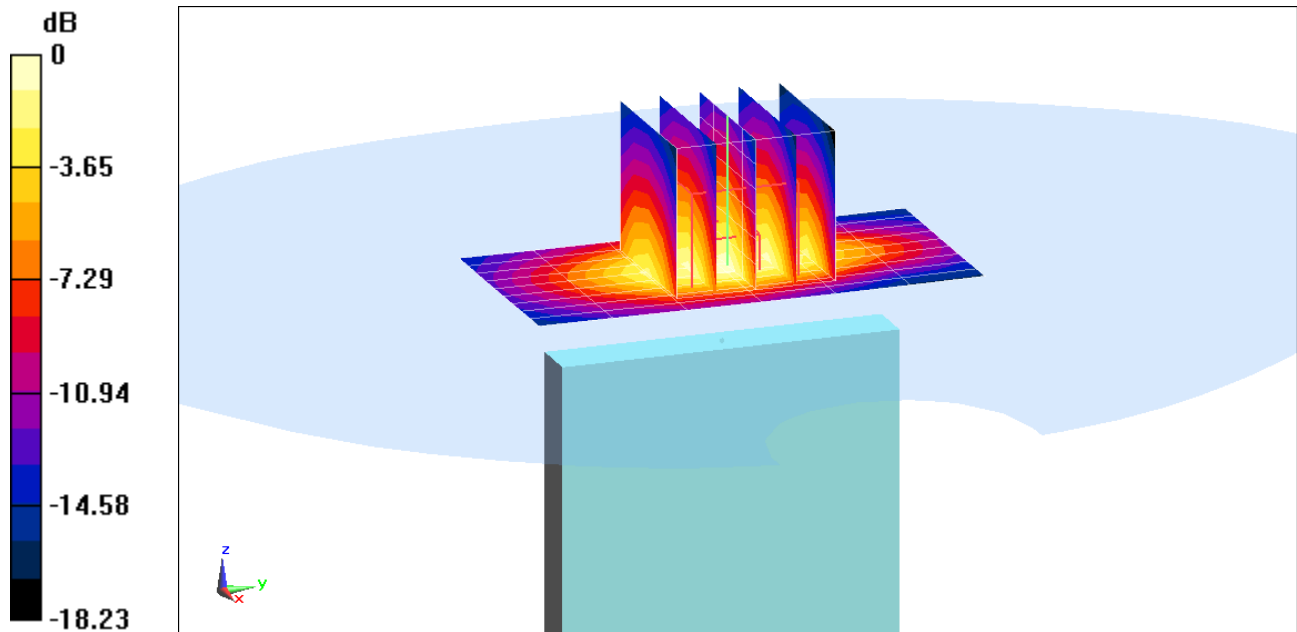

0 dB = 0.931 W/kg = -0.31 dBW/kg

# PCTEST ENGINEERING LABORATORY, INC.

**DUT: A3LSMG950N; Type: Portable Handset; Serial: E3D12**

Communication System: UID 0, UMTS; Frequency: 836.6 MHz; Duty Cycle: 1:1  
Medium: 835 Body; Medium parameters used (interpolated):  
 $f = 836.6 \text{ MHz}$ ;  $\sigma = 0.987 \text{ S/m}$ ;  $\epsilon_r = 53.534$ ;  $\rho = 1000 \text{ kg/m}^3$   
Phantom section: Flat Section; Space: 1.5 cm

Test Date: 03-08-2017; Ambient Temp: 24.5°C; Tissue Temp: 24.1°C

Probe: ES3DV3 - SN3318; ConvF(6.37, 6.37, 6.37); Calibrated: 2/10/2017;  
Sensor-Surface: 3mm (Mechanical Surface Detection)  
Electronics: DAE4 Sn665; Calibrated: 2/9/2017  
Phantom: SAM with CRP (Left); Type: SAM; Serial: 1715  
Measurement SW: DASY52, Version 52.8 (8); SEMCAD X Version 14.6.10 (7331)

**Mode: UMTS 850, Body SAR, Back side, Mid.ch**

**Area Scan (9x15x1):** Measurement grid: dx=15mm, dy=15mm

**Zoom Scan (5x5x7)/Cube 0:** Measurement grid: dx=8mm, dy=8mm, dz=5mm

Reference Value = 17.24 V/m; Power Drift = 0.00 dB

Peak SAR (extrapolated) = 0.357 W/kg

**SAR(1 g) = 0.269 W/kg**

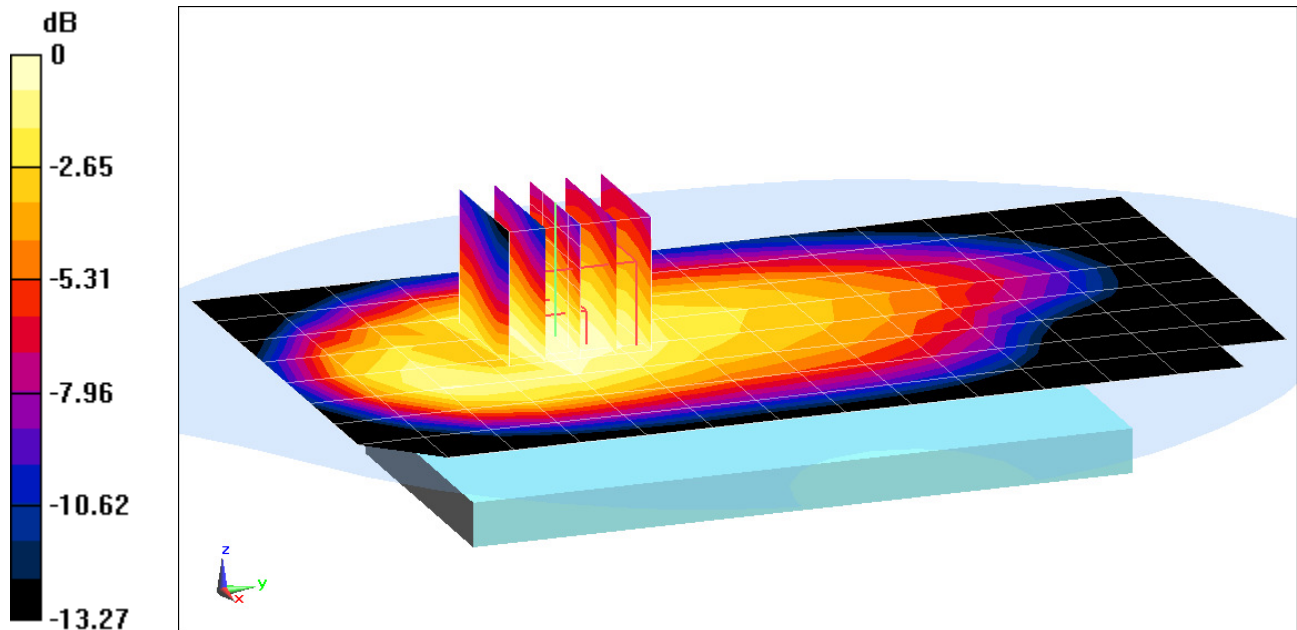

0 dB = 0.301 W/kg = -5.21 dBW/kg

# PCTEST ENGINEERING LABORATORY, INC.

**DUT: A3LSMG950N; Type: Portable Handset; Serial: E3D12**

Communication System: UID 0, UMTS; Frequency: 836.6 MHz; Duty Cycle: 1:1  
Medium: 835 Body; Medium parameters used (interpolated):  
 $f = 836.6 \text{ MHz}$ ;  $\sigma = 0.987 \text{ S/m}$ ;  $\epsilon_r = 53.534$ ;  $\rho = 1000 \text{ kg/m}^3$   
Phantom section: Flat Section; Space: 1.0 cm

Test Date: 03-08-2017; Ambient Temp: 24.5°C; Tissue Temp: 24.1°C

Probe: ES3DV3 - SN3318; ConvF(6.37, 6.37, 6.37); Calibrated: 2/10/2017;  
Sensor-Surface: 3mm (Mechanical Surface Detection)  
Electronics: DAE4 Sn665; Calibrated: 2/9/2017  
Phantom: SAM with CRP (Left); Type: SAM; Serial: 1715  
Measurement SW: DASY52, Version 52.8 (8); SEMCAD X Version 14.6.10 (7331)

**Mode: UMTS 850, Body SAR, Back side, Mid.ch**

**Area Scan (9x15x1):** Measurement grid: dx=15mm, dy=15mm

**Zoom Scan (5x5x7)/Cube 0:** Measurement grid: dx=8mm, dy=8mm, dz=5mm

Reference Value = 18.61 V/m; Power Drift = -0.04 dB

Peak SAR (extrapolated) = 0.542 W/kg

**SAR(1 g) = 0.322 W/kg**

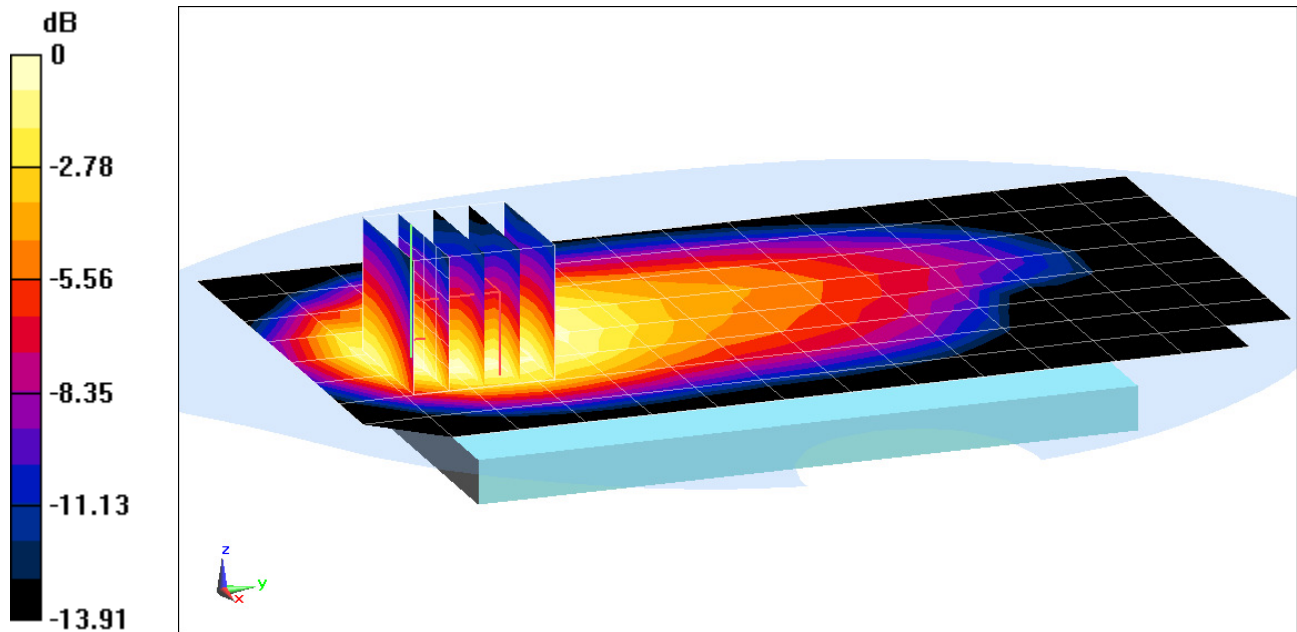

0 dB = 0.390 W/kg = -4.09 dBW/kg

# PCTEST ENGINEERING LABORATORY, INC.

**DUT: A3LSMG950N; Type: Portable Handset; Serial: E3D11**

Communication System: UID 0, UMTS; Frequency: 1880 MHz; Duty Cycle: 1:1  
Medium: 1900 Body; Medium parameters used:  
 $f = 1880 \text{ MHz}$ ;  $\sigma = 1.516 \text{ S/m}$ ;  $\epsilon_r = 52.299$ ;  $\rho = 1000 \text{ kg/m}^3$   
Phantom section: Flat Section; Space: 1.5 cm

Test Date: 03-07-2017; Ambient Temp: 23.2°C; Tissue Temp: 21.9°C

Probe: ES3DV3 - SN3334; ConvF(4.91, 4.91, 4.91); Calibrated: 11/15/2016;  
Sensor-Surface: 3mm (Mechanical Surface Detection)  
Electronics: DAE4 Sn1334; Calibrated: 11/11/2016

Phantom: SAM with CRP v4.0 Left; Type: QD000P40CD; Serial: TP:1692  
Measurement SW: DASY52, Version 52.8 (8); SEMCAD X Version 14.6.10 (7331)

**Mode: UMTS 1900, Body SAR, Back side, Mid.ch**

**Area Scan (9x15x1):** Measurement grid:  $dx=15\text{mm}$ ,  $dy=15\text{mm}$

**Zoom Scan (5x5x7)/Cube 0:** Measurement grid:  $dx=8\text{mm}$ ,  $dy=8\text{mm}$ ,  $dz=5\text{mm}$

Reference Value = 16.25 V/m; Power Drift = -0.06 dB

Peak SAR (extrapolated) = 0.553 W/kg

**SAR(1 g) = 0.350 W/kg**

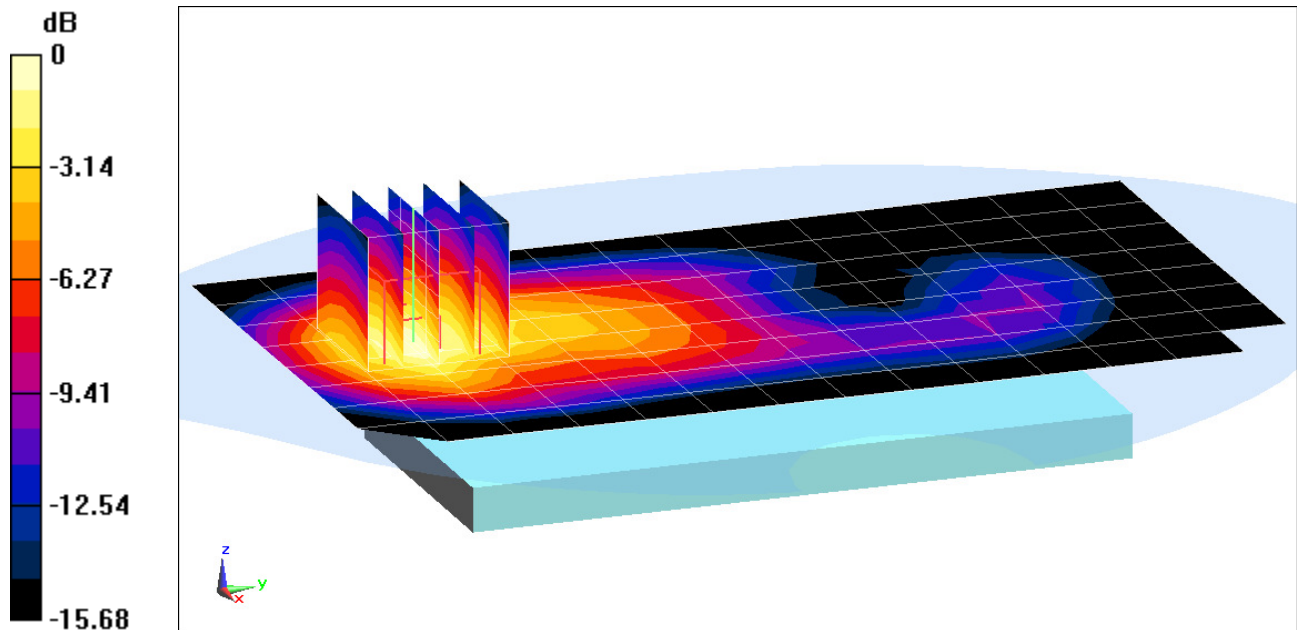

0 dB = 0.422 W/kg = -3.75 dBW/kg

# PCTEST ENGINEERING LABORATORY, INC.

**DUT: A3LSMG950N; Type: Portable Handset; Serial: E3D11**

Communication System: UID 0, UMTS; Frequency: 1880 MHz; Duty Cycle: 1:1  
Medium: 1900 Body; Medium parameters used:  
 $f = 1880 \text{ MHz}$ ;  $\sigma = 1.516 \text{ S/m}$ ;  $\epsilon_r = 52.299$ ;  $\rho = 1000 \text{ kg/m}^3$   
Phantom section: Flat Section; Space: 1.0 cm

Test Date: 03-07-2017; Ambient Temp: 23.2°C; Tissue Temp: 21.9°C

Probe: ES3DV3 - SN3334; ConvF(4.91, 4.91, 4.91); Calibrated: 11/15/2016;  
Sensor-Surface: 3mm (Mechanical Surface Detection)  
Electronics: DAE4 Sn1334; Calibrated: 11/11/2016  
Phantom: SAM with CRP v4.0 Left; Type: QD000P40CD; Serial: TP:1692  
Measurement SW: DASY52, Version 52.8 (8); SEMCAD X Version 14.6.10 (7331)

**Mode: UMTS 1900, Body SAR, Bottom Edge, Mid.ch**

**Area Scan (10x7x1):** Measurement grid: dx=5mm, dy=15mm

**Zoom Scan (5x5x7)/Cube 0:** Measurement grid: dx=8mm, dy=8mm, dz=5mm

Reference Value = 22.13 V/m; Power Drift = -0.01 dB

Peak SAR (extrapolated) = 1.06 W/kg

**SAR(1 g) = 0.631 W/kg**

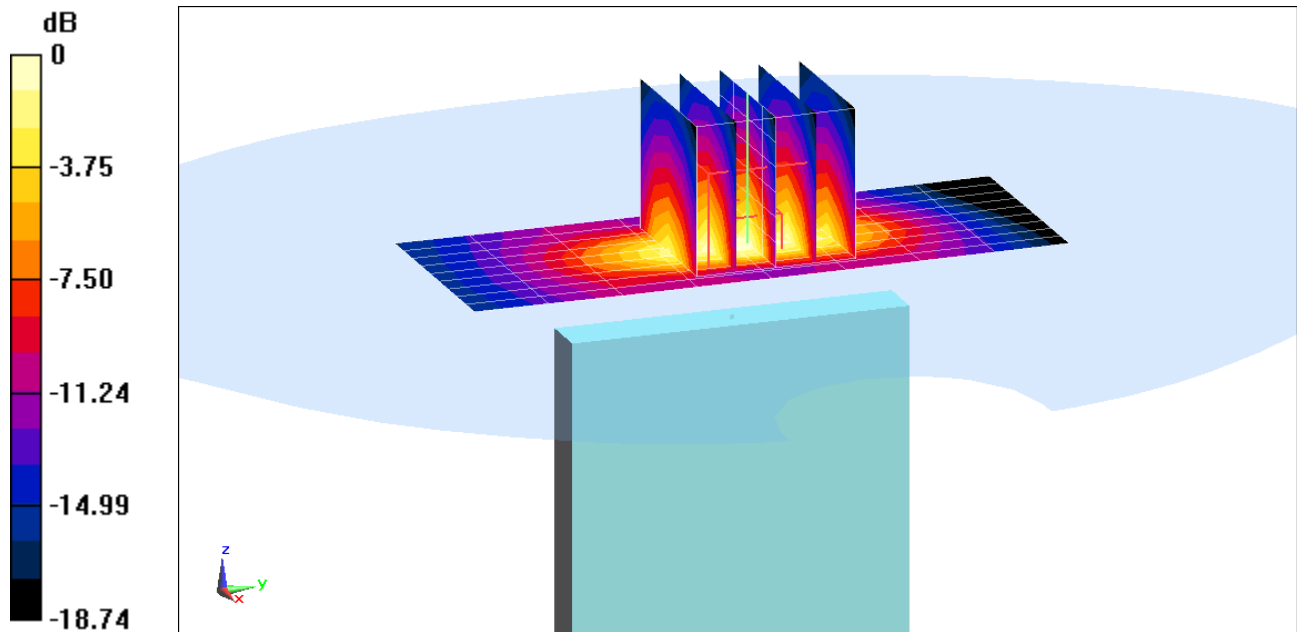

0 dB = 0.788 W/kg = -1.03 dBW/kg

# PCTEST ENGINEERING LABORATORY, INC.

**DUT: A3LSMG950N; Type: Portable Handset; Serial: E3D11**

Communication System: UID 0, LTE Band 12; Frequency: 707.5 MHz; Duty Cycle: 1:1

Medium: 750 Body; Medium parameters used (interpolated):

$f = 707.5 \text{ MHz}$ ;  $\sigma = 0.92 \text{ S/m}$ ;  $\epsilon_r = 56.989$ ;  $\rho = 1000 \text{ kg/m}^3$

Phantom section: Flat Section; Space: 1.5 cm

Test Date: 03-07-2017; Ambient Temp: 24.5°C; Tissue Temp: 23.0°C

Probe: ES3DV3 - SN3213; ConvF(6.38, 6.38, 6.38); Calibrated: 2/10/2017;

Sensor-Surface: 3mm (Mechanical Surface Detection)

Electronics: DAE4 Sn1272; Calibrated: 2/9/2017

Phantom: SAM Right; Type: SAM; Serial: 1757

Measurement SW: DASY52, Version 52.8 (8); SEMCAD X Version 14.6.10 (7331)

**Mode: LTE Band 12, Body SAR, Back side, Mid.ch**

**10 MHz Bandwidth, QPSK, 1 RB, 0 RB Offset**

**Area Scan (9x13x1):** Measurement grid:  $dx=15\text{mm}$ ,  $dy=15\text{mm}$

**Zoom Scan (6x6x7)/Cube 0:** Measurement grid:  $dx=8\text{mm}$ ,  $dy=8\text{mm}$ ,  $dz=5\text{mm}$

Reference Value = 10.90 V/m; Power Drift = 0.01 dB

Peak SAR (extrapolated) = 0.146 W/kg

**SAR(1 g) = 0.102 W/kg**

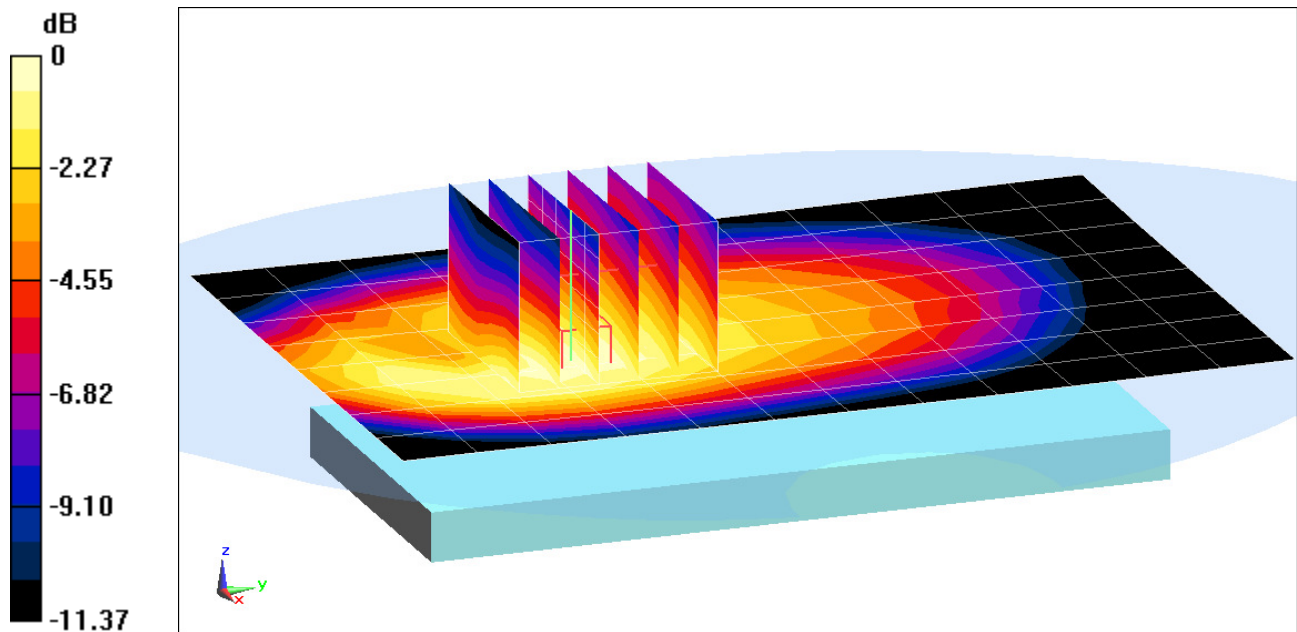

0 dB = 0.115 W/kg = -9.39 dBW/kg

# PCTEST ENGINEERING LABORATORY, INC.

**DUT: A3LSMG950N; Type: Portable Handset; Serial: E3D11**

Communication System: UID 0, LTE Band 12; Frequency: 707.5 MHz; Duty Cycle: 1:1  
Medium: 750 Body; Medium parameters used (interpolated):  
 $f = 707.5 \text{ MHz}$ ;  $\sigma = 0.92 \text{ S/m}$ ;  $\epsilon_r = 56.989$ ;  $\rho = 1000 \text{ kg/m}^3$   
Phantom section: Flat Section; Space: 1.0 cm

Test Date: 03-07-2017; Ambient Temp: 24.5°C; Tissue Temp: 23.0°C

Probe: ES3DV3 - SN3213; ConvF(6.38, 6.38, 6.38); Calibrated: 2/10/2017;  
Sensor-Surface: 3mm (Mechanical Surface Detection)  
Electronics: DAE4 Sn1272; Calibrated: 2/9/2017  
Phantom: SAM Right; Type: SAM; Serial: 1757  
Measurement SW: DASY52, Version 52.8 (8); SEMCAD X Version 14.6.10 (7331)

**Mode: LTE Band 12, Body SAR, Back side, Mid.ch**  
**10 MHz Bandwidth, QPSK, 1 RB, 25 RB Offset**

**Area Scan (9x13x1):** Measurement grid:  $dx=15\text{mm}$ ,  $dy=15\text{mm}$   
**Zoom Scan (6x6x7)/Cube 0:** Measurement grid:  $dx=8\text{mm}$ ,  $dy=8\text{mm}$ ,  $dz=5\text{mm}$   
Reference Value = 13.17 V/m; Power Drift = -0.06 dB  
Peak SAR (extrapolated) = 0.260 W/kg  
**SAR(1 g) = 0.147 W/kg**

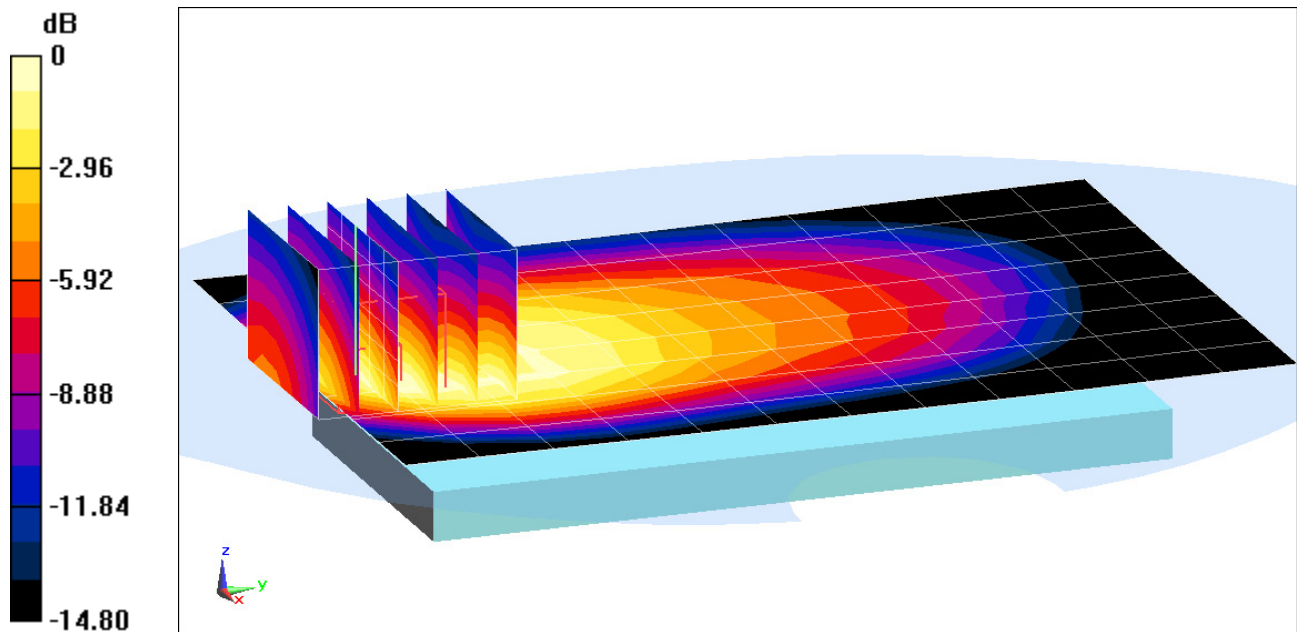

0 dB = 0.177 W/kg = -7.52 dBW/kg

# PCTEST ENGINEERING LABORATORY, INC.

**DUT: A3LSMG950N; Type: Portable Handset; Serial: E3D11**

Communication System: UID 0, LTE Band 13; Frequency: 782 MHz; Duty Cycle: 1:1

Medium: 750 Body; Medium parameters used (interpolated):

$f = 782 \text{ MHz}$ ;  $\sigma = 0.986 \text{ S/m}$ ;  $\epsilon_r = 56.229$ ;  $\rho = 1000 \text{ kg/m}^3$

Phantom section: Flat Section; Space: 1.5 cm

Test Date: 03-07-2017; Ambient Temp: 24.5°C; Tissue Temp: 23.0°C

Probe: ES3DV3 - SN3213; ConvF(6.38, 6.38, 6.38); Calibrated: 2/10/2017;

Sensor-Surface: 3mm (Mechanical Surface Detection)

Electronics: DAE4 Sn1272; Calibrated: 2/9/2017

Phantom: SAM Right; Type: SAM; Serial: 1757

Measurement SW: DASY52, Version 52.8 (8); SEMCAD X Version 14.6.10 (7331)

**Mode: LTE Band 13, Body SAR, Back side, Mid.ch**

**10 MHz Bandwidth, QPSK, 1 RB, 0 RB Offset**

**Area Scan (9x13x1):** Measurement grid:  $dx=15\text{mm}$ ,  $dy=15\text{mm}$

**Zoom Scan (5x6x7)/Cube 0:** Measurement grid:  $dx=8\text{mm}$ ,  $dy=8\text{mm}$ ,  $dz=5\text{mm}$

Reference Value = 16.36 V/m; Power Drift = -0.13 dB

Peak SAR (extrapolated) = 0.315 W/kg

**SAR(1 g) = 0.244 W/kg**

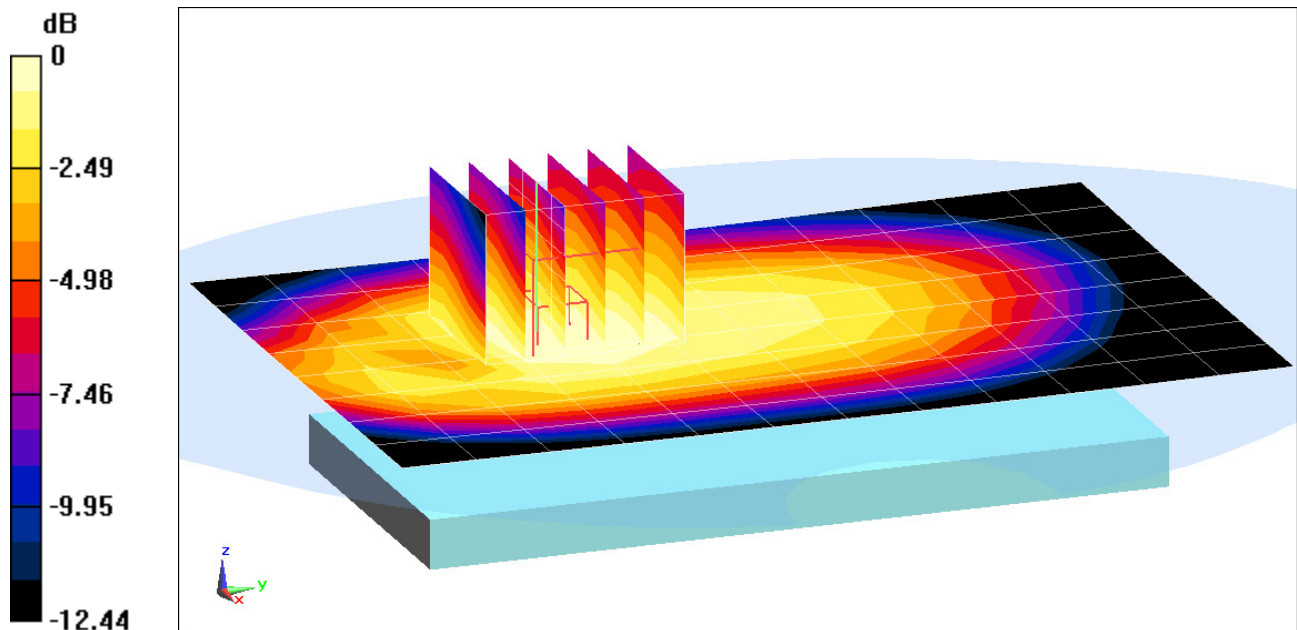

0 dB = 0.269 W/kg = -5.70 dBW/kg

# PCTEST ENGINEERING LABORATORY, INC.

**DUT: A3LSMG950N; Type: Portable Handset; Serial: E3D11**

Communication System: UID 0, LTE Band 13; Frequency: 782 MHz; Duty Cycle: 1:1  
Medium: 750 Body; Medium parameters used (interpolated):  
 $f = 782 \text{ MHz}$ ;  $\sigma = 0.986 \text{ S/m}$ ;  $\epsilon_r = 56.229$ ;  $\rho = 1000 \text{ kg/m}^3$   
Phantom section: Flat Section; Space: 1.0 cm

Test Date: 03-07-2017; Ambient Temp: 24.5°C; Tissue Temp: 23.0°C

Probe: ES3DV3 - SN3213; ConvF(6.38, 6.38, 6.38); Calibrated: 2/10/2017;  
Sensor-Surface: 3mm (Mechanical Surface Detection)  
Electronics: DAE4 Sn1272; Calibrated: 2/9/2017  
Phantom: SAM Right; Type: SAM; Serial: 1757  
Measurement SW: DASY52, Version 52.8 (8); SEMCAD X Version 14.6.10 (7331)

**Mode: LTE Band 13, Body SAR, Back side, Mid.ch**  
**10 MHz Bandwidth, QPSK, 1 RB, 0 RB Offset**

**Area Scan (9x15x1):** Measurement grid:  $dx=15\text{mm}$ ,  $dy=15\text{mm}$   
**Zoom Scan (6x6x7)/Cube 0:** Measurement grid:  $dx=8\text{mm}$ ,  $dy=8\text{mm}$ ,  $dz=5\text{mm}$   
Reference Value = 18.00 V/m; Power Drift = 0.02 dB  
Peak SAR (extrapolated) = 0.509 W/kg  
**SAR(1 g) = 0.292 W/kg**

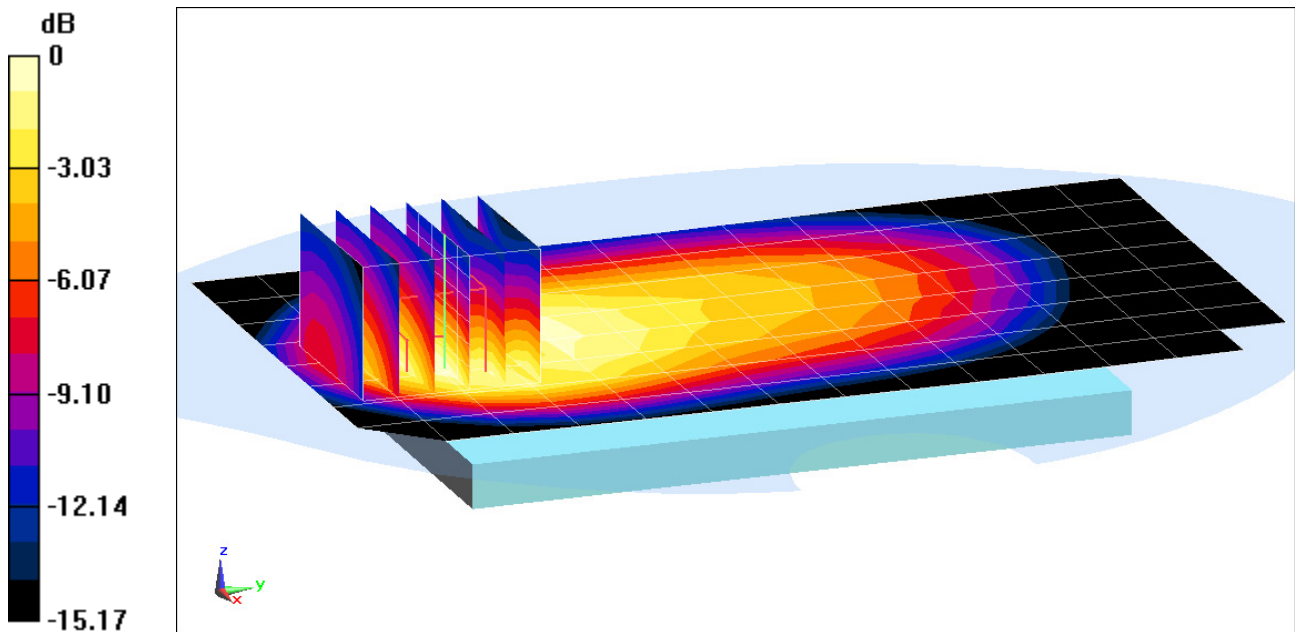

0 dB = 0.350 W/kg = -4.56 dBW/kg

# PCTEST ENGINEERING LABORATORY, INC.

**DUT: A3LSMG950N; Type: Portable Handset; Serial: E3D12**

Communication System: UID 0, LTE Band 26; Frequency: 831.5 MHz; Duty Cycle: 1:1  
Medium: 835 Body; Medium parameters used (interpolated):  
 $f = 831.5 \text{ MHz}$ ;  $\sigma = 0.983 \text{ S/m}$ ;  $\epsilon_r = 53.581$ ;  $\rho = 1000 \text{ kg/m}^3$   
Phantom section: Flat Section; Space: 1.5 cm

Test Date: 03-08-2017; Ambient Temp: 24.5°C; Tissue Temp: 24.1°C

Probe: ES3DV3 - SN3318; ConvF(6.37, 6.37, 6.37); Calibrated: 2/10/2017;  
Sensor-Surface: 3mm (Mechanical Surface Detection)  
Electronics: DAE4 Sn665; Calibrated: 2/9/2017  
Phantom: SAM with CRP (Left); Type: SAM; Serial: 1715  
Measurement SW: DASY52, Version 52.8 (8); SEMCAD X Version 14.6.10 (7331)

**Mode: LTE Band 26 (Cell.), Body SAR, Back side, Mid.ch**  
**15 MHz Bandwidth, QPSK, 1 RB, 36 RB Offset**

**Area Scan (9x15x1):** Measurement grid:  $dx=15\text{mm}$ ,  $dy=15\text{mm}$   
**Zoom Scan (5x5x7)/Cube 0:** Measurement grid:  $dx=8\text{mm}$ ,  $dy=8\text{mm}$ ,  $dz=5\text{mm}$   
Reference Value = 15.84 V/m; Power Drift = 0.00 dB  
Peak SAR (extrapolated) = 0.296 W/kg  
**SAR(1 g) = 0.226 W/kg**

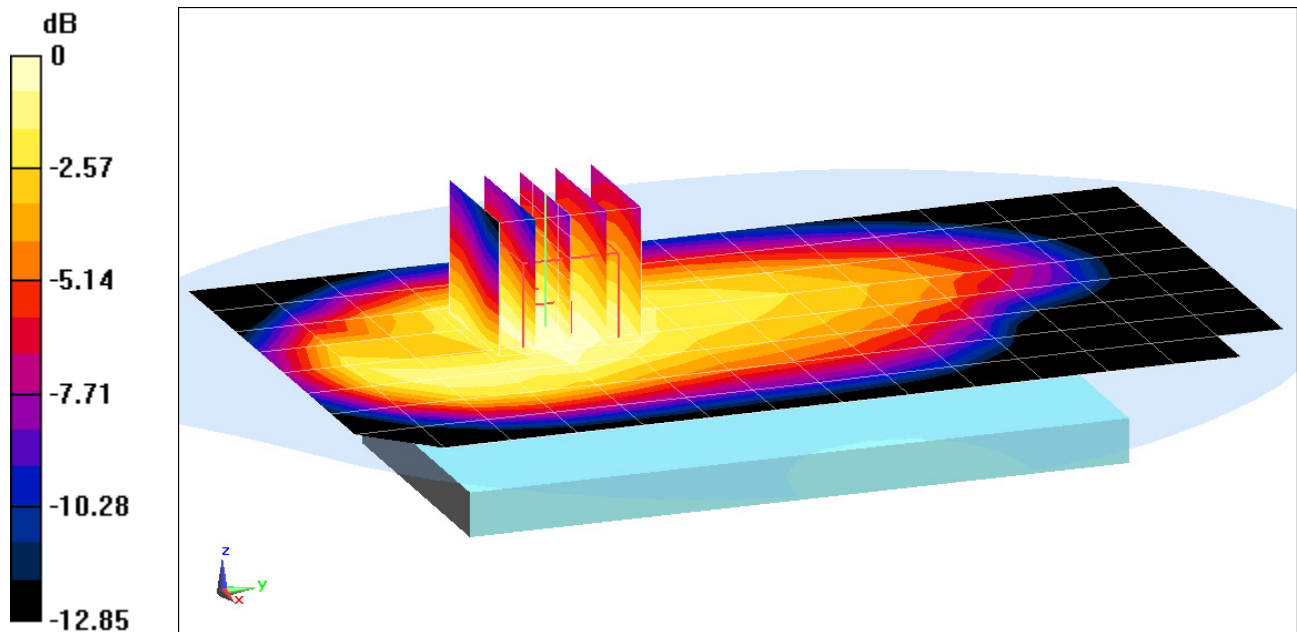

0 dB = 0.251 W/kg = -6.00 dBW/kg

# PCTEST ENGINEERING LABORATORY, INC.

**DUT: A3LSMG950N; Type: Portable Handset; Serial: E3D12**

Communication System: UID 0, LTE Band 26; Frequency: 831.5 MHz; Duty Cycle: 1:1  
Medium: 835 Body; Medium parameters used (interpolated):  
 $f = 831.5 \text{ MHz}$ ;  $\sigma = 0.983 \text{ S/m}$ ;  $\epsilon_r = 53.581$ ;  $\rho = 1000 \text{ kg/m}^3$   
Phantom section: Flat Section; Space: 1.0 cm

Test Date: 03-08-2017; Ambient Temp: 24.5°C; Tissue Temp: 24.1°C

Probe: ES3DV3 - SN3318; ConvF(6.37, 6.37, 6.37); Calibrated: 2/10/2017;  
Sensor-Surface: 3mm (Mechanical Surface Detection)  
Electronics: DAE4 Sn665; Calibrated: 2/9/2017  
Phantom: SAM with CRP (Left); Type: SAM; Serial: 1715  
Measurement SW: DASY52, Version 52.8 (8); SEMCAD X Version 14.6.10 (7331)

**Mode: LTE Band 26 (Cell.), Body SAR, Back side, Mid.ch**  
**15 MHz Bandwidth, QPSK, 1 RB, 36 RB Offset**

**Area Scan (9x15x1):** Measurement grid:  $dx=15\text{mm}$ ,  $dy=15\text{mm}$   
**Zoom Scan (5x6x7)/Cube 0:** Measurement grid:  $dx=8\text{mm}$ ,  $dy=8\text{mm}$ ,  $dz=5\text{mm}$   
Reference Value = 19.46 V/m; Power Drift = -0.01 dB  
Peak SAR (extrapolated) = 0.599 W/kg  
**SAR(1 g) = 0.359 W/kg**

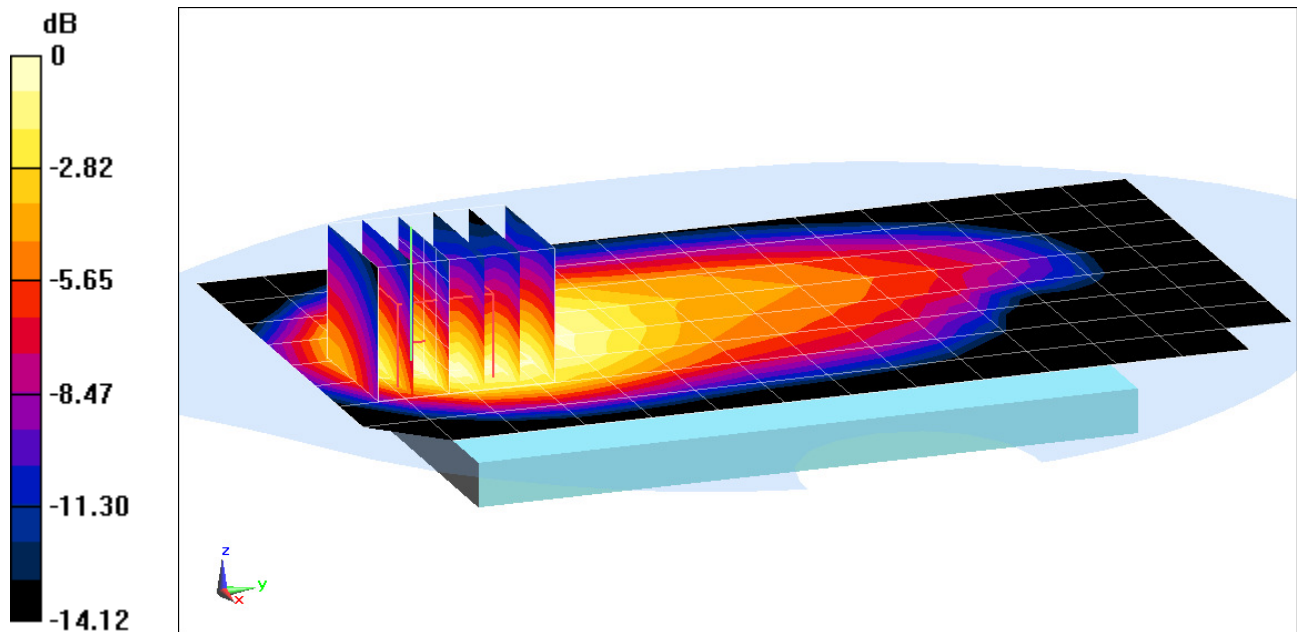

0 dB = 0.436 W/kg = -3.61 dBW/kg

# PCTEST ENGINEERING LABORATORY, INC.

**DUT: A3LSMG950N; Type: Portable Handset; Serial: E3D12**

Communication System: UID 0, LTE Band 5; Frequency: 836.5 MHz; Duty Cycle: 1:1  
Medium: 835 Body; Medium parameters used (interpolated):  
 $f = 836.5$  MHz;  $\sigma = 0.987$  S/m;  $\epsilon_r = 53.535$ ;  $\rho = 1000$  kg/m<sup>3</sup>  
Phantom section: Flat Section; Space: 1.5 cm

Test Date: 03-08-2017; Ambient Temp: 24.5°C; Tissue Temp: 24.1°C

Probe: ES3DV3 - SN3318; ConvF(6.37, 6.37, 6.37); Calibrated: 2/10/2017;  
Sensor-Surface: 3mm (Mechanical Surface Detection)  
Electronics: DAE4 Sn665; Calibrated: 2/9/2017  
Phantom: SAM with CRP (Left); Type: SAM; Serial: 1715  
Measurement SW: DASY52, Version 52.8 (8); SEMCAD X Version 14.6.10 (7331)

**Mode: LTE Band 5 (Cell.), Body SAR, Back side, Mid.ch, Ant A**  
**10 MHz Bandwidth, QPSK, 1 RB, 0 RB Offset**

**Area Scan (9x14x1):** Measurement grid: dx=15mm, dy=15mm  
**Zoom Scan (5x5x7)/Cube 0:** Measurement grid: dx=8mm, dy=8mm, dz=5mm  
Reference Value = 16.78 V/m; Power Drift = 0.00 dB  
Peak SAR (extrapolated) = 0.342 W/kg  
**SAR(1 g) = 0.257 W/kg**

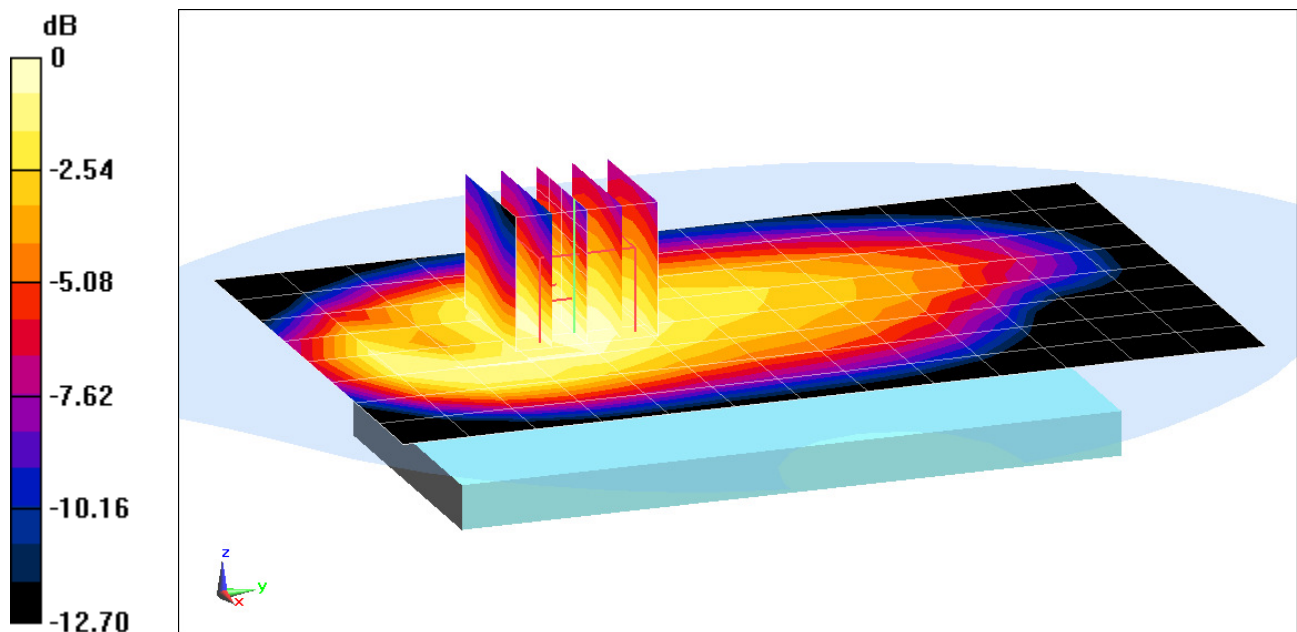

0 dB = 0.284 W/kg = -5.47 dBW/kg

# PCTEST ENGINEERING LABORATORY, INC.

**DUT: A3LSMG950N; Type: Portable Handset; Serial: E3D12**

Communication System: UID 0, LTE Band 5; Frequency: 836.5 MHz; Duty Cycle: 1:1  
Medium: 835 Body; Medium parameters used (interpolated):  
 $f = 836.5$  MHz;  $\sigma = 0.987$  S/m;  $\epsilon_r = 53.535$ ;  $\rho = 1000$  kg/m<sup>3</sup>  
Phantom section: Flat Section; Space: 1.0 cm

Test Date: 03-08-2017; Ambient Temp: 24.5°C; Tissue Temp: 24.1°C

Probe: ES3DV3 - SN3318; ConvF(6.37, 6.37, 6.37); Calibrated: 2/10/2017;  
Sensor-Surface: 3mm (Mechanical Surface Detection)  
Electronics: DAE4 Sn665; Calibrated: 2/9/2017  
Phantom: SAM with CRP (Left); Type: SAM; Serial: 1715  
Measurement SW: DASY52, Version 52.8 (8); SEMCAD X Version 14.6.10 (7331)

**Mode: LTE Band 5 (Cell.), Body SAR, Back side, Mid.ch, Ant A**  
**10 MHz Bandwidth, QPSK, 1 RB, 0 RB Offset**

**Area Scan (9x14x1):** Measurement grid: dx=15mm, dy=15mm  
**Zoom Scan (5x5x7)/Cube 0:** Measurement grid: dx=8mm, dy=8mm, dz=5mm  
Reference Value = 24.01 V/m; Power Drift = 0.05 dB  
Peak SAR (extrapolated) = 0.860 W/kg  
**SAR(1 g) = 0.508 W/kg**

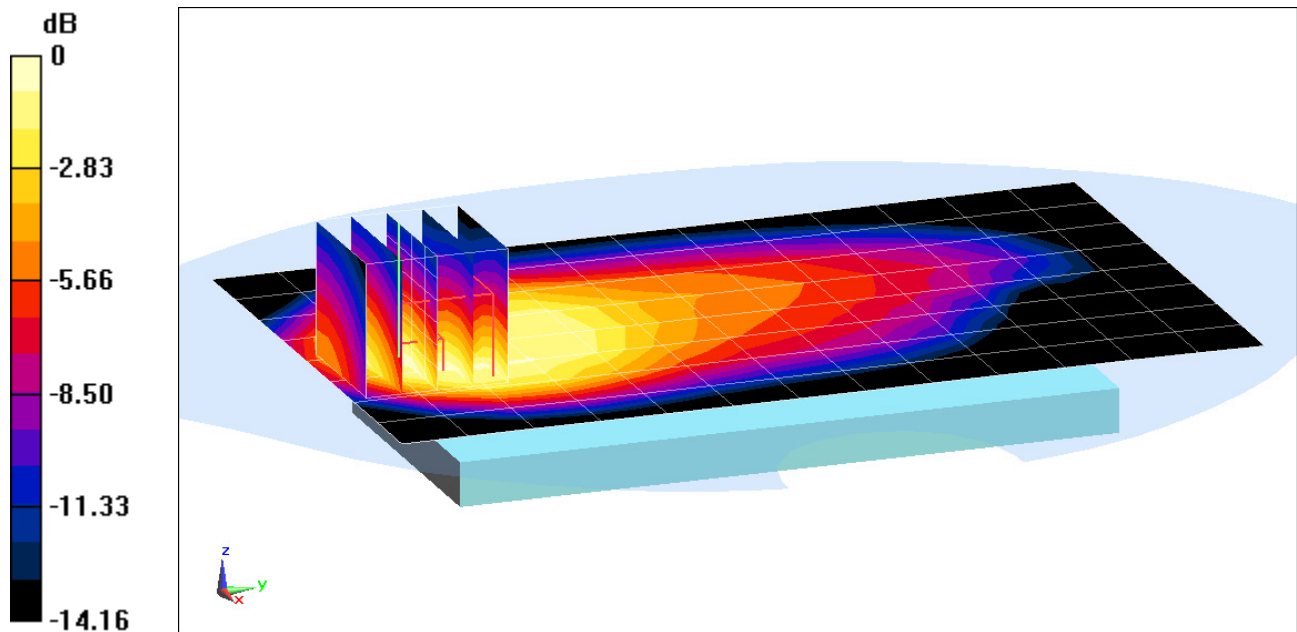

0 dB = 0.625 W/kg = -2.04 dBW/kg

# PCTEST ENGINEERING LABORATORY, INC.

**DUT: A3LSMG950N; Type: Portable Handset; Serial: E3D11**

Communication System: UID 0, LTE Band 4 (AWS); Frequency: 1732.5 MHz; Duty Cycle: 1:1  
Medium: 1750 Body; Medium parameters used (interpolated):  
 $f = 1732.5 \text{ MHz}$ ;  $\sigma = 1.442 \text{ S/m}$ ;  $\epsilon_r = 51.255$ ;  $\rho = 1000 \text{ kg/m}^3$   
Phantom section: Flat Section; Space: 1.5 cm

Test Date: 03-06-2017; Ambient Temp: 21.5°C; Tissue Temp: 20.7°C

Probe: ES3DV3 - SN3213; ConvF(5.09, 5.09, 5.09); Calibrated: 2/10/2017;  
Sensor-Surface: 3mm (Mechanical Surface Detection)  
Electronics: DAE4 Sn1272; Calibrated: 2/9/2017  
Phantom: SAM Front; Type: QD000P40CD; Serial: TP:1758  
Measurement SW: DASY52, Version 52.8 (8); SEMCAD X Version 14.6.10 (7331)

**Mode: LTE Band 4 (AWS), Body SAR, Back side, Mid.ch**  
**20 MHz Bandwidth, QPSK, 1 RB, 0 RB Offset**

**Area Scan (9x15x1):** Measurement grid:  $dx=15\text{mm}$ ,  $dy=15\text{mm}$   
**Zoom Scan (5x5x7)/Cube 0:** Measurement grid:  $dx=8\text{mm}$ ,  $dy=8\text{mm}$ ,  $dz=5\text{mm}$   
Reference Value = 17.04 V/m; Power Drift = 0.00 dB  
Peak SAR (extrapolated) = 0.562 W/kg  
**SAR(1 g) = 0.377 W/kg**

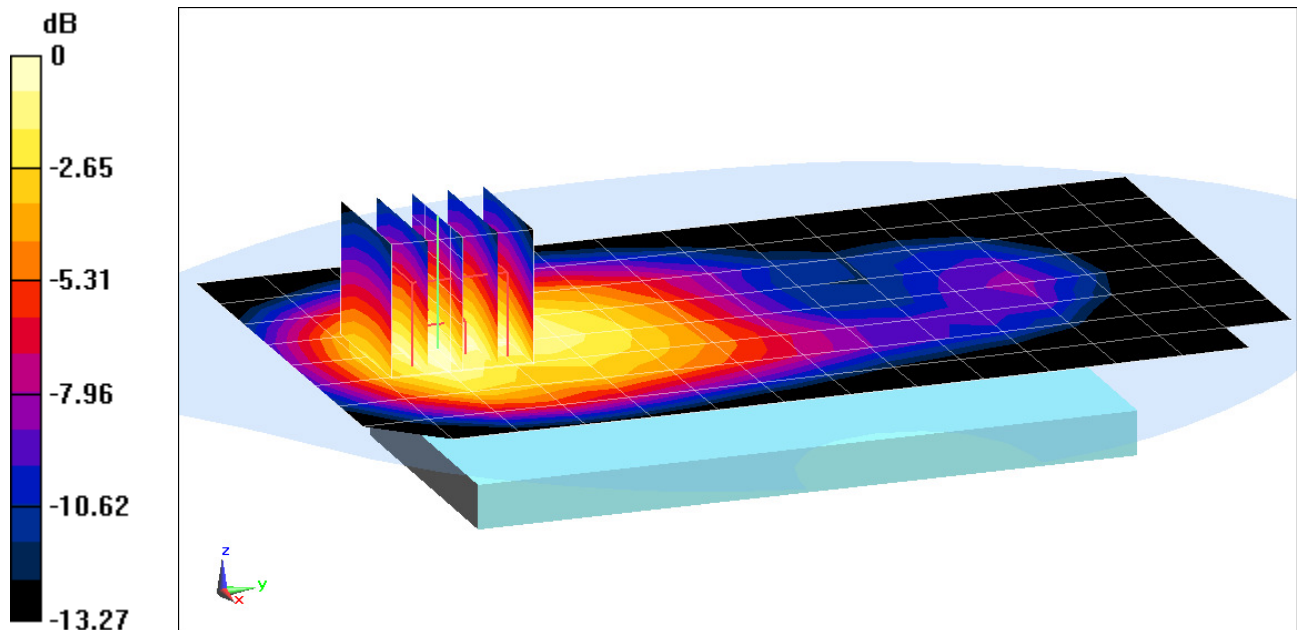

0 dB = 0.440 W/kg = -3.57 dBW/kg

# PCTEST ENGINEERING LABORATORY, INC.

**DUT: A3LSMG950N; Type: Portable Handset; Serial: E3D11**

Communication System: UID 0, LTE Band 4 (AWS); Frequency: 1732.5 MHz; Duty Cycle: 1:1  
Medium: 1750 Body; Medium parameters used (interpolated):  
 $f = 1732.5 \text{ MHz}$ ;  $\sigma = 1.442 \text{ S/m}$ ;  $\epsilon_r = 51.255$ ;  $\rho = 1000 \text{ kg/m}^3$   
Phantom section: Flat Section; Space: 1.0 cm

Test Date: 03-06-2017; Ambient Temp: 21.5°C; Tissue Temp: 20.7°C

Probe: ES3DV3 - SN3213; ConvF(5.09, 5.09, 5.09); Calibrated: 2/10/2017;  
Sensor-Surface: 3mm (Mechanical Surface Detection)  
Electronics: DAE4 Sn1272; Calibrated: 2/9/2017  
Phantom: SAM Front; Type: QD000P40CD; Serial: TP:1758  
Measurement SW: DASY52, Version 52.8 (8); SEMCAD X Version 14.6.10 (7331)

**Mode: LTE Band 4 (AWS), Body SAR, Bottom Edge, Mid.ch**  
**20 MHz Bandwidth, QPSK, 50 RB, 0 RB Offset**

**Area Scan (11x7x1):** Measurement grid: dx=5mm, dy=15mm  
**Zoom Scan (5x5x7)/Cube 0:** Measurement grid: dx=8mm, dy=8mm, dz=5mm  
Reference Value = 18.41 V/m; Power Drift = 0.00 dB  
Peak SAR (extrapolated) = 0.692 W/kg  
**SAR(1 g) = 0.424 W/kg**

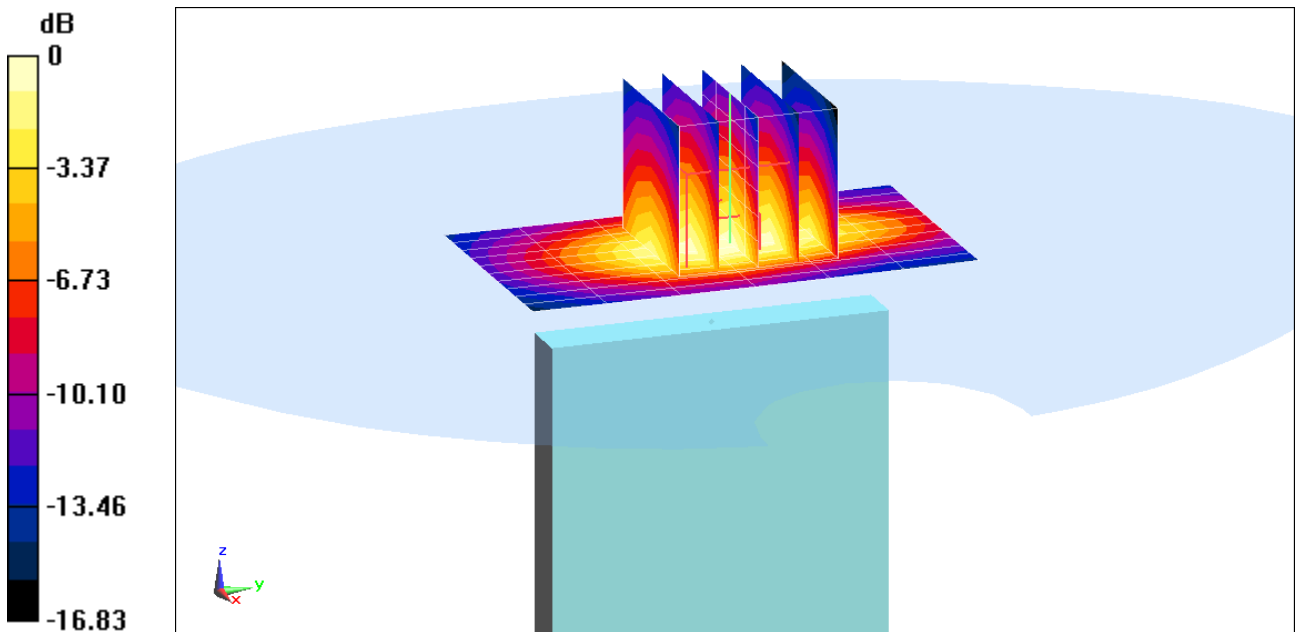

0 dB = 0.521 W/kg = -2.83 dBW/kg

# PCTEST ENGINEERING LABORATORY, INC.

**DUT: A3LSMG950N; Type: Portable Handset; Serial: E3D11**

Communication System: UID 0, LTE Band 25 (PCS); Frequency: 1905 MHz; Duty Cycle: 1:1  
Medium: 1900 Body; Medium parameters used (interpolated):  
 $f = 1905 \text{ MHz}$ ;  $\sigma = 1.549 \text{ S/m}$ ;  $\epsilon_r = 52.229$ ;  $\rho = 1000 \text{ kg/m}^3$   
Phantom section: Flat Section; Space: 1.5 cm

Test Date: 03-07-2017; Ambient Temp: 23.2°C; Tissue Temp: 21.9°C

Probe: ES3DV3 - SN3334; ConvF(4.91, 4.91, 4.91); Calibrated: 11/15/2016;  
Sensor-Surface: 3mm (Mechanical Surface Detection)  
Electronics: DAE4 Sn1334; Calibrated: 11/11/2016

Phantom: SAM with CRP v4.0 Left; Type: QD000P40CD; Serial: TP:1692  
Measurement SW: DASY52, Version 52.8 (8); SEMCAD X Version 14.6.10 (7331)

**Mode: LTE Band 25 (PCS), Body SAR, Back side, High.ch**  
**20 MHz Bandwidth, QPSK, 1 RB, 99 RB Offset**

**Area Scan (9x15x1):** Measurement grid:  $dx=15\text{mm}$ ,  $dy=15\text{mm}$   
**Zoom Scan (5x5x7)/Cube 0:** Measurement grid:  $dx=8\text{mm}$ ,  $dy=8\text{mm}$ ,  $dz=5\text{mm}$   
Reference Value = 16.15 V/m; Power Drift = -0.06 dB  
Peak SAR (extrapolated) = 0.577 W/kg  
**SAR(1 g) = 0.360 W/kg**

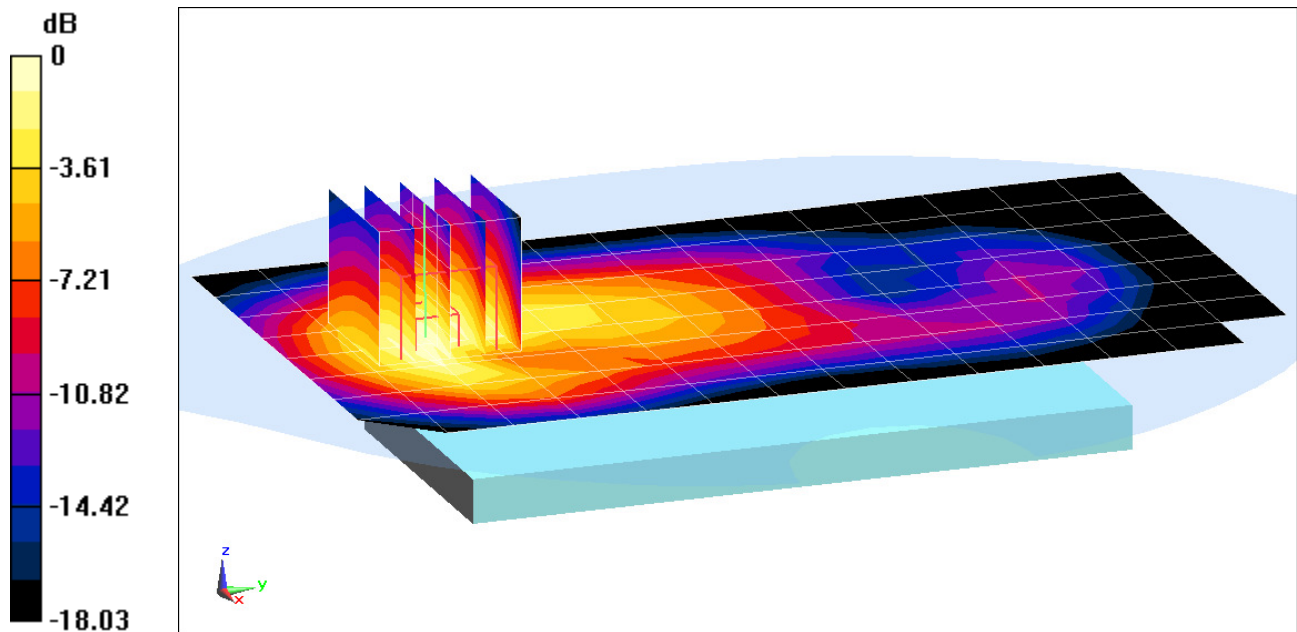

0 dB = 0.426 W/kg = -3.71 dBW/kg

# PCTEST ENGINEERING LABORATORY, INC.

**DUT: A3LSMG950N; Type: Portable Handset; Serial: E3D11**

Communication System: UID 0, LTE Band 25 (PCS); Frequency: 1905 MHz; Duty Cycle: 1:1  
Medium: 1900 Body; Medium parameters used (interpolated):  
 $f = 1905 \text{ MHz}$ ;  $\sigma = 1.549 \text{ S/m}$ ;  $\epsilon_r = 52.229$ ;  $\rho = 1000 \text{ kg/m}^3$   
Phantom section: Flat Section; Space: 1.0 cm

Test Date: 03-07-2017; Ambient Temp: 23.2°C; Tissue Temp: 21.9°C

Probe: ES3DV3 - SN3334; ConvF(4.91, 4.91, 4.91); Calibrated: 11/15/2016;  
Sensor-Surface: 3mm (Mechanical Surface Detection)  
Electronics: DAE4 Sn1334; Calibrated: 11/11/2016

Phantom: SAM with CRP v4.0 Left; Type: QD000P40CD; Serial: TP:1692  
Measurement SW: DASY52, Version 52.8 (8); SEMCAD X Version 14.6.10 (7331)

**Mode: LTE Band 25 (PCS), Body SAR, Bottom Edge, High.ch**  
**20 MHz Bandwidth, QPSK, 50 RB, 0 RB Offset**

**Area Scan (9x9x1):** Measurement grid:  $dx=5\text{mm}$ ,  $dy=15\text{mm}$   
**Zoom Scan (5x5x7)/Cube 0:** Measurement grid:  $dx=8\text{mm}$ ,  $dy=8\text{mm}$ ,  $dz=5\text{mm}$   
Reference Value = 15.63 V/m; Power Drift = -0.07 dB  
Peak SAR (extrapolated) = 0.548 W/kg  
**SAR(1 g) = 0.322 W/kg**

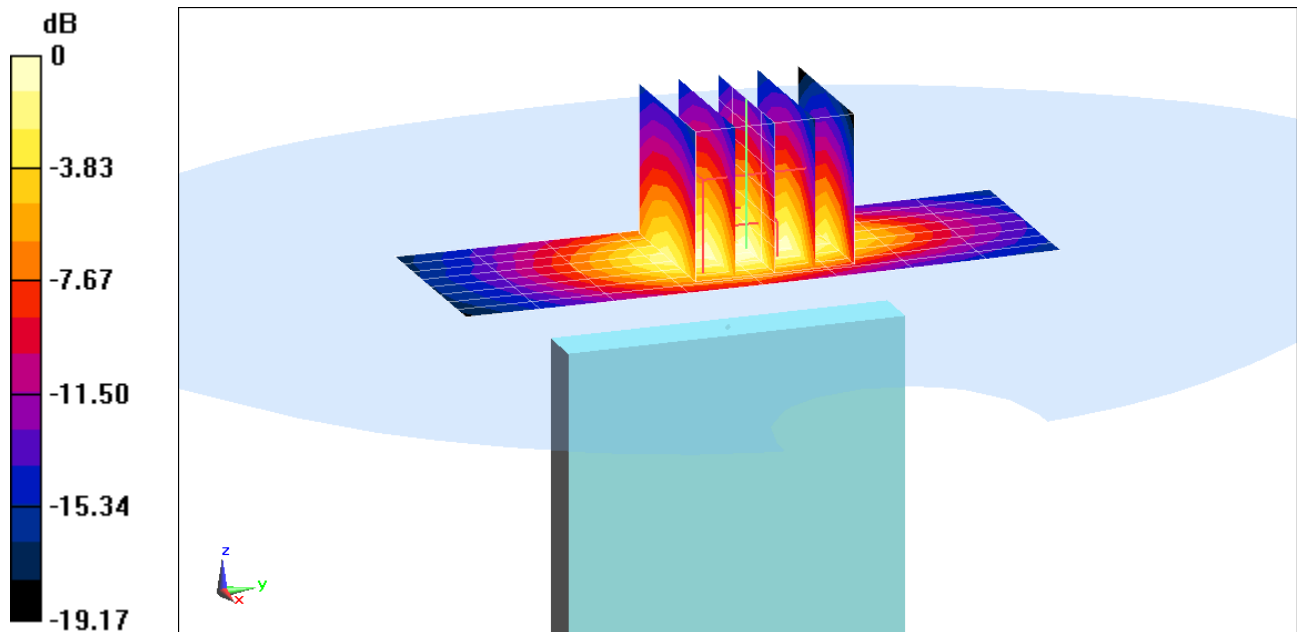

0 dB = 0.398 W/kg = -4.00 dBW/kg

# PCTEST ENGINEERING LABORATORY, INC.

**DUT: A3LSMG950N; Type: Portable Handset; Serial: E3D02**

Communication System: UID 0, LTE Band 41; Frequency: 2506 MHz; Duty Cycle: 1:1.58  
Medium: 2450 Body; Medium parameters used (interpolated):  
 $f = 2506 \text{ MHz}$ ;  $\sigma = 2.114 \text{ S/m}$ ;  $\epsilon_r = 52.637$ ;  $\rho = 1000 \text{ kg/m}^3$   
Phantom section: Flat Section; Space: 1.5 cm

Test Date: 03-09-2017; Ambient Temp: 24.0°C; Tissue Temp: 22.1°C

Probe: EX3DV4 - SN7406; ConvF(7.24, 7.24, 7.24); Calibrated: 4/19/2016;  
Sensor-Surface: 1.4mm (Mechanical Surface Detection)  
Electronics: DAE4 Sn1407; Calibrated: 4/14/2016  
Phantom: SAM 5.0 front; Type: QD000P40CD; Serial: TP:-1648  
Measurement SW: DASY52, Version 52.8 (8); SEMCAD X Version 14.6.10 (7331)

**Mode: LTE Band 41, Body SAR, Back side, Low.ch**  
**20 MHz Bandwidth, QPSK, 50 RB, 50 RB Offset**

**Area Scan (10x16x1):** Measurement grid: dx=12mm, dy=12mm  
**Zoom Scan (8x8x7)/Cube 0:** Measurement grid: dx=5mm, dy=5mm, dz=5mm  
Reference Value = 6.669 V/m; Power Drift = 0.04 dB  
Peak SAR (extrapolated) = 0.188 W/kg  
**SAR(1 g) = 0.096 W/kg**

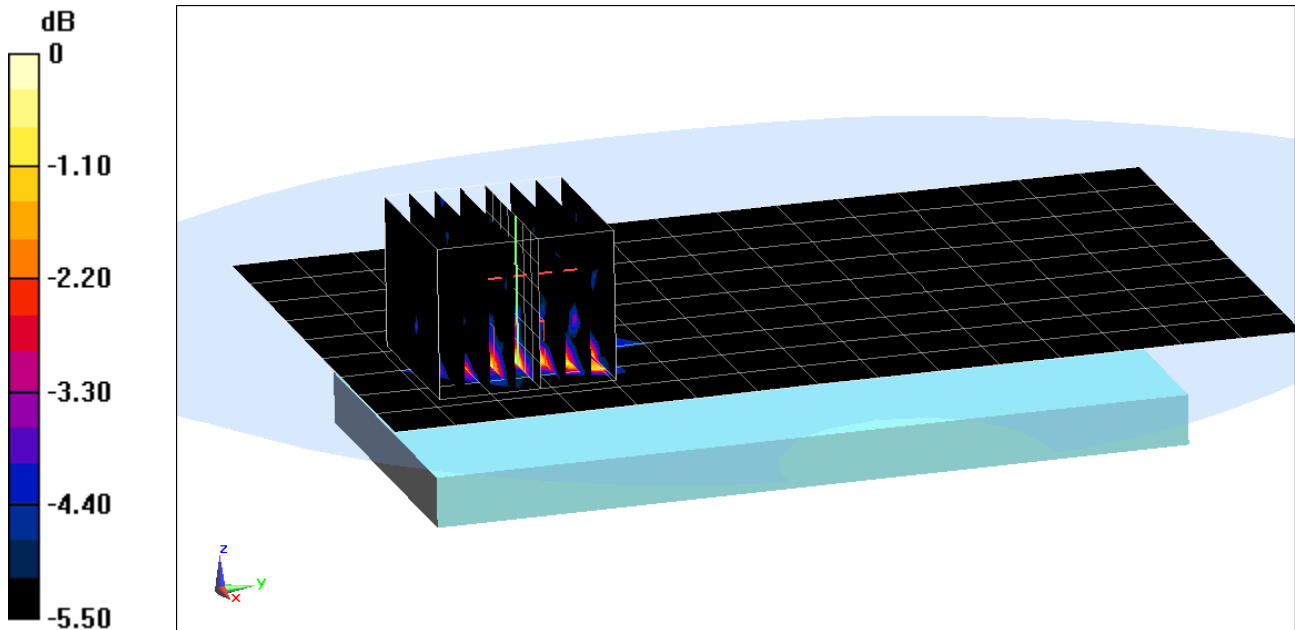

0 dB = 0.152 W/kg = -8.18 dBW/kg

# PCTEST ENGINEERING LABORATORY, INC.

**DUT: A3LSMG950N; Type: Portable Handset; Serial: E3D02**

Communication System: UID 0, LTE Band 41; Frequency: 2506 MHz; Duty Cycle: 1:1.58

Medium: 2450 Body; Medium parameters used (interpolated):

$f = 2506 \text{ MHz}$ ;  $\sigma = 2.114 \text{ S/m}$ ;  $\epsilon_r = 52.637$ ;  $\rho = 1000 \text{ kg/m}^3$

Phantom section: Flat Section; Space: 1.0 cm

Test Date: 03-09-2017; Ambient Temp: 24.0°C; Tissue Temp: 22.1°C

Probe: EX3DV4 - SN7406; ConvF(7.24, 7.24, 7.24); Calibrated: 4/19/2016;

Sensor-Surface: 1.4mm (Mechanical Surface Detection)

Electronics: DAE4 Sn1407; Calibrated: 4/14/2016

Phantom: SAM 5.0 front; Type: QD000P40CD; Serial: TP:-1648

Measurement SW: DASY52, Version 52.8 (8); SEMCAD X Version 14.6.10 (7331)

**Mode: LTE Band 41, Body SAR, Back side, Low.ch**  
**20 MHz Bandwidth, QPSK, 50 RB, 50 RB Offset**

**Area Scan (10x16x1):** Measurement grid: dx=12mm, dy=12mm

**Zoom Scan (7x8x7)/Cube 0:** Measurement grid: dx=5mm, dy=5mm, dz=5mm

Reference Value = 11.34 V/m; Power Drift = 0.08 dB

Peak SAR (extrapolated) = 0.514 W/kg

**SAR(1 g) = 0.248 W/kg**

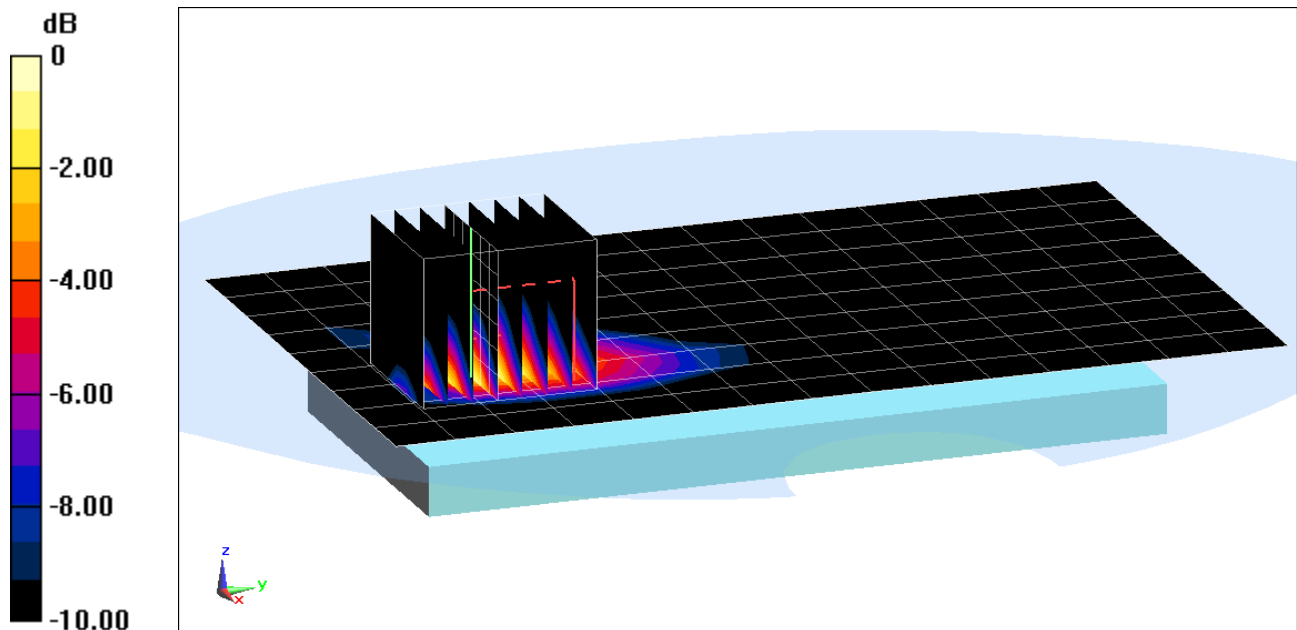

0 dB = 0.396 W/kg = -4.02 dBW/kg

# PCTEST ENGINEERING LABORATORY, INC.

**DUT: A3LSMG950N; Type: Portable Handset; Serial: E3D11**

Communication System: UID 0, IEEE 802.11b; Frequency: 2437 MHz; Duty Cycle: 1:1  
Medium: 2450 Body; Medium parameters used (interpolated):  
 $f = 2437 \text{ MHz}$ ;  $\sigma = 2.016 \text{ S/m}$ ;  $\epsilon_r = 52.939$ ;  $\rho = 1000 \text{ kg/m}^3$   
Phantom section: Flat Section; Space: 1.5 cm

Test Date: 03-09-2017; Ambient Temp: 24.0°C; Tissue Temp: 22.1°C

Probe: EX3DV4 - SN7406; ConvF(7.24, 7.24, 7.24); Calibrated: 4/19/2016;  
Sensor-Surface: 1.4mm (Mechanical Surface Detection)  
Electronics: DAE4 Sn1407; Calibrated: 4/14/2016  
Phantom: SAM 5.0 front; Type: QD000P40CD; Serial: TP:-1648  
Measurement SW: DASY52, Version 52.8 (8); SEMCAD X Version 14.6.10 (7331)

**Mode: IEEE 802.11b, Antenna 1, 22 MHz Bandwidth, Body SAR, Ch 6, 1 Mbps, Back Side**

**Area Scan (10x16x1):** Measurement grid: dx=12mm, dy=12mm  
**Zoom Scan (7x7x7)/Cube 0:** Measurement grid: dx=5mm, dy=5mm, dz=5mm  
Reference Value = 6.828 V/m; Power Drift = -0.19 dB  
Peak SAR (extrapolated) = 0.173 W/kg  
**SAR(1 g) = 0.092 W/kg**

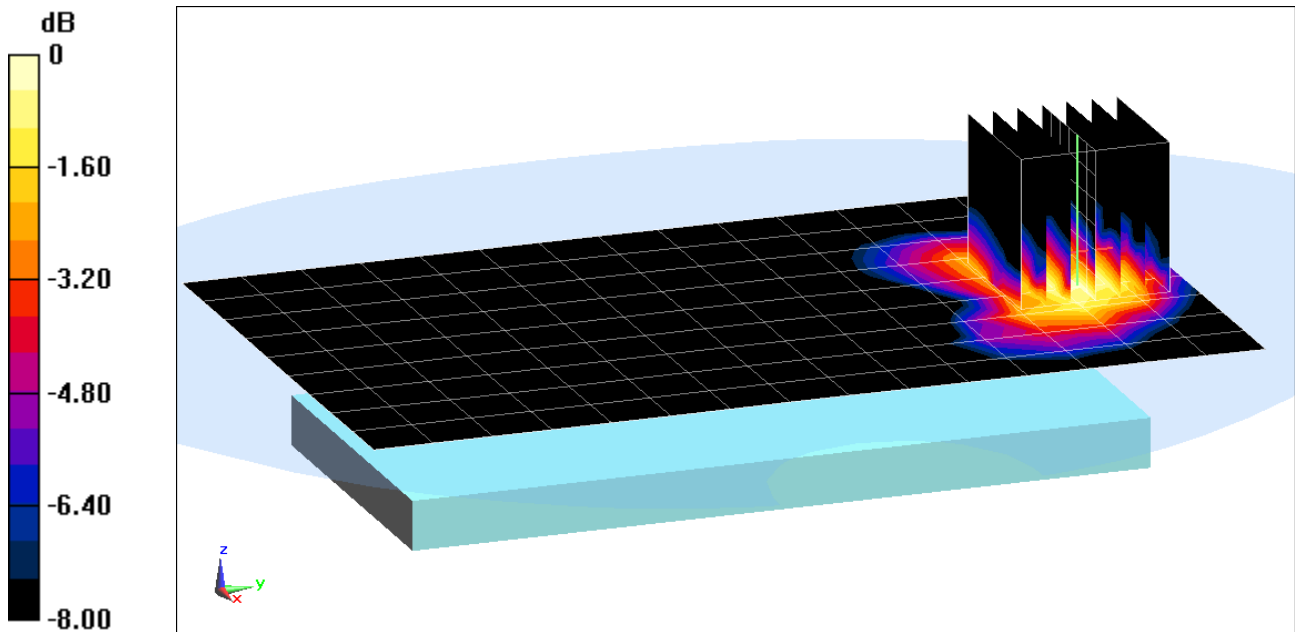

0 dB = 0.143 W/kg = -8.45 dBW/kg

# PCTEST ENGINEERING LABORATORY, INC.

**DUT: A3LSMG950N; Type: Portable Handset; Serial: E3D11**

Communication System: UID 0, IEEE 802.11b; Frequency: 2437 MHz; Duty Cycle: 1:1  
Medium: 2450 Body; Medium parameters used (interpolated):  
 $f = 2437 \text{ MHz}$ ;  $\sigma = 2.016 \text{ S/m}$ ;  $\epsilon_r = 52.939$ ;  $\rho = 1000 \text{ kg/m}^3$   
Phantom section: Flat Section; Space: 1.0 cm

Test Date: 03-09-2017; Ambient Temp: 24.0°C; Tissue Temp: 22.1°C

Probe: EX3DV4 - SN7406; ConvF(7.24, 7.24, 7.24); Calibrated: 4/19/2016;  
Sensor-Surface: 1.4mm (Mechanical Surface Detection)  
Electronics: DAE4 Sn1407; Calibrated: 4/14/2016  
Phantom: SAM 5.0 front; Type: QD000P40CD; Serial: TP:-1648  
Measurement SW: DASY52, Version 52.8 (8); SEMCAD X Version 14.6.10 (7331)

**Mode: IEEE 802.11b, Antenna 1, 22 MHz Bandwidth, Body SAR, Ch 6, 1 Mbps, Top Edge**

**Area Scan (10x9x1):** Measurement grid: dx=5mm, dy=12mm  
**Zoom Scan (7x7x7)/Cube 0:** Measurement grid: dx=5mm, dy=5mm, dz=5mm  
Reference Value = 11.02 V/m; Power Drift = 0.17 dB  
Peak SAR (extrapolated) = 0.475 W/kg  
**SAR(1 g) = 0.233 W/kg**

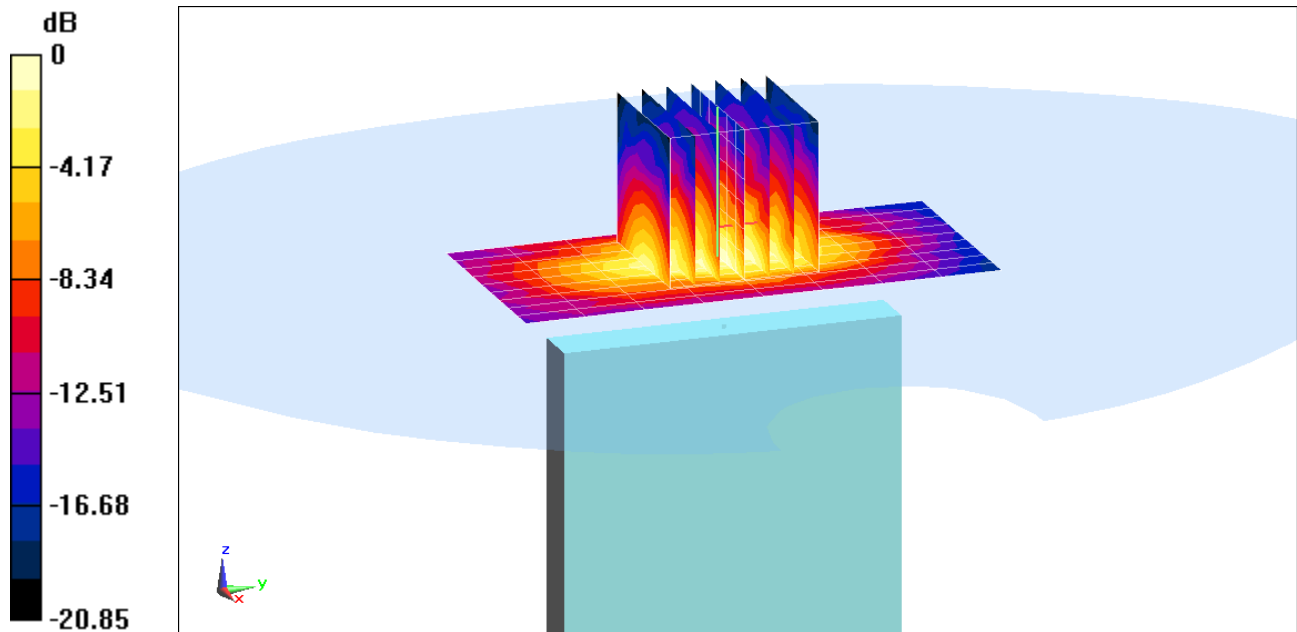

0 dB = 0.370 W/kg = -4.32 dBW/kg

# PCTEST ENGINEERING LABORATORY, INC.

**DUT: A3LSMG950N; Type: Portable Handset; Serial: E3D02**

Communication System: UID 0, 802.11a 5.2-5.8 GHz Band; Frequency: 5825 MHz; Duty Cycle: 1:1

Medium: 5GHz Body; Medium parameters used:

$f = 5825 \text{ MHz}$ ;  $\sigma = 6.308 \text{ S/m}$ ;  $\epsilon_r = 46.089$ ;  $\rho = 1000 \text{ kg/m}^3$

Phantom section: Flat Section; Space: 1.5 cm

Test Date: 03-20-2017; Ambient Temp: 23.1°C; Tissue Temp: 21.0°C

Probe: EX3DV4 - SN7308; ConvF(4.04, 4.04, 4.04); Calibrated: 7/21/2016;

Sensor-Surface: 1.4mm (Mechanical Surface Detection)

Electronics: DAE4 Sn859; Calibrated: 5/11/2016

Phantom: SAM Left; Type: QD000P40CC; Serial: TP: 1375

Measurement SW: DASY52, Version 52.8 (8); SEMCAD X Version 14.6.10 (7331)

**Mode: IEEE 802.11a, Antenna 1, UNII-3, 20 MHz Bandwidth**

**Body SAR, Ch 165, 6 Mbps, Back Side**

**Area Scan (11x18x1):** Measurement grid: dx=10mm, dy=10mm

**Zoom Scan (7x7x7)/Cube 0:** Measurement grid: dx=4mm, dy=4mm, dz=1.4mm; Graded Ratio: 1.4

Reference Value = 6.136 V/m; Power Drift = 0.14 dB

Peak SAR (extrapolated) = 0.864 W/kg

**SAR(1 g) = 0.211 W/kg**

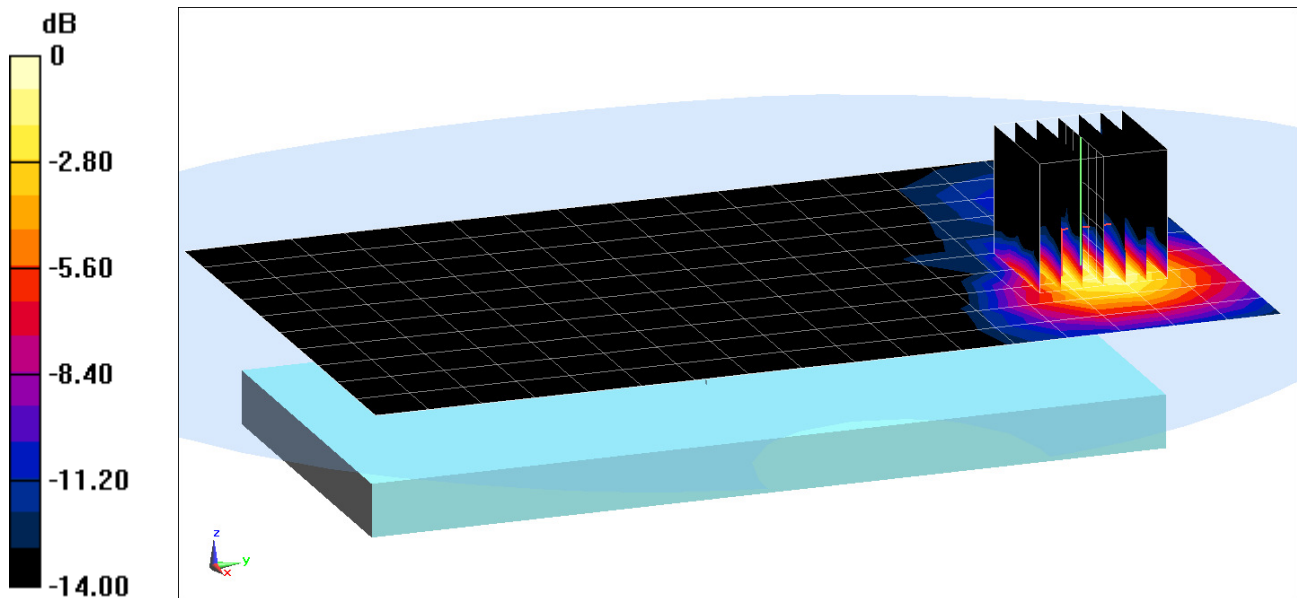

0 dB = 0.508 W/kg = -2.94 dBW/kg

# PCTEST ENGINEERING LABORATORY, INC.

**DUT: A3LSMG950N; Type: Portable Handset; Serial: E3D02**

Communication System: UID 0, 802.11a 5.2-5.8 GHz Band; Frequency: 5825 MHz; Duty Cycle: 1:1

Medium: 5GHz Body; Medium parameters used:

$f = 5825 \text{ MHz}$ ;  $\sigma = 6.308 \text{ S/m}$ ;  $\epsilon_r = 46.089$ ;  $\rho = 1000 \text{ kg/m}^3$

Phantom section: Flat Section; Space: 1.0 cm

Test Date: 03-20-2017; Ambient Temp: 23.1°C; Tissue Temp: 21.0°C

Probe: EX3DV4 - SN7308; ConvF(4.04, 4.04, 4.04); Calibrated: 7/21/2016;

Sensor-Surface: 1.4mm (Mechanical Surface Detection)

Electronics: DAE4 Sn859; Calibrated: 5/11/2016

Phantom: SAM Left; Type: QD000P40CC; Serial: TP: 1375

Measurement SW: DASY52, Version 52.8 (8); SEMCAD X Version 14.6.10 (7331)

**Mode: IEEE 802.11a, Antenna 1, UNII-3, 20 MHz Bandwidth**

**Body SAR, Ch 165, 6 Mbps, Back Side**

**Area Scan (11x19x1):** Measurement grid: dx=10mm, dy=10mm

**Zoom Scan (7x7x7)/Cube 0:** Measurement grid: dx=4mm, dy=4mm, dz=1.4mm; Graded Ratio: 1.4

Reference Value = 7.917 V/m; Power Drift = -0.03 dB

Peak SAR (extrapolated) = 1.38 W/kg

**SAR(1 g) = 0.309 W/kg**

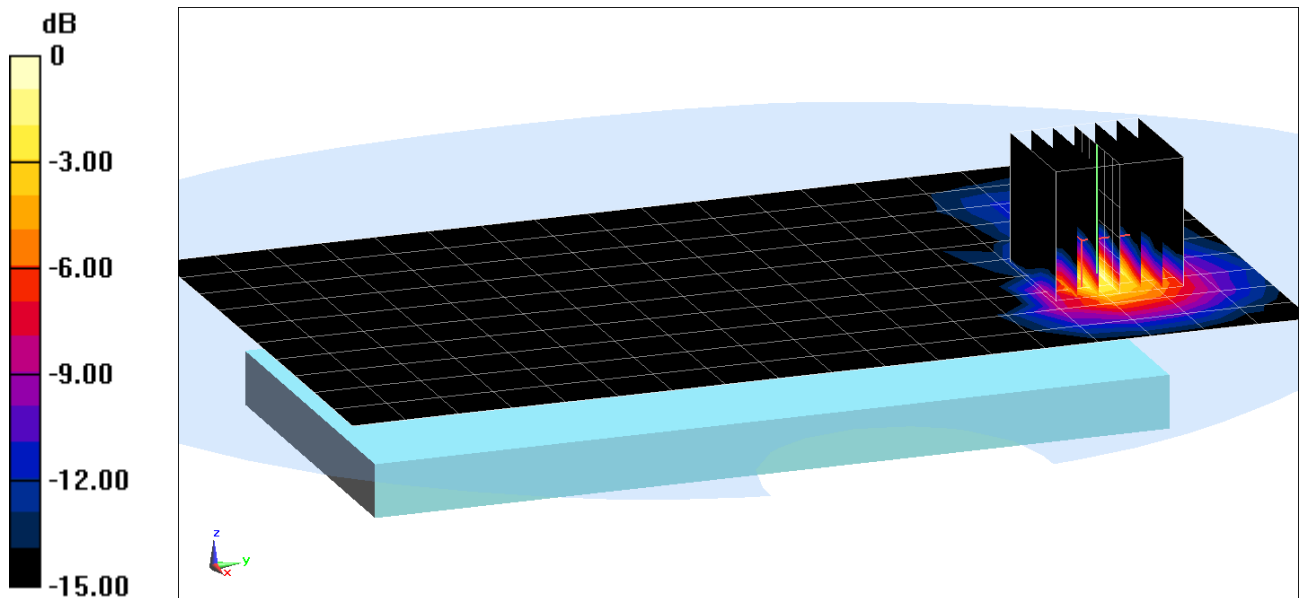

0 dB = 0.828 W/kg = -0.82 dBW/kg

# PCTEST ENGINEERING LABORATORY, INC.

**DUT: A3LSMG950N; Type: Portable Handset; Serial: E3D11**

Communication System: UID 0, Bluetooth; Frequency: 2441 MHz; Duty Cycle: 1:1.306

Medium: 2450 Body; Medium parameters used (interpolated):

$f = 2441$  MHz;  $\sigma = 2.021$  S/m;  $\epsilon_r = 52.926$ ;  $\rho = 1000$  kg/m<sup>3</sup>

Phantom section: Flat Section; Space: 1.5 cm

Test Date: 03-09-2017; Ambient Temp: 24.0°C; Tissue Temp: 22.1°C

Probe: EX3DV4 - SN7406; ConvF(7.24, 7.24, 7.24); Calibrated: 4/19/2016;

Sensor-Surface: 1.4mm (Mechanical Surface Detection)

Electronics: DAE4 Sn1407; Calibrated: 4/14/2016

Phantom: SAM 5.0 front; Type: QD000P40CD; Serial: TP:-1648

Measurement SW: DASY52, Version 52.8 (8); SEMCAD X Version 14.6.10 (7331)

**Mode: Bluetooth, Body SAR, Ch 39, 1 Mbps, Back Side**

**Area Scan (11x17x1):** Measurement grid: dx=12mm, dy=12mm

**Zoom Scan (7x7x7)/Cube 0:** Measurement grid: dx=5mm, dy=5mm, dz=5mm

Reference Value = 3.136 V/m; Power Drift = 0.20 dB

Peak SAR (extrapolated) = 0.0540 W/kg

**SAR(1 g) = 0.026 W/kg**

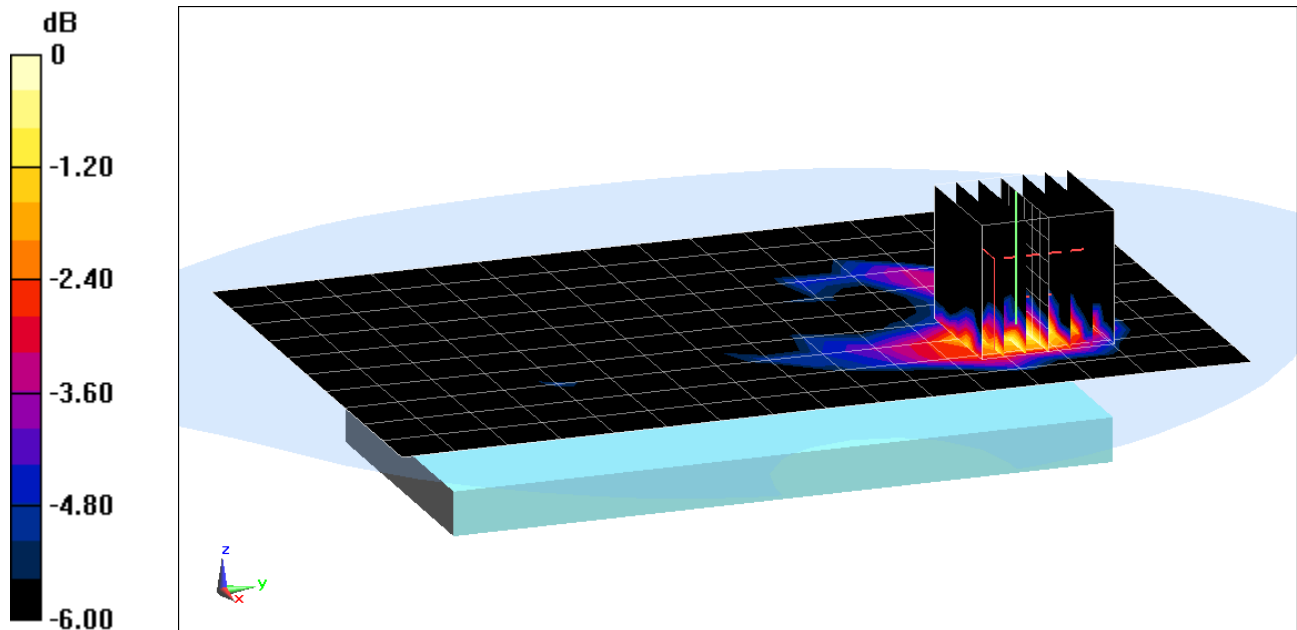

0 dB = 0.0417 W/kg = -13.80 dBW/kg

# PCTEST ENGINEERING LABORATORY, INC.

**DUT: A3LSMG950N; Type: Portable Handset; Serial: E3D11**

Communication System: UID 0, Bluetooth; Frequency: 2441 MHz; Duty Cycle: 1:1.306  
Medium: 2450 Body; Medium parameters used (interpolated):  
 $f = 2441 \text{ MHz}$ ;  $\sigma = 2.021 \text{ S/m}$ ;  $\epsilon_r = 52.926$ ;  $\rho = 1000 \text{ kg/m}^3$   
Phantom section: Flat Section; Space: 1.0 cm

Test Date: 03-09-2017; Ambient Temp: 24.0°C; Tissue Temp: 22.1°C

Probe: EX3DV4 - SN7406; ConvF(7.24, 7.24, 7.24); Calibrated: 4/19/2016;  
Sensor-Surface: 1.4mm (Mechanical Surface Detection)  
Electronics: DAE4 Sn1407; Calibrated: 4/14/2016  
Phantom: SAM 5.0 front; Type: QD000P40CD; Serial: TP:-1648  
Measurement SW: DASY52, Version 52.8 (8); SEMCAD X Version 14.6.10 (7331)

**Mode: Bluetooth, Body SAR, Ch 39, 2 Mbps, Back Side**

**Area Scan (11x17x1):** Measurement grid: dx=12mm, dy=12mm  
**Zoom Scan (9x8x7)/Cube 0:** Measurement grid: dx=5mm, dy=5mm, dz=5mm  
Reference Value = 1.414 V/m; Power Drift = 0.21 dB  
Peak SAR (extrapolated) = 0.0160 W/kg  
**SAR(1 g) = 0.008 W/kg**

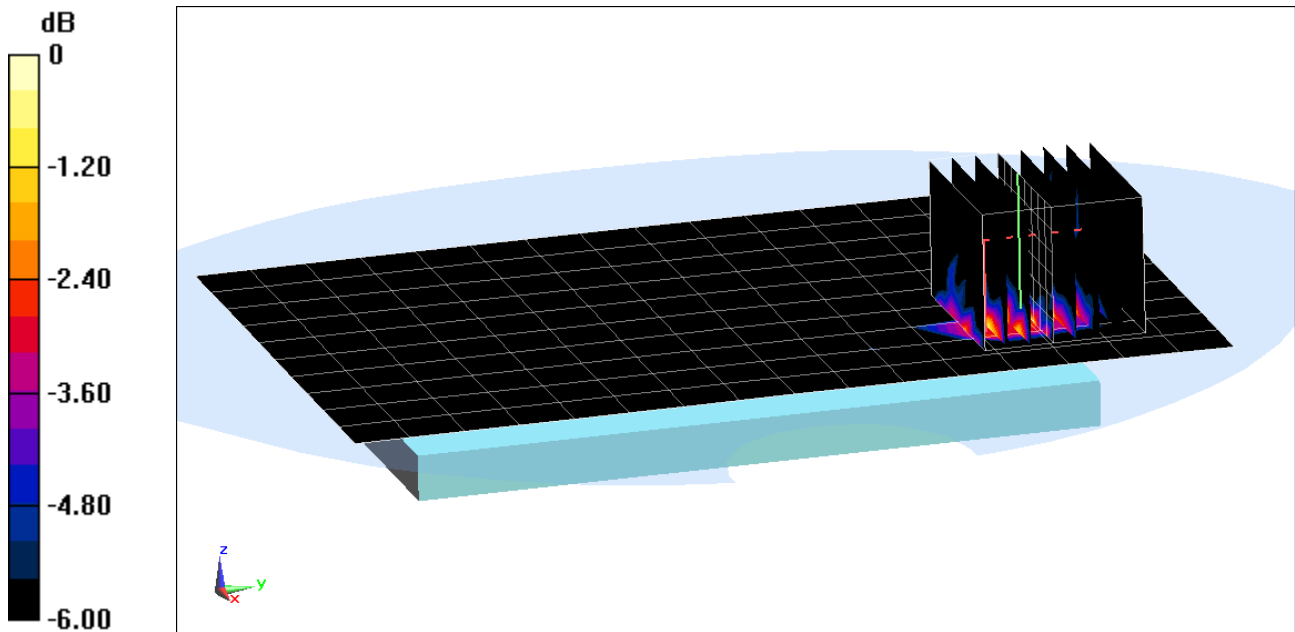

0 dB = 0.0125 W/kg = -19.03 dBW/kg

## APPENDIX B: SYSTEM VERIFICATION

# PCTEST ENGINEERING LABORATORY, INC.

**DUT: Dipole 750 MHz; Type: D750V3; Serial: 1161**

Communication System: UID 0, CW; Frequency: 750 MHz; Duty Cycle: 1:1

Medium: 750 Head; Medium parameters used (interpolated):

$f = 750 \text{ MHz}$ ;  $\sigma = 0.9 \text{ S/m}$ ;  $\epsilon_r = 40.393$ ;  $\rho = 1000 \text{ kg/m}^3$

Phantom section: Flat Section; Space: 1.5 cm

Test Date: 03-16-2017; Ambient Temp: 21.1°C; Tissue Temp: 21.3°C

Probe: ES3DV3 - SN3287; ConvF(6.96, 6.96, 6.96); Calibrated: 9/19/2016;

Sensor-Surface: 3mm (Mechanical Surface Detection)

Electronics: DAE4 Sn1408; Calibrated: 9/14/2016

Phantom: SAM Left; Type: QD000P40CA; Serial: TP:82355

Measurement SW: DASY52, Version 52.8 (8); SEMCAD X Version 14.6.10 (7331)

## 750 MHz System Verification at 23.0 dBm (200 mW)

**Area Scan (7x15x1):** Measurement grid: dx=15mm, dy=15mm

**Zoom Scan (5x5x7)/Cube 0:** Measurement grid: dx=8mm, dy=8mm, dz=5mm

Peak SAR (extrapolated) = 2.35 W/kg

**SAR(1 g) = 1.58 W/kg**

Deviation(1 g) = -3.30%

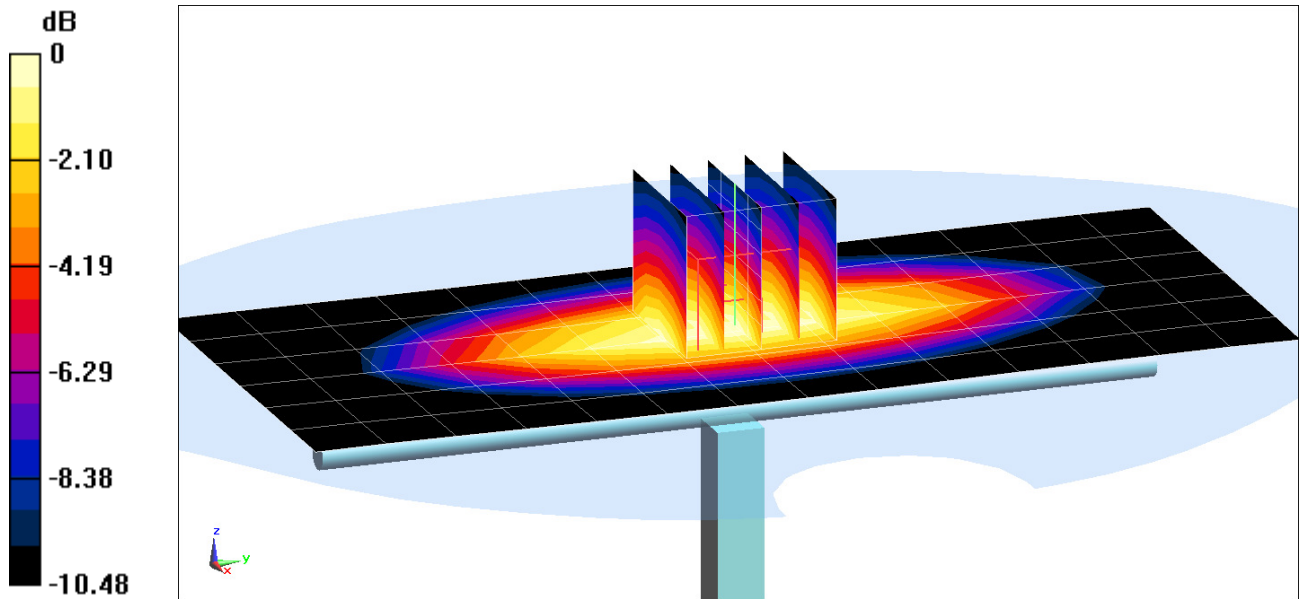

0 dB = 1.85 W/kg = 2.67 dBW/kg

# PCTEST ENGINEERING LABORATORY, INC.

**DUT: Dipole 835 MHz; Type: D835V2; Serial: 4d047**

Communication System: UID 0, CW; Frequency: 835 MHz; Duty Cycle: 1:1

Medium: 835 Head; Medium parameters used:

$f = 835 \text{ MHz}$ ;  $\sigma = 0.901 \text{ S/m}$ ;  $\epsilon_r = 41.7$ ;  $\rho = 1000 \text{ kg/m}^3$

Phantom section: Flat Section; Space: 1.5 cm

Test Date: 03-08-2017; Ambient Temp: 23.5°C; Tissue Temp: 21.2°C

Probe: EX3DV4 - SN7409; ConvF(10.04, 10.04, 10.04); Calibrated: 5/17/2016;

Sensor-Surface: 1.4mm (Mechanical Surface Detection)

Electronics: DAE4 Sn859; Calibrated: 5/11/2016

Phantom: SAM Right; Type: QD000P40CD; Serial: TP:7535

Measurement SW: DASY52, Version 52.8 (8); SEMCAD X Version 14.6.10 (7331)

## 835 MHz System Verification at 23.0 dBm (200 mW)

**Area Scan (7x14x1):** Measurement grid: dx=15mm, dy=15mm

**Zoom Scan (5x5x7)/Cube 0:** Measurement grid: dx=8mm, dy=8mm, dz=5mm

Peak SAR (extrapolated) = 2.68 W/kg

**SAR(1 g) = 1.79 W/kg**

Deviation(1 g) = -1.97%

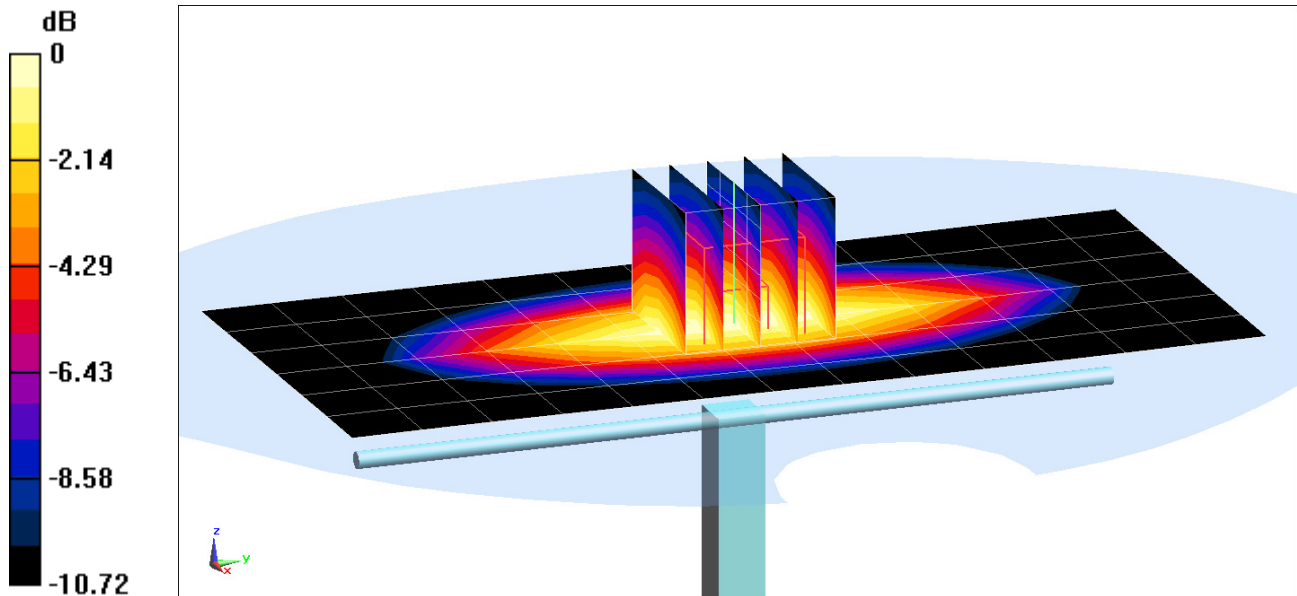

0 dB = 2.38 W/kg = 3.77 dBW/kg

# PCTEST ENGINEERING LABORATORY, INC.

**DUT: Dipole 1750 MHz; Type: D1765V2; Serial: 1008**

Communication System: UID 0, CW; Frequency: 1750 MHz; Duty Cycle: 1:1

Medium: 1750 Head; Medium parameters used:

$f = 1750 \text{ MHz}$ ;  $\sigma = 1.381 \text{ S/m}$ ;  $\epsilon_r = 39.006$ ;  $\rho = 1000 \text{ kg/m}^3$

Phantom section: Flat Section; Space: 1.0 cm

Test Date: 03-13-2017; Ambient Temp: 22.5°C; Tissue Temp: 21.5°C

Probe: ES3DV3 - SN3213; ConvF(5.49, 5.49, 5.49); Calibrated: 2/10/2017;

Sensor-Surface: 3mm (Mechanical Surface Detection)

Electronics: DAE4 Sn1272; Calibrated: 2/9/2017

Phantom: SAM Front; Type: QD000P40CD; Serial: TP:1758

Measurement SW: DASY52, Version 52.8 (8); SEMCAD X Version 14.6.10 (7331)

## 1750 MHz System Verification at 20.0 dBm (100 mW)

**Area Scan (7x9x1):** Measurement grid: dx=15mm, dy=15mm

**Zoom Scan (5x5x7)/Cube 0:** Measurement grid: dx=8mm, dy=8mm, dz=5mm

Peak SAR (extrapolated) = 6.59 W/kg

**SAR(1 g) = 3.63 W/kg**

Deviation(1 g) = -1.09%

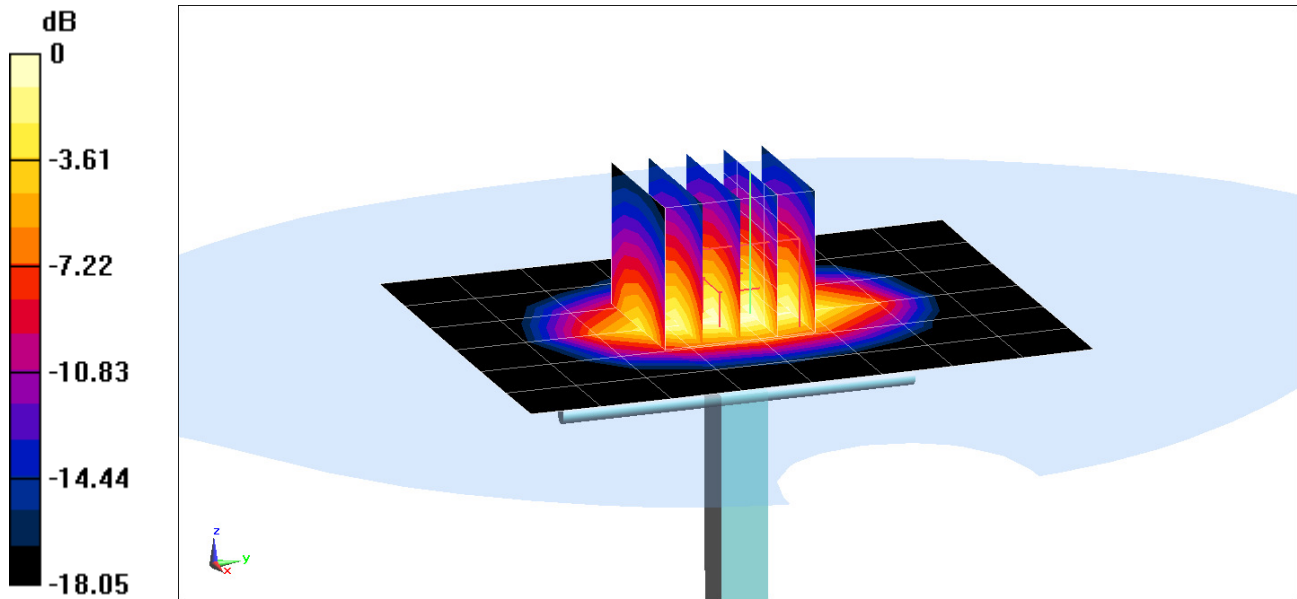

0 dB = 4.53 W/kg = 6.56 dBW/kg

# PCTEST ENGINEERING LABORATORY, INC.

**DUT: Dipole 1900 MHz; Type: D1900V2; Serial: 5d149**

Communication System: UID 0, CW; Frequency: 1900 MHz; Duty Cycle: 1:1

Medium: 1900 Head; Medium parameters used (interpolated):

$f = 1900$  MHz;  $\sigma = 1.441$  S/m;  $\epsilon_r = 39.998$ ;  $\rho = 1000$  kg/m<sup>3</sup>

Phantom section: Flat Section; Space: 1.0 cm

Test Date: 03-13-2017; Ambient Temp: 21.8°C; Tissue Temp: 22.3°C

Probe: ES3DV3 - SN3318; ConvF(5.31, 5.31, 5.31); Calibrated: 2/10/2017;

Sensor-Surface: 3mm (Mechanical Surface Detection)

Electronics: DAE4 Sn665; Calibrated: 2/9/2017

Phantom: SAM with CRP (Left); Type: SAM; Serial: 1715

Measurement SW: DASY52, Version 52.8 (8); SEMCAD X Version 14.6.10 (7331)

## 1900 MHz System Verification at 20.0 dBm (100 mW)

**Area Scan (7x10x1):** Measurement grid: dx=15mm, dy=15mm

**Zoom Scan (5x5x7)/Cube 0:** Measurement grid: dx=8mm, dy=8mm, dz=5mm

Peak SAR (extrapolated) = 7.30 W/kg

**SAR(1 g) = 3.96 W/kg**

Deviation(1 g) = -1.25%

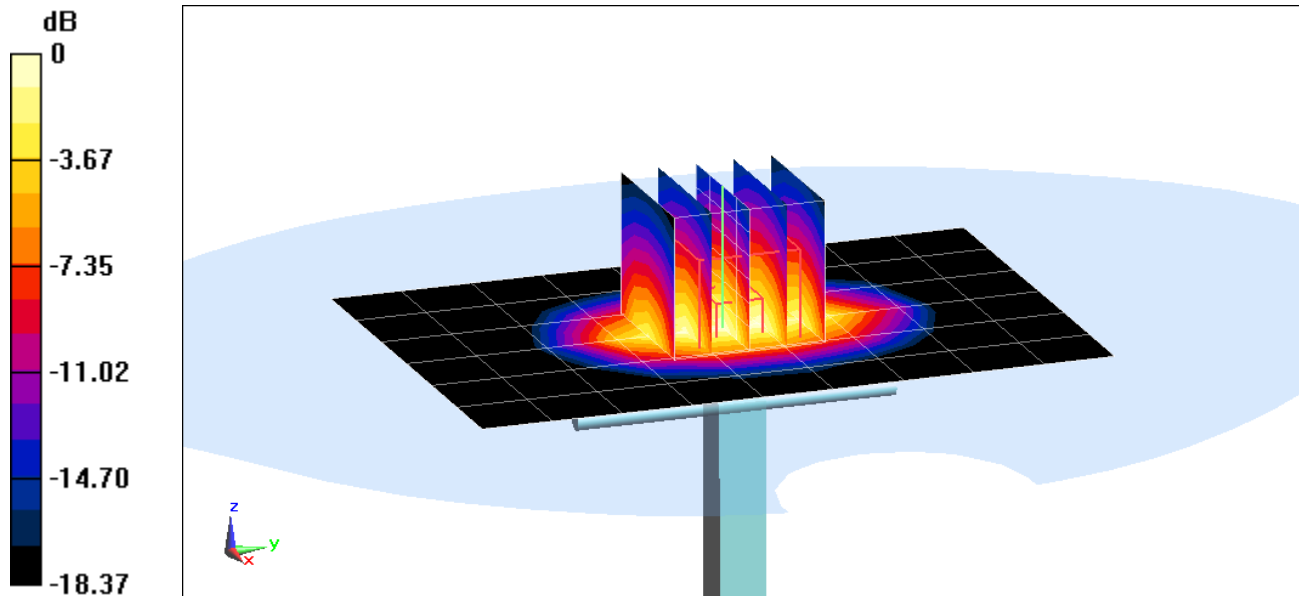

0 dB = 5.04 W/kg = 7.02 dBW/kg

# PCTEST ENGINEERING LABORATORY, INC.

**DUT: Dipole 2450 MHz; Type: D2450V2; Serial: 797**

Communication System: UID 0, CW; Frequency: 2450 MHz; Duty Cycle: 1:1

Medium: 2450 Head; Medium parameters used:

$f = 2450 \text{ MHz}$ ;  $\sigma = 1.871 \text{ S/m}$ ;  $\epsilon_r = 37.716$ ;  $\rho = 1000 \text{ kg/m}^3$

Phantom section: Flat Section; Space: 1.0 cm

Test Date: 03-09-2017; Ambient Temp: 20.9°C; Tissue Temp: 22.1°C

Probe: ES3DV3 - SN3287; ConvF(4.54, 4.54, 4.54); Calibrated: 9/19/2016;

Sensor-Surface: 3mm (Mechanical Surface Detection)

Electronics: DAE4 Sn1408; Calibrated: 9/14/2016

Phantom: SAM Front; Type: SAM; Serial: 1686

Measurement SW: DASY52, Version 52.8 (8); SEMCAD X Version 14.6.10 (7331)

## 2450 MHz System Verification at 20.0 dBm (100 mW)

**Area Scan (8x9x1):** Measurement grid: dx=12mm, dy=12mm

**Zoom Scan (7x7x7)/Cube 0:** Measurement grid: dx=5mm, dy=5mm, dz=5mm

Peak SAR (extrapolated) = 11.7 W/kg

**SAR(1 g) = 5.48 W/kg**

Deviation(1 g) = 5.18%

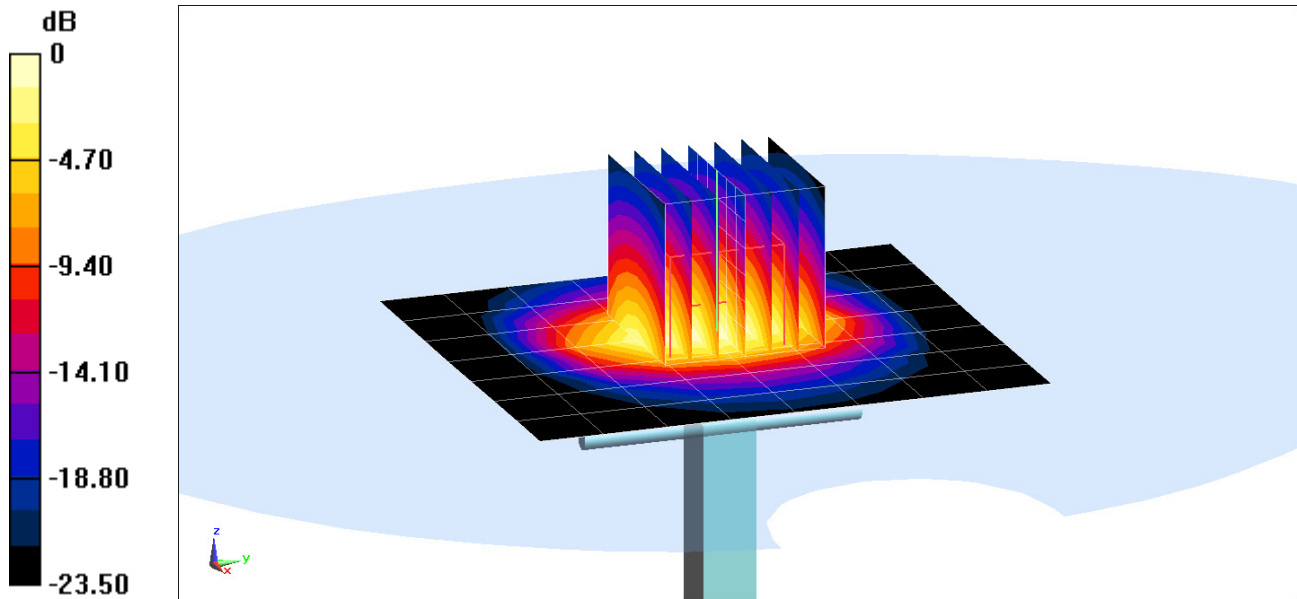

0 dB = 7.22 W/kg = 8.59 dBW/kg

# PCTEST ENGINEERING LABORATORY, INC.

**DUT: Dipole 2600 MHz; Type: D2600V2; Serial: 1126**

Communication System: UID 0, CW; Frequency: 2600 MHz; Duty Cycle: 1:1

Medium: 2450 Head; Medium parameters used:

$f = 2600$  MHz;  $\sigma = 2.022$  S/m;  $\epsilon_r = 38.139$ ;  $\rho = 1000$  kg/m<sup>3</sup>

Phantom section: Flat Section; Space: 1.0 cm

Test Date: 03-06-2017; Ambient Temp: 23.6°C; Tissue Temp: 20.8°C

Probe: ES3DV3 - SN3287; ConvF(4.41, 4.41, 4.41); Calibrated: 9/19/2016;

Sensor-Surface: 3mm (Mechanical Surface Detection)

Electronics: DAE4 Sn1408; Calibrated: 9/14/2016

Phantom: SAM Front; Type: SAM; Serial: 1686

Measurement SW: DASY52, Version 52.8 (8); SEMCAD X Version 14.6.10 (7331)

## 2600 MHz System Verification at 20.0 dBm (100 mW)

**Area Scan (8x9x1):** Measurement grid: dx=12mm, dy=12mm

**Zoom Scan (7x7x7)/Cube 0:** Measurement grid: dx=5mm, dy=5mm, dz=5mm

Peak SAR (extrapolated) = 13.3 W/kg

**SAR(1 g) = 5.91 W/kg**

Deviation(1 g) = 4.97%

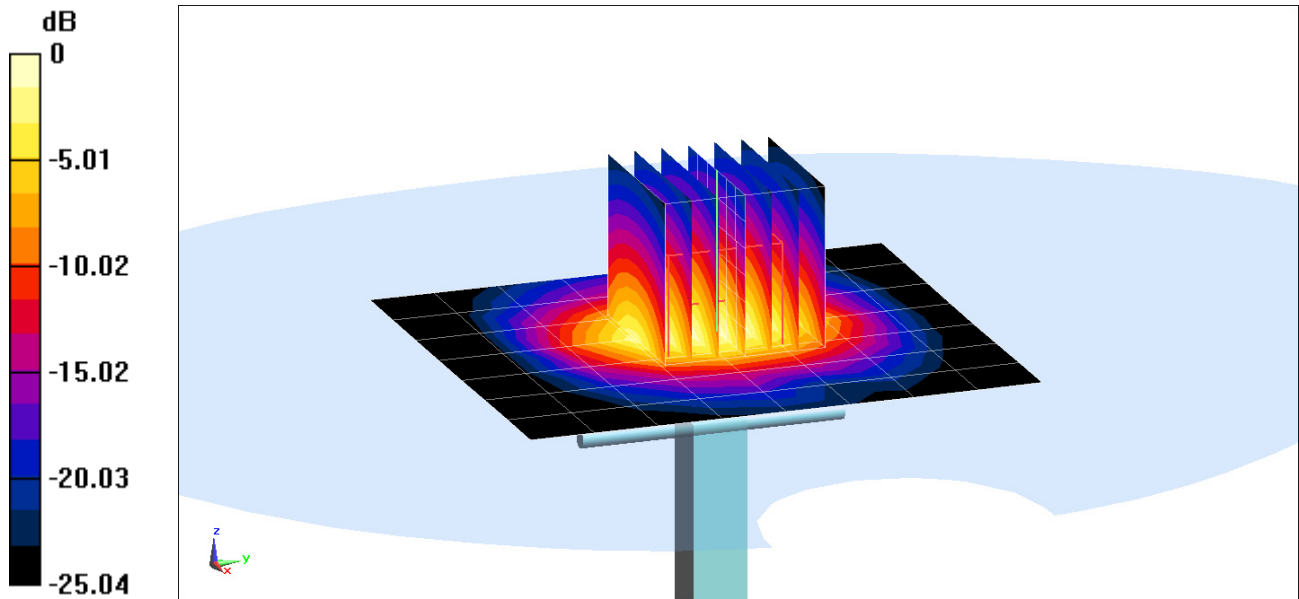

0 dB = 7.85 W/kg = 8.95 dBW/kg

# PCTEST ENGINEERING LABORATORY, INC.

**DUT: Dipole 5 GHz; Type: D5GHzV2; Serial: 1120**

Communication System: UID 0, CW; Frequency: 5250 MHz; Duty Cycle: 1:1  
Medium: 5GHz Head; Medium parameters used (interpolated):  
 $f = 5250 \text{ MHz}$ ;  $\sigma = 4.776 \text{ S/m}$ ;  $\epsilon_r = 35.735$ ;  $\rho = 1000 \text{ kg/m}^3$   
Phantom section: Flat Section; Space: 1.0 cm

Test Date: 03-13-2017; Ambient Temp: 20.2°C; Tissue Temp: 19.9°C

Probe: EX3DV4 - SN3914; ConvF(5.49, 5.49, 5.49); Calibrated: 2/13/2017;  
Sensor-Surface: 1.4mm (Mechanical Surface Detection)  
Electronics: DAE4 Sn1334; Calibrated: 11/11/2016  
Phantom: SAM with CRP v4.0; Type: QD000P40CD; Serial: TP:1800  
Measurement SW: DASY52, Version 52.8 (8); SEMCAD X Version 14.6.10 (7331)

## 5250 MHz System Verification at 17.0 dBm (50 mW)

**Area Scan (7x7x1):** Measurement grid: dx=10mm, dy=10mm

**Zoom Scan (8x8x7)/Cube 0:** Measurement grid: dx=4mm, dy=4mm, dz=1.4mm; Graded Ratio: 1.4

Peak SAR (extrapolated) = 17.8 W/kg

**SAR(1 g) = 3.93 W/kg**

Deviation(1 g) = -5.53%

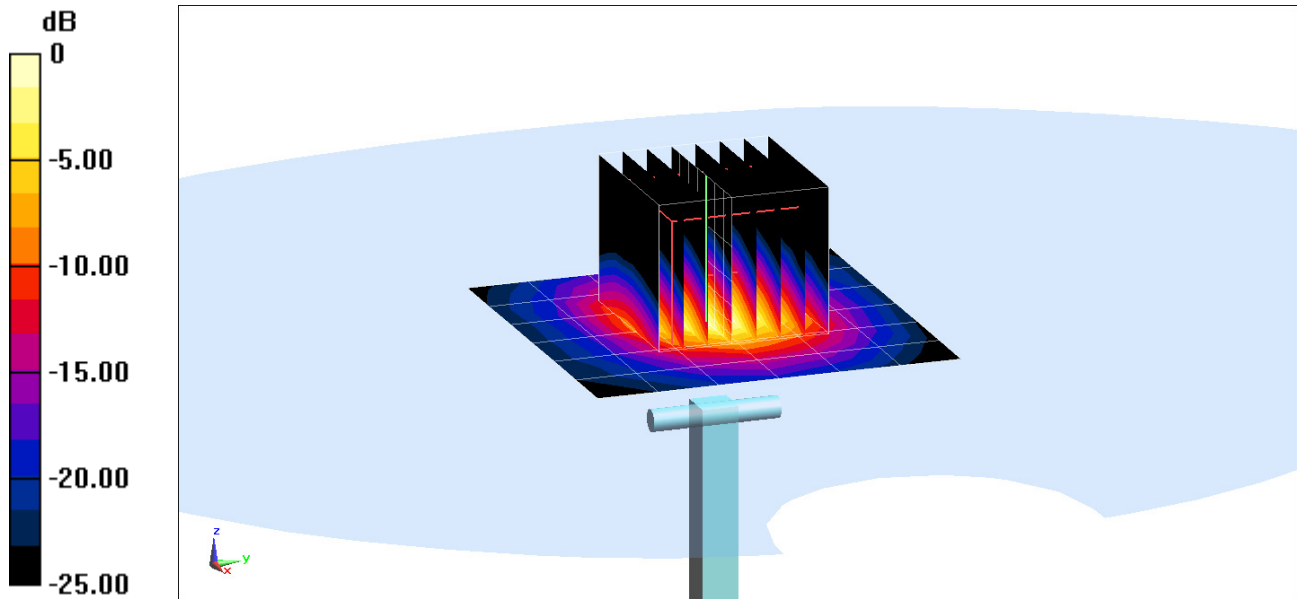

0 dB = 9.43 W/kg = 9.75 dBW/kg

# PCTEST ENGINEERING LABORATORY, INC.

**DUT: Dipole 5 GHz; Type: D5GHzV2; Serial: 1120**

Communication System: UID 0, CW; Frequency: 5600 MHz; Duty Cycle: 1:1

Medium: 5GHz Head; Medium parameters used:

$f = 5600 \text{ MHz}$ ;  $\sigma = 5.144 \text{ S/m}$ ;  $\epsilon_r = 35.182$ ;  $\rho = 1000 \text{ kg/m}^3$

Phantom section: Flat Section; Space: 1.0 cm

Test Date: 03-13-2017; Ambient Temp: 20.2°C; Tissue Temp: 19.9°C

Probe: EX3DV4 - SN3914; ConvF(4.94, 4.94, 4.94); Calibrated: 2/13/2017;

Sensor-Surface: 1.4mm (Mechanical Surface Detection)

Electronics: DAE4 Sn1334; Calibrated: 11/11/2016

Phantom: SAM with CRP v4.0; Type: QD000P40CD; Serial: TP:1800

Measurement SW: DASY52, Version 52.8 (8); SEMCAD X Version 14.6.10 (7331)

## 5600 MHz System Verification at 17.0 dBm (50 mW)

**Area Scan (7x7x1):** Measurement grid: dx=10mm, dy=10mm

**Zoom Scan (8x8x7)/Cube 0:** Measurement grid: dx=4mm, dy=4mm, dz=1.4mm; Graded Ratio: 1.4

Peak SAR (extrapolated) = 18.3 W/kg

**SAR(1 g) = 3.97 W/kg**

Deviation(1 g) = -7.46%

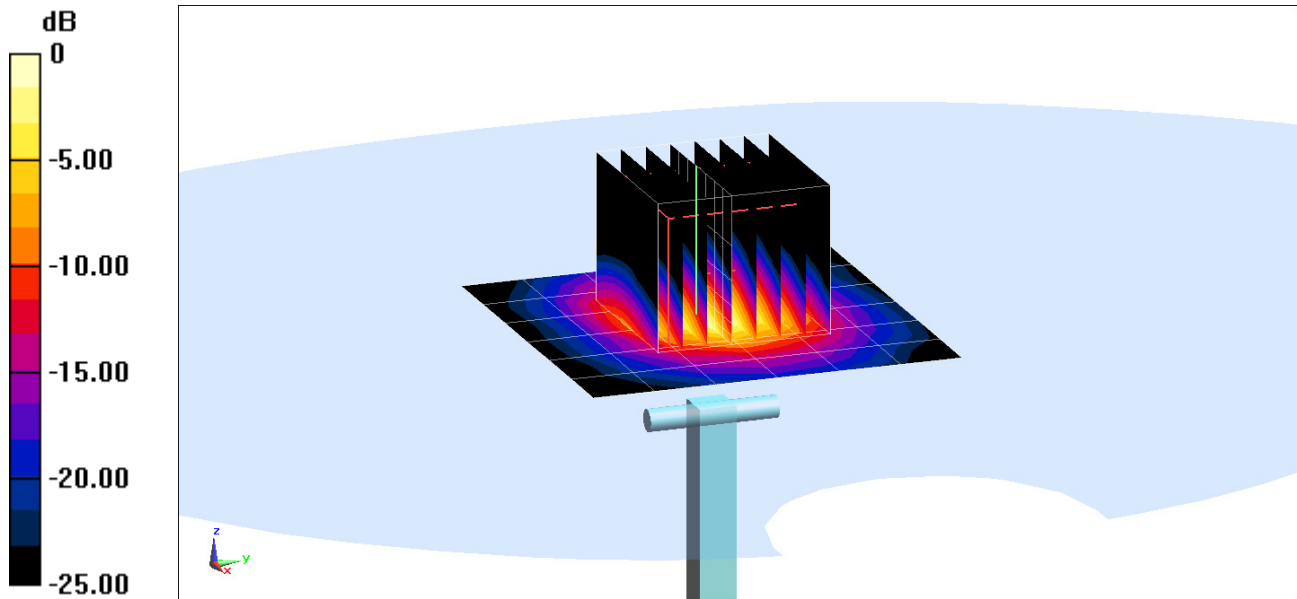

0 dB = 10.0 W/kg = 10.00 dBW/kg

# PCTEST ENGINEERING LABORATORY, INC.

**DUT: Dipole 5 GHz; Type: D5GHzV2; Serial: 1120**

Communication System: UID 0, CW; Frequency: 5750 MHz; Duty Cycle: 1:1  
Medium: 5GHz Head; Medium parameters used (interpolated):  
 $f = 5750 \text{ MHz}$ ;  $\sigma = 5.288 \text{ S/m}$ ;  $\epsilon_r = 35.008$ ;  $\rho = 1000 \text{ kg/m}^3$   
Phantom section: Flat Section; Space: 1.0 cm

Test Date: 03-13-2017; Ambient Temp: 20.2°C; Tissue Temp: 19.9°C

Probe: EX3DV4 - SN3914; ConvF(4.91, 4.91, 4.91); Calibrated: 2/13/2017;  
Sensor-Surface: 1.4mm (Mechanical Surface Detection)  
Electronics: DAE4 Sn1334; Calibrated: 11/11/2016  
Phantom: SAM with CRP v4.0; Type: QD000P40CD; Serial: TP:1800  
Measurement SW: DASY52, Version 52.8 (8); SEMCAD X Version 14.6.10 (7331)

## 5750 MHz System Verification at 17.0 dBm (50 mW)

**Area Scan (7x7x1):** Measurement grid: dx=10mm, dy=10mm

**Zoom Scan (8x8x7)/Cube 0:** Measurement grid: dx=4mm, dy=4mm, dz=1.4mm; Graded Ratio: 1.4

Peak SAR (extrapolated) = 19.5 W/kg

**SAR(1 g) = 4.05 W/kg**

Deviation(1 g) = -0.98%

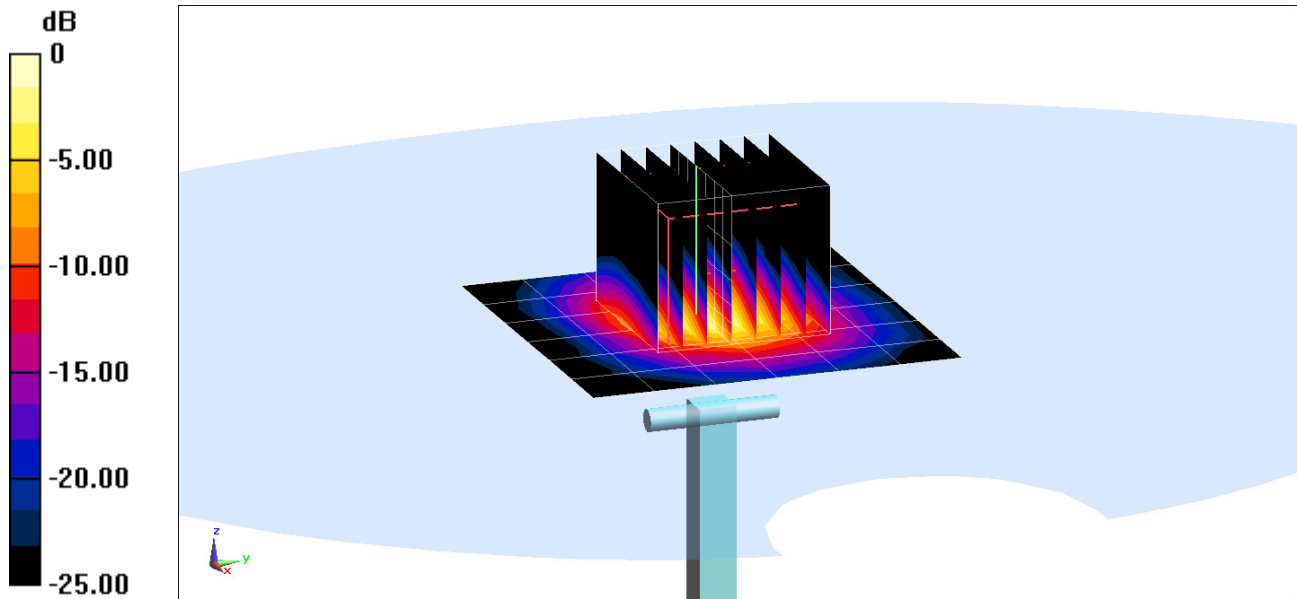

# PCTEST ENGINEERING LABORATORY, INC.

**DUT: Dipole 750 MHz; Type: D750V3; Serial: 1003**

Communication System: UID 0, CW; Frequency: 750 MHz; Duty Cycle: 1:1

Medium: 750 Body; Medium parameters used (interpolated):

$f = 750 \text{ MHz}$ ;  $\sigma = 0.955 \text{ S/m}$ ;  $\epsilon_r = 56.554$ ;  $\rho = 1000 \text{ kg/m}^3$

Phantom section: Flat Section; Space: 1.5 cm

Test Date: 03-07-2017; Ambient Temp: 24.5°C; Tissue Temp: 23.0°C

Probe: ES3DV3 - SN3213; ConvF(6.38, 6.38, 6.38); Calibrated: 2/10/2017;

Sensor-Surface: 3mm (Mechanical Surface Detection)

Electronics: DAE4 Sn1272; Calibrated: 2/9/2017

Phantom: ELI v5.0; Type: QDOVA002AA; Serial: TP:2027

Measurement SW: DASY52, Version 52.8 (8); SEMCAD X Version 14.6.10 (7331)

## 750 MHz System Verification at 23.0 dBm (200 mW)

**Area Scan (7x15x1):** Measurement grid: dx=15mm, dy=15mm

**Zoom Scan (5x5x7)/Cube 0:** Measurement grid: dx=8mm, dy=8mm, dz=5mm

Peak SAR (extrapolated) = 2.57 W/kg

**SAR(1 g) = 1.74 W/kg**

Deviation(1 g) = -1.02%

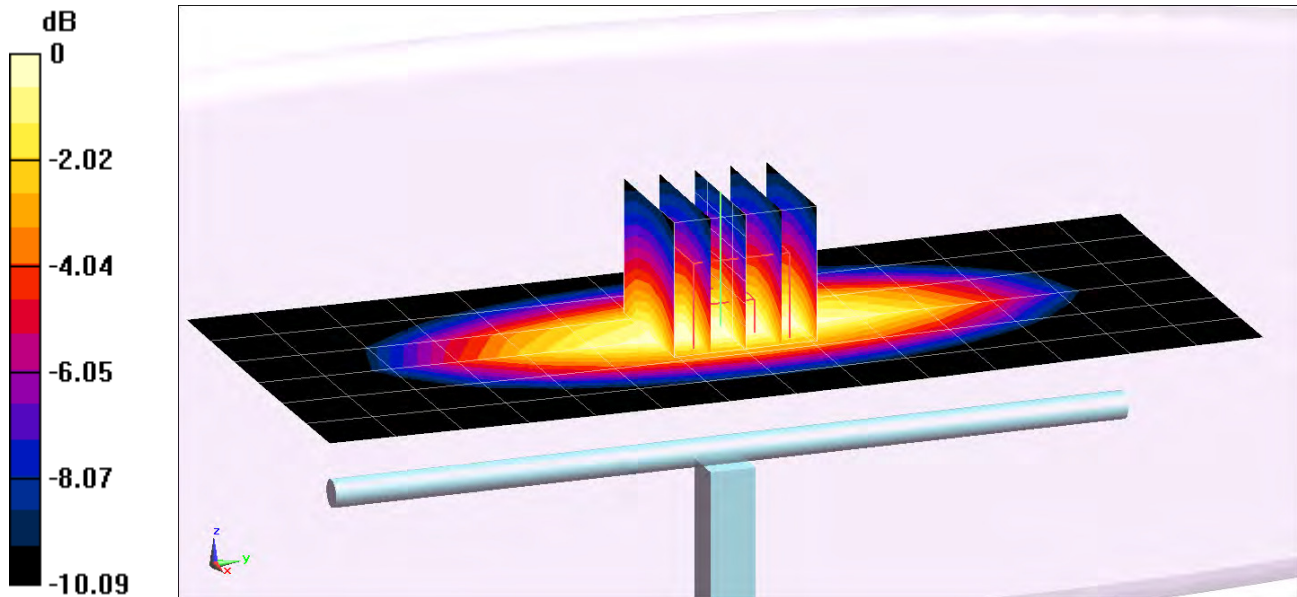

0 dB = 2.03 W/kg = 3.07 dBW/kg

# PCTEST ENGINEERING LABORATORY, INC.

**DUT: Dipole 835 MHz; Type: D835V2; Serial: 4d047**

Communication System: UID 0, CW; Frequency: 835 MHz; Duty Cycle: 1:1

Medium: 835 Body; Medium parameters used:

$f = 835 \text{ MHz}$ ;  $\sigma = 0.986 \text{ S/m}$ ;  $\epsilon_r = 53.55$ ;  $\rho = 1000 \text{ kg/m}^3$

Phantom section: Flat Section; Space: 1.5 cm

Test Date: 03-08-2017; Ambient Temp: 24.5°C; Tissue Temp: 24.1°C

Probe: ES3DV3 - SN3318; ConvF(6.37, 6.37, 6.37); Calibrated: 2/10/2017;

Sensor-Surface: 3mm (Mechanical Surface Detection)

Electronics: DAE4 Sn665; Calibrated: 2/9/2017

Phantom: SAM with CRP (Left); Type: SAM; Serial: 1715

Measurement SW: DASY52, Version 52.8 (8); SEMCAD X Version 14.6.10 (7331)

## 835 MHz System Verification at 23.0 dBm (200 mW)

**Area Scan (7x14x1):** Measurement grid: dx=15mm, dy=15mm

**Zoom Scan (5x5x7)/Cube 0:** Measurement grid: dx=8mm, dy=8mm, dz=5mm

Peak SAR (extrapolated) = 2.85 W/kg

**SAR(1 g) = 1.96 W/kg**

Deviation(1 g) = 2.40%

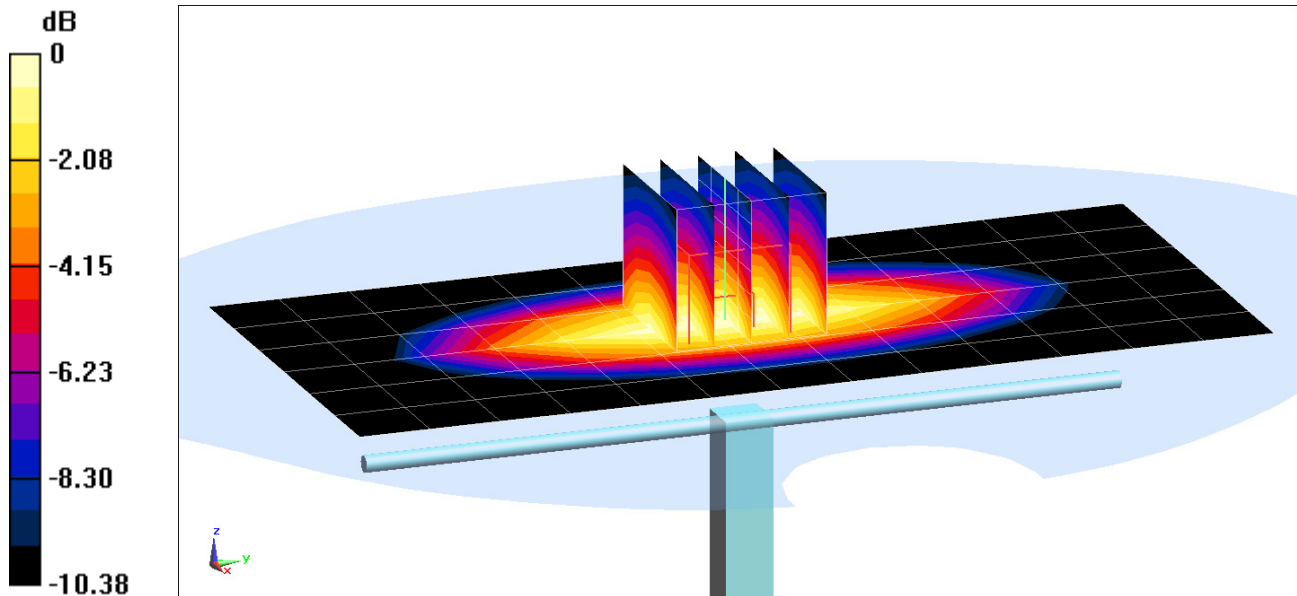

0 dB = 2.28 W/kg = 3.58 dBW/kg

# PCTEST ENGINEERING LABORATORY, INC.

**DUT: Dipole 1750 MHz; Type: D1765V2; Serial: 1008**

Communication System: UID 0, CW; Frequency: 1750 MHz; Duty Cycle: 1:1

Medium: 1750 Body; Medium parameters used:

$f = 1750 \text{ MHz}$ ;  $\sigma = 1.467 \text{ S/m}$ ;  $\epsilon_r = 51.204$ ;  $\rho = 1000 \text{ kg/m}^3$

Phantom section: Flat Section; Space: 1.0 cm

Test Date: 03-06-2017; Ambient Temp: 21.5°C; Tissue Temp: 20.7°C

Probe: ES3DV3 - SN3213; ConvF(5.09, 5.09, 5.09); Calibrated: 2/10/2017;

Sensor-Surface: 3mm (Mechanical Surface Detection)

Electronics: DAE4 Sn1272; Calibrated: 2/9/2017

Phantom: SAM Front; Type: QD000P40CD; Serial: TP:1758

Measurement SW: DASY52, Version 52.8 (8); SEMCAD X Version 14.6.10 (7331)

## 1750 MHz System Verification at 20.0 dBm (100 mW)

**Area Scan (7x9x1):** Measurement grid: dx=15mm, dy=15mm

**Zoom Scan (5x5x7)/Cube 0:** Measurement grid: dx=8mm, dy=8mm, dz=5mm

Peak SAR (extrapolated) = 6.52 W/kg

**SAR(1 g) = 3.66 W/kg**

Deviation(1 g) = -1.88%

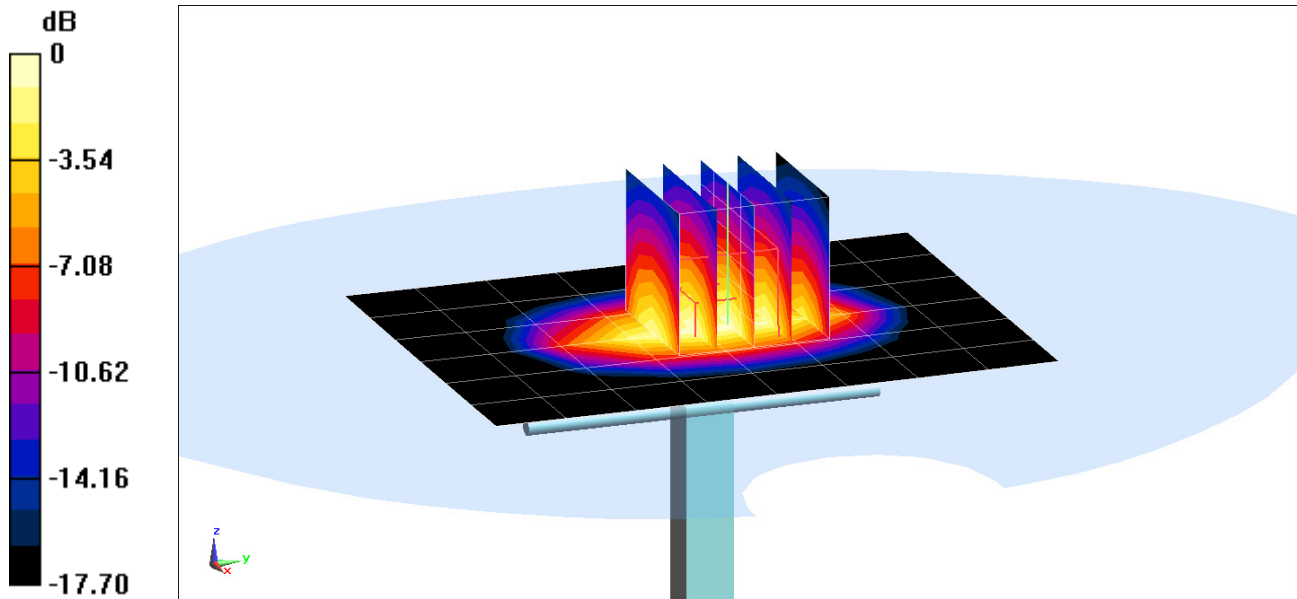

0 dB = 4.54 W/kg = 6.57 dBW/kg

# PCTEST ENGINEERING LABORATORY, INC.

**DUT: Dipole 1900 MHz; Type: D1900V2; Serial: 5d149**

Communication System: UID 0, CW; Frequency: 1900 MHz; Duty Cycle: 1:1

Medium: 1900 Body; Medium parameters used (interpolated):

$f = 1900$  MHz;  $\sigma = 1.542$  S/m;  $\epsilon_r = 52.243$ ;  $\rho = 1000$  kg/m<sup>3</sup>

Phantom section: Flat Section; Space: 1.0 cm

Test Date: 03-07-2017; Ambient Temp: 23.2°C; Tissue Temp: 21.9°C

Probe: ES3DV3 - SN3334; ConvF(4.91, 4.91, 4.91); Calibrated: 11/15/2016;

Sensor-Surface: 3mm (Mechanical Surface Detection)

Electronics: DAE4 Sn1334; Calibrated: 11/11/2016

Phantom: SAM with CRP v4.0 Left; Type: QD000P40CD; Serial: TP:1692

Measurement SW: DASY52, Version 52.8 (8); SEMCAD X Version 14.6.10 (7331)

## 1900 MHz System Verification at 20.0 dBm (100 mW)

**Area Scan (7x10x1):** Measurement grid: dx=15mm, dy=15mm

**Zoom Scan (5x5x7)/Cube 0:** Measurement grid: dx=8mm, dy=8mm, dz=5mm

Peak SAR (extrapolated) = 7.23 W/kg

**SAR(1 g) = 4.06 W/kg**

Deviation(1 g) = 1.75%

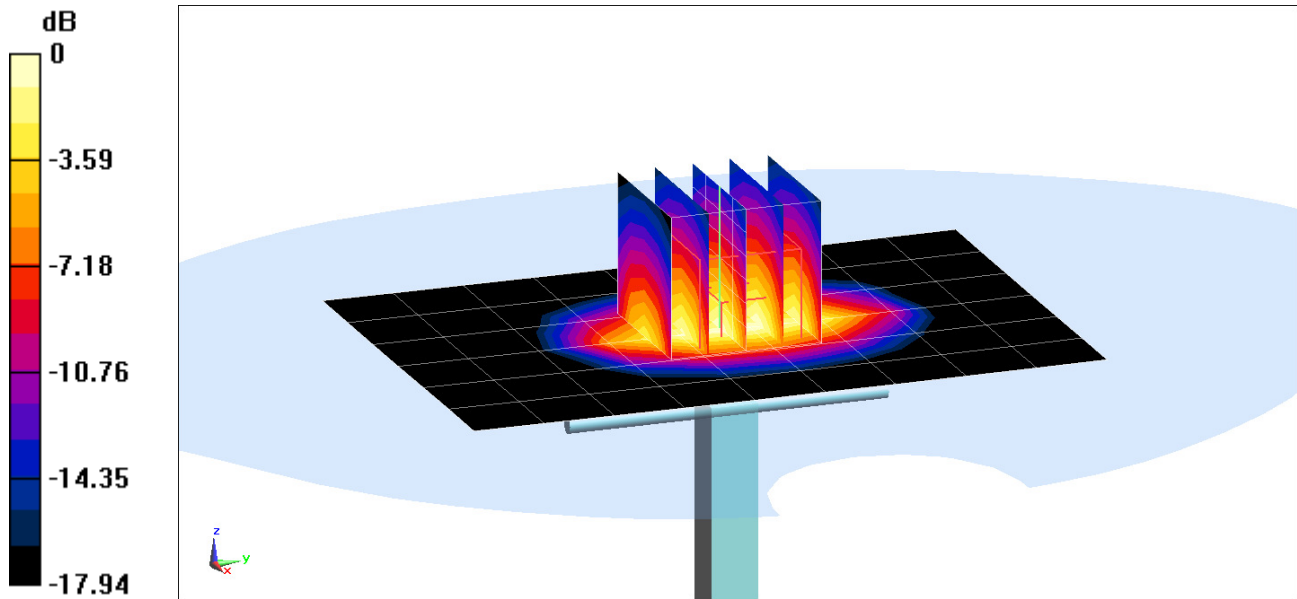

0 dB = 5.08 W/kg = 7.06 dBW/kg

# PCTEST ENGINEERING LABORATORY, INC.

**DUT: Dipole 2450 MHz; Type: D2450V2; Serial: 981**

Communication System: UID 0, CW; Frequency: 2450 MHz; Duty Cycle: 1:1

Medium: 2450 Body; Medium parameters used:

$f = 2450 \text{ MHz}$ ;  $\sigma = 2.033 \text{ S/m}$ ;  $\epsilon_r = 52.897$ ;  $\rho = 1000 \text{ kg/m}^3$

Phantom section: Flat Section; Space: 1.0 cm

Test Date: 03-09-2017; Ambient Temp: 24.0°C; Tissue Temp: 22.1°C

Probe: EX3DV4 - SN7406; ConvF(7.24, 7.24, 7.24); Calibrated: 04/19/2016;

Sensor-Surface: 1.4mm (Mechanical Surface Detection)

Electronics: DAE4 Sn1407; Calibrated: 04/14/2016

Phantom: SAM 5.0 front; Type: QD000P40CD; Serial: TP:-1648

Measurement SW: DASY52, Version 52.8 (8); SEMCAD X Version 14.6.10 (7331)

## 2450 MHz System Verification at 20.0 dBm (100 mW)

**Area Scan (8x9x1):** Measurement grid: dx=12mm, dy=12mm

**Zoom Scan (7x7x7)/Cube 0:** Measurement grid: dx=5mm, dy=5mm, dz=5mm

Peak SAR (extrapolated) = 10.2 W/kg

**SAR(1 g) = 4.96 W/kg**

Deviation(1 g) = -2.36 %

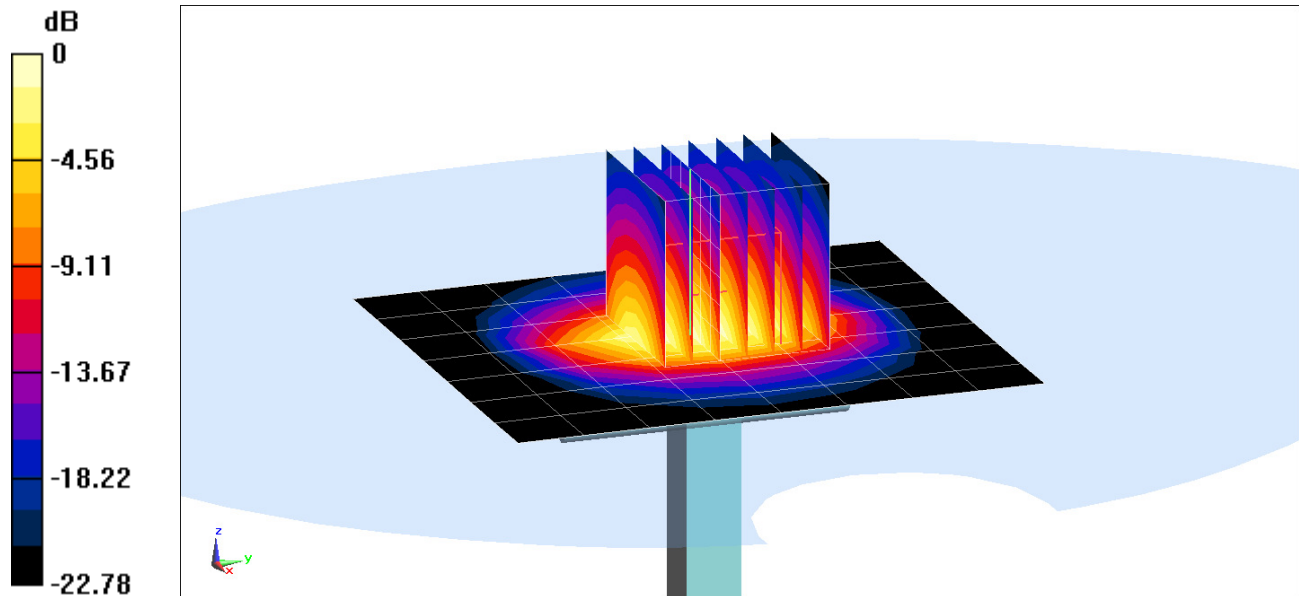

0 dB = 8.19 W/kg = 9.13 dBW/kg

# PCTEST ENGINEERING LABORATORY, INC.

**DUT: Dipole 2600 MHz; Type: D2600V2; Serial: 1071**

Communication System: UID 0, CW; Frequency: 2600 MHz; Duty Cycle: 1:1

Medium: 2450 Body; Medium parameters used:

$f = 2600$  MHz;  $\sigma = 2.247$  S/m;  $\epsilon_r = 52.247$ ;  $\rho = 1000$  kg/m<sup>3</sup>

Phantom section: Flat Section; Space: 1.0 cm

Test Date: 03-09-2017; Ambient Temp: 24.0°C; Tissue Temp: 22.1°C

Probe: EX3DV4 - SN7406; ConvF(6.94, 6.94, 6.94); Calibrated: 04/19/2016;

Sensor-Surface: 1.4mm (Mechanical Surface Detection)

Electronics: DAE4 Sn1407; Calibrated: 04/14/2016

Phantom: SAM 5.0 front; Type: QD000P40CD; Serial: TP:-1648

Measurement SW: DASY52, Version 52.8 (8); SEMCAD X Version 14.6.10 (7331)

## 2600 MHz System Verification at 20.0 dBm (100 mW)

**Area Scan (8x9x1):** Measurement grid: dx=12mm, dy=12mm

**Zoom Scan (7x7x7)/Cube 0:** Measurement grid: dx=5mm, dy=5mm, dz=5mm

Peak SAR (extrapolated) = 12.7 W/kg

**SAR(1 g) = 5.70 W/kg**

Deviation(1 g) = 5.17%

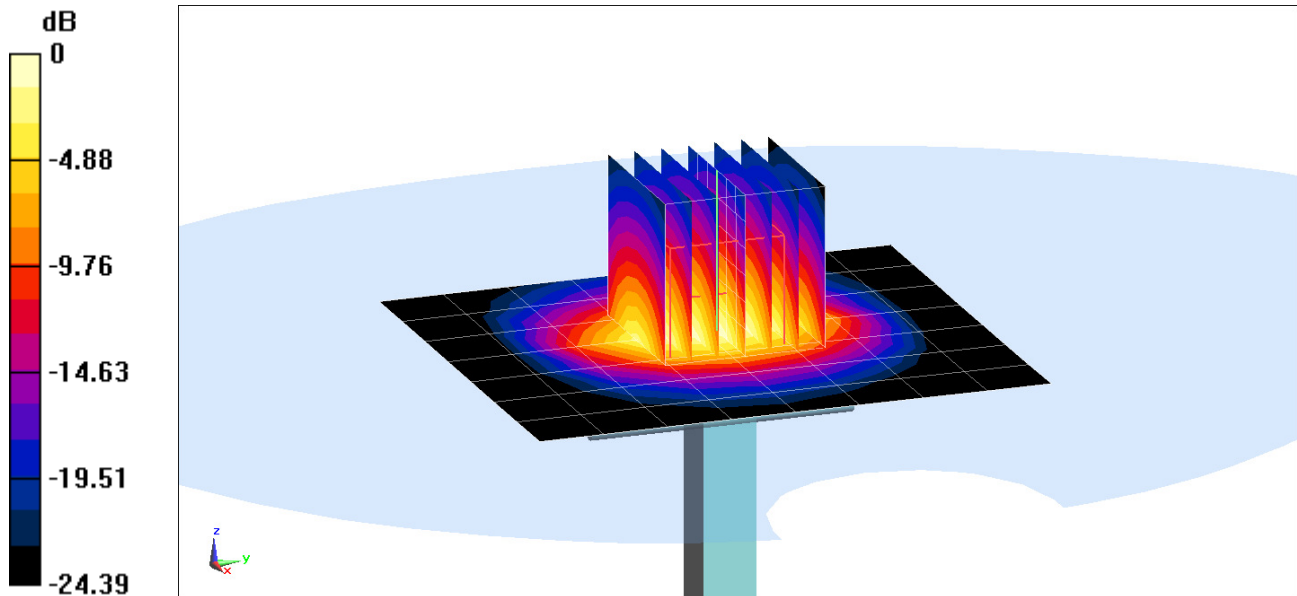

0 dB = 9.91 W/kg = 9.96 dBW/kg

# PCTEST ENGINEERING LABORATORY, INC.

**DUT: Dipole 5 GHz; Type: D5GHzV2; Serial: 1237**

Communication System: UID 0, CW; Frequency: 5250 MHz; Duty Cycle: 1:1  
Medium: 5GHz Body; Medium parameters used (interpolated):  
 $f = 5250 \text{ MHz}$ ;  $\sigma = 5.524 \text{ S/m}$ ;  $\epsilon_r = 47.038$ ;  $\rho = 1000 \text{ kg/m}^3$   
Phantom section: Flat Section; Space: 1.0 cm

Test Date: 03-20-2017; Ambient Temp: 23.1°C; Tissue Temp: 21.0°C

Probe: EX3DV4 - SN7308; ConvF(4.45, 4.45, 4.45); Calibrated: 7/21/2016;  
Sensor-Surface: 1.4mm (Mechanical Surface Detection)  
Electronics: DAE4 Sn859; Calibrated: 5/11/2016  
Phantom: SAM Left; Type: QD000P40CC; Serial: TP: 1375  
Measurement SW: DASY52, Version 52.8 (8); SEMCAD X Version 14.6.10 (7331)

## 5250 MHz System Verification at 17.0 dBm (50 mW)

**Area Scan (7x7x1):** Measurement grid: dx=10mm, dy=10mm

**Zoom Scan (8x8x7)/Cube 0:** Measurement grid: dx=4mm, dy=4mm, dz=1.4mm; Graded Ratio: 1.4

Peak SAR (extrapolated) = 15.1 W/kg

**SAR(1 g) = 3.68 W/kg**

Deviation(1 g) = -1.60%

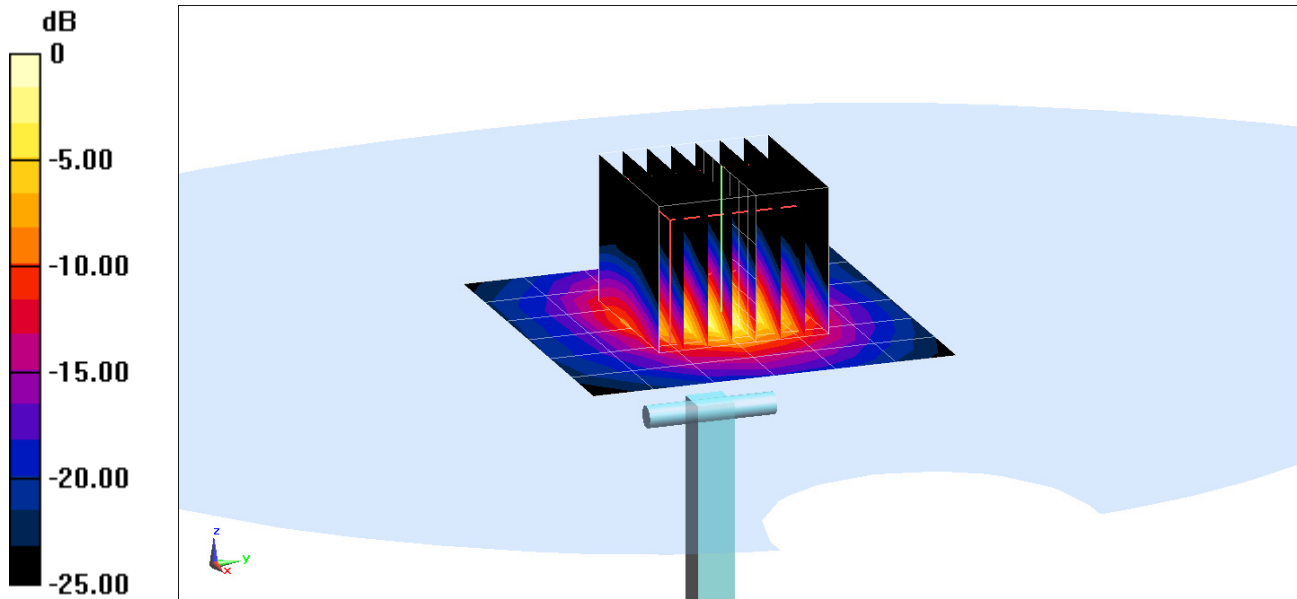

0 dB = 8.99 W/kg = 9.54 dBW/kg

# PCTEST ENGINEERING LABORATORY, INC.

**DUT: Dipole 5 GHz; Type: D5GHzV2; Serial: 1237**

Communication System: UID 0, CW; Frequency: 5600 MHz; Duty Cycle: 1:1

Medium: 5GHz Body; Medium parameters used:

$f = 5600 \text{ MHz}$ ;  $\sigma = 6.009 \text{ S/m}$ ;  $\epsilon_r = 46.52$ ;  $\rho = 1000 \text{ kg/m}^3$

Phantom section: Flat Section; Space: 1.0 cm

Test Date: 03-20-2017; Ambient Temp: 23.1°C; Tissue Temp: 21.0°C

Probe: EX3DV4 - SN7308; ConvF(3.75, 3.75, 3.75); Calibrated: 7/21/2016;

Sensor-Surface: 1.4mm (Mechanical Surface Detection)

Electronics: DAE4 Sn859; Calibrated: 5/11/2016

Phantom: SAM Left; Type: QD000P40CC; Serial: TP: 1375

Measurement SW: DASY52, Version 52.8 (8); SEMCAD X Version 14.6.10 (7331)

## 5600 MHz System Verification at 17.0 dBm (50 mW)

**Area Scan (7x7x1):** Measurement grid: dx=10mm, dy=10mm

**Zoom Scan (8x8x7)/Cube 0:** Measurement grid: dx=4mm, dy=4mm, dz=1.4mm; Graded Ratio: 1.4

Peak SAR (extrapolated) = 16.8 W/kg

**SAR(1 g) = 4.06 W/kg**

Deviation(1 g) = 5.45%

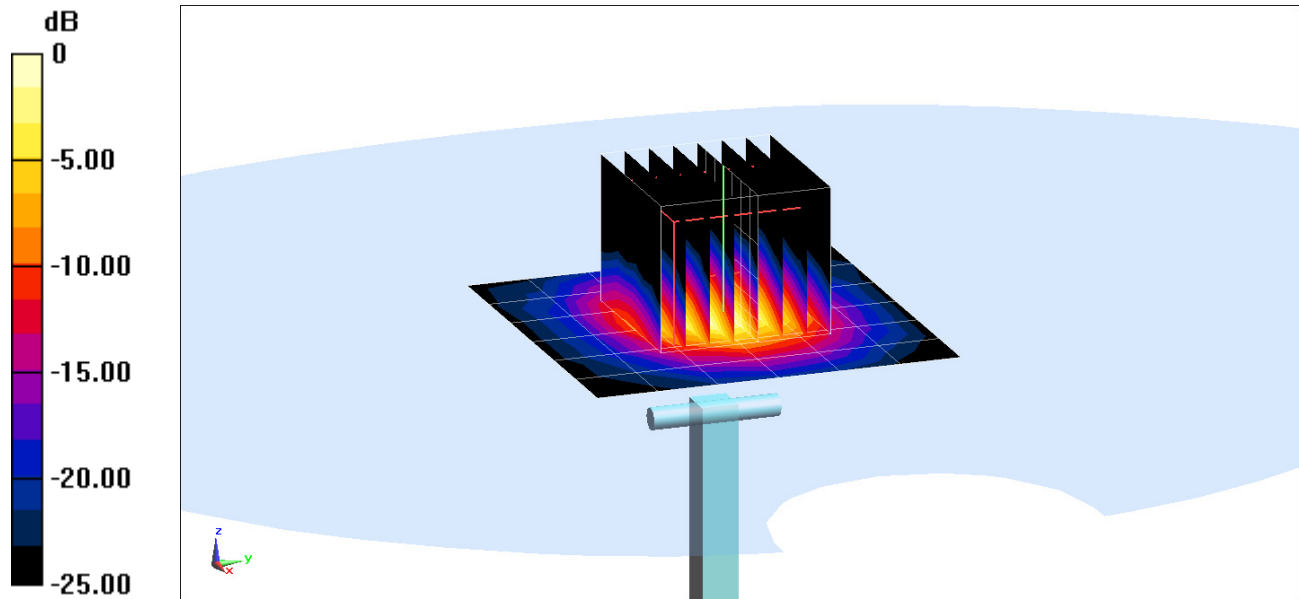

0 dB = 9.61 W/kg = 9.83 dBW/kg

# PCTEST ENGINEERING LABORATORY, INC.

**DUT: Dipole 5 GHz; Type: D5GHzV2; Serial: 1237**

Communication System: UID 0, CW; Frequency: 5750 MHz; Duty Cycle: 1:1  
Medium: 5GHz Body; Medium parameters used (interpolated):  
 $f = 5750 \text{ MHz}$ ;  $\sigma = 6.203 \text{ S/m}$ ;  $\epsilon_r = 46.288$ ;  $\rho = 1000 \text{ kg/m}^3$   
Phantom section: Flat Section; Space: 1.0 cm

Test Date: 03-20-2017; Ambient Temp: 23.1°C; Tissue Temp: 21.0°C

Probe: EX3DV4 - SN7308; ConvF(4.04, 4.04, 4.04); Calibrated: 7/21/2016;  
Sensor-Surface: 1.4mm (Mechanical Surface Detection)  
Electronics: DAE4 Sn859; Calibrated: 5/11/2016  
Phantom: SAM Left; Type: QD000P40CC; Serial: TP: 1375  
Measurement SW: DASY52, Version 52.8 (8); SEMCAD X Version 14.6.10 (7331)

## 5750 MHz System Verification at 17.0 dBm (50 mW)

**Area Scan (7x7x1):** Measurement grid: dx=10mm, dy=10mm

**Zoom Scan (8x8x7)/Cube 0:** Measurement grid: dx=4mm, dy=4mm, dz=1.4mm; Graded Ratio: 1.4

Peak SAR (extrapolated) = 15.3 W/kg

**SAR(1 g) = 3.53 W/kg**

Deviation(1 g) = -6.37%

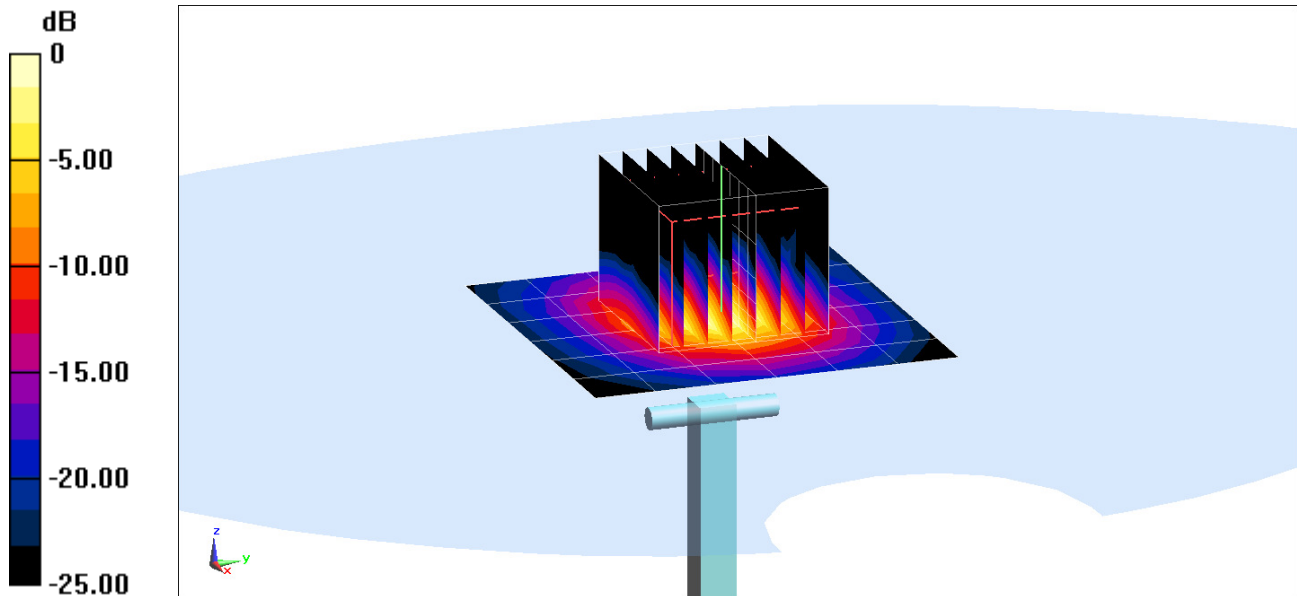

0 dB = 8.68 W/kg = 9.39 dBW/kg

## APPENDIX C: PROBE CALIBRATION

**Calibration Laboratory of  
Schmid & Partner  
Engineering AG**  
Zeughausstrasse 43, 8004 Zurich, Switzerland



**S** Schweizerischer Kalibrierdienst  
**C** Service suisse d'étalonnage  
**S** Servizio svizzero di taratura  
Swiss Calibration Service

Accredited by the Swiss Accreditation Service (SAS)  
The Swiss Accreditation Service is one of the signatories to the EA  
Multilateral Agreement for the recognition of calibration certificates

Accreditation No.: **SCS 0108**

Client **PC Test**

Certificate No: **ES3-3287\_Sep16**

## CALIBRATION CERTIFICATE

Object: **ES3DV3 - SN:3287**

Calibration procedure(s): **QA CAL-01.v9, QA CAL-23.v5, QA CAL-25.v6**  
**Calibration procedure for dosimetric E-field probes**

Calibration date: **September 19, 2016**

*BNV*  
*09-28-2016*

This calibration certificate documents the traceability to national standards, which realize the physical units of measurements (SI).  
The measurements and the uncertainties with confidence probability are given on the following pages and are part of the certificate.

All calibrations have been conducted in the closed laboratory facility: environment temperature (22 ± 3)°C and humidity < 70%.

Calibration Equipment used (M&TE critical for calibration)

Primary Standards	ID	Cal Date (Certificate No.)	Scheduled Calibration
Power meter NRP	SN: 104778	06-Apr-16 (No. 217-02288/02289)	Apr-17
Power sensor NRP-Z91	SN: 103244	06-Apr-16 (No. 217-02288)	Apr-17
Power sensor NRP-Z91	SN: 103245	06-Apr-16 (No. 217-02289)	Apr-17
Reference 20 dB Attenuator	SN: S5277 (20x)	05-Apr-16 (No. 217-02293)	Apr-17
Reference Probe ES3DV2	SN: 3013	31-Dec-15 (No. ES3-3013_Dec15)	Dec-16
DAE4	SN: 660	23-Dec-15 (No. DAE4-660_Dec15)	Dec-16
Secondary Standards	ID	Check Date (in house)	Scheduled Check
Power meter E4419B	SN: GB41293874	06-Apr-16 (in house check Jun-16)	In house check: Jun-18
Power sensor E4412A	SN: MY41498087	06-Apr-16 (in house check Jun-16)	In house check: Jun-18
Power sensor E4412A	SN: 000110210	06-Apr-16 (in house check Jun-16)	In house check: Jun-18
RF generator HP 8648C	SN: US3642U01700	04-Aug-99 (in house check Jun-16)	In house check: Jun-18
Network Analyzer HP 8753E	SN: US37390585	18-Oct-01 (in house check Oct-15)	In house check: Oct-16

Calibrated by:	Name <b>Leif Klysner</b>	Function <b>Laboratory Technician</b>	Signature <i>Leif Klysner</i>
Approved by:	Name <b>Katja Pokovic</b>	Function <b>Technical Manager</b>	Signature <i>Katja Pokovic</i>

Issued: September 20, 2016

This calibration certificate shall not be reproduced except in full without written approval of the laboratory.



Accredited by the Swiss Accreditation Service (SAS)

The Swiss Accreditation Service is one of the signatories to the EA  
Multilateral Agreement for the recognition of calibration certificates

Accreditation No.: **SCS 0108**

### Glossary:

TSL	tissue simulating liquid
NORM <sub>x,y,z</sub>	sensitivity in free space
ConvF	sensitivity in TSL / NORM <sub>x,y,z</sub>
DCP	diode compression point
CF	crest factor (1/duty_cycle) of the RF signal
A, B, C, D	modulation dependent linearization parameters
Polarization $\varphi$	$\varphi$ rotation around probe axis
Polarization $\vartheta$	$\vartheta$ rotation around an axis that is in the plane normal to probe axis (at measurement center), i.e., $\vartheta = 0$ is normal to probe axis
Connector Angle	information used in DASY system to align probe sensor X to the robot coordinate system

### Calibration is Performed According to the Following Standards:

- IEEE Std 1528-2013, "IEEE Recommended Practice for Determining the Peak Spatial-Averaged Specific Absorption Rate (SAR) in the Human Head from Wireless Communications Devices: Measurement Techniques", June 2013
- IEC 62209-1, "Procedure to measure the Specific Absorption Rate (SAR) for hand-held devices used in close proximity to the ear (frequency range of 300 MHz to 3 GHz)", February 2005
- IEC 62209-2, "Procedure to determine the Specific Absorption Rate (SAR) for wireless communication devices used in close proximity to the human body (frequency range of 30 MHz to 6 GHz)", March 2010
- KDB 865664, "SAR Measurement Requirements for 100 MHz to 6 GHz"

### Methods Applied and Interpretation of Parameters:

- NORM<sub>x,y,z</sub>**: Assessed for E-field polarization  $\vartheta = 0$  ( $f \leq 900$  MHz in TEM-cell;  $f > 1800$  MHz: R22 waveguide). NORM<sub>x,y,z</sub> are only intermediate values, i.e., the uncertainties of NORM<sub>x,y,z</sub> does not affect the  $E^2$ -field uncertainty inside TSL (see below ConvF).
- NORM(f)<sub>x,y,z</sub>** = NORM<sub>x,y,z</sub> \* frequency\_response (see Frequency Response Chart). This linearization is implemented in DASY4 software versions later than 4.2. The uncertainty of the frequency response is included in the stated uncertainty of ConvF.
- DCP<sub>x,y,z</sub>**: DCP are numerical linearization parameters assessed based on the data of power sweep with CW signal (no uncertainty required). DCP does not depend on frequency nor media.
- PAR**: PAR is the Peak to Average Ratio that is not calibrated but determined based on the signal characteristics
- A<sub>x,y,z</sub>; B<sub>x,y,z</sub>; C<sub>x,y,z</sub>; D<sub>x,y,z</sub>; VR<sub>x,y,z</sub>**: A, B, C, D are numerical linearization parameters assessed based on the data of power sweep for specific modulation signal. The parameters do not depend on frequency nor media. VR is the maximum calibration range expressed in RMS voltage across the diode.
- ConvF and Boundary Effect Parameters**: Assessed in flat phantom using E-field (or Temperature Transfer Standard for  $f \leq 800$  MHz) and inside waveguide using analytical field distributions based on power measurements for  $f > 800$  MHz. The same setups are used for assessment of the parameters applied for boundary compensation (alpha, depth) of which typical uncertainty values are given. These parameters are used in DASY4 software to improve probe accuracy close to the boundary. The sensitivity in TSL corresponds to NORM<sub>x,y,z</sub> \* ConvF whereby the uncertainty corresponds to that given for ConvF. A frequency dependent ConvF is used in DASY version 4.4 and higher which allows extending the validity from  $\pm 50$  MHz to  $\pm 100$  MHz.
- Spherical isotropy (3D deviation from isotropy)**: in a field of low gradients realized using a flat phantom exposed by a patch antenna.
- Sensor Offset**: The sensor offset corresponds to the offset of virtual measurement center from the probe tip (on probe axis). No tolerance required.
- Connector Angle**: The angle is assessed using the information gained by determining the NORM<sub>x</sub> (no uncertainty required).

# Probe ES3DV3

## SN:3287

Manufactured: June 7, 2010  
Calibrated: September 19, 2016

Calibrated for DASY/EASY Systems  
(Note: non-compatible with DASY2 system!)

# DASY/EASY - Parameters of Probe: ES3DV3 - SN:3287

## Basic Calibration Parameters

	Sensor X	Sensor Y	Sensor Z	Unc (k=2)
Norm ( $\mu\text{V}/(\text{V}/\text{m})^2$ ) <sup>A</sup>	0.87	0.98	1.00	$\pm 10.1\%$
DCP (mV) <sup>B</sup>	101.9	101.4	106.1	

## Modulation Calibration Parameters

UID	Communication System Name		A dB	B dB $\sqrt{\mu\text{V}}$	C	D dB	VR mV	Unc <sup>E</sup> (k=2)
0	CW	X	0.0	0.0	1.0	0.00	198.4	$\pm 3.5\%$
		Y	0.0	0.0	1.0		189.6	
		Z	0.0	0.0	1.0		184.8	

Note: For details on UID parameters see Appendix.

## Sensor Model Parameters

	C1 fF	C2 fF	$\alpha$ V <sup>-1</sup>	T1 ms.V <sup>-2</sup>	T2 ms.V <sup>-1</sup>	T3 ms	T4 V <sup>-2</sup>	T5 V <sup>-1</sup>	T6
X	65.67	459.4	34.07	29.08	2.68	5.077	2	0.308	1.009
Y	71.46	511.8	35.31	29.86	3.707	5.1	0.748	0.607	1.009
Z	50.48	357.3	34.55	27.84	2.262	5.1	1.583	0.279	1.01

The reported uncertainty of measurement is stated as the standard uncertainty of measurement multiplied by the coverage factor k=2, which for a normal distribution corresponds to a coverage probability of approximately 95%.

<sup>A</sup> The uncertainties of Norm X,Y,Z do not affect the E<sup>2</sup>-field uncertainty inside TSL (see Pages 5 and 6).

<sup>B</sup> Numerical linearization parameter: uncertainty not required.

<sup>E</sup> Uncertainty is determined using the max. deviation from linear response applying rectangular distribution and is expressed for the square of the field value.

## DASY/EASY - Parameters of Probe: ES3DV3 - SN:3287

### Calibration Parameter Determined in Head Tissue Simulating Media

f (MHz) <sup>c</sup>	Relative Permittivity <sup>F</sup>	Conductivity (S/m) <sup>F</sup>	ConvF X	ConvF Y	ConvF Z	Alpha <sup>G</sup>	Depth <sup>G</sup> (mm)	Unc (k=2)
750	41.9	0.89	6.96	6.96	6.96	0.44	1.36	± 12.0 %
835	41.5	0.90	6.67	6.67	6.67	0.29	1.69	± 12.0 %
1750	40.1	1.37	5.49	5.49	5.49	0.43	1.42	± 12.0 %
1900	40.0	1.40	5.27	5.27	5.27	0.41	1.45	± 12.0 %
2300	39.5	1.67	4.86	4.86	4.86	0.61	1.28	± 12.0 %
2450	39.2	1.80	4.54	4.54	4.54	0.47	1.51	± 12.0 %
2600	39.0	1.96	4.41	4.41	4.41	0.77	1.18	± 12.0 %

<sup>c</sup> Frequency validity above 300 MHz of ± 100 MHz only applies for DASY v4.4 and higher (see Page 2), else it is restricted to ± 50 MHz. The uncertainty is the RSS of the ConvF uncertainty at calibration frequency and the uncertainty for the indicated frequency band. Frequency validity below 300 MHz is ± 10, 25, 40, 50 and 70 MHz for ConvF assessments at 30, 64, 128, 150 and 220 MHz respectively. Above 5 GHz frequency validity can be extended to ± 110 MHz.

<sup>F</sup> At frequencies below 3 GHz, the validity of tissue parameters ( $\epsilon$  and  $\sigma$ ) can be relaxed to ± 10% if liquid compensation formula is applied to measured SAR values. At frequencies above 3 GHz, the validity of tissue parameters ( $\epsilon$  and  $\sigma$ ) is restricted to ± 5%. The uncertainty is the RSS of the ConvF uncertainty for indicated target tissue parameters.

<sup>G</sup> Alpha/Depth are determined during calibration. SPEAG warrants that the remaining deviation due to the boundary effect after compensation is always less than ± 1% for frequencies below 3 GHz and below ± 2% for frequencies between 3-6 GHz at any distance larger than half the probe tip diameter from the boundary.

## DASY/EASY - Parameters of Probe: ES3DV3 - SN:3287

### Calibration Parameter Determined in Body Tissue Simulating Media

f (MHz) <sup>C</sup>	Relative Permittivity <sup>F</sup>	Conductivity (S/m) <sup>F</sup>	ConvF X	ConvF Y	ConvF Z	Alpha <sup>G</sup>	Depth <sup>G</sup> (mm)	Unc (k=2)
750	55.5	0.96	6.64	6.64	6.64	0.27	1.86	± 12.0 %
835	55.2	0.97	6.55	6.55	6.55	0.50	1.37	± 12.0 %
1750	53.4	1.49	5.11	5.11	5.11	0.33	1.85	± 12.0 %
1900	53.3	1.52	4.94	4.94	4.94	0.42	1.59	± 12.0 %
2300	52.9	1.81	4.55	4.55	4.55	0.55	1.42	± 12.0 %
2450	52.7	1.95	4.35	4.35	4.35	0.80	1.09	± 12.0 %
2600	52.5	2.16	4.12	4.12	4.12	0.80	1.10	± 12.0 %

<sup>C</sup> Frequency validity above 300 MHz of ± 100 MHz only applies for DASY v4.4 and higher (see Page 2), else it is restricted to ± 50 MHz. The uncertainty is the RSS of the ConvF uncertainty at calibration frequency and the uncertainty for the indicated frequency band. Frequency validity below 300 MHz is ± 10, 25, 40, 50 and 70 MHz for ConvF assessments at 30, 64, 128, 150 and 220 MHz respectively. Above 5 GHz frequency validity can be extended to ± 110 MHz.

<sup>F</sup> At frequencies below 3 GHz, the validity of tissue parameters ( $\epsilon$  and  $\sigma$ ) can be relaxed to ± 10% if liquid compensation formula is applied to measured SAR values. At frequencies above 3 GHz, the validity of tissue parameters ( $\epsilon$  and  $\sigma$ ) is restricted to ± 5%. The uncertainty is the RSS of the ConvF uncertainty for indicated target tissue parameters.

<sup>G</sup> Alpha/Depth are determined during calibration. SPEAG warrants that the remaining deviation due to the boundary effect after compensation is always less than ± 1% for frequencies below 3 GHz and below ± 2% for frequencies between 3-6 GHz at any distance larger than half the probe tip diameter from the boundary.

### Frequency Response of E-Field (TEM-Cell:ifi110 EXX, Waveguide: R22)

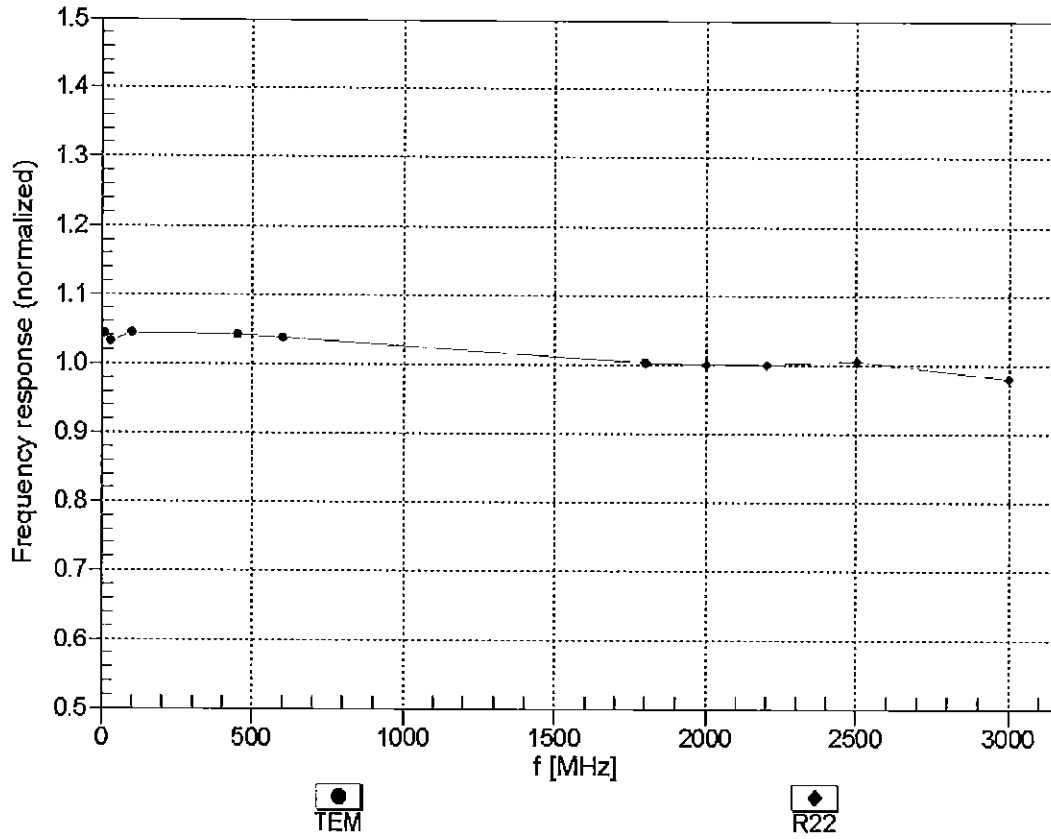

Uncertainty of Frequency Response of E-field:  $\pm 6.3\%$  ( $k=2$ )

## Receiving Pattern ( $\phi$ ), $\vartheta = 0^\circ$

f=600 MHz, TEM

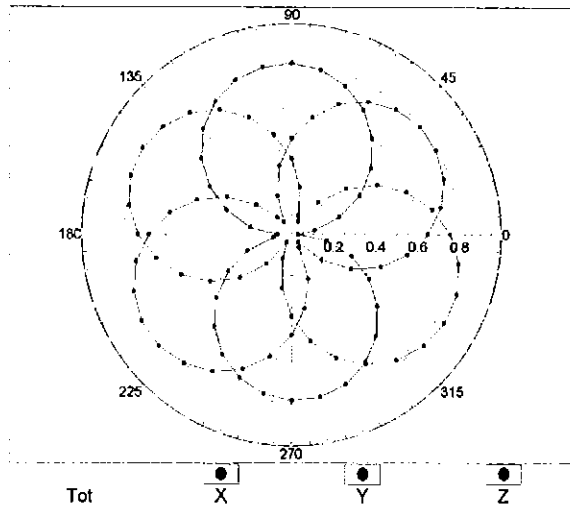

f=1800 MHz, R22

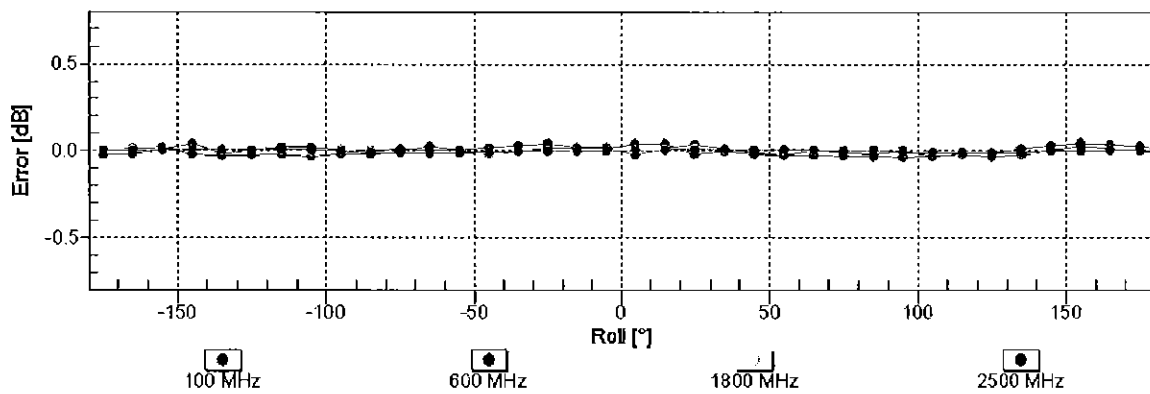
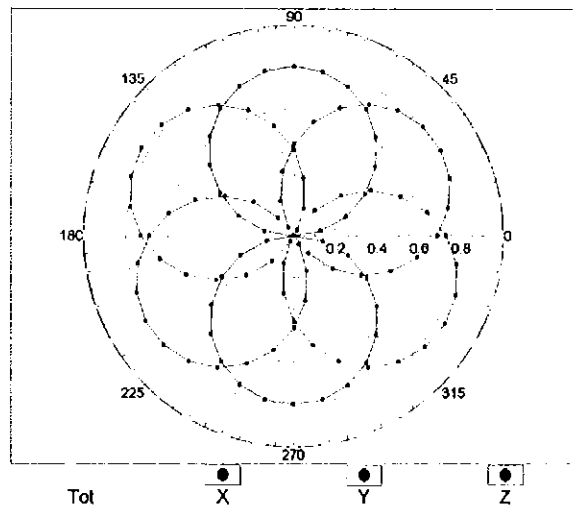

Uncertainty of Axial Isotropy Assessment:  $\pm 0.5\%$  (k=2)

## Dynamic Range $f(SAR_{head})$ (TEM cell , $f_{eval}= 1900$ MHz)

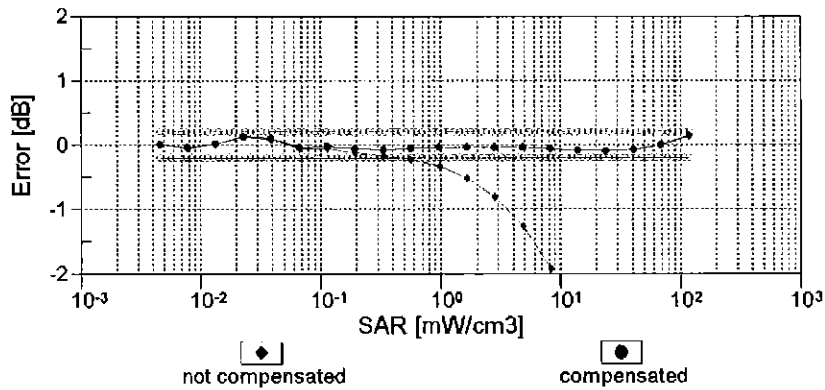
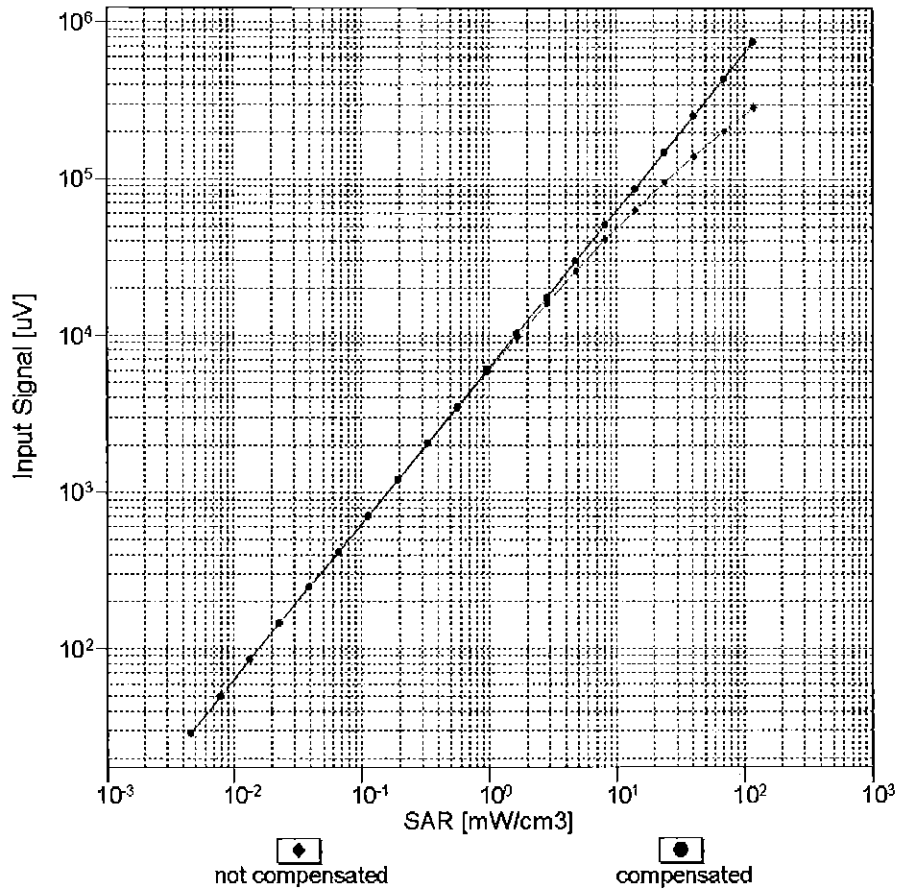

**Uncertainty of Linearity Assessment: ± 0.6% (k=2)**

# Conversion Factor Assessment

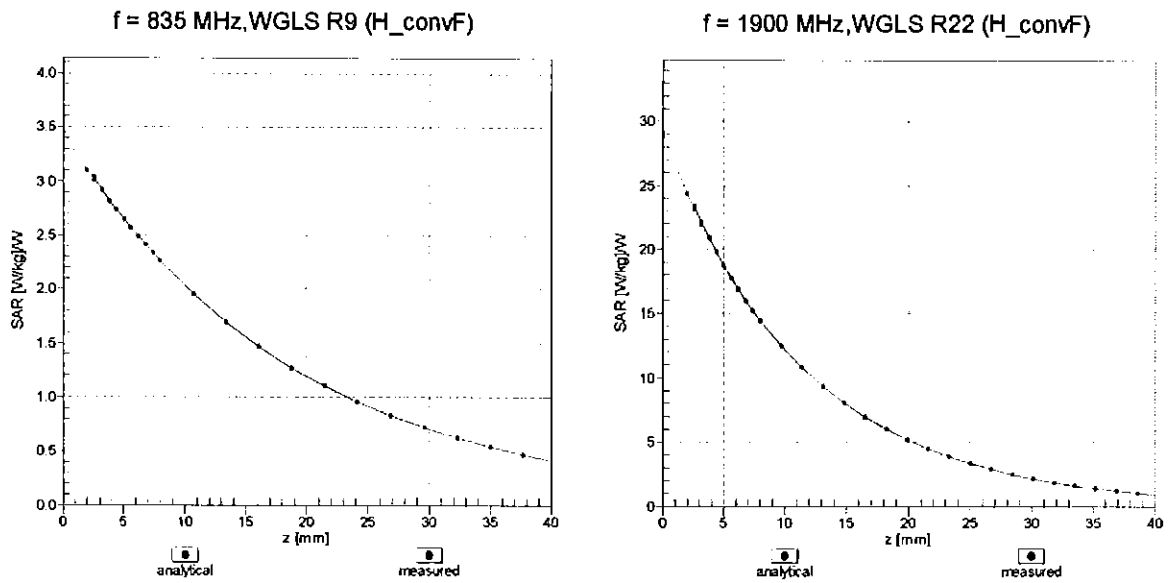

## Deviation from Isotropy in Liquid Error ( $\phi, \vartheta$ ), f = 900 MHz

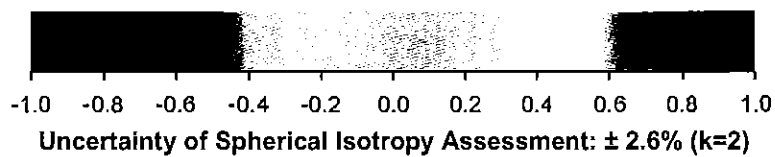
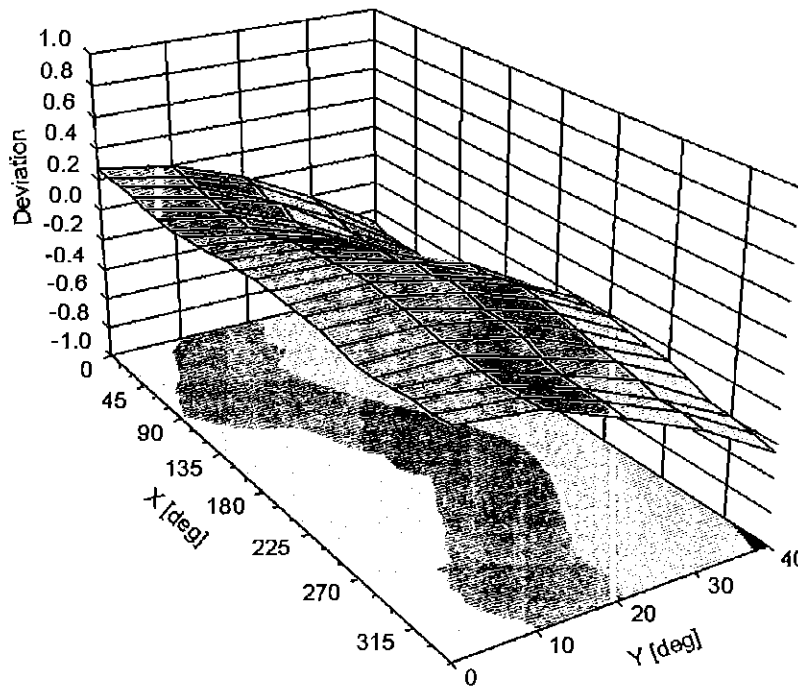

## DASY/EASY - Parameters of Probe: ES3DV3 - SN:3287

### Other Probe Parameters

Sensor Arrangement	Triangular
Connector Angle (°)	84.9
Mechanical Surface Detection Mode	enabled
Optical Surface Detection Mode	disabled
Probe Overall Length	337 mm
Probe Body Diameter	10 mm
Tip Length	10 mm
Tip Diameter	4 mm
Probe Tip to Sensor X Calibration Point	2 mm
Probe Tip to Sensor Y Calibration Point	2 mm
Probe Tip to Sensor Z Calibration Point	2 mm
Recommended Measurement Distance from Surface	3 mm

**Appendix: Modulation Calibration Parameters**

UID	Communication System Name		A dB	B dB $\mu$ V	C	D dB	VR mV	Max Unc <sup>E</sup> (k=2)
0	CW	X	0.00	0.00	1.00	0.00	198.4	$\pm 3.5\%$
		Y	0.00	0.00	1.00		189.6	
		Z	0.00	0.00	1.00		184.8	
10010- CAA	SAR Validation (Square, 100ms, 10ms)	X	9.57	81.27	19.66	10.00	25.0	$\pm 9.6\%$
		Y	9.48	81.17	20.59		25.0	
		Z	11.44	84.72	20.81		25.0	
10011- CAB	UMTS-FDD (WCDMA)	X	1.41	73.12	18.60	0.00	150.0	$\pm 9.6\%$
		Y	1.09	67.36	15.29		150.0	
		Z	1.04	67.24	15.12		150.0	
10012- CAB	IEEE 802.11b WiFi 2.4 GHz (DSSS, 1 Mbps)	X	1.39	66.79	17.15	0.41	150.0	$\pm 9.6\%$
		Y	1.33	64.98	15.75		150.0	
		Z	1.31	64.97	15.66		150.0	
10013- CAB	IEEE 802.11g WiFi 2.4 GHz (DSSS-OFDM, 6 Mbps)	X	5.20	67.40	17.54	1.46	150.0	$\pm 9.6\%$
		Y	5.27	67.18	17.41		150.0	
		Z	5.09	67.33	17.40		150.0	
10021- DAB	GSM-FDD (TDMA, GMSK)	X	25.12	98.64	27.15	9.39	50.0	$\pm 9.6\%$
		Y	16.05	91.61	25.96		50.0	
		Z	54.58	112.47	31.02		50.0	
10023- DAB	GPRS-FDD (TDMA, GMSK, TN 0)	X	21.90	96.28	26.48	9.57	50.0	$\pm 9.6\%$
		Y	15.04	90.31	25.57		50.0	
		Z	40.95	107.64	29.77		50.0	
10024- DAB	GPRS-FDD (TDMA, GMSK, TN 0-1)	X	100.00	118.44	30.60	6.56	60.0	$\pm 9.6\%$
		Y	56.85	112.42	30.28		60.0	
		Z	100.00	119.26	30.80		60.0	
10025- DAB	EDGE-FDD (TDMA, 8PSK, TN 0)	X	15.98	100.03	37.68	12.57	50.0	$\pm 9.6\%$
		Y	12.36	89.89	33.32		50.0	
		Z	14.92	100.13	38.33		50.0	
10026- DAB	EDGE-FDD (TDMA, 8PSK, TN 0-1)	X	19.89	102.72	35.15	9.56	60.0	$\pm 9.6\%$
		Y	15.11	94.49	32.22		60.0	
		Z	21.16	106.39	36.94		60.0	
10027- DAB	GPRS-FDD (TDMA, GMSK, TN 0-1-2)	X	100.00	117.46	29.21	4.80	80.0	$\pm 9.6\%$
		Y	100.00	119.97	30.83		80.0	
		Z	100.00	118.35	29.47		80.0	
10028- DAB	GPRS-FDD (TDMA, GMSK, TN 0-1-2-3)	X	100.00	117.97	28.63	3.55	100.0	$\pm 9.6\%$
		Y	100.00	119.91	29.91		100.0	
		Z	100.00	118.74	28.84		100.0	
10029- DAB	EDGE-FDD (TDMA, 8PSK, TN 0-1-2)	X	14.03	95.19	31.54	7.80	80.0	$\pm 9.6\%$
		Y	11.54	89.32	29.33		80.0	
		Z	13.09	95.17	31.96		80.0	
10030- CAA	IEEE 802.15.1 Bluetooth (GFSK, DH1)	X	100.00	117.04	29.36	5.30	70.0	$\pm 9.6\%$
		Y	100.00	119.78	31.12		70.0	
		Z	100.00	117.69	29.49		70.0	
10031- CAA	IEEE 802.15.1 Bluetooth (GFSK, DH3)	X	100.00	120.90	28.34	1.88	100.0	$\pm 9.6\%$
		Y	100.00	121.14	28.78		100.0	
		Z	100.00	119.84	27.78		100.0	

10032-CAA	IEEE 802.15.1 Bluetooth (GFSK, DH5)	X	100.00	128.75	30.50	1.17	100.0	± 9.6 %
		Y	100.00	125.19	29.33		100.0	
		Z	100.00	124.54	28.68		100.0	
10033-CAA	IEEE 802.15.1 Bluetooth (PI/4-DQPSK, DH1)	X	24.47	102.44	28.62	5.30	70.0	± 9.6 %
		Y	12.93	91.34	25.64		70.0	
		Z	20.22	99.06	27.27		70.0	
10034-CAA	IEEE 802.15.1 Bluetooth (PI/4-DQPSK, DH3)	X	15.75	99.73	26.60	1.88	100.0	± 9.6 %
		Y	6.06	84.29	21.90		100.0	
		Z	7.41	86.87	21.79		100.0	
10035-CAA	IEEE 802.15.1 Bluetooth (PI/4-DQPSK, DH5)	X	8.06	91.60	24.06	1.17	100.0	± 9.6 %
		Y	3.71	78.74	19.66		100.0	
		Z	4.06	80.00	19.16		100.0	
10036-CAA	IEEE 802.15.1 Bluetooth (8-DPSK, DH1)	X	31.59	106.91	29.95	5.30	70.0	± 9.6 %
		Y	14.71	93.73	26.48		70.0	
		Z	25.49	103.04	28.49		70.0	
10037-CAA	IEEE 802.15.1 Bluetooth (8-DPSK, DH3)	X	15.02	99.00	26.34	1.88	100.0	± 9.6 %
		Y	5.91	83.93	21.74		100.0	
		Z	6.95	86.01	21.48		100.0	
10038-CAA	IEEE 802.15.1 Bluetooth (8-DPSK, DH5)	X	8.64	92.97	24.58	1.17	100.0	± 9.6 %
		Y	3.82	79.37	19.97		100.0	
		Z	4.16	80.58	19.47		100.0	
10039-CAB	CDMA2000 (1xRTT, RC1)	X	3.32	80.83	20.52	0.00	150.0	± 9.6 %
		Y	1.99	71.59	16.56		150.0	
		Z	1.78	71.38	15.53		150.0	
10042-CAB	IS-54 / IS-136 FDD (TDMA/FDM, PI/4-DQPSK, Halfrate)	X	93.96	116.51	30.17	7.78	50.0	± 9.6 %
		Y	28.36	100.31	27.04		50.0	
		Z	100.00	118.01	30.46		50.0	
10044-CAA	IS-91/EIA/TIA-553 FDD (FDMA, FM)	X	0.00	110.81	0.68	0.00	150.0	± 9.6 %
		Y	0.00	94.68	0.92		150.0	
		Z	0.01	95.27	0.89		150.0	
10048-CAA	DECT (TDD, TDMA/FDM, GFSK, Full Slot, 24)	X	12.13	84.40	24.33	13.80	25.0	± 9.6 %
		Y	11.03	81.88	24.36		25.0	
		Z	15.47	90.17	26.32		25.0	
10049-CAA	DECT (TDD, TDMA/FDM, GFSK, Double Slot, 12)	X	14.56	88.92	24.53	10.79	40.0	± 9.6 %
		Y	12.34	85.94	24.48		40.0	
		Z	20.46	95.78	26.73		40.0	
10056-CAA	UMTS-TDD (TD-SCDMA, 1.28 Mcps)	X	13.90	88.80	25.15	9.03	50.0	± 9.6 %
		Y	11.60	84.93	24.34		50.0	
		Z	15.96	92.01	26.12		50.0	
10058-DAB	EDGE-FDD (TDMA, 8PSK, TN 0-1-2-3)	X	10.54	89.79	28.95	6.55	100.0	± 9.6 %
		Y	9.17	85.43	27.21		100.0	
		Z	9.28	88.15	28.66		100.0	
10059-CAB	IEEE 802.11b WiFi 2.4 GHz (DSSS, 2 Mbps)	X	1.62	69.54	18.42	0.61	110.0	± 9.6 %
		Y	1.52	67.09	16.78		110.0	
		Z	1.47	67.00	16.67		110.0	
10060-CAB	IEEE 802.11b WiFi 2.4 GHz (DSSS, 5.5 Mbps)	X	100.00	133.57	34.76	1.30	110.0	± 9.6 %
		Y	47.37	119.92	31.34		110.0	
		Z	100.00	131.70	33.88		110.0	

10061-CAB	IEEE 802.11b WiFi 2.4 GHz (DSSS, 11 Mbps)	X	24.29	111.37	31.49	2.04	110.0	± 9.6 %
		Y	7.57	90.21	25.12		110.0	
		Z	8.96	94.42	26.47		110.0	
10062-CAB	IEEE 802.11a/h WiFi 5 GHz (OFDM, 6 Mbps)	X	4.94	67.26	16.92	0.49	100.0	± 9.6 %
		Y	4.99	66.94	16.70		100.0	
		Z	4.80	67.06	16.67		100.0	
10063-CAB	IEEE 802.11a/h WiFi 5 GHz (OFDM, 9 Mbps)	X	4.98	67.42	17.05	0.72	100.0	± 9.6 %
		Y	5.03	67.12	16.85		100.0	
		Z	4.84	67.22	16.80		100.0	
10064-CAB	IEEE 802.11a/h WiFi 5 GHz (OFDM, 12 Mbps)	X	5.33	67.75	17.30	0.86	100.0	± 9.6 %
		Y	5.40	67.50	17.13		100.0	
		Z	5.14	67.52	17.06		100.0	
10065-CAB	IEEE 802.11a/h WiFi 5 GHz (OFDM, 18 Mbps)	X	5.22	67.77	17.45	1.21	100.0	± 9.6 %
		Y	5.30	67.55	17.30		100.0	
		Z	5.05	67.55	17.23		100.0	
10066-CAB	IEEE 802.11a/h WiFi 5 GHz (OFDM, 24 Mbps)	X	5.28	67.89	17.67	1.46	100.0	± 9.6 %
		Y	5.37	67.69	17.54		100.0	
		Z	5.11	67.69	17.47		100.0	
10067-CAB	IEEE 802.11a/h WiFi 5 GHz (OFDM, 36 Mbps)	X	5.58	67.96	18.07	2.04	100.0	± 9.6 %
		Y	5.70	67.83	17.99		100.0	
		Z	5.44	67.94	17.97		100.0	
10068-CAB	IEEE 802.11a/h WiFi 5 GHz (OFDM, 48 Mbps)	X	5.73	68.36	18.44	2.55	100.0	± 9.6 %
		Y	5.86	68.26	18.38		100.0	
		Z	5.56	68.20	18.31		100.0	
10069-CAB	IEEE 802.11a/h WiFi 5 GHz (OFDM, 54 Mbps)	X	5.80	68.22	18.58	2.67	100.0	± 9.6 %
		Y	5.93	68.12	18.53		100.0	
		Z	5.64	68.21	18.51		100.0	
10071-CAB	IEEE 802.11g WiFi 2.4 GHz (DSSS/OFDM, 9 Mbps)	X	5.34	67.61	17.91	1.99	100.0	± 9.6 %
		Y	5.43	67.44	17.80		100.0	
		Z	5.23	67.57	17.79		100.0	
10072-CAB	IEEE 802.11g WiFi 2.4 GHz (DSSS/OFDM, 12 Mbps)	X	5.41	68.20	18.23	2.30	100.0	± 9.6 %
		Y	5.52	68.04	18.13		100.0	
		Z	5.28	68.10	18.11		100.0	
10073-CAB	IEEE 802.11g WiFi 2.4 GHz (DSSS/OFDM, 18 Mbps)	X	5.54	68.52	18.63	2.83	100.0	± 9.6 %
		Y	5.67	68.41	18.56		100.0	
		Z	5.42	68.46	18.55		100.0	
10074-CAB	IEEE 802.11g WiFi 2.4 GHz (DSSS/OFDM, 24 Mbps)	X	5.57	68.60	18.89	3.30	100.0	± 9.6 %
		Y	5.71	68.53	18.84		100.0	
		Z	5.46	68.55	18.80		100.0	
10075-CAB	IEEE 802.11g WiFi 2.4 GHz (DSSS/OFDM, 36 Mbps)	X	5.74	69.13	19.40	3.82	90.0	± 9.6 %
		Y	5.91	69.12	19.39		90.0	
		Z	5.60	68.97	19.28		90.0	
10076-CAB	IEEE 802.11g WiFi 2.4 GHz (DSSS/OFDM, 48 Mbps)	X	5.73	68.87	19.48	4.15	90.0	± 9.6 %
		Y	5.91	68.89	19.48		90.0	
		Z	5.64	68.84	19.44		90.0	
10077-CAB	IEEE 802.11g WiFi 2.4 GHz (DSSS/OFDM, 54 Mbps)	X	5.76	68.96	19.58	4.30	90.0	± 9.6 %
		Y	5.95	68.98	19.59		90.0	
		Z	5.68	68.95	19.55		90.0	

10081-CAB	CDMA2000 (1xRTT, RC3)	X	1.45	73.74	17.54	0.00	150.0	± 9.6 %
		Y	1.01	66.70	13.93		150.0	
		Z	0.86	65.95	12.65		150.0	
10082-CAB	IS-54 / IS-136 FDD (TDMA/FDM, PI/4-DQPSK, Fullrate)	X	2.22	64.23	9.03	4.77	80.0	± 9.6 %
		Y	2.60	65.39	10.25		80.0	
		Z	2.07	64.06	8.86		80.0	
10090-DAB	GPRS-FDD (TDMA, GMSK, TN 0-4)	X	100.00	118.52	30.65	6.56	60.0	± 9.6 %
		Y	54.54	111.83	30.17		60.0	
		Z	100.00	119.33	30.85		60.0	
10097-CAB	UMTS-FDD (HSDPA)	X	2.07	69.87	17.29	0.00	150.0	± 9.6 %
		Y	1.87	67.25	15.70		150.0	
		Z	1.83	67.53	15.55		150.0	
10098-CAB	UMTS-FDD (HSUPA, Subtest 2)	X	2.03	69.88	17.28	0.00	150.0	± 9.6 %
		Y	1.83	67.20	15.65		150.0	
		Z	1.80	67.49	15.52		150.0	
10099-DAB	EDGE-FDD (TDMA, 8PSK, TN 0-4)	X	19.79	102.55	35.10	9.56	60.0	± 9.6 %
		Y	15.06	94.38	32.19		60.0	
		Z	21.07	106.24	36.89		60.0	
10100-CAB	LTE-FDD (SC-FDMA, 100% RB, 20 MHz, QPSK)	X	3.71	73.15	18.05	0.00	150.0	± 9.6 %
		Y	3.34	70.68	16.71		150.0	
		Z	3.15	70.31	16.60		150.0	
10101-CAB	LTE-FDD (SC-FDMA, 100% RB, 20 MHz, 16-QAM)	X	3.53	68.94	16.73	0.00	150.0	± 9.6 %
		Y	3.44	67.88	16.03		150.0	
		Z	3.28	67.66	15.91		150.0	
10102-CAB	LTE-FDD (SC-FDMA, 100% RB, 20 MHz, 64-QAM)	X	3.62	68.78	16.77	0.00	150.0	± 9.6 %
		Y	3.55	67.81	16.12		150.0	
		Z	3.38	67.61	16.00		150.0	
10103-CAB	LTE-TDD (SC-FDMA, 100% RB, 20 MHz, QPSK)	X	9.03	78.84	21.45	3.98	65.0	± 9.6 %
		Y	8.52	77.08	20.81		65.0	
		Z	8.79	79.04	21.64		65.0	
10104-CAB	LTE-TDD (SC-FDMA, 100% RB, 20 MHz, 16-QAM)	X	8.83	77.31	21.70	3.98	65.0	± 9.6 %
		Y	8.68	76.21	21.28		65.0	
		Z	8.45	77.10	21.68		65.0	
10105-CAB	LTE-TDD (SC-FDMA, 100% RB, 20 MHz, 64-QAM)	X	8.12	75.63	21.27	3.98	65.0	± 9.6 %
		Y	7.58	73.53	20.37		65.0	
		Z	7.68	75.16	21.11		65.0	
10108-CAC	LTE-FDD (SC-FDMA, 100% RB, 10 MHz, QPSK)	X	3.26	72.24	17.88	0.00	150.0	± 9.6 %
		Y	2.97	69.86	16.52		150.0	
		Z	2.76	69.54	16.43		150.0	
10109-CAC	LTE-FDD (SC-FDMA, 100% RB, 10 MHz, 16-QAM)	X	3.21	68.83	16.74	0.00	150.0	± 9.6 %
		Y	3.12	67.65	15.97		150.0	
		Z	2.93	67.47	15.80		150.0	
10110-CAC	LTE-FDD (SC-FDMA, 100% RB, 5 MHz, QPSK)	X	2.68	71.31	17.65	0.00	150.0	± 9.6 %
		Y	2.45	68.82	16.19		150.0	
		Z	2.25	68.65	16.05		150.0	
10111-CAC	LTE-FDD (SC-FDMA, 100% RB, 5 MHz, 16-QAM)	X	2.94	69.70	17.25	0.00	150.0	± 9.6 %
		Y	2.81	68.04	16.25		150.0	
		Z	2.63	68.09	16.01		150.0	

10112-CAC	LTE-FDD (SC-FDMA, 100% RB, 10 MHz, 64-QAM)	X	3.32	68.66	16.72	0.00	150.0	± 9.6 %
		Y	3.24	67.56	16.01		150.0	
		Z	3.06	67.45	15.85		150.0	
10113-CAC	LTE-FDD (SC-FDMA, 100% RB, 5 MHz, 64-QAM)	X	3.09	69.65	17.28	0.00	150.0	± 9.6 %
		Y	2.97	68.11	16.35		150.0	
		Z	2.78	68.22	16.13		150.0	
10114-CAB	IEEE 802.11n (HT Greenfield, 13.5 Mbps, BPSK)	X	5.30	67.67	16.69	0.00	150.0	± 9.6 %
		Y	5.32	67.34	16.45		150.0	
		Z	5.18	67.41	16.46		150.0	
10115-CAB	IEEE 802.11n (HT Greenfield, 81 Mbps, 16-QAM)	X	5.68	67.95	16.83	0.00	150.0	± 9.6 %
		Y	5.74	67.75	16.66		150.0	
		Z	5.49	67.60	16.57		150.0	
10116-CAB	IEEE 802.11n (HT Greenfield, 135 Mbps, 64-QAM)	X	5.43	67.93	16.74	0.00	150.0	± 9.6 %
		Y	5.45	67.58	16.50		150.0	
		Z	5.29	67.63	16.50		150.0	
10117-CAB	IEEE 802.11n (HT Mixed, 13.5 Mbps, BPSK)	X	5.31	67.69	16.73	0.00	150.0	± 9.6 %
		Y	5.33	67.35	16.48		150.0	
		Z	5.15	67.28	16.42		150.0	
10118-CAB	IEEE 802.11n (HT Mixed, 81 Mbps, 16-QAM)	X	5.73	68.05	16.89	0.00	150.0	± 9.6 %
		Y	5.76	67.71	16.65		150.0	
		Z	5.58	67.82	16.69		150.0	
10119-CAB	IEEE 802.11n (HT Mixed, 135 Mbps, 64-QAM)	X	5.40	67.88	16.73	0.00	150.0	± 9.6 %
		Y	5.42	67.54	16.49		150.0	
		Z	5.26	67.56	16.48		150.0	
10140-CAB	LTE-FDD (SC-FDMA, 100% RB, 15 MHz, 16-QAM)	X	3.67	68.77	16.68	0.00	150.0	± 9.6 %
		Y	3.60	67.81	16.05		150.0	
		Z	3.42	67.62	15.92		150.0	
10141-CAB	LTE-FDD (SC-FDMA, 100% RB, 15 MHz, 64-QAM)	X	3.79	68.75	16.79	0.00	150.0	± 9.6 %
		Y	3.72	67.84	16.19		150.0	
		Z	3.54	67.70	16.08		150.0	
10142-CAC	LTE-FDD (SC-FDMA, 100% RB, 3 MHz, QPSK)	X	2.48	71.58	17.67	0.00	150.0	± 9.6 %
		Y	2.22	68.66	16.03		150.0	
		Z	2.02	68.57	15.71		150.0	
10143-CAC	LTE-FDD (SC-FDMA, 100% RB, 3 MHz, 16-QAM)	X	2.90	70.86	17.43	0.00	150.0	± 9.6 %
		Y	2.68	68.61	16.20		150.0	
		Z	2.48	68.71	15.71		150.0	
10144-CAC	LTE-FDD (SC-FDMA, 100% RB, 3 MHz, 64-QAM)	X	2.65	68.53	15.87	0.00	150.0	± 9.6 %
		Y	2.53	66.90	14.94		150.0	
		Z	2.29	66.75	14.27		150.0	
10145-CAC	LTE-FDD (SC-FDMA, 100% RB, 1.4 MHz, QPSK)	X	2.00	71.65	16.48	0.00	150.0	± 9.6 %
		Y	1.64	67.49	14.42		150.0	
		Z	1.28	65.53	12.17		150.0	
10146-CAC	LTE-FDD (SC-FDMA, 100% RB, 1.4 MHz, 16-QAM)	X	6.65	82.42	19.81	0.00	150.0	± 9.6 %
		Y	3.51	73.00	16.51		150.0	
		Z	2.73	70.16	13.72		150.0	
10147-CAC	LTE-FDD (SC-FDMA, 100% RB, 1.4 MHz, 64-QAM)	X	11.62	90.60	22.70	0.00	150.0	± 9.6 %
		Y	4.34	76.22	18.03		150.0	
		Z	3.53	73.44	15.25		150.0	

10149-CAB	LTE-FDD (SC-FDMA, 50% RB, 20 MHz, 16-QAM)	X	3.22	68.90	16.79	0.00	150.0	± 9.6 %
		Y	3.13	67.70	16.01		150.0	
		Z	2.94	67.52	15.84		150.0	
10150-CAB	LTE-FDD (SC-FDMA, 50% RB, 20 MHz, 64-QAM)	X	3.33	68.71	16.76	0.00	150.0	± 9.6 %
		Y	3.25	67.61	16.05		150.0	
		Z	3.06	67.50	15.89		150.0	
10151-CAB	LTE-TDD (SC-FDMA, 50% RB, 20 MHz, QPSK)	X	9.59	81.08	22.43	3.98	65.0	± 9.6 %
		Y	8.87	78.87	21.64		65.0	
		Z	9.33	81.38	22.62		65.0	
10152-CAB	LTE-TDD (SC-FDMA, 50% RB, 20 MHz, 16-QAM)	X	8.50	77.58	21.63	3.98	65.0	± 9.6 %
		Y	8.30	76.31	21.16		65.0	
		Z	8.08	77.33	21.50		65.0	
10153-CAB	LTE-TDD (SC-FDMA, 50% RB, 20 MHz, 64-QAM)	X	8.85	78.28	22.25	3.98	65.0	± 9.6 %
		Y	8.62	76.95	21.75		65.0	
		Z	8.48	78.15	22.17		65.0	
10154-CAC	LTE-FDD (SC-FDMA, 50% RB, 10 MHz, QPSK)	X	2.77	71.95	18.01	0.00	150.0	± 9.6 %
		Y	2.51	69.32	16.50		150.0	
		Z	2.29	69.01	16.28		150.0	
10155-CAC	LTE-FDD (SC-FDMA, 50% RB, 10 MHz, 16-QAM)	X	2.94	69.69	17.25	0.00	150.0	± 9.6 %
		Y	2.80	68.03	16.25		150.0	
		Z	2.63	68.10	16.02		150.0	
10156-CAC	LTE-FDD (SC-FDMA, 50% RB, 5 MHz, QPSK)	X	2.40	72.31	17.91	0.00	150.0	± 9.6 %
		Y	2.09	68.89	16.05		150.0	
		Z	1.86	68.62	15.51		150.0	
10157-CAC	LTE-FDD (SC-FDMA, 50% RB, 5 MHz, 16-QAM)	X	2.55	69.65	16.30	0.00	150.0	± 9.6 %
		Y	2.36	67.46	15.11		150.0	
		Z	2.12	67.25	14.30		150.0	
10158-CAC	LTE-FDD (SC-FDMA, 50% RB, 10 MHz, 64-QAM)	X	3.10	69.70	17.32	0.00	150.0	± 9.6 %
		Y	2.97	68.15	16.39		150.0	
		Z	2.78	68.27	16.17		150.0	
10159-CAC	LTE-FDD (SC-FDMA, 50% RB, 5 MHz, 64-QAM)	X	2.69	70.18	16.62	0.00	150.0	± 9.6 %
		Y	2.48	67.89	15.40		150.0	
		Z	2.22	67.66	14.56		150.0	
10160-CAB	LTE-FDD (SC-FDMA, 50% RB, 15 MHz, QPSK)	X	3.10	70.43	17.35	0.00	150.0	± 9.6 %
		Y	2.94	68.69	16.29		150.0	
		Z	2.78	68.69	16.25		150.0	
10161-CAB	LTE-FDD (SC-FDMA, 50% RB, 15 MHz, 16-QAM)	X	3.22	68.62	16.74	0.00	150.0	± 9.6 %
		Y	3.14	67.48	16.00		150.0	
		Z	2.96	67.42	15.82		150.0	
10162-CAB	LTE-FDD (SC-FDMA, 50% RB, 15 MHz, 64-QAM)	X	3.32	68.61	16.76	0.00	150.0	± 9.6 %
		Y	3.24	67.49	16.04		150.0	
		Z	3.07	67.56	15.92		150.0	
10166-CAC	LTE-FDD (SC-FDMA, 50% RB, 1.4 MHz, QPSK)	X	4.32	72.20	20.50	3.01	150.0	± 9.6 %
		Y	4.09	70.13	19.37		150.0	
		Z	3.89	71.03	19.86		150.0	
10167-CAC	LTE-FDD (SC-FDMA, 50% RB, 1.4 MHz, 16-QAM)	X	6.13	77.20	21.71	3.01	150.0	± 9.6 %
		Y	5.31	73.40	20.02		150.0	
		Z	5.17	75.28	20.82		150.0	

10168-CAC	LTE-FDD (SC-FDMA, 50% RB, 1.4 MHz, 64-QAM)	X	6.94	79.87	23.11	3.01	150.0	± 9.6 %
		Y	5.79	75.28	21.14		150.0	
		Z	5.82	77.80	22.20		150.0	
10169-CAB	LTE-FDD (SC-FDMA, 1 RB, 20 MHz, QPSK)	X	4.47	76.31	22.20	3.01	150.0	± 9.6 %
		Y	3.93	72.42	20.26		150.0	
		Z	3.45	71.87	20.27		150.0	
10170-CAB	LTE-FDD (SC-FDMA, 1 RB, 20 MHz, 16-QAM)	X	9.97	90.37	26.89	3.01	150.0	± 9.6 %
		Y	6.08	79.64	22.84		150.0	
		Z	5.69	81.07	23.66		150.0	
10171-AAB	LTE-FDD (SC-FDMA, 1 RB, 20 MHz, 64-QAM)	X	6.58	81.51	22.72	3.01	150.0	± 9.6 %
		Y	4.82	74.69	19.94		150.0	
		Z	4.39	75.54	20.48		150.0	
10172-CAB	LTE-TDD (SC-FDMA, 1 RB, 20 MHz, QPSK)	X	73.64	126.23	37.77	6.02	65.0	± 9.6 %
		Y	18.65	98.22	29.94		65.0	
		Z	50.70	122.38	37.42		65.0	
10173-CAB	LTE-TDD (SC-FDMA, 1 RB, 20 MHz, 16-QAM)	X	94.74	123.96	35.21	6.02	65.0	± 9.6 %
		Y	22.61	98.04	28.47		65.0	
		Z	96.90	127.66	36.64		65.0	
10174-CAB	LTE-TDD (SC-FDMA, 1 RB, 20 MHz, 64-QAM)	X	56.11	113.11	31.91	6.02	65.0	± 9.6 %
		Y	18.59	93.53	26.66		65.0	
		Z	65.46	118.77	33.84		65.0	
10175-CAC	LTE-FDD (SC-FDMA, 1 RB, 10 MHz, QPSK)	X	4.37	75.74	21.85	3.01	150.0	± 9.6 %
		Y	3.86	71.99	19.97		150.0	
		Z	3.41	71.52	20.02		150.0	
10176-CAC	LTE-FDD (SC-FDMA, 1 RB, 10 MHz, 16-QAM)	X	9.99	90.41	26.90	3.01	150.0	± 9.6 %
		Y	6.09	79.66	22.85		150.0	
		Z	5.70	81.10	23.67		150.0	
10177-CAE	LTE-FDD (SC-FDMA, 1 RB, 5 MHz, QPSK)	X	4.43	76.02	22.00	3.01	150.0	± 9.6 %
		Y	3.90	72.21	20.10		150.0	
		Z	3.44	71.69	20.11		150.0	
10178-CAC	LTE-FDD (SC-FDMA, 1 RB, 5 MHz, 16-QAM)	X	9.65	89.71	26.63	3.01	150.0	± 9.6 %
		Y	5.97	79.26	22.66		150.0	
		Z	5.62	80.80	23.53		150.0	
10179-CAC	LTE-FDD (SC-FDMA, 1 RB, 10 MHz, 64-QAM)	X	7.97	85.43	24.54	3.01	150.0	± 9.6 %
		Y	5.36	76.88	21.19		150.0	
		Z	4.98	78.13	21.92		150.0	
10180-CAC	LTE-FDD (SC-FDMA, 1 RB, 5 MHz, 64-QAM)	X	6.51	81.29	22.61	3.01	150.0	± 9.6 %
		Y	4.79	74.55	19.86		150.0	
		Z	4.38	75.44	20.42		150.0	
10181-CAB	LTE-FDD (SC-FDMA, 1 RB, 15 MHz, QPSK)	X	4.42	75.99	21.99	3.01	150.0	± 9.6 %
		Y	3.90	72.19	20.09		150.0	
		Z	3.43	71.67	20.11		150.0	
10182-CAB	LTE-FDD (SC-FDMA, 1 RB, 15 MHz, 16-QAM)	X	9.63	89.67	26.62	3.01	150.0	± 9.6 %
		Y	5.96	79.23	22.65		150.0	
		Z	5.61	80.77	23.51		150.0	
10183-AAA	LTE-FDD (SC-FDMA, 1 RB, 15 MHz, 64-QAM)	X	6.50	81.25	22.60	3.01	150.0	± 9.6 %
		Y	4.78	74.53	19.85		150.0	
		Z	4.37	75.41	20.41		150.0	

10184-CAC	LTE-FDD (SC-FDMA, 1 RB, 3 MHz, QPSK)	X	4.44	76.05	22.02	3.01	150.0	± 9.6 %
		Y	3.91	72.24	20.12		150.0	
		Z	3.45	71.72	20.13		150.0	
10185-CAC	LTE-FDD (SC-FDMA, 1 RB, 3 MHz, 16-QAM)	X	9.70	89.80	26.67	3.01	150.0	± 9.6 %
		Y	5.99	79.32	22.68		150.0	
		Z	5.64	80.86	23.56		150.0	
10186-AAC	LTE-FDD (SC-FDMA, 1 RB, 3 MHz, 64-QAM)	X	6.54	81.37	22.64	3.01	150.0	± 9.6 %
		Y	4.81	74.60	19.88		150.0	
		Z	4.39	75.50	20.45		150.0	
10187-CAC	LTE-FDD (SC-FDMA, 1 RB, 1.4 MHz, QPSK)	X	4.45	76.10	22.07	3.01	150.0	± 9.6 %
		Y	3.92	72.26	20.15		150.0	
		Z	3.46	71.78	20.19		150.0	
10188-CAC	LTE-FDD (SC-FDMA, 1 RB, 1.4 MHz, 16-QAM)	X	10.51	91.45	27.34	3.01	150.0	± 9.6 %
		Y	6.26	80.23	23.14		150.0	
		Z	5.89	81.76	24.00		150.0	
10189-AAC	LTE-FDD (SC-FDMA, 1 RB, 1.4 MHz, 64-QAM)	X	6.85	82.27	23.07	3.01	150.0	± 9.6 %
		Y	4.94	75.14	20.19		150.0	
		Z	4.52	76.06	20.77		150.0	
10193-CAB	IEEE 802.11n (HT Greenfield, 6.5 Mbps, BPSK)	X	4.73	67.10	16.51	0.00	150.0	± 9.6 %
		Y	4.75	66.68	16.23		150.0	
		Z	4.57	66.79	16.16		150.0	
10194-CAB	IEEE 802.11n (HT Greenfield, 39 Mbps, 16-QAM)	X	4.94	67.48	16.62	0.00	150.0	± 9.6 %
		Y	4.96	67.08	16.34		150.0	
		Z	4.75	67.11	16.28		150.0	
10195-CAB	IEEE 802.11n (HT Greenfield, 65 Mbps, 64-QAM)	X	4.98	67.48	16.62	0.00	150.0	± 9.6 %
		Y	5.00	67.07	16.34		150.0	
		Z	4.79	67.14	16.30		150.0	
10196-CAB	IEEE 802.11n (HT Mixed, 6.5 Mbps, BPSK)	X	4.76	67.21	16.55	0.00	150.0	± 9.6 %
		Y	4.78	66.80	16.27		150.0	
		Z	4.58	66.86	16.18		150.0	
10197-CAB	IEEE 802.11n (HT Mixed, 39 Mbps, 16-QAM)	X	4.96	67.50	16.63	0.00	150.0	± 9.6 %
		Y	4.98	67.09	16.35		150.0	
		Z	4.76	67.14	16.30		150.0	
10198-CAB	IEEE 802.11n (HT Mixed, 65 Mbps, 64-QAM)	X	4.99	67.50	16.63	0.00	150.0	± 9.6 %
		Y	5.01	67.09	16.35		150.0	
		Z	4.79	67.16	16.31		150.0	
10219-CAB	IEEE 802.11n (HT Mixed, 7.2 Mbps, BPSK)	X	4.71	67.23	16.53	0.00	150.0	± 9.6 %
		Y	4.73	66.82	16.24		150.0	
		Z	4.53	66.87	16.14		150.0	
10220-CAB	IEEE 802.11n (HT Mixed, 43.3 Mbps, 16-QAM)	X	4.96	67.50	16.63	0.00	150.0	± 9.6 %
		Y	4.98	67.10	16.35		150.0	
		Z	4.76	67.11	16.29		150.0	
10221-CAB	IEEE 802.11n (HT Mixed, 72.2 Mbps, 64-QAM)	X	4.99	67.43	16.62	0.00	150.0	± 9.6 %
		Y	5.01	67.03	16.34		150.0	
		Z	4.80	67.09	16.30		150.0	
10222-CAB	IEEE 802.11n (HT Mixed, 15 Mbps, BPSK)	X	5.29	67.72	16.73	0.00	150.0	± 9.6 %
		Y	5.31	67.38	16.49		150.0	
		Z	5.12	67.29	16.41		150.0	

10223-CAB	IEEE 802.11n (HT Mixed, 90 Mbps, 16-QAM)	X	5.67	68.03	16.90	0.00	150.0	± 9.6 %
		Y	5.70	67.71	16.67		150.0	
		Z	5.43	67.50	16.54		150.0	
10224-CAB	IEEE 802.11n (HT Mixed, 150 Mbps, 64-QAM)	X	5.35	67.84	16.72	0.00	150.0	± 9.6 %
		Y	5.37	67.51	16.48		150.0	
		Z	5.17	67.40	16.39		150.0	
10225-CAB	UMTS-FDD (HSPA+)	X	3.03	67.01	16.18	0.00	150.0	± 9.6 %
		Y	3.00	66.12	15.59		150.0	
		Z	2.84	66.23	15.31		150.0	
10226-CAA	LTE-TDD (SC-FDMA, 1 RB, 1.4 MHz, 16-QAM)	X	100.00	125.13	35.58	6.02	65.0	± 9.6 %
		Y	23.60	98.91	28.82		65.0	
		Z	100.00	128.43	36.91		65.0	
10227-CAA	LTE-TDD (SC-FDMA, 1 RB, 1.4 MHz, 64-QAM)	X	61.16	114.83	32.47	6.02	65.0	± 9.6 %
		Y	19.96	94.87	27.16		65.0	
		Z	73.77	120.96	34.46		65.0	
10228-CAA	LTE-TDD (SC-FDMA, 1 RB, 1.4 MHz, QPSK)	X	72.18	126.53	38.01	6.02	65.0	± 9.6 %
		Y	21.44	101.40	31.05		65.0	
		Z	53.16	123.89	37.96		65.0	
10229-CAB	LTE-TDD (SC-FDMA, 1 RB, 3 MHz, 16-QAM)	X	94.57	123.93	35.21	6.02	65.0	± 9.6 %
		Y	22.66	98.06	28.49		65.0	
		Z	96.87	127.65	36.65		65.0	
10230-CAB	LTE-TDD (SC-FDMA, 1 RB, 3 MHz, 64-QAM)	X	56.39	113.28	31.99	6.02	65.0	± 9.6 %
		Y	19.26	94.16	26.88		65.0	
		Z	66.99	119.13	33.93		65.0	
10231-CAB	LTE-TDD (SC-FDMA, 1 RB, 3 MHz, QPSK)	X	66.18	124.67	37.45	6.02	65.0	± 9.6 %
		Y	20.62	100.55	30.72		65.0	
		Z	48.89	122.07	37.41		65.0	
10232-CAB	LTE-TDD (SC-FDMA, 1 RB, 5 MHz, 16-QAM)	X	94.69	123.96	35.21	6.02	65.0	± 9.6 %
		Y	22.64	98.05	28.48		65.0	
		Z	97.00	127.68	36.66		65.0	
10233-CAB	LTE-TDD (SC-FDMA, 1 RB, 5 MHz, 64-QAM)	X	56.52	113.33	32.00	6.02	65.0	± 9.6 %
		Y	19.26	94.17	26.88		65.0	
		Z	67.07	119.16	33.94		65.0	
10234-CAB	LTE-TDD (SC-FDMA, 1 RB, 5 MHz, QPSK)	X	60.26	122.59	36.81	6.02	65.0	± 9.6 %
		Y	19.81	99.63	30.34		65.0	
		Z	45.11	120.21	36.81		65.0	
10235-CAB	LTE-TDD (SC-FDMA, 1 RB, 10 MHz, 16-QAM)	X	95.38	124.09	35.25	6.02	65.0	± 9.6 %
		Y	22.67	98.09	28.50		65.0	
		Z	97.77	127.84	36.70		65.0	
10236-CAB	LTE-TDD (SC-FDMA, 1 RB, 10 MHz, 64-QAM)	X	57.18	113.50	32.04	6.02	65.0	± 9.6 %
		Y	19.38	94.26	26.90		65.0	
		Z	68.10	119.39	33.99		65.0	
10237-CAB	LTE-TDD (SC-FDMA, 1 RB, 10 MHz, QPSK)	X	67.28	125.01	37.54	6.02	65.0	± 9.6 %
		Y	20.74	100.68	30.76		65.0	
		Z	49.59	122.38	37.49		65.0	
10238-CAB	LTE-TDD (SC-FDMA, 1 RB, 15 MHz, 16-QAM)	X	95.00	124.02	35.23	6.02	65.0	± 9.6 %
		Y	22.64	98.06	28.49		65.0	
		Z	97.19	127.73	36.66		65.0	

10239-CAB	LTE-TDD (SC-FDMA, 1 RB, 15 MHz, 64-QAM)	X	56.67	113.39	32.01	6.02	65.0	± 9.6 %
		Y	19.26	94.19	26.88		65.0	
		Z	67.13	119.19	33.94		65.0	
10240-CAB	LTE-TDD (SC-FDMA, 1 RB, 15 MHz, QPSK)	X	67.00	124.93	37.52	6.02	65.0	± 9.6 %
		Y	20.68	100.63	30.74		65.0	
		Z	49.37	122.30	37.47		65.0	
10241-CAA	LTE-TDD (SC-FDMA, 50% RB, 1.4 MHz, 16-QAM)	X	14.43	89.77	28.56	6.98	65.0	± 9.6 %
		Y	12.31	85.00	26.80		65.0	
		Z	13.89	90.56	28.94		65.0	
10242-CAA	LTE-TDD (SC-FDMA, 50% RB, 1.4 MHz, 64-QAM)	X	13.70	88.57	28.03	6.98	65.0	± 9.6 %
		Y	10.82	82.08	25.53		65.0	
		Z	13.16	89.30	28.37		65.0	
10243-CAA	LTE-TDD (SC-FDMA, 50% RB, 1.4 MHz, QPSK)	X	10.55	84.90	27.56	6.98	65.0	± 9.6 %
		Y	8.88	79.49	25.25		65.0	
		Z	9.99	85.03	27.70		65.0	
10244-CAB	LTE-TDD (SC-FDMA, 50% RB, 3 MHz, 16-QAM)	X	11.43	83.67	22.47	3.98	65.0	± 9.6 %
		Y	9.78	80.48	21.64		65.0	
		Z	9.76	81.22	20.90		65.0	
10245-CAB	LTE-TDD (SC-FDMA, 50% RB, 3 MHz, 64-QAM)	X	11.21	83.09	22.22	3.98	65.0	± 9.6 %
		Y	9.71	80.13	21.47		65.0	
		Z	9.48	80.50	20.58		65.0	
10246-CAB	LTE-TDD (SC-FDMA, 50% RB, 3 MHz, QPSK)	X	10.58	85.22	23.00	3.98	65.0	± 9.6 %
		Y	8.86	81.57	21.94		65.0	
		Z	9.16	83.05	21.67		65.0	
10247-CAB	LTE-TDD (SC-FDMA, 50% RB, 5 MHz, 16-QAM)	X	8.25	78.94	21.22	3.98	65.0	± 9.6 %
		Y	7.85	77.32	20.79		65.0	
		Z	7.47	77.61	20.18		65.0	
10248-CAB	LTE-TDD (SC-FDMA, 50% RB, 5 MHz, 64-QAM)	X	8.20	78.37	20.99	3.98	65.0	± 9.6 %
		Y	7.89	76.93	20.61		65.0	
		Z	7.41	77.03	19.93		65.0	
10249-CAB	LTE-TDD (SC-FDMA, 50% RB, 5 MHz, QPSK)	X	11.20	86.28	23.89	3.98	65.0	± 9.6 %
		Y	9.29	82.26	22.62		65.0	
		Z	10.48	85.66	23.36		65.0	
10250-CAB	LTE-TDD (SC-FDMA, 50% RB, 10 MHz, 16-QAM)	X	8.93	80.25	22.81	3.98	65.0	± 9.6 %
		Y	8.46	78.37	22.14		65.0	
		Z	8.46	79.88	22.48		65.0	
10251-CAB	LTE-TDD (SC-FDMA, 50% RB, 10 MHz, 64-QAM)	X	8.39	77.98	21.64	3.98	65.0	± 9.6 %
		Y	8.12	76.54	21.14		65.0	
		Z	7.98	77.74	21.34		65.0	
10252-CAB	LTE-TDD (SC-FDMA, 50% RB, 10 MHz, QPSK)	X	10.53	84.51	23.78	3.98	65.0	± 9.6 %
		Y	9.19	81.18	22.63		65.0	
		Z	10.24	84.82	23.86		65.0	
10253-CAB	LTE-TDD (SC-FDMA, 50% RB, 15 MHz, 16-QAM)	X	8.25	76.95	21.44	3.98	65.0	± 9.6 %
		Y	8.10	75.77	21.00		65.0	
		Z	7.89	76.78	21.28		65.0	
10254-CAB	LTE-TDD (SC-FDMA, 50% RB, 15 MHz, 64-QAM)	X	8.62	77.66	22.02	3.98	65.0	± 9.6 %
		Y	8.44	76.43	21.56		65.0	
		Z	8.28	77.57	21.89		65.0	

10255-CAB	LTE-TDD (SC-FDMA, 50% RB, 15 MHz, QPSK)	X	9.25	80.67	22.52	3.98	65.0	± 9.6 %
		Y	8.61	78.53	21.74		65.0	
		Z	9.00	80.97	22.67		65.0	
10256-CAA	LTE-TDD (SC-FDMA, 100% RB, 1.4 MHz, 16-QAM)	X	10.45	81.80	21.06	3.98	65.0	± 9.6 %
		Y	9.25	79.43	20.63		65.0	
		Z	8.10	77.76	18.69		65.0	
10257-CAA	LTE-TDD (SC-FDMA, 100% RB, 1.4 MHz, 64-QAM)	X	10.14	80.97	20.68	3.98	65.0	± 9.6 %
		Y	9.17	78.95	20.38		65.0	
		Z	7.78	76.81	18.23		65.0	
10258-CAA	LTE-TDD (SC-FDMA, 100% RB, 1.4 MHz, QPSK)	X	9.51	83.16	21.76	3.98	65.0	± 9.6 %
		Y	8.34	80.46	21.12		65.0	
		Z	7.35	79.00	19.46		65.0	
10259-CAB	LTE-TDD (SC-FDMA, 100% RB, 3 MHz, 16-QAM)	X	8.50	79.32	21.74	3.98	65.0	± 9.6 %
		Y	8.08	77.61	21.22		65.0	
		Z	7.86	78.44	21.00		65.0	
10260-CAB	LTE-TDD (SC-FDMA, 100% RB, 3 MHz, 64-QAM)	X	8.50	79.04	21.65	3.98	65.0	± 9.6 %
		Y	8.14	77.44	21.18		65.0	
		Z	7.85	78.11	20.87		65.0	
10261-CAB	LTE-TDD (SC-FDMA, 100% RB, 3 MHz, QPSK)	X	10.46	84.88	23.66	3.98	65.0	± 9.6 %
		Y	8.99	81.35	22.49		65.0	
		Z	9.90	84.54	23.31		65.0	
10262-CAB	LTE-TDD (SC-FDMA, 100% RB, 5 MHz, 16-QAM)	X	8.92	80.22	22.77	3.98	65.0	± 9.6 %
		Y	8.45	78.35	22.11		65.0	
		Z	8.45	79.83	22.45		65.0	
10263-CAB	LTE-TDD (SC-FDMA, 100% RB, 5 MHz, 64-QAM)	X	8.39	77.98	21.64	3.98	65.0	± 9.6 %
		Y	8.12	76.54	21.14		65.0	
		Z	7.97	77.72	21.33		65.0	
10264-CAB	LTE-TDD (SC-FDMA, 100% RB, 5 MHz, QPSK)	X	10.46	84.37	23.71	3.98	65.0	± 9.6 %
		Y	9.15	81.08	22.57		65.0	
		Z	10.16	84.65	23.78		65.0	
10265-CAB	LTE-TDD (SC-FDMA, 100% RB, 10 MHz, 16-QAM)	X	8.50	77.59	21.64	3.98	65.0	± 9.6 %
		Y	8.29	76.32	21.16		65.0	
		Z	8.08	77.33	21.51		65.0	
10266-CAB	LTE-TDD (SC-FDMA, 100% RB, 10 MHz, 64-QAM)	X	8.85	78.27	22.25	3.98	65.0	± 9.6 %
		Y	8.62	76.95	21.75		65.0	
		Z	8.48	78.14	22.17		65.0	
10267-CAB	LTE-TDD (SC-FDMA, 100% RB, 10 MHz, QPSK)	X	9.58	81.04	22.42	3.98	65.0	± 9.6 %
		Y	8.86	78.85	21.63		65.0	
		Z	9.31	81.34	22.60		65.0	
10268-CAB	LTE-TDD (SC-FDMA, 100% RB, 15 MHz, 16-QAM)	X	8.89	76.95	21.70	3.98	65.0	± 9.6 %
		Y	8.78	75.95	21.31		65.0	
		Z	8.54	76.83	21.69		65.0	
10269-CAB	LTE-TDD (SC-FDMA, 100% RB, 15 MHz, 64-QAM)	X	8.79	76.51	21.59	3.98	65.0	± 9.6 %
		Y	8.71	75.58	21.23		65.0	
		Z	8.47	76.42	21.58		65.0	
10270-CAB	LTE-TDD (SC-FDMA, 100% RB, 15 MHz, QPSK)	X	8.98	78.26	21.47	3.98	65.0	± 9.6 %
		Y	8.66	76.86	20.96		65.0	
		Z	8.70	78.39	21.61		65.0	

10274-CAB	UMTS-FDD (HSUPA, Subtest 5, 3GPP Rel8.10)	X	2.76	67.40	16.12	0.00	150.0	± 9.6 %
		Y	2.68	66.20	15.35		150.0	
		Z	2.61	66.55	15.21		150.0	
10275-CAB	UMTS-FDD (HSUPA, Subtest 5, 3GPP Rel8.4)	X	1.97	71.33	17.64	0.00	150.0	± 9.6 %
		Y	1.71	67.84	15.61		150.0	
		Z	1.63	67.82	15.44		150.0	
10277-CAA	PHS (QPSK)	X	5.79	70.12	14.44	9.03	50.0	± 9.6 %
		Y	6.71	72.04	16.24		50.0	
		Z	5.20	69.01	13.39		50.0	
10278-CAA	PHS (QPSK, BW 884MHz, Rolloff 0.5)	X	10.14	81.72	21.64	9.03	50.0	± 9.6 %
		Y	10.00	81.13	22.16		50.0	
		Z	8.80	79.36	20.19		50.0	
10279-CAA	PHS (QPSK, BW 884MHz, Rolloff 0.38)	X	10.33	81.92	21.72	9.03	50.0	± 9.6 %
		Y	10.19	81.33	22.24		50.0	
		Z	8.92	79.53	20.27		50.0	
10290-AAB	CDMA2000, RC1, SO55, Full Rate	X	2.41	75.76	18.30	0.00	150.0	± 9.6 %
		Y	1.70	69.18	15.23		150.0	
		Z	1.46	68.58	14.00		150.0	
10291-AAB	CDMA2000, RC3, SO55, Full Rate	X	1.39	73.22	17.31	0.00	150.0	± 9.6 %
		Y	0.98	66.45	13.79		150.0	
		Z	0.85	65.74	12.53		150.0	
10292-AAB	CDMA2000, RC3, SO32, Full Rate	X	2.43	83.14	21.70	0.00	150.0	± 9.6 %
		Y	1.15	69.63	15.75		150.0	
		Z	1.04	69.40	14.71		150.0	
10293-AAB	CDMA2000, RC3, SO3, Full Rate	X	5.22	96.14	26.57	0.00	150.0	± 9.6 %
		Y	1.48	73.58	17.97		150.0	
		Z	1.47	74.43	17.37		150.0	
10295-AAB	CDMA2000, RC1, SO3, 1/8th Rate 25 fr.	X	10.48	83.75	24.32	9.03	50.0	± 9.6 %
		Y	9.84	81.54	23.85		50.0	
		Z	11.88	86.37	24.91		50.0	
10297-AAA	LTE-FDD (SC-FDMA, 50% RB, 20 MHz, QPSK)	X	3.28	72.37	17.95	0.00	150.0	± 9.6 %
		Y	2.98	69.95	16.59		150.0	
		Z	2.77	69.63	16.49		150.0	
10298-AAB	LTE-FDD (SC-FDMA, 50% RB, 3 MHz, QPSK)	X	2.26	72.62	17.48	0.00	150.0	± 9.6 %
		Y	1.88	68.51	15.39		150.0	
		Z	1.59	67.65	14.14		150.0	
10299-AAB	LTE-FDD (SC-FDMA, 50% RB, 3 MHz, 16-QAM)	X	6.40	81.89	20.37	0.00	150.0	± 9.6 %
		Y	3.78	73.44	17.26		150.0	
		Z	3.62	73.66	16.18		150.0	
10300-AAB	LTE-FDD (SC-FDMA, 50% RB, 3 MHz, 64-QAM)	X	3.72	72.73	16.07	0.00	150.0	± 9.6 %
		Y	2.96	68.88	14.55		150.0	
		Z	2.44	67.52	12.75		150.0	
10301-AAA	IEEE 802.16e WIMAX (29:18, 5ms, 10MHz, QPSK, PUSC)	X	5.70	68.03	18.84	4.17	80.0	± 9.6 %
		Y	5.77	67.36	18.35		80.0	
		Z	5.64	68.37	18.74		80.0	
10302-AAA	IEEE 802.16e WIMAX (29:18, 5ms, 10MHz, QPSK, PUSC, 3 CTRL symbols)	X	6.21	68.72	19.60	4.96	80.0	± 9.6 %
		Y	6.41	68.65	19.47		80.0	
		Z	6.13	69.05	19.54		80.0	

10303-AAA	IEEE 802.16e WiMAX (31:15, 5ms, 10MHz, 64QAM, PUSC)	X	6.07	68.83	19.70	4.96	80.0	± 9.6 %
		Y	6.30	68.82	19.58		80.0	
		Z	5.97	69.08	19.56		80.0	
10304-AAA	IEEE 802.16e WiMAX (29:18, 5ms, 10MHz, 64QAM, PUSC)	X	5.71	68.13	18.89	4.17	80.0	± 9.6 %
		Y	5.89	68.01	18.73		80.0	
		Z	5.61	68.35	18.73		80.0	
10305-AAA	IEEE 802.16e WiMAX (31:15, 10ms, 10MHz, 64QAM, PUSC, 15 symbols)	X	6.90	74.81	23.11	6.02	50.0	± 9.6 %
		Y	9.48	82.28	26.60		50.0	
		Z	9.03	82.45	26.20		50.0	
10306-AAA	IEEE 802.16e WiMAX (29:18, 10ms, 10MHz, 64QAM, PUSC, 18 symbols)	X	6.40	71.34	21.64	6.02	50.0	± 9.6 %
		Y	6.75	71.50	21.57		50.0	
		Z	6.43	72.04	21.56		50.0	
10307-AAA	IEEE 802.16e WiMAX (29:18, 10ms, 10MHz, QPSK, PUSC, 18 symbols)	X	6.49	72.10	21.82	6.02	50.0	± 9.6 %
		Y	6.85	72.21	21.70		50.0	
		Z	6.50	72.67	21.67		50.0	
10308-AAA	IEEE 802.16e WiMAX (29:18, 10ms, 10MHz, 16QAM, PUSC)	X	6.53	72.49	22.02	6.02	50.0	± 9.6 %
		Y	6.89	72.58	21.88		50.0	
		Z	6.59	73.18	21.92		50.0	
10309-AAA	IEEE 802.16e WiMAX (29:18, 10ms, 10MHz, 16QAM, AMC 2x3, 18 symbols)	X	6.52	71.66	21.81	6.02	50.0	± 9.6 %
		Y	6.86	71.77	21.70		50.0	
		Z	6.53	72.35	21.74		50.0	
10310-AAA	IEEE 802.16e WiMAX (29:18, 10ms, 10MHz, QPSK, AMC 2x3, 18 symbols)	X	6.41	71.57	21.66	6.02	50.0	± 9.6 %
		Y	6.75	71.71	21.56		50.0	
		Z	6.45	72.29	21.59		50.0	
10311-AAA	LTE-FDD (SC-FDMA, 100% RB, 15 MHz, QPSK)	X	3.66	71.55	17.51	0.00	150.0	± 9.6 %
		Y	3.33	69.32	16.27		150.0	
		Z	3.12	68.94	16.14		150.0	
10313-AAA	iDEN 1:3	X	8.19	79.62	19.16	6.99	70.0	± 9.6 %
		Y	7.35	77.72	18.90		70.0	
		Z	8.21	80.46	19.57		70.0	
10314-AAA	iDEN 1:6	X	11.35	86.83	24.06	10.00	30.0	± 9.6 %
		Y	8.72	81.68	22.69		30.0	
		Z	10.81	87.34	24.49		30.0	
10315-AAB	IEEE 802.11b WiFi 2.4 GHz (DSSS, 1 Mbps, 96pc duty cycle)	X	1.24	66.34	16.99	0.17	150.0	± 9.6 %
		Y	1.18	64.44	15.46		150.0	
		Z	1.17	64.45	15.36		150.0	
10316-AAB	IEEE 802.11g WiFi 2.4 GHz (ERP-OFDM, 6 Mbps, 96pc duty cycle)	X	4.83	67.25	16.68	0.17	150.0	± 9.6 %
		Y	4.86	66.88	16.43		150.0	
		Z	4.68	66.99	16.39		150.0	
10317-AAB	IEEE 802.11a WiFi 5 GHz (OFDM, 6 Mbps, 96pc duty cycle)	X	4.83	67.25	16.68	0.17	150.0	± 9.6 %
		Y	4.86	66.88	16.43		150.0	
		Z	4.68	66.99	16.39		150.0	
10400-AAC	IEEE 802.11ac WiFi (20MHz, 64-QAM, 99pc duty cycle)	X	4.96	67.54	16.61	0.00	150.0	± 9.6 %
		Y	4.98	67.13	16.32		150.0	
		Z	4.75	67.19	16.29		150.0	
10401-AAC	IEEE 802.11ac WiFi (40MHz, 64-QAM, 99pc duty cycle)	X	5.54	67.49	16.61	0.00	150.0	± 9.6 %
		Y	5.56	67.14	16.37		150.0	
		Z	5.45	67.43	16.49		150.0	

10402-AAC	IEEE 802.11ac WiFi (80MHz, 64-QAM, 99pc duty cycle)	X	5.87	68.11	16.75	0.00	150.0	± 9.6 %
		Y	5.89	67.80	16.54		150.0	
		Z	5.70	67.70	16.47		150.0	
10403-AAB	CDMA2000 (1xEV-DO, Rev. 0)	X	2.41	75.76	18.30	0.00	115.0	± 9.6 %
		Y	1.70	69.18	15.23		115.0	
		Z	1.46	68.58	14.00		115.0	
10404-AAB	CDMA2000 (1xEV-DO, Rev. A)	X	2.41	75.76	18.30	0.00	115.0	± 9.6 %
		Y	1.70	69.18	15.23		115.0	
		Z	1.46	68.58	14.00		115.0	
10406-AAB	CDMA2000, RC3, SO32, SCH0, Full Rate	X	100.00	120.32	30.30	0.00	100.0	± 9.6 %
		Y	37.67	108.93	28.46		100.0	
		Z	100.00	119.28	29.39		100.0	
10410-AAA	LTE-TDD (SC-FDMA, 1 RB, 10 MHz, QPSK, UL Subframe=2,3,4,7,8,9)	X	100.00	118.51	29.90	3.23	80.0	± 9.6 %
		Y	100.00	119.74	30.88		80.0	
		Z	100.00	120.99	30.71		80.0	
10415-AAA	IEEE 802.11b WiFi 2.4 GHz (DSSS, 1 Mbps, 99pc duty cycle)	X	1.06	64.54	16.02	0.00	150.0	± 9.6 %
		Y	1.03	62.90	14.57		150.0	
		Z	1.03	63.04	14.51		150.0	
10416-AAA	IEEE 802.11g WiFi 2.4 GHz (ERP-OFDM, 6 Mbps, 99pc duty cycle)	X	4.73	67.12	16.55	0.00	150.0	± 9.6 %
		Y	4.75	66.70	16.25		150.0	
		Z	4.58	66.83	16.23		150.0	
10417-AAA	IEEE 802.11a/h WiFi 5 GHz (OFDM, 6 Mbps, 99pc duty cycle)	X	4.73	67.12	16.55	0.00	150.0	± 9.6 %
		Y	4.75	66.70	16.25		150.0	
		Z	4.58	66.83	16.23		150.0	
10418-AAA	IEEE 802.11g WiFi 2.4 GHz (DSSS-OFDM, 6 Mbps, 99pc duty cycle, Long preamble)	X	4.72	67.27	16.56	0.00	150.0	± 9.6 %
		Y	4.73	66.83	16.25		150.0	
		Z	4.56	66.98	16.24		150.0	
10419-AAA	IEEE 802.11g WiFi 2.4 GHz (DSSS-OFDM, 6 Mbps, 99pc duty cycle, Short preamble)	X	4.75	67.23	16.56	0.00	150.0	± 9.6 %
		Y	4.76	66.80	16.26		150.0	
		Z	4.59	66.94	16.24		150.0	
10422-AAA	IEEE 802.11n (HT Greenfield, 7.2 Mbps, BPSK)	X	4.87	67.22	16.56	0.00	150.0	± 9.6 %
		Y	4.89	66.82	16.28		150.0	
		Z	4.71	66.94	16.26		150.0	
10423-AAA	IEEE 802.11n (HT Greenfield, 43.3 Mbps, 16-QAM)	X	5.09	67.62	16.71	0.00	150.0	± 9.6 %
		Y	5.12	67.23	16.44		150.0	
		Z	4.88	67.27	16.38		150.0	
10424-AAA	IEEE 802.11n (HT Greenfield, 72.2 Mbps, 64-QAM)	X	5.00	67.56	16.68	0.00	150.0	± 9.6 %
		Y	5.02	67.15	16.39		150.0	
		Z	4.80	67.22	16.35		150.0	
10425-AAA	IEEE 802.11n (HT Greenfield, 15 Mbps, BPSK)	X	5.55	67.83	16.78	0.00	150.0	± 9.6 %
		Y	5.59	67.55	16.57		150.0	
		Z	5.40	67.57	16.55		150.0	
10426-AAA	IEEE 802.11n (HT Greenfield, 90 Mbps, 16-QAM)	X	5.56	67.88	16.79	0.00	150.0	± 9.6 %
		Y	5.60	67.58	16.58		150.0	
		Z	5.41	67.59	16.56		150.0	

10427-AAA	IEEE 802.11n (HT Greenfield, 150 Mbps, 64-QAM)	X	5.59	67.91	16.80	0.00	150.0	± 9.6 %
		Y	5.63	67.61	16.59		150.0	
		Z	5.42	67.56	16.54		150.0	
10430-AAA	LTE-FDD (OFDMA, 5 MHz, E-TM 3.1)	X	4.54	71.07	18.70	0.00	150.0	± 9.6 %
		Y	4.46	69.99	18.11		150.0	
		Z	4.20	70.41	17.89		150.0	
10431-AAA	LTE-FDD (OFDMA, 10 MHz, E-TM 3.1)	X	4.50	67.77	16.69	0.00	150.0	± 9.6 %
		Y	4.51	67.23	16.34		150.0	
		Z	4.26	67.36	16.21		150.0	
10432-AAA	LTE-FDD (OFDMA, 15 MHz, E-TM 3.1)	X	4.78	67.63	16.67	0.00	150.0	± 9.6 %
		Y	4.80	67.18	16.37		150.0	
		Z	4.56	67.25	16.29		150.0	
10433-AAA	LTE-FDD (OFDMA, 20 MHz, E-TM 3.1)	X	5.01	67.62	16.71	0.00	150.0	± 9.6 %
		Y	5.04	67.21	16.43		150.0	
		Z	4.81	67.25	16.37		150.0	
10434-AAA	W-CDMA (BS Test Model 1, 64 DPCH)	X	4.66	71.93	18.79	0.00	150.0	± 9.6 %
		Y	4.53	70.61	18.11		150.0	
		Z	4.27	71.15	17.82		150.0	
10435-AAA	LTE-TDD (SC-FDMA, 1 RB, 20 MHz, QPSK, UL Subframe=2,3,4,7,8,9)	X	100.00	118.35	29.82	3.23	80.0	± 9.6 %
		Y	100.00	119.61	30.82		80.0	
		Z	100.00	120.81	30.62		80.0	
10447-AAA	LTE-FDD (OFDMA, 5 MHz, E-TM 3.1, Clipping 44%)	X	3.85	68.02	16.38	0.00	150.0	± 9.6 %
		Y	3.83	67.22	15.92		150.0	
		Z	3.54	67.32	15.53		150.0	
10448-AAA	LTE-FDD (OFDMA, 10 MHz, E-TM 3.1, Clipping 44%)	X	4.31	67.56	16.56	0.00	150.0	± 9.6 %
		Y	4.32	66.99	16.19		150.0	
		Z	4.10	67.13	16.07		150.0	
10449-AAA	LTE-FDD (OFDMA, 15 MHz, E-TM 3.1, Clipping 44%)	X	4.56	67.47	16.59	0.00	150.0	± 9.6 %
		Y	4.57	66.98	16.26		150.0	
		Z	4.37	67.07	16.19		150.0	
10450-AAA	LTE-FDD (OFDMA, 20 MHz, E-TM 3.1, Clipping 44%)	X	4.73	67.38	16.58	0.00	150.0	± 9.6 %
		Y	4.74	66.94	16.27		150.0	
		Z	4.56	67.01	16.22		150.0	
10451-AAA	W-CDMA (BS Test Model 1, 64 DPCH, Clipping 44%)	X	3.81	68.42	16.23	0.00	150.0	± 9.6 %
		Y	3.77	67.50	15.73		150.0	
		Z	3.44	67.49	15.16		150.0	
10456-AAA	IEEE 802.11ac WiFi (160MHz, 64-QAM, 99pc duty cycle)	X	6.40	68.45	16.93	0.00	150.0	± 9.6 %
		Y	6.44	68.23	16.77		150.0	
		Z	6.27	68.12	16.71		150.0	
10457-AAA	UMTS-FDD (DC-HSDPA)	X	3.89	65.77	16.30	0.00	150.0	± 9.6 %
		Y	3.90	65.36	15.99		150.0	
		Z	3.82	65.47	15.93		150.0	
10458-AAA	CDMA2000 (1xEV-DO, Rev. B, 2 carriers)	X	3.60	67.53	15.71	0.00	150.0	± 9.6 %
		Y	3.56	66.59	15.22		150.0	
		Z	3.27	66.88	14.62		150.0	
10459-AAA	CDMA2000 (1xEV-DO, Rev. B, 3 carriers)	X	4.70	65.53	16.21	0.00	150.0	± 9.6 %
		Y	4.63	64.60	15.71		150.0	
		Z	4.27	64.85	15.38		150.0	

10460-AAA	UMTS-FDD (WCDMA, AMR)	X	1.28	75.29	20.20	0.00	150.0	± 9.6 %
		Y	0.92	67.71	15.91		150.0	
		Z	0.90	67.71	15.78		150.0	
10461-AAA	LTE-TDD (SC-FDMA, 1 RB, 1.4 MHz, QPSK, UL Subframe=2,3,4,7,8,9)	X	100.00	122.97	32.01	3.29	80.0	± 9.6 %
		Y	100.00	121.34	31.70		80.0	
		Z	100.00	125.58	32.88		80.0	
10462-AAA	LTE-TDD (SC-FDMA, 1 RB, 1.4 MHz, 16-QAM, UL Subframe=2,3,4,7,8,9)	X	100.00	108.03	24.84	3.23	80.0	± 9.6 %
		Y	100.00	109.86	26.18		80.0	
		Z	100.00	108.99	24.93		80.0	
10463-AAA	LTE-TDD (SC-FDMA, 1 RB, 1.4 MHz, 64-QAM, UL Subframe=2,3,4,7,8,9)	X	100.00	105.21	23.49	3.23	80.0	± 9.6 %
		Y	47.92	99.26	23.13		80.0	
		Z	100.00	105.71	23.36		80.0	
10464-AAA	LTE-TDD (SC-FDMA, 1 RB, 3 MHz, QPSK, UL Subframe=2,3,4,7,8,9)	X	100.00	121.12	31.00	3.23	80.0	± 9.6 %
		Y	100.00	119.76	30.82		80.0	
		Z	100.00	123.61	31.80		80.0	
10465-AAA	LTE-TDD (SC-FDMA, 1 RB, 3 MHz, 16-QAM, UL Subframe=2,3,4,7,8,9)	X	100.00	107.54	24.59	3.23	80.0	± 9.6 %
		Y	92.10	108.50	25.75		80.0	
		Z	100.00	108.47	24.68		80.0	
10466-AAA	LTE-TDD (SC-FDMA, 1 RB, 3 MHz, 64-QAM, UL Subframe=2,3,4,7,8,9)	X	100.00	104.76	23.28	3.23	80.0	± 9.6 %
		Y	27.79	92.79	21.40		80.0	
		Z	53.71	98.96	21.73		80.0	
10467-AAA	LTE-TDD (SC-FDMA, 1 RB, 5 MHz, QPSK, UL Subframe=2,3,4,7,8,9)	X	100.00	121.32	31.10	3.23	80.0	± 9.6 %
		Y	100.00	119.93	30.90		80.0	
		Z	100.00	123.83	31.91		80.0	
10468-AAA	LTE-TDD (SC-FDMA, 1 RB, 5 MHz, 16-QAM, UL Subframe=2,3,4,7,8,9)	X	100.00	107.68	24.66	3.23	80.0	± 9.6 %
		Y	100.00	109.58	26.02		80.0	
		Z	100.00	108.64	24.75		80.0	
10469-AAA	LTE-TDD (SC-FDMA, 1 RB, 5 MHz, 64-QAM, UL Subframe=2,3,4,7,8,9)	X	100.00	104.76	23.27	3.23	80.0	± 9.6 %
		Y	28.45	93.06	21.47		80.0	
		Z	57.15	99.60	21.88		80.0	
10470-AAA	LTE-TDD (SC-FDMA, 1 RB, 10 MHz, QPSK, UL Subframe=2,3,4,7,8,9)	X	100.00	121.35	31.10	3.23	80.0	± 9.6 %
		Y	100.00	119.95	30.90		80.0	
		Z	100.00	123.86	31.91		80.0	
10471-AAA	LTE-TDD (SC-FDMA, 1 RB, 10 MHz, 16-QAM, UL Subframe=2,3,4,7,8,9)	X	100.00	107.63	24.63	3.23	80.0	± 9.6 %
		Y	100.00	109.54	26.00		80.0	
		Z	100.00	108.59	24.73		80.0	
10472-AAA	LTE-TDD (SC-FDMA, 1 RB, 10 MHz, 64-QAM, UL Subframe=2,3,4,7,8,9)	X	100.00	104.72	23.24	3.23	80.0	± 9.6 %
		Y	28.52	93.08	21.46		80.0	
		Z	57.07	99.54	21.85		80.0	
10473-AAA	LTE-TDD (SC-FDMA, 1 RB, 15 MHz, QPSK, UL Subframe=2,3,4,7,8,9)	X	100.00	121.32	31.09	3.23	80.0	± 9.6 %
		Y	100.00	119.92	30.89		80.0	
		Z	100.00	123.84	31.90		80.0	
10474-AAA	LTE-TDD (SC-FDMA, 1 RB, 15 MHz, 16-QAM, UL Subframe=2,3,4,7,8,9)	X	100.00	107.64	24.63	3.23	80.0	± 9.6 %
		Y	100.00	109.55	26.00		80.0	
		Z	100.00	108.60	24.73		80.0	
10475-AAA	LTE-TDD (SC-FDMA, 1 RB, 15 MHz, 64-QAM, UL Subframe=2,3,4,7,8,9)	X	100.00	104.73	23.25	3.23	80.0	± 9.6 %
		Y	28.13	92.93	21.42		80.0	
		Z	55.36	99.25	21.78		80.0	

10477-AAA	LTE-TDD (SC-FDMA, 1 RB, 20 MHz, 16-QAM, UL Subframe=2,3,4,7,8,9)	X	100.00	107.49	24.56	3.23	80.0	± 9.6 %
		Y	96.57	109.01	25.85		80.0	
		Z	100.00	108.42	24.64		80.0	
10478-AAA	LTE-TDD (SC-FDMA, 1 RB, 20 MHz, 64-QAM, UL Subframe=2,3,4,7,8,9)	X	100.00	104.68	23.23	3.23	80.0	± 9.6 %
		Y	27.68	92.72	21.36		80.0	
		Z	53.23	98.81	21.67		80.0	
10479-AAA	LTE-TDD (SC-FDMA, 50% RB, 1.4 MHz, QPSK, UL Subframe=2,3,4,7,8,9)	X	26.63	104.01	29.13	3.23	80.0	± 9.6 %
		Y	9.63	86.48	23.96		80.0	
		Z	24.30	102.59	28.22		80.0	
10480-AAA	LTE-TDD (SC-FDMA, 50% RB, 1.4 MHz, 16-QAM, UL Subframe=2,3,4,7,8,9)	X	38.31	102.90	27.02	3.23	80.0	± 9.6 %
		Y	11.50	85.06	22.20		80.0	
		Z	29.11	98.49	25.10		80.0	
10481-AAA	LTE-TDD (SC-FDMA, 50% RB, 1.4 MHz, 64-QAM, UL Subframe=2,3,4,7,8,9)	X	30.40	98.59	25.52	3.23	80.0	± 9.6 %
		Y	10.74	83.47	21.41		80.0	
		Z	20.94	92.98	23.18		80.0	
10482-AAA	LTE-TDD (SC-FDMA, 50% RB, 3 MHz, QPSK, UL Subframe=2,3,4,7,8,9)	X	8.51	84.82	22.25	2.23	80.0	± 9.6 %
		Y	5.60	77.58	19.80		80.0	
		Z	5.41	78.09	19.19		80.0	
10483-AAA	LTE-TDD (SC-FDMA, 50% RB, 3 MHz, 16-QAM, UL Subframe=2,3,4,7,8,9)	X	14.01	88.92	23.41	2.23	80.0	± 9.6 %
		Y	8.14	80.18	20.73		80.0	
		Z	9.32	82.50	20.44		80.0	
10484-AAA	LTE-TDD (SC-FDMA, 50% RB, 3 MHz, 64-QAM, UL Subframe=2,3,4,7,8,9)	X	12.47	87.00	22.82	2.23	80.0	± 9.6 %
		Y	7.81	79.33	20.43		80.0	
		Z	8.26	80.64	19.81		80.0	
10485-AAA	LTE-TDD (SC-FDMA, 50% RB, 5 MHz, QPSK, UL Subframe=2,3,4,7,8,9)	X	8.06	84.25	22.66	2.23	80.0	± 9.6 %
		Y	5.75	77.87	20.37		80.0	
		Z	5.68	79.10	20.42		80.0	
10486-AAA	LTE-TDD (SC-FDMA, 50% RB, 5 MHz, 16-QAM, UL Subframe=2,3,4,7,8,9)	X	5.66	75.87	19.43	2.23	80.0	± 9.6 %
		Y	4.94	72.86	18.29		80.0	
		Z	4.62	73.05	17.69		80.0	
10487-AAA	LTE-TDD (SC-FDMA, 50% RB, 5 MHz, 64-QAM, UL Subframe=2,3,4,7,8,9)	X	5.56	75.25	19.19	2.23	80.0	± 9.6 %
		Y	4.94	72.51	18.16		80.0	
		Z	4.56	72.51	17.46		80.0	
10488-AAA	LTE-TDD (SC-FDMA, 50% RB, 10 MHz, QPSK, UL Subframe=2,3,4,7,8,9)	X	7.10	80.82	21.84	2.23	80.0	± 9.6 %
		Y	5.79	76.47	20.13		80.0	
		Z	5.49	77.19	20.36		80.0	
10489-AAA	LTE-TDD (SC-FDMA, 50% RB, 10 MHz, 16-QAM, UL Subframe=2,3,4,7,8,9)	X	5.34	73.87	19.44	2.23	80.0	± 9.6 %
		Y	5.00	71.87	18.57		80.0	
		Z	4.68	72.17	18.47		80.0	
10490-AAA	LTE-TDD (SC-FDMA, 50% RB, 10 MHz, 64-QAM, UL Subframe=2,3,4,7,8,9)	X	5.35	73.36	19.26	2.23	80.0	± 9.6 %
		Y	5.06	71.53	18.46		80.0	
		Z	4.74	71.87	18.36		80.0	
10491-AAA	LTE-TDD (SC-FDMA, 50% RB, 15 MHz, QPSK, UL Subframe=2,3,4,7,8,9)	X	6.36	77.12	20.56	2.23	80.0	± 9.6 %
		Y	5.66	74.28	19.36		80.0	
		Z	5.31	74.67	19.54		80.0	
10492-AAA	LTE-TDD (SC-FDMA, 50% RB, 15 MHz, 16-QAM, UL Subframe=2,3,4,7,8,9)	X	5.41	72.24	18.98	2.23	80.0	± 9.6 %
		Y	5.23	70.84	18.33		80.0	
		Z	4.89	71.01	18.29		80.0	

10493-AAA	LTE-TDD (SC-FDMA, 50% RB, 15 MHz, 64-QAM, UL Subframe=2,3,4,7,8,9)	X	5.44	71.94	18.88	2.23	80.0	± 9.6 %
		Y	5.28	70.63	18.27		80.0	
		Z	4.94	70.81	18.22		80.0	
10494-AAA	LTE-TDD (SC-FDMA, 50% RB, 20 MHz, QPSK, UL Subframe=2,3,4,7,8,9)	X	7.43	79.70	21.31	2.23	80.0	± 9.6 %
		Y	6.30	76.13	19.88		80.0	
		Z	5.88	76.40	20.05		80.0	
10495-AAA	LTE-TDD (SC-FDMA, 50% RB, 20 MHz, 16-QAM, UL Subframe=2,3,4,7,8,9)	X	5.56	72.97	19.25	2.23	80.0	± 9.6 %
		Y	5.33	71.45	18.55		80.0	
		Z	4.97	71.48	18.50		80.0	
10496-AAA	LTE-TDD (SC-FDMA, 50% RB, 20 MHz, 64-QAM, UL Subframe=2,3,4,7,8,9)	X	5.54	72.39	19.06	2.23	80.0	± 9.6 %
		Y	5.37	71.03	18.42		80.0	
		Z	5.01	71.08	18.38		80.0	
10497-AAA	LTE-TDD (SC-FDMA, 100% RB, 1.4 MHz, QPSK, UL Subframe=2,3,4,7,8,9)	X	7.31	82.38	20.82	2.23	80.0	± 9.6 %
		Y	4.87	75.75	18.64		80.0	
		Z	4.03	73.68	16.68		80.0	
10498-AAA	LTE-TDD (SC-FDMA, 100% RB, 1.4 MHz, 16-QAM, UL Subframe=2,3,4,7,8,9)	X	4.73	73.29	16.69	2.23	80.0	± 9.6 %
		Y	4.12	70.77	15.97		80.0	
		Z	2.73	66.24	12.60		80.0	
10499-AAA	LTE-TDD (SC-FDMA, 100% RB, 1.4 MHz, 64-QAM, UL Subframe=2,3,4,7,8,9)	X	4.59	72.54	16.27	2.23	80.0	± 9.6 %
		Y	4.10	70.38	15.70		80.0	
		Z	2.62	65.47	12.11		80.0	
10500-AAA	LTE-TDD (SC-FDMA, 100% RB, 3 MHz, QPSK, UL Subframe=2,3,4,7,8,9)	X	7.19	81.83	22.01	2.23	80.0	± 9.6 %
		Y	5.57	76.69	20.07		80.0	
		Z	5.44	77.85	20.24		80.0	
10501-AAA	LTE-TDD (SC-FDMA, 100% RB, 3 MHz, 16-QAM, UL Subframe=2,3,4,7,8,9)	X	5.46	74.81	19.33	2.23	80.0	± 9.6 %
		Y	4.94	72.30	18.33		80.0	
		Z	4.65	72.67	17.97		80.0	
10502-AAA	LTE-TDD (SC-FDMA, 100% RB, 3 MHz, 64-QAM, UL Subframe=2,3,4,7,8,9)	X	5.46	74.43	19.15	2.23	80.0	± 9.6 %
		Y	4.98	72.05	18.20		80.0	
		Z	4.68	72.41	17.81		80.0	
10503-AAA	LTE-TDD (SC-FDMA, 100% RB, 5 MHz, QPSK, UL Subframe=2,3,4,7,8,9)	X	6.99	80.56	21.73	2.23	80.0	± 9.6 %
		Y	5.72	76.28	20.04		80.0	
		Z	5.42	76.98	20.27		80.0	
10504-AAA	LTE-TDD (SC-FDMA, 100% RB, 5 MHz, 16-QAM, UL Subframe=2,3,4,7,8,9)	X	5.31	73.78	19.39	2.23	80.0	± 9.6 %
		Y	4.98	71.79	18.52		80.0	
		Z	4.66	72.08	18.42		80.0	
10505-AAA	LTE-TDD (SC-FDMA, 100% RB, 5 MHz, 64-QAM, UL Subframe=2,3,4,7,8,9)	X	5.32	73.26	19.21	2.23	80.0	± 9.6 %
		Y	5.03	71.44	18.41		80.0	
		Z	4.72	71.78	18.31		80.0	
10506-AAA	LTE-TDD (SC-FDMA, 100% RB, 10 MHz, QPSK, UL Subframe=2,3,4,7,8,9)	X	7.35	79.52	21.23	2.23	80.0	± 9.6 %
		Y	6.24	75.99	19.82		80.0	
		Z	5.83	76.25	19.98		80.0	
10507-AAA	LTE-TDD (SC-FDMA, 100% RB, 10 MHz, 16-QAM, UL Subframe=2,3,4,7,8,9)	X	5.53	72.90	19.22	2.23	80.0	± 9.6 %
		Y	5.31	71.39	18.51		80.0	
		Z	4.95	71.42	18.47		80.0	

10508-AAA	LTE-TDD (SC-FDMA, 100% RB, 10 MHz, 64-QAM, UL Subframe=2,3,4,7,8,9)	X	5.52	72.31	19.02	2.23	80.0	± 9.6 %
		Y	5.35	70.96	18.38		80.0	
		Z	4.99	71.02	18.34		80.0	
10509-AAA	LTE-TDD (SC-FDMA, 100% RB, 15 MHz, QPSK, UL Subframe=2,3,4,7,8,9)	X	6.86	76.40	20.08	2.23	80.0	± 9.6 %
		Y	6.23	74.05	19.09		80.0	
		Z	5.83	74.13	19.18		80.0	
10510-AAA	LTE-TDD (SC-FDMA, 100% RB, 15 MHz, 16-QAM, UL Subframe=2,3,4,7,8,9)	X	5.89	72.04	18.91	2.23	80.0	± 9.6 %
		Y	5.75	70.91	18.36		80.0	
		Z	5.36	70.80	18.32		80.0	
10511-AAA	LTE-TDD (SC-FDMA, 100% RB, 15 MHz, 64-QAM, UL Subframe=2,3,4,7,8,9)	X	5.86	71.58	18.77	2.23	80.0	± 9.6 %
		Y	5.75	70.55	18.27		80.0	
		Z	5.39	70.48	18.23		80.0	
10512-AAA	LTE-TDD (SC-FDMA, 100% RB, 20 MHz, QPSK, UL Subframe=2,3,4,7,8,9)	X	7.85	79.24	20.97	2.23	80.0	± 9.6 %
		Y	6.75	76.04	19.69		80.0	
		Z	6.30	76.05	19.77		80.0	
10513-AAA	LTE-TDD (SC-FDMA, 100% RB, 20 MHz, 16-QAM, UL Subframe=2,3,4,7,8,9)	X	5.88	72.72	19.16	2.23	80.0	± 9.6 %
		Y	5.70	71.43	18.55		80.0	
		Z	5.29	71.21	18.47		80.0	
10514-AAA	LTE-TDD (SC-FDMA, 100% RB, 20 MHz, 64-QAM, UL Subframe=2,3,4,7,8,9)	X	5.77	72.00	18.94	2.23	80.0	± 9.6 %
		Y	5.64	70.86	18.38		80.0	
		Z	5.26	70.69	18.32		80.0	
10515-AAA	IEEE 802.11b WiFi 2.4 GHz (DSSS, 2 Mbps, 99pc duty cycle)	X	1.03	64.88	16.19	0.00	150.0	± 9.6 %
		Y	0.99	63.07	14.62		150.0	
		Z	0.99	63.20	14.56		150.0	
10516-AAA	IEEE 802.11b WiFi 2.4 GHz (DSSS, 5.5 Mbps, 99pc duty cycle)	X	1.64	91.04	26.85	0.00	150.0	± 9.6 %
		Y	0.59	69.22	16.60		150.0	
		Z	0.59	69.23	16.57		150.0	
10517-AAA	IEEE 802.11b WiFi 2.4 GHz (DSSS, 11 Mbps, 99pc duty cycle)	X	0.96	68.68	17.89	0.00	150.0	± 9.6 %
		Y	0.84	64.94	15.18		150.0	
		Z	0.84	64.94	15.09		150.0	
10518-AAA	IEEE 802.11a/h WiFi 5 GHz (OFDM, 9 Mbps, 99pc duty cycle)	X	4.73	67.22	16.54	0.00	150.0	± 9.6 %
		Y	4.75	66.79	16.24		150.0	
		Z	4.57	66.91	16.20		150.0	
10519-AAA	IEEE 802.11a/h WiFi 5 GHz (OFDM, 12 Mbps, 99pc duty cycle)	X	4.96	67.51	16.67	0.00	150.0	± 9.6 %
		Y	4.99	67.12	16.39		150.0	
		Z	4.76	67.15	16.33		150.0	
10520-AAA	IEEE 802.11a/h WiFi 5 GHz (OFDM, 18 Mbps, 99pc duty cycle)	X	4.82	67.52	16.62	0.00	150.0	± 9.6 %
		Y	4.84	67.09	16.32		150.0	
		Z	4.61	67.11	16.25		150.0	
10521-AAA	IEEE 802.11a/h WiFi 5 GHz (OFDM, 24 Mbps, 99pc duty cycle)	X	4.75	67.54	16.61	0.00	150.0	± 9.6 %
		Y	4.77	67.10	16.31		150.0	
		Z	4.54	67.10	16.23		150.0	
10522-AAA	IEEE 802.11a/h WiFi 5 GHz (OFDM, 36 Mbps, 99pc duty cycle)	X	4.79	67.47	16.62	0.00	150.0	± 9.6 %
		Y	4.80	67.00	16.30		150.0	
		Z	4.60	67.19	16.31		150.0	

10523-AAA	IEEE 802.11a/h WiFi 5 GHz (OFDM, 48 Mbps, 99pc duty cycle)	X	4.66	67.41	16.50	0.00	150.0	± 9.6 %
		Y	4.67	66.95	16.18		150.0	
		Z	4.48	67.04	16.16		150.0	
10524-AAA	IEEE 802.11a/h WiFi 5 GHz (OFDM, 54 Mbps, 99pc duty cycle)	X	4.74	67.44	16.62	0.00	150.0	± 9.6 %
		Y	4.76	66.99	16.31		150.0	
		Z	4.54	67.10	16.28		150.0	
10525-AAA	IEEE 802.11ac WiFi (20MHz, MCS0, 99pc duty cycle)	X	4.69	66.48	16.21	0.00	150.0	± 9.6 %
		Y	4.70	66.02	15.89		150.0	
		Z	4.53	66.15	15.87		150.0	
10526-AAA	IEEE 802.11ac WiFi (20MHz, MCS1, 99pc duty cycle)	X	4.91	66.90	16.35	0.00	150.0	± 9.6 %
		Y	4.91	66.43	16.04		150.0	
		Z	4.70	66.52	16.01		150.0	
10527-AAA	IEEE 802.11ac WiFi (20MHz, MCS2, 99pc duty cycle)	X	4.82	66.89	16.32	0.00	150.0	± 9.6 %
		Y	4.83	66.42	16.00		150.0	
		Z	4.62	66.47	15.95		150.0	
10528-AAA	IEEE 802.11ac WiFi (20MHz, MCS3, 99pc duty cycle)	X	4.84	66.91	16.35	0.00	150.0	± 9.6 %
		Y	4.85	66.44	16.03		150.0	
		Z	4.63	66.49	15.99		150.0	
10529-AAA	IEEE 802.11ac WiFi (20MHz, MCS4, 99pc duty cycle)	X	4.84	66.91	16.35	0.00	150.0	± 9.6 %
		Y	4.85	66.44	16.03		150.0	
		Z	4.63	66.49	15.99		150.0	
10531-AAA	IEEE 802.11ac WiFi (20MHz, MCS6, 99pc duty cycle)	X	4.86	67.08	16.39	0.00	150.0	± 9.6 %
		Y	4.87	66.60	16.06		150.0	
		Z	4.63	66.60	16.00		150.0	
10532-AAA	IEEE 802.11ac WiFi (20MHz, MCS7, 99pc duty cycle)	X	4.71	66.97	16.35	0.00	150.0	± 9.6 %
		Y	4.72	66.49	16.02		150.0	
		Z	4.49	66.45	15.93		150.0	
10533-AAA	IEEE 802.11ac WiFi (20MHz, MCS8, 99pc duty cycle)	X	4.86	66.93	16.33	0.00	150.0	± 9.6 %
		Y	4.87	66.45	16.01		150.0	
		Z	4.64	66.54	15.97		150.0	
10534-AAA	IEEE 802.11ac WiFi (40MHz, MCS0, 99pc duty cycle)	X	5.34	67.03	16.36	0.00	150.0	± 9.6 %
		Y	5.36	66.66	16.11		150.0	
		Z	5.17	66.62	16.06		150.0	
10535-AAA	IEEE 802.11ac WiFi (40MHz, MCS1, 99pc duty cycle)	X	5.42	67.17	16.42	0.00	150.0	± 9.6 %
		Y	5.43	66.80	16.16		150.0	
		Z	5.24	66.80	16.14		150.0	
10536-AAA	IEEE 802.11ac WiFi (40MHz, MCS2, 99pc duty cycle)	X	5.29	67.18	16.41	0.00	150.0	± 9.6 %
		Y	5.30	66.78	16.13		150.0	
		Z	5.11	66.74	16.09		150.0	
10537-AAA	IEEE 802.11ac WiFi (40MHz, MCS3, 99pc duty cycle)	X	5.35	67.14	16.39	0.00	150.0	± 9.6 %
		Y	5.36	66.75	16.12		150.0	
		Z	5.16	66.71	16.08		150.0	
10538-AAA	IEEE 802.11ac WiFi (40MHz, MCS4, 99pc duty cycle)	X	5.47	67.20	16.46	0.00	150.0	± 9.6 %
		Y	5.49	66.85	16.21		150.0	
		Z	5.26	66.74	16.13		150.0	
10540-AAA	IEEE 802.11ac WiFi (40MHz, MCS6, 99pc duty cycle)	X	5.36	67.15	16.45	0.00	150.0	± 9.6 %
		Y	5.38	66.77	16.18		150.0	
		Z	5.19	66.76	16.16		150.0	

10541-AAA	IEEE 802.11ac WiFi (40MHz, MCS7, 99pc duty cycle)	X	5.35	67.08	16.42	0.00	150.0	± 9.6 %
		Y	5.38	66.75	16.17		150.0	
		Z	5.16	66.62	16.08		150.0	
10542-AAA	IEEE 802.11ac WiFi (40MHz, MCS8, 99pc duty cycle)	X	5.49	67.08	16.42	0.00	150.0	± 9.6 %
		Y	5.51	66.73	16.18		150.0	
		Z	5.31	66.69	16.13		150.0	
10543-AAA	IEEE 802.11ac WiFi (40MHz, MCS9, 99pc duty cycle)	X	5.58	67.09	16.44	0.00	150.0	± 9.6 %
		Y	5.61	66.77	16.21		150.0	
		Z	5.39	66.74	16.17		150.0	
10544-AAA	IEEE 802.11ac WiFi (80MHz, MCS0, 99pc duty cycle)	X	5.61	67.12	16.33	0.00	150.0	± 9.6 %
		Y	5.62	66.77	16.09		150.0	
		Z	5.48	66.74	16.05		150.0	
10545-AAA	IEEE 802.11ac WiFi (80MHz, MCS1, 99pc duty cycle)	X	5.83	67.51	16.46	0.00	150.0	± 9.6 %
		Y	5.84	67.15	16.22		150.0	
		Z	5.68	67.16	16.22		150.0	
10546-AAA	IEEE 802.11ac WiFi (80MHz, MCS2, 99pc duty cycle)	X	5.72	67.42	16.44	0.00	150.0	± 9.6 %
		Y	5.73	67.08	16.20		150.0	
		Z	5.55	66.95	16.13		150.0	
10547-AAA	IEEE 802.11ac WiFi (80MHz, MCS3, 99pc duty cycle)	X	5.81	67.48	16.46	0.00	150.0	± 9.6 %
		Y	5.83	67.17	16.24		150.0	
		Z	5.62	66.99	16.14		150.0	
10548-AAA	IEEE 802.11ac WiFi (80MHz, MCS4, 99pc duty cycle)	X	6.10	68.50	16.94	0.00	150.0	± 9.6 %
		Y	6.15	68.24	16.74		150.0	
		Z	5.89	67.98	16.61		150.0	
10550-AAA	IEEE 802.11ac WiFi (80MHz, MCS6, 99pc duty cycle)	X	5.74	67.36	16.42	0.00	150.0	± 9.6 %
		Y	5.75	67.01	16.18		150.0	
		Z	5.57	66.96	16.14		150.0	
10551-AAA	IEEE 802.11ac WiFi (80MHz, MCS7, 99pc duty cycle)	X	5.76	67.47	16.43	0.00	150.0	± 9.6 %
		Y	5.78	67.14	16.20		150.0	
		Z	5.58	67.00	16.12		150.0	
10552-AAA	IEEE 802.11ac WiFi (80MHz, MCS8, 99pc duty cycle)	X	5.66	67.23	16.33	0.00	150.0	± 9.6 %
		Y	5.67	66.89	16.10		150.0	
		Z	5.49	66.80	16.03		150.0	
10553-AAA	IEEE 802.11ac WiFi (80MHz, MCS9, 99pc duty cycle)	X	5.75	67.26	16.37	0.00	150.0	± 9.6 %
		Y	5.76	66.93	16.14		150.0	
		Z	5.58	66.84	16.08		150.0	
10554-AAA	IEEE 1602.11ac WiFi (160MHz, MCS0, 99pc duty cycle)	X	6.01	67.49	16.42	0.00	150.0	± 9.6 %
		Y	6.02	67.17	16.20		150.0	
		Z	5.89	67.10	16.15		150.0	
10555-AAA	IEEE 1602.11ac WiFi (160MHz, MCS1, 99pc duty cycle)	X	6.17	67.85	16.56	0.00	150.0	± 9.6 %
		Y	6.20	67.56	16.36		150.0	
		Z	6.02	67.41	16.28		150.0	
10556-AAA	IEEE 1602.11ac WiFi (160MHz, MCS2, 99pc duty cycle)	X	6.18	67.83	16.55	0.00	150.0	± 9.6 %
		Y	6.19	67.51	16.33		150.0	
		Z	6.04	67.46	16.30		150.0	
10557-AAA	IEEE 1602.11ac WiFi (160MHz, MCS3, 99pc duty cycle)	X	6.17	67.82	16.57	0.00	150.0	± 9.6 %
		Y	6.19	67.52	16.36		150.0	
		Z	6.00	67.36	16.27		150.0	

10558-AAA	IEEE 1602.11ac WiFi (160MHz, MCS4, 99pc duty cycle)	X	6.23	68.01	16.68	0.00	150.0	± 9.6 %
		Y	6.25	67.72	16.47		150.0	
		Z	6.05	67.53	16.37		150.0	
10560-AAA	IEEE 1602.11ac WiFi (160MHz, MCS6, 99pc duty cycle)	X	6.22	67.85	16.63	0.00	150.0	± 9.6 %
		Y	6.25	67.56	16.43		150.0	
		Z	6.05	67.37	16.33		150.0	
10561-AAA	IEEE 1602.11ac WiFi (160MHz, MCS7, 99pc duty cycle)	X	6.13	67.79	16.64	0.00	150.0	± 9.6 %
		Y	6.15	67.49	16.43		150.0	
		Z	5.97	67.35	16.35		150.0	
10562-AAA	IEEE 1602.11ac WiFi (160MHz, MCS8, 99pc duty cycle)	X	6.29	68.28	16.89	0.00	150.0	± 9.6 %
		Y	6.33	68.01	16.70		150.0	
		Z	6.10	67.74	16.55		150.0	
10563-AAA	IEEE 1602.11ac WiFi (160MHz, MCS9, 99pc duty cycle)	X	6.57	68.63	17.00	0.00	150.0	± 9.6 %
		Y	6.57	68.27	16.77		150.0	
		Z	6.35	68.10	16.68		150.0	
10564-AAA	IEEE 802.11g WiFi 2.4 GHz (DSSS-OFDM, 9 Mbps, 99pc duty cycle)	X	5.07	67.31	16.69	0.46	150.0	± 9.6 %
		Y	5.10	66.95	16.44		150.0	
		Z	4.91	67.04	16.40		150.0	
10565-AAA	IEEE 802.11g WiFi 2.4 GHz (DSSS-OFDM, 12 Mbps, 99pc duty cycle)	X	5.34	67.80	17.01	0.46	150.0	± 9.6 %
		Y	5.38	67.46	16.78		150.0	
		Z	5.14	67.47	16.71		150.0	
10566-AAA	IEEE 802.11g WiFi 2.4 GHz (DSSS-OFDM, 18 Mbps, 99pc duty cycle)	X	5.17	67.69	16.85	0.46	150.0	± 9.6 %
		Y	5.21	67.33	16.61		150.0	
		Z	4.97	67.33	16.54		150.0	
10567-AAA	IEEE 802.11g WiFi 2.4 GHz (DSSS-OFDM, 24 Mbps, 99pc duty cycle)	X	5.20	68.09	17.20	0.46	150.0	± 9.6 %
		Y	5.23	67.71	16.94		150.0	
		Z	5.00	67.68	16.86		150.0	
10568-AAA	IEEE 802.11g WiFi 2.4 GHz (DSSS-OFDM, 36 Mbps, 99pc duty cycle)	X	5.08	67.38	16.59	0.46	150.0	± 9.6 %
		Y	5.11	67.01	16.33		150.0	
		Z	4.90	67.16	16.34		150.0	
10569-AAA	IEEE 802.11g WiFi 2.4 GHz (DSSS-OFDM, 48 Mbps, 99pc duty cycle)	X	5.14	68.11	17.22	0.46	150.0	± 9.6 %
		Y	5.16	67.71	16.95		150.0	
		Z	4.96	67.77	16.91		150.0	
10570-AAA	IEEE 802.11g WiFi 2.4 GHz (DSSS-OFDM, 54 Mbps, 99pc duty cycle)	X	5.18	67.92	17.15	0.46	150.0	± 9.6 %
		Y	5.21	67.52	16.88		150.0	
		Z	4.99	67.63	16.86		150.0	
10571-AAA	IEEE 802.11b WiFi 2.4 GHz (DSSS, 1 Mbps, 90pc duty cycle)	X	1.45	67.97	17.69	0.46	130.0	± 9.6 %
		Y	1.38	65.84	16.15		130.0	
		Z	1.34	65.80	16.05		130.0	
10572-AAA	IEEE 802.11b WiFi 2.4 GHz (DSSS, 2 Mbps, 90pc duty cycle)	X	1.49	68.86	18.18	0.46	130.0	± 9.6 %
		Y	1.40	66.47	16.51		130.0	
		Z	1.36	66.39	16.40		130.0	
10573-AAA	IEEE 802.11b WiFi 2.4 GHz (DSSS, 5.5 Mbps, 90pc duty cycle)	X	100.00	149.30	40.22	0.46	130.0	± 9.6 %
		Y	3.11	88.03	23.54		130.0	
		Z	3.23	89.37	24.00		130.0	
10574-AAA	IEEE 802.11b WiFi 2.4 GHz (DSSS, 11 Mbps, 90pc duty cycle)	X	2.21	80.01	23.13	0.46	130.0	± 9.6 %
		Y	1.65	72.75	19.44		130.0	
		Z	1.56	72.33	19.21		130.0	

10575-AAA	IEEE 802.11g WiFi 2.4 GHz (DSSS-OFDM, 6 Mbps, 90pc duty cycle)	X	4.88	67.15	16.77	0.46	130.0	± 9.6 %
		Y	4.92	66.81	16.54		130.0	
		Z	4.73	66.93	16.51		130.0	
10576-AAA	IEEE 802.11g WiFi 2.4 GHz (DSSS-OFDM, 9 Mbps, 90pc duty cycle)	X	4.91	67.32	16.84	0.46	130.0	± 9.6 %
		Y	4.94	66.97	16.61		130.0	
		Z	4.75	67.08	16.56		130.0	
10577-AAA	IEEE 802.11g WiFi 2.4 GHz (DSSS-OFDM, 12 Mbps, 90pc duty cycle)	X	5.15	67.65	17.01	0.46	130.0	± 9.6 %
		Y	5.20	67.33	16.79		130.0	
		Z	4.96	67.36	16.73		130.0	
10578-AAA	IEEE 802.11g WiFi 2.4 GHz (DSSS-OFDM, 18 Mbps, 90pc duty cycle)	X	5.05	67.86	17.13	0.46	130.0	± 9.6 %
		Y	5.09	67.50	16.89		130.0	
		Z	4.85	67.51	16.82		130.0	
10579-AAA	IEEE 802.11g WiFi 2.4 GHz (DSSS-OFDM, 24 Mbps, 90pc duty cycle)	X	4.82	67.24	16.51	0.46	130.0	± 9.6 %
		Y	4.87	66.90	16.27		130.0	
		Z	4.63	66.89	16.19		130.0	
10580-AAA	IEEE 802.11g WiFi 2.4 GHz (DSSS-OFDM, 36 Mbps, 90pc duty cycle)	X	4.86	67.17	16.48	0.46	130.0	± 9.6 %
		Y	4.91	66.83	16.25		130.0	
		Z	4.68	66.92	16.22		130.0	
10581-AAA	IEEE 802.11g WiFi 2.4 GHz (DSSS-OFDM, 48 Mbps, 90pc duty cycle)	X	4.96	67.97	17.11	0.46	130.0	± 9.6 %
		Y	5.00	67.61	16.86		130.0	
		Z	4.76	67.57	16.77		130.0	
10582-AAA	IEEE 802.11g WiFi 2.4 GHz (DSSS-OFDM, 54 Mbps, 90pc duty cycle)	X	4.78	66.97	16.29	0.46	130.0	± 9.6 %
		Y	4.83	66.64	16.06		130.0	
		Z	4.58	66.67	16.00		130.0	
10583-AAA	IEEE 802.11a/h WiFi 5 GHz (OFDM, 6 Mbps, 90pc duty cycle)	X	4.88	67.15	16.77	0.46	130.0	± 9.6 %
		Y	4.92	66.81	16.54		130.0	
		Z	4.73	66.93	16.51		130.0	
10584-AAA	IEEE 802.11a/h WiFi 5 GHz (OFDM, 9 Mbps, 90pc duty cycle)	X	4.91	67.32	16.84	0.46	130.0	± 9.6 %
		Y	4.94	66.97	16.61		130.0	
		Z	4.75	67.08	16.56		130.0	
10585-AAA	IEEE 802.11a/h WiFi 5 GHz (OFDM, 12 Mbps, 90pc duty cycle)	X	5.15	67.65	17.01	0.46	130.0	± 9.6 %
		Y	5.20	67.33	16.79		130.0	
		Z	4.96	67.36	16.73		130.0	
10586-AAA	IEEE 802.11a/h WiFi 5 GHz (OFDM, 18 Mbps, 90pc duty cycle)	X	5.05	67.86	17.13	0.46	130.0	± 9.6 %
		Y	5.09	67.50	16.89		130.0	
		Z	4.85	67.51	16.82		130.0	
10587-AAA	IEEE 802.11a/h WiFi 5 GHz (OFDM, 24 Mbps, 90pc duty cycle)	X	4.82	67.24	16.51	0.46	130.0	± 9.6 %
		Y	4.87	66.90	16.27		130.0	
		Z	4.63	66.89	16.19		130.0	
10588-AAA	IEEE 802.11a/h WiFi 5 GHz (OFDM, 36 Mbps, 90pc duty cycle)	X	4.86	67.17	16.48	0.46	130.0	± 9.6 %
		Y	4.91	66.83	16.25		130.0	
		Z	4.68	66.92	16.22		130.0	
10589-AAA	IEEE 802.11a/h WiFi 5 GHz (OFDM, 48 Mbps, 90pc duty cycle)	X	4.96	67.97	17.11	0.46	130.0	± 9.6 %
		Y	5.00	67.61	16.86		130.0	
		Z	4.76	67.57	16.77		130.0	
10590-AAA	IEEE 802.11a/h WiFi 5 GHz (OFDM, 54 Mbps, 90pc duty cycle)	X	4.78	66.97	16.29	0.46	130.0	± 9.6 %
		Y	4.83	66.64	16.06		130.0	
		Z	4.58	66.67	16.00		130.0	

10591-AAA	IEEE 802.11n (HT Mixed, 20MHz, MCS0, 90pc duty cycle)	X	5.03	67.20	16.86	0.46	130.0	± 9.6 %
		Y	5.07	66.88	16.64		130.0	
		Z	4.88	66.97	16.60		130.0	
10592-AAA	IEEE 802.11n (HT Mixed, 20MHz, MCS1, 90pc duty cycle)	X	5.21	67.55	16.98	0.46	130.0	± 9.6 %
		Y	5.26	67.23	16.76		130.0	
		Z	5.03	67.30	16.73		130.0	
10593-AAA	IEEE 802.11n (HT Mixed, 20MHz, MCS2, 90pc duty cycle)	X	5.14	67.52	16.89	0.46	130.0	± 9.6 %
		Y	5.19	67.20	16.68		130.0	
		Z	4.96	67.23	16.62		130.0	
10594-AAA	IEEE 802.11n (HT Mixed, 20MHz, MCS3, 90pc duty cycle)	X	5.19	67.66	17.03	0.46	130.0	± 9.6 %
		Y	5.24	67.33	16.81		130.0	
		Z	5.01	67.38	16.76		130.0	
10595-AAA	IEEE 802.11n (HT Mixed, 20MHz, MCS4, 90pc duty cycle)	X	5.17	67.65	16.95	0.46	130.0	± 9.6 %
		Y	5.23	67.33	16.73		130.0	
		Z	4.98	67.35	16.67		130.0	
10596-AAA	IEEE 802.11n (HT Mixed, 20MHz, MCS5, 90pc duty cycle)	X	5.11	67.64	16.94	0.46	130.0	± 9.6 %
		Y	5.16	67.30	16.71		130.0	
		Z	4.92	67.35	16.67		130.0	
10597-AAA	IEEE 802.11n (HT Mixed, 20MHz, MCS6, 90pc duty cycle)	X	5.06	67.59	16.86	0.46	130.0	± 9.6 %
		Y	5.11	67.26	16.64		130.0	
		Z	4.87	67.26	16.56		130.0	
10598-AAA	IEEE 802.11n (HT Mixed, 20MHz, MCS7, 90pc duty cycle)	X	5.05	67.87	17.14	0.46	130.0	± 9.6 %
		Y	5.09	67.53	16.91		130.0	
		Z	4.85	67.47	16.80		130.0	
10599-AAA	IEEE 802.11n (HT Mixed, 40MHz, MCS0, 90pc duty cycle)	X	5.68	67.76	17.01	0.46	130.0	± 9.6 %
		Y	5.74	67.54	16.84		130.0	
		Z	5.54	67.51	16.80		130.0	
10600-AAA	IEEE 802.11n (HT Mixed, 40MHz, MCS1, 90pc duty cycle)	X	5.91	68.42	17.31	0.46	130.0	± 9.6 %
		Y	6.00	68.29	17.19		130.0	
		Z	5.69	67.96	17.01		130.0	
10601-AAA	IEEE 802.11n (HT Mixed, 40MHz, MCS2, 90pc duty cycle)	X	5.75	68.03	17.13	0.46	130.0	± 9.6 %
		Y	5.81	67.81	16.96		130.0	
		Z	5.57	67.70	16.89		130.0	
10602-AAA	IEEE 802.11n (HT Mixed, 40MHz, MCS3, 90pc duty cycle)	X	5.85	68.05	17.05	0.46	130.0	± 9.6 %
		Y	5.93	67.91	16.93		130.0	
		Z	5.67	67.73	16.83		130.0	
10603-AAA	IEEE 802.11n (HT Mixed, 40MHz, MCS4, 90pc duty cycle)	X	5.97	68.46	17.38	0.46	130.0	± 9.6 %
		Y	6.05	68.29	17.25		130.0	
		Z	5.74	68.01	17.09		130.0	
10604-AAA	IEEE 802.11n (HT Mixed, 40MHz, MCS5, 90pc duty cycle)	X	5.70	67.75	17.03	0.46	130.0	± 9.6 %
		Y	5.76	67.53	16.86		130.0	
		Z	5.55	67.48	16.81		130.0	
10605-AAA	IEEE 802.11n (HT Mixed, 40MHz, MCS6, 90pc duty cycle)	X	5.80	68.03	17.16	0.46	130.0	± 9.6 %
		Y	5.86	67.81	17.00		130.0	
		Z	5.67	67.84	17.00		130.0	
10606-AAA	IEEE 802.11n (HT Mixed, 40MHz, MCS7, 90pc duty cycle)	X	5.58	67.53	16.79	0.46	130.0	± 9.6 %
		Y	5.62	67.26	16.60		130.0	
		Z	5.41	67.19	16.54		130.0	

10607-AAA	IEEE 802.11ac WiFi (20MHz, MCS0, 90pc duty cycle)	X	4.86	66.52	16.48	0.46	130.0	± 9.6 %
		Y	4.89	66.14	16.23		130.0	
		Z	4.71	66.27	16.21		130.0	
10608-AAA	IEEE 802.11ac WiFi (20MHz, MCS1, 90pc duty cycle)	X	5.09	66.96	16.64	0.46	130.0	± 9.6 %
		Y	5.12	66.58	16.39		130.0	
		Z	4.90	66.67	16.37		130.0	
10609-AAA	IEEE 802.11ac WiFi (20MHz, MCS2, 90pc duty cycle)	X	4.98	66.85	16.52	0.46	130.0	± 9.6 %
		Y	5.01	66.47	16.26		130.0	
		Z	4.79	66.53	16.22		130.0	
10610-AAA	IEEE 802.11ac WiFi (20MHz, MCS3, 90pc duty cycle)	X	5.03	67.01	16.67	0.46	130.0	± 9.6 %
		Y	5.06	66.63	16.42		130.0	
		Z	4.84	66.68	16.37		130.0	
10611-AAA	IEEE 802.11ac WiFi (20MHz, MCS4, 90pc duty cycle)	X	4.96	66.86	16.54	0.46	130.0	± 9.6 %
		Y	4.99	66.50	16.29		130.0	
		Z	4.76	66.50	16.23		130.0	
10612-AAA	IEEE 802.11ac WiFi (20MHz, MCS5, 90pc duty cycle)	X	4.97	67.00	16.58	0.46	130.0	± 9.6 %
		Y	5.01	66.61	16.31		130.0	
		Z	4.77	66.66	16.28		130.0	
10613-AAA	IEEE 802.11ac WiFi (20MHz, MCS6, 90pc duty cycle)	X	4.99	66.94	16.49	0.46	130.0	± 9.6 %
		Y	5.03	66.55	16.23		130.0	
		Z	4.77	66.56	16.17		130.0	
10614-AAA	IEEE 802.11ac WiFi (20MHz, MCS7, 90pc duty cycle)	X	4.92	67.15	16.73	0.46	130.0	± 9.6 %
		Y	4.95	66.76	16.47		130.0	
		Z	4.71	66.71	16.38		130.0	
10615-AAA	IEEE 802.11ac WiFi (20MHz, MCS8, 90pc duty cycle)	X	4.95	66.65	16.31	0.46	130.0	± 9.6 %
		Y	4.99	66.28	16.06		130.0	
		Z	4.76	66.36	16.03		130.0	
10616-AAA	IEEE 802.11ac WiFi (40MHz, MCS0, 90pc duty cycle)	X	5.51	67.07	16.65	0.46	130.0	± 9.6 %
		Y	5.55	66.78	16.45		130.0	
		Z	5.35	66.74	16.40		130.0	
10617-AAA	IEEE 802.11ac WiFi (40MHz, MCS1, 90pc duty cycle)	X	5.58	67.18	16.67	0.46	130.0	± 9.6 %
		Y	5.62	66.89	16.46		130.0	
		Z	5.43	66.92	16.46		130.0	
10618-AAA	IEEE 802.11ac WiFi (40MHz, MCS2, 90pc duty cycle)	X	5.47	67.27	16.74	0.46	130.0	± 9.6 %
		Y	5.50	66.95	16.52		130.0	
		Z	5.31	66.92	16.47		130.0	
10619-AAA	IEEE 802.11ac WiFi (40MHz, MCS3, 90pc duty cycle)	X	5.49	67.07	16.57	0.46	130.0	± 9.6 %
		Y	5.52	66.76	16.36		130.0	
		Z	5.33	66.76	16.33		130.0	
10620-AAA	IEEE 802.11ac WiFi (40MHz, MCS4, 90pc duty cycle)	X	5.62	67.19	16.68	0.46	130.0	± 9.6 %
		Y	5.67	66.93	16.49		130.0	
		Z	5.42	66.79	16.40		130.0	
10621-AAA	IEEE 802.11ac WiFi (40MHz, MCS5, 90pc duty cycle)	X	5.59	67.25	16.82	0.46	130.0	± 9.6 %
		Y	5.63	66.98	16.62		130.0	
		Z	5.41	66.88	16.56		130.0	
10622-AAA	IEEE 802.11ac WiFi (40MHz, MCS6, 90pc duty cycle)	X	5.58	67.35	16.86	0.46	130.0	± 9.6 %
		Y	5.62	67.06	16.66		130.0	
		Z	5.43	67.06	16.64		130.0	

10623-AAA	IEEE 802.11ac WiFi (40MHz, MCS7, 90pc duty cycle)	X	5.48	66.99	16.57	0.46	130.0	± 9.6 %
		Y	5.54	66.75	16.40		130.0	
		Z	5.31	66.61	16.29		130.0	
10624-AAA	IEEE 802.11ac WiFi (40MHz, MCS8, 90pc duty cycle)	X	5.65	67.09	16.68	0.46	130.0	± 9.6 %
		Y	5.69	66.81	16.49		130.0	
		Z	5.50	66.79	16.45		130.0	
10625-AAA	IEEE 802.11ac WiFi (40MHz, MCS9, 90pc duty cycle)	X	6.03	68.01	17.18	0.46	130.0	± 9.6 %
		Y	6.05	67.65	16.95		130.0	
		Z	5.88	67.81	17.01		130.0	
10626-AAA	IEEE 802.11ac WiFi (80MHz, MCS0, 90pc duty cycle)	X	5.76	67.09	16.57	0.46	130.0	± 9.6 %
		Y	5.79	66.81	16.38		130.0	
		Z	5.64	66.79	16.35		130.0	
10627-AAA	IEEE 802.11ac WiFi (80MHz, MCS1, 90pc duty cycle)	X	6.01	67.60	16.77	0.46	130.0	± 9.6 %
		Y	6.04	67.32	16.58		130.0	
		Z	5.89	67.37	16.60		130.0	
10628-AAA	IEEE 802.11ac WiFi (80MHz, MCS2, 90pc duty cycle)	X	5.83	67.28	16.56	0.46	130.0	± 9.6 %
		Y	5.87	67.01	16.37		130.0	
		Z	5.69	66.92	16.32		130.0	
10629-AAA	IEEE 802.11ac WiFi (80MHz, MCS3, 90pc duty cycle)	X	5.93	67.36	16.58	0.46	130.0	± 9.6 %
		Y	5.99	67.16	16.43		130.0	
		Z	5.77	67.00	16.35		130.0	
10630-AAA	IEEE 802.11ac WiFi (80MHz, MCS4, 90pc duty cycle)	X	6.47	69.11	17.45	0.46	130.0	± 9.6 %
		Y	6.56	68.99	17.34		130.0	
		Z	6.24	68.58	17.14		130.0	
10631-AAA	IEEE 802.11ac WiFi (80MHz, MCS5, 90pc duty cycle)	X	6.36	68.89	17.53	0.46	130.0	± 9.6 %
		Y	6.44	68.71	17.39		130.0	
		Z	6.09	68.24	17.15		130.0	
10632-AAA	IEEE 802.11ac WiFi (80MHz, MCS6, 90pc duty cycle)	X	6.00	67.73	16.97	0.46	130.0	± 9.6 %
		Y	6.05	67.48	16.79		130.0	
		Z	5.85	67.39	16.74		130.0	
10633-AAA	IEEE 802.11ac WiFi (80MHz, MCS7, 90pc duty cycle)	X	5.95	67.59	16.73	0.46	130.0	± 9.6 %
		Y	6.01	67.38	16.58		130.0	
		Z	5.74	67.05	16.41		130.0	
10634-AAA	IEEE 802.11ac WiFi (80MHz, MCS8, 90pc duty cycle)	X	5.92	67.56	16.78	0.46	130.0	± 9.6 %
		Y	5.98	67.34	16.62		130.0	
		Z	5.72	67.07	16.47		130.0	
10635-AAA	IEEE 802.11ac WiFi (80MHz, MCS9, 90pc duty cycle)	X	5.80	66.87	16.18	0.46	130.0	± 9.6 %
		Y	5.85	66.64	16.01		130.0	
		Z	5.62	66.48	15.93		130.0	
10636-AAA	IEEE 1602.11ac WiFi (160MHz, MCS0, 90pc duty cycle)	X	6.16	67.47	16.65	0.46	130.0	± 9.6 %
		Y	6.19	67.22	16.49		130.0	
		Z	6.06	67.16	16.44		130.0	
10637-AAA	IEEE 1602.11ac WiFi (160MHz, MCS1, 90pc duty cycle)	X	6.34	67.89	16.84	0.46	130.0	± 9.6 %
		Y	6.39	67.69	16.69		130.0	
		Z	6.22	67.55	16.62		130.0	
10638-AAA	IEEE 1602.11ac WiFi (160MHz, MCS2, 90pc duty cycle)	X	6.33	67.82	16.78	0.46	130.0	± 9.6 %
		Y	6.36	67.57	16.61		130.0	
		Z	6.21	67.52	16.58		130.0	

10639-AAA	IEEE 1602.11ac WiFi (160MHz, MCS3, 90pc duty cycle)	X	6.34	67.88	16.86	0.46	130.0	± 9.6 %
		Y	6.38	67.64	16.70		130.0	
		Z	6.19	67.47	16.60		130.0	
10640-AAA	IEEE 1602.11ac WiFi (160MHz, MCS4, 90pc duty cycle)	X	6.37	67.96	16.84	0.46	130.0	± 9.6 %
		Y	6.42	67.75	16.69		130.0	
		Z	6.20	67.51	16.57		130.0	
10641-AAA	IEEE 1602.11ac WiFi (160MHz, MCS5, 90pc duty cycle)	X	6.36	67.66	16.71	0.46	130.0	± 9.6 %
		Y	6.40	67.44	16.56		130.0	
		Z	6.24	67.40	16.53		130.0	
10642-AAA	IEEE 1602.11ac WiFi (160MHz, MCS6, 90pc duty cycle)	X	6.44	68.03	17.05	0.46	130.0	± 9.6 %
		Y	6.49	67.81	16.91		130.0	
		Z	6.28	67.62	16.80		130.0	
10643-AAA	IEEE 1602.11ac WiFi (160MHz, MCS7, 90pc duty cycle)	X	6.26	67.70	16.80	0.46	130.0	± 9.6 %
		Y	6.31	67.48	16.64		130.0	
		Z	6.12	67.34	16.57		130.0	
10644-AAA	IEEE 1602.11ac WiFi (160MHz, MCS8, 90pc duty cycle)	X	6.50	68.41	17.18	0.46	130.0	± 9.6 %
		Y	6.57	68.25	17.05		130.0	
		Z	6.29	67.86	16.85		130.0	
10645-AAA	IEEE 1602.11ac WiFi (160MHz, MCS9, 90pc duty cycle)	X	6.78	68.77	17.29	0.46	130.0	± 9.6 %
		Y	6.81	68.48	17.11		130.0	
		Z	6.68	68.60	17.18		130.0	
10646-AAB	LTE-TDD (SC-FDMA, 1 RB, 5 MHz, QPSK, UL Subframe=2,7)	X	37.14	116.21	38.03	9.30	60.0	± 9.6 %
		Y	19.95	100.33	33.06		60.0	
		Z	62.05	131.91	43.22		60.0	
10647-AAA	LTE-TDD (SC-FDMA, 1 RB, 20 MHz, QPSK, UL Subframe=2,7)	X	38.52	117.84	38.64	9.30	60.0	± 9.6 %
		Y	20.25	101.35	33.50		60.0	
		Z	63.43	133.45	43.81		60.0	
10648-AAA	CDMA2000 (1x Advanced)	X	1.03	68.68	14.68	0.00	150.0	± 9.6 %
		Y	0.85	64.54	12.30		150.0	
		Z	0.71	63.65	10.90		150.0	

<sup>E</sup> Uncertainty is determined using the max. deviation from linear response applying rectangular distribution and is expressed for the square of the field value.



Accredited by the Swiss Accreditation Service (SAS)  
The Swiss Accreditation Service is one of the signatories to the EA  
Multilateral Agreement for the recognition of calibration certificates

Accreditation No.: **SCS 0108**

Client **PC Test**

Certificate No: **EX3-7409\_May16**

**CALIBRATION CERTIFICATE**

Object **EX3DV4 - SN:7409**

Calibration procedure(s) **QA CAL-01.v9, QA CAL-23.v5, QA CAL-25.v6**  
**Calibration procedure for dosimetric E-field probes**

Calibration date: **May 17, 2016**

This calibration certificate documents the traceability to national standards, which realize the physical units of measurements (SI).  
The measurements and the uncertainties with confidence probability are given on the following pages and are part of the certificate.

All calibrations have been conducted in the closed laboratory facility: environment temperature (22 ± 3)°C and humidity < 70%.

Calibration Equipment used (M&TE critical for calibration)

*BN ✓  
05/23/16*

Primary Standards	ID	Cal Date (Certificate No.)	Scheduled Calibration
Power meter NRP	SN: 104778	06-Apr-16 (No. 217-02288/02289)	Apr-17
Power sensor NRP-Z91	SN: 103244	06-Apr-16 (No. 217-02288)	Apr-17
Power sensor NRP-Z91	SN: 103245	06-Apr-16 (No. 217-02289)	Apr-17
Reference 20 dB Attenuator	SN: S5277 (20x)	05-Apr-16 (No. 217-02293)	Apr-17
Reference Probe ES3DV2	SN: 3013	31-Dec-15 (No. ES3-3013_Dec15)	Dec-16
DAE4	SN: 660	23-Dec-15 (No. DAE4-660_Dec15)	Dec-16
Secondary Standards	ID	Check Date (in house)	Scheduled Check
Power meter E4419B	SN: GB41293874	06-Apr-16 (No. 217-02285/02284)	In house check: Jun-16
Power sensor E4412A	SN: MY41498087	06-Apr-16 (No. 217-02285)	In house check: Jun-16
Power sensor E4412A	SN: 000110210	06-Apr-16 (No. 217-02284)	In house check: Jun-16
RF generator HP 8648C	SN: US3642U01700	04-Aug-99 (in house check Apr-13)	In house check: Jun-16
Network Analyzer HP 8753E	SN: US37390585	18-Oct-01 (in house check Oct-15)	In house check: Oct-16

Calibrated by:	Name <b>Michael Weber</b>	Function <b>Laboratory Technician</b>	Signature <i>M. Weber</i>
Approved by:	Name <b>Katja Pokovic</b>	Function <b>Technical Manager</b>	Signature <i>Katja Pokovic</i>
			Issued: May 18, 2016

This calibration certificate shall not be reproduced except in full without written approval of the laboratory.



Accredited by the Swiss Accreditation Service (SAS)

Accreditation No.: **SCS 0108**

The Swiss Accreditation Service is one of the signatories to the EA  
Multilateral Agreement for the recognition of calibration certificates

**Glossary:**

TSL	tissue simulating liquid
NORM <sub>x,y,z</sub>	sensitivity in free space
ConvF	sensitivity in TSL / NORM <sub>x,y,z</sub>
DCP	diode compression point
CF	crest factor (1/duty_cycle) of the RF signal
A, B, C, D	modulation dependent linearization parameters
Polarization $\varphi$	$\varphi$ rotation around probe axis
Polarization $\vartheta$	$\vartheta$ rotation around an axis that is in the plane normal to probe axis (at measurement center), i.e., $\vartheta = 0$ is normal to probe axis
Connector Angle	information used in DASY system to align probe sensor X to the robot coordinate system

**Calibration is Performed According to the Following Standards:**

- a) IEEE Std 1528-2013, "IEEE Recommended Practice for Determining the Peak Spatial-Averaged Specific Absorption Rate (SAR) in the Human Head from Wireless Communications Devices: Measurement Techniques", June 2013
- b) IEC 62209-1, "Procedure to measure the Specific Absorption Rate (SAR) for hand-held devices used in close proximity to the ear (frequency range of 300 MHz to 3 GHz)", February 2005
- c) IEC 62209-2, "Procedure to determine the Specific Absorption Rate (SAR) for wireless communication devices used in close proximity to the human body (frequency range of 30 MHz to 6 GHz)", March 2010
- d) KDB 865664, "SAR Measurement Requirements for 100 MHz to 6 GHz"

**Methods Applied and Interpretation of Parameters:**

- *NORM<sub>x,y,z</sub>*: Assessed for E-field polarization  $\vartheta = 0$  ( $f \leq 900$  MHz in TEM-cell;  $f > 1800$  MHz: R22 waveguide). *NORM<sub>x,y,z</sub>* are only intermediate values, i.e., the uncertainties of *NORM<sub>x,y,z</sub>* does not affect the  $E^2$ -field uncertainty inside TSL (see below *ConvF*).
- *NORM(f)<sub>x,y,z</sub>* = *NORM<sub>x,y,z</sub>* \* *frequency\_response* (see Frequency Response Chart). This linearization is implemented in DASY4 software versions later than 4.2. The uncertainty of the frequency response is included in the stated uncertainty of *ConvF*.
- *DCP<sub>x,y,z</sub>*: DCP are numerical linearization parameters assessed based on the data of power sweep with CW signal (no uncertainty required). DCP does not depend on frequency nor media.
- *PAR*: PAR is the Peak to Average Ratio that is not calibrated but determined based on the signal characteristics
- *A<sub>x,y,z</sub>; B<sub>x,y,z</sub>; C<sub>x,y,z</sub>; D<sub>x,y,z</sub>; VR<sub>x,y,z</sub>; A, B, C, D* are numerical linearization parameters assessed based on the data of power sweep for specific modulation signal. The parameters do not depend on frequency nor media. *VR* is the maximum calibration range expressed in RMS voltage across the diode.
- *ConvF and Boundary Effect Parameters*: Assessed in flat phantom using E-field (or Temperature Transfer Standard for  $f \leq 800$  MHz) and inside waveguide using analytical field distributions based on power measurements for  $f > 800$  MHz. The same setups are used for assessment of the parameters applied for boundary compensation (alpha, depth) of which typical uncertainty values are given. These parameters are used in DASY4 software to improve probe accuracy close to the boundary. The sensitivity in TSL corresponds to *NORM<sub>x,y,z</sub>* \* *ConvF* whereby the uncertainty corresponds to that given for *ConvF*. A frequency dependent *ConvF* is used in DASY version 4.4 and higher which allows extending the validity from  $\pm 50$  MHz to  $\pm 100$  MHz.
- *Spherical isotropy (3D deviation from isotropy)*: in a field of low gradients realized using a flat phantom exposed by a patch antenna.
- *Sensor Offset*: The sensor offset corresponds to the offset of virtual measurement center from the probe tip (on probe axis). No tolerance required.
- *Connector Angle*: The angle is assessed using the information gained by determining the *NORM<sub>x</sub>* (no uncertainty required).

# Probe EX3DV4

## SN:7409

Manufactured: November 24, 2015  
Calibrated: May 17, 2016

Calibrated for DASY/EASY Systems  
(Note: non-compatible with DASY2 system!)

## DASY/EASY - Parameters of Probe: EX3DV4 - SN:7409

### Basic Calibration Parameters

	Sensor X	Sensor Y	Sensor Z	Unc (k=2)
Norm ( $\mu\text{V}/(\text{V}/\text{m})^2$ ) <sup>A</sup>	0.39	0.34	0.39	$\pm 10.1 \%$
DCP (mV) <sup>B</sup>	106.3	102.2	99.4	

### Modulation Calibration Parameters

UID	Communication System Name		A dB	B dB $\sqrt{\mu\text{V}}$	C	D dB	VR mV	Unc <sup>F</sup> (k=2)
0	CW	X	0.0	0.0	1.0	0.00	141.2	$\pm 3.3 \%$
		Y	0.0	0.0	1.0		127.3	
		Z	0.0	0.0	1.0		131.8	
10010- CAA	SAR Validation (Square, 100ms, 10ms)	X	0.39	53.8	5.5	10.00	42.5	$\pm 1.2 \%$
		Y	0.55	54.7	5.9		41.8	
		Z	0.85	58.7	9.1		41.6	
10012- CAB	IEEE 802.11b WiFi 2.4 GHz (DSSS, 1 Mbps)	X	3.55	75.3	22.2	1.87	149.7	$\pm 0.7 \%$
		Y	3.32	72.6	21.0		139.7	
		Z	2.84	68.8	19.0		144.7	
10100- CAB	LTE-FDD (SC-FDMA, 100% RB, 20 MHz, QPSK)	X	5.98	66.6	19.3	5.67	113.6	$\pm 0.9 \%$
		Y	6.17	66.7	19.4		107.1	
		Z	6.13	66.1	18.8		110.9	
10103- CAB	LTE-TDD (SC-FDMA, 100% RB, 20 MHz, QPSK)	X	6.59	66.2	21.1	9.29	123.5	$\pm 1.4 \%$
		Y	7.27	67.9	22.1		121.1	
		Z	7.01	66.4	21.1		119.9	
10108- CAC	LTE-FDD (SC-FDMA, 100% RB, 10 MHz, QPSK)	X	5.72	66.1	19.2	5.80	111.4	$\pm 1.2 \%$
		Y	6.34	67.6	20.0		149.2	
		Z	6.02	65.9	19.0		109.0	
10151- CAB	LTE-TDD (SC-FDMA, 50% RB, 20 MHz, QPSK)	X	6.27	66.1	21.2	9.28	116.8	$\pm 1.4 \%$
		Y	6.89	67.6	22.1		114.7	
		Z	6.69	66.0	21.0		116.4	
10154- CAC	LTE-FDD (SC-FDMA, 50% RB, 10 MHz, QPSK)	X	5.37	65.9	19.1	5.75	107.3	$\pm 1.2 \%$
		Y	5.98	67.2	19.9		143.3	
		Z	6.01	66.7	19.4		149.2	
10160- CAB	LTE-FDD (SC-FDMA, 50% RB, 15 MHz, QPSK)	X	5.76	66.2	19.2	5.82	109.5	$\pm 1.2 \%$
		Y	6.43	67.6	20.0		148.3	
		Z	6.05	65.6	18.7		107.5	
10169- CAB	LTE-FDD (SC-FDMA, 1 RB, 20 MHz, QPSK)	X	4.24	65.6	19.3	5.73	127.4	$\pm 0.9 \%$
		Y	4.54	66.4	19.8		120.4	
		Z	4.62	65.9	19.3		123.8	
10172- CAB	LTE-TDD (SC-FDMA, 1 RB, 20 MHz, QPSK)	X	4.91	68.0	22.7	9.21	126.7	$\pm 1.4 \%$
		Y	5.24	68.8	23.3		124.0	
		Z	5.35	68.1	22.5		125.0	
10175- CAC	LTE-FDD (SC-FDMA, 1 RB, 10 MHz, QPSK)	X	4.27	65.8	19.4	5.72	128.9	$\pm 0.9 \%$
		Y	4.52	66.2	19.7		121.2	
		Z	4.63	65.9	19.3		125.2	

10181-CAB	LTE-FDD (SC-FDMA, 1 RB, 15 MHz, QPSK)	X	4.26	65.7	19.4	5.72	125.9	±0.9 %
		Y	4.47	66.0	19.5		120.6	
		Z	4.60	65.7	19.2		123.0	
10237-CAB	LTE-TDD (SC-FDMA, 1 RB, 10 MHz, QPSK)	X	4.89	67.9	22.6	9.21	125.9	±1.7 %
		Y	5.26	69.0	23.4		123.8	
		Z	5.32	67.8	22.3		124.3	
10252-CAB	LTE-TDD (SC-FDMA, 50% RB, 10 MHz, QPSK)	X	6.04	66.8	21.7	9.24	149.2	±1.4 %
		Y	6.64	68.1	22.6		148.9	
		Z	6.48	66.5	21.4		147.5	
10267-CAB	LTE-TDD (SC-FDMA, 100% RB, 10 MHz, QPSK)	X	6.27	66.1	21.2	9.30	119.1	±1.4 %
		Y	6.88	67.4	22.0		115.9	
		Z	6.73	66.1	21.1		117.6	
10297-AAA	LTE-FDD (SC-FDMA, 50% RB, 20 MHz, QPSK)	X	5.71	66.0	19.2	5.81	110.7	±0.9 %
		Y	6.41	67.8	20.2		149.8	
		Z	5.98	65.7	18.9		107.9	
10311-AAA	LTE-FDD (SC-FDMA, 100% RB, 15 MHz, QPSK)	X	6.23	66.3	19.4	6.06	112.8	±0.9 %
		Y	6.51	66.6	19.5		107.4	
		Z	6.49	66.1	19.0		109.4	

The reported uncertainty of measurement is stated as the standard uncertainty of measurement multiplied by the coverage factor  $k=2$ , which for a normal distribution corresponds to a coverage probability of approximately 95%.

<sup>A</sup> The uncertainties of Norm X,Y,Z do not affect the  $E^2$ -field uncertainty inside TSL. (see Pages 6 and 7).

<sup>B</sup> Numerical linearization parameter: uncertainty not required.

<sup>E</sup> Uncertainty is determined using the max. deviation from linear response applying rectangular distribution and is expressed for the square of the field value.

## DASY/EASY - Parameters of Probe: EX3DV4 - SN:7409

### Calibration Parameter Determined in Head Tissue Simulating Media

f (MHz) <sup>C</sup>	Relative Permittivity <sup>F</sup>	Conductivity (S/m) <sup>F</sup>	ConvF X	ConvF Y	ConvF Z	Alpha <sup>G</sup>	Depth <sup>G</sup> (mm)	Unc (k=2)
750	41.9	0.89	10.73	10.73	10.73	0.62	0.83	± 12.0 %
835	41.5	0.90	10.04	10.04	10.04	0.45	0.93	± 12.0 %
1750	40.1	1.37	8.05	8.05	8.05	0.38	0.80	± 12.0 %
1900	40.0	1.40	7.69	7.69	7.69	0.41	0.80	± 12.0 %
2300	39.5	1.67	7.22	7.22	7.22	0.25	0.92	± 12.0 %
2450	39.2	1.80	6.90	6.90	6.90	0.30	0.93	± 12.0 %
2600	39.0	1.96	6.77	6.77	6.77	0.32	0.83	± 12.0 %

<sup>C</sup> Frequency validity above 300 MHz of ± 100 MHz only applies for DASY v4.4 and higher (see Page 2), else it is restricted to ± 50 MHz. The uncertainty is the RSS of the ConvF uncertainty at calibration frequency and the uncertainty for the indicated frequency band. Frequency validity below 300 MHz is ± 10, 25, 40, 50 and 70 MHz for ConvF assessments at 30, 64, 128, 150 and 220 MHz respectively. Above 5 GHz frequency validity can be extended to ± 110 MHz.

<sup>F</sup> At frequencies below 3 GHz, the validity of tissue parameters ( $\epsilon$  and  $\sigma$ ) can be relaxed to ± 10% if liquid compensation formula is applied to measured SAR values. At frequencies above 3 GHz, the validity of tissue parameters ( $\epsilon$  and  $\sigma$ ) is restricted to ± 5%. The uncertainty is the RSS of the ConvF uncertainty for indicated target tissue parameters.

<sup>G</sup> Alpha/Depth are determined during calibration. SPEAG warrants that the remaining deviation due to the boundary effect after compensation is always less than ± 1% for frequencies below 3 GHz and below ± 2% for frequencies between 3-6 GHz at any distance larger than half the probe lip diameter from the boundary.

## DASY/EASY - Parameters of Probe: EX3DV4 - SN:7409

### Calibration Parameter Determined in Body Tissue Simulating Media

f (MHz) <sup>C</sup>	Relative Permittivity <sup>F</sup>	Conductivity (S/m) <sup>F</sup>	ConvF X	ConvF Y	ConvF Z	Alpha <sup>G</sup>	Depth <sup>G</sup> (mm)	Unc (k=2)
750	55.5	0.96	9.46	9.46	9.46	0.52	0.80	± 12.0 %
835	55.2	0.97	9.33	9.33	9.33	0.34	1.04	± 12.0 %
1750	53.4	1.49	7.72	7.72	7.72	0.44	0.80	± 12.0 %
1900	53.3	1.52	7.47	7.47	7.47	0.43	0.80	± 12.0 %
2300	52.9	1.81	7.22	7.22	7.22	0.36	0.85	± 12.0 %
2450	52.7	1.95	7.10	7.10	7.10	0.39	0.80	± 12.0 %
2600	52.5	2.16	6.83	6.83	6.83	0.39	0.86	± 12.0 %

<sup>C</sup> Frequency validity above 300 MHz of ± 100 MHz only applies for DASY v4.4 and higher (see Page 2), else it is restricted to ± 50 MHz. The uncertainty is the RSS of the ConvF uncertainty at calibration frequency and the uncertainty for the indicated frequency band. Frequency validity below 300 MHz is ± 10, 25, 40, 50 and 70 MHz for ConvF assessments at 30, 64, 128, 150 and 220 MHz respectively. Above 5 GHz frequency validity can be extended to ± 110 MHz.

<sup>F</sup> At frequencies below 3 GHz, the validity of tissue parameters ( $\epsilon$  and  $\sigma$ ) can be relaxed to ± 10% if liquid compensation formula is applied to measured SAR values. At frequencies above 3 GHz, the validity of tissue parameters ( $\epsilon$  and  $\sigma$ ) is restricted to ± 5%. The uncertainty is the RSS of the ConvF uncertainty for indicated target tissue parameters.

<sup>G</sup> Alpha/Depth are determined during calibration. SPEAG warrants that the remaining deviation due to the boundary effect after compensation is always less than ± 1% for frequencies below 3 GHz and below ± 2% for frequencies between 3-6 GHz at any distance larger than half the probe tip diameter from the boundary.

### Frequency Response of E-Field (TEM-Cell:ifi110 EXX, Waveguide: R22)

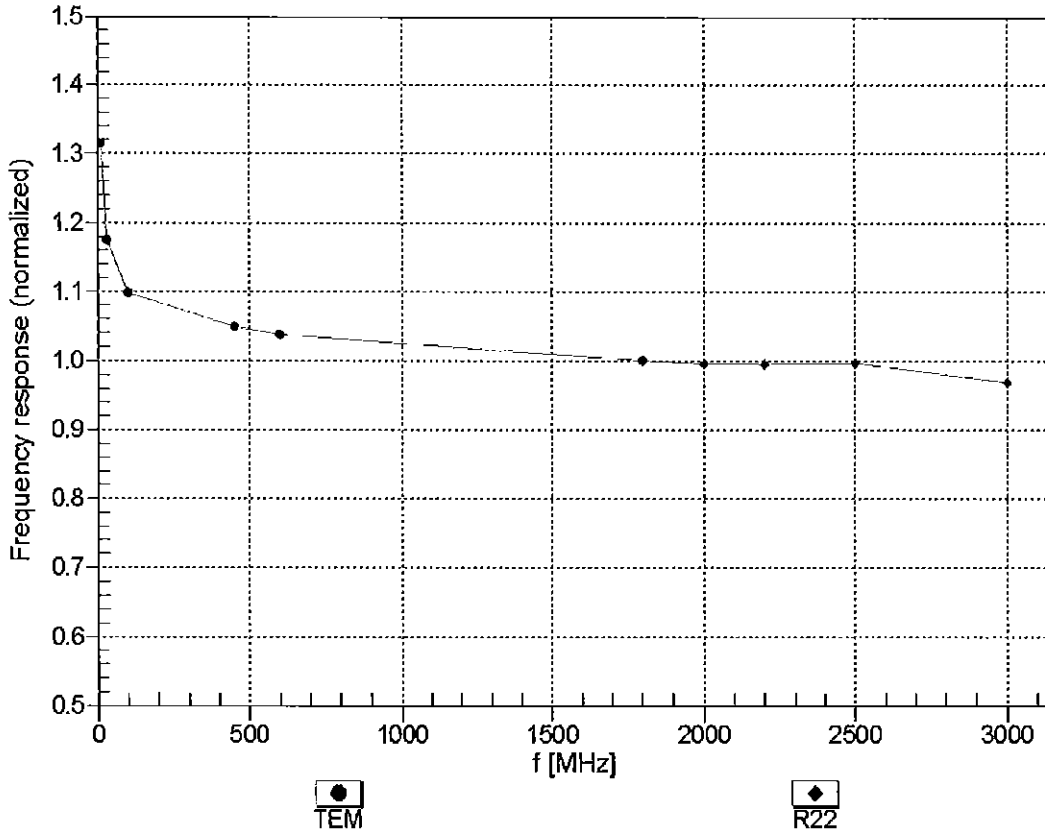

Uncertainty of Frequency Response of E-field:  $\pm 6.3\%$  (k=2)

### Receiving Pattern ( $\phi$ ), $\theta = 0^\circ$

f=600 MHz,TEM

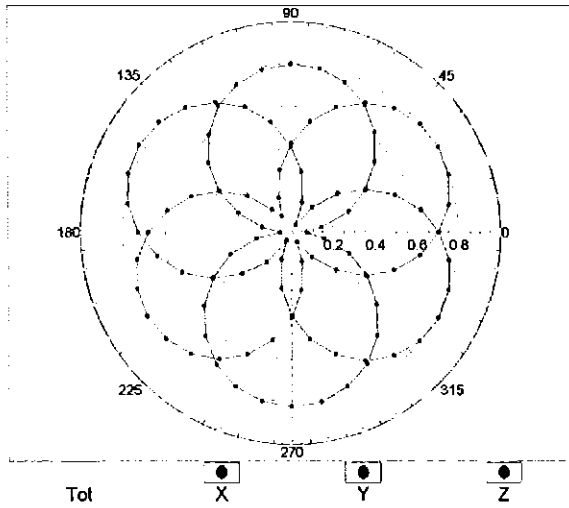

f=1800 MHz,R22

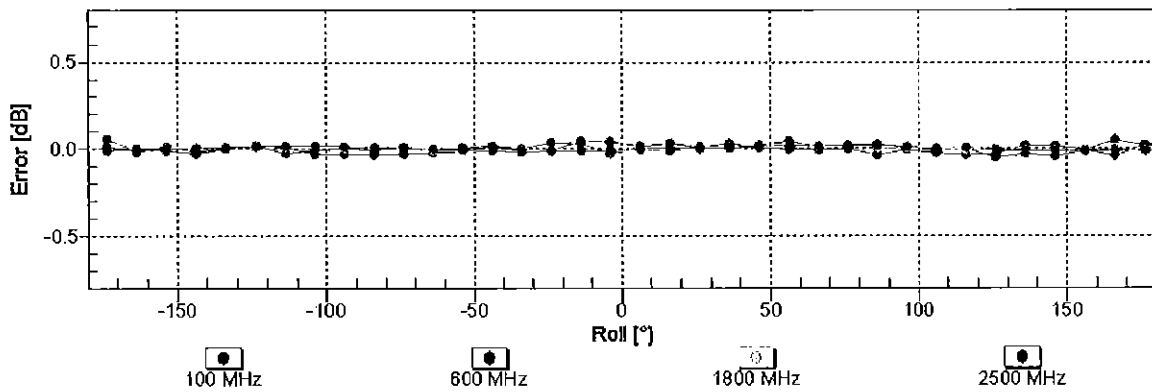
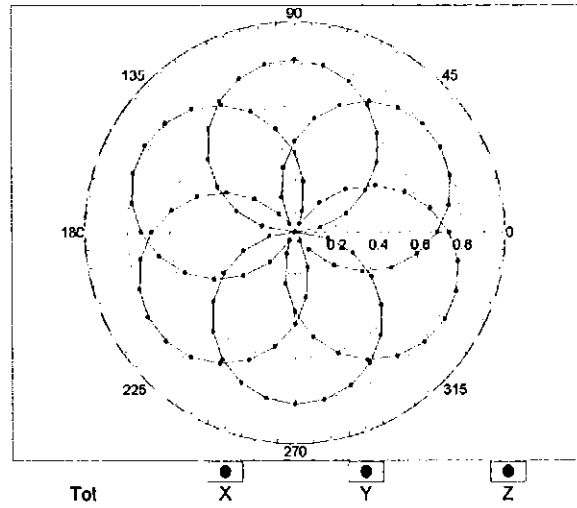

Uncertainty of Axial Isotropy Assessment:  $\pm 0.5\%$  (k=2)

### Dynamic Range f(SAR<sub>head</sub>) (TEM cell , f<sub>eval</sub>= 1900 MHz)

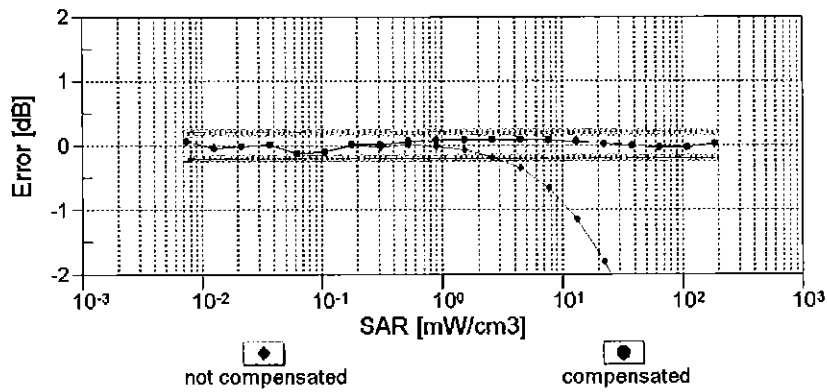
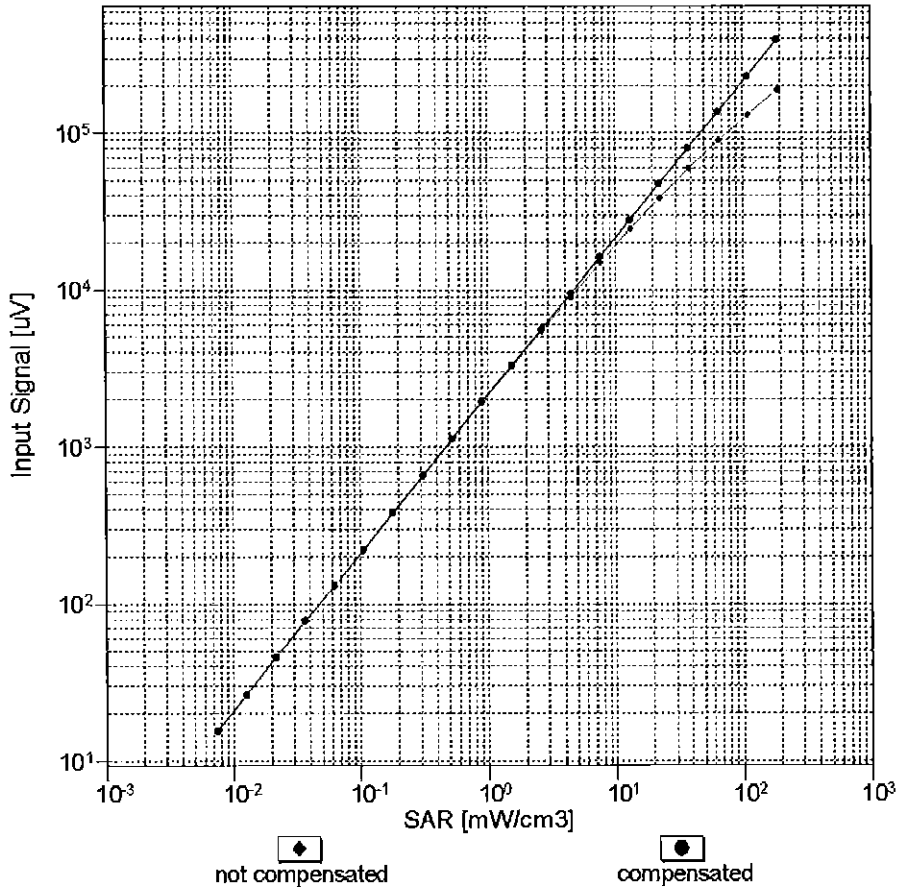

Uncertainty of Linearity Assessment: ± 0.6% (k=2)

# Conversion Factor Assessment

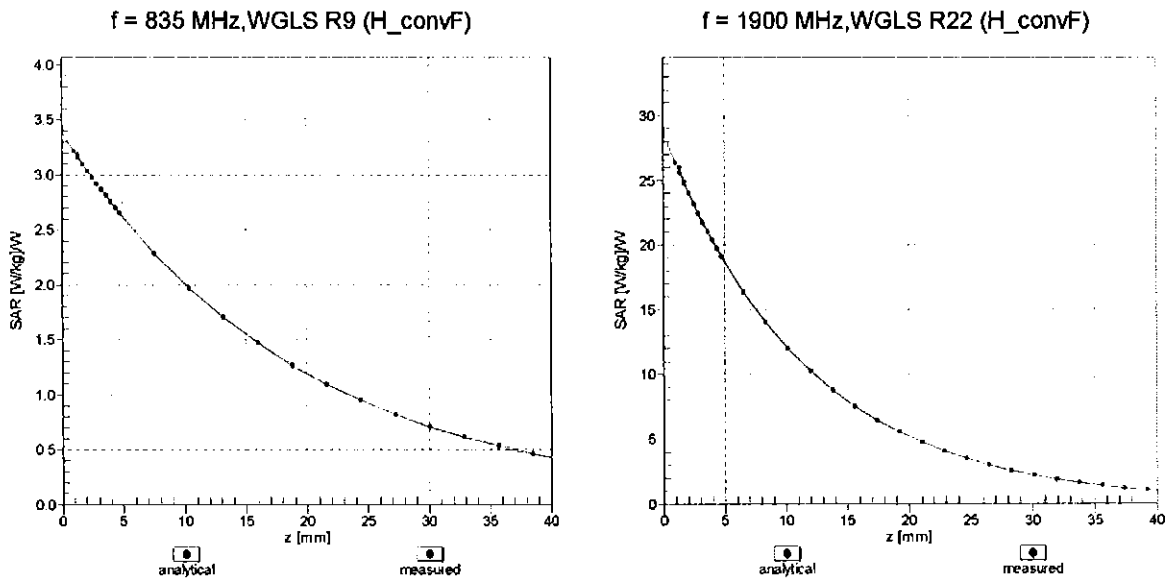

## Deviation from Isotropy in Liquid Error ( $\phi, \vartheta$ ), f = 900 MHz

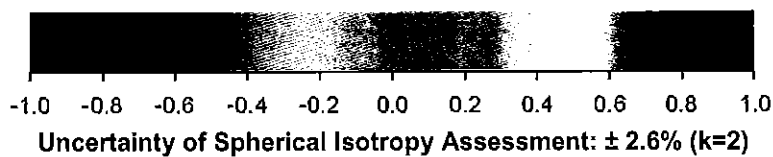
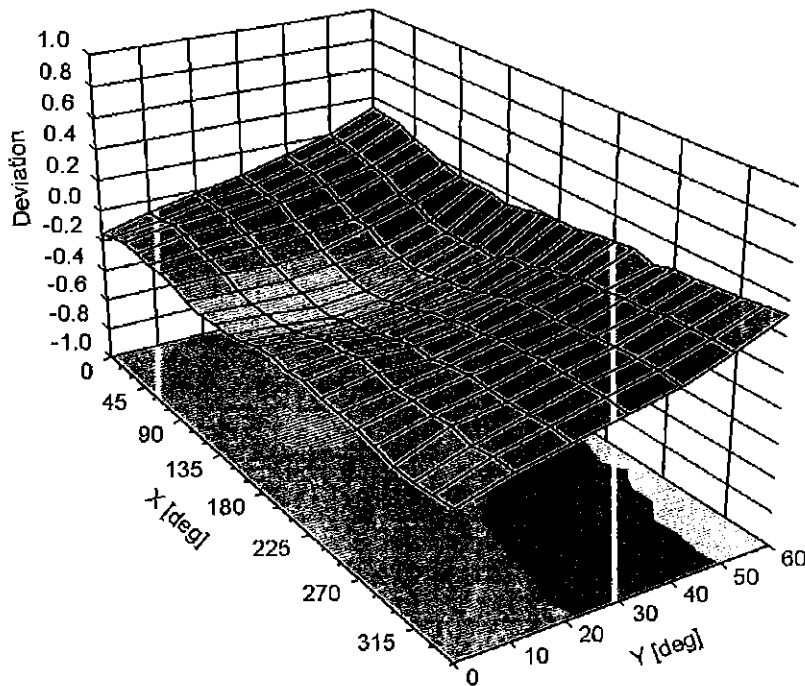

## DASY/EASY - Parameters of Probe: EX3DV4 - SN:7409

### Other Probe Parameters

Sensor Arrangement	Triangular
Connector Angle (°)	36.2
Mechanical Surface Detection Mode	enabled
Optical Surface Detection Mode	disabled
Probe Overall Length	337 mm
Probe Body Diameter	10 mm
Tip Length	9 mm
Tip Diameter	2.5 mm
Probe Tip to Sensor X Calibration Point	1 mm
Probe Tip to Sensor Y Calibration Point	1 mm
Probe Tip to Sensor Z Calibration Point	1 mm
Recommended Measurement Distance from Surface	1.4 mm



Accredited by the Swiss Accreditation Service (SAS)  
The Swiss Accreditation Service is one of the signatories to the EA  
Multilateral Agreement for the recognition of calibration certificates

Accreditation No.: **SCS 0108**

Client **PC Test**

Certificate No: **ES3-3213\_Feb17**

**CALIBRATION CERTIFICATE**

Object **ES3DV3 - SN:3213**

Calibration procedure(s) **QA CAL-01.v9, QA CAL-23.v5, QA CAL-25.v6  
Calibration procedure for dosimetric E-field probes**

Calibration date: **February 10, 2017**

This calibration certificate documents the traceability to national standards, which realize the physical units of measurements (SI).  
The measurements and the uncertainties with confidence probability are given on the following pages and are part of the certificate.

All calibrations have been conducted in the closed laboratory facility: environment temperature (22 ± 3)°C and humidity < 70%.

Calibration Equipment used (M&TE critical for calibration)

*Bny  
03-01-2017*

Primary Standards	ID	Cal Date (Certificate No.)	Scheduled Calibration
Power meter NRP	SN: 104778	06-Apr-16 (No. 217-02288/02289)	Apr-17
Power sensor NRP-Z91	SN: 103244	06-Apr-16 (No. 217-02288)	Apr-17
Power sensor NRP-Z91	SN: 103245	06-Apr-16 (No. 217-02289)	Apr-17
Reference 20 dB Attenuator	SN: S5277 (20x)	05-Apr-16 (No. 217-02293)	Apr-17
Reference Probe ES3DV2	SN: 3013	31-Dec-16 (No. ES3-3013_Dec16)	Dec-17
DAE4	SN: 660	7-Dec-16 (No. DAE4-660_Dec16)	Dec-17
Secondary Standards	ID	Check Date (in house)	Scheduled Check
Power meter E4419B	SN: GB41293874	06-Apr-16 (in house check Jun-16)	In house check: Jun-18
Power sensor E4412A	SN: MY41498087	06-Apr-16 (in house check Jun-16)	In house check: Jun-18
Power sensor E4412A	SN: 000110210	06-Apr-16 (in house check Jun-16)	In house check: Jun-18
RF generator HP 8648C	SN: US3642U01700	04-Aug-99 (in house check Jun-16)	In house check: Jun-18
Network Analyzer HP 8753E	SN: US37390585	18-Oct-01 (in house check Oct-16)	In house check: Oct-17

Calibrated by: **Claudio Leubler** (Name) **Laboratory Technician** (Function) *[Signature]* (Signature)

Approved by: **Katja Pokovic** (Name) **Technical Manager** (Function) *[Signature]* (Signature)

Issued: February 13, 2017

This calibration certificate shall not be reproduced except in full without written approval of the laboratory.



Accredited by the Swiss Accreditation Service (SAS)  
The Swiss Accreditation Service is one of the signatories to the EA  
Multilateral Agreement for the recognition of calibration certificates

Accreditation No.: **SCS 0108**

**Glossary:**

TSL	tissue simulating liquid
NORM <sub>x,y,z</sub>	sensitivity in free space
ConvF	sensitivity in TSL / NORM <sub>x,y,z</sub>
DCP	diode compression point
CF	crest factor (1/duty_cycle) of the RF signal
A, B, C, D	modulation dependent linearization parameters
Polarization $\phi$	$\phi$ rotation around probe axis
Polarization $\vartheta$	$\vartheta$ rotation around an axis that is in the plane normal to probe axis (at measurement center), i.e., $\vartheta = 0$ is normal to probe axis
Connector Angle	information used in DASY system to align probe sensor X to the robot coordinate system

**Calibration is Performed According to the Following Standards:**

- a) IEEE Std 1528-2013, "IEEE Recommended Practice for Determining the Peak Spatial-Averaged Specific Absorption Rate (SAR) in the Human Head from Wireless Communications Devices: Measurement Techniques", June 2013
- b) IEC 62209-1, "Procedure to measure the Specific Absorption Rate (SAR) for hand-held devices used in close proximity to the ear (frequency range of 300 MHz to 3 GHz)", February 2005
- c) IEC 62209-2, "Procedure to determine the Specific Absorption Rate (SAR) for wireless communication devices used in close proximity to the human body (frequency range of 30 MHz to 6 GHz)", March 2010
- d) KDB 865664, "SAR Measurement Requirements for 100 MHz to 6 GHz"

**Methods Applied and Interpretation of Parameters:**

- *NORM<sub>x,y,z</sub>*: Assessed for E-field polarization  $\vartheta = 0$  ( $f \leq 900$  MHz in TEM-cell;  $f > 1800$  MHz: R22 waveguide). *NORM<sub>x,y,z</sub>* are only intermediate values, i.e., the uncertainties of *NORM<sub>x,y,z</sub>* does not affect the  $E^2$ -field uncertainty inside TSL (see below *ConvF*).
- *NORM(f)<sub>x,y,z</sub>* = *NORM<sub>x,y,z</sub>* \* *frequency\_response* (see Frequency Response Chart). This linearization is implemented in DASY4 software versions later than 4.2. The uncertainty of the frequency response is included in the stated uncertainty of *ConvF*.
- *DCP<sub>x,y,z</sub>*: DCP are numerical linearization parameters assessed based on the data of power sweep with CW signal (no uncertainty required). DCP does not depend on frequency nor media.
- *PAR*: PAR is the Peak to Average Ratio that is not calibrated but determined based on the signal characteristics
- *A<sub>x,y,z</sub>*; *B<sub>x,y,z</sub>*; *C<sub>x,y,z</sub>*; *D<sub>x,y,z</sub>*; *VR<sub>x,y,z</sub>*: *A*, *B*, *C*, *D* are numerical linearization parameters assessed based on the data of power sweep for specific modulation signal. The parameters do not depend on frequency nor media. *VR* is the maximum calibration range expressed in RMS voltage across the diode.
- *ConvF and Boundary Effect Parameters*: Assessed in flat phantom using E-field (or Temperature Transfer Standard for  $f \leq 800$  MHz) and inside waveguide using analytical field distributions based on power measurements for  $f > 800$  MHz. The same setups are used for assessment of the parameters applied for boundary compensation (alpha, depth) of which typical uncertainty values are given. These parameters are used in DASY4 software to improve probe accuracy close to the boundary. The sensitivity in TSL corresponds to *NORM<sub>x,y,z</sub>* \* *ConvF* whereby the uncertainty corresponds to that given for *ConvF*. A frequency dependent *ConvF* is used in DASY version 4.4 and higher which allows extending the validity from  $\pm 50$  MHz to  $\pm 100$  MHz.
- *Spherical isotropy (3D deviation from isotropy)*: in a field of low gradients realized using a flat phantom exposed by a patch antenna.
- *Sensor Offset*: The sensor offset corresponds to the offset of virtual measurement center from the probe tip (on probe axis). No tolerance required.
- *Connector Angle*: The angle is assessed using the information gained by determining the *NORM<sub>x</sub>* (no uncertainty required).

# Probe ES3DV3

## SN:3213

Manufactured: October 14, 2008  
Calibrated: February 10, 2017

Calibrated for DASY/EASY Systems  
(Note: non-compatible with DASY2 system!)

## DASY/EASY - Parameters of Probe: ES3DV3 - SN:3213

### Basic Calibration Parameters

	Sensor X	Sensor Y	Sensor Z	Unc (k=2)
Norm ( $\mu\text{V}/(\text{V}/\text{m})^2$ ) <sup>A</sup>	1.44	1.32	1.29	$\pm 10.1 \%$
DCP (mV) <sup>B</sup>	101.3	102.3	101.6	

### Modulation Calibration Parameters

UID	Communication System Name		A dB	B dB $\sqrt{\mu\text{V}}$	C	D dB	VR mV	Unc <sup>E</sup> (k=2)
0	CW	X	0.0	0.0	1.0	0.00	228.2	$\pm 3.5 \%$
		Y	0.0	0.0	1.0		230.0	
		Z	0.0	0.0	1.0		221.7	

Note: For details on UID parameters see Appendix.

### Sensor Model Parameters

	C1 fF	C2 fF	$\alpha$ $\text{V}^{-1}$	T1 $\text{ms}\cdot\text{V}^{-2}$	T2 $\text{ms}\cdot\text{V}^{-1}$	T3 ms	T4 $\text{V}^{-2}$	T5 $\text{V}^{-1}$	T6
X	56.23	407.2	35.93	28.85	2.251	5.1	1.129	0.439	1.012
Y	55.47	400.7	35.87	28.65	2.277	5.1	1.321	0.386	1.013
Z	51.67	374.7	36	28.45	2.103	5.1	0.358	0.504	1.009

The reported uncertainty of measurement is stated as the standard uncertainty of measurement multiplied by the coverage factor  $k=2$ , which for a normal distribution corresponds to a coverage probability of approximately 95%.

<sup>A</sup> The uncertainties of Norm X,Y,Z do not affect the  $E^2$ -field uncertainty inside TSL (see Pages 5 and 6).

<sup>B</sup> Numerical linearization parameter: uncertainty not required.

<sup>E</sup> Uncertainty is determined using the max. deviation from linear response applying rectangular distribution and is expressed for the square of the field value.

## DASY/EASY - Parameters of Probe: ES3DV3 - SN:3213

### Calibration Parameter Determined in Head Tissue Simulating Media

f (MHz) <sup>C</sup>	Relative Permittivity <sup>F</sup>	Conductivity (S/m) <sup>F</sup>	ConvF X	ConvF Y	ConvF Z	Alpha <sup>G</sup>	Depth <sup>G</sup> (mm)	Unc (k=2)
750	41.9	0.89	6.85	6.85	6.85	0.80	1.18	± 12.0 %
835	41.5	0.90	6.49	6.49	6.49	0.49	1.52	± 12.0 %
1750	40.1	1.37	5.49	5.49	5.49	0.60	1.35	± 12.0 %
1900	40.0	1.40	5.29	5.29	5.29	0.68	1.27	± 12.0 %
2300	39.5	1.67	4.95	4.95	4.95	0.70	1.28	± 12.0 %
2450	39.2	1.80	4.70	4.70	4.70	0.80	1.24	± 12.0 %
2600	39.0	1.96	4.52	4.52	4.52	0.78	1.28	± 12.0 %

<sup>C</sup> Frequency validity above 300 MHz of ± 100 MHz only applies for DASY v4.4 and higher (see Page 2), else it is restricted to ± 50 MHz. The uncertainty is the RSS of the ConvF uncertainty at calibration frequency and the uncertainty for the indicated frequency band. Frequency validity below 300 MHz is ± 10, 25, 40, 50 and 70 MHz for ConvF assessments at 30, 64, 128, 150 and 220 MHz respectively. Above 5 GHz frequency validity can be extended to ± 110 MHz.

<sup>F</sup> At frequencies below 3 GHz, the validity of tissue parameters ( $\epsilon$  and  $\sigma$ ) can be relaxed to ± 10% if liquid compensation formula is applied to measured SAR values. At frequencies above 3 GHz, the validity of tissue parameters ( $\epsilon$  and  $\sigma$ ) is restricted to ± 5%. The uncertainty is the RSS of the ConvF uncertainty for indicated target tissue parameters.

<sup>G</sup> Alpha/Depth are determined during calibration. SPEAG warrants that the remaining deviation due to the boundary effect after compensation is always less than ± 1% for frequencies below 3 GHz and below ± 2% for frequencies between 3-6 GHz at any distance larger than half the probe tip diameter from the boundary.

## DASY/EASY - Parameters of Probe: ES3DV3 - SN:3213

### Calibration Parameter Determined in Body Tissue Simulating Media

f (MHz) <sup>C</sup>	Relative Permittivity <sup>F</sup>	Conductivity (S/m) <sup>F</sup>	ConvF X	ConvF Y	ConvF Z	Alpha <sup>G</sup>	Depth <sup>G</sup> (mm)	Unc (k=2)
750	55.5	0.96	6.38	6.38	6.38	0.60	1.31	± 12.0 %
835	55.2	0.97	6.28	6.28	6.28	0.80	1.20	± 12.0 %
1750	53.4	1.49	5.09	5.09	5.09	0.66	1.33	± 12.0 %
1900	53.3	1.52	4.94	4.94	4.94	0.40	1.85	± 12.0 %
2300	52.9	1.81	4.69	4.69	4.69	0.80	1.24	± 12.0 %
2450	52.7	1.95	4.53	4.53	4.53	0.72	1.28	± 12.0 %
2600	52.5	2.16	4.32	4.32	4.32	0.80	1.20	± 12.0 %

<sup>C</sup> Frequency validity above 300 MHz of ± 100 MHz only applies for DASY v4.4 and higher (see Page 2), else it is restricted to ± 50 MHz. The uncertainty is the RSS of the ConvF uncertainty at calibration frequency and the uncertainty for the indicated frequency band. Frequency validity below 300 MHz is ± 10, 25, 40, 50 and 70 MHz for ConvF assessments at 30, 64, 128, 150 and 220 MHz respectively. Above 5 GHz frequency validity can be extended to ± 110 MHz.

<sup>F</sup> At frequencies below 3 GHz, the validity of tissue parameters ( $\epsilon$  and  $\sigma$ ) can be relaxed to ± 10% if liquid compensation formula is applied to measured SAR values. At frequencies above 3 GHz, the validity of tissue parameters ( $\epsilon$  and  $\sigma$ ) is restricted to ± 5%. The uncertainty is the RSS of the ConvF uncertainty for indicated target tissue parameters.

<sup>G</sup> Alpha/Depth are determined during calibration. SPEAG warrants that the remaining deviation due to the boundary effect after compensation is always less than ± 1% for frequencies below 3 GHz and below ± 2% for frequencies between 3-6 GHz at any distance larger than half the probe tip diameter from the boundary.

### Frequency Response of E-Field (TEM-Cell:ifi110 EXX, Waveguide: R22)

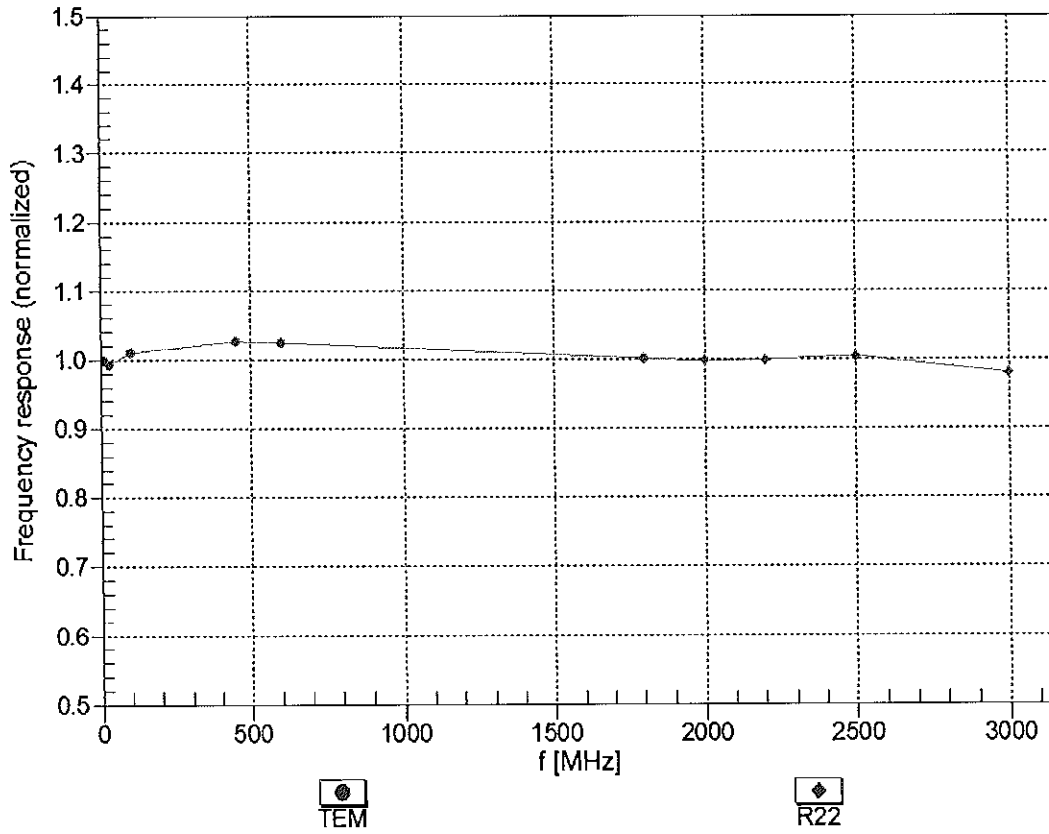

Uncertainty of Frequency Response of E-field:  $\pm 6.3\%$  (k=2)

### Receiving Pattern ( $\phi$ ), $\theta = 0^\circ$

f=600 MHz, TEM

f=1800 MHz, R22

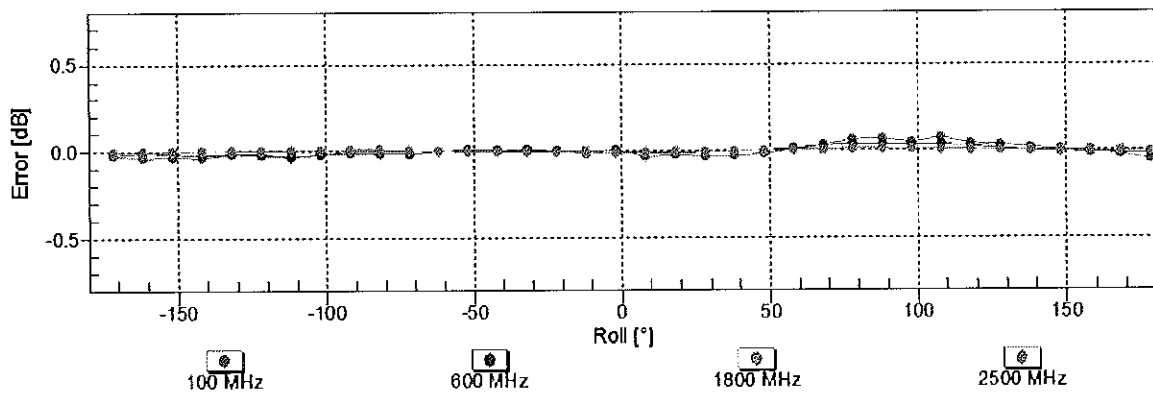
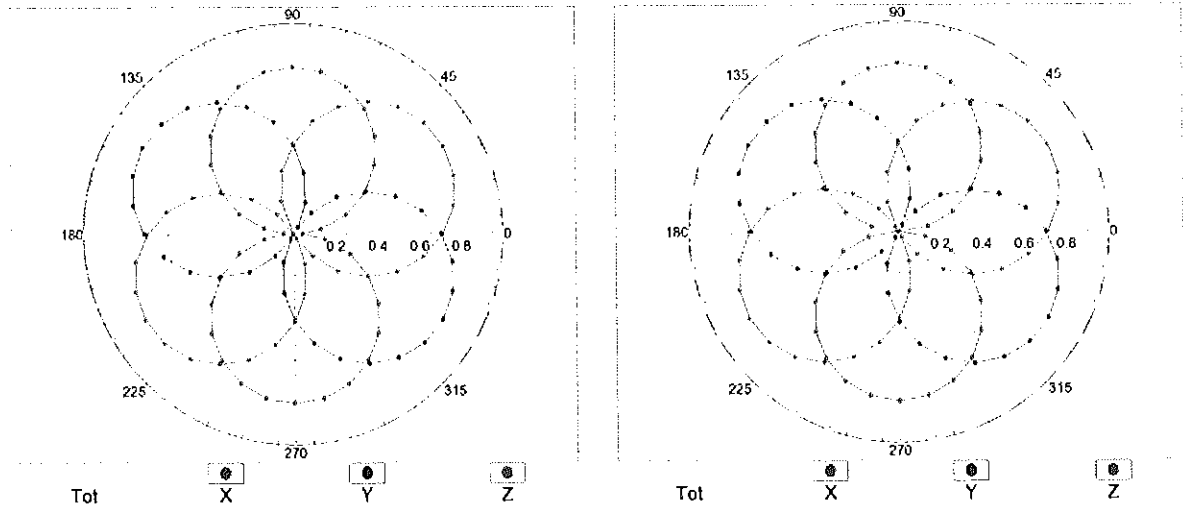

Uncertainty of Axial Isotropy Assessment:  $\pm 0.5\%$  ( $k=2$ )

### Dynamic Range $f(\text{SAR}_{\text{head}})$ (TEM cell , $f_{\text{eval}} = 1900 \text{ MHz}$ )

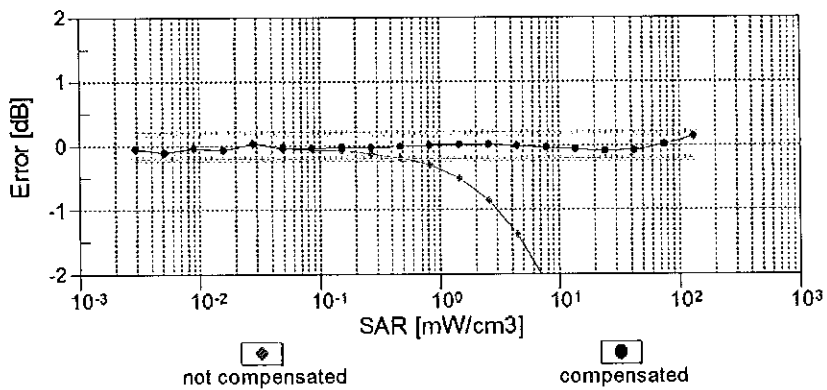
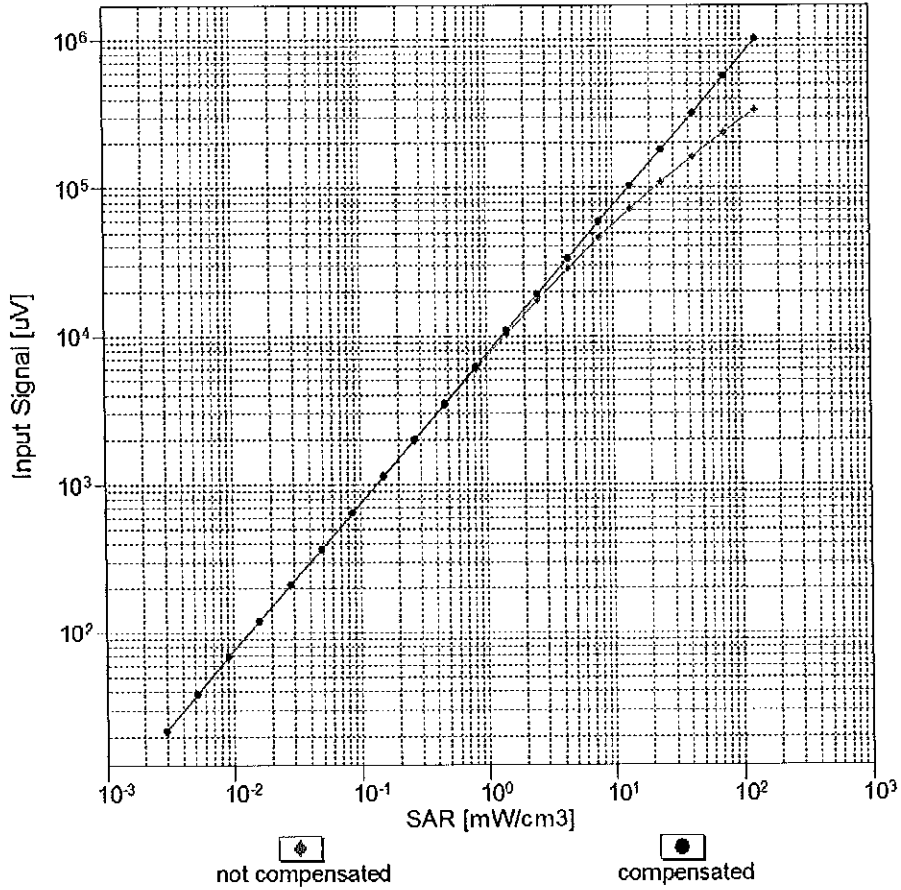

Uncertainty of Linearity Assessment:  $\pm 0.6\%$  ( $k=2$ )

# Conversion Factor Assessment

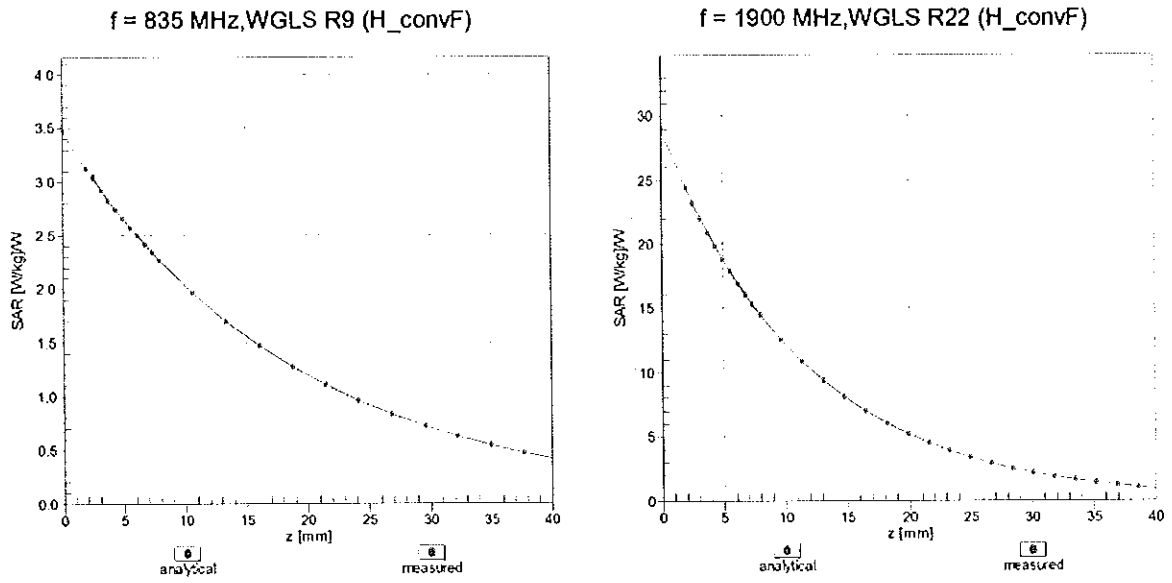

## Deviation from Isotropy in Liquid Error ( $\phi, \vartheta$ ), f = 900 MHz

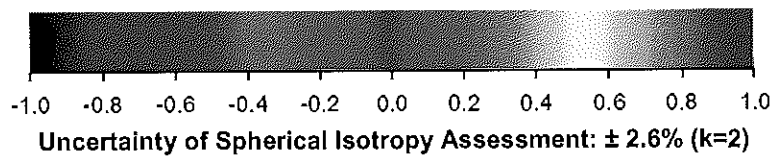
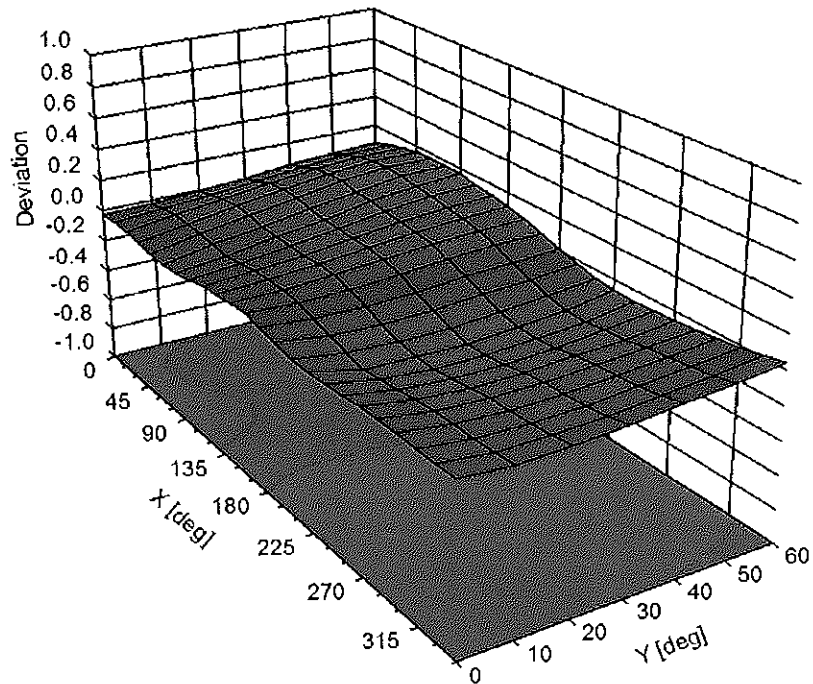

**DASY/EASY - Parameters of Probe: ES3DV3 - SN:3213****Other Probe Parameters**

Sensor Arrangement	Triangular
Connector Angle (°)	98.2
Mechanical Surface Detection Mode	enabled
Optical Surface Detection Mode	disabled
Probe Overall Length	337 mm
Probe Body Diameter	10 mm
Tip Length	10 mm
Tip Diameter	4 mm
Probe Tip to Sensor X Calibration Point	2 mm
Probe Tip to Sensor Y Calibration Point	2 mm
Probe Tip to Sensor Z Calibration Point	2 mm
Recommended Measurement Distance from Surface	3 mm

**Appendix: Modulation Calibration Parameters**

UID	Communication System Name		A dB	B dB $\sqrt{\mu}$ V	C	D dB	VR mV	Max Unc <sup>E</sup> (k=2)
0	CW	X	0.00	0.00	1.00	0.00	228.2	± 3.5 %
		Y	0.00	0.00	1.00		230.0	
		Z	0.00	0.00	1.00		221.7	
10010- CAA	SAR Validation (Square, 100ms, 10ms)	X	11.07	84.26	20.62	10.00	25.0	± 9.6 %
		Y	10.49	83.36	20.27		25.0	
		Z	11.03	84.22	20.43		25.0	
10011- CAB	UMTS-FDD (WCDMA)	X	1.04	66.65	14.82	0.00	150.0	± 9.6 %
		Y	1.16	69.13	16.33		150.0	
		Z	1.01	66.30	14.54		150.0	
10012- CAB	IEEE 802.11b WiFi 2.4 GHz (DSSS, 1 Mbps)	X	1.30	64.60	15.49	0.41	150.0	± 9.6 %
		Y	1.33	65.49	16.22		150.0	
		Z	1.28	64.47	15.36		150.0	
10013- CAB	IEEE 802.11g WiFi 2.4 GHz (DSSS-OFDM, 6 Mbps)	X	5.14	67.15	17.39	1.46	150.0	± 9.6 %
		Y	5.14	67.35	17.57		150.0	
		Z	5.09	67.17	17.37		150.0	
10021- DAC	GSM-FDD (TDMA, GMSK)	X	62.94	114.81	31.61	9.39	50.0	± 9.6 %
		Y	41.95	107.82	29.66		50.0	
		Z	94.76	121.25	33.03		50.0	
10023- DAC	GPRS-FDD (TDMA, GMSK, TN 0)	X	46.50	109.76	30.33	9.57	50.0	± 9.6 %
		Y	33.70	104.15	28.69		50.0	
		Z	62.69	114.46	31.37		50.0	
10024- DAC	GPRS-FDD (TDMA, GMSK, TN 0-1)	X	100.00	119.19	30.75	6.56	60.0	± 9.6 %
		Y	100.00	118.97	30.64		60.0	
		Z	100.00	118.83	30.48		60.0	
10025- DAC	EDGE-FDD (TDMA, 8PSK, TN 0)	X	18.95	107.68	41.29	12.57	50.0	± 9.6 %
		Y	31.91	124.81	47.58		50.0	
		Z	17.05	104.98	40.36		50.0	
10026- DAC	EDGE-FDD (TDMA, 8PSK, TN 0-1)	X	20.29	105.23	36.57	9.56	60.0	± 9.6 %
		Y	28.92	114.92	39.99		60.0	
		Z	20.11	105.49	36.71		60.0	
10027- DAC	GPRS-FDD (TDMA, GMSK, TN 0-1-2)	X	100.00	118.17	29.38	4.80	80.0	± 9.6 %
		Y	100.00	118.12	29.34		80.0	
		Z	100.00	117.81	29.12		80.0	
10028- DAC	GPRS-FDD (TDMA, GMSK, TN 0-1-2-3)	X	100.00	118.40	28.68	3.55	100.0	± 9.6 %
		Y	100.00	118.60	28.76		100.0	
		Z	100.00	118.00	28.41		100.0	
10029- DAC	EDGE-FDD (TDMA, 8PSK, TN 0-1-2)	X	12.78	94.46	31.72	7.80	80.0	± 9.6 %
		Y	16.27	100.85	34.22		80.0	
		Z	12.37	94.11	31.64		80.0	
10030- CAA	IEEE 802.15.1 Bluetooth (GFSK, DH1)	X	100.00	117.61	29.45	5.30	70.0	± 9.6 %
		Y	100.00	117.52	29.40		70.0	
		Z	100.00	117.17	29.14		70.0	
10031- CAA	IEEE 802.15.1 Bluetooth (GFSK, DH3)	X	100.00	119.11	27.47	1.88	100.0	± 9.6 %
		Y	100.00	120.30	27.96		100.0	
		Z	100.00	118.27	27.02		100.0	

10032-CAA	IEEE 802.15.1 Bluetooth (GFSK, DH5)	X	100.00	123.13	28.10	1.17	100.0	± 9.6 %
		Y	100.00	125.86	29.19		100.0	
		Z	100.00	121.81	27.46		100.0	
10033-CAA	IEEE 802.15.1 Bluetooth (PI/4-DQPSK, DH1)	X	19.81	99.27	27.58	5.30	70.0	± 9.6 %
		Y	23.75	102.32	28.48		70.0	
		Z	20.10	99.19	27.31		70.0	
10034-CAA	IEEE 802.15.1 Bluetooth (PI/4-DQPSK, DH3)	X	6.18	84.61	21.36	1.88	100.0	± 9.6 %
		Y	8.74	90.01	23.19		100.0	
		Z	6.07	84.02	20.83		100.0	
10035-CAA	IEEE 802.15.1 Bluetooth (PI/4-DQPSK, DH5)	X	3.50	78.04	18.75	1.17	100.0	± 9.6 %
		Y	4.77	82.88	20.59		100.0	
		Z	3.40	77.42	18.19		100.0	
10036-CAA	IEEE 802.15.1 Bluetooth (8-DPSK, DH1)	X	25.06	103.36	28.83	5.30	70.0	± 9.6 %
		Y	30.48	106.66	29.76		70.0	
		Z	25.78	103.46	28.61		70.0	
10037-CAA	IEEE 802.15.1 Bluetooth (8-DPSK, DH3)	X	5.91	84.02	21.13	1.88	100.0	± 9.6 %
		Y	8.37	89.43	22.97		100.0	
		Z	5.74	83.28	20.55		100.0	
10038-CAA	IEEE 802.15.1 Bluetooth (8-DPSK, DH5)	X	3.58	78.59	19.05	1.17	100.0	± 9.6 %
		Y	4.93	83.62	20.94		100.0	
		Z	3.47	77.94	18.48		100.0	
10039-CAB	CDMA2000 (1xRTT, RC1)	X	1.75	70.49	15.41	0.00	150.0	± 9.6 %
		Y	2.11	73.63	16.88		150.0	
		Z	1.63	69.80	14.78		150.0	
10042-CAB	IS-54 / IS-136 FDD (TDMA/FDM, PI/4-DQPSK, Halfrate)	X	100.00	117.99	30.44	7.78	50.0	± 9.6 %
		Y	100.00	117.70	30.30		50.0	
		Z	100.00	117.57	30.13		50.0	
10044-CAA	IS-91/EIA/TIA-553 FDD (FDMA, FM)	X	0.01	92.86	0.28	0.00	150.0	± 9.6 %
		Y	0.00	128.30	10.22		150.0	
		Z	0.01	91.94	0.27		150.0	
10048-CAA	DECT (TDD, TDMA/FDM, GFSK, Full Slot, 24)	X	16.43	91.36	26.72	13.80	25.0	± 9.6 %
		Y	14.26	88.55	25.69		25.0	
		Z	18.21	93.36	27.20		25.0	
10049-CAA	DECT (TDD, TDMA/FDM, GFSK, Double Slot, 12)	X	21.81	96.95	27.09	10.79	40.0	± 9.6 %
		Y	18.36	93.74	25.99		40.0	
		Z	24.94	99.20	27.59		40.0	
10056-CAA	UMTS-TDD (TD-SCDMA, 1.28 Mcps)	X	16.12	92.43	26.40	9.03	50.0	± 9.6 %
		Y	16.40	92.69	26.46		50.0	
		Z	16.84	93.23	26.48		50.0	
10058-DAC	EDGE-FDD (TDMA, 8PSK, TN 0-1-2-3)	X	9.13	87.64	28.49	6.55	100.0	± 9.6 %
		Y	10.85	92.11	30.40		100.0	
		Z	8.80	87.14	28.33		100.0	
10059-CAB	IEEE 802.11b WiFi 2.4 GHz (DSSS, 2 Mbps)	X	1.45	66.53	16.46	0.61	110.0	± 9.6 %
		Y	1.51	67.75	17.33		110.0	
		Z	1.43	66.36	16.31		110.0	
10060-CAB	IEEE 802.11b WiFi 2.4 GHz (DSSS, 5.5 Mbps)	X	71.32	126.43	32.69	1.30	110.0	± 9.6 %
		Y	100.00	133.00	34.47		110.0	
		Z	56.46	122.77	31.74		110.0	

10061-CAB	IEEE 802.11b WiFi 2.4 GHz (DSSS, 11 Mbps)	X	7.70	91.83	25.70	2.04	110.0	± 9.6 %
		Y	12.85	101.15	28.77		110.0	
		Z	7.42	91.30	25.47		110.0	
10062-CAB	IEEE 802.11a/h WiFi 5 GHz (OFDM, 6 Mbps)	X	4.86	66.91	16.67	0.49	100.0	± 9.6 %
		Y	4.87	67.10	16.85		100.0	
		Z	4.81	66.91	16.64		100.0	
10063-CAB	IEEE 802.11a/h WiFi 5 GHz (OFDM, 9 Mbps)	X	4.90	67.06	16.81	0.72	100.0	± 9.6 %
		Y	4.91	67.26	16.99		100.0	
		Z	4.85	67.06	16.78		100.0	
10064-CAB	IEEE 802.11a/h WiFi 5 GHz (OFDM, 12 Mbps)	X	5.22	67.40	17.08	0.86	100.0	± 9.6 %
		Y	5.23	67.59	17.25		100.0	
		Z	5.16	67.38	17.04		100.0	
10065-CAB	IEEE 802.11a/h WiFi 5 GHz (OFDM, 18 Mbps)	X	5.12	67.42	17.25	1.21	100.0	± 9.6 %
		Y	5.13	67.61	17.43		100.0	
		Z	5.06	67.40	17.21		100.0	
10066-CAB	IEEE 802.11a/h WiFi 5 GHz (OFDM, 24 Mbps)	X	5.18	67.55	17.48	1.46	100.0	± 9.6 %
		Y	5.19	67.76	17.66		100.0	
		Z	5.11	67.52	17.44		100.0	
10067-CAB	IEEE 802.11a/h WiFi 5 GHz (OFDM, 36 Mbps)	X	5.50	67.74	17.95	2.04	100.0	± 9.6 %
		Y	5.51	67.96	18.15		100.0	
		Z	5.44	67.76	17.93		100.0	
10068-CAB	IEEE 802.11a/h WiFi 5 GHz (OFDM, 48 Mbps)	X	5.63	68.06	18.32	2.55	100.0	± 9.6 %
		Y	5.64	68.30	18.53		100.0	
		Z	5.56	68.03	18.28		100.0	
10069-CAB	IEEE 802.11a/h WiFi 5 GHz (OFDM, 54 Mbps)	X	5.71	68.03	18.50	2.67	100.0	± 9.6 %
		Y	5.72	68.29	18.74		100.0	
		Z	5.64	68.03	18.48		100.0	
10071-CAB	IEEE 802.11g WiFi 2.4 GHz (DSSS/OFDM, 9 Mbps)	X	5.28	67.38	17.78	1.99	100.0	± 9.6 %
		Y	5.29	67.59	17.97		100.0	
		Z	5.23	67.40	17.76		100.0	
10072-CAB	IEEE 802.11g WiFi 2.4 GHz (DSSS/OFDM, 12 Mbps)	X	5.33	67.91	18.09	2.30	100.0	± 9.6 %
		Y	5.34	68.14	18.30		100.0	
		Z	5.28	67.91	18.07		100.0	
10073-CAB	IEEE 802.11g WiFi 2.4 GHz (DSSS/OFDM, 18 Mbps)	X	5.46	68.24	18.51	2.83	100.0	± 9.6 %
		Y	5.48	68.51	18.74		100.0	
		Z	5.40	68.25	18.50		100.0	
10074-CAB	IEEE 802.11g WiFi 2.4 GHz (DSSS/OFDM, 24 Mbps)	X	5.49	68.30	18.76	3.30	100.0	± 9.6 %
		Y	5.51	68.58	19.00		100.0	
		Z	5.44	68.31	18.74		100.0	
10075-CAB	IEEE 802.11g WiFi 2.4 GHz (DSSS/OFDM, 36 Mbps)	X	5.63	68.74	19.25	3.82	90.0	± 9.6 %
		Y	5.66	69.06	19.51		90.0	
		Z	5.57	68.71	19.21		90.0	
10076-CAB	IEEE 802.11g WiFi 2.4 GHz (DSSS/OFDM, 48 Mbps)	X	5.64	68.56	19.38	4.15	90.0	± 9.6 %
		Y	5.68	68.89	19.66		90.0	
		Z	5.60	68.57	19.36		90.0	
10077-CAB	IEEE 802.11g WiFi 2.4 GHz (DSSS/OFDM, 54 Mbps)	X	5.68	68.64	19.49	4.30	90.0	± 9.6 %
		Y	5.71	68.99	19.77		90.0	
		Z	5.64	68.66	19.47		90.0	

10081-CAB	CDMA2000 (1xRTT, RC3)	X	0.88	65.55	12.70	0.00	150.0	± 9.6 %
		Y	1.01	67.94	14.05		150.0	
		Z	0.82	64.98	12.07		150.0	
10082-CAB	IS-54 / IS-136 FDD (TDMA/FDM, PI/4-DQPSK, Fullrate)	X	2.05	63.91	8.77	4.77	80.0	± 9.6 %
		Y	2.06	64.02	8.81		80.0	
		Z	1.95	63.58	8.48		80.0	
10090-DAC	GPRS-FDD (TDMA, GMSK, TN 0-4)	X	100.00	119.26	30.80	6.56	60.0	± 9.6 %
		Y	100.00	119.04	30.70		60.0	
		Z	100.00	118.90	30.53		60.0	
10097-CAB	UMTS-FDD (HSDPA)	X	1.83	67.01	15.38	0.00	150.0	± 9.6 %
		Y	1.91	68.15	16.11		150.0	
		Z	1.80	66.92	15.21		150.0	
10098-CAB	UMTS-FDD (HSUPA, Subtest 2)	X	1.79	66.97	15.34	0.00	150.0	± 9.6 %
		Y	1.88	68.14	16.10		150.0	
		Z	1.76	66.87	15.18		150.0	
10099-DAC	EDGE-FDD (TDMA, 8PSK, TN 0-4)	X	20.23	105.10	36.53	9.56	60.0	± 9.6 %
		Y	28.70	114.68	39.91		60.0	
		Z	20.06	105.38	36.67		60.0	
10100-CAC	LTE-FDD (SC-FDMA, 100% RB, 20 MHz, QPSK)	X	3.16	69.99	16.45	0.00	150.0	± 9.6 %
		Y	3.31	71.03	17.06		150.0	
		Z	3.09	69.73	16.33		150.0	
10101-CAC	LTE-FDD (SC-FDMA, 100% RB, 20 MHz, 16-QAM)	X	3.32	67.51	15.87	0.00	150.0	± 9.6 %
		Y	3.38	68.00	16.23		150.0	
		Z	3.27	67.36	15.78		150.0	
10102-CAC	LTE-FDD (SC-FDMA, 100% RB, 20 MHz, 64-QAM)	X	3.43	67.46	15.96	0.00	150.0	± 9.6 %
		Y	3.47	67.89	16.28		150.0	
		Z	3.37	67.33	15.88		150.0	
10103-CAC	LTE-TDD (SC-FDMA, 100% RB, 20 MHz, QPSK)	X	8.65	78.54	21.48	3.98	65.0	± 9.6 %
		Y	8.85	79.12	21.77		65.0	
		Z	8.48	78.45	21.46		65.0	
10104-CAC	LTE-TDD (SC-FDMA, 100% RB, 20 MHz, 16-QAM)	X	8.46	76.91	21.67	3.98	65.0	± 9.6 %
		Y	8.66	77.60	22.06		65.0	
		Z	8.34	76.89	21.66		65.0	
10105-CAC	LTE-TDD (SC-FDMA, 100% RB, 20 MHz, 64-QAM)	X	7.58	74.70	20.99	3.98	65.0	± 9.6 %
		Y	7.79	75.45	21.40		65.0	
		Z	7.31	74.25	20.79		65.0	
10108-CAD	LTE-FDD (SC-FDMA, 100% RB, 10 MHz, QPSK)	X	2.79	69.24	16.28	0.00	150.0	± 9.6 %
		Y	2.91	70.28	16.91		150.0	
		Z	2.71	69.00	16.16		150.0	
10109-CAD	LTE-FDD (SC-FDMA, 100% RB, 10 MHz, 16-QAM)	X	2.98	67.28	15.76	0.00	150.0	± 9.6 %
		Y	3.03	67.83	16.15		150.0	
		Z	2.92	67.15	15.65		150.0	
10110-CAD	LTE-FDD (SC-FDMA, 100% RB, 5 MHz, QPSK)	X	2.28	68.31	15.91	0.00	150.0	± 9.6 %
		Y	2.39	69.47	16.63		150.0	
		Z	2.21	68.09	15.75		150.0	
10111-CAD	LTE-FDD (SC-FDMA, 100% RB, 5 MHz, 16-QAM)	X	2.66	67.75	15.94	0.00	150.0	± 9.6 %
		Y	2.72	68.40	16.37		150.0	
		Z	2.60	67.66	15.80		150.0	

10112-CAD	LTE-FDD (SC-FDMA, 100% RB, 10 MHz, 64-QAM)	X	3.11	67.26	15.82	0.00	150.0	± 9.6 %
		Y	3.15	67.75	16.17		150.0	
		Z	3.05	67.15	15.72		150.0	
10113-CAD	LTE-FDD (SC-FDMA, 100% RB, 5 MHz, 64-QAM)	X	2.82	67.88	16.07	0.00	150.0	± 9.6 %
		Y	2.87	68.46	16.46		150.0	
		Z	2.76	67.81	15.94		150.0	
10114-CAB	IEEE 802.11n (HT Greenfield, 13.5 Mbps, BPSK)	X	5.24	67.28	16.46	0.00	150.0	± 9.6 %
		Y	5.25	67.46	16.63		150.0	
		Z	5.20	67.29	16.46		150.0	
10115-CAB	IEEE 802.11n (HT Greenfield, 81 Mbps, 16-QAM)	X	5.61	67.64	16.65	0.00	150.0	± 9.6 %
		Y	5.61	67.79	16.81		150.0	
		Z	5.52	67.52	16.58		150.0	
10116-CAB	IEEE 802.11n (HT Greenfield, 135 Mbps, 64-QAM)	X	5.36	67.55	16.52	0.00	150.0	± 9.6 %
		Y	5.37	67.74	16.69		150.0	
		Z	5.32	67.53	16.51		150.0	
10117-CAB	IEEE 802.11n (HT Mixed, 13.5 Mbps, BPSK)	X	5.22	67.23	16.45	0.00	150.0	± 9.6 %
		Y	5.23	67.39	16.61		150.0	
		Z	5.17	67.16	16.41		150.0	
10118-CAB	IEEE 802.11n (HT Mixed, 81 Mbps, 16-QAM)	X	5.69	67.85	16.77	0.00	150.0	± 9.6 %
		Y	5.70	68.02	16.93		150.0	
		Z	5.63	67.79	16.73		150.0	
10119-CAB	IEEE 802.11n (HT Mixed, 135 Mbps, 64-QAM)	X	5.34	67.49	16.51	0.00	150.0	± 9.6 %
		Y	5.35	67.67	16.67		150.0	
		Z	5.29	67.47	16.49		150.0	
10140-CAC	LTE-FDD (SC-FDMA, 100% RB, 15 MHz, 16-QAM)	X	3.47	67.47	15.89	0.00	150.0	± 9.6 %
		Y	3.51	67.91	16.21		150.0	
		Z	3.41	67.34	15.80		150.0	
10141-CAC	LTE-FDD (SC-FDMA, 100% RB, 15 MHz, 64-QAM)	X	3.59	67.54	16.05	0.00	150.0	± 9.6 %
		Y	3.63	67.94	16.35		150.0	
		Z	3.53	67.43	15.97		150.0	
10142-CAD	LTE-FDD (SC-FDMA, 100% RB, 3 MHz, QPSK)	X	2.05	68.16	15.60	0.00	150.0	± 9.6 %
		Y	2.17	69.48	16.39		150.0	
		Z	1.97	67.92	15.36		150.0	
10143-CAD	LTE-FDD (SC-FDMA, 100% RB, 3 MHz, 16-QAM)	X	2.51	68.28	15.68	0.00	150.0	± 9.6 %
		Y	2.59	69.11	16.17		150.0	
		Z	2.43	68.15	15.43		150.0	
10144-CAD	LTE-FDD (SC-FDMA, 100% RB, 3 MHz, 64-QAM)	X	2.35	66.54	14.37	0.00	150.0	± 9.6 %
		Y	2.42	67.28	14.84		150.0	
		Z	2.27	66.32	14.07		150.0	
10145-CAD	LTE-FDD (SC-FDMA, 100% RB, 1.4 MHz, QPSK)	X	1.37	65.72	12.66	0.00	150.0	± 9.6 %
		Y	1.46	66.99	13.37		150.0	
		Z	1.25	64.89	11.82		150.0	
10146-CAD	LTE-FDD (SC-FDMA, 100% RB, 1.4 MHz, 16-QAM)	X	3.11	71.69	15.06	0.00	150.0	± 9.6 %
		Y	3.87	74.93	16.48		150.0	
		Z	2.20	67.57	12.72		150.0	
10147-CAD	LTE-FDD (SC-FDMA, 100% RB, 1.4 MHz, 64-QAM)	X	3.99	75.14	16.65	0.00	150.0	± 9.6 %
		Y	5.26	79.21	18.27		150.0	
		Z	2.59	69.69	13.85		150.0	

10149-CAC	LTE-FDD (SC-FDMA, 50% RB, 20 MHz, 16-QAM)	X	2.99	67.34	15.80	0.00	150.0	± 9.6 %
		Y	3.04	67.88	16.19		150.0	
		Z	2.93	67.20	15.70		150.0	
10150-CAC	LTE-FDD (SC-FDMA, 50% RB, 20 MHz, 64-QAM)	X	3.11	67.30	15.85	0.00	150.0	± 9.6 %
		Y	3.16	67.79	16.21		150.0	
		Z	3.05	67.19	15.76		150.0	
10151-CAC	LTE-TDD (SC-FDMA, 50% RB, 20 MHz, QPSK)	X	9.14	80.78	22.44	3.98	65.0	± 9.6 %
		Y	9.49	81.66	22.85		65.0	
		Z	9.14	81.08	22.55		65.0	
10152-CAC	LTE-TDD (SC-FDMA, 50% RB, 20 MHz, 16-QAM)	X	8.08	77.12	21.52	3.98	65.0	± 9.6 %
		Y	8.33	77.95	21.96		65.0	
		Z	7.95	77.09	21.46		65.0	
10153-CAC	LTE-TDD (SC-FDMA, 50% RB, 20 MHz, 64-QAM)	X	8.46	77.89	22.17	3.98	65.0	± 9.6 %
		Y	8.68	78.63	22.56		65.0	
		Z	8.36	77.94	22.15		65.0	
10154-CAD	LTE-FDD (SC-FDMA, 50% RB, 10 MHz, QPSK)	X	2.33	68.67	16.15	0.00	150.0	± 9.6 %
		Y	2.44	69.83	16.86		150.0	
		Z	2.25	68.43	15.98		150.0	
10155-CAD	LTE-FDD (SC-FDMA, 50% RB, 10 MHz, 16-QAM)	X	2.66	67.76	15.95	0.00	150.0	± 9.6 %
		Y	2.72	68.41	16.38		150.0	
		Z	2.60	67.68	15.82		150.0	
10156-CAD	LTE-FDD (SC-FDMA, 50% RB, 5 MHz, QPSK)	X	1.90	68.21	15.44	0.00	150.0	± 9.6 %
		Y	2.03	69.70	16.30		150.0	
		Z	1.81	67.89	15.12		150.0	
10157-CAD	LTE-FDD (SC-FDMA, 50% RB, 5 MHz, 16-QAM)	X	2.18	67.00	14.41	0.00	150.0	± 9.6 %
		Y	2.26	67.93	14.96		150.0	
		Z	2.09	66.73	14.04		150.0	
10158-CAD	LTE-FDD (SC-FDMA, 50% RB, 10 MHz, 64-QAM)	X	2.82	67.92	16.11	0.00	150.0	± 9.6 %
		Y	2.87	68.51	16.50		150.0	
		Z	2.76	67.86	15.98		150.0	
10159-CAD	LTE-FDD (SC-FDMA, 50% RB, 5 MHz, 64-QAM)	X	2.28	67.39	14.67	0.00	150.0	± 9.6 %
		Y	2.36	68.28	15.19		150.0	
		Z	2.18	67.11	14.29		150.0	
10160-CAC	LTE-FDD (SC-FDMA, 50% RB, 15 MHz, QPSK)	X	2.82	68.45	16.16	0.00	150.0	± 9.6 %
		Y	2.91	69.30	16.70		150.0	
		Z	2.76	68.35	16.07		150.0	
10161-CAC	LTE-FDD (SC-FDMA, 50% RB, 15 MHz, 16-QAM)	X	3.01	67.20	15.78	0.00	150.0	± 9.6 %
		Y	3.05	67.71	16.14		150.0	
		Z	2.95	67.10	15.68		150.0	
10162-CAC	LTE-FDD (SC-FDMA, 50% RB, 15 MHz, 64-QAM)	X	3.11	67.31	15.88	0.00	150.0	± 9.6 %
		Y	3.16	67.80	16.23		150.0	
		Z	3.06	67.24	15.78		150.0	
10166-CAD	LTE-FDD (SC-FDMA, 50% RB, 1.4 MHz, QPSK)	X	3.96	70.63	19.76	3.01	150.0	± 9.6 %
		Y	4.08	71.58	20.41		150.0	
		Z	3.69	69.63	19.19		150.0	
10167-CAD	LTE-FDD (SC-FDMA, 50% RB, 1.4 MHz, 16-QAM)	X	5.16	74.36	20.54	3.01	150.0	± 9.6 %
		Y	5.47	75.92	21.41		150.0	
		Z	4.54	72.52	19.67		150.0	

10168-CAD	LTE-FDD (SC-FDMA, 50% RB, 1.4 MHz, 64-QAM)	X	5.71	76.55	21.79	3.01	150.0	± 9.6 %
		Y	6.04	78.08	22.60		150.0	
		Z	4.98	74.53	20.87		150.0	
10169-CAC	LTE-FDD (SC-FDMA, 1 RB, 20 MHz, QPSK)	X	3.56	71.66	20.23	3.01	150.0	± 9.6 %
		Y	3.72	73.10	21.16		150.0	
		Z	3.12	69.36	19.09		150.0	
10170-CAC	LTE-FDD (SC-FDMA, 1 RB, 20 MHz, 16-QAM)	X	5.50	79.49	23.11	3.01	150.0	± 9.6 %
		Y	6.14	82.25	24.43		150.0	
		Z	4.23	74.96	21.26		150.0	
10171-AAC	LTE-FDD (SC-FDMA, 1 RB, 20 MHz, 64-QAM)	X	4.39	74.63	20.21	3.01	150.0	± 9.6 %
		Y	4.87	77.16	21.52		150.0	
		Z	3.55	71.26	18.74		150.0	
10172-CAC	LTE-TDD (SC-FDMA, 1 RB, 20 MHz, QPSK)	X	36.90	115.61	35.71	6.02	65.0	± 9.6 %
		Y	89.16	134.58	40.97		65.0	
		Z	21.04	105.02	32.65		65.0	
10173-CAC	LTE-TDD (SC-FDMA, 1 RB, 20 MHz, 16-QAM)	X	54.93	117.26	34.23	6.02	65.0	± 9.6 %
		Y	100.00	128.92	37.35		65.0	
		Z	30.85	107.44	31.57		65.0	
10174-CAC	LTE-TDD (SC-FDMA, 1 RB, 20 MHz, 64-QAM)	X	39.60	109.76	31.68	6.02	65.0	± 9.6 %
		Y	70.95	120.74	34.73		65.0	
		Z	23.48	101.22	29.25		65.0	
10175-CAD	LTE-FDD (SC-FDMA, 1 RB, 10 MHz, QPSK)	X	3.51	71.32	19.98	3.01	150.0	± 9.6 %
		Y	3.68	72.77	20.92		150.0	
		Z	3.08	69.09	18.87		150.0	
10176-CAD	LTE-FDD (SC-FDMA, 1 RB, 10 MHz, 16-QAM)	X	5.51	79.52	23.12	3.01	150.0	± 9.6 %
		Y	6.15	82.28	24.44		150.0	
		Z	4.23	74.98	21.27		150.0	
10177-CAF	LTE-FDD (SC-FDMA, 1 RB, 5 MHz, QPSK)	X	3.54	71.49	20.08	3.01	150.0	± 9.6 %
		Y	3.71	72.93	21.01		150.0	
		Z	3.11	69.22	18.95		150.0	
10178-CAD	LTE-FDD (SC-FDMA, 1 RB, 5 MHz, 16-QAM)	X	5.43	79.21	22.98	3.01	150.0	± 9.6 %
		Y	6.06	81.97	24.30		150.0	
		Z	4.19	74.78	21.16		150.0	
10179-CAD	LTE-FDD (SC-FDMA, 1 RB, 10 MHz, 64-QAM)	X	4.90	76.90	21.51	3.01	150.0	± 9.6 %
		Y	5.47	79.59	22.84		150.0	
		Z	3.86	73.02	19.88		150.0	
10180-CAD	LTE-FDD (SC-FDMA, 1 RB, 5 MHz, 64-QAM)	X	4.38	74.54	20.15	3.01	150.0	± 9.6 %
		Y	4.86	77.07	21.46		150.0	
		Z	3.54	71.20	18.69		150.0	
10181-CAC	LTE-FDD (SC-FDMA, 1 RB, 15 MHz, QPSK)	X	3.54	71.47	20.07	3.01	150.0	± 9.6 %
		Y	3.70	72.91	21.00		150.0	
		Z	3.10	69.21	18.95		150.0	
10182-CAC	LTE-FDD (SC-FDMA, 1 RB, 15 MHz, 16-QAM)	X	5.42	79.19	22.97	3.01	150.0	± 9.6 %
		Y	6.05	81.94	24.29		150.0	
		Z	4.19	74.76	21.15		150.0	
10183-AAB	LTE-FDD (SC-FDMA, 1 RB, 15 MHz, 64-QAM)	X	4.37	74.51	20.14	3.01	150.0	± 9.6 %
		Y	4.85	77.04	21.45		150.0	
		Z	3.53	71.17	18.68		150.0	

10184-CAD	LTE-FDD (SC-FDMA, 1 RB, 3 MHz, QPSK)	X	3.55	71.52	20.09	3.01	150.0	± 9.6 %
		Y	3.72	72.96	21.02		150.0	
		Z	3.11	69.25	18.97		150.0	
10185-CAD	LTE-FDD (SC-FDMA, 1 RB, 3 MHz, 16-QAM)	X	5.45	79.27	23.00	3.01	150.0	± 9.6 %
		Y	6.09	82.03	24.33		150.0	
		Z	4.20	74.82	21.19		150.0	
10186-AAD	LTE-FDD (SC-FDMA, 1 RB, 3 MHz, 64-QAM)	X	4.39	74.59	20.17	3.01	150.0	± 9.6 %
		Y	4.88	77.13	21.49		150.0	
		Z	3.55	71.24	18.71		150.0	
10187-CAD	LTE-FDD (SC-FDMA, 1 RB, 1.4 MHz, QPSK)	X	3.56	71.57	20.15	3.01	150.0	± 9.6 %
		Y	3.73	73.01	21.08		150.0	
		Z	3.12	69.30	19.03		150.0	
10188-CAD	LTE-FDD (SC-FDMA, 1 RB, 1.4 MHz, 16-QAM)	X	5.67	80.08	23.42	3.01	150.0	± 9.6 %
		Y	6.33	82.86	24.73		150.0	
		Z	4.33	75.42	21.53		150.0	
10189-AAD	LTE-FDD (SC-FDMA, 1 RB, 1.4 MHz, 64-QAM)	X	4.51	75.09	20.47	3.01	150.0	± 9.6 %
		Y	5.01	77.67	21.79		150.0	
		Z	3.62	71.63	18.97		150.0	
10193-CAB	IEEE 802.11n (HT Greenfield, 6.5 Mbps, BPSK)	X	4.64	66.65	16.17	0.00	150.0	± 9.6 %
		Y	4.65	66.84	16.35		150.0	
		Z	4.59	66.64	16.13		150.0	
10194-CAB	IEEE 802.11n (HT Greenfield, 39 Mbps, 16-QAM)	X	4.82	67.00	16.30	0.00	150.0	± 9.6 %
		Y	4.83	67.19	16.48		150.0	
		Z	4.76	66.96	16.26		150.0	
10195-CAB	IEEE 802.11n (HT Greenfield, 65 Mbps, 64-QAM)	X	4.87	67.02	16.31	0.00	150.0	± 9.6 %
		Y	4.87	67.22	16.49		150.0	
		Z	4.81	67.00	16.28		150.0	
10196-CAB	IEEE 802.11n (HT Mixed, 6.5 Mbps, BPSK)	X	4.65	66.74	16.20	0.00	150.0	± 9.6 %
		Y	4.66	66.93	16.38		150.0	
		Z	4.59	66.71	16.15		150.0	
10197-CAB	IEEE 802.11n (HT Mixed, 39 Mbps, 16-QAM)	X	4.84	67.02	16.31	0.00	150.0	± 9.6 %
		Y	4.85	67.22	16.49		150.0	
		Z	4.78	66.99	16.27		150.0	
10198-CAB	IEEE 802.11n (HT Mixed, 65 Mbps, 64-QAM)	X	4.87	67.04	16.32	0.00	150.0	± 9.6 %
		Y	4.88	67.24	16.50		150.0	
		Z	4.81	67.01	16.29		150.0	
10219-CAB	IEEE 802.11n (HT Mixed, 7.2 Mbps, BPSK)	X	4.60	66.74	16.16	0.00	150.0	± 9.6 %
		Y	4.61	66.94	16.34		150.0	
		Z	4.54	66.71	16.11		150.0	
10220-CAB	IEEE 802.11n (HT Mixed, 43.3 Mbps, 16-QAM)	X	4.84	67.00	16.31	0.00	150.0	± 9.6 %
		Y	4.84	67.20	16.48		150.0	
		Z	4.77	66.96	16.26		150.0	
10221-CAB	IEEE 802.11n (HT Mixed, 72.2 Mbps, 64-QAM)	X	4.88	66.97	16.31	0.00	150.0	± 9.6 %
		Y	4.89	67.16	16.49		150.0	
		Z	4.82	66.95	16.28		150.0	
10222-CAB	IEEE 802.11n (HT Mixed, 15 Mbps, BPSK)	X	5.20	67.24	16.45	0.00	150.0	± 9.6 %
		Y	5.21	67.41	16.61		150.0	
		Z	5.15	67.17	16.40		150.0	

10223-CAB	IEEE 802.11n (HT Mixed, 90 Mbps, 16-QAM)	X	5.54	67.51	16.61	0.00	150.0	± 9.6 %
		Y	5.54	67.65	16.76		150.0	
		Z	5.46	67.41	16.55		150.0	
10224-CAB	IEEE 802.11n (HT Mixed, 150 Mbps, 64-QAM)	X	5.24	67.33	16.42	0.00	150.0	± 9.6 %
		Y	5.25	67.50	16.58		150.0	
		Z	5.19	67.27	16.38		150.0	
10225-CAB	UMTS-FDD (HSPA+)	X	2.89	66.01	15.34	0.00	150.0	± 9.6 %
		Y	2.91	66.41	15.64		150.0	
		Z	2.83	65.96	15.20		150.0	
10226-CAA	LTE-TDD (SC-FDMA, 1 RB, 1.4 MHz, 16-QAM)	X	60.00	119.05	34.79	6.02	65.0	± 9.6 %
		Y	100.00	129.10	37.47		65.0	
		Z	33.08	108.86	32.05		65.0	
10227-CAA	LTE-TDD (SC-FDMA, 1 RB, 1.4 MHz, 64-QAM)	X	44.36	111.89	32.33	6.02	65.0	± 9.6 %
		Y	77.77	122.52	35.25		65.0	
		Z	27.85	104.26	30.19		65.0	
10228-CAA	LTE-TDD (SC-FDMA, 1 RB, 1.4 MHz, QPSK)	X	40.71	118.07	36.50	6.02	65.0	± 9.6 %
		Y	92.59	135.95	41.44		65.0	
		Z	26.22	109.78	34.13		65.0	
10229-CAB	LTE-TDD (SC-FDMA, 1 RB, 3 MHz, 16-QAM)	X	54.96	117.26	34.24	6.02	65.0	± 9.6 %
		Y	100.00	128.91	37.35		65.0	
		Z	30.93	107.47	31.58		65.0	
10230-CAB	LTE-TDD (SC-FDMA, 1 RB, 3 MHz, 64-QAM)	X	41.37	110.53	31.89	6.02	65.0	± 9.6 %
		Y	71.92	120.98	34.79		65.0	
		Z	26.25	103.12	29.80		65.0	
10231-CAB	LTE-TDD (SC-FDMA, 1 RB, 3 MHz, QPSK)	X	37.97	116.54	36.00	6.02	65.0	± 9.6 %
		Y	84.76	133.97	40.88		65.0	
		Z	24.71	108.49	33.69		65.0	
10232-CAC	LTE-TDD (SC-FDMA, 1 RB, 5 MHz, 16-QAM)	X	54.99	117.28	34.24	6.02	65.0	± 9.6 %
		Y	100.00	128.92	37.35		65.0	
		Z	30.92	107.48	31.58		65.0	
10233-CAC	LTE-TDD (SC-FDMA, 1 RB, 5 MHz, 64-QAM)	X	41.40	110.55	31.90	6.02	65.0	± 9.6 %
		Y	72.14	121.04	34.81		65.0	
		Z	26.24	103.13	29.80		65.0	
10234-CAC	LTE-TDD (SC-FDMA, 1 RB, 5 MHz, QPSK)	X	35.49	114.97	35.47	6.02	65.0	± 9.6 %
		Y	77.34	131.82	40.23		65.0	
		Z	23.39	107.20	33.21		65.0	
10235-CAC	LTE-TDD (SC-FDMA, 1 RB, 10 MHz, 16-QAM)	X	55.28	117.39	34.27	6.02	65.0	± 9.6 %
		Y	100.00	128.93	37.36		65.0	
		Z	31.03	107.56	31.61		65.0	
10236-CAC	LTE-TDD (SC-FDMA, 1 RB, 10 MHz, 64-QAM)	X	41.91	110.74	31.95	6.02	65.0	± 9.6 %
		Y	73.33	121.30	34.87		65.0	
		Z	26.52	103.28	29.84		65.0	
10237-CAC	LTE-TDD (SC-FDMA, 1 RB, 10 MHz, QPSK)	X	38.41	116.80	36.08	6.02	65.0	± 9.6 %
		Y	86.80	134.49	41.01		65.0	
		Z	24.91	108.68	33.74		65.0	
10238-CAC	LTE-TDD (SC-FDMA, 1 RB, 15 MHz, 16-QAM)	X	55.05	117.31	34.25	6.02	65.0	± 9.6 %
		Y	100.00	128.93	37.35		65.0	
		Z	30.91	107.49	31.58		65.0	

10239-CAC	LTE-TDD (SC-FDMA, 1 RB, 15 MHz, 64-QAM)	X	41.42	110.58	31.91	6.02	65.0	± 9.6 %
		Y	72.33	121.11	34.83		65.0	
		Z	26.22	103.13	29.80		65.0	
10240-CAC	LTE-TDD (SC-FDMA, 1 RB, 15 MHz, QPSK)	X	38.25	116.72	36.05	6.02	65.0	± 9.6 %
		Y	86.28	134.37	40.98		65.0	
		Z	24.82	108.62	33.73		65.0	
10241-CAA	LTE-TDD (SC-FDMA, 50% RB, 1.4 MHz, 16-QAM)	X	12.92	88.42	28.30	6.98	65.0	± 9.6 %
		Y	14.47	91.50	29.64		65.0	
		Z	11.71	86.68	27.54		65.0	
10242-CAA	LTE-TDD (SC-FDMA, 50% RB, 1.4 MHz, 64-QAM)	X	12.30	87.28	27.78	6.98	65.0	± 9.6 %
		Y	13.91	90.55	29.21		65.0	
		Z	10.78	84.84	26.74		65.0	
10243-CAA	LTE-TDD (SC-FDMA, 50% RB, 1.4 MHz, QPSK)	X	9.57	83.58	27.27	6.98	65.0	± 9.6 %
		Y	10.70	86.76	28.80		65.0	
		Z	8.63	81.57	26.33		65.0	
10244-CAB	LTE-TDD (SC-FDMA, 50% RB, 3 MHz, 16-QAM)	X	9.97	81.73	21.53	3.98	65.0	± 9.6 %
		Y	10.43	82.64	21.91		65.0	
		Z	8.76	79.58	20.36		65.0	
10245-CAB	LTE-TDD (SC-FDMA, 50% RB, 3 MHz, 64-QAM)	X	9.75	81.12	21.26	3.98	65.0	± 9.6 %
		Y	10.17	81.97	21.61		65.0	
		Z	8.56	78.97	20.07		65.0	
10246-CAB	LTE-TDD (SC-FDMA, 50% RB, 3 MHz, QPSK)	X	9.14	83.08	21.95	3.98	65.0	± 9.6 %
		Y	9.72	84.22	22.38		65.0	
		Z	8.89	82.67	21.56		65.0	
10247-CAC	LTE-TDD (SC-FDMA, 50% RB, 5 MHz, 16-QAM)	X	7.53	77.68	20.47	3.98	65.0	± 9.6 %
		Y	7.73	78.28	20.74		65.0	
		Z	7.33	77.37	20.13		65.0	
10248-CAC	LTE-TDD (SC-FDMA, 50% RB, 5 MHz, 64-QAM)	X	7.50	77.17	20.25	3.98	65.0	± 9.6 %
		Y	7.71	77.80	20.54		65.0	
		Z	7.27	76.81	19.89		65.0	
10249-CAC	LTE-TDD (SC-FDMA, 50% RB, 5 MHz, QPSK)	X	10.17	85.08	23.35	3.98	65.0	± 9.6 %
		Y	10.94	86.52	23.90		65.0	
		Z	10.18	85.27	23.26		65.0	
10250-CAC	LTE-TDD (SC-FDMA, 50% RB, 10 MHz, 16-QAM)	X	8.40	79.60	22.53	3.98	65.0	± 9.6 %
		Y	8.67	80.38	22.90		65.0	
		Z	8.32	79.67	22.46		65.0	
10251-CAC	LTE-TDD (SC-FDMA, 50% RB, 10 MHz, 64-QAM)	X	7.96	77.51	21.40	3.98	65.0	± 9.6 %
		Y	8.23	78.35	21.83		65.0	
		Z	7.84	77.49	21.29		65.0	
10252-CAC	LTE-TDD (SC-FDMA, 50% RB, 10 MHz, QPSK)	X	9.91	84.03	23.67	3.98	65.0	± 9.6 %
		Y	10.54	85.36	24.22		65.0	
		Z	9.99	84.47	23.78		65.0	
10253-CAC	LTE-TDD (SC-FDMA, 50% RB, 15 MHz, 16-QAM)	X	7.87	76.54	21.30	3.98	65.0	± 9.6 %
		Y	8.11	77.33	21.72		65.0	
		Z	7.77	76.53	21.24		65.0	
10254-CAC	LTE-TDD (SC-FDMA, 50% RB, 15 MHz, 64-QAM)	X	8.25	77.30	21.90	3.98	65.0	± 9.6 %
		Y	8.47	78.02	22.29		65.0	
		Z	8.16	77.35	21.86		65.0	

10255- CAC	LTE-TDD (SC-FDMA, 50% RB, 15 MHz, QPSK)	X	8.82	80.37	22.51	3.98	65.0	± 9.6 %
		Y	9.18	81.32	22.95		65.0	
		Z	8.82	80.67	22.60		65.0	
10256- CAA	LTE-TDD (SC-FDMA, 100% RB, 1.4 MHz, 16-QAM)	X	8.67	79.06	19.69	3.98	65.0	± 9.6 %
		Y	9.00	79.76	19.98		65.0	
		Z	7.35	76.40	18.22		65.0	
10257- CAA	LTE-TDD (SC-FDMA, 100% RB, 1.4 MHz, 64-QAM)	X	8.39	78.18	19.27	3.98	65.0	± 9.6 %
		Y	8.67	78.82	19.53		65.0	
		Z	7.11	75.57	17.80		65.0	
10258- CAA	LTE-TDD (SC-FDMA, 100% RB, 1.4 MHz, QPSK)	X	7.67	79.80	20.11	3.98	65.0	± 9.6 %
		Y	7.97	80.50	20.36		65.0	
		Z	7.13	78.64	19.35		65.0	
10259- CAB	LTE-TDD (SC-FDMA, 100% RB, 3 MHz, 16-QAM)	X	7.87	78.36	21.19	3.98	65.0	± 9.6 %
		Y	8.11	79.04	21.50		65.0	
		Z	7.72	78.21	20.96		65.0	
10260- CAB	LTE-TDD (SC-FDMA, 100% RB, 3 MHz, 64-QAM)	X	7.88	78.07	21.09	3.98	65.0	± 9.6 %
		Y	8.10	78.72	21.39		65.0	
		Z	7.71	77.89	20.85		65.0	
10261- CAB	LTE-TDD (SC-FDMA, 100% RB, 3 MHz, QPSK)	X	9.63	83.94	23.25	3.98	65.0	± 9.6 %
		Y	10.30	85.33	23.81		65.0	
		Z	9.64	84.17	23.22		65.0	
10262- CAC	LTE-TDD (SC-FDMA, 100% RB, 5 MHz, 16-QAM)	X	8.39	79.56	22.49	3.98	65.0	± 9.6 %
		Y	8.66	80.34	22.86		65.0	
		Z	8.31	79.62	22.42		65.0	
10263- CAC	LTE-TDD (SC-FDMA, 100% RB, 5 MHz, 64-QAM)	X	7.95	77.50	21.40	3.98	65.0	± 9.6 %
		Y	8.22	78.34	21.82		65.0	
		Z	7.83	77.47	21.29		65.0	
10264- CAC	LTE-TDD (SC-FDMA, 100% RB, 5 MHz, QPSK)	X	9.83	83.88	23.59	3.98	65.0	± 9.6 %
		Y	10.46	85.22	24.15		65.0	
		Z	9.91	84.30	23.70		65.0	
10265- CAC	LTE-TDD (SC-FDMA, 100% RB, 10 MHz, 16-QAM)	X	8.08	77.12	21.52	3.98	65.0	± 9.6 %
		Y	8.33	77.96	21.96		65.0	
		Z	7.95	77.09	21.47		65.0	
10266- CAC	LTE-TDD (SC-FDMA, 100% RB, 10 MHz, 64-QAM)	X	8.45	77.88	22.16	3.98	65.0	± 9.6 %
		Y	8.68	78.62	22.55		65.0	
		Z	8.36	77.93	22.14		65.0	
10267- CAC	LTE-TDD (SC-FDMA, 100% RB, 10 MHz, QPSK)	X	9.12	80.75	22.43	3.98	65.0	± 9.6 %
		Y	9.47	81.62	22.84		65.0	
		Z	9.12	81.04	22.54		65.0	
10268- CAC	LTE-TDD (SC-FDMA, 100% RB, 15 MHz, 16-QAM)	X	8.54	76.63	21.68	3.98	65.0	± 9.6 %
		Y	8.73	77.26	22.04		65.0	
		Z	8.44	76.63	21.67		65.0	
10269- CAC	LTE-TDD (SC-FDMA, 100% RB, 15 MHz, 64-QAM)	X	8.47	76.21	21.58	3.98	65.0	± 9.6 %
		Y	8.64	76.83	21.94		65.0	
		Z	8.37	76.22	21.56		65.0	
10270- CAC	LTE-TDD (SC-FDMA, 100% RB, 15 MHz, QPSK)	X	8.62	78.00	21.50	3.98	65.0	± 9.6 %
		Y	8.81	78.56	21.80		65.0	
		Z	8.57	78.16	21.57		65.0	

10274-CAB	UMTS-FDD (HSUPA, Subtest 5, 3GPP Rel8.10)	X	2.63	66.22	15.16	0.00	150.0	± 9.6 %
		Y	2.68	66.76	15.56		150.0	
		Z	2.60	66.20	15.05		150.0	
10275-CAB	UMTS-FDD (HSUPA, Subtest 5, 3GPP Rel8.4)	X	1.63	67.34	15.24	0.00	150.0	± 9.6 %
		Y	1.75	68.91	16.21		150.0	
		Z	1.59	67.10	15.04		150.0	
10277-CAA	PHS (QPSK)	X	5.23	69.17	13.58	9.03	50.0	± 9.6 %
		Y	5.23	69.14	13.54		50.0	
		Z	4.94	68.42	12.95		50.0	
10278-CAA	PHS (QPSK, BW 884MHz, Rolloff 0.5)	X	9.44	80.92	21.03	9.03	50.0	± 9.6 %
		Y	9.27	80.52	20.82		50.0	
		Z	8.80	79.60	20.21		50.0	
10279-CAA	PHS (QPSK, BW 884MHz, Rolloff 0.38)	X	9.60	81.11	21.12	9.03	50.0	± 9.6 %
		Y	9.45	80.75	20.93		50.0	
		Z	8.93	79.76	20.30		50.0	
10290-AAB	CDMA2000, RC1, SO55, Full Rate	X	1.49	68.14	14.07	0.00	150.0	± 9.6 %
		Y	1.71	70.53	15.29		150.0	
		Z	1.38	67.47	13.43		150.0	
10291-AAB	CDMA2000, RC3, SO55, Full Rate	X	0.87	65.35	12.59	0.00	150.0	± 9.6 %
		Y	0.98	67.67	13.90		150.0	
		Z	0.81	64.81	11.96		150.0	
10292-AAB	CDMA2000, RC3, SO32, Full Rate	X	1.01	68.28	14.43	0.00	150.0	± 9.6 %
		Y	1.28	72.37	16.47		150.0	
		Z	0.94	67.61	13.77		150.0	
10293-AAB	CDMA2000, RC3, SO3, Full Rate	X	1.31	72.09	16.62	0.00	150.0	± 9.6 %
		Y	1.86	78.07	19.28		150.0	
		Z	1.24	71.48	16.00		150.0	
10295-AAB	CDMA2000, RC1, SO3, 1/8th Rate 25 fr.	X	11.68	86.43	25.21	9.03	50.0	± 9.6 %
		Y	12.34	87.51	25.61		50.0	
		Z	12.30	87.31	25.27		50.0	
10297-AAB	LTE-FDD (SC-FDMA, 50% RB, 20 MHz, QPSK)	X	2.80	69.32	16.34	0.00	150.0	± 9.6 %
		Y	2.92	70.37	16.97		150.0	
		Z	2.72	69.08	16.22		150.0	
10298-AAC	LTE-FDD (SC-FDMA, 50% RB, 3 MHz, QPSK)	X	1.65	67.43	14.29	0.00	150.0	± 9.6 %
		Y	1.78	69.00	15.16		150.0	
		Z	1.54	66.87	13.72		150.0	
10299-AAC	LTE-FDD (SC-FDMA, 50% RB, 3 MHz, 16-QAM)	X	3.71	73.80	16.79	0.00	150.0	± 9.6 %
		Y	4.50	76.98	18.19		150.0	
		Z	2.80	70.24	14.88		150.0	
10300-AAC	LTE-FDD (SC-FDMA, 50% RB, 3 MHz, 64-QAM)	X	2.66	68.22	13.61	0.00	150.0	± 9.6 %
		Y	2.97	70.07	14.57		150.0	
		Z	2.16	65.95	12.13		150.0	
10301-AAA	IEEE 802.16e WiMAX (29:18, 5ms, 10MHz, QPSK, PUSC)	X	5.56	67.67	18.53	4.17	80.0	± 9.6 %
		Y	5.78	68.72	19.18		80.0	
		Z	5.51	67.68	18.44		80.0	
10302-AAA	IEEE 802.16e WiMAX (29:18, 5ms, 10MHz, QPSK, PUSC, 3 CTRL symbols)	X	6.08	68.43	19.36	4.96	80.0	± 9.6 %
		Y	6.31	69.64	20.14		80.0	
		Z	6.00	68.40	19.26		80.0	

10303-AAA	IEEE 802.16e WiMAX (31:15, 5ms, 10MHz, 64QAM, PUSC)	X	5.91	68.44	19.38	4.96	80.0	± 9.6 %
		Y	6.17	69.77	20.23		80.0	
		Z	5.83	68.37	19.25		80.0	
10304-AAA	IEEE 802.16e WiMAX (29:18, 5ms, 10MHz, 64QAM, PUSC)	X	5.57	67.76	18.57	4.17	80.0	± 9.6 %
		Y	5.77	68.85	19.27		80.0	
		Z	5.49	67.73	18.47		80.0	
10305-AAA	IEEE 802.16e WiMAX (31:15, 10ms, 10MHz, 64QAM, PUSC, 15 symbols)	X	7.72	78.82	24.99	6.02	50.0	± 9.6 %
		Y	9.80	85.05	27.90		50.0	
		Z	7.68	78.78	24.73		50.0	
10306-AAA	IEEE 802.16e WiMAX (29:18, 10ms, 10MHz, 64QAM, PUSC, 18 symbols)	X	6.19	70.81	21.17	6.02	50.0	± 9.6 %
		Y	6.78	73.45	22.69		50.0	
		Z	6.09	70.68	20.96		50.0	
10307-AAA	IEEE 802.16e WiMAX (29:18, 10ms, 10MHz, QPSK, PUSC, 18 symbols)	X	6.23	71.39	21.28	6.02	50.0	± 9.6 %
		Y	6.93	74.34	22.91		50.0	
		Z	6.66	74.17	22.78		50.0	
10308-AAA	IEEE 802.16e WiMAX (29:18, 10ms, 10MHz, 16QAM, PUSC)	X	6.84	74.87	23.29	6.02	50.0	± 9.6 %
		Y	7.04	74.94	23.20		50.0	
		Z	6.77	74.83	23.10		50.0	
10309-AAA	IEEE 802.16e WiMAX (29:18, 10ms, 10MHz, 16QAM, AMC 2x3, 18 symbols)	X	6.29	71.13	21.36	6.02	50.0	± 9.6 %
		Y	6.92	73.87	22.92		50.0	
		Z	6.18	70.98	21.13		50.0	
10310-AAA	IEEE 802.16e WiMAX (29:18, 10ms, 10MHz, QPSK, AMC 2x3, 18 symbols)	X	6.19	71.01	21.18	6.02	50.0	± 9.6 %
		Y	6.82	73.78	22.75		50.0	
		Z	6.55	73.55	22.58		50.0	
10311-AAB	LTE-FDD (SC-FDMA, 100% RB, 15 MHz, QPSK)	X	3.15	68.64	16.01	0.00	150.0	± 9.6 %
		Y	3.28	69.57	16.56		150.0	
		Z	3.07	68.40	15.89		150.0	
10313-AAA	iDEN 1:3	X	7.93	80.00	19.43	6.99	70.0	± 9.6 %
		Y	8.50	81.06	19.83		70.0	
		Z	7.91	80.08	19.40		70.0	
10314-AAA	iDEN 1:6	X	10.36	86.77	24.35	10.00	30.0	± 9.6 %
		Y	11.09	87.90	24.72		30.0	
		Z	10.57	87.37	24.52		30.0	
10315-AAB	IEEE 802.11b WiFi 2.4 GHz (DSSS, 1 Mbps, 96pc duty cycle)	X	1.16	64.08	15.18	0.17	150.0	± 9.6 %
		Y	1.19	64.95	15.92		150.0	
		Z	1.15	63.96	15.05		150.0	
10316-AAB	IEEE 802.11g WiFi 2.4 GHz (ERP-OFDM, 6 Mbps, 96pc duty cycle)	X	4.74	66.85	16.40	0.17	150.0	± 9.6 %
		Y	4.75	67.05	16.58		150.0	
		Z	4.69	66.84	16.36		150.0	
10317-AAB	IEEE 802.11a WiFi 5 GHz (OFDM, 6 Mbps, 96pc duty cycle)	X	4.74	66.85	16.40	0.17	150.0	± 9.6 %
		Y	4.75	67.05	16.58		150.0	
		Z	4.69	66.84	16.36		150.0	
10400-AAC	IEEE 802.11ac WiFi (20MHz, 64-QAM, 99pc duty cycle)	X	4.83	67.07	16.30	0.00	150.0	± 9.6 %
		Y	4.84	67.29	16.50		150.0	
		Z	4.76	67.04	16.26		150.0	
10401-AAC	IEEE 802.11ac WiFi (40MHz, 64-QAM, 99pc duty cycle)	X	5.51	67.29	16.49	0.00	150.0	± 9.6 %
		Y	5.53	67.49	16.67		150.0	
		Z	5.49	67.36	16.51		150.0	

10402-AAC	IEEE 802.11ac WiFi (80MHz, 64-QAM, 99pc duty cycle)	X	5.79	67.69	16.53	0.00	150.0	± 9.6 %
		Y	5.79	67.83	16.67		150.0	
		Z	5.72	67.60	16.48		150.0	
10403-AAB	CDMA2000 (1xEV-DO, Rev. 0)	X	1.49	68.14	14.07	0.00	115.0	± 9.6 %
		Y	1.71	70.53	15.29		115.0	
		Z	1.38	67.47	13.43		115.0	
10404-AAB	CDMA2000 (1xEV-DO, Rev. A)	X	1.49	68.14	14.07	0.00	115.0	± 9.6 %
		Y	1.71	70.53	15.29		115.0	
		Z	1.38	67.47	13.43		115.0	
10406-AAB	CDMA2000, RC3, SO32, SCH0, Full Rate	X	100.00	122.23	31.08	0.00	100.0	± 9.6 %
		Y	100.00	122.94	31.38		100.0	
		Z	21.98	102.39	26.35		100.0	
10410-AAB	LTE-TDD (SC-FDMA, 1 RB, 10 MHz, QPSK, UL Subframe=2,3,4,7,8,9)	X	100.00	121.68	31.26	3.23	80.0	± 9.6 %
		Y	100.00	122.54	31.65		80.0	
		Z	100.00	121.97	31.19		80.0	
10415-AAA	IEEE 802.11b WiFi 2.4 GHz (DSSS, 1 Mbps, 99pc duty cycle)	X	1.03	62.73	14.35	0.00	150.0	± 9.6 %
		Y	1.04	63.46	15.05		150.0	
		Z	1.02	62.64	14.23		150.0	
10416-AAA	IEEE 802.11g WiFi 2.4 GHz (ERP-OFDM, 6 Mbps, 99pc duty cycle)	X	4.64	66.69	16.23	0.00	150.0	± 9.6 %
		Y	4.65	66.89	16.41		150.0	
		Z	4.59	66.68	16.20		150.0	
10417-AAA	IEEE 802.11a/h WiFi 5 GHz (OFDM, 6 Mbps, 99pc duty cycle)	X	4.64	66.69	16.23	0.00	150.0	± 9.6 %
		Y	4.65	66.89	16.41		150.0	
		Z	4.59	66.68	16.20		150.0	
10418-AAA	IEEE 802.11g WiFi 2.4 GHz (DSSS-OFDM, 6 Mbps, 99pc duty cycle, Long preamble)	X	4.63	66.83	16.23	0.00	150.0	± 9.6 %
		Y	4.64	67.04	16.42		150.0	
		Z	4.58	66.82	16.21		150.0	
10419-AAA	IEEE 802.11g WiFi 2.4 GHz (DSSS-OFDM, 6 Mbps, 99pc duty cycle, Short preamble)	X	4.65	66.79	16.24	0.00	150.0	± 9.6 %
		Y	4.66	66.99	16.43		150.0	
		Z	4.60	66.78	16.21		150.0	
10422-AAA	IEEE 802.11n (HT Greenfield, 7.2 Mbps, BPSK)	X	4.78	66.81	16.27	0.00	150.0	± 9.6 %
		Y	4.78	67.00	16.45		150.0	
		Z	4.72	66.79	16.24		150.0	
10423-AAA	IEEE 802.11n (HT Greenfield, 43.3 Mbps, 16-QAM)	X	4.96	67.16	16.40	0.00	150.0	± 9.6 %
		Y	4.97	67.35	16.58		150.0	
		Z	4.89	67.12	16.36		150.0	
10424-AAA	IEEE 802.11n (HT Greenfield, 72.2 Mbps, 64-QAM)	X	4.88	67.10	16.36	0.00	150.0	± 9.6 %
		Y	4.88	67.30	16.54		150.0	
		Z	4.81	67.07	16.33		150.0	
10425-AAA	IEEE 802.11n (HT Greenfield, 15 Mbps, BPSK)	X	5.49	67.52	16.59	0.00	150.0	± 9.6 %
		Y	5.50	67.70	16.76		150.0	
		Z	5.44	67.51	16.58		150.0	
10426-AAA	IEEE 802.11n (HT Greenfield, 90 Mbps, 16-QAM)	X	5.49	67.54	16.59	0.00	150.0	± 9.6 %
		Y	5.50	67.71	16.76		150.0	
		Z	5.45	67.53	16.59		150.0	

10427-AAA	IEEE 802.11n (HT Greenfield, 150 Mbps, 64-QAM)	X	5.50	67.50	16.57	0.00	150.0	± 9.6 %
		Y	5.51	67.67	16.73		150.0	
		Z	5.45	67.48	16.56		150.0	
10430-AAA	LTE-FDD (OFDMA, 5 MHz, E-TM 3.1)	X	4.25	70.00	17.85	0.00	150.0	± 9.6 %
		Y	4.23	70.09	17.93		150.0	
		Z	4.19	70.14	17.80		150.0	
10431-AAA	LTE-FDD (OFDMA, 10 MHz, E-TM 3.1)	X	4.34	67.20	16.23	0.00	150.0	± 9.6 %
		Y	4.36	67.46	16.45		150.0	
		Z	4.27	67.18	16.16		150.0	
10432-AAA	LTE-FDD (OFDMA, 15 MHz, E-TM 3.1)	X	4.64	67.12	16.31	0.00	150.0	± 9.6 %
		Y	4.65	67.34	16.50		150.0	
		Z	4.57	67.09	16.26		150.0	
10433-AAA	LTE-FDD (OFDMA, 20 MHz, E-TM 3.1)	X	4.89	67.13	16.38	0.00	150.0	± 9.6 %
		Y	4.90	67.33	16.56		150.0	
		Z	4.82	67.10	16.34		150.0	
10434-AAA	W-CDMA (BS Test Model 1, 64 DPCH)	X	4.31	70.67	17.79	0.00	150.0	± 9.6 %
		Y	4.30	70.79	17.87		150.0	
		Z	4.25	70.82	17.71		150.0	
10435-AAB	LTE-TDD (SC-FDMA, 1 RB, 20 MHz, QPSK, UL Subframe=2,3,4,7,8,9)	X	100.00	121.51	31.18	3.23	80.0	± 9.6 %
		Y	100.00	122.37	31.57		80.0	
		Z	100.00	121.79	31.11		80.0	
10447-AAA	LTE-FDD (OFDMA, 5 MHz, E-TM 3.1, Clipping 44%)	X	3.63	67.13	15.60	0.00	150.0	± 9.6 %
		Y	3.66	67.50	15.86		150.0	
		Z	3.54	67.07	15.44		150.0	
10448-AAA	LTE-FDD (OFDMA, 10 MHz, E-TM 3.1, Clipping 44%)	X	4.17	66.96	16.08	0.00	150.0	± 9.6 %
		Y	4.19	67.23	16.30		150.0	
		Z	4.10	66.94	16.02		150.0	
10449-AAA	LTE-FDD (OFDMA, 15 MHz, E-TM 3.1, Clipping 44%)	X	4.44	66.92	16.19	0.00	150.0	± 9.6 %
		Y	4.45	67.15	16.39		150.0	
		Z	4.38	66.90	16.14		150.0	
10450-AAA	LTE-FDD (OFDMA, 20 MHz, E-TM 3.1, Clipping 44%)	X	4.63	66.87	16.23	0.00	150.0	± 9.6 %
		Y	4.64	67.08	16.41		150.0	
		Z	4.58	66.85	16.19		150.0	
10451-AAA	W-CDMA (BS Test Model 1, 64 DPCH, Clipping 44%)	X	3.53	67.33	15.28	0.00	150.0	± 9.6 %
		Y	3.57	67.74	15.55		150.0	
		Z	3.43	67.21	15.05		150.0	
10456-AAA	IEEE 802.11ac WiFi (160MHz, 64-QAM, 99pc duty cycle)	X	6.35	68.11	16.76	0.00	150.0	± 9.6 %
		Y	6.36	68.24	16.90		150.0	
		Z	6.31	68.06	16.74		150.0	
10457-AAA	UMTS-FDD (DC-HSDPA)	X	3.86	65.32	15.94	0.00	150.0	± 9.6 %
		Y	3.86	65.52	16.13		150.0	
		Z	3.83	65.31	15.89		150.0	
10458-AAA	CDMA2000 (1xEV-DO, Rev. B, 2 carriers)	X	3.37	66.71	14.79	0.00	150.0	± 9.6 %
		Y	3.41	67.16	15.08		150.0	
		Z	3.26	66.61	14.51		150.0	
10459-AAA	CDMA2000 (1xEV-DO, Rev. B, 3 carriers)	X	4.52	65.23	15.77	0.00	150.0	± 9.6 %
		Y	4.60	65.75	16.11		150.0	
		Z	4.38	65.07	15.54		150.0	

10460-AAA	UMTS-FDD (WCDMA, AMR)	X	0.89	66.92	15.35	0.00	150.0	± 9.6 %
		Y	1.01	69.93	17.18		150.0	
		Z	0.86	66.57	15.06		150.0	
10461-AAA	LTE-TDD (SC-FDMA, 1 RB, 1.4 MHz, QPSK, UL Subframe=2,3,4,7,8,9)	X	100.00	125.62	33.15	3.29	80.0	± 9.6 %
		Y	100.00	127.39	33.94		80.0	
		Z	100.00	125.16	32.74		80.0	
10462-AAA	LTE-TDD (SC-FDMA, 1 RB, 1.4 MHz, 16-QAM, UL Subframe=2,3,4,7,8,9)	X	100.00	110.62	25.96	3.23	80.0	± 9.6 %
		Y	100.00	111.65	26.39		80.0	
		Z	84.76	108.06	25.05		80.0	
10463-AAA	LTE-TDD (SC-FDMA, 1 RB, 1.4 MHz, 64-QAM, UL Subframe=2,3,4,7,8,9)	X	100.00	107.62	24.51	3.23	80.0	± 9.6 %
		Y	100.00	108.53	24.89		80.0	
		Z	14.33	86.37	18.99		80.0	
10464-AAA	LTE-TDD (SC-FDMA, 1 RB, 3 MHz, QPSK, UL Subframe=2,3,4,7,8,9)	X	100.00	123.78	32.14	3.23	80.0	± 9.6 %
		Y	100.00	125.58	32.94		80.0	
		Z	100.00	123.19	31.67		80.0	
10465-AAA	LTE-TDD (SC-FDMA, 1 RB, 3 MHz, 16-QAM, UL Subframe=2,3,4,7,8,9)	X	100.00	110.13	25.71	3.23	80.0	± 9.6 %
		Y	100.00	111.18	26.15		80.0	
		Z	35.58	97.99	22.58		80.0	
10466-AAA	LTE-TDD (SC-FDMA, 1 RB, 3 MHz, 64-QAM, UL Subframe=2,3,4,7,8,9)	X	95.39	106.65	24.18	3.23	80.0	± 9.6 %
		Y	100.00	108.07	24.67		80.0	
		Z	9.21	81.47	17.50		80.0	
10467-AAB	LTE-TDD (SC-FDMA, 1 RB, 5 MHz, QPSK, UL Subframe=2,3,4,7,8,9)	X	100.00	123.99	32.23	3.23	80.0	± 9.6 %
		Y	100.00	125.80	33.04		80.0	
		Z	100.00	123.41	31.77		80.0	
10468-AAB	LTE-TDD (SC-FDMA, 1 RB, 5 MHz, 16-QAM, UL Subframe=2,3,4,7,8,9)	X	100.00	110.29	25.79	3.23	80.0	± 9.6 %
		Y	100.00	111.34	26.23		80.0	
		Z	43.78	100.42	23.20		80.0	
10469-AAB	LTE-TDD (SC-FDMA, 1 RB, 5 MHz, 64-QAM, UL Subframe=2,3,4,7,8,9)	X	99.99	107.17	24.29	3.23	80.0	± 9.6 %
		Y	100.00	108.09	24.67		80.0	
		Z	9.38	81.68	17.56		80.0	
10470-AAB	LTE-TDD (SC-FDMA, 1 RB, 10 MHz, QPSK, UL Subframe=2,3,4,7,8,9)	X	100.00	124.02	32.24	3.23	80.0	± 9.6 %
		Y	100.00	125.83	33.05		80.0	
		Z	100.00	123.44	31.77		80.0	
10471-AAB	LTE-TDD (SC-FDMA, 1 RB, 10 MHz, 16-QAM, UL Subframe=2,3,4,7,8,9)	X	100.00	110.24	25.76	3.23	80.0	± 9.6 %
		Y	100.00	111.29	26.20		80.0	
		Z	43.76	100.38	23.18		80.0	
10472-AAB	LTE-TDD (SC-FDMA, 1 RB, 10 MHz, 64-QAM, UL Subframe=2,3,4,7,8,9)	X	100.00	107.12	24.26	3.23	80.0	± 9.6 %
		Y	100.00	108.04	24.64		80.0	
		Z	9.36	81.64	17.53		80.0	
10473-AAB	LTE-TDD (SC-FDMA, 1 RB, 15 MHz, QPSK, UL Subframe=2,3,4,7,8,9)	X	100.00	123.99	32.23	3.23	80.0	± 9.6 %
		Y	100.00	125.81	33.03		80.0	
		Z	100.00	123.41	31.76		80.0	
10474-AAB	LTE-TDD (SC-FDMA, 1 RB, 15 MHz, 16-QAM, UL Subframe=2,3,4,7,8,9)	X	100.00	110.25	25.76	3.23	80.0	± 9.6 %
		Y	100.00	111.30	26.20		80.0	
		Z	42.90	100.17	23.13		80.0	
10475-AAB	LTE-TDD (SC-FDMA, 1 RB, 15 MHz, 64-QAM, UL Subframe=2,3,4,7,8,9)	X	99.25	107.05	24.25	3.23	80.0	± 9.6 %
		Y	100.00	108.06	24.65		80.0	
		Z	9.24	81.52	17.50		80.0	

10477-AAB	LTE-TDD (SC-FDMA, 1 RB, 20 MHz, 16-QAM, UL Subframe=2,3,4,7,8,9)	X	100.00	110.09	25.68	3.23	80.0	± 9.6 %
		Y	100.00	111.14	26.12		80.0	
		Z	37.23	98.47	22.68		80.0	
10478-AAB	LTE-TDD (SC-FDMA, 1 RB, 20 MHz, 64-QAM, UL Subframe=2,3,4,7,8,9)	X	95.92	106.64	24.15	3.23	80.0	± 9.6 %
		Y	100.00	108.00	24.62		80.0	
		Z	9.13	81.36	17.44		80.0	
10479-AAA	LTE-TDD (SC-FDMA, 50% RB, 1.4 MHz, QPSK, UL Subframe=2,3,4,7,8,9)	X	15.99	96.17	26.79	3.23	80.0	± 9.6 %
		Y	25.94	104.65	29.40		80.0	
		Z	12.83	92.51	25.34		80.0	
10480-AAA	LTE-TDD (SC-FDMA, 50% RB, 1.4 MHz, 16-QAM, UL Subframe=2,3,4,7,8,9)	X	19.48	93.48	24.25	3.23	80.0	± 9.6 %
		Y	30.64	100.38	26.28		80.0	
		Z	12.85	87.46	22.08		80.0	
10481-AAA	LTE-TDD (SC-FDMA, 50% RB, 1.4 MHz, 64-QAM, UL Subframe=2,3,4,7,8,9)	X	16.00	89.85	22.83	3.23	80.0	± 9.6 %
		Y	23.58	95.63	24.59		80.0	
		Z	10.55	84.00	20.64		80.0	
10482-AAA	LTE-TDD (SC-FDMA, 50% RB, 3 MHz, QPSK, UL Subframe=2,3,4,7,8,9)	X	5.04	76.94	19.04	2.23	80.0	± 9.6 %
		Y	6.02	79.79	20.13		80.0	
		Z	4.78	76.30	18.55		80.0	
10483-AAA	LTE-TDD (SC-FDMA, 50% RB, 3 MHz, 16-QAM, UL Subframe=2,3,4,7,8,9)	X	9.12	82.48	20.94	2.23	80.0	± 9.6 %
		Y	10.77	85.20	21.94		80.0	
		Z	6.99	78.47	19.09		80.0	
10484-AAA	LTE-TDD (SC-FDMA, 50% RB, 3 MHz, 64-QAM, UL Subframe=2,3,4,7,8,9)	X	8.29	80.89	20.40	2.23	80.0	± 9.6 %
		Y	9.58	83.28	21.31		80.0	
		Z	6.43	77.10	18.60		80.0	
10485-AAB	LTE-TDD (SC-FDMA, 50% RB, 5 MHz, QPSK, UL Subframe=2,3,4,7,8,9)	X	5.28	77.72	20.08	2.23	80.0	± 9.6 %
		Y	6.19	80.50	21.18		80.0	
		Z	5.13	77.51	19.85		80.0	
10486-AAB	LTE-TDD (SC-FDMA, 50% RB, 5 MHz, 16-QAM, UL Subframe=2,3,4,7,8,9)	X	4.51	72.42	17.68	2.23	80.0	± 9.6 %
		Y	4.81	73.61	18.21		80.0	
		Z	4.36	72.13	17.34		80.0	
10487-AAB	LTE-TDD (SC-FDMA, 50% RB, 5 MHz, 64-QAM, UL Subframe=2,3,4,7,8,9)	X	4.47	71.97	17.49	2.23	80.0	± 9.6 %
		Y	4.74	73.05	17.98		80.0	
		Z	4.32	71.65	17.14		80.0	
10488-AAB	LTE-TDD (SC-FDMA, 50% RB, 10 MHz, QPSK, UL Subframe=2,3,4,7,8,9)	X	5.28	76.23	20.05	2.23	80.0	± 9.6 %
		Y	5.88	78.28	20.95		80.0	
		Z	5.13	76.06	19.94		80.0	
10489-AAB	LTE-TDD (SC-FDMA, 50% RB, 10 MHz, 16-QAM, UL Subframe=2,3,4,7,8,9)	X	4.61	71.60	18.35	2.23	80.0	± 9.6 %
		Y	4.82	72.56	18.83		80.0	
		Z	4.51	71.52	18.23		80.0	
10490-AAB	LTE-TDD (SC-FDMA, 50% RB, 10 MHz, 64-QAM, UL Subframe=2,3,4,7,8,9)	X	4.69	71.33	18.26	2.23	80.0	± 9.6 %
		Y	4.87	72.22	18.72		80.0	
		Z	4.59	71.26	18.14		80.0	
10491-AAB	LTE-TDD (SC-FDMA, 50% RB, 15 MHz, QPSK, UL Subframe=2,3,4,7,8,9)	X	5.21	74.00	19.31	2.23	80.0	± 9.6 %
		Y	5.57	75.36	19.96		80.0	
		Z	5.08	73.85	19.24		80.0	
10492-AAB	LTE-TDD (SC-FDMA, 50% RB, 15 MHz, 16-QAM, UL Subframe=2,3,4,7,8,9)	X	4.87	70.59	18.20	2.23	80.0	± 9.6 %
		Y	5.02	71.33	18.60		80.0	
		Z	4.77	70.51	18.12		80.0	

10493-AAB	LTE-TDD (SC-FDMA, 50% RB, 15 MHz, 64-QAM, UL Subframe=2,3,4,7,8,9)	X	4.93	70.41	18.14	2.23	80.0	± 9.6 %
		Y	5.07	71.11	18.53		80.0	
		Z	4.83	70.34	18.06		80.0	
10494-AAB	LTE-TDD (SC-FDMA, 50% RB, 20 MHz, QPSK, UL Subframe=2,3,4,7,8,9)	X	5.74	75.68	19.79	2.23	80.0	± 9.6 %
		Y	6.23	77.26	20.51		80.0	
		Z	5.57	75.46	19.70		80.0	
10495-AAB	LTE-TDD (SC-FDMA, 50% RB, 20 MHz, 16-QAM, UL Subframe=2,3,4,7,8,9)	X	4.94	71.08	18.40	2.23	80.0	± 9.6 %
		Y	5.11	71.86	18.83		80.0	
		Z	4.84	70.96	18.32		80.0	
10496-AAB	LTE-TDD (SC-FDMA, 50% RB, 20 MHz, 64-QAM, UL Subframe=2,3,4,7,8,9)	X	4.99	70.71	18.29	2.23	80.0	± 9.6 %
		Y	5.14	71.42	18.69		80.0	
		Z	4.89	70.61	18.21		80.0	
10497-AAA	LTE-TDD (SC-FDMA, 100% RB, 1.4 MHz, QPSK, UL Subframe=2,3,4,7,8,9)	X	3.95	73.39	16.94	2.23	80.0	± 9.6 %
		Y	4.59	75.63	17.82		80.0	
		Z	3.56	72.03	16.04		80.0	
10498-AAA	LTE-TDD (SC-FDMA, 100% RB, 1.4 MHz, 16-QAM, UL Subframe=2,3,4,7,8,9)	X	2.99	67.14	13.42	2.23	80.0	± 9.6 %
		Y	3.17	68.04	13.81		80.0	
		Z	2.58	65.48	12.27		80.0	
10499-AAA	LTE-TDD (SC-FDMA, 100% RB, 1.4 MHz, 64-QAM, UL Subframe=2,3,4,7,8,9)	X	2.90	66.50	13.01	2.23	80.0	± 9.6 %
		Y	3.06	67.30	13.36		80.0	
		Z	2.49	64.82	11.82		80.0	
10500-AAA	LTE-TDD (SC-FDMA, 100% RB, 3 MHz, QPSK, UL Subframe=2,3,4,7,8,9)	X	5.14	76.64	19.91	2.23	80.0	± 9.6 %
		Y	5.86	79.02	20.91		80.0	
		Z	5.00	76.51	19.75		80.0	
10501-AAA	LTE-TDD (SC-FDMA, 100% RB, 3 MHz, 16-QAM, UL Subframe=2,3,4,7,8,9)	X	4.55	72.03	17.90	2.23	80.0	± 9.6 %
		Y	4.80	73.10	18.41		80.0	
		Z	4.43	71.87	17.67		80.0	
10502-AAA	LTE-TDD (SC-FDMA, 100% RB, 3 MHz, 64-QAM, UL Subframe=2,3,4,7,8,9)	X	4.59	71.80	17.77	2.23	80.0	± 9.6 %
		Y	4.83	72.81	18.25		80.0	
		Z	4.47	71.64	17.53		80.0	
10503-AAB	LTE-TDD (SC-FDMA, 100% RB, 5 MHz, QPSK, UL Subframe=2,3,4,7,8,9)	X	5.22	76.03	19.96	2.23	80.0	± 9.6 %
		Y	5.81	78.08	20.86		80.0	
		Z	5.07	75.86	19.85		80.0	
10504-AAB	LTE-TDD (SC-FDMA, 100% RB, 5 MHz, 16-QAM, UL Subframe=2,3,4,7,8,9)	X	4.59	71.52	18.30	2.23	80.0	± 9.6 %
		Y	4.80	72.48	18.79		80.0	
		Z	4.49	71.43	18.18		80.0	
10505-AAB	LTE-TDD (SC-FDMA, 100% RB, 5 MHz, 64-QAM, UL Subframe=2,3,4,7,8,9)	X	4.66	71.24	18.21	2.23	80.0	± 9.6 %
		Y	4.85	72.13	18.67		80.0	
		Z	4.56	71.17	18.09		80.0	
10506-AAB	LTE-TDD (SC-FDMA, 100% RB, 10 MHz, QPSK, UL Subframe=2,3,4,7,8,9)	X	5.69	75.54	19.72	2.23	80.0	± 9.6 %
		Y	6.18	77.12	20.44		80.0	
		Z	5.52	75.31	19.63		80.0	
10507-AAB	LTE-TDD (SC-FDMA, 100% RB, 10 MHz, 16-QAM, UL Subframe=2,3,4,7,8,9)	X	4.93	71.03	18.37	2.23	80.0	± 9.6 %
		Y	5.09	71.81	18.80		80.0	
		Z	4.82	70.90	18.29		80.0	

10508-AAB	LTE-TDD (SC-FDMA, 100% RB, 10 MHz, 64-QAM, UL Subframe=2,3,4,7,8,9)	X	4.98	70.65	18.25	2.23	80.0	± 9.6 %
		Y	5.12	71.36	18.65		80.0	
		Z	4.87	70.54	18.17		80.0	
10509-AAB	LTE-TDD (SC-FDMA, 100% RB, 15 MHz, QPSK, UL Subframe=2,3,4,7,8,9)	X	5.75	73.61	18.99	2.23	80.0	± 9.6 %
		Y	6.04	74.62	19.49		80.0	
		Z	5.61	73.42	18.92		80.0	
10510-AAB	LTE-TDD (SC-FDMA, 100% RB, 15 MHz, 16-QAM, UL Subframe=2,3,4,7,8,9)	X	5.37	70.52	18.25	2.23	80.0	± 9.6 %
		Y	5.50	71.12	18.60		80.0	
		Z	5.26	70.38	18.18		80.0	
10511-AAB	LTE-TDD (SC-FDMA, 100% RB, 15 MHz, 64-QAM, UL Subframe=2,3,4,7,8,9)	X	5.39	70.20	18.16	2.23	80.0	± 9.6 %
		Y	5.51	70.76	18.50		80.0	
		Z	5.29	70.08	18.10		80.0	
10512-AAB	LTE-TDD (SC-FDMA, 100% RB, 20 MHz, QPSK, UL Subframe=2,3,4,7,8,9)	X	6.17	75.45	19.55	2.23	80.0	± 9.6 %
		Y	6.61	76.77	20.16		80.0	
		Z	5.99	75.18	19.45		80.0	
10513-AAB	LTE-TDD (SC-FDMA, 100% RB, 20 MHz, 16-QAM, UL Subframe=2,3,4,7,8,9)	X	5.29	70.93	18.40	2.23	80.0	± 9.6 %
		Y	5.44	71.61	18.78		80.0	
		Z	5.18	70.76	18.31		80.0	
10514-AAB	LTE-TDD (SC-FDMA, 100% RB, 20 MHz, 64-QAM, UL Subframe=2,3,4,7,8,9)	X	5.26	70.42	18.25	2.23	80.0	± 9.6 %
		Y	5.39	71.03	18.61		80.0	
		Z	5.16	70.27	18.17		80.0	
10515-AAA	IEEE 802.11b WiFi 2.4 GHz (DSSS, 2 Mbps, 99pc duty cycle)	X	0.99	62.88	14.39	0.00	150.0	± 9.6 %
		Y	1.01	63.69	15.14		150.0	
		Z	0.98	62.78	14.25		150.0	
10516-AAA	IEEE 802.11b WiFi 2.4 GHz (DSSS, 5.5 Mbps, 99pc duty cycle)	X	0.57	67.90	15.77	0.00	150.0	± 9.6 %
		Y	0.79	74.76	19.51		150.0	
		Z	0.54	67.33	15.34		150.0	
10517-AAA	IEEE 802.11b WiFi 2.4 GHz (DSSS, 11 Mbps, 99pc duty cycle)	X	0.83	64.48	14.80	0.00	150.0	± 9.6 %
		Y	0.88	66.11	16.05		150.0	
		Z	0.82	64.26	14.59		150.0	
10518-AAA	IEEE 802.11a/h WiFi 5 GHz (OFDM, 9 Mbps, 99pc duty cycle)	X	4.64	66.76	16.21	0.00	150.0	± 9.6 %
		Y	4.64	66.97	16.39		150.0	
		Z	4.58	66.75	16.17		150.0	
10519-AAA	IEEE 802.11a/h WiFi 5 GHz (OFDM, 12 Mbps, 99pc duty cycle)	X	4.84	67.04	16.35	0.00	150.0	± 9.6 %
		Y	4.85	67.24	16.53		150.0	
		Z	4.77	67.00	16.30		150.0	
10520-AAA	IEEE 802.11a/h WiFi 5 GHz (OFDM, 18 Mbps, 99pc duty cycle)	X	4.69	67.00	16.26	0.00	150.0	± 9.6 %
		Y	4.70	67.20	16.45		150.0	
		Z	4.62	66.95	16.22		150.0	
10521-AAA	IEEE 802.11a/h WiFi 5 GHz (OFDM, 24 Mbps, 99pc duty cycle)	X	4.62	66.99	16.24	0.00	150.0	± 9.6 %
		Y	4.63	67.20	16.43		150.0	
		Z	4.55	66.94	16.20		150.0	
10522-AAA	IEEE 802.11a/h WiFi 5 GHz (OFDM, 36 Mbps, 99pc duty cycle)	X	4.67	67.03	16.31	0.00	150.0	± 9.6 %
		Y	4.69	67.25	16.50		150.0	
		Z	4.61	67.03	16.28		150.0	

10523-AAA	IEEE 802.11a/h WiFi 5 GHz (OFDM, 48 Mbps, 99pc duty cycle)	X	4.55	66.89	16.15	0.00	150.0	± 9.6 %
		Y	4.56	67.11	16.34		150.0	
		Z	4.49	66.88	16.12		150.0	
10524-AAA	IEEE 802.11a/h WiFi 5 GHz (OFDM, 54 Mbps, 99pc duty cycle)	X	4.62	66.97	16.28	0.00	150.0	± 9.6 %
		Y	4.63	67.19	16.48		150.0	
		Z	4.56	66.95	16.25		150.0	
10525-AAA	IEEE 802.11ac WiFi (20MHz, MCS0, 99pc duty cycle)	X	4.59	65.99	15.86	0.00	150.0	± 9.6 %
		Y	4.60	66.20	16.05		150.0	
		Z	4.54	65.98	15.83		150.0	
10526-AAA	IEEE 802.11ac WiFi (20MHz, MCS1, 99pc duty cycle)	X	4.77	66.38	16.01	0.00	150.0	± 9.6 %
		Y	4.79	66.60	16.20		150.0	
		Z	4.71	66.35	15.98		150.0	
10527-AAA	IEEE 802.11ac WiFi (20MHz, MCS2, 99pc duty cycle)	X	4.69	66.34	15.95	0.00	150.0	± 9.6 %
		Y	4.71	66.56	16.15		150.0	
		Z	4.63	66.30	15.91		150.0	
10528-AAA	IEEE 802.11ac WiFi (20MHz, MCS3, 99pc duty cycle)	X	4.71	66.36	15.99	0.00	150.0	± 9.6 %
		Y	4.72	66.58	16.18		150.0	
		Z	4.65	66.32	15.95		150.0	
10529-AAA	IEEE 802.11ac WiFi (20MHz, MCS4, 99pc duty cycle)	X	4.71	66.36	15.99	0.00	150.0	± 9.6 %
		Y	4.72	66.58	16.18		150.0	
		Z	4.65	66.32	15.95		150.0	
10531-AAA	IEEE 802.11ac WiFi (20MHz, MCS6, 99pc duty cycle)	X	4.71	66.48	16.01	0.00	150.0	± 9.6 %
		Y	4.73	66.71	16.20		150.0	
		Z	4.64	66.43	15.96		150.0	
10532-AAA	IEEE 802.11ac WiFi (20MHz, MCS7, 99pc duty cycle)	X	4.56	66.33	15.94	0.00	150.0	± 9.6 %
		Y	4.58	66.56	16.14		150.0	
		Z	4.50	66.27	15.89		150.0	
10533-AAA	IEEE 802.11ac WiFi (20MHz, MCS8, 99pc duty cycle)	X	4.72	66.39	15.97	0.00	150.0	± 9.6 %
		Y	4.73	66.61	16.16		150.0	
		Z	4.65	66.36	15.93		150.0	
10534-AAA	IEEE 802.11ac WiFi (40MHz, MCS0, 99pc duty cycle)	X	5.24	66.54	16.07	0.00	150.0	± 9.6 %
		Y	5.25	66.71	16.24		150.0	
		Z	5.19	66.49	16.04		150.0	
10535-AAA	IEEE 802.11ac WiFi (40MHz, MCS1, 99pc duty cycle)	X	5.31	66.70	16.14	0.00	150.0	± 9.6 %
		Y	5.33	66.88	16.31		150.0	
		Z	5.26	66.68	16.13		150.0	
10536-AAA	IEEE 802.11ac WiFi (40MHz, MCS2, 99pc duty cycle)	X	5.18	66.65	16.10	0.00	150.0	± 9.6 %
		Y	5.19	66.84	16.27		150.0	
		Z	5.12	66.60	16.07		150.0	
10537-AAA	IEEE 802.11ac WiFi (40MHz, MCS3, 99pc duty cycle)	X	5.24	66.63	16.10	0.00	150.0	± 9.6 %
		Y	5.25	66.81	16.26		150.0	
		Z	5.19	66.58	16.06		150.0	
10538-AAA	IEEE 802.11ac WiFi (40MHz, MCS4, 99pc duty cycle)	X	5.35	66.69	16.17	0.00	150.0	± 9.6 %
		Y	5.36	66.87	16.33		150.0	
		Z	5.28	66.62	16.12		150.0	
10540-AAA	IEEE 802.11ac WiFi (40MHz, MCS6, 99pc duty cycle)	X	5.26	66.66	16.17	0.00	150.0	± 9.6 %
		Y	5.27	66.85	16.34		150.0	
		Z	5.21	66.63	16.14		150.0	

10541-AAA	IEEE 802.11ac WiFi (40MHz, MCS7, 99pc duty cycle)	X	5.23	66.53	16.10	0.00	150.0	± 9.6 %
		Y	5.24	66.71	16.26		150.0	
		Z	5.18	66.49	16.06		150.0	
10542-AAA	IEEE 802.11ac WiFi (40MHz, MCS8, 99pc duty cycle)	X	5.39	66.62	16.16	0.00	150.0	± 9.6 %
		Y	5.40	66.79	16.32		150.0	
		Z	5.34	66.57	16.12		150.0	
10543-AAA	IEEE 802.11ac WiFi (40MHz, MCS9, 99pc duty cycle)	X	5.48	66.66	16.19	0.00	150.0	± 9.6 %
		Y	5.49	66.83	16.36		150.0	
		Z	5.42	66.63	16.18		150.0	
10544-AAA	IEEE 802.11ac WiFi (80MHz, MCS0, 99pc duty cycle)	X	5.54	66.65	16.07	0.00	150.0	± 9.6 %
		Y	5.55	66.80	16.22		150.0	
		Z	5.50	66.61	16.04		150.0	
10545-AAA	IEEE 802.11ac WiFi (80MHz, MCS1, 99pc duty cycle)	X	5.76	67.11	16.24	0.00	150.0	± 9.6 %
		Y	5.77	67.28	16.40		150.0	
		Z	5.71	67.07	16.23		150.0	
10546-AAA	IEEE 802.11ac WiFi (80MHz, MCS2, 99pc duty cycle)	X	5.63	66.91	16.16	0.00	150.0	± 9.6 %
		Y	5.64	67.07	16.32		150.0	
		Z	5.57	66.84	16.12		150.0	
10547-AAA	IEEE 802.11ac WiFi (80MHz, MCS3, 99pc duty cycle)	X	5.72	67.00	16.20	0.00	150.0	± 9.6 %
		Y	5.72	67.16	16.35		150.0	
		Z	5.65	66.88	16.14		150.0	
10548-AAA	IEEE 802.11ac WiFi (80MHz, MCS4, 99pc duty cycle)	X	6.07	68.22	16.78	0.00	150.0	± 9.6 %
		Y	6.08	68.42	16.96		150.0	
		Z	5.98	68.06	16.70		150.0	
10550-AAA	IEEE 802.11ac WiFi (80MHz, MCS6, 99pc duty cycle)	X	5.65	66.89	16.16	0.00	150.0	± 9.6 %
		Y	5.66	67.05	16.31		150.0	
		Z	5.60	66.86	16.14		150.0	
10551-AAA	IEEE 802.11ac WiFi (80MHz, MCS7, 99pc duty cycle)	X	5.65	66.93	16.14	0.00	150.0	± 9.6 %
		Y	5.66	67.09	16.29		150.0	
		Z	5.60	66.87	16.11		150.0	
10552-AAA	IEEE 802.11ac WiFi (80MHz, MCS8, 99pc duty cycle)	X	5.56	66.71	16.04	0.00	150.0	± 9.6 %
		Y	5.57	66.86	16.19		150.0	
		Z	5.51	66.66	16.01		150.0	
10553-AAA	IEEE 802.11ac WiFi (80MHz, MCS9, 99pc duty cycle)	X	5.65	66.77	16.10	0.00	150.0	± 9.6 %
		Y	5.66	66.92	16.25		150.0	
		Z	5.60	66.70	16.07		150.0	
10554-AAA	IEEE 1602.11ac WiFi (160MHz, MCS0, 99pc duty cycle)	X	5.95	67.04	16.18	0.00	150.0	± 9.6 %
		Y	5.96	67.19	16.31		150.0	
		Z	5.91	66.99	16.15		150.0	
10555-AAA	IEEE 1602.11ac WiFi (160MHz, MCS1, 99pc duty cycle)	X	6.09	67.37	16.32	0.00	150.0	± 9.6 %
		Y	6.11	67.53	16.46		150.0	
		Z	6.05	67.32	16.29		150.0	
10556-AAA	IEEE 1602.11ac WiFi (160MHz, MCS2, 99pc duty cycle)	X	6.11	67.40	16.33	0.00	150.0	± 9.6 %
		Y	6.12	67.56	16.47		150.0	
		Z	6.07	67.36	16.30		150.0	
10557-AAA	IEEE 1602.11ac WiFi (160MHz, MCS3, 99pc duty cycle)	X	6.08	67.33	16.31	0.00	150.0	± 9.6 %
		Y	6.09	67.48	16.45		150.0	
		Z	6.03	67.26	16.27		150.0	

10558-AAA	IEEE 1602.11ac WiFi (160MHz, MCS4, 99pc duty cycle)	X	6.14	67.52	16.42	0.00	150.0	± 9.6 %
		Y	6.15	67.67	16.56		150.0	
		Z	6.09	67.43	16.37		150.0	
10560-AAA	IEEE 1602.11ac WiFi (160MHz, MCS6, 99pc duty cycle)	X	6.13	67.34	16.37	0.00	150.0	± 9.6 %
		Y	6.14	67.49	16.51		150.0	
		Z	6.07	67.26	16.33		150.0	
10561-AAA	IEEE 1602.11ac WiFi (160MHz, MCS7, 99pc duty cycle)	X	6.05	67.31	16.39	0.00	150.0	± 9.6 %
		Y	6.06	67.47	16.54		150.0	
		Z	6.00	67.24	16.36		150.0	
10562-AAA	IEEE 1602.11ac WiFi (160MHz, MCS8, 99pc duty cycle)	X	6.21	67.80	16.64	0.00	150.0	± 9.6 %
		Y	6.22	67.97	16.79		150.0	
		Z	6.14	67.67	16.57		150.0	
10563-AAA	IEEE 1602.11ac WiFi (160MHz, MCS9, 99pc duty cycle)	X	6.60	68.52	16.95	0.00	150.0	± 9.6 %
		Y	6.61	68.70	17.11		150.0	
		Z	6.44	68.18	16.78		150.0	
10564-AAA	IEEE 802.11g WiFi 2.4 GHz (DSSS-OFDM, 9 Mbps, 99pc duty cycle)	X	4.98	66.92	16.42	0.46	150.0	± 9.6 %
		Y	4.99	67.12	16.60		150.0	
		Z	4.93	66.90	16.38		150.0	
10565-AAA	IEEE 802.11g WiFi 2.4 GHz (DSSS-OFDM, 12 Mbps, 99pc duty cycle)	X	5.22	67.37	16.73	0.46	150.0	± 9.6 %
		Y	5.23	67.55	16.90		150.0	
		Z	5.16	67.34	16.69		150.0	
10566-AAA	IEEE 802.11g WiFi 2.4 GHz (DSSS-OFDM, 18 Mbps, 99pc duty cycle)	X	5.06	67.23	16.56	0.46	150.0	± 9.6 %
		Y	5.06	67.43	16.74		150.0	
		Z	4.99	67.19	16.51		150.0	
10567-AAA	IEEE 802.11g WiFi 2.4 GHz (DSSS-OFDM, 24 Mbps, 99pc duty cycle)	X	5.08	67.57	16.87	0.46	150.0	± 9.6 %
		Y	5.08	67.74	17.03		150.0	
		Z	5.01	67.53	16.84		150.0	
10568-AAA	IEEE 802.11g WiFi 2.4 GHz (DSSS-OFDM, 36 Mbps, 99pc duty cycle)	X	4.98	67.03	16.35	0.46	150.0	± 9.6 %
		Y	4.99	67.26	16.56		150.0	
		Z	4.91	67.01	16.31		150.0	
10569-AAA	IEEE 802.11g WiFi 2.4 GHz (DSSS-OFDM, 48 Mbps, 99pc duty cycle)	X	5.02	67.62	16.91	0.46	150.0	± 9.6 %
		Y	5.03	67.78	17.06		150.0	
		Z	4.97	67.61	16.89		150.0	
10570-AAA	IEEE 802.11g WiFi 2.4 GHz (DSSS-OFDM, 54 Mbps, 99pc duty cycle)	X	5.07	67.49	16.86	0.46	150.0	± 9.6 %
		Y	5.07	67.68	17.03		150.0	
		Z	5.00	67.48	16.83		150.0	
10571-AAA	IEEE 802.11b WiFi 2.4 GHz (DSSS, 1 Mbps, 90pc duty cycle)	X	1.33	65.38	15.85	0.46	130.0	± 9.6 %
		Y	1.37	66.42	16.66		130.0	
		Z	1.31	65.23	15.71		130.0	
10572-AAA	IEEE 802.11b WiFi 2.4 GHz (DSSS, 2 Mbps, 90pc duty cycle)	X	1.35	65.94	16.19	0.46	130.0	± 9.6 %
		Y	1.40	67.08	17.03		130.0	
		Z	1.33	65.79	16.04		130.0	
10573-AAA	IEEE 802.11b WiFi 2.4 GHz (DSSS, 5.5 Mbps, 90pc duty cycle)	X	2.45	84.59	22.30	0.46	130.0	± 9.6 %
		Y	10.53	109.30	30.18		130.0	
		Z	2.23	83.07	21.66		130.0	
10574-AAA	IEEE 802.11b WiFi 2.4 GHz (DSSS, 11 Mbps, 90pc duty cycle)	X	1.51	71.42	18.78	0.46	130.0	± 9.6 %
		Y	1.69	74.14	20.31		130.0	
		Z	1.47	71.09	18.56		130.0	

10575-AAA	IEEE 802.11g WiFi 2.4 GHz (DSSS-OFDM, 6 Mbps, 90pc duty cycle)	X	4.80	66.79	16.52	0.46	130.0	± 9.6 %
		Y	4.80	66.99	16.70		130.0	
		Z	4.74	66.78	16.48		130.0	
10576-AAA	IEEE 802.11g WiFi 2.4 GHz (DSSS-OFDM, 9 Mbps, 90pc duty cycle)	X	4.82	66.93	16.57	0.46	130.0	± 9.6 %
		Y	4.83	67.13	16.75		130.0	
		Z	4.77	66.93	16.54		130.0	
10577-AAA	IEEE 802.11g WiFi 2.4 GHz (DSSS-OFDM, 12 Mbps, 90pc duty cycle)	X	5.04	67.25	16.75	0.46	130.0	± 9.6 %
		Y	5.04	67.43	16.92		130.0	
		Z	4.97	67.22	16.71		130.0	
10578-AAA	IEEE 802.11g WiFi 2.4 GHz (DSSS-OFDM, 18 Mbps, 90pc duty cycle)	X	4.93	67.39	16.83	0.46	130.0	± 9.6 %
		Y	4.93	67.57	17.00		130.0	
		Z	4.87	67.36	16.79		130.0	
10579-AAA	IEEE 802.11g WiFi 2.4 GHz (DSSS-OFDM, 24 Mbps, 90pc duty cycle)	X	4.71	66.78	16.21	0.46	130.0	± 9.6 %
		Y	4.73	67.02	16.43		130.0	
		Z	4.65	66.73	16.16		130.0	
10580-AAA	IEEE 802.11g WiFi 2.4 GHz (DSSS-OFDM, 36 Mbps, 90pc duty cycle)	X	4.76	66.79	16.23	0.46	130.0	± 9.6 %
		Y	4.77	67.05	16.45		130.0	
		Z	4.69	66.76	16.18		130.0	
10581-AAA	IEEE 802.11g WiFi 2.4 GHz (DSSS-OFDM, 48 Mbps, 90pc duty cycle)	X	4.83	67.44	16.78	0.46	130.0	± 9.6 %
		Y	4.84	67.63	16.95		130.0	
		Z	4.77	67.41	16.74		130.0	
10582-AAA	IEEE 802.11g WiFi 2.4 GHz (DSSS-OFDM, 54 Mbps, 90pc duty cycle)	X	4.66	66.56	16.03	0.46	130.0	± 9.6 %
		Y	4.68	66.83	16.26		130.0	
		Z	4.59	66.51	15.97		130.0	
10583-AAA	IEEE 802.11a/h WiFi 5 GHz (OFDM, 6 Mbps, 90pc duty cycle)	X	4.80	66.79	16.52	0.46	130.0	± 9.6 %
		Y	4.80	66.99	16.70		130.0	
		Z	4.74	66.78	16.48		130.0	
10584-AAA	IEEE 802.11a/h WiFi 5 GHz (OFDM, 9 Mbps, 90pc duty cycle)	X	4.82	66.93	16.57	0.46	130.0	± 9.6 %
		Y	4.83	67.13	16.75		130.0	
		Z	4.77	66.93	16.54		130.0	
10585-AAA	IEEE 802.11a/h WiFi 5 GHz (OFDM, 12 Mbps, 90pc duty cycle)	X	5.04	67.25	16.75	0.46	130.0	± 9.6 %
		Y	5.04	67.43	16.92		130.0	
		Z	4.97	67.22	16.71		130.0	
10586-AAA	IEEE 802.11a/h WiFi 5 GHz (OFDM, 18 Mbps, 90pc duty cycle)	X	4.93	67.39	16.83	0.46	130.0	± 9.6 %
		Y	4.93	67.57	17.00		130.0	
		Z	4.87	67.36	16.79		130.0	
10587-AAA	IEEE 802.11a/h WiFi 5 GHz (OFDM, 24 Mbps, 90pc duty cycle)	X	4.71	66.78	16.21	0.46	130.0	± 9.6 %
		Y	4.73	67.02	16.43		130.0	
		Z	4.65	66.73	16.16		130.0	
10588-AAA	IEEE 802.11a/h WiFi 5 GHz (OFDM, 36 Mbps, 90pc duty cycle)	X	4.76	66.79	16.23	0.46	130.0	± 9.6 %
		Y	4.77	67.05	16.45		130.0	
		Z	4.69	66.76	16.18		130.0	
10589-AAA	IEEE 802.11a/h WiFi 5 GHz (OFDM, 48 Mbps, 90pc duty cycle)	X	4.83	67.44	16.78	0.46	130.0	± 9.6 %
		Y	4.84	67.63	16.95		130.0	
		Z	4.77	67.41	16.74		130.0	
10590-AAA	IEEE 802.11a/h WiFi 5 GHz (OFDM, 54 Mbps, 90pc duty cycle)	X	4.66	66.56	16.03	0.46	130.0	± 9.6 %
		Y	4.68	66.83	16.26		130.0	
		Z	4.59	66.51	15.97		130.0	

10591-AAA	IEEE 802.11n (HT Mixed, 20MHz, MCS0, 90pc duty cycle)	X	4.94	66.84	16.61	0.46	130.0	± 9.6 %
		Y	4.95	67.02	16.78		130.0	
		Z	4.89	66.83	16.58		130.0	
10592-AAA	IEEE 802.11n (HT Mixed, 20MHz, MCS1, 90pc duty cycle)	X	5.11	67.18	16.74	0.46	130.0	± 9.6 %
		Y	5.11	67.36	16.91		130.0	
		Z	5.05	67.16	16.71		130.0	
10593-AAA	IEEE 802.11n (HT Mixed, 20MHz, MCS2, 90pc duty cycle)	X	5.04	67.12	16.64	0.46	130.0	± 9.6 %
		Y	5.04	67.31	16.81		130.0	
		Z	4.97	67.08	16.60		130.0	
10594-AAA	IEEE 802.11n (HT Mixed, 20MHz, MCS3, 90pc duty cycle)	X	5.09	67.26	16.77	0.46	130.0	± 9.6 %
		Y	5.09	67.44	16.95		130.0	
		Z	5.02	67.24	16.74		130.0	
10595-AAA	IEEE 802.11n (HT Mixed, 20MHz, MCS4, 90pc duty cycle)	X	5.06	67.23	16.68	0.46	130.0	± 9.6 %
		Y	5.07	67.42	16.86		130.0	
		Z	4.99	67.20	16.64		130.0	
10596-AAA	IEEE 802.11n (HT Mixed, 20MHz, MCS5, 90pc duty cycle)	X	5.00	67.23	16.68	0.46	130.0	± 9.6 %
		Y	5.01	67.44	16.87		130.0	
		Z	4.93	67.20	16.65		130.0	
10597-AAA	IEEE 802.11n (HT Mixed, 20MHz, MCS6, 90pc duty cycle)	X	4.95	67.15	16.58	0.46	130.0	± 9.6 %
		Y	4.96	67.36	16.77		130.0	
		Z	4.88	67.11	16.54		130.0	
10598-AAA	IEEE 802.11n (HT Mixed, 20MHz, MCS7, 90pc duty cycle)	X	4.92	67.37	16.82	0.46	130.0	± 9.6 %
		Y	4.93	67.55	16.99		130.0	
		Z	4.86	67.32	16.78		130.0	
10599-AAA	IEEE 802.11n (HT Mixed, 40MHz, MCS0, 90pc duty cycle)	X	5.62	67.44	16.83	0.46	130.0	± 9.6 %
		Y	5.62	67.59	16.99		130.0	
		Z	5.57	67.41	16.81		130.0	
10600-AAA	IEEE 802.11n (HT Mixed, 40MHz, MCS1, 90pc duty cycle)	X	5.83	68.08	17.13	0.46	130.0	± 9.6 %
		Y	5.83	68.26	17.31		130.0	
		Z	5.75	67.98	17.08		130.0	
10601-AAA	IEEE 802.11n (HT Mixed, 40MHz, MCS2, 90pc duty cycle)	X	5.67	67.70	16.95	0.46	130.0	± 9.6 %
		Y	5.68	67.87	17.12		130.0	
		Z	5.61	67.65	16.92		130.0	
10602-AAA	IEEE 802.11n (HT Mixed, 40MHz, MCS3, 90pc duty cycle)	X	5.76	67.70	16.88	0.46	130.0	± 9.6 %
		Y	5.77	67.88	17.05		130.0	
		Z	5.71	67.69	16.87		130.0	
10603-AAA	IEEE 802.11n (HT Mixed, 40MHz, MCS4, 90pc duty cycle)	X	5.83	67.96	17.13	0.46	130.0	± 9.6 %
		Y	5.84	68.14	17.30		130.0	
		Z	5.78	67.93	17.11		130.0	
10604-AAA	IEEE 802.11n (HT Mixed, 40MHz, MCS5, 90pc duty cycle)	X	5.62	67.40	16.84	0.46	130.0	± 9.6 %
		Y	5.63	67.56	17.00		130.0	
		Z	5.57	67.37	16.81		130.0	
10605-AAA	IEEE 802.11n (HT Mixed, 40MHz, MCS6, 90pc duty cycle)	X	5.75	67.79	17.04	0.46	130.0	± 9.6 %
		Y	5.76	67.98	17.22		130.0	
		Z	5.71	67.80	17.04		130.0	
10606-AAA	IEEE 802.11n (HT Mixed, 40MHz, MCS7, 90pc duty cycle)	X	5.50	67.17	16.59	0.46	130.0	± 9.6 %
		Y	5.51	67.36	16.78		130.0	
		Z	5.45	67.15	16.57		130.0	

10607-AAA	IEEE 802.11ac WiFi (20MHz, MCS0, 90pc duty cycle)	X	4.77	66.11	16.20	0.46	130.0	± 9.6 %
		Y	4.78	66.31	16.38		130.0	
		Z	4.72	66.10	16.17		130.0	
10608-AAA	IEEE 802.11ac WiFi (20MHz, MCS1, 90pc duty cycle)	X	4.97	66.53	16.37	0.46	130.0	± 9.6 %
		Y	4.98	66.73	16.55		130.0	
		Z	4.91	66.51	16.34		130.0	
10609-AAA	IEEE 802.11ac WiFi (20MHz, MCS2, 90pc duty cycle)	X	4.86	66.39	16.22	0.46	130.0	± 9.6 %
		Y	4.87	66.61	16.41		130.0	
		Z	4.80	66.37	16.19		130.0	
10610-AAA	IEEE 802.11ac WiFi (20MHz, MCS3, 90pc duty cycle)	X	4.91	66.54	16.37	0.46	130.0	± 9.6 %
		Y	4.92	66.75	16.55		130.0	
		Z	4.85	66.52	16.34		130.0	
10611-AAA	IEEE 802.11ac WiFi (20MHz, MCS4, 90pc duty cycle)	X	4.83	66.37	16.24	0.46	130.0	± 9.6 %
		Y	4.84	66.58	16.42		130.0	
		Z	4.77	66.34	16.20		130.0	
10612-AAA	IEEE 802.11ac WiFi (20MHz, MCS5, 90pc duty cycle)	X	4.85	66.53	16.28	0.46	130.0	± 9.6 %
		Y	4.86	66.77	16.48		130.0	
		Z	4.78	66.50	16.25		130.0	
10613-AAA	IEEE 802.11ac WiFi (20MHz, MCS6, 90pc duty cycle)	X	4.86	66.45	16.19	0.46	130.0	± 9.6 %
		Y	4.87	66.68	16.39		130.0	
		Z	4.79	66.40	16.14		130.0	
10614-AAA	IEEE 802.11ac WiFi (20MHz, MCS7, 90pc duty cycle)	X	4.79	66.59	16.39	0.46	130.0	± 9.6 %
		Y	4.80	66.80	16.57		130.0	
		Z	4.72	66.55	16.34		130.0	
10615-AAA	IEEE 802.11ac WiFi (20MHz, MCS8, 90pc duty cycle)	X	4.84	66.22	16.03	0.46	130.0	± 9.6 %
		Y	4.85	66.46	16.24		130.0	
		Z	4.77	66.19	15.99		130.0	
10616-AAA	IEEE 802.11ac WiFi (40MHz, MCS0, 90pc duty cycle)	X	5.43	66.66	16.42	0.46	130.0	± 9.6 %
		Y	5.44	66.83	16.58		130.0	
		Z	5.38	66.62	16.39		130.0	
10617-AAA	IEEE 802.11ac WiFi (40MHz, MCS1, 90pc duty cycle)	X	5.49	66.80	16.46	0.46	130.0	± 9.6 %
		Y	5.50	66.99	16.63		130.0	
		Z	5.45	66.83	16.47		130.0	
10618-AAA	IEEE 802.11ac WiFi (40MHz, MCS2, 90pc duty cycle)	X	5.38	66.84	16.49	0.46	130.0	± 9.6 %
		Y	5.39	67.01	16.65		130.0	
		Z	5.33	66.80	16.47		130.0	
10619-AAA	IEEE 802.11ac WiFi (40MHz, MCS3, 90pc duty cycle)	X	5.41	66.69	16.36	0.46	130.0	± 9.6 %
		Y	5.42	66.88	16.53		130.0	
		Z	5.36	66.66	16.34		130.0	
10620-AAA	IEEE 802.11ac WiFi (40MHz, MCS4, 90pc duty cycle)	X	5.51	66.76	16.45	0.46	130.0	± 9.6 %
		Y	5.52	66.94	16.61		130.0	
		Z	5.45	66.69	16.40		130.0	
10621-AAA	IEEE 802.11ac WiFi (40MHz, MCS5, 90pc duty cycle)	X	5.49	66.80	16.57	0.46	130.0	± 9.6 %
		Y	5.49	66.95	16.72		130.0	
		Z	5.43	66.76	16.55		130.0	
10622-AAA	IEEE 802.11ac WiFi (40MHz, MCS6, 90pc duty cycle)	X	5.50	66.97	16.65	0.46	130.0	± 9.6 %
		Y	5.51	67.14	16.81		130.0	
		Z	5.46	66.96	16.64		130.0	

10623-AAA	IEEE 802.11ac WiFi (40MHz, MCS7, 90pc duty cycle)	X	5.38	66.52	16.31	0.46	130.0	± 9.6 %
		Y	5.39	66.70	16.48		130.0	
		Z	5.33	66.49	16.29		130.0	
10624-AAA	IEEE 802.11ac WiFi (40MHz, MCS8, 90pc duty cycle)	X	5.58	66.73	16.48	0.46	130.0	± 9.6 %
		Y	5.59	66.90	16.64		130.0	
		Z	5.52	66.69	16.46		130.0	
10625-AAA	IEEE 802.11ac WiFi (40MHz, MCS9, 90pc duty cycle)	X	6.03	67.94	17.14	0.46	130.0	± 9.6 %
		Y	6.04	68.15	17.32		130.0	
		Z	5.94	67.84	17.08		130.0	
10626-AAA	IEEE 802.11ac WiFi (80MHz, MCS0, 90pc duty cycle)	X	5.70	66.70	16.37	0.46	130.0	± 9.6 %
		Y	5.71	66.85	16.51		130.0	
		Z	5.66	66.67	16.35		130.0	
10627-AAA	IEEE 802.11ac WiFi (80MHz, MCS1, 90pc duty cycle)	X	5.98	67.34	16.65	0.46	130.0	± 9.6 %
		Y	5.99	67.51	16.80		130.0	
		Z	5.93	67.32	16.64		130.0	
10628-AAA	IEEE 802.11ac WiFi (80MHz, MCS2, 90pc duty cycle)	X	5.76	66.88	16.35	0.46	130.0	± 9.6 %
		Y	5.78	67.04	16.51		130.0	
		Z	5.72	66.82	16.32		130.0	
10629-AAA	IEEE 802.11ac WiFi (80MHz, MCS3, 90pc duty cycle)	X	5.85	66.94	16.38	0.46	130.0	± 9.6 %
		Y	5.86	67.11	16.54		130.0	
		Z	5.81	66.93	16.37		130.0	
10630-AAA	IEEE 802.11ac WiFi (80MHz, MCS4, 90pc duty cycle)	X	6.47	68.96	17.39	0.46	130.0	± 9.6 %
		Y	6.50	69.20	17.59		130.0	
		Z	6.37	68.78	17.30		130.0	
10631-AAA	IEEE 802.11ac WiFi (80MHz, MCS5, 90pc duty cycle)	X	6.25	68.39	17.28	0.46	130.0	± 9.6 %
		Y	6.25	68.53	17.42		130.0	
		Z	6.15	68.22	17.20		130.0	
10632-AAA	IEEE 802.11ac WiFi (80MHz, MCS6, 90pc duty cycle)	X	5.93	67.33	16.77	0.46	130.0	± 9.6 %
		Y	5.93	67.47	16.90		130.0	
		Z	5.89	67.32	16.77		130.0	
10633-AAA	IEEE 802.11ac WiFi (80MHz, MCS7, 90pc duty cycle)	X	5.83	67.02	16.45	0.46	130.0	± 9.6 %
		Y	5.83	67.17	16.59		130.0	
		Z	5.76	66.93	16.40		130.0	
10634-AAA	IEEE 802.11ac WiFi (80MHz, MCS8, 90pc duty cycle)	X	5.80	67.01	16.50	0.46	130.0	± 9.6 %
		Y	5.81	67.15	16.64		130.0	
		Z	5.75	66.94	16.47		130.0	
10635-AAA	IEEE 802.11ac WiFi (80MHz, MCS9, 90pc duty cycle)	X	5.71	66.44	15.97	0.46	130.0	± 9.6 %
		Y	5.72	66.63	16.15		130.0	
		Z	5.64	66.35	15.92		130.0	
10636-AAA	IEEE 1602.11ac WiFi (160MHz, MCS0, 90pc duty cycle)	X	6.12	67.11	16.48	0.46	130.0	± 9.6 %
		Y	6.13	67.25	16.62		130.0	
		Z	6.09	67.07	16.46		130.0	
10637-AAA	IEEE 1602.11ac WiFi (160MHz, MCS1, 90pc duty cycle)	X	6.30	67.52	16.67	0.46	130.0	± 9.6 %
		Y	6.31	67.68	16.81		130.0	
		Z	6.26	67.49	16.65		130.0	
10638-AAA	IEEE 1602.11ac WiFi (160MHz, MCS2, 90pc duty cycle)	X	6.30	67.50	16.63	0.46	130.0	± 9.6 %
		Y	6.31	67.65	16.78		130.0	
		Z	6.26	67.46	16.61		130.0	

10639-AAA	IEEE 1602.11ac WiFi (160MHz, MCS3, 90pc duty cycle)	X	6.28	67.46	16.65	0.46	130.0	± 9.6 %
		Y	6.28	67.59	16.79		130.0	
		Z	6.23	67.38	16.62		130.0	
10640-AAA	IEEE 1602.11ac WiFi (160MHz, MCS4, 90pc duty cycle)	X	6.30	67.54	16.64	0.46	130.0	± 9.6 %
		Y	6.31	67.70	16.79		130.0	
		Z	6.24	67.43	16.59		130.0	
10641-AAA	IEEE 1602.11ac WiFi (160MHz, MCS5, 90pc duty cycle)	X	6.31	67.32	16.55	0.46	130.0	± 9.6 %
		Y	6.32	67.48	16.70		130.0	
		Z	6.28	67.31	16.54		130.0	
10642-AAA	IEEE 1602.11ac WiFi (160MHz, MCS6, 90pc duty cycle)	X	6.36	67.59	16.84	0.46	130.0	± 9.6 %
		Y	6.36	67.71	16.97		130.0	
		Z	6.31	67.52	16.81		130.0	
10643-AAA	IEEE 1602.11ac WiFi (160MHz, MCS7, 90pc duty cycle)	X	6.20	67.31	16.61	0.46	130.0	± 9.6 %
		Y	6.21	67.47	16.77		130.0	
		Z	6.16	67.26	16.58		130.0	
10644-AAA	IEEE 1602.11ac WiFi (160MHz, MCS8, 90pc duty cycle)	X	6.42	67.97	16.97	0.46	130.0	± 9.6 %
		Y	6.43	68.15	17.13		130.0	
		Z	6.34	67.82	16.88		130.0	
10645-AAA	IEEE 1602.11ac WiFi (160MHz, MCS9, 90pc duty cycle)	X	6.93	69.02	17.44	0.46	130.0	± 9.6 %
		Y	6.97	69.27	17.65		130.0	
		Z	6.82	68.81	17.34		130.0	
10646-AAC	LTE-TDD (SC-FDMA, 1 RB, 5 MHz, QPSK, UL Subframe=2,7)	X	47.20	124.94	41.34	9.30	60.0	± 9.6 %
		Y	100.00	143.87	46.72		60.0	
		Z	42.87	123.31	40.85		60.0	
10647-AAB	LTE-TDD (SC-FDMA, 1 RB, 20 MHz, QPSK, UL Subframe=2,7)	X	47.80	126.16	41.84	9.30	60.0	± 9.6 %
		Y	100.00	144.94	47.17		60.0	
		Z	42.80	124.20	41.27		60.0	
10648-AAA	CDMA2000 (1x Advanced)	X	0.75	63.57	11.13	0.00	150.0	± 9.6 %
		Y	0.80	64.99	12.02		150.0	
		Z	0.70	63.11	10.54		150.0	

<sup>E</sup> Uncertainty is determined using the max. deviation from linear response applying rectangular distribution and is expressed for the square of the field value.