



## SAR EVALUATION REPORT

**Applicant Name:**  
 Samsung Electronics, Co. Ltd.  
 129, Samsung-ro, Maetan dong,  
 Yeongtong-gu, Suwon-si  
 Gyeonggi-do 443-742, Korea

**Date of Testing:**  
 01/12/15 - 02/11/15  
**Test Site/Location:**  
 PCTEST Lab, Columbia, MD, USA  
**Document Serial No.:**  
 0Y1502060403.A3L

**FCC ID:** A3LSMG920I

**APPLICANT:** SAMSUNG ELECTRONICS, CO. LTD.

**DUT Type:** Portable Handset  
**Application Type:** Certification  
**FCC Rule Part(s):** CFR §2.1093  
**Model(s):** SM-G920I

Equipment Class	Band & Mode	Operating Modes	Tx Frequency	SAR		
				1 gm Head (W/kg)	1 gm Body-Worn (W/kg)	1 gm Hotspot (W/kg)
PCE	GSM/GPRS/EDGE 850	Voice/Data	824.20 - 848.80 MHz	0.19	0.33	0.52
PCE	UMTS 850	Voice/Data	826.40 - 846.60 MHz	0.27	0.47	0.47
PCE	UMTS 1750	Voice/Data	1712.4 - 1752.5 MHz	0.26	0.55	1.01
PCE	GSM/GPRS/EDGE 1900	Voice/Data	1850.20 - 1909.80 MHz	< 0.1	0.40	0.94
PCE	UMTS 1900	Voice/Data	1852.4 - 1907.6 MHz	0.13	0.76	1.00
PCE	LTE Band 12	Data	699.7 - 715.3 MHz	0.14	0.31	0.31
PCE	LTE Band 26	Data	814.7 - 848.3 MHz	0.20	0.38	0.45
PCE	LTE Band 4 (AWS)	Data	1710.7 - 1754.3 MHz	0.24	0.73	1.05
PCE	LTE Band 2 (PCS)	Data	1850.7 - 1909.3 MHz	0.11	0.60	0.95
DTS	2.4 GHz WLAN	Data	2412 - 2462 MHz	0.84	< 0.1	< 0.1
NII	U-NII-1	Data	5180 - 5240 MHz	N/A		
NII	U-NII-2A	Data	5260 - 5320 MHz	0.31	< 0.1	
NII	U-NII-2C < 5.65 GHz	Data	5500 - 5580 MHz	0.18	< 0.1	
NII	U-NII-2C > 5.65 GHz + U-NII-3	Data	5660 - 5825 MHz	< 0.1	< 0.1	< 0.1
DSS	Bluetooth	Data	2402 - 2480 MHz		< 0.1	
<b>Simultaneous SAR per KDB 690783 D01v01r03:</b>				1.11	0.93	1.13



This wireless portable device has been shown to be capable of compliance for localized specific absorption rate (SAR) for uncontrolled environment/general population exposure limits specified in ANSI/IEEE C95.1-1992 and has been tested in accordance with the measurement procedures specified in Section 1.8 of this report; for North American frequency bands only.

I attest to the accuracy of data. All measurements reported herein were performed by me or were made under my supervision and are correct to the best of my knowledge and belief. I assume full responsibility for the completeness of these measurements and vouch for the qualifications of all persons taking them. Test results reported herein relate only to the item(s) tested.

  
 Randy Ortanez  
 President





The SAR Tick is an initiative of the Mobile Manufacturers Forum (MMF). While a product may be considered eligible, use of the SAR Tick logo requires an agreement with the MMF. Further details can be obtained by emailing: [sartick@mmfai.info](mailto:sartick@mmfai.info).

<b>FCC ID:</b> A3LSMG920I		<b>SAR EVALUATION REPORT</b>		<b>Reviewed by:</b> Quality Manager
<b>Document S/N:</b> 0Y1502060403.A3L	<b>Test Dates:</b> 01/12/15 - 02/11/15	<b>DUT Type:</b> Portable Handset	Page 1 of 72	

# T A B L E O F C O N T E N T S

1	DEVICE UNDER TEST .....	3
2	LTE INFORMATION .....	9
3	INTRODUCTION .....	10
4	DOSIMETRIC ASSESSMENT .....	11
5	DEFINITION OF REFERENCE POINTS .....	12
6	TEST CONFIGURATION POSITIONS FOR HANDSETS .....	13
7	RF EXPOSURE LIMITS .....	16
8	FCC MEASUREMENT PROCEDURES.....	17
9	RF CONDUCTED POWERS.....	23
10	SYSTEM VERIFICATION.....	46
11	SAR DATA SUMMARY .....	48
12	FCC MULTI-TX AND ANTENNA SAR CONSIDERATIONS.....	58
13	SAR MEASUREMENT VARIABILITY .....	66
14	EQUIPMENT LIST.....	67
15	MEASUREMENT UNCERTAINTIES .....	68
16	CONCLUSION.....	70
17	REFERENCES .....	71
APPENDIX A: SAR TEST PLOTS		
APPENDIX B: SAR DIPOLE VERIFICATION PLOTS		
APPENDIX C: PROBE AND DIPOLE CALIBRATION CERTIFICATES		
APPENDIX D: SAR TISSUE SPECIFICATIONS		
APPENDIX E: SAR SYSTEM VALIDATION		
APPENDIX F: DUT ANTENNA DIAGRAM & SAR TEST SETUP PHOTOGRAPH		

<b>FCC ID:</b> A3LSMG920I		<b>SAR EVALUATION REPORT</b>		<b>Reviewed by:</b> Quality Manager
<b>Document S/N:</b> 0Y1502060403.A3L	<b>Test Dates:</b> 01/12/15 - 02/11/15	<b>DUT Type:</b> Portable Handset	Page 2 of 72	

# 1 DEVICE UNDER TEST

## 1.1 Device Overview



Band & Mode	Operating Modes	Tx Frequency
GSM/GPRS/EDGE 850	Voice/Data	824.20 - 848.80 MHz
UMTS 850	Voice/Data	826.40 - 846.60 MHz
UMTS 1750	Voice/Data	1712.4 - 1752.5 MHz
GSM/GPRS/EDGE 1900	Voice/Data	1850.20 - 1909.80 MHz
UMTS 1900	Voice/Data	1852.4 - 1907.6 MHz
LTE Band 12	Data	699.7 - 715.3 MHz
LTE Band 17	Data	706.5 - 713.5 MHz
LTE Band 26	Data	814.7 - 848.3 MHz
LTE Band 5	Data	824.7 - 848.3 MHz
LTE Band 4 (AWS)	Data	1710.7 - 1754.3 MHz
LTE Band 2 (PCS)	Data	1850.7 - 1909.3 MHz
2.4 GHz WLAN	Data	2412 - 2462 MHz
U-NII-1	Data	5180 - 5240 MHz
U-NII-2A	Data	5260 - 5320 MHz
U-NII-2C < 5.65 GHz	Data	5500 - 5580 MHz
U-NII-2C > 5.65 GHz + U-NII-3	Data	5660 - 5825 MHz
Bluetooth	Data	2402 - 2480 MHz
Bluetooth LE	Data	2402 - 2480 MHz
NFC	Data	13.56 MHz
ANT+	Data	2402 - 2480 MHz

## 1.2 Nominal and Maximum Output Power Specifications

This device operates using the following maximum and nominal output power specifications. SAR values were scaled to the maximum allowed power to determine compliance per KDB Publication 447498 D01v05.

Mode / Band		Voice (dBm)	Burst Average GMSK (dBm)				Burst Average 8-PSK (dBm)			
		1 TX Slot	1 TX Slots	2 TX Slots	3 TX Slots	4 TX Slots	1 TX Slots	2 TX Slots	3 TX Slots	4 TX Slots
GSM/GPRS/EDGE 850	Maximum	<b>33.0</b>	<b>33.0</b>	<b>32.0</b>	<b>28.0</b>	<b>27.5</b>	<b>26.0</b>	<b>25.0</b>	<b>22.0</b>	<b>21.5</b>
	Nominal	<b>32.5</b>	<b>32.5</b>	<b>31.5</b>	<b>27.5</b>	<b>27.0</b>	<b>25.5</b>	<b>24.5</b>	<b>21.5</b>	<b>21.0</b>
GSM/GPRS/EDGE 1900	Maximum	<b>30.0</b>	<b>30.0</b>	<b>29.0</b>	<b>25.5</b>	<b>25.0</b>	<b>26.0</b>	<b>25.5</b>	<b>21.5</b>	<b>20.5</b>
	Nominal	<b>29.5</b>	<b>29.5</b>	<b>28.5</b>	<b>25.0</b>	<b>24.5</b>	<b>25.5</b>	<b>25.0</b>	<b>21.0</b>	<b>20.0</b>



Mode / Band		Modulated Average (dBm)			
		3GPP WCDMA Rel 99	3GPP HSDPA Rel 5	3GPP HSUPA Rel 6	3GPP DC-HSDPA Rel 8
UMTS Band 5 (850 MHz)	Maximum	<b>24.5</b>	<b>24.5</b>	<b>24.5</b>	<b>24.5</b>
	Nominal	<b>24.0</b>	<b>24.0</b>	<b>24.0</b>	<b>24.0</b>
UMTS Band 4 (1750 MHz)	Maximum	<b>23.0</b>	<b>23.0</b>	<b>23.0</b>	<b>23.0</b>
	Nominal	<b>22.5</b>	<b>22.5</b>	<b>22.5</b>	<b>22.5</b>
UMTS Band 2 (1900 MHz)	Maximum	<b>22.5</b>	<b>22.5</b>	<b>22.5</b>	<b>22.5</b>
	Nominal	<b>22.0</b>	<b>22.0</b>	<b>22.0</b>	<b>22.0</b>

FCC ID: A3LSMG920I	 <b>PCTEST</b> ENGINEERING LABORATORY, INC.	<b>SAR EVALUATION REPORT</b>		Reviewed by: Quality Manager
Document S/N: 0Y1502060403.A3L	Test Dates: 01/12/15 - 02/11/15	DUT Type: Portable Handset	Page 3 of 72	

Mode / Band		Modulated Average (dBm)
LTE Band 12/17	Maximum	24.5
	Nominal	24.0
LTE Band 26/5	Maximum	24.5
	Nominal	24.0
LTE Band 4 (AWS)	Maximum	22.0
	Nominal	21.5
LTE Band 2 (PCS)	Maximum	22.0
	Nominal	21.5

### Single Transmission Chain WLAN/BT

Mode / Band		Modulated Average (dBm)
IEEE 802.11b (2.4 GHz)	Maximum	17.5
	Nominal	17.0
IEEE 802.11g (2.4 GHz)	Maximum	14.5
	Nominal	14.0
IEEE 802.11n (2.4 GHz)	Maximum	13.5
	Nominal	13.0
IEEE 802.11a (5 GHz)	Maximum	13.5
	Nominal	13.0
IEEE 802.11n (5 GHz) 20 MHz Bandwidth	Maximum	13.5
	Nominal	13.0
IEEE 802.11ac (5 GHz) 20 MHz Bandwidth	Maximum	13.5
	Nominal	13.0
IEEE 802.11n (5 GHz) 40 MHz Bandwidth	Maximum	11.5
	Nominal	11.0
IEEE 802.11ac (5 GHz) 40 MHz Bandwidth	Maximum	11.5
	Nominal	11.0
IEEE 802.11ac (5 GHz) 80 MHz Bandwidth	Maximum	9.5
	Nominal	9.0
Bluetooth	Maximum	13.0
	Nominal	12.5
Bluetooth LE	Maximum	9.0
	Nominal	8.5

FCC ID: A3LSMG920I	 <b>PCTEST</b> ENGINEERING LABORATORY, INC.	<b>SAR EVALUATION REPORT</b>		<b>Reviewed by:</b> Quality Manager
<b>Document S/N:</b> 0Y1502060403.A3L	<b>Test Dates:</b> 01/12/15 - 02/11/15	<b>DUT Type:</b> Portable Handset	Page 4 of 72	

### MIMO WLAN

Mode / Band		Modulated Average (dBm)
IEEE 802.11n (2.4 GHz)	Maximum	16.5
	Nominal	16.0
IEEE 802.11n (5 GHz) 20 MHz Bandwidth	Maximum	16.0
	Nominal	15.5
IEEE 802.11ac (5 GHz) 20 MHz Bandwidth	Maximum	16.0
	Nominal	15.5
IEEE 802.11n (5 GHz) 40 MHz Bandwidth	Maximum	14.5
	Nominal	14.0
IEEE 802.11ac (5 GHz) 40 MHz Bandwidth	Maximum	14.5
	Nominal	14.0
IEEE 802.11ac (5 GHz) 80 MHz Bandwidth	Maximum	12.5
	Nominal	12.0



### 1.3 DUT Antenna Locations

The overall dimensions of this device are > 9 x 5 cm. The overall diagonal dimension of the device is <160 mm and the diagonal display is <150 mm. A diagram showing the location of the device antennas can be found in Appendix F. Exact antenna dimensions and separation distances are shown in the Technical Descriptions in the FCC filing.

**Table 1-1  
Mobile Hotspot Sides for SAR Testing**

Mode	Back	Front	Top	Bottom	Right	Left
GPRS 850	Yes	Yes	No	Yes	Yes	Yes
UMTS 850	Yes	Yes	No	Yes	Yes	Yes
UMTS 1750	Yes	Yes	No	Yes	Yes	Yes
GPRS 1900	Yes	Yes	No	Yes	Yes	Yes
UMTS 1900	Yes	Yes	No	Yes	Yes	Yes
LTE Band 12	Yes	Yes	No	Yes	Yes	Yes
LTE Band 26	Yes	Yes	No	Yes	Yes	Yes
LTE Band 4 (AWS)	Yes	Yes	No	Yes	Yes	Yes
LTE Band 2 (PCS)	Yes	Yes	No	Yes	Yes	Yes
2.4 GHz WLAN ANT 1	Yes	Yes	Yes	No	No	Yes
2.4 GHz WLAN ANT 2	Yes	Yes	Yes	No	Yes	No
U-NII-3 ANT 1	Yes	Yes	Yes	No	No	Yes
U-NII-3 ANT 2	Yes	Yes	Yes	No	Yes	No

Note: Particular DUT edges were not required to be evaluated for Wireless Router SAR if the edges were greater than 2.5 cm from the transmitting antenna according to FCC KDB Publication 941225 D06 guidance, page 2. The distances between the transmit antennas and the edges of the device are included in the filing. When wireless router mode is enabled, U-NII-1, U-NII-2A and U-NII-2C WLAN operations are disabled. Therefore U-NII-1, U-NII-2A and U-NII-2C WLAN operations are not considered in this section.

FCC ID: A3LSMG920I	 <b>SAR EVALUATION REPORT</b> 		Reviewed by: Quality Manager
Document S/N: 0Y1502060403.A3L	Test Dates: 01/12/15 - 02/11/15	DUT Type: Portable Handset	Page 5 of 72

## 1.4 Near Field Communications (NFC) Antenna

This DUT has NFC operations. The NFC antenna is integrated into the device for this model. Therefore, all SAR tests were performed with the device which already incorporates the NFC antenna. A diagram showing the location of the NFC antenna can be found in Appendix F.

## 1.5 Simultaneous Transmission Capabilities

According to FCC KDB Publication 447498 D05v01, transmitters are considered to be transmitting simultaneously when there is overlapping transmission, with the exception of transmissions during network hand-offs with maximum hand-off duration less than 30 seconds. Possible transmission paths for the DUT are shown in

Figure 1-1 and are color-coded to indicate communication modes which share the same path. Modes which share the same transmission path cannot transmit simultaneously with one another.





**Figure 1-1**  
**Simultaneous Transmission Paths**

This device contains multiple transmitters that may operate simultaneously, and therefore requires a simultaneous transmission analysis according to FCC KDB Publication 447498 D01v05 3) procedures.

**Table 1-2**  
**Simultaneous Transmission Scenarios**

No.	Capable Transmit Configuration	Head	Body-Worn Accessory	Wireless Router	Notes
1	GSM voice + 2.4 GHz WI-FI	Yes	Yes	N/A	
2	GSM voice + 5 GHz WI-FI	Yes	Yes	N/A	
3	GSM voice + 2.4 GHz Bluetooth	N/A	Yes	N/A	
4	UMTS + 2.4 GHz WI-FI	Yes	Yes	Yes	
5	UMTS + 5 GHz WI-FI	Yes	Yes	Yes	
6	UMTS + 2.4 GHz Bluetooth	N/A	Yes	N/A	
7	LTE + 2.4 GHz WI-FI	Yes*	Yes*	Yes	*-Pre-installed VOIP applications are considered.
8	LTE + 5 GHz WI-FI	Yes*	Yes*	Yes	*-Pre-installed VOIP applications are considered.
9	LTE + 2.4 GHz Bluetooth	N/A	Yes*	N/A	*-Pre-installed VOIP applications are considered.
10	GPRS/EDGE + 2.4 GHz WI-FI	N/A	N/A	Yes	
11	GPRS/EDGE + 5 GHz WI-FI	N/A	N/A	Yes	

- 2.4 GHz WLAN, 5 GHz WLAN, and 2.4 GHz Bluetooth share the same antenna path and cannot transmit simultaneously.
- All licensed modes share the same antenna path and cannot transmit simultaneously.
- When the user utilizes multiple services in UMTS 3G mode it uses multi-Radio Access Bearer or multi-RAB. The power control is based on a physical control channel (Dedicated Physical Control Channel [DPCCH]) and power control will be adjusted to meet the needs of both services. Therefore, the UMTS+WLAN scenario also represents the UMTS Voice/DATA + WLAN Hotspot scenario.
- Per the manufacturer, WIFI Direct is not expected to be used in conjunction with a held-to-ear or body-worn accessory voice call. Therefore, there are no simultaneous transmission scenarios involving WIFI direct beyond that listed in the above table.

FCC ID: A3LSMG920I	 <b>PCTEST</b> ENGINEERING LABORATORY, INC.	<b>SAR EVALUATION REPORT</b>		<b>Reviewed by:</b> Quality Manager
<b>Document S/N:</b> 0Y1502060403.A3L	<b>Test Dates:</b> 01/12/15 - 02/11/15	<b>DUT Type:</b> Portable Handset	Page 6 of 72	

5. 5 GHz Wireless Router is only supported by software for U-NII-3 channels 149-165, therefore all other 5 GHz channels were not evaluated for wireless router conditions.
6. This device supports 2x2 MIMO Tx for WLAN 802.11n/ac. The WLAN antennas can transmit independently or together when operating with MIMO.

## 1.6 Miscellaneous SAR Test Considerations

### (A) WIFI/BT

Since Wireless Router operations are not allowed by the chipset firmware using U-NII-1, U-NII-2A & U-NII-2C WIFI, only 2.4 GHz and U-NII-3 WIFI Hotspot SAR tests and combinations are considered for SAR with respect to Wireless Router configurations according to FCC KDB 941225 D06.

Since U-NII-1 and U-NII-2A bands have the same maximum output power and the highest reported SAR for U-NII-2A is less than 1.2 W/kg, SAR is not required for U-NII-1 band according to FCC KDB 248227 D01 DR02-41929.

Since this device supports the band gap channels, the channels in the U-NII-2C band above 5.65 GHz were grouped with the channels in the U-NII-3 as a single aggregate band. The channels in U-NII-2C below 5.65 GHz were considered separately for SAR evaluation.

This device supports IEEE 802.11ac with the following features:

- a) Up to 80 MHz Bandwidth only
- b) No aggregate channel configurations
- c) 2 Tx antenna output
- d) 256 QAM is supported
- e) Band gap channels are supported

Per FCC KDB 447498 D01v05, the 1g SAR exclusion threshold for distances <50mm is defined by the following equation:

$$\frac{\text{Max Power of Channel (mW)}}{\text{Test Separation Dist (mm)}} * \sqrt{\text{Frequency(GHz)}} \leq 3.0$$



Based on the maximum conducted power of Bluetooth LE (rounded to the nearest mW) and the antenna to user separation distance, body-worn Bluetooth LE SAR was not required;  $[(8/10) * \sqrt{2.480}] = 1.3 < 3.0$ . Per KDB Publication 447498 D01v05, the maximum power of the channel was rounded to the nearest mW before calculation.

### (B) Licensed Transmitter(s)

GSM/GPRS/EDGE DTM is not supported for US bands. Therefore, the GSM Voice modes in this report do not transmit simultaneously with GPRS/EDGE Data.

This device is only capable of QPSK HSUPA in the uplink. Therefore, no additional SAR tests are required beyond that described for devices with HSUPA in KDB 941225 D01.

LTE SAR for the higher modulations and lower bandwidths were not tested since the maximum average output power of all required channels and configurations was not more than 0.5 dB higher than the highest bandwidth; and the reported LTE SAR for the highest bandwidth was less than 1.45 W/kg for all configurations according to FCC KDB 941225 D05.

FCC ID: A3LSMG920I	 PCTEST ENGINEERING LABORATORY, INC.	SAR EVALUATION REPORT		Reviewed by: Quality Manager
Document S/N: 0Y1502060403.A3L	Test Dates: 01/12/15 - 02/11/15	DUT Type: Portable Handset	Page 7 of 72	

This device supports both LTE Band 5 (Cell) and LTE Band 26. Since the supported frequency span for LTE Band 5 (Cell) falls completely within the supported frequency span for LTE Band 26, both LTE bands have the same target power, and both LTE bands share the same transmission path, SAR was only assessed for LTE Band 26.

This device supports both LTE Band 12 and LTE Band 17. Since the supported frequency span for LTE Band 17 falls completely within the supported frequency span for LTE Band 12, both LTE bands have the same target power, and both LTE bands share the same transmission path, SAR was only assessed for LTE Band 12.

## 1.7 Power Reduction for SAR

There is no power reduction used for any band/mode implemented in this device for SAR purposes.



## 1.8 Guidance Applied

- IEEE 1528-2003
- FCC KDB Publication 941225 D01, D05, D06 (2G/3G/4G and Hotspot)
- FCC KDB Publication 248227 D01 DR02-41929 (SAR Considerations for 802.11 Devices)
- FCC KDB Publication 447498 D01v05r02 (General SAR Guidance)
- FCC KDB Publication 865664 D01v01r03, D02v01r01 (SAR Measurements up to 6 GHz)
- October 2013 TCB Workshop Notes (GPRS Testing Considerations)

## 1.9 Device Serial Numbers

Several samples with identical hardware were used to support SAR testing. The manufacturer has confirmed that the device(s) tested have the same physical, mechanical and thermal characteristics and are within operational tolerances expected for production units.



	Head Serial Number	Body-Worn Serial Number	Hotspot Serial Number
GSM/GPRS/EDGE 850	146AD	146D0	146D0
UMTS 850	1565F	1565F	1565F
UMTS 1750	1565F	1565F	1565F
GSM/GPRS/EDGE 1900	146D0	146D0	146D0
UMTS 1900	1565F	1565F	1565F
LTE Band 12	146AD	1565F	1565F
LTE Band 26	146AD	146AD	146AD
LTE Band 4 (AWS)	146AD	146AD	146AD
LTE Band 2 (PCS)	1565F	1565F	1565F
2.4 GHz WLAN	05C58	066BE	066BE
U-NII-2A & U-NII-2C	05C9A	066BE	-
U-NII-3	05C9A	066BE	066BE
Bluetooth	-	066BE	-

FCC ID: A3LSMG920I	 <b>PCTEST</b> ENGINEERING LABORATORY, INC.	<b>SAR EVALUATION REPORT</b>		<b>Reviewed by:</b> Quality Manager
<b>Document S/N:</b> 0Y1502060403.A3L	<b>Test Dates:</b> 01/12/15 - 02/11/15	<b>DUT Type:</b> Portable Handset	Page 8 of 72	

## 2

## LTE INFORMATION

LTE Information			
<b>FCC ID</b>	<b>A3LSMG920I</b>		
Form Factor	Portable Handset		
Frequency Range of each LTE transmission band	LTE Band 12 (699.7 - 715.3 MHz)		
	LTE Band 17 (706.5 - 713.5 MHz)		
	LTE Band 26 (814.7 - 848.3 MHz)		
	LTE Band 5 (Cell) (824.7 - 848.3 MHz)		
	LTE Band 4 (AWS) (1710.7 - 1754.3 MHz)		
	LTE Band 2 (PCS) (1850.7 - 1909.3 MHz)		
Channel Bandwidths	LTE Band 12: 1.4 MHz, 3 MHz, 5 MHz, 10 MHz		
	LTE Band 17: 5 MHz, 10 MHz		
	LTE Band 26: 1.4 MHz, 3 MHz, 5 MHz, 10 MHz, 15 MHz		
	LTE Band 5 (Cell): 1.4 MHz, 3 MHz, 5 MHz, 10 MHz		
	LTE Band 4 (AWS): 1.4 MHz, 3 MHz, 5 MHz, 10 MHz, 15 MHz, 20 MHz		
	LTE Band 2 (PCS): 1.4 MHz, 3 MHz, 5 MHz, 10 MHz, 15 MHz, 20 MHz		
Channel Numbers and Frequencies (MHz)	Low	Mid	High
LTE Band 12: 1.4 MHz	699.7 (23017)	707.5 (23095)	715.3 (23173)
LTE Band 12: 3 MHz	700.5 (23025)	707.5 (23095)	714.5 (23165)
LTE Band 12: 5 MHz	701.5 (23035)	707.5 (23095)	713.5 (23155)
LTE Band 12: 10 MHz	704 (23060)	707.5 (23095)	711 (23130)
LTE Band 17: 5 MHz	706.5 (23085)	710 (23790)	713.5 (23825)
LTE Band 17: 10 MHz	709 (23780)	710 (23790)	711 (23800)
LTE Band 26: 1.4 MHz	814.7 (26697)	831.5 (26865)	848.3 (27033)
LTE Band 26: 3 MHz	815.5 (26705)	831.5 (26865)	847.5 (27025)
LTE Band 26: 5 MHz	816.5 (26715)	831.5 (26865)	846.5 (27015)
LTE Band 26: 10 MHz	819 (26740)	831.5 (26865)	844 (26990)
LTE Band 26: 15 MHz	831.5 (26865)	836.5 (26915)	841.5 (26965)
LTE Band 5 (Cell): 1.4 MHz	824.7 (20407)	836.5 (20525)	848.3 (20643)
LTE Band 5 (Cell): 3 MHz	825.5 (20415)	836.5 (20525)	847.5 (20635)
LTE Band 5 (Cell): 5 MHz	826.5 (20425)	836.5 (20525)	846.5 (20625)
LTE Band 5 (Cell): 10 MHz	829 (20450)	836.5 (20525)	844 (20600)
LTE Band 4 (AWS): 1.4 MHz	1710.7 (19957)	1732.5 (20175)	1754.3 (20393)
LTE Band 4 (AWS): 3 MHz	1711.5 (19965)	1732.5 (20175)	1753.5 (20385)
LTE Band 4 (AWS): 5 MHz	1712.5 (19975)	1732.5 (20175)	1752.5 (20375)
LTE Band 4 (AWS): 10 MHz	1715 (20000)	1732.5 (20175)	1750 (20350)
LTE Band 4 (AWS): 15 MHz	1717.5 (20025)	1732.5 (20175)	1747.5 (20325)
LTE Band 4 (AWS): 20 MHz	1720 (20050)	1732.5 (20175)	1745 (20300)
LTE Band 2 (PCS): 1.4 MHz	1850.7 (18607)	1880 (18900)	1909.3 (19193)
LTE Band 2 (PCS): 3 MHz	1851.5 (18615)	1880 (18900)	1908.5 (19185)
LTE Band 2 (PCS): 5 MHz	1852.5 (18625)	1880 (18900)	1907.5 (19175)
LTE Band 2 (PCS): 10 MHz	1855 (18650)	1880 (18900)	1905 (19150)
LTE Band 2 (PCS): 15 MHz	1857.5 (18675)	1880 (18900)	1902.5 (19125)
LTE Band 2 (PCS): 20 MHz	1860 (18700)	1880 (18900)	1900 (19100)
UE Category	6		
Modulations Supported in UL	QPSK, 16QAM		
LTE MPR Permanently implemented per 3GPP TS 36.101 section 6.2.3~6.2.5? (manufacturer attestation to be provided)	YES		
A-MPR (Additional MPR) disabled for SAR Testing?	YES		
LTE Carrier Aggregation Possible Combinations	LTE Carrier Aggregation is not supported in the US for this model		
LTE Carrier Aggregation Additional Information	This device does not support full LTE Release 10 operations in the US. The following LTE Release 10 Features are not supported in the US: Carrier Aggregation, Relay, HetNet, Enhanced MIMO, eICI, WFI Offloading, MDH, eMBMA, Cross-Carrier Scheduling, Enhanced SC-FDMA.		

<b>FCC ID:</b> A3LSMG920I	 <b>PCTEST</b> ENGINEERING LABORATORY, INC.	<b>SAR EVALUATION REPORT</b>		<b>Reviewed by:</b> Quality Manager
<b>Document S/N:</b> 0Y1502060403.A3L	<b>Test Dates:</b> 01/12/15 - 02/11/15	<b>DUT Type:</b> Portable Handset	Page 9 of 72	

## 3 INTRODUCTION

The FCC and Industry Canada have adopted the guidelines for evaluating the environmental effects of radio frequency (RF) radiation in ET Docket 93-62 on Aug. 6, 1996 and Health Canada Safety Code 6 to protect the public and workers from the potential hazards of RF emissions due to FCC-regulated portable devices. [1]

The safety limits used for the environmental evaluation measurements are based on the criteria published by the American National Standards Institute (ANSI) for localized specific absorption rate (SAR) in IEEE/ANSI C95.1-1992 Standard for Safety Levels with Respect to Human Exposure to Radio Frequency Electromagnetic Fields, 3 kHz to 300 GHz [3] and Health Canada RF Exposure Guidelines Safety Code 6 [22]. The measurement procedure described in IEEE/ANSI C95.3-2002 Recommended Practice for the Measurement of Potentially Hazardous Electromagnetic Fields - RF and Microwave [4] is used for guidance in measuring the Specific Absorption Rate (SAR) due to the RF radiation exposure from the Equipment Under Test (EUT). These criteria for SAR evaluation are similar to those recommended by the International Committee for Non-Ionizing Radiation Protection (ICNIRP) in Biological Effects and Exposure Criteria for Radiofrequency Electromagnetic Fields,” Report No. Vol 74. SAR is a measure of the rate of energy absorption due to exposure to an RF transmitting source. SAR values have been related to threshold levels for potential biological hazards.

### 3.1 SAR Definition

Specific Absorption Rate is defined as the time derivative (rate) of the incremental energy (dU) absorbed by (dissipated in) an incremental mass (dm) contained in a volume element (dV) of a given density (ρ). It is also defined as the rate of RF energy absorption per unit mass at a point in an absorbing body (see Equation 3-1).

**Equation 3-1**  
**SAR Mathematical Equation**

$$SAR = \frac{d}{dt} \left( \frac{dU}{dm} \right) = \frac{d}{dt} \left( \frac{dU}{\rho dv} \right)$$



**SAR is expressed in units of Watts per Kilogram (W/kg).**

$$SAR = \frac{\sigma \cdot E^2}{\rho}$$

where:

- σ = conductivity of the tissue-simulating material (S/m)
- ρ = mass density of the tissue-simulating material (kg/m<sup>3</sup>)
- E = Total RMS electric field strength (V/m)

NOTE: The primary factors that control rate of energy absorption were found to be the wavelength of the incident field in relation to the dimensions and geometry of the irradiated organism, the orientation of the organism in relation to the polarity of field vectors, the presence of reflecting surfaces, and whether conductive contact is made by the organism with a ground plane.[6]

FCC ID: A3LSMG920I		<b>SAR EVALUATION REPORT</b>		Reviewed by: Quality Manager
Document S/N: 0Y1502060403.A3L	Test Dates: 01/12/15 - 02/11/15	DUT Type: Portable Handset	Page 10 of 72	

# 4 DOSIMETRIC ASSESSMENT

## 4.1 Measurement Procedure

The evaluation was performed using the following procedure compliant to FCC KDB Publication 865664 D01v01 and IEEE 1528-2013:

1. The SAR distribution at the exposed side of the head or body was measured at a distance no greater than 5.0 mm from the inner surface of the shell. The area covered the entire dimension of the device-head and body interface and the horizontal grid resolution was determined per FCC KDB Publication 865664 D01v01 (See Table 4-1) and IEEE 1528-2013.
2. The point SAR measurement was taken at the maximum SAR region determined from Step 1 to enable the monitoring of SAR fluctuations/drifts during the 1g/10g cube evaluation. SAR at this fixed point was measured and used as a reference value.
3. Based on the area scan data, the peak of the region with maximum SAR was determined by spline interpolation. Around this point, a volume was assessed according to the measurement resolution and volume size requirements of FCC KDB Publication 865664 D01v01 (See Table 4-1) and IEEE 1528-2013. On the basis of this data set, the spatial peak SAR value was evaluated with the following procedure (see references or the DASY manual online for more details):
  - a. SAR values at the inner surface of the phantom are extrapolated from the measured values along the line away from the surface with spacing no greater than that in Table 4-1. The extrapolation was based on a least-squares algorithm. A polynomial of the fourth order was calculated through the points in the z-axis (normal to the phantom shell).
  - b. After the maximum interpolated values were calculated between the points in the cube, the SAR was averaged over the spatial volume (1g or 10g) using a 3D-Spline interpolation algorithm. The 3D-spline is composed of three one-dimensional splines with the “Not a knot” condition (in x, y, and z directions). The volume was then integrated with the trapezoidal algorithm. One thousand points (10 x 10 x 10) were obtained through interpolation, in order to calculate the averaged SAR.
  - c. All neighboring volumes were evaluated until no neighboring volume with a higher average value was found.
4. The SAR reference value, at the same location as step 2, was re-measured after the zoom scan was complete to calculate the SAR drift. If the drift deviated by more than 5%, the SAR test and drift measurements were repeated.

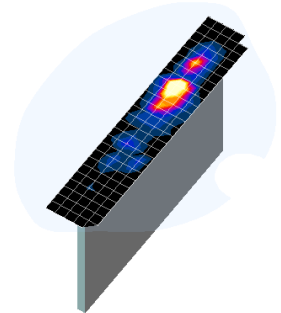



**Figure 4-1**  
**Sample SAR Area Scan**

**Table 4-1**  
**Area and Zoom Scan Resolutions per FCC KDB Publication 865664 D01v01\***

Frequency	Maximum Area Scan Resolution (mm) ( $\Delta x_{area}, \Delta y_{area}$ )	Maximum Zoom Scan Resolution (mm) ( $\Delta x_{zoom}, \Delta y_{zoom}$ )	Maximum Zoom Scan Spatial Resolution (mm)			Minimum Zoom Scan Volume (mm) (x, y, z)
			Uniform Grid	Graded Grid		
			$\Delta z_{zoom}(n)$	$\Delta z_{zoom}(1)^*$	$\Delta z_{zoom}(n>1)^*$	
≤ 2 GHz	≤ 15	≤ 8	≤ 5	≤ 4	≤ 1.5* $\Delta z_{zoom}(n-1)$	≥ 30
2-3 GHz	≤ 12	≤ 5	≤ 5	≤ 4	≤ 1.5* $\Delta z_{zoom}(n-1)$	≥ 30
3-4 GHz	≤ 12	≤ 5	≤ 4	≤ 3	≤ 1.5* $\Delta z_{zoom}(n-1)$	≥ 28
4-5 GHz	≤ 10	≤ 4	≤ 3	≤ 2.5	≤ 1.5* $\Delta z_{zoom}(n-1)$	≥ 25
5-6 GHz	≤ 10	≤ 4	≤ 2	≤ 2	≤ 1.5* $\Delta z_{zoom}(n-1)$	≥ 22

\*Also compliant to IEEE 1528-2013 Table 6

FCC ID: A3LSMG920I	 <b>SAR EVALUATION REPORT</b> 		Reviewed by: Quality Manager
Document S/N: 0Y1502060403.A3L	Test Dates: 01/12/15 - 02/11/15	DUT Type: Portable Handset	Page 11 of 72

# 5

## DEFINITION OF REFERENCE POINTS

### 5.1 EAR REFERENCE POINT

Figure 5-2 shows the front, back and side views of the SAM Twin Phantom. The point “M” is the reference point for the center of the mouth, “LE” is the left ear reference point (ERP), and “RE” is the right ERP. The ERP is 15mm posterior to the entrance to the ear canal (EEC) along the B-M line (Back-Mouth), as shown in Figure 5-1. The plane passing through the two ear canals and M is defined as the Reference Plane. The line N-F (Neck-Front), also called the Reference Pivoting Line, is not perpendicular to the reference plane (see Figure 5-1). Line B-M is perpendicular to the N-F line. Both N-F and B-M lines are marked on the external phantom shell to facilitate handset positioning [5].

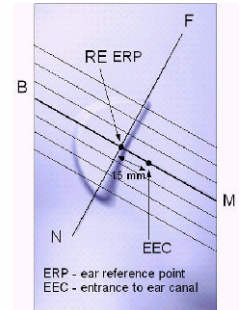

**Figure 5-1**  
Close-Up Side view of ERP

### 5.2 HANDSET REFERENCE POINTS

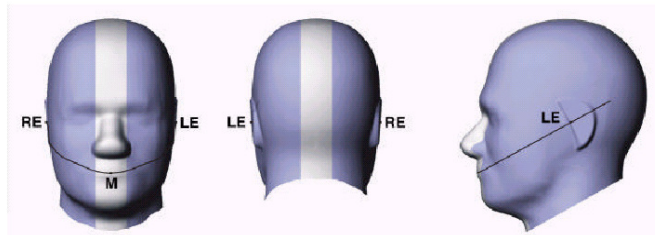

Two imaginary lines on the handset were established: the vertical centerline and the horizontal line. The test device was placed in a normal operating position with the acoustic output located along the “vertical centerline” on the front of the device aligned to the “ear reference point” (See Figure 5-3). The acoustic output was then located at the same level as the center of the ear reference point. The test device was positioned so that the “vertical centerline” was bisecting the front surface of the handset at its top and bottom edges, positioning the “ear reference point” on the outer surface of the both the left and right head phantoms on the ear reference point.

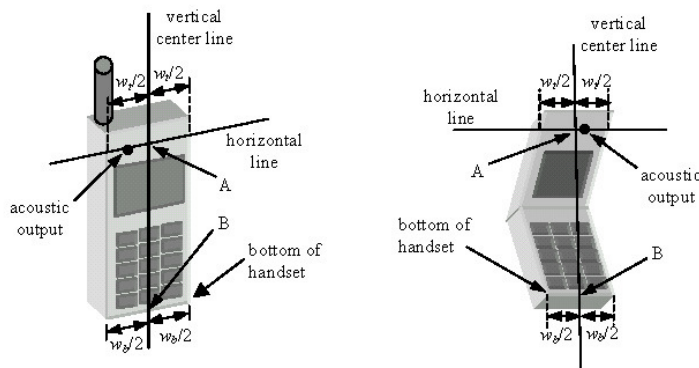

**Figure 5-2**  
Front, back and side view of SAM Twin Phantom



**Figure 5-3**  
Handset Vertical Center & Horizontal Line Reference Points

FCC ID: A3LSMG920I	 PCTEST ENGINEERING LABORATORY, INC.	SAR EVALUATION REPORT	 SAMSUNG	Reviewed by: Quality Manager
Document S/N: 0Y1502060403.A3L	Test Dates: 01/12/15 - 02/11/15	DUT Type: Portable Handset		Page 12 of 72

## 6 TEST CONFIGURATION POSITIONS FOR HANDSETS

### 6.1 Device Holder

The device holder is made out of low-loss POM material having the following dielectric parameters: relative permittivity  $\epsilon = 3$  and loss tangent  $\delta = 0.02$ .

### 6.2 Positioning for Cheek

1. The test device was positioned with the device close to the surface of the phantom such that point A is on the (virtual) extension of the line passing through points RE and LE on the phantom (see Figure 6-1), such that the plane defined by the vertical center line and the horizontal line of the phone is approximately parallel to the sagittal plane of the phantom.

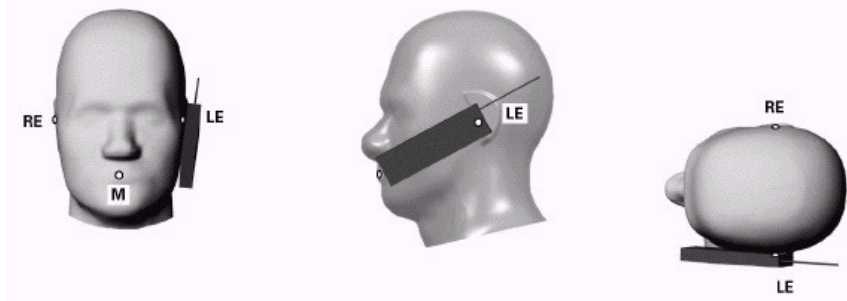



**Figure 6-1 Front, Side and Top View of Cheek Position**

2. The handset was translated towards the phantom along the line passing through RE & LE until the handset touches the pinna.
3. While maintaining the handset in this plane, the handset was rotated around the LE-RE line until the vertical centerline was in the reference plane.
4. The phone was then rotated around the vertical centerline until the phone (horizontal line) was symmetrical with respect to the line NF.
5. While maintaining the vertical centerline in the reference plane, keeping point A on the line passing through RE and LE, and maintaining the device contact with the ear, the device was rotated about the NF line until any point on the handset made contact with a phantom point below the ear (cheek) (See Figure 6-2).

### 6.3 Positioning for Ear / 15° Tilt

With the test device aligned in the “Cheek Position”:

1. While maintaining the orientation of the phone, the phone was retracted parallel to the reference plane far enough to enable a rotation of the phone by 15 degrees.
2. The phone was then rotated around the horizontal line by 15 degrees.
3. While maintaining the orientation of the phone, the phone was moved parallel to the reference plane until any part of the handset touched the head. (In this position, point A was located on the line RE-LE). The tilted position is obtained when the contact is on the pinna. If the contact was at any location other than the pinna, the angle of the phone would then be reduced. In this situation, the tilted position was obtained when any part of the phone was in contact of the ear as well as a second part of the phone was in contact with the head (see Figure 6-2).

FCC ID: A3LSMG920I	 PCTEST ENGINEERING LABORATORY, INC.	SAR EVALUATION REPORT	 SAMSUNG	Reviewed by: Quality Manager
Document S/N: 0Y1502060403.A3L	Test Dates: 01/12/15 - 02/11/15	DUT Type: Portable Handset	Page 13 of 72	

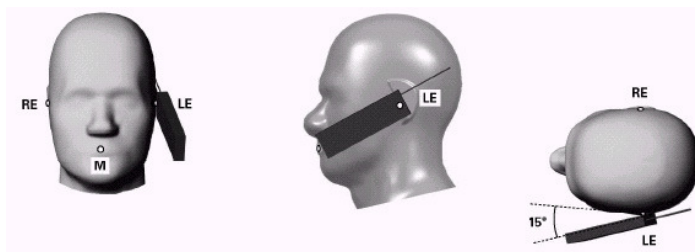

**Figure 6-2 Front, Side and Top View of Ear/15° Tilt Position**

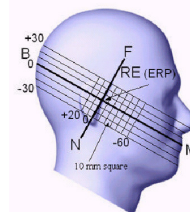

**Figure 6-3 Side view w/ relevant markings**

## 6.4 SAR Evaluations near the Mouth/Jaw Regions of the SAM Phantom

Antennas located near the bottom of a phone may require SAR measurements around the mouth and jaw regions of the SAM head phantom. This typically applies to clam-shell style phones that are generally longer in the unfolded normal use positions or to certain older style long rectangular phones. Per IEEE 1528-2013, a rotated SAM phantom is necessary to allow probe access to such regions. Both SAM heads of the TwinSAM-Chin20 are rotated 20 degrees around the NF line. Each head can be removed from the table for emptying and cleaning.



Under these circumstances, the following procedures apply, adopted from the FCC guidance on SAR handsets document FCC KDB Publication 648474 D04\_v01. The SAR required in these regions of SAM should be measured using a flat phantom. The phone should be positioned with a separation distance of 4 mm between the ear reference point (ERP) and the outer surface of the flat phantom shell. While maintaining this distance at the ERP location, the low (bottom) edge of the phone should be lowered from the phantom to establish the same separation distance between the peak SAR location identified by the truncated partial SAR distribution measured with the SAM phantom. The distance from the peak SAR location to the phone is determined by the straight line passing perpendicularly through the phantom surface. When it is not feasible to maintain 4 mm separation at the ERP while also establishing the required separation at the peak SAR location, the top edge of the phone will be allowed to touch the phantom with a separation < 4 mm at the ERP. The phone should not be tilted to the left or right while placed in this inclined position to the flat phantom.

## 6.5 Body-Worn Accessory Configurations

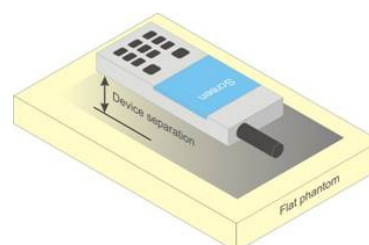
Body-worn operating configurations are tested with the belt-clips and holsters attached to the device and positioned against a flat phantom in a normal use configuration (see Figure 6-4). Per FCC KDB Publication 648474 D04v01, Body-worn accessory exposure is typically related to voice mode operations when handsets are carried in body-worn accessories. The body-worn accessory procedures in FCC KDB Publication 447498 D01v05 should be used to test for body-worn accessory SAR compliance, without a headset connected to it. This enables the test results for such configuration to be compatible with that required for hotspot mode when the body-worn accessory test separation distance is greater than or equal to that required for hotspot mode, when applicable. When the reported SAR for a body-worn accessory, measured without a headset connected to the handset, is > 1.2 W/kg, the highest reported SAR configuration for that wireless mode and frequency band should be repeated for that body-worn accessory with a headset attached to the handset.



**Figure 6-4 Sample Body-Worn Diagram**

FCC ID: A3LSMG920I	 PCTEST ENGINEERING LABORATORY, INC.	SAR EVALUATION REPORT	 SAMSUNG	Reviewed by: Quality Manager
Document S/N: 0Y1502060403.A3L	Test Dates: 01/12/15 - 02/11/15	DUT Type: Portable Handset		Page 14 of 72

Accessories for Body-worn operation configurations are divided into two categories: those that do not contain metallic components and those that do contain metallic components. When multiple accessories that do not contain metallic components are supplied with the device, the device is tested with only the accessory that dictates the closest spacing to the body. Then multiple accessories that contain metallic components are tested with the device with each accessory. If multiple accessories share an identical metallic component (i.e. the same metallic belt-clip used with different holsters with no other metallic components) only the accessory that dictates the closest spacing to the body is tested.

Body-worn accessories may not always be supplied or available as options for some devices intended to be authorized for body-worn use. In this case, a test configuration with a separation distance between the back of the device and the flat phantom is used. Test position spacing was documented. Transmitters that are designed to operate in front of a person's face, as in push-to-talk configurations, are tested for SAR compliance with the front of the device positioned to face the flat phantom in head fluid. For devices that are carried next to the body such as a shoulder, waist or chest-worn transmitters, SAR compliance is tested with the accessories, including headsets and microphones, attached to the device and positioned against a flat phantom in a normal use configuration.

## 6.6 Extremity Exposure Configurations



Devices that are designed or intended for use on extremities or mainly operated in extremity only exposure conditions; i.e., hands, wrists, feet and ankles, may require extremity SAR evaluation. When the device also operates in close proximity to the user's body, SAR compliance for the body is also required. The 1-g body and 10-g extremity SAR Exclusion Thresholds found in KDB Publication 44798 D01v05 should be applied to determine SAR test requirements.

Per KDB Publication 447498 D01v05, Cell phones (handsets) are not normally designed to be used on extremities or operated in extremity only exposure conditions. The maximum output power levels of handsets generally do not require extremity SAR testing to show compliance. Therefore, extremity SAR was not evaluated for this device.

## 6.7 Wireless Router Configurations

Some battery-operated handsets have the capability to transmit and receive user data through simultaneous transmission of WIFI simultaneously with a separate licensed transmitter. The FCC has provided guidance in FCC KDB Publication 941225 D06 where SAR test considerations for handsets ( $L \times W \geq 9 \text{ cm} \times 5 \text{ cm}$ ) are based on a composite test separation distance of 10 mm from the front, back and edges of the device containing transmitting antennas within 2.5 cm of their edges, determined from general mixed use conditions for this type of devices. Since the hotspot SAR results may overlap with the body-worn accessory SAR requirements, the more conservative configurations can be considered, thus excluding some body-worn accessory SAR tests.

When the user enables the personal wireless router functions for the handset, actual operations include simultaneous transmission of both the WIFI transmitter and another licensed transmitter. Both transmitters often do not transmit at the same transmitting frequency and thus cannot be evaluated for SAR under actual use conditions due to the limitations of the SAR assessment probes. Therefore, SAR must be evaluated for each frequency transmission and mode separately and spatially summed with the WIFI transmitter according to FCC KDB Publication 447498 D01v05 publication procedures. The "Portable Hotspot" feature on the handset was NOT activated during SAR assessments, to ensure the SAR measurements were evaluated for a single transmission frequency RF signal at a time.

FCC ID: A3LSMG920I	 <b>PCTEST</b> ENGINEERING LABORATORY, INC.	<b>SAR EVALUATION REPORT</b>		<b>Reviewed by:</b> Quality Manager
<b>Document S/N:</b> 0Y1502060403.A3L	<b>Test Dates:</b> 01/12/15 - 02/11/15	<b>DUT Type:</b> Portable Handset	Page 15 of 72	

# 7 RF EXPOSURE LIMITS

## 7.1 Uncontrolled Environment

UNCONTROLLED ENVIRONMENTS are defined as locations where there is the exposure of individuals who have no knowledge or control of their exposure. The general population/uncontrolled exposure limits are applicable to situations in which the general public may be exposed or in which persons who are exposed as a consequence of their employment may not be made fully aware of the potential for exposure or cannot exercise control over their exposure. Members of the general public would come under this category when exposure is not employment-related; for example, in the case of a wireless transmitter that exposes persons in its vicinity.



## 7.2 Controlled Environment

CONTROLLED ENVIRONMENTS are defined as locations where there is exposure that may be incurred by persons who are aware of the potential for exposure, (i.e. as a result of employment or occupation). In general, occupational/controlled exposure limits are applicable to situations in which persons are exposed as a consequence of their employment, who have been made fully aware of the potential for exposure and can exercise control over their exposure. This exposure category is also applicable when the exposure is of a transient nature due to incidental passage through a location where the exposure levels may be higher than the general population/uncontrolled limits, but the exposed person is fully aware of the potential for exposure and can exercise control over his or her exposure by leaving the area or by some other appropriate means.

**Table 7-1  
SAR Human Exposure Specified in ANSI/IEEE C95.1-1992 and Health Canada Safety Code 6**

HUMAN EXPOSURE LIMITS		
	UNCONTROLLED ENVIRONMENT <i>General Population</i> (W/kg) or (mW/g)	CONTROLLED ENVIRONMENT <i>Occupational</i> (W/kg) or (mW/g)
<b>Peak Spatial Average SAR</b> Head	1.6	8.0
<b>Whole Body SAR</b>	0.08	0.4
<b>Peak Spatial Average SAR</b> Hands, Feet, Ankle, Wrists, etc.	4.0	20

1. The Spatial Peak value of the SAR averaged over any 1 gram of tissue (defined as a tissue volume in the shape of a cube) and over the appropriate averaging time.
2. The Spatial Average value of the SAR averaged over the whole body.
3. The Spatial Peak value of the SAR averaged over any 10 grams of tissue (defined as a tissue volume in the shape of a cube) and over the appropriate averaging time.

FCC ID: A3LSMG920I	 <b>PCTEST</b> ENGINEERING LABORATORY, INC.	<b>SAR EVALUATION REPORT</b>		<b>Reviewed by:</b> Quality Manager
<b>Document S/N:</b> 0Y1502060403.A3L	<b>Test Dates:</b> 01/12/15 - 02/11/15	<b>DUT Type:</b> Portable Handset	Page 16 of 72	

## 8 FCC MEASUREMENT PROCEDURES

Power measurements for licensed transmitters are performed using a base station simulator under digital average power.

### 8.1 Measured and Reported SAR

Per FCC KDB Publication 447498 D01v05, when SAR is not measured at the maximum power level allowed for production units, the results must be scaled to the maximum tune-up tolerance limit according to the power applied to the individual channels tested to determine compliance. For simultaneous transmission, the measured aggregate SAR must be scaled according to the sum of the differences between the maximum tune-up tolerance and actual power used to test each transmitter. When SAR is measured at or scaled to the maximum tune-up tolerance limit, the results are referred to as *reported* SAR. The highest *reported* SAR results are identified on the grant of equipment authorization according to procedures in KDB 690783 D01v01r02.



### 8.2 3G SAR Test Reduction Procedure

In FCC KDB Publication 941225 D01, certain transmission modes within a frequency band and wireless mode evaluated for SAR are defined as primary modes. The equivalent modes considered for SAR test reduction are denoted as secondary modes. When the maximum output power including tune-up tolerance specified for production units in a secondary mode is  $\leq 0.25$  dB higher than the primary mode or when the highest reported SAR of the primary mode, scaled by the ratio of specified maximum output power and tune-up tolerance of secondary to primary mode, is  $\leq 1.2$  W/kg, SAR measurements are not required for the secondary mode. These criteria are referred to as the 3G SAR test reduction procedure. When the 3G SAR test reduction procedure is not satisfied, SAR measurements are additionally required for the secondary mode.

### 8.3 Procedures Used to Establish RF Signal for SAR

The following procedures are according to FCC KDB Publication 941225 D01 “3G SAR Measurement Procedures.”

The device is placed into a simulated call using a base station simulator in a RF shielded chamber. Establishing connections in this manner ensure a consistent means for testing SAR and are recommended for evaluating SAR [4]. Devices under test are evaluated prior to testing, with a fully charged battery and were configured to operate at maximum output power. In order to verify that the device is tested throughout the SAR test at maximum output power, the SAR measurement system measures a “point SAR” at an arbitrary reference point at the start and end of the 1 gram SAR evaluation, to assess for any power drifts during the evaluation. If the power drift deviates by more than 5%, the SAR test and drift measurements are repeated.

FCC ID: A3LSMG920I		SAR EVALUATION REPORT		Reviewed by: Quality Manager
Document S/N: 0Y1502060403.A3L	Test Dates: 01/12/15 - 02/11/15	DUT Type: Portable Handset	Page 17 of 72	

## 8.4 SAR Measurement Conditions for UMTS

### 8.4.1 Output Power Verification

Maximum output power is verified on the High, Middle and Low channels according to the general descriptions in section 5.2 of 3GPP TS 34.121, using the appropriate RMC with TPC (transmit power control) set to all "1s" or applying the required inner loop power control procedures to maintain maximum output power while HSUPA is active. Results for all applicable physical channel configurations (DPCCH, DPDCH<sub>n</sub> and spreading codes, HS-DPCCH etc) are tabulated in this test report. All configurations that are not supported by the DUT or cannot be measured due to technical or equipment limitations are identified.

### 8.4.2 Head SAR Measurements

SAR for next to the ear head exposure is measured using a 12.2 kbps RMC with TPC bits configured to all "1's". The 3G SAR test reduction procedure is applied to AMR configurations with 12.2 kbps RMC as the primary mode. Otherwise, SAR is measured for 12.2 kbps AMR in 3.4 kbps SRB (signaling radio bearer) using the highest reported SAR configuration in 12.2 kbps RMC for head exposure.

### 8.4.3 Body SAR Measurements

SAR for body exposure configurations is measured using the 12.2 kbps RMC with the TPC bits all "1s". The 3G SAR test reduction procedure is applied to other spreading codes and multiple DPDCH<sub>n</sub> configurations supported by the handset with 12.2 kbps RMC as the primary mode. Otherwise, SAR is measured using an applicable RMC configuration with the corresponding spreading code or DPDCH<sub>n</sub>, for the highest reported SAR configuration in 12.2 kbps RMC.

### 8.4.4 SAR Measurements with Rel 5 HSDPA

The 3G SAR test reduction procedure is applied to HSDPA body configurations with 12.2 kbps RMC as the primary mode. Otherwise, Body SAR for HSDPA is measured using an FRC with H-Set 1 in Sub-test 1 and a 12.2 kbps RMC configured in Test Loop Mode 1, for the highest reported SAR configuration in 12.2 kbps RMC without HSDPA. Handsets with both HSDPA and HSUPA are tested according to Release 6 HSPA test procedures.



### 8.4.5 SAR Measurements with Rel 6 HSUPA

The 3G SAR test reduction procedure is applied to HSPA (HSUPA/HSDPA with RMC) body configurations with 12.2 kbps RMC as the primary mode. Otherwise, Body SAR for HSPA is measured with E-DCH Sub-test 5, using H-Set 1 and QPSK for FRC and a 12.2 kbps RMC configured in Test Loop Mode 1 and power control algorithm 2, according to the highest reported body SAR configuration in 12.2 kbps RMC without HSPA.

When VOIP applies to head exposure, the 3G SAR test reduction procedure is applied with 12.2 kbps RMC as the primary mode; otherwise, the same HSPA configuration used for body SAR measurements are applied to head exposure testing.

### 8.4.6 SAR Measurement Conditions for DC-HSDPA

SAR is required for Rel. 8 DC-HSDPA when SAR is required for Rel. 5 HSDPA; otherwise, the 3G SAR test reduction procedure is applied to DC-HSDPA with 12.2 kbps RMC as the primary mode. Power is measured for DC-HSDPA according to the H-Set 12, FRC configuration in Table C.8.1.12 of 3GPP TS 34.121-1 to determine SAR test reduction. A primary and a secondary serving HS-DSCH Cell are required to perform the power measurement and for the results to be acceptable.

FCC ID: A3LSMG920I	 PCTEST ENGINEERING LABORATORY, INC.	SAR EVALUATION REPORT		Reviewed by: Quality Manager
Document S/N: 0Y1502060403.A3L	Test Dates: 01/12/15 - 02/11/15	DUT Type: Portable Handset	Page 18 of 72	

## 8.5 SAR Measurement Conditions for LTE

LTE modes are tested according to FCC KDB 941225 D05 publication. Establishing connections with base station simulators ensure a consistent means for testing SAR and are recommended for evaluating SAR [4]. The R&S CMW500 or Anritsu MT8820C simulators are used for LTE output power measurements and SAR testing. Closed loop power control was used so the UE transmits with maximum output power during SAR testing. SAR tests were performed with the same number of RB and RB offsets transmitting on all TTI frames (maximum TTI).

### 8.5.1 Spectrum Plots for RB Configurations

A properly configured base station simulator was used for SAR tests and power measurements. Therefore, spectrum plots for RB configurations were not required to be included in this report.

### 8.5.2 MPR

MPR is permanently implemented for this device by the manufacturer. The specific manufacturer target MPR is indicated alongside the SAR results. MPR is enabled for this device, according to 3GPP TS36.101 Section 6.2.3 – 6.2.5 under Table 6.2.3-1.



### 8.5.3 A-MPR

A-MPR (Additional MPR) has been disabled for all SAR tests by setting NS=01 on the base station simulator.

### 8.5.4 Required RB Size and RB Offsets for SAR Testing

According to FCC KDB 941225 D05:

- a. Per Section 5.2.1, SAR is required for QPSK 1 RB Allocation for the largest bandwidth
  - i. The required channel and offset combination with the highest maximum output power is required for SAR.
  - ii. When the reported SAR is  $\leq 0.8$  W/kg, testing of the remaining RB offset configurations and required test channels is not required. Otherwise, SAR is required for the remaining required test channels using the RB offset configuration with highest output power for that channel.
  - iii. When the reported SAR for a required test channel is  $> 1.45$  W/kg, SAR is required for all RB offset configurations for that channel.
- b. Per Section 5.2.2, SAR is required for 50% RB allocation using the largest bandwidth following the same procedures outlined in Section 5.2.1.
- c. Per Section 5.2.3, QPSK SAR is not required for the 100% allocation when the highest maximum output power for the 100% allocation is less than the highest maximum output power of the 1 RB and 50% RB allocations and the reported SAR for the 1 RB and 50% RB allocations is  $< 0.8$  W/kg.
- d. Per Section 5.2.4 and 5.3, SAR tests for higher order modulations and lower bandwidths configurations are not required when the conducted power of the required test configurations determined by Sections 5.2.1 through 5.2.3 is less than or equal to  $\frac{1}{2}$  dB higher than the equivalent configuration using QPSK modulation and when the QPSK SAR for those configurations is  $< 1.45$  W/kg.

FCC ID: A3LSMG920I	 PCTEST ENGINEERING LABORATORY, INC.	SAR EVALUATION REPORT	 SAMSUNG	Reviewed by: Quality Manager
Document S/N: 0Y1502060403.A3L	Test Dates: 01/12/15 - 02/11/15	DUT Type: Portable Handset	Page 19 of 72	

## 8.6 SAR Testing with 802.11 Transmitters

The normal network operating configurations of 802.11 transmitters are not suitable for SAR measurements. Unpredictable fluctuations in network traffic and antenna diversity conditions can introduce undesirable variations in SAR results. The SAR for these devices should be measured using chipset based test mode software to ensure the results are consistent and reliable. See KDB Publication 248227 D01 DR02-41929 for more details.

### 8.6.1 General Device Setup

Chipset based test mode software is hardware dependent and generally varies among manufacturers. The device operating parameters established in test mode for SAR measurements must be identical to those programmed in production units, including output power levels, amplifier gain settings and other RF performance tuning parameters.

A periodic duty factor is required for current generation SAR systems to measure SAR. When 802.11 frame gaps are accounted for in the transmission, a maximum transmission duty factor of 92 - 96% is typically achievable in most test mode configurations. A minimum transmission duty factor of 85% is required to avoid certain hardware and device implementation issues related to wide range SAR scaling. The reported SAR is scaled to 100% transmission duty factor to determine compliance at the maximum tune-up tolerance limit.



### 8.6.2 U-NII-1 and U-NII-2A

For devices that operate in both U-NII-1 and U-NII-2A bands, when the same maximum output power is specified for both bands, SAR measurement using OFDM SAR test procedures is not required for U-NII-1 unless the highest reported SAR for U-NII-2A is  $> 1.2$  W/kg. When different maximum output powers are specified for the bands, SAR measurement for the U-NII band with the lower maximum output power is not required unless the highest reported SAR for the U-NII band with the higher maximum output power, adjusted by the ratio of lower to higher specified maximum output power for the two bands, is  $> 1.2$  W/kg.

### 8.6.3 U-NII-2C and U-NII-3

The frequency range covered by U-NII-2C and U-NII-3 is 380 MHz (5.47 – 5.85 GHz), which requires a minimum of at least two SAR probe calibration frequency points to support SAR measurements. When Terminal Doppler Weather Radar (TDWR) restriction applies, the channels at 5.60 – 5.65 GHz in U-NII-2C band must be disabled with acceptable mechanisms and documented in the equipment certification.

Unless band gap channels are permanently disabled, SAR must be considered for these channels. To maintain SAR measurement accuracy and to facilitate test reduction, the channels in U-NII-2C band above 5.65 GHz are grouped with the 5.8 GHz channels in U-NII-3 band or §15.247 5.8 GHz band to enable two SAR probe calibration frequency points to cover the bands, including the band gap channels. When band gap channels are disabled, each band is tested independently according to the normally required OFDM SAR measurement and probe calibration frequency points requirements.

FCC ID: A3LSMG920I	 PCTEST ENGINEERING LABORATORY, INC.	SAR EVALUATION REPORT		Reviewed by: Quality Manager
Document S/N: 0Y1502060403.A3L	Test Dates: 01/12/15 - 02/11/15	DUT Type: Portable Handset		Page 20 of 72

### 8.6.4 Initial Test Position Procedure

For exposure conditions with multiple test positions, such as handset operating next to the ear, devices with hotspot mode, or UMPC mini-tablet, procedures for initial test position can be applied. Using the transmission mode determined by the DSSS procedure or initial test configuration, area scans are measured for all positions in an exposure condition. The test position with the highest extrapolated (peak) SAR is used as the initial test position. When reported SAR for the initial test position is  $\leq 0.4$  W/kg, no additional testing for the remaining test positions is required. Otherwise, SAR is evaluated at the subsequent highest peak SAR positions until the reported SAR result is  $\leq 0.8$  W/kg or all test positions are measured.

### 8.6.5 2.4 GHz SAR Test Requirements



SAR is measured for 2.4 GHz 802.11b DSSS using either the fixed test position or, when applicable, the initial test position procedure. SAR test reduction is determined according to the following:

- 1) When the reported SAR of the highest measured maximum output power channel for the exposure configuration is  $\leq 0.8$  W/kg, no further SAR testing is required for 802.11b DSSS in that exposure configuration.
- 2) When the reported SAR is  $> 0.8$  W/kg, SAR is required for that position using the next highest measured output power channel. When any reported SAR is  $> 1.2$  W/kg, SAR is required for the third channel; i.e., all channels require testing.

2.4 GHz 802.11 g/n OFDM are additionally evaluated for SAR if the highest reported SAR for 802.11b, adjusted by the ratio of the OFDM to DSSS specified maximum output power, is  $> 1.2$  W/kg. When SAR is required for OFDM modes in 2.4 GHz band, the Initial Test Configuration Procedures should be followed.

### 8.6.6 OFDM Transmission Mode and SAR Test Channel Selection

For the 2.4 GHz and 5 GHz bands, when the same maximum output power was specified for multiple OFDM transmission mode configurations in a frequency band or aggregated band, SAR is measured using the configuration with the largest channel bandwidth, lowest order modulation and lowest data rate. When the maximum output power of a channel is the same for equivalent OFDM configurations (for example 802.11a, 802.11n and 802.11ac, or 802.11g and 802.11n, with the same channel bandwidth, modulation, and data rate, etc.), the lower order 802.11 mode (i.e. 802.11a then 802.11n and 802.11ac, or 802.11g then 802.11n) is used for SAR measurement. When the maximum output power are the same for multiple test channels, either according to the default or additional power measurement requirements, SAR is measured using the channel closest to the middle of the frequency band or aggregated band. When there are multiple channels with the same maximum output power, SAR is measured using the higher number channel.

FCC ID: A3LSMG920I	 <b>PCTEST</b> ENGINEERING LABORATORY, INC.	<b>SAR EVALUATION REPORT</b>		<b>Reviewed by:</b> Quality Manager
<b>Document S/N:</b> 0Y1502060403.A3L	<b>Test Dates:</b> 01/12/15 - 02/11/15	<b>DUT Type:</b> Portable Handset	Page 21 of 72	

### 8.6.7 Initial Test Configuration Procedure

For OFDM, in both 2.4 and 5 GHz bands, an initial test configuration is determined for each frequency band and aggregated band, according to the transmission mode with the highest maximum output power specified for SAR measurements. When the same maximum output power is specified for multiple OFDM transmission mode configurations in a frequency band or aggregated band, SAR is measured using the configuration(s) with the largest channel bandwidth, lowest order modulation, and lowest data rate. If the average RF output powers of the highest identical transmission modes are within 0.25 dB of each other, mid channel of the transmission mode with highest average RF output power is the initial test channel. Otherwise, the channel of the transmission mode with the highest average RF output conducted power will be the initial test configuration.



When the reported SAR is  $\leq 0.8$  W/kg, no additional measurements on other test channels are required. Otherwise, SAR is evaluated using the subsequent highest average RF output channel until the reported SAR result is  $\leq 1.2$  W/kg or all channels are measured. When there are multiple untested channels having the same subsequent highest average RF output power, the channel with higher frequency from the lowest 802.11 mode is considered for SAR measurements (See Section 8.6.6).

### 8.6.8 Subsequent Test Configuration Procedures

For OFDM configurations in each frequency band and aggregated band, SAR is evaluated for initial test configuration using the fixed test position or the initial test position procedure. When the highest reported SAR (for the initial test configuration), adjusted by the ratio of the specified maximum output power of the subsequent test configuration to initial test configuration, is  $\leq 1.2$  W/kg, no additional SAR tests for the subsequent test configurations are required.

### 8.6.9 MIMO SAR considerations

Per KDB 248227 D01 DR02-41929, the simultaneous SAR provisions in KDB Publication 447498 should be applied to determine simultaneous transmission SAR test exclusion for WIFI MIMO. If the sum of 1g single transmission SAR measurements is  $< 1.6$  W/kg, no additional SAR measurements for MIMO are required. Alternatively, SAR for MIMO can be measured with all antennas transmitting simultaneously at the specified maximum output power of MIMO operation.

FCC ID: A3LSMG920I	 <b>PCTEST</b> ENGINEERING LABORATORY, INC.	<b>SAR EVALUATION REPORT</b>		<b>Reviewed by:</b> Quality Manager
<b>Document S/N:</b> 0Y1502060403.A3L	<b>Test Dates:</b> 01/12/15 - 02/11/15	<b>DUT Type:</b> Portable Handset	Page 22 of 72	

# 9 RF CONDUCTED POWERS

## 9.1 GSM Conducted Powers



		Maximum Burst-Averaged Output Power								
		Voice	GPRS/EDGE Data (GMSK)				EDGE Data (8-PSK)			
Band	Channel	GSM [dBm] CS (1 Slot)	GPRS [dBm] 1 Tx Slot	GPRS [dBm] 2 Tx Slot	GPRS [dBm] 3 Tx Slot	GPRS [dBm] 4 Tx Slot	EDGE [dBm] 1 Tx Slot	EDGE [dBm] 2 Tx Slot	EDGE [dBm] 3 Tx Slot	EDGE [dBm] 4 Tx Slot
GSM 850	128	32.58	32.42	<b>31.51</b>	27.05	27.00	25.66	24.43	21.62	21.49
	190	32.46	32.50	<b>31.60</b>	27.10	27.11	25.58	24.56	21.65	21.44
	251	32.56	32.55	<b>31.62</b>	27.11	27.20	25.59	24.40	21.70	21.47
GSM 1900	512	29.82	29.86	<b>28.83</b>	25.43	25.00	25.20	24.93	20.99	20.26
	661	29.93	29.87	<b>28.95</b>	25.25	24.98	25.37	24.91	21.09	20.21
	810	29.91	29.98	<b>28.98</b>	25.21	24.95	25.12	24.97	21.08	20.32
		Calculated Maximum Frame-Averaged Output Power								
		Voice	GPRS/EDGE Data (GMSK)				EDGE Data (8-PSK)			
Band	Channel	GSM [dBm] CS (1 Slot)	GPRS [dBm] 1 Tx Slot	GPRS [dBm] 2 Tx Slot	GPRS [dBm] 3 Tx Slot	GPRS [dBm] 4 Tx Slot	EDGE [dBm] 1 Tx Slot	EDGE [dBm] 2 Tx Slot	EDGE [dBm] 3 Tx Slot	EDGE [dBm] 4 Tx Slot
GSM 850	128	23.55	23.39	<b>25.49</b>	22.79	23.99	16.63	18.41	17.36	18.48
	190	23.43	23.47	<b>25.58</b>	22.84	24.10	16.55	18.54	17.39	18.43
	251	23.53	23.52	<b>25.60</b>	22.85	24.19	16.56	18.38	17.44	18.46
GSM 1900	512	20.79	20.83	<b>22.81</b>	21.17	21.99	16.17	18.91	16.73	17.25
	661	20.90	20.84	<b>22.93</b>	20.99	21.97	16.34	18.89	16.83	17.20
	810	20.88	20.95	<b>22.96</b>	20.95	21.94	16.09	18.95	16.82	17.31
GSM 850	Frame	23.47	23.47	<b>25.48</b>	23.24	23.99	16.47	18.48	17.24	17.99
GSM 1900	Avg.Targets:	20.47	20.47	<b>22.48</b>	20.74	21.49	16.47	18.98	16.74	16.99

Note:

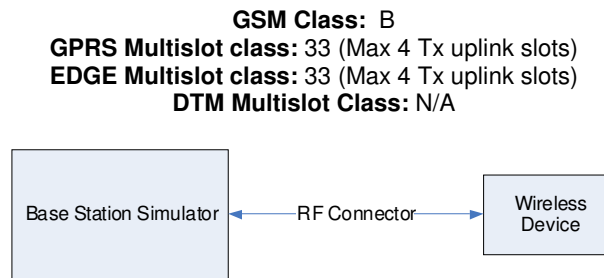
- Both burst-averaged and calculated frame-averaged powers are included. Frame-averaged power was calculated from the measured burst-averaged power by converting the slot powers into linear units and calculating the energy over 8 timeslots.
- GPRS/EDGE (GMSK) output powers were measured with coding scheme setting of 1 (CS1) on the base station simulator. CS1 was configured to measure GPRS output power measurements and SAR to ensure GMSK modulation in the signal. Our Investigation has shown that CS1 - CS4 settings do not have any impact on the output levels or modulation in the GPRS modes.
- EDGE (8-PSK) output powers were measured with MCS7 on the base station simulator. MCS7 coding scheme was used to measure the output powers for EDGE since investigation has shown that choosing MCS7 coding scheme will ensure 8-PSK modulation. It has been shown that MCS levels that produce 8PSK modulation do not have an impact on output power.



**Figure 9-1**  
Power Measurement Setup

FCC ID: A3LSMG920I		<b>SAR EVALUATION REPORT</b>		Reviewed by: Quality Manager
Document S/N: 0Y1502060403.A3L	Test Dates: 01/12/15 - 02/11/15	DUT Type: Portable Handset	Page 23 of 72	

## 9.2 UMTS Conducted Powers

3GPP Release Version	Mode	3GPP 34.121 Subtest	Cellular Band [dBm]			AWS Band [dBm]			PCS Band [dBm]			3GPP MPR [dB]
			4132	4183	4233	1312	1412	1862	9262	9400	9538	
99	WCDMA	12.2 kbps RMC	24.36	24.33	24.33	22.54	22.43	22.35	22.09	22.03	22.00	-
99		12.2 kbps AMR	24.33	24.29	24.32	22.52	22.37	22.33	22.08	22.01	22.03	-
6	HSDPA	Subtest 1	24.40	24.36	24.38	22.77	22.55	22.67	22.25	22.18	22.40	0
6		Subtest 2	24.32	24.40	24.48	22.96	22.73	22.92	21.70	21.62	21.86	0
6		Subtest 3	22.46	22.43	22.52	22.31	22.35	22.43	21.15	21.07	21.30	0.5
6		Subtest 4	22.24	22.17	22.28	22.38	22.18	22.38	21.22	21.13	21.29	0.5
6	HSUPA	Subtest 1	24.06	24.08	24.27	21.90	21.74	21.83	21.82	21.77	21.85	0
6		Subtest 2	22.30	22.22	22.32	20.59	20.58	20.96	21.87	21.82	21.92	2
6		Subtest 3	23.11	23.07	23.16	21.28	21.27	21.36	22.48	22.41	22.33	1
6		Subtest 4	22.26	22.38	22.18	20.57	20.43	21.09	21.77	21.62	21.72	2
6		Subtest 5	24.10	24.21	24.46	22.00	21.74	21.58	21.84	21.59	21.96	0
8	DC-HSDPA	Subtest 1	24.09	24.40	24.19	22.95	22.89	23.00	22.41	22.50	22.45	0
8		Subtest 2	23.89	24.14	23.95	22.73	22.63	22.87	22.27	22.29	22.27	0
8		Subtest 3	23.64	23.95	23.86	22.48	22.50	22.47	21.80	21.97	21.82	0.5
8		Subtest 4	23.29	23.79	23.33	22.10	22.10	22.21	21.92	21.86	21.65	0.5



### DC-HSDPA considerations

- 3GPP Specification 34.121-1 Release 8 Ver 8.10.0 was used for DC-HSDPA guidance
- H-Set 12 (QPSK) was confirmed to be used during DC-HSDPA measurements
- 3G SAR test reduction procedure is applied to DC-HSDPA with 12.2 kbps RMC as the primary mode
- The DUT supports UE category 24 for HSDPA

It is expected by the manufacturer that MPR for some HSPA subtests may be up to 2 dB more than specified by 3GPP, but also as low as 0 dB according to the chipset implementation in this model.



**Figure 9-2**  
**Power Measurement Setup**

FCC ID: A3LSMG920I	 <b>PCTEST</b> ENGINEERING LABORATORY, INC.	<b>SAR EVALUATION REPORT</b>		<b>Reviewed by:</b> Quality Manager
<b>Document S/N:</b> 0Y1502060403.A3L	<b>Test Dates:</b> 01/12/15 - 02/11/15	<b>DUT Type:</b> Portable Handset	Page 24 of 72	

## 9.3 LTE Conducted Powers

### 9.3.1 LTE Band 12



**Table 9-1  
LTE Band 12 Conducted Powers - 10 MHz Bandwidth**

	Frequency [MHz]	Channel	Bandwidth [MHz]	Modulation	RB Size	RB Offset	Conducted Power [dBm]	MPR Allowed per 3GPP [dB]	MPR [dB]
Mid	707.5	23095	10	QPSK	1	0	24.04	0	0
	707.5	23095	10	QPSK	1	25	24.03	0	0
	707.5	23095	10	QPSK	1	49	<b>24.06</b>	0	0
	707.5	23095	10	QPSK	25	0	22.83	0-1	1
	707.5	23095	10	QPSK	25	12	22.75	0-1	1
	707.5	23095	10	QPSK	25	25	<b>22.84</b>	0-1	1
	707.5	23095	10	QPSK	50	0	22.79	0-1	1
	707.5	23095	10	16QAM	1	0	22.61	0-1	1
	707.5	23095	10	16QAM	1	25	22.66	0-1	1
	707.5	23095	10	16QAM	1	49	22.62	0-1	1
	707.5	23095	10	16QAM	25	0	21.76	0-2	2
	707.5	23095	10	16QAM	25	12	21.79	0-2	2
	707.5	23095	10	16QAM	25	25	21.80	0-2	2
	707.5	23095	10	16QAM	50	0	21.77	0-2	2

Note: LTE Band 12 at 10 MHz bandwidth does not support three non-overlapping channels. Per KDB Publication 941225 D05, when a device supports overlapping channel assignment in a channel bandwidth configuration, the middle channel of the group of overlapping channels should be selected for testing.



**Table 9-2  
LTE Band 12 Conducted Powers - 5 MHz Bandwidth**

	Frequency [MHz]	Channel	Bandwidth [MHz]	Modulation	RB Size	RB Offset	Conducted Power [dBm]	MPR Allowed per 3GPP [dB]	MPR [dB]
Low	701.5	23035	5	QPSK	1	0	24.14	0	0
	701.5	23035	5	QPSK	1	12	24.46	0	0
	701.5	23035	5	QPSK	1	24	24.44	0	0
	701.5	23035	5	QPSK	12	0	22.80	0-1	1
	701.5	23035	5	QPSK	12	6	22.85	0-1	1
	701.5	23035	5	QPSK	12	13	22.70	0-1	1
	701.5	23035	5	QPSK	25	0	22.74	0-1	1
	701.5	23035	5	16-QAM	1	0	23.31	0-1	1
	701.5	23035	5	16-QAM	1	12	23.17	0-1	1
	701.5	23035	5	16-QAM	1	24	23.15	0-1	1
	701.5	23035	5	16-QAM	12	0	21.65	0-2	2
	701.5	23035	5	16-QAM	12	6	21.63	0-2	2
	701.5	23035	5	16-QAM	12	13	21.61	0-2	2
	701.5	23035	5	16-QAM	25	0	21.55	0-2	2
	701.5	23035	5	16-QAM	25	0	21.55	0-2	2
	Mid	707.5	23095	5	QPSK	1	0	24.24	0
707.5		23095	5	QPSK	1	12	24.30	0	0
707.5		23095	5	QPSK	1	24	24.28	0	0
707.5		23095	5	QPSK	12	0	22.85	0-1	1
707.5		23095	5	QPSK	12	6	22.71	0-1	1
707.5		23095	5	QPSK	12	13	22.76	0-1	1
707.5		23095	5	QPSK	25	0	22.71	0-1	1
707.5		23095	5	16-QAM	1	0	23.00	0-1	1
707.5		23095	5	16-QAM	1	12	22.95	0-1	1
707.5		23095	5	16-QAM	1	24	23.02	0-1	1
707.5		23095	5	16-QAM	12	0	21.63	0-2	2
707.5		23095	5	16-QAM	12	6	21.69	0-2	2
707.5		23095	5	16-QAM	12	13	21.63	0-2	2
707.5		23095	5	16-QAM	25	0	21.74	0-2	2
707.5		23095	5	16-QAM	25	0	21.74	0-2	2
High		713.5	23155	5	QPSK	1	0	24.30	0
	713.5	23155	5	QPSK	1	12	24.23	0	0
	713.5	23155	5	QPSK	1	24	24.48	0	0
	713.5	23155	5	QPSK	12	0	23.00	0-1	1
	713.5	23155	5	QPSK	12	6	23.19	0-1	1
	713.5	23155	5	QPSK	12	13	23.18	0-1	1
	713.5	23155	5	QPSK	25	0	22.99	0-1	1
	713.5	23155	5	16-QAM	1	0	23.10	0-1	1
	713.5	23155	5	16-QAM	1	12	22.98	0-1	1
	713.5	23155	5	16-QAM	1	24	22.98	0-1	1
	713.5	23155	5	16-QAM	12	0	21.92	0-2	2
	713.5	23155	5	16-QAM	12	6	21.96	0-2	2
	713.5	23155	5	16-QAM	12	13	21.90	0-2	2
	713.5	23155	5	16-QAM	25	0	22.00	0-2	2
	713.5	23155	5	16-QAM	25	0	22.00	0-2	2

FCC ID: A3LSMG920I	 PCTEST ENGINEERING LABORATORY, INC.	SAR EVALUATION REPORT	 SAMSUNG	Reviewed by: Quality Manager
Document S/N: 0Y1502060403.A3L	Test Dates: 01/12/15 - 02/11/15	DUT Type: Portable Handset	Page 25 of 72	



**Table 9-3  
LTE Band 12 Conducted Powers - 3 MHz Bandwidth**

	Frequency [MHz]	Channel	Bandwidth [MHz]	Modulation	RB Size	RB Offset	Conducted Power [dBm]	MPR Allowed per 3GPP [dB]	MPR [dB]
Low	700.5	23025	3	QPSK	1	0	24.33	0	0
	700.5	23025	3	QPSK	1	7	24.36	0	0
	700.5	23025	3	QPSK	1	14	24.30	0	0
	700.5	23025	3	QPSK	8	0	22.85	0-1	1
	700.5	23025	3	QPSK	8	4	22.74	0-1	1
	700.5	23025	3	QPSK	8	7	22.83	0-1	1
	700.5	23025	3	QPSK	15	0	23.00	0-1	1
	700.5	23025	3	16-QAM	1	0	23.07	0-1	1
	700.5	23025	3	16-QAM	1	7	23.06	0-1	1
	700.5	23025	3	16-QAM	1	14	22.95	0-1	1
	700.5	23025	3	16-QAM	8	0	21.90	0-2	2
	700.5	23025	3	16-QAM	8	4	21.85	0-2	2
700.5	23025	3	16-QAM	8	7	21.86	0-2	2	
700.5	23025	3	16-QAM	15	0	21.82	0-2	2	
Mid	707.5	23095	3	QPSK	1	0	24.23	0	0
	707.5	23095	3	QPSK	1	7	24.22	0	0
	707.5	23095	3	QPSK	1	14	24.19	0	0
	707.5	23095	3	QPSK	8	0	22.73	0-1	1
	707.5	23095	3	QPSK	8	4	22.74	0-1	1
	707.5	23095	3	QPSK	8	7	22.73	0-1	1
	707.5	23095	3	QPSK	15	0	22.73	0-1	1
	707.5	23095	3	16-QAM	1	0	22.53	0-1	1
	707.5	23095	3	16-QAM	1	7	22.50	0-1	1
	707.5	23095	3	16-QAM	1	14	22.54	0-1	1
	707.5	23095	3	16-QAM	8	0	21.61	0-2	2
	707.5	23095	3	16-QAM	8	4	21.73	0-2	2
707.5	23095	3	16-QAM	8	7	21.71	0-2	2	
707.5	23095	3	16-QAM	15	0	21.66	0-2	2	
High	714.5	23165	3	QPSK	1	0	24.19	0	0
	714.5	23165	3	QPSK	1	7	24.19	0	0
	714.5	23165	3	QPSK	1	14	24.20	0	0
	714.5	23165	3	QPSK	8	0	22.74	0-1	1
	714.5	23165	3	QPSK	8	4	22.75	0-1	1
	714.5	23165	3	QPSK	8	7	22.74	0-1	1
	714.5	23165	3	QPSK	15	0	22.73	0-1	1
	714.5	23165	3	16-QAM	1	0	22.59	0-1	1
	714.5	23165	3	16-QAM	1	7	22.50	0-1	1
	714.5	23165	3	16-QAM	1	14	22.54	0-1	1
	714.5	23165	3	16-QAM	8	0	21.64	0-2	2
	714.5	23165	3	16-QAM	8	4	21.73	0-2	2
714.5	23165	3	16-QAM	8	7	21.74	0-2	2	
714.5	23165	3	16-QAM	15	0	21.69	0-2	2	

FCC ID: A3LSMG920I	 <b>PCTEST</b> ENGINEERING LABORATORY, INC.	<b>SAR EVALUATION REPORT</b>		<b>Reviewed by:</b> Quality Manager
<b>Document S/N:</b> 0Y1502060403.A3L	<b>Test Dates:</b> 01/12/15 - 02/11/15	<b>DUT Type:</b> Portable Handset		Page 26 of 72

**Table 9-4  
LTE Band 12 Conducted Powers - 1.4 MHz Bandwidth**

	Frequency [MHz]	Channel	Bandwidth [MHz]	Modulation	RB Size	RB Offset	Conducted Power [dBm]	MPR Allowed per 3GPP [dB]	MPR [dB]
Low	699.7	23017	1.4	QPSK	1	0	24.36	0	0
	699.7	23017	1.4	QPSK	1	2	24.43	0	0
	699.7	23017	1.4	QPSK	1	5	24.42	0	0
	699.7	23017	1.4	QPSK	3	0	24.23	0	0
	699.7	23017	1.4	QPSK	3	2	24.10	0	0
	699.7	23017	1.4	QPSK	3	3	24.14	0	0
	699.7	23017	1.4	QPSK	6	0	23.09	0-1	1
	699.7	23017	1.4	16-QAM	1	0	23.02	0-1	1
	699.7	23017	1.4	16-QAM	1	2	22.94	0-1	1
	699.7	23017	1.4	16-QAM	1	5	22.92	0-1	1
	699.7	23017	1.4	16-QAM	3	0	22.50	0-1	1
	699.7	23017	1.4	16-QAM	3	2	22.55	0-1	1
	699.7	23017	1.4	16-QAM	3	3	22.52	0-1	1
699.7	23017	1.4	16-QAM	6	0	22.13	0-2	2	
Mid	707.5	23095	1.4	QPSK	1	0	24.22	0	0
	707.5	23095	1.4	QPSK	1	2	24.24	0	0
	707.5	23095	1.4	QPSK	1	5	24.29	0	0
	707.5	23095	1.4	QPSK	3	0	23.80	0	0
	707.5	23095	1.4	QPSK	3	2	23.94	0	0
	707.5	23095	1.4	QPSK	3	3	23.96	0	0
	707.5	23095	1.4	QPSK	6	0	22.76	0-1	1
	707.5	23095	1.4	16-QAM	1	0	22.50	0-1	1
	707.5	23095	1.4	16-QAM	1	2	22.58	0-1	1
	707.5	23095	1.4	16-QAM	1	5	22.51	0-1	1
	707.5	23095	1.4	16-QAM	3	0	22.60	0-1	1
	707.5	23095	1.4	16-QAM	3	2	22.65	0-1	1
	707.5	23095	1.4	16-QAM	3	3	22.50	0-1	1
707.5	23095	1.4	16-QAM	6	0	21.77	0-2	2	
High	715.3	23173	1.4	QPSK	1	0	24.50	0	0
	715.3	23173	1.4	QPSK	1	2	24.50	0	0
	715.3	23173	1.4	QPSK	1	5	24.45	0	0
	715.3	23173	1.4	QPSK	3	0	24.29	0	0
	715.3	23173	1.4	QPSK	3	2	24.27	0	0
	715.3	23173	1.4	QPSK	3	3	24.24	0	0
	715.3	23173	1.4	QPSK	6	0	23.12	0-1	1
	715.3	23173	1.4	16-QAM	1	0	23.03	0-1	1
	715.3	23173	1.4	16-QAM	1	2	23.00	0-1	1
	715.3	23173	1.4	16-QAM	1	5	23.08	0-1	1
	715.3	23173	1.4	16-QAM	3	0	22.60	0-1	1
	715.3	23173	1.4	16-QAM	3	2	22.62	0-1	1
	715.3	23173	1.4	16-QAM	3	3	22.57	0-1	1
715.3	23173	1.4	16-QAM	6	0	22.10	0-2	2	

FCC ID: A3LSMG920I	 <b>PCTEST</b> ENGINEERING LABORATORY, INC.	<b>SAR EVALUATION REPORT</b>		<b>Reviewed by:</b> Quality Manager
<b>Document S/N:</b> 0Y1502060403.A3L	<b>Test Dates:</b> 01/12/15 - 02/11/15	<b>DUT Type:</b> Portable Handset		Page 27 of 72

9.3.2

LTE Band 26



Table 9-5  
LTE Band 26 Conducted Powers - 15 MHz Bandwidth

	Frequency [MHz]	Channel	Bandwidth [MHz]	Modulation	RB Size	RB Offset	Conducted Power [dBm]	MPR Allowed per 3GPP [dB]	MPR [dB]
Mid	836.5	26915	15	QPSK	1	0	23.86	0	0
	836.5	26915	15	QPSK	1	36	23.97	0	0
	836.5	26915	15	QPSK	1	74	23.86	0	0
	836.5	26915	15	QPSK	36	0	23.03	0-1	1
	836.5	26915	15	QPSK	36	18	23.04	0-1	1
	836.5	26915	15	QPSK	36	37	23.02	0-1	1
	836.5	26915	15	QPSK	75	0	23.03	0-1	1
	836.5	26915	15	16QAM	1	0	22.61	0-1	1
	836.5	26915	15	16QAM	1	36	22.71	0-1	1
	836.5	26915	15	16QAM	1	74	22.75	0-1	1
	836.5	26915	15	16QAM	36	0	22.05	0-2	2
	836.5	26915	15	16QAM	36	18	22.12	0-2	2
	836.5	26915	15	16QAM	36	37	22.15	0-2	2
	836.5	26915	15	16QAM	75	0	22.05	0-2	2

Note: LTE Band 26 at 15 MHz bandwidth is only supported for FCC Rule Part 22H. There are not three non-overlapping channels within FCC Rule Part 22H. Per KDB Publication 941225 D05v02, when a device supports overlapping channel assignment in a channel bandwidth configuration, the middle channel of the group of overlapping channels should be selected for testing.



Table 9-6  
LTE Band 26 Conducted Powers - 10 MHz Bandwidth

	Frequency [MHz]	Channel	Bandwidth [MHz]	Modulation	RB Size	RB Offset	Conducted Power [dBm]	MPR Allowed per 3GPP [dB]	MPR [dB]	
Low	819	26740	10	QPSK	1	0	23.91	0	0	
	819	26740	10	QPSK	1	25	23.96	0	0	
	819	26740	10	QPSK	1	49	23.84	0	0	
	819	26740	10	QPSK	25	0	23.11	0-1	1	
	819	26740	10	QPSK	25	12	23.20	0-1	1	
	819	26740	10	QPSK	25	25	23.16	0-1	1	
	819	26740	10	QPSK	50	0	23.10	0-1	1	
	819	26740	10	16QAM	1	0	22.98	0-1	1	
	819	26740	10	16QAM	1	25	22.89	0-1	1	
	819	26740	10	16QAM	1	49	22.72	0-1	1	
	819	26740	10	16QAM	25	0	22.04	0-2	2	
	819	26740	10	16QAM	25	12	22.10	0-2	2	
	819	26740	10	16QAM	25	25	22.05	0-2	2	
	819	26740	10	16QAM	50	0	22.06	0-2	2	
	Mid	831.5	26865	10	QPSK	1	0	23.96	0	0
		831.5	26865	10	QPSK	1	25	23.88	0	0
		831.5	26865	10	QPSK	1	49	23.86	0	0
		831.5	26865	10	QPSK	25	0	23.06	0-1	1
831.5		26865	10	QPSK	25	12	23.15	0-1	1	
831.5		26865	10	QPSK	25	25	23.16	0-1	1	
831.5		26865	10	QPSK	50	0	23.13	0-1	1	
831.5		26865	10	16QAM	1	0	22.75	0-1	1	
831.5		26865	10	16QAM	1	25	22.79	0-1	1	
831.5		26865	10	16QAM	1	49	22.52	0-1	1	
831.5		26865	10	16QAM	25	0	22.00	0-2	2	
831.5		26865	10	16QAM	25	12	22.10	0-2	2	
831.5		26865	10	16QAM	25	25	22.12	0-2	2	
831.5		26865	10	16QAM	50	0	21.98	0-2	2	
High		844	26990	10	QPSK	1	0	24.09	0	0
		844	26990	10	QPSK	1	25	24.06	0	0
		844	26990	10	QPSK	1	49	23.84	0	0
		844	26990	10	QPSK	25	0	23.27	0-1	1
	844	26990	10	QPSK	25	12	23.28	0-1	1	
	844	26990	10	QPSK	25	25	23.21	0-1	1	
	844	26990	10	QPSK	50	0	23.22	0-1	1	
	844	26990	10	16QAM	1	0	22.62	0-1	1	
	844	26990	10	16QAM	1	25	22.52	0-1	1	
	844	26990	10	16QAM	1	49	22.58	0-1	1	
	844	26990	10	16QAM	25	0	22.20	0-2	2	
	844	26990	10	16QAM	25	12	22.12	0-2	2	
	844	26990	10	16QAM	25	25	22.15	0-2	2	
	844	26990	10	16QAM	50	0	22.13	0-2	2	

FCC ID: A3LSMG920I	 PCTEST ENGINEERING LABORATORY, INC.	SAR EVALUATION REPORT		Reviewed by: Quality Manager
Document S/N: 0Y1502060403.A3L	Test Dates: 01/12/15 - 02/11/15	DUT Type: Portable Handset	Page 28 of 72	



**Table 9-7  
LTE Band 26 Conducted Powers - 5 MHz Bandwidth**

	Frequency [MHz]	Channel	Bandwidth [MHz]	Modulation	RB Size	RB Offset	Conducted Power [dBm]	MPR Allowed per 3GPP [dB]	MPR [dB]
Low	816.5	26715	5	QPSK	1	0	24.09	0	0
	816.5	26715	5	QPSK	1	12	24.03	0	0
	816.5	26715	5	QPSK	1	24	24.04	0	0
	816.5	26715	5	QPSK	12	0	23.11	0-1	1
	816.5	26715	5	QPSK	12	6	23.15	0-1	1
	816.5	26715	5	QPSK	12	13	23.15	0-1	1
	816.5	26715	5	QPSK	25	0	23.04	0-1	1
	816.5	26715	5	16-QAM	1	0	22.66	0-1	1
	816.5	26715	5	16-QAM	1	12	22.64	0-1	1
	816.5	26715	5	16-QAM	1	24	22.70	0-1	1
	816.5	26715	5	16-QAM	12	0	22.03	0-2	2
	816.5	26715	5	16-QAM	12	6	22.06	0-2	2
816.5	26715	5	16-QAM	12	13	22.07	0-2	2	
816.5	26715	5	16-QAM	25	0	22.06	0-2	2	
Mid	831.5	26865	5	QPSK	1	0	23.84	0	0
	831.5	26865	5	QPSK	1	12	23.81	0	0
	831.5	26865	5	QPSK	1	24	23.92	0	0
	831.5	26865	5	QPSK	12	0	23.06	0-1	1
	831.5	26865	5	QPSK	12	6	23.11	0-1	1
	831.5	26865	5	QPSK	12	13	23.08	0-1	1
	831.5	26865	5	QPSK	25	0	23.00	0-1	1
	831.5	26865	5	16-QAM	1	0	22.63	0-1	1
	831.5	26865	5	16-QAM	1	12	22.64	0-1	1
	831.5	26865	5	16-QAM	1	24	22.69	0-1	1
	831.5	26865	5	16-QAM	12	0	21.95	0-2	2
	831.5	26865	5	16-QAM	12	6	21.99	0-2	2
831.5	26865	5	16-QAM	12	13	22.05	0-2	2	
831.5	26865	5	16-QAM	25	0	21.95	0-2	2	
High	846.5	27015	5	QPSK	1	0	24.09	0	0
	846.5	27015	5	QPSK	1	12	24.00	0	0
	846.5	27015	5	QPSK	1	24	23.91	0	0
	846.5	27015	5	QPSK	12	0	23.19	0-1	1
	846.5	27015	5	QPSK	12	6	23.23	0-1	1
	846.5	27015	5	QPSK	12	13	23.18	0-1	1
	846.5	27015	5	QPSK	25	0	23.19	0-1	1
	846.5	27015	5	16-QAM	1	0	22.50	0-1	1
	846.5	27015	5	16-QAM	1	12	22.73	0-1	1
	846.5	27015	5	16-QAM	1	24	22.69	0-1	1
	846.5	27015	5	16-QAM	12	0	22.14	0-2	2
	846.5	27015	5	16-QAM	12	6	22.18	0-2	2
846.5	27015	5	16-QAM	12	13	22.14	0-2	2	
846.5	27015	5	16-QAM	25	0	22.11	0-2	2	

FCC ID: A3LSMG9201	 <b>PCTEST</b> ENGINEERING LABORATORY, INC.	<b>SAR EVALUATION REPORT</b>		<b>Reviewed by:</b> Quality Manager
<b>Document S/N:</b> 0Y1502060403.A3L	<b>Test Dates:</b> 01/12/15 - 02/11/15	<b>DUT Type:</b> Portable Handset	Page 29 of 72	



**Table 9-8  
LTE Band 26 Conducted Powers - 3 MHz Bandwidth**

	Frequency [MHz]	Channel	Bandwidth [MHz]	Modulation	RB Size	RB Offset	Conducted Power [dBm]	MPR Allowed per 3GPP [dB]	MPR [dB]
Low	815.5	26705	3	QPSK	1	0	24.05	0	0
	815.5	26705	3	QPSK	1	7	24.09	0	0
	815.5	26705	3	QPSK	1	14	24.10	0	0
	815.5	26705	3	QPSK	8	0	23.04	0-1	1
	815.5	26705	3	QPSK	8	4	23.14	0-1	1
	815.5	26705	3	QPSK	8	7	23.12	0-1	1
	815.5	26705	3	QPSK	15	0	23.06	0-1	1
	815.5	26705	3	16-QAM	1	0	22.81	0-1	1
	815.5	26705	3	16-QAM	1	7	22.79	0-1	1
	815.5	26705	3	16-QAM	1	14	22.84	0-1	1
	815.5	26705	3	16-QAM	8	0	22.01	0-2	2
	815.5	26705	3	16-QAM	8	4	22.10	0-2	2
Mid	831.5	26865	3	QPSK	1	0	24.15	0	0
	831.5	26865	3	QPSK	1	7	24.11	0	0
	831.5	26865	3	QPSK	1	14	24.11	0	0
	831.5	26865	3	QPSK	8	0	23.04	0-1	1
	831.5	26865	3	QPSK	8	4	23.09	0-1	1
	831.5	26865	3	QPSK	8	7	23.15	0-1	1
	831.5	26865	3	QPSK	15	0	23.11	0-1	1
	831.5	26865	3	16-QAM	1	0	22.76	0-1	1
	831.5	26865	3	16-QAM	1	7	22.76	0-1	1
	831.5	26865	3	16-QAM	1	14	22.85	0-1	1
	831.5	26865	3	16-QAM	8	0	21.96	0-2	2
	831.5	26865	3	16-QAM	8	4	22.02	0-2	2
High	847.5	27025	3	QPSK	1	0	24.02	0	0
	847.5	27025	3	QPSK	1	7	24.00	0	0
	847.5	27025	3	QPSK	1	14	23.94	0	0
	847.5	27025	3	QPSK	8	0	23.25	0-1	1
	847.5	27025	3	QPSK	8	4	23.21	0-1	1
	847.5	27025	3	QPSK	8	7	23.13	0-1	1
	847.5	27025	3	QPSK	15	0	23.21	0-1	1
	847.5	27025	3	16-QAM	1	0	22.54	0-1	1
	847.5	27025	3	16-QAM	1	7	22.89	0-1	1
	847.5	27025	3	16-QAM	1	14	22.50	0-1	1
	847.5	27025	3	16-QAM	8	0	22.13	0-2	2
	847.5	27025	3	16-QAM	8	4	22.08	0-2	2
847.5	27025	3	16-QAM	8	7	21.98	0-2	2	
847.5	27025	3	16-QAM	15	0	22.11	0-2	2	

FCC ID: A3LSMG920I	 <b>PCTEST</b> <small>ENGINEERING LABORATORY, INC.</small>	<b>SAR EVALUATION REPORT</b>		Reviewed by: Quality Manager
Document S/N: 0Y1502060403.A3L	Test Dates: 01/12/15 - 02/11/15	DUT Type: Portable Handset	Page 30 of 72	

**Table 9-9  
LTE Band 26 Conducted Powers - 1.4 MHz Bandwidth**

	Frequency [MHz]	Channel	Bandwidth [MHz]	Modulation	RB Size	RB Offset	Conducted Power [dBm]	MPR Allowed per 3GPP [dB]	MPR [dB]
Low	814.7	26697	1.4	QPSK	1	0	23.98	0	0
	814.7	26697	1.4	QPSK	1	2	24.03	0	0
	814.7	26697	1.4	QPSK	1	5	23.97	0	0
	814.7	26697	1.4	QPSK	3	0	23.58	0	0
	814.7	26697	1.4	QPSK	3	2	23.67	0	0
	814.7	26697	1.4	QPSK	3	3	23.66	0	0
	814.7	26697	1.4	QPSK	6	0	23.07	0-1	1
	814.7	26697	1.4	16-QAM	1	0	22.62	0-1	1
	814.7	26697	1.4	16-QAM	1	2	22.63	0-1	1
	814.7	26697	1.4	16-QAM	1	5	22.66	0-1	1
	814.7	26697	1.4	16-QAM	3	0	22.60	0-1	1
	814.7	26697	1.4	16-QAM	3	2	22.58	0-1	1
814.7	26697	1.4	16-QAM	3	3	22.51	0-1	1	
814.7	26697	1.4	16-QAM	6	0	21.91	0-2	2	
Mid	831.5	26865	1.4	QPSK	1	0	24.08	0	0
	831.5	26865	1.4	QPSK	1	2	24.05	0	0
	831.5	26865	1.4	QPSK	1	5	24.13	0	0
	831.5	26865	1.4	QPSK	3	0	23.77	0	0
	831.5	26865	1.4	QPSK	3	2	23.81	0	0
	831.5	26865	1.4	QPSK	3	3	23.77	0	0
	831.5	26865	1.4	QPSK	6	0	23.15	0-1	1
	831.5	26865	1.4	16-QAM	1	0	22.61	0-1	1
	831.5	26865	1.4	16-QAM	1	2	22.72	0-1	1
	831.5	26865	1.4	16-QAM	1	5	22.50	0-1	1
	831.5	26865	1.4	16-QAM	3	0	22.51	0-1	1
	831.5	26865	1.4	16-QAM	3	2	22.52	0-1	1
831.5	26865	1.4	16-QAM	3	3	22.50	0-1	1	
831.5	26865	1.4	16-QAM	6	0	22.06	0-2	2	
High	848.3	27033	1.4	QPSK	1	0	23.81	0	0
	848.3	27033	1.4	QPSK	1	2	23.81	0	0
	848.3	27033	1.4	QPSK	1	5	23.81	0	0
	848.3	27033	1.4	QPSK	3	0	23.77	0	0
	848.3	27033	1.4	QPSK	3	2	23.71	0	0
	848.3	27033	1.4	QPSK	3	3	23.63	0	0
	848.3	27033	1.4	QPSK	6	0	23.18	0-1	1
	848.3	27033	1.4	16-QAM	1	0	22.86	0-1	1
	848.3	27033	1.4	16-QAM	1	2	22.88	0-1	1
	848.3	27033	1.4	16-QAM	1	5	22.88	0-1	1
	848.3	27033	1.4	16-QAM	3	0	22.54	0-1	1
	848.3	27033	1.4	16-QAM	3	2	22.51	0-1	1
848.3	27033	1.4	16-QAM	3	3	22.50	0-1	1	
848.3	27033	1.4	16-QAM	6	0	22.18	0-2	2	

FCC ID: A3LSMG9201	 <b>PCTEST</b> ENGINEERING LABORATORY, INC.	<b>SAR EVALUATION REPORT</b>		<b>Reviewed by:</b> Quality Manager
<b>Document S/N:</b> 0Y1502060403.A3L	<b>Test Dates:</b> 01/12/15 - 02/11/15	<b>DUT Type:</b> Portable Handset		Page 31 of 72

### 9.3.3

### LTE Band 4 (AWS)



**Table 9-10**  
**LTE Band 4 (AWS) Conducted Powers - 20 MHz Bandwidth**

	Frequency [MHz]	Channel	Bandwidth [MHz]	Modulation	RB Size	RB Offset	Conducted Power [dBm]	MPR Allowed per 3GPP [dB]	MPR [dB]
Mid	1732.5	20175	20	QPSK	1	0	21.15	0	0
	1732.5	20175	20	QPSK	1	50	21.17	0	0
	1732.5	20175	20	QPSK	1	99	21.03	0	0
	1732.5	20175	20	QPSK	50	0	20.41	0-1	1
	1732.5	20175	20	QPSK	50	25	20.42	0-1	1
	1732.5	20175	20	QPSK	50	50	20.45	0-1	1
	1732.5	20175	20	QPSK	100	0	20.37	0-1	1
	1732.5	20175	20	16QAM	1	0	20.10	0-1	1
	1732.5	20175	20	16QAM	1	50	20.08	0-1	1
	1732.5	20175	20	16QAM	1	99	20.11	0-1	1
	1732.5	20175	20	16QAM	50	0	19.37	0-2	2
	1732.5	20175	20	16QAM	50	25	19.49	0-2	2
	1732.5	20175	20	16QAM	50	50	19.42	0-2	2
	1732.5	20175	20	16QAM	100	0	19.51	0-2	2

Note: LTE Band 4 (AWS) at 20 MHz bandwidth does not support three non-overlapping channels. Per KDB Publication 941225 D05, when a device supports overlapping channel assignment in a channel bandwidth configuration, the middle channel of the group of overlapping channels should be selected for testing.



**Table 9-11**  
**LTE Band 4 (AWS) Conducted Powers - 15 MHz Bandwidth**

	Frequency [MHz]	Channel	Bandwidth [MHz]	Modulation	RB Size	RB Offset	Conducted Power [dBm]	MPR Allowed per 3GPP [dB]	MPR [dB]
Low	1717.5	20025	15	QPSK	1	0	21.37	0	0
	1717.5	20025	15	QPSK	1	36	21.43	0	0
	1717.5	20025	15	QPSK	1	74	21.19	0	0
	1717.5	20025	15	QPSK	36	0	20.72	0-1	1
	1717.5	20025	15	QPSK	36	18	20.79	0-1	1
	1717.5	20025	15	QPSK	36	37	20.61	0-1	1
	1717.5	20025	15	QPSK	75	0	20.65	0-1	1
	1717.5	20025	15	16QAM	1	0	20.50	0-1	1
	1717.5	20025	15	16QAM	1	36	20.39	0-1	1
	1717.5	20025	15	16QAM	1	74	20.28	0-1	1
	1717.5	20025	15	16QAM	36	0	19.81	0-2	2
	1717.5	20025	15	16QAM	36	18	19.77	0-2	2
	1717.5	20025	15	16QAM	36	37	19.68	0-2	2
	1717.5	20025	15	16QAM	75	0	19.60	0-2	2
	1732.5	20175	15	QPSK	1	0	21.25	0	0
	1732.5	20175	15	QPSK	1	36	21.18	0	0
1732.5	20175	15	QPSK	1	74	21.30	0	0	
1732.5	20175	15	QPSK	36	0	20.79	0-1	1	
1732.5	20175	15	QPSK	36	18	20.75	0-1	1	
1732.5	20175	15	QPSK	36	37	20.68	0-1	1	
1732.5	20175	15	QPSK	75	0	20.61	0-1	1	
1732.5	20175	15	16QAM	1	0	20.71	0-1	1	
1732.5	20175	15	16QAM	1	36	20.38	0-1	1	
1732.5	20175	15	16QAM	1	74	20.39	0-1	1	
1732.5	20175	15	16QAM	36	0	19.77	0-2	2	
1732.5	20175	15	16QAM	36	18	19.69	0-2	2	
1732.5	20175	15	16QAM	36	37	19.67	0-2	2	
1732.5	20175	15	16QAM	75	0	19.66	0-2	2	
High	1747.5	20325	15	QPSK	1	0	21.25	0	0
	1747.5	20325	15	QPSK	1	36	21.30	0	0
	1747.5	20325	15	QPSK	1	74	21.22	0	0
	1747.5	20325	15	QPSK	36	0	20.70	0-1	1
	1747.5	20325	15	QPSK	36	18	20.65	0-1	1
	1747.5	20325	15	QPSK	36	37	20.58	0-1	1
	1747.5	20325	15	QPSK	75	0	20.63	0-1	1
	1747.5	20325	15	16QAM	1	0	20.40	0-1	1
	1747.5	20325	15	16QAM	1	36	20.33	0-1	1
	1747.5	20325	15	16QAM	1	74	20.40	0-1	1
	1747.5	20325	15	16QAM	36	0	19.63	0-2	2
	1747.5	20325	15	16QAM	36	18	19.55	0-2	2
	1747.5	20325	15	16QAM	36	37	19.53	0-2	2
	1747.5	20325	15	16QAM	75	0	19.54	0-2	2

FCC ID: A3LSMG920I	 PCTEST ENGINEERING LABORATORY, INC.	SAR EVALUATION REPORT		Reviewed by: Quality Manager
Document S/N: 0Y1502060403.A3L	Test Dates: 01/12/15 - 02/11/15	DUT Type: Portable Handset	Page 32 of 72	



**Table 9-12**  
**LTE Band 4 (AWS) Conducted Powers - 10 MHz Bandwidth**

	Frequency [MHz]	Channel	Bandwidth [MHz]	Modulation	RB Size	RB Offset	Conducted Power [dBm]	MPR Allowed per 3GPP [dB]	MPR [dB]
Low	1715	20000	10	QPSK	1	0	21.37	0	0
	1715	20000	10	QPSK	1	25	21.32	0	0
	1715	20000	10	QPSK	1	49	21.23	0	0
	1715	20000	10	QPSK	25	0	20.64	0-1	1
	1715	20000	10	QPSK	25	12	20.67	0-1	1
	1715	20000	10	QPSK	25	25	20.62	0-1	1
	1715	20000	10	QPSK	50	0	20.59	0-1	1
	1715	20000	10	16QAM	1	0	20.31	0-1	1
	1715	20000	10	16QAM	1	25	20.10	0-1	1
	1715	20000	10	16QAM	1	49	20.17	0-1	1
	1715	20000	10	16QAM	25	0	19.55	0-2	2
	1715	20000	10	16QAM	25	12	19.61	0-2	2
1715	20000	10	16QAM	25	25	19.56	0-2	2	
1715	20000	10	16QAM	50	0	19.62	0-2	2	
Mid	1732.5	20175	10	QPSK	1	0	21.45	0	0
	1732.5	20175	10	QPSK	1	25	21.40	0	0
	1732.5	20175	10	QPSK	1	49	21.40	0	0
	1732.5	20175	10	QPSK	25	0	20.61	0-1	1
	1732.5	20175	10	QPSK	25	12	20.68	0-1	1
	1732.5	20175	10	QPSK	25	25	20.63	0-1	1
	1732.5	20175	10	QPSK	50	0	20.69	0-1	1
	1732.5	20175	10	16QAM	1	0	20.48	0-1	1
	1732.5	20175	10	16QAM	1	25	20.38	0-1	1
	1732.5	20175	10	16QAM	1	49	20.39	0-1	1
	1732.5	20175	10	16QAM	25	0	19.68	0-2	2
	1732.5	20175	10	16QAM	25	12	19.77	0-2	2
1732.5	20175	10	16QAM	25	25	19.57	0-2	2	
1732.5	20175	10	16QAM	50	0	19.62	0-2	2	
High	1750	20350	10	QPSK	1	0	21.29	0	0
	1750	20350	10	QPSK	1	25	21.34	0	0
	1750	20350	10	QPSK	1	49	21.18	0	0
	1750	20350	10	QPSK	25	0	20.60	0-1	1
	1750	20350	10	QPSK	25	12	20.54	0-1	1
	1750	20350	10	QPSK	25	25	20.58	0-1	1
	1750	20350	10	QPSK	50	0	20.55	0-1	1
	1750	20350	10	16QAM	1	0	20.07	0-1	1
	1750	20350	10	16QAM	1	25	20.12	0-1	1
	1750	20350	10	16QAM	1	49	20.13	0-1	1
	1750	20350	10	16QAM	25	0	19.71	0-2	2
	1750	20350	10	16QAM	25	12	19.66	0-2	2
1750	20350	10	16QAM	25	25	19.60	0-2	2	
1750	20350	10	16QAM	50	0	19.46	0-2	2	

FCC ID: A3LSMG9201	 <b>PCTEST</b> <small>ENGINEERING LABORATORY, INC.</small>	<b>SAR EVALUATION REPORT</b>		Reviewed by: Quality Manager
Document S/N: 0Y1502060403.A3L	Test Dates: 01/12/15 - 02/11/15	DUT Type: Portable Handset		Page 33 of 72



**Table 9-13**  
**LTE Band 4 (AWS) Conducted Powers - 5 MHz Bandwidth**

	Frequency [MHz]	Channel	Bandwidth [MHz]	Modulation	RB Size	RB Offset	Conducted Power [dBm]	MPR Allowed per 3GPP [dB]	MPR [dB]
Low	1712.5	19975	5	QPSK	1	0	21.42	0	0
	1712.5	19975	5	QPSK	1	12	21.29	0	0
	1712.5	19975	5	QPSK	1	24	21.38	0	0
	1712.5	19975	5	QPSK	12	0	20.66	0-1	1
	1712.5	19975	5	QPSK	12	6	20.64	0-1	1
	1712.5	19975	5	QPSK	12	13	20.61	0-1	1
	1712.5	19975	5	QPSK	25	0	20.62	0-1	1
	1712.5	19975	5	16-QAM	1	0	20.44	0-1	1
	1712.5	19975	5	16-QAM	1	12	20.40	0-1	1
	1712.5	19975	5	16-QAM	1	24	20.38	0-1	1
	1712.5	19975	5	16-QAM	12	0	19.59	0-2	2
	1712.5	19975	5	16-QAM	12	6	19.59	0-2	2
1712.5	19975	5	16-QAM	12	13	19.57	0-2	2	
1712.5	19975	5	16-QAM	25	0	19.52	0-2	2	
Mid	1732.5	20175	5	QPSK	1	0	21.47	0	0
	1732.5	20175	5	QPSK	1	12	21.56	0	0
	1732.5	20175	5	QPSK	1	24	21.50	0	0
	1732.5	20175	5	QPSK	12	0	20.66	0-1	1
	1732.5	20175	5	QPSK	12	6	20.68	0-1	1
	1732.5	20175	5	QPSK	12	13	20.68	0-1	1
	1732.5	20175	5	QPSK	25	0	20.63	0-1	1
	1732.5	20175	5	16-QAM	1	0	20.49	0-1	1
	1732.5	20175	5	16-QAM	1	12	20.38	0-1	1
	1732.5	20175	5	16-QAM	1	24	20.29	0-1	1
	1732.5	20175	5	16-QAM	12	0	19.69	0-2	2
	1732.5	20175	5	16-QAM	12	6	19.69	0-2	2
1732.5	20175	5	16-QAM	12	13	19.68	0-2	2	
1732.5	20175	5	16-QAM	25	0	19.63	0-2	2	
High	1752.5	20375	5	QPSK	1	0	21.24	0	0
	1752.5	20375	5	QPSK	1	12	21.21	0	0
	1752.5	20375	5	QPSK	1	24	21.30	0	0
	1752.5	20375	5	QPSK	12	0	20.66	0-1	1
	1752.5	20375	5	QPSK	12	6	20.66	0-1	1
	1752.5	20375	5	QPSK	12	13	20.63	0-1	1
	1752.5	20375	5	QPSK	25	0	20.60	0-1	1
	1752.5	20375	5	16-QAM	1	0	20.37	0-1	1
	1752.5	20375	5	16-QAM	1	12	20.35	0-1	1
	1752.5	20375	5	16-QAM	1	24	20.40	0-1	1
	1752.5	20375	5	16-QAM	12	0	19.55	0-2	2
	1752.5	20375	5	16-QAM	12	6	19.57	0-2	2
1752.5	20375	5	16-QAM	12	13	19.50	0-2	2	
1752.5	20375	5	16-QAM	25	0	19.48	0-2	2	

FCC ID: A3LSMG9201	 <b>PCTEST</b> ENGINEERING LABORATORY, INC.	<b>SAR EVALUATION REPORT</b>		<b>Reviewed by:</b> Quality Manager
<b>Document S/N:</b> 0Y1502060403.A3L	<b>Test Dates:</b> 01/12/15 - 02/11/15	<b>DUT Type:</b> Portable Handset		Page 34 of 72



**Table 9-14**  
**LTE Band 4 (AWS) Conducted Powers - 3 MHz Bandwidth**

	Frequency [MHz]	Channel	Bandwidth [MHz]	Modulation	RB Size	RB Offset	Conducted Power [dBm]	MPR Allowed per 3GPP [dB]	MPR [dB]
Low	1711.5	19965	3	QPSK	1	0	21.28	0	0
	1711.5	19965	3	QPSK	1	7	21.33	0	0
	1711.5	19965	3	QPSK	1	14	21.23	0	0
	1711.5	19965	3	QPSK	8	0	20.95	0-1	1
	1711.5	19965	3	QPSK	8	4	21.00	0-1	1
	1711.5	19965	3	QPSK	8	7	20.91	0-1	1
	1711.5	19965	3	QPSK	15	0	20.63	0-1	1
	1711.5	19965	3	16-QAM	1	0	20.60	0-1	1
	1711.5	19965	3	16-QAM	1	7	20.61	0-1	1
	1711.5	19965	3	16-QAM	1	14	20.47	0-1	1
	1711.5	19965	3	16-QAM	8	0	19.55	0-2	2
	1711.5	19965	3	16-QAM	8	4	19.54	0-2	2
1711.5	19965	3	16-QAM	8	7	19.52	0-2	2	
1711.5	19965	3	16-QAM	15	0	19.59	0-2	2	
Mid	1732.5	20175	3	QPSK	1	0	21.56	0	0
	1732.5	20175	3	QPSK	1	7	21.45	0	0
	1732.5	20175	3	QPSK	1	14	21.62	0	0
	1732.5	20175	3	QPSK	8	0	20.70	0-1	1
	1732.5	20175	3	QPSK	8	4	20.71	0-1	1
	1732.5	20175	3	QPSK	8	7	20.70	0-1	1
	1732.5	20175	3	QPSK	15	0	20.68	0-1	1
	1732.5	20175	3	16-QAM	1	0	20.26	0-1	1
	1732.5	20175	3	16-QAM	1	7	20.20	0-1	1
	1732.5	20175	3	16-QAM	1	14	20.33	0-1	1
	1732.5	20175	3	16-QAM	8	0	19.68	0-2	2
	1732.5	20175	3	16-QAM	8	4	19.68	0-2	2
1732.5	20175	3	16-QAM	8	7	19.71	0-2	2	
1732.5	20175	3	16-QAM	15	0	19.68	0-2	2	
High	1753.5	20385	3	QPSK	1	0	21.38	0	0
	1753.5	20385	3	QPSK	1	7	21.40	0	0
	1753.5	20385	3	QPSK	1	14	21.31	0	0
	1753.5	20385	3	QPSK	8	0	20.58	0-1	1
	1753.5	20385	3	QPSK	8	4	20.56	0-1	1
	1753.5	20385	3	QPSK	8	7	20.55	0-1	1
	1753.5	20385	3	QPSK	15	0	20.55	0-1	1
	1753.5	20385	3	16-QAM	1	0	20.71	0-1	1
	1753.5	20385	3	16-QAM	1	7	20.63	0-1	1
	1753.5	20385	3	16-QAM	1	14	20.67	0-1	1
	1753.5	20385	3	16-QAM	8	0	19.64	0-2	2
	1753.5	20385	3	16-QAM	8	4	19.62	0-2	2
1753.5	20385	3	16-QAM	8	7	19.63	0-2	2	
1753.5	20385	3	16-QAM	15	0	19.57	0-2	2	

FCC ID: A3LSMG9201	 <b>PCTEST</b> <small>ENGINEERING LABORATORY, INC.</small>	<b>SAR EVALUATION REPORT</b>		<b>Reviewed by:</b> Quality Manager
<b>Document S/N:</b> 0Y1502060403.A3L	<b>Test Dates:</b> 01/12/15 - 02/11/15	<b>DUT Type:</b> Portable Handset		Page 35 of 72

**Table 9-15  
LTE Band 4 (AWS) Conducted Powers - 1.4 MHz Bandwidth**

	Frequency [MHz]	Channel	Bandwidth [MHz]	Modulation	RB Size	RB Offset	Conducted Power [dBm]	MPR Allowed per 3GPP [dB]	MPR [dB]
Low	1710.7	19957	1.4	QPSK	1	0	21.24	0	0
	1710.7	19957	1.4	QPSK	1	2	21.29	0	0
	1710.7	19957	1.4	QPSK	1	5	21.31	0	0
	1710.7	19957	1.4	QPSK	3	0	21.11	0	0
	1710.7	19957	1.4	QPSK	3	2	21.16	0	0
	1710.7	19957	1.4	QPSK	3	3	21.14	0	0
	1710.7	19957	1.4	QPSK	6	0	20.63	0-1	1
	1710.7	19957	1.4	16-QAM	1	0	20.34	0-1	1
	1710.7	19957	1.4	16-QAM	1	2	20.29	0-1	1
	1710.7	19957	1.4	16-QAM	1	5	20.31	0-1	1
	1710.7	19957	1.4	16-QAM	3	0	20.01	0-1	1
	1710.7	19957	1.4	16-QAM	3	2	20.00	0-1	1
1710.7	19957	1.4	16-QAM	3	3	20.01	0-1	1	
1710.7	19957	1.4	16-QAM	6	0	19.38	0-2	2	
Mid	1732.5	20175	1.4	QPSK	1	0	21.48	0	0
	1732.5	20175	1.4	QPSK	1	2	21.35	0	0
	1732.5	20175	1.4	QPSK	1	5	21.35	0	0
	1732.5	20175	1.4	QPSK	3	0	21.30	0	0
	1732.5	20175	1.4	QPSK	3	2	21.24	0	0
	1732.5	20175	1.4	QPSK	3	3	21.19	0	0
	1732.5	20175	1.4	QPSK	6	0	20.66	0-1	1
	1732.5	20175	1.4	16-QAM	1	0	20.47	0-1	1
	1732.5	20175	1.4	16-QAM	1	2	20.42	0-1	1
	1732.5	20175	1.4	16-QAM	1	5	20.54	0-1	1
	1732.5	20175	1.4	16-QAM	3	0	20.18	0-1	1
	1732.5	20175	1.4	16-QAM	3	2	20.07	0-1	1
1732.5	20175	1.4	16-QAM	3	3	20.14	0-1	1	
1732.5	20175	1.4	16-QAM	6	0	19.56	0-2	2	
High	1754.3	20393	1.4	QPSK	1	0	21.31	0	0
	1754.3	20393	1.4	QPSK	1	2	21.36	0	0
	1754.3	20393	1.4	QPSK	1	5	21.31	0	0
	1754.3	20393	1.4	QPSK	3	0	21.14	0	0
	1754.3	20393	1.4	QPSK	3	2	21.16	0	0
	1754.3	20393	1.4	QPSK	3	3	21.12	0	0
	1754.3	20393	1.4	QPSK	6	0	20.60	0-1	1
	1754.3	20393	1.4	16-QAM	1	0	20.58	0-1	1
	1754.3	20393	1.4	16-QAM	1	2	20.44	0-1	1
	1754.3	20393	1.4	16-QAM	1	5	20.54	0-1	1
	1754.3	20393	1.4	16-QAM	3	0	20.20	0-1	1
	1754.3	20393	1.4	16-QAM	3	2	20.11	0-1	1
1754.3	20393	1.4	16-QAM	3	3	20.07	0-1	1	
1754.3	20393	1.4	16-QAM	6	0	19.62	0-2	2	



FCC ID: A3LSMG9201	 <b>PCTEST</b> ENGINEERING LABORATORY, INC.	<b>SAR EVALUATION REPORT</b>		<b>Reviewed by:</b> Quality Manager
<b>Document S/N:</b> 0Y1502060403.A3L	<b>Test Dates:</b> 01/12/15 - 02/11/15	<b>DUT Type:</b> Portable Handset		Page 36 of 72

### 9.3.4

### LTE Band 2 (PCS)



**Table 9-16**  
**LTE Band 2 (PCS) Conducted Powers - 20 MHz Bandwidth**

	Frequency [MHz]	Channel	Bandwidth [MHz]	Modulation	RB Size	RB Offset	Conducted Power [dBm]	MPR Allowed per 3GPP [dB]	MPR [dB]
Low	1860	18700	20	QPSK	1	0	21.63	0	0
	1860	18700	20	QPSK	1	50	<b>21.73</b>	0	0
	1860	18700	20	QPSK	1	99	21.56	0	0
	1860	18700	20	QPSK	50	0	<b>20.55</b>	0-1	1
	1860	18700	20	QPSK	50	25	20.54	0-1	1
	1860	18700	20	QPSK	50	50	20.38	0-1	1
	1860	18700	20	QPSK	100	0	20.43	0-1	1
	1860	18700	20	16QAM	1	0	20.69	0-1	1
	1860	18700	20	16QAM	1	50	20.63	0-1	1
	1860	18700	20	16QAM	1	99	20.61	0-1	1
	1860	18700	20	16QAM	50	0	19.98	0-2	2
	1860	18700	20	16QAM	50	25	19.97	0-2	2
1860	18700	20	16QAM	50	50	19.93	0-2	2	
1860	18700	20	16QAM	100	0	19.87	0-2	2	
Mid	1880.0	18900	20	QPSK	1	0	21.52	0	0
	1880.0	18900	20	QPSK	1	50	21.48	0	0
	1880.0	18900	20	QPSK	1	99	21.43	0	0
	1880.0	18900	20	QPSK	50	0	20.39	0-1	1
	1880.0	18900	20	QPSK	50	25	20.37	0-1	1
	1880.0	18900	20	QPSK	50	50	20.26	0-1	1
	1880.0	18900	20	QPSK	100	0	20.26	0-1	1
	1880.0	18900	20	16QAM	1	0	20.51	0-1	1
	1880.0	18900	20	16QAM	1	50	20.42	0-1	1
	1880.0	18900	20	16QAM	1	99	20.43	0-1	1
	1880.0	18900	20	16QAM	50	0	19.96	0-2	2
	1880.0	18900	20	16QAM	50	25	19.93	0-2	2
1880.0	18900	20	16QAM	50	50	19.85	0-2	2	
1880.0	18900	20	16QAM	100	0	19.80	0-2	2	
High	1900	19100	20	QPSK	1	0	21.35	0	0
	1900	19100	20	QPSK	1	50	21.38	0	0
	1900	19100	20	QPSK	1	99	21.49	0	0
	1900	19100	20	QPSK	50	0	20.36	0-1	1
	1900	19100	20	QPSK	50	25	20.23	0-1	1
	1900	19100	20	QPSK	50	50	20.27	0-1	1
	1900	19100	20	QPSK	100	0	20.32	0-1	1
	1900	19100	20	16QAM	1	0	20.45	0-1	1
	1900	19100	20	16QAM	1	50	20.52	0-1	1
	1900	19100	20	16QAM	1	99	20.46	0-1	1
	1900	19100	20	16QAM	50	0	19.75	0-2	2
	1900	19100	20	16QAM	50	25	19.78	0-2	2
1900	19100	20	16QAM	50	50	19.72	0-2	2	
1900	19100	20	16QAM	100	0	19.85	0-2	2	

FCC ID: A3LSMG920I	 <b>PCTEST</b> ENGINEERING LABORATORY, INC.	<b>SAR EVALUATION REPORT</b>		<b>Reviewed by:</b> Quality Manager
<b>Document S/N:</b> 0Y1502060403.A3L	<b>Test Dates:</b> 01/12/15 - 02/11/15	<b>DUT Type:</b> Portable Handset	Page 37 of 72	



**Table 9-17**  
**LTE Band 2 (PCS) Conducted Powers - 15 MHz Bandwidth**

	Frequency [MHz]	Channel	Bandwidth [MHz]	Modulation	RB Size	RB Offset	Conducted Power [dBm]	MPR Allowed per 3GPP [dB]	MPR [dB]
Low	1857.5	18675	15	QPSK	1	0	21.72	0	0
	1857.5	18675	15	QPSK	1	36	21.79	0	0
	1857.5	18675	15	QPSK	1	74	21.66	0	0
	1857.5	18675	15	QPSK	36	0	20.43	0-1	1
	1857.5	18675	15	QPSK	36	18	20.51	0-1	1
	1857.5	18675	15	QPSK	36	37	20.46	0-1	1
	1857.5	18675	15	QPSK	75	0	20.34	0-1	1
	1857.5	18675	15	16QAM	1	0	20.70	0-1	1
	1857.5	18675	15	16QAM	1	36	20.53	0-1	1
	1857.5	18675	15	16QAM	1	74	20.53	0-1	1
	1857.5	18675	15	16QAM	36	0	19.92	0-2	2
	1857.5	18675	15	16QAM	36	18	19.99	0-2	2
	1857.5	18675	15	16QAM	36	37	19.92	0-2	2
1857.5	18675	15	16QAM	75	0	19.91	0-2	2	
Mid	1880.0	18900	15	QPSK	1	0	21.60	0	0
	1880.0	18900	15	QPSK	1	36	21.46	0	0
	1880.0	18900	15	QPSK	1	74	21.50	0	0
	1880.0	18900	15	QPSK	36	0	20.29	0-1	1
	1880.0	18900	15	QPSK	36	18	20.20	0-1	1
	1880.0	18900	15	QPSK	36	37	20.15	0-1	1
	1880.0	18900	15	QPSK	75	0	20.15	0-1	1
	1880.0	18900	15	16QAM	1	0	20.50	0-1	1
	1880.0	18900	15	16QAM	1	36	20.43	0-1	1
	1880.0	18900	15	16QAM	1	74	20.37	0-1	1
	1880.0	18900	15	16QAM	36	0	19.86	0-2	2
	1880.0	18900	15	16QAM	36	18	19.70	0-2	2
	1880.0	18900	15	16QAM	36	37	19.75	0-2	2
1880.0	18900	15	16QAM	75	0	19.72	0-2	2	
High	1902.5	19125	15	QPSK	1	0	21.71	0	0
	1902.5	19125	15	QPSK	1	36	21.66	0	0
	1902.5	19125	15	QPSK	1	74	21.74	0	0
	1902.5	19125	15	QPSK	36	0	20.46	0-1	1
	1902.5	19125	15	QPSK	36	18	20.34	0-1	1
	1902.5	19125	15	QPSK	36	37	20.42	0-1	1
	1902.5	19125	15	QPSK	75	0	20.39	0-1	1
	1902.5	19125	15	16QAM	1	0	20.61	0-1	1
	1902.5	19125	15	16QAM	1	36	20.77	0-1	1
	1902.5	19125	15	16QAM	1	74	20.74	0-1	1
	1902.5	19125	15	16QAM	36	0	19.94	0-2	2
	1902.5	19125	15	16QAM	36	18	19.78	0-2	2
	1902.5	19125	15	16QAM	36	37	19.86	0-2	2
1902.5	19125	15	16QAM	75	0	19.90	0-2	2	

FCC ID: A3LSMG920I	 <b>PCTEST</b> ENGINEERING LABORATORY, INC.	<b>SAR EVALUATION REPORT</b>		<b>Reviewed by:</b> Quality Manager
<b>Document S/N:</b> 0Y1502060403.A3L	<b>Test Dates:</b> 01/12/15 - 02/11/15	<b>DUT Type:</b> Portable Handset	Page 38 of 72	



**Table 9-18**  
**LTE Band 2 (PCS) Conducted Powers - 10 MHz Bandwidth**

	Frequency [MHz]	Channel	Bandwidth [MHz]	Modulation	RB Size	RB Offset	Conducted Power [dBm]	MPR Allowed per 3GPP [dB]	MPR [dB]
Low	1855	18650	10	QPSK	1	0	21.75	0	0
	1855	18650	10	QPSK	1	25	21.64	0	0
	1855	18650	10	QPSK	1	49	21.85	0	0
	1855	18650	10	QPSK	25	0	20.45	0-1	1
	1855	18650	10	QPSK	25	12	20.52	0-1	1
	1855	18650	10	QPSK	25	25	20.46	0-1	1
	1855	18650	10	QPSK	50	0	20.47	0-1	1
	1855	18650	10	16QAM	1	0	20.69	0-1	1
	1855	18650	10	16QAM	1	25	20.66	0-1	1
	1855	18650	10	16QAM	1	49	20.71	0-1	1
	1855	18650	10	16QAM	25	0	19.97	0-2	2
	1855	18650	10	16QAM	25	12	20.00	0-2	2
Mid	1855	18650	10	16QAM	25	25	19.96	0-2	2
	1855	18650	10	16QAM	50	0	19.93	0-2	2
	1880.0	18900	10	QPSK	1	0	21.59	0	0
	1880.0	18900	10	QPSK	1	25	21.50	0	0
	1880.0	18900	10	QPSK	1	49	21.49	0	0
	1880.0	18900	10	QPSK	25	0	20.31	0-1	1
	1880.0	18900	10	QPSK	25	12	20.29	0-1	1
	1880.0	18900	10	QPSK	25	25	20.22	0-1	1
	1880.0	18900	10	QPSK	50	0	20.23	0-1	1
	1880.0	18900	10	16QAM	1	0	20.55	0-1	1
	1880.0	18900	10	16QAM	1	25	20.40	0-1	1
	1880.0	18900	10	16QAM	1	49	20.46	0-1	1
High	1880.0	18900	10	16QAM	25	0	19.85	0-2	2
	1880.0	18900	10	16QAM	25	12	19.82	0-2	2
	1880.0	18900	10	16QAM	25	25	19.77	0-2	2
	1880.0	18900	10	16QAM	50	0	19.73	0-2	2
	1905	19150	10	QPSK	1	0	21.61	0	0
	1905	19150	10	QPSK	1	25	21.67	0	0
	1905	19150	10	QPSK	1	49	21.81	0	0
	1905	19150	10	QPSK	25	0	20.48	0-1	1
	1905	19150	10	QPSK	25	12	20.39	0-1	1
	1905	19150	10	QPSK	25	25	20.41	0-1	1
	1905	19150	10	QPSK	50	0	20.35	0-1	1
	1905	19150	10	16QAM	1	0	20.71	0-1	1
1905	19150	10	16QAM	1	25	20.38	0-1	1	
1905	19150	10	16QAM	1	49	20.74	0-1	1	
1905	19150	10	16QAM	25	0	19.89	0-2	2	
1905	19150	10	16QAM	25	12	19.87	0-2	2	
1905	19150	10	16QAM	25	25	19.89	0-2	2	
1905	19150	10	16QAM	50	0	19.85	0-2	2	

FCC ID: A3LSMG9201	 <b>PCTEST</b> <small>ENGINEERING LABORATORY, INC.</small>	<b>SAR EVALUATION REPORT</b>		Reviewed by: Quality Manager
Document S/N: 0Y1502060403.A3L	Test Dates: 01/12/15 - 02/11/15	DUT Type: Portable Handset	Page 39 of 72	



**Table 9-19**  
**LTE Band 2 (PCS) Conducted Powers - 5 MHz Bandwidth**

	Frequency [MHz]	Channel	Bandwidth [MHz]	Modulation	RB Size	RB Offset	Conducted Power [dBm]	MPR Allowed per 3GPP [dB]	MPR [dB]
Low	1852.5	18625	5	QPSK	1	0	21.90	0	0
	1852.5	18625	5	QPSK	1	12	21.87	0	0
	1852.5	18625	5	QPSK	1	24	21.93	0	0
	1852.5	18625	5	QPSK	12	0	20.55	0-1	1
	1852.5	18625	5	QPSK	12	6	20.60	0-1	1
	1852.5	18625	5	QPSK	12	13	20.59	0-1	1
	1852.5	18625	5	QPSK	25	0	20.54	0-1	1
	1852.5	18625	5	16-QAM	1	0	20.84	0-1	1
	1852.5	18625	5	16-QAM	1	12	20.79	0-1	1
	1852.5	18625	5	16-QAM	1	24	20.81	0-1	1
	1852.5	18625	5	16-QAM	12	0	19.96	0-2	2
	1852.5	18625	5	16-QAM	12	6	19.99	0-2	2
	1852.5	18625	5	16-QAM	12	13	19.99	0-2	2
1852.5	18625	5	16-QAM	25	0	20.00	0-2	2	
Mid	1880.0	18900	5	QPSK	1	0	21.56	0	0
	1880.0	18900	5	QPSK	1	12	21.57	0	0
	1880.0	18900	5	QPSK	1	24	21.44	0	0
	1880.0	18900	5	QPSK	12	0	20.25	0-1	1
	1880.0	18900	5	QPSK	12	6	20.24	0-1	1
	1880.0	18900	5	QPSK	12	13	20.23	0-1	1
	1880.0	18900	5	QPSK	25	0	20.20	0-1	1
	1880.0	18900	5	16-QAM	1	0	20.52	0-1	1
	1880.0	18900	5	16-QAM	1	12	20.64	0-1	1
	1880.0	18900	5	16-QAM	1	24	20.63	0-1	1
	1880.0	18900	5	16-QAM	12	0	19.77	0-2	2
	1880.0	18900	5	16-QAM	12	6	19.71	0-2	2
	1880.0	18900	5	16-QAM	12	13	19.70	0-2	2
1880.0	18900	5	16-QAM	25	0	19.63	0-2	2	
High	1907.5	19175	5	QPSK	1	0	21.69	0	0
	1907.5	19175	5	QPSK	1	12	21.66	0	0
	1907.5	19175	5	QPSK	1	24	21.67	0	0
	1907.5	19175	5	QPSK	12	0	20.37	0-1	1
	1907.5	19175	5	QPSK	12	6	20.45	0-1	1
	1907.5	19175	5	QPSK	12	13	20.40	0-1	1
	1907.5	19175	5	QPSK	25	0	20.40	0-1	1
	1907.5	19175	5	16-QAM	1	0	20.78	0-1	1
	1907.5	19175	5	16-QAM	1	12	20.70	0-1	1
	1907.5	19175	5	16-QAM	1	24	20.72	0-1	1
	1907.5	19175	5	16-QAM	12	0	19.86	0-2	2
	1907.5	19175	5	16-QAM	12	6	19.83	0-2	2
	1907.5	19175	5	16-QAM	12	13	19.89	0-2	2
1907.5	19175	5	16-QAM	25	0	19.74	0-2	2	

FCC ID: A3LSMG9201	 <b>PCTEST</b> ENGINEERING LABORATORY, INC.	<b>SAR EVALUATION REPORT</b>		<b>Reviewed by:</b> Quality Manager
<b>Document S/N:</b> 0Y1502060403.A3L	<b>Test Dates:</b> 01/12/15 - 02/11/15	<b>DUT Type:</b> Portable Handset	Page 40 of 72	



**Table 9-20  
LTE Band 2 (PCS) Conducted Powers - 3 MHz Bandwidth**

	Frequency [MHz]	Channel	Bandwidth [MHz]	Modulation	RB Size	RB Offset	Conducted Power [dBm]	MPR Allowed per 3GPP [dB]	MPR [dB]
Low	1851.5	18615	3	QPSK	1	0	22.00	0	0
	1851.5	18615	3	QPSK	1	7	21.97	0	0
	1851.5	18615	3	QPSK	1	14	21.98	0	0
	1851.5	18615	3	QPSK	8	0	20.62	0-1	1
	1851.5	18615	3	QPSK	8	4	20.58	0-1	1
	1851.5	18615	3	QPSK	8	7	20.60	0-1	1
	1851.5	18615	3	QPSK	15	0	20.55	0-1	1
	1851.5	18615	3	16-QAM	1	0	20.74	0-1	1
	1851.5	18615	3	16-QAM	1	7	20.74	0-1	1
	1851.5	18615	3	16-QAM	1	14	20.62	0-1	1
	1851.5	18615	3	16-QAM	8	0	19.99	0-2	2
	1851.5	18615	3	16-QAM	8	4	19.98	0-2	2
	1851.5	18615	3	16-QAM	8	7	20.00	0-2	2
1851.5	18615	3	16-QAM	15	0	20.00	0-2	2	
Mid	1880.0	18900	3	QPSK	1	0	21.53	0	0
	1880.0	18900	3	QPSK	1	7	21.58	0	0
	1880.0	18900	3	QPSK	1	14	21.41	0	0
	1880.0	18900	3	QPSK	8	0	20.25	0-1	1
	1880.0	18900	3	QPSK	8	4	20.19	0-1	1
	1880.0	18900	3	QPSK	8	7	20.19	0-1	1
	1880.0	18900	3	QPSK	15	0	20.20	0-1	1
	1880.0	18900	3	16-QAM	1	0	20.65	0-1	1
	1880.0	18900	3	16-QAM	1	7	20.66	0-1	1
	1880.0	18900	3	16-QAM	1	14	20.81	0-1	1
	1880.0	18900	3	16-QAM	8	0	19.76	0-2	2
	1880.0	18900	3	16-QAM	8	4	19.62	0-2	2
	1880.0	18900	3	16-QAM	8	7	19.66	0-2	2
1880.0	18900	3	16-QAM	15	0	19.65	0-2	2	
High	1908.5	19185	3	QPSK	1	0	21.78	0	0
	1908.5	19185	3	QPSK	1	7	21.70	0	0
	1908.5	19185	3	QPSK	1	14	21.74	0	0
	1908.5	19185	3	QPSK	8	0	20.36	0-1	1
	1908.5	19185	3	QPSK	8	4	20.41	0-1	1
	1908.5	19185	3	QPSK	8	7	20.44	0-1	1
	1908.5	19185	3	QPSK	15	0	20.38	0-1	1
	1908.5	19185	3	16-QAM	1	0	20.76	0-1	1
	1908.5	19185	3	16-QAM	1	7	20.70	0-1	1
	1908.5	19185	3	16-QAM	1	14	20.77	0-1	1
	1908.5	19185	3	16-QAM	8	0	19.88	0-2	2
	1908.5	19185	3	16-QAM	8	4	19.86	0-2	2
	1908.5	19185	3	16-QAM	8	7	19.88	0-2	2
1908.5	19185	3	16-QAM	15	0	19.84	0-2	2	

FCC ID: A3LSMG9201	 <b>PCTEST</b> <small>ENGINEERING LABORATORY, INC.</small>	<b>SAR EVALUATION REPORT</b>		Reviewed by: Quality Manager
Document S/N: 0Y1502060403.A3L	Test Dates: 01/12/15 - 02/11/15	DUT Type: Portable Handset	Page 41 of 72	

**Table 9-21  
LTE Band 2 (PCS) Conducted Powers - 1.4 MHz Bandwidth**

	Frequency [MHz]	Channel	Bandwidth [MHz]	Modulation	RB Size	RB Offset	Conducted Power [dBm]	MPR Allowed per 3GPP [dB]	MPR [dB]
Low	1850.7	18607	1.4	QPSK	1	0	21.86	0	0
	1850.7	18607	1.4	QPSK	1	2	21.84	0	0
	1850.7	18607	1.4	QPSK	1	5	21.77	0	0
	1850.7	18607	1.4	QPSK	3	0	21.62	0	0
	1850.7	18607	1.4	QPSK	3	2	21.71	0	0
	1850.7	18607	1.4	QPSK	3	3	21.65	0	0
	1850.7	18607	1.4	QPSK	6	0	20.66	0-1	1
	1850.7	18607	1.4	16-QAM	1	0	20.77	0-1	1
	1850.7	18607	1.4	16-QAM	1	2	20.90	0-1	1
	1850.7	18607	1.4	16-QAM	1	5	20.85	0-1	1
	1850.7	18607	1.4	16-QAM	3	0	20.66	0-1	1
	1850.7	18607	1.4	16-QAM	3	2	20.61	0-1	1
	1850.7	18607	1.4	16-QAM	3	3	20.49	0-1	1
1850.7	18607	1.4	16-QAM	6	0	20.00	0-2	2	
Mid	1880.0	18900	1.4	QPSK	1	0	21.85	0	0
	1880.0	18900	1.4	QPSK	1	2	21.82	0	0
	1880.0	18900	1.4	QPSK	1	5	21.76	0	0
	1880.0	18900	1.4	QPSK	3	0	21.70	0	0
	1880.0	18900	1.4	QPSK	3	2	21.72	0	0
	1880.0	18900	1.4	QPSK	3	3	21.66	0	0
	1880.0	18900	1.4	QPSK	6	0	20.66	0-1	1
	1880.0	18900	1.4	16-QAM	1	0	20.75	0-1	1
	1880.0	18900	1.4	16-QAM	1	2	20.72	0-1	1
	1880.0	18900	1.4	16-QAM	1	5	20.69	0-1	1
	1880.0	18900	1.4	16-QAM	3	0	20.66	0-1	1
	1880.0	18900	1.4	16-QAM	3	2	20.59	0-1	1
	1880.0	18900	1.4	16-QAM	3	3	20.63	0-1	1
1880.0	18900	1.4	16-QAM	6	0	19.61	0-2	2	
High	1909.3	19193	1.4	QPSK	1	0	21.65	0	0
	1909.3	19193	1.4	QPSK	1	2	21.63	0	0
	1909.3	19193	1.4	QPSK	1	5	21.63	0	0
	1909.3	19193	1.4	QPSK	3	0	21.59	0	0
	1909.3	19193	1.4	QPSK	3	2	21.55	0	0
	1909.3	19193	1.4	QPSK	3	3	21.50	0	0
	1909.3	19193	1.4	QPSK	6	0	20.45	0-1	1
	1909.3	19193	1.4	16-QAM	1	0	20.54	0-1	1
	1909.3	19193	1.4	16-QAM	1	2	20.41	0-1	1
	1909.3	19193	1.4	16-QAM	1	5	20.51	0-1	1
	1909.3	19193	1.4	16-QAM	3	0	20.28	0-1	1
	1909.3	19193	1.4	16-QAM	3	2	20.38	0-1	1
	1909.3	19193	1.4	16-QAM	3	3	20.32	0-1	1
1909.3	19193	1.4	16-QAM	6	0	19.88	0-2	2	

FCC ID: A3LSMG920I	 <b>PCTEST</b> <small>ENGINEERING LABORATORY, INC.</small>	<b>SAR EVALUATION REPORT</b>		Reviewed by: Quality Manager
Document S/N: 0Y1502060403.A3L	Test Dates: 01/12/15 - 02/11/15	DUT Type: Portable Handset		Page 42 of 72



## 9.4 WLAN Conducted Powers

**Table 9-22**  
**2.4 GHz Average RF Power**

Antenna	Freq [MHz]	Channel	2.4 GHz Conducted Power [dBm]
			IEEE Transmission Mode
			802.11b
Antenna 1	2412	1	16.63
	2437	6	16.92
	2462	11	16.61
Antenna 2	2412	1	17.45
	2437	6	16.67
	2462	11	16.66

**Table 9-23**  
**2.4 GHz Average RF Power - MIMO**

Antenna	Freq [MHz]	Channel	2.4 GHz Conducted Power [dBm]
			IEEE Transmission Mode
			802.11n
MIMO	2412	1	16.08
	2437	6	15.89
	2462	11	15.72

FCC ID: A3LSMG920I	 <b>PCTEST</b> ENGINEERING LABORATORY, INC.	<b>SAR EVALUATION REPORT</b>		<b>Reviewed by:</b> Quality Manager
<b>Document S/N:</b> 0Y1502060403.A3L	<b>Test Dates:</b> 01/12/15 - 02/11/15	<b>DUT Type:</b> Portable Handset	Page 43 of 72	

**Table 9-24  
5 GHz (20 MHz Bandwidth) Average RF Power**



Antenna	Freq [MHz]	Channel	5 GHz (20 MHz) Conducted Power [dBm]		
			IEEE Transmission Mode		
			802.11a	802.11n	802.11ac
Antenna 1	5180	36	12.66	12.53	12.47
	5200	40	12.60	12.49	12.42
	5220	44	12.49	12.39	12.44
	5240	48	12.50	12.40	12.28
	5260	52	<b>12.59</b>	12.56	12.50
	5280	56	12.55	12.40	12.40
	5300	60	12.43	12.40	12.37
	5320	64	12.46	12.35	12.26
	5500	100	<b>12.79</b>	12.61	12.59
	5540	108	12.53	12.55	12.65
	5580	116	12.75	12.71	12.77
	5660	132	<b>12.86</b>	12.86	12.80
	5745	149	12.55	12.65	12.59
	5825	165	<b>12.75</b>	12.30	12.68
Antenna 2	5180	36	13.24	13.00	12.98
	5200	40	12.98	12.93	12.97
	5220	44	12.96	12.81	12.92
	5240	48	12.83	12.72	12.75
	5260	52	<b>13.00</b>	12.89	12.85
	5280	56	12.87	12.81	12.83
	5300	60	12.75	12.66	12.71
	5320	64	12.70	12.56	12.59
	5500	100	<b>12.84</b>	12.69	12.79
	5540	108	12.57	12.64	12.72
	5580	116	12.79	12.80	12.75
	5660	132	<b>12.82</b>	12.80	12.81
	5745	149	<b>12.58</b>	12.43	12.42
	5825	165	12.47	12.36	12.49

Justification for test configurations for WLAN per KDB Publication 248227 D01DR02-41929:

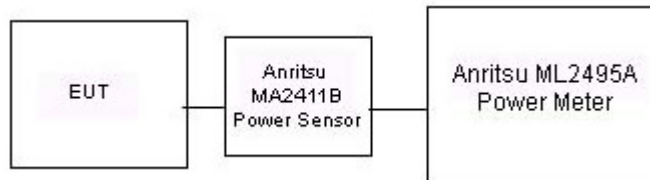
- Power measurements were performed for the transmission mode configuration with the highest maximum output power specified for production units.
- For transmission modes with the same maximum output power specification, powers were measured for the largest channel bandwidth, lowest order modulation and lowest data rate.
- For transmission modes with identical maximum specified output power, channel bandwidth, modulation and data rates, power measurements were required for all identical configurations.
- For each transmission mode configuration, powers were measured for the highest and lowest channels; and at the mid-band channel(s) when there were at least 3 channels supported. For configurations with multiple mid-band channels, due to an even number of channels, both channels were measured.
- The bolded data rate and channel above were tested for SAR.



**Figure 9-3  
Power Measurement Setup**

FCC ID: A3LSMG920I		SAR EVALUATION REPORT		Reviewed by: Quality Manager
Document S/N: 0Y1502060403.A3L	Test Dates: 01/12/15 - 02/11/15	DUT Type: Portable Handset	Page 44 of 72	

## 9.5 Bluetooth Conducted Powers

Table 9-25  
Bluetooth RF Conducted Powers

Frequency [MHz]	Data Rate [Mbps]	Channel No.	Avg Conducted Power	
			[dBm]	[mW]
2402	1.0	0	11.12	12.938
2441	1.0	39	<b>12.59</b>	18.168
2480	1.0	78	10.20	10.478
2402	2.0	0	8.25	6.682
2441	2.0	39	8.54	7.149
2480	2.0	78	7.90	6.173
2402	3.0	0	8.23	6.652
2441	3.0	39	8.49	7.055
2480	3.0	78	7.89	6.151

The bolded data rate and channel above were tested for SAR.

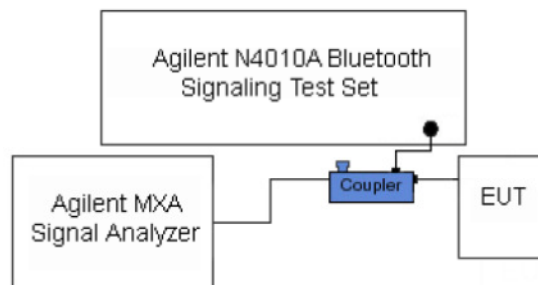



Figure 9-4  
Power Measurement Setup

FCC ID: A3LSMG920I	 PCTEST ENGINEERING LABORATORY, INC.	SAR EVALUATION REPORT	 SAMSUNG	Reviewed by: Quality Manager
Document S/N: 0Y1502060403.A3L	Test Dates: 01/12/15 - 02/11/15	DUT Type: Portable Handset	Page 45 of 72	



# 10 SYSTEM VERIFICATION

## 10.1 Tissue Verification

**Table 10-1  
Measured Tissue Properties**

Calibrated for Tests Performed on:	Tissue Type	Tissue Temp During Calibration (C°)	Measured Frequency (MHz)	Measured Conductivity, $\sigma$ (S/m)	Measured Dielectric Constant, $\epsilon$	TARGET Conductivity, $\sigma$ (S/m)	TARGET Dielectric Constant, $\epsilon$	% dev $\sigma$	% dev $\epsilon$
02/11/2015	750H	22.5	695	0.856	41.530	0.889	42.227	-3.71%	-1.65%
			710	0.872	41.350	0.890	42.149	-2.02%	-1.90%
			725	0.885	41.173	0.891	42.071	-0.67%	-2.13%
			740	0.899	40.994	0.893	41.994	0.67%	-2.38%
			755	0.913	40.796	0.894	41.916	2.13%	-2.67%
02/09/2015	835H	20.8	820	0.877	40.256	0.899	41.578	-2.45%	-3.18%
			835	0.891	40.070	0.900	41.500	-1.00%	-3.45%
			850	0.905	39.873	0.916	41.500	-1.20%	-3.92%
02/10/2015	1750H	22.4	1710	1.317	38.709	1.348	40.142	-2.30%	-3.57%
			1750	1.359	38.547	1.371	40.079	-0.88%	-3.82%
			1790	1.396	38.350	1.394	40.016	0.14%	-4.16%
02/09/2015	1900H	23.0	1850	1.390	39.088	1.400	40.000	-0.71%	-2.28%
			1880	1.422	38.997	1.400	40.000	1.57%	-2.51%
			1910	1.451	38.821	1.400	40.000	3.64%	-2.95%
01/12/2015	2450H	23.0	2401	1.801	38.324	1.756	39.287	2.56%	-2.45%
			2450	1.856	38.105	1.800	39.200	3.11%	-2.79%
			2499	1.909	37.944	1.853	39.138	3.02%	-3.05%
02/05/2015	2450H	23.0	2401	1.744	41.109	1.756	39.287	-0.68%	4.64%
			2450	1.803	40.927	1.800	39.200	0.17%	4.41%
			2499	1.854	40.746	1.853	39.138	0.05%	4.11%
01/19/2015	5200H-5800H	21.0	5260	4.732	35.798	4.717	35.917	0.32%	-0.33%
			5300	4.785	35.717	4.758	35.871	0.57%	-0.43%
			5500	4.989	35.418	4.963	35.643	0.52%	-0.63%
			5600	5.119	35.278	5.065	35.529	1.07%	-0.71%
			5660	5.175	35.157	5.127	35.460	0.94%	-0.85%
02/09/2015	750B	22.1	680	0.922	57.317	0.958	55.804	-3.76%	2.71%
			695	0.936	57.160	0.959	55.745	-2.40%	2.54%
			710	0.951	56.970	0.960	55.687	-0.94%	2.30%
			725	0.964	56.855	0.961	55.629	0.31%	2.20%
			740	0.977	56.692	0.963	55.570	1.45%	2.02%
			755	0.990	56.537	0.964	55.512	2.70%	1.85%
02/09/2015	835B	21.8	820	0.986	53.576	0.969	55.258	1.75%	-3.04%
			835	1.001	53.427	0.970	55.200	3.20%	-3.21%
			850	1.014	53.264	0.988	55.154	2.63%	-3.43%
02/10/2015	1750B	21.1	1710	1.451	52.140	1.463	53.537	-0.82%	-2.61%
			1750	1.498	52.009	1.488	53.432	0.67%	-2.66%
			1790	1.538	51.836	1.514	53.326	1.59%	-2.79%
02/09/2015	1900B	23.0	1850	1.496	52.492	1.520	53.300	-1.58%	-1.52%
			1880	1.528	52.387	1.520	53.300	0.53%	-1.71%
			1910	1.564	52.253	1.520	53.300	2.89%	-1.96%
01/12/2015	2450B	23.0	2401	1.922	52.122	1.903	52.765	1.00%	-1.22%
			2450	1.990	51.901	1.950	52.700	2.05%	-1.52%
			2499	2.058	51.716	2.019	52.638	1.93%	-1.75%
02/02/2015	2450B	23.5	2401	1.886	52.813	1.903	52.765	-0.89%	0.09%
			2450	1.956	52.631	1.950	52.700	0.31%	-0.13%
			2499	2.017	52.443	2.019	52.638	-0.10%	-0.37%
01/13/2015	5200B-5800B	23.1	5260	5.532	47.218	5.369	48.933	3.04%	-3.50%
			5300	5.589	47.162	5.416	48.879	3.19%	-3.51%
			5500	5.847	46.781	5.650	48.607	3.49%	-3.76%
			5600	5.996	46.661	5.766	48.471	3.99%	-3.73%
			5660	6.065	46.504	5.883	48.336	3.09%	-3.79%
			5745	6.175	46.360	5.982	48.220	3.23%	-3.86%
			5800	6.263	46.274	6.000	48.200	4.38%	-4.00%
			5825	6.292	46.232	6.029	48.166	4.36%	-4.02%

The above measured tissue parameters were used in the DASY software. The DASY software was used to perform interpolation to determine the dielectric parameters at the SAR test device frequencies (per KDB Publication 865664 and IEEE 1528-2013 6.6.1.2). The tissue parameters listed in the SAR test plots may slightly differ from the table above due to significant digit rounding in the software.

FCC ID: A3LSMG920I	 PCTEST ENGINEERING LABORATORY, INC.	SAR EVALUATION REPORT		Reviewed by: Quality Manager
Document S/N: 0Y1502060403.A3L	Test Dates: 01/12/15 - 02/11/15	DUT Type: Portable Handset		Page 46 of 72

## 10.2 Test System Verification

Prior to SAR assessment, the system is verified to  $\pm 10\%$  of the SAR measurement on the reference dipole at the time of calibration by the calibration facility. Full system validation status and result summary can be found in Appendix E.

**Table 10-3  
System Verification Results**

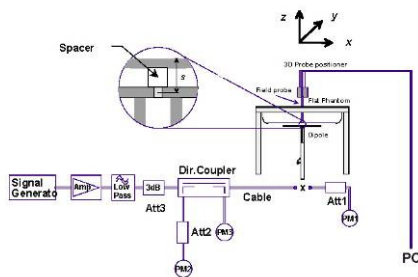

System Verification TARGET & MEASURED												
SAR System #	Tissue Frequency (MHz)	Tissue Type	Date:	Amb. Temp (°C)	Liquid Temp (°C)	Input Power (W)	Dipole SN	Probe SN	Measured SAR <sub>1g</sub> (W/kg)	1 W Target SAR <sub>1g</sub> (W/kg)	1 W Normalized SAR <sub>1g</sub> (W/kg)	Deviation <sub>1g</sub> (%)
G	750	HEAD	02/11/2015	23.9	22.5	0.100	1054	3213	0.816	8.330	8.160	-2.04%
K	835	HEAD	02/09/2015	24.0	21.2	0.100	4d133	3288	0.934	9.200	9.340	1.52%
D	1750	HEAD	02/10/2015	24.5	22.5	0.100	1008	3263	3.810	36.900	38.100	3.25%
D	1900	HEAD	02/09/2015	24.3	23.0	0.100	5d149	3263	4.060	40.200	40.600	1.00%
D	2450	HEAD	01/12/2015	23.0	23.0	0.100	719	3263	5.320	52.100	53.200	2.11%
G	2450	HEAD	02/05/2015	23.5	23.0	0.100	719	3258	5.320	52.100	53.200	2.11%
E	5300	HEAD	01/19/2015	23.0	21.1	0.100	1120	7308	7.700	83.400	77.000	-7.67%
E	5500	HEAD	01/19/2015	23.2	21.2	0.100	1120	7308	7.840	84.900	78.400	-7.66%
E	5600	HEAD	01/19/2015	23.1	21.0	0.100	1120	7308	8.200	82.200	82.000	-0.24%
G	750	BODY	02/09/2015	23.6	23.0	0.447	1054	3213	4.010	8.640	8.977	3.90%
K	835	BODY	02/09/2015	24.0	21.8	0.100	4d133	3288	1.000	9.350	10.000	6.95%
J	1750	BODY	02/10/2015	23.7	21.9	0.100	1008	3022	3.580	37.600	35.800	-4.79%
E	1900	BODY	02/09/2015	23.0	22.4	0.100	5d149	3332	4.120	40.400	41.200	1.98%
G	2450	BODY	01/12/2015	23.9	23.0	0.100	719	3258	5.540	51.800	55.400	6.95%
I	2450	BODY	02/02/2015	24.4	23.5	0.100	719	3209	5.420	51.800	54.200	4.63%
H	5300	BODY	01/13/2015	22.2	23.0	0.100	1191	3920	7.360	79.900	73.600	-7.88%
H	5500	BODY	01/13/2015	22.0	23.2	0.100	1191	3920	7.500	83.100	75.000	-9.75%
H	5600	BODY	01/13/2015	22.1	23.1	0.100	1191	3920	7.740	84.100	77.400	-7.97%
H	5800	BODY	01/13/2015	22.2	23.0	0.100	1191	3920	7.040	78.000	70.400	-9.74%



**Figure 10-1  
System Verification Setup Diagram**



**Figure 10-2  
System Verification Setup Photo**

FCC ID: A3LSMG920I	 PCTEST ENGINEERING LABORATORY, INC.	SAR EVALUATION REPORT	 SAMSUNG	Reviewed by: Quality Manager
Document S/N: 0Y1502060403.A3L	Test Dates: 01/12/15 - 02/11/15	DUT Type: Portable Handset	Page 47 of 72	

# 11 SAR DATA SUMMARY

## 11.1 Standalone Head SAR Data

**Table 11-1  
GSM 850 Head SAR**



MEASUREMENT RESULTS														
FREQUENCY		Mode/Band	Service	Maximum Allowed Power [dBm]	Conducted Power [dBm]	Power Drift [dB]	Side	Test Position	Device Serial Number	Duty Cycle	SAR (1g)	Scaling Factor	Scaled SAR (1g)	Plot #
MHz	Ch.										(W/kg)		(W/kg)	
836.60	190	GSM 850	GSM	33.0	32.46	0.06	Right	Cheek	146AD	1:8.3	0.170	1.132	0.192	A1
836.60	190	GSM 850	GSM	33.0	32.46	0.16	Right	Tilt	146AD	1:8.3	0.090	1.132	0.102	
836.60	190	GSM 850	GSM	33.0	32.46	0.03	Left	Cheek	146AD	1:8.3	0.147	1.132	0.166	
836.60	190	GSM 850	GSM	33.0	32.46	0.07	Left	Tilt	146AD	1:8.3	0.091	1.132	0.103	
ANSI / IEEE C95.1 1992 - SAFETY LIMIT Spatial Peak Uncontrolled Exposure/General Population								Head 1.6 W/kg (mW/g) averaged over 1 gram						

**Table 11-2  
UMTS 850 Head SAR**

MEASUREMENT RESULTS														
FREQUENCY		Mode/Band	Service	Maximum Allowed Power [dBm]	Conducted Power [dBm]	Power Drift [dB]	Side	Test Position	Device Serial Number	Duty Cycle	SAR (1g)	Scaling Factor	Scaled SAR (1g)	Plot #
MHz	Ch.										(W/kg)		(W/kg)	
836.60	4183	UMTS 850	RMC	24.5	24.33	0.04	Right	Cheek	1565F	1:1	0.241	1.040	0.251	
836.60	4183	UMTS 850	RMC	24.5	24.33	-0.07	Right	Tilt	1565F	1:1	0.151	1.040	0.157	
836.60	4183	UMTS 850	RMC	24.5	24.33	0.03	Left	Cheek	1565F	1:1	0.256	1.040	0.266	A2
836.60	4183	UMTS 850	RMC	24.5	24.33	0.04	Left	Tilt	1565F	1:1	0.159	1.040	0.165	
ANSI / IEEE C95.1 1992 - SAFETY LIMIT Spatial Peak Uncontrolled Exposure/General Population								Head 1.6 W/kg (mW/g) averaged over 1 gram						

**Table 11-3  
UMTS 1750 Head SAR**

MEASUREMENT RESULTS														
FREQUENCY		Mode/Band	Service	Maximum Allowed Power [dBm]	Conducted Power [dBm]	Power Drift [dB]	Side	Test Position	Device Serial Number	Duty Cycle	SAR (1g)	Scaling Factor	Scaled SAR (1g)	Plot #
MHz	Ch.										(W/kg)		(W/kg)	
1732.40	1412	UMTS 1750	RMC	23.0	22.43	0.03	Right	Cheek	1565F	1:1	0.148	1.140	0.169	
1732.40	1412	UMTS 1750	RMC	23.0	22.43	0.07	Right	Tilt	1565F	1:1	0.097	1.140	0.111	
1732.40	1412	UMTS 1750	RMC	23.0	22.43	0.06	Left	Cheek	1565F	1:1	0.224	1.140	0.255	A3
1732.40	1412	UMTS 1750	RMC	23.0	22.43	0.04	Left	Tilt	1565F	1:1	0.099	1.140	0.113	
ANSI / IEEE C95.1 1992 - SAFETY LIMIT Spatial Peak Uncontrolled Exposure/General Population								Head 1.6 W/kg (mW/g) averaged over 1 gram						

FCC ID: A3LSMG920I	 PCTEST ENGINEERING LABORATORY, INC.	SAR EVALUATION REPORT		Reviewed by: Quality Manager
Document S/N: 0Y1502060403.A3L	Test Dates: 01/12/15 - 02/11/15	DUT Type: Portable Handset	Page 48 of 72	

**Table 11-4  
GSM 1900 Head SAR**

MEASUREMENT RESULTS														
FREQUENCY		Mode/Band	Service	Maximum Allowed Power [dBm]	Conducted Power [dBm]	Power Drift [dB]	Side	Test Position	Device Serial Number	Duty Cycle	SAR (1g)	Scaling Factor	Scaled SAR (1g)	Plot #
MHz	Ch.										(W/kg)		(W/kg)	
1880.00	661	GSM 1900	GSM	30.0	29.93	0.02	Right	Cheek	146D0	1:8.3	0.058	1.016	0.059	
1880.00	661	GSM 1900	GSM	30.0	29.93	0.12	Right	Tilt	146D0	1:8.3	0.024	1.016	0.024	
1880.00	661	GSM 1900	GSM	30.0	29.93	-0.07	Left	Cheek	146D0	1:8.3	0.061	1.016	0.062	A4
1880.00	661	GSM 1900	GSM	30.0	29.93	0.19	Left	Tilt	146D0	1:8.3	0.023	1.016	0.023	
ANSI / IEEE C95.1 1992 - SAFETY LIMIT Spatial Peak Uncontrolled Exposure/General Population							Head 1.6 W/kg (mW/g) averaged over 1 gram							

**Table 11-5  
UMTS 1900 Head SAR**



MEASUREMENT RESULTS														
FREQUENCY		Mode/Band	Service	Maximum Allowed Power [dBm]	Conducted Power [dBm]	Power Drift [dB]	Side	Test Position	Device Serial Number	Duty Cycle	SAR (1g)	Scaling Factor	Scaled SAR (1g)	Plot #
MHz	Ch.										(W/kg)		(W/kg)	
1880.00	9400	UMTS 1900	RMC	22.5	22.03	0.13	Right	Cheek	1565F	1:1	0.118	1.114	0.131	
1880.00	9400	UMTS 1900	RMC	22.5	22.03	0.00	Right	Tilt	1565F	1:1	0.046	1.114	0.051	
1880.00	9400	UMTS 1900	RMC	22.5	22.03	0.00	Left	Cheek	1565F	1:1	0.120	1.114	0.134	A5
1880.00	9400	UMTS 1900	RMC	22.5	22.03	0.18	Left	Tilt	1565F	1:1	0.049	1.114	0.055	
ANSI / IEEE C95.1 1992 - SAFETY LIMIT Spatial Peak Uncontrolled Exposure/General Population							Head 1.6 W/kg (mW/g) averaged over 1 gram							

**Table 11-6  
LTE Band 12 Head SAR**

MEASUREMENT RESULTS																			
FREQUENCY		Mode	Bandwidth [MHz]	Maximum Allowed Power [dBm]	Conducted Power [dBm]	Power Drift [dB]	MPR [dB]	Side	Test Position	Modulation	RB Size	RB Offset	Device Serial Number	Duty Cycle	SAR (1g)	Scaling Factor	Scaled SAR (1g)	Plot #	
MHz	Ch.														(W/kg)		(W/kg)		
707.50	23095	Mid	LTE Band 12	10	24.5	24.06	-0.02	0	Right	Cheek	QPSK	1	49	146AD	1:1	0.110	1.107	0.122	
707.50	23095	Mid	LTE Band 12	10	23.5	22.84	0.09	1	Right	Cheek	QPSK	25	25	146AD	1:1	0.075	1.164	0.087	
707.50	23095	Mid	LTE Band 12	10	24.5	24.06	0.13	0	Right	Tilt	QPSK	1	49	146AD	1:1	0.071	1.107	0.079	
707.50	23095	Mid	LTE Band 12	10	23.5	22.84	0.09	1	Right	Tilt	QPSK	25	25	146AD	1:1	0.044	1.164	0.051	
707.50	23095	Mid	LTE Band 12	10	24.5	24.06	-0.05	0	Left	Cheek	QPSK	1	49	146AD	1:1	0.127	1.107	0.141	A6
707.50	23095	Mid	LTE Band 12	10	23.5	22.84	-0.08	1	Left	Cheek	QPSK	25	25	146AD	1:1	0.094	1.164	0.109	
707.50	23095	Mid	LTE Band 12	10	24.5	24.06	0.13	0	Left	Tilt	QPSK	1	49	146AD	1:1	0.072	1.107	0.080	
707.50	23095	Mid	LTE Band 12	10	23.5	22.84	0.05	1	Left	Tilt	QPSK	25	25	146AD	1:1	0.053	1.164	0.062	
ANSI / IEEE C95.1 1992 - SAFETY LIMIT Spatial Peak Uncontrolled Exposure/General Population							Head 1.6 W/kg (mW/g) averaged over 1 gram												

**Table 11-7  
LTE Band 26 Head SAR**

MEASUREMENT RESULTS																			
FREQUENCY		Mode	Bandwidth [MHz]	Maximum Allowed Power [dBm]	Conducted Power [dBm]	Power Drift [dB]	MPR [dB]	Side	Test Position	Modulation	RB Size	RB Offset	Device Serial Number	Duty Cycle	SAR (1g)	Scaling Factor	Scaled SAR (1g)	Plot #	
MHz	Ch.														(W/kg)		(W/kg)		
836.50	26915	Mid	LTE Band 26	15	24.5	23.97	-0.10	0	Right	Cheek	QPSK	1	36	146AD	1:1	0.170	1.130	0.192	
836.50	26915	Mid	LTE Band 26	15	23.5	23.04	-0.02	1	Right	Cheek	QPSK	36	18	146AD	1:1	0.142	1.112	0.158	
836.50	26915	Mid	LTE Band 26	15	24.5	23.97	0.09	0	Right	Tilt	QPSK	1	36	146AD	1:1	0.102	1.130	0.115	
836.50	26915	Mid	LTE Band 26	15	23.5	23.04	0.05	1	Right	Tilt	QPSK	36	18	146AD	1:1	0.092	1.112	0.102	
836.50	26915	Mid	LTE Band 26	15	24.5	23.97	0.01	0	Left	Cheek	QPSK	1	36	146AD	1:1	0.175	1.130	0.198	A7
836.50	26915	Mid	LTE Band 26	15	23.5	23.04	0.10	1	Left	Cheek	QPSK	36	18	146AD	1:1	0.144	1.112	0.160	
836.50	26915	Mid	LTE Band 26	15	24.5	23.97	0.14	0	Left	Tilt	QPSK	1	36	146AD	1:1	0.119	1.130	0.134	
836.50	26915	Mid	LTE Band 26	15	23.5	23.04	0.11	1	Left	Tilt	QPSK	36	18	146AD	1:1	0.095	1.112	0.106	
ANSI / IEEE C95.1 1992 - SAFETY LIMIT Spatial Peak Uncontrolled Exposure/General Population							Head 1.6 W/kg (mW/g) averaged over 1 gram												

FCC ID: A3LSMG9201	 <b>PCTEST</b> <small>ENGINEERING LABORATORY, INC.</small>	<b>SAR EVALUATION REPORT</b>		Reviewed by: Quality Manager
Document S/N: 0Y1502060403.A3L	Test Dates: 01/12/15 - 02/11/15	DUT Type: Portable Handset	Page 49 of 72	

**Table 11-8  
LTE Band 4 (AWS) Head SAR**

MEASUREMENT RESULTS																			
FREQUENCY		Mode	Bandwidth [MHz]	Maximum Allowed Power [dBm]	Conducted Power [dBm]	Power Drift [dB]	MPR [dB]	Side	Test Position	Modulation	RB Size	RB Offset	Device Serial Number	Duty Cycle	SAR (1g)	Scaling Factor	Scaled SAR (1g)	Plot #	
MHz	Ch.														(W/kg)		(W/kg)		
1732.50	20175	Md	LTE Band 4 (AWS)	20	22.0	21.17	0.11	0	Right	Cheek	QPSK	1	50	146AD	1:1	0.103	1.211	0.125	
1732.50	20175	Md	LTE Band 4 (AWS)	20	21.0	20.45	0.09	1	Right	Cheek	QPSK	50	50	146AD	1:1	0.087	1.135	0.099	
1732.50	20175	Md	LTE Band 4 (AWS)	20	22.0	21.17	0.07	0	Right	Tilt	QPSK	1	50	146AD	1:1	0.074	1.211	0.090	
1732.50	20175	Md	LTE Band 4 (AWS)	20	21.0	20.45	0.03	1	Right	Tilt	QPSK	50	50	146AD	1:1	0.062	1.135	0.070	
1732.50	20175	Md	LTE Band 4 (AWS)	20	22.0	21.17	0.05	0	Left	Cheek	QPSK	1	50	146AD	1:1	0.201	1.211	0.243	AB
1732.50	20175	Md	LTE Band 4 (AWS)	20	21.0	20.45	0.08	1	Left	Cheek	QPSK	50	50	146AD	1:1	0.159	1.135	0.180	
1732.50	20175	Md	LTE Band 4 (AWS)	20	22.0	21.17	-0.01	0	Left	Tilt	QPSK	1	50	146AD	1:1	0.080	1.211	0.097	
1732.50	20175	Md	LTE Band 4 (AWS)	20	21.0	20.45	0.07	1	Left	Tilt	QPSK	50	50	146AD	1:1	0.071	1.135	0.081	
ANSI / IEEE C95.1 1992 - SAFETY LIMIT Spatial Peak Uncontrolled Exposure/General Population										Head 1.6 W/kg (mW/g) averaged over 1 gram									



**Table 11-9  
LTE Band 2 (PCS) Head SAR**

MEASUREMENT RESULTS																			
FREQUENCY		Mode	Bandwidth [MHz]	Maximum Allowed Power [dBm]	Conducted Power [dBm]	Power Drift [dB]	MPR [dB]	Side	Test Position	Modulation	RB Size	RB Offset	Device Serial Number	Duty Cycle	SAR (1g)	Scaling Factor	Scaled SAR (1g)	Plot #	
MHz	Ch.														(W/kg)		(W/kg)		
1860.00	18700	Low	LTE Band 2 (PCS)	20	22.0	21.73	0.02	0	Right	Cheek	QPSK	1	50	1565F	1:1	0.103	1.064	0.110	
1860.00	18700	Low	LTE Band 2 (PCS)	20	21.0	20.55	0.05	1	Right	Cheek	QPSK	50	0	1565F	1:1	0.074	1.109	0.082	
1860.00	18700	Low	LTE Band 2 (PCS)	20	22.0	21.73	-0.01	0	Right	Tilt	QPSK	1	50	1565F	1:1	0.042	1.064	0.045	
1860.00	18700	Low	LTE Band 2 (PCS)	20	21.0	20.55	-0.01	1	Right	Tilt	QPSK	50	0	1565F	1:1	0.034	1.109	0.038	
1860.00	18700	Low	LTE Band 2 (PCS)	20	22.0	21.73	0.01	0	Left	Cheek	QPSK	1	50	1565F	1:1	0.106	1.064	0.113	A9
1860.00	18700	Low	LTE Band 2 (PCS)	20	21.0	20.55	0.04	1	Left	Cheek	QPSK	50	0	1565F	1:1	0.078	1.109	0.087	
1860.00	18700	Low	LTE Band 2 (PCS)	20	22.0	21.73	0.09	0	Left	Tilt	QPSK	1	50	1565F	1:1	0.050	1.064	0.053	
1860.00	18700	Low	LTE Band 2 (PCS)	20	21.0	20.55	0.09	1	Left	Tilt	QPSK	50	0	1565F	1:1	0.037	1.109	0.041	
ANSI / IEEE C95.1 1992 - SAFETY LIMIT Spatial Peak Uncontrolled Exposure/General Population										Head 1.6 W/kg (mW/g) averaged over 1 gram									

**Table 11-10  
DTS Head SAR**

MEASUREMENT RESULTS																			
FREQUENCY		Mode	Service	Bandwidth [MHz]	Maximum Allowed Power [dBm]	Conducted Power [dBm]	Power Drift [dB]	Side	Test Position	Antenna Config.	Device Serial Number	Data Rate (Mbps)	Duty Cycle (%)	Peak SAR of Area Scan	SAR (1g)	Scaling Factor (Power)	Scaling Factor (Duty Cycle)	Scaled SAR (1g)	Plot #
MHz	Ch.													(W/kg)	(W/kg)		(W/kg)	(W/kg)	
2437	6	802.11b	DSSS	22	17.5	16.92	0.14	Right	Cheek	1	05C58	1	99.44	0.588	0.417	1.143	1.006	0.480	
2437	6	802.11b	DSSS	22	17.5	16.92	0.00	Right	Tilt	1	05C58	1	99.44	0.271	0.198	1.143	1.006	0.227	
2437	6	802.11b	DSSS	22	17.5	16.92	-	Left	Cheek	1	05C58	1	99.44	0.143	-	1.143	1.006	-	
2437	6	802.11b	DSSS	22	17.5	16.92	-	Left	Tilt	1	05C58	1	99.44	0.091	-	1.143	1.006	-	
2412	1	802.11b	DSSS	22	17.5	17.45	-	Right	Cheek	2	05C58	1	99.35	0.316	-	1.012	1.007	-	
2412	1	802.11b	DSSS	22	17.5	17.45	-	Right	Tilt	2	05C58	1	99.35	0.199	-	1.012	1.007	-	
2412	1	802.11b	DSSS	22	17.5	17.45	0.02	Left	Cheek	2	05C58	1	99.35	1.028	0.825	1.012	1.007	0.841	A10
2437	6	802.11b	DSSS	22	17.5	16.67	0.14	Left	Cheek	2	05C58	1	99.35	0.681	0.640	1.211	1.007	0.780	
2412	1	802.11b	DSSS	22	17.5	17.45	0.05	Left	Tilt	2	05C58	1	99.35	0.437	0.366	1.012	1.007	0.373	
2412	1	802.11n	OFDM	20	16.5	16.08	-	Right	Cheek	MIMO	05C58	6.5	98.82	0.201	-	1.102	1.012	-	
2412	1	802.11n	OFDM	20	16.5	16.08	-	Right	Tilt	MIMO	05C58	6.5	98.82	0.089	-	1.102	1.012	-	
2412	1	802.11n	OFDM	20	16.5	16.08	-0.07	Left	Cheek	MIMO	05C58	6.5	98.82	0.432	0.288	1.102	1.012	0.321	
2412	1	802.11n	OFDM	20	16.5	16.08	-	Left	Tilt	MIMO	05C58	6.5	98.82	0.190	-	1.102	1.012	-	
2412	1	802.11b	DSSS	22	17.5	17.45	0.05	Left	Cheek	2	05C58	1	99.35	1.009	0.767	1.012	1.007	0.781	
ANSI / IEEE C95.1 1992 - SAFETY LIMIT Spatial Peak Uncontrolled Exposure/General Population										Head 1.6 W/kg (mW/g) averaged over 1 gram									

Blue entry represents variability measurement.

FCC ID: A3LSMG9201		SAR EVALUATION REPORT		Reviewed by: Quality Manager
Document S/N: 0Y1502060403.A3L	Test Dates: 01/12/15 - 02/11/15	DUT Type: Portable Handset	Page 50 of 72	



**Table 11-11  
NII Head SAR**

MEASUREMENT RESULTS																			
FREQUENCY		Mode	Service	Bandwidth [MHz]	Maximum Allowed Power [dBm]	Conducted Power [dBm]	Power Drift [dB]	Side	Test Position	Antenna Config.	Device Serial Number	Data Rate (Mbps)	Duty Cycle (%)	Peak SAR of Area Scan [W/kg]	SAR (1g) [W/kg]	Scaling Factor (Power)	Scaling Factor (Duty Cycle)	Scaled SAR (1g) [W/kg]	Plot #
MHz	Ch.																		
5260	52	802.11a	OFDM	20	13.5	12.59	-	Right	Cheek	1	05C9A	6	98.95	0.541	-	1.233	1.011	-	-
5260	52	802.11a	OFDM	20	13.5	12.59	0.12	Right	Tilt	1	05C9A	6	98.95	0.644	0.250	1.233	1.011	0.311	A11
5260	52	802.11a	OFDM	20	13.5	12.59	-	Left	Cheek	1	05C9A	6	98.95	0.253	-	1.233	1.011	-	-
5260	52	802.11a	OFDM	20	13.5	12.59	-	Left	Tilt	1	05C9A	6	98.95	0.277	-	1.233	1.011	-	-
5260	52	802.11a	OFDM	20	13.5	13.00	-	Right	Cheek	2	05C9A	6	98.83	0.015	-	1.122	1.012	-	-
5260	52	802.11a	OFDM	20	13.5	13.00	-	Right	Tilt	2	05C9A	6	98.83	0.025	-	1.122	1.012	-	-
5260	52	802.11a	OFDM	20	13.5	13.00	0.13	Left	Cheek	2	05C9A	6	98.83	0.043	0.017	1.122	1.012	0.019	-
5260	52	802.11a	OFDM	20	13.5	13.00	-	Left	Tilt	2	05C9A	6	98.83	0.036	-	1.122	1.012	-	-
5500	100	802.11a	OFDM	20	13.5	12.79	0.15	Right	Cheek	1	05C9A	6	98.95	0.304	0.148	1.178	1.011	0.176	-
5500	100	802.11a	OFDM	20	13.5	12.79	-	Right	Tilt	1	05C9A	6	98.95	0.180	-	1.178	1.011	-	-
5500	100	802.11a	OFDM	20	13.5	12.79	-	Left	Cheek	1	05C9A	6	98.95	0.130	-	1.178	1.011	-	-
5500	100	802.11a	OFDM	20	13.5	12.79	-	Left	Tilt	1	05C9A	6	98.95	0.063	-	1.178	1.011	-	-
5500	100	802.11a	OFDM	20	13.5	12.84	-	Right	Cheek	2	05C9A	6	98.83	0.020	-	1.164	1.012	-	-
5500	100	802.11a	OFDM	20	13.5	12.84	-	Right	Tilt	2	05C9A	6	98.83	0.012	-	1.164	1.012	-	-
5500	100	802.11a	OFDM	20	13.5	12.84	-	Left	Cheek	2	05C9A	6	98.83	0.041	-	1.164	1.012	-	-
5500	100	802.11a	OFDM	20	13.5	12.84	0.14	Left	Tilt	2	05C9A	6	98.83	0.046	0.022	1.164	1.012	0.026	-
5660	132	802.11a	OFDM	20	13.5	12.86	0.17	Right	Cheek	1	05C9A	6	98.95	0.190	0.076	1.159	1.011	0.089	-
5660	132	802.11a	OFDM	20	13.5	12.86	-	Right	Tilt	1	05C9A	6	98.95	0.121	-	1.159	1.011	-	-
5660	132	802.11a	OFDM	20	13.5	12.86	-	Left	Cheek	1	05C9A	6	98.95	0.094	-	1.159	1.011	-	-
5660	132	802.11a	OFDM	20	13.5	12.86	-	Left	Tilt	1	05C9A	6	98.95	0.061	-	1.159	1.011	-	-
5660	132	802.11a	OFDM	20	13.5	12.82	-	Right	Cheek	2	05C9A	6	98.83	0.051	-	1.169	1.012	-	-
5660	132	802.11a	OFDM	20	13.5	12.82	-	Right	Tilt	2	05C9A	6	98.83	0.046	-	1.169	1.012	-	-
5660	132	802.11a	OFDM	20	13.5	12.82	0.01	Left	Cheek	2	05C9A	6	98.83	0.075	0.028	1.169	1.012	0.033	-
5660	132	802.11a	OFDM	20	13.5	12.82	-	Left	Tilt	2	05C9A	6	98.83	0.048	-	1.169	1.012	-	-
ANSI / IEEE C95.1 1992 - SAFETY LIMIT Spatial Peak Uncontrolled Exposure/General Population									Head 1.6 W/kg (mW/g) averaged over 1 gram										

## 11.2 Standalone Body-Worn SAR Data

**Table 11-12  
GSM/UMTS Body-Worn SAR Data**

MEASUREMENT RESULTS															
FREQUENCY		Mode	Service	Maximum Allowed Power [dBm]	Conducted Power [dBm]	Power Drift [dB]	Spacing	Device Serial Number	# of Time Slots	Duty Cycle	Side	SAR (1g) [W/kg]	Scaling Factor	Scaled SAR (1g) [W/kg]	Plot #
MHz	Ch.														
836.60	190	GSM 850	GSM	33.0	32.46	0.01	10 mm	146D0	1	1:8.3	back	0.290	1.132	0.328	A12
836.60	4183	UMTS 850	RMC	24.5	24.33	-0.01	10 mm	1565F	N/A	1:1	back	0.454	1.040	0.472	A14
1732.40	1412	UMTS 1750	RMC	23.0	22.43	0.00	10 mm	1565F	N/A	1:1	back	0.480	1.140	0.547	A15
1880.00	661	GSM 1900	GSM	30.0	29.93	0.02	10 mm	146D0	1	1:8.3	back	0.390	1.016	0.396	A17
1880.00	9400	UMTS 1900	RMC	22.5	22.03	0.01	10 mm	1565F	N/A	1:1	back	0.684	1.114	0.762	A19
ANSI / IEEE C95.1 1992 - SAFETY LIMIT Spatial Peak Uncontrolled Exposure/General Population									Body 1.6 W/kg (mW/g) averaged over 1 gram						

FCC ID: A3LSMG9201		SAR EVALUATION REPORT		Reviewed by: Quality Manager
Document S/N: 0Y1502060403.A3L	Test Dates: 01/12/15 - 02/11/15	DUT Type: Portable Handset	Page 51 of 72	

**Table 11-13  
LTE Body-Worn SAR**

MEASUREMENT RESULTS																			
FREQUENCY		Mode	Bandwidth [MHz]	Maximum Allowed Power [dBm]	Conducted Power [dBm]	Power Drift [dB]	MPR [dB]	Device Serial Number	Modulation	RB Size	RB Offset	Spacing	Side	Duty Cycle	SAR (1g) (W/kg)	Scaling Factor	Scaled SAR (1g) (W/kg)	Plot #	
MHz	Ch.																		
707.50	23095	Mid	LTE Band 12	10	24.5	24.06	-0.02	0	1565F	QPSK	1	49	10 mm	back	1:1	0.283	1.107	0.313	A21
707.50	23095	Mid	LTE Band 12	10	23.5	22.84	0.01	1	1565F	QPSK	25	25	10 mm	back	1:1	0.200	1.164	0.233	
836.50	26915	Mid	LTE Band 26	15	24.5	23.97	-0.03	0	146AD	QPSK	1	36	10 mm	back	1:1	0.336	1.130	0.380	A22
836.50	26915	Mid	LTE Band 26	15	23.5	23.04	0.01	1	146AD	QPSK	36	18	10 mm	back	1:1	0.289	1.112	0.321	
1732.50	20175	Mid	LTE Band 4 (AWS)	20	22.0	21.17	-0.05	0	146AD	QPSK	1	50	10 mm	back	1:1	0.602	1.211	0.729	A24
1732.50	20175	Mid	LTE Band 4 (AWS)	20	21.0	20.45	-0.16	1	146AD	QPSK	50	50	10 mm	back	1:1	0.505	1.135	0.573	
1860.00	18700	Low	LTE Band 2 (PCS)	20	22.0	21.73	0.09	0	1565F	QPSK	1	50	10 mm	back	1:1	0.560	1.064	0.596	A26
1860.00	18700	Low	LTE Band 2 (PCS)	20	21.0	20.55	0.04	1	1565F	QPSK	50	0	10 mm	back	1:1	0.445	1.109	0.494	
ANSI / IEEE C95.1 1992 - SAFETY LIMIT Spatial Peak Uncontrolled Exposure/General Population												Body 1.6 W/kg (mW/g) averaged over 1 gram							

**Table 11-14  
DTS Body-Worn SAR**



MEASUREMENT RESULTS																			
FREQUENCY		Mode	Service	Bandwidth [MHz]	Maximum Allowed Power [dBm]	Conducted Power [dBm]	Power Drift [dB]	Spacing	Antenna Config.	Device Serial Number	Data Rate (Mbps)	Side	Duty Cycle (%)	Peak SAR of Area Scan (W/kg)	SAR (1g) (W/kg)	Scaling Factor (Power)	Scaling Factor (Duty Cycle)	Scaled SAR (1g) (W/kg)	Plot #
MHz	Ch.																		
2437	6	802.11b	DSSS	22	17.5	16.92	0.04	10 mm	1	066BE	1	back	99.44	0.029	0.023	1.143	1.006	0.026	
2412	1	802.11b	DSSS	22	17.5	17.45	0.13	10 mm	2	066BE	1	back	99.35	0.051	0.044	1.012	1.007	0.045	A28
ANSI / IEEE C95.1 1992 - SAFETY LIMIT Spatial Peak Uncontrolled Exposure/General Population												Body 1.6 W/kg (mW/g) averaged over 1 gram							

**Table 11-15  
DSS Body-Worn SAR**

MEASUREMENT RESULTS																	
FREQUENCY		Mode	Service	Maximum Allowed Power [dBm]	Conducted Power [dBm]	Power Drift [dB]	Spacing	Device Serial Number	Data Rate (Mbps)	Side	Duty Cycle	SAR (1g) (W/kg)	Scaling Factor	Scaled SAR (1g) (W/kg)	Plot #		
MHz	Ch.																
2441	39	Bluetooth	FHSS	13.0	12.59	0.14	10 mm	066BE	1	back	1:1	0.002	1.099	0.002	A30		
ANSI / IEEE C95.1 1992 - SAFETY LIMIT Spatial Peak Uncontrolled Exposure/General Population												Body 1.6 W/kg (mW/g) averaged over 1 gram					

**Table 11-16  
NII Body-Worn SAR**

MEASUREMENT RESULTS																			
FREQUENCY		Mode	Service	Bandwidth [MHz]	Maximum Allowed Power [dBm]	Conducted Power [dBm]	Power Drift [dB]	Spacing	Antenna Config.	Device Serial Number	Data Rate (Mbps)	Side	Duty Cycle	Peak SAR of Area Scan (W/kg)	SAR (1g) (W/kg)	Scaling Factor (Power)	Scaling Factor (Duty Cycle)	Scaled SAR (1g) (W/kg)	Plot #
MHz	Ch.																		
5260	52	802.11a	OFDM	20	13.5	12.59	0.12	10 mm	1	066BE	6	back	98.95	0.096	0.044	1.233	1.011	0.055	A31
5260	52	802.11a	OFDM	20	13.5	13.00	0.15	10 mm	2	066BE	6	back	98.83	0.076	0.028	1.122	1.012	0.031	
5500	100	802.11a	OFDM	20	13.5	12.79	0.11	10 mm	1	066BE	6	back	98.95	0.025	0.009	1.178	1.011	0.011	
5500	100	802.11a	OFDM	20	13.5	12.84	0.18	10 mm	2	066BE	6	back	98.83	0.022	0.007	1.164	1.012	0.008	
5660	132	802.11a	OFDM	20	13.5	12.86	0.12	10 mm	1	066BE	6	back	98.95	0.024	0.011	1.159	1.011	0.013	
5660	132	802.11a	OFDM	20	13.5	12.82	0.11	10 mm	2	066BE	6	back	98.83	0.011	0.000	1.169	1.012	0.000	
ANSI / IEEE C95.1 1992 - SAFETY LIMIT Spatial Peak Uncontrolled Exposure/General Population												Body 1.6 W/kg (mW/g) averaged over 1 gram							



FCC ID: A3LSMG9201	 PCTEST <small>ENGINEERING LABORATORY, INC.</small>	<b>SAR EVALUATION REPORT</b>	 SAMSUNG	Reviewed by: Quality Manager
Document S/N: 0Y1502060403.A3L	Test Dates: 01/12/15 - 02/11/15	DUT Type: Portable Handset	Page 52 of 72	

## 11.3 Standalone Wireless Router SAR Data

Table 11-17  
GPRS/UMTS Hotspot SAR Data

MEASUREMENT RESULTS															
FREQUENCY		Mode	Service	Maximum Allowed Power [dBm]	Conducted Power [dBm]	Power Drift [dB]	Spacing	Device Serial Number	# of GPRS Slots	Duty Cycle	Side	SAR (1g)	Scaling Factor	Scaled SAR (1g)	Plot #
MHz	Ch.											(W/kg)		(W/kg)	
836.60	190	GSM 850	GPRS	32.0	31.60	-0.02	10 mm	146D0	2	1:4.15	back	0.447	1.096	0.490	
836.60	190	GSM 850	GPRS	32.0	31.60	-0.02	10 mm	146D0	2	1:4.15	front	0.417	1.096	0.457	
836.60	190	GSM 850	GPRS	32.0	31.60	0.06	10 mm	146D0	2	1:4.15	bottom	0.168	1.096	0.184	
836.60	190	GSM 850	GPRS	32.0	31.60	-0.03	10 mm	146D0	2	1:4.15	right	0.441	1.096	0.483	
836.60	190	GSM 850	GPRS	32.0	31.60	-0.06	10 mm	146D0	2	1:4.15	left	0.472	1.096	0.517	A13
836.60	4183	UMTS 850	RMC	24.5	24.33	-0.01	10 mm	1565F	N/A	1:1	back	0.454	1.040	0.472	A14
836.60	4183	UMTS 850	RMC	24.5	24.33	0.01	10 mm	1565F	N/A	1:1	front	0.422	1.040	0.439	
836.60	4183	UMTS 850	RMC	24.5	24.33	-0.04	10 mm	1565F	N/A	1:1	bottom	0.150	1.040	0.156	
836.60	4183	UMTS 850	RMC	24.5	24.33	-0.02	10 mm	1565F	N/A	1:1	right	0.413	1.040	0.430	
836.60	4183	UMTS 850	RMC	24.5	24.33	-0.01	10 mm	1565F	N/A	1:1	left	0.426	1.040	0.443	
1732.40	1412	UMTS 1750	RMC	23.0	22.43	0.00	10 mm	1565F	N/A	1:1	back	0.480	1.140	0.547	
1732.40	1412	UMTS 1750	RMC	23.0	22.43	0.06	10 mm	1565F	N/A	1:1	front	0.560	1.140	0.638	
1712.40	1312	UMTS 1750	RMC	23.0	22.54	0.04	10 mm	1565F	N/A	1:1	bottom	0.909	1.112	1.011	
1732.40	1412	UMTS 1750	RMC	23.0	22.43	0.03	10 mm	1565F	N/A	1:1	bottom	0.822	1.140	0.937	
1752.50	1862	UMTS 1750	RMC	23.0	22.35	0.07	10 mm	1565F	N/A	1:1	bottom	0.715	1.161	0.830	
1732.40	1412	UMTS 1750	RMC	23.0	22.43	0.03	10 mm	1565F	N/A	1:1	right	0.054	1.140	0.062	
1732.40	1412	UMTS 1750	RMC	23.0	22.43	0.06	10 mm	1565F	N/A	1:1	left	0.301	1.140	0.343	
1712.40	1312	UMTS 1750	RMC	23.0	22.54	0.03	10 mm	1565F	N/A	1:1	bottom	0.911	1.112	1.013	A16
1880.00	661	GSM 1900	GPRS	29.0	28.95	-0.05	10 mm	146D0	2	1:4.15	back	0.589	1.012	0.596	
1880.00	661	GSM 1900	GPRS	29.0	28.95	-0.11	10 mm	146D0	2	1:4.15	front	0.543	1.012	0.550	
1850.20	512	GSM 1900	GPRS	29.0	28.83	-0.11	10 mm	146D0	2	1:4.15	bottom	0.907	1.040	0.943	A18
1880.00	661	GSM 1900	GPRS	29.0	28.95	-0.06	10 mm	146D0	2	1:4.15	bottom	0.832	1.012	0.842	
1909.80	810	GSM 1900	GPRS	29.0	28.98	-0.09	10 mm	146D0	2	1:4.15	bottom	0.675	1.005	0.678	
1880.00	661	GSM 1900	GPRS	29.0	28.95	0.12	10 mm	146D0	2	1:4.15	right	0.039	1.012	0.039	
1880.00	661	GSM 1900	GPRS	29.0	28.95	0.03	10 mm	146D0	2	1:4.15	left	0.185	1.012	0.187	
1850.20	512	GSM 1900	GPRS	29.0	28.83	-0.06	10 mm	146D0	2	1:4.15	bottom	0.882	1.040	0.917	
1880.00	9400	UMTS 1900	RMC	22.5	22.03	0.01	10 mm	1565F	N/A	1:1	back	0.684	1.114	0.762	
1880.00	9400	UMTS 1900	RMC	22.5	22.03	-0.04	10 mm	1565F	N/A	1:1	front	0.635	1.114	0.707	
1852.40	9262	UMTS 1900	RMC	22.5	22.09	-0.01	10 mm	1565F	N/A	1:1	bottom	0.905	1.099	0.995	A20
1880.00	9400	UMTS 1900	RMC	22.5	22.03	-0.03	10 mm	1565F	N/A	1:1	bottom	0.889	1.114	0.990	
1907.60	9538	UMTS 1900	RMC	22.5	22.00	-0.02	10 mm	1565F	N/A	1:1	bottom	0.838	1.122	0.940	
1880.00	9400	UMTS 1900	RMC	22.5	22.03	0.13	10 mm	1565F	N/A	1:1	right	0.057	1.114	0.063	
1880.00	9400	UMTS 1900	RMC	22.5	22.03	0.08	10 mm	1565F	N/A	1:1	left	0.226	1.114	0.252	
ANSI / IEEE C95.1 1992 - SAFETY LIMIT Spatial Peak Uncontrolled Exposure/General Population							Body 1.6 W/kg (mW/g) averaged over 1 gram								

Blue entry represents variability measurement.

FCC ID: A3LSMG920I	 <b>SAR EVALUATION REPORT</b>			Reviewed by: Quality Manager
Document S/N: 0Y1502060403.A3L	Test Dates: 01/12/15 - 02/11/15	DUT Type: Portable Handset		Page 53 of 72

**Table 11-18  
LTE Band 12 Hotspot SAR**



MEASUREMENT RESULTS																			
FREQUENCY		Mode	Bandwidth [MHz]	Maximum Allowed Power [dBm]	Conducted Power [dBm]	Power Drift [dB]	MPR [dB]	Device Serial Number	Modulation	RB Size	RB Offset	Spacing	Side	Duty Cycle	SAR (1g) (W/kg)	Scaling Factor	Scaled SAR (1g) (W/kg)	Plot #	
MHz	Ch.																		
707.50	23095	Mid	LTE Band 12	10	24.5	24.06	-0.02	0	1565F	QPSK	1	49	10 mm	back	1:1	0.283	1.107	0.313	A21
707.50	23095	Mid	LTE Band 12	10	23.5	22.84	0.01	1	1565F	QPSK	25	25	10 mm	back	1:1	0.199	1.164	0.232	
707.50	23095	Mid	LTE Band 12	10	24.5	24.06	0.08	0	1565F	QPSK	1	49	10 mm	front	1:1	0.260	1.107	0.288	
707.50	23095	Mid	LTE Band 12	10	23.5	22.84	-0.06	1	1565F	QPSK	25	25	10 mm	front	1:1	0.181	1.164	0.211	
707.50	23095	Mid	LTE Band 12	10	24.5	24.06	-0.16	0	1565F	QPSK	1	49	10 mm	bottom	1:1	0.055	1.107	0.061	
707.50	23095	Mid	LTE Band 12	10	23.5	22.84	0.02	1	1565F	QPSK	25	25	10 mm	bottom	1:1	0.035	1.164	0.041	
707.50	23095	Mid	LTE Band 12	10	24.5	24.06	-0.01	0	1565F	QPSK	1	49	10 mm	right	1:1	0.132	1.107	0.146	
707.50	23095	Mid	LTE Band 12	10	23.5	22.84	-0.08	1	1565F	QPSK	25	25	10 mm	right	1:1	0.081	1.164	0.094	
707.50	23095	Mid	LTE Band 12	10	24.5	24.06	-0.11	0	1565F	QPSK	1	49	10 mm	left	1:1	0.151	1.107	0.167	
707.50	23095	Mid	LTE Band 12	10	23.5	22.84	-0.03	1	1565F	QPSK	25	25	10 mm	left	1:1	0.080	1.164	0.093	
ANSI / IEEE C95.1 1992 - SAFETY LIMIT Spatial Peak Uncontrolled Exposure/General Population								Body 1.6 W/kg (mW/g) averaged over 1 gram											

**Table 11-19  
LTE Band 26 Hotspot SAR**

MEASUREMENT RESULTS																			
FREQUENCY		Mode	Bandwidth [MHz]	Maximum Allowed Power [dBm]	Conducted Power [dBm]	Power Drift [dB]	MPR [dB]	Device Serial Number	Modulation	RB Size	RB Offset	Spacing	Side	Duty Cycle	SAR (1g) (W/kg)	Scaling Factor	Scaled SAR (1g) (W/kg)	Plot #	
MHz	Ch.																		
836.50	26915	Mid	LTE Band 26	15	24.5	23.97	-0.03	0	146AD	QPSK	1	36	10 mm	back	1:1	0.336	1.130	0.380	
836.50	26915	Mid	LTE Band 26	15	23.5	23.04	0.01	1	146AD	QPSK	36	18	10 mm	back	1:1	0.289	1.112	0.321	
836.50	26915	Mid	LTE Band 26	15	24.5	23.97	0.03	0	146AD	QPSK	1	36	10 mm	front	1:1	0.325	1.130	0.367	
836.50	26915	Mid	LTE Band 26	15	23.5	23.04	0.00	1	146AD	QPSK	36	18	10 mm	front	1:1	0.278	1.112	0.309	
836.50	26915	Mid	LTE Band 26	15	24.5	23.97	-0.07	0	146AD	QPSK	1	36	10 mm	bottom	1:1	0.119	1.130	0.134	
836.50	26915	Mid	LTE Band 26	15	23.5	23.04	-0.05	1	146AD	QPSK	36	18	10 mm	bottom	1:1	0.102	1.112	0.113	
836.50	26915	Mid	LTE Band 26	15	24.5	23.97	0.09	0	146AD	QPSK	1	36	10 mm	right	1:1	0.359	1.130	0.406	
836.50	26915	Mid	LTE Band 26	15	23.5	23.04	0.00	1	146AD	QPSK	36	18	10 mm	right	1:1	0.310	1.112	0.345	
836.50	26915	Mid	LTE Band 26	15	24.5	23.97	-0.11	0	146AD	QPSK	1	36	10 mm	left	1:1	0.401	1.130	0.453	A23
836.50	26915	Mid	LTE Band 26	15	23.5	23.04	0.11	1	146AD	QPSK	36	18	10 mm	left	1:1	0.313	1.112	0.348	
ANSI / IEEE C95.1 1992 - SAFETY LIMIT Spatial Peak Uncontrolled Exposure/General Population								Body 1.6 W/kg (mW/g) averaged over 1 gram											

**Table 11-20  
LTE Band 4 (AWS) Hotspot SAR**

MEASUREMENT RESULTS																			
FREQUENCY		Mode	Bandwidth [MHz]	Maximum Allowed Power [dBm]	Conducted Power [dBm]	Power Drift [dB]	MPR [dB]	Device Serial Number	Modulation	RB Size	RB Offset	Spacing	Side	Duty Cycle	SAR (1g) (W/kg)	Scaling Factor	Scaled SAR (1g) (W/kg)	Plot #	
MHz	Ch.																		
1732.50	20175	Mid	LTE Band 4 (AWS)	20	22.0	21.17	-0.05	0	146AD	QPSK	1	50	10 mm	back	1:1	0.602	1.211	0.729	
1732.50	20175	Mid	LTE Band 4 (AWS)	20	21.0	20.45	-0.16	1	146AD	QPSK	50	50	10 mm	back	1:1	0.505	1.135	0.573	
1732.50	20175	Mid	LTE Band 4 (AWS)	20	22.0	21.17	0.01	0	146AD	QPSK	1	50	10 mm	front	1:1	0.634	1.211	0.768	
1732.50	20175	Mid	LTE Band 4 (AWS)	20	21.0	20.45	-0.06	1	146AD	QPSK	50	50	10 mm	front	1:1	0.543	1.135	0.616	
1732.50	20175	Mid	LTE Band 4 (AWS)	20	22.0	21.17	0.08	0	146AD	QPSK	1	50	10 mm	bottom	1:1	0.867	1.211	1.050	A25
1732.50	20175	Mid	LTE Band 4 (AWS)	20	21.0	20.45	-0.01	1	146AD	QPSK	50	50	10 mm	bottom	1:1	0.756	1.135	0.858	
1732.50	20175	Mid	LTE Band 4 (AWS)	20	21.0	20.37	-0.11	1	146AD	QPSK	100	0	10 mm	bottom	1:1	0.751	1.156	0.868	
1732.50	20175	Mid	LTE Band 4 (AWS)	20	22.0	21.17	-0.03	0	146AD	QPSK	1	50	10 mm	right	1:1	0.039	1.211	0.047	
1732.50	20175	Mid	LTE Band 4 (AWS)	20	21.0	20.45	-0.07	1	146AD	QPSK	50	50	10 mm	right	1:1	0.034	1.135	0.039	
1732.50	20175	Mid	LTE Band 4 (AWS)	20	22.0	21.17	-0.02	0	146AD	QPSK	1	50	10 mm	left	1:1	0.219	1.211	0.265	
1732.50	20175	Mid	LTE Band 4 (AWS)	20	21.0	20.45	-0.01	1	146AD	QPSK	50	50	10 mm	left	1:1	0.191	1.135	0.217	
ANSI / IEEE C95.1 1992 - SAFETY LIMIT Spatial Peak Uncontrolled Exposure/General Population								Body 1.6 W/kg (mW/g) averaged over 1 gram											



FCC ID: A3LSMG9201		SAR EVALUATION REPORT		Reviewed by: Quality Manager
Document S/N: 0Y1502060403.A3L	Test Dates: 01/12/15 - 02/11/15	DUT Type: Portable Handset		Page 54 of 72

**Table 11-21  
LTE Band 2 (PCS) Hotspot SAR**

MEASUREMENT RESULTS																			
FREQUENCY		Mode	Bandwidth [MHz]	Maximum Allowed Power [dBm]	Conducted Power [dBm]	Power Drift [dB]	MPR [dB]	Device Serial Number	Modulation	RB Size	RB Offset	Spacing	Side	Duty Cycle	SAR (1g) (W/kg)	Scaling Factor	Scaled SAR (1g) (W/kg)	Plot #	
MHz	Ch.																		
1860.00	18700	Low	LTE Band 2 (PCS)	20	22.0	21.73	0.09	0	1565F	QPSK	1	50	10 mm	back	1:1	0.560	1.064	0.596	
1860.00	18700	Low	LTE Band 2 (PCS)	20	21.0	20.55	0.04	1	1565F	QPSK	50	0	10 mm	back	1:1	0.445	1.109	0.494	
1860.00	18700	Low	LTE Band 2 (PCS)	20	22.0	21.73	-0.03	0	1565F	QPSK	1	50	10 mm	front	1:1	0.571	1.064	0.608	
1860.00	18700	Low	LTE Band 2 (PCS)	20	21.0	20.55	0.01	1	1565F	QPSK	50	0	10 mm	front	1:1	0.443	1.109	0.491	
1860.00	18700	Low	LTE Band 2 (PCS)	20	22.0	21.73	0.02	0	1565F	QPSK	1	50	10 mm	bottom	1:1	0.767	1.064	0.816	
1880.00	18900	Mid	LTE Band 2 (PCS)	20	22.0	21.52	0.00	0	1565F	QPSK	1	0	10 mm	bottom	1:1	0.851	1.117	0.951	A27
1900.00	19100	High	LTE Band 2 (PCS)	20	22.0	21.49	-0.04	0	1565F	QPSK	1	99	10 mm	bottom	1:1	0.779	1.125	0.876	
1860.00	18700	Low	LTE Band 2 (PCS)	20	21.0	20.55	-0.09	1	1565F	QPSK	50	0	10 mm	bottom	1:1	0.631	1.109	0.700	
1860.00	18700	Low	LTE Band 2 (PCS)	20	21.0	20.43	0.04	1	1565F	QPSK	100	0	10 mm	bottom	1:1	0.616	1.140	0.702	
1860.00	18700	Low	LTE Band 2 (PCS)	20	22.0	21.73	0.10	0	1565F	QPSK	1	50	10 mm	right	1:1	0.051	1.064	0.054	
1860.00	18700	Low	LTE Band 2 (PCS)	20	21.0	20.55	0.06	1	1565F	QPSK	50	0	10 mm	right	1:1	0.036	1.109	0.040	
1860.00	18700	Low	LTE Band 2 (PCS)	20	22.0	21.73	0.15	0	1565F	QPSK	1	50	10 mm	left	1:1	0.195	1.064	0.207	
1860.00	18700	Low	LTE Band 2 (PCS)	20	21.0	20.55	0.04	1	1565F	QPSK	50	0	10 mm	left	1:1	0.151	1.109	0.167	
ANSI / IEEE C95.1 1992 - SAFETY LIMIT Spatial Peak Uncontrolled Exposure/General Population								Body 1.6 W/kg (mW/g) averaged over 1 gram											

**Table 11-22  
WLAN Hotspot SAR**

MEASUREMENT RESULTS																			
FREQUENCY		Mode	Service	Bandwidth [MHz]	Maximum Allowed Power [dBm]	Conducted Power [dBm]	Power Drift [dB]	Spacing	Antenna Config.	Device Serial Number	Data Rate (Mbps)	Side	Duty Cycle (%)	Peak SAR of Area Scan (W/kg)	SAR (1g) (W/kg)	Scaling Factor (Power)	Scaling Factor (Duty Cycle)	Scaled SAR (1g) (W/kg)	Plot #
MHz	Ch.																		
2437	6	802.11b	DSSS	22	17.5	16.92	0.04	10 mm	1	066BE	1	back	99.44	0.029	0.023	1.143	1.006	0.026	
2437	6	802.11b	DSSS	22	17.5	16.92	-	10 mm	1	066BE	1	front	99.44	0.025	-	1.143	1.006	-	
2437	6	802.11b	DSSS	22	17.5	16.92	-	10 mm	1	066BE	1	top	99.44	0.017	-	1.143	1.006	-	
2437	6	802.11b	DSSS	22	17.5	16.92	-	10 mm	1	066BE	1	left	99.44	0.018	-	1.143	1.006	-	
2412	1	802.11b	DSSS	22	17.5	17.45	-	10 mm	2	066BE	1	back	99.35	0.051	-	1.012	1.007	-	
2412	1	802.11b	DSSS	22	17.5	17.45	0.18	10 mm	2	066BE	1	front	99.35	0.056	0.054	1.012	1.007	0.055	A29
2412	1	802.11b	DSSS	22	17.5	17.45	-	10 mm	2	066BE	1	top	99.35	0.006	-	1.012	1.007	-	
2412	1	802.11b	DSSS	22	17.5	17.45	-	10 mm	2	066BE	1	right	99.35	0.012	-	1.012	1.007	-	
5825	165	802.11a	OFDM	20	13.5	12.75	-	10 mm	1	066BE	6	back	98.95	0.023	-	1.189	1.011	-	
5825	165	802.11a	OFDM	20	13.5	12.75	0.20	10 mm	1	066BE	6	front	98.95	0.029	0.002	1.189	1.011	0.002	A32
5825	165	802.11a	OFDM	20	13.5	12.75	-	10 mm	1	066BE	6	top	98.95	0.005	-	1.189	1.011	-	
5825	165	802.11a	OFDM	20	13.5	12.75	-	10 mm	1	066BE	6	left	98.95	0.011	-	1.189	1.011	-	
5745	149	802.11a	OFDM	20	13.5	12.58	-	10 mm	2	066BE	6	back	98.83	0.019	-	1.236	1.012	-	
5745	149	802.11a	OFDM	20	13.5	12.58	0.16	10 mm	2	066BE	6	front	98.83	0.036	0.001	1.236	1.012	0.001	
5745	149	802.11a	OFDM	20	13.5	12.58	-	10 mm	2	066BE	6	top	98.83	0.011	-	1.236	1.012	-	
5745	149	802.11a	OFDM	20	13.5	12.58	-	10 mm	2	066BE	6	right	98.83	0.008	-	1.236	1.012	-	
ANSI / IEEE C95.1 1992 - SAFETY LIMIT Spatial Peak Uncontrolled Exposure/General Population								Body 1.6 W/kg (mW/g) averaged over 1 gram											

FCC ID: A3LSMG920I		SAR EVALUATION REPORT		Reviewed by: Quality Manager
Document S/N: 0Y1502060403.A3L	Test Dates: 01/12/15 - 02/11/15	DUT Type: Portable Handset	Page 55 of 72	

## 11.4 SAR Test Notes

### General Notes:



1. The test data reported are the worst-case SAR values according to test procedures specified in IEEE 1528-2003, and FCC KDB Publication 447498 D01v05.
2. Batteries are fully charged at the beginning of the SAR measurements.
3. Liquid tissue depth was at least 15.0 cm for all frequencies.
4. The manufacturer has confirmed that the device(s) tested have the same physical, mechanical and thermal characteristics and are within operational tolerances expected for production units.
5. SAR results were scaled to the maximum allowed power to demonstrate compliance per FCC KDB Publication 447498 D01v05.
6. Device was tested using a fixed spacing for body-worn accessory testing. A separation distance of 10 mm was considered because the manufacturer has determined that there will be body-worn accessories available in the marketplace for users to support this separation distance.
7. Per FCC KDB Publication 648474 D04v01, body-worn SAR was evaluated without a headset connected to the device. Since the standalone reported body-worn SAR was  $\leq 1.2$  W/kg, no additional body-worn SAR evaluations using a headset cable were required.
8. Per FCC KDB 865664 D01 v01, variability SAR tests were performed when the measured SAR results for a frequency band were greater than 0.8 W/kg. Repeated SAR measurements are highlighted in the tables above for clarity. Please see Section 13 for variability analysis.
9. During SAR Testing for the Wireless Router conditions per FCC KDB Publication 941225 D06, the actual Portable Hotspot operation (with actual simultaneous transmission of a transmitter with WIFI) was not activated (See Section 6.7 for more details).

### GSM Test Notes:

1. Body-Worn accessory testing is typically associated with voice operations. Therefore, GSM voice was evaluated for body-worn SAR.
2. Justification for reduced test configurations per KDB Publication 941225 D01 and October 2013 TCB Workshop Notes: The source-based frame-averaged output power was evaluated for all GPRS/EDGE slot configurations. The configuration with the highest target frame averaged output power was evaluated for hotspot SAR. When the maximum frame-averaged powers are equivalent across two or more slots (within 0.25 dB), the configuration with the most number of time slots was tested.
3. Per FCC KDB Publication 447498 D01v05, if the reported (scaled) SAR measured at the middle channel or highest output power channel for each test configuration is  $\leq 0.8$  W/kg then testing at the other channels is not required for such test configuration(s). When the maximum output power variation across the required test channels is  $> \frac{1}{2}$  dB, instead of the middle channel, the highest output power channel was used.

### UMTS Notes:

1. UMTS mode was tested under RMC 12.2 kbps with HSPA Inactive per KDB Publication 941225 D01. SAR tests for HSPA and AMR were not required per 3G Test Reduction Procedures.
2. Per FCC KDB Publication 447498 D01v05, if the reported (scaled) SAR measured at the middle channel or highest output power channel for each test configuration is  $\leq 0.8$  W/kg then testing at the other channels is not required for such test configuration(s). When the maximum output power variation across the required test channels is  $> \frac{1}{2}$  dB, instead of the middle channel, the highest output power channel was used.



FCC ID: A3LSMG920I	 <b>PCTEST</b> ENGINEERING LABORATORY, INC.	<b>SAR EVALUATION REPORT</b>		<b>Reviewed by:</b> Quality Manager
<b>Document S/N:</b> 0Y1502060403.A3L	<b>Test Dates:</b> 01/12/15 - 02/11/15	<b>DUT Type:</b> Portable Handset	Page 56 of 72	

LTE Notes:

1. LTE Considerations: LTE test configurations are determined according to SAR Evaluation Considerations for LTE Devices in FCC KDB Publication 941225 D05. The general test procedures used for testing can be found in Section 8.5.4.
2. MPR is permanently implemented for this device by the manufacturer. The specific manufacturer target MPR is indicated alongside the SAR results. MPR is enabled for this device, according to 3GPP TS36.101 Section 6.2.3 – 6.2.5 under Table 6.2.3-1.
3. A-MPR was disabled for all SAR tests by setting NS=01 on the base station simulator. SAR tests were performed with the same number of RB and RB offsets transmitting on all TTI frames (maximum TTI).

WLAN Notes:

1. For held-to-ear and hotspot operations, the initial test position procedures were applied. The test position with the highest extrapolated peak SAR will be used as the initial test position. When reported SAR for the initial test position is  $\leq 0.4$  W/kg, no additional testing for the remaining test positions is required. Otherwise, SAR is evaluated at the subsequent highest peak SAR positions until the reported SAR result is  $\leq 0.8$  W/kg or all test positions are measured.
2. Justification for test configurations for WLAN per KDB Publication 248227 D01DR02-41929 for 2.4 GHz WIFI single transmission chain operations, the highest measured maximum output power channel for DSSS was selected for SAR measurement. SAR for OFDM modes (2.4 GHz 802.11g/n) was not required due to the maximum allowed powers and the highest reported DSSS SAR. See Section 8.6.5 for more information.
3. Justification for test configurations for WLAN per KDB Publication 248227 D01DR02-41929 for 5 GHz WIFI single transmission chain operations, the initial test configuration was selected according to the transmission mode with the highest maximum allowed powers. Other transmission modes were not investigated since the highest reported SAR for initial test configuration adjusted by the ratio of maximum output powers is less than 1.2 W/kg. See Section 8.6.6 for more information.
4. Per KDB Publication 248227 D01DR02-41929, MIMO SAR was measured with both antennas transmitting simultaneously at the specified maximum output power in MIMO mode following the initial test configuration procedures for 2.4 GHz head SAR. Per KDB Publication 248227 D01DR02-41929, SAR for MIMO for all other bands and exposure conditions was evaluated by following the simultaneous SAR provisions from KDB Publication 447498. Please see Section 12 for complete analysis.
5. When the maximum reported 1g averaged SAR is  $\leq 0.8$  W/kg, SAR testing on additional channels was not required. Otherwise, SAR for the next highest output power channel was required until the reported SAR result was  $\leq 1.20$  W/kg or all test channels were measured.
6. The device was configured to transmit continuously at the required data rate, channel bandwidth and signal modulation, using the highest transmission duty factor supported by the test mode tools. The reported SAR was scaled to the 100% transmission duty factor to determine compliance. Procedures used to measure the duty factor are identical to that in the associated EMC test reports.
7. Only channels in the U-NII-2C ( $> 5.65$  GHz WIFI) & U-NII-3 aggregate band that support wireless router were considered for hotspot SAR tests.

FCC ID: A3LSMG920I	 <b>PCTEST</b> <small>ENGINEERING LABORATORY, INC.</small>	<b>SAR EVALUATION REPORT</b>	 <b>Reviewed by:</b> Quality Manager
Document S/N: 0Y1502060403.A3L	Test Dates: 01/12/15 - 02/11/15	DUT Type: Portable Handset	Page 57 of 72

## 12 FCC MULTI-TX AND ANTENNA SAR CONSIDERATIONS

### 12.1 Introduction

The following procedures adopted from FCC KDB Publication 447498 D01v05r02 are applicable to devices with built-in unlicensed transmitters such as 802.11a/b/g/n/ac and Bluetooth devices which may simultaneously transmit with the licensed transmitter.

### 12.2 Simultaneous Transmission Procedures

This device contains transmitters that may operate simultaneously. Therefore simultaneous transmission analysis is required. Per FCC KDB 447498 D01v05 IV.C.1.iii and IEEE 1528-2013 Section 6.3.4.1.2, simultaneous transmission SAR test exclusion may be applied when the sum of the 1-g SAR for all the simultaneous transmitting antennas in a specific physical test configuration is  $\leq 1.6$  W/kg. The different test positions in an exposure condition may be considered collectively to determine SAR test exclusion according to the sum of 1-g SAR.

When standalone SAR is not required to be measured, per FCC KDB 447498 D01v05 4.3.2 2), the following equation must be used to estimate the standalone 1g SAR for simultaneous transmission assessment involving that transmitter.



$$\text{Estimated SAR} = \frac{\sqrt{f(\text{GHz})}}{7.5} * \frac{(\text{Max Power of channel, mW})}{\text{Min. Separation Distance, mm}}$$

**Table 12-1  
Estimated SAR**

Mode	Frequency	Maximum Allowed Power	Separation Distance (Body)	Estimated SAR (Body)
	[MHz]	[dBm]	[mm]	[W/kg]
Bluetooth LE	2480	9.00	10	0.168

Note:

1. Held-to ear configurations are not applicable to Bluetooth operations and therefore were not considered for simultaneous transmission. Per KDB Publication 447498 D01v05, the maximum power of the channel was rounded to the nearest mW before calculation.
2. The highest Reported SAR for each exposure condition is used for SAR summation purpose.
3. Head SAR for 2.4 GHz MIMO was measured with both antennas transmitting simultaneously at the specified maximum output power in MIMO mode following the initial test configuration procedures.
4. MIMO SAR for 5 GHz head and all SAR for body-worn and hotspot exposure conditions for both bands was determined by the sum of 1g single transmission chain SAR values because the summation represents higher output power and yields more conservative result per KDB 248227 D01 DR02-41929."

FCC ID: A3LSMG920I	 <b>PCTEST</b> <small>ENGINEERING LABORATORY, INC.</small>	<b>SAR EVALUATION REPORT</b>	 <b>Reviewed by:</b> Quality Manager
Document S/N: 0Y1502060403.A3L	Test Dates: 01/12/15 - 02/11/15	DUT Type: Portable Handset	Page 58 of 72

## 12.3 Head SAR Simultaneous Transmission Analysis

Table 12-2

Simultaneous Transmission Scenario with 2.4 GHz WLAN – Antenna 1 (Held to Ear)

Exposure Condition	Mode	2G/3G/4G SAR (W/kg)	2.4 GHz WLAN Ant 1 SAR (W/kg)	Σ SAR (W/kg)
Head SAR	GSM 850	0.192	0.480	0.672
	UMTS 850	0.266	0.480	<b>0.746</b>
	UMTS 1750	0.255	0.480	0.735
	GSM 1900	0.062	0.480	0.542
	UMTS 1900	0.134	0.480	0.614
	LTE Band 12	0.141	0.480	0.621
	LTE Band 26	0.198	0.480	0.678
	LTE Band 4 (AWS)	0.243	0.480	0.723
	LTE Band 2 (PCS)	0.113	0.480	0.593

Table 12-3



Simultaneous Transmission Scenario with 2.4 GHz WLAN - Antenna 2 (Held to Ear)

Exposure Condition	Mode	2G/3G/4G SAR (W/kg)	2.4 GHz WLAN Ant 2 SAR (W/kg)	Σ SAR (W/kg)
Head SAR	GSM 850	0.192	0.841	1.033
	UMTS 850	0.266	0.841	<b>1.107</b>
	UMTS 1750	0.255	0.841	1.096
	GSM 1900	0.062	0.841	0.903
	UMTS 1900	0.134	0.841	0.975
	LTE Band 12	0.141	0.841	0.982
	LTE Band 26	0.198	0.841	1.039
	LTE Band 4 (AWS)	0.243	0.841	1.084
	LTE Band 2 (PCS)	0.113	0.841	0.954

Table 12-4

Simultaneous Transmission Scenario with 2.4 GHz WLAN - MIMO (Held to Ear)

Exposure Condition	Mode	2G/3G/4G SAR (W/kg)	2.4 GHz WLAN MIMO SAR (W/kg)	Σ SAR (W/kg)
Head SAR	GSM 850	0.192	0.321	0.513
	UMTS 850	0.266	0.321	<b>0.587</b>
	UMTS 1750	0.255	0.321	0.576
	GSM 1900	0.062	0.321	0.383
	UMTS 1900	0.134	0.321	0.455
	LTE Band 12	0.141	0.321	0.462
	LTE Band 26	0.198	0.321	0.519
	LTE Band 4 (AWS)	0.243	0.321	0.564
	LTE Band 2 (PCS)	0.113	0.321	0.434

FCC ID: A3LSMG920I	 <b>SAR EVALUATION REPORT</b> 		Reviewed by: Quality Manager
Document S/N: 0Y1502060403.A3L	Test Dates: 01/12/15 - 02/11/15	DUT Type: Portable Handset	Page 59 of 72

**Table 12-5**  
**Simultaneous Transmission Scenario with 5 GHz WLAN - Antenna 1 (Held to Ear)**

Exposure Condition	Mode	2G/3G/4G SAR (W/kg)	5 GHz WLAN Ant 1 SAR (W/kg)	Σ SAR (W/kg)
Head SAR	GSM 850	0.192	0.311	0.503
	UMTS 850	0.266	0.311	<b>0.577</b>
	UMTS 1750	0.255	0.311	0.566
	GSM 1900	0.062	0.311	0.373
	UMTS 1900	0.134	0.311	0.445
	LTE Band 12	0.141	0.311	0.452
	LTE Band 26	0.198	0.311	0.509
	LTE Band 4 (AWS)	0.243	0.311	0.554
	LTE Band 2 (PCS)	0.113	0.311	0.424

The worst case 5 GHz WIFI reported SAR for each head configuration was considered for simultaneous SAR exclusion via summation of standalone SAR, regardless of whether the WIFI channel has WIFI Hotspot capability, for simplicity to determine compliance. Please note that the actual simultaneous transmission SAR will not exceed the summed levels indicated.

**Table 12-6**  
**Simultaneous Transmission Scenario with 5 GHz WLAN - Antenna 2 (Held to Ear)**



Exposure Condition	Mode	2G/3G/4G SAR (W/kg)	5 GHz WLAN Ant 2 SAR (W/kg)	Σ SAR (W/kg)
Head SAR	GSM 850	0.192	0.033	0.225
	UMTS 850	0.266	0.033	<b>0.299</b>
	UMTS 1750	0.255	0.033	0.288
	GSM 1900	0.062	0.033	0.095
	UMTS 1900	0.134	0.033	0.167
	LTE Band 12	0.141	0.033	0.174
	LTE Band 26	0.198	0.033	0.231
	LTE Band 4 (AWS)	0.243	0.033	0.276
	LTE Band 2 (PCS)	0.113	0.033	0.146

The worst case 5 GHz WIFI reported SAR for each head configuration was considered for simultaneous SAR exclusion via summation of standalone SAR, regardless of whether the WIFI channel has WIFI Hotspot capability, for simplicity to determine compliance. Please note that the actual simultaneous transmission SAR will not exceed the summed levels indicated.

**Table 12-7**  
**Simultaneous Transmission Scenario with 5 GHz WLAN - MIMO (Held to Ear)**

Exposure Condition	Mode	2G/3G/4G SAR (W/kg)	5 GHz WLAN Ant 1 SAR (W/kg)	5 GHz WLAN Ant 2 SAR (W/kg)	Σ SAR (W/kg)
Head SAR	GSM 850	0.192	0.311	0.033	0.536
	UMTS 850	0.266	0.311	0.033	<b>0.610</b>
	UMTS 1750	0.255	0.311	0.033	0.599
	GSM 1900	0.062	0.311	0.033	0.406
	UMTS 1900	0.134	0.311	0.033	0.478
	LTE Band 12	0.141	0.311	0.033	0.485
	LTE Band 26	0.198	0.311	0.033	0.542
	LTE Band 4 (AWS)	0.243	0.311	0.033	0.587
	LTE Band 2 (PCS)	0.113	0.311	0.033	0.457

The worst case 5 GHz WIFI reported SAR for each head configuration was considered for simultaneous SAR exclusion via summation of standalone SAR, regardless of whether the WIFI channel has WIFI Hotspot capability, for simplicity to determine compliance. Please note that the actual simultaneous transmission SAR will not exceed the summed levels indicated.

FCC ID: A3LSMG920I		<b>SAR EVALUATION REPORT</b>		Reviewed by: Quality Manager
Document S/N: 0Y1502060403.A3L	Test Dates: 01/12/15 - 02/11/15	DUT Type: Portable Handset	Page 60 of 72	

## 12.4 Body-Worn Simultaneous Transmission Analysis

Table 12-8

Simultaneous Transmission Scenario with 2.4 GHz WLAN – Antenna 1 (Body-Worn at 1.0 cm)

Exposure Condition	Mode	2G/3G/4G SAR (W/kg)	2.4 GHz WLAN Ant 1 SAR (W/kg)	Σ SAR (W/kg)
Body-Worn	GSM 850	0.328	0.026	0.354
	UMTS 850	0.472	0.026	0.498
	UMTS 1750	0.547	0.026	0.573
	GSM 1900	0.396	0.026	0.422
	UMTS 1900	0.762	0.026	<b>0.788</b>
	LTE Band 12	0.313	0.026	0.339
	LTE Band 26	0.380	0.026	0.406
	LTE Band 4 (AWS)	0.729	0.026	0.755
LTE Band 2 (PCS)	0.596	0.026	0.622	

Table 12-9



Simultaneous Transmission Scenario with 2.4 GHz WLAN - Antenna 2 (Body-Worn at 1.0 cm)

Exposure Condition	Mode	2G/3G/4G SAR (W/kg)	2.4 GHz WLAN Ant 2 SAR (W/kg)	Σ SAR (W/kg)
Body-Worn	GSM 850	0.328	0.045	0.373
	UMTS 850	0.472	0.045	0.517
	UMTS 1750	0.547	0.045	0.592
	GSM 1900	0.396	0.045	0.441
	UMTS 1900	0.762	0.045	<b>0.807</b>
	LTE Band 12	0.313	0.045	0.358
	LTE Band 26	0.380	0.045	0.425
	LTE Band 4 (AWS)	0.729	0.045	0.774
LTE Band 2 (PCS)	0.596	0.045	0.641	

Table 12-10

Simultaneous Transmission Scenario with 2.4 GHz WLAN - MIMO (Body-Worn at 1.0 cm)

Exposure Condition	Mode	2G/3G/4G SAR (W/kg)	2.4 GHz WLAN Ant 1 SAR (W/kg)	2.4 GHz WLAN Ant 2 SAR (W/kg)	Σ SAR (W/kg)
Body-Worn	GSM 850	0.328	0.026	0.045	0.399
	UMTS 850	0.472	0.026	0.045	0.543
	UMTS 1750	0.547	0.026	0.045	0.618
	GSM 1900	0.396	0.026	0.045	0.467
	UMTS 1900	0.762	0.026	0.045	<b>0.833</b>
	LTE Band 12	0.313	0.026	0.045	0.384
	LTE Band 26	0.380	0.026	0.045	0.451
	LTE Band 4 (AWS)	0.729	0.026	0.045	0.800
LTE Band 2 (PCS)	0.596	0.026	0.045	0.667	

FCC ID: A3LSMG920I	 <b>PCTEST</b> ENGINEERING LABORATORY, INC.	<b>SAR EVALUATION REPORT</b>		<b>Reviewed by:</b> Quality Manager
<b>Document S/N:</b> 0Y1502060403.A3L	<b>Test Dates:</b> 01/12/15 - 02/11/15	<b>DUT Type:</b> Portable Handset	Page 61 of 72	

**Table 12-11**  
**Simultaneous Transmission Scenario with 5 GHz WLAN - Antenna 1 (Body-Worn at 1.0 cm)**

Exposure Condition	Mode	2G/3G/4G SAR (W/kg)	5 GHz WLAN Ant 1 SAR (W/kg)	Σ SAR (W/kg)
Body-Worn	GSM 850	0.328	0.055	0.383
	UMTS 850	0.472	0.055	0.527
	UMTS 1750	0.547	0.055	0.602
	GSM 1900	0.396	0.055	0.451
	UMTS 1900	0.762	0.055	<b>0.817</b>
	LTE Band 12	0.313	0.055	0.368
	LTE Band 26	0.380	0.055	0.435
	LTE Band 4 (AWS)	0.729	0.055	0.784
	LTE Band 2 (PCS)	0.596	0.055	0.651

The worst case 5 GHz WIFI reported SAR for each body-worn configuration was considered for simultaneous SAR exclusion via summation of standalone SAR, regardless of whether the WIFI channel has WIFI Hotspot capability, for simplicity to determine compliance. Please note that the actual simultaneous transmission SAR will not exceed the summed levels indicated.

**Table 12-12**  
**Simultaneous Transmission Scenario with 5 GHz WLAN - Antenna 2 (Body-Worn at 1.0 cm)**



Exposure Condition	Mode	2G/3G/4G SAR (W/kg)	5 GHz WLAN Ant 2 SAR (W/kg)	Σ SAR (W/kg)
Body-Worn	GSM 850	0.328	0.031	0.359
	UMTS 850	0.472	0.031	0.503
	UMTS 1750	0.547	0.031	0.578
	GSM 1900	0.396	0.031	0.427
	UMTS 1900	0.762	0.031	<b>0.793</b>
	LTE Band 12	0.313	0.031	0.344
	LTE Band 26	0.380	0.031	0.411
	LTE Band 4 (AWS)	0.729	0.031	0.760
	LTE Band 2 (PCS)	0.596	0.031	0.627

The worst case 5 GHz WIFI reported SAR for each body-worn configuration was considered for simultaneous SAR exclusion via summation of standalone SAR, regardless of whether the WIFI channel has WIFI Hotspot capability, for simplicity to determine compliance. Please note that the actual simultaneous transmission SAR will not exceed the summed levels indicated.

**Table 12-13**  
**Simultaneous Transmission Scenario with 5 GHz WLAN - MIMO (Body-Worn at 1.0 cm)**

Exposure Condition	Mode	2G/3G/4G SAR (W/kg)	5 GHz WLAN Ant 1 SAR (W/kg)	5 GHz WLAN Ant 2 SAR (W/kg)	Σ SAR (W/kg)
Body-Worn	GSM 850	0.328	0.055	0.031	0.414
	UMTS 850	0.472	0.055	0.031	0.558
	UMTS 1750	0.547	0.055	0.031	0.633
	GSM 1900	0.396	0.055	0.031	0.482
	UMTS 1900	0.762	0.055	0.031	<b>0.848</b>
	LTE Band 12	0.313	0.055	0.031	0.399
	LTE Band 26	0.380	0.055	0.031	0.466
	LTE Band 4 (AWS)	0.729	0.055	0.031	0.815
	LTE Band 2 (PCS)	0.596	0.055	0.031	0.682

The worst case 5 GHz WIFI reported SAR for each body-worn configuration was considered for simultaneous SAR exclusion via summation of standalone SAR, regardless of whether the WIFI channel has WIFI Hotspot capability, for simplicity to determine compliance. Please note that the actual simultaneous transmission SAR will not exceed the summed levels indicated.

FCC ID: A3LSMG920I	 <b>PCTEST</b> <small>ENGINEERING LABORATORY, INC.</small>	<b>SAR EVALUATION REPORT</b>		<b>Reviewed by:</b> Quality Manager
<b>Document S/N:</b> 0Y1502060403.A3L	<b>Test Dates:</b> 01/12/15 - 02/11/15	<b>DUT Type:</b> Portable Handset	Page 62 of 72	

**Table 12-14**  
**Simultaneous Transmission Scenario with Bluetooth (Body-Worn at 1.0 cm)**



Exposure Condition	Mode	2G/3G/4G SAR (W/kg)	Bluetooth SAR (W/kg)	Σ SAR (W/kg)
Body-Worn	GSM 850	0.328	0.168	0.496
	UMTS 850	0.472	0.168	0.640
	UMTS 1750	0.547	0.168	0.715
	GSM 1900	0.396	0.168	0.564
	UMTS 1900	0.762	0.168	<b>0.930</b>
	LTE Band 12	0.313	0.168	0.481
	LTE Band 26	0.380	0.168	0.548
	LTE Band 4 (AWS)	0.729	0.168	0.897
	LTE Band 2 (PCS)	0.596	0.168	0.764

Estimated Bluetooth LE SAR results were used in the above table to determine simultaneous transmission SAR test exclusion since they were more conservative than Bluetooth reported SAR.

## 12.5 Hotspot SAR Simultaneous Transmission Analysis

**Table 12-15**  
**Simultaneous Transmission Scenario with 2.4 GHz WLAN – Antenna 1 (Hotspot at 1.0 cm)**

Exposure Condition	Mode	2G/3G/4G SAR (W/kg)	2.4 GHz WLAN Ant 1 SAR (W/kg)	Σ SAR (W/kg)
Hotspot SAR	GPRS 850	0.517	0.026	0.543
	UMTS 850	0.472	0.026	0.498
	UMTS 1750	1.013	0.026	1.039
	GPRS 1900	0.943	0.026	0.969
	UMTS 1900	0.995	0.026	1.021
	LTE Band 12	0.313	0.026	0.339
	LTE Band 26	0.453	0.026	0.479
	LTE Band 4 (AWS)	1.050	0.026	<b>1.076</b>
	LTE Band 2 (PCS)	0.951	0.026	0.977

FCC ID: A3LSMG920I	 <b>PCTEST</b> <small>ENGINEERING LABORATORY, INC.</small>	<b>SAR EVALUATION REPORT</b>		Reviewed by: Quality Manager
Document S/N: 0Y1502060403.A3L	Test Dates: 01/12/15 - 02/11/15	DUT Type: Portable Handset	Page 63 of 72	

**Table 12-16**  
**Simultaneous Transmission Scenario with 2.4 GHz WLAN – Antenna 2 (Hotspot at 1.0 cm)**



Exposure Condition	Mode	2G/3G/4G SAR (W/kg)	2.4 GHz WLAN Ant 2 SAR (W/kg)	Σ SAR (W/kg)
Hotspot SAR	GPRS 850	0.517	0.055	0.572
	UMTS 850	0.472	0.055	0.527
	UMTS 1750	1.013	0.055	1.068
	GPRS 1900	0.943	0.055	0.998
	UMTS 1900	0.995	0.055	1.050
	LTE Band 12	0.313	0.055	0.368
	LTE Band 26	0.453	0.055	0.508
	LTE Band 4 (AWS)	1.050	0.055	<b>1.105</b>
	LTE Band 2 (PCS)	0.951	0.055	1.006

**Table 12-17**  
**Simultaneous Transmission Scenario with 2.4 GHz WLAN – MIMO (Hotspot at 1.0 cm)**

Exposure Condition	Mode	2G/3G/4G SAR (W/kg)	2.4 GHz WLAN Ant 1 SAR (W/kg)	2.4 GHz WLAN Ant 2 SAR (W/kg)	Σ SAR (W/kg)
Hotspot SAR	GPRS 850	0.517	0.026	0.055	0.598
	UMTS 850	0.472	0.026	0.055	0.553
	UMTS 1750	1.013	0.026	0.055	1.094
	GPRS 1900	0.943	0.026	0.055	1.024
	UMTS 1900	0.995	0.026	0.055	1.076
	LTE Band 12	0.313	0.026	0.055	0.394
	LTE Band 26	0.453	0.026	0.055	0.534
	LTE Band 4 (AWS)	1.050	0.026	0.055	<b>1.131</b>
	LTE Band 2 (PCS)	0.951	0.026	0.055	1.032

**Table 12-18**  
**Simultaneous Transmission Scenario with 5 GHz WLAN – Antenna 1 (Hotspot at 1.0 cm)**

Exposure Condition	Mode	2G/3G/4G SAR (W/kg)	5 GHz WLAN Ant 1 SAR (W/kg)	Σ SAR (W/kg)
Hotspot SAR	GPRS 850	0.517	0.002	0.519
	UMTS 850	0.472	0.002	0.474
	UMTS 1750	1.013	0.002	1.015
	GPRS 1900	0.943	0.002	0.945
	UMTS 1900	0.995	0.002	0.997
	LTE Band 12	0.313	0.002	0.315
	LTE Band 26	0.453	0.002	0.455
	LTE Band 4 (AWS)	1.050	0.002	<b>1.052</b>
	LTE Band 2 (PCS)	0.951	0.002	0.953

FCC ID: A3LSMG920I	 <b>PCTEST</b> <small>ENGINEERING LABORATORY, INC.</small>	<b>SAR EVALUATION REPORT</b>		<b>Reviewed by:</b> Quality Manager
<b>Document S/N:</b> 0Y1502060403.A3L	<b>Test Dates:</b> 01/12/15 - 02/11/15	<b>DUT Type:</b> Portable Handset		Page 64 of 72

**Table 12-19**  
**Simultaneous Transmission Scenario with 5 GHz WLAN – Antenna 2 (Hotspot at 1.0 cm)**



Exposure Condition	Mode	2G/3G/4G SAR (W/kg)	5 GHz WLAN Ant 2 SAR (W/kg)	Σ SAR (W/kg)
Hotspot SAR	GPRS 850	0.517	0.001	0.518
	UMTS 850	0.472	0.001	0.473
	UMTS 1750	1.013	0.001	1.014
	GPRS 1900	0.943	0.001	0.944
	UMTS 1900	0.995	0.001	0.996
	LTE Band 12	0.313	0.001	0.314
	LTE Band 26	0.453	0.001	0.454
	LTE Band 4 (AWS)	1.050	0.001	<b>1.051</b>
	LTE Band 2 (PCS)	0.951	0.001	0.952

**Table 12-20**  
**Simultaneous Transmission Scenario with 5 GHz WLAN – MIMO (Hotspot at 1.0 cm)**

Exposure Condition	Mode	2G/3G/4G SAR (W/kg)	5 GHz WLAN Ant 1 SAR (W/kg)	5 GHz WLAN Ant 2 SAR (W/kg)	Σ SAR (W/kg)
Hotspot SAR	GPRS 850	0.517	0.002	0.001	0.520
	UMTS 850	0.472	0.002	0.001	0.475
	UMTS 1750	1.013	0.002	0.001	1.016
	GPRS 1900	0.943	0.002	0.001	0.946
	UMTS 1900	0.995	0.002	0.001	0.998
	LTE Band 12	0.313	0.002	0.001	0.316
	LTE Band 26	0.453	0.002	0.001	0.456
	LTE Band 4 (AWS)	1.050	0.002	0.001	<b>1.053</b>
	LTE Band 2 (PCS)	0.951	0.002	0.001	0.954

## 12.6 Simultaneous Transmission Conclusion

The above numerical summed SAR results for all the worst-case simultaneous transmission conditions were below the SAR limit. Therefore, the above analysis is sufficient to determine that simultaneous transmission cases will not exceed the SAR limit and therefore no measured volumetric simultaneous SAR summation is required per FCC KDB Publication 447498 D01v05 and IEEE 1528-2013 Section 6.3.4.1.2.

FCC ID: A3LSMG920I	 <b>PCTEST</b> <small>ENGINEERING LABORATORY, INC.</small>	<b>SAR EVALUATION REPORT</b>		Reviewed by: Quality Manager
Document S/N: 0Y1502060403.A3L	Test Dates: 01/12/15 - 02/11/15	DUT Type: Portable Handset	Page 65 of 72	

# 13 SAR MEASUREMENT VARIABILITY

## 13.1 Measurement Variability

Per FCC KDB Publication 865664 D01v01, SAR measurement variability was assessed for each frequency band, which was determined by the SAR probe calibration point and tissue-equivalent medium used for the device measurements. When both head and body tissue-equivalent media were required for SAR measurements in a frequency band, the variability measurement procedures were applied to the tissue medium with the highest measured SAR, using the highest measured SAR configuration for that tissue-equivalent medium. These additional measurements were repeated after the completion of all measurements requiring the same head or body tissue-equivalent medium in a frequency band. The test device was returned to ambient conditions (normal room temperature) with the battery fully charged before it was re-mounted on the device holder for the repeated measurement(s) to minimize any unexpected variations in the repeated results.

SAR Measurement Variability was assessed using the following procedures for each frequency band:

- 1) When the original highest measured SAR is  $\geq 0.80$  W/kg, the measurement was repeated once.
- 2) A second repeated measurement was performed only if the ratio of largest to smallest SAR for the original and first repeated measurements was  $> 1.20$  or when the original or repeated measurement was  $\geq 1.45$  W/kg (~ 10% from the 1-g SAR limit).
- 3) A third repeated measurement was performed only if the original, first or second repeated measurement was  $\geq 1.5$  W/kg and the ratio of largest to smallest SAR for the original, first and second repeated measurements is  $> 1.20$ .
- 4) Repeated measurements are not required when the original highest measured SAR is  $< 0.80$  W/kg.

**Table 13-1  
Head SAR Measurement Variability Results**



HEAD VARIABILITY RESULTS														
Band	FREQUENCY		Mode/Band	Service	Side	Test Position	Data Rate (Mbps)	Measured SAR (1g)	1st Repeated SAR (1g)	Ratio	2nd Repeated SAR (1g)	Ratio	3rd Repeated SAR (1g)	Ratio
	MHz	Ch.						(W/kg)	(W/kg)		(W/kg)		(W/kg)	
2450	2412.00	1	802.11b 22 MHz Bandwidth	DSSS , ANT 2	Left	Cheek	1	0.825	0.767	1.08	N/A	N/A	N/A	N/A
ANSI / IEEE C95.1 1992 - SAFETY LIMIT Spatial Peak Uncontrolled Exposure/General Population								Head 1.6 W/kg (mW/g) averaged over 1 gram						

**Table 13-2  
Body SAR Measurement Variability Results**

BODY VARIABILITY RESULTS														
Band	FREQUENCY		Mode	Service	# of Time Slots	Side	Spacing	Measured SAR (1g)	1st Repeated SAR (1g)	Ratio	2nd Repeated SAR (1g)	Ratio	3rd Repeated SAR (1g)	Ratio
	MHz	Ch.						(W/kg)	(W/kg)		(W/kg)		(W/kg)	
1750	1712.40	1312	UMTS 1750	RMC	N/A	bottom	10 mm	0.909	0.911	1.00	N/A	N/A	N/A	N/A
1900	1850.20	512	GSM 1900	GPRS	2	bottom	10 mm	0.907	0.882	1.03	N/A	N/A	N/A	N/A
ANSI / IEEE C95.1 1992 - SAFETY LIMIT Spatial Peak Uncontrolled Exposure/General Population								Body 1.6 W/kg (mW/g) averaged over 1 gram						

## 13.2 Measurement Uncertainty

The measured SAR was  $< 1.5$  W/kg for all frequency bands. Therefore, per KDB Publication 865664 D01v01, the extended measurement uncertainty analysis per IEEE 1528-2003 was not required.



FCC ID: A3LSMG920I	 PCTEST ENGINEERING LABORATORY, INC.	SAR EVALUATION REPORT		Reviewed by: Quality Manager
Document S/N: 0Y1502060403.A3L	Test Dates: 01/12/15 - 02/11/15	DUT Type: Portable Handset	Page 66 of 72	

# 14 EQUIPMENT LIST

Manufacturer	Model	Description	Cal Date	Cal Interval	Cal Due	Serial Number
SPEAG	DAE4	Dasy Data Acquisition Electronics	2/26/2014	Annual	2/26/2015	665
SPEAG	DAE4	Dasy Data Acquisition Electronics	5/14/2014	Annual	5/14/2015	859
SPEAG	DAE4	Dasy Data Acquisition Electronics	8/12/2014	Annual	8/12/2015	1322
SPEAG	DAE4	Dasy Data Acquisition Electronics	9/17/2014	Annual	9/17/2015	1323
SPEAG	DAE4	Dasy Data Acquisition Electronics	3/17/2014	Annual	3/17/2015	1334
SPEAG	DAE4	Dasy Data Acquisition Electronics	9/18/2014	Annual	9/18/2015	1364
SPEAG	DAE4	Dasy Data Acquisition Electronics	4/11/2014	Annual	4/11/2015	1368
SPEAG	DAE4	Dasy Data Acquisition Electronics	1/19/2015	Annual	1/19/2016	1407
SPEAG	D1765V2	1765 MHz SAR Dipole	5/7/2014	Annual	5/7/2015	1008
SPEAG	D1900V2	1900 MHz SAR Dipole	7/23/2014	Annual	7/23/2015	5d149
SPEAG	D2450V2	2450 MHz SAR Dipole	8/11/2014	Annual	8/11/2015	719
SPEAG	D5GHV2	5 GHz SAR Dipole	2/26/2014	Annual	2/26/2015	1120
SPEAG	D5GHV2	5 GHz SAR Dipole	9/25/2014	Annual	9/25/2015	1191
SPEAG	D750V3	750 MHz Dipole	3/17/2014	Annual	3/17/2015	1054
SPEAG	D835V2	835 MHz SAR Dipole	7/24/2014	Annual	7/24/2015	4d133
SPEAG	ES30V2	SAR Probe	8/19/2014	Annual	8/19/2015	3022
SPEAG	ES30V3	SAR Probe	3/19/2014	Annual	3/19/2015	3209
SPEAG	ES30V3	SAR Probe	2/25/2014	Annual	2/25/2015	3258
SPEAG	ES30V3	SAR Probe	5/15/2014	Annual	5/15/2015	3263
SPEAG	ES30V3	SAR Probe	9/24/2014	Annual	9/24/2015	3288
SPEAG	EX30V4	SAR Probe	12/12/2014	Annual	12/12/2015	3920
SPEAG	EX30V4	SAR Probe	7/16/2014	Annual	7/16/2015	7308
SPEAG	ES30V3	SAR Probe	1/20/2015	Annual	1/20/2016	3213
SPEAG	ES30V3	SAR Probe	9/18/2014	Annual	9/18/2015	3332
Agilent	8594A	(9kHz-2.9GHz) Spectrum Analyzer	N/A	N/A	N/A	3051A00187
Agilent	8648D	(9kHz-4GHz) Signal Generator	4/15/2014	Annual	4/15/2015	3629U00687
Agilent	8753E	(30kHz-6GHz) Network Analyzer	12/30/2014	Annual	12/30/2015	JP38020182
Agilent	8753ES	S-Parameter Network Analyzer	5/22/2014	Annual	5/22/2015	US39170118
Agilent	E4438C	ESG Vector Signal Generator	4/25/2014	Annual	4/25/2015	MY42082385
Agilent	E4438C	ESG Vector Signal Generator	3/31/2014	Annual	3/31/2015	MY42082659
Agilent	E5515C	Wireless Communications Test Set	11/20/2014	Biennial	11/20/2016	GB43163447
Agilent	E5515C	Wireless Communications Test Set	3/18/2014	Annual	3/18/2015	GB46110872
Agilent	E8257D	(250kHz-20GHz) Signal Generator	4/15/2014	Annual	4/15/2015	MY45470194
Agilent	N5182A	MKG Vector Signal Generator	4/15/2014	Annual	4/15/2015	MY47420651
Agilent	N5182A	MKG Vector Signal Generator	4/15/2014	Annual	4/15/2015	MY47420800
Agilent	N9020A	MKA Signal Analyzer	10/27/2014	Annual	10/27/2015	US46470561
Agilent	N4010A	Wireless Connectivity Test Set	N/A	N/A	N/A	GB46170464
Amplifier Research	1S516G	Amplifier	CBT	N/A	CBT	433971
Amplifier Research	1S516G	Amplifier	CBT	N/A	CBT	433978
Anritsu	MA24106A	USB Power Sensor	5/14/2014	Annual	5/14/2015	1231538
Anritsu	MA24106A	USB Power Sensor	5/15/2014	Annual	5/15/2015	1244512
Anritsu	MA2411B	Pulse Power Sensor	11/17/2014	Annual	11/17/2015	1126066
Anritsu	MA2411B	Pulse Power Sensor	11/17/2014	Annual	11/17/2015	1207364
Anritsu	MA2411B	Pulse Power Sensor	3/25/2014	Annual	3/25/2015	1207470
Anritsu	MA2411B	Pulse Power Sensor	11/13/2014	Annual	11/13/2015	1339018
Anritsu	ML2469A	Power Meter	3/14/2014	Annual	3/14/2015	1306009
Anritsu	MT8820C	Radio Communication Analyzer	9/19/2014	Annual	9/19/2015	6201144418
Anritsu	MT8820C	Radio Communication Analyzer	11/18/2014	Annual	11/18/2015	6201300731
COMTECH	AR85729-5	Solid State Amplifier	CBT	N/A	CBT	M155A00-009
COMTECH	AR85729-5/5759B	Solid State Amplifier	CBT	N/A	CBT	M3W1A00-1002
Control Company	4052	Long Stem Thermometer	9/27/2013	Biennial	9/27/2015	130567447
Control Company	36934-158	Wall-Mounted Thermometer	4/29/2014	Biennial	4/29/2016	122014488
Control Company	61220-416	Long-Stem Thermometer	4/29/2014	Biennial	4/29/2016	111331323
Fisher Scientific	15-077-960	Digital Thermometer	12/4/2013	Biennial	12/4/2015	130764551
Fisher Scientific	15-077-960	Digital Thermometer	12/4/2013	Biennial	12/4/2015	130764558
Fisher Scientific	S97611	Thermometer	4/12/2013	Biennial	4/12/2015	130219303
Fisher Scientific	S97611	Thermometer	4/12/2013	Biennial	4/12/2015	130219304
Gigatronics	87071A	(0.05-18GHz) Power Sensor	10/30/2014	Annual	10/30/2015	1833460
Gigatronics	8651A	Universal Power Meter	10/30/2014	Annual	10/30/2015	8650319
MCL	BW-N6WS+	6dB Attenuator	CBT	N/A	CBT	1139
MiniCircuits	SLP-2400+	Low Pass Filter	CBT	N/A	CBT	R897950903
MiniCircuits	VLF-6000+	Low Pass Filter	CBT	N/A	CBT	N/A
MiniCircuits	VLF-6000+	Low Pass Filter	CBT	N/A	CBT	N/A
Mini-Circuits	BW-N20W5	Power Attenuator	CBT	N/A	CBT	1226
Mini-Circuits	BW-N20W5+	DC to 18 GHz Precision Fixed 20 dB Attenuator	CBT	N/A	CBT	N/A
Mini-Circuits	NLP-1200+	Low Pass Filter DC to 1000 MHz	CBT	N/A	CBT	N/A
Mini-Circuits	NLP-2950+	Low Pass Filter DC to 2700 MHz	CBT	N/A	CBT	N/A
Minutony	CD-67CX	Digital Caliper	5/8/2014	Biennial	5/8/2016	13264165
Narda	4014C-6	4 - 8 GHz SMA 6 dB Directional Coupler	CBT	N/A	CBT	N/A
Narda	4772-3	Attenuator (3dB)	CBT	N/A	CBT	9406
Narda	BW-S3W2	Attenuator (3dB)	CBT	N/A	CBT	120
Pasternack	PE2208-6	Bidirectional Coupler	CBT	N/A	CBT	N/A
Pasternack	PE2209-10	Bidirectional Coupler	CBT	N/A	CBT	N/A
Rohde & Schwarz	CMU200	Base Station Simulator	12/4/2014	Annual	12/4/2015	833855/0010
Rohde & Schwarz	CMU200	Base Station Simulator	4/24/2014	Annual	4/24/2015	836371/0079
Rohde & Schwarz	CMW500	Radio Communication Tester	10/3/2014	Annual	10/3/2015	100976
Rohde & Schwarz	CMW500	Radio Communication Tester	10/4/2013	Biennial	10/4/2015	103962
Seekonk	NC-100	Torque Wrench	3/18/2014	Biennial	3/18/2016	22313
Seekonk	NC-100	Torque Wrench 5/16", 8" lbs	3/18/2014	Biennial	3/18/2016	N/A
SPEAG	DAK-3.5	Dielectric Assessment Kit	5/6/2014	Annual	5/6/2015	1070
Tektronix	RSA6114A	Real Time Spectrum Analyzer	4/16/2014	Annual	4/16/2015	8010177
VWR	36934-158	Wall-Mounted Thermometer	8/8/2013	Biennial	8/8/2015	13047877

Note:

1. CBT (Calibrated Before Testing). Prior to testing, the measurement paths containing a cable, amplifier, attenuator, coupler or filter were connected to a calibrated source (i.e. a signal generator) to determine the losses of the measurement path. The power meter offset was then adjusted to compensate for the measurement system losses. This level offset is stored within the power meter before measurements are made. This calibration verification procedure applies to the system verification and output power measurements. The calibrated reading is then taken directly from the power meter after compensation of the losses for all final power measurements.
2. Each equipment item was used solely within its respective calibration period.



FCC ID: A3LSMG9201	 PCTEST ENGINEERING LABORATORY, INC.	<b>SAR EVALUATOR REPORT</b>		<b>Reviewed by:</b> Quality Manager
<b>Document S/N:</b> 0Y1502060403.A3L	<b>Test Dates:</b> 01/12/15 - 02/11/15	<b>DUT Type:</b> Portable Handset	Page 67 of 72	

# 15 MEASUREMENT UNCERTAINTIES

Applicable for frequencies less than 3000 MHz.

a	b	c	d	e= f(d,k)	f	g	h = c x f/e	i = c x g/e	k
Uncertainty Component	IEEE 1528 Sec.	Tol. (± %)	Prob. Dist.	Div.	c <sub>i</sub> 1gm	c <sub>i</sub> 10 gms	1gm u <sub>i</sub> (± %)	10gms u <sub>i</sub> (± %)	v <sub>i</sub>
<b>Measurement System</b>									
Probe Calibration	E.2.1	6.0	N	1	1.0	1.0	6.0	6.0	∞
Axial Isotropy	E.2.2	0.25	N	1	0.7	0.7	0.2	0.2	∞
Hemishperical Isotropy	E.2.2	1.3	N	1	1.0	1.0	1.3	1.3	∞
Boundary Effect	E.2.3	0.4	N	1	1.0	1.0	0.4	0.4	∞
Linearity	E.2.4	0.3	N	1	1.0	1.0	0.3	0.3	∞
System Detection Limits	E.2.5	5.1	N	1	1.0	1.0	5.1	5.1	∞
Readout Electronics	E.2.6	1.0	N	1	1.0	1.0	1.0	1.0	∞
Response Time	E.2.7	0.8	R	1.73	1.0	1.0	0.5	0.5	∞
Integration Time	E.2.8	2.6	R	1.73	1.0	1.0	1.5	1.5	∞
RF Ambient Conditions	E.6.1	3.0	R	1.73	1.0	1.0	1.7	1.7	∞
Probe Positioner Mechanical Tolerance	E.6.2	0.4	R	1.73	1.0	1.0	0.2	0.2	∞
Probe Positioning w/ respect to Phantom	E.6.3	2.9	R	1.73	1.0	1.0	1.7	1.7	∞
Extrapolation, Interpolation & Integration algorithms for Max. SAR Evaluation	E.5	1.0	R	1.73	1.0	1.0	0.6	0.6	∞
<b>Test Sample Related</b>									
Test Sample Positioning	E.4.2	6.0	N	1	1.0	1.0	6.0	6.0	287
Device Holder Uncertainty	E.4.1	3.32	R	1.73	1.0	1.0	1.9	1.9	∞
Output Power Variation - SAR drift measurement	6.6.2	5.0	R	1.73	1.0	1.0	2.9	2.9	∞
<b>Phantom &amp; Tissue Parameters</b>									
Phantom Uncertainty (Shape & Thickness tolerances)	E.3.1	4.0	R	1.73	1.0	1.0	2.3	2.3	∞
Liquid Conductivity - deviation from target values	E.3.2	5.0	R	1.73	0.64	0.43	1.8	1.2	∞
Liquid Conductivity - measurement uncertainty	E.3.3	3.8	N	1	0.64	0.43	2.4	1.6	6
Liquid Permittivity - deviation from target values	E.3.2	5.0	R	1.73	0.60	0.49	1.7	1.4	∞
Liquid Permittivity - measurement uncertainty	E.3.3	4.5	N	1	0.60	0.49	2.7	2.2	6
<b>Combined Standard Uncertainty (k=1)</b>	RSS						12.1	11.7	299
<b>Expanded Uncertainty</b> (95% CONFIDENCE LEVEL)	k=2						24.2	23.5	



The above measurement uncertainties are according to IEEE Std. 1528-2003

FCC ID: A3LSMG920I	 <b>PCTEST</b> ENGINEERING LABORATORY, INC.	<b>SAR EVALUATION REPORT</b>		<b>Reviewed by:</b> Quality Manager
<b>Document S/N:</b> 0Y1502060403.A3L	<b>Test Dates:</b> 01/12/15 - 02/11/15	<b>DUT Type:</b> Portable Handset		Page 68 of 72

Applicable for frequencies up to 6 GHz.

a	b	c	d	e= f(d,k)	f	g	h= c x f/e	i= c x g/e	k
Uncertainty Component	IEEE 1528 Sec.	Tol. (± %)	Prob. Dist.	Div.	c <sub>i</sub> 1gm	c <sub>i</sub> 10 gms	1gm u <sub>i</sub> (± %)	10gms u <sub>i</sub> (± %)	v <sub>i</sub>
<b>Measurement System</b>									
Probe Calibration	E.2.1	6.55	N	1	1.0	1.0	6.6	6.6	∞
Axial Isotropy	E.2.2	0.25	N	1	0.7	0.7	0.2	0.2	∞
Hemishperical Isotropy	E.2.2	1.3	N	1	1.0	1.0	1.3	1.3	∞
Boundary Effect	E.2.3	0.4	N	1	1.0	1.0	0.4	0.4	∞
Linearity	E.2.4	0.3	N	1	1.0	1.0	0.3	0.3	∞
System Detection Limits	E.2.5	5.1	N	1	1.0	1.0	5.1	5.1	∞
Readout Electronics	E.2.6	1.0	N	1	1.0	1.0	1.0	1.0	∞
Response Time	E.2.7	0.8	R	1.73	1.0	1.0	0.5	0.5	∞
Integration Time	E.2.8	2.6	R	1.73	1.0	1.0	1.5	1.5	∞
RF Ambient Conditions	E.6.1	3.0	R	1.73	1.0	1.0	1.7	1.7	∞
Probe Positioner Mechanical Tolerance	E.6.2	0.4	R	1.73	1.0	1.0	0.2	0.2	∞
Probe Positioning w/ respect to Phantom	E.6.3	2.9	R	1.73	1.0	1.0	1.7	1.7	∞
Extrapolation, Interpolation & Integration algorithms for Max. SAR Evaluation	E.5	1.0	R	1.73	1.0	1.0	0.6	0.6	∞
<b>Test Sample Related</b>									
Test Sample Positioning	E.4.2	6.0	N	1	1.0	1.0	6.0	6.0	287
Device Holder Uncertainty	E.4.1	3.32	R	1.73	1.0	1.0	1.9	1.9	∞
Output Power Variation - SAR drift measurement	6.6.2	5.0	R	1.73	1.0	1.0	2.9	2.9	∞
<b>Phantom &amp; Tissue Parameters</b>									
Phantom Uncertainty (Shape & Thickness tolerances)	E.3.1	4.0	R	1.73	1.0	1.0	2.3	2.3	∞
Liquid Conductivity - deviation from target values	E.3.2	5.0	R	1.73	0.64	0.43	1.8	1.2	∞
Liquid Conductivity - measurement uncertainty	E.3.3	3.8	N	1	0.64	0.43	2.4	1.6	6
Liquid Permittivity - deviation from target values	E.3.2	5.0	R	1.73	0.60	0.49	1.7	1.4	∞
Liquid Permittivity - measurement uncertainty	E.3.3	4.5	N	1	0.60	0.49	2.7	2.2	6
<b>Combined Standard Uncertainty (k=1)</b>				RSS			12.4	12.0	299
<b>Expanded Uncertainty</b> (95% CONFIDENCE LEVEL)				k=2			24.7	24.0	

The above measurement uncertainties are according to IEEE Std. 1528-2003



FCC ID: A3LSMG920I	 <b>PCTEST</b> ENGINEERING LABORATORY, INC.	<b>SAR EVALUATION REPORT</b>		<b>Reviewed by:</b> Quality Manager
<b>Document S/N:</b> 0Y1502060403.A3L	<b>Test Dates:</b> 01/12/15 - 02/11/15	<b>DUT Type:</b> Portable Handset		Page 69 of 72

## 16 CONCLUSION

### 16.1 Measurement Conclusion



The SAR evaluation indicates that the EUT complies with the RF radiation exposure limits of the FCC and Industry Canada, with respect to all parameters subject to this test. These measurements were taken to simulate the RF effects of RF exposure under worst-case conditions. Precise laboratory measures were taken to assure repeatability of the tests. The results and statements relate only to the item(s) tested.

Please note that the absorption and distribution of electromagnetic energy in the body are very complex phenomena that depend on the mass, shape, and size of the body, the orientation of the body with respect to the field vectors, and the electrical properties of both the body and the environment. Other variables that may play a substantial role in possible biological effects are those that characterize the environment (e.g. ambient temperature, air velocity, relative humidity, and body insulation) and those that characterize the individual (e.g. age, gender, activity level, debilitation, or disease). Because various factors may interact with one another to vary the specific biological outcome of an exposure to electromagnetic fields, any protection guide should consider maximal amplification of biological effects as a result of field-body interactions, environmental conditions, and physiological variables. [3]



<b>FCC ID:</b> A3LSMG920I	 <b>PCTEST</b> ENGINEERING LABORATORY, INC.	<b>SAR EVALUATION REPORT</b>		<b>Reviewed by:</b> Quality Manager
<b>Document S/N:</b> 0Y1502060403.A3L	<b>Test Dates:</b> 01/12/15 - 02/11/15	<b>DUT Type:</b> Portable Handset	Page 70 of 72	

## 17 REFERENCES

- [1] Federal Communications Commission, ET Docket 93-62, Guidelines for Evaluating the Environmental Effects of Radiofrequency Radiation, Aug. 1996.
- [2] ANSI/IEEE C95.1-2005, American National Standard safety levels with respect to human exposure to radio frequency electromagnetic fields, 3kHz to 300GHz, New York: IEEE, 2006.
- [3] ANSI/IEEE C95.1-1992, American National Standard safety levels with respect to human exposure to radio frequency electromagnetic fields, 3kHz to 300GHz, New York: IEEE, Sept. 1992.
- [4] ANSI/IEEE C95.3-2002, IEEE Recommended Practice for the Measurement of Potentially Hazardous Electromagnetic Fields - RF and Microwave, New York: IEEE, December 2002.
- [5] IEEE Standards Coordinating Committee 39 –Standards Coordinating Committee 34 – IEEE Std. 1528-2003, Recommended Practice for Determining the Peak Spatial-Average Specific Absorption Rate (SAR) in the Human Head Due to Wireless Communications Devices: Measurement Techniques.
- [6] NCRP, National Council on Radiation Protection and Measurements, Biological Effects and Exposure Criteria for RadioFrequency Electromagnetic Fields, NCRP Report No. 86, 1986. Reprinted Feb. 1995.
- [7] T. Schmid, O. Egger, N. Kuster, Automated E-field scanning system for dosimetric assessments, IEEE Transaction on Microwave Theory and Techniques, vol. 44, Jan. 1996, pp. 105-113.
- [8] K. Pokovic, T. Schmid, N. Kuster, Robust setup for precise calibration of E-field probes in tissue simulating liquids at mobile communications frequencies, ICECOM97, Oct. 1997, pp. 1-124.
- [9] K. Pokovic, T. Schmid, and N. Kuster, E-field Probe with improved isotropy in brain simulating liquids, Proceedings of the ELMAR, Zadar, Croatia, June 23-25, 1996, pp. 172-175.
- [10] Schmid & Partner Engineering AG, Application Note: Data Storage and Evaluation, June 1998, p2.
- [11] V. Hombach, K. Meier, M. Burkhardt, E. Kuhn, N. Kuster, The Dependence of EM Energy Absorption upon Human Modeling at 900 MHz, IEEE Transaction on Microwave Theory and Techniques, vol. 44 no. 10, Oct. 1996, pp. 1865-1873.
- [12] N. Kuster and Q. Balzano, Energy absorption mechanism by biological bodies in the near field of dipole antennas above 300MHz, IEEE Transaction on Vehicular Technology, vol. 41, no. 1, Feb. 1992, pp. 17-23.
- [13] G. Hartsgrove, A. Kraszewski, A. Surowiec, Simulated Biological Materials for Electromagnetic Radiation Absorption Studies, University of Ottawa, Bioelectromagnetics, Canada: 1987, pp. 29-36.
- [14] Q. Balzano, O. Garay, T. Manning Jr., Electromagnetic Energy Exposure of Simulated Users of Portable Cellular Telephones, IEEE Transactions on Vehicular Technology, vol. 44, no.3, Aug. 1995.
- [15] W. Gander, Computermathematick, Birkhaeuser, Basel, 1992.
- [16] W.H. Press, S.A. Teukolsky, W.T. Vetterling, and B.P. Flannery, Numerical Recipes in C, The Art of Scientific Computing, Second edition, Cambridge University Press, 1992.
- [17] N. Kuster, R. Kastle, T. Schmid, Dosimetric evaluation of mobile communications equipment with known precision, IEEE Transaction on Communications, vol. E80-B, no. 5, May 1997, pp. 645-652.

FCC ID: A3LSMG920I	 <b>PCTEST</b> ENGINEERING LABORATORY, INC.	<b>SAR EVALUATION REPORT</b>		<b>Reviewed by:</b> Quality Manager
<b>Document S/N:</b> 0Y1502060403.A3L	<b>Test Dates:</b> 01/12/15 - 02/11/15	<b>DUT Type:</b> Portable Handset	Page 71 of 72	

- [18] CENELEC CLC/SC111B, European Prestandard (prENV 50166-2), Human Exposure to Electromagnetic Fields High-frequency: 10kHz-300GHz, Jan. 1995.
- [19] Prof. Dr. Niels Kuster, ETH, Eidgenössische Technische Hochschule Zürich, Dosimetric Evaluation of the Cellular Phone.
- [20] IEC 62209-1, Human exposure to radio frequency fields from hand-held and body-mounted wireless communication devices - Human models, instrumentation, and procedures - Part 1: Procedure to determine the specific absorption rate (SAR) for hand-held devices used in close proximity to the ear (frequency range of 300 MHz to 3 GHz), Feb. 2005.
- [21] Industry Canada RSS-102 Radio Frequency Exposure Compliance of Radiocommunication Apparatus (All Frequency Bands) Issue 4, March 2010.
- [22] Health Canada Safety Code 6 Limits of Human Exposure to Radio Frequency Electromagnetic Fields in the Frequency Range from 3 kHz – 300 GHz, 2009
- [23] FCC SAR Test Procedures for 2G-3G Devices, Mobile Hotspot and UMPC Devices KDB Publications 941225, D01-D07
- [24] SAR Measurement Guidance for IEEE 802.11 Transmitters, KDB Publication 248227 D01 DR02-41929
- [25] FCC SAR Considerations for Handsets with Multiple Transmitters and Antennas, KDB Publications 648474 D03-D04
- [26] FCC SAR Evaluation Considerations for Laptop, Notebook, Netbook and Tablet Computers, FCC KDB Publication 616217 D04
- [27] FCC SAR Measurement and Reporting Requirements for 100MHz – 6 GHz, KDB Publications 865664 D01-D02
- [28] FCC General RF Exposure Guidance and SAR Procedures for Dongles, KDB Publication 447498, D01-D02
- [29] Anexo à Resolução No. 533, de 10 de Setembro de 2009.
- [30] IEC 62209-2, Human exposure to radio frequency fields from hand-held and body-mounted wireless communication devices - Human models, instrumentation, and procedures - Part 2: Procedure to determine the specific absorption rate (SAR) for wireless communication devices used in close proximity to the human body (frequency range of 30 MHz to 6 GHz), Mar. 2010.

<b>FCC ID:</b> A3LSMG920I	 <b>PCTEST</b> ENGINEERING LABORATORY, INC.	<b>SAR EVALUATION REPORT</b>		<b>Reviewed by:</b> Quality Manager
<b>Document S/N:</b> 0Y1502060403.A3L	<b>Test Dates:</b> 01/12/15 - 02/11/15	<b>DUT Type:</b> Portable Handset	Page 72 of 72	

## APPENDIX A: SAR TEST DATA

# PCTEST ENGINEERING LABORATORY, INC.

**DUT: A3LSMG920I; Type: Portable Handset; Serial: 146AD**

Communication System: UID 0, GSM; Frequency: 836.6 MHz; Duty Cycle: 1:8.3  
Medium: 835 Head Medium parameters used (interpolated):  
 $f = 836.6 \text{ MHz}$ ;  $\sigma = 0.892 \text{ S/m}$ ;  $\epsilon_r = 40.049$ ;  $\rho = 1000 \text{ kg/m}^3$   
Phantom section: Right Section

Test Date: 02-09-2015; Ambient Temp: 24.0°C; Tissue Temp: 21.2°C

Probe: ES3DV3 - SN3288; ConvF(6.51, 6.51, 6.51); Calibrated: 9/24/2014;  
Sensor-Surface: 3mm (Mechanical Surface Detection)  
Electronics: DAE4 Sn1364; Calibrated: 9/18/2014  
Phantom: SAM with CRP v4.0; Type: QD000P40CD; Serial: TP:1797  
Measurement SW: DASY52, Version 52.8 (8); SEMCAD X Version 14.6.10 (7331)

**Mode: GSM 850, Right Head, Cheek, Mid.ch**

**Area Scan (8x13x1):** Measurement grid:  $dx=15\text{mm}$ ,  $dy=15\text{mm}$

**Zoom Scan (6x5x7)/Cube 0:** Measurement grid:  $dx=8\text{mm}$ ,  $dy=8\text{mm}$ ,  $dz=5\text{mm}$

Reference Value = 14.01 V/m; Power Drift = 0.06 dB

Peak SAR (extrapolated) = 0.213 W/kg

**SAR(1 g) = 0.170 W/kg**

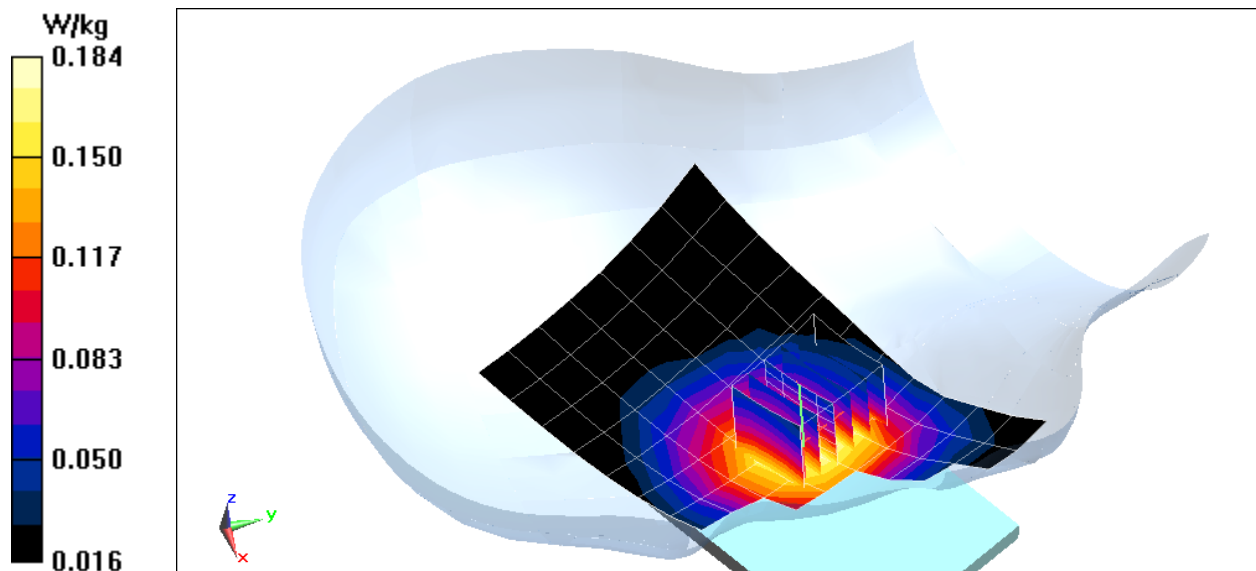

# PCTEST ENGINEERING LABORATORY, INC.

**DUT: A3LSMG920I; Type: Portable Handset; Serial: 1565F**

Communication System: UID 0, UMTS; Frequency: 836.6 MHz; Duty Cycle: 1:1  
Medium: 835 Head Medium parameters used (interpolated):  
 $f = 836.6 \text{ MHz}$ ;  $\sigma = 0.892 \text{ S/m}$ ;  $\epsilon_r = 40.049$ ;  $\rho = 1000 \text{ kg/m}^3$   
Phantom section: Left Section

Test Date: 02-09-2015; Ambient Temp: 24.0°C; Tissue Temp: 21.2°C

Probe: ES3DV3 - SN3288; ConvF(6.51, 6.51, 6.51); Calibrated: 9/24/2014;  
Sensor-Surface: 3mm (Mechanical Surface Detection)  
Electronics: DAE4 Sn1364; Calibrated: 9/18/2014  
Phantom: SAM with CRP v4.0; Type: QD000P40CD; Serial: TP:1797  
Measurement SW: DASY52, Version 52.8 (8); SEMCAD X Version 14.6.10 (7331)

**Mode: UMTS 850, Left Head, Cheek, Mid.ch**

**Area Scan (8x13x1):** Measurement grid:  $dx=15\text{mm}$ ,  $dy=15\text{mm}$

**Zoom Scan (5x5x7)/Cube 0:** Measurement grid:  $dx=8\text{mm}$ ,  $dy=8\text{mm}$ ,  $dz=5\text{mm}$

Reference Value = 17.37 V/m; Power Drift = 0.03 dB

Peak SAR (extrapolated) = 0.329 W/kg

**SAR(1 g) = 0.256 W/kg**

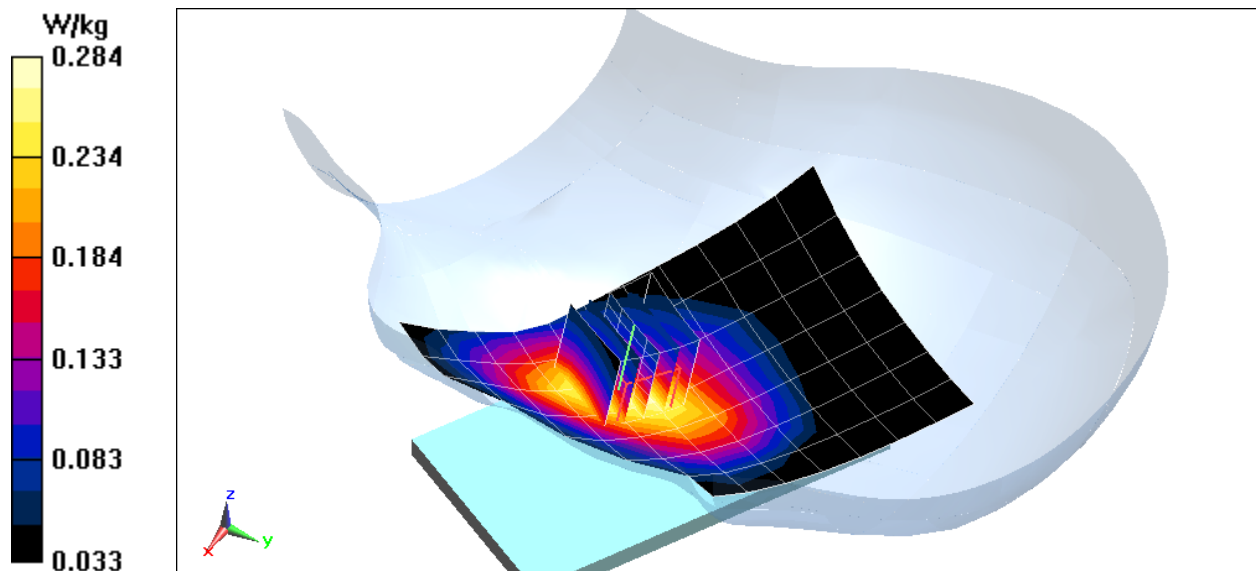

# PCTEST ENGINEERING LABORATORY, INC.

**DUT: A3LSMG920I; Type: Portable Handset; Serial: 1565F**

Communication System: UID 0, UMTS (0); Frequency: 1732.4 MHz; Duty Cycle: 1:1  
Medium: 1750 Head Medium parameters used (interpolated):  
 $f = 1732.4$  MHz;  $\sigma = 1.341$  S/m;  $\epsilon_r = 38.618$ ;  $\rho = 1000$  kg/m<sup>3</sup>  
Phantom section: Left Section

Test Date: 02-10-2015; Ambient Temp: 24.5°C; Tissue Temp: 22.5°C

Probe: ES3DV3 - SN3263; ConvF(5.41, 5.41, 5.41); Calibrated: 5/15/2014;  
Sensor-Surface: 3mm (Mechanical Surface Detection)  
Electronics: DAE4 Sn859; Calibrated: 5/14/2014  
Phantom: SAM v5.0 Left; Type: QD000P40CD; Serial: TP: 1687  
Measurement SW: DASY52, Version 52.8 (8); SEMCAD X Version 14.6.10 (7331)

**Mode: AWS UMTS, Left Head, Cheek, Mid.ch**

**Area Scan (9x15x1):** Measurement grid: dx=15mm, dy=15mm

**Zoom Scan (5x5x7)/Cube 0:** Measurement grid: dx=8mm, dy=8mm, dz=5mm

Reference Value = 13.15 V/m; Power Drift = 0.06 dB

Peak SAR (extrapolated) = 0.317 W/kg

**SAR(1 g) = 0.224 W/kg**

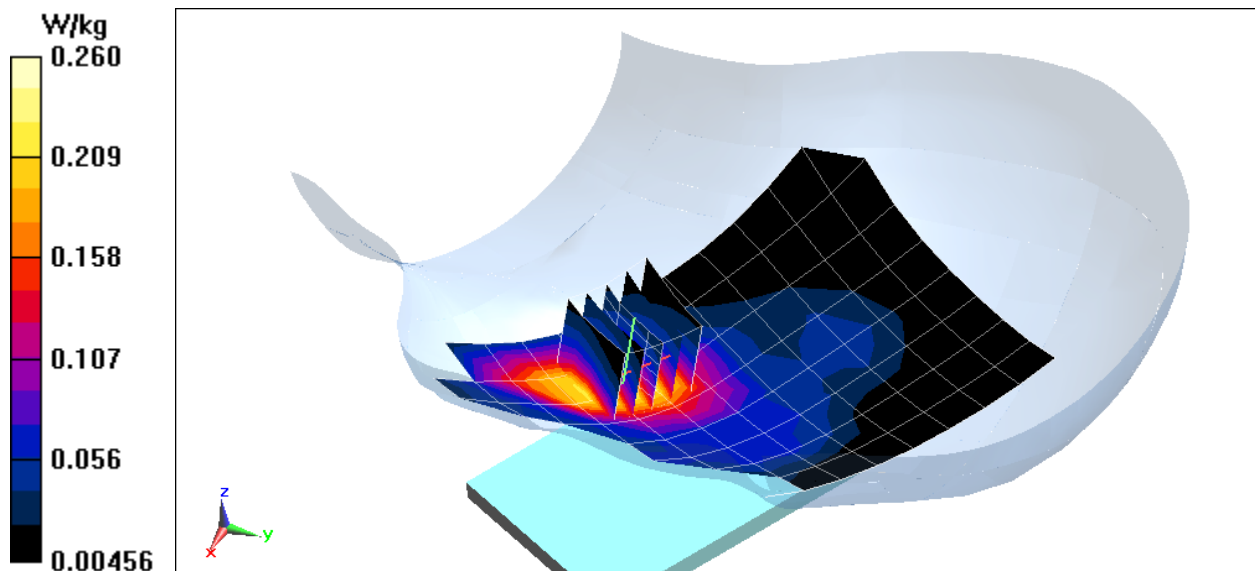

# PCTEST ENGINEERING LABORATORY, INC.

**DUT: A3LSMG920I; Type: Portable Handset; Serial: 146D0**

Communication System: UID 0, GSM1900; Frequency: 1880 MHz; Duty Cycle: 1:8.3  
Medium: 1900 Head Medium parameters used:  
 $f = 1880 \text{ MHz}$ ;  $\sigma = 1.422 \text{ S/m}$ ;  $\epsilon_r = 38.997$ ;  $\rho = 1000 \text{ kg/m}^3$   
Phantom section: Left Section

Test Date: 02-09-2015; Ambient Temp: 24.3°C; Tissue Temp: 23.0°C

Probe: ES3DV3 - SN3263; ConvF(5.08, 5.08, 5.08); Calibrated: 5/15/2014;  
Sensor-Surface: 3mm (Mechanical Surface Detection)  
Electronics: DAE4 Sn859; Calibrated: 5/14/2014  
Phantom: SAM v5.0 front; Type: QD000P40CD; Serial: TP-1646  
Measurement SW: DASY52, Version 52.8 (8); SEMCAD X Version 14.6.10 (7331)

**Mode: GSM 1900, Left Head, Cheek, Mid.ch**

**Area Scan (9x13x1):** Measurement grid: dx=15mm, dy=15mm

**Zoom Scan (5x5x7)/Cube 0:** Measurement grid: dx=8mm, dy=8mm, dz=5mm

Reference Value = 6.980 V/m; Power Drift = -0.07 dB

Peak SAR (extrapolated) = 0.0980 W/kg

**SAR(1 g) = 0.061 W/kg**

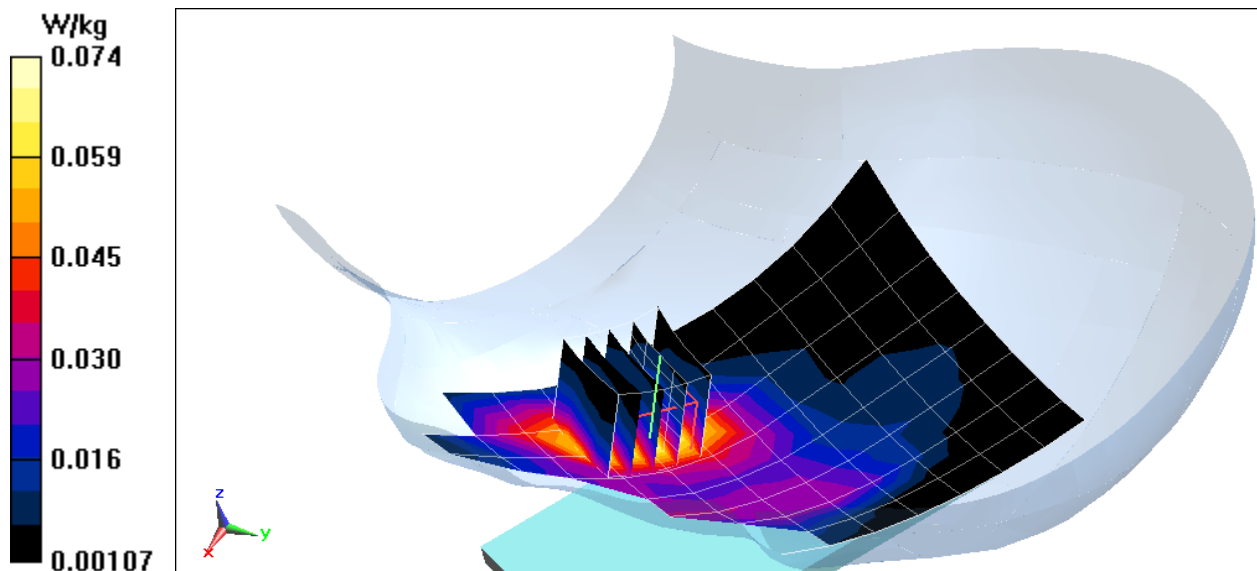

# PCTEST ENGINEERING LABORATORY, INC.

**DUT: A3LSMG920I; Type: Portable Handset; Serial: 1565F**

Communication System: UID 0, UMTS; Frequency: 1880 MHz; Duty Cycle: 1:1  
Medium: 1900 Head Medium parameters used:  
 $f = 1880 \text{ MHz}$ ;  $\sigma = 1.422 \text{ S/m}$ ;  $\epsilon_r = 38.997$ ;  $\rho = 1000 \text{ kg/m}^3$   
Phantom section: Left Section

Test Date: 02-09-2015; Ambient Temp: 24.3°C; Tissue Temp: 23.0°C

Probe: ES3DV3 - SN3263; ConvF(5.08, 5.08, 5.08); Calibrated: 5/15/2014;  
Sensor-Surface: 3mm (Mechanical Surface Detection)  
Electronics: DAE4 Sn859; Calibrated: 5/14/2014  
Phantom: SAM v5.0 front; Type: QD000P40CD; Serial: TP-1646  
Measurement SW: DASY52, Version 52.8 (8); SEMCAD X Version 14.6.10 (7331)

**Mode: UMTS 1900, Left Head, Cheek, Mid.ch**

**Area Scan (9x15x1):** Measurement grid:  $dx=15\text{mm}$ ,  $dy=15\text{mm}$

**Zoom Scan (5x5x7)/Cube 0:** Measurement grid:  $dx=8\text{mm}$ ,  $dy=8\text{mm}$ ,  $dz=5\text{mm}$

Reference Value = 9.228 V/m; Power Drift = 0.00 dB

Peak SAR (extrapolated) = 0.187 W/kg

**SAR(1 g) = 0.120 W/kg**

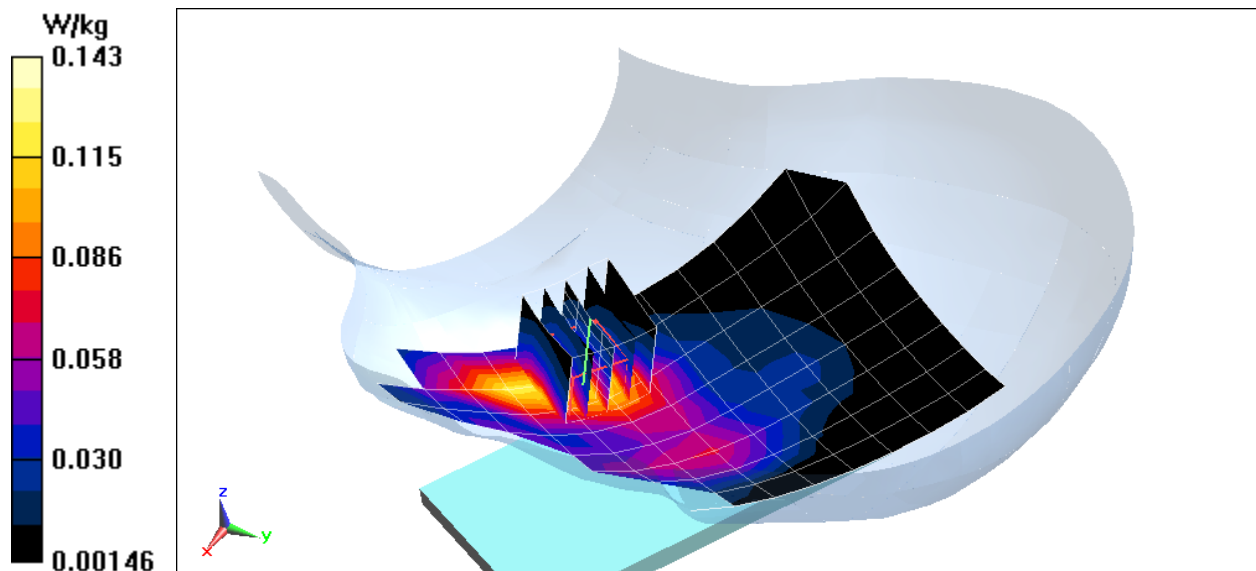

# PCTEST ENGINEERING LABORATORY, INC.

**DUT: A3LSMG920I; Type: Portable Handset; Serial: 146AD**

Communication System: UID 0, LTE Band 12 (0); Frequency: 707.5 MHz; Duty Cycle: 1:1  
Medium: 750 Head Medium parameters used (interpolated):  
 $f = 707.5 \text{ MHz}$ ;  $\sigma = 0.869 \text{ S/m}$ ;  $\epsilon_r = 41.385$ ;  $\rho = 1000 \text{ kg/m}^3$   
Phantom section: Left Section

Test Date: 02-11-2015; Ambient Temp: 23.9°C; Tissue Temp: 22.5°C

Probe: ES3DV3 - SN3213; ConvF(6.45, 6.45, 6.45); Calibrated: 1/20/2015;  
Sensor-Surface: 3mm (Mechanical Surface Detection)  
Electronics: DAE4 Sn1407; Calibrated: 1/19/2015  
Phantom: SAM Front; Type: SAM; Serial: 1686  
Measurement SW: DASY52, Version 52.8 (8); SEMCAD X Version 14.6.10 (7331)

**Mode: LTE Band 12, Left Head, Cheek, Mid.ch, QPSK,  
10 MHz Bandwidth, 1 RB, 49 RB Offset**

**Area Scan (8x13x1):** Measurement grid:  $dx=15\text{mm}$ ,  $dy=15\text{mm}$   
**Zoom Scan (5x5x7)/Cube 0:** Measurement grid:  $dx=8\text{mm}$ ,  $dy=8\text{mm}$ ,  $dz=5\text{mm}$   
Reference Value = 12.91 V/m; Power Drift = -0.05 dB  
Peak SAR (extrapolated) = 0.166 W/kg  
**SAR (1 g) = 0.127 W/kg**

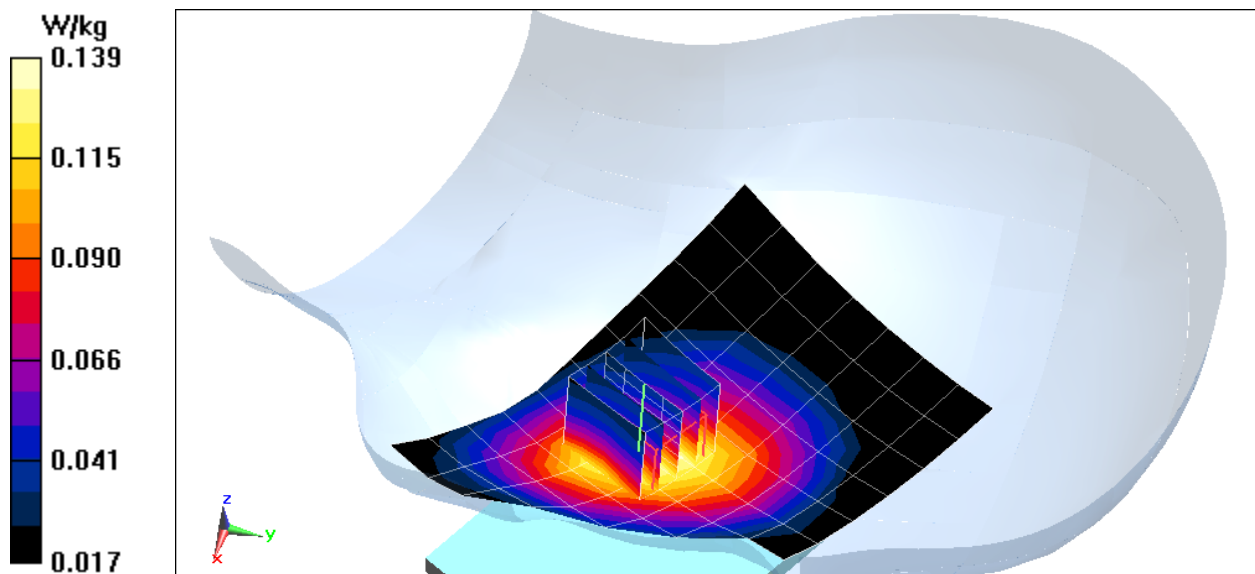

# PCTEST ENGINEERING LABORATORY, INC.

**DUT: A3LSMG920I; Type: Portable Handset; Serial: 146AD**

Communication System: UID 0, LTE Band 26 (0); Frequency: 836.5 MHz; Duty Cycle: 1:1  
Medium: 835 Head Medium parameters used (interpolated):  
 $f = 836.5 \text{ MHz}$ ;  $\sigma = 0.892 \text{ S/m}$ ;  $\epsilon_r = 40.05$ ;  $\rho = 1000 \text{ kg/m}^3$   
Phantom section: Left Section

Test Date: 02-09-2015; Ambient Temp: 24.0°C; Tissue Temp: 21.2°C

Probe: ES3DV3 - SN3288; ConvF(6.51, 6.51, 6.51); Calibrated: 9/24/2014;  
Sensor-Surface: 3mm (Mechanical Surface Detection)  
Electronics: DAE4 Sn1364; Calibrated: 9/18/2014  
Phantom: SAM with CRP v4.0; Type: QD000P40CD; Serial: TP:1797  
Measurement SW: DASY52, Version 52.8 (8); SEMCAD X Version 14.6.10 (7331)

**Mode: LTE Band 26, Left Head, Cheek, Mid.ch,  
15 MHz Bandwidth, QPSK, 1 RB, 36 RB Offset**

**Area Scan (9x15x1):** Measurement grid: dx=15mm, dy=15mm  
**Zoom Scan (5x5x7)/Cube 0:** Measurement grid: dx=8mm, dy=8mm, dz=5mm  
Reference Value = 15.05 V/m; Power Drift = 0.01 dB  
Peak SAR (extrapolated) = 0.223 W/kg  
**SAR(1 g) = 0.175 W/kg**

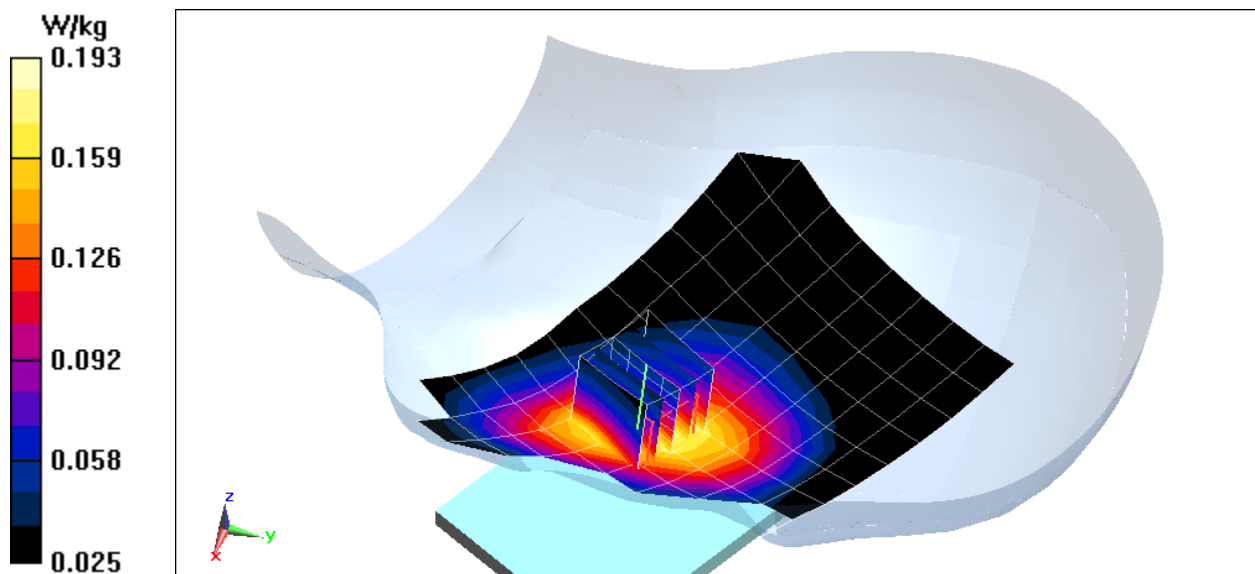

# PCTEST ENGINEERING LABORATORY, INC.

**DUT: A3LSMG920I; Type: Portable Handset; Serial: 146AD**

Communication System: UID 0, LTE RF Band 4 (0); Frequency: 1732.5 MHz; Duty Cycle: 1:1  
Medium: 1750 Head Medium parameters used (interpolated):  
 $f = 1732.5 \text{ MHz}$ ;  $\sigma = 1.341 \text{ S/m}$ ;  $\epsilon_r = 38.618$ ;  $\rho = 1000 \text{ kg/m}^3$   
Phantom section: Left Section

Test Date: 02-10-2015; Ambient Temp: 24.5°C; Tissue Temp: 22.5°C

Probe: ES3DV3 - SN3263; ConvF(5.41, 5.41, 5.41); Calibrated: 5/15/2014;  
Sensor-Surface: 3mm (Mechanical Surface Detection)  
Electronics: DAE4 Sn859; Calibrated: 5/14/2014  
Phantom: SAM v5.0 Left; Type: QD000P40CD; Serial: TP: 1687  
Measurement SW: DASY52, Version 52.8 (8); SEMCAD X Version 14.6.10 (7331)

**Mode: LTE Band 4 (AWS), Left Head, Cheek, Mid.ch,  
20 MHz Bandwidth, QPSK, 1 RB, 50 RB Offset**

**Area Scan (9x15x1):** Measurement grid: dx=15mm, dy=15mm  
**Zoom Scan (6x6x7)/Cube 0:** Measurement grid: dx=8mm, dy=8mm, dz=5mm  
Reference Value = 13.02 V/m; Power Drift = 0.05 dB  
Peak SAR (extrapolated) = 0.293 W/kg  
**SAR(1 g) = 0.201 W/kg**

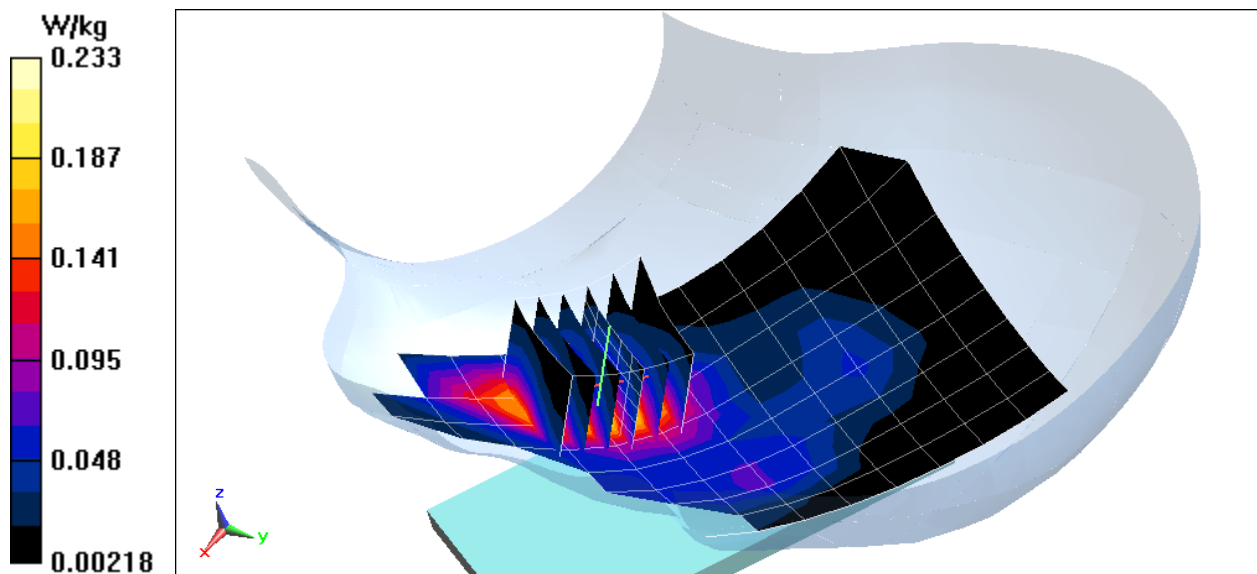

# PCTEST ENGINEERING LABORATORY, INC.

**DUT: A3LSMG920I; Type: Portable Handset; Serial: 1565F**

Communication System: UID 0, LTE Band 2 (PCS) (0); Frequency: 1860 MHz; Duty Cycle: 1:1  
Medium: 1900 Head Medium parameters used (interpolated):  
 $f = 1860 \text{ MHz}$ ;  $\sigma = 1.401 \text{ S/m}$ ;  $\epsilon_r = 39.058$ ;  $\rho = 1000 \text{ kg/m}^3$   
Phantom section: Left Section

Test Date: 02-09-2015; Ambient Temp: 24.3°C; Tissue Temp: 23.0°C

Probe: ES3DV3 - SN3263; ConvF(5.08, 5.08, 5.08); Calibrated: 5/15/2014;  
Sensor-Surface: 3mm (Mechanical Surface Detection)  
Electronics: DAE4 Sn859; Calibrated: 5/14/2014  
Phantom: SAM v5.0 front; Type: QD000P40CD; Serial: TP-1646  
Measurement SW: DASY52, Version 52.8 (8); SEMCAD X Version 14.6.10 (7331)

**Mode: LTE Band 2 (PCS), Left Head, Cheek, Low.ch, QPSK,  
20 MHz Bandwidth, 1 RB, 50 RB Offset**

**Area Scan (9x13x1):** Measurement grid:  $dx=15\text{mm}$ ,  $dy=15\text{mm}$   
**Zoom Scan (5x5x7)/Cube 0:** Measurement grid:  $dx=8\text{mm}$ ,  $dy=8\text{mm}$ ,  $dz=5\text{mm}$   
Reference Value = 9.738 V/m; Power Drift = 0.01 dB  
Peak SAR (extrapolated) = 0.169 W/kg  
**SAR(1 g) = 0.106 W/kg**

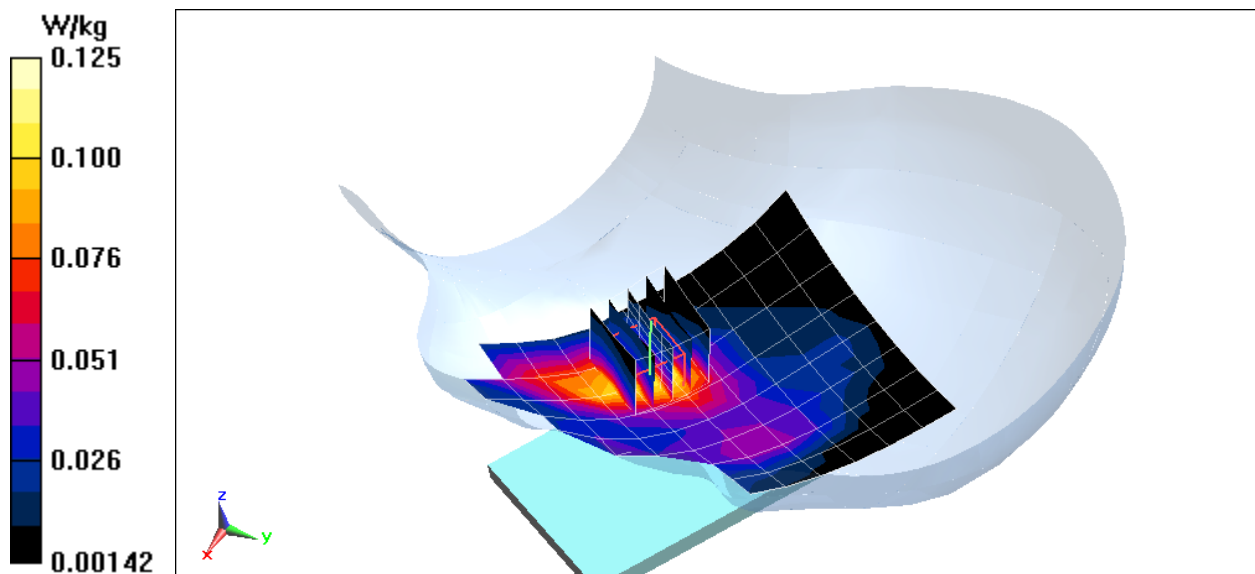

# PCTEST ENGINEERING LABORATORY, INC.

**DUT: A3LSMG920I; Type: Portable Handset; Serial: 05C58**

Communication System: UID 0, IEEE 802.11b; Frequency: 2412 MHz; Duty Cycle: 1:1  
Medium: 2450 Head Medium parameters used (interpolated):  
 $f = 2412 \text{ MHz}$ ;  $\sigma = 1.813 \text{ S/m}$ ;  $\epsilon_r = 38.275$ ;  $\rho = 1000 \text{ kg/m}^3$   
Phantom section: Left Section

Test Date: 01-12-2015; Ambient Temp: 23.0°C; Tissue Temp: 23.0°C

Probe: ES3DV3 - SN3263; ConvF(4.47, 4.47, 4.47); Calibrated: 5/15/2014;  
Sensor-Surface: 3mm (Mechanical Surface Detection)  
Electronics: DAE4 Sn859; Calibrated: 5/14/2014  
Phantom: SAM v5.0 Left; Type: QD000P40CD; Serial: TP: 1687  
Measurement SW: DASY52, Version 52.8 (8); SEMCAD X Version 14.6.10 (7331)

**Mode: IEEE 802.11b, 22 MHz Bandwidth**  
**Left Head, Cheek, Ch 01, 1 Mbps, Antenna 2**

**Area Scan (11x16x1):** Measurement grid: dx=12mm, dy=12mm  
**Zoom Scan (7x7x7)/Cube 0:** Measurement grid: dx=5mm, dy=5mm, dz=5mm  
Reference Value = 23.28 V/m; Power Drift = 0.02 dB  
Peak SAR (extrapolated) = 1.74 W/kg  
**SAR (1 g) = 0.825 W/kg**

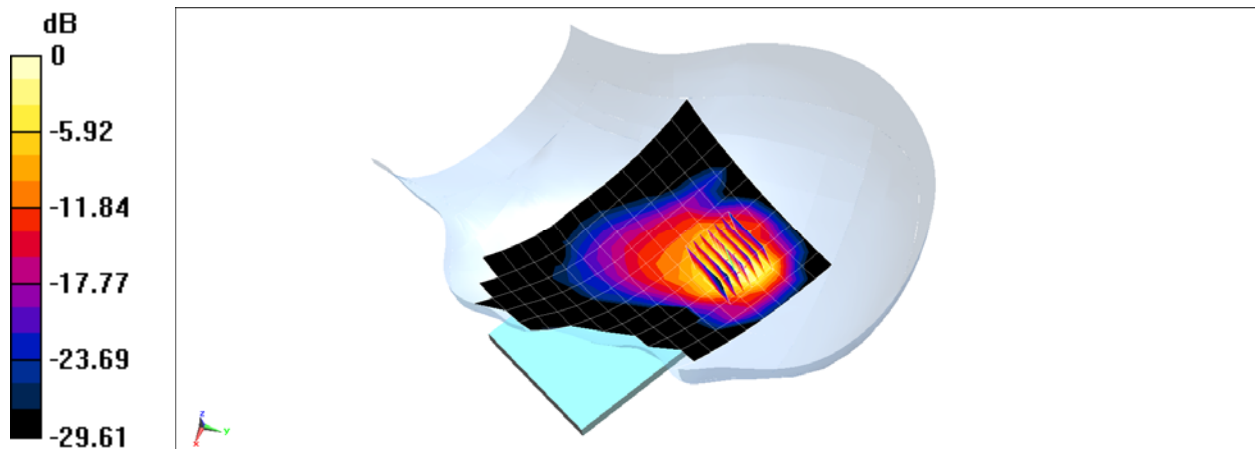

# PCTEST ENGINEERING LABORATORY, INC.

**DUT: A3LSMG920I; Type: Portable Handset; Serial: 05C9A**

Communication System: UID 0, IEEE 802.11a; Frequency: 5260 MHz; Duty Cycle: 1:1  
Medium: 5 GHz Head Medium parameters used:  
 $f = 5260 \text{ MHz}$ ;  $\sigma = 4.732 \text{ S/m}$ ;  $\epsilon_r = 35.798$ ;  $\rho = 1000 \text{ kg/m}^3$   
Phantom section: Right Section

Test Date: 01-19-2015; Ambient Temp: 23.0°C; Tissue Temp: 21.1°C

Probe: EX3DV4 - SN7308; ConvF(5.37, 5.37, 5.37); Calibrated: 7/16/2014;  
Sensor-Surface: 1.4mm (Mechanical Surface Detection)  
Electronics: DAE4 Sn1323; Calibrated: 9/17/2014  
Phantom: SAM V5.0 Right; Type: QD000P40CD; Serial: 1647  
Measurement SW: DASY52, Version 52.8 (8); SEMCAD X Version 14.6.10 (7331)

**Mode: IEEE 802.11a, U-NII-2A, 20 MHz Bandwidth  
Right Head, Tilt, Ch 52, 6 Mbps, Antenna 1**

**Area Scan (13x14x1):** Measurement grid:  $dx=10\text{mm}$ ,  $dy=10\text{mm}$

**Zoom Scan (7x7x7)/Cube 0:** Measurement grid:  $dx=4\text{mm}$ ,  $dy=4\text{mm}$ ,  $dz=1.4\text{mm}$ ; Graded Ratio = 1.4

Reference Value = 7.739 V/m; Power Drift = 0.12 dB

Peak SAR (extrapolated) = 1.17 W/kg

**SAR (1 g) = 0.250 W/kg**

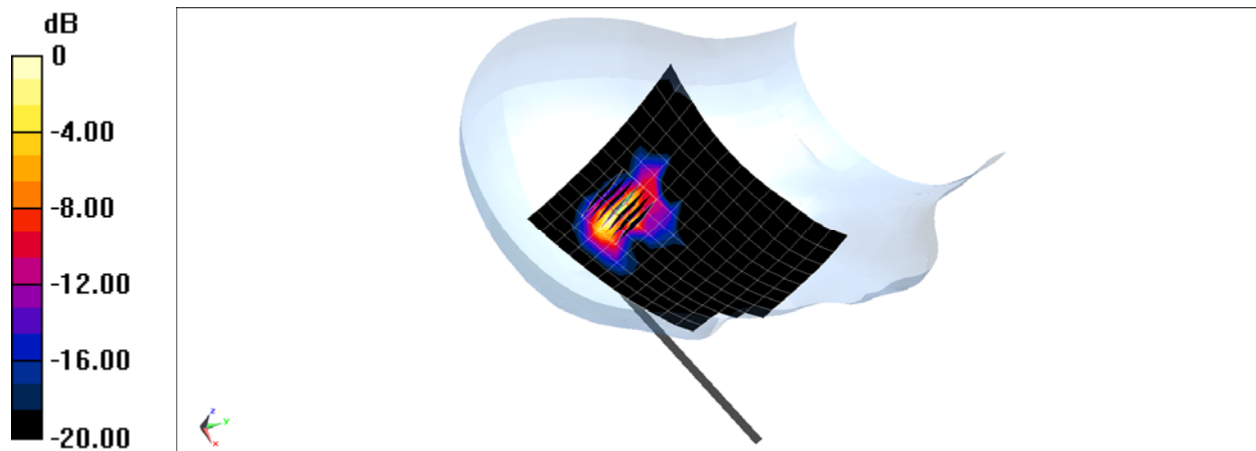

# PCTEST ENGINEERING LABORATORY, INC.

**DUT: A3LSMG920I; Type: Portable Handset; Serial: 146D0**

Communication System: UID 0, GSM850 (0); Frequency: 836.6 MHz; Duty Cycle: 1:8.3  
Medium: 835 Body Medium parameters used (interpolated):  
 $f = 836.6 \text{ MHz}$ ;  $\sigma = 1.002 \text{ S/m}$ ;  $\epsilon_r = 53.41$ ;  $\rho = 1000 \text{ kg/m}^3$   
Phantom section: Flat Section; Space: 1.0 cm

Test Date: 02-09-2015; Ambient Temp: 24.0°C; Tissue Temp: 21.8°C

Probe: ES3DV3 - SN3288; ConvF(6.32, 6.32, 6.32); Calibrated: 9/24/2014;  
Sensor-Surface: 3mm (Mechanical Surface Detection)  
Electronics: DAE4 Sn1364; Calibrated: 9/18/2014  
Phantom: ELI v5.0; Type: QDOVA001BB; Serial: 1229  
Measurement SW: DASY52, Version 52.8 (8); SEMCAD X Version 14.6.10 (7331)

**Mode: GSM 850, Body SAR, Back Side, Mid.ch**

**Area Scan (9x15x1):** Measurement grid: dx=15mm, dy=15mm

**Zoom Scan (5x5x7)/Cube 0:** Measurement grid: dx=8mm, dy=8mm, dz=5mm

Reference Value = 17.82 V/m; Power Drift = 0.01 dB

Peak SAR (extrapolated) = 0.498 W/kg

**SAR(1 g) = 0.290 W/kg**

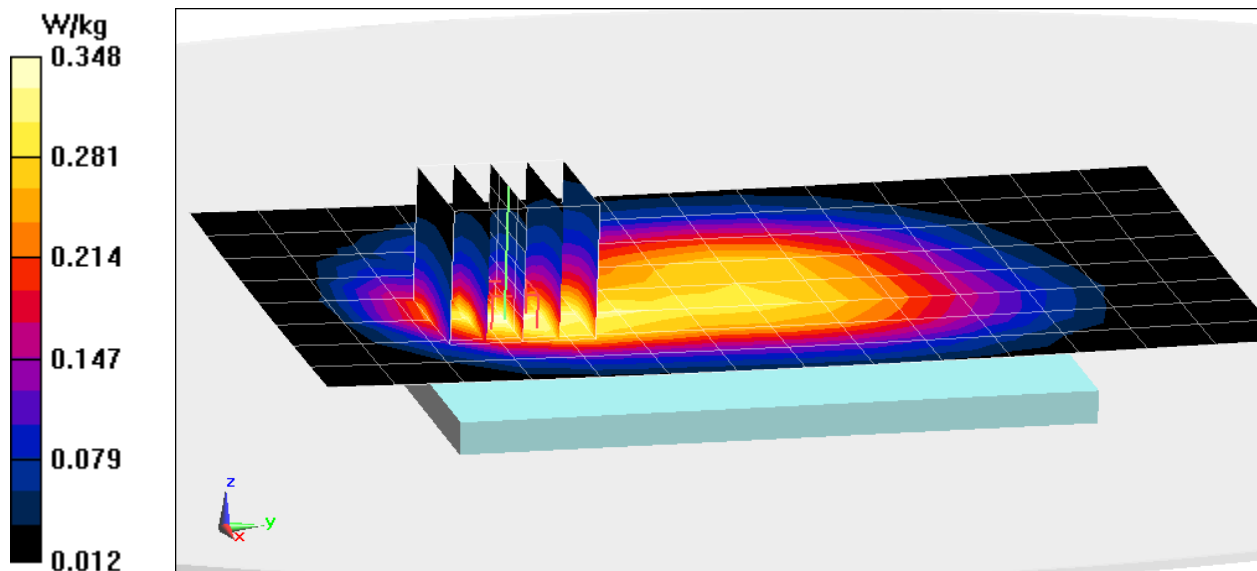

# PCTEST ENGINEERING LABORATORY, INC.

**DUT: A3LSMG920I; Type: Portable Handset; Serial: 146D0**

Communication System: UID 0, GSM GPRS; 2 Tx slots (0); Frequency: 836.6 MHz; Duty Cycle: 1:4.15  
Medium: 835 Body Medium parameters used (interpolated):  
 $f = 836.6 \text{ MHz}$ ;  $\sigma = 1.002 \text{ S/m}$ ;  $\epsilon_r = 53.41$ ;  $\rho = 1000 \text{ kg/m}^3$   
Phantom section: Flat Section; Space: 1.0 cm

Test Date: 02-09-2015; Ambient Temp: 24.0°C; Tissue Temp: 21.8°C

Probe: ES3DV3 - SN3288; ConvF(6.32, 6.32, 6.32); Calibrated: 9/24/2014;  
Sensor-Surface: 3mm (Mechanical Surface Detection)  
Electronics: DAE4 Sn1364; Calibrated: 9/18/2014  
Phantom: ELI v5.0; Type: QDOVA001BB; Serial: 1229  
Measurement SW: DASY52, Version 52.8 (8); SEMCAD X Version 14.6.10 (7331)

**Mode: GPRS 850, Body SAR, Left Edge, Mid.ch, 2 Tx Slots**

**Area Scan (10x13x1):** Measurement grid: dx=5mm, dy=15mm

**Zoom Scan (5x5x7)/Cube 0:** Measurement grid: dx=8mm, dy=8mm, dz=5mm

Reference Value = 22.65 V/m; Power Drift = -0.06 dB

Peak SAR (extrapolated) = 0.695 W/kg

**SAR(1 g) = 0.472 W/kg**

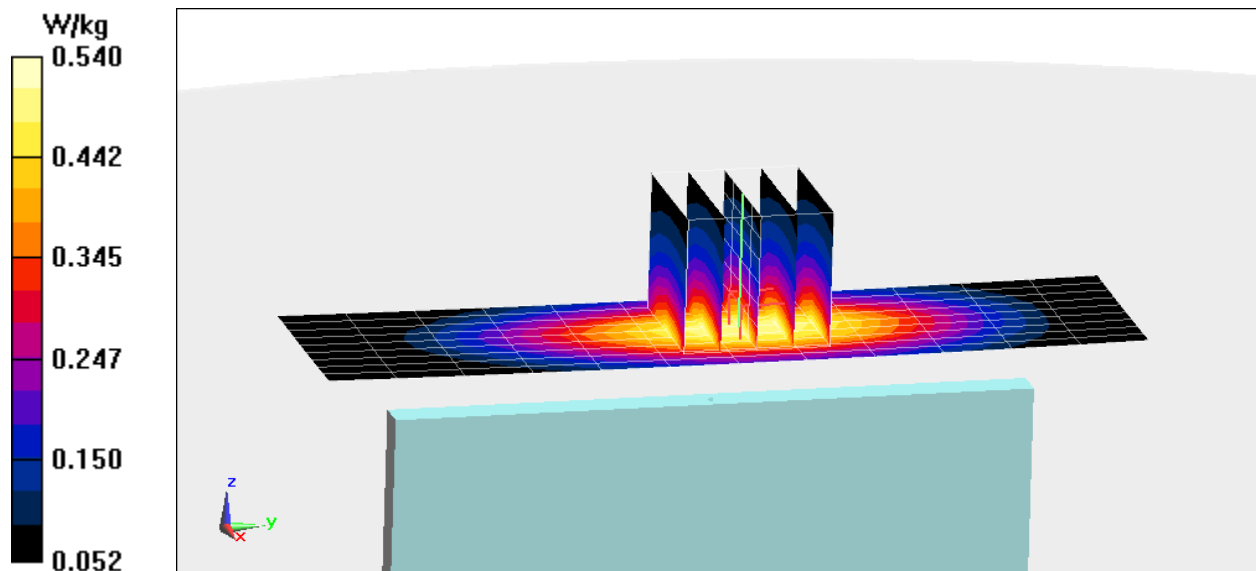

# PCTEST ENGINEERING LABORATORY, INC.

**DUT: A3LSMG920I; Type: Portable Handset; Serial: 1565F**

Communication System: UID 0, UMTS; Frequency: 836.6 MHz; Duty Cycle: 1:1  
Medium: 835 Body Medium parameters used (interpolated):  
 $f = 836.6 \text{ MHz}$ ;  $\sigma = 1.002 \text{ S/m}$ ;  $\epsilon_r = 53.41$ ;  $\rho = 1000 \text{ kg/m}^3$   
Phantom section: Flat Section; Space: 1.0 cm

Test Date: 02-09-2015; Ambient Temp: 24.0°C; Tissue Temp: 21.8°C

Probe: ES3DV3 - SN3288; ConvF(6.32, 6.32, 6.32); Calibrated: 9/24/2014;  
Sensor-Surface: 3mm (Mechanical Surface Detection)  
Electronics: DAE4 Sn1364; Calibrated: 9/18/2014  
Phantom: ELI v5.0; Type: QDOVA001BB; Serial: 1229  
Measurement SW: DASY52, Version 52.8 (8); SEMCAD X Version 14.6.10 (7331)

**Mode: UMTS 850, Body SAR, Back Side, Mid.ch**

**Area Scan (9x15x1):** Measurement grid: dx=15mm, dy=15mm

**Zoom Scan (5x5x7)/Cube 0:** Measurement grid: dx=8mm, dy=8mm, dz=5mm

Reference Value = 22.04 V/m; Power Drift = -0.01 dB

Peak SAR (extrapolated) = 0.716 W/kg

**SAR(1 g) = 0.454 W/kg**

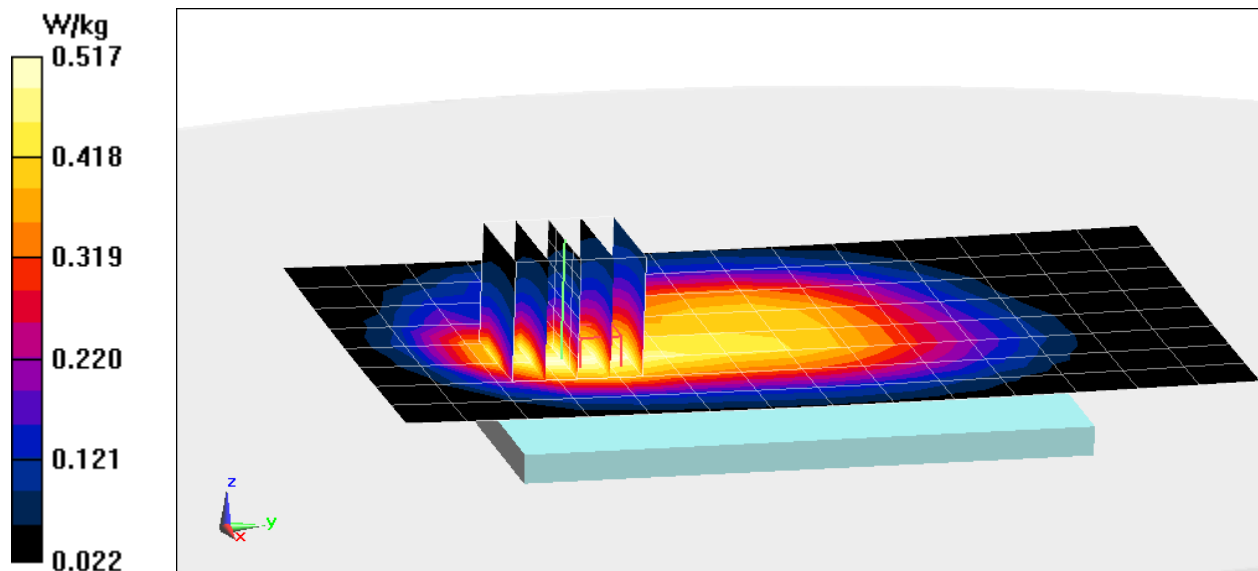

# PCTEST ENGINEERING LABORATORY, INC.

**DUT: A3LSMG920I; Type: Portable Handset; Serial: 1565F**

Communication System: UID 0, UMTS (0); Frequency: 1732.4 MHz; Duty Cycle: 1:1  
Medium: 1750 Body Medium parameters used (interpolated):  
 $f = 1732.4$  MHz;  $\sigma = 1.477$  S/m;  $\epsilon_r = 52.067$ ;  $\rho = 1000$  kg/m<sup>3</sup>  
Phantom section: Flat Section; Space: 1.0 cm

Test Date: 02-10-2015; Ambient Temp: 23.7°C; Tissue Temp: 21.9°C

Probe: ES3DV2 - SN3022; ConvF(4.7, 4.7, 4.7); Calibrated: 8/19/2014;  
Sensor-Surface: 3mm (Mechanical Surface Detection)  
Electronics: DAE4 Sn1322; Calibrated: 8/12/2014  
Phantom: SAM with CRP v4.0; Type: QD000P40CD; Serial: TP:1800  
Measurement SW: DASY52, Version 52.8 (8); SEMCAD X Version 14.6.10 (7331)

**Mode: AWS UMTS, Body SAR, Back side, Mid.ch**

**Area Scan (9x15x1):** Measurement grid: dx=15mm, dy=15mm

**Zoom Scan (6x5x7)/Cube 0:** Measurement grid: dx=8mm, dy=8mm, dz=5mm

Reference Value = 19.21 V/m; Power Drift = 0.00 dB

Peak SAR (extrapolated) = 0.787 W/kg

**SAR(1 g) = 0.480 W/kg**

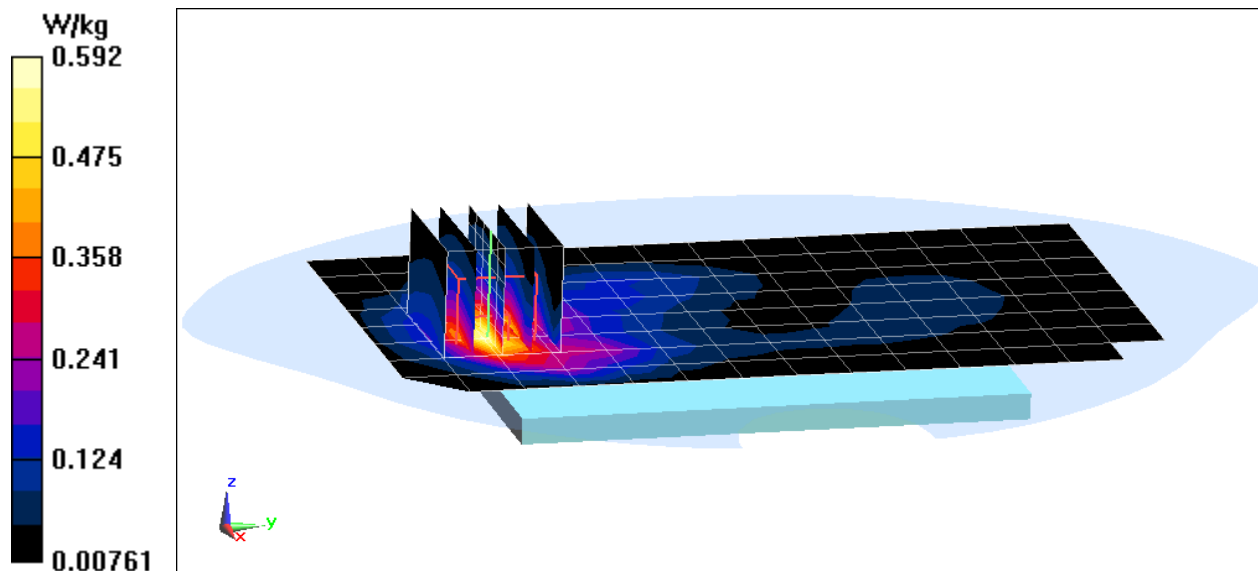

# PCTEST ENGINEERING LABORATORY, INC.

**DUT: A3LSMG920I; Type: Portable Handset; Serial: 1565F**

Communication System: UID 0, UMTS (0); Frequency: 1712.4 MHz; Duty Cycle: 1:1  
Medium: 1750 Medium parameters used (interpolated):  
 $f = 1712.4$  MHz;  $\sigma = 1.454$  S/m;  $\epsilon_r = 52.132$ ;  $\rho = 1000$  kg/m<sup>3</sup>  
Phantom section: Flat Section; Space: 1.0 cm

Test Date: 02-10-2015; Ambient Temp: 23.7°C; Tissue Temp: 21.9°C

Probe: ES3DV2 - SN3022; ConvF(4.7, 4.7, 4.7); Calibrated: 8/19/2014;  
Sensor-Surface: 3mm (Mechanical Surface Detection)  
Electronics: DAE4 Sn1322; Calibrated: 8/12/2014  
Phantom: SAM with CRP v4.0; Type: QD000P40CD; Serial: TP:1800  
Measurement SW: DASY52, Version 52.8 (8); SEMCAD X Version 14.6.10 (7331)

**Mode: AWS UMTS, Body SAR, Bottom Edge, Low.ch**

**Area Scan (10x7x1):** Measurement grid: dx=5mm, dy=15mm

**Zoom Scan (5x5x7)/Cube 0:** Measurement grid: dx=8mm, dy=8mm, dz=5mm

Reference Value = 26.21 V/m; Power Drift = 0.03 dB

Peak SAR (extrapolated) = 1.48 W/kg

**SAR(1 g) = 0.911 W/kg**

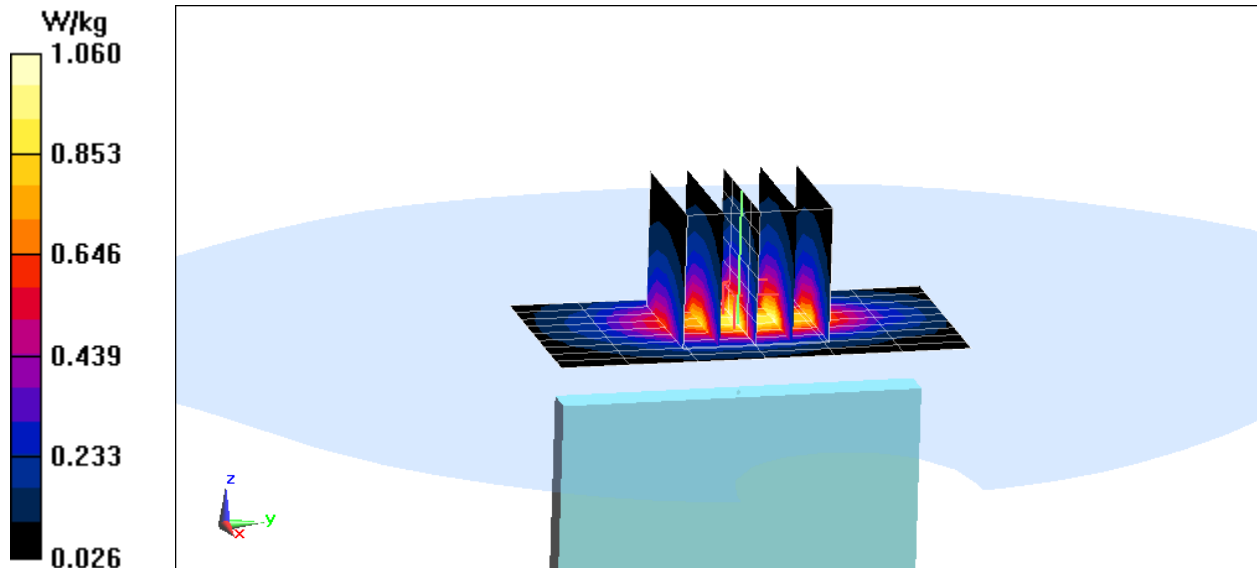

# PCTEST ENGINEERING LABORATORY, INC.

**DUT: A3LSMG920I; Type: Portable Handset; Serial: 146D0**

Communication System: UID 0, GSM; Frequency: 1880 MHz; Duty Cycle: 1:8.3  
Medium: 1900 Body Medium parameters used:  
 $f = 1880 \text{ MHz}$ ;  $\sigma = 1.528 \text{ S/m}$ ;  $\epsilon_r = 52.387$ ;  $\rho = 1000 \text{ kg/m}^3$   
Phantom section: Flat Section; Space: 1.0 cm

Test Date: 02-09-2015; Ambient Temp: 23.0°C; Tissue Temp: 22.4°C

Probe: ES3DV3 - SN3332; ConvF(4.64, 4.64, 4.64); Calibrated: 9/18/2014;  
Sensor-Surface: 3mm (Mechanical Surface Detection)  
Electronics: DAE4 Sn1323; Calibrated: 9/17/2014  
Phantom: SAM 5.0 front; Type: QD000P40CD; Serial: TP:-1648  
Measurement SW: DASY52, Version 52.8 (8); SEMCAD X Version 14.6.10 (7331)

**Mode: GSM 1900, Body SAR, Back side, Mid.ch**

**Area Scan (9x13x1):** Measurement grid:  $dx=15\text{mm}$ ,  $dy=15\text{mm}$

**Zoom Scan (5x5x7)/Cube 0:** Measurement grid:  $dx=8\text{mm}$ ,  $dy=8\text{mm}$ ,  $dz=5\text{mm}$

Reference Value = 15.23 V/m; Power Drift = 0.02 dB

Peak SAR (extrapolated) = 0.655 W/kg

**SAR(1 g) = 0.390 W/kg**

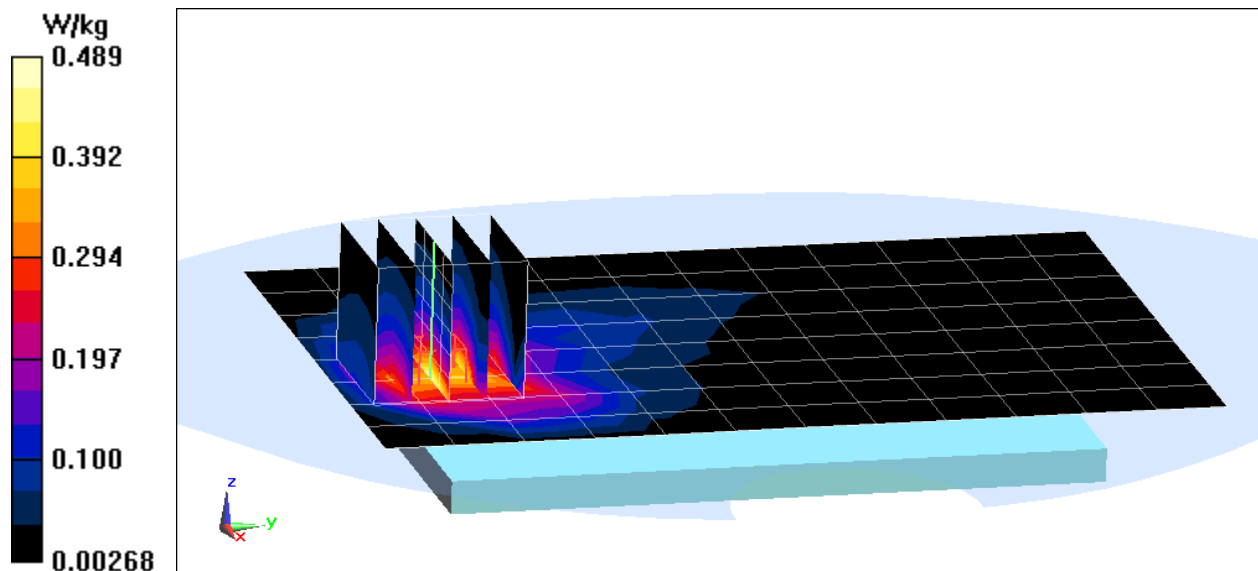

# PCTEST ENGINEERING LABORATORY, INC.

**DUT: A3LSMG920I; Type: Portable Handset; Serial: 146D0**

Communication System: UID 0, GSM1900 GPRS; 2 Tx slots; Frequency: 1850.2 MHz; Duty Cycle: 1:4.15  
Medium: 1900 Body Medium parameters used (interpolated):  
 $f = 1850.2 \text{ MHz}$ ;  $\sigma = 1.496 \text{ S/m}$ ;  $\epsilon_r = 52.491$ ;  $\rho = 1000 \text{ kg/m}^3$   
Phantom section: Flat Section; Space: 1.0 cm

Test Date: 02-09-2015; Ambient Temp: 23.0°C; Tissue Temp: 22.4°C

Probe: ES3DV3 - SN3332; ConvF(4.64, 4.64, 4.64); Calibrated: 9/18/2014;  
Sensor-Surface: 3mm (Mechanical Surface Detection)  
Electronics: DAE4 Sn1323; Calibrated: 9/17/2014  
Phantom: SAM 5.0 front; Type: QD000P40CD; Serial: TP:-1648  
Measurement SW: DASY52, Version 52.8 (8); SEMCAD X Version 14.6.10 (7331)

**Mode: GPRS 1900, Body SAR, Bottom Edge, Low.ch, 2 Tx Slots**

**Area Scan (9x9x1):** Measurement grid: dx=5mm, dy=15mm  
**Zoom Scan (5x5x7)/Cube 0:** Measurement grid: dx=8mm, dy=8mm, dz=5mm  
Reference Value = 25.98 V/m; Power Drift = -0.11 dB  
Peak SAR (extrapolated) = 1.48 W/kg  
**SAR(1 g) = 0.907 W/kg**

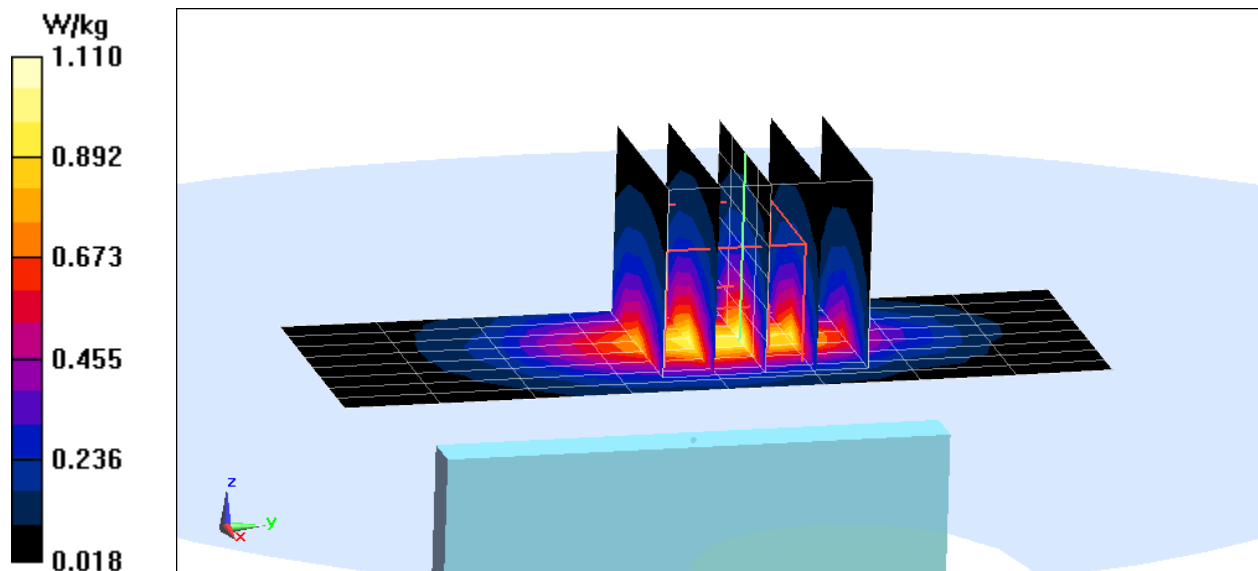

# PCTEST ENGINEERING LABORATORY, INC.

**DUT: A3LSMG920I; Type: Portable Handset; Serial: 1565F**

Communication System: UID 0, UMTS; Frequency: 1880 MHz; Duty Cycle: 1:1  
Medium: 1900 Body Medium parameters used:  
 $f = 1880 \text{ MHz}$ ;  $\sigma = 1.528 \text{ S/m}$ ;  $\epsilon_r = 52.387$ ;  $\rho = 1000 \text{ kg/m}^3$   
Phantom section: Flat Section; Space: 1.0 cm

Test Date: 02-09-2015; Ambient Temp: 23.0°C; Tissue Temp: 22.4°C

Probe: ES3DV3 - SN3332; ConvF(4.64, 4.64, 4.64); Calibrated: 9/18/2014;  
Sensor-Surface: 3mm (Mechanical Surface Detection)  
Electronics: DAE4 Sn1323; Calibrated: 9/17/2014  
Phantom: SAM 5.0 front; Type: QD000P40CD; Serial: TP:-1648  
Measurement SW: DASY52, Version 52.8 (8); SEMCAD X Version 14.6.10 (7331)

**Mode: UMTS 1900, Body SAR, Back side, Mid.ch**

**Area Scan (9x13x1):** Measurement grid: dx=15mm, dy=15mm

**Zoom Scan (6x5x7)/Cube 0:** Measurement grid: dx=8mm, dy=8mm, dz=5mm

Reference Value = 22.70 V/m; Power Drift = 0.01 dB

Peak SAR (extrapolated) = 1.16 W/kg

**SAR(1 g) = 0.684 W/kg**

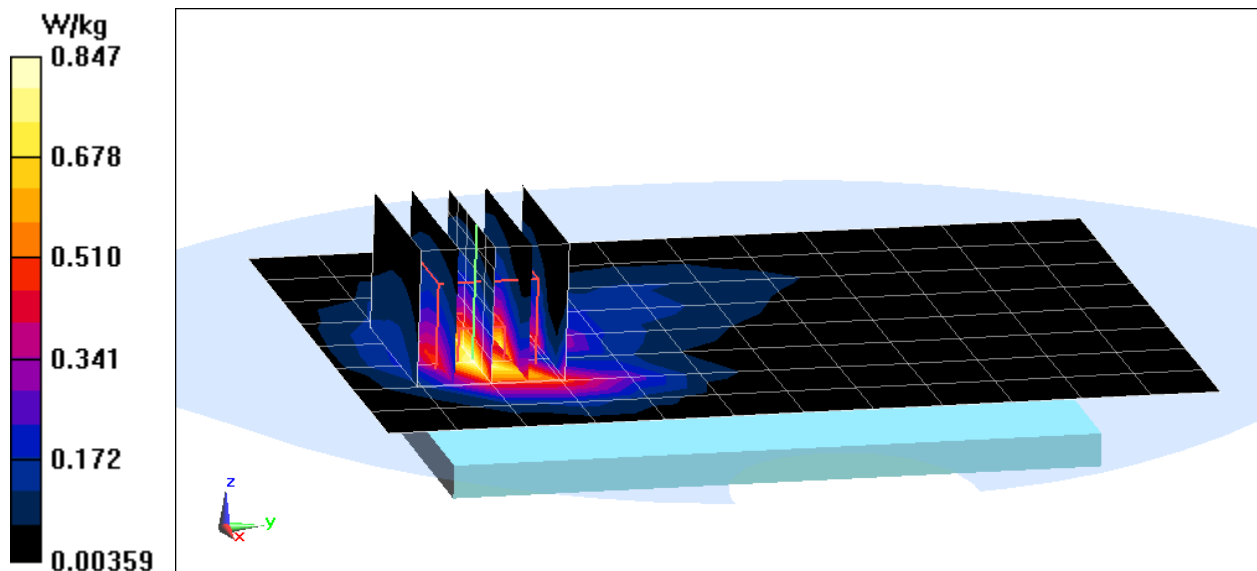

# PCTEST ENGINEERING LABORATORY, INC.

**DUT: A3LSMG920I; Type: Portable Handset; Serial: 1565F**

Communication System: UID 0, UMTS; Frequency: 1852.4 MHz; Duty Cycle: 1:1  
Medium: 1900 Body Medium parameters used (interpolated):  
 $f = 1852.4 \text{ MHz}$ ;  $\sigma = 1.499 \text{ S/m}$ ;  $\epsilon_r = 52.484$ ;  $\rho = 1000 \text{ kg/m}^3$   
Phantom section: Flat Section; Space: 1.0 cm

Test Date: 02-09-2015; Ambient Temp: 23.0°C; Tissue Temp: 22.4°C

Probe: ES3DV3 - SN3332; ConvF(4.64, 4.64, 4.64); Calibrated: 9/18/2014;  
Sensor-Surface: 3mm (Mechanical Surface Detection)  
Electronics: DAE4 Sn1323; Calibrated: 9/17/2014  
Phantom: SAM 5.0 front; Type: QD000P40CD; Serial: TP:-1648  
Measurement SW: DASY52, Version 52.8 (8); SEMCAD X Version 14.6.10 (7331)

**Mode: UMTS 1900, Body SAR, Bottom Edge, Low.ch**

**Area Scan (9x9x1):** Measurement grid: dx=5mm, dy=15mm  
**Zoom Scan (5x5x7)/Cube 0:** Measurement grid: dx=8mm, dy=8mm, dz=5mm  
Reference Value = 26.05 V/m; Power Drift = -0.01 dB  
Peak SAR (extrapolated) = 1.49 W/kg  
**SAR(1 g) = 0.905 W/kg**

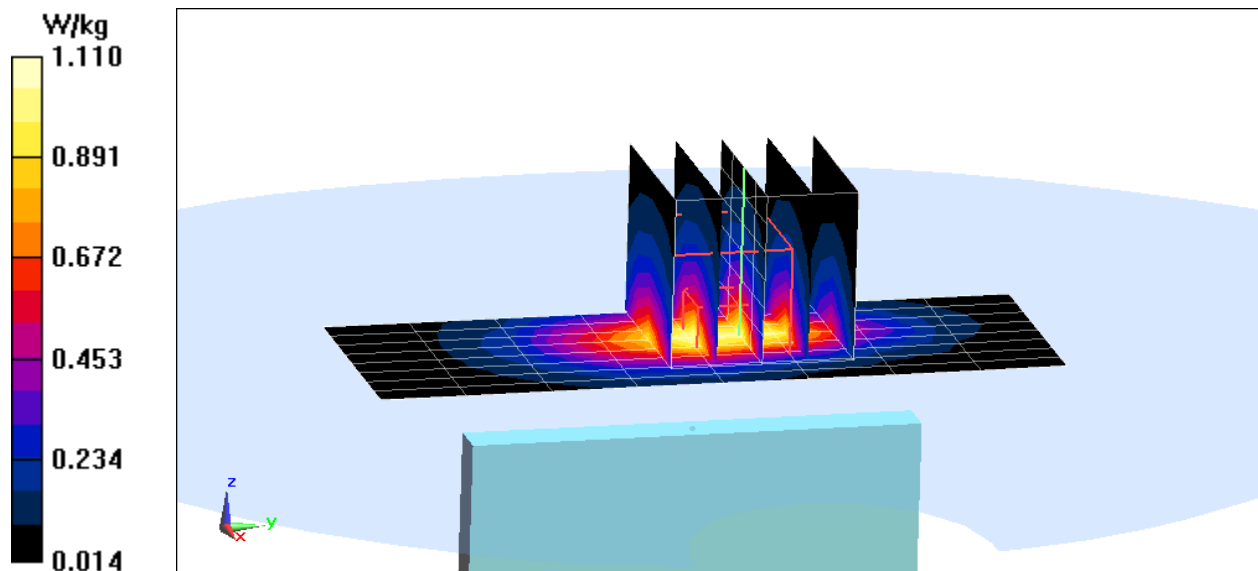

# PCTEST ENGINEERING LABORATORY, INC.

**DUT: A3LSMG920I; Type: Portable Handset; Serial: 1565F**

Communication System: UID 0, LTE Band 12 (0); Frequency: 707.5 MHz; Duty Cycle: 1:1  
Medium: 750 Body Medium parameters used (interpolated):  
 $f = 707.5 \text{ MHz}$ ;  $\sigma = 0.948 \text{ S/m}$ ;  $\epsilon_r = 57.002$ ;  $\rho = 1000 \text{ kg/m}^3$   
Phantom section: Flat Section; Space: 1.0 cm

Test Date: 02-09-2015; Ambient Temp: 23.6°C; Tissue Temp: 23.0°C

Probe: ES3DV3 - SN3213; ConvF(6.11, 6.11, 6.11); Calibrated: 1/20/2015;  
Sensor-Surface: 3mm (Mechanical Surface Detection)  
Electronics: DAE4 Sn1407; Calibrated: 1/19/2015  
Phantom: ELI v5.0; Type: QDOVA002AA; Serial: TP-1158  
Measurement SW: DASY52, Version 52.8 (8); SEMCAD X Version 14.6.10 (7331)

**Mode: LTE Band 12, Body SAR, Back side, Mid.ch,  
10 MHz Bandwidth, QPSK, 1 RB, 49 RB Offset**

**Area Scan (9x13x1):** Measurement grid: dx=15mm, dy=15mm  
**Zoom Scan (5x7x7)/Cube 0:** Measurement grid: dx=8mm, dy=8mm, dz=5mm  
Reference Value = 17.84 V/m; Power Drift = -0.02 dB  
Peak SAR (extrapolated) = 0.412 W/kg  
**SAR (1 g) = 0.283 W/kg**

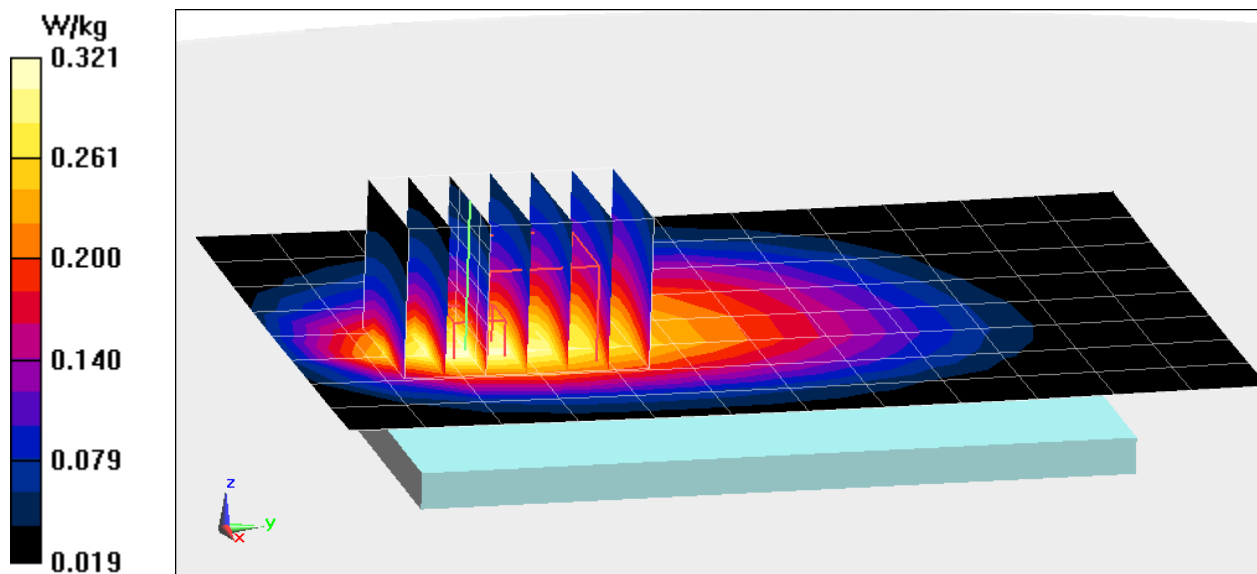

# PCTEST ENGINEERING LABORATORY, INC.

**DUT: A3LSMG920I; Type: Portable Handset; Serial: 146AD**

Communication System: UID 0, LTE Band 26 (0); Frequency: 836.5 MHz; Duty Cycle: 1:1  
Medium: 835 Body Medium parameters used (interpolated):  
 $f = 836.5 \text{ MHz}$ ;  $\sigma = 1.002 \text{ S/m}$ ;  $\epsilon_r = 53.411$ ;  $\rho = 1000 \text{ kg/m}^3$   
Phantom section: Flat Section; Space: 1.0 cm

Test Date: 02-09-2015; Ambient Temp: 24.0°C; Tissue Temp: 21.8°C

Probe: ES3DV3 - SN3288; ConvF(6.32, 6.32, 6.32); Calibrated: 9/24/2014;  
Sensor-Surface: 3mm (Mechanical Surface Detection)  
Electronics: DAE4 Sn1364; Calibrated: 9/18/2014  
Phantom: ELI v5.0; Type: QDOVA001BB; Serial: 1229  
Measurement SW: DASY52, Version 52.8 (8); SEMCAD X Version 14.6.10 (7331)

**Mode: LTE Band 26, Body SAR, Back Side, Mid.ch,  
15 MHz Bandwidth, QPSK, 1 RB, 36 RB Offset**

**Area Scan (9x15x1):** Measurement grid: dx=15mm, dy=15mm  
**Zoom Scan (5x5x7)/Cube 0:** Measurement grid: dx=8mm, dy=8mm, dz=5mm  
Reference Value = 19.02 V/m; Power Drift = -0.03 dB  
Peak SAR (extrapolated) = 0.548 W/kg  
**SAR(1 g) = 0.336 W/kg**

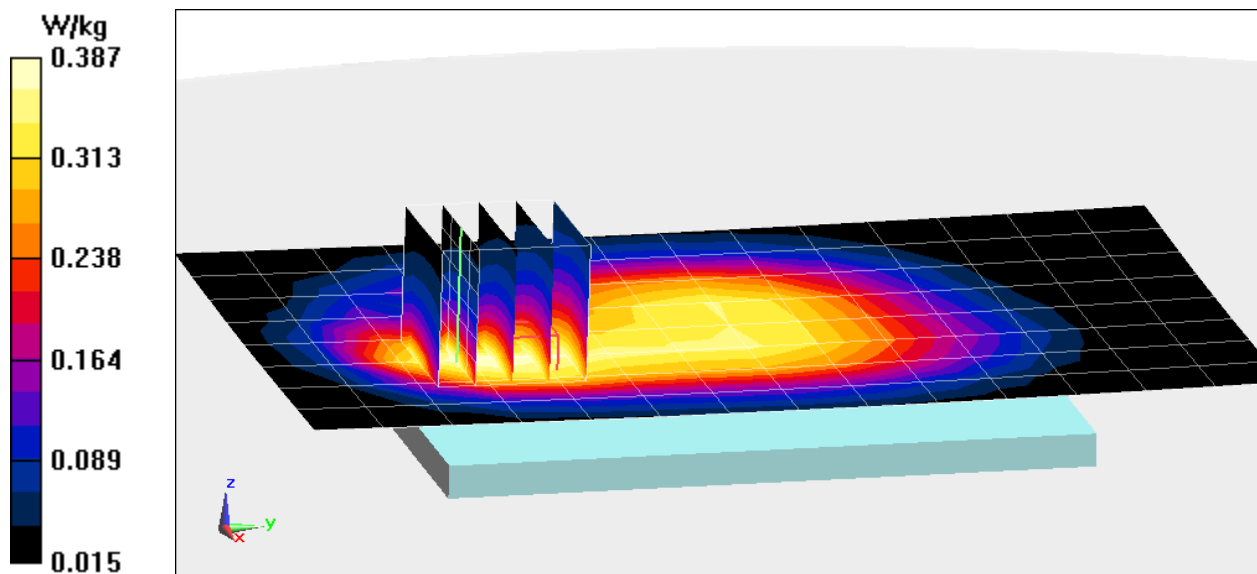

# PCTEST ENGINEERING LABORATORY, INC.

**DUT: A3LSMG920I; Type: Portable Handset; Serial: 146AD**

Communication System: UID 0, LTE Band 26 (0); Frequency: 836.5 MHz; Duty Cycle: 1:1  
Medium: 835 Body Medium parameters used (interpolated):  
 $f = 836.5 \text{ MHz}$ ;  $\sigma = 1.002 \text{ S/m}$ ;  $\epsilon_r = 53.411$ ;  $\rho = 1000 \text{ kg/m}^3$   
Phantom section: Flat Section; Space: 1.0 cm

Test Date: 02-09-2015; Ambient Temp: 24.0°C; Tissue Temp: 21.8°C

Probe: ES3DV3 - SN3288; ConvF(6.32, 6.32, 6.32); Calibrated: 9/24/2014;  
Sensor-Surface: 3mm (Mechanical Surface Detection)  
Electronics: DAE4 Sn1364; Calibrated: 9/18/2014  
Phantom: ELI v5.0; Type: QDOVA001BB; Serial: 1229  
Measurement SW: DASY52, Version 52.8 (8); SEMCAD X Version 14.6.10 (7331)

**Mode: LTE Band 26, Body SAR, Left Edge, Mid.ch,  
15 MHz Bandwidth, QPSK, 1 RB, 36 RB Offset**

**Area Scan (11x13x1):** Measurement grid: dx=5mm, dy=15mm  
**Zoom Scan (5x5x7)/Cube 0:** Measurement grid: dx=8mm, dy=8mm, dz=5mm  
Reference Value = 20.82 V/m; Power Drift = -0.11 dB  
Peak SAR (extrapolated) = 0.593 W/kg  
**SAR(1 g) = 0.401 W/kg**

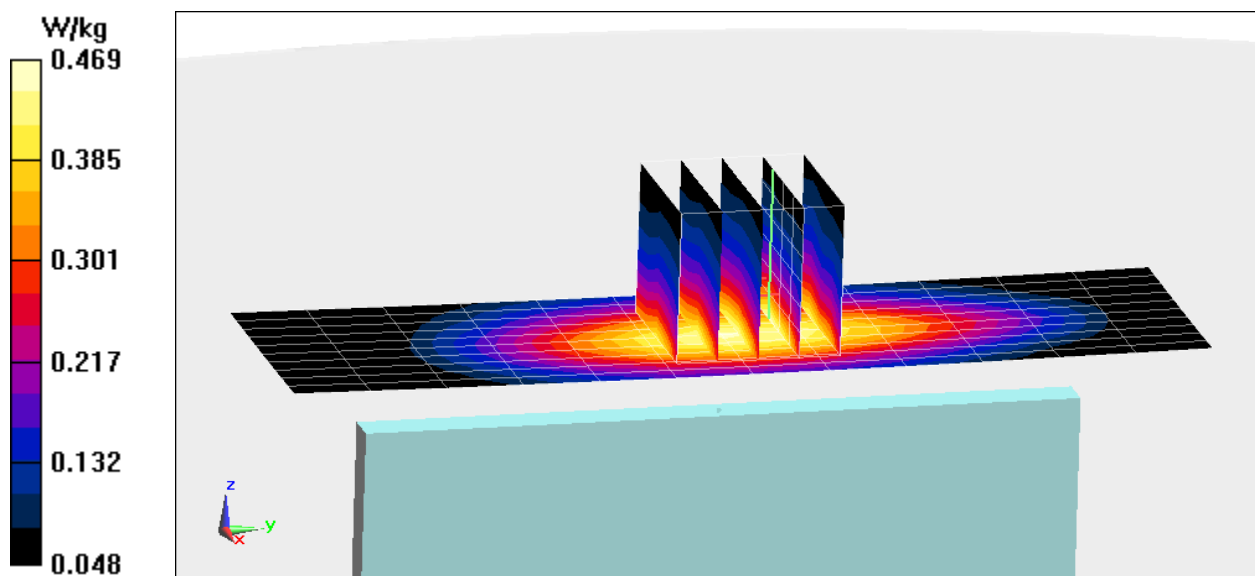

# PCTEST ENGINEERING LABORATORY, INC.

**DUT: A3LSMG920I; Type: Portable Handset; Serial: 146AD**

Communication System: UID 0, LTE Band 4 (AWS); Frequency: 1732.5 MHz; Duty Cycle: 1:1  
Medium: 1750 Body Medium parameters used (interpolated):  
 $f = 1732.5$  MHz;  $\sigma = 1.477$  S/m;  $\epsilon_r = 52.066$ ;  $\rho = 1000$  kg/m<sup>3</sup>  
Phantom section: Flat Section; Space: 1.0 cm

Test Date: 02-10-2015; Ambient Temp: 23.7°C; Tissue Temp: 21.9°C

Probe: ES3DV2 - SN3022; ConvF(4.7, 4.7, 4.7); Calibrated: 8/19/2014;  
Sensor-Surface: 3mm (Mechanical Surface Detection)

Electronics: DAE4 Sn1322; Calibrated: 8/12/2014

Phantom: SAM with CRP v4.0; Type: QD000P40CD; Serial: TP:1800

Measurement SW: DASY52, Version 52.8 (8); SEMCAD X Version 14.6.10 (7331)

**Mode: LTE Band 4 (AWS), Body SAR, Back side, Mid.ch,  
20 MHz Bandwidth, QPSK, 1 RB, 50 RB Offset**

**Area Scan (9x15x1):** Measurement grid: dx=15mm, dy=15mm

**Zoom Scan (5x5x7)/Cube 0:** Measurement grid: dx=8mm, dy=8mm, dz=5mm

Reference Value = 21.30 V/m; Power Drift = -0.05 dB

Peak SAR (extrapolated) = 1.00 W/kg

**SAR(1 g) = 0.602 W/kg**

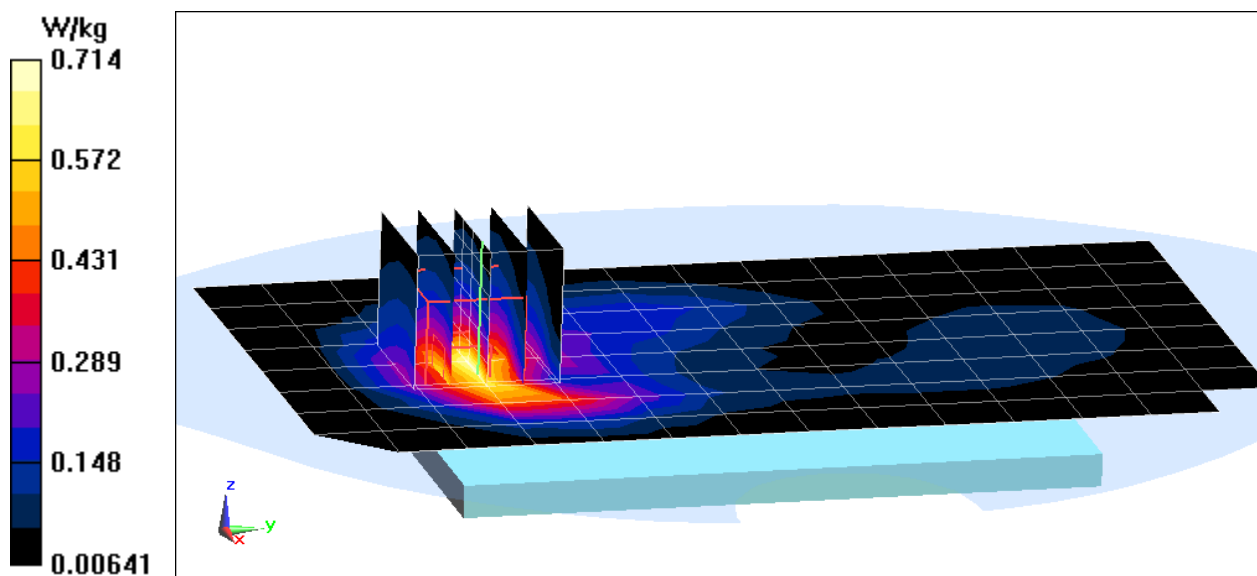

# PCTEST ENGINEERING LABORATORY, INC.

**DUT: A3LSMG920I; Type: Portable Handset; Serial: 146AD**

Communication System: UID 0, LTE Band 4 (AWS) (0); Frequency: 1732.5 MHz; Duty Cycle: 1:1  
Medium: 1750 Body Medium parameters used (interpolated):  
 $f = 1732.5 \text{ MHz}$ ;  $\sigma = 1.477 \text{ S/m}$ ;  $\epsilon_r = 52.066$ ;  $\rho = 1000 \text{ kg/m}^3$   
Phantom section: Flat Section; Space: 1.0 cm

Test Date: 02-10-2015; Ambient Temp: 23.7°C; Tissue Temp: 21.9°C

Probe: ES3DV2 - SN3022; ConvF(4.7, 4.7, 4.7); Calibrated: 8/19/2014;

Sensor-Surface: 3mm (Mechanical Surface Detection)

Electronics: DAE4 Sn1322; Calibrated: 8/12/2014

Phantom: SAM with CRP v4.0; Type: QD000P40CD; Serial: TP:1800

Measurement SW: DASY52, Version 52.8 (8); SEMCAD X Version 14.6.10 (7331)

**Mode: LTE Band 4 (AWS), Body SAR, Bottom Edge, Mid.ch,  
20 MHz Bandwidth, QPSK, 1 RB, 50 RB Offset**

**Area Scan (13x7x1):** Measurement grid: dx=5mm, dy=15mm

**Zoom Scan (5x5x7)/Cube 0:** Measurement grid: dx=8mm, dy=8mm, dz=5mm

Reference Value = 25.82 V/m; Power Drift = 0.08 dB

Peak SAR (extrapolated) = 1.43 W/kg

**SAR(1 g) = 0.867 W/kg**

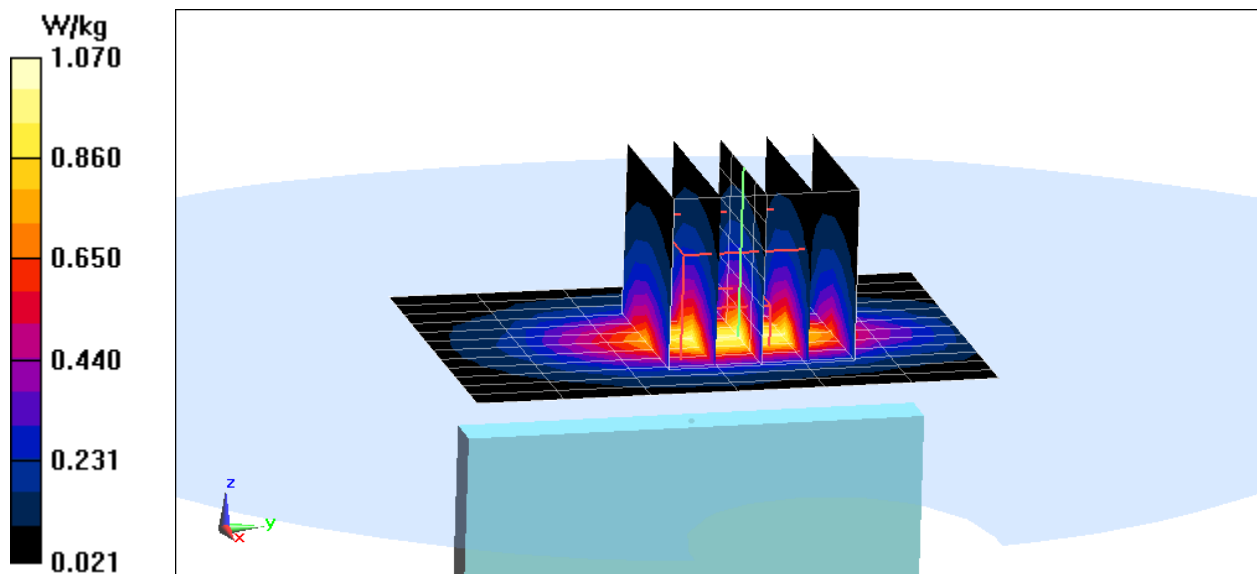

# PCTEST ENGINEERING LABORATORY, INC.

**DUT: A3LSMG920I; Type: Portable Handset; Serial: 1565F**

Communication System: UID 0, LTE Band 2 (PCS) (0); Frequency: 1860 MHz; Duty Cycle: 1:1  
Medium: 1900 Body Medium parameters used (interpolated):  
 $f = 1860 \text{ MHz}$ ;  $\sigma = 1.507 \text{ S/m}$ ;  $\epsilon_r = 52.457$ ;  $\rho = 1000 \text{ kg/m}^3$   
Phantom section: Flat Section; Space: 1.0 cm

Test Date: 02-09-2015; Ambient Temp: 23.0°C; Tissue Temp: 22.4°C

Probe: ES3DV3 - SN3332; ConvF(4.64, 4.64, 4.64); Calibrated: 9/18/2014;  
Sensor-Surface: 3mm (Mechanical Surface Detection)  
Electronics: DAE4 Sn1323; Calibrated: 9/17/2014  
Phantom: SAM 5.0 front; Type: QD000P40CD; Serial: TP:-1648  
Measurement SW: DASY52, Version 52.8 (8); SEMCAD X Version 14.6.10 (7331)

**Mode: LTE Band 2 (PCS), Body SAR, Back side, Low.ch,  
20 MHz Bandwidth, QPSK, 1 RB, 50 RB Offset**

**Area Scan (9x15x1):** Measurement grid: dx=15mm, dy=15mm  
**Zoom Scan (6x5x7)/Cube 0:** Measurement grid: dx=8mm, dy=8mm, dz=5mm  
Reference Value = 20.56 V/m; Power Drift = 0.09 dB  
Peak SAR (extrapolated) = 0.919 W/kg  
**SAR(1 g) = 0.560 W/kg**

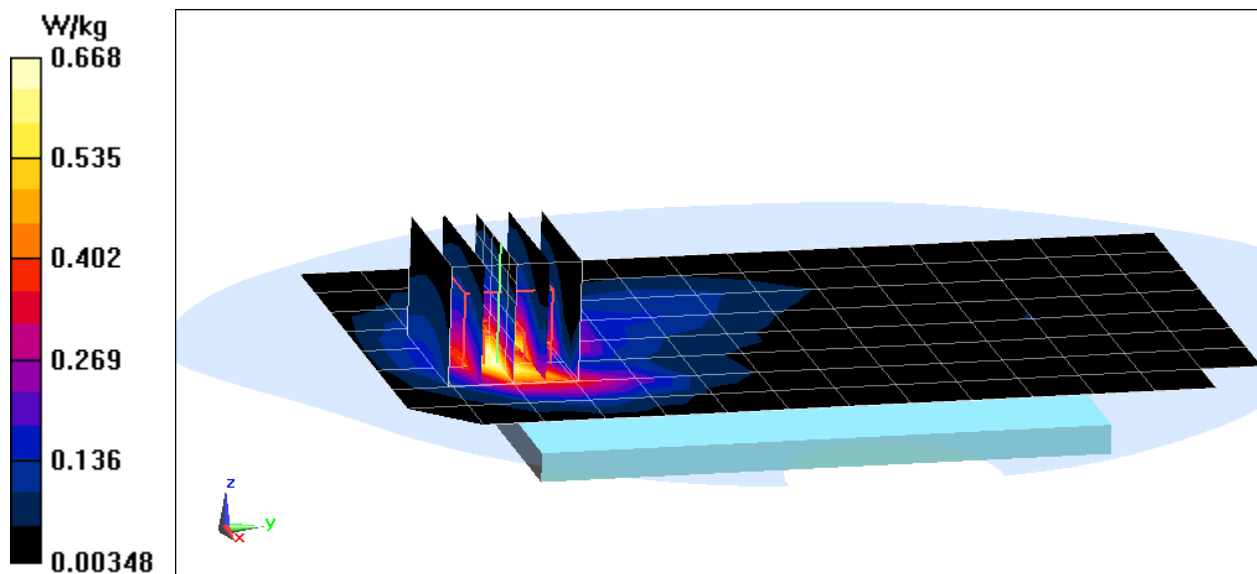

# PCTEST ENGINEERING LABORATORY, INC.

**DUT: A3LSMG920I; Type: Portable Handset; Serial: 1565F**

Communication System: UID 0, LTE Band 2 (PCS) (0); Frequency: 1880 MHz; Duty Cycle: 1:1  
Medium: 1900 Body Medium parameters used:  
 $f = 1880 \text{ MHz}$ ;  $\sigma = 1.528 \text{ S/m}$ ;  $\epsilon_r = 52.387$ ;  $\rho = 1000 \text{ kg/m}^3$   
Phantom section: Flat Section; Space: 1.0 cm

Test Date: 02-09-2015; Ambient Temp: 23.0°C; Tissue Temp: 22.4°C

Probe: ES3DV3 - SN3332; ConvF(4.64, 4.64, 4.64); Calibrated: 9/18/2014;  
Sensor-Surface: 3mm (Mechanical Surface Detection)  
Electronics: DAE4 Sn1323; Calibrated: 9/17/2014  
Phantom: SAM 5.0 front; Type: QD000P40CD; Serial: TP:-1648  
Measurement SW: DASY52, Version 52.8 (8); SEMCAD X Version 14.6.10 (7331)

**Mode: LTE Band 2 (PCS), Body SAR, Bottom Edge, Mid.ch,  
20 MHz Bandwidth, QPSK, 1 RB, 0 RB Offset**

**Area Scan (10x8x1):** Measurement grid: dx=5mm, dy=15mm  
**Zoom Scan (5x5x7)/Cube 0:** Measurement grid: dx=8mm, dy=8mm, dz=5mm  
Reference Value = 25.51 V/m; Power Drift = 0.00 dB  
Peak SAR (extrapolated) = 1.39 W/kg  
**SAR(1 g) = 0.851 W/kg**

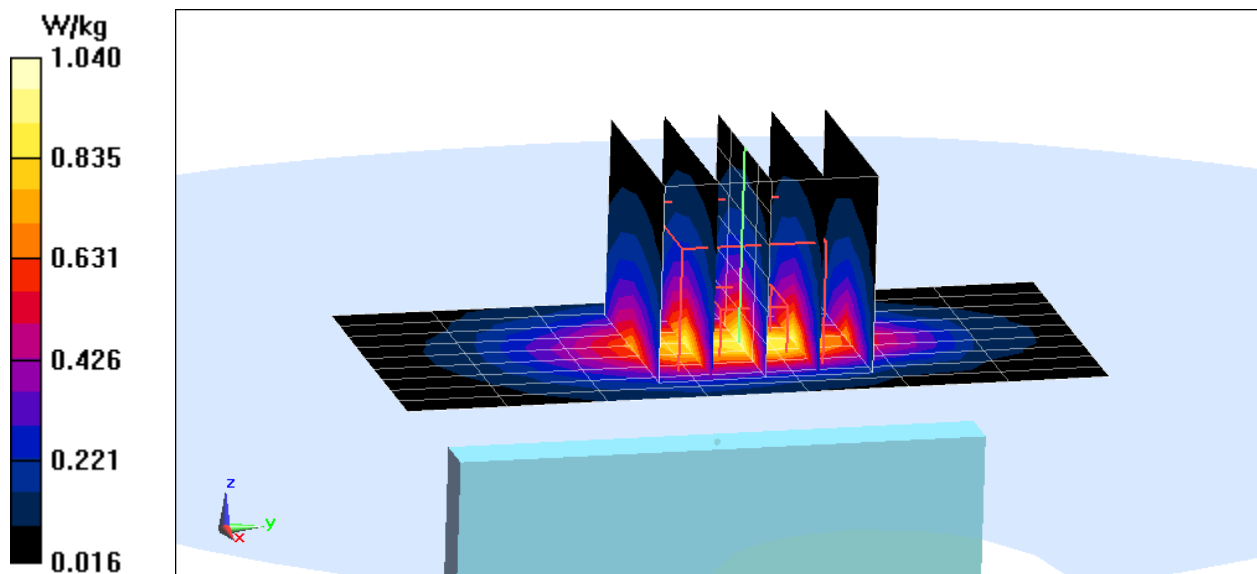

# PCTEST ENGINEERING LABORATORY, INC.

**DUT: A3LSMG920I; Type: Portable Handset; Serial: 066BE**

Communication System: UID 0, IEEE 802.11b; Frequency: 2412 MHz; Duty Cycle: 1:1  
Medium: 2450 Body Medium parameters used (interpolated):  
 $f = 2412 \text{ MHz}$ ;  $\sigma = 1.937 \text{ S/m}$ ;  $\epsilon_r = 52.072$ ;  $\rho = 1000 \text{ kg/m}^3$   
Phantom section: Flat Section; Space: 1.0 cm

Test Date: 01-12-2015; Ambient Temp: 23.9°C; Tissue Temp: 23.0°C

Probe: ES3DV3 - SN3258; ConvF(4.14, 4.14, 4.14); Calibrated: 2/25/2014;  
Sensor-Surface: 3mm (Mechanical Surface Detection)  
Electronics: DAE4 Sn665; Calibrated: 2/26/2014  
Phantom: ELI v5.0; Type: QDOVA002AA; Serial: TP-1158  
Measurement SW: DASY52, Version 52.8 (8); SEMCAD X Version 14.6.10 (7331)

**Mode: IEEE 802.11b, 22 MHz Bandwidth, Body SAR  
Ch 01, 1 Mbps, Back Side, Antenna 2**

**Area Scan (9x16x1):** Measurement grid:  $dx=12\text{mm}$ ,  $dy=12\text{mm}$   
**Zoom Scan (7x7x7)/Cube 0:** Measurement grid:  $dx=5\text{mm}$ ,  $dy=5\text{mm}$ ,  $dz=5\text{mm}$   
Reference Value = 4.912 V/m; Power Drift = 0.13 dB  
Peak SAR (extrapolated) = 0.0850 W/kg  
**SAR (1 g) = 0.0435 W/kg**

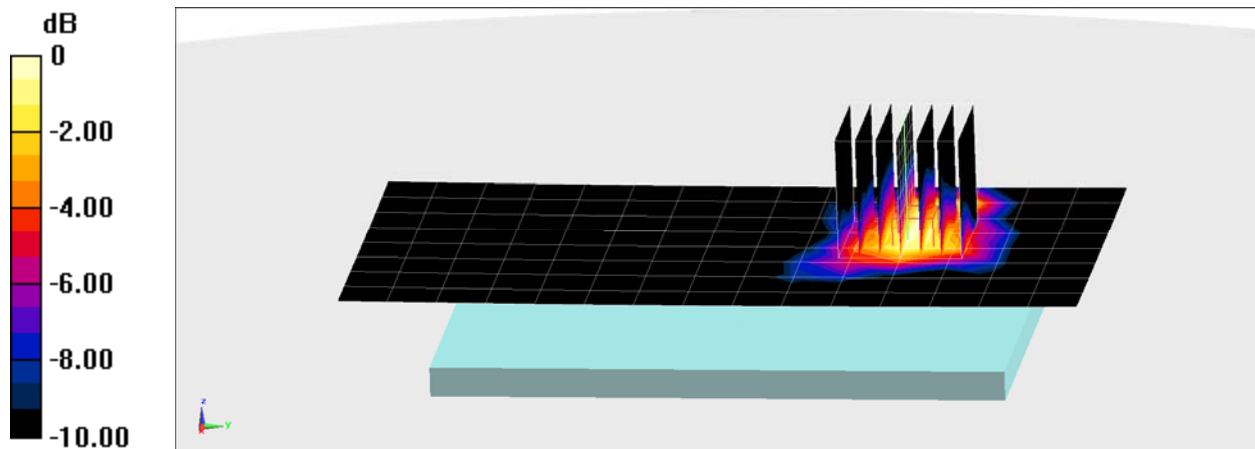

# PCTEST ENGINEERING LABORATORY, INC.

**DUT: A3LSMG920I; Type: Portable Handset; Serial: 066BE**

Communication System: UID 0, IEEE 802.11b; Frequency: 2412 MHz; Duty Cycle: 1:1  
Medium: 2450 Body Medium parameters used (interpolated):  
 $f = 2412 \text{ MHz}$ ;  $\sigma = 1.937 \text{ S/m}$ ;  $\epsilon_r = 52.072$ ;  $\rho = 1000 \text{ kg/m}^3$   
Phantom section: Flat Section; Space: 1.0 cm

Test Date: 01-12-2015; Ambient Temp: 23.9°C; Tissue Temp: 23.0°C

Probe: ES3DV3 - SN3258; ConvF(4.14, 4.14, 4.14); Calibrated: 2/25/2014;  
Sensor-Surface: 3mm (Mechanical Surface Detection)  
Electronics: DAE4 Sn665; Calibrated: 2/26/2014  
Phantom: ELI v5.0; Type: QDOVA002AA; Serial: TP-1158  
Measurement SW: DASY52, Version 52.8 (8); SEMCAD X Version 14.6.10 (7331)

**Mode: IEEE 802.11b, 22 MHz Bandwidth, Body SAR  
Ch 01, 1 Mbps, Front Side, Antenna 2**

**Area Scan (9x16x1):** Measurement grid: dx=12mm, dy=12mm  
**Zoom Scan (7x7x7)/Cube 0:** Measurement grid: dx=5mm, dy=5mm, dz=5mm  
Reference Value = 3.559 V/m; Power Drift = 0.18 dB  
Peak SAR (extrapolated) = 0.104 W/kg  
**SAR (1 g) = 0.0541 W/kg**

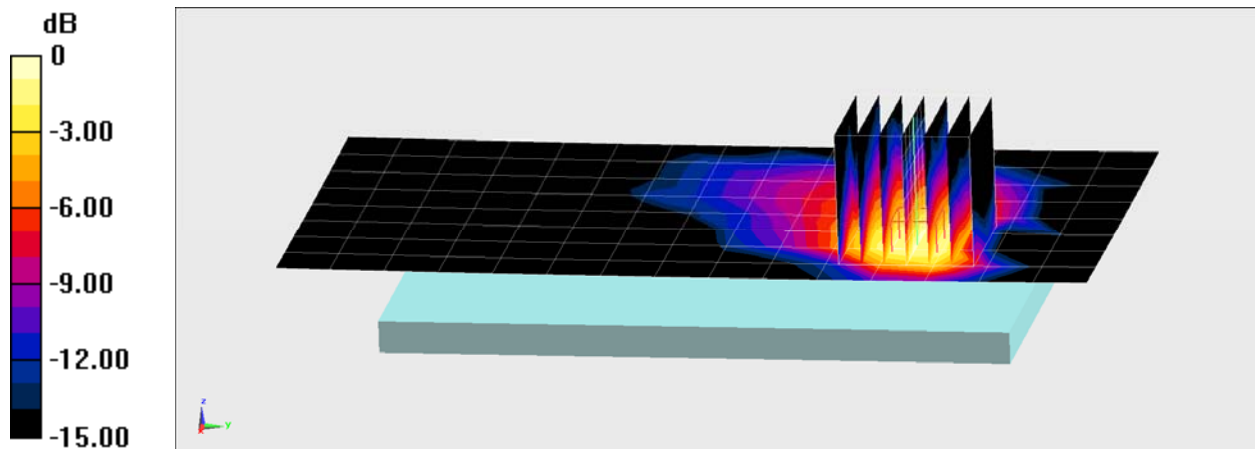

# PCTEST ENGINEERING LABORATORY, INC.

**DUT: A3LSMG920I; Type: Portable Handset; Serial: 066BE**

Communication System: UID 0, Bluetooth; Frequency: 2441 MHz; Duty Cycle: 1:1  
Medium: 2450 Body Medium parameters used (interpolated):  
 $f = 2441 \text{ MHz}$ ;  $\sigma = 1.943 \text{ S/m}$ ;  $\epsilon_r = 52.664$ ;  $\rho = 1000 \text{ kg/m}^3$   
Phantom section: Flat Section; Space: 1.0 cm

Test Date: 02-02-2015; Ambient Temp: 24.4°C; Tissue Temp: 23.5°C

Probe: ES3DV3 - SN3209; ConvF(4.2, 4.2, 4.2); Calibrated: 3/19/2014;  
Sensor-Surface: 3mm (Mechanical Surface Detection)  
Electronics: DAE4 Sn1334; Calibrated: 3/17/2014  
Phantom: SAM left; Type: QD000P40CD; Serial: TP:1715  
Measurement SW: DASY52, Version 52.8 (8); SEMCAD X Version 14.6.10 (7331)

**Mode: Bluetooth, Body SAR, Ch 39, 01 Mbps, Back Side**

**Area Scan (11x18x1):** Measurement grid:  $dx=12\text{mm}$ ,  $dy=12\text{mm}$

**Zoom Scan (7x7x7)/Cube 0:** Measurement grid:  $dx=5\text{mm}$ ,  $dy=5\text{mm}$ ,  $dz=5\text{mm}$

Reference Value = 0.6110 V/m; Power Drift = 0.14 dB

Peak SAR (extrapolated) = 0.0110 W/kg

**SAR (1 g) = 0.00244 W/kg**

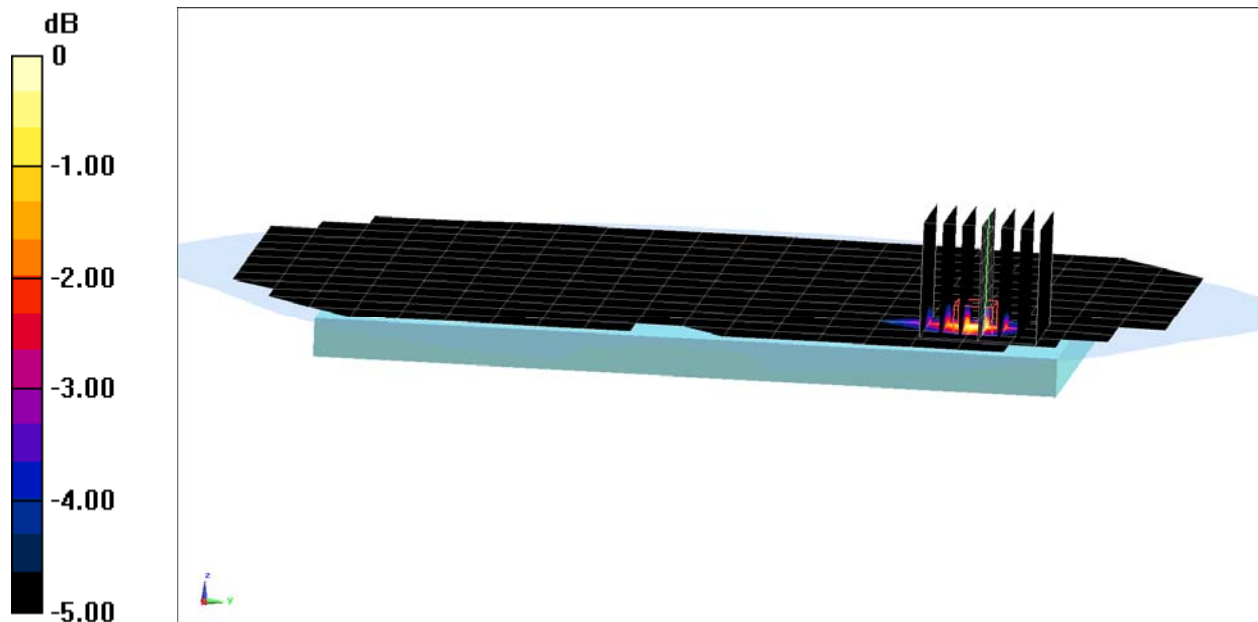

# PCTEST ENGINEERING LABORATORY, INC.

**DUT: A3LSMG920I; Type: Portable Handset; Serial: 066BE**

Communication System: UID 0, 802.11a; Frequency: 5260 MHz; Duty Cycle: 1:1  
Medium: 5 GHz Body Medium parameters used:  
 $f = 5260 \text{ MHz}$ ;  $\sigma = 5.532 \text{ S/m}$ ;  $\epsilon_r = 47.218$ ;  $\rho = 1000 \text{ kg/m}^3$   
Phantom section: Flat Section; Space: 1.0 cm

Test Date: 01-13-2015; Ambient Temp: 22.2°C; Tissue Temp: 23.0°C

Probe: EX3DV4 - SN3920; ConvF(4.16, 4.16, 4.16); Calibrated: 12/12/2014;  
Sensor-Surface: 1.4mm (Mechanical Surface Detection)  
Electronics: DAE4 Sn1368; Calibrated: 4/11/2014  
Phantom: SAM; Type: QD000P40CD; Serial: TP:1758  
Measurement SW: DASY52, Version 52.8 (8); SEMCAD X Version 14.6.10 (7331)

**Mode: IEEE 802.11a, U-NII-2A, 20 MHz Bandwidth**  
**Body SAR, Ch 52, 6 Mbps, Back Side, Antenna 1**

**Area Scan (13x19x1):** Measurement grid: dx=10mm, dy=10mm

**Zoom Scan (7x7x7)/Cube 0:** Measurement grid: dx=4mm, dy=4mm, dz=1.4mm; Graded Ratio = 1.4  
Reference Value = 2.831 V/m; Power Drift = 0.12 dB  
Peak SAR (extrapolated) = 0.172 W/kg  
**SAR (1 g) = 0.0442 W/kg**

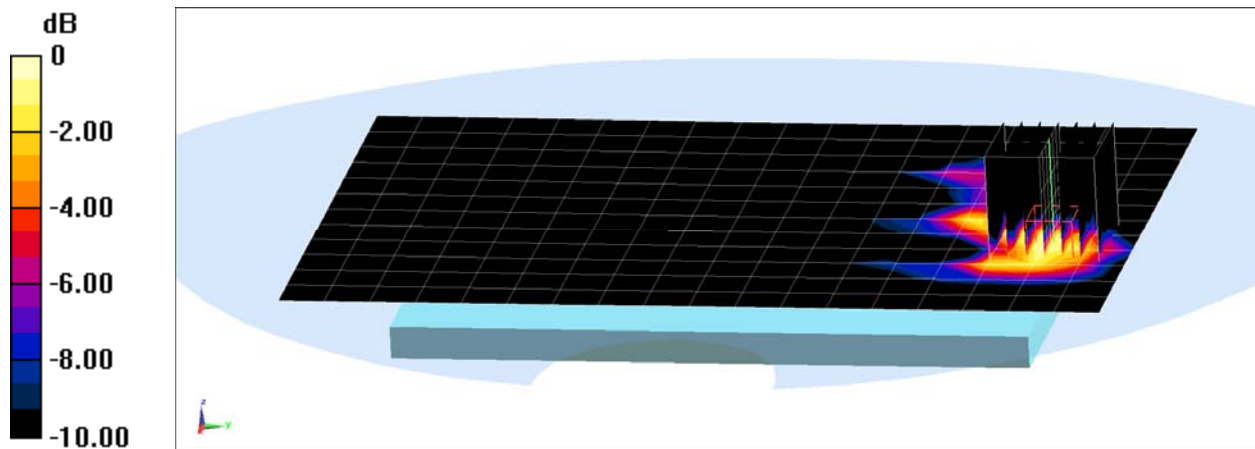

# PCTEST ENGINEERING LABORATORY, INC.

**DUT: A3LSMG920I; Type: Portable Handset; Serial: 066BE**

Communication System: UID 0, 802.11a; Frequency: 5825 MHz; Duty Cycle: 1:1  
Medium: 5 GHz Body Medium parameters used:  
 $f = 5825 \text{ MHz}$ ;  $\sigma = 6.292 \text{ S/m}$ ;  $\epsilon_r = 46.232$ ;  $\rho = 1000 \text{ kg/m}^3$   
Phantom section: Flat Section; Space: 1.0 cm

Test Date: 01-13-2015; Ambient Temp: 22.2°C; Tissue Temp: 23.0°C

Probe: EX3DV4 - SN3920; ConvF(3.93, 3.93, 3.93); Calibrated: 12/12/2014;  
Sensor-Surface: 1.4mm (Mechanical Surface Detection)  
Electronics: DAE4 Sn1368; Calibrated: 4/11/2014  
Phantom: SAM; Type: QD000P40CD; Serial: TP:1758  
Measurement SW: DASY52, Version 52.8 (8); SEMCAD X Version 14.6.10 (7331)

**Mode: IEEE 802.11a, U-NII-3, 20 MHz Bandwidth**  
**Body SAR, Ch 165, 6 Mbps, Front Side, Antenna 1**

**Area Scan (13x21x1):** Measurement grid: dx=10mm, dy=10mm

**Zoom Scan (8x8x7)/Cube 0:** Measurement grid: dx=4mm, dy=4mm, dz=1.4mm; Graded Ratio = 1.4  
Reference Value = 1.156 V/m; Power Drift = 0.20 dB  
Peak SAR (extrapolated) = 0.150 W/kg  
**SAR (1 g) = 0.00248 W/kg**

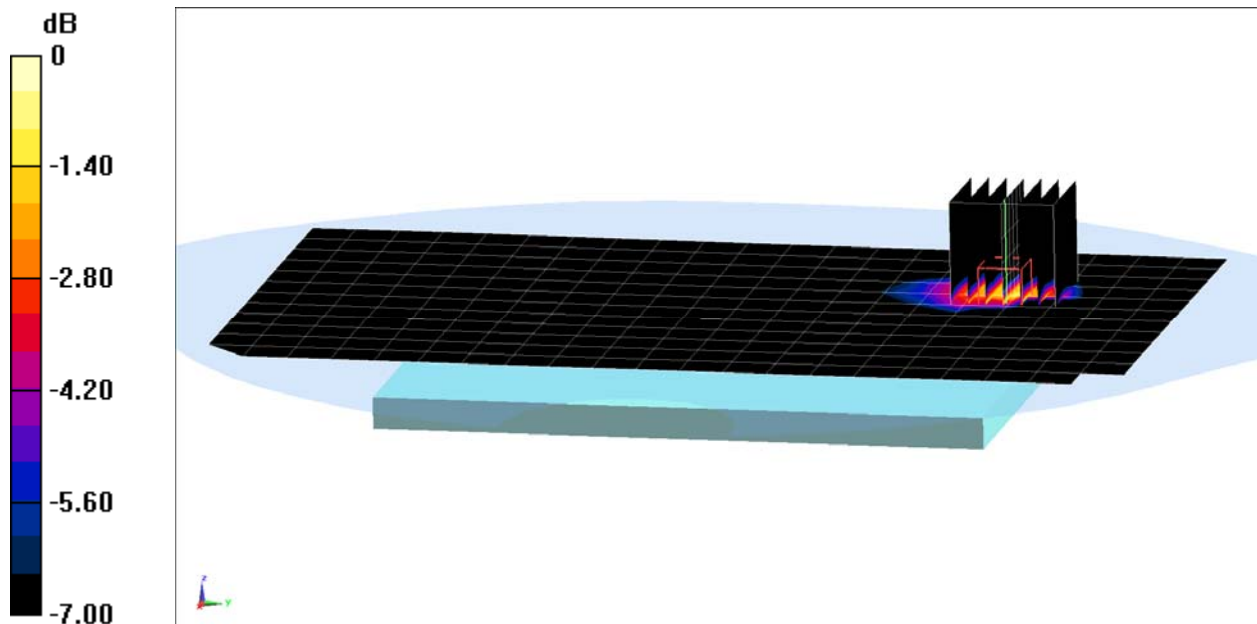

## APPENDIX B: SYSTEM VERIFICATION

# PCTEST ENGINEERING LABORATORY, INC.

**DUT: Dipole 750 MHz; Type: D750V3; Serial: 1054**

Communication System: UID 0, CW; Frequency: 750 MHz; Duty Cycle: 1:1

Medium: 750 Head Medium parameters used (interpolated):

$f = 750 \text{ MHz}$ ;  $\sigma = 0.908 \text{ S/m}$ ;  $\epsilon_r = 40.862$ ;  $\rho = 1000 \text{ kg/m}^3$

Phantom section: Flat Section; Space: 1.5 cm

Test Date: 02-11-2015; Ambient Temp: 23.9°C; Tissue Temp: 22.5°C

Probe: ES3DV3 - SN3213; ConvF(6.45, 6.45, 6.45); Calibrated: 1/20/2015;

Sensor-Surface: 3mm (Mechanical Surface Detection)

Electronics: DAE4 Sn1407; Calibrated: 1/19/2015

Phantom: SAM Front; Type: SAM; Serial: 1686

Measurement SW: DASY52, Version 52.8 (8); SEMCAD X Version 14.6.10 (7331)

## 750 MHz System Verification

**Area Scan (7x15x1):** Measurement grid: dx=15mm, dy=15mm

**Zoom Scan (5x5x7)/Cube 0:** Measurement grid: dx=8mm, dy=8mm, dz=5mm

Input Power = 20.0 dBm (100 mW)

Peak SAR (extrapolated) = 1.21 W/kg

**SAR (1 g) = 0.816 W/kg**

Deviation = -2.04 %

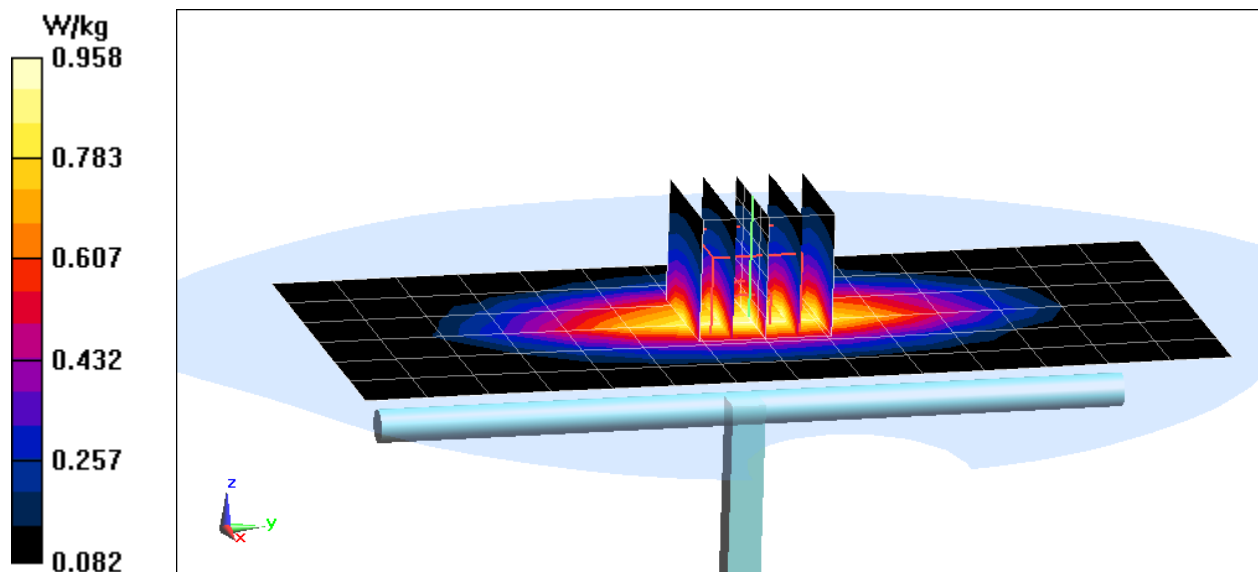

# PCTEST ENGINEERING LABORATORY, INC.

**DUT: Dipole 835 MHz; Type: D835V2; Serial: 4d133**

Communication System: UID 0, CW; Frequency: 835 MHz; Duty Cycle: 1:1

Medium: 835 Head Medium parameters used:

$f = 835 \text{ MHz}$ ;  $\sigma = 0.891 \text{ S/m}$ ;  $\epsilon_r = 40.07$ ;  $\rho = 1000 \text{ kg/m}^3$

Phantom section: Flat Section; Space: 1.5 cm

Test Date: 02-09-2015; Ambient Temp: 24.0°C; Tissue Temp: 21.2°C

Probe: ES3DV3 - SN3288; ConvF(6.51, 6.51, 6.51); Calibrated: 9/24/2014;

Sensor-Surface: 3mm (Mechanical Surface Detection)

Electronics: DAE4 Sn1364; Calibrated: 9/18/2014

Phantom: SAM with CRP v4.0; Type: QD000P40CD; Serial: TP:1797

Measurement SW: DASY52, Version 52.8 (8); SEMCAD X Version 14.6.10 (7331)

## 835 MHz System Verification

**Area Scan (7x14x1):** Measurement grid: dx=15mm, dy=15mm

**Zoom Scan (5x5x7)/Cube 0:** Measurement grid: dx=8mm, dy=8mm, dz=5mm

Input Power = 20.0 dBm (100 mW)

Peak SAR (extrapolated) = 1.42 W/kg

**SAR(1 g) = 0.934 W/kg**

Deviation = 1.52 %

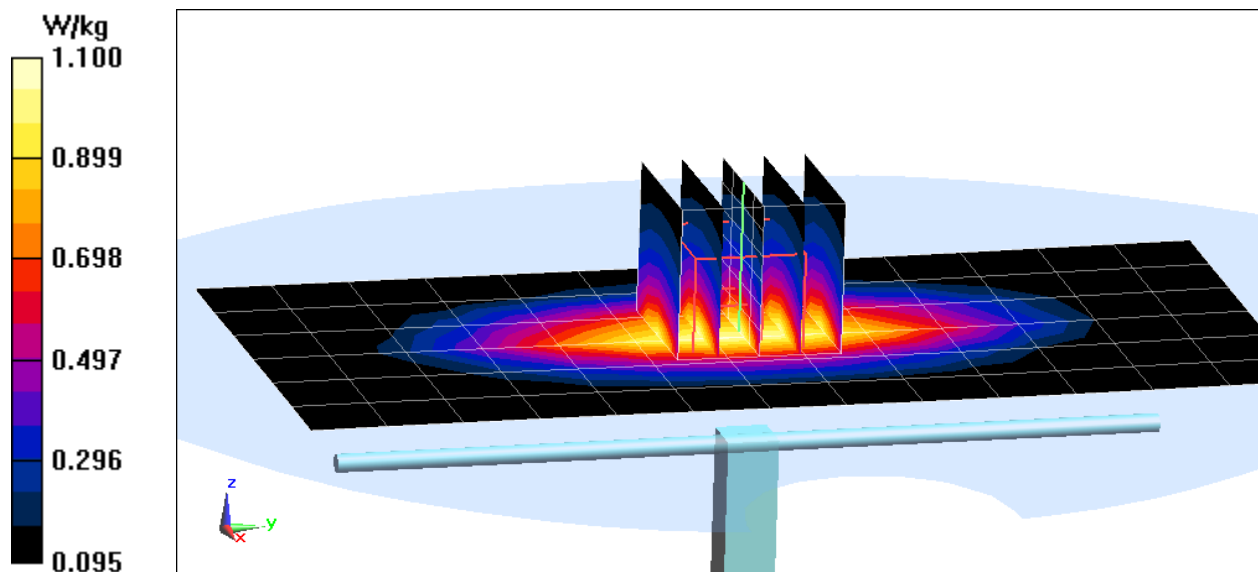

# PCTEST ENGINEERING LABORATORY, INC.

**DUT: Dipole 1765 MHz; Type: D1765V2; Serial: 1008**

Communication System: UID 0, CW; Frequency: 1750 MHz; Duty Cycle: 1:1  
Medium: 1750 Head Medium parameters used:  
 $f = 1750 \text{ MHz}$ ;  $\sigma = 1.359 \text{ S/m}$ ;  $\epsilon_r = 38.547$ ;  $\rho = 1000 \text{ kg/m}^3$   
Phantom section: Flat Section; Space: 1.0 cm

Test Date: 02-10-2015; Ambient Temp: 24.5°C; Tissue Temp: 22.5°C

Probe: ES3DV3 - SN3263; ConvF(5.41, 5.41, 5.41); Calibrated: 5/15/2014;  
Sensor-Surface: 3mm (Mechanical Surface Detection)  
Electronics: DAE4 Sn859; Calibrated: 5/14/2014  
Phantom: SAM v5.0 Left; Type: QD000P40CD; Serial: TP: 1687  
Measurement SW: DASY52, Version 52.8 (8); SEMCAD X Version 14.6.10 (7331)

## 1750 MHz System Verification

**Area Scan (7x9x1):** Measurement grid: dx=15mm, dy=15mm

**Zoom Scan (5x5x7)/Cube 0:** Measurement grid: dx=8mm, dy=8mm, dz=5mm

Input Power = 20.0 dBm (100 mW)

Peak SAR (extrapolated) = 6.83 W/kg

**SAR(1 g) = 3.81 W/kg**

Deviation = 3.25 %

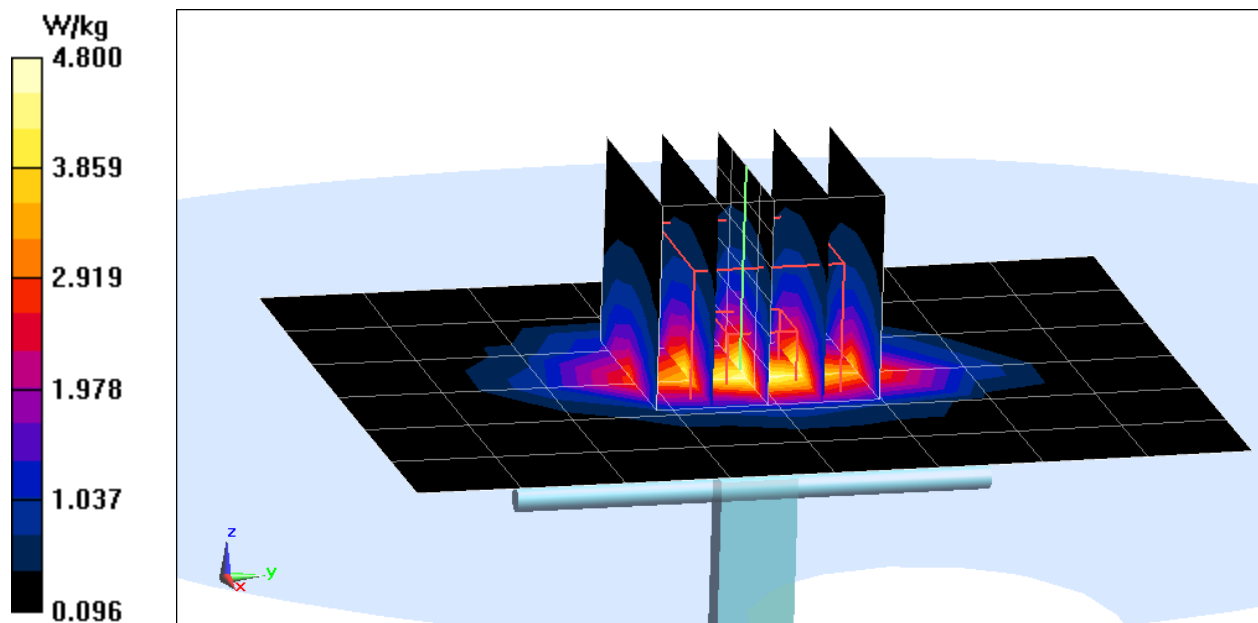

# PCTEST ENGINEERING LABORATORY, INC.

**DUT: Dipole 1900MHz; Type: D1900V2; Serial: 5d149**

Communication System: UID 0, CW; Frequency: 1900 MHz; Duty Cycle: 1:1

Medium: 1900 Head Medium parameters used (interpolated):

$f = 1900 \text{ MHz}$ ;  $\sigma = 1.441 \text{ S/m}$ ;  $\epsilon_r = 38.88$ ;  $\rho = 1000 \text{ kg/m}^3$

Phantom section: Flat Section; Space: 1.0 cm

Test Date: 02-09-2015; Ambient Temp: 24.3°C; Tissue Temp: 23.0°C

Probe: ES3DV3 - SN3263; ConvF(5.08, 5.08, 5.08); Calibrated: 5/15/2014;

Sensor-Surface: 3mm (Mechanical Surface Detection)

Electronics: DAE4 Sn859; Calibrated: 5/14/2014

Phantom: SAM v5.0 front; Type: QD000P40CD; Serial: TP-1646

Measurement SW: DASY52, Version 52.8 (8); SEMCAD X Version 14.6.10 (7331)

## 1900 MHz System Verification

**Area Scan (7x10x1):** Measurement grid: dx=15mm, dy=15mm

**Zoom Scan (5x5x7)/Cube 0:** Measurement grid: dx=8mm, dy=8mm, dz=5mm

Input Power = 20.0 dBm (100 mW)

Peak SAR (extrapolated) = 6.96 W/kg

**SAR(1 g) = 4.06 W/kg**

Deviation = 1.00 %

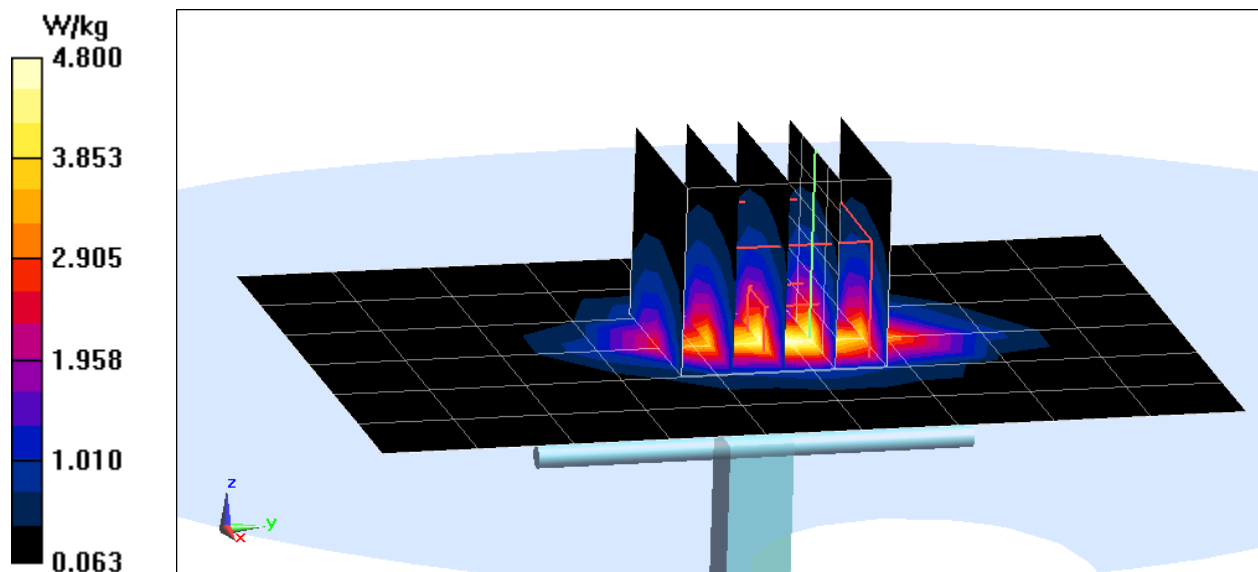

# PCTEST ENGINEERING LABORATORY, INC.

**DUT: Dipole 2450 MHz; Type: D2450V2; Serial: 719**

Communication System: UID 0, CW; Frequency: 2450 MHz; Duty Cycle: 1:1

Medium: 2450 Head Medium parameters used:

$f = 2450$  MHz;  $\sigma = 1.856$  S/m;  $\epsilon_r = 38.105$ ;  $\rho = 1000$  kg/m<sup>3</sup>

Phantom section: Flat Section; Space: 1.0 cm

Test Date: 01-12-2015; Ambient Temp: 23.0°C; Tissue Temp: 23.0°C

Probe: ES3DV3 - SN3263; ConvF(4.47, 4.47, 4.47); Calibrated: 5/15/2014;

Sensor-Surface: 3mm (Mechanical Surface Detection)

Electronics: DAE4 Sn859; Calibrated: 5/14/2014

Phantom: SAM v5.0 Left; Type: QD000P40CD; Serial: TP: 1687

Measurement SW: DASY52, Version 52.8 (8); SEMCAD X Version 14.6.10 (7331)

## 2450 MHz System Verification

**Area Scan (8x9x1):** Measurement grid: dx=12mm, dy=12mm

**Zoom Scan (7x7x7)/Cube 0:** Measurement grid: dx=5mm, dy=5mm, dz=5mm

Input Power = 20.0 dBm (100 mW)

Peak SAR (extrapolated) = 11.4 W/kg

**SAR (1 g) = 5.32 W/kg**

Deviation = 2.11%

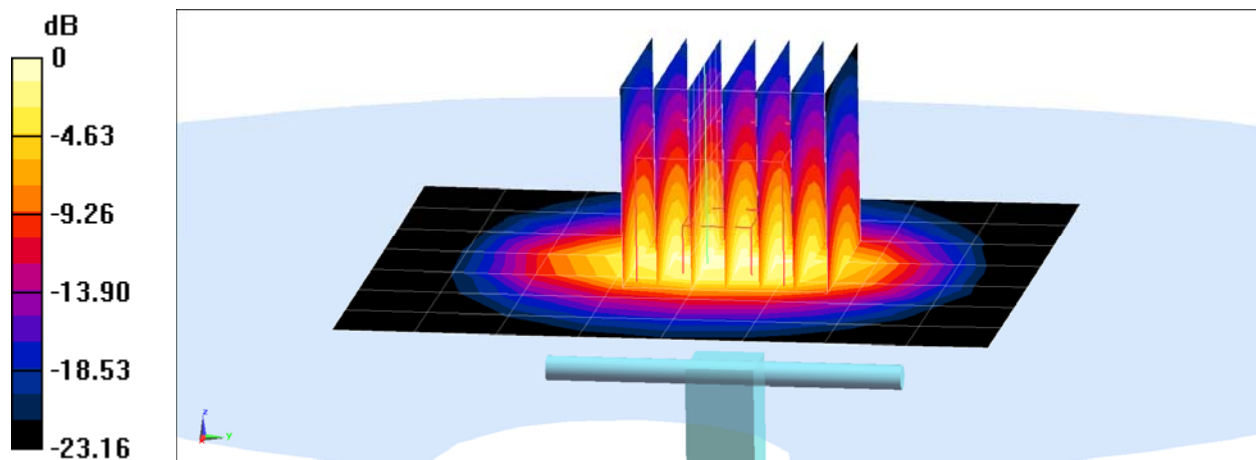

# PCTEST ENGINEERING LABORATORY, INC.

**DUT: Dipole 2450 MHz; Type: D2450V2; Serial: 719**

Communication System: UID 0, CW; Frequency: 2450 MHz; Duty Cycle: 1:1

Medium: 2450 Head Medium parameters used:

$f = 2450 \text{ MHz}$ ;  $\sigma = 1.803 \text{ S/m}$ ;  $\epsilon_r = 40.927$ ;  $\rho = 1000 \text{ kg/m}^3$

Phantom section: Flat Section; Space: 1.0 cm

Test Date: 02-05-2015; Ambient Temp: 23.5°C; Tissue Temp: 23.0°C

Probe: ES3DV3 - SN3258; ConvF(4.52, 4.52, 4.52); Calibrated: 2/25/2014;

Sensor-Surface: 3mm (Mechanical Surface Detection)

Electronics: DAE4 Sn665; Calibrated: 2/26/2014

Phantom: SAM Front; Type: SAM; Serial: 1686

Measurement SW: DASY52, Version 52.8 (8); SEMCAD X Version 14.6.10 (7331)

## 2450 MHz System Verification

**Area Scan (8x9x1):** Measurement grid: dx=12mm, dy=12mm

**Zoom Scan (7x7x7)/Cube 0:** Measurement grid: dx=5mm, dy=5mm, dz=5mm

Input Power = 20.0 dBm (100 mW)

Peak SAR (extrapolated) = 10.9 W/kg

**SAR (1 g) = 5.32 W/kg**

Deviation = 2.11%

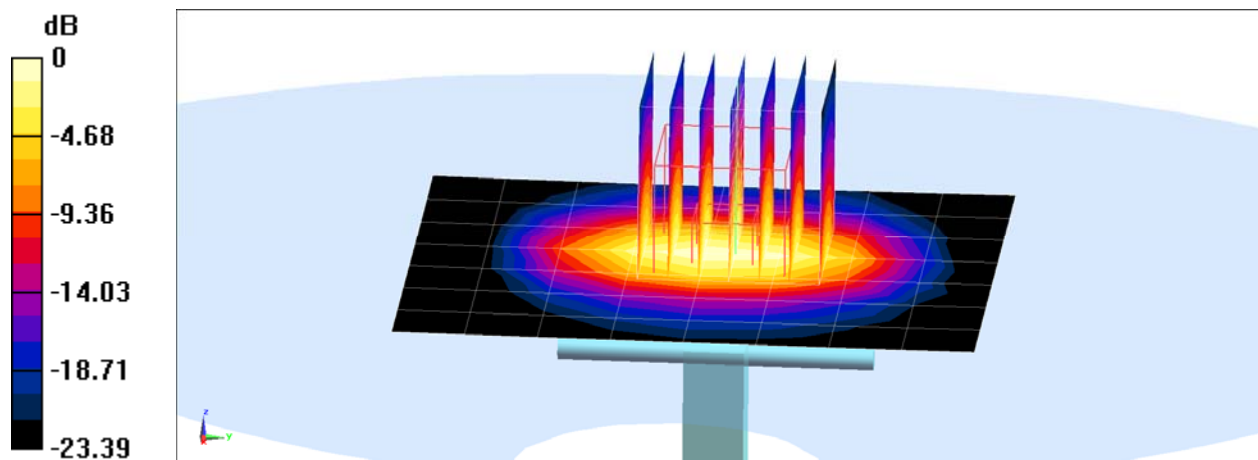

# PCTEST ENGINEERING LABORATORY, INC.

**DUT: Dipole 5300 MHz; Type: D5GHzV2; Serial: 1120**

Communication System: UID 0, CW; Frequency: 5300 MHz; Duty Cycle: 1:1

Medium: 5 GHz Head Medium parameters used:

$f = 5300 \text{ MHz}$ ;  $\sigma = 4.785 \text{ S/m}$ ;  $\epsilon_r = 35.717$ ;  $\rho = 1000 \text{ kg/m}^3$

Phantom section: Flat Section; Space: 1.0 cm

Test Date: 01-19-2015; Ambient Temp: 23.0°C; Tissue Temp: 21.1°C

Probe: EX3DV4 - SN7308; ConvF(5.37, 5.37, 5.37); Calibrated: 7/16/2014;

Sensor-Surface: 1.4mm (Mechanical Surface Detection)

Electronics: DAE4 Sn1323; Calibrated: 9/17/2014

Phantom: SAM V5.0 Right; Type: QD000P40CD; Serial: 1647

Measurement SW: DASY52, Version 52.8 (8); SEMCAD X Version 14.6.10 (7331)

## 5300 MHz System Verification

**Area Scan (7x8x1):** Measurement grid: dx=10mm, dy=10mm

**Zoom Scan (8x8x7)/Cube 0:** Measurement grid: dx=4mm, dy=4mm, dz=1.4mm; Graded Ratio = 1.4

Input Power = 20.0 dBm (100 mW)

Peak SAR (extrapolated) = 32.6 W/kg

**SAR (1 g) = 7.7 W/kg**

Deviation = -7.67%

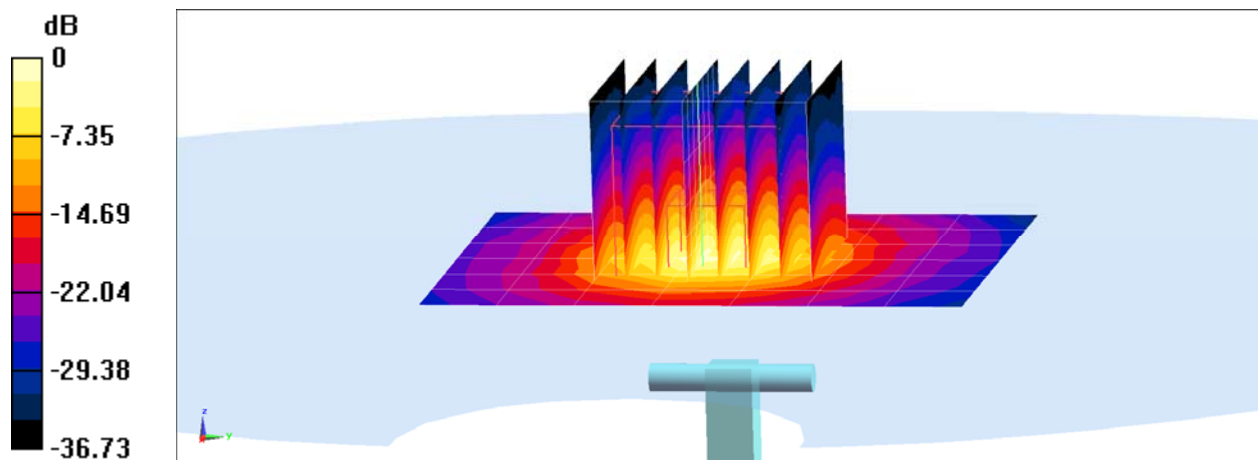

# PCTEST ENGINEERING LABORATORY, INC.

**DUT: Dipole 5500 MHz; Type: D5GHzV2; Serial: 1120**

Communication System: UID 0, CW; Frequency: 5500 MHz; Duty Cycle: 1:1

Medium: 5 GHz Head Medium parameters used:

$f = 5500$  MHz;  $\sigma = 4.989$  S/m;  $\epsilon_r = 35.418$ ;  $\rho = 1000$  kg/m<sup>3</sup>

Phantom section: Flat Section; Space: 1.0 cm

Test Date: 01-19-2015; Ambient Temp: 23.2°C; Tissue Temp: 21.2°C

Probe: EX3DV4 - SN7308; ConvF(4.64, 4.64, 4.64); Calibrated: 7/16/2014;

Sensor-Surface: 1.4mm (Mechanical Surface Detection)

Electronics: DAE4 Sn1323; Calibrated: 9/17/2014

Phantom: SAM V5.0 Right; Type: QD000P40CD; Serial: 1647

Measurement SW: DASY52, Version 52.8 (8); SEMCAD X Version 14.6.10 (7331)

## 5500 MHz System Verification

**Area Scan (7x7x1):** Measurement grid: dx=10mm, dy=10mm

**Zoom Scan (8x8x7)/Cube 0:** Measurement grid: dx=4mm, dy=4mm, dz=1.4mm; Graded Ratio = 1.4

Input Power = 20.0 dBm (100 mW)

Peak SAR (extrapolated) = 33.7 W/kg

**SAR (1 g) = 7.84 W/kg**

Deviation = -7.66%

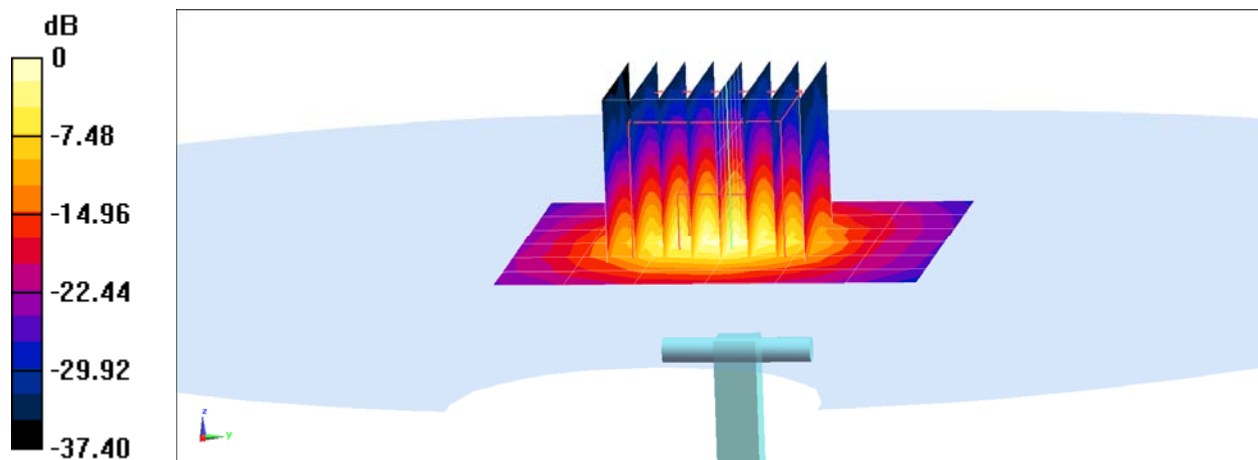

# PCTEST ENGINEERING LABORATORY, INC.

**DUT: Dipole 5600 MHz; Type: D5GHzV2; Serial: 1120**

Communication System: UID 0, CW; Frequency: 5600 MHz; Duty Cycle: 1:1

Medium: 5 GHz Head Medium parameters used:

$f = 5600 \text{ MHz}$ ;  $\sigma = 5.119 \text{ S/m}$ ;  $\epsilon_r = 35.278$ ;  $\rho = 1000 \text{ kg/m}^3$

Phantom section: Flat Section; Space: 1.0 cm

Test Date: 01-19-2015; Ambient Temp: 23.1°C; Tissue Temp: 21.0°C

Probe: EX3DV4 - SN7308; ConvF(4.64, 4.64, 4.64); Calibrated: 7/16/2014;

Sensor-Surface: 1.4mm (Mechanical Surface Detection)

Electronics: DAE4 Sn1323; Calibrated: 9/17/2014

Phantom: SAM V5.0 Right; Type: QD000P40CD; Serial: 1647

Measurement SW: DASY52, Version 52.8 (8); SEMCAD X Version 14.6.10 (7331)

## 5600 MHz System Verification

**Area Scan (7x7x1):** Measurement grid: dx=10mm, dy=10mm

**Zoom Scan (8x8x7)/Cube 0:** Measurement grid: dx=4mm, dy=4mm, dz=1.4mm; Graded Ratio = 1.4

Input Power = 20.0 dBm (100 mW)

Peak SAR (extrapolated) = 35.6 W/kg

**SAR (1 g) = 8.2 W/kg**

Deviation = -0.24%

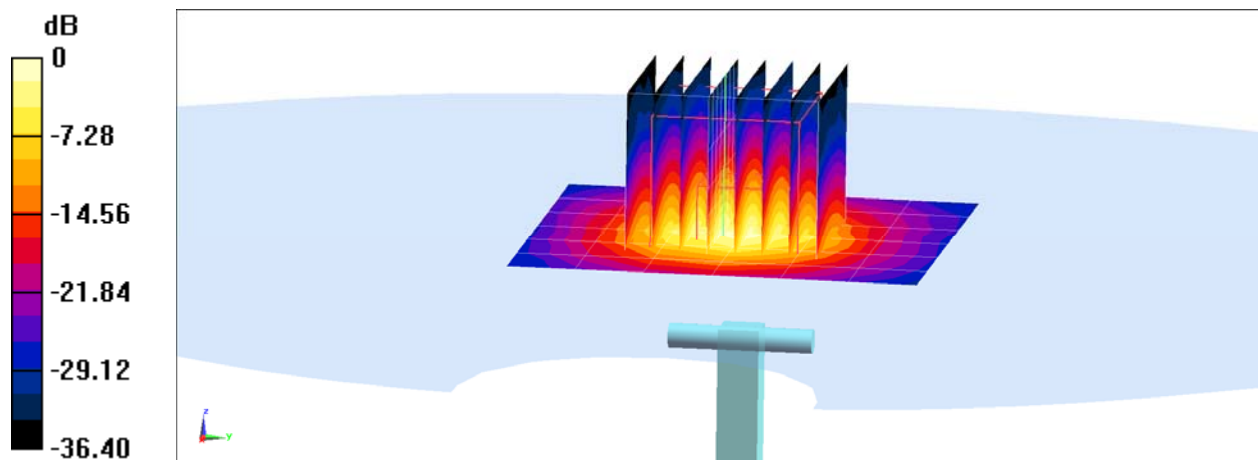

# PCTEST ENGINEERING LABORATORY, INC.

**DUT: Dipole 750 MHz; Type: D750V3; Serial: 1054**

Communication System: UID 0, CW; Frequency: 750 MHz; Duty Cycle: 1:1

Medium: 750 Body Medium parameters used (interpolated):

$f = 750 \text{ MHz}$ ;  $\sigma = 0.986 \text{ S/m}$ ;  $\epsilon_r = 56.589$ ;  $\rho = 1000 \text{ kg/m}^3$

Phantom section: Flat Section; Space: 1.5 cm

Test Date: 02-09-2015; Ambient Temp: 23.6°C; Tissue Temp: 23.0°C

Probe: ES3DV3 - SN3213; ConvF(6.11, 6.11, 6.11); Calibrated: 1/20/2015;

Sensor-Surface: 3mm (Mechanical Surface Detection)

Electronics: DAE4 Sn1407; Calibrated: 1/19/2015

Phantom: ELI v5.0; Type: QDOVA002AA; Serial: TP-1158

Measurement SW: DASY52, Version 52.8 (8); SEMCAD X Version 14.6.10 (7331)

## 750 MHz System Verification

**Area Scan (7x15x1):** Measurement grid:  $dx=15\text{mm}$ ,  $dy=15\text{mm}$

**Zoom Scan (5x5x7)/Cube 0:** Measurement grid:  $dx=8\text{mm}$ ,  $dy=8\text{mm}$ ,  $dz=5\text{mm}$

Input Power = 26.5 dBm (447 mW)

Peak SAR (extrapolated) = 5.79 W/kg

**SAR (1 g) = 4.01 W/kg**

Deviation = 3.90 %

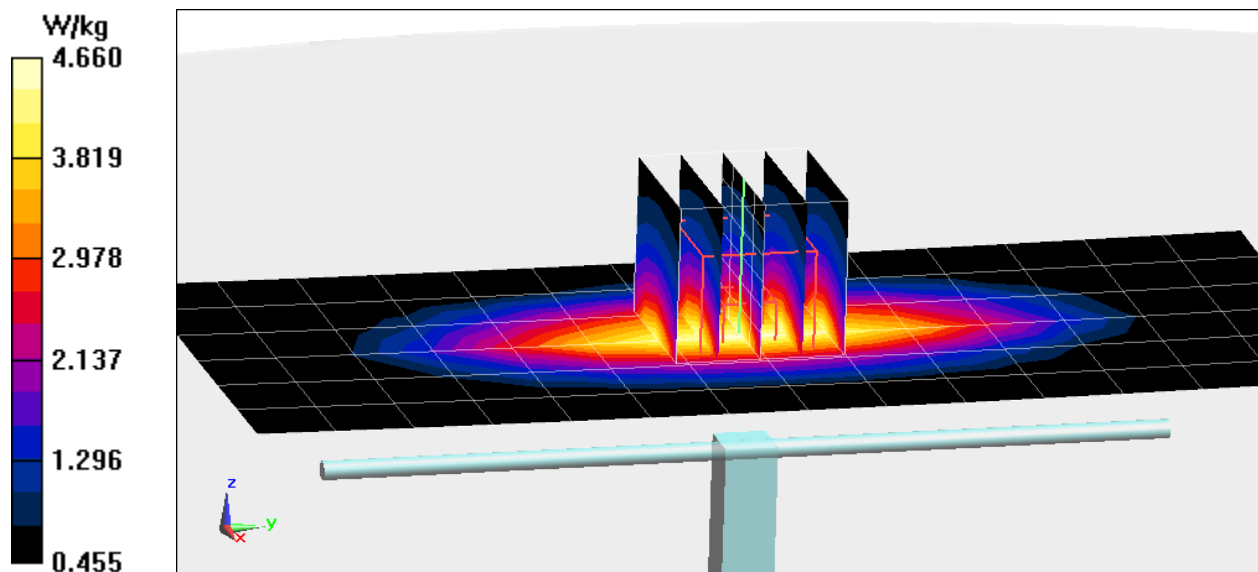

# PCTEST ENGINEERING LABORATORY, INC.

**DUT: Dipole 835 MHz; Type: D835V2; Serial: 4d133**

Communication System: UID 0, CW; Frequency: 835 MHz; Duty Cycle: 1:1

Medium: 835 Body Medium parameters used:

$f = 835 \text{ MHz}$ ;  $\sigma = 1.001 \text{ S/m}$ ;  $\epsilon_r = 53.427$ ;  $\rho = 1000 \text{ kg/m}^3$

Phantom section: Flat Section; Space: 1.5 cm

Test Date: 02-09-2015; Ambient Temp: 24.0°C; Tissue Temp: 21.8°C

Probe: ES3DV3 - SN3288; ConvF(6.32, 6.32, 6.32); Calibrated: 9/24/2014;

Sensor-Surface: 3mm (Mechanical Surface Detection)

Electronics: DAE4 Sn1364; Calibrated: 9/18/2014

Phantom: ELI v5.0; Type: QDOVA001BB; Serial: 1229

Measurement SW: DASY52, Version 52.8 (8); SEMCAD X Version 14.6.10 (7331)

## 835 MHz System Verification

**Area Scan (7x14x1):** Measurement grid: dx=15mm, dy=15mm

**Zoom Scan (5x5x7)/Cube 0:** Measurement grid: dx=8mm, dy=8mm, dz=5mm

Input Power = 20.0 dBm (100 mW)

Peak SAR (extrapolated) = 1.50 W/kg

**SAR(1 g) = 1 W/kg**

Deviation = 6.95 %

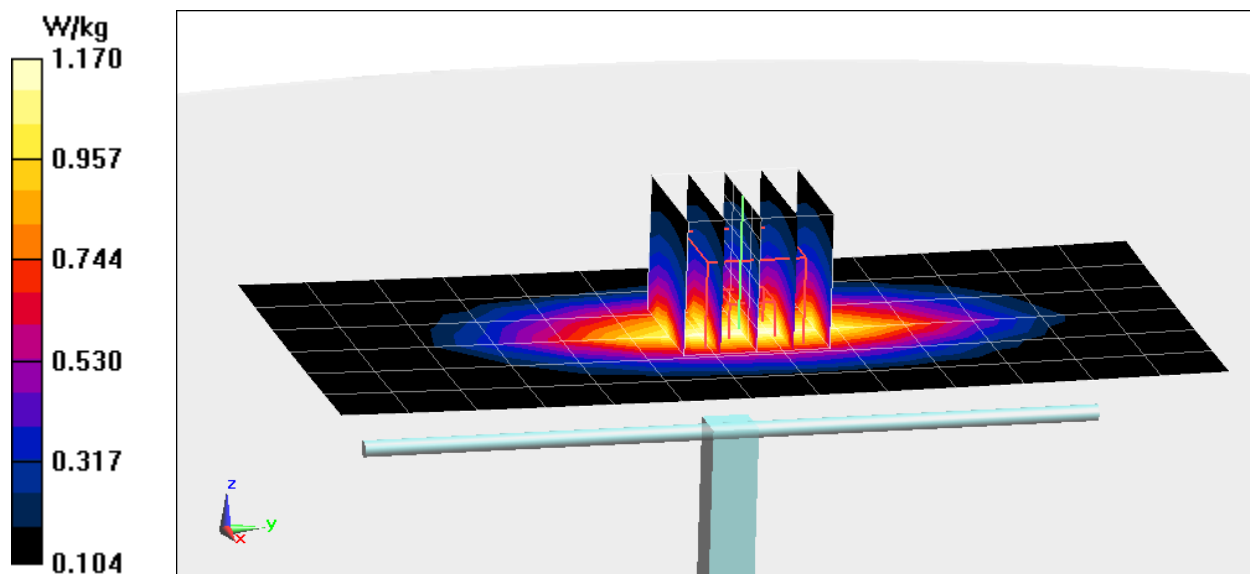

# PCTEST ENGINEERING LABORATORY, INC.

**DUT: Dipole 1765 MHz; Type: D1765V2; Serial: 1008**

Communication System: UID 0, CW; Frequency: 1750 MHz; Duty Cycle: 1:1

Medium: 1750 Body Medium parameters used:

$f = 1750$  MHz;  $\sigma = 1.498$  S/m;  $\epsilon_r = 52.009$ ;  $\rho = 1000$  kg/m<sup>3</sup>

Phantom section: Flat Section; Space: 1.0 cm

Test Date: 02-10-2015; Ambient Temp: 23.7°C; Tissue Temp: 21.9°C

Probe: ES3DV2 - SN3022; ConvF(4.7, 4.7, 4.7); Calibrated: 8/19/2014;

Sensor-Surface: 3mm (Mechanical Surface Detection)

Electronics: DAE4 Sn1322; Calibrated: 8/12/2014

Phantom: SAM with CRP v4.0; Type: QD000P40CD; Serial: TP:1800

Measurement SW: DASY52, Version 52.8 (8); SEMCAD X Version 14.6.10 (7331)

## 1750 MHz System Verification

**Area Scan (7x9x1):** Measurement grid: dx=15mm, dy=15mm

**Zoom Scan (5x5x7)/Cube 0:** Measurement grid: dx=8mm, dy=8mm, dz=5mm

Input Power = 20.0 dBm (100 mW)

Peak SAR (extrapolated) = 6.32 W/kg

**SAR(1 g) = 3.58 W/kg**

Deviation = -4.79 %

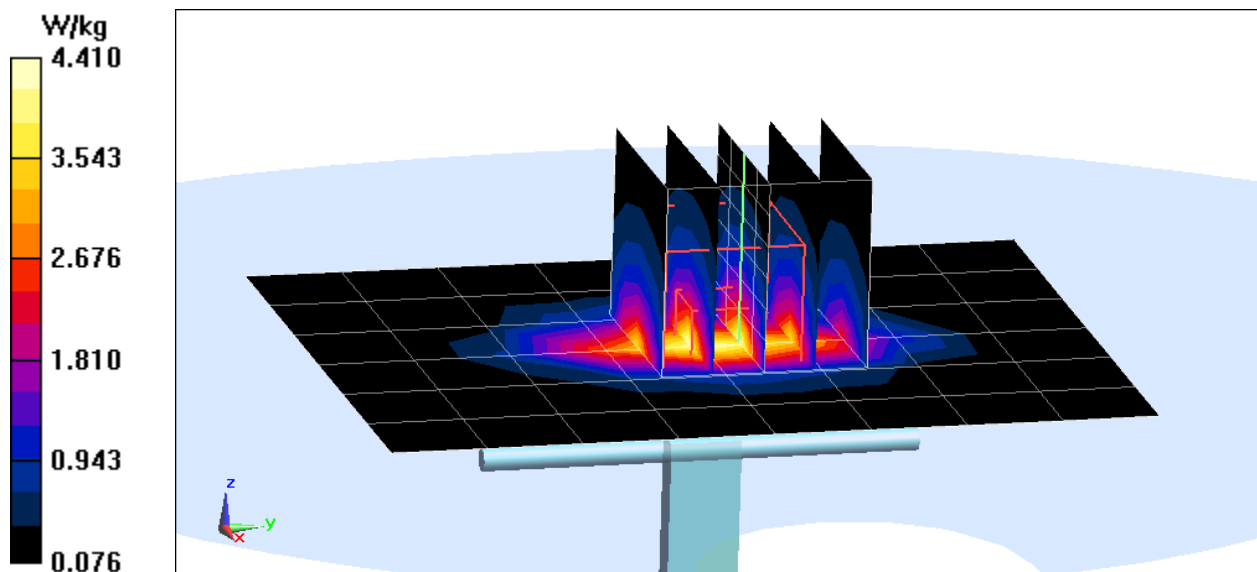

# PCTEST ENGINEERING LABORATORY, INC.

**DUT: Dipole 1900 MHz; Type: D1900V2; Serial: 5d149**

Communication System: UID 0, CW; Frequency: 1900 MHz; Duty Cycle: 1:1  
Medium: 1900 Body Medium parameters used (interpolated):  
 $f = 1900 \text{ MHz}$ ;  $\sigma = 1.552 \text{ S/m}$ ;  $\epsilon_r = 52.298$ ;  $\rho = 1000 \text{ kg/m}^3$   
Phantom section: Flat Section; Space: 1.0 cm

Test Date: 02-09-2015; Ambient Temp: 23.0°C; Tissue Temp: 22.4°C

Probe: ES3DV3 - SN3332; ConvF(4.64, 4.64, 4.64); Calibrated: 9/18/2014;  
Sensor-Surface: 3mm (Mechanical Surface Detection)  
Electronics: DAE4 Sn1323; Calibrated: 9/17/2014  
Phantom: SAM 5.0 front; Type: QD000P40CD; Serial: TP:-1648  
Measurement SW: DASY52, Version 52.8 (8); SEMCAD X Version 14.6.10 (7331)

## 1900 MHz System Verification

**Area Scan (7x10x1):** Measurement grid: dx=15mm, dy=15mm

**Zoom Scan (5x5x7)/Cube 0:** Measurement grid: dx=8mm, dy=8mm, dz=5mm

Input Power = 20.0 dBm (100 mW)

Peak SAR (extrapolated) = 7.28 W/kg

**SAR(1 g) = 4.12 W/kg**

Deviation = 1.98 %

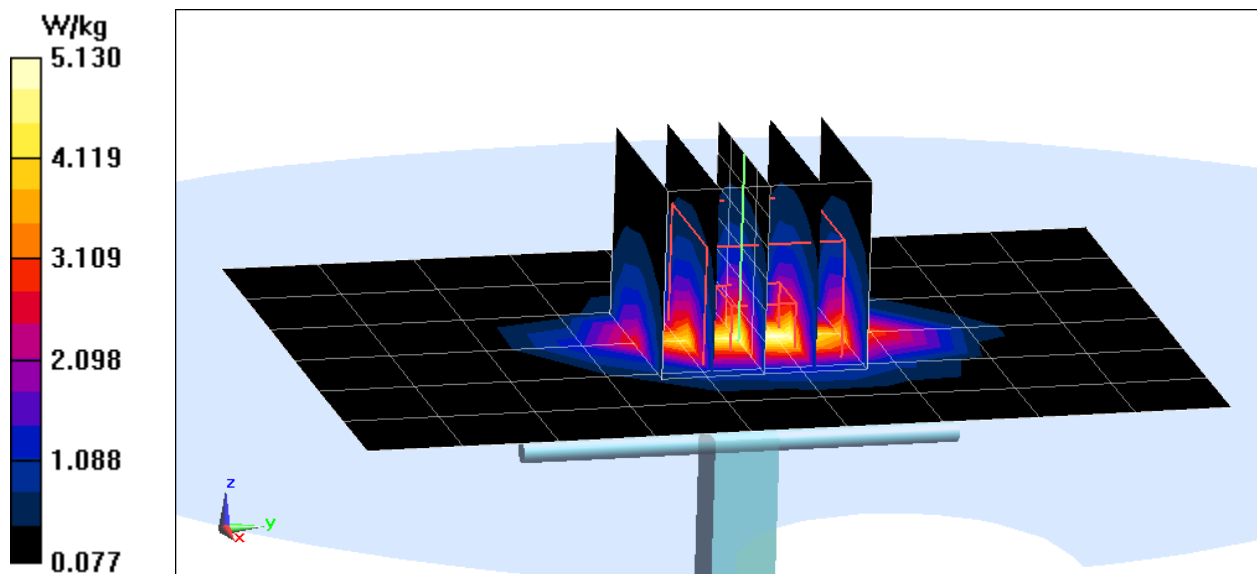

# PCTEST ENGINEERING LABORATORY, INC.

**DUT: Dipole 2450 MHz; Type: D2450V2; Serial: 719**

Communication System: UID 0, CW; Frequency: 2450 MHz; Duty Cycle: 1:1

Medium: 2450 Body Medium parameters used:

$f = 2450 \text{ MHz}$ ;  $\sigma = 1.99 \text{ S/m}$ ;  $\epsilon_r = 51.901$ ;  $\rho = 1000 \text{ kg/m}^3$

Phantom section: Flat Section; Space: 1.0 cm

Test Date: 01-12-2015; Ambient Temp: 23.9°C; Tissue Temp: 23.0°C

Probe: ES3DV3 - SN3258; ConvF(4.14, 4.14, 4.14); Calibrated: 2/25/2014;

Sensor-Surface: 3mm (Mechanical Surface Detection)

Electronics: DAE4 Sn665; Calibrated: 2/26/2014

Phantom: ELI v5.0; Type: QDOVA002AA; Serial: TP-1158

Measurement SW: DASY52, Version 52.8 (8); SEMCAD X Version 14.6.10 (7331)

## 2450 MHz System Verification

**Area Scan (8x9x1):** Measurement grid: dx=12mm, dy=12mm

**Zoom Scan (7x7x7)/Cube 0:** Measurement grid: dx=5mm, dy=5mm, dz=5mm

Input Power = 20.0 dBm (100 mW)

Peak SAR (extrapolated) = 11.5 W/kg

**SAR (1 g) = 5.54 W/kg**

Deviation = 6.95%

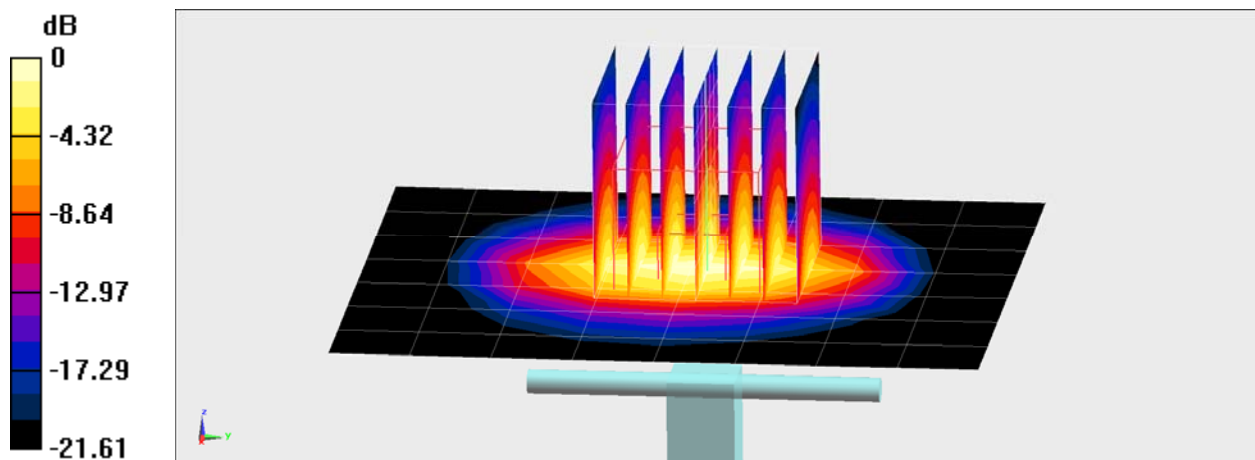

# PCTEST ENGINEERING LABORATORY, INC.

**DUT: Dipole 2450 MHz; Type: D2450V2; Serial: 719**

Communication System: UID 0, CW; Frequency: 2450 MHz; Duty Cycle: 1:1

Medium: 2450 Body Medium parameters used:

$f = 2450$  MHz;  $\sigma = 1.956$  S/m;  $\epsilon_r = 52.631$ ;  $\rho = 1000$  kg/m<sup>3</sup>

Phantom section: Flat Section; Space: 1.0 cm

Test Date: 02-02-2015; Ambient Temp: 24.4°C; Tissue Temp: 23.5°C

Probe: ES3DV3 - SN3209; ConvF(4.2, 4.2, 4.2); Calibrated: 3/19/2014;

Sensor-Surface: 3mm (Mechanical Surface Detection)

Electronics: DAE4 Sn1334; Calibrated: 3/17/2014

Phantom: SAM left; Type: QD000P40CD; Serial: TP:1715

Measurement SW: DASY52, Version 52.8 (8); SEMCAD X Version 14.6.10 (7331)

## 2450 MHz System Verification

**Area Scan (8x9x1):** Measurement grid: dx=12mm, dy=12mm

**Zoom Scan (7x9x7)/Cube 0:** Measurement grid: dx=5mm, dy=5mm, dz=5mm

Input Power = 20.0 dBm (100 mW)

Peak SAR (extrapolated) = 11.7 W/kg

**SAR (1 g) = 5.42 W/kg**

Deviation = 4.63%

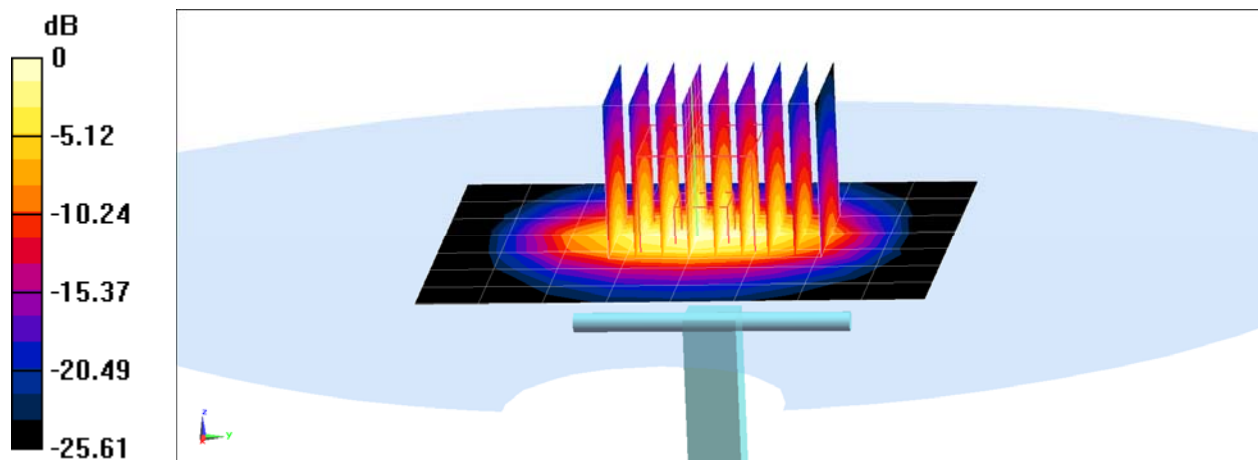

# PCTEST ENGINEERING LABORATORY, INC.

**DUT: Dipole 5300 MHz; Type: D5GHzV2; Serial: 1191**

Communication System: UID 0, CW; Frequency: 5300 MHz; Duty Cycle: 1:1

Medium: 5 GHz Body Medium parameters used:

$f = 5300 \text{ MHz}$ ;  $\sigma = 5.589 \text{ S/m}$ ;  $\epsilon_r = 47.162$ ;  $\rho = 1000 \text{ kg/m}^3$

Phantom section: Flat Section; Space: 1.0 cm

Test Date: 01-13-2015; Ambient Temp: 22.2°C; Tissue Temp: 23.0°C

Probe: EX3DV4 - SN3920; ConvF(4.16, 4.16, 4.16); Calibrated: 12/12/2014;

Sensor-Surface: 1.4mm (Mechanical Surface Detection)

Electronics: DAE4 Sn1368; Calibrated: 4/11/2014

Phantom: SAM; Type: QD000P40CD; Serial: TP:1758

Measurement SW: DASY52, Version 52.8 (8); SEMCAD X Version 14.6.10 (7331)

## 5300 MHz System Verification

**Area Scan (7x8x1):** Measurement grid: dx=10mm, dy=10mm

**Zoom Scan (8x8x7)/Cube 0:** Measurement grid: dx=4mm, dy=4mm, dz=1.4mm; Graded Ratio = 1.4

Input Power = 20.0 dBm (100 mW)

Peak SAR (extrapolated) = 30.1 W/kg

**SAR (1 g) = 7.36 W/kg**

Deviation = -7.88%

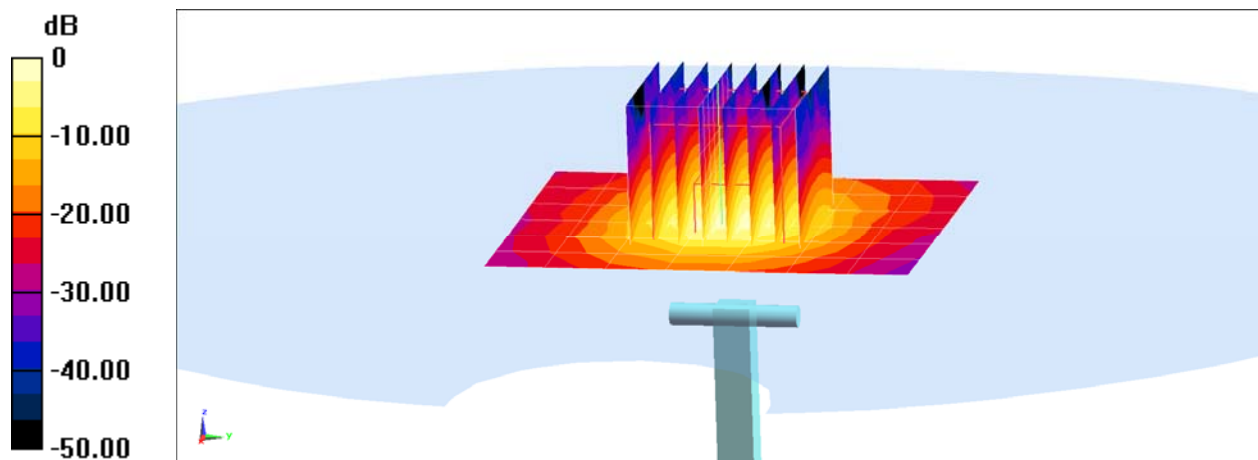

# PCTEST ENGINEERING LABORATORY, INC.

**DUT: Dipole 5500 MHz; Type: D5GHzV2; Serial: 1191**

Communication System: UID 0, CW; Frequency: 5500 MHz; Duty Cycle: 1:1

Medium: 5 GHz Body Medium parameters used:

$f = 5500 \text{ MHz}$ ;  $\sigma = 5.847 \text{ S/m}$ ;  $\epsilon_r = 46.781$ ;  $\rho = 1000 \text{ kg/m}^3$

Phantom section: Flat Section; Space: 1.0 cm

Test Date: 01-13-2015; Ambient Temp: 22.0°C; Tissue Temp: 23.2°C

Probe: EX3DV4 - SN3920; ConvF(3.79, 3.79, 3.79); Calibrated: 12/12/2014;

Sensor-Surface: 1.4mm (Mechanical Surface Detection)

Electronics: DAE4 Sn1368; Calibrated: 4/11/2014

Phantom: SAM; Type: QD000P40CD; Serial: TP:1758

Measurement SW: DASY52, Version 52.8 (8); SEMCAD X Version 14.6.10 (7331)

## 5500 MHz System Verification

**Area Scan (7x7x1):** Measurement grid: dx=10mm, dy=10mm

**Zoom Scan (8x8x7)/Cube 0:** Measurement grid: dx=4mm, dy=4mm, dz=1.4mm; Graded Ratio = 1.4

Input Power = 20.0 dBm (100 mW)

Peak SAR (extrapolated) = 31.3 W/kg

**SAR (1 g) = 7.5 W/kg**

Deviation = -9.75%

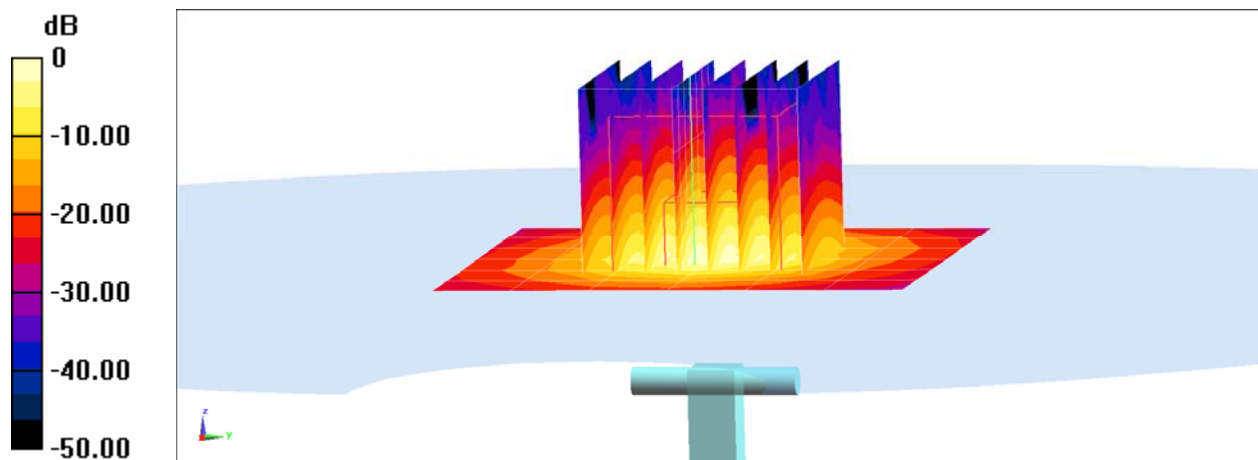

# PCTEST ENGINEERING LABORATORY, INC.

**DUT: Dipole 5600 MHz; Type: D5GHzV2; Serial: 1191**

Communication System: UID 0, CW; Frequency: 5600 MHz; Duty Cycle: 1:1

Medium: 5 GHz Body Medium parameters used:

$f = 5600 \text{ MHz}$ ;  $\sigma = 5.996 \text{ S/m}$ ;  $\epsilon_r = 46.661$ ;  $\rho = 1000 \text{ kg/m}^3$

Phantom section: Flat Section; Space: 1.0 cm

Test Date: 01-13-2015; Ambient Temp: 22.1°C; Tissue Temp: 23.1°C

Probe: EX3DV4 - SN3920; ConvF(3.66, 3.66, 3.66); Calibrated: 12/12/2014;

Sensor-Surface: 1.4mm (Mechanical Surface Detection)

Electronics: DAE4 Sn1368; Calibrated: 4/11/2014

Phantom: SAM; Type: QD000P40CD; Serial: TP:1758

Measurement SW: DASY52, Version 52.8 (8); SEMCAD X Version 14.6.10 (7331)

## 5600 MHz System Verification

**Area Scan (7x7x1):** Measurement grid: dx=10mm, dy=10mm

**Zoom Scan (8x8x7)/Cube 0:** Measurement grid: dx=4mm, dy=4mm, dz=1.4mm; Graded Ratio = 1.4

Input Power = 20.0 dBm (100 mW)

Peak SAR (extrapolated) = 32.9 W/kg

**SAR (1 g) = 7.74 W/kg**

Deviation = -7.97%

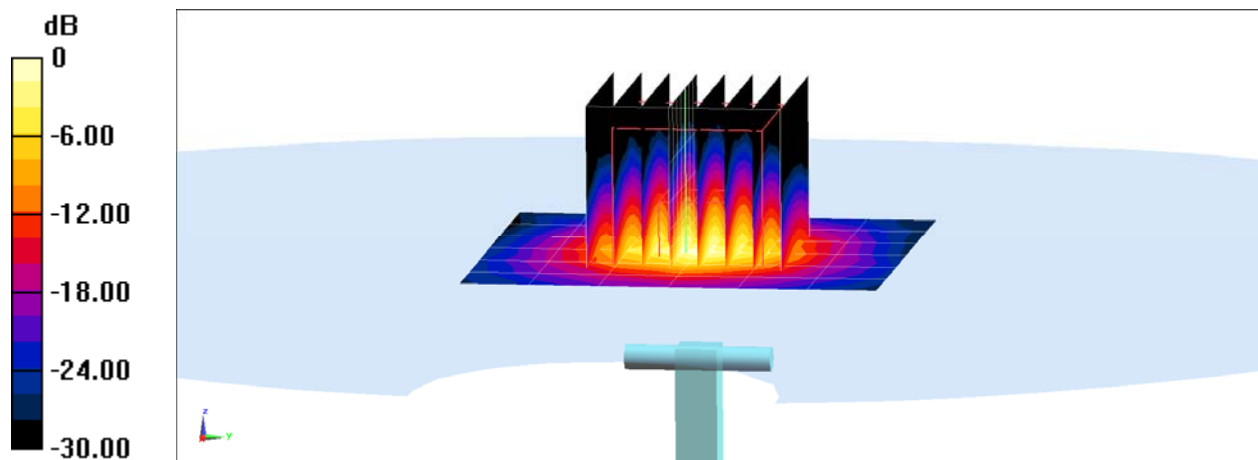

# PCTEST ENGINEERING LABORATORY, INC.

**DUT: Dipole 5800 MHz; Type: D5GHzV2; Serial: 1191**

Communication System: UID 0, CW; Frequency: 5800 MHz; Duty Cycle: 1:1

Medium: 5 GHz Body Medium parameters used:

$f = 5800 \text{ MHz}$ ;  $\sigma = 6.263 \text{ S/m}$ ;  $\epsilon_r = 46.274$ ;  $\rho = 1000 \text{ kg/m}^3$

Phantom section: Flat Section; Space: 1.0 cm

Test Date: 01-13-2015; Ambient Temp: 22.2°C; Tissue Temp: 23.0°C

Probe: EX3DV4 - SN3920; ConvF(3.93, 3.93, 3.93); Calibrated: 12/12/2014;

Sensor-Surface: 1.4mm (Mechanical Surface Detection)

Electronics: DAE4 Sn1368; Calibrated: 4/11/2014

Phantom: SAM; Type: QD000P40CD; Serial: TP:1758

Measurement SW: DASY52, Version 52.8 (8); SEMCAD X Version 14.6.10 (7331)

## 5800 MHz System Verification

**Area Scan (7x7x1):** Measurement grid: dx=10mm, dy=10mm

**Zoom Scan (8x8x7)/Cube 0:** Measurement grid: dx=4mm, dy=4mm, dz=1.4mm; Graded Ratio = 1.4

Input Power = 20.0 dBm (100 mW)

Peak SAR (extrapolated) = 31.7 W/kg

**SAR (1 g) = 7.04 W/kg**

Deviation = -9.74%

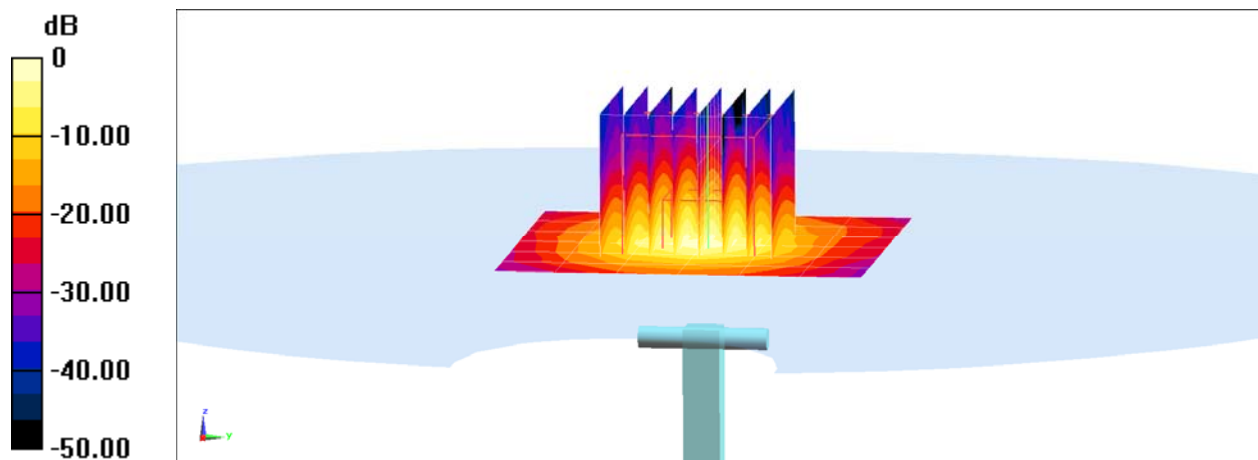

## APPENDIX C: PROBE CALIBRATION



Accredited by the Swiss Accreditation Service (SAS)  
The Swiss Accreditation Service is one of the signatories to the EA  
Multilateral Agreement for the recognition of calibration certificates

Accreditation No.: **SCS 108**

Client **PC Test**

Certificate No: **D5GHzV2-1191\_Sep14**

**CALIBRATION CERTIFICATE**

Object **D5GHzV2 - SN:1191**

Calibration procedure(s) **QA CAL-22.v2  
Calibration procedure for dipole validation kits between 3-6 GHz**

*CC  
11/14*

Calibration date: **September 25, 2014**

This calibration certificate documents the traceability to national standards, which realize the physical units of measurements (SI).  
The measurements and the uncertainties with confidence probability are given on the following pages and are part of the certificate.

All calibrations have been conducted in the closed laboratory facility: environment temperature (22 ± 3)°C and humidity < 70%.

Calibration Equipment used (M&TE critical for calibration)

Primary Standards	ID #	Cal Date (Certificate No.)	Scheduled Calibration
Power meter EPM-442A	GB37480704	09-Oct-13 (No. 217-01827)	Oct-14
Power sensor HP 8481A	US37292783	09-Oct-13 (No. 217-01827)	Oct-14
Power sensor HP 8481A	MY41092317	09-Oct-13 (No. 217-01828)	Oct-14
Reference 20 dB Attenuator	SN: 5058 (20k)	03-Apr-14 (No. 217-01918)	Apr-15
Type-N mismatch combination	SN: 5047.2 / 06327	03-Apr-14 (No. 217-01921)	Apr-15
Reference Probe EX3DV4	SN: 3503	30-Dec-13 (No. EX3-3503_Dec13)	Dec-14
DAE4	SN: 601	18-Aug-14 (No. DAE4-601_Aug14)	Aug-15
Secondary Standards	ID #	Check Date (in house)	Scheduled Check
RF generator R&S SMT-06	100005	04-Aug-99 (in house check Oct-13)	In house check: Oct-16
Network Analyzer HP 8753E	US37390585 S4206	18-Oct-01 (in house check Oct-13)	In house check: Oct-14

Calibrated by: **Claudio Leubler**      Name: Claudio Leubler      Function: Laboratory Technician

Signature

Approved by: **Katja Pokovic**      Name: Katja Pokovic      Technical Manager

Issued: September 25, 2014

This calibration certificate shall not be reproduced except in full without written approval of the laboratory.

**Calibration Laboratory of  
Schmid & Partner  
Engineering AG**  
Zeughausstrasse 43, 8004 Zurich, Switzerland



**S** Schweizerischer Kalibrierdienst  
**C** Service suisse d'étalonnage  
**S** Servizio svizzero di taratura  
**S** Swiss Calibration Service

Accreditation No.: **SCS 108**

Accredited by the Swiss Accreditation Service (SAS)  
The Swiss Accreditation Service is one of the signatories to the EA  
Multilateral Agreement for the recognition of calibration certificates

### Glossary:

TSL	tissue simulating liquid
ConvF	sensitivity in TSL / NORM x,y,z
N/A	not applicable or not measured

### Calibration is Performed According to the Following Standards:

- IEC 62209-2, "Evaluation of Human Exposure to Radio Frequency Fields from Handheld and Body-Mounted Wireless Communication Devices in the Frequency Range of 30 MHz to 6 GHz: Human models, Instrumentation, and Procedures"; Part 2: "Procedure to determine the Specific Absorption Rate (SAR) for including accessories and multiple transmitters", March 2010
- KDB 865664, "SAR Measurement Requirements for 100 MHz to 6 GHz"
- IEEE Std 1528-2013, "IEEE Recommended Practice for Determining the Peak Spatial-Averaged Specific Absorption Rate (SAR) in the Human Head from Wireless Communications Devices: Measurement Techniques", June 2013

### Additional Documentation:

- DASY4/5 System Handbook

### Methods Applied and Interpretation of Parameters:

- Measurement Conditions:** Further details are available from the Validation Report at the end of the certificate. All figures stated in the certificate are valid at the frequency indicated.
- Antenna Parameters with TSL:** The dipole is mounted with the spacer to position its feed point exactly below the center marking of the flat phantom section, with the arms oriented parallel to the body axis.
- Feed Point Impedance and Return Loss:** These parameters are measured with the dipole positioned under the liquid filled phantom. The impedance stated is transformed from the measurement at the SMA connector to the feed point. The Return Loss ensures low reflected power. No uncertainty required.
- Electrical Delay:** One-way delay between the SMA connector and the antenna feed point. No uncertainty required.
- SAR measured:** SAR measured at the stated antenna input power.
- SAR normalized:** SAR as measured, normalized to an input power of 1 W at the antenna connector.
- SAR for nominal TSL parameters:** The measured TSL parameters are used to calculate the nominal SAR result.

The reported uncertainty of measurement is stated as the standard uncertainty of measurement multiplied by the coverage factor  $k=2$ , which for a normal distribution corresponds to a coverage probability of approximately 95%.

## Measurement Conditions

DASY system configuration, as far as not given on page 1.

DASY Version	DASY5	V52.8.8
Extrapolation	Advanced Extrapolation	
Phantom	Modular Flat Phantom V5.0	
Distance Dipole Center - TSL	10 mm	with Spacer
Zoom Scan Resolution	dx, dy = 4.0 mm, dz = 1.4 mm	Graded Ratio = 1.4 (Z direction)
Frequency	5200 MHz ± 1 MHz 5300 MHz ± 1 MHz 5500 MHz ± 1 MHz 5600 MHz ± 1 MHz 5800 MHz ± 1 MHz	

## Head TSL parameters at 5200 MHz

The following parameters and calculations were applied.

	Temperature	Permittivity	Conductivity
Nominal Head TSL parameters	22.0 °C	36.0	4.66 mho/m
Measured Head TSL parameters	(22.0 ± 0.2) °C	34.9 ± 6 %	4.54 mho/m ± 6 %
Head TSL temperature change during test	< 0.5 °C	----	----

## SAR result with Head TSL at 5200 MHz

SAR averaged over 1 cm <sup>3</sup> (1 g) of Head TSL	Condition	
SAR measured	100 mW input power	8.17 W/kg
SAR for nominal Head TSL parameters	normalized to 1W	<b>81.1 W/kg ± 19.9 % (k=2)</b>

SAR averaged over 10 cm <sup>3</sup> (10 g) of Head TSL	condition	
SAR measured	100 mW input power	2.33 W/kg
SAR for nominal Head TSL parameters	normalized to 1W	<b>23.1 W/kg ± 19.5 % (k=2)</b>

### Head TSL parameters at 5300 MHz

The following parameters and calculations were applied.

	Temperature	Permittivity	Conductivity
Nominal Head TSL parameters	22.0 °C	35.9	4.76 mho/m
Measured Head TSL parameters	(22.0 ± 0.2) °C	34.8 ± 6 %	4.64 mho/m ± 6 %
Head TSL temperature change during test	< 0.5 °C	----	----

### SAR result with Head TSL at 5300 MHz

SAR averaged over 1 cm <sup>3</sup> (1 g) of Head TSL	Condition	
SAR measured	100 mW input power	8.64 W/kg
SAR for nominal Head TSL parameters	normalized to 1W	85.8 W / kg ± 19.9 % (k=2)

SAR averaged over 10 cm <sup>3</sup> (10 g) of Head TSL	condition	
SAR measured	100 mW input power	2.47 W/kg
SAR for nominal Head TSL parameters	normalized to 1W	24.5 W/kg ± 19.5 % (k=2)

### Head TSL parameters at 5500 MHz

The following parameters and calculations were applied.

	Temperature	Permittivity	Conductivity
Nominal Head TSL parameters	22.0 °C	35.6	4.96 mho/m
Measured Head TSL parameters	(22.0 ± 0.2) °C	34.5 ± 6 %	4.83 mho/m ± 6 %
Head TSL temperature change during test	< 0.5 °C	----	----

### SAR result with Head TSL at 5500 MHz

SAR averaged over 1 cm <sup>3</sup> (1 g) of Head TSL	Condition	
SAR measured	100 mW input power	8.93 W/kg
SAR for nominal Head TSL parameters	normalized to 1W	88.6 W/kg ± 19.9 % (k=2)

SAR averaged over 10 cm <sup>3</sup> (10 g) of Head TSL	condition	
SAR measured	100 mW input power	2.54 W/kg
SAR for nominal Head TSL parameters	normalized to 1W	25.2 W/kg ± 19.5 % (k=2)

### Head TSL parameters at 5600 MHz

The following parameters and calculations were applied.

	Temperature	Permittivity	Conductivity
Nominal Head TSL parameters	22.0 °C	35.5	5.07 mho/m
Measured Head TSL parameters	(22.0 ± 0.2) °C	34.4 ± 6 %	4.93 mho/m ± 6 %
Head TSL temperature change during test	< 0.5 °C	----	----

### SAR result with Head TSL at 5600 MHz

SAR averaged over 1 cm <sup>3</sup> (1 g) of Head TSL	Condition	
SAR measured	100 mW input power	8.76 W/kg
SAR for nominal Head TSL parameters	normalized to 1W	86.9 W/kg ± 19.9 % (k=2)

SAR averaged over 10 cm <sup>3</sup> (10 g) of Head TSL	condition	
SAR measured	100 mW input power	2.49 W/kg
SAR for nominal Head TSL parameters	normalized to 1W	24.7 W/kg ± 19.5 % (k=2)

### Head TSL parameters at 5800 MHz

The following parameters and calculations were applied.

	Temperature	Permittivity	Conductivity
Nominal Head TSL parameters	22.0 °C	35.3	5.27 mho/m
Measured Head TSL parameters	(22.0 ± 0.2) °C	34.1 ± 6 %	5.14 mho/m ± 6 %
Head TSL temperature change during test	< 0.5 °C	----	----

### SAR result with Head TSL at 5800 MHz

SAR averaged over 1 cm <sup>3</sup> (1 g) of Head TSL	Condition	
SAR measured	100 mW input power	8.30 W/kg
SAR for nominal Head TSL parameters	normalized to 1W	82.3 W/kg ± 19.9 % (k=2)

SAR averaged over 10 cm <sup>3</sup> (10 g) of Head TSL	condition	
SAR measured	100 mW input power	2.35 W/kg
SAR for nominal Head TSL parameters	normalized to 1W	23.3 W/kg ± 19.5 % (k=2)

### Body TSL parameters at 5200 MHz

The following parameters and calculations were applied.

	Temperature	Permittivity	Conductivity
Nominal Body TSL parameters	22.0 °C	49.0	5.30 mho/m
Measured Body TSL parameters	(22.0 ± 0.2) °C	47.1 ± 6 %	5.40 mho/m ± 6 %
Body TSL temperature change during test	< 0.5 °C	----	----

### SAR result with Body TSL at 5200 MHz

SAR averaged over 1 cm <sup>3</sup> (1 g) of Body TSL	Condition	
SAR measured	100 mW input power	7.84 W/kg
SAR for nominal Body TSL parameters	normalized to 1W	77.8 W/kg ± 19.9 % (k=2)

SAR averaged over 10 cm <sup>3</sup> (10 g) of Body TSL	condition	
SAR measured	100 mW input power	2.18 W/kg
SAR for nominal Body TSL parameters	normalized to 1W	21.6 W/kg ± 19.5 % (k=2)

### Body TSL parameters at 5300 MHz

The following parameters and calculations were applied.

	Temperature	Permittivity	Conductivity
Nominal Body TSL parameters	22.0 °C	48.9	5.42 mho/m
Measured Body TSL parameters	(22.0 ± 0.2) °C	46.9 ± 6 %	5.53 mho/m ± 6 %
Body TSL temperature change during test	< 0.5 °C	----	----

### SAR result with Body TSL at 5300 MHz

SAR averaged over 1 cm <sup>3</sup> (1 g) of Body TSL	Condition	
SAR measured	100 mW input power	8.05 W/kg
SAR for nominal Body TSL parameters	normalized to 1W	79.9 W/kg ± 19.9 % (k=2)

SAR averaged over 10 cm <sup>3</sup> (10 g) of Body TSL	condition	
SAR measured	100 mW input power	2.25 W/kg
SAR for nominal Body TSL parameters	normalized to 1W	22.3 W/kg ± 19.5 % (k=2)

### Body TSL parameters at 5500 MHz

The following parameters and calculations were applied.

	Temperature	Permittivity	Conductivity
Nominal Body TSL parameters	22.0 °C	48.6	5.65 mho/m
Measured Body TSL parameters	(22.0 ± 0.2) °C	46.6 ± 6 %	5.79 mho/m ± 6 %
Body TSL temperature change during test	< 0.5 °C	----	----

### SAR result with Body TSL at 5500 MHz

SAR averaged over 1 cm <sup>3</sup> (1 g) of Body TSL	Condition	
SAR measured	100 mW input power	8.37 W/kg
SAR for nominal Body TSL parameters	normalized to 1W	83.1 W/kg ± 19.9 % (k=2)

SAR averaged over 10 cm <sup>3</sup> (10 g) of Body TSL	condition	
SAR measured	100 mW input power	2.32 W/kg
SAR for nominal Body TSL parameters	normalized to 1W	23.0 W/kg ± 19.5 % (k=2)

### Body TSL parameters at 5600 MHz

The following parameters and calculations were applied.

	Temperature	Permittivity	Conductivity
Nominal Body TSL parameters	22.0 °C	48.5	5.77 mho/m
Measured Body TSL parameters	(22.0 ± 0.2) °C	46.4 ± 6 %	5.93 mho/m ± 6 %
Body TSL temperature change during test	< 0.5 °C	----	----

### SAR result with Body TSL at 5600 MHz

SAR averaged over 1 cm <sup>3</sup> (1 g) of Body TSL	Condition	
SAR measured	100 mW input power	8.48 W/kg
SAR for nominal Body TSL parameters	normalized to 1W	84.1 W/kg ± 19.9 % (k=2)

SAR averaged over 10 cm <sup>3</sup> (10 g) of Body TSL	condition	
SAR measured	100 mW input power	2.35 W/kg
SAR for nominal Body TSL parameters	normalized to 1W	23.3 W/kg ± 19.5 % (k=2)

### Body TSL parameters at 5800 MHz

The following parameters and calculations were applied.

	Temperature	Permittivity	Conductivity
Nominal Body TSL parameters	22.0 °C	48.2	6.00 mho/m
Measured Body TSL parameters	(22.0 ± 0.2) °C	46.1 ± 6 %	6.21 mho/m ± 6 %
Body TSL temperature change during test	< 0.5 °C	----	----

### SAR result with Body TSL at 5800 MHz

SAR averaged over 1 cm <sup>3</sup> (1 g) of Body TSL	Condition	
SAR measured	100 mW input power	7.86 W/kg
SAR for nominal Body TSL parameters	normalized to 1W	78.0 W/kg ± 19.9 % (k=2)

SAR averaged over 10 cm <sup>3</sup> (10 g) of Body TSL	condition	
SAR measured	100 mW input power	2.17 W/kg
SAR for nominal Body TSL parameters	normalized to 1W	21.5 W/kg ± 19.5 % (k=2)

## Appendix (Additional assessments outside the scope of SCS108)

### Antenna Parameters with Head TSL at 5200 MHz

Impedance, transformed to feed point	51.8 $\Omega$ - 9.9 j $\Omega$
Return Loss	- 20.1 dB

### Antenna Parameters with Head TSL at 5300 MHz

Impedance, transformed to feed point	54.5 $\Omega$ - 1.5 j $\Omega$
Return Loss	- 26.8 dB

### Antenna Parameters with Head TSL at 5500 MHz

Impedance, transformed to feed point	49.6 $\Omega$ - 2.0 j $\Omega$
Return Loss	- 33.9 dB

### Antenna Parameters with Head TSL at 5600 MHz

Impedance, transformed to feed point	56.5 $\Omega$ - 4.4 j $\Omega$
Return Loss	- 22.7 dB

### Antenna Parameters with Head TSL at 5800 MHz

Impedance, transformed to feed point	56.6 $\Omega$ + 4.4 j $\Omega$
Return Loss	- 22.6 dB

### Antenna Parameters with Body TSL at 5200 MHz

Impedance, transformed to feed point	51.9 $\Omega$ - 8.1 j $\Omega$
Return Loss	- 21.8 dB

### Antenna Parameters with Body TSL at 5300 MHz

Impedance, transformed to feed point	54.5 $\Omega$ + 0.1 j $\Omega$
Return Loss	- 27.3 dB

### Antenna Parameters with Body TSL at 5500 MHz

Impedance, transformed to feed point	50.2 $\Omega$ - 0.6 j $\Omega$
Return Loss	- 43.8 dB

### Antenna Parameters with Body TSL at 5600 MHz

Impedance, transformed to feed point	57.5 $\Omega$ - 3.2 j $\Omega$
Return Loss	- 22.4 dB

### Antenna Parameters with Body TSL at 5800 MHz

Impedance, transformed to feed point	57.2 $\Omega$ + 5.2 j $\Omega$
Return Loss	- 21.7 dB

### General Antenna Parameters and Design

Electrical Delay (one direction)	1.202 ns
----------------------------------	----------

After long term use with 100W radiated power, only a slight warming of the dipole near the feedpoint can be measured.

The dipole is made of standard semirigid coaxial cable. The center conductor of the feeding line is directly connected to the second arm of the dipole. The antenna is therefore short-circuited for DC-signals. On some of the dipoles, small end caps are added to the dipole arms in order to improve matching when loaded according to the position as explained in the "Measurement Conditions" paragraph. The SAR data are not affected by this change. The overall dipole length is still according to the Standard.

No excessive force must be applied to the dipole arms, because they might bend or the soldered connections near the feedpoint may be damaged.

### Additional EUT Data

Manufactured by	SPEAG
Manufactured on	April 01, 2014

## DASY5 Validation Report for Head TSL

Date: 25.09.2014

Test Laboratory: SPEAG, Zurich, Switzerland

**DUT: Dipole 5GHz; Type: D5GHzV2; Serial: D5GHzV2 - SN:1191**

Communication System: UID 0 - CW; Frequency: 5200 MHz, Frequency: 5300 MHz, Frequency: 5500 MHz, Frequency: 5600 MHz, Frequency: 5800 MHz

Medium parameters used:  $f = 5200$  MHz;  $\sigma = 4.54$  S/m;  $\epsilon_r = 34.9$ ;  $\rho = 1000$  kg/m<sup>3</sup>

Medium parameters used:  $f = 5300$  MHz;  $\sigma = 4.64$  S/m;  $\epsilon_r = 34.8$ ;  $\rho = 1000$  kg/m<sup>3</sup>

Medium parameters used:  $f = 5500$  MHz;  $\sigma = 4.83$  S/m;  $\epsilon_r = 34.5$ ;  $\rho = 1000$  kg/m<sup>3</sup>

Medium parameters used:  $f = 5600$  MHz;  $\sigma = 4.93$  S/m;  $\epsilon_r = 34.4$ ;  $\rho = 1000$  kg/m<sup>3</sup>

Medium parameters used:  $f = 5800$  MHz;  $\sigma = 5.14$  S/m;  $\epsilon_r = 34.1$ ;  $\rho = 1000$  kg/m<sup>3</sup>

Phantom section: Flat Section

Measurement Standard: DASY5 (IBEE/IEC/ANSI C63.19-2011)

DASY52 Configuration:

- Probe: EX3DV4 - SN3503; ConvF(5.52, 5.52, 5.52); Calibrated: 30.12.2013, ConvF(5.2, 5.2, 5.2); Calibrated: 30.12.2013, ConvF(5.01, 5.01, 5.01); Calibrated: 30.12.2013, ConvF(4.86, 4.86, 4.86); Calibrated: 30.12.2013, ConvF(4.91, 4.91, 4.91); Calibrated: 30.12.2013;
- Sensor-Surface: 1.4mm (Mechanical Surface Detection)
- Electronics: DAE4 Sn601; Calibrated: 18.08.2014
- Phantom: Flat Phantom 5.0 (front); Type: QD000P50AA; Serial: 1001
- DASY52 52.8.8(1222); SEMCAD X 14.6.10(7331)

**Dipole Calibration for Head Tissue/Pin=100mW, dist=10mm, f=5200 MHz/Zoom Scan,**

**dist=1.4mm (8x8x7)/Cube 0:** Measurement grid: dx=4mm, dy=4mm, dz=1.4mm

Reference Value = 65.20 V/m; Power Drift = 0.04 dB

Peak SAR (extrapolated) = 30.0 W/kg

**SAR(1 g) = 8.17 W/kg; SAR(10 g) = 2.33 W/kg**

Maximum value of SAR (measured) = 18.5 W/kg

**Dipole Calibration for Head Tissue/Pin=100mW, dist=10mm, f=5300 MHz/Zoom Scan,**

**dist=1.4mm (8x8x7)/Cube 0:** Measurement grid: dx=4mm, dy=4mm, dz=1.4mm

Reference Value = 65.90 V/m; Power Drift = 0.09 dB

Peak SAR (extrapolated) = 32.7 W/kg

**SAR(1 g) = 8.64 W/kg; SAR(10 g) = 2.47 W/kg**

Maximum value of SAR (measured) = 19.8 W/kg

**Dipole Calibration for Head Tissue/Pin=100mW, dist=10mm, f=5500 MHz/Zoom Scan,**

**dist=1.4mm (8x8x7)/Cube 0:** Measurement grid: dx=4mm, dy=4mm, dz=1.4mm

Reference Value = 65.91 V/m; Power Drift = 0.09 dB

Peak SAR (extrapolated) = 35.3 W/kg

**SAR(1 g) = 8.93 W/kg; SAR(10 g) = 2.54 W/kg**

Maximum value of SAR (measured) = 20.9 W/kg

**Dipole Calibration for Head Tissue/Pin=100mW, dist=10mm, f=5600 MHz/Zoom Scan, dist=1.4mm (8x8x7)/Cube 0:** Measurement grid: dx=4mm, dy=4mm, dz=1.4mm

Reference Value = 65.29 V/m; Power Drift = 0.07 dB

Peak SAR (extrapolated) = 34.8 W/kg

**SAR(1 g) = 8.76 W/kg; SAR(10 g) = 2.49 W/kg**

Maximum value of SAR (measured) = 20.7 W/kg

**Dipole Calibration for Head Tissue/Pin=100mW, dist=10mm, f=5800 MHz/Zoom Scan, dist=1.4mm (8x8x7)/Cube 0:** Measurement grid: dx=4mm, dy=4mm, dz=1.4mm

Reference Value = 62.74 V/m; Power Drift = 0.06 dB

Peak SAR (extrapolated) = 34.4 W/kg

**SAR(1 g) = 8.3 W/kg; SAR(10 g) = 2.35 W/kg**

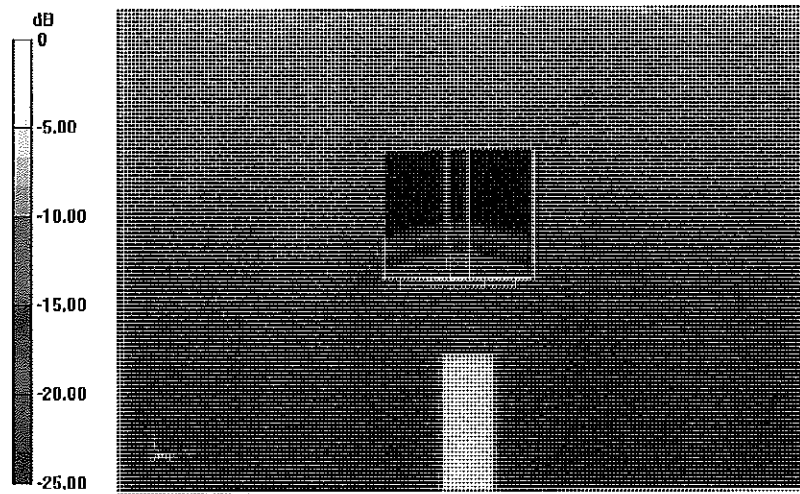

0 dB = 19.8 W/kg = 12.97 dBW/kg

# Impedance Measurement Plot for Head TSL

25 Sep 2014 11:07:52

CH1 S11 1 U FS 1: 51.911  $\Omega$  -9.9180  $\Omega$  3.0860 pF 5 200.000 000 MHz

\*  
Del  
Cor  
Avg  
0  
H1d

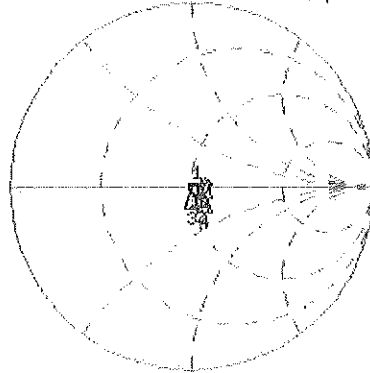

CH1 Markers

2: 54.518  $\Omega$   
-1.5078  $\Omega$   
5.30000 GHz  
3: 49.566  $\Omega$   
-1.9707  $\Omega$   
5.50000 GHz  
4: 56.516  $\Omega$   
-4.3633  $\Omega$   
5.60000 GHz  
5: 56.555  $\Omega$   
4.3904  $\Omega$   
5.80000 GHz

CH2 S11 LOG 5 dB/REF -20 dB 1:-20.126 dB 5 200.000 000 MHz

Cor  
Avg  
0  
H1d

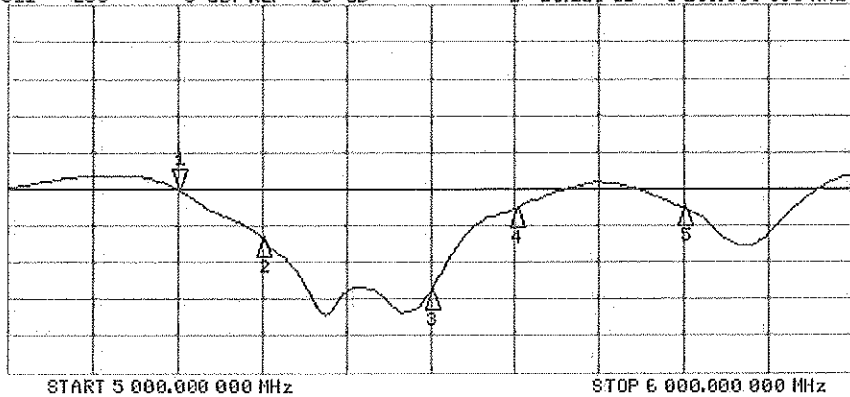

CH2 Markers

2: -26.825 dB  
5.30000 GHz  
3: -33.870 dB  
5.50000 GHz  
4: -22.660 dB  
5.60000 GHz  
5: -22.611 dB  
5.80000 GHz

## DASY5 Validation Report for Body TSL

Date: 24.09.2014

Test Laboratory: SPEAG, Zurich, Switzerland

**DUT: Dipole 5GHz; Type: D5GHzV2; Serial: D5GHzV2 - SN:1191**

Communication System: UID 0 - CW; Frequency: 5200 MHz, Frequency: 5300 MHz, Frequency: 5500 MHz, Frequency: 5600 MHz, Frequency: 5800 MHz

Medium parameters used:  $f = 5200$  MHz;  $\sigma = 5.4$  S/m;  $\epsilon_r = 47.1$ ;  $\rho = 1000$  kg/m<sup>3</sup>

Medium parameters used:  $f = 5300$  MHz;  $\sigma = 5.53$  S/m;  $\epsilon_r = 46.9$ ;  $\rho = 1000$  kg/m<sup>3</sup>

Medium parameters used:  $f = 5500$  MHz;  $\sigma = 5.79$  S/m;  $\epsilon_r = 46.6$ ;  $\rho = 1000$  kg/m<sup>3</sup>

Medium parameters used:  $f = 5600$  MHz;  $\sigma = 5.93$  S/m;  $\epsilon_r = 46.4$ ;  $\rho = 1000$  kg/m<sup>3</sup>

Medium parameters used:  $f = 5800$  MHz;  $\sigma = 6.21$  S/m;  $\epsilon_r = 46.1$ ;  $\rho = 1000$  kg/m<sup>3</sup>

Phantom section: Flat Section

Measurement Standard: DASY5 (IEEB/IEC/ANSI C63.19-2011)

DASY52 Configuration:

- Probe: EX3DV4 - SN3503; ConvF(5.01, 5.01, 5.01); Calibrated: 30.12.2013, ConvF(4.76, 4.76, 4.76); Calibrated: 30.12.2013, ConvF(4.52, 4.52, 4.52); Calibrated: 30.12.2013, ConvF(4.3, 4.3, 4.3); Calibrated: 30.12.2013, ConvF(4.47, 4.47, 4.47); Calibrated: 30.12.2013;
- Sensor-Surface: 1.4mm (Mechanical Surface Detection)
- Electronics: DAE4 Sn601; Calibrated: 18.08.2014
- Phantom: Flat Phantom 5.0 (back); Type: QD000P50AA; Serial: 1002
- DASY52 52.8.8(1222); SEMCAD X 14.6.10(7331)

**Dipole Calibration for Body Tissue/Pin=100mW, dist=10mm, f=5200 MHz/Zoom Scan, dist=1.4mm (8x8x7)/Cube 0:** Measurement grid: dx=4mm, dy=4mm, dz=1.4mm

Reference Value = 60.46 V/m; Power Drift = 0.02 dB

Peak SAR (extrapolated) = 30.7 W/kg

**SAR(1 g) = 7.84 W/kg; SAR(10 g) = 2.18 W/kg**

Maximum value of SAR (measured) = 18.5 W/kg

**Dipole Calibration for Body Tissue/Pin=100mW, dist=10mm, f=5300 MHz/Zoom Scan, dist=1.4mm (8x8x7)/Cube 0:** Measurement grid: dx=4mm, dy=4mm, dz=1.4mm

Reference Value = 60.42 V/m; Power Drift = 0.03 dB

Peak SAR (extrapolated) = 32.1 W/kg

**SAR(1 g) = 8.05 W/kg; SAR(10 g) = 2.25 W/kg**

Maximum value of SAR (measured) = 19.1 W/kg

**Dipole Calibration for Body Tissue/Pin=100mW, dist=10mm, f=5500 MHz/Zoom Scan, dist=1.4mm (8x8x7)/Cube 0:** Measurement grid: dx=4mm, dy=4mm, dz=1.4mm

Reference Value = 60.44 V/m; Power Drift = 0.02 dB

Peak SAR (extrapolated) = 35.8 W/kg

**SAR(1 g) = 8.37 W/kg; SAR(10 g) = 2.32 W/kg**

Maximum value of SAR (measured) = 20.4 W/kg

**Dipole Calibration for Body Tissue/Pin=100mW, dist=10mm, f=5600 MHz/Zoom Scan, dist=1.4mm (8x8x7)/Cube 0:** Measurement grid: dx=4mm, dy=4mm, dz=1.4mm  
Reference Value = 60.44 V/m; Power Drift = 0.01 dB  
Peak SAR (extrapolated) = 37.0 W/kg  
SAR(1 g) = 8.48 W/kg; SAR(10 g) = 2.35 W/kg  
Maximum value of SAR (measured) = 20.9 W/kg

**Dipole Calibration for Body Tissue/Pin=100mW, dist=10mm, f=5800 MHz/Zoom Scan, dist=1.4mm (8x8x7)/Cube 0:** Measurement grid: dx=4mm, dy=4mm, dz=1.4mm  
Reference Value = 56.69 V/m; Power Drift = 0.01 dB  
Peak SAR (extrapolated) = 36.4 W/kg  
SAR(1 g) = 7.86 W/kg; SAR(10 g) = 2.17 W/kg  
Maximum value of SAR (measured) = 19.7 W/kg

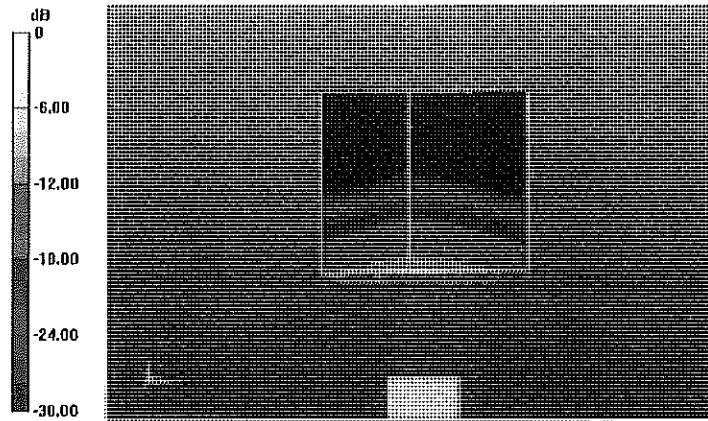

0 dB = 19.7 W/kg = 12.94 dBW/kg

# Impedance Measurement Plot for Body TSL

24 Sep 2014 11:05:50

[CH1] S11 1 U FS 1: 51.867  $\Omega$  -8.0566  $\Omega$  3.7989 pF 5 200.000 000 MHz

#  
Del  
Cor  
Avg  
16  
H1d

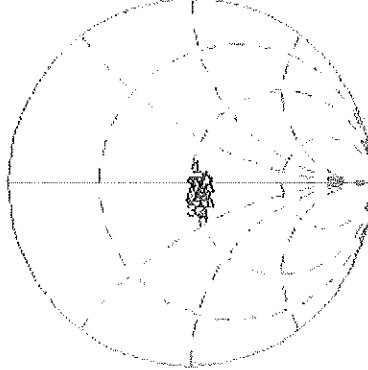

CH1 Markers

- 2: 54.531  $\Omega$   
0.1015  $\Omega$   
5.30000 GHz
- 3: 50.207  $\Omega$   
-613.28 pF  
5.50000 GHz
- 4: 57.480  $\Omega$   
-3.1563  $\Omega$   
5.60000 GHz
- 5: 57.150  $\Omega$   
5.1934  $\Omega$   
5.80000 GHz

CH2 S11 LOG 5 dB/REF -20 dB 1: -21.835 dB 5 200.000 000 MHz

Cor  
Avg  
16  
H1d

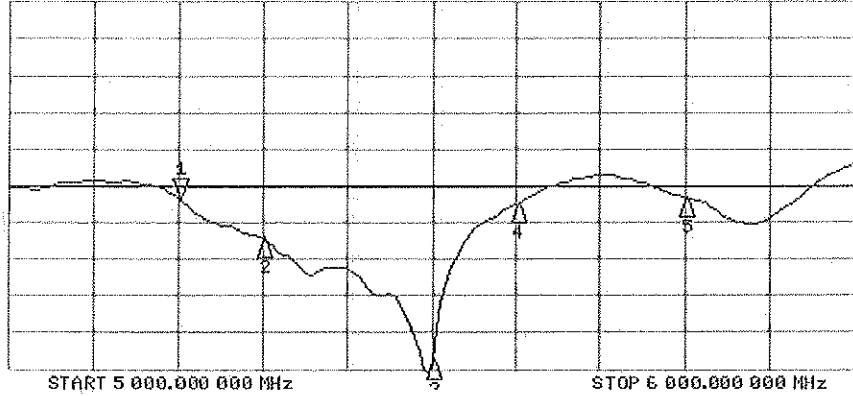

CH2 Markers

- 2: -27.251 dB  
5.30000 GHz
- 3: -43.776 dB  
5.50000 GHz
- 4: -22.442 dB  
5.60000 GHz
- 5: -21.682 dB  
5.80000 GHz

**Calibration Laboratory of  
Schmid & Partner  
Engineering AG**  
Zeughausstrasse 43, 8004 Zurich, Switzerland



**S** Schweizerischer Kalibrierdienst  
**C** Service suisse d'étalonnage  
**S** Servizio svizzero di taratura  
Swiss Calibration Service

Accredited by the Swiss Accreditation Service (SAS)  
The Swiss Accreditation Service is one of the signatories to the EA  
Multilateral Agreement for the recognition of calibration certificates

Accreditation No.: **SCS 108**

Client **PC Test**

Certificate No: **EX3-7308\_Jul14**

**CALIBRATION CERTIFICATE**

Object **EX3DV4 - SN:7308**

Calibration procedure(s) **QA CAL-01.v9, QA CAL-14.v4, QA CAL-23.v5, QA CAL-25.v6**  
Calibration procedure for dosimetric E-field probes CC  
11/11/14

Calibration date: **July 16, 2014**

This calibration certificate documents the traceability to national standards, which realize the physical units of measurements (SI).  
The measurements and the uncertainties with confidence probability are given on the following pages and are part of the certificate.

All calibrations have been conducted in the closed laboratory facility: environment temperature (22 ± 3)°C and humidity < 70%.

Calibration Equipment used (M&TE critical for calibration)

Primary Standards	ID	Cal Date (Certificate No.)	Scheduled Calibration
Power meter E4419B	GB41293874	03-Apr-14 (No. 217-01911)	Apr-15
Power sensor E4412A	MY41498087	03-Apr-14 (No. 217-01911)	Apr-15
Reference 3 dB Attenuator	SN: S5054 (3c)	03-Apr-14 (No. 217-01915)	Apr-15
Reference 20 dB Attenuator	SN: S5277 (20x)	03-Apr-14 (No. 217-01919)	Apr-15
Reference 30 dB Attenuator	SN: S5129 (30b)	03-Apr-14 (No. 217-01920)	Apr-15
Reference Probe ES3DV2	SN: 3013	30-Dec-13 (No. ES3-3013_Dec13)	Dec-14
DAE4	SN: 660	13-Dec-13 (No. DAE4-660_Dec13)	Dec-14
Secondary Standards	ID	Check Date (in house)	Scheduled Check
RF generator HP 8648C	US3642U01700	4-Aug-99 (in house check Apr-13)	In house check: Apr-16
Network Analyzer HP 8753E	US37390585	18-Oct-01 (in house check Oct-13)	In house check: Oct-14

Calibrated by:	Name <b>Jeton Kastrati</b>	Function <b>Laboratory Technician</b>	Signature 
Approved by:	Name <b>Katja Pokovic</b>	Function <b>Technical Manager</b>	Signature 
			Issued: July 21, 2014

This calibration certificate shall not be reproduced except in full without written approval of the laboratory.



Accredited by the Swiss Accreditation Service (SAS)  
The Swiss Accreditation Service is one of the signatories to the EA  
Multilateral Agreement for the recognition of calibration certificates

Accreditation No.: **SCS 108**

**Glossary:**

TSL	tissue simulating liquid
NORM <sub>x,y,z</sub>	sensitivity in free space
ConvF	sensitivity in TSL / NORM <sub>x,y,z</sub>
DCP	diode compression point
CF	crest factor (1/duty_cycle) of the RF signal
A, B, C, D	modulation dependent linearization parameters
Polarization φ	φ rotation around probe axis
Polarization θ	θ rotation around an axis that is in the plane normal to probe axis (at measurement center), i.e., θ = 0 is normal to probe axis
Connector Angle	information used in DASY system to align probe sensor X to the robot coordinate system

**Calibration is Performed According to the Following Standards:**

- a) IEEE Std 1528-2013, "IEEE Recommended Practice for Determining the Peak Spatial-Averaged Specific Absorption Rate (SAR) in the Human Head from Wireless Communications Devices: Measurement Techniques", June 2013
- b) IEC 62209-1, "Procedure to measure the Specific Absorption Rate (SAR) for hand-held devices used in close proximity to the ear (frequency range of 300 MHz to 3 GHz)", February 2005

**Methods Applied and Interpretation of Parameters:**

- **NORM<sub>x,y,z</sub>**: Assessed for E-field polarization θ = 0 (f ≤ 900 MHz in TEM-cell; f > 1800 MHz: R22 waveguide). NORM<sub>x,y,z</sub> are only intermediate values, i.e., the uncertainties of NORM<sub>x,y,z</sub> does not affect the E<sup>2</sup>-field uncertainty inside TSL (see below ConvF).
- **NORM(f)<sub>x,y,z</sub> = NORM<sub>x,y,z</sub> \* frequency\_response** (see Frequency Response Chart). This linearization is implemented in DASY4 software versions later than 4.2. The uncertainty of the frequency response is included in the stated uncertainty of ConvF.
- **DCP<sub>x,y,z</sub>**: DCP are numerical linearization parameters assessed based on the data of power sweep with CW signal (no uncertainty required). DCP does not depend on frequency nor media.
- **PAR**: PAR is the Peak to Average Ratio that is not calibrated but determined based on the signal characteristics
- **A<sub>x,y,z</sub>; B<sub>x,y,z</sub>; C<sub>x,y,z</sub>; D<sub>x,y,z</sub>; VR<sub>x,y,z</sub>; A, B, C, D** are numerical linearization parameters assessed based on the data of power sweep for specific modulation signal. The parameters do not depend on frequency nor media. VR is the maximum calibration range expressed in RMS voltage across the diode.
- **ConvF and Boundary Effect Parameters**: Assessed in flat phantom using E-field (or Temperature Transfer Standard for f ≤ 800 MHz) and inside waveguide using analytical field distributions based on power measurements for f > 800 MHz. The same setups are used for assessment of the parameters applied for boundary compensation (alpha, depth) of which typical uncertainty values are given. These parameters are used in DASY4 software to improve probe accuracy close to the boundary. The sensitivity in TSL corresponds to NORM<sub>x,y,z</sub> \* ConvF whereby the uncertainty corresponds to that given for ConvF. A frequency dependent ConvF is used in DASY version 4.4 and higher which allows extending the validity from ± 50 MHz to ± 100 MHz.
- **Spherical isotropy (3D deviation from isotropy)**: in a field of low gradients realized using a flat phantom exposed by a patch antenna.
- **Sensor Offset**: The sensor offset corresponds to the offset of virtual measurement center from the probe tip (on probe axis). No tolerance required.
- **Connector Angle**: The angle is assessed using the information gained by determining the NORM<sub>x</sub> (no uncertainty required).

# Probe EX3DV4

SN:7308

Manufactured: March 11, 2014  
Calibrated: July 16, 2014

Calibrated for DASY/EASY Systems  
(Note: non-compatible with DASY2 system!)

## DASY/EASY - Parameters of Probe: EX3DV4 - SN:7308

### Basic Calibration Parameters

	Sensor X	Sensor Y	Sensor Z	Unc (k=2)
Norm ( $\mu\text{V}/(\text{V}/\text{m})^2$ ) <sup>A</sup>	0.50	0.60	0.45	$\pm 10.1 \%$
DCP (mV) <sup>B</sup>	100.8	98.6	99.9	

### Modulation Calibration Parameters

UID	Communication System Name		A dB	B dB $\sqrt{\mu\text{V}}$	C	D dB	VR mV	Unc <sup>F</sup> (k=2)
0	CW	X	0.0	0.0	1.0	0.00	160.9	$\pm 2.5 \%$
		Y	0.0	0.0	1.0		132.5	
		Z	0.0	0.0	1.0		154.1	
10012-CAA	IEEE 802.11b WiFi 2.4 GHz (DSSS, 1 Mbps)	X	2.79	68.0	18.3	1.87	125.2	$\pm 0.5 \%$
		Y	2.74	67.3	17.9		142.6	
		Z	2.74	67.2	17.7		119.7	
10062-CAA	IEEE 802.11a/h WiFi 5 GHz (OFDM, 6 Mbps)	X	10.26	68.8	21.6	8.68	124.2	$\pm 2.5 \%$
		Y	10.73	69.7	22.0		144.6	
		Z	9.98	68.3	21.3		116.1	
10114-CAA	IEEE 802.11n (HT Greenfield, 13.5 Mbps, BPSK)	X	10.24	68.6	21.0	8.10	125.1	$\pm 2.2 \%$
		Y	9.68	67.1	20.1		99.7	
		Z	10.17	68.5	21.0		122.8	
10117-CAA	IEEE 802.11n (HT Mixed, 13.5 Mbps, BPSK)	X	10.27	68.7	21.0	8.07	126.1	$\pm 2.2 \%$
		Y	9.67	67.0	20.1		100.6	
		Z	10.12	68.4	20.9		123.9	
10193-CAA	IEEE 802.11n (HT Greenfield, 6.5 Mbps, BPSK)	X	9.83	68.2	20.9	8.09	120.3	$\pm 2.5 \%$
		Y	10.37	69.4	21.5		147.5	
		Z	9.71	68.2	20.9		116.9	
10196-CAA	IEEE 802.11n (HT Mixed, 6.5 Mbps, BPSK)	X	9.80	68.2	20.9	8.10	120.4	$\pm 1.9 \%$
		Y	9.54	67.2	20.3		102.9	
		Z	9.65	68.0	20.8		116.5	
10219-CAA	IEEE 802.11n (HT Mixed, 7.2 Mbps, BPSK)	X	9.67	68.0	20.8	8.03	119.1	$\pm 1.9 \%$
		Y	9.41	67.1	20.2		102.5	
		Z	9.54	68.0	20.8		116.0	
10222-CAA	IEEE 802.11n (HT Mixed, 15 Mbps, BPSK)	X	10.21	68.6	21.0	8.06	125.9	$\pm 2.2 \%$
		Y	9.84	67.5	20.4		106.4	
		Z	10.09	68.4	20.9		122.3	
10315-AAA	IEEE 802.11b WiFi 2.4 GHz (DSSS, 1 Mbps, 96pc duty cycle)	X	2.92	69.3	18.9	1.71	123.4	$\pm 0.5 \%$
		Y	2.80	68.0	18.2		107.9	
		Z	2.85	68.3	18.3		122.3	
10317-AAA	IEEE 802.11a WiFi 5 GHz (OFDM, 6 Mbps, 96pc duty cycle)	X	9.98	68.4	21.2	8.36	119.4	$\pm 1.9 \%$
		Y	9.66	67.3	20.5		101.7	
		Z	9.79	68.1	21.0		115.6	

10400-AAA	IEEE 802.11ac WiFi (20MHz, 64-QAM, 99pc duty cycle)	X	10.10	68.5	21.2	8.37	121.3	±2.2 %
		Y	9.82	67.5	20.6		103.5	
		Z	9.90	68.2	21.1		116.6	
10402-AAA	IEEE 802.11ac WiFi (80MHz, 64-QAM, 99pc duty cycle)	X	11.17	69.7	21.7	8.53	131.0	±2.2 %
		Y	10.57	68.2	20.8		110.9	
		Z	11.01	69.4	21.5		128.1	

The reported uncertainty of measurement is stated as the standard uncertainty of measurement multiplied by the coverage factor  $k=2$ , which for a normal distribution corresponds to a coverage probability of approximately 95%.

<sup>A</sup> The uncertainties of NormX,Y,Z do not affect the  $E^2$ -field uncertainty inside TSL (see Pages 6 and 7).

<sup>B</sup> Numerical linearization parameter; uncertainty not required.

<sup>E</sup> Uncertainty is determined using the max. deviation from linear response applying rectangular distribution and is expressed for the square of the field value.

## DASY/EASY - Parameters of Probe: EX3DV4 - SN:7308

### Calibration Parameter Determined in Head Tissue Simulating Media

f (MHz) <sup>c</sup>	Relative Permittivity <sup>F</sup>	Conductivity (S/m) <sup>F</sup>	ConvF X	ConvF Y	ConvF Z	Alpha <sup>G</sup>	Depth <sup>G</sup> (mm)	Unct. (k=2)
5250	35.9	4.71	5.37	5.37	5.37	0.30	1.80	± 13.1 %
5600	35.5	5.07	4.64	4.64	4.64	0.35	1.80	± 13.1 %
5750	35.4	5.22	4.81	4.81	4.81	0.40	1.80	± 13.1 %

<sup>c</sup> Frequency validity above 300 MHz of ± 100 MHz only applies for DASY v4.4 and higher (see Page 2), else it is restricted to ± 50 MHz. The uncertainty is the RSS of the ConvF uncertainty at calibration frequency and the uncertainty for the indicated frequency band. Frequency validity below 300 MHz is ± 10, 25, 40, 50 and 70 MHz for ConvF assessments at 30, 64, 128, 150 and 220 MHz respectively. Above 5 GHz frequency validity can be extended to ± 110 MHz.

<sup>F</sup> At frequencies below 3 GHz, the validity of tissue parameters ( $\epsilon$  and  $\sigma$ ) can be relaxed to ± 10% if liquid compensation formula is applied to measured SAR values. At frequencies above 3 GHz, the validity of tissue parameters ( $\epsilon$  and  $\sigma$ ) is restricted to ± 5%. The uncertainty is the RSS of the ConvF uncertainty for indicated target tissue parameters.

<sup>G</sup> Alpha/Depth are determined during calibration. SPEAG warrants that the remaining deviation due to the boundary effect after compensation is always less than ± 1% for frequencies below 3 GHz and below ± 2% for frequencies between 3-6 GHz at any distance larger than half the probe tip diameter from the boundary.

## DASY/EASY - Parameters of Probe: EX3DV4 - SN:7308

### Calibration Parameter Determined in Body Tissue Simulating Media

f (MHz) <sup>C</sup>	Relative Permittivity <sup>F</sup>	Conductivity (S/m) <sup>F</sup>	ConvF X	ConvF Y	ConvF Z	Alpha <sup>G</sup>	Depth <sup>G</sup> (mm)	Unct. (k=2)
5250	48.9	5.36	4.60	4.60	4.60	0.35	1.90	± 13.1 %
5600	48.5	5.77	4.09	4.09	4.09	0.40	1.90	± 13.1 %
5750	48.3	5.94	4.22	4.22	4.22	0.50	1.90	± 13.1 %

<sup>C</sup> Frequency validity above 300 MHz of ± 100 MHz only applies for DASY v4.4 and higher (see Page 2), else it is restricted to ± 50 MHz. The uncertainty is the RSS of the ConvF uncertainty at calibration frequency and the uncertainty for the indicated frequency band. Frequency validity below 300 MHz is ± 10, 25, 40, 50 and 70 MHz for ConvF assessments at 30, 64, 128, 150 and 220 MHz respectively. Above 5 GHz frequency validity can be extended to ± 110 MHz.

<sup>F</sup> At frequencies below 3 GHz, the validity of tissue parameters ( $\epsilon$  and  $\sigma$ ) can be relaxed to ± 10% if liquid compensation formula is applied to measured SAR values. At frequencies above 3 GHz, the validity of tissue parameters ( $\epsilon$  and  $\sigma$ ) is restricted to ± 5%. The uncertainty is the RSS of the ConvF uncertainty for indicated target tissue parameters.

<sup>G</sup> Alpha/Depth are determined during calibration. SPEAG warrants that the remaining deviation due to the boundary effect after compensation is always less than ± 1% for frequencies below 3 GHz and below ± 2% for frequencies between 3-6 GHz at any distance larger than half the probe tip diameter from the boundary.

### Frequency Response of E-Field (TEM-Cell:ifi110 EXX, Waveguide: R22)

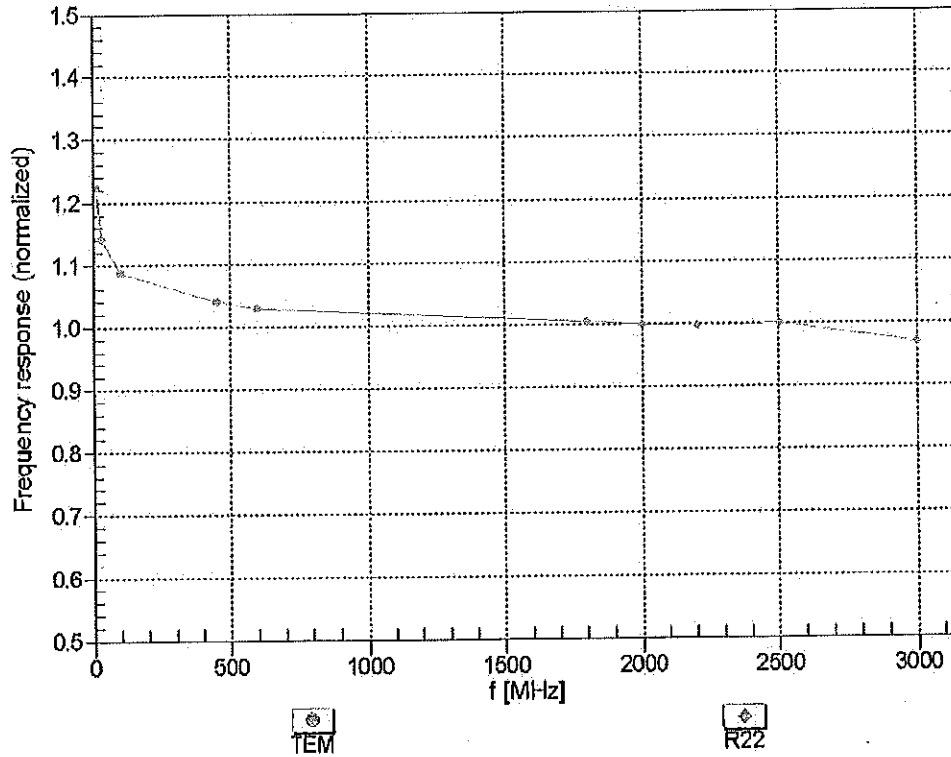

Uncertainty of Frequency Response of E-field:  $\pm 6.3\%$  ( $k=2$ )

### Receiving Pattern ( $\phi$ ), $\theta = 0^\circ$

f=600 MHz, TEM

f=1800 MHz, R22

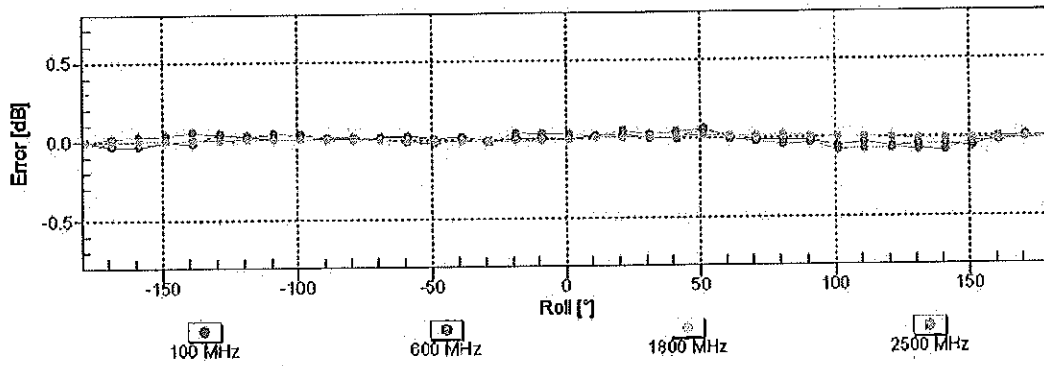
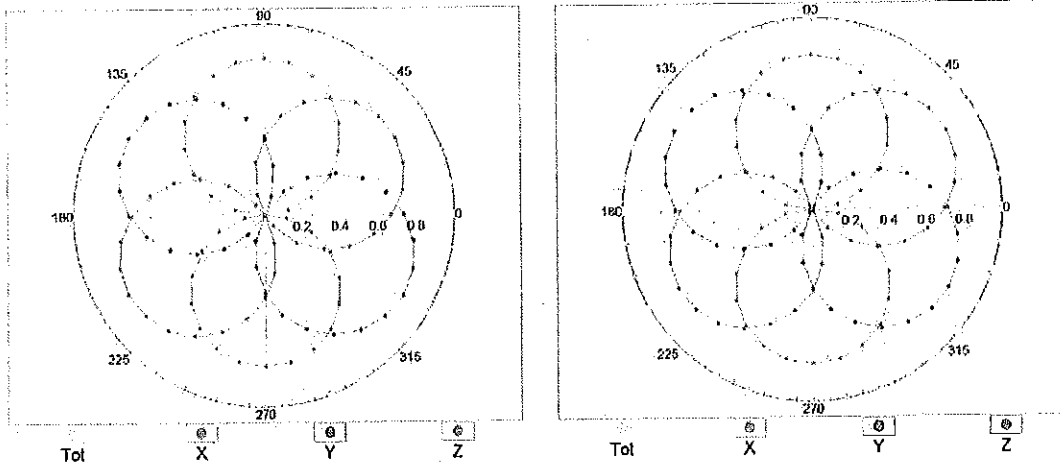

Uncertainty of Axial Isotropy Assessment:  $\pm 0.5\%$  (k=2)

### Dynamic Range f(SAR<sub>head</sub>) (TEM cell , f<sub>eval</sub>= 1900 MHz)

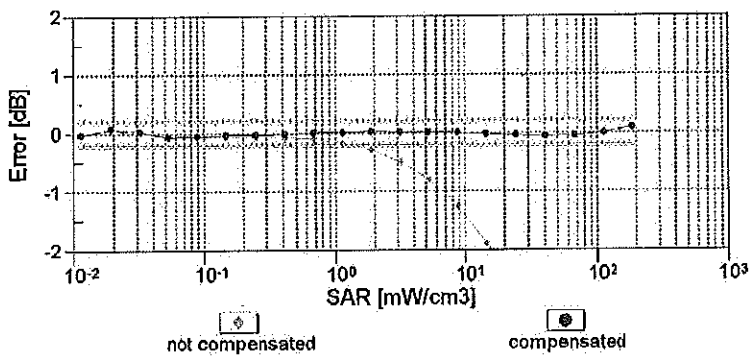
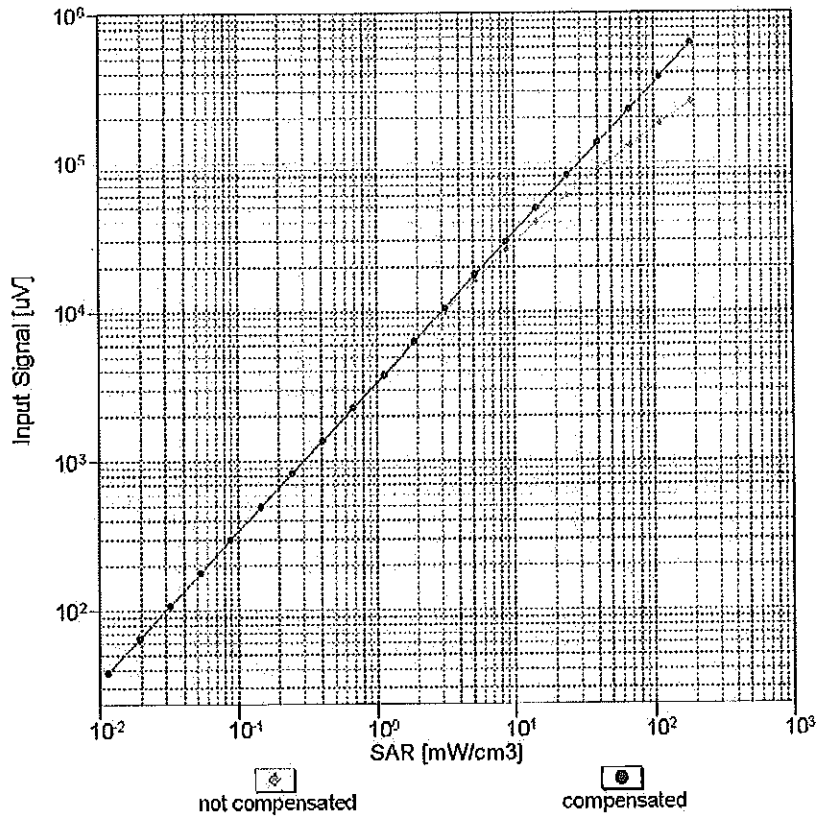

Uncertainty of Linearity Assessment: ± 0.6% (k=2)

## Conversion Factor Assessment

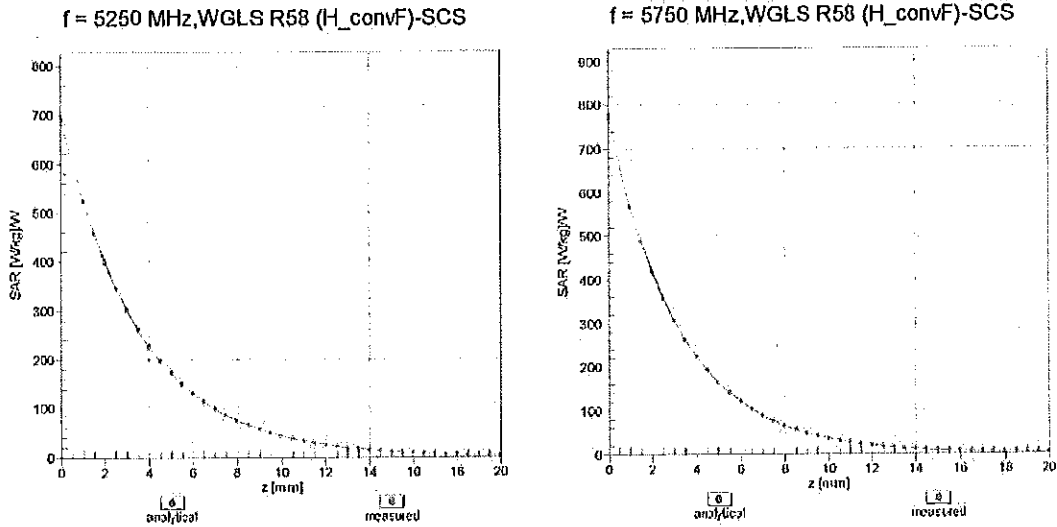

## Deviation from Isotropy in Liquid Error ( $\phi, \theta$ ), f = 900 MHz

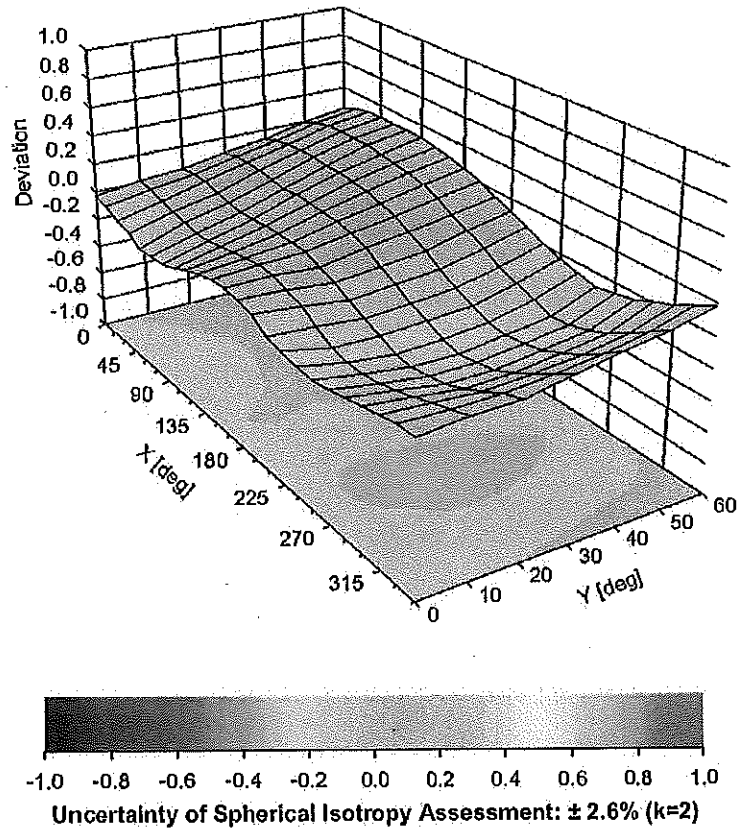

**DASY/EASY - Parameters of Probe: EX3DV4 - SN:7308****Other Probe Parameters**

Sensor Arrangement	Triangular
Connector Angle (°)	-68.9
Mechanical Surface Detection Mode	enabled
Optical Surface Detection Mode	disabled
Probe Overall Length	337 mm
Probe Body Diameter	10 mm
Tip Length	9 mm
Tip Diameter	2.5 mm
Probe Tip to Sensor X Calibration Point	1 mm
Probe Tip to Sensor Y Calibration Point	1 mm
Probe Tip to Sensor Z Calibration Point	1 mm
Recommended Measurement Distance from Surface	1.4 mm



Accredited by the Swiss Accreditation Service (SAS)  
The Swiss Accreditation Service is one of the signatories to the EA  
Multilateral Agreement for the recognition of calibration certificates

Accreditation No.: **SCS 108**

Client **PC Test**

Certificate No: **D1765V2-1008\_May14**

**CALIBRATION CERTIFICATE**

Object **D1765V2 - SN: 1008**

Calibration procedure(s) **QA CAL-05.v9  
Calibration procedure for dipole validation kits above 700 MHz**

*CCV  
6/2/14*

Calibration date: **May 07, 2014**

This calibration certificate documents the traceability to national standards, which realize the physical units of measurements (SI).  
The measurements and the uncertainties with confidence probability are given on the following pages and are part of the certificate.

All calibrations have been conducted in the closed laboratory facility: environment temperature (22 ± 3)°C and humidity < 70%.

Calibration Equipment used (M&TE critical for calibration)

Primary Standards	ID #	Cal Date (Certificate No.)	Scheduled Calibration
Power meter EPM-442A	GB37480704	09-Oct-13 (No. 217-01827)	Oct-14
Power sensor HP 8481A	US37292783	09-Oct-13 (No. 217-01827)	Oct-14
Power sensor HP 8481A	MY41092317	09-Oct-13 (No. 217-01828)	Oct-14
Reference 20 dB Attenuator	SN: 5058 (20k)	03-Apr-14 (No. 217-01918)	Apr-15
Type-N mismatch combination	SN: 5047.2 / 06327	03-Apr-14 (No. 217-01921)	Apr-15
Reference Probe ES3DV3	SN: 3205	30-Dec-13 (No. ES3-3205_Dec13)	Dec-14
DAE4	SN: 601	30-Apr-14 (No. DAE4-601_Apr14)	Apr-15
Secondary Standards	ID #	Check Date (in house)	Scheduled Check
RF generator R&S SMT-06	100005	04-Aug-99 (in house check Oct-13)	In house check: Oct-16
Network Analyzer HP 8753E	US37390585 S4206	18-Oct-01 (in house check Oct-13)	In house check: Oct-14

Calibrated by: **Name** Jeton Kastrati **Function** Laboratory Technician **Signature** *[Signature]*

Approved by: **Name** Katja Pokovic **Technical Manager** *[Signature]*

Issued: May 12, 2014

This calibration certificate shall not be reproduced except in full without written approval of the laboratory.



Accredited by the Swiss Accreditation Service (SAS)  
The Swiss Accreditation Service is one of the signatories to the EA  
Multilateral Agreement for the recognition of calibration certificates

Accreditation No.: **SCS 108**

**Glossary:**

TSL	tissue simulating liquid
ConvF	sensitivity in TSL / NORM x,y,z
N/A	not applicable or not measured

**Calibration is Performed According to the Following Standards:**

- a) IEEE Std 1528-2013, "IEEE Recommended Practice for Determining the Peak Spatial-Averaged Specific Absorption Rate (SAR) in the Human Head from Wireless Communications Devices: Measurement Techniques", June 2013
- b) IEC 62209-1, "Procedure to measure the Specific Absorption Rate (SAR) for hand-held devices used in close proximity to the ear (frequency range of 300 MHz to 3 GHz)", February 2005
- c) KDB 865664, "SAR Measurement Requirements for 100 MHz to 6 GHz"

**Additional Documentation:**

- d) DASY4/5 System Handbook

**Methods Applied and Interpretation of Parameters:**

- *Measurement Conditions:* Further details are available from the Validation Report at the end of the certificate. All figures stated in the certificate are valid at the frequency indicated.
- *Antenna Parameters with TSL:* The dipole is mounted with the spacer to position its feed point exactly below the center marking of the flat phantom section, with the arms oriented parallel to the body axis.
- *Feed Point Impedance and Return Loss:* These parameters are measured with the dipole positioned under the liquid filled phantom. The impedance stated is transformed from the measurement at the SMA connector to the feed point. The Return Loss ensures low reflected power. No uncertainty required.
- *Electrical Delay:* One-way delay between the SMA connector and the antenna feed point. No uncertainty required.
- *SAR measured:* SAR measured at the stated antenna input power.
- *SAR normalized:* SAR as measured, normalized to an input power of 1 W at the antenna connector.
- *SAR for nominal TSL parameters:* The measured TSL parameters are used to calculate the nominal SAR result.

The reported uncertainty of measurement is stated as the standard uncertainty of measurement multiplied by the coverage factor  $k=2$ , which for a normal distribution corresponds to a coverage probability of approximately 95%.

## Measurement Conditions

DASY system configuration, as far as not given on page 1.

DASY Version	DASY5	V52.8.8
Extrapolation	Advanced Extrapolation	
Phantom	Modular Flat Phantom	
Distance Dipole Center - TSL	10 mm	with Spacer
Zoom Scan Resolution	dx, dy, dz = 5 mm	
Frequency	1750 MHz $\pm$ 1 MHz	

## Head TSL parameters

The following parameters and calculations were applied.

	Temperature	Permittivity	Conductivity
Nominal Head TSL parameters	22.0 °C	40.1	1.37 mho/m
Measured Head TSL parameters	(22.0 $\pm$ 0.2) °C	39.0 $\pm$ 6 %	1.36 mho/m $\pm$ 6 %
Head TSL temperature change during test	< 0.5 °C	----	----

## SAR result with Head TSL

SAR averaged over 1 cm <sup>3</sup> (1 g) of Head TSL	Condition	
SAR measured	250 mW input power	9.23 W/kg
SAR for nominal Head TSL parameters	normalized to 1W	<b>36.9 W/kg <math>\pm</math> 17.0 % (k=2)</b>

SAR averaged over 10 cm <sup>3</sup> (10 g) of Head TSL	condition	
SAR measured	250 mW input power	4.87 W/kg
SAR for nominal Head TSL parameters	normalized to 1W	<b>19.5 W/kg <math>\pm</math> 16.5 % (k=2)</b>

## Body TSL parameters

The following parameters and calculations were applied.

	Temperature	Permittivity	Conductivity
Nominal Body TSL parameters	22.0 °C	53.4	1.49 mho/m
Measured Body TSL parameters	(22.0 $\pm$ 0.2) °C	52.2 $\pm$ 6 %	1.48 mho/m $\pm$ 6 %
Body TSL temperature change during test	< 0.5 °C	----	----

## SAR result with Body TSL

SAR averaged over 1 cm <sup>3</sup> (1 g) of Body TSL	Condition	
SAR measured	250 mW input power	9.41 W/kg
SAR for nominal Body TSL parameters	normalized to 1W	<b>37.6 W/kg <math>\pm</math> 17.0 % (k=2)</b>

SAR averaged over 10 cm <sup>3</sup> (10 g) of Body TSL	condition	
SAR measured	250 mW input power	5.02 W/kg
SAR for nominal Body TSL parameters	normalized to 1W	<b>20.1 W/kg <math>\pm</math> 16.5 % (k=2)</b>

## Appendix

### Antenna Parameters with Head TSL

Impedance, transformed to feed point	47.7 $\Omega$ - 6.1 j $\Omega$
Return Loss	- 23.6 dB

### Antenna Parameters with Body TSL

Impedance, transformed to feed point	43.7 $\Omega$ - 6.4 j $\Omega$
Return Loss	- 20.4 dB

### General Antenna Parameters and Design

Electrical Delay (one direction)	1.211 ns
----------------------------------	----------

After long term use with 100W radiated power, only a slight warming of the dipole near the feedpoint can be measured.

The dipole is made of standard semirigid coaxial cable. The center conductor of the feeding line is directly connected to the second arm of the dipole. The antenna is therefore short-circuited for DC-signals. On some of the dipoles, small end caps are added to the dipole arms in order to improve matching when loaded according to the position as explained in the "Measurement Conditions" paragraph. The SAR data are not affected by this change. The overall dipole length is still according to the Standard.

No excessive force must be applied to the dipole arms, because they might bend or the soldered connections near the feedpoint may be damaged.

### Additional EUT Data

Manufactured by	SPEAG
Manufactured on	October 06, 2005

## DASY5 Validation Report for Head TSL

Date: 07.05.2014

Test Laboratory: SPEAG, Zurich, Switzerland

**DUT: Dipole 1765 MHz; Type: D1765V2; Serial: D1765V2 - SN: 1008**

Communication System: UID 0 - CW; Frequency: 1750 MHz

Medium parameters used:  $f = 1750$  MHz;  $\sigma = 1.36$  S/m;  $\epsilon_r = 39$ ;  $\rho = 1000$  kg/m<sup>3</sup>

Phantom section: Flat Section

Measurement Standard: DASY5 (IEEE/IEC/ANSI C63.19-2007)

DASY52 Configuration:

- Probe: ES3DV3 - SN3205; ConvF(5.23, 5.23, 5.23); Calibrated: 30.12.2013;
- Sensor-Surface: 3mm (Mechanical Surface Detection)
- Electronics: DAE4 Sn601; Calibrated: 30.04.2014
- Phantom: Flat Phantom 5.0 (front); Type: QD000P50AA; Serial: 1001
- DASY52 52.8.8(1222); SEMCAD X 14.6.10(7331)

### Dipole Calibration for Head Tissue/Pin=250 mW, d=10mm/Zoom Scan (7x7x7)/Cube 0:

Measurement grid: dx=5mm, dy=5mm, dz=5mm

Reference Value = 96.06 V/m; Power Drift = 0.01 dB

Peak SAR (extrapolated) = 16.7 W/kg

**SAR(1 g) = 9.23 W/kg; SAR(10 g) = 4.87 W/kg**

Maximum value of SAR (measured) = 11.7 W/kg

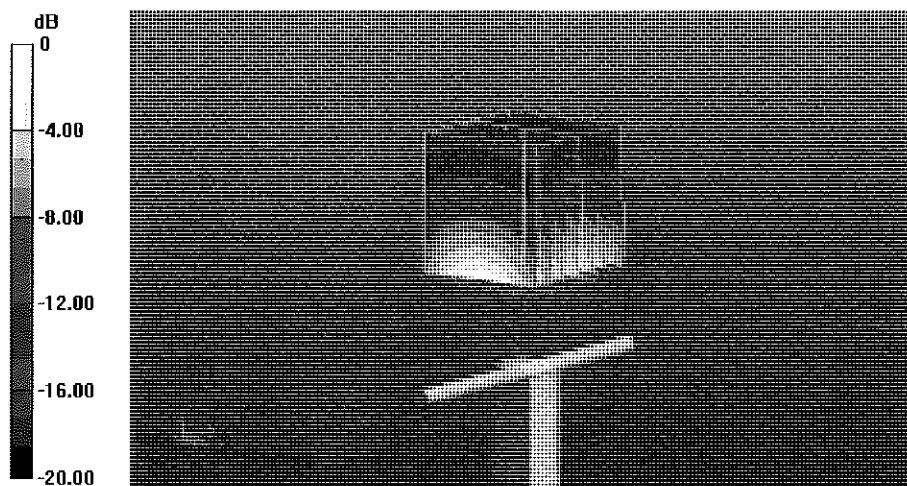

0 dB = 11.7 W/kg = 10.68 dBW/kg

# Impedance Measurement Plot for Head TSL

7 May 2014 09:22:35

CH1 S11 1 U FS 1: 47.709  $\Omega$  -6.0566  $\Omega$  15.016 pF 1 750.000 000 MHz

\*  
De1  
C $\Delta$   
Avg  
16  
H1 d

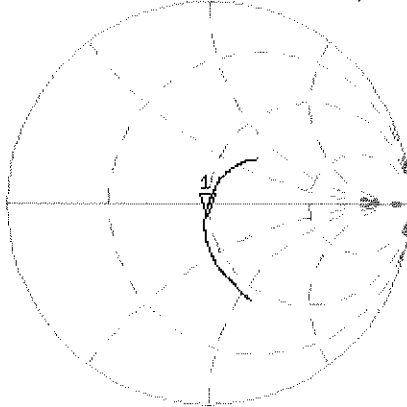

CH2 S11 LOG 5 dB/REF -20 dB 1:-23.588 dB 1 750.000 000 MHz

C $\Delta$   
Avg  
16  
H1 d

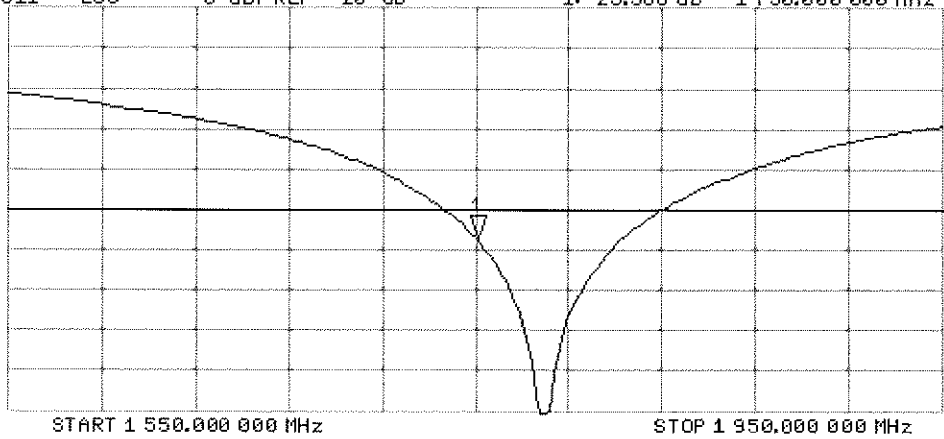

## DASY5 Validation Report for Body TSL

Date: 07.05.2014

Test Laboratory: SPEAG, Zurich, Switzerland

**DUT: Dipole 1765 MHz; Type: D1765V2; Serial: D1765V2 - SN: 1008**

Communication System: UID 0 - CW; Frequency: 1750 MHz

Medium parameters used:  $f = 1750$  MHz;  $\sigma = 1.48$  S/m;  $\epsilon_r = 52.2$ ;  $\rho = 1000$  kg/m<sup>3</sup>

Phantom section: Flat Section

Measurement Standard: DASY5 (IEEE/IEC/ANSI C63.19-2007)

DASY52 Configuration:

- Probe: ES3DV3 - SN3205; ConvF(4.89, 4.89, 4.89); Calibrated: 30.12.2013;
- Sensor-Surface: 3mm (Mechanical Surface Detection)
- Electronics: DAE4 Sn601; Calibrated: 30.04.2014
- Phantom: Flat Phantom 5.0 (back); Type: QD000P50AA; Serial: 1002
- DASY52 52.8.8(1222); SEMCAD X 14.6.10(7331)

### Dipole Calibration for Body Tissue/Pin=250 mW, d=10mm/Zoom Scan (7x7x7)/Cube 0:

Measurement grid: dx=5mm, dy=5mm, dz=5mm

Reference Value = 93.01 V/m; Power Drift = 0.00 dB

Peak SAR (extrapolated) = 16.3 W/kg

**SAR(1 g) = 9.41 W/kg; SAR(10 g) = 5.02 W/kg**

Maximum value of SAR (measured) = 11.8 W/kg

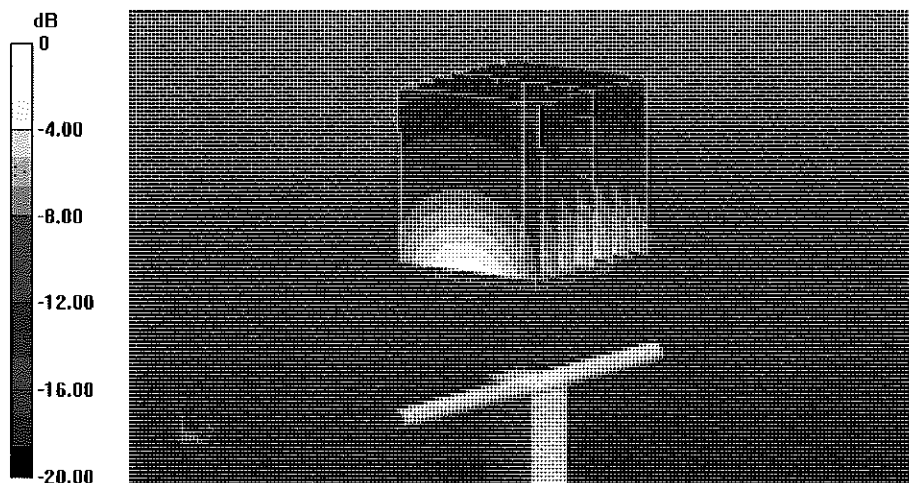

# Impedance Measurement Plot for Body TSL

7 May 2014 09:21:55

CH1 S11 1 U FS 1: 43.727  $\angle$  -6.3691  $\angle$  14.279 pF 1 750.000 000 MHz

\*  
De1

CA

Avg  
16

H1d

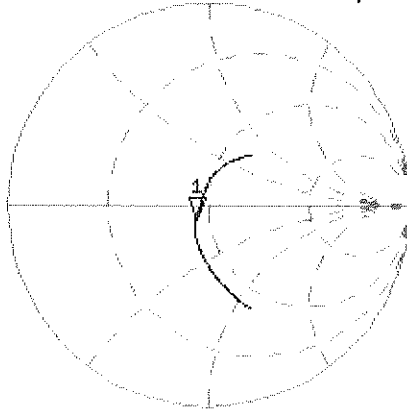

CH2 S11 LOG 5 dB/REF -20 dB 1:-20.428 dB 1 750.000 000 MHz

CA

Avg  
16

H1d

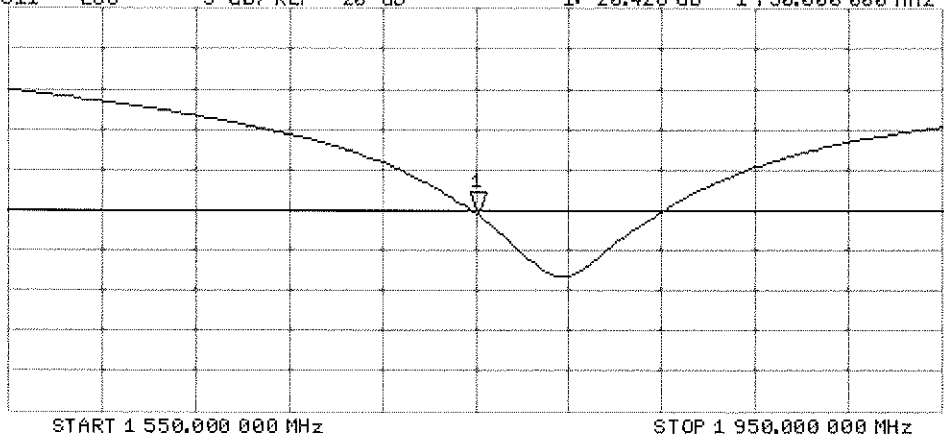



Accredited by the Swiss Accreditation Service (SAS)  
The Swiss Accreditation Service is one of the signatories to the EA  
Multilateral Agreement for the recognition of calibration certificates

Accreditation No.: **SCS 108**

Client **PC Test**

Certificate No: **D1900V2-5d149\_Jul14**

**CALIBRATION CERTIFICATE**

Object **D1900V2 - SN: 5d149**

Calibration procedure(s) **QA CAL-05.v9  
Calibration procedure for dipole validation kits above 700 MHz**

CC  
11/5/14

Calibration date: **July 23, 2014**

This calibration certificate documents the traceability to national standards, which realize the physical units of measurements (SI).  
The measurements and the uncertainties with confidence probability are given on the following pages and are part of the certificate.

All calibrations have been conducted in the closed laboratory facility: environment temperature (22 ± 3)°C and humidity < 70%.

Calibration Equipment used (M&TE critical for calibration)

Primary Standards	ID #	Cal Date (Certificate No.)	Scheduled Calibration
Power meter EPM-442A	GB37480704	09-Oct-13 (No. 217-01827)	Oct-14
Power sensor HP 8481A	US37292783	09-Oct-13 (No. 217-01827)	Oct-14
Power sensor HP 8481A	MY41092317	09-Oct-13 (No. 217-01828)	Oct-14
Reference 20 dB Attenuator	SN: 5058 (20k)	03-Apr-14 (No. 217-01918)	Apr-15
Type-N mismatch combination	SN: 5047.2 / 06327	03-Apr-14 (No. 217-01921)	Apr-15
Reference Probe ES3DV3	SN: 3205	30-Dec-13 (No. ES3-3205_Dec13)	Dec-14
DAE4	SN: 601	30-Apr-14 (No. DAE4-601_Apr14)	Apr-15
Secondary Standards	ID #	Check Date (In house)	Scheduled Check
RF generator R&S SMT-06	100005	04-Aug-99 (in house check Oct-13)	in house check: Oct-16
Network Analyzer HP 8753E	US37390585 S4206	18-Oct-01 (in house check Oct-13)	in house check: Oct-14

Calibrated by:	Name <b>Jeton Kastrati</b>	Function <b>Laboratory Technician</b>	Signature 
Approved by:	Name <b>Katja Pokovic</b>	Technical Manager	

Issued: July 23, 2014

This calibration certificate shall not be reproduced except in full without written approval of the laboratory.



Accredited by the Swiss Accreditation Service (SAS)  
The Swiss Accreditation Service is one of the signatories to the EA  
Multilateral Agreement for the recognition of calibration certificates

Accreditation No.: **SCS 108**

**Glossary:**

TSL	tissue simulating liquid
ConvF	sensitivity in TSL / NORM x,y,z
N/A	not applicable or not measured

**Calibration is Performed According to the Following Standards:**

- a) IEEE Std 1528-2013, "IEEE Recommended Practice for Determining the Peak Spatial-Averaged Specific Absorption Rate (SAR) in the Human Head from Wireless Communications Devices: Measurement Techniques", June 2013
- b) IEC 62209-1, "Procedure to measure the Specific Absorption Rate (SAR) for hand-held devices used in close proximity to the ear (frequency range of 300 MHz to 3 GHz)", February 2005
- c) KDB 865664, "SAR Measurement Requirements for 100 MHz to 6 GHz"

**Additional Documentation:**

- d) DASY4/5 System Handbook

**Methods Applied and Interpretation of Parameters:**

- *Measurement Conditions:* Further details are available from the Validation Report at the end of the certificate. All figures stated in the certificate are valid at the frequency indicated.
- *Antenna Parameters with TSL:* The dipole is mounted with the spacer to position its feed point exactly below the center marking of the flat phantom section, with the arms oriented parallel to the body axis.
- *Feed Point Impedance and Return Loss:* These parameters are measured with the dipole positioned under the liquid filled phantom. The impedance stated is transformed from the measurement at the SMA connector to the feed point. The Return Loss ensures low reflected power. No uncertainty required.
- *Electrical Delay:* One-way delay between the SMA connector and the antenna feed point. No uncertainty required.
- *SAR measured:* SAR measured at the stated antenna input power.
- *SAR normalized:* SAR as measured, normalized to an input power of 1 W at the antenna connector.
- *SAR for nominal TSL parameters:* The measured TSL parameters are used to calculate the nominal SAR result.

The reported uncertainty of measurement is stated as the standard uncertainty of measurement multiplied by the coverage factor  $k=2$ , which for a normal distribution corresponds to a coverage probability of approximately 95%.

## Measurement Conditions

DASY system configuration, as far as not given on page 1.

DASY Version	DASY5	V52.8.8
Extrapolation	Advanced Extrapolation	
Phantom	Modular Flat Phantom	
Distance Dipole Center - TSL	10 mm	with Spacer
Zoom Scan Resolution	dx, dy, dz = 5 mm	
Frequency	1900 MHz ± 1 MHz	

## Head TSL parameters

The following parameters and calculations were applied.

	Temperature	Permittivity	Conductivity
Nominal Head TSL parameters	22.0 °C	40.0	1.40 mho/m
Measured Head TSL parameters	(22.0 ± 0.2) °C	39.5 ± 6 %	1.38 mho/m ± 6 %
Head TSL temperature change during test	< 0.5 °C	----	----

## SAR result with Head TSL

SAR averaged over 1 cm <sup>3</sup> (1 g) of Head TSL	Condition	
SAR measured	250 mW input power	10.0 W/kg
SAR for nominal Head TSL parameters	normalized to 1W	40.2 W/kg ± 17.0 % (k=2)

SAR averaged over 10 cm <sup>3</sup> (10 g) of Head TSL	condition	
SAR measured	250 mW input power	5.24 W/kg
SAR for nominal Head TSL parameters	normalized to 1W	21.0 W/kg ± 16.5 % (k=2)

## Body TSL parameters

The following parameters and calculations were applied.

	Temperature	Permittivity	Conductivity
Nominal Body TSL parameters	22.0 °C	53.3	1.52 mho/m
Measured Body TSL parameters	(22.0 ± 0.2) °C	52.5 ± 6 %	1.51 mho/m ± 6 %
Body TSL temperature change during test	< 0.5 °C	----	----

## SAR result with Body TSL

SAR averaged over 1 cm <sup>3</sup> (1 g) of Body TSL	Condition	
SAR measured	250 mW input power	10.1 W/kg
SAR for nominal Body TSL parameters	normalized to 1W	40.4 W/kg ± 17.0 % (k=2)

SAR averaged over 10 cm <sup>3</sup> (10 g) of Body TSL	condition	
SAR measured	250 mW input power	5.33 W/kg
SAR for nominal Body TSL parameters	normalized to 1W	21.3 W/kg ± 16.5 % (k=2)

## Appendix (Additional assessments outside the scope of SCS108)

### Antenna Parameters with Head TSL

Impedance, transformed to feed point	52.6 $\Omega$ + 5.5 j $\Omega$
Return Loss	- 24.6 dB

### Antenna Parameters with Body TSL

Impedance, transformed to feed point	48.8 $\Omega$ + 6.1 j $\Omega$
Return Loss	- 24.0 dB

### General Antenna Parameters and Design

Electrical Delay (one direction)	1.197 ns
----------------------------------	----------

After long term use with 100W radiated power, only a slight warming of the dipole near the feedpoint can be measured.

The dipole is made of standard semirigid coaxial cable. The center conductor of the feeding line is directly connected to the second arm of the dipole. The antenna is therefore short-circuited for DC-signals. On some of the dipoles, small end caps are added to the dipole arms in order to improve matching when loaded according to the position as explained in the "Measurement Conditions" paragraph. The SAR data are not affected by this change. The overall dipole length is still according to the Standard.

No excessive force must be applied to the dipole arms, because they might bend or the soldered connections near the feedpoint may be damaged.

### Additional EUT Data

Manufactured by	SPEAG
Manufactured on	March 11, 2011

# DASY5 Validation Report for Head TSL

Date: 23.07.2014

Test Laboratory: SPEAG, Zurich, Switzerland

**DUT: Dipole 1900 MHz; Type: D1900V2; Serial: D1900V2 - SN: 5d149**

Communication System: UID 0 - CW; Frequency: 1900 MHz

Medium parameters used:  $f = 1900 \text{ MHz}$ ;  $\sigma = 1.38 \text{ S/m}$ ;  $\epsilon_r = 39.5$ ;  $\rho = 1000 \text{ kg/m}^3$

Phantom section: Flat Section

Measurement Standard: DASY5 (IEEE/IEC/ANSI C63.19-2011)

DASY52 Configuration:

- Probe: ES3DV3 - SN3205; ConvF(5.06, 5.06, 5.06); Calibrated: 30.12.2013;
- Sensor-Surface: 3mm (Mechanical Surface Detection)
- Electronics: DAE4 Sn601; Calibrated: 30.04.2014
- Phantom: Flat Phantom 5.0 (front); Type: QD000P50AA; Serial: 100I
- DASY52 52.8.8(1222); SEMCAD X 14.6.10(7331)

## Dipole Calibration for Head Tissue/ $P_{in}=250 \text{ mW}$ , $d=10\text{mm}$ /Zoom Scan (7x7x7)/Cube 0:

Measurement grid:  $dx=5\text{mm}$ ,  $dy=5\text{mm}$ ,  $dz=5\text{mm}$

Reference Value =  $98.92 \text{ V/m}$ ; Power Drift =  $0.02 \text{ dB}$

Peak SAR (extrapolated) =  $18.4 \text{ W/kg}$

**SAR(1 g) =  $10 \text{ W/kg}$ ; SAR(10 g) =  $5.24 \text{ W/kg}$**

Maximum value of SAR (measured) =  $12.8 \text{ W/kg}$

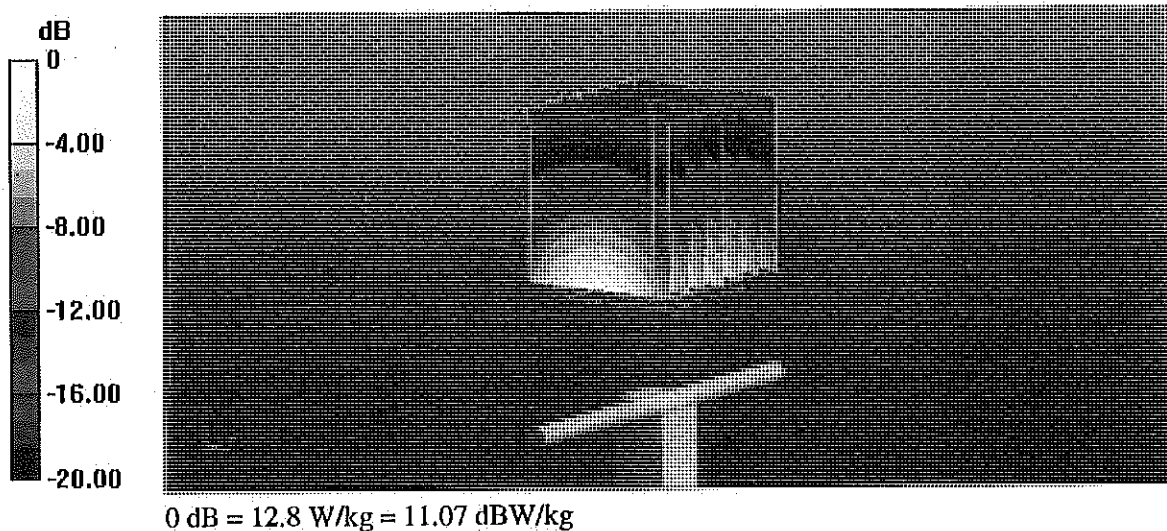

# Impedance Measurement Plot for Head TSL

23 Jul 2014 10:46:05

CH1 S11 1 U FS 1: 52.600  $\Omega$  5.4570  $\Omega$  457.11 pF 1 900.000 000 MHz

\*  
Del  
Cor

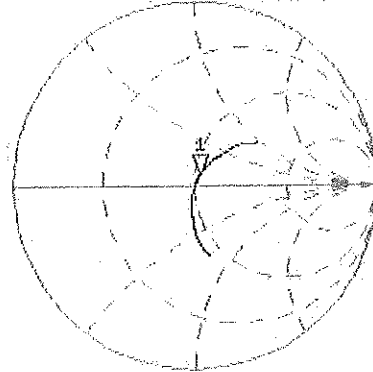

avg  
16

H1d

CH2 S11 LOG 5 dB/REF -20 dB 1: -24.600 dB 1 900.000 000 MHz

Cor

avg  
16

H1d

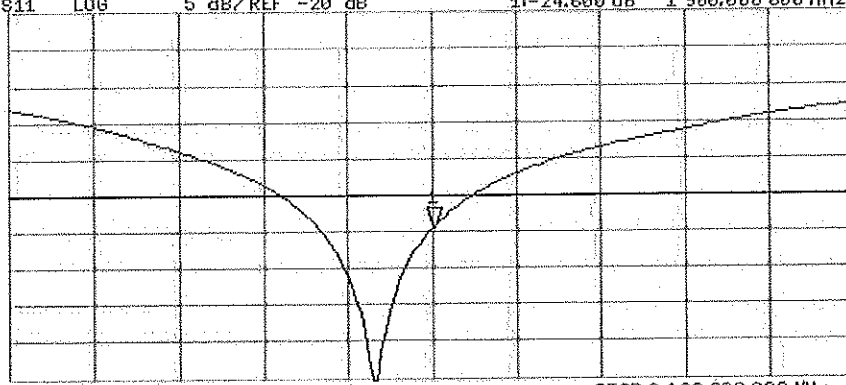

## DASY5 Validation Report for Body TSL

Date: 23.07.2014

Test Laboratory: SPEAG, Zurich, Switzerland

**DUT: Dipole 1900 MHz; Type: D1900V2; Serial: D1900V2 - SN: 5d149**

Communication System: UID 0 - CW; Frequency: 1900 MHz

Medium parameters used:  $f = 1900$  MHz;  $\sigma = 1.51$  S/m;  $\epsilon_r = 52.5$ ;  $\rho = 1000$  kg/m<sup>3</sup>

Phantom section: Flat Section

Measurement Standard: DASY5 (IEEE/IEC/ANSI C63.19-2011)

DASY52 Configuration:

- Probe: ES3DV3 - SN3205; ConvF(4.76, 4.76, 4.76); Calibrated: 30.12.2013;
- Sensor-Surface: 3mm (Mechanical Surface Detection)
- Electronics: DAE4 Sn601; Calibrated: 30.04.2014
- Phantom: Flat Phantom 5.0 (back); Type: QD000P50AA; Serial: 1002
- DASY52 52.8.8(1222); SEMCAD X 14.6.10(7331)

### Dipole Calibration for Body Tissue/Pin=250 mW, d=10mm/Zoom Scan (7x7x7)/Cube 0:

Measurement grid: dx=5mm, dy=5mm, dz=5mm

Reference Value = 95.83 V/m; Power Drift = -0.01 dB

Peak SAR (extrapolated) = 17.6 W/kg

**SAR(1 g) = 10.1 W/kg; SAR(10 g) = 5.33 W/kg**

Maximum value of SAR (measured) = 12.8 W/kg

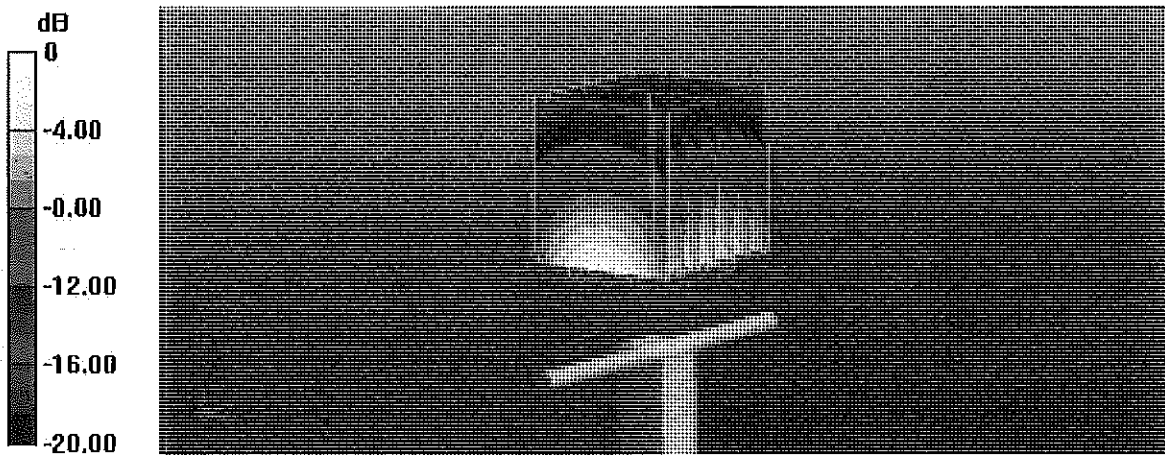

0 dB = 12.8 W/kg = 11.07 dBW/kg

# Impedance Measurement Plot for Body TSL

23 Jul 2014 10:45:45

CH1 S11 1 U FS 1: 48.789  $\Omega$  6.1426  $\Omega$  514.54 pF 1 900.000 000 MHz

\*  
Del  
Cor

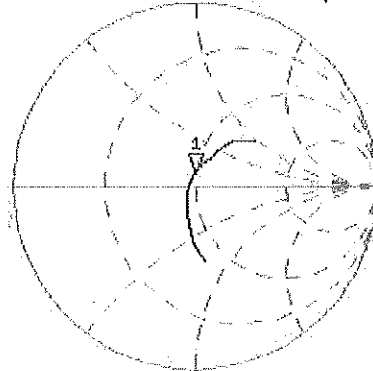

Avg  
16  
H1d

CH2 S11 LOG 5 dB/REF -20 dB 1: -23.974 dB 1 900.000 000 MHz

Cor  
Avg  
16  
H1d

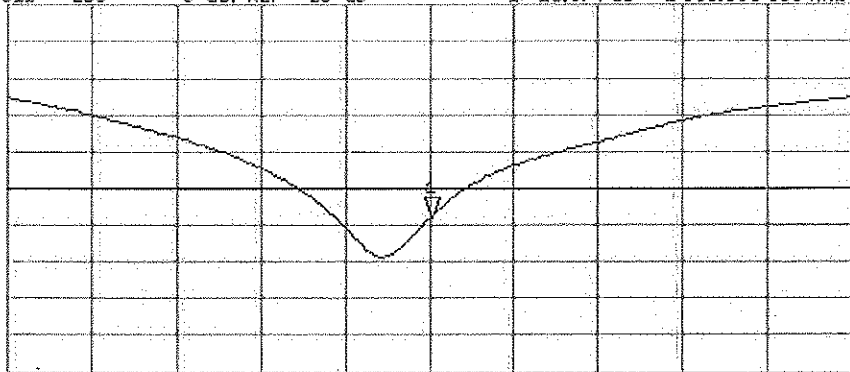

START 1 700.000 000 MHz

STOP 2 100.000 000 MHz



Accredited by the Swiss Accreditation Service (SAS)  
The Swiss Accreditation Service is one of the signatories to the EA  
Multilateral Agreement for the recognition of calibration certificates

Accreditation No.: **SCS 108**

Client **PC Test**

Certificate No: **D2450V2-719\_Aug14**

**CALIBRATION CERTIFICATE**

Object **D2450V2 - SN: 719**

Calibration procedure(s) **QA CAL-05.v9  
Calibration procedure for dipole validation kits above 700 MHz**

Calibration date: **August 11, 2014**

*✓ KOK 9/8/14*

This calibration certificate documents the traceability to national standards, which realize the physical units of measurements (SI).  
The measurements and the uncertainties with confidence probability are given on the following pages and are part of the certificate.

All calibrations have been conducted in the closed laboratory facility: environment temperature (22 ± 3)°C and humidity < 70%.

Calibration Equipment used (M&TE critical for calibration)

Primary Standards	ID #	Cal Date (Certificate No.)	Scheduled Calibration
Power meter EPM-442A	GB37480704	09-Oct-13 (No. 217-01827)	Oct-14
Power sensor HP 8481A	US37292783	09-Oct-13 (No. 217-01827)	Oct-14
Power sensor HP 8481A	MY41092317	09-Oct-13 (No. 217-01828)	Oct-14
Reference 20 dB Attenuator	SN: 5058 (20k)	03-Apr-14 (No. 217-01918)	Apr-15
Type-N mismatch combination	SN: 5047.2 / 06327	03-Apr-14 (No. 217-01921)	Apr-15
Reference Probe ES3DV3	SN: 3205	30-Dec-13 (No. ES3-3205_Dec13)	Dec-14
DAE4	SN: 601	30-Apr-14 (No. DAE4-601_Apr14)	Apr-15
Secondary Standards	ID #	Check Date (in house)	Scheduled Check
RF generator R&S SMT-06	100005	04-Aug-99 (in house check Oct-13)	In house check: Oct-16
Network Analyzer HP 8753E	US37390585 S4206	18-Oct-01 (in house check Oct-13)	In house check: Oct-14

Calibrated by: **Michael Weber**      Function: **Laboratory Technician**      Signature: *M. Weber*

Approved by: **Katja Pokovic**      Technical Manager      *[Signature]*

Issued: August 12, 2014

This calibration certificate shall not be reproduced except in full without written approval of the laboratory.



Accredited by the Swiss Accreditation Service (SAS)  
The Swiss Accreditation Service is one of the signatories to the EA  
Multilateral Agreement for the recognition of calibration certificates

Accreditation No.: **SCS 108**

**Glossary:**

TSL	tissue simulating liquid
ConvF	sensitivity in TSL / NORM x,y,z
N/A	not applicable or not measured

**Calibration is Performed According to the Following Standards:**

- IEEE Std 1528-2013, "IEEE Recommended Practice for Determining the Peak Spatial-Averaged Specific Absorption Rate (SAR) in the Human Head from Wireless Communications Devices: Measurement Techniques", June 2013
- IEC 62209-1, "Procedure to measure the Specific Absorption Rate (SAR) for hand-held devices used in close proximity to the ear (frequency range of 300 MHz to 3 GHz)", February 2005
- KDB 865664, "SAR Measurement Requirements for 100 MHz to 6 GHz"

**Additional Documentation:**

- DASY4/5 System Handbook

**Methods Applied and Interpretation of Parameters:**

- Measurement Conditions:* Further details are available from the Validation Report at the end of the certificate. All figures stated in the certificate are valid at the frequency indicated.
- Antenna Parameters with TSL:* The dipole is mounted with the spacer to position its feed point exactly below the center marking of the flat phantom section, with the arms oriented parallel to the body axis.
- Feed Point Impedance and Return Loss:* These parameters are measured with the dipole positioned under the liquid filled phantom. The impedance stated is transformed from the measurement at the SMA connector to the feed point. The Return Loss ensures low reflected power. No uncertainty required.
- Electrical Delay:* One-way delay between the SMA connector and the antenna feed point. No uncertainty required.
- SAR measured:* SAR measured at the stated antenna input power.
- SAR normalized:* SAR as measured, normalized to an input power of 1 W at the antenna connector.
- SAR for nominal TSL parameters:* The measured TSL parameters are used to calculate the nominal SAR result.

The reported uncertainty of measurement is stated as the standard uncertainty of measurement multiplied by the coverage factor  $k=2$ , which for a normal distribution corresponds to a coverage probability of approximately 95%.

## Measurement Conditions

DASY system configuration, as far as not given on page 1.

DASY Version	DASY5	V52.8.8
Extrapolation	Advanced Extrapolation	
Phantom	Modular Flat Phantom	
Distance Dipole Center - TSL	10 mm	with Spacer
Zoom Scan Resolution	dx, dy, dz = 5 mm	
Frequency	2450 MHz $\pm$ 1 MHz	

## Head TSL parameters

The following parameters and calculations were applied.

	Temperature	Permittivity	Conductivity
Nominal Head TSL parameters	22.0 °C	39.2	1.80 mho/m
Measured Head TSL parameters	(22.0 $\pm$ 0.2) °C	38.0 $\pm$ 6 %	1.82 mho/m $\pm$ 6 %
Head TSL temperature change during test	< 0.5 °C	----	----

## SAR result with Head TSL

SAR averaged over 1 cm <sup>3</sup> (1 g) of Head TSL	Condition	
SAR measured	250 mW input power	13.2 W/kg
SAR for nominal Head TSL parameters	normalized to 1W	<b>52.1 W/kg <math>\pm</math> 17.0 % (k=2)</b>

SAR averaged over 10 cm <sup>3</sup> (10 g) of Head TSL	condition	
SAR measured	250 mW input power	6.09 W/kg
SAR for nominal Head TSL parameters	normalized to 1W	<b>24.2 W/kg <math>\pm</math> 16.5 % (k=2)</b>

## Body TSL parameters

The following parameters and calculations were applied.

	Temperature	Permittivity	Conductivity
Nominal Body TSL parameters	22.0 °C	52.7	1.95 mho/m
Measured Body TSL parameters	(22.0 $\pm$ 0.2) °C	50.5 $\pm$ 6 %	2.02 mho/m $\pm$ 6 %
Body TSL temperature change during test	< 0.5 °C	----	----

## SAR result with Body TSL

SAR averaged over 1 cm <sup>3</sup> (1 g) of Body TSL	Condition	
SAR measured	250 mW input power	13.3 W/kg
SAR for nominal Body TSL parameters	normalized to 1W	<b>51.8 W/kg <math>\pm</math> 17.0 % (k=2)</b>

SAR averaged over 10 cm <sup>3</sup> (10 g) of Body TSL	condition	
SAR measured	250 mW input power	6.10 W/kg
SAR for nominal Body TSL parameters	normalized to 1W	<b>24.0 W/kg <math>\pm</math> 16.5 % (k=2)</b>

## Appendix (Additional assessments outside the scope of SCS108)

### Antenna Parameters with Head TSL

Impedance, transformed to feed point	54.9 $\Omega$ + 3.0 j $\Omega$
Return Loss	- 25.2 dB

### Antenna Parameters with Body TSL

Impedance, transformed to feed point	50.9 $\Omega$ + 5.8 j $\Omega$
Return Loss	- 24.7 dB

### General Antenna Parameters and Design

Electrical Delay (one direction)	1.149 ns
----------------------------------	----------

After long term use with 100W radiated power, only a slight warming of the dipole near the feedpoint can be measured.

The dipole is made of standard semirigid coaxial cable. The center conductor of the feeding line is directly connected to the second arm of the dipole. The antenna is therefore short-circuited for DC-signals. On some of the dipoles, small end caps are added to the dipole arms in order to improve matching when loaded according to the position as explained in the "Measurement Conditions" paragraph. The SAR data are not affected by this change. The overall dipole length is still according to the Standard.

No excessive force must be applied to the dipole arms, because they might bend or the soldered connections near the feedpoint may be damaged.

### Additional EUT Data

Manufactured by	SPEAG
Manufactured on	September 10, 2002

## DASY5 Validation Report for Head TSL

Date: 11.08.2014

Test Laboratory: SPEAG, Zurich, Switzerland

**DUT: Dipole 2450 MHz; Type: D2450V2; Serial: D2450V2 - SN: 719**

Communication System: UID 0 - CW; Frequency: 2450 MHz

Medium parameters used:  $f = 2450$  MHz;  $\sigma = 1.82$  S/m;  $\epsilon_r = 38$ ;  $\rho = 1000$  kg/m<sup>3</sup>

Phantom section: Flat Section

Measurement Standard: DASY5 (IEEE/IEC/ANSI C63.19-2011)

DASY52 Configuration:

- Probe: ES3DV3 - SN3205; ConvF(4.53, 4.53, 4.53); Calibrated: 30.12.2013;
- Sensor-Surface: 3mm (Mechanical Surface Detection)
- Electronics: DAE4 Sn601; Calibrated: 30.04.2014
- Phantom: Flat Phantom 5.0 (front); Type: QD000P50AA; Serial: 1001
- DASY52 52.8.8(1222); SEMCAD X 14.6.10(7331)

### Dipole Calibration for Head Tissue/Pin=250 mW, d=10mm/Zoom Scan (7x7x7)/Cube 0:

Measurement grid: dx=5mm, dy=5mm, dz=5mm

Reference Value = 101.6 V/m; Power Drift = 0.03 dB

Peak SAR (extrapolated) = 27.5 W/kg

**SAR(1 g) = 13.2 W/kg; SAR(10 g) = 6.09 W/kg**

Maximum value of SAR (measured) = 17.4 W/kg

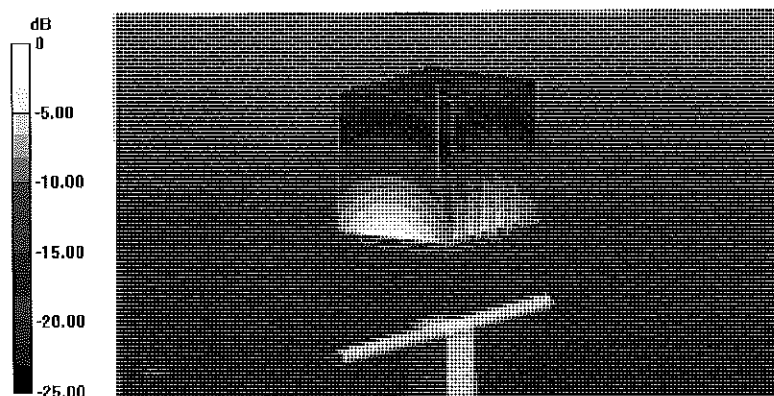

0 dB = 17.4 W/kg = 12.41 dBW/kg

# Impedance Measurement Plot for Head TSL

11 Aug 2014 11:49:06

CH1 S11 1 U FS

1: 54.887  $\Omega$  3.0391  $\Omega$  197.42 pF

2 450.000 000 MHz

#  
Del  
C $\Delta$

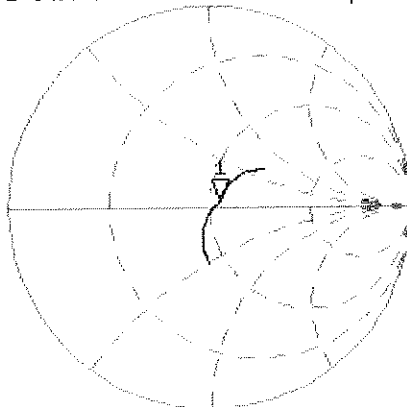

Avg  
16

H1 d

CH2 S11 LOG 5 dB/REF -20 dB 1: -25.212 dB 2 450.000 000 MHz

C $\Delta$

Avg  
16

H1 d

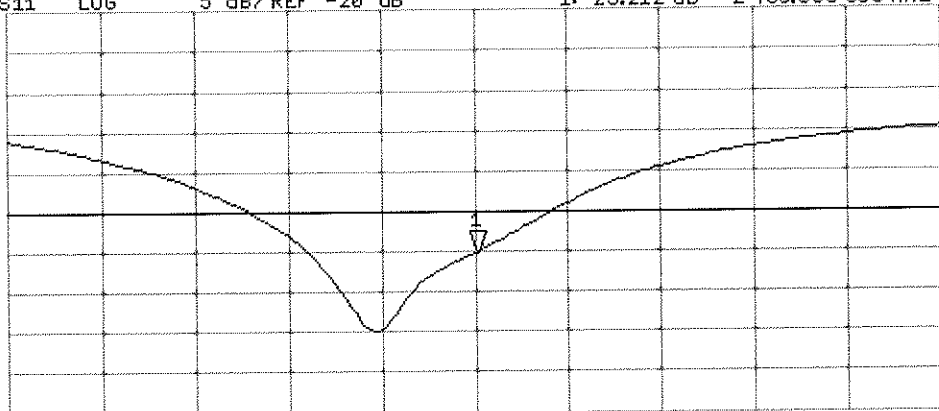

START 2 250.000 000 MHz

STOP 2 650.000 000 MHz

## DASY5 Validation Report for Body TSL

Date: 11.08.2014

Test Laboratory: SPEAG, Zurich, Switzerland

**DUT: Dipole 2450 MHz; Type: D2450V2; Serial: D2450V2 - SN: 719**

Communication System: UID 0 - CW; Frequency: 2450 MHz

Medium parameters used:  $f = 2450$  MHz;  $\sigma = 2.02$  S/m;  $\epsilon_r = 50.5$ ;  $\rho = 1000$  kg/m<sup>3</sup>

Phantom section: Flat Section

Measurement Standard: DASY5 (IEEE/IEC/ANSI C63.19-2011)

DASY52 Configuration:

- Probe: ES3DV3 - SN3205; ConvF(4.35, 4.35, 4.35); Calibrated: 30.12.2013;
- Sensor-Surface: 3mm (Mechanical Surface Detection)
- Electronics: DAE4 Sn601; Calibrated: 30.04.2014
- Phantom: Flat Phantom 5.0 (back); Type: QD000P50AA; Serial: 1002
- DASY52 52.8.8(1222); SEMCAD X 14.6.10(7331)

### Dipole Calibration for Body Tissue/Pin=250 mW, d=10mm/Zoom Scan (7x7x7)/Cube 0:

Measurement grid: dx=5mm, dy=5mm, dz=5mm

Reference Value = 96.08 V/m; Power Drift = -0.01 dB

Peak SAR (extrapolated) = 27.9 W/kg

**SAR(1 g) = 13.3 W/kg; SAR(10 g) = 6.1 W/kg**

Maximum value of SAR (measured) = 17.6 W/kg

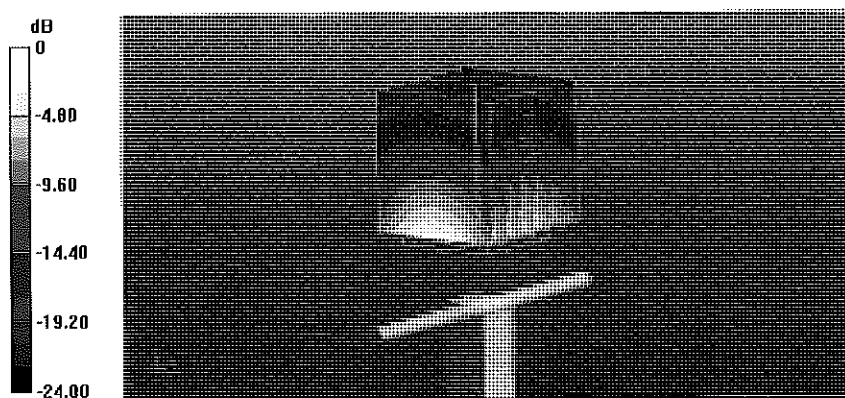

0 dB = 17.6 W/kg = 12.46 dBW/kg

# Impedance Measurement Plot for Body TSL

11 Aug 2014 11:48:32

CH1 S11 1 U FS 1: 50.928  $\Delta$  5.8223  $\Delta$  378.22 pF 2 450.000 000 MHz

\*  
De1

CA

Avg  
15

H1 d

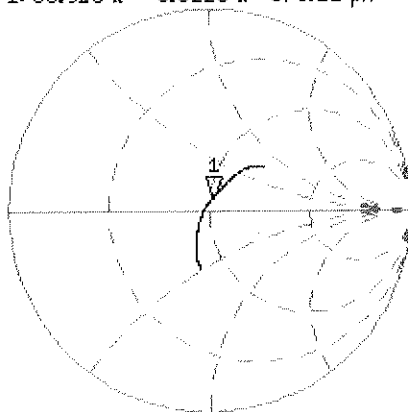

CH2 S11 LOG 5 dB/REF -20 dB 1: -24.679 dB 2 450.000 000 MHz

CA

Avg  
15

H1 d

