



SAR EVALUATION REPORT

Applicant Name:
 Samsung Electronics, Co. Ltd.
 129, Samsung-ro, Maetan dong,
 Yeongtong-gu, Suwon-si
 Gyeonggi-do 443-742, Korea

Date of Testing:
 02/03/14 - 02/10/14
Test Site/Location:
 PCTEST Lab, Columbia, MD, USA
Document Serial No.:
 0Y1402030286-R1.A3L

FCC ID: A3LSMG900S

APPLICANT: SAMSUNG ELECTRONICS, CO. LTD.

DUT Type: Portable Handset
Application Type: Certification
FCC Rule Part(s): CFR §2.1093
Model(s): SM-G900S, SM-G900L, SM-G900K

Equipment Class	Band & Mode	Tx Frequency	SAR		
			1 gm Head (W/kg)	1 gm Body-Worn (W/kg)	1 gm Hotspot (W/kg)
PCE	UMTS 850	826.40 - 846.60 MHz	0.51	0.71	0.71
PCE	GSM/GPRS 1900	1850.20 - 1909.80 MHz	0.18	0.42	0.71
PCE	UMTS 1900	1852.4 - 1907.6 MHz	0.32	0.57	0.88
PCE	LTE Band 5 (Cell)	826.5 - 846.5 MHz	0.50	0.83	0.83
PCE	LTE Band 17	706.5 - 713.5 MHz	0.14	0.35	0.35
DTS	2.4 GHz WLAN	2412 - 2462 MHz	0.55	0.27	0.27
DTS	5.8 GHz WLAN	5745 - 5825 MHz	0.41	<0.1	0.21
NII	5.2 GHz WLAN	5180 - 5240 MHz	0.14	<0.1	
NII	5.3 GHz WLAN	5260 - 5320 MHz	0.22	<0.1	
NII	5.5 GHz WLAN	5500 - 5700 MHz	0.49	<0.1	
DSS/DTS	Bluetooth	2402 - 2480 MHz	N/A		
Simultaneous SAR per KDB 690783 D01v01r02:			1.10		

This wireless portable device has been shown to be capable of compliance for localized specific absorption rate (SAR) for uncontrolled environment/general population exposure limits specified in ANSI/IEEE C95.1-1992 and has been tested in accordance with the measurement procedures specified in Section 1.8 of this report; for North American frequency bands only.

Note: This revised Test Report (S/N: 0Y1402030286-R1.A3L) supersedes and replaces the previously issued test report on the same subject device for the same type of testing as indicated. Please discard or destroy the previously issued test report(s) and dispose of it accordingly.

I attest to the accuracy of data. All measurements reported herein were performed by me or were made under my supervision and are correct to the best of my knowledge and belief. I assume full responsibility for the completeness of these measurements and vouch for the qualifications of all persons taking them. Test results reported herein relate only to the item(s) tested.

Randy Ortanez
 President



FCC ID: A3LSMG900S	SAR EVALUATION REPORT		Reviewed by: Quality Manager
Document S/N: 0Y1402030286-R1.A3L	Test Dates: 02/03/14 – 02/10/14	DUT Type: Portable Handset	Page 1 of 64

T A B L E O F C O N T E N T S

1	DEVICE UNDER TEST	3
2	LTE INFORMATION	9
3	INTRODUCTION	10
4	DOSIMETRIC ASSESSMENT	11
5	DEFINITION OF REFERENCE POINTS	12
6	TEST CONFIGURATION POSITIONS FOR HANDSETS	13
7	RF EXPOSURE LIMITS	17
8	FCC MEASUREMENT PROCEDURES.....	18
9	RF CONDUCTED POWERS.....	22
10	SYSTEM VERIFICATION.....	35
11	SAR DATA SUMMARY	37
12	FCC MULTI-TX AND ANTENNA SAR CONSIDERATIONS.....	49
13	SAR MEASUREMENT VARIABILITY	58
14	EQUIPMENT LIST.....	59
15	MEASUREMENT UNCERTAINTIES	60
16	CONCLUSION.....	62
17	REFERENCES	63
APPENDIX A: SAR TEST PLOTS		
APPENDIX B: SAR DIPOLE VERIFICATION PLOTS		
APPENDIX C: PROBE AND DIPOLE CALIBRATION CERTIFICATES		
APPENDIX D: SAR TISSUE SPECIFICATIONS		
APPENDIX E: SAR SYSTEM VALIDATION		
APPENDIX F: SAR TEST SETUP PHOTOGRAPHS		

FCC ID: A3LSMG900S		SAR EVALUATION REPORT		Reviewed by: Quality Manager
Document S/N: OY1402030286-R1.A3L	Test Dates: 02/03/14 – 02/10/14	DUT Type: Portable Handset		Page 2 of 64

1 DEVICE UNDER TEST

1.1 Device Overview

Band & Mode	Operating Modes	Tx Frequency
UMTS 850	Voice/Data	826.40 - 846.60 MHz
GSM/GPRS 1900	Voice/Data	1850.20 - 1909.80 MHz
UMTS 1900	Voice/Data	1852.4 - 1907.6 MHz
LTE Band 5 (Cell)	Data	826.5 - 846.5 MHz
LTE Band 17	Data	706.5 - 713.5 MHz
2.4 GHz WLAN	Data	2412 - 2462 MHz
5.8 GHz WLAN	Data	5745 - 5825 MHz
5.2 GHz WLAN	Data	5180 - 5240 MHz
5.3 GHz WLAN	Data	5260 - 5320 MHz
5.5 GHz WLAN	Data	5500 - 5700 MHz
Bluetooth	Data	2402 - 2480 MHz
NFC	Data	13.56 MHz
ANT+	Data	2402 - 2480 MHz

1.2 Nominal and Maximum Output Power Specifications

This device operates using the following maximum and nominal output power specifications. SAR values were scaled to the maximum allowed power to determine compliance per KDB Publication 447498 D01v05.

Mode / Band		Voice (dBm)	Burst Average GMSK (dBm)			
		1 TX Slot	1 TX Slots	2 TX Slots	3 TX Slots	4 TX Slots
GSM/GPRS 1900	Maximum	31.5	31.5	30.0	29.0	27.0
	Nominal	31.0	31.0	29.5	28.5	26.5

Mode / Band		Modulated Average (dBm)		
		3GPP WCDMA Rel 99	3GPP HSDPA Rel 5	3GPP HSUPA Rel 6
UMTS Band 5 (850 MHz)	Maximum	24.0	23.0	23.0
	Nominal	23.5	22.5	22.5
UMTS Band 2 (1900 MHz)	Maximum	23.5	22.5	22.5
	Nominal	23.0	22.0	22.0

Mode / Band		Modulated Average (dBm)
LTE Band 5	Maximum	24.5
	Nominal	24.0
LTE Band 17	Maximum	23.5
	Nominal	23.0

FCC ID: A3LSMG900S	 PCTEST ENGINEERING LABORATORY, INC.	SAR EVALUATION REPORT		Reviewed by: Quality Manager
Document S/N: OY1402030286-R1.A3L	Test Dates: 02/03/14 – 02/10/14	DUT Type: Portable Handset		Page 3 of 64

Mode / Band		Modulated Average (dBm)
IEEE 802.11b (2.4 GHz)	Maximum	17.5
	Nominal	17.0
IEEE 802.11g (2.4 GHz)	Maximum	14.5
	Nominal	14.0
IEEE 802.11n (2.4 GHz)	Maximum	12.5
	Nominal	12.0
IEEE 802.11a (5 GHz)	Maximum	12.5
	Nominal	12.0
IEEE 802.11ac (5 GHz)	Maximum	10.5
	Nominal	10.0
IEEE 802.11n (5 GHz)	Maximum	12.5
	Nominal	12.0
Bluetooth	Maximum	10.5
	Nominal	10.0
Bluetooth LE	Maximum	8.0
	Nominal	7.5

1.3 DUT Antenna Locations

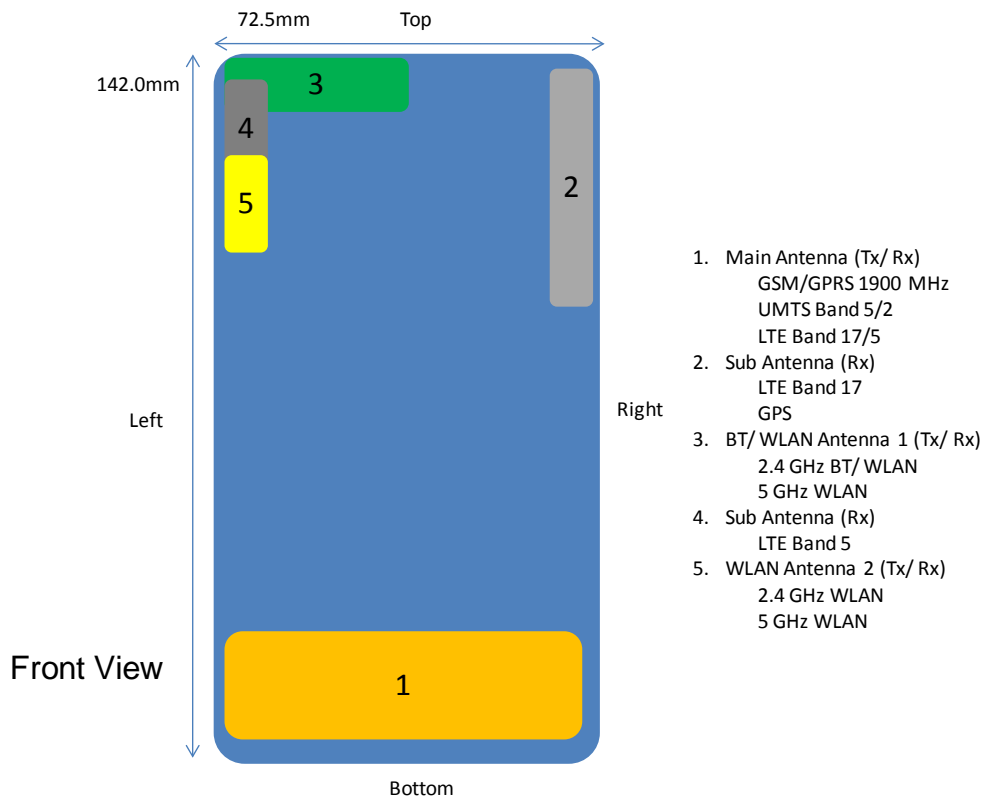

Note: Exact antenna dimensions and separation distances are shown in the Technical Descriptions in the FCC Filing.

Figure 1-1
DUT Antenna Locations

FCC ID: A3LSMG900S	PCTEST ENGINEERING LABORATORY, INC.	SAR EVALUATION REPORT		Reviewed by: Quality Manager
Document S/N: OY1402030286-R1.A3L	Test Dates: 02/03/14 – 02/10/14	DUT Type: Portable Handset		Page 4 of 64

**Table 1-1
Mobile Hotspot Sides for SAR Testing**

Mobile Hotspot Sides for SAR Testing						
Mode	Back	Front	Top	Bottom	Right	Left
UMTS 850	Yes	Yes	No	Yes	Yes	Yes
GPRS 1900	Yes	Yes	No	Yes	Yes	Yes
UMTS 1900	Yes	Yes	No	Yes	Yes	Yes
LTE Band 5 (Cell)	Yes	Yes	No	Yes	Yes	Yes
LTE Band 17	Yes	Yes	No	Yes	Yes	Yes
2.4 GHz WLAN	Yes	Yes	Yes	No	No	Yes
5.8 GHz WLAN	Yes	Yes	Yes	No	No	Yes



Note: Particular DUT edges were not required to be evaluated for Wireless Router and/or Extremity SAR if the edges were greater than 2.5 cm from the transmitting antenna according to FCC KDB Publication 941225 D06v01 guidance, page 2 and FCC KDB Publication 648474 D04 Handset SAR v01r01 guidance, page 2. When the wireless router mode is enabled, all 5 GHz NII bands are disabled. Therefore 5 GHz NII WIFI is not considered in this section

1.4 Near Field Communications (NFC) Antenna

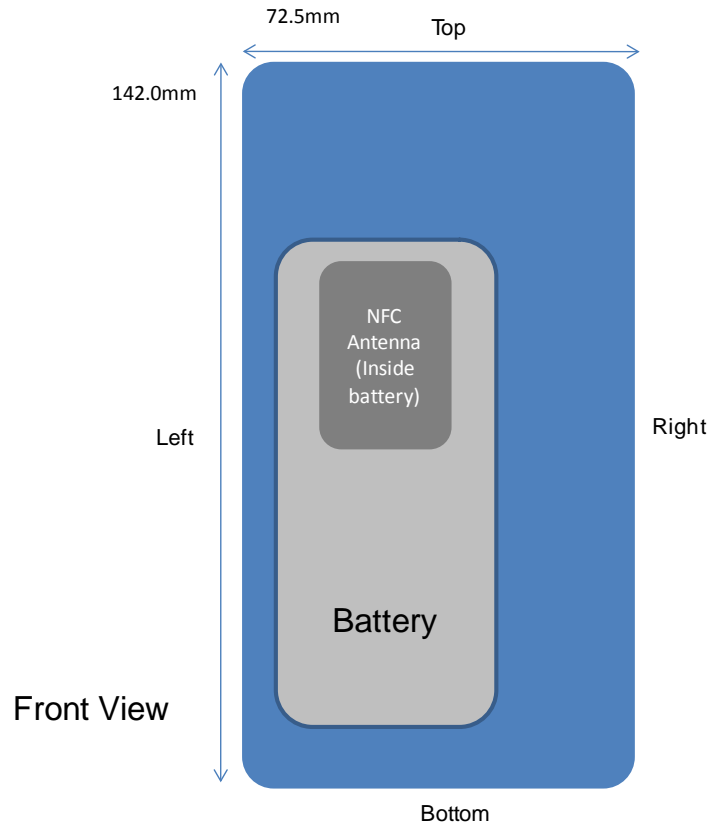
This DUT has NFC operations. The NFC antenna is integrated into the specialized battery. The SAR tests were performed with the specialized battery (model: EB-BG900BBK).



**Figure 1-2
NFC Antenna Locations**

FCC ID: A3LSMG900S	 PCTEST ENGINEERING LABORATORY, INC.	SAR EVALUATION REPORT		Reviewed by: Quality Manager
Document S/N: OY1402030286-R1.A3L	Test Dates: 02/03/14 – 02/10/14	DUT Type: Portable Handset		Page 5 of 64

1.5 Simultaneous Transmission Capabilities

According to FCC KDB Publication 447498 D05v01, transmitters are considered to be transmitting simultaneously when there is overlapping transmission, with the exception of transmissions during network hand-offs with maximum hand-off duration less than 30 seconds. Possible transmission paths for the DUT are shown in Figure 1-3 and are color-coded to indicate communication modes which share the same path. Modes which share the same transmission path cannot transmit simultaneously with one another.

This device supports MIMO Tx for WLAN 802.11n/ac. Each WLAN antenna can transmit independently or together when operating with MIMO.

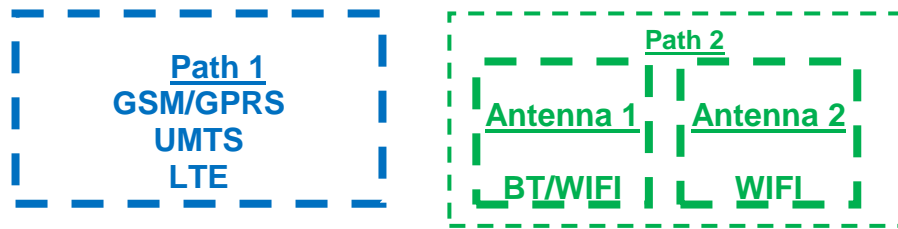

Figure 1-3
Simultaneous Transmission Paths

This device contains multiple transmitters that may operate simultaneously, and therefore requires a simultaneous transmission analysis according to FCC KDB Publication 447498 D01v05 3) procedures.

Table 1-2
Simultaneous Transmission Scenarios

No.	Capable Transmit Configuration	Head	Body-Worn Accessory	Wireless Router	Notes
1	GSM voice + 2.4 GHz WI-FI	Yes	Yes	N/A	
2	GSM voice + 5 GHz WI-FI	Yes	Yes	N/A	
3	GSM voice + 2.4 GHz Bluetooth	N/A	Yes	N/A	
4	UMTS + 2.4 GHz WI-FI	Yes	Yes	Yes	
5	UMTS + 5 GHz WI-FI	Yes	Yes	Yes	
6	UMTS + 2.4 GHz Bluetooth	N/A	Yes	N/A	
7	LTE + 2.4 GHz WI-FI	Yes*	Yes*	Yes	*-Pre-installed VOIP applications are considered.
8	LTE + 5 GHz WI-FI	Yes*	Yes*	Yes	*-Pre-installed VOIP applications are considered.
9	LTE + 2.4 GHz Bluetooth	N/A	Yes*	N/A	*-Pre-installed VOIP applications are considered.
10	GPRS + 2.4 GHz WI-FI	N/A	N/A	Yes	
11	GPRS + 5 GHz WI-FI	N/A	N/A	Yes	

- 2.4 GHz WLAN, 2.4 GHz Bluetooth, and 5 GHz WLAN share the same antenna path and cannot transmit simultaneously
- (*) = for VOIP 3rd party applications possibly installed and used by end-user.
- GSM/GPRS, LTE and UMTS share the same antenna path and cannot transmit simultaneously.
- When the user utilizes multiple services in UMTS 3G mode it uses multi-Radio Access Bearer or multi-RAB. The power control is based on a physical control channel (Dedicated Physical Control Channel [DPCCH]) and power control will be adjusted to meet the needs of both services. Therefore, the UMTS+WLAN scenario also represents the UMTS Voice/DATA + WLAN Hotspot scenario.
- Per the manufacturer, WIFI Direct is not expected to be used in conjunction with a held-to-ear or body-worn accessory voice call. Therefore, no simultaneous transmission scenarios involving WIFI direct are specified above.
- When Hotspot is enabled, 5.2 GHz - 5.7 GHz bands are disabled. Therefore, only 2.4 GHz and 5.8 GHz WIFI Wireless Router SAR Data was required.
- This device supports 2x2 MIMO Tx for WLAN 802.11n/ac. Each WLAN antenna can transmit independently or together when operating with MIMO.

FCC ID: A3LSMG900S	PCTEST ENGINEERING LABORATORY, INC.	SAR EVALUATION REPORT		Reviewed by: Quality Manager
Document S/N: OY1402030286-R1.A3L	Test Dates: 02/03/14 – 02/10/14	DUT Type: Portable Handset		Page 6 of 64

1.6 SAR Test Exclusions Applied

(A) WIFI/BT

Per FCC KDB 447498 D01v05, the SAR exclusion threshold for distances <50mm is defined by the following equation:

$$\frac{\text{Max Power of Channel (mW)}}{\text{Test Separation Dist (mm)}} * \sqrt{\text{Frequency(GHz)}} \leq 3.0$$

Based on the maximum conducted power of Bluetooth (rounded to the nearest mW) and the antenna to user separation distance, Bluetooth SAR was not required; $[(11/10) * \sqrt{2.441}] = 1.7 < 3.0$. Per KDB Publication 447498 D01v05, the maximum power of the channel was rounded to the nearest mW before calculation.

This device supports 40 MHz Bandwidths for IEEE 802.11n for 5 GHz WIFI only

Since Wireless Router operations are not allowed by the chipset firmware using 5 GHz NII WIFI, only 2.4 GHz WIFI and 5 GHz DTS WIFI Hotspot SAR tests and combinations are considered for SAR with respect to Wireless Router configurations according to FCC KDB 941225 D06v01.

This device supports IEEE 802.11ac with the following features:

- a) Up to 80 MHz Bandwidth only
- b) No aggregate channel configurations
- c) 2 Tx antenna output
- d) 256 QAM is supported
- e) No new 5 GHz channels

(B) Licensed Transmitter(s)

GSM/GPRS DTM is not supported for US bands. Therefore, the GSM Voice modes in this report do not transmit simultaneously with GPRS Data.

This device is only capable of QPSK HSUPA in the uplink. Therefore, no additional SAR tests are required beyond that described for devices with HSUPA in KDB 941225 D01v02.



LTE SAR for the higher modulations and lower bandwidths were not tested since the maximum average output power of all required channels and configurations was not more than 0.5 dB higher than the highest bandwidth; and the reported LTE SAR for the highest bandwidth was less than 1.45 W/kg for all configurations according to FCC KDB 941225 D05v02.

1.7 Power Reduction for SAR

There is no power reduction used for any band/mode implemented in this device for SAR purposes.

1.8 Guidance Applied



- IEEE 1528-2003
- FCC KDB Publication 941225 D01-D02, D05-D06 (2G/3G/4G and Hotspot)
- FCC KDB Publication 248227 D01v01r02 (SAR Considerations for 802.11 Devices)
- FCC KDB Publication 447498 D01v05 (General SAR Guidance)
- FCC KDB Publication 865664 D01-D02 (SAR Measurements up to 6 GHz)
- April 2013 TCB Workshop Notes (IEEE 802.11ac)
- October 2013 TCB Workshop Notes (GPRS Testing Considerations)

FCC ID: A3LSMG900S	 PCTEST ENGINEERING LABORATORY, INC.	SAR EVALUATION REPORT		Reviewed by: Quality Manager
Document S/N: OY1402030286-R1.A3L	Test Dates: 02/03/14 – 02/10/14	DUT Type: Portable Handset		Page 7 of 64

1.9 Device Serial Numbers

Several samples with identical hardware were used to support SAR testing. The manufacturer has confirmed that the device(s) tested have the same physical, mechanical and thermal characteristics and are within operational tolerances expected for production units.

	Head Serial Number	Body-Worn Serial Number	Hotspot Serial Number
UMTS 850	F1188	F1188	F1188
GSM/GPRS 1900	F1187	F1188	F1188
UMTS 1900	F1187	F1188	F1188
LTE Band 5 (Cell)	F1187	F1187	F1187
LTE Band 17	F1187	F1187	F1187
2.4 GHz WLAN	F1185	419EF	419EF
5 GHz WLAN	F1186	F1186	F1186

FCC ID: A3LSMG900S	 PCTEST ENGINEERING LABORATORY, INC.	SAR EVALUATION REPORT		Reviewed by: Quality Manager
Document S/N: OY1402030286-R1.A3L	Test Dates: 02/03/14 – 02/10/14	DUT Type: Portable Handset		Page 8 of 64

2

LTE INFORMATION

LTE Information			
FCC ID	A3LSMG900S		
Form Factor	Portable Handset		
Frequency Range of each LTE transmission band	LTE Band 5 (Cell) (826.5 - 846.5 MHz)		
	LTE Band 17 (706.5 - 713.5 MHz)		
Channel Bandwidths	LTE Band 5 (Cell): 5 MHz, 10 MHz		
	LTE Band 17: 5 MHz, 10 MHz		
Channel Numbers and Frequencies (MHz)	Low	Mid	High
LTE Band 5 (Cell): 5 MHz	826.5 (20425)	836.5 (20525)	846.5 (20625)
LTE Band 5 (Cell): 10 MHz	829 (20450)	836.5 (20525)	844 (20600)
LTE Band 17: 5 MHz	706.5 (23755)	710 (23790)	713.5 (23825)
LTE Band 17: 10 MHz	709 (23780)	710 (23790)	711 (23800)
UE Category	3		
Modulations Supported in UL	QPSK, 16QAM		
LTE MPR Permanently implemented per 3GPP TS 36.101 section 6.2.3~6.2.5? (manufacturer attestation to be provided)	YES		
A-MPR (Additional MPR) disabled for SAR Testing?	YES		

FCC ID: A3LSMG900S	 PCTEST ENGINEERING LABORATORY, INC.	SAR EVALUATION REPORT		Reviewed by: Quality Manager
Document S/N: OY1402030286-R1.A3L	Test Dates: 02/03/14 – 02/10/14	DUT Type: Portable Handset	Page 9 of 64	

3 INTRODUCTION

The FCC and Industry Canada have adopted the guidelines for evaluating the environmental effects of radio frequency (RF) radiation in ET Docket 93-62 on Aug. 6, 1996 and Health Canada Safety Code 6 to protect the public and workers from the potential hazards of RF emissions due to FCC-regulated portable devices. [1]

The safety limits used for the environmental evaluation measurements are based on the criteria published by the American National Standards Institute (ANSI) for localized specific absorption rate (SAR) in IEEE/ANSI C95.1-1992 Standard for Safety Levels with Respect to Human Exposure to Radio Frequency Electromagnetic Fields, 3 kHz to 300 GHz [3] and Health Canada RF Exposure Guidelines Safety Code 6 [22]. The measurement procedure described in IEEE/ANSI C95.3-2002 Recommended Practice for the Measurement of Potentially Hazardous Electromagnetic Fields - RF and Microwave [4] is used for guidance in measuring the Specific Absorption Rate (SAR) due to the RF radiation exposure from the Equipment Under Test (EUT). These criteria for SAR evaluation are similar to those recommended by the International Committee for Non-Ionizing Radiation Protection (ICNIRP) in Biological Effects and Exposure Criteria for Radiofrequency Electromagnetic Fields,” Report No. Vol 74. SAR is a measure of the rate of energy absorption due to exposure to an RF transmitting source. SAR values have been related to threshold levels for potential biological hazards.

3.1 SAR Definition

Specific Absorption Rate is defined as the time derivative (rate) of the incremental energy (dU) absorbed by (dissipated in) an incremental mass (dm) contained in a volume element (dV) of a given density (ρ). It is also defined as the rate of RF energy absorption per unit mass at a point in an absorbing body (see Equation 3-1).

**Equation 3-1
SAR Mathematical Equation**

$$SAR = \frac{d}{dt} \left(\frac{dU}{dm} \right) = \frac{d}{dt} \left(\frac{dU}{\rho dv} \right)$$

SAR is expressed in units of Watts per Kilogram (W/kg).

$$SAR = \frac{\sigma \cdot E^2}{\rho}$$

where:

- σ = conductivity of the tissue-simulating material (S/m)
- ρ = mass density of the tissue-simulating material (kg/m³)
- E = Total RMS electric field strength (V/m)

NOTE: The primary factors that control rate of energy absorption were found to be the wavelength of the incident field in relation to the dimensions and geometry of the irradiated organism, the orientation of the organism in relation to the polarity of field vectors, the presence of reflecting surfaces, and whether conductive contact is made by the organism with a ground plane.[6]

FCC ID: A3LSMG900S		SAR EVALUATION REPORT		Reviewed by: Quality Manager
Document S/N: OY1402030286-R1.A3L	Test Dates: 02/03/14 – 02/10/14	DUT Type: Portable Handset	Page 10 of 64	

4 DOSIMETRIC ASSESSMENT

4.1 Measurement Procedure

The evaluation was performed using the following procedure compliant to FCC KDB Publication 865664 D01v01 and IEEE 1528-2013:

1. The SAR distribution at the exposed side of the head or body was measured at a distance no greater than 5.0 mm from the inner surface of the shell. The area covered the entire dimension of the device-head and body interface and the horizontal grid resolution was determined per FCC KDB Publication 865664 D01v01 (See Table 4-1) and IEEE 1528-2013.
2. The point SAR measurement was taken at the maximum SAR region determined from Step 1 to enable the monitoring of SAR fluctuations/drifts during the 1g/10g cube evaluation. SAR at this fixed point was measured and used as a reference value.
3. Based on the area scan data, the peak of the region with maximum SAR was determined by spline interpolation. Around this point, a volume was assessed according to the measurement resolution and volume size requirements of FCC KDB Publication 865664 D01v01 (See Table 4-1) and IEEE 1528-2013. On the basis of this data set, the spatial peak SAR value was evaluated with the following procedure (see references or the DASYS manual online for more details):
 - a. SAR values at the inner surface of the phantom are extrapolated from the measured values along the line away from the surface with spacing no greater than that in Table 4-1. The extrapolation was based on a least-squares algorithm. A polynomial of the fourth order was calculated through the points in the z-axis (normal to the phantom shell).
 - b. After the maximum interpolated values were calculated between the points in the cube, the SAR was averaged over the spatial volume (1g or 10g) using a 3D-Spline interpolation algorithm. The 3D-spline is composed of three one-dimensional splines with the “Not a knot” condition (in x, y, and z directions). The volume was then integrated with the trapezoidal algorithm. One thousand points (10 x 10 x 10) were obtained through interpolation, in order to calculate the averaged SAR.
 - c. All neighboring volumes were evaluated until no neighboring volume with a higher average value was found.
4. The SAR reference value, at the same location as step 2, was re-measured after the zoom scan was complete to calculate the SAR drift. If the drift deviated by more than 5%, the SAR test and drift measurements were repeated.

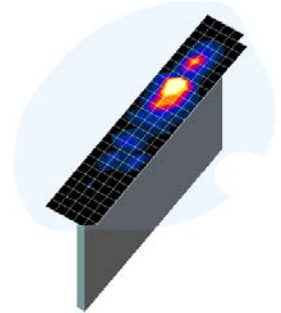



**Figure 4-1
Sample SAR Area
Scan**

**Table 4-1
Area and Zoom Scan Resolutions per FCC KDB Publication 865664 D01v01***

Frequency	Maximum Area Scan Resolution (mm) ($\Delta x_{area}, \Delta y_{area}$)	Maximum Zoom Scan Resolution (mm) ($\Delta x_{zoom}, \Delta y_{zoom}$)	Maximum Zoom Scan Spatial Resolution (mm)			Minimum Zoom Scan Volume (mm) (x,y,z)
			Uniform Grid $\Delta z_{zoom}(n)$	Graded Grid		
				$\Delta z_{zoom}(1)^*$	$\Delta z_{zoom}(n>1)^*$	
≤ 2 GHz	≤ 15	≤ 8	≤ 5	≤ 4	≤ 1.5* $\Delta z_{zoom}(n-1)$	≥ 30
2-3 GHz	≤ 12	≤ 5	≤ 5	≤ 4	≤ 1.5* $\Delta z_{zoom}(n-1)$	≥ 30
3-4 GHz	≤ 12	≤ 5	≤ 4	≤ 3	≤ 1.5* $\Delta z_{zoom}(n-1)$	≥ 28
4-5 GHz	≤ 10	≤ 4	≤ 3	≤ 2.5	≤ 1.5* $\Delta z_{zoom}(n-1)$	≥ 25
5-6 GHz	≤ 10	≤ 4	≤ 2	≤ 2	≤ 1.5* $\Delta z_{zoom}(n-1)$	≥ 22

*Also compliant to IEEE 1528-2013 Table 6

FCC ID: A3LSMG900S	 PCTEST ENGINEERING LABORATORY, INC.	SAR EVALUATION REPORT		Reviewed by: Quality Manager
Document S/N: OY1402030286-R1.A3L	Test Dates: 02/03/14 – 02/10/14	DUT Type: Portable Handset	Page 11 of 64	

5 DEFINITION OF REFERENCE POINTS

5.1 EAR REFERENCE POINT

Figure 5-2 shows the front, back and side views of the SAM Twin Phantom. The point “M” is the reference point for the center of the mouth, “LE” is the left ear reference point (ERP), and “RE” is the right ERP. The ERP is 15mm posterior to the entrance to the ear canal (EEC) along the B-M line (Back-Mouth), as shown in Figure 5-1. The plane passing through the two ear canals and M is defined as the Reference Plane. The line N-F (Neck-Front), also called the Reference Pivoting Line, is not perpendicular to the reference plane (see Figure 5-1). Line B-M is perpendicular to the N-F line. Both N-F and B-M lines are marked on the external phantom shell to facilitate handset positioning [5].

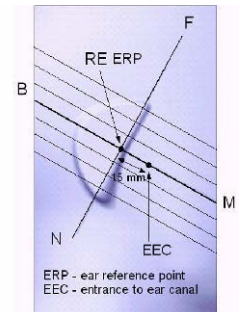

Figure 5-1
Close-Up Side view of ERP

5.2 HANDSET REFERENCE POINTS

Two imaginary lines on the handset were established: the vertical centerline and the horizontal line. The test device was placed in a normal operating position with the acoustic output located along the “vertical centerline” on the front of the device aligned to the “ear reference point” (See Figure 5-3). The acoustic output was then located at the same level as the center of the ear reference point. The test device was positioned so that the “vertical centerline” was bisecting the front surface of the handset at its top and bottom edges, positioning the “ear reference point” on the outer surface of the both the left and right head phantoms on the ear reference point.



Figure 5-2
Front, back and side view of SAM Twin Phantom

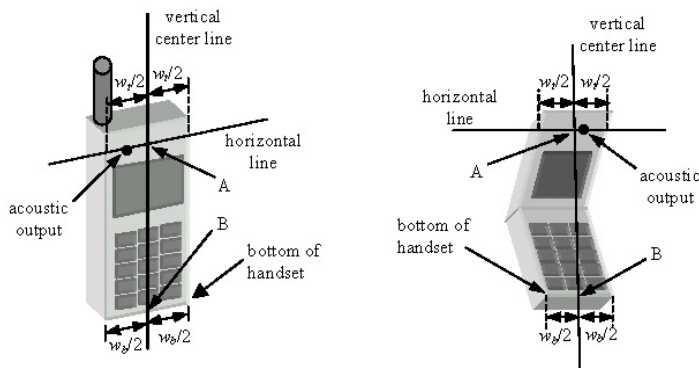



Figure 5-3
Handset Vertical Center & Horizontal Line Reference Points

FCC ID: A3LSMG900S	 PCTEST ENGINEERING LABORATORY, INC.	SAR EVALUATION REPORT		Reviewed by: Quality Manager
Document S/N: OY1402030286-R1.A3L	Test Dates: 02/03/14 – 02/10/14	DUT Type: Portable Handset		Page 12 of 64

6 TEST CONFIGURATION POSITIONS FOR HANDSETS

6.1 Device Holder

The device holder is made out of low-loss POM material having the following dielectric parameters: relative permittivity $\epsilon = 3$ and loss tangent $\delta = 0.02$.

6.2 Positioning for Cheek

1. The test device was positioned with the device close to the surface of the phantom such that point A is on the (virtual) extension of the line passing through points RE and LE on the phantom (see Figure 6-1), such that the plane defined by the vertical center line and the horizontal line of the phone is approximately parallel to the sagittal plane of the phantom.

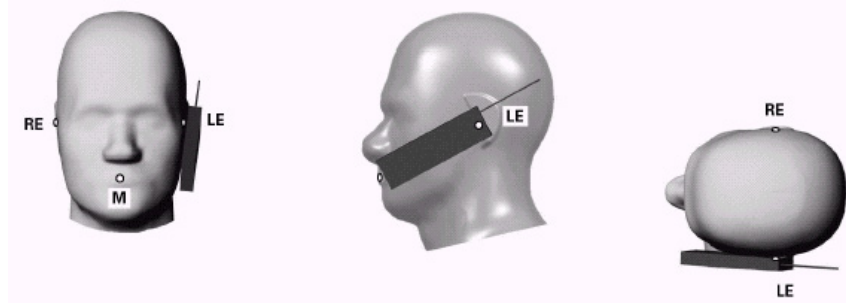



Figure 6-1 Front, Side and Top View of Cheek Position

2. The handset was translated towards the phantom along the line passing through RE & LE until the handset touches the pinna.
3. While maintaining the handset in this plane, the handset was rotated around the LE-RE line until the vertical centerline was in the reference plane.
4. The phone was then rotated around the vertical centerline until the phone (horizontal line) was symmetrical with respect to the line NF.
5. While maintaining the vertical centerline in the reference plane, keeping point A on the line passing through RE and LE, and maintaining the device contact with the ear, the device was rotated about the NF line until any point on the handset made contact with a phantom point below the ear (cheek) (See Figure 6-2).

6.3 Positioning for Ear / 15° Tilt

With the test device aligned in the “Cheek Position”:

1. While maintaining the orientation of the phone, the phone was retracted parallel to the reference plane far enough to enable a rotation of the phone by 15 degrees.
2. The phone was then rotated around the horizontal line by 15 degrees.
3. While maintaining the orientation of the phone, the phone was moved parallel to the reference plane until any part of the handset touched the head. (In this position, point A was located on the line RE-LE). The tilted position is obtained when the contact is on the pinna. If the contact was at any location other than the pinna, the angle of the phone would then be reduced. In this situation, the tilted position was obtained when any part of the phone was in contact of the ear as well as a second part of the phone was in contact with the head (see Figure 6-2).

FCC ID: A3LSMG900S	 PCTEST ENGINEERING LABORATORY, INC.	SAR EVALUATION REPORT		Reviewed by: Quality Manager
Document S/N: OY1402030286-R1.A3L	Test Dates: 02/03/14 – 02/10/14	DUT Type: Portable Handset		Page 13 of 64

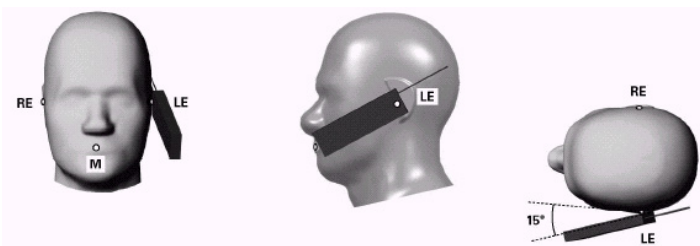

Figure 6-2 Front, Side and Top View of Ear/15° Tilt Position

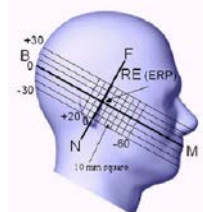

Figure 6-3 Side view w/ relevant markings

6.4 SAR Evaluations near the Mouth/Jaw Regions of the SAM Phantom

Antennas located near the bottom of a phone may require SAR measurements around the mouth and jaw regions of the SAM head phantom. This typically applies to clam-shell style phones that are generally longer in the unfolded normal use positions or to certain older style long rectangular phones. Per IEEE 1528-2013, a rotated SAM phantom is necessary to allow probe access to such regions. Both SAM heads of the TwinSAM-Chin20 are rotated 20 degrees around the NF line. Each head can be removed from the table for emptying and cleaning.

Under these circumstances, the following procedures apply, adopted from the FCC guidance on SAR handsets document FCC KDB Publication 648474 D04_v01. The SAR required in these regions of SAM should be measured using a flat phantom. The phone should be positioned with a separation distance of 4 mm between the ear reference point (ERP) and the outer surface of the flat phantom shell. While maintaining this distance at the ERP location, the low (bottom) edge of the phone should be lowered from the phantom to establish the same separation distance between the peak SAR location identified by the truncated partial SAR distribution measured with the SAM phantom. The distance from the peak SAR location to the phone is determined by the straight line passing perpendicularly through the phantom surface. When it is not feasible to maintain 4 mm separation at the ERP while also establishing the required separation at the peak SAR location, the top edge of the phone will be allowed to touch the phantom with a separation < 4 mm at the ERP. The phone should not be tilted to the left or right while placed in this inclined position to the flat phantom.

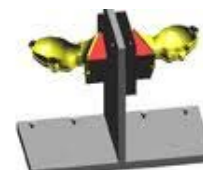



Figure 6-4 Twin SAM Chin20

FCC ID: A3LSMG900S	 PCTEST ENGINEERING LABORATORY, INC.	SAR EVALUATION REPORT		Reviewed by: Quality Manager
Document S/N: OY1402030286-R1.A3L	Test Dates: 02/03/14 – 02/10/14	DUT Type: Portable Handset		Page 14 of 64

6.5 Body-Worn Accessory Configurations

Body-worn operating configurations are tested with the belt-clips and holsters attached to the device and positioned against a flat phantom in a normal use configuration (see Figure 6-5). Per FCC KDB Publication 648474 D04v01, Body-worn accessory exposure is typically related to voice mode operations when handsets are carried in body-worn accessories. The body-worn accessory procedures in FCC KDB Publication 447498 D01v05 should be used to test for body-worn accessory SAR compliance, without a headset connected to it. This enables the test results for such configuration to be compatible with that required for hotspot mode when the body-worn accessory test separation distance is greater than or equal to that required for hotspot mode, when applicable. When the reported SAR for a body-worn accessory, measured without a headset connected to the handset, is $> 1.2 \text{ W/kg}$, the highest reported SAR configuration for that wireless mode and frequency band should be repeated for that body-worn accessory with a headset attached to the handset.

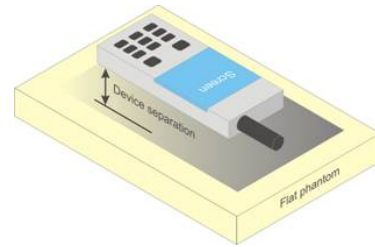

Figure 6-5
Sample Body-Worn Diagram

Accessories for Body-worn operation configurations are divided into two categories: those that do not contain metallic components and those that do contain metallic components. When multiple accessories that do not contain metallic components are supplied with the device, the device is tested with only the accessory that dictates the closest spacing to the body. Then multiple accessories that contain metallic components are tested with the device with each accessory. If multiple accessories share an identical metallic component (i.e. the same metallic belt-clip used with different holsters with no other metallic components) only the accessory that dictates the closest spacing to the body is tested.

Body-worn accessories may not always be supplied or available as options for some devices intended to be authorized for body-worn use. In this case, a test configuration with a separation distance between the back of the device and the flat phantom is used. Test position spacing was documented. Transmitters that are designed to operate in front of a person's face, as in push-to-talk configurations, are tested for SAR compliance with the front of the device positioned to face the flat phantom in head fluid. For devices that are carried next to the body such as a shoulder, waist or chest-worn transmitters, SAR compliance is tested with the accessories, including headsets and microphones, attached to the device and positioned against a flat phantom in a normal use configuration.

6.6 Extremity Exposure Configurations

Devices that are designed or intended for use on extremities or mainly operated in extremity only exposure conditions; i.e., hands, wrists, feet and ankles, may require extremity SAR evaluation. When the device also operates in close proximity to the user's body, SAR compliance for the body is also required. The 1-g body and 10-g extremity SAR Exclusion Thresholds found in KDB Publication 44798 D01v05 should be applied to determine SAR test requirements.



Per KDB Publication 44798 D01v05, Cell phones (handsets) are not normally designed to be used on extremities or operated in extremity only exposure conditions. The maximum output power levels of handsets generally do not require extremity SAR testing to show compliance. Therefore, extremity SAR was not evaluated for this device.

FCC ID: A3LSMG900S		SAR EVALUATION REPORT		Reviewed by: Quality Manager
Document S/N: OY1402030286-R1.A3L	Test Dates: 02/03/14 – 02/10/14	DUT Type: Portable Handset	Page 15 of 64	

6.7 Wireless Router Configurations

Some battery-operated handsets have the capability to transmit and receive user data through simultaneous transmission of WIFI simultaneously with a separate licensed transmitter. The FCC has provided guidance in FCC KDB Publication 941225 D06 v01 where SAR test considerations for handsets ($L \times W \geq 9 \text{ cm} \times 5 \text{ cm}$) are based on a composite test separation distance of 10 mm from the front, back and edges of the device containing transmitting antennas within 2.5 cm of their edges, determined from general mixed use conditions for this type of devices. Since the hotspot SAR results may overlap with the body-worn accessory SAR requirements, the more conservative configurations can be considered, thus excluding some body-worn accessory SAR tests.

When the user enables the personal wireless router functions for the handset, actual operations include simultaneous transmission of both the WIFI transmitter and another licensed transmitter. Both transmitters often do not transmit at the same transmitting frequency and thus cannot be evaluated for SAR under actual use conditions due to the limitations of the SAR assessment probes. Therefore, SAR must be evaluated for each frequency transmission and mode separately and spatially summed with the WIFI transmitter according to FCC KDB Publication 447498 D01v05 publication procedures. The "Portable Hotspot" feature on the handset was NOT activated during SAR assessments, to ensure the SAR measurements were evaluated for a single transmission frequency RF signal at a time.

FCC ID: A3LSMG900S	 SAR EVALUATION REPORT 		Reviewed by: Quality Manager
Document S/N: 0Y1402030286-R1.A3L	Test Dates: 02/03/14 – 02/10/14	DUT Type: Portable Handset	Page 16 of 64

7 RF EXPOSURE LIMITS

7.1 Uncontrolled Environment

UNCONTROLLED ENVIRONMENTS are defined as locations where there is the exposure of individuals who have no knowledge or control of their exposure. The general population/uncontrolled exposure limits are applicable to situations in which the general public may be exposed or in which persons who are exposed as a consequence of their employment may not be made fully aware of the potential for exposure or cannot exercise control over their exposure. Members of the general public would come under this category when exposure is not employment-related; for example, in the case of a wireless transmitter that exposes persons in its vicinity.

7.2 Controlled Environment

CONTROLLED ENVIRONMENTS are defined as locations where there is exposure that may be incurred by persons who are aware of the potential for exposure, (i.e. as a result of employment or occupation). In general, occupational/controlled exposure limits are applicable to situations in which persons are exposed as a consequence of their employment, who have been made fully aware of the potential for exposure and can exercise control over their exposure. This exposure category is also applicable when the exposure is of a transient nature due to incidental passage through a location where the exposure levels may be higher than the general population/uncontrolled limits, but the exposed person is fully aware of the potential for exposure and can exercise control over his or her exposure by leaving the area or by some other appropriate means.

**Table 7-1
SAR Human Exposure Specified in ANSI/IEEE C95.1-1992 and Health Canada Safety Code 6**

HUMAN EXPOSURE LIMITS		
	UNCONTROLLED ENVIRONMENT <i>General Population</i> (W/kg) or (mW/g)	CONTROLLED ENVIRONMENT <i>Occupational</i> (W/kg) or (mW/g)
Peak Spatial Average SAR Head	1.6	8.0
Whole Body SAR	0.08	0.4
Peak Spatial Average SAR Hands, Feet, Ankle, Wrists, etc.	4.0	20

1. The Spatial Peak value of the SAR averaged over any 1 gram of tissue (defined as a tissue volume in the shape of a cube) and over the appropriate averaging time.
2. The Spatial Average value of the SAR averaged over the whole body.
3. The Spatial Peak value of the SAR averaged over any 10 grams of tissue (defined as a tissue volume in the shape of a cube) and over the appropriate averaging time.

FCC ID: A3LSMG900S	 PCTEST ENGINEERING LABORATORY, INC.	SAR EVALUATION REPORT		Reviewed by: Quality Manager
Document S/N: OY1402030286-R1.A3L	Test Dates: 02/03/14 – 02/10/14	DUT Type: Portable Handset		Page 17 of 64

8 FCC MEASUREMENT PROCEDURES

Power measurements were performed using a base station simulator under digital average power.

8.1 Measured and Reported SAR

Per FCC KDB Publication 447498 D01v05, When SAR is not measured at the maximum power level allowed for production units, the results must be scaled to the maximum tune-up tolerance limit according to the power applied to the individual channels tested to determine compliance. For simultaneous transmission, the measured aggregate SAR must be scaled according to the sum of the differences between the maximum tune-up tolerance and actual power used to test each transmitter. When SAR is measured at or scaled to the maximum tune-up tolerance limit, the results are referred to as *reported* SAR. The highest *reported* SAR results are identified on the grant of equipment authorization according to procedures in KDB 690783 D01v01r02.

8.2 Procedures Used to Establish RF Signal for SAR

The following procedures are according to FCC KDB Publication 941225 D01 "SAR Measurement Procedures for 3G Devices" v02, October 2007.

The device was placed into a simulated call using a base station simulator in a RF shielded chamber. Establishing connections in this manner ensure a consistent means for testing SAR and are recommended for evaluating SAR [4]. Devices under test were evaluated prior to testing, with a fully charged battery and were configured to operate at maximum output power. In order to verify that the device was tested throughout the SAR test at maximum output power, the SAR measurement system measures a "point SAR" at an arbitrary reference point at the start and end of the 1 gram SAR evaluation, to assess for any power drifts during the evaluation. If the power drift deviated by more than 5%, the SAR test and drift measurements were repeated.

8.3 SAR Measurement Conditions for UMTS

8.3.1 Output Power Verification

Maximum output power is measured on the High, Middle and Low channels for each applicable transmission band according to the general descriptions in section 5.2 of 3GPP TS 34.121, using the appropriate RMC or AMR with TPC (transmit power control) set to all "1s".

Maximum output power is verified on the High, Middle and Low channels according to the general descriptions in section 5.2 of 3GPP TS 34.121 (release 5), using the appropriate RMC with TPC (transmit power control) set to all "1s" or applying the required inner loop power control procedures to maintain maximum output power while HSUPA is active. Results for all applicable physical channel configurations (DPCCH, DPDCHn and spreading codes, HS-DPCCH etc) are tabulated in this test report. All configurations that are not supported by the DUT or cannot be measured due to technical or equipment limitations are identified.

8.3.2 Head SAR Measurements for Handsets

SAR for head exposure configurations is measured using the 12.2 kbps RMC with TPC bits configured to all "1s". SAR in AMR configurations is not required when the maximum average output of each RF channel for 12.2 kbps AMR is less than 0.25 dB higher than that measured in 12.2 kbps RMC. Otherwise, SAR is measured on the maximum output channel in 12.2 AMR with a

FCC ID: A3LSMG900S	 PCTEST ENGINEERING LABORATORY, INC.	SAR EVALUATION REPORT		Reviewed by: Quality Manager
Document S/N: OY1402030286-R1.A3L	Test Dates: 02/03/14 – 02/10/14	DUT Type: Portable Handset		Page 18 of 64

3.4 kbps SRB (signaling radio bearer) using the exposure configuration that resulted in the highest SAR for that RF channel in the 12.2 kbps RMC mode.

8.3.3 Body SAR Measurements

SAR for body exposure configurations is measured using the 12.2 kbps RMC with the TPC bits all “1s”.

8.3.4 SAR Measurements for Handsets with Rel 5 HSDPA

Body SAR for HSDPA is not required for handsets with HSDPA capabilities when the maximum average output power of each RF channel with HSDPA active is less than 0.25 dB higher than that measured without HSDPA using 12.2 kbps RMC and the maximum SAR for 12.2 kbps RMC is $\leq 75\%$ of the SAR limit. Otherwise, SAR is measured for HSDPA, using an FRC with H-Set 1 in Sub-test 1 and a 12.2 kbps RMC configured in Test Loop Mode 1, using the highest body SAR configuration measured in 12.2 kbps RMC without HSDPA, on the maximum output channel with the body exposure configuration that resulted in the highest SAR in 12.2 kbps RMC mode for that RF channel.

The H-set used in FRC for HSDPA should be configured according to the UE category of a test device. The number of HS-DSCH/HSPDSCHs, HARQ processes, minimum inter-TTI interval, transport block sizes and RV coding sequence are defined by the applicable H-set. To maintain a consistent test configuration and stable transmission conditions, QPSK is used in the FRC for SAR testing. HS-DPCCH should be configured with a CQI feedback cycle of 2 ms to maintain a constant rate of active CQI slots. DPCCH and DPDCH gain factors of $\beta_c=9$ and $\beta_d=15$, and power offset parameters of $\Delta_{ACK} = \Delta_{NACK} = 5$ and $\Delta_{CQI}=2$ is used. The CQI value is determined by the UE category, transport block size, number of HS-PDSCHs and modulation used in the FRC.

Sub-Test	β_c	β_d	β_d (SF)	β_c/β_d	β_{HS} (Note 1, Note 2)	CM (dB) (Note 3)	MPR (dB) (Note 3)
1	2/15	15/15	64	2/15	4/15	0.0	0.0
2	12/15 (Note 4)	15/15 (Note 4)	64	12/15 (Note 4)	24/15	1.0	0.0
3	15/15	8/15	64	15/8	30/15	1.5	0.5
4	15/15	4/15	64	15/4	30/15	1.5	0.5

Note 1: $\Delta_{ACK}, \Delta_{NACK}$ and $\Delta_{CQI} = 8 \Leftrightarrow A_{HS} = \beta_{HS}/\beta_c = 30/15 \Leftrightarrow \beta_{HS} = 30/15 * \beta_c$.
 Note 2: For the HS-DPCCH power mask requirement test in clause 5.2C, 5.7A, and the Error Vector Magnitude (EVM) with HS-DPCCH test in clause 5.13.1A, and HSDPA EVM with phase discontinuity in clause 5.13.1AA, Δ_{ACK} and $\Delta_{NACK} = 8$ ($A_{HS} = 30/15$) with $\beta_{HS} = 30/15 * \beta_c$, and $\Delta_{CQI} = 7$ ($A_{HS} = 24/15$) with $\beta_{HS} = 24/15 * \beta_c$.
 Note 3: CM = 1 for $\beta_c/\beta_d = 12/15$, $\beta_{HS}/\beta_c = 24/15$. For all other combinations of DPDCH, DPCCH and HS-DPCCH the MPR is based on the relative CM difference. This is applicable for only UEs that support HSDPA in release 6 and later releases.

Figure 8-1
Table C.10.1.4 of TS 234.121-1

8.3.5 SAR Measurements for Handsets with Rel 6 HSUPA

Body SAR for HSUPA is not required when the maximum average output of each RF channel with HSUPA/HSDPA active is less than 0.25 dB higher than as measured without HSUPA/HSDPA using 12.2 kbps RMC and maximum SAR for 12.2 kbps RMC is $\leq 75\%$ of the SAR limit. Otherwise SAR is measured on the maximum output channel for the body exposure configuration produced highest SAR in 12.2 kbps RMC for that RF channel, using the additional procedures under “Release 6 HSPA data devices”

FCC ID: A3LSMG900S	 PCTEST ENGINEERING LABORATORY, INC.	SAR EVALUATION REPORT		Reviewed by: Quality Manager
Document S/N: OY1402030286-R1.A3L	Test Dates: 02/03/14 – 02/10/14	DUT Type: Portable Handset		Page 19 of 64

Head SAR for VOIP operations under HSPA is not required when maximum average output of each RF channel with HSPA is less than 0.25 dB higher than as measured using 12.2 kbps RMC. Otherwise SAR is measured using same HSPA configuration as used for body SAR.

Sub-test	β_c	β_a	β_a (SF)	β_c/β_a	$\beta_{1st}^{(1)}$	β_{ec}	β_{ed}	β_{ed} (SF)	β_{ed} (codes)	CM ⁽²⁾ (dB)	MPR (dB)	AG ⁽⁴⁾ Index	E-TFCI
1	11/15 ⁽³⁾	15/15 ⁽³⁾	64	11/15 ⁽³⁾	22/15	209/225	1039/225	4	1	1.0	0.0	20	75
2	6/15	15/15	64	6/15	12/15	12/15	94/75	4	1	3.0	2.0	12	67
3	15/15	9/15	64	15/9	30/15	30/15	$\beta_{ec}: 47/15$ $\beta_{ed}: 47/15$	4	2	2.0	1.0	15	92
4	2/15	15/15	64	2/15	4/15	2/15	56/75	4	1	3.0	2.0	17	71
5	15/15 ⁽⁴⁾	15/15 ⁽⁴⁾	64	15/15 ⁽⁴⁾	30/15	24/15	134/15	4	1	1.0	0.0	21	81

Note 1: Δ_{ACK} , Δ_{NACK} and $\Delta_{CQI} = 8 \Leftrightarrow A_{1st} = \beta_{1st}/\beta_c = 30/15 \Leftrightarrow \beta_{1st} = 30/15 * \beta_c$.

Note 2: CM = 1 for $\beta_c/\beta_a = 12/15$, $\beta_{1st}/\beta_c = 24/15$. For all other combinations of DPDCH, DPCCH, HS-DPCCH, E-DPDCH and E-DPCCH the MPR is based on the relative CM difference.

Note 3: For subtest 1 the β_c/β_a ratio of 11/15 for the TFC during the measurement period (TF1, TF0) is achieved by setting the signaled gain factors for the reference TFC (TF1, TF1) to $\beta_c = 10/15$ and $\beta_a = 15/15$.

Note 4: For subtest 5 the β_c/β_a ratio of 15/15 for the TFC during the measurement period (TF1, TF0) is achieved by setting the signaled gain factors for the reference TFC (TF1, TF1) to $\beta_c = 14/15$ and $\beta_a = 15/15$.

Note 5: Testing UE using E-DPDCH Physical Layer category 1 Sub-test 3 is not required according to TS 25.306 Table 5.1g.

Note 6: β_{ed} can not be set directly; it is set by Absolute Grant Value.

8.4 SAR Measurement Conditions for LTE

LTE modes were tested according to FCC KDB 941225 D05v02 publication. Please see notes after the tabulated SAR data for required test configurations. Establishing connections with base station simulators ensure a consistent means for testing SAR and are recommended for evaluating SAR [4]. The R&S CMW500 was used for LTE output power measurements and SAR testing. Closed loop power control was used so the UE transmits with maximum output power during SAR testing. SAR tests were performed with the same number of RB and RB offsets transmitting on all TTI frames (maximum TTI).

8.4.1 Spectrum Plots for RB Configurations

A properly configured base station simulator was used for SAR tests and power measurements. Therefore, spectrum plots for RB configurations were not required to be included in this report.

8.4.2 MPR

MPR is permanently implemented for this device by the manufacturer. The specific manufacturer target MPR is indicated alongside the SAR results. MPR is enabled for this device, according to 3GPP TS36.101 Section 6.2.3 – 6.2.5 under Table 6.2.3-1.

8.4.3 A-MPR

A-MPR (Additional MPR) has been disabled for all SAR tests by setting NS=01 on the base station simulator.

8.4.4 Required RB Size and RB Offsets for SAR Testing

According to FCC KDB 941225 D05v02r01:

- a. Per Section 5.2.1, SAR is required for QPSK 1 RB Allocation for the largest bandwidth
 - i. The required channel and offset combination with the highest maximum output power is required for SAR.
 - ii. When the reported SAR is ≤ 0.8 W/kg, testing of the remaining RB offset configurations and required test channels is not required. Otherwise, SAR is required for the remaining required test channels using the RB offset configuration with highest output power for that channel.

FCC ID: A3LSMG900S	 PCTEST ENGINEERING LABORATORY, INC.	SAR EVALUATION REPORT		Reviewed by: Quality Manager
Document S/N: OY1402030286-R1.A3L	Test Dates: 02/03/14 – 02/10/14	DUT Type: Portable Handset		Page 20 of 64

- iii. When the reported SAR for a required test channel is > 1.45 W/kg, SAR is required for all RB offset configurations for that channel.
- b. Per Section 5.2.2, SAR is required for 50% RB allocation using the largest bandwidth following the same procedures outlined in Section 5.2.1.
- c. Per Section 5.2.3, QPSK SAR is not required for the 100% allocation when the highest maximum output power for the 100% allocation is less than the highest maximum output power of the 1 RB and 50% RB allocations and the reported SAR for the 1 RB and 50% RB allocations is < 0.8 W/kg.
- d. Per Section 5.2.4 and 5.3, SAR tests for higher order modulations and lower bandwidths configurations are not required when the conducted power of the required test configurations determined by Sections 5.2.1 through 5.2.3 is less than or equal to ½ dB higher than the equivalent configuration using QPSK modulation and when the QPSK SAR for those configurations is <1.45 W/kg.

8.5 SAR Testing with 802.11 Transmitters

Normal network operating configurations are not suitable for measuring the SAR of 802.11 a/b/g/n /ac transmitters. Unpredictable fluctuations in network traffic and antenna diversity conditions can introduce undesirable variations in SAR results. The SAR for these devices should be measured using chipset based test mode software to ensure the results are consistent and reliable. See KDB Publication 248227 D01v01r02 for more details.

8.5.1 General Device Setup

Chipset based test mode software is hardware dependent and generally varies among manufacturers. The device operating parameters established in test mode for SAR measurements must be identical to those programmed in production units, including output power levels, amplifier gain settings and other RF performance tuning parameters. The test frequencies should correspond to actual channel frequencies defined for domestic use. SAR for devices with switched diversity should be measured with only one antenna transmitting at a time during each SAR measurement, according to a fixed modulation and data rate. The same data pattern should be used for all measurements.

8.5.2 Frequency Channel Configurations [24]



For 2.4 GHz, the highest average RF output power channel between the low, mid and high channel at the lowest data rate was selected for SAR evaluation in 802.11b mode. 802.11g/n modes and higher data rates for 802.11b were additionally evaluated for SAR if the output power of the respective mode was 0.25 dB or higher than the powers of the SAR configurations tested in the 802.11b mode.

For 5 GHz, the highest average RF output power channel across the default test channels at the lowest data rate was selected for SAR evaluation in 802.11a. When the adjacent channels are higher in power than the default channels, these "required channels" were considered instead of the default channels for SAR testing. 802.11n modes and higher data rates for 802.11a/n were evaluated only if the respective mode was higher than 0.25 dB or more than the 802.11a mode. 802.11ac SAR was evaluated for highest 802.11a configuration in each 5 GHz band and each exposure condition. 802.11ac modes were additionally evaluated for SAR if the output power for the respective mode was more than 0.25 dB higher than powers of 802.11a modes.

If the maximum extrapolated peak SAR of the zoom scan for the highest output channel was less than 1.6 W/kg and if the 1g averaged SAR was less than 0.8 W/kg, SAR testing was not required for the other test channels in the band.

8.5.3 MIMO SAR Considerations

Per KDB 248227, SAR for MIMO was measured with both transmitting simultaneously and was evaluated independently of SISO operation. For 2.4 GHz MIMO, 802.11n was evaluated. For 5 GHz MIMO, 20 MHz BW 802.11n was evaluated. Additional evaluations for 40 MHz bandwidth 802.11n and 802.11ac were not required since the maximum allowed output power was not higher than 802.11n 20 MHz Bandwidth.

FCC ID: A3LSMG900S	 PCTEST ENGINEERING LABORATORY, INC.	SAR EVALUATION REPORT		Reviewed by: Quality Manager
Document S/N: OY1402030286-R1.A3L	Test Dates: 02/03/14 – 02/10/14	DUT Type: Portable Handset	Page 21 of 64	

9 RF CONDUCTED POWERS

9.1 GSM Conducted Powers

		Maximum Burst-Averaged Output Power				
		Voice	GPRS Data (GMSK)			
Band	Channel	GSM [dBm] CS (1 Slot)	GPRS [dBm] 1 Tx Slot	GPRS [dBm] 2 Tx Slot	GPRS [dBm] 3 Tx Slot	GPRS [dBm] 4 Tx Slot
GSM 1900	512	31.16	31.19	29.79	28.69	27.00
	661	31.29	31.42	29.89	28.71	26.99
	810	31.09	31.13	29.79	28.80	26.97
		Calculated Maximum Frame-Averaged Output Power				
		Voice	GPRS Data (GMSK)			
Band	Channel	GSM [dBm] CS (1 Slot)	GPRS [dBm] 1 Tx Slot	GPRS [dBm] 2 Tx Slot	GPRS [dBm] 3 Tx Slot	GPRS [dBm] 4 Tx Slot
GSM 1900	512	22.13	22.16	23.77	24.43	23.99
	661	22.26	22.39	23.87	24.45	23.98
	810	22.06	22.10	23.77	24.54	23.96
GSM 1900	Frame Avg.Targets:	21.97	21.97	23.48	24.24	23.49

Notes:

- Both burst-averaged and calculated frame-averaged powers are included. Frame-averaged power was calculated from the measured burst-averaged power by converting the slot powers into linear units and calculating the energy over 8 timeslots.
- Justification for reduced test configurations per KDB Publication 941225 D03v01 and October 2013 TCB Workshop Notes: The source-based frame-averaged output power was evaluated for all GPRS slot configurations. The configuration with the highest target frame averaged output power was evaluated for body SAR. When the maximum frame-averaged powers are equivalent across two or more slots (within 0.25 dB), the configuration with the most number of time slots was tested.
- GPRS (GMSK) output powers were measured with coding scheme setting of 1 (CS1) on the base station simulator. CS1 was configured to measure GPRS output power measurements and SAR to ensure GMSK modulation in the signal. Our Investigation has shown that CS1 - CS4 settings do not have any impact on the output levels or modulation in the GPRS modes.

GSM Class: B
GPRS Multislot class: 12 (Max 4 Tx uplink slots)
EDGE Multislot class: N/A
DTM Multislot Class: N/A



Figure 9-1
Power Measurement Setup

FCC ID: A3LSMG900S	 PCTEST ENGINEERING LABORATORY, INC.	SAR EVALUATION REPORT		Reviewed by: Quality Manager
Document S/N: OY1402030286-R1.A3L	Test Dates: 02/03/14 – 02/10/14	DUT Type: Portable Handset	Page 22 of 64	

9.2 UMTS Conducted Powers

3GPP Release Version	Mode	3GPP 34.121 Subtest	Cellular Band [dBm]			PCS Band [dBm]			3GPP MPR [dB]
			4132	4183	4233	9262	9400	9538	
99	WCDMA	12.2 kbps RMC	23.18	23.17	23.36	23.37	23.29	23.00	-
99		12.2 kbps AMR	23.12	23.14	23.31	23.10	23.20	22.97	-
6	HSDPA	Subtest 1	22.10	21.89	22.06	22.05	21.97	21.87	0
6		Subtest 2	22.00	21.68	22.03	21.79	22.13	22.06	0
6		Subtest 3	21.46	21.24	21.64	21.67	21.55	21.16	0.5
6		Subtest 4	21.26	21.39	21.48	21.79	21.54	21.10	0.5
6	HSUPA	Subtest 1	21.64	21.18	21.75	21.25	21.00	21.50	0
6		Subtest 2	20.01	19.61	20.25	20.11	20.22	20.61	2
6		Subtest 3	20.42	20.60	20.74	20.47	20.27	20.53	1
6		Subtest 4	20.89	20.63	20.74	20.71	20.89	21.38	2
6		Subtest 5	21.48	21.31	21.59	21.47	21.06	21.45	0

Notes:

1. UMTS SAR was tested under RMC 12.2 kbps with HSPA Inactive per KDB Publication 941225 D01v02. HSPA SAR was not required since the average output power of the HSPA subtests was not more than 0.25 dB higher than the RMC level and SAR was less than 1.2 W/kg.
2. This device does not support DC-HSDPA.
3. It is expected by the manufacturer that MPR for some HSUPA subtests may be up to 2 dB more than specified by 3GPP, but also as low as 0 dB according to the chipset implementation in this model.



Figure 9-2
Power Measurement Setup

9.3 LTE Conducted Powers

9.3.1 LTE Band 5 (Cell)

Table 9-1
LTE Band 5 (Cell) Conducted Powers - 10 MHz Bandwidth

	Frequency [MHz]	Channel	Bandwidth [MHz]	Modulation	RB Size	RB Offset	Conducted Power [dBm]	Target MPR [dB]	MPR Allowed per 3GPP [dB]
Mid	836.5	20525	10	QPSK	1	0	24.21	0	0
	836.5	20525	10	QPSK	1	25	24.34	0	0
	836.5	20525	10	QPSK	1	49	24.32	0	0
	836.5	20525	10	QPSK	25	0	23.05	1	0-1
	836.5	20525	10	QPSK	25	12	23.00	1	0-1
	836.5	20525	10	QPSK	25	25	23.09	1	0-1
	836.5	20525	10	QPSK	50	0	23.03	1	0-1
	836.5	20525	10	16QAM	1	0	23.43	1	0-1
	836.5	20525	10	16QAM	1	25	23.27	1	0-1
	836.5	20525	10	16QAM	1	49	23.28	1	0-1
	836.5	20525	10	16QAM	25	0	22.12	2	0-2
	836.5	20525	10	16QAM	25	12	22.14	2	0-2
	836.5	20525	10	16QAM	25	25	22.23	2	0-2
	836.5	20525	10	16QAM	50	0	22.07	2	0-2

Note: LTE Band 5 (Cell) at 10 MHz bandwidth does not support three non-overlapping channels. Per KDB Publication 941225 D05v02, when a device supports overlapping channel assignment in a channel bandwidth configuration, the middle channel of the group of overlapping channels should be selected for testing.

FCC ID: A3LSMG900S	PCTEST ENGINEERING LABORATORY, INC.	SAR EVALUATION REPORT		Reviewed by: Quality Manager
Document S/N: OY1402030286-R1.A3L	Test Dates: 02/03/14 – 02/10/14	DUT Type: Portable Handset		Page 23 of 64

**Table 9-2
LTE Band 5 (Cell) Conducted Powers - 5 MHz Bandwidth**

	Frequency [MHz]	Channel	Bandwidth [MHz]	Modulation	RB Size	RB Offset	Conducted Power [dBm]	Target MPR [dB]	MPR Allowed per 3GPP [dB]
Low	826.5	20425	5	QPSK	1	0	24.26	0	0
	826.5	20425	5	QPSK	1	12	24.25	0	0
	826.5	20425	5	QPSK	1	24	24.38	0	0
	826.5	20425	5	QPSK	12	0	22.98	1	0-1
	826.5	20425	5	QPSK	12	6	23.00	1	0-1
	826.5	20425	5	QPSK	12	13	23.03	1	0-1
	826.5	20425	5	QPSK	25	0	22.97	1	0-1
	826.5	20425	5	16-QAM	1	0	23.38	1	0-1
	826.5	20425	5	16-QAM	1	12	23.50	1	0-1
	826.5	20425	5	16-QAM	1	24	23.42	1	0-1
	826.5	20425	5	16-QAM	12	0	22.02	2	0-2
	826.5	20425	5	16-QAM	12	6	21.96	2	0-2
	826.5	20425	5	16-QAM	12	13	22.11	2	0-2
826.5	20425	5	16-QAM	25	0	22.14	2	0-2	
Mid	836.5	20525	5	QPSK	1	0	24.28	0	0
	836.5	20525	5	QPSK	1	12	24.37	0	0
	836.5	20525	5	QPSK	1	24	24.35	0	0
	836.5	20525	5	QPSK	12	0	23.02	1	0-1
	836.5	20525	5	QPSK	12	6	23.07	1	0-1
	836.5	20525	5	QPSK	12	13	23.12	1	0-1
	836.5	20525	5	QPSK	25	0	23.05	1	0-1
	836.5	20525	5	16-QAM	1	0	23.50	1	0-1
	836.5	20525	5	16-QAM	1	12	23.42	1	0-1
	836.5	20525	5	16-QAM	1	24	23.45	1	0-1
	836.5	20525	5	16-QAM	12	0	22.06	2	0-2
	836.5	20525	5	16-QAM	12	6	22.04	2	0-2
	836.5	20525	5	16-QAM	12	13	22.19	2	0-2
836.5	20525	5	16-QAM	25	0	22.13	2	0-2	
High	846.5	20625	5	QPSK	1	0	24.35	0	0
	846.5	20625	5	QPSK	1	12	24.30	0	0
	846.5	20625	5	QPSK	1	24	24.37	0	0
	846.5	20625	5	QPSK	12	0	23.17	1	0-1
	846.5	20625	5	QPSK	12	6	23.03	1	0-1
	846.5	20625	5	QPSK	12	13	23.02	1	0-1
	846.5	20625	5	QPSK	25	0	23.10	1	0-1
	846.5	20625	5	16-QAM	1	0	23.20	1	0-1
	846.5	20625	5	16-QAM	1	12	22.96	1	0-1
	846.5	20625	5	16-QAM	1	24	23.49	1	0-1
	846.5	20625	5	16-QAM	12	0	22.24	2	0-2
	846.5	20625	5	16-QAM	12	6	22.11	2	0-2
	846.5	20625	5	16-QAM	12	13	22.11	2	0-2
846.5	20625	5	16-QAM	25	0	22.15	2	0-2	

FCC ID: A3LSMG900S	 PCTEST ENGINEERING LABORATORY, INC.	SAR EVALUATION REPORT		Reviewed by: Quality Manager
Document S/N: OY1402030286-R1.A3L	Test Dates: 02/03/14 – 02/10/14	DUT Type: Portable Handset		Page 24 of 64

9.3.2

LTE Band 17

Table 9-3
LTE Band 17 Conducted Powers - 10 MHz Bandwidth

	Frequency [MHz]	Channel	Bandwidth [MHz]	Modulation	RB Size	RB Offset	Conducted Power [dBm]	Target MPR [dB]	MPR Allowed per 3GPP [dB]
Mid	710.0	23790	10	QPSK	1	0	23.48	0	0
	710.0	23790	10	QPSK	1	25	23.49	0	0
	710.0	23790	10	QPSK	1	49	23.44	0	0
	710.0	23790	10	QPSK	25	0	22.37	1	0-1
	710.0	23790	10	QPSK	25	12	22.35	1	0-1
	710.0	23790	10	QPSK	25	25	22.41	1	0-1
	710.0	23790	10	QPSK	50	0	22.38	1	0-1
	710.0	23790	10	16QAM	1	0	22.00	1	0-1
	710.0	23790	10	16QAM	1	25	21.98	1	0-1
	710.0	23790	10	16QAM	1	49	21.99	1	0-1
	710.0	23790	10	16QAM	25	0	21.46	2	0-2
	710.0	23790	10	16QAM	25	12	21.40	2	0-2
	710.0	23790	10	16QAM	25	25	21.42	2	0-2
	710.0	23790	10	16QAM	50	0	21.35	2	0-2

Note: LTE Band 17 at 10 MHz bandwidth does not support three non-overlapping channels. Per KDB Publication 941225 D05v02, when a device supports overlapping channel assignment in a channel bandwidth configuration, the middle channel of the group of overlapping channels should be selected for testing.

Table 9-4
LTE Band 17 Conducted Powers - 5 MHz Bandwidth

	Frequency [MHz]	Channel	Bandwidth [MHz]	Modulation	RB Size	RB Offset	Conducted Power [dBm]	Target MPR [dB]	MPR Allowed per 3GPP [dB]
Mid	710.0	23790	5	QPSK	1	0	23.50	0	0
	710.0	23790	5	QPSK	1	12	23.42	0	0
	710.0	23790	5	QPSK	1	24	23.49	0	0
	710.0	23790	5	QPSK	12	0	22.41	1	0-1
	710.0	23790	5	QPSK	12	6	22.40	1	0-1
	710.0	23790	5	QPSK	12	13	22.31	1	0-1
	710.0	23790	5	QPSK	25	0	22.43	1	0-1
	710.0	23790	5	16-QAM	1	0	22.42	1	0-1
	710.0	23790	5	16-QAM	1	12	22.50	1	0-1
	710.0	23790	5	16-QAM	1	24	22.49	1	0-1
	710.0	23790	5	16-QAM	12	0	21.34	2	0-2
	710.0	23790	5	16-QAM	12	6	21.27	2	0-2
	710.0	23790	5	16-QAM	12	13	21.35	2	0-2
	710.0	23790	5	16-QAM	25	0	21.37	2	0-2

Note: LTE Band 17 at 5 MHz bandwidth does not support three non-overlapping channels. Per KDB Publication 941225 D05v02, when a device supports overlapping channel assignment in a channel bandwidth configuration, the middle channel of the group of overlapping channels should be selected for testing.

9.4 Antenna 1 WLAN Conducted Powers

Table 9-5
IEEE 802.11b Average RF Power Antenna 1

Mode	Freq [MHz]	Channel	802.11b Conducted Power [dBm]			
			Data Rate [Mbps]			
			1	2	5.5	11
802.11b	2412	1*	16.65	16.85	16.90	16.93
802.11b	2437	6*	16.75	16.89	16.74	16.90
802.11b	2462	11*	16.76	16.45	16.88	16.93

FCC ID: A3LSMG900S	 PCTEST ENGINEERING LABORATORY, INC.	SAR EVALUATION REPORT		Reviewed by: Quality Manager
Document S/N: OY1402030286-R1.A3L	Test Dates: 02/03/14 – 02/10/14	DUT Type: Portable Handset		Page 25 of 64

**Table 9-6
IEEE 802.11g Average RF Power Antenna 1**

Mode	Freq [MHz]	Channel	802.11g Conducted Power [dBm]							
			Data Rate [Mbps]							
			6	9	12	18	24	36	48	54
802.11g	2412	1	13.71	13.99	14.05	13.97	14.17	13.99	14.20	13.91
802.11g	2437	6	13.87	14.35	13.87	13.43	13.59	14.01	13.82	13.53
802.11g	2462	11	13.90	13.83	14.05	14.06	14.17	13.74	13.58	14.14

**Table 9-7
IEEE 802.11n Average RF Power Antenna 1**

Mode	Freq [MHz]	Channel	802.11n (2.4GHz) Conducted Power [dBm]							
			Data Rate [Mbps]							
			6.5	13	19.5	26	39	52	58.5	65
802.11n	2412	1	11.43	11.46	11.72	12.02	12.05	12.09	12.05	12.09
802.11n	2437	6	11.84	12.29	12.43	12.35	11.26	11.88	11.91	11.84
802.11n	2462	11	11.99	11.42	12.39	11.51	11.34	11.64	12.12	12.25

**Table 9-8
IEEE 802.11a Average RF Power Antenna 1**

Mode	Freq [MHz]	Channel	802.11a Conducted Power [dBm]							
			Data Rate [Mbps]							
			6	9	12	18	24	36	48	54
802.11a	5180	36*	11.56	11.53	11.65	11.64	11.79	11.79	11.80	11.63
802.11a	5200	40	11.48	11.56	11.50	11.55	11.24	11.34	11.74	11.56
802.11a	5220	44	11.51	11.59	11.42	11.58	11.35	11.74	11.72	11.51
802.11a	5240	48*	11.48	11.25	11.39	11.30	11.28	11.45	11.52	11.73
802.11a	5260	52*	11.61	11.38	11.60	11.69	11.77	11.50	11.48	11.72
802.11a	5280	56	11.50	11.35	11.51	11.72	11.55	11.68	11.61	11.54
802.11a	5300	60	11.49	11.73	11.53	11.43	11.63	11.59	11.26	11.25
802.11a	5320	64*	11.33	11.29	11.33	11.24	11.54	11.57	11.14	11.23
802.11a	5500	100	11.51	11.33	11.66	11.54	11.76	11.38	11.60	11.31
802.11a	5520	104*	11.50	11.32	11.43	11.52	11.74	11.54	11.59	11.65
802.11a	5540	108	11.24	11.27	11.38	11.31	11.18	11.45	11.14	11.40
802.11a	5560	112	11.25	11.43	11.01	11.22	11.13	11.23	11.46	11.18
802.11a	5580	116*	12.07	12.15	12.21	12.23	12.31	11.92	12.24	12.17
802.11a	5600	120	N/A	N/A	N/A	N/A	N/A	N/A	N/A	N/A
802.11a	5620	124	N/A	N/A	N/A	N/A	N/A	N/A	N/A	N/A
802.11a	5640	128	N/A	N/A	N/A	N/A	N/A	N/A	N/A	N/A
802.11a	5660	132	12.08	12.03	11.71	11.80	12.08	12.18	12.18	11.76
802.11a	5680	136*	11.86	11.87	11.94	12.12	12.13	11.95	11.84	11.86
802.11a	5700	140	11.82	11.86	11.72	12.02	11.96	11.74	11.85	11.59
802.11a	5745	149*	11.84	11.88	11.98	11.64	12.07	12.06	11.61	12.06
802.11a	5765	153	11.85	11.84	11.83	12.01	11.67	11.98	12.07	11.98
802.11a	5785	157*	11.90	11.88	12.14	12.11	12.01	11.99	11.83	11.82
802.11a	5805	161	11.79	11.73	12.01	12.00	11.57	12.05	11.74	11.98
802.11a	5825	165*	11.76	11.88	11.88	11.86	11.62	11.91	11.93	11.76

Per FCC KDB Publication 443999 and RSS-210 A9.2(3), transmission on channels which overlap the 5600-5650 MHz is prohibited as a client. This device does not transmit any beacons or initiate any transmissions in 5.3 and 5.5 GHz Band.

(*) – indicates default channels per KDB Publication 248227 D01v01r02. When the adjacent channels are higher in power than the default channels, these “required channels” are considered for SAR testing instead of the default channels.



FCC ID: A3LSMG900S	 PCTEST ENGINEERING LABORATORY, INC.	SAR EVALUATION REPORT		Reviewed by: Quality Manager
Document S/N: OY1402030286-R1.A3L	Test Dates: 02/03/14 – 02/10/14	DUT Type: Portable Handset	Page 26 of 64	

Table 9-9
IEEE 802.11n Average RF Power – 20 MHz Bandwidth Antenna 1

Mode	Freq [MHz]	Channel	20MHz BW 802.11n (5GHz) Conducted Power [dBm]							
			Data Rate [Mbps]							
			6.5	13	19.5	26	39	52	58.5	65
802.11n	5180	36	11.36	11.45	11.52	11.80	11.80	11.73	11.80	11.76
802.11n	5200	40	11.55	11.21	11.78	11.77	11.32	11.33	11.38	11.79
802.11n	5220	44	11.40	11.48	11.22	11.56	11.40	11.50	11.46	11.24
802.11n	5240	48	11.34	11.02	11.33	11.02	11.14	11.64	11.18	11.58
802.11n	5260	52	11.63	11.54	11.23	11.48	11.35	11.31	11.34	11.35
802.11n	5280	56	11.48	11.26	11.53	11.64	11.49	11.05	11.19	11.39
802.11n	5300	60	11.36	11.19	11.21	11.30	10.99	11.75	11.64	11.20
802.11n	5320	64	11.36	10.94	11.73	11.56	11.80	11.32	11.37	11.22
802.11n	5500	100	11.46	11.17	11.24	11.50	11.05	11.81	11.55	11.86
802.11n	5520	104	11.35	11.18	11.18	11.15	11.43	11.44	11.27	11.46
802.11n	5540	108	12.27	12.07	11.94	12.30	12.29	12.27	12.01	12.32
802.11n	5560	112	12.06	12.32	12.31	12.26	11.98	11.81	11.90	12.30
802.11n	5580	116	11.96	11.90	11.96	12.22	12.15	11.57	12.06	11.74
802.11n	5600	120	N/A	N/A	N/A	N/A	N/A	N/A	N/A	N/A
802.11n	5620	124	N/A	N/A	N/A	N/A	N/A	N/A	N/A	N/A
802.11n	5640	128	N/A	N/A	N/A	N/A	N/A	N/A	N/A	N/A
802.11n	5660	132	11.91	11.49	11.68	12.25	12.23	11.62	11.98	11.59
802.11n	5680	136	11.82	11.96	12.02	11.46	11.55	11.95	11.53	11.66
802.11n	5700	140	11.69	11.70	12.08	12.01	11.79	11.55	11.90	12.02
802.11n	5745	149	11.92	12.11	12.03	11.91	12.13	11.93	11.99	12.14
802.11n	5765	153	11.63	11.70	11.20	11.92	11.90	11.52	11.55	11.38
802.11n	5785	157	11.76	11.50	11.92	11.83	12.12	11.48	12.14	12.09
802.11n	5805	161	11.77	11.94	12.14	11.62	11.82	11.96	12.07	12.11
802.11n	5825	165	11.49	11.23	11.18	11.32	11.72	11.54	11.55	11.32

Table 9-10
IEEE 802.11n Average RF Power – 40 MHz Bandwidth Antenna 1

Mode	Freq [MHz]	Channel	40MHz BW 802.11n (5GHz) Conducted Power [dBm]							
			Data Rate [Mbps]							
			13.5	27	40.5	54	81	108	121.5	135
802.11n	5190	38	11.07	11.01	11.17	11.12	11.33	11.31	11.14	11.40
802.11n	5230	46	10.96	11.01	10.97	11.25	11.09	10.96	11.32	11.32
802.11n	5270	54	11.12	11.16	11.22	11.17	10.89	11.04	11.30	10.98
802.11n	5310	62	11.01	10.67	11.13	11.28	11.04	10.96	11.35	11.02
802.11n	5510	102	11.84	12.04	12.07	12.09	11.89	11.75	12.03	12.19
802.11n	5550	110	11.66	11.65	11.77	11.34	11.38	11.82	11.51	11.57
802.11n	5590	118	N/A	N/A	N/A	N/A	N/A	N/A	N/A	N/A
802.11n	5630	126	N/A	N/A	N/A	N/A	N/A	N/A	N/A	N/A
802.11n	5670	134	11.49	11.19	11.30	11.79	11.31	11.51	11.71	11.68
802.11n	5755	151	11.45	11.25	11.08	11.50	11.39	11.20	11.13	11.79
802.11n	5795	159	11.52	11.30	11.69	11.52	11.86	11.17	11.22	11.82

FCC ID: A3LSMG900S	 PCTEST ENGINEERING LABORATORY, INC.	SAR EVALUATION REPORT		Reviewed by: Quality Manager
Document S/N: OY1402030286-R1.A3L	Test Dates: 02/03/14 – 02/10/14	DUT Type: Portable Handset		Page 27 of 64

**Table 9-11
IEEE 802.11ac Average RF Power – 80 MHz Bandwidth Antenna 1**

Mode	Freq [MHz]	Channel	80MHz BW 802.11ac (5GHz) Conducted Power [dBm]									
			Data Rate [Mbps]									
			29.3	58.5	87.8	117	175.5	234	263.3	292.5	351	390
802.11ac	5210	42	9.37	9.29	9.22	9.60	9.53	9.59	9.58	9.60	9.57	9.60
802.11ac	5290	58	9.64	9.51	9.70	9.54	9.28	9.64	9.23	9.41	9.06	8.86
802.11ac	5530	106	9.20	8.94	8.53	9.43	9.42	9.39	9.42	8.56	9.36	8.74
802.11ac	5775	155	9.76	9.88	9.40	9.98	9.80	9.90	9.42	9.31	9.99	9.21

Justification for reduced test configurations for WIFI channels per KDB Publication 248227 D01v01r02 and October 2012/April 2013 FCC/TCB Meeting Notes:

- For 2.4 GHz, highest average RF output power channel for the lowest data rate for IEEE 802.11b were selected for SAR evaluation. Other IEEE 802.11 modes (including 802.11g/n) were not investigated since the average output powers over all channels and data rates were not more than 0.25 dB higher than the tested channel in the lowest data rate of IEEE 802.11b mode.
- For 5 GHz, highest average RF output power channel for the lowest data rate for IEEE 802.11a were selected for SAR evaluation. Other IEEE 802.11 modes (including 802.11n) were not investigated since the average output powers over all channels and data rates were not more than 0.25 dB higher than the tested channel in the lowest data rate of IEEE 802.11a mode.
- Full SAR tests for all IEEE 802.11ac configurations were not required because the average output power was not more than 0.25 dB higher than IEEE 802.11a mode. IEEE 802.11ac was evaluated for the highest IEEE 802.11a position in each 5 GHz band and exposure condition.
- When the maximum extrapolated peak SAR of the zoom scan for the maximum output channel is <1.6 W/kg and the reported 1g averaged SAR is <0.8 W/kg, SAR testing on other channels is not required. Otherwise, the other default (or corresponding required) test channels were additionally tested using the lowest data rate.
- The bolded data rate and channel above were tested for SAR.

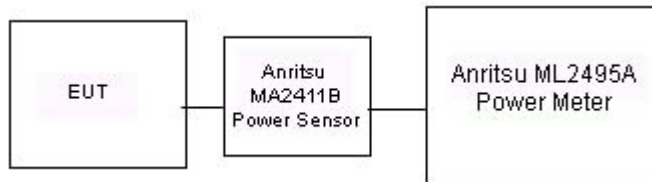

**Figure 9-3
Power Measurement Setup for Bandwidths < 50 MHz**

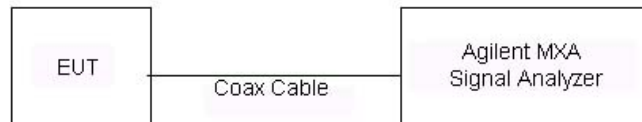

**Figure 9-4
Power Measurement Setup for Bandwidths > 50 MHz**

FCC ID: A3LSMG900S	 PCTEST <small>ENGINEERING LABORATORY, INC.</small>	SAR EVALUATION REPORT		Reviewed by: Quality Manager
Document S/N: OY1402030286-R1.A3L	Test Dates: 02/03/14 – 02/10/14	DUT Type: Portable Handset	Page 28 of 64	

9.5 Antenna 2 WLAN Conducted Powers

Table 9-12
IEEE 802.11b Average RF Power Antenna 2

Mode	Freq [MHz]	Channel	802.11b Conducted Power [dBm]			
			Data Rate [Mbps]			
			1	2	5.5	11
802.11b	2412	1*	16.61	16.69	16.57	16.60
802.11b	2437	6*	16.43	16.60	16.64	16.61
802.11b	2462	11*	16.59	16.45	16.68	16.66

Table 9-13
IEEE 802.11g Average RF Power Antenna 2

Mode	Freq [MHz]	Channel	802.11g Conducted Power [dBm]							
			Data Rate [Mbps]							
			6	9	12	18	24	36	48	54
802.11g	2412	1	13.57	13.34	13.44	13.40	13.65	13.54	13.64	13.60
802.11g	2437	6	13.52	13.64	13.73	13.79	13.27	13.56	13.44	13.39
802.11g	2462	11	13.73	13.74	13.79	13.79	14.03	13.47	13.49	13.76

Table 9-14
IEEE 802.11n Average RF Power Antenna 2

Mode	Freq [MHz]	Channel	802.11n (2.4GHz) Conducted Power [dBm]							
			Data Rate [Mbps]							
			6.5	13	19.5	26	39	52	58.5	65
802.11n	2412	1	11.41	11.20	11.38	11.64	11.60	11.49	11.57	11.51
802.11n	2437	6	11.33	11.42	11.76	11.27	11.12	10.95	11.10	11.59
802.11n	2462	11	11.54	11.46	11.24	11.69	11.33	11.64	11.32	11.76



FCC ID: A3LSMG900S	 PCTEST ENGINEERING LABORATORY, INC.	SAR EVALUATION REPORT		Reviewed by: Quality Manager
Document S/N: OY1402030286-R1.A3L	Test Dates: 02/03/14 – 02/10/14	DUT Type: Portable Handset		Page 29 of 64

Table 9-15
IEEE 802.11a Average RF Power Antenna 2

Mode	Freq [MHz]	Channel	802.11a Conducted Power [dBm]							
			Data Rate [Mbps]							
			6	9	12	18	24	36	48	54
802.11a	5180	36*	12.00	11.79	11.86	11.98	12.12	12.09	12.16	12.17
802.11a	5200	40	12.01	11.65	11.88	11.86	12.11	12.03	12.13	11.91
802.11a	5220	44	11.96	12.05	12.03	11.85	12.23	11.83	12.00	11.75
802.11a	5240	48*	11.96	12.09	11.92	12.24	11.96	11.90	12.11	11.95
802.11a	5260	52*	11.78	11.86	11.90	11.61	11.62	11.90	12.06	11.66
802.11a	5280	56	11.84	11.88	11.99	11.59	11.75	11.85	11.66	11.46
802.11a	5300	60	11.77	11.41	11.49	11.43	11.72	11.84	11.96	11.86
802.11a	5320	64*	11.80	11.71	11.49	12.03	11.61	11.90	11.85	11.79
802.11a	5500	100	11.69	11.55	11.46	11.32	12.02	11.92	11.37	11.98
802.11a	5520	104*	11.80	11.80	11.52	11.92	11.47	12.01	11.78	11.92
802.11a	5540	108	11.75	11.96	11.55	11.46	11.47	11.45	11.68	11.46
802.11a	5560	112	11.77	11.81	12.03	11.80	11.72	12.01	12.04	11.57
802.11a	5580	116*	11.76	11.56	11.50	11.87	11.60	11.40	11.73	11.80
802.11a	5600	120	N/A	N/A	N/A	N/A	N/A	N/A	N/A	N/A
802.11a	5620	124	N/A	N/A	N/A	N/A	N/A	N/A	N/A	N/A
802.11a	5640	128	N/A	N/A	N/A	N/A	N/A	N/A	N/A	N/A
802.11a	5660	132	11.62	11.59	11.24	11.39	11.62	11.66	11.73	11.27
802.11a	5680	136*	11.45	11.45	11.71	11.34	11.57	11.34	11.72	11.11
802.11a	5700	140	11.47	11.13	11.32	11.30	11.40	11.20	11.47	11.81
802.11a	5745	149*	11.69	11.57	11.59	11.60	11.73	11.80	11.68	11.40
802.11a	5765	153	11.67	11.85	11.65	11.39	11.77	11.48	11.78	11.80
802.11a	5785	157*	11.41	11.45	11.77	11.28	11.41	11.47	11.26	11.52
802.11a	5805	161	12.16	12.26	11.88	12.35	11.97	11.95	11.99	12.11
802.11a	5825	165*	11.88	11.59	11.91	11.97	12.10	11.51	11.55	12.14

Per FCC KDB Publication 443999 and RSS-210 A9.2(3), transmission on channels which overlap the 5600-5650 MHz is prohibited as a client. This device does not transmit any beacons or initiate any transmissions in 5.3 and 5.5 GHz Band.

(*) – indicates default channels per KDB Publication 248227 D01v01r02. When the adjacent channels are higher in power than the default channels, these “required channels” are considered for SAR testing instead of the default channels.





FCC ID: A3LSMG900S	 PCTEST ENGINEERING LABORATORY, INC.	SAR EVALUATION REPORT		Reviewed by: Quality Manager
Document S/N: OY1402030286-R1.A3L	Test Dates: 02/03/14 – 02/10/14	DUT Type: Portable Handset	Page 30 of 64	

Table 9-16
IEEE 802.11n Average RF Power – 20 MHz Bandwidth Antenna 2

Mode	Freq [MHz]	Channel	20MHz BW 802.11n (5GHz) Conducted Power [dBm]							
			Data Rate [Mbps]							
			6.5	13	19.5	26	39	52	58.5	65
802.11n	5180	36	11.83	11.66	11.70	11.99	12.02	11.95	11.84	11.91
802.11n	5200	40	11.84	11.98	11.93	11.63	11.64	12.06	11.97	11.84
802.11n	5220	44	11.86	11.50	11.69	11.50	12.19	11.90	11.94	12.05
802.11n	5240	48	11.72	11.73	11.87	11.36	11.86	11.71	11.62	11.39
802.11n	5260	52	11.76	11.87	11.82	11.68	11.75	11.69	11.58	11.72
802.11n	5280	56	11.72	11.46	11.99	11.52	11.51	11.42	12.05	11.97
802.11n	5300	60	11.65	11.34	11.82	11.96	11.88	11.61	11.34	11.75
802.11n	5320	64	11.57	11.83	11.41	11.59	11.90	11.59	11.87	11.39
802.11n	5500	100	11.68	11.75	12.03	11.59	11.92	11.67	11.68	11.77
802.11n	5520	104	11.70	11.41	11.98	11.97	12.04	11.85	11.92	11.62
802.11n	5540	108	11.69	11.61	12.01	11.35	11.46	11.77	11.90	11.68
802.11n	5560	112	11.69	11.77	11.41	11.89	11.46	11.96	11.90	11.94
802.11n	5580	116	11.61	11.83	11.35	11.87	11.53	11.92	11.55	11.37
802.11n	5600	120	N/A	N/A	N/A	N/A	N/A	N/A	N/A	N/A
802.11n	5620	124	N/A	N/A	N/A	N/A	N/A	N/A	N/A	N/A
802.11n	5640	128	N/A	N/A	N/A	N/A	N/A	N/A	N/A	N/A
802.11n	5660	132	11.61	11.62	11.63	11.40	11.34	11.50	11.74	11.44
802.11n	5680	136	11.46	11.43	11.72	11.40	11.54	11.42	11.60	11.11
802.11n	5700	140	11.47	11.46	11.42	11.71	11.28	11.28	11.53	11.65
802.11n	5745	149	11.61	11.39	11.69	11.57	11.54	11.68	11.51	11.46
802.11n	5765	153	11.51	11.85	11.55	11.62	11.16	11.58	11.49	11.52
802.11n	5785	157	11.31	10.98	11.19	11.13	11.26	10.99	11.38	11.59
802.11n	5805	161	12.09	12.18	11.98	11.74	11.78	12.34	11.94	12.03
802.11n	5825	165	11.85	11.58	11.64	11.94	12.16	11.71	11.77	12.11

Table 9-17
IEEE 802.11n Average RF Power – 40 MHz Bandwidth Antenna 2

Mode	Freq [MHz]	Channel	40MHz BW 802.11n (5GHz) Conducted Power [dBm]							
			Data Rate [Mbps]							
			13.5	27	40.5	54	81	108	121.5	135
802.11n	5190	38	11.94	11.83	11.68	12.05	12.04	12.02	12.03	12.01
802.11n	5230	46	11.86	12.03	11.51	11.90	12.13	11.75	12.20	12.13
802.11n	5270	54	11.70	11.84	11.78	11.82	11.70	11.41	11.56	11.71
802.11n	5310	62	11.60	11.49	11.84	11.58	11.53	11.65	11.46	11.70
802.11n	5510	102	11.72	11.53	11.55	11.55	11.51	11.66	12.01	11.39
802.11n	5550	110	11.64	11.29	11.70	11.95	11.41	11.69	11.64	11.73
802.11n	5590	118	N/A	N/A	N/A	N/A	N/A	N/A	N/A	N/A
802.11n	5630	126	N/A	N/A	N/A	N/A	N/A	N/A	N/A	N/A
802.11n	5670	134	11.39	11.43	11.69	11.12	11.33	11.54	11.63	11.50
802.11n	5755	151	11.51	11.60	11.73	11.30	11.51	11.66	11.80	11.63
802.11n	5795	159	12.24	12.30	12.39	12.16	12.08	12.31	12.35	11.90

FCC ID: A3LSMG900S	 PCTEST ENGINEERING LABORATORY, INC.	SAR EVALUATION REPORT		Reviewed by: Quality Manager
Document S/N: OY1402030286-R1.A3L	Test Dates: 02/03/14 – 02/10/14	DUT Type: Portable Handset		Page 31 of 64

**Table 9-18
IEEE 802.11ac Average RF Power – 80 MHz Bandwidth Antenna 2**

Mode	Freq [MHz]	Channel	80MHz BW 802.11ac (5GHz) Conducted Power [dBm]									
			Data Rate [Mbps]									
			29.3	58.5	87.8	117	175.5	234	263.3	292.5	351	390
802.11ac	5210	42	9.40	9.52	9.41	9.59	9.63	9.62	9.58	9.60	9.61	9.59
802.11ac	5290	58	9.53	9.16	9.76	9.72	9.49	9.26	9.27	9.63	9.75	9.33
802.11ac	5530	106	9.53	9.46	9.61	9.30	9.09	9.17	9.47	9.60	9.17	9.41
802.11ac	5775	155	10.07	10.31	9.75	10.30	10.10	10.08	10.12	10.29	9.90	10.26

Justification for reduced test configurations for WIFI channels per KDB Publication 248227 D01v01r02 and October 2012/April 2013 FCC/TCB Meeting Notes:

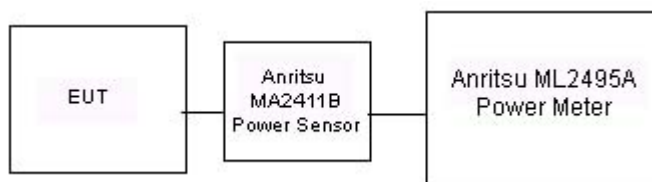

- For 2.4 GHz, highest average RF output power channel for the lowest data rate for IEEE 802.11b were selected for SAR evaluation. Other IEEE 802.11 modes (including 802.11g/n) were not investigated since the average output powers over all channels and data rates were not more than 0.25 dB higher than the tested channel in the lowest data rate of IEEE 802.11b mode.
- For 5 GHz, highest average RF output power channel for the lowest data rate for IEEE 802.11a were selected for SAR evaluation. Other IEEE 802.11 modes (including 802.11n) were not investigated since the average output powers over all channels and data rates were not more than 0.25 dB higher than the tested channel in the lowest data rate of IEEE 802.11a mode.
- Full SAR tests for all IEEE 802.11ac configurations were not required because the average output power was not more than 0.25 dB higher than IEEE 802.11a mode. IEEE 802.11ac was evaluated for the highest IEEE 802.11a position in each 5 GHz band and exposure condition.
- When the maximum extrapolated peak SAR of the zoom scan for the maximum output channel is <1.6 W/kg and the reported 1g averaged SAR is <0.8 W/kg, SAR testing on other channels is not required. Otherwise, the other default (or corresponding required) test channels were additionally tested using the lowest data rate.
- The bolded data rate and channel above were tested for SAR.

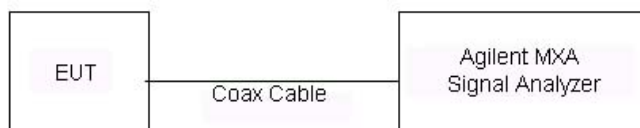

**Figure 9-5
Power Measurement Setup for Bandwidths < 50 MHz**



**Figure 9-6
Power Measurement Setup for Bandwidths > 50 MHz**

FCC ID: A3LSMG900S	 PCTEST <small>ENGINEERING LABORATORY, INC.</small>	SAR EVALUATION REPORT		Reviewed by: Quality Manager
Document S/N: OY1402030286-R1.A3L	Test Dates: 02/03/14 – 02/10/14	DUT Type: Portable Handset	Page 32 of 64	

9.6 MIMO WLAN Conducted Powers

Table 9-19
IEEE 802.11n Average RF Power MIMO

Mode	Freq [MHz]	Channel	Data Rate
			13.0
802.11n	2412	1*	12.21
802.11n	2437	6*	12.32
802.11n	2462	11*	12.30

Table 9-20
IEEE 802.11n Average RF Power – 20 MHz Bandwidth MIMO

Mode	Freq [MHz]	Channel	Data Rate
			13.0
802.11n	5180	36*	11.74
802.11n	5200	40	11.86
802.11n	5220	44	11.86
802.11n	5240	48*	11.65
802.11n	5260	52*	11.83
802.11n	5280	56	11.66
802.11n	5300	60	11.85
802.11n	5320	64*	11.63
802.11n	5500	100	11.54
802.11n	5520	104*	11.61
802.11n	5540	108	11.56
802.11n	5560	112	11.51
802.11n	5580	116*	11.40
802.11n	5600	120	N/A
802.11n	5620	124	N/A
802.11n	5640	128	N/A
802.11n	5660	132	11.43
802.11n	5680	136*	12.24
802.11n	5700	140	12.23
802.11n	5745	149*	12.14
802.11n	5765	153	12.09
802.11n	5785	157*	12.20
802.11n	5805	161	11.98
802.11n	5825	165*	11.75

FCC ID: A3LSMG900S	 PCTEST ENGINEERING LABORATORY, INC.	SAR EVALUATION REPORT		Reviewed by: Quality Manager
Document S/N: OY1402030286-R1.A3L	Test Dates: 02/03/14 – 02/10/14	DUT Type: Portable Handset		Page 33 of 64

**Table 9-21
IEEE 802.11n Average RF Power – 40 MHz Bandwidth MIMO**



Mode	Freq [MHz]	Channel	Data Rate
			27.0
802.11n	5190	38	11.77
802.11n	5230	46	11.64
802.11n	5270	54	11.78
802.11n	5310	62	11.68
802.11n	5510	102	11.66
802.11n	5550	110	11.53
802.11n	5590	118	N/A
802.11n	5630	126	N/A
802.11n	5670	134	12.33
802.11n	5755	151	12.24
802.11n	5795	159	12.02

**Table 9-22
IEEE 802.11ac Average RF Power – 80 MHz Bandwidth MIMO**

Mode	Freq [MHz]	Channel	Data Rate
			58.5
802.11ac	5210	42	9.58
802.11ac	5290	58	9.62
802.11ac	5530	106	10.48
802.11ac	5775	155	9.90

Justification for reduced test configurations for WIFI channels per KDB Publication 248227 D01v01r02 and October 2012 FCC/TCB Meeting Notes:

- For 2.4 GHz, highest average RF output power channel for the lowest data rate for IEEE 802.11n were selected for SAR evaluation.
- For 5 GHz, highest average RF output power channel for the lowest data rate for IEEE 802.11n were selected for SAR evaluation.
- When the maximum extrapolated peak SAR of the zoom scan for the maximum output channel is <1.6 W/kg and the reported 1g averaged SAR is <0.8 W/kg, SAR testing on other channels is not required. Otherwise, the other default (or corresponding required) test channels were additionally tested using the lowest data rate.
- The bolded data rate and channel above were tested for SAR.
- Per KDB 662911 D01v02r01, the individual spectra for each 2x2 MIMO WIFI Antenna were summed mathematically in linear power units for the MIMO output power measurements

FCC ID: A3LSMG900S	 PCTEST ENGINEERING LABORATORY, INC.	SAR EVALUATION REPORT		Reviewed by: Quality Manager
Document S/N: OY1402030286-R1.A3L	Test Dates: 02/03/14 – 02/10/14	DUT Type: Portable Handset		Page 34 of 64

10 SYSTEM VERIFICATION

10.1 Tissue Verification

**Table 10-1
Measured Tissue Properties**

Calibrated for Tests Performed on:	Tissue Type	Tissue Temp During Calibration (C°)	Measured Frequency (MHz)	Measured Conductivity, σ (S/m)	Measured Dielectric Constant, ϵ	TARGET Conductivity, σ (S/m)	TARGET Dielectric Constant, ϵ	% dev σ	% dev ϵ
02/06/2014	740H	22.7	710	0.898	42.062	0.890	42.149	0.90%	-0.21%
			725	0.911	41.844	0.891	42.071	2.24%	-0.54%
			740	0.924	41.614	0.893	41.994	3.47%	-0.90%
			755	0.938	41.441	0.894	41.916	4.92%	-1.13%
02/06/2014	835H	23.1	820	0.905	42.126	0.899	41.578	0.67%	1.32%
			835	0.919	41.961	0.900	41.500	2.11%	1.11%
			850	0.931	41.766	0.916	41.500	1.64%	0.64%
02/10/2014	835H	22.9	820	0.917	42.790	0.899	41.578	2.00%	2.92%
			835	0.932	42.598	0.900	41.500	3.56%	2.65%
			850	0.944	42.413	0.916	41.500	3.06%	2.20%
02/10/2014	1900H	22.2	1850	1.395	38.754	1.400	40.000	-0.36%	-3.12%
			1880	1.425	38.619	1.400	40.000	1.79%	-3.45%
			1910	1.454	38.465	1.400	40.000	3.86%	-3.84%
02/06/2014	2450H	21.4	2401	1.782	38.220	1.756	39.287	1.48%	-2.72%
			2450	1.832	38.027	1.800	39.200	1.78%	-2.99%
			2499	1.890	37.837	1.853	39.138	2.00%	-3.32%
			5180	4.533	37.666	4.635	36.009	-2.20%	4.60%
02/06/2014	5200H-5800H	23.1	5200	4.566	37.509	4.655	35.986	-1.91%	4.23%
			5220	4.623	37.545	4.676	35.963	-1.13%	4.40%
			5260	4.663	37.698	4.717	35.917	-1.14%	4.96%
			5280	4.656	37.637	4.737	35.894	-1.71%	4.86%
			5300	4.651	37.509	4.758	35.871	-2.25%	4.57%
			5500	4.925	37.305	4.963	35.643	-0.77%	4.66%
			5520	4.924	37.347	4.983	35.620	-1.18%	4.85%
			5540	4.911	37.289	5.004	35.597	-1.86%	4.75%
			5580	4.954	37.020	5.045	35.551	-1.80%	4.13%
			5600	5.017	37.024	5.065	35.529	-0.95%	4.21%
			5660	5.049	37.140	5.127	35.460	-1.52%	4.74%
			5680	5.034	36.990	5.147	35.437	-2.20%	4.38%
			5765	5.199	37.033	5.234	35.340	-0.67%	4.79%
			5785	5.182	36.998	5.255	35.317	-1.39%	4.76%
			5800	5.176	36.885	5.270	35.300	-1.78%	4.49%
			5805	5.175	36.876	5.275	35.294	-1.90%	4.48%
			02/06/2014	740B	23.5	710	0.920	54.230	0.960
725	0.934	54.077				0.961	55.629	-2.81%	-2.79%
740	0.948	53.897				0.963	55.570	-1.56%	-3.01%
755	0.961	53.761				0.964	55.512	-0.31%	-3.15%
02/05/2014	835B	23.1	820	0.999	53.826	0.969	55.258	3.10%	-2.59%
			835	1.014	53.696	0.970	55.200	4.54%	-2.72%
			850	1.027	53.534	0.988	55.154	3.95%	-2.94%
02/06/2014	1900B	22.5	1850	1.509	52.013	1.520	53.300	-0.72%	-2.41%
			1880	1.542	51.914	1.520	53.300	1.45%	-2.60%
			1910	1.573	51.827	1.520	53.300	3.49%	-2.76%
02/10/2014	1900B	22.2	1850	1.525	51.969	1.520	53.300	0.33%	-2.50%
			1880	1.561	51.837	1.520	53.300	2.70%	-2.74%
			1910	1.595	51.735	1.520	53.300	4.93%	-2.94%
02/03/2014	2450B	22.8	2401	1.971	51.560	1.903	52.765	3.57%	-2.28%
			2450	2.039	51.366	1.950	52.700	4.56%	-2.53%
			2499	2.099	51.177	2.019	52.638	3.96%	-2.78%
			5180	5.172	47.680	5.276	49.041	-1.97%	-2.78%
02/03/2014	5200B-5800B	22.6	5200	5.168	47.598	5.299	49.014	-2.47%	-2.89%
			5220	5.189	47.462	5.323	48.987	-2.52%	-3.11%
			5260	5.259	47.183	5.369	48.933	-2.05%	-3.58%
			5280	5.313	47.205	5.393	48.906	-1.48%	-3.48%
			5300	5.352	47.314	5.416	48.879	-1.18%	-3.20%
			5500	5.579	46.639	5.650	48.607	-1.26%	-4.05%
			5520	5.640	46.533	5.673	48.580	-0.58%	-4.21%
			5540	5.696	46.550	5.696	48.553	0.00%	-4.13%
			5580	5.764	46.751	5.743	48.499	0.37%	-3.60%
			5600	5.749	46.646	5.766	48.471	-0.29%	-3.77%
			5660	5.868	46.242	5.837	48.390	0.53%	-4.44%
			5680	5.927	46.381	5.860	48.363	1.14%	-4.10%
			5765	5.986	45.986	5.959	48.248	0.45%	-4.69%
			5785	6.049	45.975	5.982	48.220	1.12%	-4.66%
			5800	6.097	46.032	6.000	48.200	1.62%	-4.50%
			5805	6.109	46.051	6.006	48.193	1.71%	-4.44%

The above measured tissue parameters were used in the DASY software. The DASY software was used to perform interpolation to determine the dielectric parameters at the SAR test device frequencies (per KDB 865664 and IEEE 1528-2013 6.6.1.2). The tissue parameters listed in the SAR test plots may slightly differ from the table above due to significant digit rounding in the software.

FCC ID: A3LSMG900S	 PCTEST ENGINEERING LABORATORY, INC.	SAR EVALUATION REPORT		Reviewed by: Quality Manager
Document S/N: OY1402030286-R1.A3L	Test Dates: 02/03/14 – 02/10/14	DUT Type: Portable Handset		Page 35 of 64

10.2 Test System Verification

Prior to SAR assessment, the system is verified to $\pm 10\%$ of the SAR measurement on the reference dipole at the time of calibration by the calibration facility. Full system validation status and result summary can be found in Appendix E.

**Table 10-2
System Verification Results**

System Verification TARGET & MEASURED												
SAR System #	Tissue Frequency (MHz)	Tissue Type	Date:	Amb. Temp (°C)	Liquid Temp (°C)	Input Power (W)	Dipole SN	Probe SN	Measured SAR _{1g} (W/kg)	1 W Target SAR _{1g} (W/kg)	1 W Normalized SAR _{1g} (W/kg)	Deviation _{1g} (%)
I	750	HEAD	02/06/2014	24.4	24.0	0.100	1046	3319	0.813	8.500	8.130	-4.35%
J	835	HEAD	02/06/2014	24.2	23.1	0.100	4d119	3332	0.937	9.680	9.370	-3.20%
H	835	HEAD	02/10/2014	23.9	23.1	0.100	4d119	3589	0.965	9.680	9.650	-0.31%
D	1900	HEAD	02/10/2014	22.8	22.2	0.100	5d149	3022	3.720	40.400	37.200	-7.92%
K	2450	HEAD	02/06/2014	24.3	21.4	0.100	719	3287	5.050	53.200	50.500	-5.08%
E	5200	HEAD	02/06/2014	24.5	23.5	0.100	1120	3914	7.840	76.000	78.400	3.16%
E	5300	HEAD	02/06/2014	24.1	23.5	0.100	1120	3914	7.960	78.700	79.600	1.14%
E	5500	HEAD	02/06/2014	23.9	23.5	0.100	1120	3914	7.910	80.100	79.100	-1.25%
E	5600	HEAD	02/06/2014	24.0	23.4	0.100	1120	3914	7.970	79.900	79.700	-0.25%
E	5800	HEAD	02/06/2014	24.1	23.5	0.100	1120	3914	7.400	74.900	74.000	-1.20%
J	750	BODY	02/06/2014	24.3	23.5	0.100	1046	3332	0.881	8.770	8.810	0.46%
G	835	BODY	02/05/2014	22.9	21.4	0.100	4d119	3209	1.020	9.540	10.200	6.92%
D	1900	BODY	02/06/2014	23.1	22.5	0.100	5d149	3022	4.050	40.500	40.500	0.00%
D	1900	BODY	02/10/2014	23.3	22.2	0.100	5d149	3022	4.020	40.500	40.200	-0.74%
G	2450	BODY	02/03/2014	24.4	22.8	0.100	719	3209	5.050	51.700	50.500	-2.32%
E	5200	BODY	02/03/2014	24.5	22.6	0.040	1120	3914	3.110	76.600	77.750	1.50%
E	5300	BODY	02/03/2014	24.4	22.6	0.040	1120	3914	3.260	76.800	81.500	6.12%
E	5500	BODY	02/03/2014	24.3	22.6	0.040	1120	3914	3.270	79.800	81.750	2.44%
E	5600	BODY	02/03/2014	24.5	22.5	0.040	1120	3914	3.380	80.700	84.500	4.71%
E	5800	BODY	02/03/2014	24.5	22.7	0.040	1120	3914	3.050	75.500	76.250	0.99%

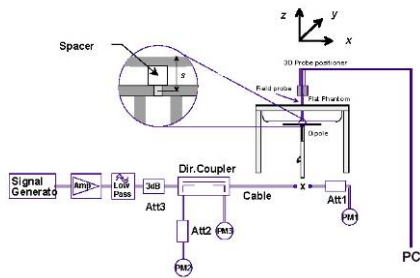

**Figure 10-1
System Verification Setup Diagram**



**Figure 10-2
System Verification Setup Photo**

FCC ID: A3LSMG900S	PCTEST ENGINEERING LABORATORY, INC.	SAR EVALUATION REPORT		Reviewed by: Quality Manager
Document S/N: OY1402030286-R1.A3L	Test Dates: 02/03/14 – 02/10/14	DUT Type: Portable Handset		Page 36 of 64

11 SAR DATA SUMMARY

11.1 Standalone Head SAR Data

**Table 11-1
UMTS 850 Head SAR**



MEASUREMENT RESULTS														
FREQUENCY		Mode/Band	Service	Maximum Allowed Power [dBm]	Conducted Power [dBm]	Power Drift [dB]	Side	Test Position	Device Serial Number	Duty Cycle	SAR (1g)	Scaling Factor	Scaled SAR (1g)	Plot #
MHz	Ch.										(W/kg)		(W/kg)	
836.60	4183	UMTS 850	RMC	24.0	23.17	0.04	Right	Cheek	F1188	1:1	0.325	1.211	0.394	
836.60	4183	UMTS 850	RMC	24.0	23.17	0.06	Right	Tilt	F1188	1:1	0.207	1.211	0.251	
836.60	4183	UMTS 850	RMC	24.0	23.17	0.04	Left	Cheek	F1188	1:1	0.417	1.211	0.505	A1
836.60	4183	UMTS 850	RMC	24.0	23.17	-0.05	Left	Tilt	F1188	1:1	0.174	1.211	0.211	
ANSI / IEEE C95.1 1992 - SAFETY LIMIT Spatial Peak Uncontrolled Exposure/General Population							Head 1.6 W/kg (mW/g) averaged over 1 gram							

**Table 11-2
GSM 1900 Head SAR**

MEASUREMENT RESULTS														
FREQUENCY		Mode/Band	Service	Maximum Allowed Power [dBm]	Conducted Power [dBm]	Power Drift [dB]	Side	Test Position	Device Serial Number	Duty Cycle	SAR (1g)	Scaling Factor	Scaled SAR (1g)	Plot #
MHz	Ch.										(W/kg)		(W/kg)	
1880.00	661	GSM 1900	GSM	31.5	31.29	0.01	Right	Cheek	F1187	1:8.3	0.132	1.050	0.139	
1880.00	661	GSM 1900	GSM	31.5	31.29	0.00	Right	Tilt	F1187	1:8.3	0.074	1.050	0.078	
1880.00	661	GSM 1900	GSM	31.5	31.29	-0.04	Left	Cheek	F1187	1:8.3	0.168	1.050	0.176	A2
1880.00	661	GSM 1900	GSM	31.5	31.29	0.01	Left	Tilt	F1187	1:8.3	0.052	1.050	0.055	
ANSI / IEEE C95.1 1992 - SAFETY LIMIT Spatial Peak Uncontrolled Exposure/General Population							Head 1.6 W/kg (mW/g) averaged over 1 gram							

**Table 11-3
UMTS 1900 Head SAR**

MEASUREMENT RESULTS														
FREQUENCY		Mode/Band	Service	Maximum Allowed Power [dBm]	Conducted Power [dBm]	Power Drift [dB]	Side	Test Position	Device Serial Number	Duty Cycle	SAR (1g)	Scaling Factor	Scaled SAR (1g)	Plot #
MHz	Ch.										(W/kg)		(W/kg)	
1880.00	9400	UMTS 1900	RMC	23.5	23.29	-0.02	Right	Cheek	F1187	1:1	0.187	1.050	0.196	
1880.00	9400	UMTS 1900	RMC	23.5	23.29	0.04	Right	Tilt	F1187	1:1	0.111	1.050	0.117	
1880.00	9400	UMTS 1900	RMC	23.5	23.29	0.01	Left	Cheek	F1187	1:1	0.300	1.050	0.315	A3
1880.00	9400	UMTS 1900	RMC	23.5	23.29	-0.03	Left	Tilt	F1187	1:1	0.077	1.050	0.081	
ANSI / IEEE C95.1 1992 - SAFETY LIMIT Spatial Peak Uncontrolled Exposure/General Population							Head 1.6 W/kg (mW/g) averaged over 1 gram							

FCC ID: A3LSMG900S	 PCTEST ENGINEERING LABORATORY, INC.	SAR EVALUATION REPORT		Reviewed by: Quality Manager
Document S/N: OY1402030286-R1.A3L	Test Dates: 02/03/14 – 02/10/14	DUT Type: Portable Handset		Page 37 of 64

**Table 11-4
LTE Band 5 (Cell) Head SAR**



MEASUREMENT RESULTS																			
FREQUENCY		Mode	Bandwidth [MHz]	Maximum Allowed Power [dBm]	Conducted Power [dBm]	Power Drift [dB]	MPR [dB]	Side	Test Position	Modulation	RB Size	RB Offset	Device Serial Number	Duty Cycle	SAR (1g) (W/kg)	Scaling Factor	Scaled SAR (1g) (W/kg)	Plot #	
MHz	Ch.																		
836.50	20525	Mid	LTE Band 5 (Cell)	10	24.5	24.34	0.03	0	Right	Cheek	QPSK	1	25	F1187	1:1	0.450	1.038	0.467	
836.50	20525	Mid	LTE Band 5 (Cell)	10	23.5	23.09	0.01	1	Right	Cheek	QPSK	25	25	F1187	1:1	0.294	1.099	0.323	
836.50	20525	Mid	LTE Band 5 (Cell)	10	24.5	24.34	-0.06	0	Right	Tilt	QPSK	1	25	F1187	1:1	0.242	1.038	0.251	
836.50	20525	Mid	LTE Band 5 (Cell)	10	23.5	23.09	0.04	1	Right	Tilt	QPSK	25	25	F1187	1:1	0.181	1.099	0.199	
836.50	20525	Mid	LTE Band 5 (Cell)	10	24.5	24.34	0.04	0	Left	Cheek	QPSK	1	25	F1187	1:1	0.485	1.038	0.503	A4
836.50	20525	Mid	LTE Band 5 (Cell)	10	23.5	23.09	0.01	1	Left	Cheek	QPSK	25	25	F1187	1:1	0.393	1.099	0.432	
836.50	20525	Mid	LTE Band 5 (Cell)	10	24.5	24.34	0.06	0	Left	Tilt	QPSK	1	25	F1187	1:1	0.239	1.038	0.248	
836.50	20525	Mid	LTE Band 5 (Cell)	10	23.5	23.09	0.01	1	Left	Tilt	QPSK	25	25	F1187	1:1	0.191	1.099	0.210	
ANSI / IEEE C95.1 1992 - SAFETY LIMIT Spatial Peak Uncontrolled Exposure/General Population										Head 1.6 W/kg (mW/g) averaged over 1 gram									

**Table 11-5
LTE Band 17 Head SAR**

MEASUREMENT RESULTS																			
FREQUENCY		Mode	Bandwidth [MHz]	Maximum Allowed Power [dBm]	Conducted Power [dBm]	Power Drift [dB]	MPR [dB]	Side	Test Position	Modulation	RB Size	RB Offset	Device Serial Number	Duty Cycle	SAR (1g) (W/kg)	Scaling Factor	Scaled SAR (1g) (W/kg)	Plot #	
MHz	Ch.																		
710.00	23790	Mid	LTE Band 17	10	23.5	23.49	-0.02	0	Right	Cheek	QPSK	1	25	F1187	1:1	0.126	1.002	0.126	
710.00	23790	Mid	LTE Band 17	10	22.5	22.41	0.05	1	Right	Cheek	QPSK	25	25	F1187	1:1	0.099	1.021	0.101	
710.00	23790	Mid	LTE Band 17	10	23.5	23.49	-0.17	0	Right	Tilt	QPSK	1	25	F1187	1:1	0.093	1.002	0.093	
710.00	23790	Mid	LTE Band 17	10	22.5	22.41	0.05	1	Right	Tilt	QPSK	25	25	F1187	1:1	0.071	1.021	0.072	
710.00	23790	Mid	LTE Band 17	10	23.5	23.49	0.06	0	Left	Cheek	QPSK	1	25	F1187	1:1	0.144	1.002	0.144	A5
710.00	23790	Mid	LTE Band 17	10	22.5	22.41	-0.06	1	Left	Cheek	QPSK	25	25	F1187	1:1	0.114	1.021	0.116	
710.00	23790	Mid	LTE Band 17	10	23.5	23.49	0.08	0	Left	Tilt	QPSK	1	25	F1187	1:1	0.101	1.002	0.101	
710.00	23790	Mid	LTE Band 17	10	22.5	22.41	0.18	1	Left	Tilt	QPSK	25	25	F1187	1:1	0.077	1.021	0.079	
ANSI / IEEE C95.1 1992 - SAFETY LIMIT Spatial Peak Uncontrolled Exposure/General Population										Head 1.6 W/kg (mW/g) averaged over 1 gram									

**Table 11-6
DTS Head SAR Antenna 1**

MEASUREMENT RESULTS																
FREQUENCY		Mode	Service	Maximum Allowed Power [dBm]	Conducted Power [dBm]	Power Drift [dB]	Side	Test Position	Device Serial Number	Data Rate (Mbps)	Duty Cycle	SAR (1g) (W/kg)	Scaling Factor	Scaled SAR (1g) (W/kg)	Plot #	
MHz	Ch.															
2462	11	IEEE 802.11b	DSSS	17.5	16.76	0.10	Right	Cheek	F1185	1	1:1	0.465	1.186	0.551	A6	
2462	11	IEEE 802.11b	DSSS	17.5	16.76	0.12	Right	Tilt	F1185	1	1:1	0.416	1.186	0.493		
2462	11	IEEE 802.11b	DSSS	17.5	16.76	0.11	Left	Cheek	F1185	1	1:1	0.312	1.186	0.370		
2462	11	IEEE 802.11b	DSSS	17.5	16.76	0.16	Left	Tilt	F1185	1	1:1	0.359	1.186	0.426		
5785	157	IEEE 802.11a	OFDM	12.5	11.90	-0.03	Right	Cheek	F1186	6	1:1	0.293	1.148	0.336		
5765	153	IEEE 802.11a	OFDM	12.5	11.85	-0.06	Right	Tilt	F1186	6	1:1	0.354	1.161	0.411		
5785	157	IEEE 802.11a	OFDM	12.5	11.90	0.05	Right	Tilt	F1186	6	1:1	0.359	1.148	0.412	A7	
5805	161	IEEE 802.11a	OFDM	12.5	11.79	0.03	Right	Tilt	F1186	6	1:1	0.333	1.178	0.392		
5775	155	IEEE 802.11ac	OFDM	10.5	9.76	0.08	Right	Tilt	F1186	29.3	1:1	0.199	1.186	0.236		
5785	157	IEEE 802.11a	OFDM	12.5	11.90	0.14	Left	Cheek	F1186	6	1:1	0.339	1.148	0.389		
5785	157	IEEE 802.11a	OFDM	12.5	11.90	-0.05	Left	Tilt	F1186	6	1:1	0.343	1.148	0.394		
ANSI / IEEE C95.1 1992 - SAFETY LIMIT Spatial Peak Uncontrolled Exposure/General Population										Head 1.6 W/kg (mW/g) averaged over 1 gram						



FCC ID: A3LSMG900S	 PCTEST ENGINEERING LABORATORY, INC.	SAR EVALUATION REPORT		Reviewed by: Quality Manager
Document S/N: OY1402030286-R1.A3L	Test Dates: 02/03/14 – 02/10/14	DUT Type: Portable Handset		Page 38 of 64

**Table 11-7
NII Head SAR Antenna 1**

MEASUREMENT RESULTS															
FREQUENCY		Mode	Service	Maximum Allowed Power [dBm]	Conducted Power [dBm]	Power Drift [dB]	Side	Test Position	Device Serial Number	Data Rate (Mbps)	Duty Cycle	SAR (1g)	Scaling Factor	Scaled SAR (1g)	Plot #
MHz	Ch.											(W/kg)		(W/kg)	
5180	36	IEEE 802.11a	OFDM	12.5	11.56	0.21	Right	Cheek	F1186	6	1:1	0.099	1.242	0.123	
5180	36	IEEE 802.11a	OFDM	12.5	11.56	0.16	Right	Tilt	F1186	6	1:1	0.111	1.242	0.138	
5210	42	IEEE 802.11ac	OFDM	10.5	9.37	-0.01	Right	Tilt	F1186	29.3	1:1	0.068	1.297	0.088	
5180	36	IEEE 802.11a	OFDM	12.5	11.56	0.17	Left	Cheek	F1186	6	1:1	0.094	1.242	0.117	
5180	36	IEEE 802.11a	OFDM	12.5	11.56	0.04	Left	Tilt	F1186	6	1:1	0.104	1.242	0.129	
5260	52	IEEE 802.11a	OFDM	12.5	11.61	0.03	Right	Cheek	F1186	6	1:1	0.149	1.227	0.183	
5260	52	IEEE 802.11a	OFDM	12.5	11.61	0.17	Right	Tilt	F1186	6	1:1	0.175	1.227	0.215	
5290	58	IEEE 802.11ac	OFDM	10.5	9.64	0.04	Right	Tilt	F1186	29.3	1:1	0.111	1.219	0.135	
5260	52	IEEE 802.11a	OFDM	12.5	11.61	0.21	Left	Cheek	F1186	6	1:1	0.136	1.227	0.167	
5260	52	IEEE 802.11a	OFDM	12.5	11.61	0.03	Left	Tilt	F1186	6	1:1	0.156	1.227	0.191	
5660	132	IEEE 802.11a	OFDM	12.5	12.08	-0.03	Right	Cheek	F1186	6	1:1	0.243	1.102	0.268	
5660	132	IEEE 802.11a	OFDM	12.5	12.08	-0.03	Right	Tilt	F1186	6	1:1	0.379	1.102	0.418	
5500	100	IEEE 802.11a	OFDM	12.5	11.51	0.00	Right	Tilt	F1186	6	1:1	0.389	1.256	0.489	A8
5580	116	IEEE 802.11a	OFDM	12.5	12.07	-0.05	Right	Tilt	F1186	6	1:1	0.323	1.104	0.357	
5530	106	IEEE 802.11ac	OFDM	10.5	9.20	-0.01	Right	Tilt	F1186	29.3	1:1	0.213	1.349	0.287	
5660	132	IEEE 802.11a	OFDM	12.5	12.08	-0.04	Left	Cheek	F1186	6	1:1	0.317	1.102	0.349	
5660	132	IEEE 802.11a	OFDM	12.5	12.08	0.19	Left	Tilt	F1186	6	1:1	0.350	1.102	0.386	
ANSI / IEEE C95.1 1992 - SAFETY LIMIT Spatial Peak Uncontrolled Exposure/General Population								Head 1.6 W/kg (mW/g) averaged over 1 gram							

**Table 11-8
DTS Head SAR Antenna 2**

MEASUREMENT RESULTS															
FREQUENCY		Mode	Service	Maximum Allowed Power [dBm]	Conducted Power [dBm]	Power Drift [dB]	Side	Test Position	Device Serial Number	Data Rate (Mbps)	Duty Cycle	SAR (1g)	Scaling Factor	Scaled SAR (1g)	Plot #
MHz	Ch.											(W/kg)		(W/kg)	
2412	1	IEEE 802.11b	DSSS	17.5	16.61	0.08	Right	Cheek	F1185	1	1:1	0.133	1.227	0.163	
2412	1	IEEE 802.11b	DSSS	17.5	16.61	0.00	Right	Tilt	F1185	1	1:1	0.093	1.227	0.114	
2412	1	IEEE 802.11b	DSSS	17.5	16.61	0.20	Left	Cheek	F1185	1	1:1	0.054	1.227	0.066	
2412	1	IEEE 802.11b	DSSS	17.5	16.61	0.03	Left	Tilt	F1185	1	1:1	0.064	1.227	0.079	
5805	161	IEEE 802.11a	OFDM	12.5	12.16	0.03	Right	Cheek	F1186	6	1:1	0.034	1.081	0.037	
5805	161	IEEE 802.11a	OFDM	12.5	12.16	-0.04	Right	Tilt	F1186	6	1:1	0.041	1.081	0.044	
5775	155	IEEE 802.11ac	OFDM	10.5	10.07	-0.02	Right	Tilt	F1186	29.3	1:1	0.020	1.104	0.022	
5805	161	IEEE 802.11a	OFDM	12.5	12.16	0.03	Left	Cheek	F1186	6	1:1	0.011	1.081	0.012	
5805	161	IEEE 802.11a	OFDM	12.5	12.16	0.03	Left	Tilt	F1186	6	1:1	0.004	1.081	0.004	
ANSI / IEEE C95.1 1992 - SAFETY LIMIT Spatial Peak Uncontrolled Exposure/General Population								Head 1.6 W/kg (mW/g) averaged over 1 gram							

FCC ID: A3LSMG900S	 PCTEST ENGINEERING LABORATORY, INC.	SAR EVALUATION REPORT		Reviewed by: Quality Manager
Document S/N: OY1402030286-R1.A3L	Test Dates: 02/03/14 – 02/10/14	DUT Type: Portable Handset		Page 39 of 64

**Table 11-9
NII Head SAR Antenna 2**

MEASUREMENT RESULTS															
FREQUENCY		Mode	Service	Maximum Allowed Power [dBm]	Conducted Power [dBm]	Power Drift [dB]	Side	Test Position	Device Serial Number	Data Rate (Mbps)	Duty Cycle	SAR (1g)	Scaling Factor	Scaled SAR (1g)	Plot #
MHz	Ch.											(W/kg)		(W/kg)	
5200	40	IEEE 802.11a	OFDM	12.5	12.01	-0.11	Right	Cheek	F1186	6	1:1	0.119	1.119	0.133	
5210	42	IEEE 802.11ac	OFDM	10.5	9.40	0.20	Right	Cheek	F1186	29.3	1:1	0.076	1.288	0.098	
5200	40	IEEE 802.11a	OFDM	12.5	12.01	0.11	Right	Tilt	F1186	6	1:1	0.016	1.119	0.018	
5200	40	IEEE 802.11a	OFDM	12.5	12.01	0.11	Left	Cheek	F1186	6	1:1	0.016	1.119	0.018	
5200	40	IEEE 802.11a	OFDM	12.5	12.01	0.04	Left	Tilt	F1186	6	1:1	0.005	1.119	0.006	
5280	56	IEEE 802.11a	OFDM	12.5	11.84	0.14	Right	Cheek	F1186	6	1:1	0.102	1.164	0.119	
5290	58	IEEE 802.11ac	OFDM	10.5	9.53	0.06	Right	Cheek	F1186	29.3	1:1	0.066	1.250	0.083	
5280	56	IEEE 802.11a	OFDM	12.5	11.84	-0.16	Right	Tilt	F1186	6	1:1	0.010	1.164	0.012	
5280	56	IEEE 802.11a	OFDM	12.5	11.84	0.03	Left	Cheek	F1186	6	1:1	0.010	1.164	0.012	
5280	56	IEEE 802.11a	OFDM	12.5	11.84	0.13	Left	Tilt	F1186	6	1:1	0.006	1.164	0.007	
5520	104	IEEE 802.11a	OFDM	12.5	11.80	-0.05	Right	Cheek	F1186	6	1:1	0.036	1.175	0.042	
5530	106	IEEE 802.11ac	OFDM	10.5	9.53	-0.04	Right	Cheek	F1186	29.3	1:1	0.021	1.250	0.026	
5520	104	IEEE 802.11a	OFDM	12.5	11.80	-0.11	Right	Tilt	F1186	6	1:1	0.008	1.175	0.009	
5520	104	IEEE 802.11a	OFDM	12.5	11.80	0.11	Left	Cheek	F1186	6	1:1	0.000	1.175	0.000	
5520	104	IEEE 802.11a	OFDM	12.5	11.80	0.00	Left	Tilt	F1186	6	1:1	0.001	1.175	0.001	
ANSI / IEEE C95.1 1992 - SAFETY LIMIT Spatial Peak Uncontrolled Exposure/General Population								Head 1.6 W/kg (mW/g) averaged over 1 gram							

**Table 11-10
DTS Head SAR MIMO**

MEASUREMENT RESULTS															
FREQUENCY		Mode	Service	Maximum Allowed Power [dBm]	Conducted Power [dBm]	Power Drift [dB]	Side	Test Position	Device Serial Number	Data Rate (Mbps)	Duty Cycle	SAR (1g)	Scaling Factor	Scaled SAR (1g)	Plot #
MHz	Ch.											(W/kg)		(W/kg)	
2437	6	IEEE 802.11n	OFDM	12.5	12.32	0.04	Right	Cheek	F1185	13	1:1	0.124	1.042	0.129	
2437	6	IEEE 802.11n	OFDM	12.5	12.32	0.05	Right	Tilt	F1185	13	1:1	0.092	1.042	0.096	
2437	6	IEEE 802.11n	OFDM	12.5	12.32	0.14	Left	Cheek	F1185	13	1:1	0.089	1.042	0.093	
2437	6	IEEE 802.11n	OFDM	12.5	12.32	0.15	Left	Tilt	F1185	13	1:1	0.071	1.042	0.074	
5785	157	IEEE 802.11n	OFDM	12.5	12.20	0.05	Right	Cheek	F1186	13	1:1	0.006	1.072	0.006	
5785	157	IEEE 802.11n	OFDM	12.5	12.20	0.11	Right	Tilt	F1186	13	1:1	0.051	1.072	0.055	
5785	157	IEEE 802.11n	OFDM	12.5	12.20	0.05	Left	Cheek	F1186	13	1:1	0.053	1.072	0.057	
5785	157	IEEE 802.11n	OFDM	12.5	12.20	0.08	Left	Tilt	F1186	13	1:1	0.054	1.072	0.058	
ANSI / IEEE C95.1 1992 - SAFETY LIMIT Spatial Peak Uncontrolled Exposure/General Population								Head 1.6 W/kg (mW/g) averaged over 1 gram							

FCC ID: A3LSMG900S	 PCTEST ENGINEERING LABORATORY, INC.	SAR EVALUATION REPORT		Reviewed by: Quality Manager
Document S/N: OY1402030286-R1.A3L	Test Dates: 02/03/14 – 02/10/14	DUT Type: Portable Handset		Page 40 of 64

**Table 11-11
NII Head SAR Antenna MIMO**

MEASUREMENT RESULTS															
FREQUENCY		Mode	Service	Maximum Allowed Power [dBm]	Conducted Power [dBm]	Power Drift [dB]	Side	Test Position	Device Serial Number	Data Rate (Mbps)	Duty Cycle	SAR (1g) (W/kg)	Scaling Factor	Scaled SAR (1g) (W/kg)	Plot #
MHz	Ch.														
5220	44	IEEE 802.11n	OFDM	12.5	11.86	0.05	Right	Cheek	F1186	13	1:1	0.033	1.159	0.038	
5220	44	IEEE 802.11n	OFDM	12.5	11.86	0.12	Right	Tilt	F1186	13	1:1	0.017	1.159	0.020	
5220	44	IEEE 802.11n	OFDM	12.5	11.86	0.04	Left	Cheek	F1186	13	1:1	0.017	1.159	0.020	
5220	44	IEEE 802.11n	OFDM	12.5	11.86	0.03	Left	Tilt	F1186	13	1:1	0.016	1.159	0.019	
5300	60	IEEE 802.11n	OFDM	12.5	11.85	0.10	Right	Cheek	F1186	13	1:1	0.023	1.161	0.027	
5300	60	IEEE 802.11n	OFDM	12.5	11.85	-0.03	Right	Tilt	F1186	13	1:1	0.025	1.161	0.029	
5300	60	IEEE 802.11n	OFDM	12.5	11.85	0.02	Left	Cheek	F1186	13	1:1	0.022	1.161	0.026	
5300	60	IEEE 802.11n	OFDM	12.5	11.85	0.15	Left	Tilt	F1186	13	1:1	0.022	1.161	0.026	
5680	136	IEEE 802.11n	OFDM	12.5	12.24	0.14	Right	Cheek	F1186	13	1:1	0.018	1.062	0.019	
5680	136	IEEE 802.11n	OFDM	12.5	12.24	0.05	Right	Tilt	F1186	13	1:1	0.076	1.062	0.081	
5680	136	IEEE 802.11n	OFDM	12.5	12.24	0.01	Left	Cheek	F1186	13	1:1	0.059	1.062	0.063	
5680	136	IEEE 802.11n	OFDM	12.5	12.24	0.10	Left	Tilt	F1186	13	1:1	0.063	1.062	0.067	
ANSI / IEEE C95.1 1992 - SAFETY LIMIT Spatial Peak Uncontrolled Exposure/General Population								Head 1.6 W/kg (mW/g) averaged over 1 gram							



11.2 Standalone Body-Worn SAR Data

**Table 11-12
GSM/UMTS Body-Worn SAR Data**

MEASUREMENT RESULTS															
FREQUENCY		Mode	Service	Maximum Allowed Power [dBm]	Conducted Power [dBm]	Power Drift [dB]	Spacing	Device Serial Number	# of Time Slots	Duty Cycle	Side	SAR (1g) (W/kg)	Scaling Factor	Scaled SAR (1g) (W/kg)	Plot #
MHz	Ch.														
836.60	4183	UMTS 850	RMC	24.0	23.17	0.00	10 mm	F1188	N/A	1:1	back	0.585	1.211	0.708	A9
1880.00	661	GSM 1900	GSM	31.5	31.29	-0.09	10 mm	F1188	1	1:8.3	back	0.404	1.050	0.424	A10
1880.00	9400	UMTS 1900	RMC	23.5	23.29	0.01	10 mm	F1188	N/A	1:1	back	0.544	1.050	0.571	A12
ANSI / IEEE C95.1 1992 - SAFETY LIMIT Spatial Peak Uncontrolled Exposure/General Population								Body 1.6 W/kg (mW/g) averaged over 1 gram							

**Table 11-13
LTE Body-Worn SAR**

MEASUREMENT RESULTS																			
FREQUENCY		Mode	Bandwidth [MHz]	Maximum Allowed Power [dBm]	Conducted Power [dBm]	Power Drift [dB]	MPR [dB]	Device Serial Number	Modulation	RB Size	RB Offset	Spacing	Side	Duty Cycle	SAR (1g) (W/kg)	Scaling Factor	Scaled SAR (1g) (W/kg)	Plot #	
MHz	Ch.																		
836.50	20525	Mid	LTE Band 5 (Cell)	10	24.5	24.34	0.00	0	F1187	QPSK	1	25	10 mm	back	1:1	0.797	1.038	0.827	A14
836.50	20525	Mid	LTE Band 5 (Cell)	10	23.5	23.09	0.03	1	F1187	QPSK	25	25	10 mm	back	1:1	0.611	1.099	0.671	
836.50	20525	Mid	LTE Band 5 (Cell)	10	23.5	23.03	0.00	1	F1187	QPSK	50	0	10 mm	back	1:1	0.589	1.114	0.656	
710.00	23790	Mid	LTE Band 17	10	23.5	23.49	0.03	0	F1187	QPSK	1	25	10 mm	back	1:1	0.352	1.002	0.353	A15
710.00	23790	Mid	LTE Band 17	10	22.5	22.41	-0.03	1	F1187	QPSK	25	25	10 mm	back	1:1	0.264	1.021	0.270	
ANSI / IEEE C95.1 1992 - SAFETY LIMIT Spatial Peak Uncontrolled Exposure/General Population								Body 1.6 W/kg (mW/g) averaged over 1 gram											

FCC ID: A3LSMG900S	 PCTEST ENGINEERING LABORATORY, INC.	SAR EVALUATION REPORT		Reviewed by: Quality Manager
Document S/N: OY1402030286-R1.A3L	Test Dates: 02/03/14 – 02/10/14	DUT Type: Portable Handset		Page 41 of 64

**Table 11-14
DTS Body-Worn SAR Antenna 1**



MEASUREMENT RESULTS															
FREQUENCY		Mode	Service	Maximum Allowed Power [dBm]	Conducted Power [dBm]	Power Drift [dB]	Spacing	Device Serial Number	Data Rate (Mbps)	Side	Duty Cycle	SAR (1g)	Scaling Factor	Scaled SAR (1g)	Plot #
MHz	Ch.											(W/kg)		(W/kg)	
2462	11	IEEE 802.11b	DSSS	17.5	16.76	-0.05	10 mm	419EF	1	back	1:1	0.113	1.186	0.134	
5785	157	IEEE 802.11a	OFDM	12.5	11.90	-0.05	10 mm	F1186	6	back	1:1	0.080	1.148	0.092	A17
5775	155	IEEE 802.11ac	OFDM	10.5	9.76	-0.12	10 mm	F1186	29.3	back	1:1	0.041	1.186	0.049	
ANSI / IEEE C95.1 1992 - SAFETY LIMIT Spatial Peak Uncontrolled Exposure/General Population							Body 1.6 W/kg (mW/g) averaged over 1 gram								

**Table 11-15
NII Body-Worn SAR Antenna 1**

MEASUREMENT RESULTS															
FREQUENCY		Mode	Service	Maximum Allowed Power [dBm]	Conducted Power [dBm]	Power Drift [dB]	Spacing	Device Serial Number	Data Rate (Mbps)	Side	Duty Cycle	SAR (1g)	Scaling Factor	Scaled SAR (1g)	Plot #
MHz	Ch.											(W/kg)		(W/kg)	
5180	36	IEEE 802.11a	OFDM	12.5	11.56	-0.03	10 mm	F1186	6	back	1:1	0.032	1.242	0.040	
5210	42	IEEE 802.11ac	OFDM	10.5	9.37	-0.10	10 mm	F1186	29.3	back	1:1	0.023	1.297	0.030	
5260	52	IEEE 802.11a	OFDM	12.5	11.61	-0.07	10 mm	F1186	6	back	1:1	0.042	1.227	0.052	
5290	58	IEEE 802.11ac	OFDM	10.5	9.64	-0.17	10 mm	F1186	29.3	back	1:1	0.027	1.219	0.033	
5660	132	IEEE 802.11a	OFDM	12.5	12.08	0.02	10 mm	F1186	6	back	1:1	0.072	1.102	0.079	A18
5530	106	IEEE 802.11ac	OFDM	10.5	9.20	-0.19	10 mm	F1186	29.3	back	1:1	0.048	1.349	0.065	
ANSI / IEEE C95.1 1992 - SAFETY LIMIT Spatial Peak Uncontrolled Exposure/General Population							Body 1.6 W/kg (mW/g) averaged over 1 gram								

**Table 11-16
DTS Body-Worn SAR Antenna 2**

MEASUREMENT RESULTS															
FREQUENCY		Mode	Service	Maximum Allowed Power [dBm]	Conducted Power [dBm]	Power Drift [dB]	Spacing	Device Serial Number	Data Rate (Mbps)	Side	Duty Cycle	SAR (1g)	Scaling Factor	Scaled SAR (1g)	Plot #
MHz	Ch.											(W/kg)		(W/kg)	
2412	1	IEEE 802.11b	DSSS	17.5	16.61	0.00	10 mm	419EF	1	back	1:1	0.222	1.227	0.272	A16
5805	161	IEEE 802.11a	OFDM	12.5	12.16	-0.03	10 mm	F1186	6	back	1:1	0.023	1.081	0.025	
5775	155	IEEE 802.11ac	OFDM	10.5	10.07	-0.03	10 mm	F1186	29.3	back	1:1	0.009	1.104	0.010	
ANSI / IEEE C95.1 1992 - SAFETY LIMIT Spatial Peak Uncontrolled Exposure/General Population							Body 1.6 W/kg (mW/g) averaged over 1 gram								

FCC ID: A3LSMG900S	 PCTEST ENGINEERING LABORATORY, INC.	SAR EVALUATION REPORT		Reviewed by: Quality Manager
Document S/N: OY1402030286-R1.A3L	Test Dates: 02/03/14 – 02/10/14	DUT Type: Portable Handset		Page 42 of 64

**Table 11-17
NII Body-Worn SAR Antenna 2**



MEASUREMENT RESULTS															
FREQUENCY		Mode	Service	Maximum Allowed Power [dBm]	Conducted Power [dBm]	Power Drift [dB]	Spacing	Device Serial Number	Data Rate (Mbps)	Side	Duty Cycle	SAR (1g)	Scaling Factor	Scaled SAR (1g)	Plot #
MHz	Ch.											(W/kg)		(W/kg)	
5200	40	IEEE 802.11a	OFDM	12.5	12.01	-0.05	10 mm	F1186	6	back	1:1	0.049	1.119	0.055	
5210	42	IEEE 802.11ac	OFDM	10.5	9.40	-0.14	10 mm	F1186	29.3	back	1:1	0.024	1.288	0.031	
5280	56	IEEE 802.11a	OFDM	12.5	11.84	0.02	10 mm	F1186	6	back	1:1	0.039	1.164	0.045	
5290	58	IEEE 802.11ac	OFDM	10.5	9.53	0.08	10 mm	F1186	29.3	back	1:1	0.020	1.250	0.025	
5520	104	IEEE 802.11a	OFDM	12.5	11.80	0.12	10 mm	F1186	6	back	1:1	0.006	1.175	0.007	
5530	106	IEEE 802.11ac	OFDM	10.5	9.53	-0.09	10 mm	F1186	29.3	back	1:1	0.010	1.250	0.013	
ANSI / IEEE C95.1 1992 - SAFETY LIMIT Spatial Peak Uncontrolled Exposure/General Population							Body 1.6 W/kg (mW/g) averaged over 1 gram								

**Table 11-18
DTS Body-Worn SAR MIMO**

MEASUREMENT RESULTS															
FREQUENCY		Mode	Service	Maximum Allowed Power [dBm]	Conducted Power [dBm]	Power Drift [dB]	Spacing	Device Serial Number	Data Rate (Mbps)	Side	Duty Cycle	SAR (1g)	Scaling Factor	Scaled SAR (1g)	Plot #
MHz	Ch.											(W/kg)		(W/kg)	
2437	6	IEEE 802.11n	OFDM	12.5	12.32	0.10	10 mm	419EF	13	back	1:1	0.079	1.042	0.082	
5785	157	IEEE 802.11n	OFDM	12.5	12.20	0.12	10 mm	F1186	13	back	1:1	0.009	1.072	0.010	
ANSI / IEEE C95.1 1992 - SAFETY LIMIT Spatial Peak Uncontrolled Exposure/General Population							Body 1.6 W/kg (mW/g) averaged over 1 gram								

**Table 11-19
NII Body-Worn SAR MIMO**

MEASUREMENT RESULTS															
FREQUENCY		Mode	Service	Maximum Allowed Power [dBm]	Conducted Power [dBm]	Power Drift [dB]	Spacing	Device Serial Number	Data Rate (Mbps)	Side	Duty Cycle	SAR (1g)	Scaling Factor	Scaled SAR (1g)	Plot #
MHz	Ch.											(W/kg)		(W/kg)	
5220	44	IEEE 802.11n	OFDM	12.5	11.86	0.10	10 mm	F1186	13	back	1:1	0.027	1.159	0.031	
5300	60	IEEE 802.11n	OFDM	12.5	11.85	0.04	10 mm	F1186	13	back	1:1	0.023	1.161	0.027	
5680	136	IEEE 802.11n	OFDM	12.5	12.24	-0.16	10 mm	F1186	13	back	1:1	0.012	1.062	0.013	
ANSI / IEEE C95.1 1992 - SAFETY LIMIT Spatial Peak Uncontrolled Exposure/General Population							Body 1.6 W/kg (mW/g) averaged over 1 gram								

FCC ID: A3LSMG900S	 PCTEST ENGINEERING LABORATORY, INC.	SAR EVALUATION REPORT		Reviewed by: Quality Manager
Document S/N: OY1402030286-R1.A3L	Test Dates: 02/03/14 – 02/10/14	DUT Type: Portable Handset		Page 43 of 64

11.3 Standalone Wireless Router SAR Data



**Table 11-20
GPRS/UMTS Hotspot SAR Data**

MEASUREMENT RESULTS															
FREQUENCY		Mode	Service	Maximum Allowed Power [dBm]	Conducted Power [dBm]	Power Drift [dB]	Spacing	Device Serial Number	# of GPRS Slots	Duty Cycle	Side	SAR (1g)	Scaling Factor	Scaled SAR (1g)	Plot #
MHz	Ch.											(W/kg)		(W/kg)	
836.60	4183	UMTS 850	RMC	24.0	23.17	0.00	10 mm	F1188	N/A	1:1	back	0.585	1.211	0.708	A9
836.60	4183	UMTS 850	RMC	24.0	23.17	-0.03	10 mm	F1188	N/A	1:1	front	0.469	1.211	0.568	
836.60	4183	UMTS 850	RMC	24.0	23.17	0.01	10 mm	F1188	N/A	1:1	bottom	0.137	1.211	0.166	
836.60	4183	UMTS 850	RMC	24.0	23.17	0.01	10 mm	F1188	N/A	1:1	right	0.343	1.211	0.415	
836.60	4183	UMTS 850	RMC	24.0	23.17	-0.12	10 mm	F1188	N/A	1:1	left	0.543	1.211	0.658	
1880.00	661	GSM 1900	GPRS	29.0	28.71	-0.09	10 mm	F1188	3	1:2.76	back	0.517	1.069	0.553	
1880.00	661	GSM 1900	GPRS	29.0	28.71	0.04	10 mm	F1188	3	1:2.76	front	0.665	1.069	0.711	A11
1880.00	661	GSM 1900	GPRS	29.0	28.71	0.01	10 mm	F1188	3	1:2.76	bottom	0.376	1.069	0.402	
1880.00	661	GSM 1900	GPRS	29.0	28.71	0.05	10 mm	F1188	3	1:2.76	right	0.032	1.069	0.034	
1880.00	661	GSM 1900	GPRS	29.0	28.71	0.06	10 mm	F1188	3	1:2.76	left	0.218	1.069	0.233	
1880.00	9400	UMTS 1900	RMC	23.5	23.29	0.01	10 mm	F1188	N/A	1:1	back	0.544	1.050	0.571	
1852.40	9262	UMTS 1900	RMC	23.5	23.37	-0.02	10 mm	F1188	N/A	1:1	front	0.856	1.030	0.882	A13
1880.00	9400	UMTS 1900	RMC	23.5	23.29	0.03	10 mm	F1188	N/A	1:1	front	0.768	1.050	0.806	
1907.60	9538	UMTS 1900	RMC	23.5	23.00	0.05	10 mm	F1188	N/A	1:1	front	0.695	1.122	0.780	
1880.00	9400	UMTS 1900	RMC	23.5	23.29	0.02	10 mm	F1188	N/A	1:1	bottom	0.645	1.050	0.677	
1880.00	9400	UMTS 1900	RMC	23.5	23.29	0.10	10 mm	F1188	N/A	1:1	right	0.042	1.050	0.044	
1880.00	9400	UMTS 1900	RMC	23.5	23.29	-0.01	10 mm	F1188	N/A	1:1	left	0.268	1.050	0.281	
1852.40	9262	UMTS 1900	RMC	23.5	23.37	0.11	10 mm	F1188	N/A	1:1	front	0.845	1.030	0.870	
ANSI / IEEE C95.1 1992 - SAFETY LIMIT Spatial Peak Uncontrolled Exposure/General Population										Body 1.6 W/kg (mW/g) averaged over 1 gram					

Note: Blue entry indicates variability measurements.

**Table 11-21
LTE Band 5 (Cell) Hotspot SAR**

MEASUREMENT RESULTS																			
FREQUENCY		Mode	Bandwidth [MHz]	Maximum Allowed Power [dBm]	Conducted Power [dBm]	Power Drift [dB]	MPR [dB]	Device Serial Number	Modulation	RB Size	RB Offset	Spacing	Side	Duty Cycle	SAR (1g)	Scaling Factor	Scaled SAR (1g)	Plot #	
MHz	Ch.														(W/kg)		(W/kg)		
836.50	20525	Mid	LTE Band 5 (Cell)	10	24.5	24.34	0.00	0	F1187	QPSK	1	25	10 mm	back	1:1	0.797	1.038	0.827	A14
836.50	20525	Mid	LTE Band 5 (Cell)	10	23.5	23.09	0.03	1	F1187	QPSK	25	25	10 mm	back	1:1	0.611	1.099	0.671	
836.50	20525	Mid	LTE Band 5 (Cell)	10	23.5	23.03	0.00	1	F1187	QPSK	50	0	10 mm	back	1:1	0.589	1.114	0.656	
836.50	20525	Mid	LTE Band 5 (Cell)	10	24.5	24.34	0.00	0	F1187	QPSK	1	25	10 mm	front	1:1	0.663	1.038	0.688	
836.50	20525	Mid	LTE Band 5 (Cell)	10	23.5	23.09	-0.05	1	F1187	QPSK	25	25	10 mm	front	1:1	0.512	1.099	0.563	
836.50	20525	Mid	LTE Band 5 (Cell)	10	24.5	24.34	0.03	0	F1187	QPSK	1	25	10 mm	bottom	1:1	0.207	1.038	0.215	
836.50	20525	Mid	LTE Band 5 (Cell)	10	23.5	23.09	-0.11	1	F1187	QPSK	25	25	10 mm	bottom	1:1	0.155	1.099	0.170	
836.50	20525	Mid	LTE Band 5 (Cell)	10	24.5	24.34	-0.05	0	F1187	QPSK	1	25	10 mm	right	1:1	0.494	1.038	0.513	
836.50	20525	Mid	LTE Band 5 (Cell)	10	23.5	23.09	0.02	1	F1187	QPSK	25	25	10 mm	right	1:1	0.363	1.099	0.399	
836.50	20525	Mid	LTE Band 5 (Cell)	10	24.5	24.34	-0.06	0	F1187	QPSK	1	25	10 mm	left	1:1	0.739	1.038	0.767	
836.50	20525	Mid	LTE Band 5 (Cell)	10	23.5	23.09	0.07	1	F1187	QPSK	25	25	10 mm	left	1:1	0.551	1.099	0.606	
ANSI / IEEE C95.1 1992 - SAFETY LIMIT Spatial Peak Uncontrolled Exposure/General Population										Body 1.6 W/kg (mW/g) averaged over 1 gram									



FCC ID: A3LSMG900S	 PCTEST ENGINEERING LABORATORY, INC.	SAR EVALUATION REPORT		Reviewed by: Quality Manager
Document S/N: OY1402030286-R1.A3L	Test Dates: 02/03/14 – 02/10/14	DUT Type: Portable Handset		Page 44 of 64

**Table 11-22
LTE Band 17 Hotspot SAR**

MEASUREMENT RESULTS																			
FREQUENCY		Mode	Bandwidth [MHz]	Maximum Allowed Power [dBm]	Conducted Power [dBm]	Power Drift [dB]	MPR [dB]	Device Serial Number	Modulation	RB Size	RB Offset	Spacing	Side	Duty Cycle	SAR (1g) (W/kg)	Scaling Factor	Scaled SAR (1g) (W/kg)	Plot #	
MHz	Ch.																		
710.00	23790	Mid	LTE Band 17	10	23.5	23.49	0.03	0	F1187	QPSK	1	25	10 mm	back	1:1	0.352	1.002	0.353	A15
710.00	23790	Mid	LTE Band 17	10	22.5	22.41	-0.03	1	F1187	QPSK	25	25	10 mm	back	1:1	0.264	1.021	0.270	
710.00	23790	Mid	LTE Band 17	10	23.5	23.49	0.00	0	F1187	QPSK	1	25	10 mm	front	1:1	0.266	1.002	0.267	
710.00	23790	Mid	LTE Band 17	10	22.5	22.41	0.04	1	F1187	QPSK	25	25	10 mm	front	1:1	0.206	1.021	0.210	
710.00	23790	Mid	LTE Band 17	10	23.5	23.49	0.02	0	F1187	QPSK	1	25	10 mm	bottom	1:1	0.083	1.002	0.083	
710.00	23790	Mid	LTE Band 17	10	22.5	22.41	0.20	1	F1187	QPSK	25	25	10 mm	bottom	1:1	0.063	1.021	0.064	
710.00	23790	Mid	LTE Band 17	10	23.5	23.49	0.03	0	F1187	QPSK	1	25	10 mm	right	1:1	0.148	1.002	0.151	
710.00	23790	Mid	LTE Band 17	10	22.5	22.41	0.05	1	F1187	QPSK	25	25	10 mm	right	1:1	0.097	1.021	0.151	
710.00	23790	Mid	LTE Band 17	10	23.5	23.49	0.04	0	F1187	QPSK	1	25	10 mm	left	1:1	0.231	1.002	0.231	
710.00	23790	Mid	LTE Band 17	10	22.5	22.41	0.03	1	F1187	QPSK	25	25	10 mm	left	1:1	0.228	1.021	0.233	
ANSI / IEEE C95.1 1992 - SAFETY LIMIT Spatial Peak Uncontrolled Exposure/General Population								Body 1.6 W/kg (mW/g) averaged over 1 gram											

**Table 11-23
WLAN Hotspot SAR Antenna 1**

MEASUREMENT RESULTS															
FREQUENCY		Mode	Service	Maximum Allowed Power [dBm]	Conducted Power [dBm]	Power Drift [dB]	Spacing	Device Serial Number	Data Rate (Mbps)	Side	Duty Cycle	SAR (1g) (W/kg)	Scaling Factor	Scaled SAR (1g) (W/kg)	Plot #
MHz	Ch.														
2462	11	IEEE 802.11b	DSSS	17.5	16.76	-0.05	10 mm	419EF	1	back	1:1	0.113	1.186	0.134	
2462	11	IEEE 802.11b	DSSS	17.5	16.76	0.02	10 mm	419EF	1	front	1:1	0.079	1.186	0.094	
2462	11	IEEE 802.11b	DSSS	17.5	16.76	0.07	10 mm	419EF	1	top	1:1	0.055	1.186	0.065	
2462	11	IEEE 802.11b	DSSS	17.5	16.76	0.02	10 mm	419EF	1	left	1:1	0.037	1.186	0.044	
5785	157	IEEE 802.11a	OFDM	12.5	11.90	-0.05	10 mm	F1186	6	back	1:1	0.080	1.148	0.092	
5785	157	IEEE 802.11a	OFDM	12.5	11.90	-0.15	10 mm	F1186	6	front	1:1	0.057	1.148	0.065	
5785	157	IEEE 802.11a	OFDM	12.5	11.90	-0.02	10 mm	F1186	6	top	1:1	0.184	1.148	0.211	A19
5775	155	IEEE 802.11ac	OFDM	10.5	9.76	-0.01	10 mm	F1186	29.3	top	1:1	0.094	1.186	0.111	
5785	157	IEEE 802.11a	OFDM	12.5	11.90	-0.14	10 mm	F1186	6	left	1:1	0.014	1.148	0.016	
ANSI / IEEE C95.1 1992 - SAFETY LIMIT Spatial Peak Uncontrolled Exposure/General Population								Body 1.6 W/kg (mW/g) averaged over 1 gram							

FCC ID: A3LSMG900S	 PCTEST ENGINEERING LABORATORY, INC.	SAR EVALUATION REPORT		Reviewed by: Quality Manager
Document S/N: OY1402030286-R1.A3L	Test Dates: 02/03/14 – 02/10/14	DUT Type: Portable Handset		Page 45 of 64

**Table 11-24
WLAN Hotspot SAR Antenna 2**

MEASUREMENT RESULTS															
FREQUENCY		Mode	Service	Maximum Allowed Power [dBm]	Conducted Power [dBm]	Power Drift [dB]	Spacing	Device Serial Number	Data Rate (Mbps)	Side	Duty Cycle	SAR (1g)	Scaling Factor	Scaled SAR (1g)	Plot #
MHz	Ch.											(W/kg)		(W/kg)	
2412	1	IEEE 802.11b	DSSS	17.5	16.61	0.00	10 mm	419EF	1	back	1:1	0.222	1.227	0.272	A16
2412	1	IEEE 802.11b	DSSS	17.5	16.61	0.04	10 mm	419EF	1	front	1:1	0.089	1.227	0.109	
2412	1	IEEE 802.11b	DSSS	17.5	16.61	0.14	10 mm	419EF	1	top	1:1	0.021	1.227	0.026	
2412	1	IEEE 802.11b	DSSS	17.5	16.61	0.09	10 mm	419EF	1	left	1:1	0.121	1.227	0.148	
5805	161	IEEE 802.11a	OFDM	12.5	12.16	-0.03	10 mm	F1186	6	back	1:1	0.023	1.081	0.025	
5805	161	IEEE 802.11a	OFDM	12.5	12.16	-0.07	10 mm	F1186	6	front	1:1	0.011	1.081	0.012	
5805	161	IEEE 802.11a	OFDM	12.5	12.16	0.03	10 mm	F1186	6	top	1:1	0.026	1.081	0.028	
5775	155	IEEE 802.11ac	OFDM	10.5	10.07	0.16	10 mm	F1186	29.3	top	1:1	0.011	1.104	0.012	
5805	161	IEEE 802.11a	OFDM	12.5	12.16	-0.04	10 mm	F1186	6	left	1:1	0.014	1.081	0.015	
ANSI / IEEE C95.1 1992 - SAFETY LIMIT Spatial Peak Uncontrolled Exposure/General Population							Body 1.6 W/kg (mW/g) averaged over 1 gram								



**Table 11-25
WLAN Hotspot SAR MIMO**

MEASUREMENT RESULTS															
FREQUENCY		Mode	Service	Maximum Allowed Power [dBm]	Conducted Power [dBm]	Power Drift [dB]	Spacing	Device Serial Number	Data Rate (Mbps)	Side	Duty Cycle	SAR (1g)	Scaling Factor	Scaled SAR (1g)	Plot #
MHz	Ch.											(W/kg)		(W/kg)	
2437	6	IEEE 802.11n	OFDM	12.5	12.32	0.10	10 mm	419EF	13	back	1:1	0.079	1.042	0.082	
2437	6	IEEE 802.11n	OFDM	12.5	12.32	0.07	10 mm	419EF	13	front	1:1	0.021	1.042	0.022	
2437	6	IEEE 802.11n	OFDM	12.5	12.32	-0.17	10 mm	419EF	13	top	1:1	0.012	1.042	0.013	
2437	6	IEEE 802.11n	OFDM	12.5	12.32	0.18	10 mm	419EF	13	left	1:1	0.022	1.042	0.023	
5785	157	IEEE 802.11n	OFDM	12.5	12.20	0.12	10 mm	F1186	13	back	1:1	0.009	1.072	0.010	
5785	157	IEEE 802.11n	OFDM	12.5	12.20	-0.14	10 mm	F1186	13	front	1:1	0.011	1.072	0.012	
5785	157	IEEE 802.11n	OFDM	12.5	12.20	-0.11	10 mm	F1186	13	top	1:1	0.026	1.072	0.028	
5785	157	IEEE 802.11n	OFDM	12.5	12.20	-0.04	10 mm	F1186	13	left	1:1	0.005	1.072	0.005	
ANSI / IEEE C95.1 1992 - SAFETY LIMIT Spatial Peak Uncontrolled Exposure/General Population							Body 1.6 W/kg (mW/g) averaged over 1 gram								

11.4 SAR Test Notes

General Notes:

1. The test data reported are the worst-case SAR values according to test procedures specified in IEEE 1528-2003, and FCC KDB Publication 447498 D01v05.
2. Batteries are fully charged at the beginning of the SAR measurements. A specialized battery was used for all SAR measurements.
3. Liquid tissue depth was at least 15.0 cm for all frequencies.
4. The manufacturer has confirmed that the device(s) tested have the same physical, mechanical and thermal characteristics and are within operational tolerances expected for production units.
5. SAR results were scaled to the maximum allowed power to demonstrate compliance per FCC KDB Publication 447498 D01v05.

FCC ID: A3LSMG900S	 PCTEST ENGINEERING LABORATORY, INC.	SAR EVALUATION REPORT		Reviewed by: Quality Manager
Document S/N: OY1402030286-R1.A3L	Test Dates: 02/03/14 – 02/10/14	DUT Type: Portable Handset		Page 46 of 64

6. Device was tested using a fixed spacing for body-worn accessory testing. A separation distance of 10 mm was considered because the manufacturer has determined that there will be body-worn accessories available in the marketplace for users to support this separation distance.
7. Per FCC KDB Publication 648474 D04v01, body-worn SAR was evaluated without a headset connected to the device. Since the standalone reported body-worn SAR was ≤ 1.2 W/kg, no additional SAR evaluations using a headset cable were required.
8. Per FCC KDB 865664 D01 v01, variability SAR tests were performed when the measured SAR results for a frequency band were greater than 0.8 W/kg. Repeated SAR measurements are highlighted in the tables above for clarity. Please see Section 13 for variability analysis.
9. During SAR Testing for the Wireless Router conditions per FCC KDB Publication 941225 D06v01, the actual Portable Hotspot operation (with actual simultaneous transmission of a transmitter with WIFI) was not activated (See Section 6.7 for more details).

GSM Test Notes:

1. Body-Worn accessory testing is typically associated with voice operations. Therefore, GSM voice was evaluated for body-worn SAR.
2. Justification for reduced test configurations per KDB Publication 941225 D03v01 and October 2013 TCB Workshop Notes: The source-based frame-averaged output power was evaluated for all GPRS slot configurations. The configuration with the highest target frame averaged output power was evaluated for hotspot SAR. When the maximum frame-averaged powers are equivalent across two or more slots (within 0.25 dB), the configuration with the most number of time slots was tested.
3. Per FCC KDB Publication 447498 D01v05, if the reported (scaled) SAR measured at the middle channel or highest output power channel for each test configuration is ≤ 0.8 W/kg then testing at the other channels is not required for such test configuration(s). When the maximum output power variation across the required test channels is $> \frac{1}{2}$ dB, instead of the middle channel, the highest output power channel was used.

UMTS Notes:

1. UMTS mode in was tested under RMC 12.2 kbps with HSPA Inactive per KDB Publication 941225 D01v02. HSPA SAR was not required since the average output power of the HSPA subtests was not more than 0.25 dB higher than the RMC level and SAR was less than 1.2 W/kg.
2. Per FCC KDB Publication 447498 D01v05, when the reported (scaled) SAR measured at the middle channel > 0.8 W/kg then testing at the other channels is required for such test configuration(s). When the maximum output power variation across the required test channels is $> \frac{1}{2}$ dB, instead of the middle channel, the highest output power channel must be used.

LTE Notes:

1. LTE Considerations: LTE test configurations are determined according to SAR Evaluation Considerations for LTE Devices in FCC KDB Publication 941225 D05v02r01. The general test procedures used for testing can be found in Section 8.4.4.
2. MPR is permanently implemented for this device by the manufacturer. The specific manufacturer target MPR is indicated alongside the SAR results. MPR is enabled for this device, according to 3GPP TS36.101 Section 6.2.3 – 6.2.5 under Table 6.2.3-1.
3. A-MPR was disabled for all SAR tests by setting NS=01 on the base station simulator. SAR tests were performed with the same number of RB and RB offsets transmitting on all TTI frames (maximum TTI).

FCC ID: A3LSMG900S	 SAR EVALUATION REPORT 		Reviewed by: Quality Manager
Document S/N: OY1402030286-R1.A3L	Test Dates: 02/03/14 – 02/10/14	DUT Type: Portable Handset	Page 47 of 64

WLAN Notes:

1. Justification for reduced test configurations for SISO WIFI antenna channels per KDB Publication 248227 D01v01r02 and October 2012 FCC/TCB Meeting Notes for 2.4 GHz WIFI: Highest average RF output power channel for the lowest data rate was selected for SAR evaluation in 802.11b. Other IEEE 802.11 modes (including 802.11g/n) were not investigated since the average output powers over all channels and data rates were not more than 0.25 dB higher than the tested channel in the lowest data rate of IEEE 802.11b mode.
2. Justification for reduced test configurations for SISO WIFI channels per KDB Publication 248227 D01v01r02 and October 2012 FCC/TCB Meeting Notes for 5 GHz WIFI: Highest average RF output power channel for the lowest data rate was selected for SAR evaluation in 802.11a. Other IEEE 802.11 modes (including 802.11n 20 MHz and 40 MHz bandwidths) were not investigated since the average output powers over all channels and data rates were not more than 0.25 dB higher than the tested channel in the lowest data rate of IEEE 802.11a mode.
3. Per KDB 248227, SAR for MIMO was measured with both transmitting simultaneously and was evaluated independently of SISO operation. For 2.4 GHz MIMO, 802.11n was evaluated. For 5 GHz MIMO, 20 MHz BW 802.11n was evaluated. Additional evaluations for 40 MHz bandwidth 802.11n and 802.11ac were not required since the maximum allowed output power was not higher than 802.11n 20 MHz Bandwidth.
4. Per April 2013 TCB Workshop notes, full SAR tests for SISO IEEE 802.11ac configurations were not required because the average output power was not more than 0.25 dB higher than IEEE 802.11a mode. IEEE 802.11ac was evaluated for the highest IEEE 802.11a position in each 5 GHz band and exposure condition.
5. WIFI transmission was verified using an uncalibrated spectrum analyzer.
6. When the maximum extrapolated peak SAR of the zoom scan for the maximum output channel is >1.6 W/kg or the reported 1g averaged SAR is >0.8 W/kg, SAR testing on other default channels was required.
7. When Hotspot is enabled, all 5 GHz NII bands are disabled. Therefore, only 2.4 GHz and 5 GHz DTS WIFI Wireless Router SAR Data was required.

FCC ID: A3LSMG900S		SAR EVALUATION REPORT		Reviewed by: Quality Manager
Document S/N: OY1402030286-R1.A3L	Test Dates: 02/03/14 – 02/10/14	DUT Type: Portable Handset		Page 48 of 64

12 FCC MULTI-TX AND ANTENNA SAR CONSIDERATIONS

12.1 Introduction

The following procedures adopted from FCC KDB Publication 447498 D01v05 are applicable to handsets with built-in unlicensed transmitters such as 802.11a/b/g/n/ac and Bluetooth devices which may simultaneously transmit with the licensed transmitter.

12.2 Simultaneous Transmission Procedures



This device contains transmitters that may operate simultaneously. Therefore simultaneous transmission analysis is required. Per FCC KDB 447498 D01v05 IV.C.1.iii and IEEE 1528-2013 Section 6.3.4.1.2, simultaneous transmission SAR test exclusion may be applied when the sum of the 1-g SAR for all the simultaneous transmitting antennas in a specific physical test configuration is ≤ 1.6 W/kg. When standalone SAR is not required to be measured, per FCC KDB 447498 D01v05 4.3.2 2), the following equation must be used to estimate the standalone 1g SAR for simultaneous transmission assessment involving that transmitter.

$$\text{Estimated SAR} = \frac{\sqrt{f(\text{GHz})}}{7.5} * \frac{(\text{Max Power of channel, mW})}{\text{Min. Separation Distance, mm}}$$

Table 12-1
Estimated SAR

Mode	Frequency	Maximum Allowed Power	Separation Distance (Body)	Estimated SAR (Body)
	[MHz]	[dBm]	[mm]	[W/kg]
Bluetooth	2441	10.50	10	0.229

Note: Held-to ear configurations are not applicable to Bluetooth operations and therefore were not considered for simultaneous transmission. Per KDB Publication 447498 D01v05, the maximum power of the channel was rounded to the nearest mW before calculation.

FCC ID: A3LSMG900S	 PCTEST ENGINEERING LABORATORY, INC.	SAR EVALUATION REPORT		Reviewed by: Quality Manager
Document S/N: OY1402030286-R1.A3L	Test Dates: 02/03/14 – 02/10/14	DUT Type: Portable Handset		Page 49 of 64

12.3 Head SAR Simultaneous Transmission Analysis

Table 12-2
Simultaneous Transmission Scenario with 2.4 GHz WLAN (Held to Ear) Antenna 1

Simult Tx	Configuration	UMTS 850 SAR (W/kg)	2.4 GHz WLAN SAR (W/kg)	Σ SAR (W/kg)	Simult Tx	Configuration	GSM 1900 SAR (W/kg)	2.4 GHz WLAN SAR (W/kg)	Σ SAR (W/kg)
Head SAR	Right Cheek	0.394	0.551	0.945	Head SAR	Right Cheek	0.139	0.551	0.690
	Right Tilt	0.251	0.493	0.744		Right Tilt	0.078	0.493	0.571
	Left Cheek	0.505	0.370	0.875		Left Cheek	0.176	0.370	0.546
	Left Tilt	0.211	0.426	0.637		Left Tilt	0.055	0.426	0.481
Simult Tx	Configuration	UMTS 1900 SAR (W/kg)	2.4 GHz WLAN SAR (W/kg)	Σ SAR (W/kg)	Simult Tx	Configuration	LTE Band 5 (Cell) SAR (W/kg)	2.4 GHz WLAN SAR (W/kg)	Σ SAR (W/kg)
Head SAR	Right Cheek	0.196	0.551	0.747	Head SAR	Right Cheek	0.467	0.551	1.018
	Right Tilt	0.117	0.493	0.610		Right Tilt	0.251	0.493	0.744
	Left Cheek	0.315	0.370	0.685		Left Cheek	0.503	0.370	0.873
	Left Tilt	0.081	0.426	0.507		Left Tilt	0.248	0.426	0.674
Simult Tx	Configuration	LTE Band 17 SAR (W/kg)	2.4 GHz WLAN SAR (W/kg)	Σ SAR (W/kg)					
Head SAR	Right Cheek	0.126	0.551	0.677					
	Right Tilt	0.093	0.493	0.586					
	Left Cheek	0.144	0.370	0.514					
	Left Tilt	0.101	0.426	0.527					

Table 12-3
Simultaneous Transmission Scenario with 5 GHz WLAN (Held to Ear) Antenna 1

Simult Tx	Configuration	UMTS 850 SAR (W/kg)	5 GHz WLAN SAR (W/kg)	Σ SAR (W/kg)	Simult Tx	Configuration	GSM 1900 SAR (W/kg)	5 GHz WLAN SAR (W/kg)	Σ SAR (W/kg)
Head SAR	Right Cheek	0.394	0.336	0.730	Head SAR	Right Cheek	0.139	0.336	0.475
	Right Tilt	0.251	0.489	0.740		Right Tilt	0.078	0.489	0.567
	Left Cheek	0.505	0.389	0.894		Left Cheek	0.176	0.389	0.565
	Left Tilt	0.211	0.394	0.605		Left Tilt	0.055	0.394	0.449
Simult Tx	Configuration	UMTS 1900 SAR (W/kg)	5 GHz WLAN SAR (W/kg)	Σ SAR (W/kg)	Simult Tx	Configuration	LTE Band 5 (Cell) SAR (W/kg)	5 GHz WLAN SAR (W/kg)	Σ SAR (W/kg)
Head SAR	Right Cheek	0.196	0.336	0.532	Head SAR	Right Cheek	0.467	0.336	0.803
	Right Tilt	0.117	0.489	0.606		Right Tilt	0.251	0.489	0.740
	Left Cheek	0.315	0.389	0.704		Left Cheek	0.503	0.389	0.892
	Left Tilt	0.081	0.394	0.475		Left Tilt	0.248	0.394	0.642
Simult Tx	Configuration	LTE Band 17 SAR (W/kg)	5 GHz WLAN SAR (W/kg)	Σ SAR (W/kg)					
Head SAR	Right Cheek	0.126	0.336	0.462					
	Right Tilt	0.093	0.489	0.582					
	Left Cheek	0.144	0.389	0.533					
	Left Tilt	0.101	0.394	0.495					

The worst case 5 GHz WLAN reported SAR for each configuration was used for SAR summation, regardless of whether the WLAN channel has WIFI Hotspot capability. Therefore, the summations above represent the absolute worst cases for simultaneous transmission with 5 GHz WLAN.

FCC ID: A3LSMG900S	 PCTEST ENGINEERING LABORATORY, INC.	SAR EVALUATION REPORT		Reviewed by: Quality Manager
Document S/N: OY1402030286-R1.A3L	Test Dates: 02/03/14 – 02/10/14	DUT Type: Portable Handset	Page 50 of 64	

Table 12-4
Simultaneous Transmission Scenario with 2.4 GHz WLAN (Held to Ear) Antenna 2

Simult Tx	Configuration	UMTS 850 SAR (W/kg)	2.4 GHz WLAN SAR (W/kg)	Σ SAR (W/kg)	Simult Tx	Configuration	GSM 1900 SAR (W/kg)	2.4 GHz WLAN SAR (W/kg)	Σ SAR (W/kg)
Head SAR	Right Cheek	0.394	0.163	0.557	Head SAR	Right Cheek	0.139	0.163	0.302
	Right Tilt	0.251	0.114	0.365		Right Tilt	0.078	0.114	0.192
	Left Cheek	0.505	0.066	0.571		Left Cheek	0.176	0.066	0.242
	Left Tilt	0.211	0.079	0.290		Left Tilt	0.055	0.079	0.134
Simult Tx	Configuration	UMTS 1900 SAR (W/kg)	2.4 GHz WLAN SAR (W/kg)	Σ SAR (W/kg)	Simult Tx	Configuration	LTE Band 5 (Cell) SAR (W/kg)	2.4 GHz WLAN SAR (W/kg)	Σ SAR (W/kg)
Head SAR	Right Cheek	0.196	0.163	0.359	Head SAR	Right Cheek	0.467	0.163	0.630
	Right Tilt	0.117	0.114	0.231		Right Tilt	0.251	0.114	0.365
	Left Cheek	0.315	0.066	0.381		Left Cheek	0.503	0.066	0.569
	Left Tilt	0.081	0.079	0.160		Left Tilt	0.248	0.079	0.327
Simult Tx	Configuration	LTE Band 17 SAR (W/kg)	2.4 GHz WLAN SAR (W/kg)	Σ SAR (W/kg)					
Head SAR	Right Cheek	0.126	0.163	0.289					
	Right Tilt	0.093	0.114	0.207					
	Left Cheek	0.144	0.066	0.210					
	Left Tilt	0.101	0.079	0.180					

Table 12-5
Simultaneous Transmission Scenario with 5 GHz WLAN (Held to Ear) Antenna 2

Simult Tx	Configuration	UMTS 850 SAR (W/kg)	5 GHz WLAN SAR (W/kg)	Σ SAR (W/kg)	Simult Tx	Configuration	GSM 1900 SAR (W/kg)	5 GHz WLAN SAR (W/kg)	Σ SAR (W/kg)
Head SAR	Right Cheek	0.394	0.133	0.527	Head SAR	Right Cheek	0.139	0.133	0.272
	Right Tilt	0.251	0.044	0.295		Right Tilt	0.078	0.044	0.122
	Left Cheek	0.505	0.018	0.523		Left Cheek	0.176	0.018	0.194
	Left Tilt	0.211	0.007	0.218		Left Tilt	0.055	0.007	0.062
Simult Tx	Configuration	UMTS 1900 SAR (W/kg)	5 GHz WLAN SAR (W/kg)	Σ SAR (W/kg)	Simult Tx	Configuration	LTE Band 5 (Cell) SAR (W/kg)	5 GHz WLAN SAR (W/kg)	Σ SAR (W/kg)
Head SAR	Right Cheek	0.196	0.133	0.329	Head SAR	Right Cheek	0.467	0.133	0.600
	Right Tilt	0.117	0.044	0.161		Right Tilt	0.251	0.044	0.295
	Left Cheek	0.315	0.018	0.333		Left Cheek	0.503	0.018	0.521
	Left Tilt	0.081	0.007	0.088		Left Tilt	0.248	0.007	0.255
Simult Tx	Configuration	LTE Band 17 SAR (W/kg)	5 GHz WLAN SAR (W/kg)	Σ SAR (W/kg)					
Head SAR	Right Cheek	0.126	0.133	0.259					
	Right Tilt	0.093	0.044	0.137					
	Left Cheek	0.144	0.018	0.162					
	Left Tilt	0.101	0.007	0.108					

The worst case 5 GHz WLAN reported SAR for each configuration was used for SAR summation, regardless of whether the WLAN channel has WIFI Hotspot capability. Therefore, the summations above represent the absolute worst cases for simultaneous transmission with 5 GHz WLAN.

FCC ID: A3LSMG900S	 PCTEST ENGINEERING LABORATORY, INC.	SAR EVALUATION REPORT		Reviewed by: Quality Manager
Document S/N: OY1402030286-R1.A3L	Test Dates: 02/03/14 – 02/10/14	DUT Type: Portable Handset	Page 51 of 64	



Table 12-6
Simultaneous Transmission Scenario with 2.4 GHz WLAN (Held to Ear) MIMO

Simult Tx	Configuration	UMTS 850 SAR (W/kg)	2.4 GHz WLAN SAR (W/kg)	Σ SAR (W/kg)	Simult Tx	Configuration	GSM 1900 SAR (W/kg)	2.4 GHz WLAN SAR (W/kg)	Σ SAR (W/kg)
Head SAR	Right Cheek	0.394	0.129	0.523	Head SAR	Right Cheek	0.139	0.129	0.268
	Right Tilt	0.251	0.096	0.347		Right Tilt	0.078	0.096	0.174
	Left Cheek	0.505	0.093	0.598		Left Cheek	0.176	0.093	0.269
	Left Tilt	0.211	0.074	0.285		Left Tilt	0.055	0.074	0.129
Simult Tx	Configuration	UMTS 1900 SAR (W/kg)	2.4 GHz WLAN SAR (W/kg)	Σ SAR (W/kg)	Simult Tx	Configuration	LTE Band 5 (Cell) SAR (W/kg)	2.4 GHz WLAN SAR (W/kg)	Σ SAR (W/kg)
Head SAR	Right Cheek	0.196	0.129	0.325	Head SAR	Right Cheek	0.467	0.129	0.596
	Right Tilt	0.117	0.096	0.213		Right Tilt	0.251	0.096	0.347
	Left Cheek	0.315	0.093	0.408		Left Cheek	0.503	0.093	0.596
	Left Tilt	0.081	0.074	0.155		Left Tilt	0.248	0.074	0.322
Simult Tx	Configuration	LTE Band 17 SAR (W/kg)	2.4 GHz WLAN SAR (W/kg)	Σ SAR (W/kg)					
Head SAR	Right Cheek	0.126	0.129	0.255					
	Right Tilt	0.093	0.096	0.189					
	Left Cheek	0.144	0.093	0.237					
	Left Tilt	0.101	0.074	0.175					

Table 12-7
Simultaneous Transmission Scenario with 5 GHz WLAN (Held to Ear) MIMO

Simult Tx	Configuration	UMTS 850 SAR (W/kg)	5 GHz WLAN SAR (W/kg)	Σ SAR (W/kg)	Simult Tx	Configuration	GSM 1900 SAR (W/kg)	5 GHz WLAN SAR (W/kg)	Σ SAR (W/kg)
Head SAR	Right Cheek	0.394	0.038	0.432	Head SAR	Right Cheek	0.139	0.038	0.177
	Right Tilt	0.251	0.081	0.332		Right Tilt	0.078	0.081	0.159
	Left Cheek	0.505	0.063	0.568		Left Cheek	0.176	0.063	0.239
	Left Tilt	0.211	0.067	0.278		Left Tilt	0.055	0.067	0.122
Simult Tx	Configuration	UMTS 1900 SAR (W/kg)	5 GHz WLAN SAR (W/kg)	Σ SAR (W/kg)	Simult Tx	Configuration	LTE Band 5 (Cell) SAR (W/kg)	5 GHz WLAN SAR (W/kg)	Σ SAR (W/kg)
Head SAR	Right Cheek	0.196	0.038	0.234	Head SAR	Right Cheek	0.467	0.038	0.505
	Right Tilt	0.117	0.081	0.198		Right Tilt	0.251	0.081	0.332
	Left Cheek	0.315	0.063	0.378		Left Cheek	0.503	0.063	0.566
	Left Tilt	0.081	0.067	0.148		Left Tilt	0.248	0.067	0.315
Simult Tx	Configuration	LTE Band 17 SAR (W/kg)	5 GHz WLAN SAR (W/kg)	Σ SAR (W/kg)					
Head SAR	Right Cheek	0.126	0.038	0.164					
	Right Tilt	0.093	0.081	0.174					
	Left Cheek	0.144	0.063	0.207					
	Left Tilt	0.101	0.067	0.168					

The worst case 5 GHz WLAN reported SAR for each configuration was used for SAR summation, regardless of whether the WLAN channel has WIFI Hotspot capability. Therefore, the summations above represent the absolute worst cases for simultaneous transmission with 5 GHz WLAN.

FCC ID: A3LSMG900S	 PCTEST ENGINEERING LABORATORY, INC.	SAR EVALUATION REPORT		Reviewed by: Quality Manager
Document S/N: OY1402030286-R1.A3L	Test Dates: 02/03/14 – 02/10/14	DUT Type: Portable Handset	Page 52 of 64	

12.4 Body-Worn Simultaneous Transmission Analysis

Table 12-8
Simultaneous Transmission Scenario with 2.4 GHz WLAN (Body-Worn at 1.0 cm) Antenna 1

Configuration	Mode	2G/3G/4G SAR (W/kg)	2.4 GHz WLAN SAR (W/kg)	Σ SAR (W/kg)
Back Side	UMTS 850	0.708	0.134	0.842
Back Side	GSM 1900	0.424	0.134	0.558
Back Side	UMTS 1900	0.571	0.134	0.705
Back Side	LTE Band 5 (Cell)	0.827	0.134	0.961
Back Side	LTE Band 17	0.353	0.134	0.487

Table 12-9
Simultaneous Transmission Scenario with 5 GHz WLAN (Body-Worn at 1.0 cm) Antenna 1

Configuration	Mode	2G/3G/4G SAR (W/kg)	5 GHz WLAN SAR (W/kg)	Σ SAR (W/kg)
Back Side	UMTS 850	0.708	0.092	0.800
Back Side	GSM 1900	0.424	0.092	0.516
Back Side	UMTS 1900	0.571	0.092	0.663
Back Side	LTE Band 5 (Cell)	0.827	0.092	0.919
Back Side	LTE Band 17	0.353	0.092	0.445

The worst case 5 GHz WLAN reported SAR for each configuration was used for SAR summation, regardless of whether the WLAN channel has WIFI Hotspot capability. Therefore, the summations above represent the absolute worst cases for simultaneous transmission with 5 GHz WLAN.

Table 12-10
Simultaneous Transmission Scenario with Bluetooth (Body-Worn at 1.0 cm) Antenna 1

Configuration	Mode	2G/3G/4G SAR (W/kg)	Bluetooth SAR (W/kg)	Σ SAR (W/kg)
Back Side	UMTS 850	0.708	0.229	0.937
Back Side	GSM 1900	0.424	0.229	0.653
Back Side	UMTS 1900	0.571	0.229	0.800
Back Side	LTE Band 5 (Cell)	0.827	0.229	1.056
Back Side	LTE Band 17	0.353	0.229	0.582

Bluetooth SAR was not required to be measured per FCC KDB 447498. Estimated SAR results were used in the above tables to determine simultaneous transmission SAR test exclusion.

Table 12-11
Simultaneous Transmission Scenario with 2.4 GHz WLAN (Body-Worn at 1.0 cm) Antenna 2

Configuration	Mode	2G/3G/4G SAR (W/kg)	2.4 GHz WLAN SAR (W/kg)	Σ SAR (W/kg)
Back Side	UMTS 850	0.708	0.272	0.980
Back Side	GSM 1900	0.424	0.272	0.696
Back Side	UMTS 1900	0.571	0.272	0.843
Back Side	LTE Band 5 (Cell)	0.827	0.272	1.099
Back Side	LTE Band 17	0.353	0.272	0.625

Table 12-12
Simultaneous Transmission Scenario with 5 GHz WLAN (Body-Worn at 1.0 cm) Antenna 2

Configuration	Mode	2G/3G/4G SAR (W/kg)	5 GHz WLAN SAR (W/kg)	Σ SAR (W/kg)
Back Side	UMTS 850	0.708	0.055	0.763
Back Side	GSM 1900	0.424	0.055	0.479
Back Side	UMTS 1900	0.571	0.055	0.626
Back Side	LTE Band 5 (Cell)	0.827	0.055	0.882
Back Side	LTE Band 17	0.353	0.055	0.408

The worst case 5 GHz WLAN reported SAR for each configuration was used for SAR summation, regardless of whether the WLAN channel has WIFI Hotspot capability. Therefore, the summations above represent the absolute worst cases for simultaneous transmission with 5 GHz WLAN.

FCC ID: A3LSMG900S	 PCTEST ENGINEERING LABORATORY, INC.	SAR EVALUATION REPORT		Reviewed by: Quality Manager
Document S/N: OY1402030286-R1.A3L	Test Dates: 02/03/14 – 02/10/14	DUT Type: Portable Handset		Page 53 of 64

Table 12-13
Simultaneous Transmission Scenario with 2.4 GHz WLAN (Body-Worn at 1.0 cm) MIMO

Configuration	Mode	2G/3G/4G SAR (W/kg)	2.4 GHz WLAN SAR (W/kg)	Σ SAR (W/kg)
Back Side	UMTS 850	0.708	0.082	0.790
Back Side	GSM 1900	0.424	0.082	0.506
Back Side	UMTS 1900	0.571	0.082	0.653
Back Side	LTE Band 5 (Cell)	0.827	0.082	0.909
Back Side	LTE Band 17	0.353	0.082	0.435

Table 12-14
Simultaneous Transmission Scenario with 5 GHz WLAN (Body-Worn at 1.0 cm) MIMO

Configuration	Mode	2G/3G/4G SAR (W/kg)	5 GHz WLAN SAR (W/kg)	Σ SAR (W/kg)
Back Side	UMTS 850	0.708	0.031	0.739
Back Side	GSM 1900	0.424	0.031	0.455
Back Side	UMTS 1900	0.571	0.031	0.602
Back Side	LTE Band 5 (Cell)	0.827	0.031	0.858
Back Side	LTE Band 17	0.353	0.031	0.384

The worst case 5 GHz WLAN reported SAR for each configuration was used for SAR summation, regardless of whether the WLAN channel has WIFI Hotspot capability. Therefore, the summations above represent the absolute worst cases for simultaneous transmission with 5 GHz WLAN.

12.5 Hotspot SAR Simultaneous Transmission Analysis

Per FCC KDB Publication 941225 D06v01, the devices edges with antennas more than 2.5 cm from edge are not required to be evaluated for SAR ("-").

Table 12-15
Simultaneous Transmission Scenario (2.4 GHz Hotspot at 1.0 cm) Antenna 1

Simult Tx	Configuration	UMTS 850 SAR (W/kg)	2.4 GHz WLAN SAR (W/kg)	Σ SAR (W/kg)	Simult Tx	Configuration	GPRS 1900 SAR (W/kg)	2.4 GHz WLAN SAR (W/kg)	Σ SAR (W/kg)
Body SAR	Back	0.708	0.134	0.842	Body SAR	Back	0.553	0.134	0.687
	Front	0.568	0.094	0.662		Front	0.711	0.094	0.805
	Top	-	0.065	0.065		Top	-	0.065	0.065
	Bottom	0.166	-	0.166		Bottom	0.402	-	0.402
	Right	0.415	-	0.415		Right	0.034	-	0.034
	Left	0.658	0.044	0.702		Left	0.233	0.044	0.277
Simult Tx	Configuration	UMTS 1900 SAR (W/kg)	2.4 GHz WLAN SAR (W/kg)	Σ SAR (W/kg)	Simult Tx	Configuration	LTE Band 5 (Cell) SAR (W/kg)	2.4 GHz WLAN SAR (W/kg)	Σ SAR (W/kg)
Body SAR	Back	0.571	0.134	0.705	Body SAR	Back	0.827	0.134	0.961
	Front	0.882	0.094	0.976		Front	0.688	0.094	0.782
	Top	-	0.065	0.065		Top	-	0.065	0.065
	Bottom	0.677	-	0.677		Bottom	0.215	-	0.215
	Right	0.044	-	0.044		Right	0.513	-	0.513
	Left	0.281	0.044	0.325		Left	0.767	0.044	0.811
Simult Tx	Configuration	LTE Band 17 SAR (W/kg)	2.4 GHz WLAN SAR (W/kg)	Σ SAR (W/kg)					
Body SAR	Back	0.353	0.134	0.487					
	Front	0.267	0.094	0.361					
	Top	-	0.065	0.065					
	Bottom	0.083	-	0.083					
	Right	0.151	-	0.151					
	Left	0.233	0.044	0.277					

FCC ID: A3LSMG900S	 PCTEST ENGINEERING LABORATORY, INC.	SAR EVALUATION REPORT		Reviewed by: Quality Manager
Document S/N: OY1402030286-R1.A3L	Test Dates: 02/03/14 – 02/10/14	DUT Type: Portable Handset	Page 54 of 64	

Table 12-16
Simultaneous Transmission Scenario (5 GHz Hotspot at 1.0 cm) Antenna 1

Simult Tx	Configuration	UMTS 850 SAR (W/kg)	5 GHz WLAN SAR (W/kg)	Σ SAR (W/kg)	Simult Tx	Configuration	GPRS 1900 SAR (W/kg)	5 GHz WLAN SAR (W/kg)	Σ SAR (W/kg)
Body SAR	Back	0.708	0.092	0.800	Body SAR	Back	0.553	0.092	0.645
	Front	0.568	0.065	0.633		Front	0.711	0.065	0.776
	Top	-	0.211	0.211		Top	-	0.211	0.211
	Bottom	0.166	-	0.166		Bottom	0.402	-	0.402
	Right	0.415	-	0.415		Right	0.034	-	0.034
	Left	0.658	0.016	0.674		Left	0.233	0.016	0.249
Simult Tx	Configuration	UMTS 1900 SAR (W/kg)	5 GHz WLAN SAR (W/kg)	Σ SAR (W/kg)	Simult Tx	Configuration	LTE Band 5 (Cell) SAR (W/kg)	5 GHz WLAN SAR (W/kg)	Σ SAR (W/kg)
Body SAR	Back	0.571	0.092	0.663	Body SAR	Back	0.827	0.092	0.919
	Front	0.882	0.065	0.947		Front	0.688	0.065	0.753
	Top	-	0.211	0.211		Top	-	0.211	0.211
	Bottom	0.677	-	0.677		Bottom	0.215	-	0.215
	Right	0.044	-	0.044		Right	0.513	-	0.513
	Left	0.281	0.016	0.297		Left	0.767	0.016	0.783
Simult Tx	Configuration	LTE Band 17 SAR (W/kg)	5 GHz WLAN SAR (W/kg)	Σ SAR (W/kg)					
Body SAR	Back	0.353	0.092	0.445					
	Front	0.267	0.065	0.332					
	Top	-	0.211	0.211					
	Bottom	0.083	-	0.083					
	Right	0.151	-	0.151					
	Left	0.233	0.016	0.249					

Table 12-17
Simultaneous Transmission Scenario (2.4 GHz Hotspot at 1.0 cm) Antenna 2

Simult Tx	Configuration	UMTS 850 SAR (W/kg)	2.4 GHz WLAN SAR (W/kg)	Σ SAR (W/kg)	Simult Tx	Configuration	GPRS 1900 SAR (W/kg)	2.4 GHz WLAN SAR (W/kg)	Σ SAR (W/kg)
Body SAR	Back	0.708	0.272	0.980	Body SAR	Back	0.553	0.272	0.825
	Front	0.568	0.109	0.677		Front	0.711	0.109	0.820
	Top	-	0.026	0.026		Top	-	0.026	0.026
	Bottom	0.166	-	0.166		Bottom	0.402	-	0.402
	Right	0.415	-	0.415		Right	0.034	-	0.034
	Left	0.658	0.148	0.806		Left	0.233	0.148	0.381
Simult Tx	Configuration	UMTS 1900 SAR (W/kg)	2.4 GHz WLAN SAR (W/kg)	Σ SAR (W/kg)	Simult Tx	Configuration	LTE Band 5 (Cell) SAR (W/kg)	2.4 GHz WLAN SAR (W/kg)	Σ SAR (W/kg)
Body SAR	Back	0.571	0.272	0.843	Body SAR	Back	0.827	0.272	1.099
	Front	0.882	0.109	0.991		Front	0.688	0.109	0.797
	Top	-	0.026	0.026		Top	-	0.026	0.026
	Bottom	0.677	-	0.677		Bottom	0.215	-	0.215
	Right	0.044	-	0.044		Right	0.513	-	0.513
	Left	0.281	0.148	0.429		Left	0.767	0.148	0.915
Simult Tx	Configuration	LTE Band 17 SAR (W/kg)	2.4 GHz WLAN SAR (W/kg)	Σ SAR (W/kg)					
Body SAR	Back	0.353	0.272	0.625					
	Front	0.267	0.109	0.376					
	Top	-	0.026	0.026					
	Bottom	0.083	-	0.083					
	Right	0.151	-	0.151					
	Left	0.233	0.148	0.381					



FCC ID: A3LSMG900S	 PCTEST ENGINEERING LABORATORY, INC.	SAR EVALUATION REPORT		Reviewed by: Quality Manager
Document S/N: OY1402030286-R1.A3L	Test Dates: 02/03/14 – 02/10/14	DUT Type: Portable Handset		Page 55 of 64

Table 12-18
Simultaneous Transmission Scenario (5 GHz Hotspot at 1.0 cm) Antenna 2

Simult Tx	Configuration	UMTS 850 SAR (W/kg)	5 GHz WLAN SAR (W/kg)	Σ SAR (W/kg)	Simult Tx	Configuration	GPRS 1900 SAR (W/kg)	5 GHz WLAN SAR (W/kg)	Σ SAR (W/kg)
Body SAR	Back	0.708	0.025	0.733	Body SAR	Back	0.553	0.025	0.578
	Front	0.568	0.012	0.580		Front	0.711	0.012	0.723
	Top	-	0.028	0.028		Top	-	0.028	0.028
	Bottom	0.166	-	0.166		Bottom	0.402	-	0.402
	Right	0.415	-	0.415		Right	0.034	-	0.034
	Left	0.658	0.015	0.673		Left	0.233	0.015	0.248
Simult Tx	Configuration	UMTS 1900 SAR (W/kg)	5 GHz WLAN SAR (W/kg)	Σ SAR (W/kg)	Simult Tx	Configuration	LTE Band 5 (Cell) SAR (W/kg)	5 GHz WLAN SAR (W/kg)	Σ SAR (W/kg)
Body SAR	Back	0.571	0.025	0.596	Body SAR	Back	0.827	0.025	0.852
	Front	0.882	0.012	0.894		Front	0.688	0.012	0.700
	Top	-	0.028	0.028		Top	-	0.028	0.028
	Bottom	0.677	-	0.677		Bottom	0.215	-	0.215
	Right	0.044	-	0.044		Right	0.513	-	0.513
	Left	0.281	0.015	0.296		Left	0.767	0.015	0.782
Simult Tx	Configuration	LTE Band 17 SAR (W/kg)	5 GHz WLAN SAR (W/kg)	Σ SAR (W/kg)					
Body SAR	Back	0.353	0.025	0.378					
	Front	0.267	0.012	0.279					
	Top	-	0.028	0.028					
	Bottom	0.083	-	0.083					
	Right	0.151	-	0.151					
	Left	0.233	0.015	0.248					

Table 12-19
Simultaneous Transmission Scenario (2.4 GHz Hotspot at 1.0 cm) MIMO

Simult Tx	Configuration	UMTS 850 SAR (W/kg)	2.4 GHz WLAN SAR (W/kg)	Σ SAR (W/kg)	Simult Tx	Configuration	GPRS 1900 SAR (W/kg)	2.4 GHz WLAN SAR (W/kg)	Σ SAR (W/kg)
Body SAR	Back	0.708	0.082	0.790	Body SAR	Back	0.553	0.082	0.635
	Front	0.568	0.022	0.590		Front	0.711	0.022	0.733
	Top	-	0.013	0.013		Top	-	0.013	0.013
	Bottom	0.166	-	0.166		Bottom	0.402	-	0.402
	Right	0.415	-	0.415		Right	0.034	-	0.034
	Left	0.658	0.023	0.681		Left	0.233	0.023	0.256
Simult Tx	Configuration	UMTS 1900 SAR (W/kg)	2.4 GHz WLAN SAR (W/kg)	Σ SAR (W/kg)	Simult Tx	Configuration	LTE Band 5 (Cell) SAR (W/kg)	2.4 GHz WLAN SAR (W/kg)	Σ SAR (W/kg)
Body SAR	Back	0.571	0.082	0.653	Body SAR	Back	0.827	0.082	0.909
	Front	0.882	0.022	0.904		Front	0.688	0.022	0.710
	Top	-	0.013	0.013		Top	-	0.013	0.013
	Bottom	0.677	-	0.677		Bottom	0.215	-	0.215
	Right	0.044	-	0.044		Right	0.513	-	0.513
	Left	0.281	0.023	0.304		Left	0.767	0.023	0.790
Simult Tx	Configuration	LTE Band 17 SAR (W/kg)	2.4 GHz WLAN SAR (W/kg)	Σ SAR (W/kg)					
Body SAR	Back	0.353	0.082	0.435					
	Front	0.267	0.022	0.289					
	Top	-	0.013	0.013					
	Bottom	0.083	-	0.083					
	Right	0.151	-	0.151					
	Left	0.233	0.023	0.256					



FCC ID: A3LSMG900S	 PCTEST ENGINEERING LABORATORY, INC.	SAR EVALUATION REPORT		Reviewed by: Quality Manager
Document S/N: OY1402030286-R1.A3L	Test Dates: 02/03/14 – 02/10/14	DUT Type: Portable Handset		Page 56 of 64

**Table 12-20
Simultaneous Transmission Scenario (5 GHz Hotspot at 1.0 cm) MIMO**

Simult Tx	Configuration	UMTS 850 SAR (W/kg)	5 GHz WLAN SAR (W/kg)	Σ SAR (W/kg)	Simult Tx	Configuration	GPRS 1900 SAR (W/kg)	5 GHz WLAN SAR (W/kg)	Σ SAR (W/kg)
Body SAR	Back	0.708	0.010	0.718	Body SAR	Back	0.553	0.010	0.563
	Front	0.568	0.012	0.580		Front	0.711	0.012	0.723
	Top	-	0.028	0.028		Top	-	0.028	0.028
	Bottom	0.166	-	0.166		Bottom	0.402	-	0.402
	Right	0.415	-	0.415		Right	0.034	-	0.034
	Left	0.658	0.005	0.663		Left	0.233	0.005	0.238
Simult Tx	Configuration	UMTS 1900 SAR (W/kg)	5 GHz WLAN SAR (W/kg)	Σ SAR (W/kg)	Simult Tx	Configuration	LTE Band 5 (Cell) SAR (W/kg)	5 GHz WLAN SAR (W/kg)	Σ SAR (W/kg)
Body SAR	Back	0.571	0.010	0.581	Body SAR	Back	0.827	0.010	0.837
	Front	0.882	0.012	0.894		Front	0.688	0.012	0.700
	Top	-	0.028	0.028		Top	-	0.028	0.028
	Bottom	0.677	-	0.677		Bottom	0.215	-	0.215
	Right	0.044	-	0.044		Right	0.513	-	0.513
	Left	0.281	0.005	0.286		Left	0.767	0.005	0.772
Simult Tx	Configuration	LTE Band 17 SAR (W/kg)	5 GHz WLAN SAR (W/kg)	Σ SAR (W/kg)					
Body SAR	Back	0.353	0.010	0.363					
	Front	0.267	0.012	0.279					
	Top	-	0.028	0.028					
	Bottom	0.083	-	0.083					
	Right	0.151	-	0.151					
	Left	0.233	0.005	0.238					

12.6 Simultaneous Transmission Conclusion

The above numerical summed SAR results for all the worst-case simultaneous transmission conditions were below the SAR limit. Therefore, the above analysis is sufficient to determine that simultaneous transmission cases will not exceed the SAR limit and therefore no measured volumetric simultaneous SAR summation is required per FCC KDB Publication 447498 D01v05 and IEEE 1528-2013 Section 6.3.4.1.2.

FCC ID: A3LSMG900S	 PCTEST ENGINEERING LABORATORY, INC.	SAR EVALUATION REPORT		Reviewed by: Quality Manager
Document S/N: OY1402030286-R1.A3L	Test Dates: 02/03/14 – 02/10/14	DUT Type: Portable Handset	Page 57 of 64	

13 SAR MEASUREMENT VARIABILITY

13.1 Measurement Variability

Per FCC KDB Publication 865664 D01v01, SAR measurement variability was assessed for each frequency band, which was determined by the SAR probe calibration point and tissue-equivalent medium used for the device measurements. When both head and body tissue-equivalent media were required for SAR measurements in a frequency band, the variability measurement procedures were applied to the tissue medium with the highest measured SAR, using the highest measured SAR configuration for that tissue-equivalent medium. These additional measurements were repeated after the completion of all measurements requiring the same head or body tissue-equivalent medium in a frequency band. The test device was returned to ambient conditions (normal room temperature) with the battery fully charged before it was re-mounted on the device holder for the repeated measurement(s) to minimize any unexpected variations in the repeated results.

SAR Measurement Variability was assessed using the following procedures for each frequency band:



- 1) When the original highest measured SAR is ≥ 0.80 W/kg, the measurement was repeated once.
- 2) A second repeated measurement was performed only if the ratio of largest to smallest SAR for the original and first repeated measurements was > 1.20 or when the original or repeated measurement was ≥ 1.45 W/kg (~ 10% from the 1-g SAR limit).
- 3) A third repeated measurement was performed only if the original, first or second repeated measurement was ≥ 1.5 W/kg and the ratio of largest to smallest SAR for the original, first and second repeated measurements is > 1.20 .
- 4) Repeated measurements are not required when the original highest measured SAR is < 0.80 W/kg

Table 13-1
Body SAR Measurement Variability Results

BODY VARIABILITY RESULTS													
Band	FREQUENCY		Mode	Service	Side	Spacing	Measured SAR (1g)	1st Repeated SAR (1g)	Ratio	2nd Repeated SAR (1g)	Ratio	3rd Repeated SAR (1g)	Ratio
	MHz	Ch.					(W/kg)	(W/kg)		(W/kg)		(W/kg)	
1900	1852.40	9262	UMTS 1900	RMC	front	10 mm	0.856	0.845	1.01	N/A	N/A	N/A	N/A
ANSI / IEEE C95.1 1992 - SAFETY LIMIT Spatial Peak Uncontrolled Exposure/General Population						Body 1.6 W/kg (mW/g) averaged over 1 gram							

13.2 Measurement Uncertainty

The measured SAR was < 1.5 W/kg for all frequency bands. Therefore, per KDB Publication 865664 D01v01, the extended measurement uncertainty analysis per IEEE 1528-2003 was not required.



FCC ID: A3LSMG900S	 PCTEST ENGINEERING LABORATORY, INC.	SAR EVALUATION REPORT		Reviewed by: Quality Manager
Document S/N: OY1402030286-R1.A3L	Test Dates: 02/03/14 – 02/10/14	DUT Type: Portable Handset		Page 58 of 64

14 EQUIPMENT LIST

Manufacturer	Model	Description	Cal Date	Cal Interval	Cal Due	Serial Number
Agilent	E8257D	(250kHz-20GHz) Signal Generator	4/16/2013	Annual	4/16/2014	MY45470194
Agilent	8753E	(30kHz-6GHz) Network Analyzer	7/23/2013	Annual	7/23/2014	US37390350
Agilent	8648D	(9kHz-4GHz) Signal Generator	4/17/2013	Annual	4/17/2014	3629U00687
Agilent	N9020A	MXA Signal Analyzer	10/29/2013	Annual	10/29/2014	US46470561
Agilent	N5182A	MXG Vector Signal Generator	10/28/2013	Annual	10/28/2014	US46240505
Agilent	8753ES	S-Parameter Network Analyzer	10/29/2013	Annual	10/29/2014	US39170122
Agilent	E5515C	Wireless Communications Test Set	10/18/2012	Biennial	10/18/2014	GB43193563
Agilent	85047A	S-Parameter Test Set	N/A	N/A	N/A	2904A00579
Amplifier Research	5S1G4	5W, 800MHz-4.2GHz	CBT	N/A	CBT	21910
Anritsu	ML2438A	Power Meter	2/14/2013	Annual	2/14/2014	98150041
Anritsu	ML2495A	Power Meter	10/31/2013	Annual	10/31/2014	1039008
Anritsu	MA2481A	Power Sensor	10/30/2013	Annual	10/30/2014	5605
Anritsu	MA2481A	Power Sensor	2/14/2013	Annual	2/14/2014	5318
Anritsu	MA2411B	Pulse Power Sensor	11/14/2013	Annual	11/14/2014	1126066
Anritsu	MT8820C	Radio Communication Analyzer	12/12/2013	Annual	12/12/2014	6201300731
Anritsu	MA24106A	USB Power Sensor	1/3/2014	Annual	1/3/2015	1344557
COMTECH	AR85729-5/5759B	Solid State Amplifier	CBT	N/A	CBT	M3W1A00-1002
COMTECH	AR85729-5	Solid State Amplifier	CBT	N/A	CBT	M15SA00-009
Fisher Scientific	15-077-960	Thermometer	11/6/2012	Biennial	11/6/2014	122640025
Gigatronics	80701A	(0.05-18GHz) Power Sensor	10/30/2013	Annual	10/30/2014	1833460
Gigatronics	8651A	Universal Power Meter	10/30/2013	Annual	10/30/2014	8650319
MCL	BW-N6W5+	6dB Attenuator	CBT	N/A	CBT	1139
MiniCircuits	SLP-2400+	Low Pass Filter	CBT	N/A	CBT	R8979500903
MiniCircuits	VLF-6000+	Low Pass Filter	CBT	N/A	CBT	N/A
Mini-Circuits	BW-N20W5+	DC to 18 GHz Precision Fixed 20 dB Attenuator	CBT	N/A	CBT	N/A
Mini-Circuits	NLP-1200+	Low Pass Filter DC to 1000 MHz	CBT	N/A	CBT	N/A
Mini-Circuits	NLP-2950+	Low Pass Filter DC to 2700 MHz	CBT	N/A	CBT	N/A
Mini-Circuits	BW-N20W5	Power Attenuator	CBT	N/A	CBT	1226
Narda	4014C-6	4 - 8 GHz SMA 6 dB Directional Coupler	CBT	N/A	CBT	N/A
Narda	4772-3	Attenuator (3dB)	CBT	N/A	CBT	9406
Narda	BW-S3W2	Attenuator (3dB)	CBT	N/A	CBT	120
Pasternack	PE2208-6	Bidirectional Coupler	CBT	N/A	CBT	N/A
Pasternack	PE2209-10	Bidirectional Coupler	CBT	N/A	CBT	N/A
Rohde & Schwarz	CMU200	Base Station Simulator	9/23/2013	Annual	9/23/2014	109892
Rohde & Schwarz	CMW500	LTE Radio Communication Tester	6/6/2013	Annual	6/6/2014	111427
Rohde & Schwarz	SMIQ03B	Signal Generator	4/17/2013	Annual	4/17/2014	DE27259
Rohde & Schwarz	SME06	Signal Generator	10/30/2013	Annual	10/30/2014	832026
Rohde & Schwarz	NRV5	Single Channel Power Meter	10/31/2013	Annual	10/31/2014	835360/0079
Rohde & Schwarz	NRVd	Dual Channel Power Meter	10/12/2012	Biennial	10/12/2014	101695
Rohde & Schwarz	NRV-232	Peak Power Sensor	10/12/2012	Biennial	10/12/2014	836019/013
Seekonk	NC-100	Torque Wrench (8" lb)	3/5/2012	Triennial	3/5/2015	N/A
SPEAG	D1900V2	1900 MHz SAR Dipole	7/22/2013	Annual	7/22/2014	5d149
SPEAG	D2450V2	2450 MHz SAR Dipole	8/23/2013	Annual	8/23/2014	719
SPEAG	D5GHV2	5 GHz SAR Dipole	2/14/2013	Annual	2/14/2014	1120
SPEAG	D750V3	750 MHz Dipole	2/13/2013	Annual	2/13/2014	1046
SPEAG	D835V2	835 MHz SAR Dipole	4/25/2013	Annual	4/25/2014	4d119
SPEAG	DAE4	Dasy Data Acquisition Electronics	3/8/2013	Annual	3/8/2014	1334
SPEAG	DAE4	Dasy Data Acquisition Electronics	4/22/2013	Annual	4/22/2014	1364
SPEAG	DAE4	Dasy Data Acquisition Electronics	4/22/2013	Annual	4/22/2014	1368
SPEAG	DAE4	Dasy Data Acquisition Electronics	8/21/2013	Annual	8/21/2014	1322
SPEAG	DAE4	Dasy Data Acquisition Electronics	11/18/2013	Annual	11/18/2014	1407
SPEAG	DAE4	Dasy Data Acquisition Electronics	11/19/2013	Annual	11/19/2014	1333
SPEAG	DAE4	Dasy Data Acquisition Electronics	11/19/2013	Annual	11/19/2014	1408
SPEAG	DAE4	Dasy Data Acquisition Electronics	1/22/2014	Annual	1/22/2015	1272
SPEAG	DAK-3.5	Dielectric Assessment Kit	11/13/2013	Annual	11/13/2014	1091
SPEAG	ES3DV3	SAR Probe	3/15/2013	Annual	3/15/2014	3209
SPEAG	ES3DV3	SAR Probe	4/29/2013	Annual	4/29/2014	3319
SPEAG	ES3DV2	SAR Probe	8/22/2013	Annual	8/22/2014	3022
SPEAG	EX3DV4	SAR Probe	10/23/2013	Annual	10/23/2014	3914
SPEAG	ES3DV3	SAR Probe	11/25/2013	Annual	11/25/2014	3332
SPEAG	EX3DV4	SAR Probe	1/29/2014	Annual	1/29/2015	3589
SPEAG	ES3DV3	SAR Probe	11/20/2013	Annual	11/20/2014	3287
Tektronix	RSA6114A	Real Time Spectrum Analyzer	4/17/2013	Annual	4/17/2014	B010177
VWR	36934-158	Wall-Mounted Thermometer	8/8/2013	Annual	8/8/2014	130258636
VWR	23226-658	Long Stem Thermometer	7/11/2012	Biennial	7/11/2014	122389330

Note:

1. CBT (Calibrated Before Testing). Prior to testing, the measurement paths containing a cable, amplifier, attenuator, coupler or filter were connected to a calibrated source (i.e. a signal generator) to determine the losses of the measurement path. The power meter offset was then adjusted to compensate for the measurement system losses. This level offset is stored within the power meter before measurements are made. This calibration verification procedure applies to the system verification and output power measurements. The calibrated reading is then taken directly from the power meter after compensation of the losses for all final power measurements.
2. Each equipment item was used solely within its respective calibration period.

FCC ID: A3LSMG900S		SAR EVALUATION REPORT		Reviewed by: Quality Manager
Document S/N: OY1402030286-R1.A3L	Test Dates: 02/03/14 – 02/10/14	DUT Type: Portable Handset		Page 59 of 64

15 MEASUREMENT UNCERTAINTIES

Applicable for frequencies less than 3000 MHz.

a	b	c	d	e= f(d,k)	f	g	h = c x f/e	i = c x g/e	k
Uncertainty Component	IEEE 1528 Sec.	Tol. (± %)	Prob. Dist.	Div.	c _i 1gm	c _i 10 gms	1gm u _i (± %)	10gms u _i (± %)	v _i
Measurement System									
Probe Calibration	E.2.1	6.0	N	1	1.0	1.0	6.0	6.0	∞
Axial Isotropy	E.2.2	0.25	N	1	0.7	0.7	0.2	0.2	∞
Hemishperical Isotropy	E.2.2	1.3	N	1	1.0	1.0	1.3	1.3	∞
Boundary Effect	E.2.3	0.4	N	1	1.0	1.0	0.4	0.4	∞
Linearity	E.2.4	0.3	N	1	1.0	1.0	0.3	0.3	∞
System Detection Limits	E.2.5	5.1	N	1	1.0	1.0	5.1	5.1	∞
Readout Electronics	E.2.6	1.0	N	1	1.0	1.0	1.0	1.0	∞
Response Time	E.2.7	0.8	R	1.73	1.0	1.0	0.5	0.5	∞
Integration Time	E.2.8	2.6	R	1.73	1.0	1.0	1.5	1.5	∞
RF Ambient Conditions	E.6.1	3.0	R	1.73	1.0	1.0	1.7	1.7	∞
Probe Positioner Mechanical Tolerance	E.6.2	0.4	R	1.73	1.0	1.0	0.2	0.2	∞
Probe Positioning w/ respect to Phantom	E.6.3	2.9	R	1.73	1.0	1.0	1.7	1.7	∞
Extrapolation, Interpolation & Integration algorithms for Max. SAR Evaluation	E.5	1.0	R	1.73	1.0	1.0	0.6	0.6	∞
Test Sample Related									
Test Sample Positioning	E.4.2	6.0	N	1	1.0	1.0	6.0	6.0	287
Device Holder Uncertainty	E.4.1	3.32	R	1.73	1.0	1.0	1.9	1.9	∞
Output Power Variation - SAR drift measurement	6.6.2	5.0	R	1.73	1.0	1.0	2.9	2.9	∞
Phantom & Tissue Parameters									
Phantom Uncertainty (Shape & Thickness tolerances)	E.3.1	4.0	R	1.73	1.0	1.0	2.3	2.3	∞
Liquid Conductivity - deviation from target values	E.3.2	5.0	R	1.73	0.64	0.43	1.8	1.2	∞
Liquid Conductivity - measurement uncertainty	E.3.3	3.8	N	1	0.64	0.43	2.4	1.6	6
Liquid Permittivity - deviation from target values	E.3.2	5.0	R	1.73	0.60	0.49	1.7	1.4	∞
Liquid Permittivity - measurement uncertainty	E.3.3	4.5	N	1	0.60	0.49	2.7	2.2	6
Combined Standard Uncertainty (k=1)				RSS			12.1	11.7	299
Expanded Uncertainty (95% CONFIDENCE LEVEL)				k=2			24.2	23.5	

The above measurement uncertainties are according to IEEE Std. 1528-2003

FCC ID: A3LSMG900S	 PCTEST ENGINEERING LABORATORY, INC.	SAR EVALUATION REPORT		Reviewed by: Quality Manager
Document S/N: OY1402030286-R1.A3L	Test Dates: 02/03/14 – 02/10/14	DUT Type: Portable Handset		Page 60 of 64

Applicable for frequencies up to 6 GHz.

a	b	c	d	e= f(d,k)	f	g	h= c x f/e	i= c x g/e	k	
Uncertainty Component	IEEE 1528 Sec.	Tol. (± %)	Prob. Dist.	Div.	c _i 1gm	c _i 10 gms	1gm u _i (± %)	10gms u _i (± %)	v _i	
Measurement System										
Probe Calibration	E.2.1	6.55	N	1	1.0	1.0	6.6	6.6	∞	
Axial Isotropy	E.2.2	0.25	N	1	0.7	0.7	0.2	0.2	∞	
Hemishperical Isotropy	E.2.2	1.3	N	1	1.0	1.0	1.3	1.3	∞	
Boundary Effect	E.2.3	0.4	N	1	1.0	1.0	0.4	0.4	∞	
Linearity	E.2.4	0.3	N	1	1.0	1.0	0.3	0.3	∞	
System Detection Limits	E.2.5	5.1	N	1	1.0	1.0	5.1	5.1	∞	
Readout Electronics	E.2.6	1.0	N	1	1.0	1.0	1.0	1.0	∞	
Response Time	E.2.7	0.8	R	1.73	1.0	1.0	0.5	0.5	∞	
Integration Time	E.2.8	2.6	R	1.73	1.0	1.0	1.5	1.5	∞	
RF Ambient Conditions	E.6.1	3.0	R	1.73	1.0	1.0	1.7	1.7	∞	
Probe Positioner Mechanical Tolerance	E.6.2	0.4	R	1.73	1.0	1.0	0.2	0.2	∞	
Probe Positioning w/ respect to Phantom	E.6.3	2.9	R	1.73	1.0	1.0	1.7	1.7	∞	
Extrapolation, Interpolation & Integration algorithms for Max. SAR Evaluation	E.5	1.0	R	1.73	1.0	1.0	0.6	0.6	∞	
Test Sample Related										
Test Sample Positioning	E.4.2	6.0	N	1	1.0	1.0	6.0	6.0	287	
Device Holder Uncertainty	E.4.1	3.32	R	1.73	1.0	1.0	1.9	1.9	∞	
Output Power Variation - SAR drift measurement	6.6.2	5.0	R	1.73	1.0	1.0	2.9	2.9	∞	
Phantom & Tissue Parameters										
Phantom Uncertainty (Shape & Thickness tolerances)	E.3.1	4.0	R	1.73	1.0	1.0	2.3	2.3	∞	
Liquid Conductivity - deviation from target values	E.3.2	5.0	R	1.73	0.64	0.43	1.8	1.2	∞	
Liquid Conductivity - measurement uncertainty	E.3.3	3.8	N	1	0.64	0.43	2.4	1.6	6	
Liquid Permittivity - deviation from target values	E.3.2	5.0	R	1.73	0.60	0.49	1.7	1.4	∞	
Liquid Permittivity - measurement uncertainty	E.3.3	4.5	N	1	0.60	0.49	2.7	2.2	6	
Combined Standard Uncertainty (k=1)							RSS	12.4	12.0	299
Expanded Uncertainty (95% CONFIDENCE LEVEL)							k=2	24.7	24.0	

The above measurement uncertainties are according to IEEE Std. 1528-2003

FCC ID: A3LSMG900S	 PCTEST ENGINEERING LABORATORY, INC.	SAR EVALUATION REPORT		Reviewed by: Quality Manager
Document S/N: OY1402030286-R1.A3L	Test Dates: 02/03/14 – 02/10/14	DUT Type: Portable Handset		Page 61 of 64

16 CONCLUSION

16.1 Measurement Conclusion

The SAR evaluation indicates that the EUT complies with the RF radiation exposure limits of the FCC and Industry Canada, with respect to all parameters subject to this test. These measurements were taken to simulate the RF effects of RF exposure under worst-case conditions. Precise laboratory measures were taken to assure repeatability of the tests. The results and statements relate only to the item(s) tested.

Please note that the absorption and distribution of electromagnetic energy in the body are very complex phenomena that depend on the mass, shape, and size of the body, the orientation of the body with respect to the field vectors, and the electrical properties of both the body and the environment. Other variables that may play a substantial role in possible biological effects are those that characterize the environment (e.g. ambient temperature, air velocity, relative humidity, and body insulation) and those that characterize the individual (e.g. age, gender, activity level, debilitation, or disease). Because various factors may interact with one another to vary the specific biological outcome of an exposure to electromagnetic fields, any protection guide should consider maximal amplification of biological effects as a result of field-body interactions, environmental conditions, and physiological variables. [3]

FCC ID: A3LSMG900S	 PCTEST ENGINEERING LABORATORY, INC.	SAR EVALUATION REPORT		Reviewed by: Quality Manager
Document S/N: OY1402030286-R1.A3L	Test Dates: 02/03/14 – 02/10/14	DUT Type: Portable Handset		Page 62 of 64

17 REFERENCES

- [1] Federal Communications Commission, ET Docket 93-62, Guidelines for Evaluating the Environmental Effects of Radiofrequency Radiation, Aug. 1996.
- [2] ANSI/IEEE C95.1-2005, American National Standard safety levels with respect to human exposure to radio frequency electromagnetic fields, 3kHz to 300GHz, New York: IEEE, 2006.
- [3] ANSI/IEEE C95.1-1992, American National Standard safety levels with respect to human exposure to radio frequency electromagnetic fields, 3kHz to 300GHz, New York: IEEE, Sept. 1992.
- [4] ANSI/IEEE C95.3-2002, IEEE Recommended Practice for the Measurement of Potentially Hazardous Electromagnetic Fields - RF and Microwave, New York: IEEE, December 2002.
- [5] IEEE Standards Coordinating Committee 39 –Standards Coordinating Committee 34 – IEEE Std. 1528-2003, Recommended Practice for Determining the Peak Spatial-Average Specific Absorption Rate (SAR) in the Human Body Due to Wireless Communications Devices.
- [6] NCRP, National Council on Radiation Protection and Measurements, Biological Effects and Exposure Criteria for RadioFrequency Electromagnetic Fields, NCRP Report No. 86, 1986. Reprinted Feb. 1995.
- [7] T. Schmid, O. Egger, N. Kuster, Automated E-field scanning system for dosimetric assessments, IEEE Transaction on Microwave Theory and Techniques, vol. 44, Jan. 1996, pp. 105-113.
- [8] K. Pokovic, T. Schmid, N. Kuster, Robust setup for precise calibration of E-field probes in tissue simulating liquids at mobile communications frequencies, ICECOM97, Oct. 1997, pp. -124.
- [9] K. Pokovic, T. Schmid, and N. Kuster, E-field Probe with improved isotropy in brain simulating liquids, Proceedings of the ELMAR, Zadar, Croatia, June 23-25, 1996, pp. 172-175.
- [10] Schmid & Partner Engineering AG, Application Note: Data Storage and Evaluation, June 1998, p2.
- [11] V. Hombach, K. Meier, M. Burkhardt, E. Kuhn, N. Kuster, The Dependence of EM Energy Absorption upon Human Modeling at 900 MHz, IEEE Transaction on Microwave Theory and Techniques, vol. 44 no. 10, Oct. 1996, pp. 1865-1873.
- [12] N. Kuster and Q. Balzano, Energy absorption mechanism by biological bodies in the near field of dipole antennas above 300MHz, IEEE Transaction on Vehicular Technology, vol. 41, no. 1, Feb. 1992, pp. 17-23.
- [13] G. Hartsgrrove, A. Kraszewski, A. Surowiec, Simulated Biological Materials for Electromagnetic Radiation Absorption Studies, University of Ottawa, Bioelectromagnetics, Canada: 1987, pp. 29-36.
- [14] Q. Balzano, O. Garay, T. Manning Jr., Electromagnetic Energy Exposure of Simulated Users of Portable Cellular Telephones, IEEE Transactions on Vehicular Technology, vol. 44, no.3, Aug. 1995.
- [15] W. Gander, Computermathematick, Birkhaeuser, Basel, 1992.
- [16] W.H. Press, S.A. Teukolsky, W.T. Vetterling, and B.P. Flannery, Numerical Recipes in C, The Art of Scientific Computing, Second edition, Cambridge University Press, 1992.
- [17] N. Kuster, R. Kastle, T. Schmid, Dosimetric evaluation of mobile communications equipment with known precision, IEEE Transaction on Communications, vol. E80-B, no. 5, May 1997, pp. 645-652.

FCC ID: A3LSMG900S	 PCTEST ENGINEERING LABORATORY, INC.	SAR EVALUATION REPORT		Reviewed by: Quality Manager
Document S/N: OY1402030286-R1.A3L	Test Dates: 02/03/14 – 02/10/14	DUT Type: Portable Handset	Page 63 of 64	

- [18] CENELEC CLC/SC111B, European Prestandard (prENV 50166-2), Human Exposure to Electromagnetic Fields High-frequency: 10kHz-300GHz, Jan. 1995.
- [19] Prof. Dr. Niels Kuster, ETH, Eidgenössische Technische Hochschule Zürich, Dosimetric Evaluation of the Cellular Phone.
- [20] IEC 62209-1, Human exposure to radio frequency fields from hand-held and body-mounted wireless communication devices - Human models, instrumentation, and procedures - Part 1: Procedure to determine the specific absorption rate (SAR) for hand-held devices used in close proximity to the ear (frequency range of 300 MHz to 3 GHz), Feb. 2005.
- [21] Industry Canada RSS-102 Radio Frequency Exposure Compliance of Radiocommunication Apparatus (All Frequency Bands) Issue 4, March 2010.
- [22] Health Canada Safety Code 6 Limits of Human Exposure to Radio Frequency Electromagnetic Fields in the Frequency Range from 3 kHz – 300 GHz, 2009
- [23] FCC SAR Test Procedures for 2G-3G Devices, Mobile Hotspot and UMPC Devices KDB Publications 941225, D01-D07
- [24] SAR Measurement procedures for IEEE 802.11a/b/g KDB Publication 248227 D01v01r02
- [25] FCC SAR Considerations for Handsets with Multiple Transmitters and Antennas, KDB Publications 648474 D02-D04
- [26] FCC SAR Evaluation Considerations for Laptop, Notebook, Netbook and Tablet Computers, FCC KDB Publication 616217 D04
- [27] FCC SAR Measurement and Reporting Requirements for 100MHz – 6 GHz, KDB Publications 865664 D01-D02
- [28] FCC General RF Exposure Guidance and SAR Procedures for Dongles, KDB Publication 447498, D01-D02
- [29] Anexo à Resolução No. 533, de 10 de Setembro de 2009.
- [30] IEC 62209-2, Human exposure to radio frequency fields from hand-held and body-mounted wireless communication devices - Human models, instrumentation, and procedures - Part 2: Procedure to determine the specific absorption rate (SAR) for wireless communication devices used in close proximity to the human body (frequency range of 30 MHz to 6 GHz), Mar. 2010.

FCC ID: A3LSMG900S	 SAR EVALUATION REPORT 		Reviewed by: Quality Manager
Document S/N: OY1402030286-R1.A3L	Test Dates: 02/03/14 – 02/10/14	DUT Type: Portable Handset	Page 64 of 64

APPENDIX A: SAR TEST DATA

PCTEST ENGINEERING LABORATORY, INC.

DUT: A3LSMG900S; Type: Portable Handset; Serial: F1188

Communication System: UID 0, UMTS; Frequency: 836.6 MHz; Duty Cycle: 1:1

Medium: 835 Head Medium parameters used (interpolated):

$f = 836.6 \text{ MHz}$; $\sigma = 0.92 \text{ S/m}$; $\epsilon_r = 41.94$; $\rho = 1000 \text{ kg/m}^3$

Phantom section: Left Section

Test Date: 02-06-2014; Ambient Temp: 24.2°C; Tissue Temp: 23.1°C

Probe: ES3DV3 - SN3332; ConvF(6.29, 6.29, 6.29); Calibrated: 11/25/2013;

Sensor-Surface: 4mm (Mechanical Surface Detection)

Electronics: DAE4 Sn1407; Calibrated: 11/18/2013

Phantom: SAM with CRP v4.0; Type: QD000P40CD; Serial: TP:1800

Measurement SW: DASY52, Version 52.8 (7); SEMCAD X Version 14.6.10 (7164)

Mode: UMTS 850, Left Head, Cheek, Mid.ch

Area Scan (8x13x1): Measurement grid: dx=15mm, dy=15mm

Zoom Scan (5x5x7)/Cube 0: Measurement grid: dx=8mm, dy=8mm, dz=5mm

Reference Value = 21.730 V/m; Power Drift = 0.04 dB

Peak SAR (extrapolated) = 0.555 W/kg

SAR(1 g) = 0.417 W/kg

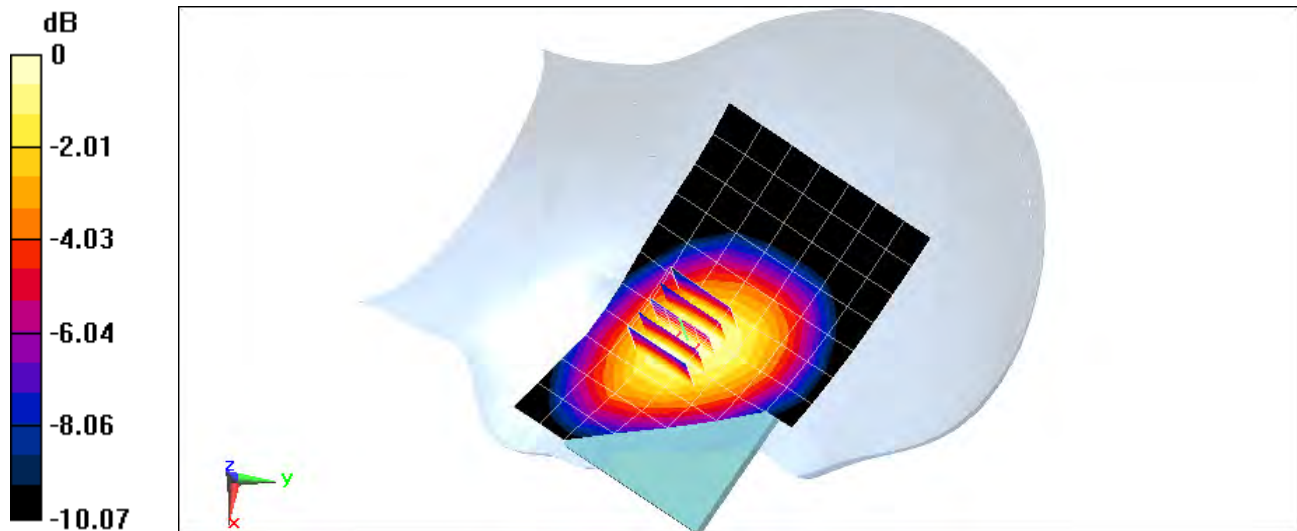

0 dB = 0.442 W/kg = -3.55 dBW/kg

PCTEST ENGINEERING LABORATORY, INC.

DUT: A3LSMG900S; Type: Portable Handset; Serial: F1187

Communication System: UID 0, GSM; Frequency: 1880 MHz; Duty Cycle: 1:8.3

Medium: 1900 Head Medium parameters used:

$f = 1880 \text{ MHz}$; $\sigma = 1.425 \text{ S/m}$; $\epsilon_r = 38.619$; $\rho = 1000 \text{ kg/m}^3$

Phantom section: Left Section

Test Date: 02-10-2014; Ambient Temp: 22.8°C; Tissue Temp: 22.2°C

Probe: ES3DV2 - SN3022; ConvF(5.03, 5.03, 5.03); Calibrated: 8/22/2013;

Sensor-Surface: 4mm (Mechanical Surface Detection)

Electronics: DAE4 Sn1322; Calibrated: 8/21/2013

Phantom: SAM v5.0 Left; Type: QD000P40CD; Serial: TP: 1687

Measurement SW: DASY52, Version 52.8 (7); SEMCAD X Version 14.6.10 (7164)

Mode: GSM 1900, Left Head, Cheek, Mid.ch

Area Scan (8x12x1): Measurement grid: dx=15mm, dy=15mm

Zoom Scan (5x5x7)/Cube 0: Measurement grid: dx=8mm, dy=8mm, dz=5mm

Reference Value = 11.477 V/m; Power Drift = -0.04 dB

Peak SAR (extrapolated) = 0.249 W/kg

SAR(1 g) = 0.168 W/kg

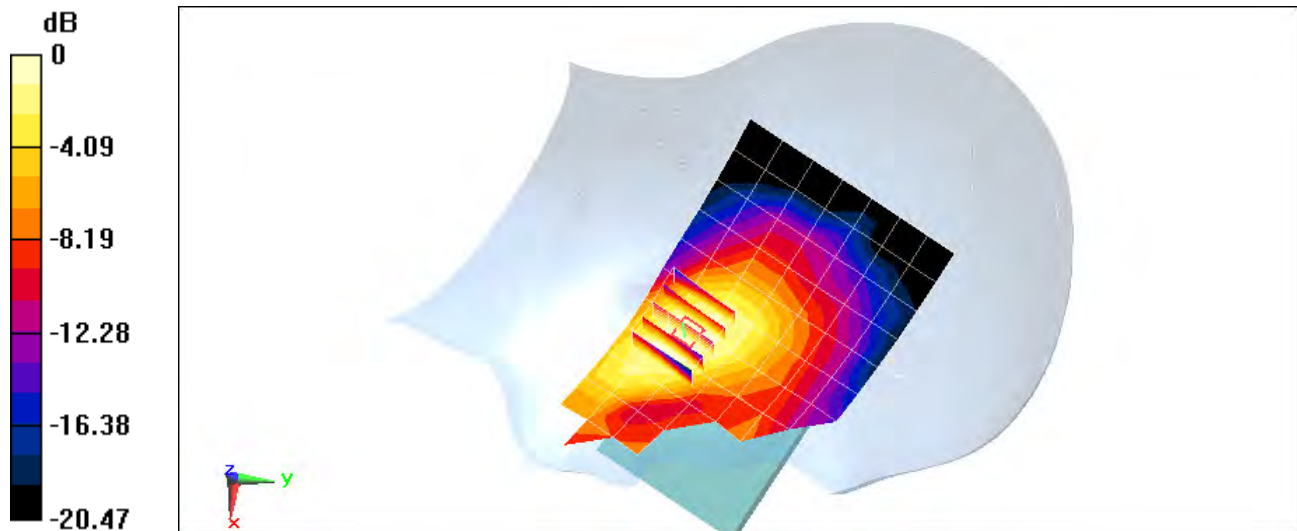

0 dB = 0.182 W/kg = -7.40 dBW/kg

PCTEST ENGINEERING LABORATORY, INC.

DUT: A3LSMG900S; Type: Portable Handset; Serial: F1187

Communication System: UID 0, UMTS; Frequency: 1880 MHz; Duty Cycle: 1:1

Medium: 1900 Head Medium parameters used:

$f = 1880 \text{ MHz}$; $\sigma = 1.425 \text{ S/m}$; $\epsilon_r = 38.619$; $\rho = 1000 \text{ kg/m}^3$

Phantom section: Left Section

Test Date: 02-10-2014; Ambient Temp: 22.8°C; Tissue Temp: 22.2°C

Probe: ES3DV2 - SN3022; ConvF(5.03, 5.03, 5.03); Calibrated: 8/22/2013;

Sensor-Surface: 4mm (Mechanical Surface Detection)

Electronics: DAE4 Sn1322; Calibrated: 8/21/2013

Phantom: SAM v5.0 Left; Type: QD000P40CD; Serial: TP: 1687

Measurement SW: DASY52, Version 52.8 (7); SEMCAD X Version 14.6.10 (7164)

Mode: UMTS 1900, Left Head, Cheek, Mid.ch

Area Scan (8x12x1): Measurement grid: dx=15mm, dy=15mm

Zoom Scan (5x5x7)/Cube 0: Measurement grid: dx=8mm, dy=8mm, dz=5mm

Reference Value = 15.535 V/m; Power Drift = 0.01 dB

Peak SAR (extrapolated) = 0.455 W/kg

SAR(1 g) = 0.300 W/kg

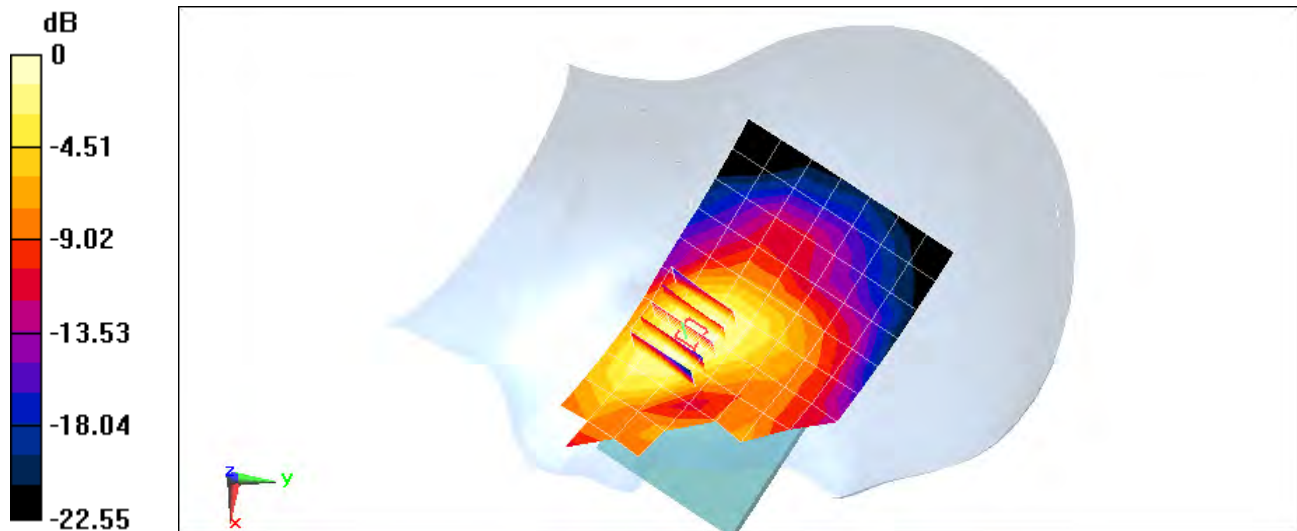

0 dB = 0.327 W/kg = -4.85 dBW/kg

PCTEST ENGINEERING LABORATORY, INC.

DUT: A3LSMG900S; Type: Portable Handset; Serial: F1187

Communication System: UID 0, LTE Band 5 (Cell.); Frequency: 836.5 MHz; Duty Cycle: 1:1

Medium: 835 Head Medium parameters used (interpolated):

$f = 836.5 \text{ MHz}$; $\sigma = 0.933 \text{ S/m}$; $\epsilon_r = 42.58$; $\rho = 1000 \text{ kg/m}^3$

Phantom section: Left Section

Test Date: 02-10-2014; Ambient Temp: 23.9°C; Tissue Temp: 23.1°C

Probe: EX3DV4 - SN3589; ConvF(8.49, 8.49, 8.49); Calibrated: 1/29/2014;

Sensor-Surface: 4mm (Mechanical Surface Detection)

Electronics: DAE4 Sn1272; Calibrated: 1/22/2014

Phantom: SAM; Type: QD000P40CD; Serial: TP:1758

Measurement SW: DASY52, Version 52.8 (7); SEMCAD X Version 14.6.10 (7164)

**Mode: LTE Band 5 (Cell.), Left Head, Cheek, Mid.ch, QPSK,
10 MHz Bandwidth, 1 RB, 25 RB Offset**

Area Scan (9x15x1): Measurement grid: dx=15mm, dy=15mm

Zoom Scan (6x6x7)/Cube 0: Measurement grid: dx=8mm, dy=8mm, dz=5mm

Reference Value = 24.262 V/m; Power Drift = 0.04 dB

Peak SAR (extrapolated) = 0.610 W/kg

SAR(1 g) = 0.485 W/kg

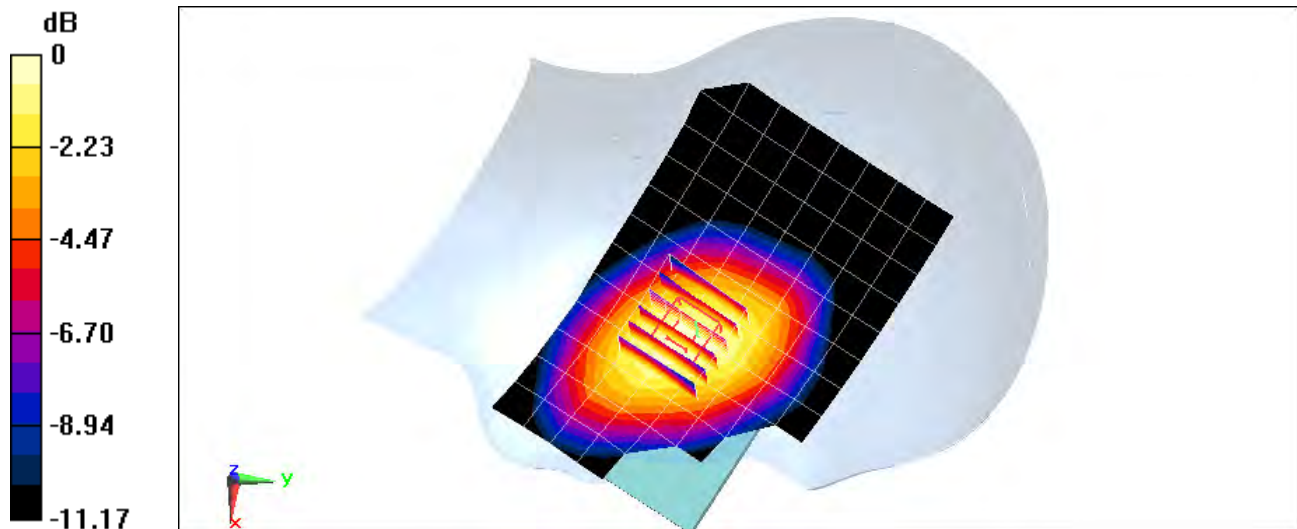

0 dB = 0.500 W/kg = -3.01 dBW/kg

PCTEST ENGINEERING LABORATORY, INC.

DUT: A3LSMG900S; Type: Portable Handset; Serial: F1187

Communication System: UID 0, LTE Band 17; Frequency: 710 MHz; Duty Cycle: 1:1

Medium: 740 Head Medium parameters used:

$f = 710 \text{ MHz}$; $\sigma = 0.898 \text{ S/m}$; $\epsilon_r = 42.062$; $\rho = 1000 \text{ kg/m}^3$

Phantom section: Left Section

Test Date: 02-06-2014; Ambient Temp: 24.4°C; Tissue Temp: 24.0°C

Probe: ES3DV3 - SN3319; ConvF(6.49, 6.49, 6.49); Calibrated: 4/29/2013;

Sensor-Surface: 4mm (Mechanical Surface Detection)

Electronics: DAE4 Sn1368; Calibrated: 4/22/2013

Phantom: SAM front; Type: QD000P40CD; Serial: TP:1759

Measurement SW: DASY52, Version 52.8 (7); SEMCAD X Version 14.6.10 (7164)

**Mode: LTE Band 17, Left Head, Cheek, Mid.ch, QPSK,
10 MHz Bandwidth, 1 RB, 25 RB Offset**

Area Scan (8x13x1): Measurement grid: dx=15mm, dy=15mm

Zoom Scan (5x5x7)/Cube 0: Measurement grid: dx=8mm, dy=8mm, dz=5mm

Reference Value = 7.631 V/m; Power Drift = 0.06 dB

Peak SAR (extrapolated) = 0.174 W/kg

SAR(1 g) = 0.144 W/kg

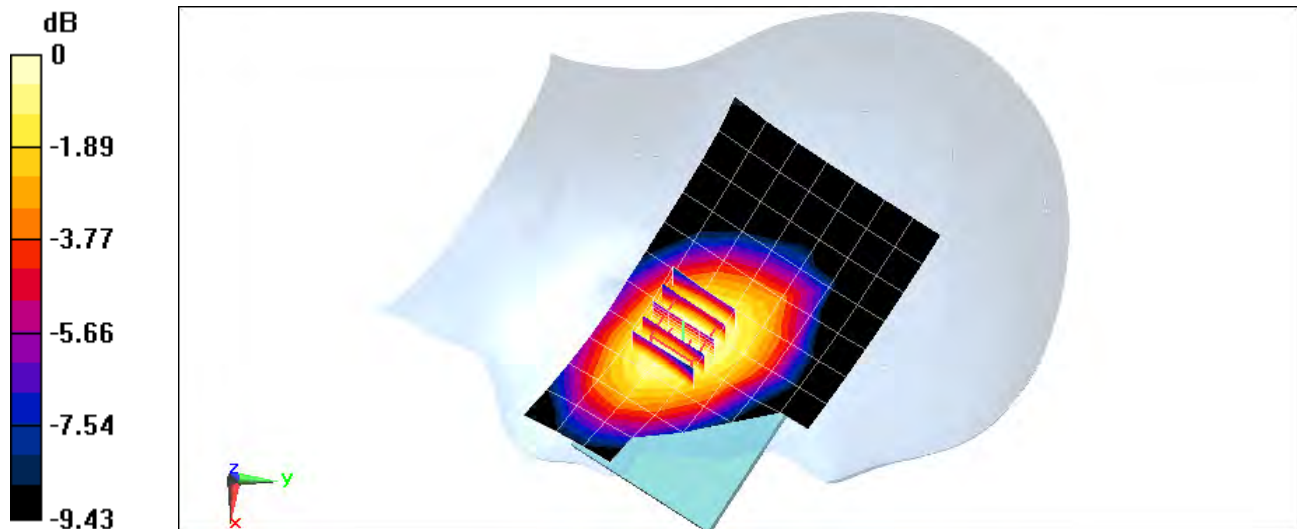

0 dB = 0.150 W/kg = -8.24 dBW/kg

PCTEST ENGINEERING LABORATORY, INC.

DUT: A3LSMG900S; Type: Portable Handset; Serial: F1185

Communication System: UID 0, IEEE 802.11b; Frequency: 2462 MHz; Duty Cycle: 1:1

Medium: 2450 Head Medium parameters used (interpolated):

$f = 2462 \text{ MHz}; \sigma = 1.846 \text{ S/m}; \epsilon_r = 37.98; \rho = 1000 \text{ kg/m}^3$

Phantom section: Right Section

Test Date: 02-06-2014; Ambient Temp: 24.3°C; Tissue Temp: 21.4°C

Probe: ES3DV3 - SN3287; ConvF(4.43, 4.43, 4.43); Calibrated: 11/20/2013;

Sensor-Surface: 3mm (Mechanical Surface Detection)

Electronics: DAE4 Sn1408; Calibrated: 11/19/2013

Phantom: SAM with CRP v4.0; Type: QD000P40CD; Serial: TP:1797

Measurement SW: DASY52, Version 52.8 (7); SEMCAD X Version 14.6.10 (7164)

Mode: Antenna 1, IEEE 802.11b, Right Head, Cheek, Ch 11, 1 Mbps

Area Scan (11x18x1): Measurement grid: dx=12mm, dy=12mm

Zoom Scan (7x7x7)/Cube 0: Measurement grid: dx=5mm, dy=5mm, dz=5mm

Reference Value = 16.511 V/m; Power Drift = 0.10 dB

Peak SAR (extrapolated) = 0.971 W/kg

SAR(1 g) = 0.465 W/kg

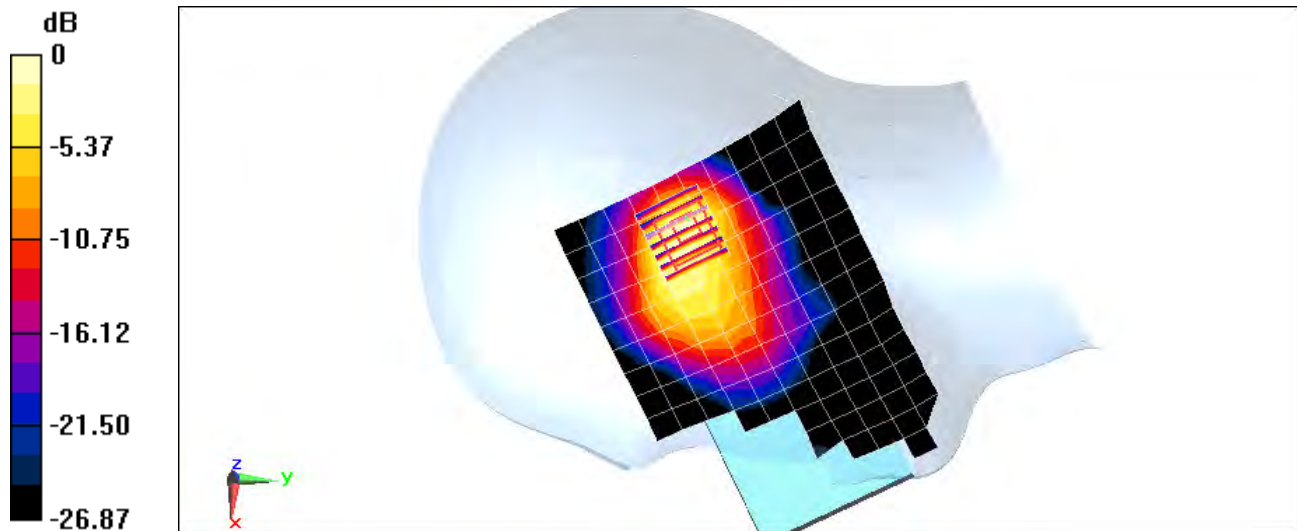

0 dB = 0.604 W/kg = -2.19 dBW/kg

PCTEST ENGINEERING LABORATORY, INC.

DUT: A3LSMG900S; Type: Portable Handset; Serial: F1186

Communication System: UID 0, IEEE 802.11a; Frequency: 5785 MHz; Duty Cycle: 1:1

Medium: 5 GHz Head Medium parameters used:

$$f = 5785 \text{ MHz}; \sigma = 5.182 \text{ S/m}; \epsilon_r = 36.998; \rho = 1000 \text{ kg/m}^3$$

Phantom section: Right Section

Test Date: 02-06-2014; Ambient Temp: 24.1°C; Tissue Temp: 23.5°C

Probe: EX3DV4 - SN3914; ConvF(4.52, 4.52, 4.52); Calibrated: 10/23/2013;

Sensor-Surface: 1.4mm (Mechanical Surface Detection)

Electronics: DAE4 Sn1333; Calibrated: 11/19/2013

Phantom: SAM V5.0 Right; Type: QD000P40CD; Serial: 1647

Measurement SW: DASY52, Version 52.8 (7); SEMCAD X Version 14.6.10 (7164)

Mode: Antenna 1, IEEE 802.11a, 5.8 GHz, Right Head, Tilt, Ch 157, 6 Mbps

Area Scan (11x19x1): Measurement grid: dx=10mm, dy=10mm

Zoom Scan (7x7x7)/Cube 0: Measurement grid: dx=4mm, dy=4mm, dz=1.4mm; Graded Ratio: 1.4

Reference Value = 8.087 V/m; Power Drift = 0.05 dB

Peak SAR (extrapolated) = 1.70 W/kg

SAR(1 g) = 0.359 W/kg

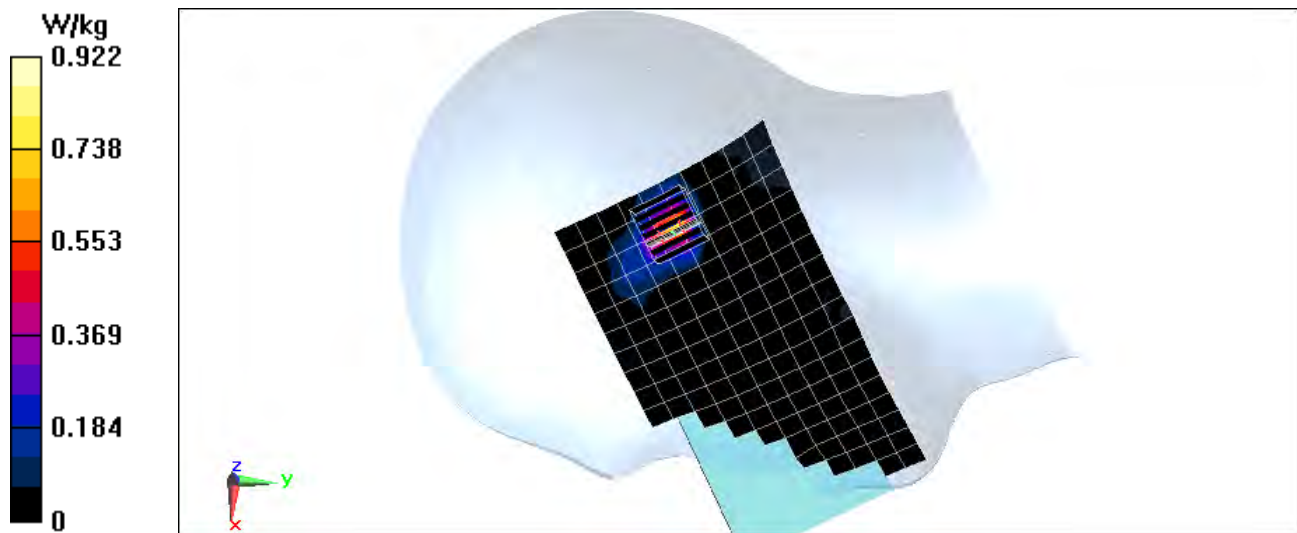

PCTEST ENGINEERING LABORATORY, INC.

DUT: A3LSMG900S; Type: Portable Handset; Serial: F1186

Communication System: UID 0, IEEE 802.11a; Frequency: 5500 MHz; Duty Cycle: 1:1

Medium: 5 GHz Head Medium parameters used:

$$f = 5500 \text{ MHz}; \sigma = 4.925 \text{ S/m}; \epsilon_r = 37.305; \rho = 1000 \text{ kg/m}^3$$

Phantom section: Right Section

Test Date: 02-06-2014; Ambient Temp: 23.9°C; Tissue Temp: 23.5°C

Probe: EX3DV4 - SN3914; ConvF(4.55, 4.55, 4.55); Calibrated: 10/23/2013;

Sensor-Surface: 1.4mm (Mechanical Surface Detection)

Electronics: DAE4 Sn1333; Calibrated: 11/19/2013

Phantom: SAM V5.0 Right; Type: QD000P40CD; Serial: 1647

Measurement SW: DASYS2, Version 52.8 (7); SEMCAD X Version 14.6.10 (7164)

Mode: Antenna 1, IEEE 802.11a, 5.5-5.8 GHz, Right Head, Tilt, Ch 100, 6 Mbps

Area Scan (11x19x1): Measurement grid: dx=10mm, dy=10mm

Zoom Scan (7x7x7)/Cube 0: Measurement grid: dx=4mm, dy=4mm, dz=1.4mm; Graded Ratio: 1.4

Reference Value = 8.445 V/m; Power Drift = 0.00 dB

Peak SAR (extrapolated) = 1.60 W/kg

SAR(1 g) = 0.389 W/kg

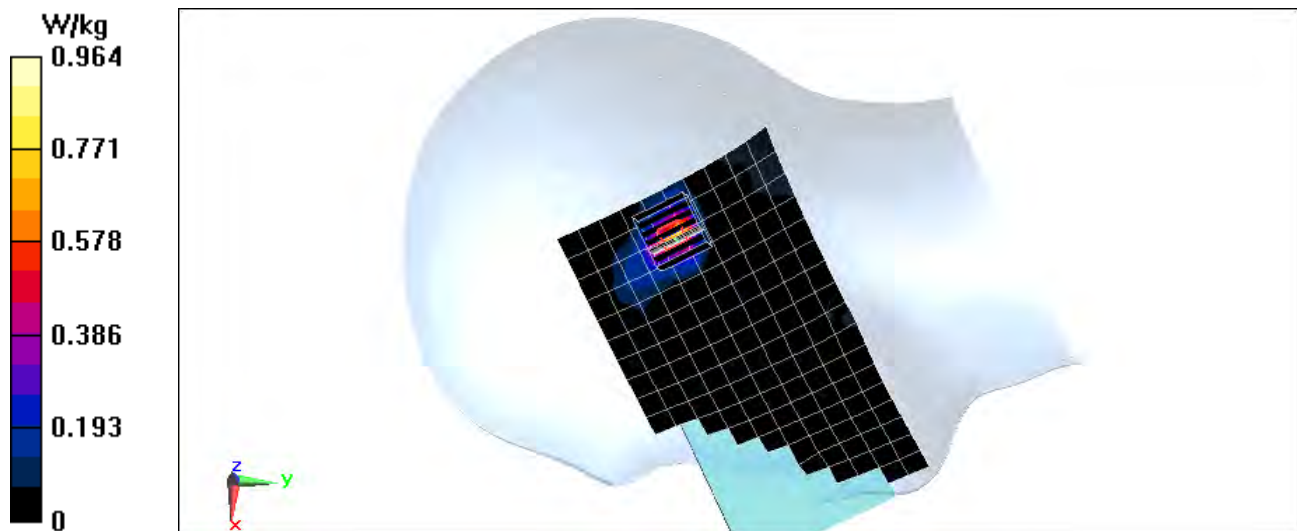

PCTEST ENGINEERING LABORATORY, INC.

DUT: A3LSMG900S; Type: Portable Handset; Serial: F1188

Communication System: UID 0, UMTS; Frequency: 836.6 MHz; Duty Cycle: 1:1

Medium: 835 Body Medium parameters used (interpolated):

$f = 836.6 \text{ MHz}$; $\sigma = 1.015 \text{ S/m}$; $\epsilon_r = 53.679$; $\rho = 1000 \text{ kg/m}^3$

Phantom section: Flat Section ; Space: 1.0 cm

Test Date: 02-05-2014; Ambient Temp: 22.9°C; Tissue Temp: 21.4°C

Probe: ES3DV3 - SN3209; ConvF(6.28, 6.28, 6.28); Calibrated: 3/15/2013;

Sensor-Surface: 4mm (Mechanical Surface Detection)

Electronics: DAE4 Sn1334; Calibrated: 3/8/2013

Phantom: SAM Front; Type: SAM; Serial: 1686

Measurement SW: DASYS2, Version 52.8 (7); SEMCAD X Version 14.6.10 (7164)

Mode: UMTS 850, Body SAR, Back side, Mid.ch

Area Scan (8x13x1): Measurement grid: dx=15mm, dy=15mm

Zoom Scan (5x5x7)/Cube 0: Measurement grid: dx=8mm, dy=8mm, dz=5mm

Reference Value = 24.957 V/m; Power Drift = 0.00 dB

Peak SAR (extrapolated) = 0.734 W/kg

SAR(1 g) = 0.585 W/kg

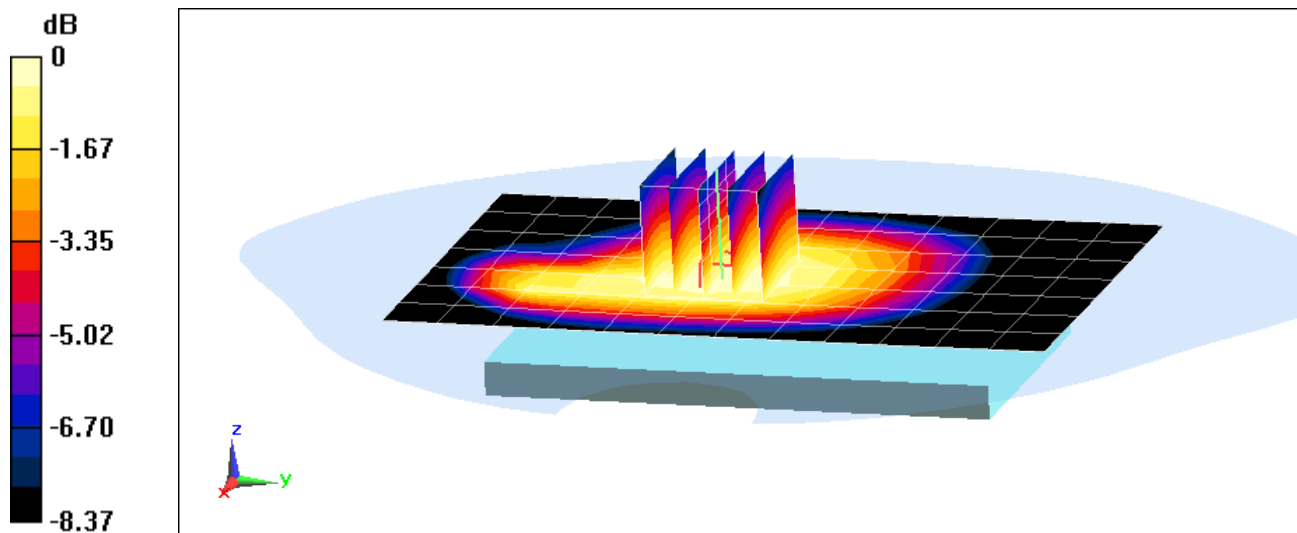

0 dB = 0.613 W/kg = -2.13 dBW/kg

PCTEST ENGINEERING LABORATORY, INC.

DUT: A3LSMG900S; Type: Portable Handset; Serial: F1188

Communication System: UID 0, GSM; Frequency: 1880 MHz; Duty Cycle: 1:8.3

Medium: 1900 Body Medium parameters used:

$f = 1880 \text{ MHz}$; $\sigma = 1.542 \text{ S/m}$; $\epsilon_r = 51.914$; $\rho = 1000 \text{ kg/m}^3$

Phantom section: Flat Section ; Space: 1.0 cm

Test Date: 02-28-2014; Ambient Temp: 23.1°C; Tissue Temp: 22.5°C

Probe: ES3DV2 - SN3022; ConvF(4.49, 4.49, 4.49); Calibrated: 8/22/2013;

Sensor-Surface: 4mm (Mechanical Surface Detection)

Electronics: DAE4 Sn1322; Calibrated: 8/21/2013

Phantom: SAM v5.0 front; Type: QD000P40CD; Serial: TP-1646

Measurement SW: DASY52, Version 52.8 (7); SEMCAD X Version 14.6.10 (7164)

Mode: GSM 1900, Body SAR, Back side, Mid.ch

Area Scan (9x15x1): Measurement grid: dx=15mm, dy=15mm

Zoom Scan (5x5x7)/Cube 0: Measurement grid: dx=8mm, dy=8mm, dz=5mm

Reference Value = 16.357 V/m; Power Drift = -0.09 dB

Peak SAR (extrapolated) = 0.749 W/kg

SAR(1 g) = 0.404 W/kg

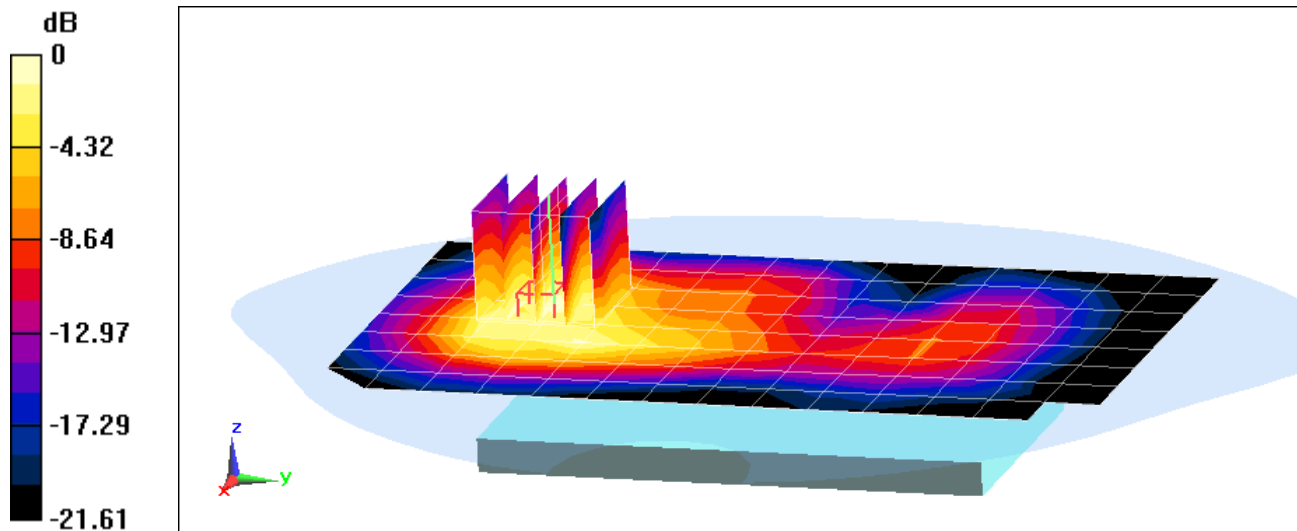

0 dB = 0.424 W/kg = -3.73 dBW/kg

PCTEST ENGINEERING LABORATORY, INC.

DUT: A3LSMG900S; Type: Portable Handset; Serial: F1188

Communication System: UID 0, GSM GPRS; 3 Tx slots; Frequency: 1880 MHz; Duty Cycle: 1:2.76

Medium: 1900 Body Medium parameters used:

$$f = 1880 \text{ MHz}; \sigma = 1.542 \text{ S/m}; \epsilon_r = 51.914; \rho = 1000 \text{ kg/m}^3$$

Phantom section: Flat Section ; Space: 1.0 cm

Test Date: 02-06-2014; Ambient Temp: 23.1°C; Tissue Temp: 22.5°C

Probe: ES3DV2 - SN3022; ConvF(4.49, 4.49, 4.49); Calibrated: 8/22/2013;

Sensor-Surface: 4mm (Mechanical Surface Detection)

Electronics: DAE4 Sn1322; Calibrated: 8/21/2013

Phantom: SAM v5.0 front; Type: QD000P40CD; Serial: TP-1646

Measurement SW: DASYS2, Version 52.8 (7); SEMCAD X Version 14.6.10 (7164)

Mode: GPRS 1900, Body SAR, Front side, Mid.ch, 3 Tx Slots

Area Scan (9x15x1): Measurement grid: dx=15mm, dy=15mm

Zoom Scan (5x5x7)/Cube 0: Measurement grid: dx=8mm, dy=8mm, dz=5mm

Reference Value = 22.772 V/m; Power Drift = 0.04 dB

Peak SAR (extrapolated) = 1.24 W/kg

SAR(1 g) = 0.665 W/kg

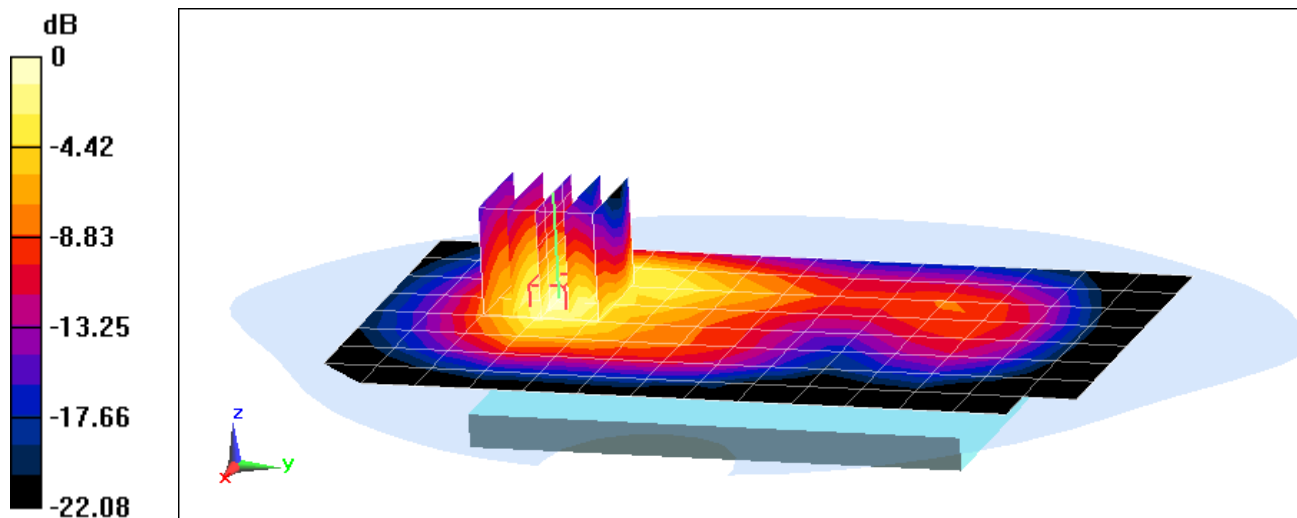

0 dB = 0.763 W/kg = -1.17 dBW/kg

PCTEST ENGINEERING LABORATORY, INC.

DUT: A3LSMG900S; Type: Portable Handset; Serial: F1188

Communication System: UID 0, UMTS; Frequency: 1880 MHz; Duty Cycle: 1:1

Medium: 1900 Body Medium parameters used:

$f = 1880 \text{ MHz}$; $\sigma = 1.542 \text{ S/m}$; $\epsilon_r = 51.914$; $\rho = 1000 \text{ kg/m}^3$

Phantom section: Flat Section ; Space: 1.0 cm

Test Date: 02-06-2014; Ambient Temp: 23.1°C; Tissue Temp: 22.5°C

Probe: ES3DV2 - SN3022; ConvF(4.49, 4.49, 4.49); Calibrated: 8/22/2013;

Sensor-Surface: 4mm (Mechanical Surface Detection)

Electronics: DAE4 Sn1322; Calibrated: 8/21/2013

Phantom: SAM v5.0 front; Type: QD000P40CD; Serial: TP-1646

Measurement SW: DASY52, Version 52.8 (7); SEMCAD X Version 14.6.10 (7164)

Mode: UMTS 1900, Body SAR, Back side, Mid.ch

Area Scan (9x15x1): Measurement grid: dx=15mm, dy=15mm

Zoom Scan (5x5x7)/Cube 0: Measurement grid: dx=8mm, dy=8mm, dz=5mm

Reference Value = 19.276 V/m; Power Drift = 0.01 dB

Peak SAR (extrapolated) = 0.990 W/kg

SAR(1 g) = 0.544 W/kg

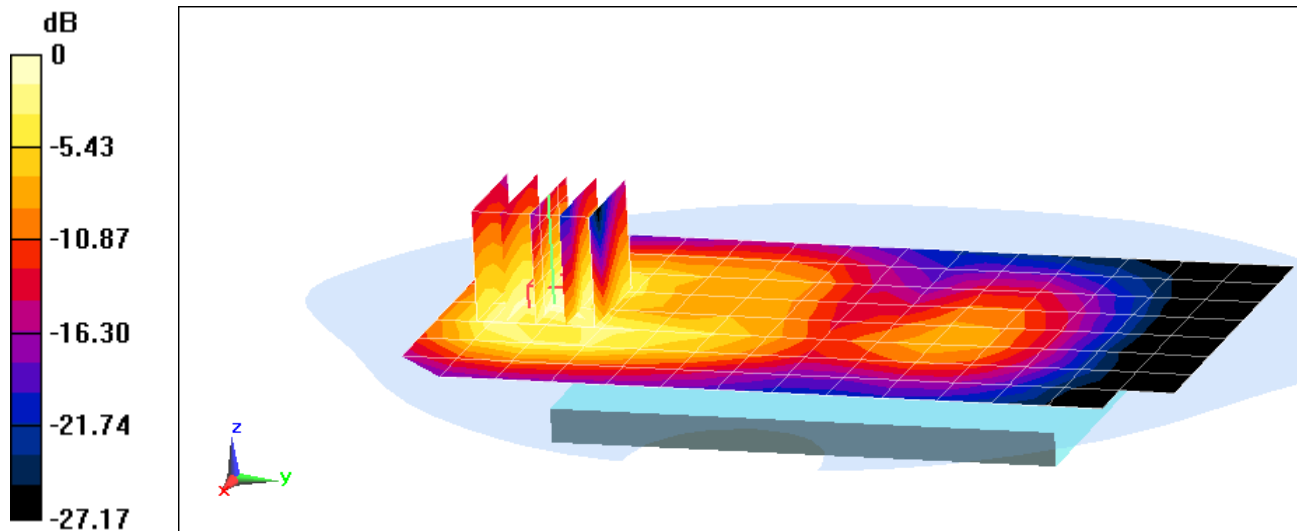

0 dB = 0.614 W/kg = -2.12 dBW/kg

PCTEST ENGINEERING LABORATORY, INC.

DUT: A3LSMG900S; Type: Portable Handset; Serial: F1188

Communication System: UID 0, UMTS; Frequency: 1852.4 MHz; Duty Cycle: 1:1

Medium: 1900 Body Medium parameters used (interpolated):

$f = 1852.4 \text{ MHz}$; $\sigma = 1.528 \text{ S/m}$; $\epsilon_r = 51.958$; $\rho = 1000 \text{ kg/m}^3$

Phantom section: Flat Section ; Space: 1.0 cm

Test Date: 02-10-2014; Ambient Temp: 23.3°C; Tissue Temp: 22.2°C

Probe: ES3DV2 - SN3022; ConvF(4.49, 4.49, 4.49); Calibrated: 8/22/2013;

Sensor-Surface: 4mm (Mechanical Surface Detection)

Electronics: DAE4 Sn1322; Calibrated: 8/21/2013

Phantom: SAM v5.0 front; Type: QD000P40CD; Serial: TP-1646

Measurement SW: DASYS2, Version 52.8 (7); SEMCAD X Version 14.6.10 (7164)

Mode: UMTS 1900, Body SAR, Front side, Low.ch

Area Scan (8x12x1): Measurement grid: dx=15mm, dy=15mm

Zoom Scan (5x5x7)/Cube 0: Measurement grid: dx=8mm, dy=8mm, dz=5mm

Reference Value = 24.573 V/m; Power Drift = -0.02 dB

Peak SAR (extrapolated) = 1.51 W/kg

SAR(1 g) = 0.856 W/kg

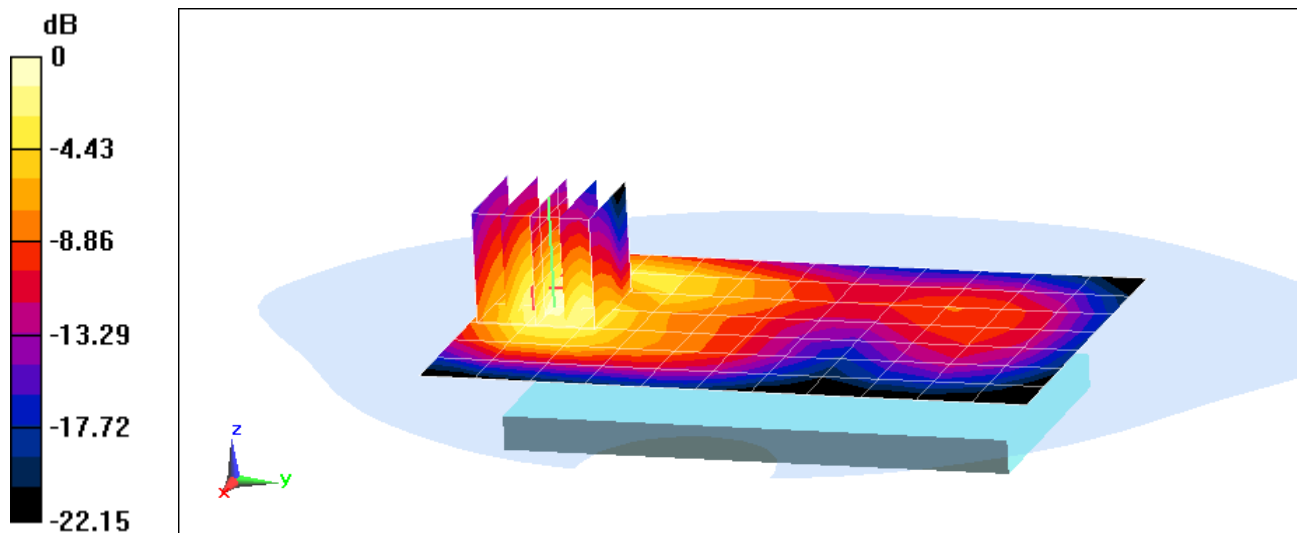

0 dB = 0.955 W/kg = -0.20 dBW/kg

PCTEST ENGINEERING LABORATORY, INC.

DUT: A3LSMG900S; Type: Portable Handset; Serial: F1187

Communication System: UID 0, LTE Band 5 (Cell.); Frequency: 836.5 MHz; Duty Cycle: 1:1

Medium: 835 Body Medium parameters used (interpolated):

$f = 836.5 \text{ MHz}$; $\sigma = 1.015 \text{ S/m}$; $\epsilon_r = 53.68$; $\rho = 1000 \text{ kg/m}^3$

Phantom section: Flat Section ; Space: 1.0 cm

Test Date: 02-05-2014; Ambient Temp: 22.9°C; Tissue Temp: 21.4°C

Probe: ES3DV3 - SN3209; ConvF(6.28, 6.28, 6.28); Calibrated: 3/15/2013;

Sensor-Surface: 4mm (Mechanical Surface Detection)

Electronics: DAE4 Sn1334; Calibrated: 3/8/2013

Phantom: SAM Front; Type: SAM; Serial: 1686

Measurement SW: DASY52, Version 52.8 (7); SEMCAD X Version 14.6.10 (7164)

**Mode: LTE Band 5 (Cell.), Body SAR, Back side, Mid.ch,
10 MHz Bandwidth, QPSK, 1 RB, 25 RB Offset**

Area Scan (8x13x1): Measurement grid: dx=15mm, dy=15mm

Zoom Scan (5x5x7)/Cube 0: Measurement grid: dx=8mm, dy=8mm, dz=5mm

Reference Value = 29.155 V/m; Power Drift = 0.00 dB

Peak SAR (extrapolated) = 1.00 W/kg

SAR(1 g) = 0.797 W/kg

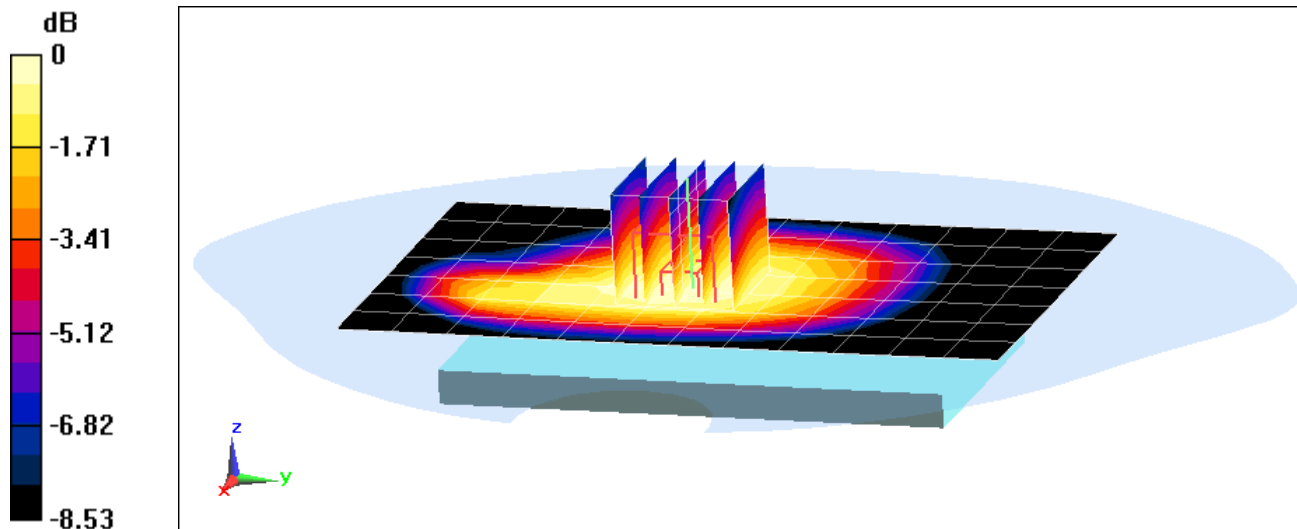

0 dB = 0.836 W/kg = -0.78 dBW/kg

PCTEST ENGINEERING LABORATORY, INC.

DUT: A3LSMG900S; Type: Portable Handset; Serial: F1187

Communication System: UID 0, LTE Band 17; Frequency: 710 MHz; Duty Cycle: 1:1

Medium: 740 Body Medium parameters used:

$f = 710 \text{ MHz}$; $\sigma = 0.92 \text{ S/m}$; $\epsilon_r = 54.23$; $\rho = 1000 \text{ kg/m}^3$

Phantom section: Flat Section ; Space: 1.0 cm

Test Date: 02-06-2014; Ambient Temp: 24.3°C; Tissue Temp: 23.5°C

Probe: ES3DV3 - SN3332; ConvF(6.21, 6.21, 6.21); Calibrated: 11/25/2013;

Sensor-Surface: 4mm (Mechanical Surface Detection)

Electronics: DAE4 Sn1407; Calibrated: 11/18/2013

Phantom: ELI v5.0; Type: QDOVA001BB; Serial: 1226

Measurement SW: DASY52, Version 52.8 (7); SEMCAD X Version 14.6.10 (7164)

**Mode: LTE Band 17, Body SAR, Back side, Mid.ch,
10 MHz Bandwidth, QPSK, 1 RB, 25 RB Offset**

Area Scan (8x13x1): Measurement grid: dx=15mm, dy=15mm

Zoom Scan (7x9x7)/Cube 0: Measurement grid: dx=8mm, dy=8mm, dz=5mm

Reference Value = 19.746 V/m; Power Drift = 0.03 dB

Peak SAR (extrapolated) = 0.556 W/kg

SAR(1 g) = 0.352 W/kg

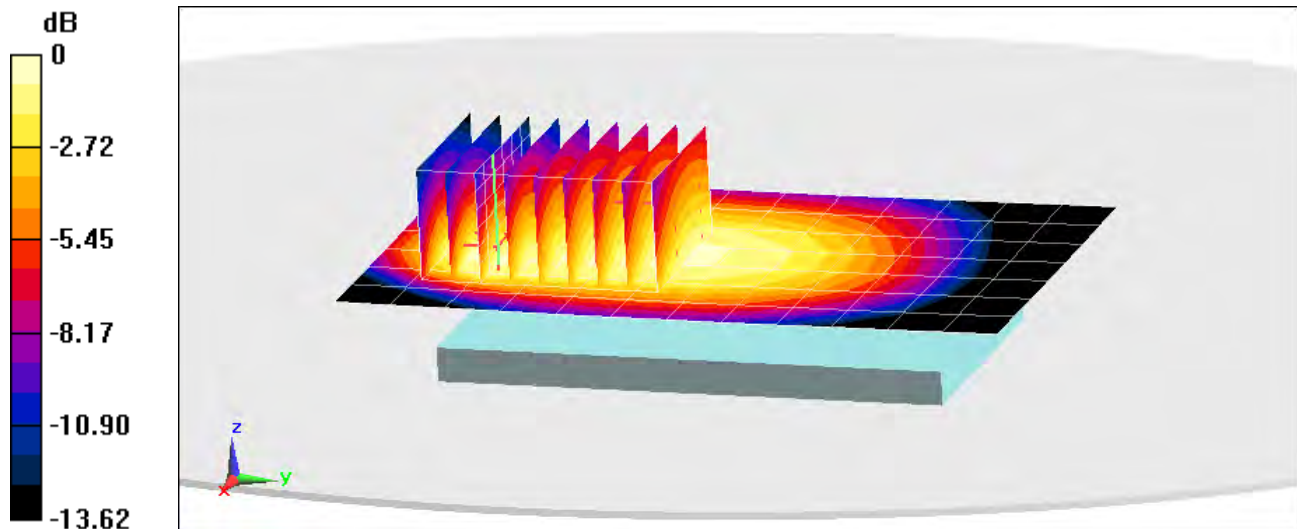

0 dB = 0.376 W/kg = -4.25 dBW/kg

PCTEST ENGINEERING LABORATORY, INC.

DUT: A3LSMG900S; Type: Portable Handset; Serial: 419EF

Communication System: UID 0, IEEE 802.11b; Frequency: 2412 MHz; Duty Cycle: 1:1

Medium: 2450 Body Medium parameters used (interpolated):

$f = 2412 \text{ MHz}$; $\sigma = 1.986 \text{ S/m}$; $\epsilon_r = 51.516$; $\rho = 1000 \text{ kg/m}^3$

Phantom section: Flat Section ; Space: 1.0 cm

Test Date: 02-03-2014; Ambient Temp: 24.4°C; Tissue Temp: 22.8°C

Probe: ES3DV3 - SN3209; ConvF(4.34, 4.34, 4.34); Calibrated: 3/15/2013;

Sensor-Surface: 3mm (Mechanical Surface Detection)

Electronics: DAE4 Sn1334; Calibrated: 3/8/2013

Phantom: ELI v5.0; Type: QDOVA002AA; Serial: TP-1158

Measurement SW: DASYS2, Version 52.8 (7); SEMCAD X Version 14.6.10 (7164)

Mode: Antenna 2, IEEE 802.11b, Body SAR, Ch 01, 1 Mbps, Back Side

Area Scan (11x16x1): Measurement grid: dx=12mm, dy=12mm

Zoom Scan (7x7x7)/Cube 0: Measurement grid: dx=5mm, dy=5mm, dz=5mm

Reference Value = 10.980 V/m; Power Drift = 0.00 dB

Peak SAR (extrapolated) = 0.458 W/kg

SAR(1 g) = 0.222 W/kg

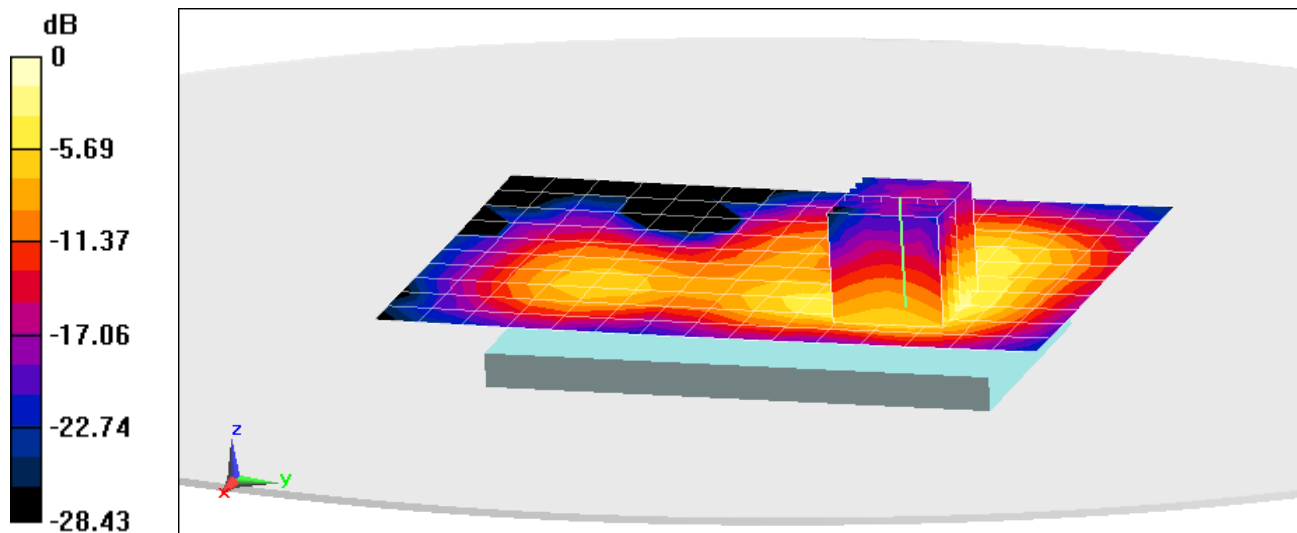

0 dB = 0.289 W/kg = -5.39 dBW/kg

PCTEST ENGINEERING LABORATORY, INC.

DUT: A3LSMG900S; Type: Portable Handset; Serial: F1186

Communication System: UID 0, IEEE 802.11a; Frequency: 5785 MHz; Duty Cycle: 1:1

Medium: 5 GHz Body Medium parameters used:

$f = 5785 \text{ MHz}$; $\sigma = 6.049 \text{ S/m}$; $\epsilon_r = 45.975$; $\rho = 1000 \text{ kg/m}^3$

Phantom section: Flat Section ; Space: 1.0 cm

Test Date: 02-03-2014; Ambient Temp: 24.5°C; Tissue Temp: 22.7°C

Probe: EX3DV4 - SN3914; ConvF(4.14, 4.14, 4.14); Calibrated: 10/23/2013;

Sensor-Surface: 1.4mm (Mechanical Surface Detection)

Electronics: DAE4 Sn1333; Calibrated: 11/19/2013

Phantom: SAM 5.0 front; Type: QD000P40CD; Serial: TP:-1648

Measurement SW: DASY52, Version 52.8 (7); SEMCAD X Version 14.6.10 (7164)

Mode: Antenna 1, IEEE 802.11a, 5.8 GHz, Body SAR, Ch 157, 6 Mbps, Back Side

Area Scan (11x18x1): Measurement grid: dx=10mm, dy=10mm

Zoom Scan (7x8x7)/Cube 0: Measurement grid: dx=4mm, dy=4mm, dz=1.4mm; Graded Ratio: 1.4

Reference Value = 3.800 V/m; Power Drift = -0.05 dB

Peak SAR (extrapolated) = 0.384 W/kg

SAR(1 g) = 0.080 W/kg

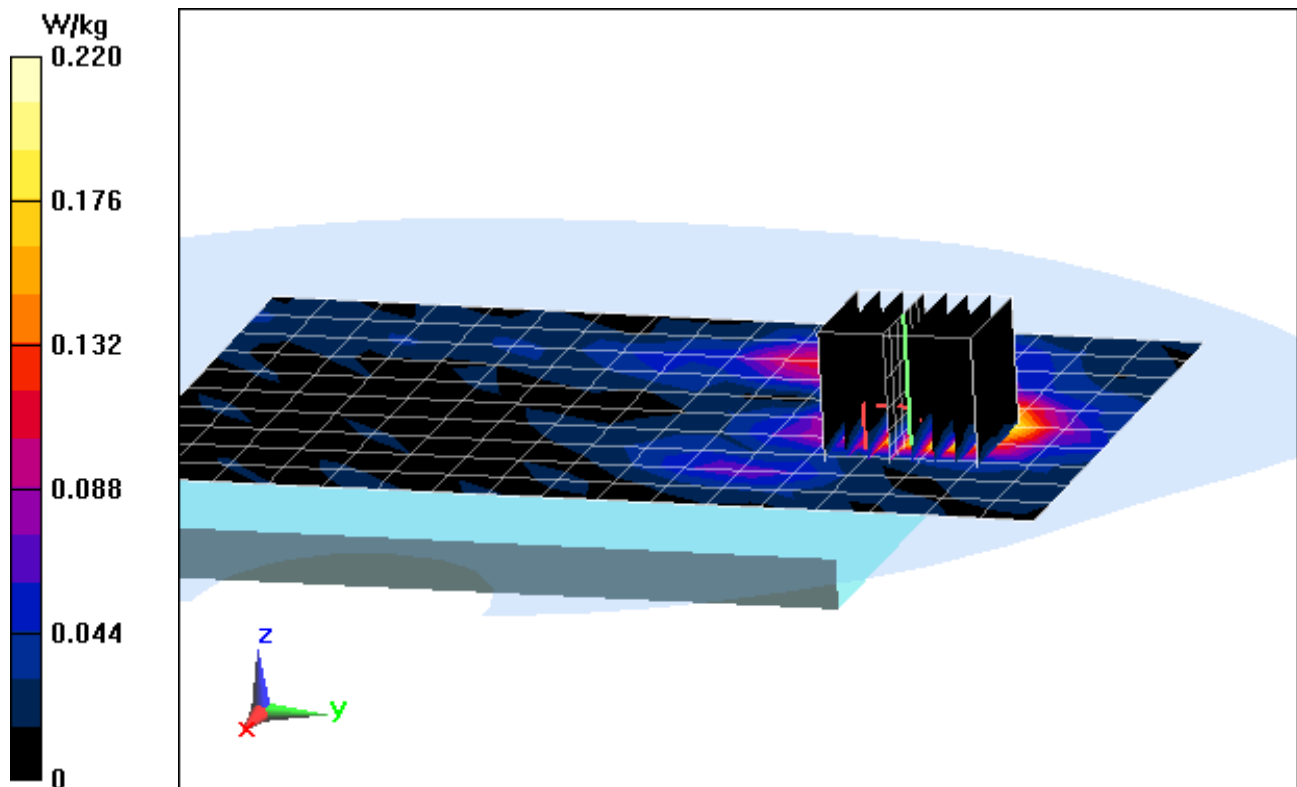

PCTEST ENGINEERING LABORATORY, INC.

DUT: A3LSMG900S; Type: Portable Handset; Serial: F1186

Communication System: UID 0, IEEE 802.11a; Frequency: 5660 MHz; Duty Cycle: 1:1

Medium: 5 GHz Body Medium parameters used:

$f = 5660 \text{ MHz}$; $\sigma = 5.868 \text{ S/m}$; $\epsilon_r = 46.242$; $\rho = 1000 \text{ kg/m}^3$

Phantom section: Flat Section ; Space: 1.0 cm

Test Date: 02-03-2014; Ambient Temp: 24.5°C; Tissue Temp: 22.5°C

Probe: EX3DV4 - SN3914; ConvF(3.97, 3.97, 3.97); Calibrated: 10/23/2013;

Sensor-Surface: 1.4mm (Mechanical Surface Detection)

Electronics: DAE4 Sn1333; Calibrated: 11/19/2013

Phantom: SAM 5.0 front; Type: QD000P40CD; Serial: TP:-1648

Measurement SW: DASY52, Version 52.8 (7); SEMCAD X Version 14.6.10 (7164)

Mode: Antenna 1, IEEE 802.11a, 5.5-5.7 GHz, Body SAR, Ch 132, 6 Mbps, Back Side

Area Scan (11x18x1): Measurement grid: dx=10mm, dy=10mm

Zoom Scan (7x7x7)/Cube 0: Measurement grid: dx=4mm, dy=4mm, dz=1.4mm; Graded Ratio: 1.4

Reference Value = 3.609 V/m; Power Drift = 0.02 dB

Peak SAR (extrapolated) = 0.359 W/kg

SAR(1 g) = 0.072 W/kg

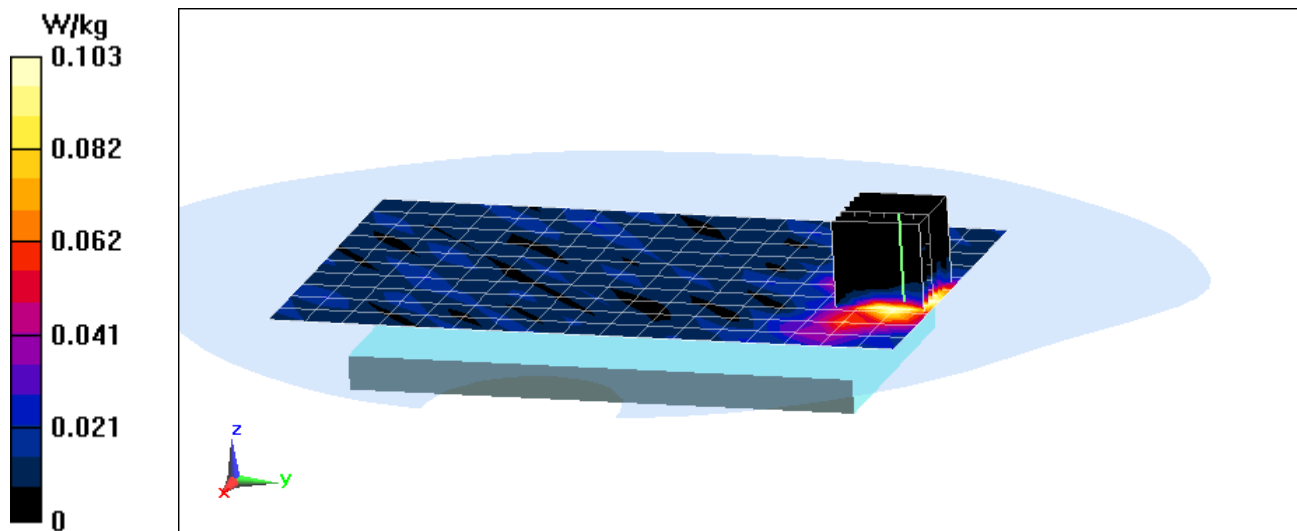

PCTEST ENGINEERING LABORATORY, INC.

DUT: A3LSMG900S; Type: Portable Handset; Serial: F1186

Communication System: UID 0, IEEE 802.11a; Frequency: 5785 MHz; Duty Cycle: 1:1

Medium: 5 GHz Body Medium parameters used:

$f = 5785 \text{ MHz}$; $\sigma = 6.049 \text{ S/m}$; $\epsilon_r = 45.975$; $\rho = 1000 \text{ kg/m}^3$

Phantom section: Flat Section ; Space: 1.0 cm

Test Date: 02-03-2014; Ambient Temp: 24.5°C; Tissue Temp: 22.7°C

Probe: EX3DV4 - SN3914; ConvF(4.14, 4.14, 4.14); Calibrated: 10/23/2013;

Sensor-Surface: 1.4mm (Mechanical Surface Detection)

Electronics: DAE4 Sn1333; Calibrated: 11/19/2013

Phantom: SAM 5.0 front; Type: QD000P40CD; Serial: TP:-1648

Measurement SW: DASY52, Version 52.8 (7); SEMCAD X Version 14.6.10 (7164)

Mode: Antenna 1, IEEE 802.11a, 5.8 GHz, Body SAR, Ch 157, 6 Mbps, Top Side

Area Scan (10x11x1): Measurement grid: dx=5mm, dy=10mm

Zoom Scan (7x7x7)/Cube 0: Measurement grid: dx=4mm, dy=4mm, dz=1.4mm; Graded Ratio: 1.4

Reference Value = 5.359 V/m; Power Drift = -0.02 dB

Peak SAR (extrapolated) = 0.915 W/kg

SAR(1 g) = 0.184 W/kg

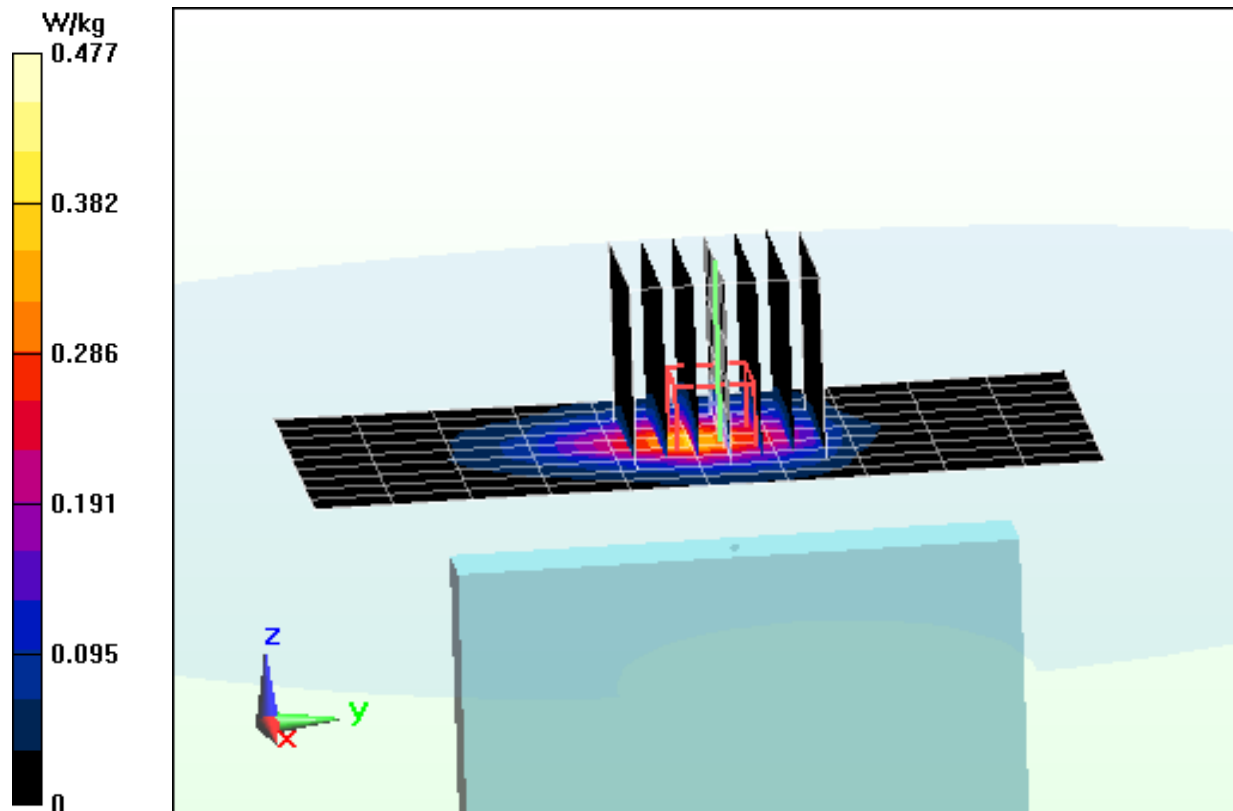

APPENDIX B: SYSTEM VERIFICATION

PCTEST ENGINEERING LABORATORY, INC.

DUT: SAR Dipole 750 MHz; Type: D750V3; Serial: 1046

Communication System: UID 0, CW; Frequency: 750 MHz; Duty Cycle: 1:1

Medium: 740 Head Medium parameters used (interpolated):

$f = 750 \text{ MHz}$; $\sigma = 0.933 \text{ S/m}$; $\epsilon_r = 41.499$; $\rho = 1000 \text{ kg/m}^3$

Phantom section: Flat Section ; Space: 1.5 cm

Test Date: 02-06-2014; Ambient Temp: 24.4°C; Tissue Temp: 24.0°C

Probe: ES3DV3 - SN3319; ConvF(6.49, 6.49, 6.49); Calibrated: 4/29/2013;

Sensor-Surface: 4mm (Mechanical Surface Detection)

Electronics: DAE4 Sn1368; Calibrated: 4/22/2013

Phantom: SAM front; Type: QD000P40CD; Serial: TP:1759

Measurement SW: DASY52, Version 52.8 (7); SEMCAD X Version 14.6.10 (7164)

750 MHz System Verification

Area Scan (7x15x1): Measurement grid: dx=15mm, dy=15mm

Zoom Scan (5x5x7)/Cube 0: Measurement grid: dx=8mm, dy=8mm, dz=5mm

Input Power: 20 dBm (100 mW)

Peak SAR (extrapolated) = 1.19 W/kg

SAR(1 g) = 0.813 W/kg

Deviation: -4.35%

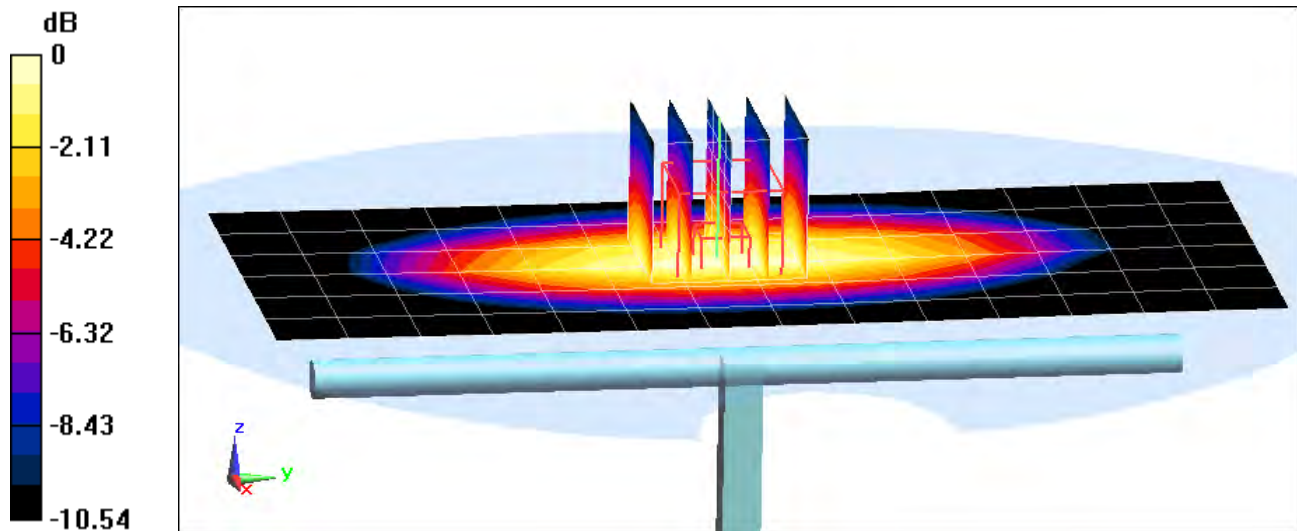

0 dB = 0.882 W/kg = -0.55 dBW/kg

PCTEST ENGINEERING LABORATORY, INC.

DUT: SAR Dipole 835 MHz; Type: D835V3; Serial: 4d119

Communication System: UID 0, CW; Frequency: 835 MHz; Duty Cycle: 1:1

Medium: 835 Head Medium parameters used:

$f = 835 \text{ MHz}$; $\sigma = 0.919 \text{ S/m}$; $\epsilon_r = 41.961$; $\rho = 1000 \text{ kg/m}^3$

Phantom section: Flat Section ; Space: 1.5 cm

Test Date: 02-06-2014; Ambient Temp: 24.2°C; Tissue Temp: 23.1°C

Probe: ES3DV3 - SN3332; ConvF(6.29, 6.29, 6.29); Calibrated: 11/25/2013;

Sensor-Surface: 4mm (Mechanical Surface Detection)

Electronics: DAE4 Sn1407; Calibrated: 11/18/2013

Phantom: SAM with CRP v4.0; Type: QD000P40CD; Serial: TP:1800

Measurement SW: DASY52, Version 52.8 (7); SEMCAD X Version 14.6.10 (7164)

835 MHz System Verification

Area Scan (7x14x1): Measurement grid: dx=15mm, dy=15mm

Zoom Scan (5x5x7)/Cube 0: Measurement grid: dx=8mm, dy=8mm, dz=5mm

Input Power: 20 dBm (100 mW)

Peak SAR (extrapolated) = 1.49 W/kg

SAR(1 g) = 0.937 W/kg

Deviation: -3.20%

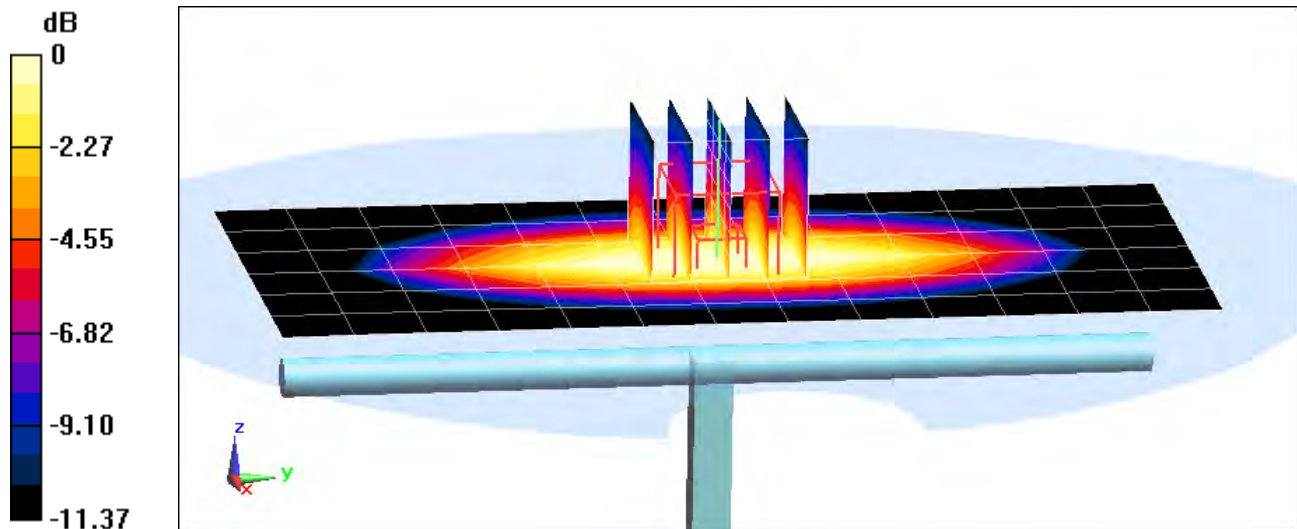

0 dB = 1.03 W/kg = 0.13 dBW/kg

PCTEST ENGINEERING LABORATORY, INC.

DUT: SAR Dipole 835 MHz; Type: D835V2; Serial: 4d119

Communication System: UID 0, CW; Frequency: 835 MHz; Duty Cycle: 1:1

Medium: 835 Head Medium parameters used:

$f = 835 \text{ MHz}$; $\sigma = 0.932 \text{ S/m}$; $\epsilon_r = 42.598$; $\rho = 1000 \text{ kg/m}^3$

Phantom section: Flat Section ; Space: 1.5 cm

Test Date: 02-10-2014; Ambient Temp: 23.9°C; Tissue Temp: 23.1°C

Probe: EX3DV4 - SN3589; ConvF(8.49, 8.49, 8.49); Calibrated: 1/29/2014;

Sensor-Surface: 4mm (Mechanical Surface Detection)

Electronics: DAE4 Sn1272; Calibrated: 1/22/2014

Phantom: SAM; Type: QD000P40CD; Serial: TP:1758

Measurement SW: DASYS2, Version 52.8 (7); SEMCAD X Version 14.6.10 (7164)

835 MHz System Verification

Area Scan (7x14x1): Measurement grid: dx=15mm, dy=15mm

Zoom Scan (5x5x7)/Cube 0: Measurement grid: dx=8mm, dy=8mm, dz=5mm

Input Power: 20 dBm (100 mW)

Peak SAR (extrapolated) = 1.44 W/kg

SAR(1 g) = 0.965 W/kg

Deviation: -0.31%

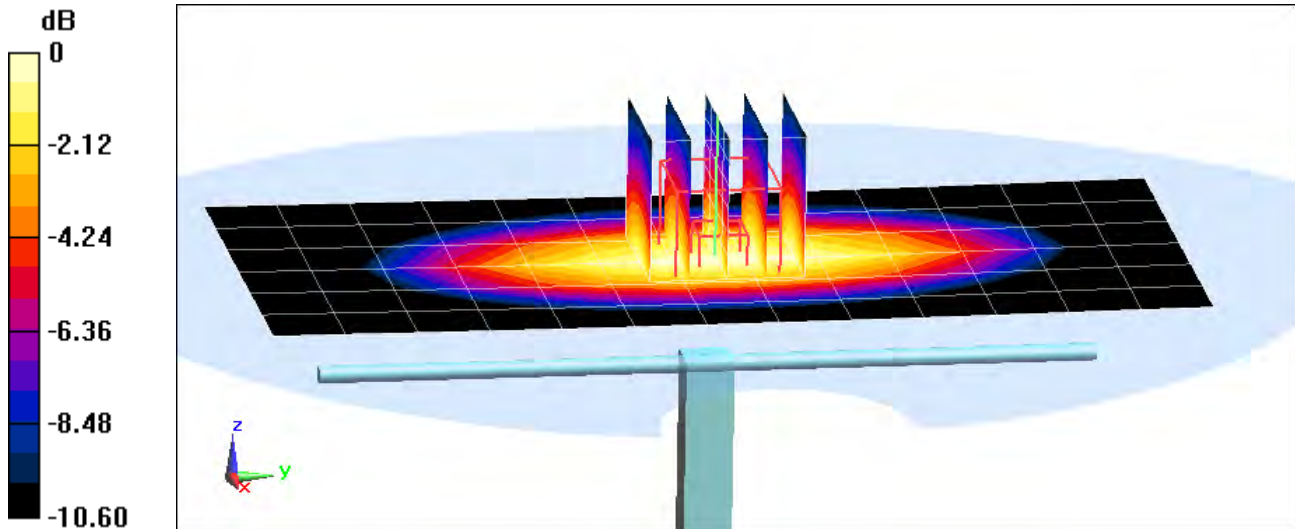

0 dB = 1.04 W/kg = 0.17 dBW/kg

PCTEST ENGINEERING LABORATORY, INC.

DUT: SAR Dipole 1900 MHz; Type: D1900V2; Serial: 5d149

Communication System: UID 0, CW; Frequency: 1900 MHz; Duty Cycle: 1:1

Medium: 1900 Head Medium parameters used (interpolated):

$f = 1900 \text{ MHz}$; $\sigma = 1.444 \text{ S/m}$; $\epsilon_r = 38.516$; $\rho = 1000 \text{ kg/m}^3$

Phantom section: Flat Section ; Space: 1.0 cm

Test Date: 02-10-2014; Ambient Temp: 22.8°C; Tissue Temp: 22.2°C

Probe: ES3DV2 - SN3022; ConvF(5.03, 5.03, 5.03); Calibrated: 8/22/2013;

Sensor-Surface: 4mm (Mechanical Surface Detection)

Electronics: DAE4 Sn1322; Calibrated: 8/21/2013

Phantom: SAM v5.0 Left; Type: QD000P40CD; Serial: TP: 1687

Measurement SW: DASY52, Version 52.8 (7); SEMCAD X Version 14.6.10 (7164)

1900 MHz System Verification

Area Scan (7x10x1): Measurement grid: dx=15mm, dy=15mm

Zoom Scan (5x5x7)/Cube 0: Measurement grid: dx=8mm, dy=8mm, dz=5mm

Input Power: 20 dBm (100 mW)

Peak SAR (extrapolated) = 6.92 W/kg

SAR(1 g) = 3.72 W/kg

Deviation: -7.92%

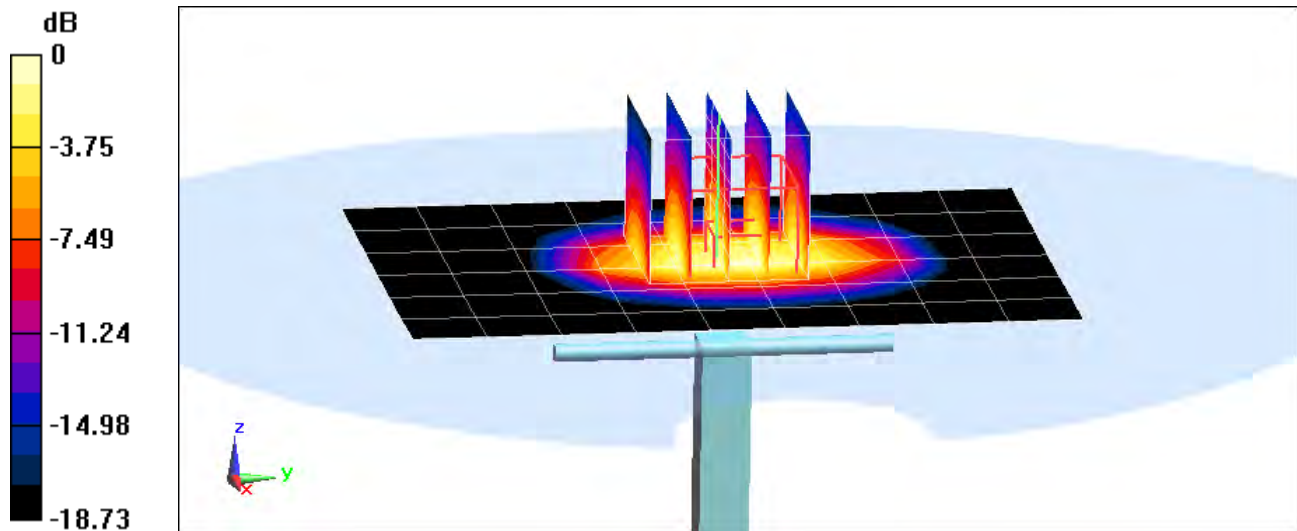

0 dB = 4.11 W/kg = 6.14 dBW/kg

PCTEST ENGINEERING LABORATORY, INC.

DUT: SAR Dipole 2450 MHz; Type: D2450V2; Serial: 719

Communication System: UID 0, CW; Frequency: 2450 MHz; Duty Cycle: 1:1

Medium: 2450 Head Medium parameters used:

$f = 2450 \text{ MHz}$; $\sigma = 1.832 \text{ S/m}$; $\epsilon_r = 38.027$; $\rho = 1000 \text{ kg/m}^3$

Phantom section: Flat Section ; Space: 1.0 cm

Test Date: 02-06-2014; Ambient Temp: 24.3°C; Tissue Temp: 21.4°C

Probe: ES3DV3 - SN3287; ConvF(4.43, 4.43, 4.43); Calibrated: 11/20/2013;

Sensor-Surface: 3mm (Mechanical Surface Detection)

Electronics: DAE4 Sn1408; Calibrated: 11/19/2013

Phantom: SAM with CRP v4.0; Type: QD000P40CD; Serial: TP:1797

Measurement SW: DASY52, Version 52.8 (7); SEMCAD X Version 14.6.10 (7164)

2450 MHz System Verification

Area Scan (8x9x1): Measurement grid: dx=12mm, dy=12mm

Zoom Scan (7x7x7)/Cube 0: Measurement grid: dx=5mm, dy=5mm, dz=5mm

Input Power: 20 dBm (100 mW)

Peak SAR (extrapolated) = 10.3 W/kg

SAR(1 g) = 5.05 W/kg

Deviation:-5.08%

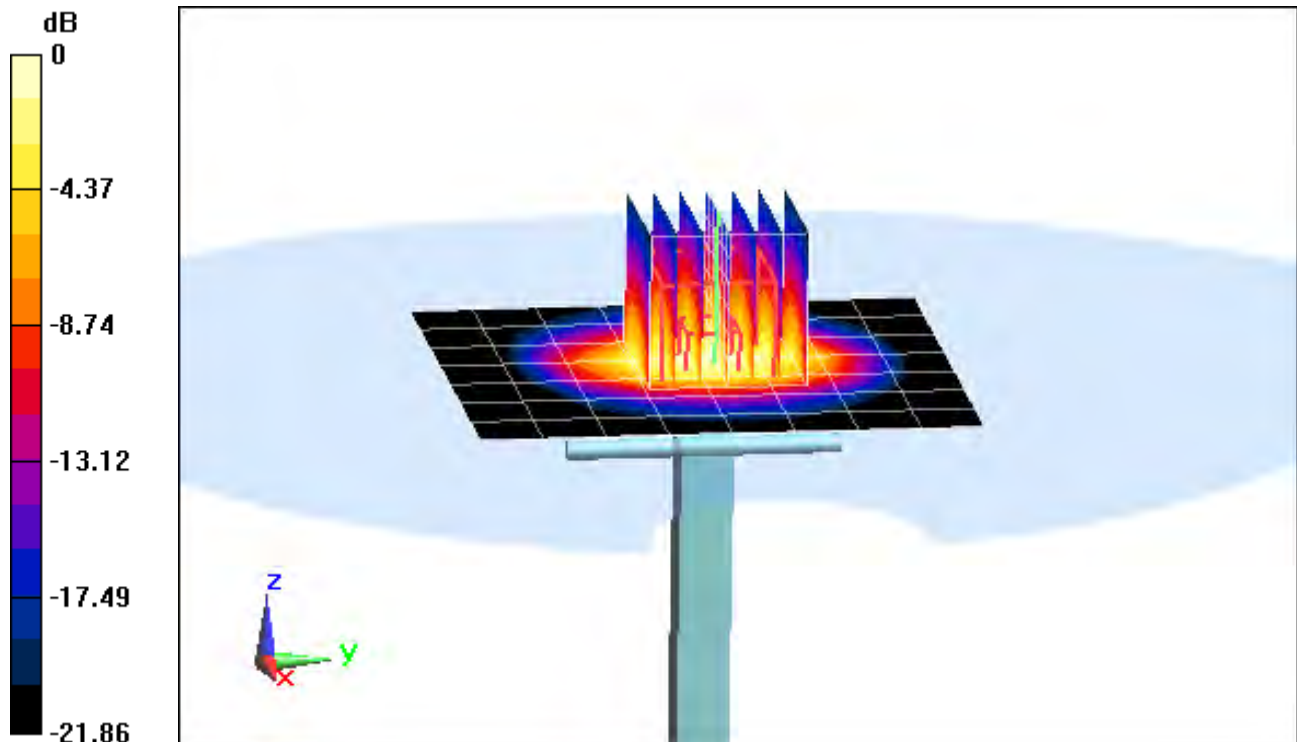

0 dB = 6.54 W/kg = 8.16 dBW/kg

PCTEST ENGINEERING LABORATORY, INC.

DUT: SAR Dipole 5200 MHz; Type: D5GHzV2; Serial: 1120

Communication System: UID 0, CW; Frequency: 5200 MHz; Duty Cycle: 1:1

Medium: 5 GHz Head; Medium parameters used:

$f = 5200 \text{ MHz}$; $\sigma = 4.566 \text{ S/m}$; $\epsilon_r = 37.509$; $\rho = 1000 \text{ kg/m}^3$

Phantom section: Flat Section; Space: 1.0 cm

Test Date: 02-06-2014; Ambient Temp: 24.5°C; Tissue Temp: 23.5°C

Probe: EX3DV4 - SN3914; ConvF(4.99, 4.99, 4.99); Calibrated: 10/23/2013;

Sensor-Surface: 1.4mm (Mechanical Surface Detection)

Electronics: DAE4 Sn1333; Calibrated: 11/19/2013

Phantom: SAM V5.0 Right; Type: QD000P40CD; Serial: 1647

Measurement SW: DASY52, Version 52.8 (7);SEMCAD X Version 14.6.10 (7164)

5200 MHz System Verification

Area Scan (7x8x1): Measurement grid: dx=10mm, dy=10mm

Zoom Scan (7x7x7)/Cube 0: Measurement grid: dx=4mm, dy=4mm, dz=1.4mm; Graded Ratio: 1.4

Input Power: 20 dBm (100 mW)

Peak SAR (extrapolated) = 32.8 W/kg

SAR(1 g) = 7.84 W/kg

Deviation : 3.16%

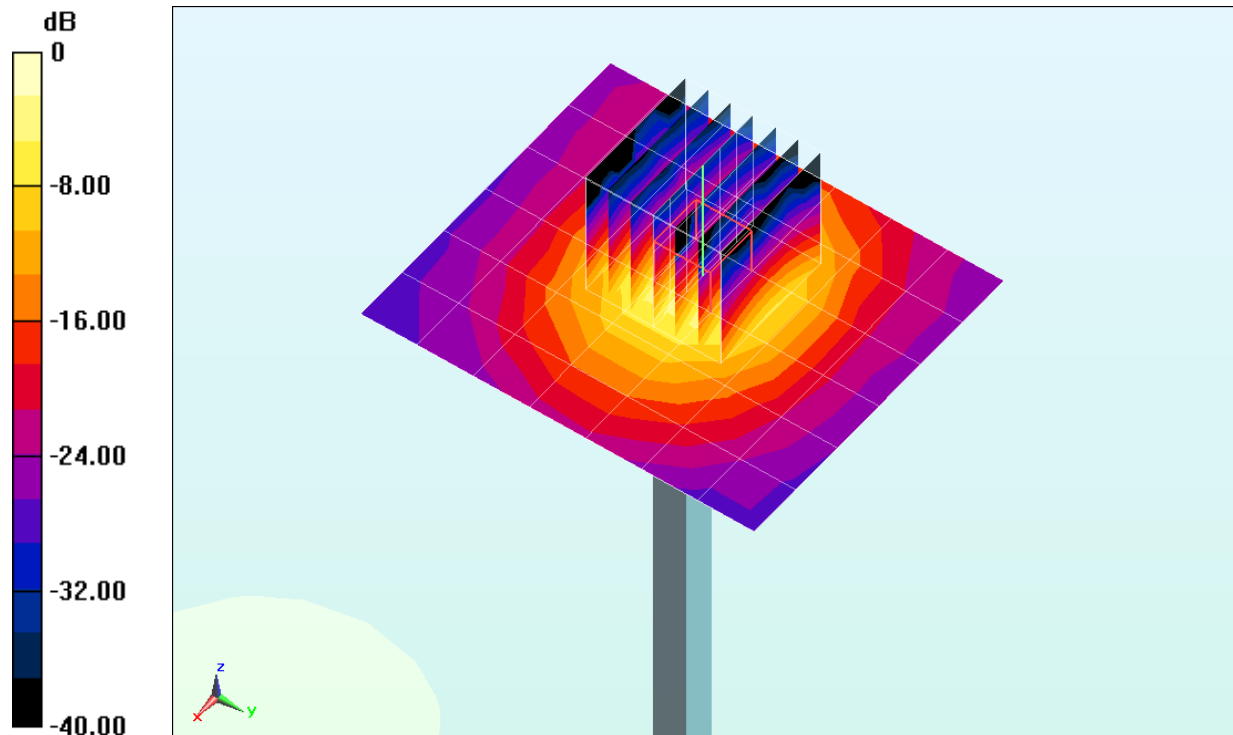

0 dB = 19.8 W/kg = 12.97 dBW/kg

PCTEST ENGINEERING LABORATORY, INC.

DUT: SAR Dipole 5300 MHz; Type: D5GHzV2; Serial: 1120

Communication System: UID 0, CW; Frequency: 5300 MHz; Duty Cycle: 1:1

Medium: 5 GHz Head; Medium parameters used:

$f = 5300 \text{ MHz}$; $\sigma = 4.651 \text{ S/m}$; $\epsilon_r = 37.509$; $\rho = 1000 \text{ kg/m}^3$

Phantom section: Flat Section; Space: 1.0 cm

Test Date: 02-06-2014; Ambient Temp: 24.1°C; Tissue Temp: 23.5°C

Probe: EX3DV4 - SN3914; ConvF(4.82, 4.82, 4.82); Calibrated: 10/23/2013;

Sensor-Surface: 1.4mm (Mechanical Surface Detection)

Electronics: DAE4 Sn1333; Calibrated: 11/19/2013

Phantom: SAM V5.0 Right; Type: QD000P40CD; Serial: 1647

Measurement SW: DASY52, Version 52.8 (7);SEMCAD X Version 14.6.10 (7164)

5300 MHz System Verification

Area Scan (7x8x1): Measurement grid: dx=10mm, dy=10mm

Zoom Scan (7x7x7)/Cube 0: Measurement grid: dx=4mm, dy=4mm, dz=1.4mm; Graded Ratio: 1.4

Input Power: 20 dBm (100 mW)

Peak SAR (extrapolated) = 34.5 W/kg

SAR(1 g) = 7.96 W/kg

Deviation : 1.14%

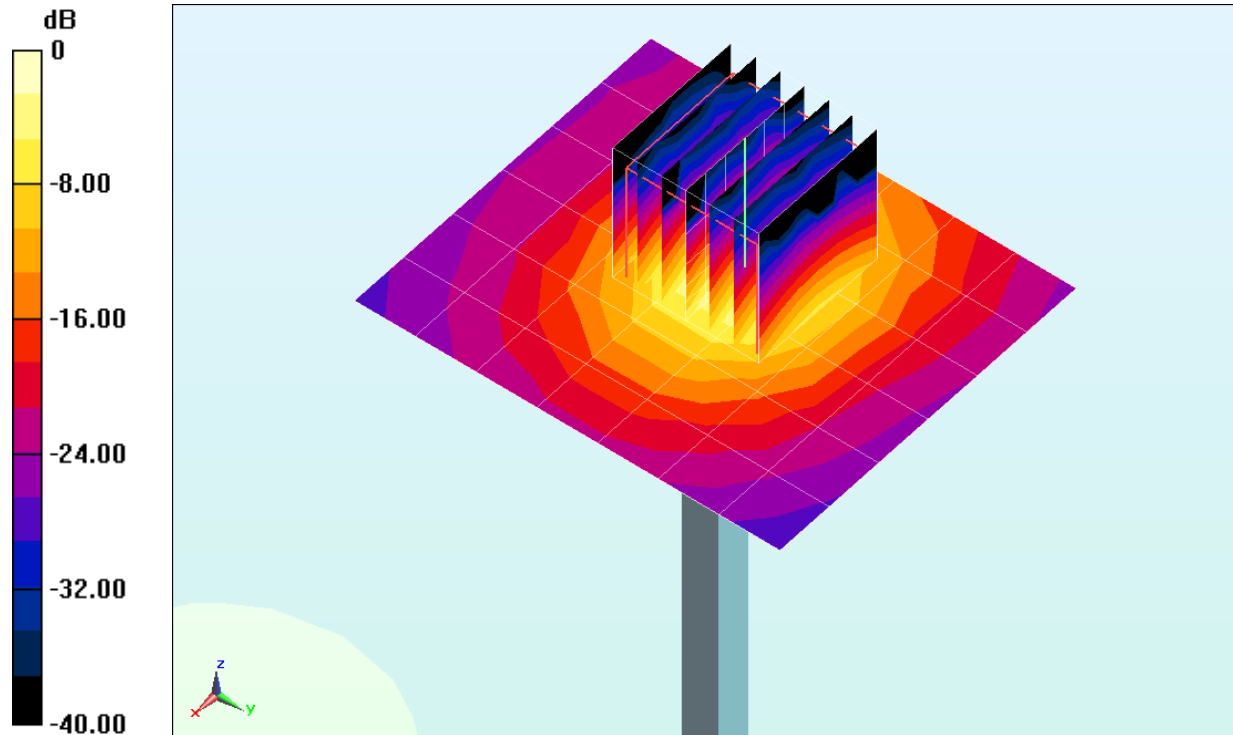

0 dB = 20.4 W/kg = 13.10 dBW/kg

PCTEST ENGINEERING LABORATORY, INC.

DUT: SAR Dipole 5500 MHz; Type: D5GHzV2; Serial: 1120

Communication System: UID 0, CW; Frequency: 5500 MHz; Duty Cycle: 1:1

Medium: 5 GHz Head; Medium parameters used:

$f = 5500 \text{ MHz}$; $\sigma = 4.925 \text{ S/m}$; $\epsilon_r = 37.305$; $\rho = 1000 \text{ kg/m}^3$

Phantom section: Flat Section; Space: 1.0 cm

Test Date: 02-06-2014; Ambient Temp: 23.9°C; Tissue Temp: 23.5°C

Probe: EX3DV4 - SN3914; ConvF(4.55, 4.55, 4.55); Calibrated: 10/23/2013;

Sensor-Surface: 1.4mm (Mechanical Surface Detection)

Electronics: DAE4 Sn1333; Calibrated: 11/19/2013

Phantom: SAM V5.0 Right; Type: QD000P40CD; Serial: 1647

Measurement SW: DASYS2, Version 52.8 (7); SEMCAD X Version 14.6.10 (7164)

5500 MHz System Verification

Area Scan (7x8x1): Measurement grid: dx=10mm, dy=10mm

Zoom Scan (7x7x7)/Cube 0: Measurement grid: dx=4mm, dy=4mm, dz=1.4mm; Graded Ratio: 1.4

Input Power: 20 dBm (100 mW)

Peak SAR (extrapolated) = 34.0 W/kg

SAR(1 g) = 7.91 W/kg

Deviation : -1.25%

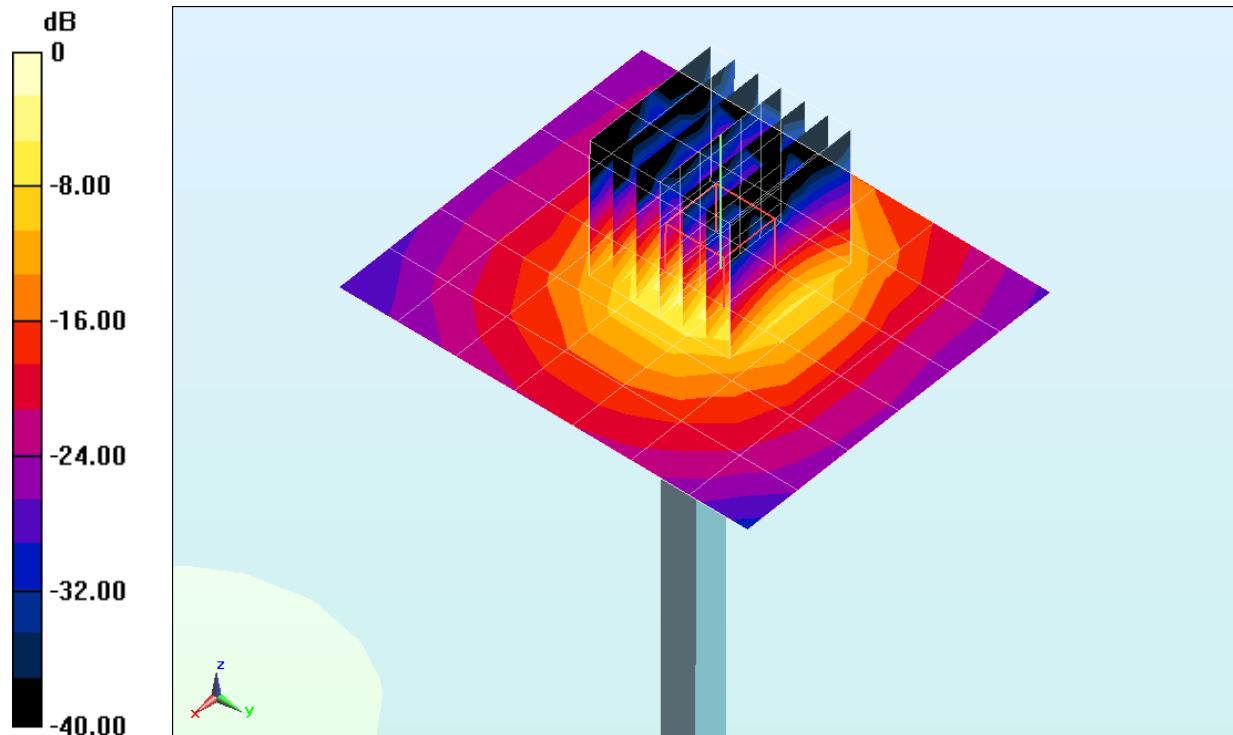

0 dB = 20.3 W/kg = 13.07 dBW/kg

PCTEST ENGINEERING LABORATORY, INC.

DUT: SAR Dipole 5600 MHz; Type: D5GHzV2; Serial: 1120

Communication System: UID 0, CW; Frequency: 5600 MHz; Duty Cycle: 1:1

Medium: 5 GHz Head; Medium parameters used:

$f = 5600 \text{ MHz}$; $\sigma = 5.017 \text{ S/m}$; $\epsilon_r = 37.024$; $\rho = 1000 \text{ kg/m}^3$

Phantom section: Flat Section; Space: 1.0 cm

Test Date: 02-06-2014; Ambient Temp: 24.0°C; Tissue Temp: 23.4°C

Probe: EX3DV4 - SN3914; ConvF(4.37, 4.37, 4.37); Calibrated: 10/23/2013;

Sensor-Surface: 1.4mm (Mechanical Surface Detection)

Electronics: DAE4 Sn1333; Calibrated: 11/19/2013

Phantom: SAM V5.0 Right; Type: QD000P40CD; Serial: 1647

Measurement SW: DASY52, Version 52.8 (7);SEMCAD X Version 14.6.10 (7164)

5600 MHz System Verification

Area Scan (7x8x1): Measurement grid: dx=10mm, dy=10mm

Zoom Scan (7x7x7)/Cube 0: Measurement grid: dx=4mm, dy=4mm, dz=1.4mm; Graded Ratio: 1.4

Input Power: 20 dBm (100 mW)

Peak SAR (extrapolated) = 36.1 W/kg

SAR(1 g) = 7.97 W/kg

Deviation : -0.25%

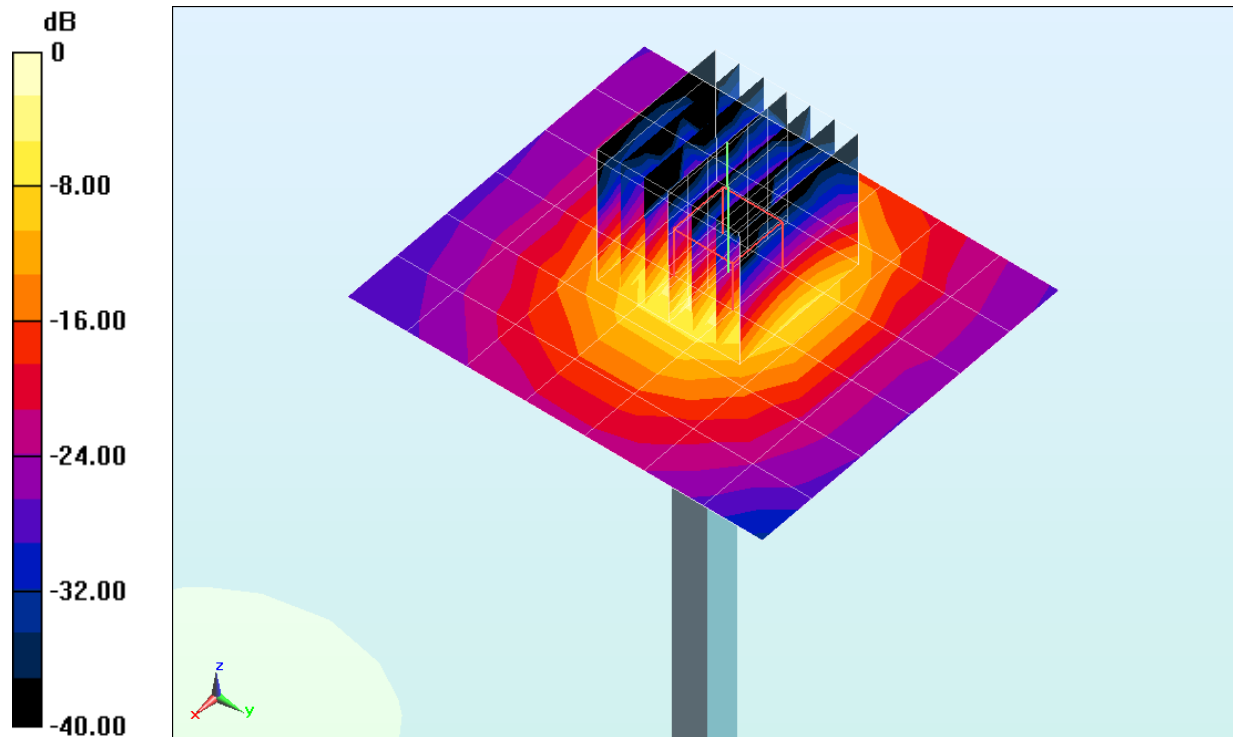

0 dB = 20.9 W/kg = 13.20 dBW/kg

PCTEST ENGINEERING LABORATORY, INC.

DUT: SAR Dipole 5800 MHz; Type: D5GHzV2; Serial: 1120

Communication System: UID 0, CW; Frequency: 5800 MHz; Duty Cycle: 1:1

Medium: 5 GHz Head; Medium parameters used:

$f = 5800 \text{ MHz}$; $\sigma = 5.176 \text{ S/m}$; $\epsilon_r = 36.885$; $\rho = 1000 \text{ kg/m}^3$

Phantom section: Flat Section; Space: 1.0 cm

Test Date: 02-06-2014; Ambient Temp: 24.1°C; Tissue Temp: 23.5°C

Probe: EX3DV4 - SN3914; ConvF(4.52, 4.52, 4.52); Calibrated: 10/23/2013;

Sensor-Surface: 1.4mm (Mechanical Surface Detection)

Electronics: DAE4 Sn1333; Calibrated: 11/19/2013

Phantom: SAM V5.0 Right; Type: QD000P40CD; Serial: 1647

Measurement SW: DASY52, Version 52.8 (7);SEMCAD X Version 14.6.10 (7164)

5800 MHz System Verification

Area Scan (7x8x1): Measurement grid: dx=10mm, dy=10mm

Zoom Scan (7x7x7)/Cube 0: Measurement grid: dx=4mm, dy=4mm, dz=1.4mm; Graded Ratio: 1.4

Input Power: 20 dBm (100 mW)

Peak SAR (extrapolated) = 34.8 W/kg

SAR(1 g) = 7.40 W/kg

Deviation : -1.20%

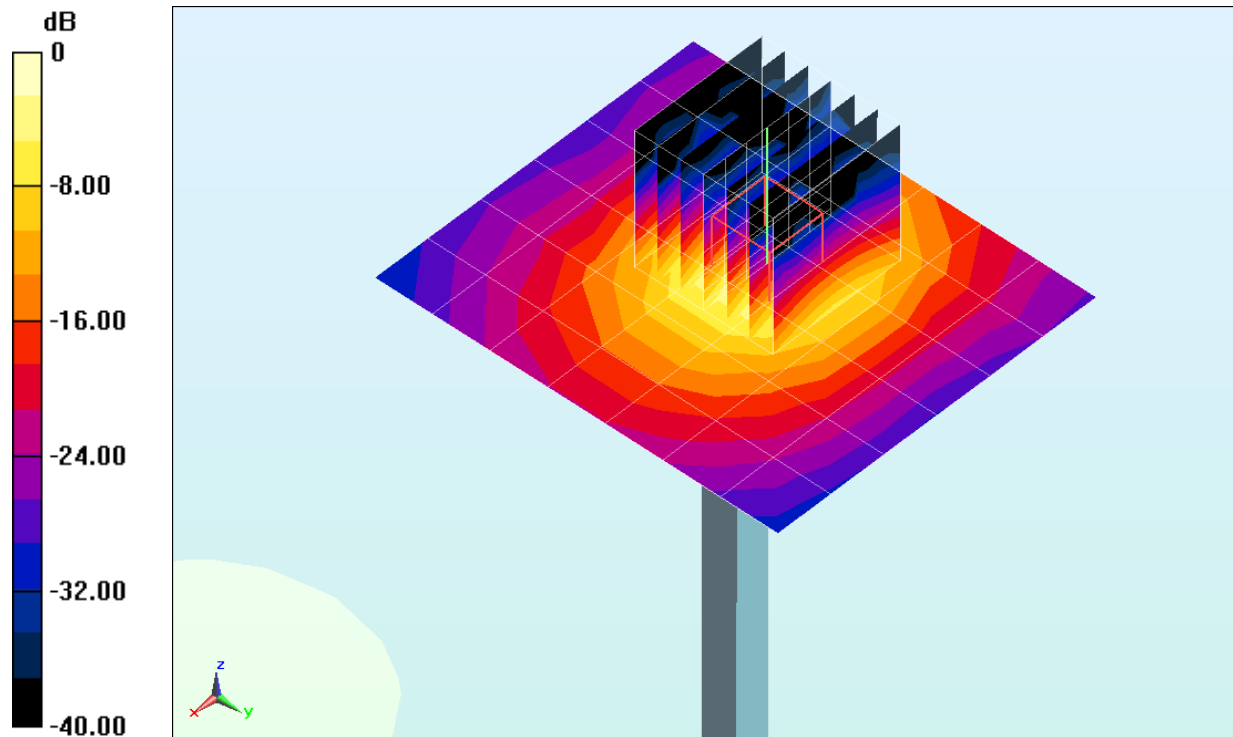

0 dB = 19.5 W/kg = 12.90 dBW/kg

PCTEST ENGINEERING LABORATORY, INC.

DUT: SAR Dipole 750 MHz; Type: D750V3; Serial: 1046

Communication System: UID 0, CW; Frequency: 750 MHz; Duty Cycle: 1:1

Medium: 740 Body Medium parameters used (interpolated):

$f = 750 \text{ MHz}$; $\sigma = 0.957 \text{ S/m}$; $\epsilon_r = 53.806$; $\rho = 1000 \text{ kg/m}^3$

Phantom section: Flat Section ; Space: 1.5 cm

Test Date: 02-06-2014; Ambient Temp: 24.3°C; Tissue Temp: 23.5°C

Probe: ES3DV3 - SN3332; ConvF(6.21, 6.21, 6.21); Calibrated: 11/25/2013;

Sensor-Surface: 4mm (Mechanical Surface Detection)

Electronics: DAE4 Sn1407; Calibrated: 11/18/2013

Phantom: ELI v5.0; Type: QDOVA001BB; Serial: 1226

Measurement SW: DASY52, Version 52.8 (7); SEMCAD X Version 14.6.10 (7164)

750MHz System Verification

Area Scan (7x13x1): Measurement grid: dx=15mm, dy=15mm

Zoom Scan (5x5x7)/Cube 0: Measurement grid: dx=8mm, dy=8mm, dz=5mm

Input Power: 20 dBm (100 mW)

Peak SAR (extrapolated) = 1.28 W/kg

SAR(1 g) = 0.881 W/kg

Deviation: 0.46%

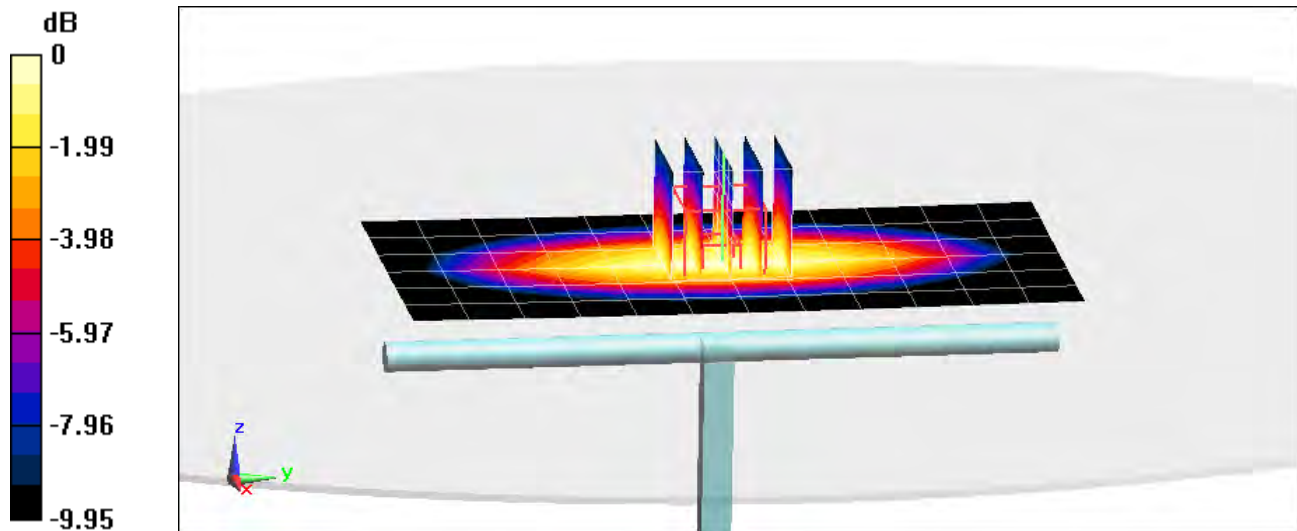

0 dB = 0.952 W/kg = -0.21 dBW/kg

PCTEST ENGINEERING LABORATORY, INC.

DUT: SAR Dipole 835 MHz; Type: D835V2; Serial: 4d119

Communication System: UID 0, CW; Frequency: 835 MHz; Duty Cycle: 1:1

Medium: 835 Body Medium parameters used:

$f = 835 \text{ MHz}$; $\sigma = 1.014 \text{ S/m}$; $\epsilon_r = 53.696$; $\rho = 1000 \text{ kg/m}^3$

Phantom section: Flat Section ; Space: 1.5 cm

Test Date: 02-05-2014; Ambient Temp: 22.9°C; Tissue Temp: 21.4°C

Probe: ES3DV3 - SN3209; ConvF(6.28, 6.28, 6.28); Calibrated: 3/15/2013;

Sensor-Surface: 4mm (Mechanical Surface Detection)

Electronics: DAE4 Sn1334; Calibrated: 3/8/2013

Phantom: SAM Front; Type: SAM; Serial: 1686

Measurement SW: DASY52, Version 52.8 (7); SEMCAD X Version 14.6.10 (7164)

835 MHz System Verification

Area Scan (7x14x1): Measurement grid: dx=15mm, dy=15mm

Zoom Scan (5x5x7)/Cube 0: Measurement grid: dx=8mm, dy=8mm, dz=5mm

Input Power: 20 dBm (100 mW)

Peak SAR (extrapolated) = 1.48 W/kg

SAR(1 g) = 1.02 W/kg

Deviation: 6.92%

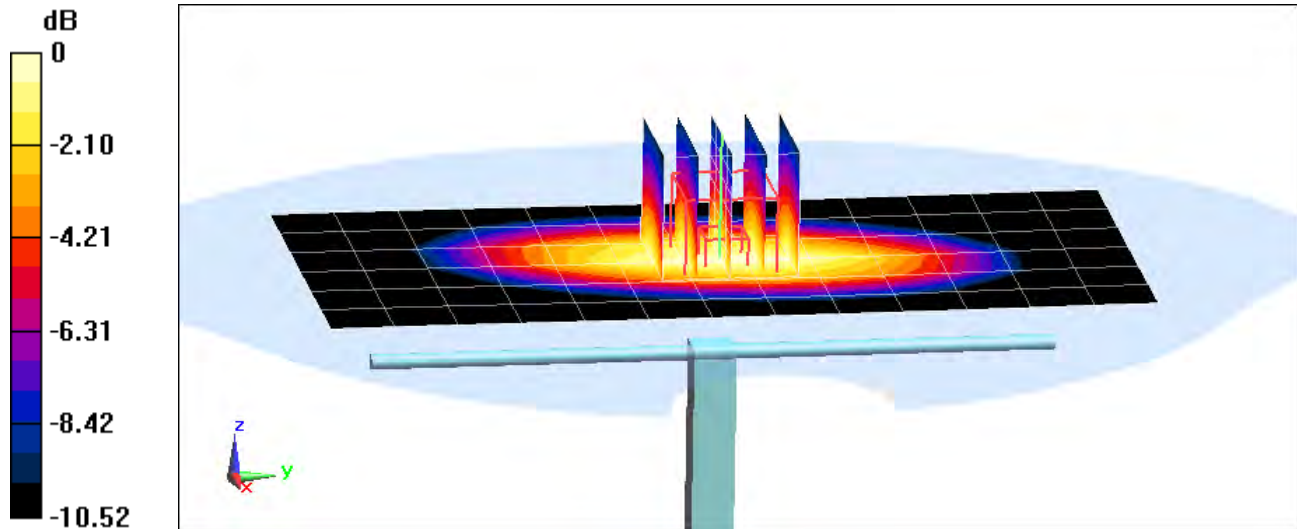

0 dB = 1.10 W/kg = 0.41 dBW/kg

PCTEST ENGINEERING LABORATORY, INC.

DUT: SAR Dipole 1900 MHz; Type: D1900V2; Serial: 5d149

Communication System: UID 0, CW; Frequency: 1900 MHz; Duty Cycle: 1:1

Medium: 1900 Body Medium parameters used (interpolated):

$f = 1900 \text{ MHz}$; $\sigma = 1.584 \text{ S/m}$; $\epsilon_r = 51.769$; $\rho = 1000 \text{ kg/m}^3$

Phantom section: Flat Section ; Space: 1.0 cm

Test Date: 02-10-2014; Ambient Temp: 23.3°C; Tissue Temp: 22.2°C

Probe: ES3DV2 - SN3022; ConvF(4.49, 4.49, 4.49); Calibrated: 8/22/2013;

Sensor-Surface: 4mm (Mechanical Surface Detection)

Electronics: DAE4 Sn1322; Calibrated: 8/21/2013

Phantom: SAM v5.0 front; Type: QD000P40CD; Serial: TP-1646

Measurement SW: DASY52, Version 52.8 (7); SEMCAD X Version 14.6.10 (7164)

1900 MHz System Verification

Area Scan (7x10x1): Measurement grid: dx=15mm, dy=15mm

Zoom Scan (5x5x7)/Cube 0: Measurement grid: dx=8mm, dy=8mm, dz=5mm

Input Power: 20 dBm (100 mW)

Peak SAR (extrapolated) = 7.28 W/kg

SAR(1 g) = 4.02 W/kg

Deviation: -0.74%

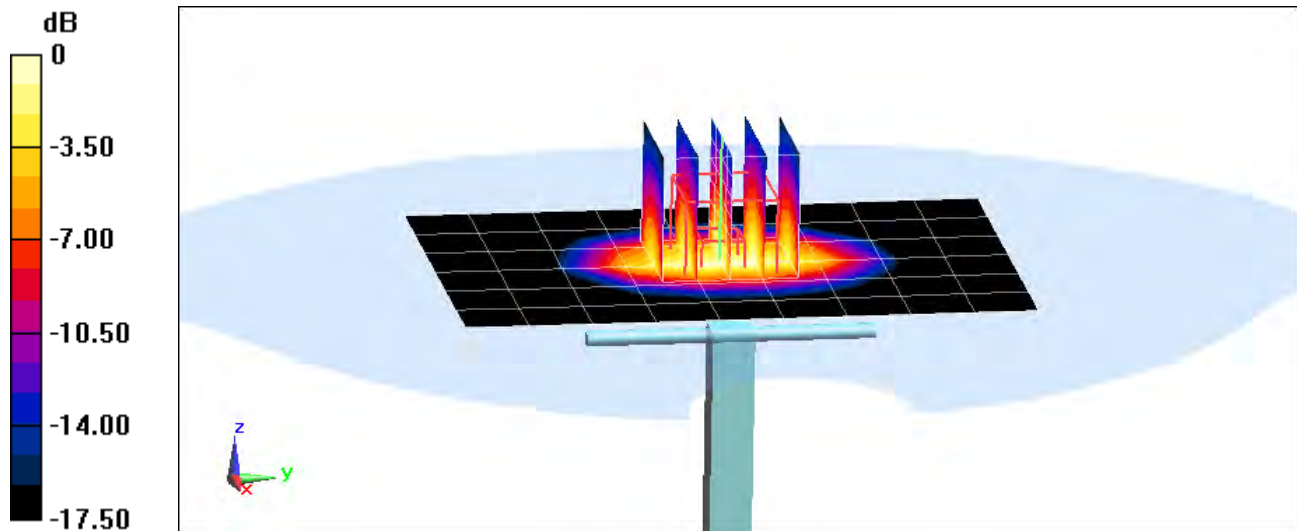

0 dB = 4.53 W/kg = 6.56 dBW/kg

PCTEST ENGINEERING LABORATORY, INC.

DUT: SAR Dipole 2450 MHz; Type: D2450V2; Serial: 719

Communication System: UID 0, CW; Frequency: 2450 MHz; Duty Cycle: 1:1

Medium: 2450 Body Medium parameters used:

$f = 2450 \text{ MHz}$; $\sigma = 2.039 \text{ S/m}$; $\epsilon_r = 51.366$; $\rho = 1000 \text{ kg/m}^3$

Phantom section: Flat Section ; Space: 1.0 cm

Test Date: 02-03-2014; Ambient Temp: 24.4°C; Tissue Temp: 22.8°C

Probe: ES3DV3 - SN3209; ConvF(4.34, 4.34, 4.34); Calibrated: 3/15/2013;

Sensor-Surface: 3mm (Mechanical Surface Detection)

Electronics: DAE4 Sn1334; Calibrated: 3/8/2013

Phantom: ELI v5.0; Type: QDOVA002AA; Serial: TP-1158

Measurement SW: DASY52, Version 52.8 (7); SEMCAD X Version 14.6.10 (7164)

2450 MHz System Verification

Area Scan (8x9x1): Measurement grid: dx=12mm, dy=12mm

Zoom Scan (7x7x7)/Cube 0: Measurement grid: dx=5mm, dy=5mm, dz=5mm

Input Power: 20 dBm (100 mW)

Peak SAR (extrapolated) = 10.6 W/kg

SAR(1 g) = 5.05 W/kg

Deviation: -2.32%

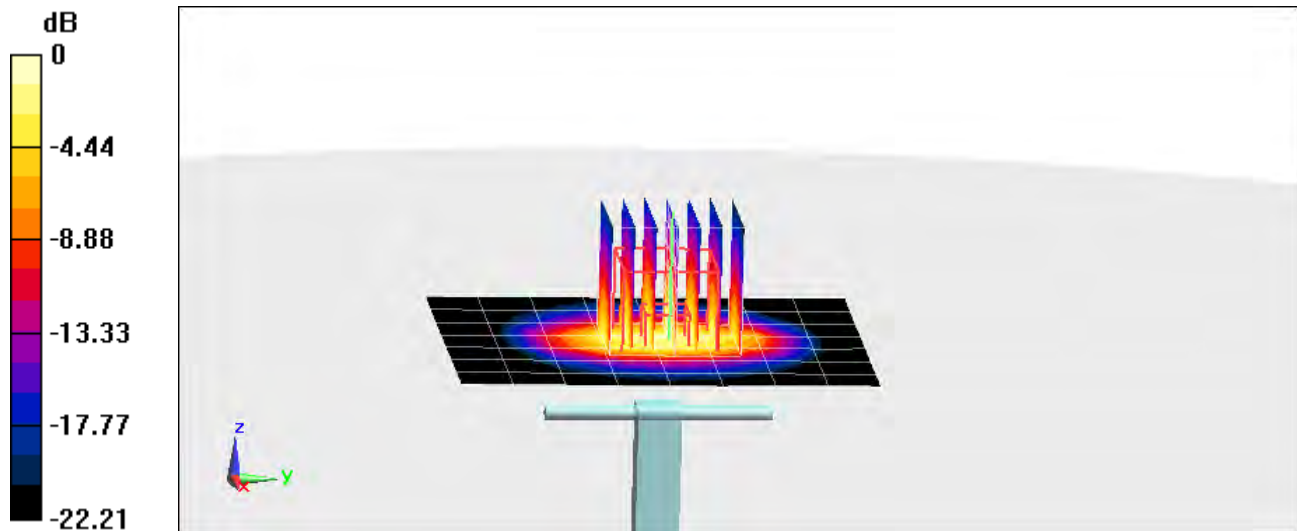

0 dB = 6.63 W/kg = 8.22 dBW/kg

PCTEST ENGINEERING LABORATORY, INC.

DUT: SAR Dipole 5200 MHz; Type: D5GHzV2; Serial: 1120

Communication System: UID 0, CW; Frequency: 5200 MHz; Duty Cycle: 1:1

Medium: 5 GHz Body Medium parameters used:

$f = 5200 \text{ MHz}$; $\sigma = 5.168 \text{ S/m}$; $\epsilon_r = 47.598$; $\rho = 1000 \text{ kg/m}^3$

Phantom section: Flat Section ; Space: 1.0 cm

Test Date: 02-03-2014; Ambient Temp: 24.5°C; Tissue Temp: 22.6°C

Probe: EX3DV4 - SN3914; ConvF(4.52, 4.52, 4.52); Calibrated: 10/23/2013;

Sensor-Surface: 1.4mm (Mechanical Surface Detection)

Electronics: DAE4 Sn1333; Calibrated: 11/19/2013

Phantom: SAM 5.0 front; Type: QD000P40CD; Serial: TP:-1648

Measurement SW: DASYS2, Version 52.8 (7); SEMCAD X Version 14.6.10 (7164)

5200 MHz System Verification

Area Scan (7x8x1): Measurement grid: dx=10mm, dy=10mm

Zoom Scan (8x8x7)/Cube 0: Measurement grid: dx=4mm, dy=4mm, dz=1.4mm; Graded Ratio: 1.4

Input Power: 16 dBm (40 mW)

Peak SAR (extrapolated) = 13.2 W/kg

SAR(1 g) = 3.11 W/kg

Deviation: 1.50%

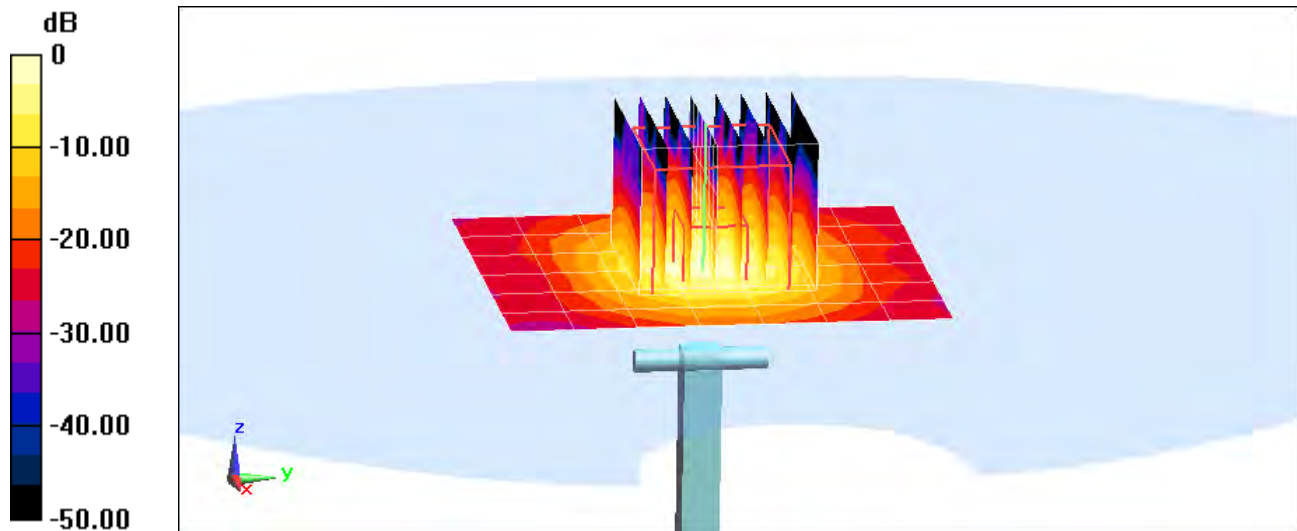

0 dB = 7.88 W/kg = 8.97 dBW/kg

PCTEST ENGINEERING LABORATORY, INC.

DUT: SAR Dipole 5300 MHz; Type: D5GHzV2; Serial: 1120

Communication System: UID 0, CW; Frequency: 5300 MHz; Duty Cycle: 1:1

Medium: 5 GHz Body Medium parameters used:

$f = 5300 \text{ MHz}$; $\sigma = 5.352 \text{ S/m}$; $\epsilon_r = 47.314$; $\rho = 1000 \text{ kg/m}^3$

Phantom section: Flat Section ; Space: 1.0 cm

Test Date: 02-03-2014; Ambient Temp: 24.4°C; Tissue Temp: 22.6°C

Probe: EX3DV4 - SN3914; ConvF(4.32, 4.32, 4.32); Calibrated: 10/23/2013;

Sensor-Surface: 1.4mm (Mechanical Surface Detection)

Electronics: DAE4 Sn1333; Calibrated: 11/19/2013

Phantom: SAM 5.0 front; Type: QD000P40CD; Serial: TP:-1648

Measurement SW: DASYS2, Version 52.8 (7); SEMCAD X Version 14.6.10 (7164)

5300 MHz System Verification

Area Scan (7x8x1): Measurement grid: dx=10mm, dy=10mm

Zoom Scan (9x9x7)/Cube 0: Measurement grid: dx=4mm, dy=4mm, dz=1.4mm; Graded Ratio: 1.4

Input Power: 16 dBm (40 mW)

Peak SAR (extrapolated) = 14.4 W/kg

SAR(1 g) = 3.26 W/kg

Deviation: 6.12%

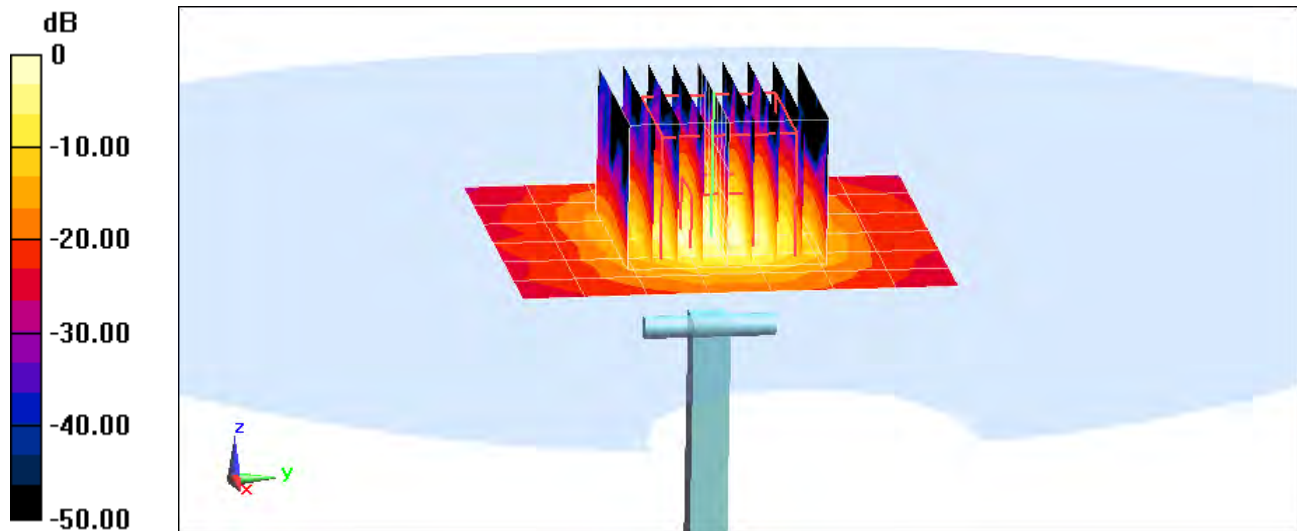

0 dB = 8.34 W/kg = 9.21 dBW/kg

PCTEST ENGINEERING LABORATORY, INC.

DUT: SAR Dipole 5500 MHz; Type: D5GHzV2; Serial: 1120

Communication System: UID 0, CW; Frequency: 5500 MHz; Duty Cycle: 1:1

Medium: 5 GHz Body Medium parameters used:

$f = 5500 \text{ MHz}$; $\sigma = 5.579 \text{ S/m}$; $\epsilon_r = 46.639$; $\rho = 1000 \text{ kg/m}^3$

Phantom section: Flat Section ; Space: 1.0 cm

Test Date: 02-03-2014; Ambient Temp: 24.3°C; Tissue Temp: 22.6°C

Probe: EX3DV4 - SN3914; ConvF(4.07, 4.07, 4.07); Calibrated: 10/23/2013;

Sensor-Surface: 1.4mm (Mechanical Surface Detection)

Electronics: DAE4 Sn1333; Calibrated: 11/19/2013

Phantom: SAM 5.0 front; Type: QD000P40CD; Serial: TP:-1648

Measurement SW: DASYS2, Version 52.8 (7); SEMCAD X Version 14.6.10 (7164)

5500 MHz System Verification

Area Scan (7x8x1): Measurement grid: dx=10mm, dy=10mm

Zoom Scan (7x7x7)/Cube 0: Measurement grid: dx=4mm, dy=4mm, dz=1.4mm; Graded Ratio: 1.4

Input Power: 16 dBm (40 mW)

Peak SAR (extrapolated) = 15.3 W/kg

SAR(1 g) = 3.27 W/kg

Deviation: 2.44%

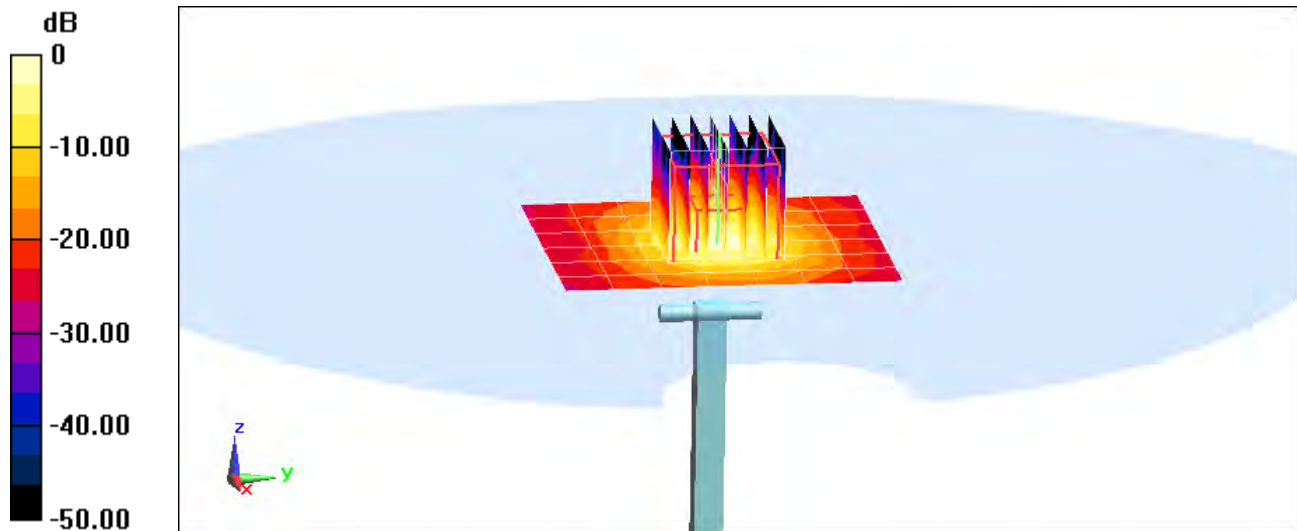

0 dB = 8.61 W/kg = 9.35 dBW/kg

PCTEST ENGINEERING LABORATORY, INC.

DUT: SAR Dipole 5600 MHz; Type: D5GHzV2; Serial: 1120

Communication System: UID 0, CW; Frequency: 5600 MHz; Duty Cycle: 1:1

Medium: 5 GHz Body Medium parameters used:

$f = 5600 \text{ MHz}$; $\sigma = 5.749 \text{ S/m}$; $\epsilon_r = 46.646$; $\rho = 1000 \text{ kg/m}^3$

Phantom section: Flat Section ; Space: 1.0 cm

Test Date: 02-03-2014; Ambient Temp: 24.5°C; Tissue Temp: 22.5°C

Probe: EX3DV4 - SN3914; ConvF(3.97, 3.97, 3.97); Calibrated: 10/23/2013;

Sensor-Surface: 1.4mm (Mechanical Surface Detection)

Electronics: DAE4 Sn1333; Calibrated: 11/19/2013

Phantom: SAM 5.0 front; Type: QD000P40CD; Serial: TP:-1648

Measurement SW: DASYS2, Version 52.8 (7); SEMCAD X Version 14.6.10 (7164)

5600 MHz System Verification

Area Scan (7x8x1): Measurement grid: dx=10mm, dy=10mm

Zoom Scan (8x8x7)/Cube 0: Measurement grid: dx=4mm, dy=4mm, dz=1.4mm; Graded Ratio: 1.4

Input Power: 16 dBm (40 mW)

Peak SAR (extrapolated) = 16.2 W/kg

SAR(1 g) = 3.38 W/kg

Deviation: 4.71%

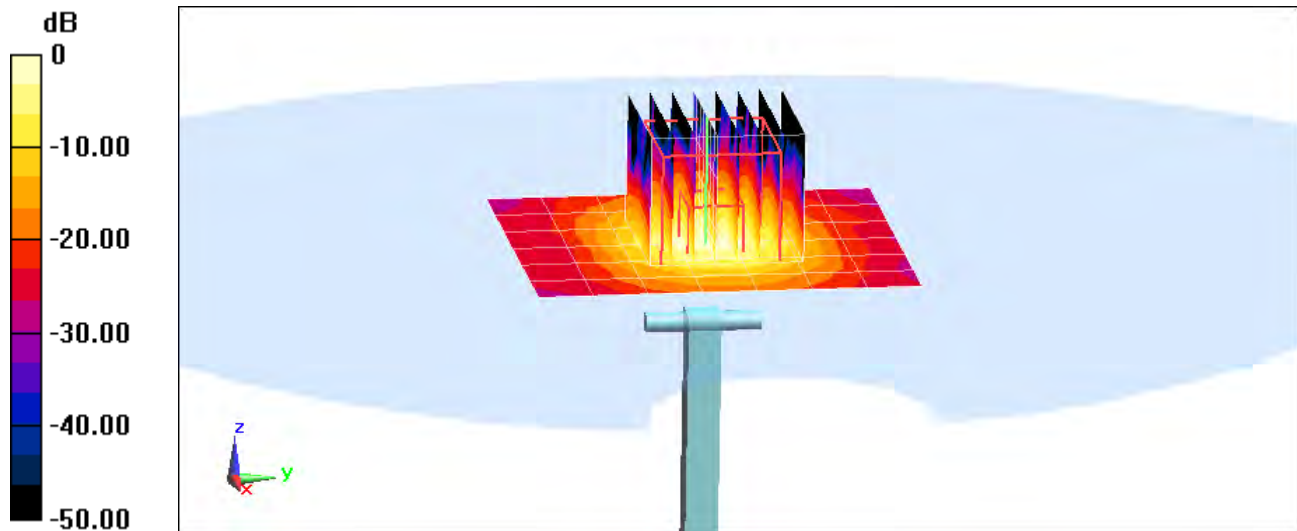

0 dB = 8.93 W/kg = 9.51 dBW/kg

PCTEST ENGINEERING LABORATORY, INC.

DUT: SAR Dipole 5800 MHz; Type: D5GHzV2; Serial: 1120

Communication System: UID 0, CW; Frequency: 5800 MHz; Duty Cycle: 1:1

Medium: 5 GHz Body Medium parameters used:

$f = 5800 \text{ MHz}$; $\sigma = 6.097 \text{ S/m}$; $\epsilon_r = 46.032$; $\rho = 1000 \text{ kg/m}^3$

Phantom section: Flat Section ; Space: 1.0 cm

Test Date: 02-03-2014; Ambient Temp: 24.5°C; Tissue Temp: 22.7°C

Probe: EX3DV4 - SN3914; ConvF(4.14, 4.14, 4.14); Calibrated: 10/23/2013;

Sensor-Surface: 1.4mm (Mechanical Surface Detection)

Electronics: DAE4 Sn1333; Calibrated: 11/19/2013

Phantom: SAM 5.0 front; Type: QD000P40CD; Serial: TP:-1648

Measurement SW: DASY52, Version 52.8 (7); SEMCAD X Version 14.6.10 (7164)

5800 MHz System Verification

Area Scan (7x7x1): Measurement grid: dx=10mm, dy=10mm

Zoom Scan (8x8x7)/Cube 0: Measurement grid: dx=4mm, dy=4mm, dz=1.4mm; Graded Ratio: 1.4

Input Power: 16 dBm (40 mW)

Peak SAR (extrapolated) = 15.2 W/kg

SAR(1 g) = 3.05 W/kg

Deviation: 0.99%

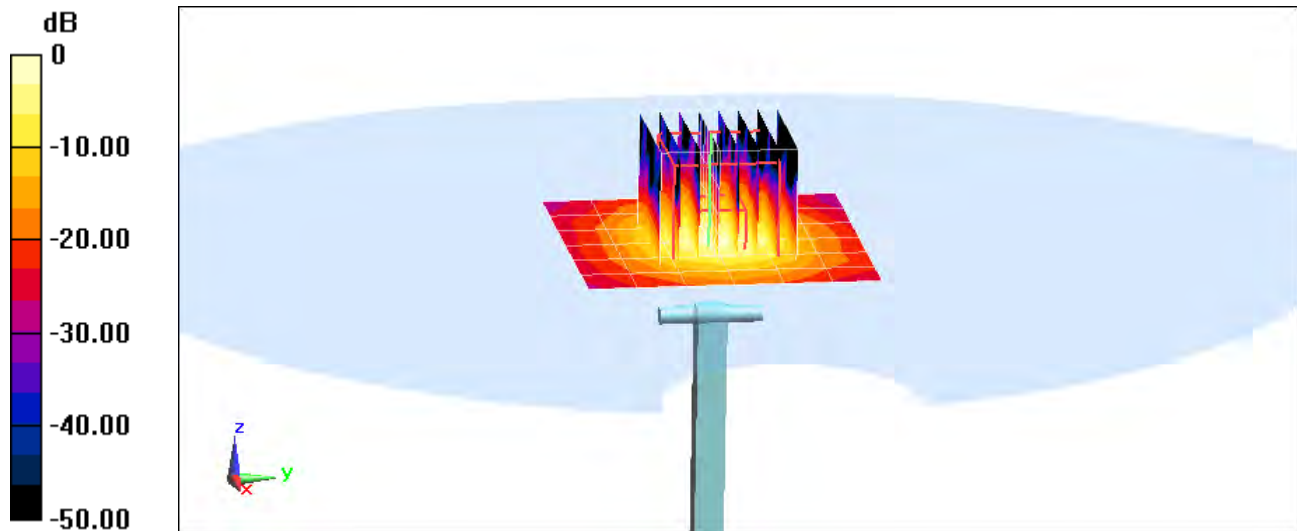

0 dB = 7.72 W/kg = 8.88 dBW/kg

APPENDIX C: PROBE CALIBRATION



Accredited by the Swiss Accreditation Service (SAS)
The Swiss Accreditation Service is one of the signatories to the EA
Multilateral Agreement for the recognition of calibration certificates

Accreditation No.: **SCS 108**

Client **PC Test**

Certificate No: **ES3-3332_Nov13**

CALIBRATION CERTIFICATE

Object **ES3DV3 - SN:3332**

Calibration procedure(s) **QA CAL-01.v9, QA CAL-23.v5, QA CAL-25.v6
Calibration procedure for dosimetric E-field probes**

Calibration date: **November 25, 2013**

*VCC
1/12/13*

This calibration certificate documents the traceability to national standards, which realize the physical units of measurements (SI).
The measurements and the uncertainties with confidence probability are given on the following pages and are part of the certificate.

All calibrations have been conducted in the closed laboratory facility: environment temperature (22 ± 3)°C and humidity < 70%.

Calibration Equipment used (M&TE critical for calibration)

Primary Standards	ID	Cal Date (Certificate No.)	Scheduled Calibration
Power meter E4419B	GB41293874	04-Apr-13 (No. 217-01733)	Apr-14
Power sensor E4412A	MY41498087	04-Apr-13 (No. 217-01733)	Apr-14
Reference 3 dB Attenuator	SN: S5054 (3c)	04-Apr-13 (No. 217-01737)	Apr-14
Reference 20 dB Attenuator	SN: S5277 (20x)	04-Apr-13 (No. 217-01735)	Apr-14
Reference 30 dB Attenuator	SN: S5129 (30b)	04-Apr-13 (No. 217-01738)	Apr-14
Reference Probe ES3DV2	SN: 3013	28-Dec-12 (No. ES3-3013_Dec12)	Dec-13
DAE4	SN: 660	4-Sep-13 (No. DAE4-660_Sep13)	Sep-14
Secondary Standards	ID	Check Date (in house)	Scheduled Check
RF generator HP 8648C	US3642U01700	4-Aug-99 (in house check Apr-13)	In house check: Apr-15
Network Analyzer HP 8753E	US37390585	18-Oct-01 (in house check Oct-13)	In house check: Oct-14

Calibrated by:	Name Leif Klysner	Function Laboratory Technician	Signature <i>Leif Klysner</i>
Approved by:	Name Katja Pokovic	Function Technical Manager	Signature <i>Katja Pokovic</i>

Issued: November 25, 2013

This calibration certificate shall not be reproduced except in full without written approval of the laboratory.



Accredited by the Swiss Accreditation Service (SAS)

Accreditation No.: **SCS 108**

The Swiss Accreditation Service is one of the signatories to the EA
Multilateral Agreement for the recognition of calibration certificates

Glossary:

TSL	tissue simulating liquid
NORM _{x,y,z}	sensitivity in free space
ConvF	sensitivity in TSL / NORM _{x,y,z}
DCP	diode compression point
CF	crest factor (1/duty_cycle) of the RF signal
A, B, C, D	modulation dependent linearization parameters
Polarization φ	φ rotation around probe axis
Polarization ϑ	ϑ rotation around an axis that is in the plane normal to probe axis (at measurement center), i.e., $\vartheta = 0$ is normal to probe axis
Connector Angle	information used in DASY system to align probe sensor X to the robot coordinate system

Calibration is Performed According to the Following Standards:

- IEEE Std 1528-2013, "IEEE Recommended Practice for Determining the Peak Spatial-Averaged Specific Absorption Rate (SAR) in the Human Head from Wireless Communications Devices: Measurement Techniques", June 2013
- IEC 62209-1, "Procedure to measure the Specific Absorption Rate (SAR) for hand-held devices used in close proximity to the ear (frequency range of 300 MHz to 3 GHz)", February 2005

Methods Applied and Interpretation of Parameters:

- NORM_{x,y,z}**: Assessed for E-field polarization $\vartheta = 0$ ($f \leq 900$ MHz in TEM-cell; $f > 1800$ MHz: R22 waveguide). NORM_{x,y,z} are only intermediate values, i.e., the uncertainties of NORM_{x,y,z} does not affect the E^2 -field uncertainty inside TSL (see below *ConvF*).
- NORM(f)_{x,y,z}** = NORM_{x,y,z} * *frequency_response* (see Frequency Response Chart). This linearization is implemented in DASY4 software versions later than 4.2. The uncertainty of the frequency response is included in the stated uncertainty of *ConvF*.
- DCP_{x,y,z}**: DCP are numerical linearization parameters assessed based on the data of power sweep with CW signal (no uncertainty required). DCP does not depend on frequency nor media.
- PAR**: PAR is the Peak to Average Ratio that is not calibrated but determined based on the signal characteristics
- A_{x,y,z}; B_{x,y,z}; C_{x,y,z}; D_{x,y,z}; VR_{x,y,z}; A, B, C, D** are numerical linearization parameters assessed based on the data of power sweep for specific modulation signal. The parameters do not depend on frequency nor media. VR is the maximum calibration range expressed in RMS voltage across the diode.
- ConvF and Boundary Effect Parameters**: Assessed in flat phantom using E-field (or Temperature Transfer Standard for $f \leq 800$ MHz) and inside waveguide using analytical field distributions based on power measurements for $f > 800$ MHz. The same setups are used for assessment of the parameters applied for boundary compensation (alpha, depth) of which typical uncertainty values are given. These parameters are used in DASY4 software to improve probe accuracy close to the boundary. The sensitivity in TSL corresponds to NORM_{x,y,z} * *ConvF* whereby the uncertainty corresponds to that given for *ConvF*. A frequency dependent *ConvF* is used in DASY version 4.4 and higher which allows extending the validity from ± 50 MHz to ± 100 MHz.
- Spherical isotropy (3D deviation from isotropy)**: in a field of low gradients realized using a flat phantom exposed by a patch antenna.
- Sensor Offset**: The sensor offset corresponds to the offset of virtual measurement center from the probe tip (on probe axis). No tolerance required.
- Connector Angle**: The angle is assessed using the information gained by determining the NORM_x (no uncertainty required).

Probe ES3DV3

SN:3332

Manufactured: January 24, 2012
Calibrated: November 25, 2013

Calibrated for DASY/EASY Systems
(Note: non-compatible with DASY2 system!)

DASY/EASY - Parameters of Probe: ES3DV3 - SN:3332

Basic Calibration Parameters

	Sensor X	Sensor Y	Sensor Z	Unc (k=2)
Norm ($\mu\text{V}/(\text{V}/\text{m})^2$) ^A	0.94	1.16	0.97	± 10.1 %
DCP (mV) ^B	103.5	101.0	111.0	

Modulation Calibration Parameters

UID	Communication System Name		A dB	B dB $\sqrt{\mu\text{V}}$	C	D dB	VR mV	Unc ^E (k=2)
0	CW	X	0.0	0.0	1.0	0.00	179.7	±2.5 %
		Y	0.0	0.0	1.0		147.3	
		Z	0.0	0.0	1.0		188.8	

The reported uncertainty of measurement is stated as the standard uncertainty of measurement multiplied by the coverage factor k=2, which for a normal distribution corresponds to a coverage probability of approximately 95%.

^A The uncertainties of NormX,Y,Z do not affect the E²-field uncertainty inside TSL (see Pages 5 and 6).

^B Numerical linearization parameter: uncertainty not required.

^E Uncertainty is determined using the max. deviation from linear response applying rectangular distribution and is expressed for the square of the field value.

DASY/EASY - Parameters of Probe: ES3DV3 - SN:3332

Calibration Parameter Determined in Head Tissue Simulating Media

f (MHz) ^C	Relative Permittivity ^F	Conductivity (S/m) ^F	ConvF X	ConvF Y	ConvF Z	Alpha ^G	Depth ^G (mm)	Unct. (k=2)
750	41.9	0.89	6.46	6.46	6.46	0.52	1.42	± 12.0 %
850	41.5	0.92	6.29	6.29	6.29	0.78	1.17	± 12.0 %
1750	40.1	1.37	5.27	5.27	5.27	0.80	1.10	± 12.0 %
1900	40.0	1.40	5.06	5.06	5.06	0.80	1.18	± 12.0 %
2450	39.2	1.80	4.50	4.50	4.50	0.80	1.19	± 12.0 %
2600	39.0	1.96	4.38	4.38	4.38	0.76	1.31	± 12.0 %

^C Frequency validity of ± 100 MHz only applies for DASY v4.4 and higher (see Page 2), else it is restricted to ± 50 MHz. The uncertainty is the RSS of the ConvF uncertainty at calibration frequency and the uncertainty for the indicated frequency band.

^F At frequencies below 3 GHz, the validity of tissue parameters (ϵ and σ) can be relaxed to ± 10% if liquid compensation formula is applied to measured SAR values. At frequencies above 3 GHz, the validity of tissue parameters (ϵ and σ) is restricted to ± 5%. The uncertainty is the RSS of the ConvF uncertainty for indicated target tissue parameters.

^G Alpha/Depth are determined during calibration. SPEAG warrants that the remaining deviation due to the boundary effect after compensation is always less than ± 1% for frequencies below 3 GHz and below ± 2% for frequencies between 3-6 GHz at any distance larger than half the probe tip diameter from the boundary.

DASY/EASY - Parameters of Probe: ES3DV3 - SN:3332

Calibration Parameter Determined in Body Tissue Simulating Media

f (MHz) ^C	Relative Permittivity ^F	Conductivity (S/m) ^F	ConvF X	ConvF Y	ConvF Z	Alpha ^G	Depth (mm) ^G	Unct. (k=2)
750	55.5	0.96	6.21	6.21	6.21	0.80	1.19	± 12.0 %
850	55.2	0.99	6.08	6.08	6.08	0.51	1.48	± 12.0 %
1750	53.4	1.49	4.93	4.93	4.93	0.42	1.72	± 12.0 %
1900	53.3	1.52	4.70	4.70	4.70	0.48	1.59	± 12.0 %
2450	52.7	1.95	4.24	4.24	4.24	0.80	1.01	± 12.0 %
2600	52.5	2.16	4.07	4.07	4.07	0.80	0.50	± 12.0 %

^C Frequency validity of ± 100 MHz only applies for DASY v4.4 and higher (see Page 2), else it is restricted to ± 50 MHz. The uncertainty is the RSS of the ConvF uncertainty at calibration frequency and the uncertainty for the indicated frequency band.

^F At frequencies below 3 GHz, the validity of tissue parameters (ϵ and σ) can be relaxed to ± 10% if liquid compensation formula is applied to measured SAR values. At frequencies above 3 GHz, the validity of tissue parameters (ϵ and σ) is restricted to ± 5%. The uncertainty is the RSS of the ConvF uncertainty for indicated target tissue parameters.

^G Alpha/Depth are determined during calibration. SPEAG warrants that the remaining deviation due to the boundary effect after compensation is always less than ± 1% for frequencies below 3 GHz and below ± 2% for frequencies between 3-6 GHz at any distance larger than half the probe tip diameter from the boundary.

Frequency Response of E-Field (TEM-Cell:ifi110 EXX, Waveguide: R22)

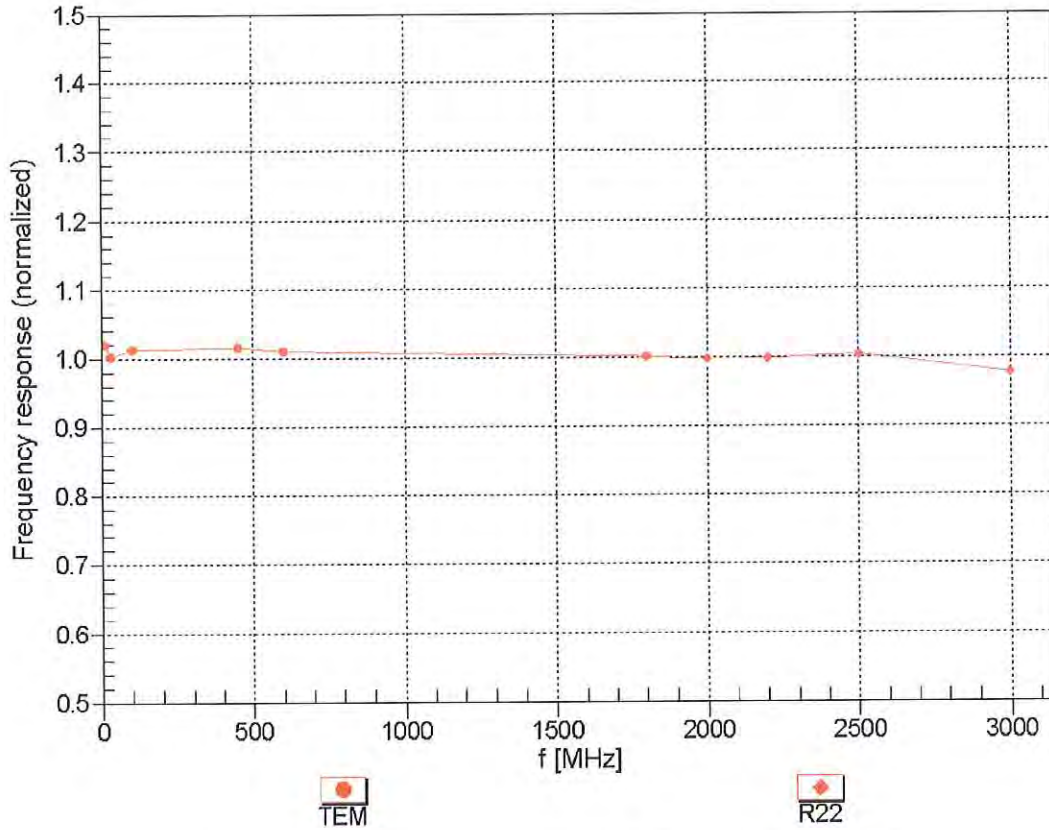

Uncertainty of Frequency Response of E-field: $\pm 6.3\%$ (k=2)

Receiving Pattern (ϕ), $\vartheta = 0^\circ$

f=600 MHz,TEM

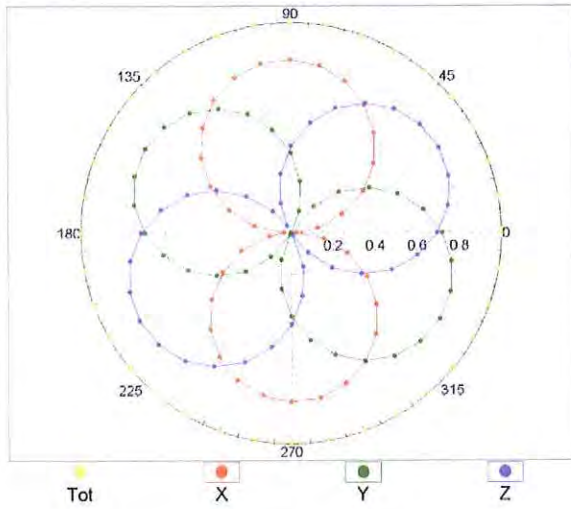

f=1800 MHz,R22

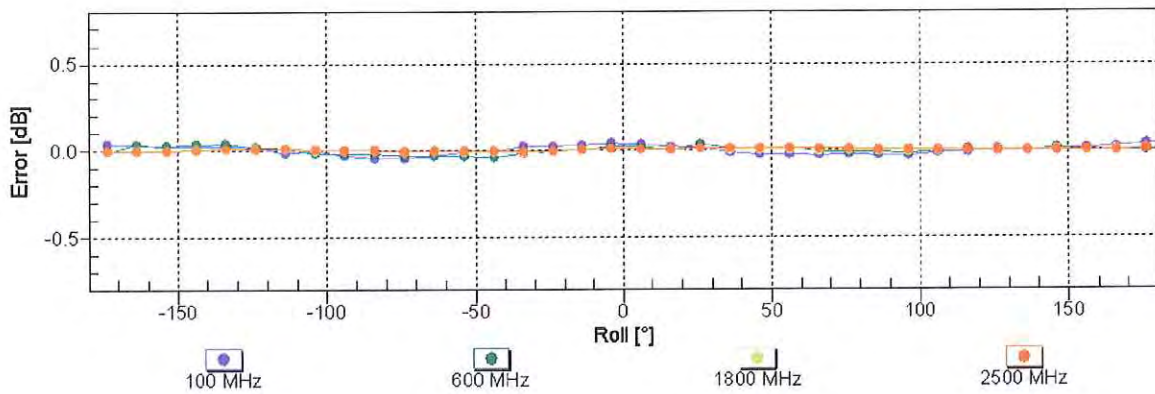
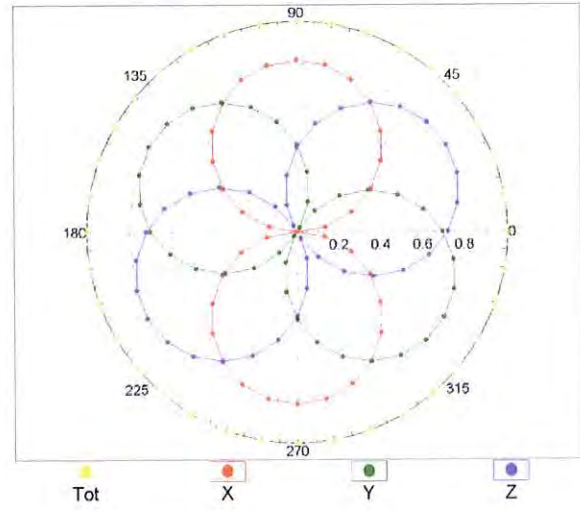

Uncertainty of Axial Isotropy Assessment: $\pm 0.5\%$ (k=2)

Dynamic Range $f(\text{SAR}_{\text{head}})$ (TEM cell , $f = 900 \text{ MHz}$)

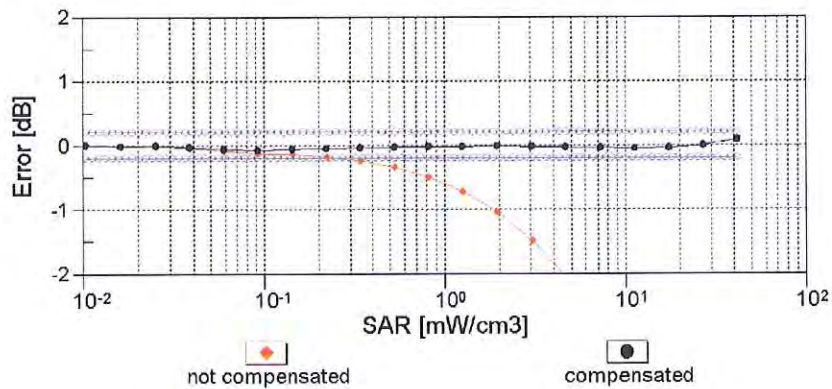
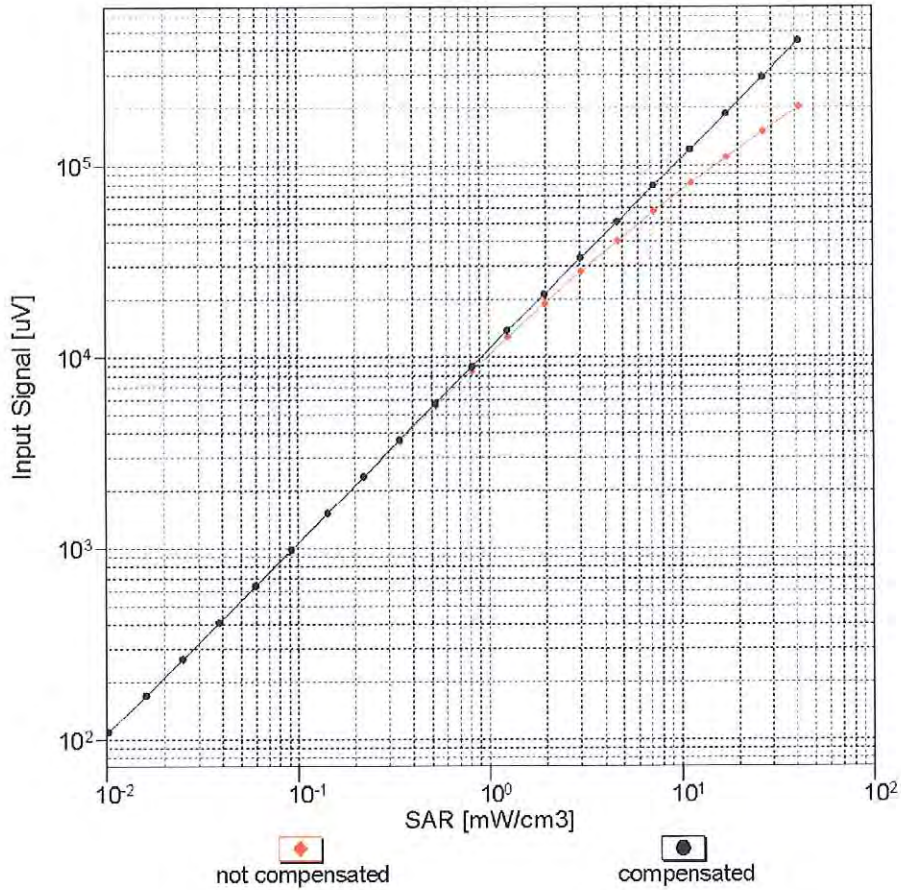

Uncertainty of Linearity Assessment: $\pm 0.6\%$ ($k=2$)

Conversion Factor Assessment

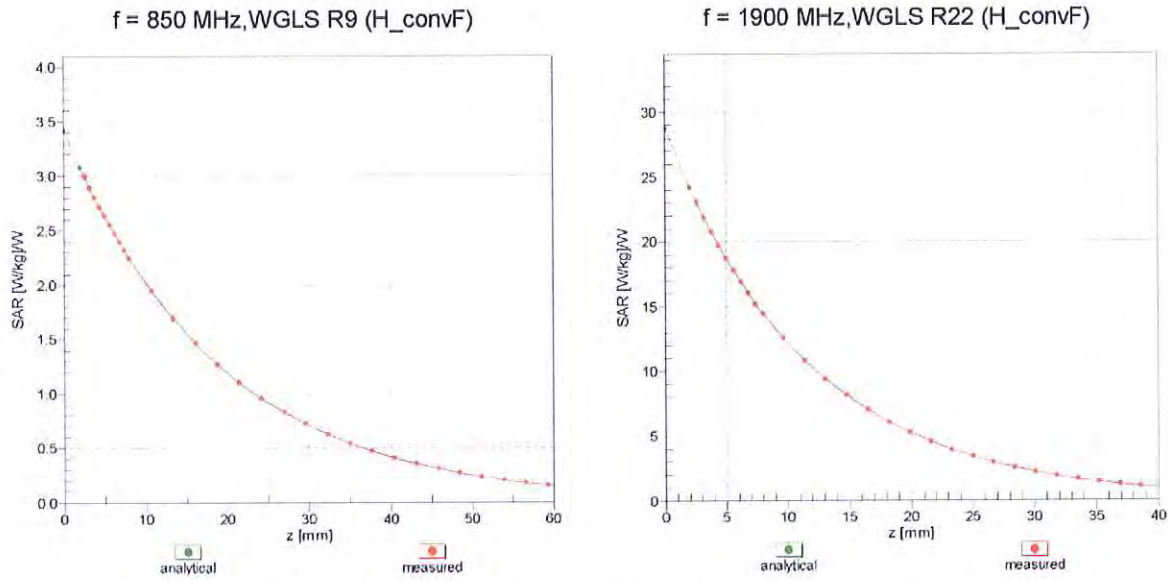

Deviation from Isotropy in Liquid Error (ϕ, ϑ), f = 900 MHz

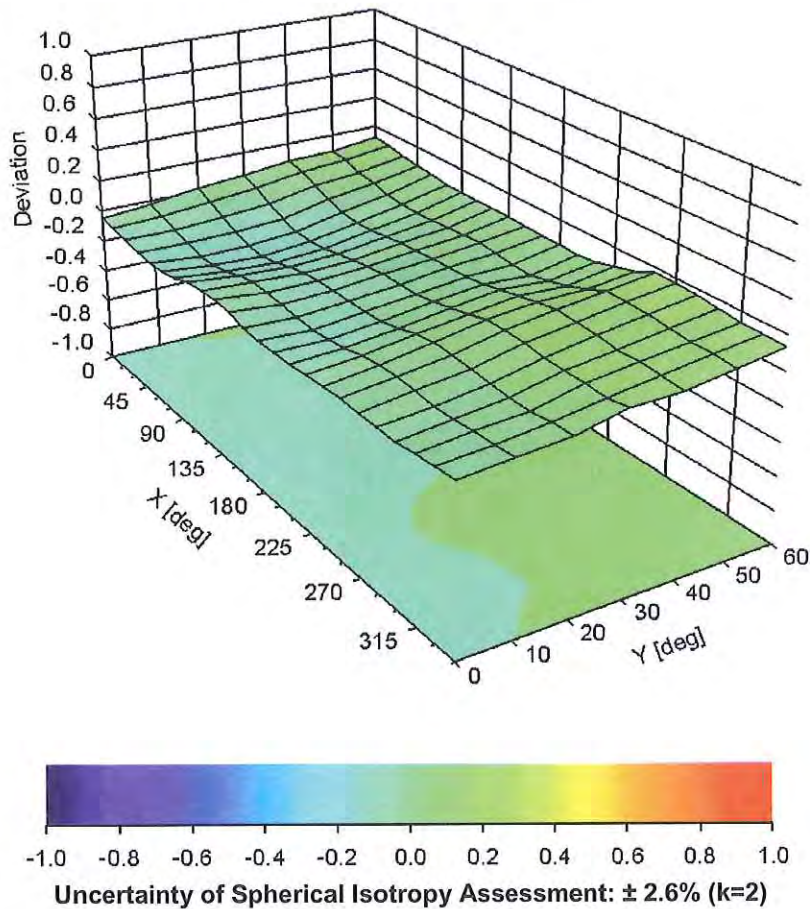

DASY/EASY - Parameters of Probe: ES3DV3 - SN:3332

Other Probe Parameters

Sensor Arrangement	Triangular
Connector Angle (°)	-3.9
Mechanical Surface Detection Mode	enabled
Optical Surface Detection Mode	disabled
Probe Overall Length	337 mm
Probe Body Diameter	10 mm
Tip Length	10 mm
Tip Diameter	4 mm
Probe Tip to Sensor X Calibration Point	2 mm
Probe Tip to Sensor Y Calibration Point	2 mm
Probe Tip to Sensor Z Calibration Point	2 mm
Recommended Measurement Distance from Surface	3 mm



Accredited by the Swiss Accreditation Service (SAS)
The Swiss Accreditation Service is one of the signatories to the EA
Multilateral Agreement for the recognition of calibration certificates

Accreditation No.: **SCS 108**

Client **PC Test**

Certificate No: **D1900V2-5d149_Jul13**

CALIBRATION CERTIFICATE

Object **D1900V2 - SN: 5d149**

Calibration procedure(s) **QA CAL-05.v9
Calibration procedure for dipole validation kits above 700 MHz**

Calibration date: **July 22, 2013**

*✓
Kok
8/19/13*

This calibration certificate documents the traceability to national standards, which realize the physical units of measurements (SI).
The measurements and the uncertainties with confidence probability are given on the following pages and are part of the certificate.

All calibrations have been conducted in the closed laboratory facility: environment temperature (22 ± 3)°C and humidity < 70%.

Calibration Equipment used (M&TE critical for calibration)

Primary Standards	ID #	Cal Date (Certificate No.)	Scheduled Calibration
Power meter EPM-442A	GB37480704	01-Nov-12 (No. 217-01640)	Oct-13
Power sensor HP 8481A	US37292783	01-Nov-12 (No. 217-01640)	Oct-13
Reference 20 dB Attenuator	SN: 5058 (20k)	04-Apr-13 (No. 217-01736)	Apr-14
Type-N mismatch combination	SN: 5047.3 / 06327	04-Apr-13 (No. 217-01739)	Apr-14
Reference Probe ES3DV3	SN: 3205	28-Dec-12 (No. ES3-3205_Dec12)	Dec-13
DAE4	SN: 601	25-Apr-13 (No. DAE4-601_Apr13)	Apr-14
Secondary Standards	ID #	Check Date (in house)	Scheduled Check
Power sensor HP 8481A	MY41092317	18-Oct-02 (in house check Oct-11)	In house check: Oct-13
RF generator R&S SMT-06	100005	04-Aug-99 (in house check Oct-11)	In house check: Oct-13
Network Analyzer HP 8753E	US37390585 S4206	18-Oct-01 (in house check Oct-12)	In house check: Oct-13

Calibrated by: **Jeton Kastrati** Name: **Jeton Kastrati** Function: **Laboratory Technician** Signature: *[Signature]*

Approved by: **Katja Pokovic** Name: **Katja Pokovic** Function: **Technical Manager** Signature: *[Signature]*

Issued: July 22, 2013

This calibration certificate shall not be reproduced except in full without written approval of the laboratory.



Accredited by the Swiss Accreditation Service (SAS)
The Swiss Accreditation Service is one of the signatories to the EA
Multilateral Agreement for the recognition of calibration certificates

Accreditation No.: **SCS 108**

Glossary:

TSL	tissue simulating liquid
ConvF	sensitivity in TSL / NORM x,y,z
N/A	not applicable or not measured

Calibration is Performed According to the Following Standards:

- a) IEEE Std 1528-2003, "IEEE Recommended Practice for Determining the Peak Spatial-Averaged Specific Absorption Rate (SAR) in the Human Head from Wireless Communications Devices: Measurement Techniques", December 2003
- b) IEC 62209-1, "Procedure to measure the Specific Absorption Rate (SAR) for hand-held devices used in close proximity to the ear (frequency range of 300 MHz to 3 GHz)", February 2005
- c) Federal Communications Commission Office of Engineering & Technology (FCC OET), "Evaluating Compliance with FCC Guidelines for Human Exposure to Radiofrequency Electromagnetic Fields; Additional Information for Evaluating Compliance of Mobile and Portable Devices with FCC Limits for Human Exposure to Radiofrequency Emissions", Supplement C (Edition 01-01) to Bulletin 65

Additional Documentation:

- d) DASY4/5 System Handbook

Methods Applied and Interpretation of Parameters:

- *Measurement Conditions:* Further details are available from the Validation Report at the end of the certificate. All figures stated in the certificate are valid at the frequency indicated.
- *Antenna Parameters with TSL:* The dipole is mounted with the spacer to position its feed point exactly below the center marking of the flat phantom section, with the arms oriented parallel to the body axis.
- *Feed Point Impedance and Return Loss:* These parameters are measured with the dipole positioned under the liquid filled phantom. The impedance stated is transformed from the measurement at the SMA connector to the feed point. The Return Loss ensures low reflected power. No uncertainty required.
- *Electrical Delay:* One-way delay between the SMA connector and the antenna feed point. No uncertainty required.
- *SAR measured:* SAR measured at the stated antenna input power.
- *SAR normalized:* SAR as measured, normalized to an input power of 1 W at the antenna connector.
- *SAR for nominal TSL parameters:* The measured TSL parameters are used to calculate the nominal SAR result.

The reported uncertainty of measurement is stated as the standard uncertainty of measurement multiplied by the coverage factor $k=2$, which for a normal distribution corresponds to a coverage probability of approximately 95%.

Measurement Conditions

DASY system configuration, as far as not given on page 1.

DASY Version	DASY5	V52.8.7
Extrapolation	Advanced Extrapolation	
Phantom	Modular Flat Phantom	
Distance Dipole Center - TSL	10 mm	with Spacer
Zoom Scan Resolution	dx, dy, dz = 5 mm	
Frequency	1900 MHz \pm 1 MHz	

Head TSL parameters

The following parameters and calculations were applied.

	Temperature	Permittivity	Conductivity
Nominal Head TSL parameters	22.0 °C	40.0	1.40 mho/m
Measured Head TSL parameters	(22.0 \pm 0.2) °C	38.9 \pm 6 %	1.36 mho/m \pm 6 %
Head TSL temperature change during test	< 0.5 °C	----	----

SAR result with Head TSL

SAR averaged over 1 cm³ (1 g) of Head TSL	Condition	
SAR measured	250 mW input power	9.99 W/kg
SAR for nominal Head TSL parameters	normalized to 1W	40.4 W/kg \pm 17.0 % (k=2)

SAR averaged over 10 cm³ (10 g) of Head TSL	condition	
SAR measured	250 mW input power	5.28 W/kg
SAR for nominal Head TSL parameters	normalized to 1W	21.3 W/kg \pm 16.5 % (k=2)

Body TSL parameters

The following parameters and calculations were applied.

	Temperature	Permittivity	Conductivity
Nominal Body TSL parameters	22.0 °C	53.3	1.52 mho/m
Measured Body TSL parameters	(22.0 \pm 0.2) °C	53.4 \pm 6 %	1.49 mho/m \pm 6 %
Body TSL temperature change during test	< 0.5 °C	----	----

SAR result with Body TSL

SAR averaged over 1 cm³ (1 g) of Body TSL	Condition	
SAR measured	250 mW input power	10.0 W/kg
SAR for nominal Body TSL parameters	normalized to 1W	40.5 W/kg \pm 17.0 % (k=2)

SAR averaged over 10 cm³ (10 g) of Body TSL	condition	
SAR measured	250 mW input power	5.36 W/kg
SAR for nominal Body TSL parameters	normalized to 1W	21.6 W/kg \pm 16.5 % (k=2)

Appendix

Antenna Parameters with Head TSL

Impedance, transformed to feed point	52.9 Ω + 6.0 j Ω
Return Loss	- 23.8 dB

Antenna Parameters with Body TSL

Impedance, transformed to feed point	48.5 Ω + 6.4 j Ω
Return Loss	- 23.5 dB

General Antenna Parameters and Design

Electrical Delay (one direction)	1.196 ns
----------------------------------	----------

After long term use with 100W radiated power, only a slight warming of the dipole near the feedpoint can be measured.

The dipole is made of standard semirigid coaxial cable. The center conductor of the feeding line is directly connected to the second arm of the dipole. The antenna is therefore short-circuited for DC-signals. On some of the dipoles, small end caps are added to the dipole arms in order to improve matching when loaded according to the position as explained in the "Measurement Conditions" paragraph. The SAR data are not affected by this change. The overall dipole length is still according to the Standard.

No excessive force must be applied to the dipole arms, because they might bend or the soldered connections near the feedpoint may be damaged.

Additional EUT Data

Manufactured by	SPEAG
Manufactured on	March 11, 2011

DASY5 Validation Report for Head TSL

Date: 22.07.2013

Test Laboratory: SPEAG, Zurich, Switzerland

DUT: Dipole 1900 MHz; Type: D1900V2; Serial: D1900V2 - SN: 5d149

Communication System: UID 0 - CW ; Frequency: 1900 MHz

Medium parameters used: $f = 1900$ MHz; $\sigma = 1.36$ S/m; $\epsilon_r = 38.9$; $\rho = 1000$ kg/m³

Phantom section: Flat Section

Measurement Standard: DASY5 (IEEE/IEC/ANSI C63.19-2007)

DASY52 Configuration:

- Probe: ES3DV3 - SN3205; ConvF(4.98, 4.98, 4.98); Calibrated: 28.12.2012;
- Sensor-Surface: 3mm (Mechanical Surface Detection)
- Electronics: DAE4 Sn601; Calibrated: 25.04.2013
- Phantom: Flat Phantom 5.0 (front); Type: QD000P50AA; Serial: 1001
- DASY52 52.8.7(1137); SEMCAD X 14.6.10(7164)

Dipole Calibration for Head Tissue/Pin=250 mW, d=10mm/Zoom Scan (7x7x7)/Cube 0:

Measurement grid: dx=5mm, dy=5mm, dz=5mm

Reference Value = 96.173 V/m; Power Drift = 0.04 dB

Peak SAR (extrapolated) = 18.0 W/kg

SAR(1 g) = 9.99 W/kg; SAR(10 g) = 5.28 W/kg

Maximum value of SAR (measured) = 12.4 W/kg

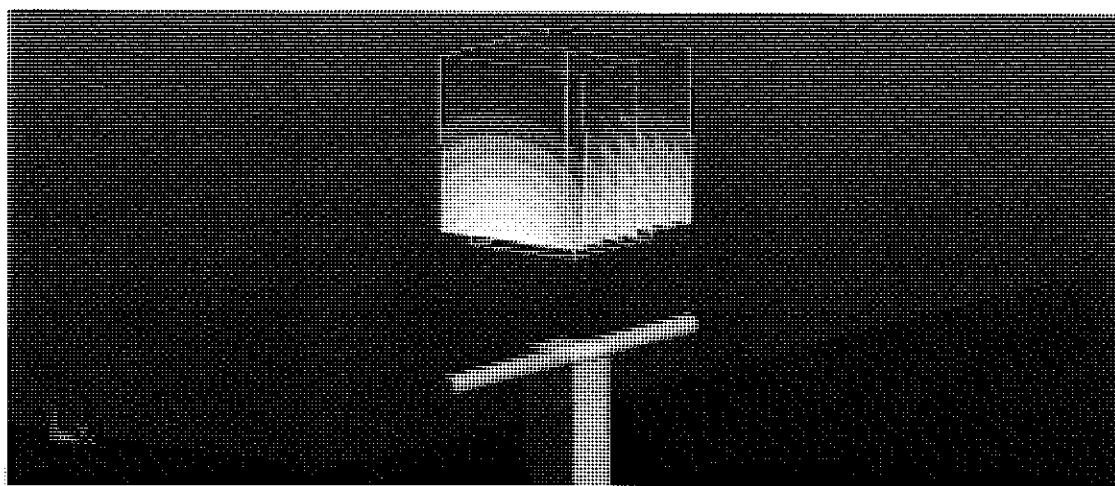
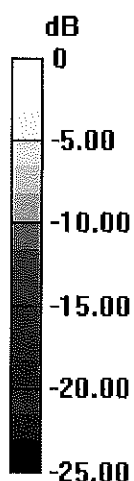

0 dB = 12.4 W/kg = 10.93 dBW/kg

Impedance Measurement Plot for Head TSL

22 Jul 2013 11:59:34

CH1 S11 1 U FS 1: 52.941 Ω 6.0059 Ω 503.09 ρH 1 900.000 000 MHz

*
De1
CA
Avg
16
H1d

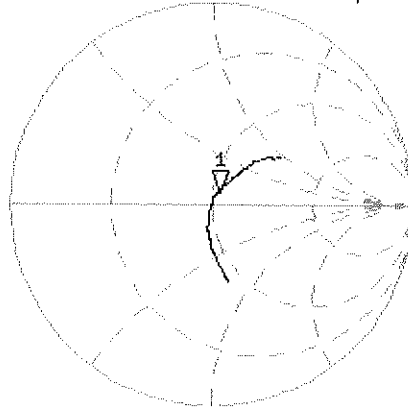

CH2 S11 LOG 5 dB/REF -20 dB 1:-23.758 dB 1 900.000 000 MHz

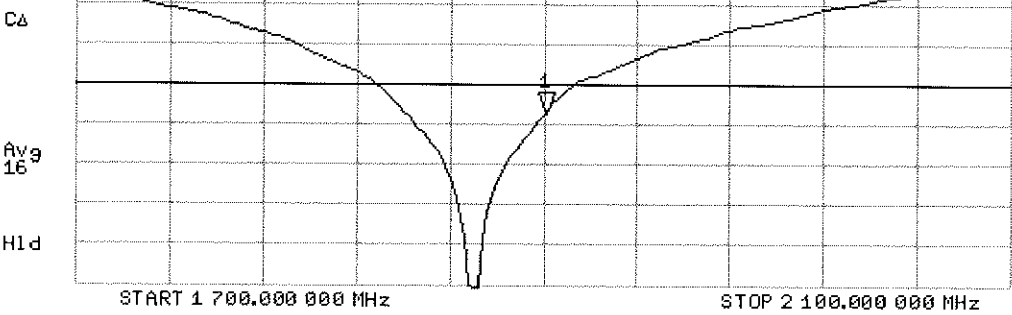

DASY5 Validation Report for Body TSL

Date: 22.07.2013

Test Laboratory: SPEAG, Zurich, Switzerland

DUT: Dipole 1900 MHz; Type: D1900V2; Serial: D1900V2 - SN: 5d149

Communication System: UID 0 - CW ; Frequency: 1900 MHz

Medium parameters used: $f = 1900 \text{ MHz}$; $\sigma = 1.49 \text{ S/m}$; $\epsilon_r = 53.4$; $\rho = 1000 \text{ kg/m}^3$

Phantom section: Flat Section

Measurement Standard: DASY5 (IEEE/IEC/ANSI C63.19-2007)

DASY52 Configuration:

- Probe: ES3DV3 - SN3205; ConvF(4.6, 4.6, 4.6); Calibrated: 28.12.2012;
- Sensor-Surface: 3mm (Mechanical Surface Detection)
- Electronics: DAE4 Sn601; Calibrated: 25.04.2013
- Phantom: Flat Phantom 5.0 (back); Type: QD000P50AA; Serial: 1002
- DASY52 52.8.7(1137); SEMCAD X 14.6.10(7164)

Dipole Calibration for Body Tissue/Pin=250 mW, d=10mm/Zoom Scan (7x7x7)/Cube 0:

Measurement grid: dx=5mm, dy=5mm, dz=5mm

Reference Value = 96.173 V/m; Power Drift = 0.01 dB

Peak SAR (extrapolated) = 17.0 W/kg

SAR(1 g) = 10 W/kg; SAR(10 g) = 5.36 W/kg

Maximum value of SAR (measured) = 12.6 W/kg

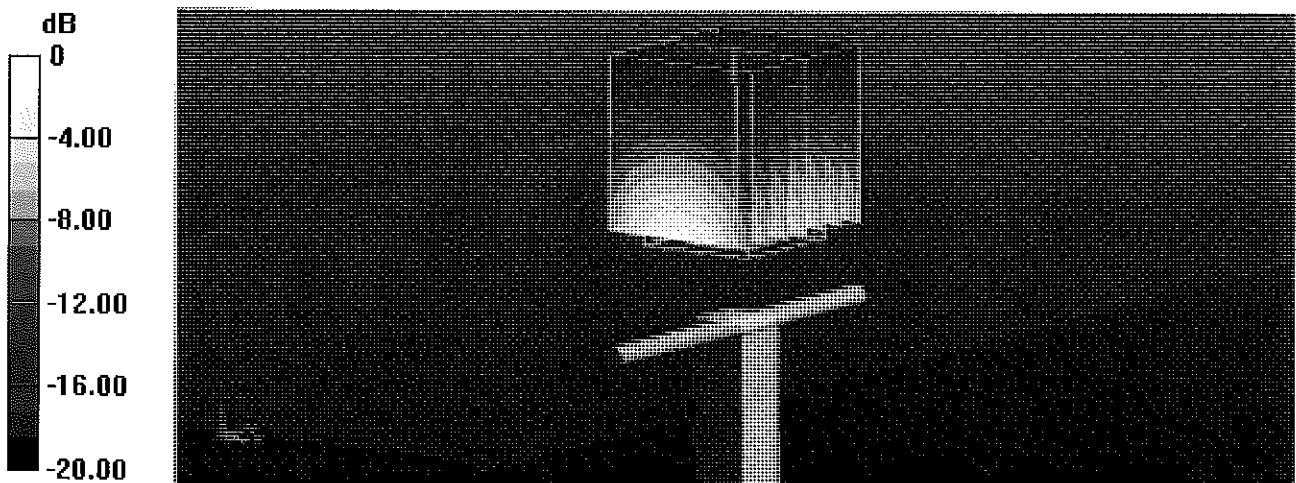

0 dB = 12.6 W/kg = 11.00 dBW/kg

Impedance Measurement Plot for Body TSL

22 Jul 2013 11:32:14

CH1 S11 1 U FS 1: 48.525 Ω 6.3906 μ 535.32 pF 1 900.000 000 MHz

*
De1
CA

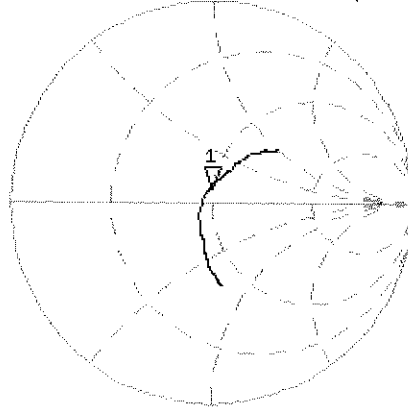

Avg
16

H1d

CH2 S11 LOG 5 dB/REF -20 dB 1:-23.547 dB 1 900.000 000 MHz

CA

Avg
16

H1d

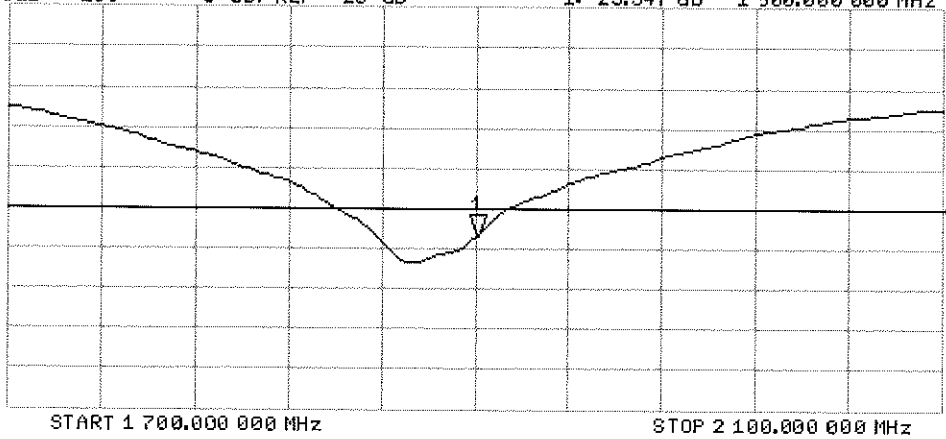



Accredited by the Swiss Accreditation Service (SAS)
The Swiss Accreditation Service is one of the signatories to the EA
Multilateral Agreement for the recognition of calibration certificates

Accreditation No.: **SCS 108**

Client **PC Test**

Certificate No: **D2450V2-719_Aug13**

CALIBRATION CERTIFICATE

Object **D2450V2 - SN: 719**

Calibration procedure(s) **QA CAL-05.v9
Calibration procedure for dipole validation kits above 700 MHz**

Calibration date: **August 23, 2013**

*✓cc
9/13/13*

This calibration certificate documents the traceability to national standards, which realize the physical units of measurements (SI).
The measurements and the uncertainties with confidence probability are given on the following pages and are part of the certificate.

All calibrations have been conducted in the closed laboratory facility: environment temperature (22 ± 3)°C and humidity < 70%.

Calibration Equipment used (M&TE critical for calibration)

Primary Standards	ID #	Cal Date (Certificate No.)	Scheduled Calibration
Power meter EPM-442A	GB37480704	01-Nov-12 (No. 217-01640)	Oct-13
Power sensor HP 8481A	US37292783	01-Nov-12 (No. 217-01640)	Oct-13
Reference 20 dB Attenuator	SN: 5058 (20k)	04-Apr-13 (No. 217-01736)	Apr-14
Type-N mismatch combination	SN: 5047.3 / 06327	04-Apr-13 (No. 217-01739)	Apr-14
Reference Probe ES3DV3	SN: 3205	28-Dec-12 (No. ES3-3205_Dec12)	Dec-13
DAE4	SN: 601	25-Apr-13 (No. DAE4-601_Apr13)	Apr-14
Secondary Standards	ID #	Check Date (in house)	Scheduled Check
Power sensor HP 8481A	MY41092317	18-Oct-02 (in house check Oct-11)	In house check: Oct-13
RF generator R&S SMT-06	100005	04-Aug-99 (in house check Oct-11)	In house check: Oct-13
Network Analyzer HP 8753E	US37390585 S4206	18-Oct-01 (in house check Oct-12)	In house check: Oct-13

Calibrated by:	Name Jeton Kastrati	Function Laboratory Technician	Signature
Approved by:	Name Katja Pokovic	Function Technical Manager	Signature

Issued: August 23, 2013

This calibration certificate shall not be reproduced except in full without written approval of the laboratory.



Accredited by the Swiss Accreditation Service (SAS)

The Swiss Accreditation Service is one of the signatories to the EA
Multilateral Agreement for the recognition of calibration certificates

Accreditation No.: **SCS 108**

Glossary:

TSL	tissue simulating liquid
ConvF	sensitivity in TSL / NORM x,y,z
N/A	not applicable or not measured

Calibration is Performed According to the Following Standards:

- IEEE Std 1528-2003, "IEEE Recommended Practice for Determining the Peak Spatial-Averaged Specific Absorption Rate (SAR) in the Human Head from Wireless Communications Devices: Measurement Techniques", December 2003
- IEC 62209-1, "Procedure to measure the Specific Absorption Rate (SAR) for hand-held devices used in close proximity to the ear (frequency range of 300 MHz to 3 GHz)", February 2005
- KDB 865664, "SAR Measurement Requirements for 100 MHz to 6 GHz"

Additional Documentation:

- DASY4/5 System Handbook

Methods Applied and Interpretation of Parameters:

- Measurement Conditions:* Further details are available from the Validation Report at the end of the certificate. All figures stated in the certificate are valid at the frequency indicated.
- Antenna Parameters with TSL:* The dipole is mounted with the spacer to position its feed point exactly below the center marking of the flat phantom section, with the arms oriented parallel to the body axis.
- Feed Point Impedance and Return Loss:* These parameters are measured with the dipole positioned under the liquid filled phantom. The impedance stated is transformed from the measurement at the SMA connector to the feed point. The Return Loss ensures low reflected power. No uncertainty required.
- Electrical Delay:* One-way delay between the SMA connector and the antenna feed point. No uncertainty required.
- SAR measured:* SAR measured at the stated antenna input power.
- SAR normalized:* SAR as measured, normalized to an input power of 1 W at the antenna connector.
- SAR for nominal TSL parameters:* The measured TSL parameters are used to calculate the nominal SAR result.

The reported uncertainty of measurement is stated as the standard uncertainty of measurement multiplied by the coverage factor $k=2$, which for a normal distribution corresponds to a coverage probability of approximately 95%.

Measurement Conditions

DASY system configuration, as far as not given on page 1.

DASY Version	DASY5	V52.8.7
Extrapolation	Advanced Extrapolation	
Phantom	Modular Flat Phantom	
Distance Dipole Center - TSL	10 mm	with Spacer
Zoom Scan Resolution	dx, dy, dz = 5 mm	
Frequency	2450 MHz \pm 1 MHz	

Head TSL parameters

The following parameters and calculations were applied.

	Temperature	Permittivity	Conductivity
Nominal Head TSL parameters	22.0 °C	39.2	1.80 mho/m
Measured Head TSL parameters	(22.0 \pm 0.2) °C	37.8 \pm 6 %	1.80 mho/m \pm 6 %
Head TSL temperature change during test	< 0.5 °C	----	----

SAR result with Head TSL

SAR averaged over 1 cm³ (1 g) of Head TSL	Condition	
SAR measured	250 mW input power	13.4 W/kg
SAR for nominal Head TSL parameters	normalized to 1W	53.2 W/kg \pm 17.0 % (k=2)

SAR averaged over 10 cm³ (10 g) of Head TSL	condition	
SAR measured	250 mW input power	6.23 W/kg
SAR for nominal Head TSL parameters	normalized to 1W	24.8 W/kg \pm 16.5 % (k=2)

Body TSL parameters

The following parameters and calculations were applied.

	Temperature	Permittivity	Conductivity
Nominal Body TSL parameters	22.0 °C	52.7	1.95 mho/m
Measured Body TSL parameters	(22.0 \pm 0.2) °C	50.6 \pm 6 %	2.03 mho/m \pm 6 %
Body TSL temperature change during test	< 0.5 °C	----	----

SAR result with Body TSL

SAR averaged over 1 cm³ (1 g) of Body TSL	Condition	
SAR measured	250 mW input power	13.3 W/kg
SAR for nominal Body TSL parameters	normalized to 1W	51.7 W/kg \pm 17.0 % (k=2)

SAR averaged over 10 cm³ (10 g) of Body TSL	condition	
SAR measured	250 mW input power	6.14 W/kg
SAR for nominal Body TSL parameters	normalized to 1W	24.1 W/kg \pm 16.5 % (k=2)

Appendix

Antenna Parameters with Head TSL

Impedance, transformed to feed point	54.6 Ω + 3.5 j Ω
Return Loss	- 25.1 dB

Antenna Parameters with Body TSL

Impedance, transformed to feed point	51.1 Ω + 5.4 j Ω
Return Loss	- 25.3 dB

General Antenna Parameters and Design

Electrical Delay (one direction)	1.149 ns
----------------------------------	----------

After long term use with 100W radiated power, only a slight warming of the dipole near the feedpoint can be measured.

The dipole is made of standard semirigid coaxial cable. The center conductor of the feeding line is directly connected to the second arm of the dipole. The antenna is therefore short-circuited for DC-signals. On some of the dipoles, small end caps are added to the dipole arms in order to improve matching when loaded according to the position as explained in the "Measurement Conditions" paragraph. The SAR data are not affected by this change. The overall dipole length is still according to the Standard.

No excessive force must be applied to the dipole arms, because they might bend or the soldered connections near the feedpoint may be damaged.

Additional EUT Data

Manufactured by	SPEAG
Manufactured on	September 10, 2002

DASY5 Validation Report for Head TSL

Date: 22.08.2013

Test Laboratory: SPEAG, Zurich, Switzerland

DUT: Dipole 2450 MHz; Type: D2450V2; Serial: D2450V2 - SN: 719

Communication System: UID 0 - CW ; Frequency: 2450 MHz

Medium parameters used: $f = 2450$ MHz; $\sigma = 1.8$ S/m; $\epsilon_r = 37.8$; $\rho = 1000$ kg/m³

Phantom section: Flat Section

Measurement Standard: DASY5 (IEEE/IEC/ANSI C63.19-2007)

DASY52 Configuration:

- Probe: ES3DV3 - SN3205; ConvF(4.52, 4.52, 4.52); Calibrated: 28.12.2012;
- Sensor-Surface: 3mm (Mechanical Surface Detection)
- Electronics: DAE4 Sn601; Calibrated: 25.04.2013
- Phantom: Flat Phantom 5.0 (front); Type: QD000P50AA; Serial: 1001
- DASY52 52.8.7(1137); SEMCAD X 14.6.10(7164)

Dipole Calibration for Head Tissue/Pin=250 mW, d=10mm/Zoom Scan (7x7x7)/Cube 0:

Measurement grid: dx=5mm, dy=5mm, dz=5mm

Reference Value = 100.7 V/m; Power Drift = 0.06 dB

Peak SAR (extrapolated) = 27.9 W/kg

SAR(1 g) = 13.4 W/kg; SAR(10 g) = 6.23 W/kg

Maximum value of SAR (measured) = 17.0 W/kg

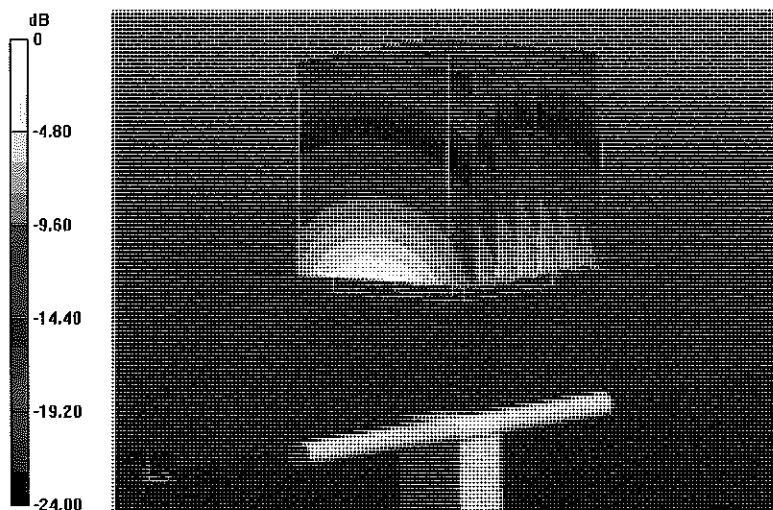

Impedance Measurement Plot for Head TSL

22 Aug 2013 11:00:15

CH1 S11 1 U FS

4: 54.639 Ω 3.5215 Ω 228.76 pF

2 450.000 000 MHz

*
De1
CA

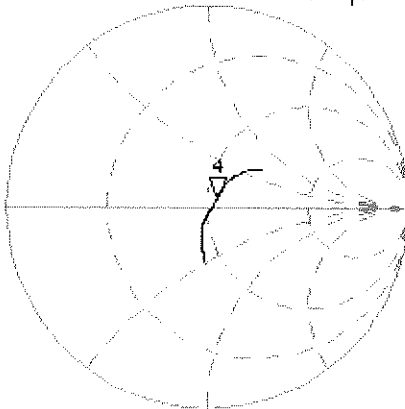

Avg
16

H1d

CH2 S11 LOG

5 dB/REF -20 dB

4: -25.093 dB 2 450.000 000 MHz

CA

Avg
16

H1d

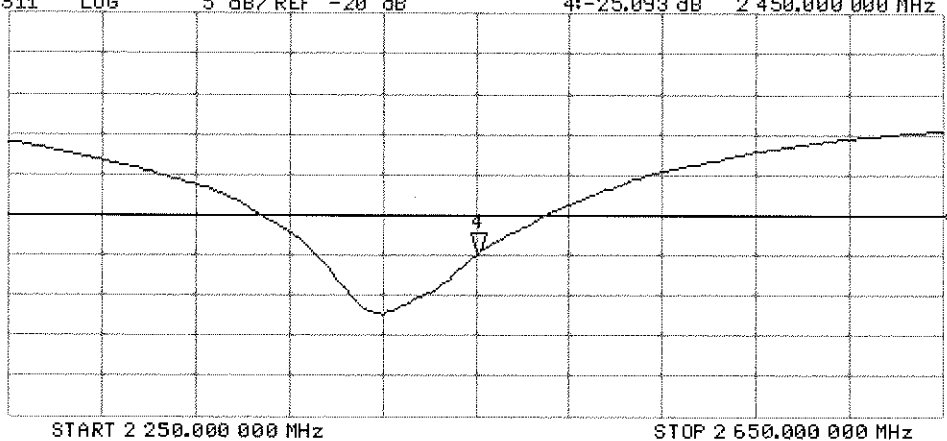

DASY5 Validation Report for Body TSL

Date: 23.08.2013

Test Laboratory: SPEAG, Zurich, Switzerland

DUT: Dipole 2450 MHz; Type: D2450V2; Serial: D2450V2 - SN: 719

Communication System: UID 0 - CW ; Frequency: 2450 MHz

Medium parameters used: $f = 2450$ MHz; $\sigma = 2.03$ S/m; $\epsilon_r = 50.6$; $\rho = 1000$ kg/m³

Phantom section: Flat Section

Measurement Standard: DASY5 (IEEE/IEC/ANSI C63.19-2007)

DASY52 Configuration:

- Probe: ES3DV3 - SN3205; ConvF(4.42, 4.42, 4.42); Calibrated: 28.12.2012;
- Sensor-Surface: 3mm (Mechanical Surface Detection)
- Electronics: DAE4 Sn601; Calibrated: 25.04.2013
- Phantom: Flat Phantom 5.0 (back); Type: QD000P50AA; Serial: 1002
- DASY52 52.8.7(1137); SEMCAD X 14.6.10(7164)

Dipole Calibration for Body Tissue/Pin=250 mW, d=10mm/Zoom Scan (7x7x7)/Cube 0:

Measurement grid: dx=5mm, dy=5mm, dz=5mm

Reference Value = 94.688 V/m; Power Drift = 0.06 dB

Peak SAR (extrapolated) = 27.9 W/kg

SAR(1 g) = 13.3 W/kg; SAR(10 g) = 6.14 W/kg

Maximum value of SAR (measured) = 17.2 W/kg

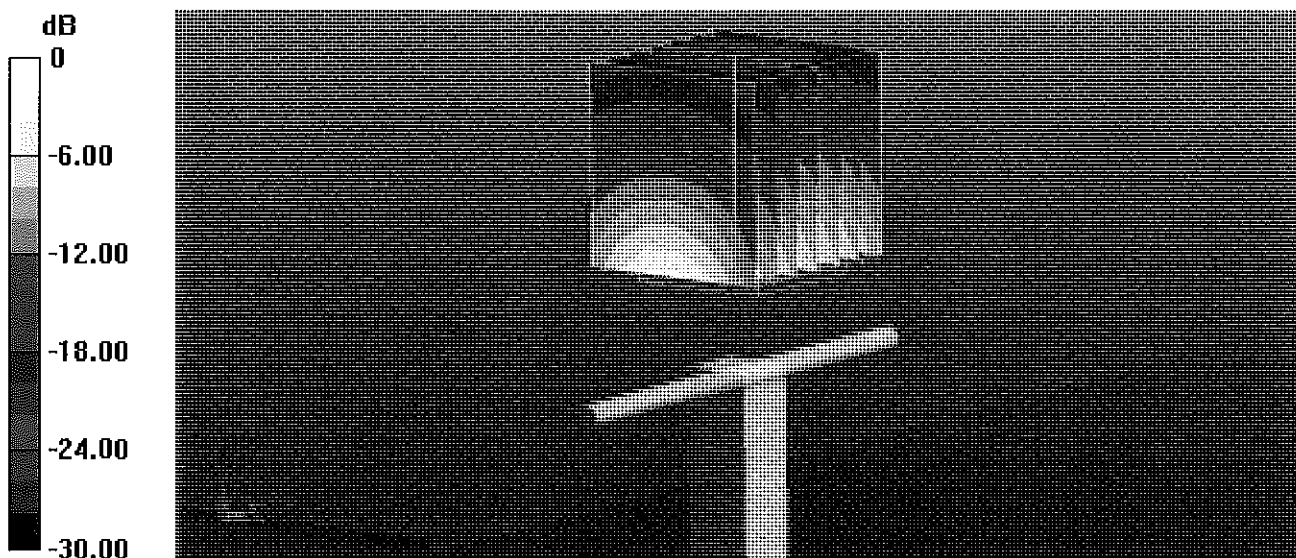

0 dB = 17.2 W/kg = 12.36 dBW/kg

Impedance Measurement Plot for Body TSL

23 Aug 2013 09:00:38

CH1 S11 1 U FS

3: 51.135 Ω 5.3965 Ω 350.56 pF

2 450.000 000 MHz

De1

CΔ

Avg
16

H1 d

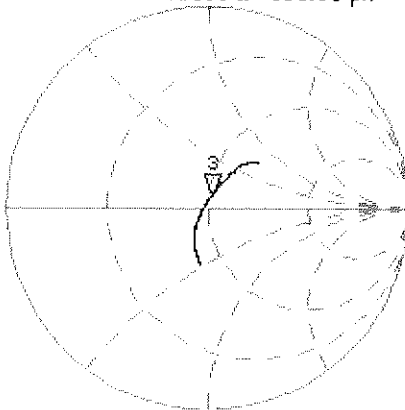

CH2 S11 LOG

5 dB/REF -20 dB

3:-25.274 dB

2 450.000 000 MHz

CΔ

Avg
16

H1 d

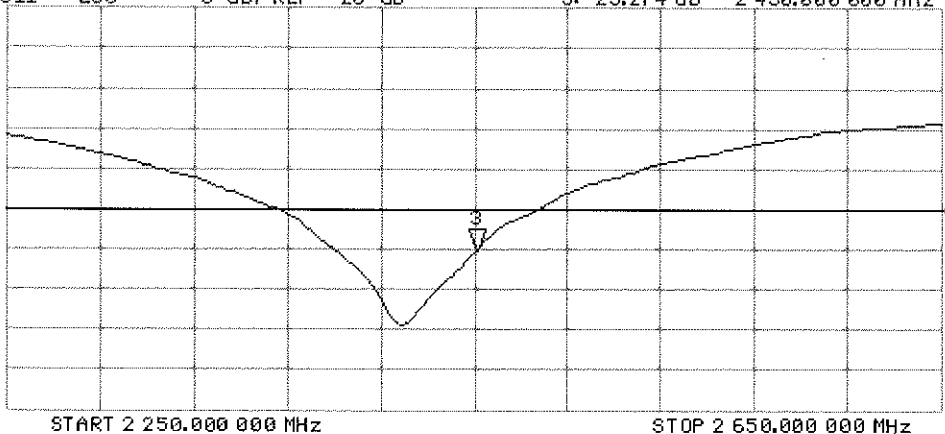



Accredited by the Swiss Accreditation Service (SAS)
The Swiss Accreditation Service is one of the signatories to the EA
Multilateral Agreement for the recognition of calibration certificates

Accreditation No.: **SCS 108**

Client **PC Test**

Certificate No: **D5GHzV2-1120_Feb13**

CALIBRATION CERTIFICATE

Object **D5GHzV2 - SN: 1120**

Calibration procedure(s) **QA CAL-22.v2
Calibration procedure for dipole validation kits between 3-6 GHz**

Calibration date: **February 14, 2013**

*✓
Kok
2/2/13*

This calibration certificate documents the traceability to national standards, which realize the physical units of measurements (SI).
The measurements and the uncertainties with confidence probability are given on the following pages and are part of the certificate.

All calibrations have been conducted in the closed laboratory facility: environment temperature (22 ± 3)°C and humidity < 70%.

Calibration Equipment used (M&TE critical for calibration)

Primary Standards	ID #	Cal Date (Certificate No.)	Scheduled Calibration
Power meter EPM-442A	GB37480704	01-Nov-12 (No. 217-01640)	Oct-13
Power sensor HP 8481A	US37292783	01-Nov-12 (No. 217-01640)	Oct-13
Reference 20 dB Attenuator	SN: 5058 (20k)	27-Mar-12 (No. 217-01530)	Apr-13
Type-N mismatch combination	SN: 5047.3 / 06327	27-Mar-12 (No. 217-01533)	Apr-13
Reference Probe EX3DV4	SN: 3503	28-Dec-12 (No. EX3-3503_Dec12)	Dec-13
DAE4	SN: 601	27-Jun-12 (No. DAE4-601_Jun12)	Jun-13
Secondary Standards	ID #	Check Date (in house)	Scheduled Check
Power sensor HP 8481A	MY41092317	18-Oct-02 (in house check Oct-11)	In house check: Oct-13
RF generator R&S SMT-06	100005	04-Aug-99 (in house check Oct-11)	In house check: Oct-13
Network Analyzer HP 8753E	US37390585 S4206	18-Oct-01 (in house check Oct-12)	In house check: Oct-13

Calibrated by: **Israe El-Naouq** Function: **Laboratory Technician**

Signature

Israe El-Naouq
Katja Pokovic

Approved by: **Katja Pokovic** Technical Manager

Issued: February 14, 2013

This calibration certificate shall not be reproduced except in full without written approval of the laboratory.



Accredited by the Swiss Accreditation Service (SAS)

The Swiss Accreditation Service is one of the signatories to the EA
Multilateral Agreement for the recognition of calibration certificates

Accreditation No.: **SCS 108**

Glossary:

TSL	tissue simulating liquid
ConvF	sensitivity in TSL / NORM x,y,z
N/A	not applicable or not measured

Calibration is Performed According to the Following Standards:

- a) IEC 62209-2, "Evaluation of Human Exposure to Radio Frequency Fields from Handheld and Body-Mounted Wireless Communication Devices in the Frequency Range of 30 MHz to 6 GHz: Human models, Instrumentation, and Procedures"; Part 2: "Procedure to determine the Specific Absorption Rate (SAR) for including accessories and multiple transmitters", March 2010
- b) Federal Communications Commission Office of Engineering & Technology (FCC OET), "Evaluating Compliance with FCC Guidelines for Human Exposure to Radiofrequency Electromagnetic Fields; Additional Information for Evaluating Compliance of Mobile and Portable Devices with FCC Limits for Human Exposure to Radiofrequency Emissions", Supplement C (Edition 01-01) to Bulletin 65

Additional Documentation:

- c) DASY4/5 System Handbook

Methods Applied and Interpretation of Parameters:

- *Measurement Conditions:* Further details are available from the Validation Report at the end of the certificate. All figures stated in the certificate are valid at the frequency indicated.
- *Antenna Parameters with TSL:* The dipole is mounted with the spacer to position its feed point exactly below the center marking of the flat phantom section, with the arms oriented parallel to the body axis.
- *Feed Point Impedance and Return Loss:* These parameters are measured with the dipole positioned under the liquid filled phantom. The impedance stated is transformed from the measurement at the SMA connector to the feed point. The Return Loss ensures low reflected power. No uncertainty required.
- *Electrical Delay:* One-way delay between the SMA connector and the antenna feed point. No uncertainty required.
- *SAR measured:* SAR measured at the stated antenna input power.
- *SAR normalized:* SAR as measured, normalized to an input power of 1 W at the antenna connector.
- *SAR for nominal TSL parameters:* The measured TSL parameters are used to calculate the nominal SAR result.

The reported uncertainty of measurement is stated as the standard uncertainty of measurement multiplied by the coverage factor $k=2$, which for a normal distribution corresponds to a coverage probability of approximately 95%.

Measurement Conditions

DASY system configuration, as far as not given on page 1.

DASY Version	DASY5	V52.8.5
Extrapolation	Advanced Extrapolation	
Phantom	Modular Flat Phantom V5.0	
Distance Dipole Center - TSL	10 mm	with Spacer
Zoom Scan Resolution	dx, dy = 4.0 mm, dz = 1.4 mm	Graded Ratio = 1.4 (Z direction)
Frequency	5200 MHz ± 1 MHz 5300 MHz ± 1 MHz 5500 MHz ± 1 MHz 5600 MHz ± 1 MHz 5800 MHz ± 1 MHz	

Head TSL parameters at 5200 MHz

The following parameters and calculations were applied.

	Temperature	Permittivity	Conductivity
Nominal Head TSL parameters	22.0 °C	36.0	4.66 mho/m
Measured Head TSL parameters	(22.0 ± 0.2) °C	34.7 ± 6 %	4.47 mho/m ± 6 %
Head TSL temperature change during test	< 0.5 °C	----	----

SAR result with Head TSL at 5200 MHz

SAR averaged over 1 cm³ (1 g) of Head TSL	Condition	
SAR measured	100 mW input power	7.67 W/kg
SAR for nominal Head TSL parameters	normalized to 1W	76.0 W/kg ± 19.9 % (k=2)

SAR averaged over 10 cm³ (10 g) of Head TSL	condition	
SAR measured	100 mW input power	2.18 W/kg
SAR for nominal Head TSL parameters	normalized to 1W	21.5 W/kg ± 19.5 % (k=2)

Head TSL parameters at 5300 MHz

The following parameters and calculations were applied.

	Temperature	Permittivity	Conductivity
Nominal Head TSL parameters	22.0 °C	35.9	4.76 mho/m
Measured Head TSL parameters	(22.0 ± 0.2) °C	34.5 ± 6 %	4.57 mho/m ± 6 %
Head TSL temperature change during test	< 0.5 °C	----	----

SAR result with Head TSL at 5300 MHz

SAR averaged over 1 cm ³ (1 g) of Head TSL	Condition	
SAR measured	100 mW input power	7.94 W/kg
SAR for nominal Head TSL parameters	normalized to 1W	78.7 W / kg ± 19.9 % (k=2)

SAR averaged over 10 cm ³ (10 g) of Head TSL	condition	
SAR measured	100 mW input power	2.27 W/kg
SAR for nominal Head TSL parameters	normalized to 1W	22.4 W/kg ± 19.5 % (k=2)

Head TSL parameters at 5500 MHz

The following parameters and calculations were applied.

	Temperature	Permittivity	Conductivity
Nominal Head TSL parameters	22.0 °C	35.6	4.96 mho/m
Measured Head TSL parameters	(22.0 ± 0.2) °C	34.2 ± 6 %	4.74 mho/m ± 6 %
Head TSL temperature change during test	< 0.5 °C	----	----

SAR result with Head TSL at 5500 MHz

SAR averaged over 1 cm ³ (1 g) of Head TSL	Condition	
SAR measured	100 mW input power	8.09 W/kg
SAR for nominal Head TSL parameters	normalized to 1W	80.1 W/kg ± 19.9 % (k=2)

SAR averaged over 10 cm ³ (10 g) of Head TSL	condition	
SAR measured	100 mW input power	2.29 W/kg
SAR for nominal Head TSL parameters	normalized to 1W	22.6 W/kg ± 19.5 % (k=2)

Head TSL parameters at 5600 MHz

The following parameters and calculations were applied.

	Temperature	Permittivity	Conductivity
Nominal Head TSL parameters	22.0 °C	35.5	5.07 mho/m
Measured Head TSL parameters	(22.0 ± 0.2) °C	34.1 ± 6 %	4.83 mho/m ± 6 %
Head TSL temperature change during test	< 0.5 °C	----	----

SAR result with Head TSL at 5600 MHz

SAR averaged over 1 cm ³ (1 g) of Head TSL	Condition	
SAR measured	100 mW input power	8.08 W/kg
SAR for nominal Head TSL parameters	normalized to 1W	79.9 W/kg ± 19.9 % (k=2)

SAR averaged over 10 cm ³ (10 g) of Head TSL	condition	
SAR measured	100 mW input power	2.28 W/kg
SAR for nominal Head TSL parameters	normalized to 1W	22.5 W/kg ± 19.5 % (k=2)

Head TSL parameters at 5800 MHz

The following parameters and calculations were applied.

	Temperature	Permittivity	Conductivity
Nominal Head TSL parameters	22.0 °C	35.3	5.27 mho/m
Measured Head TSL parameters	(22.0 ± 0.2) °C	33.9 ± 6 %	5.05 mho/m ± 6 %
Head TSL temperature change during test	< 0.5 °C	----	----

SAR result with Head TSL at 5800 MHz

SAR averaged over 1 cm ³ (1 g) of Head TSL	Condition	
SAR measured	100 mW input power	7.57 W/kg
SAR for nominal Head TSL parameters	normalized to 1W	74.9 W/kg ± 19.9 % (k=2)

SAR averaged over 10 cm ³ (10 g) of Head TSL	condition	
SAR measured	100 mW input power	2.13 W/kg
SAR for nominal Head TSL parameters	normalized to 1W	21.0 W/kg ± 19.5 % (k=2)

Body TSL parameters at 5200 MHz

The following parameters and calculations were applied.

	Temperature	Permittivity	Conductivity
Nominal Body TSL parameters	22.0 °C	49.0	5.30 mho/m
Measured Body TSL parameters	(22.0 ± 0.2) °C	46.9 ± 6 %	5.36 mho/m ± 6 %
Body TSL temperature change during test	< 0.5 °C	----	----

SAR result with Body TSL at 5200 MHz

SAR averaged over 1 cm ³ (1 g) of Body TSL	Condition	
SAR measured	100 mW input power	7.73 W/kg
SAR for nominal Body TSL parameters	normalized to 1W	76.6 W/kg ± 19.9 % (k=2)

SAR averaged over 10 cm ³ (10 g) of Body TSL	condition	
SAR measured	100 mW input power	2.17 W/kg
SAR for nominal Body TSL parameters	normalized to 1W	21.5 W/kg ± 19.5 % (k=2)

Body TSL parameters at 5300 MHz

The following parameters and calculations were applied.

	Temperature	Permittivity	Conductivity
Nominal Body TSL parameters	22.0 °C	48.9	5.42 mho/m
Measured Body TSL parameters	(22.0 ± 0.2) °C	46.7 ± 6 %	5.48 mho/m ± 6 %
Body TSL temperature change during test	< 0.5 °C	----	----

SAR result with Body TSL at 5300 MHz

SAR averaged over 1 cm ³ (1 g) of Body TSL	Condition	
SAR measured	100 mW input power	7.75 W/kg
SAR for nominal Body TSL parameters	normalized to 1W	76.8 W/kg ± 19.9 % (k=2)

SAR averaged over 10 cm ³ (10 g) of Body TSL	condition	
SAR measured	100 mW input power	2.18 W/kg
SAR for nominal Body TSL parameters	normalized to 1W	21.5 W/kg ± 19.5 % (k=2)

Body TSL parameters at 5500 MHz

The following parameters and calculations were applied.

	Temperature	Permittivity	Conductivity
Nominal Body TSL parameters	22.0 °C	48.6	5.65 mho/m
Measured Body TSL parameters	(22.0 ± 0.2) °C	46.3 ± 6 %	5.71 mho/m ± 6 %
Body TSL temperature change during test	< 0.5 °C	----	----

SAR result with Body TSL at 5500 MHz

SAR averaged over 1 cm ³ (1 g) of Body TSL	Condition	
SAR measured	100 mW input power	8.06 W/kg
SAR for nominal Body TSL parameters	normalized to 1W	79.8 W/kg ± 19.9 % (k=2)

SAR averaged over 10 cm ³ (10 g) of Body TSL	condition	
SAR measured	100 mW input power	2.24 W/kg
SAR for nominal Body TSL parameters	normalized to 1W	22.1 W/kg ± 19.5 % (k=2)

Body TSL parameters at 5600 MHz

The following parameters and calculations were applied.

	Temperature	Permittivity	Conductivity
Nominal Body TSL parameters	22.0 °C	48.5	5.77 mho/m
Measured Body TSL parameters	(22.0 ± 0.2) °C	46.2 ± 6 %	5.83 mho/m ± 6 %
Body TSL temperature change during test	< 0.5 °C	----	----

SAR result with Body TSL at 5600 MHz

SAR averaged over 1 cm ³ (1 g) of Body TSL	Condition	
SAR measured	100 mW input power	8.15 W/kg
SAR for nominal Body TSL parameters	normalized to 1W	80.7 W/kg ± 19.9 % (k=2)

SAR averaged over 10 cm ³ (10 g) of Body TSL	condition	
SAR measured	100 mW input power	2.26 W/kg
SAR for nominal Body TSL parameters	normalized to 1W	22.3 W/kg ± 19.5 % (k=2)

Body TSL parameters at 5800 MHz

The following parameters and calculations were applied.

	Temperature	Permittivity	Conductivity
Nominal Body TSL parameters	22.0 °C	48.2	6.00 mho/m
Measured Body TSL parameters	(22.0 ± 0.2) °C	45.9 ± 6 %	6.12 mho/m ± 6 %
Body TSL temperature change during test	< 0.5 °C	----	----

SAR result with Body TSL at 5800 MHz

SAR averaged over 1 cm ³ (1 g) of Body TSL	Condition	
SAR measured	100 mW input power	7.62 W/kg
SAR for nominal Body TSL parameters	normalized to 1W	75.5 W/kg ± 19.9 % (k=2)

SAR averaged over 10 cm ³ (10 g) of Body TSL	condition	
SAR measured	100 mW input power	2.12 W/kg
SAR for nominal Body TSL parameters	normalized to 1W	20.9 W/kg ± 19.5 % (k=2)

Appendix

Antenna Parameters with Head TSL at 5200 MHz

Impedance, transformed to feed point	53.8 Ω - 6.3 j Ω
Return Loss	- 23.0 dB

Antenna Parameters with Head TSL at 5300 MHz

Impedance, transformed to feed point	50.1 Ω + 0.5 j Ω
Return Loss	- 45.3 dB

Antenna Parameters with Head TSL at 5500 MHz

Impedance, transformed to feed point	51.0 Ω - 0.9 j Ω
Return Loss	- 37.9 dB

Antenna Parameters with Head TSL at 5600 MHz

Impedance, transformed to feed point	55.3 Ω - 0.9 j Ω
Return Loss	- 25.8 dB

Antenna Parameters with Head TSL at 5800 MHz

Impedance, transformed to feed point	53.5 Ω + 3.3 j Ω
Return Loss	- 26.7 dB

Antenna Parameters with Body TSL at 5200 MHz

Impedance, transformed to feed point	53.7 Ω - 4.8 j Ω
Return Loss	- 24.8 dB

Antenna Parameters with Body TSL at 5300 MHz

Impedance, transformed to feed point	50.2 Ω + 2.4 j Ω
Return Loss	- 32.5 dB

Antenna Parameters with Body TSL at 5500 MHz

Impedance, transformed to feed point	51.6 Ω - 1.5 j Ω
Return Loss	- 33.3 dB

Antenna Parameters with Body TSL at 5600 MHz

Impedance, transformed to feed point	57.4 Ω + 0.9 j Ω
Return Loss	- 23.2 dB

Antenna Parameters with Body TSL at 5800 MHz

Impedance, transformed to feed point	$53.5 \Omega + 3.2 j\Omega$
Return Loss	- 26.7 dB

General Antenna Parameters and Design

Electrical Delay (one direction)	1.206 ns
----------------------------------	----------

After long term use with 100W radiated power, only a slight warming of the dipole near the feedpoint can be measured.

The dipole is made of standard semirigid coaxial cable. The center conductor of the feeding line is directly connected to the second arm of the dipole. The antenna is therefore short-circuited for DC-signals. On some of the dipoles, small end caps are added to the dipole arms in order to improve matching when loaded according to the position as explained in the "Measurement Conditions" paragraph. The SAR data are not affected by this change. The overall dipole length is still according to the Standard.

No excessive force must be applied to the dipole arms, because they might bend or the soldered connections near the feedpoint may be damaged.

Additional EUT Data

Manufactured by	SPEAG
Manufactured on	September 08, 2011

DASY5 Validation Report for Head TSL

Date: 08.02.2013

Test Laboratory: SPEAG, Zurich, Switzerland

DUT: Dipole 5GHz; Type: D5GHzV2; Serial: D5GHzV2 - SN: 1120

Communication System: CW; Frequency: 5200 MHz, Frequency: 5300 MHz, Frequency: 5500 MHz, Frequency: 5600 MHz, Frequency: 5800 MHz

Medium parameters used: $f = 5200$ MHz; $\sigma = 4.47$ S/m; $\epsilon_r = 34.7$; $\rho = 1000$ kg/m³, Medium parameters used: $f = 5300$ MHz; $\sigma = 4.57$ S/m; $\epsilon_r = 34.5$; $\rho = 1000$ kg/m³, Medium parameters used: $f = 5500$ MHz; $\sigma = 4.74$ S/m; $\epsilon_r = 34.2$; $\rho = 1000$ kg/m³, Medium parameters used: $f = 5600$ MHz; $\sigma = 4.83$ S/m; $\epsilon_r = 34.1$; $\rho = 1000$ kg/m³, Medium parameters used: $f = 5800$ MHz; $\sigma = 5.05$ S/m; $\epsilon_r = 33.9$; $\rho = 1000$ kg/m³

Phantom section: Flat Section

Measurement Standard: DASY5 (IEEE/IEC/ANSI C63.19-2007)

DASY52 Configuration:

- Probe: EX3DV4 - SN3503; ConvF(5.41, 5.41, 5.41); Calibrated: 28.12.2012, ConvF(5.1, 5.1, 5.1); Calibrated: 28.12.2012, ConvF(4.91, 4.91, 4.91); Calibrated: 28.12.2012, ConvF(4.76, 4.76, 4.76); Calibrated: 28.12.2012, ConvF(4.81, 4.81, 4.81); Calibrated: 28.12.2012;
- Sensor-Surface: 1.4mm (Mechanical Surface Detection)
- Electronics: DAE4 Sn601; Calibrated: 27.06.2012
- Phantom: Flat Phantom 5.0 (front); Type: QD000P50AA; Serial: 1001
- DASY52 52.8.5(1059); SEMCAD X 14.6.8(7028)

Dipole Calibration for Head Tissue/Pin=100mW, dist=10mm, f=5200 MHz/Zoom Scan, dist=1.4mm (8x8x7)/Cube 0: Measurement grid: dx=4mm, dy=4mm, dz=1.4mm

Reference Value = 61.561 V/m; Power Drift = 0.05 dB

Peak SAR (extrapolated) = 28.8 W/kg

SAR(1 g) = 7.67 W/kg; SAR(10 g) = 2.18 W/kg

Maximum value of SAR (measured) = 17.7 W/kg

Dipole Calibration for Head Tissue/Pin=100mW, dist=10mm, f=5300 MHz/Zoom Scan, dist=1.4mm (8x8x7)/Cube 0: Measurement grid: dx=4mm, dy=4mm, dz=1.4mm

Reference Value = 62.429 V/m; Power Drift = 0.03 dB

Peak SAR (extrapolated) = 30.3 W/kg

SAR(1 g) = 7.94 W/kg; SAR(10 g) = 2.27 W/kg

Maximum value of SAR (measured) = 18.5 W/kg

Dipole Calibration for Head Tissue/Pin=100mW, dist=10mm, f=5500 MHz/Zoom Scan, dist=1.4mm (8x8x7)/Cube 0: Measurement grid: dx=4mm, dy=4mm, dz=1.4mm

Reference Value = 61.998 V/m; Power Drift = 0.08 dB

Peak SAR (extrapolated) = 32.7 W/kg

SAR(1 g) = 8.09 W/kg; SAR(10 g) = 2.29 W/kg

Maximum value of SAR (measured) = 19.3 W/kg

Dipole Calibration for Head Tissue/Pin=100mW, dist=10mm, f=5600 MHz/Zoom Scan, dist=1.4mm (8x8x7)/Cube 0: Measurement grid: dx=4mm, dy=4mm, dz=1.4mm
Reference Value = 62.540 V/m; Power Drift = 0.02 dB
Peak SAR (extrapolated) = 33.3 W/kg
SAR(1 g) = 8.08 W/kg; SAR(10 g) = 2.28 W/kg
Maximum value of SAR (measured) = 19.5 W/kg

Dipole Calibration for Head Tissue/Pin=100mW, dist=10mm, f=5800 MHz/Zoom Scan, dist=1.4mm (8x8x7)/Cube 0: Measurement grid: dx=4mm, dy=4mm, dz=1.4mm
Reference Value = 58.600 V/m; Power Drift = 0.09 dB
Peak SAR (extrapolated) = 32.9 W/kg
SAR(1 g) = 7.57 W/kg; SAR(10 g) = 2.13 W/kg
Maximum value of SAR (measured) = 18.8 W/kg

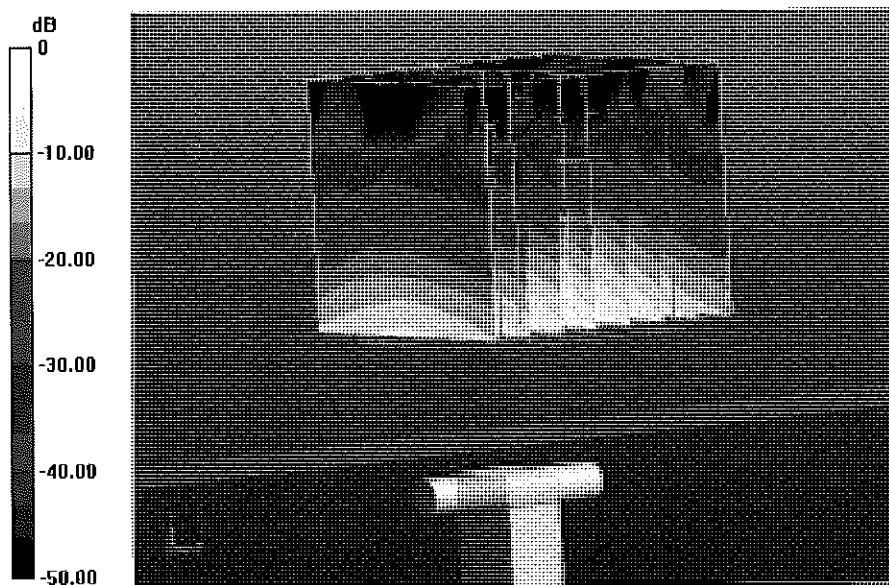

0 dB = 18.8 W/kg = 12.74 dBW/kg

Impedance Measurement Plot for Head TSL

8 Feb 2013 10:10:29

CH1 S11 1 U FS 1: 53.764 Ω -6.3086 Ω 4.8516 pF 5 200.000 000 MHz

*
De1
Cor
Avg
0
H1d

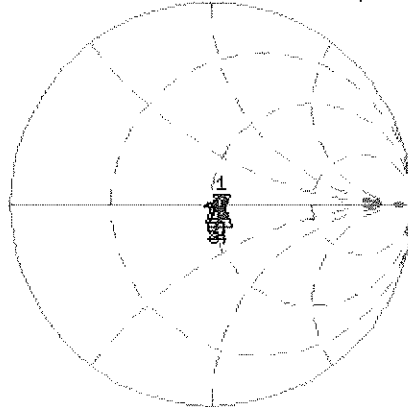

CH1 Markers
2: 50.104 Ω
0.5313 Ω
5.30000 GHz
3: 50.959 Ω
-853.52 m Ω
5.50000 GHz
4: 55.305 Ω
-902.34 m Ω
5.60000 GHz
5: 53.500 Ω
3.3027 Ω
5.80000 GHz

CH2 S11 LOG 5 dB/REF -20 dB 1: -23.013 dB 5 200.000 000 MHz

Cor
Avg
0
H1d

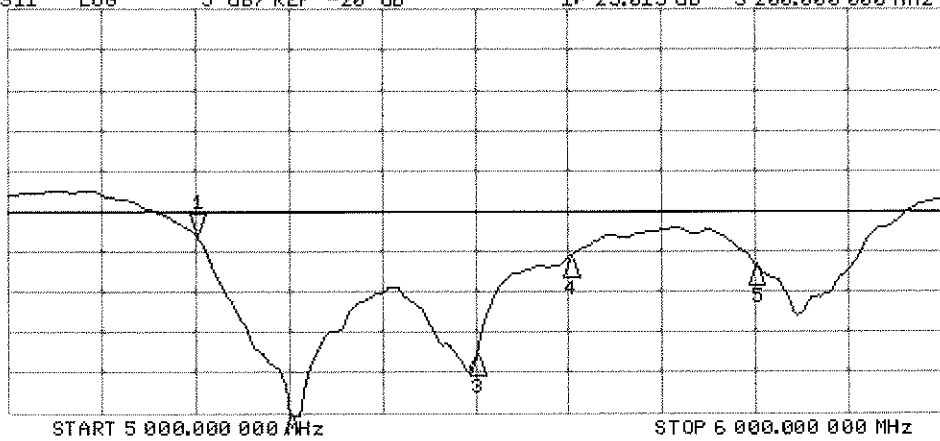

CH2 Markers
2: -45.321 dB
5.30000 GHz
3: -37.887 dB
5.50000 GHz
4: -25.835 dB
5.60000 GHz
5: -26.651 dB
5.80000 GHz

DASY5 Validation Report for Body TSL

Date: 14.02.2013

Test Laboratory: SPEAG, Zurich, Switzerland

DUT: Dipole 5GHz; Type: D5GHzV2; Serial: D5GHzV2 - SN: 1120

Communication System: CW; Frequency: 5200 MHz, Frequency: 5300 MHz, Frequency: 5500 MHz, Frequency: 5600 MHz, Frequency: 5800 MHz

Medium parameters used: $f = 5200$ MHz; $\sigma = 5.36$ S/m; $\epsilon_r = 46.9$; $\rho = 1000$ kg/m³, Medium parameters used: $f = 5300$ MHz; $\sigma = 5.48$ S/m; $\epsilon_r = 46.7$; $\rho = 1000$ kg/m³, Medium parameters used: $f = 5500$ MHz; $\sigma = 5.71$ S/m; $\epsilon_r = 46.3$; $\rho = 1000$ kg/m³, Medium parameters used: $f = 5600$ MHz; $\sigma = 5.83$ S/m; $\epsilon_r = 46.2$; $\rho = 1000$ kg/m³, Medium parameters used: $f = 5800$ MHz; $\sigma = 6.12$ S/m; $\epsilon_r = 45.9$; $\rho = 1000$ kg/m³

Phantom section: Flat Section

Measurement Standard: DASY5 (IEEE/IEC/ANSI C63.19-2007)

DASY52 Configuration:

- Probe: EX3DV4 - SN3503; ConvF(4.91, 4.91, 4.91); Calibrated: 28.12.2012, ConvF(4.67, 4.67, 4.67); Calibrated: 28.12.2012, ConvF(4.43, 4.43, 4.43); Calibrated: 28.12.2012, ConvF(4.22, 4.22, 4.22); Calibrated: 28.12.2012, ConvF(4.38, 4.38, 4.38); Calibrated: 28.12.2012;
- Sensor-Surface: 1.4mm (Mechanical Surface Detection)
- Electronics: DAE4 Sn601; Calibrated: 27.06.2012
- Phantom: Flat Phantom 5.0 (back); Type: QD000P50AA; Serial: 1002
- DASY52 52.8.5(1059); SEMCAD X 14.6.8(7028)

Dipole Calibration for Body Tissue/Pin=100mW, dist=10mm, f=5200 MHz/Zoom Scan, dist=1.4mm (8x8x7)/Cube 0: Measurement grid: dx=4mm, dy=4mm, dz=1.4mm

Reference Value = 61.053 V/m; Power Drift = -0.08 dB

Peak SAR (extrapolated) = 31.1 W/kg

SAR(1 g) = 7.73 W/kg; SAR(10 g) = 2.17 W/kg

Maximum value of SAR (measured) = 18.2 W/kg

Dipole Calibration for Body Tissue/Pin=100mW, dist=10mm, f=5300 MHz/Zoom Scan, dist=1.4mm (8x8x7)/Cube 0: Measurement grid: dx=4mm, dy=4mm, dz=1.4mm

Reference Value = 60.021 V/m; Power Drift = -0.02 dB

Peak SAR (extrapolated) = 32.1 W/kg

SAR(1 g) = 7.75 W/kg; SAR(10 g) = 2.18 W/kg

Maximum value of SAR (measured) = 18.5 W/kg

Dipole Calibration for Body Tissue/Pin=100mW, dist=10mm, f=5500 MHz/Zoom Scan, dist=1.4mm (8x8x7)/Cube 0: Measurement grid: dx=4mm, dy=4mm, dz=1.4mm

Reference Value = 59.894 V/m; Power Drift = -0.02 dB

Peak SAR (extrapolated) = 35.3 W/kg

SAR(1 g) = 8.06 W/kg; SAR(10 g) = 2.24 W/kg

Maximum value of SAR (measured) = 19.4 W/kg

Dipole Calibration for Body Tissue/Pin=100mW, dist=10mm, f=5600 MHz/Zoom Scan, dist=1.4mm (8x8x7)/Cube 0: Measurement grid: dx=4mm, dy=4mm, dz=1.4mm
Reference Value = 59.730 V/m; Power Drift = -0.02 dB
Peak SAR (extrapolated) = 36.8 W/kg
SAR(1 g) = 8.15 W/kg; SAR(10 g) = 2.26 W/kg
Maximum value of SAR (measured) = 19.9 W/kg

Dipole Calibration for Body Tissue/Pin=100mW, dist=10mm, f=5800 MHz/Zoom Scan, dist=1.4mm (8x8x7)/Cube 0: Measurement grid: dx=4mm, dy=4mm, dz=1.4mm
Reference Value = 56.663 V/m; Power Drift = -0.02 dB
Peak SAR (extrapolated) = 36.4 W/kg
SAR(1 g) = 7.62 W/kg; SAR(10 g) = 2.12 W/kg
Maximum value of SAR (measured) = 19.0 W/kg

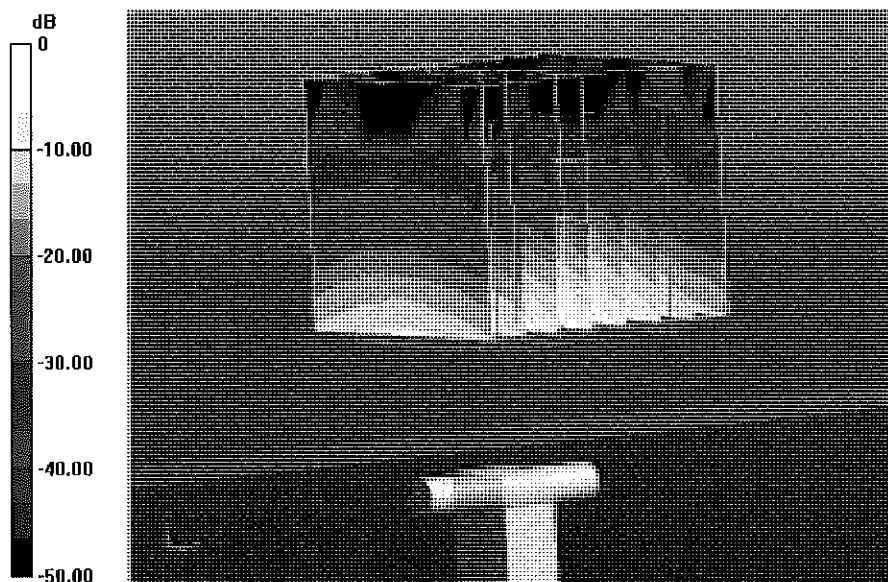

0 dB = 19.0 W/kg = 12.79 dBW/kg

Impedance Measurement Plot for Body TSL

14 Feb 2013 15:47:05

CH1 S11 1 U FS 1: 53.672 Ω -4.7539 Ω 6.4382 pF 5 200.000 000 MHz

*
De1
Cor
Avg
16
H1d

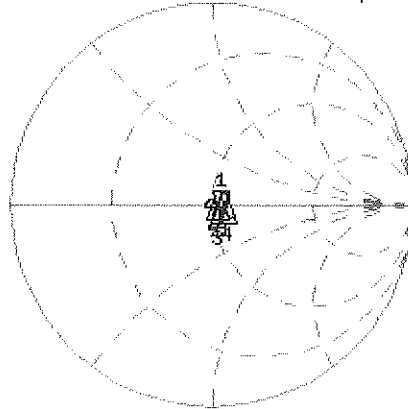

CH1 Markers
2: 50.250 Ω
2.3555 Ω
5.30000 GHz
3: 51.629 Ω
-1.4824 Ω
5.50000 GHz
4: 57.389 Ω
0.9180 Ω
5.60000 GHz
5: 53.543 Ω
3.2441 Ω
5.80000 GHz

CH2 S11 LOG 5 dB/REF -20 dB 1: -24.750 dB 5 200.000 000 MHz

Cor
Avg
16
H1d

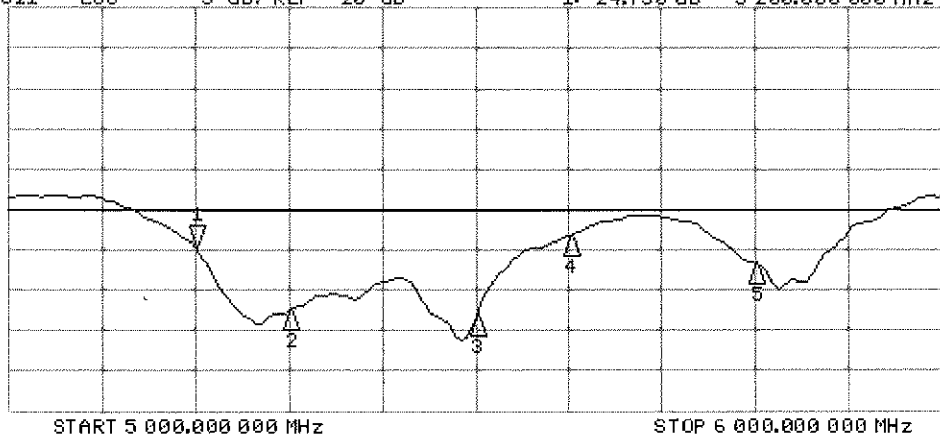

CH2 Markers
2: -32.508 dB
5.30000 GHz
3: -33.267 dB
5.50000 GHz
4: -23.183 dB
5.60000 GHz
5: -26.672 dB
5.80000 GHz



Accredited by the Swiss Accreditation Service (SAS)
The Swiss Accreditation Service is one of the signatories to the EA
Multilateral Agreement for the recognition of calibration certificates

Accreditation No.: **SCS 108**

Client **PC Test**

Certificate No: **D750V3-1046_Feb13**

CALIBRATION CERTIFICATE

Object **D750V3 - SN: 1046**

Calibration procedure(s) **QA CAL-05.v9
Calibration procedure for dipole validation kits above 700 MHz**

Calibration date: **February 13, 2013**

*✓
KOK
2/21/13*

This calibration certificate documents the traceability to national standards, which realize the physical units of measurements (SI).
The measurements and the uncertainties with confidence probability are given on the following pages and are part of the certificate.

All calibrations have been conducted in the closed laboratory facility: environment temperature (22 ± 3)°C and humidity < 70%.

Calibration Equipment used (M&TE critical for calibration)

Primary Standards	ID #	Cal Date (Certificate No.)	Scheduled Calibration
Power meter EPM-442A	GB37480704	01-Nov-12 (No. 217-01640)	Oct-13
Power sensor HP 8481A	US37292783	01-Nov-12 (No. 217-01640)	Oct-13
Reference 20 dB Attenuator	SN: 5058 (20k)	27-Mar-12 (No. 217-01530)	Apr-13
Type-N mismatch combination	SN: 5047.3 / 06327	27-Mar-12 (No. 217-01533)	Apr-13
Reference Probe ES3DV3	SN: 3205	28-Dec-12 (No. ES3-3205_Dec12)	Dec-13
DAE4	SN: 601	27-Jun-12 (No. DAE4-601_Jun12)	Jun-13
Secondary Standards	ID #	Check Date (in house)	Scheduled Check
Power sensor HP 8481A	MY41092317	18-Oct-02 (in house check Oct-11)	In house check: Oct-13
RF generator R&S SMT-06	100005	04-Aug-99 (in house check Oct-11)	In house check: Oct-13
Network Analyzer HP 8753E	US37390585 S4206	18-Oct-01 (in house check Oct-12)	In house check: Oct-13

Calibrated by:	Name Leif Klysner	Function Laboratory Technician	Signature
Approved by:	Name Katja Pokovic	Function Technical Manager	Signature

Issued: February 13, 2013

This calibration certificate shall not be reproduced except in full without written approval of the laboratory.



Accredited by the Swiss Accreditation Service (SAS)
The Swiss Accreditation Service is one of the signatories to the EA
Multilateral Agreement for the recognition of calibration certificates

Accreditation No.: **SCS 108**

Glossary:

TSL	tissue simulating liquid
ConvF	sensitivity in TSL / NORM x,y,z
N/A	not applicable or not measured

Calibration is Performed According to the Following Standards:

- IEEE Std 1528-2003, "IEEE Recommended Practice for Determining the Peak Spatial-Averaged Specific Absorption Rate (SAR) in the Human Head from Wireless Communications Devices: Measurement Techniques", December 2003
- IEC 62209-1, "Procedure to measure the Specific Absorption Rate (SAR) for hand-held devices used in close proximity to the ear (frequency range of 300 MHz to 3 GHz)", February 2005
- Federal Communications Commission Office of Engineering & Technology (FCC OET), "Evaluating Compliance with FCC Guidelines for Human Exposure to Radiofrequency Electromagnetic Fields; Additional Information for Evaluating Compliance of Mobile and Portable Devices with FCC Limits for Human Exposure to Radiofrequency Emissions", Supplement C (Edition 01-01) to Bulletin 65

Additional Documentation:

- DASY4/5 System Handbook

Methods Applied and Interpretation of Parameters:

- Measurement Conditions:** Further details are available from the Validation Report at the end of the certificate. All figures stated in the certificate are valid at the frequency indicated.
- Antenna Parameters with TSL:** The dipole is mounted with the spacer to position its feed point exactly below the center marking of the flat phantom section, with the arms oriented parallel to the body axis.
- Feed Point Impedance and Return Loss:** These parameters are measured with the dipole positioned under the liquid filled phantom. The impedance stated is transformed from the measurement at the SMA connector to the feed point. The Return Loss ensures low reflected power. No uncertainty required.
- Electrical Delay:** One-way delay between the SMA connector and the antenna feed point. No uncertainty required.
- SAR measured:** SAR measured at the stated antenna input power.
- SAR normalized:** SAR as measured, normalized to an input power of 1 W at the antenna connector.
- SAR for nominal TSL parameters:** The measured TSL parameters are used to calculate the nominal SAR result.

The reported uncertainty of measurement is stated as the standard uncertainty of measurement multiplied by the coverage factor $k=2$, which for a normal distribution corresponds to a coverage probability of approximately 95%.

Measurement Conditions

DASY system configuration, as far as not given on page 1.

DASY Version	DASY5	V52.8.5
Extrapolation	Advanced Extrapolation	
Phantom	Modular Flat Phantom	
Distance Dipole Center - TSL	15 mm	with Spacer
Zoom Scan Resolution	dx, dy, dz = 5 mm	
Frequency	750 MHz \pm 1 MHz	

Head TSL parameters

The following parameters and calculations were applied.

	Temperature	Permittivity	Conductivity
Nominal Head TSL parameters	22.0 °C	41.9	0.89 mho/m
Measured Head TSL parameters	(22.0 \pm 0.2) °C	41.2 \pm 6 %	0.91 mho/m \pm 6 %
Head TSL temperature change during test	< 0.5 °C	----	----

SAR result with Head TSL

SAR averaged over 1 cm ³ (1 g) of Head TSL	Condition	
SAR measured	250 mW input power	2.17 W/kg
SAR for nominal Head TSL parameters	normalized to 1W	8.50 W/kg \pm 17.0 % (k=2)

SAR averaged over 10 cm ³ (10 g) of Head TSL	condition	
SAR measured	250 mW input power	1.41 W/kg
SAR for nominal Head TSL parameters	normalized to 1W	5.55 W/kg \pm 16.5 % (k=2)

Body TSL parameters

The following parameters and calculations were applied.

	Temperature	Permittivity	Conductivity
Nominal Body TSL parameters	22.0 °C	55.5	0.96 mho/m
Measured Body TSL parameters	(22.0 \pm 0.2) °C	54.8 \pm 6 %	0.99 mho/m \pm 6 %
Body TSL temperature change during test	< 0.5 °C	----	----

SAR result with Body TSL

SAR averaged over 1 cm ³ (1 g) of Body TSL	Condition	
SAR measured	250 mW input power	2.25 W/kg
SAR for nominal Body TSL parameters	normalized to 1W	8.77 W/kg \pm 17.0 % (k=2)

SAR averaged over 10 cm ³ (10 g) of Body TSL	condition	
SAR measured	250 mW input power	1.49 W/kg
SAR for nominal Body TSL parameters	normalized to 1W	5.84 W/kg \pm 16.5 % (k=2)

Appendix

Antenna Parameters with Head TSL

Impedance, transformed to feed point	56.3 Ω + 1.4 j Ω
Return Loss	- 24.3 dB

Antenna Parameters with Body TSL

Impedance, transformed to feed point	52.0 Ω - 1.1 j Ω
Return Loss	- 32.9 dB

General Antenna Parameters and Design

Electrical Delay (one direction)	1.038 ns
----------------------------------	----------

After long term use with 100W radiated power, only a slight warming of the dipole near the feedpoint can be measured.

The dipole is made of standard semirigid coaxial cable. The center conductor of the feeding line is directly connected to the second arm of the dipole. The antenna is therefore short-circuited for DC-signals. On some of the dipoles, small end caps are added to the dipole arms in order to improve matching when loaded according to the position as explained in the "Measurement Conditions" paragraph. The SAR data are not affected by this change. The overall dipole length is still according to the Standard.

No excessive force must be applied to the dipole arms, because they might bend or the soldered connections near the feedpoint may be damaged.

Additional EUT Data

Manufactured by	SPEAG
Manufactured on	September 02, 2011

DASY5 Validation Report for Head TSL

Date: 13.02.2013

Test Laboratory: SPEAG, Zurich, Switzerland

DUT: Dipole 750 MHz; Type: D750V3; Serial: D750V3 - SN: 1046

Communication System: CW; Frequency: 750 MHz

Medium parameters used: $f = 750$ MHz; $\sigma = 0.91$ S/m; $\epsilon_r = 41.2$; $\rho = 1000$ kg/m³

Phantom section: Flat Section

Measurement Standard: DASY5 (IEEE/IEC/ANSI C63.19-2007)

DASY52 Configuration:

- Probe: ES3DV3 - SN3205; ConvF(6.28, 6.28, 6.28); Calibrated: 28.12.2012;
- Sensor-Surface: 3mm (Mechanical Surface Detection)
- Electronics: DAE4 Sn601; Calibrated: 27.06.2012
- Phantom: Flat Phantom 4.9L; Type: QD000P49AA; Serial: 1001
- DASY52 52.8.5(1059); SEMCAD X 14.6.8(7028)

Dipole Calibration for Head Tissue/Pin=250 mW, d=15mm/Zoom Scan (7x7x7)/Cube 0:

Measurement grid: dx=5mm, dy=5mm, dz=5mm

Reference Value = 52.942 V/m; Power Drift = 0.02 dB

Peak SAR (extrapolated) = 3.32 W/kg

SAR(1 g) = 2.17 W/kg; SAR(10 g) = 1.41 W/kg

Maximum value of SAR (measured) = 2.55 W/kg

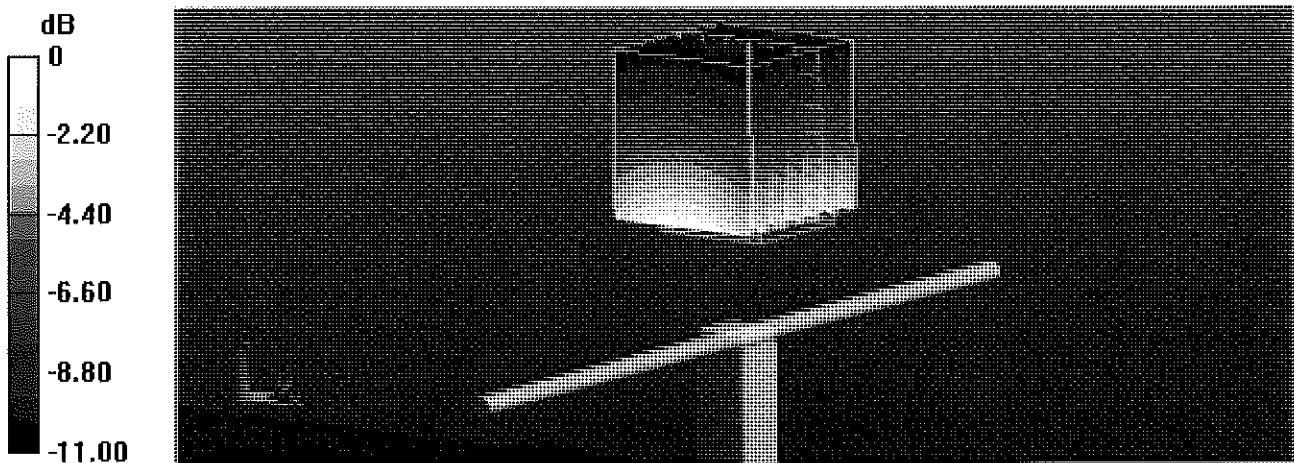

0 dB = 2.55 W/kg = 4.07 dBW/kg

Impedance Measurement Plot for Head TSL

13 Feb 2013 16:15:52

CH1 S11 1 U FS

1: 56.305 Ω 1.4043 Ω 298.00 pF

750.000 000 MHz

*
De1
Cor

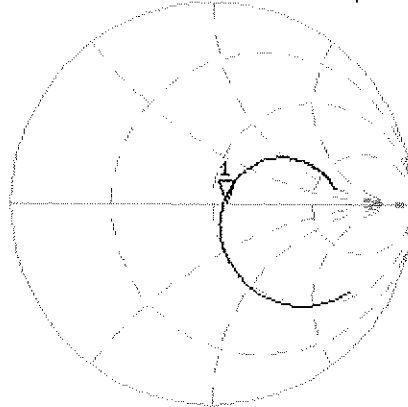

avg
16

H1d

CH2 S11 LOG 5 dB/REF -20 dB 1:-24.327 dB 750.000 000 MHz

Cor

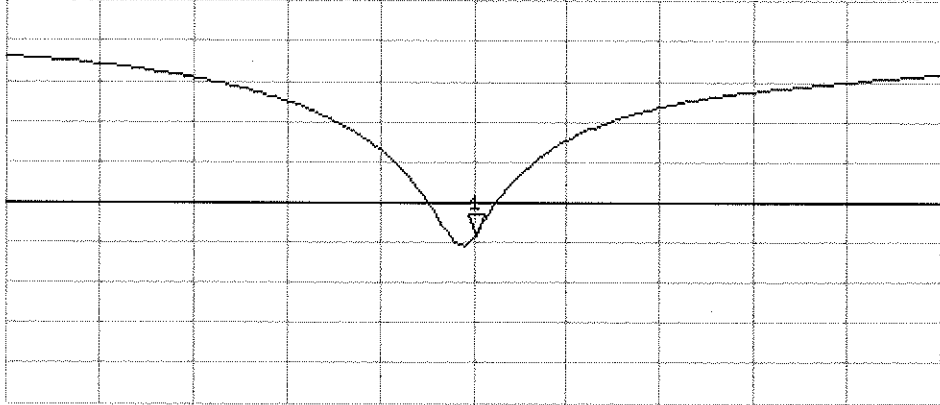

avg
16

H1d

START 550.000 000 MHz

STOP 950.000 000 MHz

DASY5 Validation Report for Body TSL

Date: 13.02.2013

Test Laboratory: SPEAG, Zurich, Switzerland

DUT: Dipole 750 MHz; Type: D750V3; Serial: D750V3 - SN: 1046

Communication System: CW; Frequency: 750 MHz

Medium parameters used: $f = 750$ MHz; $\sigma = 0.99$ S/m; $\epsilon_r = 54.8$; $\rho = 1000$ kg/m³

Phantom section: Flat Section

Measurement Standard: DASY5 (IEEE/IEC/ANSI C63.19-2007)

DASY52 Configuration:

- Probe: ES3DV3 - SN3205; ConvF(6.11, 6.11, 6.11); Calibrated: 28.12.2012;
- Sensor-Surface: 3mm (Mechanical Surface Detection)
- Electronics: DAE4 Sn601; Calibrated: 27.06.2012
- Phantom: Flat Phantom 4.9L; Type: QD000P49AA; Serial: 1001
- DASY52 52.8.5(1059); SEMCAD X 14.6.8(7028)

Dipole Calibration for Body Tissue/Pin=250 mW, d=15mm/Zoom Scan (7x7x7)/Cube 0:

Measurement grid: dx=5mm, dy=5mm, dz=5mm

Reference Value = 52.942 V/m; Power Drift = 0.02 dB

Peak SAR (extrapolated) = 3.29 W/kg

SAR(1 g) = 2.25 W/kg; SAR(10 g) = 1.49 W/kg

Maximum value of SAR (measured) = 2.61 W/kg

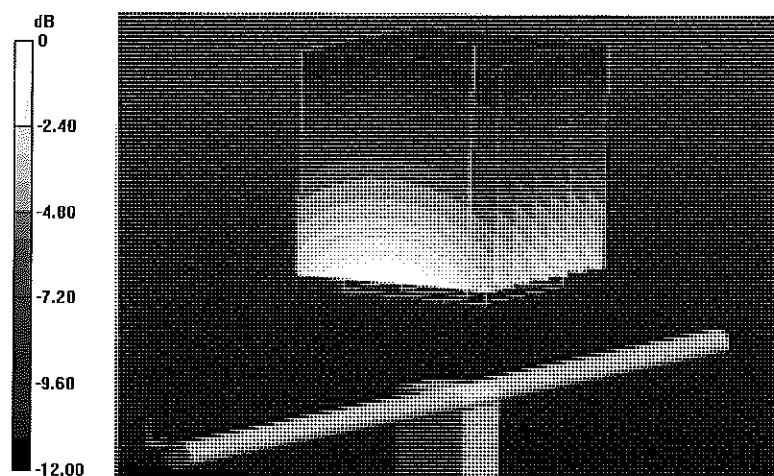

0 dB = 2.61 W/kg = 4.17 dBW/kg

Impedance Measurement Plot for Body TSL

13 Feb 2013 10:40:44
CH1 S11 1 U FS 1: 52.045 Ω -1.0898 Ω 194.71 pF 750.000 000 MHz

Del
CA

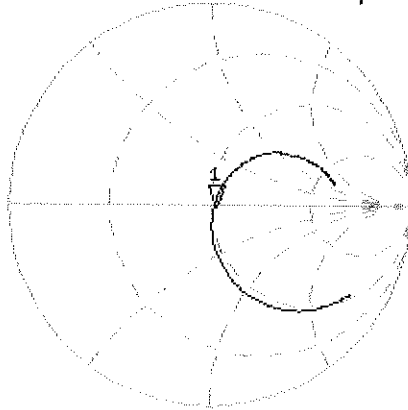

Avg
16

H1d

CH2 S11 LOG 5 dB/REF -20 dB 1: -32.854 dB 750.000 000 MHz

CA

Avg
16

H1d

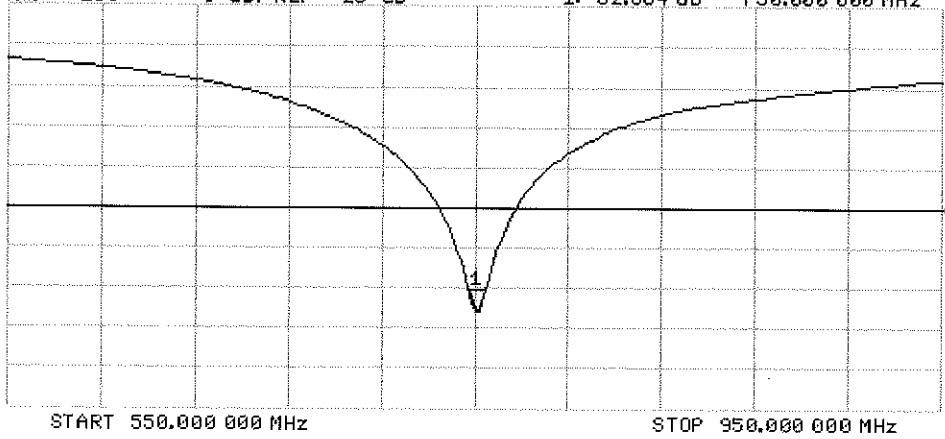



Accredited by the Swiss Accreditation Service (SAS)
The Swiss Accreditation Service is one of the signatories to the EA
Multilateral Agreement for the recognition of calibration certificates

Accreditation No.: **SCS 108**

Client **PC Test**

Certificate No: **D835V2-4d119_Apr13**

CALIBRATION CERTIFICATE

Object **D835V2 - SN: 4d119**

Calibration procedure(s) **QA CAL-05.v9
Calibration procedure for dipole validation kits above 700 MHz**

Calibration date: **April 25, 2013**

✓
KOK
5/8/13

This calibration certificate documents the traceability to national standards, which realize the physical units of measurements (SI).
The measurements and the uncertainties with confidence probability are given on the following pages and are part of the certificate.

All calibrations have been conducted in the closed laboratory facility: environment temperature (22 ± 3)°C and humidity < 70%.

Calibration Equipment used (M&TE critical for calibration)

Primary Standards	ID #	Cal Date (Certificate No.)	Scheduled Calibration
Power meter EPM-442A	GB37480704	01-Nov-12 (No. 217-01640)	Oct-13
Power sensor HP 8481A	US37292783	01-Nov-12 (No. 217-01640)	Oct-13
Reference 20 dB Attenuator	SN: 5058 (20k)	04-Apr-13 (No. 217-01736)	Apr-14
Type-N mismatch combination	SN: 5047.3 / 06327	04-Apr-13 (No. 217-01739)	Apr-14
Reference Probe ES3DV3	SN: 3205	28-Dec-12 (No. ES3-3205_Dec12)	Dec-13
DAE4	SN: 909	11-Sep-12 (No. DAE4-909_Sep12)	Sep-13
Secondary Standards	ID #	Check Date (in house)	Scheduled Check
Power sensor HP 8481A	MY41092317	18-Oct-02 (in house check Oct-11)	In house check: Oct-13
RF generator R&S SMT-06	100005	04-Aug-99 (in house check Oct-11)	In house check: Oct-13
Network Analyzer HP 8753E	US37390585 S4206	18-Oct-01 (in house check Oct-12)	In house check: Oct-13

Calibrated by: **Claudio Leubler** Name: Claudio Leubler Function: Laboratory Technician

Approved by: **Katja Pokovic** Name: Katja Pokovic Technical Manager

Signature

Issued: April 26, 2013

This calibration certificate shall not be reproduced except in full without written approval of the laboratory.



Accredited by the Swiss Accreditation Service (SAS)
The Swiss Accreditation Service is one of the signatories to the EA
Multilateral Agreement for the recognition of calibration certificates

Accreditation No.: **SCS 108**

Glossary:

TSL	tissue simulating liquid
ConvF	sensitivity in TSL / NORM x,y,z
N/A	not applicable or not measured

Calibration is Performed According to the Following Standards:

- a) IEEE Std 1528-2003, "IEEE Recommended Practice for Determining the Peak Spatial-Averaged Specific Absorption Rate (SAR) in the Human Head from Wireless Communications Devices: Measurement Techniques", December 2003
- b) IEC 62209-1, "Procedure to measure the Specific Absorption Rate (SAR) for hand-held devices used in close proximity to the ear (frequency range of 300 MHz to 3 GHz)", February 2005
- c) Federal Communications Commission Office of Engineering & Technology (FCC OET), "Evaluating Compliance with FCC Guidelines for Human Exposure to Radiofrequency Electromagnetic Fields; Additional Information for Evaluating Compliance of Mobile and Portable Devices with FCC Limits for Human Exposure to Radiofrequency Emissions", Supplement C (Edition 01-01) to Bulletin 65

Additional Documentation:

- d) DASY4/5 System Handbook

Methods Applied and Interpretation of Parameters:

- *Measurement Conditions:* Further details are available from the Validation Report at the end of the certificate. All figures stated in the certificate are valid at the frequency indicated.
- *Antenna Parameters with TSL:* The dipole is mounted with the spacer to position its feed point exactly below the center marking of the flat phantom section, with the arms oriented parallel to the body axis.
- *Feed Point Impedance and Return Loss:* These parameters are measured with the dipole positioned under the liquid filled phantom. The impedance stated is transformed from the measurement at the SMA connector to the feed point. The Return Loss ensures low reflected power. No uncertainty required.
- *Electrical Delay:* One-way delay between the SMA connector and the antenna feed point. No uncertainty required.
- *SAR measured:* SAR measured at the stated antenna input power.
- *SAR normalized:* SAR as measured, normalized to an input power of 1 W at the antenna connector.
- *SAR for nominal TSL parameters:* The measured TSL parameters are used to calculate the nominal SAR result.

The reported uncertainty of measurement is stated as the standard uncertainty of measurement multiplied by the coverage factor $k=2$, which for a normal distribution corresponds to a coverage probability of approximately 95%.

Measurement Conditions

DASY system configuration, as far as not given on page 1.

DASY Version	DASY5	V52.8.6
Extrapolation	Advanced Extrapolation	
Phantom	Modular Flat Phantom	
Distance Dipole Center - TSL	15 mm	with Spacer
Zoom Scan Resolution	dx, dy, dz = 5 mm	
Frequency	835 MHz \pm 1 MHz	

Head TSL parameters

The following parameters and calculations were applied.

	Temperature	Permittivity	Conductivity
Nominal Head TSL parameters	22.0 °C	41.5	0.90 mho/m
Measured Head TSL parameters	(22.0 \pm 0.2) °C	40.8 \pm 6 %	0.94 mho/m \pm 6 %
Head TSL temperature change during test	< 0.5 °C	----	----

SAR result with Head TSL

SAR averaged over 1 cm ³ (1 g) of Head TSL	Condition	
SAR measured	250 mW input power	2.51 W/kg
SAR for nominal Head TSL parameters	normalized to 1W	9.68 W/kg \pm 17.0 % (k=2)

SAR averaged over 10 cm ³ (10 g) of Head TSL	condition	
SAR measured	250 mW input power	1.62 W/kg
SAR for nominal Head TSL parameters	normalized to 1W	6.30 W/kg \pm 16.5 % (k=2)

Body TSL parameters

The following parameters and calculations were applied.

	Temperature	Permittivity	Conductivity
Nominal Body TSL parameters	22.0 °C	55.2	0.97 mho/m
Measured Body TSL parameters	(22.0 \pm 0.2) °C	54.0 \pm 6 %	1.01 mho/m \pm 6 %
Body TSL temperature change during test	< 0.5 °C	----	----

SAR result with Body TSL

SAR averaged over 1 cm ³ (1 g) of Body TSL	Condition	
SAR measured	250 mW input power	2.47 W/kg
SAR for nominal Body TSL parameters	normalized to 1W	9.54 W/kg \pm 17.0 % (k=2)

SAR averaged over 10 cm ³ (10 g) of Body TSL	condition	
SAR measured	250 mW input power	1.62 W/kg
SAR for nominal Body TSL parameters	normalized to 1W	6.31 W/kg \pm 16.5 % (k=2)

Appendix

Antenna Parameters with Head TSL

Impedance, transformed to feed point	50.1 Ω - 4.7 j Ω
Return Loss	- 26.6 dB

Antenna Parameters with Body TSL

Impedance, transformed to feed point	45.8 Ω - 6.3 j Ω
Return Loss	- 22.1 dB

General Antenna Parameters and Design

Electrical Delay (one direction)	1.385 ns
----------------------------------	----------

After long term use with 100W radiated power, only a slight warming of the dipole near the feedpoint can be measured.

The dipole is made of standard semirigid coaxial cable. The center conductor of the feeding line is directly connected to the second arm of the dipole. The antenna is therefore short-circuited for DC-signals. On some of the dipoles, small end caps are added to the dipole arms in order to improve matching when loaded according to the position as explained in the "Measurement Conditions" paragraph. The SAR data are not affected by this change. The overall dipole length is still according to the Standard.

No excessive force must be applied to the dipole arms, because they might bend or the soldered connections near the feedpoint may be damaged.

Additional EUT Data

Manufactured by	SPEAG
Manufactured on	June 29, 2010

DASY5 Validation Report for Head TSL

Date: 25.04.2013

Test Laboratory: SPEAG, Zurich, Switzerland

DUT: Dipole 835 MHz; Type: D835V2; Serial: D835V2 - SN: 4d119

Communication System: UID 0 - CW; Frequency: 835 MHz

Medium parameters used: $f = 835$ MHz; $\sigma = 0.94$ S/m; $\epsilon_r = 40.8$; $\rho = 1000$ kg/m³

Phantom section: Flat Section

Measurement Standard: DASY5 (IEEE/IEC/ANSI C63.19-2007)

DASY52 Configuration:

- Probe: ES3DV3 - SN3205; ConvF(6.05, 6.05, 6.05); Calibrated: 28.12.2012;
- Sensor-Surface: 3mm (Mechanical Surface Detection)
- Electronics: DAE4 Sn909; Calibrated: 11.09.2012
- Phantom: Flat Phantom 4.9L; Type: QD000P49AA; Serial: 1001
- DASY52 52.8.6(1115); SEMCAD X 14.6.9(7117)

Dipole Calibration for Head Tissue/Pin=250 mW, d=15mm/Zoom Scan (7x7x7)/Cube 0:

Measurement grid: dx=5mm, dy=5mm, dz=5mm

Reference Value = 57.387 V/m; Power Drift = 0.03 dB

Peak SAR (extrapolated) = 3.86 W/kg

SAR(1 g) = 2.51 W/kg; SAR(10 g) = 1.62 W/kg

Maximum value of SAR (measured) = 2.93 W/kg

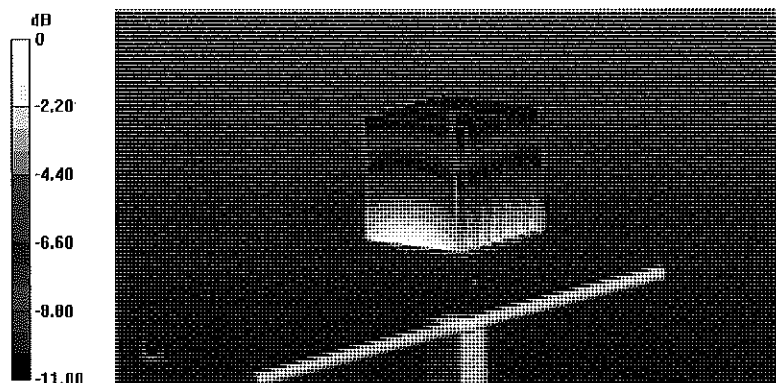

0 dB = 2.93 W/kg = 4.67 dBW/kg

Impedance Measurement Plot for Head TSL

25 Apr 2013 09:11:06

CH1 S11 1 U FS

1: 50.061 Ω -4.6621 Ω 40.884 pF

835.000 000 MHz

*
Del

CA

Avg
16

H1 d

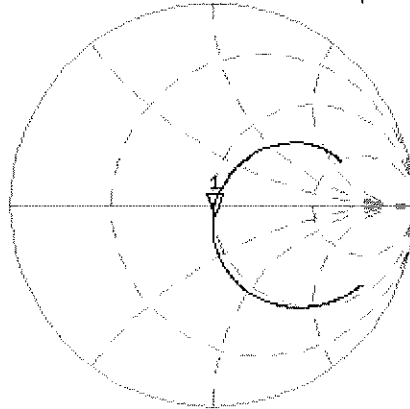

CH2 S11 LOG

5 dB/REF -20 dB

1: -26.641 dB 835.000 000 MHz

CA

Avg
16

H1 d

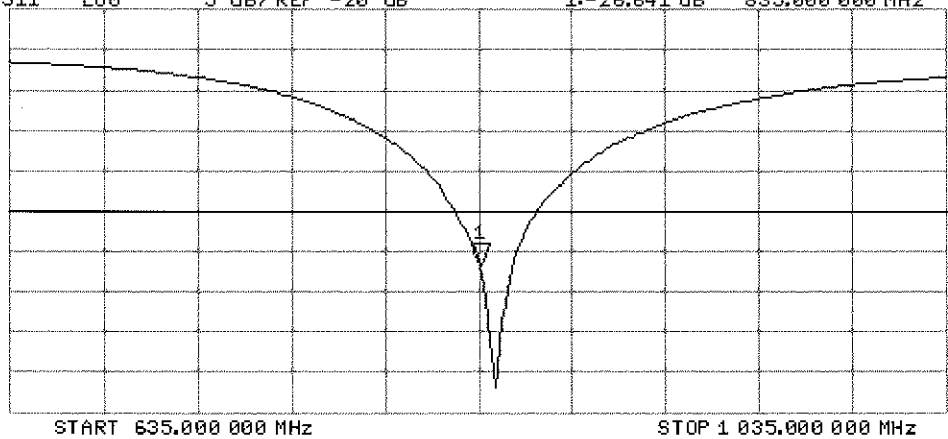

DASY5 Validation Report for Body TSL

Date: 24.04.2013

Test Laboratory: SPEAG, Zurich, Switzerland

DUT: Dipole 835 MHz; Type: D835V2; Serial: D835V2 - SN: 4d119

Communication System: UID 0 - CW; Frequency: 835 MHz

Medium parameters used: $f = 835$ MHz; $\sigma = 1.01$ S/m; $\epsilon_r = 54$; $\rho = 1000$ kg/m³

Phantom section: Flat Section

Measurement Standard: DASY5 (IEEE/IEC/ANSI C63.19-2007)

DASY52 Configuration:

- Probe: ES3DV3 - SN3205; ConvF(6.04, 6.04, 6.04); Calibrated: 28.12.2012;
- Sensor-Surface: 3mm (Mechanical Surface Detection)
- Electronics: DAE4 Sn909; Calibrated: 11.09.2012
- Phantom: Flat Phantom 4.9L; Type: QD000P49AA; Serial: 1001
- DASY52 52.8.6(1115); SEMCAD X 14.6.9(7117)

Dipole Calibration for Body Tissue/Pin=250 mW, d=15mm/Zoom Scan (7x7x7)/Cube 0:

Measurement grid: dx=5mm, dy=5mm, dz=5mm

Reference Value = 55.178 V/m; Power Drift = 0.03 dB

Peak SAR (extrapolated) = 3.68 W/kg

SAR(1 g) = 2.47 W/kg; SAR(10 g) = 1.62 W/kg

Maximum value of SAR (measured) = 2.89 W/kg

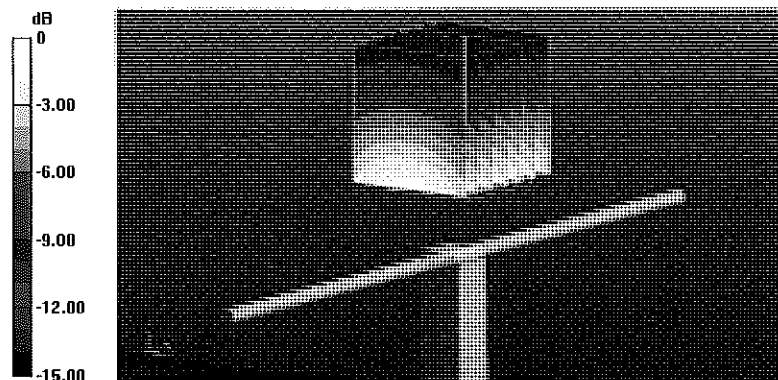

0 dB = 2.89 W/kg = 4.61 dBW/kg

Impedance Measurement Plot for Body TSL

24 Apr 2013 11:33:44

CH1 S11 1 U FS

2: 45.773 Ω -6.2773 Δ 30.364 pF

835.000 000 MHz

*
DeI

CΔ

Avg
16

H1d

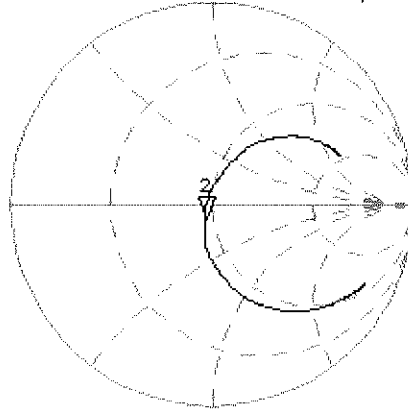

CH2 S11 LOG

5 dB/REF -20 dB

2: -22.065 dB

835.000 000 MHz

CΔ

Avg
16

H1d

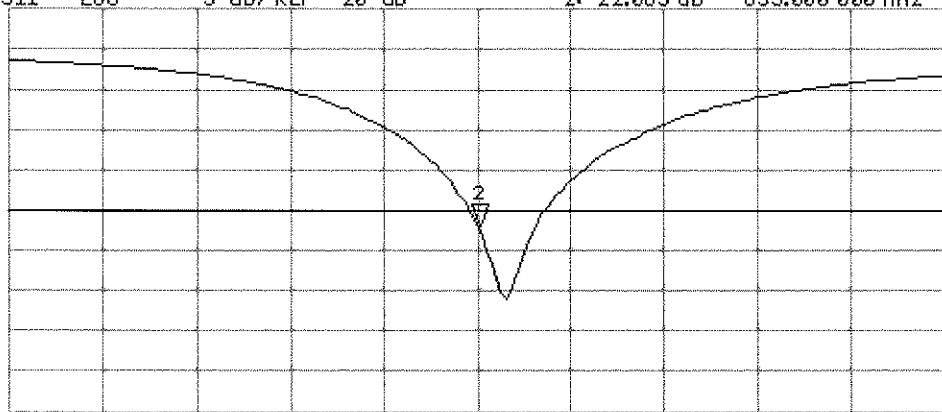

START 635.000 000 MHz

STOP 1 035.000 000 MHz



Accredited by the Swiss Accreditation Service (SAS)
 The Swiss Accreditation Service is one of the signatories to the EA
 Multilateral Agreement for the recognition of calibration certificates

Accreditation No.: **SCS 108**

Client **PC Test**

Certificate No.: **ES3-3022_Aug13**

CALIBRATION CERTIFICATE

Object **ES3DV2 - SN:3022**

Calibration procedure(s) **QA CAL-01.v9, QA CAL-23.v5, QA CAL-25.v6
 Calibration procedure for dosimetric E-field probes**

Calibration date: **August 22, 2013** *UTC*
9/13/13

This calibration certificate documents the traceability to national standards, which realize the physical units of measurements (SI).
 The measurements and the uncertainties with confidence probability are given on the following pages and are part of the certificate.

All calibrations have been conducted in the closed laboratory facility: environment temperature (22 ± 3)°C and humidity < 70%.

Calibration Equipment used (M&TE critical for calibration)

Primary Standards	ID	Cal Date (Certificate No.)	Scheduled Calibration
Power meter E4419B	GB41293874	04-Apr-13 (No. 217-01733)	Apr-14
Power sensor E4412A	MY41498087	04-Apr-13 (No. 217-01733)	Apr-14
Reference 3 dB Attenuator	SN: S5054 (3c)	04-Apr-13 (No. 217-01737)	Apr-14
Reference 20 dB Attenuator	SN: S5277 (20x)	04-Apr-13 (No. 217-01735)	Apr-14
Reference 30 dB Attenuator	SN: S5129 (30b)	04-Apr-13 (No. 217-01738)	Apr-14
Reference Probe ES3DV2	SN: 3013	28-Dec-12 (No. ES3-3013_Dec12)	Dec-13
DAE4	SN: 660	31-Jan-13 (No. DAE4-660_Jan13)	Jan-14
Secondary Standards	ID	Check Date (in house)	Scheduled Check
RF generator HP 8648C	US3642U01700	4-Aug-99 (in house check Apr-13)	In house check: Apr-15
Network Analyzer HP 8753E	US37390585	18-Oct-01 (in house check Oct-12)	In house check: Oct-13

	Name	Function	Signature
Calibrated by:	Jeton Kastrati	Laboratory Technician	
Approved by:	Katja Pokovic	Technical Manager	

Issued: August 23, 2013

This calibration certificate shall not be reproduced except in full without written approval of the laboratory.



Accredited by the Swiss Accreditation Service (SAS)

Accreditation No.: **SCS 108**

The Swiss Accreditation Service is one of the signatories to the EA
Multilateral Agreement for the recognition of calibration certificates

Glossary:

TSL	tissue simulating liquid
NORM _{x,y,z}	sensitivity in free space
ConvF	sensitivity in TSL / NORM _{x,y,z}
DCP	diode compression point
CF	crest factor (1/duty_cycle) of the RF signal
A, B, C, D	modulation dependent linearization parameters
Polarization φ	φ rotation around probe axis
Polarization ϑ	ϑ rotation around an axis that is in the plane normal to probe axis (at measurement center), i.e., $\vartheta = 0$ is normal to probe axis

Calibration is Performed According to the Following Standards:

- IEEE Std 1528-2003, "IEEE Recommended Practice for Determining the Peak Spatial-Averaged Specific Absorption Rate (SAR) in the Human Head from Wireless Communications Devices: Measurement Techniques", December 2003
- IEC 62209-1, "Procedure to measure the Specific Absorption Rate (SAR) for hand-held devices used in close proximity to the ear (frequency range of 300 MHz to 3 GHz)", February 2005

Methods Applied and Interpretation of Parameters:

- NORM_{x,y,z}**: Assessed for E-field polarization $\vartheta = 0$ ($f \leq 900$ MHz in TEM-cell; $f > 1800$ MHz: R22 waveguide). NORM_{x,y,z} are only intermediate values, i.e., the uncertainties of NORM_{x,y,z} does not affect the E²-field uncertainty inside TSL (see below ConvF).
- NORM(f)_{x,y,z}** = NORM_{x,y,z} * frequency_response (see Frequency Response Chart). This linearization is implemented in DASY4 software versions later than 4.2. The uncertainty of the frequency response is included in the stated uncertainty of ConvF.
- DCP_{x,y,z}**: DCP are numerical linearization parameters assessed based on the data of power sweep with CW signal (no uncertainty required). DCP does not depend on frequency nor media.
- PAR**: PAR is the Peak to Average Ratio that is not calibrated but determined based on the signal characteristics
- A_{x,y,z}; B_{x,y,z}; C_{x,y,z}; D_{x,y,z}; VR_{x,y,z}**: A, B, C, D are numerical linearization parameters assessed based on the data of power sweep for specific modulation signal. The parameters do not depend on frequency nor media. VR is the maximum calibration range expressed in RMS voltage across the diode.
- ConvF and Boundary Effect Parameters**: Assessed in flat phantom using E-field (or Temperature Transfer Standard for $f \leq 800$ MHz) and inside waveguide using analytical field distributions based on power measurements for $f > 800$ MHz. The same setups are used for assessment of the parameters applied for boundary compensation (alpha, depth) of which typical uncertainty values are given. These parameters are used in DASY4 software to improve probe accuracy close to the boundary. The sensitivity in TSL corresponds to NORM_{x,y,z} * ConvF whereby the uncertainty corresponds to that given for ConvF. A frequency dependent ConvF is used in DASY version 4.4 and higher which allows extending the validity from ± 50 MHz to ± 100 MHz.
- Spherical isotropy (3D deviation from isotropy)**: in a field of low gradients realized using a flat phantom exposed by a patch antenna.
- Sensor Offset**: The sensor offset corresponds to the offset of virtual measurement center from the probe tip (on probe axis). No tolerance required.

Probe ES3DV2

SN:3022

Manufactured: April 15, 2003
Calibrated: August 22, 2013

Calibrated for DASY/EASY Systems
(Note: non-compatible with DASY2 system!)

DASY/EASY - Parameters of Probe: ES3DV2 - SN:3022

Basic Calibration Parameters

	Sensor X	Sensor Y	Sensor Z	Unc (k=2)
Norm ($\mu\text{V}/(\text{V}/\text{m})^2$) ^A	1.00	1.04	0.99	± 10.1 %
DCP (mV) ^B	100.7	97.4	99.7	

Modulation Calibration Parameters

UID	Communication System Name		A dB	B dB/μV	C	D dB	VR mV	Unc ^E (k=2)
0	CW	X	0.0	0.0	1.0	0.00	178.6	±3.0 %
		Y	0.0	0.0	1.0		141.9	
		Z	0.0	0.0	1.0		134.7	

The reported uncertainty of measurement is stated as the standard uncertainty of measurement multiplied by the coverage factor k=2, which for a normal distribution corresponds to a coverage probability of approximately 95%.

^A The uncertainties of NormX,Y,Z do not affect the E²-field uncertainty inside TSL (see Pages 5 and 6).

^B Numerical linearization parameter: uncertainty not required.

^E Uncertainty is determined using the max. deviation from linear response applying rectangular distribution and is expressed for the square of the field value.

DASY/EASY - Parameters of Probe: ES3DV2 - SN:3022

Calibration Parameter Determined in Head Tissue Simulating Media

f (MHz) ^C	Relative Permittivity ^F	Conductivity (S/m) ^F	ConvF X	ConvF Y	ConvF Z	Alpha	Depth (mm)	Unct. (k=2)
750	41.9	0.89	6.21	6.21	6.21	0.19	2.37	± 12.0 %
835	41.5	0.90	6.09	6.09	6.09	0.30	1.70	± 12.0 %
1750	40.1	1.37	5.19	5.19	5.19	0.65	1.23	± 12.0 %
1900	40.0	1.40	5.03	5.03	5.03	0.51	1.43	± 12.0 %
2450	39.2	1.80	4.36	4.36	4.36	0.51	1.51	± 12.0 %
2600	39.0	1.96	4.16	4.16	4.16	0.74	1.29	± 12.0 %

^C Frequency validity of ± 100 MHz only applies for DASY v4.4 and higher (see Page 2), else it is restricted to ± 50 MHz. The uncertainty is the RSS of the ConvF uncertainty at calibration frequency and the uncertainty for the indicated frequency band.

^F At frequencies below 3 GHz, the validity of tissue parameters (ϵ and σ) can be relaxed to ± 10% if liquid compensation formula is applied to measured SAR values. At frequencies above 3 GHz, the validity of tissue parameters (ϵ and σ) is restricted to ± 5%. The uncertainty is the RSS of the ConvF uncertainty for indicated target tissue parameters.

DASY/EASY - Parameters of Probe: ES3DV2 - SN:3022

Calibration Parameter Determined in Body Tissue Simulating Media

f (MHz) ^C	Relative Permittivity ^F	Conductivity (S/m) ^F	ConvF X	ConvF Y	ConvF Z	Alpha	Depth (mm)	Unct. (k=2)
750	55.5	0.96	5.92	5.92	5.92	0.24	1.99	± 12.0 %
835	55.2	0.97	5.91	5.91	5.91	0.29	1.85	± 12.0 %
1750	53.4	1.49	4.75	4.75	4.75	0.52	1.52	± 12.0 %
1900	53.3	1.52	4.49	4.49	4.49	0.49	1.56	± 12.0 %
2450	52.7	1.95	4.01	4.01	4.01	0.70	1.02	± 12.0 %
2600	52.5	2.16	3.85	3.85	3.85	0.58	0.90	± 12.0 %

^C Frequency validity of ± 100 MHz only applies for DASY v4.4 and higher (see Page 2), else it is restricted to ± 50 MHz. The uncertainty is the RSS of the ConvF uncertainty at calibration frequency and the uncertainty for the indicated frequency band.

^F At frequencies below 3 GHz, the validity of tissue parameters (ϵ and σ) can be relaxed to ± 10% if liquid compensation formula is applied to measured SAR values. At frequencies above 3 GHz, the validity of tissue parameters (ϵ and σ) is restricted to ± 5%. The uncertainty is the RSS of the ConvF uncertainty for indicated target tissue parameters.

Frequency Response of E-Field (TEM-Cell:ifi110 EXX, Waveguide: R22)

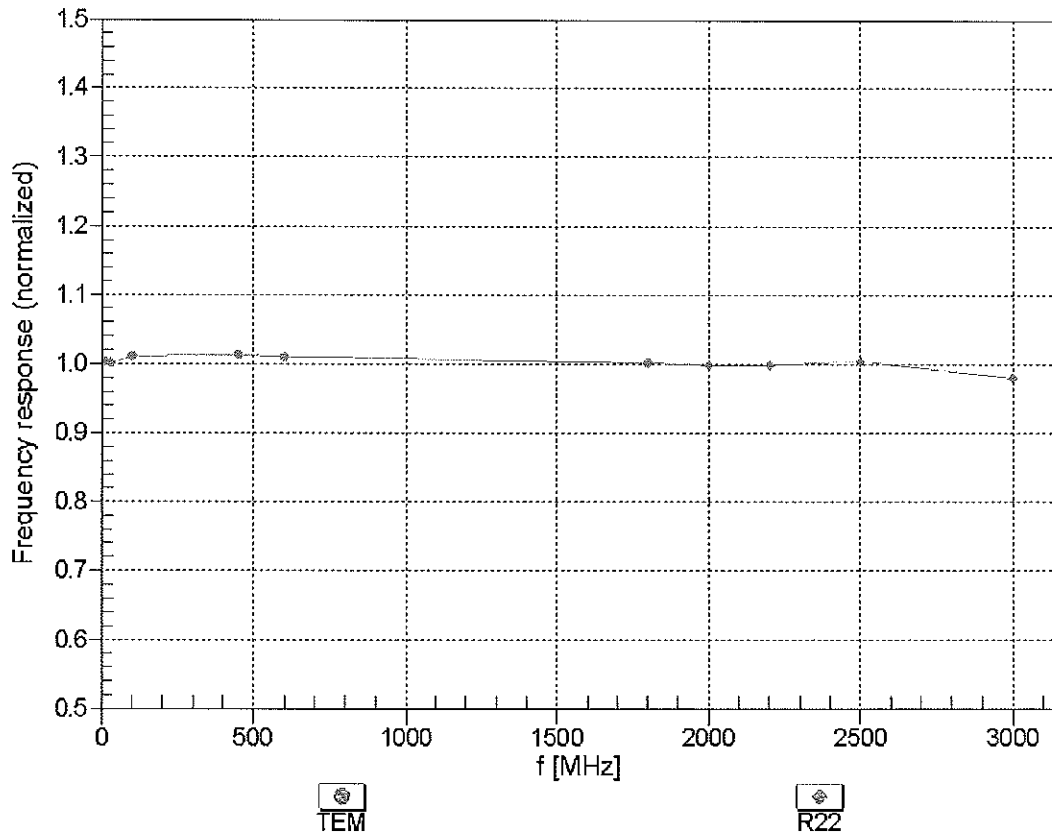

Uncertainty of Frequency Response of E-field: $\pm 6.3\%$ (k=2)

Receiving Pattern (ϕ), $\theta = 0^\circ$

f=600 MHz,TEM

f=1800 MHz,R22

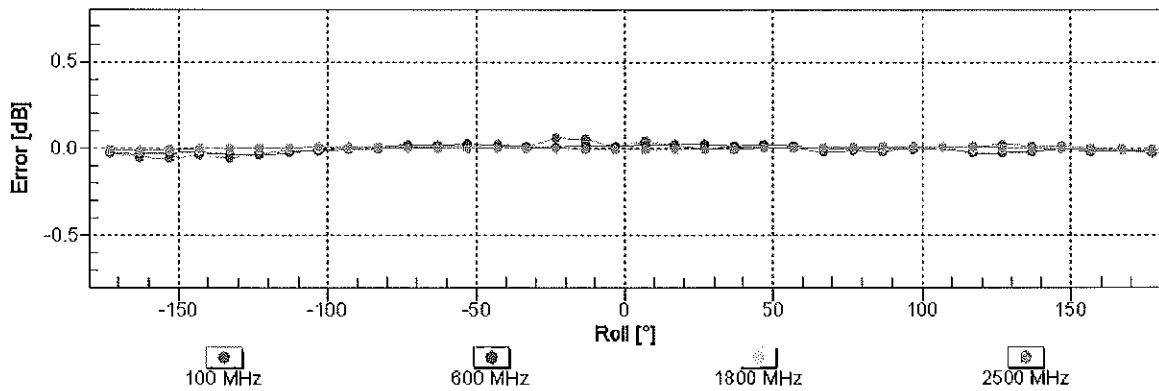
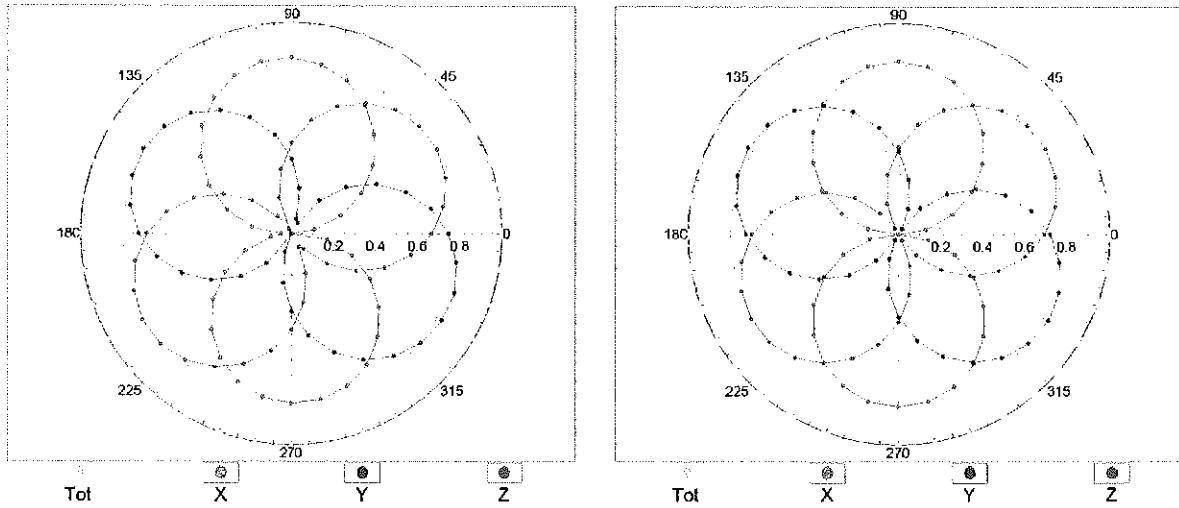

Uncertainty of Axial Isotropy Assessment: $\pm 0.5\%$ ($k=2$)

Dynamic Range f(SAR_{head}) (TEM cell , f = 900 MHz)

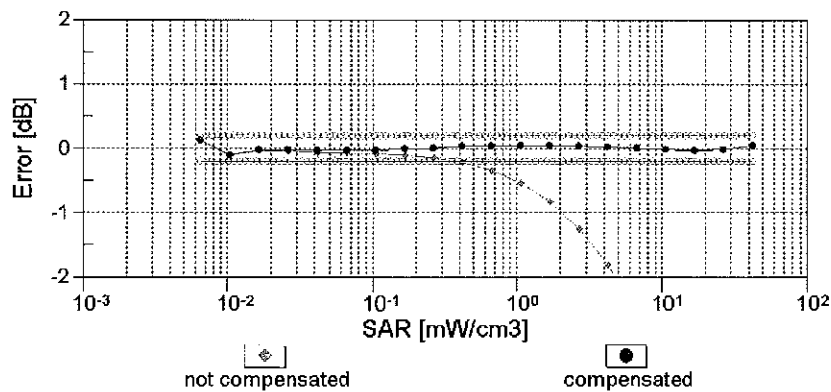
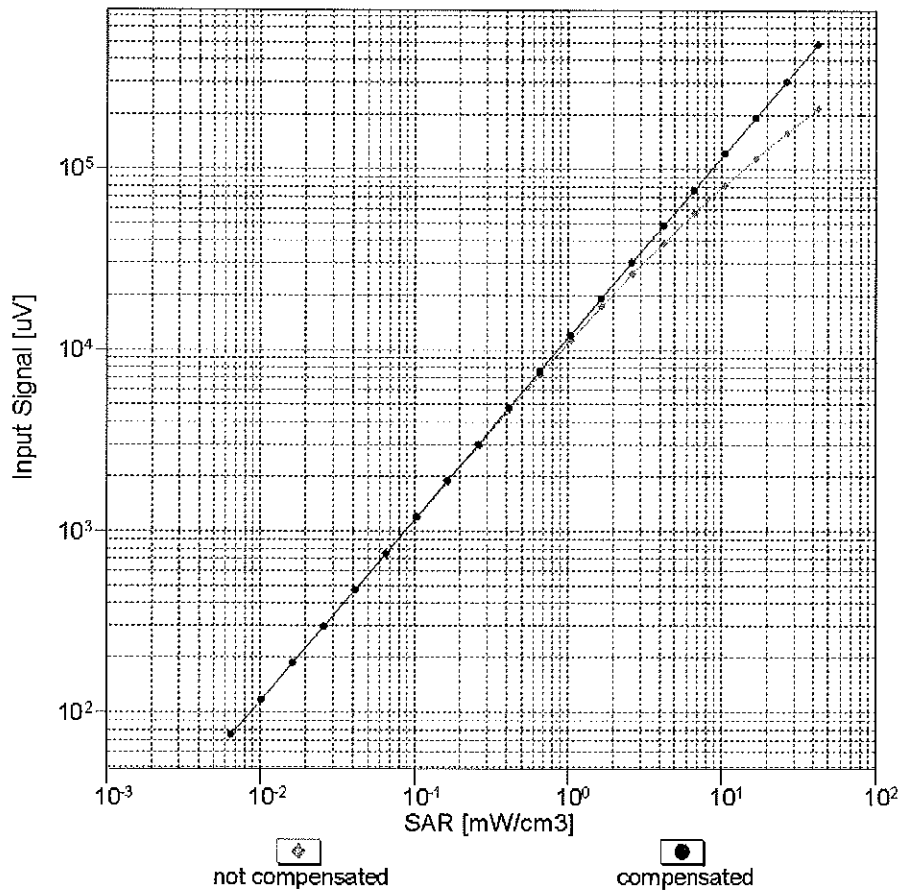

Uncertainty of Linearity Assessment: ± 0.6% (k=2)

Conversion Factor Assessment

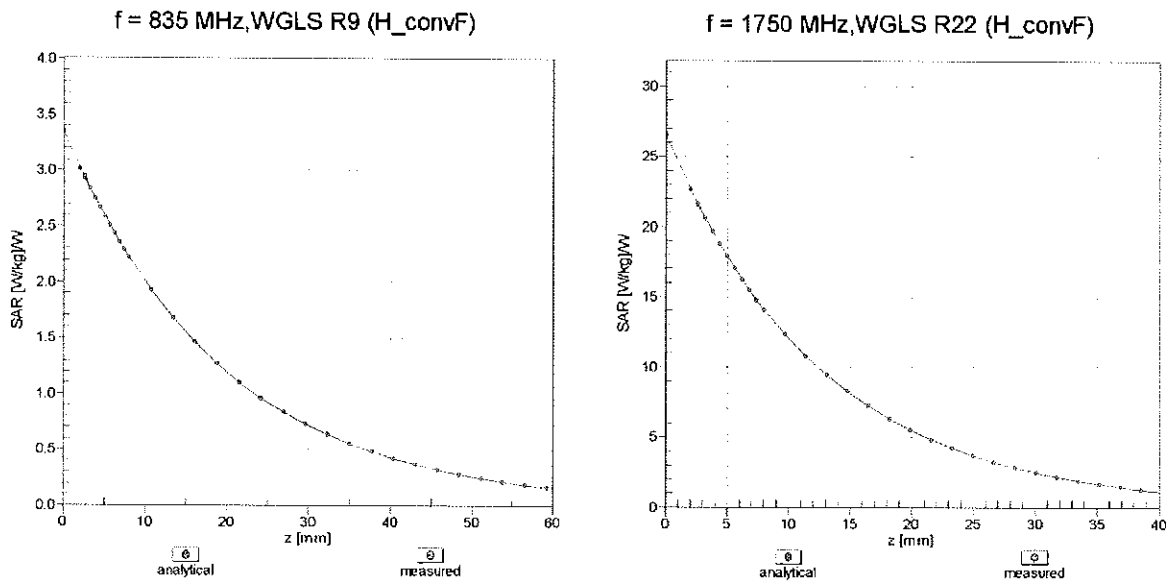

Deviation from Isotropy in Liquid Error (ϕ, θ), f = 900 MHz

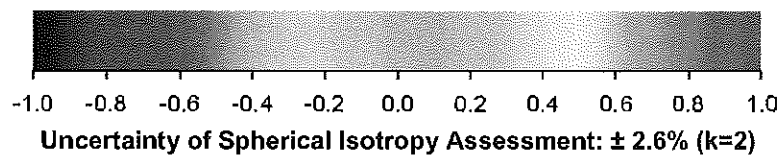
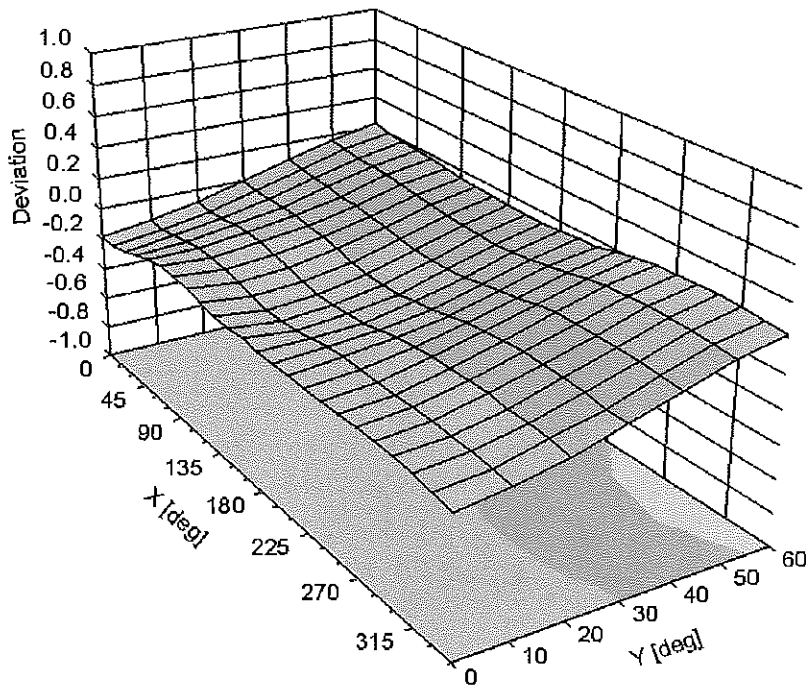

DASY/EASY - Parameters of Probe: ES3DV2 - SN:3022

Other Probe Parameters

Sensor Arrangement	Triangular
Connector Angle (°)	-83.1
Mechanical Surface Detection Mode	enabled
Optical Surface Detection Mode	disabled
Probe Overall Length	337 mm
Probe Body Diameter	10 mm
Tip Length	10 mm
Tip Diameter	4 mm
Probe Tip to Sensor X Calibration Point	2 mm
Probe Tip to Sensor Y Calibration Point	2 mm
Probe Tip to Sensor Z Calibration Point	2 mm
Recommended Measurement Distance from Surface	3 mm



Accredited by the Swiss Accreditation Service (SAS)
The Swiss Accreditation Service is one of the signatories to the EA
Multilateral Agreement for the recognition of calibration certificates

Accreditation No.: **SCS 108**

Client **PC Test**

Certificate No: **ES3-3319_Apr13**

CALIBRATION CERTIFICATE

Object **ES3DV3 - SN:3319**

Calibration procedure(s) **QA CAL-01.v8, QA CAL-23.v4, QA CAL-25.v4
Calibration procedure for dosimetric E-field probes**

Calibration date: **April 29, 2013**

VCC
6/14/13

This calibration certificate documents the traceability to national standards, which realize the physical units of measurements (SI).
The measurements and the uncertainties with confidence probability are given on the following pages and are part of the certificate.

All calibrations have been conducted in the closed laboratory facility: environment temperature (22 ± 3)°C and humidity < 70%.

Calibration Equipment used (M&TE critical for calibration)

Primary Standards	ID	Cal Date (Certificate No.)	Scheduled Calibration
Power meter E4419B	GB41293874	04-Apr-13 (No. 217-01733)	Apr-14
Power sensor E4412A	MY41498087	04-Apr-13 (No. 217-01733)	Apr-14
Reference 3 dB Attenuator	SN: S5054 (3c)	04-Apr-13 (No. 217-01737)	Apr-14
Reference 20 dB Attenuator	SN: S5277 (20x)	04-Apr-13 (No. 217-01735)	Apr-14
Reference 30 dB Attenuator	SN: S5129 (30b)	04-Apr-13 (No. 217-01738)	Apr-14
Reference Probe ES3DV2	SN: 3013	28-Dec-12 (No. ES3-3013_Dec12)	Dec-13
DAE4	SN: 660	31-Jan-13 (No. DAE4-660_Jan13)	Jan-14
Secondary Standards	ID	Check Date (in house)	Scheduled Check
RF generator HP 8648C	US3642U01700	4-Aug-99 (in house check Apr-13)	In house check: Apr-15
Network Analyzer HP 8753E	US37390585	18-Oct-01 (in house check Oct-12)	In house check: Oct-13

	Name	Function	Signature
Calibrated by:	Dimce Iliev	Laboratory Technician	
Approved by:	Katja Pokovic	Technical Manager	
			Issued: April 29, 2013

This calibration certificate shall not be reproduced except in full without written approval of the laboratory.



Accredited by the Swiss Accreditation Service (SAS)

Accreditation No.: **SCS 108**

The Swiss Accreditation Service is one of the signatories to the EA Multilateral Agreement for the recognition of calibration certificates

Glossary:

TSL	tissue simulating liquid
NORM _{x,y,z}	sensitivity in free space
ConvF	sensitivity in TSL / NORM _{x,y,z}
DCP	diode compression point
CF	crest factor (1/duty_cycle) of the RF signal
A, B, C, D	modulation dependent linearization parameters
Polarization φ	φ rotation around probe axis
Polarization ϑ	ϑ rotation around an axis that is in the plane normal to probe axis (at measurement center), i.e., $\vartheta = 0$ is normal to probe axis

Calibration is Performed According to the Following Standards:

- a) IEEE Std 1528-2003, "IEEE Recommended Practice for Determining the Peak Spatial-Averaged Specific Absorption Rate (SAR) in the Human Head from Wireless Communications Devices: Measurement Techniques", December 2003
- b) IEC 62209-1, "Procedure to measure the Specific Absorption Rate (SAR) for hand-held devices used in close proximity to the ear (frequency range of 300 MHz to 3 GHz)", February 2005

Methods Applied and Interpretation of Parameters:

- *NORM_{x,y,z}*: Assessed for E-field polarization $\vartheta = 0$ ($f \leq 900$ MHz in TEM-cell; $f > 1800$ MHz: R22 waveguide). *NORM_{x,y,z}* are only intermediate values, i.e., the uncertainties of *NORM_{x,y,z}* does not affect the E^2 -field uncertainty inside TSL (see below *ConvF*).
- *NORM(f)_{x,y,z}* = *NORM_{x,y,z}* * *frequency_response* (see Frequency Response Chart). This linearization is implemented in DASY4 software versions later than 4.2. The uncertainty of the frequency response is included in the stated uncertainty of *ConvF*.
- *DCP_{x,y,z}*: DCP are numerical linearization parameters assessed based on the data of power sweep with CW signal (no uncertainty required). DCP does not depend on frequency nor media.
- *PAR*: PAR is the Peak to Average Ratio that is not calibrated but determined based on the signal characteristics
- *A_{x,y,z}*; *B_{x,y,z}*; *C_{x,y,z}*; *D_{x,y,z}*; *VR_{x,y,z}*; *A, B, C, D* are numerical linearization parameters assessed based on the data of power sweep for specific modulation signal. The parameters do not depend on frequency nor media. *VR* is the maximum calibration range expressed in RMS voltage across the diode.
- *ConvF* and *Boundary Effect Parameters*: Assessed in flat phantom using E-field (or Temperature Transfer Standard for $f \leq 800$ MHz) and inside waveguide using analytical field distributions based on power measurements for $f > 800$ MHz. The same setups are used for assessment of the parameters applied for boundary compensation (alpha, depth) of which typical uncertainty values are given. These parameters are used in DASY4 software to improve probe accuracy close to the boundary. The sensitivity in TSL corresponds to *NORM_{x,y,z}* * *ConvF* whereby the uncertainty corresponds to that given for *ConvF*. A frequency dependent *ConvF* is used in DASY version 4.4 and higher which allows extending the validity from ± 50 MHz to ± 100 MHz.
- *Spherical isotropy (3D deviation from isotropy)*: in a field of low gradients realized using a flat phantom exposed by a patch antenna.
- *Sensor Offset*: The sensor offset corresponds to the offset of virtual measurement center from the probe tip (on probe axis). No tolerance required.

Probe ES3DV3

SN:3319

Manufactured: January 10, 2012
Calibrated: April 29, 2013

Calibrated for DASY/EASY Systems
(Note: non-compatible with DASY2 system!)

DASY/EASY - Parameters of Probe: ES3DV3 - SN:3319

Basic Calibration Parameters

	Sensor X	Sensor Y	Sensor Z	Unc (k=2)
Norm ($\mu\text{V}/(\text{V}/\text{m})^2$) ^A	1.12	1.20	1.22	$\pm 10.1 \%$
DCP (mV) ^B	100.7	102.6	102.4	

Modulation Calibration Parameters

UID	Communication System Name		A dB	B dB $\sqrt{\mu\text{V}}$	C	D dB	VR mV	Unc ^E (k=2)
0	CW	X	0.0	0.0	1.0	0.00	152.0	$\pm 3.8 \%$
		Y	0.0	0.0	1.0		159.0	
		Z	0.0	0.0	1.0		149.8	

The reported uncertainty of measurement is stated as the standard uncertainty of measurement multiplied by the coverage factor $k=2$, which for a normal distribution corresponds to a coverage probability of approximately 95%.

^A The uncertainties of NormX,Y,Z do not affect the E^2 -field uncertainty inside TSL (see Pages 5 and 6).

^B Numerical linearization parameter: uncertainty not required.

^E Uncertainty is determined using the max. deviation from linear response applying rectangular distribution and is expressed for the square of the field value.

DASY/EASY - Parameters of Probe: ES3DV3 - SN:3319

Calibration Parameter Determined in Head Tissue Simulating Media

f (MHz) ^C	Relative Permittivity ^F	Conductivity (S/m) ^F	ConvF X	ConvF Y	ConvF Z	Alpha	Depth (mm)	Unct. (k=2)
750	41.9	0.89	6.49	6.49	6.49	0.28	1.97	± 12.0 %
850	41.5	0.92	6.23	6.23	6.23	0.42	1.57	± 12.0 %
1900	40.0	1.40	5.22	5.22	5.22	0.80	1.24	± 12.0 %
2450	39.2	1.80	4.57	4.57	4.57	0.80	1.32	± 12.0 %

^C Frequency validity of ± 100 MHz only applies for DASY v4.4 and higher (see Page 2), else it is restricted to ± 50 MHz. The uncertainty is the RSS of the ConvF uncertainty at calibration frequency and the uncertainty for the indicated frequency band.

^F At frequencies below 3 GHz, the validity of tissue parameters (ϵ and σ) can be relaxed to ± 10% if liquid compensation formula is applied to measured SAR values. At frequencies above 3 GHz, the validity of tissue parameters (ϵ and σ) is restricted to ± 5%. The uncertainty is the RSS of the ConvF uncertainty for indicated target tissue parameters.

DASY/EASY - Parameters of Probe: ES3DV3 - SN:3319

Calibration Parameter Determined in Body Tissue Simulating Media

f (MHz) ^C	Relative Permittivity ^F	Conductivity (S/m) ^F	ConvF X	ConvF Y	ConvF Z	Alpha	Depth (mm)	Unct. (k=2)
750	55.5	0.96	6.30	6.30	6.30	0.45	1.53	± 12.0 %
850	55.2	0.99	6.15	6.15	6.15	0.42	1.65	± 12.0 %
1900	53.3	1.52	4.85	4.85	4.85	0.63	1.49	± 12.0 %
2450	52.7	1.95	4.32	4.32	4.32	0.69	1.20	± 12.0 %

^C Frequency validity of ± 100 MHz only applies for DASY v4.4 and higher (see Page 2), else it is restricted to ± 50 MHz. The uncertainty is the RSS of the ConvF uncertainty at calibration frequency and the uncertainty for the indicated frequency band.

^F At frequencies below 3 GHz, the validity of tissue parameters (ϵ and σ) can be relaxed to ± 10% if liquid compensation formula is applied to measured SAR values. At frequencies above 3 GHz, the validity of tissue parameters (ϵ and σ) is restricted to ± 5%. The uncertainty is the RSS of the ConvF uncertainty for indicated target tissue parameters.

Frequency Response of E-Field (TEM-Cell:ifi110 EXX, Waveguide: R22)

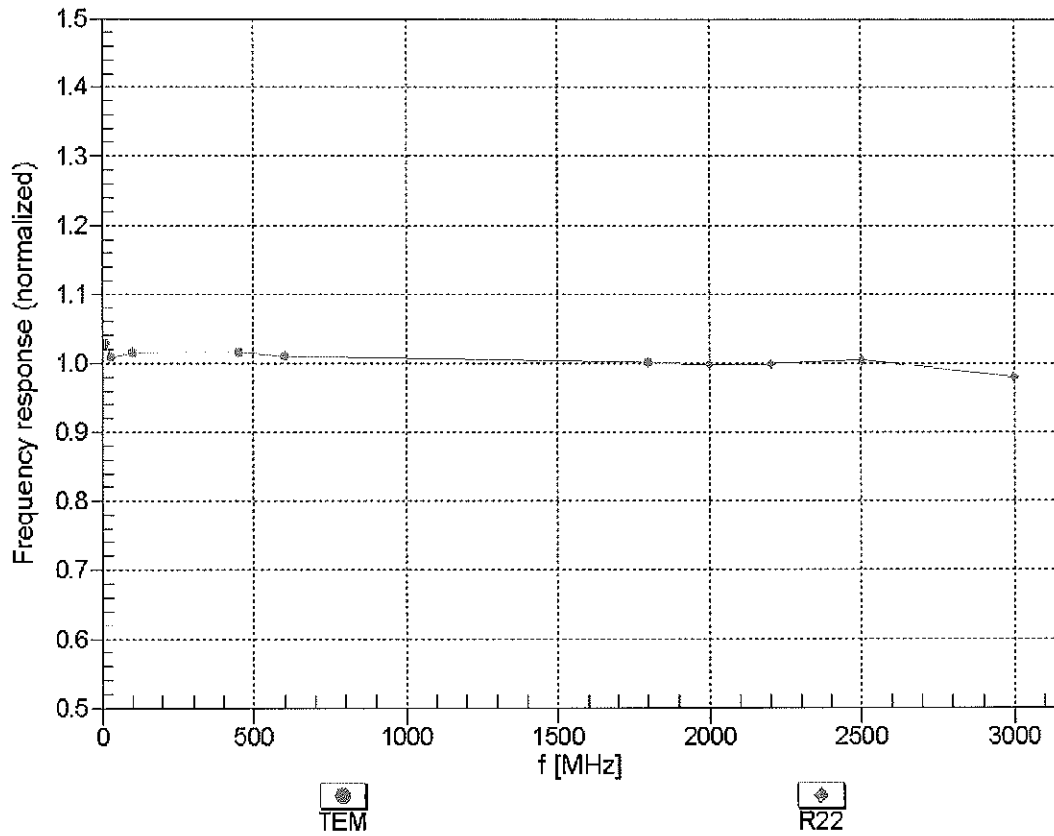

Uncertainty of Frequency Response of E-field: $\pm 6.3\%$ (k=2)

Receiving Pattern (ϕ), $\theta = 0^\circ$

f=600 MHz,TEM

f=1800 MHz,R22

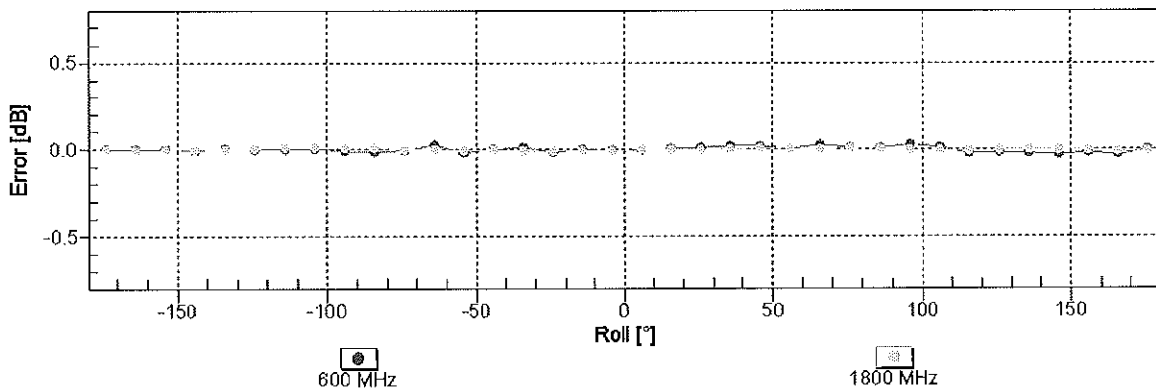
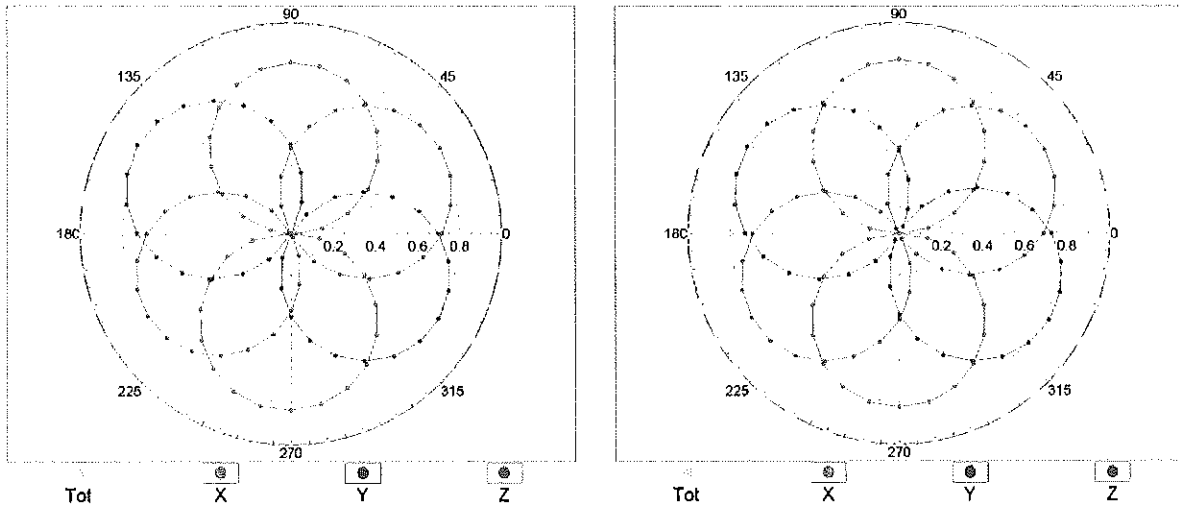

Uncertainty of Axial Isotropy Assessment: $\pm 0.5\%$ (k=2)

Dynamic Range $f(SAR_{head})$ (TEM cell , $f = 900$ MHz)

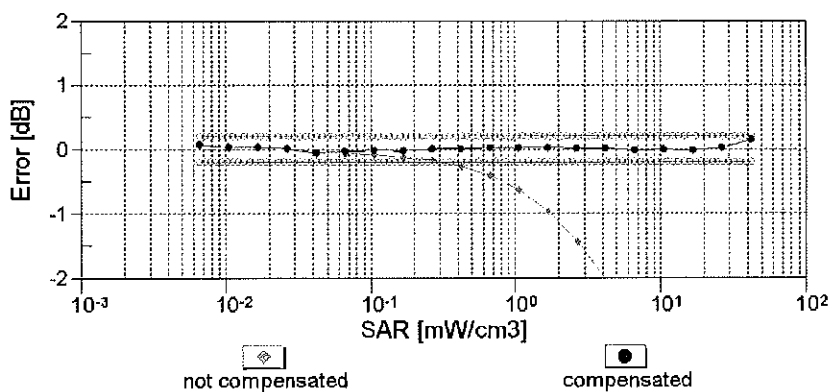
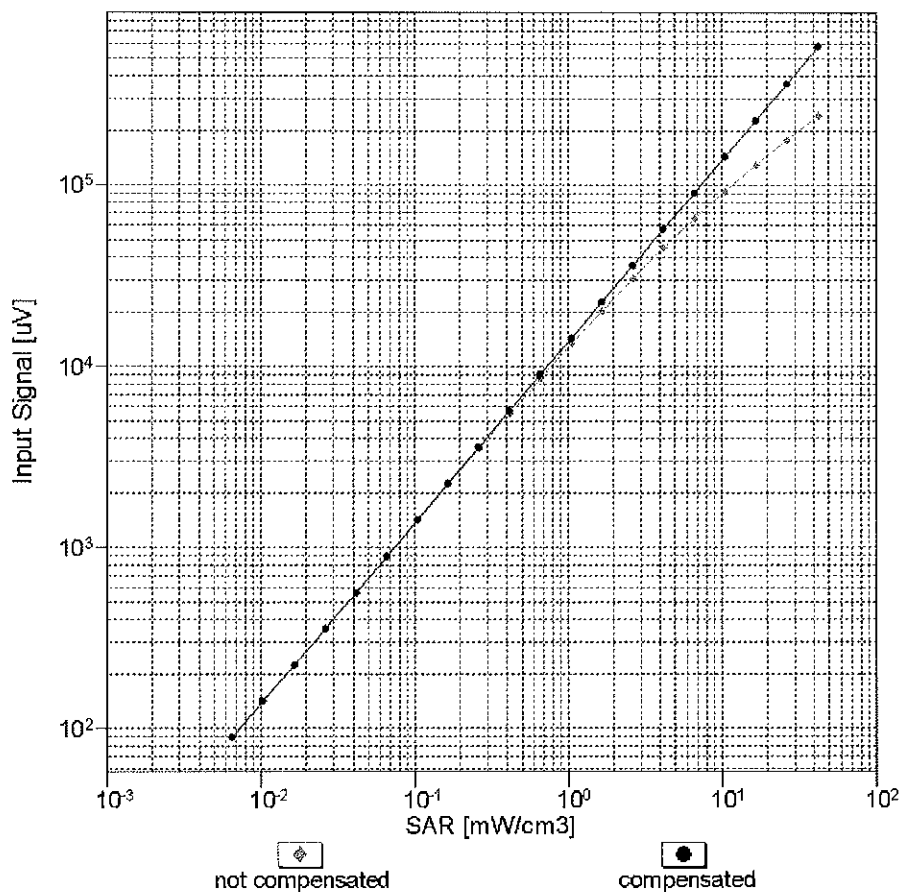

Uncertainty of Linearity Assessment: $\pm 0.6\%$ ($k=2$)

Conversion Factor Assessment

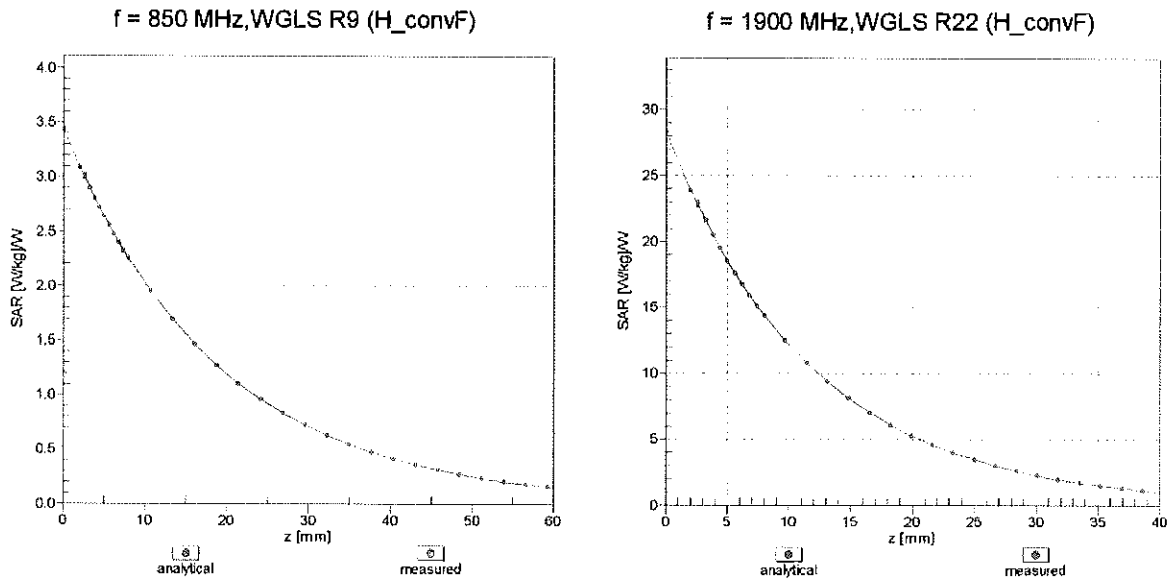

Deviation from Isotropy in Liquid Error (ϕ, θ), f = 900 MHz

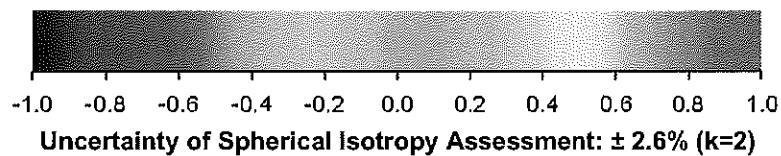
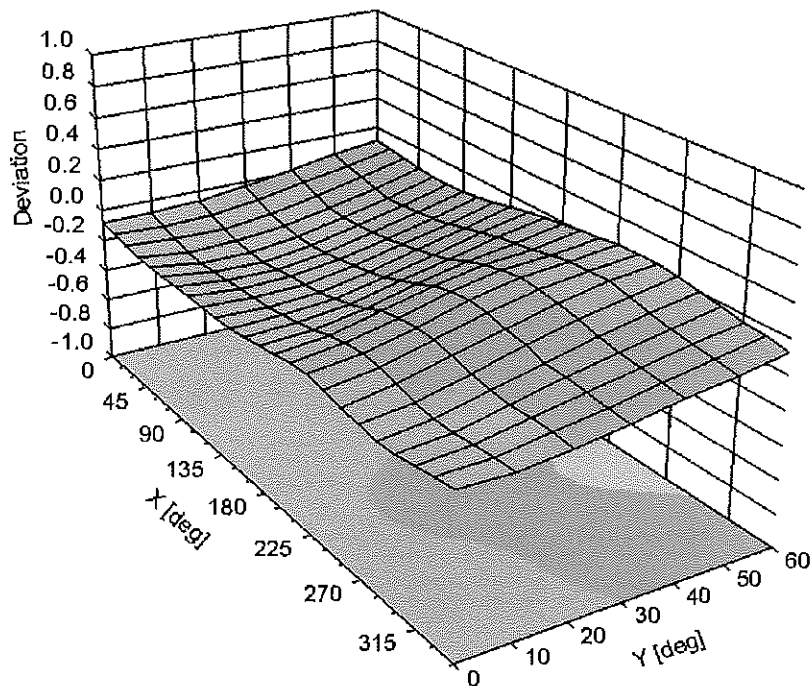

DASY/EASY - Parameters of Probe: ES3DV3 - SN:3319

Other Probe Parameters

Sensor Arrangement	Triangular
Connector Angle (°)	-104.1
Mechanical Surface Detection Mode	enabled
Optical Surface Detection Mode	disabled
Probe Overall Length	337 mm
Probe Body Diameter	10 mm
Tip Length	10 mm
Tip Diameter	4 mm
Probe Tip to Sensor X Calibration Point	2 mm
Probe Tip to Sensor Y Calibration Point	2 mm
Probe Tip to Sensor Z Calibration Point	2 mm
Recommended Measurement Distance from Surface	3 mm

Additional Conversion Factors for Dosimetric E-Field Probe

Type:	ES3DV3
Serial Number:	3319
Place of Assessment:	Zurich
Date of Assessment:	June 19, 2013
Probe Calibration Date:	April 29, 2013

Schmid & Partner Engineering AG hereby certifies that conversion factor(s) of this probe have been evaluated on the date indicated above. The assessment was performed using the FDTD numerical code SEMCAD of Schmid & Partner Engineering AG. The evaluation is coupled with measured conversion factors (probe calibration date indicated above). The uncertainty of the numerical assessment is based on the extrapolation from measured value at 835 MHz or at 1900 MHz.

Assessed by:

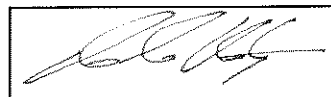

✓
KOK
6/25/13

Dosimetric E-Field Probe ES3DV3 SN:3319Conversion factor (\pm standard deviation)1750 \pm 50 MHz *ConvF* 5.59 \pm 7% $\epsilon_r = 40.1 \pm 5\%$
 $\sigma = 1.37 \pm 5\%$ mho/m
(head tissue)1750 \pm 50 MHz *ConvF* 5.22 \pm 7% $\epsilon_r = 53.4 \pm 5\%$
 $\sigma = 1.49 \pm 5\%$ mho/m
(body tissue)**Important Note:**

For numerically assessed probe conversion factors, parameters Alpha and Delta in the DASY software must have the following entries: Alpha = 0 and Delta = 1.

Please see also DASY Manual.



Accredited by the Swiss Accreditation Service (SAS)
The Swiss Accreditation Service is one of the signatories to the EA
Multilateral Agreement for the recognition of calibration certificates

Accreditation No.: **SCS 108**

Client **PC Test**

Certificate No: **ES3-3209_Mar13**

CALIBRATION CERTIFICATE

Object **ES3DV3 - SN:3209**

Calibration procedure(s) **QA CAL-01.v8, QA CAL-23.v4, QA CAL-25.v4
Calibration procedure for dosimetric E-field probes**

Calibration date: **March 15, 2013**

This calibration certificate documents the traceability to national standards, which realize the physical units of measurements (SI).
The measurements and the uncertainties with confidence probability are given on the following pages and are part of the certificate.

All calibrations have been conducted in the closed laboratory facility: environment temperature (22 ± 3)°C and humidity < 70%.

✓ KOK 3/22/13

Calibration Equipment used (M&TE critical for calibration)

Primary Standards	ID	Cal Date (Certificate No.)	Scheduled Calibration
Power meter E4419B	GB41293874	29-Mar-12 (No. 217-01508)	Apr-13
Power sensor E4412A	MY41498087	29-Mar-12 (No. 217-01508)	Apr-13
Reference 3 dB Attenuator	SN: S5054 (3c)	27-Mar-12 (No. 217-01531)	Apr-13
Reference 20 dB Attenuator	SN: S5086 (20b)	27-Mar-12 (No. 217-01529)	Apr-13
Reference 30 dB Attenuator	SN: S5129 (30b)	27-Mar-12 (No. 217-01532)	Apr-13
Reference Probe ES3DV2	SN: 3013	28-Dec-12 (No. ES3-3013_Dec12)	Dec-13
DAE4	SN: 660	31-Jan-13 (No. DAE4-660_Jan13)	Jan-14
Secondary Standards	ID	Check Date (in house)	Scheduled Check
RF generator HP 8648C	US3642U01700	4-Aug-99 (in house check Apr-11)	In house check: Apr-13
Network Analyzer HP 8753E	US37390585	18-Oct-01 (in house check Oct-12)	In house check: Oct-13

	Name	Function	Signature
Calibrated by:	Israe El-Naouq	Laboratory Technician	<i>Israe El-Naouq</i>
Approved by:	Katja Pokovic	Technical Manager	<i>Katja Pokovic</i>

Issued: March 15, 2013

This calibration certificate shall not be reproduced except in full without written approval of the laboratory.

80244



Accredited by the Swiss Accreditation Service (SAS)

Accreditation No.: **SCS 108**

The Swiss Accreditation Service is one of the signatories to the EA
 Multilateral Agreement for the recognition of calibration certificates

Glossary:

TSL	tissue simulating liquid
NORM _{x,y,z}	sensitivity in free space
ConvF	sensitivity in TSL / NORM _{x,y,z}
DCP	diode compression point
CF	crest factor (1/duty_cycle) of the RF signal
A, B, C, D	modulation dependent linearization parameters
Polarization φ	φ rotation around probe axis
Polarization ϑ	ϑ rotation around an axis that is in the plane normal to probe axis (at measurement center), i.e., ϑ = 0 is normal to probe axis

Calibration is Performed According to the Following Standards:

- a) IEEE Std 1528-2003, "IEEE Recommended Practice for Determining the Peak Spatial-Averaged Specific Absorption Rate (SAR) in the Human Head from Wireless Communications Devices: Measurement Techniques", December 2003
- b) IEC 62209-1, "Procedure to measure the Specific Absorption Rate (SAR) for hand-held devices used in close proximity to the ear (frequency range of 300 MHz to 3 GHz)", February 2005

Methods Applied and Interpretation of Parameters:

- *NORM_{x,y,z}*: Assessed for E-field polarization ϑ = 0 (f ≤ 900 MHz in TEM-cell; f > 1800 MHz: R22 waveguide). *NORM_{x,y,z}* are only intermediate values, i.e., the uncertainties of *NORM_{x,y,z}* does not affect the E²-field uncertainty inside TSL (see below *ConvF*).
- *NORM(f)_{x,y,z}* = *NORM_{x,y,z}* * *frequency_response* (see Frequency Response Chart). This linearization is implemented in DASY4 software versions later than 4.2. The uncertainty of the frequency response is included in the stated uncertainty of *ConvF*.
- *DCP_{x,y,z}*: DCP are numerical linearization parameters assessed based on the data of power sweep with CW signal (no uncertainty required). DCP does not depend on frequency nor media.
- *PAR*: *PAR* is the Peak to Average Ratio that is not calibrated but determined based on the signal characteristics
- *A_{x,y,z}; B_{x,y,z}; C_{x,y,z}; D_{x,y,z}; VR_{x,y,z}; A, B, C, D* are numerical linearization parameters assessed based on the data of power sweep for specific modulation signal. The parameters do not depend on frequency nor media. *VR* is the maximum calibration range expressed in RMS voltage across the diode.
- *ConvF and Boundary Effect Parameters*: Assessed in flat phantom using E-field (or Temperature Transfer Standard for f ≤ 800 MHz) and inside waveguide using analytical field distributions based on power measurements for f > 800 MHz. The same setups are used for assessment of the parameters applied for boundary compensation (alpha, depth) of which typical uncertainty values are given. These parameters are used in DASY4 software to improve probe accuracy close to the boundary. The sensitivity in TSL corresponds to *NORM_{x,y,z}* * *ConvF* whereby the uncertainty corresponds to that given for *ConvF*. A frequency dependent *ConvF* is used in DASY version 4.4 and higher which allows extending the validity from ± 50 MHz to ± 100 MHz.
- *Spherical isotropy (3D deviation from isotropy)*: in a field of low gradients realized using a flat phantom exposed by a patch antenna.
- *Sensor Offset*: The sensor offset corresponds to the offset of virtual measurement center from the probe tip (on probe axis). No tolerance required.

Probe ES3DV3

SN:3209

Manufactured: October 14, 2008
Calibrated: March 15, 2013

Calibrated for DASY/EASY Systems
(Note: non-compatible with DASY2 system!)

DASY/EASY - Parameters of Probe: ES3DV3 - SN:3209

Basic Calibration Parameters

	Sensor X	Sensor Y	Sensor Z	Unc (k=2)
Norm ($\mu\text{V}/(\text{V}/\text{m})^2$) ^A	1.35	1.33	1.14	$\pm 10.1 \%$
DCP (mV) ^B	99.2	97.8	98.3	

Modulation Calibration Parameters

UID	Communication System Name		A dB	B dB $\sqrt{\mu\text{V}}$	C	D dB	VR mV	Unc ^E (k=2)
0	CW	X	0.0	0.0	1.0	0.00	163.6	$\pm 3.5 \%$
		Y	0.0	0.0	1.0		170.3	
		Z	0.0	0.0	1.0		158.7	

The reported uncertainty of measurement is stated as the standard uncertainty of measurement multiplied by the coverage factor $k=2$, which for a normal distribution corresponds to a coverage probability of approximately 95%.

^A The uncertainties of NormX,Y,Z do not affect the E^2 -field uncertainty inside TSL (see Pages 5 and 6).

^B Numerical linearization parameter: uncertainty not required.

^E Uncertainty is determined using the max. deviation from linear response applying rectangular distribution and is expressed for the square of the field value.

DASY/EASY - Parameters of Probe: ES3DV3 - SN:3209

Calibration Parameter Determined in Head Tissue Simulating Media

f (MHz) ^C	Relative Permittivity ^F	Conductivity (S/m) ^F	ConvF X	ConvF Y	ConvF Z	Alpha	Depth (mm)	Unct. (k=2)
750	41.9	0.89	6.74	6.74	6.74	0.76	1.18	± 12.0 %
835	41.5	0.90	6.46	6.46	6.46	0.31	1.81	± 12.0 %
1750	40.1	1.37	5.39	5.39	5.39	0.80	1.21	± 12.0 %
1900	40.0	1.40	5.21	5.21	5.21	0.78	1.26	± 12.0 %
2450	39.2	1.80	4.57	4.57	4.57	0.65	1.43	± 12.0 %
2600	39.0	1.96	4.43	4.43	4.43	0.75	1.36	± 12.0 %

^C Frequency validity of ± 100 MHz only applies for DASY v4.4 and higher (see Page 2), else it is restricted to ± 50 MHz. The uncertainty is the RSS of the ConvF uncertainty at calibration frequency and the uncertainty for the indicated frequency band.

^F At frequencies below 3 GHz, the validity of tissue parameters (ϵ and σ) can be relaxed to ± 10% if liquid compensation formula is applied to measured SAR values. At frequencies above 3 GHz, the validity of tissue parameters (ϵ and σ) is restricted to ± 5%. The uncertainty is the RSS of the ConvF uncertainty for indicated target tissue parameters.

DASY/EASY - Parameters of Probe: ES3DV3 - SN:3209

Calibration Parameter Determined in Body Tissue Simulating Media

f (MHz) ^C	Relative Permittivity ^F	Conductivity (S/m) ^F	ConvF X	ConvF Y	ConvF Z	Alpha	Depth (mm)	Unct. (k=2)
750	55.5	0.96	6.38	6.38	6.38	0.80	1.16	± 12.0 %
835	55.2	0.97	6.28	6.28	6.28	0.52	1.45	± 12.0 %
1750	53.4	1.49	5.03	5.03	5.03	0.58	1.45	± 12.0 %
1900	53.3	1.52	4.77	4.77	4.77	0.70	1.36	± 12.0 %
2450	52.7	1.95	4.34	4.34	4.34	0.80	1.15	± 12.0 %
2600	52.5	2.16	4.11	4.11	4.11	0.80	1.00	± 12.0 %

^C Frequency validity of ± 100 MHz only applies for DASY v4.4 and higher (see Page 2), else it is restricted to ± 50 MHz. The uncertainty is the RSS of the ConvF uncertainty at calibration frequency and the uncertainty for the indicated frequency band.

^F At frequencies below 3 GHz, the validity of tissue parameters (ϵ and σ) can be relaxed to ± 10% if liquid compensation formula is applied to measured SAR values. At frequencies above 3 GHz, the validity of tissue parameters (ϵ and σ) is restricted to ± 5%. The uncertainty is the RSS of the ConvF uncertainty for indicated target tissue parameters.

Frequency Response of E-Field (TEM-Cell:ifi110 EXX, Waveguide: R22)

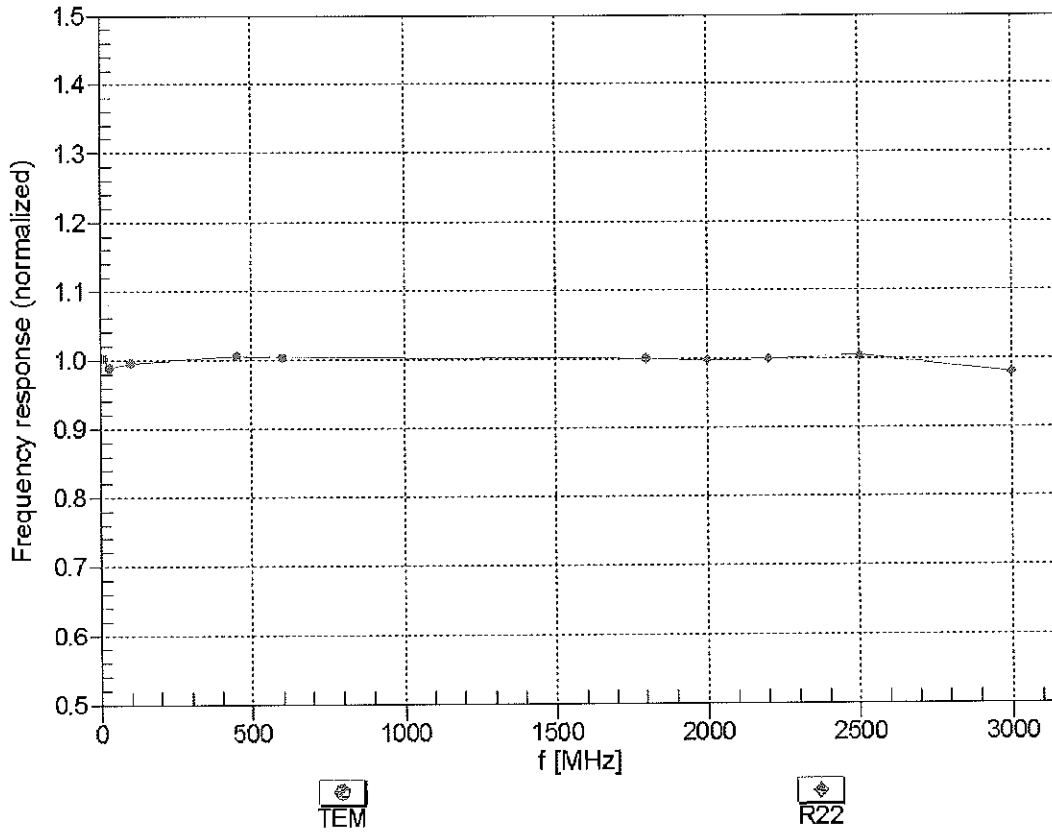

Uncertainty of Frequency Response of E-field: $\pm 6.3\%$ (k=2)

Receiving Pattern (ϕ), $\theta = 0^\circ$

f=600 MHz,TEM

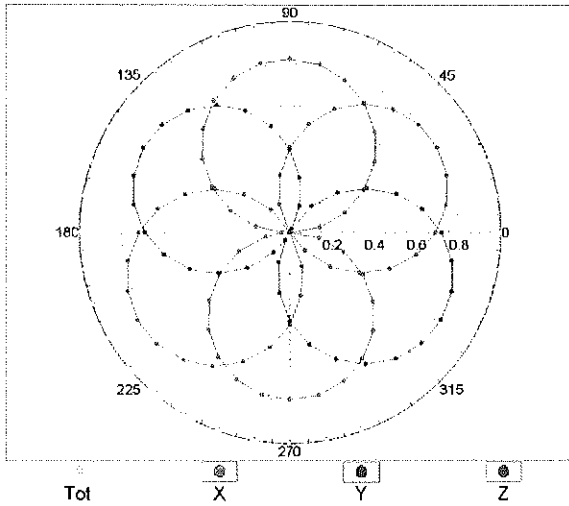

f=1800 MHz,R22

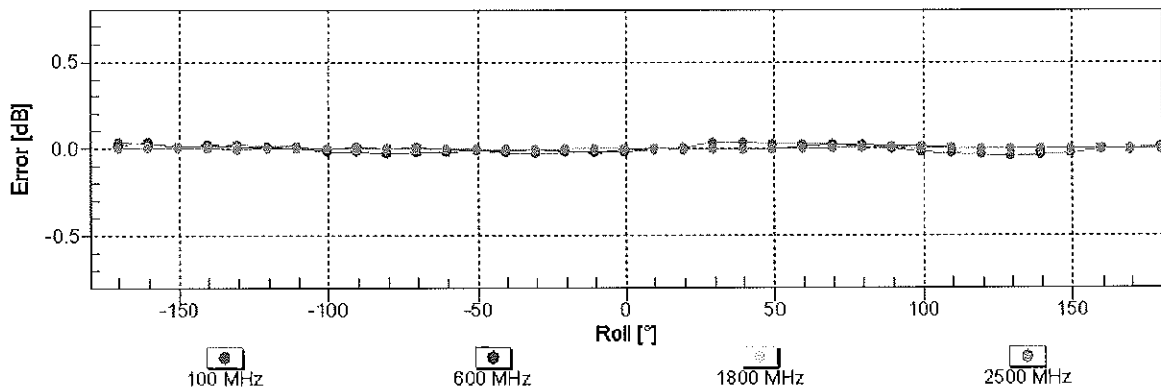
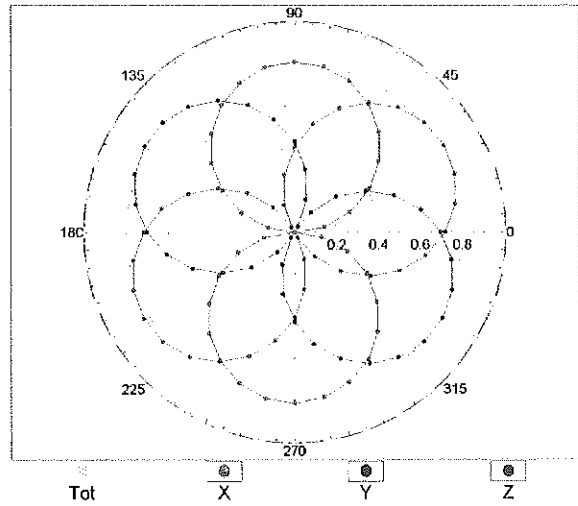

Uncertainty of Axial Isotropy Assessment: $\pm 0.5\%$ (k=2)

Dynamic Range $f(SAR_{head})$ (TEM cell , $f = 900$ MHz)

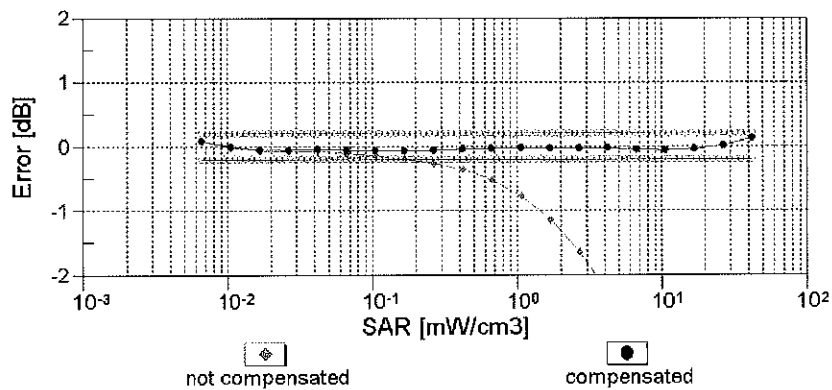
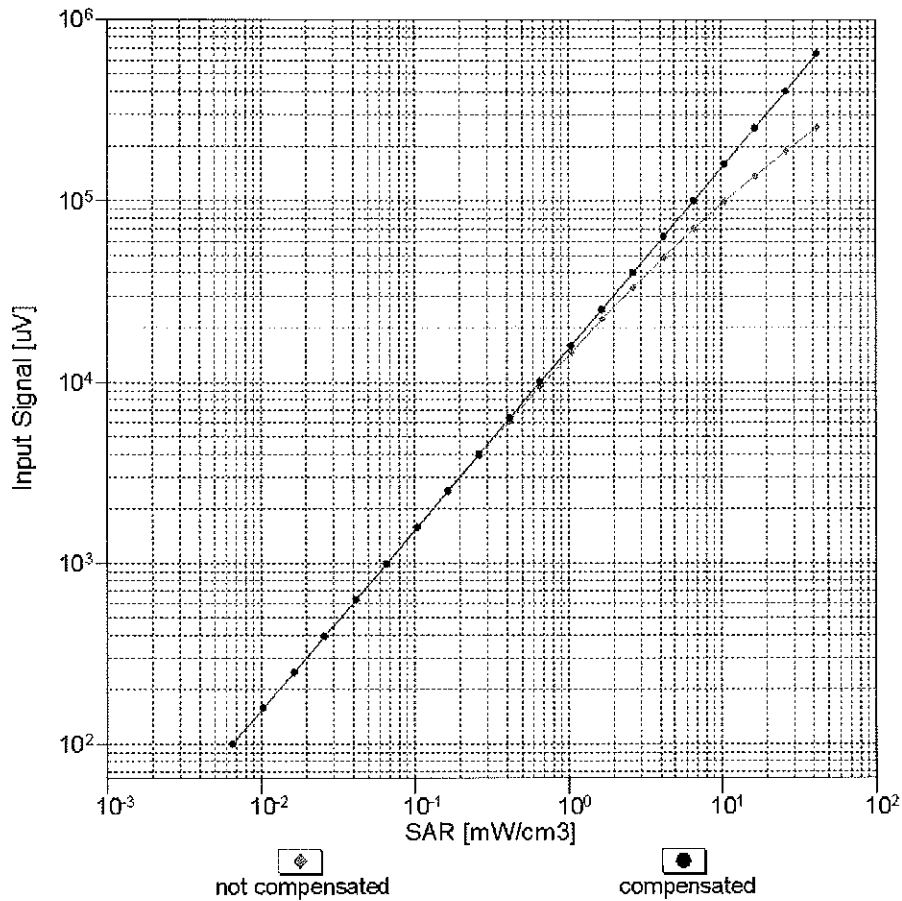

Uncertainty of Linearity Assessment: $\pm 0.6\%$ ($k=2$)

Conversion Factor Assessment

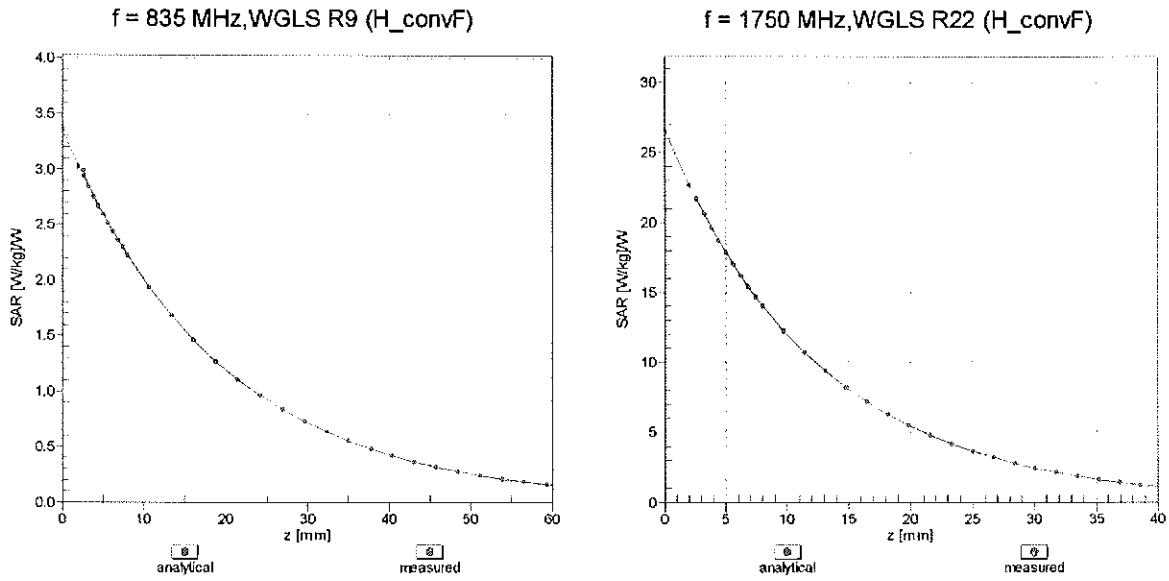

Deviation from Isotropy in Liquid Error (ϕ, θ), f = 900 MHz

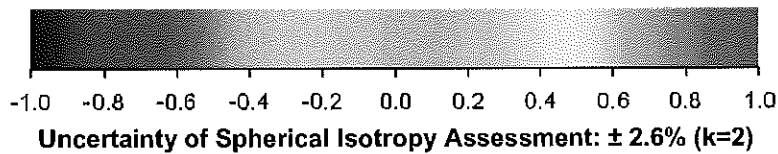
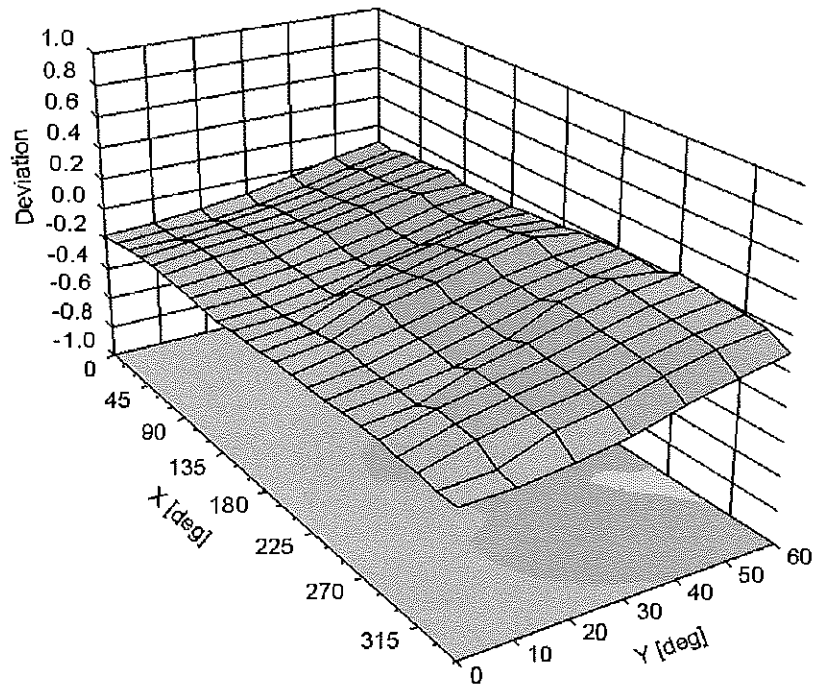

DASY/EASY - Parameters of Probe: ES3DV3 - SN:3209

Other Probe Parameters

Sensor Arrangement	Triangular
Connector Angle (°)	-40.6
Mechanical Surface Detection Mode	enabled
Optical Surface Detection Mode	disabled
Probe Overall Length	337 mm
Probe Body Diameter	10 mm
Tip Length	10 mm
Tip Diameter	4 mm
Probe Tip to Sensor X Calibration Point	2 mm
Probe Tip to Sensor Y Calibration Point	2 mm
Probe Tip to Sensor Z Calibration Point	2 mm
Recommended Measurement Distance from Surface	3 mm

**Calibration Laboratory of
Schmid & Partner
Engineering AG**
Zeughausstrasse 43, 8004 Zurich, Switzerland



SCS Schweizerischer Kalibrierdienst
Service suisse d'étalonnage
Servizio svizzero di taratura
Swiss Calibration Service

Accredited by the Swiss Accreditation Service (SAS)
The Swiss Accreditation Service is one of the signatories to the EA
Multilateral Agreement for the recognition of calibration certificates

Accreditation No.: **SCS 108**

Client **PC Test**

Certificate No: **ES3-3287_Nov13**

CALIBRATION CERTIFICATE

Object **ES3DV3 - SN:3287**

Calibration procedure(s) **QA CAL-01.v9, QA CAL-23.v5, QA CAL-25.v6
Calibration procedure for dosimetric E-field probes**

Calibration date: **November 20, 2013** ✓ CC 11/20/2013

This calibration certificate documents the traceability to national standards, which realize the physical units of measurements (SI).
The measurements and the uncertainties with confidence probability are given on the following pages and are part of the certificate.

All calibrations have been conducted in the closed laboratory facility: environment temperature (22 ± 3)°C and humidity < 70%.

Calibration Equipment used (M&TE critical for calibration)

Primary Standards	ID	Cal Date (Certificate No.)	Scheduled Calibration
Power meter E4419B	GB41293874	04-Apr-13 (No. 217-01733)	Apr-14
Power sensor E4412A	MY41498087	04-Apr-13 (No. 217-01733)	Apr-14
Reference 3 dB Attenuator	SN: S5054 (3c)	04-Apr-13 (No. 217-01737)	Apr-14
Reference 20 dB Attenuator	SN: S5277 (20x)	04-Apr-13 (No. 217-01735)	Apr-14
Reference 30 dB Attenuator	SN: S5129 (30b)	04-Apr-13 (No. 217-01738)	Apr-14
Reference Probe ES3DV2	SN: 3013	28-Dec-12 (No. ES3-3013_Dec12)	Dec-13
DAE4	SN: 660	4-Sep-13 (No. DAE4-660_Sep13)	Sep-14
Secondary Standards	ID	Check Date (in house)	Scheduled Check
RF generator HP 8648C	US3642U01700	4-Aug-99 (in house check Apr-13)	In house check: Apr-15
Network Analyzer HP 8753E	US37390585	18-Oct-01 (in house check Oct-13)	In house check: Oct-14

	Name	Function	Signature
Calibrated by:	Leif Klysner	Laboratory Technician	
Approved by:	Kalja Pokovic	Technical Manager	

Issued: November 20, 2013

This calibration certificate shall not be reproduced except in full without written approval of the laboratory.



Accredited by the Swiss Accreditation Service (SAS)
 The Swiss Accreditation Service is one of the signatories to the EA
 Multilateral Agreement for the recognition of calibration certificates

Accreditation No.: **SCS 108**

Glossary:

TSL	tissue simulating liquid
NORM _{x,y,z}	sensitivity in free space
ConvF	sensitivity in TSL / NORM _{x,y,z}
DCP	diode compression point
CF	crest factor (1/duty_cycle) of the RF signal
A, B, C, D	modulation dependent linearization parameters
Polarization φ	φ rotation around probe axis
Polarization ϑ	ϑ rotation around an axis that is in the plane normal to probe axis (at measurement center), i.e., ϑ = 0 is normal to probe axis
Connector Angle	information used in DASY system to align probe sensor X to the robot coordinate system

Calibration is Performed According to the Following Standards:

- a) IEEE Std 1528-2013, "IEEE Recommended Practice for Determining the Peak Spatial-Averaged Specific Absorption Rate (SAR) in the Human Head from Wireless Communications Devices: Measurement Techniques", June 2013
- b) IEC 62209-1, "Procedure to measure the Specific Absorption Rate (SAR) for hand-held devices used in close proximity to the ear (frequency range of 300 MHz to 3 GHz)", February 2005

Methods Applied and Interpretation of Parameters:

- **NORM_{x,y,z}**: Assessed for E-field polarization ϑ = 0 (f ≤ 900 MHz in TEM-cell; f > 1800 MHz: R22 waveguide). NORM_{x,y,z} are only intermediate values, i.e., the uncertainties of NORM_{x,y,z} does not affect the E²-field uncertainty inside TSL (see below *ConvF*).
- **NORM(f)_{x,y,z}** = NORM_{x,y,z} * *frequency_response* (see Frequency Response Chart). This linearization is implemented in DASY4 software versions later than 4.2. The uncertainty of the frequency response is included in the stated uncertainty of *ConvF*.
- **DCP_{x,y,z}**: DCP are numerical linearization parameters assessed based on the data of power sweep with CW signal (no uncertainty required). DCP does not depend on frequency nor media.
- **PAR**: PAR is the Peak to Average Ratio that is not calibrated but determined based on the signal characteristics
- **A_{x,y,z}; B_{x,y,z}; C_{x,y,z}; D_{x,y,z}; VR_{x,y,z}**: A, B, C, D are numerical linearization parameters assessed based on the data of power sweep for specific modulation signal. The parameters do not depend on frequency nor media. VR is the maximum calibration range expressed in RMS voltage across the diode.
- **ConvF and Boundary Effect Parameters**: Assessed in flat phantom using E-field (or Temperature Transfer Standard for f ≤ 800 MHz) and inside waveguide using analytical field distributions based on power measurements for f > 800 MHz. The same setups are used for assessment of the parameters applied for boundary compensation (alpha, depth) of which typical uncertainty values are given. These parameters are used in DASY4 software to improve probe accuracy close to the boundary. The sensitivity in TSL corresponds to NORM_{x,y,z} * ConvF whereby the uncertainty corresponds to that given for ConvF. A frequency dependent ConvF is used in DASY version 4.4 and higher which allows extending the validity from ± 50 MHz to ± 100 MHz.
- **Spherical isotropy (3D deviation from isotropy)**: in a field of low gradients realized using a flat phantom exposed by a patch antenna.
- **Sensor Offset**: The sensor offset corresponds to the offset of virtual measurement center from the probe tip (on probe axis). No tolerance required.
- **Connector Angle**: The angle is assessed using the information gained by determining the NORM_x (no uncertainty required).

Probe ES3DV3

SN:3287

Manufactured: June 7, 2010
Calibrated: November 20, 2013

Calibrated for DASY/EASY Systems
(Note: non-compatible with DASY2 system!)

DASY/EASY - Parameters of Probe: ES3DV3 - SN:3287

Basic Calibration Parameters

	Sensor X	Sensor Y	Sensor Z	Unc (k=2)
Norm ($\mu\text{V}/(\text{V}/\text{m})^2$) ^A	1.31	1.25	1.25	$\pm 10.1\%$
DCP (mV) ^B	102.6	102.5	100.4	

Modulation Calibration Parameters

UID	Communication System Name		A dB	B dB $\sqrt{\mu\text{V}}$	C	D dB	VR mV	Unc ^E (k=2)
0	CW	X	0.0	0.0	1.0	0.00	157.3	$\pm 2.7\%$
		Y	0.0	0.0	1.0		159.9	
		Z	0.0	0.0	1.0		152.5	
10010- CAA	SAR Validation (Square, 100ms, 10ms)	X	2.23	57.9	9.9	10.00	45.7	$\pm 1.4\%$
		Y	2.13	57.6	9.8		46.6	
		Z	3.31	61.1	11.8		47.6	
10011- CAA	UMTS-FDD (WCDMA)	X	3.25	66.3	17.9	2.91	124.8	$\pm 0.5\%$
		Y	3.16	65.7	17.4		127.4	
		Z	3.15	65.5	17.4		122.8	
10012- CAA	IEEE 802.11b WiFi 2.4 GHz (DSSS, 1 Mbps)	X	3.08	68.7	18.3	1.87	127.2	$\pm 0.7\%$
		Y	3.03	68.2	17.9		129.4	
		Z	2.87	67.0	17.3		126.5	
10021- DAA	GSM-FDD (TDMA, GMSK)	X	15.99	90.6	25.0	9.39	99.9	$\pm 1.2\%$
		Y	12.41	86.6	23.6		101.5	
		Z	29.18	99.9	28.5		109.2	
10023- DAA	GPRS-FDD (TDMA, GMSK, TN 0)	X	25.67	98.9	27.8	9.57	97.9	$\pm 1.7\%$
		Y	14.20	88.5	24.3		100.6	
		Z	27.68	99.8	28.8		107.7	
10024- DAA	GPRS-FDD (TDMA, GMSK, TN 0-1)	X	42.95	99.6	24.9	6.56	124.4	$\pm 1.4\%$
		Y	45.27	99.9	24.8		128.8	
		Z	42.64	99.6	25.5		135.7	
10027- DAA	GPRS-FDD (TDMA, GMSK, TN 0-1-2)	X	27.78	91.3	21.1	4.80	136.0	$\pm 1.4\%$
		Y	32.74	93.9	21.9		146.6	
		Z	23.93	89.5	21.1		144.8	
10028- DAA	GPRS-FDD (TDMA, GMSK, TN 0-1-2-3)	X	59.17	99.6	22.4	3.55	142.5	$\pm 1.2\%$
		Y	78.76	99.7	21.7		104.9	
		Z	38.06	94.2	21.4		148.8	
10032- CAA	IEEE 802.15.1 Bluetooth (GFSK, DH5)	X	93.35	99.7	19.5	1.16	108.1	$\pm 0.9\%$
		Y	96.67	94.0	16.9		114.7	
		Z	98.17	96.2	18.2		108.9	
10039- CAA	CDMA2000 (1xRTT, RC1)	X	4.84	66.7	18.8	4.57	126.5	$\pm 0.9\%$
		Y	4.83	66.6	18.6		134.4	
		Z	4.76	66.0	18.3		125.9	
10081- CAA	CDMA2000 (1xRTT, RC3)	X	4.00	66.2	18.5	3.97	121.9	$\pm 0.7\%$
		Y	3.91	65.5	17.9		128.9	
		Z	3.88	65.2	17.8		120.7	

10098-CAA	UMTS-FDD (HSUPA, Subtest 2)	X	4.66	66.6	18.4	3.98	132.5	±0.7 %
		Y	4.66	66.5	18.2		141.3	
		Z	4.54	65.9	17.9		130.7	
10100-CAB	LTE-FDD (SC-FDMA, 100% RB, 20 MHz, QPSK)	X	6.65	68.3	20.1	5.67	139.5	±1.4 %
		Y	6.69	68.3	19.9		148.9	
		Z	6.60	67.9	19.8		137.5	
10108-CAB	LTE-FDD (SC-FDMA, 100% RB, 10 MHz, QPSK)	X	6.52	67.8	20.0	5.80	137.3	±1.4 %
		Y	6.53	67.6	19.7		147.5	
		Z	6.51	67.6	19.8		135.3	
10110-CAB	LTE-FDD (SC-FDMA, 100% RB, 5 MHz, QPSK)	X	6.19	67.2	19.7	5.75	134.3	±1.2 %
		Y	6.24	67.3	19.6		142.9	
		Z	6.23	67.1	19.6		132.3	
10151-CAB	LTE-TDD (SC-FDMA, 50% RB, 20 MHz, QPSK)	X	11.56	79.1	27.9	9.28	130.1	±3.0 %
		Y	11.01	76.8	26.2		141.9	
		Z	12.98	81.2	28.7		135.7	
10154-CAB	LTE-FDD (SC-FDMA, 50% RB, 10 MHz, QPSK)	X	6.25	67.4	19.8	5.75	135.1	±1.2 %
		Y	6.17	66.9	19.3		143.6	
		Z	6.16	66.8	19.4		132.8	
10160-CAB	LTE-FDD (SC-FDMA, 50% RB, 15 MHz, QPSK)	X	6.66	67.8	20.0	5.82	140.3	±1.4 %
		Y	6.72	67.9	19.9		148.8	
		Z	6.66	67.6	19.8		137.4	
10169-CAB	LTE-FDD (SC-FDMA, 1 RB, 20 MHz, QPSK)	X	5.05	66.7	19.5	5.73	117.8	±0.9 %
		Y	4.93	66.0	18.9		125.0	
		Z	5.08	66.3	19.3		116.3	
10172-CAB	LTE-TDD (SC-FDMA, 1 RB, 20 MHz, QPSK)	X	8.47	76.8	26.9	9.21	100.3	±2.2 %
		Y	8.06	74.6	25.3		107.5	
		Z	9.43	78.2	27.4		102.5	
10175-CAB	LTE-FDD (SC-FDMA, 1 RB, 10 MHz, QPSK)	X	4.98	66.3	19.3	5.72	118.2	±0.9 %
		Y	4.96	66.1	19.0		119.9	
		Z	5.03	66.1	19.1		116.1	
10181-CAB	LTE-FDD (SC-FDMA, 1 RB, 15 MHz, QPSK)	X	5.06	66.7	19.6	5.72	118.7	±0.9 %
		Y	4.97	66.2	19.1		120.0	
		Z	5.03	66.1	19.1		116.3	
10225-CAA	UMTS-FDD (HSPA+)	X	6.78	66.1	18.9	5.97	105.3	±1.2 %
		Y	6.68	65.7	18.6		106.8	
		Z	7.32	67.6	19.7		148.0	
10237-CAB	LTE-TDD (SC-FDMA, 1 RB, 10 MHz, QPSK)	X	8.56	77.1	27.1	9.21	100.8	±1.9 %
		Y	8.33	75.8	26.1		103.8	
		Z	9.39	78.0	27.3		101.9	
10252-CAB	LTE-TDD (SC-FDMA, 50% RB, 10 MHz, QPSK)	X	10.58	77.8	27.4	9.24	123.3	±2.5 %
		Y	10.48	76.9	26.5		128.1	
		Z	11.79	79.6	28.0		127.0	
10267-CAB	LTE-TDD (SC-FDMA, 100% RB, 10 MHz, QPSK)	X	11.52	79.1	27.9	9.30	130.1	±2.7 %
		Y	11.24	77.7	26.9		136.0	
		Z	12.96	81.2	28.8		134.8	

10274-CAA	UMTS-FDD (HSUPA, Subtest 5, 3GPP Rel8.10)	X	6.14	67.4	19.0	4.87	145.5	±1.2 %
		Y	6.19	67.4	19.0		149.2	
		Z	6.10	66.9	18.8		142.3	
10275-CAA	UMTS-FDD (HSUPA, Subtest 5, 3GPP Rel8.4)	X	4.41	66.4	18.3	3.96	126.4	±0.7 %
		Y	4.43	66.3	18.2		130.4	
		Z	4.36	65.9	18.0		123.8	
10291-AAA	CDMA2000, RC3, SO55, Full Rate	X	3.57	65.9	17.9	3.46	120.0	±0.5 %
		Y	3.55	65.6	17.6		121.7	
		Z	3.50	65.1	17.5		117.2	
10292-AAA	CDMA2000, RC3, SO32, Full Rate	X	3.55	66.1	18.0	3.39	121.3	±0.5 %
		Y	3.54	66.0	17.8		123.6	
		Z	3.45	65.2	17.4		118.9	
10297-AAA	LTE-FDD (SC-FDMA, 50% RB, 20 MHz, QPSK)	X	6.53	67.8	20.0	5.81	136.2	±1.2 %
		Y	6.48	67.5	19.6		139.3	
		Z	6.52	67.6	19.8		134.1	
10311-AAA	LTE-FDD (SC-FDMA, 100% RB, 15 MHz, QPSK)	X	7.12	68.4	20.4	6.06	141.7	±1.4 %
		Y	7.11	68.3	20.1		145.3	
		Z	7.14	68.4	20.3		139.8	
10315-AAA	IEEE 802.11b WiFi 2.4 GHz (DSSS, 1 Mbps, 96pc duty cycle)	X	2.79	67.6	18.0	1.71	125.5	±0.5 %
		Y	2.71	66.9	17.3		128.2	
		Z	2.64	66.2	17.0		123.5	
10403-AAA	CDMA2000 (1xEV-DO, Rev. 0)	X	4.78	67.5	18.3	3.76	130.6	±0.5 %
		Y	4.77	67.5	18.2		133.8	
		Z	4.65	66.5	17.8		130.0	
10404-AAA	CDMA2000 (1xEV-DO, Rev. A)	X	4.83	68.2	18.6	3.77	129.2	±0.7 %
		Y	4.68	67.4	18.0		131.9	
		Z	4.52	66.3	17.7		128.7	

The reported uncertainty of measurement is stated as the standard uncertainty of measurement multiplied by the coverage factor $k=2$, which for a normal distribution corresponds to a coverage probability of approximately 95%.

^A The uncertainties of NormX,Y,Z do not affect the E^2 -field uncertainty inside TSL (see Pages 7 and 8).

^B Numerical linearization parameter: uncertainty not required.

^E Uncertainty is determined using the max. deviation from linear response applying rectangular distribution and is expressed for the square of the field value.

DASY/EASY - Parameters of Probe: ES3DV3 - SN:3287

Calibration Parameter Determined in Head Tissue Simulating Media

f (MHz) ^C	Relative Permittivity ^F	Conductivity (S/m) ^F	ConvF X	ConvF Y	ConvF Z	Alpha ^G	Depth ^G (mm)	Unct. (k=2)
750	41.9	0.89	6.52	6.52	6.52	0.47	1.46	± 12.0 %
835	41.5	0.90	6.30	6.30	6.30	0.40	1.59	± 12.0 %
1750	40.1	1.37	5.27	5.27	5.27	0.63	1.34	± 12.0 %
1900	40.0	1.40	5.08	5.08	5.08	0.62	1.37	± 12.0 %
2450	39.2	1.80	4.43	4.43	4.43	0.79	1.28	± 12.0 %
2600	39.0	1.96	4.29	4.29	4.29	0.77	1.38	± 12.0 %

^C Frequency validity of ± 100 MHz only applies for DASY v4.4 and higher (see Page 2), else it is restricted to ± 50 MHz. The uncertainty is the RSS of the ConvF uncertainty at calibration frequency and the uncertainty for the indicated frequency band.

^F At frequencies below 3 GHz, the validity of tissue parameters (ϵ and σ) can be relaxed to ± 10% if liquid compensation formula is applied to measured SAR values. At frequencies above 3 GHz, the validity of tissue parameters (ϵ and σ) is restricted to ± 5%. The uncertainty is the RSS of the ConvF uncertainty for indicated target tissue parameters.

^G Alpha/Depth are determined during calibration. SPEAG warrants that the remaining deviation due to the boundary effect after compensation is always less than ± 1% for frequencies below 3 GHz and below ± 2% for frequencies between 3-6 GHz at any distance larger than half the probe tip diameter from the boundary.

DASY/EASY - Parameters of Probe: ES3DV3 - SN:3287

Calibration Parameter Determined in Body Tissue Simulating Media

f (MHz) ^C	Relative Permittivity ^F	Conductivity (S/m) ^F	ConvF X	ConvF Y	ConvF Z	Alpha ^G	Depth ^G (mm)	Unct. (k=2)
750	55.5	0.96	6.09	6.09	6.09	0.55	1.37	± 12.0 %
835	55.2	0.97	6.04	6.04	6.04	0.55	1.39	± 12.0 %
1750	53.4	1.49	4.93	4.93	4.93	0.39	1.73	± 12.0 %
1900	53.3	1.52	4.67	4.67	4.67	0.38	1.75	± 12.0 %
2450	52.7	1.95	4.17	4.17	4.17	0.60	1.20	± 12.0 %
2600	52.5	2.16	4.00	4.00	4.00	0.60	1.10	± 12.0 %

^C Frequency validity of ± 100 MHz only applies for DASY v4.4 and higher (see Page 2), else it is restricted to ± 50 MHz. The uncertainty is the RSS of the ConvF uncertainty at calibration frequency and the uncertainty for the indicated frequency band.

^F At frequencies below 3 GHz, the validity of tissue parameters (ϵ and σ) can be relaxed to ± 10% if liquid compensation formula is applied to measured SAR values. At frequencies above 3 GHz, the validity of tissue parameters (ϵ and σ) is restricted to ± 5%. The uncertainty is the RSS of the ConvF uncertainty for indicated target tissue parameters.

^G Alpha/Depth are determined during calibration. SPEAG warrants that the remaining deviation due to the boundary effect after compensation is always less than ± 1% for frequencies below 3 GHz and below ± 2% for frequencies between 3-6 GHz at any distance larger than half the probe tip diameter from the boundary.

Frequency Response of E-Field (TEM-Cell:ifi110 EXX, Waveguide: R22)

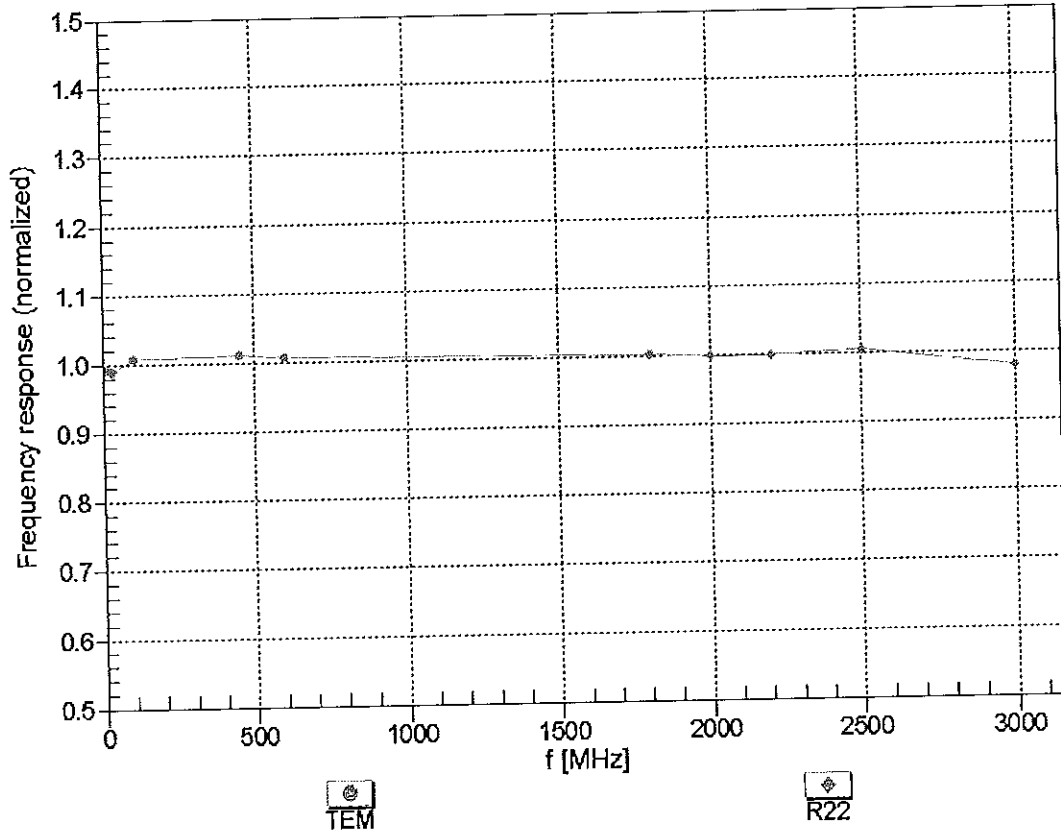

Uncertainty of Frequency Response of E-field: $\pm 6.3\%$ (k=2)

Receiving Pattern (ϕ), $\vartheta = 0^\circ$

f=600 MHz, TEM

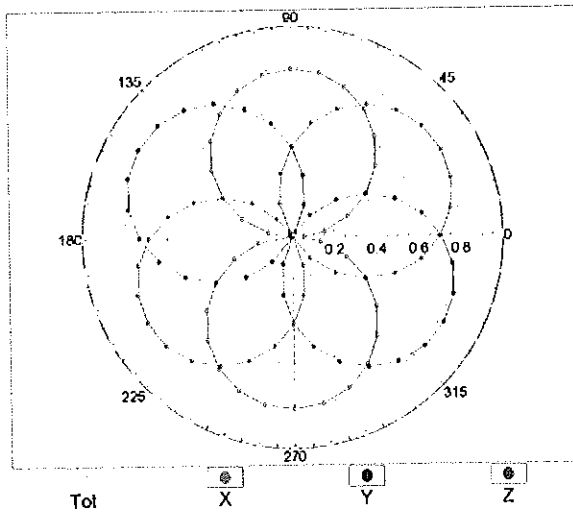

f=1800 MHz, R22

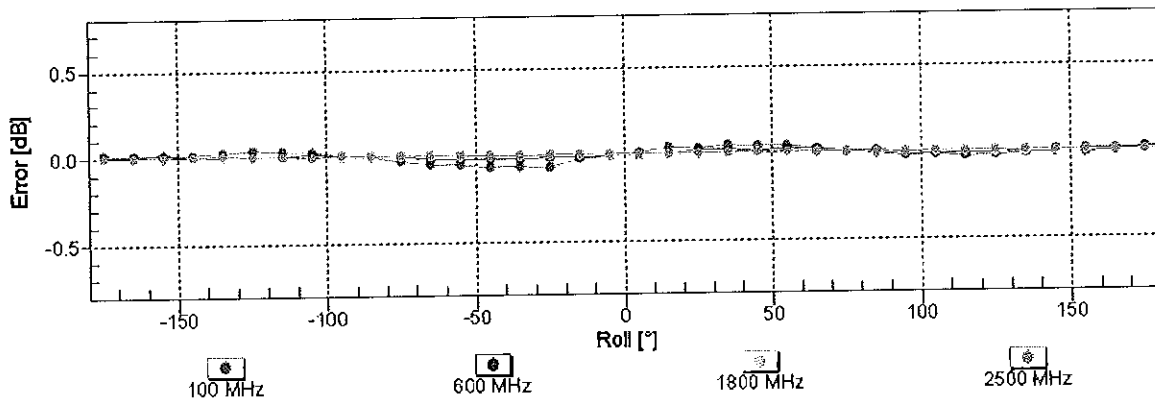
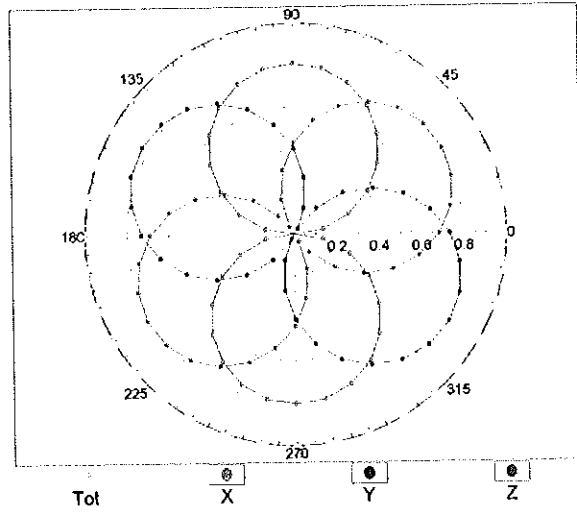

Uncertainty of Axial Isotropy Assessment: $\pm 0.5\%$ (k=2)

Dynamic Range f(SAR_{head}) (TEM cell , f = 900 MHz)

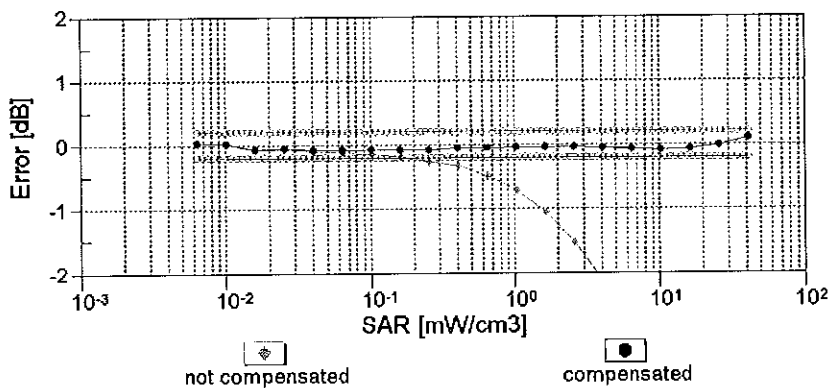
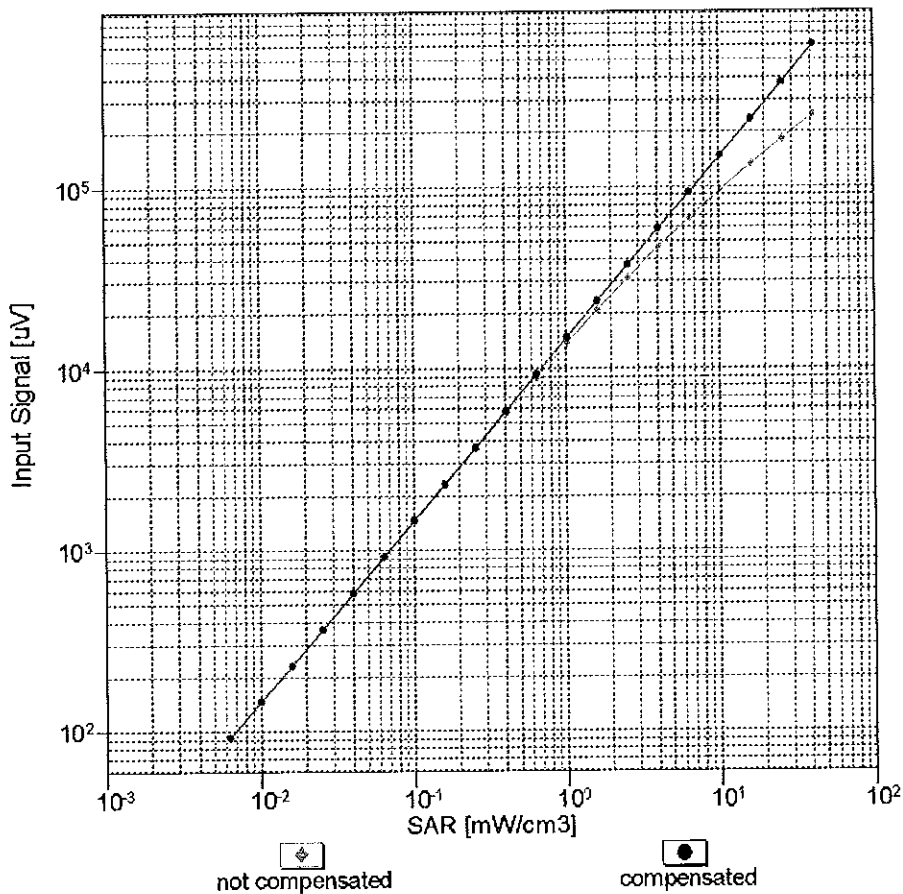

Uncertainty of Linearity Assessment: ± 0.6% (k=2)

Conversion Factor Assessment

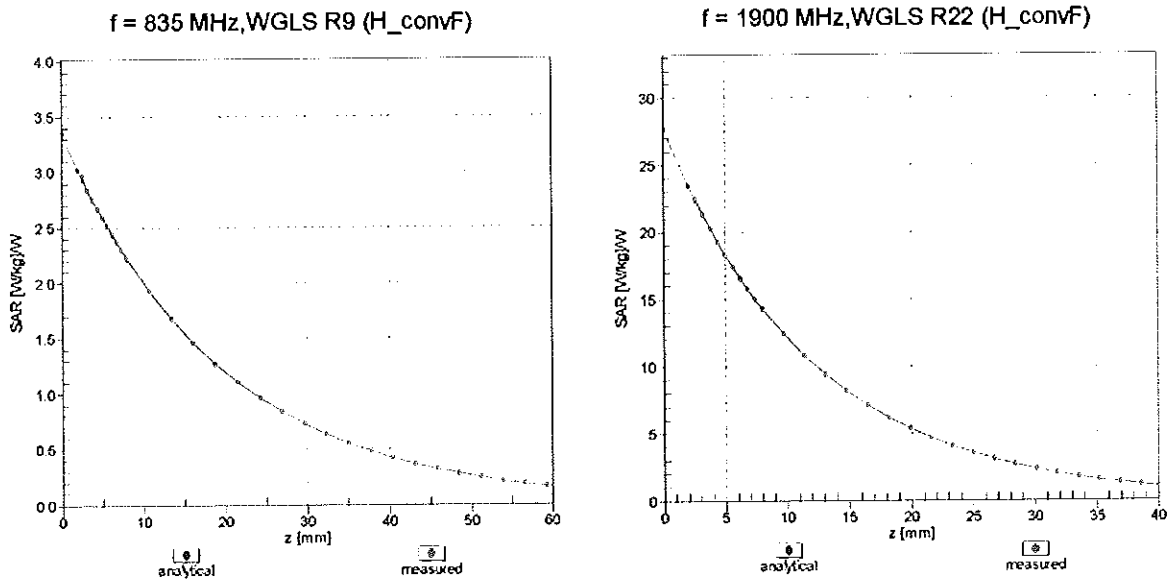

Deviation from Isotropy in Liquid

Error (ϕ, θ), f = 900 MHz

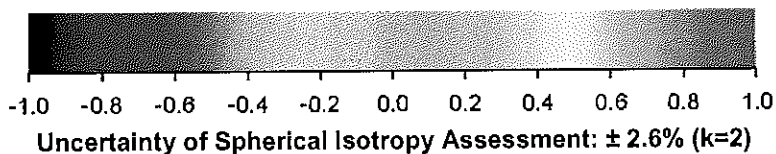
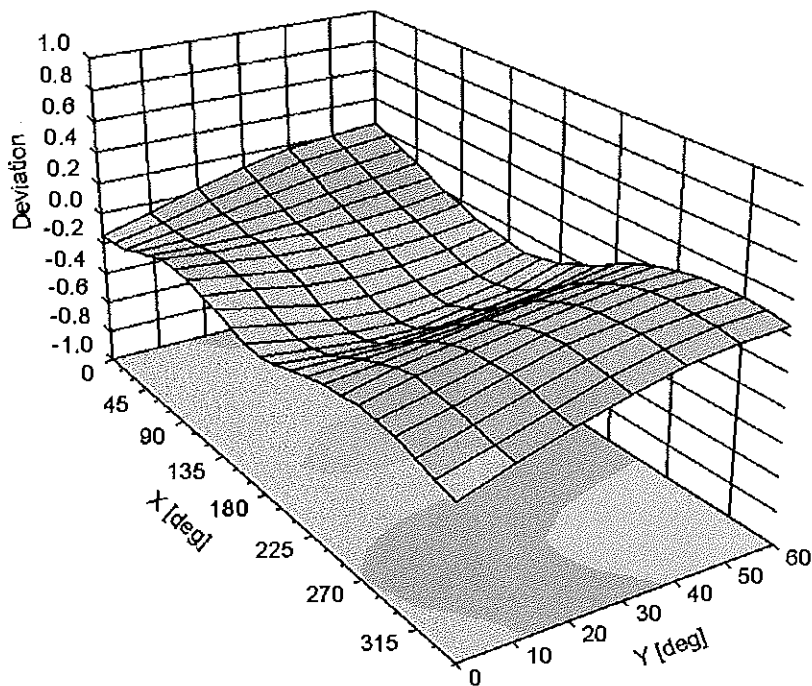

DASY/EASY - Parameters of Probe: ES3DV3 - SN:3287**Other Probe Parameters**

Sensor Arrangement	Triangular
Connector Angle (°)	-15
Mechanical Surface Detection Mode	enabled
Optical Surface Detection Mode	disabled
Probe Overall Length	337 mm
Probe Body Diameter	10 mm
Tip Length	10 mm
Tip Diameter	4 mm
Probe Tip to Sensor X Calibration Point	2 mm
Probe Tip to Sensor Y Calibration Point	2 mm
Probe Tip to Sensor Z Calibration Point	2 mm
Recommended Measurement Distance from Surface	3 mm

Calibration Laboratory of
Schmid & Partner
Engineering AG
Zeughausstrasse 43, 8004 Zurich, Switzerland



SCS Schweizerischer Kalibrierdienst
Service suisse d'étalonnage
Servizio svizzero di taratura
Swiss Calibration Service

Accredited by the Swiss Accreditation Service (SAS)
The Swiss Accreditation Service is one of the signatories to the EA
Multilateral Agreement for the recognition of calibration certificates

Accreditation No.: SCS 108

Client **PC Test**

Certificate No: **EX3-3914_Oct13**

CALIBRATION CERTIFICATE

Object: **EX3DV4 - SN:3914**

Calibration procedure(s): **DIA CAL-01 v3, GA CAL-14 v4, GA CAL-23 v5, DIA CAL-25 v6**
Calibration procedure for dielectric E-field probes

Calibration date: **October 23, 2013** VCC
11/20/2013

This calibration certificate documents the traceability to national standards, which realize the physical units of measurements (SI).
The measurements and the uncertainties with confidence probability are given on the following pages and are part of the certificate.

All calibrations have been conducted in the closed laboratory facility: environment temperature (22 ± 3)°C and humidity < 70%.

Calibration Equipment used (M&TE critical for calibration)

Primary Standards	ID	Cal Date (Certificate No.)	Scheduled Calibration
Power meter E4419B	GB41293874	04-Apr-13 (No. 217-01733)	Apr-14
Power sensor E4412A	MY41498087	04-Apr-13 (No. 217-01733)	Apr-14
Reference 3 dB Attenuator	SN: S5054 (3c)	04-Apr-13 (No. 217-01737)	Apr-14
Reference 20 dB Attenuator	SN: S5277 (20x)	04-Apr-13 (No. 217-01735)	Apr-14
Reference 30 dB Attenuator	SN: S5129 (30b)	04-Apr-13 (No. 217-01738)	Apr-14
Reference Probe ES3DV2	SN: 3013	28-Dec-12 (No. ES3-3013_Dec12)	Dec-13
DAE4	SN: 660	4-Sep-13 (No. DAE4-660_Sep13)	Sep-14
Secondary Standards	ID	Check Date (in house)	Scheduled Check
RF generator HP 8648C	US3642U01700	4-Aug-99 (in house check Apr-13)	In house check: Apr-15
Network Analyzer HP 8753E	US37390585	18-Oct-01 (in house check Oct-13)	In house check: Oct-14

Calibrated by:	Name Leif Klysner	Function Laboratory Technician	Signature
Approved by:	Name Katja Pokovic	Function Technical Manager	

Issued: October 25, 2013

This calibration certificate shall not be reproduced except in full without written approval of the laboratory.

PC# 81072



Accredited by the Swiss Accreditation Service (SAS)
 The Swiss Accreditation Service is one of the signatories to the EA
 Multilateral Agreement for the recognition of calibration certificates

Accreditation No.: **SCS 108**

Glossary:

TSL	tissue simulating liquid
NORM _{x,y,z}	sensitivity in free space
ConvF	sensitivity in TSL / NORM _{x,y,z}
DCP	diode compression point
CF	crest factor (1/duty_cycle) of the RF signal
A, B, C, D	modulation dependent linearization parameters
Polarization φ	φ rotation around probe axis
Polarization ϑ	ϑ rotation around an axis that is in the plane normal to probe axis (at measurement center), i.e., $\vartheta = 0$ is normal to probe axis
Connector Angle	information used in DASY system to align probe sensor X to the robot coordinate system

Calibration is Performed According to the Following Standards:

- a) IEEE Std 1528-2013, "IEEE Recommended Practice for Determining the Peak Spatial-Averaged Specific Absorption Rate (SAR) in the Human Head from Wireless Communications Devices: Measurement Techniques", June 2013
- b) IEC 62209-1, "Procedure to measure the Specific Absorption Rate (SAR) for hand-held devices used in close proximity to the ear (frequency range of 300 MHz to 3 GHz)", February 2005

Methods Applied and Interpretation of Parameters:

- *NORM_{x,y,z}*: Assessed for E-field polarization $\vartheta = 0$ ($f \leq 900$ MHz in TEM-cell; $f > 1800$ MHz: R22 waveguide). *NORM_{x,y,z}* are only intermediate values, i.e., the uncertainties of *NORM_{x,y,z}* does not affect the E^2 -field uncertainty inside TSL (see below *ConvF*).
- *NORM(f)_{x,y,z}* = *NORM_{x,y,z}* * *frequency_response* (see Frequency Response Chart). This linearization is implemented in DASY4 software versions later than 4.2. The uncertainty of the frequency response is included in the stated uncertainty of *ConvF*.
- *DCP_{x,y,z}*: DCP are numerical linearization parameters assessed based on the data of power sweep with CW signal (no uncertainty required). DCP does not depend on frequency nor media.
- *PAR*: PAR is the Peak to Average Ratio that is not calibrated but determined based on the signal characteristics
- *A_{x,y,z}*; *B_{x,y,z}*; *C_{x,y,z}*; *D_{x,y,z}*; *VR_{x,y,z}*; *A, B, C, D* are numerical linearization parameters assessed based on the data of power sweep for specific modulation signal. The parameters do not depend on frequency nor media. *VR* is the maximum calibration range expressed in RMS voltage across the diode.
- *ConvF* and *Boundary Effect Parameters*: Assessed in flat phantom using E-field (or Temperature Transfer Standard for $f \leq 800$ MHz) and inside waveguide using analytical field distributions based on power measurements for $f > 800$ MHz. The same setups are used for assessment of the parameters applied for boundary compensation (alpha, depth) of which typical uncertainty values are given. These parameters are used in DASY4 software to improve probe accuracy close to the boundary. The sensitivity in TSL corresponds to *NORM_{x,y,z}* * *ConvF* whereby the uncertainty corresponds to that given for *ConvF*. A frequency dependent *ConvF* is used in DASY version 4.4 and higher which allows extending the validity from ± 50 MHz to ± 100 MHz.
- *Spherical isotropy (3D deviation from isotropy)*: in a field of low gradients realized using a flat phantom exposed by a patch antenna.
- *Sensor Offset*: The sensor offset corresponds to the offset of virtual measurement center from the probe tip (on probe axis). No tolerance required.
- *Connector Angle*: The angle is assessed using the information gained by determining the *NORM_x* (no uncertainty required).

Probe EX3DV4

SN:3914

Manufactured: December 18, 2012
Calibrated: October 23, 2013

Calibrated for DASY/EASY Systems
(Note: non-compatible with DASY2 system!)

DASY/EASY - Parameters of Probe: EX3DV4 - SN:3914

Basic Calibration Parameters

	Sensor X	Sensor Y	Sensor Z	Unc (k=2)
Norm ($\mu\text{V}/(\text{V}/\text{m})^2$) ^A	0.47	0.49	0.51	$\pm 10.1 \%$
DCP (mV) ^B	99.2	98.9	98.2	

Modulation Calibration Parameters

UID	Communication System Name		A dB	B dB $\sqrt{\mu\text{V}}$	C	D dB	VR mV	Unc ^E (k=2)
0	CW	X	0.0	0.0	1.0	0.00	158.3	$\pm 3.0 \%$
		Y	0.0	0.0	1.0		154.6	
		Z	0.0	0.0	1.0		170.8	
10010- CAA	SAR Validation (Square, 100ms, 10ms)	X	0.71	53.3	6.1	10.00	48.4	$\pm 2.5 \%$
		Y	2.43	67.0	13.8		39.9	
		Z	4.18	68.7	13.8		45.7	
10011- CAA	UMTS-FDD (WCDMA)	X	3.05	64.4	16.5	2.91	122.4	$\pm 0.5 \%$
		Y	3.31	66.5	18.2		123.5	
		Z	3.34	66.3	17.8		136.6	
10012- CAA	IEEE 802.11b WiFi 2.4 GHz (DSSS, 1 Mbps)	X	2.49	64.8	16.1	1.87	120.6	$\pm 0.5 \%$
		Y	2.94	68.6	18.7		123.6	
		Z	2.63	65.9	17.0		135.4	
10021- DAA	GSM-FDD (TDMA, GMSK)	X	1.52	61.5	10.9	9.39	83.6	$\pm 1.2 \%$
		Y	2.22	67.4	15.0		116.0	
		Z	2.47	66.8	14.7		95.9	
10023- DAA	GPRS-FDD (TDMA, GMSK, TN 0)	X	1.73	63.3	11.9	9.57	81.5	$\pm 1.7 \%$
		Y	2.11	66.2	14.2		111.8	
		Z	2.76	69.0	16.0		93.6	
10024- DAA	GPRS-FDD (TDMA, GMSK, TN 0-1)	X	1.34	62.1	9.4	6.56	121.0	$\pm 1.2 \%$
		Y	4.24	78.6	17.9		130.0	
		Z	2.91	70.7	14.9		141.4	
10027- DAA	GPRS-FDD (TDMA, GMSK, TN 0-1-2)	X	1.25	63.5	9.7	4.80	143.5	$\pm 1.4 \%$
		Y	1.59	66.9	12.2		149.7	
		Z	2.98	71.5	14.0		123.3	
10028- DAA	GPRS-FDD (TDMA, GMSK, TN 0-1-2-3)	X	0.51	58.3	7.4	3.55	113.4	$\pm 1.2 \%$
		Y	25.43	100.0	22.6		121.3	
		Z	38.67	97.5	20.6		133.3	
10032- CAA	IEEE 802.15.1 Bluetooth (GFSK, DH5)	X	0.28	58.6	5.3	1.16	134.7	$\pm 0.9 \%$
		Y	65.75	99.6	18.6		141.3	
		Z	0.20	55.6	4.1		112.1	
10039- CAA	CDMA2000 (1xRTT, RC1)	X	4.33	64.6	17.4	4.57	113.8	$\pm 0.7 \%$
		Y	4.55	66.0	18.6		120.8	
		Z	4.85	66.2	18.4		135.9	
10062- CAA	IEEE 802.11a/h WiFi 5 GHz (OFDM, 6 Mbps)	X	9.83	67.6	20.7	8.68	109.0	$\pm 2.5 \%$
		Y	10.06	68.4	21.5		118.2	
		Z	10.66	69.2	21.7		134.0	

10081-CAA	CDMA2000 (1xRTT, RC3)	X	3.59	63.9	16.9	3.97	113.6	±0.7 %
		Y	3.84	65.6	18.2		119.6	
		Z	3.95	65.4	17.8		134.5	
10098-CAA	UMTS-FDD (HSUPA, Subtest 2)	X	4.41	65.2	17.3	3.98	126.0	±0.7 %
		Y	4.73	66.9	18.6		132.5	
		Z	4.51	65.5	17.7		105.6	
10100-CAB	LTE-FDD (SC-FDMA, 100% RB, 20 MHz, QPSK)	X	6.26	66.2	18.6	5.67	130.5	±1.2 %
		Y	6.61	67.7	19.8		139.3	
		Z	6.21	66.0	18.7		107.7	
10108-CAB	LTE-FDD (SC-FDMA, 100% RB, 10 MHz, QPSK)	X	6.13	65.8	18.6	5.80	126.3	±1.2 %
		Y	6.40	67.1	19.6		135.6	
		Z	6.10	65.5	18.5		107.4	
10110-CAB	LTE-FDD (SC-FDMA, 100% RB, 5 MHz, QPSK)	X	5.78	65.3	18.3	5.75	123.1	±1.2 %
		Y	5.97	66.3	19.2		131.5	
		Z	5.86	65.3	18.4		104.9	
10114-CAA	IEEE 802.11n (HT Greenfield, 13.5 Mbps, BPSK)	X	9.92	67.7	20.3	8.10	115.7	±2.5 %
		Y	10.25	68.7	21.2		126.8	
		Z	10.71	69.4	21.3		146.0	
10117-CAA	IEEE 802.11n (HT Mixed, 13.5 Mbps, BPSK)	X	9.95	67.8	20.3	8.07	116.6	±2.5 %
		Y	10.26	68.7	21.1		128.3	
		Z	10.70	69.4	21.3		146.9	
10151-CAB	LTE-TDD (SC-FDMA, 50% RB, 20 MHz, QPSK)	X	7.19	67.3	21.5	9.28	145.0	±2.2 %
		Y	7.40	68.3	22.4		110.8	
		Z	7.79	68.4	22.0		128.0	
10154-CAB	LTE-FDD (SC-FDMA, 50% RB, 10 MHz, QPSK)	X	5.79	65.3	18.3	5.75	124.2	±1.2 %
		Y	6.03	66.5	19.4		131.9	
		Z	6.29	66.9	19.3		149.7	
10160-CAB	LTE-FDD (SC-FDMA, 50% RB, 15 MHz, QPSK)	X	6.23	65.9	18.6	5.82	128.3	±1.2 %
		Y	6.51	67.2	19.7		136.9	
		Z	6.24	65.7	18.6		107.3	
10169-CAB	LTE-FDD (SC-FDMA, 1 RB, 20 MHz, QPSK)	X	4.83	66.0	18.9	5.73	147.5	±1.2 %
		Y	4.72	65.8	19.2		113.8	
		Z	5.03	66.1	19.1		129.7	
10172-CAB	LTE-TDD (SC-FDMA, 1 RB, 20 MHz, QPSK)	X	5.83	69.2	22.8	9.21	149.9	±1.9 %
		Y	5.81	69.4	23.4		120.3	
		Z	6.38	70.0	23.2		137.2	
10175-CAB	LTE-FDD (SC-FDMA, 1 RB, 10 MHz, QPSK)	X	4.86	66.1	18.9	5.72	149.8	±1.2 %
		Y	4.72	65.8	19.2		113.3	
		Z	5.09	66.4	19.1		126.0	
10181-CAB	LTE-FDD (SC-FDMA, 1 RB, 15 MHz, QPSK)	X	4.83	66.0	18.9	5.72	146.3	±1.2 %
		Y	4.69	65.6	19.1		112.2	
		Z	5.02	66.1	19.0		125.1	
10193-CAA	IEEE 802.11n (HT Greenfield, 6.5 Mbps, BPSK)	X	9.51	67.4	20.2	8.09	108.6	±2.5 %
		Y	9.72	68.1	20.9		118.2	
		Z	10.30	68.9	21.1		135.0	

10196-CAA	IEEE 802.11n (HT Mixed, 6.5 Mbps, BPSK)	X	9.52	67.4	20.2	8.10	111.6	±2.5 %
		Y	9.79	68.3	21.1		121.3	
		Z	10.30	68.9	21.2		139.2	
10219-CAA	IEEE 802.11n (HT Mixed, 7.2 Mbps, BPSK)	X	9.47	67.4	20.2	8.03	111.8	±2.2 %
		Y	9.67	68.3	21.0		120.0	
		Z	10.20	68.9	21.1		138.0	
10222-CAA	IEEE 802.11n (HT Mixed, 15 Mbps, BPSK)	X	9.96	67.9	20.4	8.06	118.4	±2.5 %
		Y	10.25	68.8	21.2		128.2	
		Z	10.65	69.3	21.3		144.5	
10225-CAA	UMTS-FDD (HSPA+)	X	6.96	66.7	18.9	5.97	140.0	±1.4 %
		Y	7.23	67.9	20.0		148.9	
		Z	7.03	66.4	18.9		115.6	
10237-CAB	LTE-TDD (SC-FDMA, 1 RB, 10 MHz, QPSK)	X	5.51	67.5	21.8	9.21	114.2	±1.9 %
		Y	5.82	69.4	23.4		123.0	
		Z	6.49	70.6	23.6		140.2	
10252-CAB	LTE-TDD (SC-FDMA, 50% RB, 10 MHz, QPSK)	X	6.83	67.1	21.4	9.24	136.6	±1.9 %
		Y	7.30	69.4	23.2		147.3	
		Z	7.36	68.1	22.0		117.5	
10267-CAB	LTE-TDD (SC-FDMA, 100% RB, 10 MHz, QPSK)	X	7.26	67.5	21.6	9.30	142.7	±1.9 %
		Y	7.44	68.4	22.4		110.5	
		Z	7.84	68.7	22.2		122.6	
10274-CAA	UMTS-FDD (HSUPA, Subtest 5, 3GPP Rel8.10)	X	5.86	66.2	18.2	4.87	135.4	±0.9 %
		Y	6.12	67.5	19.2		142.3	
		Z	5.91	65.9	18.2		107.6	
10275-CAA	UMTS-FDD (HSUPA, Subtest 5, 3GPP Rel8.4)	X	4.17	64.8	17.3	3.96	115.6	±0.7 %
		Y	4.42	66.4	18.5		124.6	
		Z	4.47	66.0	18.0		132.6	
10291-AAA	CDMA2000, RC3, SO55, Full Rate	X	3.36	64.7	17.1	3.46	109.4	±0.5 %
		Y	3.55	66.2	18.3		118.2	
		Z	3.60	65.6	17.7		120.9	
10292-AAA	CDMA2000, RC3, SO32, Full Rate	X	3.34	64.9	17.2	3.39	110.1	±0.5 %
		Y	3.57	66.7	18.5		121.0	
		Z	3.54	65.6	17.7		123.9	
10297-AAA	LTE-FDD (SC-FDMA, 50% RB, 20 MHz, QPSK)	X	6.14	65.8	18.6	5.81	125.1	±1.2 %
		Y	6.44	67.2	19.7		135.7	
		Z	6.52	67.0	19.3		142.2	
10311-AAA	LTE-FDD (SC-FDMA, 100% RB, 15 MHz, QPSK)	X	6.76	66.6	19.1	6.06	131.8	±1.4 %
		Y	7.03	67.8	20.0		142.5	
		Z	7.15	67.7	19.7		148.6	
10315-AAA	IEEE 802.11b WiFi 2.4 GHz (DSSS, 1 Mbps, 96pc duty cycle)	X	2.42	64.6	16.1	1.71	116.8	±0.5 %
		Y	3.00	69.3	19.0		126.9	
		Z	2.61	66.3	17.2		128.2	
10317-AAA	IEEE 802.11a WiFi 5 GHz (OFDM, 6 Mbps, 96pc duty cycle)	X	9.71	67.6	20.5	8.36	111.7	±2.5 %
		Y	9.99	68.6	21.4		122.2	
		Z	10.38	68.9	21.3		129.5	

10400-AAA	IEEE 802.11ac WiFi (20MHz, 64-QAM, 99pc duty cycle)	X	9.83	67.8	20.6	8.37	112.9	±2.5 %
		Y	10.09	68.7	21.4		123.9	
		Z	10.48	68.9	21.3		130.5	
10402-AAA	IEEE 802.11ac WiFi (80MHz, 64-QAM, 99pc duty cycle)	X	10.61	68.3	20.7	8.53	121.1	±2.5 %
		Y	11.25	70.0	21.9		135.4	
		Z	11.15	69.4	21.4		137.4	
10403-AAA	CDMA2000 (1xEV-DO, Rev. 0)	X	4.51	67.4	17.8	3.76	119.2	±0.5 %
		Y	4.91	69.5	19.3		128.3	
		Z	4.84	67.5	18.1		135.4	
10404-AAA	CDMA2000 (1xEV-DO, Rev. A)	X	4.51	67.7	18.0	3.77	117.4	±0.5 %
		Y	4.92	69.8	19.5		125.4	
		Z	4.71	67.3	18.0		131.9	

The reported uncertainty of measurement is stated as the standard uncertainty of measurement multiplied by the coverage factor $k=2$, which for a normal distribution corresponds to a coverage probability of approximately 95%.

^A The uncertainties of NormX,Y,Z do not affect the E^2 -field uncertainty inside TSL (see Pages 8 and 9).

^B Numerical linearization parameter: uncertainty not required.

^E Uncertainty is determined using the max. deviation from linear response applying rectangular distribution and is expressed for the square of the field value.

DASY/EASY - Parameters of Probe: EX3DV4 - SN:3914

Calibration Parameter Determined in Head Tissue Simulating Media

f (MHz) ^C	Relative Permittivity ^F	Conductivity (S/m) ^F	ConvF X	ConvF Y	ConvF Z	Alpha ^G	Depth ^G (mm)	Unct. (k=2)
750	41.9	0.89	9.70	9.70	9.70	0.34	1.01	± 12.0 %
835	41.5	0.90	9.34	9.34	9.34	0.67	0.67	± 12.0 %
1750	40.1	1.37	7.99	7.99	7.99	0.79	0.56	± 12.0 %
1900	40.0	1.40	7.69	7.69	7.69	0.80	0.58	± 12.0 %
2450	39.2	1.80	6.95	6.95	6.95	0.41	0.77	± 12.0 %
2600	39.0	1.96	6.79	6.79	6.79	0.40	0.82	± 12.0 %
5200	36.0	4.66	4.99	4.99	4.99	0.30	1.80	± 13.1 %
5300	35.9	4.76	4.82	4.82	4.82	0.30	1.80	± 13.1 %
5500	35.6	4.96	4.55	4.55	4.55	0.35	1.80	± 13.1 %
5600	35.5	5.07	4.37	4.37	4.37	0.35	1.80	± 13.1 %
5800	35.3	5.27	4.52	4.52	4.52	0.35	1.80	± 13.1 %

^C Frequency validity of ± 100 MHz only applies for DASY v4.4 and higher (see Page 2), else it is restricted to ± 50 MHz. The uncertainty is the RSS of the ConvF uncertainty at calibration frequency and the uncertainty for the indicated frequency band.

^F At frequencies below 3 GHz, the validity of tissue parameters (ϵ and σ) can be relaxed to ± 10% if liquid compensation formula is applied to measured SAR values. At frequencies above 3 GHz, the validity of tissue parameters (ϵ and σ) is restricted to ± 5%. The uncertainty is the RSS of the ConvF uncertainty for indicated target tissue parameters.

^G Alpha/Depth are determined during calibration. SPEAG warrants that the remaining deviation due to the boundary effect after compensation is always less than ± 1% for frequencies below 3 GHz and below ± 2% for frequencies between 3-6 GHz at any distance larger than half the probe tip diameter from the boundary.

DASY/EASY - Parameters of Probe: EX3DV4 - SN:3914

Calibration Parameter Determined in Body Tissue Simulating Media

f (MHz) ^C	Relative Permittivity ^F	Conductivity (S/m) ^F	ConvF X	ConvF Y	ConvF Z	Alpha ^G	Depth ^G (mm)	Unct. (k=2)
750	55.5	0.96	9.39	9.39	9.39	0.63	0.74	± 12.0 %
835	55.2	0.97	9.31	9.31	9.31	0.56	0.76	± 12.0 %
1750	53.4	1.49	7.89	7.89	7.89	0.32	1.03	± 12.0 %
1900	53.3	1.52	7.51	7.51	7.51	0.51	0.76	± 12.0 %
2450	52.7	1.95	7.02	7.02	7.02	0.80	0.50	± 12.0 %
2600	52.5	2.16	6.81	6.81	6.81	0.80	0.50	± 12.0 %
5200	49.0	5.30	4.52	4.52	4.52	0.35	1.90	± 13.1 %
5300	48.9	5.42	4.32	4.32	4.32	0.35	1.90	± 13.1 %
5500	48.6	5.65	4.07	4.07	4.07	0.35	1.90	± 13.1 %
5600	48.5	5.77	3.97	3.97	3.97	0.35	1.90	± 13.1 %
5800	48.2	6.00	4.14	4.14	4.14	0.40	1.90	± 13.1 %

^C Frequency validity of ± 100 MHz only applies for DASY v4.4 and higher (see Page 2), else it is restricted to ± 50 MHz. The uncertainty is the RSS of the ConvF uncertainty at calibration frequency and the uncertainty for the indicated frequency band.

^F At frequencies below 3 GHz, the validity of tissue parameters (ϵ and σ) can be relaxed to ± 10% if liquid compensation formula is applied to measured SAR values. At frequencies above 3 GHz, the validity of tissue parameters (ϵ and σ) is restricted to ± 5%. The uncertainty is the RSS of the ConvF uncertainty for indicated target tissue parameters.

^G Alpha/Depth are determined during calibration. SPEAG warrants that the remaining deviation due to the boundary effect after compensation is always less than ± 1% for frequencies below 3 GHz and below ± 2% for frequencies between 3-6 GHz at any distance larger than half the probe tip diameter from the boundary.

Frequency Response of E-Field

(TEM-Cell:ifi110 EXX, Waveguide: R22)

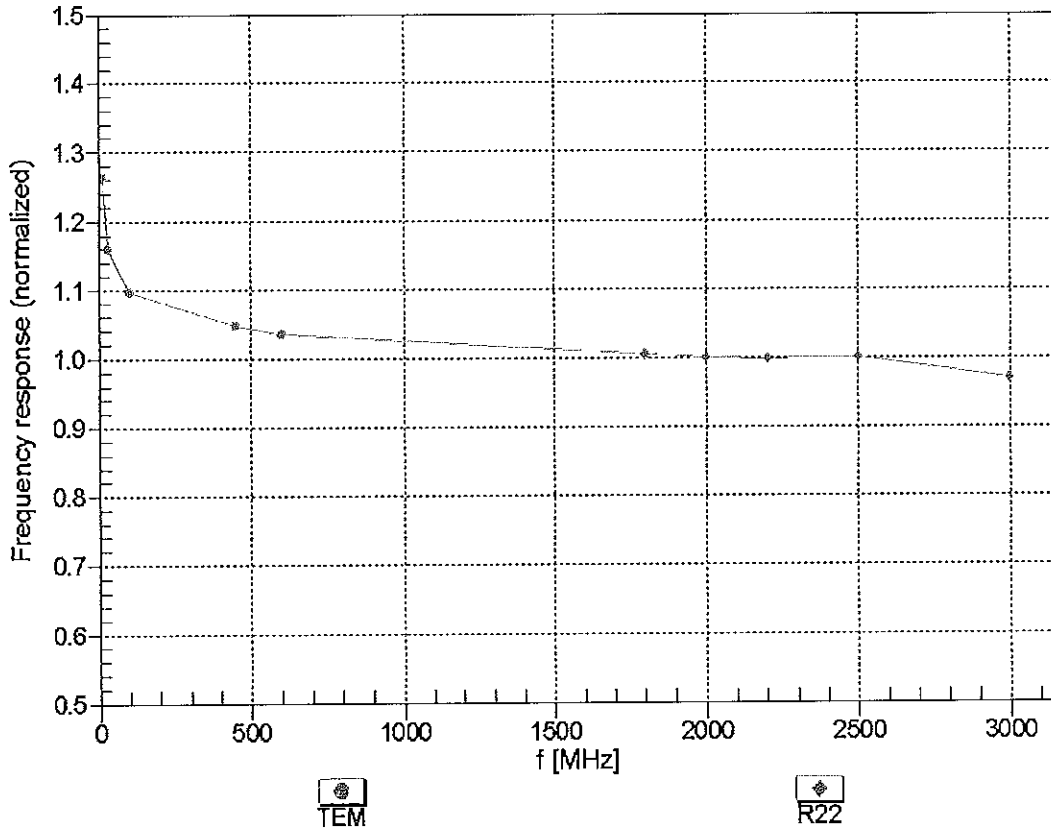

Uncertainty of Frequency Response of E-field: $\pm 6.3\%$ (k=2)

Receiving Pattern (ϕ), $\theta = 0^\circ$

f=600 MHz,TEM

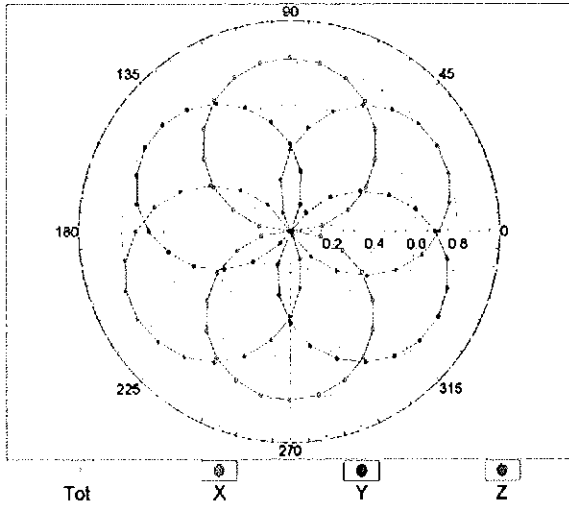

f=1800 MHz,R22

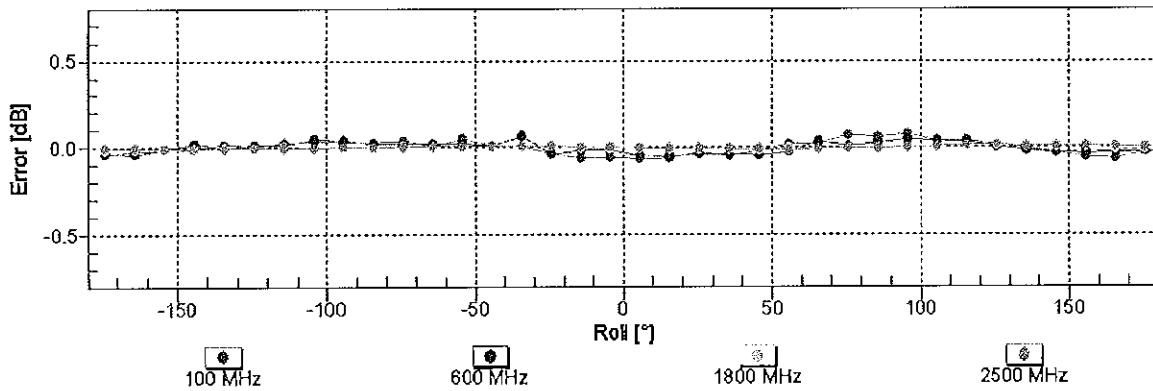
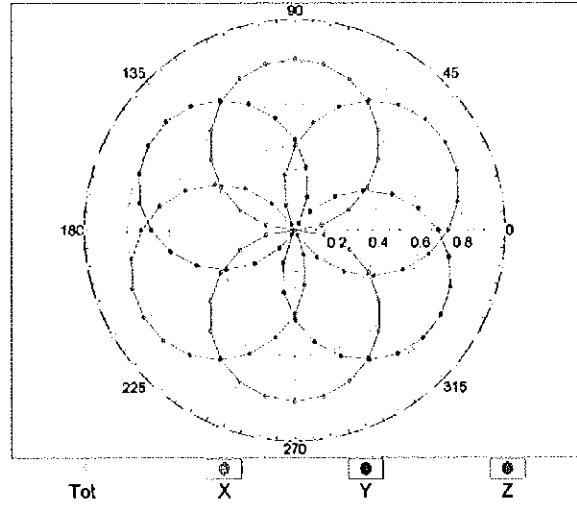

Uncertainty of Axial Isotropy Assessment: $\pm 0.5\%$ (k=2)

Dynamic Range $f(SAR_{head})$ (TEM cell , $f = 900$ MHz)

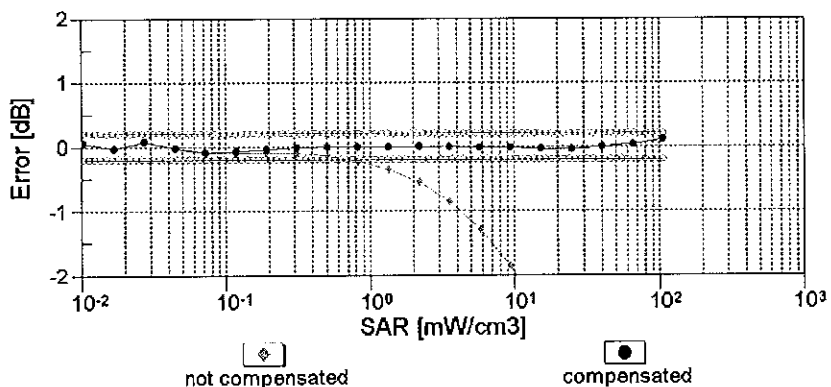
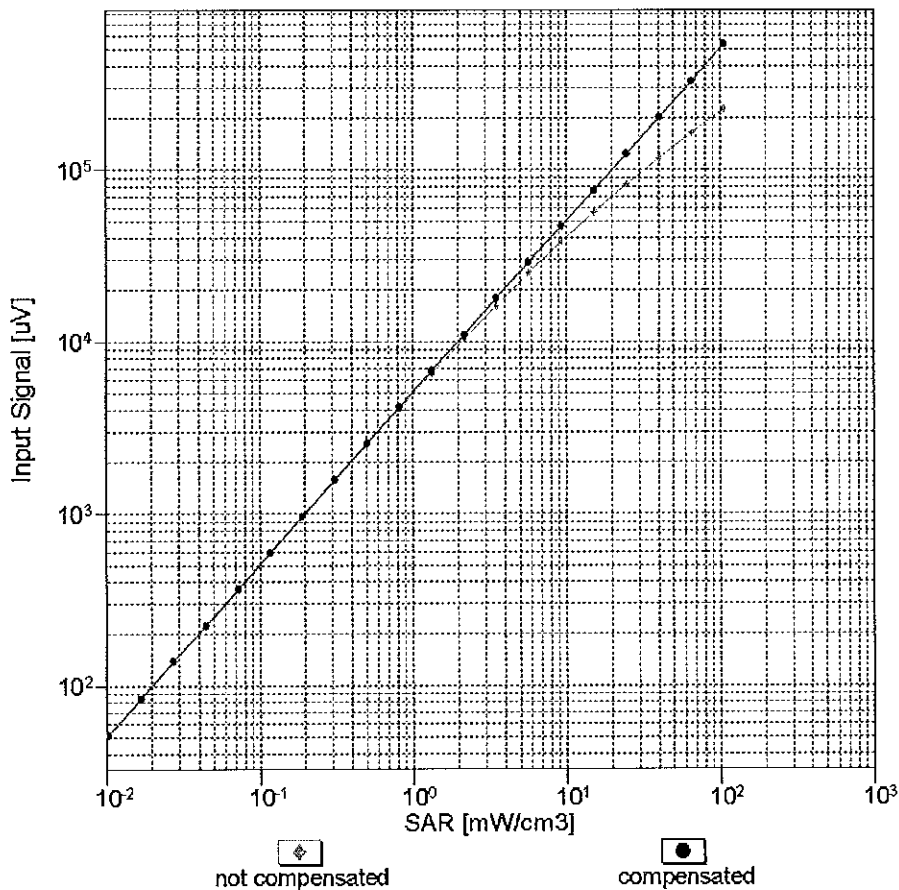

Uncertainty of Linearity Assessment: $\pm 0.6\%$ ($k=2$)

Conversion Factor Assessment

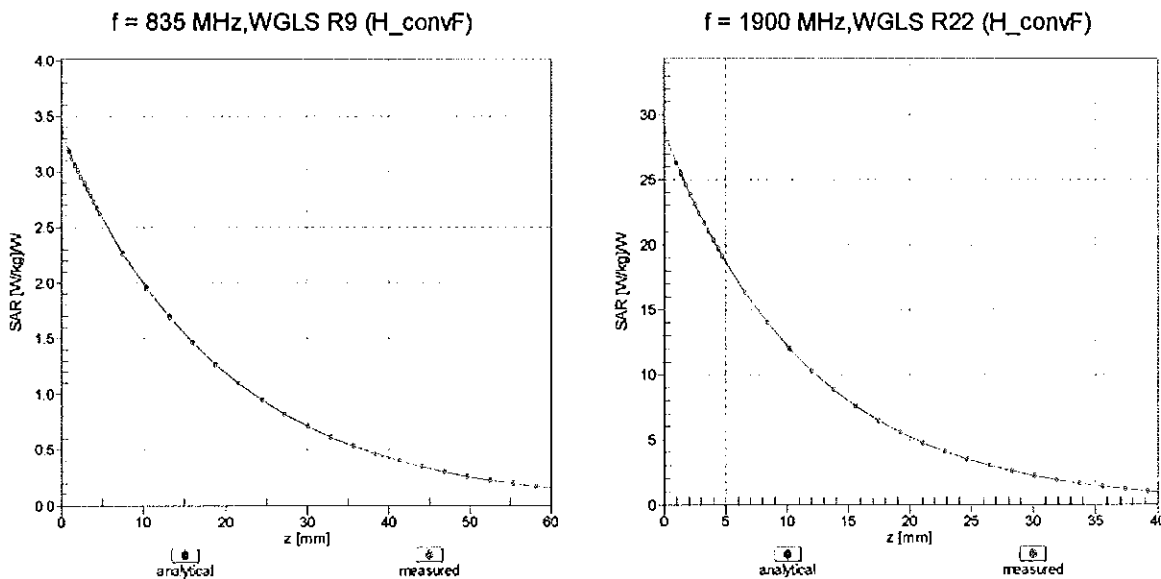

Deviation from Isotropy in Liquid

Error (ϕ, θ), f = 900 MHz

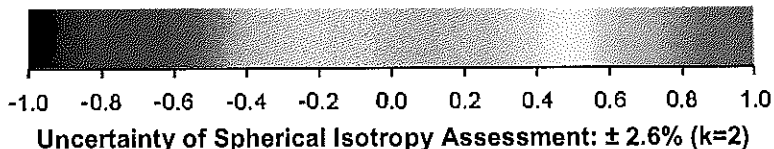
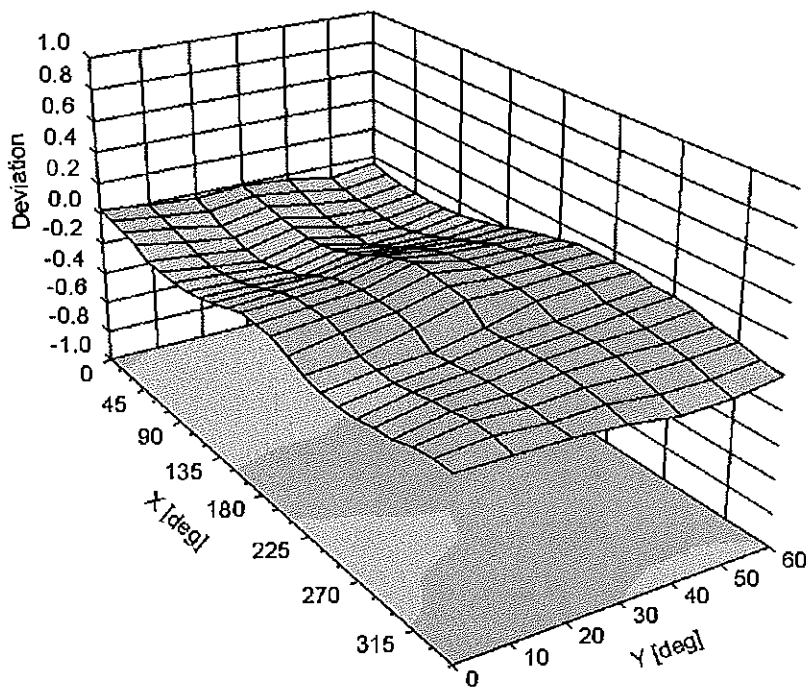

DASY/EASY - Parameters of Probe: EX3DV4 - SN:3914**Other Probe Parameters**

Sensor Arrangement	Triangular
Connector Angle (°)	-24.3
Mechanical Surface Detection Mode	enabled
Optical Surface Detection Mode	disabled
Probe Overall Length	337 mm
Probe Body Diameter	10 mm
Tip Length	9 mm
Tip Diameter	2.5 mm
Probe Tip to Sensor X Calibration Point	1 mm
Probe Tip to Sensor Y Calibration Point	1 mm
Probe Tip to Sensor Z Calibration Point	1 mm
Recommended Measurement Distance from Surface	2 mm



Accredited by the Swiss Accreditation Service (SAS)
The Swiss Accreditation Service is one of the signatories to the EA
Multilateral Agreement for the recognition of calibration certificates

Accreditation No.: **SCS 108**

Client **PC Test**

Certificate No: **EX3-3589_Jan14**

CALIBRATION CERTIFICATE

Object **EX3DV4 - SN:3589**

Calibration procedure(s) **QA CAL-01.v9, QA CAL-14.v4, QA CAL-23.v5, QA CAL-25.v6
Calibration procedure for dosimetric E-field probes**

Calibration date: **January 29, 2014**

This calibration certificate documents the traceability to national standards, which realize the physical units of measurements (SI).
The measurements and the uncertainties with confidence probability are given on the following pages and are part of the certificate.

All calibrations have been conducted in the closed laboratory facility: environment temperature (22 ± 3)°C and humidity < 70%.

Calibration Equipment used (M&TE critical for calibration)

*CC ✓
25/14*

Primary Standards	ID	Cal Date (Certificate No.)	Scheduled Calibration
Power meter E4419B	GB41293874	04-Apr-13 (No. 217-01733)	Apr-14
Power sensor E4412A	MY41498087	04-Apr-13 (No. 217-01733)	Apr-14
Reference 3 dB Attenuator	SN: S5054 (3c)	04-Apr-13 (No. 217-01737)	Apr-14
Reference 20 dB Attenuator	SN: S5277 (20x)	04-Apr-13 (No. 217-01735)	Apr-14
Reference 30 dB Attenuator	SN: S5129 (30b)	04-Apr-13 (No. 217-01738)	Apr-14
Reference Probe ES3DV2	SN: 3013	30-Dec-13 (No. ES3-3013_Dec13)	Dec-14
DAE4	SN: 660	13-Dec-13 (No. DAE4-660_Dec13)	Dec-14
Secondary Standards	ID	Check Date (in house)	Scheduled Check
RF generator HP 8648C	US3642U01700	4-Aug-99 (in house check Apr-13)	In house check: Apr-16
Network Analyzer HP 8753E	US37390585	18-Oct-01 (in house check Oct-13)	In house check: Oct-14

Calibrated by:	Name Claudio Leubler	Function Laboratory Technician	Signature
Approved by:	Name Katja Pokovic	Function Technical Manager	Signature
			Issued: January 30, 2014

This calibration certificate shall not be reproduced except in full without written approval of the laboratory.

PC-T-1 783



Accredited by the Swiss Accreditation Service (SAS)
The Swiss Accreditation Service is one of the signatories to the EA
Multilateral Agreement for the recognition of calibration certificates

Accreditation No.: **SCS 108**

Glossary:

TSL	tissue simulating liquid
NORM _{x,y,z}	sensitivity in free space
ConvF	sensitivity in TSL / NORM _{x,y,z}
DCP	diode compression point
CF	crest factor (1/duty_cycle) of the RF signal
A, B, C, D	modulation dependent linearization parameters
Polarization φ	φ rotation around probe axis
Polarization ϑ	ϑ rotation around an axis that is in the plane normal to probe axis (at measurement center), i.e., $\vartheta = 0$ is normal to probe axis
Connector Angle	information used in DASY system to align probe sensor X to the robot coordinate system

Calibration is Performed According to the Following Standards:

- IEEE Std 1528-2013, "IEEE Recommended Practice for Determining the Peak Spatial-Averaged Specific Absorption Rate (SAR) in the Human Head from Wireless Communications Devices: Measurement Techniques", June 2013
- IEC 62209-1, "Procedure to measure the Specific Absorption Rate (SAR) for hand-held devices used in close proximity to the ear (frequency range of 300 MHz to 3 GHz)", February 2005

Methods Applied and Interpretation of Parameters:

- NORM_{x,y,z}**: Assessed for E-field polarization $\vartheta = 0$ ($f \leq 900$ MHz in TEM-cell; $f > 1800$ MHz: R22 waveguide). NORM_{x,y,z} are only intermediate values, i.e., the uncertainties of NORM_{x,y,z} does not affect the E²-field uncertainty inside TSL (see below ConvF).
- NORM(f)_{x,y,z}** = NORM_{x,y,z} * frequency_response (see Frequency Response Chart). This linearization is implemented in DASY4 software versions later than 4.2. The uncertainty of the frequency response is included in the stated uncertainty of ConvF.
- DCP_{x,y,z}**: DCP are numerical linearization parameters assessed based on the data of power sweep with CW signal (no uncertainty required). DCP does not depend on frequency nor media.
- PAR**: PAR is the Peak to Average Ratio that is not calibrated but determined based on the signal characteristics
- A_{x,y,z}; B_{x,y,z}; C_{x,y,z}; D_{x,y,z}; VR_{x,y,z}**: A, B, C, D are numerical linearization parameters assessed based on the data of power sweep for specific modulation signal. The parameters do not depend on frequency nor media. VR is the maximum calibration range expressed in RMS voltage across the diode.
- ConvF and Boundary Effect Parameters**: Assessed in flat phantom using E-field (or Temperature Transfer Standard for $f \leq 800$ MHz) and inside waveguide using analytical field distributions based on power measurements for $f > 800$ MHz. The same setups are used for assessment of the parameters applied for boundary compensation (alpha, depth) of which typical uncertainty values are given. These parameters are used in DASY4 software to improve probe accuracy close to the boundary. The sensitivity in TSL corresponds to NORM_{x,y,z} * ConvF whereby the uncertainty corresponds to that given for ConvF. A frequency dependent ConvF is used in DASY version 4.4 and higher which allows extending the validity from ± 50 MHz to ± 100 MHz.
- Spherical isotropy (3D deviation from isotropy)**: in a field of low gradients realized using a flat phantom exposed by a patch antenna.
- Sensor Offset**: The sensor offset corresponds to the offset of virtual measurement center from the probe tip (on probe axis). No tolerance required.
- Connector Angle**: The angle is assessed using the information gained by determining the NORM_x (no uncertainty required).

Probe EX3DV4

SN:3589

Manufactured: March 30, 2006
Calibrated: January 29, 2014

Calibrated for DASY/EASY Systems
(Note: non-compatible with DASY2 system!)

DASY/EASY - Parameters of Probe: EX3DV4 - SN:3589

Basic Calibration Parameters

	Sensor X	Sensor Y	Sensor Z	Unc (k=2)
Norm ($\mu V/(V/m)^2$) ^A	0.46	0.40	0.40	$\pm 10.1 \%$
DCP (mV) ^B	101.2	100.8	98.0	

Modulation Calibration Parameters

UID	Communication System Name		A dB	B dB $\sqrt{\mu V}$	C	D dB	VR mV	Unc ^E (k=2)
0	CW	X	0.0	0.0	1.0	0.00	150.4	$\pm 3.8 \%$
		Y	0.0	0.0	1.0		142.3	
		Z	0.0	0.0	1.0		171.7	
10010- CAA	SAR Validation (Square, 100ms, 10ms)	X	6.00	69.5	14.2	10.00	42.1	$\pm 0.9 \%$
		Y	7.03	71.8	15.0		40.3	
		Z	3.33	64.6	12.1		44.6	
10011- CAA	UMTS-FDD (WCDMA)	X	3.26	66.2	17.8	2.91	117.6	$\pm 0.9 \%$
		Y	3.38	66.8	18.2		113.0	
		Z	2.79	62.4	14.7		133.2	
10012- CAA	IEEE 802.11b WiFi 2.4 GHz (DSSS, 1 Mbps)	X	2.77	66.8	17.4	1.87	117.4	$\pm 0.7 \%$
		Y	3.22	69.6	18.8		113.5	
		Z	2.22	62.0	13.8		135.2	
10021- DAA	GSM-FDD (TDMA, GMSK)	X	3.61	69.7	16.6	9.39	91.2	$\pm 1.7 \%$
		Y	5.48	77.1	19.6		125.1	
		Z	2.18	62.5	12.6		75.3	
10023- DAA	GPRS-FDD (TDMA, GMSK, TN 0)	X	3.01	66.4	14.9	9.57	86.1	$\pm 2.7 \%$
		Y	7.02	82.0	22.0		120.5	
		Z	2.13	62.9	12.7		71.4	
10024- DAA	GPRS-FDD (TDMA, GMSK, TN 0-1)	X	18.01	91.8	22.6	6.56	132.3	$\pm 1.7 \%$
		Y	8.55	83.0	19.9		134.3	
		Z	4.04	72.4	15.7		139.6	
10027- DAA	GPRS-FDD (TDMA, GMSK, TN 0-1-2)	X	4.70	74.7	15.9	4.80	107.5	$\pm 1.7 \%$
		Y	4.94	76.1	16.4		107.8	
		Z	2.97	68.7	12.8		127.1	
10028- DAA	GPRS-FDD (TDMA, GMSK, TN 0-1-2-3)	X	67.89	99.9	21.4	3.55	114.7	$\pm 2.7 \%$
		Y	48.02	99.7	21.9		116.6	
		Z	1.36	61.4	7.8		134.4	
10032- CAA	IEEE 802.15.1 Bluetooth (GFSK, DH5)	X	97.41	97.0	17.7	1.16	129.2	$\pm 3.0 \%$
		Y	71.47	99.8	19.3		130.9	
		Z	0.29	53.5	0.9		109.2	
10039- CAA	CDMA2000 (1xRTT, RC1)	X	4.62	65.4	18.0	4.57	113.0	$\pm 1.7 \%$
		Y	4.74	66.1	18.4		111.5	
		Z	4.22	63.3	15.9		133.6	
10062- CAA	IEEE 802.11a/h WiFi 5 GHz (OFDM, 6 Mbps)	X	10.10	67.8	20.8	8.68	108.0	$\pm 2.7 \%$
		Y	10.07	68.1	21.1		108.1	
		Z	10.03	67.6	20.2		130.3	

10098-CAA	UMTS-FDD (HSUPA, Subtest 2)	X	4.53	65.7	17.8	3.98	122.5	±0.9 %
		Y	4.72	66.6	18.4		123.1	
		Z	4.38	64.5	16.7		147.3	
10100-CAB	LTE-FDD (SC-FDMA, 100% RB, 20 MHz, QPSK)	X	6.32	66.5	18.8	5.67	126.9	±1.2 %
		Y	6.50	67.2	19.4		128.9	
		Z	5.80	64.3	17.3		107.2	
10108-CAB	LTE-FDD (SC-FDMA, 100% RB, 10 MHz, QPSK)	X	6.22	66.1	18.8	5.80	124.2	±1.7 %
		Y	6.39	66.9	19.4		126.7	
		Z	6.10	65.2	17.7		149.4	
10110-CAB	LTE-FDD (SC-FDMA, 100% RB, 5 MHz, QPSK)	X	5.94	65.8	18.7	5.75	121.3	±1.7 %
		Y	6.05	66.3	19.1		123.1	
		Z	5.80	65.0	17.7		144.5	
10114-CAA	IEEE 802.11n (HT Greenfield, 13.5 Mbps, BPSK)	X	10.01	67.7	20.3	8.10	113.9	±2.5 %
		Y	10.16	68.3	20.8		117.0	
		Z	9.96	67.5	19.8		135.3	
10117-CAA	IEEE 802.11n (HT Mixed, 13.5 Mbps, BPSK)	X	10.07	67.9	20.4	8.07	115.2	±2.5 %
		Y	10.16	68.2	20.7		118.4	
		Z	10.02	67.7	19.9		138.0	
10151-CAB	LTE-TDD (SC-FDMA, 50% RB, 20 MHz, QPSK)	X	7.89	68.4	21.8	9.28	108.1	±1.9 %
		Y	8.15	69.7	22.8		109.4	
		Z	7.38	66.5	20.4		123.2	
10154-CAB	LTE-FDD (SC-FDMA, 50% RB, 10 MHz, QPSK)	X	5.94	65.7	18.6	5.75	122.1	±1.7 %
		Y	6.03	66.3	19.0		122.5	
		Z	5.79	65.0	17.7		144.0	
10160-CAB	LTE-FDD (SC-FDMA, 50% RB, 15 MHz, QPSK)	X	6.38	66.3	18.9	5.82	126.0	±1.7 %
		Y	6.54	67.0	19.4		128.2	
		Z	6.16	65.3	17.8		146.9	
10169-CAB	LTE-FDD (SC-FDMA, 1 RB, 20 MHz, QPSK)	X	5.17	66.5	19.2	5.73	149.7	±1.2 %
		Y	4.95	65.8	19.0		108.3	
		Z	4.64	63.9	17.1		125.3	
10172-CAB	LTE-TDD (SC-FDMA, 1 RB, 20 MHz, QPSK)	X	6.79	70.4	23.0	9.21	120.6	±3.0 %
		Y	6.96	72.0	24.2		122.8	
		Z	6.43	69.3	22.0		136.7	
10175-CAB	LTE-FDD (SC-FDMA, 1 RB, 10 MHz, QPSK)	X	5.15	66.4	19.1	5.72	143.0	±1.4 %
		Y	5.23	67.1	19.6		145.8	
		Z	4.60	63.7	17.0		121.1	
10181-CAB	LTE-FDD (SC-FDMA, 1 RB, 15 MHz, QPSK)	X	5.11	66.2	19.0	5.72	141.0	±1.4 %
		Y	5.27	67.3	19.7		144.9	
		Z	4.54	63.4	16.8		119.2	
10193-CAA	IEEE 802.11n (HT Greenfield, 6.5 Mbps, BPSK)	X	9.57	67.1	20.1	8.09	102.2	±2.2 %
		Y	9.59	67.4	20.4		105.3	
		Z	9.73	67.6	20.0		129.6	
10196-CAA	IEEE 802.11n (HT Mixed, 6.5 Mbps, BPSK)	X	9.61	67.3	20.2	8.10	104.6	±2.5 %
		Y	9.63	67.6	20.5		107.8	
		Z	9.63	67.3	19.8		130.9	

10219-CAA	IEEE 802.11n (HT Mixed, 7.2 Mbps, BPSK)	X	9.61	67.5	20.3	8.03	109.2	±2.7 %
		Y	9.54	67.5	20.4		107.4	
		Z	9.53	67.2	19.7		130.7	
10222-CAA	IEEE 802.11n (HT Mixed, 15 Mbps, BPSK)	X	10.00	67.8	20.4	8.06	114.1	±2.7 %
		Y	10.01	68.0	20.6		112.3	
		Z	9.96	67.6	19.9		137.1	
10225-CAA	UMTS-FDD (HSPA+)	X	7.18	66.9	19.2	5.97	137.5	±1.4 %
		Y	7.25	67.4	19.5		134.4	
		Z	6.48	64.4	17.3		114.6	
10237-CAB	LTE-TDD (SC-FDMA, 1 RB, 10 MHz, QPSK)	X	6.93	71.0	23.5	9.21	123.5	±3.0 %
		Y	6.88	71.6	24.0		119.3	
		Z	6.63	70.1	22.4		141.3	
10252-CAB	LTE-TDD (SC-FDMA, 50% RB, 10 MHz, QPSK)	X	8.19	70.5	23.1	9.24	142.9	±2.5 %
		Y	8.46	72.0	24.2		143.3	
		Z	7.10	67.0	20.8		119.9	
10267-CAB	LTE-TDD (SC-FDMA, 100% RB, 10 MHz, QPSK)	X	7.83	68.1	21.6	9.30	104.2	±2.2 %
		Y	8.07	69.4	22.7		103.0	
		Z	7.49	67.2	20.9		125.2	
10274-CAA	UMTS-FDD (HSUPA, Subtest 5, 3GPP Rel8.10)	X	5.96	66.2	18.3	4.87	128.1	±1.7 %
		Y	6.12	67.0	18.8		126.0	
		Z	5.31	63.8	16.4		110.2	
10275-CAA	UMTS-FDD (HSUPA, Subtest 5, 3GPP Rel8.4)	X	4.30	65.5	17.8	3.96	110.5	±1.2 %
		Y	4.47	66.4	18.4		110.3	
		Z	3.92	63.1	15.6		135.7	
10291-AAA	CDMA2000, RC3, SO55, Full Rate	X	3.59	65.7	17.7	3.46	138.1	±1.2 %
		Y	3.85	67.2	18.6		146.7	
		Z	3.08	61.7	14.7		123.3	
10292-AAA	CDMA2000, RC3, SO32, Full Rate	X	3.59	66.0	17.8	3.39	144.2	±0.9 %
		Y	3.83	67.5	18.7		148.4	
		Z	3.18	63.1	15.7		128.6	
10297-AAA	LTE-FDD (SC-FDMA, 50% RB, 20 MHz, QPSK)	X	6.13	65.8	18.7	5.81	116.5	±1.7 %
		Y	6.30	66.6	19.2		119.4	
		Z	6.20	65.9	18.4		145.6	
10311-AAA	LTE-FDD (SC-FDMA, 100% RB, 15 MHz, QPSK)	X	6.70	66.4	19.0	6.06	122.5	±1.4 %
		Y	6.92	67.3	19.6		124.5	
		Z	6.28	65.0	17.9		103.7	
10315-AAA	IEEE 802.11b WiFi 2.4 GHz (DSSS, 1 Mbps, 96pc duty cycle)	X	2.66	66.7	17.4	1.71	109.5	±0.7 %
		Y	3.18	70.0	19.2		111.5	
		Z	2.08	61.6	13.4		134.4	
10317-AAA	IEEE 802.11a WiFi 5 GHz (OFDM, 6 Mbps, 96pc duty cycle)	X	9.78	67.4	20.4	8.36	103.5	±2.5 %
		Y	9.81	67.7	20.7		107.1	
		Z	9.86	67.6	20.3		129.5	
10400-AAA	IEEE 802.11ac WiFi (20MHz, 64-QAM, 99pc duty cycle)	X	9.86	67.5	20.4	8.37	104.9	±2.7 %
		Y	9.93	67.9	20.8		107.9	
		Z	9.97	67.7	20.2		134.3	

10402-AAA	IEEE 802.11ac WiFi (80MHz, 64-QAM, 99pc duty cycle)	X	10.47	67.9	20.5	8.53	109.9	±3.0 %
		Y	10.86	68.8	21.1		116.0	
		Z	10.68	68.2	20.4		142.5	
10403-AAA	CDMA2000 (1xEV-DO, Rev. 0)	X	4.74	67.0	17.9	3.76	114.9	±0.9 %
		Y	5.02	68.5	18.7		116.6	
		Z	4.23	64.4	15.8		145.1	
10404-AAA	CDMA2000 (1xEV-DO, Rev. A)	X	4.71	67.1	17.9	3.77	112.3	±1.4 %
		Y	4.95	68.5	18.7		115.0	
		Z	4.01	63.4	15.1		138.9	

The reported uncertainty of measurement is stated as the standard uncertainty of measurement multiplied by the coverage factor $k=2$, which for a normal distribution corresponds to a coverage probability of approximately 95%.

^A The uncertainties of NormX,Y,Z do not affect the E^2 -field uncertainty inside TSL (see Pages 8 and 9).

^B Numerical linearization parameter: uncertainty not required.

^E Uncertainty is determined using the max. deviation from linear response applying rectangular distribution and is expressed for the square of the field value.

DASY/EASY - Parameters of Probe: EX3DV4 - SN:3589

Calibration Parameter Determined in Head Tissue Simulating Media

f (MHz) ^C	Relative Permittivity ^F	Conductivity (S/m) ^F	ConvF X	ConvF Y	ConvF Z	Alpha ^G	Depth ^G (mm)	Unct. (k=2)
750	41.9	0.89	8.86	8.86	8.86	0.80	0.62	± 12.0 %
835	41.5	0.90	8.49	8.49	8.49	0.45	0.82	± 12.0 %
1750	40.1	1.37	7.31	7.31	7.31	0.80	0.60	± 12.0 %
1900	40.0	1.40	7.05	7.05	7.05	0.52	0.73	± 12.0 %
2450	39.2	1.80	6.45	6.45	6.45	0.29	1.08	± 12.0 %
2600	39.0	1.96	6.24	6.24	6.24	0.76	0.62	± 12.0 %
5200	36.0	4.66	4.78	4.78	4.78	0.30	1.80	± 13.1 %
5300	35.9	4.76	4.58	4.58	4.58	0.30	1.80	± 13.1 %
5500	35.6	4.96	4.44	4.44	4.44	0.31	1.80	± 13.1 %
5600	35.5	5.07	4.20	4.20	4.20	0.35	1.80	± 13.1 %
5800	35.3	5.27	4.39	4.39	4.39	0.32	1.80	± 13.1 %

^C Frequency validity of ± 100 MHz only applies for DASY v4.4 and higher (see Page 2), else it is restricted to ± 50 MHz. The uncertainty is the RSS of the ConvF uncertainty at calibration frequency and the uncertainty for the indicated frequency band.

^F At frequencies below 3 GHz, the validity of tissue parameters (ϵ and σ) can be relaxed to ± 10% if liquid compensation formula is applied to measured SAR values. At frequencies above 3 GHz, the validity of tissue parameters (ϵ and σ) is restricted to ± 5%. The uncertainty is the RSS of the ConvF uncertainty for indicated target tissue parameters.

^G Alpha/Depth are determined during calibration. SPEAG warrants that the remaining deviation due to the boundary effect after compensation is always less than ± 1% for frequencies below 3 GHz and below ± 2% for frequencies between 3-6 GHz at any distance larger than half the probe tip diameter from the boundary.

DASY/EASY - Parameters of Probe: EX3DV4 - SN:3589

Calibration Parameter Determined in Body Tissue Simulating Media

f (MHz) ^C	Relative Permittivity ^F	Conductivity (S/m) ^F	ConvF X	ConvF Y	ConvF Z	Alpha ^G	Depth (mm) ^G	Unct. (k=2)
750	55.5	0.96	8.34	8.34	8.34	0.66	0.72	± 12.0 %
835	55.2	0.97	8.29	8.29	8.29	0.31	1.11	± 12.0 %
1750	53.4	1.49	6.68	6.68	6.68	0.80	0.61	± 12.0 %
1900	53.3	1.52	6.54	6.54	6.54	0.72	0.64	± 12.0 %
2450	52.7	1.95	6.26	6.26	6.26	0.80	0.57	± 12.0 %
2600	52.5	2.16	6.08	6.08	6.08	0.68	0.50	± 12.0 %
5200	49.0	5.30	4.19	4.19	4.19	0.38	1.90	± 13.1 %
5300	48.9	5.42	3.98	3.98	3.98	0.38	1.90	± 13.1 %
5500	48.6	5.65	3.76	3.76	3.76	0.42	1.90	± 13.1 %
5600	48.5	5.77	3.81	3.81	3.81	0.30	1.90	± 13.1 %
5800	48.2	6.00	3.97	3.97	3.97	0.43	1.90	± 13.1 %

^C Frequency validity of ± 100 MHz only applies for DASY v4.4 and higher (see Page 2), else it is restricted to ± 50 MHz. The uncertainty is the RSS of the ConvF uncertainty at calibration frequency and the uncertainty for the indicated frequency band.

^F At frequencies below 3 GHz, the validity of tissue parameters (ϵ and σ) can be relaxed to ± 10% if liquid compensation formula is applied to measured SAR values. At frequencies above 3 GHz, the validity of tissue parameters (ϵ and σ) is restricted to ± 5%. The uncertainty is the RSS of the ConvF uncertainty for indicated target tissue parameters.

^G Alpha/Depth are determined during calibration. SPEAG warrants that the remaining deviation due to the boundary effect after compensation is always less than ± 1% for frequencies below 3 GHz and below ± 2% for frequencies between 3-6 GHz at any distance larger than half the probe tip diameter from the boundary.

Frequency Response of E-Field (TEM-Cell:ifi110 EXX, Waveguide: R22)

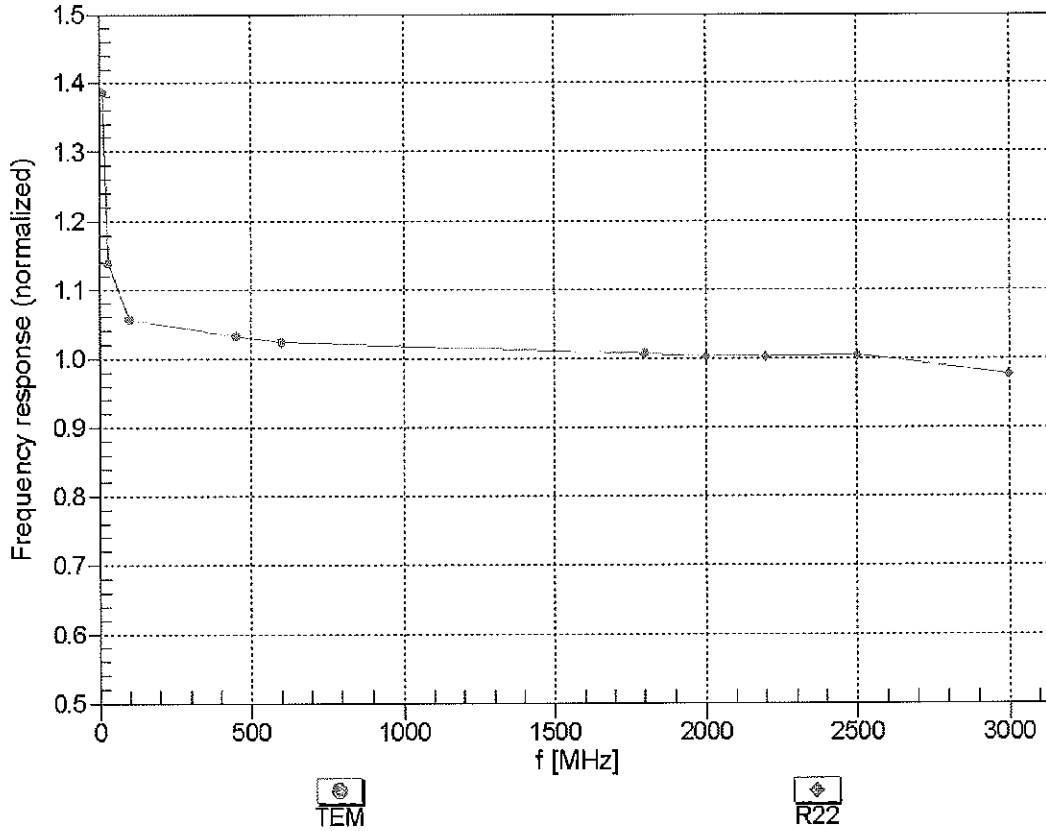

Uncertainty of Frequency Response of E-field: $\pm 6.3\%$ (k=2)

Receiving Pattern (ϕ), $\vartheta = 0^\circ$

f=600 MHz, TEM

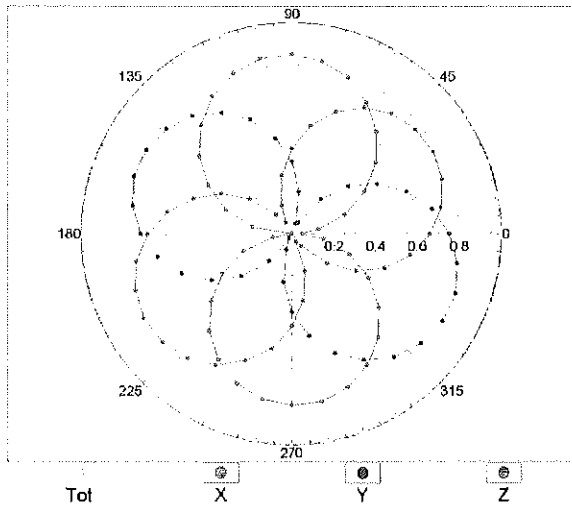

f=1800 MHz, R22

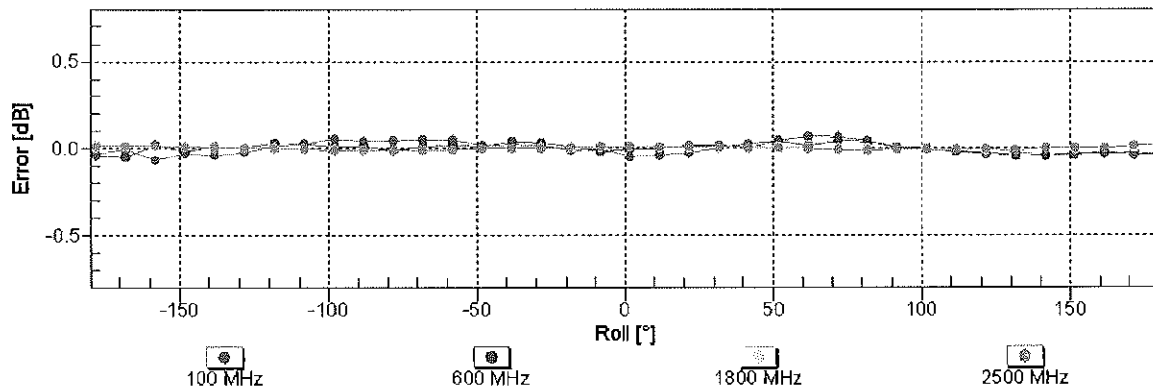
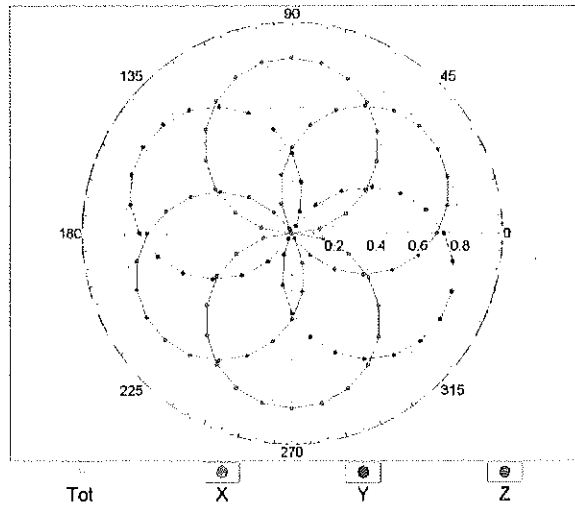

Uncertainty of Axial Isotropy Assessment: $\pm 0.5\%$ (k=2)

Dynamic Range $f(\text{SAR}_{\text{head}})$ (TEM cell , $f = 900 \text{ MHz}$)

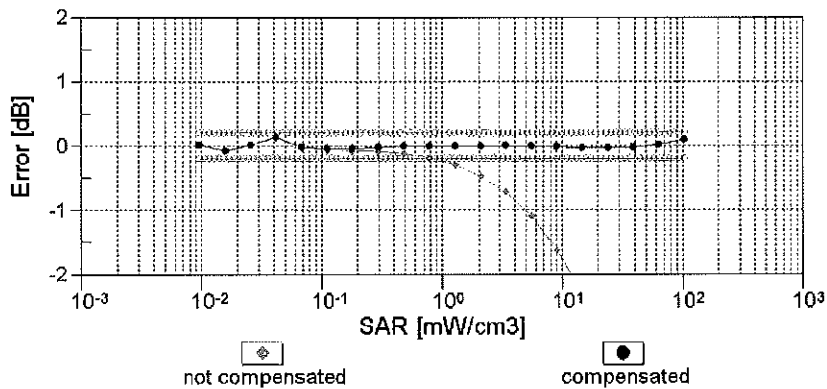
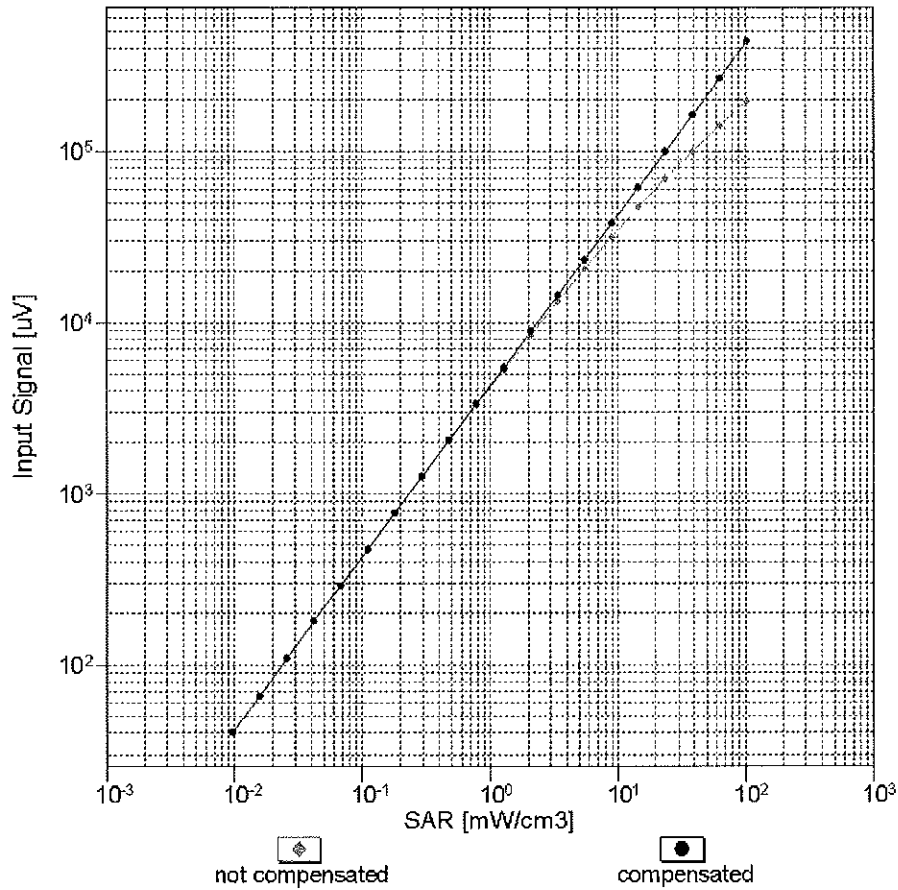

Uncertainty of Linearity Assessment: $\pm 0.6\%$ ($k=2$)

Conversion Factor Assessment

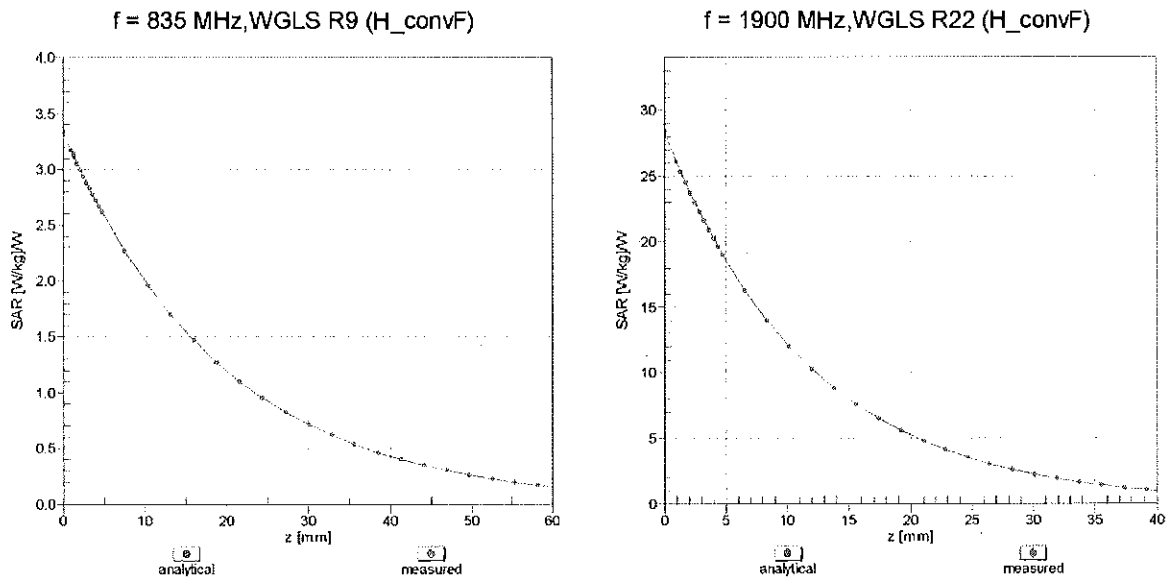

Deviation from Isotropy in Liquid Error (ϕ, ϑ), f = 900 MHz

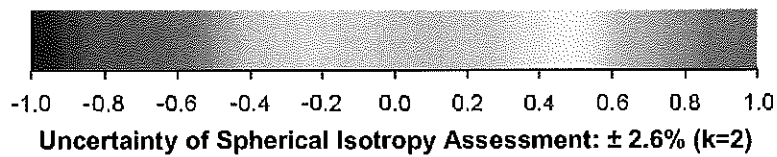
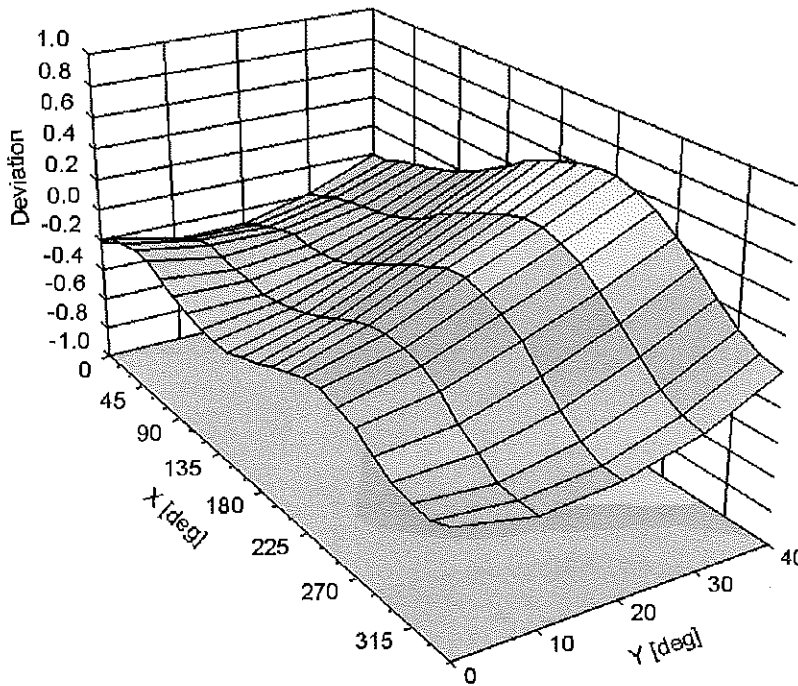

DASY/EASY - Parameters of Probe: EX3DV4 - SN:3589

Other Probe Parameters

Sensor Arrangement	Triangular
Connector Angle (°)	-38.2
Mechanical Surface Detection Mode	enabled
Optical Surface Detection Mode	disabled
Probe Overall Length	337 mm
Probe Body Diameter	10 mm
Tip Length	9 mm
Tip Diameter	2.5 mm
Probe Tip to Sensor X Calibration Point	1 mm
Probe Tip to Sensor Y Calibration Point	1 mm
Probe Tip to Sensor Z Calibration Point	1 mm
Recommended Measurement Distance from Surface	2 mm

APPENDIX D: SAR TISSUE SPECIFICATIONS

Measurement Procedure for Tissue verification:



- 1) The network analyzer and probe system was configured and calibrated.
- 2) The probe was immersed in the tissue. The tissue was placed in a nonmetallic container. Trapped air bubbles beneath the flange were minimized by placing the probe at a slight angle.
- 3) The complex admittance with respect to the probe aperture was measured
- 4) The complex relative permittivity ϵ can be calculated from the below equation (Pournaropoulos and Misra):

$$Y = \frac{j2\omega\epsilon_r\epsilon_0}{[\ln(b/a)]^2} \int_a^b \int_a^b \int_0^\pi \cos\phi' \frac{\exp[-j\omega r(\mu_0\epsilon_r'\epsilon_0)^{1/2}]}{r} d\phi' d\rho' d\rho$$

where Y is the admittance of the probe in contact with the sample, the primed and unprimed coordinates refer to source and observation points, respectively, $r^2 = \rho^2 + \rho'^2 - 2\rho\rho' \cos\phi'$, ω is the angular frequency, and $j = \sqrt{-1}$.

**Table D-I
Composition of the Tissue Equivalent Matter**

Frequency (MHz)	750	750	835	835	1900	1900	2450	2450	5200-5800	5200-5800			
Tissue	Head	Body	Head	Body	Head	Body	Head	Body	Head	Body			
Ingredients (% by weight)													
Bactericide	See Page 2&3	See Page 2	0.1	0.1			See Page 4		See Page 5				
DGBE					44.92	29.44				26.7			
HEC			1	1									
NaCl			1.45	0.94	0.18	0.39				0.1			
Sucrose			57	44.9									
Polysorbate (Tween) 80											20		
Water					40.45	53.06		54.9		70.17			80

FCC ID: A3LSMG900S		SAR EVALUATION REPORT		Reviewed by: Quality Manager
Test Dates: 02/03/14 – 02/10/14	DUT Type: Portable Handset			APPENDIX D: Page 1 of 5

2 Composition / Information on ingredients

The Item is composed of the following ingredients:

H ₂ O	Water, 35 – 58%
Sucrose	Sugar, white, refined, 40 – 60%
NaCl	Sodium Chloride, 0 – 6%
Hydroxyethyl-cellulose	Medium Viscosity (CAS# 9004-62-0), <0.3%
Preventol-D7	Preservative: aqueous preparation, (CAS# 55965-84-9), containing 5-chloro-2-methyl-3(2H)-isothiazolone and 2-methyl-3(2H)-isothiazolone, 0.1 – 0.7%

Relevant for safety; Refer to the respective Safety Data Sheet*.

Figure D-1
Composition of 750 MHz Head and Body Tissue Equivalent Matter

Note: 750MHz liquid recipes are proprietary SPEAG. Since the composition is approximate to the actual liquids utilized, the manufacturer tissue-equivalent liquid data sheets are provided below.

Measurement Certificate / Material Test

Item Name	Body Tissue Simulating Liquid (MSL750V2)
Product No.	SL AAM 075 AA (Charge: 130313-1)
Manufacturer	SPEAG

Measurement Method

TSL dielectric parameters measured using calibrated OCP probe.

Setup Validation

Validation results were within $\pm 2.5\%$ towards the target values of Methanol.

Target Parameters

Target parameters as defined in the IEEE 1528 and IEC 62209 compliance standards.

Test Condition

Ambient Environment temperatur (22 ± 3)°C and humidity < 70%.
 TSL Temperature 22°C
 Test Date 13-Mar-13
 Operator IEN

Additional Information

TSL Density 1.212 g/cm³
 TSL Heat-capacity 3.006 kJ/(kg*K)

f [MHz]	Measured			Target		Diff.to Target [%]	
	HP-e'	HP-e''	sigma	eps	sigma	Δ-eps	Δ-sigma
600	57.5	24.64	0.82	56.1	0.95	2.5	-13.6
625	57.2	24.31	0.84	56.0	0.95	2.1	-11.4
650	57.0	23.99	0.87	55.9	0.96	1.8	-9.2
675	56.7	23.69	0.89	55.8	0.96	1.5	-7.1
700	56.4	23.39	0.91	55.7	0.96	1.2	-5.1
725	56.2	23.18	0.93	55.6	0.96	1.0	-2.8
750	55.9	22.97	0.96	55.5	0.96	0.7	-0.5
775	55.7	22.78	0.98	55.4	0.97	0.4	1.7
800	55.4	22.60	1.01	55.3	0.97	0.1	4.0
825	55.2	22.44	1.03	55.2	0.98	-0.2	5.3
838	55.0	22.36	1.04	55.2	0.98	-0.3	5.9
850	54.9	22.28	1.05	55.2	0.99	-0.4	6.6
875	54.7	22.16	1.08	55.1	1.02	-0.7	5.8
900	54.5	22.03	1.10	55.0	1.05	-1.0	5.1
925	54.2	21.83	1.13	55.0	1.06	-1.3	6.2
950	54.0	21.82	1.15	54.9	1.08	-1.7	7.2
975	53.8	21.74	1.18	54.9	1.09	-2.0	8.5
1000	53.6	21.66	1.21	54.8	1.10	-2.3	9.7

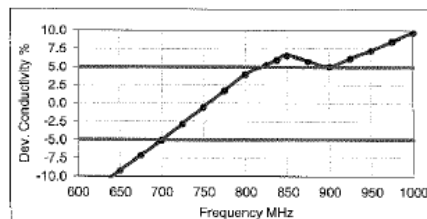
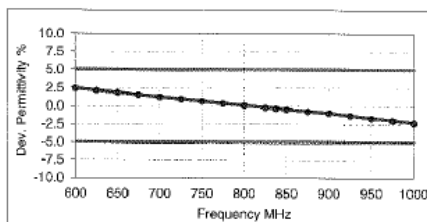



Figure D-2
750MHz Body Tissue Equivalent Matter

FCC ID: A3LSMG900S		SAR EVALUATION REPORT		Reviewed by: Quality Manager
Test Dates: 02/03/14 – 02/10/14	DUT Type: Portable Handset			APPENDIX D: Page 2 of 5

Measurement Certificate / Material Test

Item Name	Head Tissue Simulating Liquid (HSL750V2)
Product No.	SL AAH 075 AA (Charge: 130312-4)
Manufacturer	SPEAG

Measurement Method

TSL dielectric parameters measured using calibrated OCP probe.

Setup Validation

Validation results were within $\pm 2.5\%$ towards the target values of Methanol.

Target Parameters

Target parameters as defined in the IEEE 1528 and IEC 62209 compliance standards.

Test Condition

Ambient	Environment temperatur (22 ± 3)°C and humidity < 70%.
TSL Temperature	22°C
Test Date	13-Mar-13
Operator	IEN

Additional Information

TSL Density	1.284 g/cm ³
TSL Heat-capacity	2.701 kJ/(kg*K)

f [MHz]	Measured			Target		Diff. to Target [%]	
	HP-e'	HP-e''	sigma	eps	sigma	Δ-eps	Δ-sigma
600	44.6	23.25	0.78	42.7	0.88	4.3	-12.0
625	44.2	23.00	0.80	42.6	0.88	3.8	-9.5
650	43.8	22.76	0.82	42.5	0.89	3.2	-7.1
675	43.4	22.50	0.84	42.3	0.89	2.6	-4.9
700	43.1	22.24	0.87	42.2	0.89	2.1	-2.6
725	42.7	22.06	0.89	42.1	0.89	1.6	-0.2
750	42.4	21.88	0.91	41.9	0.89	1.1	2.2
775	42.1	21.72	0.94	41.8	0.90	0.6	4.6
800	41.7	21.55	0.96	41.7	0.90	0.1	6.9
825	41.4	21.40	0.98	41.6	0.91	-0.4	8.3
838	41.3	21.32	0.99	41.5	0.91	-0.8	9.0
850	41.1	21.24	1.00	41.5	0.92	-0.9	9.6
875	40.8	21.11	1.03	41.5	0.94	-1.6	9.0
900	40.6	20.99	1.05	41.5	0.97	-2.3	8.3
925	40.3	20.87	1.07	41.5	0.98	-2.9	9.4
950	40.0	20.76	1.10	41.4	0.99	-3.5	10.3
975	39.7	20.66	1.12	41.4	1.00	-4.0	11.5
1000	39.5	20.57	1.14	41.3	1.01	-4.5	12.7

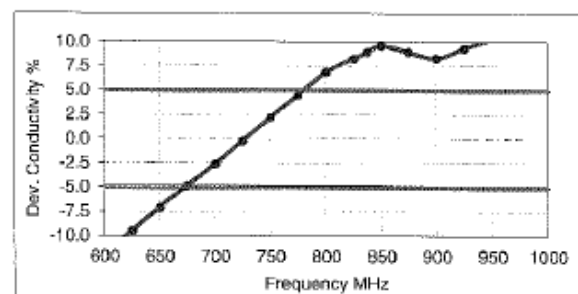
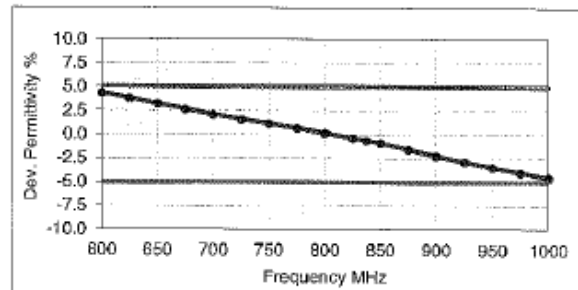



Figure D-3
750MHz Head Tissue Equivalent Matter

FCC ID: A3LSMG900S		SAR EVALUATION REPORT		Reviewed by: Quality Manager
Test Dates: 02/03/14 – 02/10/14	DUT Type: Portable Handset			APPENDIX D: Page 3 of 5

2 Composition / Information on ingredients

The Item is composed of the following ingredients:

H2O	Water, 52 – 75%
C8H18O3	Diethylene glycol monobutyl ether (DGBE), 25 – 48% (CAS-No. 112-34-5, EC-No. 203-961-6, EC-index-No. 603-096-00-8) Relevant for safety; Refer to the respective Safety Data Sheet*.
NaCl	Sodium Chloride, <1.0%

Figure D-4
Composition of 2.4 GHz Head Tissue Equivalent Matter

Note: 2.4 GHz head liquid recipes are proprietary SPEAG. Since the composition is approximate to the actual liquids utilized, the manufacturer tissue-equivalent liquid data sheets are provided below.

Measurement Certificate / Material Test

Item Name	Head Tissue Simulating Liquid (HSL2450V2)
Product No.	SL AAH 245 BA (Charge: 130212-2)
Manufacturer	SPEAG

Measurement Method

TSL dielectric parameters measured using calibrated OCP probe.

Setup Validation

Validation results were within $\pm 2.5\%$ towards the target values of Methanol.

Target Parameters

Target parameters as defined in the IEEE 1528 and IEC 62209 compliance standards.

Test Condition

Ambient	Environment temperatur ($22 \pm 3^\circ\text{C}$ and humidity < 70%.
TSL Temperature	23°C
Test Date	13-Feb-13
Operator	DI

Additional information

TSL Density	0.988 g/cm ³
TSL Heat-capacity	3.680 kJ/(kg*K)

f (MHz)	Measured			Target		Diff. to Target [%]	
	HP-e'	HP-e''	sigma	eps	sigma	Δ-eps	Δ-sigma
1900	40.4	11.94	1.26	40.0	1.40	1.0	-9.9
1925	40.3	12.02	1.29	40.0	1.40	0.7	-8.0
1950	40.2	12.11	1.31	40.0	1.40	0.5	-6.2
1975	40.1	12.20	1.34	40.0	1.40	0.2	-4.2
2000	40.0	12.29	1.37	40.0	1.40	-0.1	-2.3
2025	39.9	12.39	1.40	40.0	1.42	-0.2	-1.9
2050	39.8	12.49	1.42	39.9	1.44	-0.4	-1.4
2075	39.6	12.57	1.45	39.9	1.47	-0.6	-1.1
2100	39.5	12.65	1.48	39.8	1.49	-0.7	-0.7
2125	39.4	12.74	1.51	39.8	1.51	-0.9	-0.4
2150	39.3	12.82	1.53	39.7	1.53	-1.0	0.0
2175	39.2	12.89	1.56	39.7	1.56	-1.2	0.3
2200	39.1	12.97	1.59	39.6	1.58	-1.3	0.6
2225	39.0	13.04	1.61	39.6	1.60	-1.5	0.9
2250	38.9	13.11	1.64	39.6	1.62	-1.7	1.2
2275	38.8	13.20	1.67	39.5	1.64	-1.8	1.6
2300	38.7	13.28	1.70	39.5	1.67	-2.0	2.0
2325	38.6	13.35	1.73	39.4	1.69	-2.1	2.3
2350	38.5	13.42	1.75	39.4	1.71	-2.3	2.6
2375	38.4	13.50	1.78	39.3	1.73	-2.4	2.9
2400	38.3	13.58	1.81	39.3	1.76	-2.6	3.3
2425	38.2	13.65	1.84	39.2	1.78	-2.7	3.6
2450	38.1	13.73	1.87	39.2	1.80	-2.9	4.0
2475	38.0	13.79	1.90	39.2	1.83	-3.1	3.9
2500	37.9	13.85	1.93	39.1	1.85	-3.3	3.9
2525	37.8	13.94	1.96	39.1	1.88	-3.4	4.0
2550	37.7	14.02	1.99	39.1	1.91	-3.6	4.2
2575	37.6	14.09	2.02	39.0	1.94	-3.8	4.3
2600	37.5	14.17	2.05	39.0	1.96	-4.0	4.4
2625	37.4	14.23	2.08	39.0	1.99	-4.2	4.4
2650	37.3	14.29	2.11	38.9	2.02	-4.3	4.4
2675	37.1	14.36	2.14	38.9	2.05	-4.5	4.5
2700	37.0	14.43	2.17	38.9	2.07	-4.8	4.6

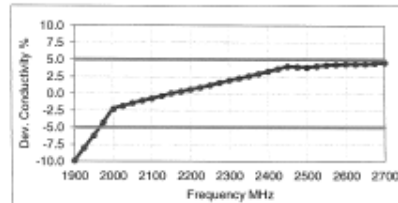
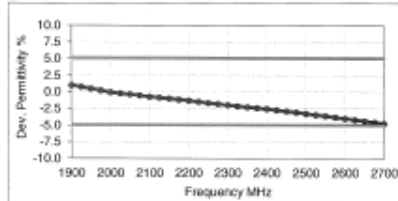

Figure D-5
2.4 GHz Head Tissue Equivalent Matter

FCC ID: A3LSMG900S		SAR EVALUATION REPORT		Reviewed by: Quality Manager
Test Dates: 02/03/14 – 02/10/14	DUT Type: Portable Handset			APPENDIX D: Page 4 of 5

2 Composition / Information on ingredients

The Item is composed of the following ingredients:

Water	50 – 65%
Mineral oil	10 – 30%
Emulsifiers	8 – 25%
Sodium salt	0 – 1.5%

Figure D-6
Composition of 5 GHz Head Tissue Equivalent Matter

Note: 5GHz head liquid recipes are proprietary SPEAG. Since the composition is approximate to the actual liquids utilized, the manufacturer tissue-equivalent liquid data sheets are provided below.

Measurement Certificate / Material Test

Item Name	Head Tissue Simulating Liquid (HBBL3500-5800V5)
Product No.	SL AAH 502 AB (Charge: 120402-2)
Manufacturer	SPEAG

Measurement Method

TSL dielectric parameters measured using calibrated OCP probe (type DAK).

Target Parameters

Target parameters as defined in the IEEE 1528 and IEC 62209 compliance standards.

Test Condition

Ambient Condition	22°C ; 30% humidity
TSL Temperature	22°C
Test Date	4-Apr-12

Additional Information

TSL Density	0.985 g/cm ³
TSL Heat-capacity	3.383 kJ/(kg*K)

Results

f [MHz]	Measured			Target		Diff. to Target [%]	
	HP-e'	HP-e''	sigma	eps	sigma	Δ-eps	Δ-sigma
3400	38.7	14.96	2.93	38.0	2.81	1.8	0.7
3500	38.6	14.91	2.90	37.9	2.91	1.7	-0.3
3600	38.5	14.92	2.99	37.8	3.02	1.7	-0.9
3700	38.3	14.92	3.07	37.7	3.12	1.7	-1.5
3800	38.2	14.94	3.16	37.6	3.22	1.7	-1.9
3900	38.1	14.95	3.24	37.5	3.32	1.7	-2.4
4000	38.0	15.00	3.34	37.4	3.43	1.8	-2.5
4100	37.9	15.04	3.43	37.2	3.53	1.8	-2.6
4200	37.8	15.08	3.52	37.1	3.63	1.8	-2.9
4300	37.7	15.14	3.62	37.0	3.73	1.8	-3.0
4400	37.5	15.18	3.71	36.9	3.84	1.7	-3.1
4500	37.4	15.20	3.81	36.8	3.94	1.6	-3.3
4600	37.3	15.29	3.91	36.7	4.04	1.6	-3.2
4700	37.1	15.34	4.01	36.6	4.14	1.5	-3.2
4800	37.0	15.39	4.11	36.4	4.25	1.4	-3.2
4850	36.9	15.43	4.16	36.4	4.30	1.3	-3.1
4900	36.8	15.45	4.21	36.3	4.35	1.3	-3.1
4950	36.7	15.47	4.26	36.3	4.40	1.2	-3.1
5000	36.7	15.50	4.31	36.2	4.45	1.2	-3.1
5050	36.6	15.55	4.37	36.2	4.50	1.1	-3.0
5100	36.5	15.60	4.43	36.1	4.55	1.1	-2.8
5150	36.4	15.62	4.48	36.0	4.60	1.0	-2.8
5200	36.4	15.65	4.53	36.0	4.66	1.0	-2.8
5250	36.3	15.67	4.58	35.9	4.71	1.0	-2.8
5300	36.2	15.70	4.63	35.9	4.76	1.0	-2.7
5350	36.1	15.70	4.67	35.8	4.81	0.9	-2.9
5400	36.1	15.74	4.73	35.8	4.86	0.8	-2.7
5450	36.0	15.75	4.77	35.7	4.91	0.9	-2.8
5500	35.9	15.78	4.82	35.6	4.96	0.8	-2.9
5550	35.9	15.80	4.88	35.6	5.01	0.8	-2.7
5600	35.8	15.82	4.93	35.5	5.07	0.7	-2.7
5650	35.7	15.86	4.98	35.5	5.12	0.7	-2.6
5700	35.7	15.88	5.03	35.4	5.17	0.7	-2.6
5750	35.6	15.90	5.08	35.4	5.22	0.6	-2.6
5800	35.5	15.94	5.14	35.3	5.27	0.6	-2.4
5850	35.4	15.98	5.20	35.3	5.34	0.4	-2.5
5900	35.4	16.02	5.26	35.3	5.40	0.2	-2.6

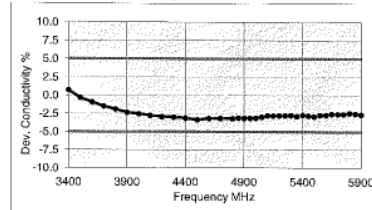
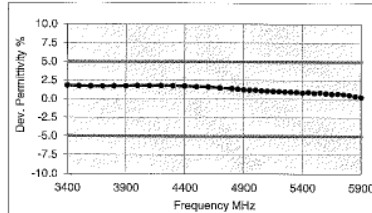



Figure D-7
5GHz Head Tissue Equivalent Matter

FCC ID: A3LSMG900S		SAR EVALUATION REPORT		Reviewed by: Quality Manager
Test Dates: 02/03/14 – 02/10/14	DUT Type: Portable Handset			APPENDIX D: Page 5 of 5

APPENDIX E: SAR SYSTEM VALIDATION



Per FCC KDB 865664 D02v01, SAR system validation status should be documented to confirm measurement accuracy. The SAR systems (including SAR probes, system components and software versions) used for this device were validated against its performance specifications prior to the SAR measurements. Reference dipoles were used with the required tissue- equivalent media for system validation, according to the procedures outlined in FCC KDB 865664 D01 v01 and IEEE 1528-2013. Since SAR probe calibrations are frequency dependent, each probe calibration point was validated at a frequency within the valid frequency range of the probe calibration point, using the system that normally operates with the probe for routine SAR measurements and according to the required tissue-equivalent media.

A tabulated summary of the system validation status including the validation date(s), measurement frequencies, SAR probes and tissue dielectric parameters has been included.

Table E-I
SAR System Validation Summary

SAR SYSTEM #	FREQ. [MHz]	DATE	PROBE SN	PROBE TYPE	PROBE CAL. POINT		COND.	PERM.	CW VALIDATION			MOD. VALIDATION		
							(σ)	(ϵ_r)	SENSI-TIVITY	PROBE LINEARITY	PROBE ISOTROPY	MOD. TYPE	DUTY FACTOR	PAR
I	750	6/27/2013	3319	ES3DV3	750	Head	0.918	41.73	PASS	PASS	PASS	N/A	N/A	N/A
J	835	1/15/2014	3332	ES3DV3	835	Head	0.900	40.49	PASS	PASS	PASS	GMSK	PASS	N/A
H	835	2/7/2014	3589	EX3DV4	835	Head	0.892	40.40	PASS	PASS	PASS	GMSK	PASS	N/A
D	1900	9/30/2013	3022	ES3DV2	1900	Head	1.419	39.22	PASS	PASS	PASS	GMSK	PASS	N/A
K	2450	2/6/2014	3287	ES3DV3	2450	Head	1.832	38.03	PASS	PASS	PASS	OFDM	N/A	PASS
E	5200	12/3/2013	3914	EX3DV4	5200	Head	4.482	34.70	PASS	PASS	PASS	OFDM	N/A	PASS
E	5300	12/3/2013	3914	EX3DV4	5300	Head	4.604	34.60	PASS	PASS	PASS	OFDM	N/A	PASS
E	5500	12/3/2013	3914	EX3DV4	5500	Head	4.821	34.28	PASS	PASS	PASS	OFDM	N/A	PASS
E	5600	12/3/2013	3914	EX3DV4	5600	Head	4.907	34.13	PASS	PASS	PASS	OFDM	N/A	PASS
E	5800	12/3/2013	3914	EX3DV4	5800	Head	5.133	33.89	PASS	PASS	PASS	OFDM	N/A	PASS
J	750	1/22/2014	3332	ES3DV3	750	Body	0.951	54.04	PASS	PASS	PASS	N/A	N/A	N/A
G	835	1/6/2014	3209	ES3DV3	835	Body	0.989	53.83	PASS	PASS	PASS	GMSK	PASS	N/A
D	1900	9/10/2013	3022	ES3DV2	1900	Body	1.516	52.49	PASS	PASS	PASS	GMSK	PASS	N/A
G	2450	1/17/2014	3209	ES3DV3	2450	Body	2.041	50.74	PASS	PASS	PASS	OFDM	N/A	PASS
E	5200	12/7/2013	3914	EX3DV4	5200	Body	5.330	48.16	PASS	PASS	PASS	OFDM	N/A	PASS
E	5300	12/7/2013	3914	EX3DV4	5300	Body	5.481	47.91	PASS	PASS	PASS	OFDM	N/A	PASS
E	5500	12/7/2013	3914	EX3DV4	5500	Body	5.807	47.39	PASS	PASS	PASS	OFDM	N/A	PASS
E	5600	12/7/2013	3914	EX3DV4	5600	Body	5.933	47.15	PASS	PASS	PASS	OFDM	N/A	PASS
E	5800	12/7/2013	3914	EX3DV4	5800	Body	6.240	46.70	PASS	PASS	PASS	OFDM	N/A	PASS

NOTE: While the probes have been calibrated for both a CW and modulated signal, all measurements were performed using communication systems calibrated for CW signals only. Modulations in the table above represent test configurations for which the measurement system has been validated per FCC KDB Publication 865664 D01v01 for scenarios when CW probe calibrations are used with other signal types. SAR systems were validated for modulated signals with a periodic duty cycle, such as GMSK, or with a high peak to average ratio (>5 dB), such as OFDM according to KDB 865664.

FCC ID: A3LSMG900S	 PCTEST ENGINEERING LABORATORY, INC.	SAR EVALUATION REPORT		Reviewed by: Quality Manager
Test Dates: 02/03/14 – 02/10/14	DUT Type: Portable Handset	APPENDIX E: Page 1 of 1		