



## SAR EVALUATION REPORT

**Applicant Name:**  
 Samsung Electronics, Co. Ltd.  
 129, Samsung-ro, Maetan dong,  
 Yeongtong-gu, Suwon-si  
 Gyeonggi-do 443-742, Korea

**Date of Testing:**  
 02/03/14 - 03/31/14  
**Test Site/Location:**  
 PCTEST Lab, Columbia, MD, USA  
**Document Serial No.:**  
 OY1403190578.A3L

**FCC ID:** A3LSMG900R7

**APPLICANT:** SAMSUNG ELECTRONICS, CO. LTD.

**DUT Type:** Portable Handset  
**Application Type:** Certification  
**FCC Rule Part(s):** CFR §2.1093  
**Model(s):** SM-G900R7



Equipment Class	Band & Mode	Tx Frequency	SAR		
			1 gm Head (W/kg)	1 gm Body-Worn (W/kg)	1 gm Hotspot (W/kg)
PCE	Cell. CDMA/EVDO	824.70 - 848.31 MHz	0.61	0.78	0.78
PCE	PCS CDMA/EVDO	1851.25 - 1908.75 MHz	0.62	0.53	0.57
PCE	LTE Band 12	701.5 - 713.5 MHz	0.34	0.41	0.52
PCE	LTE Band 4 (AWS)	1712.5 - 1752.5 MHz	0.38	0.51	0.59
PCE	LTE Band 25 (PCS)	1852.5 - 1912.5 MHz	0.63	0.22	0.57
DTS	2.4 GHz WLAN	2412 - 2462 MHz	0.19	0.26	0.26
DTS	5.8 GHz WLAN	5745 - 5825 MHz	0.17	0.33	0.33
NII	5.2 GHz WLAN	5180 - 5240 MHz	< 0.1	0.24	
NII	5.3 GHz WLAN	5260 - 5320 MHz	< 0.1	0.23	
NII	5.5 GHz WLAN	5500 - 5700 MHz	0.22	0.35	
DSS/DTS	Bluetooth	2402 - 2480 MHz	N/A		
<b>Simultaneous SAR per KDB 690783 D01v01r02:</b>			1.55		

This wireless portable device has been shown to be capable of compliance for localized specific absorption rate (SAR) for uncontrolled environment/general population exposure limits specified in ANSI/IEEE C95.1-1992 and has been tested in accordance with the measurement procedures specified in Section 1.9 of this report; for North American frequency bands only.

I attest to the accuracy of data. All measurements reported herein were performed by me or were made under my supervision and are correct to the best of my knowledge and belief. I assume full responsibility for the completeness of these measurements and vouch for the qualifications of all persons taking them. Test results reported herein relate only to the item(s) tested.



  
 Randy Ortanez  
 President



FCC ID: A3LSMG900R7		SAR EVALUATION REPORT		Reviewed by: Quality Manager
Document S/N: OY1403190578.A3L	Test Dates: 02/03/14 - 03/31/14	DUT Type: Portable Handset	Page 1 of 79	

# T A B L E O F C O N T E N T S

1	DEVICE UNDER TEST .....	3
2	LTE INFORMATION .....	10
3	INTRODUCTION .....	11
4	DOSIMETRIC ASSESSMENT .....	12
5	DEFINITION OF REFERENCE POINTS .....	13
6	TEST CONFIGURATION POSITIONS FOR HANDSETS .....	14
7	RF EXPOSURE LIMITS .....	18
8	FCC MEASUREMENT PROCEDURES.....	19
9	RF CONDUCTED POWERS.....	24
10	SYSTEM VERIFICATION.....	40
11	SAR DATA SUMMARY .....	42
12	FCC MULTI-TX AND ANTENNA SAR CONSIDERATIONS.....	52
13	SAR MEASUREMENT VARIABILITY .....	73
14	EQUIPMENT LIST.....	74
15	MEASUREMENT UNCERTAINTIES .....	75
16	CONCLUSION.....	77
17	REFERENCES .....	78
APPENDIX A: SAR TEST PLOTS		
APPENDIX B: SAR DIPOLE VERIFICATION PLOTS		
APPENDIX C: PROBE AND DIPOLE CALIBRATION CERTIFICATES		
APPENDIX D: SAR TISSUE SPECIFICATIONS		
APPENDIX E: SAR SYSTEM VALIDATION		
APPENDIX F: SAR TEST SETUP PHOTOGRAPHS		

<b>FCC ID:</b> A3LSMG900R7	 <small>ENGINEERING LABORATORY, INC.</small>	<b>SAR EVALUATION REPORT</b>		<b>Reviewed by:</b> Quality Manager
<b>Document S/N:</b> 0Y1403190578.A3L	<b>Test Dates:</b> 02/03/14 - 03/31/14	<b>DUT Type:</b> Portable Handset		Page 2 of 79

# 1 DEVICE UNDER TEST

## 1.1 Device Overview

Band & Mode	Operating Modes	Tx Frequency
Cell. CDMA/EVDO	Voice/Data	824.70 - 848.31 MHz
PCS CDMA/EVDO	Voice/Data	1851.25 - 1908.75 MHz
LTE Band 12	Data	701.5 - 713.5 MHz
LTE Band 4 (AWS)	Data	1712.5 - 1752.5 MHz
LTE Band 2 (PCS)	Data	1852.5 - 1907.5 MHz
LTE Band 25 (PCS)	Data	1852.5 - 1912.5 MHz
2.4 GHz WLAN	Data	2412 - 2462 MHz
5.8 GHz WLAN	Data	5745 - 5825 MHz
5.2 GHz WLAN	Data	5180 - 5240 MHz
5.3 GHz WLAN	Data	5260 - 5320 MHz
5.5 GHz WLAN	Data	5500 - 5700 MHz
Bluetooth	Data	2402 - 2480 MHz
NFC	Data	13.56 MHz
ANT+	Data	2402 - 2480 MHz

## 1.2 Power Reduction for SAR

This device utilizes power reduction using an independent single fixed level of reduction through a static table look-up, triggered by a single event/operation for the following modes:

### 1.2.1 CDMA2000

- PCS CDMA/EVDO power is reduced when Hotspot is active.

### 1.2.2 WI-FI



- Power is reduced for all held-to-ear exposure conditions.

## 1.3 Nominal and Maximum Output Power Specifications

This device operates using the following maximum and nominal output power specifications. SAR values were scaled to the maximum allowed power to determine compliance per KDB Publication 447498 D01v05.

### 1.3.1 Maximum Power

Mode / Band		Modulated Average (dBm)
Cell. CDMA/EVDO	Maximum	25.0
	Nominal	24.5
PCS CDMA/EVDO	Maximum	25.0
	Nominal	24.5

FCC ID: A3LSMG900R7	 <b>SAR EVALUATION REPORT</b> 	Reviewed by: Quality Manager
Document S/N: OY1403190578.A3L	Test Dates: 02/03/14 - 03/31/14	DUT Type: Portable Handset
		Page 3 of 79

Mode / Band		Modulated Average (dBm)
LTE Band 12	Maximum	23.5
	Nominal	23.0
LTE Band 4 (AWS)	Maximum	23.5
	Nominal	23.0
LTE Band 2 (PCS)	Maximum	23.5
	Nominal	23.0
LTE Band 25 (PCS)	Maximum	23.5
	Nominal	23.0



Mode / Band		Modulated Average (dBm)
IEEE 802.11b (2.4 GHz)	Maximum	17.5
	Nominal	17.0
IEEE 802.11g (2.4 GHz)	Maximum	14.5
	Nominal	14.0
IEEE 802.11n (2.4 GHz)	Maximum	14.0
	Nominal	13.5
IEEE 802.11a (5 GHz)	Maximum	14.0
	Nominal	13.5
IEEE 802.11n (5 GHz, 20 MHz Bandwidth)	Maximum	13.5
	Nominal	13.0
IEEE 802.11n (5 GHz, 40 MHz Bandwidth)	Maximum	12.5
	Nominal	12.0
IEEE 802.11ac (5 GHz, 80 MHz Bandwidth)	Maximum	11.5
	Nominal	11.0
Bluetooth	Maximum	10.0
	Nominal	9.5
Bluetooth LE	Maximum	8.5
	Nominal	8.0

### 1.3.2 Reduced Power with Hotspot Mode Activated

Mode / Band		Modulated Average (dBm)
PCS CDMA/EVDO	Maximum	23.0
	Nominal	22.5

### 1.3.3 Reduced Power – Held-to-Ear

Mode / Band		Modulated Average (dBm)
IEEE 802.11b (2.4 GHz)	Maximum	12.5
	Nominal	12.0
IEEE 802.11g (2.4 GHz)	Maximum	12.5
	Nominal	12.0
IEEE 802.11n (2.4 GHz)	Maximum	12.5
	Nominal	12.0
IEEE 802.11a (5 GHz)	Maximum	7.5
	Nominal	7.0
IEEE 802.11n (5 GHz, 20 MHz Bandwidth)	Maximum	7.5
	Nominal	7.0
IEEE 802.11n (5 GHz, 40 MHz Bandwidth)	Maximum	7.5
	Nominal	7.0
IEEE 802.11ac (5 GHz, 80 MHz Bandwidth)	Maximum	7.5
	Nominal	7.0

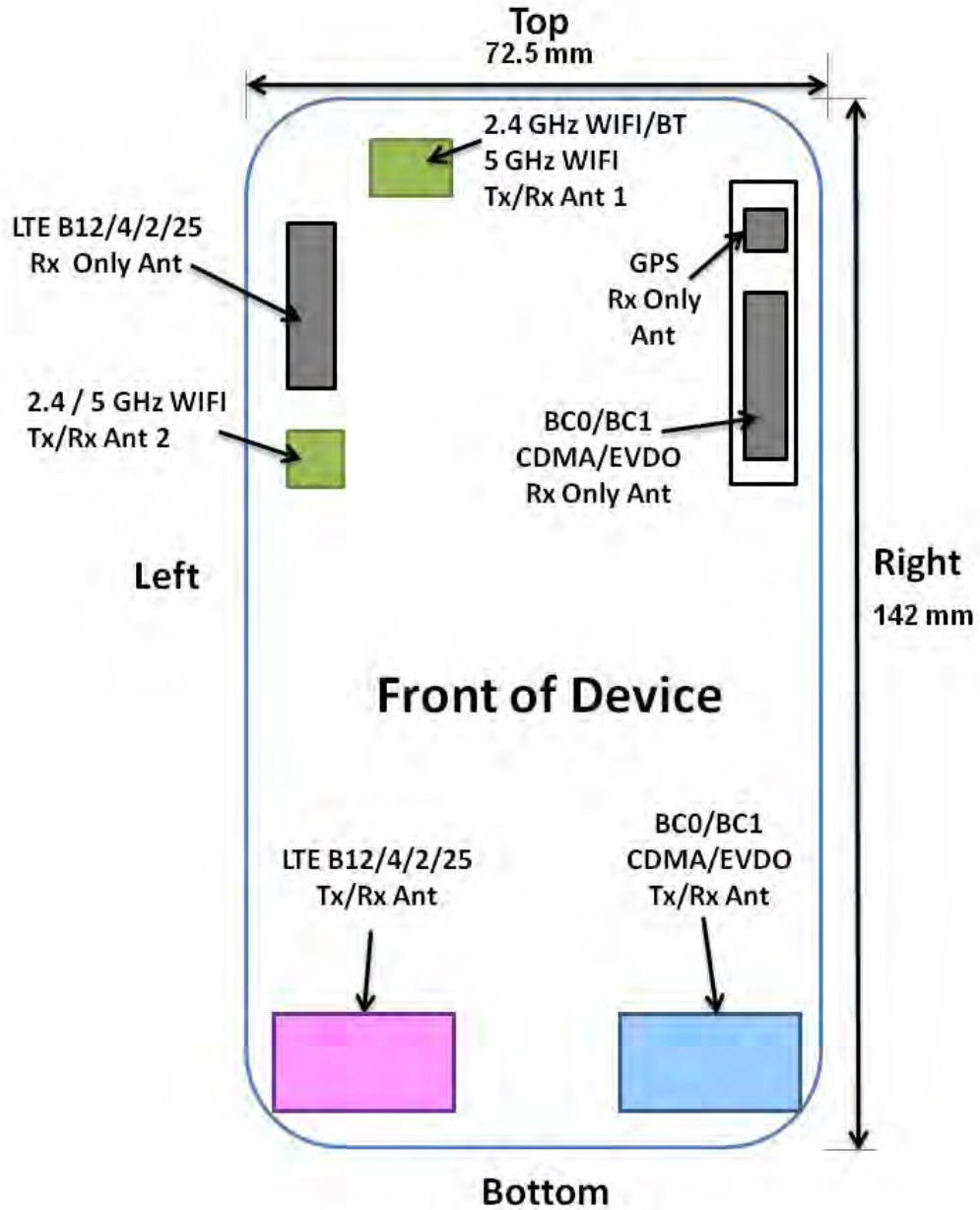

FCC ID: A3LSMG900R7	 <b>PCTEST</b> ENGINEERING LABORATORY, INC.	<b>SAR EVALUATION REPORT</b>		<b>Reviewed by:</b> Quality Manager
<b>Document S/N:</b> OY1403190578.A3L	<b>Test Dates:</b> 02/03/14 - 03/31/14	<b>DUT Type:</b> Portable Handset	Page 4 of 79	

## 1.4 DUT Antenna Locations



Note: Exact antenna dimensions and separation distances are shown in the Technical Descriptions in the FCC Filing.

**Figure 1-1**  
**DUT Antenna Locations**

FCC ID: A3LSMG900R7	 <b>PCTEST</b> ENGINEERING LABORATORY, INC.	SAR EVALUATION REPORT		Reviewed by: Quality Manager
Document S/N: 0Y1403190578.A3L	Test Dates: 02/03/14 - 03/31/14	DUT Type: Portable Handset		Page 5 of 79

**Table 1-1  
Mobile Hotspot Sides for SAR Testing**

Mode	Back	Front	Top	Bottom	Right	Left
Cell. EVDO	Yes	Yes	No	Yes	Yes	No
PCS EVDO	Yes	Yes	No	Yes	Yes	No
LTE Band 12	Yes	Yes	No	Yes	No	Yes
LTE Band 4 (AWS)	Yes	Yes	No	Yes	No	Yes
LTE Band 25 (PCS)	Yes	Yes	No	Yes	No	Yes
2.4 GHz WLAN	Yes	Yes	Yes	No	No	Yes
5.8 GHz WLAN	Yes	Yes	Yes	No	No	Yes



Note: Particular DUT edges were not required to be evaluated for Wireless Router SAR if the edges were greater than 2.5 cm from the transmitting antenna according to FCC KDB Publication 941225 D06v01 guidance, page 2.

### 1.5 Near Field Communications (NFC) Antenna

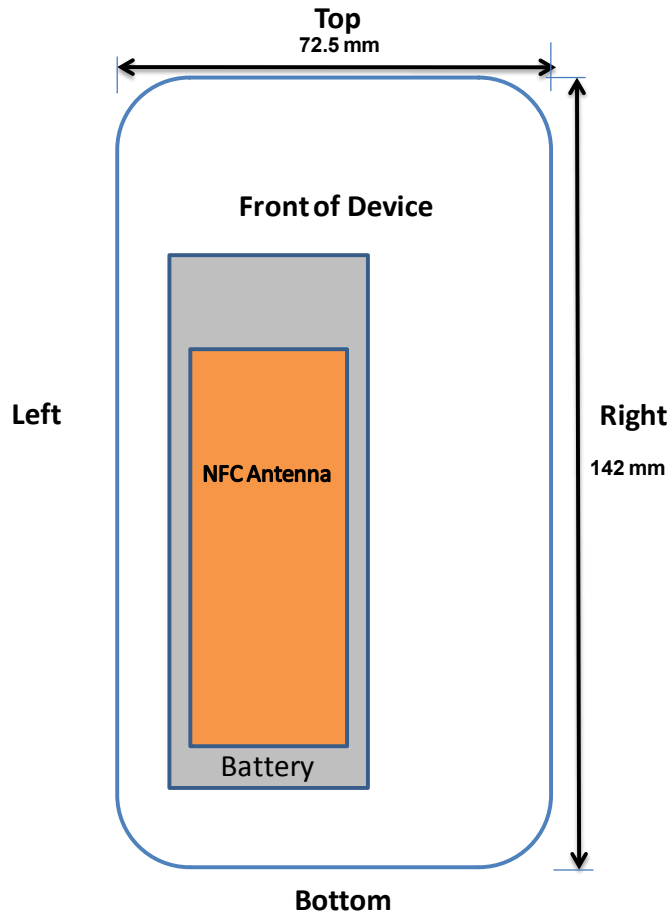
This DUT has NFC operations. The NFC antenna is integrated into the specialized battery. The SAR tests were performed with the specialized battery (model: EB-BG900BBU).



**Figure 1-2  
NFC Antenna Locations**

FCC ID: A3LSMG900R7	 <b>PCTEST</b> ENGINEERING LABORATORY, INC.	<b>SAR EVALUATION REPORT</b>		Reviewed by: Quality Manager
Document S/N: 0Y1403190578.A3L	Test Dates: 02/03/14 - 03/31/14	DUT Type: Portable Handset		Page 6 of 79

## 1.6 Simultaneous Transmission Capabilities

According to FCC KDB Publication 447498 D05v01, transmitters are considered to be transmitting simultaneously when there is overlapping transmission, with the exception of transmissions during network hand-offs with maximum hand-off duration less than 30 seconds. Possible transmission paths for the DUT are shown in Figure 1-3 and are color-coded to indicate communication modes which share the same path. Modes which share the same transmission path cannot transmit simultaneously with one another. This device supports MIMO Tx for WLAN 802.11n/ac. Each WLAN antenna can transmit independently or together when operating with MIMO.



Figure 1-3

Simultaneous Transmission Paths

This device contains multiple transmitters that may operate simultaneously, and therefore requires a simultaneous transmission analysis according to FCC KDB Publication 447498 D01v05 3) procedures.

Table 1-2  
Simultaneous Transmission Scenarios



No.	Capable Transmit Configuration	Head	Body-Worn Accessory	Wireless Router	Notes
1	1x CDMA voice + 2.4 GHz WI-FI	Yes	Yes	N/A	
2	1x CDMA voice + 5 GHz WI-FI	Yes	Yes	N/A	
3	1x CDMA voice + 2.4 GHz Bluetooth	N/A	Yes	N/A	
4	LTE + 2.4 GHz WI-FI	Yes*	Yes*	Yes	*-Pre-installed VOIP applications are considered.
5	LTE + 5 GHz WI-FI	Yes*	Yes*	Yes	*-Pre-installed VOIP applications are considered.
6	LTE + 2.4 GHz Bluetooth	N/A	Yes*	N/A	*-Pre-installed VOIP applications are considered.
7	CDMA/EVDO data + 2.4 GHz WI-FI	Yes*	Yes*	Yes	*-Pre-installed VOIP applications are considered.
8	CDMA/EVDO data + 5 GHz WI-FI	Yes*	Yes*	Yes	*-Pre-installed VOIP applications are considered.
9	CDMA/EVDO data + 2.4 GHz Bluetooth	N/A	Yes*	N/A	*-Pre-installed VOIP applications are considered.
10	1x CDMA voice + LTE	Yes	Yes	N/A	
11	1x CDMA voice + LTE + 2.4 GHz WI-FI	Yes	Yes	Yes	
12	1x CDMA voice + LTE + 5 GHz WI-FI	Yes	Yes	Yes	
13	1x CDMA voice + LTE + 2.4 GHz Bluetooth	N/A	Yes	N/A	
14	1x CDMA voice + CDMA/EVDO data	N/A	N/A	N/A	Not supported by HW
15	CDMA/EVDO data + LTE	N/A	N/A	N/A	Not supported by SW

Note:

- Per the manufacturer, WIFI Direct is not expected to be used in conjunction with a held-to-ear or body-worn accessory voice call. Therefore, there are no simultaneous transmission scenarios involving WIFI direct beyond that listed in the above table.
- This device supports 2x2 MIMO Tx for WLAN 802.11n/ac. Each WLAN antenna can transmit independently or together when operating with MIMO.

## 1.7 Wireless Charging Cover

This DUT may be used with a standard battery cover or with an optional wireless charging battery cover. Per FCC KDB Publication 648474 D04, SAR was measured using the standard battery cover and then repeated with the wireless charging battery cover for the highest reported SAR for each wireless technology, frequency band, operating mode, and exposure condition. No other additional test with wireless charging cover was required since all reported SAR were less than 1.2 W/kg.

FCC ID: A3LSMG900R7	 PCTEST ENGINEERING LABORATORY, INC.	SAR EVALUATION REPORT		Reviewed by: Quality Manager
Document S/N: 0Y1403190578.A3L	Test Dates: 02/03/14 - 03/31/14	DUT Type: Portable Handset		Page 7 of 79

## 1.8 SAR Test Exclusions Applied

### (A) WIFI/BT

Since Wireless Router operations are not allowed by the chipset firmware using 5 GHz NII WIFI, only 2.4 GHz and 5.8 GHz WIFI Hotspot SAR tests and combinations are considered for SAR with respect to Wireless Router configurations according to FCC KDB 941225 D06v01.

Per FCC KDB 447498 D01v05, the SAR exclusion threshold for distances <50mm is defined by the following equation:

$$\frac{\text{Max Power of Channel (mW)}}{\text{Test Separation Dist (mm)}} * \sqrt{\text{Frequency(GHz)}} \leq 3.0$$

Based on the maximum conducted power of Bluetooth (rounded to the nearest mW) and the antenna to user separation distance, Bluetooth SAR was not required;  $[(10/15) * \sqrt{2.441}] = 1.0 < 3.0$ . Per KDB Publication 447498 D01v05, the maximum power of the channel was rounded to the nearest mW before calculation.

This device supports 20 MHz and 40 MHz Bandwidths for IEEE 802.11n for 5 GHz WIFI only. SISO IEEE 802.11n was not evaluated for SAR since the average output power of 20 MHz and 40 MHz bandwidths was not more than 0.25 dB higher than the average output power of IEEE 802.11a.

This device supports IEEE 802.11ac with the following features:



- a) Up to 80 MHz Bandwidth only
- b) No aggregate channel configurations
- c) 2 Tx antenna output
- d) 256 QAM is supported
- e) No new 5 GHz channels

### (B) Licensed Transmitter(s)

LTE SAR for the higher modulations and lower bandwidths were not tested since the maximum average output power of all required channels and configurations was not more than 0.5 dB higher than the highest bandwidth; and the reported LTE SAR for the highest bandwidth was less than 1.45 W/kg for all configurations according to FCC KDB 941225 D05v02.

CDMA 1X Advanced technology was not required for SAR since the maximum output powers for 1x Advanced was not more than 0.25 dB higher than the maximum measured powers for 1x and the measured SAR in any 1x mode exposure conditions was not greater than 1.2 W/kg.

This Device additionally supports LTE Band 2. All LTE bands share the same transmission path. LTE Band 2 was not evaluated for SAR since the supported frequency range falls within the LTE Band 25 supported frequency range.

FCC ID: A3LSMG900R7		SAR EVALUATION REPORT		Reviewed by: Quality Manager
Document S/N: 0Y1403190578.A3L	Test Dates: 02/03/14 - 03/31/14	DUT Type: Portable Handset	Page 8 of 79	



## 1.9 Guidance Applied

- IEEE 1528-2003
- FCC KDB Publication 941225 D01-D06 (1x Advanced, 2G/3G/4G, and Hotspot)
- FCC KDB Publication 248227 D01v01r02 (SAR Considerations for 802.11 Devices)
- FCC KDB Publication 447498 D01v05 (General SAR Guidance)
- FCC KDB Publication 865664 D01-D02 (SAR Measurements up to 6 GHz)
- FCC KDB Publication 648474 D03-D04 (Wireless Charging Cover)
- April 2013 TCB Workshop Notes (IEEE 802.11ac)

## 1.10 Device Serial Numbers

Several samples with identical hardware were used to support SAR testing. The manufacturer has confirmed that the device(s) tested have the same physical, mechanical and thermal characteristics and are within operational tolerances expected for production units.



	Head Serial Number	Head Serial Number (reduced power)	Body-Worn Serial Number	Hotspot Serial Number
Cell. CDMA/EVDO	32EF0	-	32EF0	32EF0
PCS CDMA/EVDO	32EC6	3R725	32EF0	3R725
LTE Band 12	32EC6	-	32EF0	32EF0
LTE Band 4 (AWS)	32EC6	-	32EC6	32EC6
LTE Band 25 (PCS)	32EC6	-	32E32	32E32
2.4 GHz WLAN	-	328C6	00F05	00F05
5 GHz WLAN	-	31F35	32712, 15ECE	32712, 15ECE

FCC ID: A3LSMG900R7	 <b>PCTEST</b> ENGINEERING LABORATORY, INC.	<b>SAR EVALUATION REPORT</b>		<b>Reviewed by:</b> Quality Manager
<b>Document S/N:</b> 0Y1403190578.A3L	<b>Test Dates:</b> 02/03/14 - 03/31/14	<b>DUT Type:</b> Portable Handset	Page 9 of 79	

## 2

## LTE INFORMATION

LTE Information			
FCC ID	A3LSMG900R7		
Form Factor	Portable Handset		
Frequency Range of each LTE transmission band	LTE Band 12 (701.5 - 713.5 MHz)		
	LTE Band 4 (AWS) (1712.5 - 1752.5 MHz)		
	LTE Band 2 (PCS) (1852.5 - 1907.5 MHz)		
	LTE Band 25 (PCS) (1852.5 - 1912.5 MHz)		
Channel Bandwidths	LTE Band 12: 5 MHz, 10 MHz		
	LTE Band 4 (AWS): 5 MHz, 10 MHz		
	LTE Band 2 (PCS): 5 MHz, 10 MHz		
	LTE Band 25 (PCS): 5 MHz, 10 MHz		
Channel Numbers and Frequencies (MHz)	Low	Mid	High
LTE Band 12: 5 MHz	701.5 (23035)	707.5 (23095)	713.5 (23155)
LTE Band 12: 10 MHz	704 (23060)	707.5 (23095)	711 (23130)
LTE Band 4 (AWS): 5 MHz	1712.5 (19975)	1732.5 (20175)	1752.5 (20375)
LTE Band 4 (AWS): 10 MHz	1715 (20000)	1732.5 (20175)	1750 (20350)
LTE Band 2 (PCS): 5 MHz	1852.5 (18625)	1880 (18900)	1907.5 (19175)
LTE Band 2 (PCS): 10 MHz	1855 (18650)	1880 (18900)	1905 (19150)
LTE Band 25 (PCS): 5 MHz	1852.5 (26065)	1882.5 (26365)	1912.5 (26665)
LTE Band 25 (PCS): 10 MHz	1855 (26090)	1882.5 (26365)	1910 (26640)
UE Category	3		
Modulations Supported in UL	QPSK, 16QAM		
LTE MPR Permanently implemented per 3GPP TS 36.101 section 6.2.3~6.2.5? (manufacturer attestation to be provided)	YES		
A-MPR (Additional MPR) disabled for SAR Testing?	YES		

FCC ID: A3LSMG900R7	 PCTEST ENGINEERING LABORATORY, INC.	SAR EVALUATION REPORT		Reviewed by: Quality Manager
Document S/N: 0Y1403190578.A3L	Test Dates: 02/03/14 - 03/31/14	DUT Type: Portable Handset	Page 10 of 79	

## 3 INTRODUCTION

The FCC and Industry Canada have adopted the guidelines for evaluating the environmental effects of radio frequency (RF) radiation in ET Docket 93-62 on Aug. 6, 1996 and Health Canada Safety Code 6 to protect the public and workers from the potential hazards of RF emissions due to FCC-regulated portable devices. [1]

The safety limits used for the environmental evaluation measurements are based on the criteria published by the American National Standards Institute (ANSI) for localized specific absorption rate (SAR) in IEEE/ANSI C95.1-1992 Standard for Safety Levels with Respect to Human Exposure to Radio Frequency Electromagnetic Fields, 3 kHz to 300 GHz [3] and Health Canada RF Exposure Guidelines Safety Code 6 [22]. The measurement procedure described in IEEE/ANSI C95.3-2002 Recommended Practice for the Measurement of Potentially Hazardous Electromagnetic Fields - RF and Microwave [4] is used for guidance in measuring the Specific Absorption Rate (SAR) due to the RF radiation exposure from the Equipment Under Test (EUT). These criteria for SAR evaluation are similar to those recommended by the International Committee for Non-Ionizing Radiation Protection (ICNIRP) in Biological Effects and Exposure Criteria for Radiofrequency Electromagnetic Fields,” Report No. Vol 74. SAR is a measure of the rate of energy absorption due to exposure to an RF transmitting source. SAR values have been related to threshold levels for potential biological hazards.

### 3.1 SAR Definition

Specific Absorption Rate is defined as the time derivative (rate) of the incremental energy (dU) absorbed by (dissipated in) an incremental mass (dm) contained in a volume element (dV) of a given density (ρ). It is also defined as the rate of RF energy absorption per unit mass at a point in an absorbing body (see Equation 3-1).

**Equation 3-1**  
**SAR Mathematical Equation**

$$SAR = \frac{d}{dt} \left( \frac{dU}{dm} \right) = \frac{d}{dt} \left( \frac{dU}{\rho dv} \right)$$



**SAR is expressed in units of Watts per Kilogram (W/kg).**

$$SAR = \frac{\sigma \cdot E^2}{\rho}$$

where:

- σ = conductivity of the tissue-simulating material (S/m)
- ρ = mass density of the tissue-simulating material (kg/m<sup>3</sup>)
- E = Total RMS electric field strength (V/m)

NOTE: The primary factors that control rate of energy absorption were found to be the wavelength of the incident field in relation to the dimensions and geometry of the irradiated organism, the orientation of the organism in relation to the polarity of field vectors, the presence of reflecting surfaces, and whether conductive contact is made by the organism with a ground plane.[6]

FCC ID: A3LSMG900R7		<b>SAR EVALUATION REPORT</b>		Reviewed by: Quality Manager
Document S/N: 0Y1403190578.A3L	Test Dates: 02/03/14 - 03/31/14	DUT Type: Portable Handset	Page 11 of 79	

## 4 DOSIMETRIC ASSESSMENT

### 4.1 Measurement Procedure

The evaluation was performed using the following procedure compliant to FCC KDB Publication 865664 D01v01 and IEEE 1528-2013:

1. The SAR distribution at the exposed side of the head or body was measured at a distance no greater than 5.0 mm from the inner surface of the shell. The area covered the entire dimension of the device-head and body interface and the horizontal grid resolution was determined per FCC KDB Publication 865664 D01v01 (See Table 4-1) and IEEE 1528-2013.
2. The point SAR measurement was taken at the maximum SAR region determined from Step 1 to enable the monitoring of SAR fluctuations/drifts during the 1g/10g cube evaluation. SAR at this fixed point was measured and used as a reference value.
3. Based on the area scan data, the peak of the region with maximum SAR was determined by spline interpolation. Around this point, a volume was assessed according to the measurement resolution and volume size requirements of FCC KDB Publication 865664 D01v01 (See Table 4-1) and IEEE 1528-2013. On the basis of this data set, the spatial peak SAR value was evaluated with the following procedure (see references or the DASY manual online for more details):
  - a. SAR values at the inner surface of the phantom are extrapolated from the measured values along the line away from the surface with spacing no greater than that in Table 4-1. The extrapolation was based on a least-squares algorithm. A polynomial of the fourth order was calculated through the points in the z-axis (normal to the phantom shell).
  - b. After the maximum interpolated values were calculated between the points in the cube, the SAR was averaged over the spatial volume (1g or 10g) using a 3D-Spline interpolation algorithm. The 3D-spline is composed of three one-dimensional splines with the “Not a knot” condition (in x, y, and z directions). The volume was then integrated with the trapezoidal algorithm. One thousand points (10 x 10 x 10) were obtained through interpolation, in order to calculate the averaged SAR.
  - c. All neighboring volumes were evaluated until no neighboring volume with a higher average value was found.
4. The SAR reference value, at the same location as step 2, was re-measured after the zoom scan was complete to calculate the SAR drift. If the drift deviated by more than 5%, the SAR test and drift measurements were repeated.

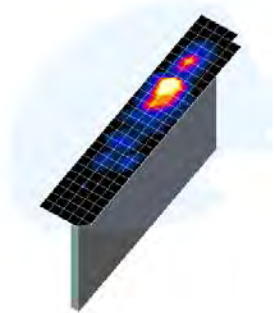



**Figure 4-1**  
Sample SAR Area Scan

**Table 4-1**  
Area and Zoom Scan Resolutions per FCC KDB Publication 865664 D01v01\*

Frequency	Maximum Area Scan Resolution (mm) ( $\Delta x_{\text{area}}, \Delta y_{\text{area}}$ )	Maximum Zoom Scan Resolution (mm) ( $\Delta x_{\text{zoom}}, \Delta y_{\text{zoom}}$ )	Maximum Zoom Scan Spatial Resolution (mm)			Minimum Zoom Scan Volume (mm) (x, y, z)
			Uniform Grid	Graded Grid		
			$\Delta z_{\text{zoom}}(n)$	$\Delta z_{\text{zoom}}(1)^*$	$\Delta z_{\text{zoom}}(n>1)^*$	
≤ 2 GHz	≤ 15	≤ 8	≤ 5	≤ 4	≤ 1.5* $\Delta z_{\text{zoom}}(n-1)$	≥ 30
2-3 GHz	≤ 12	≤ 5	≤ 5	≤ 4	≤ 1.5* $\Delta z_{\text{zoom}}(n-1)$	≥ 30
3-4 GHz	≤ 12	≤ 5	≤ 4	≤ 3	≤ 1.5* $\Delta z_{\text{zoom}}(n-1)$	≥ 28
4-5 GHz	≤ 10	≤ 4	≤ 3	≤ 2.5	≤ 1.5* $\Delta z_{\text{zoom}}(n-1)$	≥ 25
5-6 GHz	≤ 10	≤ 4	≤ 2	≤ 2	≤ 1.5* $\Delta z_{\text{zoom}}(n-1)$	≥ 22

\*Also compliant to IEEE 1528-2013 Table 6

FCC ID: A3LSMG900R7		<b>SAR EVALUATION REPORT</b>		Reviewed by: Quality Manager
Document S/N: OY1403190578.A3L	Test Dates: 02/03/14 - 03/31/14	DUT Type: Portable Handset	Page 12 of 79	

# 5 DEFINITION OF REFERENCE POINTS

## 5.1 EAR REFERENCE POINT

Figure 5-2 shows the front, back and side views of the SAM Twin Phantom. The point “M” is the reference point for the center of the mouth, “LE” is the left ear reference point (ERP), and “RE” is the right ERP. The ERP is 15mm posterior to the entrance to the ear canal (EEC) along the B-M line (Back-Mouth), as shown in Figure 5-1. The plane passing through the two ear canals and M is defined as the Reference Plane. The line N-F (Neck-Front), also called the Reference Pivoting Line, is not perpendicular to the reference plane (see Figure 5-1). Line B-M is perpendicular to the N-F line. Both N-F and B-M lines are marked on the external phantom shell to facilitate handset positioning [5].

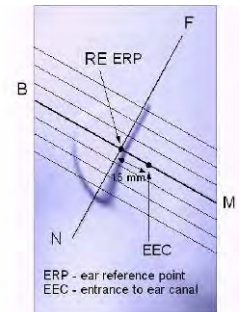

**Figure 5-1**  
Close-Up Side view of ERP

## 5.2 HANDSET REFERENCE POINTS



Two imaginary lines on the handset were established: the vertical centerline and the horizontal line. The test device was placed in a normal operating position with the acoustic output located along the “vertical centerline” on the front of the device aligned to the “ear reference point” (See Figure 5-3). The acoustic output was then located at the same level as the center of the ear reference point. The test device was positioned so that the “vertical centerline” was bisecting the front surface of the handset at its top and bottom edges, positioning the “ear reference point” on the outer surface of the both the left and right head phantoms on the ear reference point.

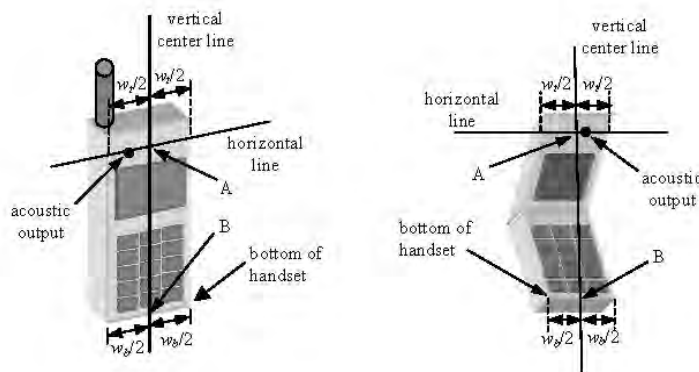

**Figure 5-2**  
Front, back and side view of SAM Twin Phantom



**Figure 5-3**  
Handset Vertical Center & Horizontal Line Reference Points

FCC ID: A3LSMG900R7	 PCTEST ENGINEERING LABORATORY, INC.	SAR EVALUATION REPORT		Reviewed by: Quality Manager
Document S/N: OY1403190578.A3L	Test Dates: 02/03/14 - 03/31/14	DUT Type: Portable Handset		Page 13 of 79

## 6 TEST CONFIGURATION POSITIONS FOR HANDSETS

### 6.1 Device Holder

The device holder is made out of low-loss POM material having the following dielectric parameters: relative permittivity  $\epsilon = 3$  and loss tangent  $\delta = 0.02$ .

### 6.2 Positioning for Cheek

1. The test device was positioned with the device close to the surface of the phantom such that point A is on the (virtual) extension of the line passing through points RE and LE on the phantom (see Figure 6-1), such that the plane defined by the vertical center line and the horizontal line of the phone is approximately parallel to the sagittal plane of the phantom.

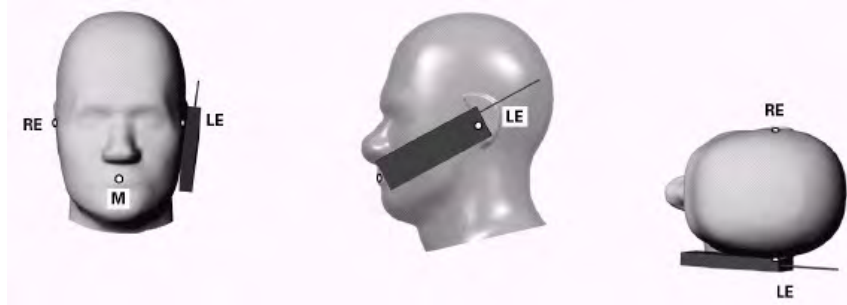



Figure 6-1 Front, Side and Top View of Cheek Position

2. The handset was translated towards the phantom along the line passing through RE & LE until the handset touches the pinna.
3. While maintaining the handset in this plane, the handset was rotated around the LE-RE line until the vertical centerline was in the reference plane.
4. The phone was then rotated around the vertical centerline until the phone (horizontal line) was symmetrical with respect to the line NF.
5. While maintaining the vertical centerline in the reference plane, keeping point A on the line passing through RE and LE, and maintaining the device contact with the ear, the device was rotated about the NF line until any point on the handset made contact with a phantom point below the ear (cheek) (See Figure 6-2).

### 6.3 Positioning for Ear / 15° Tilt

With the test device aligned in the “Cheek Position”:

1. While maintaining the orientation of the phone, the phone was retracted parallel to the reference plane far enough to enable a rotation of the phone by 15 degrees.
2. The phone was then rotated around the horizontal line by 15 degrees.
3. While maintaining the orientation of the phone, the phone was moved parallel to the reference plane until any part of the handset touched the head. (In this position, point A was located on the line RE-LE). The tilted position is obtained when the contact is on the pinna. If the contact was at any location other than the pinna, the angle of the phone would then be reduced. In this situation, the tilted position was obtained when any part of the phone was in contact of the ear as well as a second part of the phone was in contact with the head (see Figure 6-2).

FCC ID: A3LSMG900R7		SAR EVALUATION REPORT		Reviewed by: Quality Manager
Document S/N: OY1403190578.A3L	Test Dates: 02/03/14 - 03/31/14	DUT Type: Portable Handset	Page 14 of 79	

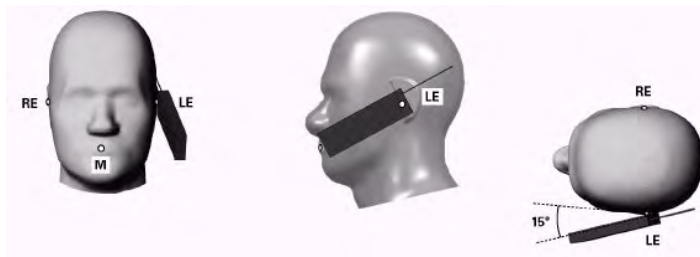

**Figure 6-2 Front, Side and Top View of Ear/15° Tilt Position**

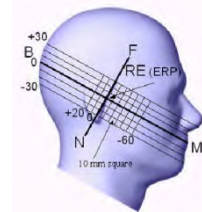

**Figure 6-3 Side view w/ relevant markings**



## 6.4 SAR Evaluations near the Mouth/Jaw Regions of the SAM Phantom

Antennas located near the bottom of a phone may require SAR measurements around the mouth and jaw regions of the SAM head phantom. This typically applies to clam-shell style phones that are generally longer in the unfolded normal use positions or to certain older style long rectangular phones. Per IEEE 1528-2013, a rotated SAM phantom is necessary to allow probe access to such regions. Both SAM heads of the TwinSAM-Chin20 are rotated 20 degrees around the NF line. Each head can be removed from the table for emptying and cleaning.

Under these circumstances, the following procedures apply, adopted from the FCC guidance on SAR handsets document FCC KDB Publication 648474 D04\_v01. The SAR required in these regions of SAM should be measured using a flat phantom. The phone should be positioned with a separation distance of 4 mm between the ear reference point (ERP) and the outer surface of the flat phantom shell. While maintaining this distance at the ERP location, the low (bottom) edge of the phone should be lowered from the phantom to establish the same separation distance between the peak SAR location identified by the truncated partial SAR distribution measured with the SAM phantom. The distance from the peak SAR location to the phone is determined by the straight line passing perpendicularly through the phantom surface. When it is not feasible to maintain 4 mm separation at the ERP while also establishing the required separation at the peak SAR location, the top edge of the phone will be allowed to touch the phantom with a separation < 4 mm at the ERP. The phone should not be tilted to the left or right while placed in this inclined position to the flat phantom.

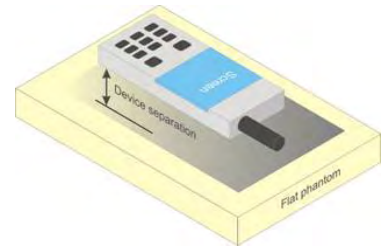

**Figure 6-4 Twin SAM Chin20**

FCC ID: A3LSMG900R7	 <b>PCTEST</b> ENGINEERING LABORATORY, INC.	<b>SAR EVALUATION REPORT</b>		<b>Reviewed by:</b> Quality Manager
<b>Document S/N:</b> OY1403190578.A3L	<b>Test Dates:</b> 02/03/14 - 03/31/14	<b>DUT Type:</b> Portable Handset	Page 15 of 79	

## 6.5 Body-Worn Accessory Configurations

Body-worn operating configurations are tested with the belt-clips and holsters attached to the device and positioned against a flat phantom in a normal use configuration (see Figure 6-5). Per FCC KDB Publication 648474 D04v01, Body-worn accessory exposure is typically related to voice mode operations when handsets are carried in body-worn accessories. The body-worn accessory procedures in FCC KDB Publication 447498 D01v05 should be used to test for body-worn accessory SAR compliance, without a headset connected to it. This enables the test results for such configuration to be compatible with that required for hotspot mode when the body-worn accessory test separation distance is greater than or equal to that required for hotspot mode, when applicable. When the reported SAR for a body-worn accessory, measured without a headset connected to the handset, is  $> 1.2 \text{ W/kg}$ , the highest reported SAR configuration for that wireless mode and frequency band should be repeated for that body-worn accessory with a headset attached to the handset.



**Figure 6-5**  
**Sample Body-Worn Diagram**



Accessories for Body-worn operation configurations are divided into two categories: those that do not contain metallic components and those that do contain metallic components. When multiple accessories that do not contain metallic components are supplied with the device, the device is tested with only the accessory that dictates the closest spacing to the body. Then multiple accessories that contain metallic components are tested with the device with each accessory. If multiple accessories share an identical metallic component (i.e. the same metallic belt-clip used with different holsters with no other metallic components) only the accessory that dictates the closest spacing to the body is tested.

Body-worn accessories may not always be supplied or available as options for some devices intended to be authorized for body-worn use. In this case, a test configuration with a separation distance between the back of the device and the flat phantom is used. Test position spacing was documented. Transmitters that are designed to operate in front of a person's face, as in push-to-talk configurations, are tested for SAR compliance with the front of the device positioned to face the flat phantom in head fluid. For devices that are carried next to the body such as a shoulder, waist or chest-worn transmitters, SAR compliance is tested with the accessories, including headsets and microphones, attached to the device and positioned against a flat phantom in a normal use configuration.

## 6.6 Extremity Exposure Configurations

Devices that are designed or intended for use on extremities or mainly operated in extremity only exposure conditions; i.e., hands, wrists, feet and ankles, may require extremity SAR evaluation. When the device also operates in close proximity to the user's body, SAR compliance for the body is also required. The 1-g body and 10-g extremity SAR Exclusion Thresholds found in KDB Publication 44798 D01v05 should be applied to determine SAR test requirements.



Per KDB Publication 44798 D01v05, Cell phones (handsets) are not normally designed to be used on extremities or operated in extremity only exposure conditions. The maximum output power levels of handsets generally do not require extremity SAR testing to show compliance. Therefore, extremity SAR was not evaluated for this device.

FCC ID: A3LSMG900R7		SAR EVALUATION REPORT		Reviewed by: Quality Manager
Document S/N: 0Y1403190578.A3L	Test Dates: 02/03/14 - 03/31/14	DUT Type: Portable Handset	Page 16 of 79	

## 6.7 Wireless Router Configurations

Some battery-operated handsets have the capability to transmit and receive user data through simultaneous transmission of WIFI simultaneously with a separate licensed transmitter. The FCC has provided guidance in FCC KDB Publication 941225 D06 v01 where SAR test considerations for handsets ( $L \times W \geq 9 \text{ cm} \times 5 \text{ cm}$ ) are based on a composite test separation distance of 10 mm from the front, back and edges of the device containing transmitting antennas within 2.5 cm of their edges, determined from general mixed use conditions for this type of devices. Since the hotspot SAR results may overlap with the body-worn accessory SAR requirements, the more conservative configurations can be considered, thus excluding some body-worn accessory SAR tests.

When the user enables the personal wireless router functions for the handset, actual operations include simultaneous transmission of both the WIFI transmitter and another licensed transmitter. Both transmitters often do not transmit at the same transmitting frequency and thus cannot be evaluated for SAR under actual use conditions due to the limitations of the SAR assessment probes. Therefore, SAR must be evaluated for each frequency transmission and mode separately and spatially summed with the WIFI transmitter according to FCC KDB Publication 447498 D01v05 publication procedures. The "Portable Hotspot" feature on the handset was NOT activated during SAR assessments, to ensure the SAR measurements were evaluated for a single transmission frequency RF signal at a time.

FCC ID: A3LSMG900R7		SAR EVALUATION REPORT		Reviewed by: Quality Manager
Document S/N: 0Y1403190578.A3L	Test Dates: 02/03/14 - 03/31/14	DUT Type: Portable Handset		Page 17 of 79

# 7 RF EXPOSURE LIMITS

## 7.1 Uncontrolled Environment

UNCONTROLLED ENVIRONMENTS are defined as locations where there is the exposure of individuals who have no knowledge or control of their exposure. The general population/uncontrolled exposure limits are applicable to situations in which the general public may be exposed or in which persons who are exposed as a consequence of their employment may not be made fully aware of the potential for exposure or cannot exercise control over their exposure. Members of the general public would come under this category when exposure is not employment-related; for example, in the case of a wireless transmitter that exposes persons in its vicinity.



## 7.2 Controlled Environment

CONTROLLED ENVIRONMENTS are defined as locations where there is exposure that may be incurred by persons who are aware of the potential for exposure, (i.e. as a result of employment or occupation). In general, occupational/controlled exposure limits are applicable to situations in which persons are exposed as a consequence of their employment, who have been made fully aware of the potential for exposure and can exercise control over their exposure. This exposure category is also applicable when the exposure is of a transient nature due to incidental passage through a location where the exposure levels may be higher than the general population/uncontrolled limits, but the exposed person is fully aware of the potential for exposure and can exercise control over his or her exposure by leaving the area or by some other appropriate means.

**Table 7-1  
SAR Human Exposure Specified in ANSI/IEEE C95.1-1992 and Health Canada Safety Code 6**

HUMAN EXPOSURE LIMITS		
	UNCONTROLLED ENVIRONMENT <i>General Population</i> (W/kg) or (mW/g)	CONTROLLED ENVIRONMENT <i>Occupational</i> (W/kg) or (mW/g)
<b>Peak Spatial Average SAR</b> Head	1.6	8.0
<b>Whole Body SAR</b>	0.08	0.4
<b>Peak Spatial Average SAR</b> Hands, Feet, Ankle, Wrists, etc.	4.0	20

1. The Spatial Peak value of the SAR averaged over any 1 gram of tissue (defined as a tissue volume in the shape of a cube) and over the appropriate averaging time.
2. The Spatial Average value of the SAR averaged over the whole body.
3. The Spatial Peak value of the SAR averaged over any 10 grams of tissue (defined as a tissue volume in the shape of a cube) and over the appropriate averaging time.

FCC ID: A3LSMG900R7	 <b>PCTEST</b> ENGINEERING LABORATORY, INC.	<b>SAR EVALUATION REPORT</b>		<b>Reviewed by:</b> Quality Manager
<b>Document S/N:</b> 0Y1403190578.A3L	<b>Test Dates:</b> 02/03/14 - 03/31/14	<b>DUT Type:</b> Portable Handset	Page 18 of 79	

## 8 FCC MEASUREMENT PROCEDURES

Power measurements were performed using a base station simulator under digital average power.

### 8.1 Measured and Reported SAR

Per FCC KDB Publication 447498 D01v05, When SAR is not measured at the maximum power level allowed for production units, the results must be scaled to the maximum tune-up tolerance limit according to the power applied to the individual channels tested to determine compliance. For simultaneous transmission, the measured aggregate SAR must be scaled according to the sum of the differences between the maximum tune-up tolerance and actual power used to test each transmitter. When SAR is measured at or scaled to the maximum tune-up tolerance limit, the results are referred to as *reported* SAR. The highest *reported* SAR results are identified on the grant of equipment authorization according to procedures in KDB 690783 D01v01r02.

### 8.2 Procedures Used to Establish RF Signal for SAR

The following procedures are according to FCC KDB Publication 941225 D01 "SAR Measurement Procedures for 3G Devices" v02, October 2007.

The device was placed into a simulated call using a base station simulator in a RF shielded chamber. Establishing connections in this manner ensure a consistent means for testing SAR and are recommended for evaluating SAR [4]. Devices under test were evaluated prior to testing, with a fully charged battery and were configured to operate at maximum output power. In order to verify that the device was tested throughout the SAR test at maximum output power, the SAR measurement system measures a "point SAR" at an arbitrary reference point at the start and end of the 1 gram SAR evaluation, to assess for any power drifts during the evaluation. If the power drift deviated by more than 5%, the SAR test and drift measurements were repeated.



### 8.3 SAR Measurement Conditions for CDMA2000

The following procedures were performed according to FCC KDB Publication 941225 D01 "SAR Measurement Procedures for 3G Devices" v02, October 2007.

#### 8.3.1 Output Power Verification

See 3GPP2 C.S0011/TIA-98-E as recommended by "SAR Measurement Procedures for 3G Devices" v02, October 2007. Maximum output power is verified on the High, Middle and Low channels according to procedures in section 4.4.5.2 of 3GPP2 C.S0011/TIA-98-E. SO55 tests were measured with power control bits in the "All Up" condition.

1. If the mobile station (MS) supports Reverse TCH RC 1 and Forward TCH RC 1, set up a call using Fundamental Channel Test Mode 1 (RC=1/1) with 9600 bps data rate only.
2. Under RC1, C.S0011 Table 4.4.5.2-1, Table 8-1 parameters were applied.
3. If the MS supports the RC 3 Reverse FCH, RC3 Reverse SCH<sub>0</sub> and demodulation of RC 3,4, or 5, set up a call using Supplemental Channel Test Mode 3 (RC 3/3) with 9600 bps Fundamental Channel and 9600 bps SCH<sub>0</sub> data rate.
4. Under RC3, C.S0011 Table 4.4.5.2-2, Table 8-2 was applied.

FCC ID: A3LSMG900R7		SAR EVALUATION REPORT		Reviewed by: Quality Manager
Document S/N: 0Y1403190578.A3L	Test Dates: 02/03/14 - 03/31/14	DUT Type: Portable Handset	Page 19 of 79	

**Table 8-1  
Parameters for Max. Power for RC1**

Parameter	Units	Value
$I_{or}$	dBm/1.23 MHz	-104
$\frac{Pilot E_c}{I_{or}}$	dB	-7
$\frac{Traffic E_c}{I_{or}}$	dB	-7.4

**Table 8-2  
Parameters for Max. Power for RC3**

Parameter	Units	Value
$I_{or}$	dBm/1.23 MHz	-86
$\frac{Pilot E_c}{I_{or}}$	dB	-7
$\frac{Traffic E_c}{I_{or}}$	dB	-7.4

5. FCHs were configured at full rate for maximum SAR with “All Up” power control bits.

### 8.3.2 CDMA2000 1x Advanced

This device additionally supports 1x Advanced. Conducted powers were measured using SO75 with RC8 on the uplink and RC11 on the downlink per KDB Publication 941225 D02v02. Smart blanking was disabled for all measurements. The EUT was configured with forward power control Mode 000 and reverse power control at 400 bps. Conducted powers were measured on an Agilent 8960 Series 10 Wireless Communications Test Set, Model E5515C using the CDMA2000 1x Advanced application, Option E1962B-410.

Based on the maximum output power measured for 1x Advanced, SAR is required for 1x advanced when if the maximum output for 1x Advanced is more than 0.25 dB higher than the maximum measured for 1x. Also, if the measured SAR in any 1x mode exposure conditions (head, body etc.) is larger than 1.2 W/kg, the highest of those configurations above 1.2 W/kg for each exposure condition in 1x Advanced has to be repeated. All measured SAR in 1x mode higher than 1.5 W/kg must be repeated for 1x Advanced.

### 8.3.3 Head SAR Measurements



SAR for head exposure configurations is measured in RC3 with the DUT configured to transmit at full rate using Loopback Service Option SO55. SAR for RC1 is not required when the maximum average output of each channel is less than ¼ dB higher than that measured in RC3. Otherwise, SAR is measured on the maximum output channel in RC1 using the exposure configuration that results in the highest SAR for that channel in RC3.

Head SAR was additionally evaluated using EVDO Rev. A to support compliance for VoIP operations. See Section 8.3.5 for EVDO Rev. A configuration parameters.

### 8.3.4 Body SAR Measurements

SAR for body exposure configurations is measured in RC3 with the DUT configured to transmit at full rate on FCH with all other code channels disabled using TDSO / SO32. SAR for multiple code channels (FCH + SCH<sub>n</sub>) is not required when the maximum average output of each RF channel is less than ¼ dB higher than that measured with FCH only. Otherwise, SAR is measured on the maximum output channel (FCH + SCH<sub>n</sub>) with FCH at full rate and SCH<sub>0</sub> enabled at 9600 bps using the exposure configuration that results in the highest SAR for that channel with FCH only. When multiple code channels are enabled, the DUT output may shift by more than 0.5 dB and lead to higher SAR drifts and SCH dropouts. Body SAR was measured using TDSO / SO32 with power control bits in the “All Up”

Body SAR in RC1 is not required when the maximum average output of each channel is less than ¼ dB higher than that measured in RC3. Otherwise, SAR is measured on the maximum output channel in RC1; with Loopback Service Option SO55, at full rate, using the body exposure configuration that results in the highest SAR for that channel in RC3.

FCC ID: A3LSMG900R7	 <b>PCTEST</b> ENGINEERING LABORATORY, INC.	<b>SAR EVALUATION REPORT</b>		<b>Reviewed by:</b> Quality Manager
<b>Document S/N:</b> OY1403190578.A3L	<b>Test Dates:</b> 02/03/14 - 03/31/14	<b>DUT Type:</b> Portable Handset	Page 20 of 79	

### 8.3.5 Handsets with EVDO

For handsets with Ev-Do capabilities, when the maximum average output of each channel in Rev. 0 is less than ¼ dB higher than that measured in RC3 (1x RTT), body SAR for EV-DO is not required. Otherwise, SAR for Rev. 0 is measured on the maximum output channel at 153.6 kbps using the body exposure configuration that results in the highest SAR for that channel in RC3. SAR for Rev. A is not required when the maximum average output of each channel is less than that measured in Rev. 0 or less than ¼ dB higher than that measured in RC3. Otherwise, SAR is measured on the maximum output channel for Rev. A using a Reverse Data Channel payload size of 4096 bits and a Termination Target of 16 slots defined for Subtype 2 Physical Layer configurations. A Forward Traffic Channel data rate corresponding to the 2-slot version of 307.2 kbps with the ACK Channel transmitting in all slots would be configured in the downlink for both Rev. 0 and Rev. A.

### 8.3.6 Body SAR Measurements for EVDO Hotspot

Hotspot Body SAR is measured using Subtype 0/1 Physical Layer configurations for Rev. 0 per KDB Publication 941225 D01 procedures for “1x Ev-Do data Devices”. SAR for Subtype 2 Physical layer configurations is not required for Rev. A when the maximum average output of each RF channels is less than that measured in Subtype 0/1 Physical layer configurations. Otherwise, SAR is measured on the maximum output channel for Rev. A using the exposure configuration that results in the highest SAR for the RF channels in Rev. 0. The AT is tested with a Reverse Data Channel rate of 153.6 kbps in Subtype 0/1 Physical Layer configurations; and a Reverse Data Channel payload size of 4096 bits and Termination Target of 16 slots in Subtype 2 Physical Layer configurations.

SAR is not required for 1x RTT for Ev-Do devices that also support 1x RTT voice and/or data operations, when the maximum average output of each channel is less than 1/4 dB higher than that measured in Subtype 0/1 Physical Layer configurations for Rev. 0. Otherwise, CDMA “Body-SAR Measurement” procedures for “CDMA 2000 1x Handsets” were applied.

## 8.4 SAR Measurement Conditions for LTE



LTE modes were tested according to FCC KDB 941225 D05v02 publication. Please see notes after the tabulated SAR data for required test configurations. Establishing connections with base station simulators ensure a consistent means for testing SAR and are recommended for evaluating SAR [4]. The R&S CMW500 was used for LTE output power measurements and SAR testing. Closed loop power control was used so the UE transmits with maximum output power during SAR testing. SAR tests were performed with the same number of RB and RB offsets transmitting on all TTI frames (maximum TTI).

### 8.4.1 Spectrum Plots for RB Configurations

A properly configured base station simulator was used for SAR tests and power measurements. Therefore, spectrum plots for RB configurations were not required to be included in this report.

### 8.4.2 MPR

MPR is permanently implemented for this device by the manufacturer. The specific manufacturer target MPR is indicated alongside the SAR results. MPR is enabled for this device, according to 3GPP TS36.101 Section 6.2.3 – 6.2.5 under Table 6.2.3-1.

FCC ID: A3LSMG900R7	 <b>PCTEST</b> ENGINEERING LABORATORY, INC.	<b>SAR EVALUATION REPORT</b>		<b>Reviewed by:</b> Quality Manager
<b>Document S/N:</b> OY1403190578.A3L	<b>Test Dates:</b> 02/03/14 - 03/31/14	<b>DUT Type:</b> Portable Handset	Page 21 of 79	

### 8.4.3 A-MPR

A-MPR (Additional MPR) has been disabled for all SAR tests by setting NS=01 on the base station simulator.

### 8.4.4 Required RB Size and RB Offsets for SAR Testing

According to FCC KDB 941225 D05v02r01:

- a. Per Section 5.2.1, SAR is required for QPSK 1 RB Allocation for the largest bandwidth
  - i. The required channel and offset combination with the highest maximum output power is required for SAR.
  - ii. When the reported SAR is  $\leq 0.8$  W/kg, testing of the remaining RB offset configurations and required test channels is not required. Otherwise, SAR is required for the remaining required test channels using the RB offset configuration with highest output power for that channel.
  - iii. When the reported SAR for a required test channel is  $> 1.45$  W/kg, SAR is required for all RB offset configurations for that channel.
- b. Per Section 5.2.2, SAR is required for 50% RB allocation using the largest bandwidth following the same procedures outlined in Section 5.2.1.
- c. Per Section 5.2.3, QPSK SAR is not required for the 100% allocation when the highest maximum output power for the 100% allocation is less than the highest maximum output power of the 1 RB and 50% RB allocations and the reported SAR for the 1 RB and 50% RB allocations is  $< 0.8$  W/kg.
- d. Per Section 5.2.4 and 5.3, SAR tests for higher order modulations and lower bandwidths configurations are not required when the conducted power of the required test configurations determined by Sections 5.2.1 through 5.2.3 is less than or equal to  $\frac{1}{2}$  dB higher than the equivalent configuration using QPSK modulation and when the QPSK SAR for those configurations is  $< 1.45$  W/kg.

## 8.5 SAR Testing with 802.11 Transmitters



Normal network operating configurations are not suitable for measuring the SAR of 802.11 a/b/g/n /ac transmitters. Unpredictable fluctuations in network traffic and antenna diversity conditions can introduce undesirable variations in SAR results. The SAR for these devices should be measured using chipset based test mode software to ensure the results are consistent and reliable. See KDB Publication 248227 D01v01r02 for more details.

### 8.5.1 General Device Setup

Chipset based test mode software is hardware dependent and generally varies among manufacturers. The device operating parameters established in test mode for SAR measurements must be identical to those programmed in production units, including output power levels, amplifier gain settings and other RF performance tuning parameters. The test frequencies should correspond to actual channel frequencies defined for domestic use. SAR for devices with switched diversity should be measured with only one antenna transmitting at a time during each SAR measurement, according to a fixed modulation and data rate. The same data pattern should be used for all measurements.

### 8.5.2 Frequency Channel Configurations [24]

For 2.4 GHz, the highest average RF output power channel between the low, mid and high channel at the lowest data rate was selected for SAR evaluation in 802.11b mode. 802.11g/n modes and higher data rates for 802.11b were additionally evaluated for SAR if the output power of the respective mode was 0.25 dB or higher than the powers of the SAR configurations tested in the 802.11b mode.



FCC ID: A3LSMG900R7		SAR EVALUATION REPORT		Reviewed by: Quality Manager
Document S/N: OY1403190578.A3L	Test Dates: 02/03/14 - 03/31/14	DUT Type: Portable Handset	Page 22 of 79	

For 5 GHz, the highest average RF output power channel across the default test channels at the lowest data rate was selected for SAR evaluation in 802.11a. When the adjacent channels are higher in power than the default channels, these “required channels” were considered instead of the default channels for SAR testing. 802.11n modes and higher data rates for 802.11a/n were evaluated only if the respective mode was higher than 0.25 dB or more than the 802.11a mode. 802.11ac SAR was evaluated for highest 802.11a configuration in each 5 GHz band and each exposure condition. 802.11ac modes were additionally evaluated for SAR if the output power for the respective mode was more than 0.25 dB higher than powers of 802.11a modes.

If the maximum extrapolated peak SAR of the zoom scan for the highest output channel was less than 1.6 W/kg and if the 1g averaged SAR was less than 0.8 W/kg, SAR testing was not required for the other test channels in the band.

### 8.5.3 MIMO SAR Considerations

Per KDB 248227, SAR for MIMO was measured with both antennas transmitting simultaneously and was evaluated independently of SISO operation. For 2.4 GHz MIMO, 802.11n was evaluated. For 5 GHz MIMO, 20 MHz Bandwidth 802.11n was evaluated. Additional evaluations for 40 MHz bandwidth 802.11n and 802.11ac were not required since the maximum allowed output power was not higher than 802.11n 20 MHz bandwidth.

FCC ID: A3LSMG900R7		SAR EVALUATION REPORT		Reviewed by: Quality Manager
Document S/N: 0Y1403190578.A3L	Test Dates: 02/03/14 - 03/31/14	DUT Type: Portable Handset		Page 23 of 79

# 9 RF CONDUCTED POWERS

## 9.1 CDMA Conducted Powers

**Table 9-1**  
**Maximum CDMA Conducted Powers with Hotspot Inactive**

Band	Channel	Frequency	SO55 [dBm]	SO55 [dBm]	SO75 [dBm]	TDSO SO32 [dBm]	TDSO SO32 [dBm]	1x EvDO Rev. 0 [dBm]	1x EvDO Rev. A [dBm]
	F-RC	MHz	RC1	RC3	RC11	FCH+SCH	FCH	(RTAP)	(RETAP)
Cellular	1013	824.7	24.43	24.35	24.45	24.32	24.33	24.40	24.39
	384	836.52	24.48	24.40	24.51	24.39	24.37	24.44	24.40
	777	848.31	24.67	24.56	24.69	24.55	24.56	24.61	24.58
PCS	25	1851.25	24.63	24.54	24.60	24.53	24.50	24.55	24.51
	600	1880	24.59	24.49	24.56	24.49	24.46	24.52	24.46
	1175	1908.75	24.65	24.55	24.61	24.54	24.53	24.54	24.52

**Table 9-2**  
**Reduced CDMA Conducted Powers with Hotspot Active**

Band	Channel	Rule Part	Frequency	SO55 [dBm]	SO55 [dBm]	SO75 [dBm]	TDSO SO32 [dBm]	TDSO SO32 [dBm]	1x EvDO Rev. 0 [dBm]	1x EvDO Rev. A [dBm]
	F-RC		MHz	RC1	RC3	RC11	FCH+SCH	FCH	(RTAP)	(RETAP)
PCS	25	24E	1851.25	22.63	22.70	22.67	22.71	22.72	22.70	22.68
	600	24E	1880	22.16	22.29	22.30	22.27	22.32	22.31	22.28
	1175	24E	1908.75	22.51	22.56	22.60	22.54	22.56	22.55	22.52

Note: RC1 is only applicable for IS-95 compatibility.

Per KDB Publication 941225 D01v02:



1. Head SAR was tested with SO55 RC3. SO55 RC1 was not required since the average output power was not more than 0.25 dB than the SO55 RC3 powers.
2. Body-Worn SAR was tested with 1x RTT with TDSO / SO32 FCH Only. Ev-Do and TDSO / SO32 FCH+SCH SAR tests were not required since the average output power was not more than 0.25 dB higher than the TDSO / SO32 FCH only powers.
3. Hotspot SAR is measured using Subtype 0/1 Physical Layer configurations for Rev. 0. If the average output power of Subtype 2 for Rev. A is less than the Rev. 0 power levels, then Rev. A SAR is not required. Otherwise, SAR is measured on the maximum output channel for Rev. A using the exposure configuration that results in the highest SAR for that RF channel in Rev. 0.
4. CDMA 1x-RTT SAR was additionally required to be evaluated for Hotspot exposure conditions to support simultaneous transmission capabilities.
5. Head SAR was additionally evaluated with EVDO Rev. A to determine compliance for held-to-ear VoIP operations.

Per KDB Publication 941225 D02v02:

1. CDMA 1X Advanced technology was not required for SAR since the maximum output powers for 1x Advanced was not more than 0.25 dB higher than the maximum measured powers for 1x and the measured SAR in any 1x mode exposure conditions was not greater than 1.2 W/kg. See Section 8.3.2 for 1x Advanced test set up.



**Figure 9-1**  
**Power Measurement Setup**

FCC ID: A3LSMG900R7	 <b>PCTEST</b> ENGINEERING LABORATORY, INC.	<b>SAR EVALUATION REPORT</b>		Reviewed by: Quality Manager
Document S/N: OY1403190578.A3L	Test Dates: 02/03/14 - 03/31/14	DUT Type: Portable Handset	Page 24 of 79	

## 9.2 LTE Conducted Powers

### 9.2.1 LTE Band 12



**Table 9-3**  
**LTE Band 12 Conducted Powers - 10 MHz Bandwidth**

	Frequency [MHz]	Channel	Bandwidth [MHz]	Modulation	RB Size	RB Offset	Conducted Power [dBm]	MPR Allowed per 3GPP [dB]	MPR [dB]
Mid	707.5	23095	10	QPSK	1	0	23.08	0	0
	707.5	23095	10	QPSK	1	25	23.03	0	0
	707.5	23095	10	QPSK	1	49	23.04	0	0
	707.5	23095	10	QPSK	25	0	22.02	0-1	1
	707.5	23095	10	QPSK	25	12	21.98	0-1	1
	707.5	23095	10	QPSK	25	25	21.97	0-1	1
	707.5	23095	10	QPSK	50	0	21.93	0-1	1
	707.5	23095	10	16QAM	1	0	21.87	0-1	1
	707.5	23095	10	16QAM	1	25	22.03	0-1	1
	707.5	23095	10	16QAM	1	49	21.87	0-1	1
	707.5	23095	10	16QAM	25	0	21.01	0-2	2
	707.5	23095	10	16QAM	25	12	20.88	0-2	2
	707.5	23095	10	16QAM	25	25	20.90	0-2	2
	707.5	23095	10	16QAM	50	0	20.84	0-2	2

Note: LTE Band 12 at 10 MHz bandwidth does not support three non-overlapping channels. Per KDB Publication 941225 D05v02, when a device supports overlapping channel assignment in a channel bandwidth configuration, the middle channel of the group of overlapping channels should be selected for testing.

**Table 9-4**  
**LTE Band 12 Conducted Powers - 5 MHz Bandwidth**

	Frequency [MHz]	Channel	Bandwidth [MHz]	Modulation	RB Size	RB Offset	Conducted Power [dBm]	MPR Allowed per 3GPP [dB]	MPR [dB]	
Low	701.5	23035	5	QPSK	1	0	23.24	0	0	
	701.5	23035	5	QPSK	1	12	23.22	0	0	
	701.5	23035	5	QPSK	1	24	23.18	0	0	
	701.5	23035	5	QPSK	12	0	22.05	0-1	1	
	701.5	23035	5	QPSK	12	6	22.16	0-1	1	
	701.5	23035	5	QPSK	12	13	22.06	0-1	1	
	701.5	23035	5	QPSK	25	0	22.00	0-1	1	
	701.5	23035	5	16-QAM	1	0	22.20	0-1	1	
	701.5	23035	5	16-QAM	1	12	22.27	0-1	1	
	701.5	23035	5	16-QAM	1	24	22.16	0-1	1	
	701.5	23035	5	16-QAM	12	0	21.00	0-2	2	
	701.5	23035	5	16-QAM	12	6	21.11	0-2	2	
	701.5	23035	5	16-QAM	12	13	20.95	0-2	2	
	701.5	23035	5	16-QAM	25	0	21.03	0-2	2	
	Mid	707.5	23095	5	QPSK	1	0	23.18	0	0
		707.5	23095	5	QPSK	1	12	23.07	0	0
		707.5	23095	5	QPSK	1	24	23.11	0	0
		707.5	23095	5	QPSK	12	0	21.98	0-1	1
707.5		23095	5	QPSK	12	6	21.94	0-1	1	
707.5		23095	5	QPSK	12	13	21.99	0-1	1	
707.5		23095	5	QPSK	25	0	21.96	0-1	1	
707.5		23095	5	16-QAM	1	0	22.02	0-1	1	
707.5		23095	5	16-QAM	1	12	22.10	0-1	1	
707.5		23095	5	16-QAM	1	24	22.08	0-1	1	
707.5		23095	5	16-QAM	12	0	20.87	0-2	2	
707.5		23095	5	16-QAM	12	6	20.82	0-2	2	
707.5		23095	5	16-QAM	12	13	20.93	0-2	2	
707.5		23095	5	16-QAM	25	0	20.91	0-2	2	
High		713.5	23155	5	QPSK	1	0	23.16	0	0
		713.5	23155	5	QPSK	1	12	23.11	0	0
		713.5	23155	5	QPSK	1	24	22.91	0	0
		713.5	23155	5	QPSK	12	0	21.93	0-1	1
	713.5	23155	5	QPSK	12	6	21.93	0-1	1	
	713.5	23155	5	QPSK	12	13	21.86	0-1	1	
	713.5	23155	5	QPSK	25	0	21.84	0-1	1	
	713.5	23155	5	16-QAM	1	0	21.92	0-1	1	
	713.5	23155	5	16-QAM	1	12	21.78	0-1	1	
	713.5	23155	5	16-QAM	1	24	21.94	0-1	1	
	713.5	23155	5	16-QAM	12	0	20.82	0-2	2	
	713.5	23155	5	16-QAM	12	6	20.69	0-2	2	
	713.5	23155	5	16-QAM	12	13	20.70	0-2	2	
	713.5	23155	5	16-QAM	25	0	20.78	0-2	2	

FCC ID: A3LSMG900R7	 PCTEST ENGINEERING LABORATORY, INC.	SAR EVALUATION REPORT		Reviewed by: Quality Manager
Document S/N: OY1403190578.A3L	Test Dates: 02/03/14 - 03/31/14	DUT Type: Portable Handset	Page 25 of 79	



## 9.2.2 LTE Band 4 (AWS)

**Table 9-5**  
**LTE Band 4 (AWS) Conducted Powers - 10 MHz Bandwidth**

Frequency [MHz]	Channel	Bandwidth [MHz]	Modulation	RB Size	RB Offset	Conducted Power [dBm]	MPR Allowed per 3GPP [dB]	MPR [dB]	
Low	1715	20000	10	QPSK	1	0	23.50	0	0
	1715	20000	10	QPSK	1	25	23.47	0	0
	1715	20000	10	QPSK	1	49	23.43	0	0
	1715	20000	10	QPSK	25	0	22.36	0-1	1
	1715	20000	10	QPSK	25	12	22.43	0-1	1
	1715	20000	10	QPSK	25	25	22.31	0-1	1
	1715	20000	10	QPSK	50	0	22.40	0-1	1
	1715	20000	10	16QAM	1	0	22.46	0-1	1
	1715	20000	10	16QAM	1	25	22.44	0-1	1
	1715	20000	10	16QAM	1	49	22.34	0-1	1
	1715	20000	10	16QAM	25	0	21.22	0-2	2
	1715	20000	10	16QAM	25	12	21.32	0-2	2
	1715	20000	10	16QAM	25	25	21.27	0-2	2
	1715	20000	10	16QAM	50	0	21.28	0-2	2
	1715	20000	10	16QAM	50	0	21.27	0-2	2
Mid	1732.5	20175	10	QPSK	1	0	23.40	0	0
	1732.5	20175	10	QPSK	1	25	23.34	0	0
	1732.5	20175	10	QPSK	1	49	23.42	0	0
	1732.5	20175	10	QPSK	25	0	22.34	0-1	1
	1732.5	20175	10	QPSK	25	12	22.22	0-1	1
	1732.5	20175	10	QPSK	25	25	22.21	0-1	1
	1732.5	20175	10	QPSK	50	0	22.24	0-1	1
	1732.5	20175	10	16QAM	1	0	22.33	0-1	1
	1732.5	20175	10	16QAM	1	25	22.16	0-1	1
	1732.5	20175	10	16QAM	1	49	22.41	0-1	1
	1732.5	20175	10	16QAM	25	0	21.20	0-2	2
	1732.5	20175	10	16QAM	25	12	21.22	0-2	2
	1732.5	20175	10	16QAM	25	25	21.18	0-2	2
	1732.5	20175	10	16QAM	50	0	21.26	0-2	2
	1732.5	20175	10	16QAM	50	0	21.26	0-2	2
High	1750	20350	10	QPSK	1	0	23.49	0	0
	1750	20350	10	QPSK	1	25	23.33	0	0
	1750	20350	10	QPSK	1	49	23.31	0	0
	1750	20350	10	QPSK	25	0	22.30	0-1	1
	1750	20350	10	QPSK	25	12	22.24	0-1	1
	1750	20350	10	QPSK	25	25	22.17	0-1	1
	1750	20350	10	QPSK	50	0	22.33	0-1	1
	1750	20350	10	16QAM	1	0	22.46	0-1	1
	1750	20350	10	16QAM	1	25	22.22	0-1	1
	1750	20350	10	16QAM	1	49	22.36	0-1	1
	1750	20350	10	16QAM	25	0	21.27	0-2	2
	1750	20350	10	16QAM	25	12	21.18	0-2	2
	1750	20350	10	16QAM	25	25	21.14	0-2	2
	1750	20350	10	16QAM	50	0	21.17	0-2	2
	1750	20350	10	16QAM	50	0	21.17	0-2	2

**Table 9-6**  
**LTE Band 4 (AWS) Conducted Powers - 5 MHz Bandwidth**

Frequency [MHz]	Channel	Bandwidth [MHz]	Modulation	RB Size	RB Offset	Conducted Power [dBm]	MPR Allowed per 3GPP [dB]	MPR [dB]	
Low	1712.5	19975	5	QPSK	1	0	23.43	0	0
	1712.5	19975	5	QPSK	1	12	23.47	0	0
	1712.5	19975	5	QPSK	1	24	23.49	0	0
	1712.5	19975	5	QPSK	12	0	22.37	0-1	1
	1712.5	19975	5	QPSK	12	6	22.26	0-1	1
	1712.5	19975	5	QPSK	12	13	22.32	0-1	1
	1712.5	19975	5	QPSK	25	0	22.39	0-1	1
	1712.5	19975	5	16-QAM	1	0	22.41	0-1	1
	1712.5	19975	5	16-QAM	1	12	22.20	0-1	1
	1712.5	19975	5	16-QAM	1	24	22.36	0-1	1
	1712.5	19975	5	16-QAM	12	0	21.24	0-2	2
	1712.5	19975	5	16-QAM	12	6	21.11	0-2	2
	1712.5	19975	5	16-QAM	12	13	21.15	0-2	2
	1712.5	19975	5	16-QAM	25	0	21.31	0-2	2
	1712.5	19975	5	16-QAM	25	0	21.31	0-2	2
Mid	1732.5	20175	5	QPSK	1	0	23.40	0	0
	1732.5	20175	5	QPSK	1	12	23.34	0	0
	1732.5	20175	5	QPSK	1	24	23.33	0	0
	1732.5	20175	5	QPSK	12	0	22.18	0-1	1
	1732.5	20175	5	QPSK	12	6	22.16	0-1	1
	1732.5	20175	5	QPSK	12	13	22.24	0-1	1
	1732.5	20175	5	QPSK	25	0	22.17	0-1	1
	1732.5	20175	5	16-QAM	1	0	22.37	0-1	1
	1732.5	20175	5	16-QAM	1	12	22.08	0-1	1
	1732.5	20175	5	16-QAM	1	24	22.29	0-1	1
	1732.5	20175	5	16-QAM	12	0	21.18	0-2	2
	1732.5	20175	5	16-QAM	12	6	21.08	0-2	2
	1732.5	20175	5	16-QAM	12	13	21.06	0-2	2
	1732.5	20175	5	16-QAM	25	0	21.01	0-2	2
	1732.5	20175	5	16-QAM	25	0	21.01	0-2	2
High	1752.5	20375	5	QPSK	1	0	23.49	0	0
	1752.5	20375	5	QPSK	1	12	23.34	0	0
	1752.5	20375	5	QPSK	1	24	23.39	0	0
	1752.5	20375	5	QPSK	12	0	22.28	0-1	1
	1752.5	20375	5	QPSK	12	6	22.16	0-1	1
	1752.5	20375	5	QPSK	12	13	22.25	0-1	1
	1752.5	20375	5	QPSK	25	0	22.18	0-1	1
	1752.5	20375	5	16-QAM	1	0	22.50	0-1	1
	1752.5	20375	5	16-QAM	1	12	22.10	0-1	1
	1752.5	20375	5	16-QAM	1	24	22.05	0-1	1
	1752.5	20375	5	16-QAM	12	0	21.19	0-2	2
	1752.5	20375	5	16-QAM	12	6	21.11	0-2	2
	1752.5	20375	5	16-QAM	12	13	21.10	0-2	2
	1752.5	20375	5	16-QAM	25	0	21.12	0-2	2
	1752.5	20375	5	16-QAM	25	0	21.12	0-2	2

FCC ID: A3LSMG900R7		SAR EVALUATION REPORT		Reviewed by: Quality Manager
Document S/N: OY1403190578.A3L	Test Dates: 02/03/14 - 03/31/14	DUT Type: Portable Handset		Page 26 of 79

9.2.3

LTE Band 2 / 25 (PCS)



Table 9-7  
LTE Band 2 / 25 (PCS) Conducted Powers - 10 MHz Bandwidth

Operating Bands	Frequency [MHz]	Channel	Bandwidth [MHz]	Modulation	RB Size	RB Offset	Conducted Power [dBm]	MPR Allowed per 3GPP [dB]	MPR [dB]	
Low	2.25	1855	26090	10	QPSK	1	0	22.71	0	0
		1855	26090	10	QPSK	1	25	23.21	0	0
		1855	26090	10	QPSK	1	49	23.06	0	0
		1855	26090	10	QPSK	25	0	22.02	0-1	1
		1855	26090	10	QPSK	25	12	22.09	0-1	1
		1855	26090	10	QPSK	25	25	22.09	0-1	1
		1855	26090	10	QPSK	50	0	22.05	0-1	1
		1855	26090	10	16QAM	1	0	22.08	0-1	1
		1855	26090	10	16QAM	1	25	21.92	0-1	1
		1855	26090	10	16QAM	1	49	22.00	0-1	1
		1855	26090	10	16QAM	25	0	21.03	0-2	2
		1855	26090	10	16QAM	25	12	21.04	0-2	2
		1855	26090	10	16QAM	25	25	21.12	0-2	2
		1855	26090	10	16QAM	50	0	21.07	0-2	2
		Mid	2.25	1880.0	26340	10	QPSK	1	0	23.12
1880.0	26340			10	QPSK	1	25	23.15	0	0
1880.0	26340			10	QPSK	1	49	23.22	0	0
1880.0	26340			10	QPSK	25	0	22.08	0-1	1
1880.0	26340			10	QPSK	25	12	22.09	0-1	1
1880.0	26340			10	QPSK	25	25	22.14	0-1	1
1880.0	26340			10	QPSK	50	0	22.14	0-1	1
1880.0	26340			10	16QAM	1	0	22.00	0-1	1
1880.0	26340			10	16QAM	1	25	21.98	0-1	1
1880.0	26340			10	16QAM	1	49	22.12	0-1	1
1880.0	26340			10	16QAM	25	0	21.12	0-2	2
1880.0	26340			10	16QAM	25	12	21.14	0-2	2
1880.0	26340			10	16QAM	25	25	21.11	0-2	2
1880.0	26340			10	16QAM	50	0	21.11	0-2	2
High	25			1910	26640	10	QPSK	1	0	23.35
		1910	26640	10	QPSK	1	25	23.12	0	0
		1910	26640	10	QPSK	1	49	23.10	0	0
		1910	26640	10	QPSK	25	0	22.21	0-1	1
		1910	26640	10	QPSK	25	12	22.11	0-1	1
		1910	26640	10	QPSK	25	25	22.06	0-1	1
		1910	26640	10	QPSK	50	0	22.18	0-1	1
		1910	26640	10	16QAM	1	0	22.31	0-1	1
		1910	26640	10	16QAM	1	25	22.16	0-1	1
		1910	26640	10	16QAM	1	49	22.23	0-1	1
		1910	26640	10	16QAM	25	0	21.22	0-2	2
		1910	26640	10	16QAM	25	12	21.21	0-2	2
		1910	26640	10	16QAM	25	25	21.23	0-2	2
		1910	26640	10	16QAM	50	0	21.16	0-2	2

Table 9-8  
LTE Band 2 / 25 (PCS) Conducted Powers - 5 MHz Bandwidth

Operating Bands	Frequency [MHz]	Channel	Bandwidth [MHz]	Modulation	RB Size	RB Offset	Conducted Power [dBm]	MPR Allowed per 3GPP [dB]	MPR [dB]	
Low	2.25	1852.5	26065	5	QPSK	1	0	22.62	0	0
		1852.5	26065	5	QPSK	1	12	22.79	0	0
		1852.5	26065	5	QPSK	1	24	23.14	0	0
		1852.5	26065	5	QPSK	12	0	21.69	0-1	1
		1852.5	26065	5	QPSK	12	6	21.85	0-1	1
		1852.5	26065	5	QPSK	12	13	22.16	0-1	1
		1852.5	26065	5	QPSK	25	0	21.90	0-1	1
		1852.5	26065	5	16-QAM	1	0	21.88	0-1	1
		1852.5	26065	5	16-QAM	1	12	22.06	0-1	1
		1852.5	26065	5	16-QAM	1	24	21.93	0-1	1
		1852.5	26065	5	16-QAM	12	0	20.76	0-2	2
		1852.5	26065	5	16-QAM	12	6	20.84	0-2	2
		1852.5	26065	5	16-QAM	12	13	21.05	0-2	2
		1852.5	26065	5	16-QAM	25	0	20.88	0-2	2
		Mid	2.25	1880.0	26340	5	QPSK	1	0	23.21
1880.0	26340			5	QPSK	1	12	23.24	0	0
1880.0	26340			5	QPSK	1	24	23.26	0	0
1880.0	26340			5	QPSK	12	0	22.14	0-1	1
1880.0	26340			5	QPSK	12	6	22.13	0-1	1
1880.0	26340			5	QPSK	12	13	22.10	0-1	1
1880.0	26340			5	QPSK	25	0	22.06	0-1	1
1880.0	26340			5	16-QAM	1	0	22.12	0-1	1
1880.0	26340			5	16-QAM	1	12	22.11	0-1	1
1880.0	26340			5	16-QAM	1	24	22.16	0-1	1
1880.0	26340			5	16-QAM	12	0	21.06	0-2	2
1880.0	26340			5	16-QAM	12	6	21.10	0-2	2
1880.0	26340			5	16-QAM	12	13	21.01	0-2	2
1880.0	26340			5	16-QAM	25	0	21.19	0-2	2
High	25			1912.5	26665	5	QPSK	1	0	23.12
		1912.5	26665	5	QPSK	1	12	23.08	0	0
		1912.5	26665	5	QPSK	1	24	23.07	0	0
		1912.5	26665	5	QPSK	12	0	22.17	0-1	1
		1912.5	26665	5	QPSK	12	6	22.12	0-1	1
		1912.5	26665	5	QPSK	12	13	22.24	0-1	1
		1912.5	26665	5	QPSK	25	0	22.17	0-1	1
		1912.5	26665	5	16-QAM	1	0	22.32	0-1	1
		1912.5	26665	5	16-QAM	1	12	22.25	0-1	1
		1912.5	26665	5	16-QAM	1	24	22.40	0-1	1
		1912.5	26665	5	16-QAM	12	0	21.15	0-2	2
		1912.5	26665	5	16-QAM	12	6	21.09	0-2	2
		1912.5	26665	5	16-QAM	12	13	21.17	0-2	2
		1912.5	26665	5	16-QAM	25	0	21.11	0-2	2

Note: LTE Bands 2 and 25 conducted powers were considered simultaneously when evaluating required SAR test channels/configurations.

FCC ID: A3LSMG900R7		SAR EVALUATION REPORT		Reviewed by: Quality Manager
Document S/N: OY1403190578.A3L	Test Dates: 02/03/14 - 03/31/14	DUT Type: Portable Handset	Page 27 of 79	

## 9.3 WLAN Conducted Powers

### 9.3.1 Maximum WLAN Conducted Powers

Per KDB 662911 D01v02r01, the individual spectra for each 2x2 MIMO WIFI Antenna were summed mathematically in linear power units for the MIMO output power measurements.

**Table 9-9**  
**IEEE 802.11b Average RF Power**

Antenna	Freq [MHz]	Channel	802.11b Conducted Power [dBm]			
			Data Rate [Mbps]			
			1	2	5.5	11
Antenna 1	2412	1*	16.57	16.54	16.74	16.62
	2437	6*	17.05	17.02	17.22	17.10
	2462	11*	16.81	16.78	16.98	16.86
Antenna 2	2412	1*	17.07	17.24	17.29	17.17
	2437	6*	16.54	16.71	16.76	16.64
	2462	11*	16.49	16.66	16.71	16.59

**Table 9-10**  
**IEEE 802.11g Average RF Power**



Antenna	Freq [MHz]	Channel	802.11g Conducted Power [dBm]							
			Data Rate [Mbps]							
			6	9	12	18	24	36	48	54
Antenna 1	2412	1	14.09	13.97	14.10	13.92	14.22	14.25	14.21	14.24
	2437	6	13.90	13.78	13.91	13.73	14.03	14.06	14.02	14.05
	2462	11	13.54	13.42	13.55	13.37	13.67	13.70	13.66	13.69
Antenna 2	2412	1	13.82	13.62	13.57	13.61	13.94	14.04	14.12	14.11
	2437	6	13.64	13.44	13.39	13.43	13.76	13.86	13.94	13.93
	2462	11	13.37	13.17	13.12	13.16	13.49	13.59	13.67	13.66

**Table 9-11**  
**IEEE 802.11n Average RF Power**

Antenna	Freq [MHz]	Channel	802.11n (2.4GHz) Conducted Power [dBm]								
			Data Rate [Mbps]								
			6.5	13	19.5	26	39	52	58.5	65	
Antenna 1	2412	1	13.14	13.34	13.17	13.39	13.34	13.42	13.45	13.24	
	2437	6	12.95	13.15	12.98	13.20	13.15	13.23	13.26	13.05	
	2462	11	12.81	13.01	12.84	13.06	13.01	13.09	13.12	12.91	
Antenna 2	2412	1	12.93	12.97	12.82	12.94	13.07	13.12	13.09	13.14	
	2437	6	12.85	12.89	12.74	12.86	12.99	13.04	13.01	13.06	
	2462	11	12.64	12.68	12.53	12.65	12.78	12.83	12.80	12.85	

**Table 9-12**  
**MIMO IEEE 802.11n Average RF Power**

Antenna	Freq [MHz]	Channel	802.11n (2.4GHz) Conducted Power [dBm]
			Data Rate [Mbps]
			13
MIMO	2412	1	13.87
	2437	6	13.64
	2462	11	13.48



FCC ID: A3LSMG900R7	 PCTEST ENGINEERING LABORATORY, INC.	SAR EVALUATION REPORT		Reviewed by: Quality Manager
Document S/N: OY1403190578.A3L	Test Dates: 02/03/14 - 03/31/14	DUT Type: Portable Handset		Page 28 of 79

**Table 9-13  
IEEE 802.11a Average RF Power**

Antenna	Mode	Freq [MHz]	Channel	802.11a Conducted Power [dBm]							
				Data Rate [Mbps]							
				6	9	12	18	24	36	48	54
Antenna 1	802.11a	5180	36*	13.02	12.76	12.89	12.84	13.11	13.18	13.24	13.17
	802.11a	5200	40	13.08	12.82	12.95	12.90	13.17	13.24	13.30	13.23
	802.11a	5220	44	13.12	12.86	12.99	12.94	13.21	13.28	13.34	13.27
	802.11a	5240	48*	12.93	12.67	12.80	12.75	13.02	13.09	13.15	13.08
	802.11a	5260	52*	12.85	12.78	13.04	12.99	12.67	12.54	12.68	12.65
	802.11a	5280	56	12.97	12.90	13.16	13.11	12.79	12.66	12.80	12.77
	802.11a	5300	60	12.57	12.50	12.76	12.71	12.39	12.26	12.40	12.37
	802.11a	5320	64*	12.54	12.47	12.73	12.68	12.36	12.23	12.37	12.34
	802.11a	5500	100	13.33	12.62	13.26	13.19	13.11	13.37	13.32	13.26
	802.11a	5520	104*	13.36	12.65	13.29	13.22	13.14	13.40	13.35	13.29
	802.11a	5540	108	13.41	12.70	13.34	13.27	13.19	13.45	13.40	13.34
	802.11a	5560	112	13.27	12.56	13.20	13.13	13.05	13.31	13.26	13.20
	802.11a	5580	116*	13.40	12.69	13.33	13.26	13.18	13.44	13.39	13.33
	802.11a	5600	120	N/A	N/A	N/A	N/A	N/A	N/A	N/A	N/A
	802.11a	5620	124	N/A	N/A	N/A	N/A	N/A	N/A	N/A	N/A
	802.11a	5640	128	N/A	N/A	N/A	N/A	N/A	N/A	N/A	N/A
	802.11a	5660	132	13.19	12.48	13.12	13.05	12.97	13.23	13.18	13.12
	802.11a	5680	136*	13.01	12.30	12.94	12.87	12.79	13.05	13.00	12.94
	802.11a	5700	140	13.06	12.35	12.99	12.92	12.84	13.10	13.05	12.99
	802.11a	5745	149*	13.31	13.12	13.33	13.25	12.81	12.63	12.79	12.56
802.11a	5765	153	13.21	13.02	13.23	13.15	12.71	12.53	12.69	12.46	
802.11a	5785	157*	13.15	12.96	13.17	13.09	12.65	12.47	12.63	12.40	
802.11a	5805	161	13.20	13.01	13.22	13.14	12.70	12.52	12.68	12.45	
802.11a	5825	165*	12.98	12.79	13.00	12.92	12.48	12.30	12.46	12.23	
Antenna 2	802.11a	5180	36*	13.94	13.87	13.97	13.37	13.72	13.92	13.34	13.48
	802.11a	5200	40	13.84	13.77	13.87	13.27	13.62	13.82	13.24	13.38
	802.11a	5220	44	13.86	13.79	13.89	13.29	13.64	13.84	13.26	13.40
	802.11a	5240	48*	13.74	13.67	13.77	13.17	13.52	13.72	13.14	13.28
	802.11a	5260	52*	13.21	12.91	12.98	12.92	13.42	13.35	13.10	13.44
	802.11a	5280	56	13.02	12.72	12.79	12.73	13.23	13.16	12.91	13.25
	802.11a	5300	60	13.11	12.81	12.88	12.82	13.32	13.25	13.00	13.34
	802.11a	5320	64*	12.99	12.69	12.76	12.70	13.20	13.13	12.88	13.22
	802.11a	5500	100	13.26	12.98	13.22	13.16	13.44	13.40	13.04	12.94
	802.11a	5520	104*	13.17	12.89	13.13	13.07	13.35	13.31	12.95	12.85
	802.11a	5540	108	13.04	12.76	13.00	12.94	13.22	13.18	12.82	12.72
	802.11a	5560	112	13.21	12.93	13.17	13.11	13.39	13.35	12.99	12.89
	802.11a	5580	116*	12.91	12.63	12.87	12.81	13.09	13.05	12.69	12.59
	802.11a	5600	120	N/A	N/A	N/A	N/A	N/A	N/A	N/A	N/A
	802.11a	5620	124	N/A	N/A	N/A	N/A	N/A	N/A	N/A	N/A
	802.11a	5640	128	N/A	N/A	N/A	N/A	N/A	N/A	N/A	N/A
	802.11a	5660	132	13.01	12.73	12.97	12.91	13.19	13.15	12.79	12.69
	802.11a	5680	136*	12.81	12.53	12.77	12.71	12.99	12.95	12.59	12.49
	802.11a	5700	140	12.61	12.33	12.57	12.51	12.79	12.75	12.39	12.29
	802.11a	5745	149*	13.37	13.09	12.91	12.95	13.35	13.17	13.24	13.37
802.11a	5765	153	13.44	13.16	12.98	13.02	13.42	13.24	13.31	13.44	
802.11a	5785	157*	13.31	13.03	12.85	12.89	13.29	13.11	13.18	13.31	
802.11a	5805	161	13.11	12.83	12.65	12.69	13.09	12.91	12.98	13.11	
802.11a	5825	165*	13.25	12.97	12.79	12.83	13.23	13.05	13.12	13.25	



Per FCC KDB Publication 443999 and RSS-210 A9.2(3), transmission on channels which overlap the 5600-5650 MHz is prohibited as a client. This device does not transmit any beacons or initiate any transmissions in 5.3 and 5.5 GHz Band.

(\*) – indicates default channels per KDB Publication 248227 D01v01r02. When the adjacent channels are higher in power then the default channels, these “required channels” are considered for SAR testing instead of the default channels.

FCC ID: A3LSMG900R7		SAR EVALUATION REPORT		Reviewed by: Quality Manager
Document S/N: OY1403190578.A3L	Test Dates: 02/03/14 - 03/31/14	DUT Type: Portable Handset	Page 29 of 79	



**Table 9-14  
IEEE 802.11n Average RF Power – 20 MHz Bandwidth**

Antenna	Freq [MHz]	Channel	20MHz BW 802.11n (5GHz) Conducted Power [dBm]							
			Data Rate [Mbps]							
			6.5	13	19.5	26	39	52	58.5	65
Antenna 1	5180	36	12.89	13.27	12.81	12.92	13.24	13.35	13.21	13.28
	5200	40	12.83	13.31	12.75	12.86	13.18	13.32	13.15	13.22
	5220	44	12.92	13.30	12.84	12.95	13.27	13.34	13.24	13.31
	5240	48	12.72	13.20	12.64	12.75	13.07	13.27	13.04	13.11
	5260	52	13.09	12.57	12.75	13.21	13.14	12.92	13.02	13.14
	5280	56	13.02	12.50	12.68	13.20	13.07	12.85	12.95	13.07
	5300	60	12.91	12.39	12.57	13.19	12.96	12.74	12.84	12.96
	5320	64	13.21	12.69	12.87	13.17	13.21	13.04	13.14	13.21
	5500	100	13.14	13.28	13.21	13.39	13.33	12.97	13.02	13.07
	5520	104	13.08	13.22	13.15	13.33	13.27	12.91	12.96	13.01
	5540	108	13.25	13.39	13.32	13.48	13.44	13.08	13.13	13.18
	5560	112	13.29	13.43	13.36	13.44	13.48	13.12	13.17	13.22
	5580	116	13.21	13.35	13.28	13.46	13.40	13.04	13.09	13.14
	5600	120	N/A	N/A	N/A	N/A	N/A	N/A	N/A	N/A
	5620	124	N/A	N/A	N/A	N/A	N/A	N/A	N/A	N/A
	5640	128	N/A	N/A	N/A	N/A	N/A	N/A	N/A	N/A
	5660	132	12.82	12.96	12.89	13.07	13.01	12.65	12.70	12.75
	5680	136	13.04	13.18	13.11	13.29	13.23	12.87	12.92	12.97
	5700	140	12.81	12.95	12.88	13.06	13.00	12.64	12.69	12.74
	5745	149	12.74	12.95	13.14	13.21	13.15	13.01	12.94	13.08
5765	153	12.56	12.77	12.96	13.03	12.97	12.83	12.76	12.90	
5785	157	12.72	12.93	13.12	13.19	13.13	12.99	12.92	13.06	
5805	161	12.52	12.73	12.92	12.99	12.93	12.79	12.72	12.86	
5825	165	12.74	12.95	13.14	13.21	13.15	13.01	12.94	13.08	
Antenna 2	5180	36	12.78	12.95	13.02	13.11	13.04	13.07	12.99	13.12
	5200	40	12.96	13.13	13.20	13.29	13.22	13.25	13.17	13.30
	5220	44	12.72	12.89	12.96	13.05	12.98	13.01	12.93	13.06
	5240	48	12.84	13.01	13.08	13.17	13.10	13.13	13.05	13.18
	5260	52	13.15	13.02	13.25	13.37	13.34	13.17	13.27	13.25
	5280	56	13.04	12.91	13.14	13.26	13.23	13.06	13.16	13.14
	5300	60	13.12	12.99	13.22	13.34	13.31	13.14	13.24	13.22
	5320	64	12.89	12.76	12.99	13.11	13.08	12.91	13.01	12.99
	5500	100	13.01	13.18	13.27	13.24	13.28	13.32	13.29	13.32
	5520	104	13.18	13.35	13.44	13.41	13.45	13.44	13.46	13.42
	5540	108	13.01	13.18	13.27	13.24	13.28	13.32	13.29	13.32
	5560	112	13.09	13.26	13.35	13.32	13.36	13.40	13.37	13.40
	5580	116	13.04	13.21	13.30	13.27	13.31	13.35	13.32	13.35
	5600	120	N/A	N/A	N/A	N/A	N/A	N/A	N/A	N/A
	5620	124	N/A	N/A	N/A	N/A	N/A	N/A	N/A	N/A
	5640	128	N/A	N/A	N/A	N/A	N/A	N/A	N/A	N/A
	5660	132	12.82	12.99	13.08	13.05	13.09	13.13	13.10	13.13
	5680	136	12.68	12.85	12.94	12.91	12.95	12.99	12.96	12.99
	5700	140	12.60	12.77	12.86	12.83	12.87	12.91	12.88	12.91
	5745	149	13.08	13.12	13.27	13.29	13.25	13.21	13.30	13.24
5765	153	13.11	13.15	13.30	13.32	13.28	13.24	13.33	13.27	
5785	157	13.21	13.25	13.40	13.42	13.38	13.34	13.43	13.37	
5805	161	13.25	13.29	13.44	13.46	13.42	13.38	13.47	13.41	
5825	165	13.16	13.20	13.35	13.37	13.33	13.29	13.38	13.32	

FCC ID: A3LSMG900R7	 <b>PCTEST</b> ENGINEERING LABORATORY, INC.	<b>SAR EVALUATION REPORT</b>		Reviewed by: Quality Manager
Document S/N: OY1403190578.A3L	Test Dates: 02/03/14 - 03/31/14	DUT Type: Portable Handset	Page 30 of 79	

**Table 9-15**  
**MIMO IEEE 802.11n Average RF Power – 20 MHz Bandwidth**

Antenna	Freq [MHz]	Channel	20MHz BW 802.11n (5GHz) Conducted Power [dBm]
			Data Rate [Mbps]
			13
MIMO	5180	36	12.63
	5200	40	12.60
	5220	44	12.62
	5240	48	12.55
	5260	52	12.75
	5280	56	12.76
	5300	60	12.77
	5320	64	12.63
	5500	100	12.30
	5520	104	12.28
	5540	108	12.25
	5560	112	12.24
	5580	116	12.18
	5600	120	N/A
	5620	124	N/A
	5640	128	N/A
	5660	132	12.08
	5680	136	12.12
	5700	140	12.06
	5745	149	13.44
	5765	153	13.47
	5785	157	13.44
5805	161	13.43	
5825	165	13.41	



FCC ID: A3LSMG900R7	 PCTEST ENGINEERING LABORATORY, INC.	SAR EVALUATION REPORT		Reviewed by: Quality Manager
Document S/N: 0Y1403190578.A3L	Test Dates: 02/03/14 - 03/31/14	DUT Type: Portable Handset	Page 31 of 79	

**Table 9-16**  
**IEEE 802.11n Average RF Power – 40 MHz Bandwidth**

Antenna	Freq [MHz]	Channel	40MHz BW 802.11n (5GHz) Conducted Power [dBm]							
			Data Rate [Mbps]							
			13.5	27	40.5	54	81	108	121.5	135
Antenna 1	5190	38	11.42	12.05	12.24	12.28	11.93	12.12	12.38	12.24
	5230	46	11.26	11.89	12.08	12.12	11.77	11.96	12.22	12.08
	5270	54	11.29	11.85	12.09	12.35	12.14	12.36	12.04	12.12
	5310	62	11.36	11.92	12.16	12.42	12.21	12.43	12.11	12.19
	5510	102	11.45	11.48	11.65	11.84	11.67	11.95	11.72	11.62
	5550	110	11.69	11.72	11.89	12.08	11.91	12.19	11.96	11.86
	5590	118	N/A	N/A	N/A	N/A	N/A	N/A	N/A	N/A
	5630	126	N/A	N/A	N/A	N/A	N/A	N/A	N/A	N/A
	5670	134	11.51	11.54	11.71	11.90	11.73	12.01	11.78	11.68
	5755	151	11.43	11.23	11.42	11.48	11.52	11.46	11.32	11.47
5795	159	11.29	11.09	11.28	11.34	11.38	11.32	11.18	11.33	
Antenna 2	5190	38	12.25	12.38	12.41	12.25	12.34	12.43	12.32	12.29
	5230	46	12.17	12.30	12.33	12.17	12.26	12.35	12.24	12.21
	5270	54	11.54	11.52	11.61	11.79	11.35	11.62	11.55	11.67
	5310	62	11.41	11.39	11.48	11.66	11.22	11.49	11.42	11.54
	5510	102	11.67	11.85	11.58	11.79	11.82	11.98	11.67	11.54
	5550	110	11.61	11.79	11.52	11.73	11.76	11.92	11.61	11.48
	5590	118	N/A	N/A	N/A	N/A	N/A	N/A	N/A	N/A
	5630	126	N/A	N/A	N/A	N/A	N/A	N/A	N/A	N/A
	5670	134	11.32	11.50	11.23	11.44	11.47	11.63	11.32	11.19
	5755	151	11.74	11.84	11.81	12.02	12.05	11.98	11.90	11.84
5795	159	11.77	11.87	11.84	12.05	12.08	12.01	11.93	11.87	

**Table 9-17**  
**MIMO IEEE 802.11n Average RF Power – 40 MHz Bandwidth**

Antenna	Mode	Freq [MHz]	Channel	40MHz BW 802.11n (5GHz) Conducted Power [dBm]
				Data Rate [Mbps]
				27
MIMO	802.11n	5190	38	11.63
	802.11n	5230	46	11.79
	802.11n	5270	54	11.58
	802.11n	5310	62	11.73
	802.11n	5510	102	12.33
	802.11n	5550	110	12.41
	802.11n	5590	118	N/A
	802.11n	5630	126	N/A
	802.11n	5670	134	12.14
	802.11n	5755	151	12.44
802.11n	5795	159	12.28	



FCC ID: A3LSMG900R7	 <b>PCTEST</b> ENGINEERING LABORATORY, INC.	<b>SAR EVALUATION REPORT</b>		Reviewed by: Quality Manager
Document S/N: OY1403190578.A3L	Test Dates: 02/03/14 - 03/31/14	DUT Type: Portable Handset	Page 32 of 79	

**Table 9-18**  
**IEEE 802.11ac Average RF Power – 80 MHz Bandwidth**

Antenna	Freq [MHz]	Channel	80MHz BW 802.11ac (5GHz) Conducted Power [dBm]									
			Data Rate [Mbps]									
			29.3	58.5	87.8	117	175.5	234	263.3	292.5	351	390
Antenna 1	5210	42	10.71	10.76	10.69	10.77	10.94	10.92	10.87	10.91	10.88	10.79
	5290	58	10.77	10.81	10.72	10.60	10.98	10.87	10.91	10.82	10.87	10.97
	5530	106	11.15	11.18	11.11	11.38	11.17	11.32	11.34	11.21	11.25	11.37
	5775	155	11.25	11.14	10.94	11.09	11.32	10.92	11.10	11.17	10.89	10.52
Antenna 2	5210	42	10.78	10.61	10.64	10.59	10.86	10.79	10.81	10.95	11.01	10.98
	5290	58	10.94	10.75	10.74	10.93	11.05	11.01	11.12	11.07	10.95	11.18
	5530	106	10.98	10.84	10.97	10.75	11.14	11.04	11.16	11.07	11.12	11.14
	5775	155	11.26	11.23	11.14	11.24	11.37	11.24	11.42	11.38	11.27	11.35

**Table 9-19**  
**MIMO IEEE 802.11ac Average RF Power – 80 MHz Bandwidth**

Antenna	Freq [MHz]	Channel	80MHz BW 802.11ac (5GHz) Conducted Power [dBm]
			Data Rate [Mbps]
			58.5
MIMO	5210	42	11.23
	5290	58	11.27
	5530	106	10.89
	5775	155	10.76

FCC ID: A3LSMG900R7	 <b>PCTEST</b> ENGINEERING LABORATORY, INC.	<b>SAR EVALUATION REPORT</b>		Reviewed by: Quality Manager
Document S/N: OY1403190578.A3L	Test Dates: 02/03/14 - 03/31/14	DUT Type: Portable Handset	Page 33 of 79	

### 9.3.2 Reduced WLAN Conducted Powers

Per KDB 662911 D01v02r01, the individual spectra for each 2x2 MIMO WIFI Antenna were summed mathematically in linear power units for the MIMO output power measurements.

**Table 9-20**  
**IEEE 802.11b Average RF Power**

Antenna	Freq [MHz]	Channel	802.11b Conducted Power [dBm]			
			Data Rate [Mbps]			
			1	2	5.5	11
Antenna 1	2412	1*	11.94	12.03	12.09	12.08
	2437	6*	11.23	11.39	11.31	11.33
	2462	11*	11.27	11.36	11.39	11.48
Antenna 2	2412	1*	11.74	11.67	11.75	11.70
	2437	6*	11.50	11.43	11.35	11.44
	2462	11*	11.39	11.35	11.32	11.27

**Table 9-21**  
**IEEE 802.11g Average RF Power**



Antenna	Freq [MHz]	Channel	802.11g Conducted Power [dBm]							
			Data Rate [Mbps]							
			6	9	12	18	24	36	48	54
Antenna 1	2412	1	11.42	11.55	11.52	11.41	11.46	11.44	11.40	11.38
	2437	6	11.87	11.92	11.93	11.87	11.98	11.93	11.92	11.94
	2462	11	11.89	11.71	11.75	11.79	11.82	11.82	11.81	11.81
Antenna 2	2412	1	11.66	11.78	11.61	11.76	11.75	11.73	11.59	11.78
	2437	6	11.63	11.62	11.80	11.77	11.69	11.76	11.75	11.76
	2462	11	11.38	11.51	11.49	11.43	11.44	11.50	11.47	11.45

**Table 9-22**  
**IEEE 802.11n Average RF Power**

Antenna	Freq [MHz]	Channel	802.11n (2.4GHz) Conducted Power [dBm]							
			Data Rate [Mbps]							
			6.5	13	19.5	26	39	52	58.5	65
Antenna 1	2412	1	11.25	11.25	11.30	11.18	11.24	11.24	11.32	11.31
	2437	6	11.90	11.89	11.90	11.85	11.90	11.79	11.92	11.79
	2462	11	11.66	11.78	11.78	11.64	11.81	11.70	11.75	11.70
Antenna 2	2412	1	11.83	11.97	11.93	11.92	11.81	11.97	11.91	11.81
	2437	6	11.73	11.70	11.69	11.79	11.82	11.78	11.83	11.69
	2462	11	11.69	11.79	11.75	11.77	11.85	11.75	11.70	11.71

**Table 9-23**  
**MIMO IEEE 802.11n Average RF Power**

Antenna	Freq [MHz]	Channel	802.11n (2.4GHz)
			Conducted Power [dBm]
			Data Rate [Mbps]
			13
MIMO	2412	1	11.85
	2437	6	11.70
	2462	11	11.34



FCC ID: A3LSMG900R7	 <b>PCTEST</b> ENGINEERING LABORATORY, INC.	<b>SAR EVALUATION REPORT</b>		Reviewed by: Quality Manager
Document S/N: OY1403190578.A3L	Test Dates: 02/03/14 - 03/31/14	DUT Type: Portable Handset		Page 34 of 79

**Table 9-24  
IEEE 802.11a Average RF Power**

Antenna	Mode	Freq [MHz]	Channel	802.11a Conducted Power [dBm]							
				Data Rate [Mbps]							
				6	9	12	18	24	36	48	54
Antenna 1	802.11a	5180	36*	6.74	6.47	6.64	6.39	6.48	6.32	6.29	6.47
	802.11a	5200	40	6.66	6.37	6.71	6.56	6.51	6.35	6.43	6.40
	802.11a	5220	44	6.74	6.50	6.78	6.59	6.69	6.43	6.58	6.48
	802.11a	5240	48*	6.32	6.63	6.47	6.22	6.27	6.62	6.39	6.31
	802.11a	5260	52*	6.69	6.55	6.39	6.69	6.59	6.61	6.47	6.64
	802.11a	5280	56	6.58	6.87	6.69	6.87	6.67	6.53	6.77	6.91
	802.11a	5300	60	6.53	6.57	6.79	6.68	6.55	6.91	6.65	6.89
	802.11a	5320	64*	6.63	6.84	6.47	6.63	6.69	6.89	6.86	6.46
	802.11a	5500	100	6.82	6.48	6.44	6.82	6.67	6.67	6.77	6.65
	802.11a	5520	104*	6.74	6.68	6.82	6.88	6.88	6.87	6.69	6.55
	802.11a	5540	108	6.45	6.67	6.40	6.87	6.54	6.65	6.48	6.46
	802.11a	5560	112	6.66	6.59	6.91	6.62	6.89	6.79	6.52	6.46
	802.11a	5580	116*	6.83	6.62	6.45	6.39	6.75	6.63	6.82	6.37
	802.11a	5600	120	N/A	N/A	N/A	N/A	N/A	N/A	N/A	N/A
	802.11a	5620	124	N/A	N/A	N/A	N/A	N/A	N/A	N/A	N/A
	802.11a	5640	128	N/A	N/A	N/A	N/A	N/A	N/A	N/A	N/A
	802.11a	5660	132	6.39	6.55	6.64	6.73	6.44	6.46	6.82	6.80
	802.11a	5680	136*	6.56	6.44	6.56	6.79	6.38	6.52	6.71	6.59
	802.11a	5700	140	6.33	6.46	6.49	6.36	6.42	6.66	6.31	6.58
	802.11a	5745	149*	6.84	6.88	6.55	6.64	6.92	6.63	6.81	6.78
802.11a	5765	153	6.53	6.69	6.67	6.41	6.58	6.49	6.69	6.76	
802.11a	5785	157*	6.87	6.79	6.66	6.86	6.70	6.67	6.90	6.75	
802.11a	5805	161	6.56	6.64	6.55	6.66	6.37	6.40	6.76	6.55	
802.11a	5825	165*	6.67	6.70	6.27	6.53	6.56	6.47	6.55	6.25	
Antenna 2	802.11a	5180	36*	6.65	6.70	6.75	6.82	6.77	6.70	6.83	6.76
	802.11a	5200	40	6.72	6.84	6.75	6.74	6.79	6.75	6.88	6.79
	802.11a	5220	44	6.86	6.89	6.79	6.86	6.87	6.79	6.93	6.81
	802.11a	5240	48*	6.70	6.63	6.64	6.63	6.74	6.72	6.77	6.81
	802.11a	5260	52*	6.95	7.02	6.99	6.93	6.94	6.88	6.98	6.86
	802.11a	5280	56	6.83	6.91	6.78	6.85	6.92	6.80	6.83	6.81
	802.11a	5300	60	6.83	6.90	6.98	6.95	6.93	6.97	6.87	6.93
	802.11a	5320	64*	6.90	6.90	6.85	6.70	6.83	6.83	6.81	6.90
	802.11a	5500	100	5.71	5.77	5.69	5.76	5.77	5.81	5.75	5.67
	802.11a	5520	104*	5.79	5.75	5.88	5.76	5.82	5.87	5.92	5.73
	802.11a	5540	108	5.81	5.70	5.76	5.86	5.88	5.79	5.69	5.84
	802.11a	5560	112	5.83	5.85	5.92	5.95	6.00	5.99	5.95	5.85
	802.11a	5580	116*	5.86	5.80	5.94	5.96	5.93	5.95	5.90	5.82
	802.11a	5600	120	N/A	N/A	N/A	N/A	N/A	N/A	N/A	N/A
	802.11a	5620	124	N/A	N/A	N/A	N/A	N/A	N/A	N/A	N/A
	802.11a	5640	128	N/A	N/A	N/A	N/A	N/A	N/A	N/A	N/A
	802.11a	5660	132	5.74	5.86	5.84	5.87	5.87	5.87	5.89	5.77
	802.11a	5680	136*	6.01	5.97	5.85	5.90	6.01	6.00	5.95	6.03
	802.11a	5700	140	5.91	5.93	5.89	5.94	6.01	5.95	5.92	5.94
	802.11a	5745	149*	6.29	6.43	6.31	6.31	6.42	6.25	6.44	6.31
802.11a	5765	153	6.58	6.66	6.50	6.66	6.57	6.57	6.57	6.62	
802.11a	5785	157*	6.47	6.57	6.47	6.54	6.54	6.42	6.58	6.40	
802.11a	5805	161	6.37	6.40	6.52	6.43	6.42	6.53	6.53	6.50	
802.11a	5825	165*	6.33	6.41	6.44	6.37	6.46	6.47	6.36	6.33	



Per FCC KDB Publication 443999 and RSS-210 A9.2(3), transmission on channels which overlap the 5600-5650 MHz is prohibited as a client. This device does not transmit any beacons or initiate any transmissions in 5.3 and 5.5 GHz Band.

(\*) – indicates default channels per KDB Publication 248227 D01v01r02. When the adjacent channels are higher in power then the default channels, these “required channels” are considered for SAR testing instead of the default channels.

FCC ID: A3LSMG900R7		SAR EVALUATION REPORT		Reviewed by: Quality Manager
Document S/N: OY1403190578.A3L	Test Dates: 02/03/14 - 03/31/14	DUT Type: Portable Handset	Page 35 of 79	

**Table 9-25**  
**IEEE 802.11n Average RF Power – 20 MHz Bandwidth**

Antenna	Freq [MHz]	Channel	20MHz BW 802.11n (5GHz) Conducted Power [dBm]							
			Data Rate [Mbps]							
			6.5	13	19.5	26	39	52	58.5	65
Antenna 1	5180	36	6.73	6.95	6.84	6.72	6.70	6.96	6.61	6.49
	5200	40	6.92	6.46	6.87	6.92	6.65	6.80	6.83	6.66
	5220	44	6.70	6.35	6.72	6.46	6.53	6.76	6.77	6.69
	5240	48	6.36	6.36	6.65	6.54	6.33	6.50	6.37	6.55
	5260	52	6.69	6.57	6.22	6.55	6.60	6.65	6.22	6.53
	5280	56	6.56	6.41	6.33	6.60	6.35	6.48	6.61	6.50
	5300	60	6.43	6.38	6.58	6.73	6.41	6.40	6.40	6.35
	5320	64	6.39	6.66	6.74	6.44	6.65	6.60	6.79	6.68
	5500	100	6.73	6.83	6.69	6.99	6.70	6.73	6.94	6.92
	5520	104	6.92	6.66	6.49	6.63	6.60	6.68	6.60	6.96
	5540	108	6.74	6.42	6.63	6.51	6.63	6.68	6.45	6.77
	5560	112	6.58	6.58	7.00	6.92	6.75	6.67	6.82	6.88
	5580	116	6.94	6.75	6.87	6.84	6.79	6.88	6.75	6.91
	5600	120	N/A	N/A	N/A	N/A	N/A	N/A	N/A	N/A
	5620	124	N/A	N/A	N/A	N/A	N/A	N/A	N/A	N/A
	5640	128	N/A	N/A	N/A	N/A	N/A	N/A	N/A	N/A
	5660	132	7.07	6.97	7.05	6.87	6.86	6.63	7.07	6.80
	5680	136	6.92	6.90	6.48	6.88	6.45	6.96	6.74	6.47
	5700	140	6.87	6.84	6.62	6.70	6.68	6.56	6.53	6.71
	5745	149	6.49	6.72	6.62	6.54	6.80	6.95	6.56	6.68
5765	153	6.44	6.70	6.74	6.80	6.69	6.62	6.81	6.71	
5785	157	6.49	6.65	6.64	6.83	6.66	6.59	6.47	6.77	
5805	161	6.20	6.57	6.37	6.25	6.51	6.44	6.66	6.26	
5825	165	6.58	6.63	6.53	6.31	6.70	6.30	6.75	6.59	
Antenna 2	5180	36	6.66	6.73	6.58	6.64	6.66	6.57	6.67	6.71
	5200	40	6.84	6.91	6.98	6.99	6.88	6.98	6.86	6.90
	5220	44	6.68	6.76	6.81	6.67	6.74	6.78	6.80	6.84
	5240	48	6.76	6.74	6.81	6.83	6.81	6.77	6.85	6.79
	5260	52	6.74	6.83	6.77	6.75	6.71	6.74	6.89	6.82
	5280	56	6.83	6.67	6.76	6.67	6.71	6.81	6.73	6.70
	5300	60	6.78	6.97	6.78	6.80	6.86	6.91	6.93	6.97
	5320	64	6.69	6.74	6.83	6.79	6.78	6.81	6.84	6.85
	5500	100	5.70	5.63	5.70	5.70	5.74	5.65	5.75	5.71
	5520	104	5.92	5.97	5.90	5.90	5.98	5.90	5.95	5.93
	5540	108	5.76	5.90	5.76	5.84	5.83	5.90	5.86	5.76
	5560	112	6.04	5.97	5.90	5.95	5.96	5.95	5.97	6.02
	5580	116	6.03	5.92	6.01	6.11	5.97	5.92	6.09	6.10
	5600	120	N/A	N/A	N/A	N/A	N/A	N/A	N/A	N/A
	5620	124	N/A	N/A	N/A	N/A	N/A	N/A	N/A	N/A
	5640	128	N/A	N/A	N/A	N/A	N/A	N/A	N/A	N/A
	5660	132	5.91	5.95	5.85	5.88	5.84	5.92	5.82	5.90
	5680	136	5.86	5.94	5.92	5.83	5.89	5.99	5.82	5.98
	5700	140	5.78	5.82	5.93	5.92	5.91	5.90	5.83	5.78
	5745	149	6.44	6.44	6.59	6.47	6.49	6.43	6.46	6.51
5765	153	6.60	6.61	6.56	6.66	6.65	6.69	6.73	6.69	
5785	157	6.60	6.52	6.70	6.56	6.57	6.60	6.54	6.57	
5805	161	6.65	6.66	6.59	6.63	6.64	6.57	6.60	6.63	
5825	165	6.54	6.39	6.52	6.45	6.47	6.43	6.49	6.53	



FCC ID: A3LSMG900R7	 <b>PCTEST</b> ENGINEERING LABORATORY, INC.	<b>SAR EVALUATION REPORT</b>		Reviewed by: Quality Manager
Document S/N: OY1403190578.A3L	Test Dates: 02/03/14 - 03/31/14	DUT Type: Portable Handset	Page 36 of 79	

**Table 9-26**  
**MIMO IEEE 802.11n Average RF Power – 20 MHz Bandwidth**

Antenna	Freq [MHz]	Channel	20MHz BW 802.11n (5GHz)	
			Conducted Power [dBm]	
			Data Rate [Mbps]	
MIMO	5180	36	5.98	
	5200	40	6.02	
	5220	44	6.04	
	5240	48	6.06	
	5260	52	5.64	
	5280	56	5.62	
	5300	60	5.67	
	5320	64	5.62	
	5500	100	7.38	
	5520	104	7.31	
	5540	108	7.33	
	5560	112	7.30	
	5580	116	7.36	
	5600	120	N/A	
	5620	124	N/A	
	5640	128	N/A	
	5660	132	7.22	
	5680	136	7.19	
	5700	140	7.29	
	5745	149	6.52	
5765	153	6.57		
5785	157	6.54		
5805	161	6.41		
5825	165	6.44		

**Table 9-27**  
**IEEE 802.11n Average RF Power – 40 MHz Bandwidth**

Mode	Freq [MHz]	Channel	40MHz BW 802.11n (5GHz) Conducted Power [dBm]							
			Data Rate [Mbps]							
			13.5	27	40.5	54	81	108	121.5	135
Antenna 1	5190	38	6.57	6.46	6.55	6.31	6.24	6.72	6.49	6.15
	5230	46	6.54	6.97	6.18	6.14	6.91	6.71	6.80	6.66
	5270	54	6.35	6.36	6.25	6.64	6.85	6.33	6.27	6.81
	5310	62	6.39	6.33	6.24	6.84	6.82	6.63	6.02	6.86
	5510	102	6.59	6.84	6.25	6.59	6.87	6.78	6.58	6.35
	5550	110	6.64	6.69	6.85	7.07	6.27	6.69	6.87	7.02
	5590	118	N/A	N/A	N/A	N/A	N/A	N/A	N/A	N/A
	5630	126	N/A	N/A	N/A	N/A	N/A	N/A	N/A	N/A
	5670	134	6.69	6.17	6.39	6.42	6.20	6.42	6.82	6.36
	5755	151	6.77	6.74	6.76	6.80	6.25	6.05	5.92	6.29
5795	159	6.54	6.56	6.36	6.18	6.69	6.07	6.51	6.67	
Antenna 2	5190	38	6.63	6.73	6.66	6.80	6.67	6.72	6.69	6.76
	5230	46	6.74	6.62	6.72	6.58	6.62	6.69	6.64	6.72
	5270	54	6.72	6.67	6.58	6.64	6.72	6.65	6.67	6.60
	5310	62	6.92	6.81	6.87	6.75	6.87	6.81	6.75	6.79
	5510	102	5.56	5.67	5.62	5.58	5.52	5.59	5.57	5.52
	5550	110	5.73	5.70	5.76	5.62	5.62	5.77	5.79	5.62
	5590	118	N/A	N/A	N/A	N/A	N/A	N/A	N/A	N/A
	5630	126	N/A	N/A	N/A	N/A	N/A	N/A	N/A	N/A
	5670	134	5.63	5.57	5.73	5.71	5.66	5.65	5.58	5.63
	5755	151	6.52	6.53	6.52	6.41	6.40	6.52	6.52	6.44
5795	159	6.44	6.41	6.40	6.42	6.46	6.30	6.37	6.43	

FCC ID: A3LSMG900R7		<b>SAR EVALUATION REPORT</b>		Reviewed by: Quality Manager
Document S/N: OY1403190578.A3L	Test Dates: 02/03/14 - 03/31/14	DUT Type: Portable Handset	Page 37 of 79	

**Table 9-28**  
**MIMO IEEE 802.11n Average RF Power – 40 MHz Bandwidth**



Antenna	Freq [MHz]	Channel	40MHz BW 802.11n (5GHz) Conducted Power [dBm]
			Data Rate [Mbps]
			27
MIMO	5190	38	6.06
	5230	46	6.09
	5270	54	6.10
	5310	62	6.08
	5510	102	7.39
	5550	110	7.33
	5590	118	N/A
	5630	126	N/A
	5670	134	7.38
	5755	151	5.90
5795	159	6.01	

**Table 9-29**  
**IEEE 802.11ac Average RF Power – 80 MHz Bandwidth**

Antenna	Freq [MHz]	Channel	80MHz BW 802.11ac (5GHz) Conducted Power [dBm]									
			Data Rate [Mbps]									
			29.3	58.5	87.8	117	175.5	234	263.3	292.5	351	390
Antenna 1	5210	42	6.56	6.50	6.64	6.61	6.50	6.46	6.59	6.39	6.40	6.50
	5290	58	6.48	6.32	6.35	6.44	6.35	6.45	6.40	6.42	6.50	6.33
	5530	106	6.51	6.57	6.40	6.33	6.45	6.47	6.50	6.39	6.34	6.54
	5775	155	6.38	6.33	6.47	6.33	6.29	6.41	6.37	6.55	6.46	6.46
Antenna 2	5210	42	6.63	6.58	6.60	6.59	6.54	6.52	6.53	6.52	6.61	6.51
	5290	58	6.55	6.52	6.44	6.46	6.41	6.50	6.52	6.52	6.41	6.54
	5530	106	5.57	5.44	5.50	5.61	5.48	5.53	5.61	5.46	5.60	5.46
	5775	155	6.25	6.13	6.13	6.28	6.21	6.11	6.10	6.11	6.26	6.21

**Table 9-30**  
**MIMO IEEE 802.11ac Average RF Power – 80 MHz Bandwidth**

Antenna	Freq [MHz]	Channel	80MHz BW 802.11ac (5GHz)
			Data Rate [Mbps]
			58.5
MIMO	5210	42	5.94
	5290	58	5.56
	5530	106	7.27
	5775	155	7.41

FCC ID: A3LSMG900R7	 <b>PCTEST</b> <small>ENGINEERING LABORATORY, INC.</small>	<b>SAR EVALUATION REPORT</b>		Reviewed by: Quality Manager
Document S/N: OY1403190578.A3L	Test Dates: 02/03/14 - 03/31/14	DUT Type: Portable Handset	Page 38 of 79	

Justification for reduced test configurations for WIFI channels per KDB Publication 248227 D01v01r02 and October 2012/April 2013 FCC/TCB Meeting Notes:

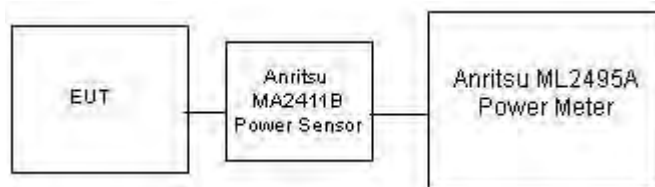

- For SISO 2.4 GHz, highest average RF output power channel for the lowest data rate for IEEE 802.11b were selected for SAR evaluation. Other IEEE 802.11 modes (including 802.11g/n) were not investigated since the average output powers over all channels and data rates were not more than 0.25 dB higher than the tested channel in the lowest data rate of IEEE 802.11b mode.
- For SISO 5 GHz, highest average RF output power channel for the lowest data rate for IEEE 802.11a were selected for SAR evaluation. Other IEEE 802.11 modes (including 802.11n 20 MHz and 40 MHz) were not investigated since the average output powers over all channels and data rates were not more than 0.25 dB higher than the tested channel in the lowest data rate of IEEE 802.11a mode.
- For MIMO 2.4 GHz, highest average RF output power channel for the lowest data rate for IEEE 802.11n were selected for SAR evaluation.
- For MIMO 5 GHz, highest average RF output power channel for the lowest data rate for IEEE 802.11n were selected for SAR evaluation.
- Full SAR tests for all IEEE 802.11ac configurations were not required because the average output power was not more than 0.25 dB higher than IEEE 802.11a mode. IEEE 802.11ac was evaluated for the highest IEEE 802.11a position in each 5 GHz band and exposure condition.
- When the maximum extrapolated peak SAR of the zoom scan for the maximum output channel is <1.6 W/kg and the reported 1g averaged SAR is <0.8 W/kg, SAR testing on other channels is not required. Otherwise, the other default (or corresponding required) test channels were additionally tested using the lowest data rate.
- The bolded data rate and channel above were tested for SAR.

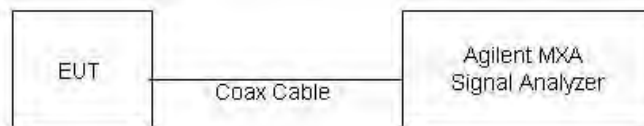

**Figure 9-2**  
**Power Measurement Setup for Bandwidths < 50 MHz**



**Figure 9-3**  
**Power Measurement Setup for Bandwidths > 50 MHz**

FCC ID: A3LSMG900R7	 <b>PCTEST</b> ENGINEERING LABORATORY, INC.	<b>SAR EVALUATION REPORT</b>		<b>Reviewed by:</b> Quality Manager
<b>Document S/N:</b> OY1403190578.A3L	<b>Test Dates:</b> 02/03/14 - 03/31/14	<b>DUT Type:</b> Portable Handset	Page 39 of 79	



# 10 SYSTEM VERIFICATION

## 10.1 Tissue Verification

**Table 10-1  
Measured Tissue Properties**

Calibrated for Tests Performed on:	Tissue Type	Tissue Temp During Calibration (C)	Measured Frequency (MHz)	Measured Conductivity, $\sigma$ (S/m)	Measured Dielectric Constant, $\epsilon$	TARGET Conductivity, $\sigma$ (S/m)	TARGET Dielectric Constant, $\epsilon$	% dev $\sigma$	% dev $\epsilon$
2/17/2014	750H	22.6	695	0.883	44.059	0.889	42.227	-0.67%	4.34%
			710	0.894	43.792	0.890	42.149	0.45%	3.90%
			725	0.904	43.648	0.891	42.071	1.46%	3.75%
			740	0.920	43.468	0.893	41.994	3.02%	3.51%
			755	0.933	43.196	0.894	41.916	4.36%	3.05%
2/17/2014	835H	22.8	820	0.892	41.437	0.899	41.578	-0.78%	-0.34%
			835	0.906	41.195	0.900	41.500	0.67%	-0.73%
			850	0.919	40.975	0.916	41.500	0.33%	-1.27%
2/18/2014	1750H	22.9	1710	1.359	38.666	1.348	40.142	0.82%	-3.68%
			1750	1.400	38.485	1.371	40.079	2.12%	-3.98%
			1790	1.441	38.294	1.394	40.016	3.37%	-4.30%
2/19/2014	1900H	21.9	1850	1.395	38.419	1.400	40.000	-0.36%	-3.95%
			1880	1.427	38.295	1.400	40.000	1.93%	-4.26%
			1910	1.459	38.171	1.400	40.000	4.21%	-4.57%
2/18/2014	2450H	22.8	2401	1.822	38.991	1.756	39.287	3.76%	-0.75%
			2450	1.879	38.816	1.800	39.200	4.39%	-0.98%
			2499	1.935	38.638	1.853	39.138	4.43%	-1.28%
2/3/2014	5200H-5800H	23.0	5180	4.474	36.244	4.635	36.009	-3.47%	0.65%
			5200	4.508	36.214	4.655	35.986	-3.16%	0.63%
			5220	4.522	36.197	4.676	35.963	-3.29%	0.65%
			5240	4.538	36.162	4.696	35.940	-3.36%	0.62%
			5260	4.570	36.130	4.717	35.917	-3.12%	0.59%
			5280	4.590	36.108	4.737	35.894	-3.10%	0.60%
			5300	4.605	36.076	4.758	35.871	-3.22%	0.57%
			5500	4.822	35.798	4.963	35.643	-2.84%	0.43%
			5520	4.842	35.754	4.983	35.620	-2.83%	0.38%
			5540	4.868	35.725	5.004	35.597	-2.72%	0.36%
			5580	4.910	35.706	5.045	35.551	-2.68%	0.44%
			5600	4.925	35.697	5.065	35.529	-2.76%	0.47%
			5680	5.006	35.596	5.147	35.437	-2.74%	0.45%
			5765	5.088	35.493	5.234	35.340	-2.79%	0.43%
			5785	5.101	35.458	5.255	35.317	-2.93%	0.40%
2/18/2014	750B	21.0	695	0.928	55.021	0.959	55.745	-3.23%	-1.30%
			710	0.941	54.929	0.960	55.687	-1.98%	-1.36%
			725	0.956	54.753	0.961	55.629	-0.52%	-1.57%
			740	0.967	54.564	0.963	55.570	0.42%	-1.81%
			755	0.980	54.460	0.964	55.512	1.66%	-1.90%
			820	0.958	55.243	0.969	55.258	-1.14%	-0.03%
			835	0.976	55.109	0.970	55.200	0.62%	-0.16%
			850	0.992	54.892	0.988	55.154	0.40%	-0.48%
			1710	1.466	54.473	1.463	53.537	0.21%	1.75%
			1750	1.511	54.336	1.488	53.432	1.55%	1.69%
2/18/2014	1750B	23.0	1790	1.554	54.171	1.514	53.326	2.64%	1.58%
			1850	1.489	53.263	1.520	53.300	-2.04%	-0.07%
			1880	1.525	53.183	1.520	53.300	0.33%	-0.22%
2/17/2014	1900B	23.2	1910	1.558	53.102	1.520	53.300	2.50%	-0.37%
			1850	1.510	51.115	1.520	53.300	-0.66%	-4.10%
			1880	1.545	51.042	1.520	53.300	1.64%	-4.24%
3/31/2014	1900B	23.3	1910	1.581	50.925	1.520	53.300	4.01%	-4.46%
			2401	1.872	51.518	1.903	52.765	-1.63%	-2.36%
			2450	1.937	51.331	1.950	52.700	-0.67%	-2.60%
2/12/2014	2450B	24.0	2499	1.998	51.123	2.019	52.638	-1.04%	-2.88%
			5180	5.116	47.453	5.276	49.041	-3.03%	-3.24%
			5200	5.147	47.331	5.299	49.014	-2.87%	-3.43%
2/6/2014	5200B-5800B	24.3	5220	5.173	47.224	5.323	48.987	-2.82%	-3.60%
			5260	5.256	47.134	5.369	48.933	-2.10%	-3.68%
			5280	5.277	47.164	5.393	48.906	-2.15%	-3.56%
			5300	5.298	47.170	5.416	48.879	-2.18%	-3.50%
			5500	5.600	46.464	5.650	48.607	-0.88%	-4.41%
			5520	5.646	46.503	5.673	48.580	-0.48%	-4.28%
			5540	5.663	46.576	5.696	48.553	-0.58%	-4.07%
			5745	5.980	45.916	5.936	48.275	0.74%	-4.89%
			5765	6.028	45.890	5.959	48.248	1.16%	-4.89%
			5785	6.055	45.952	5.982	48.220	1.22%	-4.70%
			5800	6.062	45.987	6.000	48.200	1.03%	-4.59%

The above measured tissue parameters were used in the DASY software. The DASY software was used to perform interpolation to determine the dielectric parameters at the SAR test device frequencies (per KDB 865664 and IEEE 1528-2013 6.6.1.2). The tissue parameters listed in the SAR test plots may slightly differ from the table above due to significant digit rounding in the software.

FCC ID: A3LSMG900R7		SAR EVALUATION REPORT		Reviewed by: Quality Manager
Document S/N: OY1403190578.A3L	Test Dates: 02/03/14 - 03/31/14	DUT Type: Portable Handset		Page 40 of 79

## 10.2 Test System Verification

Prior to SAR assessment, the system is verified to  $\pm 10\%$  of the SAR measurement on the reference dipole at the time of calibration by the calibration facility. Full system validation status and result summary can be found in Appendix E.

**Table 10-2**  
**System Verification Results**

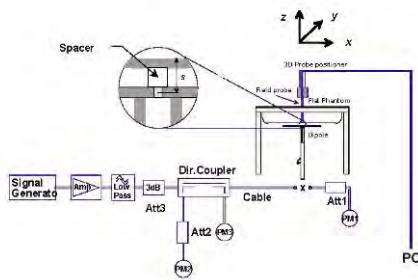

System Verification TARGET & MEASURED												
SAR System #	Tissue Frequency (MHz)	Tissue Type	Date:	Amb. Temp (°C)	Liquid Temp (°C)	Input Power (W)	Dipole SN	Probe SN	Measured SAR <sub>1g</sub> (W/kg)	1 W Target SAR <sub>1g</sub> (W/kg)	1 W Normalized SAR <sub>1g</sub> (W/kg)	Deviation <sub>1g</sub> (%)
B	750	HEAD	02/17/2014	23.2	22.6	0.100	1054	3288	0.856	8.500	8.560	0.71%
H	835	HEAD	02/17/2014	24.3	22.9	0.100	4d119	3318	0.935	9.680	9.350	-3.41%
B	1750	HEAD	02/18/2014	23.4	22.9	0.100	1008	3288	3.550	36.800	35.500	-3.53%
C	1900	HEAD	02/19/2014	23.7	21.9	0.100	5d141	3263	3.970	40.800	39.700	-2.70%
K	2450	HEAD	02/18/2014	23.5	23.0	0.100	719	3287	5.180	53.200	51.800	-2.63%
A	5200	HEAD	02/03/2014	24.4	23.0	0.100	1007	3920	7.720	77.500	77.200	-0.39%
A	5300	HEAD	02/03/2014	24.4	23.1	0.100	1007	3920	7.900	80.200	79.000	-1.50%
A	5500	HEAD	02/03/2014	24.2	23.2	0.100	1007	3920	7.740	81.400	77.400	-4.91%
A	5600	HEAD	02/03/2014	24.5	23.3	0.100	1007	3920	7.900	80.000	79.000	-1.25%
A	5800	HEAD	02/03/2014	24.3	23.3	0.100	1007	3920	7.680	77.500	76.800	-0.90%
C	750	BODY	02/18/2014	19.9	20.6	0.100	1054	3263	0.882	8.720	8.820	1.15%
C	835	BODY	02/17/2014	19.7	19.7	0.100	4d133	3263	0.953	9.610	9.530	-0.83%
B	1750	BODY	02/18/2014	23.4	23.0	0.100	1008	3288	3.760	38.200	37.600	-1.57%
I	1900	BODY	02/17/2014	23.7	23.2	0.100	5d149	3319	3.830	40.500	38.300	-5.43%
D	1900	BODY	03/31/2014	23.2	21.6	0.100	5d149	3022	4.200	40.500	42.000	3.70%
H	2450	BODY	02/12/2014	24.4	24.0	0.100	719	3318	5.410	51.700	54.100	4.64%
E	5200	BODY	02/06/2014	24.0	23.8	0.100	1120	3914	7.700	76.600	77.000	0.52%
E	5300	BODY	02/06/2014	24.0	23.8	0.100	1120	3914	7.650	76.800	76.500	-0.39%
E	5500	BODY	02/06/2014	24.1	23.8	0.100	1120	3914	7.840	79.800	78.400	-1.75%
E	5800	BODY	02/06/2014	24.1	23.7	0.100	1120	3914	7.170	75.500	71.700	-5.03%



**Figure 10-1**  
**System Verification Setup Diagram**



**Figure 10-2**  
**System Verification Setup Photo**

FCC ID: A3LSMG900R7		SAR EVALUATION REPORT		Reviewed by: Quality Manager
Document S/N: 0Y1403190578.A3L	Test Dates: 02/03/14 - 03/31/14	DUT Type: Portable Handset	Page 41 of 79	

# 11 SAR DATA SUMMARY



## 11.1 Standalone Head SAR Data

**Table 11-1  
Cell. CDMA/EVDO Head SAR**

MEASUREMENT RESULTS															
FREQUENCY		Mode/Band	Service	Maximum Allowed Power [dBm]	Conducted Power [dBm]	Power Drift [dB]	Side	Test Position	Cover Type	Device Serial Number	Duty Cycle	SAR (1g)	Scaling Factor	Scaled SAR (1g)	Plot #
MHz	Ch.											(W/kg)		(W/kg)	
836.52	384	Cell. CDMA	RC3 / SO55	25.0	24.40	0.05	Right	Cheek	Standard	32EF0	1:1	0.533	1.148	0.612	A1
836.52	384	Cell. CDMA	RC3 / SO55	25.0	24.40	0.20	Right	Cheek	Wireless Charging	32EF0	1:1	0.512	1.148	0.588	
836.52	384	Cell. CDMA	RC3 / SO55	25.0	24.40	0.01	Right	Tilt	Standard	32EF0	1:1	0.306	1.148	0.351	
836.52	384	Cell. CDMA	RC3 / SO55	25.0	24.40	0.02	Left	Cheek	Standard	32EF0	1:1	0.398	1.148	0.457	
836.52	384	Cell. CDMA	RC3 / SO55	25.0	24.40	-0.02	Left	Tilt	Standard	32EF0	1:1	0.265	1.148	0.304	
836.52	384	Cell. CDMA	EVDO Rev. A	25.0	24.40	-0.04	Right	Cheek	Standard	32EF0	1:1	0.532	1.148	0.611	
836.52	384	Cell. CDMA	EVDO Rev. A	25.0	24.40	-0.06	Right	Cheek	Wireless Charging	32EF0	1:1	0.512	1.148	0.588	
836.52	384	Cell. CDMA	EVDO Rev. A	25.0	24.40	-0.02	Right	Tilt	Standard	32EF0	1:1	0.285	1.148	0.327	
836.52	384	Cell. CDMA	EVDO Rev. A	25.0	24.40	0.01	Left	Cheek	Standard	32EF0	1:1	0.430	1.148	0.494	
836.52	384	Cell. CDMA	EVDO Rev. A	25.0	24.40	-0.01	Left	Tilt	Standard	32EF0	1:1	0.290	1.148	0.333	
ANSI / IEEE C95.1 1992 - SAFETY LIMIT Spatial Peak Uncontrolled Exposure/General Population									Head 1.6 W/kg (mW/g) averaged over 1 gram						

**Table 11-2  
PCS CDMA/EVDO Head SAR**

MEASUREMENT RESULTS															
FREQUENCY		Mode/Band	Service	Maximum Allowed Power [dBm]	Conducted Power [dBm]	Power Drift [dB]	Side	Test Position	Cover Type	Device Serial Number	Duty Cycle	SAR (1g)	Scaling Factor	Scaled SAR (1g)	Plot #
MHz	Ch.											(W/kg)		(W/kg)	
1880.00	600	PCS CDMA	RC3 / SO55	25.0	24.49	0.01	Right	Cheek	Standard	32EC6	1:1	0.439	1.125	0.494	
1880.00	600	PCS CDMA	RC3 / SO55	25.0	24.49	-0.05	Right	Cheek	Wireless Charging	32EC6	1:1	0.500	1.125	0.563	
1880.00	600	PCS CDMA	RC3 / SO55	25.0	24.49	-0.04	Right	Tilt	Standard	32EC6	1:1	0.232	1.125	0.261	
1880.00	600	PCS CDMA	RC3 / SO55	25.0	24.49	-0.07	Left	Cheek	Standard	32EC6	1:1	0.254	1.125	0.286	
1880.00	600	PCS CDMA	RC3 / SO55	25.0	24.49	-0.01	Left	Tilt	Standard	32EC6	1:1	0.179	1.125	0.201	
1880.00	600	PCS CDMA	RC3 / SO55	23.0	22.29	-0.02	Right	Cheek	Standard	3R725	1:1	0.294	1.178	0.346	
1880.00	600	PCS CDMA	RC3 / SO55	23.0	22.29	0.13	Right	Tilt	Standard	3R725	1:1	0.111	1.178	0.131	
1880.00	600	PCS CDMA	RC3 / SO55	23.0	22.29	0.12	Left	Cheek	Standard	3R725	1:1	0.228	1.178	0.269	
1880.00	600	PCS CDMA	RC3 / SO55	23.0	22.29	0.16	Left	Tilt	Standard	3R725	1:1	0.082	1.178	0.097	
1880.00	600	PCS CDMA	EVDO Rev. A	25.0	24.46	-0.04	Right	Cheek	Standard	32EC6	1:1	0.465	1.132	0.526	
1880.00	600	PCS CDMA	EVDO Rev. A	25.0	24.46	0.03	Right	Cheek	Wireless Charging	32EC6	1:1	0.543	1.132	0.615	A2
1880.00	600	PCS CDMA	EVDO Rev. A	25.0	24.46	0.03	Right	Tilt	Standard	32EC6	1:1	0.227	1.132	0.257	
1880.00	600	PCS CDMA	EVDO Rev. A	25.0	24.46	-0.02	Left	Cheek	Standard	32EC6	1:1	0.263	1.132	0.298	
1880.00	600	PCS CDMA	EVDO Rev. A	25.0	24.46	0.13	Left	Tilt	Standard	32EC6	1:1	0.188	1.132	0.213	
1880.00	600	PCS CDMA	EVDO Rev. A	23.0	22.28	0.00	Right	Cheek	Standard	3R725	1:1	0.298	1.180	0.352	
1880.00	600	PCS CDMA	EVDO Rev. A	23.0	22.28	0.03	Right	Tilt	Standard	3R725	1:1	0.117	1.180	0.138	
1880.00	600	PCS CDMA	EVDO Rev. A	23.0	22.28	0.00	Left	Cheek	Standard	3R725	1:1	0.230	1.180	0.271	
1880.00	600	PCS CDMA	EVDO Rev. A	23.0	22.28	-0.05	Left	Tilt	Standard	3R725	1:1	0.094	1.180	0.111	
ANSI / IEEE C95.1 1992 - SAFETY LIMIT Spatial Peak Uncontrolled Exposure/General Population									Head 1.6 W/kg (mW/g) averaged over 1 gram						

FCC ID: A3LSMG900R7		SAR EVALUATION REPORT		Reviewed by: Quality Manager
Document S/N: OY1403190578.A3L	Test Dates: 02/03/14 - 03/31/14	DUT Type: Portable Handset	Page 42 of 79	

**Table 11-3  
LTE Band 12 Head SAR**



MEASUREMENT RESULTS																				
FREQUENCY		Mode	Bandwidth [MHz]	Cover Type	Maximum Allowed Power [dBm]	Conducted Power [dBm]	Power Drift [dB]	MPR [dB]	Side	Test Position	Modulation	RB Size	RB Offset	Device Serial Number	Duty Cycle	SAR (1g) (W/kg)	Scaling Factor	Scaled SAR (1g) (W/kg)	Plot #	
Mhz	Ch.																			
707.50	23095	Mid	LTE Band 12	10	Standard	23.5	23.08	-0.02	0	Right	Cheek	QPSK	1	0	32EC6	1:1	0.238	1.102	0.262	
707.50	23095	Mid	LTE Band 12	10	Standard	22.5	22.02	0.03	1	Right	Cheek	QPSK	25	0	32EC6	1:1	0.167	1.117	0.187	
707.50	23095	Mid	LTE Band 12	10	Standard	23.5	23.08	0.14	0	Right	Tilt	QPSK	1	0	32EC6	1:1	0.167	1.102	0.184	
707.50	23095	Mid	LTE Band 12	10	Standard	22.5	22.02	-0.17	1	Right	Tilt	QPSK	25	0	32EC6	1:1	0.116	1.117	0.130	
707.50	23095	Mid	LTE Band 12	10	Standard	23.5	23.08	0.06	0	Left	Cheek	QPSK	1	0	32EC6	1:1	0.305	1.102	0.336	A3
707.50	23095	Mid	LTE Band 12	10	Wireless Charging	23.5	23.08	0.17	0	Left	Cheek	QPSK	1	0	32EC6	1:1	0.227	1.102	0.250	
707.50	23095	Mid	LTE Band 12	10	Standard	22.5	22.02	0.06	1	Left	Cheek	QPSK	25	0	32EC6	1:1	0.245	1.117	0.274	
707.50	23095	Mid	LTE Band 12	10	Standard	23.5	23.08	0.08	0	Left	Tilt	QPSK	1	0	32EC6	1:1	0.163	1.102	0.180	
707.50	23095	Mid	LTE Band 12	10	Standard	22.5	22.02	0.02	1	Left	Tilt	QPSK	25	0	32EC6	1:1	0.135	1.117	0.151	
ANSI / IEEE C95.1 1992 - SAFETY LIMIT Spatial Peak Uncontrolled Exposure/General Population										Head 1.6 W/kg (mW/g) averaged over 1 gram										

**Table 11-4  
LTE Band 4 (AWS) Head SAR**

MEASUREMENT RESULTS																				
FREQUENCY		Mode	Bandwidth [MHz]	Cover Type	Maximum Allowed Power [dBm]	Conducted Power [dBm]	Power Drift [dB]	MPR [dB]	Side	Test Position	Modulation	RB Size	RB Offset	Device Serial Number	Duty Cycle	SAR (1g) (W/kg)	Scaling Factor	Scaled SAR (1g) (W/kg)	Plot #	
Mhz	Ch.																			
1715.00	20000	Low	LTE Band 4 (AWS)	10	Standard	23.5	23.50	0.00	0	Right	Cheek	QPSK	1	0	32EC6	1:1	0.132	1.000	0.132	
1715.00	20000	Low	LTE Band 4 (AWS)	10	Standard	22.5	22.43	0.13	1	Right	Cheek	QPSK	25	12	32EC6	1:1	0.147	1.016	0.149	
1715.00	20000	Low	LTE Band 4 (AWS)	10	Standard	23.5	23.50	0.19	0	Right	Tilt	QPSK	1	0	32EC6	1:1	0.138	1.000	0.138	
1715.00	20000	Low	LTE Band 4 (AWS)	10	Standard	22.5	22.43	-0.03	1	Right	Tilt	QPSK	25	12	32EC6	1:1	0.141	1.016	0.143	
1715.00	20000	Low	LTE Band 4 (AWS)	10	Standard	23.5	23.50	-0.04	0	Left	Cheek	QPSK	1	0	32EC6	1:1	0.382	1.000	0.382	A4
1715.00	20000	Low	LTE Band 4 (AWS)	10	Wireless Charging	23.5	23.50	-0.07	0	Left	Cheek	QPSK	1	0	32EC6	1:1	0.294	1.000	0.294	
1715.00	20000	Low	LTE Band 4 (AWS)	10	Standard	22.5	22.43	-0.01	1	Left	Cheek	QPSK	25	12	32EC6	1:1	0.288	1.016	0.293	
1715.00	20000	Low	LTE Band 4 (AWS)	10	Standard	23.5	23.50	-0.01	0	Left	Tilt	QPSK	1	0	32EC6	1:1	0.128	1.000	0.128	
1715.00	20000	Low	LTE Band 4 (AWS)	10	Standard	22.5	22.43	-0.10	1	Left	Tilt	QPSK	25	12	32EC6	1:1	0.122	1.016	0.124	
ANSI / IEEE C95.1 1992 - SAFETY LIMIT Spatial Peak Uncontrolled Exposure/General Population										Head 1.6 W/kg (mW/g) averaged over 1 gram										



**Table 11-5  
LTE Band 25 (PCS) Head SAR**

MEASUREMENT RESULTS																				
FREQUENCY		Mode	Bandwidth [MHz]	Cover Type	Maximum Allowed Power [dBm]	Conducted Power [dBm]	Power Drift [dB]	MPR [dB]	Side	Test Position	Modulation	RB Size	RB Offset	Device Serial Number	Duty Cycle	SAR (1g) (W/kg)	Scaling Factor	Scaled SAR (1g) (W/kg)	Plot #	
Mhz	Ch.																			
1910.00	26640	High	LTE Band 25 (PCS)	10	Standard	23.5	23.35	-0.02	0	Right	Cheek	QPSK	1	0	32EC6	1:1	0.337	1.035	0.349	
1910.00	26640	High	LTE Band 25 (PCS)	10	Standard	22.5	22.21	0.01	1	Right	Cheek	QPSK	25	0	32EC6	1:1	0.265	1.069	0.283	
1910.00	26640	High	LTE Band 25 (PCS)	10	Standard	23.5	23.35	0.01	0	Right	Tilt	QPSK	1	0	32EC6	1:1	0.260	1.035	0.269	
1910.00	26640	High	LTE Band 25 (PCS)	10	Standard	22.5	22.21	0.00	1	Right	Tilt	QPSK	25	0	32EC6	1:1	0.201	1.069	0.215	
1910.00	26640	High	LTE Band 25 (PCS)	10	Standard	23.5	23.35	0.04	0	Left	Cheek	QPSK	1	0	32EC6	1:1	0.613	1.035	0.634	A5
1910.00	26640	High	LTE Band 25 (PCS)	10	Wireless Charging	23.5	23.35	0.03	0	Left	Cheek	QPSK	1	0	32EC6	1:1	0.605	1.035	0.626	
1910.00	26640	High	LTE Band 25 (PCS)	10	Standard	22.5	22.21	0.02	1	Left	Cheek	QPSK	25	0	32EC6	1:1	0.469	1.069	0.501	
1910.00	26640	High	LTE Band 25 (PCS)	10	Standard	23.5	23.35	0.05	0	Left	Tilt	QPSK	1	0	32EC6	1:1	0.220	1.035	0.228	
1910.00	26640	High	LTE Band 25 (PCS)	10	Standard	22.5	22.21	0.07	1	Left	Tilt	QPSK	25	0	32EC6	1:1	0.159	1.069	0.170	
ANSI / IEEE C95.1 1992 - SAFETY LIMIT Spatial Peak Uncontrolled Exposure/General Population										Head 1.6 W/kg (mW/g) averaged over 1 gram										

FCC ID: A3LSMG900R7		SAR EVALUATION REPORT		Reviewed by: Quality Manager
Document S/N: OY1403190578.A3L	Test Dates: 02/03/14 - 03/31/14	DUT Type: Portable Handset	Page 43 of 79	



**Table 11-6  
DTS Head SAR**

MEASUREMENT RESULTS																	
FREQUENCY		Mode	Service	Maximum Allowed Power [dBm]	Conducted Power [dBm]	Power Drift [dB]	Side	Test Position	Antenna	Cover Type	Device Serial Number	Data Rate (Mbps)	Duty Cycle	SAR (1g)	Scaling Factor	Scaled SAR (1g)	Plot #
MHz	Ch.													(W/kg)		(W/kg)	
2412	1	IEEE 802.11b	DSSS	12.5	11.94	0.20	Right	Cheek	1	Standard	328C6	1	1:1	0.163	1.138	0.185	A6
2412	1	IEEE 802.11b	DSSS	12.5	11.94	0.02	Right	Cheek	1	Wireless Charging	328C6	1	1:1	0.156	1.138	0.178	
2412	1	IEEE 802.11b	DSSS	12.5	11.94	-0.04	Right	Tilt	1	Standard	328C6	1	1:1	0.158	1.138	0.180	
2412	1	IEEE 802.11b	DSSS	12.5	11.94	0.02	Left	Cheek	1	Standard	328C6	1	1:1	0.129	1.138	0.147	
2412	1	IEEE 802.11b	DSSS	12.5	11.94	0.03	Left	Tilt	1	Standard	328C6	1	1:1	0.128	1.138	0.146	
2412	1	IEEE 802.11b	DSSS	12.5	11.74	0.10	Right	Cheek	2	Standard	328C6	1	1:1	0.033	1.191	0.039	
2412	1	IEEE 802.11b	DSSS	12.5	11.74	0.12	Right	Tilt	2	Standard	328C6	1	1:1	0.007	1.191	0.008	
2412	1	IEEE 802.11b	DSSS	12.5	11.74	0.06	Left	Cheek	2	Standard	328C6	1	1:1	0.009	1.191	0.011	
2412	1	IEEE 802.11b	DSSS	12.5	11.74	0.20	Left	Tilt	2	Standard	328C6	1	1:1	0.004	1.191	0.005	
2412	1	IEEE 802.11n	OFDM	12.5	11.85	-0.08	Right	Cheek	MIMO	Standard	328C6	13	1:1	0.089	1.161	0.103	
2412	1	IEEE 802.11n	OFDM	12.5	11.85	-0.10	Right	Tilt	MIMO	Standard	328C6	13	1:1	0.078	1.161	0.091	
2412	1	IEEE 802.11n	OFDM	12.5	11.85	0.03	Left	Cheek	MIMO	Standard	328C6	13	1:1	0.104	1.161	0.121	
2412	1	IEEE 802.11n	OFDM	12.5	11.85	0.03	Left	Tilt	MIMO	Standard	328C6	13	1:1	0.107	1.161	0.124	
2412	1	IEEE 802.11n	OFDM	12.5	11.85	-0.02	Left	Tilt	MIMO	Wireless Charging	328C6	13	1:1	0.098	1.161	0.114	
5785	157	IEEE 802.11a	OFDM	7.5	6.87	0.06	Right	Cheek	1	Standard	31F35	6	1:1	0.014	1.156	0.016	
5785	157	IEEE 802.11a	OFDM	7.5	6.87	0.10	Right	Tilt	1	Standard	31F35	6	1:1	0.022	1.156	0.025	
5775	155	IEEE 802.11ac	OFDM	7.5	6.38	0.04	Right	Tilt	1	Standard	31F35	29.3	1:1	0.013	1.294	0.017	
5785	157	IEEE 802.11a	OFDM	7.5	6.87	0.16	Left	Cheek	1	Standard	31F35	6	1:1	0.011	1.156	0.013	
5785	157	IEEE 802.11a	OFDM	7.5	6.87	0.04	Left	Tilt	1	Standard	31F35	6	1:1	0.014	1.156	0.016	
5765	153	IEEE 802.11a	OFDM	7.5	6.58	0.06	Right	Cheek	2	Standard	31F35	6	1:1	0.134	1.236	0.166	A7
5775	155	IEEE 802.11ac	OFDM	7.5	6.25	0.06	Right	Cheek	2	Standard	31F35	29.3	1:1	0.112	1.334	0.149	
5765	153	IEEE 802.11a	OFDM	7.5	6.58	0.06	Right	Tilt	2	Standard	31F35	6	1:1	0.060	1.236	0.074	
5765	153	IEEE 802.11a	OFDM	7.5	6.58	0.04	Left	Cheek	2	Standard	31F35	6	1:1	0.037	1.236	0.046	
5765	153	IEEE 802.11a	OFDM	7.5	6.58	-0.07	Left	Tilt	2	Standard	31F35	6	1:1	0.034	1.236	0.042	
5765	153	IEEE 802.11n	OFDM	7.5	6.57	-0.05	Right	Cheek	MIMO	Standard	31F35	13	1:1	0.019	1.239	0.024	
5765	153	IEEE 802.11n	OFDM	7.5	6.57	0.03	Right	Tilt	MIMO	Standard	31F35	13	1:1	0.014	1.239	0.017	
5765	153	IEEE 802.11n	OFDM	7.5	6.57	0.07	Left	Cheek	MIMO	Standard	31F35	13	1:1	0.016	1.239	0.020	
5765	153	IEEE 802.11n	OFDM	7.5	6.57	0.05	Left	Tilt	MIMO	Standard	31F35	13	1:1	0.011	1.239	0.014	
ANSI / IEEE C95.1 1992 - SAFETY LIMIT Spatial Peak Uncontrolled Exposure/General Population							Head 1.6 W/kg (mW/g) averaged over 1 gram										

FCC ID: A3LSMG900R7		<b>SAR EVALUATION REPORT</b>		Reviewed by: Quality Manager
Document S/N: OY1403190578.A3L	Test Dates: 02/03/14 - 03/31/14	DUT Type: Portable Handset	Page 44 of 79	

**Table 11-7  
NII Head SAR**

MEASUREMENT RESULTS																	
FREQUENCY		Mode	Service	Maximum Allowed Power [dBm]	Conducted Power [dBm]	Power Drift [dB]	Side	Test Position	Antenna	Cover Type	Device Serial Number	Data Rate (Mbps)	Duty Cycle	SAR (1g) (W/kg)	Scaling Factor	Scaled SAR (1g) (W/kg)	Plot #
MHz	Ch.																
5180	36	IEEE 802.11a	OFDM	7.5	6.74	0.08	Right	Cheek	1	Standard	31F35	6	1:1	0.053	1.191	0.063	
5210	42	IEEE 802.11ac	OFDM	7.5	6.56	0.02	Right	Cheek	1	Standard	31F35	29.3	1:1	0.039	1.242	0.048	
5180	36	IEEE 802.11a	OFDM	7.5	6.74	0.12	Right	Tilt	1	Standard	31F35	6	1:1	0.052	1.191	0.062	
5180	36	IEEE 802.11a	OFDM	7.5	6.74	-0.10	Left	Cheek	1	Standard	31F35	6	1:1	0.035	1.191	0.042	
5180	36	IEEE 802.11a	OFDM	7.5	6.74	-0.10	Left	Tilt	1	Standard	31F35	6	1:1	0.038	1.191	0.045	
5220	44	IEEE 802.11a	OFDM	7.5	6.86	0.07	Right	Cheek	2	Standard	31F35	6	1:1	0.022	1.159	0.025	
5210	42	IEEE 802.11ac	OFDM	7.5	6.63	0.04	Right	Cheek	2	Standard	31F35	29.3	1:1	0.021	1.222	0.026	
5220	44	IEEE 802.11a	OFDM	7.5	6.86	0.09	Right	Tilt	2	Standard	31F35	6	1:1	0.011	1.159	0.013	
5220	44	IEEE 802.11a	OFDM	7.5	6.86	0.00	Left	Cheek	2	Standard	31F35	6	1:1	0.000	1.159	0.000	
5220	44	IEEE 802.11a	OFDM	7.5	6.86	0.00	Left	Tilt	2	Standard	31F35	6	1:1	0.000	1.159	0.000	
5240	48	IEEE 802.11n	OFDM	7.5	6.06	0.08	Right	Cheek	MIMO	Standard	31F35	13	1:1	0.032	1.393	0.045	
5240	48	IEEE 802.11n	OFDM	7.5	6.06	0.07	Right	Cheek	MIMO	Wireless Charging	31F35	13	1:1	0.044	1.393	0.061	
5240	48	IEEE 802.11n	OFDM	7.5	6.06	0.11	Right	Tilt	MIMO	Standard	31F35	13	1:1	0.012	1.393	0.017	
5240	48	IEEE 802.11n	OFDM	7.5	6.06	0.21	Left	Cheek	MIMO	Standard	31F35	13	1:1	0.009	1.393	0.013	
5240	48	IEEE 802.11n	OFDM	7.5	6.06	0.06	Left	Tilt	MIMO	Standard	31F35	13	1:1	0.009	1.393	0.013	
5260	52	IEEE 802.11a	OFDM	7.5	6.69	0.08	Right	Cheek	1	Standard	31F35	6	1:1	0.047	1.205	0.057	
5260	52	IEEE 802.11a	OFDM	7.5	6.69	0.12	Right	Tilt	1	Standard	31F35	6	1:1	0.052	1.205	0.063	
5290	58	IEEE 802.11ac	OFDM	7.5	6.48	0.07	Right	Tilt	1	Standard	31F35	29.3	1:1	0.035	1.265	0.044	
5260	52	IEEE 802.11a	OFDM	7.5	6.69	0.06	Left	Cheek	1	Standard	31F35	6	1:1	0.032	1.205	0.039	
5260	52	IEEE 802.11a	OFDM	7.5	6.69	0.06	Left	Tilt	1	Standard	31F35	6	1:1	0.041	1.205	0.049	
5260	52	IEEE 802.11a	OFDM	7.5	6.95	0.07	Right	Cheek	2	Standard	31F35	6	1:1	0.047	1.135	0.053	
5290	58	IEEE 802.11ac	OFDM	7.5	6.55	0.11	Right	Cheek	2	Standard	31F35	29.3	1:1	0.036	1.245	0.045	
5260	52	IEEE 802.11a	OFDM	7.5	6.95	-0.07	Right	Tilt	2	Standard	31F35	6	1:1	0.013	1.135	0.015	
5260	52	IEEE 802.11a	OFDM	7.5	6.95	0.08	Left	Cheek	2	Standard	31F35	6	1:1	0.007	1.135	0.008	
5260	52	IEEE 802.11a	OFDM	7.5	6.95	-0.12	Left	Tilt	2	Standard	31F35	6	1:1	0.006	1.135	0.007	
5300	60	IEEE 802.11n	OFDM	7.5	5.67	0.00	Right	Cheek	MIMO	Standard	31F35	13	1:1	0.009	1.524	0.014	
5300	60	IEEE 802.11n	OFDM	7.5	5.67	0.15	Right	Tilt	MIMO	Standard	31F35	13	1:1	0.010	1.524	0.015	
5300	60	IEEE 802.11n	OFDM	7.5	5.67	0.08	Left	Cheek	MIMO	Standard	31F35	13	1:1	0.009	1.524	0.014	
5300	60	IEEE 802.11n	OFDM	7.5	5.67	0.03	Left	Tilt	MIMO	Standard	31F35	13	1:1	0.009	1.524	0.014	
5580	116	IEEE 802.11a	OFDM	7.5	6.83	0.08	Right	Cheek	1	Standard	31F35	6	1:1	0.022	1.167	0.026	
5580	116	IEEE 802.11a	OFDM	7.5	6.83	0.09	Right	Tilt	1	Standard	31F35	6	1:1	0.029	1.167	0.034	
5530	106	IEEE 802.11ac	OFDM	7.5	6.51	0.05	Right	Tilt	1	Standard	31F35	29.3	1:1	0.044	1.256	0.055	
5580	116	IEEE 802.11a	OFDM	7.5	6.83	0.02	Left	Cheek	1	Standard	31F35	6	1:1	0.016	1.167	0.019	
5580	116	IEEE 802.11a	OFDM	7.5	6.83	0.16	Left	Tilt	1	Standard	31F35	6	1:1	0.019	1.167	0.022	
5680	136	IEEE 802.11a	OFDM	7.5	6.01	0.02	Right	Cheek	2	Standard	31F35	6	1:1	0.154	1.409	0.217	A8
5680	136	IEEE 802.11a	OFDM	7.5	6.01	0.02	Right	Cheek	2	Wireless Charging	31F35	6	1:1	0.133	1.409	0.187	
5530	106	IEEE 802.11ac	OFDM	7.5	5.57	0.02	Right	Cheek	2	Standard	31F35	29.3	1:1	0.045	1.560	0.070	
5680	136	IEEE 802.11a	OFDM	7.5	6.01	0.06	Right	Tilt	2	Standard	31F35	6	1:1	0.057	1.409	0.080	
5680	136	IEEE 802.11a	OFDM	7.5	6.01	0.14	Left	Cheek	2	Standard	31F35	6	1:1	0.032	1.409	0.045	
5680	136	IEEE 802.11a	OFDM	7.5	6.01	-0.08	Left	Tilt	2	Standard	31F35	6	1:1	0.031	1.409	0.044	
5500	100	IEEE 802.11n	OFDM	7.5	7.38	0.18	Right	Cheek	MIMO	Standard	31F35	13	1:1	0.010	1.028	0.010	
5500	100	IEEE 802.11n	OFDM	7.5	7.38	0.07	Right	Tilt	MIMO	Standard	31F35	13	1:1	0.014	1.028	0.014	
5500	100	IEEE 802.11n	OFDM	7.5	7.38	-0.20	Left	Cheek	MIMO	Standard	31F35	13	1:1	0.012	1.028	0.012	
5500	100	IEEE 802.11n	OFDM	7.5	7.38	0.19	Left	Tilt	MIMO	Standard	31F35	13	1:1	0.011	1.028	0.011	
ANSI / IEEE C95.1 1992 - SAFETY LIMIT Spatial Peak Uncontrolled Exposure/General Population								Head 1.6 W/kg (mW/g) averaged over 1 gram									

FCC ID: A3LSMG900R7		SAR EVALUATION REPORT		Reviewed by: Quality Manager
Document S/N: OY1403190578.A3L	Test Dates: 02/03/14 - 03/31/14	DUT Type: Portable Handset	Page 45 of 79	

## 11.2 Standalone Body-Worn SAR Data

**Table 11-8  
CDMA Body-Worn SAR Data**



MEASUREMENT RESULTS															
FREQUENCY		Mode	Service	Maximum Allowed Power [dBm]	Conducted Power [dBm]	Power Drift [dB]	Spacing	Cover Type	Device Serial Number	Duty Cycle	Side	SAR (1g)	Scaling Factor	Scaled SAR (1g)	Plot #
MHz	Ch.											(W/kg)		(W/kg)	
836.52	384	Cell. CDMA	TDSO / SO32	25.0	24.37	-0.04	10 mm	Standard	32EF0	1:1	back	0.670	1.156	0.775	A9
836.52	384	Cell. CDMA	TDSO / SO32	25.0	24.37	0.01	10 mm	Wireless Charging	32EF0	1:1	back	0.560	1.156	0.647	
1880.00	600	PCS CDMA	TDSO / SO32	25.0	24.46	-0.02	15 mm	Standard	32EF0	1:1	back	0.465	1.132	0.526	A11
1880.00	600	PCS CDMA	TDSO / SO32	25.0	24.46	-0.04	15 mm	Wireless Charging	32EF0	1:1	back	0.393	1.132	0.445	
ANSI / IEEE C95.1 1992 - SAFETY LIMIT Spatial Peak Uncontrolled Exposure/General Population							Body 1.6 W/kg (mW/g) averaged over 1 gram								

**Table 11-9  
LTE Body-Worn SAR**

MEASUREMENT RESULTS																				
FREQUENCY		Mode	Bandwidth [MHz]	Cover Type	Maximum Allowed Power [dBm]	Conducted Power [dBm]	Power Drift [dB]	MPR [dB]	Device Serial Number	Modulation	RB Size	RB Offset	Spacing	Side	Duty Cycle	SAR (1g)	Scaling Factor	Scaled SAR (1g)	Plot #	
MHz	Ch.															(W/kg)		(W/kg)		
707.50	23095	Mid	LTE Band 12	10	Standard	23.5	23.08	0.01	0	32EF0	QPSK	1	0	10 mm	back	1:1	0.369	1.102	0.407	A13
707.50	23095	Mid	LTE Band 12	10	Wireless Charging	23.5	23.08	0.01	0	32EF0	QPSK	1	0	10 mm	back	1:1	0.243	1.102	0.268	
707.50	23095	Mid	LTE Band 12	10	Standard	22.5	22.02	0.03	1	32EF0	QPSK	25	0	10 mm	back	1:1	0.271	1.117	0.303	
1715.00	20000	Low	LTE Band 4 (AWS)	10	Standard	23.5	23.50	0.00	0	32EC6	QPSK	1	0	10 mm	back	1:1	0.509	1.000	0.509	A15
1715.00	20000	Low	LTE Band 4 (AWS)	10	Wireless Charging	23.5	23.50	0.05	0	32EC6	QPSK	1	0	10 mm	back	1:1	0.252	1.000	0.252	
1715.00	20000	Low	LTE Band 4 (AWS)	10	Standard	22.5	22.43	-0.09	1	32EC6	QPSK	25	12	10 mm	back	1:1	0.321	1.016	0.326	
1910.00	26640	High	LTE Band 25 (PCS)	10	Standard	23.5	23.35	-0.02	0	32E32	QPSK	1	0	10 mm	back	1:1	0.182	1.035	0.188	
1910.00	26640	High	LTE Band 25 (PCS)	10	Wireless Charging	23.5	23.35	0.01	0	32E32	QPSK	1	0	10 mm	back	1:1	0.209	1.035	0.216	A17
1910.00	26640	High	LTE Band 25 (PCS)	10	Standard	22.5	22.21	0.09	1	32E32	QPSK	25	0	10 mm	back	1:1	0.176	1.069	0.188	
ANSI / IEEE C95.1 1992 - SAFETY LIMIT Spatial Peak Uncontrolled Exposure/General Population							Body 1.6 W/kg (mW/g) averaged over 1 gram													

**Table 11-10  
DTS Body-Worn SAR**

MEASUREMENT RESULTS																	
FREQUENCY		Mode	Service	Maximum Allowed Power [dBm]	Conducted Power [dBm]	Power Drift [dB]	Spacing	Antenna	Cover Type	Device Serial Number	Data Rate (Mbps)	Side	Duty Cycle	SAR (1g)	Scaling Factor	Scaled SAR (1g)	Plot #
MHz	Ch.													(W/kg)		(W/kg)	
2437	6	IEEE 802.11b	DSSS	17.5	17.05	-0.08	10 mm	1	Standard	00F05	1	back	1:1	0.235	1.109	0.261	A19
2437	6	IEEE 802.11b	DSSS	17.5	17.05	0.16	10 mm	1	Wireless Charging	00F05	1	back	1:1	0.103	1.109	0.114	
2412	1	IEEE 802.11b	DSSS	17.5	17.07	0.04	10 mm	2	Standard	00F05	1	back	1:1	0.087	1.104	0.096	
2412	1	IEEE 802.11n	OFDM	14.0	13.87	0.11	10 mm	MIMO	Standard	00F05	13	back	1:1	0.066	1.030	0.068	
2412	1	IEEE 802.11n	OFDM	14.0	13.87	0.10	10 mm	MIMO	Wireless Charging	00F05	13	back	1:1	0.053	1.030	0.055	
5745	149	IEEE 802.11a	OFDM	14.0	13.31	0.06	10 mm	1	Standard	32712	6	back	1:1	0.138	1.172	0.162	
5775	155	IEEE 802.11ac	OFDM	11.5	11.25	0.09	10 mm	1	Standard	32712	29.3	back	1:1	0.041	1.059	0.043	
5765	153	IEEE 802.11a	OFDM	14.0	13.44	0.10	10 mm	2	Standard	15ECE	6	back	1:1	0.287	1.138	0.327	A20
5775	155	IEEE 802.11ac	OFDM	11.5	11.26	0.03	10 mm	2	Standard	15ECE	29.3	back	1:1	0.128	1.057	0.135	
5765	153	IEEE 802.11n	OFDM	13.5	13.47	0.16	10 mm	MIMO	Standard	15ECE	13	back	1:1	0.220	1.007	0.222	
5765	153	IEEE 802.11n	OFDM	13.5	13.47	0.00	10 mm	MIMO	Wireless Charging	15ECE	13	back	1:1	0.121	1.007	0.122	
ANSI / IEEE C95.1 1992 - SAFETY LIMIT Spatial Peak Uncontrolled Exposure/General Population							Body 1.6 W/kg (mW/g) averaged over 1 gram										

FCC ID: A3LSMG900R7		<b>SAR EVALUATION REPORT</b>		Reviewed by: Quality Manager
Document S/N: OY1403190578.A3L	Test Dates: 02/03/14 - 03/31/14	DUT Type: Portable Handset	Page 46 of 79	



**Table 11-11  
NII Body-Worn SAR**

MEASUREMENT RESULTS																	
FREQUENCY		Mode	Service	Maximum Allowed Power [dBm]	Conducted Power [dBm]	Power Drift [dB]	Spacing	Antenna	Cover Type	Device Serial Number	Data Rate (Mbps)	Side	Duty Cycle	SAR (1g) (W/kg)	Scaling Factor	Scaled SAR (1g) (W/kg)	Plot #
MHz	Ch.																
5220	44	IEEE 802.11a	OFDM	14.0	13.12	0.06	10 mm	1	Standard	32712	6	back	1:1	0.196	1.225	0.240	
5210	42	IEEE 802.11ac	OFDM	11.5	10.71	0.09	10 mm	1	Standard	32712	29.3	back	1:1	0.079	1.199	0.095	
5180	36	IEEE 802.11a	OFDM	14.0	13.94	-0.12	10 mm	2	Standard	15ECE	6	back	1:1	0.104	1.014	0.105	
5210	42	IEEE 802.11ac	OFDM	11.5	10.78	0.18	10 mm	2	Standard	15ECE	29.3	back	1:1	0.056	1.180	0.066	
5180	36	IEEE 802.11n	OFDM	13.5	12.63	0.07	10 mm	MIMO	Standard	15ECE	13	back	1:1	0.065	1.222	0.079	
5280	56	IEEE 802.11a	OFDM	14.0	12.97	0.10	10 mm	1	Standard	32712	6	back	1:1	0.162	1.268	0.205	
5290	58	IEEE 802.11ac	OFDM	11.5	10.77	0.04	10 mm	1	Standard	32712	29.3	back	1:1	0.080	1.183	0.095	
5260	52	IEEE 802.11a	OFDM	14.0	13.21	-0.04	10 mm	2	Standard	15ECE	6	back	1:1	0.195	1.199	0.234	
5290	58	IEEE 802.11ac	OFDM	11.5	10.94	0.08	10 mm	2	Standard	15ECE	29.3	back	1:1	0.074	1.138	0.084	
5300	60	IEEE 802.11n	OFDM	13.5	12.77	0.09	10 mm	MIMO	Standard	15ECE	13	back	1:1	0.060	1.183	0.071	
5540	108	IEEE 802.11a	OFDM	14.0	13.41	0.05	10 mm	1	Standard	32712	6	back	1:1	0.235	1.146	0.269	
5530	106	IEEE 802.11ac	OFDM	11.5	11.15	0.03	10 mm	1	Standard	32712	29.3	back	1:1	0.119	1.084	0.129	
5500	100	IEEE 802.11a	OFDM	14.0	13.26	0.03	10 mm	2	Standard	15ECE	6	back	1:1	0.296	1.186	0.351	A21
5500	100	IEEE 802.11a	OFDM	14.0	13.26	0.03	10 mm	2	Wireless Charging	15ECE	6	back	1:1	0.167	1.186	0.198	
5530	106	IEEE 802.11ac	OFDM	11.5	10.98	-0.03	10 mm	2	Standard	15ECE	29.3	back	1:1	0.099	1.127	0.112	
5500	100	IEEE 802.11n	OFDM	13.5	12.30	0.06	10 mm	MIMO	Standard	15ECE	13	back	1:1	0.075	1.318	0.099	
ANSI / IEEE C95.1 1992 - SAFETY LIMIT Spatial Peak Uncontrolled Exposure/General Population							Body 1.6 W/kg (mW/g) averaged over 1 gram										

**11.3 Standalone Wireless Router SAR Data**

**Table 11-12  
CDMA/EVDO Hotspot SAR Data**

MEASUREMENT RESULTS																
FREQUENCY		Mode	Service	Maximum Allowed Power [dBm]	Conducted Power [dBm]	Power Drift [dB]	Spacing	Cover Type	Device Serial Number	Duty Cycle	Side	SAR (1g) (W/kg)	Scaling Factor	Scaled SAR (1g) (W/kg)	Plot #	
MHz	Ch.															
836.52	384	Cell. CDMA	TDSO / SO32	25.0	24.37	-0.04	10 mm	Standard	32EF0	1:1	back	0.670	1.156	0.775		
836.52	384	Cell. CDMA	TDSO / SO32	25.0	24.37	0.03	10 mm	Standard	32EF0	1:1	front	0.596	1.156	0.689		
836.52	384	Cell. CDMA	TDSO / SO32	25.0	24.37	0.04	10 mm	Standard	32EF0	1:1	bottom	0.442	1.156	0.511		
836.52	384	Cell. CDMA	TDSO / SO32	25.0	24.37	-0.02	10 mm	Standard	32EF0	1:1	right	0.673	1.156	0.778	A10	
836.52	384	Cell. CDMA	TDSO / SO32	25.0	24.37	0.05	10 mm	Wireless Charging	32EF0	1:1	right	0.664	1.156	0.768		
836.52	384	Cell. CDMA	EVDO Rev. 0	25.0	24.44	-0.02	10 mm	Standard	32EF0	1:1	back	0.673	1.138	0.766		
836.52	384	Cell. CDMA	EVDO Rev. 0	25.0	24.44	0.01	10 mm	Wireless Charging	32EF0	1:1	back	0.560	1.138	0.637		
836.52	384	Cell. CDMA	EVDO Rev. 0	25.0	24.44	-0.01	10 mm	Standard	32EF0	1:1	front	0.600	1.138	0.683		
836.52	384	Cell. CDMA	EVDO Rev. 0	25.0	24.44	-0.04	10 mm	Standard	32EF0	1:1	bottom	0.457	1.138	0.520		
836.52	384	Cell. CDMA	EVDO Rev. 0	25.0	24.44	0.00	10 mm	Standard	32EF0	1:1	right	0.672	1.138	0.765		
1880.00	600	PCS CDMA	TDSO / SO32	23.0	22.32	-0.02	10 mm	Standard	3R725	1:1	back	0.482	1.169	0.563		
1880.00	600	PCS CDMA	TDSO / SO32	23.0	22.32	-0.04	10 mm	Wireless Charging	3R725	1:1	back	0.380	1.169	0.444		
1880.00	600	PCS CDMA	TDSO / SO32	23.0	22.32	-0.01	10 mm	Standard	3R725	1:1	front	0.386	1.169	0.451		
1880.00	600	PCS CDMA	TDSO / SO32	23.0	22.32	-0.01	10 mm	Standard	3R725	1:1	bottom	0.370	1.169	0.433		
1880.00	600	PCS CDMA	TDSO / SO32	23.0	22.32	0.06	10 mm	Standard	3R725	1:1	right	0.303	1.169	0.354		
1880.00	600	PCS CDMA	EVDO Rev. 0	23.0	22.31	0.05	10 mm	Standard	3R725	1:1	back	0.489	1.172	0.573	A12	
1880.00	600	PCS CDMA	EVDO Rev. 0	23.0	22.31	-0.06	10 mm	Wireless Charging	3R725	1:1	back	0.341	1.172	0.400		
1880.00	600	PCS CDMA	EVDO Rev. 0	23.0	22.31	0.01	10 mm	Standard	3R725	1:1	front	0.339	1.172	0.397		
1880.00	600	PCS CDMA	EVDO Rev. 0	23.0	22.31	0.02	10 mm	Standard	3R725	1:1	bottom	0.394	1.172	0.462		
1880.00	600	PCS CDMA	EVDO Rev. 0	23.0	22.31	-0.01	10 mm	Standard	3R725	1:1	right	0.317	1.172	0.372		
ANSI / IEEE C95.1 1992 - SAFETY LIMIT Spatial Peak Uncontrolled Exposure/General Population							Body 1.6 W/kg (mW/g) averaged over 1 gram									

FCC ID: A3LSMG900R7		SAR EVALUATION REPORT		Reviewed by: Quality Manager
Document S/N: OY1403190578.A3L	Test Dates: 02/03/14 - 03/31/14	DUT Type: Portable Handset	Page 47 of 79	

**Table 11-13  
LTE Band 12 Hotspot SAR**



MEASUREMENT RESULTS																				
FREQUENCY		Mode	Bandwidth [MHz]	Cover Type	Maximum Allowed Power [dBm]	Conducted Power [dBm]	Power Drift [dB]	MPR [dB]	Device Serial Number	Modulation	RB Size	RB Offset	Spacing	Side	Duty Cycle	SAR (1g) (W/kg)	Scaling Factor	Scaled SAR (1g) (W/kg)	Plot #	
MHz	Ch.																			
707.50	23095	Mid	LTE Band 12	10	Standard	23.5	23.08	0.01	0	32EF0	QPSK	1	0	10 mm	back	1:1	0.369	1.102	0.407	
707.50	23095	Mid	LTE Band 12	10	Standard	22.5	22.02	0.03	1	32EF0	QPSK	25	0	10 mm	back	1:1	0.271	1.117	0.303	
707.50	23095	Mid	LTE Band 12	10	Standard	23.5	23.08	0.01	0	32EF0	QPSK	1	0	10 mm	front	1:1	0.467	1.102	0.515	A14
707.50	23095	Mid	LTE Band 12	10	Wireless Charging	23.5	23.08	-0.01	0	32EF0	QPSK	1	0	10 mm	front	1:1	0.382	1.102	0.421	
707.50	23095	Mid	LTE Band 12	10	Standard	22.5	22.02	0.02	1	32EF0	QPSK	25	0	10 mm	front	1:1	0.347	1.117	0.388	
707.50	23095	Mid	LTE Band 12	10	Standard	23.5	23.08	-0.03	0	32EF0	QPSK	1	0	10 mm	bottom	1:1	0.313	1.102	0.345	
707.50	23095	Mid	LTE Band 12	10	Standard	22.5	22.02	-0.03	1	32EF0	QPSK	25	0	10 mm	bottom	1:1	0.233	1.117	0.260	
707.50	23095	Mid	LTE Band 12	10	Standard	23.5	23.08	0.00	0	32EF0	QPSK	1	0	10 mm	left	1:1	0.316	1.102	0.348	
707.50	23095	Mid	LTE Band 12	10	Standard	22.5	22.02	0.05	1	32EF0	QPSK	25	0	10 mm	left	1:1	0.239	1.117	0.267	
ANSI / IEEE C95.1 1992 - SAFETY LIMIT Spatial Peak Uncontrolled Exposure/General Population										Body 1.6 W/kg (mW/g) averaged over 1 gram										

**Table 11-14  
LTE Band 4 (AWS) Hotspot SAR**

MEASUREMENT RESULTS																				
FREQUENCY		Mode	Bandwidth [MHz]	Cover Type	Maximum Allowed Power [dBm]	Conducted Power [dBm]	Power Drift [dB]	MPR [dB]	Device Serial Number	Modulation	RB Size	RB Offset	Spacing	Side	Duty Cycle	SAR (1g) (W/kg)	Scaling Factor	Scaled SAR (1g) (W/kg)	Plot #	
MHz	Ch.																			
1715.00	20000	Low	LTE Band 4 (AWS)	10	Standard	23.5	23.50	0.00	0	32EC6	QPSK	1	0	10 mm	back	1:1	0.509	1.000	0.509	
1715.00	20000	Low	LTE Band 4 (AWS)	10	Standard	22.5	22.43	-0.09	1	32EC6	QPSK	25	12	10 mm	back	1:1	0.321	1.016	0.326	
1715.00	20000	Low	LTE Band 4 (AWS)	10	Standard	23.5	23.50	-0.01	0	32EC6	QPSK	1	0	10 mm	front	1:1	0.586	1.000	0.586	A16
1715.00	20000	Low	LTE Band 4 (AWS)	10	Wireless Charging	23.5	23.50	0.02	0	32EC6	QPSK	1	0	10 mm	front	1:1	0.338	1.000	0.338	
1715.00	20000	Low	LTE Band 4 (AWS)	10	Standard	22.5	22.43	0.02	1	32EC6	QPSK	25	12	10 mm	front	1:1	0.389	1.016	0.395	
1715.00	20000	Low	LTE Band 4 (AWS)	10	Standard	23.5	23.50	-0.04	0	32EC6	QPSK	1	0	10 mm	bottom	1:1	0.140	1.000	0.140	
1715.00	20000	Low	LTE Band 4 (AWS)	10	Standard	22.5	22.43	-0.03	1	32EC6	QPSK	25	12	10 mm	bottom	1:1	0.141	1.016	0.143	
1715.00	20000	Low	LTE Band 4 (AWS)	10	Standard	23.5	23.50	-0.05	0	32EC6	QPSK	1	0	10 mm	left	1:1	0.183	1.000	0.183	
1715.00	20000	Low	LTE Band 4 (AWS)	10	Standard	22.5	22.43	0.03	1	32EC6	QPSK	25	12	10 mm	left	1:1	0.148	1.016	0.150	
ANSI / IEEE C95.1 1992 - SAFETY LIMIT Spatial Peak Uncontrolled Exposure/General Population										Body 1.6 W/kg (mW/g) averaged over 1 gram										



**Table 11-15  
LTE Band 25 (PCS) Hotspot SAR**

MEASUREMENT RESULTS																				
FREQUENCY		Mode	Bandwidth [MHz]	Cover Type	Maximum Allowed Power [dBm]	Conducted Power [dBm]	Power Drift [dB]	MPR [dB]	Device Serial Number	Modulation	RB Size	RB Offset	Spacing	Side	Duty Cycle	SAR (1g) (W/kg)	Scaling Factor	Scaled SAR (1g) (W/kg)	Plot #	
MHz	Ch.																			
1910.00	26640	High	LTE Band 25 (PCS)	10	Standard	23.5	23.35	-0.02	0	32E32	QPSK	1	0	10 mm	back	1:1	0.182	1.035	0.188	
1910.00	26640	High	LTE Band 25 (PCS)	10	Standard	22.5	22.21	0.09	1	32E32	QPSK	25	0	10 mm	back	1:1	0.176	1.069	0.188	
1910.00	26640	High	LTE Band 25 (PCS)	10	Standard	23.5	23.35	-0.04	0	32E32	QPSK	1	0	10 mm	front	1:1	0.394	1.035	0.408	
1910.00	26640	High	LTE Band 25 (PCS)	10	Wireless Charging	23.5	23.35	0.00	0	32E32	QPSK	1	0	10 mm	front	1:1	0.547	1.035	0.566	A18
1910.00	26640	High	LTE Band 25 (PCS)	10	Standard	22.5	22.21	-0.02	1	32E32	QPSK	25	0	10 mm	front	1:1	0.359	1.069	0.384	
1910.00	26640	High	LTE Band 25 (PCS)	10	Standard	23.5	23.35	0.05	0	32E32	QPSK	1	0	10 mm	bottom	1:1	0.098	1.035	0.101	
1910.00	26640	High	LTE Band 25 (PCS)	10	Standard	22.5	22.21	0.11	1	32E32	QPSK	25	0	10 mm	bottom	1:1	0.079	1.069	0.084	
1910.00	26640	High	LTE Band 25 (PCS)	10	Standard	23.5	23.35	0.04	0	32E32	QPSK	1	0	10 mm	left	1:1	0.244	1.035	0.253	
1910.00	26640	High	LTE Band 25 (PCS)	10	Standard	22.5	22.21	-0.05	1	32E32	QPSK	25	0	10 mm	left	1:1	0.239	1.069	0.255	
ANSI / IEEE C95.1 1992 - SAFETY LIMIT Spatial Peak Uncontrolled Exposure/General Population										Body 1.6 W/kg (mW/g) averaged over 1 gram										

FCC ID: A3LSMG900R7		SAR EVALUATION REPORT		Reviewed by: Quality Manager
Document S/N: OY1403190578.A3L	Test Dates: 02/03/14 - 03/31/14	DUT Type: Portable Handset	Page 48 of 79	

**Table 11-16  
WLAN Hotspot SAR**

MEASUREMENT RESULTS																	
FREQUENCY		Mode	Service	Maximum Allowed Power [dBm]	Conducted Power [dBm]	Power Drift [dB]	Spacing	Antenna	Cover Type	Device Serial Number	Data Rate (Mbps)	Side	Duty Cycle	SAR (1g)	Scaling Factor	Scaled SAR (1g)	Plot #
MHz	Ch.													(W/kg)		(W/kg)	
2437	6	IEEE 802.11b	DSSS	17.5	17.05	-0.08	10 mm	1	Standard	00F05	1	back	1:1	0.235	1.109	0.261	A19
2437	6	IEEE 802.11b	DSSS	17.5	17.05	0.16	10 mm	1	Wireless Charging	00F05	1	back	1:1	0.103	1.109	0.114	
2437	6	IEEE 802.11b	DSSS	17.5	17.05	0.06	10 mm	1	Standard	00F05	1	front	1:1	0.193	1.109	0.214	
2437	6	IEEE 802.11b	DSSS	17.5	17.05	0.04	10 mm	1	Standard	00F05	1	top	1:1	0.114	1.109	0.126	
2437	6	IEEE 802.11b	DSSS	17.5	17.05	0.04	10 mm	1	Standard	00F05	1	left	1:1	0.111	1.109	0.123	
2412	1	IEEE 802.11b	DSSS	17.5	17.07	0.04	10 mm	2	Standard	00F05	1	back	1:1	0.087	1.104	0.096	
2412	1	IEEE 802.11b	DSSS	17.5	17.07	0.09	10 mm	2	Standard	00F05	1	front	1:1	0.053	1.104	0.059	
2412	1	IEEE 802.11b	DSSS	17.5	17.07	0.06	10 mm	2	Standard	00F05	1	top	1:1	0.022	1.104	0.024	
2412	1	IEEE 802.11b	DSSS	17.5	17.07	0.05	10 mm	2	Standard	00F05	1	left	1:1	0.077	1.104	0.085	
2412	1	IEEE 802.11n	OFDM	14.0	13.87	0.11	10 mm	MIMO	Standard	00F05	13	back	1:1	0.066	1.030	0.068	
2412	1	IEEE 802.11n	OFDM	14.0	13.87	0.10	10 mm	MIMO	Wireless Charging	00F05	13	back	1:1	0.053	1.030	0.055	
2412	1	IEEE 802.11n	OFDM	14.0	13.87	0.04	10 mm	MIMO	Standard	00F05	13	front	1:1	0.056	1.030	0.058	
2412	1	IEEE 802.11n	OFDM	14.0	13.87	0.04	10 mm	MIMO	Standard	00F05	13	top	1:1	0.037	1.030	0.038	
2412	1	IEEE 802.11n	OFDM	14.0	13.87	0.15	10 mm	MIMO	Standard	00F05	13	left	1:1	0.029	1.030	0.030	
5745	149	IEEE 802.11a	OFDM	14.0	13.31	0.06	10 mm	1	Standard	32712	6	back	1:1	0.138	1.172	0.162	
5745	149	IEEE 802.11a	OFDM	14.0	13.31	0.12	10 mm	1	Standard	32712	6	front	1:1	0.089	1.172	0.104	
5745	149	IEEE 802.11a	OFDM	14.0	13.31	-0.02	10 mm	1	Standard	32712	6	top	1:1	0.260	1.172	0.305	
5775	155	IEEE 802.11ac	OFDM	11.5	11.25	0.02	10 mm	1	Standard	32712	29.3	top	1:1	0.104	1.059	0.110	
5745	149	IEEE 802.11a	OFDM	14.0	13.31	0.05	10 mm	1	Standard	32712	6	left	1:1	0.025	1.172	0.029	
5765	153	IEEE 802.11a	OFDM	14.0	13.44	0.10	10 mm	2	Standard	15ECE	6	back	1:1	0.287	1.138	0.327	A20
5765	153	IEEE 802.11a	OFDM	14.0	13.44	0.17	10 mm	2	Wireless Charging	15ECE	6	back	1:1	0.204	1.138	0.232	
5775	155	IEEE 802.11ac	OFDM	11.5	11.26	0.03	10 mm	2	Standard	15ECE	29.3	back	1:1	0.128	1.057	0.135	
5765	153	IEEE 802.11a	OFDM	14.0	13.44	0.04	10 mm	2	Standard	15ECE	6	front	1:1	0.078	1.138	0.089	
5765	153	IEEE 802.11a	OFDM	14.0	13.44	0.04	10 mm	2	Standard	15ECE	6	top	1:1	0.066	1.138	0.075	
5765	153	IEEE 802.11a	OFDM	14.0	13.44	0.02	10 mm	2	Standard	15ECE	6	left	1:1	0.173	1.138	0.197	
5765	153	IEEE 802.11n	OFDM	13.5	13.47	0.16	10 mm	MIMO	Standard	15ECE	13	back	1:1	0.220	1.007	0.222	
5765	153	IEEE 802.11n	OFDM	13.5	13.47	0.00	10 mm	MIMO	Wireless Charging	15ECE	13	back	1:1	0.121	1.007	0.122	
5765	153	IEEE 802.11n	OFDM	13.5	13.47	-0.01	10 mm	MIMO	Standard	15ECE	13	front	1:1	0.032	1.007	0.032	
5765	153	IEEE 802.11n	OFDM	13.5	13.47	0.06	10 mm	MIMO	Standard	15ECE	13	top	1:1	0.097	1.007	0.098	
5765	153	IEEE 802.11n	OFDM	13.5	13.47	0.03	10 mm	MIMO	Standard	15ECE	13	left	1:1	0.060	1.007	0.060	
ANSI / IEEE C95.1 1992 - SAFETY LIMIT Spatial Peak							Body 1.6 W/kg (mW/g) averaged over 1 gram										
Uncontrolled Exposure/General Population																	

FCC ID: A3LSMG900R7		<b>SAR EVALUATION REPORT</b>		Reviewed by: Quality Manager
Document S/N: OY1403190578.A3L	Test Dates: 02/03/14 - 03/31/14	DUT Type: Portable Handset	Page 49 of 79	



## 11.4 SAR Test Notes

### General Notes:

1. The test data reported are the worst-case SAR values according to test procedures specified in IEEE 1528-2003, and FCC KDB Publication 447498 D01v05.
2. Batteries are fully charged at the beginning of the SAR measurements. A specialized battery was used for all SAR measurements.
3. Liquid tissue depth was at least 15.0 cm for all frequencies.
4. The manufacturer has confirmed that the device(s) tested have the same physical, mechanical and thermal characteristics and are within operational tolerances expected for production units.
5. SAR results were scaled to the maximum allowed power to demonstrate compliance per FCC KDB Publication 447498 D01v05.
6. Device was tested using a fixed spacing for body-worn accessory testing. A separation distance of 15 mm was considered because the manufacturer has determined that there will be body-worn accessories available in the marketplace for users to support this separation distance. A test separation distance of 10 mm for body-worn SAR was also used for CDMA BC0, LTE Bands 12/4/25, and 2.4/5 GHz WLAN as it is more conservative.
7. Per FCC KDB Publication 648474 D04v01, SAR was evaluated without a headset connected to the device. Since the standalone reported SAR was  $\leq 1.2$  W/kg, no additional SAR evaluations using a headset cable were required.
8. Per FCC KDB 865664 D01 v01, variability SAR tests were not required since the measured SAR results for all frequency bands were less than 0.8 W/kg. Please see Section 13 for more information.
9. During SAR Testing for the Wireless Router conditions per FCC KDB Publication 941225 D06v01, the actual Portable Hotspot operation (with actual simultaneous transmission of a transmitter with WIFI) was not activated (See Section 6.7 for more details).
10. This DUT may be used with a wireless charging cover. Per FCC KDB Publication 648474 D04, SAR was measured using the standard battery cover and then repeated with the wireless charging cover for the highest reported SAR for each wireless technology, frequency band, operating mode, and exposure condition. No other additional testing with the wireless charging battery cover was required since all reported SAR was under 1.2 W/kg.

### CDMA Notes:

1. Head SAR for CDMA2000 mode was tested under RC3/SO55 per FCC KDB Publication 941225 D01v02.
2. Body-Worn SAR was tested with 1x RTT with TDSO / SO32 FCH Only. EVDO and TDSO / SO32 FCH+SCH SAR tests were not required since the average output power was not more than 0.25 dB higher than the TDSO / SO32 FCH only powers, per FCC KDB Publication 941225 D01v02.
3. CDMA Wireless Router SAR is measured using Subtype 0/1 Physical Layer configurations for Rev. 0 according to KDB 941225 D01 procedures for data devices. Since the average output power of Subtype 2 for Rev. A is less than the Rev. 0 power levels, EVDO Rev. A SAR is not required.
4. Head SAR was additionally evaluated using EVDO Rev. A to determine compliance for VoIP operations.
5. Per FCC KDB Publication 447498 D01v05, if the reported (scaled) SAR measured at the middle channel or highest output power channel for each test configuration is  $\leq 0.8$  W/kg then testing at the other channels is not required for such test configuration(s). When the maximum output power variation across the required test channels is  $> \frac{1}{2}$  dB, instead of the middle channel, the highest output power channel was used.
6. This device applies power reduction for PCS CDMA modes when Hotspot is active. Therefore, PCS CDMA/EVDO modes were evaluated at hotspot reduced power levels. There is no power reduction applied to the Cellular CDMA/EVDO modes.

FCC ID: A3LSMG900R7		SAR EVALUATION REPORT		Reviewed by: Quality Manager
Document S/N: OY1403190578.A3L	Test Dates: 02/03/14 - 03/31/14	DUT Type: Portable Handset	Page 50 of 79	



7. CDMA 1x-RTT SAR was required to be evaluated for Hotspot exposure conditions to support simultaneous transmission capabilities.

**LTE Notes:**

1. LTE Considerations: LTE test configurations are determined according to SAR Evaluation Considerations for LTE Devices in FCC KDB Publication 941225 D05v02r01. The general test procedures used for testing can be found in Section 8.4.4.
2. MPR is permanently implemented for this device by the manufacturer. The specific manufacturer target MPR is indicated alongside the SAR results. MPR is enabled for this device, according to 3GPP TS36.101 Section 6.2.3 – 6.2.5 under Table 6.2.3-1.
3. A-MPR was disabled for all SAR tests by setting NS=01 on the base station simulator. SAR tests were performed with the same number of RB and RB offsets transmitting on all TTI frames (maximum TTI).

**WLAN Notes:**

1. Justification for reduced test configurations for SISO WIFI channels per KDB Publication 248227 D01v01r02 and October 2012 FCC/TCB Meeting Notes for 2.4 GHz WIFI: Highest average RF output power channel for the lowest data rate was selected for SAR evaluation in 802.11b. Other IEEE 802.11 modes (including 802.11g/n) were not investigated since the average output powers over all channels and data rates were not more than 0.25 dB higher than the tested channel in the lowest data rate of IEEE 802.11b mode.
2. Justification for reduced test configurations for SISO WIFI channels per KDB Publication 248227 D01v01r02 and October 2012 FCC/TCB Meeting Notes for 5 GHz WIFI: Highest average RF output power channel for the lowest data rate was selected for SAR evaluation in 802.11a. Other IEEE 802.11 modes (including 802.11n 20 MHz and 40 MHz bandwidths) were not investigated since the average output powers over all channels and data rates were not more than 0.25 dB higher than the tested channel in the lowest data rate of IEEE 802.11a mode.
3. Per April 2013 TCB Workshop notes, full SAR tests for all IEEE 802.11ac configurations were not required because the average output power was not more than 0.25 dB higher than IEEE 802.11a mode. IEEE 802.11ac was evaluated for the highest IEEE 802.11a position in each 5 GHz band and exposure condition.
4. WIFI transmission was verified using an uncalibrated spectrum analyzer.
5. This device only supports Hotspot for 2.4 GHz and 5.8 GHz bands. Therefore all other bands were not evaluated for Hotspot SAR conditions.
6. Since the maximum extrapolated peak SAR of the zoom scan for the maximum output channel is <1.6 W/kg and the reported 1g averaged SAR is <0.8 W/kg, SAR testing on other default channels was not required.
7. Per KDB 248227, SAR for MIMO was measured with both antennas transmitting simultaneously and was evaluated independently of SISO operation. For 2.4 GHz MIMO, 802.11n mode was evaluated for SAR. For 5 GHz MIMO, 802.11n 20 MHz Bandwidth mode was evaluated since the maximum allowed output power was higher than 802.11ac mode powers.
8. This device requires WIFI power reduction for SAR compliance. It always applies power reduction on the WIFI transmitter in voice or VOIP held-to-ear scenarios, and does not impact any other transmitter in the device. Therefore WIFI head SAR was evaluated at reduced power levels.
9. WLAN Body-Worn tests were performed at distance of 10 mm to represent a more conservative test configuration.

<b>FCC ID:</b> A3LSMG900R7	 <b>PCTEST</b> ENGINEERING LABORATORY, INC.	<b>SAR EVALUATION REPORT</b>		<b>Reviewed by:</b> Quality Manager
<b>Document S/N:</b> 0Y1403190578.A3L	<b>Test Dates:</b> 02/03/14 - 03/31/14	<b>DUT Type:</b> Portable Handset	Page 51 of 79	

# 12 FCC MULTI-TX AND ANTENNA SAR CONSIDERATIONS

## 12.1 Introduction

The following procedures adopted from FCC KDB Publication 447498 D01v05 are applicable to handsets with built-in unlicensed transmitters such as 802.11a/b/g/n/ac and Bluetooth devices which may simultaneously transmit with the licensed transmitter.

## 12.2 Simultaneous Transmission Procedures

This device contains transmitters that may operate simultaneously. Therefore simultaneous transmission analysis is required. Per FCC KDB 447498 D01v05 IV.C.1.iii and IEEE 1528-2013 Section 6.3.4.1.2, simultaneous transmission SAR test exclusion may be applied when the sum of the 1-g SAR for all the simultaneous transmitting antennas in a specific physical test configuration is  $\leq 1.6$  W/kg. When standalone SAR is not required to be measured, per FCC KDB 447498 D01v05 4.3.2 2), the following equation must be used to estimate the standalone 1g SAR for simultaneous transmission assessment involving that transmitter.

$$\text{Estimated SAR} = \frac{\sqrt{f(\text{GHz})}}{7.5} * \frac{(\text{Max Power of channel, mW})}{\text{Min. Separation Distance, mm}}$$

**Table 12-1  
Estimated SAR**



Mode	Frequency	Maximum Allowed Power	Separation Distance (Body)	Estimated SAR (Body)
	[MHz]	[dBm]	[mm]	[W/kg]
Bluetooth	2441	10.00	15	<b>0.139</b>

Note: Held-to ear configurations are not applicable to Bluetooth operations and therefore were not considered for simultaneous transmission. Per KDB Publication 447498 D01v05, the maximum power of the channel was rounded to the nearest mW before calculation.

## 12.3 Head SAR Simultaneous Transmission Analysis

**Table 12-2  
Simultaneous Transmission Scenario with 2.4 GHz WLAN Antenna 1 (Held to Ear)**

Simult Tx	Configuration	Cell. CDMA SAR (W/kg)	2.4 GHz WLAN Antenna 1 SAR (W/kg)	$\Sigma$ SAR (W/kg)	Simult Tx	Configuration	Cell. EVDO SAR (W/kg)	2.4 GHz WLAN Antenna 1 SAR (W/kg)	$\Sigma$ SAR (W/kg)
Head SAR	Right Cheek	0.612	0.185	<b>0.797</b>	Head SAR	Right Cheek	0.611	0.185	<b>0.796</b>
	Right Tilt	0.351	0.180	0.531		Right Tilt	0.327	0.180	0.507
	Left Cheek	0.457	0.147	0.604		Left Cheek	0.494	0.147	0.641
	Left Tilt	0.304	0.146	0.450		Left Tilt	0.333	0.146	0.479
Simult Tx	Configuration	PCS CDMA SAR (W/kg)	2.4 GHz WLAN Antenna 1 SAR (W/kg)	$\Sigma$ SAR (W/kg)	Simult Tx	Configuration	PCS EVDO SAR (W/kg)	2.4 GHz WLAN Antenna 1 SAR (W/kg)	$\Sigma$ SAR (W/kg)
Head SAR	Right Cheek	0.563	0.185	<b>0.748</b>	Head SAR	Right Cheek	0.352	0.185	<b>0.537</b>
	Right Tilt	0.261	0.180	0.441		Right Tilt	0.138	0.180	0.318
	Left Cheek	0.286	0.147	0.433		Left Cheek	0.271	0.147	0.418
	Left Tilt	0.201	0.146	0.347		Left Tilt	0.111	0.146	0.257

FCC ID: A3LSMG900R7	 <b>PCTEST</b> ENGINEERING LABORATORY, INC.	<b>SAR EVALUATION REPORT</b>		Reviewed by: Quality Manager
Document S/N: OY1403190578.A3L	Test Dates: 02/03/14 - 03/31/14	DUT Type: Portable Handset	Page 52 of 79	

Simult Tx	Configuration	LTE Band 12 SAR (W/kg)	2.4 GHz WLAN Antenna 1 SAR (W/kg)	Σ SAR (W/kg)	Simult Tx	Configuration	LTE Band 4 (AWS) SAR (W/kg)	2.4 GHz WLAN Antenna 1 SAR (W/kg)	Σ SAR (W/kg)
Head SAR	Right Cheek	0.262	0.185	0.447	Head SAR	Right Cheek	0.149	0.185	0.334
	Right Tilt	0.184	0.180	0.364		Right Tilt	0.143	0.180	0.323
	Left Cheek	0.336	0.147	<b>0.483</b>		Left Cheek	0.382	0.147	<b>0.529</b>
	Left Tilt	0.180	0.146	0.326		Left Tilt	0.128	0.146	0.274

Simult Tx	Configuration	LTE Band 25 (PCS) SAR (W/kg)	2.4 GHz WLAN Antenna 1 SAR (W/kg)	Σ SAR (W/kg)
Head SAR	Right Cheek	0.349	0.185	0.534
	Right Tilt	0.269	0.180	0.449
	Left Cheek	0.634	0.147	<b>0.781</b>
	Left Tilt	0.228	0.146	0.374

**Table 12-3**  
**Simultaneous Transmission Scenario with 2.4 GHz WLAN Antenna 2 (Held to Ear)**

Simult Tx	Configuration	Cell. CDMA SAR (W/kg)	2.4 GHz WLAN Antenna 2 SAR (W/kg)	Σ SAR (W/kg)	Simult Tx	Configuration	Cell. EVDO SAR (W/kg)	2.4 GHz WLAN Antenna 2 SAR (W/kg)	Σ SAR (W/kg)
Head SAR	Right Cheek	0.612	0.039	<b>0.651</b>	Head SAR	Right Cheek	0.611	0.039	<b>0.650</b>
	Right Tilt	0.351	0.008	0.359		Right Tilt	0.327	0.008	0.335
	Left Cheek	0.457	0.011	0.468		Left Cheek	0.494	0.011	0.505
	Left Tilt	0.304	0.005	0.309		Left Tilt	0.333	0.005	0.338



Simult Tx	Configuration	PCS CDMA SAR (W/kg)	2.4 GHz WLAN Antenna 2 SAR (W/kg)	Σ SAR (W/kg)	Simult Tx	Configuration	PCS EVDO SAR (W/kg)	2.4 GHz WLAN Antenna 2 SAR (W/kg)	Σ SAR (W/kg)
Head SAR	Right Cheek	0.563	0.039	<b>0.602</b>	Head SAR	Right Cheek	0.352	0.039	<b>0.391</b>
	Right Tilt	0.261	0.008	0.269		Right Tilt	0.138	0.008	0.146
	Left Cheek	0.286	0.011	0.297		Left Cheek	0.271	0.011	0.282
	Left Tilt	0.201	0.005	0.206		Left Tilt	0.111	0.005	0.116

Simult Tx	Configuration	LTE Band 12 SAR (W/kg)	2.4 GHz WLAN Antenna 2 SAR (W/kg)	Σ SAR (W/kg)	Simult Tx	Configuration	LTE Band 4 (AWS) SAR (W/kg)	2.4 GHz WLAN Antenna 2 SAR (W/kg)	Σ SAR (W/kg)
Head SAR	Right Cheek	0.262	0.039	0.301	Head SAR	Right Cheek	0.149	0.039	0.188
	Right Tilt	0.184	0.008	0.192		Right Tilt	0.143	0.008	0.151
	Left Cheek	0.336	0.011	<b>0.347</b>		Left Cheek	0.382	0.011	<b>0.393</b>
	Left Tilt	0.180	0.005	0.185		Left Tilt	0.128	0.005	0.133

Simult Tx	Configuration	LTE Band 25 (PCS) SAR (W/kg)	2.4 GHz WLAN Antenna 2 SAR (W/kg)	Σ SAR (W/kg)
Head SAR	Right Cheek	0.349	0.039	0.388
	Right Tilt	0.269	0.008	0.277
	Left Cheek	0.634	0.011	<b>0.645</b>
	Left Tilt	0.228	0.005	0.233



FCC ID: A3LSMG900R7		SAR EVALUATION REPORT		Reviewed by: Quality Manager
Document S/N: 0Y1403190578.A3L	Test Dates: 02/03/14 - 03/31/14	DUT Type: Portable Handset	Page 53 of 79	

**Table 12-4**  
**Simultaneous Transmission Scenario with 2.4 GHz WLAN MIMO (Held to Ear)**

Simult Tx	Configuration	Cell. CDMA SAR (W/kg)	2.4 GHz WLAN MIMO SAR (W/kg)	Σ SAR (W/kg)	Simult Tx	Configuration	Cell. EVDO SAR (W/kg)	2.4 GHz WLAN MIMO SAR (W/kg)	Σ SAR (W/kg)
Head SAR	Right Cheek	0.612	0.103	<b>0.715</b>	Head SAR	Right Cheek	0.611	0.103	<b>0.714</b>
	Right Tilt	0.351	0.091	0.442		Right Tilt	0.327	0.091	0.418
	Left Cheek	0.457	0.121	0.578		Left Cheek	0.494	0.121	0.615
	Left Tilt	0.304	0.124	0.428		Left Tilt	0.333	0.124	0.457
Simult Tx	Configuration	PCS CDMA SAR (W/kg)	2.4 GHz WLAN MIMO SAR (W/kg)	Σ SAR (W/kg)	Simult Tx	Configuration	PCS EVDO SAR (W/kg)	2.4 GHz WLAN MIMO SAR (W/kg)	Σ SAR (W/kg)
Head SAR	Right Cheek	0.563	0.103	<b>0.666</b>	Head SAR	Right Cheek	0.352	0.103	<b>0.455</b>
	Right Tilt	0.261	0.091	0.352		Right Tilt	0.138	0.091	0.229
	Left Cheek	0.286	0.121	0.407		Left Cheek	0.271	0.121	0.392
	Left Tilt	0.201	0.124	0.325		Left Tilt	0.111	0.124	0.235
Simult Tx	Configuration	LTE Band 12 SAR (W/kg)	2.4 GHz WLAN MIMO SAR (W/kg)	Σ SAR (W/kg)	Simult Tx	Configuration	LTE Band 4 (AWS) SAR (W/kg)	2.4 GHz WLAN MIMO SAR (W/kg)	Σ SAR (W/kg)
Head SAR	Right Cheek	0.262	0.103	0.365	Head SAR	Right Cheek	0.149	0.103	0.252
	Right Tilt	0.184	0.091	0.275		Right Tilt	0.143	0.091	0.234
	Left Cheek	0.336	0.121	<b>0.457</b>		Left Cheek	0.382	0.121	<b>0.503</b>
	Left Tilt	0.180	0.124	0.304		Left Tilt	0.128	0.124	0.252
Simult Tx	Configuration	LTE Band 25 (PCS) SAR (W/kg)	2.4 GHz WLAN MIMO SAR (W/kg)	Σ SAR (W/kg)					
Head SAR	Right Cheek	0.349	0.103	0.452					
	Right Tilt	0.269	0.091	0.360					
	Left Cheek	0.634	0.121	<b>0.755</b>					
	Left Tilt	0.228	0.124	0.352					

**Table 12-5**  
**Simultaneous Transmission Scenario with 5 GHz WLAN Antenna 1 (Held to Ear)**

Simult Tx	Configuration	Cell. CDMA SAR (W/kg)	5 GHz WLAN Antenna 1 SAR (W/kg)	Σ SAR (W/kg)	Simult Tx	Configuration	Cell. EVDO SAR (W/kg)	5 GHz WLAN Antenna 1 SAR (W/kg)	Σ SAR (W/kg)
Head SAR	Right Cheek	0.612	0.063	<b>0.675</b>	Head SAR	Right Cheek	0.611	0.063	<b>0.674</b>
	Right Tilt	0.351	0.063	0.414		Right Tilt	0.327	0.063	0.390
	Left Cheek	0.457	0.042	0.499		Left Cheek	0.494	0.042	0.536
	Left Tilt	0.304	0.049	0.353		Left Tilt	0.333	0.049	0.382
Simult Tx	Configuration	PCS CDMA SAR (W/kg)	5 GHz WLAN Antenna 1 SAR (W/kg)	Σ SAR (W/kg)	Simult Tx	Configuration	PCS EVDO SAR (W/kg)	5 GHz WLAN Antenna 1 SAR (W/kg)	Σ SAR (W/kg)
Head SAR	Right Cheek	0.563	0.063	<b>0.626</b>	Head SAR	Right Cheek	0.352	0.063	<b>0.415</b>
	Right Tilt	0.261	0.063	0.324		Right Tilt	0.138	0.063	0.201
	Left Cheek	0.286	0.042	0.328		Left Cheek	0.271	0.042	0.313
	Left Tilt	0.201	0.049	0.250		Left Tilt	0.111	0.049	0.160

FCC ID: A3LSMG900R7	 <b>PCTEST</b> ENGINEERING LABORATORY, INC.	<b>SAR EVALUATION REPORT</b>		Reviewed by: Quality Manager
Document S/N: OY1403190578.A3L	Test Dates: 02/03/14 - 03/31/14	DUT Type: Portable Handset	Page 54 of 79	

Simult Tx	Configuration	LTE Band 12 SAR (W/kg)	5 GHz WLAN Antenna 1 SAR (W/kg)	Σ SAR (W/kg)	Simult Tx	Configuration	LTE Band 4 (AWS) SAR (W/kg)	5 GHz WLAN Antenna 1 SAR (W/kg)	Σ SAR (W/kg)
Head SAR	Right Cheek	0.262	0.063	0.325	Head SAR	Right Cheek	0.149	0.063	0.212
	Right Tilt	0.184	0.063	0.247		Right Tilt	0.143	0.063	0.206
	Left Cheek	0.336	0.042	<b>0.378</b>		Left Cheek	0.382	0.042	<b>0.424</b>
	Left Tilt	0.180	0.049	0.229		Left Tilt	0.128	0.049	0.177

Simult Tx	Configuration	LTE Band 25 (PCS) SAR (W/kg)	5 GHz WLAN Antenna 1 SAR (W/kg)	Σ SAR (W/kg)
Head SAR	Right Cheek	0.349	0.063	0.412
	Right Tilt	0.269	0.063	0.332
	Left Cheek	0.634	0.042	<b>0.676</b>
	Left Tilt	0.228	0.049	0.277

The worst case 5 GHz WIFI reported SAR for each head configuration was considered for simultaneous SAR exclusion via summation of standalone SAR, regardless of whether the WIFI channel has WIFI Hotspot capability, for simplicity to determine compliance. Please note that the actual simultaneous transmission SAR will not exceed the summed levels indicated.

**Table 12-6**  
**Simultaneous Transmission Scenario with 5 GHz WLAN Antenna 2 (Held to Ear)**

Simult Tx	Configuration	Cell. CDMA SAR (W/kg)	5 GHz WLAN Antenna 2 SAR (W/kg)	Σ SAR (W/kg)	Simult Tx	Configuration	Cell. EVDO SAR (W/kg)	5 GHz WLAN Antenna 2 SAR (W/kg)	Σ SAR (W/kg)
Head SAR	Right Cheek	0.612	0.217	<b>0.829</b>	Head SAR	Right Cheek	0.611	0.217	<b>0.828</b>
	Right Tilt	0.351	0.080	0.431		Right Tilt	0.327	0.080	0.407
	Left Cheek	0.457	0.046	0.503		Left Cheek	0.494	0.046	0.540
	Left Tilt	0.304	0.044	0.348		Left Tilt	0.333	0.044	0.377

Simult Tx	Configuration	PCS CDMA SAR (W/kg)	5 GHz WLAN Antenna 2 SAR (W/kg)	Σ SAR (W/kg)	Simult Tx	Configuration	PCS EVDO SAR (W/kg)	5 GHz WLAN Antenna 2 SAR (W/kg)	Σ SAR (W/kg)
Head SAR	Right Cheek	0.563	0.217	<b>0.780</b>	Head SAR	Right Cheek	0.352	0.217	<b>0.569</b>
	Right Tilt	0.261	0.080	0.341		Right Tilt	0.138	0.080	0.218
	Left Cheek	0.286	0.046	0.332		Left Cheek	0.271	0.046	0.317
	Left Tilt	0.201	0.044	0.245		Left Tilt	0.111	0.044	0.155



  

Simult Tx	Configuration	LTE Band 12 SAR (W/kg)	5 GHz WLAN Antenna 2 SAR (W/kg)	Σ SAR (W/kg)	Simult Tx	Configuration	LTE Band 4 (AWS) SAR (W/kg)	5 GHz WLAN Antenna 2 SAR (W/kg)	Σ SAR (W/kg)
Head SAR	Right Cheek	0.262	0.217	<b>0.479</b>	Head SAR	Right Cheek	0.149	0.217	0.366
	Right Tilt	0.184	0.080	0.264		Right Tilt	0.143	0.080	0.223
	Left Cheek	0.336	0.046	0.382		Left Cheek	0.382	0.046	<b>0.428</b>
	Left Tilt	0.180	0.044	0.224		Left Tilt	0.128	0.044	0.172

Simult Tx	Configuration	LTE Band 25 (PCS) SAR (W/kg)	5 GHz WLAN Antenna 2 SAR (W/kg)	Σ SAR (W/kg)
Head SAR	Right Cheek	0.349	0.217	0.566
	Right Tilt	0.269	0.080	0.349
	Left Cheek	0.634	0.046	<b>0.680</b>
	Left Tilt	0.228	0.044	0.272

The worst case 5 GHz WIFI reported SAR for each head configuration was considered for simultaneous SAR exclusion via summation of standalone SAR, regardless of whether the WIFI channel has WIFI Hotspot capability, for simplicity to determine compliance. Please note that the actual simultaneous transmission SAR will not exceed the summed levels indicated.

FCC ID: A3LSMG900R7		<b>SAR EVALUATION REPORT</b>		Reviewed by: Quality Manager
Document S/N: 0Y1403190578.A3L	Test Dates: 02/03/14 - 03/31/14	DUT Type: Portable Handset		Page 55 of 79

**Table 12-7**  
**Simultaneous Transmission Scenario with 5 GHz WLAN MIMO (Held to Ear)**

Simult Tx	Configuration	Cell. CDMA SAR (W/kg)	5 GHz WLAN MIMO SAR (W/kg)	Σ SAR (W/kg)	Simult Tx	Configuration	Cell. EVDO SAR (W/kg)	5 GHz WLAN MIMO SAR (W/kg)	Σ SAR (W/kg)
Head SAR	Right Cheek	0.612	0.061	<b>0.673</b>	Head SAR	Right Cheek	0.611	0.061	<b>0.672</b>
	Right Tilt	0.351	0.017	0.368		Right Tilt	0.327	0.017	0.344
	Left Cheek	0.457	0.020	0.477		Left Cheek	0.494	0.020	0.514
	Left Tilt	0.304	0.014	0.318		Left Tilt	0.333	0.014	0.347
Simult Tx	Configuration	PCS CDMA SAR (W/kg)	5 GHz WLAN MIMO SAR (W/kg)	Σ SAR (W/kg)	Simult Tx	Configuration	PCS EVDO SAR (W/kg)	5 GHz WLAN MIMO SAR (W/kg)	Σ SAR (W/kg)
Head SAR	Right Cheek	0.563	0.061	<b>0.624</b>	Head SAR	Right Cheek	0.352	0.061	<b>0.413</b>
	Right Tilt	0.261	0.017	0.278		Right Tilt	0.138	0.017	0.155
	Left Cheek	0.286	0.020	0.306		Left Cheek	0.271	0.020	0.291
	Left Tilt	0.201	0.014	0.215		Left Tilt	0.111	0.014	0.125
Simult Tx	Configuration	LTE Band 12 SAR (W/kg)	5 GHz WLAN MIMO SAR (W/kg)	Σ SAR (W/kg)	Simult Tx	Configuration	LTE Band 4 (AWS) SAR (W/kg)	5 GHz WLAN MIMO SAR (W/kg)	Σ SAR (W/kg)
Head SAR	Right Cheek	0.262	0.061	0.323	Head SAR	Right Cheek	0.149	0.061	0.210
	Right Tilt	0.184	0.017	0.201		Right Tilt	0.143	0.017	0.160
	Left Cheek	0.336	0.020	<b>0.356</b>		Left Cheek	0.382	0.020	<b>0.402</b>
	Left Tilt	0.180	0.014	0.194		Left Tilt	0.128	0.014	0.142
Simult Tx	Configuration	LTE Band 25 (PCS) SAR (W/kg)	5 GHz WLAN MIMO SAR (W/kg)	Σ SAR (W/kg)					
Head SAR	Right Cheek	0.349	0.061	0.410					
	Right Tilt	0.269	0.017	0.286					
	Left Cheek	0.634	0.020	<b>0.654</b>					
	Left Tilt	0.228	0.014	0.242					



The worst case 5 GHz WIFI reported SAR for each head configuration was considered for simultaneous SAR exclusion via summation of standalone SAR, regardless of whether the WIFI channel has WIFI Hotspot capability, for simplicity to determine compliance. Please note that the actual simultaneous transmission SAR will not exceed the summed levels indicated.

## 12.4 Body-Worn Simultaneous Transmission Analysis

Note: For SAR summation for body back side at 15 mm CDMA BC0, LTE Band 12/4/25, and WLAN SAR values for 10 mm were used since the 10 mm test distance was more conservative. “<” denotes that the 10 mm SAR values were used for the respective modes for summation purposes.

**Table 12-8**  
**Simultaneous Transmission Scenario with 2.4 GHz WLAN Antenna 1 (Body-Worn at 1.5 cm)**

Configuration	Mode	CDMA/LTE SAR (W/kg)	2.4 GHz WLAN Antenna 1 SAR (W/kg)	Σ SAR (W/kg)
Back Side	Cell. CDMA	< 0.775	< 0.261	< <b>1.036</b>
Back Side	PCS CDMA	0.526	< 0.261	< 0.787
Back Side	LTE Band 12	< 0.407	< 0.261	< 0.668
Back Side	LTE Band 4 (AWS)	< 0.509	< 0.261	< 0.770
Back Side	LTE Band 25 (PCS)	< 0.216	< 0.261	< 0.477

FCC ID: A3LSMG900R7	 <b>PCTEST</b> ENGINEERING LABORATORY, INC.	<b>SAR EVALUATION REPORT</b>		Reviewed by: Quality Manager
Document S/N: OY1403190578.A3L	Test Dates: 02/03/14 - 03/31/14	DUT Type: Portable Handset	Page 56 of 79	

**Table 12-9**  
**Simultaneous Transmission Scenario with 2.4 GHz WLAN Antenna 2 (Body-Worn at 1.5 cm)**

Configuration	Mode	CDMA/LTE SAR (W/kg)	2.4 GHz WLAN Antenna 2 SAR (W/kg)	Σ SAR (W/kg)
Back Side	Cell. CDMA	< 0.775	< 0.096	< <b>0.871</b>
Back Side	PCS CDMA	0.526	< 0.096	< 0.622
Back Side	LTE Band 12	< 0.407	< 0.096	< 0.503
Back Side	LTE Band 4 (AWS)	< 0.509	< 0.096	< 0.605
Back Side	LTE Band 25 (PCS)	< 0.216	< 0.096	< 0.312



**Table 12-10**  
**Simultaneous Transmission Scenario with 2.4 GHz WLAN MIMO (Body-Worn at 1.5 cm)**

Configuration	Mode	CDMA/LTE SAR (W/kg)	2.4 GHz WLAN MIMO SAR (W/kg)	Σ SAR (W/kg)
Back Side	Cell. CDMA	< 0.775	< 0.068	< <b>0.843</b>
Back Side	PCS CDMA	0.526	< 0.068	< 0.594
Back Side	LTE Band 12	< 0.407	< 0.068	< 0.475
Back Side	LTE Band 4 (AWS)	< 0.509	< 0.068	< 0.577
Back Side	LTE Band 25 (PCS)	< 0.216	< 0.068	< 0.284

**Table 12-11**  
**Simultaneous Transmission Scenario with 5 GHz WLAN Antenna 1 (Body-Worn at 1.5 cm)**

Configuration	Mode	CDMA/LTE SAR (W/kg)	5 GHz WLAN Antenna 1 SAR (W/kg)	Σ SAR (W/kg)
Back Side	Cell. CDMA	< 0.775	< 0.269	< <b>1.044</b>
Back Side	PCS CDMA	0.526	< 0.269	< 0.795
Back Side	LTE Band 12	< 0.407	< 0.269	< 0.676
Back Side	LTE Band 4 (AWS)	< 0.509	< 0.269	< 0.778
Back Side	LTE Band 25 (PCS)	< 0.216	< 0.269	< 0.485

The worst case 5 GHz WIFI reported SAR for each body-worn configuration was considered for simultaneous SAR exclusion via summation of standalone SAR, regardless of whether the WIFI channel has WIFI Hotspot capability, for simplicity to determine compliance. Please note that the actual simultaneous transmission SAR will not exceed the summed levels indicated.

FCC ID: A3LSMG900R7		<b>SAR EVALUATION REPORT</b>		Reviewed by: Quality Manager
Document S/N: 0Y1403190578.A3L	Test Dates: 02/03/14 - 03/31/14	DUT Type: Portable Handset		Page 57 of 79

**Table 12-12**  
**Simultaneous Transmission Scenario with 5 GHz WLAN Antenna 2 (Body-Worn at 1.5 cm)**

Configuration	Mode	CDMA/LTE SAR (W/kg)	5 GHz WLAN Antenna 2 SAR (W/kg)	Σ SAR (W/kg)
Back Side	Cell. CDMA	< 0.775	< 0.351	< <b>1.126</b>
Back Side	PCS CDMA	0.526	< 0.351	< 0.877
Back Side	LTE Band 12	< 0.407	< 0.351	< 0.758
Back Side	LTE Band 4 (AWS)	< 0.509	< 0.351	< 0.860
Back Side	LTE Band 25 (PCS)	< 0.216	< 0.351	< 0.567

The worst case 5 GHz WIFI reported SAR for each body-worn configuration was considered for simultaneous SAR exclusion via summation of standalone SAR, regardless of whether the WIFI channel has WIFI Hotspot capability, for simplicity to determine compliance. Please note that the actual simultaneous transmission SAR will not exceed the summed levels indicated.

**Table 12-13**  
**Simultaneous Transmission Scenario with 5 GHz WLAN MIMO (Body-Worn at 1.5 cm)**



Configuration	Mode	CDMA/LTE SAR (W/kg)	5 GHz WLAN MIMO SAR (W/kg)	Σ SAR (W/kg)
Back Side	Cell. CDMA	< 0.775	< 0.222	< <b>0.997</b>
Back Side	PCS CDMA	0.526	< 0.222	< 0.748
Back Side	LTE Band 12	< 0.407	< 0.222	< 0.629
Back Side	LTE Band 4 (AWS)	< 0.509	< 0.222	< 0.731
Back Side	LTE Band 25 (PCS)	< 0.216	< 0.222	< 0.438

The worst case 5 GHz WIFI reported SAR for each body-worn configuration was considered for simultaneous SAR exclusion via summation of standalone SAR, regardless of whether the WIFI channel has WIFI Hotspot capability, for simplicity to determine compliance. Please note that the actual simultaneous transmission SAR will not exceed the summed levels indicated.

**Table 12-14**  
**Simultaneous Transmission Scenario with Bluetooth (Body-Worn at 1.5 cm)**

Configuration	Mode	CDMA/LTE SAR (W/kg)	Bluetooth SAR (W/kg)	Σ SAR (W/kg)
Back Side	Cell. CDMA	< 0.775	0.139	< <b>0.914</b>
Back Side	PCS CDMA	0.526	0.139	0.665
Back Side	LTE Band 12	< 0.407	0.139	< 0.546
Back Side	LTE Band 4 (AWS)	< 0.509	0.139	< 0.648
Back Side	LTE Band 25 (PCS)	< 0.216	0.139	< 0.355

Note: Bluetooth SAR was not required to be measured per FCC KDB 447498. Estimated SAR results were used in the above table to determine simultaneous transmission SAR test exclusion.

FCC ID: A3LSMG900R7	 <b>PCTEST</b> <small>ENGINEERING LABORATORY, INC.</small>	<b>SAR EVALUATION REPORT</b>		<b>Reviewed by:</b> Quality Manager
<b>Document S/N:</b> OY1403190578.A3L	<b>Test Dates:</b> 02/03/14 - 03/31/14	<b>DUT Type:</b> Portable Handset	Page 58 of 79	

## 12.5 Hotspot SAR Simultaneous Transmission Analysis



Per FCC KDB Publication 941225 D06v01, the devices edges with antennas more than 2.5 cm from edge are not required to be evaluated for SAR (“-”).

**Table 12-15**  
**Simultaneous Transmission Scenario (2.4 GHz Hotspot Antenna 1 at 1.0 cm)**

Simult Tx	Configuration	Cell. EVDO SAR (W/kg)	2.4 GHz WLAN Antenna 1 SAR (W/kg)	Σ SAR (W/kg)	Simult Tx	Configuration	PCS EVDO SAR (W/kg)	2.4 GHz WLAN Antenna 1 SAR (W/kg)	Σ SAR (W/kg)
Body SAR	Back	0.766	0.261	<b>1.027</b>	Body SAR	Back	0.573	0.261	<b>0.834</b>
	Front	0.683	0.214	0.897		Front	0.397	0.214	0.611
	Top	-	0.126	0.126		Top	-	0.126	0.126
	Bottom	0.520	-	0.520		Bottom	0.462	-	0.462
	Right	0.765	-	0.765		Right	0.372	-	0.372
	Left	-	0.123	0.123		Left	-	0.123	0.123
Simult Tx	Configuration	LTE Band 12 SAR (W/kg)	2.4 GHz WLAN Antenna 1 SAR (W/kg)	Σ SAR (W/kg)	Simult Tx	Configuration	LTE Band 4 (AWS) SAR (W/kg)	2.4 GHz WLAN Antenna 1 SAR (W/kg)	Σ SAR (W/kg)
Body SAR	Back	0.407	0.261	0.668	Body SAR	Back	0.509	0.261	0.770
	Front	0.515	0.214	<b>0.729</b>		Front	0.586	0.214	<b>0.800</b>
	Top	-	0.126	0.126		Top	-	0.126	0.126
	Bottom	0.345	-	0.345		Bottom	0.143	-	0.143
	Right	-	-	0.000		Right	-	-	0.000
	Left	0.348	0.123	0.471		Left	0.183	0.123	0.306
Simult Tx	Configuration	LTE Band 25 (PCS) SAR (W/kg)	2.4 GHz WLAN Antenna 1 SAR (W/kg)	Σ SAR (W/kg)					
Body SAR	Back	0.188	0.261	0.449					
	Front	0.566	0.214	<b>0.780</b>					
	Top	-	0.126	0.126					
	Bottom	0.101	-	0.101					
	Right	-	-	0.000					
	Left	0.255	0.123	0.378					

**Table 12-16**  
**Simultaneous Transmission Scenario (2.4 GHz Hotspot Antenna 2 at 1.0 cm)**

Simult Tx	Configuration	Cell. EVDO SAR (W/kg)	2.4 GHz WLAN Antenna 2 SAR (W/kg)	Σ SAR (W/kg)	Simult Tx	Configuration	PCS EVDO SAR (W/kg)	2.4 GHz WLAN Antenna 2 SAR (W/kg)	Σ SAR (W/kg)
Body SAR	Back	0.766	0.096	<b>0.862</b>	Body SAR	Back	0.573	0.096	<b>0.669</b>
	Front	0.683	0.059	0.742		Front	0.397	0.059	0.456
	Top	-	0.024	0.024		Top	-	0.024	0.024
	Bottom	0.520	-	0.520		Bottom	0.462	-	0.462
	Right	0.765	-	0.765		Right	0.372	-	0.372
	Left	-	0.085	0.085		Left	-	0.085	0.085
Simult Tx	Configuration	LTE Band 12 SAR (W/kg)	2.4 GHz WLAN Antenna 2 SAR (W/kg)	Σ SAR (W/kg)	Simult Tx	Configuration	LTE Band 4 (AWS) SAR (W/kg)	2.4 GHz WLAN Antenna 2 SAR (W/kg)	Σ SAR (W/kg)
Body SAR	Back	0.407	0.096	0.503	Body SAR	Back	0.509	0.096	0.605
	Front	0.515	0.059	<b>0.574</b>		Front	0.586	0.059	<b>0.645</b>
	Top	-	0.024	0.024		Top	-	0.024	0.024
	Bottom	0.345	-	0.345		Bottom	0.143	-	0.143
	Right	-	-	0.000		Right	-	-	0.000
	Left	0.348	0.085	0.433		Left	0.183	0.085	0.268
Simult Tx	Configuration	LTE Band 25 (PCS) SAR (W/kg)	2.4 GHz WLAN Antenna 2 SAR (W/kg)	Σ SAR (W/kg)					
Body SAR	Back	0.188	0.096	<b>0.284</b>					
	Front	0.566	0.059	0.625					
	Top	-	0.024	0.024					
	Bottom	0.101	-	0.101					
	Right	-	-	0.000					
	Left	0.255	0.085	0.340					

FCC ID: A3LSMG900R7		<b>SAR EVALUATION REPORT</b>		Reviewed by: Quality Manager
Document S/N: OY1403190578.A3L	Test Dates: 02/03/14 - 03/31/14	DUT Type: Portable Handset	Page 59 of 79	

**Table 12-17**  
**Simultaneous Transmission Scenario (2.4 GHz Hotspot MIMO at 1.0 cm)**



Simult Tx	Configuration	Cell. EVDO SAR (W/kg)	2.4 GHz WLAN MIMO SAR (W/kg)	Σ SAR (W/kg)	Simult Tx	Configuration	PCS EVDO SAR (W/kg)	2.4 GHz WLAN MIMO SAR (W/kg)	Σ SAR (W/kg)
Body SAR	Back	0.766	0.068	<b>0.834</b>	Body SAR	Back	0.573	0.068	<b>0.641</b>
	Front	0.683	0.058	0.741		Front	0.397	0.058	0.455
	Top	-	0.038	0.038		Top	-	0.038	0.038
	Bottom	0.520	-	0.520		Bottom	0.462	-	0.462
	Right	0.765	-	0.765		Right	0.372	-	0.372
	Left	-	0.030	0.030		Left	-	0.030	0.030
Simult Tx	Configuration	LTE Band 12 SAR (W/kg)	2.4 GHz WLAN MIMO SAR (W/kg)	Σ SAR (W/kg)	Simult Tx	Configuration	LTE Band 4 (AWS) SAR (W/kg)	2.4 GHz WLAN MIMO SAR (W/kg)	Σ SAR (W/kg)
Body SAR	Back	0.407	0.068	0.475	Body SAR	Back	0.509	0.068	0.577
	Front	0.515	0.058	<b>0.573</b>		Front	0.586	0.058	<b>0.644</b>
	Top	-	0.038	0.038		Top	-	0.038	0.038
	Bottom	0.345	-	0.345		Bottom	0.143	-	0.143
	Right	-	-	0.000		Right	-	-	0.000
	Left	0.348	0.030	0.378		Left	0.183	0.030	0.213

Simult Tx	Configuration	LTE Band 25 (PCS) SAR (W/kg)	2.4 GHz WLAN MIMO SAR (W/kg)	Σ SAR (W/kg)
Body SAR	Back	0.188	0.068	0.256
	Front	0.566	0.058	<b>0.624</b>
	Top	-	0.038	0.038
	Bottom	0.101	-	0.101
	Right	-	-	0.000
	Left	0.255	0.030	0.285

**Table 12-18**  
**Simultaneous Transmission Scenario (5.8 GHz Hotspot Antenna 1 at 1.0 cm)**

Simult Tx	Configuration	Cell. EVDO SAR (W/kg)	5.8 GHz WLAN Antenna 1 SAR (W/kg)	Σ SAR (W/kg)	Simult Tx	Configuration	PCS EVDO SAR (W/kg)	5.8 GHz WLAN Antenna 1 SAR (W/kg)	Σ SAR (W/kg)
Body SAR	Back	0.766	0.162	<b>0.928</b>	Body SAR	Back	0.573	0.162	<b>0.735</b>
	Front	0.683	0.104	0.787		Front	0.397	0.104	0.501
	Top	-	0.305	0.305		Top	-	0.305	0.305
	Bottom	0.520	-	0.520		Bottom	0.462	-	0.462
	Right	0.765	-	0.765		Right	0.372	-	0.372
	Left	-	0.029	0.029		Left	-	0.029	0.029
Simult Tx	Configuration	LTE Band 12 SAR (W/kg)	5.8 GHz WLAN Antenna 1 SAR (W/kg)	Σ SAR (W/kg)	Simult Tx	Configuration	LTE Band 4 (AWS) SAR (W/kg)	5.8 GHz WLAN Antenna 1 SAR (W/kg)	Σ SAR (W/kg)
Body SAR	Back	0.407	0.162	0.569	Body SAR	Back	0.509	0.162	0.671
	Front	0.515	0.104	<b>0.619</b>		Front	0.586	0.104	<b>0.690</b>
	Top	-	0.305	0.305		Top	-	0.305	0.305
	Bottom	0.345	-	0.345		Bottom	0.143	-	0.143
	Right	-	-	0.000		Right	-	-	0.000
	Left	0.348	0.029	0.377		Left	0.183	0.029	0.212

Simult Tx	Configuration	LTE Band 25 (PCS) SAR (W/kg)	5.8 GHz WLAN Antenna 1 SAR (W/kg)	Σ SAR (W/kg)
Body SAR	Back	0.188	0.162	0.350
	Front	0.566	0.104	<b>0.670</b>
	Top	-	0.305	0.305
	Bottom	0.101	-	0.101
	Right	-	-	0.000
	Left	0.255	0.029	0.284



FCC ID: A3LSMG900R7		SAR EVALUATION REPORT		Reviewed by: Quality Manager
Document S/N: OY1403190578.A3L	Test Dates: 02/03/14 - 03/31/14	DUT Type: Portable Handset		Page 60 of 79

**Table 12-19**  
**Simultaneous Transmission Scenario (5.8 GHz Hotspot Antenna 2 at 1.0 cm)**

Simult Tx	Configuration	Cell. EVDO SAR (W/kg)	5.8 GHz WLAN Antenna 2 SAR (W/kg)	Σ SAR (W/kg)	Simult Tx	Configuration	PCS EVDO SAR (W/kg)	5.8 GHz WLAN Antenna 2 SAR (W/kg)	Σ SAR (W/kg)
Body SAR	Back	0.766	0.327	<b>1.093</b>	Body SAR	Back	0.573	0.327	<b>0.900</b>
	Front	0.683	0.089	0.772		Front	0.397	0.089	0.486
	Top	-	0.075	0.075		Top	-	0.075	0.075
	Bottom	0.520	-	0.520		Bottom	0.462	-	0.462
	Right	0.765	-	0.765		Right	0.372	-	0.372
	Left	-	0.197	0.197		Left	-	0.197	0.197
Simult Tx	Configuration	LTE Band 12 SAR (W/kg)	5.8 GHz WLAN Antenna 2 SAR (W/kg)	Σ SAR (W/kg)	Simult Tx	Configuration	LTE Band 4 (AWS) SAR (W/kg)	5.8 GHz WLAN Antenna 2 SAR (W/kg)	Σ SAR (W/kg)
Body SAR	Back	0.407	0.327	<b>0.734</b>	Body SAR	Back	0.509	0.327	<b>0.836</b>
	Front	0.515	0.089	0.604		Front	0.586	0.089	0.675
	Top	-	0.075	0.075		Top	-	0.075	0.075
	Bottom	0.345	-	0.345		Bottom	0.143	-	0.143
	Right	-	-	0.000		Right	-	-	0.000
	Left	0.348	0.197	0.545		Left	0.183	0.197	0.380
Simult Tx	Configuration	LTE Band 25 (PCS) SAR (W/kg)	5.8 GHz WLAN Antenna 2 SAR (W/kg)	Σ SAR (W/kg)					
Body SAR	Back	0.188	0.327	0.515					
	Front	0.566	0.089	<b>0.655</b>					
	Top	-	0.075	0.075					
	Bottom	0.101	-	0.101					
	Right	-	-	0.000					
	Left	0.255	0.197	0.452					

**Table 12-20**  
**Simultaneous Transmission Scenario (5.8 GHz Hotspot MIMO at 1.0 cm)**

Simult Tx	Configuration	Cell. EVDO SAR (W/kg)	5.8 GHz WLAN MIMO SAR (W/kg)	Σ SAR (W/kg)	Simult Tx	Configuration	PCS EVDO SAR (W/kg)	5.8 GHz WLAN MIMO SAR (W/kg)	Σ SAR (W/kg)
Body SAR	Back	0.766	0.222	<b>0.988</b>	Body SAR	Back	0.573	0.222	<b>0.795</b>
	Front	0.683	0.032	0.715		Front	0.397	0.032	0.429
	Top	-	0.098	0.098		Top	-	0.098	0.098
	Bottom	0.520	-	0.520		Bottom	0.462	-	0.462
	Right	0.765	-	0.765		Right	0.372	-	0.372
	Left	-	0.060	0.060		Left	-	0.060	0.060
Simult Tx	Configuration	LTE Band 12 SAR (W/kg)	5.8 GHz WLAN MIMO SAR (W/kg)	Σ SAR (W/kg)	Simult Tx	Configuration	LTE Band 4 (AWS) SAR (W/kg)	5.8 GHz WLAN MIMO SAR (W/kg)	Σ SAR (W/kg)
Body SAR	Back	0.407	0.222	<b>0.629</b>	Body SAR	Back	0.509	0.222	<b>0.731</b>
	Front	0.515	0.032	0.547		Front	0.586	0.032	0.618
	Top	-	0.098	0.098		Top	-	0.098	0.098
	Bottom	0.345	-	0.345		Bottom	0.143	-	0.143
	Right	-	-	0.000		Right	-	-	0.000
	Left	0.348	0.060	0.408		Left	0.183	0.060	0.243
Simult Tx	Configuration	LTE Band 25 (PCS) SAR (W/kg)	5.8 GHz WLAN MIMO SAR (W/kg)	Σ SAR (W/kg)					
Body SAR	Back	0.188	0.222	0.410					
	Front	0.566	0.032	<b>0.598</b>					
	Top	-	0.098	0.098					
	Bottom	0.101	-	0.101					
	Right	-	-	0.000					
	Left	0.255	0.060	0.315					

FCC ID: A3LSMG900R7	 <b>PCTEST</b> <small>ENGINEERING LABORATORY, INC.</small>	<b>SAR EVALUATION REPORT</b>		Reviewed by: Quality Manager
Document S/N: OY1403190578.A3L	Test Dates: 02/03/14 - 03/31/14	DUT Type: Portable Handset	Page 61 of 79	

## 12.6 SVLTE Simultaneous Transmission Analysis

Notes:



1. For SAR summation for body-worn back side at 15 mm CDMA BC0, LTE Band 12/4/25, and WLAN SAR values for 10 mm were used since the 10 mm test distance was more conservative. For these modes, "<" denotes that the 10 mm SAR values were used for summation purposes.
2. For summation for body-worn back side at 15 mm CDMA BC1 maximum output power SAR was used since it is more conservative than the reduced output power SAR. For CDMA BC1, "<" denotes that the maximum output power SAR was used for summation purposes.

**Table 12-21**  
**Simultaneous Transmission Scenario (Held to Ear)**

Simult Tx	Configuration	Cell. CDMA SAR (W/kg)	LTE Band 12 SAR (W/kg)	Σ SAR (W/kg)	Simult Tx	Configuration	PCS CDMA SAR (W/kg)	LTE Band 12 SAR (W/kg)	Σ SAR (W/kg)
Head SAR	Right Cheek	0.612	0.262	<b>0.874</b>	Head SAR	Right Cheek	0.563	0.262	<b>0.825</b>
	Right Tilt	0.351	0.184	0.535		Right Tilt	0.261	0.184	0.445
	Left Cheek	0.457	0.336	0.793		Left Cheek	0.286	0.336	0.622
	Left Tilt	0.304	0.180	0.484		Left Tilt	0.201	0.180	0.381
Simult Tx	Configuration	Cell. CDMA SAR (W/kg)	LTE Band 4 (AWS) SAR (W/kg)	Σ SAR (W/kg)	Simult Tx	Configuration	PCS CDMA SAR (W/kg)	LTE Band 4 (AWS) SAR (W/kg)	Σ SAR (W/kg)
Head SAR	Right Cheek	0.612	0.149	0.761	Head SAR	Right Cheek	0.563	0.149	<b>0.712</b>
	Right Tilt	0.351	0.143	0.494		Right Tilt	0.261	0.143	0.404
	Left Cheek	0.457	0.382	<b>0.839</b>		Left Cheek	0.286	0.382	0.668
	Left Tilt	0.304	0.128	0.432		Left Tilt	0.201	0.128	0.329
Simult Tx	Configuration	Cell. CDMA SAR (W/kg)	LTE Band 25 (PCS) SAR (W/kg)	Σ SAR (W/kg)	Simult Tx	Configuration	PCS CDMA SAR (W/kg)	LTE Band 25 (PCS) SAR (W/kg)	Σ SAR (W/kg)
Head SAR	Right Cheek	0.612	0.349	0.961	Head SAR	Right Cheek	0.563	0.349	0.912
	Right Tilt	0.351	0.269	0.620		Right Tilt	0.261	0.269	0.530
	Left Cheek	0.457	0.634	<b>1.091</b>		Left Cheek	0.286	0.634	<b>0.920</b>
	Left Tilt	0.304	0.228	0.532		Left Tilt	0.201	0.228	0.429

**Table 12-22**  
**Simultaneous Transmission Scenario with 2.4 GHz WLAN Antenna 1 (Held to Ear)**

Simult Tx	Configuration	Cell. CDMA SAR (W/kg)	LTE Band 12 SAR (W/kg)	2.4 GHz WLAN Antenna 1 SAR (W/kg)	Σ SAR (W/kg)	Simult Tx	Configuration	PCS CDMA SAR (W/kg)	LTE Band 12 SAR (W/kg)	2.4 GHz WLAN Antenna 1 SAR (W/kg)	Σ SAR (W/kg)
	Tx Antenna	1	2	3	1+2+3		Tx Antenna	1	2	3	1+2+3
Head SAR	Right Cheek	0.612	0.262	0.185	<b>1.059</b>	Head SAR	Right Cheek	0.346	0.262	0.185	<b>0.793</b>
	Right Tilt	0.351	0.184	0.180	0.715		Right Tilt	0.131	0.184	0.180	0.495
	Left Cheek	0.457	0.336	0.147	0.940		Left Cheek	0.269	0.336	0.147	0.752
	Left Tilt	0.304	0.180	0.146	0.630		Left Tilt	0.097	0.180	0.146	0.423
Simult Tx	Configuration	Cell. CDMA SAR (W/kg)	LTE Band 4 (AWS) SAR (W/kg)	2.4 GHz WLAN Antenna 1 SAR (W/kg)	Σ SAR (W/kg)	Simult Tx	Configuration	PCS CDMA SAR (W/kg)	LTE Band 4 (AWS) SAR (W/kg)	2.4 GHz WLAN Antenna 1 SAR (W/kg)	Σ SAR (W/kg)
	Tx Antenna	1	2	3	1+2+3		Tx Antenna	1	2	3	1+2+3
Head SAR	Right Cheek	0.612	0.149	0.185	0.946	Head SAR	Right Cheek	0.346	0.149	0.185	0.680
	Right Tilt	0.351	0.143	0.180	0.674		Right Tilt	0.131	0.143	0.180	0.454
	Left Cheek	0.457	0.382	0.147	<b>0.986</b>		Left Cheek	0.269	0.382	0.147	<b>0.798</b>
	Left Tilt	0.304	0.128	0.146	0.578		Left Tilt	0.097	0.128	0.146	0.371

FCC ID: A3LSMG900R7		<b>SAR EVALUATION REPORT</b>		Reviewed by: Quality Manager
Document S/N: OY1403190578.A3L	Test Dates: 02/03/14 - 03/31/14	DUT Type: Portable Handset		Page 62 of 79

Simult Tx	Configuration	Cell. CDMA SAR (W/kg)	LTE Band 25 (PCS) SAR (W/kg)	2.4 GHz WLAN Antenna 1 SAR (W/kg)	Σ SAR (W/kg)	Simult Tx	Configuration	PCS CDMA SAR (W/kg)	LTE Band 25 (PCS) SAR (W/kg)	2.4 GHz WLAN Antenna 1 SAR (W/kg)	Σ SAR (W/kg)
	Tx Antenna	1	2	3	1+2+3		Tx Antenna	1	2	3	1+2+3
Head SAR	Right Cheek	0.612	0.349	0.185	1.146	Head SAR	Right Cheek	0.346	0.349	0.185	0.880
	Right Tilt	0.351	0.269	0.180	0.800		Right Tilt	0.131	0.269	0.180	0.580
	Left Cheek	0.457	0.634	0.147	<b>1.238</b>		Left Cheek	0.269	0.634	0.147	<b>1.050</b>
	Left Tilt	0.304	0.228	0.146	0.678		Left Tilt	0.097	0.228	0.146	0.471

**Table 12-23**  
**Simultaneous Transmission Scenario with 2.4 GHz WLAN Antenna 2 (Held to Ear)**

Simult Tx	Configuration	Cell. CDMA SAR (W/kg)	LTE Band 12 SAR (W/kg)	2.4 GHz WLAN Antenna 2 SAR (W/kg)	Σ SAR (W/kg)	Simult Tx	Configuration	PCS CDMA SAR (W/kg)	LTE Band 12 SAR (W/kg)	2.4 GHz WLAN Antenna 2 SAR (W/kg)	Σ SAR (W/kg)
	Tx Antenna	1	2	3	1+2+3		Tx Antenna	1	2	3	1+2+3
Head SAR	Right Cheek	0.612	0.262	0.039	<b>0.913</b>	Head SAR	Right Cheek	0.346	0.262	0.039	<b>0.647</b>
	Right Tilt	0.351	0.184	0.008	0.543		Right Tilt	0.131	0.184	0.008	0.323
	Left Cheek	0.457	0.336	0.011	0.804		Left Cheek	0.269	0.336	0.011	0.616
	Left Tilt	0.304	0.180	0.005	0.489		Left Tilt	0.097	0.180	0.005	0.282



Simult Tx	Configuration	Cell. CDMA SAR (W/kg)	LTE Band 4 (AWS) SAR (W/kg)	2.4 GHz WLAN Antenna 2 SAR (W/kg)	Σ SAR (W/kg)	Simult Tx	Configuration	PCS CDMA SAR (W/kg)	LTE Band 4 (AWS) SAR (W/kg)	2.4 GHz WLAN Antenna 2 SAR (W/kg)	Σ SAR (W/kg)
	Tx Antenna	1	2	3	1+2+3		Tx Antenna	1	2	3	1+2+3
Head SAR	Right Cheek	0.612	0.149	0.039	0.800	Head SAR	Right Cheek	0.346	0.149	0.039	0.534
	Right Tilt	0.351	0.143	0.008	0.502		Right Tilt	0.131	0.143	0.008	0.282
	Left Cheek	0.457	0.382	0.011	<b>0.850</b>		Left Cheek	0.269	0.382	0.011	<b>0.662</b>
	Left Tilt	0.304	0.128	0.005	0.437		Left Tilt	0.097	0.128	0.005	0.230

Simult Tx	Configuration	Cell. CDMA SAR (W/kg)	LTE Band 25 (PCS) SAR (W/kg)	2.4 GHz WLAN Antenna 2 SAR (W/kg)	Σ SAR (W/kg)	Simult Tx	Configuration	PCS CDMA SAR (W/kg)	LTE Band 25 (PCS) SAR (W/kg)	2.4 GHz WLAN Antenna 2 SAR (W/kg)	Σ SAR (W/kg)
	Tx Antenna	1	2	3	1+2+3		Tx Antenna	1	2	3	1+2+3
Head SAR	Right Cheek	0.612	0.349	0.039	1.000	Head SAR	Right Cheek	0.346	0.349	0.039	0.734
	Right Tilt	0.351	0.269	0.008	0.628		Right Tilt	0.131	0.269	0.008	0.408
	Left Cheek	0.457	0.634	0.011	<b>1.102</b>		Left Cheek	0.269	0.634	0.011	<b>0.914</b>
	Left Tilt	0.304	0.228	0.005	0.537		Left Tilt	0.097	0.228	0.005	0.330

**Table 12-24**  
**Simultaneous Transmission Scenario with 2.4 GHz WLAN MIMO (Held to Ear)**

Simult Tx	Configuration	Cell. CDMA SAR (W/kg)	LTE Band 12 SAR (W/kg)	2.4 GHz WLAN MIMO SAR (W/kg)	Σ SAR (W/kg)	Simult Tx	Configuration	PCS CDMA SAR (W/kg)	LTE Band 12 SAR (W/kg)	2.4 GHz WLAN MIMO SAR (W/kg)	Σ SAR (W/kg)
	Tx Antenna	1	2	3	1+2+3		Tx Antenna	1	2	3	1+2+3
Head SAR	Right Cheek	0.612	0.262	0.103	<b>0.977</b>	Head SAR	Right Cheek	0.346	0.262	0.103	0.711
	Right Tilt	0.351	0.184	0.091	0.626		Right Tilt	0.131	0.184	0.091	0.406
	Left Cheek	0.457	0.336	0.121	0.914		Left Cheek	0.269	0.336	0.121	<b>0.726</b>
	Left Tilt	0.304	0.180	0.124	0.608		Left Tilt	0.097	0.180	0.124	0.401

FCC ID: A3LSMG900R7	 <b>PCTEST</b> <small>ENGINEERING LABORATORY, INC.</small>	<b>SAR EVALUATION REPORT</b>		Reviewed by: Quality Manager
Document S/N: OY1403190578.A3L	Test Dates: 02/03/14 - 03/31/14	DUT Type: Portable Handset	Page 63 of 79	

Simult Tx	Configuration	Cell. CDMA SAR (W/kg)	LTE Band 4 (AWS) SAR (W/kg)	2.4 GHz WLAN MIMO SAR (W/kg)	Σ SAR (W/kg)	Simult Tx	Configuration	PCS CDMA SAR (W/kg)	LTE Band 4 (AWS) SAR (W/kg)	2.4 GHz WLAN MIMO SAR (W/kg)	Σ SAR (W/kg)
	Tx Antenna	1	2	3	1+2+3		Tx Antenna	1	2	3	1+2+3
Head SAR	Right Cheek	0.612	0.149	0.103	0.864	Head SAR	Right Cheek	0.346	0.149	0.103	0.598
	Right Tilt	0.351	0.143	0.091	0.585		Right Tilt	0.131	0.143	0.091	0.365
	Left Cheek	0.457	0.382	0.121	<b>0.960</b>		Left Cheek	0.269	0.382	0.121	<b>0.772</b>
	Left Tilt	0.304	0.128	0.124	0.556		Left Tilt	0.097	0.128	0.124	0.349
Simult Tx	Configuration	Cell. CDMA SAR (W/kg)	LTE Band 25 (PCS) SAR (W/kg)	2.4 GHz WLAN MIMO SAR (W/kg)	Σ SAR (W/kg)	Simult Tx	Configuration	PCS CDMA SAR (W/kg)	LTE Band 25 (PCS) SAR (W/kg)	2.4 GHz WLAN MIMO SAR (W/kg)	Σ SAR (W/kg)
	Tx Antenna	1	2	3	1+2+3		Tx Antenna	1	2	3	1+2+3
Head SAR	Right Cheek	0.612	0.349	0.103	1.064	Head SAR	Right Cheek	0.346	0.349	0.103	0.798
	Right Tilt	0.351	0.269	0.091	0.711		Right Tilt	0.131	0.269	0.091	0.491
	Left Cheek	0.457	0.634	0.121	<b>1.212</b>		Left Cheek	0.269	0.634	0.121	<b>1.024</b>
	Left Tilt	0.304	0.228	0.124	0.656		Left Tilt	0.097	0.228	0.124	0.449



**Table 12-25**  
**Simultaneous Transmission Scenario with 5 GHz WLAN Antenna 1 (Held to Ear)**

Simult Tx	Configuration	Cell. CDMA SAR (W/kg)	LTE Band 12 SAR (W/kg)	5 GHz WLAN Antenna 1 SAR (W/kg)	Σ SAR (W/kg)	Simult Tx	Configuration	PCS CDMA SAR (W/kg)	LTE Band 12 SAR (W/kg)	5 GHz WLAN Antenna 1 SAR (W/kg)	Σ SAR (W/kg)
	Tx Antenna	1	2	3	1+2+3		Tx Antenna	1	2	3	1+2+3
Head SAR	Right Cheek	0.612	0.262	0.063	<b>0.937</b>	Head SAR	Right Cheek	0.346	0.262	0.063	<b>0.671</b>
	Right Tilt	0.351	0.184	0.063	0.598		Right Tilt	0.131	0.184	0.063	0.378
	Left Cheek	0.457	0.336	0.042	0.835		Left Cheek	0.269	0.336	0.042	0.647
	Left Tilt	0.304	0.180	0.049	0.533		Left Tilt	0.097	0.180	0.049	0.326
Simult Tx	Configuration	Cell. CDMA SAR (W/kg)	LTE Band 4 (AWS) SAR (W/kg)	5 GHz WLAN Antenna 1 SAR (W/kg)	Σ SAR (W/kg)	Simult Tx	Configuration	PCS CDMA SAR (W/kg)	LTE Band 4 (AWS) SAR (W/kg)	5 GHz WLAN Antenna 1 SAR (W/kg)	Σ SAR (W/kg)
	Tx Antenna	1	2	3	1+2+3		Tx Antenna	1	2	3	1+2+3
Head SAR	Right Cheek	0.612	0.149	0.063	0.824	Head SAR	Right Cheek	0.346	0.149	0.063	0.558
	Right Tilt	0.351	0.143	0.063	0.557		Right Tilt	0.131	0.143	0.063	0.337
	Left Cheek	0.457	0.382	0.042	<b>0.881</b>		Left Cheek	0.269	0.382	0.042	<b>0.693</b>
	Left Tilt	0.304	0.128	0.049	0.481		Left Tilt	0.097	0.128	0.049	0.274
Simult Tx	Configuration	Cell. CDMA SAR (W/kg)	LTE Band 25 (PCS) SAR (W/kg)	5 GHz WLAN Antenna 1 SAR (W/kg)	Σ SAR (W/kg)	Simult Tx	Configuration	PCS CDMA SAR (W/kg)	LTE Band 25 (PCS) SAR (W/kg)	5 GHz WLAN Antenna 1 SAR (W/kg)	Σ SAR (W/kg)
	Tx Antenna	1	2	3	1+2+3		Tx Antenna	1	2	3	1+2+3
Head SAR	Right Cheek	0.612	0.349	0.063	1.024	Head SAR	Right Cheek	0.346	0.349	0.063	0.758
	Right Tilt	0.351	0.269	0.063	0.683		Right Tilt	0.131	0.269	0.063	0.463
	Left Cheek	0.457	0.634	0.042	<b>1.133</b>		Left Cheek	0.269	0.634	0.042	<b>0.945</b>
	Left Tilt	0.304	0.228	0.049	0.581		Left Tilt	0.097	0.228	0.049	0.374

The worst case 5 GHz WIFI reported SAR for each head configuration was considered for simultaneous SAR exclusion via summation of standalone SAR, regardless of whether the WIFI channel has WIFI Hotspot capability, for simplicity to determine compliance. Please note that the actual simultaneous transmission SAR will not exceed the summed levels indicated.

**Table 12-26**  
**Simultaneous Transmission Scenario with 5 GHz WLAN Antenna 2 (Held to Ear)**

Simult Tx	Configuration	Cell. CDMA SAR (W/kg)	LTE Band 12 SAR (W/kg)	5 GHz WLAN Antenna 2 SAR (W/kg)	Σ SAR (W/kg)	Simult Tx	Configuration	PCS CDMA SAR (W/kg)	LTE Band 12 SAR (W/kg)	5 GHz WLAN Antenna 2 SAR (W/kg)	Σ SAR (W/kg)
	Tx Antenna	1	2	3	1+2+3		Tx Antenna	1	2	3	1+2+3
Head SAR	Right Cheek	0.612	0.262	0.217	<b>1.091</b>	Head SAR	Right Cheek	0.346	0.262	0.217	<b>0.825</b>
	Right Tilt	0.351	0.184	0.080	0.615		Right Tilt	0.131	0.184	0.080	0.395
	Left Cheek	0.457	0.336	0.046	0.839		Left Cheek	0.269	0.336	0.046	0.651
	Left Tilt	0.304	0.180	0.044	0.528		Left Tilt	0.097	0.180	0.044	0.321

FCC ID: A3LSMG900R7	 <b>PCTEST</b> ENGINEERING LABORATORY, INC.	<b>SAR EVALUATION REPORT</b>		Reviewed by: Quality Manager
Document S/N: OY1403190578.A3L	Test Dates: 02/03/14 - 03/31/14	DUT Type: Portable Handset	Page 64 of 79	



Simult Tx	Configuration	Cell. CDMA SAR (W/kg)	LTE Band 4 (AWS) SAR (W/kg)	5 GHz WLAN Antenna 2 SAR (W/kg)	Σ SAR (W/kg)	Simult Tx	Configuration	PCS CDMA SAR (W/kg)	LTE Band 4 (AWS) SAR (W/kg)	5 GHz WLAN Antenna 2 SAR (W/kg)	Σ SAR (W/kg)
	Tx Antenna	1	2	3	1+2+3		Tx Antenna	1	2	3	1+2+3
Head SAR	Right Cheek	0.612	0.149	0.061	<b>0.935</b>	Head SAR	Right Cheek	0.346	0.149	0.061	<b>0.712</b>
	Right Tilt	0.351	0.184	0.017	0.552		Right Tilt	0.131	0.143	0.080	0.354
	Left Cheek	0.457	0.382	0.046	0.885		Left Cheek	0.269	0.382	0.046	0.697
	Left Tilt	0.304	0.128	0.044	0.476		Left Tilt	0.097	0.128	0.044	0.269
Simult Tx	Configuration	Cell. CDMA SAR (W/kg)	LTE Band 25 (PCS) SAR (W/kg)	5 GHz WLAN Antenna 2 SAR (W/kg)	Σ SAR (W/kg)	Simult Tx	Configuration	PCS CDMA SAR (W/kg)	LTE Band 25 (PCS) SAR (W/kg)	5 GHz WLAN Antenna 2 SAR (W/kg)	Σ SAR (W/kg)
	Tx Antenna	1	2	3	1+2+3		Tx Antenna	1	2	3	1+2+3
Head SAR	Right Cheek	0.612	0.349	0.217	<b>1.178</b>	Head SAR	Right Cheek	0.346	0.349	0.217	0.912
	Right Tilt	0.351	0.269	0.080	0.700		Right Tilt	0.131	0.269	0.080	0.480
	Left Cheek	0.457	0.634	0.046	1.137		Left Cheek	0.269	0.634	0.046	<b>0.949</b>
	Left Tilt	0.304	0.228	0.044	0.576		Left Tilt	0.097	0.228	0.044	0.369

The worst case 5 GHz WIFI reported SAR for each head configuration was considered for simultaneous SAR exclusion via summation of standalone SAR, regardless of whether the WIFI channel has WIFI Hotspot capability, for simplicity to determine compliance. Please note that the actual simultaneous transmission SAR will not exceed the summed levels indicated.

**Table 12-27**  
**Simultaneous Transmission Scenario with 5 GHz WLAN MIMO (Held to Ear)**

Simult Tx	Configuration	Cell. CDMA SAR (W/kg)	LTE Band 12 SAR (W/kg)	5 GHz WLAN MIMO SAR (W/kg)	Σ SAR (W/kg)	Simult Tx	Configuration	PCS CDMA SAR (W/kg)	LTE Band 12 SAR (W/kg)	5 GHz WLAN MIMO SAR (W/kg)	Σ SAR (W/kg)
	Tx Antenna	1	2	3	1+2+3		Tx Antenna	1	2	3	1+2+3
Head SAR	Right Cheek	0.612	0.262	0.061	<b>0.935</b>	Head SAR	Right Cheek	0.346	0.262	0.061	<b>0.669</b>
	Right Tilt	0.351	0.184	0.017	0.552		Right Tilt	0.131	0.184	0.017	0.332
	Left Cheek	0.457	0.336	0.020	0.813		Left Cheek	0.269	0.336	0.020	0.625
	Left Tilt	0.304	0.180	0.014	0.498		Left Tilt	0.097	0.180	0.014	0.291
Simult Tx	Configuration	Cell. CDMA SAR (W/kg)	LTE Band 4 (AWS) SAR (W/kg)	5 GHz WLAN MIMO SAR (W/kg)	Σ SAR (W/kg)	Simult Tx	Configuration	PCS CDMA SAR (W/kg)	LTE Band 4 (AWS) SAR (W/kg)	5 GHz WLAN MIMO SAR (W/kg)	Σ SAR (W/kg)
	Tx Antenna	1	2	3	1+2+3		Tx Antenna	1	2	3	1+2+3
Head SAR	Right Cheek	0.612	0.149	0.061	0.822	Head SAR	Right Cheek	0.346	0.149	0.061	0.556
	Right Tilt	0.351	0.143	0.017	0.511		Right Tilt	0.131	0.143	0.017	0.291
	Left Cheek	0.457	0.382	0.020	<b>0.859</b>		Left Cheek	0.269	0.382	0.020	<b>0.671</b>
	Left Tilt	0.304	0.128	0.014	0.446		Left Tilt	0.097	0.128	0.014	0.239
Simult Tx	Configuration	Cell. CDMA SAR (W/kg)	LTE Band 25 (PCS) SAR (W/kg)	5 GHz WLAN MIMO SAR (W/kg)	Σ SAR (W/kg)	Simult Tx	Configuration	PCS CDMA SAR (W/kg)	LTE Band 25 (PCS) SAR (W/kg)	5 GHz WLAN MIMO SAR (W/kg)	Σ SAR (W/kg)
	Tx Antenna	1	2	3	1+2+3		Tx Antenna	1	2	3	1+2+3
Head SAR	Right Cheek	0.612	0.349	0.061	1.022	Head SAR	Right Cheek	0.346	0.349	0.061	0.756
	Right Tilt	0.351	0.269	0.017	0.637		Right Tilt	0.131	0.269	0.017	0.417
	Left Cheek	0.457	0.634	0.020	<b>1.111</b>		Left Cheek	0.269	0.634	0.020	<b>0.923</b>
	Left Tilt	0.304	0.228	0.014	0.546		Left Tilt	0.097	0.228	0.014	0.339

The worst case 5 GHz WIFI reported SAR for each head configuration was considered for simultaneous SAR exclusion via summation of standalone SAR, regardless of whether the WIFI channel has WIFI Hotspot capability, for simplicity to determine compliance. Please note that the actual simultaneous transmission SAR will not exceed the summed levels indicated.

FCC ID: A3LSMG900R7	 <b>PCTEST</b> ENGINEERING LABORATORY, INC.	<b>SAR EVALUATION REPORT</b>		<b>Reviewed by:</b> Quality Manager
<b>Document S/N:</b> OY1403190578.A3L	<b>Test Dates:</b> 02/03/14 - 03/31/14	<b>DUT Type:</b> Portable Handset	Page 65 of 79	

**Table 12-28**  
**Simultaneous Transmission Scenario (Body-Worn at 1.5 cm)**

Configuration	Mode	CDMA SAR (W/kg)	LTE Band 12 SAR (W/kg)	Σ SAR (W/kg)	Configuration	Mode	CDMA SAR (W/kg)	LTE Band 4 (AWS) SAR (W/kg)	Σ SAR (W/kg)
Back Side	Cell. CDMA	< 0.775	< 0.407	< <b>1.182</b>	Back Side	Cell. CDMA	< 0.775	< 0.509	< <b>1.284</b>
Back Side	PCS CDMA	0.526	< 0.407	< 0.933	Back Side	PCS CDMA	0.526	< 0.509	< 1.035

Configuration	Mode	CDMA SAR (W/kg)	LTE Band 25 (PCS) SAR (W/kg)	Σ SAR (W/kg)
Back Side	Cell. CDMA	< 0.775	< 0.216	< <b>0.991</b>
Back Side	PCS CDMA	0.526	< 0.216	< 0.742

**Table 12-29**  
**Simultaneous Transmission Scenario with 2.4 GHz WLAN Antenna 1 (Body-Worn at 1.5 cm)**

Configuration	Mode	CDMA SAR (W/kg)	LTE Band 12 SAR (W/kg)	2.4 GHz WLAN Antenna 1 SAR (W/kg)	Σ SAR (W/kg)	SPLSR		
						Tx Antenna	1+2	1+3
Back Side	Cell. CDMA	< 0.775	< 0.407	< 0.261	< <b>1.443</b>	N/A	N/A	N/A
Back Side	PCS CDMA	< 0.526	< 0.407	< 0.261	< 1.194	N/A	N/A	N/A

Configuration	Mode	CDMA SAR (W/kg)	LTE Band 4 (AWS) SAR (W/kg)	2.4 GHz WLAN Antenna 1 SAR (W/kg)	Σ SAR (W/kg)	SPLSR		
						Tx Antenna	1+2	1+3
Back Side	Cell. CDMA	< 0.775	< 0.509	< 0.261	< <b>1.545</b>	N/A	N/A	N/A
Back Side	PCS CDMA	< 0.526	< 0.509	< 0.261	< 1.296	N/A	N/A	N/A

Configuration	Mode	CDMA SAR (W/kg)	LTE Band 25 (PCS) SAR (W/kg)	2.4 GHz WLAN Antenna 1 SAR (W/kg)	Σ SAR (W/kg)	SPLSR		
						Tx Antenna	1+2	1+3
Back Side	Cell. CDMA	< 0.775	< 0.216	< 0.261	< <b>1.252</b>	N/A	N/A	N/A
Back Side	PCS CDMA	< 0.526	< 0.216	< 0.261	< 1.003	N/A	N/A	N/A

**Table 12-30**  
**Simultaneous Transmission Scenario with 2.4 GHz WLAN Antenna 2 (Body-Worn at 1.5 cm)**



Configuration	Mode	CDMA SAR (W/kg)	LTE Band 12 SAR (W/kg)	2.4 GHz WLAN Antenna 2 SAR (W/kg)	Σ SAR (W/kg)	SPLSR		
						Tx Antenna	1+2	1+3
Back Side	Cell. CDMA	< 0.775	< 0.407	< 0.096	< <b>1.278</b>	N/A	N/A	N/A
Back Side	PCS CDMA	< 0.526	< 0.407	< 0.096	< 1.029	N/A	N/A	N/A

Configuration	Mode	CDMA SAR (W/kg)	LTE Band 4 (AWS) SAR (W/kg)	2.4 GHz WLAN Antenna 2 SAR (W/kg)	Σ SAR (W/kg)	SPLSR		
						Tx Antenna	1+2	1+3
Back Side	Cell. CDMA	< 0.775	< 0.509	< 0.096	< <b>1.380</b>	N/A	N/A	N/A
Back Side	PCS CDMA	< 0.526	< 0.509	< 0.096	< 1.131	N/A	N/A	N/A

Configuration	Mode	CDMA SAR (W/kg)	LTE Band 25 (PCS) SAR (W/kg)	2.4 GHz WLAN Antenna 2 SAR (W/kg)	Σ SAR (W/kg)	SPLSR		
						Tx Antenna	1+2	1+3
Back Side	Cell. CDMA	< 0.775	< 0.216	< 0.096	< <b>1.087</b>	N/A	N/A	N/A
Back Side	PCS CDMA	< 0.526	< 0.216	< 0.096	< 0.838	N/A	N/A	N/A

FCC ID: A3LSMG900R7		<b>SAR EVALUATION REPORT</b>		Reviewed by: Quality Manager
Document S/N: 0Y1403190578.A3L	Test Dates: 02/03/14 - 03/31/14	DUT Type: Portable Handset		Page 66 of 79



**Table 12-31**  
**Simultaneous Transmission Scenario with 2.4 GHz WLAN MIMO (Body-Worn at 1.5 cm)**

Configuration	Mode	CDMA SAR (W/kg)	LTE Band 12 SAR (W/kg)	2.4 GHz WLAN MIMO SAR (W/kg)	Σ SAR (W/kg)	SPLSR		
	Tx Antenna	1	2	3	1+2+3	1+2	1+3	2+3
Back Side	Cell. CDMA	< 0.775	< 0.407	< 0.068	< <b>1.250</b>	N/A	N/A	N/A
Back Side	PCS CDMA	< 0.526	< 0.407	< 0.068	< 1.001	N/A	N/A	N/A
Configuration	Mode	CDMA SAR (W/kg)	LTE Band 4 (AWS) SAR (W/kg)	2.4 GHz WLAN MIMO SAR (W/kg)	Σ SAR (W/kg)	SPLSR		
	Tx Antenna	1	2	3	1+2+3	1+2	1+3	2+3
Back Side	Cell. CDMA	< 0.775	< 0.509	< 0.068	< <b>1.352</b>	N/A	N/A	N/A
Back Side	PCS CDMA	< 0.526	< 0.509	< 0.068	< 1.103	N/A	N/A	N/A
Configuration	Mode	CDMA SAR (W/kg)	LTE Band 25 (PCS) SAR (W/kg)	2.4 GHz WLAN MIMO SAR (W/kg)	Σ SAR (W/kg)	SPLSR		
	Tx Antenna	1	2	3	1+2+3	1+2	1+3	2+3
Back Side	Cell. CDMA	< 0.775	< 0.216	< 0.068	< <b>1.059</b>	N/A	N/A	N/A
Back Side	PCS CDMA	< 0.526	< 0.216	< 0.068	< 0.810	N/A	N/A	N/A

**Table 12-32**  
**Simultaneous Transmission Scenario with 5 GHz WLAN Antenna 1 (Body-Worn at 1.5 cm)**

Configuration	Mode	CDMA SAR (W/kg)	LTE Band 12 SAR (W/kg)	5 GHz WLAN Antenna 1 SAR (W/kg)	Σ SAR (W/kg)	SPLSR		
	Tx Antenna	1	2	3	1+2+3	1+2	1+3	2+3
Back Side	Cell. CDMA	< 0.775	< 0.407	< 0.269	< <b>1.451</b>	N/A	N/A	N/A
Back Side	PCS CDMA	< 0.526	< 0.407	< 0.269	< 1.202	N/A	N/A	N/A
Configuration	Mode	CDMA SAR (W/kg)	LTE Band 4 (AWS) SAR (W/kg)	5 GHz WLAN Antenna 1 SAR (W/kg)	Σ SAR (W/kg)	SPLSR		
	Tx Antenna	1	2	3	1+2+3	1+2	1+3	2+3
Back Side	Cell. CDMA	< 0.775	< 0.509	< 0.269	< <b>1.553</b>	N/A	N/A	N/A
Back Side	PCS CDMA	< 0.526	< 0.509	< 0.269	< 1.304	N/A	N/A	N/A
Configuration	Mode	CDMA SAR (W/kg)	LTE Band 25 (PCS) SAR (W/kg)	5 GHz WLAN Antenna 1 SAR (W/kg)	Σ SAR (W/kg)	SPLSR		
	Tx Antenna	1	2	3	1+2+3	1+2	1+3	2+3
Back Side	Cell. CDMA	< 0.775	< 0.216	< 0.269	< <b>1.260</b>	N/A	N/A	N/A
Back Side	PCS CDMA	< 0.526	< 0.216	< 0.269	< 1.011	N/A	N/A	N/A

Notes: The worst case 5 GHz WIFI reported SAR for each body-worn configuration was considered for simultaneous SAR exclusion via summation of standalone SAR, regardless of whether the WIFI channel has WIFI Hotspot capability, for simplicity to determine compliance. Please note that the actual simultaneous transmission SAR will not exceed the summed levels indicated.

FCC ID: A3LSMG900R7	 <b>PCTEST</b> ENGINEERING LABORATORY, INC.	<b>SAR EVALUATION REPORT</b>		Reviewed by: Quality Manager
Document S/N: OY1403190578.A3L	Test Dates: 02/03/14 - 03/31/14	DUT Type: Portable Handset	Page 67 of 79	

**Table 12-33**  
**Simultaneous Transmission Scenario with 5 GHz WLAN Antenna 2 (Body-Worn at 1.5 cm)**

Configuration	Mode	CDMA SAR (W/kg)	LTE Band 12 SAR (W/kg)	5 GHz WLAN Antenna 2 SAR (W/kg)	Σ SAR (W/kg)	SPLSR		
	Tx Antenna	1	2	3	1+2+3	1+2	1+3	2+3
Back Side	Cell. CDMA	< 0.775	< 0.407	< 0.351	< <b>1.533</b>	N/A	N/A	N/A
Back Side	PCS CDMA	< 0.526	< 0.407	< 0.351	< 1.284	N/A	N/A	N/A
Configuration	Mode	CDMA SAR (W/kg)	LTE Band 4 (AWS) SAR (W/kg)	5 GHz WLAN Antenna 2 SAR (W/kg)	Σ SAR (W/kg)	SPLSR		
	Tx Antenna	1	2	3	1+2+3	1+2	1+3	2+3
Back Side	Cell. CDMA	< 0.775	< 0.509	< 0.351	See Note 1	< 0.02	< 0.03	< 0.01
Back Side	PCS CDMA	< 0.526	< 0.509	< 0.351	< <b>1.386</b>	N/A	N/A	N/A
Configuration	Mode	CDMA SAR (W/kg)	LTE Band 25 (PCS) SAR (W/kg)	5 GHz WLAN Antenna 2 SAR (W/kg)	Σ SAR (W/kg)	SPLSR		
	Tx Antenna	1	2	3	1+2+3	1+2	1+3	2+3
Back Side	Cell. CDMA	< 0.775	< 0.216	< 0.351	< <b>1.342</b>	N/A	N/A	N/A
Back Side	PCS CDMA	< 0.526	< 0.216	< 0.351	< 1.093	N/A	N/A	N/A



Notes:

1. No evaluation was performed to determine the aggregate 1g SAR for these configurations as the SPLS ratio between the antenna pairs was not higher than 0.04 per FCC KDB Publication 447498 D01v05r01. See Section 12.7 for SPLS ratio analysis.
2. The worst case 5 GHz WIFI reported SAR for each body-worn configuration was considered for simultaneous SAR exclusion via summation of standalone SAR, regardless of whether the WIFI channel has WIFI Hotspot capability, for simplicity to determine compliance. Please note that the actual simultaneous transmission SAR will not exceed the summed levels indicated.

**Table 12-34**  
**Simultaneous Transmission Scenario with 5 GHz WLAN MIMO (Body-Worn at 1.5 cm)**

Configuration	Mode	CDMA SAR (W/kg)	LTE Band 12 SAR (W/kg)	5 GHz WLAN MIMO SAR (W/kg)	Σ SAR (W/kg)	SPLSR		
	Tx Antenna	1	2	3	1+2+3	1+2	1+3	2+3
Back Side	Cell. CDMA	< 0.775	< 0.407	< 0.222	< <b>1.404</b>	N/A	N/A	N/A
Back Side	PCS CDMA	< 0.526	< 0.407	< 0.222	< 1.155	N/A	N/A	N/A
Configuration	Mode	CDMA SAR (W/kg)	LTE Band 4 (AWS) SAR (W/kg)	5 GHz WLAN MIMO SAR (W/kg)	Σ SAR (W/kg)	SPLSR		
	Tx Antenna	1	2	3	1+2+3	1+2	1+3	2+3
Back Side	Cell. CDMA	< 0.775	< 0.509	< 0.222	< <b>1.506</b>	N/A	N/A	N/A
Back Side	PCS CDMA	< 0.526	< 0.509	< 0.222	< 1.257	N/A	N/A	N/A
Configuration	Mode	CDMA SAR (W/kg)	LTE Band 25 (PCS) SAR (W/kg)	5 GHz WLAN MIMO SAR (W/kg)	Σ SAR (W/kg)	SPLSR		
	Tx Antenna	1	2	3	1+2+3	1+2	1+3	2+3
Back Side	Cell. CDMA	< 0.775	< 0.216	< 0.222	< <b>1.213</b>	N/A	N/A	N/A
Back Side	PCS CDMA	< 0.526	< 0.216	< 0.222	< 0.964	N/A	N/A	N/A

Notes: The worst case 5 GHz WIFI reported SAR for each body-worn configuration was considered for simultaneous SAR exclusion via summation of standalone SAR, regardless of whether the WIFI channel has WIFI Hotspot capability, for simplicity to determine compliance. Please note that the actual simultaneous transmission SAR will not exceed the summed levels indicated.

FCC ID: A3LSMG900R7		<b>SAR EVALUATION REPORT</b>		Reviewed by: Quality Manager
Document S/N: OY1403190578.A3L	Test Dates: 02/03/14 - 03/31/14	DUT Type: Portable Handset		Page 68 of 79

**Table 12-35**  
**Simultaneous Transmission Scenario with Bluetooth (Body-Worn at 1.5 cm)**

Configuration	Mode	CDMA SAR (W/kg)	LTE Band 12 SAR (W/kg)	Bluetooth SAR (W/kg)	Σ SAR (W/kg)	Configuration	Mode	CDMA SAR (W/kg)	LTE Band 4 (AWS) SAR (W/kg)	Bluetooth SAR (W/kg)	Σ SAR (W/kg)
		1	2	3	1+2+3			1	2	3	1+2+3
Back Side	Cell. CDMA	< 0.775	< 0.407	0.139	< 1.321	Back Side	Cell. CDMA	< 0.775	< 0.509	0.139	< 1.423
Back Side	PCS CDMA	0.526	< 0.407	0.139	< 1.072	Back Side	PCS CDMA	0.526	< 0.509	0.139	< 1.174

Configuration	Mode	CDMA SAR (W/kg)	LTE Band 25 (PCS) SAR (W/kg)	Bluetooth SAR (W/kg)	Σ SAR (W/kg)
		1	2	3	1+2+3
Back Side	Cell. CDMA	< 0.775	< 0.216	0.139	< 1.130
Back Side	PCS CDMA	0.526	< 0.216	0.139	< 0.881

Notes: Bluetooth SAR was not required to be measured per FCC KDB 447498. Estimated SAR results were used in the above table to determine simultaneous transmission SAR test exclusion.

**Table 12-36**  
**Simultaneous Transmission Scenario with 2.4 GHz WLAN Antenna 1 (Hotspot at 1.0 cm)**

Simult Tx	Configuration	Cell. CDMA SAR (W/kg)	LTE Band 12 SAR (W/kg)	2.4 GHz WLAN Antenna 1 SAR (W/kg)	Σ SAR (W/kg)	SPLSR			Simult Tx	Configuration	PCS CDMA SAR (W/kg)	LTE Band 4 (AWS) SAR (W/kg)	2.4 GHz WLAN Antenna 1 SAR (W/kg)	Σ SAR (W/kg)	SPLSR		
		1	2	3	1+2+3	1+2	1+3	2+3			1	2	3	1+2+3	1+2	1+3	2+3
Body SAR	Back	0.775	0.407	0.261	1.443	N/A	N/A	N/A	Body SAR	Back	0.563	0.407	0.261	1.231	N/A	N/A	N/A
	Front	0.689	0.515	0.214	1.418	N/A	N/A	N/A		Front	0.451	0.515	0.214	1.180	N/A	N/A	N/A
	Top	-	-	0.126	0.126	N/A	N/A	N/A		Top	-	-	0.126	0.126	N/A	N/A	N/A
	Bottom	0.511	0.345	-	0.856	N/A	N/A	N/A		Bottom	0.433	0.345	-	0.778	N/A	N/A	N/A
	Right	0.778	-	-	0.778	N/A	N/A	N/A		Right	0.354	-	-	0.354	N/A	N/A	N/A
	Left	-	0.348	0.123	0.471	N/A	N/A	N/A		Left	-	0.348	0.123	0.471	N/A	N/A	N/A

Simult Tx	Configuration	Cell. CDMA SAR (W/kg)	LTE Band 4 (AWS) SAR (W/kg)	2.4 GHz WLAN Antenna 1 SAR (W/kg)	Σ SAR (W/kg)	SPLSR			Simult Tx	Configuration	PCS CDMA SAR (W/kg)	LTE Band 4 (AWS) SAR (W/kg)	2.4 GHz WLAN Antenna 1 SAR (W/kg)	Σ SAR (W/kg)	SPLSR		
		1	2	3	1+2+3	1+2	1+3	2+3			1	2	3	1+2+3	1+2	1+3	2+3
Body SAR	Back	0.775	0.509	0.261	1.545	N/A	N/A	N/A	Body SAR	Back	0.563	0.509	0.261	1.333	N/A	N/A	N/A
	Front	0.689	0.586	0.214	1.489	N/A	N/A	N/A		Front	0.451	0.586	0.214	1.251	N/A	N/A	N/A
	Top	-	-	0.126	0.126	N/A	N/A	N/A		Top	-	-	0.126	0.126	N/A	N/A	N/A
	Bottom	0.511	0.143	-	0.654	N/A	N/A	N/A		Bottom	0.433	0.143	-	0.576	N/A	N/A	N/A
	Right	0.778	-	-	0.778	N/A	N/A	N/A		Right	0.354	-	-	0.354	N/A	N/A	N/A
	Left	-	0.183	0.123	0.306	N/A	N/A	N/A		Left	-	0.183	0.123	0.306	N/A	N/A	N/A



Simult Tx	Configuration	Cell. CDMA SAR (W/kg)	LTE Band 25 (PCS) SAR (W/kg)	2.4 GHz WLAN Antenna 1 SAR (W/kg)	Σ SAR (W/kg)	SPLSR			Simult Tx	Configuration	PCS CDMA SAR (W/kg)	LTE Band 25 (PCS) SAR (W/kg)	2.4 GHz WLAN Antenna 1 SAR (W/kg)	Σ SAR (W/kg)	SPLSR		
		1	2	3	1+2+3	1+2	1+3	2+3			1	2	3	1+2+3	1+2	1+3	2+3
Body SAR	Back	0.775	0.188	0.261	1.224	N/A	N/A	N/A	Body SAR	Back	0.563	0.188	0.261	1.012	N/A	N/A	N/A
	Front	0.689	0.586	0.214	1.469	N/A	N/A	N/A		Front	0.451	0.586	0.214	1.231	N/A	N/A	N/A
	Top	-	-	0.126	0.126	N/A	N/A	N/A		Top	-	-	0.126	0.126	N/A	N/A	N/A
	Bottom	0.511	0.101	-	0.612	N/A	N/A	N/A		Bottom	0.433	0.101	-	0.534	N/A	N/A	N/A
	Right	0.778	-	-	0.778	N/A	N/A	N/A		Right	0.354	-	-	0.354	N/A	N/A	N/A
	Left	-	0.255	0.123	0.378	N/A	N/A	N/A		Left	-	0.255	0.123	0.378	N/A	N/A	N/A

**Table 12-37**  
**Simultaneous Transmission Scenario with 2.4 GHz WLAN Antenna 2 (Hotspot at 1.0 cm)**

Simult Tx	Configuration	Cell. CDMA SAR (W/kg)	LTE Band 12 SAR (W/kg)	2.4 GHz WLAN Antenna 2 SAR (W/kg)	Σ SAR (W/kg)	SPLSR			Simult Tx	Configuration	PCS CDMA SAR (W/kg)	LTE Band 12 SAR (W/kg)	2.4 GHz WLAN Antenna 2 SAR (W/kg)	Σ SAR (W/kg)	SPLSR		
		1	2	3	1+2+3	1+2	1+3	2+3			1	2	3	1+2+3	1+2	1+3	2+3
Body SAR	Back	0.775	0.407	0.096	1.278	N/A	N/A	N/A	Body SAR	Back	0.563	0.407	0.096	1.066	N/A	N/A	N/A
	Front	0.689	0.515	0.059	1.263	N/A	N/A	N/A		Front	0.451	0.515	0.059	1.025	N/A	N/A	N/A
	Top	-	-	0.024	0.024	N/A	N/A	N/A		Top	-	-	0.024	0.024	N/A	N/A	N/A
	Bottom	0.511	0.345	-	0.856	N/A	N/A	N/A		Bottom	0.433	0.345	-	0.778	N/A	N/A	N/A
	Right	0.778	-	-	0.778	N/A	N/A	N/A		Right	0.354	-	-	0.354	N/A	N/A	N/A
	Left	-	0.348	0.085	0.433	N/A	N/A	N/A		Left	-	0.348	0.085	0.433	N/A	N/A	N/A

Simult Tx	Configuration	Cell. CDMA SAR (W/kg)	LTE Band 4 (AWS) SAR (W/kg)	2.4 GHz WLAN Antenna 2 SAR (W/kg)	Σ SAR (W/kg)	SPLSR			Simult Tx	Configuration	PCS CDMA SAR (W/kg)	LTE Band 4 (AWS) SAR (W/kg)	2.4 GHz WLAN Antenna 2 SAR (W/kg)	Σ SAR (W/kg)	SPLSR		
		1	2	3	1+2+3	1+2	1+3	2+3			1	2	3	1+2+3	1+2	1+3	2+3
Body SAR	Back	0.775	0.509	0.096	1.380	N/A	N/A	N/A	Body SAR	Back	0.563	0.509	0.096	1.168	N/A	N/A	N/A
	Front	0.689	0.586	0.059	1.334	N/A	N/A	N/A		Front	0.451	0.586	0.059	1.096	N/A	N/A	N/A
	Top	-	-	0.024	0.024	N/A	N/A	N/A		Top	-	-	0.024	0.024	N/A	N/A	N/A
	Bottom	0.511	0.143	-	0.654	N/A	N/A	N/A		Bottom	0.433	0.143	-	0.576	N/A	N/A	N/A
	Right	0.778	-	-	0.778	N/A	N/A	N/A		Right	0.354	-	-	0.354	N/A	N/A	N/A
	Left	-	0.183	0.085	0.268	N/A	N/A	N/A		Left	-	0.183	0.085	0.268	N/A	N/A	N/A

FCC ID: A3LSMG900R7		<b>SAR EVALUATION REPORT</b>		Reviewed by: Quality Manager
Document S/N: OY1403190578.A3L	Test Dates: 02/03/14 - 03/31/14	DUT Type: Portable Handset	Page 69 of 79	

Simult Tx	Configuration	Cell. CDMA SAR (W/kg)	LTE Band 25 (PCS) SAR (W/kg)	2.4 GHz WLAN Antenna 2 SAR (W/kg)	Σ SAR (W/kg)	SPLSR			Simult Tx	Configuration	PCS CDMA SAR (W/kg)	LTE Band 25 (PCS) SAR (W/kg)	2.4 GHz WLAN Antenna 2 SAR (W/kg)	Σ SAR (W/kg)	SPLSR		
		1	2	3		1+2+3	1+2	1+3			2+3	1	2		3	1+2+3	1+2
Body SAR	Back	0.775	0.188	0.096	1.059	N/A	N/A	N/A	Body SAR	Back	0.563	0.188	0.096	0.847	N/A	N/A	N/A
	Front	0.689	0.566	0.059	1.314	N/A	N/A	N/A		Front	0.451	0.566	0.059	1.076	N/A	N/A	N/A
	Top	-	-	0.024	0.024	N/A	N/A	N/A		Top	-	-	0.024	0.024	N/A	N/A	N/A
	Bottom	0.511	0.101	-	0.612	N/A	N/A	N/A		Bottom	0.433	0.101	-	0.534	N/A	N/A	N/A
	Right	0.778	-	-	0.778	N/A	N/A	N/A		Right	0.354	-	-	0.354	N/A	N/A	N/A
	Left	-	0.255	0.085	0.340	N/A	N/A	N/A		Left	-	0.255	-	0.085	0.340	N/A	N/A

Table 12-38

Simultaneous Transmission Scenario with 2.4 GHz WLAN MIMO (Hotspot at 1.0 cm)



Simult Tx	Configuration	Cell. CDMA SAR (W/kg)	LTE Band 12 SAR (W/kg)	2.4 GHz WLAN MIMO SAR (W/kg)	Σ SAR (W/kg)	SPLSR			Simult Tx	Configuration	PCS CDMA SAR (W/kg)	LTE Band 12 SAR (W/kg)	2.4 GHz WLAN MIMO SAR (W/kg)	Σ SAR (W/kg)	SPLSR		
		1	2	3		1+2+3	1+2	1+3			2+3	1	2		3	1+2+3	1+2
Body SAR	Back	0.775	0.407	0.068	1.250	N/A	N/A	N/A	Body SAR	Back	0.563	0.407	0.068	1.038	N/A	N/A	N/A
	Front	0.689	0.515	0.058	1.262	N/A	N/A	N/A		Front	0.451	0.515	0.058	1.024	N/A	N/A	N/A
	Top	-	-	0.038	0.038	N/A	N/A	N/A		Top	-	-	0.038	0.038	N/A	N/A	N/A
	Bottom	0.511	0.345	-	0.856	N/A	N/A	N/A		Bottom	0.433	0.345	-	0.778	N/A	N/A	N/A
	Right	0.778	-	-	0.778	N/A	N/A	N/A		Right	0.354	-	-	0.354	N/A	N/A	N/A
	Left	-	0.348	0.030	0.378	N/A	N/A	N/A		Left	-	0.348	0.030	0.378	N/A	N/A	N/A

Simult Tx	Configuration	Cell. CDMA SAR (W/kg)	LTE Band 4 (AWS) SAR (W/kg)	2.4 GHz WLAN MIMO SAR (W/kg)	Σ SAR (W/kg)	SPLSR			Simult Tx	Configuration	PCS CDMA SAR (W/kg)	LTE Band 4 (AWS) SAR (W/kg)	2.4 GHz WLAN MIMO SAR (W/kg)	Σ SAR (W/kg)	SPLSR		
		1	2	3		1+2+3	1+2	1+3			2+3	1	2		3	1+2+3	1+2
Body SAR	Back	0.775	0.509	0.068	1.352	N/A	N/A	N/A	Body SAR	Back	0.563	0.509	0.068	1.140	N/A	N/A	N/A
	Front	0.689	0.586	0.058	1.333	N/A	N/A	N/A		Front	0.451	0.586	0.058	1.095	N/A	N/A	N/A
	Top	-	-	0.038	0.038	N/A	N/A	N/A		Top	-	-	0.038	0.038	N/A	N/A	N/A
	Bottom	0.511	0.143	-	0.654	N/A	N/A	N/A		Bottom	0.433	0.143	-	0.576	N/A	N/A	N/A
	Right	0.778	-	-	0.778	N/A	N/A	N/A		Right	0.354	-	-	0.354	N/A	N/A	N/A
	Left	-	0.183	0.030	0.213	N/A	N/A	N/A		Left	-	0.183	0.030	0.213	N/A	N/A	N/A

Table 12-39

Simultaneous Transmission Scenario (5.8 GHz Hotspot Antenna 1 at 1.0 cm)

Simult Tx	Configuration	Cell. CDMA SAR (W/kg)	LTE Band 12 SAR (W/kg)	5.8 GHz WLAN Antenna 1 SAR (W/kg)	Σ SAR (W/kg)	SPLSR			Simult Tx	Configuration	PCS CDMA SAR (W/kg)	LTE Band 12 SAR (W/kg)	5.8 GHz WLAN Antenna 1 SAR (W/kg)	Σ SAR (W/kg)	SPLSR		
		1	2	3		1+2+3	1+2	1+3			2+3	1	2		3	1+2+3	1+2
Body SAR	Back	0.775	0.407	0.162	1.344	N/A	N/A	N/A	Body SAR	Back	0.563	0.407	0.162	1.132	N/A	N/A	N/A
	Front	0.689	0.515	0.104	1.308	N/A	N/A	N/A		Front	0.451	0.515	0.104	1.070	N/A	N/A	N/A
	Top	-	-	0.305	0.305	N/A	N/A	N/A		Top	-	-	0.305	0.305	N/A	N/A	N/A
	Bottom	0.511	0.345	-	0.856	N/A	N/A	N/A		Bottom	0.433	0.345	-	0.778	N/A	N/A	N/A
	Right	0.778	-	-	0.778	N/A	N/A	N/A		Right	0.354	-	-	0.354	N/A	N/A	N/A
	Left	-	0.348	0.029	0.377	N/A	N/A	N/A		Left	-	0.348	0.029	0.377	N/A	N/A	N/A

FCC ID: A3LSMG900R7		SAR EVALUATION REPORT		Reviewed by: Quality Manager
Document S/N: OY1403190578.A3L	Test Dates: 02/03/14 - 03/31/14	DUT Type: Portable Handset	Page 70 of 79	

**Table 12-40**  
**Simultaneous Transmission Scenario (5.8 GHz Hotspot Antenna 2 at 1.0 cm)**

Simult Tx	Configuration	Cell. CDMA SAR (W/kg)	LTE Band 12 SAR (W/kg)	5.8 GHz WLAN Antenna 2 SAR (W/kg)	Σ SAR (W/kg)	SPLSR			
		1	2	3		1+2+3	1+2	1+3	2+3
Body SAR	Tx Antenna	1	2	3	1+2+3	1+2	1+3	2+3	
	Back	0.775	0.407	0.327	1.509	N/A	N/A	N/A	
	Front	0.689	0.515	0.089	1.293	N/A	N/A	N/A	
	Top	-	-	0.075	0.075	N/A	N/A	N/A	
	Bottom	0.511	0.345	-	0.856	N/A	N/A	N/A	
	Right	0.778	-	-	0.778	N/A	N/A	N/A	
Left	-	0.348	0.197	0.545	N/A	N/A	N/A		

Simult Tx	Configuration	PCS CDMA SAR (W/kg)	LTE Band 12 SAR (W/kg)	5.8 GHz WLAN Antenna 2 SAR (W/kg)	Σ SAR (W/kg)	SPLSR			
		1	2	3		1+2+3	1+2	1+3	2+3
Body SAR	Tx Antenna	1	2	3	1+2+3	1+2	1+3	2+3	
	Back	0.563	0.407	0.327	1.297	N/A	N/A	N/A	
	Front	0.451	0.515	0.089	1.055	N/A	N/A	N/A	
	Top	-	-	0.075	0.075	N/A	N/A	N/A	
	Bottom	0.433	0.345	-	0.778	N/A	N/A	N/A	
	Right	0.354	-	-	0.354	N/A	N/A	N/A	
Left	-	0.348	0.197	0.545	N/A	N/A	N/A		

Simult Tx	Configuration	Cell. CDMA SAR (W/kg)	LTE Band 4 (AWS) SAR (W/kg)	5.8 GHz WLAN Antenna 2 SAR (W/kg)	Σ SAR (W/kg)	SPLSR			
		1	2	3		1+2+3	1+2	1+3	2+3
Body SAR	Tx Antenna	1	2	3	1+2+3	1+2	1+3	2+3	
	Back	0.775	0.509	0.327	1.606	N/A	N/A	N/A	
	Front	0.689	0.586	0.089	1.364	N/A	N/A	N/A	
	Top	-	-	0.075	0.075	N/A	N/A	N/A	
	Bottom	0.511	0.143	-	0.654	N/A	N/A	N/A	
	Right	0.778	-	-	0.778	N/A	N/A	N/A	
Left	-	0.183	0.197	0.380	N/A	N/A	N/A		

Simult Tx	Configuration	Cell. CDMA SAR (W/kg)	LTE Band 25 (PCS) SAR (W/kg)	5.8 GHz WLAN Antenna 2 SAR (W/kg)	Σ SAR (W/kg)	SPLSR			
		1	2	3		1+2+3	1+2	1+3	2+3
Body SAR	Tx Antenna	1	2	3	1+2+3	1+2	1+3	2+3	
	Back	0.775	0.188	0.327	1.290	N/A	N/A	N/A	
	Front	0.689	0.566	0.089	1.344	N/A	N/A	N/A	
	Top	-	-	0.075	0.075	N/A	N/A	N/A	
	Bottom	0.511	0.101	-	0.612	N/A	N/A	N/A	
	Right	0.778	-	-	0.778	N/A	N/A	N/A	
Left	-	0.255	0.197	0.452	N/A	N/A	N/A		

Simult Tx	Configuration	PCS CDMA SAR (W/kg)	LTE Band 25 (PCS) SAR (W/kg)	5.8 GHz WLAN Antenna 2 SAR (W/kg)	Σ SAR (W/kg)	SPLSR			
		1	2	3		1+2+3	1+2	1+3	2+3
Body SAR	Tx Antenna	1	2	3	1+2+3	1+2	1+3	2+3	
	Back	0.563	0.188	0.327	1.078	N/A	N/A	N/A	
	Front	0.451	0.566	0.089	1.106	N/A	N/A	N/A	
	Top	-	-	0.075	0.075	N/A	N/A	N/A	
	Bottom	0.433	0.101	-	0.534	N/A	N/A	N/A	
	Right	0.354	-	-	0.354	N/A	N/A	N/A	
Left	-	0.255	0.197	0.452	N/A	N/A	N/A		

**Table 12-41**  
**Simultaneous Transmission Scenario (5.8 GHz Hotspot MIMO at 1.0 cm)**

Simult Tx	Configuration	Cell. CDMA SAR (W/kg)	LTE Band 12 SAR (W/kg)	5.8 GHz WLAN MIMO SAR (W/kg)	Σ SAR (W/kg)	SPLSR			
		1	2	3		1+2+3	1+2	1+3	2+3
Body SAR	Tx Antenna	1	2	3	1+2+3	1+2	1+3	2+3	
	Back	0.775	0.407	0.222	1.404	N/A	N/A	N/A	
	Front	0.689	0.515	0.032	1.236	N/A	N/A	N/A	
	Top	-	-	0.098	0.098	N/A	N/A	N/A	
	Bottom	0.511	0.345	-	0.856	N/A	N/A	N/A	
	Right	0.778	-	-	0.778	N/A	N/A	N/A	
Left	-	0.348	0.060	0.408	N/A	N/A	N/A		

Simult Tx	Configuration	PCS CDMA SAR (W/kg)	LTE Band 4 (AWS) SAR (W/kg)	5.8 GHz WLAN MIMO SAR (W/kg)	Σ SAR (W/kg)	SPLSR			
		1	2	3		1+2+3	1+2	1+3	2+3
Body SAR	Tx Antenna	1	2	3	1+2+3	1+2	1+3	2+3	
	Back	0.563	0.509	0.222	1.294	N/A	N/A	N/A	
	Front	0.451	0.586	0.032	1.069	N/A	N/A	N/A	
	Top	-	-	0.098	0.098	N/A	N/A	N/A	
	Bottom	0.433	0.143	-	0.576	N/A	N/A	N/A	
	Right	0.354	-	-	0.354	N/A	N/A	N/A	
Left	-	0.183	0.060	0.243	N/A	N/A	N/A		

Simult Tx	Configuration	Cell. CDMA SAR (W/kg)	LTE Band 25 (PCS) SAR (W/kg)	5.8 GHz WLAN MIMO SAR (W/kg)	Σ SAR (W/kg)	SPLSR			
		1	2	3		1+2+3	1+2	1+3	2+3
Body SAR	Tx Antenna	1	2	3	1+2+3	1+2	1+3	2+3	
	Back	0.775	0.188	0.222	1.185	N/A	N/A	N/A	
	Front	0.689	0.566	0.032	1.287	N/A	N/A	N/A	
	Top	-	-	0.098	0.098	N/A	N/A	N/A	
	Bottom	0.511	0.101	-	0.612	N/A	N/A	N/A	
	Right	0.778	-	-	0.778	N/A	N/A	N/A	
Left	-	0.255	0.060	0.315	N/A	N/A	N/A		



Simult Tx	Configuration	PCS CDMA SAR (W/kg)	LTE Band 25 (PCS) SAR (W/kg)	5.8 GHz WLAN MIMO SAR (W/kg)	Σ SAR (W/kg)	SPLSR			
		1	2	3		1+2+3	1+2	1+3	2+3
Body SAR	Tx Antenna	1	2	3	1+2+3	1+2	1+3	2+3	
	Back	0.563	0.188	0.222	0.973	N/A	N/A	N/A	
	Front	0.451	0.566	0.032	1.049	N/A	N/A	N/A	
	Top	-	-	0.098	0.098	N/A	N/A	N/A	
	Bottom	0.433	0.101	-	0.534	N/A	N/A	N/A	
	Right	0.354	-	-	0.354	N/A	N/A	N/A	
Left	-	0.255	0.060	0.315	N/A	N/A	N/A		

## 12.7 SPLSR Evaluation and Analysis

Per FCC KDB Publication 447498 D01v05, when the sum of the standalone transmitters is more than 1.6 W/kg, the SAR sum to peak locations can be analyzed to determine SAR distribution overlaps. When the SAR peak to location ratio (shown below) for each pair of antennas is ≤ 0.04, simultaneous SAR evaluation is not required. The distance between the transmitters was calculated using the following formula.

$$\text{Distance}_{\text{Tx1-Tx2}} = R_i = \sqrt{(x_1 - x_2)^2 + (y_1 - y_2)^2}$$

$$\text{SPLS Ratio} = \frac{(\text{SAR}_1 + \text{SAR}_2)^{1.5}}{R_i}$$

FCC ID: A3LSMG900R7		<b>SAR EVALUATION REPORT</b>		Reviewed by: Quality Manager
Document S/N: OY1403190578.A3L	Test Dates: 02/03/14 - 03/31/14	DUT Type: Portable Handset		Page 71 of 79

The sum of the standalone SAR values was above 1.6 W/kg for the hotspot back side configuration at a separation distance of 10 mm for Cell. CDMA and LTE Band 4 operating with 5 GHz WIFI Antenna 2.

Note: Since the standalone SAR values below were measured at a separation distance of 10 mm, then they are more conservative than the body-worn back side configuration SAR values at 15 mm for Cell. CDMA and LTE Band 4 operating with 5 GHz WIFI Antenna 2. Therefore, the SPLSR analysis below is more conservative. “<” in Table 12-33 denotes that the 10 mm SAR values were used for the respective modes for SPLSR analysis.

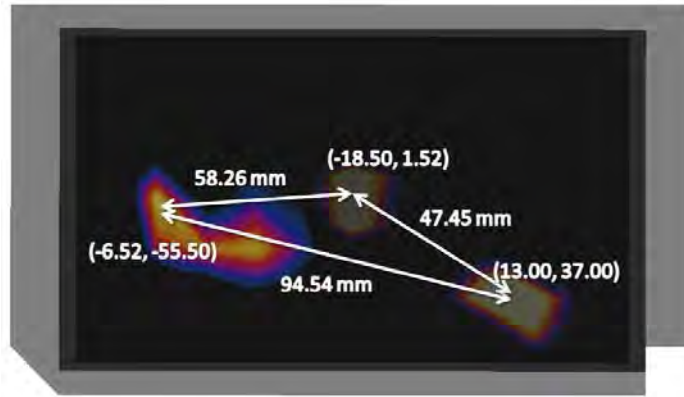

**Figure 12-1**  
Peak SAR Location Plot of Cell. CDMA, LTE Band 4, and 5 GHz WLAN Antenna 2

**Table 12-42**  
Peak SAR Locations for Body Back Side at 1.5 cm Cell. CDMA, LTE Band 4, and 5 GHz WLAN Antenna 2



Mode/Band	x (mm)	y (mm)
Cell. CDMA	-18.50	1.52
LTE Band 4	-6.52	-55.50
5 GHz WLAN Antenna 2	13.00	37.00

**Table 12-43**  
SAR Sum to Peak Location Separation Ratio Calculation

Antenna Pair		Standalone 1g SAR (W/kg)		Standalone SAR Sum (W/kg)	Peak SAR Separation Distance (mm)	SPLS Ratio
Ant "a"	Ant "b"	a	b	a+b	$D_{a-b}$	$(a+b)^{1.5}/D_{a-b}$
Cell. CDMA	LTE Band 4	0.775	0.509	1.284	58.26	0.02
LTE Band 4	5 GHz WLAN Antenna 2	0.509	0.351	0.86	94.54	0.01
5 GHz WLAN Antenna 2	Cell. CDMA	0.351	0.775	1.126	47.45	0.03

## 12.8 Simultaneous Transmission Conclusion

The above numerical summed SAR and SPLSR analysis results for all the worst-case simultaneous transmission conditions were below the SAR limit. Therefore, the above analysis is sufficient to determine that simultaneous transmission cases will not exceed the SAR limit and therefore no measured volumetric simultaneous SAR summation is required per FCC KDB Publication 447498 D01v05 and IEEE 1528-2013 Section 6.3.4.1.2.

FCC ID: A3LSMG900R7		SAR EVALUATION REPORT		Reviewed by: Quality Manager
Document S/N: OY1403190578.A3L	Test Dates: 02/03/14 - 03/31/14	DUT Type: Portable Handset		Page 72 of 79



## 13 SAR MEASUREMENT VARIABILITY

### 13.1 Measurement Variability

Per FCC KDB Publication 865664 D01v01, SAR measurement variability is assessed when measured SAR is  $> 0.80$  W/kg. Since highest measured SAR for this device was  $< 0.80$  W/kg, measurement variability was not assessed.

### 13.2 Measurement Uncertainty

The measured SAR was  $< 1.5$  W/kg for all frequency bands. Therefore, per KDB Publication 865664 D01v01, the extended measurement uncertainty analysis per IEEE 1528-2003 was not required.



FCC ID: A3LSMG900R7	 PCTEST ENGINEERING LABORATORY, INC.	SAR EVALUATION REPORT		Reviewed by: Quality Manager
Document S/N: 0Y1403190578.A3L	Test Dates: 02/03/14 - 03/31/14	DUT Type: Portable Handset	Page 73 of 79	

# 14 EQUIPMENT LIST

Manufacturer	Model	Description	Cal Date	Cal Interval	Cal Due	Serial Number
SPEAG	ES3DV3	SAR Probe	9/23/2013	Annual	9/23/2014	3288
SPEAG	ES3DV3	SAR Probe	4/29/2013	Annual	4/29/2014	3318
SPEAG	ES3DV3	SAR Probe	5/16/2013	Annual	5/16/2014	3263
SPEAG	ES3DV3	SAR Probe	11/20/2013	Annual	11/20/2014	3287
SPEAG	EX3DV4	SAR Probe	12/18/2013	Annual	12/18/2014	3920
SPEAG	ES3DV3	SAR Probe	4/29/2013	Annual	4/29/2014	3319
SPEAG	ES3DV2	SAR Probe	8/22/2013	Annual	8/22/2014	3022
SPEAG	EX3DV4	SAR Probe	10/23/2013	Annual	10/23/2014	3914
SPEAG	DAE4	Dasy Data Acquisition Electronics	9/17/2013	Annual	9/17/2014	1323
SPEAG	DAE4	Dasy Data Acquisition Electronics	4/22/2013	Annual	4/22/2014	1364
SPEAG	DAE4	Dasy Data Acquisition Electronics	5/13/2013	Annual	5/13/2014	859
SPEAG	DAE4	Dasy Data Acquisition Electronics	11/19/2013	Annual	11/19/2014	1408
SPEAG	DAE4	Dasy Data Acquisition Electronics	12/12/2013	Annual	12/12/2014	649
SPEAG	DAE4	Dasy Data Acquisition Electronics	4/22/2013	Annual	4/22/2014	1368
SPEAG	DAE4	Dasy Data Acquisition Electronics	8/21/2014	Annual	8/21/2014	1322
SPEAG	DAE4	Dasy Data Acquisition Electronics	11/19/2013	Annual	11/19/2014	1333
SPEAG	D750V3	750 MHz Dipole	3/18/2013	Annual	3/18/2014	1054
SPEAG	D835V2	835 MHz SAR Dipole	4/25/2013	Annual	4/25/2014	4d119
SPEAG	D1765V2	1765 MHz SAR Dipole	5/14/2013	Annual	5/14/2014	1008
SPEAG	D1900V2	1900 MHz SAR Dipole	5/2/2013	Annual	5/2/2014	5d141
SPEAG	D2450V2	2450 MHz SAR Dipole	8/23/2013	Annual	8/23/2014	719
SPEAG	D5GH2V2	5 GHz SAR Dipole	9/23/2013	Annual	9/23/2014	1007
SPEAG	D835V2	835 MHz SAR Dipole	7/17/2013	Annual	7/17/2014	4d133
SPEAG	D1900V2	1900 MHz SAR Dipole	7/22/2013	Annual	7/22/2014	5d149
SPEAG	DAK-3.5	Dielectric Assessment Kit	11/13/2013	Annual	11/13/2014	1091
SPEAG	D5GH2V2	5 GHz SAR Dipole	2/14/2013	Annual	2/14/2014	1120
SPEAG	DAKS-3.5	Portable Dielectric Assessment Kit	8/18/2013	Annual	8/18/2014	1008
Agilent	E5515C	Wireless Communications Test Set	5/9/2013	Biennial	5/9/2015	GB43304447
Agilent	8648D	(9kHz-4GHz) Signal Generator	4/17/2013	Annual	4/17/2014	3629U00687
Agilent	85047A	S-Parameter Test Set	N/A	N/A	N/A	2904A00579
Agilent	8753E	(30kHz-6GHz) Network Analyzer	7/23/2013	Annual	7/23/2014	US37390350
Agilent	N5182A	MXG Vector Signal Generator	10/28/2013	Annual	10/28/2014	US46240505
Agilent	8753ES	S-Parameter Network Analyzer	10/29/2013	Annual	10/29/2014	US39170122
Agilent	E5515C	Wireless Communications Test Set	10/18/2012	Biennial	10/18/2014	GB43193563
Agilent	8753E	(30kHz-6GHz) Network Analyzer	4/16/2013	Annual	4/16/2014	JP38020182
Agilent	E8257D	(250kHz-20GHz) Signal Generator	4/16/2013	Annual	4/16/2014	MY45470194
Agilent	8594A	(9kHz-2.9GHz) Spectrum Analyzer	N/A	N/A	N/A	3051A00187
Agilent	N9020A	MXA Signal Analyzer	10/29/2013	Annual	10/29/2014	US46470561
Amplifier Research	5S1G4	5W, 800MHz-4.2GHz	CBT	N/A	CBT	21910
Anritsu	MA2481A	Power Sensor	10/30/2013	Annual	10/30/2014	5605
Anritsu	MA24106A	USB Power Sensor	1/3/2014	Annual	1/3/2015	1344554
Anritsu	MA24106A	USB Power Sensor	1/3/2014	Annual	1/3/2015	1344557
Anritsu	MT8820C	Radio Communication Analyzer	12/12/2013	Annual	12/12/2014	6200901190
Anritsu	ML2495A	Power Meter	10/31/2013	Annual	10/31/2014	1039008
Anritsu	MA24106A	USB Power Sensor	1/3/2014	Annual	1/3/2015	1349501
Anritsu	MA24106A	USB Power Sensor	1/3/2014	Annual	1/3/2015	1349503
Anritsu	MT8820C	Radio Communication Analyzer	12/12/2013	Annual	12/12/2014	6201300731
Anritsu	MT8820C	Radio Communication Analyzer	6/28/2013	Annual	6/28/2014	6201240328
Anritsu	MA2411B	Pulse Power Sensor	11/14/2013	Annual	11/14/2014	1126066
COMTECH	AR85729-5/5759B	Solid State Amplifier	CBT	N/A	CBT	M3W1A00-1002
Gigatronics	8651A	Universal Power Meter	10/30/2013	Annual	10/30/2014	8650319
Gigatronics	80701A	(0.05-18GHz) Power Sensor	10/30/2013	Annual	10/30/2014	1833460
MCL	BW-N6W5+	6dB Attenuator	CBT	N/A	CBT	1139
MiniCircuits	VLF-6000+	Low Pass Filter	CBT	N/A	CBT	N/A
MiniCircuits	VLF-6000+	Low Pass Filter	CBT	N/A	CBT	N/A
MiniCircuits	SLP-2400+	Low Pass Filter	CBT	N/A	CBT	R8979500903
Mini-Circuits	NLP-2950+	Low Pass Filter DC to 2700 MHz	CBT	N/A	CBT	N/A
Mini-Circuits	NLP-1200+	Low Pass Filter DC to 1000 MHz	CBT	N/A	CBT	N/A
Mini-Circuits	BW-N20W5	Power Attenuator	CBT	N/A	CBT	1226
Mini-Circuits	BW-N20W5+	DC to 18 GHz Precision Fixed 20 dB Attenuator	CBT	N/A	CBT	N/A
Narda	BW-S3W2	Attenuator (3dB)	CBT	N/A	CBT	120
Narda	4772-3	Attenuator (3dB)	CBT	N/A	CBT	9406
Narda	4014C-6	4 - 8 GHz SMA 6 dB Directional Coupler	CBT	N/A	CBT	N/A
Pasternack	PE2209-10	Bidirectional Coupler	CBT	N/A	CBT	N/A
Pasternack	PE2208-6	Bidirectional Coupler	CBT	N/A	CBT	N/A
Rohde & Schwarz	SME06	Signal Generator	10/30/2013	Annual	10/30/2014	832026
Rohde & Schwarz	CMW500	LTE Radio Communication Tester	10/4/2013	Annual	10/4/2014	108798
Rohde & Schwarz	SMIQ03B	Signal Generator	4/17/2013	Annual	4/17/2014	DE27259
Rohde & Schwarz	CMW500	LTE Radio Communication Tester	8/5/2011	Annual	8/5/2012	112347
Rohde & Schwarz	NRVD	Dual Channel Power Meter	10/12/2012	Biennial	10/12/2014	101695
Rohde & Schwarz	NRV-232	Peak Power Sensor	10/12/2012	Biennial	10/12/2014	836019/013
Rohde & Schwarz	NRVS	Single Channel Power Meter	10/31/2013	Annual	10/31/2014	835360/0079
Seekonk	NC-100	Torque Wrench (8" lb)	11/29/2011	Triennial	11/29/2014	21053
Seekonk	NC-100	Torque Wrench (8" lb)	3/5/2012	Triennial	3/5/2015	N/A
Seekonk	NC-100	Torque Wrench (8" lb)	3/5/2012	Triennial	3/5/2015	N/A
SPEAG	DAK-3.5	Dielectric Assessment Kit	5/14/2013	Annual	5/14/2014	1070
Tektronix	RSA6114A	Real Time Spectrum Analyzer	4/17/2013	Annual	4/17/2014	B010177
VWR	23226-658	Long Stem Thermometer	6/27/2012	Biennial	6/27/2014	122363923
VWR	23226-658	Long Stem Thermometer	7/11/2012	Biennial	7/11/2014	122389334
VWR	36934-158	Wall-Mounted Thermometer	8/8/2013	Annual	8/8/2014	130258636
VWR	36934-158	Wall-Mounted Thermometer	8/8/2013	Annual	8/8/2014	130477877

Note:

1. CBT (Calibrated Before Testing). Prior to testing, the measurement paths containing a cable, amplifier, attenuator, coupler or filter were connected to a calibrated source (i.e. a signal generator) to determine the losses of the measurement path. The power meter offset was then adjusted to compensate for the measurement system losses. This level offset is stored within the power meter before measurements are made. This calibration verification procedure applies to the system verification and output power measurements. The calibrated reading is then taken directly from the power meter after compensation of the losses for all final power measurements.
2. Each equipment was used solely within its valid calibration period.



FCC ID: A3LSMG900R7		SAR EVALUATION REPORT		Reviewed by: Quality Manager
Document S/N: OY1403190578.A3L	Test Dates: 02/03/14 - 03/31/14	DUT Type: Portable Handset		Page 74 of 79

# 15 MEASUREMENT UNCERTAINTIES

Applicable for frequencies less than 3000 MHz.

a	b	c	d	e= f(d,k)	f	g	h = c x f/e	i = c x g/e	k
Uncertainty Component	IEEE 1528 Sec.	Tol. (± %)	Prob. Dist.	Div.	c <sub>i</sub> 1gm	c <sub>i</sub> 10 gms	1gm u <sub>i</sub> (± %)	10gms u <sub>i</sub> (± %)	v <sub>i</sub>
<b>Measurement System</b>									
Probe Calibration	E.2.1	6.0	N	1	1.0	1.0	6.0	6.0	∞
Axial Isotropy	E.2.2	0.25	N	1	0.7	0.7	0.2	0.2	∞
Hemishperical Isotropy	E.2.2	1.3	N	1	1.0	1.0	1.3	1.3	∞
Boundary Effect	E.2.3	0.4	N	1	1.0	1.0	0.4	0.4	∞
Linearity	E.2.4	0.3	N	1	1.0	1.0	0.3	0.3	∞
System Detection Limits	E.2.5	5.1	N	1	1.0	1.0	5.1	5.1	∞
Readout Electronics	E.2.6	1.0	N	1	1.0	1.0	1.0	1.0	∞
Response Time	E.2.7	0.8	R	1.73	1.0	1.0	0.5	0.5	∞
Integration Time	E.2.8	2.6	R	1.73	1.0	1.0	1.5	1.5	∞
RF Ambient Conditions	E.6.1	3.0	R	1.73	1.0	1.0	1.7	1.7	∞
Probe Positioner Mechanical Tolerance	E.6.2	0.4	R	1.73	1.0	1.0	0.2	0.2	∞
Probe Positioning w/ respect to Phantom	E.6.3	2.9	R	1.73	1.0	1.0	1.7	1.7	∞
Extrapolation, Interpolation & Integration algorithms for Max. SAR Evaluation	E.5	1.0	R	1.73	1.0	1.0	0.6	0.6	∞
<b>Test Sample Related</b>									
Test Sample Positioning	E.4.2	6.0	N	1	1.0	1.0	6.0	6.0	287
Device Holder Uncertainty	E.4.1	3.32	R	1.73	1.0	1.0	1.9	1.9	∞
Output Power Variation - SAR drift measurement	6.6.2	5.0	R	1.73	1.0	1.0	2.9	2.9	∞
<b>Phantom &amp; Tissue Parameters</b>									
Phantom Uncertainty (Shape & Thickness tolerances)	E.3.1	4.0	R	1.73	1.0	1.0	2.3	2.3	∞
Liquid Conductivity - deviation from target values	E.3.2	5.0	R	1.73	0.64	0.43	1.8	1.2	∞
Liquid Conductivity - measurement uncertainty	E.3.3	3.8	N	1	0.64	0.43	2.4	1.6	6
Liquid Permittivity - deviation from target values	E.3.2	5.0	R	1.73	0.60	0.49	1.7	1.4	∞
Liquid Permittivity - measurement uncertainty	E.3.3	4.5	N	1	0.60	0.49	2.7	2.2	6
<b>Combined Standard Uncertainty (k=1)</b>				RSS			12.1	11.7	299
<b>Expanded Uncertainty</b> (95% CONFIDENCE LEVEL)				k=2			24.2	23.5	



The above measurement uncertainties are according to IEEE Std. 1528-2003

FCC ID: A3LSMG900R7	 <b>PCTEST</b> ENGINEERING LABORATORY, INC.	<b>SAR EVALUATION REPORT</b>		<b>Reviewed by:</b> Quality Manager
<b>Document S/N:</b> 0Y1403190578.A3L	<b>Test Dates:</b> 02/03/14 - 03/31/14	<b>DUT Type:</b> Portable Handset	Page 75 of 79	

Applicable for frequencies up to 6 GHz.

a	b	c	d	e= f(d,k)	f	g	h = c x f/e	i = c x g/e	k	
Uncertainty Component	IEEE 1528 Sec.	Tol. (± %)	Prob. Dist.	Div.	c <sub>i</sub> 1gm	c <sub>i</sub> 10 gms	1gm u <sub>i</sub> (± %)	10gms u <sub>i</sub> (± %)	v <sub>i</sub>	
<b>Measurement System</b>										
Probe Calibration	E.2.1	6.55	N	1	1.0	1.0	6.6	6.6	∞	
Axial Isotropy	E.2.2	0.25	N	1	0.7	0.7	0.2	0.2	∞	
Hemishperical Isotropy	E.2.2	1.3	N	1	1.0	1.0	1.3	1.3	∞	
Boundary Effect	E.2.3	0.4	N	1	1.0	1.0	0.4	0.4	∞	
Linearity	E.2.4	0.3	N	1	1.0	1.0	0.3	0.3	∞	
System Detection Limits	E.2.5	5.1	N	1	1.0	1.0	5.1	5.1	∞	
Readout Electronics	E.2.6	1.0	N	1	1.0	1.0	1.0	1.0	∞	
Response Time	E.2.7	0.8	R	1.73	1.0	1.0	0.5	0.5	∞	
Integration Time	E.2.8	2.6	R	1.73	1.0	1.0	1.5	1.5	∞	
RF Ambient Conditions	E.6.1	3.0	R	1.73	1.0	1.0	1.7	1.7	∞	
Probe Positioner Mechanical Tolerance	E.6.2	0.4	R	1.73	1.0	1.0	0.2	0.2	∞	
Probe Positioning w/ respect to Phantom	E.6.3	2.9	R	1.73	1.0	1.0	1.7	1.7	∞	
Extrapolation, Interpolation & Integration algorithms for Max. SAR Evaluation	E.5	1.0	R	1.73	1.0	1.0	0.6	0.6	∞	
<b>Test Sample Related</b>										
Test Sample Positioning	E.4.2	6.0	N	1	1.0	1.0	6.0	6.0	287	
Device Holder Uncertainty	E.4.1	3.32	R	1.73	1.0	1.0	1.9	1.9	∞	
Output Power Variation - SAR drift measurement	6.6.2	5.0	R	1.73	1.0	1.0	2.9	2.9	∞	
<b>Phantom &amp; Tissue Parameters</b>										
Phantom Uncertainty (Shape & Thickness tolerances)	E.3.1	4.0	R	1.73	1.0	1.0	2.3	2.3	∞	
Liquid Conductivity - deviation from target values	E.3.2	5.0	R	1.73	0.64	0.43	1.8	1.2	∞	
Liquid Conductivity - measurement uncertainty	E.3.3	3.8	N	1	0.64	0.43	2.4	1.6	6	
Liquid Permittivity - deviation from target values	E.3.2	5.0	R	1.73	0.60	0.49	1.7	1.4	∞	
Liquid Permittivity - measurement uncertainty	E.3.3	4.5	N	1	0.60	0.49	2.7	2.2	6	
<b>Combined Standard Uncertainty (k=1)</b>							RSS	12.4	12.0	299
<b>Expanded Uncertainty</b> (95% CONFIDENCE LEVEL)							k=2	24.7	24.0	

The above measurement uncertainties are according to IEEE Std. 1528-2003



FCC ID: A3LSMG900R7		<b>SAR EVALUATION REPORT</b>		<b>Reviewed by:</b> Quality Manager
<b>Document S/N:</b> OY1403190578.A3L	<b>Test Dates:</b> 02/03/14 - 03/31/14	<b>DUT Type:</b> Portable Handset		Page 76 of 79

## 16 CONCLUSION

### 16.1 Measurement Conclusion



The SAR evaluation indicates that the EUT complies with the RF radiation exposure limits of the FCC and Industry Canada, with respect to all parameters subject to this test. These measurements were taken to simulate the RF effects of RF exposure under worst-case conditions. Precise laboratory measures were taken to assure repeatability of the tests. The results and statements relate only to the item(s) tested.

Please note that the absorption and distribution of electromagnetic energy in the body are very complex phenomena that depend on the mass, shape, and size of the body, the orientation of the body with respect to the field vectors, and the electrical properties of both the body and the environment. Other variables that may play a substantial role in possible biological effects are those that characterize the environment (e.g. ambient temperature, air velocity, relative humidity, and body insulation) and those that characterize the individual (e.g. age, gender, activity level, debilitation, or disease). Because various factors may interact with one another to vary the specific biological outcome of an exposure to electromagnetic fields, any protection guide should consider maximal amplification of biological effects as a result of field-body interactions, environmental conditions, and physiological variables. [3]



<b>FCC ID:</b> A3LSMG900R7		<b>SAR EVALUATION REPORT</b>		<b>Reviewed by:</b> Quality Manager
<b>Document S/N:</b> 0Y1403190578.A3L	<b>Test Dates:</b> 02/03/14 - 03/31/14	<b>DUT Type:</b> Portable Handset	Page 77 of 79	

## 17 REFERENCES

- [1] Federal Communications Commission, ET Docket 93-62, Guidelines for Evaluating the Environmental Effects of Radiofrequency Radiation, Aug. 1996.
- [2] ANSI/IEEE C95.1-2005, American National Standard safety levels with respect to human exposure to radio frequency electromagnetic fields, 3kHz to 300GHz, New York: IEEE, 2006.
- [3] ANSI/IEEE C95.1-1992, American National Standard safety levels with respect to human exposure to radio frequency electromagnetic fields, 3kHz to 300GHz, New York: IEEE, Sept. 1992.
- [4] ANSI/IEEE C95.3-2002, IEEE Recommended Practice for the Measurement of Potentially Hazardous Electromagnetic Fields - RF and Microwave, New York: IEEE, December 2002.
- [5] IEEE Standards Coordinating Committee 39 –Standards Coordinating Committee 34 – IEEE Std. 1528-2003, Recommended Practice for Determining the Peak Spatial-Average Specific Absorption Rate (SAR) in the Human Body Due to Wireless Communications Devices.
- [6] NCRP, National Council on Radiation Protection and Measurements, Biological Effects and Exposure Criteria for RadioFrequency Electromagnetic Fields, NCRP Report No. 86, 1986. Reprinted Feb. 1995.
- [7] T. Schmid, O. Egger, N. Kuster, Automated E-field scanning system for dosimetric assessments, IEEE Transaction on Microwave Theory and Techniques, vol. 44, Jan. 1996, pp. 105-113.
- [8] K. Pokovic, T. Schmid, N. Kuster, Robust setup for precise calibration of E-field probes in tissue simulating liquids at mobile communications frequencies, ICECOM97, Oct. 1997, pp. -124.
- [9] K. Pokovic, T. Schmid, and N. Kuster, E-field Probe with improved isotropy in brain simulating liquids, Proceedings of the ELMAR, Zadar, Croatia, June 23-25, 1996, pp. 172-175.
- [10] Schmid & Partner Engineering AG, Application Note: Data Storage and Evaluation, June 1998, p2.
- [11] V. Hombach, K. Meier, M. Burkhardt, E. Kuhn, N. Kuster, The Dependence of EM Energy Absorption upon Human Modeling at 900 MHz, IEEE Transaction on Microwave Theory and Techniques, vol. 44 no. 10, Oct. 1996, pp. 1865-1873.
- [12] N. Kuster and Q. Balzano, Energy absorption mechanism by biological bodies in the near field of dipole antennas above 300MHz, IEEE Transaction on Vehicular Technology, vol. 41, no. 1, Feb. 1992, pp. 17-23.
- [13] G. Hartsgrove, A. Kraszewski, A. Surowiec, Simulated Biological Materials for Electromagnetic Radiation Absorption Studies, University of Ottawa, Bioelectromagnetics, Canada: 1987, pp. 29-36.
- [14] Q. Balzano, O. Garay, T. Manning Jr., Electromagnetic Energy Exposure of Simulated Users of Portable Cellular Telephones, IEEE Transactions on Vehicular Technology, vol. 44, no.3, Aug. 1995.
- [15] W. Gander, Computermathematick, Birkhaeuser, Basel, 1992.
- [16] W.H. Press, S.A. Teukolsky, W.T. Vetterling, and B.P. Flannery, Numerical Recipes in C, The Art of Scientific Computing, Second edition, Cambridge University Press, 1992.
- [17] N. Kuster, R. Kastle, T. Schmid, Dosimetric evaluation of mobile communications equipment with known precision, IEEE Transaction on Communications, vol. E80-B, no. 5, May 1997, pp. 645-652.

FCC ID: A3LSMG900R7	 <b>PCTEST</b> ENGINEERING LABORATORY, INC.	<b>SAR EVALUATION REPORT</b>		<b>Reviewed by:</b> Quality Manager
<b>Document S/N:</b> OY1403190578.A3L	<b>Test Dates:</b> 02/03/14 - 03/31/14	<b>DUT Type:</b> Portable Handset	Page 78 of 79	

- [18] CENELEC CLC/SC111B, European Prestandard (prENV 50166-2), Human Exposure to Electromagnetic Fields High-frequency: 10kHz-300GHz, Jan. 1995.
- [19] Prof. Dr. Niels Kuster, ETH, Eidgenössische Technische Hochschule Zürich, Dosimetric Evaluation of the Cellular Phone.
- [20] IEC 62209-1, Human exposure to radio frequency fields from hand-held and body-mounted wireless communication devices - Human models, instrumentation, and procedures - Part 1: Procedure to determine the specific absorption rate (SAR) for hand-held devices used in close proximity to the ear (frequency range of 300 MHz to 3 GHz), Feb. 2005.
- [21] Industry Canada RSS-102 Radio Frequency Exposure Compliance of Radiocommunication Apparatus (All Frequency Bands) Issue 4, March 2010.
- [22] Health Canada Safety Code 6 Limits of Human Exposure to Radio Frequency Electromagnetic Fields in the Frequency Range from 3 kHz – 300 GHz, 2009
- [23] FCC SAR Test Procedures for 2G-3G Devices, Mobile Hotspot and UMPC Devices KDB Publications 941225, D01-D07
- [24] SAR Measurement procedures for IEEE 802.11a/b/g KDB Publication 248227 D01v01r02
- [25] FCC SAR Considerations for Handsets with Multiple Transmitters and Antennas, KDB Publications 648474 D02-D04
- [26] FCC SAR Evaluation Considerations for Laptop, Notebook, Netbook and Tablet Computers, FCC KDB Publication 616217 D04
- [27] FCC SAR Measurement and Reporting Requirements for 100MHz – 6 GHz, KDB Publications 865664 D01-D02
- [28] FCC General RF Exposure Guidance and SAR Procedures for Dongles, KDB Publication 447498, D01-D02
- [29] Anexo à Resolução No. 533, de 10 de Setembro de 2009.
- [30] IEC 62209-2, Human exposure to radio frequency fields from hand-held and body-mounted wireless communication devices - Human models, instrumentation, and procedures - Part 2: Procedure to determine the specific absorption rate (SAR) for wireless communication devices used in close proximity to the human body (frequency range of 30 MHz to 6 GHz), Mar. 2010.

<b>FCC ID:</b> A3LSMG900R7	 <b>PCTEST</b> ENGINEERING LABORATORY, INC.	<b>SAR EVALUATION REPORT</b>		<b>Reviewed by:</b> Quality Manager
<b>Document S/N:</b> 0Y1403190578.A3L	<b>Test Dates:</b> 02/03/14 - 03/31/14	<b>DUT Type:</b> Portable Handset	Page 79 of 79	

## APPENDIX A: SAR TEST DATA

# PCTEST ENGINEERING LABORATORY, INC.

**DUT: A3LSMG900R7; Type: Portable Handset; Serial: 32EF0**

Communication System: UID 0, CDMA; Frequency: 836.52 MHz; Duty Cycle: 1:1

Medium: 835 Head Medium parameters used (interpolated):

$f = 836.52 \text{ MHz}$ ;  $\sigma = 0.907 \text{ S/m}$ ;  $\epsilon_r = 41.173$ ;  $\rho = 1000 \text{ kg/m}^3$

Phantom section: Right Section

Test Date: 02-17-2014; Ambient Temp: 24.3°C; Tissue Temp: 22.9°C

Probe: ES3DV3 - SN3318; ConvF(6.33, 6.33, 6.33); Calibrated: 4/29/2013;

Sensor-Surface: 4mm (Mechanical Surface Detection)

Electronics: DAE4 Sn1364; Calibrated: 4/22/2013

Phantom: SAM; Type: QD000P40CD; Serial: TP:1758

Measurement SW: DASY52, Version 52.8 (7); SEMCAD X Version 14.6.10 (7164)

**Mode: Cell. CDMA, Right Head, Cheek, Mid.ch, Standard Cover**

**Area Scan (8x15x1):** Measurement grid: dx=15mm, dy=15mm

**Zoom Scan (5x5x7)/Cube 0:** Measurement grid: dx=8mm, dy=8mm, dz=5mm

Reference Value = 24.868 V/m; Power Drift = 0.05 dB

Peak SAR (extrapolated) = 0.664 W/kg

**SAR(1 g) = 0.533 W/kg**

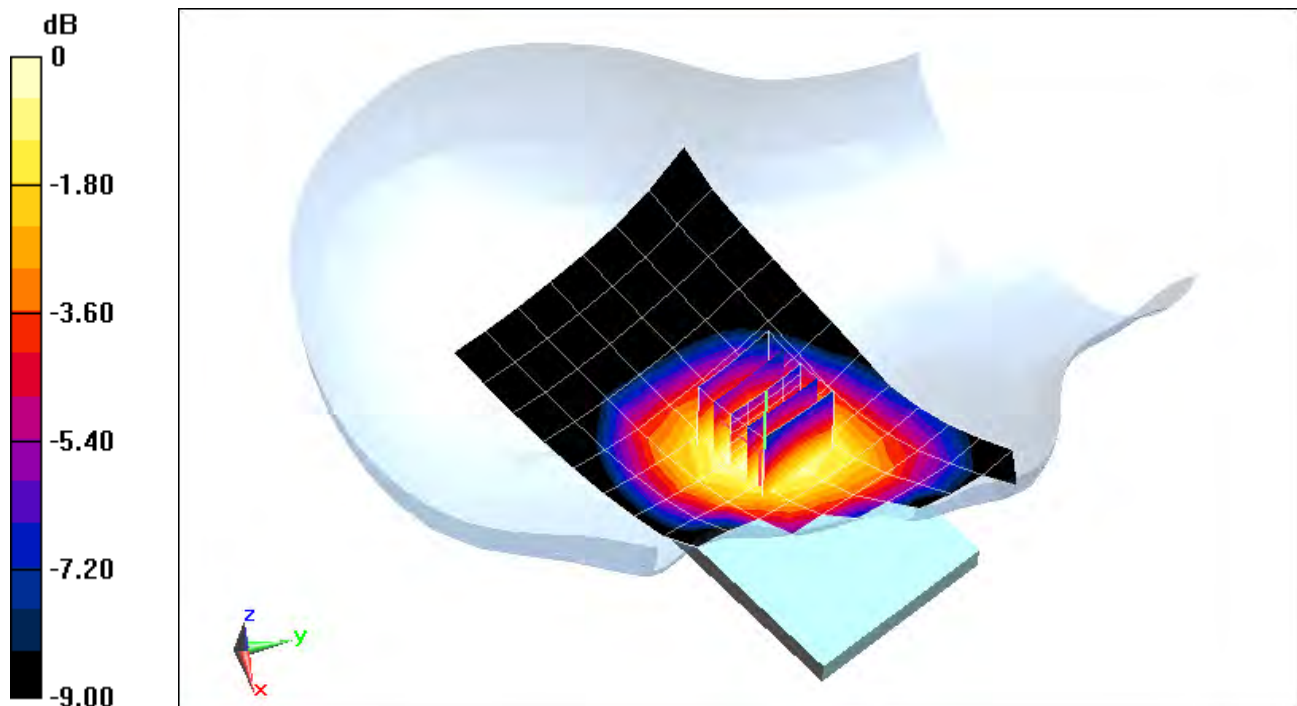

0 dB = 0.561 W/kg = -2.51 dBW/kg

# PCTEST ENGINEERING LABORATORY, INC.

**DUT: A3LSMG900R7; Type: Portable Handset; Serial: 32EC6**

Communication System: UID 0, PCS EVDO; Frequency: 1880 MHz; Duty Cycle: 1:1

Medium: 1900 Head Medium parameters used:

$f = 1880 \text{ MHz}$ ;  $\sigma = 1.427 \text{ S/m}$ ;  $\epsilon_r = 38.295$ ;  $\rho = 1000 \text{ kg/m}^3$

Phantom section: Right Section

Test Date: 02-19-2014; Ambient Temp: 23.7°C; Tissue Temp: 21.9°C

Probe: ES3DV3 - SN3263; ConvF(5.11, 5.11, 5.11); Calibrated: 5/16/2013;

Sensor-Surface: 4mm (Mechanical Surface Detection)

Electronics: DAE4 Sn859; Calibrated: 5/13/2013

Phantom: SAM Main; Type: SAM 4.0; Serial: TP-1406

Measurement SW: DASY4, Version 4.7 (80); SEMCAD X Version 14.6.10 (7164)

**Mode: PCS EVDO Rev. A, Right Head, Cheek, Mid.ch, Wireless Charging Cover**

**Area Scan (8x13x1):** Measurement grid: dx=15mm, dy=15mm

**Zoom Scan (5x5x7)/Cube 0:** Measurement grid: dx=8mm, dy=8mm, dz=5mm

Reference Value = 20.433 V/m; Power Drift = 0.03 dB

Peak SAR (extrapolated) = 0.870 W/kg

**SAR(1 g) = 0.543 W/kg**

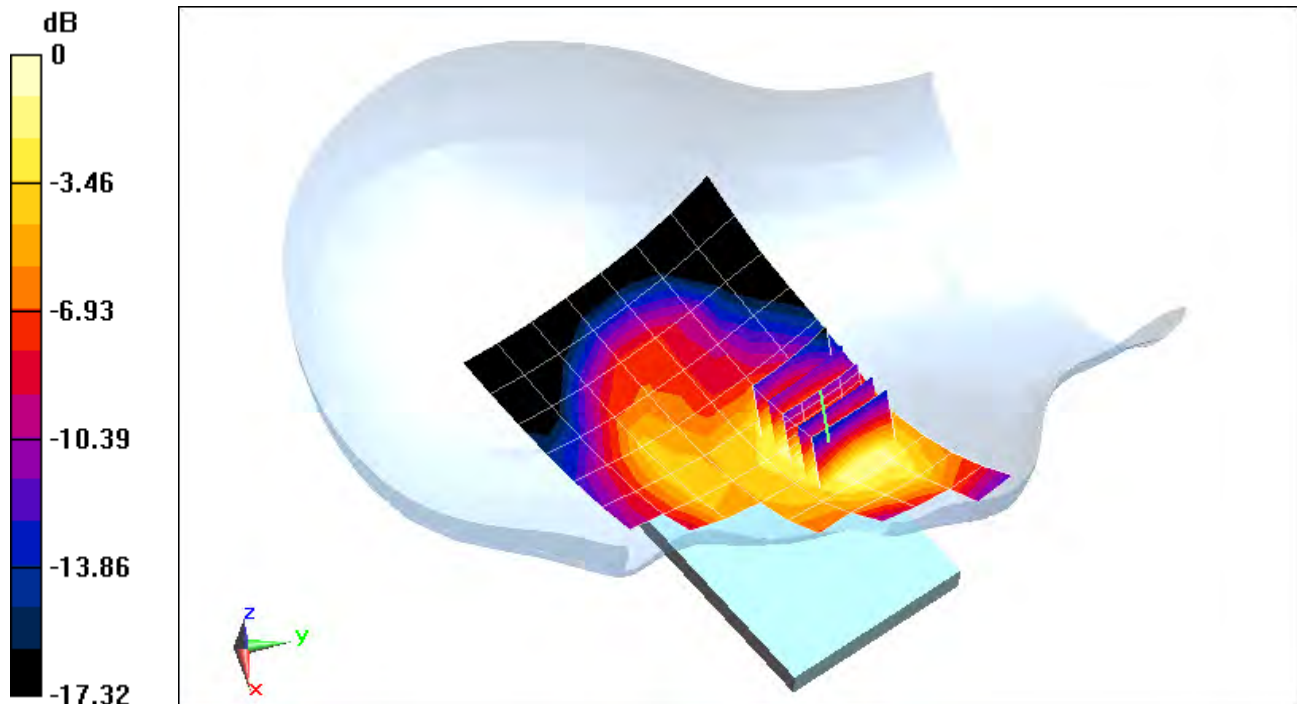

0 dB = 0.595 W/kg = -2.25 dBW/kg

# PCTEST ENGINEERING LABORATORY, INC.

**DUT: A3LSMG900R7; Type: Portable Handset; Serial: 32EC6**

Communication System: UID 0, LTE RF; Frequency: 707.5 MHz; Duty Cycle: 1:1

Medium: 750 Head Medium parameters used (interpolated):

$f = 707.5 \text{ MHz}$ ;  $\sigma = 0.892 \text{ S/m}$ ;  $\epsilon_r = 43.837$ ;  $\rho = 1000 \text{ kg/m}^3$

Phantom section: Left Section

Test Date: 02-17-2014; Ambient Temp: 23.2°C; Tissue Temp: 22.6°C

Probe: ES3DV3 - SN3288; ConvF(6.56, 6.56, 6.56); Calibrated: 9/23/2013;

Sensor-Surface: 4mm (Mechanical Surface Detection)

Electronics: DAE4 Sn1323; Calibrated: 9/17/2013

Phantom: SAM Sub Dasy B; Type: SAM 5.0; Serial: TP-1626

Measurement SW: DASY4, Version 4.7 (80); SEMCAD X Version 14.6.10 (7164)

**Mode: LTE Band 12, Left Head, Cheek, Mid.ch,  
10 MHz Bandwidth, QPSK, 1 RB, 0 RB Offset, Standard Cover**

**Area Scan (9x15x1):** Measurement grid: dx=15mm, dy=15mm

**Zoom Scan (5x5x7)/Cube 0:** Measurement grid: dx=8mm, dy=8mm, dz=5mm

Reference Value = 19.836 V/m; Power Drift = 0.06 dB

Peak SAR (extrapolated) = 0.365 W/kg

**SAR(1 g) = 0.305 W/kg**

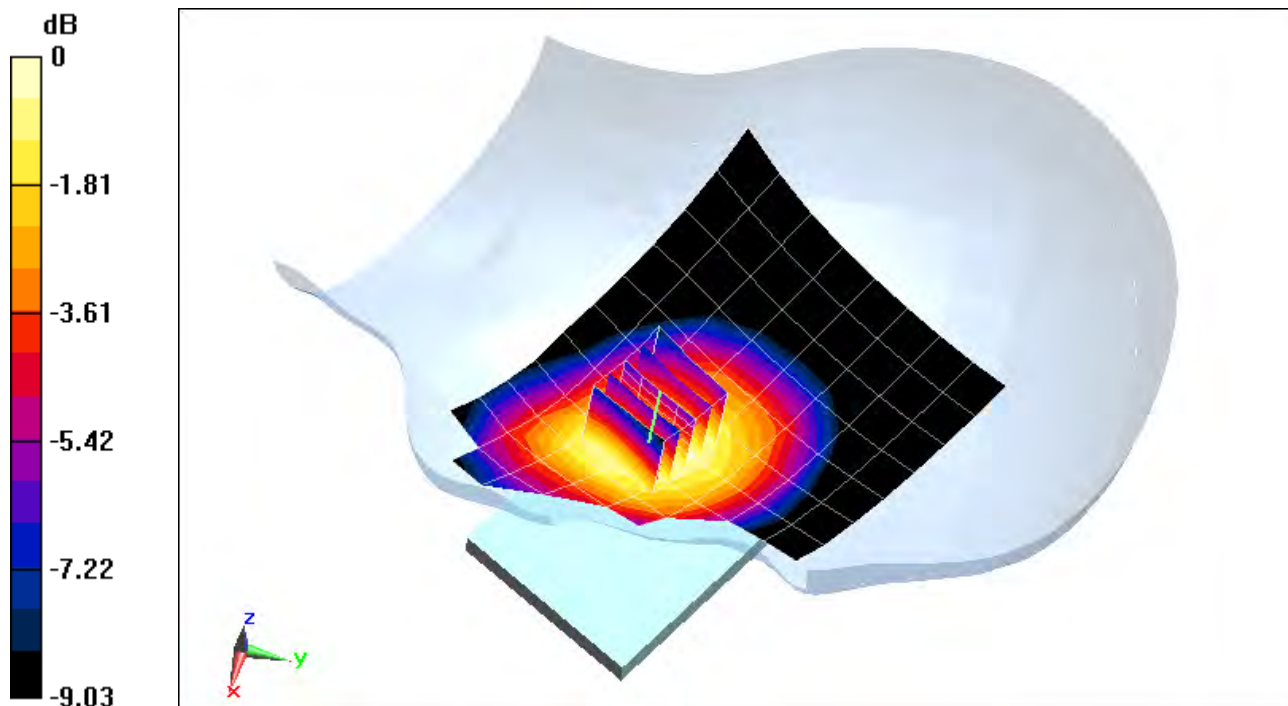

0 dB = 0.319 W/kg = -4.96 dBW/kg

# PCTEST ENGINEERING LABORATORY, INC.

**DUT: A3LSMG900R7; Type: Portable Handset; Serial: 32EC6**

Communication System: UID 0, LTE RF; Frequency: 1715 MHz; Duty Cycle: 1:1

Medium: 1750 Head Medium parameters used (interpolated):

$f = 1715 \text{ MHz}$ ;  $\sigma = 1.364 \text{ S/m}$ ;  $\epsilon_r = 38.643$ ;  $\rho = 1000 \text{ kg/m}^3$

Phantom section: Left Section

Test Date: 02-18-2014; Ambient Temp: 23.4°C; Tissue Temp: 22.9°C

Probe: ES3DV3 - SN3288; ConvF(5.67, 5.67, 5.67); Calibrated: 9/23/2013;

Sensor-Surface: 4mm (Mechanical Surface Detection)

Electronics: DAE4 Sn1323; Calibrated: 9/17/2013

Phantom: SAM Sub Dasy B; Type: SAM 5.0; Serial: TP-1626

Measurement SW: DASY4, Version 4.7 (80); SEMCAD X Version 14.6.10 (7164)

**Mode: LTE Band 4 (AWS), Left Head, Cheek, Low.ch,  
10 MHz Bandwidth, QPSK, 1 RB, 0 RB Offset, Standard Cover**

**Area Scan (9x15x1):** Measurement grid: dx=15mm, dy=15mm

**Zoom Scan (5x5x7)/Cube 0:** Measurement grid: dx=8mm, dy=8mm, dz=5mm

Reference Value = 18.145 V/m; Power Drift = -0.04 dB

Peak SAR (extrapolated) = 0.563 W/kg

**SAR(1 g) = 0.382 W/kg**

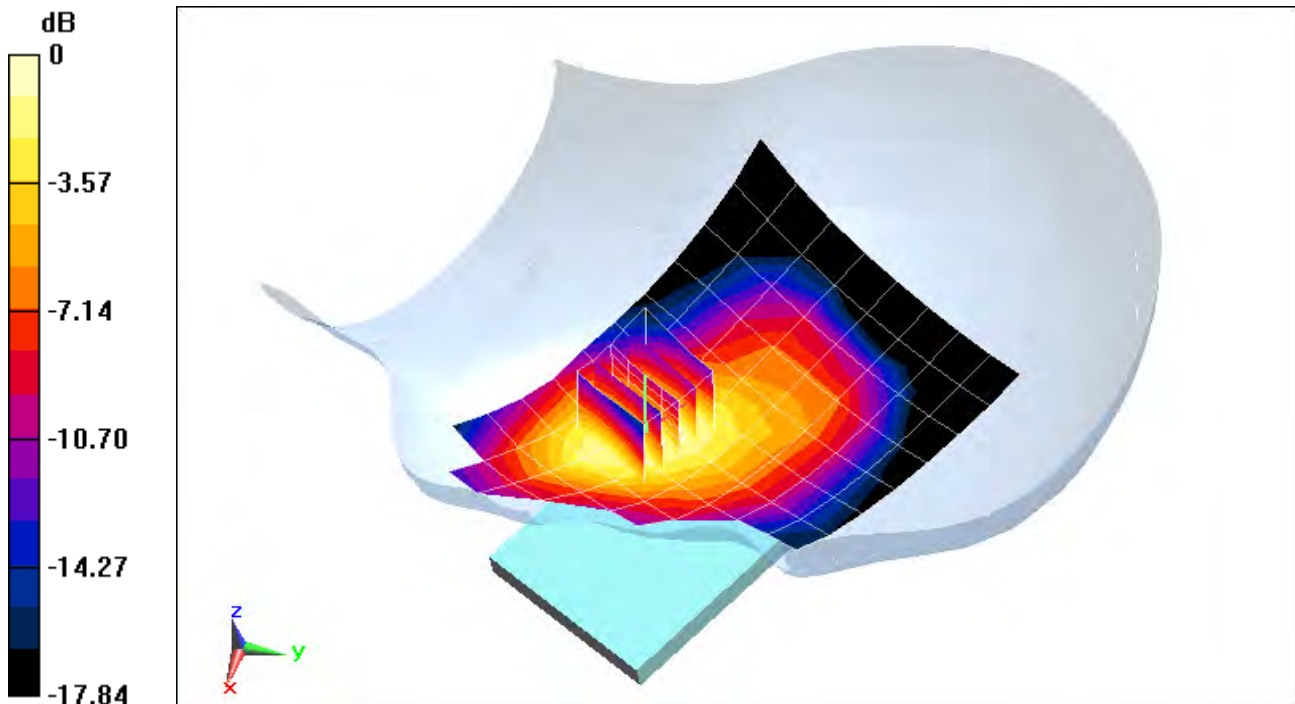

0 dB = 0.410 W/kg = -3.87 dBW/kg

# PCTEST ENGINEERING LABORATORY, INC.

**DUT: A3LSMG900R7; Type: Portable Handset; Serial: 32EC6**

Communication System: UID 0, LTE PCS 10 Mhz; Frequency: 1910 MHz; Duty Cycle: 1:1

Medium: 1900 Head Medium parameters used (interpolated):

$f = 1910 \text{ MHz}$ ;  $\sigma = 1.459 \text{ S/m}$ ;  $\epsilon_r = 38.171$ ;  $\rho = 1000 \text{ kg/m}^3$

Phantom section: Left Section

Test Date: 02-19-2014; Ambient Temp: 23.7°C; Tissue Temp: 21.9°C

Probe: ES3DV3 - SN3263; ConvF(5.11, 5.11, 5.11); Calibrated: 5/16/2013;

Sensor-Surface: 4mm (Mechanical Surface Detection)

Electronics: DAE4 Sn859; Calibrated: 5/13/2013

Phantom: SAM Main; Type: SAM 4.0; Serial: TP-1406

Measurement SW: DASY4, Version 4.7 (80); SEMCAD X Version 14.6.10 (7164)

**Mode: LTE Band 25 (PCS), Left Head, Cheek, High.Ch,  
10 MHz Bandwidth, QPSK, 1 RB, 0 RB Offset, Standard Cover**

**Area Scan (8x13x1):** Measurement grid: dx=15mm, dy=15mm

**Zoom Scan (5x5x7)/Cube 0:** Measurement grid: dx=8mm, dy=8mm, dz=5mm

Reference Value = 22.020 V/m; Power Drift = 0.04 dB

Peak SAR (extrapolated) = 0.942 W/kg

**SAR(1 g) = 0.613 W/kg**

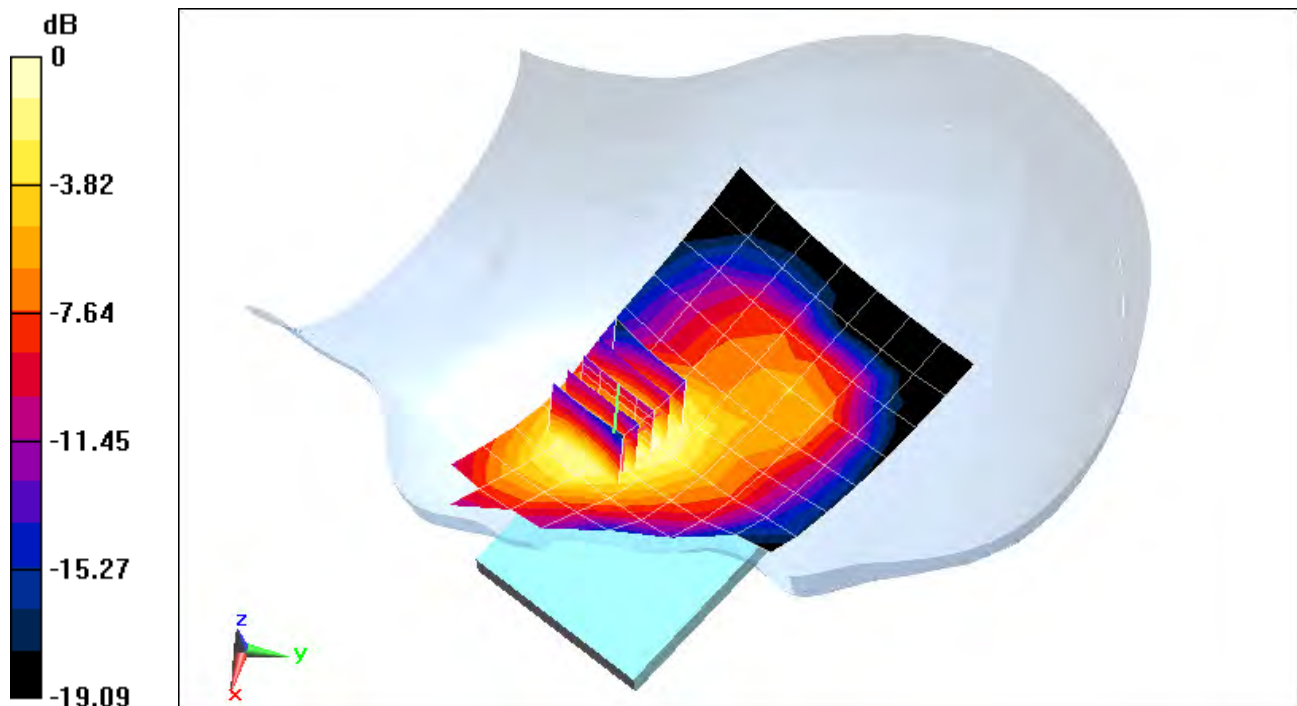

0 dB = 0.663 W/kg = -1.78 dBW/kg

# PCTEST ENGINEERING LABORATORY, INC.

**DUT: A3LSMG900R7; Type: Portable Handset; Serial: 328C6**

Communication System: UID 0, IEEE 802.11b; Frequency: 2412 MHz; Duty Cycle: 1:1  
Medium: 2450 Head; Medium parameters used (interpolated):

$$f = 2412 \text{ MHz}; \sigma = 1.835 \text{ S/m}; \epsilon_r = 38.952; \rho = 1000 \text{ kg/m}^3$$

Phantom section: Right Section

Test Date: 02-18-2014; Ambient Temp: 23.5°C; Tissue Temp: 23.0°C

Probe: ES3DV3 - SN3287; ConvF(4.43, 4.43, 4.43); Calibrated: 11/20/2013;

Sensor-Surface: 3mm (Mechanical Surface Detection)

Electronics: DAE4 Sn1408; Calibrated: 11/19/2013

Phantom: SAM with CRP v4.0; Type: QD000P40CD; Serial: TP:1797

Measurement SW: DASY52, Version 52.8 (7);SEMCAD X Version 14.6.10 (7164)

**Mode: IEEE 802.11b, Right Head, Cheek, Ch 01, 1 Mbps,  
Antenna 1, Standard Cover**

**Area Scan (10x16x1):** Measurement grid: dx=12mm, dy=12mm

**Zoom Scan (7x7x7)/Cube 0:** Measurement grid: dx=5mm, dy=5mm, dz=5mm

Reference Value = 9.492 V/m; Power Drift = 0.20 dB

Peak SAR (extrapolated) = 0.349 W/kg

**SAR(1 g) = 0.163 W/kg**

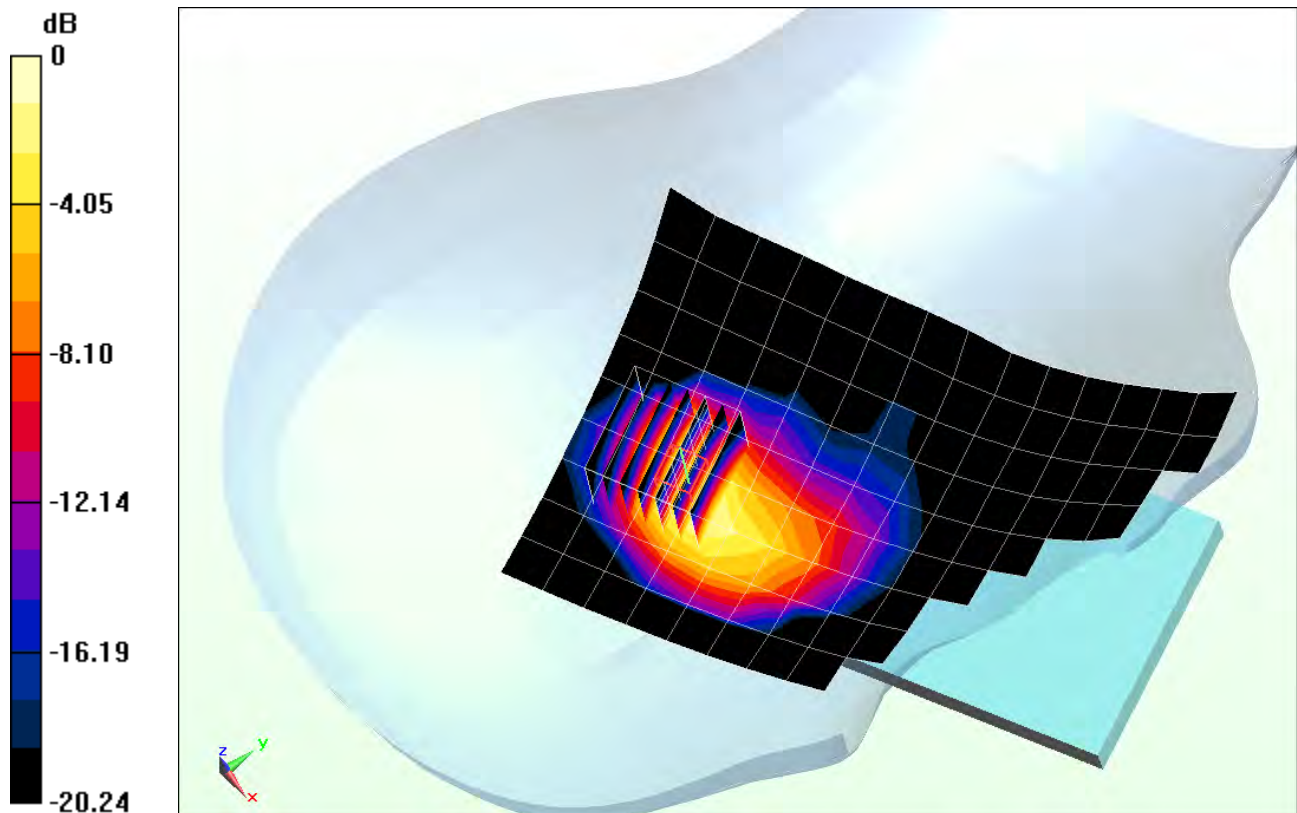

0 dB = 0.214 W/kg = -6.70 dBW/kg

# PCTEST ENGINEERING LABORATORY, INC.

**DUT: A3LSMG900R7; Type: Portable Handset; Serial: 31F35**

Communication System: UID 0, IEEE 802.11a; Frequency: 5765 MHz; Duty Cycle: 1:1  
Medium: 5 GHz Head; Medium parameters used:

$$f = 5765 \text{ MHz}; \sigma = 5.088 \text{ S/m}; \epsilon_r = 35.493; \rho = 1000 \text{ kg/m}^3$$

Phantom section: Right Section

Test Date: 02-03-2014; Ambient Temp: 24.3°C; Tissue Temp: 23.3°C

Probe: EX3DV4 - SN3920; ConvF(4.11, 4.11, 4.11); Calibrated: 12/18/2013;

Sensor-Surface: 1.4mm (Mechanical Surface Detection)

Electronics: DAE4 Sn649; Calibrated: 12/12/2013

Phantom: SAM Main; Type: SAM 4.0; Serial: TP-1114

Measurement SW: DASY4, Version 4.7 (80); SEMCAD X Version 14.6.10 (7164)

**Mode: IEEE 802.11a 5.8 GHz, Right Head, Cheek, Ch 153, 6 Mbps,  
Antenna 2, Standard Cover**

**Area Scan (13x16x1):** Measurement grid: dx=10mm, dy=10mm

**Zoom Scan (7x7x7)/Cube 0:** Measurement grid: dx=4mm, dy=4mm, dz=1.4mm; Graded Ratio: 1.4

Reference Value = 5.548 V/m; Power Drift = 0.06 dB

Peak SAR (extrapolated) = 0.650 W/kg

**SAR(1 g) = 0.134 W/kg**

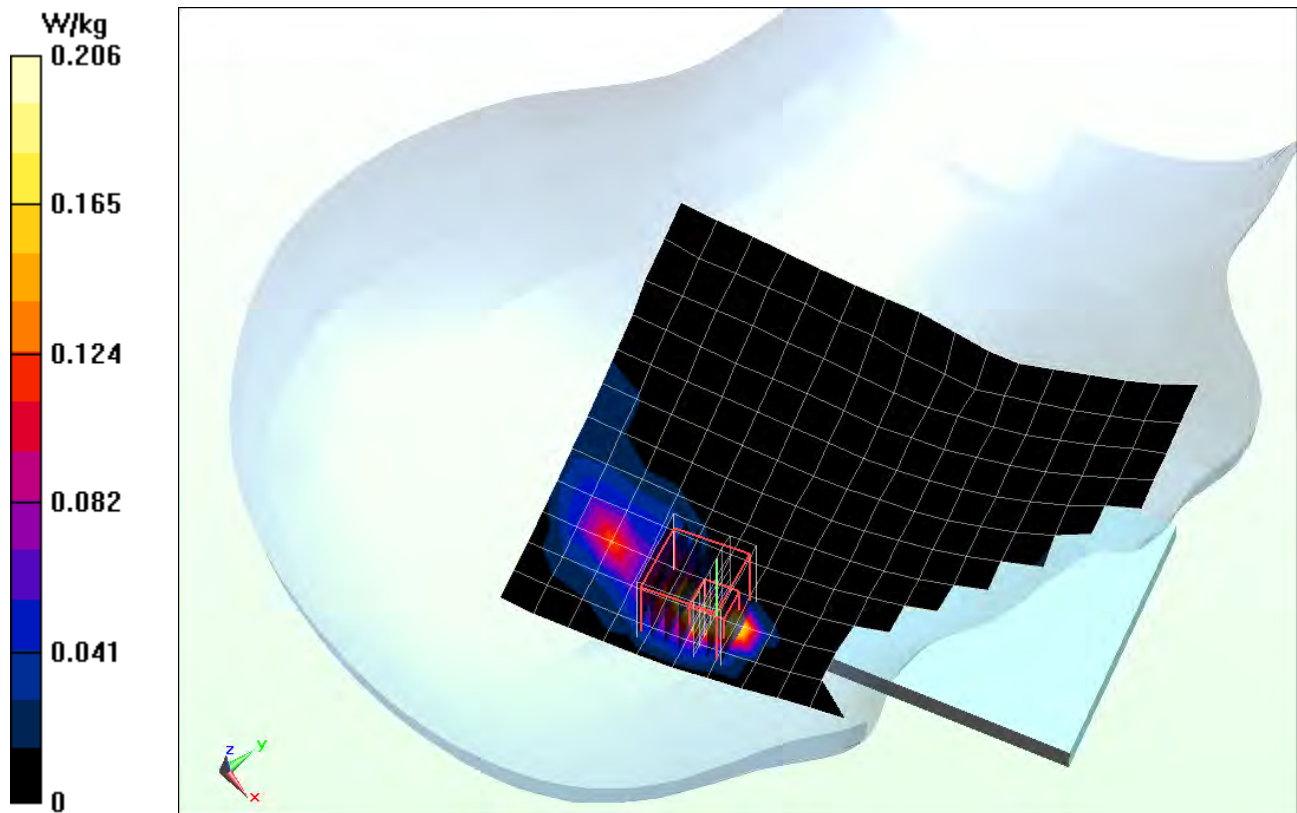

# PCTEST ENGINEERING LABORATORY, INC.

**DUT: A3LSMG900R7; Type: Portable Handset; Serial: 31F35**

Communication System: UID 0, IEEE 802.11a; Frequency: 5680 MHz; Duty Cycle: 1:1  
Medium: 5 GHz Head; Medium parameters used:

$$f = 5680 \text{ MHz}; \sigma = 5.006 \text{ S/m}; \epsilon_r = 35.596; \rho = 1000 \text{ kg/m}^3$$

Phantom section: Right Section

Test Date: 02-03-2014; Ambient Temp: 24.5°C; Tissue Temp: 23.3°C

Probe: EX3DV4 - SN3920; ConvF(4.37, 4.37, 4.37); Calibrated: 12/18/2013;

Sensor-Surface: 1.4mm (Mechanical Surface Detection)

Electronics: DAE4 Sn649; Calibrated: 12/12/2013

Phantom: SAM Main; Type: SAM 4.0; Serial: TP-1114

Measurement SW: DASY4, Version 4.7 (80); SEMCAD X Version 14.6.10 (7164)

**Mode: IEEE 802.11a 5.5 - 5.7 GHz, Right Head, Cheek, Ch 136, 6 Mbps,  
Antenna 2, Standard Cover**

**Area Scan (13x16x1):** Measurement grid: dx=10mm, dy=10mm

**Zoom Scan (7x7x7)/Cube 0:** Measurement grid: dx=4mm, dy=4mm, dz=1.4mm; Graded Ratio: 1.4

Reference Value = 5.743 V/m; Power Drift = 0.02 dB

Peak SAR (extrapolated) = 1.55 W/kg

**SAR(1 g) = 0.154 W/kg**

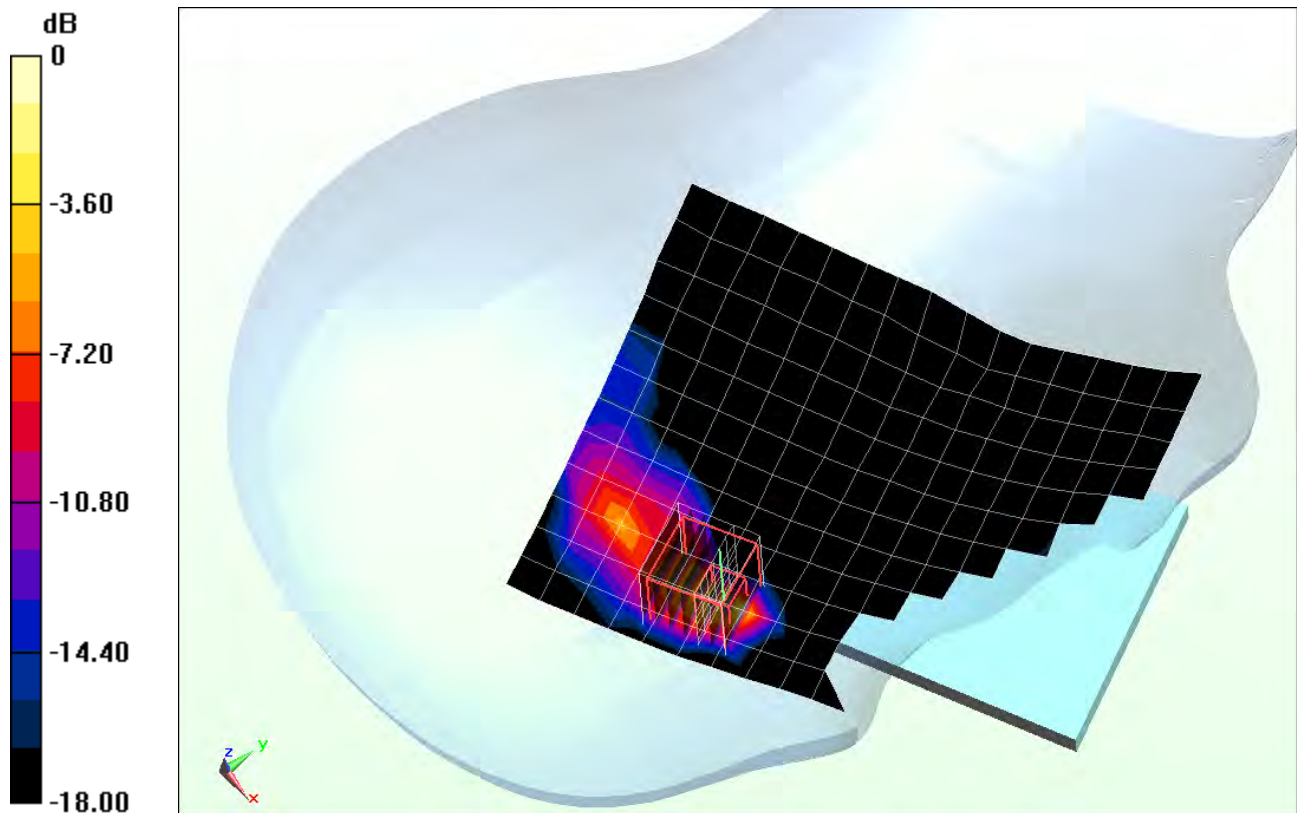

0 dB = 0.437 W/kg = -3.60 dBW/kg

# PCTEST ENGINEERING LABORATORY, INC.

**DUT: A3LSMG900R7; Type: Portable Handset; Serial: 32EF0**

Communication System: UID 0, Cellular CDMA; Frequency: 836.52 MHz; Duty Cycle: 1:1

Medium: 835 Body Medium parameters used (interpolated):

$f = 836.52 \text{ MHz}$ ;  $\sigma = 0.978 \text{ S/m}$ ;  $\epsilon_r = 55.087$ ;  $\rho = 1000 \text{ kg/m}^3$

Phantom section: Flat Section; Space: 1.0 cm

Test Date: 02-17-2014; Ambient Temp: 19.7°C; Tissue Temp: 19.7°C

Probe: ES3DV3 - SN3263; ConvF(6.29, 6.29, 6.29); Calibrated: 5/16/2013;

Sensor-Surface: 4mm (Mechanical Surface Detection)

Electronics: DAE4 Sn859; Calibrated: 5/13/2013

Phantom: SAM Sub; Type: SAM 4.0; Serial: TP-1357

Measurement SW: DASY4, Version 4.7 (80); SEMCAD X Version 14.6.10 (7164)

**Mode: Cell. CDMA, Body SAR, Back side, Mid.ch, Standard Cover**

**Area Scan (8x13x1):** Measurement grid: dx=15mm, dy=15mm

**Zoom Scan (5x5x7)/Cube 0:** Measurement grid: dx=8mm, dy=8mm, dz=5mm

Reference Value = 28.284 V/m; Power Drift = -0.04 dB

Peak SAR (extrapolated) = 0.816 W/kg

**SAR(1 g) = 0.670 W/kg**

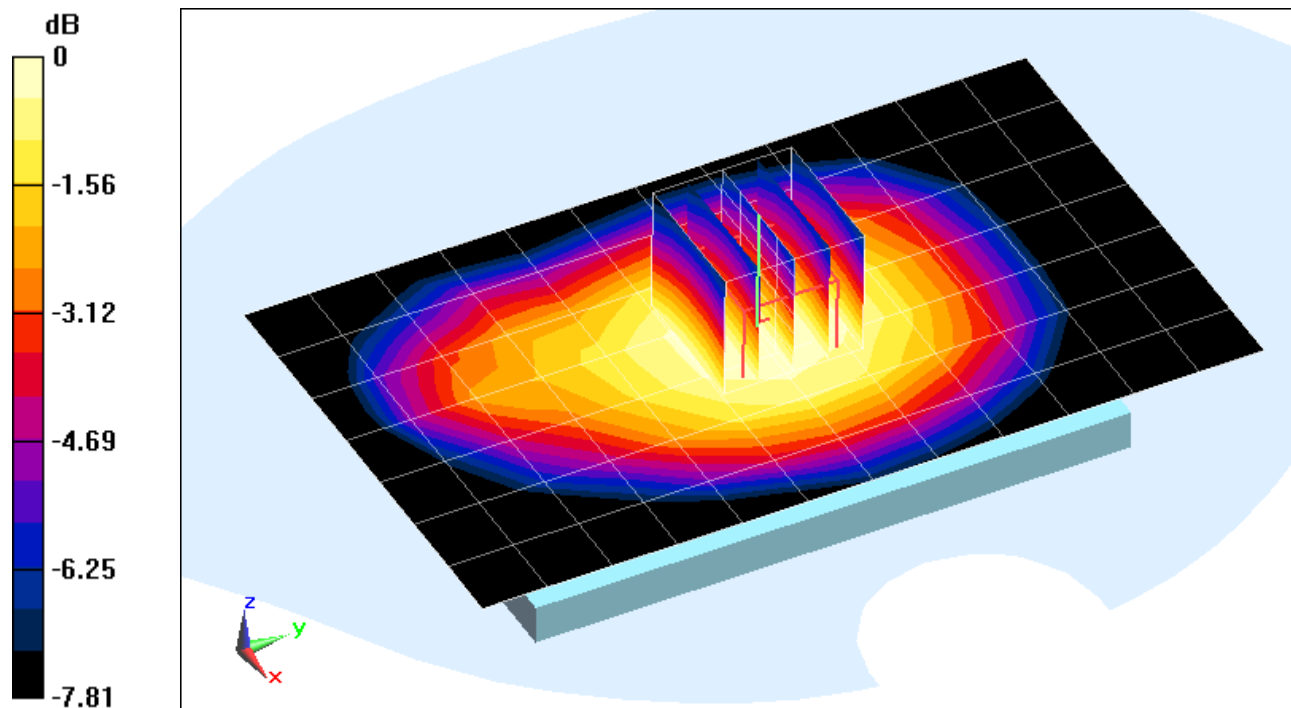

0 dB = 0.702 W/kg = -1.54 dBW/kg

# PCTEST ENGINEERING LABORATORY, INC.

**DUT: A3LSMG900R7; Type: Portable Handset; Serial: 32EF0**

Communication System: UID 0, Cellular CDMA; Frequency: 836.52 MHz; Duty Cycle: 1:1

Medium: 835 Body Medium parameters used (interpolated):

$f = 836.52$  MHz;  $\sigma = 0.978$  S/m;  $\epsilon_r = 55.087$ ;  $\rho = 1000$  kg/m<sup>3</sup>

Phantom section: Flat Section; Space: 1.0 cm

Test Date: 02-17-2014; Ambient Temp: 19.7°C; Tissue Temp: 19.7°C

Probe: ES3DV3 - SN3263; ConvF(6.29, 6.29, 6.29); Calibrated: 5/16/2013;

Sensor-Surface: 4mm (Mechanical Surface Detection)

Electronics: DAE4 Sn859; Calibrated: 5/13/2013

Phantom: SAM Sub; Type: SAM 4.0; Serial: TP-1357

Measurement SW: DASY4, Version 4.7 (80); SEMCAD X Version 14.6.10 (7164)

**Mode: Cell. CDMA, Body SAR, Right Edge, Mid.ch, Standard Cover**

**Area Scan (11x13x1):** Measurement grid: dx=5mm, dy=15mm

**Zoom Scan (5x5x7)/Cube 0:** Measurement grid: dx=8mm, dy=8mm, dz=5mm

Reference Value = 29.196 V/m; Power Drift = -0.02 dB

Peak SAR (extrapolated) = 0.904 W/kg

**SAR(1 g) = 0.673 W/kg**

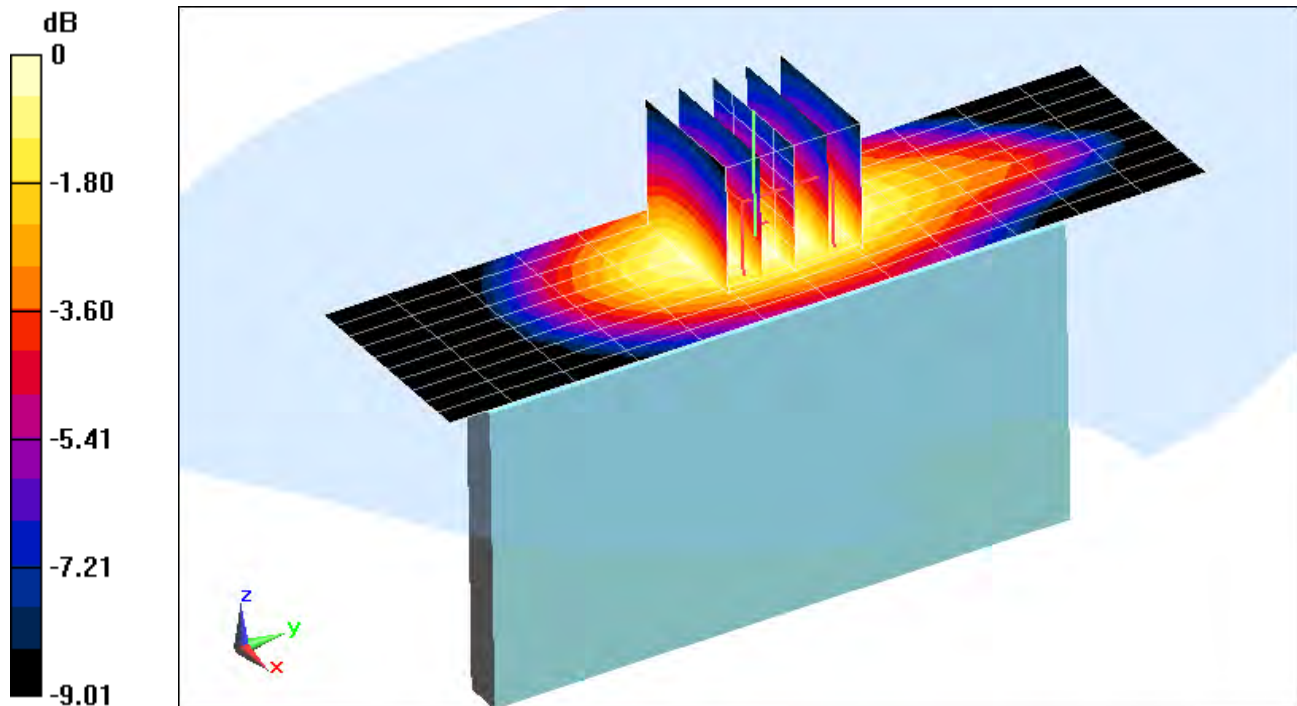

0 dB = 0.719 W/kg = -1.43 dBW/kg

# PCTEST ENGINEERING LABORATORY, INC.

**DUT: A3LSMG900R7; Type: Portable Handset; Serial: 32EF0**

Communication System: UID 0, CDMA; Frequency: 1880 MHz; Duty Cycle: 1:1

Medium: 1900 Body Medium parameters used:

$f = 1880 \text{ MHz}$ ;  $\sigma = 1.545 \text{ S/m}$ ;  $\epsilon_r = 51.042$ ;  $\rho = 1000 \text{ kg/m}^3$

Phantom section: Flat Section; Space: 1.5 cm

Test Date: 03-31-2014; Ambient Temp: 23.2°C; Tissue Temp: 21.6°C

Probe: ES3DV2 - SN3022; ConvF(4.49, 4.49, 4.49); Calibrated: 8/22/2013;

Sensor-Surface: 4mm (Mechanical Surface Detection)

Electronics: DAE4 Sn1322; Calibrated: 8/21/2013

Phantom: SAM v5.0 front; Type: QD000P40CD; Serial: TP-1646

Measurement SW: DASY52, Version 52.8 (7); SEMCAD X Version 14.6.10 (7164)

**Mode: PCS CDMA, Body SAR, Back side, Mid.ch, Standard Cover**

**Area Scan (8x13x1):** Measurement grid: dx=15mm, dy=15mm

**Zoom Scan (5x5x7)/Cube 0:** Measurement grid: dx=8mm, dy=8mm, dz=5mm

Reference Value = 18.043 V/m; Power Drift = -0.02 dB

Peak SAR (extrapolated) = 0.719 W/kg

**SAR(1 g) = 0.465 W/kg**

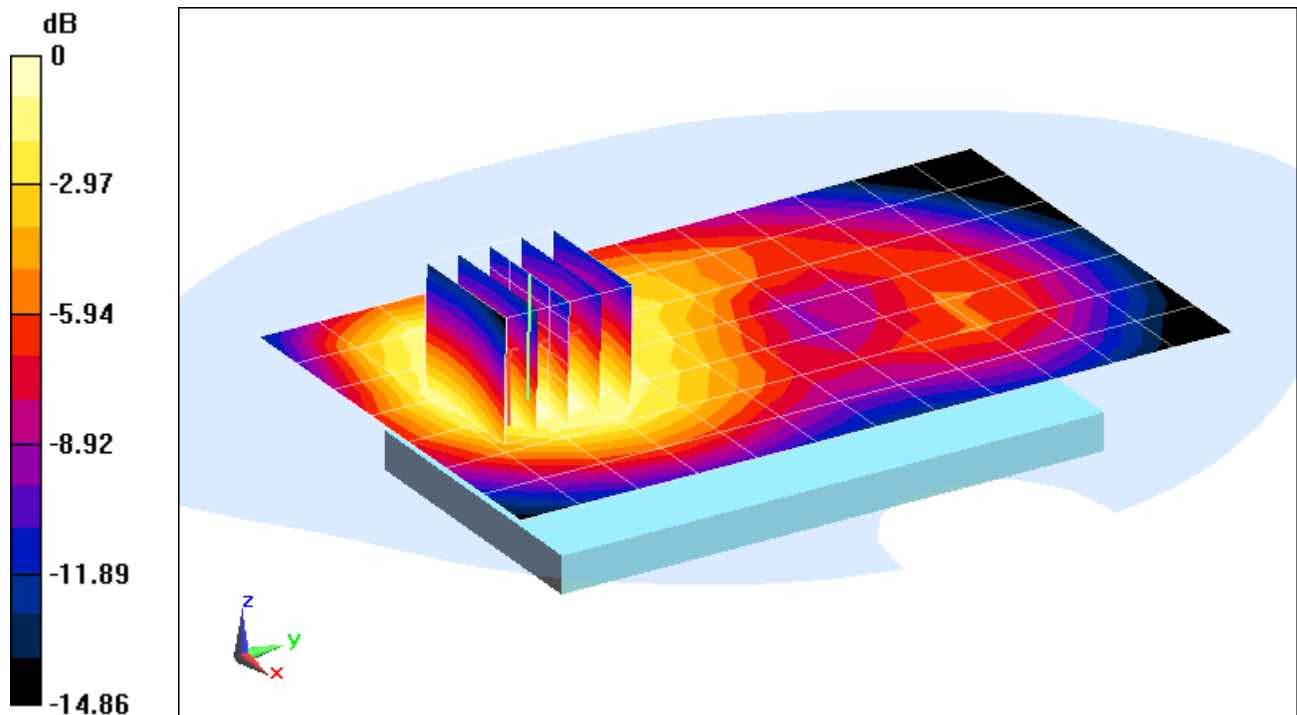

0 dB = 0.494 W/kg = -3.06 dBW/kg

# PCTEST ENGINEERING LABORATORY, INC.

**DUT: A3LSMG900R7; Type: Portable Handset; Serial: 3R725**

Communication System: UID 0, CDMA; Frequency: 1880 MHz; Duty Cycle: 1:1

Medium: 1900 Body Medium parameters used:

$f = 1880 \text{ MHz}$ ;  $\sigma = 1.545 \text{ S/m}$ ;  $\epsilon_r = 51.042$ ;  $\rho = 1000 \text{ kg/m}^3$

Phantom section: Flat Section; Space: 1.0 cm

Test Date: 03-31-2014; Ambient Temp: 23.2°C; Tissue Temp: 21.6°C

Probe: ES3DV2 - SN3022; ConvF(4.49, 4.49, 4.49); Calibrated: 8/22/2013;

Sensor-Surface: 4mm (Mechanical Surface Detection)

Electronics: DAE4 Sn1322; Calibrated: 8/21/2013

Phantom: SAM v5.0 front; Type: QD000P40CD; Serial: TP-1646

Measurement SW: DASY52, Version 52.8 (7); SEMCAD X Version 14.6.10 (7164)

**Mode: PCS EVDO Rev. 0, Body SAR, Back side, Mid.ch, Standard Cover**

**Area Scan (9x15x1):** Measurement grid: dx=15mm, dy=15mm

**Zoom Scan (6x5x7)/Cube 0:** Measurement grid: dx=8mm, dy=8mm, dz=5mm

Reference Value = 18.195 V/m; Power Drift = 0.05 dB

Peak SAR (extrapolated) = 0.838 W/kg

**SAR(1 g) = 0.489 W/kg**

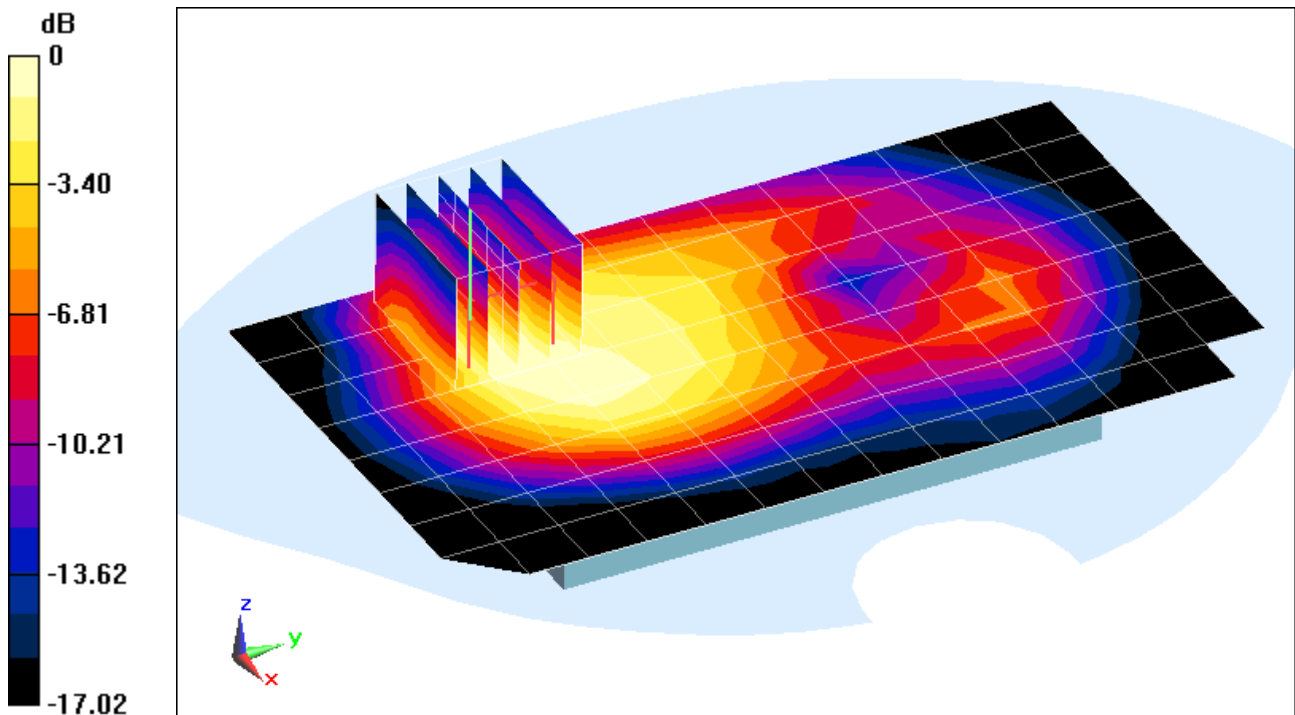

0 dB = 0.527 W/kg = -2.78 dBW/kg

# PCTEST ENGINEERING LABORATORY, INC.

**DUT: A3LSMG900R7; Type: Portable Handset; Serial: 32EF0**

Communication System: UID 0, LTE RF; Frequency: 707.5 MHz; Duty Cycle: 1:1

Medium: 750 Body Medium parameters used (interpolated):

$f = 707.5 \text{ MHz}$ ;  $\sigma = 0.939 \text{ S/m}$ ;  $\epsilon_r = 54.944$ ;  $\rho = 1000 \text{ kg/m}^3$

Phantom section: Flat Section; Space: 1.0 cm

Test Date: 02-18-2014; Ambient Temp: 19.9°C; Tissue Temp: 20.6°C

Probe: ES3DV3 - SN3263; ConvF(6.37, 6.37, 6.37); Calibrated: 5/16/2013;

Sensor-Surface: 4mm (Mechanical Surface Detection)

Electronics: DAE4 Sn859; Calibrated: 5/13/2013

Phantom: SAM Main; Type: SAM 4.0; Serial: TP-1114

Measurement SW: DASY4, Version 4.7 (80); SEMCAD X Version 14.6.10 (7164)

**Mode: LTE Band 12, Body SAR, Back side, Mid.ch,  
10 MHz Bandwidth, QPSK, 1 RB, 0 RB Offset, Standard Cover**

**Area Scan (8x13x1):** Measurement grid: dx=15mm, dy=15mm

**Zoom Scan (5x5x7)/Cube 0:** Measurement grid: dx=8mm, dy=8mm, dz=5mm

Reference Value = 20.675 V/m; Power Drift = 0.01 dB

Peak SAR (extrapolated) = 0.515 W/kg

**SAR(1 g) = 0.369 W/kg**

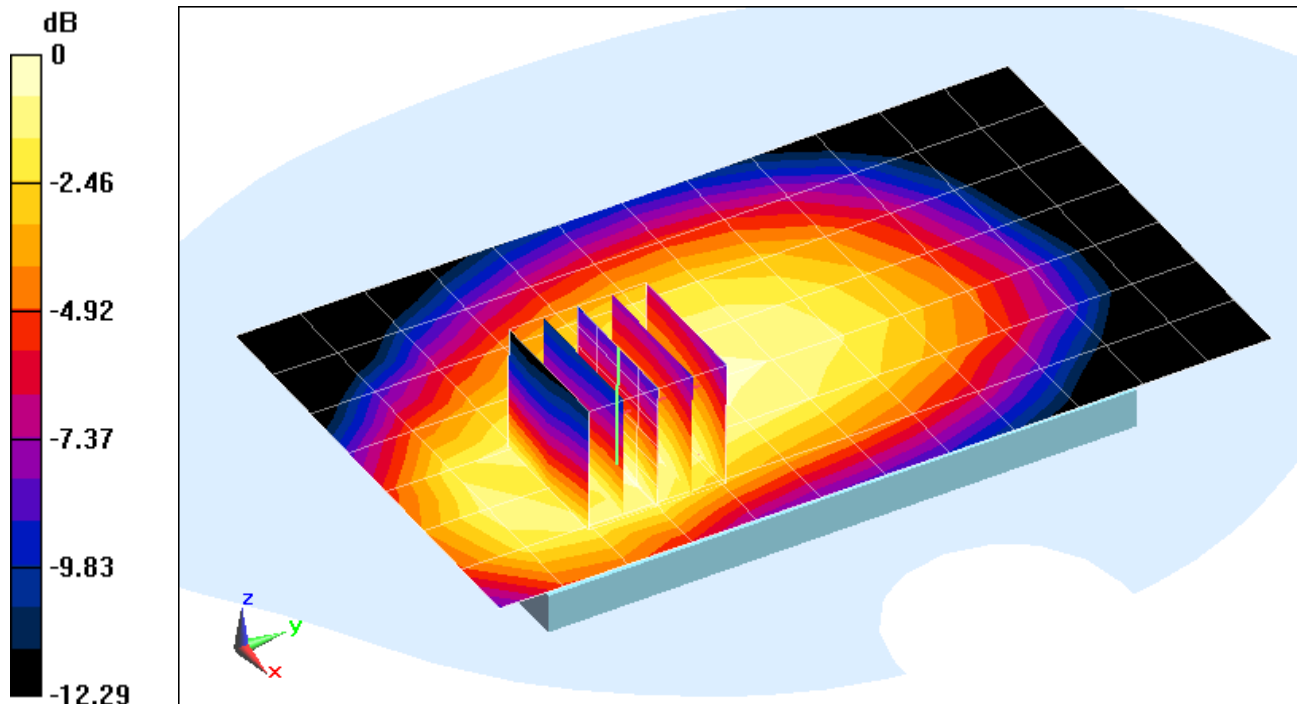

0 dB = 0.390 W/kg = -4.09 dBW/kg

# PCTEST ENGINEERING LABORATORY, INC.

**DUT: A3LSMG900R7; Type: Portable Handset; Serial: 32EF0**

Communication System: UID 0, LTE RF; Frequency: 707.5 MHz; Duty Cycle: 1:1

Medium: 750 Body Medium parameters used (interpolated):

$f = 707.5 \text{ MHz}$ ;  $\sigma = 0.939 \text{ S/m}$ ;  $\epsilon_r = 54.944$ ;  $\rho = 1000 \text{ kg/m}^3$

Phantom section: Flat Section; Space: 1.0 cm

Test Date: 02-18-2014; Ambient Temp: 19.9°C; Tissue Temp: 20.6°C

Probe: ES3DV3 - SN3263; ConvF(6.37, 6.37, 6.37); Calibrated: 5/16/2013;

Sensor-Surface: 4mm (Mechanical Surface Detection)

Electronics: DAE4 Sn859; Calibrated: 5/13/2013

Phantom: SAM Main; Type: SAM 4.0; Serial: TP-1114

Measurement SW: DASY4, Version 4.7 (80); SEMCAD X Version 14.6.10 (7164)

**Mode: LTE Band 12, Body SAR, Front side, Mid.ch,  
10 MHz Bandwidth, QPSK, 1 RB, 0 RB Offset, Standard Cover**

**Area Scan (8x13x1):** Measurement grid: dx=15mm, dy=15mm

**Zoom Scan (5x5x7)/Cube 0:** Measurement grid: dx=8mm, dy=8mm, dz=5mm

Reference Value = 23.722 V/m; Power Drift = 0.01 dB

Peak SAR (extrapolated) = 0.817 W/kg

**SAR(1 g) = 0.467 W/kg**

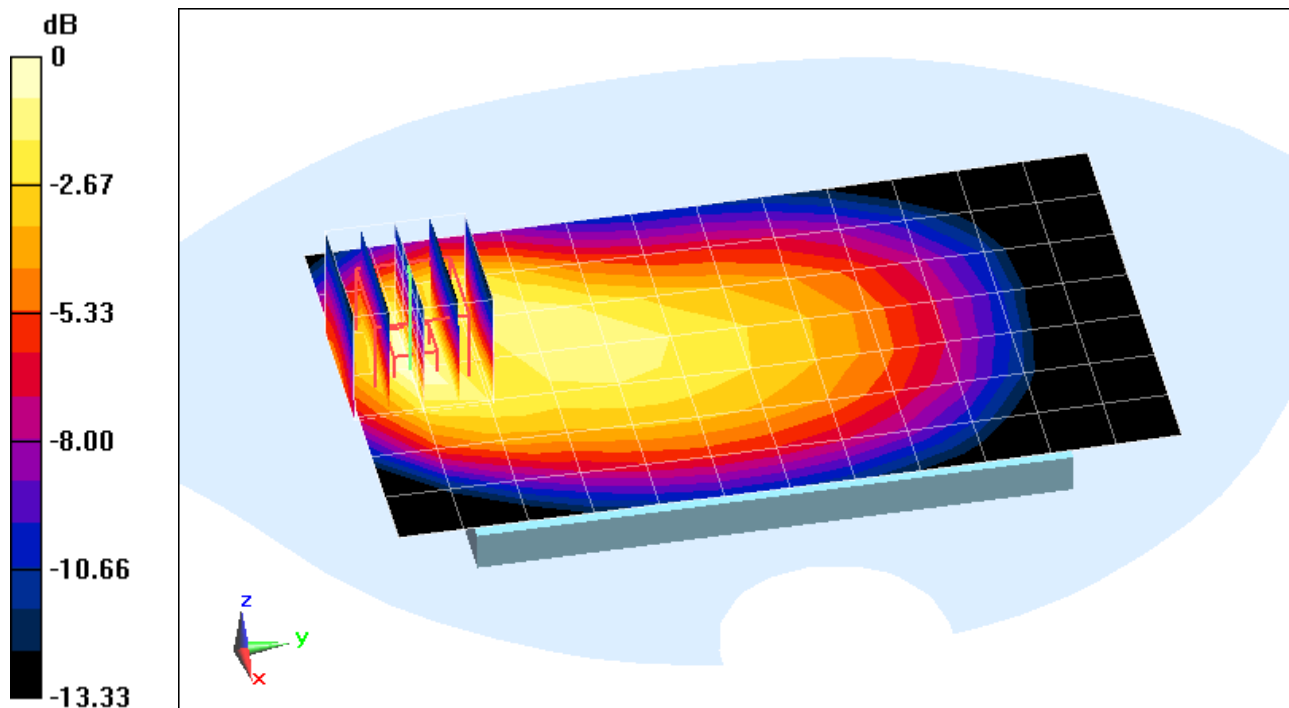

0 dB = 0.518 W/kg = -2.86 dBW/kg

# PCTEST ENGINEERING LABORATORY, INC.

**DUT: A3LSMG900R7; Type: Portable Handset; Serial: 32EC6**

Communication System: UID 0, LTE RF; Frequency: 1715 MHz; Duty Cycle: 1:1

Medium: 1750 Body Medium parameters used (interpolated):

$f = 1715 \text{ MHz}$ ;  $\sigma = 1.472 \text{ S/m}$ ;  $\epsilon_r = 54.456$ ;  $\rho = 1000 \text{ kg/m}^3$

Phantom section: Flat Section; Space: 1.0 cm

Test Date: 02-18-2014; Ambient Temp: 23.4°C; Tissue Temp: 23.0°C

Probe: ES3DV3 - SN3288; ConvF(5.1, 5.1, 5.1); Calibrated: 9/23/2013;

Sensor-Surface: 4mm (Mechanical Surface Detection)

Electronics: DAE4 Sn1323; Calibrated: 9/17/2013

Phantom: SAM with CRP; Type: SAM; Serial: TP1375

Measurement SW: DASY4, Version 4.7 (80); SEMCAD X Version 14.6.10 (7164)

**Mode: LTE Band 4 (AWS), Body SAR, Back side, Low.ch,  
10 MHz Bandwidth, QPSK, 1 RB, 0 RB Offset, Standard Cover**

**Area Scan (9x15x1):** Measurement grid: dx=15mm, dy=15mm

**Zoom Scan (5x5x7)/Cube 0:** Measurement grid: dx=8mm, dy=8mm, dz=5mm

Reference Value = 18.160 V/m; Power Drift = 0.00 dB

Peak SAR (extrapolated) = 0.908 W/kg

**SAR(1 g) = 0.509 W/kg**

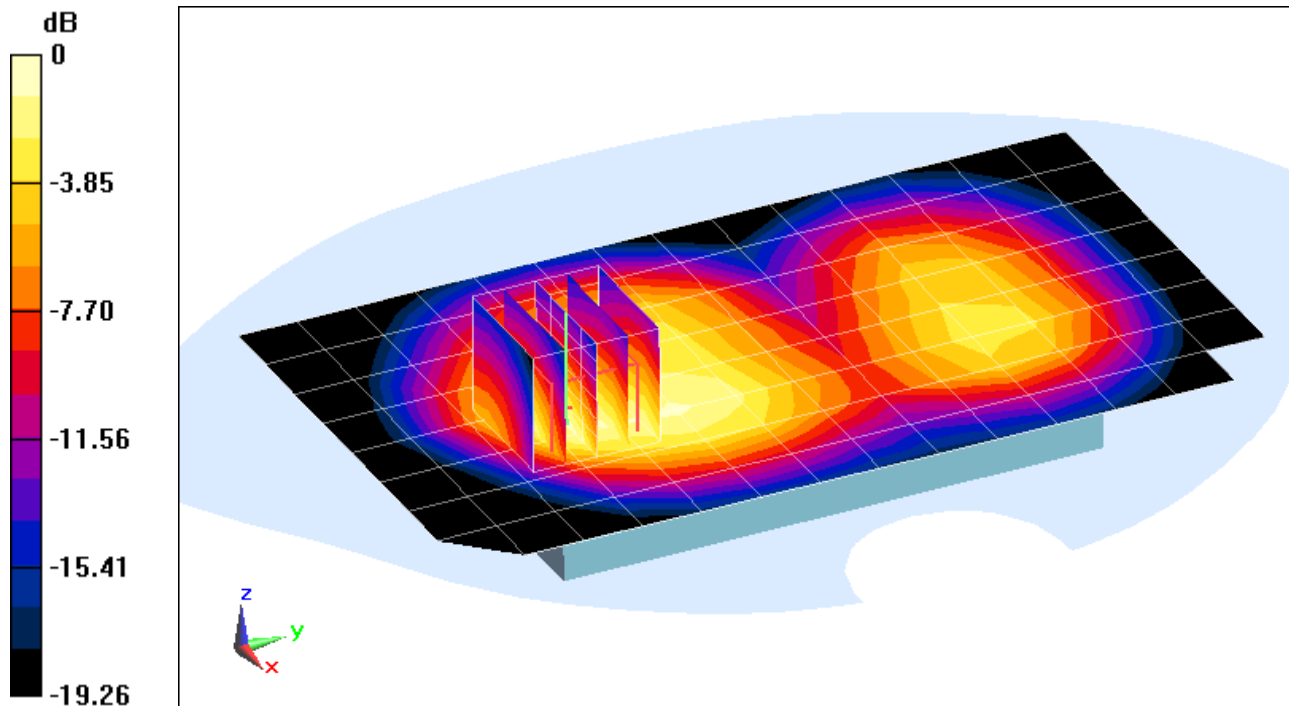

0 dB = 0.576 W/kg = -2.40 dBW/kg

# PCTEST ENGINEERING LABORATORY, INC.

**DUT: A3LSMG900R7; Type: Portable Handset; Serial: 32EC6**

Communication System: UID 0, LTE RF; Frequency: 1715 MHz; Duty Cycle: 1:1

Medium: 1750 Body Medium parameters used (interpolated):

$f = 1715 \text{ MHz}$ ;  $\sigma = 1.472 \text{ S/m}$ ;  $\epsilon_r = 54.456$ ;  $\rho = 1000 \text{ kg/m}^3$

Phantom section: Flat Section; Space: 1.0 cm

Test Date: 02-18-2014; Ambient Temp: 23.4°C; Tissue Temp: 23.0°C

Probe: ES3DV3 - SN3288; ConvF(5.1, 5.1, 5.1); Calibrated: 9/23/2013;

Sensor-Surface: 4mm (Mechanical Surface Detection)

Electronics: DAE4 Sn1323; Calibrated: 9/17/2013

Phantom: SAM with CRP; Type: SAM; Serial: TP1375

Measurement SW: DASY4, Version 4.7 (80); SEMCAD X Version 14.6.10 (7164)

**Mode: LTE Band 4 (AWS), Body SAR, Front side, Low.ch,  
10 MHz Bandwidth, QPSK, 1 RB, 0 RB Offset, Standard Cover**

**Area Scan (9x15x1):** Measurement grid: dx=15mm, dy=15mm

**Zoom Scan (5x5x7)/Cube 0:** Measurement grid: dx=8mm, dy=8mm, dz=5mm

Reference Value = 21.174 V/m; Power Drift = -0.01 dB

Peak SAR (extrapolated) = 1.09 W/kg

**SAR(1 g) = 0.586 W/kg**

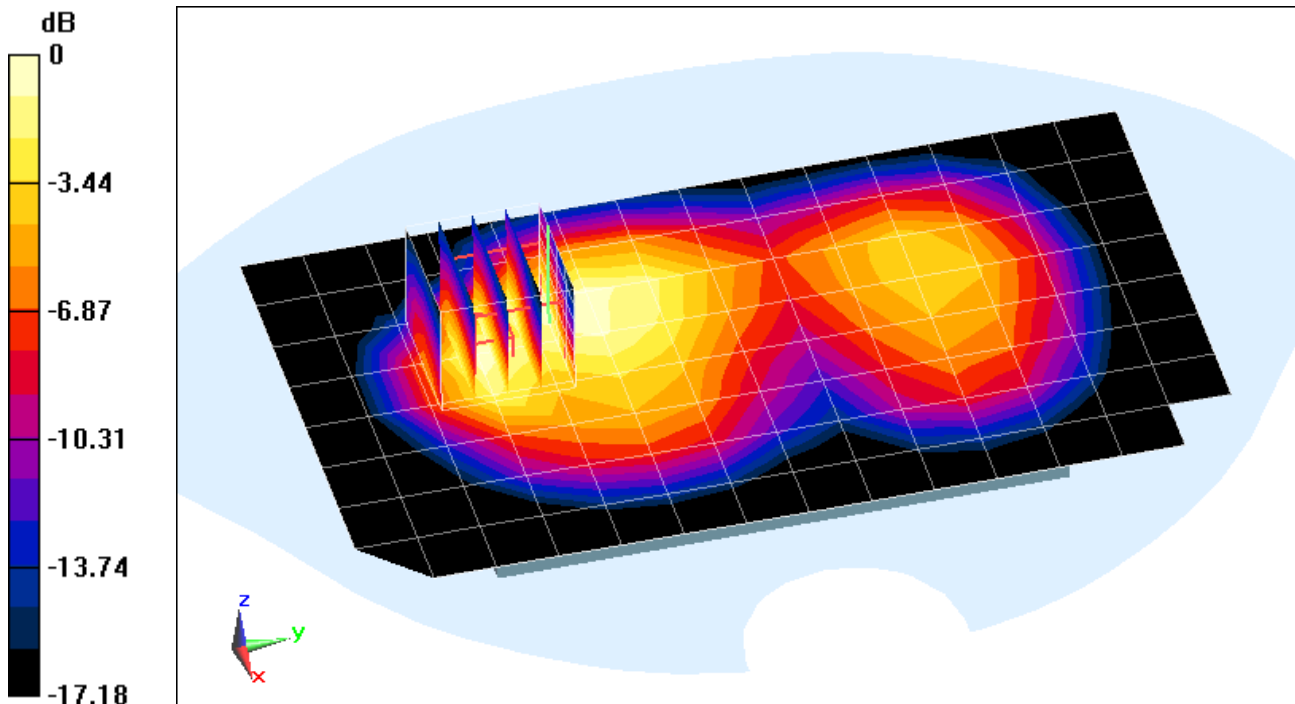

0 dB = 0.651 W/kg = -1.86 dBW/kg

# PCTEST ENGINEERING LABORATORY, INC.

**DUT: A3LSMG900R7; Type: Portable Handset; Serial: 32E32**

Communication System: UID 0, LTE Band 25 (PCS); Frequency: 1910 MHz; Duty Cycle: 1:1

Medium: 1900 Body Medium parameters used (interpolated):

$f = 1910 \text{ MHz}$ ;  $\sigma = 1.558 \text{ S/m}$ ;  $\epsilon_r = 53.102$ ;  $\rho = 1000 \text{ kg/m}^3$

Phantom section: Flat Section: Space: 1.0 cm

Test Date: 02-17-2014; Ambient Temp: 23.7°C; Tissue Temp: 23.2°C

Probe: ES3DV3 - SN3319; ConvF(4.85, 4.85, 4.85); Calibrated: 4/29/2013;

Sensor-Surface: 4mm (Mechanical Surface Detection)

Electronics: DAE4 Sn1368; Calibrated: 4/22/2013

Phantom: SAM front; Type: QD000P40CD; Serial: TP:1759

Measurement SW: DASY52, Version 52.8 (7); SEMCAD X Version 14.6.10 (7164)

**Mode: LTE Band 25 (PCS), Body SAR, Back side, High.ch,  
10 MHz Bandwidth, QPSK, 1 RB, 0 RB Offset, Wireless Charging Cover**

**Area Scan (8x13x1):** Measurement grid: dx=15mm, dy=15mm

**Zoom Scan (5x6x7)/Cube 0:** Measurement grid: dx=8mm, dy=8mm, dz=5mm

Reference Value = 12.290 V/m; Power Drift = 0.01 dB

Peak SAR (extrapolated) = 0.329 W/kg

**SAR(1 g) = 0.209 W/kg**

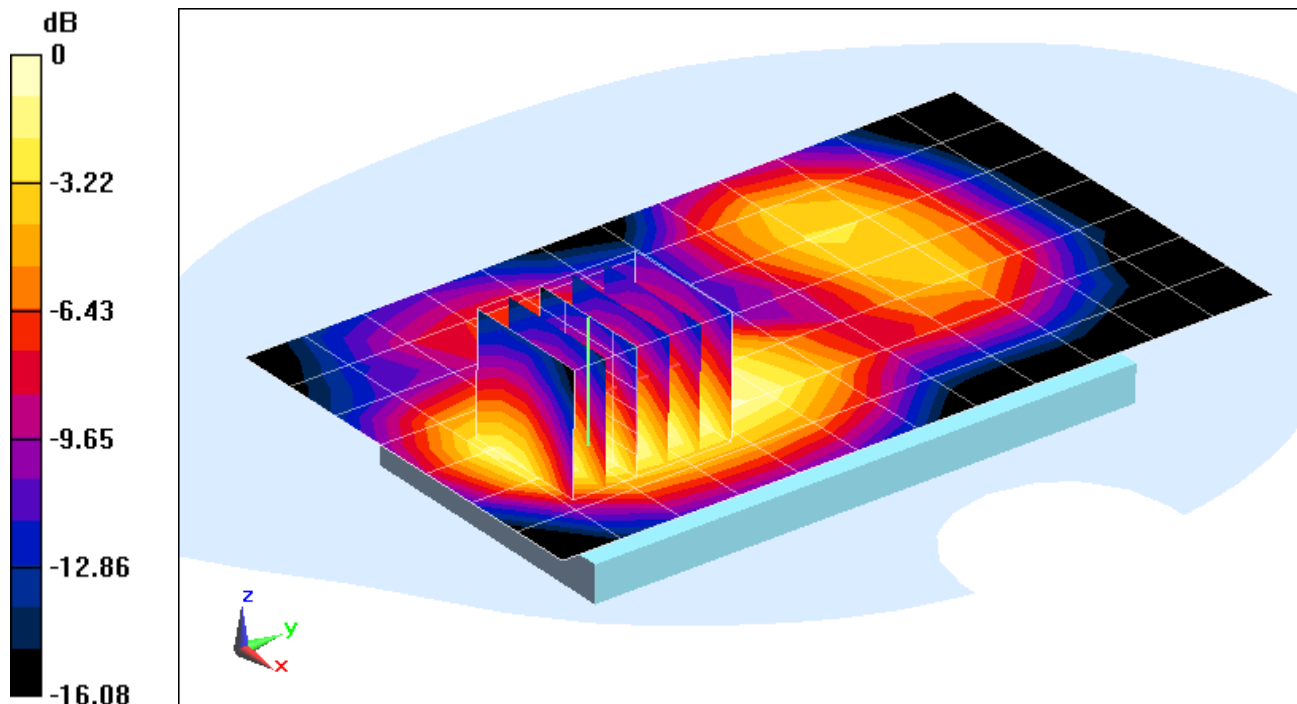

0 dB = 0.225 W/kg = -6.48 dBW/kg

# PCTEST ENGINEERING LABORATORY, INC.

**DUT: A3LSMG900R7; Type: Portable Handset; Serial: 32E32**

Communication System: UID 0, LTE Band 25 (PCS); Frequency: 1910 MHz; Duty Cycle: 1:1

Medium: 1900 Body Medium parameters used (interpolated):

$f = 1910 \text{ MHz}$ ;  $\sigma = 1.558 \text{ S/m}$ ;  $\epsilon_r = 53.102$ ;  $\rho = 1000 \text{ kg/m}^3$

Phantom section: Flat Section; Space: 1.0 cm

Test Date: 02-17-2014; Ambient Temp: 23.7°C; Tissue Temp: 23.2°C

Probe: ES3DV3 - SN3319; ConvF(4.85, 4.85, 4.85); Calibrated: 4/29/2013;

Sensor-Surface: 4mm (Mechanical Surface Detection)

Electronics: DAE4 Sn1368; Calibrated: 4/22/2013

Phantom: SAM front; Type: QD000P40CD; Serial: TP:1759

Measurement SW: DASY52, Version 52.8 (7); SEMCAD X Version 14.6.10 (7164)

**Mode: LTE Band 25 (PCS), Body SAR, Front side, High.ch,  
10 MHz Bandwidth, QPSK, 1 RB, 0 RB Offset, Wireless Charging Cover**

**Area Scan (8x13x1):** Measurement grid: dx=15mm, dy=15mm

**Zoom Scan (5x6x7)/Cube 0:** Measurement grid: dx=8mm, dy=8mm, dz=5mm

Reference Value = 19.270 V/m; Power Drift = 0.00 dB

Peak SAR (extrapolated) = 0.829 W/kg

**SAR(1 g) = 0.547 W/kg**

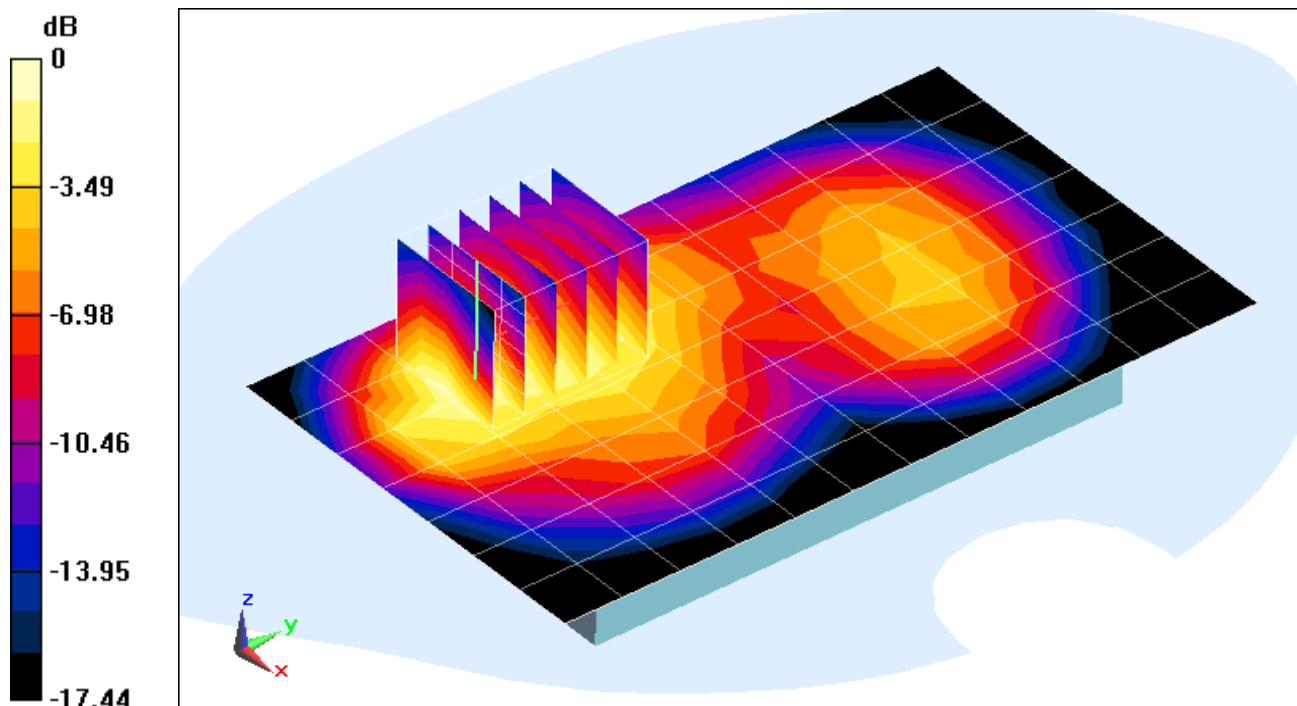

0 dB = 0.600 W/kg = -2.22 dBW/kg

# PCTEST ENGINEERING LABORATORY, INC.

**DUT: A3LSMG900R7; Type: Portable Handset; Serial: 00F05**

Communication System: UID 0, IEEE 802.11b; Frequency: 2437 MHz; Duty Cycle: 1:1

Medium: 2450 Body; Medium parameters used (interpolated):

$f = 2437 \text{ MHz}$ ;  $\sigma = 1.92 \text{ S/m}$ ;  $\epsilon_r = 51.381$ ;  $\rho = 1000 \text{ kg/m}^3$

Phantom section: Flat Section; Space: 1.0 cm

Test Date: 02-12-2014; Ambient Temp: 24.4°C; Tissue Temp: 24.0°C

Probe: ES3DV3 - SN3318; ConvF(4.31, 4.31, 4.31); Calibrated: 4/29/2013;

Sensor-Surface: 3mm (Mechanical Surface Detection)

Electronics: DAE4 Sn1364; Calibrated: 4/22/2013

Phantom: ELI left; Type: QDOVA002AA; Serial: TP:1202

Measurement SW: DASY52, Version 52.8 (7);SEMCAD X Version 14.6.10 (7164)

**Mode: IEEE 802.11b, Body SAR, Ch 06, 1 Mbps, Back Side,  
Antenna 1, Standard Cover**

**Area Scan (10x16x1):** Measurement grid: dx=12mm, dy=12mm

**Zoom Scan (7x7x7)/Cube 0:** Measurement grid: dx=5mm, dy=5mm, dz=5mm

Reference Value = 10.646 V/m; Power Drift = -0.08 dB

Peak SAR (extrapolated) = 0.434 W/kg

**SAR(1 g) = 0.235 W/kg**

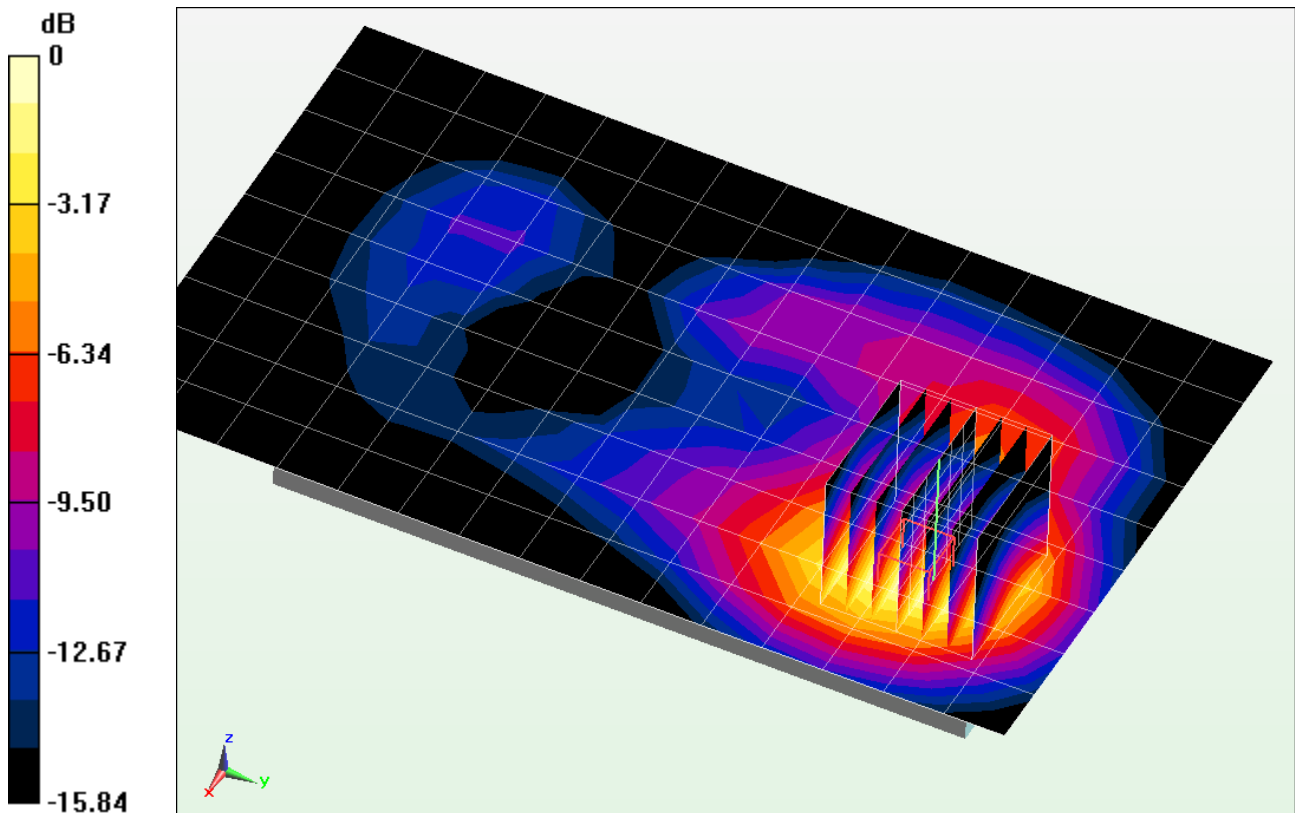

0 dB = 0.289 W/kg = -5.39 dBW/kg

# PCTEST ENGINEERING LABORATORY, INC.

**DUT: A3LSMG900R7; Type: Portable Handset; Serial: 15ECE**

Communication System: UID 0, IEEE 802.11a; Frequency: 5765 MHz; Duty Cycle: 1:1

Medium: 5 GHz Body; Medium parameters used:

$$f = 5765 \text{ MHz}; \sigma = 6.028 \text{ S/m}; \epsilon_r = 45.89; \rho = 1000 \text{ kg/m}^3$$

Phantom section: Flat Section; Space: 1.0 cm

Test Date: 02-06-2014; Ambient Temp: 24.1°C; Tissue Temp: 23.7°C

Probe: EX3DV4 - SN3914; ConvF(4.14, 4.14, 4.14); Calibrated: 10/23/2013;

Sensor-Surface: 1.4mm (Mechanical Surface Detection)

Electronics: DAE4 Sn1333; Calibrated: 11/19/2013

Phantom: SAM 5.0 front; Type: QD000P40CD; Serial: TP:-1648

Measurement SW: DASY52, Version 52.8 (7); SEMCAD X Version 14.6.10 (7164)

**Mode: IEEE 802.11a, 5.8 GHz, Body SAR, Ch 153, 6 Mbps, Back Side,  
Antenna 2, Standard Cover**

**Area Scan (11x18x1):** Measurement grid: dx=10mm, dy=10mm

**Zoom Scan (7x8x7)/Cube 0:** Measurement grid: dx=4mm, dy=4mm, dz=1.4mm; Graded Ratio: 1.4

Reference Value = 6.488 V/m; Power Drift = 0.10 dB

Peak SAR (extrapolated) = 1.47 W/kg

**SAR(1 g) = 0.287 W/kg**

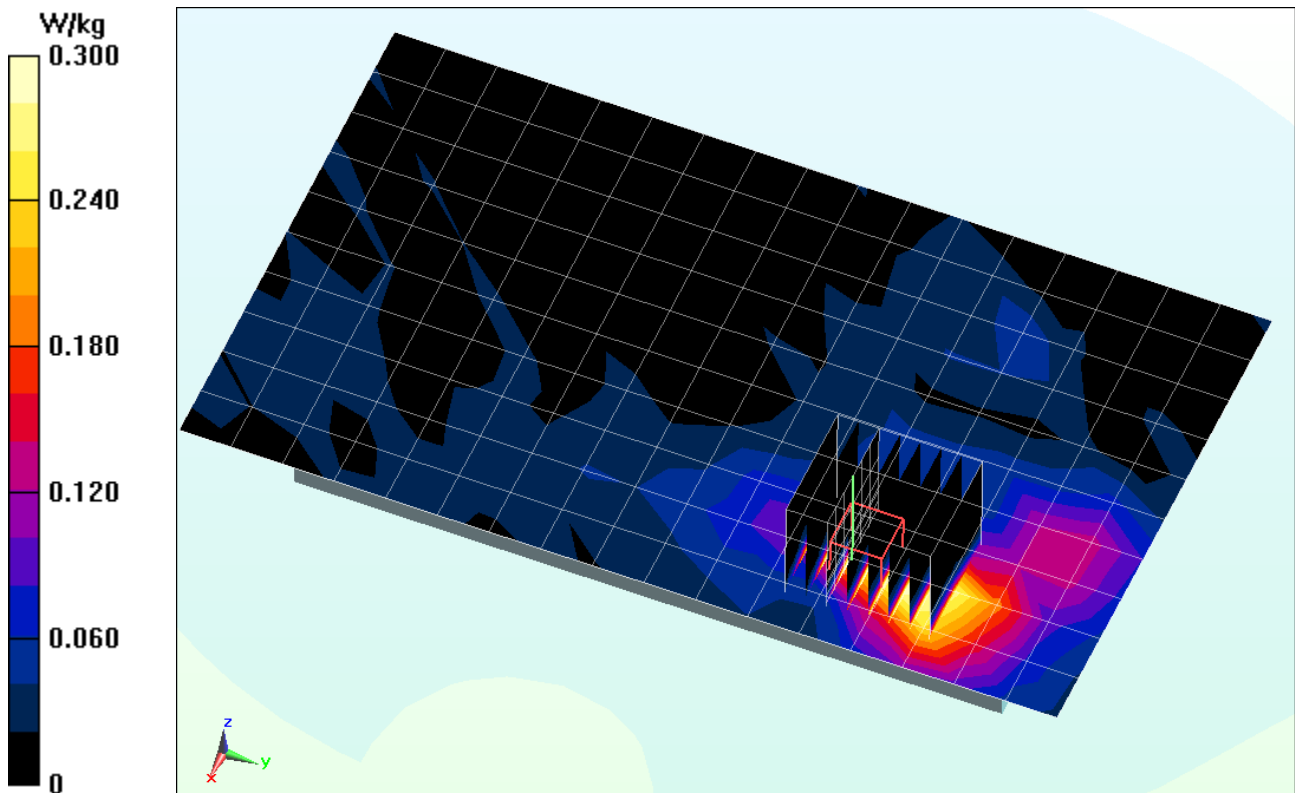

# PCTEST ENGINEERING LABORATORY, INC.

**DUT: A3LSMG900R7; Type: Portable Handset; Serial: 15ECE**

Communication System: UID 0, IEEE 802.11a; Frequency: 5500 MHz; Duty Cycle: 1:1

Medium: 5 GHz Body; Medium parameters used:

$f = 5500 \text{ MHz}$ ;  $\sigma = 5.6 \text{ S/m}$ ;  $\epsilon_r = 46.464$ ;  $\rho = 1000 \text{ kg/m}^3$

Phantom section: Flat Section; Space: 1.0 cm

Test Date: 02-06-2014; Ambient Temp: 24.1°C; Tissue Temp: 23.8°C

Probe: EX3DV4 - SN3914; ConvF(4.07, 4.07, 4.07); Calibrated: 10/23/2013;

Sensor-Surface: 1.4mm (Mechanical Surface Detection)

Electronics: DAE4 Sn1333; Calibrated: 11/19/2013

Phantom: SAM 5.0 front; Type: QD000P40CD; Serial: TP:-1648

Measurement SW: DASY52, Version 52.8 (7);SEMCAD X Version 14.6.10 (7164)

**Mode: IEEE 802.11a, 5.5 - 5.7 GHz, Body SAR, Ch 100, 6 Mbps, Back Side,  
Antenna 2, Standard Cover**

**Area Scan (11x18x1):** Measurement grid: dx=10mm, dy=10mm

**Zoom Scan (7x8x7)/Cube 0:** Measurement grid: dx=4mm, dy=4mm, dz=1.4mm; Graded Ratio: 1.4

Reference Value = 6.249 V/m; Power Drift = 0.03 dB

Peak SAR (extrapolated) = 1.49 W/kg

**SAR(1 g) = 0.296 W/kg**

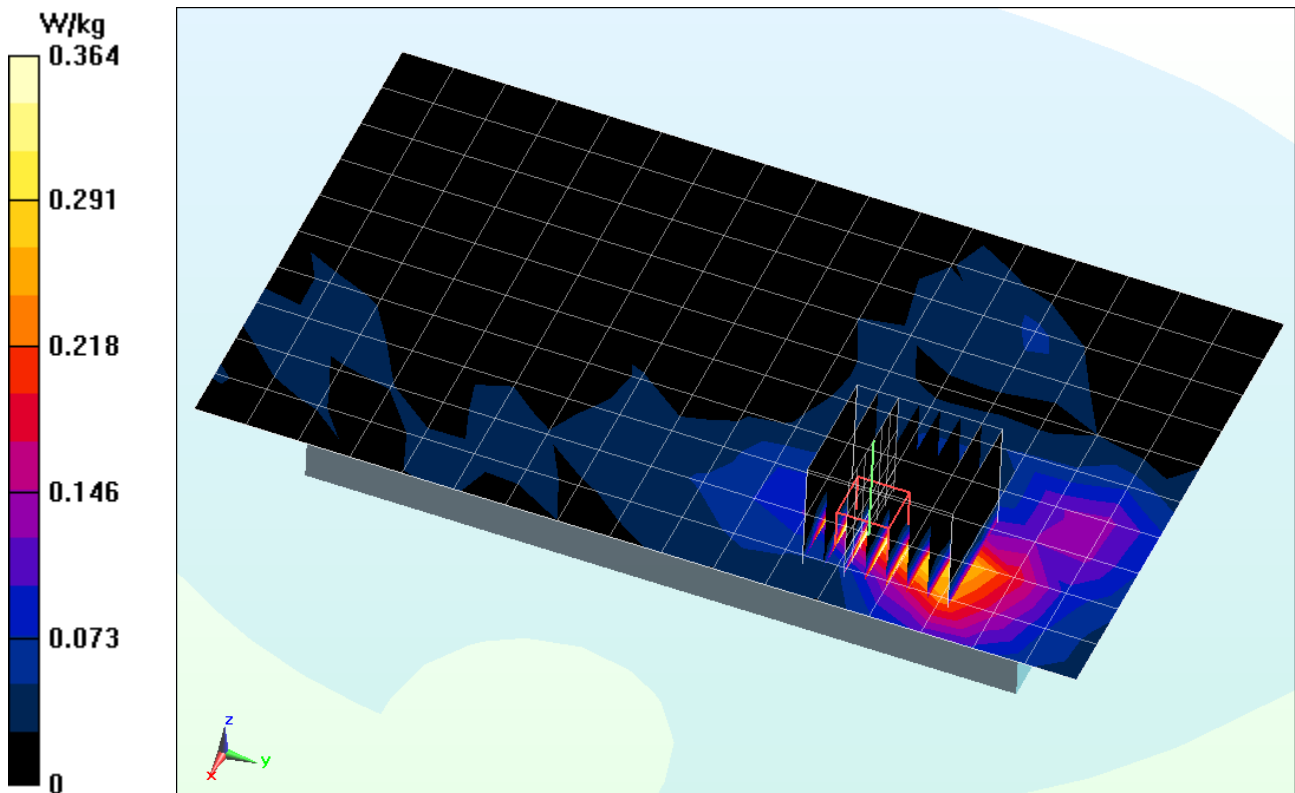

## APPENDIX B: SYSTEM VERIFICATION

# PCTEST ENGINEERING LABORATORY, INC.

**DUT: Dipole 750 MHz; Type: D750V3; Serial: 1054**

Communication System: UID 0, CW; Frequency: 750 MHz; Duty Cycle: 1:1

Medium: 750 Head Medium parameters used (interpolated):

$f = 750 \text{ MHz}$ ;  $\sigma = 0.929 \text{ S/m}$ ;  $\epsilon_r = 43.287$ ;  $\rho = 1000 \text{ kg/m}^3$

Phantom section: Flat Section; Space: 1.5 cm

Test Date: 02-17-2014; Ambient Temp: 23.2°C; Tissue Temp: 22.6°C

Probe: ES3DV3 - SN3288; ConvF(6.56, 6.56, 6.56); Calibrated: 9/23/2013;

Sensor-Surface: 4mm (Mechanical Surface Detection)

Electronics: DAE4 Sn1323; Calibrated: 9/17/2013

Phantom: SAM Sub Dasy B; Type: SAM 5.0; Serial: TP-1626

Measurement SW: DASY4, Version 4.7 (80); SEMCAD X Version 14.6.10 (7164)

## 750 MHz System Verification

**Area Scan (7x13x1):** Measurement grid: dx=15mm, dy=15mm

**Zoom Scan (5x5x7)/Cube 0:** Measurement grid: dx=8mm, dy=8mm, dz=5mm

Input Power: 20.0 dBm (100 mW)

Peak SAR (extrapolated) = 1.25 W/kg

**SAR(1 g) = 0.856 W/kg**

Deviation(1 g): 0.71%

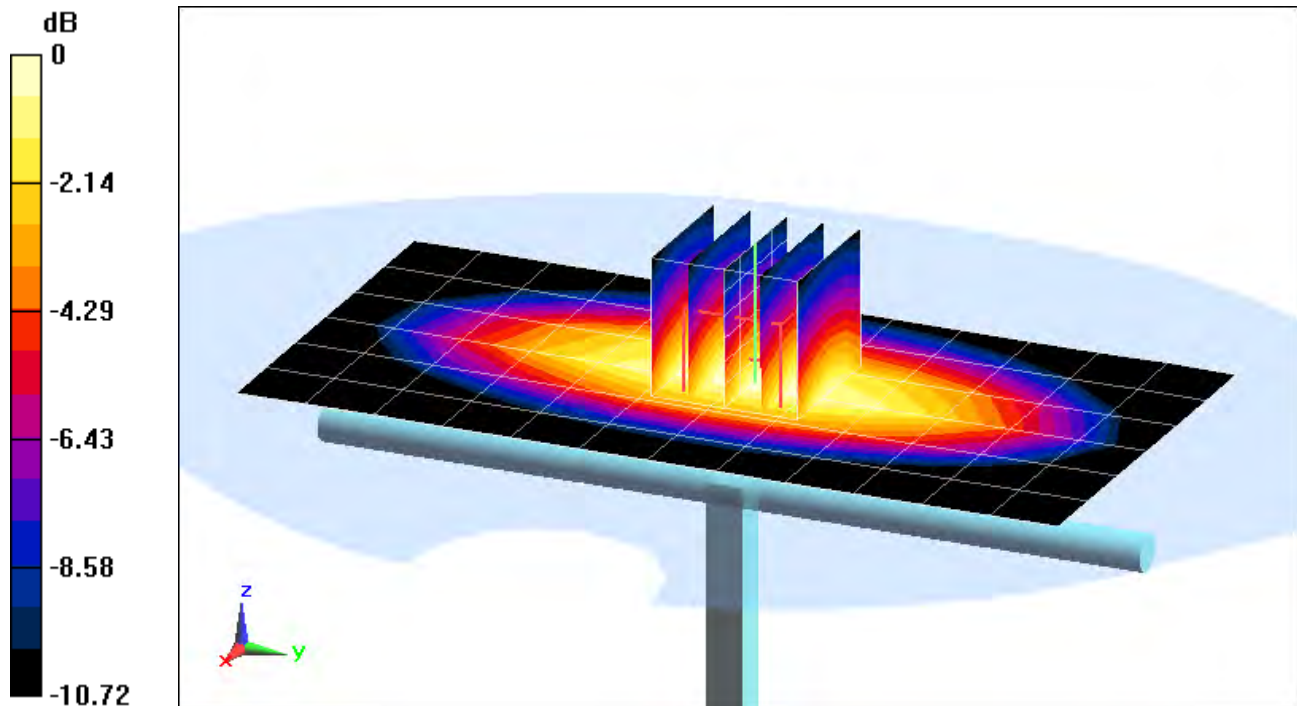

0 dB = 0.925 W/kg = -0.34 dBW/kg

# PCTEST ENGINEERING LABORATORY, INC.

**DUT: Dipole 835 MHz; Type: D835V2; Serial: 4d119**

Communication System: UID 0, CW; Frequency: 835 MHz; Duty Cycle: 1:1

Medium: 835 Head Medium parameters used:

$f = 835 \text{ MHz}$ ;  $\sigma = 0.906 \text{ S/m}$ ;  $\epsilon_r = 41.195$ ;  $\rho = 1000 \text{ kg/m}^3$

Phantom section: Flat Section; Space: 1.5 cm

Test Date: 02-17-2014; Ambient Temp: 24.3°C; Tissue Temp: 22.9°C

Probe: ES3DV3 - SN3318; ConvF(6.33, 6.33, 6.33); Calibrated: 4/29/2013;

Sensor-Surface: 4mm (Mechanical Surface Detection)

Electronics: DAE4 Sn1364; Calibrated: 4/22/2013

Phantom: SAM; Type: QD000P40CD; Serial: TP:1758

Measurement SW: DASY52, Version 52.8 (7); SEMCAD X Version 14.6.10 (7164)

## 835 MHz System Verification

**Area Scan (7x14x1):** Measurement grid: dx=15mm, dy=15mm

**Zoom Scan (5x5x7)/Cube 0:** Measurement grid: dx=8mm, dy=8mm, dz=5mm

Input Power: 20.0 dBm (100 mW)

Peak SAR (extrapolated) = 1.40 W/kg

**SAR(1 g) = 0.935 W/kg**

Deviation(1 g): -3.41%

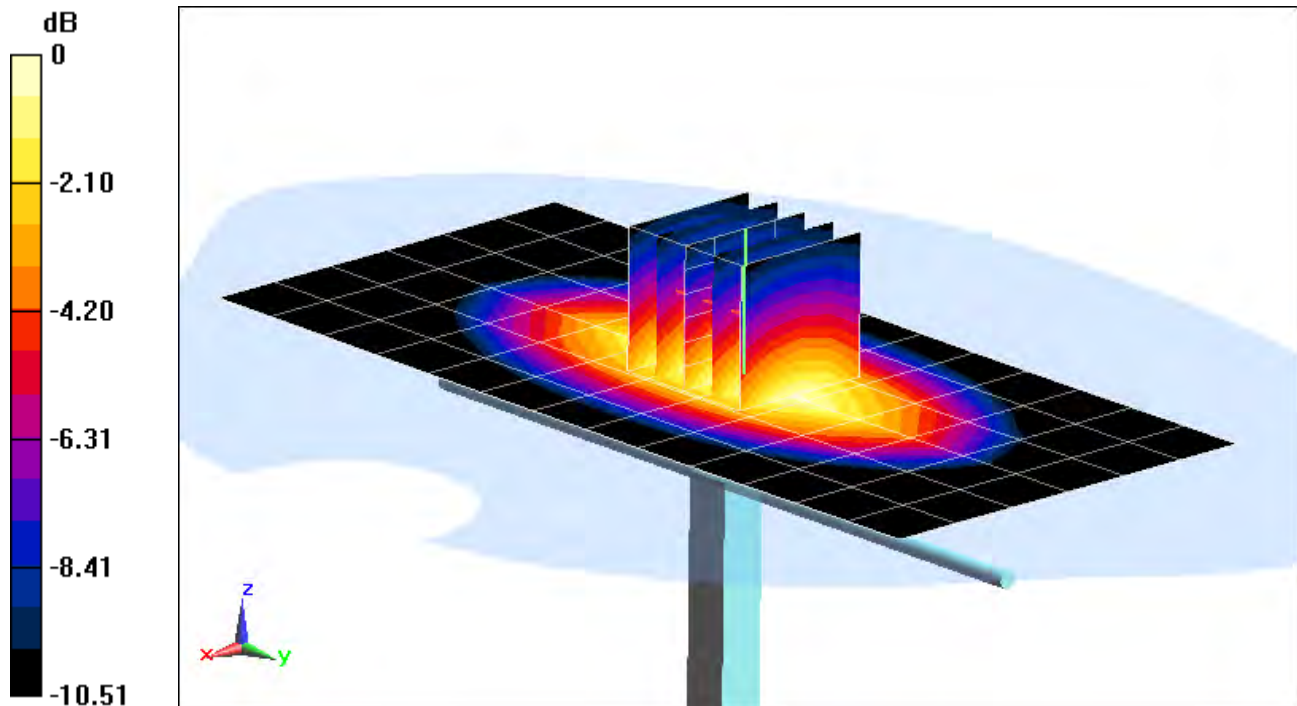

0 dB = 1.01 W/kg = 0.04 dBW/kg

# PCTEST ENGINEERING LABORATORY, INC.

**DUT: Dipole 1765 MHz; Type: D1765V2; Serial: 1008**

Communication System: UID 0, CW; Frequency: 1750 MHz; Duty Cycle: 1:1

Medium: 1750 Head Medium parameters used:

$f = 1750 \text{ MHz}$ ;  $\sigma = 1.4 \text{ S/m}$ ;  $\epsilon_r = 38.485$ ;  $\rho = 1000 \text{ kg/m}^3$

Phantom section: Flat Section; Space: 1.0 cm

Test Date: 02-18-2014; Ambient Temp: 23.4°C; Tissue Temp: 22.9°C

Probe: ES3DV3 - SN3288; ConvF(5.67, 5.67, 5.67); Calibrated: 9/23/2013;

Sensor-Surface: 4mm (Mechanical Surface Detection)

Electronics: DAE4 Sn1323; Calibrated: 9/17/2013

Phantom: SAM Sub Dasy B; Type: SAM 5.0; Serial: TP-1626

Measurement SW: DASY4, Version 4.7 (80); SEMCAD X Version 14.6.10 (7164)

## 1750 MHz System Verification

**Area Scan (6x8x1):** Measurement grid: dx=15mm, dy=15mm

**Zoom Scan (5x5x7)/Cube 0:** Measurement grid: dx=8mm, dy=8mm, dz=5mm

Input Power: 20.0 dBm (100 mW)

Peak SAR (extrapolated) = 6.54 W/kg

**SAR(1 g) = 3.55 W/kg**

Deviation(1 g): -3.53%

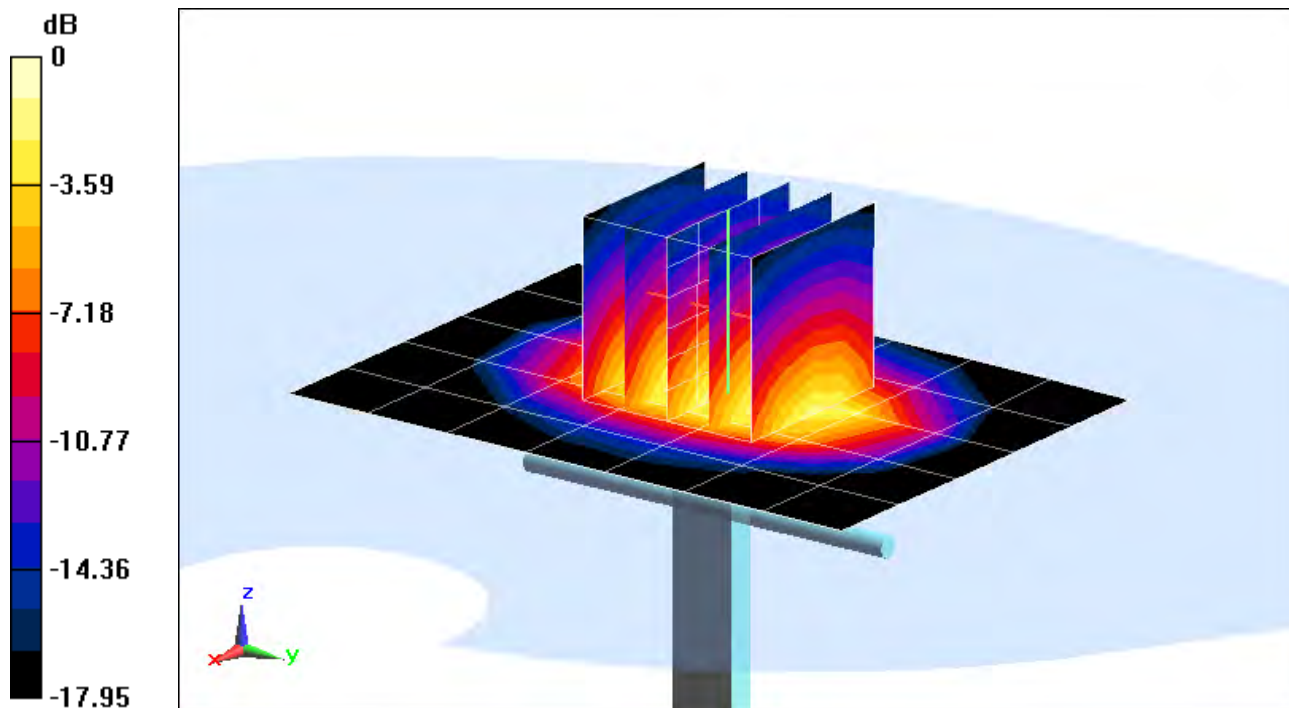

0 dB = 3.96 W/kg = 5.98 dBW/kg

# PCTEST ENGINEERING LABORATORY, INC.

**DUT: Dipole 1900 MHz; Type: D1900V2; Serial: 5d141**

Communication System: UID 0, CW; Frequency: 1900 MHz; Duty Cycle: 1:1

Medium: 1900 Head Medium parameters used (interpolated):

$f = 1900 \text{ MHz}$ ;  $\sigma = 1.448 \text{ S/m}$ ;  $\epsilon_r = 38.212$ ;  $\rho = 1000 \text{ kg/m}^3$

Phantom section: Flat Section; Space: 1.0 cm

Test Date: 02-19-2014; Ambient Temp: 23.7°C; Tissue Temp: 21.9°C

Probe: ES3DV3 - SN3263; ConvF(5.11, 5.11, 5.11); Calibrated: 5/16/2013;

Sensor-Surface: 4mm (Mechanical Surface Detection)

Electronics: DAE4 Sn859; Calibrated: 5/13/2013

Phantom: SAM Main; Type: SAM 4.0; Serial: TP-1406

Measurement SW: DASY4, Version 4.7 (80); SEMCAD X Version 14.6.10 (7164)

## 1900 MHz System Verification

**Area Scan (5x7x1):** Measurement grid: dx=15mm, dy=15mm

**Zoom Scan (5x5x7)/Cube 0:** Measurement grid: dx=8mm, dy=8mm, dz=5mm

Input Power: 20.0 dBm (100 mW)

Peak SAR (extrapolated) = 7.52 W/kg

**SAR(1 g) = 3.97 W/kg**

Deviation(1 g): -2.70%

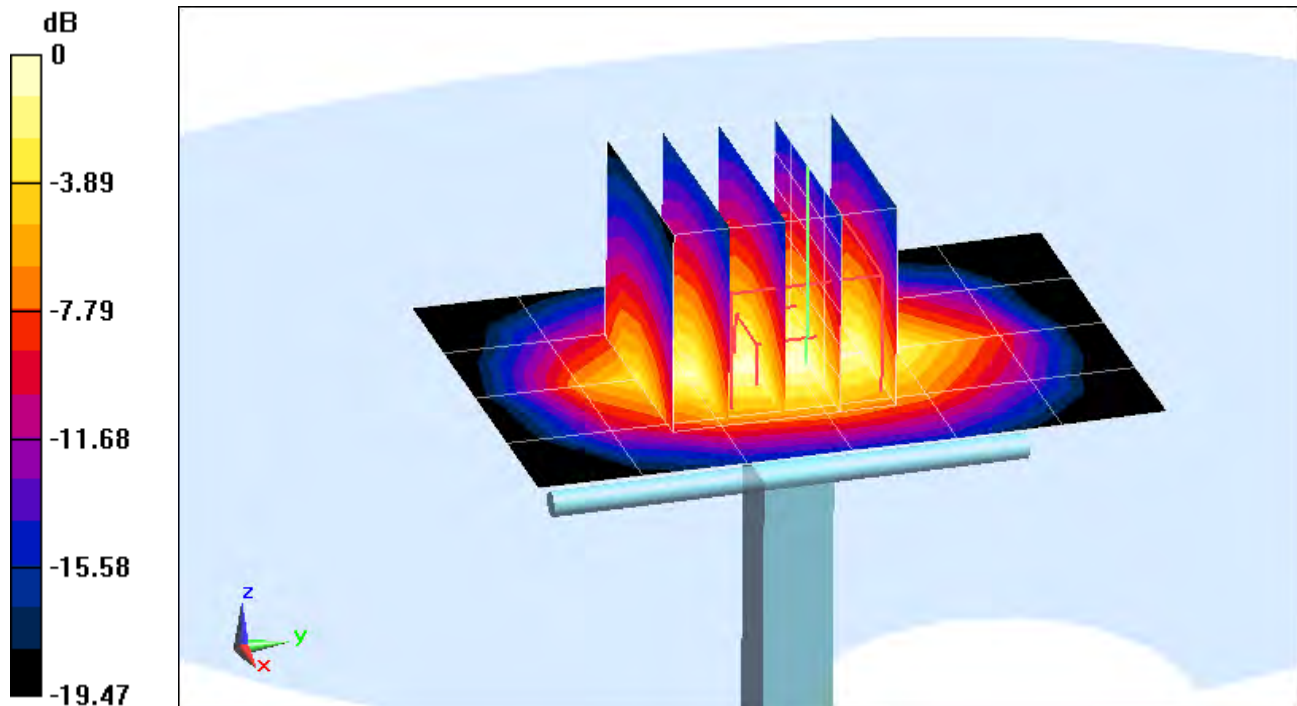

0 dB = 4.37 W/kg = 6.40 dBW/kg

# PCTEST ENGINEERING LABORATORY, INC.

**DUT: Dipole 2450 MHz; Type: D2450V2; Serial: 719**

Communication System: UID 0, CW; Frequency: 2450 MHz; Duty Cycle: 1:1

Medium: 2450 Head Medium parameters used:

$f = 2450 \text{ MHz}$ ;  $\sigma = 1.879 \text{ S/m}$ ;  $\epsilon_r = 38.816$ ;  $\rho = 1000 \text{ kg/m}^3$

Phantom section: Flat Section; Space: 1.0 cm

Test Date: 02-18-2014; Ambient Temp: 23.5°C; Tissue Temp: 23.0°C

Probe: ES3DV3 - SN3287; ConvF(4.43, 4.43, 4.43); Calibrated: 11/20/2013;

Sensor-Surface: 3mm (Mechanical Surface Detection)

Electronics: DAE4 Sn1408; Calibrated: 11/19/2013

Phantom: SAM with CRP v4.0; Type: QD000P40CD; Serial: TP:1797

Measurement SW: DASY52, Version 52.8 (7); SEMCAD X Version 14.6.10 (7164)

## 2450 MHz System Verification

**Area Scan (8x9x1):** Measurement grid: dx=12mm, dy=12mm

**Zoom Scan (7x7x7)/Cube 0:** Measurement grid: dx=5mm, dy=5mm, dz=5mm

Input Power: 20.0 dBm (100 mW)

Peak SAR (extrapolated) = 10.7 W/kg

**SAR(1 g) = 5.18 W/kg**

Deviation(1 g): -2.63%

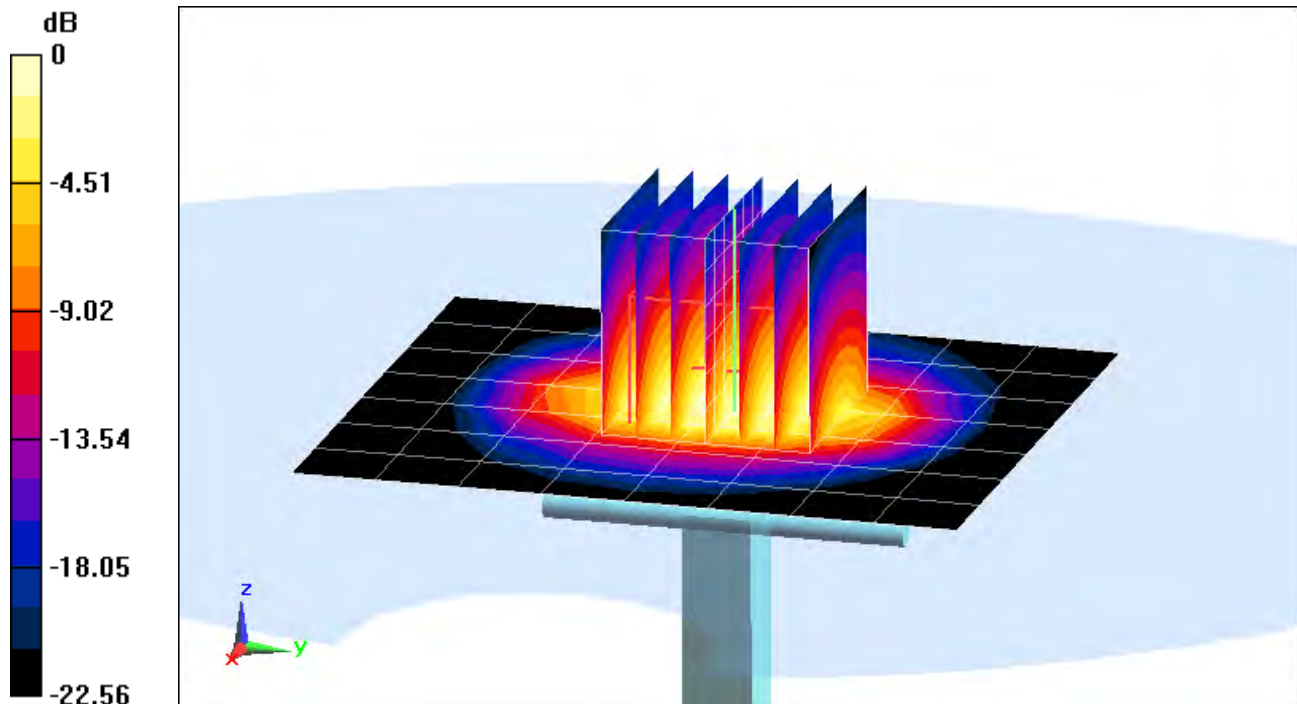

0 dB = 6.70 W/kg = 8.26 dBW/kg

# PCTEST ENGINEERING LABORATORY, INC.

**DUT: Dipole 5200 MHz; Type: D5GHzV2; Serial: 1007**

Communication System: UID 0, CW; Frequency: 5200 MHz; Duty Cycle: 1:1

Medium: 5 GHz Head Medium parameters used:

$f = 5200 \text{ MHz}$ ;  $\sigma = 4.508 \text{ S/m}$ ;  $\epsilon_r = 36.214$ ;  $\rho = 1000 \text{ kg/m}^3$

Phantom section: Flat Section; Space: 1.0 cm

Test Date: 02-03-2014; Ambient Temp: 24.4°C; Tissue Temp: 23.0°C

Probe: EX3DV4 - SN3920; ConvF(4.87, 4.87, 4.87); Calibrated: 12/18/2013;

Sensor-Surface: 1.4mm (Mechanical Surface Detection)

Electronics: DAE4 Sn649; Calibrated: 12/12/2013

Phantom: SAM Main; Type: SAM 4.0; Serial: TP-1114

Measurement SW: DASY4, Version 4.7 (80); SEMCAD X Version 14.6.10 (7164)

## 5200 MHz System Verification

**Area Scan (7x9x1):** Measurement grid: dx=10mm, dy=10mm

**Zoom Scan (9x9x7)/Cube 0:** Measurement grid: dx=4mm, dy=4mm, dz=1.4mm; Graded Ratio: 1.4

Input Power: 20.0 dBm (100 mW)

Peak SAR (extrapolated) = 31.73 W/kg

**SAR(1 g) = 7.72 W/kg**

Deviation(1 g): -0.39%

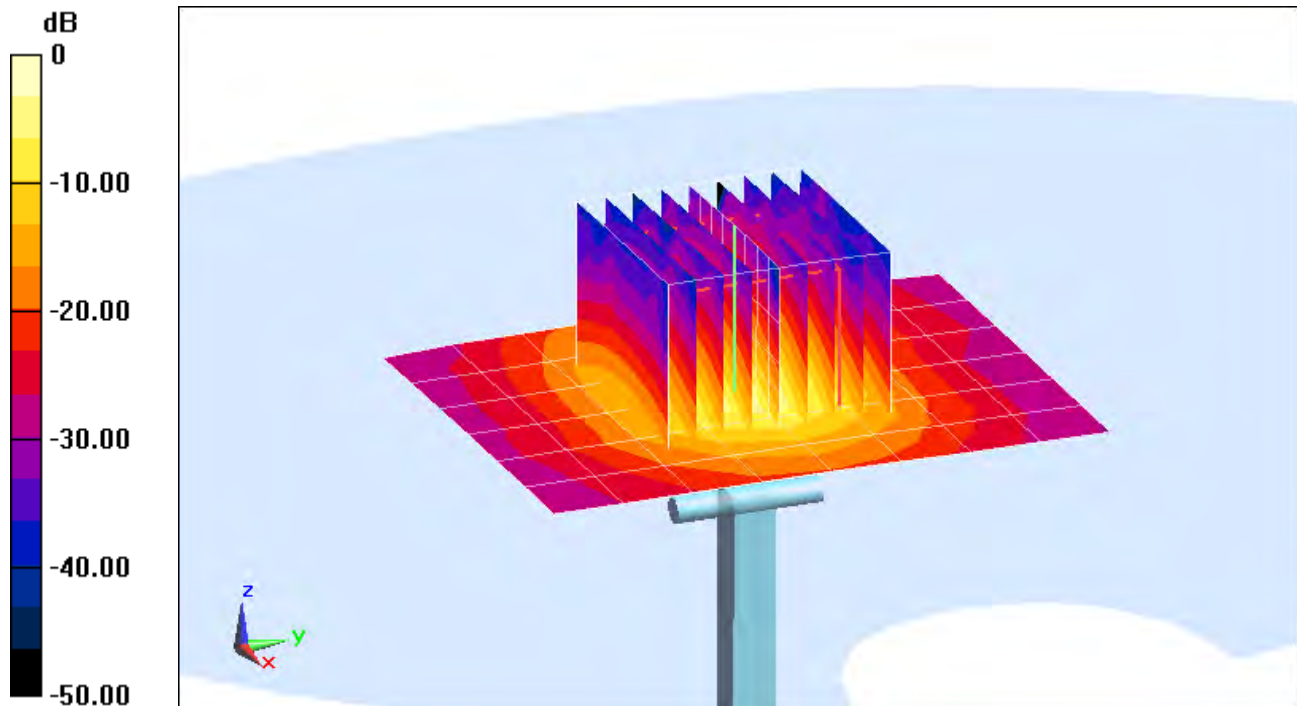

0 dB = 19.0 W/kg = 12.79 dBW/kg

# PCTEST ENGINEERING LABORATORY, INC.

**DUT: Dipole 5300 MHz; Type: D5GHzV2; Serial: 1007**

Communication System: UID 0, CW; Frequency: 5300 MHz; Duty Cycle: 1:1

Medium: 5 GHz Head Medium parameters used:

$f = 5300 \text{ MHz}$ ;  $\sigma = 4.605 \text{ S/m}$ ;  $\epsilon_r = 36.076$ ;  $\rho = 1000 \text{ kg/m}^3$

Phantom section: Flat Section; Space: 1.0 cm

Test Date: 02-03-2014; Ambient Temp: 24.4°C; Tissue Temp: 23.1°C

Probe: EX3DV4 - SN3920; ConvF(4.66, 4.66, 4.66); Calibrated: 12/18/2013;

Sensor-Surface: 1.4mm (Mechanical Surface Detection)

Electronics: DAE4 Sn649; Calibrated: 12/12/2013

Phantom: SAM Main; Type: SAM 4.0; Serial: TP-1114

Measurement SW: DASY4, Version 4.7 (80); SEMCAD X Version 14.6.10 (7164)

## 5300 MHz System Verification

**Area Scan (7x9x1):** Measurement grid: dx=10mm, dy=10mm

**Zoom Scan (9x9x7)/Cube 0:** Measurement grid: dx=4mm, dy=4mm, dz=1.4mm; Graded Ratio: 1.4

Input Power: 20.0 dBm (100 mW)

Peak SAR (extrapolated) = 33.47 W/kg

**SAR(1 g) = 7.9 W/kg**

Deviation(1 g): -1.50%

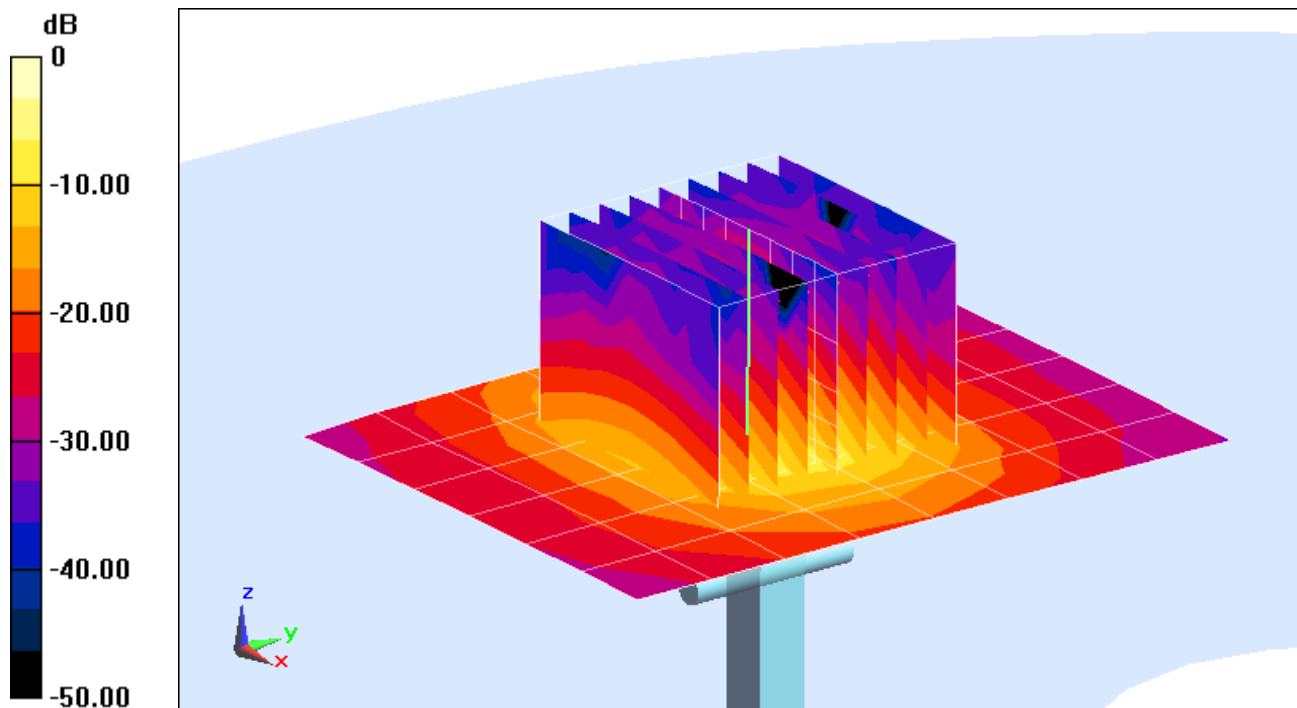

0 dB = 20.0 W/kg = 13.01 dBW/kg

# PCTEST ENGINEERING LABORATORY, INC.

**DUT: Dipole 5500 MHz; Type: D5GHzV2; Serial: 1007**

Communication System: UID 0, CW; Frequency: 5500 MHz; Duty Cycle: 1:1

Medium: 5 GHz Head Medium parameters used:

$f = 5500 \text{ MHz}$ ;  $\sigma = 4.822 \text{ S/m}$ ;  $\epsilon_r = 35.798$ ;  $\rho = 1000 \text{ kg/m}^3$

Phantom section: Flat Section; Space: 1.0 cm

Test Date: 02-03-2014; Ambient Temp: 24.2°C; Tissue Temp: 23.2°C

Probe: EX3DV4 - SN3920; ConvF(4.54, 4.54, 4.54); Calibrated: 12/18/2013;

Sensor-Surface: 1.4mm (Mechanical Surface Detection)

Electronics: DAE4 Sn649; Calibrated: 12/12/2013

Phantom: SAM Main; Type: SAM 4.0; Serial: TP-1114

Measurement SW: DASY4, Version 4.7 (80); SEMCAD X Version 14.6.10 (7164)

## 5500 MHz System Verification

**Area Scan (7x9x1):** Measurement grid: dx=10mm, dy=10mm

**Zoom Scan (9x9x7)/Cube 0:** Measurement grid: dx=4mm, dy=4mm, dz=1.4mm; Graded Ratio: 1.4

Input Power: 20.0 dBm (100 mW)

Peak SAR (extrapolated) = 36.75 W/kg

**SAR(1 g) = 7.74 W/kg**

Deviation(1 g): -4.91%

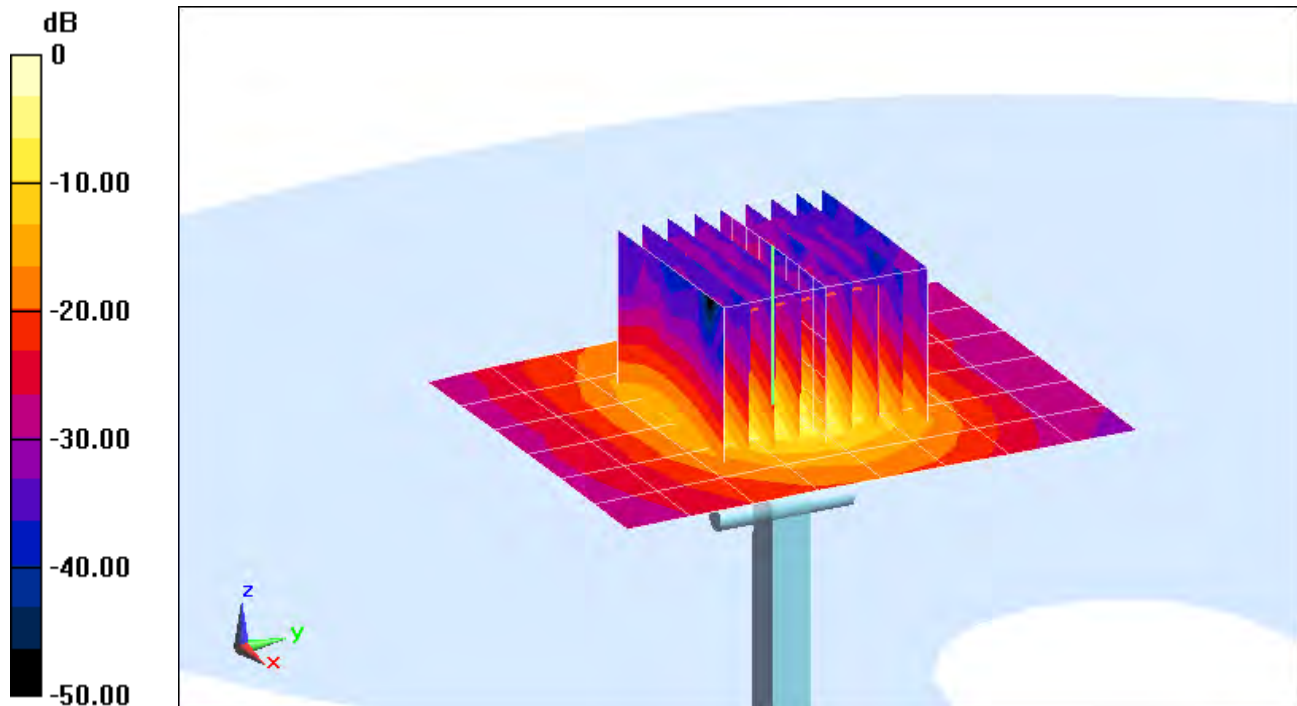

0 dB = 19.3 W/kg = 12.86 dBW/kg

# PCTEST ENGINEERING LABORATORY, INC.

**DUT: Dipole 5600 MHz; Type: D5GHzV2; Serial: 1007**

Communication System: UID 0, CW; Frequency: 5600 MHz; Duty Cycle: 1:1

Medium: 5 GHz Head Medium parameters used:

$f = 5600 \text{ MHz}$ ;  $\sigma = 4.925 \text{ S/m}$ ;  $\epsilon_r = 35.697$ ;  $\rho = 1000 \text{ kg/m}^3$

Phantom section: Flat Section; Space: 1.0 cm

Test Date: 02-03-2014; Ambient Temp: 24.5°C; Tissue Temp: 23.3°C

Probe: EX3DV4 - SN3920; ConvF(4.37, 4.37, 4.37); Calibrated: 12/18/2013;

Sensor-Surface: 1.4mm (Mechanical Surface Detection)

Electronics: DAE4 Sn649; Calibrated: 12/12/2013

Phantom: SAM Main; Type: SAM 4.0; Serial: TP-1114

Measurement SW: DASY4, Version 4.7 (80); SEMCAD X Version 14.6.10 (7164)

## 5600 MHz System Verification

**Area Scan (7x9x1):** Measurement grid: dx=10mm, dy=10mm

**Zoom Scan (9x9x7)/Cube 0:** Measurement grid: dx=4mm, dy=4mm, dz=1.4mm; Graded Ratio: 1.4

Input Power: 20.0 dBm (100 mW)

Peak SAR (extrapolated) = 34.83 W/kg

**SAR(1 g) = 7.9 W/kg**

Deviation(1 g): -1.25%

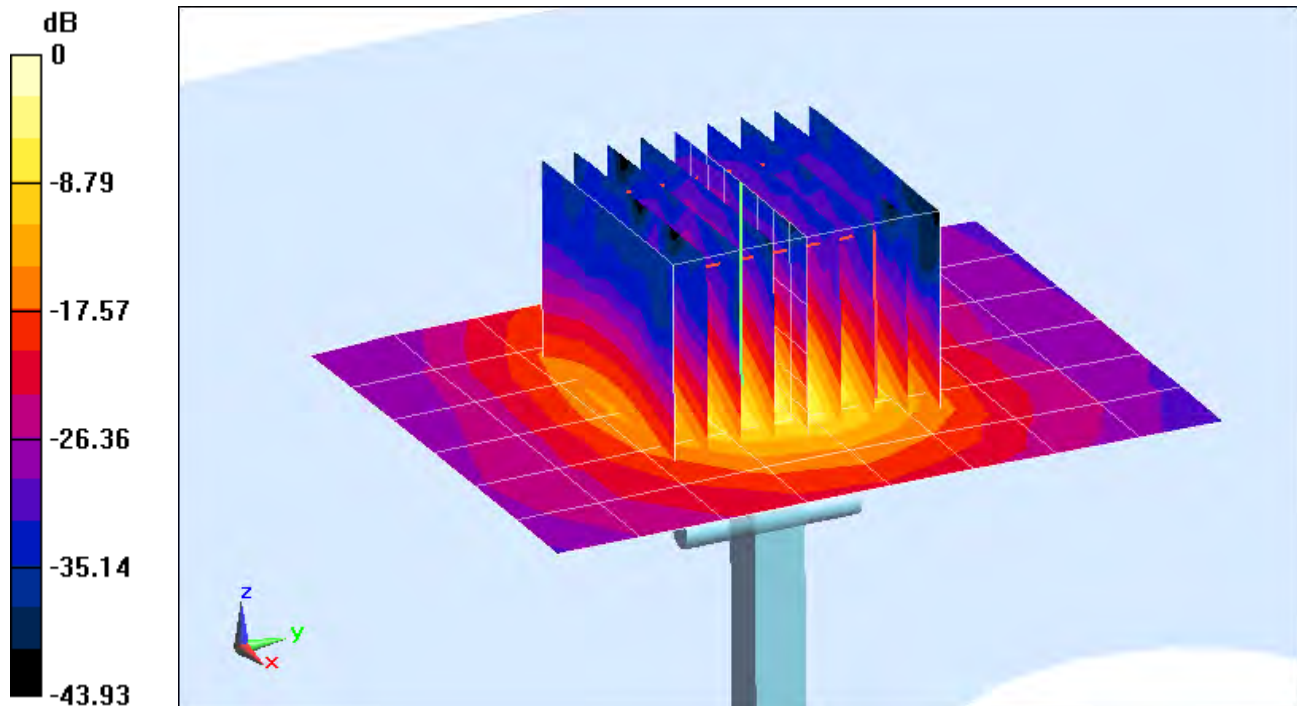

0 dB = 19.9 W/kg = 12.99 dBW/kg

# PCTEST ENGINEERING LABORATORY, INC.

**DUT: Dipole 5800 MHz; Type: D5GHzV2; Serial: 1007**

Communication System: UID 0, CW; Frequency: 5800 MHz; Duty Cycle: 1:1

Medium: 5 GHz Head Medium parameters used:

$f = 5800 \text{ MHz}$ ;  $\sigma = 5.112 \text{ S/m}$ ;  $\epsilon_r = 35.479$ ;  $\rho = 1000 \text{ kg/m}^3$

Phantom section: Flat Section; Space: 1.0 cm

Test Date: 02-03-2014; Ambient Temp: 24.3°C; Tissue Temp: 23.3°C

Probe: EX3DV4 - SN3920; ConvF(4.11, 4.11, 4.11); Calibrated: 12/18/2013;

Sensor-Surface: 1.4mm (Mechanical Surface Detection)

Electronics: DAE4 Sn649; Calibrated: 12/12/2013

Phantom: SAM Main; Type: SAM 4.0; Serial: TP-1114

Measurement SW: DASY4, Version 4.7 (80); SEMCAD X Version 14.6.10 (7164)

## 5800 MHz System Verification

**Area Scan (7x9x1):** Measurement grid: dx=10mm, dy=10mm

**Zoom Scan (9x9x7)/Cube 0:** Measurement grid: dx=4mm, dy=4mm, dz=1.4mm; Graded Ratio: 1.4

Input Power: 20.0 dBm (100 mW)

Peak SAR (extrapolated) = 34.71 W/kg

**SAR(1 g) = 7.68 W/kg**

Deviation(1 g): -0.90%

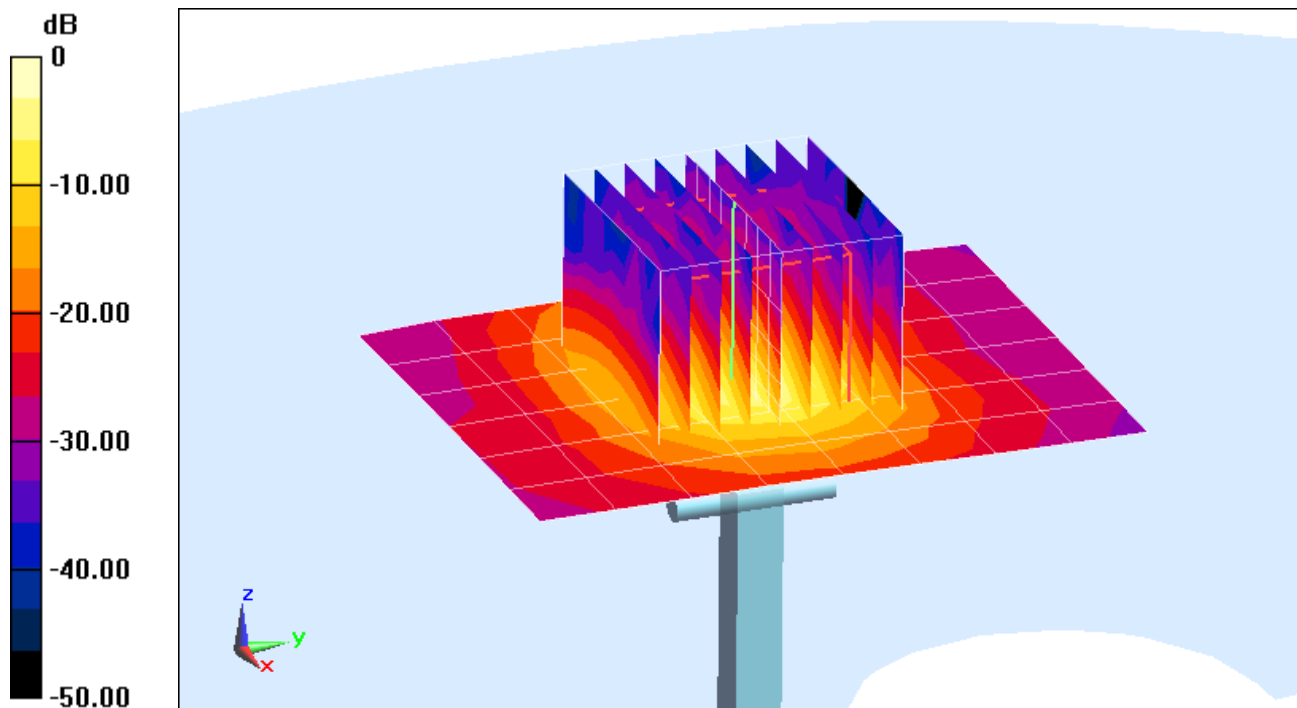

0 dB = 19.2 W/kg = 12.83 dBW/kg

# PCTEST ENGINEERING LABORATORY, INC.

**DUT: Dipole 750 MHz; Type: D750V3; Serial: 1054**

Communication System: UID 0, CW; Frequency: 750 MHz; Duty Cycle: 1:1

Medium: 750 Body Medium parameters used (interpolated):

$f = 750 \text{ MHz}$ ;  $\sigma = 0.976 \text{ S/m}$ ;  $\epsilon_r = 54.495$ ;  $\rho = 1000 \text{ kg/m}^3$

Phantom section: Flat Section; Space: 1.5 cm

Test Date: 02-18-2014; Ambient Temp: 19.9°C; Tissue Temp: 20.6°C

Probe: ES3DV3 - SN3263; ConvF(6.37, 6.37, 6.37); Calibrated: 5/16/2013;

Sensor-Surface: 4mm (Mechanical Surface Detection)

Electronics: DAE4 Sn859; Calibrated: 5/13/2013

Phantom: SAM Main; Type: SAM 4.0; Serial: TP-1114

Measurement SW: DASY4, Version 4.7 (80); SEMCAD X Version 14.6.10 (7164)

## 750 MHz System Verification

**Area Scan (7x13x1):** Measurement grid: dx=15mm, dy=15mm

**Zoom Scan (5x5x7)/Cube 0:** Measurement grid: dx=8mm, dy=8mm, dz=5mm

Input Power: 20.0 dBm (100 mW)

Peak SAR (extrapolated) = 1.27 W/kg

**SAR(1 g) = 0.882 W/kg**

Deviation(1 g): 1.15%

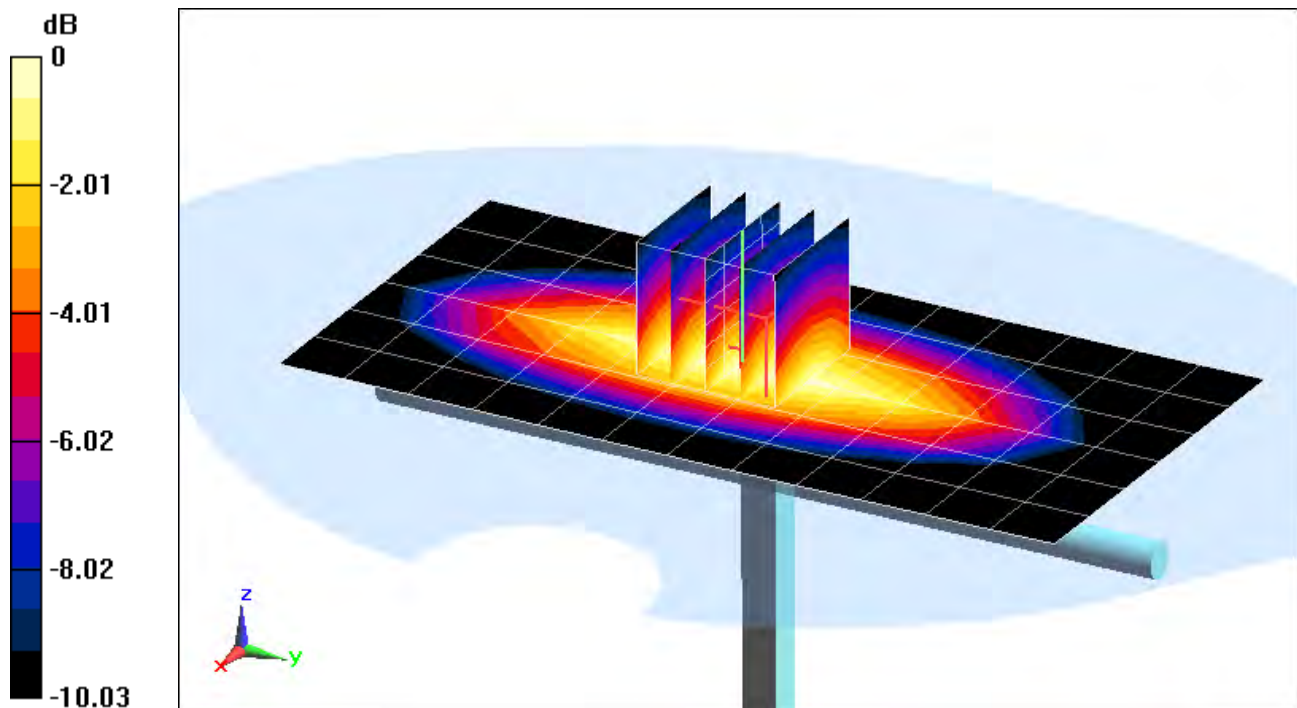

0 dB = 0.960 W/kg = -0.18 dBW/kg

# PCTEST ENGINEERING LABORATORY, INC.

**DUT: Dipole 835 MHz; Type: D835V2; Serial: 4d133**

Communication System: UID 0, CW; Frequency: 835 MHz; Duty Cycle: 1:1

Medium: 835 Body Medium parameters used:

$f = 835 \text{ MHz}$ ;  $\sigma = 0.976 \text{ S/m}$ ;  $\epsilon_r = 55.109$ ;  $\rho = 1000 \text{ kg/m}^3$

Phantom section: Flat Section; Space: 1.5 cm

Test Date: 02-17-2014; Ambient Temp: 19.7°C; Tissue Temp: 19.7°C

Probe: ES3DV3 - SN3263; ConvF(6.29, 6.29, 6.29); Calibrated: 5/16/2013;

Sensor-Surface: 4mm (Mechanical Surface Detection)

Electronics: DAE4 Sn859; Calibrated: 5/13/2013

Phantom: SAM Sub; Type: SAM 4.0; Serial: TP-1357

Measurement SW: DASY4, Version 4.7 (80); SEMCAD X Version 14.6.10 (7164)

## 835 MHz System Verification

**Area Scan (7x13x1):** Measurement grid: dx=15mm, dy=15mm

**Zoom Scan (5x5x7)/Cube 0:** Measurement grid: dx=8mm, dy=8mm, dz=5mm

Input Power: 20.0 dBm (100 mW)

Peak SAR (extrapolated) = 1.39 W/kg

**SAR(1 g) = 0.953 W/kg**

Deviation(1 g): -0.83%

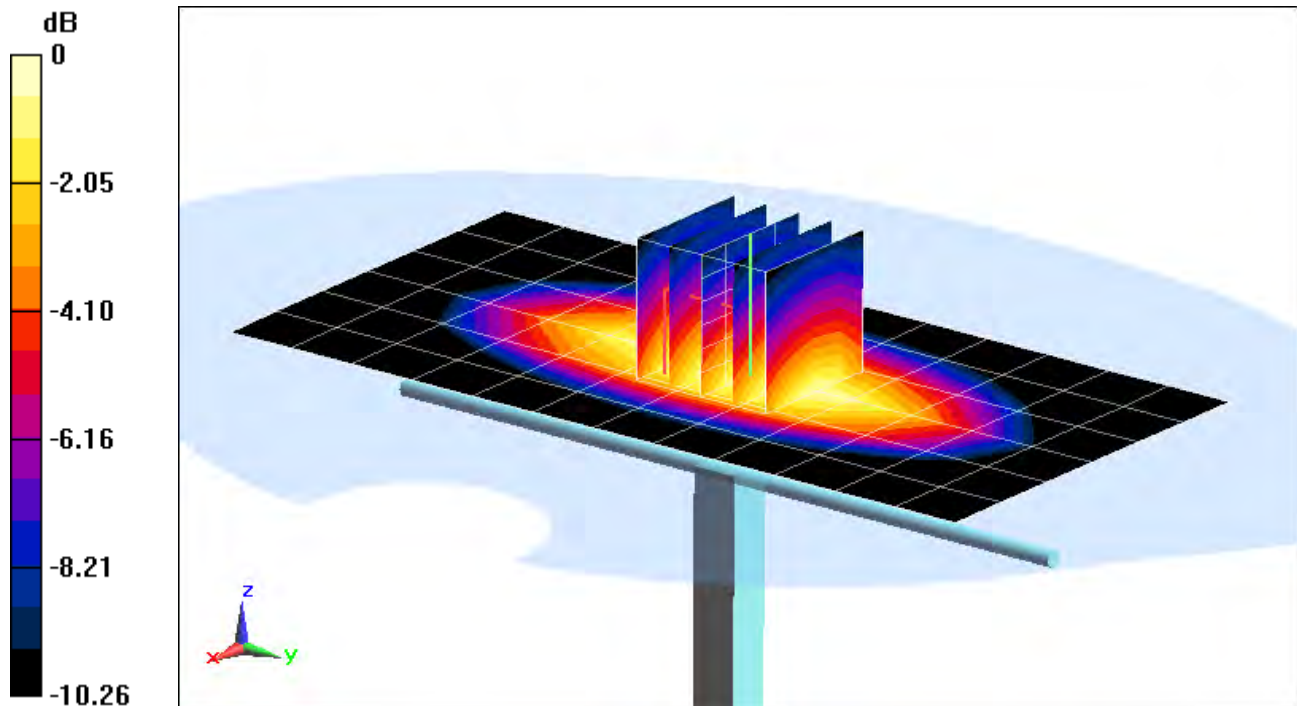

0 dB = 1.01 W/kg = 0.04 dBW/kg

# PCTEST ENGINEERING LABORATORY, INC.

**DUT: Dipole 1765 MHz; Type: D1765V2; Serial: 1008**

Communication System: UID 0, CW; Frequency: 1750 MHz; Duty Cycle: 1:1

Medium: 1750 Body Medium parameters used:

$f = 1750 \text{ MHz}$ ;  $\sigma = 1.511 \text{ S/m}$ ;  $\epsilon_r = 54.336$ ;  $\rho = 1000 \text{ kg/m}^3$

Phantom section: Flat Section; Space: 1.0 cm

Test Date: 02-18-2014; Ambient Temp: 23.4°C; Tissue Temp: 23.0°C

Probe: ES3DV3 - SN3288; ConvF(5.1, 5.1, 5.1); Calibrated: 9/23/2013;

Sensor-Surface: 4mm (Mechanical Surface Detection)

Electronics: DAE4 Sn1323; Calibrated: 9/17/2013

Phantom: SAM with CRP; Type: SAM; Serial: TP1375

Measurement SW: DASY4, Version 4.7 (80); SEMCAD X Version 14.6.10 (7164)

## 1750 MHz System Verification

**Area Scan (6x8x1):** Measurement grid: dx=15mm, dy=15mm

**Zoom Scan (5x5x7)/Cube 0:** Measurement grid: dx=8mm, dy=8mm, dz=5mm

Input Power: 20.0 dBm (100 mW)

Peak SAR (extrapolated) = 6.81 W/kg

**SAR(1 g) = 3.76 W/kg**

Deviation(1 g): -1.57%

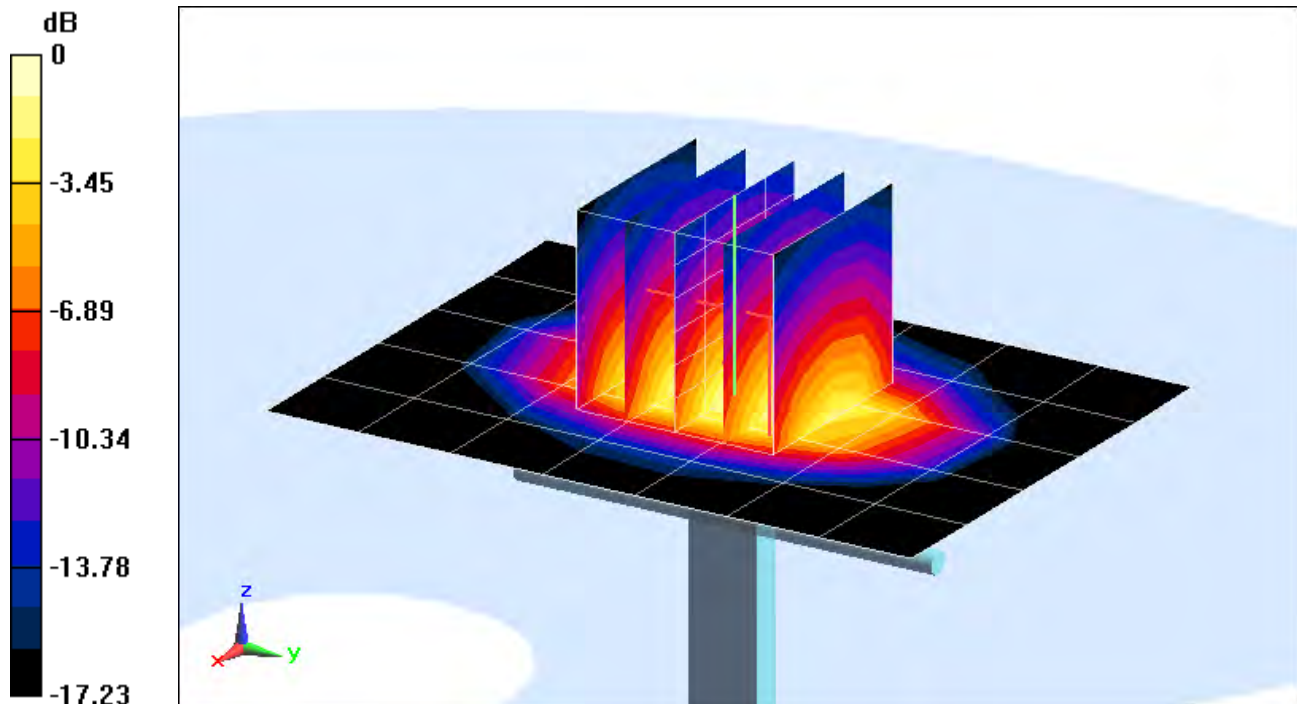

0 dB = 4.21 W/kg = 6.24 dBW/kg

# PCTEST ENGINEERING LABORATORY, INC.

**DUT: SAR Dipole 1900 MHz; Type: D1900V2; Serial: 5d149**

Communication System: UID 0, CW; Frequency: 1900 MHz; Duty Cycle: 1:1

Medium: 1900 Body Medium parameters used (interpolated):

$f = 1900 \text{ MHz}$ ;  $\sigma = 1.547 \text{ S/m}$ ;  $\epsilon_r = 53.129$ ;  $\rho = 1000 \text{ kg/m}^3$

Phantom section: Flat Section; Space: 1.0 cm

Test Date: 02-17-2014; Ambient Temp: 23.7°C; Tissue Temp: 23.2°C

Probe: ES3DV3 - SN3319; ConvF(4.85, 4.85, 4.85); Calibrated: 4/29/2013;

Sensor-Surface: 4mm (Mechanical Surface Detection)

Electronics: DAE4 Sn1368; Calibrated: 4/22/2013

Phantom: SAM front; Type: QD000P40CD; Serial: TP:1759

Measurement SW: DASY52, Version 52.8 (7); SEMCAD X Version 14.6.10 (7164)

## 1900 MHz System Verification

**Area Scan (7x10x1):** Measurement grid: dx=15mm, dy=15mm

**Zoom Scan (5x5x7)/Cube 0:** Measurement grid: dx=8mm, dy=8mm, dz=5mm

Input Power: 20.0 dBm (100 mW)

Peak SAR (extrapolated) = 6.82 W/kg

**SAR(1 g) = 3.83 W/kg**

Deviation(1 g): -5.43%

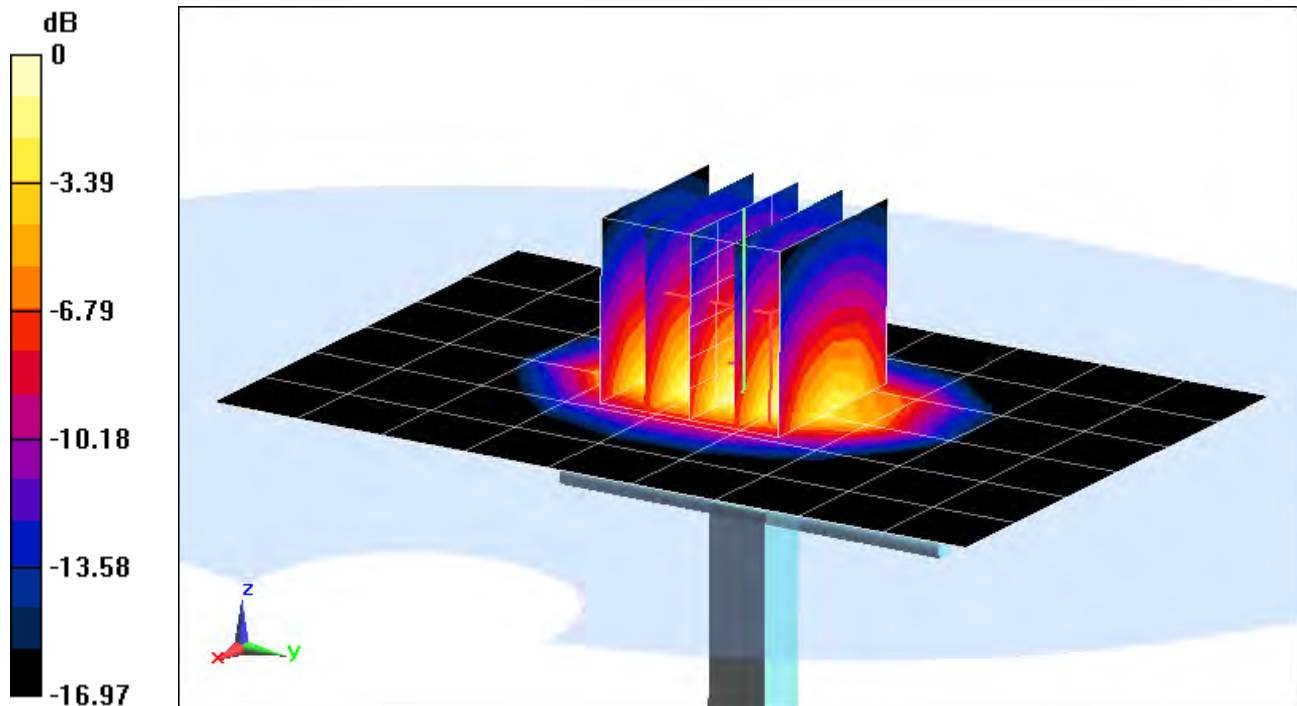

0 dB = 4.31 W/kg = 6.34 dBW/kg

# PCTEST ENGINEERING LABORATORY, INC.

**DUT: SAR Dipole 1900 MHz; Type: D1900V2; Serial: 5d149**

Communication System: UID 0, CW; Frequency: 1900 MHz; Duty Cycle: 1:1

Medium: 1900 Body Medium parameters used (interpolated):

$f = 1900 \text{ MHz}$ ;  $\sigma = 1.569 \text{ S/m}$ ;  $\epsilon_r = 50.964$ ;  $\rho = 1000 \text{ kg/m}^3$

Phantom section: Flat Section; Space: 1.0 cm

Test Date: 03-31-2014; Ambient Temp: 23.2°C; Tissue Temp: 21.6°C

Probe: ES3DV2 - SN3022; ConvF(4.49, 4.49, 4.49); Calibrated: 8/22/2013;

Sensor-Surface: 4mm (Mechanical Surface Detection)

Electronics: DAE4 Sn1322; Calibrated: 8/21/2013

Phantom: SAM v5.0 front; Type: QD000P40CD; Serial: TP-1646

Measurement SW: DASY52, Version 52.8 (7); SEMCAD X Version 14.6.10 (7164)

## 1900 MHz System Verification

**Area Scan (7x10x1):** Measurement grid: dx=15mm, dy=15mm

**Zoom Scan (5x5x7)/Cube 0:** Measurement grid: dx=8mm, dy=8mm, dz=5mm

Input Power: 20.0 dBm (100 mW)

Peak SAR (extrapolated) = 7.65 W/kg

**SAR(1 g) = 4.2 W/kg**

Deviation(1 g): 3.70%

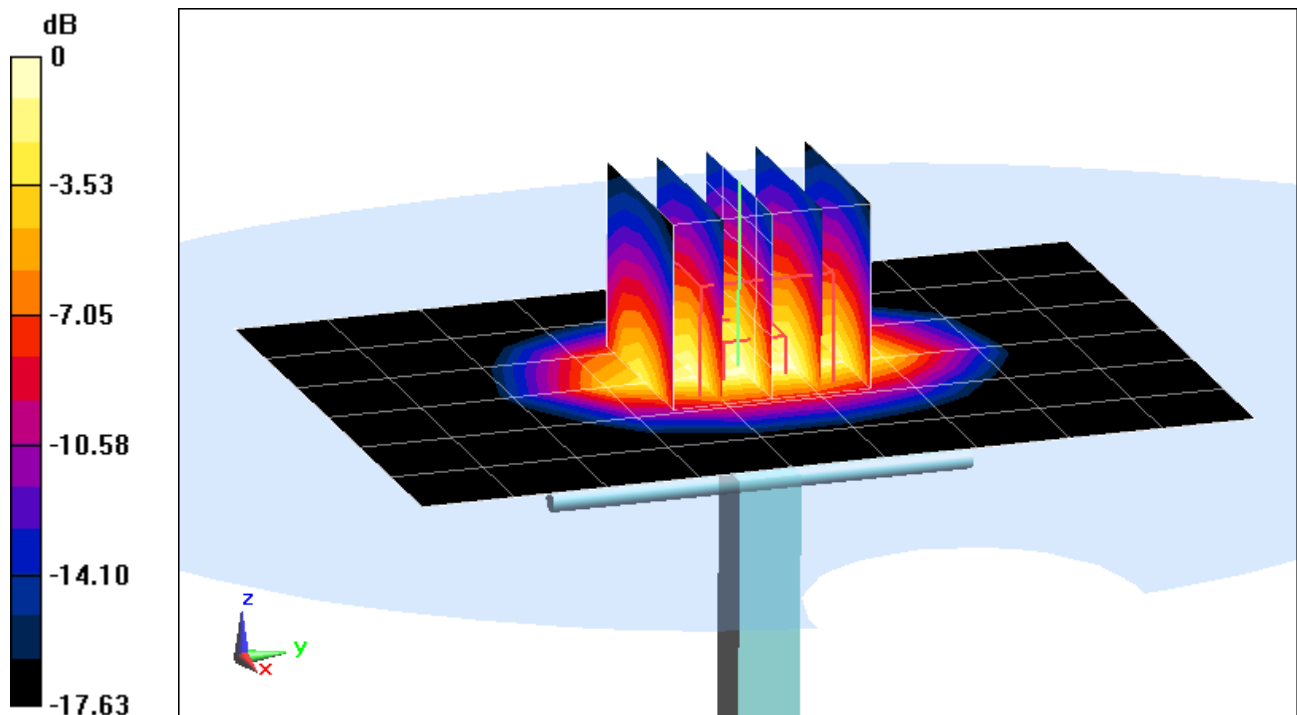

0 dB = 4.73 W/kg = 6.75 dBW/kg

# PCTEST ENGINEERING LABORATORY, INC.

**DUT: Dipole 2450 MHz; Type: D2450V2; Serial: 719**

Communication System: UID 0, CW; Frequency: 2450 MHz; Duty Cycle: 1:1

Medium: 2450 Body Medium parameters used:

$f = 2450 \text{ MHz}$ ;  $\sigma = 1.937 \text{ S/m}$ ;  $\epsilon_r = 51.331$ ;  $\rho = 1000 \text{ kg/m}^3$

Phantom section: Flat Section; Space: 1.0 cm

Test Date: 02-12-2014; Ambient Temp: 24.4°C; Tissue Temp: 24.0°C

Probe: ES3DV3 - SN3318; ConvF(4.31, 4.31, 4.31); Calibrated: 4/29/2013;

Sensor-Surface: 3mm (Mechanical Surface Detection)

Electronics: DAE4 Sn1364; Calibrated: 4/22/2013

Phantom: ELI left; Type: QDOVA002AA; Serial: TP:1202

Measurement SW: DASY52, Version 52.8 (7); SEMCAD X Version 14.6.10 (7164)

## 2450 MHz System Verification

**Area Scan (8x9x1):** Measurement grid: dx=12mm, dy=12mm

**Zoom Scan (7x7x7)/Cube 0:** Measurement grid: dx=5mm, dy=5mm, dz=5mm

Input Power: 20.0 dBm (100 mW)

Peak SAR (extrapolated) = 11.1 W/kg

**SAR(1 g) = 5.41 W/kg**

Deviation(1 g): 4.64%

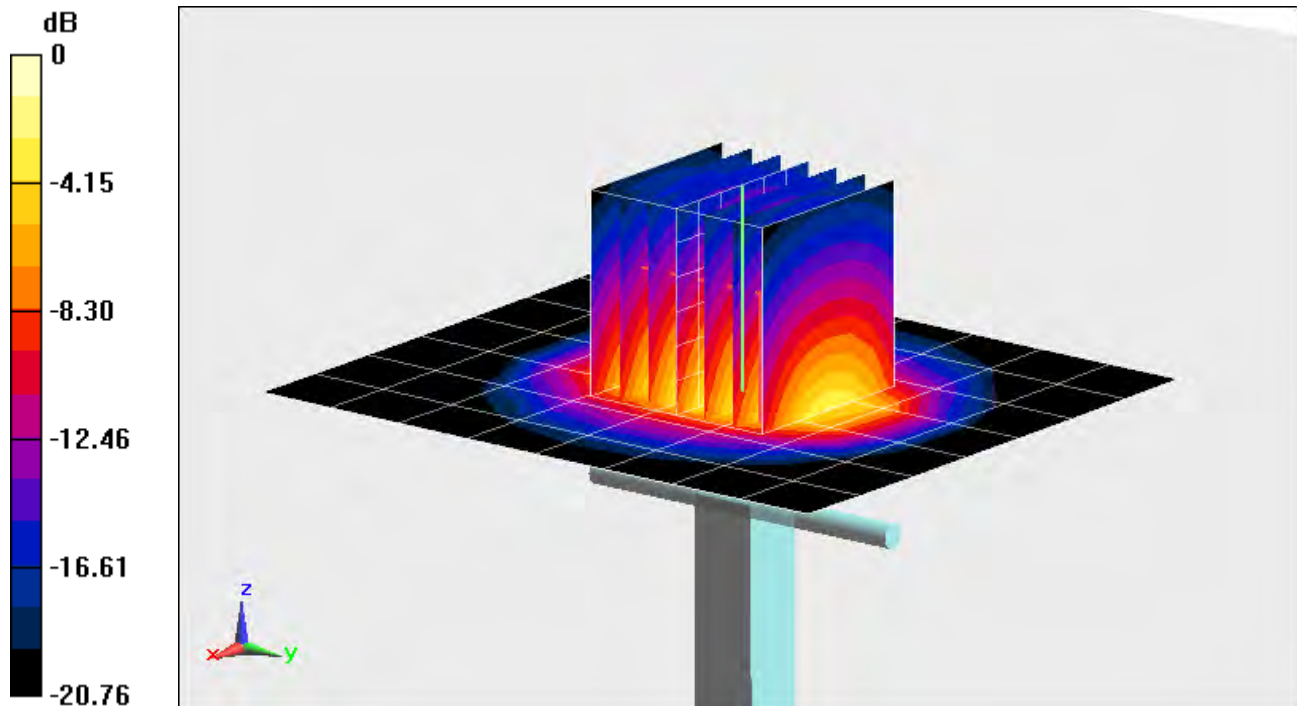

0 dB = 7.09 W/kg = 8.51 dBW/kg

# PCTEST ENGINEERING LABORATORY, INC.

**DUT: SAR Dipole 5200 MHz; Type: D5GHzV2; Serial: 1120**

Communication System: UID 0, CW; Frequency: 5200 MHz; Duty Cycle: 1:1

Medium: 5 GHz Body; Medium parameters used:

$f = 5200 \text{ MHz}$ ;  $\sigma = 5.147 \text{ S/m}$ ;  $\epsilon_r = 47.331$ ;  $\rho = 1000 \text{ kg/m}^3$

Phantom section: Flat Section; Space: 1.0 cm

Test Date: 02-06-2014; Ambient Temp: 24.0°C; Tissue Temp: 23.8°C

Probe: EX3DV4 - SN3914; ConvF(4.52, 4.52, 4.52); Calibrated: 10/23/2013;

Sensor-Surface: 1.4mm (Mechanical Surface Detection)

Electronics: DAE4 Sn1333; Calibrated: 11/19/2013

Phantom: SAM 5.0 front; Type: QD000P40CD; Serial: TP:-1648

Measurement SW: DASY52, Version 52.8 (7);SEMCAD X Version 14.6.10 (7164)

## 5200 MHz System Verification

**Area Scan (7x8x1):** Measurement grid: dx=10mm, dy=10mm

**Zoom Scan (7x7x7)/Cube 0:** Measurement grid: dx=4mm, dy=4mm, dz=1.4mm; Graded Ratio: 1.4

Input Power: 20.0 dBm (100 mW)

Peak SAR (extrapolated) = 32.9 W/kg

**SAR(1 g) = 7.7 W/kg**

Deviation(1 g): 0.52%

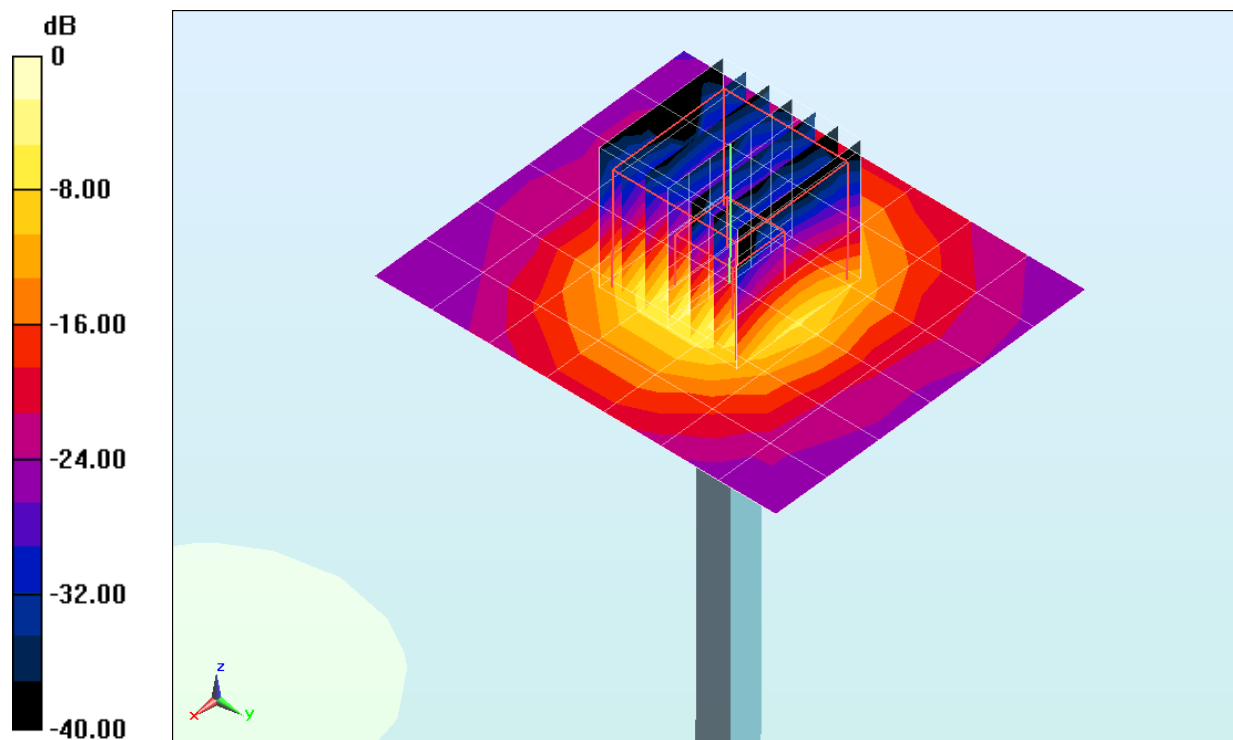

0 dB = 19.7 W/kg = 12.94 dBW/kg

# PCTEST ENGINEERING LABORATORY, INC.

**DUT: SAR Dipole 5300 MHz; Type: D5GHzV2; Serial: 1120**

Communication System: UID 0, CW; Frequency: 5300 MHz; Duty Cycle: 1:1

Medium: 5 GHz Body; Medium parameters used:

$f = 5300 \text{ MHz}$ ;  $\sigma = 5.298 \text{ S/m}$ ;  $\epsilon_r = 47.17$ ;  $\rho = 1000 \text{ kg/m}^3$

Phantom section: Flat Section; Space: 1.0 cm

Test Date: 02-06-2014; Ambient Temp: 24.0°C; Tissue Temp: 23.8°C

Probe: EX3DV4 - SN3914; ConvF(4.32, 4.32, 4.32); Calibrated: 10/23/2013;

Sensor-Surface: 1.4mm (Mechanical Surface Detection)

Electronics: DAE4 Sn1333; Calibrated: 11/19/2013

Phantom: SAM 5.0 front; Type: QD000P40CD; Serial: TP:-1648

Measurement SW: DASY52, Version 52.8 (7);SEMCAD X Version 14.6.10 (7164)

## 5300 MHz System Verification

**Area Scan (7x8x1):** Measurement grid: dx=10mm, dy=10mm

**Zoom Scan (8x8x7)/Cube 0:** Measurement grid: dx=4mm, dy=4mm, dz=1.4mm; Graded Ratio: 1.4

Input Power: 20.0 dBm (100 mW)

Peak SAR (extrapolated) = 34.0 W/kg

**SAR(1 g) = 7.65 W/kg**

Deviation(1 g): -0.39%

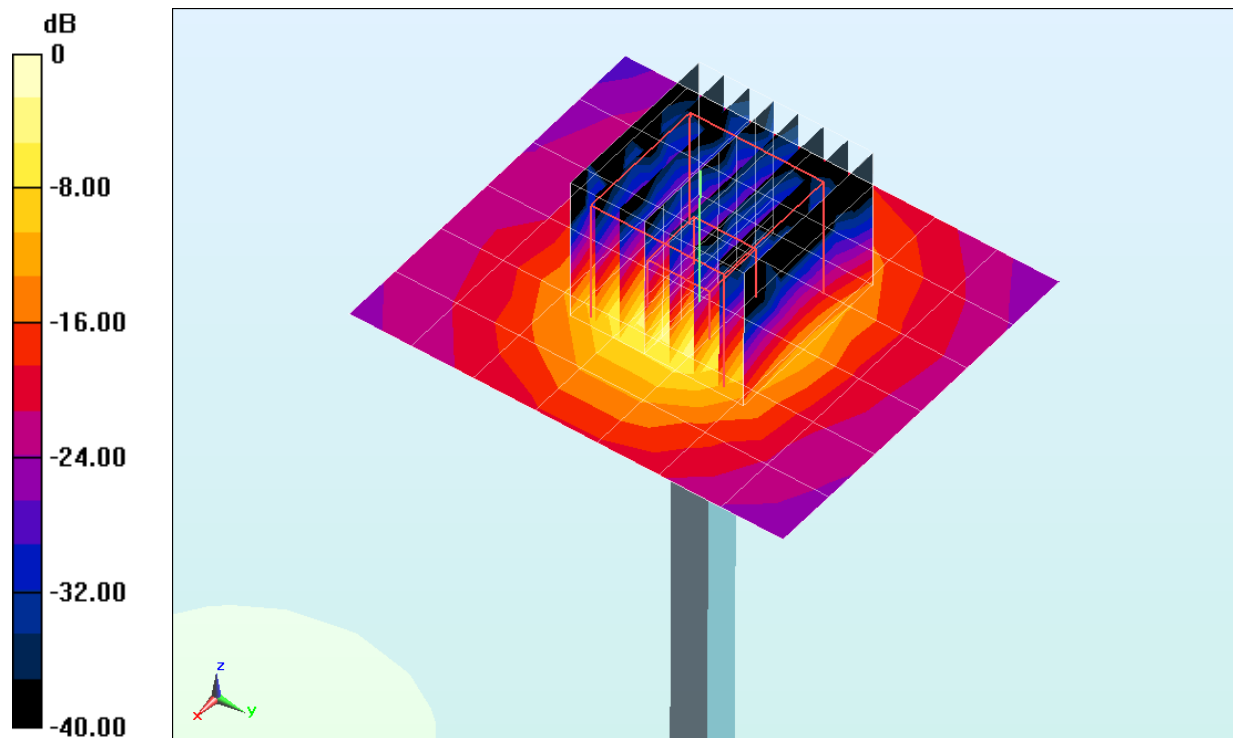

0 dB = 19.7 W/kg = 12.94 dBW/kg

# PCTEST ENGINEERING LABORATORY, INC.

**DUT: SAR Dipole 5500 MHz; Type: D5GHzV2; Serial: 1120**

Communication System: UID 0, CW; Frequency: 5500 MHz; Duty Cycle: 1:1

Medium: 5 GHz Body; Medium parameters used:

$f = 5500 \text{ MHz}$ ;  $\sigma = 5.6 \text{ S/m}$ ;  $\epsilon_r = 46.464$ ;  $\rho = 1000 \text{ kg/m}^3$

Phantom section: Flat Section; Space: 1.0 cm

Test Date: 02-06-2014; Ambient Temp: 24.1°C; Tissue Temp: 23.8°C

Probe: EX3DV4 - SN3914; ConvF(4.07, 4.07, 4.07); Calibrated: 10/23/2013;

Sensor-Surface: 1.4mm (Mechanical Surface Detection)

Electronics: DAE4 Sn1333; Calibrated: 11/19/2013

Phantom: SAM 5.0 front; Type: QD000P40CD; Serial: TP:-1648

Measurement SW: DASY52, Version 52.8 (7);SEMCAD X Version 14.6.10 (7164)

## 5500 MHz System Verification

**Area Scan (7x8x1):** Measurement grid: dx=10mm, dy=10mm

**Zoom Scan (8x8x7)/Cube 0:** Measurement grid: dx=4mm, dy=4mm, dz=1.4mm; Graded Ratio: 1.4

Input Power: 20.0 dBm (100mW)

Peak SAR (extrapolated) = 36.5 W/kg

**SAR(1 g) = 7.84 W/kg**

Deviation(1 g): -1.75%

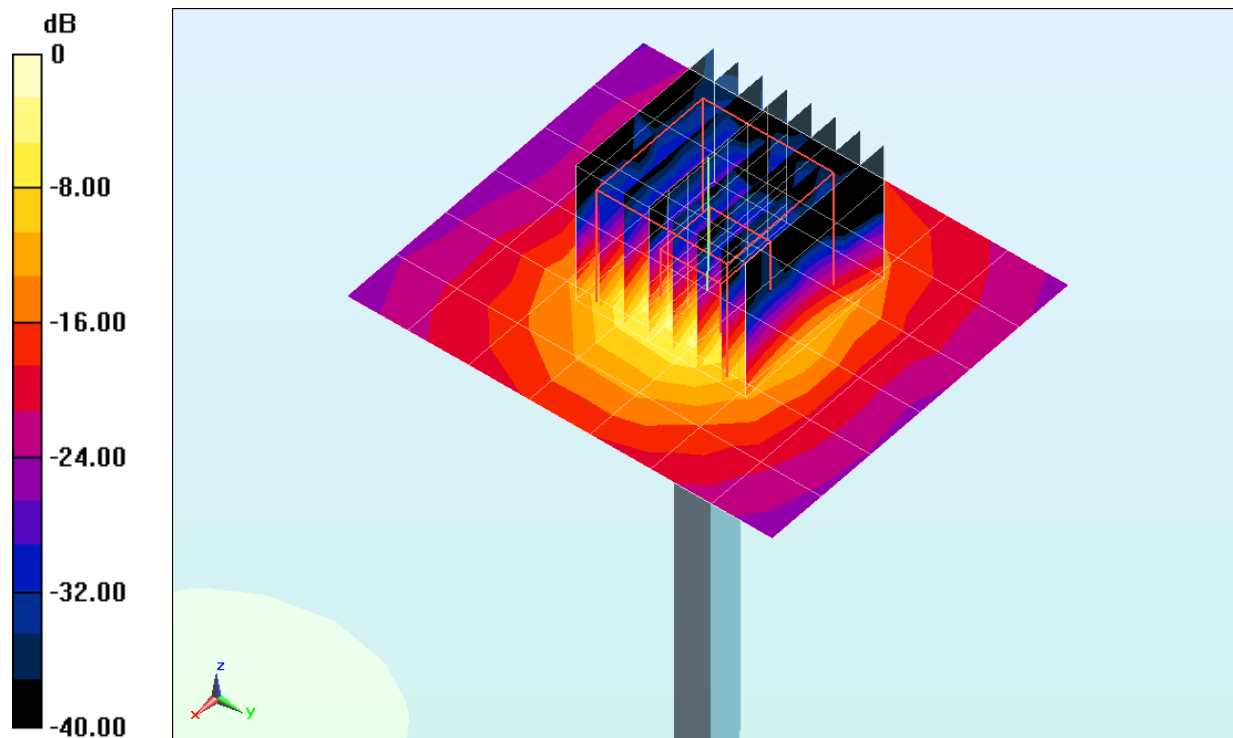

0 dB = 20.6 W/kg = 13.14 dBW/kg

# PCTEST ENGINEERING LABORATORY, INC.

**DUT: SAR Dipole 5800 MHz; Type: D5GHzV2; Serial: 1120**

Communication System: UID 0, CW; Frequency: 5800 MHz; Duty Cycle: 1:1

Medium: 5 GHz Body; Medium parameters used:

$f = 5800 \text{ MHz}$ ;  $\sigma = 6.062 \text{ S/m}$ ;  $\epsilon_r = 45.987$ ;  $\rho = 1000 \text{ kg/m}^3$

Phantom section: Flat Section; Space: 1.0 cm

Test Date: 02-06-2014; Ambient Temp: 24.1°C; Tissue Temp: 23.7°C

Probe: EX3DV4 - SN3914; ConvF(4.14, 4.14, 4.14); Calibrated: 10/23/2013;

Sensor-Surface: 1.4mm (Mechanical Surface Detection)

Electronics: DAE4 Sn1333; Calibrated: 11/19/2013

Phantom: SAM 5.0 front; Type: QD000P40CD; Serial: TP:-1648

Measurement SW: DASY52, Version 52.8 (7);SEMCAD X Version 14.6.10 (7164)

## 5800 MHz System Verification

**Area Scan (7x8x1):** Measurement grid: dx=10mm, dy=10mm

**Zoom Scan (7x7x7)/Cube 0:** Measurement grid: dx=4mm, dy=4mm, dz=1.4mm; Graded Ratio: 1.4

Input Power: 20.0 dBm (100 mW)

Peak SAR (extrapolated) = 35.3 W/kg

**SAR(1 g) = 7.17 W/kg**

Deviation(1 g): -5.03%

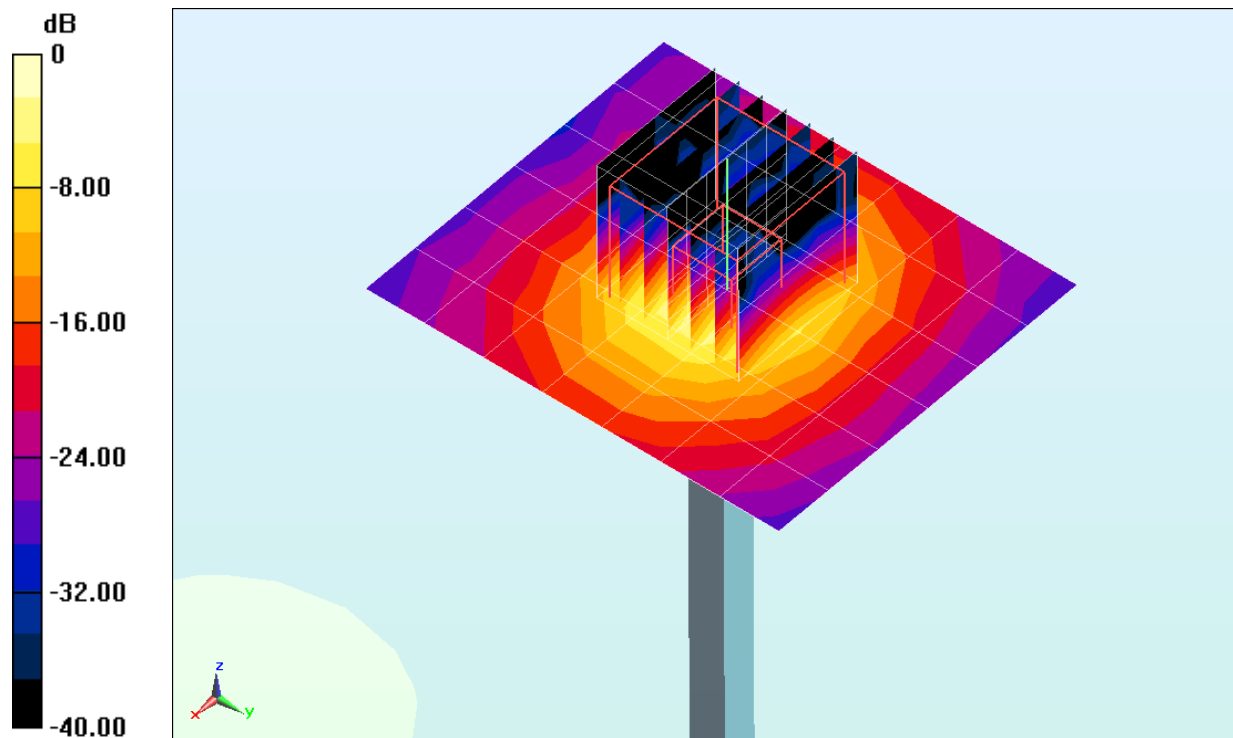

0 dB = 19.2 W/kg = 12.83 dBW/kg

## APPENDIX C: PROBE CALIBRATION



Accredited by the Swiss Accreditation Service (SAS)  
The Swiss Accreditation Service is one of the signatories to the EA  
Multilateral Agreement for the recognition of calibration certificates

Accreditation No.: **SCS 108**

Client **PC Test**

Certificate No: **ES3-3288\_Sep13/2**

**CALIBRATION CERTIFICATE (Replacement of No: ES3-3288\_Sep13)**

Object **ES3DV3 - SN:3288** CCV  
10/4/13

Calibration procedure(s) **QA CAL-01.v9, QA CAL-23.v5, QA CAL-25.v6  
Calibration procedure for dosimetric E-field probes**

Calibration date: **September 23, 2013**

This calibration certificate documents the traceability to national standards, which realize the physical units of measurements (SI).  
The measurements and the uncertainties with confidence probability are given on the following pages and are part of the certificate.

All calibrations have been conducted in the closed laboratory facility: environment temperature (22 ± 3)°C and humidity < 70%.

Calibration Equipment used (M&TE critical for calibration)

Primary Standards	ID	Cal Date (Certificate No.)	Scheduled Calibration
Power meter E4419B	GB41293874	04-Apr-13 (No. 217-01733)	Apr-14
Power sensor E4412A	MY41498087	04-Apr-13 (No. 217-01733)	Apr-14
Reference 3 dB Attenuator	SN: S5054 (3c)	04-Apr-13 (No. 217-01737)	Apr-14
Reference 20 dB Attenuator	SN: S5277 (20x)	04-Apr-13 (No. 217-01735)	Apr-14
Reference 30 dB Attenuator	SN: S5129 (30b)	04-Apr-13 (No. 217-01738)	Apr-14
Reference Probe ES3DV2	SN: 3013	28-Dec-12 (No. ES3-3013_Dec12)	Dec-13
DAE4	SN: 660	4-Sep-13 (No. DAE4-660_Sep13)	Apr-14
Secondary Standards	ID	Check Date (in house)	Scheduled Check
RF generator HP 8648C	US3642U01700	4-Aug-99 (in house check Apr-13)	In house check: Apr-15
Network Analyzer HP 8753E	US37390585	18-Oct-01 (in house check Oct-12)	In house check: Oct-13

Calibrated by:	Name <b>Jeton Kastrati</b>	Function <b>Laboratory Technician</b>	Signature 
Approved by:	Name <b>Katja Pokovic</b>	Function <b>Technical Manager</b>	

Issued: October 4, 2013

This calibration certificate shall not be reproduced except in full without written approval of the laboratory.

PCT# 80828

# Probe ES3DV3

## SN:3288

Manufactured: July 6, 2010  
Calibrated: September 23, 2013

Calibrated for DASY/EASY Systems  
(Note: non-compatible with DASY2 system!)



Accredited by the Swiss Accreditation Service (SAS)

Accreditation No.: **SCS 108**

The Swiss Accreditation Service is one of the signatories to the EA  
Multilateral Agreement for the recognition of calibration certificates

### Glossary:

TSL	tissue simulating liquid
NORM <sub>x,y,z</sub>	sensitivity in free space
ConvF	sensitivity in TSL / NORM <sub>x,y,z</sub>
DCP	diode compression point
CF	crest factor (1/duty_cycle) of the RF signal
A, B, C, D	modulation dependent linearization parameters
Polarization $\varphi$	$\varphi$ rotation around probe axis
Polarization $\vartheta$	$\vartheta$ rotation around an axis that is in the plane normal to probe axis (at measurement center), i.e., $\vartheta = 0$ is normal to probe axis

### Calibration is Performed According to the Following Standards:

- IEEE Std 1528-2013, "IEEE Recommended Practice for Determining the Peak Spatial-Averaged Specific Absorption Rate (SAR) in the Human Head from Wireless Communications Devices: Measurement Techniques", June 2013
- IEC 62209-1, "Procedure to measure the Specific Absorption Rate (SAR) for hand-held devices used in close proximity to the ear (frequency range of 300 MHz to 3 GHz)", February 2005

### Methods Applied and Interpretation of Parameters:

- NORM<sub>x,y,z</sub>**: Assessed for E-field polarization  $\vartheta = 0$  ( $f \leq 900$  MHz in TEM-cell;  $f > 1800$  MHz: R22 waveguide). NORM<sub>x,y,z</sub> are only intermediate values, i.e., the uncertainties of NORM<sub>x,y,z</sub> does not affect the E<sup>2</sup>-field uncertainty inside TSL (see below ConvF).
- NORM(f)<sub>x,y,z</sub>** = NORM<sub>x,y,z</sub> \* frequency\_response (see Frequency Response Chart). This linearization is implemented in DASY4 software versions later than 4.2. The uncertainty of the frequency response is included in the stated uncertainty of ConvF.
- DCP<sub>x,y,z</sub>**: DCP are numerical linearization parameters assessed based on the data of power sweep with CW signal (no uncertainty required). DCP does not depend on frequency nor media.
- PAR**: PAR is the Peak to Average Ratio that is not calibrated but determined based on the signal characteristics
- A<sub>x,y,z</sub>; B<sub>x,y,z</sub>; C<sub>x,y,z</sub>; D<sub>x,y,z</sub>; VR<sub>x,y,z</sub>**: A, B, C, D are numerical linearization parameters assessed based on the data of power sweep for specific modulation signal. The parameters do not depend on frequency nor media. VR is the maximum calibration range expressed in RMS voltage across the diode.
- ConvF and Boundary Effect Parameters**: Assessed in flat phantom using E-field (or Temperature Transfer Standard for  $f \leq 800$  MHz) and inside waveguide using analytical field distributions based on power measurements for  $f > 800$  MHz. The same setups are used for assessment of the parameters applied for boundary compensation (alpha, depth) of which typical uncertainty values are given. These parameters are used in DASY4 software to improve probe accuracy close to the boundary. The sensitivity in TSL corresponds to NORM<sub>x,y,z</sub> \* ConvF whereby the uncertainty corresponds to that given for ConvF. A frequency dependent ConvF is used in DASY version 4.4 and higher which allows extending the validity from  $\pm 50$  MHz to  $\pm 100$  MHz.
- Spherical isotropy (3D deviation from isotropy)**: in a field of low gradients realized using a flat phantom exposed by a patch antenna.
- Sensor Offset**: The sensor offset corresponds to the offset of virtual measurement center from the probe tip (on probe axis). No tolerance required.

## DASY/EASY - Parameters of Probe: ES3DV3 - SN:3288

### Basic Calibration Parameters

	Sensor X	Sensor Y	Sensor Z	Unc (k=2)
Norm ( $\mu V/(V/m)^2$ ) <sup>A</sup>	0.87	0.97	0.75	± 10.1 %
DCP (mV) <sup>B</sup>	103.3	103.2	100.2	

### Modulation Calibration Parameters

UID	Communication System Name		A dB	B dB $\sqrt{\mu V}$	C	D dB	VR mV	Unc <sup>E</sup> (k=2)
0	CW	X	0.0	0.0	1.0	0.00	171.1	±3.5 %
		Y	0.0	0.0	1.0		135.0	
		Z	0.0	0.0	1.0		154.3	

The reported uncertainty of measurement is stated as the standard uncertainty of measurement multiplied by the coverage factor k=2, which for a normal distribution corresponds to a coverage probability of approximately 95%.

<sup>A</sup> The uncertainties of NormX,Y,Z do not affect the E<sup>2</sup>-field uncertainty inside TSL (see Pages 5 and 6).

<sup>B</sup> Numerical linearization parameter: uncertainty not required.

<sup>E</sup> Uncertainty is determined using the max. deviation from linear response applying rectangular distribution and is expressed for the square of the field value.

## DASY/EASY - Parameters of Probe: ES3DV3 - SN:3288

### Calibration Parameter Determined in Head Tissue Simulating Media

f (MHz) <sup>C</sup>	Relative Permittivity <sup>F</sup>	Conductivity (S/m) <sup>F</sup>	ConvF X	ConvF Y	ConvF Z	Alpha	Depth (mm)	Unct. (k=2)
750	41.9	0.89	6.56	6.56	6.56	0.32	1.89	± 12.0 %
835	41.5	0.90	6.37	6.37	6.37	0.34	1.82	± 12.0 %
1750	40.1	1.37	5.67	5.67	5.67	0.56	1.51	± 12.0 %
1900	40.0	1.40	5.47	5.47	5.47	0.80	1.29	± 12.0 %
2450	39.2	1.80	4.63	4.63	4.63	0.80	1.34	± 12.0 %
2600	39.0	1.96	4.55	4.55	4.55	0.80	1.41	± 12.0 %

<sup>C</sup> Frequency validity of ± 100 MHz only applies for DASY v4.4 and higher (see Page 2), else it is restricted to ± 50 MHz. The uncertainty is the RSS of the ConvF uncertainty at calibration frequency and the uncertainty for the indicated frequency band.

<sup>F</sup> At frequencies below 3 GHz, the validity of tissue parameters ( $\epsilon$  and  $\sigma$ ) can be relaxed to ± 10% if liquid compensation formula is applied to measured SAR values. At frequencies above 3 GHz, the validity of tissue parameters ( $\epsilon$  and  $\sigma$ ) is restricted to ± 5%. The uncertainty is the RSS of the ConvF uncertainty for indicated target tissue parameters.

## DASY/EASY - Parameters of Probe: ES3DV3 - SN:3288

### Calibration Parameter Determined in Body Tissue Simulating Media

f (MHz) <sup>C</sup>	Relative Permittivity <sup>F</sup>	Conductivity (S/m) <sup>F</sup>	ConvF X	ConvF Y	ConvF Z	Alpha	Depth (mm)	Unct. (k=2)
750	55.5	0.96	6.25	6.25	6.25	0.70	1.27	± 12.0 %
835	55.2	0.97	6.27	6.27	6.27	0.75	1.22	± 12.0 %
1750	53.4	1.49	5.10	5.10	5.10	0.59	1.46	± 12.0 %
1900	53.3	1.52	4.82	4.82	4.82	0.53	1.54	± 12.0 %
2450	52.7	1.95	4.37	4.37	4.37	0.80	1.02	± 12.0 %
2600	52.5	2.16	4.14	4.14	4.14	0.64	0.94	± 12.0 %

<sup>C</sup> Frequency validity of ± 100 MHz only applies for DASY v4.4 and higher (see Page 2), else it is restricted to ± 50 MHz. The uncertainty is the RSS of the ConvF uncertainty at calibration frequency and the uncertainty for the indicated frequency band.

<sup>F</sup> At frequencies below 3 GHz, the validity of tissue parameters ( $\epsilon$  and  $\sigma$ ) can be relaxed to ± 10% if liquid compensation formula is applied to measured SAR values. At frequencies above 3 GHz, the validity of tissue parameters ( $\epsilon$  and  $\sigma$ ) is restricted to ± 5%. The uncertainty is the RSS of the ConvF uncertainty for indicated target tissue parameters.

### Frequency Response of E-Field (TEM-Cell:ifi110 EXX, Waveguide: R22)

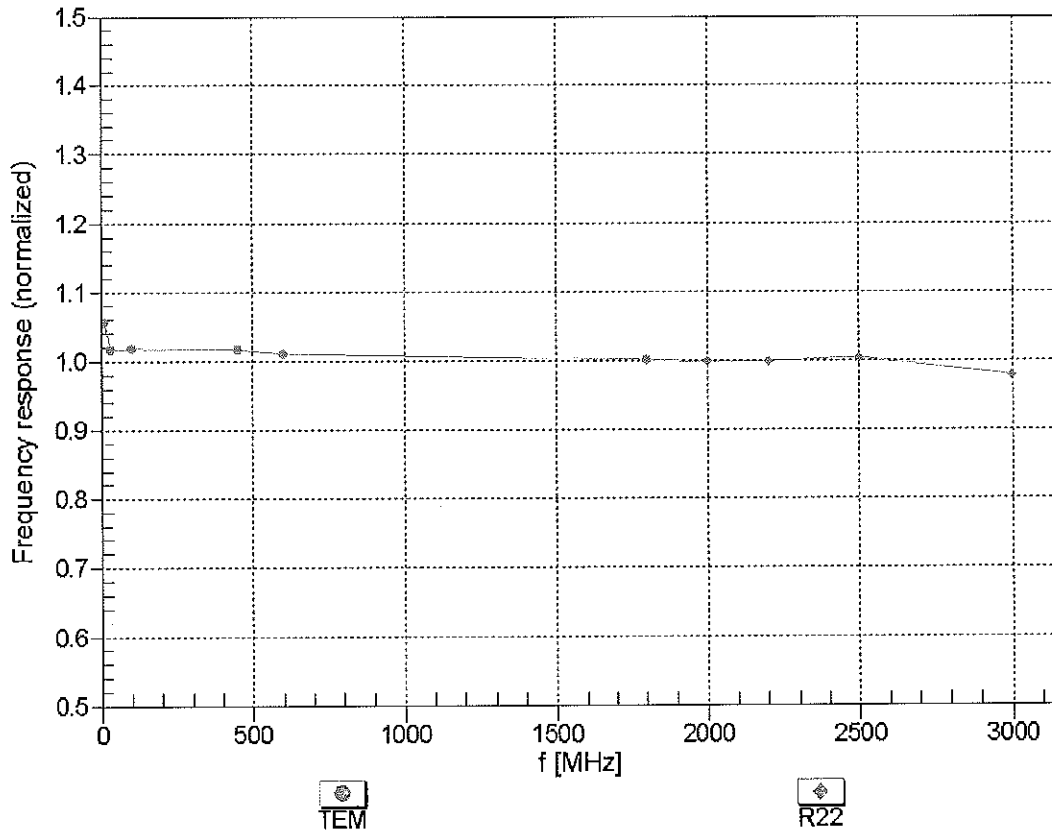

Uncertainty of Frequency Response of E-field:  $\pm 6.3\%$  (k=2)

### Receiving Pattern ( $\phi$ ), $\vartheta = 0^\circ$

f=600 MHz,TEM

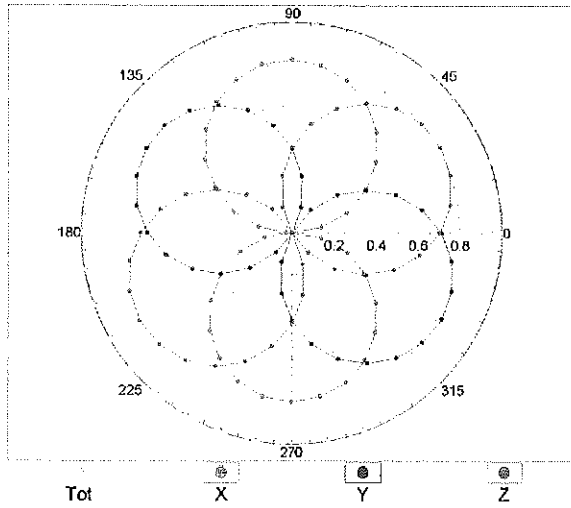

f=1800 MHz,R22

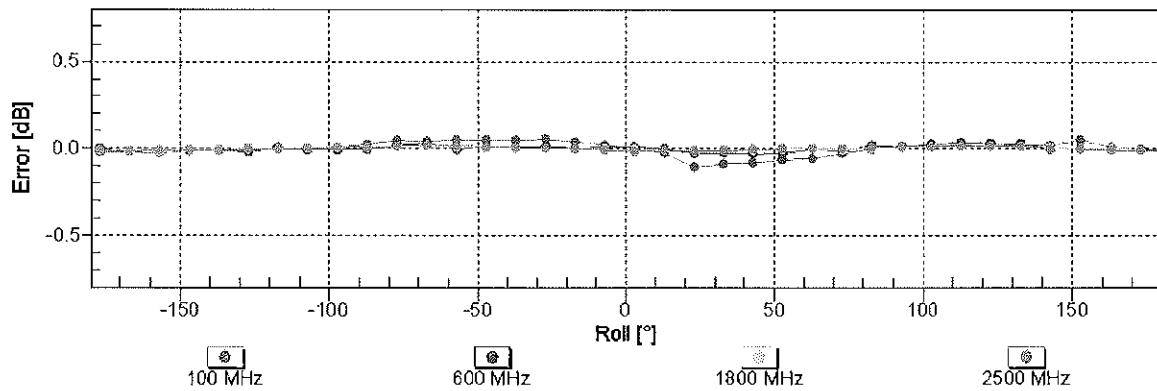
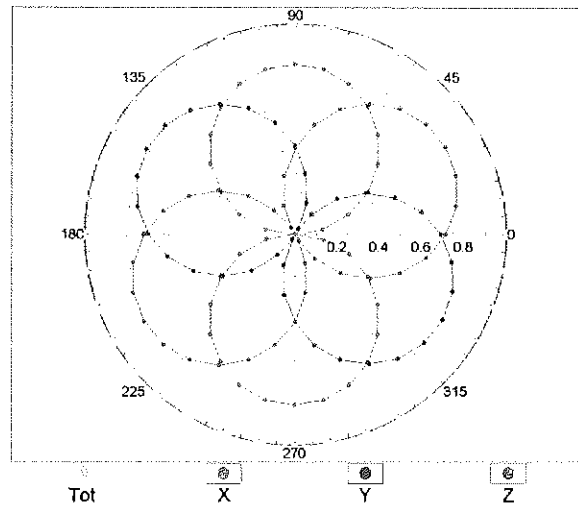

Uncertainty of Axial Isotropy Assessment:  $\pm 0.5\%$  (k=2)

### Dynamic Range $f(\text{SAR}_{\text{head}})$ (TEM cell , $f = 900 \text{ MHz}$ )

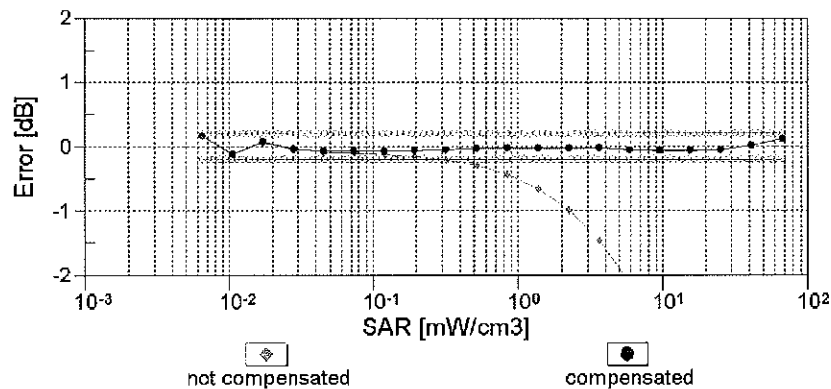
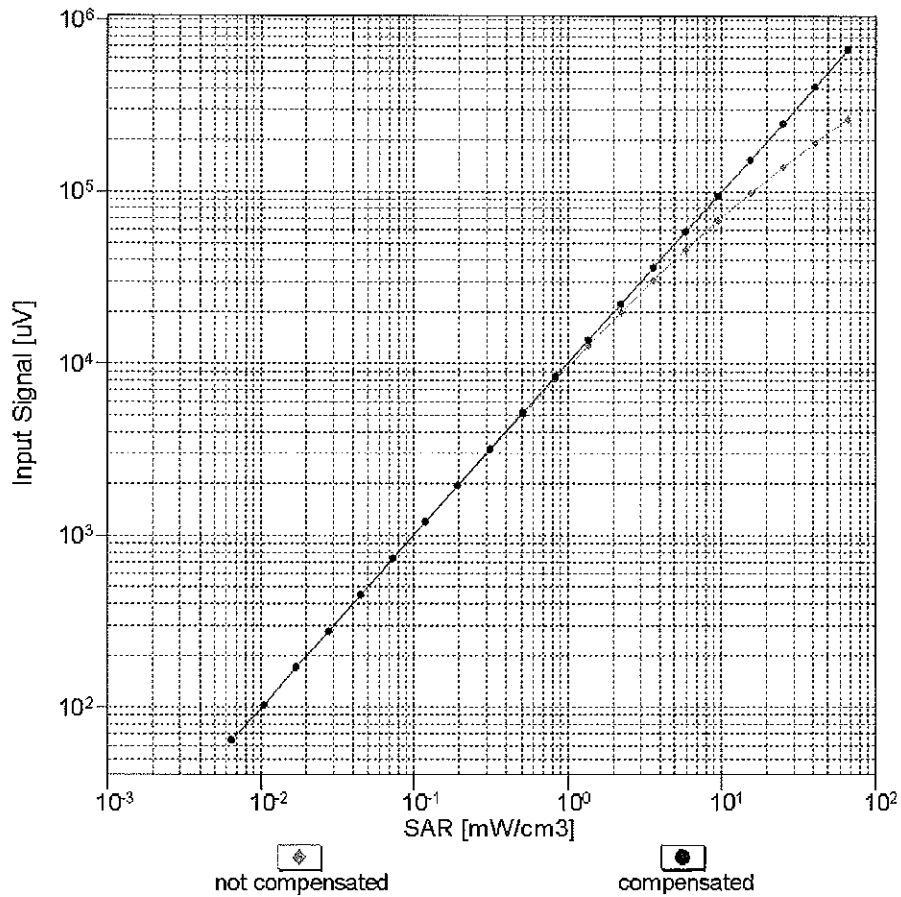

Uncertainty of Linearity Assessment:  $\pm 0.6\%$  ( $k=2$ )

# Conversion Factor Assessment

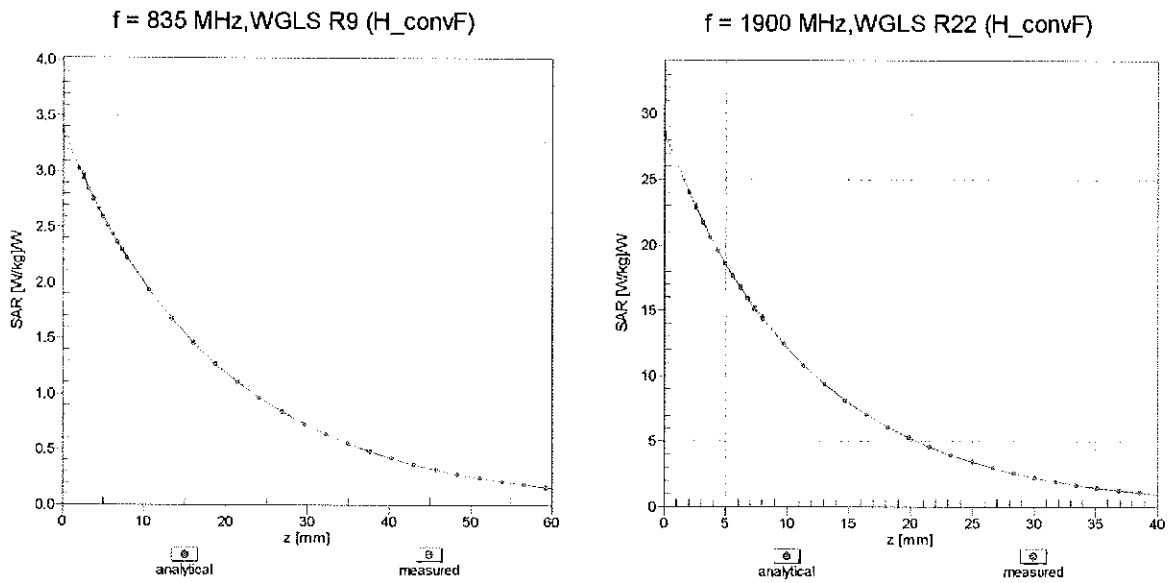

## Deviation from Isotropy in Liquid Error ( $\phi, \theta$ ), f = 900 MHz

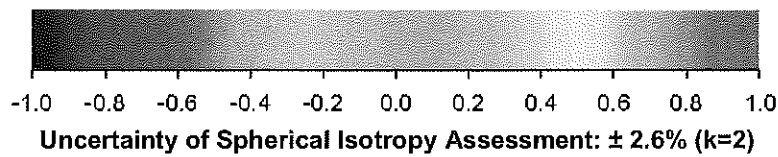
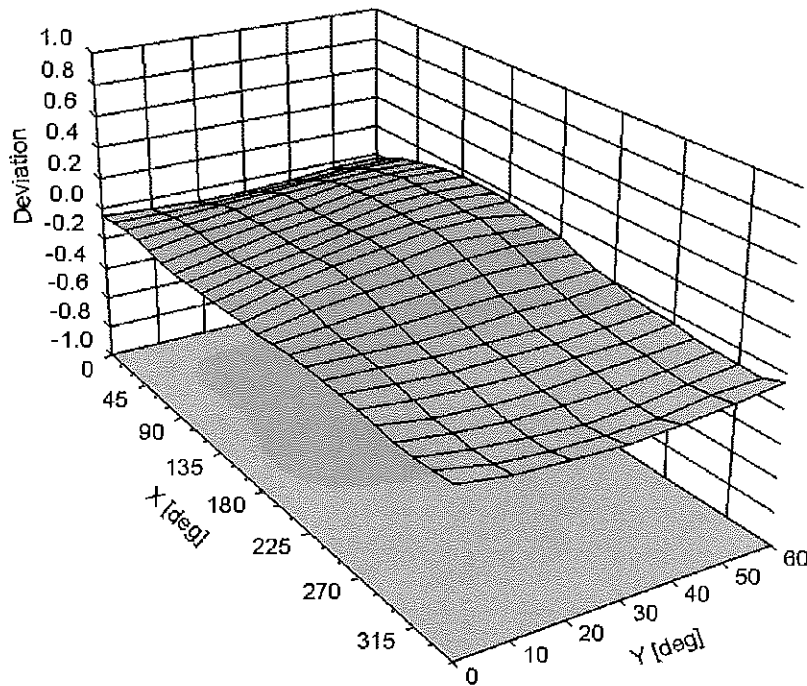

## DASY/EASY - Parameters of Probe: ES3DV3 - SN:3288

### Other Probe Parameters

Sensor Arrangement	Triangular
Connector Angle (°)	-127.1
Mechanical Surface Detection Mode	enabled
Optical Surface Detection Mode	disabled
Probe Overall Length	337 mm
Probe Body Diameter	10 mm
Tip Length	10 mm
Tip Diameter	4 mm
Probe Tip to Sensor X Calibration Point	2 mm
Probe Tip to Sensor Y Calibration Point	2 mm
Probe Tip to Sensor Z Calibration Point	2 mm
Recommended Measurement Distance from Surface	3 mm



Accredited by the Swiss Accreditation Service (SAS)  
The Swiss Accreditation Service is one of the signatories to the EA  
Multilateral Agreement for the recognition of calibration certificates

Accreditation No.: **SCS 108**

Client **PC Test**

Certificate No: **ES3-3318\_Apr13**

## CALIBRATION CERTIFICATE

Object: **ES3DV3 - SN:3318**

Calibration procedure(s): **QA CAL-01.v8, QA CAL-23.v4, QA CAL-25.v4  
Calibration procedure for dosimetric E-field probes**

Calibration date: **April 29, 2013**

VCC  
6/14/13

This calibration certificate documents the traceability to national standards, which realize the physical units of measurements (SI).  
The measurements and the uncertainties with confidence probability are given on the following pages and are part of the certificate.

All calibrations have been conducted in the closed laboratory facility: environment temperature (22 ± 3)°C and humidity < 70%.

Calibration Equipment used (M&TE critical for calibration)

Primary Standards	ID	Cal Date (Certificate No.)	Scheduled Calibration
Power meter E4419B	GB41293874	04-Apr-13 (No. 217-01733)	Apr-14
Power sensor E4412A	MY41498087	04-Apr-13 (No. 217-01733)	Apr-14
Reference 3 dB Attenuator	SN: S5054 (3c)	04-Apr-13 (No. 217-01737)	Apr-14
Reference 20 dB Attenuator	SN: S5277 (20x)	04-Apr-13 (No. 217-01735)	Apr-14
Reference 30 dB Attenuator	SN: S5129 (30b)	04-Apr-13 (No. 217-01738)	Apr-14
Reference Probe ES3DV2	SN: 3013	28-Dec-12 (No. ES3-3013_Dec12)	Dec-13
DAE4	SN: 660	31-Jan-13 (No. DAE4-660_Jan13)	Jan-14
Secondary Standards	ID	Check Date (in house)	Scheduled Check
RF generator HP 8648C	US3642U01700	4-Aug-99 (in house check Apr-13)	In house check: Apr-15
Network Analyzer HP 8753E	US37390585	18-Oct-01 (in house check Oct-12)	In house check: Oct-13

	Name	Function	Signature
Calibrated by:	Dimce Iliev	Laboratory Technician	
Approved by:	Katja Pokovic	Technical Manager	

Issued: April 29, 2013

This calibration certificate shall not be reproduced except in full without written approval of the laboratory.



Accredited by the Swiss Accreditation Service (SAS)

Accreditation No.: **SCS 108**

The Swiss Accreditation Service is one of the signatories to the EA  
 Multilateral Agreement for the recognition of calibration certificates

### Glossary:

TSL	tissue simulating liquid
NORM <sub>x,y,z</sub>	sensitivity in free space
ConvF	sensitivity in TSL / NORM <sub>x,y,z</sub>
DCP	diode compression point
CF	crest factor (1/duty_cycle) of the RF signal
A, B, C, D	modulation dependent linearization parameters
Polarization $\varphi$	$\varphi$ rotation around probe axis
Polarization $\vartheta$	$\vartheta$ rotation around an axis that is in the plane normal to probe axis (at measurement center), i.e., $\vartheta = 0$ is normal to probe axis

### Calibration is Performed According to the Following Standards:

- IEEE Std 1528-2003, "IEEE Recommended Practice for Determining the Peak Spatial-Averaged Specific Absorption Rate (SAR) in the Human Head from Wireless Communications Devices: Measurement Techniques", December 2003
- IEC 62209-1, "Procedure to measure the Specific Absorption Rate (SAR) for hand-held devices used in close proximity to the ear (frequency range of 300 MHz to 3 GHz)", February 2005

### Methods Applied and Interpretation of Parameters:

- NORM<sub>x,y,z</sub>**: Assessed for E-field polarization  $\vartheta = 0$  ( $f \leq 900$  MHz in TEM-cell;  $f > 1800$  MHz: R22 waveguide). NORM<sub>x,y,z</sub> are only intermediate values, i.e., the uncertainties of NORM<sub>x,y,z</sub> does not affect the E<sup>2</sup>-field uncertainty inside TSL (see below ConvF).
- NORM(f)<sub>x,y,z</sub>** = NORM<sub>x,y,z</sub> \* frequency\_response (see Frequency Response Chart). This linearization is implemented in DASY4 software versions later than 4.2. The uncertainty of the frequency response is included in the stated uncertainty of ConvF.
- DCP<sub>x,y,z</sub>**: DCP are numerical linearization parameters assessed based on the data of power sweep with CW signal (no uncertainty required). DCP does not depend on frequency nor media.
- PAR**: PAR is the Peak to Average Ratio that is not calibrated but determined based on the signal characteristics
- A<sub>x,y,z</sub>; B<sub>x,y,z</sub>; C<sub>x,y,z</sub>; D<sub>x,y,z</sub>; VR<sub>x,y,z</sub>**: A, B, C, D are numerical linearization parameters assessed based on the data of power sweep for specific modulation signal. The parameters do not depend on frequency nor media. VR is the maximum calibration range expressed in RMS voltage across the diode.
- ConvF and Boundary Effect Parameters**: Assessed in flat phantom using E-field (or Temperature Transfer Standard for  $f \leq 800$  MHz) and inside waveguide using analytical field distributions based on power measurements for  $f > 800$  MHz. The same setups are used for assessment of the parameters applied for boundary compensation (alpha, depth) of which typical uncertainty values are given. These parameters are used in DASY4 software to improve probe accuracy close to the boundary. The sensitivity in TSL corresponds to NORM<sub>x,y,z</sub> \* ConvF whereby the uncertainty corresponds to that given for ConvF. A frequency dependent ConvF is used in DASY version 4.4 and higher which allows extending the validity from  $\pm 50$  MHz to  $\pm 100$  MHz.
- Spherical isotropy (3D deviation from isotropy)**: in a field of low gradients realized using a flat phantom exposed by a patch antenna.
- Sensor Offset**: The sensor offset corresponds to the offset of virtual measurement center from the probe tip (on probe axis). No tolerance required.

# Probe ES3DV3

## SN:3318

Manufactured: January 10, 2012  
Calibrated: April 29, 2013

**Calibrated for DASY/EASY Systems**  
(Note: non-compatible with DASY2 system!)

## DASY/EASY - Parameters of Probe: ES3DV3 - SN:3318

### Basic Calibration Parameters

	Sensor X	Sensor Y	Sensor Z	Unc (k=2)
Norm ( $\mu\text{V}/(\text{V}/\text{m})^2$ ) <sup>A</sup>	1.15	0.92	1.29	± 10.1 %
DCP (mV) <sup>B</sup>	102.6	105.4	100.8	

### Modulation Calibration Parameters

UID	Communication System Name		A dB	B dB/ $\mu\text{V}$	C	D dB	VR mV	Unc <sup>E</sup> (k=2)
0	CW	X	0.0	0.0	1.0	0.00	153.6	±3.5 %
		Y	0.0	0.0	1.0		133.8	
		Z	0.0	0.0	1.0		154.8	

The reported uncertainty of measurement is stated as the standard uncertainty of measurement multiplied by the coverage factor k=2, which for a normal distribution corresponds to a coverage probability of approximately 95%.

<sup>A</sup> The uncertainties of NormX,Y,Z do not affect the E<sup>2</sup>-field uncertainty inside TSL (see Pages 5 and 6).

<sup>B</sup> Numerical linearization parameter: uncertainty not required.

<sup>E</sup> Uncertainty is determined using the max. deviation from linear response applying rectangular distribution and is expressed for the square of the field value.

## DASY/EASY - Parameters of Probe: ES3DV3 - SN:3318

### Calibration Parameter Determined in Head Tissue Simulating Media

f (MHz) <sup>C</sup>	Relative Permittivity <sup>F</sup>	Conductivity (S/m) <sup>F</sup>	ConvF X	ConvF Y	ConvF Z	Alpha	Depth (mm)	Unct. (k=2)
750	41.9	0.89	6.59	6.59	6.59	0.25	2.12	± 12.0 %
850	41.5	0.92	6.33	6.33	6.33	0.57	1.25	± 12.0 %
1900	40.0	1.40	5.22	5.22	5.22	0.79	1.25	± 12.0 %
2450	39.2	1.80	4.59	4.59	4.59	0.80	1.30	± 12.0 %

<sup>C</sup> Frequency validity of ± 100 MHz only applies for DASY v4.4 and higher (see Page 2), else it is restricted to ± 50 MHz. The uncertainty is the RSS of the ConvF uncertainty at calibration frequency and the uncertainty for the indicated frequency band.

<sup>F</sup> At frequencies below 3 GHz, the validity of tissue parameters ( $\epsilon$  and  $\sigma$ ) can be relaxed to ± 10% if liquid compensation formula is applied to measured SAR values. At frequencies above 3 GHz, the validity of tissue parameters ( $\epsilon$  and  $\sigma$ ) is restricted to ± 5%. The uncertainty is the RSS of the ConvF uncertainty for indicated target tissue parameters.

## DASY/EASY - Parameters of Probe: ES3DV3 - SN:3318

### Calibration Parameter Determined in Body Tissue Simulating Media

f (MHz) <sup>C</sup>	Relative Permittivity <sup>F</sup>	Conductivity (S/m) <sup>F</sup>	ConvF X	ConvF Y	ConvF Z	Alpha	Depth (mm)	Unct. (k=2)
750	55.5	0.96	6.35	6.35	6.35	0.53	1.42	± 12.0 %
850	55.2	0.99	6.21	6.21	6.21	0.57	1.38	± 12.0 %
1900	53.3	1.52	4.79	4.79	4.79	0.46	1.77	± 12.0 %
2450	52.7	1.95	4.31	4.31	4.31	0.80	1.09	± 12.0 %

<sup>C</sup> Frequency validity of ± 100 MHz only applies for DASY v4.4 and higher (see Page 2), else it is restricted to ± 50 MHz. The uncertainty is the RSS of the ConvF uncertainty at calibration frequency and the uncertainty for the indicated frequency band.

<sup>F</sup> At frequencies below 3 GHz, the validity of tissue parameters ( $\epsilon$  and  $\sigma$ ) can be relaxed to ± 10% if liquid compensation formula is applied to measured SAR values. At frequencies above 3 GHz, the validity of tissue parameters ( $\epsilon$  and  $\sigma$ ) is restricted to ± 5%. The uncertainty is the RSS of the ConvF uncertainty for indicated target tissue parameters.

### Frequency Response of E-Field (TEM-Cell:ifi110 EXX, Waveguide: R22)

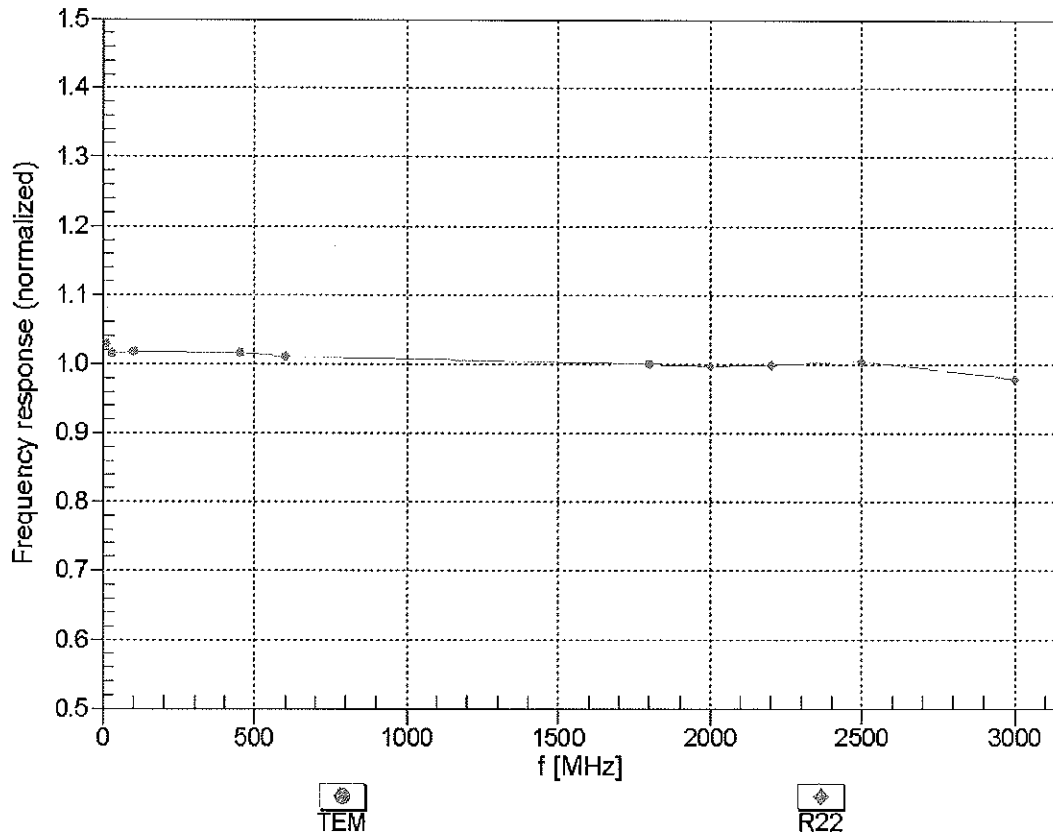

Uncertainty of Frequency Response of E-field:  $\pm 6.3\%$  (k=2)

### Receiving Pattern ( $\phi$ ), $\theta = 0^\circ$

f=600 MHz,TEM

f=1800 MHz,R22

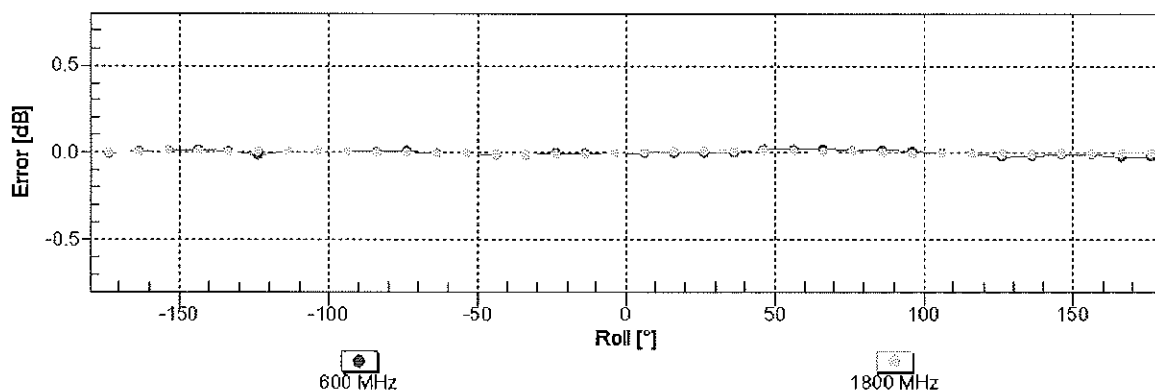
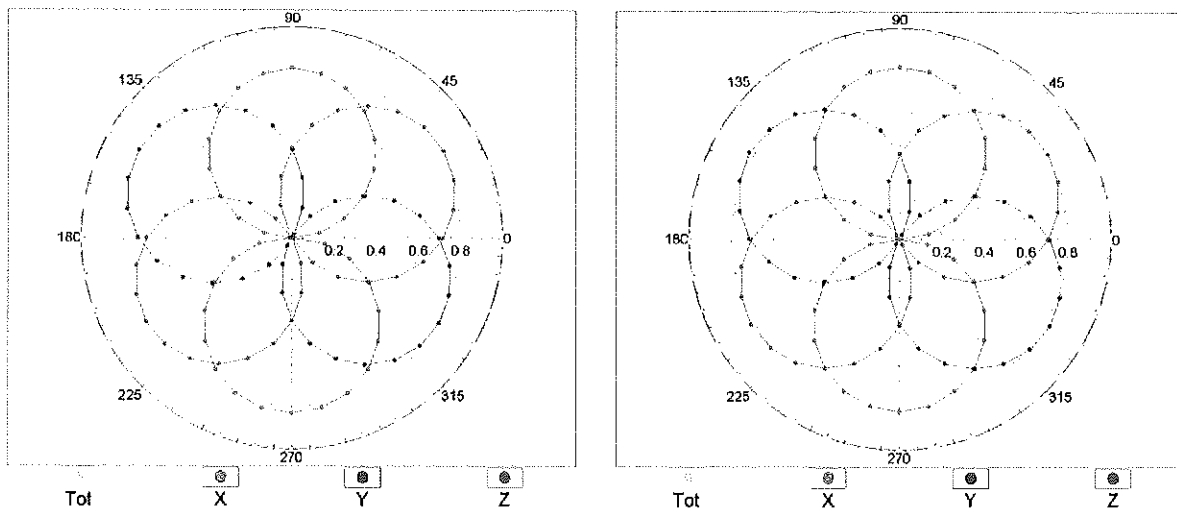

Uncertainty of Axial Isotropy Assessment:  $\pm 0.5\%$  ( $k=2$ )

### Dynamic Range f(SAR<sub>head</sub>) (TEM cell , f = 900 MHz)

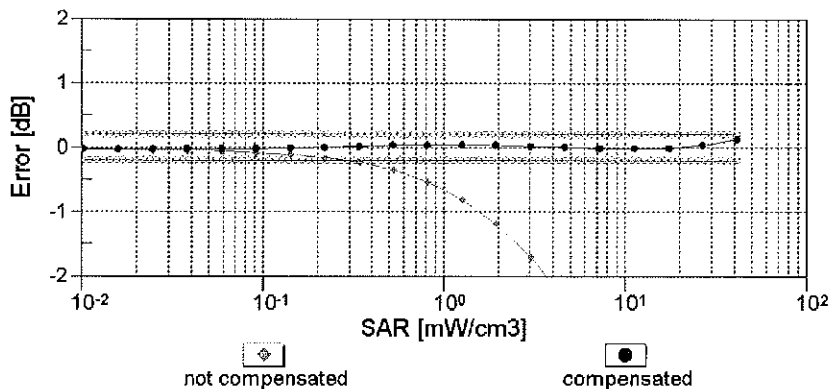
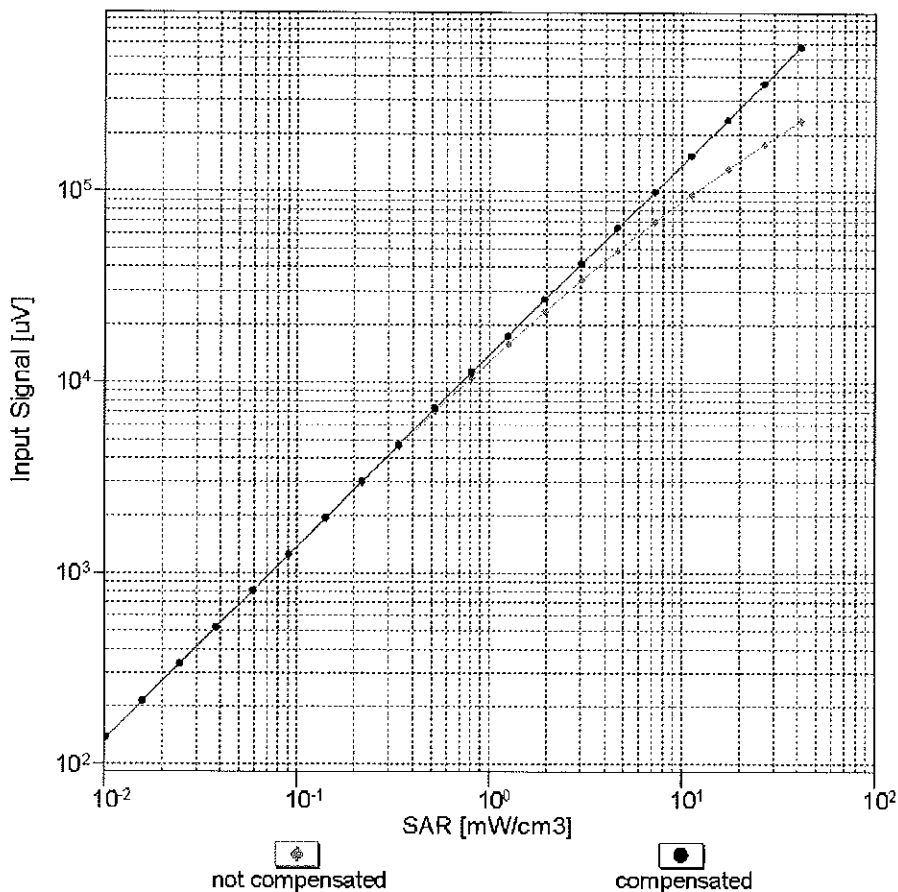

**Uncertainty of Linearity Assessment: ± 0.6% (k=2)**

# Conversion Factor Assessment

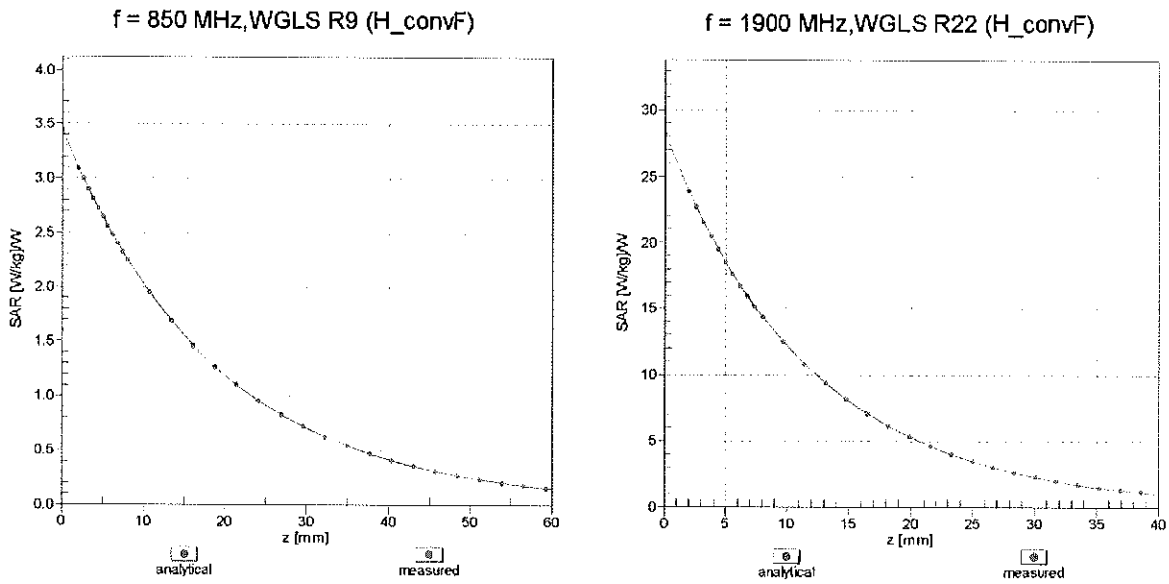

## Deviation from Isotropy in Liquid Error ( $\phi, \theta$ ), f = 900 MHz

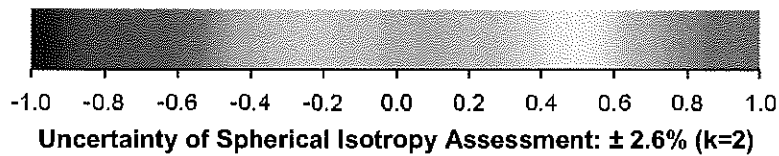
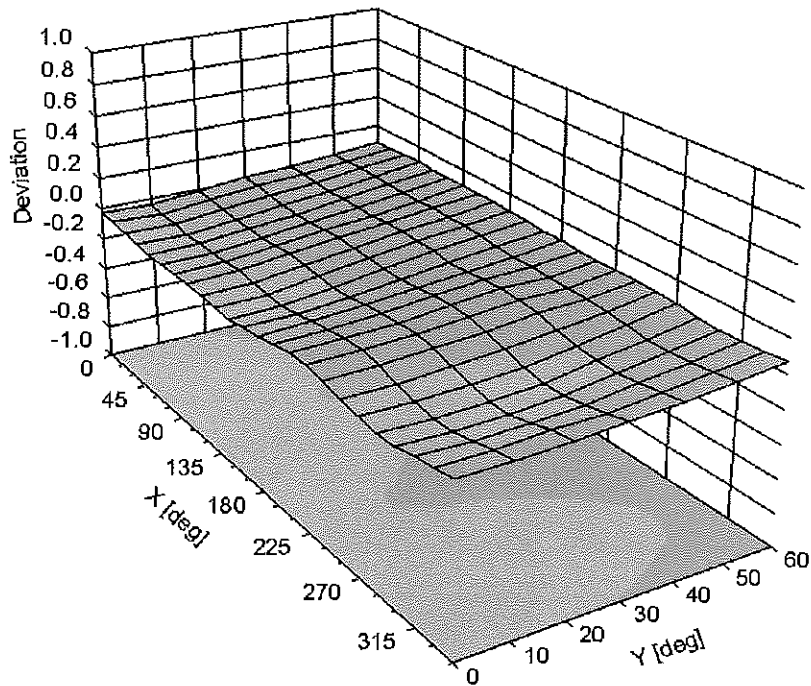

**DASY/EASY - Parameters of Probe: ES3DV3 - SN:3318****Other Probe Parameters**

Sensor Arrangement	Triangular
Connector Angle (°)	-103.8
Mechanical Surface Detection Mode	enabled
Optical Surface Detection Mode	disabled
Probe Overall Length	337 mm
Probe Body Diameter	10 mm
Tip Length	10 mm
Tip Diameter	4 mm
Probe Tip to Sensor X Calibration Point	2 mm
Probe Tip to Sensor Y Calibration Point	2 mm
Probe Tip to Sensor Z Calibration Point	2 mm
Recommended Measurement Distance from Surface	3 mm

## Additional Conversion Factors for Dosimetric E-Field Probe

Type:	<b>ES3DV3</b>
Serial Number:	<b>3318</b>
Place of Assessment:	<b>Zurich</b>
Date of Assessment:	<b>June 19, 2013</b>
Probe Calibration Date:	<b>April 29, 2013</b>

✓  
Kox  
6/25/13

Schmid & Partner Engineering AG hereby certifies that conversion factor(s) of this probe have been evaluated on the date indicated above. The assessment was performed using the FDTD numerical code SEMCAD of Schmid & Partner Engineering AG. The evaluation is coupled with measured conversion factors (probe calibration date indicated above). The uncertainty of the numerical assessment is based on the extrapolation from measured value at 835 MHz or at 1900 MHz.

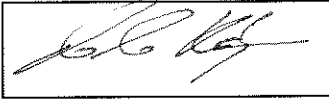
Assessed by: 

## Dosimetric E-Field Probe ES3DV3 SN:3318

Conversion factor ( $\pm$  standard deviation)

1750  $\pm$  50 MHz      *ConvF*      5.59  $\pm$  7%

$\epsilon_r = 40.1 \pm 5\%$   
 $\sigma = 1.37 \pm 5\%$  mho/m  
 (head tissue)

1750  $\pm$  50 MHz      *ConvF*      5.22  $\pm$  7%

$\epsilon_r = 53.4 \pm 5\%$   
 $\sigma = 1.49 \pm 5\%$  mho/m  
 (body tissue)

### Important Note:

For numerically assessed probe conversion factors, parameters Alpha and Delta in the DASY software must have the following entries: Alpha = 0 and Delta = 1.

**Please see also DASY Manual.**



Accredited by the Swiss Accreditation Service (SAS)  
The Swiss Accreditation Service is one of the signatories to the EA  
Multilateral Agreement for the recognition of calibration certificates

Accreditation No.: **SCS 108**

Client **PC Test**

Certificate No: **ES3-3263\_May13**

## CALIBRATION CERTIFICATE

Object **ES3DV3 - SN:3263**

Calibration procedure(s) **QA CAL-01.v8, QA CAL-23.v4, QA CAL-25.v4  
Calibration procedure for dosimetric E-field probes**

Calibration date: **May 16, 2013**

*✓ KOK  
5/23/13*

This calibration certificate documents the traceability to national standards, which realize the physical units of measurements (SI).  
The measurements and the uncertainties with confidence probability are given on the following pages and are part of the certificate.

All calibrations have been conducted in the closed laboratory facility: environment temperature (22 ± 3)°C and humidity < 70%.

Calibration Equipment used (M&TE critical for calibration)

Primary Standards	ID	Cal Date (Certificate No.)	Scheduled Calibration
Power meter E4419B	GB41293874	04-Apr-13 (No. 217-01733)	Apr-14
Power sensor E4412A	MY41498087	04-Apr-13 (No. 217-01733)	Apr-14
Reference 3 dB Attenuator	SN: S5054 (3c)	04-Apr-13 (No. 217-01737)	Apr-14
Reference 20 dB Attenuator	SN: S5277 (20x)	04-Apr-13 (No. 217-01735)	Apr-14
Reference 30 dB Attenuator	SN: S5129 (30b)	04-Apr-13 (No. 217-01738)	Apr-14
Reference Probe ES3DV2	SN: 3013	28-Dec-12 (No. ES3-3013_Dec12)	Dec-13
DAE4	SN: 660	31-Jan-13 (No. DAE4-660_Jan13)	Jan-14
Secondary Standards	ID	Check Date (in house)	Scheduled Check
RF generator HP 8648C	US3642U01700	4-Aug-99 (in house check Apr-13)	In house check: Apr-15
Network Analyzer HP 8753E	US37390585	18-Oct-01 (in house check Oct-12)	In house check: Oct-13

	Name	Function	Signature
Calibrated by:	Leif Klysner	Laboratory Technician	<i>Leif Klysner</i>
Approved by:	Katja Pokovic	Technical Manager	<i>Katja Pokovic</i>
			Issued: May 17, 2013

This calibration certificate shall not be reproduced except in full without written approval of the laboratory.



Accredited by the Swiss Accreditation Service (SAS)

Accreditation No.: **SCS 108**

The Swiss Accreditation Service is one of the signatories to the EA  
Multilateral Agreement for the recognition of calibration certificates

### Glossary:

TSL	tissue simulating liquid
NORM <sub>x,y,z</sub>	sensitivity in free space
ConvF	sensitivity in TSL / NORM <sub>x,y,z</sub>
DCP	diode compression point
CF	crest factor (1/duty_cycle) of the RF signal
A, B, C, D	modulation dependent linearization parameters
Polarization $\varphi$	$\varphi$ rotation around probe axis
Polarization $\vartheta$	$\vartheta$ rotation around an axis that is in the plane normal to probe axis (at measurement center), i.e., $\vartheta = 0$ is normal to probe axis

### Calibration is Performed According to the Following Standards:

- IEEE Std 1528-2003, "IEEE Recommended Practice for Determining the Peak Spatial-Averaged Specific Absorption Rate (SAR) in the Human Head from Wireless Communications Devices: Measurement Techniques", December 2003
- IEC 62209-1, "Procedure to measure the Specific Absorption Rate (SAR) for hand-held devices used in close proximity to the ear (frequency range of 300 MHz to 3 GHz)", February 2005

### Methods Applied and Interpretation of Parameters:

- NORM<sub>x,y,z</sub>**: Assessed for E-field polarization  $\vartheta = 0$  ( $f \leq 900$  MHz in TEM-cell;  $f > 1800$  MHz: R22 waveguide). NORM<sub>x,y,z</sub> are only intermediate values, i.e., the uncertainties of NORM<sub>x,y,z</sub> does not affect the E<sup>2</sup>-field uncertainty inside TSL (see below ConvF).
- NORM(f)<sub>x,y,z</sub>** = NORM<sub>x,y,z</sub> \* frequency\_response (see Frequency Response Chart). This linearization is implemented in DASY4 software versions later than 4.2. The uncertainty of the frequency response is included in the stated uncertainty of ConvF.
- DCP<sub>x,y,z</sub>**: DCP are numerical linearization parameters assessed based on the data of power sweep with CW signal (no uncertainty required). DCP does not depend on frequency nor media.
- PAR**: PAR is the Peak to Average Ratio that is not calibrated but determined based on the signal characteristics
- A<sub>x,y,z</sub>; B<sub>x,y,z</sub>; C<sub>x,y,z</sub>; D<sub>x,y,z</sub>; VR<sub>x,y,z</sub>; A, B, C, D** are numerical linearization parameters assessed based on the data of power sweep for specific modulation signal. The parameters do not depend on frequency nor media. VR is the maximum calibration range expressed in RMS voltage across the diode.
- ConvF and Boundary Effect Parameters**: Assessed in flat phantom using E-field (or Temperature Transfer Standard for  $f \leq 800$  MHz) and inside waveguide using analytical field distributions based on power measurements for  $f > 800$  MHz. The same setups are used for assessment of the parameters applied for boundary compensation (alpha, depth) of which typical uncertainty values are given. These parameters are used in DASY4 software to improve probe accuracy close to the boundary. The sensitivity in TSL corresponds to NORM<sub>x,y,z</sub> \* ConvF whereby the uncertainty corresponds to that given for ConvF. A frequency dependent ConvF is used in DASY version 4.4 and higher which allows extending the validity from  $\pm 50$  MHz to  $\pm 100$  MHz.
- Spherical isotropy (3D deviation from isotropy)**: in a field of low gradients realized using a flat phantom exposed by a patch antenna.
- Sensor Offset**: The sensor offset corresponds to the offset of virtual measurement center from the probe tip (on probe axis). No tolerance required.

# Probe ES3DV3

## SN:3263

Manufactured: January 25, 2010  
Calibrated: May 16, 2013

Calibrated for DASY/EASY Systems  
(Note: non-compatible with DASY2 system!)

## DASY/EASY - Parameters of Probe: ES3DV3 - SN:3263

### Basic Calibration Parameters

	Sensor X	Sensor Y	Sensor Z	Unc (k=2)
Norm ( $\mu\text{V}/(\text{V}/\text{m})^2$ ) <sup>A</sup>	1.21	1.25	1.12	$\pm 10.1 \%$
DCP (mV) <sup>B</sup>	101.2	100.2	103.7	

### Modulation Calibration Parameters

UID	Communication System Name		A dB	B dB $\sqrt{\mu\text{V}}$	C	D dB	VR mV	Unc <sup>E</sup> (k=2)
0	CW	X	0.0	0.0	1.0	0.00	156.5	$\pm 2.5 \%$
		Y	0.0	0.0	1.0		153.2	
		Z	0.0	0.0	1.0		147.2	

The reported uncertainty of measurement is stated as the standard uncertainty of measurement multiplied by the coverage factor  $k=2$ , which for a normal distribution corresponds to a coverage probability of approximately 95%.

<sup>A</sup> The uncertainties of NormX,Y,Z do not affect the  $E^2$ -field uncertainty inside TSL (see Pages 5 and 6).

<sup>B</sup> Numerical linearization parameter: uncertainty not required.

<sup>E</sup> Uncertainty is determined using the max. deviation from linear response applying rectangular distribution and is expressed for the square of the field value.

## DASY/EASY - Parameters of Probe: ES3DV3 - SN:3263

### Calibration Parameter Determined in Head Tissue Simulating Media

f (MHz) <sup>C</sup>	Relative Permittivity <sup>F</sup>	Conductivity (S/m) <sup>F</sup>	ConvF X	ConvF Y	ConvF Z	Alpha	Depth (mm)	Unct. (k=2)
750	41.9	0.89	6.51	6.51	6.51	0.21	2.29	± 12.0 %
835	41.5	0.90	6.29	6.29	6.29	0.50	1.38	± 12.0 %
1750	40.1	1.37	5.30	5.30	5.30	0.45	1.54	± 12.0 %
1900	40.0	1.40	5.11	5.11	5.11	0.57	1.38	± 12.0 %
2450	39.2	1.80	4.47	4.47	4.47	0.59	1.49	± 12.0 %
2600	39.0	1.96	4.31	4.31	4.31	0.80	1.28	± 12.0 %

<sup>C</sup> Frequency validity of ± 100 MHz only applies for DASY v4.4 and higher (see Page 2), else it is restricted to ± 50 MHz. The uncertainty is the RSS of the ConvF uncertainty at calibration frequency and the uncertainty for the indicated frequency band.

<sup>F</sup> At frequencies below 3 GHz, the validity of tissue parameters ( $\epsilon$  and  $\sigma$ ) can be relaxed to ± 10% if liquid compensation formula is applied to measured SAR values. At frequencies above 3 GHz, the validity of tissue parameters ( $\epsilon$  and  $\sigma$ ) is restricted to ± 5%. The uncertainty is the RSS of the ConvF uncertainty for indicated target tissue parameters.

## DASY/EASY - Parameters of Probe: ES3DV3 - SN:3263

### Calibration Parameter Determined in Body Tissue Simulating Media

f (MHz) <sup>C</sup>	Relative Permittivity <sup>F</sup>	Conductivity (S/m) <sup>F</sup>	ConvF X	ConvF Y	ConvF Z	Alpha	Depth (mm)	Unct. (k=2)
750	55.5	0.96	6.37	6.37	6.37	0.34	1.82	± 12.0 %
835	55.2	0.97	6.29	6.29	6.29	0.54	1.39	± 12.0 %
1750	53.4	1.49	5.01	5.01	5.01	0.72	1.27	± 12.0 %
1900	53.3	1.52	4.78	4.78	4.78	0.53	1.56	± 12.0 %
2450	52.7	1.95	4.33	4.33	4.33	0.80	1.14	± 12.0 %
2600	52.5	2.16	4.14	4.14	4.14	0.80	1.02	± 12.0 %

<sup>C</sup> Frequency validity of ± 100 MHz only applies for DASY v4.4 and higher (see Page 2), else it is restricted to ± 50 MHz. The uncertainty is the RSS of the ConvF uncertainty at calibration frequency and the uncertainty for the indicated frequency band.

<sup>F</sup> At frequencies below 3 GHz, the validity of tissue parameters ( $\epsilon$  and  $\sigma$ ) can be relaxed to ± 10% if liquid compensation formula is applied to measured SAR values. At frequencies above 3 GHz, the validity of tissue parameters ( $\epsilon$  and  $\sigma$ ) is restricted to ± 5%. The uncertainty is the RSS of the ConvF uncertainty for indicated target tissue parameters.

### Frequency Response of E-Field (TEM-Cell:ifi110 EXX, Waveguide: R22)

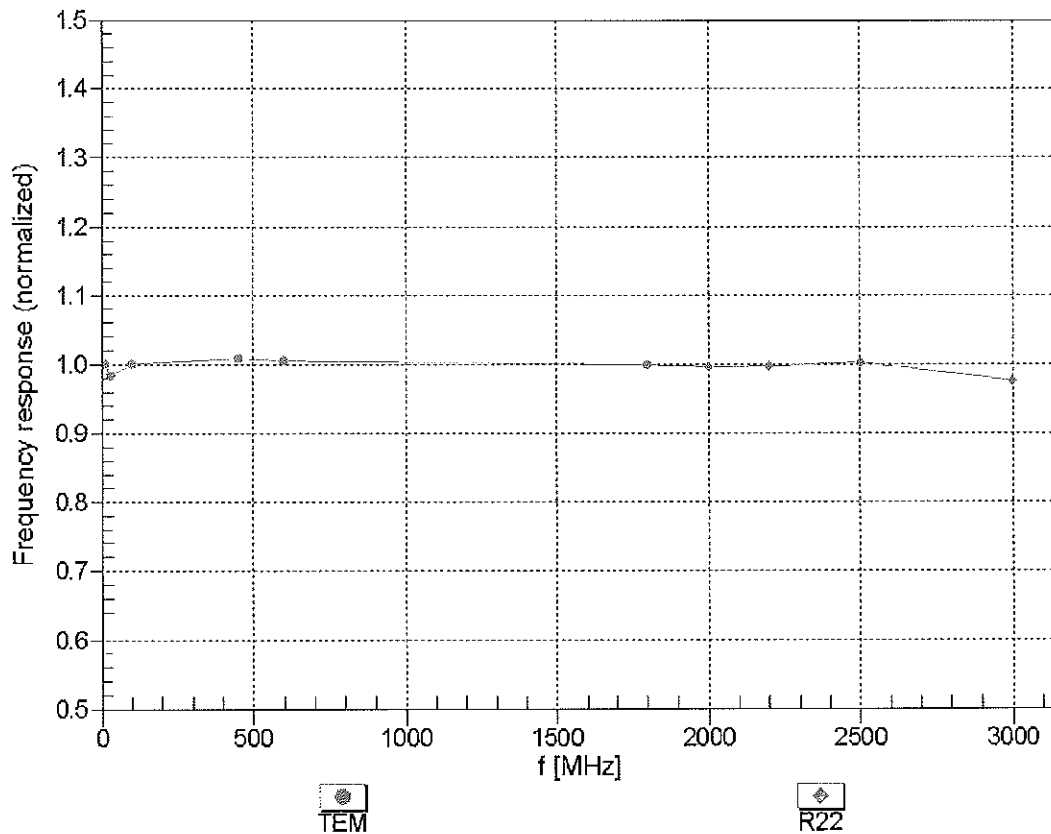

Uncertainty of Frequency Response of E-field:  $\pm 6.3\%$  (k=2)

### Receiving Pattern ( $\phi$ ), $\theta = 0^\circ$

f=600 MHz,TEM

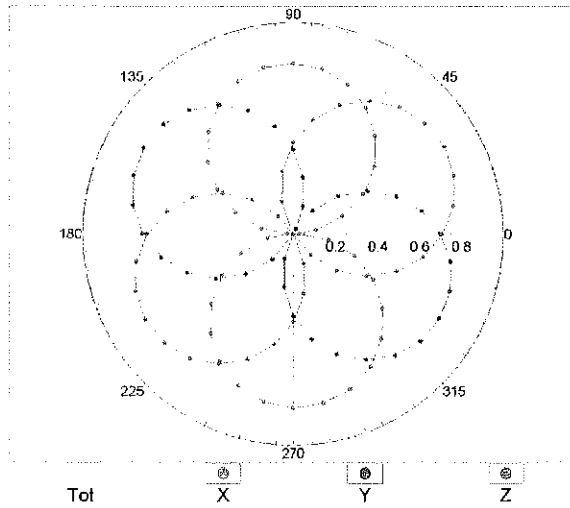

f=1800 MHz,R22

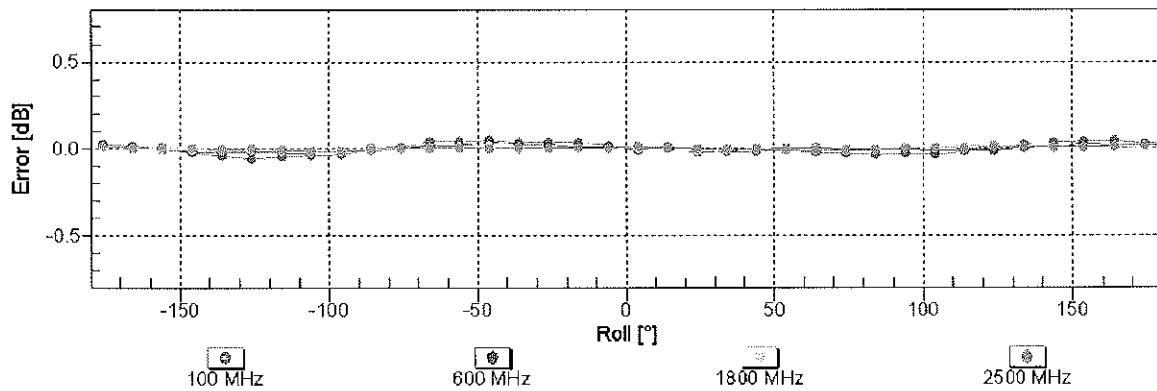
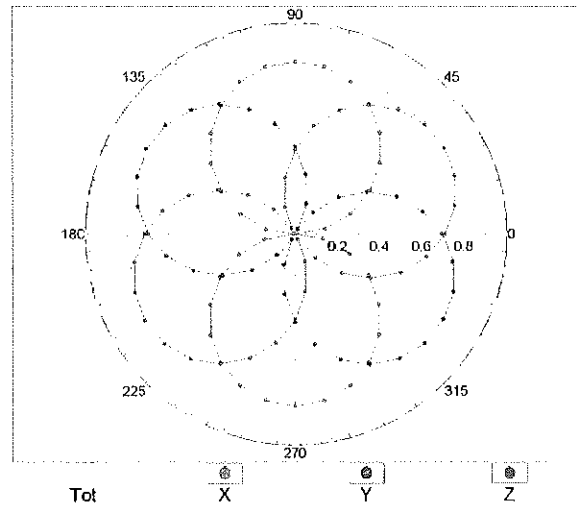

Uncertainty of Axial Isotropy Assessment:  $\pm 0.5\%$  (k=2)

### Dynamic Range f(SAR<sub>head</sub>) (TEM cell , f = 900 MHz)

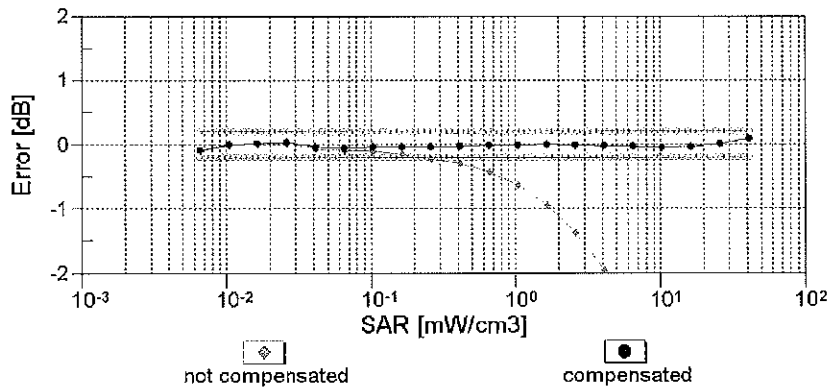
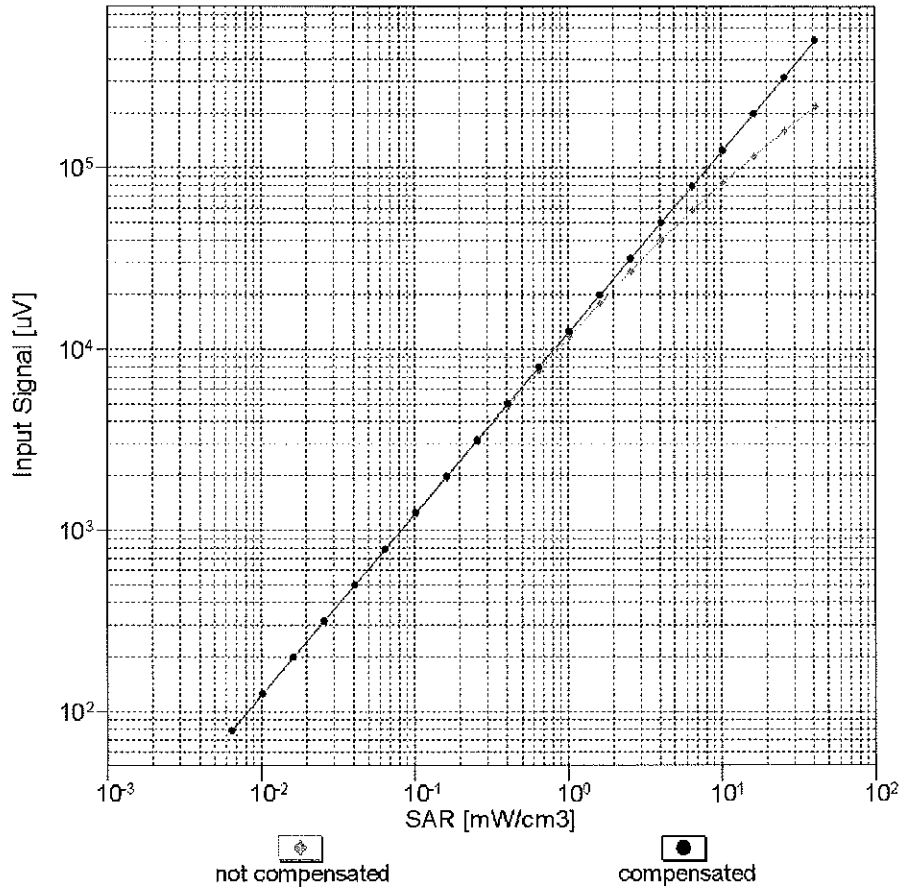

Uncertainty of Linearity Assessment: ± 0.6% (k=2)

## Conversion Factor Assessment

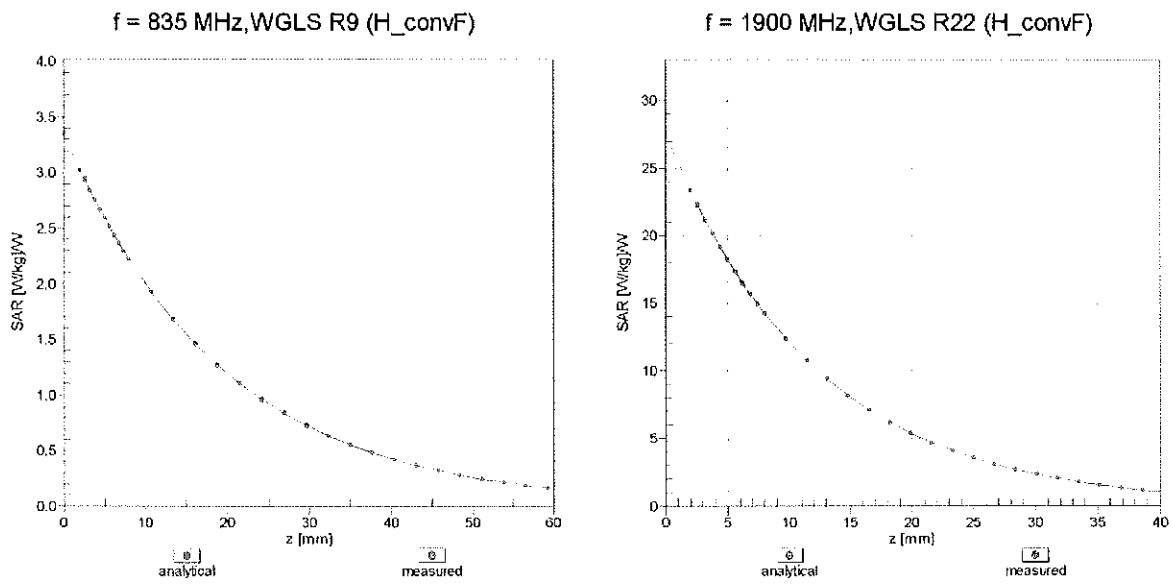

## Deviation from Isotropy in Liquid Error ( $\phi, \theta$ ), f = 900 MHz

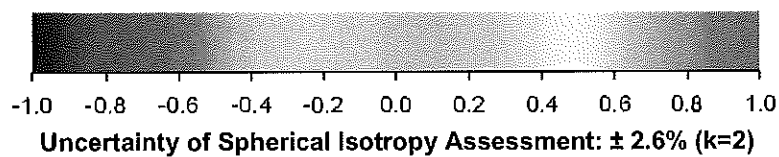
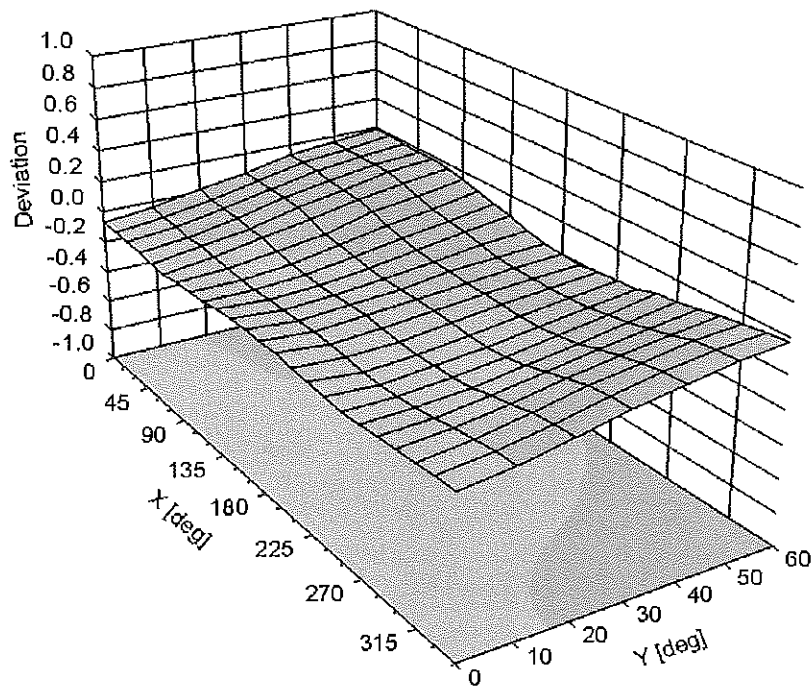

## DASY/EASY - Parameters of Probe: ES3DV3 - SN:3263

### Other Probe Parameters

Sensor Arrangement	Triangular
Connector Angle (°)	-116
Mechanical Surface Detection Mode	enabled
Optical Surface Detection Mode	disabled
Probe Overall Length	337 mm
Probe Body Diameter	10 mm
Tip Length	10 mm
Tip Diameter	4 mm
Probe Tip to Sensor X Calibration Point	2 mm
Probe Tip to Sensor Y Calibration Point	2 mm
Probe Tip to Sensor Z Calibration Point	2 mm
Recommended Measurement Distance from Surface	3 mm

**Calibration Laboratory of  
Schmid & Partner  
Engineering AG**  
Zeughausstrasse 43, 8004 Zurich, Switzerland



**SCS** Schweizerischer Kalibrierdienst  
Service suisse d'étalonnage  
Servizio svizzero di taratura  
Swiss Calibration Service

Accredited by the Swiss Accreditation Service (SAS)  
The Swiss Accreditation Service is one of the signatories to the EA  
Multilateral Agreement for the recognition of calibration certificates

Accreditation No.: **SCS 108**

Client **PC Test**

Certificate No: **ES3-3287\_Nov13**

## CALIBRATION CERTIFICATE

Object **ES3DV3 - SN:3287**

Calibration procedure(s) **QA CAL-01.v9, QA CAL-23.v5, QA CAL-25.v6  
Calibration procedure for dosimetric E-field probes**

Calibration date: **November 20, 2013** ✓ CC 11/20/2013

This calibration certificate documents the traceability to national standards, which realize the physical units of measurements (SI).  
The measurements and the uncertainties with confidence probability are given on the following pages and are part of the certificate.

All calibrations have been conducted in the closed laboratory facility: environment temperature (22 ± 3)°C and humidity < 70%.

Calibration Equipment used (M&TE critical for calibration)

Primary Standards	ID	Cal Date (Certificate No.)	Scheduled Calibration
Power meter E4419B	GB41293874	04-Apr-13 (No. 217-01733)	Apr-14
Power sensor E4412A	MY41498087	04-Apr-13 (No. 217-01733)	Apr-14
Reference 3 dB Attenuator	SN: S5054 (3c)	04-Apr-13 (No. 217-01737)	Apr-14
Reference 20 dB Attenuator	SN: S5277 (20x)	04-Apr-13 (No. 217-01735)	Apr-14
Reference 30 dB Attenuator	SN: S5129 (30b)	04-Apr-13 (No. 217-01738)	Apr-14
Reference Probe ES3DV2	SN: 3013	28-Dec-12 (No. ES3-3013_Dec12)	Dec-13
DAE4	SN: 660	4-Sep-13 (No. DAE4-660_Sep13)	Sep-14
Secondary Standards	ID	Check Date (in house)	Scheduled Check
RF generator HP 8648C	US3642U01700	4-Aug-99 (in house check Apr-13)	In house check: Apr-15
Network Analyzer HP 8753E	US37390585	18-Oct-01 (in house check Oct-13)	In house check: Oct-14

	Name	Function	Signature
Calibrated by:	Leif Klysner	Laboratory Technician	
Approved by:	Kalja Pokovic	Technical Manager	
			Issued: November 20, 2013
This calibration certificate shall not be reproduced except in full without written approval of the laboratory.			



Accredited by the Swiss Accreditation Service (SAS)  
 The Swiss Accreditation Service is one of the signatories to the EA  
 Multilateral Agreement for the recognition of calibration certificates

Accreditation No.: **SCS 108**

**Glossary:**

TSL	tissue simulating liquid
NORM <sub>x,y,z</sub>	sensitivity in free space
ConvF	sensitivity in TSL / NORM <sub>x,y,z</sub>
DCP	diode compression point
CF	crest factor (1/duty_cycle) of the RF signal
A, B, C, D	modulation dependent linearization parameters
Polarization φ	φ rotation around probe axis
Polarization ϑ	ϑ rotation around an axis that is in the plane normal to probe axis (at measurement center), i.e., ϑ = 0 is normal to probe axis
Connector Angle	information used in DASY system to align probe sensor X to the robot coordinate system

**Calibration is Performed According to the Following Standards:**

- a) IEEE Std 1528-2013, "IEEE Recommended Practice for Determining the Peak Spatial-Averaged Specific Absorption Rate (SAR) in the Human Head from Wireless Communications Devices: Measurement Techniques", June 2013
- b) IEC 62209-1, "Procedure to measure the Specific Absorption Rate (SAR) for hand-held devices used in close proximity to the ear (frequency range of 300 MHz to 3 GHz)", February 2005

**Methods Applied and Interpretation of Parameters:**

- **NORM<sub>x,y,z</sub>**: Assessed for E-field polarization ϑ = 0 (f ≤ 900 MHz in TEM-cell; f > 1800 MHz: R22 waveguide). NORM<sub>x,y,z</sub> are only intermediate values, i.e., the uncertainties of NORM<sub>x,y,z</sub> does not affect the E<sup>2</sup>-field uncertainty inside TSL (see below ConvF).
- **NORM(f)<sub>x,y,z</sub>** = NORM<sub>x,y,z</sub> \* frequency\_response (see Frequency Response Chart). This linearization is implemented in DASY4 software versions later than 4.2. The uncertainty of the frequency response is included in the stated uncertainty of ConvF.
- **DCP<sub>x,y,z</sub>**: DCP are numerical linearization parameters assessed based on the data of power sweep with CW signal (no uncertainty required). DCP does not depend on frequency nor media.
- **PAR**: PAR is the Peak to Average Ratio that is not calibrated but determined based on the signal characteristics
- **A<sub>x,y,z</sub>; B<sub>x,y,z</sub>; C<sub>x,y,z</sub>; D<sub>x,y,z</sub>; VR<sub>x,y,z</sub>**: A, B, C, D are numerical linearization parameters assessed based on the data of power sweep for specific modulation signal. The parameters do not depend on frequency nor media. VR is the maximum calibration range expressed in RMS voltage across the diode.
- **ConvF and Boundary Effect Parameters**: Assessed in flat phantom using E-field (or Temperature Transfer Standard for f ≤ 800 MHz) and inside waveguide using analytical field distributions based on power measurements for f > 800 MHz. The same setups are used for assessment of the parameters applied for boundary compensation (alpha, depth) of which typical uncertainty values are given. These parameters are used in DASY4 software to improve probe accuracy close to the boundary. The sensitivity in TSL corresponds to NORM<sub>x,y,z</sub> \* ConvF whereby the uncertainty corresponds to that given for ConvF. A frequency dependent ConvF is used in DASY version 4.4 and higher which allows extending the validity from ± 50 MHz to ± 100 MHz.
- **Spherical isotropy (3D deviation from isotropy)**: in a field of low gradients realized using a flat phantom exposed by a patch antenna.
- **Sensor Offset**: The sensor offset corresponds to the offset of virtual measurement center from the probe tip (on probe axis). No tolerance required.
- **Connector Angle**: The angle is assessed using the information gained by determining the NORM<sub>x</sub> (no uncertainty required).

# Probe ES3DV3

## SN:3287

Manufactured: June 7, 2010  
Calibrated: November 20, 2013

Calibrated for DASY/EASY Systems  
(Note: non-compatible with DASY2 system!)

## DASY/EASY - Parameters of Probe: ES3DV3 - SN:3287

### Basic Calibration Parameters

	Sensor X	Sensor Y	Sensor Z	Unc (k=2)
Norm ( $\mu\text{V}/(\text{V}/\text{m})^2$ ) <sup>A</sup>	1.31	1.25	1.25	$\pm 10.1\%$
DCP (mV) <sup>B</sup>	102.6	102.5	100.4	

### Modulation Calibration Parameters

UID	Communication System Name		A dB	B dB $\sqrt{\mu\text{V}}$	C	D dB	VR mV	Unc <sup>E</sup> (k=2)
0	CW	X	0.0	0.0	1.0	0.00	157.3	$\pm 2.7\%$
		Y	0.0	0.0	1.0		159.9	
		Z	0.0	0.0	1.0		152.5	
10010- CAA	SAR Validation (Square, 100ms, 10ms)	X	2.23	57.9	9.9	10.00	45.7	$\pm 1.4\%$
		Y	2.13	57.6	9.8		46.6	
		Z	3.31	61.1	11.8		47.6	
10011- CAA	UMTS-FDD (WCDMA)	X	3.25	66.3	17.9	2.91	124.8	$\pm 0.5\%$
		Y	3.16	65.7	17.4		127.4	
		Z	3.15	65.5	17.4		122.8	
10012- CAA	IEEE 802.11b WiFi 2.4 GHz (DSSS, 1 Mbps)	X	3.08	68.7	18.3	1.87	127.2	$\pm 0.7\%$
		Y	3.03	68.2	17.9		129.4	
		Z	2.87	67.0	17.3		126.5	
10021- DAA	GSM-FDD (TDMA, GMSK)	X	15.99	90.6	25.0	9.39	99.9	$\pm 1.2\%$
		Y	12.41	86.6	23.6		101.5	
		Z	29.18	99.9	28.5		109.2	
10023- DAA	GPRS-FDD (TDMA, GMSK, TN 0)	X	25.67	98.9	27.8	9.57	97.9	$\pm 1.7\%$
		Y	14.20	88.5	24.3		100.6	
		Z	27.68	99.8	28.8		107.7	
10024- DAA	GPRS-FDD (TDMA, GMSK, TN 0-1)	X	42.95	99.6	24.9	6.56	124.4	$\pm 1.4\%$
		Y	45.27	99.9	24.8		128.8	
		Z	42.64	99.6	25.5		135.7	
10027- DAA	GPRS-FDD (TDMA, GMSK, TN 0-1-2)	X	27.78	91.3	21.1	4.80	136.0	$\pm 1.4\%$
		Y	32.74	93.9	21.9		146.6	
		Z	23.93	89.5	21.1		144.8	
10028- DAA	GPRS-FDD (TDMA, GMSK, TN 0-1-2-3)	X	59.17	99.6	22.4	3.55	142.5	$\pm 1.2\%$
		Y	78.76	99.7	21.7		104.9	
		Z	38.06	94.2	21.4		148.8	
10032- CAA	IEEE 802.15.1 Bluetooth (GFSK, DH5)	X	93.35	99.7	19.5	1.16	108.1	$\pm 0.9\%$
		Y	96.67	94.0	16.9		114.7	
		Z	98.17	96.2	18.2		108.9	
10039- CAA	CDMA2000 (1xRTT, RC1)	X	4.84	66.7	18.8	4.57	126.5	$\pm 0.9\%$
		Y	4.83	66.6	18.6		134.4	
		Z	4.76	66.0	18.3		125.9	
10081- CAA	CDMA2000 (1xRTT, RC3)	X	4.00	66.2	18.5	3.97	121.9	$\pm 0.7\%$
		Y	3.91	65.5	17.9		128.9	
		Z	3.88	65.2	17.8		120.7	

10098-CAA	UMTS-FDD (HSUPA, Subtest 2)	X	4.66	66.6	18.4	3.98	132.5	±0.7 %
		Y	4.66	66.5	18.2		141.3	
		Z	4.54	65.9	17.9		130.7	
10100-CAB	LTE-FDD (SC-FDMA, 100% RB, 20 MHz, QPSK)	X	6.65	68.3	20.1	5.67	139.5	±1.4 %
		Y	6.69	68.3	19.9		148.9	
		Z	6.60	67.9	19.8		137.5	
10108-CAB	LTE-FDD (SC-FDMA, 100% RB, 10 MHz, QPSK)	X	6.52	67.8	20.0	5.80	137.3	±1.4 %
		Y	6.53	67.6	19.7		147.5	
		Z	6.51	67.6	19.8		135.3	
10110-CAB	LTE-FDD (SC-FDMA, 100% RB, 5 MHz, QPSK)	X	6.19	67.2	19.7	5.75	134.3	±1.2 %
		Y	6.24	67.3	19.6		142.9	
		Z	6.23	67.1	19.6		132.3	
10151-CAB	LTE-TDD (SC-FDMA, 50% RB, 20 MHz, QPSK)	X	11.56	79.1	27.9	9.28	130.1	±3.0 %
		Y	11.01	76.8	26.2		141.9	
		Z	12.98	81.2	28.7		135.7	
10154-CAB	LTE-FDD (SC-FDMA, 50% RB, 10 MHz, QPSK)	X	6.25	67.4	19.8	5.75	135.1	±1.2 %
		Y	6.17	66.9	19.3		143.6	
		Z	6.16	66.8	19.4		132.8	
10160-CAB	LTE-FDD (SC-FDMA, 50% RB, 15 MHz, QPSK)	X	6.66	67.8	20.0	5.82	140.3	±1.4 %
		Y	6.72	67.9	19.9		148.8	
		Z	6.66	67.6	19.8		137.4	
10169-CAB	LTE-FDD (SC-FDMA, 1 RB, 20 MHz, QPSK)	X	5.05	66.7	19.5	5.73	117.8	±0.9 %
		Y	4.93	66.0	18.9		125.0	
		Z	5.08	66.3	19.3		116.3	
10172-CAB	LTE-TDD (SC-FDMA, 1 RB, 20 MHz, QPSK)	X	8.47	76.8	26.9	9.21	100.3	±2.2 %
		Y	8.06	74.6	25.3		107.5	
		Z	9.43	78.2	27.4		102.5	
10175-CAB	LTE-FDD (SC-FDMA, 1 RB, 10 MHz, QPSK)	X	4.98	66.3	19.3	5.72	118.2	±0.9 %
		Y	4.96	66.1	19.0		119.9	
		Z	5.03	66.1	19.1		116.1	
10181-CAB	LTE-FDD (SC-FDMA, 1 RB, 15 MHz, QPSK)	X	5.06	66.7	19.6	5.72	118.7	±0.9 %
		Y	4.97	66.2	19.1		120.0	
		Z	5.03	66.1	19.1		116.3	
10225-CAA	UMTS-FDD (HSPA+)	X	6.78	66.1	18.9	5.97	105.3	±1.2 %
		Y	6.68	65.7	18.6		106.8	
		Z	7.32	67.6	19.7		148.0	
10237-CAB	LTE-TDD (SC-FDMA, 1 RB, 10 MHz, QPSK)	X	8.56	77.1	27.1	9.21	100.8	±1.9 %
		Y	8.33	75.8	26.1		103.8	
		Z	9.39	78.0	27.3		101.9	
10252-CAB	LTE-TDD (SC-FDMA, 50% RB, 10 MHz, QPSK)	X	10.58	77.8	27.4	9.24	123.3	±2.5 %
		Y	10.48	76.9	26.5		128.1	
		Z	11.79	79.6	28.0		127.0	
10267-CAB	LTE-TDD (SC-FDMA, 100% RB, 10 MHz, QPSK)	X	11.52	79.1	27.9	9.30	130.1	±2.7 %
		Y	11.24	77.7	26.9		136.0	
		Z	12.96	81.2	28.8		134.8	

10274-CAA	UMTS-FDD (HSUPA, Subtest 5, 3GPP Rel8.10)	X	6.14	67.4	19.0	4.87	145.5	±1.2 %
		Y	6.19	67.4	19.0		149.2	
		Z	6.10	66.9	18.8		142.3	
10275-CAA	UMTS-FDD (HSUPA, Subtest 5, 3GPP Rel8.4)	X	4.41	66.4	18.3	3.96	126.4	±0.7 %
		Y	4.43	66.3	18.2		130.4	
		Z	4.36	65.9	18.0		123.8	
10291-AAA	CDMA2000, RC3, SO55, Full Rate	X	3.57	65.9	17.9	3.46	120.0	±0.5 %
		Y	3.55	65.6	17.6		121.7	
		Z	3.50	65.1	17.5		117.2	
10292-AAA	CDMA2000, RC3, SO32, Full Rate	X	3.55	66.1	18.0	3.39	121.3	±0.5 %
		Y	3.54	66.0	17.8		123.6	
		Z	3.45	65.2	17.4		118.9	
10297-AAA	LTE-FDD (SC-FDMA, 50% RB, 20 MHz, QPSK)	X	6.53	67.8	20.0	5.81	136.2	±1.2 %
		Y	6.48	67.5	19.6		139.3	
		Z	6.52	67.6	19.8		134.1	
10311-AAA	LTE-FDD (SC-FDMA, 100% RB, 15 MHz, QPSK)	X	7.12	68.4	20.4	6.06	141.7	±1.4 %
		Y	7.11	68.3	20.1		145.3	
		Z	7.14	68.4	20.3		139.8	
10315-AAA	IEEE 802.11b WiFi 2.4 GHz (DSSS, 1 Mbps, 96pc duty cycle)	X	2.79	67.6	18.0	1.71	125.5	±0.5 %
		Y	2.71	66.9	17.3		128.2	
		Z	2.64	66.2	17.0		123.5	
10403-AAA	CDMA2000 (1xEV-DO, Rev. 0)	X	4.78	67.5	18.3	3.76	130.6	±0.5 %
		Y	4.77	67.5	18.2		133.8	
		Z	4.65	66.5	17.8		130.0	
10404-AAA	CDMA2000 (1xEV-DO, Rev. A)	X	4.83	68.2	18.6	3.77	129.2	±0.7 %
		Y	4.68	67.4	18.0		131.9	
		Z	4.52	66.3	17.7		128.7	

The reported uncertainty of measurement is stated as the standard uncertainty of measurement multiplied by the coverage factor  $k=2$ , which for a normal distribution corresponds to a coverage probability of approximately 95%.

<sup>A</sup> The uncertainties of NormX,Y,Z do not affect the  $E^2$ -field uncertainty inside TSL (see Pages 7 and 8).

<sup>B</sup> Numerical linearization parameter: uncertainty not required.

<sup>E</sup> Uncertainty is determined using the max. deviation from linear response applying rectangular distribution and is expressed for the square of the field value.

## DASY/EASY - Parameters of Probe: ES3DV3 - SN:3287

### Calibration Parameter Determined in Head Tissue Simulating Media

f (MHz) <sup>C</sup>	Relative Permittivity <sup>F</sup>	Conductivity (S/m) <sup>F</sup>	ConvF X	ConvF Y	ConvF Z	Alpha <sup>G</sup>	Depth <sup>G</sup> (mm)	Unct. (k=2)
750	41.9	0.89	6.52	6.52	6.52	0.47	1.46	± 12.0 %
835	41.5	0.90	6.30	6.30	6.30	0.40	1.59	± 12.0 %
1750	40.1	1.37	5.27	5.27	5.27	0.63	1.34	± 12.0 %
1900	40.0	1.40	5.08	5.08	5.08	0.62	1.37	± 12.0 %
2450	39.2	1.80	4.43	4.43	4.43	0.79	1.28	± 12.0 %
2600	39.0	1.96	4.29	4.29	4.29	0.77	1.38	± 12.0 %

<sup>C</sup> Frequency validity of ± 100 MHz only applies for DASY v4.4 and higher (see Page 2), else it is restricted to ± 50 MHz. The uncertainty is the RSS of the ConvF uncertainty at calibration frequency and the uncertainty for the indicated frequency band.

<sup>F</sup> At frequencies below 3 GHz, the validity of tissue parameters ( $\epsilon$  and  $\sigma$ ) can be relaxed to ± 10% if liquid compensation formula is applied to measured SAR values. At frequencies above 3 GHz, the validity of tissue parameters ( $\epsilon$  and  $\sigma$ ) is restricted to ± 5%. The uncertainty is the RSS of the ConvF uncertainty for indicated target tissue parameters.

<sup>G</sup> Alpha/Depth are determined during calibration. SPEAG warrants that the remaining deviation due to the boundary effect after compensation is always less than ± 1% for frequencies below 3 GHz and below ± 2% for frequencies between 3-6 GHz at any distance larger than half the probe tip diameter from the boundary.

## DASY/EASY - Parameters of Probe: ES3DV3 - SN:3287

### Calibration Parameter Determined in Body Tissue Simulating Media

f (MHz) <sup>C</sup>	Relative Permittivity <sup>F</sup>	Conductivity (S/m) <sup>F</sup>	ConvF X	ConvF Y	ConvF Z	Alpha <sup>G</sup>	Depth <sup>G</sup> (mm)	Unct. (k=2)
750	55.5	0.96	6.09	6.09	6.09	0.55	1.37	± 12.0 %
835	55.2	0.97	6.04	6.04	6.04	0.55	1.39	± 12.0 %
1750	53.4	1.49	4.93	4.93	4.93	0.39	1.73	± 12.0 %
1900	53.3	1.52	4.67	4.67	4.67	0.38	1.75	± 12.0 %
2450	52.7	1.95	4.17	4.17	4.17	0.60	1.20	± 12.0 %
2600	52.5	2.16	4.00	4.00	4.00	0.60	1.10	± 12.0 %

<sup>C</sup> Frequency validity of ± 100 MHz only applies for DASY v4.4 and higher (see Page 2), else it is restricted to ± 50 MHz. The uncertainty is the RSS of the ConvF uncertainty at calibration frequency and the uncertainty for the indicated frequency band.

<sup>F</sup> At frequencies below 3 GHz, the validity of tissue parameters ( $\epsilon$  and  $\sigma$ ) can be relaxed to ± 10% if liquid compensation formula is applied to measured SAR values. At frequencies above 3 GHz, the validity of tissue parameters ( $\epsilon$  and  $\sigma$ ) is restricted to ± 5%. The uncertainty is the RSS of the ConvF uncertainty for indicated target tissue parameters.

<sup>G</sup> Alpha/Depth are determined during calibration. SPEAG warrants that the remaining deviation due to the boundary effect after compensation is always less than ± 1% for frequencies below 3 GHz and below ± 2% for frequencies between 3-6 GHz at any distance larger than half the probe tip diameter from the boundary.

# Frequency Response of E-Field

(TEM-Cell:ifi110 EXX, Waveguide: R22)

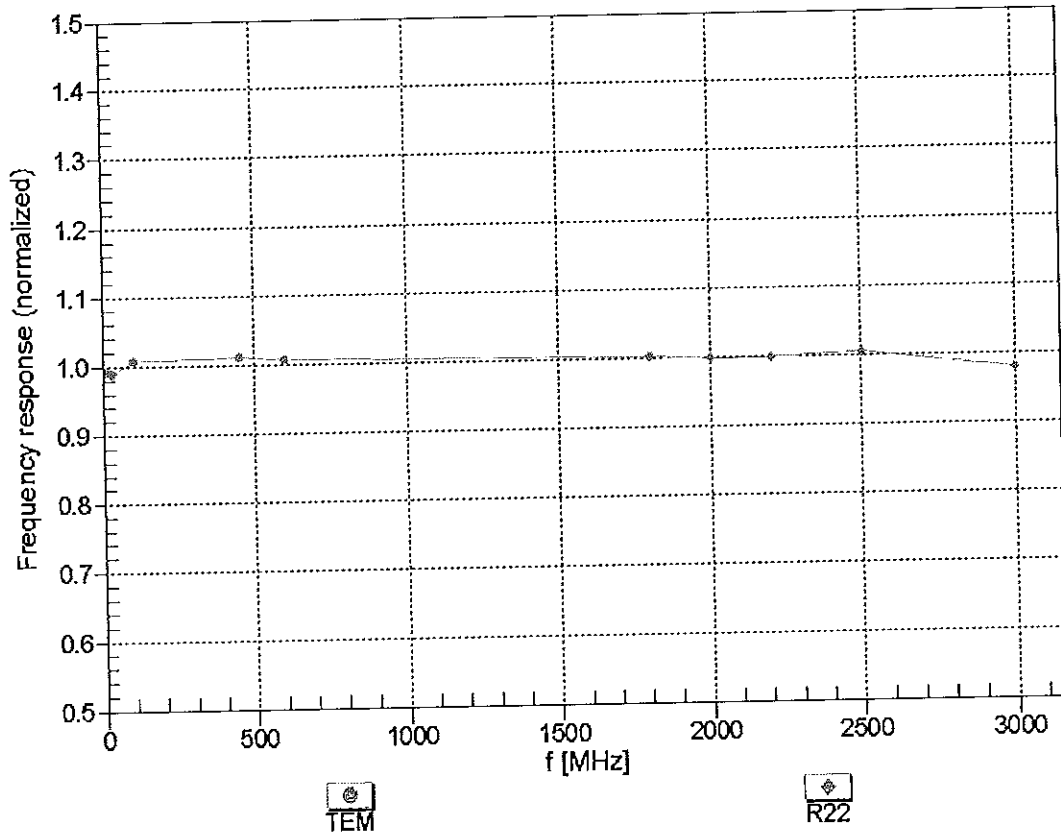

Uncertainty of Frequency Response of E-field:  $\pm 6.3\%$  (k=2)

### Receiving Pattern ( $\phi$ ), $\vartheta = 0^\circ$

f=600 MHz, TEM

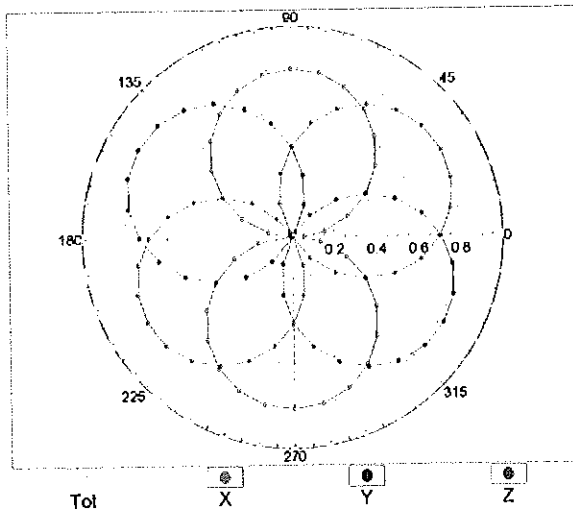

f=1800 MHz, R22

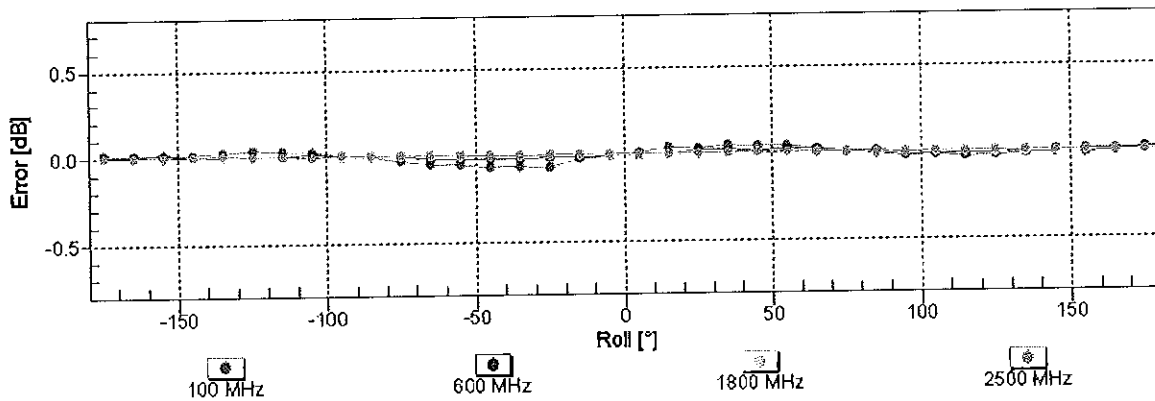
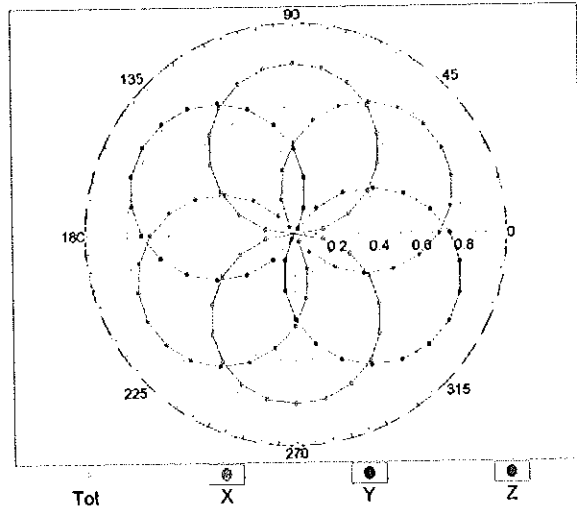

Uncertainty of Axial Isotropy Assessment:  $\pm 0.5\%$  (k=2)

### Dynamic Range f(SAR<sub>head</sub>) (TEM cell , f = 900 MHz)

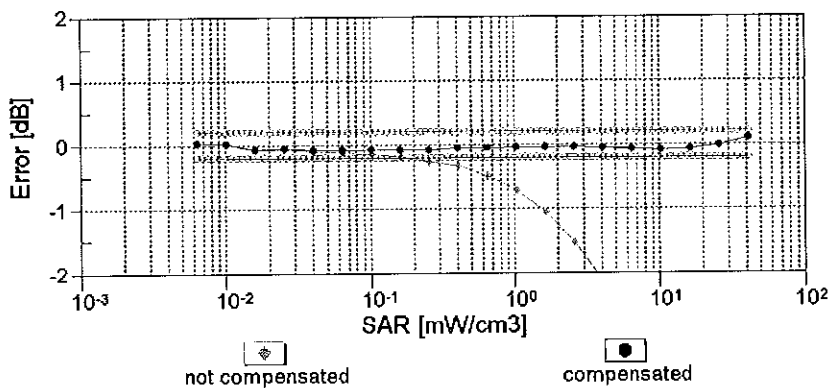
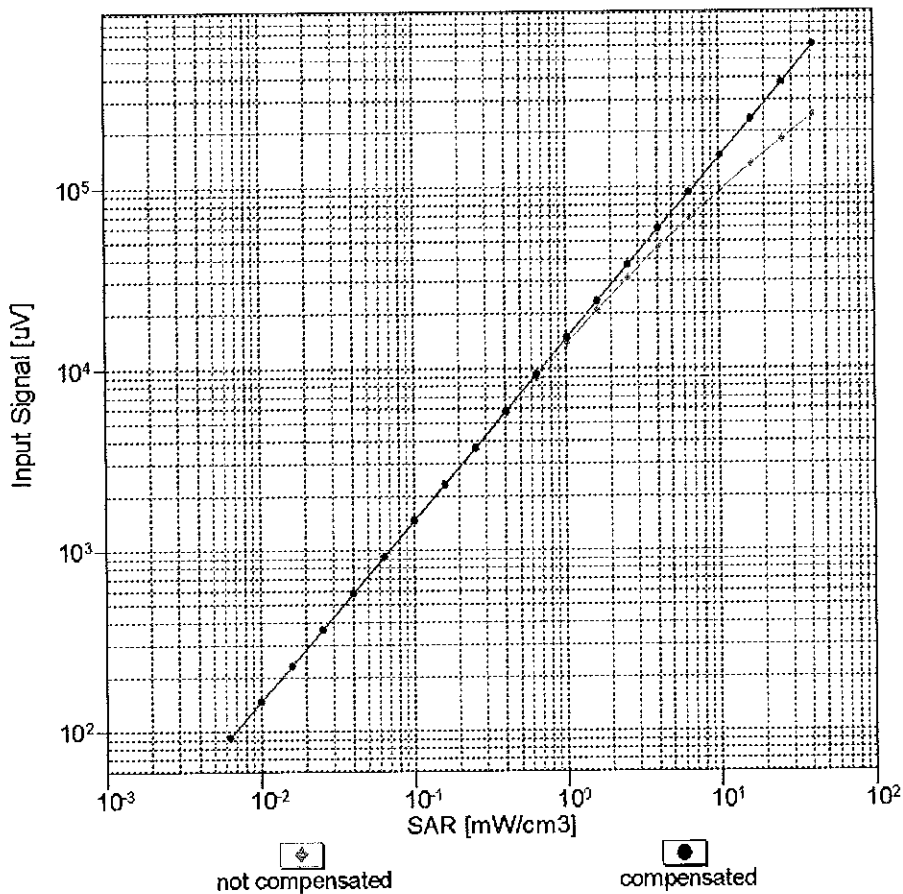

Uncertainty of Linearity Assessment: ± 0.6% (k=2)

# Conversion Factor Assessment

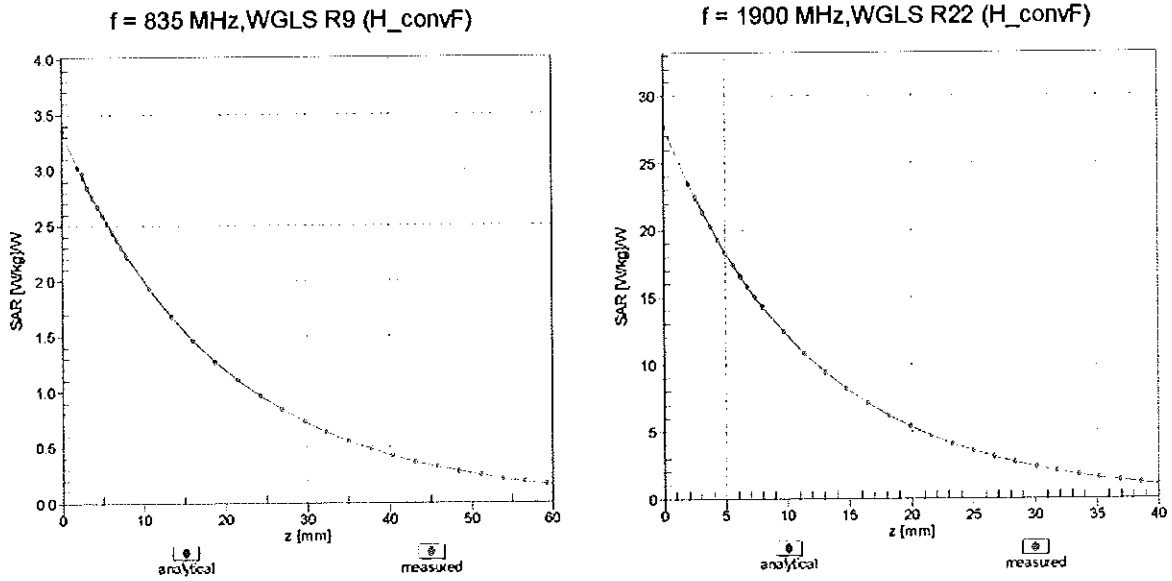

## Deviation from Isotropy in Liquid Error ( $\phi, \theta$ ), f = 900 MHz

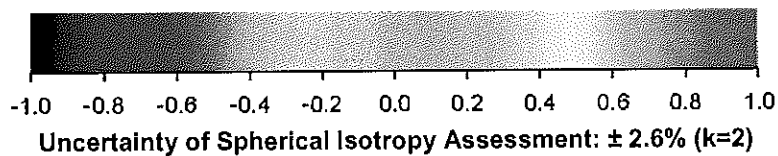
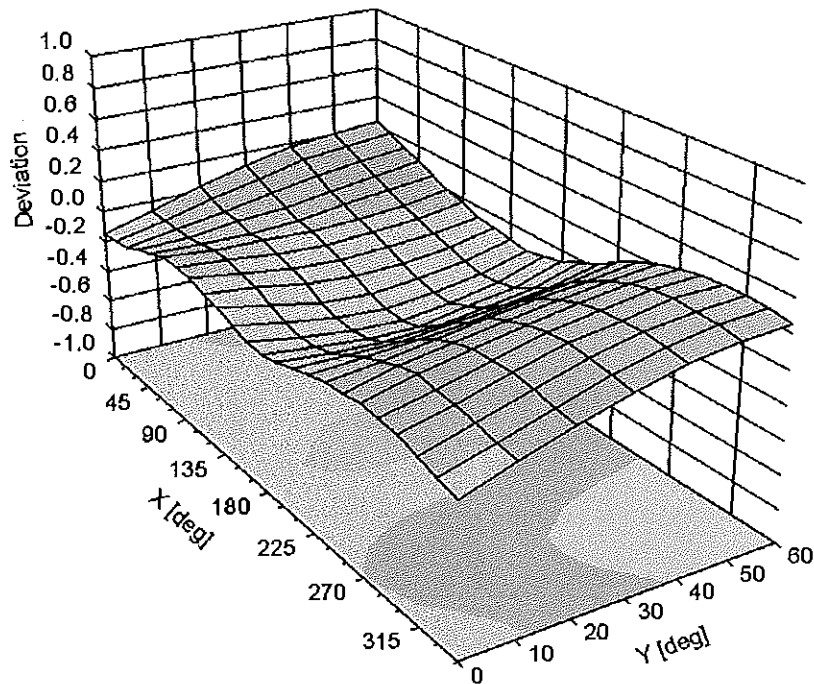

**DASY/EASY - Parameters of Probe: ES3DV3 - SN:3287****Other Probe Parameters**

Sensor Arrangement	Triangular
Connector Angle (°)	-15
Mechanical Surface Detection Mode	enabled
Optical Surface Detection Mode	disabled
Probe Overall Length	337 mm
Probe Body Diameter	10 mm
Tip Length	10 mm
Tip Diameter	4 mm
Probe Tip to Sensor X Calibration Point	2 mm
Probe Tip to Sensor Y Calibration Point	2 mm
Probe Tip to Sensor Z Calibration Point	2 mm
Recommended Measurement Distance from Surface	3 mm



Accredited by the Swiss Accreditation Service (SAS)  
The Swiss Accreditation Service is one of the signatories to the EA  
Multilateral Agreement for the recognition of calibration certificates

Accreditation No.: **SCS 108**

Client **PC Test**

Certificate No: **EX3-3920\_Dec13**

**CALIBRATION CERTIFICATE**

Object **EX3DV4 - SN:3920**

Calibration procedure(s) **QA CAL-01.v9, QA CAL-14.v4, QA CAL-23.v5, QA CAL-25.v6  
Calibration procedure for dosimetric E-field probes**

Calibration date: **December 18, 2013**

*VCC  
1/12/14*

This calibration certificate documents the traceability to national standards, which realize the physical units of measurements (SI).  
The measurements and the uncertainties with confidence probability are given on the following pages and are part of the certificate.

All calibrations have been conducted in the closed laboratory facility: environment temperature (22 ± 3)°C and humidity < 70%.

Calibration Equipment used (M&TE critical for calibration)

Primary Standards	ID	Cal Date (Certificate No.)	Scheduled Calibration
Power meter E4419B	GB41293874	04-Apr-13 (No. 217-01733)	Apr-14
Power sensor E4412A	MY41498087	04-Apr-13 (No. 217-01733)	Apr-14
Reference 3 dB Attenuator	SN: S5054 (3c)	04-Apr-13 (No. 217-01737)	Apr-14
Reference 20 dB Attenuator	SN: S5277 (20x)	04-Apr-13 (No. 217-01735)	Apr-14
Reference 30 dB Attenuator	SN: S5129 (30b)	04-Apr-13 (No. 217-01738)	Apr-14
Reference Probe ES3DV2	SN: 3013	28-Dec-12 (No. ES3-3013_Dec12)	Dec-13
DAE4	SN: 660	13-Dec-13 (No. DAE4-660_Dec13)	Dec-14
Secondary Standards	ID	Check Date (in house)	Scheduled Check
RF generator HP 8648C	US3642U01700	4-Aug-99 (in house check Apr-13)	In house check: Apr-15
Network Analyzer HP 8753E	US37390585	18-Oct-01 (in house check Oct-13)	In house check: Oct-14

	Name	Function	Signature
Calibrated by:	Leif Klysner	Laboratory Technician	<i>Leif Klysner</i>
Approved by:	Katja Pokovic	Technical Manager	<i>Katja Pokovic</i>

Issued: December 19, 2013

This calibration certificate shall not be reproduced except in full without written approval of the laboratory.



Accredited by the Swiss Accreditation Service (SAS)

Accreditation No.: **SCS 108**

The Swiss Accreditation Service is one of the signatories to the EA  
Multilateral Agreement for the recognition of calibration certificates

### Glossary:

TSL	tissue simulating liquid
NORM <sub>x,y,z</sub>	sensitivity in free space
ConvF	sensitivity in TSL / NORM <sub>x,y,z</sub>
DCP	diode compression point
CF	crest factor (1/duty_cycle) of the RF signal
A, B, C, D	modulation dependent linearization parameters
Polarization $\varphi$	$\varphi$ rotation around probe axis
Polarization $\vartheta$	$\vartheta$ rotation around an axis that is in the plane normal to probe axis (at measurement center), i.e., $\vartheta = 0$ is normal to probe axis
Connector Angle	information used in DASY system to align probe sensor X to the robot coordinate system

### Calibration is Performed According to the Following Standards:

- IEEE Std 1528-2013, "IEEE Recommended Practice for Determining the Peak Spatial-Averaged Specific Absorption Rate (SAR) in the Human Head from Wireless Communications Devices: Measurement Techniques", June 2013
- IEC 62209-1, "Procedure to measure the Specific Absorption Rate (SAR) for hand-held devices used in close proximity to the ear (frequency range of 300 MHz to 3 GHz)", February 2005

### Methods Applied and Interpretation of Parameters:

- NORM<sub>x,y,z</sub>**: Assessed for E-field polarization  $\vartheta = 0$  ( $f \leq 900$  MHz in TEM-cell;  $f > 1800$  MHz: R22 waveguide). NORM<sub>x,y,z</sub> are only intermediate values, i.e., the uncertainties of NORM<sub>x,y,z</sub> does not affect the E<sup>2</sup>-field uncertainty inside TSL (see below ConvF).
- NORM(f)<sub>x,y,z</sub>** = NORM<sub>x,y,z</sub> \* frequency\_response (see Frequency Response Chart). This linearization is implemented in DASY4 software versions later than 4.2. The uncertainty of the frequency response is included in the stated uncertainty of ConvF.
- DCP<sub>x,y,z</sub>**: DCP are numerical linearization parameters assessed based on the data of power sweep with CW signal (no uncertainty required). DCP does not depend on frequency nor media.
- PAR**: PAR is the Peak to Average Ratio that is not calibrated but determined based on the signal characteristics
- A<sub>x,y,z</sub>; B<sub>x,y,z</sub>; C<sub>x,y,z</sub>; D<sub>x,y,z</sub>; VR<sub>x,y,z</sub>; A, B, C, D** are numerical linearization parameters assessed based on the data of power sweep for specific modulation signal. The parameters do not depend on frequency nor media. VR is the maximum calibration range expressed in RMS voltage across the diode.
- ConvF and Boundary Effect Parameters**: Assessed in flat phantom using E-field (or Temperature Transfer Standard for  $f \leq 800$  MHz) and inside waveguide using analytical field distributions based on power measurements for  $f > 800$  MHz. The same setups are used for assessment of the parameters applied for boundary compensation (alpha, depth) of which typical uncertainty values are given. These parameters are used in DASY4 software to improve probe accuracy close to the boundary. The sensitivity in TSL corresponds to NORM<sub>x,y,z</sub> \* ConvF whereby the uncertainty corresponds to that given for ConvF. A frequency dependent ConvF is used in DASY version 4.4 and higher which allows extending the validity from  $\pm 50$  MHz to  $\pm 100$  MHz.
- Spherical isotropy (3D deviation from isotropy)**: in a field of low gradients realized using a flat phantom exposed by a patch antenna.
- Sensor Offset**: The sensor offset corresponds to the offset of virtual measurement center from the probe tip (on probe axis). No tolerance required.
- Connector Angle**: The angle is assessed using the information gained by determining the NORM<sub>x</sub> (no uncertainty required).

# Probe EX3DV4

## SN:3920

Manufactured: December 18, 2012  
Calibrated: December 18, 2013

Calibrated for DASY/EASY Systems  
(Note: non-compatible with DASY2 system!)

## DASY/EASY - Parameters of Probe: EX3DV4 - SN:3920

### Basic Calibration Parameters

	Sensor X	Sensor Y	Sensor Z	Unc (k=2)
Norm ( $\mu\text{V}/(\text{V}/\text{m})^2$ ) <sup>A</sup>	0.34	0.50	0.49	$\pm 10.1\%$
DCP (mV) <sup>B</sup>	102.9	99.5	98.3	

### Modulation Calibration Parameters

UID	Communication System Name		A dB	B dB $\sqrt{\mu\text{V}}$	C	D dB	VR mV	Unc <sup>E</sup> (k=2)
0	CW	X	0.0	0.0	1.0	0.00	182.5	$\pm 2.7\%$
		Y	0.0	0.0	1.0		164.9	
		Z	0.0	0.0	1.0		153.0	
10010- CAA	SAR Validation (Square, 100ms, 10ms)	X	0.76	53.8	6.5	10.00	44.1	$\pm 2.2\%$
		Y	2.33	62.8	11.4		43.7	
		Z	1.15	55.6	7.5		53.0	
10011- CAA	UMTS-FDD (WCDMA)	X	3.36	66.5	17.5	2.91	142.4	$\pm 0.5\%$
		Y	3.15	65.0	16.7		131.4	
		Z	3.26	66.0	17.7		121.6	
10012- CAA	IEEE 802.11b WiFi 2.4 GHz (DSSS, 1 Mbps)	X	2.69	66.4	16.9	1.87	138.1	$\pm 0.5\%$
		Y	2.56	65.1	16.2		130.7	
		Z	2.72	66.6	17.2		121.4	
10021- DAA	GSM-FDD (TDMA, GMSK)	X	2.06	63.4	11.7	9.39	99.7	$\pm 1.9\%$
		Y	2.43	66.1	14.1		94.7	
		Z	2.90	69.9	16.1		121.8	
10023- DAA	GPRS-FDD (TDMA, GMSK, TN 0)	X	1.94	62.4	11.3	9.57	95.1	$\pm 1.9\%$
		Y	2.31	64.8	13.1		90.1	
		Z	2.98	70.4	16.4		117.0	
10024- DAA	GPRS-FDD (TDMA, GMSK, TN 0-1)	X	2.19	67.1	12.2	6.56	140.1	$\pm 1.4\%$
		Y	2.35	67.0	12.9		134.0	
		Z	3.45	73.5	16.1		131.4	
10027- DAA	GPRS-FDD (TDMA, GMSK, TN 0-1-2)	X	1.18	61.7	8.5	4.80	121.6	$\pm 1.2\%$
		Y	1.57	63.4	10.0		116.0	
		Z	1.57	65.5	11.9		109.2	
10028- DAA	GPRS-FDD (TDMA, GMSK, TN 0-1-2-3)	X	3.80	74.5	13.3	3.55	130.3	$\pm 0.9\%$
		Y	1.00	60.5	8.0		123.9	
		Z	1.58	66.1	11.1		119.0	
10032- CAA	IEEE 802.15.1 Bluetooth (GFSK, DH5)	X	0.18	55.2	3.4	1.16	111.6	$\pm 0.7\%$
		Y	0.34	57.4	4.4		143.6	
		Z	0.40	59.2	5.7		136.6	
10039- CAA	CDMA2000 (1xRTT, RC1)	X	4.49	65.9	18.1	4.57	131.8	$\pm 0.9\%$
		Y	4.57	65.1	17.5		123.0	
		Z	4.66	65.9	18.3		118.6	
10062- CAA	IEEE 802.11a/h WiFi 5 GHz (OFDM, 6 Mbps)	X	10.09	68.6	21.3	8.68	126.5	$\pm 2.5\%$
		Y	10.31	68.5	21.1		121.9	
		Z	10.12	68.3	21.3		115.8	

10098-CAA	UMTS-FDD (HSUPA, Subtest 2)	X	4.64	66.6	18.1	3.98	144.6	±0.7 %
		Y	4.54	65.4	17.4		133.9	
		Z	4.60	66.1	18.0		128.0	
10100-CAB	LTE-FDD (SC-FDMA, 100% RB, 20 MHz, QPSK)	X	6.00	65.5	18.3	5.67	104.2	±1.4 %
		Y	6.44	66.7	18.8		138.2	
		Z	6.54	67.4	19.4		134.7	
10108-CAB	LTE-FDD (SC-FDMA, 100% RB, 10 MHz, QPSK)	X	6.37	67.0	19.2	5.80	149.0	±1.4 %
		Y	6.40	66.6	18.9		141.2	
		Z	6.40	66.9	19.4		132.1	
10110-CAB	LTE-FDD (SC-FDMA, 100% RB, 5 MHz, QPSK)	X	5.96	66.3	18.9	5.75	142.3	±1.4 %
		Y	6.05	66.1	18.7		136.6	
		Z	6.03	66.3	19.1		128.2	
10114-CAA	IEEE 802.11n (HT Greenfield, 13.5 Mbps, BPSK)	X	10.28	68.7	20.9	8.10	137.3	±2.5 %
		Y	10.32	68.5	20.7		131.3	
		Z	10.24	68.5	20.9		124.5	
10117-CAA	IEEE 802.11n (HT Mixed, 13.5 Mbps, BPSK)	X	10.29	68.8	20.9	8.07	138.5	±2.5 %
		Y	10.34	68.6	20.8		131.9	
		Z	10.26	68.5	20.9		125.5	
10151-CAB	LTE-TDD (SC-FDMA, 50% RB, 20 MHz, QPSK)	X	7.20	67.5	21.6	9.28	118.6	±2.2 %
		Y	7.59	67.9	21.6		116.7	
		Z	7.78	69.2	22.7		110.7	
10154-CAB	LTE-FDD (SC-FDMA, 50% RB, 10 MHz, QPSK)	X	5.98	66.4	18.9	5.75	142.7	±1.2 %
		Y	5.97	65.7	18.4		132.7	
		Z	6.06	66.4	19.1		128.6	
10160-CAB	LTE-FDD (SC-FDMA, 50% RB, 15 MHz, QPSK)	X	6.41	66.8	19.1	5.82	147.7	±1.4 %
		Y	6.48	66.5	18.8		137.3	
		Z	6.53	67.0	19.4		134.9	
10169-CAB	LTE-FDD (SC-FDMA, 1 RB, 20 MHz, QPSK)	X	4.59	65.5	18.6	5.73	120.3	±1.2 %
		Y	4.76	65.0	18.2		113.9	
		Z	4.82	65.6	18.9		112.0	
10172-CAB	LTE-TDD (SC-FDMA, 1 RB, 20 MHz, QPSK)	X	5.77	69.3	22.7	9.21	128.1	±1.9 %
		Y	6.15	69.3	22.6		123.8	
		Z	6.22	70.3	23.6		120.8	
10175-CAB	LTE-FDD (SC-FDMA, 1 RB, 10 MHz, QPSK)	X	4.62	65.6	18.7	5.72	120.2	±0.9 %
		Y	4.75	65.0	18.2		113.5	
		Z	4.80	65.6	18.8		110.7	
10181-CAB	LTE-FDD (SC-FDMA, 1 RB, 15 MHz, QPSK)	X	4.57	65.4	18.6	5.72	118.9	±0.9 %
		Y	4.72	64.8	18.1		113.1	
		Z	4.81	65.6	18.8		110.4	
10193-CAA	IEEE 802.11n (HT Greenfield, 6.5 Mbps, BPSK)	X	9.77	68.3	20.8	8.09	128.1	±2.5 %
		Y	9.84	67.9	20.5		117.1	
		Z	9.80	68.1	20.8		116.6	
10196-CAA	IEEE 802.11n (HT Mixed, 6.5 Mbps, BPSK)	X	9.78	68.4	20.8	8.10	128.4	±2.5 %
		Y	9.86	68.0	20.5		120.3	
		Z	9.82	68.1	20.9		119.1	

10219-CAA	IEEE 802.11n (HT Mixed, 7.2 Mbps, BPSK)	X	9.70	68.4	20.8	8.03	128.0	±2.5 %
		Y	9.79	68.0	20.5		119.6	
		Z	9.72	68.1	20.8		118.7	
10222-CAA	IEEE 802.11n (HT Mixed, 15 Mbps, BPSK)	X	10.27	68.8	20.9	8.06	137.0	±2.5 %
		Y	10.18	68.3	20.6		125.2	
		Z	10.20	68.5	20.9		124.8	
10225-CAA	UMTS-FDD (HSPA+)	X	6.64	66.1	18.7	5.97	108.8	±1.4 %
		Y	7.23	67.1	19.1		148.9	
		Z	7.31	67.7	19.7		146.5	
10237-CAB	LTE-TDD (SC-FDMA, 1 RB, 10 MHz, QPSK)	X	5.82	69.6	23.0	9.21	130.2	±1.9 %
		Y	6.14	69.2	22.6		123.9	
		Z	6.25	70.4	23.7		122.2	
10252-CAB	LTE-TDD (SC-FDMA, 50% RB, 10 MHz, QPSK)	X	6.85	67.5	21.7	9.24	112.9	±2.2 %
		Y	7.54	69.0	22.4		149.2	
		Z	7.80	70.6	23.7		147.3	
10267-CAB	LTE-TDD (SC-FDMA, 100% RB, 10 MHz, QPSK)	X	7.23	67.6	21.6	9.30	118.3	±2.2 %
		Y	7.55	67.7	21.5		111.5	
		Z	7.79	69.2	22.7		109.6	
10274-CAA	UMTS-FDD (HSUPA, Subtest 5, 3GPP Rel8.10)	X	5.64	65.9	18.1	4.87	105.5	±1.2 %
		Y	6.04	66.4	18.2		142.6	
		Z	6.09	66.9	18.7		138.4	
10275-CAA	UMTS-FDD (HSUPA, Subtest 5, 3GPP Rel8.4)	X	4.42	66.3	18.1	3.96	135.8	±0.7 %
		Y	4.26	65.0	17.3		119.3	
		Z	4.40	65.9	18.0		120.4	
10291-AAA	CDMA2000, RC3, SO55, Full Rate	X	3.62	66.7	18.1	3.46	123.6	±0.7 %
		Y	3.38	64.3	16.7		112.5	
		Z	3.59	66.0	17.9		114.3	
10292-AAA	CDMA2000, RC3, SO32, Full Rate	X	3.46	66.0	17.7	3.39	127.3	±0.5 %
		Y	3.35	64.5	16.8		113.7	
		Z	3.50	65.7	17.7		115.4	
10297-AAA	LTE-FDD (SC-FDMA, 50% RB, 20 MHz, QPSK)	X	6.35	66.9	19.2	5.81	145.7	±1.2 %
		Y	6.26	66.1	18.7		129.2	
		Z	6.42	67.0	19.4		131.3	
10311-AAA	LTE-FDD (SC-FDMA, 100% RB, 15 MHz, QPSK)	X	6.45	65.9	18.7	6.06	103.7	±1.7 %
		Y	6.90	66.9	19.1		137.2	
		Z	7.04	67.7	19.8		137.5	
10315-AAA	IEEE 802.11b WiFi 2.4 GHz (DSSS, 1 Mbps, 96pc duty cycle)	X	2.85	67.8	17.7	1.71	135.6	±0.5 %
		Y	2.45	64.7	16.0		121.4	
		Z	2.75	67.3	17.6		122.1	
10317-AAA	IEEE 802.11a WiFi 5 GHz (OFDM, 6 Mbps, 96pc duty cycle)	X	9.93	68.5	21.0	8.36	128.1	±2.7 %
		Y	10.02	68.1	20.7		117.9	
		Z	10.01	68.3	21.1		119.4	
10400-AAA	IEEE 802.11ac WiFi (20MHz, 64-QAM, 99pc duty cycle)	X	10.09	68.8	21.2	8.37	134.9	±2.5 %
		Y	10.16	68.3	20.8		119.8	
		Z	10.14	68.5	21.2		121.0	

10402-AAA	IEEE 802.11ac WiFi (80MHz, 64-QAM, 99pc duty cycle)	X	11.18	69.8	21.5	8.53	147.1	±2.7 %
		Y	10.79	68.6	20.8		126.5	
		Z	11.17	69.6	21.6		131.4	
10403-AAA	CDMA2000 (1xEV-DO, Rev. 0)	X	4.83	69.6	18.9	3.76	139.6	±0.5 %
		Y	4.70	67.1	17.6		128.1	
		Z	4.90	68.4	18.6		127.8	
10404-AAA	CDMA2000 (1xEV-DO, Rev. A)	X	4.73	69.5	18.9	3.77	134.8	±0.5 %
		Y	4.62	67.1	17.7		124.9	
		Z	4.67	67.7	18.1		125.9	

The reported uncertainty of measurement is stated as the standard uncertainty of measurement multiplied by the coverage factor  $k=2$ , which for a normal distribution corresponds to a coverage probability of approximately 95%.

<sup>A</sup> The uncertainties of NormX,Y,Z do not affect the  $E^2$ -field uncertainty inside TSL (see Pages 8 and 9).

<sup>B</sup> Numerical linearization parameter: uncertainty not required.

<sup>E</sup> Uncertainty is determined using the max. deviation from linear response applying rectangular distribution and is expressed for the square of the field value.

## DASY/EASY - Parameters of Probe: EX3DV4 - SN:3920

### Calibration Parameter Determined in Head Tissue Simulating Media

f (MHz) <sup>C</sup>	Relative Permittivity <sup>F</sup>	Conductivity (S/m) <sup>F</sup>	ConvF X	ConvF Y	ConvF Z	Alpha <sup>G</sup>	Depth <sup>G</sup> (mm)	Unct. (k=2)
750	41.9	0.89	10.05	10.05	10.05	0.27	1.13	± 12.0 %
835	41.5	0.90	9.69	9.69	9.69	0.50	0.76	± 12.0 %
1750	40.1	1.37	7.91	7.91	7.91	0.72	0.62	± 12.0 %
1900	40.0	1.40	7.70	7.70	7.70	0.77	0.61	± 12.0 %
2450	39.2	1.80	6.98	6.98	6.98	0.37	0.86	± 12.0 %
2600	39.0	1.96	6.74	6.74	6.74	0.34	0.97	± 12.0 %
5200	36.0	4.66	4.87	4.87	4.87	0.40	1.80	± 13.1 %
5300	35.9	4.76	4.66	4.66	4.66	0.40	1.80	± 13.1 %
5500	35.6	4.96	4.54	4.54	4.54	0.40	1.80	± 13.1 %
5600	35.5	5.07	4.37	4.37	4.37	0.40	1.80	± 13.1 %
5800	35.3	5.27	4.11	4.11	4.11	0.50	1.80	± 13.1 %

<sup>C</sup> Frequency validity of ± 100 MHz only applies for DASY v4.4 and higher (see Page 2), else it is restricted to ± 50 MHz. The uncertainty is the RSS of the ConvF uncertainty at calibration frequency and the uncertainty for the indicated frequency band.

<sup>F</sup> At frequencies below 3 GHz, the validity of tissue parameters ( $\epsilon$  and  $\sigma$ ) can be relaxed to ± 10% if liquid compensation formula is applied to measured SAR values. At frequencies above 3 GHz, the validity of tissue parameters ( $\epsilon$  and  $\sigma$ ) is restricted to ± 5%. The uncertainty is the RSS of the ConvF uncertainty for indicated target tissue parameters.

<sup>G</sup> Alpha/Depth are determined during calibration. SPEAG warrants that the remaining deviation due to the boundary effect after compensation is always less than ± 1% for frequencies below 3 GHz and below ± 2% for frequencies between 3-6 GHz at any distance larger than half the probe tip diameter from the boundary.

## DASY/EASY - Parameters of Probe: EX3DV4 - SN:3920

### Calibration Parameter Determined in Body Tissue Simulating Media

f (MHz) <sup>C</sup>	Relative Permittivity <sup>F</sup>	Conductivity (S/m) <sup>F</sup>	ConvF X	ConvF Y	ConvF Z	Alpha <sup>G</sup>	Depth <sup>G</sup> (mm)	Unct. (k=2)
750	55.5	0.96	9.54	9.54	9.54	0.32	1.07	± 12.0 %
835	55.2	0.97	9.47	9.47	9.47	0.45	0.85	± 12.0 %
1750	53.4	1.49	7.77	7.77	7.77	0.59	0.74	± 12.0 %
1900	53.3	1.52	7.50	7.50	7.50	0.37	0.91	± 12.0 %
2450	52.7	1.95	7.18	7.18	7.18	0.80	0.56	± 12.0 %
2600	52.5	2.16	6.91	6.91	6.91	0.80	0.57	± 12.0 %
5200	49.0	5.30	4.23	4.23	4.23	0.50	1.90	± 13.1 %
5300	48.9	5.42	4.11	4.11	4.11	0.50	1.90	± 13.1 %
5500	48.6	5.65	3.80	3.80	3.80	0.50	1.90	± 13.1 %
5600	48.5	5.77	3.62	3.62	3.62	0.50	1.90	± 13.1 %
5800	48.2	6.00	4.00	4.00	4.00	0.50	1.90	± 13.1 %

<sup>C</sup> Frequency validity of ± 100 MHz only applies for DASY v4.4 and higher (see Page 2), else it is restricted to ± 50 MHz. The uncertainty is the RSS of the ConvF uncertainty at calibration frequency and the uncertainty for the indicated frequency band.

<sup>F</sup> At frequencies below 3 GHz, the validity of tissue parameters ( $\epsilon$  and  $\sigma$ ) can be relaxed to ± 10% if liquid compensation formula is applied to measured SAR values. At frequencies above 3 GHz, the validity of tissue parameters ( $\epsilon$  and  $\sigma$ ) is restricted to ± 5%. The uncertainty is the RSS of the ConvF uncertainty for indicated target tissue parameters.

<sup>G</sup> Alpha/Depth are determined during calibration. SPEAG warrants that the remaining deviation due to the boundary effect after compensation is always less than ± 1% for frequencies below 3 GHz and below ± 2% for frequencies between 3-6 GHz at any distance larger than half the probe tip diameter from the boundary.

### Frequency Response of E-Field (TEM-Cell:ifi110 EXX, Waveguide: R22)

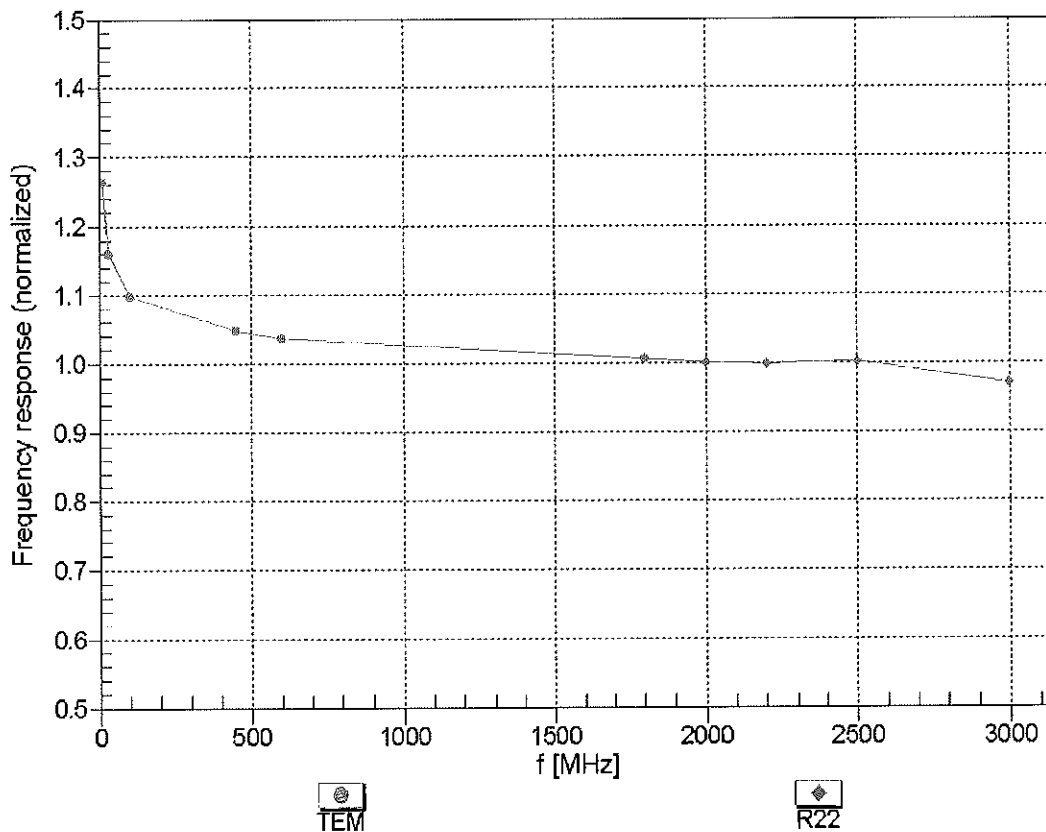

Uncertainty of Frequency Response of E-field:  $\pm 6.3\%$  (k=2)

### Receiving Pattern ( $\phi$ ), $\vartheta = 0^\circ$

f=600 MHz,TEM

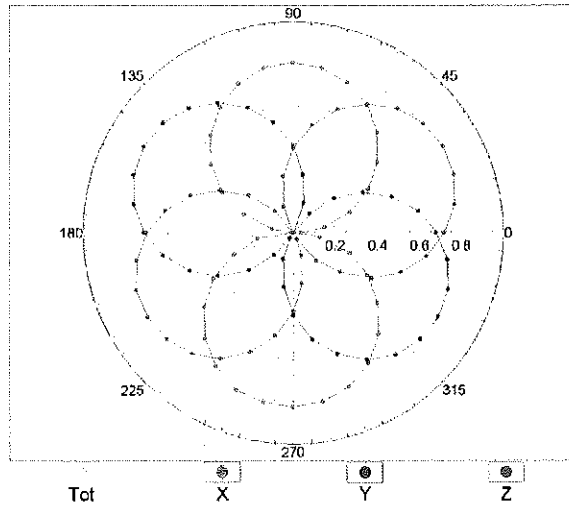

f=1800 MHz,R22

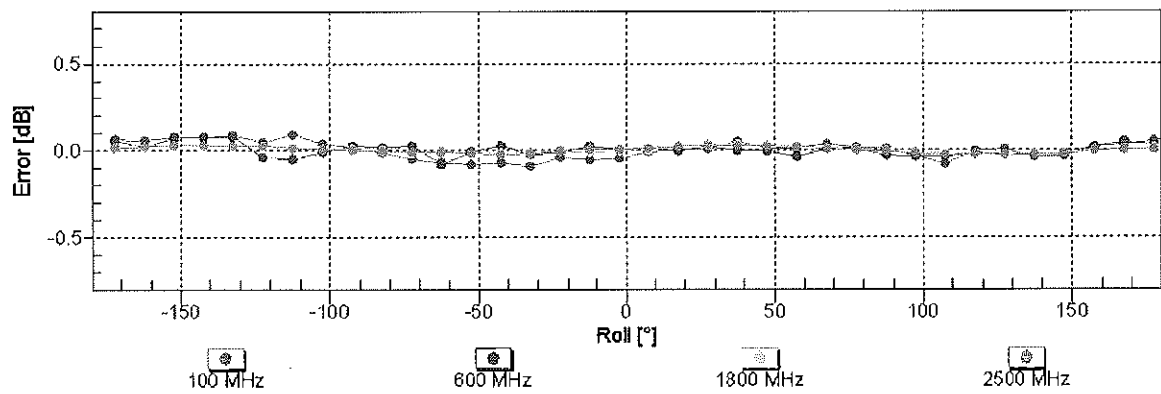
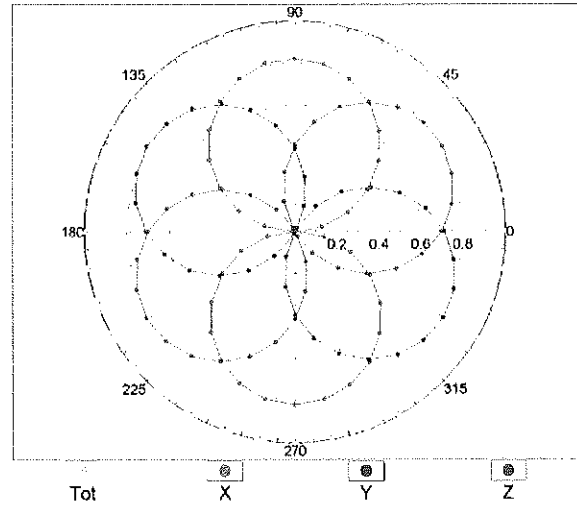

Uncertainty of Axial Isotropy Assessment:  $\pm 0.5\%$  (k=2)

### Dynamic Range f(SAR<sub>head</sub>) (TEM cell , f = 900 MHz)

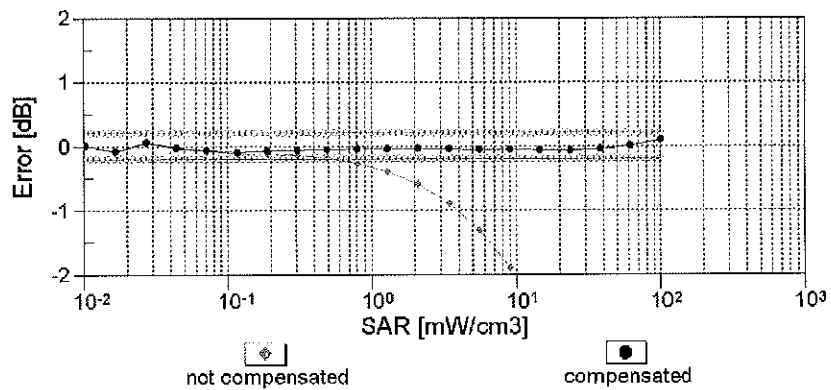
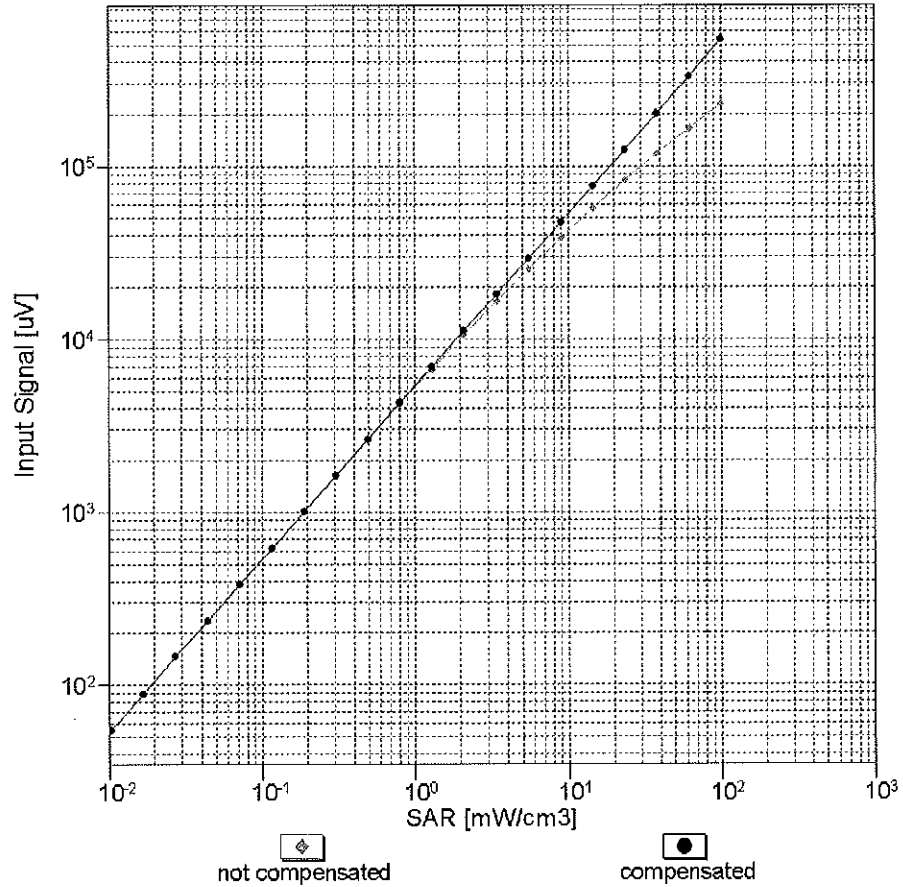

Uncertainty of Linearity Assessment: ± 0.6% (k=2)

## Conversion Factor Assessment

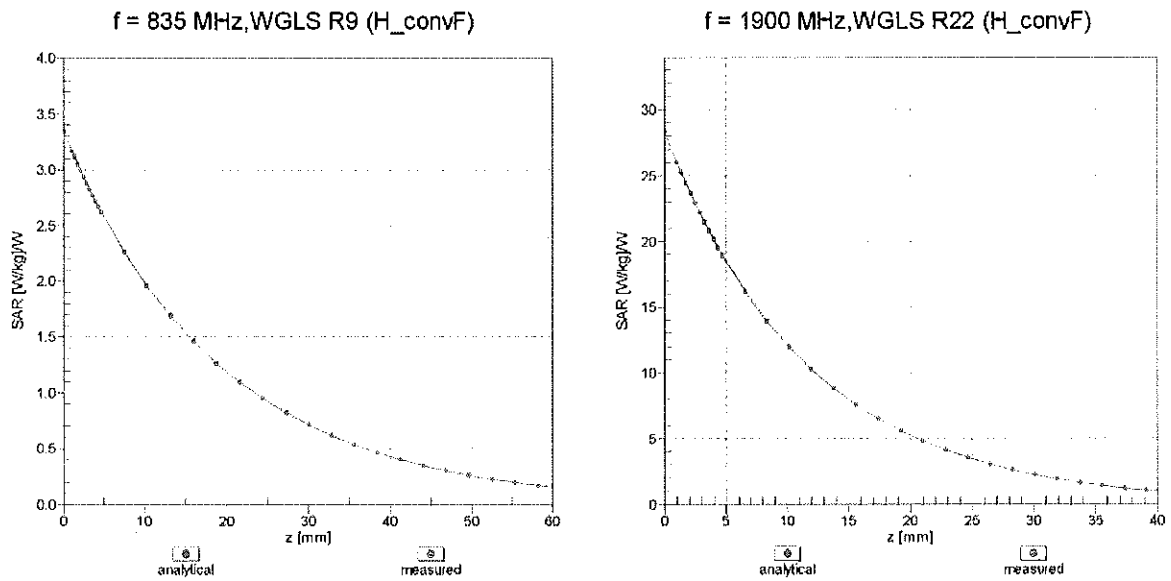

## Deviation from Isotropy in Liquid

Error ( $\phi, \theta$ ), f = 900 MHz

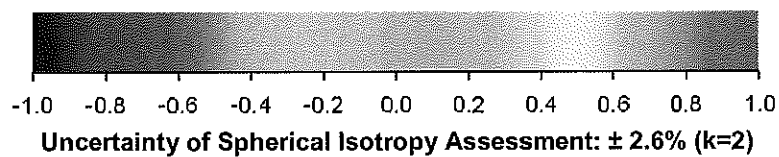
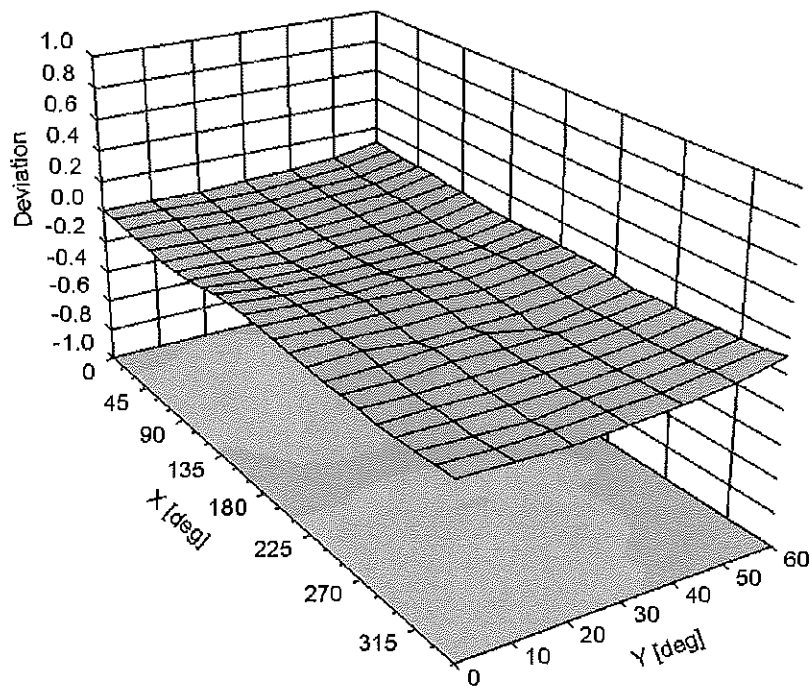

## DASY/EASY - Parameters of Probe: EX3DV4 - SN:3920

### Other Probe Parameters

Sensor Arrangement	Triangular
Connector Angle (°)	-22.4
Mechanical Surface Detection Mode	enabled
Optical Surface Detection Mode	disabled
Probe Overall Length	337 mm
Probe Body Diameter	10 mm
Tip Length	9 mm
Tip Diameter	2.5 mm
Probe Tip to Sensor X Calibration Point	1 mm
Probe Tip to Sensor Y Calibration Point	1 mm
Probe Tip to Sensor Z Calibration Point	1 mm
Recommended Measurement Distance from Surface	2 mm



Accredited by the Swiss Accreditation Service (SAS)  
The Swiss Accreditation Service is one of the signatories to the EA  
Multilateral Agreement for the recognition of calibration certificates

Accreditation No.: **SCS 108**

Client **PC Test**

Certificate No: **ES3-3319\_Apr13**

## CALIBRATION CERTIFICATE

Object **ES3DV3 - SN:3319**

Calibration procedure(s) **QA CAL-01.v8, QA CAL-23.v4, QA CAL-25.v4  
Calibration procedure for dosimetric E-field probes**

Calibration date: **April 29, 2013**

VCC  
6/14/13

This calibration certificate documents the traceability to national standards, which realize the physical units of measurements (SI).  
The measurements and the uncertainties with confidence probability are given on the following pages and are part of the certificate.

All calibrations have been conducted in the closed laboratory facility: environment temperature (22 ± 3)°C and humidity < 70%.

Calibration Equipment used (M&TE critical for calibration)

Primary Standards	ID	Cal Date (Certificate No.)	Scheduled Calibration
Power meter E4419B	GB41293874	04-Apr-13 (No. 217-01733)	Apr-14
Power sensor E4412A	MY41498087	04-Apr-13 (No. 217-01733)	Apr-14
Reference 3 dB Attenuator	SN: S5054 (3c)	04-Apr-13 (No. 217-01737)	Apr-14
Reference 20 dB Attenuator	SN: S5277 (20x)	04-Apr-13 (No. 217-01735)	Apr-14
Reference 30 dB Attenuator	SN: S5129 (30b)	04-Apr-13 (No. 217-01738)	Apr-14
Reference Probe ES3DV2	SN: 3013	28-Dec-12 (No. ES3-3013_Dec12)	Dec-13
DAE4	SN: 660	31-Jan-13 (No. DAE4-660_Jan13)	Jan-14
Secondary Standards	ID	Check Date (in house)	Scheduled Check
RF generator HP 8648C	US3642U01700	4-Aug-99 (in house check Apr-13)	In house check: Apr-15
Network Analyzer HP 8753E	US37390585	18-Oct-01 (in house check Oct-12)	In house check: Oct-13

	Name	Function	Signature
Calibrated by:	Dimce Iliev	Laboratory Technician	
Approved by:	Katja Pokovic	Technical Manager	
			Issued: April 29, 2013

This calibration certificate shall not be reproduced except in full without written approval of the laboratory.



Accredited by the Swiss Accreditation Service (SAS)

Accreditation No.: **SCS 108**

The Swiss Accreditation Service is one of the signatories to the EA  
Multilateral Agreement for the recognition of calibration certificates

### Glossary:

TSL	tissue simulating liquid
NORM <sub>x,y,z</sub>	sensitivity in free space
ConvF	sensitivity in TSL / NORM <sub>x,y,z</sub>
DCP	diode compression point
CF	crest factor (1/duty_cycle) of the RF signal
A, B, C, D	modulation dependent linearization parameters
Polarization $\varphi$	$\varphi$ rotation around probe axis
Polarization $\vartheta$	$\vartheta$ rotation around an axis that is in the plane normal to probe axis (at measurement center), i.e., $\vartheta = 0$ is normal to probe axis

### Calibration is Performed According to the Following Standards:

- IEEE Std 1528-2003, "IEEE Recommended Practice for Determining the Peak Spatial-Averaged Specific Absorption Rate (SAR) in the Human Head from Wireless Communications Devices: Measurement Techniques", December 2003
- IEC 62209-1, "Procedure to measure the Specific Absorption Rate (SAR) for hand-held devices used in close proximity to the ear (frequency range of 300 MHz to 3 GHz)", February 2005

### Methods Applied and Interpretation of Parameters:

- NORM<sub>x,y,z</sub>**: Assessed for E-field polarization  $\vartheta = 0$  ( $f \leq 900$  MHz in TEM-cell;  $f > 1800$  MHz: R22 waveguide). NORM<sub>x,y,z</sub> are only intermediate values, i.e., the uncertainties of NORM<sub>x,y,z</sub> does not affect the E<sup>2</sup>-field uncertainty inside TSL (see below ConvF).
- NORM(f)<sub>x,y,z</sub>** = NORM<sub>x,y,z</sub> \* frequency\_response (see Frequency Response Chart). This linearization is implemented in DAS4 software versions later than 4.2. The uncertainty of the frequency response is included in the stated uncertainty of ConvF.
- DCP<sub>x,y,z</sub>**: DCP are numerical linearization parameters assessed based on the data of power sweep with CW signal (no uncertainty required). DCP does not depend on frequency nor media.
- PAR**: PAR is the Peak to Average Ratio that is not calibrated but determined based on the signal characteristics
- A<sub>x,y,z</sub>; B<sub>x,y,z</sub>; C<sub>x,y,z</sub>; D<sub>x,y,z</sub>; VR<sub>x,y,z</sub>; A, B, C, D** are numerical linearization parameters assessed based on the data of power sweep for specific modulation signal. The parameters do not depend on frequency nor media. VR is the maximum calibration range expressed in RMS voltage across the diode.
- ConvF and Boundary Effect Parameters**: Assessed in flat phantom using E-field (or Temperature Transfer Standard for  $f \leq 800$  MHz) and inside waveguide using analytical field distributions based on power measurements for  $f > 800$  MHz. The same setups are used for assessment of the parameters applied for boundary compensation (alpha, depth) of which typical uncertainty values are given. These parameters are used in DAS4 software to improve probe accuracy close to the boundary. The sensitivity in TSL corresponds to NORM<sub>x,y,z</sub> \* ConvF whereby the uncertainty corresponds to that given for ConvF. A frequency dependent ConvF is used in DAS4 version 4.4 and higher which allows extending the validity from  $\pm 50$  MHz to  $\pm 100$  MHz.
- Spherical isotropy (3D deviation from isotropy)**: in a field of low gradients realized using a flat phantom exposed by a patch antenna.
- Sensor Offset**: The sensor offset corresponds to the offset of virtual measurement center from the probe tip (on probe axis). No tolerance required.

# Probe ES3DV3

## SN:3319

Manufactured: January 10, 2012  
Calibrated: April 29, 2013

Calibrated for DASY/EASY Systems  
(Note: non-compatible with DASY2 system!)

## DASY/EASY - Parameters of Probe: ES3DV3 - SN:3319

### Basic Calibration Parameters

	Sensor X	Sensor Y	Sensor Z	Unc (k=2)
Norm ( $\mu\text{V}/(\text{V}/\text{m})^2$ ) <sup>A</sup>	1.12	1.20	1.22	$\pm 10.1 \%$
DCP (mV) <sup>B</sup>	100.7	102.6	102.4	

### Modulation Calibration Parameters

UID	Communication System Name		A dB	B dB $\sqrt{\mu\text{V}}$	C	D dB	VR mV	Unc <sup>E</sup> (k=2)
0	CW	X	0.0	0.0	1.0	0.00	152.0	$\pm 3.8 \%$
		Y	0.0	0.0	1.0		159.0	
		Z	0.0	0.0	1.0		149.8	

The reported uncertainty of measurement is stated as the standard uncertainty of measurement multiplied by the coverage factor  $k=2$ , which for a normal distribution corresponds to a coverage probability of approximately 95%.

<sup>A</sup> The uncertainties of NormX,Y,Z do not affect the  $E^2$ -field uncertainty inside TSL (see Pages 5 and 6).

<sup>B</sup> Numerical linearization parameter: uncertainty not required.

<sup>E</sup> Uncertainty is determined using the max. deviation from linear response applying rectangular distribution and is expressed for the square of the field value.

## DASY/EASY - Parameters of Probe: ES3DV3 - SN:3319

### Calibration Parameter Determined in Head Tissue Simulating Media

f (MHz) <sup>C</sup>	Relative Permittivity <sup>F</sup>	Conductivity (S/m) <sup>F</sup>	ConvF X	ConvF Y	ConvF Z	Alpha	Depth (mm)	Unct. (k=2)
750	41.9	0.89	6.49	6.49	6.49	0.28	1.97	± 12.0 %
850	41.5	0.92	6.23	6.23	6.23	0.42	1.57	± 12.0 %
1900	40.0	1.40	5.22	5.22	5.22	0.80	1.24	± 12.0 %
2450	39.2	1.80	4.57	4.57	4.57	0.80	1.32	± 12.0 %

<sup>C</sup> Frequency validity of ± 100 MHz only applies for DASY v4.4 and higher (see Page 2), else it is restricted to ± 50 MHz. The uncertainty is the RSS of the ConvF uncertainty at calibration frequency and the uncertainty for the indicated frequency band.

<sup>F</sup> At frequencies below 3 GHz, the validity of tissue parameters ( $\epsilon$  and  $\sigma$ ) can be relaxed to ± 10% if liquid compensation formula is applied to measured SAR values. At frequencies above 3 GHz, the validity of tissue parameters ( $\epsilon$  and  $\sigma$ ) is restricted to ± 5%. The uncertainty is the RSS of the ConvF uncertainty for indicated target tissue parameters.

## DASY/EASY - Parameters of Probe: ES3DV3 - SN:3319

### Calibration Parameter Determined in Body Tissue Simulating Media

f (MHz) <sup>C</sup>	Relative Permittivity <sup>F</sup>	Conductivity (S/m) <sup>F</sup>	ConvF X	ConvF Y	ConvF Z	Alpha	Depth (mm)	Unct. (k=2)
750	55.5	0.96	6.30	6.30	6.30	0.45	1.53	± 12.0 %
850	55.2	0.99	6.15	6.15	6.15	0.42	1.65	± 12.0 %
1900	53.3	1.52	4.85	4.85	4.85	0.63	1.49	± 12.0 %
2450	52.7	1.95	4.32	4.32	4.32	0.69	1.20	± 12.0 %

<sup>C</sup> Frequency validity of ± 100 MHz only applies for DASY v4.4 and higher (see Page 2), else it is restricted to ± 50 MHz. The uncertainty is the RSS of the ConvF uncertainty at calibration frequency and the uncertainty for the indicated frequency band.

<sup>F</sup> At frequencies below 3 GHz, the validity of tissue parameters ( $\epsilon$  and  $\sigma$ ) can be relaxed to ± 10% if liquid compensation formula is applied to measured SAR values. At frequencies above 3 GHz, the validity of tissue parameters ( $\epsilon$  and  $\sigma$ ) is restricted to ± 5%. The uncertainty is the RSS of the ConvF uncertainty for indicated target tissue parameters.

### Frequency Response of E-Field (TEM-Cell:ifi110 EXX, Waveguide: R22)

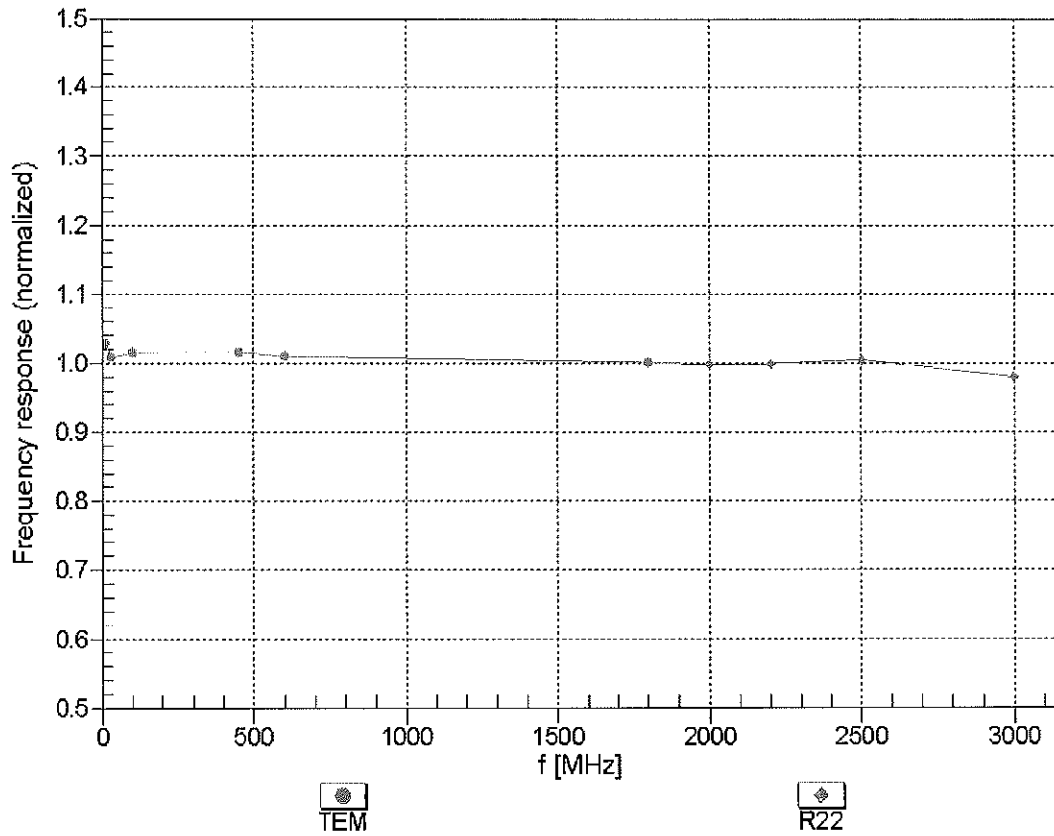

Uncertainty of Frequency Response of E-field:  $\pm 6.3\%$  (k=2)

### Receiving Pattern ( $\phi$ ), $\theta = 0^\circ$

f=600 MHz,TEM

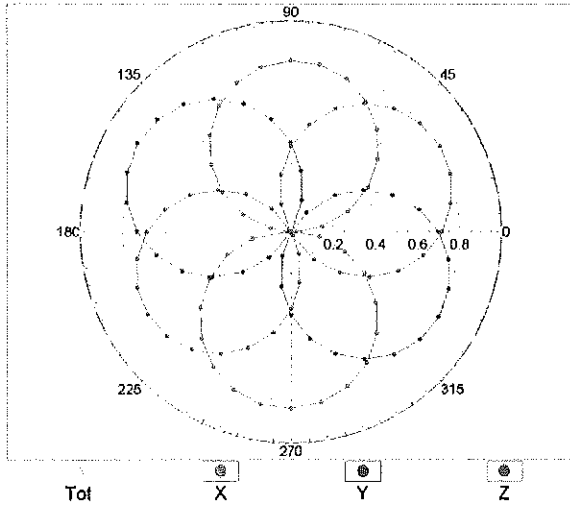

f=1800 MHz,R22

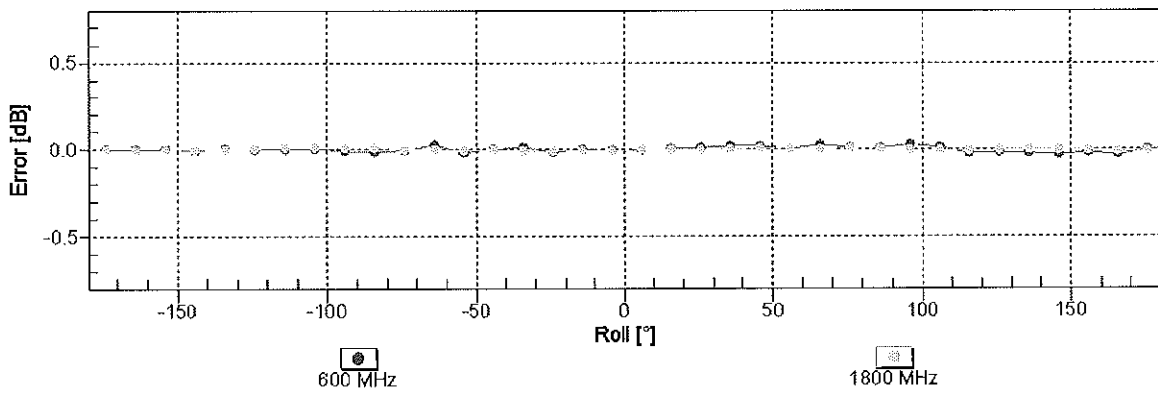
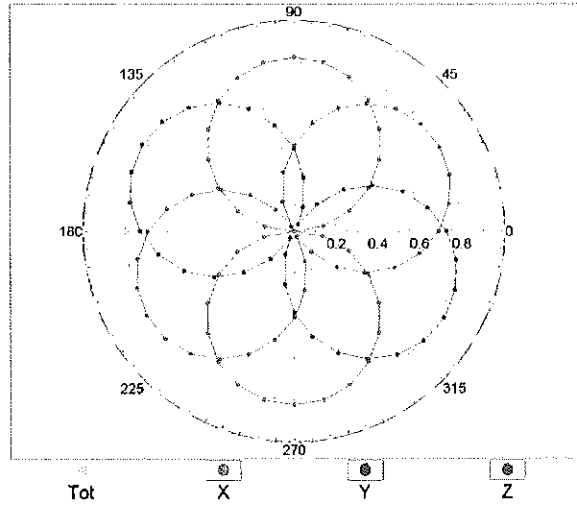

Uncertainty of Axial Isotropy Assessment:  $\pm 0.5\%$  (k=2)

### Dynamic Range $f(SAR_{head})$ (TEM cell , $f = 900$ MHz)

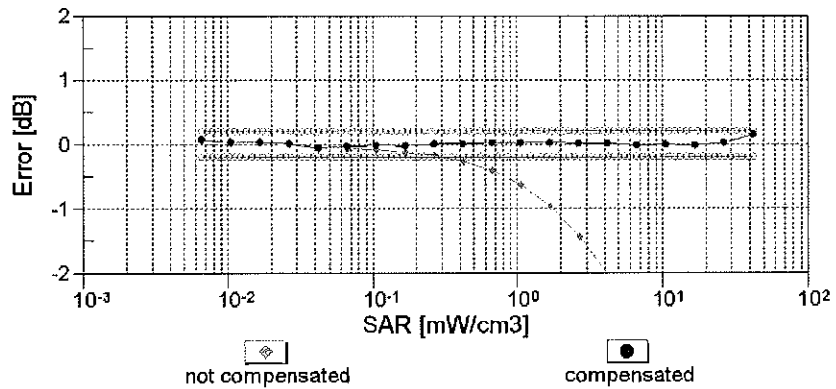
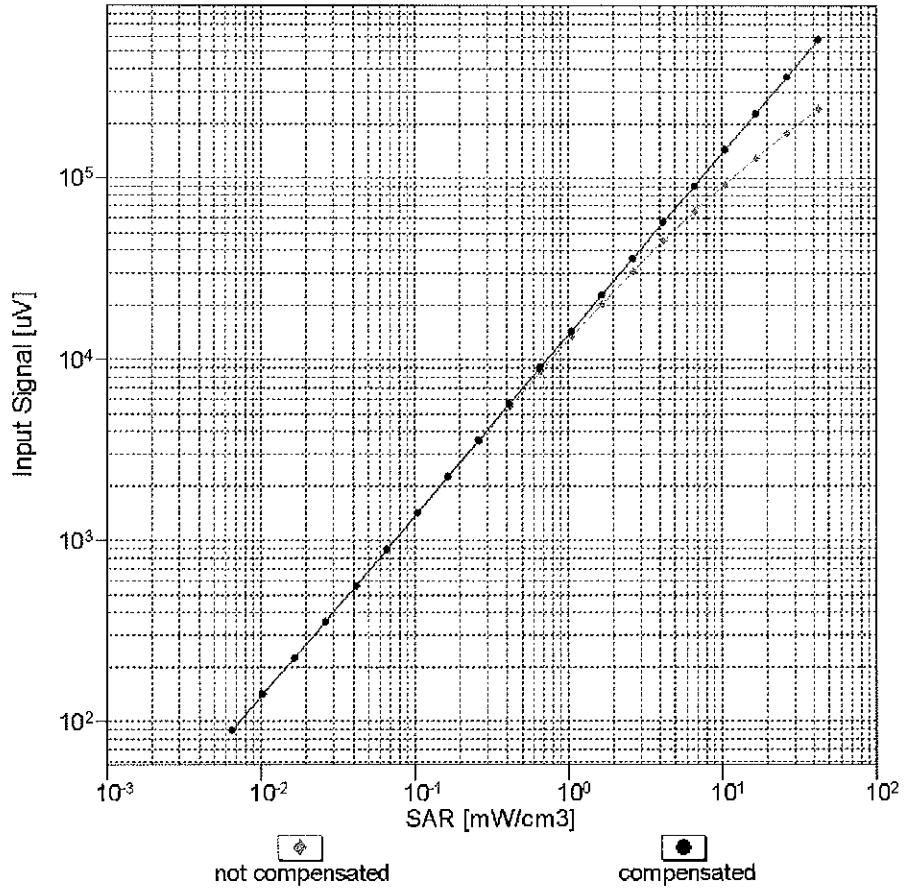

Uncertainty of Linearity Assessment:  $\pm 0.6\%$  ( $k=2$ )

# Conversion Factor Assessment

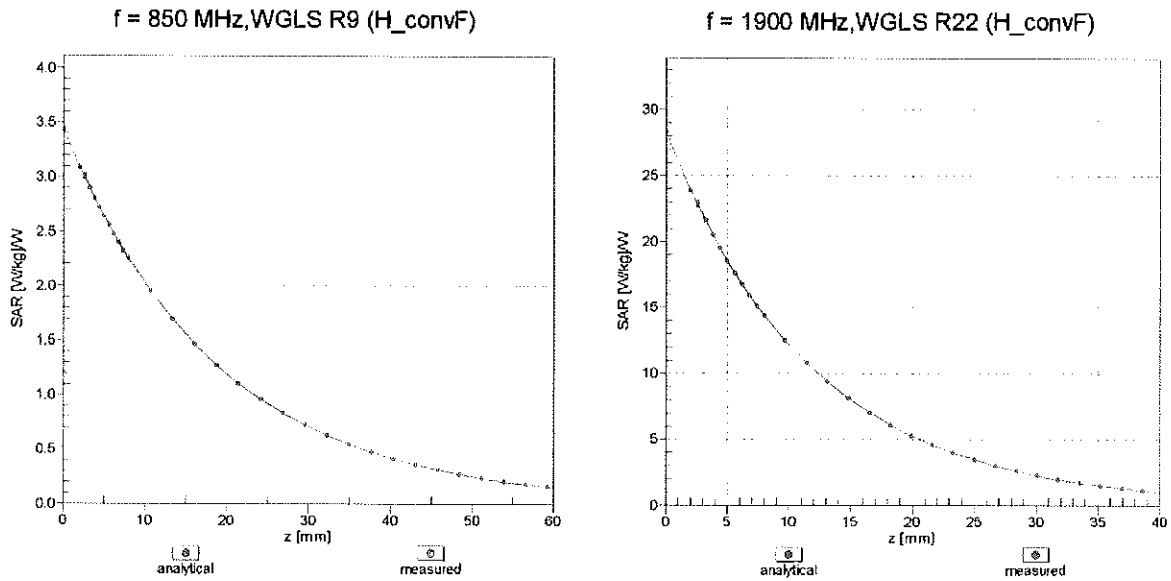

## Deviation from Isotropy in Liquid Error ( $\phi, \theta$ ), f = 900 MHz

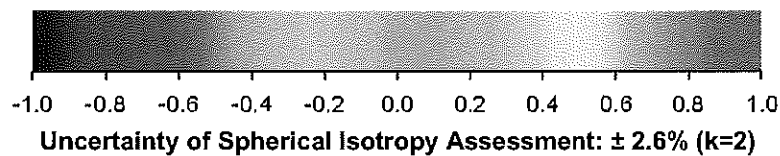
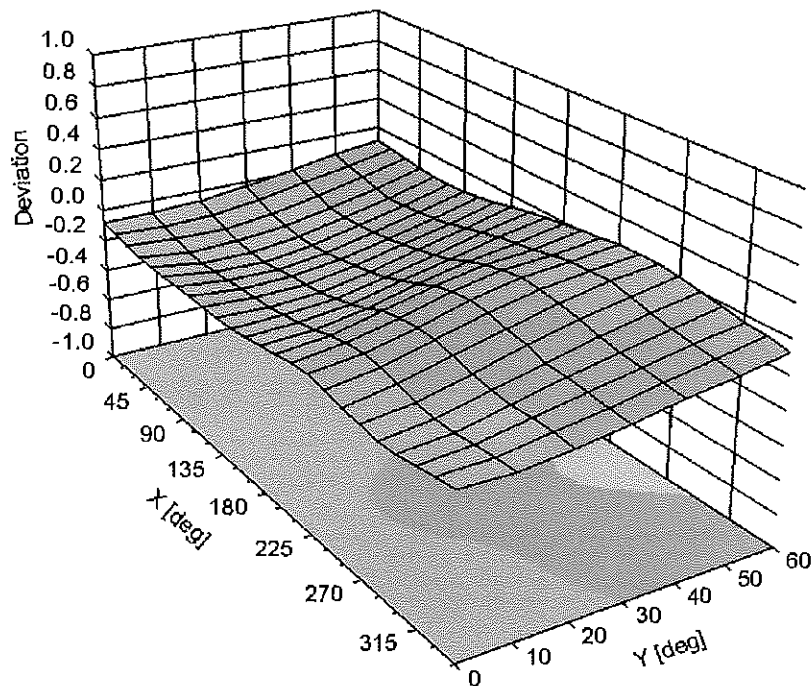

## DASY/EASY - Parameters of Probe: ES3DV3 - SN:3319

### Other Probe Parameters

Sensor Arrangement	Triangular
Connector Angle (°)	-104.1
Mechanical Surface Detection Mode	enabled
Optical Surface Detection Mode	disabled
Probe Overall Length	337 mm
Probe Body Diameter	10 mm
Tip Length	10 mm
Tip Diameter	4 mm
Probe Tip to Sensor X Calibration Point	2 mm
Probe Tip to Sensor Y Calibration Point	2 mm
Probe Tip to Sensor Z Calibration Point	2 mm
Recommended Measurement Distance from Surface	3 mm

## Additional Conversion Factors for Dosimetric E-Field Probe

Type:	<b>ES3DV3</b>
Serial Number:	<b>3319</b>
Place of Assessment:	<b>Zurich</b>
Date of Assessment:	<b>June 19, 2013</b>
Probe Calibration Date:	<b>April 29, 2013</b>

Schmid & Partner Engineering AG hereby certifies that conversion factor(s) of this probe have been evaluated on the date indicated above. The assessment was performed using the FDTD numerical code SEMCAD of Schmid & Partner Engineering AG. The evaluation is coupled with measured conversion factors (probe calibration date indicated above). The uncertainty of the numerical assessment is based on the extrapolation from measured value at 835 MHz or at 1900 MHz.

Assessed by:

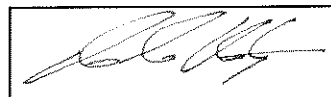

✓  
KOK  
6/25/13

## Dosimetric E-Field Probe ES3DV3 SN:3319

Conversion factor ( $\pm$  standard deviation)

1750  $\pm$  50 MHz      *ConvF*      5.59  $\pm$  7%

$\epsilon_r = 40.1 \pm 5\%$   
 $\sigma = 1.37 \pm 5\%$  mho/m  
 (head tissue)

1750  $\pm$  50 MHz      *ConvF*      5.22  $\pm$  7%

$\epsilon_r = 53.4 \pm 5\%$   
 $\sigma = 1.49 \pm 5\%$  mho/m  
 (body tissue)

### Important Note:

For numerically assessed probe conversion factors, parameters Alpha and Delta in the DASY software must have the following entries: Alpha = 0 and Delta = 1.

Please see also DASY Manual.



Accredited by the Swiss Accreditation Service (SAS)  
The Swiss Accreditation Service is one of the signatories to the EA  
Multilateral Agreement for the recognition of calibration certificates

Accreditation No.: **SCS 108**

Client **PC Test**

Certificate No: **ES3-3022\_Aug13**

**CALIBRATION CERTIFICATE**

Object **ES3DV2 - SN:3022**

Calibration procedure(s) **QA CAL-01.v9, QA CAL-23.v5, QA CAL-25.v6  
Calibration procedure for dosimetric E-field probes**

Calibration date: **August 22, 2013** *UTC*  
*9/13/13*

This calibration certificate documents the traceability to national standards, which realize the physical units of measurements (SI).  
The measurements and the uncertainties with confidence probability are given on the following pages and are part of the certificate.

All calibrations have been conducted in the closed laboratory facility: environment temperature (22 ± 3)°C and humidity < 70%.

Calibration Equipment used (M&TE critical for calibration)

Primary Standards	ID	Cal Date (Certificate No.)	Scheduled Calibration
Power meter E4419B	GB41293874	04-Apr-13 (No. 217-01733)	Apr-14
Power sensor E4412A	MY41498087	04-Apr-13 (No. 217-01733)	Apr-14
Reference 3 dB Attenuator	SN: S5054 (3c)	04-Apr-13 (No. 217-01737)	Apr-14
Reference 20 dB Attenuator	SN: S5277 (20x)	04-Apr-13 (No. 217-01735)	Apr-14
Reference 30 dB Attenuator	SN: S5129 (30b)	04-Apr-13 (No. 217-01738)	Apr-14
Reference Probe ES3DV2	SN: 3013	28-Dec-12 (No. ES3-3013_Dec12)	Dec-13
DAE4	SN: 660	31-Jan-13 (No. DAE4-660_Jan13)	Jan-14
Secondary Standards	ID	Check Date (in house)	Scheduled Check
RF generator HP 8648C	US3642U01700	4-Aug-99 (in house check Apr-13)	In house check: Apr-15
Network Analyzer HP 8753E	US37390585	18-Oct-01 (in house check Oct-12)	In house check: Oct-13

	Name	Function	Signature
Calibrated by:	Jeton Kastrati	Laboratory Technician	
Approved by:	Katja Pokovic	Technical Manager	

Issued: August 23, 2013

This calibration certificate shall not be reproduced except in full without written approval of the laboratory.



Accredited by the Swiss Accreditation Service (SAS)

Accreditation No.: **SCS 108**

The Swiss Accreditation Service is one of the signatories to the EA  
Multilateral Agreement for the recognition of calibration certificates

### Glossary:

TSL	tissue simulating liquid
NORM <sub>x,y,z</sub>	sensitivity in free space
ConvF	sensitivity in TSL / NORM <sub>x,y,z</sub>
DCP	diode compression point
CF	crest factor (1/duty_cycle) of the RF signal
A, B, C, D	modulation dependent linearization parameters
Polarization $\varphi$	$\varphi$ rotation around probe axis
Polarization $\vartheta$	$\vartheta$ rotation around an axis that is in the plane normal to probe axis (at measurement center), i.e., $\vartheta = 0$ is normal to probe axis

### Calibration is Performed According to the Following Standards:

- IEEE Std 1528-2003, "IEEE Recommended Practice for Determining the Peak Spatial-Averaged Specific Absorption Rate (SAR) in the Human Head from Wireless Communications Devices: Measurement Techniques", December 2003
- IEC 62209-1, "Procedure to measure the Specific Absorption Rate (SAR) for hand-held devices used in close proximity to the ear (frequency range of 300 MHz to 3 GHz)", February 2005

### Methods Applied and Interpretation of Parameters:

- NORM<sub>x,y,z</sub>**: Assessed for E-field polarization  $\vartheta = 0$  ( $f \leq 900$  MHz in TEM-cell;  $f > 1800$  MHz: R22 waveguide). NORM<sub>x,y,z</sub> are only intermediate values, i.e., the uncertainties of NORM<sub>x,y,z</sub> does not affect the E<sup>2</sup>-field uncertainty inside TSL (see below ConvF).
- NORM(f)<sub>x,y,z</sub>** = NORM<sub>x,y,z</sub> \* frequency\_response (see Frequency Response Chart). This linearization is implemented in DASY4 software versions later than 4.2. The uncertainty of the frequency response is included in the stated uncertainty of ConvF.
- DCP<sub>x,y,z</sub>**: DCP are numerical linearization parameters assessed based on the data of power sweep with CW signal (no uncertainty required). DCP does not depend on frequency nor media.
- PAR**: PAR is the Peak to Average Ratio that is not calibrated but determined based on the signal characteristics
- A<sub>x,y,z</sub>; B<sub>x,y,z</sub>; C<sub>x,y,z</sub>; D<sub>x,y,z</sub>; VR<sub>x,y,z</sub>**: A, B, C, D are numerical linearization parameters assessed based on the data of power sweep for specific modulation signal. The parameters do not depend on frequency nor media. VR is the maximum calibration range expressed in RMS voltage across the diode.
- ConvF and Boundary Effect Parameters**: Assessed in flat phantom using E-field (or Temperature Transfer Standard for  $f \leq 800$  MHz) and inside waveguide using analytical field distributions based on power measurements for  $f > 800$  MHz. The same setups are used for assessment of the parameters applied for boundary compensation (alpha, depth) of which typical uncertainty values are given. These parameters are used in DASY4 software to improve probe accuracy close to the boundary. The sensitivity in TSL corresponds to NORM<sub>x,y,z</sub> \* ConvF whereby the uncertainty corresponds to that given for ConvF. A frequency dependent ConvF is used in DASY version 4.4 and higher which allows extending the validity from  $\pm 50$  MHz to  $\pm 100$  MHz.
- Spherical isotropy (3D deviation from isotropy)**: in a field of low gradients realized using a flat phantom exposed by a patch antenna.
- Sensor Offset**: The sensor offset corresponds to the offset of virtual measurement center from the probe tip (on probe axis). No tolerance required.

# Probe ES3DV2

## SN:3022

Manufactured: April 15, 2003  
Calibrated: August 22, 2013

Calibrated for DASY/EASY Systems  
(Note: non-compatible with DASY2 system!)

## DASY/EASY - Parameters of Probe: ES3DV2 - SN:3022

### Basic Calibration Parameters

	Sensor X	Sensor Y	Sensor Z	Unc (k=2)
Norm ( $\mu\text{V}/(\text{V}/\text{m})^2$ ) <sup>A</sup>	1.00	1.04	0.99	± 10.1 %
DCP (mV) <sup>B</sup>	100.7	97.4	99.7	

### Modulation Calibration Parameters

UID	Communication System Name		A dB	B dB/μV	C	D dB	VR mV	Unc <sup>E</sup> (k=2)
0	CW	X	0.0	0.0	1.0	0.00	178.6	±3.0 %
		Y	0.0	0.0	1.0		141.9	
		Z	0.0	0.0	1.0		134.7	

The reported uncertainty of measurement is stated as the standard uncertainty of measurement multiplied by the coverage factor k=2, which for a normal distribution corresponds to a coverage probability of approximately 95%.

<sup>A</sup> The uncertainties of NormX,Y,Z do not affect the E<sup>2</sup>-field uncertainty inside TSL (see Pages 5 and 6).

<sup>B</sup> Numerical linearization parameter: uncertainty not required.

<sup>E</sup> Uncertainty is determined using the max. deviation from linear response applying rectangular distribution and is expressed for the square of the field value.

## DASY/EASY - Parameters of Probe: ES3DV2 - SN:3022

### Calibration Parameter Determined in Head Tissue Simulating Media

f (MHz) <sup>C</sup>	Relative Permittivity <sup>F</sup>	Conductivity (S/m) <sup>F</sup>	ConvF X	ConvF Y	ConvF Z	Alpha	Depth (mm)	Unct. (k=2)
750	41.9	0.89	6.21	6.21	6.21	0.19	2.37	± 12.0 %
835	41.5	0.90	6.09	6.09	6.09	0.30	1.70	± 12.0 %
1750	40.1	1.37	5.19	5.19	5.19	0.65	1.23	± 12.0 %
1900	40.0	1.40	5.03	5.03	5.03	0.51	1.43	± 12.0 %
2450	39.2	1.80	4.36	4.36	4.36	0.51	1.51	± 12.0 %
2600	39.0	1.96	4.16	4.16	4.16	0.74	1.29	± 12.0 %

<sup>C</sup> Frequency validity of ± 100 MHz only applies for DASY v4.4 and higher (see Page 2), else it is restricted to ± 50 MHz. The uncertainty is the RSS of the ConvF uncertainty at calibration frequency and the uncertainty for the indicated frequency band.

<sup>F</sup> At frequencies below 3 GHz, the validity of tissue parameters ( $\epsilon$  and  $\sigma$ ) can be relaxed to ± 10% if liquid compensation formula is applied to measured SAR values. At frequencies above 3 GHz, the validity of tissue parameters ( $\epsilon$  and  $\sigma$ ) is restricted to ± 5%. The uncertainty is the RSS of the ConvF uncertainty for indicated target tissue parameters.

## DASY/EASY - Parameters of Probe: ES3DV2 - SN:3022

### Calibration Parameter Determined in Body Tissue Simulating Media

f (MHz) <sup>C</sup>	Relative Permittivity <sup>F</sup>	Conductivity (S/m) <sup>F</sup>	ConvF X	ConvF Y	ConvF Z	Alpha	Depth (mm)	Unct. (k=2)
750	55.5	0.96	5.92	5.92	5.92	0.24	1.99	± 12.0 %
835	55.2	0.97	5.91	5.91	5.91	0.29	1.85	± 12.0 %
1750	53.4	1.49	4.75	4.75	4.75	0.52	1.52	± 12.0 %
1900	53.3	1.52	4.49	4.49	4.49	0.49	1.56	± 12.0 %
2450	52.7	1.95	4.01	4.01	4.01	0.70	1.02	± 12.0 %
2600	52.5	2.16	3.85	3.85	3.85	0.58	0.90	± 12.0 %

<sup>C</sup> Frequency validity of ± 100 MHz only applies for DASY v4.4 and higher (see Page 2), else it is restricted to ± 50 MHz. The uncertainty is the RSS of the ConvF uncertainty at calibration frequency and the uncertainty for the indicated frequency band.

<sup>F</sup> At frequencies below 3 GHz, the validity of tissue parameters ( $\epsilon$  and  $\sigma$ ) can be relaxed to ± 10% if liquid compensation formula is applied to measured SAR values. At frequencies above 3 GHz, the validity of tissue parameters ( $\epsilon$  and  $\sigma$ ) is restricted to ± 5%. The uncertainty is the RSS of the ConvF uncertainty for indicated target tissue parameters.

### Frequency Response of E-Field (TEM-Cell:ifi110 EXX, Waveguide: R22)

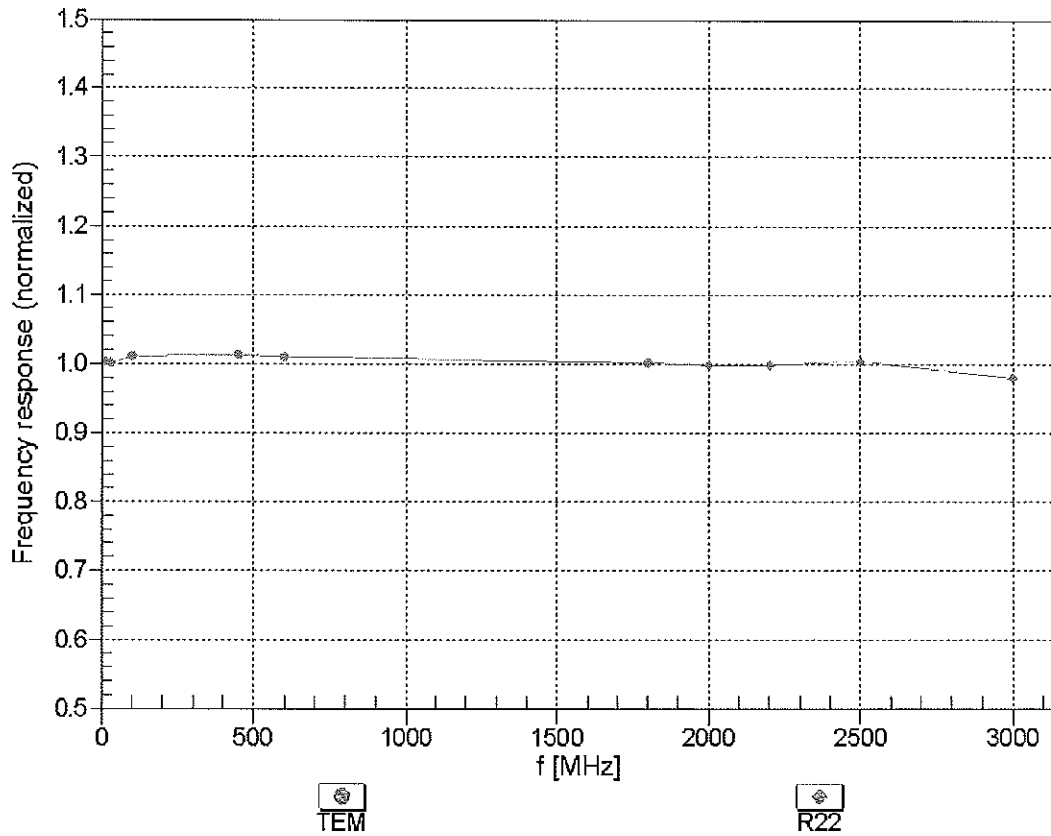

Uncertainty of Frequency Response of E-field:  $\pm 6.3\%$  (k=2)

### Receiving Pattern ( $\phi$ ), $\theta = 0^\circ$

f=600 MHz,TEM

f=1800 MHz,R22

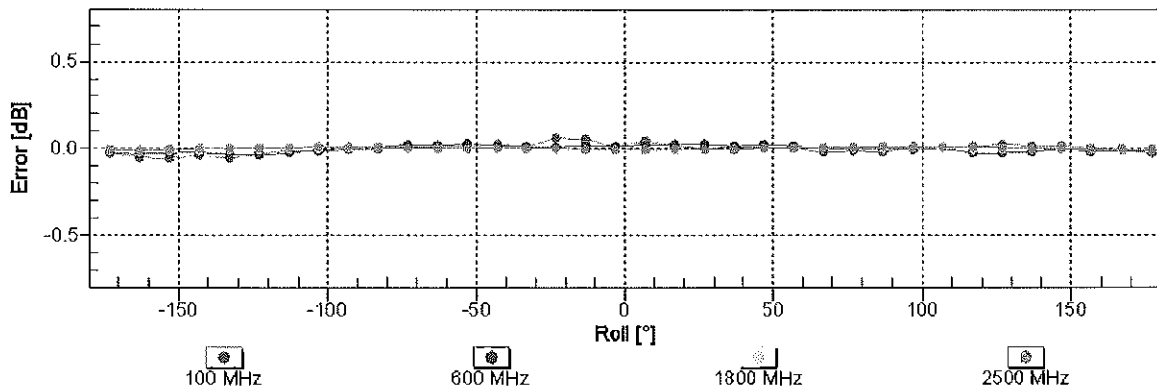
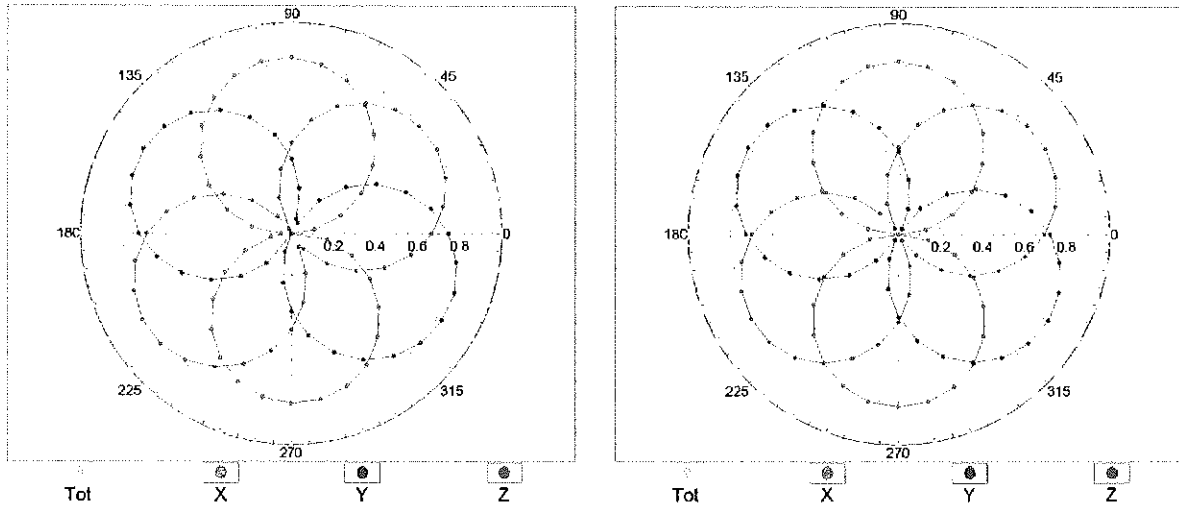

Uncertainty of Axial Isotropy Assessment:  $\pm 0.5\%$  ( $k=2$ )

### Dynamic Range f(SAR<sub>head</sub>) (TEM cell , f = 900 MHz)

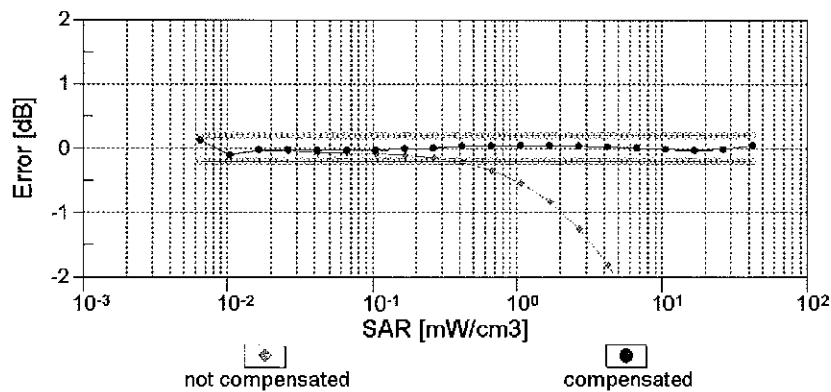
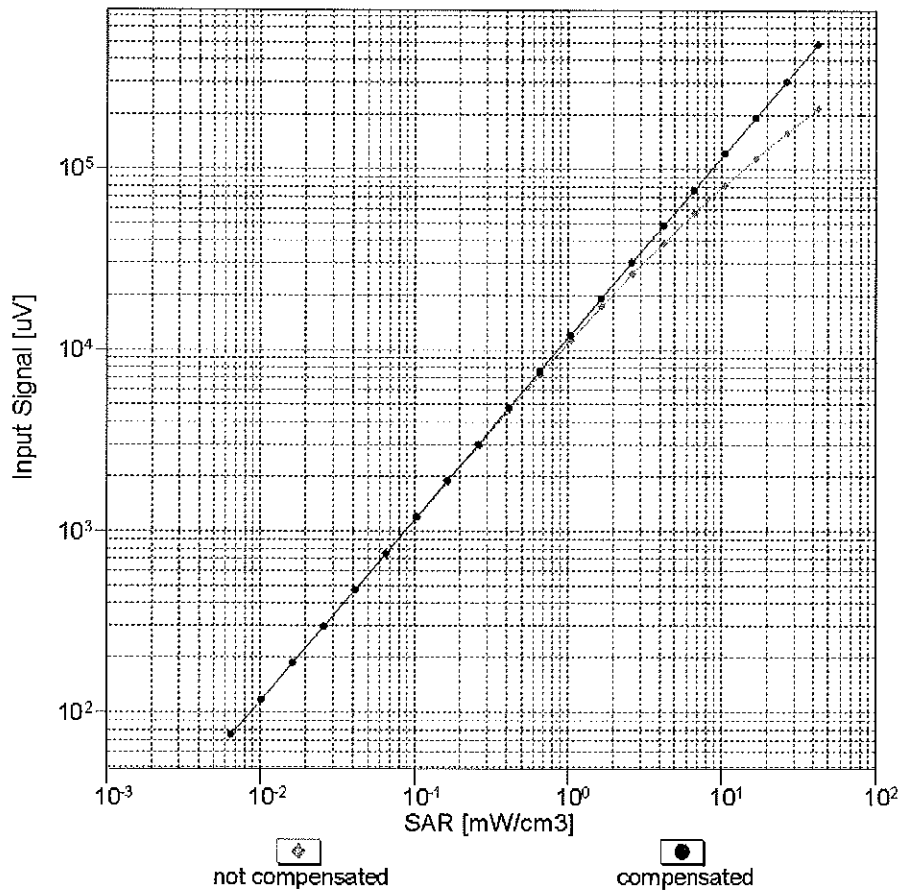

**Uncertainty of Linearity Assessment: ± 0.6% (k=2)**

# Conversion Factor Assessment

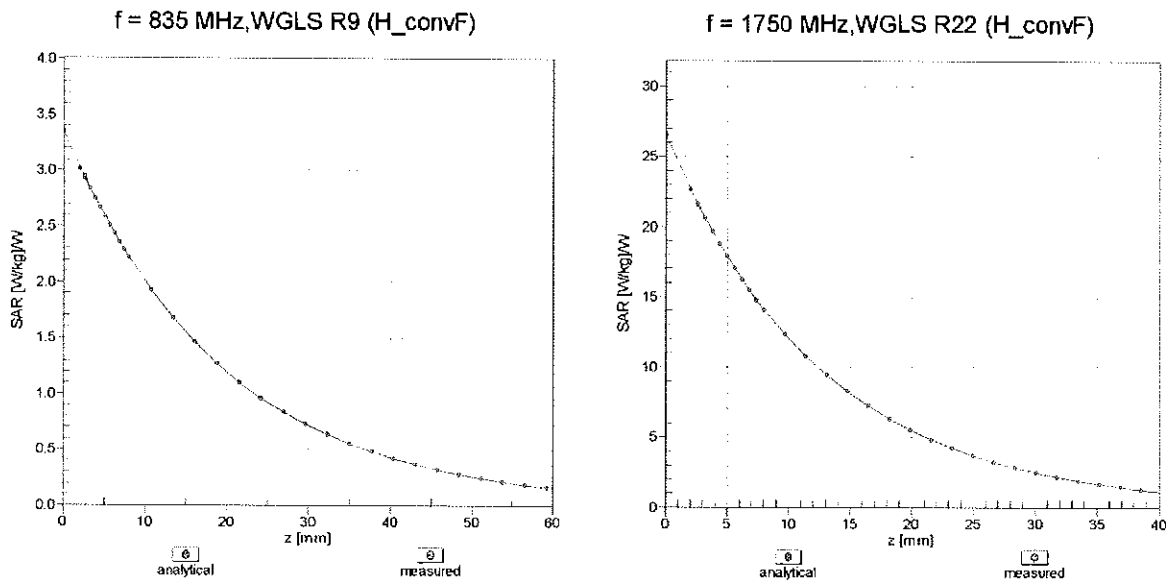

## Deviation from Isotropy in Liquid Error ( $\phi, \theta$ ), $f = 900$ MHz

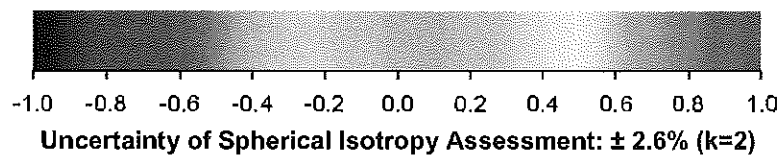
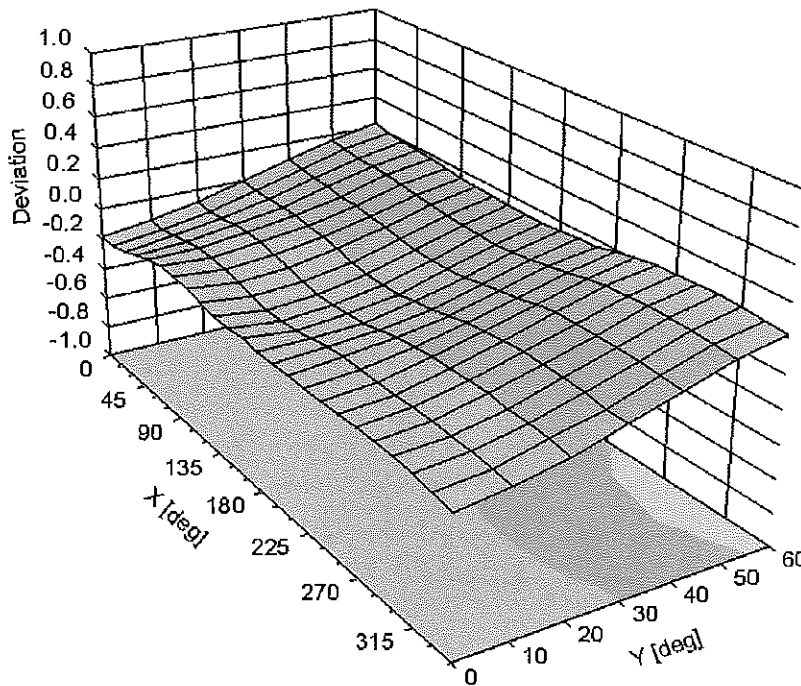

## DASY/EASY - Parameters of Probe: ES3DV2 - SN:3022

### Other Probe Parameters

Sensor Arrangement	Triangular
Connector Angle (°)	-83.1
Mechanical Surface Detection Mode	enabled
Optical Surface Detection Mode	disabled
Probe Overall Length	337 mm
Probe Body Diameter	10 mm
Tip Length	10 mm
Tip Diameter	4 mm
Probe Tip to Sensor X Calibration Point	2 mm
Probe Tip to Sensor Y Calibration Point	2 mm
Probe Tip to Sensor Z Calibration Point	2 mm
Recommended Measurement Distance from Surface	3 mm

Calibration Laboratory of  
Schmid & Partner  
Engineering AG  
Zeughausstrasse 43, 8004 Zurich, Switzerland



SCS Schweizerischer Kalibrierdienst  
Service suisse d'étalonnage  
Servizio svizzero di taratura  
Swiss Calibration Service

Accredited by the Swiss Accreditation Service (SAS)  
The Swiss Accreditation Service is one of the signatories to the EA  
Multilateral Agreement for the recognition of calibration certificates

Accreditation No.: **SCS 108**

Client **PC Test**

Certificate No: **EX3-3914\_Oct13**

**CALIBRATION CERTIFICATE**

Object **EX3DV4 - SN:3914**

Calibration procedure(s) **DIA CAL-01 v3, GA CAL-14 v4, GA CAL-23 v5, DIA CAL-25 v6  
Calibration procedure for dielectric E-field probes**

Calibration date: **October 23, 2013** VCC  
11/20/2013

This calibration certificate documents the traceability to national standards, which realize the physical units of measurements (SI).  
The measurements and the uncertainties with confidence probability are given on the following pages and are part of the certificate.

All calibrations have been conducted in the closed laboratory facility: environment temperature (22 ± 3)°C and humidity < 70%.

Calibration Equipment used (M&TE critical for calibration)

Primary Standards	ID	Cal Date (Certificate No.)	Scheduled Calibration
Power meter E4419B	GB41293874	04-Apr-13 (No. 217-01733)	Apr-14
Power sensor E4412A	MY41498087	04-Apr-13 (No. 217-01733)	Apr-14
Reference 3 dB Attenuator	SN: S5054 (3c)	04-Apr-13 (No. 217-01737)	Apr-14
Reference 20 dB Attenuator	SN: S5277 (20x)	04-Apr-13 (No. 217-01735)	Apr-14
Reference 30 dB Attenuator	SN: S5129 (30b)	04-Apr-13 (No. 217-01738)	Apr-14
Reference Probe ES3DV2	SN: 3013	28-Dec-12 (No. ES3-3013_Dec12)	Dec-13
DAE4	SN: 660	4-Sep-13 (No. DAE4-660_Sep13)	Sep-14
Secondary Standards	ID	Check Date (in house)	Scheduled Check
RF generator HP 8648C	US3642U01700	4-Aug-99 (in house check Apr-13)	In house check: Apr-15
Network Analyzer HP 8753E	US37390585	18-Oct-01 (in house check Oct-13)	In house check: Oct-14

Calibrated by:	Name <b>Leif Klysner</b>	Function <b>Laboratory Technician</b>	Signature 
Approved by:	Name <b>Katja Pokovic</b>	Function <b>Technical Manager</b>	

Issued: October 25, 2013

This calibration certificate shall not be reproduced except in full without written approval of the laboratory.

PCT # 81072



Accredited by the Swiss Accreditation Service (SAS)  
 The Swiss Accreditation Service is one of the signatories to the EA  
 Multilateral Agreement for the recognition of calibration certificates

Accreditation No.: **SCS 108**

**Glossary:**

TSL	tissue simulating liquid
NORM <sub>x,y,z</sub>	sensitivity in free space
ConvF	sensitivity in TSL / NORM <sub>x,y,z</sub>
DCP	diode compression point
CF	crest factor (1/duty_cycle) of the RF signal
A, B, C, D	modulation dependent linearization parameters
Polarization $\varphi$	$\varphi$ rotation around probe axis
Polarization $\vartheta$	$\vartheta$ rotation around an axis that is in the plane normal to probe axis (at measurement center), i.e., $\vartheta = 0$ is normal to probe axis
Connector Angle	information used in DASY system to align probe sensor X to the robot coordinate system

**Calibration is Performed According to the Following Standards:**

- a) IEEE Std 1528-2013, "IEEE Recommended Practice for Determining the Peak Spatial-Averaged Specific Absorption Rate (SAR) in the Human Head from Wireless Communications Devices: Measurement Techniques", June 2013
- b) IEC 62209-1, "Procedure to measure the Specific Absorption Rate (SAR) for hand-held devices used in close proximity to the ear (frequency range of 300 MHz to 3 GHz)", February 2005

**Methods Applied and Interpretation of Parameters:**

- *NORM<sub>x,y,z</sub>*: Assessed for E-field polarization  $\vartheta = 0$  ( $f \leq 900$  MHz in TEM-cell;  $f > 1800$  MHz: R22 waveguide). *NORM<sub>x,y,z</sub>* are only intermediate values, i.e., the uncertainties of *NORM<sub>x,y,z</sub>* does not affect the  $E^2$ -field uncertainty inside TSL (see below *ConvF*).
- *NORM(f)<sub>x,y,z</sub>* = *NORM<sub>x,y,z</sub>* \* *frequency\_response* (see Frequency Response Chart). This linearization is implemented in DASY4 software versions later than 4.2. The uncertainty of the frequency response is included in the stated uncertainty of *ConvF*.
- *DCP<sub>x,y,z</sub>*: DCP are numerical linearization parameters assessed based on the data of power sweep with CW signal (no uncertainty required). DCP does not depend on frequency nor media.
- *PAR*: PAR is the Peak to Average Ratio that is not calibrated but determined based on the signal characteristics
- *A<sub>x,y,z</sub>*; *B<sub>x,y,z</sub>*; *C<sub>x,y,z</sub>*; *D<sub>x,y,z</sub>*; *VR<sub>x,y,z</sub>*; *A, B, C, D* are numerical linearization parameters assessed based on the data of power sweep for specific modulation signal. The parameters do not depend on frequency nor media. *VR* is the maximum calibration range expressed in RMS voltage across the diode.
- *ConvF and Boundary Effect Parameters*: Assessed in flat phantom using E-field (or Temperature Transfer Standard for  $f \leq 800$  MHz) and inside waveguide using analytical field distributions based on power measurements for  $f > 800$  MHz. The same setups are used for assessment of the parameters applied for boundary compensation (alpha, depth) of which typical uncertainty values are given. These parameters are used in DASY4 software to improve probe accuracy close to the boundary. The sensitivity in TSL corresponds to *NORM<sub>x,y,z</sub>* \* *ConvF* whereby the uncertainty corresponds to that given for *ConvF*. A frequency dependent *ConvF* is used in DASY version 4.4 and higher which allows extending the validity from  $\pm 50$  MHz to  $\pm 100$  MHz.
- *Spherical isotropy (3D deviation from isotropy)*: in a field of low gradients realized using a flat phantom exposed by a patch antenna.
- *Sensor Offset*: The sensor offset corresponds to the offset of virtual measurement center from the probe tip (on probe axis). No tolerance required.
- *Connector Angle*: The angle is assessed using the information gained by determining the *NORM<sub>x</sub>* (no uncertainty required).

# Probe EX3DV4

## SN:3914

Manufactured: December 18, 2012  
Calibrated: October 23, 2013

Calibrated for DASY/EASY Systems  
(Note: non-compatible with DASY2 system!)

## DASY/EASY - Parameters of Probe: EX3DV4 - SN:3914

### Basic Calibration Parameters

	Sensor X	Sensor Y	Sensor Z	Unc (k=2)
Norm ( $\mu\text{V}/(\text{V}/\text{m})^2$ ) <sup>A</sup>	0.47	0.49	0.51	$\pm 10.1 \%$
DCP (mV) <sup>B</sup>	99.2	98.9	98.2	

### Modulation Calibration Parameters

UID	Communication System Name		A dB	B dB $\sqrt{\mu\text{V}}$	C	D dB	VR mV	Unc <sup>E</sup> (k=2)
0	CW	X	0.0	0.0	1.0	0.00	158.3	$\pm 3.0 \%$
		Y	0.0	0.0	1.0		154.6	
		Z	0.0	0.0	1.0		170.8	
10010- CAA	SAR Validation (Square, 100ms, 10ms)	X	0.71	53.3	6.1	10.00	48.4	$\pm 2.5 \%$
		Y	2.43	67.0	13.8		39.9	
		Z	4.18	68.7	13.8		45.7	
10011- CAA	UMTS-FDD (WCDMA)	X	3.05	64.4	16.5	2.91	122.4	$\pm 0.5 \%$
		Y	3.31	66.5	18.2		123.5	
		Z	3.34	66.3	17.8		136.6	
10012- CAA	IEEE 802.11b WiFi 2.4 GHz (DSSS, 1 Mbps)	X	2.49	64.8	16.1	1.87	120.6	$\pm 0.5 \%$
		Y	2.94	68.6	18.7		123.6	
		Z	2.63	65.9	17.0		135.4	
10021- DAA	GSM-FDD (TDMA, GMSK)	X	1.52	61.5	10.9	9.39	83.6	$\pm 1.2 \%$
		Y	2.22	67.4	15.0		116.0	
		Z	2.47	66.8	14.7		95.9	
10023- DAA	GPRS-FDD (TDMA, GMSK, TN 0)	X	1.73	63.3	11.9	9.57	81.5	$\pm 1.7 \%$
		Y	2.11	66.2	14.2		111.8	
		Z	2.76	69.0	16.0		93.6	
10024- DAA	GPRS-FDD (TDMA, GMSK, TN 0-1)	X	1.34	62.1	9.4	6.56	121.0	$\pm 1.2 \%$
		Y	4.24	78.6	17.9		130.0	
		Z	2.91	70.7	14.9		141.4	
10027- DAA	GPRS-FDD (TDMA, GMSK, TN 0-1-2)	X	1.25	63.5	9.7	4.80	143.5	$\pm 1.4 \%$
		Y	1.59	66.9	12.2		149.7	
		Z	2.98	71.5	14.0		123.3	
10028- DAA	GPRS-FDD (TDMA, GMSK, TN 0-1-2-3)	X	0.51	58.3	7.4	3.55	113.4	$\pm 1.2 \%$
		Y	25.43	100.0	22.6		121.3	
		Z	38.67	97.5	20.6		133.3	
10032- CAA	IEEE 802.15.1 Bluetooth (GFSK, DH5)	X	0.28	58.6	5.3	1.16	134.7	$\pm 0.9 \%$
		Y	65.75	99.6	18.6		141.3	
		Z	0.20	55.6	4.1		112.1	
10039- CAA	CDMA2000 (1xRTT, RC1)	X	4.33	64.6	17.4	4.57	113.8	$\pm 0.7 \%$
		Y	4.55	66.0	18.6		120.8	
		Z	4.85	66.2	18.4		135.9	
10062- CAA	IEEE 802.11a/h WiFi 5 GHz (OFDM, 6 Mbps)	X	9.83	67.6	20.7	8.68	109.0	$\pm 2.5 \%$
		Y	10.06	68.4	21.5		118.2	
		Z	10.66	69.2	21.7		134.0	

10081-CAA	CDMA2000 (1xRTT, RC3)	X	3.59	63.9	16.9	3.97	113.6	±0.7 %
		Y	3.84	65.6	18.2		119.6	
		Z	3.95	65.4	17.8		134.5	
10098-CAA	UMTS-FDD (HSUPA, Subtest 2)	X	4.41	65.2	17.3	3.98	126.0	±0.7 %
		Y	4.73	66.9	18.6		132.5	
		Z	4.51	65.5	17.7		105.6	
10100-CAB	LTE-FDD (SC-FDMA, 100% RB, 20 MHz, QPSK)	X	6.26	66.2	18.6	5.67	130.5	±1.2 %
		Y	6.61	67.7	19.8		139.3	
		Z	6.21	66.0	18.7		107.7	
10108-CAB	LTE-FDD (SC-FDMA, 100% RB, 10 MHz, QPSK)	X	6.13	65.8	18.6	5.80	126.3	±1.2 %
		Y	6.40	67.1	19.6		135.6	
		Z	6.10	65.5	18.5		107.4	
10110-CAB	LTE-FDD (SC-FDMA, 100% RB, 5 MHz, QPSK)	X	5.78	65.3	18.3	5.75	123.1	±1.2 %
		Y	5.97	66.3	19.2		131.5	
		Z	5.86	65.3	18.4		104.9	
10114-CAA	IEEE 802.11n (HT Greenfield, 13.5 Mbps, BPSK)	X	9.92	67.7	20.3	8.10	115.7	±2.5 %
		Y	10.25	68.7	21.2		126.8	
		Z	10.71	69.4	21.3		146.0	
10117-CAA	IEEE 802.11n (HT Mixed, 13.5 Mbps, BPSK)	X	9.95	67.8	20.3	8.07	116.6	±2.5 %
		Y	10.26	68.7	21.1		128.3	
		Z	10.70	69.4	21.3		146.9	
10151-CAB	LTE-TDD (SC-FDMA, 50% RB, 20 MHz, QPSK)	X	7.19	67.3	21.5	9.28	145.0	±2.2 %
		Y	7.40	68.3	22.4		110.8	
		Z	7.79	68.4	22.0		128.0	
10154-CAB	LTE-FDD (SC-FDMA, 50% RB, 10 MHz, QPSK)	X	5.79	65.3	18.3	5.75	124.2	±1.2 %
		Y	6.03	66.5	19.4		131.9	
		Z	6.29	66.9	19.3		149.7	
10160-CAB	LTE-FDD (SC-FDMA, 50% RB, 15 MHz, QPSK)	X	6.23	65.9	18.6	5.82	128.3	±1.2 %
		Y	6.51	67.2	19.7		136.9	
		Z	6.24	65.7	18.6		107.3	
10169-CAB	LTE-FDD (SC-FDMA, 1 RB, 20 MHz, QPSK)	X	4.83	66.0	18.9	5.73	147.5	±1.2 %
		Y	4.72	65.8	19.2		113.8	
		Z	5.03	66.1	19.1		129.7	
10172-CAB	LTE-TDD (SC-FDMA, 1 RB, 20 MHz, QPSK)	X	5.83	69.2	22.8	9.21	149.9	±1.9 %
		Y	5.81	69.4	23.4		120.3	
		Z	6.38	70.0	23.2		137.2	
10175-CAB	LTE-FDD (SC-FDMA, 1 RB, 10 MHz, QPSK)	X	4.86	66.1	18.9	5.72	149.8	±1.2 %
		Y	4.72	65.8	19.2		113.3	
		Z	5.09	66.4	19.1		126.0	
10181-CAB	LTE-FDD (SC-FDMA, 1 RB, 15 MHz, QPSK)	X	4.83	66.0	18.9	5.72	146.3	±1.2 %
		Y	4.69	65.6	19.1		112.2	
		Z	5.02	66.1	19.0		125.1	
10193-CAA	IEEE 802.11n (HT Greenfield, 6.5 Mbps, BPSK)	X	9.51	67.4	20.2	8.09	108.6	±2.5 %
		Y	9.72	68.1	20.9		118.2	
		Z	10.30	68.9	21.1		135.0	

10196-CAA	IEEE 802.11n (HT Mixed, 6.5 Mbps, BPSK)	X	9.52	67.4	20.2	8.10	111.6	±2.5 %
		Y	9.79	68.3	21.1		121.3	
		Z	10.30	68.9	21.2		139.2	
10219-CAA	IEEE 802.11n (HT Mixed, 7.2 Mbps, BPSK)	X	9.47	67.4	20.2	8.03	111.8	±2.2 %
		Y	9.67	68.3	21.0		120.0	
		Z	10.20	68.9	21.1		138.0	
10222-CAA	IEEE 802.11n (HT Mixed, 15 Mbps, BPSK)	X	9.96	67.9	20.4	8.06	118.4	±2.5 %
		Y	10.25	68.8	21.2		128.2	
		Z	10.65	69.3	21.3		144.5	
10225-CAA	UMTS-FDD (HSPA+)	X	6.96	66.7	18.9	5.97	140.0	±1.4 %
		Y	7.23	67.9	20.0		148.9	
		Z	7.03	66.4	18.9		115.6	
10237-CAB	LTE-TDD (SC-FDMA, 1 RB, 10 MHz, QPSK)	X	5.51	67.5	21.8	9.21	114.2	±1.9 %
		Y	5.82	69.4	23.4		123.0	
		Z	6.49	70.6	23.6		140.2	
10252-CAB	LTE-TDD (SC-FDMA, 50% RB, 10 MHz, QPSK)	X	6.83	67.1	21.4	9.24	136.6	±1.9 %
		Y	7.30	69.4	23.2		147.3	
		Z	7.36	68.1	22.0		117.5	
10267-CAB	LTE-TDD (SC-FDMA, 100% RB, 10 MHz, QPSK)	X	7.26	67.5	21.6	9.30	142.7	±1.9 %
		Y	7.44	68.4	22.4		110.5	
		Z	7.84	68.7	22.2		122.6	
10274-CAA	UMTS-FDD (HSUPA, Subtest 5, 3GPP Rel8.10)	X	5.86	66.2	18.2	4.87	135.4	±0.9 %
		Y	6.12	67.5	19.2		142.3	
		Z	5.91	65.9	18.2		107.6	
10275-CAA	UMTS-FDD (HSUPA, Subtest 5, 3GPP Rel8.4)	X	4.17	64.8	17.3	3.96	115.6	±0.7 %
		Y	4.42	66.4	18.5		124.6	
		Z	4.47	66.0	18.0		132.6	
10291-AAA	CDMA2000, RC3, SO55, Full Rate	X	3.36	64.7	17.1	3.46	109.4	±0.5 %
		Y	3.55	66.2	18.3		118.2	
		Z	3.60	65.6	17.7		120.9	
10292-AAA	CDMA2000, RC3, SO32, Full Rate	X	3.34	64.9	17.2	3.39	110.1	±0.5 %
		Y	3.57	66.7	18.5		121.0	
		Z	3.54	65.6	17.7		123.9	
10297-AAA	LTE-FDD (SC-FDMA, 50% RB, 20 MHz, QPSK)	X	6.14	65.8	18.6	5.81	125.1	±1.2 %
		Y	6.44	67.2	19.7		135.7	
		Z	6.52	67.0	19.3		142.2	
10311-AAA	LTE-FDD (SC-FDMA, 100% RB, 15 MHz, QPSK)	X	6.76	66.6	19.1	6.06	131.8	±1.4 %
		Y	7.03	67.8	20.0		142.5	
		Z	7.15	67.7	19.7		148.6	
10315-AAA	IEEE 802.11b WiFi 2.4 GHz (DSSS, 1 Mbps, 96pc duty cycle)	X	2.42	64.6	16.1	1.71	116.8	±0.5 %
		Y	3.00	69.3	19.0		126.9	
		Z	2.61	66.3	17.2		128.2	
10317-AAA	IEEE 802.11a WiFi 5 GHz (OFDM, 6 Mbps, 96pc duty cycle)	X	9.71	67.6	20.5	8.36	111.7	±2.5 %
		Y	9.99	68.6	21.4		122.2	
		Z	10.38	68.9	21.3		129.5	

10400-AAA	IEEE 802.11ac WiFi (20MHz, 64-QAM, 99pc duty cycle)	X	9.83	67.8	20.6	8.37	112.9	±2.5 %
		Y	10.09	68.7	21.4		123.9	
		Z	10.48	68.9	21.3		130.5	
10402-AAA	IEEE 802.11ac WiFi (80MHz, 64-QAM, 99pc duty cycle)	X	10.61	68.3	20.7	8.53	121.1	±2.5 %
		Y	11.25	70.0	21.9		135.4	
		Z	11.15	69.4	21.4		137.4	
10403-AAA	CDMA2000 (1xEV-DO, Rev. 0)	X	4.51	67.4	17.8	3.76	119.2	±0.5 %
		Y	4.91	69.5	19.3		128.3	
		Z	4.84	67.5	18.1		135.4	
10404-AAA	CDMA2000 (1xEV-DO, Rev. A)	X	4.51	67.7	18.0	3.77	117.4	±0.5 %
		Y	4.92	69.8	19.5		125.4	
		Z	4.71	67.3	18.0		131.9	

The reported uncertainty of measurement is stated as the standard uncertainty of measurement multiplied by the coverage factor  $k=2$ , which for a normal distribution corresponds to a coverage probability of approximately 95%.

<sup>A</sup> The uncertainties of NormX,Y,Z do not affect the  $E^2$ -field uncertainty inside TSL (see Pages 8 and 9).

<sup>B</sup> Numerical linearization parameter: uncertainty not required.

<sup>E</sup> Uncertainty is determined using the max. deviation from linear response applying rectangular distribution and is expressed for the square of the field value.

## DASY/EASY - Parameters of Probe: EX3DV4 - SN:3914

### Calibration Parameter Determined in Head Tissue Simulating Media

f (MHz) <sup>C</sup>	Relative Permittivity <sup>F</sup>	Conductivity (S/m) <sup>F</sup>	ConvF X	ConvF Y	ConvF Z	Alpha <sup>G</sup>	Depth <sup>G</sup> (mm)	Unct. (k=2)
750	41.9	0.89	9.70	9.70	9.70	0.34	1.01	± 12.0 %
835	41.5	0.90	9.34	9.34	9.34	0.67	0.67	± 12.0 %
1750	40.1	1.37	7.99	7.99	7.99	0.79	0.56	± 12.0 %
1900	40.0	1.40	7.69	7.69	7.69	0.80	0.58	± 12.0 %
2450	39.2	1.80	6.95	6.95	6.95	0.41	0.77	± 12.0 %
2600	39.0	1.96	6.79	6.79	6.79	0.40	0.82	± 12.0 %
5200	36.0	4.66	4.99	4.99	4.99	0.30	1.80	± 13.1 %
5300	35.9	4.76	4.82	4.82	4.82	0.30	1.80	± 13.1 %
5500	35.6	4.96	4.55	4.55	4.55	0.35	1.80	± 13.1 %
5600	35.5	5.07	4.37	4.37	4.37	0.35	1.80	± 13.1 %
5800	35.3	5.27	4.52	4.52	4.52	0.35	1.80	± 13.1 %

<sup>C</sup> Frequency validity of ± 100 MHz only applies for DASY v4.4 and higher (see Page 2), else it is restricted to ± 50 MHz. The uncertainty is the RSS of the ConvF uncertainty at calibration frequency and the uncertainty for the indicated frequency band.

<sup>F</sup> At frequencies below 3 GHz, the validity of tissue parameters ( $\epsilon$  and  $\sigma$ ) can be relaxed to ± 10% if liquid compensation formula is applied to measured SAR values. At frequencies above 3 GHz, the validity of tissue parameters ( $\epsilon$  and  $\sigma$ ) is restricted to ± 5%. The uncertainty is the RSS of the ConvF uncertainty for indicated target tissue parameters.

<sup>G</sup> Alpha/Depth are determined during calibration. SPEAG warrants that the remaining deviation due to the boundary effect after compensation is always less than ± 1% for frequencies below 3 GHz and below ± 2% for frequencies between 3-6 GHz at any distance larger than half the probe tip diameter from the boundary.

## DASY/EASY - Parameters of Probe: EX3DV4 - SN:3914

### Calibration Parameter Determined in Body Tissue Simulating Media

f (MHz) <sup>C</sup>	Relative Permittivity <sup>F</sup>	Conductivity (S/m) <sup>F</sup>	ConvF X	ConvF Y	ConvF Z	Alpha <sup>G</sup>	Depth <sup>G</sup> (mm)	Unct. (k=2)
750	55.5	0.96	9.39	9.39	9.39	0.63	0.74	± 12.0 %
835	55.2	0.97	9.31	9.31	9.31	0.56	0.76	± 12.0 %
1750	53.4	1.49	7.89	7.89	7.89	0.32	1.03	± 12.0 %
1900	53.3	1.52	7.51	7.51	7.51	0.51	0.76	± 12.0 %
2450	52.7	1.95	7.02	7.02	7.02	0.80	0.50	± 12.0 %
2600	52.5	2.16	6.81	6.81	6.81	0.80	0.50	± 12.0 %
5200	49.0	5.30	4.52	4.52	4.52	0.35	1.90	± 13.1 %
5300	48.9	5.42	4.32	4.32	4.32	0.35	1.90	± 13.1 %
5500	48.6	5.65	4.07	4.07	4.07	0.35	1.90	± 13.1 %
5600	48.5	5.77	3.97	3.97	3.97	0.35	1.90	± 13.1 %
5800	48.2	6.00	4.14	4.14	4.14	0.40	1.90	± 13.1 %

<sup>C</sup> Frequency validity of ± 100 MHz only applies for DASY v4.4 and higher (see Page 2), else it is restricted to ± 50 MHz. The uncertainty is the RSS of the ConvF uncertainty at calibration frequency and the uncertainty for the indicated frequency band.

<sup>F</sup> At frequencies below 3 GHz, the validity of tissue parameters ( $\epsilon$  and  $\sigma$ ) can be relaxed to ± 10% if liquid compensation formula is applied to measured SAR values. At frequencies above 3 GHz, the validity of tissue parameters ( $\epsilon$  and  $\sigma$ ) is restricted to ± 5%. The uncertainty is the RSS of the ConvF uncertainty for indicated target tissue parameters.

<sup>G</sup> Alpha/Depth are determined during calibration. SPEAG warrants that the remaining deviation due to the boundary effect after compensation is always less than ± 1% for frequencies below 3 GHz and below ± 2% for frequencies between 3-6 GHz at any distance larger than half the probe tip diameter from the boundary.

# Frequency Response of E-Field

(TEM-Cell:ifi110 EXX, Waveguide: R22)

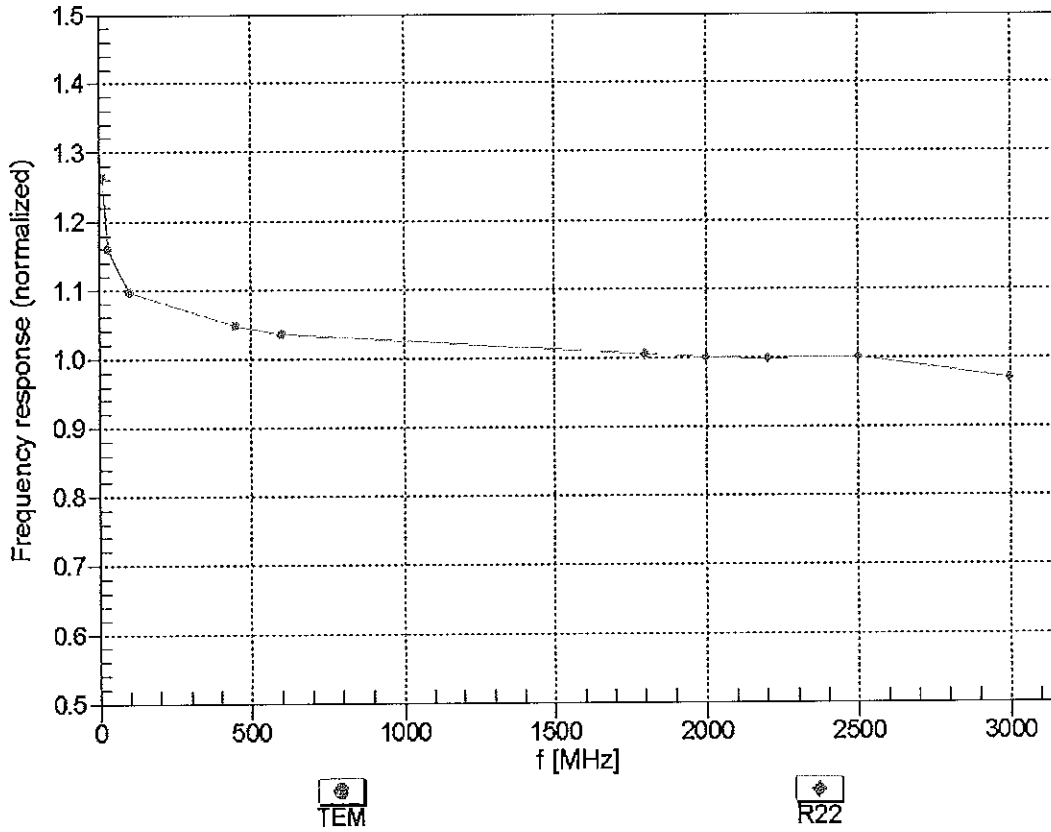

Uncertainty of Frequency Response of E-field:  $\pm 6.3\%$  (k=2)

### Receiving Pattern ( $\phi$ ), $\theta = 0^\circ$

f=600 MHz,TEM

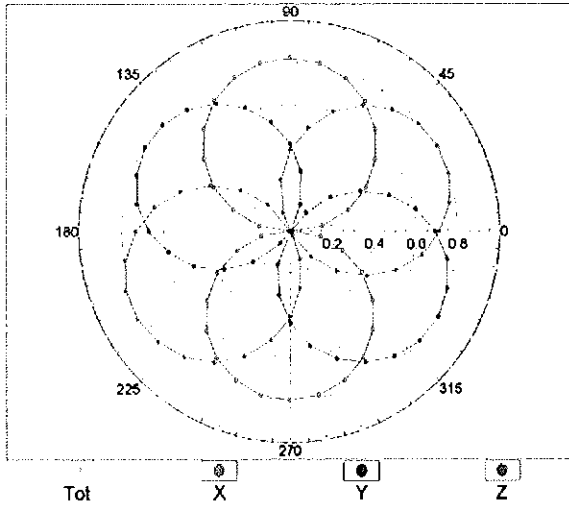

f=1800 MHz,R22

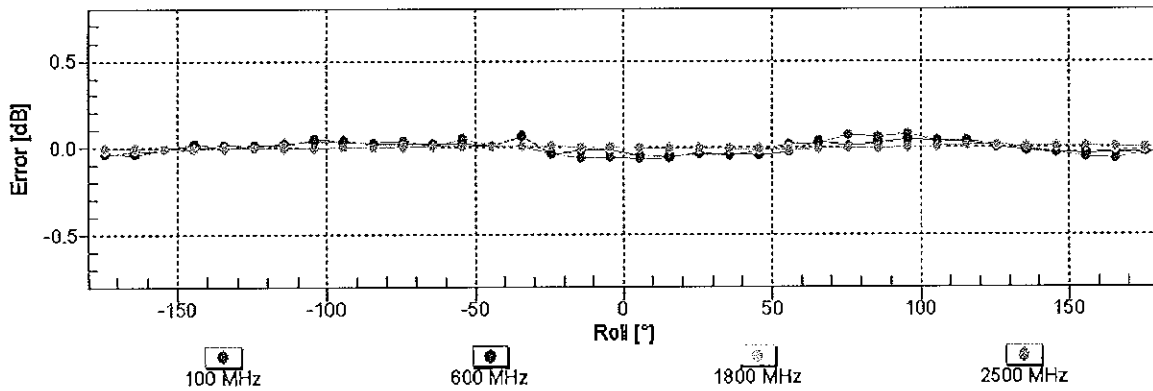
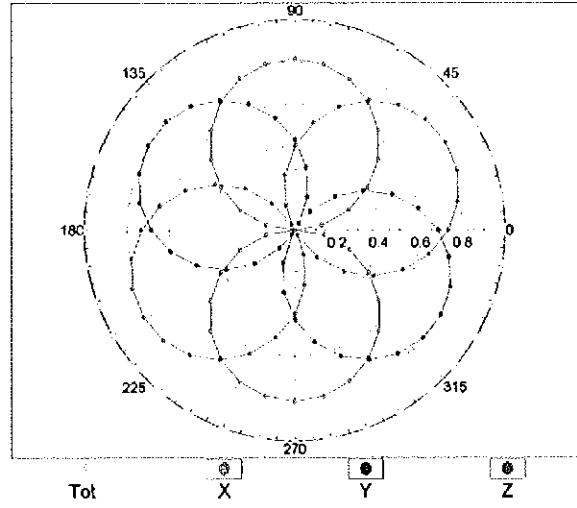

Uncertainty of Axial Isotropy Assessment:  $\pm 0.5\%$  (k=2)

### Dynamic Range $f(\text{SAR}_{\text{head}})$ (TEM cell , $f = 900 \text{ MHz}$ )

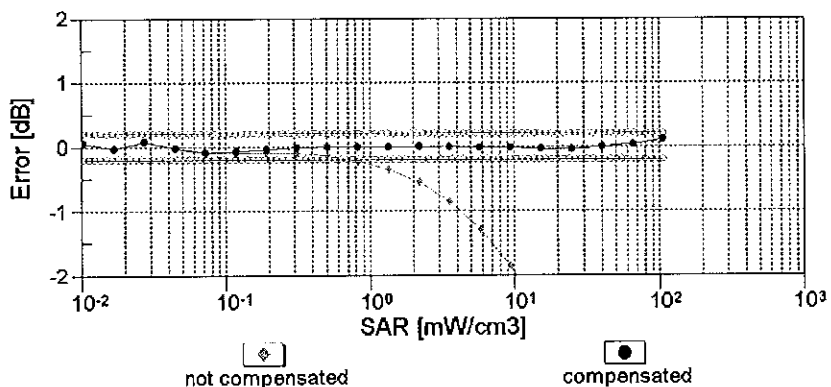
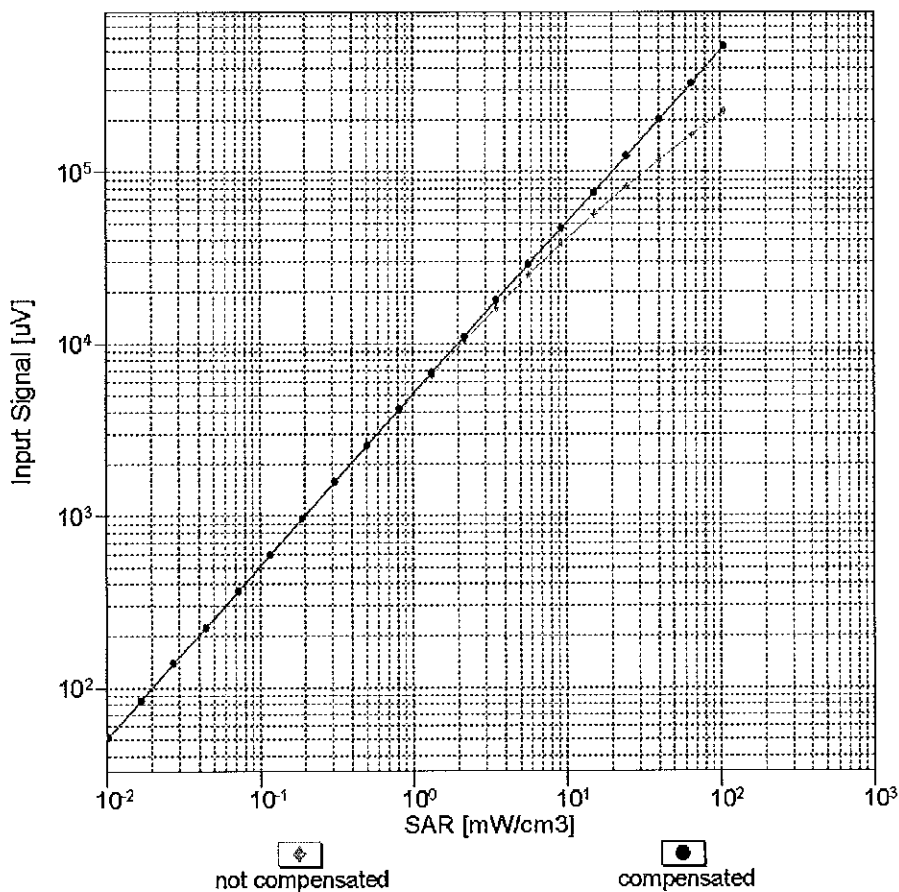

Uncertainty of Linearity Assessment:  $\pm 0.6\%$  ( $k=2$ )

# Conversion Factor Assessment

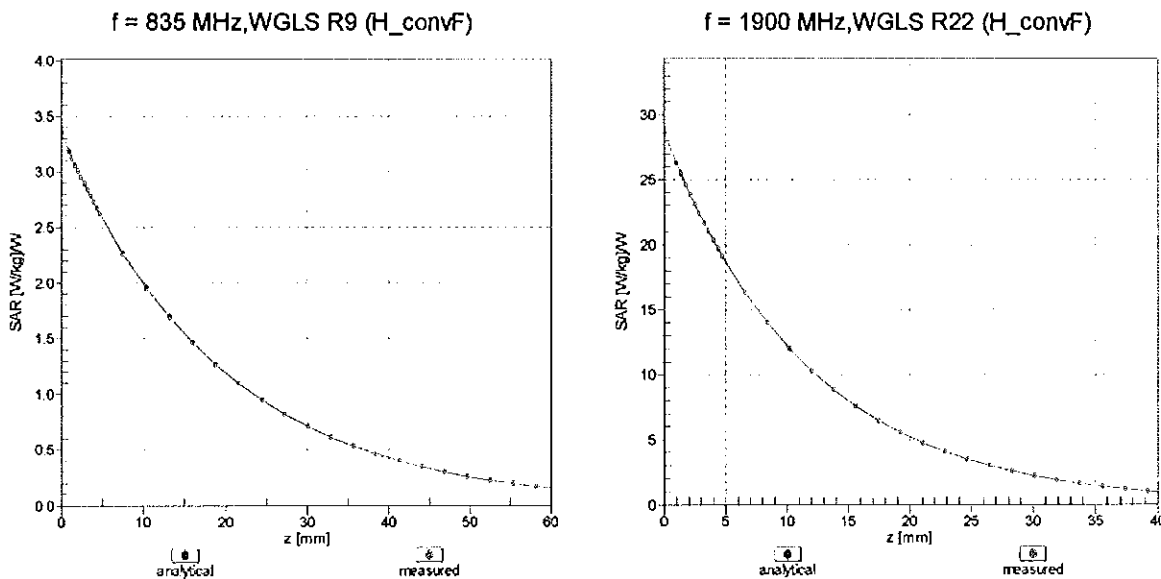

## Deviation from Isotropy in Liquid

Error ( $\phi, \theta$ ), f = 900 MHz

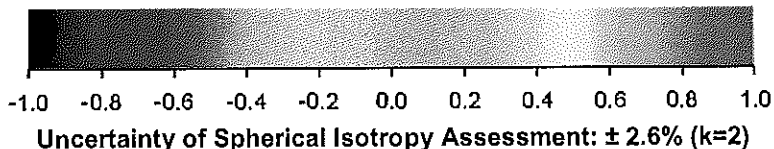
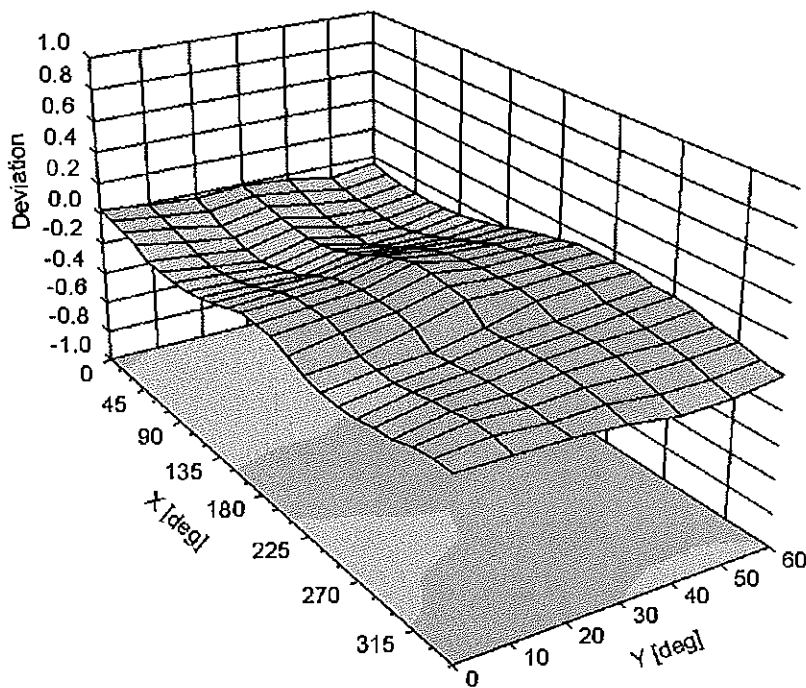

**DASY/EASY - Parameters of Probe: EX3DV4 - SN:3914****Other Probe Parameters**

Sensor Arrangement	Triangular
Connector Angle (°)	-24.3
Mechanical Surface Detection Mode	enabled
Optical Surface Detection Mode	disabled
Probe Overall Length	337 mm
Probe Body Diameter	10 mm
Tip Length	9 mm
Tip Diameter	2.5 mm
Probe Tip to Sensor X Calibration Point	1 mm
Probe Tip to Sensor Y Calibration Point	1 mm
Probe Tip to Sensor Z Calibration Point	1 mm
Recommended Measurement Distance from Surface	2 mm



Accredited by the Swiss Accreditation Service (SAS)  
The Swiss Accreditation Service is one of the signatories to the EA  
Multilateral Agreement for the recognition of calibration certificates

Accreditation No.: **SCS 108**

Client **PC Test**

Certificate No: **D750V3-1054\_Mar13**

## CALIBRATION CERTIFICATE

Object **D750V3 - SN: 1054**

Calibration procedure(s) **QA CAL-05.v9  
Calibration procedure for dipole validation kits above 700 MHz**

Calibration date: **March 18, 2013**

*✓ KOK  
3/22/13*

This calibration certificate documents the traceability to national standards, which realize the physical units of measurements (SI).  
The measurements and the uncertainties with confidence probability are given on the following pages and are part of the certificate.

All calibrations have been conducted in the closed laboratory facility: environment temperature (22 ± 3)°C and humidity < 70%.

Calibration Equipment used (M&TE critical for calibration)

Primary Standards	ID #	Cal Date (Certificate No.)	Scheduled Calibration
Power meter EPM-442A	GB37480704	01-Nov-12 (No. 217-01640)	Oct-13
Power sensor HP 8481A	US37292783	01-Nov-12 (No. 217-01640)	Oct-13
Reference 20 dB Attenuator	SN: 5058 (20k)	27-Mar-12 (No. 217-01530)	Apr-13
Type-N mismatch combination	SN: 5047.3 / 06327	27-Mar-12 (No. 217-01533)	Apr-13
Reference Probe ES3DV3	SN: 3205	28-Dec-12 (No. ES3-3205_Dec12)	Dec-13
DAE4	SN: 601	27-Jun-12 (No. DAE4-601_Jun12)	Jun-13
Secondary Standards	ID #	Check Date (in house)	Scheduled Check
Power sensor HP 8481A	MY41092317	18-Oct-02 (in house check Oct-11)	In house check: Oct-13
RF generator R&S SMT-06	100005	04-Aug-99 (in house check Oct-11)	In house check: Oct-13
Network Analyzer HP 8753E	US37390585 S4206	18-Oct-01 (in house check Oct-12)	In house check: Oct-13

Calibrated by:	Name <b>Israe El-Naouq</b>	Function <b>Laboratory Technician</b>	Signature <i>Israe El-Naouq</i>
Approved by:	Name <b>Katja Pokovic</b>	Function <b>Technical Manager</b>	Signature <i>Katja Pokovic</i>

Issued: March 18, 2013

This calibration certificate shall not be reproduced except in full without written approval of the laboratory.



Accredited by the Swiss Accreditation Service (SAS)  
The Swiss Accreditation Service is one of the signatories to the EA  
Multilateral Agreement for the recognition of calibration certificates

Accreditation No.: **SCS 108**

**Glossary:**

TSL	tissue simulating liquid
ConvF	sensitivity in TSL / NORM x,y,z
N/A	not applicable or not measured

**Calibration is Performed According to the Following Standards:**

- a) IEEE Std 1528-2003, "IEEE Recommended Practice for Determining the Peak Spatial-Averaged Specific Absorption Rate (SAR) in the Human Head from Wireless Communications Devices: Measurement Techniques", December 2003
- b) IEC 62209-1, "Procedure to measure the Specific Absorption Rate (SAR) for hand-held devices used in close proximity to the ear (frequency range of 300 MHz to 3 GHz)", February 2005
- c) Federal Communications Commission Office of Engineering & Technology (FCC OET), "Evaluating Compliance with FCC Guidelines for Human Exposure to Radiofrequency Electromagnetic Fields; Additional Information for Evaluating Compliance of Mobile and Portable Devices with FCC Limits for Human Exposure to Radiofrequency Emissions", Supplement C (Edition 01-01) to Bulletin 65

**Additional Documentation:**

- d) DASY4/5 System Handbook

**Methods Applied and Interpretation of Parameters:**

- *Measurement Conditions:* Further details are available from the Validation Report at the end of the certificate. All figures stated in the certificate are valid at the frequency indicated.
- *Antenna Parameters with TSL:* The dipole is mounted with the spacer to position its feed point exactly below the center marking of the flat phantom section, with the arms oriented parallel to the body axis.
- *Feed Point Impedance and Return Loss:* These parameters are measured with the dipole positioned under the liquid filled phantom. The impedance stated is transformed from the measurement at the SMA connector to the feed point. The Return Loss ensures low reflected power. No uncertainty required.
- *Electrical Delay:* One-way delay between the SMA connector and the antenna feed point. No uncertainty required.
- *SAR measured:* SAR measured at the stated antenna input power.
- *SAR normalized:* SAR as measured, normalized to an input power of 1 W at the antenna connector.
- *SAR for nominal TSL parameters:* The measured TSL parameters are used to calculate the nominal SAR result.

The reported uncertainty of measurement is stated as the standard uncertainty of measurement multiplied by the coverage factor  $k=2$ , which for a normal distribution corresponds to a coverage probability of approximately 95%.

## Measurement Conditions

DASY system configuration, as far as not given on page 1.

<b>DASY Version</b>	DASY5	V52.8.5
<b>Extrapolation</b>	Advanced Extrapolation	
<b>Phantom</b>	Modular Flat Phantom	
<b>Distance Dipole Center - TSL</b>	15 mm	with Spacer
<b>Zoom Scan Resolution</b>	dx, dy, dz = 5 mm	
<b>Frequency</b>	750 MHz $\pm$ 1 MHz	

## Head TSL parameters

The following parameters and calculations were applied.

	Temperature	Permittivity	Conductivity
<b>Nominal Head TSL parameters</b>	22.0 °C	41.9	0.89 mho/m
<b>Measured Head TSL parameters</b>	(22.0 $\pm$ 0.2) °C	41.1 $\pm$ 6 %	0.92 mho/m $\pm$ 6 %
<b>Head TSL temperature change during test</b>	< 0.5 °C	----	----

## SAR result with Head TSL

<b>SAR averaged over 1 cm<sup>3</sup> (1 g) of Head TSL</b>	Condition	
SAR measured	250 mW input power	2.19 W/kg
SAR for nominal Head TSL parameters	normalized to 1W	<b>8.50 W/kg <math>\pm</math> 17.0 % (k=2)</b>

<b>SAR averaged over 10 cm<sup>3</sup> (10 g) of Head TSL</b>	condition	
SAR measured	250 mW input power	1.42 W/kg
SAR for nominal Head TSL parameters	normalized to 1W	<b>5.55 W/kg <math>\pm</math> 16.5 % (k=2)</b>

## Body TSL parameters

The following parameters and calculations were applied.

	Temperature	Permittivity	Conductivity
<b>Nominal Body TSL parameters</b>	22.0 °C	55.5	0.96 mho/m
<b>Measured Body TSL parameters</b>	(22.0 $\pm$ 0.2) °C	54.2 $\pm$ 6 %	1.00 mho/m $\pm$ 6 %
<b>Body TSL temperature change during test</b>	< 0.5 °C	----	----

## SAR result with Body TSL

<b>SAR averaged over 1 cm<sup>3</sup> (1 g) of Body TSL</b>	Condition	
SAR measured	250 mW input power	2.26 W/kg
SAR for nominal Body TSL parameters	normalized to 1W	<b>8.72 W/kg <math>\pm</math> 17.0 % (k=2)</b>

<b>SAR averaged over 10 cm<sup>3</sup> (10 g) of Body TSL</b>	condition	
SAR measured	250 mW input power	1.48 W/kg
SAR for nominal Body TSL parameters	normalized to 1W	<b>5.75 W/kg <math>\pm</math> 16.5 % (k=2)</b>

## Appendix

### Antenna Parameters with Head TSL

Impedance, transformed to feed point	54.4 $\Omega$ - 0.9 j $\Omega$
Return Loss	- 27.2 dB

### Antenna Parameters with Body TSL

Impedance, transformed to feed point	49.7 $\Omega$ - 2.7 j $\Omega$
Return Loss	- 31.4 dB

### General Antenna Parameters and Design

Electrical Delay (one direction)	1.034 ns
----------------------------------	----------

After long term use with 100W radiated power, only a slight warming of the dipole near the feedpoint can be measured.

The dipole is made of standard semirigid coaxial cable. The center conductor of the feeding line is directly connected to the second arm of the dipole. The antenna is therefore short-circuited for DC-signals. On some of the dipoles, small end caps are added to the dipole arms in order to improve matching when loaded according to the position as explained in the "Measurement Conditions" paragraph. The SAR data are not affected by this change. The overall dipole length is still according to the Standard.

No excessive force must be applied to the dipole arms, because they might bend or the soldered connections near the feedpoint may be damaged.

### Additional EUT Data

Manufactured by	SPEAG
Manufactured on	November 08, 2011

# DASY5 Validation Report for Head TSL

Date: 18.03.2013

Test Laboratory: SPEAG, Zurich, Switzerland

**DUT: Dipole 750 MHz; Type: D750V3; Serial: D750V3 - SN: 1054**

Communication System: CW; Frequency: 750 MHz

Medium parameters used:  $f = 750 \text{ MHz}$ ;  $\sigma = 0.92 \text{ S/m}$ ;  $\epsilon_r = 41.1$ ;  $\rho = 1000 \text{ kg/m}^3$

Phantom section: Flat Section

Measurement Standard: DASY5 (IEEE/IEC/ANSI C63.19-2007)

DASY52 Configuration:

- Probe: ES3DV3 - SN3205; ConvF(6.28, 6.28, 6.28); Calibrated: 28.12.2012;
- Sensor-Surface: 3mm (Mechanical Surface Detection)
- Electronics: DAE4 Sn601; Calibrated: 27.06.2012
- Phantom: Flat Phantom 4.9L; Type: QD000P49AA; Serial: 1001
- DASY52 52.8.5(1059); SEMCAD X 14.6.8(7028)

## Dipole Calibration for Head Tissue/Pin=250 mW, d=15mm/Zoom Scan (7x7x7)/Cube 0:

Measurement grid: dx=5mm, dy=5mm, dz=5mm

Reference Value = 52.772 V/m; Power Drift = 0.03 dB

Peak SAR (extrapolated) = 3.33 W/kg

**SAR(1 g) = 2.19 W/kg; SAR(10 g) = 1.42 W/kg**

Maximum value of SAR (measured) = 2.55 W/kg

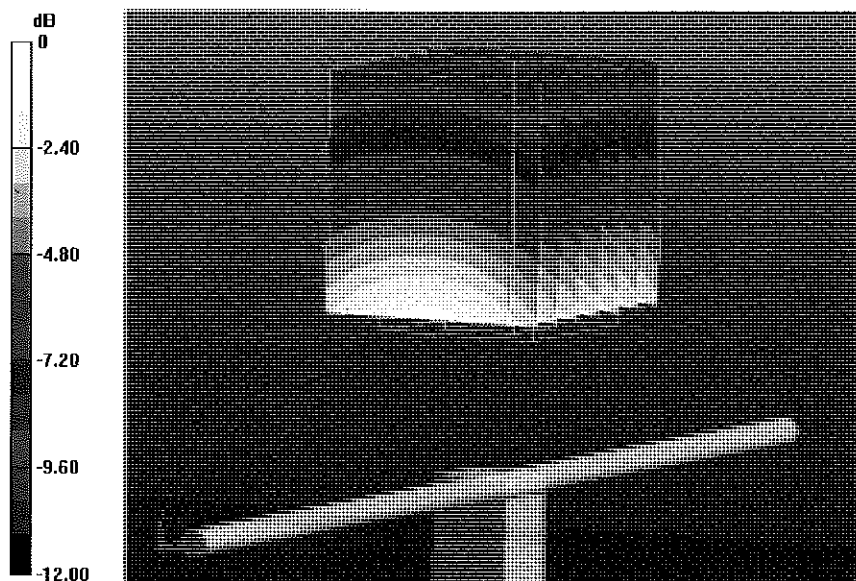

0 dB = 2.55 W/kg = 4.07 dBW/kg

# Impedance Measurement Plot for Head TSL

18 Mar 2013 13:14:09

CH1 S11 1 U FS 1: 54.449  $\Delta$  -917.97 m $\Omega$  231.17 pF 750.000 000 MHz

#  
De1  
Ca  
Avg  
16  
H1 d

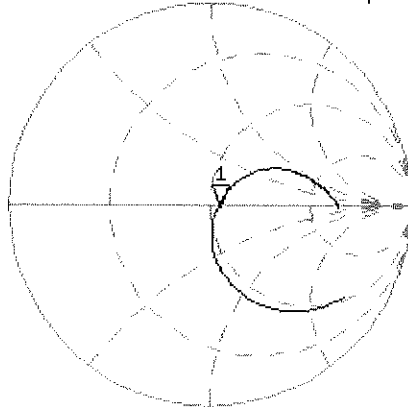

CH2 S11 LOG 5 dB/REF -20 dB 1:-27.227 dB 750.000 000 MHz

Ca  
Avg  
16  
H1 d

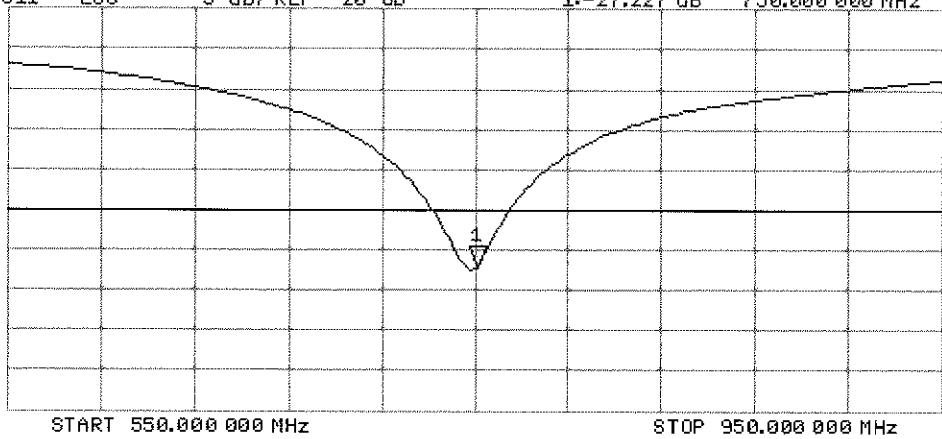

# DASY5 Validation Report for Body TSL

Date: 18.03.2013

Test Laboratory: SPEAG, Zurich, Switzerland

**DUT: Dipole 750 MHz; Type: D750V3; Serial: D750V3 - SN: 1054**

Communication System: CW; Frequency: 750 MHz

Medium parameters used:  $f = 750 \text{ MHz}$ ;  $\sigma = 1 \text{ S/m}$ ;  $\epsilon_r = 54.2$ ;  $\rho = 1000 \text{ kg/m}^3$

Phantom section: Flat Section

Measurement Standard: DASY5 (IEEE/IEC/ANSI C63.19-2007)

DASY52 Configuration:

- Probe: ES3DV3 - SN3205; ConvF(6.11, 6.11, 6.11); Calibrated: 28.12.2012;
- Sensor-Surface: 3mm (Mechanical Surface Detection)
- Electronics: DAE4 Sn601; Calibrated: 27.06.2012
- Phantom: Flat Phantom 4.9L; Type: QD000P49AA; Serial: 1001
- DASY52 52.8.5(1059); SEMCAD X 14.6.8(7028)

## Dipole Calibration for Body Tissue/Pin=250 mW, d=15mm/Zoom Scan (7x7x7)/Cube 0:

Measurement grid: dx=5mm, dy=5mm, dz=5mm

Reference Value = 52.772 V/m; Power Drift = 0.03 dB

Peak SAR (extrapolated) = 3.32 W/kg

**SAR(1 g) = 2.26 W/kg; SAR(10 g) = 1.48 W/kg**

Maximum value of SAR (measured) = 2.61 W/kg

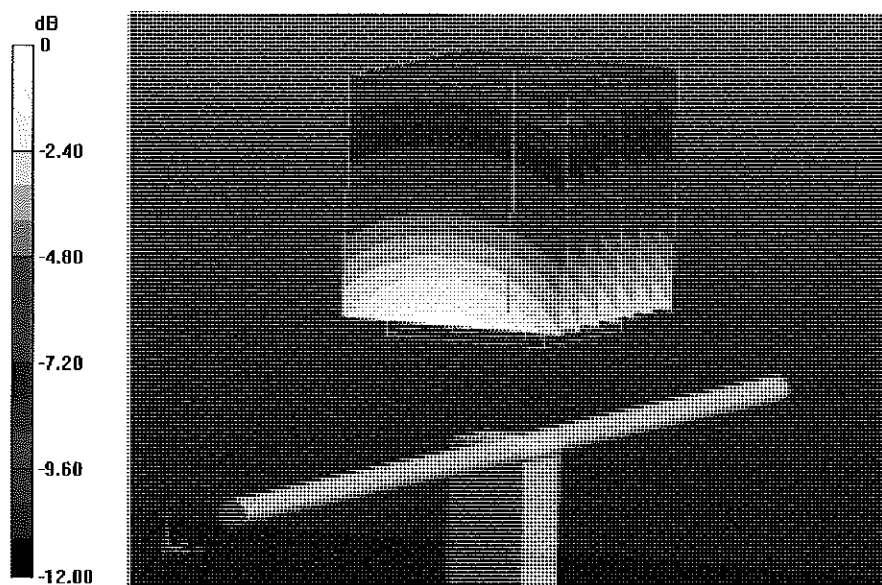

0 dB = 2.61 W/kg = 4.17 dBW/kg

# Impedance Measurement Plot for Body TSL

18 Mar 2013 12:24:11

CH1 S11 1 U FS

1: 49.717  $\Omega$  -2.6553  $\Delta$  79.890 pF

750.000 000 MHz

\*  
De1

CA

Avg  
16

H1d

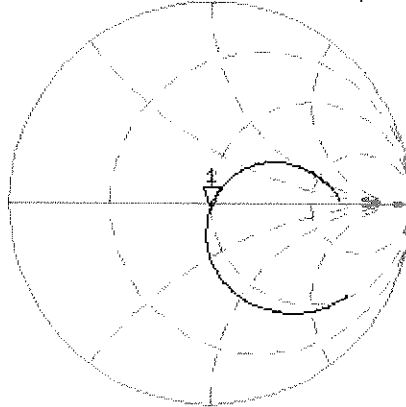

CH2 S11

LOG

5 dB/REF -20 dB

1: -31.444 dB

750.000 000 MHz

CA

Avg  
16

H1d

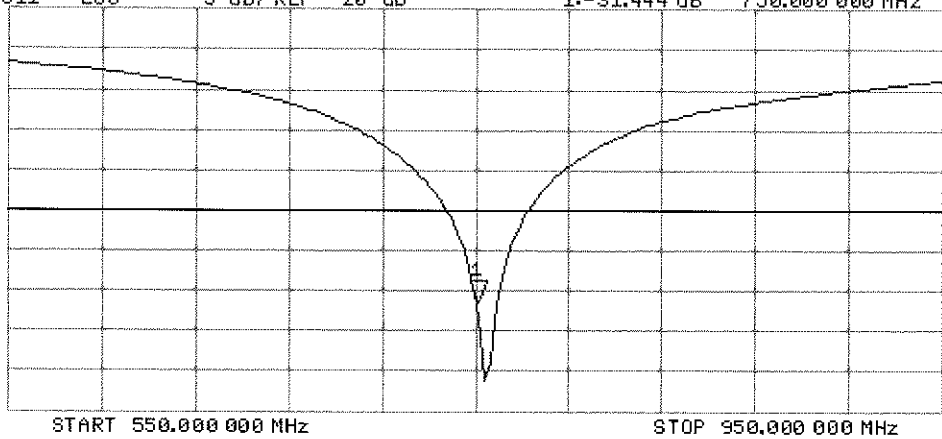



Accredited by the Swiss Accreditation Service (SAS)  
The Swiss Accreditation Service is one of the signatories to the EA  
Multilateral Agreement for the recognition of calibration certificates

Accreditation No.: **SCS 108**

Client **PC Test**

Certificate No: **D835V2-4d119\_Apr13**

## CALIBRATION CERTIFICATE

Object **D835V2 - SN: 4d119**

Calibration procedure(s) **QA CAL-05.v9  
Calibration procedure for dipole validation kits above 700 MHz**

Calibration date: **April 25, 2013**

✓  
KOK  
5/8/13

This calibration certificate documents the traceability to national standards, which realize the physical units of measurements (SI).  
The measurements and the uncertainties with confidence probability are given on the following pages and are part of the certificate.

All calibrations have been conducted in the closed laboratory facility: environment temperature ( $22 \pm 3$ )°C and humidity < 70%.

Calibration Equipment used (M&TE critical for calibration)

Primary Standards	ID #	Cal Date (Certificate No.)	Scheduled Calibration
Power meter EPM-442A	GB37480704	01-Nov-12 (No. 217-01640)	Oct-13
Power sensor HP 8481A	US37292783	01-Nov-12 (No. 217-01640)	Oct-13
Reference 20 dB Attenuator	SN: 5058 (20k)	04-Apr-13 (No. 217-01736)	Apr-14
Type-N mismatch combination	SN: 5047.3 / 06327	04-Apr-13 (No. 217-01739)	Apr-14
Reference Probe ES3DV3	SN: 3205	28-Dec-12 (No. ES3-3205_Dec12)	Dec-13
DAE4	SN: 909	11-Sep-12 (No. DAE4-909_Sep12)	Sep-13
Secondary Standards	ID #	Check Date (in house)	Scheduled Check
Power sensor HP 8481A	MY41092317	18-Oct-02 (in house check Oct-11)	In house check: Oct-13
RF generator R&S SMT-06	100005	04-Aug-99 (in house check Oct-11)	In house check: Oct-13
Network Analyzer HP 8753E	US37390585 S4206	18-Oct-01 (in house check Oct-12)	In house check: Oct-13

Calibrated by: **Claudio Leubler**      Name: Claudio Leubler      Function: Laboratory Technician

Approved by: **Katja Pokovic**      Name: Katja Pokovic      Technical Manager

Signature

Issued: April 26, 2013

This calibration certificate shall not be reproduced except in full without written approval of the laboratory.



Accredited by the Swiss Accreditation Service (SAS)  
The Swiss Accreditation Service is one of the signatories to the EA  
Multilateral Agreement for the recognition of calibration certificates

Accreditation No.: **SCS 108**

### Glossary:

TSL	tissue simulating liquid
ConvF	sensitivity in TSL / NORM x,y,z
N/A	not applicable or not measured

### Calibration is Performed According to the Following Standards:

- IEEE Std 1528-2003, "IEEE Recommended Practice for Determining the Peak Spatial-Averaged Specific Absorption Rate (SAR) in the Human Head from Wireless Communications Devices: Measurement Techniques", December 2003
- IEC 62209-1, "Procedure to measure the Specific Absorption Rate (SAR) for hand-held devices used in close proximity to the ear (frequency range of 300 MHz to 3 GHz)", February 2005
- Federal Communications Commission Office of Engineering & Technology (FCC OET), "Evaluating Compliance with FCC Guidelines for Human Exposure to Radiofrequency Electromagnetic Fields; Additional Information for Evaluating Compliance of Mobile and Portable Devices with FCC Limits for Human Exposure to Radiofrequency Emissions", Supplement C (Edition 01-01) to Bulletin 65

### Additional Documentation:

- DASY4/5 System Handbook

### Methods Applied and Interpretation of Parameters:

- Measurement Conditions:* Further details are available from the Validation Report at the end of the certificate. All figures stated in the certificate are valid at the frequency indicated.
- Antenna Parameters with TSL:* The dipole is mounted with the spacer to position its feed point exactly below the center marking of the flat phantom section, with the arms oriented parallel to the body axis.
- Feed Point Impedance and Return Loss:* These parameters are measured with the dipole positioned under the liquid filled phantom. The impedance stated is transformed from the measurement at the SMA connector to the feed point. The Return Loss ensures low reflected power. No uncertainty required.
- Electrical Delay:* One-way delay between the SMA connector and the antenna feed point. No uncertainty required.
- SAR measured:* SAR measured at the stated antenna input power.
- SAR normalized:* SAR as measured, normalized to an input power of 1 W at the antenna connector.
- SAR for nominal TSL parameters:* The measured TSL parameters are used to calculate the nominal SAR result.

The reported uncertainty of measurement is stated as the standard uncertainty of measurement multiplied by the coverage factor  $k=2$ , which for a normal distribution corresponds to a coverage probability of approximately 95%.

## Measurement Conditions

DASY system configuration, as far as not given on page 1.

DASY Version	DASY5	V52.8.6
Extrapolation	Advanced Extrapolation	
Phantom	Modular Flat Phantom	
Distance Dipole Center - TSL	15 mm	with Spacer
Zoom Scan Resolution	dx, dy, dz = 5 mm	
Frequency	835 MHz $\pm$ 1 MHz	

## Head TSL parameters

The following parameters and calculations were applied.

	Temperature	Permittivity	Conductivity
Nominal Head TSL parameters	22.0 °C	41.5	0.90 mho/m
Measured Head TSL parameters	(22.0 $\pm$ 0.2) °C	40.8 $\pm$ 6 %	0.94 mho/m $\pm$ 6 %
Head TSL temperature change during test	< 0.5 °C	----	----

## SAR result with Head TSL

SAR averaged over 1 cm <sup>3</sup> (1 g) of Head TSL	Condition	
SAR measured	250 mW input power	2.51 W/kg
SAR for nominal Head TSL parameters	normalized to 1W	<b>9.68 W/kg <math>\pm</math> 17.0 % (k=2)</b>

SAR averaged over 10 cm <sup>3</sup> (10 g) of Head TSL	condition	
SAR measured	250 mW input power	1.62 W/kg
SAR for nominal Head TSL parameters	normalized to 1W	<b>6.30 W/kg <math>\pm</math> 16.5 % (k=2)</b>

## Body TSL parameters

The following parameters and calculations were applied.

	Temperature	Permittivity	Conductivity
Nominal Body TSL parameters	22.0 °C	55.2	0.97 mho/m
Measured Body TSL parameters	(22.0 $\pm$ 0.2) °C	54.0 $\pm$ 6 %	1.01 mho/m $\pm$ 6 %
Body TSL temperature change during test	< 0.5 °C	----	----

## SAR result with Body TSL

SAR averaged over 1 cm <sup>3</sup> (1 g) of Body TSL	Condition	
SAR measured	250 mW input power	2.47 W/kg
SAR for nominal Body TSL parameters	normalized to 1W	<b>9.54 W/kg <math>\pm</math> 17.0 % (k=2)</b>

SAR averaged over 10 cm <sup>3</sup> (10 g) of Body TSL	condition	
SAR measured	250 mW input power	1.62 W/kg
SAR for nominal Body TSL parameters	normalized to 1W	<b>6.31 W/kg <math>\pm</math> 16.5 % (k=2)</b>

## Appendix

### Antenna Parameters with Head TSL

Impedance, transformed to feed point	50.1 $\Omega$ - 4.7 j $\Omega$
Return Loss	- 26.6 dB

### Antenna Parameters with Body TSL

Impedance, transformed to feed point	45.8 $\Omega$ - 6.3 j $\Omega$
Return Loss	- 22.1 dB

### General Antenna Parameters and Design

Electrical Delay (one direction)	1.385 ns
----------------------------------	----------

After long term use with 100W radiated power, only a slight warming of the dipole near the feedpoint can be measured.

The dipole is made of standard semirigid coaxial cable. The center conductor of the feeding line is directly connected to the second arm of the dipole. The antenna is therefore short-circuited for DC-signals. On some of the dipoles, small end caps are added to the dipole arms in order to improve matching when loaded according to the position as explained in the "Measurement Conditions" paragraph. The SAR data are not affected by this change. The overall dipole length is still according to the Standard.

No excessive force must be applied to the dipole arms, because they might bend or the soldered connections near the feedpoint may be damaged.

### Additional EUT Data

Manufactured by	SPEAG
Manufactured on	June 29, 2010

## DASY5 Validation Report for Head TSL

Date: 25.04.2013

Test Laboratory: SPEAG, Zurich, Switzerland

**DUT: Dipole 835 MHz; Type: D835V2; Serial: D835V2 - SN: 4d119**

Communication System: UID 0 - CW; Frequency: 835 MHz

Medium parameters used:  $f = 835$  MHz;  $\sigma = 0.94$  S/m;  $\epsilon_r = 40.8$ ;  $\rho = 1000$  kg/m<sup>3</sup>

Phantom section: Flat Section

Measurement Standard: DASY5 (IEEE/IEC/ANSI C63.19-2007)

DASY52 Configuration:

- Probe: ES3DV3 - SN3205; ConvF(6.05, 6.05, 6.05); Calibrated: 28.12.2012;
- Sensor-Surface: 3mm (Mechanical Surface Detection)
- Electronics: DAE4 Sn909; Calibrated: 11.09.2012
- Phantom: Flat Phantom 4.9L; Type: QD000P49AA; Serial: 1001
- DASY52 52.8.6(1115); SEMCAD X 14.6.9(7117)

### **Dipole Calibration for Head Tissue/Pin=250 mW, d=15mm/Zoom Scan (7x7x7)/Cube 0:**

Measurement grid: dx=5mm, dy=5mm, dz=5mm

Reference Value = 57.387 V/m; Power Drift = 0.03 dB

Peak SAR (extrapolated) = 3.86 W/kg

**SAR(1 g) = 2.51 W/kg; SAR(10 g) = 1.62 W/kg**

Maximum value of SAR (measured) = 2.93 W/kg

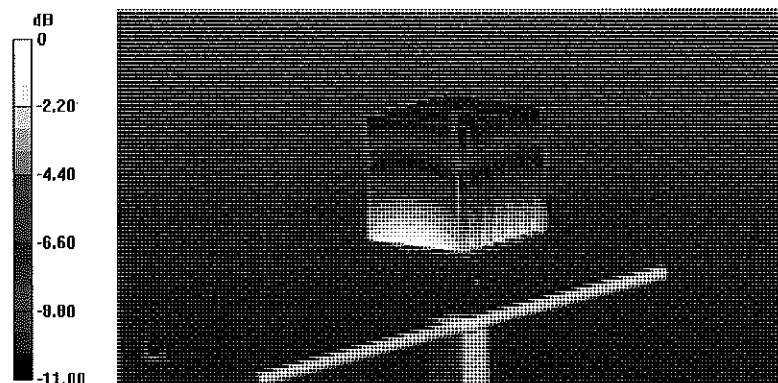

0 dB = 2.93 W/kg = 4.67 dBW/kg

# Impedance Measurement Plot for Head TSL

25 Apr 2013 09:11:06

CH1 S11 1 U FS

1: 50.061  $\Omega$  -4.6621  $\Omega$  40.884 pF

835.000 000 MHz

\*  
Del

CA

Avg  
16

H1 d

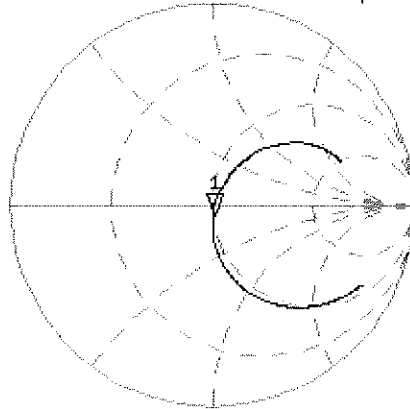

CH2 S11 LOG

5 dB/REF -20 dB

1: -26.641 dB 835.000 000 MHz

CA

Avg  
16

H1 d

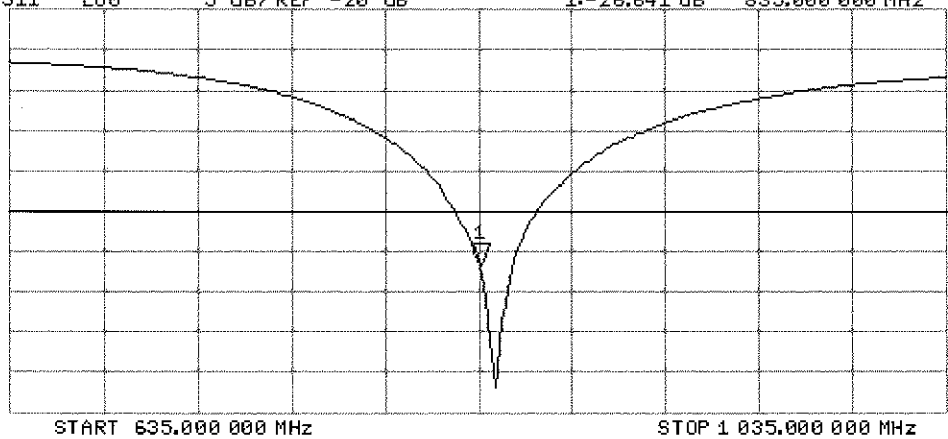

## DASY5 Validation Report for Body TSL

Date: 24.04.2013

Test Laboratory: SPEAG, Zurich, Switzerland

**DUT: Dipole 835 MHz; Type: D835V2; Serial: D835V2 - SN: 4d119**

Communication System: UID 0 - CW; Frequency: 835 MHz

Medium parameters used:  $f = 835$  MHz;  $\sigma = 1.01$  S/m;  $\epsilon_r = 54$ ;  $\rho = 1000$  kg/m<sup>3</sup>

Phantom section: Flat Section

Measurement Standard: DASY5 (IEEE/IEC/ANSI C63.19-2007)

DASY52 Configuration:

- Probe: ES3DV3 - SN3205; ConvF(6.04, 6.04, 6.04); Calibrated: 28.12.2012;
- Sensor-Surface: 3mm (Mechanical Surface Detection)
- Electronics: DAE4 Sn909; Calibrated: 11.09.2012
- Phantom: Flat Phantom 4.9L; Type: QD000P49AA; Serial: 1001
- DASY52 52.8.6(1115); SEMCAD X 14.6.9(7117)

### **Dipole Calibration for Body Tissue/Pin=250 mW, d=15mm/Zoom Scan (7x7x7)/Cube 0:**

Measurement grid: dx=5mm, dy=5mm, dz=5mm

Reference Value = 55.178 V/m; Power Drift = 0.03 dB

Peak SAR (extrapolated) = 3.68 W/kg

**SAR(1 g) = 2.47 W/kg; SAR(10 g) = 1.62 W/kg**

Maximum value of SAR (measured) = 2.89 W/kg

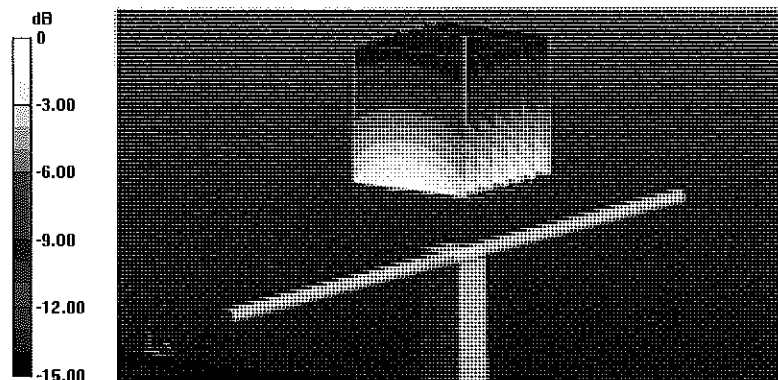

0 dB = 2.89 W/kg = 4.61 dBW/kg

# Impedance Measurement Plot for Body TSL

24 Apr 2013 11:33:44

CH1 S11 1 U FS

2: 45.773  $\Omega$  -6.2773  $\Delta$  30.364 pF

835.000 000 MHz

\*  
DeI

CΔ

Avg  
16

H1d

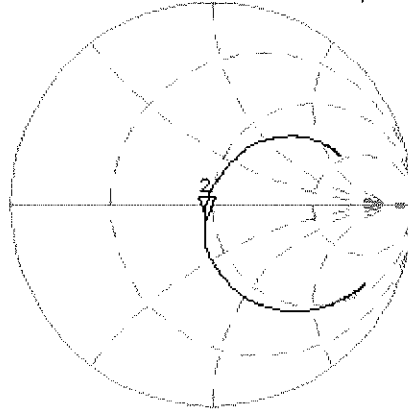

CH2 S11 LOG

5 dB/REF -20 dB

2: -22.065 dB

835.000 000 MHz

CΔ

Avg  
16

H1d

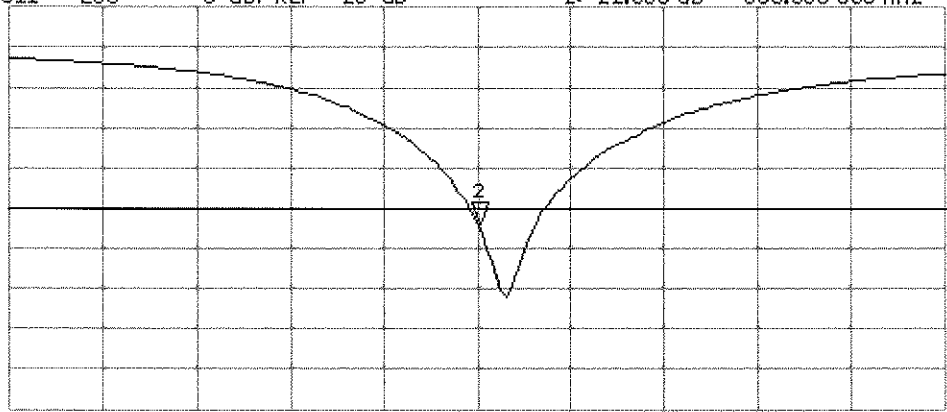

START 635.000 000 MHz

STOP 1 035.000 000 MHz



Accredited by the Swiss Accreditation Service (SAS)  
The Swiss Accreditation Service is one of the signatories to the EA  
Multilateral Agreement for the recognition of calibration certificates

Accreditation No.: **SCS 108**

Client **PC Test**

Certificate No: **D1765V2-1008\_May13**

## CALIBRATION CERTIFICATE

Object **D1765V2 - SN: 1008**

Calibration procedure(s) **QA CAL-05.v9  
Calibration procedure for dipole validation kits above 700 MHz**

Calibration date: **May 14, 2013**

*✓ 100k  
5/23/13*

This calibration certificate documents the traceability to national standards, which realize the physical units of measurements (SI).  
The measurements and the uncertainties with confidence probability are given on the following pages and are part of the certificate.

All calibrations have been conducted in the closed laboratory facility: environment temperature (22 ± 3)°C and humidity < 70%.

Calibration Equipment used (M&TE critical for calibration)

Primary Standards	ID #	Cal Date (Certificate No.)	Scheduled Calibration
Power meter EPM-442A	GB37480704	01-Nov-12 (No. 217-01640)	Oct-13
Power sensor HP 8481A	US37292783	01-Nov-12 (No. 217-01640)	Oct-13
Reference 20 dB Attenuator	SN: 5058 (20k)	04-Apr-13 (No. 217-01736)	Apr-14
Type-N mismatch combination	SN: 5047.3 / 06327	04-Apr-13 (No. 217-01739)	Apr-14
Reference Probe ES3DV3	SN: 3205	28-Dec-12 (No. ES3-3205_Dec12)	Dec-13
DAE4	SN: 601	25-Apr-13 (No. DAE4-601_Apr13)	Apr-14
Secondary Standards	ID #	Check Date (in house)	Scheduled Check
Power sensor HP 8481A	MY41092317	18-Oct-02 (in house check Oct-11)	In house check: Oct-13
RF generator R&S SMT-06	100005	04-Aug-99 (in house check Oct-11)	In house check: Oct-13
Network Analyzer HP 8753E	US37390585 S4206	18-Oct-01 (in house check Oct-12)	In house check: Oct-13

Calibrated by: **Jeton Kastat**      Name: **Jeton Kastat**      Function: **Laboratory Technician**      Signature: *[Signature]*

Approved by: **Katja Pokovic**      Name: **Katja Pokovic**      Function: **Technical Manager**      Signature: *[Signature]*

Issued: May 15, 2013

This calibration certificate shall not be reproduced except in full without written approval of the laboratory.



Accredited by the Swiss Accreditation Service (SAS)

Accreditation No.: **SCS 108**

The Swiss Accreditation Service is one of the signatories to the EA Multilateral Agreement for the recognition of calibration certificates

### Glossary:

TSL	tissue simulating liquid
ConvF	sensitivity in TSL / NORM x,y,z
N/A	not applicable or not measured

### Calibration is Performed According to the Following Standards:

- IEEE Std 1528-2003, "IEEE Recommended Practice for Determining the Peak Spatial-Averaged Specific Absorption Rate (SAR) in the Human Head from Wireless Communications Devices: Measurement Techniques", December 2003
- IEC 62209-1, "Procedure to measure the Specific Absorption Rate (SAR) for hand-held devices used in close proximity to the ear (frequency range of 300 MHz to 3 GHz)", February 2005
- Federal Communications Commission Office of Engineering & Technology (FCC OET), "Evaluating Compliance with FCC Guidelines for Human Exposure to Radiofrequency Electromagnetic Fields; Additional Information for Evaluating Compliance of Mobile and Portable Devices with FCC Limits for Human Exposure to Radiofrequency Emissions", Supplement C (Edition 01-01) to Bulletin 65

### Additional Documentation:

- DASY4/5 System Handbook

### Methods Applied and Interpretation of Parameters:

- Measurement Conditions:* Further details are available from the Validation Report at the end of the certificate. All figures stated in the certificate are valid at the frequency indicated.
- Antenna Parameters with TSL:* The dipole is mounted with the spacer to position its feed point exactly below the center marking of the flat phantom section, with the arms oriented parallel to the body axis.
- Feed Point Impedance and Return Loss:* These parameters are measured with the dipole positioned under the liquid filled phantom. The impedance stated is transformed from the measurement at the SMA connector to the feed point. The Return Loss ensures low reflected power. No uncertainty required.
- Electrical Delay:* One-way delay between the SMA connector and the antenna feed point. No uncertainty required.
- SAR measured:* SAR measured at the stated antenna input power.
- SAR normalized:* SAR as measured, normalized to an input power of 1 W at the antenna connector.
- SAR for nominal TSL parameters:* The measured TSL parameters are used to calculate the nominal SAR result.

The reported uncertainty of measurement is stated as the standard uncertainty of measurement multiplied by the coverage factor  $k=2$ , which for a normal distribution corresponds to a coverage probability of approximately 95%.

## Measurement Conditions

DASY system configuration, as far as not given on page 1.

<b>DASY Version</b>	DASY5	V52.8.6
<b>Extrapolation</b>	Advanced Extrapolation	
<b>Phantom</b>	Modular Flat Phantom	
<b>Distance Dipole Center - TSL</b>	10 mm	with Spacer
<b>Zoom Scan Resolution</b>	dx, dy, dz = 5 mm	
<b>Frequency</b>	1750 MHz $\pm$ 1 MHz	

## Head TSL parameters

The following parameters and calculations were applied.

	Temperature	Permittivity	Conductivity
<b>Nominal Head TSL parameters</b>	22.0 °C	40.1	1.37 mho/m
<b>Measured Head TSL parameters</b>	(22.0 $\pm$ 0.2) °C	39.1 $\pm$ 6 %	1.33 mho/m $\pm$ 6 %
<b>Head TSL temperature change during test</b>	< 0.5 °C	----	----

## SAR result with Head TSL

<b>SAR averaged over 1 cm<sup>3</sup> (1 g) of Head TSL</b>	Condition	
SAR measured	250 mW input power	9.09 W/kg
SAR for nominal Head TSL parameters	normalized to 1W	<b>36.8 W/kg <math>\pm</math> 17.0 % (k=2)</b>

<b>SAR averaged over 10 cm<sup>3</sup> (10 g) of Head TSL</b>	condition	
SAR measured	250 mW input power	4.85 W/kg
SAR for nominal Head TSL parameters	normalized to 1W	<b>19.6 W/kg <math>\pm</math> 16.5 % (k=2)</b>

## Body TSL parameters

The following parameters and calculations were applied.

	Temperature	Permittivity	Conductivity
<b>Nominal Body TSL parameters</b>	22.0 °C	53.4	1.49 mho/m
<b>Measured Body TSL parameters</b>	(22.0 $\pm$ 0.2) °C	51.7 $\pm$ 6 %	1.47 mho/m $\pm$ 6 %
<b>Body TSL temperature change during test</b>	< 0.5 °C	----	----

## SAR result with Body TSL

<b>SAR averaged over 1 cm<sup>3</sup> (1 g) of Body TSL</b>	Condition	
SAR measured	250 mW input power	9.53 W/kg
SAR for nominal Body TSL parameters	normalized to 1W	<b>38.2 W/kg <math>\pm</math> 17.0 % (k=2)</b>

<b>SAR averaged over 10 cm<sup>3</sup> (10 g) of Body TSL</b>	condition	
SAR measured	250 mW input power	5.10 W/kg
SAR for nominal Body TSL parameters	normalized to 1W	<b>20.4 W/kg <math>\pm</math> 16.5 % (k=2)</b>

## Appendix

### Antenna Parameters with Head TSL

Impedance, transformed to feed point	48.3 $\Omega$ - 6.4 j $\Omega$
Return Loss	- 23.5 dB

### Antenna Parameters with Body TSL

Impedance, transformed to feed point	43.8 $\Omega$ - 6.1 j $\Omega$
Return Loss	- 20.6 dB

### General Antenna Parameters and Design

Electrical Delay (one direction)	1.211 ns
----------------------------------	----------

After long term use with 100W radiated power, only a slight warming of the dipole near the feedpoint can be measured.

The dipole is made of standard semirigid coaxial cable. The center conductor of the feeding line is directly connected to the second arm of the dipole. The antenna is therefore short-circuited for DC-signals. On some of the dipoles, small end caps are added to the dipole arms in order to improve matching when loaded according to the position as explained in the "Measurement Conditions" paragraph. The SAR data are not affected by this change. The overall dipole length is still according to the Standard.

No excessive force must be applied to the dipole arms, because they might bend or the soldered connections near the feedpoint may be damaged.

### Additional EUT Data

Manufactured by	SPEAG
Manufactured on	October 06, 2005

## DASY5 Validation Report for Head TSL

Date: 14.05.2013

Test Laboratory: SPEAG, Zurich, Switzerland

**DUT: Dipole 1765 MHz; Type: D1765V2; Serial: D1765V2 - SN: 1008**

Communication System: UID 0 - CW ; Frequency: 1750 MHz

Medium parameters used:  $f = 1750$  MHz;  $\sigma = 1.33$  S/m;  $\epsilon_r = 39.1$ ;  $\rho = 1000$  kg/m<sup>3</sup>

Phantom section: Flat Section

Measurement Standard: DASY5 (IEEE/IEC/ANSI C63.19-2007)

DASY52 Configuration:

- Probe: ES3DV3 - SN3205; ConvF(5.18, 5.18, 5.18); Calibrated: 28.12.2012;
- Sensor-Surface: 3mm (Mechanical Surface Detection)
- Electronics: DAE4 Sn601; Calibrated: 25.04.2013
- Phantom: Flat Phantom 5.0 (front); Type: QD000P50AA; Serial: 1001
- DASY52 52.8.6(1115); SEMCAD X 14.6.9(7117)

### **Dipole Calibration for Head Tissue/Pin=250 mW, d=10mm/Zoom Scan (7x7x7)/Cube 0:**

Measurement grid: dx=5mm, dy=5mm, dz=5mm

Reference Value = 94.430 V/m; Power Drift = 0.01 dB

Peak SAR (extrapolated) = 16.3 W/kg

**SAR(1 g) = 9.09 W/kg; SAR(10 g) = 4.85 W/kg**

Maximum value of SAR (measured) = 11.3 W/kg

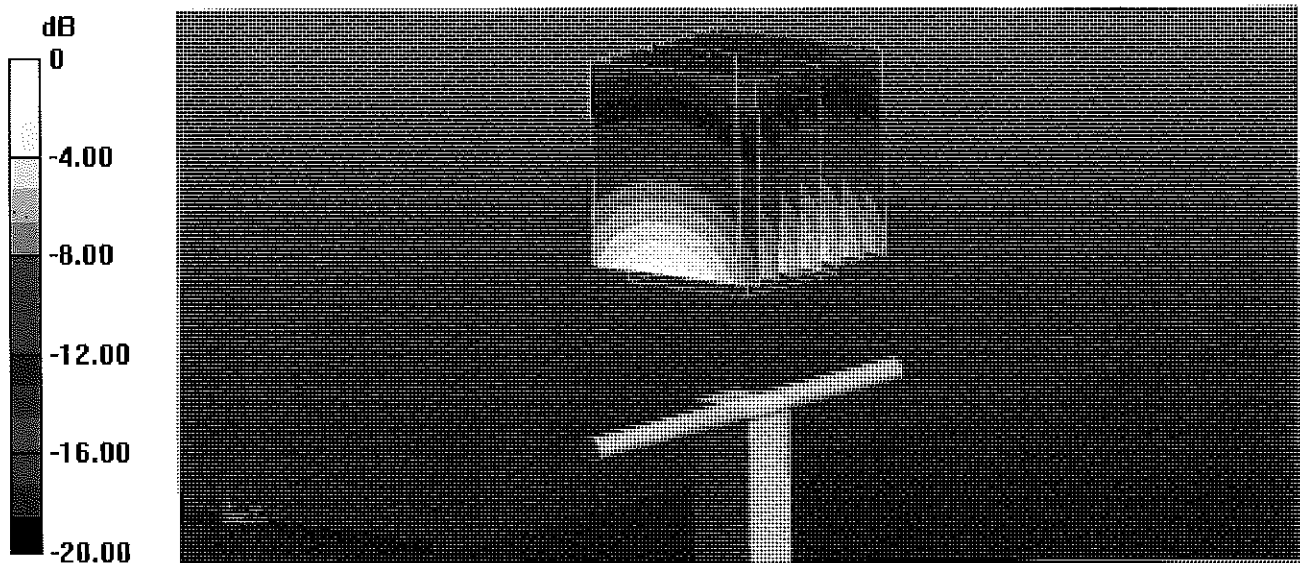

0 dB = 11.3 W/kg = 10.53 dBW/kg

# Impedance Measurement Plot for Head TSL

14 May 2013 15:57:39

CH1 S11 1 U FS 1: 48.322  $\Omega$  -6.3848  $\Omega$  14.244 pF 1 750.000 000 MHz

\*  
De1  
CΔ  
Avg  
16  
H1 d

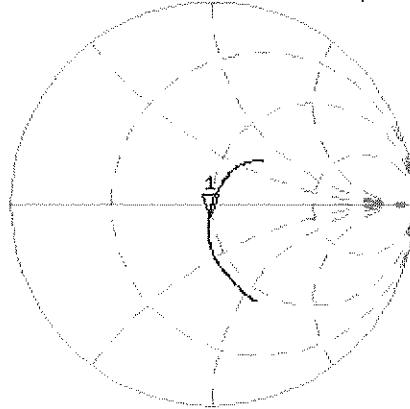

CH2 S11 LOG 5 dB/REF -20 dB 1:-23.476 dB 1 750.000 000 MHz

CΔ  
Avg  
16  
H1 d

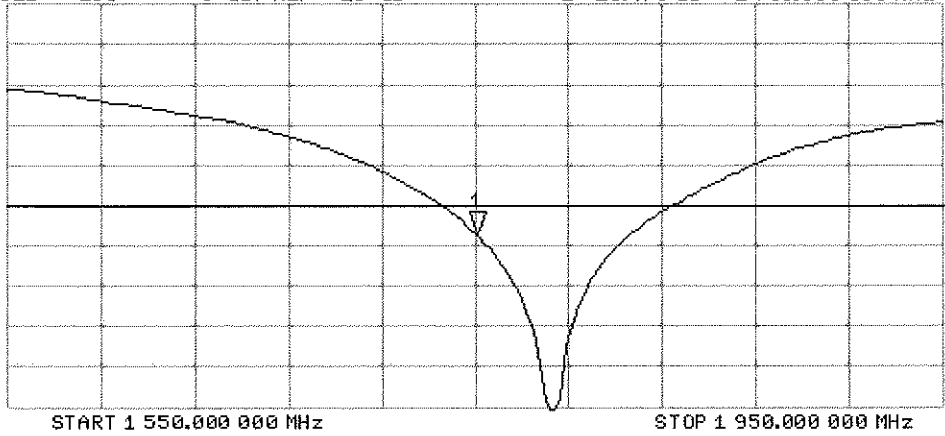

## DASY5 Validation Report for Body TSL

Date: 13.05.2013

Test Laboratory: SPEAG, Zurich, Switzerland

**DUT: Dipole 1765 MHz; Type: D1765V2; Serial: D1765V2 - SN: 1008**

Communication System: UID 0 - CW ; Frequency: 1750 MHz

Medium parameters used:  $f = 1750$  MHz;  $\sigma = 1.47$  S/m;  $\epsilon_r = 51.7$ ;  $\rho = 1000$  kg/m<sup>3</sup>

Phantom section: Flat Section

Measurement Standard: DASY5 (IEEE/IEC/ANSI C63.19-2007)

DASY52 Configuration:

- Probe: ES3DV3 - SN3205; ConvF(4.83, 4.83, 4.83); Calibrated: 28.12.2012;
- Sensor-Surface: 3mm (Mechanical Surface Detection)
- Electronics: DAE4 Sn601; Calibrated: 25.04.2013
- Phantom: Flat Phantom 5.0 (back); Type: QD000P50AA; Serial: 1002
- DASY52 52.8.6(1115); SEMCAD X 14.6.9(7117)

### **Dipole Calibration for Body Tissue/Pin=250 mW, d=10mm/Zoom Scan (7x7x7)/Cube 0:**

Measurement grid: dx=5mm, dy=5mm, dz=5mm

Reference Value = 94.430 V/m; Power Drift = 0.01 dB

Peak SAR (extrapolated) = 16.4 W/kg

**SAR(1 g) = 9.53 W/kg; SAR(10 g) = 5.1 W/kg**

Maximum value of SAR (measured) = 12.0 W/kg

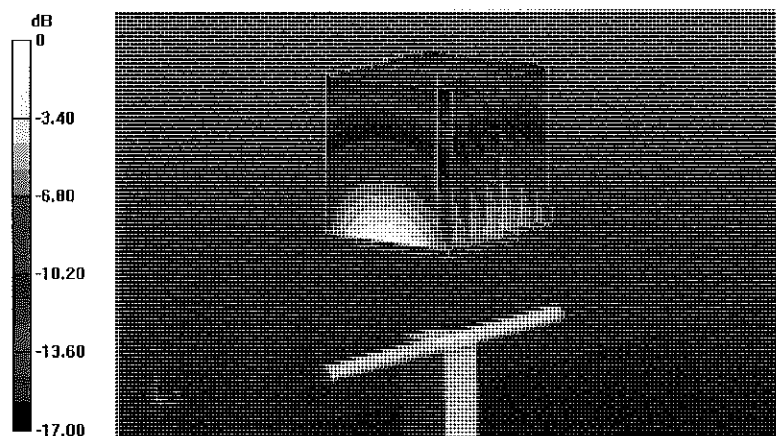

# Impedance Measurement Plot for Body TSL

13 May 2013 15:25:53

CH1 S11 1 U FS

1: 43.775  $\Omega$  -6.1426  $\Omega$  14.806 pF

1 750.000 000 MHz

\*  
De1  
Cor

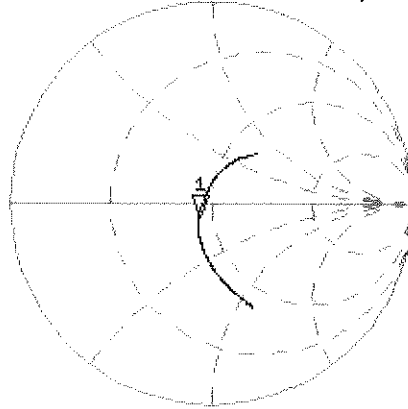

Avg  
16

H1d

CH2 S11 LOG

5 dB/REF -20 dB

1:-20.627 dB

1 750.000 000 MHz

Cor

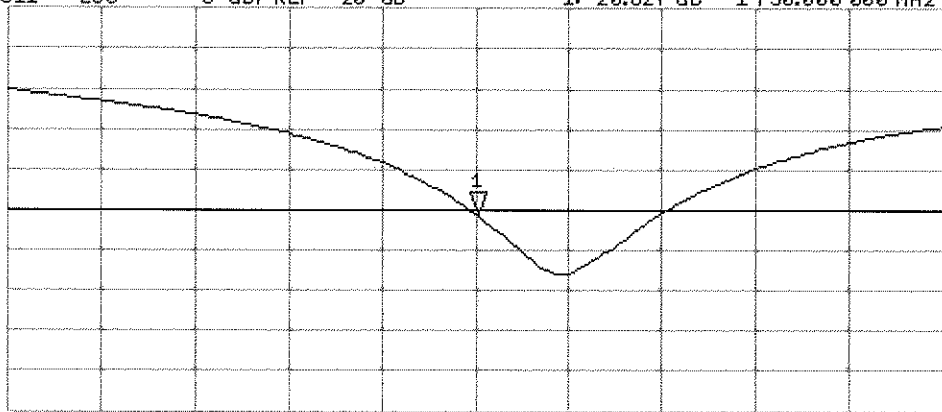

Avg  
16

H1d

START 1 550.000 000 MHz

STOP 1 950.000 000 MHz



Accredited by the Swiss Accreditation Service (SAS)  
The Swiss Accreditation Service is one of the signatories to the EA  
Multilateral Agreement for the recognition of calibration certificates

Accreditation No.: **SCS 108**

Client **PC Test**

Certificate No: **D1900V2-5d141\_May13**

## CALIBRATION CERTIFICATE

Object **D1900V2 - SN: 5d141**

Calibration procedure(s) **QA CAL-05.v9  
Calibration procedure for dipole validation kits above 700 MHz**

Calibration date: **May 02, 2013**

✓  
5/8/13

This calibration certificate documents the traceability to national standards, which realize the physical units of measurements (SI).  
The measurements and the uncertainties with confidence probability are given on the following pages and are part of the certificate.

All calibrations have been conducted in the closed laboratory facility: environment temperature ( $22 \pm 3$ )°C and humidity < 70%.

Calibration Equipment used (M&TE critical for calibration)

Primary Standards	ID #	Cal Date (Certificate No.)	Scheduled Calibration
Power meter EPM-442A	GB37480704	01-Nov-12 (No. 217-01640)	Oct-13
Power sensor HP 8481A	US37292783	01-Nov-12 (No. 217-01640)	Oct-13
Reference 20 dB Attenuator	SN: 5058 (20k)	04-Apr-13 (No. 217-01736)	Apr-14
Type-N mismatch combination	SN: 5047.3 / 06327	04-Apr-13 (No. 217-01739)	Apr-14
Reference Probe ES3DV3	SN: 3205	28-Dec-12 (No. ES3-3205_Dec12)	Dec-13
DAE4	SN: 601	25-Apr-13 (No. DAE4-601_Apr13)	Apr-14

Secondary Standards	ID #	Check Date (in house)	Scheduled Check
Power sensor HP 8481A	MY41092317	18-Oct-02 (in house check Oct-11)	In house check: Oct-13
RF generator R&S SMT-06	100005	04-Aug-99 (in house check Oct-11)	In house check: Oct-13
Network Analyzer HP 8753E	US37390585 S4206	18-Oct-01 (in house check Oct-12)	In house check: Oct-13

Calibrated by: **Claudio Leubler**      Name: Claudio Leubler      Function: Laboratory Technician

Signature

Approved by: **Katja Pokovic**      Name: Katja Pokovic      Function: Technical Manager

*[Handwritten Signature]*

Issued: May 2, 2013

This calibration certificate shall not be reproduced except in full without written approval of the laboratory.



Accredited by the Swiss Accreditation Service (SAS)

The Swiss Accreditation Service is one of the signatories to the EA  
Multilateral Agreement for the recognition of calibration certificates

Accreditation No.: **SCS 108**

### Glossary:

TSL	tissue simulating liquid
ConvF	sensitivity in TSL / NORM x,y,z
N/A	not applicable or not measured

### Calibration is Performed According to the Following Standards:

- IEEE Std 1528-2003, "IEEE Recommended Practice for Determining the Peak Spatial-Averaged Specific Absorption Rate (SAR) in the Human Head from Wireless Communications Devices: Measurement Techniques", December 2003
- IEC 62209-1, "Procedure to measure the Specific Absorption Rate (SAR) for hand-held devices used in close proximity to the ear (frequency range of 300 MHz to 3 GHz)", February 2005
- Federal Communications Commission Office of Engineering & Technology (FCC OET), "Evaluating Compliance with FCC Guidelines for Human Exposure to Radiofrequency Electromagnetic Fields; Additional Information for Evaluating Compliance of Mobile and Portable Devices with FCC Limits for Human Exposure to Radiofrequency Emissions", Supplement C (Edition 01-01) to Bulletin 65

### Additional Documentation:

- DASY4/5 System Handbook

### Methods Applied and Interpretation of Parameters:

- Measurement Conditions:* Further details are available from the Validation Report at the end of the certificate. All figures stated in the certificate are valid at the frequency indicated.
- Antenna Parameters with TSL:* The dipole is mounted with the spacer to position its feed point exactly below the center marking of the flat phantom section, with the arms oriented parallel to the body axis.
- Feed Point Impedance and Return Loss:* These parameters are measured with the dipole positioned under the liquid filled phantom. The impedance stated is transformed from the measurement at the SMA connector to the feed point. The Return Loss ensures low reflected power. No uncertainty required.
- Electrical Delay:* One-way delay between the SMA connector and the antenna feed point. No uncertainty required.
- SAR measured:* SAR measured at the stated antenna input power.
- SAR normalized:* SAR as measured, normalized to an input power of 1 W at the antenna connector.
- SAR for nominal TSL parameters:* The measured TSL parameters are used to calculate the nominal SAR result.

The reported uncertainty of measurement is stated as the standard uncertainty of measurement multiplied by the coverage factor  $k=2$ , which for a normal distribution corresponds to a coverage probability of approximately 95%.

## Measurement Conditions

DASY system configuration, as far as not given on page 1.

DASY Version	DASY5	V52.8.6
Extrapolation	Advanced Extrapolation	
Phantom	Modular Flat Phantom	
Distance Dipole Center - TSL	10 mm	with Spacer
Zoom Scan Resolution	dx, dy, dz = 5 mm	
Frequency	1900 MHz $\pm$ 1 MHz	

## Head TSL parameters

The following parameters and calculations were applied.

	Temperature	Permittivity	Conductivity
Nominal Head TSL parameters	22.0 °C	40.0	1.40 mho/m
Measured Head TSL parameters	(22.0 $\pm$ 0.2) °C	39.3 $\pm$ 6 %	1.37 mho/m $\pm$ 6 %
Head TSL temperature change during test	< 0.5 °C	----	----

## SAR result with Head TSL

SAR averaged over 1 cm <sup>3</sup> (1 g) of Head TSL	Condition	
SAR measured	250 mW input power	10.1 W/kg
SAR for nominal Head TSL parameters	normalized to 1W	<b>40.8 W/kg <math>\pm</math> 17.0 % (k=2)</b>

SAR averaged over 10 cm <sup>3</sup> (10 g) of Head TSL	condition	
SAR measured	250 mW input power	5.30 W/kg
SAR for nominal Head TSL parameters	normalized to 1W	<b>21.3 W/kg <math>\pm</math> 16.5 % (k=2)</b>

## Body TSL parameters

The following parameters and calculations were applied.

	Temperature	Permittivity	Conductivity
Nominal Body TSL parameters	22.0 °C	53.3	1.52 mho/m
Measured Body TSL parameters	(22.0 $\pm$ 0.2) °C	54.0 $\pm$ 6 %	1.51 mho/m $\pm$ 6 %
Body TSL temperature change during test	< 0.5 °C	----	----

## SAR result with Body TSL

SAR averaged over 1 cm <sup>3</sup> (1 g) of Body TSL	Condition	
SAR measured	250 mW input power	10.3 W/kg
SAR for nominal Body TSL parameters	normalized to 1W	<b>41.5 W/kg <math>\pm</math> 17.0 % (k=2)</b>

SAR averaged over 10 cm <sup>3</sup> (10 g) of Body TSL	condition	
SAR measured	250 mW input power	5.51 W/kg
SAR for nominal Body TSL parameters	normalized to 1W	<b>22.1 W/kg <math>\pm</math> 16.5 % (k=2)</b>

## Appendix

### Antenna Parameters with Head TSL

Impedance, transformed to feed point	52.6 $\Omega$ + 4.9 j $\Omega$
Return Loss	- 25.3 dB

### Antenna Parameters with Body TSL

Impedance, transformed to feed point	48.3 $\Omega$ + 5.9 j $\Omega$
Return Loss	- 24.1 dB

### General Antenna Parameters and Design

Electrical Delay (one direction)	1.199 ns
----------------------------------	----------

After long term use with 100W radiated power, only a slight warming of the dipole near the feedpoint can be measured.

The dipole is made of standard semirigid coaxial cable. The center conductor of the feeding line is directly connected to the second arm of the dipole. The antenna is therefore short-circuited for DC-signals. On some of the dipoles, small end caps are added to the dipole arms in order to improve matching when loaded according to the position as explained in the "Measurement Conditions" paragraph. The SAR data are not affected by this change. The overall dipole length is still according to the Standard.

No excessive force must be applied to the dipole arms, because they might bend or the soldered connections near the feedpoint may be damaged.

### Additional EUT Data

Manufactured by	SPEAG
Manufactured on	March 11, 2011

## DASY5 Validation Report for Head TSL

Date: 02.05.2013

Test Laboratory: SPEAG, Zurich, Switzerland

**DUT: Dipole 1900 MHz; Type: D1900V2; Serial: D1900V2 - SN: 5d141**

Communication System: UID 0 - CW; Frequency: 1900 MHz

Medium parameters used:  $f = 1900$  MHz;  $\sigma = 1.37$  S/m;  $\epsilon_r = 39.3$ ;  $\rho = 1000$  kg/m<sup>3</sup>

Phantom section: Flat Section

Measurement Standard: DASY5 (IEEE/IEC/ANSI C63.19-2007)

DASY52 Configuration:

- Probe: ES3DV3 - SN3205; ConvF(4.98, 4.98, 4.98); Calibrated: 28.12.2012;
- Sensor-Surface: 3mm (Mechanical Surface Detection)
- Electronics: DAE4 Sn601; Calibrated: 25.04.2013
- Phantom: Flat Phantom 5.0 (front); Type: QD000P50AA; Serial: 1001
- DASY52 52.8.6(1115); SEMCAD X 14.6.9(7117)

### **Dipole Calibration for Head Tissue/Pin=250 mW, d=10mm/Zoom Scan (7x7x7)/Cube 0:**

Measurement grid: dx=5mm, dy=5mm, dz=5mm

Reference Value = 97.124 V/m; Power Drift = 0.05 dB

Peak SAR (extrapolated) = 18.2 W/kg

**SAR(1 g) = 10.1 W/kg; SAR(10 g) = 5.3 W/kg**

Maximum value of SAR (measured) = 12.5 W/kg

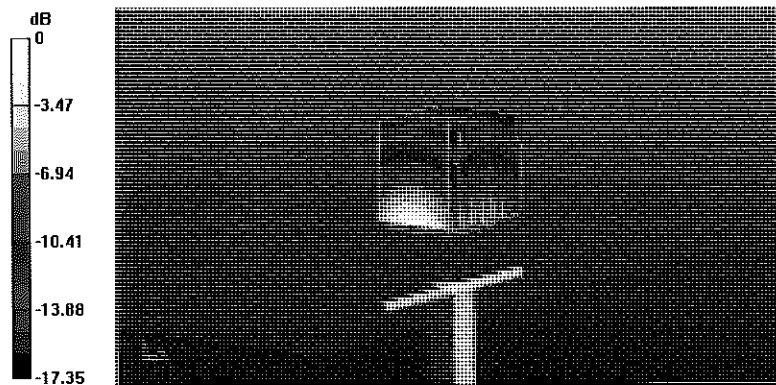

0 dB = 12.5 W/kg = 10.97 dBW/kg

# Impedance Measurement Plot for Head TSL

2 May 2013 15:38:50

CH1 S11 1 U FS 1: 52.600  $\Omega$  4.9375  $\Omega$  413.59  $\mu$ H 1 900.000 000 MHz

\*  
Del  
Cor  
Avg  
4

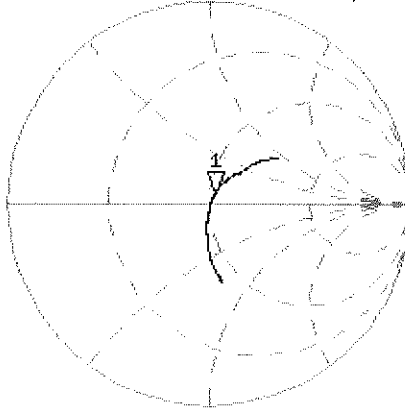

HI d

CH2 S11 LOG 5 dB/REF -20 dB 1:-25.293 dB 1 900.000 000 MHz

Cor  
Avg  
4

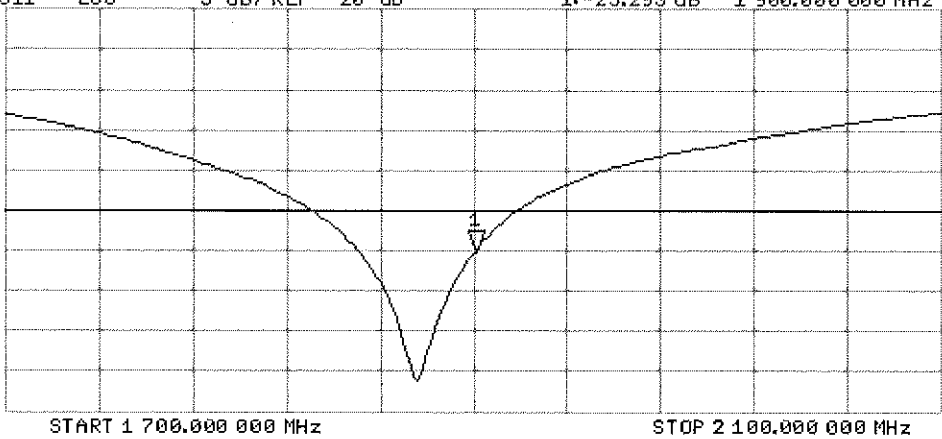

## DASY5 Validation Report for Body TSL

Date: 02.05.2013

Test Laboratory: SPEAG, Zurich, Switzerland

**DUT: Dipole 1900 MHz; Type: D1900V2; Serial: D1900V2 - SN: 5d141**

Communication System: UID 0 - CW; Frequency: 1900 MHz

Medium parameters used:  $f = 1900$  MHz;  $\sigma = 1.51$  S/m;  $\epsilon_r = 54$ ;  $\rho = 1000$  kg/m<sup>3</sup>

Phantom section: Flat Section

Measurement Standard: DASY5 (IEEE/IEC/ANSI C63.19-2007)

DASY52 Configuration:

- Probe: ES3DV3 - SN3205; ConvF(4.6, 4.6, 4.6); Calibrated: 28.12.2012;
- Sensor-Surface: 3mm (Mechanical Surface Detection)
- Electronics: DAE4 Sn601; Calibrated: 25.04.2013
- Phantom: Flat Phantom 5.0 (back); Type: QD000P50AA; Serial: 1002
- DASY52 52.8.6(1115); SEMCAD X 14.6.9(7117)

### Dipole Calibration for Body Tissue/Pin=250 mW, d=10mm/Zoom Scan (7x7x7)/Cube 0:

Measurement grid: dx=5mm, dy=5mm, dz=5mm

Reference Value = 97.124 V/m; Power Drift = -0.00 dB

Peak SAR (extrapolated) = 17.6 W/kg

**SAR(1 g) = 10.3 W/kg; SAR(10 g) = 5.51 W/kg**

Maximum value of SAR (measured) = 13.0 W/kg

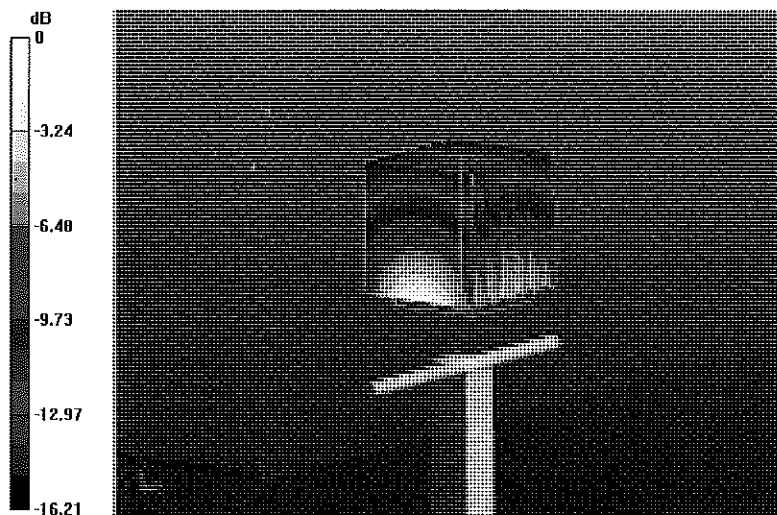

0 dB = 13.0 W/kg = 11.14 dBW/kg

# Impedance Measurement Plot for Body TSL

2 May 2013 15:38:04

[CH1] S11 1 U FS 1: 48.273  $\Omega$  5.9121  $\Omega$  495.23  $\mu$ H 1 900.000 000 MHz

\*  
De1  
Cor  
Avg  
16  
H1d

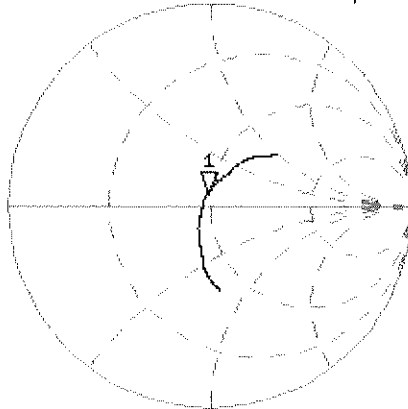

CH2 S11 LOG 5 dB/REF -20 dB 1:-24.074 dB 1 900.000 000 MHz

Cor  
Avg  
16  
H1d

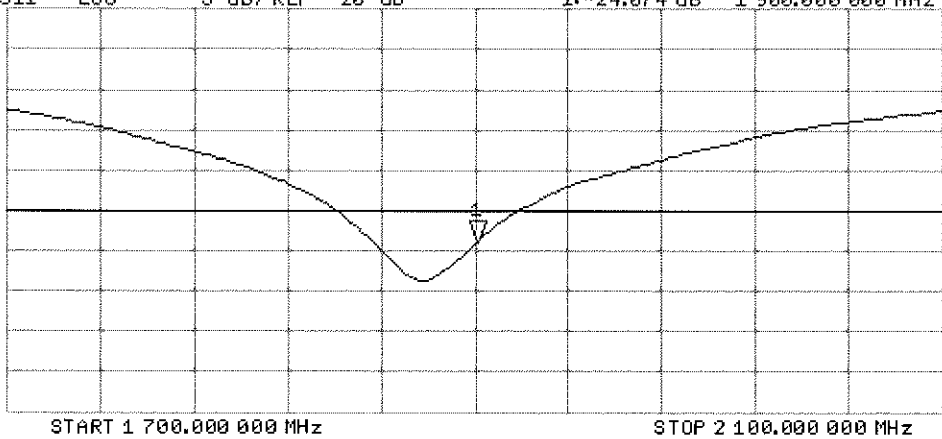



Accredited by the Swiss Accreditation Service (SAS)  
The Swiss Accreditation Service is one of the signatories to the EA  
Multilateral Agreement for the recognition of calibration certificates

Accreditation No.: **SCS 108**

Client **PC Test**

Certificate No: **D2450V2-719\_Aug13**

## CALIBRATION CERTIFICATE

Object **D2450V2 - SN: 719**

Calibration procedure(s) **QA CAL-05.v9  
Calibration procedure for dipole validation kits above 700 MHz**

Calibration date: **August 23, 2013**

*✓cc  
9/13/13*

This calibration certificate documents the traceability to national standards, which realize the physical units of measurements (SI).  
The measurements and the uncertainties with confidence probability are given on the following pages and are part of the certificate.

All calibrations have been conducted in the closed laboratory facility: environment temperature (22 ± 3)°C and humidity < 70%.

Calibration Equipment used (M&TE critical for calibration)

Primary Standards	ID #	Cal Date (Certificate No.)	Scheduled Calibration
Power meter EPM-442A	GB37480704	01-Nov-12 (No. 217-01640)	Oct-13
Power sensor HP 8481A	US37292783	01-Nov-12 (No. 217-01640)	Oct-13
Reference 20 dB Attenuator	SN: 5058 (20k)	04-Apr-13 (No. 217-01736)	Apr-14
Type-N mismatch combination	SN: 5047.3 / 06327	04-Apr-13 (No. 217-01739)	Apr-14
Reference Probe ES3DV3	SN: 3205	28-Dec-12 (No. ES3-3205_Dec12)	Dec-13
DAE4	SN: 601	25-Apr-13 (No. DAE4-601_Apr13)	Apr-14
Secondary Standards	ID #	Check Date (in house)	Scheduled Check
Power sensor HP 8481A	MY41092317	18-Oct-02 (in house check Oct-11)	In house check: Oct-13
RF generator R&S SMT-06	100005	04-Aug-99 (in house check Oct-11)	In house check: Oct-13
Network Analyzer HP 8753E	US37390585 S4206	18-Oct-01 (in house check Oct-12)	In house check: Oct-13

Calibrated by:	Name <b>Jeton Kastrati</b>	Function Laboratory Technician	Signature 
Approved by:	Name <b>Katja Pokovic</b>	Function Technical Manager	Signature 

Issued: August 23, 2013

This calibration certificate shall not be reproduced except in full without written approval of the laboratory.



Accredited by the Swiss Accreditation Service (SAS)

The Swiss Accreditation Service is one of the signatories to the EA  
Multilateral Agreement for the recognition of calibration certificates

Accreditation No.: **SCS 108**

### Glossary:

TSL	tissue simulating liquid
ConvF	sensitivity in TSL / NORM x,y,z
N/A	not applicable or not measured

### Calibration is Performed According to the Following Standards:

- IEEE Std 1528-2003, "IEEE Recommended Practice for Determining the Peak Spatial-Averaged Specific Absorption Rate (SAR) in the Human Head from Wireless Communications Devices: Measurement Techniques", December 2003
- IEC 62209-1, "Procedure to measure the Specific Absorption Rate (SAR) for hand-held devices used in close proximity to the ear (frequency range of 300 MHz to 3 GHz)", February 2005
- KDB 865664, "SAR Measurement Requirements for 100 MHz to 6 GHz"

### Additional Documentation:

- DASY4/5 System Handbook

### Methods Applied and Interpretation of Parameters:

- Measurement Conditions:* Further details are available from the Validation Report at the end of the certificate. All figures stated in the certificate are valid at the frequency indicated.
- Antenna Parameters with TSL:* The dipole is mounted with the spacer to position its feed point exactly below the center marking of the flat phantom section, with the arms oriented parallel to the body axis.
- Feed Point Impedance and Return Loss:* These parameters are measured with the dipole positioned under the liquid filled phantom. The impedance stated is transformed from the measurement at the SMA connector to the feed point. The Return Loss ensures low reflected power. No uncertainty required.
- Electrical Delay:* One-way delay between the SMA connector and the antenna feed point. No uncertainty required.
- SAR measured:* SAR measured at the stated antenna input power.
- SAR normalized:* SAR as measured, normalized to an input power of 1 W at the antenna connector.
- SAR for nominal TSL parameters:* The measured TSL parameters are used to calculate the nominal SAR result.

The reported uncertainty of measurement is stated as the standard uncertainty of measurement multiplied by the coverage factor  $k=2$ , which for a normal distribution corresponds to a coverage probability of approximately 95%.

## Measurement Conditions

DASY system configuration, as far as not given on page 1.

<b>DASY Version</b>	DASY5	V52.8.7
<b>Extrapolation</b>	Advanced Extrapolation	
<b>Phantom</b>	Modular Flat Phantom	
<b>Distance Dipole Center - TSL</b>	10 mm	with Spacer
<b>Zoom Scan Resolution</b>	dx, dy, dz = 5 mm	
<b>Frequency</b>	2450 MHz $\pm$ 1 MHz	

## Head TSL parameters

The following parameters and calculations were applied.

	Temperature	Permittivity	Conductivity
<b>Nominal Head TSL parameters</b>	22.0 °C	39.2	1.80 mho/m
<b>Measured Head TSL parameters</b>	(22.0 $\pm$ 0.2) °C	37.8 $\pm$ 6 %	1.80 mho/m $\pm$ 6 %
<b>Head TSL temperature change during test</b>	< 0.5 °C	----	----

## SAR result with Head TSL

<b>SAR averaged over 1 cm<sup>3</sup> (1 g) of Head TSL</b>	Condition	
SAR measured	250 mW input power	13.4 W/kg
SAR for nominal Head TSL parameters	normalized to 1W	<b>53.2 W/kg <math>\pm</math> 17.0 % (k=2)</b>

<b>SAR averaged over 10 cm<sup>3</sup> (10 g) of Head TSL</b>	condition	
SAR measured	250 mW input power	6.23 W/kg
SAR for nominal Head TSL parameters	normalized to 1W	<b>24.8 W/kg <math>\pm</math> 16.5 % (k=2)</b>

## Body TSL parameters

The following parameters and calculations were applied.

	Temperature	Permittivity	Conductivity
<b>Nominal Body TSL parameters</b>	22.0 °C	52.7	1.95 mho/m
<b>Measured Body TSL parameters</b>	(22.0 $\pm$ 0.2) °C	50.6 $\pm$ 6 %	2.03 mho/m $\pm$ 6 %
<b>Body TSL temperature change during test</b>	< 0.5 °C	----	----

## SAR result with Body TSL

<b>SAR averaged over 1 cm<sup>3</sup> (1 g) of Body TSL</b>	Condition	
SAR measured	250 mW input power	13.3 W/kg
SAR for nominal Body TSL parameters	normalized to 1W	<b>51.7 W/kg <math>\pm</math> 17.0 % (k=2)</b>

<b>SAR averaged over 10 cm<sup>3</sup> (10 g) of Body TSL</b>	condition	
SAR measured	250 mW input power	6.14 W/kg
SAR for nominal Body TSL parameters	normalized to 1W	<b>24.1 W/kg <math>\pm</math> 16.5 % (k=2)</b>

## Appendix

### Antenna Parameters with Head TSL

Impedance, transformed to feed point	54.6 $\Omega$ + 3.5 j $\Omega$
Return Loss	- 25.1 dB

### Antenna Parameters with Body TSL

Impedance, transformed to feed point	51.1 $\Omega$ + 5.4 j $\Omega$
Return Loss	- 25.3 dB

### General Antenna Parameters and Design

Electrical Delay (one direction)	1.149 ns
----------------------------------	----------

After long term use with 100W radiated power, only a slight warming of the dipole near the feedpoint can be measured.

The dipole is made of standard semirigid coaxial cable. The center conductor of the feeding line is directly connected to the second arm of the dipole. The antenna is therefore short-circuited for DC-signals. On some of the dipoles, small end caps are added to the dipole arms in order to improve matching when loaded according to the position as explained in the "Measurement Conditions" paragraph. The SAR data are not affected by this change. The overall dipole length is still according to the Standard.

No excessive force must be applied to the dipole arms, because they might bend or the soldered connections near the feedpoint may be damaged.

### Additional EUT Data

Manufactured by	SPEAG
Manufactured on	September 10, 2002

## DASY5 Validation Report for Head TSL

Date: 22.08.2013

Test Laboratory: SPEAG, Zurich, Switzerland

**DUT: Dipole 2450 MHz; Type: D2450V2; Serial: D2450V2 - SN: 719**

Communication System: UID 0 - CW ; Frequency: 2450 MHz

Medium parameters used:  $f = 2450$  MHz;  $\sigma = 1.8$  S/m;  $\epsilon_r = 37.8$ ;  $\rho = 1000$  kg/m<sup>3</sup>

Phantom section: Flat Section

Measurement Standard: DASY5 (IEEE/IEC/ANSI C63.19-2007)

DASY52 Configuration:

- Probe: ES3DV3 - SN3205; ConvF(4.52, 4.52, 4.52); Calibrated: 28.12.2012;
- Sensor-Surface: 3mm (Mechanical Surface Detection)
- Electronics: DAE4 Sn601; Calibrated: 25.04.2013
- Phantom: Flat Phantom 5.0 (front); Type: QD000P50AA; Serial: 1001
- DASY52 52.8.7(1137); SEMCAD X 14.6.10(7164)

### Dipole Calibration for Head Tissue/Pin=250 mW, d=10mm/Zoom Scan (7x7x7)/Cube 0:

Measurement grid: dx=5mm, dy=5mm, dz=5mm

Reference Value = 100.7 V/m; Power Drift = 0.06 dB

Peak SAR (extrapolated) = 27.9 W/kg

**SAR(1 g) = 13.4 W/kg; SAR(10 g) = 6.23 W/kg**

Maximum value of SAR (measured) = 17.0 W/kg

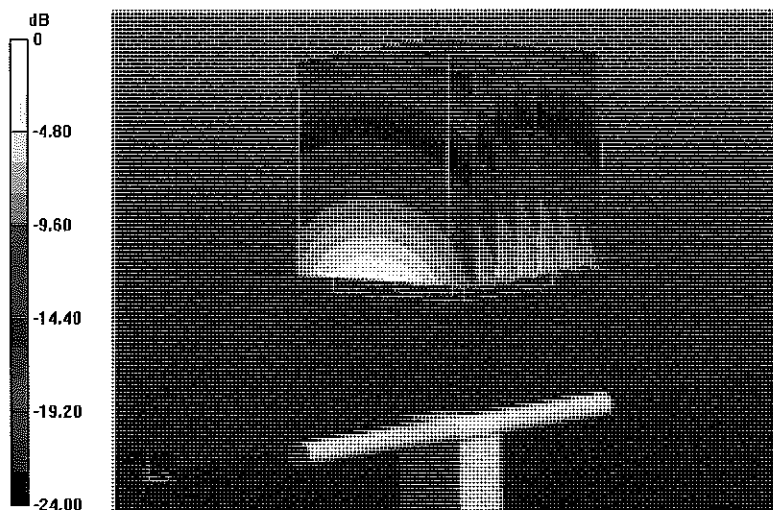

0 dB = 17.0 W/kg = 12.30 dBW/kg

# Impedance Measurement Plot for Head TSL

22 Aug 2013 11:00:15

CH1 S11 1 U FS

4: 54.639  $\Omega$  3.5215  $\Omega$  228.76 pF

2 450.000 000 MHz

\*  
De1

CA

Avg  
16

H1d

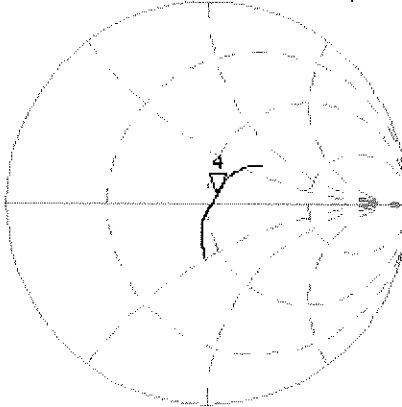

CH2 S11 LOG

5 dB/REF -20 dB

4: -25.093 dB 2 450.000 000 MHz

CA

Avg  
16

H1d

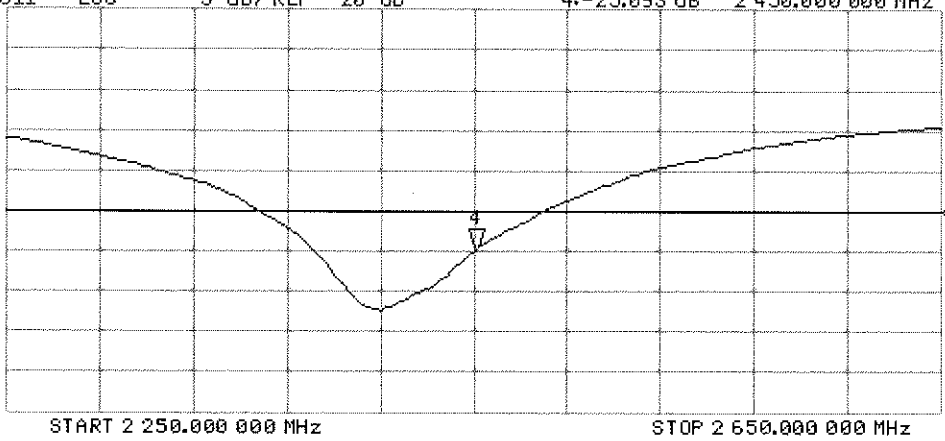

# DASY5 Validation Report for Body TSL

Date: 23.08.2013

Test Laboratory: SPEAG, Zurich, Switzerland

**DUT: Dipole 2450 MHz; Type: D2450V2; Serial: D2450V2 - SN: 719**

Communication System: UID 0 - CW ; Frequency: 2450 MHz

Medium parameters used:  $f = 2450$  MHz;  $\sigma = 2.03$  S/m;  $\epsilon_r = 50.6$ ;  $\rho = 1000$  kg/m<sup>3</sup>

Phantom section: Flat Section

Measurement Standard: DASY5 (IEEE/IEC/ANSI C63.19-2007)

DASY52 Configuration:

- Probe: ES3DV3 - SN3205; ConvF(4.42, 4.42, 4.42); Calibrated: 28.12.2012;
- Sensor-Surface: 3mm (Mechanical Surface Detection)
- Electronics: DAE4 Sn601; Calibrated: 25.04.2013
- Phantom: Flat Phantom 5.0 (back); Type: QD000P50AA; Serial: 1002
- DASY52 52.8.7(1137); SEMCAD X 14.6.10(7164)

## Dipole Calibration for Body Tissue/Pin=250 mW, d=10mm/Zoom Scan (7x7x7)/Cube 0:

Measurement grid: dx=5mm, dy=5mm, dz=5mm

Reference Value = 94.688 V/m; Power Drift = 0.06 dB

Peak SAR (extrapolated) = 27.9 W/kg

**SAR(1 g) = 13.3 W/kg; SAR(10 g) = 6.14 W/kg**

Maximum value of SAR (measured) = 17.2 W/kg

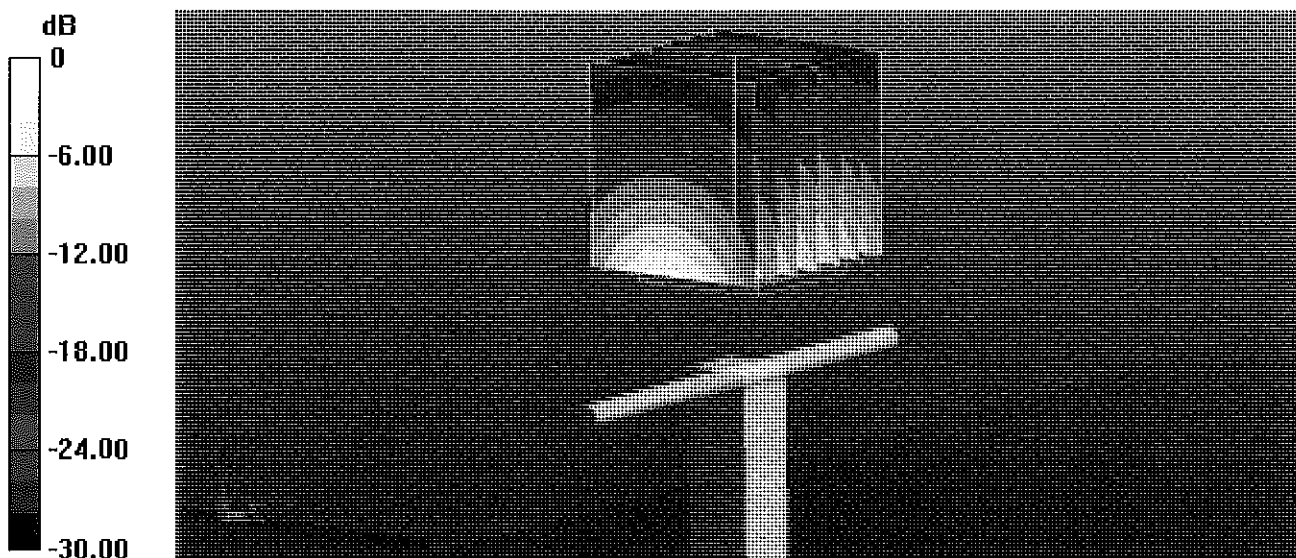

0 dB = 17.2 W/kg = 12.36 dBW/kg

# Impedance Measurement Plot for Body TSL

23 Aug 2013 09:00:38

CH1 S11 1 U FS

3: 51.135  $\Omega$  5.3965  $\Omega$  350.56 pF

2 450.000 000 MHz

#

De1

CΔ

Avg  
16

H1 d

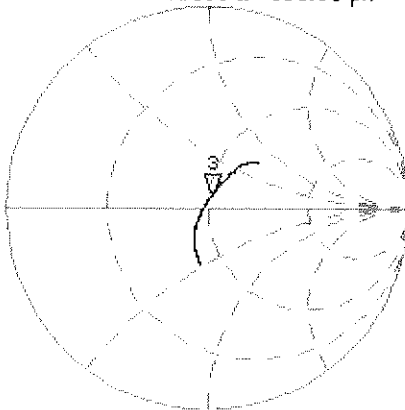

CH2 S11 LOG

5 dB/REF -20 dB

3:-25.274 dB

2 450.000 000 MHz

CΔ

Avg  
16

H1 d

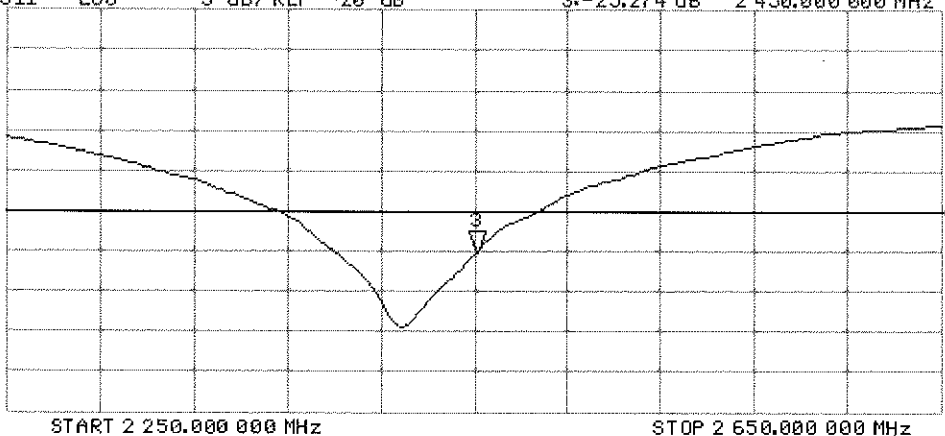



Accredited by the Swiss Accreditation Service (SAS)  
The Swiss Accreditation Service is one of the signatories to the EA  
Multilateral Agreement for the recognition of calibration certificates

Accreditation No.: **SCS 108**

Client **PC Test**

Certificate No: **D5GHzV2-1007\_Sep13/2**

**CALIBRATION CERTIFICATE (Replacement of No: D5GHzV2-1007\_Sep13)**

Object **D5GHzV2 - SN: 1007**

Calibration procedure(s) **QA CAL-22.v2**  
**Calibration procedure for dipole validation kits between 3-6 GHz**

*CCV*  
*10/15/13*

Calibration date: **September 23, 2013**

This calibration certificate documents the traceability to national standards, which realize the physical units of measurements (SI).  
The measurements and the uncertainties with confidence probability are given on the following pages and are part of the certificate.

All calibrations have been conducted in the closed laboratory facility: environment temperature (22 ± 3)°C and humidity < 70%.

Calibration Equipment used (M&TE critical for calibration)

Primary Standards	ID #	Cal Date (Certificate No.)	Scheduled Calibration
Power meter EPM-442A	GB37480704	01-Nov-12 (No. 217-01640)	Oct-13
Power sensor HP 8481A	US37292783	01-Nov-12 (No. 217-01640)	Oct-13
Reference 20 dB Attenuator	SN: 5058 (20k)	04-Apr-13 (No. 217-01736)	Apr-14
Type-N mismatch combination	SN: 5047.3 / 06327	04-Apr-13 (No. 217-01739)	Apr-14
Reference Probe EX3DV4	SN: 3503	28-Dec-12 (No. EX3-3503_Dec12)	Dec-13
DAE4	SN: 601	25-Apr-13 (No. DAE4-601_Apr13)	Apr-14
Secondary Standards	ID #	Check Date (in house)	Scheduled Check
Power sensor HP 8481A	MY41092317	18-Oct-02 (in house check Oct-11)	In house check: Oct-13
RF generator R&S SMT-06	100005	04-Aug-99 (in house check Oct-11)	In house check: Oct-13
Network Analyzer HP 8753E	US37390585 S4206	18-Oct-01 (in house check Oct-12)	In house check: Oct-13

Calibrated by:	Name <b>Leif Klysner</b>	Function <b>Laboratory Technician</b>	Signature 
Approved by:	Name <b>Katja Pokovic</b>	Function <b>Technical Manager</b>	Signature 

Issued: October 4, 2013

This calibration certificate shall not be reproduced except in full without written approval of the laboratory.



Accredited by the Swiss Accreditation Service (SAS)  
The Swiss Accreditation Service is one of the signatories to the EA  
Multilateral Agreement for the recognition of calibration certificates

Accreditation No.: **SCS 108**

### Glossary:

TSL	tissue simulating liquid
ConvF	sensitivity in TSL / NORM x,y,z
N/A	not applicable or not measured

### Calibration is Performed According to the Following Standards:

- a) IEC 62209-2, "Evaluation of Human Exposure to Radio Frequency Fields from Handheld and Body-Mounted Wireless Communication Devices in the Frequency Range of 30 MHz to 6 GHz: Human models, Instrumentation, and Procedures"; Part 2: "Procedure to determine the Specific Absorption Rate (SAR) for including accessories and multiple transmitters", March 2010
- b) KDB 865664, "SAR Measurement Requirements for 100 MHz to 6 GHz"
- c) IEEE Std 1528-2013, "IEEE Recommended Practice for Determining the Peak Spatial-Averaged Specific Absorption Rate (SAR) in the Human Head from Wireless Communications Devices: Measurement Techniques", June 2013

### Additional Documentation:

- d) DASY4/5 System Handbook

### Methods Applied and Interpretation of Parameters:

- *Measurement Conditions:* Further details are available from the Validation Report at the end of the certificate. All figures stated in the certificate are valid at the frequency indicated.
- *Antenna Parameters with TSL:* The dipole is mounted with the spacer to position its feed point exactly below the center marking of the flat phantom section, with the arms oriented parallel to the body axis.
- *Feed Point Impedance and Return Loss:* These parameters are measured with the dipole positioned under the liquid filled phantom. The impedance stated is transformed from the measurement at the SMA connector to the feed point. The Return Loss ensures low reflected power. No uncertainty required.
- *Electrical Delay:* One-way delay between the SMA connector and the antenna feed point. No uncertainty required.
- *SAR measured:* SAR measured at the stated antenna input power.
- *SAR normalized:* SAR as measured, normalized to an input power of 1 W at the antenna connector.
- *SAR for nominal TSL parameters:* The measured TSL parameters are used to calculate the nominal SAR result.

The reported uncertainty of measurement is stated as the standard uncertainty of measurement multiplied by the coverage factor  $k=2$ , which for a normal distribution corresponds to a coverage probability of approximately 95%.

## Measurement Conditions

DASY system configuration, as far as not given on page 1.

<b>DASY Version</b>	DASY5	V52.8.7
<b>Extrapolation</b>	Advanced Extrapolation	
<b>Phantom</b>	Modular Flat Phantom V5.0	
<b>Distance Dipole Center - TSL</b>	10 mm	with Spacer
<b>Zoom Scan Resolution</b>	dx, dy = 4.0 mm, dz = 1.4 mm	Graded Ratio = 1.4 (Z direction)
<b>Frequency</b>	5200 MHz ± 1 MHz 5300 MHz ± 1 MHz 5500 MHz ± 1 MHz 5600 MHz ± 1 MHz 5800 MHz ± 1 MHz	

## Head TSL parameters at 5200 MHz

The following parameters and calculations were applied.

	Temperature	Permittivity	Conductivity
<b>Nominal Head TSL parameters</b>	22.0 °C	36.0	4.66 mho/m
<b>Measured Head TSL parameters</b>	(22.0 ± 0.2) °C	35.8 ± 6 %	4.48 mho/m ± 6 %
<b>Head TSL temperature change during test</b>	< 0.5 °C	----	----

## SAR result with Head TSL at 5200 MHz

<b>SAR averaged over 1 cm<sup>3</sup> (1 g) of Head TSL</b>	Condition	
SAR measured	100 mW input power	7.77 W/kg
SAR for nominal Head TSL parameters	normalized to 1W	<b>77.5 W/kg ± 19.9 % (k=2)</b>

<b>SAR averaged over 10 cm<sup>3</sup> (10 g) of Head TSL</b>	condition	
SAR measured	100 mW input power	2.23 W/kg
SAR for nominal Head TSL parameters	normalized to 1W	<b>22.2 W/kg ± 19.5 % (k=2)</b>

### Head TSL parameters at 5300 MHz

The following parameters and calculations were applied.

	Temperature	Permittivity	Conductivity
Nominal Head TSL parameters	22.0 °C	35.9	4.76 mho/m
Measured Head TSL parameters	(22.0 ± 0.2) °C	35.6 ± 6 %	4.62 mho/m ± 6 %
Head TSL temperature change during test	< 0.5 °C	----	----

### SAR result with Head TSL at 5300 MHz

SAR averaged over 1 cm <sup>3</sup> (1 g) of Head TSL	Condition	
SAR measured	100 mW input power	8.04 W/kg
SAR for nominal Head TSL parameters	normalized to 1W	<b>80.2 W / kg ± 19.9 % (k=2)</b>

SAR averaged over 10 cm <sup>3</sup> (10 g) of Head TSL	condition	
SAR measured	100 mW input power	2.30 W/kg
SAR for nominal Head TSL parameters	normalized to 1W	<b>22.9 W/kg ± 19.5 % (k=2)</b>

### Head TSL parameters at 5500 MHz

The following parameters and calculations were applied.

	Temperature	Permittivity	Conductivity
Nominal Head TSL parameters	22.0 °C	35.6	4.96 mho/m
Measured Head TSL parameters	(22.0 ± 0.2) °C	35.4 ± 6 %	4.76 mho/m ± 6 %
Head TSL temperature change during test	< 0.5 °C	----	----

### SAR result with Head TSL at 5500 MHz

SAR averaged over 1 cm <sup>3</sup> (1 g) of Head TSL	Condition	
SAR measured	100 mW input power	8.17 W/kg
SAR for nominal Head TSL parameters	normalized to 1W	<b>81.4 W/kg ± 19.9 % (k=2)</b>

SAR averaged over 10 cm <sup>3</sup> (10 g) of Head TSL	condition	
SAR measured	100 mW input power	2.32 W/kg
SAR for nominal Head TSL parameters	normalized to 1W	<b>23.1 W/kg ± 19.5 % (k=2)</b>

### Head TSL parameters at 5600 MHz

The following parameters and calculations were applied.

	Temperature	Permittivity	Conductivity
Nominal Head TSL parameters	22.0 °C	35.5	5.07 mho/m
Measured Head TSL parameters	(22.0 ± 0.2) °C	35.2 ± 6 %	4.86 mho/m ± 6 %
Head TSL temperature change during test	< 0.5 °C	----	----

### SAR result with Head TSL at 5600 MHz

SAR averaged over 1 cm <sup>3</sup> (1 g) of Head TSL	Condition	
SAR measured	100 mW input power	8.03 W/kg
SAR for nominal Head TSL parameters	normalized to 1W	<b>80.0 W/kg ± 19.9 % (k=2)</b>

SAR averaged over 10 cm <sup>3</sup> (10 g) of Head TSL	condition	
SAR measured	100 mW input power	2.28 W/kg
SAR for nominal Head TSL parameters	normalized to 1W	<b>22.7 W/kg ± 19.5 % (k=2)</b>

### Head TSL parameters at 5800 MHz

The following parameters and calculations were applied.

	Temperature	Permittivity	Conductivity
Nominal Head TSL parameters	22.0 °C	35.3	5.27 mho/m
Measured Head TSL parameters	(22.0 ± 0.2) °C	35.0 ± 6 %	5.07 mho/m ± 6 %
Head TSL temperature change during test	< 0.5 °C	----	----

### SAR result with Head TSL at 5800 MHz

SAR averaged over 1 cm <sup>3</sup> (1 g) of Head TSL	Condition	
SAR measured	100 mW input power	7.78 W/kg
SAR for nominal Head TSL parameters	normalized to 1W	<b>77.5 W/kg ± 19.9 % (k=2)</b>

SAR averaged over 10 cm <sup>3</sup> (10 g) of Head TSL	condition	
SAR measured	100 mW input power	2.20 W/kg
SAR for nominal Head TSL parameters	normalized to 1W	<b>21.9 W/kg ± 19.5 % (k=2)</b>

### Body TSL parameters at 5200 MHz

The following parameters and calculations were applied.

	Temperature	Permittivity	Conductivity
Nominal Body TSL parameters	22.0 °C	49.0	5.30 mho/m
Measured Body TSL parameters	(22.0 ± 0.2) °C	48.3 ± 6 %	5.36 mho/m ± 6 %
Body TSL temperature change during test	< 0.5 °C	----	----

### SAR result with Body TSL at 5200 MHz

SAR averaged over 1 cm <sup>3</sup> (1 g) of Body TSL	Condition	
SAR measured	100 mW input power	7.28 W/kg
SAR for nominal Body TSL parameters	normalized to 1W	<b>72.6 W/kg ± 19.9 % (k=2)</b>

SAR averaged over 10 cm <sup>3</sup> (10 g) of Body TSL	condition	
SAR measured	100 mW input power	2.03 W/kg
SAR for nominal Body TSL parameters	normalized to 1W	<b>20.2 W/kg ± 19.5 % (k=2)</b>

### Body TSL parameters at 5300 MHz

The following parameters and calculations were applied.

	Temperature	Permittivity	Conductivity
Nominal Body TSL parameters	22.0 °C	48.9	5.42 mho/m
Measured Body TSL parameters	(22.0 ± 0.2) °C	48.1 ± 6 %	5.56 mho/m ± 6 %
Body TSL temperature change during test	< 0.5 °C	----	----

### SAR result with Body TSL at 5300 MHz

SAR averaged over 1 cm <sup>3</sup> (1 g) of Body TSL	Condition	
SAR measured	100 mW input power	7.49 W/kg
SAR for nominal Body TSL parameters	normalized to 1W	<b>74.7 W/kg ± 19.9 % (k=2)</b>

SAR averaged over 10 cm <sup>3</sup> (10 g) of Body TSL	condition	
SAR measured	100 mW input power	2.09 W/kg
SAR for nominal Body TSL parameters	normalized to 1W	<b>20.8 W/kg ± 19.5 % (k=2)</b>

### Body TSL parameters at 5500 MHz

The following parameters and calculations were applied.

	Temperature	Permittivity	Conductivity
Nominal Body TSL parameters	22.0 °C	48.6	5.65 mho/m
Measured Body TSL parameters	(22.0 ± 0.2) °C	47.8 ± 6 %	5.75 mho/m ± 6 %
Body TSL temperature change during test	< 0.5 °C	----	----

### SAR result with Body TSL at 5500 MHz

SAR averaged over 1 cm <sup>3</sup> (1 g) of Body TSL	Condition	
SAR measured	100 mW input power	7.61 W/kg
SAR for nominal Body TSL parameters	normalized to 1W	75.9 W/kg ± 19.9 % (k=2)

SAR averaged over 10 cm <sup>3</sup> (10 g) of Body TSL	condition	
SAR measured	100 mW input power	2.11 W/kg
SAR for nominal Body TSL parameters	normalized to 1W	21.0 W/kg ± 19.5 % (k=2)

### Body TSL parameters at 5600 MHz

The following parameters and calculations were applied.

	Temperature	Permittivity	Conductivity
Nominal Body TSL parameters	22.0 °C	48.5	5.77 mho/m
Measured Body TSL parameters	(22.0 ± 0.2) °C	47.6 ± 6 %	5.88 mho/m ± 6 %
Body TSL temperature change during test	< 0.5 °C	----	----

### SAR result with Body TSL at 5600 MHz

SAR averaged over 1 cm <sup>3</sup> (1 g) of Body TSL	Condition	
SAR measured	100 mW input power	7.75 W/kg
SAR for nominal Body TSL parameters	normalized to 1W	77.3 W/kg ± 19.9 % (k=2)

SAR averaged over 10 cm <sup>3</sup> (10 g) of Body TSL	condition	
SAR measured	100 mW input power	2.16 W/kg
SAR for nominal Body TSL parameters	normalized to 1W	21.5 W/kg ± 19.5 % (k=2)

### Body TSL parameters at 5800 MHz

The following parameters and calculations were applied.

	Temperature	Permittivity	Conductivity
Nominal Body TSL parameters	22.0 °C	48.2	6.00 mho/m
Measured Body TSL parameters	(22.0 ± 0.2) °C	47.3 ± 6 %	6.17 mho/m ± 6 %
Body TSL temperature change during test	< 0.5 °C	----	----

### SAR result with Body TSL at 5800 MHz

SAR averaged over 1 cm <sup>3</sup> (1 g) of Body TSL	Condition	
SAR measured	100 mW input power	7.31 W/kg
SAR for nominal Body TSL parameters	normalized to 1W	<b>72.9 W/kg ± 19.9 % (k=2)</b>

SAR averaged over 10 cm <sup>3</sup> (10 g) of Body TSL	condition	
SAR measured	100 mW input power	2.02 W/kg
SAR for nominal Body TSL parameters	normalized to 1W	<b>20.1 W/kg ± 19.5 % (k=2)</b>

## Appendix

### Antenna Parameters with Head TSL at 5200 MHz

Impedance, transformed to feed point	52.4 $\Omega$ - 11.0 j $\Omega$
Return Loss	- 19.2 dB

### Antenna Parameters with Head TSL at 5300 MHz

Impedance, transformed to feed point	56.8 $\Omega$ - 4.4 j $\Omega$
Return Loss	- 22.3 dB

### Antenna Parameters with Head TSL at 5500 MHz

Impedance, transformed to feed point	48.8 $\Omega$ - 5.4 j $\Omega$
Return Loss	- 25.1 dB

### Antenna Parameters with Head TSL at 5600 MHz

Impedance, transformed to feed point	57.3 $\Omega$ - 8.7 j $\Omega$
Return Loss	- 19.5 dB

### Antenna Parameters with Head TSL at 5800 MHz

Impedance, transformed to feed point	56.9 $\Omega$ + 1.6 j $\Omega$
Return Loss	- 23.5 dB

### Antenna Parameters with Body TSL at 5200 MHz

Impedance, transformed to feed point	53.1 $\Omega$ - 10.3 j $\Omega$
Return Loss	- 19.7 dB

### Antenna Parameters with Body TSL at 5300 MHz

Impedance, transformed to feed point	54.3 $\Omega$ - 1.5 j $\Omega$
Return Loss	- 27.2 dB

### Antenna Parameters with Body TSL at 5500 MHz

Impedance, transformed to feed point	49.7 $\Omega$ - 3.6 j $\Omega$
Return Loss	- 28.7 dB

### Antenna Parameters with Body TSL at 5600 MHz

Impedance, transformed to feed point	58.2 $\Omega$ - 5.2 j $\Omega$
Return Loss	- 20.9 dB

### Antenna Parameters with Body TSL at 5800 MHz

Impedance, transformed to feed point	58.7 $\Omega$ + 3.9 j $\Omega$
Return Loss	- 21.1 dB

### General Antenna Parameters and Design

Electrical Delay (one direction)	1.201 ns
----------------------------------	----------

After long term use with 100W radiated power, only a slight warming of the dipole near the feedpoint can be measured.

The dipole is made of standard semirigid coaxial cable. The center conductor of the feeding line is directly connected to the second arm of the dipole. The antenna is therefore short-circuited for DC-signals. On some of the dipoles, small end caps are added to the dipole arms in order to improve matching when loaded according to the position as explained in the "Measurement Conditions" paragraph. The SAR data are not affected by this change. The overall dipole length is still according to the Standard.

No excessive force must be applied to the dipole arms, because they might bend or the soldered connections near the feedpoint may be damaged.

### Additional EUT Data

Manufactured by	SPEAG
Manufactured on	August 28, 2003

## DASY5 Validation Report for Head TSL

Date: 23.09.2013

Test Laboratory: SPEAG, Zurich, Switzerland

**DUT: Dipole 5GHz; Type: D5GHzV2; Serial: D5GHzV2 - SN: 1007**

Communication System: UID 0 - CW ; Frequency: 5200 MHz, Frequency: 5300 MHz, Frequency: 5500 MHz, Frequency: 5600 MHz, Frequency: 5800 MHz

Medium parameters used:  $f = 5200$  MHz;  $\sigma = 4.48$  S/m;  $\epsilon_r = 35.8$ ;  $\rho = 1000$  kg/m<sup>3</sup>, Medium parameters used:  $f = 5300$  MHz;  $\sigma = 4.62$  S/m;  $\epsilon_r = 35.6$ ;  $\rho = 1000$  kg/m<sup>3</sup>, Medium parameters used:  $f = 5500$  MHz;  $\sigma = 4.76$  S/m;  $\epsilon_r = 35.4$ ;  $\rho = 1000$  kg/m<sup>3</sup>, Medium parameters used:  $f = 5600$  MHz;  $\sigma = 4.86$  S/m;  $\epsilon_r = 35.2$ ;  $\rho = 1000$  kg/m<sup>3</sup>, Medium parameters used:  $f = 5800$  MHz;  $\sigma = 5.07$  S/m;  $\epsilon_r = 35$ ;  $\rho = 1000$  kg/m<sup>3</sup>

Phantom section: Flat Section

Measurement Standard: DASY5 (IEEE/IEC/ANSI C63.19-2007)

DASY52 Configuration:

- Probe: EX3DV4 - SN3503; ConvF(5.41, 5.41, 5.41); Calibrated: 28.12.2012, ConvF(5.1, 5.1, 5.1); Calibrated: 28.12.2012, ConvF(4.91, 4.91, 4.91); Calibrated: 28.12.2012, ConvF(4.76, 4.76, 4.76); Calibrated: 28.12.2012, ConvF(4.81, 4.81, 4.81); Calibrated: 28.12.2012;
- Sensor-Surface: 1.4mm (Mechanical Surface Detection)
- Electronics: DAE4 Sn601; Calibrated: 25.04.2013
- Phantom: Flat Phantom 5.0 (front); Type: QD000P50AA; Serial: 1001
- DASY52 52.8.7(1137); SEMCAD X 14.6.10(7164)

**Dipole Calibration for Head Tissue/Pin=100mW, dist=10mm, f=5200 MHz/Zoom Scan, dist=1.4mm (8x8x7)/Cube 0:** Measurement grid: dx=4mm, dy=4mm, dz=1.4mm

Reference Value = 63.505 V/m; Power Drift = 0.07 dB

Peak SAR (extrapolated) = 28.1 W/kg

**SAR(1 g) = 7.77 W/kg; SAR(10 g) = 2.23 W/kg**

Maximum value of SAR (measured) = 18.1 W/kg

**Dipole Calibration for Head Tissue/Pin=100mW, dist=10mm, f=5300 MHz/Zoom Scan, dist=1.4mm (8x8x7)/Cube 0:** Measurement grid: dx=4mm, dy=4mm, dz=1.4mm

Reference Value = 63.817 V/m; Power Drift = 0.07 dB

Peak SAR (extrapolated) = 29.7 W/kg

**SAR(1 g) = 8.04 W/kg; SAR(10 g) = 2.3 W/kg**

Maximum value of SAR (measured) = 18.7 W/kg

**Dipole Calibration for Head Tissue/Pin=100mW, dist=10mm, f=5500 MHz/Zoom Scan, dist=1.4mm (8x8x7)/Cube 0:** Measurement grid: dx=4mm, dy=4mm, dz=1.4mm

Reference Value = 64.029 V/m; Power Drift = 0.07 dB

Peak SAR (extrapolated) = 32.0 W/kg

**SAR(1 g) = 8.17 W/kg; SAR(10 g) = 2.32 W/kg**

Maximum value of SAR (measured) = 19.7 W/kg

**Dipole Calibration for Head Tissue/Pin=100mW, dist=10mm, f=5600 MHz/Zoom Scan,**

**dist=1.4mm (8x8x7)/Cube 0:** Measurement grid: dx=4mm, dy=4mm, dz=1.4mm

Reference Value = 63.403 V/m; Power Drift = 0.05 dB

Peak SAR (extrapolated) = 31.3 W/kg

**SAR(1 g) = 8.03 W/kg; SAR(10 g) = 2.28 W/kg**

Maximum value of SAR (measured) = 19.3 W/kg

**Dipole Calibration for Head Tissue/Pin=100mW, dist=10mm, f=5800 MHz/Zoom Scan,**

**dist=1.4mm (8x8x7)/Cube 0:** Measurement grid: dx=4mm, dy=4mm, dz=1.4mm

Reference Value = 60.987 V/m; Power Drift = 0.06 dB

Peak SAR (extrapolated) = 31.9 W/kg

**SAR(1 g) = 7.78 W/kg; SAR(10 g) = 2.2 W/kg**

Maximum value of SAR (measured) = 19.0 W/kg

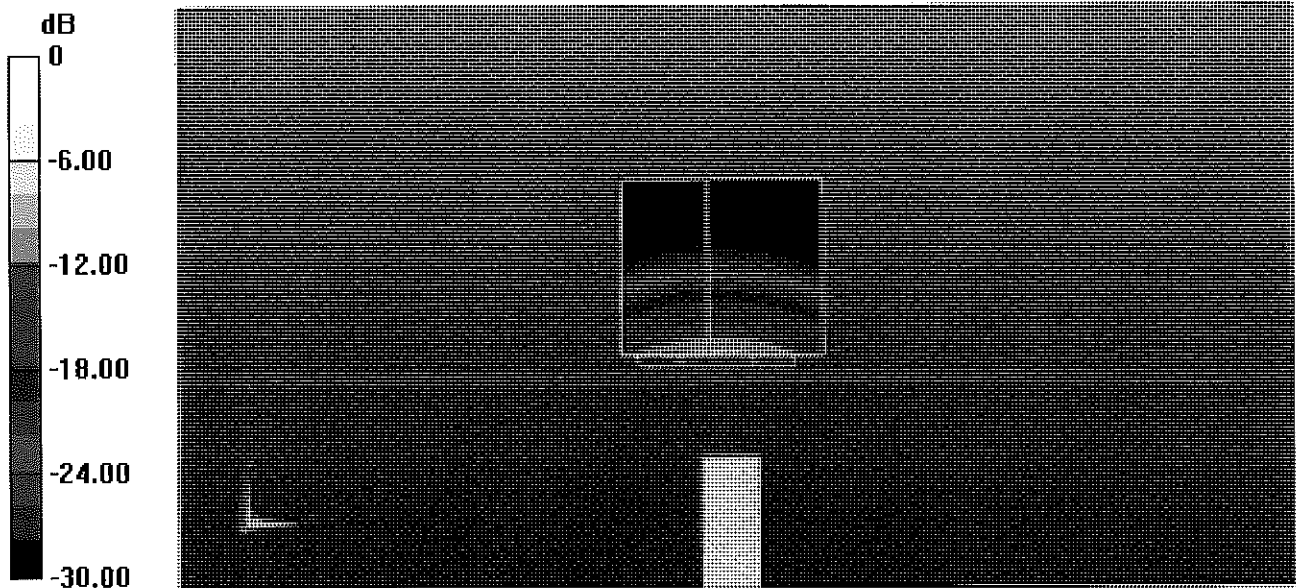

0 dB = 19.0 W/kg = 12.79 dBW/kg

# Impedance Measurement Plot for Head TSL

23 Sep 2013 11:11:14

CH1 S11 1 U FS 1: 52.408  $\Omega$  -10.990  $\Omega$  2.7849 pF 5 200.000 000 MHz

\*  
Del  
Cor  
Avg  
16  
H1d

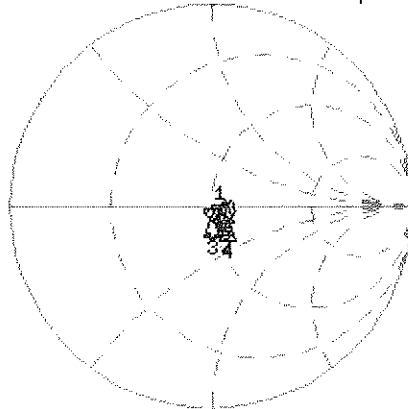

CH1 Markers

- 2: 56.846  $\Omega$   
-4.4492  $\Omega$   
5.30000 GHz
- 3: 48.834  $\Omega$   
-5.3730  $\Omega$   
5.50000 GHz
- 4: 57.303  $\Omega$   
-8.6738  $\Omega$   
5.60000 GHz
- 5: 56.939  $\Omega$   
1.5527  $\Omega$   
5.80000 GHz

CH2 S11 L00 5 dB/REF -20 dB 1: -19.232 dB 5 200.000 000 MHz

Cor  
Avg  
16  
H1d

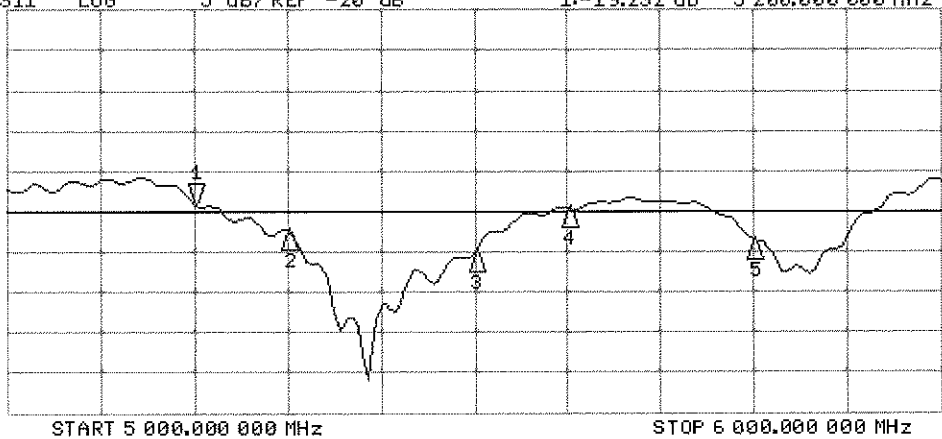

CH2 Markers

- 2: -22.341 dB  
5.30000 GHz
- 3: -25.105 dB  
5.50000 GHz
- 4: -19.547 dB  
5.60000 GHz
- 5: -23.545 dB  
5.80000 GHz

START 5 000.000 000 MHz

STOP 6 000.000 000 MHz

## DASY5 Validation Report for Body TSL

Date: 20.09.2013

Test Laboratory: SPEAG, Zurich, Switzerland

**DUT: Dipole 5GHz; Type: D5GHzV2; Serial: D5GHzV2 - SN: 1007**

Communication System: UID 0 - CW ; Frequency: 5200 MHz, Frequency: 5300 MHz, Frequency: 5500 MHz, Frequency: 5600 MHz, Frequency: 5800 MHz

Medium parameters used:  $f = 5200$  MHz;  $\sigma = 5.36$  S/m;  $\epsilon_r = 48.3$ ;  $\rho = 1000$  kg/m<sup>3</sup>, Medium parameters used:  $f = 5300$  MHz;  $\sigma = 5.56$  S/m;  $\epsilon_r = 48.1$ ;  $\rho = 1000$  kg/m<sup>3</sup>, Medium parameters used:  $f = 5500$  MHz;  $\sigma = 5.75$  S/m;  $\epsilon_r = 47.8$ ;  $\rho = 1000$  kg/m<sup>3</sup>, Medium parameters used:  $f = 5600$  MHz;  $\sigma = 5.88$  S/m;  $\epsilon_r = 47.6$ ;  $\rho = 1000$  kg/m<sup>3</sup>, Medium parameters used:  $f = 5800$  MHz;  $\sigma = 6.17$  S/m;  $\epsilon_r = 47.3$ ;  $\rho = 1000$  kg/m<sup>3</sup>

Phantom section: Flat Section

Measurement Standard: DASY5 (IEEE/IEC/ANSI C63.19-2007)

DASY52 Configuration:

- Probe: EX3DV4 - SN3503; ConvF(4.91, 4.91, 4.91); Calibrated: 28.12.2012, ConvF(4.67, 4.67, 4.67); Calibrated: 28.12.2012, ConvF(4.43, 4.43, 4.43); Calibrated: 28.12.2012, ConvF(4.22, 4.22, 4.22); Calibrated: 28.12.2012, ConvF(4.38, 4.38, 4.38); Calibrated: 28.12.2012;
- Sensor-Surface: 1.4mm (Mechanical Surface Detection)
- Electronics: DAE4 Sn601; Calibrated: 25.04.2013
- Phantom: Flat Phantom 5.0 (back); Type: QD000P50AA; Serial: 1002
- DASY52 52.8.7(1137); SEMCAD X 14.6.10(7164)

**Dipole Calibration for Body Tissue/Pin=100mW, dist=10mm, f=5200 MHz/Zoom Scan,**

**dist=1.4mm (8x8x7)/Cube 0:** Measurement grid: dx=4mm, dy=4mm, dz=1.4mm

Reference Value = 58.606 V/m; Power Drift = -0.02 dB

Peak SAR (extrapolated) = 28.6 W/kg

**SAR(1 g) = 7.28 W/kg; SAR(10 g) = 2.03 W/kg**

Maximum value of SAR (measured) = 17.2 W/kg

**Dipole Calibration for Body Tissue/Pin=100mW, dist=10mm, f=5300 MHz/Zoom Scan,**

**dist=1.4mm (8x8x7)/Cube 0:** Measurement grid: dx=4mm, dy=4mm, dz=1.4mm

Reference Value = 58.305 V/m; Power Drift = 0.01 dB

Peak SAR (extrapolated) = 30.3 W/kg

**SAR(1 g) = 7.49 W/kg; SAR(10 g) = 2.09 W/kg**

Maximum value of SAR (measured) = 17.8 W/kg

**Dipole Calibration for Body Tissue/Pin=100mW, dist=10mm, f=5500 MHz/Zoom Scan,**

**dist=1.4mm (8x8x7)/Cube 0:** Measurement grid: dx=4mm, dy=4mm, dz=1.4mm

Reference Value = 58.471 V/m; Power Drift = -0.00 dB

Peak SAR (extrapolated) = 32.4 W/kg

**SAR(1 g) = 7.61 W/kg; SAR(10 g) = 2.11 W/kg**

Maximum value of SAR (measured) = 18.5 W/kg

**Dipole Calibration for Body Tissue/Pin=100mW, dist=10mm, f=5600 MHz/Zoom Scan, dist=1.4mm (8x8x7)/Cube 0:** Measurement grid: dx=4mm, dy=4mm, dz=1.4mm

Reference Value = 58.333 V/m; Power Drift = -0.01 dB

Peak SAR (extrapolated) = 33.8 W/kg

**SAR(1 g) = 7.75 W/kg; SAR(10 g) = 2.16 W/kg**

Maximum value of SAR (measured) = 19.1 W/kg

**Dipole Calibration for Body Tissue/Pin=100mW, dist=10mm, f=5800 MHz/Zoom Scan, dist=1.4mm (8x8x7)/Cube 0:** Measurement grid: dx=4mm, dy=4mm, dz=1.4mm

Reference Value = 55.389 V/m; Power Drift = 0.00 dB

Peak SAR (extrapolated) = 34.1 W/kg

**SAR(1 g) = 7.31 W/kg; SAR(10 g) = 2.02 W/kg**

Maximum value of SAR (measured) = 18.3 W/kg

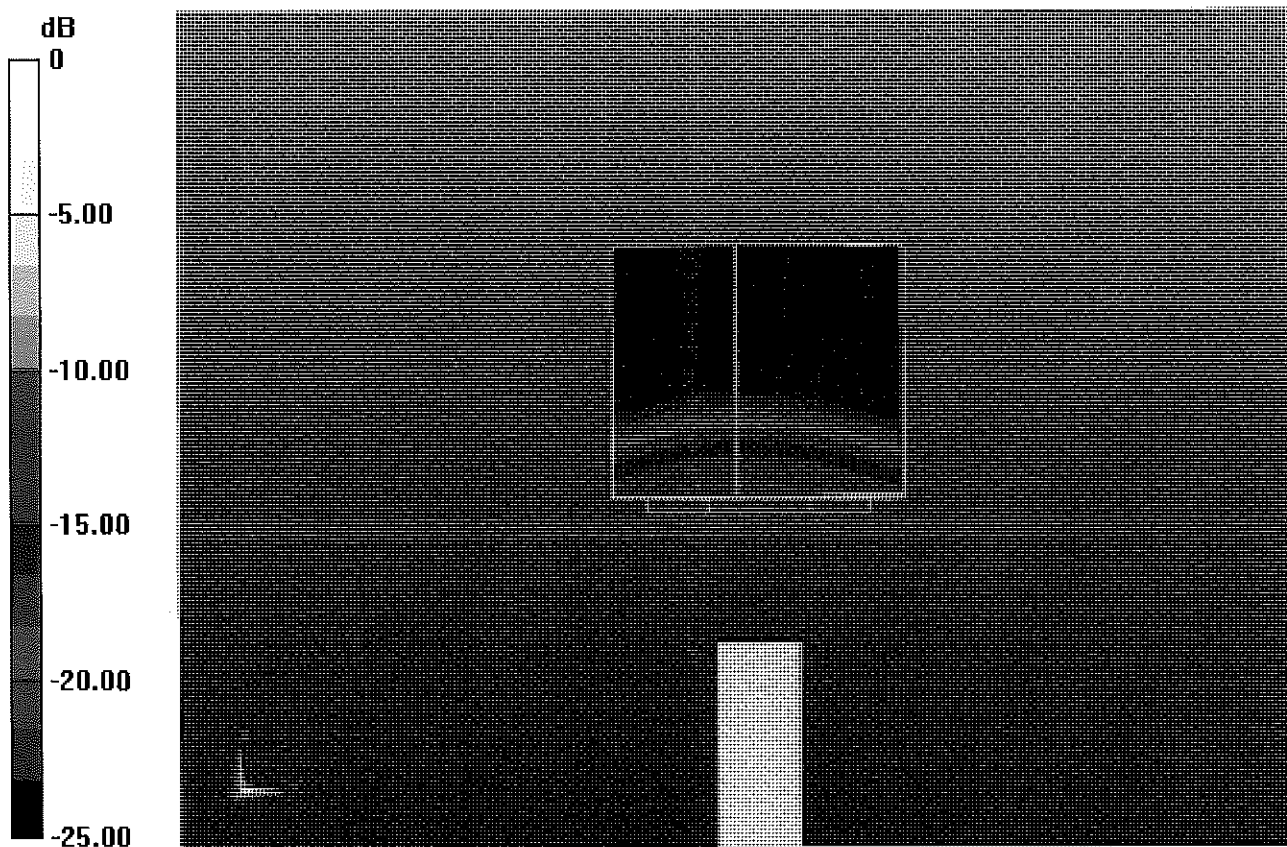

0 dB = 18.3 W/kg = 12.62 dBW/kg

# Impedance Measurement Plot for Body TSL

19 Sep 2013 15:38:51

CH1 S11 1 U FS 1: 53.098  $\Omega$  -10.264  $\Omega$  2.9820 pF 5 200.000 000 MHz

#  
De1  
Cor  
Avg  
0  
H1d

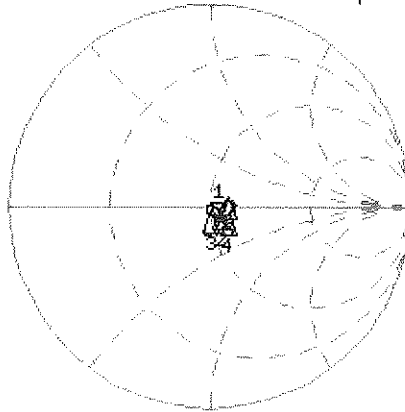

CH1 Markers

- 2: 54.285  $\Omega$   
-1.5293  $\Omega$   
5.30000 GHz
- 3: 49.717  $\Omega$   
-3.6367  $\Omega$   
5.50000 GHz
- 4: 58.225  $\Omega$   
-5.2344  $\Omega$   
5.60000 GHz
- 5: 58.725  $\Omega$   
3.9121  $\Omega$   
5.80000 GHz

CH2 S11 LOG 5 dB/REF -20 dB 1: -19.701 dB 5 200.000 000 MHz

Cor  
Avg  
0  
H1d

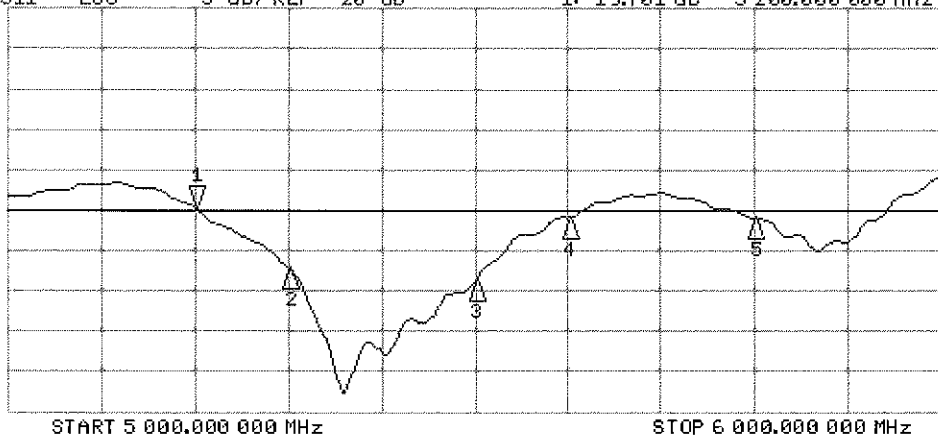

CH2 Markers

- 2: -27.201 dB  
5.30000 GHz
- 3: -28.741 dB  
5.50000 GHz
- 4: -20.917 dB  
5.60000 GHz
- 5: -21.121 dB  
5.80000 GHz



Accredited by the Swiss Accreditation Service (SAS)  
The Swiss Accreditation Service is one of the signatories to the EA  
Multilateral Agreement for the recognition of calibration certificates

Accreditation No.: **SCS 108**

Client **PC Test**

Certificate No: **D835V2-4d133\_Jul13**

## CALIBRATION CERTIFICATE

Object **D835V2 - SN: 4d133**

Calibration procedure(s) **QA CAL-05.v9  
Calibration procedure for dipole validation kits above 700 MHz**

Calibration date: **July 17, 2013**

*V  
KOK  
8/12/13*

This calibration certificate documents the traceability to national standards, which realize the physical units of measurements (SI).  
The measurements and the uncertainties with confidence probability are given on the following pages and are part of the certificate.

All calibrations have been conducted in the closed laboratory facility: environment temperature (22 ± 3)°C and humidity < 70%.

Calibration Equipment used (M&TE critical for calibration)

Primary Standards	ID #	Cal Date (Certificate No.)	Scheduled Calibration
Power meter EPM-442A	GB37480704	01-Nov-12 (No. 217-01640)	Oct-13
Power sensor HP 8481A	US37292783	01-Nov-12 (No. 217-01640)	Oct-13
Reference 20 dB Attenuator	SN: 5058 (20k)	04-Apr-13 (No. 217-01736)	Apr-14
Type-N mismatch combination	SN: 5047.3 / 06327	04-Apr-13 (No. 217-01739)	Apr-14
Reference Probe ES3DV3	SN: 3205	28-Dec-12 (No. ES3-3205_Dec12)	Dec-13
DAE4	SN: 601	25-Apr-13 (No. DAE4-601_Apr13)	Apr-14
Secondary Standards	ID #	Check Date (in house)	Scheduled Check
Power sensor HP 8481A	MY41092317	18-Oct-02 (in house check Oct-11)	In house check: Oct-13
RF generator R&S SMT-06	100005	04-Aug-99 (in house check Oct-11)	In house check: Oct-13
Network Analyzer HP 8753E	US37390585 S4206	18-Oct-01 (in house check Oct-12)	In house check: Oct-13

	<b>Name</b>	<b>Function</b>	<b>Signature</b>
Calibrated by:	Leif Klysner	Laboratory Technician	<i>Leif Klysner</i>
Approved by:	Katja Pokovic	Technical Manager	<i>Katja Pokovic</i>

Issued: July 18, 2013

This calibration certificate shall not be reproduced except in full without written approval of the laboratory.



Accredited by the Swiss Accreditation Service (SAS)  
The Swiss Accreditation Service is one of the signatories to the EA  
Multilateral Agreement for the recognition of calibration certificates

Accreditation No.: **SCS 108**

**Glossary:**

TSL	tissue simulating liquid
ConvF	sensitivity in TSL / NORM x,y,z
N/A	not applicable or not measured

**Calibration is Performed According to the Following Standards:**

- a) IEEE Std 1528-2003, "IEEE Recommended Practice for Determining the Peak Spatial-Averaged Specific Absorption Rate (SAR) in the Human Head from Wireless Communications Devices: Measurement Techniques", December 2003
- b) IEC 62209-1, "Procedure to measure the Specific Absorption Rate (SAR) for hand-held devices used in close proximity to the ear (frequency range of 300 MHz to 3 GHz)", February 2005
- c) Federal Communications Commission Office of Engineering & Technology (FCC OET), "Evaluating Compliance with FCC Guidelines for Human Exposure to Radiofrequency Electromagnetic Fields; Additional Information for Evaluating Compliance of Mobile and Portable Devices with FCC Limits for Human Exposure to Radiofrequency Emissions", Supplement C (Edition 01-01) to Bulletin 65

**Additional Documentation:**

- d) DASY4/5 System Handbook

**Methods Applied and Interpretation of Parameters:**

- *Measurement Conditions:* Further details are available from the Validation Report at the end of the certificate. All figures stated in the certificate are valid at the frequency indicated.
- *Antenna Parameters with TSL:* The dipole is mounted with the spacer to position its feed point exactly below the center marking of the flat phantom section, with the arms oriented parallel to the body axis.
- *Feed Point Impedance and Return Loss:* These parameters are measured with the dipole positioned under the liquid filled phantom. The impedance stated is transformed from the measurement at the SMA connector to the feed point. The Return Loss ensures low reflected power. No uncertainty required.
- *Electrical Delay:* One-way delay between the SMA connector and the antenna feed point. No uncertainty required.
- *SAR measured:* SAR measured at the stated antenna input power.
- *SAR normalized:* SAR as measured, normalized to an input power of 1 W at the antenna connector.
- *SAR for nominal TSL parameters:* The measured TSL parameters are used to calculate the nominal SAR result.

The reported uncertainty of measurement is stated as the standard uncertainty of measurement multiplied by the coverage factor  $k=2$ , which for a normal distribution corresponds to a coverage probability of approximately 95%.

## Measurement Conditions

DASY system configuration, as far as not given on page 1.

DASY Version	DASY5	V52.8.7
Extrapolation	Advanced Extrapolation	
Phantom	Modular Flat Phantom	
Distance Dipole Center - TSL	15 mm	with Spacer
Zoom Scan Resolution	dx, dy, dz = 5 mm	
Frequency	835 MHz ± 1 MHz	

## Head TSL parameters

The following parameters and calculations were applied.

	Temperature	Permittivity	Conductivity
Nominal Head TSL parameters	22.0 °C	41.5	0.90 mho/m
Measured Head TSL parameters	(22.0 ± 0.2) °C	41.8 ± 6 %	0.92 mho/m ± 6 %
Head TSL temperature change during test	< 0.5 °C	----	----

## SAR result with Head TSL

SAR averaged over 1 cm <sup>3</sup> (1 g) of Head TSL	Condition	
SAR measured	250 mW input power	2.44 W/kg
SAR for nominal Head TSL parameters	normalized to 1W	<b>9.62 W/kg ± 17.0 % (k=2)</b>

SAR averaged over 10 cm <sup>3</sup> (10 g) of Head TSL	condition	
SAR measured	250 mW input power	1.59 W/kg
SAR for nominal Head TSL parameters	normalized to 1W	<b>6.28 W/kg ± 16.5 % (k=2)</b>

## Body TSL parameters

The following parameters and calculations were applied.

	Temperature	Permittivity	Conductivity
Nominal Body TSL parameters	22.0 °C	55.2	0.97 mho/m
Measured Body TSL parameters	(22.0 ± 0.2) °C	54.9 ± 6 %	1.00 mho/m ± 6 %
Body TSL temperature change during test	< 0.5 °C	----	----

## SAR result with Body TSL

SAR averaged over 1 cm <sup>3</sup> (1 g) of Body TSL	Condition	
SAR measured	250 mW input power	2.46 W/kg
SAR for nominal Body TSL parameters	normalized to 1W	<b>9.61 W/kg ± 17.0 % (k=2)</b>

SAR averaged over 10 cm <sup>3</sup> (10 g) of Body TSL	condition	
SAR measured	250 mW input power	1.62 W/kg
SAR for nominal Body TSL parameters	normalized to 1W	<b>6.36 W/kg ± 16.5 % (k=2)</b>

## Appendix

### Antenna Parameters with Head TSL

Impedance, transformed to feed point	52.0 $\Omega$ - 1.8 j $\Omega$
Return Loss	- 31.8 dB

### Antenna Parameters with Body TSL

Impedance, transformed to feed point	48.2 $\Omega$ - 3.6 j $\Omega$
Return Loss	- 27.7 dB

### General Antenna Parameters and Design

Electrical Delay (one direction)	1.395 ns
----------------------------------	----------

After long term use with 100W radiated power, only a slight warming of the dipole near the feedpoint can be measured.

The dipole is made of standard semirigid coaxial cable. The center conductor of the feeding line is directly connected to the second arm of the dipole. The antenna is therefore short-circuited for DC-signals. On some of the dipoles, small end caps are added to the dipole arms in order to improve matching when loaded according to the position as explained in the "Measurement Conditions" paragraph. The SAR data are not affected by this change. The overall dipole length is still according to the Standard.

No excessive force must be applied to the dipole arms, because they might bend or the soldered connections near the feedpoint may be damaged.

### Additional EUT Data

Manufactured by	SPEAG
Manufactured on	July 22, 2011

# DASY5 Validation Report for Head TSL

Date: 17.07.2013

Test Laboratory: SPEAG, Zurich, Switzerland

**DUT: Dipole 835 MHz; Type: D835V2; Serial: D835V2 - SN: 4d133**

Communication System: UID 0 - CW ; Frequency: 835 MHz

Medium parameters used:  $f = 835 \text{ MHz}$ ;  $\sigma = 0.92 \text{ S/m}$ ;  $\epsilon_r = 41.8$ ;  $\rho = 1000 \text{ kg/m}^3$

Phantom section: Flat Section

Measurement Standard: DASY5 (IEEE/IEC/ANSI C63.19-2007)

DASY52 Configuration:

- Probe: ES3DV3 - SN3205; ConvF(6.05, 6.05, 6.05); Calibrated: 28.12.2012;
- Sensor-Surface: 3mm (Mechanical Surface Detection)
- Electronics: DAE4 Sn601; Calibrated: 25.04.2013
- Phantom: Flat Phantom 4.9L; Type: QD000P49AA; Serial: 1001
- DASY52 52.8.7(1137); SEMCAD X 14.6.10(7164)

## Dipole Calibration for Head Tissue/Pin=250 mW, d=15mm/Zoom Scan (7x7x7)/Cube 0:

Measurement grid:  $dx=5\text{mm}$ ,  $dy=5\text{mm}$ ,  $dz=5\text{mm}$

Reference Value = 57.188 V/m; Power Drift = 0.03 dB

Peak SAR (extrapolated) = 3.66 W/kg

**SAR(1 g) = 2.44 W/kg; SAR(10 g) = 1.59 W/kg**

Maximum value of SAR (measured) = 2.84 W/kg

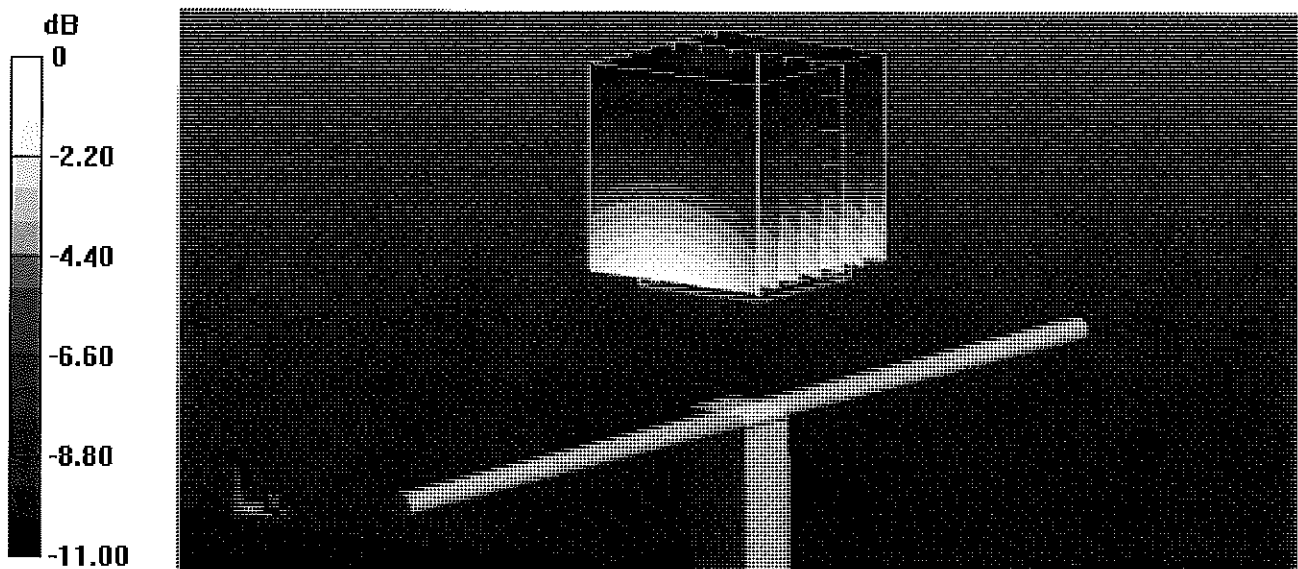

0 dB = 2.84 W/kg = 4.53 dBW/kg

# Impedance Measurement Plot for Head TSL

18 Jul 2013 09:49:17  
[CH1] S11 1 U FS 1: 51.957  $\Omega$  -1.7539  $\Omega$  100.67 pF 835.000 000 MHz

\*  
De1  
CA

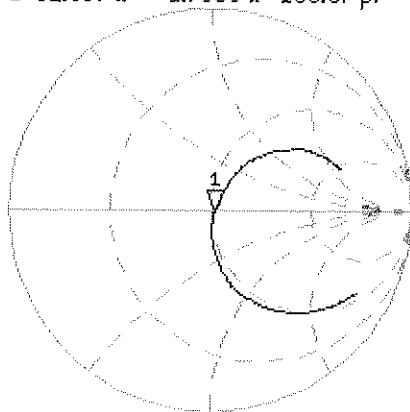

Avg  
16  
H1d

CH2 S11 LOG 5 dB/REF -20 dB 1:-31.772 dB 835.000 000 MHz

CA  
Avg  
16  
H1d

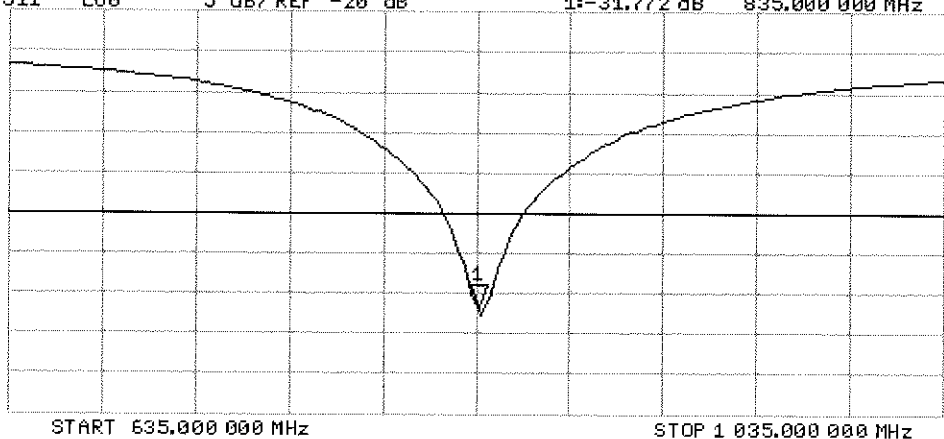

## DASY5 Validation Report for Body TSL

Date: 17.07.2013

Test Laboratory: SPEAG, Zurich, Switzerland

**DUT: Dipole 835 MHz; Type: D835V2; Serial: D835V2 - SN: 4d133**

Communication System: UID 0 - CW ; Frequency: 835 MHz

Medium parameters used:  $f = 835$  MHz;  $\sigma = 1$  S/m;  $\epsilon_r = 54.9$ ;  $\rho = 1000$  kg/m<sup>3</sup>

Phantom section: Flat Section

Measurement Standard: DASY5 (IEEE/IEC/ANSI C63.19-2007)

DASY52 Configuration:

- Probe: ES3DV3 - SN3205; ConvF(6.04, 6.04, 6.04); Calibrated: 28.12.2012;
- Sensor-Surface: 3mm (Mechanical Surface Detection)
- Electronics: DAE4 Sn601; Calibrated: 25.04.2013
- Phantom: Flat Phantom 4.9L; Type: QD000P49AA; Serial: 1001
- DASY52 52.8.7(1137); SEMCAD X 14.6.10(7164)

### Dipole Calibration for Body Tissue/Pin=250 mW, d=15mm/Zoom Scan (7x7x7)/Cube 0:

Measurement grid: dx=5mm, dy=5mm, dz=5mm

Reference Value = 55.351 V/m; Power Drift = 0.03 dB

Peak SAR (extrapolated) = 3.59 W/kg

**SAR(1 g) = 2.46 W/kg; SAR(10 g) = 1.62 W/kg**

Maximum value of SAR (measured) = 2.86 W/kg

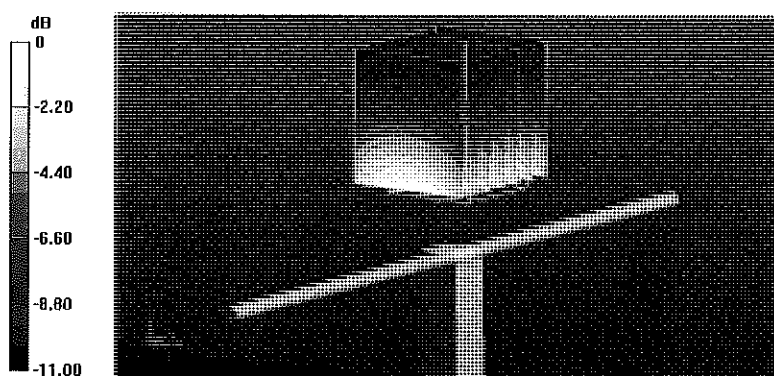

0 dB = 2.86 W/kg = 4.56 dBW/kg

# Impedance Measurement Plot for Body TSL

18 Jul 2013 09:11:04  
[CH1] S11 1 U FS 1: 48.184  $\Omega$  -3.6035  $\Omega$  52.894 pF 835.000 000 MHz

\*  
De1  
Ca

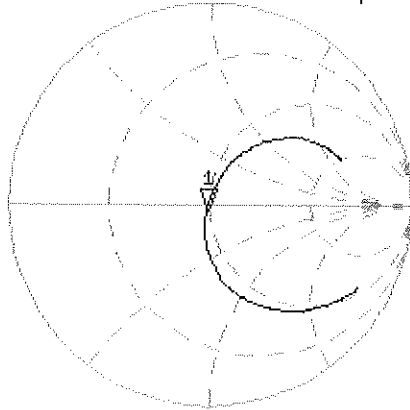

Avg  
16

H1d

CH2 S11 LOG 5 dB/REF -20 dB 1: -27.734 dB 835.000 000 MHz

Ca

Avg  
16

H1d

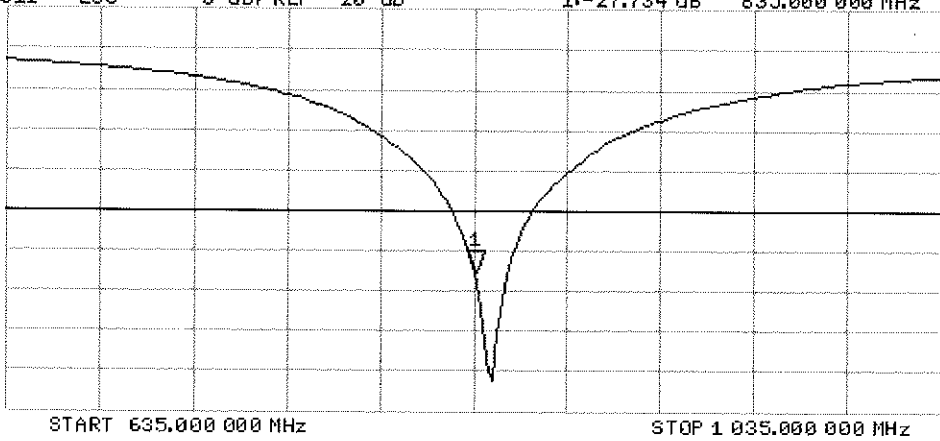



Accredited by the Swiss Accreditation Service (SAS)  
The Swiss Accreditation Service is one of the signatories to the EA  
Multilateral Agreement for the recognition of calibration certificates

Accreditation No.: **SCS 108**

Client **PC Test**

Certificate No: **D1900V2-5d149\_Jul13**

## CALIBRATION CERTIFICATE

Object **D1900V2 - SN: 5d149**

Calibration procedure(s) **QA CAL-05.v9  
Calibration procedure for dipole validation kits above 700 MHz**

Calibration date: **July 22, 2013**

*✓  
Kok  
8/19/13*

This calibration certificate documents the traceability to national standards, which realize the physical units of measurements (SI).  
The measurements and the uncertainties with confidence probability are given on the following pages and are part of the certificate.

All calibrations have been conducted in the closed laboratory facility: environment temperature (22 ± 3)°C and humidity < 70%.

Calibration Equipment used (M&TE critical for calibration)

Primary Standards	ID #	Cal Date (Certificate No.)	Scheduled Calibration
Power meter EPM-442A	GB37480704	01-Nov-12 (No. 217-01640)	Oct-13
Power sensor HP 8481A	US37292783	01-Nov-12 (No. 217-01640)	Oct-13
Reference 20 dB Attenuator	SN: 5058 (20k)	04-Apr-13 (No. 217-01736)	Apr-14
Type-N mismatch combination	SN: 5047.3 / 06327	04-Apr-13 (No. 217-01739)	Apr-14
Reference Probe ES3DV3	SN: 3205	28-Dec-12 (No. ES3-3205_Dec12)	Dec-13
DAE4	SN: 601	25-Apr-13 (No. DAE4-601_Apr13)	Apr-14
Secondary Standards	ID #	Check Date (in house)	Scheduled Check
Power sensor HP 8481A	MY41092317	18-Oct-02 (in house check Oct-11)	In house check: Oct-13
RF generator R&S SMT-06	100005	04-Aug-99 (in house check Oct-11)	In house check: Oct-13
Network Analyzer HP 8753E	US37390585 S4206	18-Oct-01 (in house check Oct-12)	In house check: Oct-13

	<b>Name</b>	<b>Function</b>	<b>Signature</b>
Calibrated by:	Jeton Kastrali	Laboratory Technician	
Approved by:	Katja Pokovic	Technical Manager	

Issued: July 22, 2013

This calibration certificate shall not be reproduced except in full without written approval of the laboratory.



Accredited by the Swiss Accreditation Service (SAS)  
The Swiss Accreditation Service is one of the signatories to the EA  
Multilateral Agreement for the recognition of calibration certificates

Accreditation No.: **SCS 108**

**Glossary:**

TSL	tissue simulating liquid
ConvF	sensitivity in TSL / NORM x,y,z
N/A	not applicable or not measured

**Calibration is Performed According to the Following Standards:**

- a) IEEE Std 1528-2003, "IEEE Recommended Practice for Determining the Peak Spatial-Averaged Specific Absorption Rate (SAR) in the Human Head from Wireless Communications Devices: Measurement Techniques", December 2003
- b) IEC 62209-1, "Procedure to measure the Specific Absorption Rate (SAR) for hand-held devices used in close proximity to the ear (frequency range of 300 MHz to 3 GHz)", February 2005
- c) Federal Communications Commission Office of Engineering & Technology (FCC OET), "Evaluating Compliance with FCC Guidelines for Human Exposure to Radiofrequency Electromagnetic Fields; Additional Information for Evaluating Compliance of Mobile and Portable Devices with FCC Limits for Human Exposure to Radiofrequency Emissions", Supplement C (Edition 01-01) to Bulletin 65

**Additional Documentation:**

- d) DASY4/5 System Handbook

**Methods Applied and Interpretation of Parameters:**

- *Measurement Conditions:* Further details are available from the Validation Report at the end of the certificate. All figures stated in the certificate are valid at the frequency indicated.
- *Antenna Parameters with TSL:* The dipole is mounted with the spacer to position its feed point exactly below the center marking of the flat phantom section, with the arms oriented parallel to the body axis.
- *Feed Point Impedance and Return Loss:* These parameters are measured with the dipole positioned under the liquid filled phantom. The impedance stated is transformed from the measurement at the SMA connector to the feed point. The Return Loss ensures low reflected power. No uncertainty required.
- *Electrical Delay:* One-way delay between the SMA connector and the antenna feed point. No uncertainty required.
- *SAR measured:* SAR measured at the stated antenna input power.
- *SAR normalized:* SAR as measured, normalized to an input power of 1 W at the antenna connector.
- *SAR for nominal TSL parameters:* The measured TSL parameters are used to calculate the nominal SAR result.

The reported uncertainty of measurement is stated as the standard uncertainty of measurement multiplied by the coverage factor  $k=2$ , which for a normal distribution corresponds to a coverage probability of approximately 95%.

## Measurement Conditions

DASY system configuration, as far as not given on page 1.

<b>DASY Version</b>	DASY5	V52.8.7
<b>Extrapolation</b>	Advanced Extrapolation	
<b>Phantom</b>	Modular Flat Phantom	
<b>Distance Dipole Center - TSL</b>	10 mm	with Spacer
<b>Zoom Scan Resolution</b>	dx, dy, dz = 5 mm	
<b>Frequency</b>	1900 MHz $\pm$ 1 MHz	

## Head TSL parameters

The following parameters and calculations were applied.

	Temperature	Permittivity	Conductivity
<b>Nominal Head TSL parameters</b>	22.0 °C	40.0	1.40 mho/m
<b>Measured Head TSL parameters</b>	(22.0 $\pm$ 0.2) °C	38.9 $\pm$ 6 %	1.36 mho/m $\pm$ 6 %
<b>Head TSL temperature change during test</b>	< 0.5 °C	----	----

## SAR result with Head TSL

<b>SAR averaged over 1 cm<sup>3</sup> (1 g) of Head TSL</b>	Condition	
SAR measured	250 mW input power	9.99 W/kg
SAR for nominal Head TSL parameters	normalized to 1W	<b>40.4 W/kg <math>\pm</math> 17.0 % (k=2)</b>

<b>SAR averaged over 10 cm<sup>3</sup> (10 g) of Head TSL</b>	condition	
SAR measured	250 mW input power	5.28 W/kg
SAR for nominal Head TSL parameters	normalized to 1W	<b>21.3 W/kg <math>\pm</math> 16.5 % (k=2)</b>

## Body TSL parameters

The following parameters and calculations were applied.

	Temperature	Permittivity	Conductivity
<b>Nominal Body TSL parameters</b>	22.0 °C	53.3	1.52 mho/m
<b>Measured Body TSL parameters</b>	(22.0 $\pm$ 0.2) °C	53.4 $\pm$ 6 %	1.49 mho/m $\pm$ 6 %
<b>Body TSL temperature change during test</b>	< 0.5 °C	----	----

## SAR result with Body TSL

<b>SAR averaged over 1 cm<sup>3</sup> (1 g) of Body TSL</b>	Condition	
SAR measured	250 mW input power	10.0 W/kg
SAR for nominal Body TSL parameters	normalized to 1W	<b>40.5 W/kg <math>\pm</math> 17.0 % (k=2)</b>

<b>SAR averaged over 10 cm<sup>3</sup> (10 g) of Body TSL</b>	condition	
SAR measured	250 mW input power	5.36 W/kg
SAR for nominal Body TSL parameters	normalized to 1W	<b>21.6 W/kg <math>\pm</math> 16.5 % (k=2)</b>

## Appendix

### Antenna Parameters with Head TSL

Impedance, transformed to feed point	52.9 $\Omega$ + 6.0 j $\Omega$
Return Loss	- 23.8 dB

### Antenna Parameters with Body TSL

Impedance, transformed to feed point	48.5 $\Omega$ + 6.4 j $\Omega$
Return Loss	- 23.5 dB

### General Antenna Parameters and Design

Electrical Delay (one direction)	1.196 ns
----------------------------------	----------

After long term use with 100W radiated power, only a slight warming of the dipole near the feedpoint can be measured.

The dipole is made of standard semirigid coaxial cable. The center conductor of the feeding line is directly connected to the second arm of the dipole. The antenna is therefore short-circuited for DC-signals. On some of the dipoles, small end caps are added to the dipole arms in order to improve matching when loaded according to the position as explained in the "Measurement Conditions" paragraph. The SAR data are not affected by this change. The overall dipole length is still according to the Standard.

No excessive force must be applied to the dipole arms, because they might bend or the soldered connections near the feedpoint may be damaged.

### Additional EUT Data

Manufactured by	SPEAG
Manufactured on	March 11, 2011

## DASY5 Validation Report for Head TSL

Date: 22.07.2013

Test Laboratory: SPEAG, Zurich, Switzerland

**DUT: Dipole 1900 MHz; Type: D1900V2; Serial: D1900V2 - SN: 5d149**

Communication System: UID 0 - CW ; Frequency: 1900 MHz

Medium parameters used:  $f = 1900$  MHz;  $\sigma = 1.36$  S/m;  $\epsilon_r = 38.9$ ;  $\rho = 1000$  kg/m<sup>3</sup>

Phantom section: Flat Section

Measurement Standard: DASY5 (IEEE/IEC/ANSI C63.19-2007)

DASY52 Configuration:

- Probe: ES3DV3 - SN3205; ConvF(4.98, 4.98, 4.98); Calibrated: 28.12.2012;
- Sensor-Surface: 3mm (Mechanical Surface Detection)
- Electronics: DAE4 Sn601; Calibrated: 25.04.2013
- Phantom: Flat Phantom 5.0 (front); Type: QD000P50AA; Serial: 1001
- DASY52 52.8.7(1137); SEMCAD X 14.6.10(7164)

### **Dipole Calibration for Head Tissue/Pin=250 mW, d=10mm/Zoom Scan (7x7x7)/Cube 0:**

Measurement grid: dx=5mm, dy=5mm, dz=5mm

Reference Value = 96.173 V/m; Power Drift = 0.04 dB

Peak SAR (extrapolated) = 18.0 W/kg

**SAR(1 g) = 9.99 W/kg; SAR(10 g) = 5.28 W/kg**

Maximum value of SAR (measured) = 12.4 W/kg

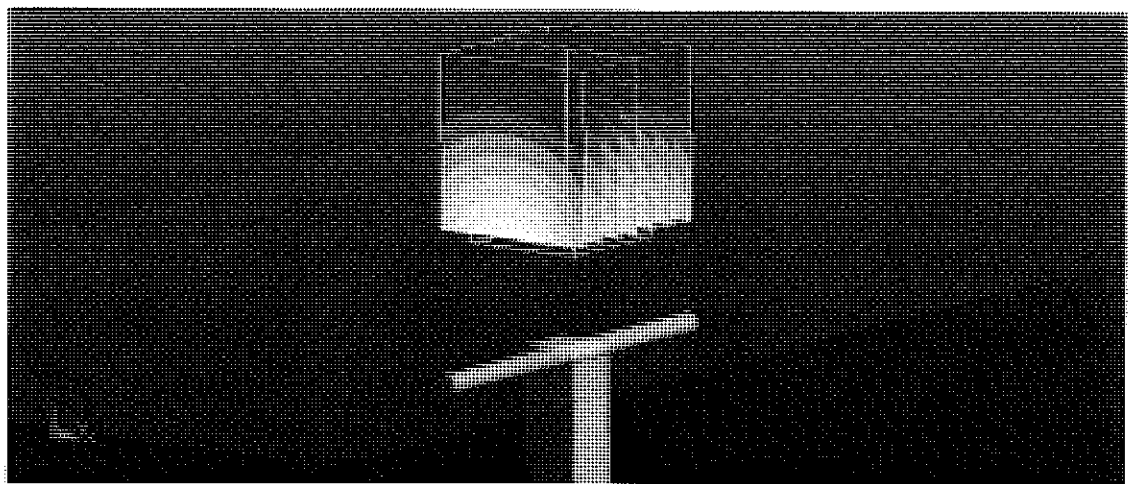
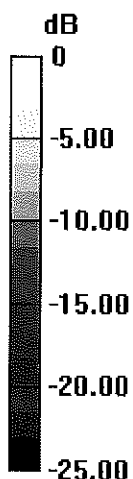

0 dB = 12.4 W/kg = 10.93 dBW/kg

# Impedance Measurement Plot for Head TSL

22 Jul 2013 11:59:34

CH1 S11 1 U FS 1: 52.941  $\Omega$  6.0059  $\Omega$  503.09  $\rho H$  1 900.000 000 MHz

\*  
De1  
CA  
Avg  
16  
H1d

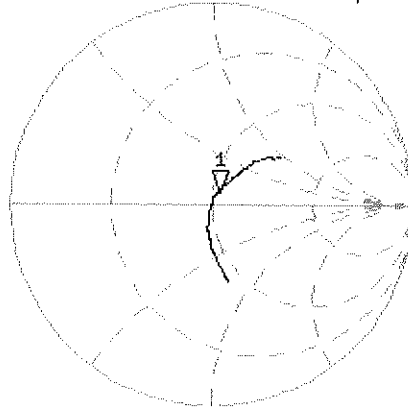

CH2 S11 LOG 5 dB/REF -20 dB 1:-23.758 dB 1 900.000 000 MHz

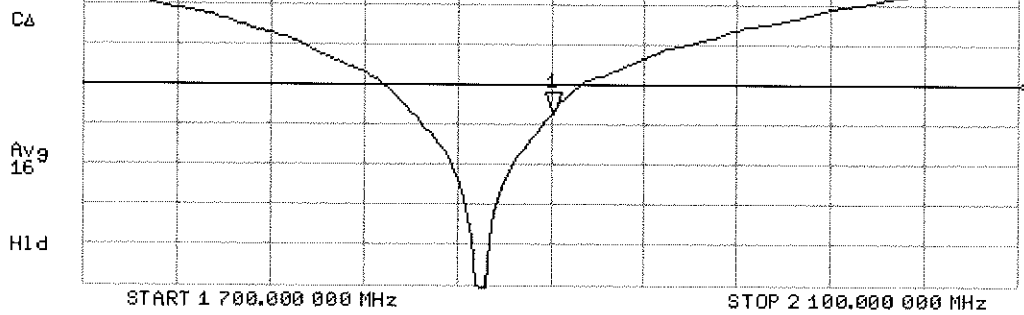

# DASY5 Validation Report for Body TSL

Date: 22.07.2013

Test Laboratory: SPEAG, Zurich, Switzerland

**DUT: Dipole 1900 MHz; Type: D1900V2; Serial: D1900V2 - SN: 5d149**

Communication System: UID 0 - CW ; Frequency: 1900 MHz

Medium parameters used:  $f = 1900$  MHz;  $\sigma = 1.49$  S/m;  $\epsilon_r = 53.4$ ;  $\rho = 1000$  kg/m<sup>3</sup>

Phantom section: Flat Section

Measurement Standard: DASY5 (IEEE/IEC/ANSI C63.19-2007)

DASY52 Configuration:

- Probe: ES3DV3 - SN3205; ConvF(4.6, 4.6, 4.6); Calibrated: 28.12.2012;
- Sensor-Surface: 3mm (Mechanical Surface Detection)
- Electronics: DAE4 Sn601; Calibrated: 25.04.2013
- Phantom: Flat Phantom 5.0 (back); Type: QD000P50AA; Serial: 1002
- DASY52 52.8.7(1137); SEMCAD X 14.6.10(7164)

## Dipole Calibration for Body Tissue/Pin=250 mW, d=10mm/Zoom Scan (7x7x7)/Cube 0:

Measurement grid: dx=5mm, dy=5mm, dz=5mm

Reference Value = 96.173 V/m; Power Drift = 0.01 dB

Peak SAR (extrapolated) = 17.0 W/kg

**SAR(1 g) = 10 W/kg; SAR(10 g) = 5.36 W/kg**

Maximum value of SAR (measured) = 12.6 W/kg

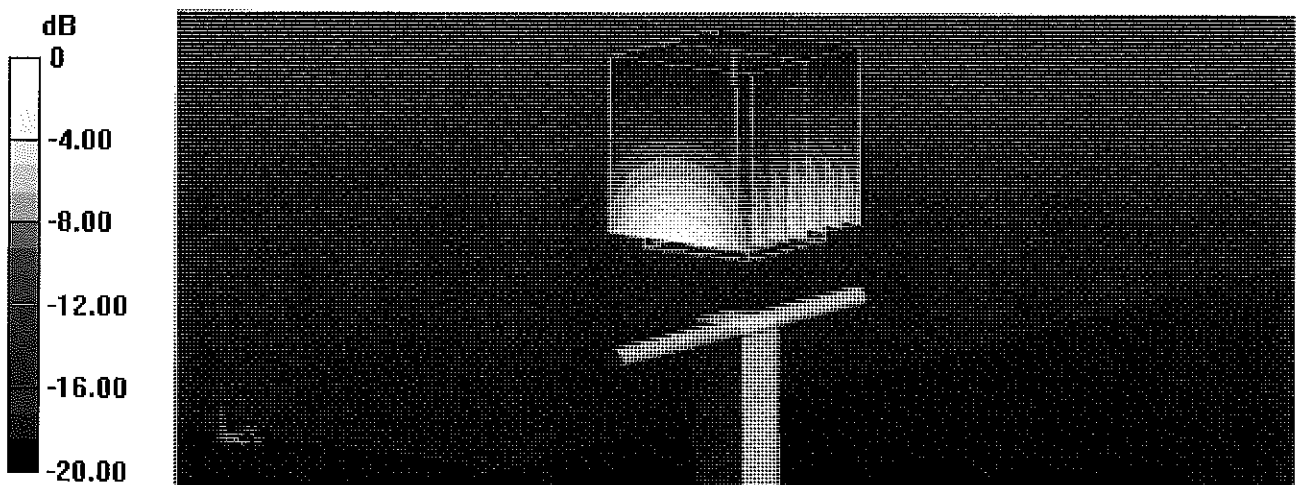

0 dB = 12.6 W/kg = 11.00 dBW/kg

# Impedance Measurement Plot for Body TSL

22 Jul 2013 11:32:14

CH1 S11 1 U FS 1: 48.525  $\Omega$  6.3906  $\mu$  535.32 pF 1 900.000 000 MHz

\*  
De1  
CA

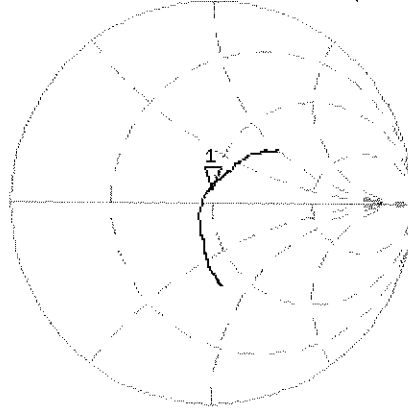

Avg  
16

H1d

CH2 S11 LOG 5 dB/REF -20 dB 1:-23.547 dB 1 900.000 000 MHz

CA

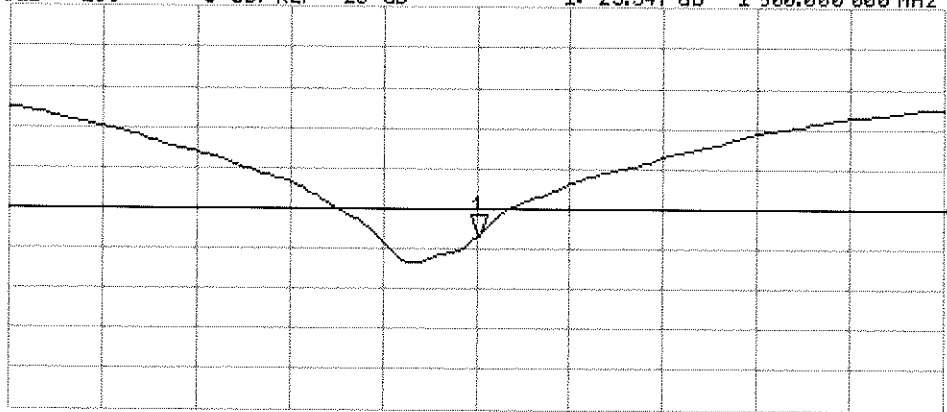

Avg  
16

H1d

START 1 700.000 000 MHz

STOP 2 100.000 000 MHz



Accredited by the Swiss Accreditation Service (SAS)  
The Swiss Accreditation Service is one of the signatories to the EA  
Multilateral Agreement for the recognition of calibration certificates

Accreditation No.: **SCS 108**

Client **PC Test**

Certificate No: **D5GHzV2-1120\_Feb13**

## CALIBRATION CERTIFICATE

Object **D5GHzV2 - SN: 1120**

Calibration procedure(s) **QA CAL-22.v2  
Calibration procedure for dipole validation kits between 3-6 GHz**

Calibration date: **February 14, 2013**

*✓  
Kok  
2/2/13*

This calibration certificate documents the traceability to national standards, which realize the physical units of measurements (SI).  
The measurements and the uncertainties with confidence probability are given on the following pages and are part of the certificate.

All calibrations have been conducted in the closed laboratory facility: environment temperature ( $22 \pm 3$ )°C and humidity < 70%.

Calibration Equipment used (M&TE critical for calibration)

Primary Standards	ID #	Cal Date (Certificate No.)	Scheduled Calibration
Power meter EPM-442A	GB37480704	01-Nov-12 (No. 217-01640)	Oct-13
Power sensor HP 8481A	US37292783	01-Nov-12 (No. 217-01640)	Oct-13
Reference 20 dB Attenuator	SN: 5058 (20k)	27-Mar-12 (No. 217-01530)	Apr-13
Type-N mismatch combination	SN: 5047.3 / 06327	27-Mar-12 (No. 217-01533)	Apr-13
Reference Probe EX3DV4	SN: 3503	28-Dec-12 (No. EX3-3503_Dec12)	Dec-13
DAE4	SN: 601	27-Jun-12 (No. DAE4-601_Jun12)	Jun-13
Secondary Standards	ID #	Check Date (in house)	Scheduled Check
Power sensor HP 8481A	MY41092317	18-Oct-02 (in house check Oct-11)	In house check: Oct-13
RF generator R&S SMT-06	100005	04-Aug-99 (in house check Oct-11)	In house check: Oct-13
Network Analyzer HP 8753E	US37390585 S4206	18-Oct-01 (in house check Oct-12)	In house check: Oct-13

Calibrated by: **Israe El-Naouq**      Function: **Laboratory Technician**

Signature

*Israe El-Naouq*  
*Katja Pokovic*

Approved by: **Katja Pokovic**      Technical Manager

Issued: February 14, 2013

This calibration certificate shall not be reproduced except in full without written approval of the laboratory.



Accredited by the Swiss Accreditation Service (SAS)  
The Swiss Accreditation Service is one of the signatories to the EA  
Multilateral Agreement for the recognition of calibration certificates

Accreditation No.: **SCS 108**

### Glossary:

TSL	tissue simulating liquid
ConvF	sensitivity in TSL / NORM x,y,z
N/A	not applicable or not measured

### Calibration is Performed According to the Following Standards:

- a) IEC 62209-2, "Evaluation of Human Exposure to Radio Frequency Fields from Handheld and Body-Mounted Wireless Communication Devices in the Frequency Range of 30 MHz to 6 GHz: Human models, Instrumentation, and Procedures"; Part 2: "Procedure to determine the Specific Absorption Rate (SAR) for including accessories and multiple transmitters", March 2010
- b) Federal Communications Commission Office of Engineering & Technology (FCC OET), "Evaluating Compliance with FCC Guidelines for Human Exposure to Radiofrequency Electromagnetic Fields; Additional Information for Evaluating Compliance of Mobile and Portable Devices with FCC Limits for Human Exposure to Radiofrequency Emissions", Supplement C (Edition 01-01) to Bulletin 65

### Additional Documentation:

- c) DASY4/5 System Handbook

### Methods Applied and Interpretation of Parameters:

- *Measurement Conditions:* Further details are available from the Validation Report at the end of the certificate. All figures stated in the certificate are valid at the frequency indicated.
- *Antenna Parameters with TSL:* The dipole is mounted with the spacer to position its feed point exactly below the center marking of the flat phantom section, with the arms oriented parallel to the body axis.
- *Feed Point Impedance and Return Loss:* These parameters are measured with the dipole positioned under the liquid filled phantom. The impedance stated is transformed from the measurement at the SMA connector to the feed point. The Return Loss ensures low reflected power. No uncertainty required.
- *Electrical Delay:* One-way delay between the SMA connector and the antenna feed point. No uncertainty required.
- *SAR measured:* SAR measured at the stated antenna input power.
- *SAR normalized:* SAR as measured, normalized to an input power of 1 W at the antenna connector.
- *SAR for nominal TSL parameters:* The measured TSL parameters are used to calculate the nominal SAR result.

The reported uncertainty of measurement is stated as the standard uncertainty of measurement multiplied by the coverage factor  $k=2$ , which for a normal distribution corresponds to a coverage probability of approximately 95%.

## Measurement Conditions

DASY system configuration, as far as not given on page 1.

<b>DASY Version</b>	DASY5	V52.8.5
<b>Extrapolation</b>	Advanced Extrapolation	
<b>Phantom</b>	Modular Flat Phantom V5.0	
<b>Distance Dipole Center - TSL</b>	10 mm	with Spacer
<b>Zoom Scan Resolution</b>	dx, dy = 4.0 mm, dz = 1.4 mm	Graded Ratio = 1.4 (Z direction)
<b>Frequency</b>	5200 MHz ± 1 MHz 5300 MHz ± 1 MHz 5500 MHz ± 1 MHz 5600 MHz ± 1 MHz 5800 MHz ± 1 MHz	

## Head TSL parameters at 5200 MHz

The following parameters and calculations were applied.

	Temperature	Permittivity	Conductivity
<b>Nominal Head TSL parameters</b>	22.0 °C	36.0	4.66 mho/m
<b>Measured Head TSL parameters</b>	(22.0 ± 0.2) °C	34.7 ± 6 %	4.47 mho/m ± 6 %
<b>Head TSL temperature change during test</b>	< 0.5 °C	----	----

## SAR result with Head TSL at 5200 MHz

<b>SAR averaged over 1 cm<sup>3</sup> (1 g) of Head TSL</b>	Condition	
SAR measured	100 mW input power	7.67 W/kg
SAR for nominal Head TSL parameters	normalized to 1W	<b>76.0 W/kg ± 19.9 % (k=2)</b>

<b>SAR averaged over 10 cm<sup>3</sup> (10 g) of Head TSL</b>	condition	
SAR measured	100 mW input power	2.18 W/kg
SAR for nominal Head TSL parameters	normalized to 1W	<b>21.5 W/kg ± 19.5 % (k=2)</b>

### Head TSL parameters at 5300 MHz

The following parameters and calculations were applied.

	Temperature	Permittivity	Conductivity
Nominal Head TSL parameters	22.0 °C	35.9	4.76 mho/m
Measured Head TSL parameters	(22.0 ± 0.2) °C	34.5 ± 6 %	4.57 mho/m ± 6 %
Head TSL temperature change during test	< 0.5 °C	----	----

### SAR result with Head TSL at 5300 MHz

SAR averaged over 1 cm <sup>3</sup> (1 g) of Head TSL	Condition	
SAR measured	100 mW input power	7.94 W/kg
SAR for nominal Head TSL parameters	normalized to 1W	<b>78.7 W / kg ± 19.9 % (k=2)</b>

SAR averaged over 10 cm <sup>3</sup> (10 g) of Head TSL	condition	
SAR measured	100 mW input power	2.27 W/kg
SAR for nominal Head TSL parameters	normalized to 1W	<b>22.4 W/kg ± 19.5 % (k=2)</b>

### Head TSL parameters at 5500 MHz

The following parameters and calculations were applied.

	Temperature	Permittivity	Conductivity
Nominal Head TSL parameters	22.0 °C	35.6	4.96 mho/m
Measured Head TSL parameters	(22.0 ± 0.2) °C	34.2 ± 6 %	4.74 mho/m ± 6 %
Head TSL temperature change during test	< 0.5 °C	----	----

### SAR result with Head TSL at 5500 MHz

SAR averaged over 1 cm <sup>3</sup> (1 g) of Head TSL	Condition	
SAR measured	100 mW input power	8.09 W/kg
SAR for nominal Head TSL parameters	normalized to 1W	<b>80.1 W/kg ± 19.9 % (k=2)</b>

SAR averaged over 10 cm <sup>3</sup> (10 g) of Head TSL	condition	
SAR measured	100 mW input power	2.29 W/kg
SAR for nominal Head TSL parameters	normalized to 1W	<b>22.6 W/kg ± 19.5 % (k=2)</b>

### Head TSL parameters at 5600 MHz

The following parameters and calculations were applied.

	Temperature	Permittivity	Conductivity
Nominal Head TSL parameters	22.0 °C	35.5	5.07 mho/m
Measured Head TSL parameters	(22.0 ± 0.2) °C	34.1 ± 6 %	4.83 mho/m ± 6 %
Head TSL temperature change during test	< 0.5 °C	----	----

### SAR result with Head TSL at 5600 MHz

SAR averaged over 1 cm <sup>3</sup> (1 g) of Head TSL	Condition	
SAR measured	100 mW input power	8.08 W/kg
SAR for nominal Head TSL parameters	normalized to 1W	<b>79.9 W/kg ± 19.9 % (k=2)</b>

SAR averaged over 10 cm <sup>3</sup> (10 g) of Head TSL	condition	
SAR measured	100 mW input power	2.28 W/kg
SAR for nominal Head TSL parameters	normalized to 1W	<b>22.5 W/kg ± 19.5 % (k=2)</b>

### Head TSL parameters at 5800 MHz

The following parameters and calculations were applied.

	Temperature	Permittivity	Conductivity
Nominal Head TSL parameters	22.0 °C	35.3	5.27 mho/m
Measured Head TSL parameters	(22.0 ± 0.2) °C	33.9 ± 6 %	5.05 mho/m ± 6 %
Head TSL temperature change during test	< 0.5 °C	----	----

### SAR result with Head TSL at 5800 MHz

SAR averaged over 1 cm <sup>3</sup> (1 g) of Head TSL	Condition	
SAR measured	100 mW input power	7.57 W/kg
SAR for nominal Head TSL parameters	normalized to 1W	<b>74.9 W/kg ± 19.9 % (k=2)</b>

SAR averaged over 10 cm <sup>3</sup> (10 g) of Head TSL	condition	
SAR measured	100 mW input power	2.13 W/kg
SAR for nominal Head TSL parameters	normalized to 1W	<b>21.0 W/kg ± 19.5 % (k=2)</b>

### Body TSL parameters at 5200 MHz

The following parameters and calculations were applied.

	Temperature	Permittivity	Conductivity
Nominal Body TSL parameters	22.0 °C	49.0	5.30 mho/m
Measured Body TSL parameters	(22.0 ± 0.2) °C	46.9 ± 6 %	5.36 mho/m ± 6 %
Body TSL temperature change during test	< 0.5 °C	----	----

### SAR result with Body TSL at 5200 MHz

SAR averaged over 1 cm <sup>3</sup> (1 g) of Body TSL	Condition	
SAR measured	100 mW input power	7.73 W/kg
SAR for nominal Body TSL parameters	normalized to 1W	<b>76.6 W/kg ± 19.9 % (k=2)</b>

SAR averaged over 10 cm <sup>3</sup> (10 g) of Body TSL	condition	
SAR measured	100 mW input power	2.17 W/kg
SAR for nominal Body TSL parameters	normalized to 1W	<b>21.5 W/kg ± 19.5 % (k=2)</b>

### Body TSL parameters at 5300 MHz

The following parameters and calculations were applied.

	Temperature	Permittivity	Conductivity
Nominal Body TSL parameters	22.0 °C	48.9	5.42 mho/m
Measured Body TSL parameters	(22.0 ± 0.2) °C	46.7 ± 6 %	5.48 mho/m ± 6 %
Body TSL temperature change during test	< 0.5 °C	----	----

### SAR result with Body TSL at 5300 MHz

SAR averaged over 1 cm <sup>3</sup> (1 g) of Body TSL	Condition	
SAR measured	100 mW input power	7.75 W/kg
SAR for nominal Body TSL parameters	normalized to 1W	<b>76.8 W/kg ± 19.9 % (k=2)</b>

SAR averaged over 10 cm <sup>3</sup> (10 g) of Body TSL	condition	
SAR measured	100 mW input power	2.18 W/kg
SAR for nominal Body TSL parameters	normalized to 1W	<b>21.5 W/kg ± 19.5 % (k=2)</b>

### Body TSL parameters at 5500 MHz

The following parameters and calculations were applied.

	Temperature	Permittivity	Conductivity
Nominal Body TSL parameters	22.0 °C	48.6	5.65 mho/m
Measured Body TSL parameters	(22.0 ± 0.2) °C	46.3 ± 6 %	5.71 mho/m ± 6 %
Body TSL temperature change during test	< 0.5 °C	----	----

### SAR result with Body TSL at 5500 MHz

SAR averaged over 1 cm <sup>3</sup> (1 g) of Body TSL	Condition	
SAR measured	100 mW input power	8.06 W/kg
SAR for nominal Body TSL parameters	normalized to 1W	<b>79.8 W/kg ± 19.9 % (k=2)</b>

SAR averaged over 10 cm <sup>3</sup> (10 g) of Body TSL	condition	
SAR measured	100 mW input power	2.24 W/kg
SAR for nominal Body TSL parameters	normalized to 1W	<b>22.1 W/kg ± 19.5 % (k=2)</b>

### Body TSL parameters at 5600 MHz

The following parameters and calculations were applied.

	Temperature	Permittivity	Conductivity
Nominal Body TSL parameters	22.0 °C	48.5	5.77 mho/m
Measured Body TSL parameters	(22.0 ± 0.2) °C	46.2 ± 6 %	5.83 mho/m ± 6 %
Body TSL temperature change during test	< 0.5 °C	----	----

### SAR result with Body TSL at 5600 MHz

SAR averaged over 1 cm <sup>3</sup> (1 g) of Body TSL	Condition	
SAR measured	100 mW input power	8.15 W/kg
SAR for nominal Body TSL parameters	normalized to 1W	<b>80.7 W/kg ± 19.9 % (k=2)</b>

SAR averaged over 10 cm <sup>3</sup> (10 g) of Body TSL	condition	
SAR measured	100 mW input power	2.26 W/kg
SAR for nominal Body TSL parameters	normalized to 1W	<b>22.3 W/kg ± 19.5 % (k=2)</b>

### Body TSL parameters at 5800 MHz

The following parameters and calculations were applied.

	Temperature	Permittivity	Conductivity
Nominal Body TSL parameters	22.0 °C	48.2	6.00 mho/m
Measured Body TSL parameters	(22.0 ± 0.2) °C	45.9 ± 6 %	6.12 mho/m ± 6 %
Body TSL temperature change during test	< 0.5 °C	----	----

### SAR result with Body TSL at 5800 MHz

SAR averaged over 1 cm <sup>3</sup> (1 g) of Body TSL	Condition	
SAR measured	100 mW input power	7.62 W/kg
SAR for nominal Body TSL parameters	normalized to 1W	<b>75.5 W/kg ± 19.9 % (k=2)</b>

SAR averaged over 10 cm <sup>3</sup> (10 g) of Body TSL	condition	
SAR measured	100 mW input power	2.12 W/kg
SAR for nominal Body TSL parameters	normalized to 1W	<b>20.9 W/kg ± 19.5 % (k=2)</b>

## Appendix

### Antenna Parameters with Head TSL at 5200 MHz

Impedance, transformed to feed point	53.8 $\Omega$ - 6.3 j $\Omega$
Return Loss	- 23.0 dB

### Antenna Parameters with Head TSL at 5300 MHz

Impedance, transformed to feed point	50.1 $\Omega$ + 0.5 j $\Omega$
Return Loss	- 45.3 dB

### Antenna Parameters with Head TSL at 5500 MHz

Impedance, transformed to feed point	51.0 $\Omega$ - 0.9 j $\Omega$
Return Loss	- 37.9 dB

### Antenna Parameters with Head TSL at 5600 MHz

Impedance, transformed to feed point	55.3 $\Omega$ - 0.9 j $\Omega$
Return Loss	- 25.8 dB

### Antenna Parameters with Head TSL at 5800 MHz

Impedance, transformed to feed point	53.5 $\Omega$ + 3.3 j $\Omega$
Return Loss	- 26.7 dB

### Antenna Parameters with Body TSL at 5200 MHz

Impedance, transformed to feed point	53.7 $\Omega$ - 4.8 j $\Omega$
Return Loss	- 24.8 dB

### Antenna Parameters with Body TSL at 5300 MHz

Impedance, transformed to feed point	50.2 $\Omega$ + 2.4 j $\Omega$
Return Loss	- 32.5 dB

### Antenna Parameters with Body TSL at 5500 MHz

Impedance, transformed to feed point	51.6 $\Omega$ - 1.5 j $\Omega$
Return Loss	- 33.3 dB

### Antenna Parameters with Body TSL at 5600 MHz

Impedance, transformed to feed point	57.4 $\Omega$ + 0.9 j $\Omega$
Return Loss	- 23.2 dB

## Antenna Parameters with Body TSL at 5800 MHz

Impedance, transformed to feed point	$53.5 \Omega + 3.2 j\Omega$
Return Loss	- 26.7 dB

## General Antenna Parameters and Design

Electrical Delay (one direction)	1.206 ns
----------------------------------	----------

After long term use with 100W radiated power, only a slight warming of the dipole near the feedpoint can be measured.

The dipole is made of standard semirigid coaxial cable. The center conductor of the feeding line is directly connected to the second arm of the dipole. The antenna is therefore short-circuited for DC-signals. On some of the dipoles, small end caps are added to the dipole arms in order to improve matching when loaded according to the position as explained in the "Measurement Conditions" paragraph. The SAR data are not affected by this change. The overall dipole length is still according to the Standard.

No excessive force must be applied to the dipole arms, because they might bend or the soldered connections near the feedpoint may be damaged.

## Additional EUT Data

Manufactured by	SPEAG
Manufactured on	September 08, 2011

## DASY5 Validation Report for Head TSL

Date: 08.02.2013

Test Laboratory: SPEAG, Zurich, Switzerland

**DUT: Dipole 5GHz; Type: D5GHzV2; Serial: D5GHzV2 - SN: 1120**

Communication System: CW; Frequency: 5200 MHz, Frequency: 5300 MHz, Frequency: 5500 MHz, Frequency: 5600 MHz, Frequency: 5800 MHz

Medium parameters used:  $f = 5200$  MHz;  $\sigma = 4.47$  S/m;  $\epsilon_r = 34.7$ ;  $\rho = 1000$  kg/m<sup>3</sup>, Medium parameters used:  $f = 5300$  MHz;  $\sigma = 4.57$  S/m;  $\epsilon_r = 34.5$ ;  $\rho = 1000$  kg/m<sup>3</sup>, Medium parameters used:  $f = 5500$  MHz;  $\sigma = 4.74$  S/m;  $\epsilon_r = 34.2$ ;  $\rho = 1000$  kg/m<sup>3</sup>, Medium parameters used:  $f = 5600$  MHz;  $\sigma = 4.83$  S/m;  $\epsilon_r = 34.1$ ;  $\rho = 1000$  kg/m<sup>3</sup>, Medium parameters used:  $f = 5800$  MHz;  $\sigma = 5.05$  S/m;  $\epsilon_r = 33.9$ ;  $\rho = 1000$  kg/m<sup>3</sup>

Phantom section: Flat Section

Measurement Standard: DASY5 (IEEE/IEC/ANSI C63.19-2007)

DASY52 Configuration:

- Probe: EX3DV4 - SN3503; ConvF(5.41, 5.41, 5.41); Calibrated: 28.12.2012, ConvF(5.1, 5.1, 5.1); Calibrated: 28.12.2012, ConvF(4.91, 4.91, 4.91); Calibrated: 28.12.2012, ConvF(4.76, 4.76, 4.76); Calibrated: 28.12.2012, ConvF(4.81, 4.81, 4.81); Calibrated: 28.12.2012;
- Sensor-Surface: 1.4mm (Mechanical Surface Detection)
- Electronics: DAE4 Sn601; Calibrated: 27.06.2012
- Phantom: Flat Phantom 5.0 (front); Type: QD000P50AA; Serial: 1001
- DASY52 52.8.5(1059); SEMCAD X 14.6.8(7028)

**Dipole Calibration for Head Tissue/Pin=100mW, dist=10mm, f=5200 MHz/Zoom Scan, dist=1.4mm (8x8x7)/Cube 0:** Measurement grid: dx=4mm, dy=4mm, dz=1.4mm

Reference Value = 61.561 V/m; Power Drift = 0.05 dB

Peak SAR (extrapolated) = 28.8 W/kg

**SAR(1 g) = 7.67 W/kg; SAR(10 g) = 2.18 W/kg**

Maximum value of SAR (measured) = 17.7 W/kg

**Dipole Calibration for Head Tissue/Pin=100mW, dist=10mm, f=5300 MHz/Zoom Scan, dist=1.4mm (8x8x7)/Cube 0:** Measurement grid: dx=4mm, dy=4mm, dz=1.4mm

Reference Value = 62.429 V/m; Power Drift = 0.03 dB

Peak SAR (extrapolated) = 30.3 W/kg

**SAR(1 g) = 7.94 W/kg; SAR(10 g) = 2.27 W/kg**

Maximum value of SAR (measured) = 18.5 W/kg

**Dipole Calibration for Head Tissue/Pin=100mW, dist=10mm, f=5500 MHz/Zoom Scan, dist=1.4mm (8x8x7)/Cube 0:** Measurement grid: dx=4mm, dy=4mm, dz=1.4mm

Reference Value = 61.998 V/m; Power Drift = 0.08 dB

Peak SAR (extrapolated) = 32.7 W/kg

**SAR(1 g) = 8.09 W/kg; SAR(10 g) = 2.29 W/kg**

Maximum value of SAR (measured) = 19.3 W/kg

**Dipole Calibration for Head Tissue/Pin=100mW, dist=10mm, f=5600 MHz/Zoom Scan, dist=1.4mm (8x8x7)/Cube 0:** Measurement grid: dx=4mm, dy=4mm, dz=1.4mm

Reference Value = 62.540 V/m; Power Drift = 0.02 dB

Peak SAR (extrapolated) = 33.3 W/kg

**SAR(1 g) = 8.08 W/kg; SAR(10 g) = 2.28 W/kg**

Maximum value of SAR (measured) = 19.5 W/kg

**Dipole Calibration for Head Tissue/Pin=100mW, dist=10mm, f=5800 MHz/Zoom Scan, dist=1.4mm (8x8x7)/Cube 0:** Measurement grid: dx=4mm, dy=4mm, dz=1.4mm

Reference Value = 58.600 V/m; Power Drift = 0.09 dB

Peak SAR (extrapolated) = 32.9 W/kg

**SAR(1 g) = 7.57 W/kg; SAR(10 g) = 2.13 W/kg**

Maximum value of SAR (measured) = 18.8 W/kg

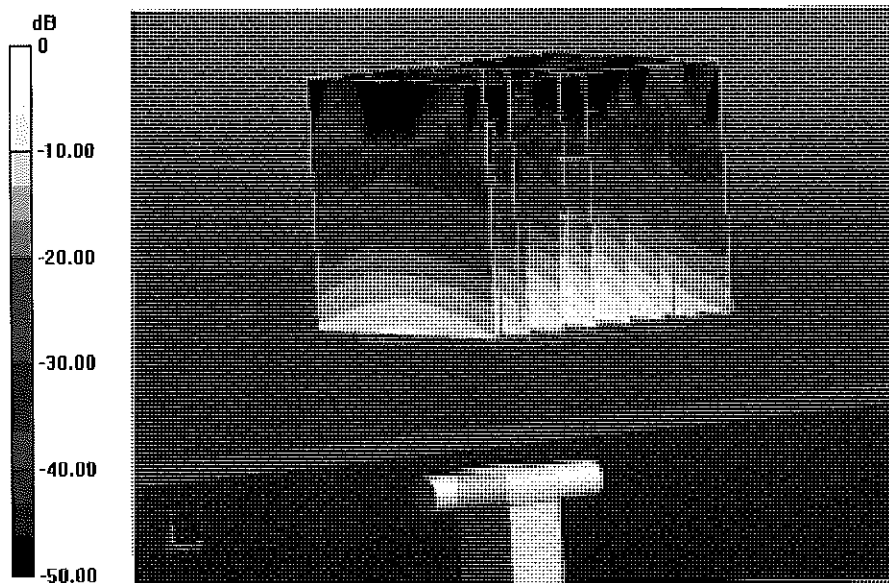

0 dB = 18.8 W/kg = 12.74 dBW/kg

# Impedance Measurement Plot for Head TSL

8 Feb 2013 10:10:29

CH1 S11 1 U FS 1: 53.764  $\Omega$  -6.3086  $\Omega$  4.8516 pF 5 200.000 000 MHz

\*  
De1  
Cor  
Avg  
0  
H1d

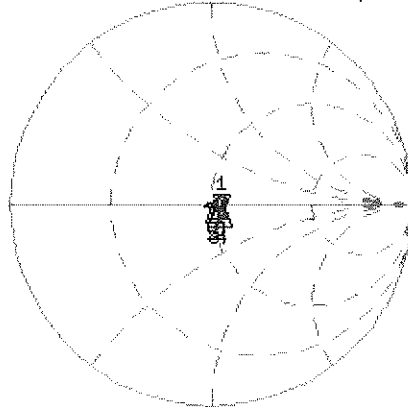

CH1 Markers  
2: 50.104  $\Omega$   
0.5313  $\Omega$   
5.30000 GHz  
3: 50.959  $\Omega$   
-853.52 m $\Omega$   
5.50000 GHz  
4: 55.305  $\Omega$   
-902.34 m $\Omega$   
5.60000 GHz  
5: 53.500  $\Omega$   
3.3027  $\Omega$   
5.80000 GHz

CH2 S11 LOG 5 dB/REF -20 dB 1: -23.013 dB 5 200.000 000 MHz

Cor  
Avg  
0  
H1d

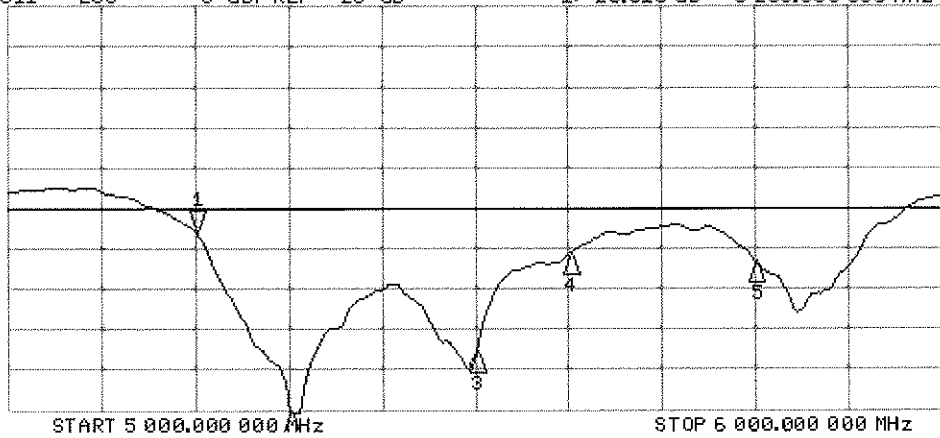

CH2 Markers  
2: -45.321 dB  
5.30000 GHz  
3: -37.887 dB  
5.50000 GHz  
4: -25.835 dB  
5.60000 GHz  
5: -26.651 dB  
5.80000 GHz

## DASY5 Validation Report for Body TSL

Date: 14.02.2013

Test Laboratory: SPEAG, Zurich, Switzerland

**DUT: Dipole 5GHz; Type: D5GHzV2; Serial: D5GHzV2 - SN: 1120**

Communication System: CW; Frequency: 5200 MHz, Frequency: 5300 MHz, Frequency: 5500 MHz, Frequency: 5600 MHz, Frequency: 5800 MHz

Medium parameters used:  $f = 5200$  MHz;  $\sigma = 5.36$  S/m;  $\epsilon_r = 46.9$ ;  $\rho = 1000$  kg/m<sup>3</sup>, Medium parameters used:  $f = 5300$  MHz;  $\sigma = 5.48$  S/m;  $\epsilon_r = 46.7$ ;  $\rho = 1000$  kg/m<sup>3</sup>, Medium parameters used:  $f = 5500$  MHz;  $\sigma = 5.71$  S/m;  $\epsilon_r = 46.3$ ;  $\rho = 1000$  kg/m<sup>3</sup>, Medium parameters used:  $f = 5600$  MHz;  $\sigma = 5.83$  S/m;  $\epsilon_r = 46.2$ ;  $\rho = 1000$  kg/m<sup>3</sup>, Medium parameters used:  $f = 5800$  MHz;  $\sigma = 6.12$  S/m;  $\epsilon_r = 45.9$ ;  $\rho = 1000$  kg/m<sup>3</sup>

Phantom section: Flat Section

Measurement Standard: DASY5 (IEEE/IEC/ANSI C63.19-2007)

DASY52 Configuration:

- Probe: EX3DV4 - SN3503; ConvF(4.91, 4.91, 4.91); Calibrated: 28.12.2012, ConvF(4.67, 4.67, 4.67); Calibrated: 28.12.2012, ConvF(4.43, 4.43, 4.43); Calibrated: 28.12.2012, ConvF(4.22, 4.22, 4.22); Calibrated: 28.12.2012, ConvF(4.38, 4.38, 4.38); Calibrated: 28.12.2012;
- Sensor-Surface: 1.4mm (Mechanical Surface Detection)
- Electronics: DAE4 Sn601; Calibrated: 27.06.2012
- Phantom: Flat Phantom 5.0 (back); Type: QD000P50AA; Serial: 1002
- DASY52 52.8.5(1059); SEMCAD X 14.6.8(7028)

**Dipole Calibration for Body Tissue/Pin=100mW, dist=10mm, f=5200 MHz/Zoom Scan,**

**dist=1.4mm (8x8x7)/Cube 0:** Measurement grid: dx=4mm, dy=4mm, dz=1.4mm

Reference Value = 61.053 V/m; Power Drift = -0.08 dB

Peak SAR (extrapolated) = 31.1 W/kg

**SAR(1 g) = 7.73 W/kg; SAR(10 g) = 2.17 W/kg**

Maximum value of SAR (measured) = 18.2 W/kg

**Dipole Calibration for Body Tissue/Pin=100mW, dist=10mm, f=5300 MHz/Zoom Scan,**

**dist=1.4mm (8x8x7)/Cube 0:** Measurement grid: dx=4mm, dy=4mm, dz=1.4mm

Reference Value = 60.021 V/m; Power Drift = -0.02 dB

Peak SAR (extrapolated) = 32.1 W/kg

**SAR(1 g) = 7.75 W/kg; SAR(10 g) = 2.18 W/kg**

Maximum value of SAR (measured) = 18.5 W/kg

**Dipole Calibration for Body Tissue/Pin=100mW, dist=10mm, f=5500 MHz/Zoom Scan,**

**dist=1.4mm (8x8x7)/Cube 0:** Measurement grid: dx=4mm, dy=4mm, dz=1.4mm

Reference Value = 59.894 V/m; Power Drift = -0.02 dB

Peak SAR (extrapolated) = 35.3 W/kg

**SAR(1 g) = 8.06 W/kg; SAR(10 g) = 2.24 W/kg**

Maximum value of SAR (measured) = 19.4 W/kg

**Dipole Calibration for Body Tissue/Pin=100mW, dist=10mm, f=5600 MHz/Zoom Scan,**

**dist=1.4mm (8x8x7)/Cube 0:** Measurement grid: dx=4mm, dy=4mm, dz=1.4mm

Reference Value = 59.730 V/m; Power Drift = -0.02 dB

Peak SAR (extrapolated) = 36.8 W/kg

**SAR(1 g) = 8.15 W/kg; SAR(10 g) = 2.26 W/kg**

Maximum value of SAR (measured) = 19.9 W/kg

**Dipole Calibration for Body Tissue/Pin=100mW, dist=10mm, f=5800 MHz/Zoom Scan,**

**dist=1.4mm (8x8x7)/Cube 0:** Measurement grid: dx=4mm, dy=4mm, dz=1.4mm

Reference Value = 56.663 V/m; Power Drift = -0.02 dB

Peak SAR (extrapolated) = 36.4 W/kg

**SAR(1 g) = 7.62 W/kg; SAR(10 g) = 2.12 W/kg**

Maximum value of SAR (measured) = 19.0 W/kg

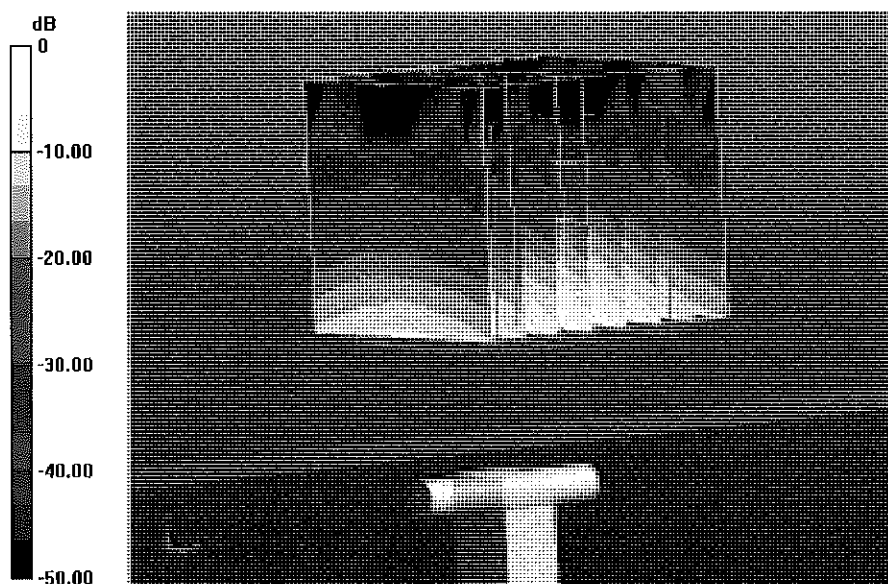

0 dB = 19.0 W/kg = 12.79 dBW/kg

# Impedance Measurement Plot for Body TSL

14 Feb 2013 15:47:05

CH1 S11 1 U FS 1: 53.672  $\Omega$  -4.7539  $\Omega$  6.4382 pF 5 200.000 000 MHz

\*  
De1  
Cor  
Avg  
16  
H1d

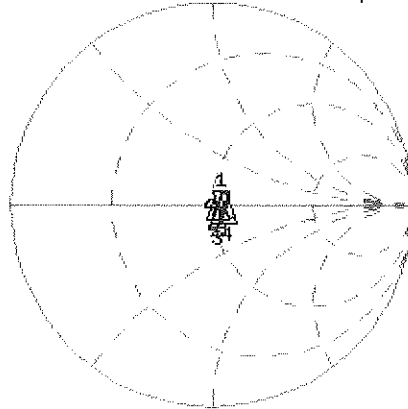

CH1 Markers  
2: 50.250  $\Omega$   
2.3555  $\Omega$   
5.30000 GHz  
3: 51.629  $\Omega$   
-1.4824  $\Omega$   
5.50000 GHz  
4: 57.389  $\Omega$   
0.9180  $\Omega$   
5.60000 GHz  
5: 53.543  $\Omega$   
3.2441  $\Omega$   
5.80000 GHz

CH2 S11 LOG 5 dB/REF -20 dB 1: -24.750 dB 5 200.000 000 MHz

Cor  
Avg  
16  
H1d

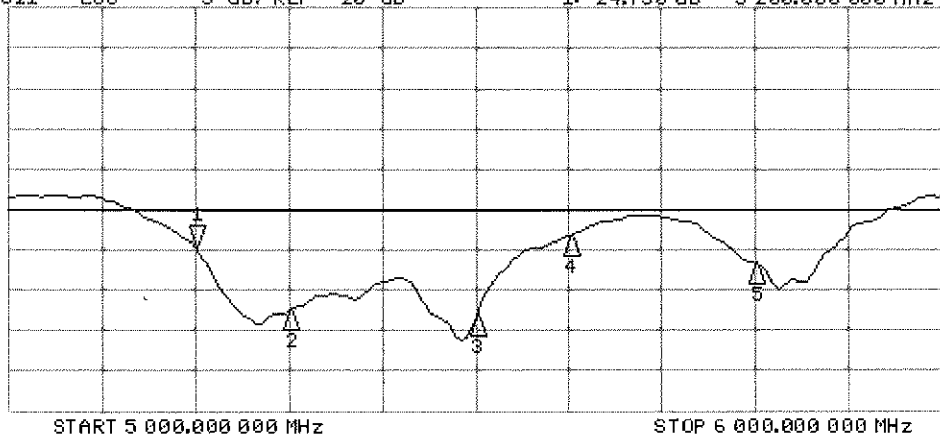

CH2 Markers  
2: -32.508 dB  
5.30000 GHz  
3: -33.267 dB  
5.50000 GHz  
4: -23.183 dB  
5.60000 GHz  
5: -26.672 dB  
5.80000 GHz

## APPENDIX D: SAR TISSUE SPECIFICATIONS

Measurement Procedure for Tissue verification:



- 1) The network analyzer and probe system was configured and calibrated.
- 2) The probe was immersed in the tissue. The tissue was placed in a nonmetallic container. Trapped air bubbles beneath the flange were minimized by placing the probe at a slight angle.
- 3) The complex admittance with respect to the probe aperture was measured
- 4) The complex relative permittivity  $\epsilon$  can be calculated from the below equation (Pournaropoulos and Misra):

$$Y = \frac{j2\omega\epsilon_r\epsilon_0}{[\ln(b/a)]^2} \int_a^b \int_a^b \int_0^\pi \cos\phi' \frac{\exp[-j\omega r(\mu_0\epsilon_r'\epsilon_0)^{1/2}]}{r} d\phi' d\rho' d\rho$$

where  $Y$  is the admittance of the probe in contact with the sample, the primed and unprimed coordinates refer to source and observation points, respectively,  $r^2 = \rho^2 + \rho'^2 - 2\rho\rho' \cos\phi'$ ,  $\omega$  is the angular frequency, and  $j = \sqrt{-1}$ .

**Table D-I**  
**Composition of the Tissue Equivalent Matter**

Frequency (MHz)	750	750	835	835	1750	1750	1900	1900	2450	2450	5200-5800	5200-5800
Tissue	Head	Body	Head	Body	Head	Body	Head	Body	Head	Body	Head	Body
Ingredients (% by weight)												
Bactericide			0.1	0.1								
DGBE					47	31	44.92	29.44		26.7		
HEC			1	1								
NaCl	See pp. 2-3	See p. 2	1.45	0.94	0.4	0.2	0.18	0.39	See p. 4	0.1	See p. 5	
Sucrose			57	44.9								20
Polysorbate (Tween) 80												
Water			40.45	53.06	52.6	68.8	54.9	70.17		73.2		80

<b>FCC ID:</b> A3LSMG900R7	 <b>SAR EVALUATION REPORT</b>		<b>Reviewed by:</b> Quality Manager
<b>Test Dates:</b> 02/03/14 - 03/31/14	<b>DUT Type:</b> Portable Handset	<b>APPENDIX D:</b> Page 1 of 5	

## 2 Composition / Information on ingredients

The Item is composed of the following ingredients:

H <sub>2</sub> O	Water, 35 – 58%
Sucrose	Sugar, white, refined, 40 – 60%
NaCl	Sodium Chloride, 0 – 6%
Hydroxyethyl-cellulose	Medium Viscosity (CAS# 9004-62-0), <0.3%
Preventol-D7	Preservative: aqueous preparation, (CAS# 55965-84-9), containing 5-chloro-2-methyl-3(2H)-isothiazolone and 2-methyl-3(2H)-isothiazolone, 0.1 – 0.7%

Relevant for safety; Refer to the respective Safety Data Sheet\*.

**Figure D-1**  
**Composition of 750 MHz Head and Body Tissue Equivalent Matter**

**Note:** 750MHz liquid recipes are proprietary SPEAG. Since the composition is approximate to the actual liquids utilized, the manufacturer tissue-equivalent liquid data sheets are provided below.

### Measurement Certificate / Material Test

Item Name	Body Tissue Simulating Liquid (MSL750V2)
Product No.	SL AAM 075 AA (Charge: 130313-1)
Manufacturer	SPEAG

#### Measurement Method

TSL dielectric parameters measured using calibrated OCP probe.

#### Setup Validation

Validation results were within  $\pm 2.5\%$  towards the target values of Methanol.

#### Target Parameters

Target parameters as defined in the IEEE 1528 and IEC 62209 compliance standards.

#### Test Condition

Ambient Environment temperature ( $22 \pm 3$ )°C and humidity < 70%.  
 TSL Temperature 22°C  
 Test Date 13-Mar-13  
 Operator IEN



#### Additional Information

TSL Density 1.212 g/cm<sup>3</sup>  
 TSL Heat-capacity 3.006 kJ/(kg\*K)

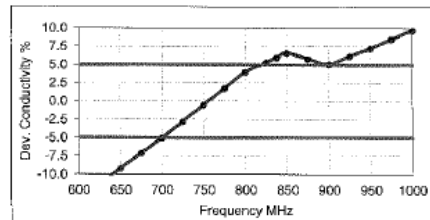
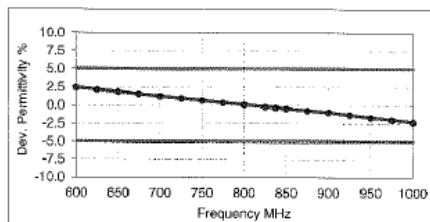
f [MHz]	Measured			Target		Diff.to Target [%]	
	HP-e'	HP-e''	sigma	eps	sigma	Δ-eps	Δ-sigma
600	57.5	24.64	0.82	56.1	0.95	2.5	-13.6
625	57.2	24.31	0.84	56.0	0.95	2.1	-11.4
650	57.0	23.99	0.87	55.9	0.96	1.8	-9.2
675	56.7	23.69	0.89	55.8	0.96	1.5	-7.1
700	56.4	23.39	0.91	55.7	0.96	1.2	-5.1
725	56.2	23.18	0.93	55.6	0.96	1.0	-2.8
<b>750</b>	<b>55.9</b>	<b>22.97</b>	<b>0.96</b>	<b>55.5</b>	<b>0.96</b>	<b>0.7</b>	<b>-0.5</b>
775	55.7	22.78	0.98	55.4	0.97	0.4	1.7
800	55.4	22.60	1.01	55.3	0.97	0.1	4.0
825	55.2	22.44	1.03	55.2	0.98	-0.2	5.3
838	55.0	22.36	1.04	55.2	0.98	-0.3	5.9
850	54.9	22.28	1.05	55.2	0.99	-0.4	6.6
875	54.7	22.16	1.08	55.1	1.02	-0.7	5.8
900	54.5	22.03	1.10	55.0	1.05	-1.0	5.1
925	54.2	21.93	1.13	55.0	1.06	-1.3	6.2
950	54.0	21.82	1.15	54.9	1.08	-1.7	7.2
975	53.8	21.74	1.18	54.9	1.09	-2.0	8.5
1000	53.6	21.66	1.21	54.8	1.10	-2.3	9.7



**Figure D-2**  
**750MHz Body Tissue Equivalent Matter**

FCC ID: A3LSMG900R7		SAR EVALUATION REPORT		Reviewed by: Quality Manager
Test Dates: 02/03/14 - 03/31/14	DUT Type: Portable Handset			APPENDIX D: Page 2 of 5

## Measurement Certificate / Material Test

Item Name	Head Tissue Simulating Liquid (HSL750V2)
Product No.	SL AAH 075 AA (Charge: 130312-4)
Manufacturer	SPEAG

### Measurement Method

TSL dielectric parameters measured using calibrated OCP probe.

### Setup Validation

Validation results were within  $\pm 2.5\%$  towards the target values of Meihanol.

### Target Parameters

Target parameters as defined in the IEEE 1528 and IEC 62209 compliance standards.

### Test Condition

Ambient	Environment temperatur ( $22 \pm 3$ )°C and humidity < 70%.
TSL Temperature	22°C
Test Date	13-Mar-13
Operator	IEN

### Additional Information

TSL Density	1.284 g/cm <sup>3</sup>
TSL Heat-capacity	2.701 kJ/(kg*K)

f (MHz)	Measured			Target		Diff. to Target [%]	
	HP-e'	HP-e''	sigma	eps	sigma	$\Delta$ -eps	$\Delta$ -sigma
600	44.6	23.25	0.78	42.7	0.88	4.3	-12.0
625	44.2	23.00	0.80	42.6	0.88	3.8	-9.5
650	43.8	22.76	0.82	42.5	0.89	3.2	-7.1
675	43.4	22.50	0.84	42.3	0.89	2.6	-4.9
700	43.1	22.24	0.87	42.2	0.89	2.1	-2.6
725	42.7	22.06	0.89	42.1	0.89	1.6	-0.2
750	42.4	21.88	0.91	41.9	0.89	1.1	2.2
775	42.1	21.72	0.94	41.8	0.90	0.6	4.6
800	41.7	21.55	0.96	41.7	0.90	0.1	6.9
825	41.4	21.40	0.98	41.6	0.91	-0.4	8.3
838	41.3	21.32	0.99	41.5	0.91	-0.8	9.0
850	41.1	21.24	1.00	41.5	0.92	-0.9	9.6
875	40.8	21.11	1.03	41.5	0.94	-1.6	9.0
900	40.6	20.99	1.05	41.5	0.97	-2.3	8.3
925	40.3	20.87	1.07	41.5	0.98	-2.9	9.4
950	40.0	20.76	1.10	41.4	0.99	-3.5	10.3
975	39.7	20.66	1.12	41.4	1.00	-4.0	11.5
1000	39.5	20.57	1.14	41.3	1.01	-4.5	12.7

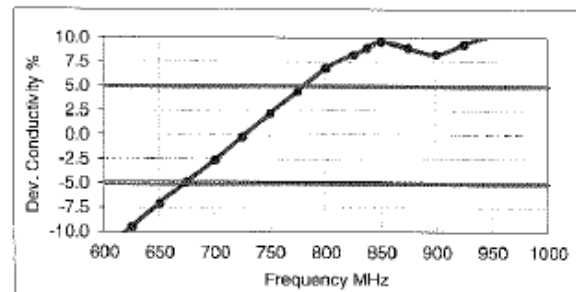
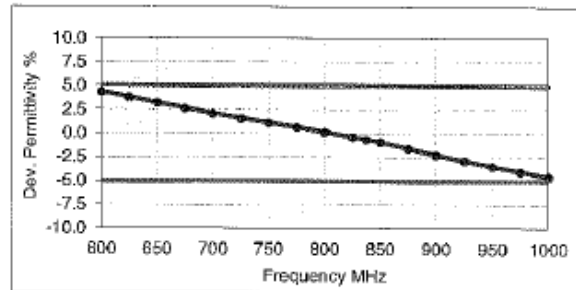



Figure D-3  
750MHz Head Tissue Equivalent Matter

FCC ID: A3LSMG900R7		SAR EVALUATION REPORT		Reviewed by: Quality Manager
Test Dates: 02/03/14 - 03/31/14	DUT Type: Portable Handset			APPENDIX D: Page 3 of 5

## 2 Composition / Information on ingredients

The Item is composed of the following ingredients:

H2O	Water, 52 – 75%
C8H18O3	Diethylene glycol monobutyl ether (DGBE), 25 – 48% (CAS-No. 112-34-5, EC-No. 203-961-6, EC-index-No. 603-096-00-8) Relevant for safety; Refer to the respective Safety Data Sheet*.
NaCl	Sodium Chloride, <1.0%

**Figure D-4**  
**Composition of 2.4 GHz Head Tissue Equivalent Matter**

**Note:** 2.4 GHz head liquid recipes are proprietary SPEAG. Since the composition is approximate to the actual liquids utilized, the manufacturer tissue-equivalent liquid data sheets are provided below.

### Measurement Certificate / Material Test

Item Name	Head Tissue Simulating Liquid (HSL2450V2)
Product No.	SL AAH 245 BA (Charge: 130212-2)
Manufacturer	SPEAG

#### Measurement Method

TSL dielectric parameters measured using calibrated OCP probe.

#### Setup Validation

Validation results were within  $\pm 2.5\%$  towards the target values of Methanol.

#### Target Parameters

Target parameters as defined in the IEEE 152B and IEC 62209 compliance standards.

#### Test Condition

Ambient	Environment temperatur (22 $\pm$ 3) <sup>o</sup> C and humidity < 70%.
TSL Temperature	23 <sup>o</sup> C
Test Date	13-Feb-13
Operator	DI



#### Additional Information

TSL Density	0.988 g/cm <sup>3</sup>
TSL Heat-capacity	3.680 kJ/(kg <sup>o</sup> K)

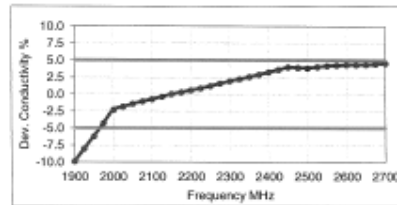
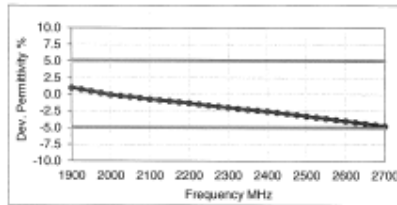
f (MHz)	Measured			Target		Diff. to Target [%]	
	HP-a	HP-a'	sigma	eps	sigma	$\Delta$ -eps	$\Delta$ -sigma
1900	40.4	11.94	1.26	40.0	1.40	1.0	-9.9
1925	40.3	12.02	1.29	40.0	1.40	0.7	-8.0
1950	40.2	12.11	1.31	40.0	1.40	0.5	-6.2
1975	40.1	12.20	1.34	40.0	1.40	0.2	-4.2
2000	40.0	12.29	1.37	40.0	1.40	-0.1	-2.3
2025	39.9	12.39	1.40	40.0	1.42	-0.2	-1.9
2050	39.8	12.49	1.42	39.9	1.44	-0.4	-1.4
2075	39.6	12.57	1.45	39.9	1.47	-0.6	-1.1
2100	39.5	12.65	1.48	39.8	1.48	-0.7	-0.7
2125	39.4	12.74	1.51	39.8	1.51	-0.9	-0.4
2150	39.3	12.82	1.53	39.7	1.53	-1.0	0.0
2175	39.2	12.89	1.56	39.7	1.56	-1.2	0.3
2200	39.1	12.97	1.59	39.6	1.58	-1.3	0.6
2225	39.0	13.04	1.61	39.6	1.60	-1.5	0.9
2250	38.9	13.11	1.64	39.6	1.62	-1.7	1.2
2275	38.8	13.20	1.67	39.5	1.64	-1.8	1.6
<b>2300</b>	<b>38.7</b>	<b>13.28</b>	<b>1.70</b>	<b>39.5</b>	<b>1.67</b>	<b>-2.0</b>	<b>2.0</b>
2325	38.6	13.35	1.73	39.4	1.69	-2.1	2.3
2350	38.5	13.42	1.75	39.4	1.71	-2.3	2.6
2375	38.4	13.50	1.78	39.3	1.73	-2.4	2.9
2400	38.3	13.58	1.81	39.3	1.76	-2.6	3.3
2425	38.2	13.65	1.84	39.2	1.78	-2.7	3.6
<b>2450</b>	<b>38.1</b>	<b>13.73</b>	<b>1.87</b>	<b>39.2</b>	<b>1.80</b>	<b>-2.9</b>	<b>4.0</b>
2475	38.0	13.79	1.90	39.2	1.83	-3.1	3.9
2500	37.9	13.85	1.93	39.1	1.85	-3.3	3.9
2525	37.8	13.94	1.96	39.1	1.88	-3.4	4.0
2550	37.7	14.02	1.99	39.1	1.91	-3.6	4.2
2575	37.6	14.09	2.02	39.0	1.94	-3.8	4.3
<b>2600</b>	<b>37.5</b>	<b>14.17</b>	<b>2.05</b>	<b>39.0</b>	<b>1.96</b>	<b>-4.0</b>	<b>4.6</b>
2625	37.4	14.23	2.08	39.0	1.99	-4.2	4.4
2650	37.3	14.29	2.11	38.9	2.02	-4.3	4.4
2675	37.1	14.36	2.14	38.9	2.05	-4.5	4.5
2700	37.0	14.43	2.17	38.9	2.07	-4.8	4.6



**Figure D-5**  
**2.4 GHz Head Tissue Equivalent Matter**

FCC ID: A3LSMG900R7		SAR EVALUATION REPORT		Reviewed by: Quality Manager
Test Dates: 02/03/14 - 03/31/14	DUT Type: Portable Handset			APPENDIX D: Page 4 of 5

## 2 Composition / Information on ingredients

The Item is composed of the following ingredients:

Water	50 – 65%
Mineral oil	10 – 30%
Emulsifiers	8 – 25%
Sodium salt	0 – 1.5%

**Figure D-6**  
**Composition of 5 GHz Head Tissue Equivalent Matter**

**Note:** 5GHz head liquid recipes are proprietary SPEAG. Since the composition is approximate to the actual liquids utilized, the manufacturer tissue-equivalent liquid data sheets are provided below.

### Measurement Certificate / Material Test

Item Name	Head Tissue Simulating Liquid (HBBL3500-5800V5)
Product No.	SL AAH 502 AB (Charge: 120402-2)
Manufacturer	SPEAG

### Measurement Method

TSL dielectric parameters measured using calibrated OCP probe (type DAK).

### Target Parameters

Target parameters as defined in the IEEE 1528 and IEC 62209 compliance standards.

### Test Condition

Ambient Condition 22°C ; 30% humidity  
TSL Temperature 22°C  
Test Date 4-Apr-12

### Additional Information



TSL Density 0.985 g/cm<sup>3</sup>  
TSL Heat-capacity 3.383 kJ/(kg\*K)

### Results

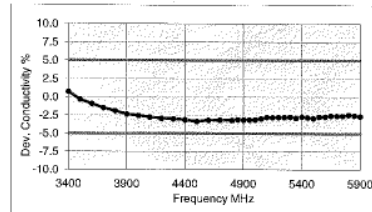
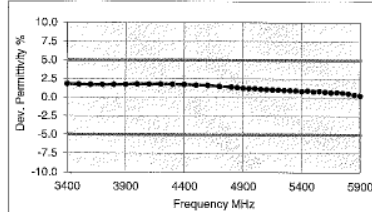
f (MHz)	Measured			Target		Diff. to Target (%)	
	HP-e'	HP-e''	sigma	eps	sigma	Δ-eps	Δ-sigma
3400	38.7	14.96	2.83	38.0	2.81	1.8	0.7
3500	38.6	14.91	2.99	37.9	2.91	1.7	-0.3
3600	38.5	14.92	2.99	37.8	3.02	1.7	-0.9
3700	38.3	14.92	3.07	37.7	3.12	1.7	-1.5
3800	38.2	14.94	3.16	37.6	3.22	1.7	-1.9
3900	38.1	14.95	3.24	37.5	3.32	1.7	-2.4
4000	38.0	15.00	3.34	37.4	3.43	1.8	-2.5
4100	37.9	15.04	3.43	37.2	3.53	1.8	-2.6
4200	37.8	15.08	3.52	37.1	3.63	1.8	-2.9
4300	37.7	15.14	3.62	37.0	3.73	1.8	-3.0
4400	37.5	15.18	3.71	36.9	3.84	1.7	-3.1
4500	37.4	15.20	3.81	36.8	3.94	1.6	-3.3
4600	37.3	15.29	3.91	36.7	4.04	1.6	-3.2
4700	37.1	15.34	4.01	36.6	4.14	1.5	-3.2
4800	37.0	15.39	4.11	36.4	4.25	1.4	-3.2
4850	36.9	15.43	4.16	36.4	4.30	1.3	-3.1
4900	36.8	15.45	4.21	36.3	4.35	1.3	-3.1
4950	36.7	15.47	4.26	36.3	4.40	1.2	-3.1
5000	36.7	15.50	4.31	36.2	4.45	1.2	-3.1
5050	36.6	15.55	4.37	36.2	4.50	1.1	-3.0
5100	36.5	15.60	4.43	36.1	4.55	1.1	-2.8
5150	36.4	15.62	4.48	36.0	4.60	1.0	-2.8
5200	36.4	15.65	4.53	36.0	4.66	1.0	-2.8
5250	36.3	15.67	4.58	35.9	4.71	1.0	-2.8
5300	36.2	15.70	4.63	35.9	4.76	1.0	-2.7
5350	36.1	15.70	4.67	35.8	4.81	0.9	-2.9
5400	36.1	15.74	4.73	35.8	4.86	0.8	-2.7
5450	36.0	15.75	4.77	35.7	4.91	0.9	-2.8
5500	35.9	15.75	4.82	35.6	4.96	0.8	-2.9
5550	35.9	15.80	4.88	35.6	5.01	0.8	-2.7
5600	35.8	15.82	4.93	35.5	5.07	0.7	-2.7
5650	35.7	15.86	4.99	35.5	5.12	0.7	-2.6
5700	35.7	15.88	5.03	35.4	5.17	0.7	-2.6
5750	35.6	15.90	5.08	35.4	5.22	0.6	-2.6
5800	35.5	15.94	5.14	35.3	5.27	0.6	-2.4
5850	35.4	15.98	5.20	35.3	5.34	0.4	-2.5
5900	35.4	16.02	5.26	35.3	5.40	0.2	-2.6



**Figure D-7**  
**5GHz Head Tissue Equivalent Matter**

FCC ID: A3LSMG900R7		SAR EVALUATION REPORT		Reviewed by: Quality Manager
Test Dates: 02/03/14 - 03/31/14	DUT Type: Portable Handset			APPENDIX D: Page 5 of 5

## APPENDIX E: SAR SYSTEM VALIDATION



Per FCC KDB 865664 D02v01, SAR system validation status should be documented to confirm measurement accuracy. The SAR systems (including SAR probes, system components and software versions) used for this device were validated against its performance specifications prior to the SAR measurements. Reference dipoles were used with the required tissue- equivalent media for system validation, according to the procedures outlined in FCC KDB 865664 D01 v01 and IEEE 1528-2013. Since SAR probe calibrations are frequency dependent, each probe calibration point was validated at a frequency within the valid frequency range of the probe calibration point, using the system that normally operates with the probe for routine SAR measurements and according to the required tissue-equivalent media.

A tabulated summary of the system validation status including the validation date(s), measurement frequencies, SAR probes and tissue dielectric parameters has been included.

**Table E-1**  
**SAR System Validation Summary**

SAR SYSTEM #	FREQ. [MHz]	DATE	PROBE SN	PROBE TYPE	PROBE CAL. POINT		COND.	PERM.	CW VALIDATION			MOD. VALIDATION		
							( $\sigma$ )	( $\epsilon_r$ )	SENSI-TIVITY	PROBE LINEARITY	PROBE ISOTROPY	MOD. TYPE	DUTY FACTOR	PAR
B	750	11/5/2013	3288	ES3DV3	750	Head	0.882	40.63	PASS	PASS	PASS	N/A	N/A	N/A
H	835	6/20/2013	3318	ES3DV3	835	Head	0.910	41.10	PASS	PASS	PASS	GMSK	PASS	N/A
B	1750	11/6/2013	3288	ES3DV3	1750	Head	1.406	40.47	PASS	PASS	PASS	N/A	N/A	N/A
C	1900	8/13/2013	3263	ES3DV3	1900	Head	1.458	38.68	PASS	PASS	PASS	GMSK	PASS	N/A
K	2450	2/8/2014	3287	ES3DV3	2450	Head	1.832	38.03	PASS	PASS	PASS	OFDM	N/A	PASS
A	5200	1/15/2014	3920	EX3DV4	5200	Head	4.529	36.23	PASS	PASS	PASS	OFDM	N/A	PASS
A	5300	1/15/2014	3920	EX3DV4	5300	Head	4.612	35.97	PASS	PASS	PASS	OFDM	N/A	PASS
A	5500	1/15/2014	3920	EX3DV4	5500	Head	4.788	35.63	PASS	PASS	PASS	OFDM	N/A	PASS
A	5600	1/15/2014	3920	EX3DV4	5600	Head	4.862	35.52	PASS	PASS	PASS	OFDM	N/A	PASS
A	5800	1/15/2014	3920	EX3DV4	5800	Head	5.122	35.25	PASS	PASS	PASS	OFDM	N/A	PASS
C	750	8/14/2013	3263	ES3DV3	750	Body	0.975	54.36	PASS	PASS	PASS	N/A	N/A	N/A
C	835	8/14/2013	3263	ES3DV3	835	Body	0.993	53.17	PASS	PASS	PASS	GMSK	PASS	N/A
B	1750	11/6/2013	3288	ES3DV3	1750	Body	1.534	51.18	PASS	PASS	PASS	N/A	N/A	N/A
I	1900	7/1/2013	3319	ES3DV3	1900	Body	1.502	52.10	PASS	PASS	PASS	GMSK	PASS	N/A
D	1900	9/10/2013	3022	ES3DV2	1900	Body	1.516	52.49	PASS	PASS	PASS	GMSK	PASS	N/A
H	2450	6/21/2013	3318	ES3DV3	2450	Body	2.006	51.66	PASS	PASS	PASS	OFDM	N/A	PASS
E	5200	12/7/2013	3914	EX3DV4	5200	Body	5.330	48.16	PASS	PASS	PASS	OFDM	N/A	PASS
E	5300	12/7/2013	3914	EX3DV4	5300	Body	5.481	47.91	PASS	PASS	PASS	OFDM	N/A	PASS
E	5500	12/7/2013	3914	EX3DV4	5500	Body	5.807	47.39	PASS	PASS	PASS	OFDM	N/A	PASS
E	5800	12/7/2013	3914	EX3DV4	5800	Body	6.240	46.70	PASS	PASS	PASS	OFDM	N/A	PASS

NOTE: While the probes have been calibrated for both CW and modulated signals, all measurements were performed using communication systems calibrated for CW signals only. Modulations in the table above represent test configurations for which the measurement system has been validated per FCC KDB Publication 865664 D01v01 for scenarios when CW probe calibrations are used with other signal types. SAR systems were validated for modulated signals with a periodic duty cycle, such as GMSK, or with a high peak to average ratio (>5 dB), such as OFDM according to KDB 865664.

FCC ID: A3LSMG900R7	 <b>PCTEST</b> ENGINEERING LABORATORY, INC.	<b>SAR EVALUATION REPORT</b>		<b>Reviewed by:</b> Quality Manager
<b>Test Dates:</b> 02/03/14 - 03/31/14	<b>DUT Type:</b> Portable Handset			APPENDIX E: Page 1 of 1