



SAR EVALUATION REPORT

Applicant Name:
Samsung Electronics, Co. Ltd.
129, Samsung-ro, Maetan dong,
Yeongtong-gu, Suwon-si
Gyeonggi-do 443-742, Korea

Date of Testing:
02/03/14 - 02/17/14
Test Site/Location:
PCTEST Lab, Columbia, MD, USA
Document Serial No.:
0Y1401270204-R2.A3L

FCC ID: A3LSMG900A

APPLICANT: SAMSUNG ELECTRONICS, CO. LTD.

DUT Type: Portable Handset
Application Type: Certification
FCC Rule Part(s): CFR §2.1093
Model(s): SM-G900A

Equipment Class	Band & Mode	Tx Frequency	SAR		
			1 gm Head (W/kg)	1 gm Body-Worn (W/kg)	1 gm Hotspot (W/kg)
PCE	GSM/GPRS/EDGE 850	824.20 - 848.80 MHz	0.33	0.49	0.56
PCE	GSM/GPRS/EDGE 1900	1850.20 - 1909.80 MHz	0.17	< 0.1	0.30
PCE	UMTS 850	826.40 - 846.60 MHz	0.27	0.48	0.48
PCE	UMTS 1900	1852.4 - 1907.6 MHz	0.48	0.29	0.29
PCE	LTE Band 17	706.5 - 713.5 MHz	0.28	0.37	0.37
PCE	LTE Band 5 (Cell)	824.7 - 848.3 MHz	0.30	0.53	0.53
PCE	LTE Band 4 (AWS)	1710.7 - 1754.3 MHz	0.50	0.64	0.64
PCE	LTE Band 2 (PCS)	1850.7 - 1909.3 MHz	0.50	0.36	0.36
DTS	2.4 GHz WLAN	2412 - 2462 MHz	0.40	0.26	0.26
DTS	5.8 GHz WLAN	5745 - 5825 MHz	0.38	0.48	0.68
NII	5.2 GHz WLAN	5180 - 5240 MHz	0.14	0.11	
NII	5.3 GHz WLAN	5260 - 5320 MHz	0.18	0.23	
NII	5.5 GHz WLAN	5500 - 5700 MHz	0.56	0.64	
DSS/DTS	Bluetooth	2402 - 2480 MHz	N/A		
Simultaneous SAR per KDB 690783 D01v01r02:			1.28		



Note: This revised Test Report (S/N: 0Y1401270204-R2.A3L) supersedes and replaces the previously issued test report on the same subject device for the same type of testing as indicated. Please discard or destroy the previously issued test report(s) and dispose of it accordingly

This wireless portable device has been shown to be capable of compliance for localized specific absorption rate (SAR) for uncontrolled environment/general population exposure limits specified in ANSI/IEEE C95.1-1992 and has been tested in accordance with the measurement procedures specified in Section 1.9 of this report; for North American frequency bands only.

I attest to the accuracy of data. All measurements reported herein were performed by me or were made under my supervision and are correct to the best of my knowledge and belief. I assume full responsibility for the completeness of these measurements and vouch for the qualifications of all persons taking them. Test results reported herein relate only to the item(s) tested.



Randy Ortanez
President



FCC ID: A3LSMG900A	 PCTEST ENGINEERING LABORATORY, INC.	SAR EVALUATION REPORT		Reviewed by: Quality Manager
Document S/N: 0Y1401270204-R2.A3L	Test Dates: 02/03/14 - 02/17/14	DUT Type: Portable Handset	Page 1 of 85	

T A B L E O F C O N T E N T S

1	DEVICE UNDER TEST	3
2	LTE INFORMATION	10
3	INTRODUCTION	11
4	DOSIMETRIC ASSESSMENT	12
5	DEFINITION OF REFERENCE POINTS	13
6	TEST CONFIGURATION POSITIONS FOR HANDSETS	14
7	RF EXPOSURE LIMITS	18
8	FCC MEASUREMENT PROCEDURES.....	19
9	RF CONDUCTED POWERS.....	24
10	SYSTEM VERIFICATION.....	49
11	SAR DATA SUMMARY	52
12	FCC MULTI-TX AND ANTENNA SAR CONSIDERATIONS.....	66
13	SAR MEASUREMENT VARIABILITY	79
14	EQUIPMENT LIST.....	80
15	MEASUREMENT UNCERTAINTIES	81
16	CONCLUSION.....	83
17	REFERENCES	84
APPENDIX A: SAR TEST PLOTS		
APPENDIX B: SAR DIPOLE VERIFICATION PLOTS		
APPENDIX C: PROBE AND DIPOLE CALIBRATION CERTIFICATES		
APPENDIX D: SAR TISSUE SPECIFICATIONS		
APPENDIX E: SAR SYSTEM VALIDATION		
APPENDIX F: SAR TEST SETUP PHOTOGRAPHS		

FCC ID: A3LSMG900A		SAR EVALUATION REPORT		Reviewed by: Quality Manager
Document S/N: 0Y1401270204-R2.A3L	Test Dates: 02/03/14 - 02/17/14	DUT Type: Portable Handset	Page 2 of 85	

1 DEVICE UNDER TEST

1.1 Device Overview

Band & Mode	Operating Modes	Tx Frequency
GSM/GPRS/EDGE 850	Voice/Data	824.20 - 848.80 MHz
GSM/GPRS/EDGE 1900	Voice/Data	1850.20 - 1909.80 MHz
UMTS 850	Voice/Data	826.40 - 846.60 MHz
UMTS 1900	Voice/Data	1852.4 - 1907.6 MHz
LTE Band 17	Data	706.5 - 713.5 MHz
LTE Band 5 (Cell)	Data	824.7 - 848.3 MHz
LTE Band 4 (AWS)	Data	1710.7 - 1754.3 MHz
LTE Band 2 (PCS)	Data	1850.7 - 1909.3 MHz
2.4 GHz WLAN	Data	2412 - 2462 MHz
5.8 GHz WLAN	Data	5745 - 5825 MHz
5.2 GHz WLAN	Data	5180 - 5240 MHz
5.3 GHz WLAN	Data	5260 - 5320 MHz
5.5 GHz WLAN	Data	5500 - 5700 MHz
Bluetooth	Data	2402 - 2480 MHz
NFC	Data	13.56 MHz
ANT+	Data	2402 - 2480 MHz

1.2 Power Reduction for SAR

This device requires power reduction for SAR compliance. It always applies power reduction in voice or VOIP held to ear scenarios on the WIFI transmitter, and does not impact any other transmitter in the device. Therefore, WIFI Head SAR was evaluated at reduced power according to the head SAR test positions described in IEEE 1528.



1.3 Nominal and Maximum Output Power Specifications

This device operates using the following maximum and nominal output power specifications. SAR values were scaled to the maximum allowed power to determine compliance per KDB Publication 447498 D01v05.

1.3.1 Maximum Power

Mode / Band		Voice (dBm)	Burst Average GMSK (dBm)		Burst Average 8-PSK (dBm)	
		1 TX Slot	1 TX Slots	2 TX Slots	1 TX Slots	2 TX Slots
GSM/GPRS/EDGE 850	Maximum	33.5	33.5	31.5	27.5	27.5
	Nominal	33.0	33.0	31.0	27.0	27.0
GSM/GPRS/EDGE 1900	Maximum	30.5	30.5	29.0	26.5	26.5
	Nominal	30.0	30.0	28.5	26.0	26.0

Mode / Band		Modulated Average		
		3GPP WCDMA Rel 99	3GPP HSDPA Rel 5	3GPP HSUPA Rel 6
UMTS Band 5 (850 MHz)	Maximum	23.5	22.5	22.5
	Nominal	23.0	22.0	22.0
UMTS Band 2 (1900 MHz)	Maximum	23.0	22.0	22.0
	Nominal	22.5	21.5	21.5



FCC ID: A3LSMG900A	 SAR EVALUATION REPORT 		Reviewed by: Quality Manager
Document S/N: OY1401270204-R2.A3L	Test Dates: 02/03/14 - 02/17/14	DUT Type: Portable Handset	Page 3 of 85

Mode / Band		Modulated Average (dBm)
LTE Band 17	Maximum	24.5
	Nominal	24.0
LTE Band 5 (Cell)	Maximum	24.0
	Nominal	23.5
LTE Band 4 (AWS)	Maximum	23.5
	Nominal	23.0
LTE Band 2 (PCS)	Maximum	23.5
	Nominal	23.0

Mode / Band		Modulated Average (dBm)
IEEE 802.11b (2.4 GHz)	Maximum	17.5
	Nominal	17.0
IEEE 802.11g (2.4 GHz)	Maximum	14.5
	Nominal	14.0
IEEE 802.11n (2.4 GHz)	Maximum	14.0
	Nominal	13.5
IEEE 802.11a (5 GHz)	Maximum	14.0
	Nominal	13.5
IEEE 802.11n (5 GHz - 20 MHz Bandwidth)	Maximum	13.5
	Nominal	13.0
IEEE 802.11n (5 GHz - 40 MHz Bandwidth)	Maximum	12.5
	Nominal	12.0
IEEE 802.11ac (5 GHz - 80 MHz Bandwidth)	Maximum	11.5
	Nominal	11.0
Bluetooth	Maximum	10.0
	Nominal	9.5
Bluetooth LE	Maximum	8.5
	Nominal	8.0

1.3.2 Reduced Power – Held-to-Ear

Mode / Band		Modulated Average (dBm)
IEEE 802.11b (2.4 GHz)	Maximum	12.5
	Nominal	12.0
IEEE 802.11g (2.4 GHz)	Maximum	12.5
	Nominal	12.0
IEEE 802.11n (2.4 GHz)	Maximum	12.5
	Nominal	12.0
IEEE 802.11a (5 GHz)	Maximum	9.5
	Nominal	9.0
IEEE 802.11n (5 GHz)	Maximum	9.5
	Nominal	9.0
IEEE 802.11ac (5 GHz)	Maximum	9.5
	Nominal	9.0

FCC ID: A3LSMG900A	 PCTEST ENGINEERING LABORATORY, INC.	SAR EVALUATION REPORT		Reviewed by: Quality Manager
Document S/N: 0Y1401270204-R2.A3L	Test Dates: 02/03/14 - 02/17/14	DUT Type: Portable Handset		Page 4 of 85

1.4 DUT Antenna Locations

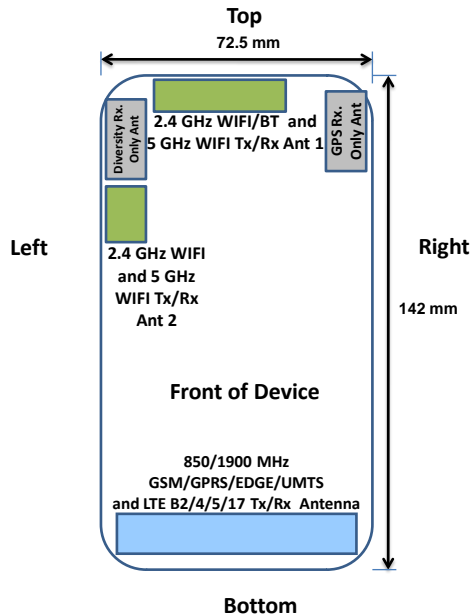

Note: Exact antenna dimensions and separation distances are described in the Technical Descriptions in the FCC Filing.

Figure 1-1
DUT Antenna Locations

Table 1-1
Mobile Hotspot Sides for SAR Testing

Mobile Hotspot Sides for SAR Testing						
Mode	Back	Front	Top	Bottom	Right	Left
GPRS 850	Yes	Yes	No	Yes	Yes	Yes
GPRS 1900	Yes	Yes	No	Yes	Yes	Yes
UMTS 850	Yes	Yes	No	Yes	Yes	Yes
UMTS 1900	Yes	Yes	No	Yes	Yes	Yes
LTE Band 17	Yes	Yes	No	Yes	Yes	Yes
LTE Band 5 (Cell)	Yes	Yes	No	Yes	Yes	Yes
LTE Band 4 (AWS)	Yes	Yes	No	Yes	Yes	Yes
LTE Band 2 (PCS)	Yes	Yes	No	Yes	Yes	Yes
2.4 GHz WLAN - Antenna 1 & MIMO	Yes	Yes	Yes	No	No	Yes
2.4 GHz WLAN - Antenna 2	Yes	Yes	No	No	No	Yes
5.8 GHz WLAN - Antenna 1 & MIMO	Yes	Yes	Yes	No	No	Yes
5.8 GHz WLAN - Antenna 2	Yes	Yes	No	No	No	Yes

Note: Particular DUT edges were not required to be evaluated for Wireless Router SAR if the edges were greater than 2.5 cm from the transmitting antenna according to FCC KDB Publication 941225 D06v01 guidance, page 2. The antenna document shows the distances between the transmit antennas and the edges of the device. Mobile hotspot for 5.2 GHz - 5.7 GHz WIFI is not supported and therefore is not considered in this section.

FCC ID: A3LSMG900A	PCTEST ENGINEERING LABORATORY, INC.	SAR EVALUATION REPORT		Reviewed by: Quality Manager
Document S/N: OY1401270204-R2.A3L	Test Dates: 02/03/14 - 02/17/14	DUT Type: Portable Handset	Page 5 of 85	

1.5 Near Field Communications (NFC) Antenna

This DUT has NFC operations. The NFC antenna is integrated into the standard battery. The SAR tests were performed with the standard battery (model: **EB-BG900BBU**).

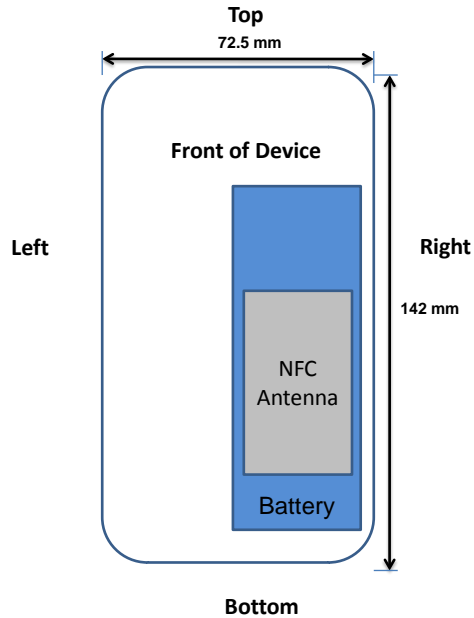

Figure 1-2
DUT Antenna Locations

1.6 Simultaneous Transmission Capabilities

According to FCC KDB Publication 447498 D05v01, transmitters are considered to be transmitting simultaneously when there is overlapping transmission, with the exception of transmissions during network hand-offs with maximum hand-off duration less than 30 seconds. Possible transmission paths for the DUT are shown in Figure 1-3 and are color-coded to indicate communication modes which share the same path. Modes which share the same transmission path cannot transmit simultaneously with one another. This device supports MIMO Tx for WLAN 802.11n/ac. Each WLAN antenna can transmit independently or together when operating with MIMO.

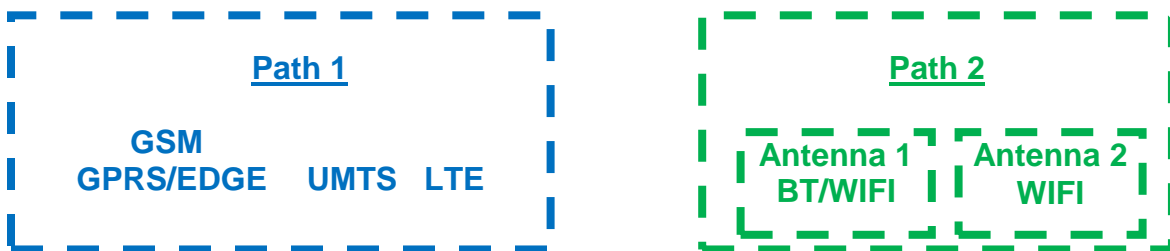



Figure 1-3
Simultaneous Transmission Paths

This device contains multiple transmitters that may operate simultaneously, and therefore requires a simultaneous transmission analysis according to FCC KDB Publication 447498 D01v05 3) procedures.

FCC ID: A3LSMG900A	 PCTEST ENGINEERING LABORATORY, INC.	SAR EVALUATION REPORT		Reviewed by: Quality Manager
Document S/N: OY1401270204-R2.A3L	Test Dates: 02/03/14 - 02/17/14	DUT Type: Portable Handset		Page 6 of 85

**Table 1-2
Simultaneous Transmission Scenarios**

No.	Capable Transmit Configuration	Head	Body-Worn Accessory	Wireless Router	Notes
1	GSM voice + 2.4 GHz Wi-Fi	Yes	Yes	N/A	
2	GSM voice + 5 GHz Wi-Fi	Yes	Yes	N/A	
3	GSM voice + 2.4 GHz Bluetooth	N/A	Yes	N/A	
4	UMTS + 2.4 GHz Wi-Fi	Yes	Yes	Yes	
5	UMTS + 5 GHz Wi-Fi	Yes	Yes	Yes	
6	UMTS + 2.4 GHz Bluetooth	N/A	Yes	N/A	
7	LTE + 2.4 GHz Wi-Fi	Yes*	Yes*	Yes	*-Pre-installed VOIP applications are considered.
8	LTE + 5 GHz Wi-Fi	Yes*	Yes*	Yes	*-Pre-installed VOIP applications are considered.
9	LTE + 2.4 GHz Bluetooth	N/A	Yes*	N/A	*-Pre-installed VOIP applications are considered.
10	GPRS/EDGE + 2.4 GHz Wi-Fi	N/A	N/A	Yes	
11	GPRS/EDGE + 5.8 GHz Wi-Fi	N/A	N/A	Yes	
12	GPRS/EDGE + 5.2-5.7 GHz Wi-Fi	N/A	N/A	N/A	Not Supported by S/W
13	UMTS Data + 5.2-5.7 GHz Wi-Fi	N/A	N/A	N/A	Not Supported by S/W

Notes:

- (*) = for VOIP 3rd party applications possibly installed and used by the end-user.
- 2.4 GHz WLAN, 2.4 GHz Bluetooth, and 5 GHz WLAN share the same antenna path and cannot transmit simultaneously.
- GSM/GPRS/EDGE, UMTS, and LTE share the same antenna and cannot transmit simultaneously.
- When the user utilizes multiple services in UMTS 3G mode it uses multi-Radio Access Bearer or multi-RAB. The power control is based on a physical control channel (Dedicated Physical Control Channel [DPCCH]) and power control will be adjusted to meet the needs of both services. Therefore, the UMTS+WLAN scenario also represents the UMTS Voice/DATA + WLAN Hotspot scenario.
- Per the manufacturer, WIFI Direct is not expected to be used in conjunction with a held-to-ear or body-worn accessory voice call. Therefore, there are no simultaneous transmission scenarios involving WIFI direct beyond that listed in the above table.
- This device supports 2x2 MIMO Tx for WLAN 802.11n/ac. Each WLAN antenna can transmit independently or together when operating with MIMO.
- 5 GHz Wireless Router is only supported for the 5.8 GHz Band by S/W, therefore all other 5 GHz NII Bands were not evaluated for wireless router conditions.

1.7 Wireless Charging Cover

This DUT may be used with a standard battery cover or with an optional wireless charging battery cover. Per FCC KDB Publication 648474 D04, SAR was measured using the standard battery cover and then repeated with the wireless charging battery cover for the highest reported SAR for each wireless technology, frequency band, operating mode, and exposure condition. No additional evaluations with wireless charging cover were required since all reported SAR values were less than 1.2 W/kg.

1.8 SAR Test Exclusions Applied



(A) WIFI/BT

Since Wireless Router operations are not allowed by the chipset firmware using 5.2 GHz - 5.7 GHz WIFI, only 2.4 GHz and 5.8 GHz WIFI Hotspot SAR tests and combinations are considered for SAR with respect to Wireless Router configurations according to FCC KDB 941225 D06v01.

This device supports 40 MHz Bandwidths for IEEE 802.11n for 5 GHz WIFI only.

This device supports IEEE 802.11ac with the following features:

- Up to 80 MHz Bandwidth only
- No aggregate channel configurations
- 2 Tx antenna output
- 256 QAM is supported
- No new 5 GHz channels

FCC ID: A3LSMG900A	 PCTEST Engineering Laboratory, Inc.	SAR EVALUATION REPORT		Reviewed by: Quality Manager
Document S/N: OY1401270204-R2.A3L	Test Dates: 02/03/14 - 02/17/14	DUT Type: Portable Handset		Page 7 of 85

Per April 2013 TCB Workshop notes, full SAR tests for all SISO IEEE 802.11ac configurations were not required because the average output power was not more than 0.25 dB higher than SISO IEEE 802.11a mode. SISO IEEE 802.11ac was evaluated for the highest SISO IEEE 802.11a position in each 5 GHz band and exposure condition.

Per FCC KDB 447498 D01v05, the SAR exclusion threshold for distances <50mm is defined by the following equation:

$$\frac{\text{Max Power of Channel (mW)}}{\text{Test Separation Dist (mm)}} * \sqrt{\text{Frequency(GHz)}} \leq 3.0$$

Based on the maximum conducted power of Bluetooth (rounded to the nearest mW) and the antenna to user separation distance, Bluetooth SAR was not required; $[(10/10) * \sqrt{2.441}] = 1.6 < 3.0$. Per KDB Publication 447498 D01v05, the maximum power of the channel was rounded to the nearest mW before calculation.

(B) Licensed Transmitter(s)

GSM/GPRS/EDGE DTM is not supported for US bands. Therefore, the GSM Voice modes in this report do not transmit simultaneously with GPRS/EDGE Data.



This device is only capable of QPSK HSUPA in the uplink. Therefore, no additional SAR tests are required beyond that described for devices with HSUPA in KDB 941225 D01v02.

LTE SAR for the higher modulations and lower bandwidths were not tested since the maximum average output power of all required channels and configurations was not more than 0.5 dB higher than the highest bandwidth; and the reported LTE SAR for the highest bandwidth was less than 1.45 W/kg for all configurations according to FCC KDB 941225 D05v02.

This device supports inter-band LTE Carrier Aggregation (CA) in the downlink only. All uplink communications are identical to Release 8 specifications. Per FCC Guidance, LTE CA SAR was not needed for testing since the data sent by uplink on uplink physical channels does not change between Rel 8 and Rel 10.

1.9 Guidance Applied



- IEEE 1528-2003
- FCC KDB Publication 941225 D01-D06 (2G/3G/4G and Hotspot)
- FCC KDB Publication 248227 D01v01r02 (SAR Considerations for 802.11 Devices)
- FCC KDB Publication 447498 D01v05 (General SAR Guidance)
- FCC KDB Publication 865664 D01-D02 (SAR Measurements up to 6 GHz)
- FCC KDB Publication 648474 D03-D04 (Wireless Charging Cover)
- April 2013 TCB Workshop Notes (IEEE 802.11ac)
- October 2013 TCB Workshop Notes (GPRS Testing Considerations)

FCC ID: A3LSMG900A	 PCTEST ENGINEERING LABORATORY, INC.	SAR EVALUATION REPORT		Reviewed by: Quality Manager
Document S/N: 0Y1401270204-R2.A3L	Test Dates: 02/03/14 - 02/17/14	DUT Type: Portable Handset		Page 8 of 85

1.10 Device Serial Numbers

Several samples were used with identical hardware to support SAR testing. The manufacturer has confirmed that the device(s) tested have the same physical, mechanical and thermal characteristics and are within operational tolerances expected for production units.



	Head Serial Number	Body-Worn Serial Number	Hotspot Serial Number
GSM/GPRS/EDGE 850	00F0B	00F0B	00F0B
GSM/GPRS/EDGE 1900	00F0D	00F0D	00F0D
UMTS 850	00F0B	00F0B	00F0B
UMTS 1900	00F0D	00F0D	00F0D
LTE Band 17	00E6B	00E6B	00E6B
LTE Band 5 (Cell)	00E6B	00E6B	00E6B
LTE Band 4 (AWS)	00F0A	00F0A	00F0A
LTE Band 2 (PCS)	00F0A	00F0A	00F0A
2.4 GHz WLAN - Antenna 1	00F05	00F05	00F05
2.4 GHz WLAN - Antenna 2	00F05	00F05	00F05
2.4 GHz WLAN - MIMO	00F05	00F05	00F05
5 GHz WLAN - Antenna 1	F1186	14524	14524
5 GHz WLAN - Antenna 2	F1186	14524	14524
5 GHz WLAN - MIMO	F1186	14524	14524

FCC ID: A3LSMG900A	 PCTEST ENGINEERING LABORATORY, INC.	SAR EVALUATION REPORT		Reviewed by: Quality Manager
Document S/N: 0Y1401270204-R2.A3L	Test Dates: 02/03/14 - 02/17/14	DUT Type: Portable Handset		Page 9 of 85

2 LTE INFORMATION

LTE Information					
FCC ID	A3LSMG900A				
Form Factor	Portable Handset				
Frequency Range of each LTE transmission band	LTE Band 17 (706.5 - 713.5 MHz)				
	LTE Band 5 (Cell) (824.7 - 848.3 MHz)				
	LTE Band 4 (AWS) (1710.7 - 1754.3 MHz)				
	LTE Band 2 (PCS) (1850.7 - 1909.3 MHz)				
Channel Bandwidths	LTE Band 17: 5 MHz, 10 MHz				
	LTE Band 5 (Cell): 1.4 MHz, 3 MHz, 5 MHz, 10 MHz				
	LTE Band 4 (AWS): 1.4 MHz, 3 MHz, 5 MHz, 10 MHz, 15 MHz, 20 MHz				
	LTE Band 2 (PCS): 1.4 MHz, 3 MHz, 5 MHz, 10 MHz, 15 MHz, 20 MHz				
Channel Numbers and Frequencies (MHz)	Low	Mid	High		
LTE Band 17: 5 MHz	706.5 (23755)	710 (23790)	713.5 (23825)		
LTE Band 17: 10 MHz	709 (23780)	710 (23790)	711 (23800)		
LTE Band 5 (Cell): 1.4 MHz	824.7 (20407)	836.5 (20525)	848.3 (20643)		
LTE Band 5 (Cell): 3 MHz	825.5 (20415)	836.5 (20525)	847.5 (20635)		
LTE Band 5 (Cell): 5 MHz	826.5 (20425)	836.5 (20525)	846.5 (20625)		
LTE Band 5 (Cell): 10 MHz	829 (20450)	836.5 (20525)	844 (20600)		
LTE Band 4 (AWS): 1.4 MHz	1710.7 (19957)	1732.5 (20175)	1754.3 (20393)		
LTE Band 4 (AWS): 3 MHz	1711.5 (19965)	1732.5 (20175)	1753.5 (20385)		
LTE Band 4 (AWS): 5 MHz	1712.5 (19975)	1732.5 (20175)	1752.5 (20375)		
LTE Band 4 (AWS): 10 MHz	1715 (20000)	1732.5 (20175)	1750 (20350)		
LTE Band 4 (AWS): 15 MHz	1717.5 (20025)	1732.5 (20175)	1747.5 (20325)		
LTE Band 4 (AWS): 20 MHz	1720 (20050)	1732.5 (20175)	1745 (20300)		
LTE Band 2 (PCS): 1.4 MHz	1850.7 (18607)	1880 (18900)	1909.3 (19193)		
LTE Band 2 (PCS): 3 MHz	1851.5 (18615)	1880 (18900)	1908.5 (19185)		
LTE Band 2 (PCS): 5 MHz	1852.5 (18625)	1880 (18900)	1907.5 (19175)		
LTE Band 2 (PCS): 10 MHz	1855 (18650)	1880 (18900)	1905 (19150)		
LTE Band 2 (PCS): 15 MHz	1857.5 (18675)	1880 (18900)	1902.5 (19125)		
LTE Band 2 (PCS): 20 MHz	1860 (18700)	1880 (18900)	1900 (19100)		
UE Category	4				
Modulations Supported in UL	QPSK, 16QAM				
LTE Carrier Aggregation Possible Considerations	B2 (PCC) + B17(SCC) 5MHz (B2)+5MHz (B17)	B2 (PCC) + B29(SCC) 5MHz (B2)+5MHz (B29)	B4 (PCC) + B17(SCC) 5MHz (B4)+5MHz (B17)	B4 (PCC) + B29(SCC) 5MHz (B4)+5MHz (B29)	B17 (PCC) + B2 (SCC) 5MHz (B17)+5MHz (B2)
	5MHz (B2)+10MHz (B17)	5MHz (B2)+10MHz (B29)	5MHz (B4)+10MHz (B17)	5MHz (B4)+10MHz (B29)	5MHz (B17)+10MHz (B2)
	10MHz (B2)+5MHz (B17)	10MHz (B2)+5MHz (B29)	10MHz (B4)+5MHz (B17)	10MHz (B4)+5MHz (B29)	10MHz (B17)+5MHz (B2)
	10MHz (B2)+10MHz (B17)	10MHz (B2)+10MHz (B29)	10MHz (B4)+10MHz (B17)	10MHz (B4)+10MHz (B29)	10MHz (B17)+10MHz (B2)
LTE Aggregation Additional Information	<p>This device does not support full CA features on 3GPP Release 10. It supports a maximum of 2 carriers in the downlink with a total maximum bandwidth of 10 MHz of the spectrum. This device does not support any intra-band operations. All uplink communications are identical to the Release 8 Specifications. Uplink communications are done on the PCC.</p> <p>Due to carrier capability, only B2 (PCC) + B17(SCC), B2 (PCC) + B29(SCC), B4 (PCC) + B17(SCC), B4 (PCC) + B29(SCC), and B17 (PCC) + B2 (SCC) are supported.</p>				
LTE MPR Permanently implemented per 3GPP TS 36.101 section 6.2.3-6.2.5? (manufacturer attestation to be provided)	YES				
A-MPR (Additional MPR) disabled for SAR Testing?	YES				

The following LTE Release 10 Features are not supported: Relay, HetNet, Enhanced MIMO, eICIC, WIFI offloading, MDT, eMBMA, Cross-Carrier Scheduling, SC-FDMA.

FCC ID: A3LSMG900A	 PCTEST Engineering Laboratory, Inc.	SAR EVALUATION REPORT		Reviewed by: Quality Manager
Document S/N: OY1401270204-R2.A3L	Test Dates: 02/03/14 - 02/17/14	DUT Type: Portable Handset		Page 10 of 85

3 INTRODUCTION

The FCC and Industry Canada have adopted the guidelines for evaluating the environmental effects of radio frequency (RF) radiation in ET Docket 93-62 on Aug. 6, 1996 and Health Canada Safety Code 6 to protect the public and workers from the potential hazards of RF emissions due to FCC-regulated portable devices. [1]

The safety limits used for the environmental evaluation measurements are based on the criteria published by the American National Standards Institute (ANSI) for localized specific absorption rate (SAR) in IEEE/ANSI C95.1-1992 Standard for Safety Levels with Respect to Human Exposure to Radio Frequency Electromagnetic Fields, 3 kHz to 300 GHz [3] and Health Canada RF Exposure Guidelines Safety Code 6 [22]. The measurement procedure described in IEEE/ANSI C95.3-2002 Recommended Practice for the Measurement of Potentially Hazardous Electromagnetic Fields - RF and Microwave [4] is used for guidance in measuring the Specific Absorption Rate (SAR) due to the RF radiation exposure from the Equipment Under Test (EUT). These criteria for SAR evaluation are similar to those recommended by the International Committee for Non-Ionizing Radiation Protection (ICNIRP) in Biological Effects and Exposure Criteria for Radiofrequency Electromagnetic Fields,” Report No. Vol 74. SAR is a measure of the rate of energy absorption due to exposure to an RF transmitting source. SAR values have been related to threshold levels for potential biological hazards.

3.1 SAR Definition

Specific Absorption Rate is defined as the time derivative (rate) of the incremental energy (dU) absorbed by (dissipated in) an incremental mass (dm) contained in a volume element (dV) of a given density (ρ). It is also defined as the rate of RF energy absorption per unit mass at a point in an absorbing body (see Equation 3-1).

**Equation 3-1
SAR Mathematical Equation**

$$SAR = \frac{d}{dt} \left(\frac{dU}{dm} \right) = \frac{d}{dt} \left(\frac{dU}{\rho dv} \right)$$



SAR is expressed in units of Watts per Kilogram (W/kg).

$$SAR = \frac{\sigma \cdot E^2}{\rho}$$

where:

- σ = conductivity of the tissue-simulating material (S/m)
- ρ = mass density of the tissue-simulating material (kg/m³)
- E = Total RMS electric field strength (V/m)

NOTE: The primary factors that control rate of energy absorption were found to be the wavelength of the incident field in relation to the dimensions and geometry of the irradiated organism, the orientation of the organism in relation to the polarity of field vectors, the presence of reflecting surfaces, and whether conductive contact is made by the organism with a ground plane.[6]

FCC ID: A3LSMG900A	 PCTEST ENGINEERING LABORATORY, INC.	SAR EVALUATION REPORT		Reviewed by: Quality Manager
Document S/N: OY1401270204-R2.A3L	Test Dates: 02/03/14 - 02/17/14	DUT Type: Portable Handset	Page 11 of 85	

4 DOSIMETRIC ASSESSMENT

4.1 Measurement Procedure

The evaluation was performed using the following procedure compliant to FCC KDB Publication 865664 D01v01 and IEEE 1528-2013:

1. The SAR distribution at the exposed side of the head or body was measured at a distance no greater than 5.0 mm from the inner surface of the shell. The area covered the entire dimension of the device-head and body interface and the horizontal grid resolution was determined per FCC KDB Publication 865664 D01v01 (See Table 4-1) and IEEE 1528-2013.
2. The point SAR measurement was taken at the maximum SAR region determined from Step 1 to enable the monitoring of SAR fluctuations/drifts during the 1g/10g cube evaluation. SAR at this fixed point was measured and used as a reference value.
3. Based on the area scan data, the peak of the region with maximum SAR was determined by spline interpolation. Around this point, a volume was assessed according to the measurement resolution and volume size requirements of FCC KDB Publication 865664 D01v01 (See Table 4-1) and IEEE 1528-2013. On the basis of this data set, the spatial peak SAR value was evaluated with the following procedure (see references or the DASY manual online for more details):
 - a. SAR values at the inner surface of the phantom are extrapolated from the measured values along the line away from the surface with spacing no greater than that in Table 4-1. The extrapolation was based on a least-squares algorithm. A polynomial of the fourth order was calculated through the points in the z-axis (normal to the phantom shell).
 - b. After the maximum interpolated values were calculated between the points in the cube, the SAR was averaged over the spatial volume (1g or 10g) using a 3D-Spline interpolation algorithm. The 3D-spline is composed of three one-dimensional splines with the “Not a knot” condition (in x, y, and z directions). The volume was then integrated with the trapezoidal algorithm. One thousand points (10 x 10 x 10) were obtained through interpolation, in order to calculate the averaged SAR.
 - c. All neighboring volumes were evaluated until no neighboring volume with a higher average value was found.
4. The SAR reference value, at the same location as step 2, was re-measured after the zoom scan was complete to calculate the SAR drift. If the drift deviated by more than 5%, the SAR test and drift measurements were repeated.

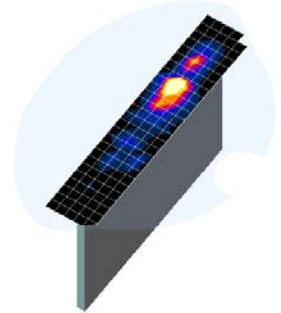



Figure 4-1
Sample SAR Area Scan

Table 4-1
Area and Zoom Scan Resolutions per FCC KDB Publication 865664 D01v01*

Frequency	Maximum Area Scan Resolution (mm) (Δx_{area} , Δy_{area})	Maximum Zoom Scan Resolution (mm) (Δx_{zoom} , Δy_{zoom})	Maximum Zoom Scan Spatial Resolution (mm)			Minimum Zoom Scan Volume (mm) (x,y,z)
			Uniform Grid $\Delta z_{zoom}(n)$	Graded Grid		
				$\Delta z_{zoom}(1)^*$	$\Delta z_{zoom}(n>1)^*$	
≤ 2 GHz	≤ 15	≤ 8	≤ 5	≤ 4	≤ 1.5* $\Delta z_{zoom}(n-1)$	≥ 30
2-3 GHz	≤ 12	≤ 5	≤ 5	≤ 4	≤ 1.5* $\Delta z_{zoom}(n-1)$	≥ 30
3-4 GHz	≤ 12	≤ 5	≤ 4	≤ 3	≤ 1.5* $\Delta z_{zoom}(n-1)$	≥ 28
4-5 GHz	≤ 10	≤ 4	≤ 3	≤ 2.5	≤ 1.5* $\Delta z_{zoom}(n-1)$	≥ 25
5-6 GHz	≤ 10	≤ 4	≤ 2	≤ 2	≤ 1.5* $\Delta z_{zoom}(n-1)$	≥ 22

*Also compliant to IEEE 1528-2013 Table 6

FCC ID: A3LSMG900A	 PCTEST Engineering Laboratory, Inc.	SAR EVALUATION REPORT		Reviewed by: Quality Manager
Document S/N: OY1401270204-R2.A3L	Test Dates: 02/03/14 - 02/17/14	DUT Type: Portable Handset	Page 12 of 85	

5

DEFINITION OF REFERENCE POINTS

5.1 EAR REFERENCE POINT

Figure 5-2 shows the front, back and side views of the SAM Twin Phantom. The point “M” is the reference point for the center of the mouth, “LE” is the left ear reference point (ERP), and “RE” is the right ERP. The ERP is 15mm posterior to the entrance to the ear canal (EEC) along the B-M line (Back-Mouth), as shown in Figure 5-1. The plane passing through the two ear canals and M is defined as the Reference Plane. The line N-F (Neck-Front), also called the Reference Pivoting Line, is not perpendicular to the reference plane (see Figure 5-1). Line B-M is perpendicular to the N-F line. Both N-F and B-M lines are marked on the external phantom shell to facilitate handset positioning [5].

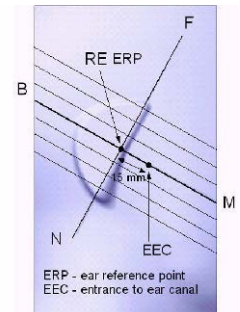

Figure 5-1
Close-Up Side view of ERP

5.2 HANDSET REFERENCE POINTS

Two imaginary lines on the handset were established: the vertical centerline and the horizontal line. The test device was placed in a normal operating position with the acoustic output located along the “vertical centerline” on the front of the device aligned to the “ear reference point” (See Figure 5-3). The acoustic output was then located at the same level as the center of the ear reference point. The test device was positioned so that the “vertical centerline” was bisecting the front surface of the handset at its top and bottom edges, positioning the “ear reference point” on the outer surface of the both the left and right head phantoms on the ear reference point.



Figure 5-2
Front, back and side view of SAM Twin Phantom

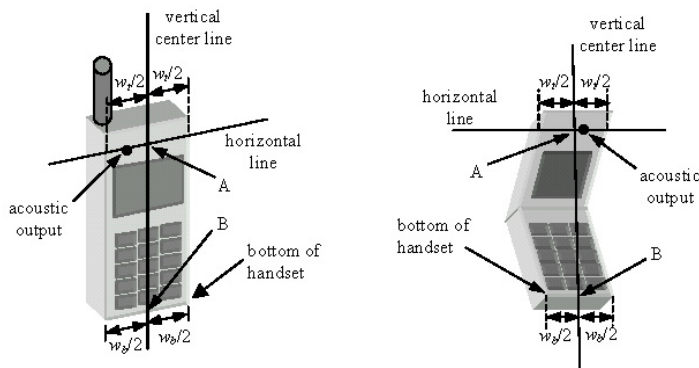

Figure 5-3
Handset Vertical Center & Horizontal Line Reference Points

FCC ID: A3LSMG900A	PCTEST ENGINEERING LABORATORY, INC.	SAR EVALUATION REPORT	SAMSUNG	Reviewed by: Quality Manager
Document S/N: OY1401270204-R2.A3L	Test Dates: 02/03/14 - 02/17/14	DUT Type: Portable Handset		Page 13 of 85

6 TEST CONFIGURATION POSITIONS FOR HANDSETS

6.1 Device Holder

The device holder is made out of low-loss POM material having the following dielectric parameters: relative permittivity $\epsilon = 3$ and loss tangent $\delta = 0.02$.

6.2 Positioning for Cheek

1. The test device was positioned with the device close to the surface of the phantom such that point A is on the (virtual) extension of the line passing through points RE and LE on the phantom (see Figure 6-1), such that the plane defined by the vertical center line and the horizontal line of the phone is approximately parallel to the sagittal plane of the phantom.

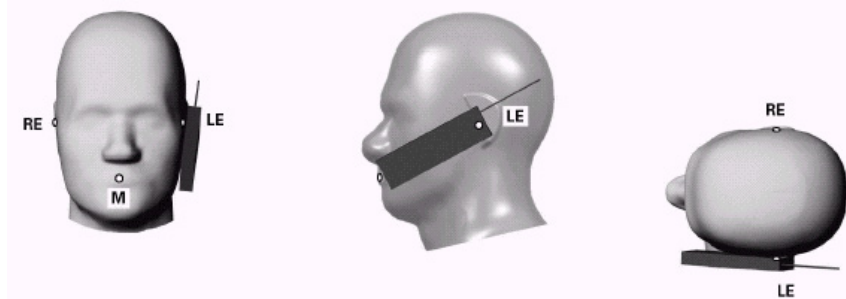



Figure 6-1 Front, Side and Top View of Cheek Position

2. The handset was translated towards the phantom along the line passing through RE & LE until the handset touches the pinna.
3. While maintaining the handset in this plane, the handset was rotated around the LE-RE line until the vertical centerline was in the reference plane.
4. The phone was then rotated around the vertical centerline until the phone (horizontal line) was symmetrical with respect to the line NF.
5. While maintaining the vertical centerline in the reference plane, keeping point A on the line passing through RE and LE, and maintaining the device contact with the ear, the device was rotated about the NF line until any point on the handset made contact with a phantom point below the ear (cheek) (See Figure 6-2).

6.3 Positioning for Ear / 15° Tilt

With the test device aligned in the “Cheek Position”:

1. While maintaining the orientation of the phone, the phone was retracted parallel to the reference plane far enough to enable a rotation of the phone by 15 degrees.
2. The phone was then rotated around the horizontal line by 15 degrees.
3. While maintaining the orientation of the phone, the phone was moved parallel to the reference plane until any part of the handset touched the head. (In this position, point A was located on the line RE-LE). The tilted position is obtained when the contact is on the pinna. If the contact was at any location other than the pinna, the angle of the phone would then be reduced. In this situation, the tilted position was obtained when any part of the phone was in contact of the ear as well as a second part of the phone was in contact with the head (see Figure 6-2).

FCC ID: A3LSMG900A	 PCTEST ENGINEERING LABORATORY, INC.	SAR EVALUATION REPORT		Reviewed by: Quality Manager
Document S/N: OY1401270204-R2.A3L	Test Dates: 02/03/14 - 02/17/14	DUT Type: Portable Handset		Page 14 of 85

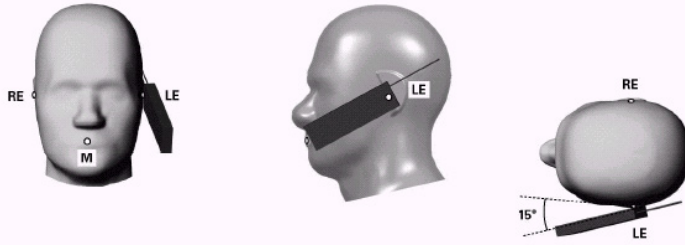

Figure 6-2 Front, Side and Top View of Ear/15° Tilt Position

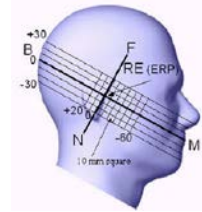

Figure 6-3 Side view w/ relevant markings

6.4 SAR Evaluations near the Mouth/Jaw Regions of the SAM Phantom

Antennas located near the bottom of a phone may require SAR measurements around the mouth and jaw regions of the SAM head phantom. This typically applies to clam-shell style phones that are generally longer in the unfolded normal use positions or to certain older style long rectangular phones. Per IEEE 1528-2013, a rotated SAM phantom is necessary to allow probe access to such regions. Both SAM heads of the TwinSAM-Chin20 are rotated 20 degrees around the NF line. Each head can be removed from the table for emptying and cleaning.

Under these circumstances, the following procedures apply, adopted from the FCC guidance on SAR handsets document FCC KDB Publication 648474 D04_v01. The SAR required in these regions of SAM should be measured using a flat phantom. The phone should be positioned with a separation distance of 4 mm between the ear reference point (ERP) and the outer surface of the flat phantom shell. While maintaining this distance at the ERP location, the low (bottom) edge of the phone should be lowered from the phantom to establish the same separation distance between the peak SAR location identified by the truncated partial SAR distribution measured with the SAM phantom. The distance from the peak SAR location to the phone is determined by the straight line passing perpendicularly through the phantom surface. When it is not feasible to maintain 4 mm separation at the ERP while also establishing the required separation at the peak SAR location, the top edge of the phone will be allowed to touch the phantom with a separation < 4 mm at the ERP. The phone should not be tilted to the left or right while placed in this inclined position to the flat phantom.

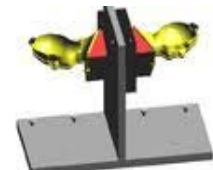



Figure 6-4 Twin SAM Chin20

FCC ID: A3LSMG900A	 PCTEST ENGINEERING LABORATORY, INC.	SAR EVALUATION REPORT		Reviewed by: Quality Manager
Document S/N: OY1401270204-R2.A3L	Test Dates: 02/03/14 - 02/17/14	DUT Type: Portable Handset		Page 15 of 85

6.5 Body-Worn Accessory Configurations

Body-worn operating configurations are tested with the belt-clips and holsters attached to the device and positioned against a flat phantom in a normal use configuration (see Figure 6-5). Per FCC KDB Publication 648474 D04v01, Body-worn accessory exposure is typically related to voice mode operations when handsets are carried in body-worn accessories. The body-worn accessory procedures in FCC KDB Publication 447498 D01v05 should be used to test for body-worn accessory SAR compliance, without a headset connected to it. This enables the test results for such configuration to be compatible with that required for hotspot mode when the body-worn accessory test separation distance is greater than or equal to that required for hotspot mode, when applicable. When the reported SAR for a body-worn accessory, measured without a headset connected to the handset, is $> 1.2 \text{ W/kg}$, the highest reported SAR configuration for that wireless mode and frequency band should be repeated for that body-worn accessory with a headset attached to the handset.

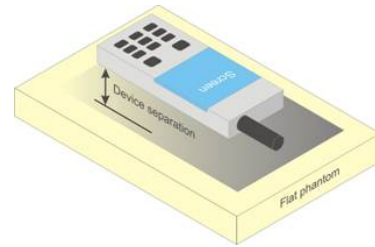

Figure 6-5
Sample Body-Worn Diagram



Accessories for Body-worn operation configurations are divided into two categories: those that do not contain metallic components and those that do contain metallic components. When multiple accessories that do not contain metallic components are supplied with the device, the device is tested with only the accessory that dictates the closest spacing to the body. Then multiple accessories that contain metallic components are tested with the device with each accessory. If multiple accessories share an identical metallic component (i.e. the same metallic belt-clip used with different holsters with no other metallic components) only the accessory that dictates the closest spacing to the body is tested.

Body-worn accessories may not always be supplied or available as options for some devices intended to be authorized for body-worn use. In this case, a test configuration with a separation distance between the back of the device and the flat phantom is used. Test position spacing was documented. Transmitters that are designed to operate in front of a person's face, as in push-to-talk configurations, are tested for SAR compliance with the front of the device positioned to face the flat phantom in head fluid. For devices that are carried next to the body such as a shoulder, waist or chest-worn transmitters, SAR compliance is tested with the accessories, including headsets and microphones, attached to the device and positioned against a flat phantom in a normal use configuration.

6.6 Extremity Exposure Configurations

Devices that are designed or intended for use on extremities or mainly operated in extremity only exposure conditions; i.e., hands, wrists, feet and ankles, may require extremity SAR evaluation. When the device also operates in close proximity to the user's body, SAR compliance for the body is also required. The 1-g body and 10-g extremity SAR Exclusion Thresholds found in KDB Publication 44798 D01v05 should be applied to determine SAR test requirements.



Per KDB Publication 44798 D01v05, Cell phones (handsets) are not normally designed to be used on extremities or operated in extremity only exposure conditions. The maximum output power levels of handsets generally do not require extremity SAR testing to show compliance. Therefore, extremity SAR was not evaluated for this device.

FCC ID: A3LSMG900A	 PCTEST ENGINEERING LABORATORY, INC.	SAR EVALUATION REPORT		Reviewed by: Quality Manager
Document S/N: 0Y1401270204-R2.A3L	Test Dates: 02/03/14 - 02/17/14	DUT Type: Portable Handset		Page 16 of 85

6.7 Wireless Router Configurations

Some battery-operated handsets have the capability to transmit and receive user data through simultaneous transmission of WIFI simultaneously with a separate licensed transmitter. The FCC has provided guidance in FCC KDB Publication 941225 D06 v01 where SAR test considerations for handsets ($L \times W \geq 9 \text{ cm} \times 5 \text{ cm}$) are based on a composite test separation distance of 10 mm from the front, back and edges of the device containing transmitting antennas within 2.5 cm of their edges, determined from general mixed use conditions for this type of devices. Since the hotspot SAR results may overlap with the body-worn accessory SAR requirements, the more conservative configurations can be considered, thus excluding some body-worn accessory SAR tests.

When the user enables the personal wireless router functions for the handset, actual operations include simultaneous transmission of both the WIFI transmitter and another licensed transmitter. Both transmitters often do not transmit at the same transmitting frequency and thus cannot be evaluated for SAR under actual use conditions due to the limitations of the SAR assessment probes. Therefore, SAR must be evaluated for each frequency transmission and mode separately and spatially summed with the WIFI transmitter according to FCC KDB Publication 447498 D01v05 publication procedures. The "Portable Hotspot" feature on the handset was NOT activated during SAR assessments, to ensure the SAR measurements were evaluated for a single transmission frequency RF signal at a time.

FCC ID: A3LSMG900A	 PCTEST ENGINEERING LABORATORY, INC.	SAR EVALUATION REPORT		Reviewed by: Quality Manager
Document S/N: 0Y1401270204-R2.A3L	Test Dates: 02/03/14 - 02/17/14	DUT Type: Portable Handset	Page 17 of 85	

7 RF EXPOSURE LIMITS

7.1 Uncontrolled Environment

UNCONTROLLED ENVIRONMENTS are defined as locations where there is the exposure of individuals who have no knowledge or control of their exposure. The general population/uncontrolled exposure limits are applicable to situations in which the general public may be exposed or in which persons who are exposed as a consequence of their employment may not be made fully aware of the potential for exposure or cannot exercise control over their exposure. Members of the general public would come under this category when exposure is not employment-related; for example, in the case of a wireless transmitter that exposes persons in its vicinity.



7.2 Controlled Environment

CONTROLLED ENVIRONMENTS are defined as locations where there is exposure that may be incurred by persons who are aware of the potential for exposure, (i.e. as a result of employment or occupation). In general, occupational/controlled exposure limits are applicable to situations in which persons are exposed as a consequence of their employment, who have been made fully aware of the potential for exposure and can exercise control over their exposure. This exposure category is also applicable when the exposure is of a transient nature due to incidental passage through a location where the exposure levels may be higher than the general population/uncontrolled limits, but the exposed person is fully aware of the potential for exposure and can exercise control over his or her exposure by leaving the area or by some other appropriate means.

**Table 7-1
SAR Human Exposure Specified in ANSI/IEEE C95.1-1992 and Health Canada Safety Code 6**

HUMAN EXPOSURE LIMITS		
	UNCONTROLLED ENVIRONMENT <i>General Population</i> (W/kg) or (mW/g)	CONTROLLED ENVIRONMENT <i>Occupational</i> (W/kg) or (mW/g)
Peak Spatial Average SAR Head	1.6	8.0
Whole Body SAR	0.08	0.4
Peak Spatial Average SAR Hands, Feet, Ankle, Wrists, etc.	4.0	20

1. The Spatial Peak value of the SAR averaged over any 1 gram of tissue (defined as a tissue volume in the shape of a cube) and over the appropriate averaging time.
2. The Spatial Average value of the SAR averaged over the whole body.
3. The Spatial Peak value of the SAR averaged over any 10 grams of tissue (defined as a tissue volume in the shape of a cube) and over the appropriate averaging time.

FCC ID: A3LSMG900A	 PCTEST ENGINEERING LABORATORY, INC.	SAR EVALUATION REPORT		Reviewed by: Quality Manager
Document S/N: OY1401270204-R2.A3L	Test Dates: 02/03/14 - 02/17/14	DUT Type: Portable Handset		Page 18 of 85

8 FCC MEASUREMENT PROCEDURES

Power measurements were performed using a base station simulator under digital average power.

8.1 Measured and Reported SAR

Per FCC KDB Publication 447498 D01v05, When SAR is not measured at the maximum power level allowed for production units, the results must be scaled to the maximum tune-up tolerance limit according to the power applied to the individual channels tested to determine compliance. For simultaneous transmission, the measured aggregate SAR must be scaled according to the sum of the differences between the maximum tune-up tolerance and actual power used to test each transmitter. When SAR is measured at or scaled to the maximum tune-up tolerance limit, the results are referred to as *reported* SAR. The highest *reported* SAR results are identified on the grant of equipment authorization according to procedures in KDB 690783 D01v01r02.

8.2 Procedures Used to Establish RF Signal for SAR

The following procedures are according to FCC KDB Publication 941225 D01 "SAR Measurement Procedures for 3G Devices" v02, October 2007.

The device was placed into a simulated call using a base station simulator in a RF shielded chamber. Establishing connections in this manner ensure a consistent means for testing SAR and are recommended for evaluating SAR [4]. Devices under test were evaluated prior to testing, with a fully charged battery and were configured to operate at maximum output power. In order to verify that the device was tested throughout the SAR test at maximum output power, the SAR measurement system measures a "point SAR" at an arbitrary reference point at the start and end of the 1 gram SAR evaluation, to assess for any power drifts during the evaluation. If the power drift deviated by more than 5%, the SAR test and drift measurements were repeated.

8.3 SAR Measurement Conditions for UMTS



8.3.1 Output Power Verification

Maximum output power is measured on the High, Middle and Low channels for each applicable transmission band according to the general descriptions in section 5.2 of 3GPP TS 34.121, using the appropriate RMC or AMR with TPC (transmit power control) set to all "1s".

Maximum output power is verified on the High, Middle and Low channels according to the general descriptions in section 5.2 of 3GPP TS 34.121 (release 5), using the appropriate RMC with TPC (transmit power control) set to all "1s" or applying the required inner loop power control procedures to maintain maximum output power while HSUPA is active. Results for all applicable physical channel configurations (DPCCH, DPDCHe and spreading codes, HS-DPCCH etc) are tabulated in this test report. All configurations that are not supported by the DUT or cannot be measured due to technical or equipment limitations are identified.

8.3.2 Head SAR Measurements for Handsets

SAR for head exposure configurations is measured using the 12.2 kbps RMC with TPC bits configured to all "1s". SAR in AMR configurations is not required when the maximum average output of each RF channel for 12.2 kbps AMR is less than 0.25 dB higher than that measured in 12.2 kbps RMC. Otherwise, SAR is measured on the maximum output channel in 12.2 AMR with a

FCC ID: A3LSMG900A	 PCTEST ENGINEERING LABORATORY, INC.	SAR EVALUATION REPORT		Reviewed by: Quality Manager
Document S/N: OY1401270204-R2.A3L	Test Dates: 02/03/14 - 02/17/14	DUT Type: Portable Handset		Page 19 of 85

3.4 kbps SRB (signaling radio bearer) using the exposure configuration that resulted in the highest SAR for that RF channel in the 12.2 kbps RMC mode.

8.3.3 Body SAR Measurements

SAR for body exposure configurations is measured using the 12.2 kbps RMC with the TPC bits all “1s”.

8.3.4 SAR Measurements for Handsets with Rel 5 HSDPA

Body SAR for HSDPA is not required for handsets with HSDPA capabilities when the maximum average output power of each RF channel with HSDPA active is less than 0.25 dB higher than that measured without HSDPA using 12.2 kbps RMC and the maximum SAR for 12.2 kbps RMC is $\leq 75\%$ of the SAR limit. Otherwise, SAR is measured for HSDPA, using an FRC with H-Set 1 in Sub-test 1 and a 12.2 kbps RMC configured in Test Loop Mode 1, using the highest body SAR configuration measured in 12.2 kbps RMC without HSDPA, on the maximum output channel with the body exposure configuration that resulted in the highest SAR in 12.2 kbps RMC mode for that RF channel.

The H-set used in FRC for HSDPA should be configured according to the UE category of a test device. The number of HS-DSCH/HSPDSCHs, HARQ processes, minimum inter-TTI interval, transport block sizes and RV coding sequence are defined by the applicable H-set. To maintain a consistent test configuration and stable transmission conditions, QPSK is used in the FRC for SAR testing. HS-DPCCH should be configured with a CQI feedback cycle of 2 ms to maintain a constant rate of active CQI slots. DPCCH and DPDCH gain factors of $\beta_c=9$ and $\beta_d=15$, and power offset parameters of $\Delta_{ACK} = \Delta_{NACK} = 5$ and $\Delta_{CQI}=2$ is used. The CQI value is determined by the UE category, transport block size, number of HS-PDSCHs and modulation used in the FRC.



Sub-Test	β_c	β_d	β_d (SF)	β_c/β_d	β_{HS} (Note 1, Note 2)	CM (dB) (Note 3)	MPR (dB) (Note 3)
1	2/15	15/15	64	2/15	4/15	0.0	0.0
2	12/15 (Note 4)	15/15 (Note 4)	64	12/15 (Note 4)	24/15	1.0	0.0
3	15/15	8/15	64	15/8	30/15	1.5	0.5
4	15/15	4/15	64	15/4	30/15	1.5	0.5

Note 1: Δ_{ACK} , Δ_{NACK} and $\Delta_{CQI} = 8 \Leftrightarrow A_{hs} = \beta_{hs}/\beta_c = 30/15 \Leftrightarrow \beta_{hs} = 30/15 * \beta_c$.
 Note 2: For the HS-DPCCH power mask requirement test in clause 5.2C, 5.7A, and the Error Vector Magnitude (EVM) with HS-DPCCH test in clause 5.13.1A, and HSDPA EVM with phase discontinuity in clause 5.13.1AA, Δ_{ACK} and $\Delta_{NACK} = 8$ ($A_{hs} = 30/15$) with $\beta_{hs} = 30/15 * \beta_c$, and $\Delta_{CQI} = 7$ ($A_{hs} = 24/15$) with $\beta_{hs} = 24/15 * \beta_c$.
 Note 3: CM = 1 for $\beta_c/\beta_d = 12/15$, $\beta_{hs}/\beta_c = 24/15$. For all other combinations of DPDCH, DPCCH and HS-DPCCH the MPR is based on the relative CM difference. This is applicable for only UEs that support HSDPA in release 6 and later releases.

Figure 8-1
Table C.10.1.4 of TS 234.121-1

8.3.5 SAR Measurements for Handsets with Rel 6 HSUPA

Body SAR for HSUPA is not required when the maximum average output of each RF channel with HSUPA/HSDPA active is less than 0.25 dB higher than as measured without HSUPA/HSDPA using 12.2 kbps RMC and maximum SAR for 12.2 kbps RMC is $\leq 75\%$ of the SAR limit. Otherwise SAR is measured on the maximum output channel for the body exposure configuration produced highest SAR in 12.2 kbps RMC for that RF channel, using the additional procedures under “Release 6 HSPA data devices”

FCC ID: A3LSMG900A	 PCTEST Engineering Laboratory, Inc.	SAR EVALUATION REPORT		Reviewed by: Quality Manager
Document S/N: OY1401270204-R2.A3L	Test Dates: 02/03/14 - 02/17/14	DUT Type: Portable Handset		Page 20 of 85

Head SAR for VOIP operations under HSPA is not required when maximum average output of each RF channel with HSPA is less than 0.25 dB higher than as measured using 12.2 kbps RMC. Otherwise SAR is measured using same HSPA configuration as used for body SAR.

Sub-test	β_c	β_d	β_d (SF)	β_c/β_d	$\beta_{hs}^{(1)}$	β_{ec}	β_{ed}	β_{ed} (SF)	β_{ed} (codes)	CM ⁽²⁾ (dB)	MPR (dB)	AG ⁽⁴⁾ Index	E-TFCI
1	11/15 ⁽³⁾	15/15 ⁽³⁾	64	11/15 ⁽³⁾	22/15	209/225	1039/225	4	1	1.0	0.0	20	75
2	6/15	15/15	64	6/15	12/15	12/15	94/75	4	1	3.0	2.0	12	67
3	15/15	9/15	64	15/9	30/15	30/15	$\beta_{ed}: 47/15$ $\beta_{ed}: 47/15$	4	2	2.0	1.0	15	92
4	2/15	15/15	64	2/15	4/15	2/15	56/75	4	1	3.0	2.0	17	71
5	15/15 ⁽⁴⁾	15/15 ⁽⁴⁾	64	15/15 ⁽⁴⁾	30/15	24/15	134/15	4	1	1.0	0.0	21	81

Note 1: $\Delta_{ACK}, \Delta_{NACK}$ and $\Delta_{CQI} = 8 \Rightarrow A_{hs} = \beta_{hs}/\beta_c = 30/15 \Leftrightarrow \beta_{hs} = 30/15 * \beta_c$.
 Note 2: CM = 1 for $\beta_c/\beta_d = 12/15$, $\beta_{hs}/\beta_c = 24/15$. For all other combinations of DPDCH, DPCCCH, HS-DPCCH, E-DPDCH and E-DPCCH the MPR is based on the relative CM difference.
 Note 3: For subtest 1 the β_c/β_d ratio of 11/15 for the TFC during the measurement period (TF1, TF0) is achieved by setting the signaled gain factors for the reference TFC (TF1, TF1) to $\beta_c = 10/15$ and $\beta_d = 15/15$.
 Note 4: For subtest 5 the β_c/β_d ratio of 15/15 for the TFC during the measurement period (TF1, TF0) is achieved by setting the signaled gain factors for the reference TFC (TF1, TF1) to $\beta_c = 14/15$ and $\beta_d = 15/15$.
 Note 5: Testing UE using E-DPDCH Physical Layer category 1 Sub-test 3 is not required according to TS 25.306 Table 5.1g.
 Note 6: β_{ed} can not be set directly; it is set by Absolute Grant Value.

8.4 SAR Measurement Conditions for LTE

LTE modes were tested according to FCC KDB 941225 D05v02 publication. Please see notes after the tabulated SAR data for required test configurations. Establishing connections with base station simulators ensure a consistent means for testing SAR and are recommended for evaluating SAR [4]. The R&S CMW500 was used for LTE output power measurements and SAR testing. Closed loop power control was used so the UE transmits with maximum output power during SAR testing. SAR tests were performed with the same number of RB and RB offsets transmitting on all TTI frames (maximum TTI).

8.4.1 Spectrum Plots for RB Configurations

A properly configured base station simulator was used for SAR tests and power measurements. Therefore, spectrum plots for RB configurations were not required to be included in this report.

8.4.2 MPR

MPR is permanently implemented for this device by the manufacturer. The specific manufacturer target MPR is indicated alongside the SAR results. MPR is enabled for this device, according to 3GPP TS36.101 Section 6.2.3 – 6.2.5 under Table 6.2.3-1.



8.4.3 A-MPR

A-MPR (Additional MPR) has been disabled for all SAR tests by setting NS=01 on the base station simulator.

8.4.4 Required RB Size and RB Offsets for SAR Testing

According to FCC KDB 941225 D05v02r01:

- a. Per Section 5.2.1, SAR is required for QPSK 1 RB Allocation for the largest bandwidth
 - i. The required channel and offset combination with the highest maximum output power is required for SAR.
 - ii. When the reported SAR is ≤ 0.8 W/kg, testing of the remaining RB offset configurations and required test channels is not required. Otherwise, SAR is required for the remaining required test channels using the RB offset configuration with highest output power for that channel.
 - iii. When the reported SAR for a required test channel is > 1.45 W/kg, SAR is required for all RB offset configurations for that channel.

FCC ID: A3LSMG900A	 PCTEST Engineering Laboratory, Inc.	SAR EVALUATION REPORT		Reviewed by: Quality Manager
Document S/N: OY1401270204-R2.A3L	Test Dates: 02/03/14 - 02/17/14	DUT Type: Portable Handset		Page 21 of 85

- b. Per Section 5.2.2, SAR is required for 50% RB allocation using the largest bandwidth following the same procedures outlined in Section 5.2.1.
- c. Per Section 5.2.3, QPSK SAR is not required for the 100% allocation when the highest maximum output power for the 100% allocation is less than the highest maximum output power of the 1 RB and 50% RB allocations and the reported SAR for the 1 RB and 50% RB allocations is < 0.8 W/kg.
- d. Per Section 5.2.4 and 5.3, SAR tests for higher order modulations and lower bandwidths configurations are not required when the conducted power of the required test configurations determined by Sections 5.2.1 through 5.2.3 is less than or equal to ½ dB higher than the equivalent configuration using QPSK modulation and when the QPSK SAR for those configurations is <1.45 W/kg.

8.4.5 Carrier Aggregation

LTE Carrier Aggregation (CA) measurements were made in accordance to 3GPP TS 36.521-1 V10.4.0 (2012-12). The RRC connection is only handled by one cell, the Primary component carrier (PCC) for downlink and uplink communications. After making a data connection to the PCC, the UE device adds the Secondary component carrier (SCC) on the downlink only. All uplink communications and acknowledgements remain identical to release 8 specifications on the PCC. Additional output powers were measured using two carriers in the downlink for the release 8 configurations with the highest output power among all channels, RB configurations and bandwidths for each uplink band. Per FCC Guidance, no SAR measurements were required.

8.5 SAR Testing with 802.11 Transmitters

Normal network operating configurations are not suitable for measuring the SAR of 802.11 a/b/g/n /ac transmitters. Unpredictable fluctuations in network traffic and antenna diversity conditions can introduce undesirable variations in SAR results. The SAR for these devices should be measured using chipset based test mode software to ensure the results are consistent and reliable. See KDB Publication 248227 D01v01r02 for more details.



8.5.1 General Device Setup

Chipset based test mode software is hardware dependent and generally varies among manufacturers. The device operating parameters established in test mode for SAR measurements must be identical to those programmed in production units, including output power levels, amplifier gain settings and other RF performance tuning parameters. The test frequencies should correspond to actual channel frequencies defined for domestic use. SAR for devices with switched diversity should be measured with only one antenna transmitting at a time during each SAR measurement, according to a fixed modulation and data rate. The same data pattern should be used for all measurements.

8.5.2 Frequency Channel Configurations [24]

For 2.4 GHz, the highest average RF output power channel between the low, mid and high channel at the lowest data rate was selected for SAR evaluation in 802.11b mode. 802.11g/n modes and higher data rates for 802.11b were additionally evaluated for SISO SAR if the output power of the respective mode was 0.25 dB or higher than the powers of the SAR configurations tested in the 802.11b mode.

For 5 GHz, the highest average RF output power channel across the default test channels at the lowest data rate was selected for SISO SAR evaluation in 802.11a. When the adjacent channels are higher in power than the default channels, these “required channels” were considered instead of the default channels for SAR testing. 802.11n modes and higher data rates for 802.11a/n were evaluated only if the respective mode was higher than 0.25 dB or more than the 802.11a mode. 802.11ac SAR was evaluated for highest 802.11a configuration in each 5 GHz band and each exposure condition.



FCC ID: A3LSMG900A	 PCTEST Engineering Laboratory, Inc.	SAR EVALUATION REPORT		Reviewed by: Quality Manager
Document S/N: OY1401270204-R2.A3L	Test Dates: 02/03/14 - 02/17/14	DUT Type: Portable Handset		Page 22 of 85

802.11ac modes were additionally evaluated for SAR if the output power for the respective mode was more than 0.25 dB higher than powers of 802.11a modes.

If the maximum extrapolated peak SAR of the zoom scan for the highest output channel was less than 1.6 W/kg and if the 1g averaged SAR was less than 0.8 W/kg, SAR testing was not required for the other test channels in the band.

8.5.3 MIMO SAR Considerations

Per KDB 248227, SAR for MIMO was measured with both transmitting simultaneously and was evaluated independently of SISO operation. For 2.4 GHz MIMO, 802.11n was evaluated. For 5 GHz MIMO, 20 MHz BW 802.11n was evaluated. Additional evaluations for 40 MHz bandwidth 802.11n and 802.11ac were not required since the maximum allowed output power was not higher than 802.11n 20 MHz Bandwidth.

FCC ID: A3LSMG900A	 SAR EVALUATION REPORT 		Reviewed by: Quality Manager
Document S/N: 0Y1401270204-R2.A3L	Test Dates: 02/03/14 - 02/17/14	DUT Type: Portable Handset	Page 23 of 85

9 RF CONDUCTED POWERS

9.1 GSM Conducted Powers

		Maximum Burst-Averaged Output Power				
		Voice	GPRS/EDGE Data (GMSK)		EDGE Data (8-PSK)	
Band	Channel	GSM [dBm] CS (1 Slot)	GPRS [dBm] 1 Tx Slot	GPRS [dBm] 2 Tx Slot	EDGE [dBm] 1 Tx Slot	EDGE [dBm] 2 Tx Slot
GSM 850	128	32.59	32.47	31.36	27.41	26.88
	190	32.52	32.38	31.32	27.23	26.77
	251	32.86	32.68	31.00	27.10	26.57
GSM 1900	512	30.04	29.89	28.44	26.12	26.02
	661	30.11	30.00	28.62	26.28	26.21
	810	30.13	29.99	28.51	26.07	26.01
		Calculated Maximum Frame-Averaged Output Power				
		Voice	GPRS/EDGE Data (GMSK)		EDGE Data (8-PSK)	
Band	Channel	GSM [dBm] CS (1 Slot)	GPRS [dBm] 1 Tx Slot	GPRS [dBm] 2 Tx Slot	EDGE [dBm] 1 Tx Slot	EDGE [dBm] 2 Tx Slot
GSM 850	128	23.56	23.44	25.34	18.38	20.86
	190	23.49	23.35	25.30	18.20	20.75
	251	23.83	23.65	24.98	18.07	20.55
GSM 1900	512	21.01	20.86	22.42	17.09	20.00
	661	21.08	20.97	22.60	17.25	20.19
	810	21.10	20.96	22.49	17.04	19.99
GSM 850	Frame	23.97	23.97	24.98	17.97	20.98
GSM 1900	Avg.Targets:	20.97	20.97	22.48	16.97	19.98

Notes:

- Both burst-averaged and calculated frame-averaged powers are included. Frame-averaged power was calculated from the measured burst-averaged power by converting the slot powers into linear units and calculating the energy over 8 timeslots.
- The source-based frame-averaged output power was evaluated for all GPRS/EDGE slot configurations. The configuration with the highest target frame averaged output power was evaluated for hotspot SAR. When the maximum frame-averaged powers are equivalent across two or more slots (within 0.25 dB), the configuration with the most number of time slots was tested.
- GPRS/EDGE (GMSK) output powers were measured with coding scheme setting of 1 (CS1) on the base station simulator. CS1 was configured to measure GPRS output power measurements and SAR to ensure GMSK modulation in the signal. Our Investigation has shown that CS1 - CS4 settings do not have any impact on the output levels or modulation in the GPRS modes.
- EDGE (8-PSK) output powers were measured with MCS7 on the base station simulator. MCS7 coding scheme was used to measure the output powers for EDGE since investigation has shown that choosing MCS7 coding scheme will ensure 8-PSK modulation. It has been shown that MCS levels that produce 8PSK modulation do not have an impact on output power.

GSM Class: B
GPRS Multislot class: 10 (Max 2 Tx uplink slots)
EDGE Multislot class: 10 (Max 2 Tx uplink slots)
DTM Multislot Class: N/A

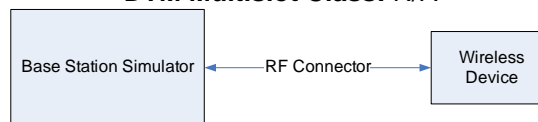

Figure 9-1
Power Measurement Setup

FCC ID: A3LSMG900A	PCTEST Engineering Laboratory, Inc.	SAR EVALUATION REPORT		Reviewed by: Quality Manager
Document S/N: OY1401270204-R2.A3L	Test Dates: 02/03/14 - 02/17/14	DUT Type: Portable Handset		Page 24 of 85

9.2 UMTS Conducted Powers

3GPP Release Version	Mode	3GPP 34.121 Subtest	Cellular Band [dBm]			PCS Band [dBm]			3GPP MPR [dB]
			4132	4183	4233	9262	9400	9538	
99	WCDMA	12.2 kbps RMC	22.44	22.43	22.50	22.76	22.62	22.63	-
99		12.2 kbps AMR	22.41	22.46	22.39	22.70	22.60	22.64	-
6	HSDPA	Subtest 1	21.00	21.03	20.98	21.38	21.43	21.47	0
6		Subtest 2	21.02	21.05	21.00	21.44	21.47	21.50	0
6		Subtest 3	20.54	20.55	20.50	21.08	20.98	21.05	0.5
6		Subtest 4	20.55	20.58	20.50	20.98	20.96	21.07	0.5
6	HSUPA	Subtest 1	20.62	20.50	20.51	21.12	21.51	21.40	0
6		Subtest 2	19.54	20.00	19.36	20.47	20.44	20.42	2
6		Subtest 3	19.75	19.83	19.85	20.27	20.22	20.59	1
6		Subtest 4	20.05	20.14	20.16	20.93	20.45	21.10	2
6		Subtest 5	20.61	20.50	20.52	21.24	21.42	21.18	0



UMTS SAR was tested under RMC 12.2 kbps with HSPA Inactive per KDB Publication 941225 D01v02. HSPA SAR was not required since the average output power of the HSPA subtests was not more than 0.25 dB higher than the RMC level and SAR was less than 1.2 W/kg.

This device does not support DC-HSDPA.

It is expected by the manufacturer that MPR for some HSPA subtests may be up to 2 dB more than specified by 3GPP, but also as low as 0 dB according to the chipset implementation in this model.



Figure 9-2
Power Measurement Setup

FCC ID: A3LSMG900A	 PCTEST ENGINEERING LABORATORY, INC.	SAR EVALUATION REPORT		Reviewed by: Quality Manager
Document S/N: OY1401270204-R2.A3L	Test Dates: 02/03/14 - 02/17/14	DUT Type: Portable Handset		Page 25 of 85

9.3 LTE Conducted Powers

9.3.1 LTE Band 17

Table 9-1
LTE Band 17 Conducted Powers - 10 MHz Bandwidth

Frequency [MHz]	Channel	Bandwidth [MHz]	Modulation	RB Size	RB Offset	Conducted Power [dBm]	MPR Allowed per 3GPP [dB]	MPR [dB]
710.0	23790	10	QPSK	1	0	22.83	0	0
	23790	10	QPSK	1	25	22.88	0	0
	23790	10	QPSK	1	49	23.00	0	0
	23790	10	QPSK	25	0	21.86	0-1	1
	23790	10	QPSK	25	12	21.85	0-1	1
	23790	10	QPSK	25	25	21.97	0-1	1
	23790	10	QPSK	50	0	21.91	0-1	1
	23790	10	16QAM	1	0	22.15	0-1	1
	23790	10	16QAM	1	25	22.27	0-1	1
	23790	10	16QAM	1	49	22.21	0-1	1
	23790	10	16QAM	25	0	20.86	0-2	2
	23790	10	16QAM	25	12	20.94	0-2	2
	23790	10	16QAM	25	25	20.97	0-2	2
	23790	10	16QAM	50	0	20.84	0-2	2

Note: LTE Band 17 at 10 MHz bandwidth does not support three non-overlapping channels. Per KDB Publication 941225 D05v02, when a device supports overlapping channel assignment in a channel bandwidth configuration, the middle channel of the group of overlapping channels should be selected for testing.

Table 9-2
LTE Band 17 Conducted Powers - 5 MHz Bandwidth

Frequency [MHz]	Channel	Bandwidth [MHz]	Modulation	RB Size	RB Offset	Conducted Power [dBm]	MPR Allowed per 3GPP [dB]	MPR [dB]
710.0	23790	5	QPSK	1	0	22.98	0	0
	23790	5	QPSK	1	12	22.73	0	0
	23790	5	QPSK	1	24	22.99	0	0
	23790	5	QPSK	12	0	21.89	0-1	1
	23790	5	QPSK	12	6	21.95	0-1	1
	23790	5	QPSK	12	13	21.94	0-1	1
	23790	5	QPSK	25	0	21.92	0-1	1
	23790	5	16-QAM	1	0	21.82	0-1	1
	23790	5	16-QAM	1	12	21.95	0-1	1
	23790	5	16-QAM	1	24	21.94	0-1	1
	23790	5	16-QAM	12	0	21.04	0-2	2
	23790	5	16-QAM	12	6	21.06	0-2	2
	23790	5	16-QAM	12	13	21.03	0-2	2
	23790	5	16-QAM	25	0	21.01	0-2	2

Note: LTE Band 17 at 5 MHz bandwidth does not support three non-overlapping channels. Per KDB Publication 941225 D05v02, when a device supports overlapping channel assignment in a channel bandwidth configuration, the middle channel of the group of overlapping channels should be selected for testing.

9.3.2 LTE Band 5 (Cell)

Table 9-3
LTE Band 5 (Cell) Conducted Powers - 10 MHz Bandwidth

Frequency [MHz]	Channel	Bandwidth [MHz]	Modulation	RB Size	RB Offset	Conducted Power [dBm]	MPR Allowed per 3GPP [dB]	MPR [dB]
836.5	20525	10	QPSK	1	0	23.08	0	0
	20525	10	QPSK	1	25	23.20	0	0
	20525	10	QPSK	1	49	23.07	0	0
	20525	10	QPSK	25	0	22.08	0-1	1
	20525	10	QPSK	25	12	22.07	0-1	1
	20525	10	QPSK	25	25	22.07	0-1	1
	20525	10	QPSK	50	0	22.07	0-1	1
	20525	10	16QAM	1	0	22.51	0-1	1
	20525	10	16QAM	1	25	22.65	0-1	1
	20525	10	16QAM	1	49	22.50	0-1	1
	20525	10	16QAM	25	0	21.10	0-2	2
	20525	10	16QAM	25	12	21.05	0-2	2
	20525	10	16QAM	25	25	21.03	0-2	2
	20525	10	16QAM	50	0	21.04	0-2	2

Note: LTE Band 5 (Cell) at 10 MHz bandwidth does not support three non-overlapping channels. Per KDB Publication 941225 D05v02, when a device supports overlapping channel assignment in a channel bandwidth configuration, the middle channel of the group of overlapping channels should be selected for testing.



FCC ID: A3LSMG900A	 PCTEST Engineering Laboratory, Inc.	SAR EVALUATION REPORT		Reviewed by: Quality Manager
Document S/N: OY1401270204-R2.A3L	Test Dates: 02/03/14 - 02/17/14	DUT Type: Portable Handset		Page 26 of 85

Table 9-4



LTE Band 5 (Cell) Conducted Powers - 5 MHz Bandwidth

	Frequency [MHz]	Channel	Bandwidth [MHz]	Modulation	RB Size	RB Offset	Conducted Power [dBm]	MPR Allowed per 3GPP [dB]	MPR [dB]
Low	826.5	20425	5	QPSK	1	0	23.08	0	0
	826.5	20425	5	QPSK	1	12	23.00	0	0
	826.5	20425	5	QPSK	1	24	23.10	0	0
	826.5	20425	5	QPSK	12	0	22.20	0-1	1
	826.5	20425	5	QPSK	12	6	22.20	0-1	1
	826.5	20425	5	QPSK	12	13	22.18	0-1	1
	826.5	20425	5	QPSK	25	0	22.21	0-1	1
	826.5	20425	5	16-QAM	1	0	22.43	0-1	1
	826.5	20425	5	16-QAM	1	12	22.26	0-1	1
	826.5	20425	5	16-QAM	1	24	22.16	0-1	1
	826.5	20425	5	16-QAM	12	0	21.05	0-2	2
	826.5	20425	5	16-QAM	12	6	21.05	0-2	2
	826.5	20425	5	16-QAM	12	13	21.07	0-2	2
	826.5	20425	5	16-QAM	25	0	21.27	0-2	2
	826.5	20425	5	16-QAM	25	0	21.27	0-2	2
Mid	836.5	20525	5	QPSK	1	0	23.58	0	0
	836.5	20525	5	QPSK	1	12	23.54	0	0
	836.5	20525	5	QPSK	1	24	23.52	0	0
	836.5	20525	5	QPSK	12	0	22.16	0-1	1
	836.5	20525	5	QPSK	12	6	22.13	0-1	1
	836.5	20525	5	QPSK	12	13	22.18	0-1	1
	836.5	20525	5	QPSK	25	0	22.07	0-1	1
	836.5	20525	5	16-QAM	1	0	22.12	0-1	1
	836.5	20525	5	16-QAM	1	12	22.13	0-1	1
	836.5	20525	5	16-QAM	1	24	22.08	0-1	1
	836.5	20525	5	16-QAM	12	0	21.30	0-2	2
	836.5	20525	5	16-QAM	12	6	21.27	0-2	2
	836.5	20525	5	16-QAM	12	13	21.38	0-2	2
	836.5	20525	5	16-QAM	25	0	21.13	0-2	2
	836.5	20525	5	16-QAM	25	0	21.13	0-2	2
High	846.5	20625	5	QPSK	1	0	23.04	0	0
	846.5	20625	5	QPSK	1	12	23.04	0	0
	846.5	20625	5	QPSK	1	24	23.02	0	0
	846.5	20625	5	QPSK	12	0	22.15	0-1	1
	846.5	20625	5	QPSK	12	6	22.12	0-1	1
	846.5	20625	5	QPSK	12	13	22.09	0-1	1
	846.5	20625	5	QPSK	25	0	22.03	0-1	1
	846.5	20625	5	16-QAM	1	0	22.24	0-1	1
	846.5	20625	5	16-QAM	1	12	22.05	0-1	1
	846.5	20625	5	16-QAM	1	24	22.12	0-1	1
	846.5	20625	5	16-QAM	12	0	21.07	0-2	2
	846.5	20625	5	16-QAM	12	6	21.04	0-2	2
	846.5	20625	5	16-QAM	12	13	21.00	0-2	2
	846.5	20625	5	16-QAM	25	0	21.26	0-2	2
	846.5	20625	5	16-QAM	25	0	21.26	0-2	2

Table 9-5

LTE Band 5 (Cell) Conducted Powers - 3 MHz Bandwidth

	Frequency [MHz]	Channel	Bandwidth [MHz]	Modulation	RB Size	RB Offset	Conducted Power [dBm]	MPR Allowed per 3GPP [dB]	MPR [dB]
Low	825.5	20415	3	QPSK	1	0	23.22	0	0
	825.5	20415	3	QPSK	1	7	23.07	0	0
	825.5	20415	3	QPSK	1	14	23.20	0	0
	825.5	20415	3	QPSK	8	0	22.18	0-1	1
	825.5	20415	3	QPSK	8	4	22.22	0-1	1
	825.5	20415	3	QPSK	8	7	22.21	0-1	1
	825.5	20415	3	QPSK	15	0	22.19	0-1	1
	825.5	20415	3	16-QAM	1	0	22.81	0-1	1
	825.5	20415	3	16-QAM	1	7	22.70	0-1	1
	825.5	20415	3	16-QAM	1	14	22.67	0-1	1
	825.5	20415	3	16-QAM	8	0	21.23	0-2	2
	825.5	20415	3	16-QAM	8	4	21.30	0-2	2
	825.5	20415	3	16-QAM	8	7	21.18	0-2	2
	825.5	20415	3	16-QAM	15	0	21.21	0-2	2
	825.5	20415	3	16-QAM	15	0	21.21	0-2	2
Mid	836.5	20525	3	QPSK	1	0	23.17	0	0
	836.5	20525	3	QPSK	1	7	23.29	0	0
	836.5	20525	3	QPSK	1	14	23.41	0	0
	836.5	20525	3	QPSK	8	0	22.16	0-1	1
	836.5	20525	3	QPSK	8	4	22.20	0-1	1
	836.5	20525	3	QPSK	8	7	22.19	0-1	1
	836.5	20525	3	QPSK	15	0	22.17	0-1	1
	836.5	20525	3	16-QAM	1	0	22.75	0-1	1
	836.5	20525	3	16-QAM	1	7	22.85	0-1	1
	836.5	20525	3	16-QAM	1	14	22.91	0-1	1
	836.5	20525	3	16-QAM	8	0	21.17	0-2	2
	836.5	20525	3	16-QAM	8	4	21.20	0-2	2
	836.5	20525	3	16-QAM	8	7	21.11	0-2	2
	836.5	20525	3	16-QAM	15	0	21.00	0-2	2
	836.5	20525	3	16-QAM	15	0	21.00	0-2	2
High	847.5	20635	3	QPSK	1	0	23.05	0	0
	847.5	20635	3	QPSK	1	7	23.04	0	0
	847.5	20635	3	QPSK	1	14	23.07	0	0
	847.5	20635	3	QPSK	8	0	22.09	0-1	1
	847.5	20635	3	QPSK	8	4	22.03	0-1	1
	847.5	20635	3	QPSK	8	7	22.06	0-1	1
	847.5	20635	3	QPSK	15	0	22.02	0-1	1
	847.5	20635	3	16-QAM	1	0	22.02	0-1	1
	847.5	20635	3	16-QAM	1	7	22.10	0-1	1
	847.5	20635	3	16-QAM	1	14	22.07	0-1	1
	847.5	20635	3	16-QAM	8	0	21.06	0-2	2
	847.5	20635	3	16-QAM	8	4	21.04	0-2	2
	847.5	20635	3	16-QAM	8	7	21.03	0-2	2
	847.5	20635	3	16-QAM	15	0	21.06	0-2	2
	847.5	20635	3	16-QAM	15	0	21.06	0-2	2

FCC ID: A3LSMG900A	 PCTEST Engineering Laboratory, Inc.	SAR EVALUATION REPORT		Reviewed by: Quality Manager
Document S/N: OY1401270204-R2.A3L	Test Dates: 02/03/14 - 02/17/14	DUT Type: Portable Handset		Page 27 of 85

**Table 9-6
LTE Band 5 (Cell) Conducted Powers -1.4 MHz Bandwidth**



	Frequency [MHz]	Channel	Bandwidth [MHz]	Modulation	RB Size	RB Offset	Conducted Power [dBm]	MPR Allowed per 3GPP [dB]	MPR [dB]
Low	824.7	20407	1.4	QPSK	1	0	23.69	0	0
	824.7	20407	1.4	QPSK	1	2	23.55	0	0
	824.7	20407	1.4	QPSK	1	5	23.56	0	0
	824.7	20407	1.4	QPSK	3	0	23.29	0	0
	824.7	20407	1.4	QPSK	3	2	23.19	0	0
	824.7	20407	1.4	QPSK	3	3	23.24	0	0
	824.7	20407	1.4	QPSK	6	0	22.30	0-1	1
	824.7	20407	1.4	16-QAM	1	0	22.67	0-1	1
	824.7	20407	1.4	16-QAM	1	2	22.82	0-1	1
	824.7	20407	1.4	16-QAM	1	5	22.51	0-1	1
	824.7	20407	1.4	16-QAM	3	0	22.49	0-1	1
	824.7	20407	1.4	16-QAM	3	2	22.01	0-1	1
	824.7	20407	1.4	16-QAM	3	3	22.42	0-1	1
	824.7	20407	1.4	16-QAM	6	0	21.40	0-2	2
	836.5	20525	1.4	QPSK	1	0	23.56	0	0
	836.5	20525	1.4	QPSK	1	2	23.55	0	0
836.5	20525	1.4	QPSK	1	5	23.53	0	0	
836.5	20525	1.4	QPSK	3	0	23.26	0	0	
836.5	20525	1.4	QPSK	3	2	23.19	0	0	
836.5	20525	1.4	QPSK	3	3	23.24	0	0	
836.5	20525	1.4	QPSK	6	0	22.32	0-1	1	
836.5	20525	1.4	16-QAM	1	0	22.75	0-1	1	
836.5	20525	1.4	16-QAM	1	2	22.70	0-1	1	
836.5	20525	1.4	16-QAM	1	5	22.61	0-1	1	
836.5	20525	1.4	16-QAM	3	0	22.46	0-1	1	
836.5	20525	1.4	16-QAM	3	2	22.41	0-1	1	
836.5	20525	1.4	16-QAM	3	3	22.32	0-1	1	
836.5	20525	1.4	16-QAM	6	0	21.49	0-2	2	
High	848.3	20643	1.4	QPSK	1	0	23.47	0	0
	848.3	20643	1.4	QPSK	1	2	23.35	0	0
	848.3	20643	1.4	QPSK	1	5	23.38	0	0
	848.3	20643	1.4	QPSK	3	0	23.00	0	0
	848.3	20643	1.4	QPSK	3	2	23.04	0	0
	848.3	20643	1.4	QPSK	3	3	23.10	0	0
	848.3	20643	1.4	QPSK	6	0	22.16	0-1	1
	848.3	20643	1.4	16-QAM	1	0	22.48	0-1	1
	848.3	20643	1.4	16-QAM	1	2	22.53	0-1	1
	848.3	20643	1.4	16-QAM	1	5	22.43	0-1	1
	848.3	20643	1.4	16-QAM	3	0	22.26	0-1	1
	848.3	20643	1.4	16-QAM	3	2	22.28	0-1	1
	848.3	20643	1.4	16-QAM	3	3	22.24	0-1	1
	848.3	20643	1.4	16-QAM	6	0	21.00	0-2	2

9.3.3 LTE Band 4 (AWS)

**Table 9-7
LTE Band 4 (AWS) Conducted Powers - 20 MHz Bandwidth**

	Frequency [MHz]	Channel	Bandwidth [MHz]	Modulation	RB Size	RB Offset	Conducted Power [dBm]	MPR Allowed per 3GPP [dB]	MPR [dB]
Mid	1732.5	20175	20	QPSK	1	0	23.23	0	0
	1732.5	20175	20	QPSK	1	50	23.13	0	0
	1732.5	20175	20	QPSK	1	99	23.22	0	0
	1732.5	20175	20	QPSK	50	0	22.22	0-1	1
	1732.5	20175	20	QPSK	50	25	22.17	0-1	1
	1732.5	20175	20	QPSK	50	50	22.18	0-1	1
	1732.5	20175	20	QPSK	100	0	22.16	0-1	1
	1732.5	20175	20	16QAM	1	0	22.25	0-1	1
	1732.5	20175	20	16QAM	1	50	22.19	0-1	1
	1732.5	20175	20	16QAM	1	99	22.22	0-1	1
	1732.5	20175	20	16QAM	50	0	21.15	0-2	2
	1732.5	20175	20	16QAM	50	25	21.16	0-2	2
	1732.5	20175	20	16QAM	50	50	21.17	0-2	2
	1732.5	20175	20	16QAM	100	0	21.16	0-2	2

Note: LTE Band 4 (AWS) at 20 MHz bandwidth does not support three non-overlapping channels. Per KDB Publication 941225 D05v02, when a device supports overlapping channel assignment in a channel bandwidth configuration, the middle channel of the group of overlapping channels should be selected for testing.

FCC ID: A3LSMG900A	 PCTEST Engineering Laboratory, Inc.	SAR EVALUATION REPORT		Reviewed by: Quality Manager
Document S/N: OY1401270204-R2.A3L	Test Dates: 02/03/14 - 02/17/14	DUT Type: Portable Handset		Page 28 of 85

**Table 9-8
LTE Band 4 (AWS) Conducted Powers - 15 MHz Bandwidth**

	Frequency [MHz]	Channel	Bandwidth [MHz]	Modulation	RB Size	RB Offset	Conducted Power [dBm]	MPR Allowed per 3GPP [dB]	MPR [dB]
Low	1717.5	20025	15	QPSK	1	0	23.50	0	0
	1717.5	20025	15	QPSK	1	36	23.41	0	0
	1717.5	20025	15	QPSK	1	74	23.18	0	0
	1717.5	20025	15	QPSK	36	0	22.46	0-1	1
	1717.5	20025	15	QPSK	36	18	22.37	0-1	1
	1717.5	20025	15	QPSK	36	37	22.24	0-1	1
	1717.5	20025	15	QPSK	75	0	22.37	0-1	1
	1717.5	20025	15	16QAM	1	0	22.49	0-1	1
	1717.5	20025	15	16QAM	1	36	22.36	0-1	1
	1717.5	20025	15	16QAM	1	74	22.17	0-1	1
	1717.5	20025	15	16QAM	36	0	21.45	0-2	2
	1717.5	20025	15	16QAM	36	18	21.36	0-2	2
	1717.5	20025	15	16QAM	36	37	21.26	0-2	2
	1717.5	20025	15	16QAM	75	0	21.41	0-2	2
	1732.5	20175	15	QPSK	1	0	23.29	0	0
1732.5	20175	15	QPSK	1	36	23.14	0	0	
1732.5	20175	15	QPSK	1	74	23.21	0	0	
1732.5	20175	15	QPSK	36	0	22.18	0-1	1	
1732.5	20175	15	QPSK	36	18	22.12	0-1	1	
1732.5	20175	15	QPSK	36	37	22.16	0-1	1	
1732.5	20175	15	QPSK	75	0	22.17	0-1	1	
1732.5	20175	15	16QAM	1	0	22.23	0-1	1	
1732.5	20175	15	16QAM	1	36	22.12	0-1	1	
1732.5	20175	15	16QAM	1	74	22.25	0-1	1	
1732.5	20175	15	16QAM	36	0	21.12	0-2	2	
1732.5	20175	15	16QAM	36	18	21.14	0-2	2	
1732.5	20175	15	16QAM	36	37	21.13	0-2	2	
1732.5	20175	15	16QAM	75	0	21.20	0-2	2	
High	1747.5	20325	15	QPSK	1	0	23.31	0	0
	1747.5	20325	15	QPSK	1	36	23.48	0	0
	1747.5	20325	15	QPSK	1	74	23.50	0	0
	1747.5	20325	15	QPSK	36	0	22.35	0-1	1
	1747.5	20325	15	QPSK	36	18	22.42	0-1	1
	1747.5	20325	15	QPSK	36	37	22.47	0-1	1
	1747.5	20325	15	QPSK	75	0	22.43	0-1	1
	1747.5	20325	15	16QAM	1	0	22.30	0-1	1
	1747.5	20325	15	16QAM	1	36	22.46	0-1	1
	1747.5	20325	15	16QAM	1	74	22.50	0-1	1
	1747.5	20325	15	16QAM	36	0	21.30	0-2	2
	1747.5	20325	15	16QAM	36	18	21.39	0-2	2
	1747.5	20325	15	16QAM	36	37	21.47	0-2	2
	1747.5	20325	15	16QAM	75	0	21.46	0-2	2

**Table 9-9
LTE Band 4 (AWS) Conducted Powers - 10 MHz Bandwidth**

	Frequency [MHz]	Channel	Bandwidth [MHz]	Modulation	RB Size	RB Offset	Conducted Power [dBm]	MPR Allowed per 3GPP [dB]	MPR [dB]
Low	1715	20000	10	QPSK	1	0	23.50	0	0
	1715	20000	10	QPSK	1	25	23.43	0	0
	1715	20000	10	QPSK	1	49	23.44	0	0
	1715	20000	10	QPSK	25	0	22.39	0-1	1
	1715	20000	10	QPSK	25	12	22.38	0-1	1
	1715	20000	10	QPSK	25	25	22.31	0-1	1
	1715	20000	10	QPSK	50	0	22.40	0-1	1
	1715	20000	10	16QAM	1	0	22.49	0-1	1
	1715	20000	10	16QAM	1	25	22.36	0-1	1
	1715	20000	10	16QAM	1	49	22.35	0-1	1
	1715	20000	10	16QAM	25	0	21.43	0-2	2
	1715	20000	10	16QAM	25	12	21.49	0-2	2
	1715	20000	10	16QAM	25	25	21.41	0-2	2
	1715	20000	10	16QAM	50	0	21.48	0-2	2
	1732.5	20175	10	QPSK	1	0	23.29	0	0
1732.5	20175	10	QPSK	1	25	23.18	0	0	
1732.5	20175	10	QPSK	1	49	23.29	0	0	
1732.5	20175	10	QPSK	25	0	22.10	0-1	1	
1732.5	20175	10	QPSK	25	12	22.09	0-1	1	
1732.5	20175	10	QPSK	25	25	22.12	0-1	1	
1732.5	20175	10	QPSK	50	0	22.14	0-1	1	
1732.5	20175	10	16QAM	1	0	22.48	0-1	1	
1732.5	20175	10	16QAM	1	25	22.33	0-1	1	
1732.5	20175	10	16QAM	1	49	22.34	0-1	1	
1732.5	20175	10	16QAM	25	0	21.45	0-2	2	
1732.5	20175	10	16QAM	25	12	21.49	0-2	2	
1732.5	20175	10	16QAM	25	25	21.41	0-2	2	
1732.5	20175	10	16QAM	50	0	21.48	0-2	2	
High	1750	20350	10	QPSK	1	0	23.47	0	0
	1750	20350	10	QPSK	1	25	23.48	0	0
	1750	20350	10	QPSK	1	49	23.49	0	0
	1750	20350	10	QPSK	25	0	22.39	0-1	1
	1750	20350	10	QPSK	25	12	22.36	0-1	1
	1750	20350	10	QPSK	25	25	22.33	0-1	1
	1750	20350	10	QPSK	50	0	22.43	0-1	1
	1750	20350	10	16QAM	1	0	22.31	0-1	1
	1750	20350	10	16QAM	1	25	22.35	0-1	1
	1750	20350	10	16QAM	1	49	22.48	0-1	1
	1750	20350	10	16QAM	25	0	21.41	0-2	2
	1750	20350	10	16QAM	25	12	21.38	0-2	2
	1750	20350	10	16QAM	25	25	21.39	0-2	2
	1750	20350	10	16QAM	50	0	21.44	0-2	2

Table 9-10
LTE Band 4 (AWS) Conducted Powers - 5 MHz Bandwidth

	Frequency [MHz]	Channel	Bandwidth [MHz]	Modulation	RB Size	RB Offset	Conducted Power [dBm]	MPR Allowed per 3GPP [dB]	MPR [dB]
Low	1712.5	19975	5	QPSK	1	0	23.49	0	0
	1712.5	19975	5	QPSK	1	12	23.44	0	0
	1712.5	19975	5	QPSK	1	24	23.45	0	0
	1712.5	19975	5	QPSK	12	0	22.35	0-1	1
	1712.5	19975	5	QPSK	12	6	22.29	0-1	1
	1712.5	19975	5	QPSK	12	13	22.30	0-1	1
	1712.5	19975	5	QPSK	25	0	22.41	0-1	1
	1712.5	19975	5	16-QAM	1	0	22.42	0-1	1
	1712.5	19975	5	16-QAM	1	12	22.35	0-1	1
	1712.5	19975	5	16-QAM	1	24	22.34	0-1	1
	1712.5	19975	5	16-QAM	12	0	21.41	0-2	2
	1712.5	19975	5	16-QAM	12	6	21.27	0-2	2
	1712.5	19975	5	16-QAM	12	13	21.25	0-2	2
	1712.5	19975	5	16-QAM	25	0	21.44	0-2	2
	1712.5	19975	5	16-QAM	25	0	21.44	0-2	2
Mid	1732.5	20175	5	QPSK	1	0	23.11	0	0
	1732.5	20175	5	QPSK	1	12	23.09	0	0
	1732.5	20175	5	QPSK	1	24	23.12	0	0
	1732.5	20175	5	QPSK	12	0	22.01	0-1	1
	1732.5	20175	5	QPSK	12	6	21.96	0-1	1
	1732.5	20175	5	QPSK	12	13	21.98	0-1	1
	1732.5	20175	5	QPSK	25	0	22.04	0-1	1
	1732.5	20175	5	16-QAM	1	0	22.06	0-1	1
	1732.5	20175	5	16-QAM	1	12	21.95	0-1	1
	1732.5	20175	5	16-QAM	1	24	22.04	0-1	1
	1732.5	20175	5	16-QAM	12	0	20.95	0-2	2
	1732.5	20175	5	16-QAM	12	6	20.98	0-2	2
	1732.5	20175	5	16-QAM	12	13	20.92	0-2	2
	1732.5	20175	5	16-QAM	25	0	21.06	0-2	2
	1732.5	20175	5	16-QAM	25	0	21.06	0-2	2
High	1752.5	20375	5	QPSK	1	0	23.47	0	0
	1752.5	20375	5	QPSK	1	12	23.49	0	0
	1752.5	20375	5	QPSK	1	24	23.50	0	0
	1752.5	20375	5	QPSK	12	0	22.32	0-1	1
	1752.5	20375	5	QPSK	12	6	22.31	0-1	1
	1752.5	20375	5	QPSK	12	13	22.41	0-1	1
	1752.5	20375	5	QPSK	25	0	22.36	0-1	1
	1752.5	20375	5	16-QAM	1	0	22.39	0-1	1
	1752.5	20375	5	16-QAM	1	12	22.40	0-1	1
	1752.5	20375	5	16-QAM	1	24	22.47	0-1	1
	1752.5	20375	5	16-QAM	12	0	21.32	0-2	2
	1752.5	20375	5	16-QAM	12	6	21.32	0-2	2
	1752.5	20375	5	16-QAM	12	13	21.42	0-2	2
	1752.5	20375	5	16-QAM	25	0	21.39	0-2	2
	1752.5	20375	5	16-QAM	25	0	21.39	0-2	2

Table 9-11
LTE Band 4 (AWS) Conducted Powers - 3 MHz Bandwidth

	Frequency [MHz]	Channel	Bandwidth [MHz]	Modulation	RB Size	RB Offset	Conducted Power [dBm]	MPR Allowed per 3GPP [dB]	MPR [dB]
Low	1711.5	19965	3	QPSK	1	0	23.45	0	0
	1711.5	19965	3	QPSK	1	7	23.42	0	0
	1711.5	19965	3	QPSK	1	14	23.44	0	0
	1711.5	19965	3	QPSK	8	0	22.37	0-1	1
	1711.5	19965	3	QPSK	8	4	22.35	0-1	1
	1711.5	19965	3	QPSK	8	7	22.29	0-1	1
	1711.5	19965	3	QPSK	15	0	22.36	0-1	1
	1711.5	19965	3	16-QAM	1	0	22.48	0-1	1
	1711.5	19965	3	16-QAM	1	7	22.34	0-1	1
	1711.5	19965	3	16-QAM	1	14	22.36	0-1	1
	1711.5	19965	3	16-QAM	8	0	21.35	0-2	2
	1711.5	19965	3	16-QAM	8	4	21.39	0-2	2
	1711.5	19965	3	16-QAM	8	7	21.28	0-2	2
	1711.5	19965	3	16-QAM	15	0	21.47	0-2	2
	1711.5	19965	3	16-QAM	15	0	21.47	0-2	2
Mid	1732.5	20175	3	QPSK	1	0	23.14	0	0
	1732.5	20175	3	QPSK	1	7	23.08	0	0
	1732.5	20175	3	QPSK	1	14	23.10	0	0
	1732.5	20175	3	QPSK	8	0	22.04	0-1	1
	1732.5	20175	3	QPSK	8	4	21.95	0-1	1
	1732.5	20175	3	QPSK	8	7	22.01	0-1	1
	1732.5	20175	3	QPSK	15	0	22.02	0-1	1
	1732.5	20175	3	16-QAM	1	0	22.04	0-1	1
	1732.5	20175	3	16-QAM	1	7	22.07	0-1	1
	1732.5	20175	3	16-QAM	1	14	22.06	0-1	1
	1732.5	20175	3	16-QAM	8	0	20.93	0-2	2
	1732.5	20175	3	16-QAM	8	4	20.90	0-2	2
	1732.5	20175	3	16-QAM	8	7	20.97	0-2	2
	1732.5	20175	3	16-QAM	15	0	21.06	0-2	2
	1732.5	20175	3	16-QAM	15	0	21.06	0-2	2
High	1753.5	20385	3	QPSK	1	0	23.48	0	0
	1753.5	20385	3	QPSK	1	7	23.49	0	0
	1753.5	20385	3	QPSK	1	14	23.50	0	0
	1753.5	20385	3	QPSK	8	0	22.36	0-1	1
	1753.5	20385	3	QPSK	8	4	22.40	0-1	1
	1753.5	20385	3	QPSK	8	7	22.44	0-1	1
	1753.5	20385	3	QPSK	15	0	22.41	0-1	1
	1753.5	20385	3	16-QAM	1	0	22.39	0-1	1
	1753.5	20385	3	16-QAM	1	7	22.42	0-1	1
	1753.5	20385	3	16-QAM	1	14	22.49	0-1	1
	1753.5	20385	3	16-QAM	8	0	21.30	0-2	2
	1753.5	20385	3	16-QAM	8	4	21.43	0-2	2
	1753.5	20385	3	16-QAM	8	7	21.41	0-2	2
	1753.5	20385	3	16-QAM	15	0	21.49	0-2	2
	1753.5	20385	3	16-QAM	15	0	21.49	0-2	2

**Table 9-12
LTE Band 4 (AWS) Conducted Powers -1.4 MHz Bandwidth**

	Frequency [MHz]	Channel	Bandwidth [MHz]	Modulation	RB Size	RB Offset	Conducted Power [dBm]	MPR Allowed per 3GPP [dB]	MPR [dB]	
Low	1710.7	19957	1.4	QPSK	1	0	23.47	0	0	
	1710.7	19957	1.4	QPSK	1	2	23.50	0	0	
	1710.7	19957	1.4	QPSK	1	5	23.49	0	0	
	1710.7	19957	1.4	QPSK	3	0	23.45	0	0	
	1710.7	19957	1.4	QPSK	3	2	23.41	0	0	
	1710.7	19957	1.4	QPSK	3	3	23.42	0	0	
	1710.7	19957	1.4	QPSK	6	0	22.36	0-1	1	
	1710.7	19957	1.4	16-QAM	1	0	22.43	0-1	1	
	1710.7	19957	1.4	16-QAM	1	2	22.45	0-1	1	
	1710.7	19957	1.4	16-QAM	1	5	22.49	0-1	1	
	1710.7	19957	1.4	16-QAM	3	0	22.42	0-1	1	
	1710.7	19957	1.4	16-QAM	3	2	22.37	0-1	1	
	1710.7	19957	1.4	16-QAM	3	3	22.39	0-1	1	
	1710.7	19957	1.4	16-QAM	6	0	21.45	0-2	2	
	Mid	1732.5	20175	1.4	QPSK	1	0	23.06	0	0
		1732.5	20175	1.4	QPSK	1	2	23.07	0	0
1732.5		20175	1.4	QPSK	1	5	23.05	0	0	
1732.5		20175	1.4	QPSK	3	0	22.97	0	0	
1732.5		20175	1.4	QPSK	3	2	22.96	0	0	
1732.5		20175	1.4	QPSK	3	3	22.95	0	0	
1732.5		20175	1.4	QPSK	6	0	22.02	0-1	1	
1732.5		20175	1.4	16-QAM	1	0	22.04	0-1	1	
1732.5		20175	1.4	16-QAM	1	2	22.09	0-1	1	
1732.5		20175	1.4	16-QAM	1	5	22.12	0-1	1	
1732.5		20175	1.4	16-QAM	3	0	22.01	0-1	1	
1732.5		20175	1.4	16-QAM	3	2	21.96	0-1	1	
1732.5		20175	1.4	16-QAM	3	3	22.02	0-1	1	
1732.5		20175	1.4	16-QAM	6	0	21.01	0-2	2	
High		1754.3	20393	1.4	QPSK	1	0	23.49	0	0
		1754.3	20393	1.4	QPSK	1	2	23.48	0	0
	1754.3	20393	1.4	QPSK	1	5	23.46	0	0	
	1754.3	20393	1.4	QPSK	3	0	23.44	0	0	
	1754.3	20393	1.4	QPSK	3	2	23.42	0	0	
	1754.3	20393	1.4	QPSK	3	3	23.47	0	0	
	1754.3	20393	1.4	QPSK	6	0	22.42	0-1	1	
	1754.3	20393	1.4	16-QAM	1	0	22.50	0-1	1	
	1754.3	20393	1.4	16-QAM	1	2	22.48	0-1	1	
	1754.3	20393	1.4	16-QAM	1	5	22.48	0-1	1	
	1754.3	20393	1.4	16-QAM	3	0	22.45	0-1	1	
	1754.3	20393	1.4	16-QAM	3	2	22.44	0-1	1	
	1754.3	20393	1.4	16-QAM	3	3	22.44	0-1	1	
	1754.3	20393	1.4	16-QAM	6	0	21.48	0-2	2	

9.3.4 LTE Band 2 (PCS)

**Table 9-13
LTE Band 2 (PCS) Conducted Powers - 20 MHz Bandwidth**

	Frequency [MHz]	Channel	Bandwidth [MHz]	Modulation	RB Size	RB Offset	Conducted Power [dBm]	MPR Allowed per 3GPP [dB]	MPR [dB]	
Low	1860	18700	20	QPSK	1	0	23.17	0	0	
	1860	18700	20	QPSK	1	50	23.40	0	0	
	1860	18700	20	QPSK	1	99	23.47	0	0	
	1860	18700	20	QPSK	50	0	22.20	0-1	1	
	1860	18700	20	QPSK	50	25	22.40	0-1	1	
	1860	18700	20	QPSK	50	50	22.41	0-1	1	
	1860	18700	20	QPSK	100	0	22.28	0-1	1	
	1860	18700	20	16QAM	1	0	22.12	0-1	1	
	1860	18700	20	16QAM	1	50	22.41	0-1	1	
	1860	18700	20	16QAM	1	99	22.32	0-1	1	
	1860	18700	20	16QAM	50	0	21.16	0-2	2	
	1860	18700	20	16QAM	50	25	21.29	0-2	2	
	1860	18700	20	16QAM	50	50	21.24	0-2	2	
	1860	18700	20	16QAM	100	0	21.17	0-2	2	
	Mid	1880.0	18900	20	QPSK	1	0	23.50	0	0
		1880.0	18900	20	QPSK	1	50	23.41	0	0
1880.0		18900	20	QPSK	1	99	23.23	0	0	
1880.0		18900	20	QPSK	50	0	22.49	0-1	1	
1880.0		18900	20	QPSK	50	25	22.40	0-1	1	
1880.0		18900	20	QPSK	50	50	22.30	0-1	1	
1880.0		18900	20	QPSK	100	0	22.37	0-1	1	
1880.0		18900	20	16QAM	1	0	22.45	0-1	1	
1880.0		18900	20	16QAM	1	50	22.35	0-1	1	
1880.0		18900	20	16QAM	1	99	22.20	0-1	1	
1880.0		18900	20	16QAM	50	0	21.39	0-2	2	
1880.0		18900	20	16QAM	50	25	21.33	0-2	2	
1880.0		18900	20	16QAM	50	50	21.18	0-2	2	
1880.0		18900	20	16QAM	100	0	21.26	0-2	2	
High		1900	19100	20	QPSK	1	0	23.17	0	0
		1900	19100	20	QPSK	1	50	23.12	0	0
	1900	19100	20	QPSK	1	99	23.29	0	0	
	1900	19100	20	QPSK	50	0	22.13	0-1	1	
	1900	19100	20	QPSK	50	25	22.15	0-1	1	
	1900	19100	20	QPSK	50	50	22.25	0-1	1	
	1900	19100	20	QPSK	100	0	22.09	0-1	1	
	1900	19100	20	16QAM	1	0	22.11	0-1	1	
	1900	19100	20	16QAM	1	50	22.12	0-1	1	
	1900	19100	20	16QAM	1	99	22.21	0-1	1	
	1900	19100	20	16QAM	50	0	21.08	0-2	2	
	1900	19100	20	16QAM	50	25	21.07	0-2	2	
	1900	19100	20	16QAM	50	50	21.18	0-2	2	
	1900	19100	20	16QAM	100	0	21.02	0-2	2	



FCC ID: A3LSMG900A	 PCTEST Engineering Laboratory, Inc.	SAR EVALUATION REPORT		Reviewed by: Quality Manager
Document S/N: OY1401270204-R2.A3L	Test Dates: 02/03/14 - 02/17/14	DUT Type: Portable Handset		Page 31 of 85

Table 9-14

LTE Band 2 (PCS) Conducted Powers - 15 MHz Bandwidth

	Frequency [MHz]	Channel	Bandwidth [MHz]	Modulation	RB Size	RB Offset	Conducted Power [dBm]	MPR Allowed per 3GPP [dB]	MPR [dB]	
Low	1857.5	18675	15	QPSK	1	0	23.17	0	0	
	1857.5	18675	15	QPSK	1	36	23.40	0	0	
	1857.5	18675	15	QPSK	1	74	23.44	0	0	
	1857.5	18675	15	QPSK	36	0	22.30	0-1	1	
	1857.5	18675	15	QPSK	36	18	22.39	0-1	1	
	1857.5	18675	15	QPSK	36	37	22.30	0-1	1	
	1857.5	18675	15	QPSK	75	0	22.38	0-1	1	
	1857.5	18675	15	16QAM	1	0	22.13	0-1	1	
	1857.5	18675	15	16QAM	1	36	22.36	0-1	1	
	1857.5	18675	15	16QAM	1	74	22.45	0-1	1	
	1857.5	18675	15	16QAM	36	0	21.21	0-2	2	
	1857.5	18675	15	16QAM	36	18	21.24	0-2	2	
	1857.5	18675	15	16QAM	36	37	21.19	0-2	2	
	1857.5	18675	15	16QAM	75	0	21.22	0-2	2	
	Mid	1880.0	18900	15	QPSK	1	0	23.49	0	0
		1880.0	18900	15	QPSK	1	36	23.43	0	0
		1880.0	18900	15	QPSK	1	74	23.34	0	0
		1880.0	18900	15	QPSK	36	0	22.30	0-1	1
1880.0		18900	15	QPSK	36	18	22.37	0-1	1	
1880.0		18900	15	QPSK	36	37	22.40	0-1	1	
1880.0		18900	15	QPSK	75	0	22.43	0-1	1	
1880.0		18900	15	16QAM	1	0	22.48	0-1	1	
1880.0		18900	15	16QAM	1	36	22.32	0-1	1	
1880.0		18900	15	16QAM	1	74	22.27	0-1	1	
1880.0		18900	15	16QAM	36	0	21.28	0-2	2	
1880.0		18900	15	16QAM	36	18	21.21	0-2	2	
1880.0		18900	15	16QAM	36	37	21.24	0-2	2	
1880.0		18900	15	16QAM	75	0	21.26	0-2	2	
High		1902.5	19125	15	QPSK	1	0	23.09	0	0
		1902.5	19125	15	QPSK	1	36	23.24	0	0
		1902.5	19125	15	QPSK	1	74	23.29	0	0
		1902.5	19125	15	QPSK	36	0	22.03	0-1	1
	1902.5	19125	15	QPSK	36	18	22.04	0-1	1	
	1902.5	19125	15	QPSK	36	37	22.15	0-1	1	
	1902.5	19125	15	QPSK	75	0	22.10	0-1	1	
	1902.5	19125	15	16QAM	1	0	22.02	0-1	1	
	1902.5	19125	15	16QAM	1	36	22.17	0-1	1	
	1902.5	19125	15	16QAM	1	74	22.20	0-1	1	
	1902.5	19125	15	16QAM	36	0	20.98	0-2	2	
	1902.5	19125	15	16QAM	36	18	21.00	0-2	2	
	1902.5	19125	15	16QAM	36	37	21.11	0-2	2	
	1902.5	19125	15	16QAM	75	0	21.06	0-2	2	

Table 9-15

LTE Band 2 (PCS) Conducted Powers - 10 MHz Bandwidth

	Frequency [MHz]	Channel	Bandwidth [MHz]	Modulation	RB Size	RB Offset	Conducted Power [dBm]	MPR Allowed per 3GPP [dB]	MPR [dB]	
Low	1855	18650	10	QPSK	1	0	23.20	0	0	
	1855	18650	10	QPSK	1	25	23.25	0	0	
	1855	18650	10	QPSK	1	49	23.41	0	0	
	1855	18650	10	QPSK	25	0	22.07	0-1	1	
	1855	18650	10	QPSK	25	12	22.05	0-1	1	
	1855	18650	10	QPSK	25	25	22.21	0-1	1	
	1855	18650	10	QPSK	50	0	22.20	0-1	1	
	1855	18650	10	16QAM	1	0	22.12	0-1	1	
	1855	18650	10	16QAM	1	25	22.17	0-1	1	
	1855	18650	10	16QAM	1	49	22.31	0-1	1	
	1855	18650	10	16QAM	25	0	21.02	0-2	2	
	1855	18650	10	16QAM	25	12	21.00	0-2	2	
	1855	18650	10	16QAM	25	25	21.20	0-2	2	
	1855	18650	10	16QAM	50	0	21.13	0-2	2	
	Mid	1880.0	18900	10	QPSK	1	0	23.49	0	0
		1880.0	18900	10	QPSK	1	25	23.42	0	0
		1880.0	18900	10	QPSK	1	49	23.36	0	0
		1880.0	18900	10	QPSK	25	0	22.34	0-1	1
1880.0		18900	10	QPSK	25	12	22.30	0-1	1	
1880.0		18900	10	QPSK	25	25	22.27	0-1	1	
1880.0		18900	10	QPSK	50	0	22.33	0-1	1	
1880.0		18900	10	16QAM	1	0	22.46	0-1	1	
1880.0		18900	10	16QAM	1	25	22.31	0-1	1	
1880.0		18900	10	16QAM	1	49	22.22	0-1	1	
1880.0		18900	10	16QAM	25	0	21.25	0-2	2	
1880.0		18900	10	16QAM	25	12	21.27	0-2	2	
1880.0		18900	10	16QAM	25	25	21.22	0-2	2	
1880.0		18900	10	16QAM	50	0	21.26	0-2	2	
High		1905	19150	10	QPSK	1	0	23.14	0	0
		1905	19150	10	QPSK	1	25	23.27	0	0
		1905	19150	10	QPSK	1	49	23.19	0	0
		1905	19150	10	QPSK	25	0	22.04	0-1	1
	1905	19150	10	QPSK	25	12	22.19	0-1	1	
	1905	19150	10	QPSK	25	25	22.12	0-1	1	
	1905	19150	10	QPSK	50	0	22.20	0-1	1	
	1905	19150	10	16QAM	1	0	22.12	0-1	1	
	1905	19150	10	16QAM	1	25	22.17	0-1	1	
	1905	19150	10	16QAM	1	49	22.23	0-1	1	
	1905	19150	10	16QAM	25	0	21.07	0-2	2	
	1905	19150	10	16QAM	25	12	21.10	0-2	2	
	1905	19150	10	16QAM	25	25	21.13	0-2	2	
	1905	19150	10	16QAM	50	0	21.14	0-2	2	

Table 9-16
LTE Band 2 (PCS) Conducted Powers - 5 MHz Bandwidth



	Frequency [MHz]	Channel	Bandwidth [MHz]	Modulation	RB Size	RB Offset	Conducted Power [dBm]	MPR Allowed per 3GPP [dB]	MPR [dB]
Low	1852.5	18625	5	QPSK	1	0	23.19	0	0
	1852.5	18625	5	QPSK	1	12	23.17	0	0
	1852.5	18625	5	QPSK	1	24	23.29	0	0
	1852.5	18625	5	QPSK	12	0	22.07	0-1	1
	1852.5	18625	5	QPSK	12	6	22.02	0-1	1
	1852.5	18625	5	QPSK	12	13	22.06	0-1	1
	1852.5	18625	5	QPSK	25	0	22.05	0-1	1
	1852.5	18625	5	16-QAM	1	0	22.12	0-1	1
	1852.5	18625	5	16-QAM	1	12	22.01	0-1	1
	1852.5	18625	5	16-QAM	1	24	22.11	0-1	1
	1852.5	18625	5	16-QAM	12	0	20.96	0-2	2
	1852.5	18625	5	16-QAM	12	6	20.90	0-2	2
	1852.5	18625	5	16-QAM	12	13	20.91	0-2	2
	1852.5	18625	5	16-QAM	25	0	20.99	0-2	2
	1880.0	18900	5	QPSK	1	0	23.49	0	0
1880.0	18900	5	QPSK	1	12	23.46	0	0	
1880.0	18900	5	QPSK	1	24	23.47	0	0	
1880.0	18900	5	QPSK	12	0	22.25	0-1	1	
1880.0	18900	5	QPSK	12	6	22.23	0-1	1	
1880.0	18900	5	QPSK	12	13	22.27	0-1	1	
1880.0	18900	5	QPSK	25	0	22.33	0-1	1	
1880.0	18900	5	16-QAM	1	0	22.46	0-1	1	
1880.0	18900	5	16-QAM	1	12	22.26	0-1	1	
1880.0	18900	5	16-QAM	1	24	22.31	0-1	1	
1880.0	18900	5	16-QAM	12	0	21.17	0-2	2	
1880.0	18900	5	16-QAM	12	6	21.15	0-2	2	
1880.0	18900	5	16-QAM	12	13	21.13	0-2	2	
1880.0	18900	5	16-QAM	25	0	21.20	0-2	2	
High	1907.5	19175	5	QPSK	1	0	23.25	0	0
	1907.5	19175	5	QPSK	1	12	23.26	0	0
	1907.5	19175	5	QPSK	1	24	23.16	0	0
	1907.5	19175	5	QPSK	12	0	22.16	0-1	1
	1907.5	19175	5	QPSK	12	6	22.17	0-1	1
	1907.5	19175	5	QPSK	12	13	22.11	0-1	1
	1907.5	19175	5	QPSK	25	0	22.14	0-1	1
	1907.5	19175	5	16-QAM	1	0	22.17	0-1	1
	1907.5	19175	5	16-QAM	1	12	22.16	0-1	1
	1907.5	19175	5	16-QAM	1	24	22.15	0-1	1
	1907.5	19175	5	16-QAM	12	0	21.03	0-2	2
	1907.5	19175	5	16-QAM	12	6	21.05	0-2	2
	1907.5	19175	5	16-QAM	12	13	21.08	0-2	2
	1907.5	19175	5	16-QAM	25	0	21.09	0-2	2

Table 9-17
LTE Band 2 (PCS) Conducted Powers - 3 MHz Bandwidth

	Frequency [MHz]	Channel	Bandwidth [MHz]	Modulation	RB Size	RB Offset	Conducted Power [dBm]	MPR Allowed per 3GPP [dB]	MPR [dB]
Low	1851.5	18615	3	QPSK	1	0	23.14	0	0
	1851.5	18615	3	QPSK	1	7	23.15	0	0
	1851.5	18615	3	QPSK	1	14	23.18	0	0
	1851.5	18615	3	QPSK	8	0	22.01	0-1	1
	1851.5	18615	3	QPSK	8	4	22.03	0-1	1
	1851.5	18615	3	QPSK	8	7	22.02	0-1	1
	1851.5	18615	3	QPSK	15	0	22.04	0-1	1
	1851.5	18615	3	16-QAM	1	0	22.08	0-1	1
	1851.5	18615	3	16-QAM	1	7	22.04	0-1	1
	1851.5	18615	3	16-QAM	1	14	22.11	0-1	1
	1851.5	18615	3	16-QAM	8	0	20.91	0-2	2
	1851.5	18615	3	16-QAM	8	4	20.92	0-2	2
	1851.5	18615	3	16-QAM	8	7	20.90	0-2	2
	1851.5	18615	3	16-QAM	15	0	21.02	0-2	2
	1880.0	18900	3	QPSK	1	0	23.45	0	0
1880.0	18900	3	QPSK	1	7	23.43	0	0	
1880.0	18900	3	QPSK	1	14	23.46	0	0	
1880.0	18900	3	QPSK	8	0	22.31	0-1	1	
1880.0	18900	3	QPSK	8	4	22.28	0-1	1	
1880.0	18900	3	QPSK	8	7	22.26	0-1	1	
1880.0	18900	3	QPSK	15	0	22.27	0-1	1	
1880.0	18900	3	16-QAM	1	0	22.32	0-1	1	
1880.0	18900	3	16-QAM	1	7	22.27	0-1	1	
1880.0	18900	3	16-QAM	1	14	22.33	0-1	1	
1880.0	18900	3	16-QAM	8	0	21.17	0-2	2	
1880.0	18900	3	16-QAM	8	4	21.16	0-2	2	
1880.0	18900	3	16-QAM	8	7	21.15	0-2	2	
1880.0	18900	3	16-QAM	15	0	21.23	0-2	2	
High	1908.5	19185	3	QPSK	1	0	23.28	0	0
	1908.5	19185	3	QPSK	1	7	23.24	0	0
	1908.5	19185	3	QPSK	1	14	23.12	0	0
	1908.5	19185	3	QPSK	8	0	22.35	0-1	1
	1908.5	19185	3	QPSK	8	4	22.12	0-1	1
	1908.5	19185	3	QPSK	8	7	22.11	0-1	1
	1908.5	19185	3	QPSK	15	0	22.14	0-1	1
	1908.5	19185	3	16-QAM	1	0	22.24	0-1	1
	1908.5	19185	3	16-QAM	1	7	22.17	0-1	1
	1908.5	19185	3	16-QAM	1	14	22.16	0-1	1
	1908.5	19185	3	16-QAM	8	0	21.07	0-2	2
	1908.5	19185	3	16-QAM	8	4	21.03	0-2	2
	1908.5	19185	3	16-QAM	8	7	21.05	0-2	2
	1908.5	19185	3	16-QAM	15	0	21.13	0-2	2

Table 9-18
LTE Band 2 (PCS) Conducted Powers -1.4 MHz Bandwidth

	Frequency [MHz]	Channel	Bandwidth [MHz]	Modulation	RB Size	RB Offset	Conducted Power [dBm]	MPR Allowed per 3GPP [dB]	MPR [dB]
Low	1850.7	18607	1.4	QPSK	1	0	23.14	0	0
	1850.7	18607	1.4	QPSK	1	2	23.13	0	0
	1850.7	18607	1.4	QPSK	1	5	23.12	0	0
	1850.7	18607	1.4	QPSK	3	0	23.05	0	0
	1850.7	18607	1.4	QPSK	3	2	23.07	0	0
	1850.7	18607	1.4	QPSK	3	3	23.01	0	0
	1850.7	18607	1.4	QPSK	6	0	22.05	0-1	1
	1850.7	18607	1.4	16-QAM	1	0	22.12	0-1	1
	1850.7	18607	1.4	16-QAM	1	2	22.08	0-1	1
	1850.7	18607	1.4	16-QAM	1	5	22.09	0-1	1
	1850.7	18607	1.4	16-QAM	3	0	22.05	0-1	1
	1850.7	18607	1.4	16-QAM	3	2	22.04	0-1	1
	1850.7	18607	1.4	16-QAM	3	3	22.05	0-1	1
	1850.7	18607	1.4	16-QAM	6	0	21.01	0-2	2
Mid	1880.0	18900	1.4	QPSK	1	0	23.40	0	0
	1880.0	18900	1.4	QPSK	1	2	23.39	0	0
	1880.0	18900	1.4	QPSK	1	5	23.45	0	0
	1880.0	18900	1.4	QPSK	3	0	23.37	0	0
	1880.0	18900	1.4	QPSK	3	2	23.34	0	0
	1880.0	18900	1.4	QPSK	3	3	23.30	0	0
	1880.0	18900	1.4	QPSK	6	0	22.31	0-1	1
	1880.0	18900	1.4	16-QAM	1	0	22.45	0-1	1
	1880.0	18900	1.4	16-QAM	1	2	22.34	0-1	1
	1880.0	18900	1.4	16-QAM	1	5	22.42	0-1	1
	1880.0	18900	1.4	16-QAM	3	0	22.32	0-1	1
	1880.0	18900	1.4	16-QAM	3	2	22.35	0-1	1
	1880.0	18900	1.4	16-QAM	3	3	22.34	0-1	1
	1880.0	18900	1.4	16-QAM	6	0	21.20	0-2	2
High	1909.3	19193	1.4	QPSK	1	0	23.24	0	0
	1909.3	19193	1.4	QPSK	1	2	23.22	0	0
	1909.3	19193	1.4	QPSK	1	5	23.06	0	0
	1909.3	19193	1.4	QPSK	3	0	23.14	0	0
	1909.3	19193	1.4	QPSK	3	2	23.15	0	0
	1909.3	19193	1.4	QPSK	3	3	23.08	0	0
	1909.3	19193	1.4	QPSK	6	0	22.25	0-1	1
	1909.3	19193	1.4	16-QAM	1	0	22.21	0-1	1
	1909.3	19193	1.4	16-QAM	1	2	22.18	0-1	1
	1909.3	19193	1.4	16-QAM	1	5	22.27	0-1	1
	1909.3	19193	1.4	16-QAM	3	0	22.15	0-1	1
	1909.3	19193	1.4	16-QAM	3	2	22.13	0-1	1
	1909.3	19193	1.4	16-QAM	3	3	22.18	0-1	1
	1909.3	19193	1.4	16-QAM	6	0	21.12	0-2	2

FCC ID: A3LSMG900A	 PCTEST <small>ENGINEERING LABORATORY, INC.</small>	SAR EVALUATION REPORT		Reviewed by: Quality Manager
Document S/N: OY1401270204-R2.A3L	Test Dates: 02/03/14 - 02/17/14	DUT Type: Portable Handset		Page 34 of 85

9.4 LTE Carrier Aggregation Conducted Powers

Table 9-19

LTE Carrier Aggregation Conducted Powers - Band 2 (PCC) + Band 17 (SCC) 10 MHz BW

Band 2 (PCC) + Band 17 (SCC), 10 MHz				
PCC MID	1880 MHz / ch.18900 + 710 MHz /ch.23790	PCC UL# RB	PCC UL RB Offset	Tx. Power (dBm)
		1	0	23.33

Table 9-20

LTE Carrier Aggregation Conducted Powers - Band 2 (PCC) + Band 29 (SCC) 10 MHz BW

Band 2 (PCC) + Band 29 (SCC), 10 MHz				
PCC MID	1880 MHz /ch.18900 + DL 722 MHz / DL ch. 9715	PCC UL# RB	PCC UL RB Offset	Tx. Power (dBm)
		1	0	23.30

Table 9-21

LTE Carrier Aggregation Conducted Powers - Band 4 (PCC) + Band 17 (SCC) 10 MHz BW

Band 4 (PCC) + Band 17 (SCC), 10MHz				
PCC LOW	1715 MHz / ch.20000 + 710 MHz /ch.23790	PCC UL# RB	PCC UL RB Offset	Tx. Power (dBm)
		1	0	23.41

Table 9-22

LTE Carrier Aggregation Conducted Powers - Band 4 (PCC) + Band 29 (SCC) 10 MHz BW

Band 4 (PCC) + Band 29 (SCC), 10 MHz				
PCC LOW	1715 MHz / ch.20000 + DL 722 MHz / DL ch. 9715	PCC UL# RB	PCC UL RB Offset	Tx. Power (dBm)
		1	0	23.40

Table 9-23

LTE Carrier Aggregation Conducted Powers - Band 17 (PCC) + Band 2 (SCC) 10 MHz BW

Band 17 (PCC) + Band 2 (SCC), 10 MHz				
PCC MID	710 MHz / ch.23790 + 1880 MHz /ch.18900	PCC UL# RB	PCC UL RB Offset	Tx. Power (dBm)
		1	49	23.04

Notes:

1. The device does not support all Rel. 10 Carrier Aggregation features due to modem chipset limitation.
2. The device only supports downlink Carrier Aggregation. Uplink Carrier Aggregation is not supported. Power measurements were performed with two DL carriers for the Release 8 configuration that had the highest output power (across all bandwidths, channels and RB Configurations) for each band
3. This device only supports inter-band CA with 5 carriers (B2+B17, B2+B29, B4+B17, B4+B29, B17+B2) with a maximum of 10 MHz of spectrum.
4. All control and acknowledge data is sent on uplink channels that operate identical to release 8 specifications.

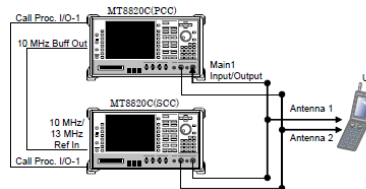

Figure 9-3
Power Measurement Setup

FCC ID: A3LSMG900A	PCTEST ENGINEERING LABORATORY, INC.	SAR EVALUATION REPORT	SAMSUNG	Reviewed by: Quality Manager
Document S/N: OY1401270204-R2.A3L	Test Dates: 02/03/14 - 02/17/14	DUT Type: Portable Handset		Page 35 of 85

9.5 WLAN Conducted Powers

9.5.1 Antenna 1 WLAN Conducted Powers

Maximum Conducted Powers

Table 9-24
IEEE 802.11b Average RF Power

Mode	Freq [MHz]	Channel	802.11b Conducted Power [dBm]			
			Data Rate [Mbps]			
			1	2	5.5	11
802.11b	2412	1*	16.57	16.54	16.74	16.62
802.11b	2437	6*	17.05	17.02	17.22	17.10
802.11b	2462	11*	16.81	16.78	16.98	16.86

Table 9-25
IEEE 802.11g Average RF Power

Mode	Freq [MHz]	Channel	802.11g Conducted Power [dBm]							
			Data Rate [Mbps]							
			6	9	12	18	24	36	48	54
802.11g	2412	1	14.09	13.97	14.10	13.92	14.22	14.25	14.21	14.24
802.11g	2437	6	13.90	13.78	13.91	13.73	14.03	14.06	14.02	14.05
802.11g	2462	11	13.54	13.42	13.55	13.37	13.67	13.70	13.66	13.69

Table 9-26
IEEE 802.11n Average RF Power

Mode	Freq [MHz]	Channel	802.11n (2.4GHz) Conducted Power [dBm]							
			Data Rate [Mbps]							
			6.5	13	19.5	26	39	52	58.5	65
802.11n	2412	1	13.14	13.34	13.17	13.39	13.34	13.42	13.45	13.24
802.11n	2437	6	12.95	13.15	12.98	13.20	13.15	13.23	13.26	13.05
802.11n	2462	11	12.81	13.01	12.84	13.06	13.01	13.09	13.12	12.91

Table 9-27
IEEE 802.11a Average RF Power

Mode	Freq [MHz]	Channel	802.11a (5GHz) Conducted Power [dBm]							
			Data Rate [Mbps]							
			6	9	12	18	24	36	48	54
802.11a	5180	36*	13.02	12.76	12.89	12.84	13.11	13.18	13.24	13.17
802.11a	5200	40	13.08	12.82	12.95	12.90	13.17	13.24	13.30	13.23
802.11a	5220	44	13.12	12.86	12.99	12.94	13.21	13.28	13.34	13.27
802.11a	5240	48*	12.93	12.67	12.80	12.75	13.02	13.09	13.15	13.08
802.11a	5260	52*	12.85	12.78	13.04	12.99	12.67	12.54	12.68	12.65
802.11a	5280	56	12.97	12.90	13.16	13.11	12.79	12.66	12.80	12.77
802.11a	5300	60	12.57	12.50	12.76	12.71	12.39	12.26	12.40	12.37
802.11a	5320	64*	12.54	12.47	12.73	12.68	12.36	12.23	12.37	12.34
802.11a	5500	100	13.33	12.62	13.26	13.19	13.11	13.37	13.32	13.26
802.11a	5520	104*	13.36	12.65	13.29	13.22	13.14	13.40	13.35	13.29
802.11a	5540	108	13.41	12.70	13.34	13.27	13.19	13.45	13.40	13.34
802.11a	5560	112	13.27	12.56	13.20	13.13	13.05	13.31	13.26	13.20
802.11a	5580	116*	13.40	12.69	13.33	13.26	13.18	13.44	13.39	13.33
802.11a	5600	120	N/A	N/A	N/A	N/A	N/A	N/A	N/A	N/A
802.11a	5620	124	N/A	N/A	N/A	N/A	N/A	N/A	N/A	N/A
802.11a	5640	128	N/A	N/A	N/A	N/A	N/A	N/A	N/A	N/A
802.11a	5660	132	13.19	12.48	13.12	13.05	12.97	13.23	13.18	13.12
802.11a	5680	136*	13.01	12.30	12.94	12.87	12.79	13.05	13.00	12.94
802.11a	5700	140	13.06	12.35	12.99	12.92	12.84	13.10	13.05	12.99
802.11a	5745	149*	13.31	13.12	13.33	13.25	12.81	12.63	12.79	12.56
802.11a	5765	153	13.21	13.02	13.23	13.15	12.71	12.53	12.69	12.46
802.11a	5785	157*	13.15	12.96	13.17	13.09	12.65	12.47	12.63	12.40
802.11a	5805	161	13.20	13.01	13.22	13.14	12.70	12.52	12.68	12.45
802.11a	5825	165*	12.98	12.79	13.00	12.92	12.48	12.30	12.46	12.23

Per FCC KDB Publication 443999 and RSS-210 A9.2(3), transmission on channels which overlap the 5600-5650 MHz is prohibited as a client. This device does not transmit any beacons or initiate any transmissions in 5.3 and 5.5 GHz Band.

(*) – indicates default channels per KDB Publication 248227 D01v01r02. When the adjacent channels are higher in power than the default channels, these “required channels” are considered for SAR testing instead of the default channels.



FCC ID: A3LSMG900A	 PCTEST Engineering Laboratory, Inc.	SAR EVALUATION REPORT		Reviewed by: Quality Manager
Document S/N: OY1401270204-R2.A3L	Test Dates: 02/03/14 - 02/17/14	DUT Type: Portable Handset		Page 36 of 85

Table 9-28
IEEE 802.11n Average RF Power – 20 MHz Bandwidth



Mode	Freq [MHz]	Channel	20MHz BW 802.11n (5GHz) Conducted Power [dBm]								
			Data Rate [Mbps]								
			6.5	13	19.5	26	39	52	58.5	65	
802.11n	5180	36	12.89	13.27	12.81	12.92	13.24	13.35	13.21	13.28	
802.11n	5200	40	12.83	13.31	12.75	12.86	13.18	13.32	13.15	13.22	
802.11n	5220	44	12.92	13.30	12.84	12.95	13.27	13.34	13.24	13.31	
802.11n	5240	48	12.72	13.20	12.64	12.75	13.07	13.27	13.04	13.11	
802.11n	5260	52	13.09	12.57	12.75	13.21	13.14	12.92	13.02	13.14	
802.11n	5280	56	13.02	12.50	12.68	13.20	13.07	12.85	12.95	13.07	
802.11n	5300	60	12.91	12.39	12.57	13.19	12.96	12.74	12.84	12.96	
802.11n	5320	64	13.21	12.69	12.87	13.17	13.21	13.04	13.14	13.21	
802.11n	5500	100	13.14	13.28	13.21	13.39	13.33	12.97	13.02	13.07	
802.11n	5520	104	13.08	13.22	13.15	13.33	13.27	12.91	12.96	13.01	
802.11n	5540	108	13.25	13.39	13.32	13.48	13.44	13.08	13.13	13.18	
802.11n	5560	112	13.29	13.43	13.36	13.44	13.48	13.12	13.17	13.22	
802.11n	5580	116	13.21	13.35	13.28	13.46	13.40	13.04	13.09	13.14	
802.11n	5600	120	N/A	N/A	N/A	N/A	N/A	N/A	N/A	N/A	
802.11n	5620	124	N/A	N/A	N/A	N/A	N/A	N/A	N/A	N/A	
802.11n	5640	128	N/A	N/A	N/A	N/A	N/A	N/A	N/A	N/A	
802.11n	5660	132	12.82	12.96	12.89	13.07	13.01	12.65	12.70	12.75	
802.11n	5680	136	13.04	13.18	13.11	13.29	13.23	12.87	12.92	12.97	
802.11n	5700	140	12.81	12.95	12.88	13.06	13.00	12.64	12.69	12.74	
802.11n	5745	149	12.74	12.95	13.14	13.21	13.15	13.01	12.94	13.08	
802.11n	5765	153	12.56	12.77	12.96	13.03	12.97	12.83	12.76	12.90	
802.11n	5785	157	12.72	12.93	13.12	13.19	13.13	12.99	12.92	13.06	
802.11n	5805	161	12.52	12.73	12.92	12.99	12.93	12.79	12.72	12.86	
802.11n	5825	165	12.74	12.95	13.14	13.21	13.15	13.01	12.94	13.08	

Table 9-29
IEEE 802.11n Average RF Power – 40 MHz Bandwidth

Mode	Freq [MHz]	Channel	40MHz BW 802.11n (5GHz) Conducted Power [dBm]								
			Data Rate [Mbps]								
			13.5	27	40.5	54	81	108	121.5	135	
802.11n	5190	38	11.42	12.05	12.24	12.28	11.93	12.12	12.38	12.24	
802.11n	5230	46	11.26	11.89	12.08	12.12	11.77	11.96	12.22	12.08	
802.11n	5270	54	11.29	11.85	12.09	12.35	12.14	12.36	12.04	12.12	
802.11n	5310	62	11.36	11.92	12.16	12.42	12.21	12.43	12.11	12.19	
802.11n	5510	102	11.45	11.48	11.65	11.84	11.67	11.95	11.72	11.62	
802.11n	5550	110	11.69	11.72	11.89	12.08	11.91	12.19	11.96	11.86	
802.11n	5590	118	N/A	N/A	N/A	N/A	N/A	N/A	N/A	N/A	
802.11n	5630	126	N/A	N/A	N/A	N/A	N/A	N/A	N/A	N/A	
802.11n	5670	134	11.51	11.54	11.71	11.90	11.73	12.01	11.78	11.68	
802.11n	5755	151	11.43	11.23	11.42	11.48	11.52	11.46	11.32	11.47	
802.11n	5795	159	11.29	11.09	11.28	11.34	11.38	11.32	11.18	11.33	

Table 9-30
IEEE 802.11ac Average RF Power – 80 MHz Bandwidth

Mode	Freq [MHz]	Channel	80MHz BW 802.11ac (5GHz) Conducted Power [dBm]									
			Data Rate [Mbps]									
			29.3	58.5	87.8	117	175.5	234	263.3	292.5	351	390
802.11ac	5210	42	10.71	10.76	10.69	10.77	10.94	10.92	10.87	10.91	10.88	10.79
802.11ac	5290	58	10.77	10.81	10.72	10.60	10.98	10.87	10.91	10.82	10.87	10.97
802.11ac	5530	106	11.15	11.18	11.11	11.38	11.17	11.32	11.34	11.21	11.25	11.37
802.11ac	5775	155	11.25	11.14	10.94	11.09	11.32	10.92	11.10	11.17	10.89	10.52

FCC ID: A3LSMG900A	 PCTEST Engineering Laboratory, Inc.	SAR EVALUATION REPORT		Reviewed by: Quality Manager
Document S/N: OY1401270204-R2.A3L	Test Dates: 02/03/14 - 02/17/14	DUT Type: Portable Handset		Page 37 of 85

Reduced Conducted Powers – Held-to-Ear

**Table 9-31
IEEE 802.11b Average RF Power**

Mode	Freq [MHz]	Channel	802.11b Conducted Power [dBm]			
			Data Rate [Mbps]			
			1	2	5.5	11
802.11b	2412	1*	11.94	12.03	12.09	12.08
802.11b	2437	6*	11.23	11.39	11.31	11.33
802.11b	2462	11*	11.27	11.36	11.39	11.48

**Table 9-32
IEEE 802.11g Average RF Power**

Mode	Freq [MHz]	Channel	802.11g Conducted Power [dBm]							
			Data Rate [Mbps]							
			6	9	12	18	24	36	48	54
802.11g	2412	1	11.42	11.55	11.52	11.41	11.46	11.44	11.40	11.38
802.11g	2437	6	11.87	11.92	11.93	11.87	11.98	11.93	11.92	11.94
802.11g	2462	11	11.89	11.71	11.75	11.79	11.82	11.82	11.81	11.81

**Table 9-33
IEEE 802.11n Average RF Power**

Mode	Freq [MHz]	Channel	802.11n (2.4GHz) Conducted Power [dBm]							
			Data Rate [Mbps]							
			6.5	13	19.5	26	39	52	58.5	65
802.11n	2412	1	11.25	11.25	11.30	11.18	11.24	11.24	11.32	11.31
802.11n	2437	6	11.90	11.89	11.90	11.85	11.90	11.79	11.92	11.79
802.11n	2462	11	11.66	11.78	11.78	11.64	11.81	11.70	11.75	11.70

**Table 9-34
IEEE 802.11a Average RF Power**

Mode	Freq [MHz]	Channel	802.11a Conducted Power [dBm]							
			Data Rate [Mbps]							
			6	9	12	18	24	36	48	54
802.11a	5180	36*	9.25	9.23	8.90	8.92	9.25	8.91	9.31	8.91
802.11a	5200	40	9.10	8.98	9.24	9.21	9.17	8.94	8.96	9.24
802.11a	5220	44	9.24	8.96	9.05	9.28	9.01	9.22	9.14	9.31
802.11a	5240	48*	9.00	9.08	9.07	9.06	8.97	8.73	9.14	9.02
802.11a	5260	52*	9.33	9.33	9.28	9.48	9.22	9.27	9.45	9.19
802.11a	5280	56	9.11	9.41	9.25	9.48	9.29	9.45	9.42	9.13
802.11a	5300	60	9.24	9.37	9.41	9.49	9.39	9.43	9.31	9.27
802.11a	5320	64*	9.30	9.25	9.30	9.21	9.33	9.46	9.34	9.29
802.11a	5500	100	9.45	9.35	9.24	9.27	9.34	9.33	9.23	9.45
802.11a	5520	104*	9.31	9.39	9.39	9.38	9.46	9.20	9.21	9.26
802.11a	5540	108	9.40	9.33	9.35	9.46	9.26	9.33	9.35	9.43
802.11a	5560	112	9.35	9.37	9.32	9.42	9.41	9.10	9.15	9.47
802.11a	5580	116*	9.46	9.47	9.44	9.41	9.42	9.38	9.17	9.24
802.11a	5600	120	N/A	N/A	N/A	N/A	N/A	N/A	N/A	N/A
802.11a	5620	124	N/A	N/A	N/A	N/A	N/A	N/A	N/A	N/A
802.11a	5640	128	N/A	N/A	N/A	N/A	N/A	N/A	N/A	N/A
802.11a	5660	132	9.36	9.47	9.43	9.40	9.46	9.45	9.34	9.46
802.11a	5680	136*	9.39	9.39	9.42	9.34	9.27	9.41	9.18	9.31
802.11a	5700	140	9.32	9.33	9.45	9.49	9.35	9.40	9.20	9.42
802.11a	5745	149*	9.12	8.89	9.32	9.30	9.26	8.94	9.09	9.13
802.11a	5765	153	9.08	8.69	8.81	8.91	9.14	9.11	8.81	8.85
802.11a	5785	157*	9.28	9.23	9.14	8.82	8.88	9.07	8.90	9.22
802.11a	5805	161	9.19	8.98	8.98	9.09	9.20	8.96	9.25	8.87
802.11a	5825	165*	8.64	8.98	8.99	8.63	8.60	8.92	9.01	8.83

Per FCC KDB Publication 443999 and RSS-210 A9.2(3), transmission on channels which overlap the 5600-5650 MHz is prohibited as a client. This device does not transmit any beacons or initiate any transmissions in 5.3 and 5.5 GHz Band.

(*) – indicates default channels per KDB Publication 248227 D01v01r02. When the adjacent channels are higher in power then the default channels, these “required channels” are considered for SAR testing instead of the default channels.



FCC ID: A3LSMG900A	 PCTEST Engineering Laboratory, Inc.	SAR EVALUATION REPORT		Reviewed by: Quality Manager
Document S/N: OY1401270204-R2.A3L	Test Dates: 02/03/14 - 02/17/14	DUT Type: Portable Handset		Page 38 of 85

Table 9-35
IEEE 802.11n Average RF Power – 20 MHz Bandwidth



Mode	Freq [MHz]	Channel	20MHz BW 802.11n (5GHz) Conducted Power [dBm]							
			Data Rate [Mbps]							
			6.5	13	19.5	26	39	52	58.5	65
802.11n	5180	36	9.33	9.04	9.28	9.45	9.16	9.40	9.18	9.41
802.11n	5200	40	9.49	9.28	9.10	9.21	9.35	9.23	9.35	9.22
802.11n	5220	44	9.26	9.00	9.20	9.30	8.91	8.96	8.99	9.29
802.11n	5240	48	9.37	9.47	9.20	9.40	9.43	9.15	9.32	9.31
802.11n	5260	52	9.40	9.46	9.22	9.41	9.21	9.14	9.43	9.31
802.11n	5280	56	9.23	9.25	9.34	8.90	9.08	8.93	9.42	9.01
802.11n	5300	60	9.14	9.13	9.04	9.28	9.29	9.15	9.48	9.12
802.11n	5320	64	9.20	9.34	9.18	9.21	9.32	9.40	9.15	9.40
802.11n	5500	100	8.23	8.71	8.22	8.65	8.48	8.36	8.63	8.52
802.11n	5520	104	8.33	8.47	8.79	8.61	8.48	8.41	8.75	8.40
802.11n	5540	108	8.38	8.46	8.42	8.26	8.74	8.57	8.56	8.59
802.11n	5560	112	8.64	8.17	8.18	8.18	8.60	8.51	8.65	8.25
802.11n	5580	116	8.73	8.72	8.53	8.32	8.34	8.78	8.32	8.48
802.11n	5600	120	N/A	N/A	N/A	N/A	N/A	N/A	N/A	N/A
802.11n	5620	124	N/A	N/A	N/A	N/A	N/A	N/A	N/A	N/A
802.11n	5640	128	N/A	N/A	N/A	N/A	N/A	N/A	N/A	N/A
802.11n	5660	132	8.29	8.59	8.52	8.40	8.46	8.41	8.65	8.24
802.11n	5680	136	8.47	8.45	8.35	8.73	8.34	8.78	8.46	8.31
802.11n	5700	140	8.43	8.80	8.67	8.48	8.42	8.43	8.81	8.83
802.11n	5745	149	9.44	9.11	9.33	9.11	9.40	9.43	9.45	9.24
802.11n	5765	153	9.19	9.16	9.33	9.07	9.27	9.15	9.33	8.91
802.11n	5785	157	9.33	9.02	8.99	8.86	8.88	9.35	9.08	9.07
802.11n	5805	161	8.92	9.19	8.79	9.02	9.11	9.11	8.93	9.01
802.11n	5825	165	8.72	9.11	8.91	8.99	9.09	9.12	9.01	8.83

Table 9-36
IEEE 802.11n Average RF Power – 40 MHz Bandwidth

Mode	Freq [MHz]	Channel	40MHz BW 802.11n (5GHz) Conducted Power [dBm]							
			Data Rate [Mbps]							
			13.5	27	40.5	54	81	108	121.5	135
802.11n	5190	38	9.12	8.69	8.58	8.33	9.01	8.72	8.62	8.92
802.11n	5230	46	8.82	8.77	9.20	9.14	8.73	8.99	9.27	9.24
802.11n	5270	54	9.25	8.55	8.99	8.65	8.92	9.16	8.74	8.48
802.11n	5310	62	8.43	9.05	8.56	8.66	8.76	8.37	9.12	8.37
802.11n	5510	102	8.27	9.16	8.98	8.83	8.71	8.97	8.40	8.73
802.11n	5550	110	8.56	8.38	8.26	8.14	8.12	8.54	8.26	8.14
802.11n	5590	118	N/A	N/A	N/A	N/A	N/A	N/A	N/A	N/A
802.11n	5630	126	N/A	N/A	N/A	N/A	N/A	N/A	N/A	N/A
802.11n	5670	134	8.14	8.44	8.22	8.09	8.87	8.71	8.85	8.70
802.11n	5755	151	8.38	7.98	8.37	8.72	8.15	8.42	8.12	8.75
802.11n	5795	159	8.29	8.91	8.49	8.28	8.43	8.91	8.78	8.37

Table 9-37
IEEE 802.11ac Average RF Power – 80 MHz Bandwidth

Mode	Freq [MHz]	Channel	80MHz BW 802.11ac (5GHz) Conducted Power [dBm]									
			Data Rate [Mbps]									
			29.3	58.5	87.8	117	175.5	234	263.3	292.5	351	390
802.11ac	5210	42	9.30	9.13	9.30	9.14	9.27	9.05	9.02	9.27	9.14	9.11
802.11ac	5290	58	8.77	8.91	8.94	8.99	8.79	8.94	8.88	8.84	8.98	8.88
802.11ac	5530	106	9.16	9.34	9.26	9.15	9.24	9.26	9.30	9.24	9.17	9.32
802.11ac	5775	155	9.01	9.01	9.04	9.09	8.99	8.87	9.12	9.01	8.88	8.91

FCC ID: A3LSMG900A	 PCTEST ENGINEERING LABORATORY, INC.	SAR EVALUATION REPORT		Reviewed by: Quality Manager
Document S/N: OY1401270204-R2.A3L	Test Dates: 02/03/14 - 02/17/14	DUT Type: Portable Handset		Page 39 of 85

Justification for reduced test configurations for WIFI channels per KDB Publication 248227 D01v01r02 and October 2012/April 2013 FCC/TCB Meeting Notes:

- For 2.4 GHz, highest average RF output power channel for the lowest data rate for IEEE 802.11b were selected for SAR evaluation. Other IEEE 802.11 modes (including 802.11g/n) were not investigated since the average output powers over all channels and data rates were not more than 0.25 dB higher than the tested channel in the lowest data rate of IEEE 802.11b mode.
- For 5 GHz, highest average RF output power channel for the lowest data rate for IEEE 802.11a were selected for SAR evaluation. Other IEEE 802.11 modes (including 802.11n 20 MHz and 40 MHz) were not investigated since the average output powers over all channels and data rates were not more than 0.25 dB higher than the tested channel in the lowest data rate of IEEE 802.11a mode.
- Full SAR tests for all IEEE 802.11ac configurations were not required because the average output power was not more than 0.25 dB higher than IEEE 802.11a mode. IEEE 802.11ac was evaluated for the highest IEEE 802.11a position in each 5 GHz band and exposure condition.
- When the maximum extrapolated peak SAR of the zoom scan for the maximum output channel is <1.6 W/kg and the reported 1g averaged SAR is <0.8 W/kg, SAR testing on other channels is not required. Otherwise, the other default (or corresponding required) test channels were additionally tested using the lowest data rate.
- The bolded data rate and channel above were tested for SAR.

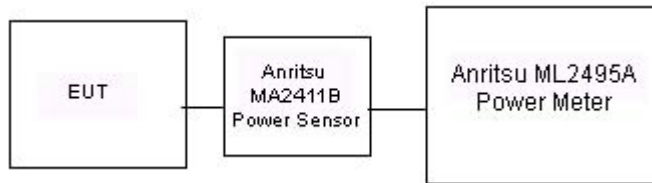

Figure 9-4
Power Measurement Setup for Bandwidths < 50 MHz

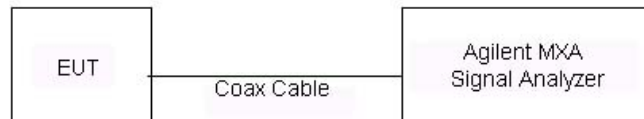



Figure 9-5
Power Measurement Setup for Bandwidths > 50 MHz

FCC ID: A3LSMG900A	 PCTEST ENGINEERING LABORATORY, INC.	SAR EVALUATION REPORT		Reviewed by: Quality Manager
Document S/N: OY1401270204-R2.A3L	Test Dates: 02/03/14 - 02/17/14	DUT Type: Portable Handset	Page 40 of 85	

9.5.2 Antenna 2 WLAN Conducted Powers

Maximum Conducted Powers

Table 9-38
IEEE 802.11b Average RF Power

Mode	Freq [MHz]	Channel	802.11b Conducted Power [dBm]			
			Data Rate [Mbps]			
			1	2	5.5	11
802.11b	2412	1*	17.07	17.24	17.29	17.17
802.11b	2437	6*	16.54	16.71	16.76	16.64
802.11b	2462	11*	16.49	16.66	16.71	16.59

Table 9-39
IEEE 802.11g Average RF Power

Mode	Freq [MHz]	Channel	802.11g Conducted Power [dBm]							
			Data Rate [Mbps]							
			6	9	12	18	24	36	48	54
802.11g	2412	1	13.82	13.62	13.57	13.61	13.94	14.04	14.12	14.11
802.11g	2437	6	13.64	13.44	13.39	13.43	13.76	13.86	13.94	13.93
802.11g	2462	11	13.37	13.17	13.12	13.16	13.49	13.59	13.67	13.66

Table 9-40
IEEE 802.11n Average RF Power

Mode	Freq [MHz]	Channel	802.11n (2.4GHz) Conducted Power [dBm]							
			Data Rate [Mbps]							
			6.5	13	19.5	26	39	52	58.5	65
802.11n	2412	1	12.93	12.97	12.82	12.94	13.07	13.12	13.09	13.14
802.11n	2437	6	12.85	12.89	12.74	12.86	12.99	13.04	13.01	13.06
802.11n	2462	11	12.64	12.68	12.53	12.65	12.78	12.83	12.80	12.85

Table 9-41
IEEE 802.11a Average RF Power

Mode	Freq [MHz]	Channel	802.11a Conducted Power [dBm]							
			Data Rate [Mbps]							
			6	9	12	18	24	36	48	54
802.11a	5180	36*	13.94	13.87	13.97	13.37	13.72	13.92	13.34	13.48
802.11a	5200	40	13.84	13.77	13.87	13.27	13.62	13.82	13.24	13.38
802.11a	5220	44	13.86	13.79	13.89	13.29	13.64	13.84	13.26	13.40
802.11a	5240	48*	13.74	13.67	13.77	13.17	13.52	13.72	13.14	13.28
802.11a	5260	52*	13.21	12.91	12.98	12.92	13.42	13.35	13.10	13.44
802.11a	5280	56	13.02	12.72	12.79	12.73	13.23	13.16	12.91	13.25
802.11a	5300	60	13.11	12.81	12.88	12.82	13.32	13.25	13.00	13.34
802.11a	5320	64*	12.99	12.69	12.76	12.70	13.20	13.13	12.88	13.22
802.11a	5500	100	13.26	12.98	13.22	13.16	13.44	13.40	13.04	12.94
802.11a	5520	104*	13.17	12.89	13.13	13.07	13.35	13.31	12.95	12.85
802.11a	5540	108	13.04	12.76	13.00	12.94	13.22	13.18	12.82	12.72
802.11a	5560	112	13.21	12.93	13.17	13.11	13.39	13.35	12.99	12.89
802.11a	5580	116*	12.91	12.63	12.87	12.81	13.09	13.05	12.69	12.59
802.11a	5600	120	N/A	N/A	N/A	N/A	N/A	N/A	N/A	N/A
802.11a	5620	124	N/A	N/A	N/A	N/A	N/A	N/A	N/A	N/A
802.11a	5640	128	N/A	N/A	N/A	N/A	N/A	N/A	N/A	N/A
802.11a	5660	132	13.01	12.73	12.97	12.91	13.19	13.15	12.79	12.69
802.11a	5680	136*	12.81	12.53	12.77	12.71	12.99	12.95	12.59	12.49
802.11a	5700	140	12.61	12.33	12.57	12.51	12.79	12.75	12.39	12.29
802.11a	5745	149*	13.37	13.09	12.91	12.95	13.35	13.17	13.24	13.37
802.11a	5765	153	13.44	13.16	12.98	13.02	13.42	13.24	13.31	13.44
802.11a	5785	157*	13.31	13.03	12.85	12.89	13.29	13.11	13.18	13.31
802.11a	5805	161	13.11	12.83	12.65	12.69	13.09	12.91	12.98	13.11
802.11a	5825	165*	13.25	12.97	12.79	12.83	13.23	13.05	13.12	13.25

Per FCC KDB Publication 443999 and RSS-210 A9.2(3), transmission on channels which overlap the 5600-5650 MHz is prohibited as a client. This device does not transmit any beacons or initiate any transmissions in 5.3 and 5.5 GHz Band.

(*) – indicates default channels per KDB Publication 248227 D01v01r02. When the adjacent channels are higher in power then the default channels, these “required channels” are considered for SAR testing instead of the default channels.



FCC ID: A3LSMG900A	 PCTEST Engineering Laboratory, Inc.	SAR EVALUATION REPORT		Reviewed by: Quality Manager
Document S/N: OY1401270204-R2.A3L	Test Dates: 02/03/14 - 02/17/14	DUT Type: Portable Handset		Page 41 of 85

Table 9-42
IEEE 802.11n Average RF Power – 20 MHz Bandwidth

Mode	Freq [MHz]	Channel	20MHz BW 802.11n (5GHz) Conducted Power [dBm]							
			Data Rate [Mbps]							
			6.5	13	19.5	26	39	52	58.5	65
802.11n	5180	36	12.78	12.95	13.02	13.11	13.04	13.07	12.99	13.12
802.11n	5200	40	12.96	13.13	13.20	13.29	13.22	13.25	13.17	13.30
802.11n	5220	44	12.72	12.89	12.96	13.05	12.98	13.01	12.93	13.06
802.11n	5240	48	12.84	13.01	13.08	13.17	13.10	13.13	13.05	13.18
802.11n	5260	52	13.15	13.02	13.25	13.37	13.34	13.17	13.27	13.25
802.11n	5280	56	13.04	12.91	13.14	13.26	13.23	13.06	13.16	13.14
802.11n	5300	60	13.12	12.99	13.22	13.34	13.31	13.14	13.24	13.22
802.11n	5320	64	12.89	12.76	12.99	13.11	13.08	12.91	13.01	12.99
802.11n	5500	100	13.01	13.18	13.27	13.24	13.28	13.32	13.29	13.32
802.11n	5520	104	13.18	13.35	13.44	13.41	13.45	13.44	13.46	13.42
802.11n	5540	108	13.01	13.18	13.27	13.24	13.28	13.32	13.29	13.32
802.11n	5560	112	13.09	13.26	13.35	13.32	13.36	13.40	13.37	13.40
802.11n	5580	116	13.04	13.21	13.30	13.27	13.31	13.35	13.32	13.35
802.11n	5600	120	N/A	N/A	N/A	N/A	N/A	N/A	N/A	N/A
802.11n	5620	124	N/A	N/A	N/A	N/A	N/A	N/A	N/A	N/A
802.11n	5640	128	N/A	N/A	N/A	N/A	N/A	N/A	N/A	N/A
802.11n	5660	132	12.82	12.99	13.08	13.05	13.09	13.13	13.10	13.13
802.11n	5680	136	12.68	12.85	12.94	12.91	12.95	12.99	12.96	12.99
802.11n	5700	140	12.60	12.77	12.86	12.83	12.87	12.91	12.88	12.91
802.11n	5745	149	13.08	13.12	13.27	13.29	13.25	13.21	13.30	13.24
802.11n	5765	153	13.11	13.15	13.30	13.32	13.28	13.24	13.33	13.27
802.11n	5785	157	13.21	13.25	13.40	13.42	13.38	13.34	13.43	13.37
802.11n	5805	161	13.25	13.29	13.44	13.46	13.42	13.38	13.47	13.41
802.11n	5825	165	13.16	13.20	13.35	13.37	13.33	13.29	13.38	13.32

Table 9-43
IEEE 802.11n Average RF Power – 40 MHz Bandwidth

Mode	Freq [MHz]	Channel	40MHz BW 802.11n (5GHz) Conducted Power [dBm]							
			Data Rate [Mbps]							
			13.5	27	40.5	54	81	108	121.5	135
802.11n	5190	38	12.25	12.38	12.41	12.25	12.34	12.43	12.32	12.29
802.11n	5230	46	12.17	12.30	12.33	12.17	12.26	12.35	12.24	12.21
802.11n	5270	54	11.54	11.52	11.61	11.79	11.35	11.62	11.55	11.67
802.11n	5310	62	11.41	11.39	11.48	11.66	11.22	11.49	11.42	11.54
802.11n	5510	102	11.67	11.85	11.58	11.79	11.82	11.98	11.67	11.54
802.11n	5550	110	11.61	11.79	11.52	11.73	11.76	11.92	11.61	11.48
802.11n	5590	118	N/A	N/A	N/A	N/A	N/A	N/A	N/A	N/A
802.11n	5630	126	N/A	N/A	N/A	N/A	N/A	N/A	N/A	N/A
802.11n	5670	134	11.32	11.50	11.23	11.44	11.47	11.63	11.32	11.19
802.11n	5755	151	11.74	11.84	11.81	12.02	12.05	11.98	11.90	11.84
802.11n	5795	159	11.77	11.87	11.84	12.05	12.08	12.01	11.93	11.87

Table 9-44
IEEE 802.11ac Average RF Power – 80 MHz Bandwidth

Mode	Freq [MHz]	Channel	80MHz BW 802.11ac (5GHz) Conducted Power [dBm]									
			Data Rate [Mbps]									
			29.3	58.5	87.8	117	175.5	234	263.3	292.5	351	390
802.11ac	5210	42	10.78	10.61	10.64	10.59	10.86	10.79	10.81	10.95	11.01	10.98
802.11ac	5290	58	10.94	10.75	10.74	10.93	11.05	11.01	11.12	11.07	10.95	11.18
802.11ac	5530	106	10.98	10.84	10.97	10.75	11.14	11.04	11.16	11.07	11.12	11.14
802.11ac	5775	155	11.26	11.23	11.14	11.24	11.37	11.24	11.42	11.38	11.27	11.35

Reduced Conducted Powers – Held-to-Ear

**Table 9-45
IEEE 802.11b Average RF Power**

Mode	Freq [MHz]	Channel	802.11b Conducted Power [dBm]			
			Data Rate [Mbps]			
			1	2	5.5	11
802.11b	2412	1*	11.74	11.67	11.75	11.70
802.11b	2437	6*	11.50	11.43	11.35	11.44
802.11b	2462	11*	11.39	11.35	11.32	11.27

**Table 9-46
IEEE 802.11g Average RF Power**

Mode	Freq [MHz]	Channel	802.11g Conducted Power [dBm]							
			Data Rate [Mbps]							
			6	9	12	18	24	36	48	54
802.11g	2412	1	11.66	11.78	11.61	11.76	11.75	11.73	11.59	11.78
802.11g	2437	6	11.63	11.62	11.80	11.77	11.69	11.76	11.75	11.76
802.11g	2462	11	11.38	11.51	11.49	11.43	11.44	11.50	11.47	11.45

**Table 9-47
IEEE 802.11n Average RF Power**

Mode	Freq [MHz]	Channel	802.11n (2.4GHz) Conducted Power [dBm]							
			Data Rate [Mbps]							
			6.5	13	19.5	26	39	52	58.5	65
802.11n	2412	1	11.83	11.97	11.93	11.92	11.81	11.97	11.91	11.81
802.11n	2437	6	11.73	11.70	11.69	11.79	11.82	11.78	11.83	11.69
802.11n	2462	11	11.69	11.79	11.75	11.77	11.85	11.75	11.70	11.71

**Table 9-48
IEEE 802.11a Average RF Power**

Mode	Freq [MHz]	Channel	802.11a Conducted Power [dBm]							
			Data Rate [Mbps]							
			6	9	12	18	24	36	48	54
802.11a	5180	36*	8.61	8.67	8.66	8.65	8.67	8.60	8.61	8.71
802.11a	5200	40	8.55	8.62	8.66	8.59	8.58	8.68	8.56	8.66
802.11a	5220	44	8.83	8.88	8.74	8.78	8.80	8.81	8.71	8.72
802.11a	5240	48*	8.65	8.77	8.78	8.79	8.80	8.79	8.80	8.72
802.11a	5260	52*	8.79	8.50	8.62	8.49	8.65	8.58	8.49	8.51
802.11a	5280	56	8.75	8.77	8.79	8.76	8.66	8.75	8.69	8.84
802.11a	5300	60	8.69	8.67	8.53	8.61	8.55	8.57	8.61	8.57
802.11a	5320	64*	8.43	8.49	8.41	8.52	8.43	8.47	8.40	8.47
802.11a	5500	100	8.70	8.88	8.85	8.77	8.76	8.90	8.80	8.87
802.11a	5520	104*	8.72	8.78	8.65	8.79	8.68	8.80	8.74	8.66
802.11a	5540	108	8.77	8.82	8.89	8.76	8.76	8.80	8.86	8.89
802.11a	5560	112	8.86	8.80	8.83	8.93	8.95	8.97	8.78	8.87
802.11a	5580	116*	8.86	8.90	8.93	8.93	9.00	8.86	8.88	8.86
802.11a	5600	120	N/A	N/A	N/A	N/A	N/A	N/A	N/A	N/A
802.11a	5620	124	N/A	N/A	N/A	N/A	N/A	N/A	N/A	N/A
802.11a	5640	128	N/A	N/A	N/A	N/A	N/A	N/A	N/A	N/A
802.11a	5660	132	8.80	8.74	8.77	8.84	8.82	8.75	8.78	8.76
802.11a	5680	136*	8.90	8.83	8.81	8.92	8.83	8.94	8.84	8.93
802.11a	5700	140	8.67	8.68	8.65	8.55	8.54	8.70	8.57	8.56
802.11a	5745	149*	9.15	9.12	9.13	9.18	9.09	9.15	9.19	9.03
802.11a	5765	153	9.19	9.18	9.26	9.12	9.25	9.18	9.11	9.17
802.11a	5785	157*	9.03	9.09	9.00	9.03	9.18	9.09	9.08	9.09
802.11a	5805	161	9.00	8.99	9.00	9.10	9.01	9.01	9.12	9.12
802.11a	5825	165*	8.99	9.24	9.10	9.22	9.20	9.21	9.13	9.08

Per FCC KDB Publication 443999 and RSS-210 A9.2(3), transmission on channels which overlap the 5600-5650 MHz is prohibited as a client. This device does not transmit any beacons or initiate any transmissions in 5.3 and 5.5 GHz Band.

(*) – indicates default channels per KDB Publication 248227 D01v01r02. When the adjacent channels are higher in power then the default channels, these “required channels” are considered for SAR testing instead of the default channels.



FCC ID: A3LSMG900A	 PCTEST Engineering Laboratory, Inc.	SAR EVALUATION REPORT		Reviewed by: Quality Manager
Document S/N: OY1401270204-R2.A3L	Test Dates: 02/03/14 - 02/17/14	DUT Type: Portable Handset	Page 43 of 85	

Table 9-49
IEEE 802.11n Average RF Power – 20 MHz Bandwidth



Mode	Freq [MHz]	Channel	20MHz BW 802.11n (5GHz) Conducted Power [dBm]							
			Data Rate [Mbps]							
			6.5	13	19.5	26	39	52	58.5	65
802.11n	5180	36	8.41	8.39	8.39	8.50	8.50	8.43	8.46	8.57
802.11n	5200	40	8.60	8.59	8.43	8.51	8.59	8.43	8.50	8.43
802.11n	5220	44	8.63	8.66	8.65	8.62	8.65	8.59	8.66	8.57
802.11n	5240	48	8.44	8.33	8.49	8.52	8.33	8.46	8.47	8.35
802.11n	5260	52	8.30	8.38	8.24	8.37	8.24	8.43	8.26	8.27
802.11n	5280	56	8.42	8.44	8.43	8.53	8.53	8.57	8.53	8.45
802.11n	5300	60	8.57	8.49	8.58	8.58	8.67	8.60	8.57	8.53
802.11n	5320	64	8.70	8.54	8.55	8.63	8.63	8.70	8.62	8.55
802.11n	5500	100	8.60	8.75	8.65	8.73	8.65	8.58	8.62	8.60
802.11n	5520	104	8.58	8.71	8.68	8.56	8.60	8.67	8.68	8.54
802.11n	5540	108	8.51	8.49	8.58	8.61	8.55	8.53	8.64	8.56
802.11n	5560	112	8.86	8.73	8.77	8.77	8.73	8.82	8.83	8.83
802.11n	5580	116	8.86	8.79	8.88	8.81	8.74	8.80	8.74	8.78
802.11n	5600	120	N/A	N/A	N/A	N/A	N/A	N/A	N/A	N/A
802.11n	5620	124	N/A	N/A	N/A	N/A	N/A	N/A	N/A	N/A
802.11n	5640	128	N/A	N/A	N/A	N/A	N/A	N/A	N/A	N/A
802.11n	5660	132	8.92	8.78	8.84	8.75	8.87	8.90	8.94	8.93
802.11n	5680	136	8.89	8.82	8.72	8.90	8.78	8.73	8.74	8.86
802.11n	5700	140	8.81	8.84	8.82	8.69	8.69	8.79	8.70	8.68
802.11n	5745	149	8.97	9.11	8.98	9.14	9.08	9.08	9.06	9.00
802.11n	5765	153	8.97	8.98	9.05	8.90	9.08	8.91	9.04	9.03
802.11n	5785	157	9.00	8.89	8.97	8.97	8.83	8.86	8.96	8.96
802.11n	5805	161	8.86	8.98	8.94	8.94	9.00	8.86	9.00	8.85
802.11n	5825	165	8.89	8.88	8.94	8.92	8.98	8.90	9.06	8.92

Table 9-50
IEEE 802.11n Average RF Power – 40 MHz Bandwidth

Mode	Freq [MHz]	Channel	40MHz BW 802.11n (5GHz) Conducted Power [dBm]							
			Data Rate [Mbps]							
			13.5	27	40.5	54	81	108	121.5	135
802.11n	5190	38	8.49	8.52	8.57	8.63	8.60	8.59	8.65	8.63
802.11n	5230	46	8.42	8.41	8.38	8.48	8.38	8.50	8.40	8.47
802.11n	5270	54	8.43	8.39	8.35	8.38	8.37	8.35	8.31	8.42
802.11n	5310	62	8.40	8.41	8.45	8.34	8.41	8.42	8.34	8.43
802.11n	5510	102	8.94	8.90	8.84	8.91	8.94	8.89	8.98	8.96
802.11n	5550	110	8.83	8.83	8.87	8.73	8.81	8.80	8.75	8.77
802.11n	5590	118	N/A	N/A	N/A	N/A	N/A	N/A	N/A	N/A
802.11n	5630	126	N/A	N/A	N/A	N/A	N/A	N/A	N/A	N/A
802.11n	5670	134	8.96	8.90	9.02	8.98	8.96	9.00	8.84	8.86
802.11n	5755	151	9.16	9.24	9.14	9.14	9.24	9.26	9.27	9.27
802.11n	5795	159	9.09	9.17	9.07	9.11	9.04	9.08	8.99	8.98

Table 9-51
IEEE 802.11ac Average RF Power – 80 MHz Bandwidth

Mode	Freq [MHz]	Channel	80MHz BW 802.11ac (5GHz) Conducted Power [dBm]									
			Data Rate [Mbps]									
			29.3	58.5	87.8	117	175.5	234	263.3	292.5	351	390
802.11ac	5210	42	8.12	8.17	8.28	8.30	8.18	8.19	8.23	8.21	8.14	8.27
802.11ac	5290	58	8.33	8.43	8.29	8.31	8.31	8.34	8.29	8.36	8.26	8.36
802.11ac	5530	106	8.52	8.46	8.56	8.60	8.49	8.41	8.54	8.43	8.50	8.51
802.11ac	5775	155	8.85	8.96	8.96	8.98	8.91	8.88	9.01	8.82	8.89	8.92

FCC ID: A3LSMG900A		SAR EVALUATION REPORT		Reviewed by: Quality Manager
Document S/N: OY1401270204-R2.A3L	Test Dates: 02/03/14 - 02/17/14	DUT Type: Portable Handset		Page 44 of 85

Justification for reduced test configurations for WIFI channels per KDB Publication 248227 D01v01r02 and October 2012/April 2013 FCC/TCB Meeting Notes:

- For 2.4 GHz, highest average RF output power channel for the lowest data rate for IEEE 802.11b were selected for SAR evaluation. Other IEEE 802.11 modes (including 802.11g/n) were not investigated since the average output powers over all channels and data rates were not more than 0.25 dB higher than the tested channel in the lowest data rate of IEEE 802.11b mode.
- For 5 GHz, highest average RF output power channel for the lowest data rate for IEEE 802.11a were selected for SAR evaluation. Other IEEE 802.11 modes (including 802.11n 20 MHz and 40 MHz) were not investigated since the average output powers over all channels and data rates were not more than 0.25 dB higher than the tested channel in the lowest data rate of IEEE 802.11a mode.
- Full SAR tests for all IEEE 802.11ac configurations were not required because the average output power was not more than 0.25 dB higher than IEEE 802.11a mode. IEEE 802.11ac was evaluated for the highest IEEE 802.11a position in each 5 GHz band and exposure condition.
- When the maximum extrapolated peak SAR of the zoom scan for the maximum output channel is <1.6 W/kg and the reported 1g averaged SAR is <0.8 W/kg, SAR testing on other channels is not required. Otherwise, the other default (or corresponding required) test channels were additionally tested using the lowest data rate.
- The bolded data rate and channel above were tested for SAR.

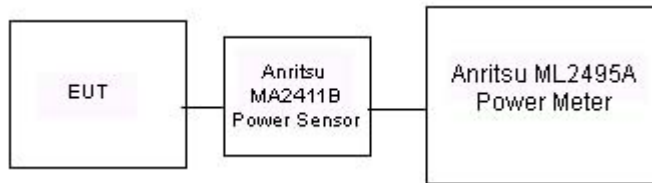

Figure 9-6
Power Measurement Setup for Bandwidths < 50 MHz

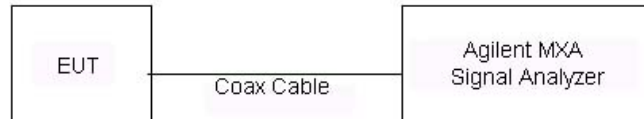



Figure 9-7
Power Measurement Setup for Bandwidths > 50 MHz

FCC ID: A3LSMG900A	 PCTEST ENGINEERING LABORATORY, INC.	SAR EVALUATION REPORT		Reviewed by: Quality Manager
Document S/N: OY1401270204-R2.A3L	Test Dates: 02/03/14 - 02/17/14	DUT Type: Portable Handset	Page 45 of 85	

9.5.3

MIMO WLAN Conducted Powers

Maximum Conducted Powers

Table 9-52
IEEE 802.11n Average RF Power MIMO

Mode	Freq [MHz]	Channel	802.11n (2.4GHz) Conducted	
			Power [dBm]	Data Rate [Mbps]
802.11n	2412	1	13.87	13
802.11n	2437	6	13.64	
802.11n	2462	11	13.48	

Table 9-48
IEEE 802.11n Average RF Power – 20 MHz Bandwidth MIMO

Mode	Freq [MHz]	Channel	20MHz BW 802.11n (5GHz)	
			Conducted Power [dBm]	Data Rate [Mbps]
802.11n	5180	36*	12.63	13
802.11n	5200	40	12.60	
802.11n	5220	44	12.62	
802.11n	5240	48*	12.55	
802.11n	5260	52*	12.75	
802.11n	5280	56	12.76	
802.11n	5300	60	12.77	
802.11n	5320	64*	12.63	
802.11n	5500	100	12.30	
802.11n	5520	104*	12.28	
802.11n	5540	108	12.25	
802.11n	5560	112	12.24	
802.11n	5580	116*	12.18	
802.11n	5600	120	N/A	
802.11n	5620	124	N/A	
802.11n	5640	128	N/A	
802.11n	5660	132	12.08	
802.11n	5680	136*	12.12	
802.11n	5700	140	12.06	
802.11n	5745	149*	13.44	
802.11n	5765	153	13.47	
802.11n	5785	157*	13.44	
802.11n	5805	161	13.43	
802.11n	5825	165*	13.41	



(*) – indicates default channels per KDB Publication 248227 D01v01r02. When the adjacent channels are higher in power than the default channels, these “required channels” are considered for SAR testing instead of the default channels.

Table 9-49
IEEE 802.11n Average RF Power – 40 MHz Bandwidth MIMO

Mode	Freq [MHz]	Channel	40MHz BW 802.11n (5GHz)	
			Conducted Power [dBm]	Data Rate [Mbps]
802.11n	5190	38	11.63	27
802.11n	5230	46	11.79	
802.11n	5270	54	11.58	
802.11n	5310	62	11.73	
802.11n	5510	102	12.33	
802.11n	5550	110	12.41	
802.11n	5590	118	N/A	
802.11n	5630	126	N/A	
802.11n	5670	134	12.14	
802.11n	5755	151	12.44	
802.11n	5795	159	12.28	

Table 9-50
IEEE 802.11ac Average RF Power – 80 MHz Bandwidth MIMO

Mode	Freq [MHz]	Channel	80MHz BW 802.11ac (5GHz)	
			Conducted Power [dBm]	Data Rate [Mbps]
802.11ac	5210	42	11.23	58.5
802.11ac	5290	58	11.27	
802.11ac	5530	106	10.89	
802.11ac	5775	155	10.76	

FCC ID: A3LSMG900A	 PCTEST ENGINEERING LABORATORY, INC.	SAR EVALUATION REPORT		Reviewed by: Quality Manager
Document S/N: OY1401270204-R2.A3L	Test Dates: 02/03/14 - 02/17/14	DUT Type: Portable Handset		Page 46 of 85

Reduced Conducted Powers – Held-to-Ear

Table 9-51
IEEE 802.11n Average RF Power MIMO

Mode	Freq [MHz]	Channel	802.11n (2.4GHz) Conducted Power [dBm]
			Data Rate [Mbps]
			13
802.11n	2412	1	11.85
802.11n	2437	6	11.70
802.11n	2462	11	11.34

Table 9-52
IEEE 802.11n Average RF Power – 20 MHz Bandwidth MIMO

Mode	Freq [MHz]	Channel	20MHz BW 802.11n (5GHz) Conducted Power [dBm]
			Data Rate [Mbps]
			13
802.11n	5180	36*	8.27
802.11n	5200	40	8.31
802.11n	5220	44	8.22
802.11n	5240	48*	8.33
802.11n	5260	52*	8.25
802.11n	5280	56	8.24
802.11n	5300	60	8.30
802.11n	5320	64*	8.23
802.11n	5500	100	9.48
802.11n	5520	104*	9.44
802.11n	5540	108	9.37
802.11n	5560	112	9.34
802.11n	5580	116*	9.44
802.11n	5600	120	N/A
802.11n	5620	124	N/A
802.11n	5640	128	N/A
802.11n	5660	132	9.35
802.11n	5680	136*	9.41
802.11n	5700	140	9.42
802.11n	5745	149*	7.64
802.11n	5765	153	7.74
802.11n	5785	157*	7.66
802.11n	5805	161	7.66
802.11n	5825	165*	7.58



(*) – indicates default channels per KDB Publication 248227 D01v01r02. When the adjacent channels are higher in power then the default channels, these “required channels” are considered for SAR testing instead of the default channels.

Table 9-53
IEEE 802.11n Average RF Power – 40 MHz Bandwidth MIMO

Mode	Freq [MHz]	Channel	40MHz BW 802.11n (5GHz) Conducted Power [dBm]
			Data Rate [Mbps]
			27
802.11n	5190	38	8.24
802.11n	5230	46	8.27
802.11n	5270	54	8.34
802.11n	5310	62	8.32
802.11n	5510	102	9.47
802.11n	5550	110	9.36
802.11n	5590	118	N/A
802.11n	5630	126	N/A
802.11n	5670	134	9.38
802.11n	5755	151	8.22
802.11n	5795	159	8.26



Table 9-54
IEEE 802.11ac Average RF Power – 80 MHz Bandwidth MIMO

Mode	Freq [MHz]	Channel	80MHz BW 802.11ac (5GHz) Conducted Power [dBm]
			Data Rate [Mbps]
			58.5
802.11ac	5210	42	9.46
802.11ac	5290	58	9.39
802.11ac	5530	106	9.40
802.11ac	5775	155	9.31

FCC ID: A3LSMG900A	 PCTEST Engineering Laboratory, Inc.	SAR EVALUATION REPORT		Reviewed by: Quality Manager
Document S/N: OY1401270204-R2.A3L	Test Dates: 02/03/14 - 02/17/14	DUT Type: Portable Handset		Page 47 of 85

Justification for reduced test configurations for WIFI channels per KDB Publication 248227 D01v01r02 and October 2012/April 2013 FCC/TCB Meeting Notes:

- For 2.4 GHz MIMO, 802.11n was evaluated.
- For 5 GHz MIMO, 20 MHz BW 802.11n was evaluated. Additional evaluations for 40 MHz bandwidth 802.11n and 802.11ac were not required since the maximum allowed output power was not higher than 802.11n 20 MHz Bandwidth.
- When the maximum extrapolated peak SAR of the zoom scan for the maximum output channel is <1.6 W/kg and the reported 1g averaged SAR is <0.8 W/kg, SAR testing on other channels is not required. Otherwise, the other default (or corresponding required) test channels were additionally tested using the lowest data rate.
- The bolded data rate and channel above were tested for SAR.

FCC ID: A3LSMG900A	 SAR EVALUATION REPORT 		Reviewed by: Quality Manager
Document S/N: 0Y1401270204-R2.A3L	Test Dates: 02/03/14 - 02/17/14	DUT Type: Portable Handset	Page 48 of 85



10 SYSTEM VERIFICATION

10.1 Tissue Verification

**Table 10-1
Measured Head Tissue Properties**

Calibrated for Tests Performed on:	Tissue Type	Tissue Temp During Calibration (C°)	Measured Frequency (MHz)	Measured Conductivity, σ (S/m)	Measured Dielectric Constant, ϵ	TARGET Conductivity, σ (S/m)	TARGET Dielectric Constant, ϵ	% dev σ	% dev ϵ
2/7/2014	750H	22.7	710	0.898	42.062	0.890	42.149	0.90%	-0.21%
			725	0.911	41.844	0.891	42.071	2.24%	-0.54%
			740	0.924	41.614	0.893	41.994	3.47%	-0.90%
			755	0.938	41.441	0.894	41.916	4.92%	-1.13%
2/7/2014	835H	23.9	820	0.878	40.566	0.899	41.578	-2.34%	-2.43%
			835	0.892	40.400	0.900	41.500	-0.89%	-2.65%
			850	0.907	40.192	0.916	41.500	-0.98%	-3.15%
2/10/2014	835H	22.9	820	0.917	42.790	0.899	41.578	2.00%	2.92%
			835	0.932	42.598	0.900	41.500	3.56%	2.65%
			850	0.944	42.413	0.916	41.500	3.06%	2.20%
2/10/2014	1750H	23.0	1710	1.381	39.178	1.348	40.142	2.45%	-2.40%
			1750	1.420	38.996	1.371	40.079	3.57%	-2.70%
			1790	1.461	38.795	1.394	40.016	4.81%	-3.05%
2/10/2014	1900H	22.8	1850	1.360	38.440	1.400	40.000	-2.86%	-3.90%
			1880	1.390	38.329	1.400	40.000	-0.71%	-4.18%
			1910	1.413	38.177	1.400	40.000	0.93%	-4.56%
2/14/2014	2450H	23.0	2401	1.779	40.217	1.756	39.287	1.31%	2.37%
			2450	1.840	40.077	1.800	39.200	2.22%	2.24%
			2499	1.891	39.887	1.853	39.138	2.05%	1.91%
2/6/2014	5200H-5800H	23.1	5180	4.533	37.666	4.635	36.009	-2.20%	4.60%
			5200	4.566	37.509	4.655	35.986	-1.91%	4.23%
			5260	4.663	37.698	4.717	35.917	-1.14%	4.96%
			5300	4.651	37.509	4.758	35.871	-2.25%	4.57%
			5500	4.925	37.305	4.963	35.643	-0.77%	4.66%
			5580	4.954	37.020	5.045	35.551	-1.80%	4.13%
			5600	5.017	37.024	5.065	35.529	-0.95%	4.21%
			5680	5.034	36.990	5.147	35.437	-2.20%	4.38%
			5745	5.200	36.954	5.214	35.363	-0.27%	4.50%
			5785	5.182	36.998	5.255	35.317	-1.39%	4.76%
			5800	5.176	36.885	5.270	35.300	-1.78%	4.49%
5805	5.175	36.876	5.275	35.294	-1.90%	4.48%			
2/17/2014	5500H	22.3	5500	4.912	36.692	4.963	35.643	-1.03%	2.94%



The above measured tissue parameters were used in the DASY software. The DASY software was used to perform interpolation to determine the dielectric parameters at the SAR test device frequencies (per KDB 865664 and IEEE 1528-2013 6.6.1.2). The tissue parameters listed in the SAR test plots may slightly differ from the table above due to significant digit rounding in the software.

FCC ID: A3LSMG900A	 PCTEST Engineering Laboratory, Inc.	SAR EVALUATION REPORT		Reviewed by: Quality Manager
Document S/N: OY1401270204-R2.A3L	Test Dates: 02/03/14 - 02/17/14	DUT Type: Portable Handset		Page 49 of 85

**Table 10-2
Measured Body Tissue Properties**

Calibrated for Tests Performed on:	Tissue Type	Tissue Temp During Calibration (C°)	Measured Frequency (MHz)	Measured Conductivity, σ (S/m)	Measured Dielectric Constant, ϵ	TARGET Conductivity, σ (S/m)	TARGET Dielectric Constant, ϵ	% dev σ	% dev ϵ
2/11/2014	750B	21.2	710	0.942	56.049	0.960	55.687	-1.88%	0.65%
			725	0.952	56.005	0.961	55.629	-0.94%	0.68%
			740	0.970	55.884	0.963	55.570	0.73%	0.57%
			755	0.985	55.578	0.964	55.512	2.18%	0.12%
2/10/2014	835B	20.4	820	0.939	54.771	0.969	55.258	-3.10%	-0.88%
			835	0.954	54.628	0.970	55.200	-1.65%	-1.04%
			850	0.969	54.462	0.988	55.154	-1.92%	-1.25%
2/10/2014	1750B	23.3	1710	1.439	52.043	1.463	53.537	-1.64%	-2.79%
			1750	1.476	51.932	1.488	53.432	-0.81%	-2.81%
			1790	1.512	51.694	1.514	53.326	-0.13%	-3.06%
2/10/2014	1900B	23.6	1850	1.489	52.437	1.520	53.300	-2.04%	-1.62%
			1880	1.523	52.350	1.520	53.300	0.20%	-1.78%
			1910	1.557	52.226	1.520	53.300	2.43%	-2.02%
2/12/2014	2450B	24.0	2401	1.872	51.518	1.903	52.765	-1.63%	-2.36%
			2450	1.937	51.331	1.950	52.700	-0.67%	-2.60%
			2499	1.998	51.123	2.019	52.638	-1.04%	-2.88%
2/3/2014	5200B - 5800B	22.6	5200	5.168	47.598	5.299	49.014	-2.47%	-2.89%
			5220	5.189	47.462	5.323	48.987	-2.52%	-3.11%
			5280	5.313	47.205	5.393	48.906	-1.48%	-3.48%
			5300	5.352	47.314	5.416	48.879	-1.18%	-3.20%
			5500	5.579	46.639	5.650	48.607	-1.26%	-4.05%
			5520	5.640	46.533	5.673	48.580	-0.58%	-4.21%
			5540	5.696	46.550	5.696	48.553	0.00%	-4.13%
			5580	5.764	46.751	5.743	48.499	0.37%	-3.60%
			5600	5.749	46.646	5.766	48.471	-0.29%	-3.77%
			5660	5.868	46.242	5.837	48.390	0.53%	-4.44%
			5745	5.965	46.140	5.936	48.275	0.49%	-4.42%
			5765	5.986	45.986	5.959	48.248	0.45%	-4.69%
			5785	6.049	45.975	5.982	48.220	1.12%	-4.66%
			5800	6.097	46.032	6.000	48.200	1.62%	-4.50%
			5805	6.109	46.051	6.006	48.193	1.71%	-4.44%
2/9/2014	5800B	22.5	5745	6.102	46.334	5.936	48.275	2.80%	-4.02%
			5765	6.128	46.297	5.959	48.248	2.84%	-4.04%
			5800	6.172	46.231	6.000	48.200	2.87%	-4.09%
			5805	6.177	46.187	6.006	48.193	2.85%	-4.16%

The above measured tissue parameters were used in the DASY software. The DASY software was used to perform interpolation to determine the dielectric parameters at the SAR test device frequencies (per KDB 865664 and IEEE 1528-2013 6.6.1.2). The tissue parameters listed in the SAR test plots may slightly differ from the table above due to significant digit rounding in the software.

FCC ID: A3LSMG900A		SAR EVALUATION REPORT		Reviewed by: Quality Manager
Document S/N: OY1401270204-R2.A3L	Test Dates: 02/03/14 - 02/17/14	DUT Type: Portable Handset		Page 50 of 85

10.2 Test System Verification

Prior to SAR assessment, the system is verified to $\pm 10\%$ of the SAR measurement on the reference dipole at the time of calibration by the calibration facility. Full system validation status and result summary can be found in Appendix E.

Table 10-3
System Verification Results

System Verification												
TARGET & MEASURED												
SAR System #	Tissue Frequency (MHz)	Tissue Type	Date:	Amb. Temp (°C)	Liquid Temp (°C)	Input Power (W)	Dipole SN	Probe SN	Measured SAR _{1g} (W/kg)	1 W Target SAR _{1g} (W/kg)	1 W Normalized SAR _{1g} (W/kg)	Deviation _{1g} (%)
I	750	HEAD	02/07/2014	24.5	23.8	0.100	1046	3319	0.813	8.500	8.130	-4.35%
H	835	HEAD	02/07/2014	24.6	24.1	0.100	4d119	3589	0.941	9.680	9.410	-2.79%
H	835	HEAD	02/10/2014	23.9	23.1	0.100	4d119	3589	0.965	9.680	9.650	-0.31%
B	1750	HEAD	02/10/2014	23.6	23.0	0.100	1008	3288	3.480	36.800	34.800	-5.43%
B	1900	HEAD	02/10/2014	23.5	22.8	0.100	5d141	3288	4.070	40.800	40.700	-0.25%
K	2450	HEAD	02/14/2014	23.9	23.2	0.100	719	3287	5.420	53.200	54.200	1.88%
E	5200	HEAD	02/06/2014	24.5	23.5	0.100	1120	3914	7.840	76.000	78.400	3.16%
E	5300	HEAD	02/06/2014	24.1	23.5	0.100	1120	3914	7.960	78.700	79.600	1.14%
E	5500	HEAD	02/06/2014	23.9	23.5	0.100	1120	3914	7.910	80.100	79.100	-1.25%
E	5500	HEAD	02/17/2014	24.3	23.0	0.040	1057	3914	3.160	84.300	79.000	-6.29%
E	5600	HEAD	02/06/2014	24.0	23.4	0.100	1120	3914	7.970	79.900	79.700	-0.25%
E	5800	HEAD	02/06/2014	24.1	23.5	0.100	1120	3914	7.400	74.900	74.000	-1.20%
C	750	BODY	02/11/2014	22.3	21.1	0.100	1054	3263	0.880	8.720	8.800	0.92%
C	835	BODY	02/10/2014	23.4	20.1	0.100	4d133	3263	0.956	9.610	9.560	-0.52%
B	1750	BODY	02/10/2014	23.6	22.9	0.100	1008	3288	3.690	38.200	36.900	-3.40%
I	1900	BODY	02/10/2014	24.4	23.6	0.100	5d149	3319	3.820	40.500	38.200	-5.68%
H	2450	BODY	02/12/2014	24.6	24.0	0.100	719	3318	5.410	51.700	54.100	4.64%
E	5200	BODY	02/03/2014	24.5	22.6	0.040	1120	3914	3.110	76.600	77.750	1.50%
E	5300	BODY	02/03/2014	24.4	22.6	0.040	1120	3914	3.260	76.800	81.500	6.12%
E	5500	BODY	02/03/2014	24.3	22.6	0.040	1120	3914	3.270	79.800	81.750	2.44%
E	5600	BODY	02/03/2014	24.5	22.5	0.040	1120	3914	3.380	80.700	84.500	4.71%
E	5800	BODY	02/03/2014	24.5	22.7	0.040	1120	3914	3.050	75.500	76.250	0.99%
E	5800	BODY	02/09/2014	24.5	23.3	0.100	1120	3914	6.940	75.500	69.400	-8.08%

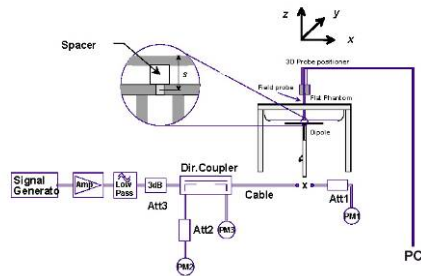

Figure 10-1
System Verification Setup Diagram



Figure 10-2
System Verification Setup Photo

FCC ID: A3LSMG900A	PCTEST Engineering Laboratory, Inc.	SAR EVALUATION REPORT		Reviewed by: Quality Manager
Document S/N: OY1401270204-R2.A3L	Test Dates: 02/03/14 - 02/17/14	DUT Type: Portable Handset		Page 51 of 85

11 SAR DATA SUMMARY

11.1 Standalone Head SAR Data

**Table 11-1
GSM 850 Head SAR**

MEASUREMENT RESULTS															
FREQUENCY		Mode/Band	Service	Maximum Allowed Power [dBm]	Conducted Power [dBm]	Power Drift [dB]	Side	Test Position	Cover Type	Device Serial Number	Duty Cycle	SAR (1g)	Scaling Factor	Scaled SAR (1g)	Plot #
MHz	Ch.											(W/kg)		(W/kg)	
836.60	190	GSM 850	GSM	33.5	32.52	0.12	Right	Cheek	Standard	00F0B	1:8.3	0.250	1.253	0.313	
836.60	190	GSM 850	GSM	33.5	32.52	0.02	Right	Tilt	Standard	00F0B	1:8.3	0.175	1.253	0.219	
836.60	190	GSM 850	GSM	33.5	32.52	0.02	Left	Cheek	Standard	00F0B	1:8.3	0.259	1.253	0.325	A1
836.60	190	GSM 850	GSM	33.5	32.52	0.01	Left	Cheek	Wireless Charging	00F0B	1:8.3	0.215	1.253	0.269	
836.60	190	GSM 850	GSM	33.5	32.52	0.06	Left	Tilt	Standard	00F0B	1:8.3	0.170	1.253	0.213	
ANSI / IEEE C95.1 1992 - SAFETY LIMIT Spatial Peak Uncontrolled Exposure/General Population							Head 1.6 W/kg (mW/g) averaged over 1 gram								

**Table 11-2
GSM 1900 Head SAR**



MEASUREMENT RESULTS															
FREQUENCY		Mode/Band	Service	Maximum Allowed Power [dBm]	Conducted Power [dBm]	Power Drift [dB]	Side	Test Position	Cover Type	Device Serial Number	Duty Cycle	SAR (1g)	Scaling Factor	Scaled SAR (1g)	Plot #
MHz	Ch.											(W/kg)		(W/kg)	
1880.00	661	GSM 1900	GSM	30.5	30.11	0.03	Right	Cheek	Standard	00F0D	1:8.3	0.065	1.094	0.071	
1880.00	661	GSM 1900	GSM	30.5	30.11	0.09	Right	Tilt	Standard	00F0D	1:8.3	0.053	1.094	0.058	
1880.00	661	GSM 1900	GSM	30.5	30.11	0.03	Left	Cheek	Standard	00F0D	1:8.3	0.151	1.094	0.165	
1880.00	661	GSM 1900	GSM	30.5	30.11	-0.13	Left	Cheek	Wireless Charging	00F0D	1:8.3	0.152	1.094	0.166	A2
1880.00	661	GSM 1900	GSM	30.5	30.11	0.15	Left	Tilt	Standard	00F0D	1:8.3	0.043	1.094	0.047	
ANSI / IEEE C95.1 1992 - SAFETY LIMIT Spatial Peak Uncontrolled Exposure/General Population							Head 1.6 W/kg (mW/g) averaged over 1 gram								

**Table 11-3
UMTS 850 Head SAR**

MEASUREMENT RESULTS															
FREQUENCY		Mode/Band	Service	Maximum Allowed Power [dBm]	Conducted Power [dBm]	Power Drift [dB]	Side	Test Position	Cover Type	Device Serial Number	Duty Cycle	SAR (1g)	Scaling Factor	Scaled SAR (1g)	Plot #
MHz	Ch.											(W/kg)		(W/kg)	
836.60	4183	UMTS 850	RMC	23.5	22.43	0.09	Right	Cheek	Standard	00F0B	1:1	0.211	1.279	0.270	
836.60	4183	UMTS 850	RMC	23.5	22.43	0.07	Right	Tilt	Standard	00F0B	1:1	0.145	1.279	0.185	
836.60	4183	UMTS 850	RMC	23.5	22.43	0.01	Left	Cheek	Standard	00F0B	1:1	0.212	1.279	0.271	A3
836.60	4183	UMTS 850	RMC	23.5	22.43	-0.03	Left	Cheek	Wireless Charging	00F0B	1:1	0.200	1.279	0.256	
836.60	4183	UMTS 850	RMC	23.5	22.43	-0.05	Left	Tilt	Standard	00F0B	1:1	0.133	1.279	0.170	
ANSI / IEEE C95.1 1992 - SAFETY LIMIT Spatial Peak Uncontrolled Exposure/General Population							Head 1.6 W/kg (mW/g) averaged over 1 gram								

**Table 11-4
UMTS 1900 Head SAR**

MEASUREMENT RESULTS															
FREQUENCY		Mode/Band	Service	Maximum Allowed Power [dBm]	Conducted Power [dBm]	Power Drift [dB]	Side	Test Position	Cover Type	Device Serial Number	Duty Cycle	SAR (1g)	Scaling Factor	Scaled SAR (1g)	Plot #
MHz	Ch.											(W/kg)		(W/kg)	
1880.00	9400	UMTS 1900	RMC	23.0	22.62	-0.08	Right	Cheek	Standard	00F0D	1:1	0.214	1.091	0.233	
1880.00	9400	UMTS 1900	RMC	23.0	22.62	-0.02	Right	Tilt	Standard	00F0D	1:1	0.215	1.091	0.235	
1880.00	9400	UMTS 1900	RMC	23.0	22.62	-0.10	Left	Cheek	Standard	00F0D	1:1	0.412	1.091	0.449	
1880.00	9400	UMTS 1900	RMC	23.0	22.62	-0.19	Left	Cheek	Wireless Charging	00F0D	1:1	0.442	1.091	0.482	A4
1880.00	9400	UMTS 1900	RMC	23.0	22.62	0.00	Left	Tilt	Standard	00F0D	1:1	0.159	1.091	0.173	
ANSI / IEEE C95.1 1992 - SAFETY LIMIT Spatial Peak Uncontrolled Exposure/General Population							Head 1.6 W/kg (mW/g) averaged over 1 gram								

FCC ID: A3LSMG900A	 PCTEST Engineering Laboratory, Inc.	SAR EVALUATION REPORT		Reviewed by: Quality Manager
Document S/N: OY1401270204-R2.A3L	Test Dates: 02/03/14 - 02/17/14	DUT Type: Portable Handset		Page 52 of 85

**Table 11-5
LTE Band 17 Head SAR**

MEASUREMENT RESULTS																				
FREQUENCY		Mode	Bandwidth [MHz]	Cover Type	Maximum Allowed Power [dBm]	Conducted Power [dBm]	Power Drift [dB]	MPR [dB]	Side	Test Position	Modulation	RB Size	RB Offset	Device Serial Number	Duty Cycle	SAR (1g)	Scaling Factor	Scaled SAR (1g) (W/kg)	Plot #	
MHz	Ch.															(W/kg)				
710.00	23790	Mid	LTE Band 17	10	Standard	24.5	23.00	0.13	0	Right	Cheek	QPSK	1	49	00E6B	1:1	0.199	1.413	0.281	A5
710.00	23790	Mid	LTE Band 17	10	Wireless Charging	24.5	23.00	0.01	0	Right	Cheek	QPSK	1	49	00E6B	1:1	0.172	1.413	0.243	
710.00	23790	Mid	LTE Band 17	10	Standard	23.5	21.97	0.12	1	Right	Cheek	QPSK	25	25	00E6B	1:1	0.165	1.422	0.235	
710.00	23790	Mid	LTE Band 17	10	Standard	24.5	23.00	0.13	0	Right	Tilt	QPSK	1	49	00E6B	1:1	0.091	1.413	0.129	
710.00	23790	Mid	LTE Band 17	10	Standard	23.5	21.97	0.13	1	Right	Tilt	QPSK	25	25	00E6B	1:1	0.069	1.422	0.098	
710.00	23790	Mid	LTE Band 17	10	Standard	24.5	23.00	0.20	0	Left	Cheek	QPSK	1	49	00E6B	1:1	0.197	1.413	0.278	
710.00	23790	Mid	LTE Band 17	10	Standard	23.5	21.97	0.13	1	Left	Cheek	QPSK	25	25	00E6B	1:1	0.166	1.422	0.236	
710.00	23790	Mid	LTE Band 17	10	Standard	24.5	23.00	0.13	0	Left	Tilt	QPSK	1	49	00E6B	1:1	0.107	1.413	0.151	
710.00	23790	Mid	LTE Band 17	10	Standard	23.5	21.97	0.11	1	Left	Tilt	QPSK	25	25	00E6B	1:1	0.089	1.422	0.127	
ANSI / IEEE C95.1 1992 - SAFETY LIMIT Spatial Peak Uncontrolled Exposure/General Population											Head 1.6 W/kg (mW/g) averaged over 1 gram									

**Table 11-6
LTE Band 5 (Cell) Head SAR**



MEASUREMENT RESULTS																				
FREQUENCY		Mode	Bandwidth [MHz]	Cover Type	Maximum Allowed Power [dBm]	Conducted Power [dBm]	Power Drift [dB]	MPR [dB]	Side	Test Position	Modulation	RB Size	RB Offset	Device Serial Number	Duty Cycle	SAR (1g)	Scaling Factor	Scaled SAR (1g) (W/kg)	Plot #	
MHz	Ch.															(W/kg)				
836.50	20525	Mid	LTE Band 5 (Cell)	10	Standard	24.0	23.20	-0.06	0	Right	Cheek	QPSK	1	25	00E6B	1:1	0.245	1.202	0.294	
836.50	20525	Mid	LTE Band 5 (Cell)	10	Standard	23.0	22.08	-0.01	1	Right	Cheek	QPSK	25	0	00E6B	1:1	0.188	1.236	0.232	
836.50	20525	Mid	LTE Band 5 (Cell)	10	Standard	24.0	23.20	-0.12	0	Right	Tilt	QPSK	1	25	00E6B	1:1	0.155	1.202	0.186	
836.50	20525	Mid	LTE Band 5 (Cell)	10	Standard	23.0	22.08	-0.13	1	Right	Tilt	QPSK	25	0	00E6B	1:1	0.130	1.236	0.161	
836.50	20525	Mid	LTE Band 5 (Cell)	10	Standard	24.0	23.20	0.03	0	Left	Cheek	QPSK	1	25	00E6B	1:1	0.247	1.202	0.297	A6
836.50	20525	Mid	LTE Band 5 (Cell)	10	Wireless Charging	24.0	23.20	0.02	0	Left	Cheek	QPSK	1	25	00E6B	1:1	0.132	1.202	0.159	
836.50	20525	Mid	LTE Band 5 (Cell)	10	Standard	23.0	22.08	0.03	1	Left	Cheek	QPSK	25	0	00E6B	1:1	0.210	1.236	0.260	
836.50	20525	Mid	LTE Band 5 (Cell)	10	Standard	24.0	23.20	0.03	0	Left	Tilt	QPSK	1	25	00E6B	1:1	0.174	1.202	0.209	
836.50	20525	Mid	LTE Band 5 (Cell)	10	Standard	23.0	22.08	0.00	1	Left	Tilt	QPSK	25	0	00E6B	1:1	0.144	1.236	0.178	
ANSI / IEEE C95.1 1992 - SAFETY LIMIT Spatial Peak Uncontrolled Exposure/General Population											Head 1.6 W/kg (mW/g) averaged over 1 gram									

**Table 11-7
LTE Band 4 (AWS) Head SAR**

MEASUREMENT RESULTS																				
FREQUENCY		Mode	Bandwidth [MHz]	Cover Type	Maximum Allowed Power [dBm]	Conducted Power [dBm]	Power Drift [dB]	MPR [dB]	Side	Test Position	Modulation	RB Size	RB Offset	Device Serial Number	Duty Cycle	SAR (1g)	Scaling Factor	Scaled SAR (1g) (W/kg)	Plot #	
MHz	Ch.															(W/kg)				
1732.50	20175	Mid	LTE Band 4 (AWS)	20	Standard	23.5	23.23	0.09	0	Right	Cheek	QPSK	1	0	00FOA	1:1	0.240	1.064	0.255	
1732.50	20175	Mid	LTE Band 4 (AWS)	20	Standard	22.5	22.22	0.07	1	Right	Cheek	QPSK	50	0	00FOA	1:1	0.167	1.067	0.178	
1732.50	20175	Mid	LTE Band 4 (AWS)	20	Standard	23.5	23.23	-0.07	0	Right	Tilt	QPSK	1	0	00FOA	1:1	0.086	1.064	0.092	
1732.50	20175	Mid	LTE Band 4 (AWS)	20	Standard	22.5	22.22	0.09	1	Right	Tilt	QPSK	50	0	00FOA	1:1	0.061	1.067	0.065	
1732.50	20175	Mid	LTE Band 4 (AWS)	20	Standard	23.5	23.23	-0.10	0	Left	Cheek	QPSK	1	0	00FOA	1:1	0.466	1.064	0.496	A7
1732.50	20175	Mid	LTE Band 4 (AWS)	20	Wireless Charging	23.5	23.23	-0.12	0	Left	Cheek	QPSK	1	0	00FOA	1:1	0.416	1.064	0.443	
1732.50	20175	Mid	LTE Band 4 (AWS)	20	Standard	22.5	22.22	-0.08	1	Left	Cheek	QPSK	50	0	00FOA	1:1	0.357	1.067	0.381	
1732.50	20175	Mid	LTE Band 4 (AWS)	20	Standard	23.5	23.23	-0.13	0	Left	Tilt	QPSK	1	0	00FOA	1:1	0.141	1.064	0.150	
1732.50	20175	Mid	LTE Band 4 (AWS)	20	Standard	22.5	22.22	0.11	1	Left	Tilt	QPSK	50	0	00FOA	1:1	0.096	1.067	0.102	
ANSI / IEEE C95.1 1992 - SAFETY LIMIT Spatial Peak Uncontrolled Exposure/General Population											Head 1.6 W/kg (mW/g) averaged over 1 gram									

**Table 11-8
LTE Band 2 (PCS) Head SAR**

MEASUREMENT RESULTS																				
FREQUENCY		Mode	Bandwidth [MHz]	Cover Type	Maximum Allowed Power [dBm]	Conducted Power [dBm]	Power Drift [dB]	MPR [dB]	Side	Test Position	Modulation	RB Size	RB Offset	Device Serial Number	Duty Cycle	SAR (1g)	Scaling Factor	Scaled SAR (1g) (W/kg)	Plot #	
MHz	Ch.															(W/kg)				
1880.00	18900	Mid	LTE Band 2 (PCS)	20	Standard	23.5	23.50	-0.06	0	Right	Cheek	QPSK	1	0	00FOA	1:1	0.273	1.000	0.273	
1880.00	18900	Mid	LTE Band 2 (PCS)	20	Standard	22.5	22.49	-0.09	1	Right	Cheek	QPSK	50	0	00FOA	1:1	0.229	1.002	0.229	
1880.00	18900	Mid	LTE Band 2 (PCS)	20	Standard	23.5	23.50	0.19	0	Right	Tilt	QPSK	1	0	00FOA	1:1	0.281	1.000	0.281	
1880.00	18900	Mid	LTE Band 2 (PCS)	20	Standard	22.5	22.49	0.06	1	Right	Tilt	QPSK	50	0	00FOA	1:1	0.233	1.002	0.233	
1880.00	18900	Mid	LTE Band 2 (PCS)	20	Standard	23.5	23.50	-0.01	0	Left	Cheek	QPSK	1	0	00FOA	1:1	0.483	1.000	0.483	
1880.00	18900	Mid	LTE Band 2 (PCS)	20	Wireless Charging	23.5	23.50	-0.13	0	Left	Cheek	QPSK	1	0	00FOA	1:1	0.495	1.000	0.495	A8
1880.00	18900	Mid	LTE Band 2 (PCS)	20	Standard	22.5	22.49	-0.05	1	Left	Cheek	QPSK	50	0	00FOA	1:1	0.415	1.002	0.416	
1880.00	18900	Mid	LTE Band 2 (PCS)	20	Standard	23.5	23.50	-0.12	0	Left	Tilt	QPSK	1	0	00FOA	1:1	0.215	1.000	0.215	
1880.00	18900	Mid	LTE Band 2 (PCS)	20	Standard	22.5	22.49	0.06	1	Left	Tilt	QPSK	50	0	00FOA	1:1	0.172	1.002	0.172	
ANSI / IEEE C95.1 1992 - SAFETY LIMIT Spatial Peak Uncontrolled Exposure/General Population											Head 1.6 W/kg (mW/g) averaged over 1 gram									



FCC ID: A3LSMG900A		SAR EVALUATION REPORT		Reviewed by: Quality Manager
Document S/N: OY1401270204-R2.A3L	Test Dates: 02/03/14 - 02/17/14	DUT Type: Portable Handset		Page 53 of 85

**Table 11-9
DTS Head - Antenna 1 WLAN SAR**

MEASUREMENT RESULTS																
FREQUENCY		Mode	Service	Maximum Allowed Power [dBm]	Conducted Power [dBm]	Power Drift [dB]	Side	Test Position	Cover Type	Device Serial Number	Data Rate (Mbps)	Duty Cycle	SAR (1g)	Scaling Factor	Scaled SAR (1g)	Plot #
MHz	Ch.												(W/kg)		(W/kg)	
2412	1	IEEE 802.11b	DSSS	12.5	11.94	0.02	Right	Cheek	Standard	00F05	1	1:1	0.354	1.138	0.403	A9
2412	1	IEEE 802.11b	DSSS	12.5	11.94	0.17	Right	Cheek	Wireless Charging	00F05	1	1:1	0.347	1.138	0.395	
2412	1	IEEE 802.11b	DSSS	12.5	11.94	0.20	Right	Tilt	Standard	00F05	1	1:1	0.272	1.138	0.310	
2412	1	IEEE 802.11b	DSSS	12.5	11.94	0.10	Left	Cheek	Standard	00F05	1	1:1	0.231	1.138	0.263	
2412	1	IEEE 802.11b	DSSS	12.5	11.94	-0.02	Left	Tilt	Standard	00F05	1	1:1	0.195	1.138	0.222	
5785	157	IEEE 802.11a	OFDM	9.5	9.28	-0.03	Right	Cheek	Standard	F1186	6	1:1	0.293	1.052	0.308	
5745	149	IEEE 802.11a	OFDM	9.5	9.12	-0.06	Right	Tilt	Standard	F1186	6	1:1	0.352	1.091	0.384	
5785	157	IEEE 802.11a	OFDM	9.5	9.28	0.05	Right	Tilt	Standard	F1186	6	1:1	0.359	1.052	0.378	A10
5805	161	IEEE 802.11a	OFDM	9.5	9.19	0.03	Right	Tilt	Standard	F1186	6	1:1	0.333	1.074	0.358	
5775	155	IEEE 802.11ac	OFDM	9.5	9.01	0.08	Right	Tilt	Standard	F1186	29.3	1:1	0.199	1.119	0.223	
5785	157	IEEE 802.11a	OFDM	9.5	9.28	0.14	Left	Cheek	Standard	F1186	6	1:1	0.339	1.052	0.357	
5785	157	IEEE 802.11a	OFDM	9.5	9.28	-0.05	Left	Tilt	Standard	F1186	6	1:1	0.343	1.052	0.361	
ANSI / IEEE C95.1 1992 - SAFETY LIMIT Spatial Peak Uncontrolled Exposure/General Population							Head 1.6 W/kg (mW/g) averaged over 1 gram									

**Table 11-10
NII Head -Antenna 1 WLAN SAR**

MEASUREMENT RESULTS																
FREQUENCY		Mode	Service	Maximum Allowed Power [dBm]	Conducted Power [dBm]	Power Drift [dB]	Side	Test Position	Cover Type	Device Serial Number	Data Rate (Mbps)	Duty Cycle	SAR (1g)	Scaling Factor	Scaled SAR (1g)	Plot #
MHz	Ch.												(W/kg)		(W/kg)	
5180	36	IEEE 802.11a	OFDM	9.5	9.25	0.21	Right	Cheek	Standard	F1186	6	1:1	0.099	1.059	0.105	
5180	36	IEEE 802.11a	OFDM	9.5	9.25	0.16	Right	Tilt	Standard	F1186	6	1:1	0.111	1.059	0.118	
5210	42	IEEE 802.11ac	OFDM	9.5	9.30	-0.01	Right	Tilt	Standard	F1186	29.3	1:1	0.068	1.047	0.071	
5180	36	IEEE 802.11a	OFDM	9.5	9.25	0.17	Left	Cheek	Standard	F1186	6	1:1	0.094	1.059	0.100	
5180	36	IEEE 802.11a	OFDM	9.5	9.25	0.04	Left	Tilt	Standard	F1186	6	1:1	0.104	1.059	0.110	
5260	52	IEEE 802.11a	OFDM	9.5	9.33	0.03	Right	Cheek	Standard	F1186	6	1:1	0.149	1.040	0.155	
5260	52	IEEE 802.11a	OFDM	9.5	9.33	0.17	Right	Tilt	Standard	F1186	6	1:1	0.175	1.040	0.182	
5290	58	IEEE 802.11ac	OFDM	9.5	8.77	0.04	Right	Tilt	Standard	F1186	29.3	1:1	0.111	1.183	0.131	
5260	52	IEEE 802.11a	OFDM	9.5	9.33	0.21	Left	Cheek	Standard	F1186	6	1:1	0.136	1.040	0.141	
5260	52	IEEE 802.11a	OFDM	9.5	9.33	0.03	Left	Tilt	Standard	F1186	6	1:1	0.156	1.040	0.162	
5580	116	IEEE 802.11a	OFDM	9.5	9.46	-0.03	Right	Cheek	Standard	F1186	6	1:1	0.232	1.009	0.234	
5500	100	IEEE 802.11a	OFDM	9.5	9.45	0.00	Right	Tilt	Standard	F1186	6	1:1	0.389	1.012	0.394	
5580	116	IEEE 802.11a	OFDM	9.5	9.46	-0.05	Right	Tilt	Standard	F1186	6	1:1	0.323	1.009	0.326	
5680	136	IEEE 802.11a	OFDM	9.5	9.39	-0.03	Right	Tilt	Standard	F1186	6	1:1	0.381	1.026	0.391	
5530	106	IEEE 802.11ac	OFDM	9.5	9.16	-0.01	Right	Tilt	Standard	F1186	29.3	1:1	0.213	1.081	0.230	
5500	100	IEEE 802.11a	OFDM	9.5	9.45	-0.15	Right	Tilt	Wireless Charging	F1186	6	1:1	0.554	1.012	0.561	A11
5580	116	IEEE 802.11a	OFDM	9.5	9.46	-0.04	Left	Cheek	Standard	F1186	6	1:1	0.303	1.009	0.306	
5580	116	IEEE 802.11a	OFDM	9.5	9.46	0.19	Left	Tilt	Standard	F1186	6	1:1	0.334	1.009	0.337	
ANSI / IEEE C95.1 1992 - SAFETY LIMIT Spatial Peak Uncontrolled Exposure/General Population							Head 1.6 W/kg (mW/g) averaged over 1 gram									

FCC ID: A3LSMG900A	 PCTEST Engineering Laboratory, Inc.	SAR EVALUATION REPORT		Reviewed by: Quality Manager
Document S/N: OY1401270204-R2.A3L	Test Dates: 02/03/14 - 02/17/14	DUT Type: Portable Handset		Page 54 of 85

**Table 11-11
DTS Head - Antenna 2 WLAN SAR**



MEASUREMENT RESULTS																
FREQUENCY		Mode	Service	Maximum Allowed Power [dBm]	Conducted Power [dBm]	Power Drift [dB]	Side	Test Position	Cover Type	Device Serial Number	Data Rate (Mbps)	Duty Cycle	SAR (1g)	Scaling Factor	Scaled SAR (1g)	Plot #
MHz	Ch.												(W/kg)		(W/kg)	
2412	1	IEEE 802.11b	DSSS	12.5	11.74	0.04	Right	Cheek	Standard	00F05	1	1:1	0.110	1.191	0.131	
2412	1	IEEE 802.11b	DSSS	12.5	11.74	0.17	Right	Tilt	Standard	00F05	1	1:1	0.025	1.191	0.030	
2412	1	IEEE 802.11b	DSSS	12.5	11.74	0.03	Left	Cheek	Standard	00F05	1	1:1	0.046	1.191	0.055	
2412	1	IEEE 802.11b	DSSS	12.5	11.74	0.04	Left	Tilt	Standard	00F05	1	1:1	0.020	1.191	0.024	
5765	153	IEEE 802.11a	OFDM	9.5	9.19	0.03	Right	Cheek	Standard	F1186	6	1:1	0.034	1.074	0.037	
5765	153	IEEE 802.11a	OFDM	9.5	9.19	-0.04	Right	Tilt	Standard	F1186	6	1:1	0.041	1.074	0.044	
5775	155	IEEE 802.11ac	OFDM	9.5	8.85	-0.02	Right	Tilt	Standard	F1186	29.3	1:1	0.020	1.161	0.023	
5765	153	IEEE 802.11a	OFDM	9.5	9.19	0.03	Left	Cheek	Standard	F1186	6	1:1	0.011	1.074	0.012	
5765	153	IEEE 802.11a	OFDM	9.5	9.19	0.03	Left	Tilt	Standard	F1186	6	1:1	0.004	1.074	0.004	
ANSI / IEEE C95.1 1992 - SAFETY LIMIT Spatial Peak Uncontrolled Exposure/General Population									Head 1.6 W/kg (mW/g) averaged over 1 gram							

**Table 11-12
NII Head -Antenna 2 WLAN SAR**

MEASUREMENT RESULTS																
FREQUENCY		Mode	Service	Maximum Allowed Power [dBm]	Conducted Power [dBm]	Power Drift [dB]	Side	Test Position	Cover Type	Device Serial Number	Data Rate (Mbps)	Duty Cycle	SAR (1g)	Scaling Factor	Scaled SAR (1g)	Plot #
MHz	Ch.												(W/kg)		(W/kg)	
5220	44	IEEE 802.11a	OFDM	9.5	8.83	-0.11	Right	Cheek	Standard	F1186	6	1:1	0.121	1.167	0.141	
5210	42	IEEE 802.11ac	OFDM	9.5	8.12	0.20	Right	Cheek	Standard	F1186	29.3	1:1	0.076	1.374	0.104	
5220	44	IEEE 802.11a	OFDM	9.5	8.83	0.11	Right	Tilt	Standard	F1186	6	1:1	0.016	1.167	0.019	
5220	44	IEEE 802.11a	OFDM	9.5	8.83	0.11	Left	Cheek	Standard	F1186	6	1:1	0.017	1.167	0.020	
5220	44	IEEE 802.11a	OFDM	9.5	8.83	0.04	Left	Tilt	Standard	F1186	6	1:1	0.005	1.167	0.006	
5260	52	IEEE 802.11a	OFDM	9.5	8.79	0.14	Right	Cheek	Standard	F1186	6	1:1	0.102	1.178	0.120	
5290	58	IEEE 802.11ac	OFDM	9.5	8.33	0.06	Right	Cheek	Standard	F1186	29.3	1:1	0.066	1.309	0.086	
5260	52	IEEE 802.11a	OFDM	9.5	8.79	-0.17	Right	Tilt	Standard	F1186	6	1:1	0.010	1.178	0.012	
5260	52	IEEE 802.11a	OFDM	9.5	8.79	0.03	Left	Cheek	Standard	F1186	6	1:1	0.010	1.178	0.012	
5260	52	IEEE 802.11a	OFDM	9.5	8.79	0.14	Left	Tilt	Standard	F1186	6	1:1	0.006	1.178	0.007	
5680	136	IEEE 802.11a	OFDM	9.5	8.90	-0.05	Right	Cheek	Standard	F1186	6	1:1	0.039	1.148	0.045	
5530	106	IEEE 802.11ac	OFDM	9.5	8.52	-0.04	Right	Cheek	Standard	F1186	29.3	1:1	0.021	1.253	0.026	
5680	136	IEEE 802.11a	OFDM	9.5	8.90	-0.12	Right	Tilt	Standard	F1186	6	1:1	0.008	1.148	0.009	
5680	136	IEEE 802.11a	OFDM	9.5	8.90	0.11	Left	Cheek	Standard	F1186	6	1:1	0.000	1.148	0.000	
5680	136	IEEE 802.11a	OFDM	9.5	8.90	0.09	Left	Tilt	Standard	F1186	6	1:1	0.001	1.148	0.001	
ANSI / IEEE C95.1 1992 - SAFETY LIMIT Spatial Peak Uncontrolled Exposure/General Population									Head 1.6 W/kg (mW/g) averaged over 1 gram							



**Table 11-13
DTS Head - MIMO WLAN SAR**

MEASUREMENT RESULTS																
FREQUENCY		Mode	Service	Maximum Allowed Power [dBm]	Conducted Power [dBm]	Power Drift [dB]	Side	Test Position	Cover Type	Device Serial Number	Data Rate (Mbps)	Duty Cycle	SAR (1g)	Scaling Factor	Scaled SAR (1g)	Plot #
MHz	Ch.												(W/kg)		(W/kg)	
2412	1	IEEE 802.11n	OFDM	12.5	11.85	0.14	Right	Cheek	Standard	00F05	13	1:1	0.205	1.161	0.238	
2412	1	IEEE 802.11n	OFDM	12.5	11.85	0.03	Right	Cheek	Wireless Charging	00F05	13	1:1	0.120	1.161	0.139	
2412	1	IEEE 802.11n	OFDM	12.5	11.85	0.15	Right	Tilt	Standard	00F05	13	1:1	0.171	1.161	0.199	
2412	1	IEEE 802.11n	OFDM	12.5	11.85	0.03	Left	Cheek	Standard	00F05	13	1:1	0.156	1.161	0.181	
2412	1	IEEE 802.11n	OFDM	12.5	11.85	0.03	Left	Tilt	Standard	00F05	13	1:1	0.129	1.161	0.150	
5765	153	IEEE 802.11n	OFDM	9.5	7.74	-0.17	Right	Cheek	Standard	F1186	13	1:1	0.006	1.500	0.009	
5765	153	IEEE 802.11n	OFDM	9.5	7.74	0.11	Right	Tilt	Standard	F1186	13	1:1	0.051	1.500	0.077	
5765	153	IEEE 802.11n	OFDM	9.5	7.74	0.05	Left	Cheek	Standard	F1186	13	1:1	0.053	1.500	0.080	
5765	153	IEEE 802.11n	OFDM	9.5	7.74	0.08	Left	Tilt	Standard	F1186	13	1:1	0.054	1.500	0.081	
ANSI / IEEE C95.1 1992 - SAFETY LIMIT Spatial Peak Uncontrolled Exposure/General Population									Head 1.6 W/kg (mW/g) averaged over 1 gram							

FCC ID: A3LSMG900A		SAR EVALUATION REPORT		Reviewed by: Quality Manager
Document S/N: OY1401270204-R2.A3L	Test Dates: 02/03/14 - 02/17/14	DUT Type: Portable Handset	Page 55 of 85	

**Table 11-14
NII Head - MIMO WLAN SAR**

MEASUREMENT RESULTS																
FREQUENCY		Mode	Service	Maximum Allowed Power [dBm]	Conducted Power [dBm]	Power Drift [dB]	Side	Test Position	Cover Type	Device Serial Number	Data Rate (Mbps)	Duty Cycle	SAR (1g) (W/kg)	Scaling Factor	Scaled SAR (1g) (W/kg)	Plot #
MHz	Ch.															
5240	48	IEEE 802.11n	OFDM	9.5	8.33	0.05	Right	Cheek	Standard	F1186	13	1:1	0.033	1.309	0.043	
5240	48	IEEE 802.11n	OFDM	9.5	8.33	0.12	Right	Tilt	Standard	F1186	13	1:1	0.018	1.309	0.024	
5240	48	IEEE 802.11n	OFDM	9.5	8.33	0.04	Left	Cheek	Standard	F1186	13	1:1	0.018	1.309	0.024	
5240	48	IEEE 802.11n	OFDM	9.5	8.33	0.03	Left	Tilt	Standard	F1186	13	1:1	0.016	1.309	0.021	
5300	60	IEEE 802.11n	OFDM	9.5	8.30	0.10	Right	Cheek	Standard	F1186	13	1:1	0.023	1.318	0.030	
5300	60	IEEE 802.11n	OFDM	9.5	8.30	-0.03	Right	Tilt	Standard	F1186	13	1:1	0.025	1.318	0.033	
5300	60	IEEE 802.11n	OFDM	9.5	8.30	0.03	Left	Cheek	Standard	F1186	13	1:1	0.022	1.318	0.029	
5300	60	IEEE 802.11n	OFDM	9.5	8.30	0.02	Left	Tilt	Standard	F1186	13	1:1	0.022	1.318	0.029	
5500	100	IEEE 802.11n	OFDM	9.5	9.48	0.03	Right	Cheek	Standard	F1186	13	1:1	0.016	1.005	0.016	
5500	100	IEEE 802.11n	OFDM	9.5	9.48	0.05	Right	Tilt	Standard	F1186	13	1:1	0.070	1.005	0.070	
5500	100	IEEE 802.11n	OFDM	9.5	9.48	0.03	Right	Tilt	Wireless Charging	F1186	13	1:1	0.048	1.005	0.048	
5500	100	IEEE 802.11n	OFDM	9.5	9.48	0.01	Left	Cheek	Standard	F1186	13	1:1	0.054	1.005	0.054	
5500	100	IEEE 802.11n	OFDM	9.5	9.48	0.10	Left	Tilt	Standard	F1186	13	1:1	0.058	1.005	0.058	
ANSI / IEEE C95.1 1992 - SAFETY LIMIT Spatial Peak Uncontrolled Exposure/General Population								Head 1.6 W/kg (mW/g) averaged over 1 gram								

FCC ID: A3LSMG900A	 PCTEST ENGINEERING LABORATORY, INC.	SAR EVALUATION REPORT		Reviewed by: Quality Manager
Document S/N: OY1401270204-R2.A3L	Test Dates: 02/03/14 - 02/17/14	DUT Type: Portable Handset		Page 56 of 85

11.2 Standalone Body-Worn SAR Data

Table 11-15
GSM/UMTS Body-Worn SAR Data

MEASUREMENT RESULTS																
FREQUENCY		Mode	Service	Maximum Allowed Power [dBm]	Conducted Power [dBm]	Power Drift [dB]	Spacing	Cover Type	Device Serial Number	# of Time Slots	Duty Cycle	Side	SAR (1g)	Scaling Factor	Scaled SAR (1g)	Plot #
MHz	Ch.												(W/kg)		(W/kg)	
836.60	190	GSM 850	GSM	33.5	32.52	-0.15	10 mm	Standard	00F0B	1	1:8.3	back	0.393	1.253	0.492	A12
836.60	190	GSM 850	GSM	33.5	32.52	-0.03	10 mm	Wireless Charging	00F0B	1	1:8.3	back	0.336	1.253	0.421	
1880.00	661	GSM 1900	GSM	30.5	30.11	0.07	10 mm	Standard	00F0D	1	1:8.3	back	0.079	1.094	0.086	A14
1880.00	661	GSM 1900	GSM	30.5	30.11	0.11	10 mm	Wireless Charging	00F0D	1	1:8.3	back	0.069	1.094	0.075	
836.60	4183	UMTS 850	RMC	23.5	22.43	-0.01	10 mm	Standard	00F0B	N/A	1:1	back	0.376	1.279	0.481	A16
836.60	4183	UMTS 850	RMC	23.5	22.43	-0.04	10 mm	Wireless Charging	00F0B	N/A	1:1	back	0.286	1.279	0.366	
1880.00	9400	UMTS 1900	RMC	23.0	22.62	0.01	10 mm	Standard	00F0D	N/A	1:1	back	0.263	1.091	0.287	A17
1880.00	9400	UMTS 1900	RMC	23.0	22.62	0.00	10 mm	Wireless Charging	00F0D	N/A	1:1	back	0.238	1.091	0.260	
ANSI / IEEE C95.1 1992 - SAFETY LIMIT Spatial Peak Uncontrolled Exposure/General Population								Body 1.6 W/kg (mW/g) averaged over 1 gram								

Table 11-16
LTE Body-Worn SAR

MEASUREMENT RESULTS																				
FREQUENCY		Mode	Bandwidth [MHz]	Cover Type	Maximum Allowed Power [dBm]	Conducted Power [dBm]	Power Drift [dB]	MPR [dB]	Device Serial Number	Modulation	RB Size	RB Offset	Spacing	Side	Duty Cycle	SAR (1g)	Scaling Factor	Scaled SAR (1g)	Plot #	
MHz	Ch.															(W/kg)		(W/kg)		
710.00	23790	Mid	LTE Band 17	10	Standard	24.5	23.00	-0.01	0	00E6B	QPSK	1	49	10 mm	back	1:1	0.262	1.413	0.370	A19
710.00	23790	Mid	LTE Band 17	10	Wireless Charging	24.5	23.00	0.03	0	00E6B	QPSK	1	49	10 mm	back	1:1	0.196	1.413	0.277	
710.00	23790	Mid	LTE Band 17	10	Standard	23.5	21.97	0.07	1	00E6B	QPSK	25	25	10 mm	back	1:1	0.213	1.422	0.303	
836.50	20525	Mid	LTE Band 5 (Cell)	10	Standard	24.0	23.20	0.00	0	00E6B	QPSK	1	25	10 mm	back	1:1	0.437	1.202	0.525	A20
836.50	20525	Mid	LTE Band 5 (Cell)	10	Wireless Charging	24.0	23.20	-0.02	0	00E6B	QPSK	1	25	10 mm	back	1:1	0.317	1.202	0.381	
836.50	20525	Mid	LTE Band 5 (Cell)	10	Standard	23.0	22.08	0.02	1	00E6B	QPSK	25	0	10 mm	back	1:1	0.350	1.236	0.433	
1732.50	20175	Mid	LTE Band 4 (AWS)	20	Standard	23.5	23.23	0.04	0	00F0A	QPSK	1	0	10 mm	back	1:1	0.602	1.064	0.641	A21
1732.50	20175	Mid	LTE Band 4 (AWS)	20	Wireless Charging	23.5	23.23	0.06	0	00F0A	QPSK	1	0	10 mm	back	1:1	0.450	1.064	0.479	
1732.50	20175	Mid	LTE Band 4 (AWS)	20	Standard	22.5	22.22	0.04	1	00F0A	QPSK	50	0	10 mm	back	1:1	0.453	1.067	0.483	
1880.00	18900	Mid	LTE Band 2 (PCS)	20	Standard	23.5	23.50	-0.02	0	00F0A	QPSK	1	0	10 mm	back	1:1	0.362	1.000	0.362	A22
1880.00	18900	Mid	LTE Band 2 (PCS)	20	Wireless Charging	23.5	23.50	0.00	0	00F0A	QPSK	1	0	10 mm	back	1:1	0.300	1.000	0.300	
1880.00	18900	Mid	LTE Band 2 (PCS)	20	Standard	22.5	22.49	-0.03	1	00F0A	QPSK	50	0	10 mm	back	1:1	0.302	1.002	0.303	
ANSI / IEEE C95.1 1992 - SAFETY LIMIT Spatial Peak Uncontrolled Exposure/General Population								Body 1.6 W/kg (mW/g) averaged over 1 gram												

Table 11-17
DTS Body-Worn - Antenna 1 WLAN SAR

MEASUREMENT RESULTS																
FREQUENCY		Mode	Service	Maximum Allowed Power [dBm]	Conducted Power [dBm]	Power Drift [dB]	Spacing	Cover Type	Device Serial Number	Data Rate (Mbps)	Side	Duty Cycle	SAR (1g)	Scaling Factor	Scaled SAR (1g)	Plot #
MHz	Ch.												(W/kg)		(W/kg)	
2437	6	IEEE 802.11b	DSSS	17.5	17.05	-0.08	10 mm	Standard	00F05	1	back	1:1	0.235	1.109	0.261	A23
2437	6	IEEE 802.11b	DSSS	17.5	17.05	0.16	10 mm	Wireless Charging	00F05	1	back	1:1	0.103	1.109	0.114	
5745	149	IEEE 802.11a	OFDM	14.0	13.31	-0.10	10 mm	Standard	14524	6	back	1:1	0.409	1.172	0.479	A24
5765	153	IEEE 802.11a	OFDM	14.0	13.21	-0.03	10 mm	Standard	14524	6	back	1:1	0.383	1.199	0.459	
5805	161	IEEE 802.11a	OFDM	14.0	13.20	0.12	10 mm	Standard	14524	6	back	1:1	0.392	1.202	0.471	
5775	155	IEEE 802.11ac	OFDM	11.5	11.25	-0.03	10 mm	Standard	14524	29.3	back	1:1	0.167	1.059	0.177	
ANSI / IEEE C95.1 1992 - SAFETY LIMIT Spatial Peak Uncontrolled Exposure/General Population								Body 1.6 W/kg (mW/g) averaged over 1 gram								



FCC ID: A3LSMG900A	 PCTEST Engineering Laboratory, Inc.	SAR EVALUATION REPORT		Reviewed by: Quality Manager
Document S/N: OY1401270204-R2.A3L	Test Dates: 02/03/14 - 02/17/14	DUT Type: Portable Handset		Page 57 of 85

Table 11-18
NII Body-Worn - Antenna 1 WLAN SAR



MEASUREMENT RESULTS																
FREQUENCY		Mode	Service	Maximum Allowed Power [dBm]	Conducted Power [dBm]	Power Drift [dB]	Spacing	Cover Type	Device Serial Number	Data Rate (Mbps)	Side	Duty Cycle	SAR (1g)	Scaling Factor	Scaled SAR (1g)	Plot #
MHz	Ch.												(W/kg)		(W/kg)	
5220	44	IEEE 802.11a	OFDM	14.0	13.12	-0.01	10 mm	Standard	14524	6	back	1:1	0.049	1.225	0.060	
5210	42	IEEE 802.11ac	OFDM	11.5	10.71	-0.09	10 mm	Standard	14524	29.3	back	1:1	0.037	1.199	0.044	
5280	56	IEEE 802.11a	OFDM	14.0	12.97	0.04	10 mm	Standard	14524	6	back	1:1	0.141	1.268	0.179	
5290	58	IEEE 802.11ac	OFDM	11.5	10.77	-0.03	10 mm	Standard	14524	29.3	back	1:1	0.071	1.183	0.084	
5540	108	IEEE 802.11a	OFDM	14.0	13.41	-0.01	10 mm	Standard	14524	6	back	1:1	0.558	1.146	0.639	A25
5580	116	IEEE 802.11a	OFDM	14.0	13.40	0.12	10 mm	Standard	14524	6	back	1:1	0.491	1.148	0.564	
5660	132	IEEE 802.11a	OFDM	14.0	13.19	-0.12	10 mm	Standard	14524	6	back	1:1	0.383	1.205	0.462	
5530	106	IEEE 802.11ac	OFDM	11.5	11.15	0.15	10 mm	Standard	14524	29.3	back	1:1	0.237	1.084	0.257	
5540	108	IEEE 802.11a	OFDM	14.0	13.41	-0.12	10 mm	Wireless Charging	14524	6	back	1:1	0.436	1.146	0.500	
ANSI / IEEE C95.1 1992 - SAFETY LIMIT Spatial Peak Uncontrolled Exposure/General Population							Body 1.6 W/kg (mW/g) averaged over 1 gram									

Table 11-19
DTS Body-Worn - Antenna 2 WLAN SAR

MEASUREMENT RESULTS																
FREQUENCY		Mode	Service	Maximum Allowed Power [dBm]	Conducted Power [dBm]	Power Drift [dB]	Spacing	Cover Type	Device Serial Number	Data Rate (Mbps)	Side	Duty Cycle	SAR (1g)	Scaling Factor	Scaled SAR (1g)	Plot #
MHz	Ch.												(W/kg)		(W/kg)	
2412	1	IEEE 802.11b	DSSS	17.5	17.07	0.04	10 mm	Standard	00F05	1	back	1:1	0.087	1.104	0.096	
5765	153	IEEE 802.11a	OFDM	14.0	13.44	0.10	10 mm	Standard	14524	6	back	1:1	0.287	1.138	0.327	
5775	155	IEEE 802.11ac	OFDM	11.5	11.26	0.03	10 mm	Standard	14524	29.3	back	1:1	0.128	1.057	0.135	
ANSI / IEEE C95.1 1992 - SAFETY LIMIT Spatial Peak Uncontrolled Exposure/General Population							Body 1.6 W/kg (mW/g) averaged over 1 gram									

Table 11-20
NII Body-Worn - Antenna 2 WLAN SAR

MEASUREMENT RESULTS																
FREQUENCY		Mode	Service	Maximum Allowed Power [dBm]	Conducted Power [dBm]	Power Drift [dB]	Spacing	Cover Type	Device Serial Number	Data Rate (Mbps)	Side	Duty Cycle	SAR (1g)	Scaling Factor	Scaled SAR (1g)	Plot #
MHz	Ch.												(W/kg)		(W/kg)	
5180	36	IEEE 802.11a	OFDM	14.0	13.94	-0.12	10 mm	Standard	14524	6	back	1:1	0.104	1.014	0.105	
5210	42	IEEE 802.11ac	OFDM	11.5	10.78	0.18	10 mm	Standard	14524	29.3	back	1:1	0.056	1.180	0.066	
5260	52	IEEE 802.11a	OFDM	14.0	13.21	-0.04	10 mm	Standard	14524	6	back	1:1	0.195	1.199	0.234	
5290	58	IEEE 802.11ac	OFDM	11.5	10.94	0.08	10 mm	Standard	14524	29.3	back	1:1	0.074	1.138	0.084	
5500	100	IEEE 802.11a	OFDM	14.0	13.26	0.03	10 mm	Standard	14524	6	back	1:1	0.296	1.186	0.351	
5530	106	IEEE 802.11ac	OFDM	11.5	10.98	-0.03	10 mm	Standard	14524	29.3	back	1:1	0.099	1.127	0.112	
ANSI / IEEE C95.1 1992 - SAFETY LIMIT Spatial Peak Uncontrolled Exposure/General Population							Body 1.6 W/kg (mW/g) averaged over 1 gram									



FCC ID: A3LSMG900A	 PCTEST ENGINEERING LABORATORY, INC.	SAR EVALUATION REPORT		Reviewed by: Quality Manager
Document S/N: OY1401270204-R2.A3L	Test Dates: 02/03/14 - 02/17/14	DUT Type: Portable Handset		Page 58 of 85

**Table 11-21
DTS Body-Worn - MIMO WLAN SAR**

MEASUREMENT RESULTS																
FREQUENCY		Mode	Service	Maximum Allowed Power [dBm]	Conducted Power [dBm]	Power Drift [dB]	Spacing	Cover Type	Device Serial Number	Data Rate (Mbps)	Side	Duty Cycle	SAR (1g)	Scaling Factor	Scaled SAR (1g)	Plot #
MHz	Ch.												(W/kg)		(W/kg)	
2412	1	IEEE 802.11n	OFDM	14.0	13.87	0.11	10 mm	Standard	00F05	13	back	1:1	0.066	1.030	0.068	
2412	1	IEEE 802.11n	OFDM	14.0	13.87	0.10	10 mm	Wireless Charging	00F05	13	back	1:1	0.053	1.030	0.055	
5765	153	IEEE 802.11n	OFDM	13.5	13.47	0.16	10 mm	Standard	14524	13	back	1:1	0.220	1.007	0.222	
5765	153	IEEE 802.11n	OFDM	13.5	13.47	0.00	10 mm	Wireless Charging	14524	13	back	1:1	0.121	1.007	0.122	
ANSI / IEEE C95.1 1992 - SAFETY LIMIT Spatial Peak Uncontrolled Exposure/General Population							Body 1.6 W/kg (mW/g) averaged over 1 gram									

**Table 11-22
NII Body-Worn - MIMO WLAN SAR**

MEASUREMENT RESULTS																
FREQUENCY		Mode	Service	Maximum Allowed Power [dBm]	Conducted Power [dBm]	Power Drift [dB]	Spacing	Cover Type	Device Serial Number	Data Rate (Mbps)	Side	Duty Cycle	SAR (1g)	Scaling Factor	Scaled SAR (1g)	Plot #
MHz	Ch.												(W/kg)		(W/kg)	
5180	36	IEEE 802.11n	OFDM	13.5	12.63	0.07	10 mm	Standard	14524	13	back	1:1	0.065	1.222	0.079	
5300	60	IEEE 802.11n	OFDM	13.5	12.77	0.09	10 mm	Standard	14524	13	back	1:1	0.060	1.183	0.071	
5500	100	IEEE 802.11n	OFDM	13.5	12.30	0.06	10 mm	Standard	14524	13	back	1:1	0.075	1.318	0.099	
ANSI / IEEE C95.1 1992 - SAFETY LIMIT Spatial Peak Uncontrolled Exposure/General Population							Body 1.6 W/kg (mW/g) averaged over 1 gram									

FCC ID: A3LSMG900A	 PCTEST ENGINEERING LABORATORY, INC.	SAR EVALUATION REPORT		Reviewed by: Quality Manager
Document S/N: OY1401270204-R2.A3L	Test Dates: 02/03/14 - 02/17/14	DUT Type: Portable Handset		Page 59 of 85

11.3 Standalone Wireless Router SAR Data

Table 11-23
GPRS/UMTS Hotspot SAR Data

MEASUREMENT RESULTS																
FREQUENCY		Mode	Service	Maximum Allowed Power [dBm]	Conducted Power [dBm]	Power Drift [dB]	Spacing	Cover Type	Device Serial Number	# of GPRS Slots	Duty Cycle	Side	SAR (1g)	Scaling Factor	Scaled SAR (1g)	Plot #
MHz	Ch.												(W/kg)		(W/kg)	
836.60	190	GSM 850	GPRS	31.5	31.32	0.14	10 mm	Standard	00F0B	2	1:4.15	back	0.521	1.042	0.543	
836.60	190	GSM 850	GPRS	31.5	31.32	0.12	10 mm	Wireless Charging	00F0B	2	1:4.15	back	0.533	1.042	0.555	A13
836.60	190	GSM 850	GPRS	31.5	31.32	0.00	10 mm	Standard	00F0B	2	1:4.15	front	0.426	1.042	0.444	
836.60	190	GSM 850	GPRS	31.5	31.32	-0.01	10 mm	Standard	00F0B	2	1:4.15	bottom	0.096	1.042	0.100	
836.60	190	GSM 850	GPRS	31.5	31.32	0.05	10 mm	Standard	00F0B	2	1:4.15	right	0.467	1.042	0.487	
836.60	190	GSM 850	GPRS	31.5	31.32	0.04	10 mm	Standard	00F0B	2	1:4.15	left	0.483	1.042	0.503	
1880.00	661	GSM 1900	GPRS	29.0	28.62	0.05	10 mm	Standard	00F0D	2	1:4.15	back	0.132	1.091	0.144	
1880.00	661	GSM 1900	GPRS	29.0	28.62	-0.04	10 mm	Standard	00F0D	2	1:4.15	front	0.274	1.091	0.299	A15
1880.00	661	GSM 1900	GPRS	29.0	28.62	-0.02	10 mm	Wireless Charging	00F0D	2	1:4.15	front	0.220	1.091	0.240	
1880.00	661	GSM 1900	GPRS	29.0	28.62	-0.01	10 mm	Standard	00F0D	2	1:4.15	bottom	0.226	1.091	0.247	
1880.00	661	GSM 1900	GPRS	29.0	28.62	0.14	10 mm	Standard	00F0D	2	1:4.15	right	0.017	1.091	0.019	
1880.00	661	GSM 1900	GPRS	29.0	28.62	0.01	10 mm	Standard	00F0D	2	1:4.15	left	0.201	1.091	0.219	
836.60	4183	UMTS 850	RMC	23.5	22.43	-0.01	10 mm	Standard	00F0B	N/A	1:1	back	0.376	1.279	0.481	A16
836.60	4183	UMTS 850	RMC	23.5	22.43	-0.04	10 mm	Wireless Charging	00F0B	N/A	1:1	back	0.286	1.279	0.366	
836.60	4183	UMTS 850	RMC	23.5	22.43	-0.03	10 mm	Standard	00F0B	N/A	1:1	front	0.297	1.279	0.380	
836.60	4183	UMTS 850	RMC	23.5	22.43	-0.03	10 mm	Standard	00F0B	N/A	1:1	bottom	0.059	1.279	0.075	
836.60	4183	UMTS 850	RMC	23.5	22.43	0.04	10 mm	Standard	00F0B	N/A	1:1	right	0.340	1.279	0.435	
836.60	4183	UMTS 850	RMC	23.5	22.43	0.01	10 mm	Standard	00F0B	N/A	1:1	left	0.289	1.279	0.370	
1880.00	9400	UMTS 1900	RMC	23.0	22.62	0.01	10 mm	Standard	00F0D	N/A	1:1	back	0.263	1.091	0.287	
1880.00	9400	UMTS 1900	RMC	23.0	22.62	0.02	10 mm	Standard	00F0D	N/A	1:1	front	0.265	1.091	0.289	A18
1880.00	9400	UMTS 1900	RMC	23.0	22.62	-0.02	10 mm	Wireless Charging	00F0D	N/A	1:1	front	0.244	1.091	0.266	
1880.00	9400	UMTS 1900	RMC	23.0	22.62	0.03	10 mm	Standard	00F0D	N/A	1:1	bottom	0.146	1.091	0.159	
1880.00	9400	UMTS 1900	RMC	23.0	22.62	0.10	10 mm	Standard	00F0D	N/A	1:1	right	0.120	1.091	0.131	
1880.00	9400	UMTS 1900	RMC	23.0	22.62	0.04	10 mm	Standard	00F0D	N/A	1:1	left	0.219	1.091	0.239	
ANSI / IEEE C95.1 1992 - SAFETY LIMIT Spatial Peak Uncontrolled Exposure/General Population									Body 1.6 W/kg (mW/g) averaged over 1 gram							

Table 11-24
LTE Band 17 Hotspot SAR

MEASUREMENT RESULTS																				
FREQUENCY		Mode	Bandwidth [MHz]	Cover Type	Maximum Allowed Power [dBm]	Conducted Power [dBm]	Power Drift [dB]	MPR [dB]	Device Serial Number	Modulation	RB Size	RB Offset	Spacing	Side	Duty Cycle	SAR (1g)	Scaling Factor	Scaled SAR (1g)	Plot #	
MHz	Ch.															(W/kg)		(W/kg)		
710.00	23790	Mid	LTE Band 17	10	Standard	24.5	23.00	-0.01	0	00E6B	QPSK	1	49	10 mm	back	1:1	0.262	1.413	0.370	A19
710.00	23790	Mid	LTE Band 17	10	Wireless Charging	24.5	23.00	0.03	0	00E6B	QPSK	1	49	10 mm	back	1:1	0.196	1.413	0.277	
710.00	23790	Mid	LTE Band 17	10	Standard	23.5	21.97	0.07	1	00E6B	QPSK	25	25	10 mm	back	1:1	0.213	1.422	0.303	
710.00	23790	Mid	LTE Band 17	10	Standard	24.5	23.00	-0.04	0	00E6B	QPSK	1	49	10 mm	front	1:1	0.234	1.413	0.331	
710.00	23790	Mid	LTE Band 17	10	Standard	23.5	21.97	0.02	1	00E6B	QPSK	25	25	10 mm	front	1:1	0.188	1.422	0.267	
710.00	23790	Mid	LTE Band 17	10	Standard	24.5	23.00	0.00	0	00E6B	QPSK	1	49	10 mm	bottom	1:1	0.049	1.413	0.069	
710.00	23790	Mid	LTE Band 17	10	Standard	23.5	21.97	0.00	1	00E6B	QPSK	25	25	10 mm	bottom	1:1	0.039	1.422	0.055	
710.00	23790	Mid	LTE Band 17	10	Standard	24.5	23.00	-0.03	0	00E6B	QPSK	1	49	10 mm	right	1:1	0.186	1.413	0.263	
710.00	23790	Mid	LTE Band 17	10	Standard	23.5	21.97	-0.07	1	00E6B	QPSK	25	25	10 mm	right	1:1	0.144	1.422	0.205	
710.00	23790	Mid	LTE Band 17	10	Standard	24.5	23.00	-0.04	0	00E6B	QPSK	1	49	10 mm	left	1:1	0.115	1.413	0.162	
710.00	23790	Mid	LTE Band 17	10	Standard	23.5	21.97	0.01	1	00E6B	QPSK	25	25	10 mm	left	1:1	0.087	1.422	0.124	
ANSI / IEEE C95.1 1992 - SAFETY LIMIT Spatial Peak Uncontrolled Exposure/General Population									Body 1.6 W/kg (mW/g) averaged over 1 gram											



FCC ID: A3LSMG900A		SAR EVALUATION REPORT		Reviewed by: Quality Manager
Document S/N: OY1401270204-R2.A3L	Test Dates: 02/03/14 - 02/17/14	DUT Type: Portable Handset		Page 60 of 85

Table 11-25
LTE Band 5 (Cell) Hotspot SAR



MEASUREMENT RESULTS																				
FREQUENCY		Mode	Bandwidth [MHz]	Cover Type	Maximum Allowed Power [dBm]	Conducted Power [dBm]	Power Drift [dB]	MPR [dB]	Device Serial Number	Modulation	RB Size	RB Offset	Spacing	Side	Duty Cycle	SAR (1g) (W/kg)	Scaling Factor	Scaled SAR (1g) (W/kg)	Plot #	
MHz	Ch.																			
836.50	20525	Mid	LTE Band 5 (Cell)	10	Standard	24.0	23.20	0.00	0	00E6B	QPSK	1	25	10 mm	back	1:1	0.437	1.202	0.525	A20
836.50	20525	Mid	LTE Band 5 (Cell)	10	Wireless Charging	24.0	23.20	-0.02	0	00E6B	QPSK	1	25	10 mm	back	1:1	0.317	1.202	0.381	
836.50	20525	Mid	LTE Band 5 (Cell)	10	Standard	23.0	22.08	0.02	1	00E6B	QPSK	25	0	10 mm	back	1:1	0.350	1.236	0.433	
836.50	20525	Mid	LTE Band 5 (Cell)	10	Standard	24.0	23.20	0.06	0	00E6B	QPSK	1	25	10 mm	front	1:1	0.340	1.202	0.409	
836.50	20525	Mid	LTE Band 5 (Cell)	10	Standard	23.0	22.08	0.02	1	00E6B	QPSK	25	0	10 mm	front	1:1	0.274	1.236	0.339	
836.50	20525	Mid	LTE Band 5 (Cell)	10	Standard	24.0	23.20	-0.01	0	00E6B	QPSK	1	25	10 mm	bottom	1:1	0.073	1.202	0.088	
836.50	20525	Mid	LTE Band 5 (Cell)	10	Standard	23.0	22.08	0.03	1	00E6B	QPSK	25	0	10 mm	bottom	1:1	0.057	1.236	0.070	
836.50	20525	Mid	LTE Band 5 (Cell)	10	Standard	24.0	23.20	0.01	0	00E6B	QPSK	1	25	10 mm	right	1:1	0.372	1.202	0.447	
836.50	20525	Mid	LTE Band 5 (Cell)	10	Standard	23.0	22.08	-0.01	1	00E6B	QPSK	25	0	10 mm	right	1:1	0.294	1.236	0.363	
836.50	20525	Mid	LTE Band 5 (Cell)	10	Standard	24.0	23.20	0.12	0	00E6B	QPSK	1	25	10 mm	left	1:1	0.330	1.202	0.397	
836.50	20525	Mid	LTE Band 5 (Cell)	10	Standard	23.0	22.08	0.03	1	00E6B	QPSK	25	0	10 mm	left	1:1	0.269	1.236	0.332	
ANSI / IEEE C95.1 1992 - SAFETY LIMIT Spatial Peak Uncontrolled Exposure/General Population										Body 1.6 W/kg (mW/g) averaged over 1 gram										

Table 11-26
LTE Band 4 (AWS) Hotspot SAR

MEASUREMENT RESULTS																				
FREQUENCY		Mode	Bandwidth [MHz]	Cover Type	Maximum Allowed Power [dBm]	Conducted Power [dBm]	Power Drift [dB]	MPR [dB]	Device Serial Number	Modulation	RB Size	RB Offset	Spacing	Side	Duty Cycle	SAR (1g) (W/kg)	Scaling Factor	Scaled SAR (1g) (W/kg)	Plot #	
MHz	Ch.																			
1732.50	20175	Mid	LTE Band 4 (AWS)	20	Standard	23.5	23.23	0.04	0	00F0A	QPSK	1	0	10 mm	back	1:1	0.602	1.064	0.641	A21
1732.50	20175	Mid	LTE Band 4 (AWS)	20	Wireless Charging	23.5	23.23	0.06	0	00F0A	QPSK	1	0	10 mm	back	1:1	0.450	1.064	0.479	
1732.50	20175	Mid	LTE Band 4 (AWS)	20	Standard	22.5	22.22	0.04	1	00F0A	QPSK	50	0	10 mm	back	1:1	0.453	1.067	0.483	
1732.50	20175	Mid	LTE Band 4 (AWS)	20	Standard	23.5	23.23	0.06	0	00F0A	QPSK	1	0	10 mm	front	1:1	0.499	1.064	0.531	
1732.50	20175	Mid	LTE Band 4 (AWS)	20	Standard	22.5	22.22	-0.04	1	00F0A	QPSK	50	0	10 mm	front	1:1	0.377	1.067	0.402	
1732.50	20175	Mid	LTE Band 4 (AWS)	20	Standard	23.5	23.23	-0.04	0	00F0A	QPSK	1	0	10 mm	bottom	1:1	0.484	1.064	0.515	
1732.50	20175	Mid	LTE Band 4 (AWS)	20	Standard	22.5	22.22	0.01	1	00F0A	QPSK	50	0	10 mm	bottom	1:1	0.380	1.067	0.405	
1732.50	20175	Mid	LTE Band 4 (AWS)	20	Standard	23.5	23.23	-0.05	0	00F0A	QPSK	1	0	10 mm	right	1:1	0.133	1.064	0.142	
1732.50	20175	Mid	LTE Band 4 (AWS)	20	Standard	22.5	22.22	0.00	1	00F0A	QPSK	50	0	10 mm	right	1:1	0.108	1.067	0.115	
1732.50	20175	Mid	LTE Band 4 (AWS)	20	Standard	23.5	23.23	0.07	0	00F0A	QPSK	1	0	10 mm	left	1:1	0.301	1.064	0.320	
1732.50	20175	Mid	LTE Band 4 (AWS)	20	Standard	22.5	22.22	0.09	1	00F0A	QPSK	50	0	10 mm	left	1:1	0.243	1.067	0.259	
ANSI / IEEE C95.1 1992 - SAFETY LIMIT Spatial Peak Uncontrolled Exposure/General Population										Body 1.6 W/kg (mW/g) averaged over 1 gram										

Table 11-27
LTE Band 2 (PCS) Hotspot SAR

MEASUREMENT RESULTS																				
FREQUENCY		Mode	Bandwidth [MHz]	Cover Type	Maximum Allowed Power [dBm]	Conducted Power [dBm]	Power Drift [dB]	MPR [dB]	Device Serial Number	Modulation	RB Size	RB Offset	Spacing	Side	Duty Cycle	SAR (1g) (W/kg)	Scaling Factor	Scaled SAR (1g) (W/kg)	Plot #	
MHz	Ch.																			
1880.00	18900	Mid	LTE Band 2 (PCS)	20	Standard	23.5	23.50	-0.02	0	00F0A	QPSK	1	0	10 mm	back	1:1	0.362	1.000	0.362	A22
1880.00	18900	Mid	LTE Band 2 (PCS)	20	Wireless Charging	23.5	23.50	0.00	0	00F0A	QPSK	1	0	10 mm	back	1:1	0.300	1.000	0.300	
1880.00	18900	Mid	LTE Band 2 (PCS)	20	Standard	22.5	22.49	-0.03	1	00F0A	QPSK	50	0	10 mm	back	1:1	0.302	1.002	0.303	
1880.00	18900	Mid	LTE Band 2 (PCS)	20	Standard	23.5	23.50	-0.01	0	00F0A	QPSK	1	0	10 mm	front	1:1	0.361	1.000	0.361	
1880.00	18900	Mid	LTE Band 2 (PCS)	20	Standard	22.5	22.49	0.09	1	00F0A	QPSK	50	0	10 mm	front	1:1	0.293	1.002	0.294	
1880.00	18900	Mid	LTE Band 2 (PCS)	20	Standard	23.5	23.50	0.05	0	00F0A	QPSK	1	0	10 mm	bottom	1:1	0.184	1.000	0.184	
1880.00	18900	Mid	LTE Band 2 (PCS)	20	Standard	22.5	22.49	-0.02	1	00F0A	QPSK	50	0	10 mm	bottom	1:1	0.152	1.002	0.152	
1880.00	18900	Mid	LTE Band 2 (PCS)	20	Standard	23.5	23.50	0.03	0	00F0A	QPSK	1	0	10 mm	right	1:1	0.153	1.000	0.153	
1880.00	18900	Mid	LTE Band 2 (PCS)	20	Standard	22.5	22.49	0.13	1	00F0A	QPSK	50	0	10 mm	right	1:1	0.124	1.002	0.124	
1880.00	18900	Mid	LTE Band 2 (PCS)	20	Standard	23.5	23.50	0.01	0	00F0A	QPSK	1	0	10 mm	left	1:1	0.240	1.000	0.240	
1880.00	18900	Mid	LTE Band 2 (PCS)	20	Standard	22.5	22.49	0.08	1	00F0A	QPSK	50	0	10 mm	left	1:1	0.209	1.002	0.209	
ANSI / IEEE C95.1 1992 - SAFETY LIMIT Spatial Peak Uncontrolled Exposure/General Population										Body 1.6 W/kg (mW/g) averaged over 1 gram										



FCC ID: A3LSMG900A		SAR EVALUATION REPORT		Reviewed by: Quality Manager
Document S/N: OY1401270204-R2.A3L	Test Dates: 02/03/14 - 02/17/14	DUT Type: Portable Handset		Page 61 of 85

**Table 11-28
Antenna 1 WLAN Hotspot SAR**

MEASUREMENT RESULTS																
FREQUENCY		Mode	Service	Maximum Allowed Power [dBm]	Conducted Power [dBm]	Power Drift [dB]	Spacing	Cover Type	Device Serial Number	Data Rate (Mbps)	Side	Duty Cycle	SAR (1g) (W/kg)	Scaling Factor	Scaled SAR (1g) (W/kg)	Plot #
MHz	Ch.															
2437	6	IEEE 802.11b	DSSS	17.5	17.05	-0.08	10 mm	Standard	00F05	1	back	1:1	0.235	1.109	0.261	A23
2437	6	IEEE 802.11b	DSSS	17.5	17.05	0.16	10 mm	Wireless Charging	00F05	1	back	1:1	0.103	1.109	0.114	
2437	6	IEEE 802.11b	DSSS	17.5	17.05	0.15	10 mm	Standard	00F05	1	front	1:1	0.193	1.109	0.214	
2437	6	IEEE 802.11b	DSSS	17.5	17.05	0.14	10 mm	Standard	00F05	1	top	1:1	0.114	1.109	0.126	
2437	6	IEEE 802.11b	DSSS	17.5	17.05	0.13	10 mm	Standard	00F05	1	left	1:1	0.111	1.109	0.123	
5745	149	IEEE 802.11a	OFDM	14.0	13.31	-0.10	10 mm	Standard	14524	6	back	1:1	0.409	1.172	0.479	
5765	153	IEEE 802.11a	OFDM	14.0	13.21	-0.03	10 mm	Standard	14524	6	back	1:1	0.383	1.199	0.459	
5805	161	IEEE 802.11a	OFDM	14.0	13.20	0.12	10 mm	Standard	14524	6	back	1:1	0.392	1.202	0.471	
5745	149	IEEE 802.11a	OFDM	14.0	13.31	0.04	10 mm	Standard	14524	6	front	1:1	0.163	1.172	0.191	
5745	149	IEEE 802.11a	OFDM	14.0	13.31	0.13	10 mm	Standard	14524	6	top	1:1	0.559	1.172	0.655	
5765	153	IEEE 802.11a	OFDM	14.0	13.21	0.19	10 mm	Standard	14524	6	top	1:1	0.545	1.199	0.653	
5805	161	IEEE 802.11a	OFDM	14.0	13.20	0.05	10 mm	Standard	14524	6	top	1:1	0.569	1.202	0.684	A26
5775	155	IEEE 802.11ac	OFDM	11.5	11.25	0.04	10 mm	Standard	14524	29.3	top	1:1	0.312	1.059	0.330	
5805	161	IEEE 802.11a	OFDM	14.0	13.20	0.20	10 mm	Wireless Charging	14524	6	top	1:1	0.495	1.202	0.595	
5745	149	IEEE 802.11a	OFDM	14.0	13.31	0.16	10 mm	Standard	14524	6	left	1:1	0.033	1.172	0.039	
ANSI / IEEE C95.1 1992 - SAFETY LIMIT Spatial Peak Uncontrolled Exposure/General Population							Body 1.6 W/kg (mW/g) averaged over 1 gram									



**Table 11-29
Antenna 2 WLAN Hotspot SAR**

MEASUREMENT RESULTS																
FREQUENCY		Mode	Service	Maximum Allowed Power [dBm]	Conducted Power [dBm]	Power Drift [dB]	Spacing	Cover Type	Device Serial Number	Data Rate (Mbps)	Side	Duty Cycle	SAR (1g) (W/kg)	Scaling Factor	Scaled SAR (1g) (W/kg)	Plot #
MHz	Ch.															
2412	1	IEEE 802.11b	DSSS	17.5	17.07	0.04	10 mm	Standard	00F05	1	back	1:1	0.087	1.104	0.096	
2412	1	IEEE 802.11b	DSSS	17.5	17.07	0.09	10 mm	Standard	00F05	1	front	1:1	0.053	1.104	0.059	
2412	1	IEEE 802.11b	DSSS	17.5	17.07	0.05	10 mm	Standard	00F05	1	left	1:1	0.077	1.104	0.085	
5765	153	IEEE 802.11a	OFDM	14.0	13.44	0.10	10 mm	Standard	14524	6	back	1:1	0.287	1.138	0.327	
5775	155	IEEE 802.11ac	OFDM	11.5	11.26	0.03	10 mm	Standard	14524	29.3	back	1:1	0.128	1.057	0.135	
5765	153	IEEE 802.11a	OFDM	14.0	13.44	0.04	10 mm	Standard	14524	6	front	1:1	0.078	1.138	0.089	
5765	153	IEEE 802.11a	OFDM	14.0	13.44	0.02	10 mm	Standard	14524	6	left	1:1	0.173	1.138	0.197	
ANSI / IEEE C95.1 1992 - SAFETY LIMIT Spatial Peak Uncontrolled Exposure/General Population							Body 1.6 W/kg (mW/g) averaged over 1 gram									

FCC ID: A3LSMG900A		SAR EVALUATION REPORT		Reviewed by: Quality Manager
Document S/N: OY1401270204-R2.A3L	Test Dates: 02/03/14 - 02/17/14	DUT Type: Portable Handset		Page 62 of 85

**Table 11-30
MIMO WLAN Hotspot SAR**

MEASUREMENT RESULTS																
FREQUENCY		Mode	Service	Maximum Allowed Power [dBm]	Conducted Power [dBm]	Power Drift [dB]	Spacing	Cover Type	Device Serial Number	Data Rate (Mbps)	Side	Duty Cycle	SAR (1g)	Scaling Factor	Scaled SAR (1g)	Plot #
MHz	Ch.												(W/kg)		(W/kg)	
2412	1	IEEE 802.11n	OFDM	14.0	13.87	0.11	10 mm	Standard	00F05	13	back	1:1	0.066	1.030	0.068	
2412	1	IEEE 802.11n	OFDM	14.0	13.87	0.10	10 mm	Wireless Charging	00F05	13	back	1:1	0.053	1.030	0.055	
2412	1	IEEE 802.11n	OFDM	14.0	13.87	0.04	10 mm	Standard	00F05	13	front	1:1	0.056	1.030	0.058	
2412	1	IEEE 802.11n	OFDM	14.0	13.87	0.04	10 mm	Standard	00F05	13	top	1:1	0.037	1.030	0.038	
2412	1	IEEE 802.11n	OFDM	14.0	13.87	0.15	10 mm	Standard	00F05	13	left	1:1	0.029	1.030	0.030	
5765	153	IEEE 802.11n	OFDM	13.5	13.47	0.16	10 mm	Standard	14524	13	back	1:1	0.220	1.007	0.222	
5765	153	IEEE 802.11n	OFDM	13.5	13.47	0.00	10 mm	Wireless Charging	14524	13	back	1:1	0.121	1.007	0.122	
5765	153	IEEE 802.11n	OFDM	13.5	13.47	-0.01	10 mm	Standard	14524	13	front	1:1	0.032	1.007	0.032	
5765	153	IEEE 802.11n	OFDM	13.5	13.47	0.06	10 mm	Standard	14524	13	top	1:1	0.097	1.007	0.098	
5765	153	IEEE 802.11n	OFDM	13.5	13.47	0.03	10 mm	Standard	14524	13	left	1:1	0.060	1.007	0.060	
ANSI / IEEE C95.1 1992 - SAFETY LIMIT Spatial Peak Uncontrolled Exposure/General Population							Body 1.6 W/kg (mW/g) averaged over 1 gram									

FCC ID: A3LSMG900A	 PCTEST ENGINEERING LABORATORY, INC.	SAR EVALUATION REPORT		Reviewed by: Quality Manager
Document S/N: OY1401270204-R2.A3L	Test Dates: 02/03/14 - 02/17/14	DUT Type: Portable Handset		Page 63 of 85

11.4 SAR Test Notes

General Notes:



1. The test data reported are the worst-case SAR values according to test procedures specified in IEEE 1528-2003, and FCC KDB Publication 447498 D01v05.
2. Batteries are fully charged at the beginning of the SAR measurements. A standard battery was used for all SAR measurements.
3. Liquid tissue depth was at least 15.0 cm for all frequencies.
4. The manufacturer has confirmed that the device(s) tested have the same physical, mechanical and thermal characteristics and are within operational tolerances expected for production units.
5. SAR results were scaled to the maximum allowed power to demonstrate compliance per FCC KDB Publication 447498 D01v05.
6. Device was tested using a fixed spacing for body-worn accessory testing. A separation distance of 10 mm was considered because the manufacturer has determined that there will be body-worn accessories available in the marketplace for users to support this separation distance.
7. Per FCC KDB Publication 648474 D04v01, SAR was evaluated without a headset connected to the device. Since the standalone reported SAR was ≤ 1.2 W/kg, no additional SAR evaluations using a headset cable were required.
8. Per FCC KDB 865664 D01 v01, variability SAR tests were not performed since the measured SAR results for all frequency bands were not greater than 0.8 W/kg. Please see Section 13 for variability analysis.
9. During SAR Testing for the Wireless Router conditions per FCC KDB Publication 941225 D06v01, the actual Portable Hotspot operation (with actual simultaneous transmission of a transmitter with WIFI) was not activated (See Section 6.7 for more details).
10. Per FCC KDB Publication 648474 D04, SAR was measured using the standard battery cover and then repeated with the wireless charging battery cover for the highest reported SAR for each wireless technology, frequency band, operating mode, and exposure condition. No additional evaluations with wireless charging cover were required since all reported SAR values were less than 1.2 W/kg.

GSM Test Notes:

1. Body-Worn accessory testing is typically associated with voice operations. Therefore, GSM voice was evaluated for body-worn SAR.
2. Justification for reduced test configurations per KDB Publication 941225 D03v01 and October 2013 TCB Workshop Notes: The source-based frame-averaged output power was evaluated for all GPRS/EDGE slot configurations. The configuration with the highest target frame averaged output power was evaluated for hotspot SAR. When the maximum frame-averaged powers are equivalent across two or more slots (within 0.25 dB), the configuration with the most number of time slots was tested.
3. Per FCC KDB Publication 447498 D01v05, if the reported (scaled) SAR measured at the middle channel or highest output power channel for each test configuration is ≤ 0.8 W/kg then testing at the other channels is not required for such test configuration(s). When the maximum output power variation across the required test channels is $> \frac{1}{2}$ dB, instead of the middle channel, the highest output power channel was used.

UMTS Notes:

1. UMTS mode in was tested under RMC 12.2 kbps with HSPA Inactive per KDB Publication 941225 D01v02. HSPA SAR was not required since the average output power of the HSPA subtests was not more than 0.25 dB higher than the RMC level and SAR was less than 1.2 W/kg.
2. Per FCC KDB Publication 447498 D01v05, if the reported (scaled) SAR measured at the middle channel or highest output power channel for each test configuration is ≤ 0.8 W/kg then testing at the other channels is not required for such test configuration(s). When the maximum output power variation across the required test channels is $> \frac{1}{2}$ dB, instead of the middle channel, the highest output power channel was used.



FCC ID: A3LSMG900A	 PCTEST ENGINEERING LABORATORY, INC.	SAR EVALUATION REPORT		Reviewed by: Quality Manager
Document S/N: OY1401270204-R2.A3L	Test Dates: 02/03/14 - 02/17/14	DUT Type: Portable Handset		Page 64 of 85

LTE Notes:

1. LTE Considerations: LTE test configurations are determined according to SAR Evaluation Considerations for LTE Devices in FCC KDB Publication 941225 D05v02r01. The general test procedures used for testing can be found in Section 8.4.4.
2. MPR is permanently implemented for this device by the manufacturer. The specific manufacturer target MPR is indicated alongside the SAR results. MPR is enabled for this device, according to 3GPP TS36.101 Section 6.2.3 – 6.2.5 under Table 6.2.3-1.
3. A-MPR was disabled for all SAR tests by setting NS=01 on the base station simulator. SAR tests were performed with the same number of RB and RB offsets transmitting on all TTI frames (maximum TTI).
4. Per FCC Guidance, LTE CA SAR was not needed for testing since the data sent by uplink on uplink physical channels does not change between Rel 8 and Rel 10.

WLAN Notes:

1. Justification for reduced test configurations for WIFI channels per KDB Publication 248227 D01v01r02 and October 2012 FCC/TCB Meeting Notes for 2.4 GHz WIFI: Highest average RF output power channel for the lowest data rate was selected for SAR evaluation in 802.11b. Other SISO IEEE 802.11 modes (including 802.11g/n) were not investigated since the average output powers over all channels and data rates were not more than 0.25 dB higher than the tested channel in the lowest data rate of SISO IEEE 802.11b mode.
2. Justification for reduced test configurations for WIFI channels per KDB Publication 248227 D01v01r02 and October 2012 FCC/TCB Meeting Notes for 5 GHz WIFI: Highest average RF output power channel for the lowest data rate was selected for SAR evaluation in 802.11a. Other SISO IEEE 802.11 modes (including 802.11n) were not investigated since the average output powers over all channels and data rates were not more than 0.25 dB higher than the tested channel in the lowest data rate of SISO IEEE 802.11a mode.
3. Per April 2013 TCB Workshop notes, full SAR tests for all SISO IEEE 802.11ac configurations were not required because the average output power was not more than 0.25 dB higher than SISO IEEE 802.11a mode. SISO IEEE 802.11ac was evaluated for the highest SISO IEEE 802.11a position in each 5 GHz band and exposure condition.
4. When Hotspot is enabled, 5.2 GHz - 5.7 GHz bands are disabled. Therefore, only 2.4 GHz and 5.8 GHz WIFI Wireless Router SAR Data was required.
5. WIFI transmission was verified using an uncalibrated spectrum analyzer.
6. When the maximum extrapolated peak SAR of the zoom scan for the maximum output channel is >1.6 W/kg or the reported 1g averaged SAR is >0.8 W/kg, SAR testing on other default channels was required.
7. Per KDB 248227, SAR for MIMO was measured with both transmitting simultaneously and was evaluated independently of SISO operation. For 2.4 GHz MIMO, 802.11n was evaluated. For 5 GHz MIMO, 20 MHz Bandwidth 802.11n was evaluated. Additional evaluations for 40 MHz bandwidth 802.11n and 802.11ac were not required since the maximum allowed output power was not higher than 802.11n 20 MHz Bandwidth.
8. For SAR compliance, this device uses power reduction when the device is in a held-to-ear RF exposure condition with WIFI data modes. Therefore, WIFI Head SAR was evaluated at reduced power levels.

FCC ID: A3LSMG900A	 PCTEST ENGINEERING LABORATORY, INC.	SAR EVALUATION REPORT		Reviewed by: Quality Manager
Document S/N: OY1401270204-R2.A3L	Test Dates: 02/03/14 - 02/17/14	DUT Type: Portable Handset	Page 65 of 85	

12 FCC MULTI-TX AND ANTENNA SAR CONSIDERATIONS

12.1 Introduction

The following procedures adopted from FCC KDB Publication 447498 D01v05 are applicable to handsets with built-in unlicensed transmitters such as 802.11a/b/g/n/ac and Bluetooth devices which may simultaneously transmit with the licensed transmitter.

12.2 Simultaneous Transmission Procedures



This device contains transmitters that may operate simultaneously. Therefore simultaneous transmission analysis is required. Per FCC KDB 447498 D01v05 IV.C.1.iii and IEEE 1528-2013 Section 6.3.4.1.2, simultaneous transmission SAR test exclusion may be applied when the sum of the 1-g SAR for all the simultaneous transmitting antennas in a specific physical test configuration is ≤ 1.6 W/kg. When standalone SAR is not required to be measured, per FCC KDB 447498 D01v05 4.3.2 2), the following equation must be used to estimate the standalone 1g SAR for simultaneous transmission assessment involving that transmitter.

$$\text{Estimated SAR} = \frac{\sqrt{f(\text{GHz})}}{7.5} * \frac{(\text{Max Power of channel, mW})}{\text{Min. Separation Distance, mm}}$$

**Table 12-1
Estimated SAR**

Mode	Frequency	Maximum Allowed Power	Separation Distance (Body)	Estimated SAR (Body)
	[MHz]	[dBm]	[mm]	[W/kg]
Bluetooth	2441	10.00	10	0.208

Note: Held-to ear configurations are not applicable to Bluetooth operations and therefore were not considered for simultaneous transmission. Per KDB Publication 447498 D01v05, the maximum power of the channel was rounded to the nearest mW before calculation.

FCC ID: A3LSMG900A		SAR EVALUATION REPORT		Reviewed by: Quality Manager
Document S/N: 0Y1401270204-R2.A3L	Test Dates: 02/03/14 - 02/17/14	DUT Type: Portable Handset	Page 66 of 85	



12.3 Head SAR Simultaneous Transmission Analysis

Table 12-2
Simultaneous Transmission Scenario with 2.4 GHz WLAN Antenna 1 (Held to Ear)

Simult Tx	Configuration	GSM 850 SAR (W/kg)	2.4 GHz WLAN SAR (W/kg)	Σ SAR (W/kg)	Simult Tx	Configuration	GSM 1900 SAR (W/kg)	2.4 GHz WLAN SAR (W/kg)	Σ SAR (W/kg)
Head SAR	Right Cheek	0.313	0.403	0.716	Head SAR	Right Cheek	0.071	0.403	0.474
	Right Tilt	0.219	0.310	0.529		Right Tilt	0.058	0.310	0.368
	Left Cheek	0.325	0.263	0.588		Left Cheek	0.166	0.263	0.429
	Left Tilt	0.213	0.222	0.435		Left Tilt	0.047	0.222	0.269
Simult Tx	Configuration	UMTS 850 SAR (W/kg)	2.4 GHz WLAN SAR (W/kg)	Σ SAR (W/kg)	Simult Tx	Configuration	UMTS 1900 SAR (W/kg)	2.4 GHz WLAN SAR (W/kg)	Σ SAR (W/kg)
Head SAR	Right Cheek	0.270	0.403	0.673	Head SAR	Right Cheek	0.233	0.403	0.636
	Right Tilt	0.185	0.310	0.495		Right Tilt	0.235	0.310	0.545
	Left Cheek	0.271	0.263	0.534		Left Cheek	0.482	0.263	0.745
	Left Tilt	0.170	0.222	0.392		Left Tilt	0.173	0.222	0.395
Simult Tx	Configuration	LTE Band 17 SAR (W/kg)	2.4 GHz WLAN SAR (W/kg)	Σ SAR (W/kg)	Simult Tx	Configuration	LTE Band 5 (Cell) SAR (W/kg)	2.4 GHz WLAN SAR (W/kg)	Σ SAR (W/kg)
Head SAR	Right Cheek	0.281	0.403	0.684	Head SAR	Right Cheek	0.294	0.403	0.697
	Right Tilt	0.129	0.310	0.439		Right Tilt	0.186	0.310	0.496
	Left Cheek	0.278	0.263	0.541		Left Cheek	0.297	0.263	0.560
	Left Tilt	0.151	0.222	0.373		Left Tilt	0.209	0.222	0.431
Simult Tx	Configuration	LTE Band 4 (AWS) SAR (W/kg)	2.4 GHz WLAN SAR (W/kg)	Σ SAR (W/kg)	Simult Tx	Configuration	LTE Band 2 (PCS) SAR (W/kg)	2.4 GHz WLAN SAR (W/kg)	Σ SAR (W/kg)
Head SAR	Right Cheek	0.255	0.403	0.658	Head SAR	Right Cheek	0.273	0.403	0.676
	Right Tilt	0.092	0.310	0.402		Right Tilt	0.281	0.310	0.591
	Left Cheek	0.496	0.263	0.759		Left Cheek	0.495	0.263	0.758
	Left Tilt	0.150	0.222	0.372		Left Tilt	0.215	0.222	0.437

Table 12-3
Simultaneous Transmission Scenario with 2.4 GHz WLAN Antenna 2 (Held to Ear)

Simult Tx	Configuration	GSM 850 SAR (W/kg)	2.4 GHz WLAN SAR (W/kg)	Σ SAR (W/kg)	Simult Tx	Configuration	GSM 1900 SAR (W/kg)	2.4 GHz WLAN SAR (W/kg)	Σ SAR (W/kg)
Head SAR	Right Cheek	0.313	0.131	0.444	Head SAR	Right Cheek	0.071	0.131	0.202
	Right Tilt	0.219	0.030	0.249		Right Tilt	0.058	0.030	0.088
	Left Cheek	0.325	0.055	0.380		Left Cheek	0.166	0.055	0.221
	Left Tilt	0.213	0.024	0.237		Left Tilt	0.047	0.024	0.071
Simult Tx	Configuration	UMTS 850 SAR (W/kg)	2.4 GHz WLAN SAR (W/kg)	Σ SAR (W/kg)	Simult Tx	Configuration	UMTS 1900 SAR (W/kg)	2.4 GHz WLAN SAR (W/kg)	Σ SAR (W/kg)
Head SAR	Right Cheek	0.270	0.131	0.401	Head SAR	Right Cheek	0.233	0.131	0.364
	Right Tilt	0.185	0.030	0.215		Right Tilt	0.235	0.030	0.265
	Left Cheek	0.271	0.055	0.326		Left Cheek	0.482	0.055	0.537
	Left Tilt	0.170	0.024	0.194		Left Tilt	0.173	0.024	0.197
Simult Tx	Configuration	LTE Band 17 SAR (W/kg)	2.4 GHz WLAN SAR (W/kg)	Σ SAR (W/kg)	Simult Tx	Configuration	LTE Band 5 (Cell) SAR (W/kg)	2.4 GHz WLAN SAR (W/kg)	Σ SAR (W/kg)
Head SAR	Right Cheek	0.281	0.131	0.412	Head SAR	Right Cheek	0.294	0.131	0.425
	Right Tilt	0.129	0.030	0.159		Right Tilt	0.186	0.030	0.216
	Left Cheek	0.278	0.055	0.333		Left Cheek	0.297	0.055	0.352
	Left Tilt	0.151	0.024	0.175		Left Tilt	0.209	0.024	0.233

FCC ID: A3LSMG900A	 PCTEST Engineering Laboratory, Inc.	SAR EVALUATION REPORT		Reviewed by: Quality Manager
Document S/N: OY1401270204-R2.A3L	Test Dates: 02/03/14 - 02/17/14	DUT Type: Portable Handset		Page 67 of 85



Simult Tx	Configuration	LTE Band 4 (AWS) SAR (W/kg)	2.4 GHz WLAN SAR (W/kg)	Σ SAR (W/kg)	Simult Tx	Configuration	LTE Band 2 (PCS) SAR (W/kg)	2.4 GHz WLAN SAR (W/kg)	Σ SAR (W/kg)
Head SAR	Right Cheek	0.255	0.131	0.386	Head SAR	Right Cheek	0.273	0.131	0.404
	Right Tilt	0.092	0.030	0.122		Right Tilt	0.281	0.030	0.311
	Left Cheek	0.496	0.055	0.551		Left Cheek	0.495	0.055	0.550
	Left Tilt	0.150	0.024	0.174		Left Tilt	0.215	0.024	0.239

Table 12-4
Simultaneous Transmission Scenario with 2.4 GHz WLAN MIMO (Held to Ear)

Simult Tx	Configuration	GSM 850 SAR (W/kg)	2.4 GHz WLAN SAR (W/kg)	Σ SAR (W/kg)	Simult Tx	Configuration	GSM 1900 SAR (W/kg)	2.4 GHz WLAN SAR (W/kg)	Σ SAR (W/kg)
Head SAR	Right Cheek	0.313	0.238	0.551	Head SAR	Right Cheek	0.071	0.238	0.309
	Right Tilt	0.219	0.199	0.418		Right Tilt	0.058	0.199	0.257
	Left Cheek	0.325	0.181	0.506		Left Cheek	0.166	0.181	0.347
	Left Tilt	0.213	0.150	0.363		Left Tilt	0.047	0.150	0.197
Head SAR	Right Cheek	0.270	0.238	0.508	Head SAR	Right Cheek	0.233	0.238	0.471
	Right Tilt	0.185	0.199	0.384		Right Tilt	0.235	0.199	0.434
	Left Cheek	0.271	0.181	0.452		Left Cheek	0.482	0.181	0.663
	Left Tilt	0.170	0.150	0.320		Left Tilt	0.173	0.150	0.323
Head SAR	Right Cheek	0.281	0.238	0.519	Head SAR	Right Cheek	0.294	0.238	0.532
	Right Tilt	0.129	0.199	0.328		Right Tilt	0.186	0.199	0.385
	Left Cheek	0.278	0.181	0.459		Left Cheek	0.297	0.181	0.478
	Left Tilt	0.151	0.150	0.301		Left Tilt	0.209	0.150	0.359
Head SAR	Right Cheek	0.255	0.238	0.493	Head SAR	Right Cheek	0.273	0.238	0.511
	Right Tilt	0.092	0.199	0.291		Right Tilt	0.281	0.199	0.480
	Left Cheek	0.496	0.181	0.677		Left Cheek	0.495	0.181	0.676
	Left Tilt	0.150	0.150	0.300		Left Tilt	0.215	0.150	0.365

Table 12-5
Simultaneous Transmission Scenario with 5 GHz WLAN Antenna 1 (Held to Ear)

Simult Tx	Configuration	GSM 850 SAR (W/kg)	5 GHz WLAN SAR (W/kg)	Σ SAR (W/kg)	Simult Tx	Configuration	GSM 1900 SAR (W/kg)	5 GHz WLAN SAR (W/kg)	Σ SAR (W/kg)
Head SAR	Right Cheek	0.313	0.308	0.621	Head SAR	Right Cheek	0.071	0.308	0.379
	Right Tilt	0.219	0.561	0.780		Right Tilt	0.058	0.561	0.619
	Left Cheek	0.325	0.357	0.682		Left Cheek	0.166	0.357	0.523
	Left Tilt	0.213	0.361	0.574		Left Tilt	0.047	0.361	0.408
Head SAR	Right Cheek	0.270	0.308	0.578	Head SAR	Right Cheek	0.233	0.308	0.541
	Right Tilt	0.185	0.561	0.746		Right Tilt	0.235	0.561	0.796
	Left Cheek	0.271	0.357	0.628		Left Cheek	0.482	0.357	0.839
	Left Tilt	0.170	0.361	0.531		Left Tilt	0.173	0.361	0.534

FCC ID: A3LSMG900A	 PCTEST ENGINEERING LABORATORY, INC.	SAR EVALUATION REPORT		Reviewed by: Quality Manager
Document S/N: OY1401270204-R2.A3L	Test Dates: 02/03/14 - 02/17/14	DUT Type: Portable Handset		Page 68 of 85

Simult Tx	Configuration	LTE Band 17 SAR (W/kg)	5 GHz WLAN SAR (W/kg)	Σ SAR (W/kg)	Simult Tx	Configuration	LTE Band 5 (Cell) SAR (W/kg)	5 GHz WLAN SAR (W/kg)	Σ SAR (W/kg)
Head SAR	Right Cheek	0.281	0.308	0.589	Head SAR	Right Cheek	0.294	0.308	0.602
	Right Tilt	0.129	0.561	0.690		Right Tilt	0.186	0.561	0.747
	Left Cheek	0.278	0.357	0.635		Left Cheek	0.297	0.357	0.654
	Left Tilt	0.151	0.361	0.512		Left Tilt	0.209	0.361	0.570
Simult Tx	Configuration	LTE Band 4 (AWS) SAR (W/kg)	5 GHz WLAN SAR (W/kg)	Σ SAR (W/kg)	Simult Tx	Configuration	LTE Band 2 (PCS) SAR (W/kg)	5 GHz WLAN SAR (W/kg)	Σ SAR (W/kg)
Head SAR	Right Cheek	0.255	0.308	0.563	Head SAR	Right Cheek	0.273	0.308	0.581
	Right Tilt	0.092	0.561	0.653		Right Tilt	0.281	0.561	0.842
	Left Cheek	0.496	0.357	0.853		Left Cheek	0.495	0.357	0.852
	Left Tilt	0.150	0.361	0.512		Left Tilt	0.215	0.361	0.576

Note: The worst case 5 GHz WLAN reported SAR for each configuration was used for SAR summation, regardless of whether the WLAN channel has WIFI Hotspot capability. Therefore, the summations above represent the absolute worst cases for simultaneous transmission with 5 GHz WLAN.

Table 12-6
Simultaneous Transmission Scenario with 5 GHz WLAN Antenna 2 (Held to Ear)

Simult Tx	Configuration	GSM 850 SAR (W/kg)	5 GHz WLAN SAR (W/kg)	Σ SAR (W/kg)	Simult Tx	Configuration	GSM 1900 SAR (W/kg)	5 GHz WLAN SAR (W/kg)	Σ SAR (W/kg)
Head SAR	Right Cheek	0.313	0.141	0.454	Head SAR	Right Cheek	0.071	0.141	0.212
	Right Tilt	0.219	0.044	0.263		Right Tilt	0.058	0.044	0.102
	Left Cheek	0.325	0.020	0.345		Left Cheek	0.166	0.020	0.186
	Left Tilt	0.213	0.007	0.220		Left Tilt	0.047	0.007	0.054
Simult Tx	Configuration	UMTS 850 SAR (W/kg)	5 GHz WLAN SAR (W/kg)	Σ SAR (W/kg)	Simult Tx	Configuration	UMTS 1900 SAR (W/kg)	5 GHz WLAN SAR (W/kg)	Σ SAR (W/kg)
Head SAR	Right Cheek	0.270	0.141	0.411	Head SAR	Right Cheek	0.233	0.141	0.374
	Right Tilt	0.185	0.044	0.229		Right Tilt	0.235	0.044	0.279
	Left Cheek	0.271	0.020	0.291		Left Cheek	0.482	0.020	0.502
	Left Tilt	0.170	0.007	0.177		Left Tilt	0.173	0.007	0.180
Simult Tx	Configuration	LTE Band 17 SAR (W/kg)	5 GHz WLAN SAR (W/kg)	Σ SAR (W/kg)	Simult Tx	Configuration	LTE Band 5 (Cell) SAR (W/kg)	5 GHz WLAN SAR (W/kg)	Σ SAR (W/kg)
Head SAR	Right Cheek	0.281	0.141	0.422	Head SAR	Right Cheek	0.294	0.141	0.435
	Right Tilt	0.129	0.044	0.173		Right Tilt	0.186	0.044	0.230
	Left Cheek	0.278	0.020	0.298		Left Cheek	0.297	0.020	0.317
	Left Tilt	0.151	0.007	0.158		Left Tilt	0.209	0.007	0.216
Simult Tx	Configuration	LTE Band 4 (AWS) SAR (W/kg)	5 GHz WLAN SAR (W/kg)	Σ SAR (W/kg)	Simult Tx	Configuration	LTE Band 2 (PCS) SAR (W/kg)	5 GHz WLAN SAR (W/kg)	Σ SAR (W/kg)
Head SAR	Right Cheek	0.255	0.141	0.396	Head SAR	Right Cheek	0.273	0.141	0.414
	Right Tilt	0.092	0.044	0.136		Right Tilt	0.281	0.044	0.325
	Left Cheek	0.496	0.020	0.516		Left Cheek	0.495	0.020	0.515
	Left Tilt	0.150	0.007	0.157		Left Tilt	0.215	0.007	0.222

Note: The worst case 5 GHz WLAN reported SAR for each configuration was used for SAR summation, regardless of whether the WLAN channel has WIFI Hotspot capability. Therefore, the summations above represent the absolute worst cases for simultaneous transmission with 5 GHz WLAN.





FCC ID: A3LSMG900A	 PCTEST Engineering Laboratory, Inc.	SAR EVALUATION REPORT		Reviewed by: Quality Manager
Document S/N: OY1401270204-R2.A3L	Test Dates: 02/03/14 - 02/17/14	DUT Type: Portable Handset		Page 69 of 85

Table 12-7
Simultaneous Transmission Scenario with 5 GHz WLAN MIMO (Held to Ear)

Simult Tx	Configuration	GSM 850 SAR (W/kg)	5 GHz WLAN SAR (W/kg)	Σ SAR (W/kg)	Simult Tx	Configuration	GSM 1900 SAR (W/kg)	5 GHz WLAN SAR (W/kg)	Σ SAR (W/kg)
Head SAR	Right Cheek	0.313	0.043	0.356	Head SAR	Right Cheek	0.071	0.043	0.114
	Right Tilt	0.219	0.077	0.296		Right Tilt	0.058	0.077	0.135
	Left Cheek	0.325	0.080	0.405		Left Cheek	0.166	0.080	0.246
	Left Tilt	0.213	0.081	0.294		Left Tilt	0.047	0.081	0.128
Head SAR	Right Cheek	0.270	0.043	0.313	Head SAR	Right Cheek	0.233	0.043	0.276
	Right Tilt	0.185	0.077	0.262		Right Tilt	0.235	0.077	0.312
	Left Cheek	0.271	0.080	0.351		Left Cheek	0.482	0.080	0.562
	Left Tilt	0.170	0.081	0.251		Left Tilt	0.173	0.081	0.254
Head SAR	Right Cheek	0.281	0.043	0.324	Head SAR	Right Cheek	0.294	0.043	0.337
	Right Tilt	0.129	0.077	0.206		Right Tilt	0.186	0.077	0.263
	Left Cheek	0.278	0.080	0.358		Left Cheek	0.297	0.080	0.377
	Left Tilt	0.151	0.081	0.232		Left Tilt	0.209	0.081	0.290
Head SAR	Right Cheek	0.255	0.043	0.298	Head SAR	Right Cheek	0.273	0.043	0.316
	Right Tilt	0.092	0.077	0.169		Right Tilt	0.281	0.077	0.358
	Left Cheek	0.496	0.080	0.576		Left Cheek	0.495	0.080	0.575
	Left Tilt	0.150	0.081	0.231		Left Tilt	0.215	0.081	0.296

Note: The worst case 5 GHz WLAN reported SAR for each configuration was used for SAR summation, regardless of whether the WLAN channel has WIFI Hotspot capability. Therefore, the summations above represent the absolute worst cases for simultaneous transmission with 5 GHz WLAN.

FCC ID: A3LSMG900A		SAR EVALUATION REPORT		Reviewed by: Quality Manager
Document S/N: OY1401270204-R2.A3L	Test Dates: 02/03/14 - 02/17/14	DUT Type: Portable Handset		Page 70 of 85

12.4 Body-Worn Simultaneous Transmission Analysis

Table 12-8

Simultaneous Transmission Scenario with 2.4 GHz WLAN Antenna 1 (Body-Worn at 1.0 cm)

Configuration	Mode	2G/3G/4G SAR (W/kg)	2.4 GHz WLAN SAR (W/kg)	Σ SAR (W/kg)
Back Side	GSM 850	0.492	0.261	0.753
Back Side	GSM 1900	0.086	0.261	0.347
Back Side	UMTS 850	0.481	0.261	0.742
Back Side	UMTS 1900	0.287	0.261	0.548
Back Side	LTE Band 17	0.370	0.261	0.631
Back Side	LTE Band 5 (Cell)	0.525	0.261	0.786
Back Side	LTE Band 4 (AWS)	0.641	0.261	0.902
Back Side	LTE Band 2 (PCS)	0.362	0.261	0.623

Table 12-9

Simultaneous Transmission Scenario with 2.4 GHz WLAN Antenna 2 (Body-Worn at 1.0 cm)

Configuration	Mode	2G/3G/4G SAR (W/kg)	2.4 GHz WLAN SAR (W/kg)	Σ SAR (W/kg)
Back Side	GSM 850	0.492	0.096	0.588
Back Side	GSM 1900	0.086	0.096	0.182
Back Side	UMTS 850	0.481	0.096	0.577
Back Side	UMTS 1900	0.287	0.096	0.383
Back Side	LTE Band 17	0.370	0.096	0.466
Back Side	LTE Band 5 (Cell)	0.525	0.096	0.621
Back Side	LTE Band 4 (AWS)	0.641	0.096	0.737
Back Side	LTE Band 2 (PCS)	0.362	0.096	0.458

Table 12-10

Simultaneous Transmission Scenario with 2.4 GHz WLAN MIMO (Body-Worn at 1.0 cm)

Configuration	Mode	2G/3G/4G SAR (W/kg)	2.4 GHz WLAN SAR (W/kg)	Σ SAR (W/kg)
Back Side	GSM 850	0.492	0.068	0.560
Back Side	GSM 1900	0.086	0.068	0.154
Back Side	UMTS 850	0.481	0.068	0.549
Back Side	UMTS 1900	0.287	0.068	0.355
Back Side	LTE Band 17	0.370	0.068	0.438
Back Side	LTE Band 5 (Cell)	0.525	0.068	0.593
Back Side	LTE Band 4 (AWS)	0.641	0.068	0.709
Back Side	LTE Band 2 (PCS)	0.362	0.068	0.430

Table 12-11

Simultaneous Transmission Scenario with 5 GHz WLAN Antenna 1 (Body-Worn at 1.0 cm)

Configuration	Mode	2G/3G/4G SAR (W/kg)	5 GHz WLAN SAR (W/kg)	Σ SAR (W/kg)
Back Side	GSM 850	0.492	0.639	1.131
Back Side	GSM 1900	0.086	0.639	0.725
Back Side	UMTS 850	0.481	0.639	1.120
Back Side	UMTS 1900	0.287	0.639	0.926
Back Side	LTE Band 17	0.370	0.639	1.009
Back Side	LTE Band 5 (Cell)	0.525	0.639	1.164
Back Side	LTE Band 4 (AWS)	0.641	0.639	1.280
Back Side	LTE Band 2 (PCS)	0.362	0.639	1.001

Note: The worst case 5 GHz WLAN reported SAR for each configuration was used for SAR summation, regardless of whether the WLAN channel has WIFI Hotspot capability. Therefore, the summations above represent the absolute worst cases for simultaneous transmission with 5 GHz WLAN.



FCC ID: A3LSMG900A	 PCTEST Engineering Laboratory, Inc.	SAR EVALUATION REPORT		Reviewed by: Quality Manager
Document S/N: OY1401270204-R2.A3L	Test Dates: 02/03/14 - 02/17/14	DUT Type: Portable Handset		Page 71 of 85

Table 12-12
Simultaneous Transmission Scenario with 5 GHz WLAN Antenna 2 (Body-Worn at 1.0 cm)

Configuration	Mode	2G/3G/4G SAR (W/kg)	5 GHz WLAN SAR (W/kg)	Σ SAR (W/kg)
Back Side	GSM 850	0.492	0.351	0.843
Back Side	GSM 1900	0.086	0.351	0.437
Back Side	UMTS 850	0.481	0.351	0.832
Back Side	UMTS 1900	0.287	0.351	0.638
Back Side	LTE Band 17	0.370	0.351	0.721
Back Side	LTE Band 5 (Cell)	0.525	0.351	0.876
Back Side	LTE Band 4 (AWS)	0.641	0.351	0.992
Back Side	LTE Band 2 (PCS)	0.362	0.351	0.713

Note: The worst case 5 GHz WLAN reported SAR for each configuration was used for SAR summation, regardless of whether the WLAN channel has WIFI Hotspot capability. Therefore, the summations above represent the absolute worst cases for simultaneous transmission with 5 GHz WLAN.

Table 12-13
Simultaneous Transmission Scenario with 5 GHz WLAN MIMO (Body-Worn at 1.0 cm)



Configuration	Mode	2G/3G/4G SAR (W/kg)	5 GHz WLAN SAR (W/kg)	Σ SAR (W/kg)
Back Side	GSM 850	0.492	0.222	0.714
Back Side	GSM 1900	0.086	0.222	0.308
Back Side	UMTS 850	0.481	0.222	0.703
Back Side	UMTS 1900	0.287	0.222	0.509
Back Side	LTE Band 17	0.370	0.222	0.592
Back Side	LTE Band 5 (Cell)	0.525	0.222	0.747
Back Side	LTE Band 4 (AWS)	0.641	0.222	0.863
Back Side	LTE Band 2 (PCS)	0.362	0.222	0.584

Note: The worst case 5 GHz WLAN reported SAR for each configuration was used for SAR summation, regardless of whether the WLAN channel has WIFI Hotspot capability. Therefore, the summations above represent the absolute worst cases for simultaneous transmission with 5 GHz WLAN.

Table 12-14
Simultaneous Transmission Scenario with Bluetooth Antenna 1 (Body-Worn at 1.0 cm)

Configuration	Mode	2G/3G/4G SAR (W/kg)	Bluetooth SAR (W/kg)	Σ SAR (W/kg)
Back Side	GSM 850	0.492	0.208	0.700
Back Side	GSM 1900	0.086	0.208	0.294
Back Side	UMTS 850	0.481	0.208	0.689
Back Side	UMTS 1900	0.287	0.208	0.495
Back Side	LTE Band 17	0.370	0.208	0.578
Back Side	LTE Band 5 (Cell)	0.525	0.208	0.733
Back Side	LTE Band 4 (AWS)	0.641	0.208	0.849
Back Side	LTE Band 2 (PCS)	0.362	0.208	0.570

Note: Bluetooth SAR was not required to be measured per FCC KDB 447498. Estimated SAR results were used in the above table to determine simultaneous transmission SAR test exclusion.

FCC ID: A3LSMG900A		SAR EVALUATION REPORT		Reviewed by: Quality Manager
Document S/N: OY1401270204-R2.A3L	Test Dates: 02/03/14 - 02/17/14	DUT Type: Portable Handset		Page 72 of 85

12.5 Hotspot SAR Simultaneous Transmission Analysis

Per FCC KDB Publication 941225 D06v01, the devices edges with antennas more than 2.5 cm from edge are not required to be evaluated for SAR (“-”).

Table 12-15
Simultaneous Transmission Scenario (2.4 GHz Antenna 1 Hotspot at 1.0 cm)

Simult Tx	Configuration	GPRS 850 SAR (W/kg)	2.4 GHz WLAN SAR (W/kg)	Σ SAR (W/kg)	Simult Tx	Configuration	GPRS 1900 SAR (W/kg)	2.4 GHz WLAN SAR (W/kg)	Σ SAR (W/kg)
Body SAR	Back	0.555	0.261	0.816	Body SAR	Back	0.144	0.261	0.405
	Front	0.444	0.214	0.658		Front	0.299	0.214	0.513
	Top	-	0.126	0.126		Top	-	0.126	0.126
	Bottom	0.100	-	0.100		Bottom	0.247	-	0.247
	Right	0.487	-	0.487		Right	0.019	-	0.019
	Left	0.503	0.123	0.626		Left	0.219	0.123	0.342
Simult Tx	Configuration	UMTS 850 SAR (W/kg)	2.4 GHz WLAN SAR (W/kg)	Σ SAR (W/kg)	Simult Tx	Configuration	UMTS 1900 SAR (W/kg)	2.4 GHz WLAN SAR (W/kg)	Σ SAR (W/kg)
Body SAR	Back	0.481	0.261	0.742	Body SAR	Back	0.287	0.261	0.548
	Front	0.380	0.214	0.594		Front	0.289	0.214	0.503
	Top	-	0.126	0.126		Top	-	0.126	0.126
	Bottom	0.075	-	0.075		Bottom	0.159	-	0.159
	Right	0.435	-	0.435		Right	0.131	-	0.131
	Left	0.370	0.123	0.493		Left	0.239	0.123	0.362
Simult Tx	Configuration	LTE Band 17 SAR (W/kg)	2.4 GHz WLAN SAR (W/kg)	Σ SAR (W/kg)	Simult Tx	Configuration	LTE Band 5 (Cell) SAR (W/kg)	2.4 GHz WLAN SAR (W/kg)	Σ SAR (W/kg)
Body SAR	Back	0.370	0.261	0.631	Body SAR	Back	0.525	0.261	0.786
	Front	0.331	0.214	0.545		Front	0.409	0.214	0.623
	Top	-	0.126	0.126		Top	-	0.126	0.126
	Bottom	0.069	-	0.069		Bottom	0.088	-	0.088
	Right	0.263	-	0.263		Right	0.447	-	0.447
	Left	0.162	0.123	0.285		Left	0.397	0.123	0.520
Simult Tx	Configuration	LTE Band 4 (AWS) SAR (W/kg)	2.4 GHz WLAN SAR (W/kg)	Σ SAR (W/kg)	Simult Tx	Configuration	LTE Band 2 (PCS) SAR (W/kg)	2.4 GHz WLAN SAR (W/kg)	Σ SAR (W/kg)
Body SAR	Back	0.641	0.261	0.902	Body SAR	Back	0.362	0.261	0.623
	Front	0.531	0.214	0.745		Front	0.361	0.214	0.575
	Top	-	0.126	0.126		Top	-	0.126	0.126
	Bottom	0.515	-	0.515		Bottom	0.184	-	0.184
	Right	0.142	-	0.142		Right	0.153	-	0.153
	Left	0.320	0.123	0.443		Left	0.240	0.123	0.363



FCC ID: A3LSMG900A	 PCTEST ENGINEERING LABORATORY, INC.	SAR EVALUATION REPORT		Reviewed by: Quality Manager
Document S/N: OY1401270204-R2.A3L	Test Dates: 02/03/14 - 02/17/14	DUT Type: Portable Handset		Page 73 of 85

Table 12-16
Simultaneous Transmission Scenario (2.4 GHz Antenna 2 Hotspot at 1.0 cm)

Simult Tx	Configuration	GPRS 850 SAR (W/kg)	2.4 GHz WLAN SAR (W/kg)	Σ SAR (W/kg)	Simult Tx	Configuration	GPRS 1900 SAR (W/kg)	2.4 GHz WLAN SAR (W/kg)	Σ SAR (W/kg)
Body SAR	Back	0.555	0.096	0.651	Body SAR	Back	0.144	0.096	0.240
	Front	0.444	0.059	0.503		Front	0.299	0.059	0.358
	Top	-	-	0.000		Top	-	-	0.000
	Bottom	0.100	-	0.100		Bottom	0.247	-	0.247
	Right	0.487	-	0.487		Right	0.019	-	0.019
	Left	0.503	0.085	0.588		Left	0.219	0.085	0.304
Simult Tx	Configuration	UMTS 850 SAR (W/kg)	2.4 GHz WLAN SAR (W/kg)	Σ SAR (W/kg)	Simult Tx	Configuration	UMTS 1900 SAR (W/kg)	2.4 GHz WLAN SAR (W/kg)	Σ SAR (W/kg)
Body SAR	Back	0.481	0.096	0.577	Body SAR	Back	0.287	0.096	0.383
	Front	0.380	0.059	0.439		Front	0.289	0.059	0.348
	Top	-	-	0.000		Top	-	-	0.000
	Bottom	0.075	-	0.075		Bottom	0.159	-	0.159
	Right	0.435	-	0.435		Right	0.131	-	0.131
	Left	0.370	0.085	0.455		Left	0.239	0.085	0.324
Simult Tx	Configuration	LTE Band 17 SAR (W/kg)	2.4 GHz WLAN SAR (W/kg)	Σ SAR (W/kg)	Simult Tx	Configuration	LTE Band 5 (Cell) SAR (W/kg)	2.4 GHz WLAN SAR (W/kg)	Σ SAR (W/kg)
Body SAR	Back	0.370	0.096	0.466	Body SAR	Back	0.525	0.096	0.621
	Front	0.331	0.059	0.390		Front	0.409	0.059	0.468
	Top	-	-	0.000		Top	-	-	0.000
	Bottom	0.069	-	0.069		Bottom	0.088	-	0.088
	Right	0.263	-	0.263		Right	0.447	-	0.447
	Left	0.162	0.085	0.247		Left	0.397	0.085	0.482
Simult Tx	Configuration	LTE Band 4 (AWS) SAR (W/kg)	2.4 GHz WLAN SAR (W/kg)	Σ SAR (W/kg)	Simult Tx	Configuration	LTE Band 2 (PCS) SAR (W/kg)	2.4 GHz WLAN SAR (W/kg)	Σ SAR (W/kg)
Body SAR	Back	0.641	0.096	0.737	Body SAR	Back	0.362	0.096	0.458
	Front	0.531	0.059	0.590		Front	0.361	0.059	0.420
	Top	-	-	0.000		Top	-	-	0.000
	Bottom	0.515	-	0.515		Bottom	0.184	-	0.184
	Right	0.142	-	0.142		Right	0.153	-	0.153
	Left	0.320	0.085	0.405		Left	0.240	0.085	0.325



FCC ID: A3LSMG900A	 PCTEST ENGINEERING LABORATORY, INC.	SAR EVALUATION REPORT		Reviewed by: Quality Manager
Document S/N: OY1401270204-R2.A3L	Test Dates: 02/03/14 - 02/17/14	DUT Type: Portable Handset		Page 74 of 85

Table 12-17
Simultaneous Transmission Scenario (2.4 GHz MIMO Hotspot at 1.0 cm)

Simult Tx	Configuration	GPRS 850 SAR (W/kg)	2.4 GHz WLAN SAR (W/kg)	Σ SAR (W/kg)	Simult Tx	Configuration	GPRS 1900 SAR (W/kg)	2.4 GHz WLAN SAR (W/kg)	Σ SAR (W/kg)
Body SAR	Back	0.555	0.068	0.623	Body SAR	Back	0.144	0.068	0.212
	Front	0.444	0.058	0.502		Front	0.299	0.058	0.357
	Top	-	0.038	0.038		Top	-	0.038	0.038
	Bottom	0.100	-	0.100		Bottom	0.247	-	0.247
	Right	0.487	-	0.487		Right	0.019	-	0.019
	Left	0.503	0.030	0.533		Left	0.219	0.030	0.249
Simult Tx	Configuration	UMTS 850 SAR (W/kg)	2.4 GHz WLAN SAR (W/kg)	Σ SAR (W/kg)	Simult Tx	Configuration	UMTS 1900 SAR (W/kg)	2.4 GHz WLAN SAR (W/kg)	Σ SAR (W/kg)
Body SAR	Back	0.481	0.068	0.549	Body SAR	Back	0.287	0.068	0.355
	Front	0.380	0.058	0.438		Front	0.289	0.058	0.347
	Top	-	0.038	0.038		Top	-	0.038	0.038
	Bottom	0.075	-	0.075		Bottom	0.159	-	0.159
	Right	0.435	-	0.435		Right	0.131	-	0.131
	Left	0.370	0.030	0.400		Left	0.239	0.030	0.269
Simult Tx	Configuration	LTE Band 17 SAR (W/kg)	2.4 GHz WLAN SAR (W/kg)	Σ SAR (W/kg)	Simult Tx	Configuration	LTE Band 5 (Cell) SAR (W/kg)	2.4 GHz WLAN SAR (W/kg)	Σ SAR (W/kg)
Body SAR	Back	0.370	0.068	0.438	Body SAR	Back	0.525	0.068	0.593
	Front	0.331	0.058	0.389		Front	0.409	0.058	0.467
	Top	-	0.038	0.038		Top	-	0.038	0.038
	Bottom	0.069	-	0.069		Bottom	0.088	-	0.088
	Right	0.263	-	0.263		Right	0.447	-	0.447
	Left	0.162	0.030	0.192		Left	0.397	0.030	0.427
Simult Tx	Configuration	LTE Band 4 (AWS) SAR (W/kg)	2.4 GHz WLAN SAR (W/kg)	Σ SAR (W/kg)	Simult Tx	Configuration	LTE Band 2 (PCS) SAR (W/kg)	2.4 GHz WLAN SAR (W/kg)	Σ SAR (W/kg)
Body SAR	Back	0.641	0.068	0.709	Body SAR	Back	0.362	0.068	0.430
	Front	0.531	0.058	0.589		Front	0.361	0.058	0.419
	Top	-	0.038	0.038		Top	-	0.038	0.038
	Bottom	0.515	-	0.515		Bottom	0.184	-	0.184
	Right	0.142	-	0.142		Right	0.153	-	0.153
	Left	0.320	0.030	0.350		Left	0.240	0.030	0.270



FCC ID: A3LSMG900A	 PCTEST ENGINEERING LABORATORY, INC.	SAR EVALUATION REPORT		Reviewed by: Quality Manager
Document S/N: 0Y1401270204-R2.A3L	Test Dates: 02/03/14 - 02/17/14	DUT Type: Portable Handset		Page 75 of 85

Table 12-18
Simultaneous Transmission Scenario (5 GHz Antenna 1 Hotspot at 1.0 cm)

Simult Tx	Configuration	GPRS 850 SAR (W/kg)	5 GHz WLAN SAR (W/kg)	Σ SAR (W/kg)	Simult Tx	Configuration	GPRS 1900 SAR (W/kg)	5 GHz WLAN SAR (W/kg)	Σ SAR (W/kg)
Body SAR	Back	0.555	0.479	1.034	Body SAR	Back	0.144	0.479	0.623
	Front	0.444	0.191	0.635		Front	0.299	0.191	0.490
	Top	-	0.684	0.684		Top	-	0.684	0.684
	Bottom	0.100	-	0.100		Bottom	0.247	-	0.247
	Right	0.487	-	0.487		Right	0.019	-	0.019
	Left	0.503	0.039	0.542		Left	0.219	0.039	0.258
Simult Tx	Configuration	UMTS 850 SAR (W/kg)	5 GHz WLAN SAR (W/kg)	Σ SAR (W/kg)	Simult Tx	Configuration	UMTS 1900 SAR (W/kg)	5 GHz WLAN SAR (W/kg)	Σ SAR (W/kg)
Body SAR	Back	0.481	0.479	0.960	Body SAR	Back	0.287	0.479	0.766
	Front	0.380	0.191	0.571		Front	0.289	0.191	0.480
	Top	-	0.684	0.684		Top	-	0.684	0.684
	Bottom	0.075	-	0.075		Bottom	0.159	-	0.159
	Right	0.435	-	0.435		Right	0.131	-	0.131
	Left	0.370	0.039	0.409		Left	0.239	0.039	0.278
Simult Tx	Configuration	LTE Band 17 SAR (W/kg)	5 GHz WLAN SAR (W/kg)	Σ SAR (W/kg)	Simult Tx	Configuration	LTE Band 5 (Cell) SAR (W/kg)	5 GHz WLAN SAR (W/kg)	Σ SAR (W/kg)
Body SAR	Back	0.370	0.479	0.849	Body SAR	Back	0.525	0.479	1.004
	Front	0.331	0.191	0.522		Front	0.409	0.191	0.600
	Top	-	0.684	0.684		Top	-	0.684	0.684
	Bottom	0.069	-	0.069		Bottom	0.088	-	0.088
	Right	0.263	-	0.263		Right	0.447	-	0.447
	Left	0.162	0.039	0.201		Left	0.397	0.039	0.436
Simult Tx	Configuration	LTE Band 4 (AWS) SAR (W/kg)	5 GHz WLAN SAR (W/kg)	Σ SAR (W/kg)	Simult Tx	Configuration	LTE Band 2 (PCS) SAR (W/kg)	5 GHz WLAN SAR (W/kg)	Σ SAR (W/kg)
Body SAR	Back	0.641	0.479	1.120	Body SAR	Back	0.362	0.479	0.841
	Front	0.531	0.191	0.722		Front	0.361	0.191	0.552
	Top	-	0.684	0.684		Top	-	0.684	0.684
	Bottom	0.515	-	0.515		Bottom	0.184	-	0.184
	Right	0.142	-	0.142		Right	0.153	-	0.153
	Left	0.320	0.039	0.359		Left	0.240	0.039	0.279

Table 12-19
Simultaneous Transmission Scenario (5 GHz Antenna 2 Hotspot at 1.0 cm)



Simult Tx	Configuration	GPRS 850 SAR (W/kg)	5 GHz WLAN SAR (W/kg)	Σ SAR (W/kg)	Simult Tx	Configuration	GPRS 1900 SAR (W/kg)	5 GHz WLAN SAR (W/kg)	Σ SAR (W/kg)
Body SAR	Back	0.555	0.327	0.882	Body SAR	Back	0.144	0.327	0.471
	Front	0.444	0.089	0.533		Front	0.299	0.089	0.388
	Top	-	-	0.000		Top	-	-	0.000
	Bottom	0.100	-	0.100		Bottom	0.247	-	0.247
	Right	0.487	-	0.487		Right	0.019	-	0.019
	Left	0.503	0.197	0.700		Left	0.219	0.197	0.416
Simult Tx	Configuration	UMTS 850 SAR (W/kg)	5 GHz WLAN SAR (W/kg)	Σ SAR (W/kg)	Simult Tx	Configuration	UMTS 1900 SAR (W/kg)	5 GHz WLAN SAR (W/kg)	Σ SAR (W/kg)
Body SAR	Back	0.481	0.327	0.808	Body SAR	Back	0.287	0.327	0.614
	Front	0.380	0.089	0.469		Front	0.289	0.089	0.378
	Top	-	-	0.000		Top	-	-	0.000
	Bottom	0.075	-	0.075		Bottom	0.159	-	0.159
	Right	0.435	-	0.435		Right	0.131	-	0.131
	Left	0.370	0.197	0.567		Left	0.239	0.197	0.436
Simult Tx	Configuration	LTE Band 17 SAR (W/kg)	5 GHz WLAN SAR (W/kg)	Σ SAR (W/kg)	Simult Tx	Configuration	LTE Band 5 (Cell) SAR (W/kg)	5 GHz WLAN SAR (W/kg)	Σ SAR (W/kg)
Body SAR	Back	0.370	0.327	0.697	Body SAR	Back	0.525	0.327	0.852
	Front	0.331	0.089	0.420		Front	0.409	0.089	0.498
	Top	-	-	0.000		Top	-	-	0.000
	Bottom	0.069	-	0.069		Bottom	0.088	-	0.088
	Right	0.263	-	0.263		Right	0.447	-	0.447
	Left	0.162	0.197	0.359		Left	0.397	0.197	0.594
Simult Tx	Configuration	LTE Band 4 (AWS) SAR (W/kg)	5 GHz WLAN SAR (W/kg)	Σ SAR (W/kg)	Simult Tx	Configuration	LTE Band 2 (PCS) SAR (W/kg)	5 GHz WLAN SAR (W/kg)	Σ SAR (W/kg)
Body SAR	Back	0.641	0.327	0.968	Body SAR	Back	0.362	0.327	0.689
	Front	0.531	0.089	0.620		Front	0.361	0.089	0.450
	Top	-	-	0.000		Top	-	-	0.000
	Bottom	0.515	-	0.515		Bottom	0.184	-	0.184
	Right	0.142	-	0.142		Right	0.153	-	0.153
	Left	0.320	0.197	0.517		Left	0.240	0.197	0.437

**Table 12-20
Simultaneous Transmission Scenario (5 GHz MIMO Hotspot at 1.0 cm)**

Simult Tx	Configuration	GPRS 850 SAR (W/kg)	5 GHz WLAN SAR (W/kg)	Σ SAR (W/kg)	Simult Tx	Configuration	GPRS 1900 SAR (W/kg)	5 GHz WLAN SAR (W/kg)	Σ SAR (W/kg)
Body SAR	Back	0.555	0.222	0.777	Body SAR	Back	0.144	0.222	0.366
	Front	0.444	0.032	0.476		Front	0.299	0.032	0.331
	Top	-	0.098	0.098		Top	-	0.098	0.098
	Bottom	0.100	-	0.100		Bottom	0.247	-	0.247
	Right	0.487	-	0.487		Right	0.019	-	0.019
	Left	0.503	0.060	0.563		Left	0.219	0.060	0.279
Simult Tx	Configuration	UMTS 850 SAR (W/kg)	5 GHz WLAN SAR (W/kg)	Σ SAR (W/kg)	Simult Tx	Configuration	UMTS 1900 SAR (W/kg)	5 GHz WLAN SAR (W/kg)	Σ SAR (W/kg)
Body SAR	Back	0.481	0.222	0.703	Body SAR	Back	0.287	0.222	0.509
	Front	0.380	0.032	0.412		Front	0.289	0.032	0.321
	Top	-	0.098	0.098		Top	-	0.098	0.098
	Bottom	0.075	-	0.075		Bottom	0.159	-	0.159
	Right	0.435	-	0.435		Right	0.131	-	0.131
	Left	0.370	0.060	0.430		Left	0.239	0.060	0.299
Simult Tx	Configuration	LTE Band 17 SAR (W/kg)	5 GHz WLAN SAR (W/kg)	Σ SAR (W/kg)	Simult Tx	Configuration	LTE Band 5 (Cell) SAR (W/kg)	5 GHz WLAN SAR (W/kg)	Σ SAR (W/kg)
Body SAR	Back	0.370	0.222	0.592	Body SAR	Back	0.525	0.222	0.747
	Front	0.331	0.032	0.363		Front	0.409	0.032	0.441
	Top	-	0.098	0.098		Top	-	0.098	0.098
	Bottom	0.069	-	0.069		Bottom	0.088	-	0.088
	Right	0.263	-	0.263		Right	0.447	-	0.447
	Left	0.162	0.060	0.222		Left	0.397	0.060	0.457
Simult Tx	Configuration	LTE Band 4 (AWS) SAR (W/kg)	5 GHz WLAN SAR (W/kg)	Σ SAR (W/kg)	Simult Tx	Configuration	LTE Band 2 (PCS) SAR (W/kg)	5 GHz WLAN SAR (W/kg)	Σ SAR (W/kg)
Body SAR	Back	0.641	0.222	0.863	Body SAR	Back	0.362	0.222	0.584
	Front	0.531	0.032	0.563		Front	0.361	0.032	0.393
	Top	-	0.098	0.098		Top	-	0.098	0.098
	Bottom	0.515	-	0.515		Bottom	0.184	-	0.184
	Right	0.142	-	0.142		Right	0.153	-	0.153
	Left	0.320	0.060	0.380		Left	0.240	0.060	0.300

12.6 Simultaneous Transmission Conclusion

The above numerical summed SAR results for all the worst-case simultaneous transmission conditions were below the SAR limit. Therefore, the above analysis is sufficient to determine that simultaneous transmission cases will not exceed the SAR limit and therefore no measured volumetric simultaneous SAR summation is required per FCC KDB Publication 447498 D01v05 and IEEE 1528-2013 Section 6.3.4.1.2.

FCC ID: A3LSMG900A	 PCTEST ENGINEERING LABORATORY, INC.	SAR EVALUATION REPORT		Reviewed by: Quality Manager
Document S/N: OY1401270204-R2.A3L	Test Dates: 02/03/14 - 02/17/14	DUT Type: Portable Handset		Page 78 of 85



13 SAR MEASUREMENT VARIABILITY

13.1 Measurement Variability

Per FCC KDB Publication 865664 D01v01, all measured SAR values were <0.8 W/kg. Therefore, no SAR measurement variability analysis was required.

13.2 Measurement Uncertainty

The measured SAR was <1.5 W/kg for all frequency bands. Therefore, per KDB Publication 865664 D01v01, the extended measurement uncertainty analysis per IEEE 1528-2003 was not required.



FCC ID: A3LSMG900A	 PCTEST ENGINEERING LABORATORY, INC.	SAR EVALUATION REPORT		Reviewed by: Quality Manager
Document S/N: 0Y1401270204-R2.A3L	Test Dates: 02/03/14 - 02/17/14	DUT Type: Portable Handset		Page 79 of 85

14 EQUIPMENT LIST

Manufacturer	Model	Description	Cal Date	Cal Interval	Cal Due	Serial Number
Agilent	85047A	S-Parameter Test Set	N/A	N/A	N/A	2904A00579
Agilent	8594A	(9kHz-2.9GHz) Spectrum Analyzer	N/A	N/A	N/A	3051A00187
Agilent	8648D	(9kHz-4GHz) Signal Generator	4/17/2013	Annual	4/17/2014	3629U00687
Agilent	8753E	(30kHz-6GHz) Network Analyzer	7/23/2013	Annual	7/23/2014	US37390350
Agilent	8753ES	S-Parameter Network Analyzer	10/29/2013	Annual	10/29/2014	US39170122
Agilent	E5515C	Wireless Communications Test Set	5/9/2013	Biennial	5/9/2015	GB43304447
Agilent	E8257D	(250kHz-20GHz) Signal Generator	4/16/2013	Annual	4/16/2014	MY45470194
Agilent	N5182A	MXG Vector Signal Generator	10/28/2013	Annual	10/28/2014	US46240505
Agilent	N9020A	MXA Signal Analyzer	10/29/2013	Annual	10/29/2014	US46470561
Amplifier Research	5S1G4	5W, 800MHz-4.2GHz	CBT	N/A	CBT	21910
Anritsu	MA24106A	USB Power Sensor	1/3/2014	Annual	1/3/2015	1349514
Anritsu	MA24106A	USB Power Sensor	1/3/2014	Annual	1/3/2015	1344554
Anritsu	MA2411B	Pulse Power Sensor	11/14/2013	Annual	11/14/2014	1126066
Anritsu	MA2481A	Power Sensor	10/30/2013	Annual	10/30/2014	5605
Anritsu	ML2495A	Power Meter	10/31/2013	Annual	10/31/2014	1039008
Anritsu	MT8820C	Radio Communication Analyzer	12/12/2013	Annual	12/12/2014	6201300731
COMTECH	AR85729-5	Solid State Amplifier	CBT	N/A	CBT	M155A00-009
COMTECH	AR85729-5/5759B	Solid State Amplifier	CBT	N/A	CBT	M3W1A00-1002
Control Company	4052	Long Stem Thermometer	9/27/2013	Biennial	9/27/2015	130567447
Fisher Scientific	15-077-960	Thermometer	11/6/2012	Biennial	11/6/2014	122640025
Fisher Scientific	15-078J	Long Stem Thermometer	10/30/2012	Biennial	10/30/2014	122626059
Gigatronics	80701A	(0.05-18GHz) Power Sensor	10/30/2013	Annual	10/30/2014	1833460
Gigatronics	8651A	Universal Power Meter	10/30/2013	Annual	10/30/2014	8650319
MCL	BW-N6W5+	6dB Attenuator	CBT	N/A	CBT	1139
MiniCircuits	SLP-2400+	Low Pass Filter	CBT	N/A	CBT	R8979500903
MiniCircuits	VLF-6000+	Low Pass Filter	CBT	N/A	CBT	N/A
MiniCircuits	VLF-6000+	Low Pass Filter	CBT	N/A	CBT	N/A
Mini-Circuits	BW-N20W5	Power Attenuator	CBT	N/A	CBT	1226
Mini-Circuits	BW-N20W5+	DC to 18 GHz Precision Fixed 20 dB Attenuator	CBT	N/A	CBT	N/A
Mini-Circuits	NLP-1200+	Low Pass Filter DC to 1000 MHz	CBT	N/A	CBT	N/A
Mini-Circuits	NLP-2950+	Low Pass Filter DC to 2700 MHz	CBT	N/A	CBT	N/A
Narda	4014C-6	4 - 8 GHz SMA 6 dB Directional Coupler	CBT	N/A	CBT	N/A
Narda	4772-3	Attenuator (3dB)	CBT	N/A	CBT	9406
Narda	BW-S3W2	Attenuator (3dB)	CBT	N/A	CBT	120
Pasternack	PE2208-6	Bidirectional Coupler	CBT	N/A	CBT	N/A
Pasternack	PE2209-10	Bidirectional Coupler	CBT	N/A	CBT	N/A
Rohde & Schwarz	CMU200	Base Station Simulator	5/3/2013	Annual	5/3/2014	836371/0079
Rohde & Schwarz	CMU200	Base Station Simulator	9/23/2013	Annual	9/23/2014	109892
Rohde & Schwarz	CMW500	LTE Radio Communication Tester	6/6/2013	Annual	6/6/2014	111427
Rohde & Schwarz	CMW500	LTE Radio Communication Tester	12/9/2013	Annual	12/9/2014	109366
Rohde & Schwarz	NRV	Dual Channel Power Meter	10/12/2012	Biennial	10/12/2014	101695
Rohde & Schwarz	NRV5	Single Channel Power Meter	10/31/2013	Annual	10/31/2014	835360/0079
Rohde & Schwarz	NRV-232	Peak Power Sensor	10/12/2012	Biennial	10/12/2014	836019/013
Rohde & Schwarz	SME06	Signal Generator	10/30/2013	Annual	10/30/2014	832026
Rohde & Schwarz	SMI03B	Signal Generator	4/17/2013	Annual	4/17/2014	DE27259
Seekonk	NC-100	Torque Wrench (8" lb)	11/29/2011	Triennial	11/29/2014	21053
SPEAG	D1765V2	1765 MHz SAR Dipole	5/14/2013	Annual	5/14/2014	1008
SPEAG	D1900V2	1900 MHz SAR Dipole	5/2/2013	Annual	5/2/2014	5d141
SPEAG	D1900V2	1900 MHz SAR Dipole	7/22/2013	Annual	7/22/2014	5d149
SPEAG	D2450V2	2450 MHz SAR Dipole	8/23/2013	Annual	8/23/2014	719
SPEAG	D5GHZV2	5 GHz SAR Dipole	1/27/2014	Annual	1/27/2015	1057
SPEAG	D5GHZV2	5 GHz SAR Dipole	2/14/2013	Annual	2/14/2014	1120
SPEAG	D750V3	750 MHz Dipole	2/13/2013	Annual	2/13/2014	1046
SPEAG	D750V3	750 MHz Dipole	3/18/2013	Annual	3/18/2014	1054
SPEAG	D835V2	835 MHz SAR Dipole	4/25/2013	Annual	4/25/2014	4d119
SPEAG	D835V2	835 MHz SAR Dipole	7/17/2013	Annual	7/17/2014	4d133
SPEAG	DAE4	Dasy Data Acquisition Electronics	5/13/2013	Annual	5/13/2014	859
SPEAG	DAE4	Dasy Data Acquisition Electronics	1/22/2014	Annual	1/22/2015	1272
SPEAG	DAE4	Dasy Data Acquisition Electronics	9/17/2013	Annual	9/17/2014	1323
SPEAG	DAE4	Dasy Data Acquisition Electronics	11/19/2013	Annual	11/19/2014	1333
SPEAG	DAE4	Dasy Data Acquisition Electronics	4/22/2013	Annual	4/22/2014	1364
SPEAG	DAE4	Dasy Data Acquisition Electronics	4/22/2013	Annual	4/22/2014	1368
SPEAG	DAE4	Dasy Data Acquisition Electronics	11/19/2013	Annual	11/19/2014	1408
SPEAG	DAK-3.5	Dielectric Assessment Kit	5/14/2013	Annual	5/14/2014	1070
SPEAG	DAKS-3.5	Portable Dielectric Assessment Kit	8/18/2013	Annual	8/18/2014	1008
SPEAG	ES3DV3	SAR Probe	5/16/2013	Annual	5/16/2014	3263
SPEAG	ES3DV3	SAR Probe	9/23/2013	Annual	9/23/2014	3288
SPEAG	ES3DV3	SAR Probe	11/20/2013	Annual	11/20/2014	3287
SPEAG	ES3DV3	SAR Probe	4/29/2013	Annual	4/29/2014	3318
SPEAG	ES3DV3	SAR Probe	4/29/2013	Annual	4/29/2014	3319
SPEAG	EX3DV4	SAR Probe	1/29/2014	Annual	1/29/2015	3589
SPEAG	EX3DV4	SAR Probe	10/23/2013	Annual	10/23/2014	3914
Tektronix	RSA6114A	Real Time Spectrum Analyzer	4/17/2013	Annual	4/17/2014	8010177
VWR	23226-658	Long Stem Thermometer	3/30/2012	Biennial	3/30/2014	122179874
VWR	36934-158	Wall-Mounted Thermometer	8/8/2013	Annual	8/8/2014	130258636

Notes:

1. CBT (Calibrated Before Testing). Prior to testing, the measurement paths containing a cable, amplifier, attenuator, coupler or filter were connected to a calibrated source (i.e. a signal generator) to determine the losses of the measurement path. The power meter offset was then adjusted to compensate for the measurement system losses. This level offset is stored within the power meter before measurements are made. This calibration verification procedure applies to the system verification and output power measurements. The calibrated reading is then taken directly from the power meter after compensation of the losses for all final power measurements.
2. Each equipment item was used solely within its respective calibration period.



FCC ID: A3LSMG900A	 PCTEST Engineering Laboratory, Inc.	SAR EVALUATION REPORT		Reviewed by: Quality Manager
Document S/N: OY1401270204-R2.A3L	Test Dates: 02/03/14 - 02/17/14	DUT Type: Portable Handset		Page 80 of 85

15 MEASUREMENT UNCERTAINTIES

Applicable for frequencies less than 3000 MHz.

a	b	c	d	e= f(d,k)	f	g	h = c x f/e	i = c x g/e	k
Uncertainty Component	IEEE 1528 Sec.	Tol. (± %)	Prob. Dist.	Div.	c _i 1gm	c _i 10 gms	1gm u _i (± %)	10gms u _i (± %)	v _i
Measurement System									
Probe Calibration	E.2.1	6.0	N	1	1.0	1.0	6.0	6.0	∞
Axial Isotropy	E.2.2	0.25	N	1	0.7	0.7	0.2	0.2	∞
Hemishperical Isotropy	E.2.2	1.3	N	1	1.0	1.0	1.3	1.3	∞
Boundary Effect	E.2.3	0.4	N	1	1.0	1.0	0.4	0.4	∞
Linearity	E.2.4	0.3	N	1	1.0	1.0	0.3	0.3	∞
System Detection Limits	E.2.5	5.1	N	1	1.0	1.0	5.1	5.1	∞
Readout Electronics	E.2.6	1.0	N	1	1.0	1.0	1.0	1.0	∞
Response Time	E.2.7	0.8	R	1.73	1.0	1.0	0.5	0.5	∞
Integration Time	E.2.8	2.6	R	1.73	1.0	1.0	1.5	1.5	∞
RF Ambient Conditions	E.6.1	3.0	R	1.73	1.0	1.0	1.7	1.7	∞
Probe Positioner Mechanical Tolerance	E.6.2	0.4	R	1.73	1.0	1.0	0.2	0.2	∞
Probe Positioning w/ respect to Phantom	E.6.3	2.9	R	1.73	1.0	1.0	1.7	1.7	∞
Extrapolation, Interpolation & Integration algorithms for Max. SAR Evaluation	E.5	1.0	R	1.73	1.0	1.0	0.6	0.6	∞
Test Sample Related									
Test Sample Positioning	E.4.2	6.0	N	1	1.0	1.0	6.0	6.0	287
Device Holder Uncertainty	E.4.1	3.32	R	1.73	1.0	1.0	1.9	1.9	∞
Output Power Variation - SAR drift measurement	6.6.2	5.0	R	1.73	1.0	1.0	2.9	2.9	∞
Phantom & Tissue Parameters									
Phantom Uncertainty (Shape & Thickness tolerances)	E.3.1	4.0	R	1.73	1.0	1.0	2.3	2.3	∞
Liquid Conductivity - deviation from target values	E.3.2	5.0	R	1.73	0.64	0.43	1.8	1.2	∞
Liquid Conductivity - measurement uncertainty	E.3.3	3.8	N	1	0.64	0.43	2.4	1.6	6
Liquid Permittivity - deviation from target values	E.3.2	5.0	R	1.73	0.60	0.49	1.7	1.4	∞
Liquid Permittivity - measurement uncertainty	E.3.3	4.5	N	1	0.60	0.49	2.7	2.2	6
Combined Standard Uncertainty (k=1)				RSS			12.1	11.7	299
Expanded Uncertainty (95% CONFIDENCE LEVEL)				k=2			24.2	23.5	



The above measurement uncertainties are according to IEEE Std. 1528-2003

FCC ID: A3LSMG900A		SAR EVALUATION REPORT		Reviewed by: Quality Manager
Document S/N: OY1401270204-R2.A3L	Test Dates: 02/03/14 - 02/17/14	DUT Type: Portable Handset		Page 81 of 85

Applicable for frequencies up to 6 GHz.

a	b	c	d	e= f(d,k)	f	g	h= c x f/e	i= c x g/e	k	
Uncertainty Component	IEEE 1528 Sec.	Tol. (± %)	Prob. Dist.	Div.	c _i 1gm	c _i 10 gms	1gm u _i (± %)	10gms u _i (± %)	v _i	
Measurement System										
Probe Calibration	E.2.1	6.55	N	1	1.0	1.0	6.6	6.6	∞	
Axial Isotropy	E.2.2	0.25	N	1	0.7	0.7	0.2	0.2	∞	
Hemishperical Isotropy	E.2.2	1.3	N	1	1.0	1.0	1.3	1.3	∞	
Boundary Effect	E.2.3	0.4	N	1	1.0	1.0	0.4	0.4	∞	
Linearity	E.2.4	0.3	N	1	1.0	1.0	0.3	0.3	∞	
System Detection Limits	E.2.5	5.1	N	1	1.0	1.0	5.1	5.1	∞	
Readout Electronics	E.2.6	1.0	N	1	1.0	1.0	1.0	1.0	∞	
Response Time	E.2.7	0.8	R	1.73	1.0	1.0	0.5	0.5	∞	
Integration Time	E.2.8	2.6	R	1.73	1.0	1.0	1.5	1.5	∞	
RF Ambient Conditions	E.6.1	3.0	R	1.73	1.0	1.0	1.7	1.7	∞	
Probe Positioner Mechanical Tolerance	E.6.2	0.4	R	1.73	1.0	1.0	0.2	0.2	∞	
Probe Positioning w/ respect to Phantom	E.6.3	2.9	R	1.73	1.0	1.0	1.7	1.7	∞	
Extrapolation, Interpolation & Integration algorithms for Max. SAR Evaluation	E.5	1.0	R	1.73	1.0	1.0	0.6	0.6	∞	
Test Sample Related										
Test Sample Positioning	E.4.2	6.0	N	1	1.0	1.0	6.0	6.0	287	
Device Holder Uncertainty	E.4.1	3.32	R	1.73	1.0	1.0	1.9	1.9	∞	
Output Power Variation - SAR drift measurement	6.6.2	5.0	R	1.73	1.0	1.0	2.9	2.9	∞	
Phantom & Tissue Parameters										
Phantom Uncertainty (Shape & Thickness tolerances)	E.3.1	4.0	R	1.73	1.0	1.0	2.3	2.3	∞	
Liquid Conductivity - deviation from target values	E.3.2	5.0	R	1.73	0.64	0.43	1.8	1.2	∞	
Liquid Conductivity - measurement uncertainty	E.3.3	3.8	N	1	0.64	0.43	2.4	1.6	6	
Liquid Permittivity - deviation from target values	E.3.2	5.0	R	1.73	0.60	0.49	1.7	1.4	∞	
Liquid Permittivity - measurement uncertainty	E.3.3	4.5	N	1	0.60	0.49	2.7	2.2	6	
Combined Standard Uncertainty (k=1)							RSS	12.4	12.0	299
Expanded Uncertainty (95% CONFIDENCE LEVEL)							k=2	24.7	24.0	

The above measurement uncertainties are according to IEEE Std. 1528-2003



FCC ID: A3LSMG900A	 PCTEST ENGINEERING LABORATORY, INC.	SAR EVALUATION REPORT		Reviewed by: Quality Manager
Document S/N: OY1401270204-R2.A3L	Test Dates: 02/03/14 - 02/17/14	DUT Type: Portable Handset		Page 82 of 85

16 CONCLUSION

16.1 Measurement Conclusion



The SAR evaluation indicates that the EUT complies with the RF radiation exposure limits of the FCC and Industry Canada, with respect to all parameters subject to this test. These measurements were taken to simulate the RF effects of RF exposure under worst-case conditions. Precise laboratory measures were taken to assure repeatability of the tests. The results and statements relate only to the item(s) tested.

Please note that the absorption and distribution of electromagnetic energy in the body are very complex phenomena that depend on the mass, shape, and size of the body, the orientation of the body with respect to the field vectors, and the electrical properties of both the body and the environment. Other variables that may play a substantial role in possible biological effects are those that characterize the environment (e.g. ambient temperature, air velocity, relative humidity, and body insulation) and those that characterize the individual (e.g. age, gender, activity level, debilitation, or disease). Because various factors may interact with one another to vary the specific biological outcome of an exposure to electromagnetic fields, any protection guide should consider maximal amplification of biological effects as a result of field-body interactions, environmental conditions, and physiological variables. [3]



FCC ID: A3LSMG900A	 PCTEST ENGINEERING LABORATORY, INC.	SAR EVALUATION REPORT		Reviewed by: Quality Manager
Document S/N: 0Y1401270204-R2.A3L	Test Dates: 02/03/14 - 02/17/14	DUT Type: Portable Handset		Page 83 of 85

17 REFERENCES

- [1] Federal Communications Commission, ET Docket 93-62, Guidelines for Evaluating the Environmental Effects of Radiofrequency Radiation, Aug. 1996.
- [2] ANSI/IEEE C95.1-2005, American National Standard safety levels with respect to human exposure to radio frequency electromagnetic fields, 3kHz to 300GHz, New York: IEEE, 2006.
- [3] ANSI/IEEE C95.1-1992, American National Standard safety levels with respect to human exposure to radio frequency electromagnetic fields, 3kHz to 300GHz, New York: IEEE, Sept. 1992.
- [4] ANSI/IEEE C95.3-2002, IEEE Recommended Practice for the Measurement of Potentially Hazardous Electromagnetic Fields - RF and Microwave, New York: IEEE, December 2002.
- [5] IEEE Standards Coordinating Committee 39 –Standards Coordinating Committee 34 – IEEE Std. 1528-2003, Recommended Practice for Determining the Peak Spatial-Average Specific Absorption Rate (SAR) in the Human Body Due to Wireless Communications Devices.
- [6] NCRP, National Council on Radiation Protection and Measurements, Biological Effects and Exposure Criteria for RadioFrequency Electromagnetic Fields, NCRP Report No. 86, 1986. Reprinted Feb. 1995.
- [7] T. Schmid, O. Egger, N. Kuster, Automated E-field scanning system for dosimetric assessments, IEEE Transaction on Microwave Theory and Techniques, vol. 44, Jan. 1996, pp. 105-113.
- [8] K. Pokovic, T. Schmid, N. Kuster, Robust setup for precise calibration of E-field probes in tissue simulating liquids at mobile communications frequencies, ICECOM97, Oct. 1997, pp. -124.
- [9] K. Pokovic, T. Schmid, and N. Kuster, E-field Probe with improved isotropy in brain simulating liquids, Proceedings of the ELMAR, Zadar, Croatia, June 23-25, 1996, pp. 172-175.
- [10] Schmid & Partner Engineering AG, Application Note: Data Storage and Evaluation, June 1998, p2.
- [11] V. Hombach, K. Meier, M. Burkhardt, E. Kuhn, N. Kuster, The Dependence of EM Energy Absorption upon Human Modeling at 900 MHz, IEEE Transaction on Microwave Theory and Techniques, vol. 44 no. 10, Oct. 1996, pp. 1865-1873.
- [12] N. Kuster and Q. Balzano, Energy absorption mechanism by biological bodies in the near field of dipole antennas above 300MHz, IEEE Transaction on Vehicular Technology, vol. 41, no. 1, Feb. 1992, pp. 17-23.
- [13] G. Hartsgrove, A. Kraszewski, A. Surowiec, Simulated Biological Materials for Electromagnetic Radiation Absorption Studies, University of Ottawa, Bioelectromagnetics, Canada: 1987, pp. 29-36.
- [14] Q. Balzano, O. Garay, T. Manning Jr., Electromagnetic Energy Exposure of Simulated Users of Portable Cellular Telephones, IEEE Transactions on Vehicular Technology, vol. 44, no.3, Aug. 1995.
- [15] W. Gander, Computermathematick, Birkhaeuser, Basel, 1992.
- [16] W.H. Press, S.A. Teukolsky, W.T. Vetterling, and B.P. Flannery, Numerical Recipes in C, The Art of Scientific Computing, Second edition, Cambridge University Press, 1992.
- [17] N. Kuster, R. Kastle, T. Schmid, Dosimetric evaluation of mobile communications equipment with known precision, IEEE Transaction on Communications, vol. E80-B, no. 5, May 1997, pp. 645-652.
- [18] CENELEC CLC/SC111B, European Prestandard (prENV 50166-2), Human Exposure to Electromagnetic Fields High-frequency: 10kHz-300GHz, Jan. 1995.

FCC ID: A3LSMG900A	 PCTEST ENGINEERING LABORATORY, INC.	SAR EVALUATION REPORT		Reviewed by: Quality Manager
Document S/N: OY1401270204-R2.A3L	Test Dates: 02/03/14 - 02/17/14	DUT Type: Portable Handset	Page 84 of 85	

- [19] Prof. Dr. Niels Kuster, ETH, Eidgenössische Technische Hochschule Zürich, Dosimetric Evaluation of the Cellular Phone.
- [20] IEC 62209-1, Human exposure to radio frequency fields from hand-held and body-mounted wireless communication devices - Human models, instrumentation, and procedures - Part 1: Procedure to determine the specific absorption rate (SAR) for hand-held devices used in close proximity to the ear (frequency range of 300 MHz to 3 GHz), Feb. 2005.
- [21] Industry Canada RSS-102 Radio Frequency Exposure Compliance of Radiocommunication Apparatus (All Frequency Bands) Issue 4, March 2010.
- [22] Health Canada Safety Code 6 Limits of Human Exposure to Radio Frequency Electromagnetic Fields in the Frequency Range from 3 kHz – 300 GHz, 2009
- [23] FCC SAR Test Procedures for 2G-3G Devices, Mobile Hotspot and UMPC Devices KDB Publications 941225, D01-D07
- [24] SAR Measurement procedures for IEEE 802.11a/b/g KDB Publication 248227 D01v01r02
- [25] FCC SAR Considerations for Handsets with Multiple Transmitters and Antennas, KDB Publications 648474 D02-D04
- [26] FCC SAR Evaluation Considerations for Laptop, Notebook, Netbook and Tablet Computers, FCC KDB Publication 616217 D04
- [27] FCC SAR Measurement and Reporting Requirements for 100MHz – 6 GHz, KDB Publications 865664 D01-D02
- [28] FCC General RF Exposure Guidance and SAR Procedures for Dongles, KDB Publication 447498, D01-D02
- [29] Anexo à Resolução No. 533, de 10 de Setembro de 2009.
- [30] IEC 62209-2, Human exposure to radio frequency fields from hand-held and body-mounted wireless communication devices - Human models, instrumentation, and procedures - Part 2: Procedure to determine the specific absorption rate (SAR) for wireless communication devices used in close proximity to the human body (frequency range of 30 MHz to 6 GHz), Mar. 2010.

FCC ID: A3LSMG900A	 PCTEST ENGINEERING LABORATORY, INC.	SAR EVALUATION REPORT		Reviewed by: Quality Manager
Document S/N: 0Y1401270204-R2.A3L	Test Dates: 02/03/14 - 02/17/14	DUT Type: Portable Handset	Page 85 of 85	

APPENDIX A: SAR TEST DATA

PCTEST ENGINEERING LABORATORY, INC.

DUT: A3LSMG900A; Type: Portable Handset; Serial: 00F0B

Communication System: UID 0, GSM; Frequency: 836.6 MHz; Duty Cycle: 1:8.3

Medium: 835 Head Medium parameters used (interpolated):

$f = 836.6 \text{ MHz}$; $\sigma = 0.894 \text{ S/m}$; $\epsilon_r = 40.378$; $\rho = 1000 \text{ kg/m}^3$

Phantom section: Left Section

Test Date: 02-07-2014; Ambient Temp: 24.6°C; Tissue Temp: 24.1°C

Probe: EX3DV4 - SN3589; ConvF(8.49, 8.49, 8.49); Calibrated: 1/29/2014;

Sensor-Surface: 4mm (Mechanical Surface Detection)

Electronics: DAE4 Sn1272; Calibrated: 1/22/2014

Phantom: SAM; Type: QD000P40CD; Serial: TP:1758

Measurement SW: DASY52, Version 52.8 (7); SEMCAD X Version 14.6.10 (7164)

Mode: GSM 850, Left Head, Cheek, Mid.ch, Standard Battery Cover

Area Scan (9x15x1): Measurement grid: dx=15mm, dy=15mm

Zoom Scan (5x5x7)/Cube 0: Measurement grid: dx=8mm, dy=8mm, dz=5mm

Reference Value = 17.022 V/m; Power Drift = 0.02 dB

Peak SAR (extrapolated) = 0.323 W/kg

SAR(1 g) = 0.259 W/kg

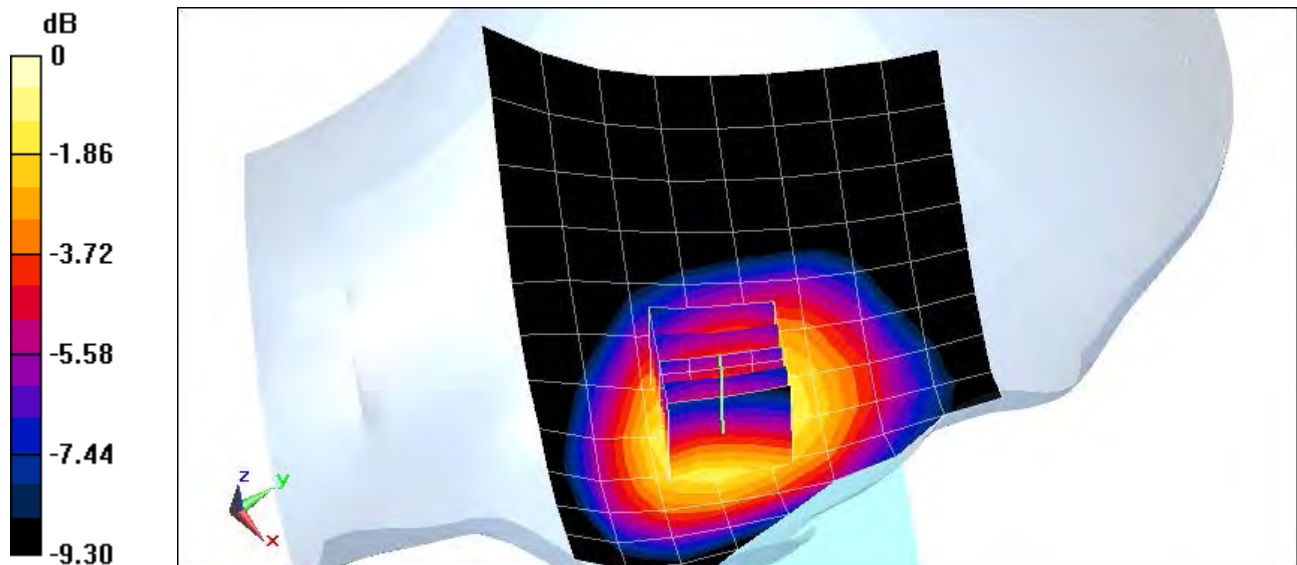

0 dB = 0.271 W/kg = -5.67 dBW/kg

PCTEST ENGINEERING LABORATORY, INC.

DUT: A3LSMG900A; Type: Portable Handset; Serial: 00F0D

Communication System: UID 0, GSM1900; Frequency: 1880 MHz; Duty Cycle: 1:8.3

Medium: 1900 Head Medium parameters used:

$f = 1880 \text{ MHz}$; $\sigma = 1.39 \text{ S/m}$; $\epsilon_r = 38.329$; $\rho = 1000 \text{ kg/m}^3$

Phantom section: Left Section

Test Date: 02-10-2014; Ambient Temp: 23.5°C; Tissue Temp: 22.8°C

Probe: ES3DV3 - SN3288; ConvF(5.47, 5.47, 5.47); Calibrated: 9/23/2013;

Sensor-Surface: 4mm (Mechanical Surface Detection)

Electronics: DAE4 Sn1323; Calibrated: 9/17/2013

Phantom: SAM with CRP; Type: SAM; Serial: TP1375

Measurement SW: DASY4, Version 4.7 (80); SEMCAD X Version 14.6.10 (7164)

Mode: GSM 1900, Left Head, Cheek, Mid.ch, Wireless Charging Cover

Area Scan (9x15x1): Measurement grid: dx=15mm, dy=15mm

Zoom Scan (5x5x7)/Cube 0: Measurement grid: dx=8mm, dy=8mm, dz=5mm

Reference Value = 10.501 V/m; Power Drift = -0.13 dB

Peak SAR (extrapolated) = 0.240 W/kg

SAR(1 g) = 0.152 W/kg

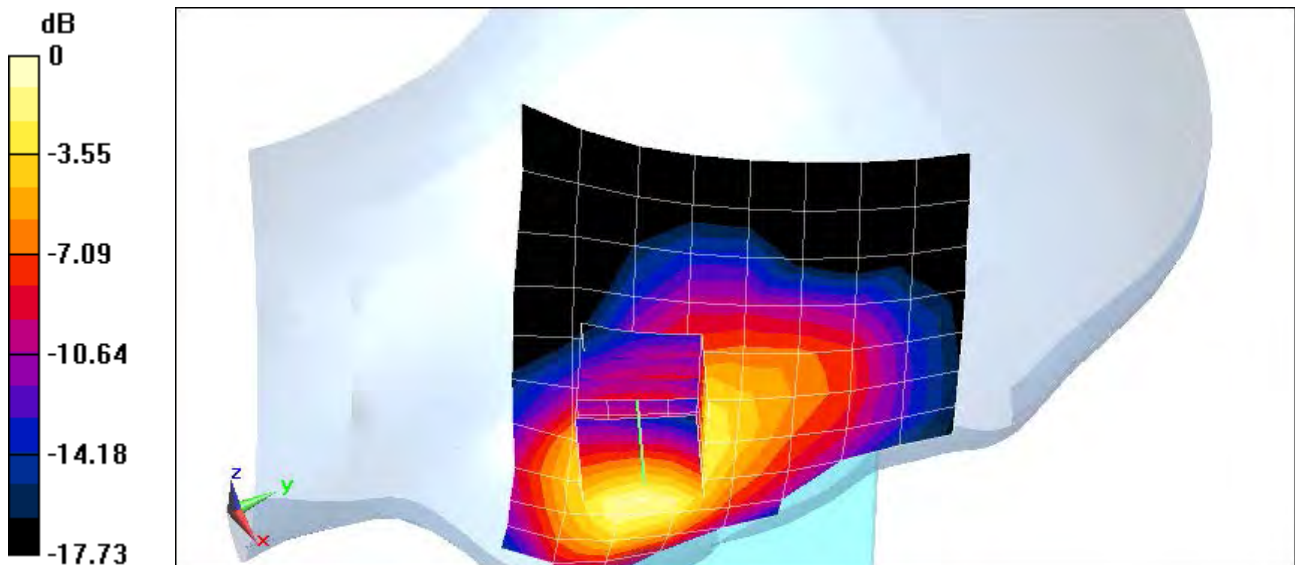

0 dB = 0.164 W/kg = -7.85 dBW/kg

PCTEST ENGINEERING LABORATORY, INC.

DUT: A3LSMG900A; Type: Portable Handset; Serial: 00F0B

Communication System: UID 0, UMTS; Frequency: 836.6 MHz; Duty Cycle: 1:1

Medium: 835 Head Medium parameters used (interpolated):

$f = 836.6 \text{ MHz}$; $\sigma = 0.894 \text{ S/m}$; $\epsilon_r = 40.378$; $\rho = 1000 \text{ kg/m}^3$

Phantom section: Left Section

Test Date: 02-07-2014; Ambient Temp: 24.6°C; Tissue Temp: 24.1°C

Probe: EX3DV4 - SN3589; ConvF(8.49, 8.49, 8.49); Calibrated: 1/29/2014;

Sensor-Surface: 4mm (Mechanical Surface Detection)

Electronics: DAE4 Sn1272; Calibrated: 1/22/2014

Phantom: SAM; Type: QD000P40CD; Serial: TP:1758

Measurement SW: DASY52, Version 52.8 (7); SEMCAD X Version 14.6.10 (7164)

Mode: UMTS 850, Left Head, Cheek, Mid.ch, Standard Battery Cover

Area Scan (8x13x1): Measurement grid: $dx=15\text{mm}$, $dy=15\text{mm}$

Zoom Scan (5x5x7)/Cube 0: Measurement grid: $dx=8\text{mm}$, $dy=8\text{mm}$, $dz=5\text{mm}$

Reference Value = 15.882 V/m; Power Drift = 0.01 dB

Peak SAR (extrapolated) = 0.265 W/kg

SAR(1 g) = 0.212 W/kg

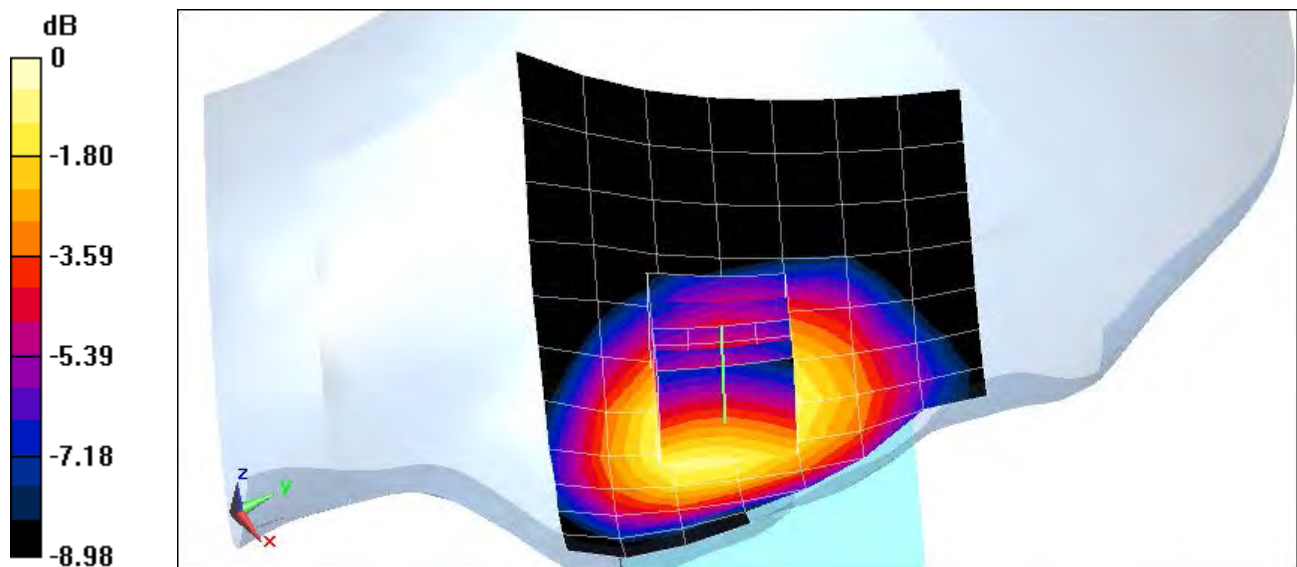

0 dB = 0.222 W/kg = -6.54 dBW/kg

PCTEST ENGINEERING LABORATORY, INC.

DUT: A3LSMG900A; Type: Portable Handset; Serial: 00F0D

Communication System: UID 0, WCDMA1900; Frequency: 1880 MHz; Duty Cycle: 1:1

Medium: 1900 Head Medium parameters used:

$f = 1880 \text{ MHz}$; $\sigma = 1.39 \text{ S/m}$; $\epsilon_r = 38.329$; $\rho = 1000 \text{ kg/m}^3$

Phantom section: Left Section

Test Date: 02-10-2014; Ambient Temp: 23.5°C; Tissue Temp: 22.8°C

Probe: ES3DV3 - SN3288; ConvF(5.47, 5.47, 5.47); Calibrated: 9/23/2013;

Sensor-Surface: 4mm (Mechanical Surface Detection)

Electronics: DAE4 Sn1323; Calibrated: 9/17/2013

Phantom: SAM with CRP; Type: SAM; Serial: TP1375

Measurement SW: DASY4, Version 4.7 (80); SEMCAD X Version 14.6.10 (7164)

Mode: UMTS 1900, Left Head, Cheek, Mid.ch, Wireless Charging Cover

Area Scan (9x15x1): Measurement grid: dx=15mm, dy=15mm

Zoom Scan (5x5x7)/Cube 0: Measurement grid: dx=8mm, dy=8mm, dz=5mm

Reference Value = 17.736 V/m; Power Drift = -0.19 dB

Peak SAR (extrapolated) = 0.676 W/kg

SAR(1 g) = 0.442 W/kg

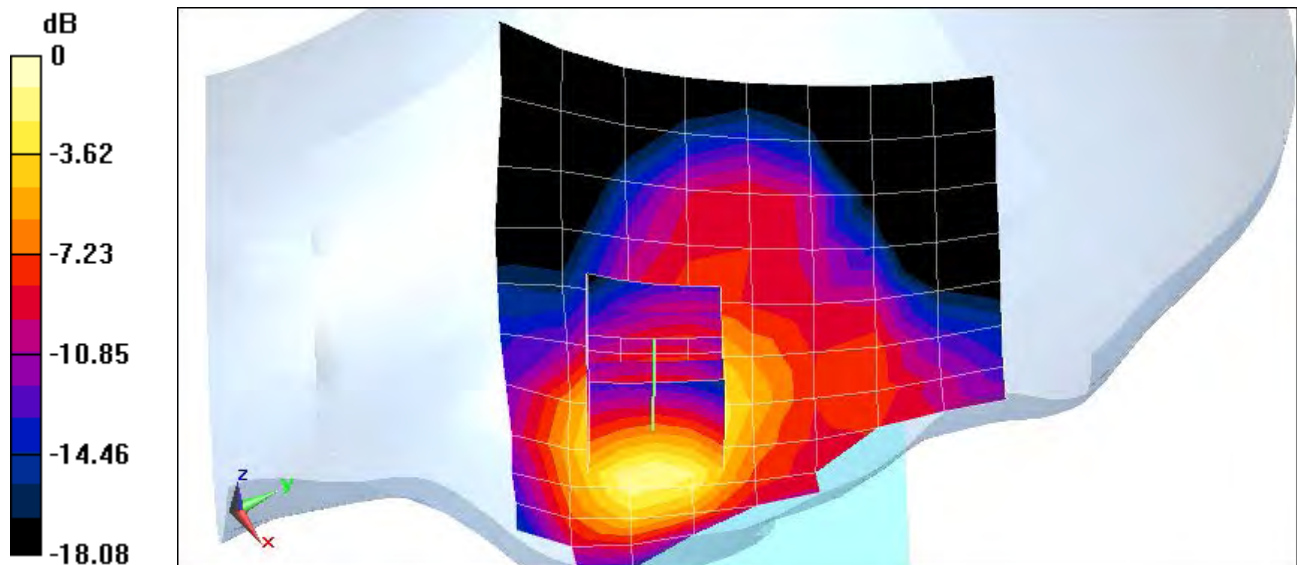

0 dB = 0.481 W/kg = -3.18 dBW/kg

PCTEST ENGINEERING LABORATORY, INC.

DUT: A3LSMG900A; Type: Portable Handset; Serial: 00E6B

Communication System: UID 0, LTE Band 17; Frequency: 710 MHz; Duty Cycle: 1:1

Medium: 750 Head Medium parameters used:

$f = 710 \text{ MHz}$; $\sigma = 0.898 \text{ S/m}$; $\epsilon_r = 42.062$; $\rho = 1000 \text{ kg/m}^3$

Phantom section: Right Section

Test Date: 02-07-2014; Ambient Temp: 24.5°C; Tissue Temp: 23.8°C

Probe: ES3DV3 - SN3319; ConvF(6.49, 6.49, 6.49); Calibrated: 4/29/2013;

Sensor-Surface: 4mm (Mechanical Surface Detection)

Electronics: DAE4 Sn1368; Calibrated: 4/22/2013

Phantom: SAM front; Type: QD000P40CD; Serial: TP:1759

Measurement SW: DASY52, Version 52.8 (7); SEMCAD X Version 14.6.10 (7164)

**Mode: LTE Band 17, Right Head, Cheek, Mid.ch, QPSK,
10 MHz Bandwidth, 1 RB, 49 RB Offset, Standard Battery Cover**

Area Scan (8x13x1): Measurement grid: dx=15mm, dy=15mm

Zoom Scan (5x5x7)/Cube 0: Measurement grid: dx=8mm, dy=8mm, dz=5mm

Reference Value = 12.240 V/m; Power Drift = 0.13 dB

Peak SAR (extrapolated) = 0.236 W/kg

SAR(1 g) = 0.199 W/kg

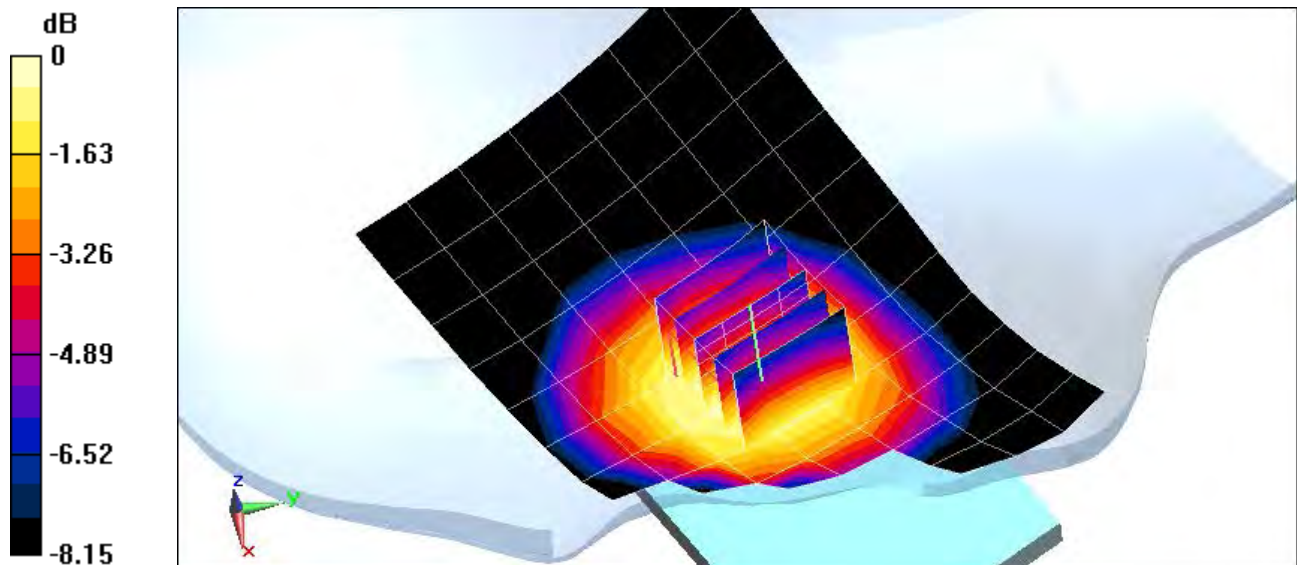

0 dB = 0.208 W/kg = -6.82 dBW/kg

PCTEST ENGINEERING LABORATORY, INC.

DUT: A3LSMG900A; Type: Portable Handset; Serial: 00E6B

Communication System: UID 0, LTE Band 5 (Cell.); Frequency: 836.5 MHz; Duty Cycle: 1:1

Medium: 835 Head Medium parameters used (interpolated):

$f = 836.5 \text{ MHz}$; $\sigma = 0.933 \text{ S/m}$; $\epsilon_r = 42.58$; $\rho = 1000 \text{ kg/m}^3$

Phantom section: Left Section

Test Date: 02-10-2014; Ambient Temp: 23.9°C; Tissue Temp: 23.1°C

Probe: EX3DV4 - SN3589; ConvF(8.49, 8.49, 8.49); Calibrated: 1/29/2014;

Sensor-Surface: 4mm (Mechanical Surface Detection)

Electronics: DAE4 Sn1272; Calibrated: 1/22/2014

Phantom: SAM; Type: QD000P40CD; Serial: TP:1758

Measurement SW: DASY52, Version 52.8 (7); SEMCAD X Version 14.6.10 (7164)

**Mode: LTE Band 5 (Cell.), Left Head, Cheek, Mid.ch, QPSK,
10 MHz Bandwidth, 1 RB, 25 RB Offset, Standard Battery Cover**

Area Scan (9x14x1): Measurement grid: dx=15mm, dy=15mm

Zoom Scan (5x5x7)/Cube 0: Measurement grid: dx=8mm, dy=8mm, dz=5mm

Reference Value = 17.056 V/m; Power Drift = 0.03 dB

Peak SAR (extrapolated) = 0.305 W/kg

SAR(1 g) = 0.247 W/kg

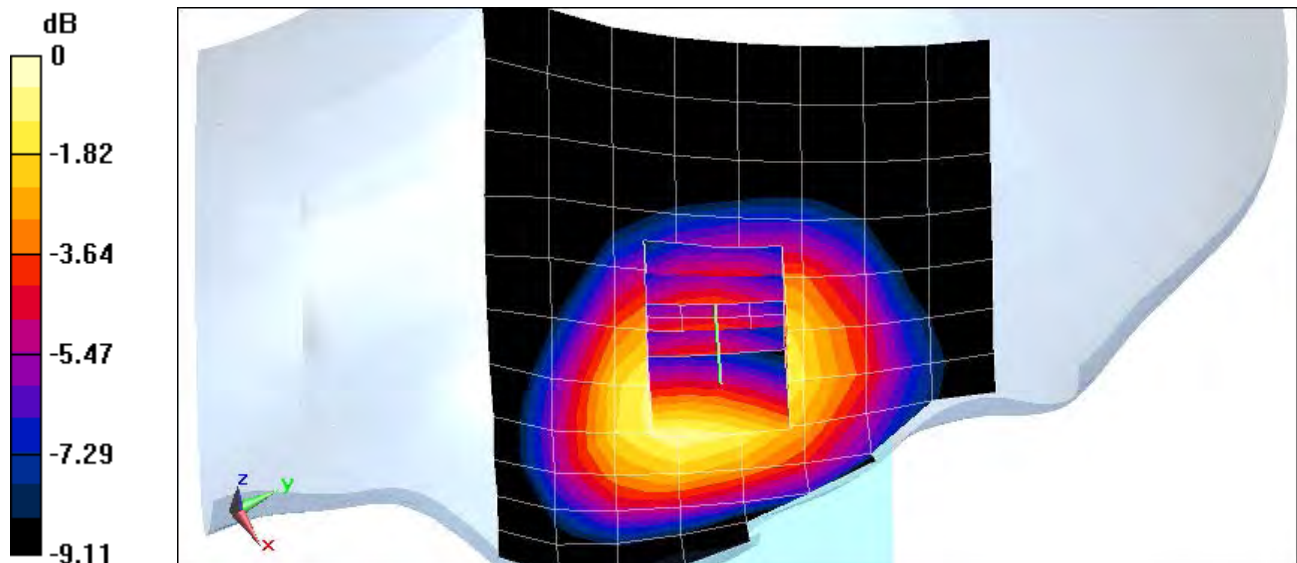

0 dB = 0.256 W/kg = -5.92 dBW/kg

PCTEST ENGINEERING LABORATORY, INC.

DUT: A3LSMG900A; Type: Portable Handset; Serial: 00F0A

Communication System: UID 0, LTE RF; Frequency: 1732.5 MHz; Duty Cycle: 1:1

Medium: 1750 Head Medium parameters used (interpolated):

$f = 1732.5$ MHz; $\sigma = 1.403$ S/m; $\epsilon_r = 39.076$; $\rho = 1000$ kg/m³

Phantom section: Left Section

Test Date: 02-10-2014; Ambient Temp: 23.6°C; Tissue Temp: 23.0°C

Probe: ES3DV3 - SN3288; ConvF(5.67, 5.67, 5.67); Calibrated: 9/23/2013;

Sensor-Surface: 4mm (Mechanical Surface Detection)

Electronics: DAE4 Sn1323; Calibrated: 9/17/2013

Phantom: SAM Sub Dasy B; Type: SAM 5.0; Serial: TP-1626

Measurement SW: DASY4, Version 4.7 (80); SEMCAD X Version 14.6.10 (7164)

**Mode: LTE Band 4 (AWS), Left Head, Cheek, Mid.ch, QPSK,
20 MHz Bandwidth, 1 RB, 0 RB Offset, Standard Battery Cover**

Area Scan (9x15x1): Measurement grid: dx=15mm, dy=15mm

Zoom Scan (5x5x7)/Cube 0: Measurement grid: dx=8mm, dy=8mm, dz=5mm

Reference Value = 20.013 V/m; Power Drift = -0.10 dB

Peak SAR (extrapolated) = 0.712 W/kg

SAR(1 g) = 0.466 W/kg

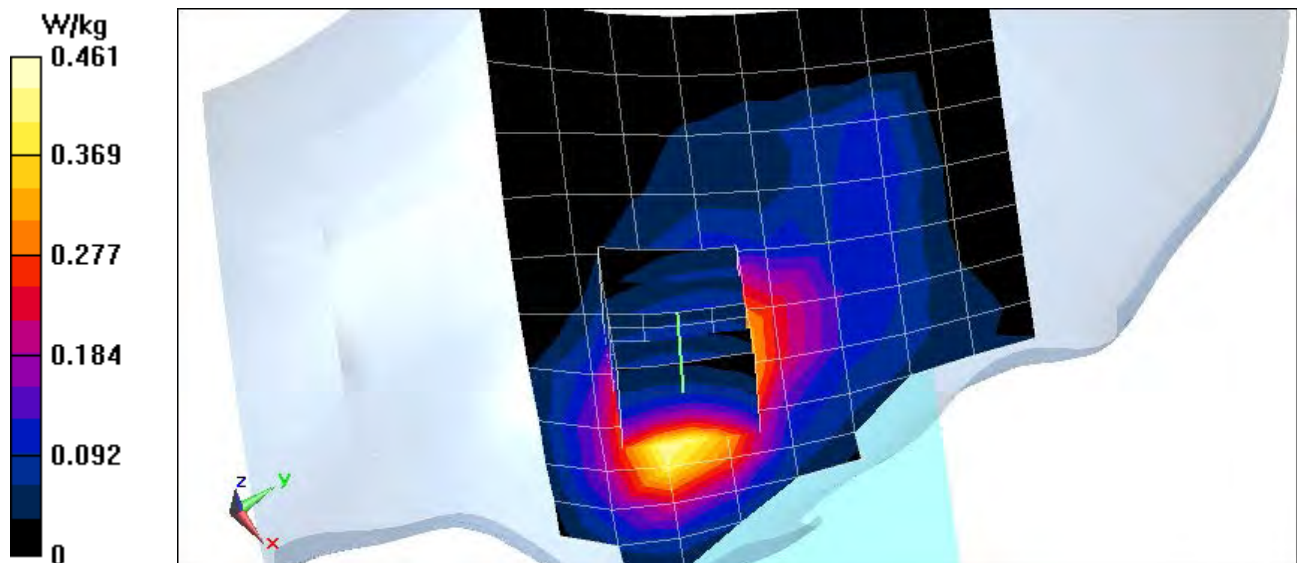

PCTEST ENGINEERING LABORATORY, INC.

DUT: A3LSMG900A; Type: Portable Handset; Serial: 00F0A

Communication System: UID 0, LTE PCS20 Mhz; Frequency: 1880 MHz; Duty Cycle: 1:1

Medium: 1900 Head Medium parameters used:

$f = 1880 \text{ MHz}$; $\sigma = 1.39 \text{ S/m}$; $\epsilon_r = 38.329$; $\rho = 1000 \text{ kg/m}^3$

Phantom section: Left Section

Test Date: 02-10-2014; Ambient Temp: 23.5°C; Tissue Temp: 22.8°C

Probe: ES3DV3 - SN3288; ConvF(5.47, 5.47, 5.47); Calibrated: 9/23/2013;

Sensor-Surface: 4mm (Mechanical Surface Detection)

Electronics: DAE4 Sn1323; Calibrated: 9/17/2013

Phantom: SAM with CRP; Type: SAM; Serial: TP1375

Measurement SW: DASY4, Version 4.7 (80); SEMCAD X Version 14.6.10 (7164)

**Mode: LTE Band 2 (PCS), Left Head, Cheek, Mid.Ch, QPSK,
20 MHz Bandwidth, 1 RB, 0 RB Offset, Wireless Charging Cover**

Area Scan (9x15x1): Measurement grid: dx=15mm, dy=15mm

Zoom Scan (5x5x7)/Cube 0: Measurement grid: dx=8mm, dy=8mm, dz=5mm

Reference Value = 19.828 V/m; Power Drift = -0.13 dB

Peak SAR (extrapolated) = 0.763 W/kg

SAR(1 g) = 0.495 W/kg

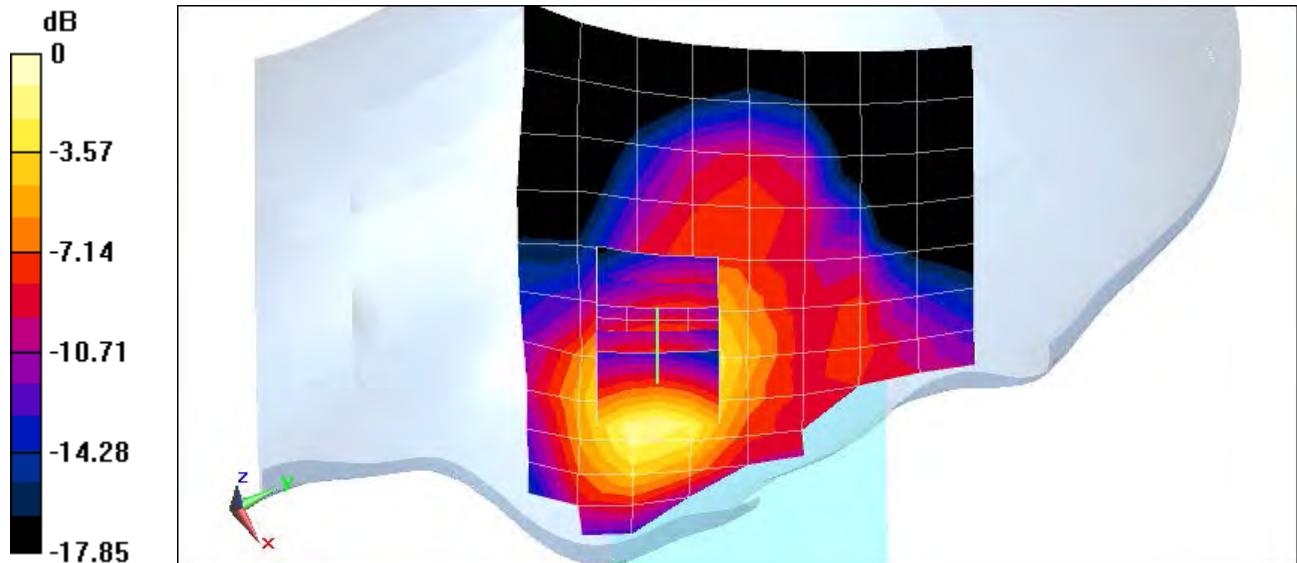

0 dB = 0.538 W/kg = -2.69 dBW/kg

PCTEST ENGINEERING LABORATORY, INC.

DUT: A3LSMG900A; Type: Portable Handset; Serial: 00F05

Communication System: UID 0, IEEE 802.11b; Frequency: 2412 MHz; Duty Cycle: 1:1

Medium: 2450 Head Medium parameters used (interpolated):

$f = 2412 \text{ MHz}$; $\sigma = 1.793 \text{ S/m}$; $\epsilon_r = 40.186$; $\rho = 1000 \text{ kg/m}^3$

Phantom section: Right Section

Test Date: 02-14-2014; Ambient Temp: 23.9°C; Tissue Temp: 23.2°C

Probe: ES3DV3 - SN3287; ConvF(4.43, 4.43, 4.43); Calibrated: 11/20/2013;

Sensor-Surface: 3mm (Mechanical Surface Detection)

Electronics: DAE4 Sn1408; Calibrated: 11/19/2013

Phantom: SAM with CRP v4.0; Type: QD000P40CD; Serial: TP:1797

Measurement SW: DASY52, Version 52.8 (7); SEMCAD X Version 14.6.10 (7164)

Mode: IEEE 802.11b, Right Head, Cheek, Ch 01, 1 Mbps, Standard Battery Cover, Antenna 1

Area Scan (10x15x1): Measurement grid: dx=12mm, dy=12mm

Zoom Scan (7x7x7)/Cube 0: Measurement grid: dx=5mm, dy=5mm, dz=5mm

Reference Value = 14.688 V/m; Power Drift = 0.02 dB

Peak SAR (extrapolated) = 0.776 W/kg

SAR(1 g) = 0.354 W/kg

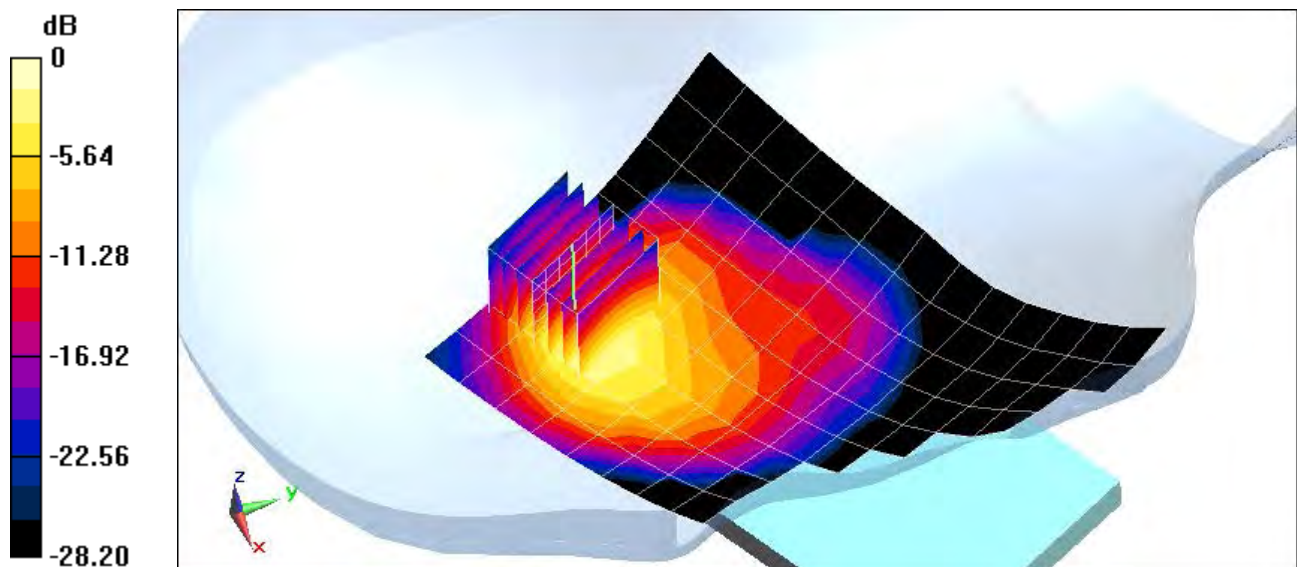

0 dB = 0.459 W/kg = -3.38 dBW/kg

PCTEST ENGINEERING LABORATORY, INC.

DUT: A3LSMG900A; Type: Portable Handset; Serial: F1186

Communication System: UID 0, IEEE 802.11a (0); Frequency: 5785 MHz; Duty Cycle: 1:1

Medium: 5 GHz Head Medium parameters used:

$f = 5785 \text{ MHz}$; $\sigma = 5.182 \text{ S/m}$; $\epsilon_r = 36.998$; $\rho = 1000 \text{ kg/m}^3$

Phantom section: Right Section

Test Date: 02-06-2014; Ambient Temp: 24.1°C; Tissue Temp: 23.5°C

Probe: EX3DV4 - SN3914; ConvF(4.52, 4.52, 4.52); Calibrated: 10/23/2013;

Sensor-Surface: 1.4mm (Mechanical Surface Detection)

Electronics: DAE4 Sn1333; Calibrated: 11/19/2013

Phantom: SAM V5.0 Right; Type: QD000P40CD; Serial: 1647

Measurement SW: DASY52, Version 52.8 (7); SEMCAD X Version 14.6.10 (7164)

**Mode: IEEE 802.11a, 5.8 GHz, Right Head, Tilt, Ch 157, 6 Mbps,
Standard Battery Cover, Antenna 1**

Area Scan (11x19x1): Measurement grid: dx=10mm, dy=10mm

Zoom Scan (7x7x7)/Cube 0: Measurement grid: dx=4mm, dy=4mm, dz=1.4mm; Graded Ratio: 1.4

Reference Value = 8.087 V/m; Power Drift = 0.05 dB

Peak SAR (extrapolated) = 1.70 W/kg

SAR(1 g) = 0.359 W/kg

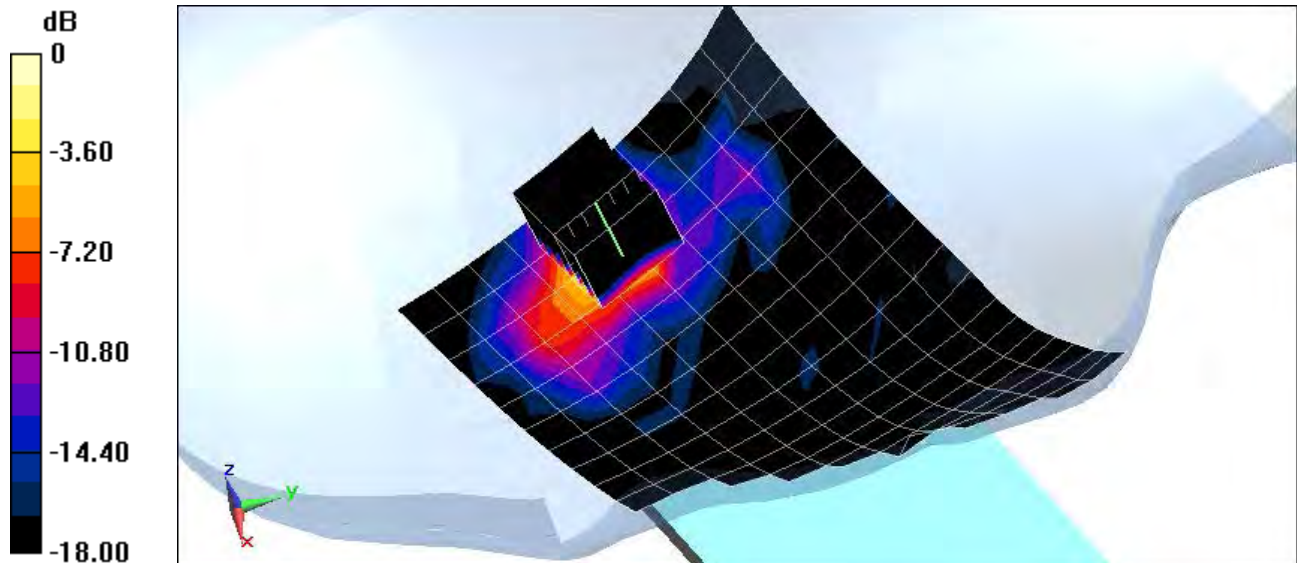

0 dB = 0.922 W/kg = -0.35 dBW/kg

PCTEST ENGINEERING LABORATORY, INC.

DUT: A3LSMG900A; Type: Portable Handset; Serial: F1186

Communication System: UID 0, IEEE 802.11a; Frequency: 5500 MHz; Duty Cycle: 1:1

Medium: 5 GHz Head Medium parameters used:

$f = 5500 \text{ MHz}$; $\sigma = 4.912 \text{ S/m}$; $\epsilon_r = 36.692$; $\rho = 1000 \text{ kg/m}^3$

Phantom section: Right Section

Test Date: 02-17-2014; Ambient Temp: 24.3°C; Tissue Temp: 23.0°C

Probe: EX3DV4 - SN3914; ConvF(4.55, 4.55, 4.55); Calibrated: 10/23/2013;

Sensor-Surface: 1.4mm (Mechanical Surface Detection)

Electronics: DAE4 Sn1333; Calibrated: 11/19/2013

Phantom: SAM V5.0 Right; Type: QD000P40CD; Serial: 1647

Measurement SW: DASY52, Version 52.8 (7); SEMCAD X Version 14.6.10 (7164)

**Mode: IEEE 802.11a, 5.5 GHz, Right Head, Tilt, Ch 100, 6 Mbps,
Wireless Charging Cover, Antenna 1**

Area Scan (12x19x1): Measurement grid: dx=10mm, dy=10mm

Zoom Scan (7x7x7)/Cube 0: Measurement grid: dx=4mm, dy=4mm, dz=1.4mm; Graded Ratio: 1.4

Reference Value = 9.699 V/m; Power Drift = -0.15 dB

Peak SAR (extrapolated) = 2.41 W/kg

SAR(1 g) = 0.554 W/kg

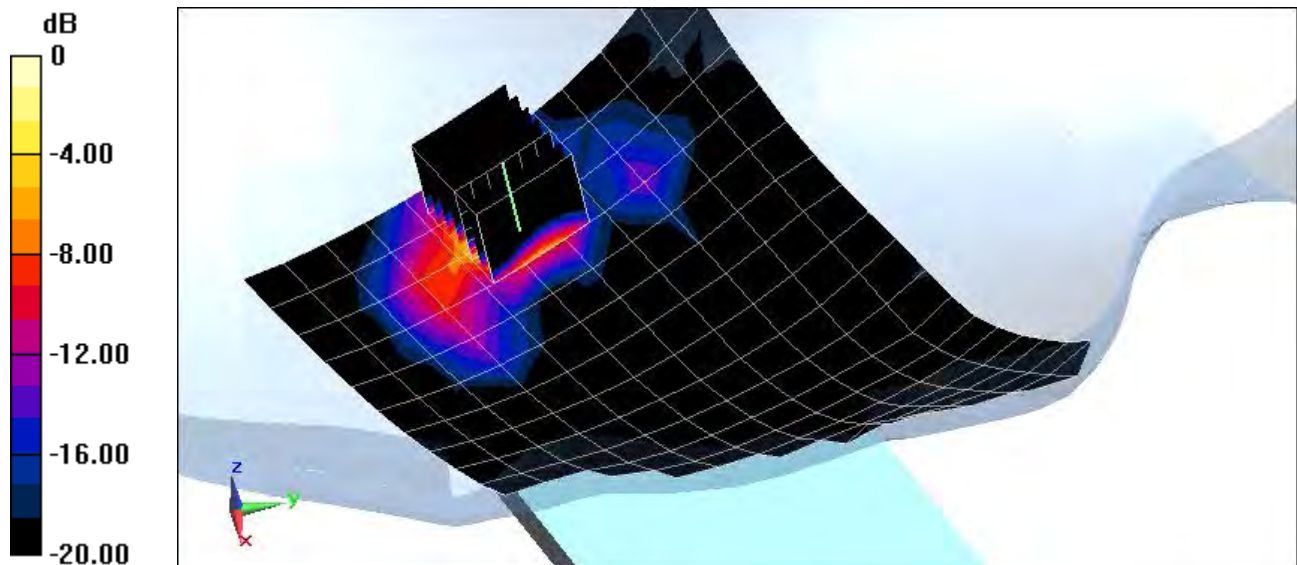

0 dB = 1.42 W/kg = 1.52 dBW/kg

PCTEST ENGINEERING LABORATORY, INC.

DUT: A3LSMG900A; Type: Portable Handset; Serial: 00F0B

Communication System: UID 0, GSM850; Frequency: 836.6 MHz; Duty Cycle: 1:8.3

Medium: 835 Body Medium parameters used (interpolated):

$f = 836.6 \text{ MHz}$; $\sigma = 0.956 \text{ S/m}$; $\epsilon_r = 54.61$; $\rho = 1000 \text{ kg/m}^3$

Phantom section: Flat Section, Space = 1.0 cm

Test Date: 02-10-2014; Ambient Temp: 23.4°C; Tissue Temp: 20.1°C

Probe: ES3DV3 - SN3263; ConvF(6.29, 6.29, 6.29); Calibrated: 5/16/2013;

Sensor-Surface: 4mm (Mechanical Surface Detection)

Electronics: DAE4 Sn859; Calibrated: 5/13/2013

Phantom: SAM Sub; Type: SAM 4.0; Serial: TP-1357

Measurement SW: DASY4, Version 4.7 (80); SEMCAD X Version 14.6.10 (7164)

Mode: GSM 850, Body SAR, Back side, Mid.ch, Standard Battery Cover

Area Scan (8x13x1): Measurement grid: $dx=15\text{mm}$, $dy=15\text{mm}$

Zoom Scan (5x5x7)/Cube 0: Measurement grid: $dx=8\text{mm}$, $dy=8\text{mm}$, $dz=5\text{mm}$

Reference Value = 20.921 V/m; Power Drift = -0.15 dB

Peak SAR (extrapolated) = 0.483 W/kg

SAR(1 g) = 0.393 W/kg

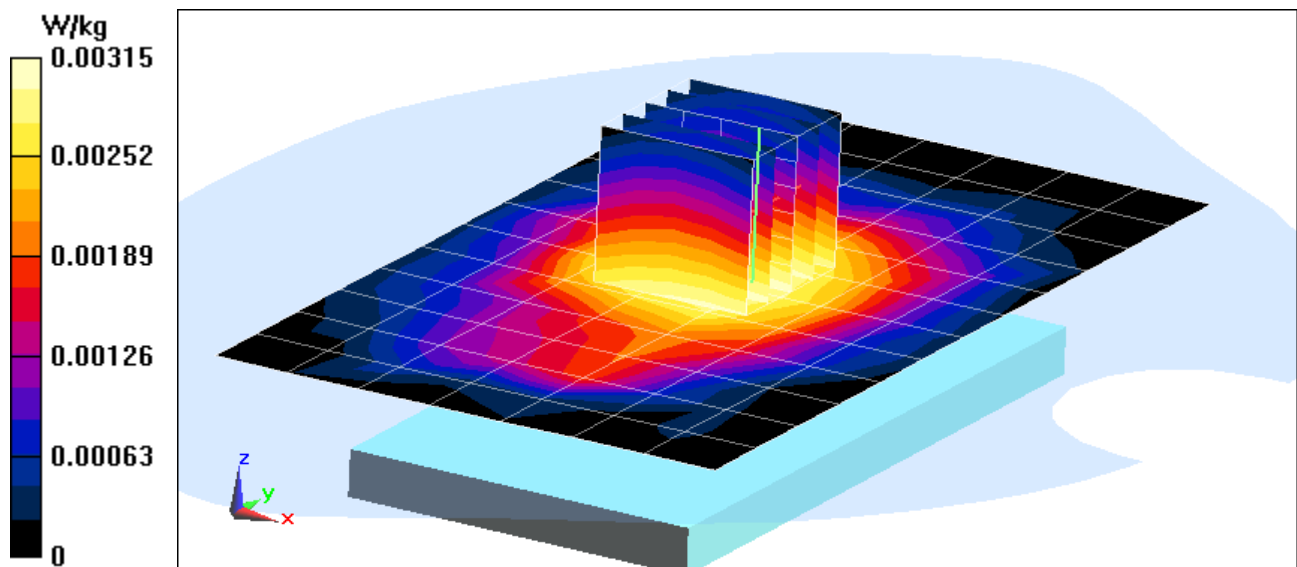

PCTEST ENGINEERING LABORATORY, INC.

DUT: A3LSMG900A; Type: Portable Handset; Serial: 00F0B

Communication System: UID 0, GSM850 GPRS; 2 Tx slots; Frequency: 836.6 MHz; Duty Cycle: 1:4.15

Medium: 835 Body Medium parameters used (interpolated):

$f = 836.6$ MHz; $\sigma = 0.956$ S/m; $\epsilon_r = 54.61$; $\rho = 1000$ kg/m³

Phantom section: Flat Section, Space = 1.0 cm

Test Date: 02-10-2014; Ambient Temp: 23.4°C; Tissue Temp: 20.1°C

Probe: ES3DV3 - SN3263; ConvF(6.29, 6.29, 6.29); Calibrated: 5/16/2013;

Sensor-Surface: 4mm (Mechanical Surface Detection)

Electronics: DAE4 Sn859; Calibrated: 5/13/2013

Phantom: SAM Sub; Type: SAM 4.0; Serial: TP-1357

Measurement SW: DASY4, Version 4.7 (80); SEMCAD X Version 14.6.10 (7164)

Mode: GPRS 850, Body SAR, Back side, Mid.ch, 2 Tx Slots, Wireless Charging Cover

Area Scan (9x15x1): Measurement grid: dx=15mm, dy=15mm

Zoom Scan (5x5x7)/Cube 0: Measurement grid: dx=8mm, dy=8mm, dz=5mm

Reference Value = 21.146 V/m; Power Drift = 0.12 dB

Peak SAR (extrapolated) = 0.865 W/kg

SAR(1 g) = 0.533 W/kg

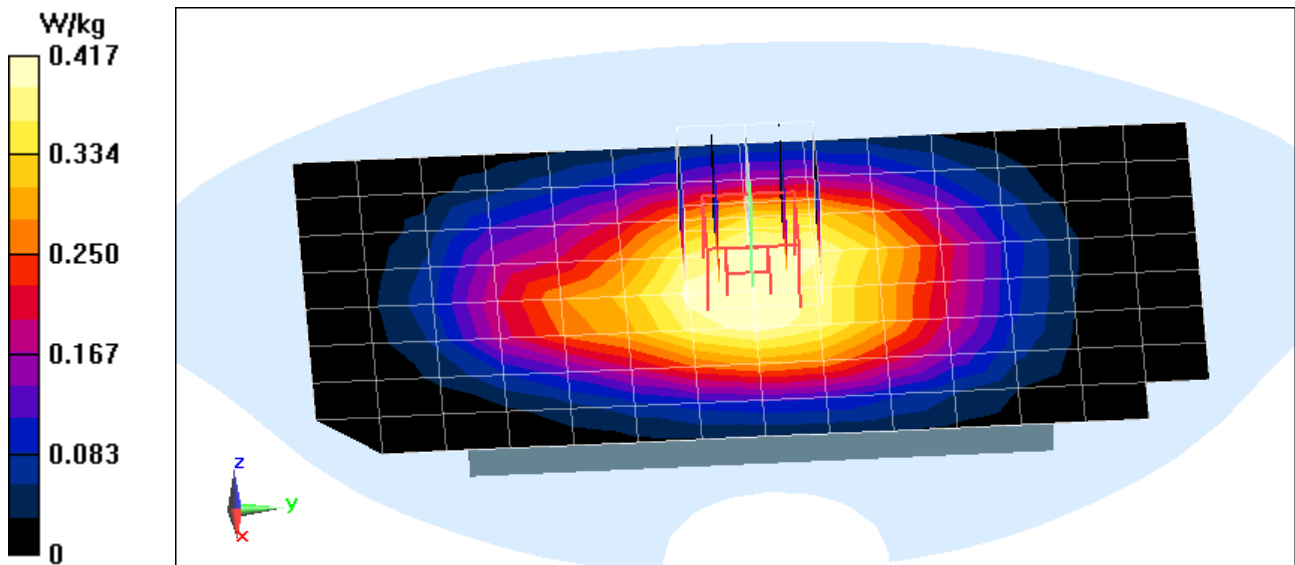

PCTEST ENGINEERING LABORATORY, INC.

DUT: A3LSMG900A; Type: Portable Handset; Serial: 00F0D

Communication System: UID 0, GSM; Frequency: 1880 MHz; Duty Cycle: 1:8.3

Medium: 1900 Body Medium parameters used:

$f = 1880 \text{ MHz}$; $\sigma = 1.523 \text{ S/m}$; $\epsilon_r = 52.35$; $\rho = 1000 \text{ kg/m}^3$

Phantom section: Flat Section, Space = 1.0 cm

Test Date: 02-10-2014; Ambient Temp: 24.4°C; Tissue Temp: 23.6°C

Probe: ES3DV3 - SN3319; ConvF(4.85, 4.85, 4.85); Calibrated: 4/29/2013;

Sensor-Surface: 4mm (Mechanical Surface Detection)

Electronics: DAE4 Sn1368; Calibrated: 4/22/2013

Phantom: SAM front; Type: QD000P40CD; Serial: TP:1759

Measurement SW: DASY52, Version 52.8 (7); SEMCAD X Version 14.6.10 (7164)

Mode: GSM 1900, Body SAR, Back side, Mid.ch, Standard Battery Cover

Area Scan (8x13x1): Measurement grid: dx=15mm, dy=15mm

Zoom Scan (5x5x7)/Cube 0: Measurement grid: dx=8mm, dy=8mm, dz=5mm

Reference Value = 7.674 V/m; Power Drift = 0.07 dB

Peak SAR (extrapolated) = 0.120 W/kg

SAR(1 g) = 0.079 W/kg

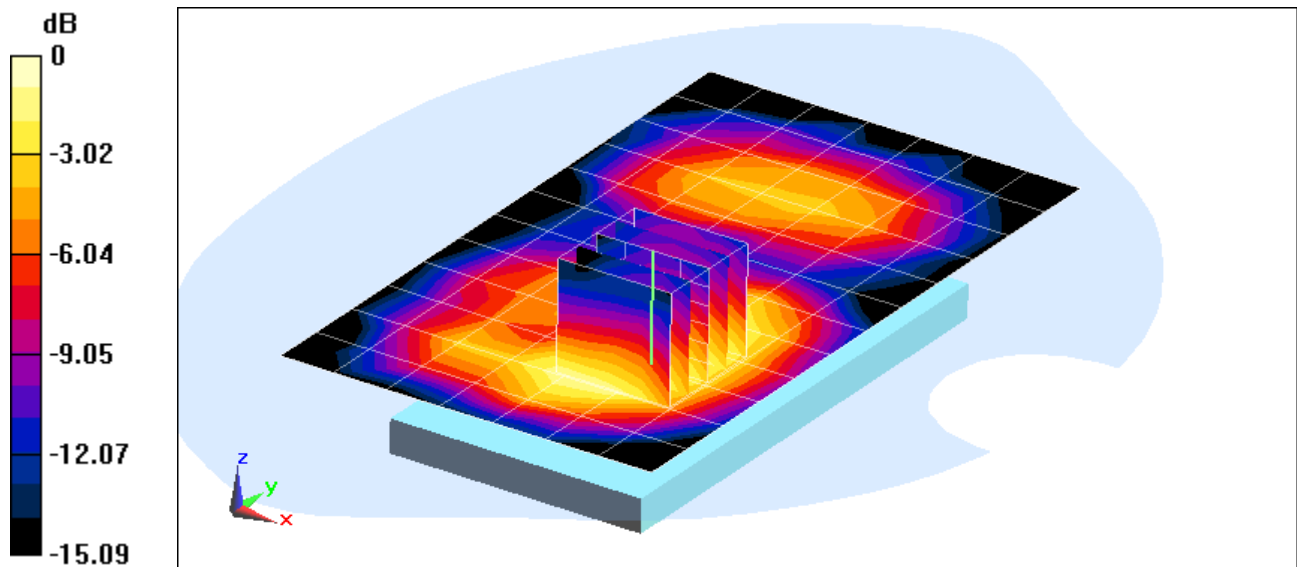

0 dB = 0.0875 W/kg = -10.58 dBW/kg

PCTEST ENGINEERING LABORATORY, INC.

DUT: A3LSMG900A; Type: Portable Handset; Serial: 00F0D

Communication System: UID 0, GSM GPRS; 2 Tx slots; Frequency: 1880 MHz; Duty Cycle: 1:4.15

Medium: 1900 Body Medium parameters used:

$$f = 1880 \text{ MHz}; \sigma = 1.523 \text{ S/m}; \epsilon_r = 52.35; \rho = 1000 \text{ kg/m}^3$$

Phantom section: Flat Section; Space = 1.0 cm

Test Date: 02-10-2014; Ambient Temp: 24.4°C; Tissue Temp: 23.6°C

Probe: ES3DV3 - SN3319; ConvF(4.85, 4.85, 4.85); Calibrated: 4/29/2013;

Sensor-Surface: 4mm (Mechanical Surface Detection)

Electronics: DAE4 Sn1368; Calibrated: 4/22/2013

Phantom: SAM front; Type: QD000P40CD; Serial: TP:1759

Measurement SW: DASY52, Version 52.8 (7); SEMCAD X Version 14.6.10 (7164)

Mode: GPRS 1900, Body SAR, Front side, Mid.ch, 2 Tx Slots, Standard Battery Cover

Area Scan (8x13x1): Measurement grid: dx=15mm, dy=15mm

Zoom Scan (5x5x7)/Cube 0: Measurement grid: dx=8mm, dy=8mm, dz=5mm

Reference Value = 13.939 V/m; Power Drift = -0.04 dB

Peak SAR (extrapolated) = 0.534 W/kg

SAR(1 g) = 0.274 W/kg

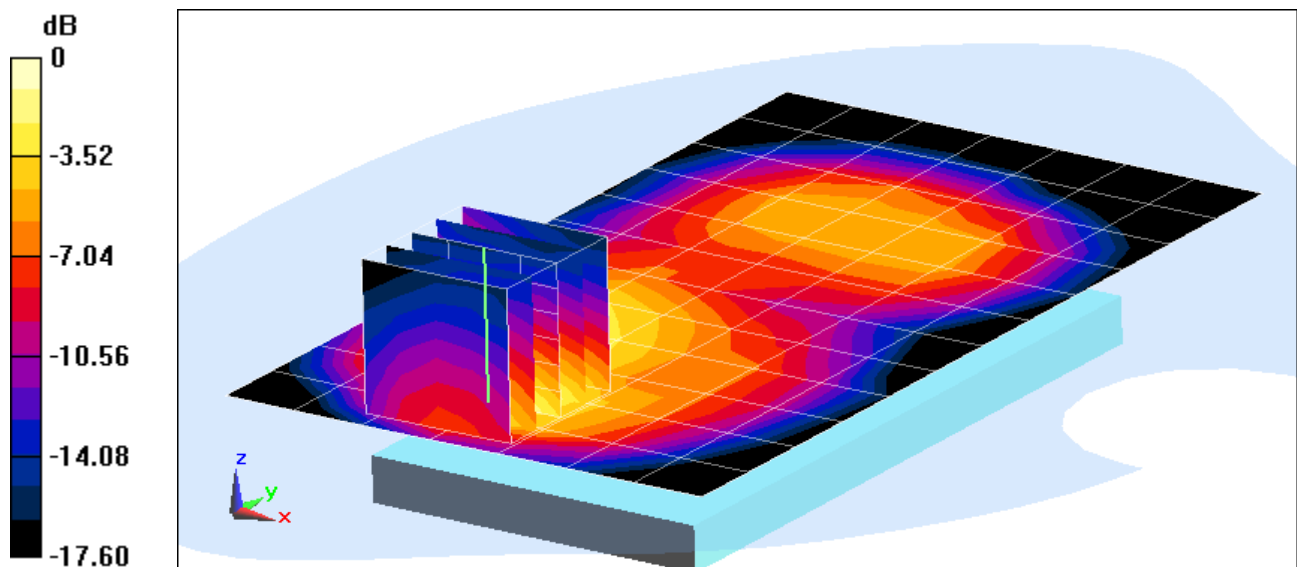

0 dB = 0.312 W/kg = -5.06 dBW/kg

PCTEST ENGINEERING LABORATORY, INC.

DUT: A3LSMG900A; Type: Portable Handset; Serial: 00F0B

Communication System: UID 0, WCDMA850; Frequency: 836.6 MHz; Duty Cycle: 1:1

Medium: 835 Body Medium parameters used (interpolated):

$f = 836.6$ MHz; $\sigma = 0.956$ S/m; $\epsilon_r = 54.61$; $\rho = 1000$ kg/m³

Phantom section: Flat Section; Space = 1.0 cm

Test Date: 02-10-2014; Ambient Temp: 23.4°C; Tissue Temp: 20.1°C

Probe: ES3DV3 - SN3263; ConvF(6.29, 6.29, 6.29); Calibrated: 5/16/2013;

Sensor-Surface: 4mm (Mechanical Surface Detection)

Electronics: DAE4 Sn859; Calibrated: 5/13/2013

Phantom: SAM Sub; Type: SAM 4.0; Serial: TP-1357

Measurement SW: DASY4, Version 4.7 (80); SEMCAD X Version 14.6.10 (7164)

Mode: UMTS 850, Body SAR, Back side, Mid.ch, Standard Battery Cover

Area Scan (8x13x1): Measurement grid: dx=15mm, dy=15mm

Zoom Scan (5x5x7)/Cube 0: Measurement grid: dx=8mm, dy=8mm, dz=5mm

Reference Value = 20.439 V/m; Power Drift = -0.01 dB

Peak SAR (extrapolated) = 0.460 W/kg

SAR(1 g) = 0.376 W/kg

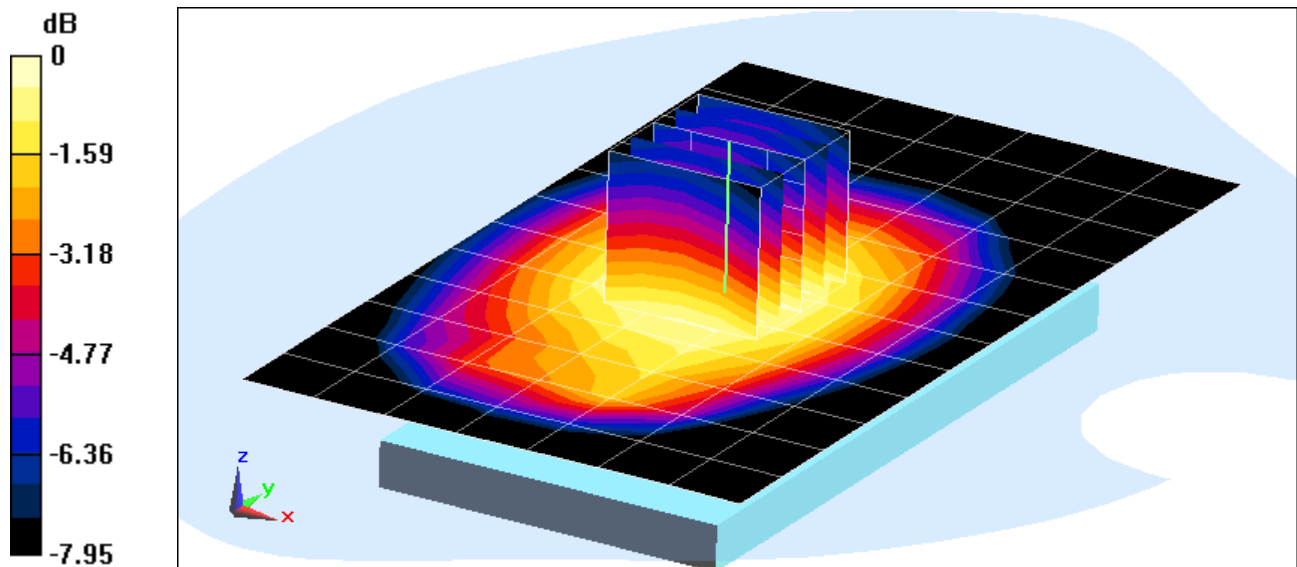

0 dB = 0.394 W/kg = -4.05 dBW/kg

PCTEST ENGINEERING LABORATORY, INC.

DUT: A3LSMG900A; Type: Portable Handset; Serial: 00F0D

Communication System: UID 0, UMTS; Frequency: 1880 MHz; Duty Cycle: 1:1

Medium: 1900 Body Medium parameters used:

$f = 1880 \text{ MHz}$; $\sigma = 1.523 \text{ S/m}$; $\epsilon_r = 52.35$; $\rho = 1000 \text{ kg/m}^3$

Phantom section: Flat Section, Space = 1.0 cm

Test Date: 02-10-2014; Ambient Temp: 24.4°C; Tissue Temp: 23.6°C

Probe: ES3DV3 - SN3319; ConvF(4.85, 4.85, 4.85); Calibrated: 4/29/2013;

Sensor-Surface: 4mm (Mechanical Surface Detection)

Electronics: DAE4 Sn1368; Calibrated: 4/22/2013

Phantom: SAM front; Type: QD000P40CD; Serial: TP:1759

Measurement SW: DASY52, Version 52.8 (7); SEMCAD X Version 14.6.10 (7164)

Mode: UMTS 1900, Body SAR, Back side, Mid.ch, Standard Battery Cover

Area Scan (8x13x1): Measurement grid: dx=15mm, dy=15mm

Zoom Scan (5x5x7)/Cube 0: Measurement grid: dx=8mm, dy=8mm, dz=5mm

Reference Value = 14.110 V/m; Power Drift = 0.01 dB

Peak SAR (extrapolated) = 0.411 W/kg

SAR(1 g) = 0.263 W/kg

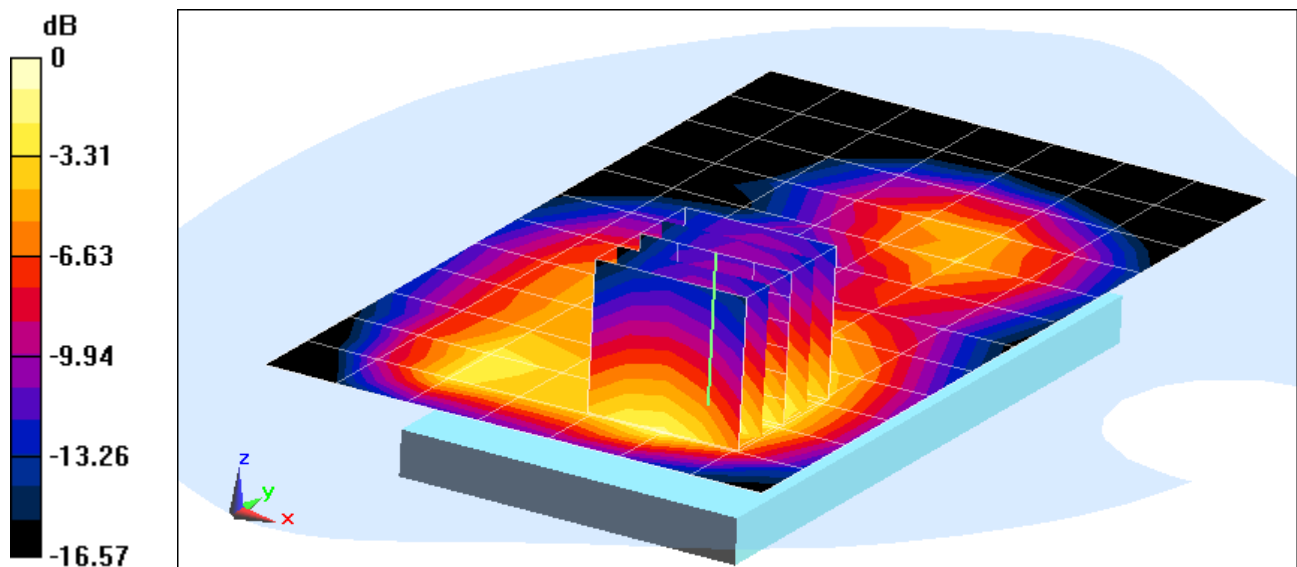

0 dB = 0.285 W/kg = -5.45 dBW/kg

PCTEST ENGINEERING LABORATORY, INC.

DUT: A3LSMG900A; Type: Portable Handset; Serial: 00F0D

Communication System: UID 0, UMTS; Frequency: 1880 MHz; Duty Cycle: 1:1

Medium: 1900 Body Medium parameters used:

$f = 1880 \text{ MHz}$; $\sigma = 1.523 \text{ S/m}$; $\epsilon_r = 52.35$; $\rho = 1000 \text{ kg/m}^3$

Phantom section: Flat Section; Space = 1.0 cm

Test Date: 02-10-2014; Ambient Temp: 24.4°C; Tissue Temp: 23.6°C

Probe: ES3DV3 - SN3319; ConvF(4.85, 4.85, 4.85); Calibrated: 4/29/2013;

Sensor-Surface: 4mm (Mechanical Surface Detection)

Electronics: DAE4 Sn1368; Calibrated: 4/22/2013

Phantom: SAM front; Type: QD000P40CD; Serial: TP:1759

Measurement SW: DASY52, Version 52.8 (7); SEMCAD X Version 14.6.10 (7164)

Mode: UMTS 1900, Body SAR, Front side, Mid.ch, Standard Battery Cover

Area Scan (8x13x1): Measurement grid: dx=15mm, dy=15mm

Zoom Scan (5x5x7)/Cube 0: Measurement grid: dx=8mm, dy=8mm, dz=5mm

Reference Value = 13.250 V/m; Power Drift = 0.02 dB

Peak SAR (extrapolated) = 0.419 W/kg

SAR(1 g) = 0.265 W/kg

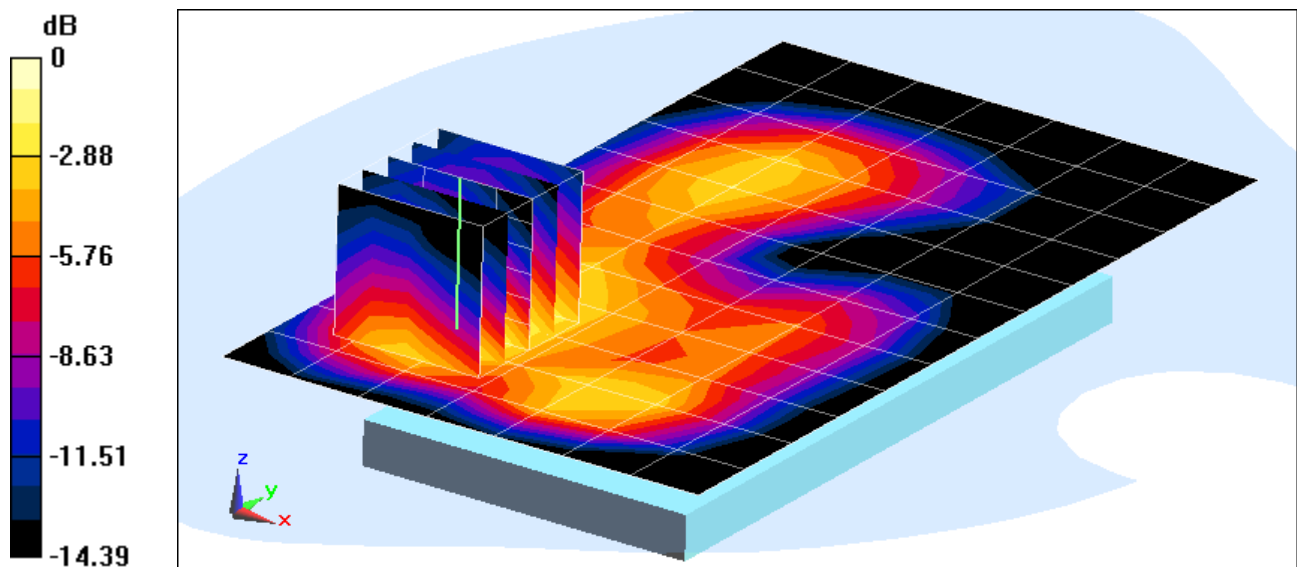

0 dB = 0.293 W/kg = -5.33 dBW/kg

PCTEST ENGINEERING LABORATORY, INC.

DUT: A3LSMG900A; Type: Portable Handset; Serial: 00E6B

Communication System: UID 0, LTE BAND 17; Frequency: 710 MHz; Duty Cycle: 1:1

Medium: 750 Body Medium parameters used:

$f = 710 \text{ MHz}$; $\sigma = 0.942 \text{ S/m}$; $\epsilon_r = 56.049$; $\rho = 1000 \text{ kg/m}^3$

Phantom section: Flat Section; Space = 1.0 cm

Test Date: 02-11-2014; Ambient Temp: 22.3°C; Tissue Temp: 21.1°C

Probe: ES3DV3 - SN3263; ConvF(6.37, 6.37, 6.37); Calibrated: 5/16/2013;

Sensor-Surface: 4mm (Mechanical Surface Detection)

Electronics: DAE4 Sn859; Calibrated: 5/13/2013

Phantom: SAM Main; Type: SAM 4.0; Serial: TP-1114

Measurement SW: DASY4, Version 4.7 (80); SEMCAD X Version 14.6.10 (7164)

**Mode: LTE Band 17, Body SAR, Back side, Mid.ch, QPSK,
10 MHz Bandwidth, 1 RB, 49 RB Offset, Standard Battery Cover**

Area Scan (8x13x1): Measurement grid: dx=15mm, dy=15mm

Zoom Scan (5x5x7)/Cube 0: Measurement grid: dx=8mm, dy=8mm, dz=5mm

Reference Value = 17.513 V/m; Power Drift = -0.01 dB

Peak SAR (extrapolated) = 0.356 W/kg

SAR(1 g) = 0.262 W/kg

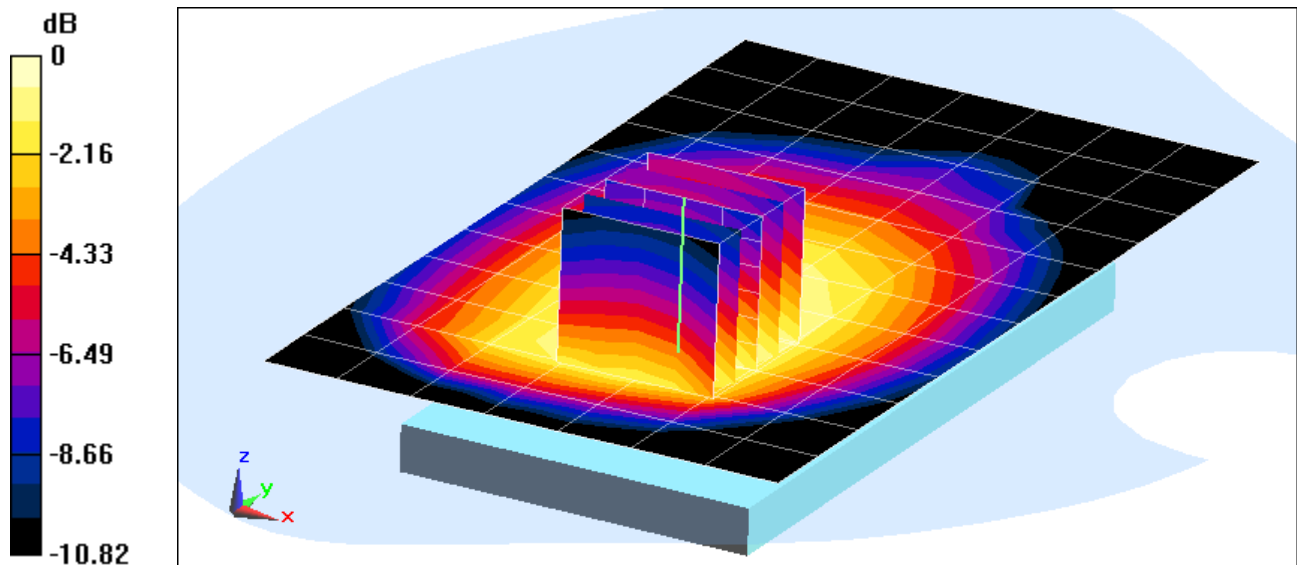

0 dB = 0.277 W/kg = -5.58 dBW/kg

PCTEST ENGINEERING LABORATORY, INC.

DUT: A3LSMG900A; Type: Portable Handset; Serial: 00E6B

Communication System: UID 0, LTE BAND 5; Frequency: 836.5 MHz; Duty Cycle: 1:1

Medium: 835 Body Medium parameters used (interpolated):

$f = 836.5 \text{ MHz}$; $\sigma = 0.956 \text{ S/m}$; $\epsilon_r = 54.611$; $\rho = 1000 \text{ kg/m}^3$

Phantom section: Flat Section; Space = 1.0 cm

Test Date: 02-10-2014; Ambient Temp: 23.4°C; Tissue Temp: 20.1°C

Probe: ES3DV3 - SN3263; ConvF(6.29, 6.29, 6.29); Calibrated: 5/16/2013;

Sensor-Surface: 4mm (Mechanical Surface Detection)

Electronics: DAE4 Sn859; Calibrated: 5/13/2013

Phantom: SAM Sub; Type: SAM 4.0; Serial: TP-1357

Measurement SW: DASY4, Version 4.7 (80); SEMCAD X Version 14.6.10 (7164)

**Mode: LTE Band 5 (Cell), Body SAR, Back side, Mid.ch, QPSK,
10 MHz Bandwidth, 1 RB, 25 RB Offset, Standard Battery Cover**

Area Scan (9x13x1): Measurement grid: dx=15mm, dy=15mm

Zoom Scan (5x5x7)/Cube 0: Measurement grid: dx=8mm, dy=8mm, dz=5mm

Reference Value = 22.083 V/m; Power Drift = 0.00 dB

Peak SAR (extrapolated) = 0.538 W/kg

SAR(1 g) = 0.437 W/kg

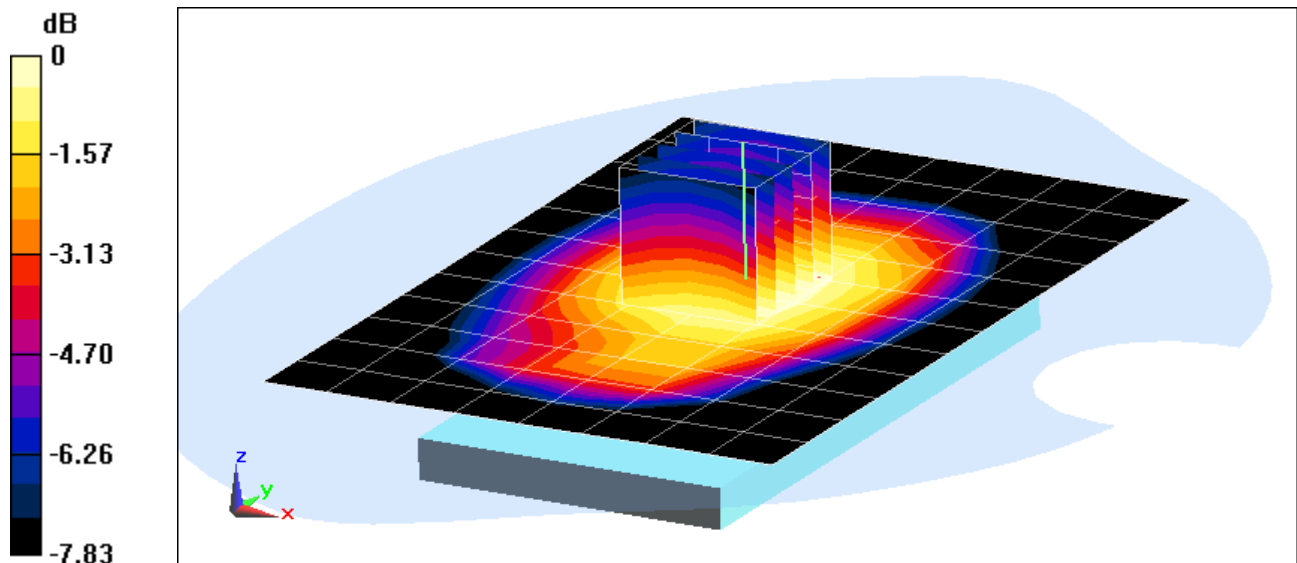

0 dB = 0.454 W/kg = -3.43 dBW/kg

PCTEST ENGINEERING LABORATORY, INC.

DUT: A3LSMG900A; Type: Portable Handset; Serial: 00F0A

Communication System: UID 0, LTE RF; Frequency: 1732.5 MHz; Duty Cycle: 1:1

Medium: 1750 Body Medium parameters used (interpolated):

$f = 1732.5 \text{ MHz}$; $\sigma = 1.46 \text{ S/m}$; $\epsilon_r = 51.981$; $\rho = 1000 \text{ kg/m}^3$

Phantom section: Flat Section, Space = 1.0 cm

Test Date: 02-10-2014; Ambient Temp: 23.6°C; Tissue Temp: 22.9°C

Probe: ES3DV3 - SN3288; ConvF(5.1, 5.1, 5.1); Calibrated: 9/23/2013;

Sensor-Surface: 4mm (Mechanical Surface Detection)

Electronics: DAE4 Sn1323; Calibrated: 9/17/2013

Phantom: SAM with CRP; Type: SAM; Serial: TP1375

Measurement SW: DASY4, Version 4.7 (80); SEMCAD X Version 14.6.10 (7164)

**Mode: LTE Band 4 (AWS), Body SAR, Back side, Mid.ch, QPSK,
20 MHz Bandwidth, 1 RB, 0 RB Offset, Standard Battery Cover**

Area Scan (9x15x1): Measurement grid: dx=15mm, dy=15mm

Zoom Scan (5x5x7)/Cube 0: Measurement grid: dx=8mm, dy=8mm, dz=5mm

Reference Value = 18.817 V/m; Power Drift = 0.04 dB

Peak SAR (extrapolated) = 0.786 W/kg

SAR(1 g) = 0.602 W/kg

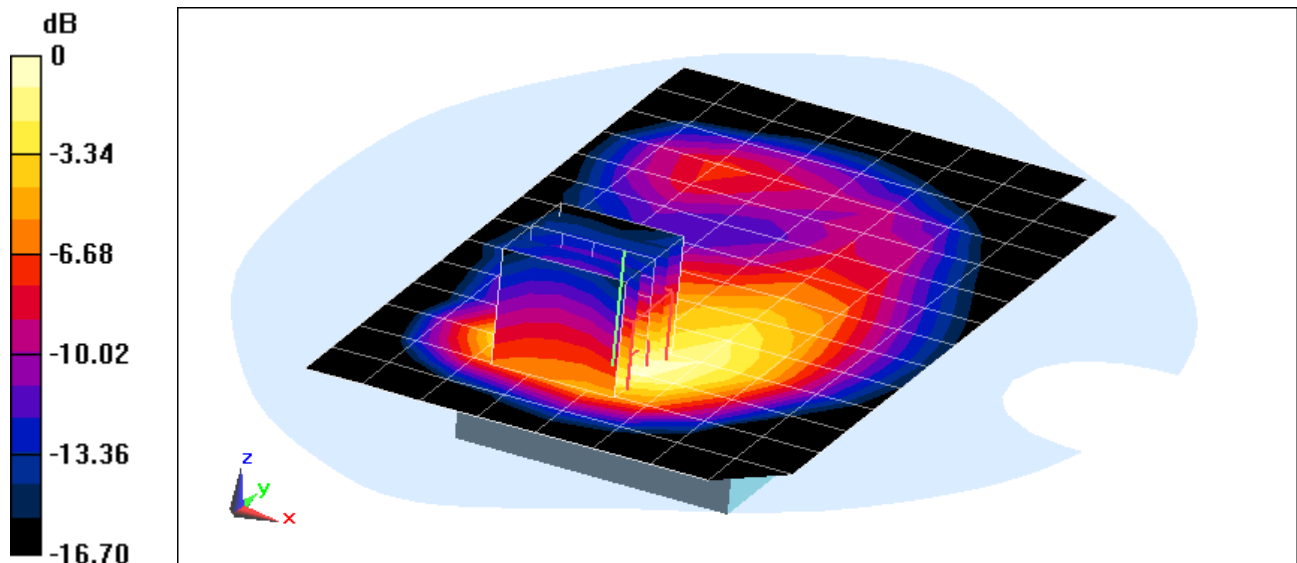

0 dB = 0.498 W/kg = -3.03 dBW/kg

PCTEST ENGINEERING LABORATORY, INC.

DUT: A3LSMG900A; Type: Portable Handset; Serial: 00F0A

Communication System: UID 0, LTE Band 2; Frequency: 1880 MHz; Duty Cycle: 1:1

Medium: 1900 Body Medium parameters used:

$f = 1880 \text{ MHz}$; $\sigma = 1.523 \text{ S/m}$; $\epsilon_r = 52.35$; $\rho = 1000 \text{ kg/m}^3$

Phantom section: Flat Section, Space = 1.0 cm

Test Date: 02-10-2014; Ambient Temp: 24.4°C; Tissue Temp: 23.6°C

Probe: ES3DV3 - SN3319; ConvF(4.85, 4.85, 4.85); Calibrated: 4/29/2013;

Sensor-Surface: 4mm (Mechanical Surface Detection)

Electronics: DAE4 Sn1368; Calibrated: 4/22/2013

Phantom: SAM front; Type: QD000P40CD; Serial: TP:1759

Measurement SW: DASY52, Version 52.8 (7); SEMCAD X Version 14.6.10 (7164)

**Mode: LTE Band 2 (PCS), Body SAR, Back side, Mid.ch, QPSK,
20 MHz Bandwidth, 1 RB, 0 RB Offset, Standard Battery Cover**

Area Scan (8x13x1): Measurement grid: dx=15mm, dy=15mm

Zoom Scan (5x5x7)/Cube 0: Measurement grid: dx=8mm, dy=8mm, dz=5mm

Reference Value = 16.656 V/m; Power Drift = -0.02 dB

Peak SAR (extrapolated) = 0.562 W/kg

SAR(1 g) = 0.362 W/kg

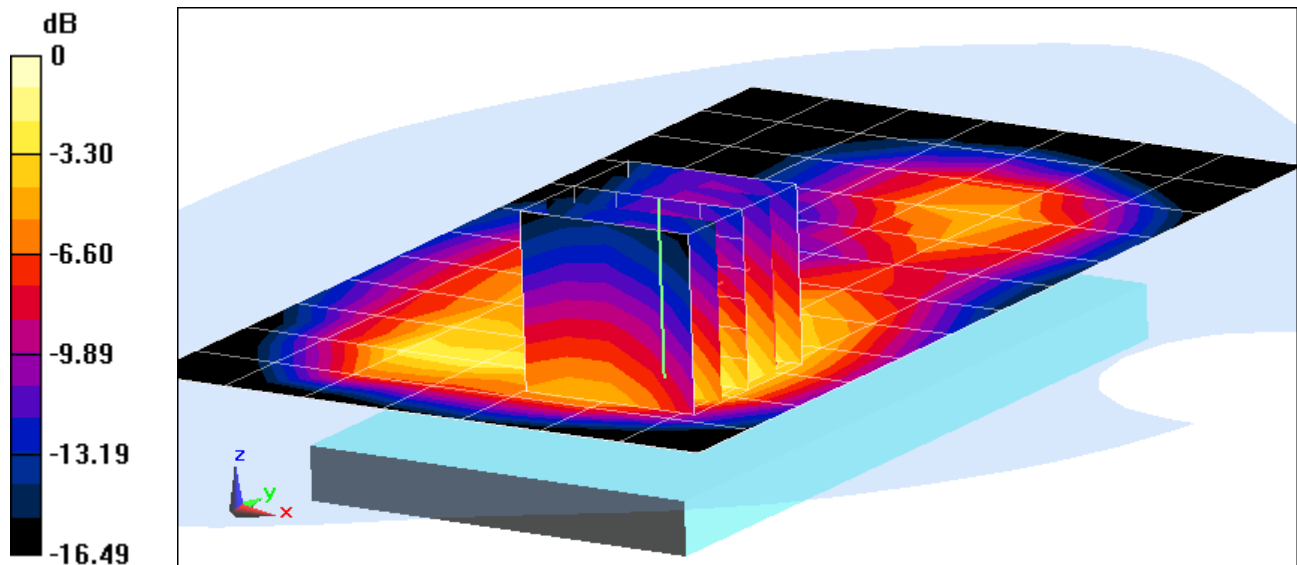

PCTEST ENGINEERING LABORATORY, INC.

DUT: A3LSMG900A; Type: Portable Handset; Serial: 00F05

Communication System: UID 0, IEEE 802.11b; Frequency: 2437 MHz; Duty Cycle: 1:1

Medium: 2450 Body Medium parameters used (interpolated):

$f = 2437 \text{ MHz}$; $\sigma = 1.92 \text{ S/m}$; $\epsilon_r = 51.381$; $\rho = 1000 \text{ kg/m}^3$

Phantom section: Flat Section, Space = 1.0 cm

Test Date: 02-12-2014; Ambient Temp: 24.6°C; Tissue Temp: 24.0°C

Probe: ES3DV3 - SN3318; ConvF(4.31, 4.31, 4.31); Calibrated: 4/29/2013;

Sensor-Surface: 3mm (Mechanical Surface Detection)

Electronics: DAE4 Sn1364; Calibrated: 4/22/2013

Phantom: ELI left; Type: QDOVA002AA; Serial: TP:1202

Measurement SW: DASY52, Version 52.8 (7); SEMCAD X Version 14.6.10 (7164)

Mode: IEEE 802.11b, Body SAR, Ch 06, 1 Mbps, Back Side, Standard Battery Cover, Antenna 1

Area Scan (10x16x1): Measurement grid: dx=12mm, dy=12mm

Zoom Scan (7x7x7)/Cube 0: Measurement grid: dx=5mm, dy=5mm, dz=5mm

Reference Value = 10.646 V/m; Power Drift = -0.08 dB

Peak SAR (extrapolated) = 0.434 W/kg

SAR(1 g) = 0.235 W/kg

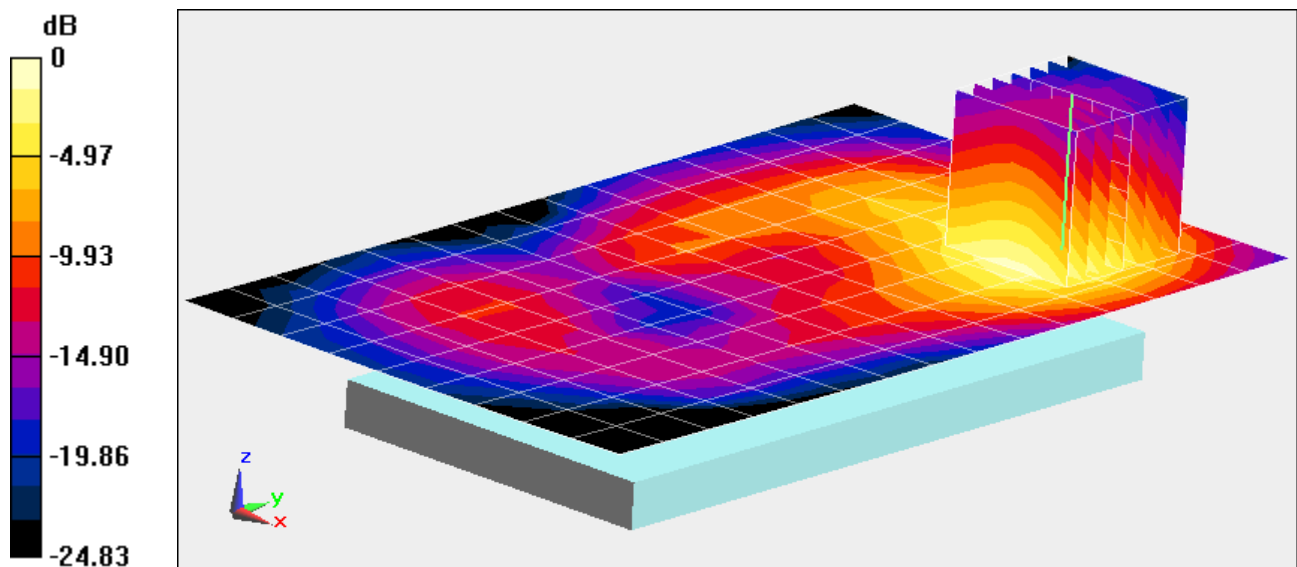

0 dB = 0.289 W/kg = -5.39 dBW/kg

PCTEST ENGINEERING LABORATORY, INC.

DUT: A3LSMG900A; Type: Portable Handset; Serial: 14524

Communication System: UID 0, IEEE 802.11a (0); Frequency: 5745 MHz; Duty Cycle: 1:1

Medium: 5 GHz Body Medium parameters used:

$f = 5745 \text{ MHz}$; $\sigma = 5.965 \text{ S/m}$; $\epsilon_r = 46.14$; $\rho = 1000 \text{ kg/m}^3$

Phantom section: Flat Section; Space = 1.0 cm

Test Date: 02-03-2014; Ambient Temp: 24.5°C; Tissue Temp: 22.7°C

Probe: EX3DV4 - SN3914; ConvF(4.14, 4.14, 4.14); Calibrated: 10/23/2013;

Sensor-Surface: 1.4mm (Mechanical Surface Detection)

Electronics: DAE4 Sn1333; Calibrated: 11/19/2013

Phantom: SAM 5.0 front; Type: QD000P40CD; Serial: TP:-1648

Measurement SW: DASY52, Version 52.8 (7); SEMCAD X Version 14.6.10 (7164)

**Mode: IEEE 802.11a, 5.8 GHz, Body SAR, Ch 149, 6 Mbps,
Back Side, Standard Battery Cover, Antenna 1**

Area Scan (11x18x1): Measurement grid: dx=10mm, dy=10mm

Zoom Scan (7x7x7)/Cube 0: Measurement grid: dx=4mm, dy=4mm, dz=1.4mm; Graded Ratio: 1.4

Reference Value = 6.092 V/m; Power Drift = -0.10 dB

Peak SAR (extrapolated) = 1.90 W/kg

SAR(1 g) = 0.409 W/kg

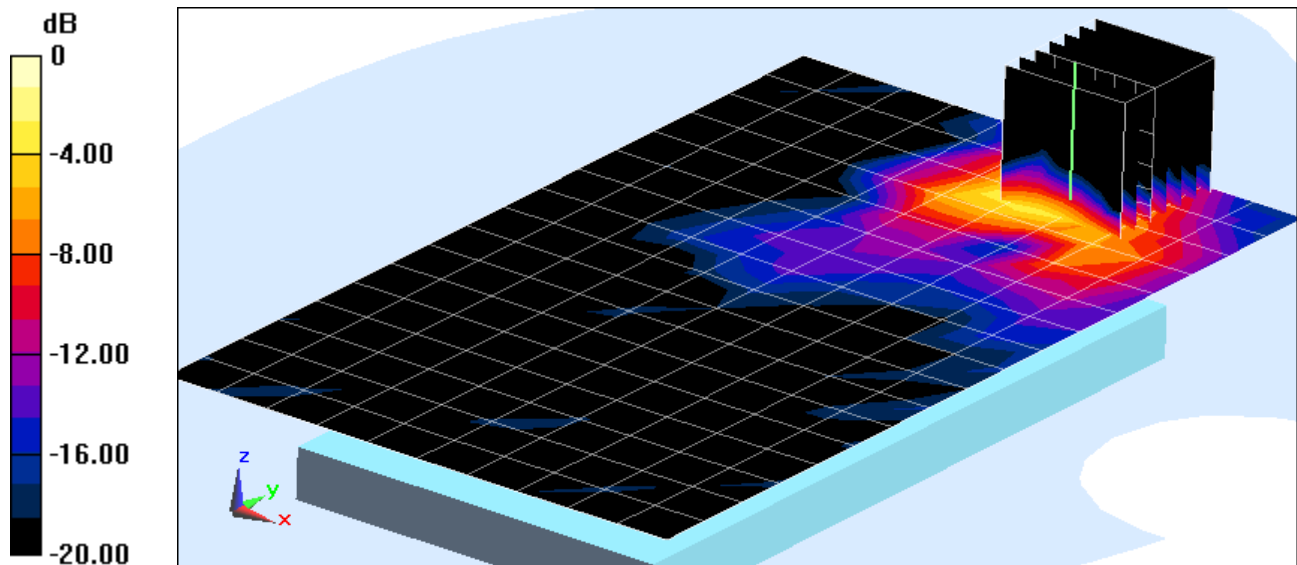

0 dB = 1.03 W/kg = 0.13 dBW/kg

PCTEST ENGINEERING LABORATORY, INC.

DUT: A3LSMG900A; Type: Portable Handset; Serial: 14524

Communication System: UID 0, IEEE 802.11a (0); Frequency: 5540 MHz; Duty Cycle: 1:1

Medium: 5 GHz Body Medium parameters used:

$f = 5540 \text{ MHz}$; $\sigma = 5.696 \text{ S/m}$; $\epsilon_r = 46.55$; $\rho = 1000 \text{ kg/m}^3$

Phantom section: Flat Section; Space = 1.0 cm

Test Date: 02-03-2014; Ambient Temp: 24.3°C; Tissue Temp: 22.6°C

Probe: EX3DV4 - SN3914; ConvF(4.07, 4.07, 4.07); Calibrated: 10/23/2013;

Sensor-Surface: 1.4mm (Mechanical Surface Detection)

Electronics: DAE4 Sn1333; Calibrated: 11/19/2013

Phantom: SAM 5.0 front; Type: QD000P40CD; Serial: TP:-1648

Measurement SW: DASY52, Version 52.8 (7); SEMCAD X Version 14.6.10 (7164)

**Mode: IEEE 802.11a, 5.5 GHz, Body SAR, Ch 108, 6 Mbps,
Back Side, Standard Battery Cover, Antenna 1**

Area Scan (11x18x1): Measurement grid: dx=10mm, dy=10mm

Zoom Scan (7x7x7)/Cube 0: Measurement grid: dx=4mm, dy=4mm, dz=1.4mm; Graded Ratio: 1.4

Reference Value = 7.275 V/m; Power Drift = -0.01 dB

Peak SAR (extrapolated) = 2.43 W/kg

SAR(1 g) = 0.558 W/kg

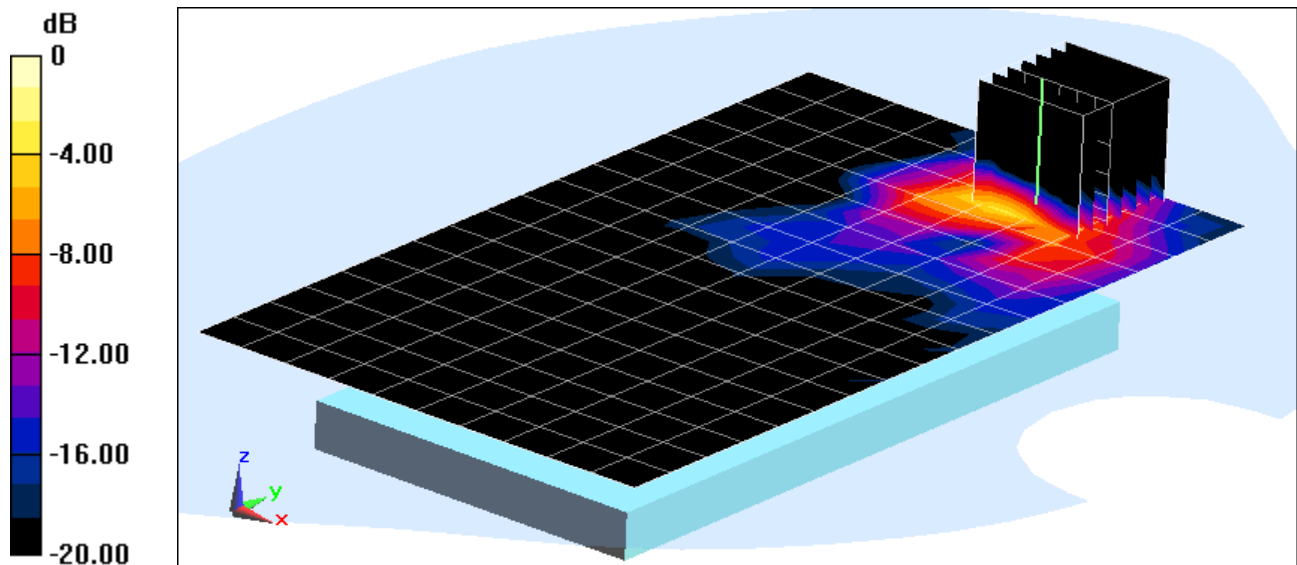

0 dB = 1.39 W/kg = 1.43 dBW/kg

PCTEST ENGINEERING LABORATORY, INC.

DUT: A3LSMG900A; Type: Portable Handset; Serial: 14524

Communication System: UID 0, IEEE 802.11a (0); 5805 MHz; Duty Cycle: 1:1
Medium: 5 GHz Body Medium parameters used:
 $f = 5805 \text{ MHz}$; $\sigma = 6.177 \text{ S/m}$; $\epsilon_r = 46.187$; $\rho = 1000 \text{ kg/m}^3$
Phantom section: Flat Section; Space = 1.0 cm

Test Date: 02-09-2014; Ambient Temp: 24.5°C; Tissue Temp: 23.3°C

Probe: EX3DV4 - SN3914; ConvF(4.14, 4.14, 4.14); Calibrated: 10/23/2013;
Sensor-Surface: 1.4mm (Mechanical Surface Detection)
Electronics: DAE4 Sn1333; Calibrated: 11/19/2013
Phantom: SAM 5.0 front; Type: QD000P40CD; Serial: TP:-1648
Measurement SW: DASY52, Version 52.8 (7); SEMCAD X Version 14.6.10 (7164)

**Mode: IEEE 802.11a, 5.8 GHz, Body SAR, Ch 161, 6 Mbps,
Top Side, Standard Battery Cover, Antenna 1**

Area Scan (10x13x1): Measurement grid: dx=5mm, dy=10mm

Zoom Scan (8x8x7)/Cube 0: Measurement grid: dx=4mm, dy=4mm, dz=1.4mm; Graded Ratio: 1.4
Reference Value = 9.289 V/m; Power Drift = 0.05 dB
Peak SAR (extrapolated) = 2.57 W/kg
SAR(1 g) = 0.569 W/kg

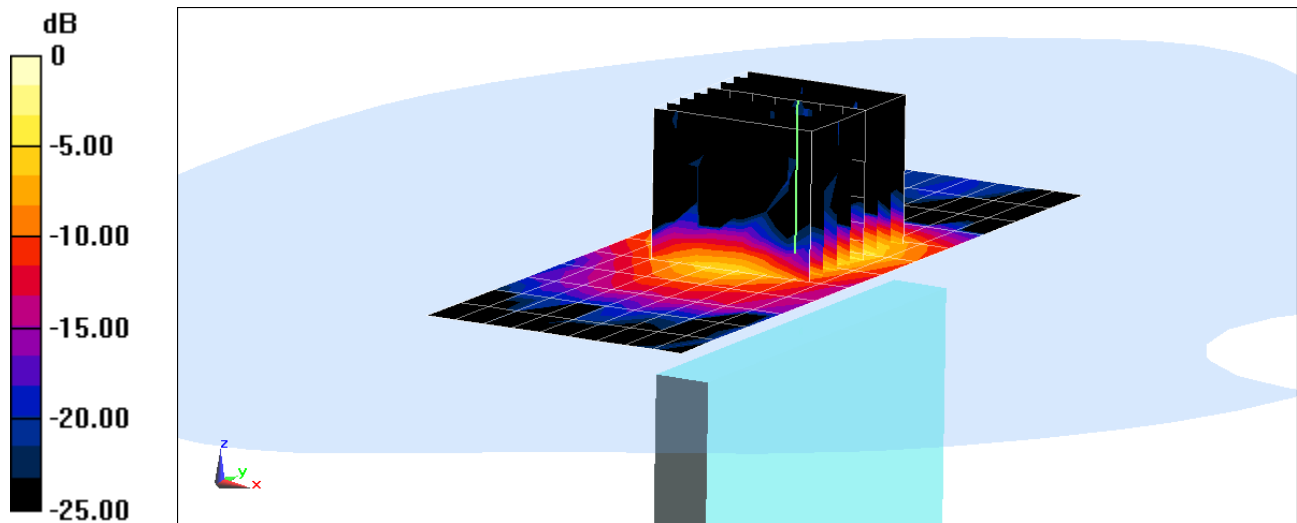

0 dB = 1.34 W/kg = 1.27 dBW/kg