



SAR EVALUATION REPORT

Applicant Name:
 Samsung Electronics, Co. Ltd.
 129, Samsung-ro, Maetan dong,
 Yeongtong-gu, Suwon-si
 Gyeonggi-do 443-742, Korea

Date of Testing:
 04/06/15 - 05/04/15
Test Site/Location:
 PCTEST Lab, Columbia, MD, USA
Document Serial No.:
 0Y1504030657.A3L

FCC ID: A3LSMG890A

APPLICANT: SAMSUNG ELECTRONICS, CO. LTD.

DUT Type: Portable Handset
Application Type: Certification
FCC Rule Part(s): CFR §2.1093
Model(s): SM-G890A

Equipment Class	Band & Mode	Tx Frequency	SAR		
			1 gm Head (W/kg)	1 gm Body-Worn (W/kg)	1 gm Hotspot (W/kg)
PCE	GSMGPRS/EDGE 850	824.20 - 848.80 MHz	0.49	0.53	1.02
PCE	GSMGPRS/EDGE 1900	1850.20 - 1909.80 MHz	0.46	0.50	0.73
PCE	UMTS 850	826.40 - 846.60 MHz	0.50	0.59	0.64
PCE	UMTS 1900	1852.4 - 1907.6 MHz	0.62	0.57	0.75
PCE	LTE Band 12	699.7 - 715.3 MHz	0.50	0.56	0.69
PCE	LTE Band 5 (Cell)	824.7 - 848.3 MHz	0.50	0.56	0.64
PCE	LTE Band 4 (AWS)	1710.7 - 1754.3 MHz	0.56	0.43	0.51
PCE	LTE Band 2 (PCS)	1850.7 - 1909.3 MHz	0.75	0.67	0.59
PCE	LTE Band 30	2307.5 - 2312.5 MHz	0.68	0.28	0.54
DTS	2.4 GHz WLAN	2412 - 2462 MHz	0.29	0.17	0.40
NII	U-NII-1	5180 - 5240 MHz	N/A		
NII	U-NII-2A	5260 - 5320 MHz	< 0.1	0.14	
NII	U-NII-2C	5500 - 5720 MHz	< 0.1	0.19	
NII	U-NII-3	5745 - 5825 MHz	< 0.1	0.19	0.19
DSS/DTS	Bluetooth	2402 - 2480 MHz	N/A		
Simultaneous SAR per KDB 690783 D01v01r03:			1.19	0.96	1.58

This wireless portable device has been shown to be capable of compliance for localized specific absorption rate (SAR) for uncontrolled environment/general population exposure limits specified in ANSI/IEEE C95.1-1992 and has been tested in accordance with the measurement procedures specified in Section 1.8 of this report; for North American frequency bands only.

I attest to the accuracy of data. All measurements reported herein were performed by me or were made under my supervision and are correct to the best of my knowledge and belief. I assume full responsibility for the completeness of these measurements and vouch for the qualifications of all persons taking them. Test results reported herein relate only to the item(s) tested.

Randy Ortanez
 President





The SAR Tick is an initiative of the Mobile Manufacturers Forum (MMF). While a product may be considered eligible, use of the SAR Tick logo requires an agreement with the MMF. Further details can be obtained by emailing: sartick@mmfai.info.

FCC ID: A3LSMG890A	PCTEST ENGINEERING LABORATORY, INC.	SAR EVALUATION REPORT		Reviewed by: Quality Manager
Document S/N: 0Y1504030657.A3L	Test Dates: 04/06/15 - 05/04/15	DUT Type: Portable Handset	Page 1 of 94	

T A B L E O F C O N T E N T S

1	DEVICE UNDER TEST	3
2	LTE INFORMATION	10
3	INTRODUCTION	12
4	DOSIMETRIC ASSESSMENT	13
5	DEFINITION OF REFERENCE POINTS	14
6	TEST CONFIGURATION POSITIONS FOR HANDSETS	15
7	RF EXPOSURE LIMITS	18
8	FCC MEASUREMENT PROCEDURES	19
9	RF CONDUCTED POWERS	24
10	SYSTEM VERIFICATION	65
11	SAR DATA SUMMARY	67
12	FCC MULTI-TX AND ANTENNA SAR CONSIDERATIONS	77
13	SAR MEASUREMENT VARIABILITY	88
14	EQUIPMENT LIST	89
15	MEASUREMENT UNCERTAINTIES	90
16	CONCLUSION	92
17	REFERENCES	93
APPENDIX A: SAR TEST PLOTS		
APPENDIX B: SAR DIPOLE VERIFICATION PLOTS		
APPENDIX C: PROBE AND DIPOLE CALIBRATION CERTIFICATES		
APPENDIX D: SAR TISSUE SPECIFICATIONS		
APPENDIX E: SAR SYSTEM VALIDATION		
APPENDIX F: DUT ANTENNA DIAGRAM & SAR TEST SETUP PHOTOGRAPHS		

FCC ID: A3LSMG890A		SAR EVALUATION REPORT		Reviewed by: Quality Manager
Document S/N: OY1504030657.A3L	Test Dates: 04/06/15 - 05/04/15	DUT Type: Portable Handset	Page 2 of 94	



1 DEVICE UNDER TEST

1.1 Device Overview

Band & Mode	Operating Modes	Tx Frequency
GSM/GPRS/EDGE 850	Voice/Data	824.20 - 848.80 MHz
GSM/GPRS/EDGE 1900	Voice/Data	1850.20 - 1909.80 MHz
UMTS 850	Voice/Data	826.40 - 846.60 MHz
UMTS 1900	Voice/Data	1852.4 - 1907.6 MHz
LTE Band 12	Voice/Data	699.7 - 715.3 MHz
LTE Band 17	Voice/Data	706.5 - 713.5 MHz
LTE Band 5 (Cell)	Voice/Data	824.7 - 848.3 MHz
LTE Band 4 (AWS)	Voice/Data	1710.7 - 1754.3 MHz
LTE Band 2 (PCS)	Voice/Data	1850.7 - 1909.3 MHz
LTE Band 30	Voice/Data	2307.5 - 2312.5 MHz
2.4 GHz WLAN	Voice/Data	2412 - 2462 MHz
U-NII-1	Voice/Data	5180 - 5240 MHz
U-NII-2A	Voice/Data	5260 - 5320 MHz
U-NII-2C	Voice/Data	5500 - 5720 MHz
U-NII-3	Voice/Data	5745 - 5825 MHz
Bluetooth	Data	2402 - 2480 MHz
Bluetooth LE	Data	2402 - 2480 MHz
NFC	Data	13.56 MHz
ANT+	Data	2402 - 2480 MHz
MST	Data	1 - 8.3 kHz

1.2 Power Reduction for SAR

This device utilizes two single step independent power reduction mechanisms for SAR compliance. For the main transmitter, there is power reduction under portable hotspot conditions for GPRS/UMTS 1900, and LTE Band 2/4. All hotspot SAR evaluations for this device were performed with the maximum allowed output power in hotspot mode. Additionally for the unlicensed transmitter, this device utilizes a proximity sensor to reduce the output power for 2.4 GHz and 5 GHz WLAN during voice or VoIP held-to-ear scenarios. Per FCC guidance, the held-to-ear exposure conditions were evaluated at reduced power level. The reduced powers for both mechanisms were confirmed via conducted power measurements at the RF port (See section 9). Detailed description of the hotspot power reduction and proximity sensor mechanisms are included in Technical Descriptions in the FCC filing.

FCC ID: A3LSMG890A	 PCTEST PROFESSIONAL CORPORATION, INC.	SAR EVALUATION REPORT		Reviewed by: Quality Manager
Document S/N: OY1504030657.A3L	Test Dates: 04/06/15 - 05/04/15	DUT Type: Portable Handset	Page 3 of 94	

1.3 Nominal and Maximum Output Power Specifications

1.3.1 Maximum PCE Power



Mode / Band		Voice (dBm)	Burst Average GMSK (dBm)		Burst Average 8-PSK (dBm)	
		1 TX Slot	1 TX Slots	2 TX Slots	1 TX Slots	2 TX Slots
GSM/GPRS/EDGE 850	Maximum	33.2	33.2	32.2	27.5	26.0
	Nominal	32.7	32.7	31.7	27.0	25.5
GSM/GPRS/EDGE 1900	Maximum	30.5	30.5	29.5	26.5	25.0
	Nominal	30.0	30.0	29.0	26.0	24.5

Mode / Band		Modulated Average (dBm)		
		3GPP WCDMA Rel 99	3GPP HSDPA Rel 5	3GPP HSUPA Rel 6
UMTS Band 5 (850 MHz)	Maximum	24.3	24.3	23.3
	Nominal	23.8	23.8	22.8
UMTS Band 2 (1900 MHz)	Maximum	24.0	24.0	23.0
	Nominal	23.5	23.5	22.5

Mode / Band		Modulated Average (dBm)
LTE Band 12	Maximum	23.9
	Nominal	23.4
LTE Band 17	Maximum	23.9
	Nominal	23.4
LTE Band 5 (Cell)	Maximum	24.0
	Nominal	23.5
LTE Band 4 (AWS)	Maximum	24.0
	Nominal	23.5
LTE Band 2 (PCS)	Maximum	24.4
	Nominal	23.9
LTE Band 30	Maximum	22.5
	Nominal	22.0

1.3.2 Maximum DTS/DSS Power

Mode / Band		Modulated Average (dBm)
IEEE 802.11b (2.4 GHz) SISO	Maximum	17.5
	Nominal	17.0
IEEE 802.11g (2.4 GHz) SISO	Maximum	16.5
	Nominal	16.0
IEEE 802.11n (2.4 GHz) SISO	Maximum	13.5
	Nominal	13.0
IEEE 802.11n (2.4 GHz) MIMO	Maximum	16.5
	Nominal	16.0
Bluetooth	Maximum	10.5
	Nominal	10.0
Bluetooth LE	Maximum	9.5
	Nominal	9.0

FCC ID: A3LSMG890A	 PCTEST PROFESSIONAL TESTING LABORATORY, INC.	SAR EVALUATION REPORT		Reviewed by: Quality Manager
Document S/N: OY1504030657.A3L	Test Dates: 04/06/15 - 05/04/15	DUT Type: Portable Handset		Page 4 of 94

1.3.3 Maximum NII Power

Mode / Band		Modulated Average (dBm)		
		20 MHz Bandwidth	40 MHz Bandwidth	80 MHz Bandwidth
IEEE 802.11a (5 GHz) SISO	Maximum	14.5		
	Nominal	14.0		
IEEE 802.11n (5 GHz) SISO	Maximum	13.5	12.5	
	Nominal	13.0	12.0	
IEEE 802.11ac (5 GHz) SISO	Maximum	13.5	12.5	11.5
	Nominal	13.0	12.0	11.0
IEEE 802.11n (5 GHz) MIMO	Maximum	16.5	15.5	
	Nominal	16.0	15.0	
IEEE 802.11ac (5 GHz) MIMO	Maximum	16.5	15.5	14.5
	Nominal	16.0	15.0	14.0

1.3.4 Reduced PCE Power – Hotspot Active



Mode / Band		Burst Average GMSK (dBm)	
		1 TX Slots	2 TX Slots
GPRS 1900	Maximum	28.2	27.2
	Nominal	27.7	26.7

Mode / Band		Modulated Average (dBm)		
		3GPP WCDMA Rel 99	3GPP HSDPA Rel 5	3GPP HSUPA Rel 6
UMTS Band 2 (1900 MHz)	Maximum	22.0	22.0	22.0
	Nominal	21.5	21.5	21.5

Mode / Band		Modulated Average (dBm)
LTE Band 4 (AWS)	Maximum	21.5
	Nominal	21.0
LTE Band 2 (PCS)	Maximum	20.5
	Nominal	20.0

1.3.5 Reduced DTS Power –Held-To-Ear

Mode / Band		Modulated Average (dBm)
IEEE 802.11b (2.4 GHz) SISO	Maximum	12.5
	Nominal	12.0
IEEE 802.11g (2.4 GHz) SISO	Maximum	12.5
	Nominal	12.0
IEEE 802.11n (2.4 GHz) SISO	Maximum	12.5
	Nominal	12.0
IEEE 802.11n (2.4 GHz) MIMO	Maximum	15.5
	Nominal	15.0

FCC ID: A3LSMG890A	 PCTEST PROFESSIONAL ENGINEERING LABORATORY, INC.	SAR EVALUATION REPORT		Reviewed by: Quality Manager
Document S/N: OY1504030657.A3L	Test Dates: 04/06/15 - 05/04/15	DUT Type: Portable Handset		Page 5 of 94

1.3.6 Reduced NII Power –Held-To-Ear

Mode / Band		Modulated Average (dBm)		
		20 MHz Bandwidth	40 MHz Bandwidth	80 MHz Bandwidth
IEEE 802.11a (5 GHz)	Maximum	9.5		
	Nominal	9.0		
IEEE 802.11n (5 GHz)	Maximum	9.5	8.5	
	Nominal	9.0	8.0	
IEEE 802.11ac (5 GHz)	Maximum	9.5	8.5	8.5
	Nominal	9.0	8.0	8.0
IEEE 802.11n (5 GHz) MIMO	Maximum	12.5	11.5	
	Nominal	12.0	11.0	
IEEE 802.11ac (5 GHz) MIMO	Maximum	12.5	11.5	11.5
	Nominal	12.0	11.0	11.0

1.4 DUT Antenna Locations

The overall dimensions of this device are > 9 x 5 cm. The overall diagonal dimension of the device is <160 mm and the diagonal display is <150 mm. A diagram showing the location of the device antennas can be found in Appendix F. Exact antenna dimensions and separation distances are shown in the Technical Descriptions in the FCC filing.



**Table 1-1
Mobile Hotspot Sides for SAR Testing**

Mode	Back	Front	Top	Bottom	Right	Left
GPRS 850	Yes	Yes	No	Yes	Yes	Yes
UMTS 850	Yes	Yes	No	Yes	Yes	Yes
GPRS 1900	Yes	Yes	No	Yes	Yes	Yes
UMTS 1900	Yes	Yes	No	Yes	Yes	Yes
LTE Band 12	Yes	Yes	No	Yes	Yes	Yes
LTE Band 5 (Cell)	Yes	Yes	No	Yes	Yes	Yes
LTE Band 4 (AWS)	Yes	Yes	No	Yes	Yes	Yes
LTE Band 2 (PCS)	Yes	Yes	No	Yes	Yes	Yes
LTE Band 30	Yes	Yes	No	Yes	Yes	Yes
2.4 GHz WLAN Antenna 1	Yes	Yes	Yes	No	No	Yes
2.4 GHz WLAN Antenna 2	Yes	Yes	Yes	No	No	Yes
U-NII-3 WLAN Antenna 1	Yes	Yes	Yes	No	No	Yes
U-NII-3 WLAN Antenna 2	Yes	Yes	Yes	No	No	Yes

Note: Particular DUT edges were not required to be evaluated for Wireless Router SAR if the edges were greater than 2.5 cm from the transmitting antenna according to FCC KDB Publication 941225 D06v02 guidance, page 2. The distances between the transmit antennas and the edges of the device are included in the filing. When wireless router mode is enabled, U-NII-1, U-NII-2A & U-NII-2C WLAN operations are disabled. Therefore U-NII-1, U-NII-2A & U-NII-2C WLAN operations are not considered in this section.

1.5 Near Field Communications (NFC) Antenna

This DUT has NFC Operations. The NFC antenna is integrated into the device for this model. Therefore, all SAR tests were performed with the device which already incorporates the NFC antenna. A diagram showing the location of the NFC antenna can be found in Appendix F

FCC ID: A3LSMG890A	 PCTEST PROFESSIONAL ENGINEERING LABORATORY, INC.	SAR EVALUATION REPORT		Reviewed by: Quality Manager
Document S/N: OY1504030657.A3L	Test Dates: 04/06/15 - 05/04/15	DUT Type: Portable Handset	Page 6 of 94	

1.6 Simultaneous Transmission Capabilities

According to FCC KDB Publication 447498 D05v01, transmitters are considered to be transmitting simultaneously when there is overlapping transmission, with the exception of transmissions during network hand-offs with maximum hand-off duration less than 30 seconds. Possible transmission paths for the DUT are shown in Figure 1-1 and are color-coded to indicate communication modes which share the same path. Modes which share the same transmission path cannot transmit simultaneously with one another.





Figure 1-1
Simultaneous Transmission Paths

This device contains multiple transmitters that may operate simultaneously, and therefore requires a simultaneous transmission analysis according to FCC KDB Publication 447498 D01v05 3) procedures.

Table 1-2
Simultaneous Transmission Scenarios

No.	Capable Transmit Configuration	Head	Body-Worn Accessory	Wireless Router
1	GSM voice + 2.4 GHz WI-FI	Yes	Yes	N/A
2	GSM voice + 5 GHz WI-FI	Yes	Yes	N/A
3	GSM voice + 2.4 GHz Bluetooth	N/A	Yes	N/A
4	UMTS + 2.4 GHz WI-FI	Yes	Yes	Yes
5	UMTS + 5 GHz WI-FI	Yes	Yes	Yes
6	UMTS + 2.4 GHz Bluetooth	N/A	Yes	N/A
7	LTE + 2.4 GHz WI-FI	Yes	Yes	Yes
8	LTE + 5 GHz WI-FI	Yes	Yes	Yes
9	LTE + 2.4 GHz Bluetooth	N/A	Yes	N/A
10	GPRS/EDGE + 2.4 GHz WI-FI	N/A	N/A	Yes
11	GPRS/EDGE + 5 GHz WI-FI	N/A	N/A	Yes

- All licensed modes share the same antenna path and cannot transmit simultaneously
- When the user utilizes multiple services in UMTS 3G mode it uses multi-Radio Access Bearer or multi-RAB. The power control is based on a physical control channel (Dedicated Physical Control Channel [DPCCH]) and power control will be adjusted to meet the needs of both services. Therefore, the UMTS+WLAN scenario also represents the UMTS Voice/DATA + WLAN Hotspot scenario.
- Per the manufacturer, WIFI Direct is not expected to be used in conjunction with a held-to-ear or body-worn accessory voice call. Therefore, there are no simultaneous transmission scenarios involving WIFI direct beyond that listed in the above table.
- 5 GHz Wireless Router is only supported for the U-NII-3 by S/W, therefore U-NII-1, U-NII-2A, and U-NII-2C were not evaluated for wireless router conditions.
- This device supports 2x2 MIMO Tx for WLAN 802.11n/ac. Each WLAN antenna can transmit independently or together when operating with MIMO.
- This device supports VoLTE and VoWifi.

FCC ID: A3LSMG890A	 PCTEST PROFESSIONAL COMMUNICATIONS TESTING, INC.	SAR EVALUATION REPORT		Reviewed by: Quality Manager
Document S/N: OY1504030657.A3L	Test Dates: 04/06/15 - 05/04/15	DUT Type: Portable Handset	Page 7 of 94	

1.7 Miscellaneous SAR Test Considerations

(A) WIFI/BT

Since Wireless Router operations are not allowed by the chipset firmware using U-NII-1, U-NII-2A & U-NII-2C WIFI, only DTS and U-NII-3 WIFI Hotspot SAR tests and combinations are considered for SAR with respect to Wireless Router configurations according to FCC KDB 941225 D06v02.

Since U-NII-1 and U-NII-2A bands have the same maximum output power and the highest reported SAR for U-NII-2A is less than 1.2 W/kg, SAR is not required for U-NII-1 band according to FCC KDB 248227 D01 Wi-Fi SAR v02.

Per FCC KDB 447498 D01v05, the 1g SAR exclusion threshold for distances <50mm is defined by the following equation:

$$\frac{\text{Max Power of Channel (mW)}}{\text{Test Separation Dist (mm)}} * \sqrt{\text{Frequency(GHz)}} \leq 3.0$$

Based on the maximum conducted power of Bluetooth (rounded to the nearest mW) and the antenna to user separation distance, body-worn Bluetooth SAR was not required; $[(11/15) * \sqrt{2.480}] = 1.2 < 3.0$. Per KDB Publication 447498 D01v05, the maximum power of the channel was rounded to the nearest mW before calculation.

This device supports IEEE 802.11ac with the following features:

- a) Up to 80 MHz Bandwidth only
- b) No aggregate channel configurations
- c) 2 Tx antenna output
- d) 256 QAM is supported
- e) Band gap channels are supported

(B) Licensed Transmitter(s)



GSM/GPRS/EDGE DTM is not supported for US bands. Therefore, the GSM Voice modes in this report do not transmit simultaneously with GPRS/EDGE Data.

This device is only capable of QPSK HSUPA in the uplink. Therefore, no additional SAR tests are required beyond that described for devices with HSUPA in KDB 941225 D01v03.

LTE SAR for the higher modulations and lower bandwidths were not tested since the maximum average output power of all required channels and configurations was not more than 0.5 dB higher than the highest bandwidth; and the reported LTE SAR for the highest bandwidth was less than 1.45 W/kg for all configurations according to FCC KDB 941225 D05v02r03.

This device supports both LTE Band 12 and LTE Band 17. Since the supported frequency span for LTE Band 17 falls completely within the supported frequency span for LTE Band 12, LTE Band 17 has same or lower target power than LTE Band 12 target power, and both LTE bands share the same transmission path, SAR was only assessed for LTE Band 12.

This device supports inter-band LTE Carrier Aggregation (CA) in the downlink only. All uplink communications are identical to Release 8 specifications. Per FCC KDB Publication 941225 D05A v01r01, SAR for LTE CA operations was not needed since the maximum average output power in LTE CA mode was not >0.25 dB higher than the maximum output power when downlink carrier aggregation was not active.

FCC ID: A3LSMG890A	 PCTEST PROFESSIONAL ENGINEERING LABORATORY, INC.	SAR EVALUATION REPORT		Reviewed by: Quality Manager
Document S/N: OY1504030657.A3L	Test Dates: 04/06/15 - 05/04/15	DUT Type: Portable Handset		Page 8 of 94



1.8 Guidance Applied

- IEEE 1528-2003
- FCC KDB Publication 941225 D01v03, D05v02r03, D05Av01, D06v02 (2G/3G/4G and Hotspot)
- FCC KDB Publication 248227 D01 Wi-Fi SAR v02 (SAR Considerations for 802.11 Devices)
- FCC KDB Publication 447498 D01v05r02 (General SAR Guidance)
- FCC KDB Publication 865664 D01v01r03, D02v01r01 (SAR Measurements up to 6 GHz)
- October 2013 TCB Workshop Notes (GPRS Testing Considerations)

1.9 Device Serial Numbers

Several samples with identical hardware were used to support SAR testing. The manufacturer has confirmed that the device(s) tested have the same physical, mechanical and thermal characteristics and are within operational tolerances expected for production units.



	Head Serial Number	Body-Worn Serial Number	Hotspot Serial Number
GSM/GPRS/EDGE 850	359356060056374	359356060056374	359356060056374
GSM/GPRS/EDGE 1900	359356060056374	359356060056374	359356060079855
UMTS 850	359356060056374	359356060056374	359356060056374
UMTS 1900	359356060056374	359356060056374	359356060056374
LTE Band 12	359356060056432	359356060056366	359356060056366
LTE Band 5 (Cell)	359356060056374	359356060056374	359356060056374
LTE Band 4 (AWS)	359356060056390	359356060056374	359356060056374
LTE Band 2 (PCS)	359356060056374	359356060056374	359356060079921
LTE Band 30	359356060056366	359356060056374	359356060056374
2.4 GHz WLAN	359356060056457	359356060056374	359356060056374
5 GHz WLAN	359356060056366	359356060056390	359356060056390

FCC ID: A3LSMG890A	 PCTEST ENGINEERING LABORATORY, INC.	SAR EVALUATION REPORT		Reviewed by: Quality Manager
Document S/N: OY1504030657.A3L	Test Dates: 04/06/15 - 05/04/15	DUT Type: Portable Handset	Page 9 of 94	



2

LTE INFORMATION

LTE Information			
FCC ID	A3LSMG890A		
Form Factor	Portable Handset		
Frequency Range of each LTE transmission band	LTE Band 12 (699.7 - 715.3 MHz)		
	LTE Band 17 (706.5 - 713.5 MHz)		
	LTE Band 5 (Cell) (824.7 - 848.3 MHz)		
	LTE Band 4 (AWS) (1710.7 - 1754.3 MHz)		
	LTE Band 2 (PCS) (1850.7 - 1909.3 MHz)		
	LTE Band 30 (2307.5 - 2312.5 MHz)		
Channel Bandwidths	LTE Band 12: 1.4 MHz, 3 MHz, 5 MHz, 10 MHz		
	LTE Band 17: 5 MHz, 10 MHz		
	LTE Band 5 (Cell): 1.4 MHz, 3 MHz, 5 MHz, 10 MHz		
	LTE Band 4 (AWS): 1.4 MHz, 3 MHz, 5 MHz, 10 MHz, 15 MHz, 20 MHz		
	LTE Band 2 (PCS): 1.4 MHz, 3 MHz, 5 MHz, 10 MHz, 15 MHz, 20 MHz		
Channel Numbers and Frequencies (MHz)	Low	Mid	High
	LTE Band 30: 5 MHz, 10 MHz		
LTE Band 12: 1.4 MHz	699.7 (23017)	707.5 (23095)	715.3 (23173)
LTE Band 12: 3 MHz	700.5 (23025)	707.5 (23095)	714.5 (23165)
LTE Band 12: 5 MHz	701.5 (23035)	707.5 (23095)	713.5 (23155)
LTE Band 12: 10 MHz	704 (23060)	707.5 (23095)	711 (23130)
LTE Band 17: 5 MHz	706.5 (23755)	710 (23790)	713.5 (23825)
LTE Band 17: 10 MHz	709 (23780)	710 (23790)	711 (23800)
LTE Band 5 (Cell): 1.4 MHz	824.7 (20407)	836.5 (20525)	848.3 (20643)
LTE Band 5 (Cell): 3 MHz	825.5 (20415)	836.5 (20525)	847.5 (20635)
LTE Band 5 (Cell): 5 MHz	826.5 (20425)	836.5 (20525)	846.5 (20625)
LTE Band 5 (Cell): 10 MHz	829 (20450)	836.5 (20525)	844 (20600)
LTE Band 4 (AWS): 1.4 MHz	1710.7 (19957)	1732.5 (20175)	1754.3 (20393)
LTE Band 4 (AWS): 3 MHz	1711.5 (19965)	1732.5 (20175)	1753.5 (20385)
LTE Band 4 (AWS): 5 MHz	1712.5 (19975)	1732.5 (20175)	1752.5 (20375)
LTE Band 4 (AWS): 10 MHz	1715 (20000)	1732.5 (20175)	1750 (20350)
LTE Band 4 (AWS): 15 MHz	1717.5 (20025)	1732.5 (20175)	1747.5 (20325)
LTE Band 4 (AWS): 20 MHz	1720 (20050)	1732.5 (20175)	1745 (20300)
LTE Band 2 (PCS): 1.4 MHz	1850.7 (18607)	1880 (18900)	1909.3 (19193)
LTE Band 2 (PCS): 3 MHz	1851.5 (18615)	1880 (18900)	1908.5 (19185)
LTE Band 2 (PCS): 5 MHz	1852.5 (18625)	1880 (18900)	1907.5 (19175)
LTE Band 2 (PCS): 10 MHz	1855 (18650)	1880 (18900)	1905 (19150)
LTE Band 2 (PCS): 15 MHz	1857.5 (18675)	1880 (18900)	1902.5 (19125)
LTE Band 2 (PCS): 20 MHz	1860 (18700)	1880 (18900)	1900 (19100)
LTE Band 30: 5 MHz	2307.5 (27685)	2310 (27710)	2312.5 (27735)
LTE Band 30: 10 MHz	N/A	2310 (27710)	N/A
UE Category	6		
Modulations Supported in UL	QPSK, 16QAM		
LTE MPR Permanently implemented per 3GPP TS 36.101 section 6.2.3~6.2.5? (manufacturer attestation to be provided)	YES		
A-MPR (Additional MPR) disabled for SAR Testing?	YES		
LTE Carrier Aggregation Possible Combinations	Please see next page for LTE Carrier Aggregation Possible Combinations		
LTE Carrier Aggregation Additional Information	<p>This device does not support full CA features on 3GPP Release 10. It supports a maximum of 2 carriers in the downlink. All uplink communications are identical to the Release 8 Specifications. Uplink communications are done on the PCC. Due to carrier capability, only the combinations listed above are supported. The following LTE Release 10 Features are not supported: Relay, HetNet, Enhanced MIMO, eICI, WIFI Offloading, MDH, eMBMA, Cross-Carrier Scheduling, Enhanced SC-FDMA.</p>		

FCC ID: A3LSMG890A	 PCTEST PROFESSIONAL CORPORATION, LLC	SAR EVALUATION REPORT		Reviewed by: Quality Manager
Document S/N: OY1504030657.A3L	Test Dates: 04/06/15 - 05/04/15	DUT Type: Portable Handset	Page 10 of 94	

B12 (PCC) + B2 (SCC)	B12 (PCC) + B30 (SCC)	B5 (PCC) + B2 (SCC)	B5 (PCC) + B4 (SCC)	B5 (PCC) + B30 (SCC)	B4 (PCC) + B17 (SCC)
3MHz (B12) + 5MHz (B2)	5MHz (B12) + 5MHz (B30)	5MHz (B5) + 5MHz (B2)	5MHz (B5) + 5MHz (B4)	5MHz (B5) + 5MHz (B30)	5MHz (B4) + 5MHz (B17)
3MHz (B12) + 10MHz (B2)	5MHz (B12) + 10MHz (B30)	5MHz (B5) + 10MHz (B2)	5MHz (B5) + 10MHz (B4)	5MHz (B5) + 10MHz (B30)	5MHz (B4) + 10MHz (B17)
3MHz (B12) + 15MHz (B2)	10MHz (B12) + 5MHz (B30)	5MHz (B5) + 15MHz (B2)	5MHz (B5) + 15MHz (B4)	10MHz (B5) + 5MHz (B30)	10MHz (B4) + 5MHz (B17)
3MHz (B12) + 20MHz (B2)	10MHz (B12) + 10MHz (B30)	5MHz (B5) + 20MHz (B2)	5MHz (B5) + 20MHz (B4)	10MHz (B5) + 10MHz (B30)	10MHz (B4) + 10MHz (B17)
5MHz (B12) + 5MHz (B2)		10MHz (B5) + 5MHz (B2)	10MHz (B5) + 5MHz (B4)		
5MHz (B12) + 10MHz (B2)		10MHz (B5) + 10MHz (B2)	10MHz (B5) + 10MHz (B4)		
5MHz (B12) + 15MHz (B2)		10MHz (B5) + 15MHz (B2)	10MHz (B5) + 15MHz (B4)		
5MHz (B12) + 20MHz (B2)		10MHz (B5) + 20MHz (B2)	10MHz (B5) + 20MHz (B4)		
10MHz (B12) + 5MHz (B2)					
10MHz (B12) + 10MHz (B2)					
10MHz (B12) + 15MHz (B2)					
10MHz (B12) + 20MHz (B2)					
B4 (PCC) + B29 (SCC)	B4 (PCC) + B5 (SCC)	B4 (PCC) + B12 (SCC)	B4 (PCC) + B30 (SCC)	B2 (PCC) + B17 (SCC)	B2 (PCC) + B29 (SCC)
5MHz (B4) + 3MHz (B29)	5MHz (B4) + 5MHz (B5)	1.4MHz (B4) + 3MHz (B12)	5MHz (B4) + 5MHz (B30)	5MHz (B2) + 5MHz (B17)	5MHz (B2) + 3MHz (B29)
5MHz (B4) + 5MHz (B29)	5MHz (B4) + 10MHz (B5)	1.4MHz (B4) + 5MHz (B12)	5MHz (B4) + 10MHz (B30)	5MHz (B2) + 10MHz (B17)	5MHz (B2) + 5MHz (B29)
5MHz (B4) + 10MHz (B29)	10MHz (B4) + 5MHz (B5)	1.4MHz (B4) + 10MHz (B12)	10MHz (B4) + 5MHz (B30)	10MHz (B2) + 5MHz (B17)	5MHz (B2) + 10MHz (B29)
10MHz (B4) + 3MHz (B29)	10MHz (B4) + 10MHz (B5)	3MHz (B4) + 3MHz (B12)	10MHz (B4) + 10MHz (B30)	10MHz (B2) + 10MHz (B17)	10MHz (B2) + 3MHz (B29)
10MHz (B4) + 5MHz (B29)	15MHz (B4) + 5MHz (B5)	3MHz (B4) + 5MHz (B12)	15MHz (B4) + 5MHz (B30)		10MHz (B2) + 5MHz (B29)
10MHz (B4) + 10MHz (B29)	15MHz (B4) + 10MHz (B5)	3MHz (B4) + 10MHz (B12)	15MHz (B4) + 10MHz (B30)		10MHz (B2) + 10MHz (B29)
15MHz (B4) + 3MHz (B29)	20MHz (B4) + 5MHz (B5)	5MHz (B4) + 3MHz (B12)	20MHz (B4) + 5MHz (B30)		15MHz (B2) + 3MHz (B29)
15MHz (B4) + 5MHz (B29)	20MHz (B2) + 10MHz (B5)	5MHz (B4) + 5MHz (B12)	20MHz (B4) + 10MHz (B30)		15MHz (B2) + 5MHz (B29)
15MHz (B4) + 10MHz (B29)		5MHz (B4) + 10MHz (B12)			15MHz (B2) + 10MHz (B29)
20MHz (B4) + 3MHz (B29)		10MHz (B4) + 3MHz (B12)			20MHz (B2) + 3MHz (B29)
20MHz (B4) + 5MHz (B29)		10MHz (B4) + 5MHz (B12)			20MHz (B2) + 5MHz (B29)
20MHz (B4) + 10MHz (B29)		10MHz (B4) + 10MHz (B12)			20MHz (B2) + 10MHz (B29)
		15MHz (B4) + 3MHz (B12)			
		15MHz (B4) + 5MHz (B12)			
		15MHz (B4) + 10MHz (B12)			
		20MHz (B4) + 3MHz (B12)			
		20MHz (B4) + 5MHz (B12)			
		20MHz (B4) + 10MHz (B12)			
B2 (PCC) + B5 (SCC)	B2 (PCC) + B12 (SCC)	B2 (PCC) + B30 (SCC)	B30 (PCC) + B2 (SCC)	B30 (PCC) + B4 (SCC)	B30 (PCC) + B5 (SCC)
5MHz (B2) + 5MHz (B5)	5MHz (B2) + 3MHz (B12)	5MHz (B2) + 5MHz (B30)	5MHz (B30) + 5MHz (B2)	5MHz (B30) + 5MHz (B4)	5MHz (B30) + 5MHz (B5)
5MHz (B2) + 10MHz (B5)	5MHz (B2) + 5MHz (B12)	5MHz (B2) + 10MHz (B30)	5MHz (B30) + 10MHz (B2)	5MHz (B30) + 10MHz (B4)	5MHz (B30) + 10MHz (B5)
10MHz (B2) + 5MHz (B5)	5MHz (B2) + 10MHz (B12)	10MHz (B2) + 5MHz (B30)	5MHz (B30) + 15MHz (B2)	5MHz (B30) + 15MHz (B4)	10MHz (B30) + 5MHz (B5)
10MHz (B2) + 10MHz (B5)	10MHz (B2) + 3MHz (B12)	10MHz (B2) + 10MHz (B30)	5MHz (B30) + 20MHz (B2)	5MHz (B30) + 20MHz (B4)	10MHz (B30) + 10MHz (B5)
15MHz (B2) + 5MHz (B5)	10MHz (B2) + 5MHz (B12)	15MHz (B2) + 5MHz (B30)	10MHz (B30) + 5MHz (B2)	10MHz (B30) + 5MHz (B4)	
15MHz (B2) + 10MHz (B5)	10MHz (B2) + 10MHz (B12)	15MHz (B2) + 10MHz (B30)	10MHz (B30) + 10MHz (B2)	10MHz (B30) + 10MHz (B4)	
20MHz (B2) + 5MHz (B5)	15MHz (B2) + 3MHz (B12)	20MHz (B2) + 5MHz (B30)	10MHz (B30) + 15MHz (B2)	10MHz (B30) + 15MHz (B4)	
20MHz (B2) + 10MHz (B5)	15MHz (B2) + 5MHz (B12)	20MHz (B2) + 10MHz (B30)	10MHz (B30) + 20MHz (B2)	10MHz (B30) + 20MHz (B4)	
	15MHz (B2) + 10MHz (B12)				
	20MHz (B2) + 3MHz (B12)				
	20MHz (B2) + 5MHz (B12)				
	20MHz (B2) + 10MHz (B12)				
B30 (PCC) + B29 (SCC)	B30 (PCC) + B12 (SCC)	B17 (PCC) + B2 (SCC)			
5MHz (B30) + 5MHz (B29)	5MHz (B30) + 5MHz (B12)	10MHz (B17) + 5MHz (B2)			
5MHz (B30) + 10MHz (B29)	5MHz (B30) + 10MHz (B12)	10MHz (B17) + 10MHz (B2)			
10MHz (B30) + 5MHz (B29)	10MHz (B30) + 5MHz (B12)	10MHz (B17) + 15MHz (B2)			
10MHz (B30) + 10MHz (B29)	10MHz (B30) + 10MHz (B12)	10MHz (B17) + 20MHz (B2)			

FCC ID: A3LSMG890A	 PCTEST PROFESSIONAL LABORATORY, INC.	SAR EVALUATION REPORT		Reviewed by: Quality Manager
Document S/N: OY1504030657.A3L	Test Dates: 04/06/15 - 05/04/15	DUT Type: Portable Handset		Page 11 of 94

3 INTRODUCTION

The FCC and Industry Canada have adopted the guidelines for evaluating the environmental effects of radio frequency (RF) radiation in ET Docket 93-62 on Aug. 6, 1996 and Health Canada Safety Code 6 to protect the public and workers from the potential hazards of RF emissions due to FCC-regulated portable devices. [1]

The safety limits used for the environmental evaluation measurements are based on the criteria published by the American National Standards Institute (ANSI) for localized specific absorption rate (SAR) in IEEE/ANSI C95.1-1992 Standard for Safety Levels with Respect to Human Exposure to Radio Frequency Electromagnetic Fields, 3 kHz to 300 GHz [3] and Health Canada RF Exposure Guidelines Safety Code 6 [22]. The measurement procedure described in IEEE/ANSI C95.3-2002 Recommended Practice for the Measurement of Potentially Hazardous Electromagnetic Fields - RF and Microwave [4] is used for guidance in measuring the Specific Absorption Rate (SAR) due to the RF radiation exposure from the Equipment Under Test (EUT). These criteria for SAR evaluation are similar to those recommended by the International Committee for Non-Ionizing Radiation Protection (ICNIRP) in Biological Effects and Exposure Criteria for Radiofrequency Electromagnetic Fields,” Report No. Vol 74. SAR is a measure of the rate of energy absorption due to exposure to an RF transmitting source. SAR values have been related to threshold levels for potential biological hazards.

3.1 SAR Definition

Specific Absorption Rate is defined as the time derivative (rate) of the incremental energy (dU) absorbed by (dissipated in) an incremental mass (dm) contained in a volume element (dV) of a given density (ρ). It is also defined as the rate of RF energy absorption per unit mass at a point in an absorbing body (see Equation 3-1).

**Equation 3-1
SAR Mathematical Equation**

$$SAR = \frac{d}{dt} \left(\frac{dU}{dm} \right) = \frac{d}{dt} \left(\frac{dU}{\rho dv} \right)$$



SAR is expressed in units of Watts per Kilogram (W/kg).

$$SAR = \frac{\sigma \cdot E^2}{\rho}$$

where:

- σ = conductivity of the tissue-simulating material (S/m)
- ρ = mass density of the tissue-simulating material (kg/m³)
- E = Total RMS electric field strength (V/m)

NOTE: The primary factors that control rate of energy absorption were found to be the wavelength of the incident field in relation to the dimensions and geometry of the irradiated organism, the orientation of the organism in relation to the polarity of field vectors, the presence of reflecting surfaces, and whether conductive contact is made by the organism with a ground plane.[6]

FCC ID: A3LSMG890A	 PCTEST PROFESSIONAL CORPORATION, INC.	SAR EVALUATION REPORT		Reviewed by: Quality Manager
Document S/N: OY1504030657.A3L	Test Dates: 04/06/15 - 05/04/15	DUT Type: Portable Handset	Page 12 of 94	

4 DOSIMETRIC ASSESSMENT

4.1 Measurement Procedure

The evaluation was performed using the following procedure compliant to FCC KDB Publication 865664 D01v01 and IEEE 1528-2013:

1. The SAR distribution at the exposed side of the head or body was measured at a distance no greater than 5.0 mm from the inner surface of the shell. The area covered the entire dimension of the device-head and body interface and the horizontal grid resolution was determined per FCC KDB Publication 865664 D01v01 (See Table 4-1) and IEEE 1528-2013.
2. The point SAR measurement was taken at the maximum SAR region determined from Step 1 to enable the monitoring of SAR fluctuations/drifts during the 1g/10g cube evaluation. SAR at this fixed point was measured and used as a reference value.
3. Based on the area scan data, the peak of the region with maximum SAR was determined by spline interpolation. Around this point, a volume was assessed according to the measurement resolution and volume size requirements of FCC KDB Publication 865664 D01v01 (See Table 4-1) and IEEE 1528-2013. On the basis of this data set, the spatial peak SAR value was evaluated with the following procedure (see references or the DASy manual online for more details):
 - a. SAR values at the inner surface of the phantom are extrapolated from the measured values along the line away from the surface with spacing no greater than that in Table 4-1. The extrapolation was based on a least-squares algorithm. A polynomial of the fourth order was calculated through the points in the z-axis (normal to the phantom shell).
 - b. After the maximum interpolated values were calculated between the points in the cube, the SAR was averaged over the spatial volume (1g or 10g) using a 3D-Spline interpolation algorithm. The 3D-spline is composed of three one-dimensional splines with the “Not a knot” condition (in x, y, and z directions). The volume was then integrated with the trapezoidal algorithm. One thousand points (10 x 10 x 10) were obtained through interpolation, in order to calculate the averaged SAR.
 - c. All neighboring volumes were evaluated until no neighboring volume with a higher average value was found.
4. The SAR reference value, at the same location as step 2, was re-measured after the zoom scan was complete to calculate the SAR drift. If the drift deviated by more than 5%, the SAR test and drift measurements were repeated.

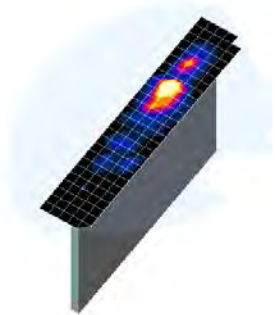



Figure 4-1
Sample SAR Area Scan

Table 4-1
Area and Zoom Scan Resolutions per FCC KDB Publication 865664 D01v01*

Frequency	Maximum Area Scan Resolution (mm) ($\Delta x_{area}, \Delta y_{area}$)	Maximum Zoom Scan Resolution (mm) ($\Delta x_{zoom}, \Delta y_{zoom}$)	Maximum Zoom Scan Spatial Resolution (mm)			Minimum Zoom Scan Volume (mm) (x,y,z)
			Uniform Grid $\Delta z_{zoom}(n)$	Graded Grid		
				$\Delta z_{zoom}(1)^*$	$\Delta z_{zoom}(n>1)^*$	
≤ 2 GHz	≤ 15	≤ 8	≤ 5	≤ 4	≤ 1.5* $\Delta z_{zoom}(n-1)$	≥ 30
2-3 GHz	≤ 12	≤ 5	≤ 5	≤ 4	≤ 1.5* $\Delta z_{zoom}(n-1)$	≥ 30
3-4 GHz	≤ 12	≤ 5	≤ 4	≤ 3	≤ 1.5* $\Delta z_{zoom}(n-1)$	≥ 28
4-5 GHz	≤ 10	≤ 4	≤ 3	≤ 2.5	≤ 1.5* $\Delta z_{zoom}(n-1)$	≥ 25
5-6 GHz	≤ 10	≤ 4	≤ 2	≤ 2	≤ 1.5* $\Delta z_{zoom}(n-1)$	≥ 22

*Also compliant to IEEE 1528-2013 Table 6

FCC ID: A3LSMG890A		SAR EVALUATION REPORT		Reviewed by: Quality Manager
Document S/N: OY1504030657.A3L	Test Dates: 04/06/15 - 05/04/15	DUT Type: Portable Handset		Page 13 of 94

5

DEFINITION OF REFERENCE POINTS

5.1 EAR REFERENCE POINT

Figure 5-2 shows the front, back and side views of the SAM Twin Phantom. The point “M” is the reference point for the center of the mouth, “LE” is the left ear reference point (ERP), and “RE” is the right ERP. The ERP is 15mm posterior to the entrance to the ear canal (EEC) along the B-M line (Back-Mouth), as shown in Figure 5-1. The plane passing through the two ear canals and M is defined as the Reference Plane. The line N-F (Neck-Front), also called the Reference Pivoting Line, is not perpendicular to the reference plane (see Figure 5-1). Line B-M is perpendicular to the N-F line. Both N-F and B-M lines are marked on the external phantom shell to facilitate handset positioning [5].

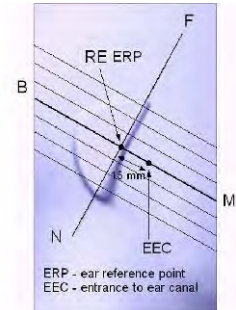

Figure 5-1
Close-Up Side view of ERP

5.2 HANDSET REFERENCE POINTS

Two imaginary lines on the handset were established: the vertical centerline and the horizontal line. The test device was placed in a normal operating position with the acoustic output located along the “vertical centerline” on the front of the device aligned to the “ear reference point” (See Figure 5-3). The acoustic output was then located at the same level as the center of the ear reference point. The test device was positioned so that the “vertical centerline” was bisecting the front surface of the handset at its top and bottom edges, positioning the “ear reference point” on the outer surface of the both the left and right head phantoms on the ear reference point.



Figure 5-2
Front, back and side view of SAM Twin Phantom

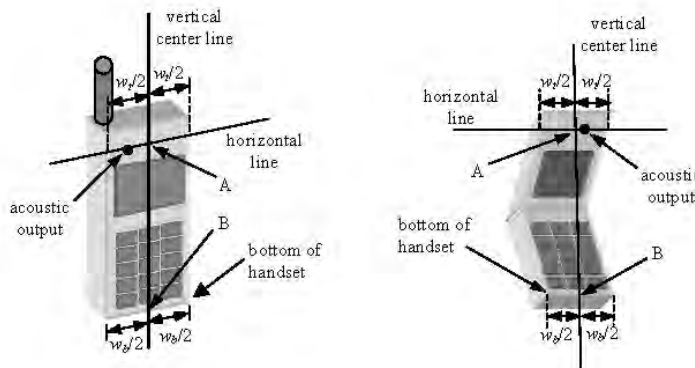



Figure 5-3
Handset Vertical Center & Horizontal Line Reference Points

FCC ID: A3LSMG890A	 PCTEST PROFESSIONAL CALIBRATION TEST, INC.	SAR EVALUATION REPORT	 SAMSUNG	Reviewed by: Quality Manager
Document S/N: OY1504030657.A3L	Test Dates: 04/06/15 - 05/04/15	DUT Type: Portable Handset		Page 14 of 94

6 TEST CONFIGURATION POSITIONS FOR HANDSETS

6.1 Device Holder

The device holder is made out of low-loss POM material having the following dielectric parameters: relative permittivity $\epsilon = 3$ and loss tangent $\delta = 0.02$.

6.2 Positioning for Cheek

1. The test device was positioned with the device close to the surface of the phantom such that point A is on the (virtual) extension of the line passing through points RE and LE on the phantom (see Figure 6-1), such that the plane defined by the vertical center line and the horizontal line of the phone is approximately parallel to the sagittal plane of the phantom.





Figure 6-1 Front, Side and Top View of Cheek Position

2. The handset was translated towards the phantom along the line passing through RE & LE until the handset touches the pinna.
3. While maintaining the handset in this plane, the handset was rotated around the LE-RE line until the vertical centerline was in the reference plane.
4. The phone was then rotated around the vertical centerline until the phone (horizontal line) was symmetrical with respect to the line NF.
5. While maintaining the vertical centerline in the reference plane, keeping point A on the line passing through RE and LE, and maintaining the device contact with the ear, the device was rotated about the NF line until any point on the handset made contact with a phantom point below the ear (cheek) (See Figure 6-2).

6.3 Positioning for Ear / 15° Tilt

With the test device aligned in the “Cheek Position”:

1. While maintaining the orientation of the phone, the phone was retracted parallel to the reference plane far enough to enable a rotation of the phone by 15 degrees.
2. The phone was then rotated around the horizontal line by 15 degrees.
3. While maintaining the orientation of the phone, the phone was moved parallel to the reference plane until any part of the handset touched the head. (In this position, point A was located on the line RE-LE). The tilted position is obtained when the contact is on the pinna. If the contact was at any location other than the pinna, the angle of the phone would then be reduced. In this situation, the tilted position was obtained when any part of the phone was in contact of the ear as well as a second part of the phone was in contact with the head (see Figure 6-2).

FCC ID: A3LSMG890A	 PCTEST PROFESSIONAL ENGINEERING LABORATORY, INC.	SAR EVALUATION REPORT		Reviewed by: Quality Manager
Document S/N: OY1504030657.A3L	Test Dates: 04/06/15 - 05/04/15	DUT Type: Portable Handset	Page 15 of 94	

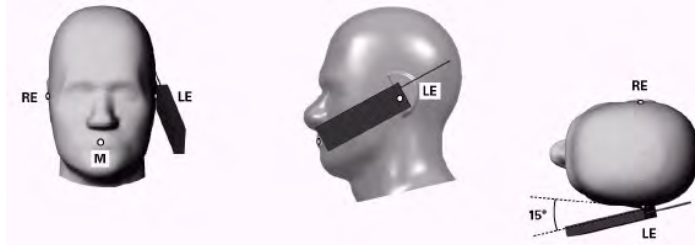

Figure 6-2 Front, Side and Top View of Ear/15° Tilt Position

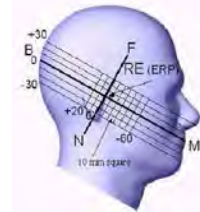

Figure 6-3 Side view w/ relevant markings

6.4 SAR Evaluations near the Mouth/Jaw Regions of the SAM Phantom

Antennas located near the bottom of a phone may require SAR measurements around the mouth and jaw regions of the SAM head phantom. This typically applies to clam-shell style phones that are generally longer in the unfolded normal use positions or to certain older style long rectangular phones. Per IEEE 1528-2013, a rotated SAM phantom is necessary to allow probe access to such regions. Both SAM heads of the TwinSAM-Chin20 are rotated 20 degrees around the NF line. Each head can be removed from the table for emptying and cleaning.

Under these circumstances, the following procedures apply, adopted from the FCC guidance on SAR handsets document FCC KDB Publication 648474 D04_v01. The SAR required in these regions of SAM should be measured using a flat phantom. The phone should be positioned with a separation distance of 4 mm between the ear reference point (ERP) and the outer surface of the flat phantom shell. While maintaining this distance at the ERP location, the low (bottom) edge of the phone should be lowered from the phantom to establish the same separation distance between the peak SAR location identified by the truncated partial SAR distribution measured with the SAM phantom. The distance from the peak SAR location to the phone is determined by the straight line passing perpendicularly through the phantom surface. When it is not feasible to maintain 4 mm separation at the ERP while also establishing the required separation at the peak SAR location, the top edge of the phone will be allowed to touch the phantom with a separation < 4 mm at the ERP. The phone should not be tilted to the left or right while placed in this inclined position to the flat phantom.

6.5 Body-Worn Accessory Configurations

Body-worn operating configurations are tested with the belt-clips and holsters attached to the device and positioned against a flat phantom in a normal use configuration (see Figure 6-4). Per FCC KDB Publication 648474 D04v01, Body-worn accessory exposure is typically related to voice mode operations when handsets are carried in body-worn accessories. The body-worn accessory procedures in FCC KDB Publication 447498 D01v05 should be used to test for body-worn accessory SAR compliance, without a headset connected to it. This enables the test results for such configuration to be compatible with that required for hotspot mode when the body-worn accessory test separation distance is greater than or equal to that required for hotspot mode, when applicable. When the reported SAR for a body-worn accessory, measured without a headset connected to the handset, is > 1.2 W/kg, the highest reported SAR configuration for that wireless mode and frequency band should be repeated for that body-worn accessory with a headset attached to the handset.

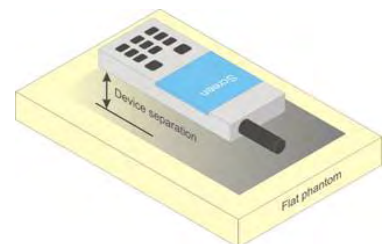



Figure 6-4 Sample Body-Worn Diagram

FCC ID: A3LSMG890A	 PCTEST PROFESSIONAL ENGINEERING LABORATORY, INC.	SAR EVALUATION REPORT	 SAMSUNG	Reviewed by: Quality Manager
Document S/N: OY1504030657.A3L	Test Dates: 04/06/15 - 05/04/15	DUT Type: Portable Handset		Page 16 of 94

Accessories for Body-worn operation configurations are divided into two categories: those that do not contain metallic components and those that do contain metallic components. When multiple accessories that do not contain metallic components are supplied with the device, the device is tested with only the accessory that dictates the closest spacing to the body. Then multiple accessories that contain metallic components are tested with the device with each accessory. If multiple accessories share an identical metallic component (i.e. the same metallic belt-clip used with different holsters with no other metallic components) only the accessory that dictates the closest spacing to the body is tested.

Body-worn accessories may not always be supplied or available as options for some devices intended to be authorized for body-worn use. In this case, a test configuration with a separation distance between the back of the device and the flat phantom is used. Test position spacing was documented. Transmitters that are designed to operate in front of a person's face, as in push-to-talk configurations, are tested for SAR compliance with the front of the device positioned to face the flat phantom in head fluid. For devices that are carried next to the body such as a shoulder, waist or chest-worn transmitters, SAR compliance is tested with the accessories, including headsets and microphones, attached to the device and positioned against a flat phantom in a normal use configuration.

6.6 Extremity Exposure Configurations

Devices that are designed or intended for use on extremities or mainly operated in extremity only exposure conditions; i.e., hands, wrists, feet and ankles, may require extremity SAR evaluation. When the device also operates in close proximity to the user's body, SAR compliance for the body is also required. The 1-g body and 10-g extremity SAR Exclusion Thresholds found in KDB Publication 44798 D01v05 should be applied to determine SAR test requirements.



Per KDB Publication 447498 D01v05, Cell phones (handsets) are not normally designed to be used on extremities or operated in extremity only exposure conditions. The maximum output power levels of handsets generally do not require extremity SAR testing to show compliance. Therefore, extremity SAR was not evaluated for this device.

6.7 Wireless Router Configurations

Some battery-operated handsets have the capability to transmit and receive user data through simultaneous transmission of WIFI simultaneously with a separate licensed transmitter. The FCC has provided guidance in FCC KDB Publication 941225 D06v02 where SAR test considerations for handsets (L x W ≥ 9 cm x 5 cm) are based on a composite test separation distance of 10 mm from the front, back and edges of the device containing transmitting antennas within 2.5 cm of their edges, determined from general mixed use conditions for this type of devices. Since the hotspot SAR results may overlap with the body-worn accessory SAR requirements, the more conservative configurations can be considered, thus excluding some body-worn accessory SAR tests.

When the user enables the personal wireless router functions for the handset, actual operations include simultaneous transmission of both the WIFI transmitter and another licensed transmitter. Both transmitters often do not transmit at the same transmitting frequency and thus cannot be evaluated for SAR under actual use conditions due to the limitations of the SAR assessment probes. Therefore, SAR must be evaluated for each frequency transmission and mode separately and spatially summed with the WIFI transmitter according to FCC KDB Publication 447498 D01v05 publication procedures. The "Portable Hotspot" feature on the handset was NOT activated during SAR assessments, to ensure the SAR measurements were evaluated for a single transmission frequency RF signal at a time.

There is power reduction for GPRS/UMTS Band 2, and LTE Band 2/4 in hotspot scenarios. The reduced powers were confirmed via conducted power measurements at the RF port (See Section 9). Detailed description of the hotspot power reduction mechanism is included in the operational description

FCC ID: A3LSMG890A		SAR EVALUATION REPORT		Reviewed by: Quality Manager
Document S/N: OY1504030657.A3L	Test Dates: 04/06/15 - 05/04/15	DUT Type: Portable Handset	Page 17 of 94	

7 RF EXPOSURE LIMITS

7.1 Uncontrolled Environment

UNCONTROLLED ENVIRONMENTS are defined as locations where there is the exposure of individuals who have no knowledge or control of their exposure. The general population/uncontrolled exposure limits are applicable to situations in which the general public may be exposed or in which persons who are exposed as a consequence of their employment may not be made fully aware of the potential for exposure or cannot exercise control over their exposure. Members of the general public would come under this category when exposure is not employment-related; for example, in the case of a wireless transmitter that exposes persons in its vicinity.



7.2 Controlled Environment

CONTROLLED ENVIRONMENTS are defined as locations where there is exposure that may be incurred by persons who are aware of the potential for exposure, (i.e. as a result of employment or occupation). In general, occupational/controlled exposure limits are applicable to situations in which persons are exposed as a consequence of their employment, who have been made fully aware of the potential for exposure and can exercise control over their exposure. This exposure category is also applicable when the exposure is of a transient nature due to incidental passage through a location where the exposure levels may be higher than the general population/uncontrolled limits, but the exposed person is fully aware of the potential for exposure and can exercise control over his or her exposure by leaving the area or by some other appropriate means.

**Table 7-1
SAR Human Exposure Specified in ANSI/IEEE C95.1-1992 and Health Canada Safety Code 6**

HUMAN EXPOSURE LIMITS		
	UNCONTROLLED ENVIRONMENT <i>General Population</i> (W/kg) or (mW/g)	CONTROLLED ENVIRONMENT <i>Occupational</i> (W/kg) or (mW/g)
Peak Spatial Average SAR Head	1.6	8.0
Whole Body SAR	0.08	0.4
Peak Spatial Average SAR Hands, Feet, Ankle, Wrists, etc.	4.0	20

1. The Spatial Peak value of the SAR averaged over any 1 gram of tissue (defined as a tissue volume in the shape of a cube) and over the appropriate averaging time.
2. The Spatial Average value of the SAR averaged over the whole body.
3. The Spatial Peak value of the SAR averaged over any 10 grams of tissue (defined as a tissue volume in the shape of a cube) and over the appropriate averaging time.

FCC ID: A3LSMG890A	 PCTEST PROFESSIONAL TESTING LABORATORY, INC.	SAR EVALUATION REPORT		Reviewed by: Quality Manager
Document S/N: OY1504030657.A3L	Test Dates: 04/06/15 - 05/04/15	DUT Type: Portable Handset	Page 18 of 94	

8 FCC MEASUREMENT PROCEDURES

Power measurements for licensed transmitters are performed using a base station simulator under digital average power.

8.1 Measured and Reported SAR

Per FCC KDB Publication 447498 D01v05, when SAR is not measured at the maximum power level allowed for production units, the results must be scaled to the maximum tune-up tolerance limit according to the power applied to the individual channels tested to determine compliance. For simultaneous transmission, the measured aggregate SAR must be scaled according to the sum of the differences between the maximum tune-up tolerance and actual power used to test each transmitter. When SAR is measured at or scaled to the maximum tune-up tolerance limit, the results are referred to as *reported* SAR. The highest *reported* SAR results are identified on the grant of equipment authorization according to procedures in KDB 690783 D01v01r02.

8.2 3G SAR Test Reduction Procedure

In FCC KDB Publication 941225 D01v03, certain transmission modes within a frequency band and wireless mode evaluated for SAR are defined as primary modes. The equivalent modes considered for SAR test reduction are denoted as secondary modes. When the maximum output power including tune-up tolerance specified for production units in a secondary mode is ≤ 0.25 dB higher than the primary mode or when the highest reported SAR of the primary mode, scaled by the ratio of specified maximum output power and tune-up tolerance of secondary to primary mode, is ≤ 1.2 W/kg, SAR measurements are not required for the secondary mode. These criteria are referred to as the 3G SAR test reduction procedure. When the 3G SAR test reduction procedure is not satisfied, SAR measurements are additionally required for the secondary mode.

8.3 Procedures Used to Establish RF Signal for SAR



The following procedures are according to FCC KDB Publication 941225 D01v03 “3G SAR Measurement Procedures.”

The device is placed into a simulated call using a base station simulator in a RF shielded chamber. Establishing connections in this manner ensure a consistent means for testing SAR and are recommended for evaluating SAR [4]. Devices under test are evaluated prior to testing, with a fully charged battery and were configured to operate at maximum output power. In order to verify that the device is tested throughout the SAR test at maximum output power, the SAR measurement system measures a “point SAR” at an arbitrary reference point at the start and end of the 1 gram SAR evaluation, to assess for any power drifts during the evaluation. If the power drift deviates by more than 5%, the SAR test and drift measurements are repeated.

8.4 SAR Measurement Conditions for UMTS

8.4.1 Output Power Verification

Maximum output power is verified on the High, Middle and Low channels according to the general descriptions in section 5.2 of 3GPP TS 34.121, using the appropriate RMC with TPC (transmit power control) set to all “1s” or applying the required inner loop power control procedures to maintain maximum output power while HSUPA is active. Results for all applicable physical channel configurations (DPCCH, DPDCHn and spreading codes, HS-DPCCH etc) are tabulated in this test report. All configurations that are not supported by the DUT or cannot be measured due to technical or equipment limitations are identified.

FCC ID: A3LSMG890A	 PCTEST PROFESSIONAL ENGINEERING LABORATORY, INC.	SAR EVALUATION REPORT		Reviewed by: Quality Manager
Document S/N: 0Y1504030657.A3L	Test Dates: 04/06/15 - 05/04/15	DUT Type: Portable Handset		Page 19 of 94

8.4.2 Head SAR Measurements

SAR for next to the ear head exposure is measured using a 12.2 kbps RMC with TPC bits configured to all “1’s”. The 3G SAR test reduction procedure is applied to AMR configurations with 12.2 kbps RMC as the primary mode. Otherwise, SAR is measured for 12.2 kbps AMR in 3.4 kbps SRB (signaling radio bearer) using the highest reported SAR configuration in 12.2 kbps RMC for head exposure.

8.4.3 Body SAR Measurements

SAR for body exposure configurations is measured using the 12.2 kbps RMC with the TPC bits all “1s”. The 3G SAR test reduction procedure is applied to other spreading codes and multiple DPDCH_n configurations supported by the handset with 12.2 kbps RMC as the primary mode. Otherwise, SAR is measured using an applicable RMC configuration with the corresponding spreading code or DPDCH_n, for the highest reported SAR configuration in 12.2 kbps RMC.

8.4.4 SAR Measurements with Rel 5 HSDPA

The 3G SAR test reduction procedure is applied to HSDPA body configurations with 12.2 kbps RMC as the primary mode. Otherwise, Body SAR for HSDPA is measured using an FRC with H-Set 1 in Sub-test 1 and a 12.2 kbps RMC configured in Test Loop Mode 1, for the highest reported SAR configuration in 12.2 kbps RMC without HSDPA. Handsets with both HSDPA and HSUPA are tested according to Release 6 HSPA test procedures.

8.4.5 SAR Measurements with Rel 6 HSUPA

The 3G SAR test reduction procedure is applied to HSPA (HSUPA/HSDPA with RMC) body configurations with 12.2 kbps RMC as the primary mode. Otherwise, Body SAR for HSPA is measured with E-DCH Sub-test 5, using H-Set 1 and QPSK for FRC and a 12.2 kbps RMC configured in Test Loop Mode 1 and power control algorithm 2, according to the highest reported body SAR configuration in 12.2 kbps RMC without HSPA.

When VOIP applies to head exposure, the 3G SAR test reduction procedure is applied with 12.2 kbps RMC as the primary mode; otherwise, the same HSPA configuration used for body SAR measurements are applied to head exposure testing.

8.5 SAR Measurement Conditions for LTE



LTE modes are tested according to FCC KDB 941225 D05v02r03 publication. Establishing connections with base station simulators ensure a consistent means for testing SAR and are recommended for evaluating SAR [4]. The R&S CMW500 or Anritsu MT8820C simulators are used for LTE output power measurements and SAR testing. Closed loop power control was used so the UE transmits with maximum output power during SAR testing. SAR tests were performed with the same number of RB and RB offsets transmitting on all TTI frames (maximum TTI).

8.5.1 Spectrum Plots for RB Configurations

A properly configured base station simulator was used for SAR tests and power measurements. Therefore, spectrum plots for RB configurations were not required to be included in this report.

8.5.2 MPR

MPR is permanently implemented for this device by the manufacturer. The specific manufacturer target MPR is indicated alongside the SAR results. MPR is enabled for this device, according to 3GPP TS36.101 Section 6.2.3 – 6.2.5 under Table 6.2.3-1.

FCC ID: A3LSMG890A	 PCTEST PROFESSIONAL COMMUNICATIONS TESTING, INC.	SAR EVALUATION REPORT		Reviewed by: Quality Manager
Document S/N: OY1504030657.A3L	Test Dates: 04/06/15 - 05/04/15	DUT Type: Portable Handset		Page 20 of 94

8.5.3 A-MPR

A-MPR (Additional MPR) has been disabled for all SAR tests by setting NS=01 on the base station simulator.

8.5.4 Required RB Size and RB Offsets for SAR Testing

According to FCC KDB 941225 D05v02r03:

- a. Per Section 4.2.1, SAR is required for QPSK 1 RB Allocation for the largest bandwidth
 - i. The required channel and offset combination with the highest maximum output power is required for SAR.
 - ii. When the reported SAR is ≤ 0.8 W/kg, testing of the remaining RB offset configurations and required test channels is not required. Otherwise, SAR is required for the remaining required test channels using the RB offset configuration with highest output power for that channel.
 - iii. When the reported SAR for a required test channel is > 1.45 W/kg, SAR is required for all RB offset configurations for that channel.
- b. Per Section 4.2.2, SAR is required for 50% RB allocation using the largest bandwidth following the same procedures outlined in Section 4.2.1.
- c. Per Section 4.2.3, QPSK SAR is not required for the 100% allocation when the highest maximum output power for the 100% allocation is less than the highest maximum output power of the 1 RB and 50% RB allocations and the reported SAR for the 1 RB and 50% RB allocations is < 0.8 W/kg.
- d. Per Section 4.2.4 and 4.3, SAR tests for higher order modulations and lower bandwidths configurations are not required when the conducted power of the required test configurations determined by Sections 4.2.1 through 4.2.3 is less than or equal to $\frac{1}{2}$ dB higher than the equivalent configuration using QPSK modulation and when the QPSK SAR for those configurations is < 1.45 W/kg.

8.5.5 Downlink Carrier Aggregation



LTE Carrier Aggregation (CA) measurements are made in accordance to 3GPP TS 36.521-1 V10.4.0 (2012-12). The RRC connection is only handled by one cell, the Primary component carrier (PCC) for downlink and uplink communications. After making a data connection to the PCC, the UE device adds the Secondary component carrier (SCC) on the downlink only. All uplink communications and acknowledgements remain identical to release 8 specifications on the PCC. Additional output powers are measured using two carriers in the downlink for the release 8 configurations with the highest output power among all channels, RB configurations and bandwidths for each uplink band. Per FCC KDB Publication 941225 D05A v01r01, no SAR measurements are required when the average output power with downlink carrier aggregation active is not more than 0.25 dB higher than the average output power with downlink carrier aggregation not active.

8.6 SAR Testing with 802.11 Transmitters

The normal network operating configurations of 802.11 transmitters are not suitable for SAR measurements. Unpredictable fluctuations in network traffic and antenna diversity conditions can introduce undesirable variations in SAR results. The SAR for these devices should be measured using chipset based test mode software to ensure the results are consistent and reliable. See KDB Publication 248227 D01 Wi-Fi SAR v02 for more details.

8.6.1 General Device Setup

Chipset based test mode software is hardware dependent and generally varies among manufacturers. The device operating parameters established in test mode for SAR measurements

FCC ID: A3LSMG890A	 PCTEST PROFESSIONAL LABORATORY, INC.	SAR EVALUATION REPORT		Reviewed by: Quality Manager
Document S/N: OY1504030657.A3L	Test Dates: 04/06/15 - 05/04/15	DUT Type: Portable Handset	Page 21 of 94	

must be identical to those programmed in production units, including output power levels, amplifier gain settings and other RF performance tuning parameters.

A periodic duty factor is required for current generation SAR systems to measure SAR. When 802.11 frame gaps are accounted for in the transmission, a maximum transmission duty factor of 92 - 96% is typically achievable in most test mode configurations. A minimum transmission duty factor of 85% is required to avoid certain hardware and device implementation issues related to wide range SAR scaling. The reported SAR is scaled to 100% transmission duty factor to determine compliance at the maximum tune-up tolerance limit.

8.6.2 U-NII-1 and U-NII-2A

For devices that operate in both U-NII-1 and U-NII-2A bands, when the same maximum output power is specified for both bands, SAR measurement using OFDM SAR test procedures is not required for U-NII-1 unless the highest reported SAR for U-NII-2A is > 1.2 W/kg. When different maximum output powers are specified for the bands, SAR measurement for the U-NII band with the lower maximum output power is not required unless the highest reported SAR for the U-NII band with the higher maximum output power, adjusted by the ratio of lower to higher specified maximum output power for the two bands, is > 1.2 W/kg.

8.6.3 U-NII-2C and U-NII-3

The frequency range covered by U-NII-2C and U-NII-3 is 380 MHz (5.47 – 5.85 GHz), which requires a minimum of at least two SAR probe calibration frequency points to support SAR measurements. When Terminal Doppler Weather Radar (TDWR) restriction applies, the channels at 5.60 – 5.65 GHz in U-NII-2C band must be disabled with acceptable mechanisms and documented in the equipment certification.

Unless band gap channels are permanently disabled, SAR must be considered for these channels. When band gap channels are disabled, each band is tested independently according to the normally required OFDM SAR measurement and probe calibration frequency points requirements. Band gap channels are supported for this model.



8.6.4 Initial Test Position Procedure

For exposure conditions with multiple test positions, such as handset operating next to the ear, devices with hotspot mode or UMPC mini-tablet, procedures for initial test position can be applied. Using the transmission mode determined by the DSSS procedure or initial test configuration, area scans are measured for all positions in an exposure condition. The test position with the highest extrapolated (peak) SAR is used as the initial test position. When reported SAR for the initial test position is ≤ 0.4 W/kg, no additional testing for the remaining test positions is required. Otherwise, SAR is evaluated at the subsequent highest peak SAR positions until the reported SAR result is ≤ 0.8 W/kg or all test positions are measured.

8.6.5 2.4 GHz SAR Test Requirements

SAR is measured for 2.4 GHz 802.11b DSSS using either the fixed test position or, when applicable, the initial test position procedure. SAR test reduction is determined according to the following:

- 1) When the reported SAR of the highest measured maximum output power channel for the exposure configuration is ≤ 0.8 W/kg, no further SAR testing is required for 802.11b DSSS in that exposure configuration.

FCC ID: A3LSMG890A	 PCTEST PROFESSIONAL CORPORATION, INC.	SAR EVALUATION REPORT		Reviewed by: Quality Manager
Document S/N: OY1504030657.A3L	Test Dates: 04/06/15 - 05/04/15	DUT Type: Portable Handset	Page 22 of 94	

- 2) When the reported SAR is > 0.8 W/kg, SAR is required for that position using the next highest measured output power channel. When any reported SAR is > 1.2 W/kg, SAR is required for the third channel; i.e., all channels require testing.

2.4 GHz 802.11 g/n OFDM are additionally evaluated for SAR if the highest reported SAR for 802.11b, adjusted by the ratio of the OFDM to DSSS specified maximum output power, is > 1.2 W/kg. When SAR is required for OFDM modes in 2.4 GHz band, the Initial Test Configuration Procedures should be followed.

8.6.6 OFDM Transmission Mode and SAR Test Channel Selection

For the 2.4 GHz and 5 GHz bands, when the maximum output power target is the same for multiple OFDM transmission mode configurations in a frequency band, SAR is measured using the configuration with the largest channel bandwidth, lowest order modulation and lowest data rate. When the maximum output power of a channel is the same for equivalent OFDM configurations; for example, 802.11a, 802.11n and 802.11ac or 802.11g and 802.11n with the same channel bandwidth, modulation and data rate etc., the lower order 802.11 mode i.e., 802.11a, then 802.11n and 802.11ac or 802.11g then 802.11n, is used for SAR measurement. SAR is measured using the maximum output power channel per KDB 248227 D01 Wi-Fi SAR v02.

8.6.7 Initial Test Configuration Procedure

For OFDM, in both 2.4 and 5 GHz bands, an initial test configuration is determined for each frequency band and aggregated band, according to the transmission mode with the highest maximum output power specified for SAR measurements. When the same maximum output power is specified for multiple OFDM transmission mode configurations in a frequency band or aggregated band, SAR is measured using the configuration(s) with the largest channel bandwidth, lowest order modulation, and lowest data rate. The channel of the transmission mode with the highest average RF output conducted power will be the initial test configuration.



When the reported SAR is ≤ 0.8 W/kg, no additional measurements on other test channels are required. Otherwise, SAR is evaluated using the subsequent highest average RF output channel until the reported SAR result is ≤ 1.2 W/kg or all channels are measured. When there are multiple untested channels having the same subsequent highest average RF output power, the channel with higher frequency from the lowest 802.11 mode is considered for SAR measurements (See Section 8.6.6).

8.6.8 Subsequent Test Configuration Procedures

For OFDM configurations in each frequency band and aggregated band, SAR is evaluated for initial test configuration using the fixed test position or the initial test position procedure. When the highest reported SAR (for the initial test configuration), adjusted by the ratio of the specified maximum output power of the subsequent test configuration to initial test configuration, is ≤ 1.2 W/kg, no additional SAR tests for the subsequent test configurations are required.

8.6.9 MIMO SAR considerations

Per KDB 248227 D01 Wi-Fi SAR v02, the simultaneous SAR provisions in KDB Publication 447498 should be applied to determine simultaneous transmission SAR test exclusion for WIFI MIMO. If the sum of 1g single transmission chain SAR measurements is < 1.6 W/kg, no additional SAR measurements for MIMO are required. Alternatively, SAR for MIMO can be measured with all antennas transmitting simultaneously at the specified maximum output power of MIMO operation.



FCC ID: A3LSMG890A	 PCTEST PROFESSIONAL CORPORATION, INC.	SAR EVALUATION REPORT	 SAMSUNG	Reviewed by: Quality Manager
Document S/N: OY1504030657.A3L	Test Dates: 04/06/15 - 05/04/15	DUT Type: Portable Handset	Page 23 of 94	

9 RF CONDUCTED POWERS

9.1 GSM Conducted Powers

9.1.1 Maximum Conducted Powers

		Maximum Burst-Averaged Output Power				
		Voice	GPRS/EDGE Data (GMSK)		EDGE Data (8-PSK)	
Band	Channel	GSM [dBm] CS (1 Slot)	GPRS [dBm] 1 Tx Slot	GPRS [dBm] 2 Tx Slot	EDGE [dBm] 1 Tx Slot	EDGE [dBm] 2 Tx Slot
GSM 850	128	32.14	32.13	31.23	27.05	25.79
	190	32.16	32.16	31.17	27.07	25.83
	251	32.09	32.10	31.27	27.31	26.00
GSM 1900	512	30.33	30.45	29.50	26.05	24.80
	661	30.11	30.21	29.47	25.76	24.56
	810	30.08	30.08	29.30	25.52	24.30
GSM 850	Targets:	32.7	32.7	31.7	27.0	25.5
GSM 1900		30.0	30.0	29.0	26.0	24.5
		Calculated Maximum Frame-Averaged Output Power				
		Voice	GPRS/EDGE Data (GMSK)		EDGE Data (8-PSK)	
Band	Channel	GSM [dBm] CS (1 Slot)	GPRS [dBm] 1 Tx Slot	GPRS [dBm] 2 Tx Slot	EDGE [dBm] 1 Tx Slot	EDGE [dBm] 2 Tx Slot
GSM 850	128	23.11	23.10	25.21	18.02	19.77
	190	23.13	23.13	25.15	18.04	19.81
	251	23.06	23.07	25.25	18.28	19.98
GSM 1900	512	21.30	21.42	23.48	17.02	18.78
	661	21.08	21.18	23.45	16.73	18.54
	810	21.05	21.05	23.28	16.49	18.28
GSM 850	Frame Avg. Targets:	23.67	23.67	25.68	17.97	19.48
GSM 1900		20.97	20.97	22.98	16.97	18.48

FCC ID: A3LSMG890A	 PCTEST PROFESSIONAL TESTING LABORATORY, INC.	SAR EVALUATION REPORT		Reviewed by: Quality Manager
Document S/N: OY1504030657.A3L	Test Dates: 04/06/15 - 05/04/15	DUT Type: Portable Handset		Page 24 of 94

9.1.2 Reduced Conducted Powers- Representing Hotspot Mode Active

		Maximum Burst-Averaged Output Power	
		GPRS Data (GMSK)	
Band	Channel	GPRS [dBm] 1 Tx Slot	GPRS [dBm] 2 Tx Slot
GSM 1900	512	27.79	26.91
	661	27.85	26.67
	810	27.70	26.74
GSM 1900	Targets:	27.7	26.7
		Calculated Maximum Frame-Averaged Output Power	
		GPRS Data (GMSK)	
Band	Channel	GPRS [dBm] 1 Tx Slot	GPRS [dBm] 2 Tx Slot
GSM 1900	512	18.76	20.89
	661	18.82	20.65
	810	18.67	20.72
GSM 1900	Frame Avg. Targets:	18.67	20.68

When hotspot is active, this device reduces the output power for GPRS/EDGE GMSK 1900 operations. The maximum output power for EDGE 8PSK is not reduced. Since the frame averaged output power of EDGE 8PSK is less than the maximum GSMK frame averaged power, no additional analysis was needed for EDGE operations.

Note:

- Both burst-averaged and calculated frame-averaged powers are included. Frame-averaged power was calculated from the measured burst-averaged power by converting the slot powers into linear units and calculating the energy over 8 timeslots.
- Per October 2013 TCB Workshop: The source-based frame-averaged output power was evaluated for all GPRS/EDGE slot configurations. The configuration with the highest target frame averaged output power was evaluated for hotspot SAR. When the maximum frame-averaged powers are equivalent across two or more slots (within 0.25 dB), the configuration with the most number of time slots was tested.
- GPRS/EDGE (GMSK) output powers were measured with coding scheme setting of 1 (CS1) on the base station simulator. CS1 was configured to measure GPRS output power measurements and SAR to ensure GMSK modulation in the signal. Our Investigation has shown that CS1 - CS4 settings do not have any impact on the output levels or modulation in the GPRS modes.
- EDGE (8-PSK) output powers were measured with MCS7 on the base station simulator. MCS7 coding scheme was used to measure the output powers for EDGE since investigation has shown that choosing MCS7 coding scheme will ensure 8-PSK modulation. It has been shown that MCS levels that produce 8PSK modulation do not have an impact on output power.

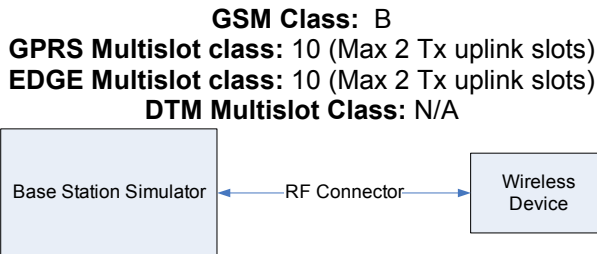



Figure 9-1
Power Measurement Setup

FCC ID: A3LSMG890A	 SAR EVALUATION REPORT 		Reviewed by: Quality Manager
Document S/N: OY1504030657.A3L	Test Dates: 04/06/15 - 05/04/15	DUT Type: Portable Handset	Page 25 of 94

9.2 UMTS Conducted Powers

9.2.1 Maximum Conducted Powers

3GPP Release Version	Mode	3GPP 34.121 Subtest	Cellular Band [dBm]			PCS Band [dBm]			3GPP MPR [dB]
			4132	4183	4233	9262	9400	9538	
99	WCDMA	12.2 kbps RMC	23.18	23.22	23.16	23.03	22.92	22.79	-
99		12.2 kbps AMR	23.20	23.16	23.02	22.95	22.83	22.77	-
6	HSDPA	Subtest 1	23.26	23.18	23.13	23.16	23.08	22.91	0
6		Subtest 2	23.25	23.20	23.16	23.13	23.06	22.99	0
6		Subtest 3	23.27	23.11	23.15	23.12	23.05	22.97	0.5
6		Subtest 4	23.29	23.23	23.17	23.07	22.98	22.93	0.5
6	HSUPA	Subtest 1	22.41	22.50	22.42	22.07	21.76	22.05	0
6		Subtest 2	22.45	22.48	22.48	22.04	21.66	21.94	2
6		Subtest 3	22.47	22.50	22.45	22.08	21.69	22.05	1
6		Subtest 4	21.87	22.06	21.97	21.07	20.71	20.89	2
6		Subtest 5	21.86	22.08	21.96	21.05	20.70	20.91	0

9.2.2 Reduced Conducted Powers- Representing Hotspot Mode Active

3GPP Release Version	Mode	3GPP 34.121 Subtest	PCS Band [dBm]			3GPP MPR [dB]
			9262	9400	9538	
99	WCDMA	12.2 kbps RMC	21.14	21.05	21.03	-
99		12.2 kbps AMR	21.07	21.10	21.02	-
6	HSDPA	Subtest 1	21.16	21.06	20.98	0
6		Subtest 2	21.18	21.07	21.04	0
6		Subtest 3	21.15	21.11	21.02	0.5
6		Subtest 4	21.14	21.04	20.97	0.5
6	HSUPA	Subtest 1	21.08	20.73	20.92	0
6		Subtest 2	20.99	20.80	20.84	2
6		Subtest 3	21.03	20.67	20.90	1
6		Subtest 4	20.00	19.65	19.76	2
6		Subtest 5	19.96	19.62	19.74	0

This device does not support DC-HSDPA

It is expected by the manufacturer that MPR for some HSPA subtests may be up to 2 dB more than specified by 3GPP, but also as low as 0 dB according to the chipset implementation in this model.

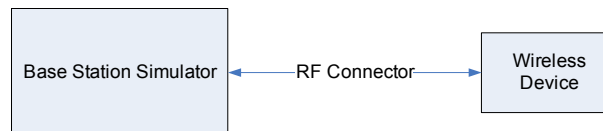



Figure 9-2
Power Measurement Setup

FCC ID: A3LSMG890A	 PCTEST PROFESSIONAL CORPORATION, INC.	SAR EVALUATION REPORT		Reviewed by: Quality Manager
Document S/N: OY1504030657.A3L	Test Dates: 04/06/15 - 05/04/15	DUT Type: Portable Handset	Page 26 of 94	

9.3 LTE Conducted Powers

9.3.1 LTE Band 12

Table 9-1
LTE Band 12 Maximum Conducted Powers - 10 MHz Bandwidth

	Frequency [MHz]	Channel	Bandwidth [MHz]	Modulation	RB Size	RB Offset	Conducted Power [dBm]	MPR Allowed per 3GPP [dB]	MPR [dB]
Mid	707.5	23095	10	QPSK	1	0	23.26	0	0
	707.5	23095	10	QPSK	1	25	23.49	0	0
	707.5	23095	10	QPSK	1	49	23.36	0	0
	707.5	23095	10	QPSK	25	0	22.38	0-1	1
	707.5	23095	10	QPSK	25	12	22.35	0-1	1
	707.5	23095	10	QPSK	25	25	22.37	0-1	1
	707.5	23095	10	QPSK	50	0	22.36	0-1	1
	707.5	23095	10	16QAM	1	0	22.14	0-1	1
	707.5	23095	10	16QAM	1	25	22.30	0-1	1
	707.5	23095	10	16QAM	1	49	22.10	0-1	1
	707.5	23095	10	16QAM	25	0	21.39	0-2	2
	707.5	23095	10	16QAM	25	12	21.36	0-2	2
	707.5	23095	10	16QAM	25	25	21.29	0-2	2
707.5	23095	10	16QAM	50	0	21.32	0-2	2	

Note: LTE Band 12 at 10 MHz bandwidth does not support three non-overlapping channels. Per KDB Publication 941225 D05v02, when a device supports overlapping channel assignment in a channel bandwidth configuration, the middle channel of the group of overlapping channels should be selected for testing.



FCC ID: A3LSMG890A	 PCTEST PROFESSIONAL ENGINEERING LABORATORY, INC.	SAR EVALUATION REPORT		Reviewed by: Quality Manager
Document S/N: OY1504030657.A3L	Test Dates: 04/06/15 - 05/04/15	DUT Type: Portable Handset		Page 27 of 94

Table 9-2
LTE Band 12 Maximum Conducted Powers - 5 MHz Bandwidth

	Frequency [MHz]	Channel	Bandwidth [MHz]	Modulation	RB Size	RB Offset	Conducted Power [dBm]	MPR Allowed per 3GPP [dB]	MPR [dB]
Low	701.5	23035	5	QPSK	1	0	23.45	0	0
	701.5	23035	5	QPSK	1	12	23.47	0	0
	701.5	23035	5	QPSK	1	24	23.48	0	0
	701.5	23035	5	QPSK	12	0	22.43	0-1	1
	701.5	23035	5	QPSK	12	6	22.44	0-1	1
	701.5	23035	5	QPSK	12	13	22.43	0-1	1
	701.5	23035	5	QPSK	25	0	22.50	0-1	1
	701.5	23035	5	16-QAM	1	0	22.45	0-1	1
	701.5	23035	5	16-QAM	1	12	22.48	0-1	1
	701.5	23035	5	16-QAM	1	24	22.50	0-1	1
	701.5	23035	5	16-QAM	12	0	21.49	0-2	2
	701.5	23035	5	16-QAM	12	6	21.43	0-2	2
701.5	23035	5	16-QAM	12	13	21.48	0-2	2	
701.5	23035	5	16-QAM	25	0	21.45	0-2	2	
Mid	707.5	23095	5	QPSK	1	0	23.48	0	0
	707.5	23095	5	QPSK	1	12	23.47	0	0
	707.5	23095	5	QPSK	1	24	23.46	0	0
	707.5	23095	5	QPSK	12	0	22.37	0-1	1
	707.5	23095	5	QPSK	12	6	22.48	0-1	1
	707.5	23095	5	QPSK	12	13	22.48	0-1	1
	707.5	23095	5	QPSK	25	0	22.40	0-1	1
	707.5	23095	5	16-QAM	1	0	22.46	0-1	1
	707.5	23095	5	16-QAM	1	12	22.44	0-1	1
	707.5	23095	5	16-QAM	1	24	22.45	0-1	1
	707.5	23095	5	16-QAM	12	0	21.40	0-2	2
	707.5	23095	5	16-QAM	12	6	21.48	0-2	2
707.5	23095	5	16-QAM	12	13	21.48	0-2	2	
707.5	23095	5	16-QAM	25	0	21.39	0-2	2	
High	713.5	23155	5	QPSK	1	0	23.46	0	0
	713.5	23155	5	QPSK	1	12	23.46	0	0
	713.5	23155	5	QPSK	1	24	23.48	0	0
	713.5	23155	5	QPSK	12	0	22.42	0-1	1
	713.5	23155	5	QPSK	12	6	22.43	0-1	1
	713.5	23155	5	QPSK	12	13	22.44	0-1	1
	713.5	23155	5	QPSK	25	0	22.50	0-1	1
	713.5	23155	5	16-QAM	1	0	22.48	0-1	1
	713.5	23155	5	16-QAM	1	12	22.46	0-1	1
	713.5	23155	5	16-QAM	1	24	22.41	0-1	1
	713.5	23155	5	16-QAM	12	0	21.50	0-2	2
	713.5	23155	5	16-QAM	12	6	21.43	0-2	2
713.5	23155	5	16-QAM	12	13	21.37	0-2	2	
713.5	23155	5	16-QAM	25	0	21.38	0-2	2	



FCC ID: A3LSMG890A	 SAR EVALUATION REPORT 	Reviewed by: Quality Manager
Document S/N: OY1504030657.A3L	Test Dates: 04/06/15 - 05/04/15	DUT Type: Portable Handset
		Page 28 of 94

Table 9-3
LTE Band 12 Maximum Conducted Powers - 3 MHz Bandwidth

	Frequency [MHz]	Channel	Bandwidth [MHz]	Modulation	RB Size	RB Offset	Conducted Power [dBm]	MPR Allowed per 3GPP [dB]	MPR [dB]
Low	700.5	23025	3	QPSK	1	0	23.48	0	0
	700.5	23025	3	QPSK	1	7	23.47	0	0
	700.5	23025	3	QPSK	1	14	23.45	0	0
	700.5	23025	3	QPSK	8	0	22.47	0-1	1
	700.5	23025	3	QPSK	8	4	22.49	0-1	1
	700.5	23025	3	QPSK	8	7	22.37	0-1	1
	700.5	23025	3	QPSK	15	0	22.49	0-1	1
	700.5	23025	3	16-QAM	1	0	22.50	0-1	1
	700.5	23025	3	16-QAM	1	7	22.47	0-1	1
	700.5	23025	3	16-QAM	1	14	22.50	0-1	1
	700.5	23025	3	16-QAM	8	0	21.50	0-2	2
	700.5	23025	3	16-QAM	8	4	21.40	0-2	2
700.5	23025	3	16-QAM	8	7	21.48	0-2	2	
700.5	23025	3	16-QAM	15	0	21.45	0-2	2	
Mid	707.5	23095	3	QPSK	1	0	23.48	0	0
	707.5	23095	3	QPSK	1	7	23.47	0	0
	707.5	23095	3	QPSK	1	14	23.45	0	0
	707.5	23095	3	QPSK	8	0	22.50	0-1	1
	707.5	23095	3	QPSK	8	4	22.45	0-1	1
	707.5	23095	3	QPSK	8	7	22.50	0-1	1
	707.5	23095	3	QPSK	15	0	22.46	0-1	1
	707.5	23095	3	16-QAM	1	0	22.47	0-1	1
	707.5	23095	3	16-QAM	1	7	22.40	0-1	1
	707.5	23095	3	16-QAM	1	14	22.48	0-1	1
	707.5	23095	3	16-QAM	8	0	21.32	0-2	2
	707.5	23095	3	16-QAM	8	4	21.40	0-2	2
707.5	23095	3	16-QAM	8	7	21.50	0-2	2	
707.5	23095	3	16-QAM	15	0	21.50	0-2	2	
High	714.5	23165	3	QPSK	1	0	23.45	0	0
	714.5	23165	3	QPSK	1	7	23.48	0	0
	714.5	23165	3	QPSK	1	14	23.46	0	0
	714.5	23165	3	QPSK	8	0	22.46	0-1	1
	714.5	23165	3	QPSK	8	4	22.41	0-1	1
	714.5	23165	3	QPSK	8	7	22.39	0-1	1
	714.5	23165	3	QPSK	15	0	22.37	0-1	1
	714.5	23165	3	16-QAM	1	0	22.47	0-1	1
	714.5	23165	3	16-QAM	1	7	22.48	0-1	1
	714.5	23165	3	16-QAM	1	14	22.46	0-1	1
	714.5	23165	3	16-QAM	8	0	21.33	0-2	2
	714.5	23165	3	16-QAM	8	4	21.39	0-2	2
714.5	23165	3	16-QAM	8	7	21.46	0-2	2	
714.5	23165	3	16-QAM	15	0	21.40	0-2	2	





FCC ID: A3LSMG890A	 PCTEST <small>PROFESSIONAL CORPORATION, INC.</small>	SAR EVALUATION REPORT		Reviewed by: Quality Manager
Document S/N: OY1504030657.A3L	Test Dates: 04/06/15 - 05/04/15	DUT Type: Portable Handset		Page 29 of 94

Table 9-4
LTE Band 12 Maximum Conducted Powers -1.4 MHz Bandwidth

	Frequency [MHz]	Channel	Bandwidth [MHz]	Modulation	RB Size	RB Offset	Conducted Power [dBm]	MPR Allowed per 3GPP [dB]	MPR [dB]
Low	699.7	23017	1.4	QPSK	1	0	23.48	0	0
	699.7	23017	1.4	QPSK	1	2	23.46	0	0
	699.7	23017	1.4	QPSK	1	5	23.46	0	0
	699.7	23017	1.4	QPSK	3	0	23.48	0	0
	699.7	23017	1.4	QPSK	3	2	23.46	0	0
	699.7	23017	1.4	QPSK	3	3	23.48	0	0
	699.7	23017	1.4	QPSK	6	0	22.38	0-1	1
	699.7	23017	1.4	16-QAM	1	0	22.50	0-1	1
	699.7	23017	1.4	16-QAM	1	2	22.45	0-1	1
	699.7	23017	1.4	16-QAM	1	5	22.50	0-1	1
	699.7	23017	1.4	16-QAM	3	0	22.48	0-1	1
	699.7	23017	1.4	16-QAM	3	2	22.35	0-1	1
699.7	23017	1.4	16-QAM	3	3	22.50	0-1	1	
699.7	23017	1.4	16-QAM	6	0	21.40	0-2	2	
Mid	707.5	23095	1.4	QPSK	1	0	23.48	0	0
	707.5	23095	1.4	QPSK	1	2	23.48	0	0
	707.5	23095	1.4	QPSK	1	5	23.45	0	0
	707.5	23095	1.4	QPSK	3	0	23.47	0	0
	707.5	23095	1.4	QPSK	3	2	23.46	0	0
	707.5	23095	1.4	QPSK	3	3	23.46	0	0
	707.5	23095	1.4	QPSK	6	0	22.45	0-1	1
	707.5	23095	1.4	16-QAM	1	0	22.47	0-1	1
	707.5	23095	1.4	16-QAM	1	2	22.48	0-1	1
	707.5	23095	1.4	16-QAM	1	5	22.50	0-1	1
	707.5	23095	1.4	16-QAM	3	0	22.30	0-1	1
	707.5	23095	1.4	16-QAM	3	2	22.37	0-1	1
707.5	23095	1.4	16-QAM	3	3	22.33	0-1	1	
707.5	23095	1.4	16-QAM	6	0	21.37	0-2	2	
High	715.3	23173	1.4	QPSK	1	0	23.47	0	0
	715.3	23173	1.4	QPSK	1	2	23.48	0	0
	715.3	23173	1.4	QPSK	1	5	23.46	0	0
	715.3	23173	1.4	QPSK	3	0	23.46	0	0
	715.3	23173	1.4	QPSK	3	2	23.48	0	0
	715.3	23173	1.4	QPSK	3	3	23.45	0	0
	715.3	23173	1.4	QPSK	6	0	22.47	0-1	1
	715.3	23173	1.4	16-QAM	1	0	22.50	0-1	1
	715.3	23173	1.4	16-QAM	1	2	22.49	0-1	1
	715.3	23173	1.4	16-QAM	1	5	22.45	0-1	1
	715.3	23173	1.4	16-QAM	3	0	22.32	0-1	1
	715.3	23173	1.4	16-QAM	3	2	22.27	0-1	1
715.3	23173	1.4	16-QAM	3	3	22.33	0-1	1	
715.3	23173	1.4	16-QAM	6	0	21.43	0-2	2	

FCC ID: A3LSMG890A	 SAR EVALUATION REPORT 	Reviewed by: Quality Manager
Document S/N: OY1504030657.A3L	Test Dates: 04/06/15 - 05/04/15	DUT Type: Portable Handset
		Page 30 of 94

9.3.2

LTE Band 5 (Cell)

Table 9-5
LTE Band 5 (Cell) Maximum Conducted Powers - 10 MHz Bandwidth

	Frequency [MHz]	Channel	Bandwidth [MHz]	Modulation	RB Size	RB Offset	Conducted Power [dBm]	MPR Allowed per 3GPP [dB]	MPR [dB]
Mid	836.5	20525	10	QPSK	1	0	23.49	0	0
	836.5	20525	10	QPSK	1	25	23.60	0	0
	836.5	20525	10	QPSK	1	49	23.34	0	0
	836.5	20525	10	QPSK	25	0	22.08	0-1	1
	836.5	20525	10	QPSK	25	12	22.02	0-1	1
	836.5	20525	10	QPSK	25	25	22.01	0-1	1
	836.5	20525	10	QPSK	50	0	22.07	0-1	1
	836.5	20525	10	16QAM	1	0	22.05	0-1	1
	836.5	20525	10	16QAM	1	25	22.46	0-1	1
	836.5	20525	10	16QAM	1	49	22.20	0-1	1
	836.5	20525	10	16QAM	25	0	21.00	0-2	2
	836.5	20525	10	16QAM	25	12	21.04	0-2	2
	836.5	20525	10	16QAM	25	25	21.00	0-2	2
836.5	20525	10	16QAM	50	0	21.02	0-2	2	

Note: LTE Band 5 (Cell) at 10 MHz bandwidth does not support three non-overlapping channels. Per KDB Publication 941225 D05v02, when a device supports overlapping channel assignment in a channel bandwidth configuration, the middle channel of the group of overlapping channels should be selected for testing.



FCC ID: A3LSMG890A	 PCTEST PROFESSIONAL LABORATORY, INC.	SAR EVALUATION REPORT		Reviewed by: Quality Manager
Document S/N: OY1504030657.A3L	Test Dates: 04/06/15 - 05/04/15	DUT Type: Portable Handset	Page 31 of 94	

Table 9-6
LTE Band 5 (Cell) Maximum Conducted Powers - 5 MHz Bandwidth

	Frequency [MHz]	Channel	Bandwidth [MHz]	Modulation	RB Size	RB Offset	Conducted Power [dBm]	MPR Allowed per 3GPP [dB]	MPR [dB]
Low	826.5	20425	5	QPSK	1	0	23.60	0	0
	826.5	20425	5	QPSK	1	12	23.57	0	0
	826.5	20425	5	QPSK	1	24	23.65	0	0
	826.5	20425	5	QPSK	12	0	22.42	0-1	1
	826.5	20425	5	QPSK	12	6	22.42	0-1	1
	826.5	20425	5	QPSK	12	13	22.40	0-1	1
	826.5	20425	5	QPSK	25	0	22.37	0-1	1
	826.5	20425	5	16-QAM	1	0	22.63	0-1	1
	826.5	20425	5	16-QAM	1	12	22.53	0-1	1
	826.5	20425	5	16-QAM	1	24	22.65	0-1	1
	826.5	20425	5	16-QAM	12	0	21.39	0-2	2
	826.5	20425	5	16-QAM	12	6	21.35	0-2	2
826.5	20425	5	16-QAM	12	13	21.32	0-2	2	
826.5	20425	5	16-QAM	25	0	21.21	0-2	2	
Mid	836.5	20525	5	QPSK	1	0	23.75	0	0
	836.5	20525	5	QPSK	1	12	23.69	0	0
	836.5	20525	5	QPSK	1	24	23.66	0	0
	836.5	20525	5	QPSK	12	0	22.41	0-1	1
	836.5	20525	5	QPSK	12	6	22.26	0-1	1
	836.5	20525	5	QPSK	12	13	22.22	0-1	1
	836.5	20525	5	QPSK	25	0	22.25	0-1	1
	836.5	20525	5	16-QAM	1	0	22.48	0-1	1
	836.5	20525	5	16-QAM	1	12	22.40	0-1	1
	836.5	20525	5	16-QAM	1	24	22.42	0-1	1
	836.5	20525	5	16-QAM	12	0	21.34	0-2	2
	836.5	20525	5	16-QAM	12	6	21.24	0-2	2
836.5	20525	5	16-QAM	12	13	21.27	0-2	2	
836.5	20525	5	16-QAM	25	0	21.28	0-2	2	
High	846.5	20625	5	QPSK	1	0	23.63	0	0
	846.5	20625	5	QPSK	1	12	23.59	0	0
	846.5	20625	5	QPSK	1	24	23.45	0	0
	846.5	20625	5	QPSK	12	0	22.43	0-1	1
	846.5	20625	5	QPSK	12	6	22.24	0-1	1
	846.5	20625	5	QPSK	12	13	22.16	0-1	1
	846.5	20625	5	QPSK	25	0	22.22	0-1	1
	846.5	20625	5	16-QAM	1	0	22.38	0-1	1
	846.5	20625	5	16-QAM	1	12	22.33	0-1	1
	846.5	20625	5	16-QAM	1	24	22.27	0-1	1
	846.5	20625	5	16-QAM	12	0	21.21	0-2	2
	846.5	20625	5	16-QAM	12	6	21.15	0-2	2
846.5	20625	5	16-QAM	12	13	21.07	0-2	2	
846.5	20625	5	16-QAM	25	0	21.09	0-2	2	



FCC ID: A3LSMG890A	 SAR EVALUATION REPORT 	Reviewed by: Quality Manager
Document S/N: OY1504030657.A3L	Test Dates: 04/06/15 - 05/04/15	DUT Type: Portable Handset
		Page 32 of 94

Table 9-7
LTE Band 5 (Cell) Maximum Conducted Powers - 3 MHz Bandwidth

	Frequency [MHz]	Channel	Bandwidth [MHz]	Modulation	RB Size	RB Offset	Conducted Power [dBm]	MPR Allowed per 3GPP [dB]	MPR [dB]
Low	825.5	20415	3	QPSK	1	0	23.92	0	0
	825.5	20415	3	QPSK	1	7	23.91	0	0
	825.5	20415	3	QPSK	1	14	23.91	0	0
	825.5	20415	3	QPSK	8	0	22.28	0-1	1
	825.5	20415	3	QPSK	8	4	22.33	0-1	1
	825.5	20415	3	QPSK	8	7	22.36	0-1	1
	825.5	20415	3	QPSK	15	0	22.33	0-1	1
	825.5	20415	3	16-QAM	1	0	22.71	0-1	1
	825.5	20415	3	16-QAM	1	7	22.62	0-1	1
	825.5	20415	3	16-QAM	1	14	22.68	0-1	1
	825.5	20415	3	16-QAM	8	0	21.18	0-2	2
	825.5	20415	3	16-QAM	8	4	21.16	0-2	2
825.5	20415	3	16-QAM	8	7	21.23	0-2	2	
825.5	20415	3	16-QAM	15	0	21.27	0-2	2	
Mid	836.5	20525	3	QPSK	1	0	23.75	0	0
	836.5	20525	3	QPSK	1	7	23.73	0	0
	836.5	20525	3	QPSK	1	14	23.71	0	0
	836.5	20525	3	QPSK	8	0	22.40	0-1	1
	836.5	20525	3	QPSK	8	4	22.31	0-1	1
	836.5	20525	3	QPSK	8	7	22.29	0-1	1
	836.5	20525	3	QPSK	15	0	22.33	0-1	1
	836.5	20525	3	16-QAM	1	0	22.78	0-1	1
	836.5	20525	3	16-QAM	1	7	22.74	0-1	1
	836.5	20525	3	16-QAM	1	14	22.71	0-1	1
	836.5	20525	3	16-QAM	8	0	21.30	0-2	2
	836.5	20525	3	16-QAM	8	4	21.19	0-2	2
836.5	20525	3	16-QAM	8	7	21.17	0-2	2	
836.5	20525	3	16-QAM	15	0	21.17	0-2	2	
High	847.5	20635	3	QPSK	1	0	23.76	0	0
	847.5	20635	3	QPSK	1	7	23.61	0	0
	847.5	20635	3	QPSK	1	14	23.57	0	0
	847.5	20635	3	QPSK	8	0	22.18	0-1	1
	847.5	20635	3	QPSK	8	4	22.14	0-1	1
	847.5	20635	3	QPSK	8	7	22.11	0-1	1
	847.5	20635	3	QPSK	15	0	22.21	0-1	1
	847.5	20635	3	16-QAM	1	0	22.78	0-1	1
	847.5	20635	3	16-QAM	1	7	22.61	0-1	1
	847.5	20635	3	16-QAM	1	14	22.52	0-1	1
	847.5	20635	3	16-QAM	8	0	21.12	0-2	2
	847.5	20635	3	16-QAM	8	4	21.10	0-2	2
847.5	20635	3	16-QAM	8	7	21.07	0-2	2	
847.5	20635	3	16-QAM	15	0	21.13	0-2	2	





FCC ID: A3LSMG890A	 SAR EVALUATION REPORT 	Reviewed by: Quality Manager
Document S/N: OY1504030657.A3L	Test Dates: 04/06/15 - 05/04/15	DUT Type: Portable Handset
		Page 33 of 94

Table 9-8
LTE Band 5 (Cell) Maximum Conducted Powers -1.4 MHz Bandwidth

	Frequency [MHz]	Channel	Bandwidth [MHz]	Modulation	RB Size	RB Offset	Conducted Power [dBm]	MPR Allowed per 3GPP [dB]	MPR [dB]
Low	824.7	20407	1.4	QPSK	1	0	23.84	0	0
	824.7	20407	1.4	QPSK	1	2	23.87	0	0
	824.7	20407	1.4	QPSK	1	5	23.86	0	0
	824.7	20407	1.4	QPSK	3	0	23.60	0	0
	824.7	20407	1.4	QPSK	3	2	23.51	0	0
	824.7	20407	1.4	QPSK	3	3	23.44	0	0
	824.7	20407	1.4	QPSK	6	0	22.42	0-1	1
	824.7	20407	1.4	16-QAM	1	0	22.91	0-1	1
	824.7	20407	1.4	16-QAM	1	2	22.72	0-1	1
	824.7	20407	1.4	16-QAM	1	5	22.75	0-1	1
	824.7	20407	1.4	16-QAM	3	0	22.23	0-1	1
	824.7	20407	1.4	16-QAM	3	2	22.12	0-1	1
824.7	20407	1.4	16-QAM	3	3	22.22	0-1	1	
824.7	20407	1.4	16-QAM	6	0	21.41	0-2	2	
Mid	836.5	20525	1.4	QPSK	1	0	23.86	0	0
	836.5	20525	1.4	QPSK	1	2	23.88	0	0
	836.5	20525	1.4	QPSK	1	5	23.86	0	0
	836.5	20525	1.4	QPSK	3	0	23.59	0	0
	836.5	20525	1.4	QPSK	3	2	23.54	0	0
	836.5	20525	1.4	QPSK	3	3	23.50	0	0
	836.5	20525	1.4	QPSK	6	0	22.53	0-1	1
	836.5	20525	1.4	16-QAM	1	0	22.85	0-1	1
	836.5	20525	1.4	16-QAM	1	2	22.75	0-1	1
	836.5	20525	1.4	16-QAM	1	5	22.90	0-1	1
	836.5	20525	1.4	16-QAM	3	0	22.38	0-1	1
	836.5	20525	1.4	16-QAM	3	2	22.33	0-1	1
836.5	20525	1.4	16-QAM	3	3	22.21	0-1	1	
836.5	20525	1.4	16-QAM	6	0	21.42	0-2	2	
High	848.3	20643	1.4	QPSK	1	0	23.50	0	0
	848.3	20643	1.4	QPSK	1	2	23.42	0	0
	848.3	20643	1.4	QPSK	1	5	23.50	0	0
	848.3	20643	1.4	QPSK	3	0	23.34	0	0
	848.3	20643	1.4	QPSK	3	2	23.25	0	0
	848.3	20643	1.4	QPSK	3	3	23.33	0	0
	848.3	20643	1.4	QPSK	6	0	22.23	0-1	1
	848.3	20643	1.4	16-QAM	1	0	22.44	0-1	1
	848.3	20643	1.4	16-QAM	1	2	22.23	0-1	1
	848.3	20643	1.4	16-QAM	1	5	22.26	0-1	1
	848.3	20643	1.4	16-QAM	3	0	22.14	0-1	1
	848.3	20643	1.4	16-QAM	3	2	22.00	0-1	1
848.3	20643	1.4	16-QAM	3	3	22.10	0-1	1	
848.3	20643	1.4	16-QAM	6	0	21.04	0-2	2	

FCC ID: A3LSMG890A	 SAR EVALUATION REPORT 	Reviewed by: Quality Manager
Document S/N: OY1504030657.A3L	Test Dates: 04/06/15 - 05/04/15	DUT Type: Portable Handset
		Page 34 of 94

9.3.3

LTE Band 4 (AWS)

Table 9-9

LTE Band 4 (AWS) Maximum Conducted Powers - 20 MHz Bandwidth-Representing Hotspot Mode Not Active

	Frequency [MHz]	Channel	Bandwidth [MHz]	Modulation	RB Size	RB Offset	Conducted Power [dBm]	MPR Allowed per 3GPP [dB]	MPR [dB]
Mid	1732.5	20175	20	QPSK	1	0	23.46	0	0
	1732.5	20175	20	QPSK	1	50	23.50	0	0
	1732.5	20175	20	QPSK	1	99	23.41	0	0
	1732.5	20175	20	QPSK	50	0	22.09	0-1	1
	1732.5	20175	20	QPSK	50	25	22.10	0-1	1
	1732.5	20175	20	QPSK	50	50	21.96	0-1	1
	1732.5	20175	20	QPSK	100	0	22.04	0-1	1
	1732.5	20175	20	16QAM	1	0	21.79	0-1	1
	1732.5	20175	20	16QAM	1	50	21.80	0-1	1
	1732.5	20175	20	16QAM	1	99	21.76	0-1	1
	1732.5	20175	20	16QAM	50	0	21.11	0-2	2
	1732.5	20175	20	16QAM	50	25	21.10	0-2	2
	1732.5	20175	20	16QAM	50	50	20.96	0-2	2
	1732.5	20175	20	16QAM	100	0	20.96	0-2	2

Note: LTE Band 4 (AWS) at 20 MHz bandwidth does not support three non-overlapping channels. Per KDB Publication 941225 D05v02, when a device supports overlapping channel assignment in a channel bandwidth configuration, the middle channel of the group of overlapping channels should be selected for testing.



FCC ID: A3LSMG890A	 PCTEST PROFESSIONAL LABORATORY, INC.	SAR EVALUATION REPORT		Reviewed by: Quality Manager
Document S/N: OY1504030657.A3L	Test Dates: 04/06/15 - 05/04/15	DUT Type: Portable Handset	Page 35 of 94	

Table 9-10

LTE Band 4 (AWS) Maximum Conducted Powers - 15 MHz Bandwidth-Representing Hotspot Mode Not Active

	Frequency [MHz]	Channel	Bandwidth [MHz]	Modulation	RB Size	RB Offset	Conducted Power [dBm]	MPR Allowed per 3GPP [dB]	MPR [dB]
Low	1717.5	20025	15	QPSK	1	0	23.12	0	0
	1717.5	20025	15	QPSK	1	36	23.33	0	0
	1717.5	20025	15	QPSK	1	74	23.29	0	0
	1717.5	20025	15	QPSK	36	0	22.44	0-1	1
	1717.5	20025	15	QPSK	36	18	22.06	0-1	1
	1717.5	20025	15	QPSK	36	37	22.03	0-1	1
	1717.5	20025	15	QPSK	75	0	21.92	0-1	1
	1717.5	20025	15	16QAM	1	0	22.17	0-1	1
	1717.5	20025	15	16QAM	1	36	22.11	0-1	1
	1717.5	20025	15	16QAM	1	74	22.20	0-1	1
	1717.5	20025	15	16QAM	36	0	21.13	0-2	2
	1717.5	20025	15	16QAM	36	18	20.98	0-2	2
1717.5	20025	15	16QAM	36	37	20.95	0-2	2	
1717.5	20025	15	16QAM	75	0	20.95	0-2	2	
Mid	1732.5	20175	15	QPSK	1	0	23.66	0	0
	1732.5	20175	15	QPSK	1	36	23.69	0	0
	1732.5	20175	15	QPSK	1	74	23.68	0	0
	1732.5	20175	15	QPSK	36	0	22.64	0-1	1
	1732.5	20175	15	QPSK	36	18	22.40	0-1	1
	1732.5	20175	15	QPSK	36	37	22.39	0-1	1
	1732.5	20175	15	QPSK	75	0	22.25	0-1	1
	1732.5	20175	15	16QAM	1	0	22.48	0-1	1
	1732.5	20175	15	16QAM	1	36	22.63	0-1	1
	1732.5	20175	15	16QAM	1	74	22.64	0-1	1
	1732.5	20175	15	16QAM	36	0	21.25	0-2	2
	1732.5	20175	15	16QAM	36	18	21.34	0-2	2
1732.5	20175	15	16QAM	36	37	21.34	0-2	2	
1732.5	20175	15	16QAM	75	0	21.31	0-2	2	
High	1747.5	20325	15	QPSK	1	0	23.51	0	0
	1747.5	20325	15	QPSK	1	36	23.69	0	0
	1747.5	20325	15	QPSK	1	74	23.63	0	0
	1747.5	20325	15	QPSK	36	0	22.38	0-1	1
	1747.5	20325	15	QPSK	36	18	22.43	0-1	1
	1747.5	20325	15	QPSK	36	37	22.37	0-1	1
	1747.5	20325	15	QPSK	75	0	22.38	0-1	1
	1747.5	20325	15	16QAM	1	0	22.64	0-1	1
	1747.5	20325	15	16QAM	1	36	22.60	0-1	1
	1747.5	20325	15	16QAM	1	74	22.60	0-1	1
	1747.5	20325	15	16QAM	36	0	21.51	0-2	2
	1747.5	20325	15	16QAM	36	18	21.44	0-2	2
1747.5	20325	15	16QAM	36	37	21.31	0-2	2	
1747.5	20325	15	16QAM	75	0	21.25	0-2	2	



FCC ID: A3LSMG890A	 PCTEST PROFESSIONAL CORPORATION, INC.	SAR EVALUATION REPORT		Reviewed by: Quality Manager
Document S/N: OY1504030657.A3L	Test Dates: 04/06/15 - 05/04/15	DUT Type: Portable Handset		Page 36 of 94

Table 9-11

LTE Band 4 (AWS) Maximum Conducted Powers - 10 MHz Bandwidth-Representing Hotspot Mode Not Active

	Frequency [MHz]	Channel	Bandwidth [MHz]	Modulation	RB Size	RB Offset	Conducted Power [dBm]	MPR Allowed per 3GPP [dB]	MPR [dB]
Low	1715	20000	10	QPSK	1	0	23.27	0	0
	1715	20000	10	QPSK	1	25	23.31	0	0
	1715	20000	10	QPSK	1	49	23.22	0	0
	1715	20000	10	QPSK	25	0	22.04	0-1	1
	1715	20000	10	QPSK	25	12	22.01	0-1	1
	1715	20000	10	QPSK	25	25	21.97	0-1	1
	1715	20000	10	QPSK	50	0	21.92	0-1	1
	1715	20000	10	16QAM	1	0	22.28	0-1	1
	1715	20000	10	16QAM	1	25	22.21	0-1	1
	1715	20000	10	16QAM	1	49	22.22	0-1	1
	1715	20000	10	16QAM	25	0	21.03	0-2	2
	1715	20000	10	16QAM	25	12	21.00	0-2	2
Mid	1732.5	20175	10	QPSK	1	0	23.50	0	0
	1732.5	20175	10	QPSK	1	25	23.70	0	0
	1732.5	20175	10	QPSK	1	49	23.66	0	0
	1732.5	20175	10	QPSK	25	0	22.42	0-1	1
	1732.5	20175	10	QPSK	25	12	22.27	0-1	1
	1732.5	20175	10	QPSK	25	25	22.24	0-1	1
	1732.5	20175	10	QPSK	50	0	22.23	0-1	1
	1732.5	20175	10	16QAM	1	0	22.38	0-1	1
	1732.5	20175	10	16QAM	1	25	22.39	0-1	1
	1732.5	20175	10	16QAM	1	49	22.40	0-1	1
	1732.5	20175	10	16QAM	25	0	21.34	0-2	2
	1732.5	20175	10	16QAM	25	12	21.31	0-2	2
High	1750	20350	10	QPSK	1	0	23.69	0	0
	1750	20350	10	QPSK	1	25	23.66	0	0
	1750	20350	10	QPSK	1	49	23.61	0	0
	1750	20350	10	QPSK	25	0	22.36	0-1	1
	1750	20350	10	QPSK	25	12	22.41	0-1	1
	1750	20350	10	QPSK	25	25	22.35	0-1	1
	1750	20350	10	QPSK	50	0	22.41	0-1	1
	1750	20350	10	16QAM	1	0	22.65	0-1	1
	1750	20350	10	16QAM	1	25	22.64	0-1	1
	1750	20350	10	16QAM	1	49	22.55	0-1	1
	1750	20350	10	16QAM	25	0	21.44	0-2	2
	1750	20350	10	16QAM	25	12	21.48	0-2	2
1750	20350	10	16QAM	25	25	21.43	0-2	2	
1750	20350	10	16QAM	50	0	21.38	0-2	2	



FCC ID: A3LSMG890A	 PCTEST PROFESSIONAL LABORATORY, INC.	SAR EVALUATION REPORT		Reviewed by: Quality Manager
Document S/N: OY1504030657.A3L	Test Dates: 04/06/15 - 05/04/15	DUT Type: Portable Handset		Page 37 of 94

Table 9-12

LTE Band 4 (AWS) Maximum Conducted Powers - 5 MHz Bandwidth- Representing Hotspot Mode Not Active

	Frequency [MHz]	Channel	Bandwidth [MHz]	Modulation	RB Size	RB Offset	Conducted Power [dBm]	MPR Allowed per 3GPP [dB]	MPR [dB]
Low	1712.5	19975	5	QPSK	1	0	23.59	0	0
	1712.5	19975	5	QPSK	1	12	23.33	0	0
	1712.5	19975	5	QPSK	1	24	23.38	0	0
	1712.5	19975	5	QPSK	12	0	22.15	0-1	1
	1712.5	19975	5	QPSK	12	6	22.09	0-1	1
	1712.5	19975	5	QPSK	12	13	22.07	0-1	1
	1712.5	19975	5	QPSK	25	0	22.06	0-1	1
	1712.5	19975	5	16-QAM	1	0	22.49	0-1	1
	1712.5	19975	5	16-QAM	1	12	22.47	0-1	1
	1712.5	19975	5	16-QAM	1	24	22.50	0-1	1
	1712.5	19975	5	16-QAM	12	0	21.06	0-2	2
	1712.5	19975	5	16-QAM	12	6	20.93	0-2	2
1712.5	19975	5	16-QAM	12	13	20.91	0-2	2	
1712.5	19975	5	16-QAM	25	0	20.87	0-2	2	
Mid	1732.5	20175	5	QPSK	1	0	23.52	0	0
	1732.5	20175	5	QPSK	1	12	23.53	0	0
	1732.5	20175	5	QPSK	1	24	23.52	0	0
	1732.5	20175	5	QPSK	12	0	22.40	0-1	1
	1732.5	20175	5	QPSK	12	6	22.33	0-1	1
	1732.5	20175	5	QPSK	12	13	22.33	0-1	1
	1732.5	20175	5	QPSK	25	0	22.30	0-1	1
	1732.5	20175	5	16-QAM	1	0	22.60	0-1	1
	1732.5	20175	5	16-QAM	1	12	22.56	0-1	1
	1732.5	20175	5	16-QAM	1	24	22.59	0-1	1
	1732.5	20175	5	16-QAM	12	0	21.36	0-2	2
	1732.5	20175	5	16-QAM	12	6	21.24	0-2	2
1732.5	20175	5	16-QAM	12	13	21.26	0-2	2	
1732.5	20175	5	16-QAM	25	0	21.23	0-2	2	
High	1752.5	20375	5	QPSK	1	0	23.54	0	0
	1752.5	20375	5	QPSK	1	12	23.62	0	0
	1752.5	20375	5	QPSK	1	24	23.51	0	0
	1752.5	20375	5	QPSK	12	0	22.38	0-1	1
	1752.5	20375	5	QPSK	12	6	22.37	0-1	1
	1752.5	20375	5	QPSK	12	13	22.34	0-1	1
	1752.5	20375	5	QPSK	25	0	22.34	0-1	1
	1752.5	20375	5	16-QAM	1	0	22.66	0-1	1
	1752.5	20375	5	16-QAM	1	12	22.59	0-1	1
	1752.5	20375	5	16-QAM	1	24	22.56	0-1	1
	1752.5	20375	5	16-QAM	12	0	21.32	0-2	2
	1752.5	20375	5	16-QAM	12	6	21.33	0-2	2
1752.5	20375	5	16-QAM	12	13	21.21	0-2	2	
1752.5	20375	5	16-QAM	25	0	21.26	0-2	2	



FCC ID: A3LSMG890A	 PCTEST PROFESSIONAL CORPORATION, INC.	SAR EVALUATION REPORT		Reviewed by: Quality Manager
Document S/N: OY1504030657.A3L	Test Dates: 04/06/15 - 05/04/15	DUT Type: Portable Handset	Page 38 of 94	

Table 9-13

LTE Band 4 (AWS) Maximum Conducted Powers - 3 MHz Bandwidth- Representing Hotspot Mode Not Active

	Frequency [MHz]	Channel	Bandwidth [MHz]	Modulation	RB Size	RB Offset	Conducted Power [dBm]	MPR Allowed per 3GPP [dB]	MPR [dB]
Low	1711.5	19965	3	QPSK	1	0	23.31	0	0
	1711.5	19965	3	QPSK	1	7	23.37	0	0
	1711.5	19965	3	QPSK	1	14	23.35	0	0
	1711.5	19965	3	QPSK	8	0	22.00	0-1	1
	1711.5	19965	3	QPSK	8	4	21.91	0-1	1
	1711.5	19965	3	QPSK	8	7	21.91	0-1	1
	1711.5	19965	3	QPSK	15	0	21.88	0-1	1
	1711.5	19965	3	16-QAM	1	0	22.33	0-1	1
	1711.5	19965	3	16-QAM	1	7	22.32	0-1	1
	1711.5	19965	3	16-QAM	1	14	22.33	0-1	1
	1711.5	19965	3	16-QAM	8	0	20.91	0-2	2
	1711.5	19965	3	16-QAM	8	4	20.84	0-2	2
1711.5	19965	3	16-QAM	8	7	20.84	0-2	2	
1711.5	19965	3	16-QAM	15	0	20.95	0-2	2	
Mid	1732.5	20175	3	QPSK	1	0	23.69	0	0
	1732.5	20175	3	QPSK	1	7	23.68	0	0
	1732.5	20175	3	QPSK	1	14	23.69	0	0
	1732.5	20175	3	QPSK	8	0	22.28	0-1	1
	1732.5	20175	3	QPSK	8	4	22.30	0-1	1
	1732.5	20175	3	QPSK	8	7	22.31	0-1	1
	1732.5	20175	3	QPSK	15	0	22.28	0-1	1
	1732.5	20175	3	16-QAM	1	0	22.64	0-1	1
	1732.5	20175	3	16-QAM	1	7	22.55	0-1	1
	1732.5	20175	3	16-QAM	1	14	22.53	0-1	1
	1732.5	20175	3	16-QAM	8	0	21.08	0-2	2
	1732.5	20175	3	16-QAM	8	4	21.10	0-2	2
1732.5	20175	3	16-QAM	8	7	21.10	0-2	2	
1732.5	20175	3	16-QAM	15	0	21.06	0-2	2	
High	1753.5	20385	3	QPSK	1	0	23.69	0	0
	1753.5	20385	3	QPSK	1	7	23.68	0	0
	1753.5	20385	3	QPSK	1	14	23.67	0	0
	1753.5	20385	3	QPSK	8	0	22.42	0-1	1
	1753.5	20385	3	QPSK	8	4	22.41	0-1	1
	1753.5	20385	3	QPSK	8	7	22.41	0-1	1
	1753.5	20385	3	QPSK	15	0	22.41	0-1	1
	1753.5	20385	3	16-QAM	1	0	22.70	0-1	1
	1753.5	20385	3	16-QAM	1	7	22.68	0-1	1
	1753.5	20385	3	16-QAM	1	14	22.67	0-1	1
	1753.5	20385	3	16-QAM	8	0	21.27	0-2	2
	1753.5	20385	3	16-QAM	8	4	21.21	0-2	2
1753.5	20385	3	16-QAM	8	7	21.20	0-2	2	
1753.5	20385	3	16-QAM	15	0	21.33	0-2	2	



FCC ID: A3LSMG890A	 PCTEST PROFESSIONAL CORPORATION, INC.	SAR EVALUATION REPORT		Reviewed by: Quality Manager
Document S/N: OY1504030657.A3L	Test Dates: 04/06/15 - 05/04/15	DUT Type: Portable Handset		Page 39 of 94

Table 9-14

LTE Band 4 (AWS) Maximum Conducted Powers -1.4 MHz Bandwidth- Representing Hotspot Mode Not Active

	Frequency [MHz]	Channel	Bandwidth [MHz]	Modulation	RB Size	RB Offset	Conducted Power [dBm]	MPR Allowed per 3GPP [dB]	MPR [dB]
Low	1710.7	19957	1.4	QPSK	1	0	23.45	0	0
	1710.7	19957	1.4	QPSK	1	2	23.38	0	0
	1710.7	19957	1.4	QPSK	1	5	23.36	0	0
	1710.7	19957	1.4	QPSK	3	0	23.16	0	0
	1710.7	19957	1.4	QPSK	3	2	23.13	0	0
	1710.7	19957	1.4	QPSK	3	3	23.07	0	0
	1710.7	19957	1.4	QPSK	6	0	21.96	0-1	1
	1710.7	19957	1.4	16-QAM	1	0	22.24	0-1	1
	1710.7	19957	1.4	16-QAM	1	2	22.35	0-1	1
	1710.7	19957	1.4	16-QAM	1	5	22.27	0-1	1
	1710.7	19957	1.4	16-QAM	3	0	22.05	0-1	1
	1710.7	19957	1.4	16-QAM	3	2	21.97	0-1	1
1710.7	19957	1.4	16-QAM	3	3	22.01	0-1	1	
1710.7	19957	1.4	16-QAM	6	0	20.88	0-2	2	
Mid	1732.5	20175	1.4	QPSK	1	0	23.62	0	0
	1732.5	20175	1.4	QPSK	1	2	23.66	0	0
	1732.5	20175	1.4	QPSK	1	5	23.59	0	0
	1732.5	20175	1.4	QPSK	3	0	23.46	0	0
	1732.5	20175	1.4	QPSK	3	2	23.42	0	0
	1732.5	20175	1.4	QPSK	3	3	23.38	0	0
	1732.5	20175	1.4	QPSK	6	0	22.29	0-1	1
	1732.5	20175	1.4	16-QAM	1	0	22.65	0-1	1
	1732.5	20175	1.4	16-QAM	1	2	22.63	0-1	1
	1732.5	20175	1.4	16-QAM	1	5	22.68	0-1	1
	1732.5	20175	1.4	16-QAM	3	0	22.17	0-1	1
	1732.5	20175	1.4	16-QAM	3	2	22.03	0-1	1
	1732.5	20175	1.4	16-QAM	3	3	22.07	0-1	1
	1732.5	20175	1.4	16-QAM	6	0	21.28	0-2	2
High	1754.3	20393	1.4	QPSK	1	0	23.66	0	0
	1754.3	20393	1.4	QPSK	1	2	23.69	0	0
	1754.3	20393	1.4	QPSK	1	5	23.67	0	0
	1754.3	20393	1.4	QPSK	3	0	23.62	0	0
	1754.3	20393	1.4	QPSK	3	2	23.57	0	0
	1754.3	20393	1.4	QPSK	3	3	23.52	0	0
	1754.3	20393	1.4	QPSK	6	0	22.51	0-1	1
	1754.3	20393	1.4	16-QAM	1	0	22.57	0-1	1
	1754.3	20393	1.4	16-QAM	1	2	22.48	0-1	1
	1754.3	20393	1.4	16-QAM	1	5	22.64	0-1	1
	1754.3	20393	1.4	16-QAM	3	0	22.37	0-1	1
	1754.3	20393	1.4	16-QAM	3	2	22.40	0-1	1
	1754.3	20393	1.4	16-QAM	3	3	22.36	0-1	1
1754.3	20393	1.4	16-QAM	6	0	21.22	0-2	2	



FCC ID: A3LSMG890A	 PCTEST PROFESSIONAL CORPORATION, INC.	SAR EVALUATION REPORT		Reviewed by: Quality Manager
Document S/N: OY1504030657.A3L	Test Dates: 04/06/15 - 05/04/15	DUT Type: Portable Handset		Page 40 of 94

Table 9-15

LTE Band 4 (AWS) Reduced Conducted Powers - 20 MHz Bandwidth- Representing Hotspot Mode Active

	Frequency [MHz]	Channel	Bandwidth [MHz]	Modulation	RB Size	RB Offset	Conducted Power [dBm]	MPR Allowed per 3GPP [dB]	MPR [dB]
Mid	1732.5	20175	20	QPSK	1	0	21.31	0	0
	1732.5	20175	20	QPSK	1	50	21.23	0	0
	1732.5	20175	20	QPSK	1	99	21.20	0	0
	1732.5	20175	20	QPSK	50	0	21.25	0-1	0
	1732.5	20175	20	QPSK	50	25	21.17	0-1	0
	1732.5	20175	20	QPSK	50	50	21.15	0-1	0
	1732.5	20175	20	QPSK	100	0	21.09	0-1	0
	1732.5	20175	20	16QAM	1	0	21.40	0-1	0
	1732.5	20175	20	16QAM	1	50	21.50	0-1	0
	1732.5	20175	20	16QAM	1	99	21.50	0-1	0
	1732.5	20175	20	16QAM	50	0	21.16	0-2	0
	1732.5	20175	20	16QAM	50	25	21.13	0-2	0
	1732.5	20175	20	16QAM	50	50	21.06	0-2	0
	1732.5	20175	20	16QAM	100	0	21.06	0-2	0

Note: LTE Band 4 (AWS) at 20 MHz bandwidth does not support three non-overlapping channels. Per KDB Publication 941225 D05v02, when a device supports overlapping channel assignment in a channel bandwidth configuration, the middle channel of the group of overlapping channels should be selected for testing.



FCC ID: A3LSMG890A	 SAR EVALUATION REPORT 		Reviewed by: Quality Manager
Document S/N: OY1504030657.A3L	Test Dates: 04/06/15 - 05/04/15	DUT Type: Portable Handset	Page 41 of 94

Table 9-16

LTE Band 4 (AWS) Reduced Conducted Powers - 15 MHz Bandwidth- Representing Hotspot Mode Active

	Frequency [MHz]	Channel	Bandwidth [MHz]	Modulation	RB Size	RB Offset	Conducted Power [dBm]	MPR Allowed per 3GPP [dB]	MPR [dB]
Low	1717.5	20025	15	QPSK	1	0	21.13	0	0
	1717.5	20025	15	QPSK	1	36	21.17	0	0
	1717.5	20025	15	QPSK	1	74	21.09	0	0
	1717.5	20025	15	QPSK	36	0	21.00	0-1	0
	1717.5	20025	15	QPSK	36	18	20.96	0-1	0
	1717.5	20025	15	QPSK	36	37	20.91	0-1	0
	1717.5	20025	15	QPSK	75	0	20.81	0-1	0
	1717.5	20025	15	16QAM	1	0	20.97	0-1	0
	1717.5	20025	15	16QAM	1	36	21.03	0-1	0
	1717.5	20025	15	16QAM	1	74	21.00	0-1	0
	1717.5	20025	15	16QAM	36	0	21.02	0-2	0
	1717.5	20025	15	16QAM	36	18	20.97	0-2	0
1717.5	20025	15	16QAM	36	37	20.93	0-2	0	
1717.5	20025	15	16QAM	75	0	20.95	0-2	0	
Mid	1732.5	20175	15	QPSK	1	0	21.25	0	0
	1732.5	20175	15	QPSK	1	36	21.31	0	0
	1732.5	20175	15	QPSK	1	74	21.33	0	0
	1732.5	20175	15	QPSK	36	0	21.29	0-1	0
	1732.5	20175	15	QPSK	36	18	21.30	0-1	0
	1732.5	20175	15	QPSK	36	37	21.31	0-1	0
	1732.5	20175	15	QPSK	75	0	21.18	0-1	0
	1732.5	20175	15	16QAM	1	0	21.41	0-1	0
	1732.5	20175	15	16QAM	1	36	21.47	0-1	0
	1732.5	20175	15	16QAM	1	74	21.47	0-1	0
	1732.5	20175	15	16QAM	36	0	21.25	0-2	0
	1732.5	20175	15	16QAM	36	18	21.34	0-2	0
1732.5	20175	15	16QAM	36	37	21.32	0-2	0	
1732.5	20175	15	16QAM	75	0	21.27	0-2	0	
High	1747.5	20325	15	QPSK	1	0	21.33	0	0
	1747.5	20325	15	QPSK	1	36	21.33	0	0
	1747.5	20325	15	QPSK	1	74	21.29	0	0
	1747.5	20325	15	QPSK	36	0	21.23	0-1	0
	1747.5	20325	15	QPSK	36	18	21.28	0-1	0
	1747.5	20325	15	QPSK	36	37	21.22	0-1	0
	1747.5	20325	15	QPSK	75	0	21.19	0-1	0
	1747.5	20325	15	16QAM	1	0	21.48	0-1	0
	1747.5	20325	15	16QAM	1	36	21.42	0-1	0
	1747.5	20325	15	16QAM	1	74	21.38	0-1	0
	1747.5	20325	15	16QAM	36	0	21.49	0-2	0
	1747.5	20325	15	16QAM	36	18	21.26	0-2	0
1747.5	20325	15	16QAM	36	37	21.23	0-2	0	
1747.5	20325	15	16QAM	75	0	21.24	0-2	0	



FCC ID: A3LSMG890A	 PCTEST PROFESSIONAL CORPORATION, INC.	SAR EVALUATION REPORT		Reviewed by: Quality Manager
Document S/N: OY1504030657.A3L	Test Dates: 04/06/15 - 05/04/15	DUT Type: Portable Handset		Page 42 of 94

Table 9-17

LTE Band 4 (AWS) Reduced Conducted Powers - 10 MHz Bandwidth- Representing Hotspot Mode Active

	Frequency [MHz]	Channel	Bandwidth [MHz]	Modulation	RB Size	RB Offset	Conducted Power [dBm]	MPR Allowed per 3GPP [dB]	MPR [dB]
Low	1715	20000	10	QPSK	1	0	21.09	0	0
	1715	20000	10	QPSK	1	25	21.10	0	0
	1715	20000	10	QPSK	1	49	21.05	0	0
	1715	20000	10	QPSK	25	0	20.91	0-1	0
	1715	20000	10	QPSK	25	12	20.87	0-1	0
	1715	20000	10	QPSK	25	25	20.82	0-1	0
	1715	20000	10	QPSK	50	0	20.81	0-1	0
	1715	20000	10	16QAM	1	0	21.01	0-1	0
	1715	20000	10	16QAM	1	25	21.08	0-1	0
	1715	20000	10	16QAM	1	49	21.01	0-1	0
	1715	20000	10	16QAM	25	0	20.92	0-2	0
	1715	20000	10	16QAM	25	12	20.86	0-2	0
Mid	1732.5	20175	10	QPSK	1	0	21.38	0	0
	1732.5	20175	10	QPSK	1	25	21.44	0	0
	1732.5	20175	10	QPSK	1	49	21.32	0	0
	1732.5	20175	10	QPSK	25	0	21.25	0-1	0
	1732.5	20175	10	QPSK	25	12	21.23	0-1	0
	1732.5	20175	10	QPSK	25	25	21.19	0-1	0
	1732.5	20175	10	QPSK	50	0	21.15	0-1	0
	1732.5	20175	10	16QAM	1	0	21.43	0-1	0
	1732.5	20175	10	16QAM	1	25	21.44	0-1	0
	1732.5	20175	10	16QAM	1	49	21.43	0-1	0
	1732.5	20175	10	16QAM	25	0	21.37	0-2	0
	1732.5	20175	10	16QAM	25	12	21.32	0-2	0
High	1750	20350	10	QPSK	1	0	21.43	0	0
	1750	20350	10	QPSK	1	25	21.44	0	0
	1750	20350	10	QPSK	1	49	21.50	0	0
	1750	20350	10	QPSK	25	0	21.30	0-1	0
	1750	20350	10	QPSK	25	12	21.34	0-1	0
	1750	20350	10	QPSK	25	25	21.27	0-1	0
	1750	20350	10	QPSK	50	0	21.24	0-1	0
	1750	20350	10	16QAM	1	0	21.50	0-1	0
	1750	20350	10	16QAM	1	25	21.47	0-1	0
	1750	20350	10	16QAM	1	49	21.48	0-1	0
	1750	20350	10	16QAM	25	0	21.37	0-2	0
	1750	20350	10	16QAM	25	12	21.36	0-2	0



FCC ID: A3LSMG890A	 PCTEST PROFESSIONAL LABORATORY, INC.	SAR EVALUATION REPORT		Reviewed by: Quality Manager
Document S/N: OY1504030657.A3L	Test Dates: 04/06/15 - 05/04/15	DUT Type: Portable Handset	Page 43 of 94	

Table 9-18

LTE Band 4 (AWS) Reduced Conducted Powers - 5 MHz Bandwidth- Representing Hotspot Mode Active

	Frequency [MHz]	Channel	Bandwidth [MHz]	Modulation	RB Size	RB Offset	Conducted Power [dBm]	MPR Allowed per 3GPP [dB]	MPR [dB]
Low	1712.5	19975	5	QPSK	1	0	21.11	0	0
	1712.5	19975	5	QPSK	1	12	21.20	0	0
	1712.5	19975	5	QPSK	1	24	21.17	0	0
	1712.5	19975	5	QPSK	12	0	20.95	0-1	0
	1712.5	19975	5	QPSK	12	6	20.93	0-1	0
	1712.5	19975	5	QPSK	12	13	20.94	0-1	0
	1712.5	19975	5	QPSK	25	0	20.92	0-1	0
	1712.5	19975	5	16-QAM	1	0	21.09	0-1	0
	1712.5	19975	5	16-QAM	1	12	21.05	0-1	0
	1712.5	19975	5	16-QAM	1	24	21.06	0-1	0
	1712.5	19975	5	16-QAM	12	0	20.99	0-2	0
	1712.5	19975	5	16-QAM	12	6	20.99	0-2	0
1712.5	19975	5	16-QAM	12	13	20.96	0-2	0	
1712.5	19975	5	16-QAM	25	0	20.92	0-2	0	
Mid	1732.5	20175	5	QPSK	1	0	21.34	0	0
	1732.5	20175	5	QPSK	1	12	21.32	0	0
	1732.5	20175	5	QPSK	1	24	21.21	0	0
	1732.5	20175	5	QPSK	12	0	21.16	0-1	0
	1732.5	20175	5	QPSK	12	6	21.17	0-1	0
	1732.5	20175	5	QPSK	12	13	21.18	0-1	0
	1732.5	20175	5	QPSK	25	0	21.12	0-1	0
	1732.5	20175	5	16-QAM	1	0	21.22	0-1	0
	1732.5	20175	5	16-QAM	1	12	21.38	0-1	0
	1732.5	20175	5	16-QAM	1	24	21.31	0-1	0
	1732.5	20175	5	16-QAM	12	0	21.29	0-2	0
	1732.5	20175	5	16-QAM	12	6	21.25	0-2	0
1732.5	20175	5	16-QAM	12	13	21.28	0-2	0	
1732.5	20175	5	16-QAM	25	0	21.25	0-2	0	
High	1752.5	20375	5	QPSK	1	0	21.42	0	0
	1752.5	20375	5	QPSK	1	12	21.37	0	0
	1752.5	20375	5	QPSK	1	24	21.38	0	0
	1752.5	20375	5	QPSK	12	0	21.30	0-1	0
	1752.5	20375	5	QPSK	12	6	21.29	0-1	0
	1752.5	20375	5	QPSK	12	13	21.26	0-1	0
	1752.5	20375	5	QPSK	25	0	21.26	0-1	0
	1752.5	20375	5	16-QAM	1	0	21.35	0-1	0
	1752.5	20375	5	16-QAM	1	12	21.30	0-1	0
	1752.5	20375	5	16-QAM	1	24	21.34	0-1	0
	1752.5	20375	5	16-QAM	12	0	21.27	0-2	0
	1752.5	20375	5	16-QAM	12	6	21.26	0-2	0
1752.5	20375	5	16-QAM	12	13	21.24	0-2	0	
1752.5	20375	5	16-QAM	25	0	21.22	0-2	0	



FCC ID: A3LSMG890A	 PCTEST PROFESSIONAL CORPORATION, INC.	SAR EVALUATION REPORT		Reviewed by: Quality Manager
Document S/N: OY1504030657.A3L	Test Dates: 04/06/15 - 05/04/15	DUT Type: Portable Handset	Page 44 of 94	

Table 9-19

LTE Band 4 (AWS) Reduced Conducted Powers - 3 MHz Bandwidth- Representing Hotspot Mode Active

	Frequency [MHz]	Channel	Bandwidth [MHz]	Modulation	RB Size	RB Offset	Conducted Power [dBm]	MPR Allowed per 3GPP [dB]	MPR [dB]
Low	1711.5	19965	3	QPSK	1	0	21.13	0	0
	1711.5	19965	3	QPSK	1	7	21.12	0	0
	1711.5	19965	3	QPSK	1	14	21.12	0	0
	1711.5	19965	3	QPSK	8	0	20.94	0-1	0
	1711.5	19965	3	QPSK	8	4	20.85	0-1	0
	1711.5	19965	3	QPSK	8	7	20.86	0-1	0
	1711.5	19965	3	QPSK	15	0	20.84	0-1	0
	1711.5	19965	3	16-QAM	1	0	21.31	0-1	0
	1711.5	19965	3	16-QAM	1	7	21.30	0-1	0
	1711.5	19965	3	16-QAM	1	14	21.21	0-1	0
	1711.5	19965	3	16-QAM	8	0	20.89	0-2	0
	1711.5	19965	3	16-QAM	8	4	20.91	0-2	0
1711.5	19965	3	16-QAM	8	7	20.91	0-2	0	
1711.5	19965	3	16-QAM	15	0	20.91	0-2	0	
Mid	1732.5	20175	3	QPSK	1	0	21.48	0	0
	1732.5	20175	3	QPSK	1	7	21.49	0	0
	1732.5	20175	3	QPSK	1	14	21.48	0	0
	1732.5	20175	3	QPSK	8	0	21.23	0-1	0
	1732.5	20175	3	QPSK	8	4	21.24	0-1	0
	1732.5	20175	3	QPSK	8	7	21.24	0-1	0
	1732.5	20175	3	QPSK	15	0	21.22	0-1	0
	1732.5	20175	3	16-QAM	1	0	21.41	0-1	0
	1732.5	20175	3	16-QAM	1	7	21.46	0-1	0
	1732.5	20175	3	16-QAM	1	14	21.47	0-1	0
	1732.5	20175	3	16-QAM	8	0	21.24	0-2	0
	1732.5	20175	3	16-QAM	8	4	21.24	0-2	0
1732.5	20175	3	16-QAM	8	7	21.25	0-2	0	
1732.5	20175	3	16-QAM	15	0	21.23	0-2	0	
High	1753.5	20385	3	QPSK	1	0	21.48	0	0
	1753.5	20385	3	QPSK	1	7	21.46	0	0
	1753.5	20385	3	QPSK	1	14	21.41	0	0
	1753.5	20385	3	QPSK	8	0	21.36	0-1	0
	1753.5	20385	3	QPSK	8	4	21.33	0-1	0
	1753.5	20385	3	QPSK	8	7	21.33	0-1	0
	1753.5	20385	3	QPSK	15	0	21.32	0-1	0
	1753.5	20385	3	16-QAM	1	0	21.46	0-1	0
	1753.5	20385	3	16-QAM	1	7	21.43	0-1	0
	1753.5	20385	3	16-QAM	1	14	21.46	0-1	0
	1753.5	20385	3	16-QAM	8	0	21.22	0-2	0
	1753.5	20385	3	16-QAM	8	4	21.21	0-2	0
1753.5	20385	3	16-QAM	8	7	21.20	0-2	0	
1753.5	20385	3	16-QAM	15	0	21.22	0-2	0	





FCC ID: A3LSMG890A	 PCTEST PROFESSIONAL CORPORATION, INC.	SAR EVALUATION REPORT		Reviewed by: Quality Manager
Document S/N: OY1504030657.A3L	Test Dates: 04/06/15 - 05/04/15	DUT Type: Portable Handset	Page 45 of 94	

Table 9-20

LTE Band 4 (AWS) Reduced Conducted Powers -1.4 MHz Bandwidth- Representing Hotspot Mode Active

	Frequency [MHz]	Channel	Bandwidth [MHz]	Modulation	RB Size	RB Offset	Conducted Power [dBm]	MPR Allowed per 3GPP [dB]	MPR [dB]
Low	1710.7	19957	1.4	QPSK	1	0	21.04	0	0
	1710.7	19957	1.4	QPSK	1	2	21.05	0	0
	1710.7	19957	1.4	QPSK	1	5	21.07	0	0
	1710.7	19957	1.4	QPSK	3	0	20.90	0	0
	1710.7	19957	1.4	QPSK	3	2	20.97	0	0
	1710.7	19957	1.4	QPSK	3	3	20.93	0	0
	1710.7	19957	1.4	QPSK	6	0	20.93	0-1	0
	1710.7	19957	1.4	16-QAM	1	0	21.25	0-1	0
	1710.7	19957	1.4	16-QAM	1	2	21.15	0-1	0
	1710.7	19957	1.4	16-QAM	1	5	21.21	0-1	0
	1710.7	19957	1.4	16-QAM	3	0	20.71	0-1	0
	1710.7	19957	1.4	16-QAM	3	2	20.67	0-1	0
1710.7	19957	1.4	16-QAM	3	3	20.61	0-1	0	
1710.7	19957	1.4	16-QAM	6	0	20.76	0-2	0	
Mid	1732.5	20175	1.4	QPSK	1	0	21.48	0	0
	1732.5	20175	1.4	QPSK	1	2	21.49	0	0
	1732.5	20175	1.4	QPSK	1	5	21.47	0	0
	1732.5	20175	1.4	QPSK	3	0	21.28	0	0
	1732.5	20175	1.4	QPSK	3	2	21.25	0	0
	1732.5	20175	1.4	QPSK	3	3	21.19	0	0
	1732.5	20175	1.4	QPSK	6	0	21.21	0-1	0
	1732.5	20175	1.4	16-QAM	1	0	21.48	0-1	0
	1732.5	20175	1.4	16-QAM	1	2	21.39	0-1	0
	1732.5	20175	1.4	16-QAM	1	5	21.43	0-1	0
	1732.5	20175	1.4	16-QAM	3	0	21.23	0-1	0
	1732.5	20175	1.4	16-QAM	3	2	21.19	0-1	0
1732.5	20175	1.4	16-QAM	3	3	21.08	0-1	0	
1732.5	20175	1.4	16-QAM	6	0	21.17	0-2	0	
High	1754.3	20393	1.4	QPSK	1	0	21.49	0	0
	1754.3	20393	1.4	QPSK	1	2	21.48	0	0
	1754.3	20393	1.4	QPSK	1	5	21.47	0	0
	1754.3	20393	1.4	QPSK	3	0	21.36	0	0
	1754.3	20393	1.4	QPSK	3	2	21.31	0	0
	1754.3	20393	1.4	QPSK	3	3	21.27	0	0
	1754.3	20393	1.4	QPSK	6	0	21.28	0-1	0
	1754.3	20393	1.4	16-QAM	1	0	21.30	0-1	0
	1754.3	20393	1.4	16-QAM	1	2	21.40	0-1	0
	1754.3	20393	1.4	16-QAM	1	5	21.45	0-1	0
	1754.3	20393	1.4	16-QAM	3	0	21.30	0-1	0
	1754.3	20393	1.4	16-QAM	3	2	21.27	0-1	0
1754.3	20393	1.4	16-QAM	3	3	21.21	0-1	0	
1754.3	20393	1.4	16-QAM	6	0	21.25	0-2	0	

FCC ID: A3LSMG890A	 PCTEST PROFESSIONAL CORPORATION, INC.	SAR EVALUATION REPORT		Reviewed by: Quality Manager
Document S/N: OY1504030657.A3L	Test Dates: 04/06/15 - 05/04/15	DUT Type: Portable Handset	Page 46 of 94	

9.3.4

LTE Band 2 (PCS)

Table 9-21

LTE Band 2 (PCS) Maximum Conducted Powers - 20 MHz Bandwidth- Representing Hotspot Mode Not Active

	Frequency [MHz]	Channel	Bandwidth [MHz]	Modulation	RB Size	RB Offset	Conducted Power [dBm]	MPR Allowed per 3GPP [dB]	MPR [dB]
Low	1860	18700	20	QPSK	1	0	23.45	0	0
	1860	18700	20	QPSK	1	50	23.49	0	0
	1860	18700	20	QPSK	1	99	23.36	0	0
	1860	18700	20	QPSK	50	0	22.06	0-1	1
	1860	18700	20	QPSK	50	25	22.05	0-1	1
	1860	18700	20	QPSK	50	50	21.97	0-1	1
	1860	18700	20	QPSK	100	0	22.02	0-1	1
	1860	18700	20	16QAM	1	0	21.76	0-1	1
	1860	18700	20	16QAM	1	50	21.70	0-1	1
	1860	18700	20	16QAM	1	99	21.94	0-1	1
	1860	18700	20	16QAM	50	0	21.01	0-2	2
	1860	18700	20	16QAM	50	25	21.09	0-2	2
	1860	18700	20	16QAM	50	50	20.95	0-2	2
1860	18700	20	16QAM	100	0	20.91	0-2	2	
Mid	1880.0	18900	20	QPSK	1	0	23.40	0	0
	1880.0	18900	20	QPSK	1	50	23.43	0	0
	1880.0	18900	20	QPSK	1	99	23.28	0	0
	1880.0	18900	20	QPSK	50	0	21.91	0-1	1
	1880.0	18900	20	QPSK	50	25	21.98	0-1	1
	1880.0	18900	20	QPSK	50	50	21.99	0-1	1
	1880.0	18900	20	QPSK	100	0	21.92	0-1	1
	1880.0	18900	20	16QAM	1	0	22.01	0-1	1
	1880.0	18900	20	16QAM	1	50	22.03	0-1	1
	1880.0	18900	20	16QAM	1	99	21.87	0-1	1
	1880.0	18900	20	16QAM	50	0	20.89	0-2	2
	1880.0	18900	20	16QAM	50	25	20.95	0-2	2
	1880.0	18900	20	16QAM	50	50	20.93	0-2	2
1880.0	18900	20	16QAM	100	0	20.85	0-2	2	
High	1900	19100	20	QPSK	1	0	23.42	0	0
	1900	19100	20	QPSK	1	50	23.50	0	0
	1900	19100	20	QPSK	1	99	23.37	0	0
	1900	19100	20	QPSK	50	0	22.23	0-1	1
	1900	19100	20	QPSK	50	25	22.09	0-1	1
	1900	19100	20	QPSK	50	50	22.11	0-1	1
	1900	19100	20	QPSK	100	0	22.17	0-1	1
	1900	19100	20	16QAM	1	0	22.04	0-1	1
	1900	19100	20	16QAM	1	50	21.75	0-1	1
	1900	19100	20	16QAM	1	99	21.96	0-1	1
	1900	19100	20	16QAM	50	0	21.10	0-2	2
	1900	19100	20	16QAM	50	25	21.04	0-2	2
	1900	19100	20	16QAM	50	50	21.03	0-2	2
1900	19100	20	16QAM	100	0	21.08	0-2	2	



FCC ID: A3LSMG890A	 PCTEST PROFESSIONAL ENGINEERING LABORATORY, INC.	SAR EVALUATION REPORT		Reviewed by: Quality Manager
Document S/N: OY1504030657.A3L	Test Dates: 04/06/15 - 05/04/15	DUT Type: Portable Handset		Page 47 of 94

Table 9-22

LTE Band 2 (PCS) Maximum Conducted Powers - 15 MHz Bandwidth- Representing Hotspot Mode Not Active

	Frequency [MHz]	Channel	Bandwidth [MHz]	Modulation	RB Size	RB Offset	Conducted Power [dBm]	MPR Allowed per 3GPP [dB]	MPR [dB]
Low	1857.5	18675	15	QPSK	1	0	23.46	0	0
	1857.5	18675	15	QPSK	1	36	23.53	0	0
	1857.5	18675	15	QPSK	1	74	23.44	0	0
	1857.5	18675	15	QPSK	36	0	22.11	0-1	1
	1857.5	18675	15	QPSK	36	18	22.15	0-1	1
	1857.5	18675	15	QPSK	36	37	22.12	0-1	1
	1857.5	18675	15	QPSK	75	0	22.07	0-1	1
	1857.5	18675	15	16QAM	1	0	22.14	0-1	1
	1857.5	18675	15	16QAM	1	36	22.15	0-1	1
	1857.5	18675	15	16QAM	1	74	22.00	0-1	1
	1857.5	18675	15	16QAM	36	0	20.98	0-2	2
	1857.5	18675	15	16QAM	36	18	21.02	0-2	2
1857.5	18675	15	16QAM	36	37	20.96	0-2	2	
1857.5	18675	15	16QAM	75	0	21.02	0-2	2	
Mid	1880.0	18900	15	QPSK	1	0	23.36	0	0
	1880.0	18900	15	QPSK	1	36	23.43	0	0
	1880.0	18900	15	QPSK	1	74	23.42	0	0
	1880.0	18900	15	QPSK	36	0	22.07	0-1	1
	1880.0	18900	15	QPSK	36	18	22.03	0-1	1
	1880.0	18900	15	QPSK	36	37	22.09	0-1	1
	1880.0	18900	15	QPSK	75	0	21.89	0-1	1
	1880.0	18900	15	16QAM	1	0	22.08	0-1	1
	1880.0	18900	15	16QAM	1	36	22.16	0-1	1
	1880.0	18900	15	16QAM	1	74	22.13	0-1	1
	1880.0	18900	15	16QAM	36	0	20.96	0-2	2
	1880.0	18900	15	16QAM	36	18	20.91	0-2	2
1880.0	18900	15	16QAM	36	37	20.94	0-2	2	
1880.0	18900	15	16QAM	75	0	20.96	0-2	2	
High	1902.5	19125	15	QPSK	1	0	23.61	0	0
	1902.5	19125	15	QPSK	1	36	23.52	0	0
	1902.5	19125	15	QPSK	1	74	23.57	0	0
	1902.5	19125	15	QPSK	36	0	22.26	0-1	1
	1902.5	19125	15	QPSK	36	18	22.18	0-1	1
	1902.5	19125	15	QPSK	36	37	22.20	0-1	1
	1902.5	19125	15	QPSK	75	0	22.07	0-1	1
	1902.5	19125	15	16QAM	1	0	22.21	0-1	1
	1902.5	19125	15	16QAM	1	36	22.18	0-1	1
	1902.5	19125	15	16QAM	1	74	22.28	0-1	1
	1902.5	19125	15	16QAM	36	0	21.09	0-2	2
	1902.5	19125	15	16QAM	36	18	21.05	0-2	2
1902.5	19125	15	16QAM	36	37	21.02	0-2	2	
1902.5	19125	15	16QAM	75	0	21.12	0-2	2	



FCC ID: A3LSMG890A	 PCTEST PROFESSIONAL ENGINEERING LABORATORY, INC.	SAR EVALUATION REPORT		Reviewed by: Quality Manager
Document S/N: OY1504030657.A3L	Test Dates: 04/06/15 - 05/04/15	DUT Type: Portable Handset	Page 48 of 94	

Table 9-23

LTE Band 2 (PCS) Maximum Conducted Powers - 10 MHz Bandwidth- Representing Hotspot Mode Not Active

	Frequency [MHz]	Channel	Bandwidth [MHz]	Modulation	RB Size	RB Offset	Conducted Power [dBm]	MPR Allowed per 3GPP [dB]	MPR [dB]
Low	1855	18650	10	QPSK	1	0	23.39	0	0
	1855	18650	10	QPSK	1	25	23.37	0	0
	1855	18650	10	QPSK	1	49	23.43	0	0
	1855	18650	10	QPSK	25	0	21.98	0-1	1
	1855	18650	10	QPSK	25	12	21.96	0-1	1
	1855	18650	10	QPSK	25	25	21.98	0-1	1
	1855	18650	10	QPSK	50	0	21.88	0-1	1
	1855	18650	10	16QAM	1	0	22.05	0-1	1
	1855	18650	10	16QAM	1	25	22.01	0-1	1
	1855	18650	10	16QAM	1	49	22.02	0-1	1
	1855	18650	10	16QAM	25	0	20.97	0-2	2
	1855	18650	10	16QAM	25	12	21.00	0-2	2
1855	18650	10	16QAM	25	25	20.89	0-2	2	
1855	18650	10	16QAM	50	0	20.90	0-2	2	
Mid	1880.0	18900	10	QPSK	1	0	23.36	0	0
	1880.0	18900	10	QPSK	1	25	23.47	0	0
	1880.0	18900	10	QPSK	1	49	23.48	0	0
	1880.0	18900	10	QPSK	25	0	22.09	0-1	1
	1880.0	18900	10	QPSK	25	12	22.13	0-1	1
	1880.0	18900	10	QPSK	25	25	22.02	0-1	1
	1880.0	18900	10	QPSK	50	0	21.97	0-1	1
	1880.0	18900	10	16QAM	1	0	22.15	0-1	1
	1880.0	18900	10	16QAM	1	25	22.19	0-1	1
	1880.0	18900	10	16QAM	1	49	22.17	0-1	1
	1880.0	18900	10	16QAM	25	0	20.92	0-2	2
	1880.0	18900	10	16QAM	25	12	21.05	0-2	2
1880.0	18900	10	16QAM	25	25	21.02	0-2	2	
1880.0	18900	10	16QAM	50	0	20.95	0-2	2	
High	1905	19150	10	QPSK	1	0	23.67	0	0
	1905	19150	10	QPSK	1	25	23.69	0	0
	1905	19150	10	QPSK	1	49	23.66	0	0
	1905	19150	10	QPSK	25	0	22.33	0-1	1
	1905	19150	10	QPSK	25	12	22.32	0-1	1
	1905	19150	10	QPSK	25	25	22.31	0-1	1
	1905	19150	10	QPSK	50	0	22.22	0-1	1
	1905	19150	10	16QAM	1	0	22.33	0-1	1
	1905	19150	10	16QAM	1	25	22.31	0-1	1
	1905	19150	10	16QAM	1	49	22.36	0-1	1
	1905	19150	10	16QAM	25	0	21.25	0-2	2
	1905	19150	10	16QAM	25	12	21.19	0-2	2
1905	19150	10	16QAM	25	25	21.17	0-2	2	
1905	19150	10	16QAM	50	0	21.19	0-2	2	



FCC ID: A3LSMG890A	 PCTEST PROFESSIONAL ENGINEERING LABORATORY, INC.	SAR EVALUATION REPORT		Reviewed by: Quality Manager
Document S/N: OY1504030657.A3L	Test Dates: 04/06/15 - 05/04/15	DUT Type: Portable Handset	Page 49 of 94	

Table 9-24

LTE Band 2 (PCS) Maximum Conducted Powers - 5 MHz Bandwidth- Representing Hotspot Mode Not Active

	Frequency [MHz]	Channel	Bandwidth [MHz]	Modulation	RB Size	RB Offset	Conducted Power [dBm]	MPR Allowed per 3GPP [dB]	MPR [dB]
Low	1852.5	18625	5	QPSK	1	0	23.42	0	0
	1852.5	18625	5	QPSK	1	12	23.48	0	0
	1852.5	18625	5	QPSK	1	24	23.56	0	0
	1852.5	18625	5	QPSK	12	0	22.02	0-1	1
	1852.5	18625	5	QPSK	12	6	22.11	0-1	1
	1852.5	18625	5	QPSK	12	13	22.08	0-1	1
	1852.5	18625	5	QPSK	25	0	21.96	0-1	1
	1852.5	18625	5	16-QAM	1	0	22.05	0-1	1
	1852.5	18625	5	16-QAM	1	12	22.20	0-1	1
	1852.5	18625	5	16-QAM	1	24	22.26	0-1	1
	1852.5	18625	5	16-QAM	12	0	20.95	0-2	2
	1852.5	18625	5	16-QAM	12	6	20.92	0-2	2
1852.5	18625	5	16-QAM	12	13	20.98	0-2	2	
1852.5	18625	5	16-QAM	25	0	21.02	0-2	2	
Mid	1880.0	18900	5	QPSK	1	0	23.39	0	0
	1880.0	18900	5	QPSK	1	12	23.49	0	0
	1880.0	18900	5	QPSK	1	24	23.54	0	0
	1880.0	18900	5	QPSK	12	0	22.07	0-1	1
	1880.0	18900	5	QPSK	12	6	22.00	0-1	1
	1880.0	18900	5	QPSK	12	13	22.05	0-1	1
	1880.0	18900	5	QPSK	25	0	21.96	0-1	1
	1880.0	18900	5	16-QAM	1	0	22.13	0-1	1
	1880.0	18900	5	16-QAM	1	12	22.20	0-1	1
	1880.0	18900	5	16-QAM	1	24	22.15	0-1	1
	1880.0	18900	5	16-QAM	12	0	20.94	0-2	2
	1880.0	18900	5	16-QAM	12	6	21.01	0-2	2
1880.0	18900	5	16-QAM	12	13	20.94	0-2	2	
1880.0	18900	5	16-QAM	25	0	20.94	0-2	2	
High	1907.5	19175	5	QPSK	1	0	23.50	0	0
	1907.5	19175	5	QPSK	1	12	23.61	0	0
	1907.5	19175	5	QPSK	1	24	23.53	0	0
	1907.5	19175	5	QPSK	12	0	22.08	0-1	1
	1907.5	19175	5	QPSK	12	6	22.17	0-1	1
	1907.5	19175	5	QPSK	12	13	22.09	0-1	1
	1907.5	19175	5	QPSK	25	0	22.10	0-1	1
	1907.5	19175	5	16-QAM	1	0	22.34	0-1	1
	1907.5	19175	5	16-QAM	1	12	22.23	0-1	1
	1907.5	19175	5	16-QAM	1	24	22.33	0-1	1
	1907.5	19175	5	16-QAM	12	0	21.06	0-2	2
	1907.5	19175	5	16-QAM	12	6	21.03	0-2	2
1907.5	19175	5	16-QAM	12	13	21.05	0-2	2	
1907.5	19175	5	16-QAM	25	0	20.99	0-2	2	



FCC ID: A3LSMG890A	 PCTEST PROFESSIONAL LABORATORY, INC.	SAR EVALUATION REPORT		Reviewed by: Quality Manager
Document S/N: OY1504030657.A3L	Test Dates: 04/06/15 - 05/04/15	DUT Type: Portable Handset	Page 50 of 94	

Table 9-25

LTE Band 2 (PCS) Maximum Conducted Powers - 3 MHz Bandwidth- Representing Hotspot Mode Not Active

	Frequency [MHz]	Channel	Bandwidth [MHz]	Modulation	RB Size	RB Offset	Conducted Power [dBm]	MPR Allowed per 3GPP [dB]	MPR [dB]
Low	1851.5	18615	3	QPSK	1	0	23.67	0	0
	1851.5	18615	3	QPSK	1	7	23.66	0	0
	1851.5	18615	3	QPSK	1	14	23.63	0	0
	1851.5	18615	3	QPSK	8	0	22.21	0-1	1
	1851.5	18615	3	QPSK	8	4	22.30	0-1	1
	1851.5	18615	3	QPSK	8	7	22.23	0-1	1
	1851.5	18615	3	QPSK	15	0	22.15	0-1	1
	1851.5	18615	3	16-QAM	1	0	22.70	0-1	1
	1851.5	18615	3	16-QAM	1	7	22.60	0-1	1
	1851.5	18615	3	16-QAM	1	14	22.49	0-1	1
	1851.5	18615	3	16-QAM	8	0	21.00	0-2	2
	1851.5	18615	3	16-QAM	8	4	21.08	0-2	2
1851.5	18615	3	16-QAM	8	7	21.14	0-2	2	
1851.5	18615	3	16-QAM	15	0	21.09	0-2	2	
Mid	1880.0	18900	3	QPSK	1	0	23.51	0	0
	1880.0	18900	3	QPSK	1	7	23.52	0	0
	1880.0	18900	3	QPSK	1	14	23.45	0	0
	1880.0	18900	3	QPSK	8	0	22.09	0-1	1
	1880.0	18900	3	QPSK	8	4	22.12	0-1	1
	1880.0	18900	3	QPSK	8	7	22.14	0-1	1
	1880.0	18900	3	QPSK	15	0	22.11	0-1	1
	1880.0	18900	3	16-QAM	1	0	22.42	0-1	1
	1880.0	18900	3	16-QAM	1	7	22.48	0-1	1
	1880.0	18900	3	16-QAM	1	14	22.51	0-1	1
	1880.0	18900	3	16-QAM	8	0	20.96	0-2	2
	1880.0	18900	3	16-QAM	8	4	21.01	0-2	2
1880.0	18900	3	16-QAM	8	7	21.00	0-2	2	
1880.0	18900	3	16-QAM	15	0	21.08	0-2	2	
High	1908.5	19185	3	QPSK	1	0	23.66	0	0
	1908.5	19185	3	QPSK	1	7	23.67	0	0
	1908.5	19185	3	QPSK	1	14	23.60	0	0
	1908.5	19185	3	QPSK	8	0	22.20	0-1	1
	1908.5	19185	3	QPSK	8	4	22.17	0-1	1
	1908.5	19185	3	QPSK	8	7	22.12	0-1	1
	1908.5	19185	3	QPSK	15	0	22.23	0-1	1
	1908.5	19185	3	16-QAM	1	0	22.53	0-1	1
	1908.5	19185	3	16-QAM	1	7	22.37	0-1	1
	1908.5	19185	3	16-QAM	1	14	22.38	0-1	1
	1908.5	19185	3	16-QAM	8	0	21.18	0-2	2
	1908.5	19185	3	16-QAM	8	4	21.15	0-2	2
1908.5	19185	3	16-QAM	8	7	21.13	0-2	2	
1908.5	19185	3	16-QAM	15	0	21.16	0-2	2	



FCC ID: A3LSMG890A	 PCTEST PROFESSIONAL ENGINEERING LABORATORY, INC.	SAR EVALUATION REPORT		Reviewed by: Quality Manager
Document S/N: OY1504030657.A3L	Test Dates: 04/06/15 - 05/04/15	DUT Type: Portable Handset		Page 51 of 94

Table 9-26

LTE Band 2 (PCS) Maximum Conducted Powers -1.4 MHz Bandwidth- Representing Hotspot Mode Not Active

	Frequency [MHz]	Channel	Bandwidth [MHz]	Modulation	RB Size	RB Offset	Conducted Power [dBm]	MPR Allowed per 3GPP [dB]	MPR [dB]
Low	1850.7	18607	1.4	QPSK	1	0	23.54	0	0
	1850.7	18607	1.4	QPSK	1	2	23.49	0	0
	1850.7	18607	1.4	QPSK	1	5	23.58	0	0
	1850.7	18607	1.4	QPSK	3	0	23.29	0	0
	1850.7	18607	1.4	QPSK	3	2	23.33	0	0
	1850.7	18607	1.4	QPSK	3	3	23.24	0	0
	1850.7	18607	1.4	QPSK	6	0	22.24	0-1	1
	1850.7	18607	1.4	16-QAM	1	0	22.67	0-1	1
	1850.7	18607	1.4	16-QAM	1	2	22.53	0-1	1
	1850.7	18607	1.4	16-QAM	1	5	22.66	0-1	1
	1850.7	18607	1.4	16-QAM	3	0	22.15	0-1	1
	1850.7	18607	1.4	16-QAM	3	2	22.17	0-1	1
1850.7	18607	1.4	16-QAM	3	3	22.23	0-1	1	
1850.7	18607	1.4	16-QAM	6	0	21.12	0-2	2	
Mid	1880.0	18900	1.4	QPSK	1	0	23.51	0	0
	1880.0	18900	1.4	QPSK	1	2	23.44	0	0
	1880.0	18900	1.4	QPSK	1	5	23.49	0	0
	1880.0	18900	1.4	QPSK	3	0	23.17	0	0
	1880.0	18900	1.4	QPSK	3	2	23.18	0	0
	1880.0	18900	1.4	QPSK	3	3	23.15	0	0
	1880.0	18900	1.4	QPSK	6	0	22.06	0-1	1
	1880.0	18900	1.4	16-QAM	1	0	22.54	0-1	1
	1880.0	18900	1.4	16-QAM	1	2	22.59	0-1	1
	1880.0	18900	1.4	16-QAM	1	5	22.65	0-1	1
	1880.0	18900	1.4	16-QAM	3	0	21.98	0-1	1
	1880.0	18900	1.4	16-QAM	3	2	21.94	0-1	1
1880.0	18900	1.4	16-QAM	3	3	22.00	0-1	1	
1880.0	18900	1.4	16-QAM	6	0	21.01	0-2	2	
High	1909.3	19193	1.4	QPSK	1	0	23.65	0	0
	1909.3	19193	1.4	QPSK	1	2	23.60	0	0
	1909.3	19193	1.4	QPSK	1	5	23.67	0	0
	1909.3	19193	1.4	QPSK	3	0	23.36	0	0
	1909.3	19193	1.4	QPSK	3	2	23.25	0	0
	1909.3	19193	1.4	QPSK	3	3	23.28	0	0
	1909.3	19193	1.4	QPSK	6	0	22.19	0-1	1
	1909.3	19193	1.4	16-QAM	1	0	22.60	0-1	1
	1909.3	19193	1.4	16-QAM	1	2	22.68	0-1	1
	1909.3	19193	1.4	16-QAM	1	5	22.64	0-1	1
	1909.3	19193	1.4	16-QAM	3	0	22.17	0-1	1
	1909.3	19193	1.4	16-QAM	3	2	22.14	0-1	1
1909.3	19193	1.4	16-QAM	3	3	22.06	0-1	1	
1909.3	19193	1.4	16-QAM	6	0	21.02	0-2	2	



FCC ID: A3LSMG890A	 PCTEST PROFESSIONAL ENGINEERING LABORATORY, INC.	SAR EVALUATION REPORT		Reviewed by: Quality Manager
Document S/N: OY1504030657.A3L	Test Dates: 04/06/15 - 05/04/15	DUT Type: Portable Handset	Page 52 of 94	

Table 9-27

LTE Band 2 (PCS) Reduced Conducted Powers - 20 MHz Bandwidth- Representing Hotspot Mode Active

	Frequency [MHz]	Channel	Bandwidth [MHz]	Modulation	RB Size	RB Offset	Conducted Power [dBm]	MPR Allowed per 3GPP [dB]	MPR [dB]
Low	1860	18700	20	QPSK	1	0	20.36	0	0
	1860	18700	20	QPSK	1	50	20.34	0	0
	1860	18700	20	QPSK	1	99	20.33	0	0
	1860	18700	20	QPSK	50	0	20.15	0-1	0
	1860	18700	20	QPSK	50	25	20.22	0-1	0
	1860	18700	20	QPSK	50	50	20.17	0-1	0
	1860	18700	20	QPSK	100	0	20.09	0-1	0
	1860	18700	20	16QAM	1	0	20.48	0-1	0
	1860	18700	20	16QAM	1	50	20.41	0-1	0
	1860	18700	20	16QAM	1	99	20.45	0-1	0
	1860	18700	20	16QAM	50	0	20.19	0-2	0
	1860	18700	20	16QAM	50	25	20.27	0-2	0
1860	18700	20	16QAM	50	50	20.25	0-2	0	
1860	18700	20	16QAM	100	0	20.22	0-2	0	
Mid	1880.0	18900	20	QPSK	1	0	20.28	0	0
	1880.0	18900	20	QPSK	1	50	20.30	0	0
	1880.0	18900	20	QPSK	1	99	20.27	0	0
	1880.0	18900	20	QPSK	50	0	20.16	0-1	0
	1880.0	18900	20	QPSK	50	25	20.06	0-1	0
	1880.0	18900	20	QPSK	50	50	20.13	0-1	0
	1880.0	18900	20	QPSK	100	0	20.05	0-1	0
	1880.0	18900	20	16QAM	1	0	20.43	0-1	0
	1880.0	18900	20	16QAM	1	50	20.37	0-1	0
	1880.0	18900	20	16QAM	1	99	20.47	0-1	0
	1880.0	18900	20	16QAM	50	0	20.21	0-2	0
	1880.0	18900	20	16QAM	50	25	20.12	0-2	0
1880.0	18900	20	16QAM	50	50	20.09	0-2	0	
1880.0	18900	20	16QAM	100	0	20.07	0-2	0	
High	1900	19100	20	QPSK	1	0	20.35	0	0
	1900	19100	20	QPSK	1	50	20.32	0	0
	1900	19100	20	QPSK	1	99	20.34	0	0
	1900	19100	20	QPSK	50	0	20.19	0-1	0
	1900	19100	20	QPSK	50	25	20.17	0-1	0
	1900	19100	20	QPSK	50	50	20.12	0-1	0
	1900	19100	20	QPSK	100	0	20.18	0-1	0
	1900	19100	20	16QAM	1	0	20.43	0-1	0
	1900	19100	20	16QAM	1	50	20.35	0-1	0
	1900	19100	20	16QAM	1	99	20.37	0-1	0
	1900	19100	20	16QAM	50	0	20.17	0-2	0
	1900	19100	20	16QAM	50	25	20.11	0-2	0
1900	19100	20	16QAM	50	50	20.05	0-2	0	
1900	19100	20	16QAM	100	0	20.13	0-2	0	



FCC ID: A3LSMG890A	 PCTEST PROFESSIONAL ENGINEERING LABORATORY, INC.	SAR EVALUATION REPORT		Reviewed by: Quality Manager
Document S/N: OY1504030657.A3L	Test Dates: 04/06/15 - 05/04/15	DUT Type: Portable Handset	Page 53 of 94	

Table 9-28

LTE Band 2 (PCS) Reduced Conducted Powers - 15 MHz Bandwidth- Representing Hotspot Mode Active

	Frequency [MHz]	Channel	Bandwidth [MHz]	Modulation	RB Size	RB Offset	Conducted Power [dBm]	MPR Allowed per 3GPP [dB]	MPR [dB]
Low	1857.5	18675	15	QPSK	1	0	20.49	0	0
	1857.5	18675	15	QPSK	1	36	20.38	0	0
	1857.5	18675	15	QPSK	1	74	20.35	0	0
	1857.5	18675	15	QPSK	36	0	20.26	0-1	0
	1857.5	18675	15	QPSK	36	18	20.27	0-1	0
	1857.5	18675	15	QPSK	36	37	20.30	0-1	0
	1857.5	18675	15	QPSK	75	0	20.25	0-1	0
	1857.5	18675	15	16QAM	1	0	20.38	0-1	0
	1857.5	18675	15	16QAM	1	36	20.31	0-1	0
	1857.5	18675	15	16QAM	1	74	20.28	0-1	0
	1857.5	18675	15	16QAM	36	0	20.23	0-2	0
	1857.5	18675	15	16QAM	36	18	20.23	0-2	0
1857.5	18675	15	16QAM	36	37	20.27	0-2	0	
1857.5	18675	15	16QAM	75	0	20.25	0-2	0	
Mid	1880.0	18900	15	QPSK	1	0	20.43	0	0
	1880.0	18900	15	QPSK	1	36	20.44	0	0
	1880.0	18900	15	QPSK	1	74	20.42	0	0
	1880.0	18900	15	QPSK	36	0	20.22	0-1	0
	1880.0	18900	15	QPSK	36	18	20.25	0-1	0
	1880.0	18900	15	QPSK	36	37	20.26	0-1	0
	1880.0	18900	15	QPSK	75	0	20.24	0-1	0
	1880.0	18900	15	16QAM	1	0	20.19	0-1	0
	1880.0	18900	15	16QAM	1	36	20.18	0-1	0
	1880.0	18900	15	16QAM	1	74	20.21	0-1	0
	1880.0	18900	15	16QAM	36	0	20.27	0-2	0
	1880.0	18900	15	16QAM	36	18	20.30	0-2	0
1880.0	18900	15	16QAM	36	37	20.34	0-2	0	
1880.0	18900	15	16QAM	75	0	20.27	0-2	0	
High	1902.5	19125	15	QPSK	1	0	20.49	0	0
	1902.5	19125	15	QPSK	1	36	20.47	0	0
	1902.5	19125	15	QPSK	1	74	20.46	0	0
	1902.5	19125	15	QPSK	36	0	20.45	0-1	0
	1902.5	19125	15	QPSK	36	18	20.37	0-1	0
	1902.5	19125	15	QPSK	36	37	20.35	0-1	0
	1902.5	19125	15	QPSK	75	0	20.33	0-1	0
	1902.5	19125	15	16QAM	1	0	20.48	0-1	0
	1902.5	19125	15	16QAM	1	36	20.46	0-1	0
	1902.5	19125	15	16QAM	1	74	20.50	0-1	0
	1902.5	19125	15	16QAM	36	0	20.39	0-2	0
	1902.5	19125	15	16QAM	36	18	20.32	0-2	0
1902.5	19125	15	16QAM	36	37	20.32	0-2	0	
1902.5	19125	15	16QAM	75	0	20.38	0-2	0	



FCC ID: A3LSMG890A	 PCTEST PROFESSIONAL ENGINEERING LABORATORY, INC.	SAR EVALUATION REPORT		Reviewed by: Quality Manager
Document S/N: OY1504030657.A3L	Test Dates: 04/06/15 - 05/04/15	DUT Type: Portable Handset		Page 54 of 94

Table 9-29

LTE Band 2 (PCS) Reduced Conducted Powers - 10 MHz Bandwidth- Representing Hotspot Mode Active

	Frequency [MHz]	Channel	Bandwidth [MHz]	Modulation	RB Size	RB Offset	Conducted Power [dBm]	MPR Allowed per 3GPP [dB]	MPR [dB]
Low	1855	18650	10	QPSK	1	0	20.50	0	0
	1855	18650	10	QPSK	1	25	20.39	0	0
	1855	18650	10	QPSK	1	49	20.47	0	0
	1855	18650	10	QPSK	25	0	20.27	0-1	0
	1855	18650	10	QPSK	25	12	20.30	0-1	0
	1855	18650	10	QPSK	25	25	20.31	0-1	0
	1855	18650	10	QPSK	50	0	20.38	0-1	0
	1855	18650	10	16QAM	1	0	20.42	0-1	0
	1855	18650	10	16QAM	1	25	20.47	0-1	0
	1855	18650	10	16QAM	1	49	20.46	0-1	0
	1855	18650	10	16QAM	25	0	20.34	0-2	0
	1855	18650	10	16QAM	25	12	20.38	0-2	0
1855	18650	10	16QAM	25	25	20.36	0-2	0	
1855	18650	10	16QAM	50	0	20.38	0-2	0	
Mid	1880.0	18900	10	QPSK	1	0	20.36	0	0
	1880.0	18900	10	QPSK	1	25	20.38	0	0
	1880.0	18900	10	QPSK	1	49	20.40	0	0
	1880.0	18900	10	QPSK	25	0	20.17	0-1	0
	1880.0	18900	10	QPSK	25	12	20.12	0-1	0
	1880.0	18900	10	QPSK	25	25	20.11	0-1	0
	1880.0	18900	10	QPSK	50	0	20.14	0-1	0
	1880.0	18900	10	16QAM	1	0	20.35	0-1	0
	1880.0	18900	10	16QAM	1	25	20.30	0-1	0
	1880.0	18900	10	16QAM	1	49	20.32	0-1	0
	1880.0	18900	10	16QAM	25	0	20.24	0-2	0
	1880.0	18900	10	16QAM	25	12	20.23	0-2	0
1880.0	18900	10	16QAM	25	25	20.22	0-2	0	
1880.0	18900	10	16QAM	50	0	20.22	0-2	0	
High	1905	19150	10	QPSK	1	0	20.47	0	0
	1905	19150	10	QPSK	1	25	20.45	0	0
	1905	19150	10	QPSK	1	49	20.40	0	0
	1905	19150	10	QPSK	25	0	20.31	0-1	0
	1905	19150	10	QPSK	25	12	20.29	0-1	0
	1905	19150	10	QPSK	25	25	20.30	0-1	0
	1905	19150	10	QPSK	50	0	20.43	0-1	0
	1905	19150	10	16QAM	1	0	20.40	0-1	0
	1905	19150	10	16QAM	1	25	20.37	0-1	0
	1905	19150	10	16QAM	1	49	20.31	0-1	0
	1905	19150	10	16QAM	25	0	20.36	0-2	0
	1905	19150	10	16QAM	25	12	20.35	0-2	0
1905	19150	10	16QAM	25	25	20.38	0-2	0	
1905	19150	10	16QAM	50	0	20.38	0-2	0	



FCC ID: A3LSMG890A	 PCTEST PROFESSIONAL ENGINEERING LABORATORY, INC.	SAR EVALUATION REPORT		Reviewed by: Quality Manager
Document S/N: OY1504030657.A3L	Test Dates: 04/06/15 - 05/04/15	DUT Type: Portable Handset	Page 55 of 94	

Table 9-30
LTE Band 2 (PCS) Reduced Conducted Powers - 5 MHz Bandwidth- Representing Hotspot Mode Active

	Frequency [MHz]	Channel	Bandwidth [MHz]	Modulation	RB Size	RB Offset	Conducted Power [dBm]	MPR Allowed per 3GPP [dB]	MPR [dB]
Low	1852.5	18625	5	QPSK	1	0	20.38	0	0
	1852.5	18625	5	QPSK	1	12	20.36	0	0
	1852.5	18625	5	QPSK	1	24	20.41	0	0
	1852.5	18625	5	QPSK	12	0	20.17	0-1	0
	1852.5	18625	5	QPSK	12	6	20.24	0-1	0
	1852.5	18625	5	QPSK	12	13	20.30	0-1	0
	1852.5	18625	5	QPSK	25	0	20.30	0-1	0
	1852.5	18625	5	16-QAM	1	0	20.44	0-1	0
	1852.5	18625	5	16-QAM	1	12	20.35	0-1	0
	1852.5	18625	5	16-QAM	1	24	20.46	0-1	0
	1852.5	18625	5	16-QAM	12	0	20.23	0-2	0
	1852.5	18625	5	16-QAM	12	6	20.20	0-2	0
1852.5	18625	5	16-QAM	12	13	20.26	0-2	0	
1852.5	18625	5	16-QAM	25	0	20.37	0-2	0	
Mid	1880.0	18900	5	QPSK	1	0	20.37	0	0
	1880.0	18900	5	QPSK	1	12	20.42	0	0
	1880.0	18900	5	QPSK	1	24	20.43	0	0
	1880.0	18900	5	QPSK	12	0	20.20	0-1	0
	1880.0	18900	5	QPSK	12	6	20.24	0-1	0
	1880.0	18900	5	QPSK	12	13	20.25	0-1	0
	1880.0	18900	5	QPSK	25	0	20.17	0-1	0
	1880.0	18900	5	16-QAM	1	0	20.22	0-1	0
	1880.0	18900	5	16-QAM	1	12	20.16	0-1	0
	1880.0	18900	5	16-QAM	1	24	20.25	0-1	0
	1880.0	18900	5	16-QAM	12	0	20.19	0-2	0
	1880.0	18900	5	16-QAM	12	6	20.10	0-2	0
1880.0	18900	5	16-QAM	12	13	20.13	0-2	0	
1880.0	18900	5	16-QAM	25	0	20.10	0-2	0	
High	1907.5	19175	5	QPSK	1	0	20.42	0	0
	1907.5	19175	5	QPSK	1	12	20.44	0	0
	1907.5	19175	5	QPSK	1	24	20.46	0	0
	1907.5	19175	5	QPSK	12	0	20.45	0-1	0
	1907.5	19175	5	QPSK	12	6	20.47	0-1	0
	1907.5	19175	5	QPSK	12	13	20.44	0-1	0
	1907.5	19175	5	QPSK	25	0	20.42	0-1	0
	1907.5	19175	5	16-QAM	1	0	20.47	0-1	0
	1907.5	19175	5	16-QAM	1	12	20.38	0-1	0
	1907.5	19175	5	16-QAM	1	24	20.46	0-1	0
	1907.5	19175	5	16-QAM	12	0	20.35	0-2	0
	1907.5	19175	5	16-QAM	12	6	20.43	0-2	0
1907.5	19175	5	16-QAM	12	13	20.43	0-2	0	
1907.5	19175	5	16-QAM	25	0	20.44	0-2	0	



FCC ID: A3LSMG890A	 PCTEST <small>PROFESSIONAL ENGINEERING LABORATORY, INC.</small>	SAR EVALUATION REPORT		Reviewed by: Quality Manager
Document S/N: OY1504030657.A3L	Test Dates: 04/06/15 - 05/04/15	DUT Type: Portable Handset		Page 56 of 94

Table 9-31
LTE Band 2 (PCS) Reduced Conducted Powers - 3 MHz Bandwidth- Representing Hotspot Mode Active

	Frequency [MHz]	Channel	Bandwidth [MHz]	Modulation	RB Size	RB Offset	Conducted Power [dBm]	MPR Allowed per 3GPP [dB]	MPR [dB]
Low	1851.5	18615	3	QPSK	1	0	20.49	0	0
	1851.5	18615	3	QPSK	1	7	20.48	0	0
	1851.5	18615	3	QPSK	1	14	20.47	0	0
	1851.5	18615	3	QPSK	8	0	20.15	0-1	0
	1851.5	18615	3	QPSK	8	4	20.19	0-1	0
	1851.5	18615	3	QPSK	8	7	20.24	0-1	0
	1851.5	18615	3	QPSK	15	0	20.26	0-1	0
	1851.5	18615	3	16-QAM	1	0	20.45	0-1	0
	1851.5	18615	3	16-QAM	1	7	20.47	0-1	0
	1851.5	18615	3	16-QAM	1	14	20.48	0-1	0
	1851.5	18615	3	16-QAM	8	0	20.11	0-2	0
	1851.5	18615	3	16-QAM	8	4	20.17	0-2	0
1851.5	18615	3	16-QAM	8	7	20.20	0-2	0	
1851.5	18615	3	16-QAM	15	0	20.17	0-2	0	
Mid	1880.0	18900	3	QPSK	1	0	20.49	0	0
	1880.0	18900	3	QPSK	1	7	20.49	0	0
	1880.0	18900	3	QPSK	1	14	20.48	0	0
	1880.0	18900	3	QPSK	8	0	20.21	0-1	0
	1880.0	18900	3	QPSK	8	4	20.22	0-1	0
	1880.0	18900	3	QPSK	8	7	20.21	0-1	0
	1880.0	18900	3	QPSK	15	0	20.17	0-1	0
	1880.0	18900	3	16-QAM	1	0	20.47	0-1	0
	1880.0	18900	3	16-QAM	1	7	20.49	0-1	0
	1880.0	18900	3	16-QAM	1	14	20.47	0-1	0
	1880.0	18900	3	16-QAM	8	0	20.16	0-2	0
	1880.0	18900	3	16-QAM	8	4	20.15	0-2	0
1880.0	18900	3	16-QAM	8	7	20.16	0-2	0	
1880.0	18900	3	16-QAM	15	0	20.09	0-2	0	
High	1908.5	19185	3	QPSK	1	0	20.46	0	0
	1908.5	19185	3	QPSK	1	7	20.44	0	0
	1908.5	19185	3	QPSK	1	14	20.45	0	0
	1908.5	19185	3	QPSK	8	0	20.17	0-1	0
	1908.5	19185	3	QPSK	8	4	20.26	0-1	0
	1908.5	19185	3	QPSK	8	7	20.28	0-1	0
	1908.5	19185	3	QPSK	15	0	20.21	0-1	0
	1908.5	19185	3	16-QAM	1	0	20.42	0-1	0
	1908.5	19185	3	16-QAM	1	7	20.37	0-1	0
	1908.5	19185	3	16-QAM	1	14	20.45	0-1	0
	1908.5	19185	3	16-QAM	8	0	20.09	0-2	0
	1908.5	19185	3	16-QAM	8	4	20.11	0-2	0
1908.5	19185	3	16-QAM	8	7	20.14	0-2	0	
1908.5	19185	3	16-QAM	15	0	20.11	0-2	0	





FCC ID: A3LSMG890A	 PCTEST <small>PROFESSIONAL ENGINEERING LABORATORY, INC.</small>	SAR EVALUATION REPORT		Reviewed by: Quality Manager
Document S/N: OY1504030657.A3L	Test Dates: 04/06/15 - 05/04/15	DUT Type: Portable Handset	Page 57 of 94	

Table 9-32

LTE Band 2 (PCS) Reduced Conducted Powers -1.4 MHz Bandwidth- Representing Hotspot Mode Active

	Frequency [MHz]	Channel	Bandwidth [MHz]	Modulation	RB Size	RB Offset	Conducted Power [dBm]	MPR Allowed per 3GPP [dB]	MPR [dB]
Low	1850.7	18607	1.4	QPSK	1	0	20.42	0	0
	1850.7	18607	1.4	QPSK	1	2	20.45	0	0
	1850.7	18607	1.4	QPSK	1	5	20.45	0	0
	1850.7	18607	1.4	QPSK	3	0	20.16	0	0
	1850.7	18607	1.4	QPSK	3	2	20.23	0	0
	1850.7	18607	1.4	QPSK	3	3	20.19	0	0
	1850.7	18607	1.4	QPSK	6	0	20.24	0-1	0
	1850.7	18607	1.4	16-QAM	1	0	20.47	0-1	0
	1850.7	18607	1.4	16-QAM	1	2	20.43	0-1	0
	1850.7	18607	1.4	16-QAM	1	5	20.46	0-1	0
	1850.7	18607	1.4	16-QAM	3	0	20.12	0-1	0
	1850.7	18607	1.4	16-QAM	3	2	20.10	0-1	0
1850.7	18607	1.4	16-QAM	3	3	20.15	0-1	0	
1850.7	18607	1.4	16-QAM	6	0	20.20	0-2	0	
Mid	1880.0	18900	1.4	QPSK	1	0	20.49	0	0
	1880.0	18900	1.4	QPSK	1	2	20.42	0	0
	1880.0	18900	1.4	QPSK	1	5	20.48	0	0
	1880.0	18900	1.4	QPSK	3	0	20.18	0	0
	1880.0	18900	1.4	QPSK	3	2	20.23	0	0
	1880.0	18900	1.4	QPSK	3	3	20.16	0	0
	1880.0	18900	1.4	QPSK	6	0	20.23	0-1	0
	1880.0	18900	1.4	16-QAM	1	0	20.47	0-1	0
	1880.0	18900	1.4	16-QAM	1	2	20.48	0-1	0
	1880.0	18900	1.4	16-QAM	1	5	20.48	0-1	0
	1880.0	18900	1.4	16-QAM	3	0	20.18	0-1	0
	1880.0	18900	1.4	16-QAM	3	2	20.09	0-1	0
1880.0	18900	1.4	16-QAM	3	3	20.12	0-1	0	
1880.0	18900	1.4	16-QAM	6	0	20.08	0-2	0	
High	1909.3	19193	1.4	QPSK	1	0	20.47	0	0
	1909.3	19193	1.4	QPSK	1	2	20.38	0	0
	1909.3	19193	1.4	QPSK	1	5	20.45	0	0
	1909.3	19193	1.4	QPSK	3	0	20.41	0	0
	1909.3	19193	1.4	QPSK	3	2	20.37	0	0
	1909.3	19193	1.4	QPSK	3	3	20.41	0	0
	1909.3	19193	1.4	QPSK	6	0	20.49	0-1	0
	1909.3	19193	1.4	16-QAM	1	0	20.48	0-1	0
	1909.3	19193	1.4	16-QAM	1	2	20.45	0-1	0
	1909.3	19193	1.4	16-QAM	1	5	20.50	0-1	0
	1909.3	19193	1.4	16-QAM	3	0	20.49	0-1	0
	1909.3	19193	1.4	16-QAM	3	2	20.28	0-1	0
1909.3	19193	1.4	16-QAM	3	3	20.33	0-1	0	
1909.3	19193	1.4	16-QAM	6	0	20.41	0-2	0	

FCC ID: A3LSMG890A	 PCTEST PROFESSIONAL ENGINEERING LABORATORY, INC.	SAR EVALUATION REPORT		Reviewed by: Quality Manager
Document S/N: OY1504030657.A3L	Test Dates: 04/06/15 - 05/04/15	DUT Type: Portable Handset		Page 58 of 94

9.3.5

LTE Band 30



Table 9-33
LTE Band 30 Maximum Conducted Powers - 10 MHz Bandwidth

	Frequency [MHz]	Channel	Bandwidth [MHz]	Modulation	RB Size	RB Offset	Conducted Power [dBm]	MPR Allowed per 3GPP [dB]	MPR [dB]
Mid	2310.0	27710	10	QPSK	1	0	22.29	0	0
	2310.0	27710	10	QPSK	1	25	22.39	0	0
	2310.0	27710	10	QPSK	1	49	22.34	0	0
	2310.0	27710	10	QPSK	25	0	21.11	0-1	1
	2310.0	27710	10	QPSK	25	12	21.16	0-1	1
	2310.0	27710	10	QPSK	25	25	21.07	0-1	1
	2310.0	27710	10	QPSK	50	0	21.10	0-1	1
	2310.0	27710	10	16QAM	1	0	21.31	0-1	1
	2310.0	27710	10	16QAM	1	25	21.47	0-1	1
	2310.0	27710	10	16QAM	1	49	21.42	0-1	1
	2310.0	27710	10	16QAM	25	0	20.17	0-2	2
	2310.0	27710	10	16QAM	25	12	20.18	0-2	2
	2310.0	27710	10	16QAM	25	25	20.11	0-2	2
	2310.0	27710	10	16QAM	50	0	20.09	0-2	2

Table 9-34
LTE Band 30 Maximum Conducted Powers - 5 MHz Bandwidth

	Frequency [MHz]	Channel	Bandwidth [MHz]	Modulation	RB Size	RB Offset	Conducted Power [dBm]	MPR Allowed per 3GPP [dB]	MPR [dB]
Mid	2310.0	27710	5	QPSK	1	0	22.47	0	0
	2310.0	27710	5	QPSK	1	12	22.46	0	0
	2310.0	27710	5	QPSK	1	24	22.45	0	0
	2310.0	27710	5	QPSK	12	0	21.45	0-1	1
	2310.0	27710	5	QPSK	12	6	21.47	0-1	1
	2310.0	27710	5	QPSK	12	13	21.34	0-1	1
	2310.0	27710	5	QPSK	25	0	21.49	0-1	1
	2310.0	27710	5	16-QAM	1	0	21.49	0-1	1
	2310.0	27710	5	16-QAM	1	12	21.42	0-1	1
	2310.0	27710	5	16-QAM	1	24	21.44	0-1	1
	2310.0	27710	5	16-QAM	12	0	20.43	0-2	2
	2310.0	27710	5	16-QAM	12	6	20.42	0-2	2
	2310.0	27710	5	16-QAM	12	13	20.44	0-2	2
	2310.0	27710	5	16-QAM	25	0	20.38	0-2	2

Note: LTE Band 30 (AWS) at 5 MHz bandwidth does not support three non-overlapping channels. Per KDB Publication 941225 D05v02, when a device supports overlapping channel assignment in a channel bandwidth configuration, the middle channel of the group of overlapping channels should be selected for testing.

FCC ID: A3LSMG890A	 PCTEST PROFESSIONAL CORPORATION, INC.	SAR EVALUATION REPORT		Reviewed by: Quality Manager
Document S/N: OY1504030657.A3L	Test Dates: 04/06/15 - 05/04/15	DUT Type: Portable Handset		Page 59 of 94

9.3.6

LTE Carrier Aggregation Conducted Powers

Table 9-35

LTE Carrier Aggregation Conducted Powers – Representing Hotspot Mode Not Active

PCC						SCC				Power	
PCC Band	PCC Bandwidth [MHz]	PCC Frequency [MHz]	PCC Channel	PCC UL/RB	PCC UL RB Offset	SCC Band	SCC Bandwidth [MHz]	SCC Frequency [MHz]	SCC Channel	LTE Rel. 10 Tx. Power (dBm)	LTE Rel. 8 Tx. Power (dBm)
LTE B12	10	707.5	23095	1	25	LTE B2	20	1980	1100	23.48	23.49
LTE B12	10	707.5	23095	1	25	LTE B30	10	2355	9820	23.47	23.49
LTE B5	5	836.5	20525	1	0	LTE B2	20	1980	1100	23.65	23.75
LTE B5	5	836.5	20525	1	0	LTE B4	20	2132.5	2175	23.74	23.75
LTE B5	5	836.5	20525	1	0	LTE B30	10	2355	9820	23.63	23.75
LTE B4	10	1732.5	20175	1	25	LTE B17	10	740	5790	23.36	23.70
LTE B4	10	1732.5	20175	1	25	LTE B29	10	722.5	9715	23.31	23.70
LTE B4	10	1732.5	20175	1	25	LTE B5	10	881.5	2525	23.30	23.70
LTE B4	10	1732.5	20175	1	25	LTE B12	10	737.5	5095	23.37	23.70
LTE B4	10	1732.5	20175	1	25	LTE B30	10	2355	9820	23.33	23.70
LTE B2	10	1905	19150	1	25	LTE B17	10	740	5790	23.55	23.69
LTE B2	10	1905	19150	1	25	LTE B29	10	722.5	9715	23.52	23.69
LTE B2	10	1905	19150	1	25	LTE B5	10	881.5	2525	23.60	23.69
LTE B2	10	1905	19150	1	25	LTE B12	10	737.5	5095	23.59	23.69
LTE B2	10	1905	19150	1	25	LTE B30	10	2355	9820	23.60	23.69
LTE B30	5	2310	27710	1	0	LTE B2	20	1980	900	22.45	22.47
LTE B30	5	2310	27710	1	0	LTE B4	20	2132.5	2175	22.46	22.47
LTE B30	5	2310	27710	1	0	LTE B5	10	881.5	2525	22.45	22.47
LTE B30	5	2310	27710	1	0	LTE B29	10	722.5	9715	22.45	22.47
LTE B30	5	2310	27710	1	0	LTE B12	10	737.5	5095	22.40	22.47

Table 9-36

LTE Carrier Aggregation Conducted Powers – Representing Hotspot Mode Active

PCC						SCC				Power	
PCC Band	PCC Bandwidth [MHz]	PCC Frequency [MHz]	PCC Channel	PCC UL/RB	PCC UL RB Offset	SCC Band	SCC Bandwidth [MHz]	SCC Frequency [MHz]	SCC Channel	LTE Rel. 10 Tx. Power (dBm)	LTE Rel. 8 Tx. Power (dBm)
LTE B4	10	1750	20350	1	49	LTE B17	10	740	5790	21.02	21.50
LTE B4	10	1750	20350	1	49	LTE B29	10	722.5	9715	20.93	21.50
LTE B4	10	1750	20350	1	49	LTE B5	10	881.5	2525	21.05	21.50
LTE B4	10	1750	20350	1	49	LTE B12	10	737.5	5095	20.92	21.50
LTE B4	10	1750	20350	1	49	LTE B30	10	2355	9820	21.02	21.50
LTE B2	10	1855	18650	1	0	LTE B17	10	740	5790	20.49	20.50
LTE B2	10	1855	18650	1	0	LTE B29	10	722.5	9715	20.45	20.50
LTE B2	10	1855	18650	1	0	LTE B5	10	881.5	2525	20.44	20.50
LTE B2	10	1855	18650	1	0	LTE B12	10	737.5	5095	20.45	20.50
LTE B2	10	1855	18650	1	0	LTE B30	10	2355	9820	20.32	20.50

Notes:

- The device does not support all Rel. 10 Carrier Aggregation features due to modem chipset limitation.
- The device only supports downlink Carrier Aggregation. Uplink Carrier Aggregation is not supported. Power measurements were performed with two DL carriers for the Release 8 configuration that had the highest output power (across all bandwidths, channels and RB Configurations) for each band.
- This device only supports inter-band CA with 2 carriers (B12+B2, B12+B30, B5+B2, B5+B4, B5+B30, B4+B17, B4+B29, B4+B5, B4+B12, B4+B30, B2+B17, B2+B29, B2+B5, B2+B12, B2+B30, B30+B2, B30+B4, B30+B5, B30+B29, B30+B12, B17+B2).
- This device supports both LTE Band 12 and LTE Band 17. Since the supported frequency span for LTE Band 17 falls completely within the supported frequency span for LTE Band 12, LTE Band 17 has same or lower target power than LTE Band 12 target power, and both LTE bands share the same transmission path, LTE CA SAR combinations were only assessed for LTE Band 12 as PCC.
- All control and acknowledge data is sent on uplink channels that operate identical to release 8 specifications.

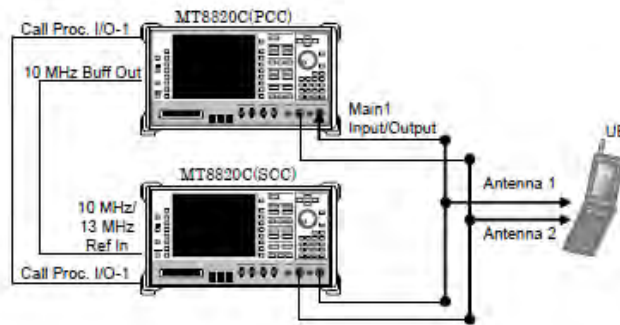

Figure 9-3
Power Measurement Setup

FCC ID: A3LSMG890A	PCTEST PROFESSIONAL CORPORATION, INC.	SAR EVALUATION REPORT		Reviewed by: Quality Manager
Document S/N: OY1504030657.A3L	Test Dates: 04/06/15 - 05/04/15	DUT Type: Portable Handset		Page 60 of 94

9.4 WLAN Conducted Powers

Table 9-37
2.4 GHz Antenna 1 Maximum Average RF Power

2.4GHz	Freq [MHz]	Channel	2.4GHz Conducted Power [dBm]	
			IEEE Transmission Mode	
			802.11b	802.11g
	2412	1	17.33	16.35
	2437	6	17.46	16.28
	2462	11	17.03	16.48

Table 9-38
2.4 GHz Antenna 2 Maximum Average RF Power

2.4GHz	Freq [MHz]	Channel	2.4GHz Conducted Power [dBm]	
			IEEE Transmission Mode	
			802.11b	802.11g
	2412	1	16.92	15.76
	2437	6	16.75	15.82
	2462	11	17.18	16.13

Table 9-39
2.4 GHz Antenna 1 Reduced Average RF Power – Held-to-Ear

2.4GHz	Freq [MHz]	Channel	2.4GHz Conducted Power [dBm]		
			IEEE Transmission Mode		
			802.11b	802.11g	802.11n
	2412	1	12.47	11.52	11.69
	2437	6	12.48	12.47	12.48
	2462	11	12.36	11.54	11.56

Table 9-40
2.4 GHz Antenna 2 Reduced Average RF Power – Held-to-Ear

2.4GHz	Freq [MHz]	Channel	2.4GHz Conducted Power [dBm]		
			IEEE Transmission Mode		
			802.11b	802.11g	802.11n
	2412	1	12.16	12.22	12.11
	2437	6	11.97	11.89	11.91
	2462	11	12.38	12.42	12.31



FCC ID: A3LSMG890A	 PCTEST PROFESSIONAL CORPORATION, INC.	SAR EVALUATION REPORT		Reviewed by: Quality Manager
Document S/N: OY1504030657.A3L	Test Dates: 04/06/15 - 05/04/15	DUT Type: Portable Handset		Page 61 of 94

Table 9-41
5 GHz Antenna 1 Maximum Average RF Power - 20 MHz Bandwidth

5GHz (20MHz Bandwidth)	Freq [MHz]	Channel	5GHz (20MHz) Conducted Power [dBm]
			IEEE
	5180	36	14.38
	5200	40	14.41
	5220	44	14.31
	5240	48	14.34
	5260	52	14.39
	5280	56	14.29
	5300	60	14.15
	5320	64	14.08
	5500	100	14.14
	5580	116	14.30
	5660	132	14.42
	5720	144	14.48
	5745	149	14.30
	5785	157	14.41
	5825	165	14.40

Table 9-42
5 GHz Antenna 2 Maximum Average RF Power - 20 MHz Bandwidth

5GHz (20MHz Bandwidth)	Freq [MHz]	Channel	5GHz (20MHz) Conducted Power [dBm]
			IEEE
	5180	36	13.96
	5200	40	13.99
	5220	44	13.72
	5240	48	13.69
	5260	52	14.02
	5280	56	13.79
	5300	60	13.90
	5320	64	13.76
	5500	100	13.79
	5580	116	13.77
	5660	132	13.72
	5720	144	14.46
	5745	149	14.44
	5785	157	14.47
	5825	165	14.26





FCC ID: A3LSMG890A		SAR EVALUATION REPORT		Reviewed by: Quality Manager
Document S/N: OY1504030657.A3L	Test Dates: 04/06/15 - 05/04/15	DUT Type: Portable Handset	Page 62 of 94	

Table 9-43
5 GHz Antenna 1 Average RF Power - 20 MHz Bandwidth – Head to Ear

5GHz (20MHz Bandwidth)	Freq [MHz]	Channel	5GHz (20MHz) Conducted Power [dBm]		
			IEEE Transmission Mode		
			802.11a	802.11n	802.11ac
5180	36	8.61	8.28	8.42	
5200	40	8.49	8.35	8.44	
5220	44	8.51	8.30	8.38	
5240	48	8.38	8.31	8.24	
5260	52	8.58	8.37	8.21	
5280	56	8.52	8.21	8.30	
5300	60	8.41	8.21	8.26	
5320	64	8.42	8.22	8.18	
5500	100	8.72	8.43	8.38	
5580	116	8.60	8.41	8.44	
5660	132	8.76	8.64	8.54	
5720	144	8.85	8.68	8.57	
5745	149	9.46	9.28	9.32	
5785	157	9.43	9.30	9.43	
5825	165	9.49	9.38	9.44	

Table 9-44
5 GHz Antenna 2 Average RF Power - 20 MHz Bandwidth – Held to Ear

5GHz (20MHz Bandwidth)	Freq [MHz]	Channel	5GHz (20MHz) Conducted Power [dBm]		
			IEEE Transmission Mode		
			802.11a	802.11n	802.11ac
5180	36	8.98	8.76	8.77	
5200	40	8.83	8.72	8.78	
5220	44	8.67	8.56	8.53	
5240	48	8.75	8.64	8.50	
5260	52	8.99	8.84	8.70	
5280	56	8.90	8.71	8.67	
5300	60	8.73	8.65	8.68	
5320	64	8.60	8.58	8.67	
5500	100	9.12	8.95	9.02	
5580	116	8.96	8.89	8.87	
5660	132	8.90	8.72	8.79	
5720	144	8.88	8.6	8.58	
5745	149	8.61	8.38	8.46	
5785	157	8.63	8.41	8.50	
5825	165	8.47	8.43	8.46	

FCC ID: A3LSMG890A		SAR EVALUATION REPORT		Reviewed by: Quality Manager
Document S/N: OY1504030657.A3L	Test Dates: 04/06/15 - 05/04/15	DUT Type: Portable Handset	Page 63 of 94	

Justification for test configurations for WLAN per KDB Publication 248227 D01 Wi-Fi SAR v02:

- Power measurements were performed for the transmission mode configuration with the highest maximum output power specified for production units.
- For transmission modes with the same maximum output power specification, powers were measured for the largest channel bandwidth, lowest order modulation and lowest data rate.
- For transmission modes with identical maximum specified output power, channel bandwidth, modulation and data rates, power measurements were required for all identical configurations.
- For each transmission mode configuration, powers were measured for the highest and lowest channels; and at the mid-band channel(s) when there were at least 3 channels supported. For configurations with multiple mid-band channels, due to an even number of channels, both channels were measured.

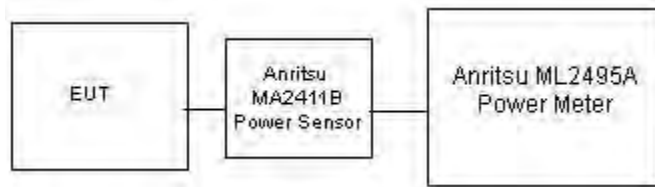



Figure 9-4
Power Measurement Setup for Bandwidths < 50 MHz

FCC ID: A3LSMG890A	 SAR EVALUATION REPORT 		Reviewed by: Quality Manager
Document S/N: OY1504030657.A3L	Test Dates: 04/06/15 - 05/04/15	DUT Type: Portable Handset	Page 64 of 94



10 SYSTEM VERIFICATION

10.1 Tissue Verification

**Table 10-1
Measured Tissue Properties**

Calibrated for Tests Performed on:	Tissue Type	Tissue Temp During Calibration (C°)	Measured Frequency (MHz)	Measured Conductivity, σ (S/m)	Measured Dielectric Constant, ϵ	TARGET Conductivity, σ (S/m)	TARGET Dielectric Constant, ϵ	%dev σ	%dev ϵ
04/08/2015	750H	21.4	695	0.873	42.343	0.889	42.227	-1.80%	0.27%
			710	0.888	42.153	0.890	42.149	-0.22%	0.01%
			725	0.902	41.923	0.891	42.071	1.23%	-0.35%
			740	0.916	41.724	0.893	41.994	2.58%	-0.64%
			755	0.929	41.542	0.894	41.916	3.91%	-0.89%
04/08/2015	835H	22.0	820	0.922	43.182	0.899	41.578	2.56%	3.86%
			835	0.936	43.008	0.900	41.500	4.00%	3.63%
			850	0.950	42.856	0.916	41.500	3.71%	3.27%
04/07/2015	1750H	23.2	1710	1.286	39.200	1.348	40.142	-4.60%	-2.35%
			1750	1.326	39.028	1.371	40.079	-3.28%	-2.62%
			1790	1.364	38.862	1.394	40.016	-2.15%	-2.88%
04/06/2015	1900H	21.0	1850	1.394	40.376	1.400	40.000	-0.43%	0.94%
			1880	1.426	40.261	1.400	40.000	1.86%	0.65%
			1910	1.457	40.101	1.400	40.000	4.07%	0.25%
04/14/2015	2300H	24.5	2300	1.672	40.966	1.670	39.500	0.12%	3.71%
			2310	1.684	40.926	1.679	39.480	0.30%	3.66%
			2320	1.693	40.855	1.687	39.460	0.36%	3.54%
04/06/2015	2450H	23.3	2401	1.819	38.987	1.756	39.287	3.59%	-0.76%
			2450	1.877	38.786	1.800	39.200	4.28%	-1.06%
			2499	1.931	38.578	1.853	39.138	4.21%	-1.43%
			5260	4.789	36.367	4.717	35.917	1.53%	1.25%
			5300	4.834	36.168	4.758	35.871	1.60%	0.83%
04/08/2015	5200H-5800H	23.0	5500	5.048	35.593	4.963	35.643	1.71%	-0.14%
			5700	5.332	35.060	5.168	35.414	3.17%	-1.00%
			5745	5.360	34.975	5.214	35.363	2.80%	-1.10%
			5785	5.439	34.773	5.255	35.317	3.50%	-1.54%
			5800	5.460	34.752	5.270	35.300	3.61%	-1.55%
04/08/2015	750B	21.9	5825	5.486	34.781	5.296	35.271	3.59%	-1.39%
			695	0.940	56.757	0.959	55.745	-1.98%	1.82%
			710	0.955	56.592	0.960	55.687	-0.52%	1.63%
			725	0.968	56.443	0.961	55.629	0.73%	1.46%
			740	0.982	56.311	0.963	55.570	1.97%	1.33%
04/06/2015	835B	21.8	755	0.997	56.209	0.964	55.512	3.42%	1.26%
			820	0.991	54.761	0.969	55.258	2.27%	-0.90%
			835	1.007	54.573	0.970	55.200	3.81%	-1.14%
			850	1.019	54.392	0.988	55.154	3.14%	-1.38%
			820	0.979	53.874	0.969	55.258	1.03%	-2.50%
04/20/2015	835B	22.0	835	0.996	53.694	0.970	55.200	2.68%	-2.73%
			850	1.009	53.530	0.988	55.154	2.13%	-2.94%
			1710	1.439	52.697	1.463	53.537	-1.64%	-1.57%
04/09/2015	1750B	22.0	1750	1.481	52.546	1.488	53.432	-0.47%	-1.66%
			1790	1.524	52.371	1.514	53.326	0.66%	-1.79%
			1850	1.523	53.463	1.520	53.300	0.20%	0.31%
04/06/2015	1900B	21.0	1880	1.558	53.351	1.520	53.300	2.50%	0.10%
			1910	1.593	53.239	1.520	53.300	4.80%	-0.11%
			1850	1.527	52.642	1.520	53.300	0.46%	-1.23%
05/04/2015	1900B	22.4	1880	1.558	52.559	1.520	53.300	2.50%	-1.39%
			1910	1.593	52.444	1.520	53.300	4.80%	-1.61%
			2300	1.752	52.878	1.809	52.900	-3.15%	-0.04%
04/09/2015	2300B	24.2	2310	1.763	52.824	1.816	52.887	-2.92%	-0.12%
			2320	1.772	52.762	1.826	52.873	-2.96%	-0.21%
			2401	1.873	52.498	1.903	52.765	-1.58%	-0.51%
04/09/2015	2450B	24.2	2450	1.938	52.335	1.950	52.700	-0.62%	-0.69%
			2499	2.001	52.182	2.019	52.638	-0.89%	-0.87%
			5260	5.430	46.764	5.369	48.933	1.14%	-4.43%
04/06/2015	5200B-5800B	22.1	5300	5.496	46.663	5.416	48.879	1.48%	-4.53%
			5700	6.007	46.084	5.883	48.336	2.11%	-4.66%
			5745	6.060	46.005	5.936	48.275	2.09%	-4.70%
			5785	6.122	45.898	5.982	48.220	2.34%	-4.82%
			5800	6.135	45.874	6.000	48.200	2.25%	-4.83%

The above measured tissue parameters were used in the DASY software. The DASY software was used to perform interpolation to determine the dielectric parameters at the SAR test device frequencies (per KDB Publication 865664 and IEEE 1528-2013 6.6.1.2). The tissue parameters listed in the SAR test plots may slightly differ from the table above due to significant digit rounding in the software.

FCC ID: A3LSMG890A	 PCTEST PROFESSIONAL CORPORATION, INC.	SAR EVALUATION REPORT		Reviewed by: Quality Manager
Document S/N: OY1504030657.A3L	Test Dates: 04/06/15 - 05/04/15	DUT Type: Portable Handset		Page 65 of 94

10.2 Test System Verification

Prior to SAR assessment, the system is verified to $\pm 10\%$ of the SAR measurement on the reference dipole at the time of calibration by the calibration facility. Full system validation status and result summary can be found in Appendix E.

Table 10-2
System Verification Results

System Verification TARGET & MEASURED												
SAR System #	Tissue Frequency (MHz)	Tissue Type	Date:	Amb. Temp (°C)	Liquid Temp (°C)	Input Power (W)	Dipole SN	Probe SN	Measured SAR _{1g} (W/kg)	1 W Target SAR _{1g} (W/kg)	1 W Normalized SAR _{1g} (W/kg)	Deviation _{1g} (%)
J	750	HEAD	04/08/2015	21.3	21.4	0.100	1003	3022	0.827	8.090	8.270	2.22%
D	835	HEAD	04/08/2015	23.8	22.0	0.100	4d133	3209	0.981	9.200	9.810	6.63%
B	1750	HEAD	04/07/2015	23.9	23.2	0.100	1051	3334	3.470	36.200	34.700	-4.14%
G	1900	HEAD	04/06/2015	22.7	21.4	0.100	5d141	3213	4.320	40.100	43.200	7.73%
G	2300	HEAD	04/14/2015	23.0	24.0	0.100	1008	3318	5.240	49.900	52.400	5.01%
E	2450	HEAD	04/06/2015	23.2	22.1	0.100	719	3332	5.400	52.100	54.000	3.65%
A	5300	HEAD	04/08/2015	22.8	23.0	0.050	1191	3914	4.220	85.800	84.400	-1.63%
A	5500	HEAD	04/08/2015	22.8	23.0	0.050	1191	3914	4.190	88.600	83.800	-5.42%
A	5800	HEAD	04/08/2015	22.8	23.0	0.050	1191	3914	4.130	82.300	82.600	0.36%
J	750	BODY	04/08/2015	21.3	21.4	0.100	1003	3022	0.893	8.460	8.930	5.56%
K	835	BODY	04/06/2015	22.5	21.8	0.100	4d133	3288	0.957	9.350	9.570	2.35%
D	835	BODY	04/20/2015	22.5	22.0	0.100	4d133	3209	1.020	9.350	10.200	9.09%
C	1750	BODY	04/09/2015	23.8	22.0	0.100	1008	3333	3.950	37.600	39.500	5.05%
J	1900	BODY	04/06/2015	20.5	21.0	0.100	5d141	3022	4.190	40.600	41.900	3.20%
J	1900	BODY	05/04/2015	22.4	22.4	0.100	5d141	3022	4.030	40.000	40.300	-0.74%
G	2300	BODY	04/09/2015	24.4	23.5	0.100	1008	3318	4.750	48.100	47.500	-1.25%
G	2450	BODY	04/09/2015	22.3	22.2	0.100	719	3318	5.410	51.800	54.100	4.44%
A	5300	BODY	04/06/2015	23.5	22.1	0.050	1191	3914	4.180	79.900	83.600	4.63%
A	5800	BODY	04/06/2015	23.5	22.1	0.050	1191	3914	4.030	78.000	80.600	3.33%

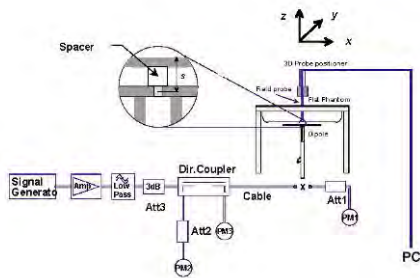

Figure 10-1
System Verification Setup Diagram



Figure 10-2
System Verification Setup Photo

FCC ID: A3LSMG890A	PCTEST PROFESSIONAL ENGINEERING LABORATORY, INC.	SAR EVALUATION REPORT	SAMSUNG	Reviewed by: Quality Manager
Document S/N: OY1504030657.A3L	Test Dates: 04/06/15 - 05/04/15	DUT Type: Portable Handset	Page 66 of 94	

11 SAR DATA SUMMARY

11.1 Standalone Head SAR Data

**Table 11-1
GSM 850 Head SAR**



MEASUREMENT RESULTS														
FREQUENCY		Mode/Band	Service	Maximum Allowed Power [dBm]	Conducted Power [dBm]	Power Drift [dB]	Side	Test Position	Device Serial Number	Duty Cycle	SAR (1g)	Scaling Factor	Scaled SAR (1g)	Plot #
MHz	Ch.										(W/kg)		(W/kg)	
836.60	190	GSM 850	GSM	33.2	32.16	0.01	Right	Cheek	359356060056374	1:8.3	0.348	1.271	0.442	
836.60	190	GSM 850	GSM	33.2	32.16	0.02	Right	Tilt	359356060056374	1:8.3	0.244	1.271	0.310	
836.60	190	GSM 850	GSM	33.2	32.16	0.12	Left	Cheek	359356060056374	1:8.3	0.383	1.271	0.487	A1
836.60	190	GSM 850	GSM	33.2	32.16	0.04	Left	Tilt	359356060056374	1:8.3	0.266	1.271	0.338	
ANSI / IEEE C95.1 1992 - SAFETY LIMIT Spatial Peak Uncontrolled Exposure/General Population								Head 1.6 W/kg (mW/g) averaged over 1 gram						

**Table 11-2
GSM 1900 Head SAR**

MEASUREMENT RESULTS														
FREQUENCY		Mode/Band	Service	Maximum Allowed Power [dBm]	Conducted Power [dBm]	Power Drift [dB]	Side	Test Position	Device Serial Number	Duty Cycle	SAR (1g)	Scaling Factor	Scaled SAR (1g)	Plot #
MHz	Ch.										(W/kg)		(W/kg)	
1880.00	661	GSM 1900	GSM	30.5	30.11	0.02	Right	Cheek	359356060056374	1:8.3	0.225	1.094	0.246	
1880.00	661	GSM 1900	GSM	30.5	30.11	0.05	Right	Tilt	359356060056374	1:8.3	0.199	1.094	0.218	
1880.00	661	GSM 1900	GSM	30.5	30.11	0.03	Left	Cheek	359356060056374	1:8.3	0.420	1.094	0.459	A2
1880.00	661	GSM 1900	GSM	30.5	30.11	0.05	Left	Tilt	359356060056374	1:8.3	0.154	1.094	0.168	
ANSI / IEEE C95.1 1992 - SAFETY LIMIT Spatial Peak Uncontrolled Exposure/General Population								Head 1.6 W/kg (mW/g) averaged over 1 gram						

**Table 11-3
UMTS 850 Head SAR**

MEASUREMENT RESULTS														
FREQUENCY		Mode/Band	Service	Maximum Allowed Power [dBm]	Conducted Power [dBm]	Power Drift [dB]	Side	Test Position	Device Serial Number	Duty Cycle	SAR (1g)	Scaling Factor	Scaled SAR (1g)	Plot #
MHz	Ch.										(W/kg)		(W/kg)	
836.60	4183	UMTS 850	RMC	24.3	23.22	0.04	Right	Cheek	359356060056374	1:1	0.350	1.282	0.449	
836.60	4183	UMTS 850	RMC	24.3	23.22	0.03	Right	Tilt	359356060056374	1:1	0.237	1.282	0.304	
836.60	4183	UMTS 850	RMC	24.3	23.22	0.01	Left	Cheek	359356060056374	1:1	0.392	1.282	0.503	A3
836.60	4183	UMTS 850	RMC	24.3	23.22	0.03	Left	Tilt	359356060056374	1:1	0.232	1.282	0.297	
ANSI / IEEE C95.1 1992 - SAFETY LIMIT Spatial Peak Uncontrolled Exposure/General Population								Head 1.6 W/kg (mW/g) averaged over 1 gram						

FCC ID: A3LSMG890A	 PCTEST ENGINEERING LABORATORY, INC.	SAR EVALUATION REPORT		Reviewed by: Quality Manager
Document S/N: OY1504030657.A3L	Test Dates: 04/06/15 - 05/04/15	DUT Type: Portable Handset		Page 67 of 94

**Table 11-4
UMTS 1900 Head SAR**



MEASUREMENT RESULTS														
FREQUENCY		Mode/Band	Service	Maximum Allowed Power [dBm]	Conducted Power [dBm]	Power Drift [dB]	Side	Test Position	Device Serial Number	Duty Cycle	SAR (1g)	Scaling Factor	Scaled SAR (1g)	Plot #
MHz	Ch.										(W/kg)		(W/kg)	
1880.00	9400	UMTS 1900	RMC	24.0	22.92	0.05	Right	Cheek	359356060056374	1:1	0.271	1.282	0.347	
1880.00	9400	UMTS 1900	RMC	24.0	22.92	0.09	Right	Tilt	359356060056374	1:1	0.228	1.282	0.292	
1880.00	9400	UMTS 1900	RMC	24.0	22.92	0.02	Left	Cheek	359356060056374	1:1	0.484	1.282	0.620	A4
1880.00	9400	UMTS 1900	RMC	24.0	22.92	0.15	Left	Tilt	359356060056374	1:1	0.184	1.282	0.236	
ANSI / IEEE C95.1 1992 - SAFETY LIMIT Spatial Peak Uncontrolled Exposure/General Population							Head 1.6 W/kg (mW/g) averaged over 1 gram							

**Table 11-5
LTE Band 12 Head SAR**

MEASUREMENT RESULTS																			
FREQUENCY		Mode	Bandwidth [MHz]	Maximum Allowed Power [dBm]	Conducted Power [dBm]	Power Drift [dB]	MPR [dB]	Side	Test Position	Modulation	RB Size	RB Offset	Device Serial Number	Duty Cycle	SAR (1g)	Scaling Factor	Scaled SAR (1g)	Plot #	
MHz	Ch.														(W/kg)		(W/kg)		
707.50	23095	Mid	LTE Band 12	10	23.9	23.49	0.06	0	Right	Cheek	QPSK	1	25	359356060056432	1:1	0.323	1.099	0.355	
707.50	23095	Mid	LTE Band 12	10	22.9	22.38	0.03	1	Right	Cheek	QPSK	25	0	359356060056432	1:1	0.195	1.127	0.220	
707.50	23095	Mid	LTE Band 12	10	23.9	23.49	0.11	0	Right	Tilt	QPSK	1	25	359356060056432	1:1	0.174	1.099	0.191	
707.50	23095	Mid	LTE Band 12	10	22.9	22.38	0.11	1	Right	Tilt	QPSK	25	0	359356060056432	1:1	0.095	1.127	0.107	
707.50	23095	Mid	LTE Band 12	10	23.9	23.49	0.04	0	Left	Cheek	QPSK	1	25	359356060056432	1:1	0.452	1.099	0.497	A5
707.50	23095	Mid	LTE Band 12	10	22.9	22.38	0.09	1	Left	Cheek	QPSK	25	0	359356060056432	1:1	0.332	1.127	0.374	
707.50	23095	Mid	LTE Band 12	10	23.9	23.49	0.03	0	Left	Tilt	QPSK	1	25	359356060056432	1:1	0.252	1.099	0.277	
707.50	23095	Mid	LTE Band 12	10	22.9	22.38	0.05	1	Left	Tilt	QPSK	25	0	359356060056432	1:1	0.180	1.127	0.203	
ANSI / IEEE C95.1 1992 - SAFETY LIMIT Spatial Peak Uncontrolled Exposure/General Population							Head 1.6 W/kg (mW/g) averaged over 1 gram												

**Table 11-6
LTE Band 5 (Cell) Head SAR**

MEASUREMENT RESULTS																			
FREQUENCY		Mode	Bandwidth [MHz]	Maximum Allowed Power [dBm]	Conducted Power [dBm]	Power Drift [dB]	MPR [dB]	Side	Test Position	Modulation	RB Size	RB Offset	Device Serial Number	Duty Cycle	SAR (1g)	Scaling Factor	Scaled SAR (1g)	Plot #	
MHz	Ch.														(W/kg)		(W/kg)		
836.50	20525	Mid	LTE Band 5 (Cell)	10	24.0	23.60	0.02	0	Right	Cheek	QPSK	1	25	359356060056374	1:1	0.407	1.096	0.446	
836.50	20525	Mid	LTE Band 5 (Cell)	10	23.0	22.08	0.09	1	Right	Cheek	QPSK	25	0	359356060056374	1:1	0.284	1.236	0.351	
836.50	20525	Mid	LTE Band 5 (Cell)	10	24.0	23.60	0.03	0	Right	Tilt	QPSK	1	25	359356060056374	1:1	0.303	1.096	0.332	
836.50	20525	Mid	LTE Band 5 (Cell)	10	23.0	22.08	0.05	1	Right	Tilt	QPSK	25	0	359356060056374	1:1	0.220	1.236	0.272	
836.50	20525	Mid	LTE Band 5 (Cell)	10	24.0	23.60	0.05	0	Left	Cheek	QPSK	1	25	359356060056374	1:1	0.456	1.096	0.500	A6
836.50	20525	Mid	LTE Band 5 (Cell)	10	23.0	22.08	0.04	1	Left	Cheek	QPSK	25	0	359356060056374	1:1	0.329	1.236	0.407	
836.50	20525	Mid	LTE Band 5 (Cell)	10	24.0	23.60	0.02	0	Left	Tilt	QPSK	1	25	359356060056374	1:1	0.280	1.096	0.307	
836.50	20525	Mid	LTE Band 5 (Cell)	10	23.0	22.08	0.08	1	Left	Tilt	QPSK	25	0	359356060056374	1:1	0.207	1.236	0.256	
ANSI / IEEE C95.1 1992 - SAFETY LIMIT Spatial Peak Uncontrolled Exposure/General Population							Head 1.6 W/kg (mW/g) averaged over 1 gram												

FCC ID: A3LSMG890A		SAR EVALUATION REPORT		Reviewed by: Quality Manager
Document S/N: OY1504030657.A3L	Test Dates: 04/06/15 - 05/04/15	DUT Type: Portable Handset		Page 68 of 94

**Table 11-7
LTE Band 4 (AWS) Head SAR**



MEASUREMENT RESULTS																			
FREQUENCY		Mode	Bandwidth [MHz]	Maximum Allowed Power [dBm]	Conducted Power [dBm]	Power Drift [dB]	MPR [dB]	Side	Test Position	Modulation	RB Size	RB Offset	Device Serial Number	Duty Cycle	SAR (1g)	Scaling Factor	Scaled SAR (1g)	Plot #	
MHz	Ch.														(W/kg)		(W/kg)		
1732.50	20175	Mid	LTE Band 4 (AWS)	20	24.0	23.50	0.10	0	Right	Cheek	QPSK	1	50	359356060056390	1:1	0.085	1.122	0.095	
1732.50	20175	Mid	LTE Band 4 (AWS)	20	23.0	22.10	0.08	1	Right	Cheek	QPSK	50	25	359356060056390	1:1	0.062	1.230	0.076	
1732.50	20175	Mid	LTE Band 4 (AWS)	20	24.0	23.50	0.02	0	Right	Tilt	QPSK	1	50	359356060056390	1:1	0.031	1.122	0.035	
1732.50	20175	Mid	LTE Band 4 (AWS)	20	23.0	22.10	0.06	1	Right	Tilt	QPSK	50	25	359356060056390	1:1	0.032	1.230	0.039	
1732.50	20175	Mid	LTE Band 4 (AWS)	20	24.0	23.50	0.07	0	Left	Cheek	QPSK	1	50	359356060056390	1:1	0.499	1.122	0.560	A7
1732.50	20175	Mid	LTE Band 4 (AWS)	20	23.0	22.10	0.02	1	Left	Cheek	QPSK	50	25	359356060056390	1:1	0.384	1.230	0.472	
1732.50	20175	Mid	LTE Band 4 (AWS)	20	24.0	23.50	0.02	0	Left	Tilt	QPSK	1	50	359356060056390	1:1	0.115	1.122	0.129	
1732.50	20175	Mid	LTE Band 4 (AWS)	20	23.0	22.10	0.03	1	Left	Tilt	QPSK	50	25	359356060056390	1:1	0.108	1.230	0.133	
ANSI / IEEE C95.1 1992 - SAFETY LIMIT Spatial Peak Uncontrolled Exposure/General Population										Head 1.6 W/kg (mW/g) averaged over 1 gram									

**Table 11-8
LTE Band 2 (PCS) Head SAR**

MEASUREMENT RESULTS																			
FREQUENCY		Mode	Bandwidth [MHz]	Maximum Allowed Power [dBm]	Conducted Power [dBm]	Power Drift [dB]	MPR [dB]	Side	Test Position	Modulation	RB Size	RB Offset	Device Serial Number	Duty Cycle	SAR (1g)	Scaling Factor	Scaled SAR (1g)	Plot #	
MHz	Ch.														(W/kg)		(W/kg)		
1900.00	19100	High	LTE Band 2 (PCS)	20	24.4	23.50	0.20	0	Right	Cheek	QPSK	1	50	359356060056374	1:1	0.286	1.230	0.352	
1900.00	19100	High	LTE Band 2 (PCS)	20	23.4	22.23	0.07	1	Right	Cheek	QPSK	50	0	359356060056374	1:1	0.228	1.309	0.298	
1900.00	19100	High	LTE Band 2 (PCS)	20	24.4	23.50	0.21	0	Right	Tilt	QPSK	1	50	359356060056374	1:1	0.302	1.230	0.371	
1900.00	19100	High	LTE Band 2 (PCS)	20	23.4	22.23	0.07	1	Right	Tilt	QPSK	50	0	359356060056374	1:1	0.215	1.309	0.281	
1900.00	19100	High	LTE Band 2 (PCS)	20	24.4	23.50	0.04	0	Left	Cheek	QPSK	1	50	359356060056374	1:1	0.607	1.230	0.747	AB
1900.00	19100	High	LTE Band 2 (PCS)	20	23.4	22.23	0.02	1	Left	Cheek	QPSK	50	0	359356060056374	1:1	0.432	1.309	0.565	
1900.00	19100	High	LTE Band 2 (PCS)	20	24.4	23.50	0.02	0	Left	Tilt	QPSK	1	50	359356060056374	1:1	0.205	1.230	0.252	
1900.00	19100	High	LTE Band 2 (PCS)	20	23.4	22.23	0.06	1	Left	Tilt	QPSK	50	0	359356060056374	1:1	0.160	1.309	0.209	
ANSI / IEEE C95.1 1992 - SAFETY LIMIT Spatial Peak Uncontrolled Exposure/General Population										Head 1.6 W/kg (mW/g) averaged over 1 gram									

**Table 11-9
LTE Band 30 Head SAR**

MEASUREMENT RESULTS																			
FREQUENCY		Mode	Bandwidth [MHz]	Maximum Allowed Power [dBm]	Conducted Power [dBm]	Power Drift [dB]	MPR [dB]	Side	Test Position	Modulation	RB Size	RB Offset	Device Serial Number	Duty Cycle	SAR (1g)	Scaling Factor	Scaled SAR (1g)	Plot #	
MHz	Ch.														(W/kg)		(W/kg)		
2310.00	27710	Mid	LTE Band 30	10	22.5	22.39	0.17	0	Right	Cheek	QPSK	1	25	359356060056366	1:1	0.666	1.026	0.683	AB
2310.00	27710	Mid	LTE Band 30	10	21.5	21.16	0.10	1	Right	Cheek	QPSK	25	12	359356060056366	1:1	0.495	1.081	0.535	
2310.00	27710	Mid	LTE Band 30	10	22.5	22.39	-0.06	0	Right	Tilt	QPSK	1	25	359356060056366	1:1	0.195	1.026	0.200	
2310.00	27710	Mid	LTE Band 30	10	21.5	21.16	-0.03	1	Right	Tilt	QPSK	25	12	359356060056366	1:1	0.145	1.081	0.157	
2310.00	27710	Mid	LTE Band 30	10	22.5	22.39	0.11	0	Left	Cheek	QPSK	1	25	359356060056366	1:1	0.297	1.026	0.305	
2310.00	27710	Mid	LTE Band 30	10	21.5	21.16	-0.02	1	Left	Cheek	QPSK	25	12	359356060056366	1:1	0.228	1.081	0.246	
2310.00	27710	Mid	LTE Band 30	10	22.5	22.39	0.03	0	Left	Tilt	QPSK	1	25	359356060056366	1:1	0.232	1.026	0.238	
2310.00	27710	Mid	LTE Band 30	10	21.5	21.16	0.06	1	Left	Tilt	QPSK	25	12	359356060056366	1:1	0.181	1.081	0.196	
ANSI / IEEE C95.1 1992 - SAFETY LIMIT Spatial Peak Uncontrolled Exposure/General Population										Head 1.6 W/kg (mW/g) averaged over 1 gram									



FCC ID: A3LSMG890A		SAR EVALUATION REPORT		Reviewed by: Quality Manager
Document S/N: OY1504030657.A3L	Test Dates: 04/06/15 - 05/04/15	DUT Type: Portable Handset	Page 69 of 94	

**Table 11-10
DTS Head SAR**

MEASUREMENT RESULTS																			
FREQUENCY		Mode	Service	Bandwidth [MHz]	Maximum Allowed Power [dBm]	Conducted Power [dBm]	Power Drift [dB]	Side	Test Position	Antenna Config.	Device Serial Number	Data Rate (Mbps)	Duty Cycle (%)	Peak SAR of Area Scan [W/kg]	SAR (1g) (W/kg)	Scaling Factor (Power)	Scaling Factor (Duty Cycle)	Scaled SAR (1g) (W/kg)	Plot #
MHz	Ch.																		
2437	6	802.11b	DSSS	22	12.5	12.48	-	Right	Cheek	1	359356060056457	1	99.8	0.358	-	1.005	1.002	-	-
2437	6	802.11b	DSSS	22	12.5	12.48	0.04	Right	Tilt	1	359356060056457	1	99.8	0.392	0.292	1.005	1.002	0.294	A10
2437	6	802.11b	DSSS	22	12.5	12.48	-	Left	Cheek	1	359356060056457	1	99.8	0.213	-	1.005	1.002	-	-
2437	6	802.11b	DSSS	22	12.5	12.48	-	Left	Tilt	1	359356060056457	1	99.8	0.235	-	1.005	1.002	-	-
2462	11	802.11b	DSSS	22	12.5	12.38	0.01	Right	Cheek	2	359356060056457	1	99.9	0.164	0.149	1.028	1.001	0.153	-
2462	11	802.11b	DSSS	22	12.5	12.38	-	Right	Tilt	2	359356060056457	1	99.9	0.091	-	1.028	1.001	-	-
2462	11	802.11b	DSSS	22	12.5	12.38	-	Left	Cheek	2	359356060056457	1	99.9	0.054	-	1.028	1.001	-	-
2462	11	802.11b	DSSS	22	12.5	12.38	-	Left	Tilt	2	359356060056457	1	99.9	0.048	-	1.028	1.001	-	-
ANSI / IEEE C95.1 1992 - SAFETY LIMIT Spatial Peak Uncontrolled Exposure/General Population												Head 1.6 W/kg (mW/g) averaged over 1 gram							

**Table 11-11
NII Head SAR**

MEASUREMENT RESULTS																			
FREQUENCY		Mode	Service	Bandwidth [MHz]	Maximum Allowed Power [dBm]	Conducted Power [dBm]	Power Drift [dB]	Side	Test Position	Antenna Config.	Device Serial Number	Data Rate (Mbps)	Duty Cycle (%)	Peak SAR of Area Scan [W/kg]	SAR (1g) (W/kg)	Scaling Factor (Power)	Scaling Factor (Duty Cycle)	Scaled SAR (1g) (W/kg)	Plot #
MHz	Ch.																		
5260	52	802.11a	OFDM	20	9.5	8.58	-	Right	Cheek	1	359356060056366	6	98.1	0.116	-	1.236	1.019	-	-
5260	52	802.11a	OFDM	20	9.5	8.58	-	Right	Tilt	1	359356060056366	6	98.1	0.098	-	1.236	1.019	-	-
5260	52	802.11a	OFDM	20	9.5	8.58	-	Left	Cheek	1	359356060056366	6	98.1	0.108	-	1.236	1.019	-	-
5260	52	802.11a	OFDM	20	9.5	8.58	0.06	Left	Tilt	1	359356060056366	6	98.1	0.131	0.042	1.236	1.019	0.053	A11
5260	52	802.11a	OFDM	20	9.5	8.99	0.17	Right	Cheek	2	359356060056366	6	97.9	0.053	0.012	1.125	1.021	0.014	-
5260	52	802.11a	OFDM	20	9.5	8.99	-	Right	Tilt	2	359356060056366	6	97.9	0.039	-	1.125	1.021	-	-
5260	52	802.11a	OFDM	20	9.5	8.99	-	Left	Cheek	2	359356060056366	6	97.9	0.015	-	1.125	1.021	-	-
5260	52	802.11a	OFDM	20	9.5	8.99	-	Left	Tilt	2	359356060056366	6	97.9	0.018	-	1.125	1.021	-	-
5720	144	802.11a	OFDM	20	9.5	8.85	-	Right	Cheek	1	359356060056366	6	98.1	0.074	-	1.161	1.019	-	-
5720	144	802.11a	OFDM	20	9.5	8.85	-	Right	Tilt	1	359356060056366	6	98.1	0.081	-	1.161	1.019	-	-
5720	144	802.11a	OFDM	20	9.5	8.85	-	Left	Cheek	1	359356060056366	6	98.1	0.075	-	1.161	1.019	-	-
5720	144	802.11a	OFDM	20	9.5	8.85	0.05	Left	Tilt	1	359356060056366	6	98.1	0.107	0.026	1.161	1.019	0.031	-
5500	100	802.11a	OFDM	20	9.5	9.12	0.09	Right	Cheek	2	359356060056366	6	97.9	0.062	0.024	1.091	1.021	0.027	-
5500	100	802.11a	OFDM	20	9.5	9.12	-	Right	Tilt	2	359356060056366	6	97.9	0.046	-	1.091	1.021	-	-
5500	100	802.11a	OFDM	20	9.5	9.12	-	Left	Cheek	2	359356060056366	6	97.9	0.053	-	1.091	1.021	-	-
5500	100	802.11a	OFDM	20	9.5	9.12	-	Left	Tilt	2	359356060056366	6	97.9	0.049	-	1.091	1.021	-	-
5825	165	802.11a	OFDM	20	9.5	9.49	-	Right	Cheek	1	359356060056366	6	98.1	0.064	-	1.002	1.019	-	-
5825	165	802.11a	OFDM	20	9.5	9.49	-	Right	Tilt	1	359356060056366	6	98.1	0.033	-	1.002	1.019	-	-
5825	165	802.11a	OFDM	20	9.5	9.49	-	Left	Cheek	1	359356060056366	6	98.1	0.115	-	1.002	1.019	-	-
5825	165	802.11a	OFDM	20	9.5	9.49	0.06	Left	Tilt	1	359356060056366	6	98.1	0.144	0.041	1.002	1.019	0.042	-
5785	157	802.11a	OFDM	20	9.5	8.63	0.10	Right	Cheek	2	359356060056366	6	97.9	0.062	0.008	1.222	1.021	0.010	-
5785	157	802.11a	OFDM	20	9.5	8.63	-	Right	Tilt	2	359356060056366	6	97.9	0.041	-	1.222	1.021	-	-
5785	157	802.11a	OFDM	20	9.5	8.63	-	Left	Cheek	2	359356060056366	6	97.9	0.038	-	1.222	1.021	-	-
5785	157	802.11a	OFDM	20	9.5	8.63	-	Left	Tilt	2	359356060056366	6	97.9	0.056	-	1.222	1.021	-	-
ANSI / IEEE C95.1 1992 - SAFETY LIMIT Spatial Peak Uncontrolled Exposure/General Population												Head 1.6 W/kg (mW/g) averaged over 1 gram							

FCC ID: A3LSMG890A		SAR EVALUATION REPORT		Reviewed by: Quality Manager
Document S/N: OY1504030657.A3L	Test Dates: 04/06/15 - 05/04/15	DUT Type: Portable Handset	Page 70 of 94	

11.2 Standalone Body-Worn SAR Data

**Table 11-12
GSM/UMTS Body-Worn SAR Data**

MEASUREMENT RESULTS															
FREQUENCY		Mode	Service	Maximum Allowed Power [dBm]	Conducted Power [dBm]	Power Drift [dB]	Spacing	Device Serial Number	# of Time Slots	Duty Cycle	Side	SAR (1g) (W/kg)	Scaling Factor	Scaled SAR (1g) (W/kg)	Plot #
MHz	Ch.														
836.60	190	GSM 850	GSM	33.2	32.16	0.00	15 mm	359356060056374	1	1:8.3	back	0.414	1.271	0.526	A12
1880.00	661	GSM 1900	GSM	30.5	30.11	0.02	15 mm	359356060056374	1	1:8.3	back	0.455	1.094	0.498	A14
836.60	4183	UMTS 850	RMC	24.3	23.22	0.00	15 mm	359356060056374	N/A	1:1	back	0.456	1.282	0.585	A16
1880.00	9400	UMTS 1900	RMC	24.0	22.92	0.05	15 mm	359356060056374	N/A	1:1	back	0.448	1.282	0.574	A18
ANSI / IEEE C95.1 1992 - SAFETY LIMIT Spatial Peak Uncontrolled Exposure/General Population								Body 1.6 W/kg (mW/g) averaged over 1 gram							

**Table 11-13
LTE Body-Worn SAR**



MEASUREMENT RESULTS																			
FREQUENCY		Mode	Bandwidth [MHz]	Maximum Allowed Power [dBm]	Conducted Power [dBm]	Power Drift [dB]	MPR [dB]	Device Serial Number	Modulation	RB Size	RB Offset	Spacing	Side	Duty Cycle	SAR (1g) (W/kg)	Scaling Factor	Scaled SAR (1g) (W/kg)	Plot #	
MHz	Ch.																		
707.50	23095	Mid	LTE Band 12	10	23.9	23.49	0.06	0	359356060056366	QPSK	1	25	15 mm	back	1:1	0.513	1.099	0.564	A20
707.50	23095	Mid	LTE Band 12	10	22.9	22.38	0.04	1	359356060056366	QPSK	25	0	15 mm	back	1:1	0.361	1.127	0.407	
836.50	20525	Mid	LTE Band 5 (Cell)	10	24.0	23.60	0.01	0	359356060056374	QPSK	1	25	15 mm	back	1:1	0.508	1.096	0.557	A22
836.50	20525	Mid	LTE Band 5 (Cell)	10	23.0	22.08	0.02	1	359356060056374	QPSK	25	0	15 mm	back	1:1	0.392	1.236	0.485	
1732.50	20175	Mid	LTE Band 4 (AWS)	20	24.0	23.50	0.00	0	359356060056374	QPSK	1	50	15 mm	back	1:1	0.380	1.122	0.426	A24
1732.50	20175	Mid	LTE Band 4 (AWS)	20	23.0	22.10	0.01	1	359356060056374	QPSK	50	25	15 mm	back	1:1	0.291	1.230	0.358	
1900.00	19100	High	LTE Band 2 (PCS)	20	24.4	23.50	0.07	0	359356060056374	QPSK	1	50	15 mm	back	1:1	0.544	1.230	0.669	A26
1900.00	19100	High	LTE Band 2 (PCS)	20	23.4	22.23	0.02	1	359356060056374	QPSK	50	0	15 mm	back	1:1	0.420	1.309	0.550	
2310.00	27710	Mid	LTE Band 30	10	22.5	22.39	0.02	0	359356060056374	QPSK	1	25	15 mm	back	1:1	0.272	1.026	0.279	A28
2310.00	27710	Mid	LTE Band 30	10	21.5	21.16	0.03	1	359356060056374	QPSK	25	12	15 mm	back	1:1	0.207	1.081	0.224	
ANSI / IEEE C95.1 1992 - SAFETY LIMIT Spatial Peak Uncontrolled Exposure/General Population								Body 1.6 W/kg (mW/g) averaged over 1 gram											

**Table 11-14
DTS Body-Worn SAR**

MEASUREMENT RESULTS																			
FREQUENCY		Mode	Service	Bandwidth [MHz]	Maximum Allowed Power [dBm]	Conducted Power [dBm]	Power Drift [dB]	Spacing	Antenna Config.	Device Serial Number	Data Rate (Mbps)	Side	Duty Cycle (%)	Peak SAR of Area Scan (W/kg)	SAR (1g) (W/kg)	Scaling Factor (Power)	Scaling Factor (Duty Cycle)	Scaled SAR (1g) (W/kg)	Plot #
MHz	Ch.																		
2437	6	802.11b	DSSS	22	17.5	17.46	0.04	15 mm	1	359356060056374	1	back	99.8	0.189	0.169	1.009	1.002	0.171	A30
2462	11	802.11b	DSSS	22	17.5	17.18	0.06	15 mm	2	359356060056374	1	back	99.9	0.098	0.086	1.076	1.001	0.093	
ANSI / IEEE C95.1 1992 - SAFETY LIMIT Spatial Peak Uncontrolled Exposure/General Population								Body 1.6 W/kg (mW/g) averaged over 1 gram											

**Table 11-15
NII Body-Worn SAR**

MEASUREMENT RESULTS																			
FREQUENCY		Mode	Service	Bandwidth [MHz]	Maximum Allowed Power [dBm]	Conducted Power [dBm]	Power Drift [dB]	Spacing	Antenna Config.	Device Serial Number	Data Rate (Mbps)	Side	Duty Cycle (%)	Peak SAR of Area Scan (W/kg)	SAR (1g) (W/kg)	Scaling Factor (Power)	Scaling Factor (Duty Cycle)	Scaled SAR (1g) (W/kg)	Plot #
MHz	Ch.																		
5260	52	802.11a	OFDM	20	14.5	14.39	0.11	10 mm	1	359356060056390	6	back	98.1	0.144	0.052	1.026	1.019	0.054	
5260	52	802.11a	OFDM	20	14.5	14.02	0.13	10 mm	2	359356060056390	6	back	97.9	0.265	0.126	1.117	1.021	0.144	
5720	144	802.11a	OFDM	20	14.5	14.48	0.06	10 mm	1	359356060056390	6	back	98.1	0.115	0.042	1.005	1.019	0.043	
5720	144	802.11a	OFDM	20	14.5	14.46	0.16	10 mm	2	359356060056390	6	back	97.9	0.474	0.187	1.009	1.021	0.193	A32
5785	157	802.11a	OFDM	20	14.5	14.41	0.05	10 mm	1	359356060056390	6	back	98.1	0.223	0.090	1.021	1.019	0.094	
5785	157	802.11a	OFDM	20	14.5	14.47	0.01	10 mm	2	359356060056390	6	back	97.9	0.463	0.186	1.007	1.021	0.191	
ANSI / IEEE C95.1 1992 - SAFETY LIMIT Spatial Peak Uncontrolled Exposure/General Population								Body 1.6 W/kg (mW/g) averaged over 1 gram											

FCC ID: A3LSMG890A		SAR EVALUATION REPORT		Reviewed by: Quality Manager
Document S/N: OY1504030657.A3L	Test Dates: 04/06/15 - 05/04/15	DUT Type: Portable Handset		Page 71 of 94

11.3 Standalone Wireless Router SAR Data

**Table 11-16
GPRS/UMTS Hotspot SAR Data**

MEASUREMENT RESULTS															
FREQUENCY		Mode	Service	Maximum Allowed Power [dBm]	Conducted Power [dBm]	Power Drift [dB]	Spacing	Device Serial Number	# of GPRS Slots	Duty Cycle	Side	SAR (1g)	Scaling Factor	Scaled SAR (1g)	Plot #
MHz	Ch.											(W/kg)		(W/kg)	
824.20	128	GSM 850	GPRS	32.2	31.23	0.10	10 mm	359356060056374	2	1.4.15	back	0.813	1.250	1.016	A13
836.60	190	GSM 850	GPRS	32.2	31.17	0.20	10 mm	359356060056374	2	1.4.15	back	0.688	1.268	0.872	
848.80	251	GSM 850	GPRS	32.2	31.27	0.15	10 mm	359356060056374	2	1.4.15	back	0.527	1.239	0.653	
836.60	190	GSM 850	GPRS	32.2	31.17	0.05	10 mm	359356060056374	2	1.4.15	front	0.567	1.268	0.719	
836.60	190	GSM 850	GPRS	32.2	31.17	0.06	10 mm	359356060056374	2	1.4.15	bottom	0.134	1.268	0.170	
836.60	190	GSM 850	GPRS	32.2	31.17	0.14	10 mm	359356060056374	2	1.4.15	right	0.375	1.268	0.476	
836.60	190	GSM 850	GPRS	32.2	31.17	0.00	10 mm	359356060056374	2	1.4.15	left	0.563	1.268	0.714	
824.20	128	GSM 850	GPRS	32.2	31.23	-0.10	10 mm	359356060056374	2	1.4.15	back	0.720	1.250	0.900	
1880.00	661	GSM 1900	GPRS	27.2	26.67	-0.19	10 mm	359356060079855	2	1.4.15	back	0.646	1.130	0.730	A15
1880.00	661	GSM 1900	GPRS	27.2	26.67	0.11	10 mm	359356060079855	2	1.4.15	front	0.641	1.130	0.724	
1880.00	661	GSM 1900	GPRS	27.2	26.67	0.00	10 mm	359356060079855	2	1.4.15	bottom	0.490	1.130	0.554	
1880.00	661	GSM 1900	GPRS	27.2	26.67	0.21	10 mm	359356060079855	2	1.4.15	right	0.074	1.130	0.084	
1880.00	661	GSM 1900	GPRS	27.2	26.67	0.20	10 mm	359356060079855	2	1.4.15	left	0.231	1.130	0.261	
836.60	4183	UMTS 850	RMC	24.3	23.22	0.01	10 mm	359356060056374	N/A	1:1	back	0.499	1.282	0.640	A17
836.60	4183	UMTS 850	RMC	24.3	23.22	0.01	10 mm	359356060056374	N/A	1:1	front	0.451	1.282	0.578	
836.60	4183	UMTS 850	RMC	24.3	23.22	0.12	10 mm	359356060056374	N/A	1:1	bottom	0.105	1.282	0.135	
836.60	4183	UMTS 850	RMC	24.3	23.22	0.03	10 mm	359356060056374	N/A	1:1	right	0.305	1.282	0.391	
836.60	4183	UMTS 850	RMC	24.3	23.22	0.01	10 mm	359356060056374	N/A	1:1	left	0.454	1.282	0.582	
1880.00	9400	UMTS 1900	RMC	22.0	21.05	0.10	10 mm	359356060056374	N/A	1:1	back	0.601	1.245	0.748	A19
1880.00	9400	UMTS 1900	RMC	22.0	21.05	0.00	10 mm	359356060056374	N/A	1:1	front	0.566	1.245	0.705	
1880.00	9400	UMTS 1900	RMC	22.0	21.05	0.01	10 mm	359356060056374	N/A	1:1	bottom	0.467	1.245	0.581	
1880.00	9400	UMTS 1900	RMC	22.0	21.05	0.01	10 mm	359356060056374	N/A	1:1	right	0.052	1.245	0.065	
1880.00	9400	UMTS 1900	RMC	22.0	21.05	0.03	10 mm	359356060056374	N/A	1:1	left	0.199	1.245	0.248	
ANSI / IEEE C95.1 1992 - SAFETY LIMIT Spatial Peak Uncontrolled Exposure/General Population							Body 1.6 W/kg (mW/g) averaged over 1 gram								

Blue entry represents variability measurement.

**Table 11-17
LTE Band 12 Hotspot SAR**

MEASUREMENT RESULTS																			
FREQUENCY		Mode	Bandwidth [MHz]	Maximum Allowed Power [dBm]	Conducted Power [dBm]	Power Drift [dB]	MPR [dB]	Device Serial Number	Modulation	RB Size	RB Offset	Spacing	Side	Duty Cycle	SAR (1g)	Scaling Factor	Scaled SAR (1g)	Plot #	
MHz	Ch.														(W/kg)		(W/kg)		
707.50	23095	Md	LTE Band 12	10	23.9	23.49	0.03	0	359356060056366	QPSK	1	25	10 mm	back	1:1	0.630	1.099	0.692	A21
707.50	23095	Md	LTE Band 12	10	22.9	22.38	0.03	1	359356060056366	QPSK	25	0	10 mm	back	1:1	0.456	1.127	0.514	
707.50	23095	Md	LTE Band 12	10	23.9	23.49	0.01	0	359356060056366	QPSK	1	25	10 mm	front	1:1	0.511	1.099	0.562	
707.50	23095	Md	LTE Band 12	10	22.9	22.38	0.01	1	359356060056366	QPSK	25	0	10 mm	front	1:1	0.375	1.127	0.423	
707.50	23095	Md	LTE Band 12	10	23.9	23.49	0.16	0	359356060056366	QPSK	1	25	10 mm	bottom	1:1	0.111	1.099	0.122	
707.50	23095	Md	LTE Band 12	10	22.9	22.38	0.06	1	359356060056366	QPSK	25	0	10 mm	bottom	1:1	0.078	1.127	0.088	
707.50	23095	Md	LTE Band 12	10	23.9	23.49	0.07	0	359356060056366	QPSK	1	25	10 mm	right	1:1	0.285	1.099	0.313	
707.50	23095	Md	LTE Band 12	10	22.9	22.38	0.07	1	359356060056366	QPSK	25	0	10 mm	right	1:1	0.187	1.127	0.211	
707.50	23095	Md	LTE Band 12	10	23.9	23.49	0.05	0	359356060056366	QPSK	1	25	10 mm	left	1:1	0.502	1.099	0.552	
707.50	23095	Md	LTE Band 12	10	22.9	22.38	0.04	1	359356060056366	QPSK	25	0	10 mm	left	1:1	0.344	1.127	0.388	
ANSI / IEEE C95.1 1992 - SAFETY LIMIT Spatial Peak Uncontrolled Exposure/General Population							Body 1.6 W/kg (mW/g) averaged over 1 gram												



FCC ID: A3LSMG890A		SAR EVALUATION REPORT		Reviewed by: Quality Manager
Document S/N: OY1504030657.A3L	Test Dates: 04/06/15 - 05/04/15	DUT Type: Portable Handset	Page 72 of 94	

Table 11-18
LTE Band 5 (Cell) Hotspot SAR



MEASUREMENT RESULTS																			
FREQUENCY		Mode	Bandwidth [MHz]	Maximum Allowed Power [dBm]	Conducted Power [dBm]	Power Drift [dB]	MPR [dB]	Device Serial Number	Modulation	RB Size	RB Offset	Spacing	Side	Duty Cycle	SAR (1g)	Scaling Factor	Scaled SAR (1g)	Plot #	
MHz	Ch.														(W/kg)		(W/kg)		
836.50	20525	Mid	LTE Band 5 (Cell)	10	24.0	23.60	0.17	0	359356060056374	QPSK	1	25	10 mm	back	1:1	0.580	1.096	0.636	A23
836.50	20525	Mid	LTE Band 5 (Cell)	10	23.0	22.08	0.03	1	359356060056374	QPSK	25	0	10 mm	back	1:1	0.432	1.236	0.534	
836.50	20525	Mid	LTE Band 5 (Cell)	10	24.0	23.60	0.01	0	359356060056374	QPSK	1	25	10 mm	front	1:1	0.504	1.096	0.552	
836.50	20525	Mid	LTE Band 5 (Cell)	10	23.0	22.08	0.08	1	359356060056374	QPSK	25	0	10 mm	front	1:1	0.385	1.236	0.476	
836.50	20525	Mid	LTE Band 5 (Cell)	10	24.0	23.60	0.13	0	359356060056374	QPSK	1	25	10 mm	bottom	1:1	0.134	1.096	0.147	
836.50	20525	Mid	LTE Band 5 (Cell)	10	23.0	22.08	0.04	1	359356060056374	QPSK	25	0	10 mm	bottom	1:1	0.101	1.236	0.125	
836.50	20525	Mid	LTE Band 5 (Cell)	10	24.0	23.60	0.09	0	359356060056374	QPSK	1	25	10 mm	right	1:1	0.332	1.096	0.364	
836.50	20525	Mid	LTE Band 5 (Cell)	10	23.0	22.08	0.05	1	359356060056374	QPSK	25	0	10 mm	right	1:1	0.258	1.236	0.319	
836.50	20525	Mid	LTE Band 5 (Cell)	10	24.0	23.60	0.05	0	359356060056374	QPSK	1	25	10 mm	left	1:1	0.544	1.096	0.596	
836.50	20525	Mid	LTE Band 5 (Cell)	10	23.0	22.08	0.07	1	359356060056374	QPSK	25	0	10 mm	left	1:1	0.417	1.236	0.515	
ANSI / IEEE C95.1 1992 - SAFETY LIMIT Spatial Peak Uncontrolled Exposure/General Population								Body 1.6 W/kg (mW/g) averaged over 1 gram											

Table 11-19
LTE Band 4 (AWS) Hotspot SAR

MEASUREMENT RESULTS																			
FREQUENCY		Mode	Bandwidth [MHz]	Maximum Allowed Power [dBm]	Conducted Power [dBm]	Power Drift [dB]	MPR [dB]	Device Serial Number	Modulation	RB Size	RB Offset	Spacing	Side	Duty Cycle	SAR (1g)	Scaling Factor	Scaled SAR (1g)	Plot #	
MHz	Ch.														(W/kg)		(W/kg)		
1732.50	20175	Mid	LTE Band 4 (AWS)	20	21.5	21.31	0.02	0	359356060056374	QPSK	1	0	10 mm	back	1:1	0.471	1.045	0.492	
1732.50	20175	Mid	LTE Band 4 (AWS)	20	21.5	21.25	0.03	0	359356060056374	QPSK	50	0	10 mm	back	1:1	0.469	1.059	0.497	
1732.50	20175	Mid	LTE Band 4 (AWS)	20	21.5	21.31	0.01	0	359356060056374	QPSK	1	0	10 mm	front	1:1	0.485	1.045	0.507	A25
1732.50	20175	Mid	LTE Band 4 (AWS)	20	21.5	21.25	0.01	0	359356060056374	QPSK	50	0	10 mm	front	1:1	0.476	1.059	0.504	
1732.50	20175	Mid	LTE Band 4 (AWS)	20	21.5	21.31	0.08	0	359356060056374	QPSK	1	0	10 mm	bottom	1:1	0.333	1.045	0.348	
1732.50	20175	Mid	LTE Band 4 (AWS)	20	21.5	21.25	0.06	0	359356060056374	QPSK	50	0	10 mm	bottom	1:1	0.335	1.059	0.355	
1732.50	20175	Mid	LTE Band 4 (AWS)	20	21.5	21.31	0.01	0	359356060056374	QPSK	1	0	10 mm	right	1:1	0.046	1.045	0.048	
1732.50	20175	Mid	LTE Band 4 (AWS)	20	21.5	21.25	0.02	0	359356060056374	QPSK	50	0	10 mm	right	1:1	0.044	1.059	0.047	
1732.50	20175	Mid	LTE Band 4 (AWS)	20	21.5	21.31	0.05	0	359356060056374	QPSK	1	0	10 mm	left	1:1	0.151	1.045	0.158	
1732.50	20175	Mid	LTE Band 4 (AWS)	20	21.5	21.25	0.00	0	359356060056374	QPSK	50	0	10 mm	left	1:1	0.152	1.059	0.161	
ANSI / IEEE C95.1 1992 - SAFETY LIMIT Spatial Peak Uncontrolled Exposure/General Population								Body 1.6 W/kg (mW/g) averaged over 1 gram											

Table 11-20
LTE Band 2 (PCS) Hotspot SAR

MEASUREMENT RESULTS																			
FREQUENCY		Mode	Bandwidth [MHz]	Maximum Allowed Power [dBm]	Conducted Power [dBm]	Power Drift [dB]	MPR [dB]	Device Serial Number	Modulation	RB Size	RB Offset	Spacing	Side	Duty Cycle	SAR (1g)	Scaling Factor	Scaled SAR (1g)	Plot #	
MHz	Ch.														(W/kg)		(W/kg)		
1860.00	18700	Low	LTE Band 2 (PCS)	20	20.5	20.36	-0.03	0	359356060079921	QPSK	1	0	10 mm	back	1:1	0.568	1.033	0.587	A27
1860.00	18700	Low	LTE Band 2 (PCS)	20	20.5	20.22	-0.11	0	359356060079921	QPSK	50	25	10 mm	back	1:1	0.537	1.067	0.573	
1860.00	18700	Low	LTE Band 2 (PCS)	20	20.5	20.36	0.06	0	359356060079921	QPSK	1	0	10 mm	front	1:1	0.538	1.033	0.556	
1860.00	18700	Low	LTE Band 2 (PCS)	20	20.5	20.22	-0.20	0	359356060079921	QPSK	50	25	10 mm	front	1:1	0.513	1.067	0.547	
1860.00	18700	Low	LTE Band 2 (PCS)	20	20.5	20.36	0.00	0	359356060079921	QPSK	1	0	10 mm	bottom	1:1	0.401	1.033	0.414	
1860.00	18700	Low	LTE Band 2 (PCS)	20	20.5	20.22	-0.19	0	359356060079921	QPSK	50	25	10 mm	bottom	1:1	0.359	1.067	0.383	
1860.00	18700	Low	LTE Band 2 (PCS)	20	20.5	20.36	0.18	0	359356060079921	QPSK	1	0	10 mm	right	1:1	0.053	1.033	0.055	
1860.00	18700	Low	LTE Band 2 (PCS)	20	20.5	20.22	0.12	0	359356060079921	QPSK	50	25	10 mm	right	1:1	0.043	1.067	0.046	
1860.00	18700	Low	LTE Band 2 (PCS)	20	20.5	20.36	-0.04	0	359356060079921	QPSK	1	0	10 mm	left	1:1	0.205	1.033	0.212	
1860.00	18700	Low	LTE Band 2 (PCS)	20	20.5	20.22	0.02	0	359356060079921	QPSK	50	25	10 mm	left	1:1	0.188	1.067	0.201	
ANSI / IEEE C95.1 1992 - SAFETY LIMIT Spatial Peak Uncontrolled Exposure/General Population								Body 1.6 W/kg (mW/g) averaged over 1 gram											

FCC ID: A3LSMG890A		SAR EVALUATION REPORT		Reviewed by: Quality Manager
Document S/N: OY1504030657.A3L	Test Dates: 04/06/15 - 05/04/15	DUT Type: Portable Handset	Page 73 of 94	

**Table 11-21
LTE Band 30 Hotspot SAR**

MEASUREMENT RESULTS																			
FREQUENCY		Mode	Bandwidth [MHz]	Maximum Allowed Power [dBm]	Conducted Power [dBm]	Power Drift [dB]	MPR [dB]	Device Serial Number	Modulation	RB Size	RB Offset	Spacing	Side	Duty Cycle	SAR (1g)	Scaling Factor	Scaled SAR (1g)	Plot #	
MHz	Ch.														(W/kg)		(W/kg)		
2310.00	27710	Mid	LTE Band 30	10	22.5	22.39	0.05	1	359356060056374	QPSK	1	25	10 mm	back	1:1	0.508	1.026	0.521	
2310.00	27710	Mid	LTE Band 30	10	21.5	21.16	0.02	1	359356060056374	QPSK	25	12	10 mm	back	1:1	0.383	1.081	0.414	
2310.00	27710	Mid	LTE Band 30	10	22.5	22.39	-0.02	0	359356060056374	QPSK	1	25	10 mm	front	1:1	0.518	1.026	0.531	
2310.00	27710	Mid	LTE Band 30	10	21.5	21.16	-0.03	1	359356060056374	QPSK	25	12	10 mm	front	1:1	0.406	1.081	0.439	
2310.00	27710	Mid	LTE Band 30	10	22.5	22.39	0.03	0	359356060056374	QPSK	1	25	10 mm	bottom	1:1	0.296	1.026	0.304	
2310.00	27710	Mid	LTE Band 30	10	21.5	21.16	0.01	1	359356060056374	QPSK	25	12	10 mm	bottom	1:1	0.226	1.081	0.244	
2310.00	27710	Mid	LTE Band 30	10	22.5	22.39	0.03	0	359356060056374	QPSK	1	25	10 mm	right	1:1	0.526	1.026	0.540	A29
2310.00	27710	Mid	LTE Band 30	10	21.5	21.16	0.05	1	359356060056374	QPSK	25	12	10 mm	right	1:1	0.392	1.081	0.424	
2310.00	27710	Mid	LTE Band 30	10	22.5	22.39	0.06	0	359356060056374	QPSK	1	25	10 mm	left	1:1	0.036	1.026	0.037	
2310.00	27710	Mid	LTE Band 30	10	21.5	21.16	0.03	1	359356060056374	QPSK	25	12	10 mm	left	1:1	0.028	1.081	0.030	
ANSI / IEEE C95.1 1992 - SAFETY LIMIT Spatial Peak Uncontrolled Exposure/General Population									Body 1.6 W/kg (mW/g) averaged over 1 gram										



**Table 11-22
WLAN Hotspot SAR**

MEASUREMENT RESULTS																			
FREQUENCY		Mode	Service	Bandwidth [MHz]	Maximum Allowed Power [dBm]	Conducted Power [dBm]	Power Drift [dB]	Spacing	Antenna Config.	Device Serial Number	Data Rate (Mbps)	Side	Duty Cycle (%)	Peak SAR of Area Scan	SAR (1g)	Scaling Factor (Power)	Scaling Factor (Duty Cycle)	Scaled SAR (1g)	Plot #
MHz	Ch.													(W/kg)	(W/kg)			(W/kg)	
2437	6	802.11b	DSSS	22	17.5	17.46	0.05	10 mm	1	359356060056374	1	back	99.8	0.450	0.390	1.009	1.002	0.395	A31
2437	6	802.11b	DSSS	22	17.5	17.46	-	10 mm	1	359356060056374	1	front	99.8	0.224	-	1.009	1.002	-	-
2437	6	802.11b	DSSS	22	17.5	17.46	-	10 mm	1	359356060056374	1	top	99.8	0.256	-	1.009	1.002	-	-
2437	6	802.11b	DSSS	22	17.5	17.46	-	10 mm	1	359356060056374	1	left	99.8	0.074	-	1.009	1.002	-	-
2462	11	802.11b	DSSS	22	17.5	17.18	0.07	10 mm	2	359356060056374	1	back	99.9	0.211	0.152	1.076	1.001	0.164	
2462	11	802.11b	DSSS	22	17.5	17.18	-	10 mm	2	359356060056374	1	front	99.9	0.084	-	1.076	1.001	-	-
2462	11	802.11b	DSSS	22	17.5	17.18	-	10 mm	2	359356060056374	1	top	99.9	0.068	-	1.076	1.001	-	-
2462	11	802.11b	DSSS	22	17.5	17.18	-	10 mm	2	359356060056374	1	left	99.9	0.129	-	1.076	1.001	-	-
5785	157	802.11a	OFDM	20	14.5	14.41	-	10 mm	1	359356060056390	6	back	98.1	0.223	-	1.021	1.019	-	-
5785	157	802.11a	OFDM	20	14.5	14.41	-	10 mm	1	359356060056390	6	front	98.1	0.063	-	1.021	1.019	-	-
5785	157	802.11a	OFDM	20	14.5	14.41	0.03	10 mm	1	359356060056390	6	top	98.1	0.239	0.103	1.021	1.019	0.107	
5785	157	802.11a	OFDM	20	14.5	14.41	-	10 mm	1	359356060056390	6	left	98.1	0.027	-	1.021	1.019	-	-
5785	157	802.11a	OFDM	20	14.5	14.47	0.01	10 mm	2	359356060056390	6	back	97.9	0.463	0.186	1.007	1.021	0.191	A33
5785	157	802.11a	OFDM	20	14.5	14.47	-	10 mm	2	359356060056390	6	front	97.9	0.084	-	1.007	1.021	-	-
5785	157	802.11a	OFDM	20	14.5	14.47	-	10 mm	2	359356060056390	6	top	97.9	0.159	-	1.007	1.021	-	-
5785	157	802.11a	OFDM	20	14.5	14.47	-	10 mm	2	359356060056390	6	left	97.9	0.366	-	1.007	1.021	-	-
ANSI / IEEE C95.1 1992 - SAFETY LIMIT Spatial Peak Uncontrolled Exposure/General Population									Body 1.6 W/kg (mW/g) averaged over 1 gram										

11.4 SAR Test Notes

General Notes:

- The test data reported are the worst-case SAR values according to test procedures specified in IEEE 1528-2003, and FCC KDB Publication 447498 D01v05.
- Batteries are fully charged at the beginning of the SAR measurements.
- Liquid tissue depth was at least 15.0 cm for all frequencies.
- The manufacturer has confirmed that the device(s) tested have the same physical, mechanical and thermal characteristics and are within operational tolerances expected for production units.
- SAR results were scaled to the maximum allowed power to demonstrate compliance per FCC KDB Publication 447498 D01v05.
- Device was tested using a fixed spacing for body-worn accessory testing. A separation distance of 15 mm was considered because the manufacturer has determined that there will be body-worn accessories available in the marketplace for users to support this separation distance. A test separation distance of 10 mm for Body-worn SAR was used for 5 GHz WLAN as it is more conservative.

FCC ID: A3LSMG890A	 PCTEST PROFESSIONAL TESTING LABORATORY, INC.	SAR EVALUATION REPORT		Reviewed by: Quality Manager
Document S/N: OY1504030657.A3L	Test Dates: 04/06/15 - 05/04/15	DUT Type: Portable Handset		Page 74 of 94

7. Per FCC KDB Publication 648474 D04v01, body-worn SAR was evaluated without a headset connected to the device. Since the standalone reported body-worn SAR was ≤ 1.2 W/kg, no additional body-worn SAR evaluations using a headset cable were required.
8. Per FCC KDB 865664 D01 v01, variability SAR tests were performed when the measured SAR results for a frequency band were greater than 0.8 W/kg. Repeated SAR measurements are highlighted in the tables above for clarity. Please see Section 13 for variability analysis.
9. During SAR Testing for the Wireless Router conditions per FCC KDB Publication 941225 D06v02, the actual Portable Hotspot operation (with actual simultaneous transmission of a transmitter with WIFI) was activated.
10. This device utilizes power reduction for GPRS/UMTS 1900 and LTE Band 2/4 under some portable hotspot conditions for SAR compliance. Therefore, these wireless router configurations were tested at reduced output power levels.

GSM Test Notes:



1. Body-Worn accessory testing is typically associated with voice operations. Therefore, GSM voice was evaluated for body-worn SAR.
2. Justification for reduced test configurations per KDB Publication 941225 D01v01 and October 2013 TCB Workshop Notes: The source-based frame-averaged output power was evaluated for all GPRS/EDGE slot configurations. The configuration with the highest target frame averaged output power was evaluated for hotspot SAR. When the maximum frame-averaged powers are equivalent across two or more slots (within 0.25 dB), the configuration with the most number of time slots was tested.
3. Per FCC KDB Publication 447498 D01v05, if the reported (scaled) SAR measured at the middle channel or highest output power channel for each test configuration is ≤ 0.8 W/kg then testing at the other channels is not required for such test configuration(s). When the maximum output power variation across the required test channels is $> \frac{1}{2}$ dB, instead of the middle channel, the highest output power channel was used.

UMTS Notes:

1. UMTS mode in was tested under RMC 12.2 kbps with HSPA not active per KDB Publication 941225 D01v03. HSPA SAR was not required since the average output power of the HSPA subtests was not more than 0.25 dB higher than the RMC level and SAR was less than 1.2 W/kg.
2. Per FCC KDB Publication 447498 D01v05, if the reported (scaled) SAR measured at the middle channel or highest output power channel for each test configuration is ≤ 0.8 W/kg then testing at the other channels is not required for such test configuration(s). When the maximum output power variation across the required test channels is $> \frac{1}{2}$ dB, instead of the middle channel, the highest output power channel was used.



LTE Notes:

1. LTE Considerations: LTE test configurations are determined according to SAR Evaluation Considerations for LTE Devices in FCC KDB Publication 941225 D05v02r03. The general test procedures used for testing can be found in Section 8.5.4.
2. MPR is permanently implemented for this device by the manufacturer. The specific manufacturer target MPR is indicated alongside the SAR results. MPR is enabled for this device, according to 3GPP TS36.101 Section 6.2.3 – 6.2.5 under Table 6.2.3-1.
3. A-MPR was disabled for all SAR tests by setting NS=01 on the base station simulator. SAR tests were performed with the same number of RB and RB offsets transmitting on all TTI frames (maximum TTI).
4. Per KDB Publication 941225 D05Av01r01, SAR for LTE CA operations was not needed since the maximum average output power in LTE CA mode was not >0.25 dB higher than the maximum output power when downlink carrier aggregation was not active.

FCC ID: A3LSMG890A		SAR EVALUATION REPORT	 Reviewed by: Quality Manager
Document S/N: OY1504030657.A3L	Test Dates: 04/06/15 - 05/04/15	DUT Type: Portable Handset	Page 75 of 94

WLAN Notes:

1. For held-to-ear and hotspot operations, the initial test position procedures were applied. The test position with the highest extrapolated peak SAR will be used as the initial test position. When reported SAR for the initial test position is ≤ 0.4 W/kg, no additional testing for the remaining test positions was required. Otherwise, SAR is evaluated at the subsequent highest peak SAR positions until the reported SAR result is ≤ 0.8 W/kg or all test positions are measured.
2. Justification for test configurations for WLAN per KDB Publication 248227 D01 Wi-Fi SAR v02 for 2.4 GHz WIFI single transmission chain operations, the highest measured maximum output power channel for DSSS was selected for SAR measurement. SAR for OFDM modes (2.4 GHz 802.11g/n) was not required due to the maximum allowed powers and the highest reported DSSS SAR. See Section 8.6.5 for more information.
3. Justification for test configurations for WLAN per KDB Publication 248227 D01 Wi-Fi SAR v02 for 5 GHz WIFI single transmission chain operations, the initial test configuration was selected according to the transmission mode with the highest maximum allowed powers. Other transmission modes were not investigated since the highest reported SAR for initial test configuration adjusted by the ratio of maximum output powers is less than 1.2 W/kg. See Section 8.6.6 for more information.
4. Per KDB Publication 248227 D01 Wi-Fi SAR v02, MIMO SAR was evaluated as the sum of antennas transmitting simultaneously at the specified maximum output power in MIMO mode following the initial test configuration procedures.
5. When the maximum reported 1g averaged SAR is ≤ 0.8 W/kg, SAR testing on additional channels was not required. Otherwise, SAR for the next highest output power channel was required until the reported SAR result was ≤ 1.20 W/kg or all test channels were measured.
6. The device was configured to transmit continuously at the required data rate, channel bandwidth and signal modulation, using the highest transmission duty factor supported by the test mode tools. The reported SAR was scaled to the 100% transmission duty factor to determine compliance. Procedures used to measure the duty factor are identical to that in the associated EMC test reports.
7. For SAR compliance, this device always uses power reduction when the device is in a held-to-ear RF exposure condition with 2.4 GHz and 5 GHz WIFI data modes. Therefore, WIFI head SAR was evaluated at reduced power levels.

FCC ID: A3LSMG890A	 SAR EVALUATION REPORT 		Reviewed by: Quality Manager
Document S/N: OY1504030657.A3L	Test Dates: 04/06/15 - 05/04/15	DUT Type: Portable Handset	Page 76 of 94

12 FCC MULTI-TX AND ANTENNA SAR CONSIDERATIONS

12.1 Introduction

The following procedures adopted from FCC KDB Publication 447498 D01v05r02 are applicable to devices with built-in unlicensed transmitters such as 802.11 and Bluetooth devices which may simultaneously transmit with the licensed transmitter.

12.2 Simultaneous Transmission Procedures

This device contains transmitters that may operate simultaneously. Therefore simultaneous transmission analysis is required. Per FCC KDB 447498 D01v05 IV.C.1.iii and IEEE 1528-2013 Section 6.3.4.1.2, simultaneous transmission SAR test exclusion may be applied when the sum of the 1-g SAR for all the simultaneous transmitting antennas in a specific physical test configuration is ≤ 1.6 W/kg. The different test positions in an exposure condition may be considered collectively to determine SAR test exclusion according to the sum of 1-g or 10-g SAR.

When standalone SAR is not required to be measured, per FCC KDB 447498 D01v05 4.3.2 2), the following equation must be used to estimate the standalone 1g SAR for simultaneous transmission assessment involving that transmitter.

$$\text{Estimated SAR} = \frac{\sqrt{f(\text{GHz})}}{7.5} * \frac{(\text{Max Power of channel, mW})}{\text{Min. Separation Distance, mm}}$$

**Table 12-1
Estimated SAR**

Mode	Frequency	Maximum Allowed Power	Separation Distance (Body)	Estimated SAR (Body)
	[MHz]	[dBm]	[mm]	[W/kg]
Bluetooth	2480	10.50	15	0.154

Notes:

- 1) Held-to ear configurations are not applicable to Bluetooth operations and therefore were not considered for simultaneous transmission. Per KDB Publication 447498 D01v05, the maximum power of the channel was rounded to the nearest mW before calculation.
- 2) Since the sum of 1g single transmission chain SAR measurements is < 1.6 W/kg, MIMO SAR for 2.4 GHz and 5 GHz head and all body-worn and hotspot exposure conditions was determined by the sum of 1g single transmission chain SAR values because the summation represents higher output power and yields more conservative result.
- 3) The highest reported SAR for each exposure condition is used for SAR summation purpose.



FCC ID: A3LSMG890A		SAR EVALUATION REPORT		Reviewed by: Quality Manager
Document S/N: OY1504030657.A3L	Test Dates: 04/06/15 - 05/04/15	DUT Type: Portable Handset	Page 77 of 94	

Table 12-2
Simultaneous Transmission Scenario with 2.4 GHz WLAN Ant 1 (Held to Ear)

Exposure Condition	Mode	2G/3G/4G SAR (W/kg)	2.4 GHz WLAN Ant 1 SAR (W/kg)	Σ SAR (W/kg)
Head SAR	GSM 850	0.487	0.294	0.781
	GSM 1900	0.459	0.294	0.753
	UMTS 850	0.503	0.294	0.797
	UMTS 1900	0.620	0.294	0.914
	LTE Band 12	0.497	0.294	0.791
	LTE Band 5 (Cell)	0.500	0.294	0.794
	LTE Band 4 (AWS)	0.560	0.294	0.854
	LTE Band 2 (PCS)	0.747	0.294	1.041
	LTE Band 30	0.683	0.294	0.977

Table 12-3
Simultaneous Transmission Scenario with 2.4 GHz WLAN Ant 2 (Held to Ear)

Exposure Condition	Mode	2G/3G/4G SAR (W/kg)	2.4 GHz WLAN Ant 2 SAR (W/kg)	Σ SAR (W/kg)
Head SAR	GSM 850	0.487	0.153	0.640
	GSM 1900	0.459	0.153	0.612
	UMTS 850	0.503	0.153	0.656
	UMTS 1900	0.620	0.153	0.773
	LTE Band 12	0.497	0.153	0.650
	LTE Band 5 (Cell)	0.500	0.153	0.653
	LTE Band 4 (AWS)	0.560	0.153	0.713
	LTE Band 2 (PCS)	0.747	0.153	0.900
	LTE Band 30	0.683	0.153	0.836



FCC ID: A3LSMG890A		SAR EVALUATION REPORT		Reviewed by: Quality Manager
Document S/N: 0Y1504030657.A3L	Test Dates: 04/06/15 - 05/04/15	DUT Type: Portable Handset	Page 78 of 94	

Table 12-4
Simultaneous Transmission Scenario with 2.4 GHz WLAN MIMO (Held to Ear)

Exposure Condition	Mode	2G/3G/4G SAR (W/kg)	2.4 GHz WLAN Ant 1 SAR (W/kg)	2.4 GHz WLAN Ant 2 SAR (W/kg)	Σ SAR (W/kg)
Head SAR	GSM 850	0.487	0.294	0.153	0.934
	GSM 1900	0.459	0.294	0.153	0.906
	UMTS 850	0.503	0.294	0.153	0.950
	UMTS 1900	0.620	0.294	0.153	1.067
	LTE Band 12	0.497	0.294	0.153	0.944
	LTE Band 5 (Cell)	0.500	0.294	0.153	0.947
	LTE Band 4 (AWS)	0.560	0.294	0.153	1.007
	LTE Band 2 (PCS)	0.747	0.294	0.153	1.194
	LTE Band 30	0.683	0.294	0.153	1.130

Table 12-5
Simultaneous Transmission Scenario with 5 GHz WLAN Ant 1 (Held to Ear)

Exposure Condition	Mode	2G/3G/4G SAR (W/kg)	5 GHz WLAN Ant 1 SAR (W/kg)	Σ SAR (W/kg)
Head SAR	GSM 850	0.487	0.053	0.540
	GSM 1900	0.459	0.053	0.512
	UMTS 850	0.503	0.053	0.556
	UMTS 1900	0.620	0.053	0.673
	LTE Band 12	0.497	0.053	0.550
	LTE Band 5 (Cell)	0.500	0.053	0.553
	LTE Band 4 (AWS)	0.560	0.053	0.613
	LTE Band 2 (PCS)	0.747	0.053	0.800
	LTE Band 30	0.683	0.053	0.736





FCC ID: A3LSMG890A		SAR EVALUATION REPORT		Reviewed by: Quality Manager
Document S/N: OY1504030657.A3L	Test Dates: 04/06/15 - 05/04/15	DUT Type: Portable Handset	Page 79 of 94	

Table 12-6
Simultaneous Transmission Scenario with 5 GHz WLAN Ant 2 (Held to Ear)

Exposure Condition	Mode	2G/3G/4G SAR (W/kg)	5 GHz WLAN Ant 2 SAR (W/kg)	Σ SAR (W/kg)
Head SAR	GSM 850	0.487	0.027	0.514
	GSM 1900	0.459	0.027	0.486
	UMTS 850	0.503	0.027	0.530
	UMTS 1900	0.620	0.027	0.647
	LTE Band 12	0.497	0.027	0.524
	LTE Band 5 (Cell)	0.500	0.027	0.527
	LTE Band 4 (AWS)	0.560	0.027	0.587
	LTE Band 2 (PCS)	0.747	0.027	0.774
	LTE Band 30	0.683	0.027	0.710

Table 12-7
Simultaneous Transmission Scenario with 5 GHz WLAN MIMO (Held to Ear)

Exposure Condition	Mode	2G/3G/4G SAR (W/kg)	5 GHz WLAN Ant 1 SAR (W/kg)	5 GHz WLAN Ant 2 SAR (W/kg)	Σ SAR (W/kg)
Head SAR	GSM 850	0.487	0.053	0.027	0.567
	GSM 1900	0.459	0.053	0.027	0.539
	UMTS 850	0.503	0.053	0.027	0.583
	UMTS 1900	0.620	0.053	0.027	0.700
	LTE Band 12	0.497	0.053	0.027	0.577
	LTE Band 5 (Cell)	0.500	0.053	0.027	0.580
	LTE Band 4 (AWS)	0.560	0.053	0.027	0.640
	LTE Band 2 (PCS)	0.747	0.053	0.027	0.827
	LTE Band 30	0.683	0.053	0.027	0.763

FCC ID: A3LSMG890A		SAR EVALUATION REPORT		Reviewed by: Quality Manager
Document S/N: 0Y1504030657.A3L	Test Dates: 04/06/15 - 05/04/15	DUT Type: Portable Handset	Page 80 of 94	

12.3 Body-Worn Simultaneous Transmission Analysis

1. For SAR summation for body-worn back side at 15mm, the SAR values at 10mm for some transmission modes were used since the 10mm test distance was more conservative. "<" denotes that the 10mm SAR values were used for summation purposes.
2. Bluetooth SAR was not required to be measured per FCC KDB 447498. Estimated SAR results were used for SAR summation for body-worn back side at 15mm to determine simultaneous transmission SAR test exclusion.

Table 12-8
Simultaneous Transmission Scenario with 2.4 GHz WLAN Ant 1 (Body-Worn at 1.5 cm)

Exposure Condition	Mode	2G/3G/4G SAR (W/kg)	2.4 GHz WLAN Ant 1 SAR (W/kg)	Σ SAR (W/kg)
Body-Worn	GSM 850	0.526	0.171	0.697
	GSM 1900	0.498	0.171	0.669
	UMTS 850	0.585	0.171	0.756
	UMTS 1900	0.574	0.171	0.745
	LTE Band 12	0.564	0.171	0.735
	LTE Band 5 (Cell)	0.557	0.171	0.728
	LTE Band 4 (AWS)	0.426	0.171	0.597
	LTE Band 2 (PCS)	0.669	0.171	0.840
	LTE Band 30	0.279	0.171	0.450

Table 12-9
Simultaneous Transmission Scenario with 2.4 GHz WLAN Ant 2 (Body-Worn at 1.5 cm)

Exposure Condition	Mode	2G/3G/4G SAR (W/kg)	2.4 GHz WLAN Ant 2 SAR (W/kg)	Σ SAR (W/kg)
Body-Worn	GSM 850	0.526	0.093	0.619
	GSM 1900	0.498	0.093	0.591
	UMTS 850	0.585	0.093	0.678
	UMTS 1900	0.574	0.093	0.667
	LTE Band 12	0.564	0.093	0.657
	LTE Band 5 (Cell)	0.557	0.093	0.650
	LTE Band 4 (AWS)	0.426	0.093	0.519
	LTE Band 2 (PCS)	0.669	0.093	0.762
	LTE Band 30	0.279	0.093	0.372



FCC ID: A3LSMG890A	 PCTEST PROFESSIONAL LABORATORY, INC.	SAR EVALUATION REPORT		Reviewed by: Quality Manager
Document S/N: OY1504030657.A3L	Test Dates: 04/06/15 - 05/04/15	DUT Type: Portable Handset		Page 81 of 94

Table 12-10
Simultaneous Transmission Scenario with 2.4 GHz WLAN MIMO (Body-Worn at 1.5 cm)

Exposure Condition	Mode	2G/3G/4G SAR (W/kg)	2.4 GHz WLAN Ant 1 SAR (W/kg)	2.4 GHz WLAN Ant 2 SAR (W/kg)	Σ SAR (W/kg)
Body-Worn	GSM 850	0.526	0.171	0.093	0.790
	GSM 1900	0.498	0.171	0.093	0.762
	UMTS 850	0.585	0.171	0.093	0.849
	UMTS 1900	0.574	0.171	0.093	0.838
	LTE Band 12	0.564	0.171	0.093	0.828
	LTE Band 5 (Cell)	0.557	0.171	0.093	0.821
	LTE Band 4 (AWS)	0.426	0.171	0.093	0.690
	LTE Band 2 (PCS)	0.669	0.171	0.093	0.933
	LTE Band 30	0.279	0.171	0.093	0.543

Table 12-11
Simultaneous Transmission Scenario with 5 GHz WLAN Ant 1 (Body-Worn at 1.5 cm)

Exposure Condition	Mode	2G/3G/4G SAR (W/kg)	5 GHz WLAN Ant 1 SAR (W/kg)	Σ SAR (W/kg)
Body-Worn	GSM 850	0.526	<0.094	<0.620
	GSM 1900	0.498	<0.094	<0.592
	UMTS 850	0.585	<0.094	<0.679
	UMTS 1900	0.574	<0.094	<0.668
	LTE Band 12	0.564	<0.094	<0.658
	LTE Band 5 (Cell)	0.557	<0.094	<0.651
	LTE Band 4 (AWS)	0.426	<0.094	<0.520
	LTE Band 2 (PCS)	0.669	<0.094	<0.763
	LTE Band 30	0.279	<0.094	<0.373



FCC ID: A3LSMG890A	 PCTEST <small>PROFESSIONAL ENGINEERING LABORATORY, INC.</small>	SAR EVALUATION REPORT		Reviewed by: Quality Manager
Document S/N: OY1504030657.A3L	Test Dates: 04/06/15 - 05/04/15	DUT Type: Portable Handset	Page 82 of 94	

Table 12-12
Simultaneous Transmission Scenario with 5 GHz WLAN Ant 2 (Body-Worn at 1.5 cm)

Exposure Condition	Mode	2G/3G/4G SAR (W/kg)	5 GHz WLAN Ant 2 SAR (W/kg)	Σ SAR (W/kg)
Body-Worn	GSM 850	0.526	<0.193	<0.719
	GSM 1900	0.498	<0.193	<0.691
	UMTS 850	0.585	<0.193	<0.778
	UMTS 1900	0.574	<0.193	<0.767
	LTE Band 12	0.564	<0.193	<0.757
	LTE Band 5 (Cell)	0.557	<0.193	<0.750
	LTE Band 4 (AWS)	0.426	<0.193	<0.619
	LTE Band 2 (PCS)	0.669	<0.193	<0.862
	LTE Band 30	0.279	<0.193	<0.472

Table 12-13
Simultaneous Transmission Scenario with 5 GHz WLAN MIMO (Body-Worn at 1.5 cm)

Exposure Condition	Mode	2G/3G/4G SAR (W/kg)	5 GHz WLAN Ant 1 SAR (W/kg)	5 GHz WLAN Ant 2 SAR (W/kg)	Σ SAR (W/kg)
Body-Worn	GSM 850	0.526	<0.094	<0.193	<0.813
	GSM 1900	0.498	<0.094	<0.193	<0.785
	UMTS 850	0.585	<0.094	<0.193	<0.872
	UMTS 1900	0.574	<0.094	<0.193	<0.861
	LTE Band 12	0.564	<0.094	<0.193	<0.851
	LTE Band 5 (Cell)	0.557	<0.094	<0.193	<0.844
	LTE Band 4 (AWS)	0.426	<0.094	<0.193	<0.713
	LTE Band 2 (PCS)	0.669	<0.094	<0.193	<0.956
	LTE Band 30	0.279	<0.094	<0.193	<0.566



FCC ID: A3LSMG890A		SAR EVALUATION REPORT		Reviewed by: Quality Manager
Document S/N: OY1504030657.A3L	Test Dates: 04/06/15 - 05/04/15	DUT Type: Portable Handset	Page 83 of 94	

Table 12-14
Simultaneous Transmission Scenario with Bluetooth (Body-Worn at 1.5 cm)

Exposure Condition	Mode	2G/3G/4G SAR (W/kg)	Bluetooth SAR (W/kg)	Σ SAR (W/kg)
Body-Worn	GSM 850	0.526	0.154	0.680
	GSM 1900	0.498	0.154	0.652
	UMTS 850	0.585	0.154	0.739
	UMTS 1900	0.574	0.154	0.728
	LTE Band 12	0.564	0.154	0.718
	LTE Band 5 (Cell)	0.557	0.154	0.711
	LTE Band 4 (AWS)	0.426	0.154	0.580
	LTE Band 2 (PCS)	0.669	0.154	0.823
	LTE Band 30	0.279	0.154	0.433

Note: Bluetooth SAR was not required to be measured per FCC KDB 447498. Estimated SAR results were used in the above table to determine simultaneous transmission SAR test exclusion.

12.4 Hotspot SAR Simultaneous Transmission Analysis

Per FCC KDB Publication 941225 D06v02, the devices edges with antennas more than 2.5 cm from edge are not required to be evaluated for SAR (“-”).

Table 12-15
Simultaneous Transmission Scenario (2.4 GHz WLAN Ant 1 at 1.0 cm)

Exposure Condition	Mode	2G/3G/4G SAR (W/kg)	2.4 GHz WLAN Ant 1 SAR (W/kg)	Σ SAR (W/kg)
Hotspot SAR	GPRS 850	1.016	0.395	1.411
	GPRS 1900	0.730	0.395	1.125
	UMTS 850	0.640	0.395	1.035
	UMTS 1900	0.748	0.395	1.143
	LTE Band 12	0.692	0.395	1.087
	LTE Band 5 (Cell)	0.636	0.395	1.031
	LTE Band 4 (AWS)	0.507	0.395	0.902
	LTE Band 2 (PCS)	0.587	0.395	0.982
	LTE Band 30	0.540	0.395	0.935



FCC ID: A3LSMG890A		SAR EVALUATION REPORT		Reviewed by: Quality Manager
Document S/N: OY1504030657.A3L	Test Dates: 04/06/15 - 05/04/15	DUT Type: Portable Handset	Page 84 of 94	

Table 12-16
Simultaneous Transmission Scenario (2.4 GHz WLAN Ant 2 at 1.0 cm)

Exposure Condition	Mode	2G/3G/4G SAR (W/kg)	2.4 GHz WLAN Ant 2 SAR (W/kg)	Σ SAR (W/kg)
Hotspot SAR	GPRS 850	1.016	0.164	1.180
	GPRS 1900	0.730	0.164	0.894
	UMTS 850	0.640	0.164	0.804
	UMTS 1900	0.748	0.164	0.912
	LTE Band 12	0.692	0.164	0.856
	LTE Band 5 (Cell)	0.636	0.164	0.800
	LTE Band 4 (AWS)	0.507	0.164	0.671
	LTE Band 2 (PCS)	0.587	0.164	0.751
	LTE Band 30	0.540	0.164	0.704

Table 12-17
Simultaneous Transmission Scenario (2.4 GHz WLAN MIMO at 1.0 cm)

Exposure Condition	Mode	2G/3G/4G SAR (W/kg)	2.4 GHz WLAN Ant 1 SAR (W/kg)	2.4 GHz WLAN Ant 2 SAR (W/kg)	Σ SAR (W/kg)
Hotspot SAR	GPRS 850	1.016	0.395	0.164	1.575
	GPRS 1900	0.730	0.395	0.164	1.289
	UMTS 850	0.640	0.395	0.164	1.199
	UMTS 1900	0.748	0.395	0.164	1.307
	LTE Band 12	0.692	0.395	0.164	1.251
	LTE Band 5 (Cell)	0.636	0.395	0.164	1.195
	LTE Band 4 (AWS)	0.507	0.395	0.164	1.066
	LTE Band 2 (PCS)	0.587	0.395	0.164	1.146
	LTE Band 30	0.540	0.395	0.164	1.099



FCC ID: A3LSMG890A	 PCTEST <small>PROFESSIONAL TESTING LABORATORY, INC.</small>	SAR EVALUATION REPORT		Reviewed by: Quality Manager
Document S/N: OY1504030657.A3L	Test Dates: 04/06/15 - 05/04/15	DUT Type: Portable Handset	Page 85 of 94	

Table 12-18
Simultaneous Transmission Scenario (5 GHz WLAN Ant 1 at 1.0 cm)

Exposure Condition	Mode	2G/3G/4G SAR (W/kg)	5 GHz WLAN Ant 1 SAR (W/kg)	Σ SAR (W/kg)
Hotspot SAR	GPRS 850	1.016	0.107	1.123
	GPRS 1900	0.730	0.107	0.837
	UMTS 850	0.640	0.107	0.747
	UMTS 1900	0.748	0.107	0.855
	LTE Band 12	0.692	0.107	0.799
	LTE Band 5 (Cell)	0.636	0.107	0.743
	LTE Band 4 (AWS)	0.507	0.107	0.614
	LTE Band 2 (PCS)	0.587	0.107	0.694
	LTE Band 30	0.540	0.107	0.647

Table 12-19
Simultaneous Transmission Scenario (5 GHz WLAN Ant 2 at 1.0 cm)

Exposure Condition	Mode	2G/3G/4G SAR (W/kg)	5 GHz WLAN Ant 2 SAR (W/kg)	Σ SAR (W/kg)
Hotspot SAR	GPRS 850	1.016	0.191	1.207
	GPRS 1900	0.730	0.191	0.921
	UMTS 850	0.640	0.191	0.831
	UMTS 1900	0.748	0.191	0.939
	LTE Band 12	0.692	0.191	0.883
	LTE Band 5 (Cell)	0.636	0.191	0.827
	LTE Band 4 (AWS)	0.507	0.191	0.698
	LTE Band 2 (PCS)	0.587	0.191	0.778
	LTE Band 30	0.540	0.191	0.731





FCC ID: A3LSMG890A		SAR EVALUATION REPORT		Reviewed by: Quality Manager
Document S/N: OY1504030657.A3L	Test Dates: 04/06/15 - 05/04/15	DUT Type: Portable Handset	Page 86 of 94	

Table 12-20
Simultaneous Transmission Scenario (5 GHz WLAN MIMO at 1.0 cm)

Exposure Condition	Mode	2G/3G/4G SAR (W/kg)	5 GHz WLAN Ant 1 SAR (W/kg)	5 GHz WLAN Ant 2 SAR (W/kg)	Σ SAR (W/kg)
Hotspot SAR	GPRS 850	1.016	0.107	0.191	1.314
	GPRS 1900	0.730	0.107	0.191	1.028
	UMTS 850	0.640	0.107	0.191	0.938
	UMTS 1900	0.748	0.107	0.191	1.046
	LTE Band 12	0.692	0.107	0.191	0.990
	LTE Band 5 (Cell)	0.636	0.107	0.191	0.934
	LTE Band 4 (AWS)	0.507	0.107	0.191	0.805
	LTE Band 2 (PCS)	0.587	0.107	0.191	0.885
	LTE Band 30	0.540	0.107	0.191	0.838

12.5 Simultaneous Transmission Conclusion

The above numerical summed SAR results for all the worst-case simultaneous transmission conditions were below the SAR limit. Therefore, the above analysis is sufficient to determine that simultaneous transmission cases will not exceed the SAR limit and therefore no measured volumetric simultaneous SAR summation is required per FCC KDB Publication 447498 D01v05 and IEEE 1528-2013 Section 6.3.4.1.2.

FCC ID: A3LSMG890A		SAR EVALUATION REPORT		Reviewed by: Quality Manager
Document S/N: OY1504030657.A3L	Test Dates: 04/06/15 - 05/04/15	DUT Type: Portable Handset	Page 87 of 94	

13 SAR MEASUREMENT VARIABILITY

13.1 Measurement Variability

Per FCC KDB Publication 865664 D01v01, SAR measurement variability was assessed for each frequency band, which was determined by the SAR probe calibration point and tissue-equivalent medium used for the device measurements. When both head and body tissue-equivalent media were required for SAR measurements in a frequency band, the variability measurement procedures were applied to the tissue medium with the highest measured SAR, using the highest measured SAR configuration for that tissue-equivalent medium. These additional measurements were repeated after the completion of all measurements requiring the same head or body tissue-equivalent medium in a frequency band. The test device was returned to ambient conditions (normal room temperature) with the battery fully charged before it was re-mounted on the device holder for the repeated measurement(s) to minimize any unexpected variations in the repeated results.

SAR Measurement Variability was assessed using the following procedures for each frequency band:



- 1) When the original highest measured SAR is ≥ 0.80 W/kg, the measurement was repeated once.
- 2) A second repeated measurement was performed only if the ratio of largest to smallest SAR for the original and first repeated measurements was > 1.20 or when the original or repeated measurement was ≥ 1.45 W/kg (~ 10% from the 1-g SAR limit).
- 3) A third repeated measurement was performed only if the original, first or second repeated measurement was ≥ 1.5 W/kg and the ratio of largest to smallest SAR for the original, first and second repeated measurements is > 1.20 .
- 4) Repeated measurements are not required when the original highest measured SAR is < 0.80 W/kg

**Table 13-1
Body SAR Measurement Variability Results**

BODY VARIABILITY RESULTS														
Band	FREQUENCY		Mode	Service	# of Time Slots	Side	Spacing	Measured SAR (1g)	1st Repeated SAR (1g)	Ratio	2nd Repeated SAR (1g)	Ratio	3rd Repeated SAR (1g)	Ratio
	MHz	Ch.						(W/kg)	(W/kg)		(W/kg)		(W/kg)	
835	824.20	128	GSM 850	GPRS	2	back	10 mm	0.813	0.720	1.13	N/A	N/A	N/A	N/A
ANSI / IEEE C95.1 1992 - SAFETY LIMIT Spatial Peak Uncontrolled Exposure/General Population							Body 1.6 W/kg (mW/g) averaged over 1 gram							

13.2 Measurement Uncertainty



The measured SAR was < 1.5 W/kg for all frequency bands. Therefore, per KDB Publication 865664 D01v01, the extended measurement uncertainty analysis per IEEE 1528-2003 was not required.

FCC ID: A3LSMG890A	 PCTEST PROFESSIONAL LABORATORY, INC.	SAR EVALUATION REPORT		Reviewed by: Quality Manager
Document S/N: OY1504030657.A3L	Test Dates: 04/06/15 - 05/04/15	DUT Type: Portable Handset	Page 88 of 94	

14 EQUIPMENT LIST

Manufacturer	Model	Description	Cal Date	Cal Interval	Cal Due	Serial Number
Gigatronics	80701A	(0.05-18GHz) Power Sensor	10/30/2014	Annual	10/30/2015	1833460
Agilent	E8257D	(250kHz-20GHz) Signal Generator	3/15/2015	Annual	3/15/2016	MY45470194
Agilent	8753E	(30kHz-6GHz) Network Analyzer	12/30/2014	Annual	12/30/2015	JP38020182
Agilent	8594A	(9kHz-2.9GHz) Spectrum Analyzer	N/A	N/A	N/A	3051A00187
Agilent	8648D	(9kHz-4GHz) Signal Generator	3/15/2015	Annual	3/15/2016	3629U00687
SPEAG	D1750V2	1750 MHz SAR Dipole	4/10/2014	Annual	4/10/2015	1051
SPEAG	D1765V2	1765 MHz SAR Dipole	5/7/2014	Annual	5/7/2015	1008
SPEAG	D1900V2	1900 MHz SAR Dipole	4/9/2014	Annual	4/9/2015	5d141
SPEAG	D1900V2	1900 MHz SAR Dipole	4/14/2015	Annual	4/14/2016	5d141
SPEAG	D2300V2	2300 MHz SAR Dipole	1/27/2015	Annual	1/27/2016	1008
SPEAG	D2450V2	2450 MHz SAR Dipole	8/11/2014	Annual	8/11/2015	719
Narda	4014C-6	4 - 8 GHz SMA 6 dB Directional Coupler	CBT	NA	CBT	N/A
SPEAG	D5GHZV2	5GHz SAR Dipole	9/25/2014	Annual	9/25/2015	1191
MCL	BW-N6W5+	6dB Attenuator	CBT	NA	CBT	1139
SPEAG	D750V3	750 MHz Dipole	1/16/2015	Annual	1/16/2016	1003
SPEAG	D835V2	835 MHz SAR Dipole	7/24/2014	Annual	7/24/2015	4d133
Amplifier Research	1551G6	Amplifier	CBT	NA	CBT	433978
Narda	4772-3	Attenuator (3dB)	CBT	NA	CBT	9406
Rohde & Schwarz	CMU200	Base Station Simulator	3/23/2015	Annual	3/23/2016	836371/0079
Pasternack	PE2208-6	Bidirectional Coupler	CBT	NA	CBT	N/A
Pasternack	PE2209-10	Bidirectional Coupler	CBT	NA	CBT	N/A
SPEAG	DAE4	Dasy Data Acquisition Electronics	8/12/2014	Annual	8/12/2015	1322
SPEAG	DAE4	Dasy Data Acquisition Electronics	9/17/2014	Annual	9/17/2015	1323
SPEAG	DAE4	Dasy Data Acquisition Electronics	9/18/2014	Annual	9/18/2015	1364
SPEAG	DAE4	Dasy Data Acquisition Electronics	10/23/2014	Annual	10/23/2015	1408
SPEAG	DAE4	Dasy Data Acquisition Electronics	10/31/2014	Annual	10/31/2015	1333
SPEAG	DAE4	Dasy Data Acquisition Electronics	12/12/2014	Annual	12/12/2015	1415
SPEAG	DAE4	Dasy Data Acquisition Electronics	1/14/2015	Annual	1/14/2016	1272
SPEAG	DAE4	Dasy Data Acquisition Electronics	1/19/2015	Annual	1/19/2016	1407
SPEAG	DAE4	Dasy Data Acquisition Electronics	3/13/2015	Annual	3/13/2016	1334
Mini-Circuits	BW-N20W5+	DC to 18 GHz Precision Fixed 20dB Attenuator	CBT	NA	CBT	N/A
SPEAG	DAK-3.5	Dielectric Assessment Kit	5/6/2014	Annual	5/6/2015	1070
Mitutoyo	CD-6-CSX	Digital Caliper	5/8/2014	Biennial	5/8/2016	13264162
Control Company	4040	Digital Thermometer	3/18/2015	Biennial	3/18/2017	150194896
Agilent	E4438C	ESG Vector Signal Generator	3/15/2015	Annual	3/15/2016	MY45091346
Agilent	E4432B	ESG-D Series Signal Generator	3/16/2015	Annual	3/16/2016	US40053896
Control Company	61220-416	Long-Stem Thermometer	4/29/2014	Biennial	4/29/2016	111331323
MiniCircuits	VLF-6000+	Low Pass Filter	CBT	NA	CBT	N/A
MiniCircuits	SLP-2400+	Low Pass Filter	CBT	NA	CBT	R8979500903
Mini-Circuits	NLP-1200+	Low Pass Filter DC to 1000 MHz	CBT	NA	CBT	N/A
Mini-Circuits	NLP-2950+	Low Pass Filter DC to 2700 MHz	CBT	NA	CBT	N/A
Agilent	N5182A	MXG Vector Signal Generator	3/16/2015	Annual	3/16/2016	MY47420651
Agilent	8753ES	Network Analyzer	3/20/2015	Annual	3/20/2016	MY40001472
Mini-Circuits	BW-N20W5	Power Attenuator	CBT	NA	CBT	1226
Anritsu	ML2495A	Power Meter	10/31/2013	Biennial	10/31/2015	941001
Anritsu	MA2411B	Pulse Power Sensor	11/17/2014	Annual	11/17/2015	1207364
Anritsu	MA2411B	Pulse Power Sensor	11/17/2014	Annual	11/17/2015	1126056
Anritsu	MT8820C	Radio Communication Analyzer	11/18/2014	Annual	11/18/2015	6201300731
Anritsu	MT8820C	Radio Communication Analyzer	3/10/2015	Annual	3/10/2016	6200901190
Rohde & Schwarz	CMW500	Radio Communication Tester	3/18/2015	Annual	3/18/2016	128633
Rohde & Schwarz	CMW500	Radio Communication Tester	4/8/2015	Annual	4/8/2016	140148
SPEAG	ES3DV2	SAR Probe	8/19/2014	Annual	8/19/2015	3022
SPEAG	ES3DV3	SAR Probe	9/18/2014	Annual	9/18/2015	3332
SPEAG	ES3DV3	SAR Probe	9/24/2014	Annual	9/24/2015	3288
SPEAG	ES3DV3	SAR Probe	10/24/2014	Annual	10/24/2015	3333
SPEAG	ES3DV3	SAR Probe	12/16/2014	Annual	12/16/2015	3334
SPEAG	ES3DV3	SAR Probe	1/20/2015	Annual	1/20/2016	3213
SPEAG	ES3DV3	SAR Probe	1/23/2015	Annual	1/23/2016	3318
SPEAG	EX3DV4	SAR Probe	2/10/2015	Annual	2/10/2016	3914
SPEAG	ES3DV3	SAR Probe	3/19/2015	Annual	3/19/2016	3209
COMTECH	AR85729-5/5759B	Solid State Amplifier	CBT	NA	CBT	M3W1A00-1002
COMTECH	AR85729-5	Solid State Amplifier	CBT	NA	CBT	M155A00-009
Agilent	8753ES	S-Parameter Network Analyzer	1/20/2015	Annual	1/20/2016	US39170122
Agilent	8753ES	S-Parameter Network Analyzer	3/12/2015	Annual	3/12/2016	MY40000670
Seekonk	NC-100	Torque Wrench	3/18/2014	Biennial	3/18/2016	22313
Seekonk	NC-100	Torque Wrench 5/16", 8" lbs	3/18/2014	Biennial	3/18/2016	N/A
Gigatronics	8651A	Universal Power Meter	10/30/2014	Annual	10/30/2015	8650319
Anritsu	MA24106A	USB Power Sensor	3/2/2015	Annual	3/2/2016	1349503
Anritsu	MA24106A	USB Power Sensor	3/3/2015	Annual	3/3/2016	1349501
Control Company	36934-158	Wall-Mounted Thermometer	4/29/2014	Biennial	4/29/2016	122014488
Agilent	E5515C	Wireless Communications Test Set	2/23/2015	Biennial	2/23/2017	G841450275
Agilent	N4010A	Wireless Connectivity Test Set	CBT	NA	CBT	G844450273

Note: CBT (Calibrated Before Testing). Prior to testing, the measurement paths containing a cable, amplifier, attenuator, coupler or filter were connected to a calibrated source (i.e. a signal generator) to determine the losses of the measurement path. The power meter offset was then adjusted to compensate for the measurement system losses. This level offset is stored within the power meter before measurements are made. This calibration verification procedure applies to the system verification and output power measurements. The calibrated reading is then taken directly from the power meter after compensation of the losses for all final power measurements. Each piece of equipment was used solely within its valid calibration period.



FCC ID: A3LSMG890A		SAR EVALUATION REPORT		Reviewed by: Quality Manager
Document S/N: OY1504030657.A3L	Test Dates: 04/06/15 - 05/04/15	DUT Type: Portable Handset		Page 89 of 94

15 MEASUREMENT UNCERTAINTIES

Applicable for frequencies less than 3000 MHz.

a	b	c	d	e= f(d,k)	f	g	h = c x f/e	i = c x g/e	k	
Uncertainty Component	IEEE 1528 Sec.	Tol. (± %)	Prob. Dist.	Div.	c _i 1gm	c _i 10 gms	1gm u _i (± %)	10gms u _i (± %)	v _i	
Measurement System										
Probe Calibration	E.2.1	6.0	N	1	1.0	1.0	6.0	6.0	∞	
Axial Isotropy	E.2.2	0.25	N	1	0.7	0.7	0.2	0.2	∞	
Hemishperical Isotropy	E.2.2	1.3	N	1	1.0	1.0	1.3	1.3	∞	
Boundary Effect	E.2.3	0.4	N	1	1.0	1.0	0.4	0.4	∞	
Linearity	E.2.4	0.3	N	1	1.0	1.0	0.3	0.3	∞	
System Detection Limits	E.2.5	5.1	N	1	1.0	1.0	5.1	5.1	∞	
Readout Electronics	E.2.6	1.0	N	1	1.0	1.0	1.0	1.0	∞	
Response Time	E.2.7	0.8	R	1.73	1.0	1.0	0.5	0.5	∞	
Integration Time	E.2.8	2.6	R	1.73	1.0	1.0	1.5	1.5	∞	
RF Ambient Conditions	E.6.1	3.0	R	1.73	1.0	1.0	1.7	1.7	∞	
Probe Positioner Mechanical Tolerance	E.6.2	0.4	R	1.73	1.0	1.0	0.2	0.2	∞	
Probe Positioning w/ respect to Phantom	E.6.3	2.9	R	1.73	1.0	1.0	1.7	1.7	∞	
Extrapolation, Interpolation & Integration algorithms for Max. SAR Evaluation	E.5	1.0	R	1.73	1.0	1.0	0.6	0.6	∞	
Test Sample Related										
Test Sample Positioning	E.4.2	6.0	N	1	1.0	1.0	6.0	6.0	287	
Device Holder Uncertainty	E.4.1	3.32	R	1.73	1.0	1.0	1.9	1.9	∞	
Output Power Variation - SAR drift measurement	6.6.2	5.0	R	1.73	1.0	1.0	2.9	2.9	∞	
Phantom & Tissue Parameters										
Phantom Uncertainty (Shape & Thickness tolerances)	E.3.1	4.0	R	1.73	1.0	1.0	2.3	2.3	∞	
Liquid Conductivity - deviation from target values	E.3.2	5.0	R	1.73	0.64	0.43	1.8	1.2	∞	
Liquid Conductivity - measurement uncertainty	E.3.3	3.8	N	1	0.64	0.43	2.4	1.6	6	
Liquid Permittivity - deviation from target values	E.3.2	5.0	R	1.73	0.60	0.49	1.7	1.4	∞	
Liquid Permittivity - measurement uncertainty	E.3.3	4.5	N	1	0.60	0.49	2.7	2.2	6	
Combined Standard Uncertainty (k=1)							RSS	12.1	11.7	299
Expanded Uncertainty (95% CONFIDENCE LEVEL)							k=2	24.2	23.5	



The above measurement uncertainties are according to IEEE Std. 1528-2003

FCC ID: A3LSMG890A	 PCTEST PROFESSIONAL ENGINEERING LABORATORY, INC.	SAR EVALUATION REPORT		Reviewed by: Quality Manager
Document S/N: OY1504030657.A3L	Test Dates: 04/06/15 - 05/04/15	DUT Type: Portable Handset		Page 90 of 94

Applicable for frequencies up to 6 GHz.

a	b	c	d	e= f(d,k)	f	g	h = c x f/e	i = c x g/e	k	
Uncertainty Component	IEEE 1528 Sec.	Tol. (± %)	Prob. Dist.	Div.	c _i 1gm	c _i 10 gms	1gm u _i (± %)	10gms u _i (± %)	v _i	
Measurement System										
Probe Calibration	E.2.1	6.55	N	1	1.0	1.0	6.6	6.6	∞	
Axial Isotropy	E.2.2	0.25	N	1	0.7	0.7	0.2	0.2	∞	
Hemishperical Isotropy	E.2.2	1.3	N	1	1.0	1.0	1.3	1.3	∞	
Boundary Effect	E.2.3	0.4	N	1	1.0	1.0	0.4	0.4	∞	
Linearity	E.2.4	0.3	N	1	1.0	1.0	0.3	0.3	∞	
System Detection Limits	E.2.5	5.1	N	1	1.0	1.0	5.1	5.1	∞	
Readout Electronics	E.2.6	1.0	N	1	1.0	1.0	1.0	1.0	∞	
Response Time	E.2.7	0.8	R	1.73	1.0	1.0	0.5	0.5	∞	
Integration Time	E.2.8	2.6	R	1.73	1.0	1.0	1.5	1.5	∞	
RF Ambient Conditions	E.6.1	3.0	R	1.73	1.0	1.0	1.7	1.7	∞	
Probe Positioner Mechanical Tolerance	E.6.2	0.4	R	1.73	1.0	1.0	0.2	0.2	∞	
Probe Positioning w/ respect to Phantom	E.6.3	2.9	R	1.73	1.0	1.0	1.7	1.7	∞	
Extrapolation, Interpolation & Integration algorithms for Max. SAR Evaluation	E.5	1.0	R	1.73	1.0	1.0	0.6	0.6	∞	
Test Sample Related										
Test Sample Positioning	E.4.2	6.0	N	1	1.0	1.0	6.0	6.0	287	
Device Holder Uncertainty	E.4.1	3.32	R	1.73	1.0	1.0	1.9	1.9	∞	
Output Power Variation - SAR drift measurement	6.6.2	5.0	R	1.73	1.0	1.0	2.9	2.9	∞	
Phantom & Tissue Parameters										
Phantom Uncertainty (Shape & Thickness tolerances)	E.3.1	4.0	R	1.73	1.0	1.0	2.3	2.3	∞	
Liquid Conductivity - deviation from target values	E.3.2	5.0	R	1.73	0.64	0.43	1.8	1.2	∞	
Liquid Conductivity - measurement uncertainty	E.3.3	3.8	N	1	0.64	0.43	2.4	1.6	6	
Liquid Permittivity - deviation from target values	E.3.2	5.0	R	1.73	0.60	0.49	1.7	1.4	∞	
Liquid Permittivity - measurement uncertainty	E.3.3	4.5	N	1	0.60	0.49	2.7	2.2	6	
Combined Standard Uncertainty (k=1)							RSS	12.4	12.0	299
Expanded Uncertainty (95% CONFIDENCE LEVEL)							k=2	24.7	24.0	

The above measurement uncertainties are according to IEEE Std. 1528-2003



FCC ID: A3LSMG890A	 PCTEST PROFESSIONAL COMMUNICATIONS TESTING, INC.	SAR EVALUATION REPORT		Reviewed by: Quality Manager
Document S/N: OY1504030657.A3L	Test Dates: 04/06/15 - 05/04/15	DUT Type: Portable Handset	Page 91 of 94	

16 CONCLUSION

16.1 Measurement Conclusion



The SAR evaluation indicates that the EUT complies with the RF radiation exposure limits of the FCC and Industry Canada, with respect to all parameters subject to this test. These measurements were taken to simulate the RF effects of RF exposure under worst-case conditions. Precise laboratory measures were taken to assure repeatability of the tests. The results and statements relate only to the item(s) tested.

Please note that the absorption and distribution of electromagnetic energy in the body are very complex phenomena that depend on the mass, shape, and size of the body, the orientation of the body with respect to the field vectors, and the electrical properties of both the body and the environment. Other variables that may play a substantial role in possible biological effects are those that characterize the environment (e.g. ambient temperature, air velocity, relative humidity, and body insulation) and those that characterize the individual (e.g. age, gender, activity level, debilitation, or disease). Because various factors may interact with one another to vary the specific biological outcome of an exposure to electromagnetic fields, any protection guide should consider maximal amplification of biological effects as a result of field-body interactions, environmental conditions, and physiological variables. [3]



FCC ID: A3LSMG890A	 PCTEST ENGINEERING LABORATORY, INC.	SAR EVALUATION REPORT		Reviewed by: Quality Manager
Document S/N: 0Y1504030657.A3L	Test Dates: 04/06/15 - 05/04/15	DUT Type: Portable Handset	Page 92 of 94	

17 REFERENCES

- [1] Federal Communications Commission, ET Docket 93-62, Guidelines for Evaluating the Environmental Effects of Radiofrequency Radiation, Aug. 1996.
- [2] ANSI/IEEE C95.1-2005, American National Standard safety levels with respect to human exposure to radio frequency electromagnetic fields, 3kHz to 300GHz, New York: IEEE, 2006.
- [3] ANSI/IEEE C95.1-1992, American National Standard safety levels with respect to human exposure to radio frequency electromagnetic fields, 3kHz to 300GHz, New York: IEEE, Sept. 1992.
- [4] ANSI/IEEE C95.3-2002, IEEE Recommended Practice for the Measurement of Potentially Hazardous Electromagnetic Fields - RF and Microwave, New York: IEEE, December 2002.
- [5] IEEE Standards Coordinating Committee 39 –Standards Coordinating Committee 34 – IEEE Std. 1528-2003, Recommended Practice for Determining the Peak Spatial-Average Specific Absorption Rate (SAR) in the Human Head Due to Wireless Communications Devices: Measurement Techniques.
- [6] NCRP, National Council on Radiation Protection and Measurements, Biological Effects and Exposure Criteria for RadioFrequency Electromagnetic Fields, NCRP Report No. 86, 1986. Reprinted Feb. 1995.
- [7] T. Schmid, O. Egger, N. Kuster, Automated E-field scanning system for dosimetric assessments, IEEE Transaction on Microwave Theory and Techniques, vol. 44, Jan. 1996, pp. 105-113.
- [8] K. Pokovic, T. Schmid, N. Kuster, Robust setup for precise calibration of E-field probes in tissue simulating liquids at mobile communications frequencies, ICECOM97, Oct. 1997, pp. -124.
- [9] K. Pokovic, T. Schmid, and N. Kuster, E-field Probe with improved isotropy in brain simulating liquids, Proceedings of the ELMAR, Zadar, Croatia, June 23-25, 1996, pp. 172-175.
- [10] Schmid & Partner Engineering AG, Application Note: Data Storage and Evaluation, June 1998, p2.
- [11] V. Hombach, K. Meier, M. Burkhardt, E. Kuhn, N. Kuster, The Dependence of EM Energy Absorption upon Human Modeling at 900 MHz, IEEE Transaction on Microwave Theory and Techniques, vol. 44 no. 10, Oct. 1996, pp. 1865-1873.
- [12] N. Kuster and Q. Balzano, Energy absorption mechanism by biological bodies in the near field of dipole antennas above 300MHz, IEEE Transaction on Vehicular Technology, vol. 41, no. 1, Feb. 1992, pp. 17-23.
- [13] G. Hartsgrove, A. Kraszewski, A. Surowiec, Simulated Biological Materials for Electromagnetic Radiation Absorption Studies, University of Ottawa, Bioelectromagnetics, Canada: 1987, pp. 29-36.
- [14] Q. Balzano, O. Garay, T. Manning Jr., Electromagnetic Energy Exposure of Simulated Users of Portable Cellular Telephones, IEEE Transactions on Vehicular Technology, vol. 44, no.3, Aug. 1995.
- [15] W. Gander, Computermathematick, Birkhaeuser, Basel, 1992.
- [16] W.H. Press, S.A. Teukolsky, W.T. Vetterling, and B.P. Flannery, Numerical Recipes in C, The Art of Scientific Computing, Second edition, Cambridge University Press, 1992.
- [17] N. Kuster, R. Kastle, T. Schmid, Dosimetric evaluation of mobile communications equipment with known precision, IEEE Transaction on Communications, vol. E80-B, no. 5, May 1997, pp. 645-652.

FCC ID: A3LSMG890A	 PCTEST PROFESSIONAL ENGINEERING LABORATORY, INC.	SAR EVALUATION REPORT		Reviewed by: Quality Manager
Document S/N: OY1504030657.A3L	Test Dates: 04/06/15 - 05/04/15	DUT Type: Portable Handset	Page 93 of 94	

- [18] CENELEC CLC/SC111B, European Prestandard (prENV 50166-2), Human Exposure to Electromagnetic Fields High-frequency: 10kHz-300GHz, Jan. 1995.
- [19] Prof. Dr. Niels Kuster, ETH, Eidgenössische Technische Hochschule Zürich, Dosimetric Evaluation of the Cellular Phone.
- [20] IEC 62209-1, Human exposure to radio frequency fields from hand-held and body-mounted wireless communication devices - Human models, instrumentation, and procedures - Part 1: Procedure to determine the specific absorption rate (SAR) for hand-held devices used in close proximity to the ear (frequency range of 300 MHz to 3 GHz), Feb. 2005.
- [21] Industry Canada RSS-102 Radio Frequency Exposure Compliance of Radiocommunication Apparatus (All Frequency Bands) Issue 4, March 2010.
- [22] Health Canada Safety Code 6 Limits of Human Exposure to Radio Frequency Electromagnetic Fields in the Frequency Range from 3 kHz – 300 GHz, 2009
- [23] FCC SAR Test Procedures for 2G-3G Devices, Mobile Hotspot and UMPC Devices KDB Publications 941225, D01-D07
- [24] SAR Measurement Guidance for IEEE 802.11 Transmitters, KDB Publication 248227 D01 Wi-Fi SAR v02
- [25] FCC SAR Considerations for Handsets with Multiple Transmitters and Antennas, KDB Publications 648474 D03-D04
- [26] FCC SAR Evaluation Considerations for Laptop, Notebook, Netbook and Tablet Computers, FCC KDB Publication 616217 D04
- [27] FCC SAR Measurement and Reporting Requirements for 100MHz – 6 GHz, KDB Publications 865664 D01-D02
- [28] FCC General RF Exposure Guidance and SAR Procedures for Dongles, KDB Publication 447498, D01-D02
- [29] Anexo à Resolução No. 533, de 10 de Setembro de 2009.
- [30] IEC 62209-2, Human exposure to radio frequency fields from hand-held and body-mounted wireless communication devices - Human models, instrumentation, and procedures - Part 2: Procedure to determine the specific absorption rate (SAR) for wireless communication devices used in close proximity to the human body (frequency range of 30 MHz to 6 GHz), Mar. 2010.

FCC ID: A3LSMG890A	 SAR EVALUATION REPORT 		Reviewed by: Quality Manager
Document S/N: 0Y1504030657.A3L	Test Dates: 04/06/15 - 05/04/15	DUT Type: Portable Handset	Page 94 of 94

APPENDIX A: SAR TEST DATA

PCTEST ENGINEERING LABORATORY, INC.

DUT: A3LSMG890A; Type: Portable Handset; Serial: 359356060056374

Communication System: UID 0, GSM; Frequency: 836.6 MHz; Duty Cycle: 1:8.3

Medium: 835 Head Medium parameters used (interpolated):

$f = 836.6 \text{ MHz}$; $\sigma = 0.937 \text{ S/m}$; $\epsilon_r = 42.992$; $\rho = 1000 \text{ kg/m}^3$

Phantom section: Left Section

Test Date: 04-08-2015; Ambient Temp: 23.8°C; Tissue Temp: 22.0°C

Probe: ES3DV3 - SN3209; ConvF(6.04, 6.04, 6.04); Calibrated: 3/19/2015;

Sensor-Surface: 3mm (Mechanical Surface Detection)

Electronics: DAE4 Sn1334; Calibrated: 3/13/2015

Phantom: SAM v5.0 Left; Type: QD000P40CD; Serial: TP: 1687

Measurement SW: DASY52, Version 52.8 (8); SEMCAD X Version 14.6.10 (7331)

Mode: GSM 850, Left Head, Cheek, Mid.ch

Area Scan (9x15x1): Measurement grid: dx=15mm, dy=15mm

Zoom Scan (5x5x7)/Cube 0: Measurement grid: dx=8mm, dy=8mm, dz=5mm

Reference Value = 20.82 V/m; Power Drift = 0.12 dB

Peak SAR (extrapolated) = 0.478 W/kg

SAR(1 g) = 0.383 W/kg

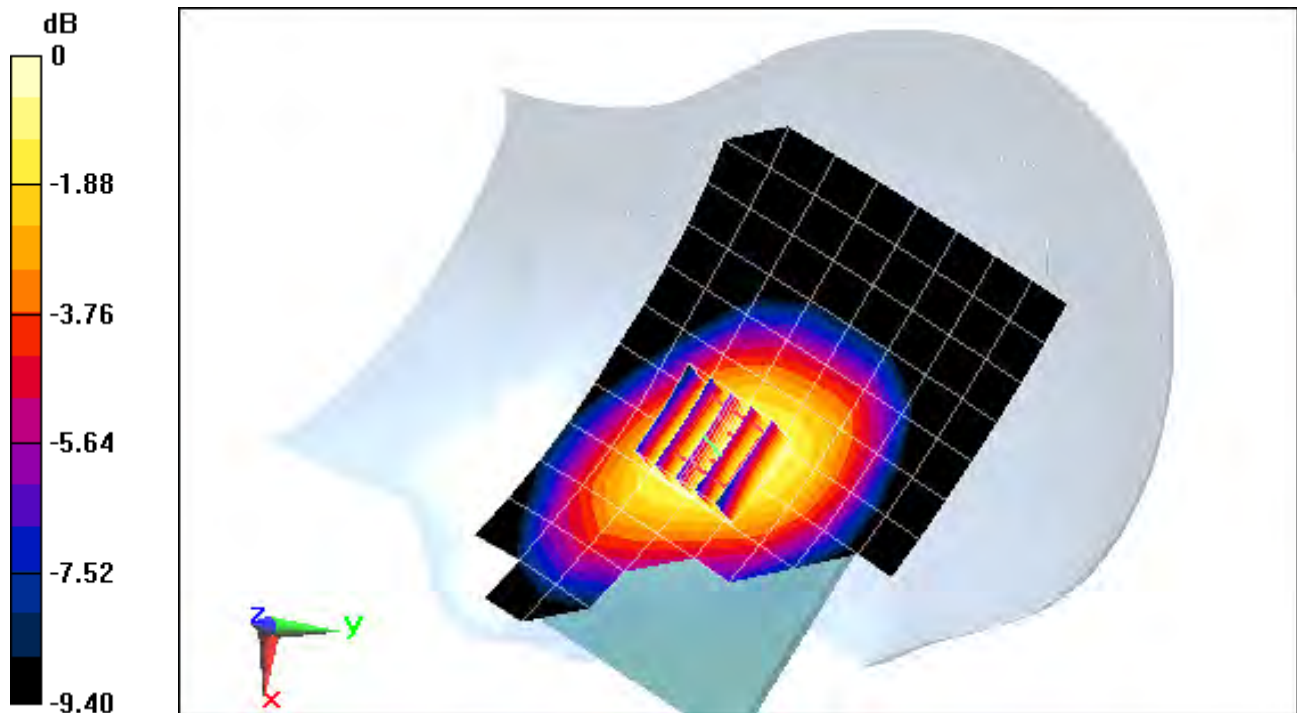

0 dB = 0.422 W/kg = -3.75 dBW/kg

PCTEST ENGINEERING LABORATORY, INC.

DUT: A3LSMG890A; Type: Portable Handset; Serial: 359356060056374

Communication System: UID 0, GSM1900; Frequency: 1880 MHz; Duty Cycle: 1:8.3

Medium: 1900 Head Medium parameters used:

$f = 1880 \text{ MHz}$; $\sigma = 1.426 \text{ S/m}$; $\epsilon_r = 40.261$; $\rho = 1000 \text{ kg/m}^3$

Phantom section: Left Section

Test Date: 04-06-2015; Ambient Temp: 22.7°C; Tissue Temp: 21.4°C

Probe: ES3DV3 - SN3213; ConvF(5.06, 5.06, 5.06); Calibrated: 1/20/2015;

Sensor-Surface: 3mm (Mechanical Surface Detection)

Electronics: DAE4 Sn1407; Calibrated: 1/19/2015

Phantom: SAM Front; Type: SAM; Serial: 1686

Measurement SW: DASY52, Version 52.8 (8); SEMCAD X Version 14.6.10 (7331)

Mode: GSM 1900, Left Head, Cheek, Mid.ch

Area Scan (9x15x1): Measurement grid: dx=15mm, dy=15mm

Zoom Scan (5x5x7)/Cube 0: Measurement grid: dx=8mm, dy=8mm, dz=5mm

Reference Value = 18.00 V/m; Power Drift = 0.03 dB

Peak SAR (extrapolated) = 0.665 W/kg

SAR(1 g) = 0.420 W/kg

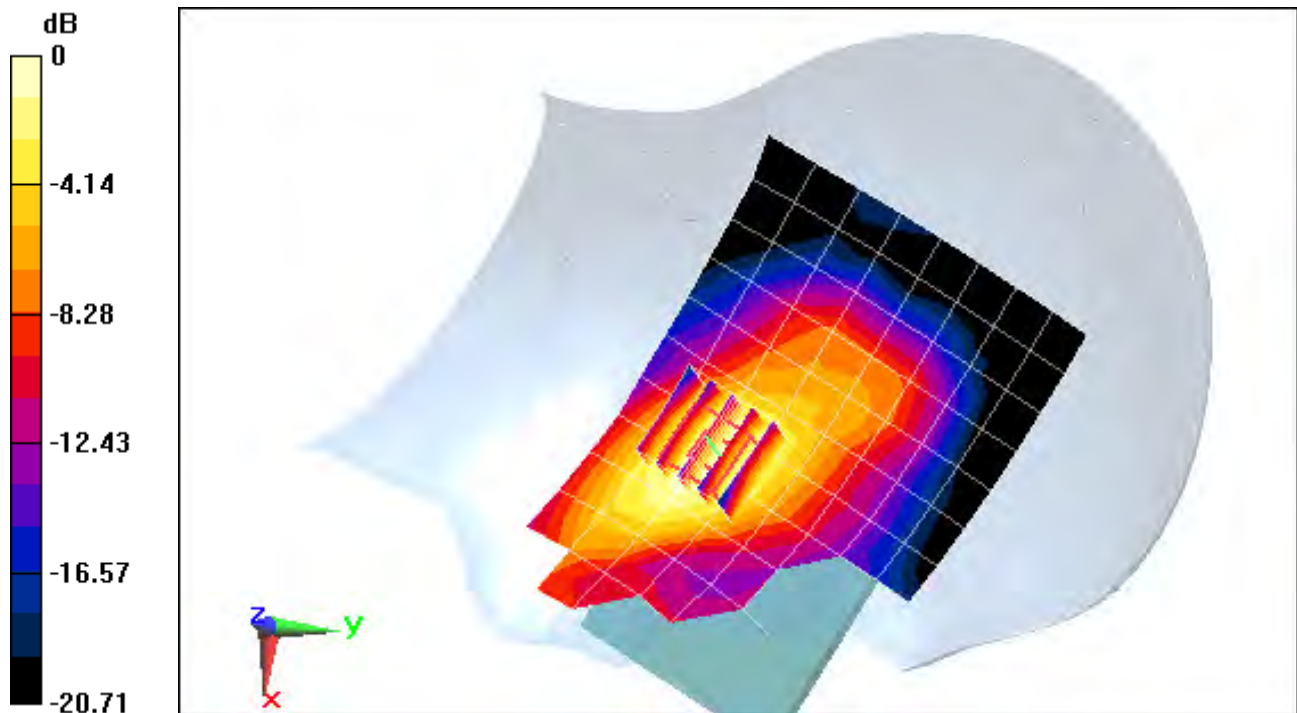

0 dB = 0.487 W/kg = -3.12 dBW/kg

PCTEST ENGINEERING LABORATORY, INC.

DUT: A3LSMG890A; Type: Portable Handset; Serial: 359356060056374

Communication System: UID 0, UMTS; Frequency: 836.6 MHz; Duty Cycle: 1:1

Medium: 835 Head Medium parameters used (interpolated):

$f = 836.6 \text{ MHz}$; $\sigma = 0.937 \text{ S/m}$; $\epsilon_r = 42.992$; $\rho = 1000 \text{ kg/m}^3$

Phantom section: Left Section

Test Date: 04-08-2015; Ambient Temp: 23.8°C; Tissue Temp: 22.0°C

Probe: ES3DV3 - SN3209; ConvF(6.04, 6.04, 6.04); Calibrated: 3/19/2015;

Sensor-Surface: 3mm (Mechanical Surface Detection)

Electronics: DAE4 Sn1334; Calibrated: 3/13/2015

Phantom: SAM v5.0 Left; Type: QD000P40CD; Serial: TP: 1687

Measurement SW: DASY52, Version 52.8 (8); SEMCAD X Version 14.6.10 (7331)

Mode: UMTS 850, Left Head, Cheek, Mid.ch

Area Scan (9x15x1): Measurement grid: dx=15mm, dy=15mm

Zoom Scan (5x5x7)/Cube 0: Measurement grid: dx=8mm, dy=8mm, dz=5mm

Reference Value = 21.23 V/m; Power Drift = 0.01 dB

Peak SAR (extrapolated) = 0.491 W/kg

SAR(1 g) = 0.392 W/kg

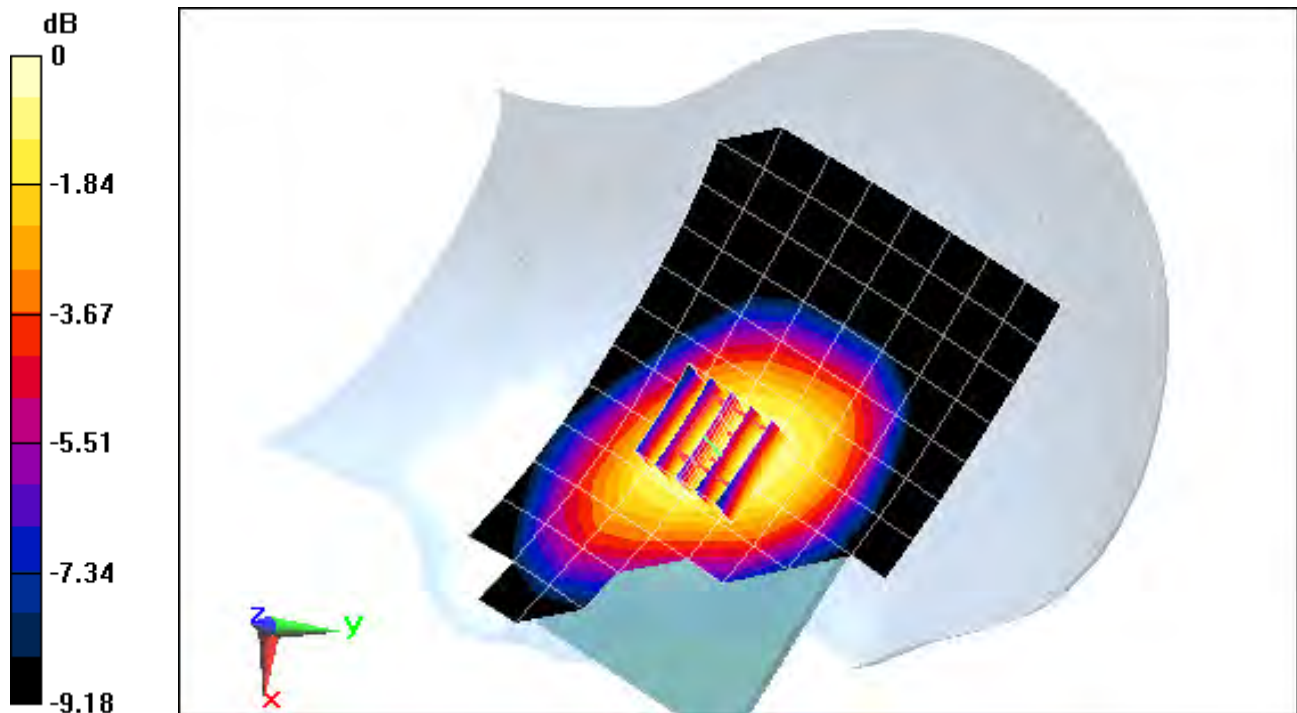

0 dB = 0.427 W/kg = -3.70 dBW/kg

PCTEST ENGINEERING LABORATORY, INC.

DUT: A3LSMG890A; Type: Portable Handset; Serial: 359356060056374

Communication System: UID 0, UMTS; Frequency: 1880 MHz; Duty Cycle: 1:1

Medium: 1900 Head Medium parameters used:

$f = 1880 \text{ MHz}$; $\sigma = 1.426 \text{ S/m}$; $\epsilon_r = 40.261$; $\rho = 1000 \text{ kg/m}^3$

Phantom section: Left Section

Test Date: 04-06-2015; Ambient Temp: 22.7°C; Tissue Temp: 21.4°C

Probe: ES3DV3 - SN3213; ConvF(5.06, 5.06, 5.06); Calibrated: 1/20/2015;

Sensor-Surface: 3mm (Mechanical Surface Detection)

Electronics: DAE4 Sn1407; Calibrated: 1/19/2015

Phantom: SAM Front; Type: SAM; Serial: 1686

Measurement SW: DASY52, Version 52.8 (8); SEMCAD X Version 14.6.10 (7331)

Mode: UMTS 1900, Left Head, Cheek, Mid.ch

Area Scan (9x14x1): Measurement grid: dx=15mm, dy=15mm

Zoom Scan (5x5x7)/Cube 0: Measurement grid: dx=8mm, dy=8mm, dz=5mm

Reference Value = 19.11 V/m; Power Drift = 0.02 dB

Peak SAR (extrapolated) = 0.755 W/kg

SAR(1 g) = 0.484 W/kg

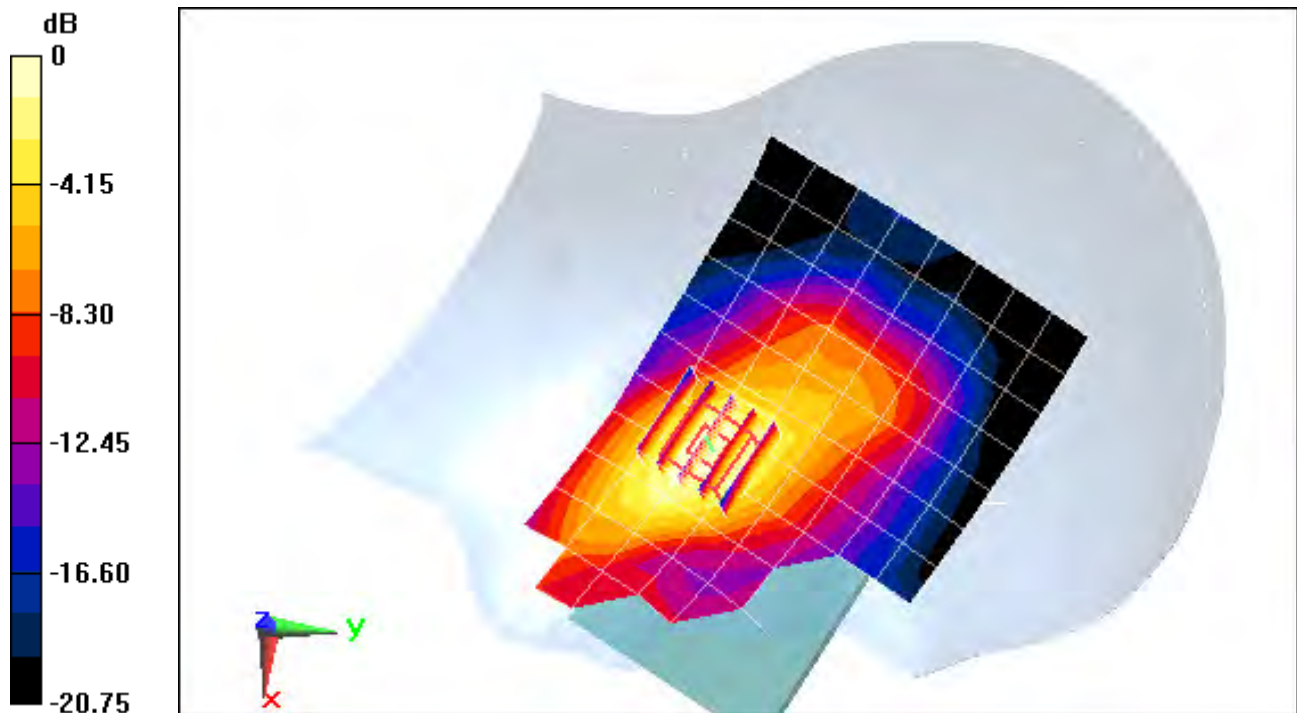

0 dB = 0.574 W/kg = -2.41 dBW/kg

PCTEST ENGINEERING LABORATORY, INC.

DUT: A3LSMG890A; Type: Portable Handset; Serial: 359356060056432

Communication System: UID 0, LTE Band 12; Frequency: 707.5 MHz; Duty Cycle: 1:1

Medium: 750 Head Medium parameters used (interpolated):

$f = 707.5 \text{ MHz}$; $\sigma = 0.885 \text{ S/m}$; $\epsilon_r = 42.185$; $\rho = 1000 \text{ kg/m}^3$

Phantom section: Left Section

Test Date: 04-08-2015; Ambient Temp: 21.3°C; Tissue Temp: 21.4°C

Probe: ES3DV2 - SN3022; ConvF(6.39, 6.39, 6.39); Calibrated: 8/19/2014;

Sensor-Surface: 3mm (Mechanical Surface Detection)

Electronics: DAE4 Sn1322; Calibrated: 8/12/2014

Phantom: SAM with CRP v4.0; Type: QD000P40CD; Serial: TP:1800

Measurement SW: DASY52, Version 52.8 (8); SEMCAD X Version 14.6.10 (7331)

**Mode: LTE Band 12, Left Head, Cheek, Mid.ch,
10 MHz Bandwidth, QPSK, 1 RB, 25 RB Offset**

Area Scan (8x14x1): Measurement grid: dx=15mm, dy=15mm

Zoom Scan (6x6x7)/Cube 0: Measurement grid: dx=8mm, dy=8mm, dz=5mm

Reference Value = 24.03 V/m; Power Drift = 0.04 dB

Peak SAR (extrapolated) = 0.573 W/kg

SAR(1 g) = 0.452 W/kg

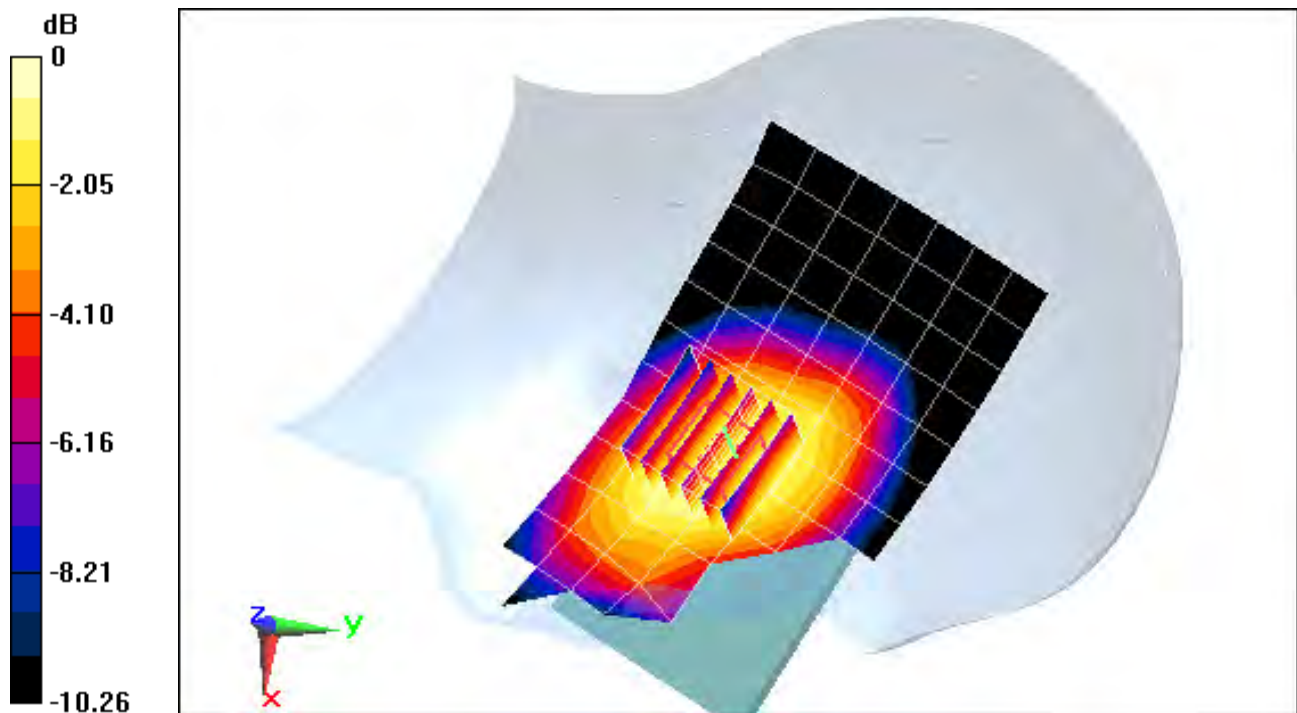

0 dB = 0.487 W/kg = -3.12 dBW/kg

PCTEST ENGINEERING LABORATORY, INC.

DUT: A3LSMG890A; Type: Portable Handset; Serial: 359356060056374

Communication System: UID 0, LTE Band 5; Frequency: 836.5 MHz; Duty Cycle: 1:1

Medium: 835 Head Medium parameters used (interpolated):

$f = 836.5 \text{ MHz}$; $\sigma = 0.937 \text{ S/m}$; $\epsilon_r = 42.993$; $\rho = 1000 \text{ kg/m}^3$

Phantom section: Left Section

Test Date: 04-08-2015; Ambient Temp: 23.8°C; Tissue Temp: 22.0°C

Probe: ES3DV3 - SN3209; ConvF(6.04, 6.04, 6.04); Calibrated: 3/19/2015;

Sensor-Surface: 3mm (Mechanical Surface Detection)

Electronics: DAE4 Sn1334; Calibrated: 3/13/2015

Phantom: SAM v5.0 Left; Type: QD000P40CD; Serial: TP: 1687

Measurement SW: DASY52, Version 52.8 (8); SEMCAD X Version 14.6.10 (7331)

**Mode: LTE Band 5 (Cell.), Left Head, Cheek, Mid.ch,
10 MHz Bandwidth, QPSK, 1 RB, 25 RB Offset**

Area Scan (9x15x1): Measurement grid: dx=15mm, dy=15mm

Zoom Scan (5x5x7)/Cube 0: Measurement grid: dx=8mm, dy=8mm, dz=5mm

Reference Value = 23.82 V/m; Power Drift = 0.05 dB

Peak SAR (extrapolated) = 0.571 W/kg

SAR(1 g) = 0.456 W/kg

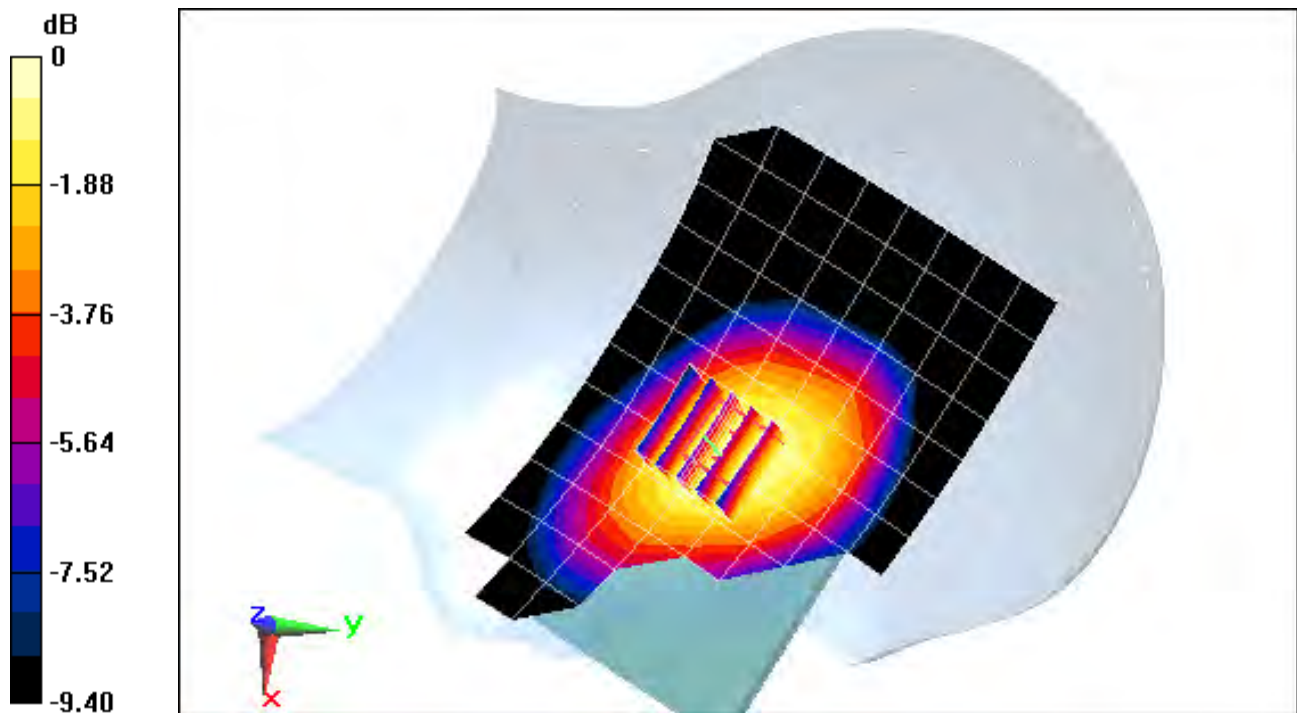

0 dB = 0.497 W/kg = -3.04 dBW/kg

PCTEST ENGINEERING LABORATORY, INC.

DUT: A3LSMG890A; Type: Portable Handset; Serial: 359356060056390

Communication System: UID 0, LTE RF Band 4; Frequency: 1732.5 MHz; Duty Cycle: 1:1

Medium: 1750 Head Medium parameters used (interpolated):

$f = 1732.5 \text{ MHz}$; $\sigma = 1.308 \text{ S/m}$; $\epsilon_r = 39.103$; $\rho = 1000 \text{ kg/m}^3$

Phantom section: Left Section

Test Date: 04-07-2015; Ambient Temp: 23.9°C; Tissue Temp: 23.2°C

Probe: ES3DV3 - SN3334; ConvF(5.21, 5.21, 5.21); Calibrated: 12/16/2014;

Sensor-Surface: 3mm (Mechanical Surface Detection)

Electronics: DAE4 Sn1415; Calibrated: 12/12/2014

Phantom: Sub Twin Sam v5.0; Type: QD000P40CD; Serial: TP:1626

Measurement SW: DASY52, Version 52.8 (8); SEMCAD X Version 14.6.10 (7331)

**Mode: LTE Band 4 (AWS), Left Head, Cheek, Mid.ch,
20 MHz Bandwidth, QPSK, 1 RB, 50 RB Offset**

Area Scan (9x15x1): Measurement grid: dx=15mm, dy=15mm

Zoom Scan (5x5x7)/Cube 0: Measurement grid: dx=8mm, dy=8mm, dz=5mm

Reference Value = 22.90 V/m; Power Drift = 0.07 dB

Peak SAR (extrapolated) = 0.739 W/kg

SAR(1 g) = 0.499 W/kg

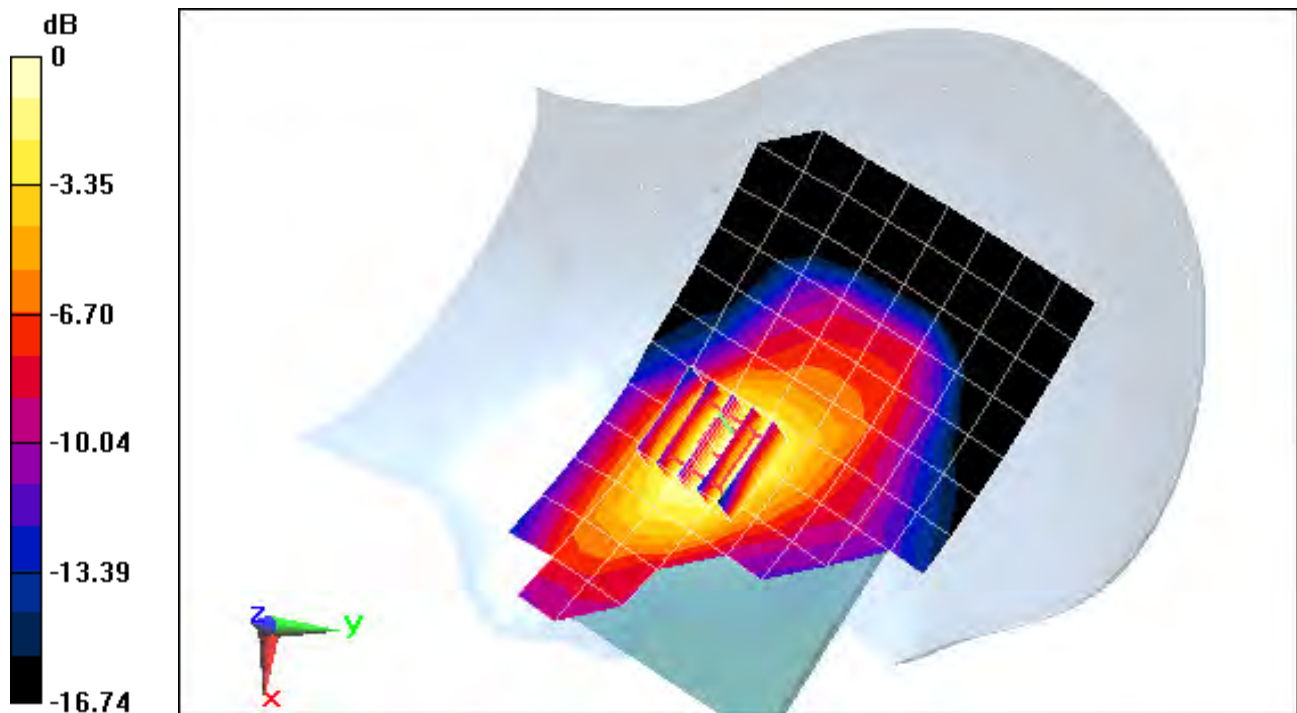

0 dB = 0.578 W/kg = -2.38 dBW/kg

PCTEST ENGINEERING LABORATORY, INC.

DUT: A3LSMG890A; Type: Portable Handset; Serial: 359356060056374

Communication System: UID 0, LTE Band 2 (PCS); Frequency: 1900 MHz; Duty Cycle: 1:1

Medium: 1900 Head Medium parameters used (interpolated):

$f = 1900 \text{ MHz}$; $\sigma = 1.447 \text{ S/m}$; $\epsilon_r = 40.154$; $\rho = 1000 \text{ kg/m}^3$

Phantom section: Left Section

Test Date: 04-06-2015; Ambient Temp: 22.7°C; Tissue Temp: 21.4°C

Probe: ES3DV3 - SN3213; ConvF(5.06, 5.06, 5.06); Calibrated: 1/20/2015;

Sensor-Surface: 3mm (Mechanical Surface Detection)

Electronics: DAE4 Sn1407; Calibrated: 1/19/2015

Phantom: SAM Front; Type: SAM; Serial: 1686

Measurement SW: DASY52, Version 52.8 (8); SEMCAD X Version 14.6.10 (7331)

**Mode: LTE Band 2 (PCS), Left Head, Cheek, High.ch, QPSK,
20 MHz Bandwidth, 1 RB, 50 RB Offset**

Area Scan (9x14x1): Measurement grid: dx=15mm, dy=15mm

Zoom Scan (5x5x7)/Cube 0: Measurement grid: dx=8mm, dy=8mm, dz=5mm

Reference Value = 22.67 V/m; Power Drift = 0.04 dB

Peak SAR (extrapolated) = 0.952 W/kg

SAR(1 g) = 0.607 W/kg

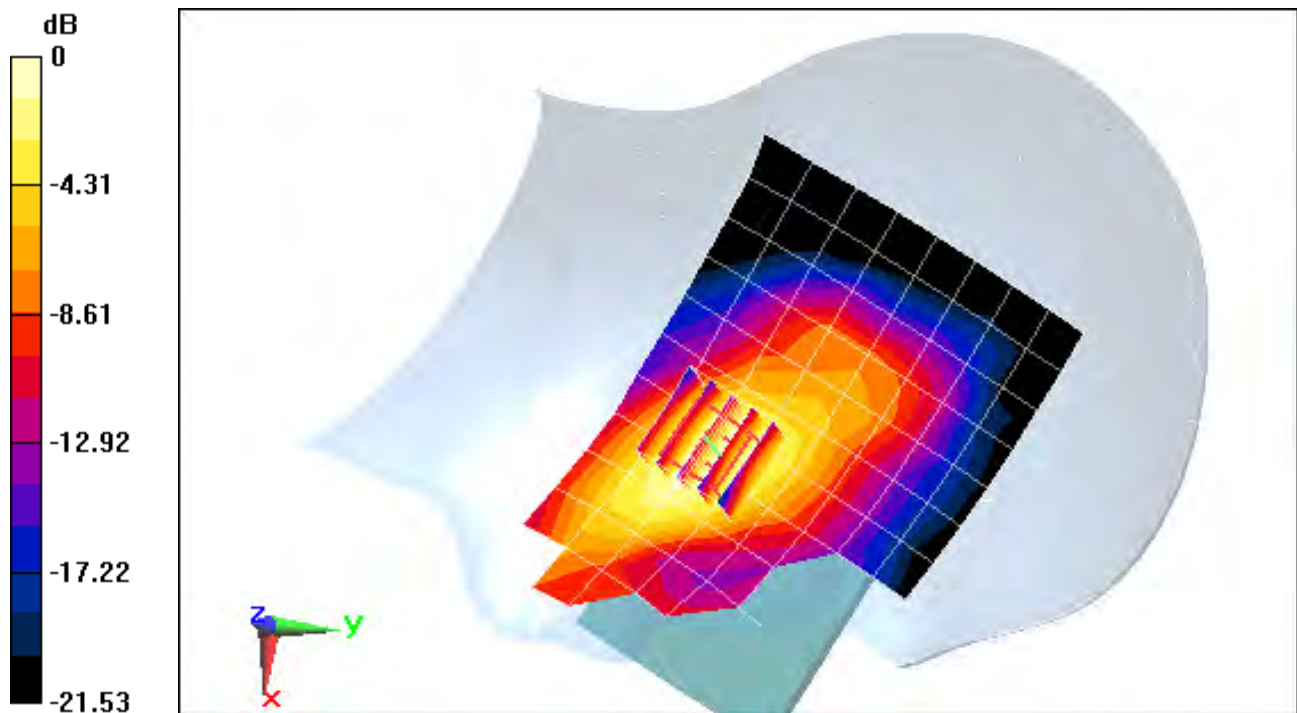

0 dB = 0.719 W/kg = -1.43 dBW/kg

PCTEST ENGINEERING LABORATORY, INC.

DUT: A3LSMG890A; Type: Portable Handset; Serial: 359356060056366

Communication System: UID 0, LTE Band 30; Frequency: 2310 MHz; Duty Cycle: 1:1

Medium: 2300 Head Medium parameters used:

$f = 2310 \text{ MHz}$; $\sigma = 1.684 \text{ S/m}$; $\epsilon_r = 40.926$; $\rho = 1000 \text{ kg/m}^3$

Phantom section: Right Section

Test Date: 04-14-2015; Ambient Temp: 23.0°C; Tissue Temp: 24.0°C

Probe: ES3DV3 - SN3318; ConvF(4.78, 4.78, 4.78); Calibrated: 1/23/2015;

Sensor-Surface: 3mm (Mechanical Surface Detection)

Electronics: DAE4 Sn1272; Calibrated: 1/14/2015

Phantom: SAM Front; Type: SAM; Serial: 1686

Measurement SW: DASY52, Version 52.8 (8); SEMCAD X Version 14.6.10 (7331)

**Mode: LTE Band 30, Right Head, Cheek, Mid.ch,
10 MHz Bandwidth, QPSK, 1 RB, 25 RB Offset**

Area Scan (10x18x1): Measurement grid: dx=12mm, dy=12mm

Zoom Scan (7x7x7)/Cube 0: Measurement grid: dx=5mm, dy=5mm, dz=5mm

Reference Value = 21.88 V/m; Power Drift = 0.17 dB

Peak SAR (extrapolated) = 1.16 W/kg

SAR(1 g) = 0.666 W/kg

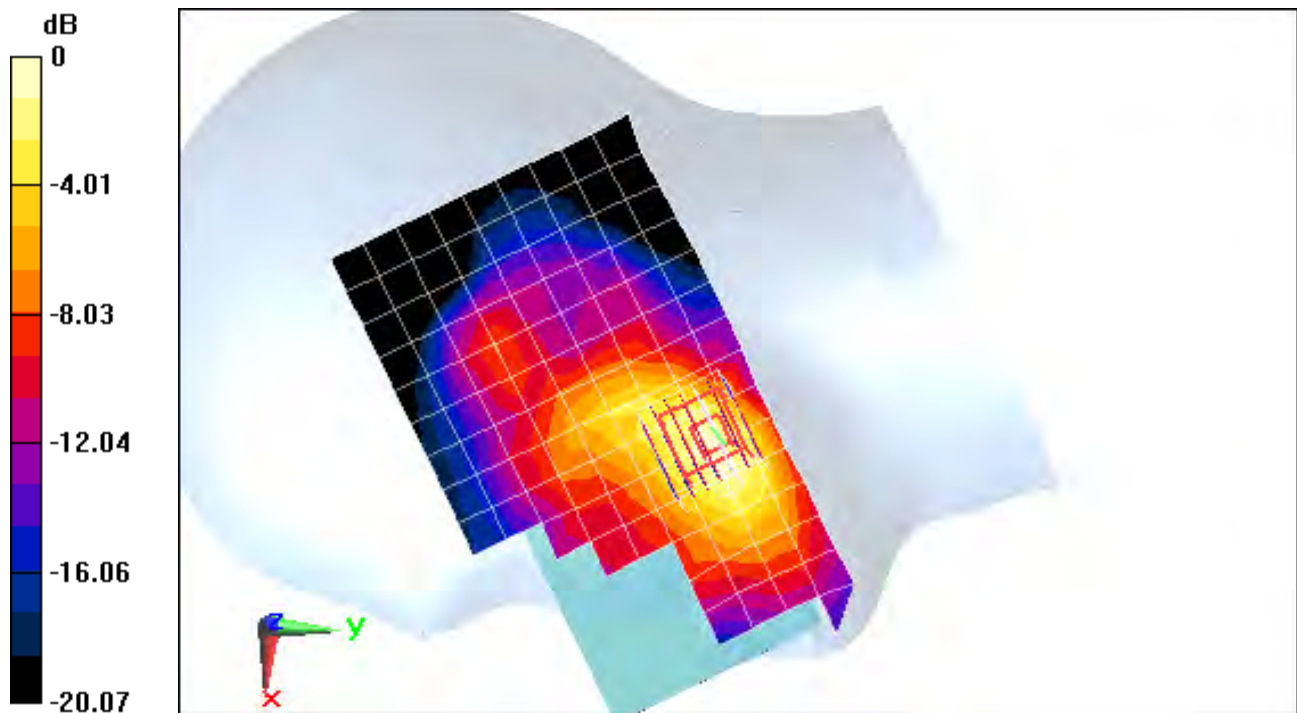

0 dB = 0.806 W/kg = -0.94 dBW/kg

PCTEST ENGINEERING LABORATORY, INC.

DUT: A3LSMG890A; Type: Portable Handset; Serial: 359356060056457

Communication System: UID 0, IEEE 802.11b; Frequency: 2437 MHz; Duty Cycle: 1:1

Medium: 2450 Head Medium parameters used (interpolated):

$f = 2437 \text{ MHz}$; $\sigma = 1.862 \text{ S/m}$; $\epsilon_r = 38.839$; $\rho = 1000 \text{ kg/m}^3$

Phantom section: Right Section

Test Date: 04-06-2015; Ambient Temp: 23.2°C; Tissue Temp: 22.1°C

Probe: ES3DV3 - SN3332; ConvF(4.49, 4.49, 4.49); Calibrated: 9/18/2014;

Sensor-Surface: 3mm (Mechanical Surface Detection)

Electronics: DAE4 Sn1323; Calibrated: 9/17/2014

Phantom: SAM V5.0 Right; Type: QD000P40CD; Serial: 1647

Measurement SW: DASY52, Version 52.8 (8); SEMCAD X Version 14.6.10 (7331)

**Mode: IEEE 802.11b, Right Head, Tilt,
22MHz Bandwidth, Ch 06, 1 Mbps, Antenna 1**

Area Scan (11x18x1): Measurement grid: dx=12mm, dy=12mm

Zoom Scan (7x7x7)/Cube 0: Measurement grid: dx=5mm, dy=5mm, dz=5mm

Reference Value = 13.63 V/m; Power Drift = 0.04 dB

Peak SAR (extrapolated) = 0.645 W/kg

SAR(1 g) = 0.292 W/kg

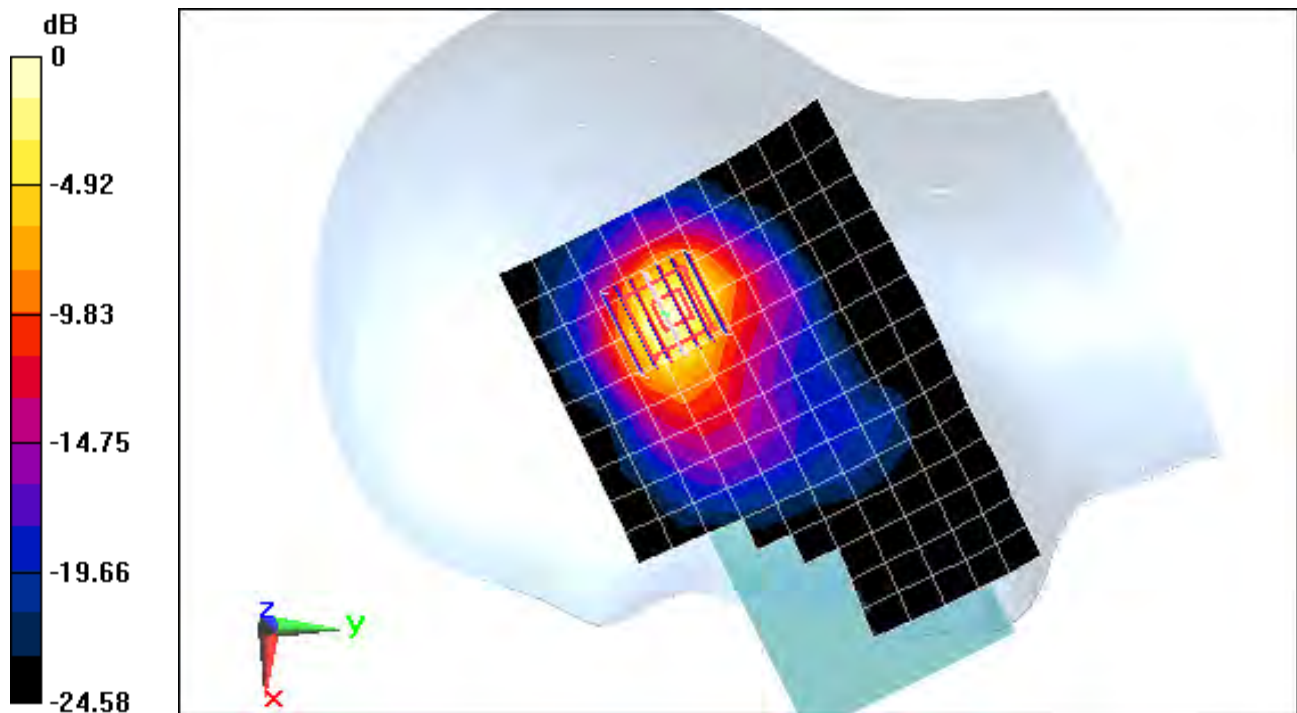

0 dB = 0.386 W/kg = -4.13 dBW/kg

PCTEST ENGINEERING LABORATORY, INC.

DUT: A3LSMG890A; Type: Portable Handset; Serial: 359356060056366

Communication System: UID 0, IEEE 802.11a; Frequency: 5260 MHz; Duty Cycle: 1:1

Medium: 5GHz Head Medium parameters used:

$f = 5260 \text{ MHz}$; $\sigma = 4.789 \text{ S/m}$; $\epsilon_r = 36.367$; $\rho = 1000 \text{ kg/m}^3$

Phantom section: Left Section

Test Date: 04-08-2015; Ambient Temp: 22.8°C; Tissue Temp: 23.0°C

Probe: EX3DV4 - SN3914; ConvF(5.06, 5.06, 5.06); Calibrated: 2/10/2015;

Sensor-Surface: 1.4mm (Mechanical Surface Detection)

Electronics: DAE4 Sn1333; Calibrated: 10/31/2014

Phantom: SAM Main ; Type: QD000P40CC; Serial: TP 1114

Measurement SW: DASY52, Version 52.8 (8); SEMCAD X Version 14.6.10 (7331)

**Mode: IEEE 802.11a, 5.3 GHz, 20 MHz Bandwidth,
Left Head, Tilt, Ch 52, 6 Mbps Antenna 1**

Area Scan (13x22x1): Measurement grid: dx=10mm, dy=10mm

Zoom Scan (7x7x7)/Cube 0: Measurement grid: dx=4mm, dy=4mm, dz=1.4mm; Graded Ratio = 1.4

Reference Value = 3.306 V/m; Power Drift = 0.06 dB

Peak SAR (extrapolated) = 0.287 W/kg

SAR(1 g) = 0.042 W/kg

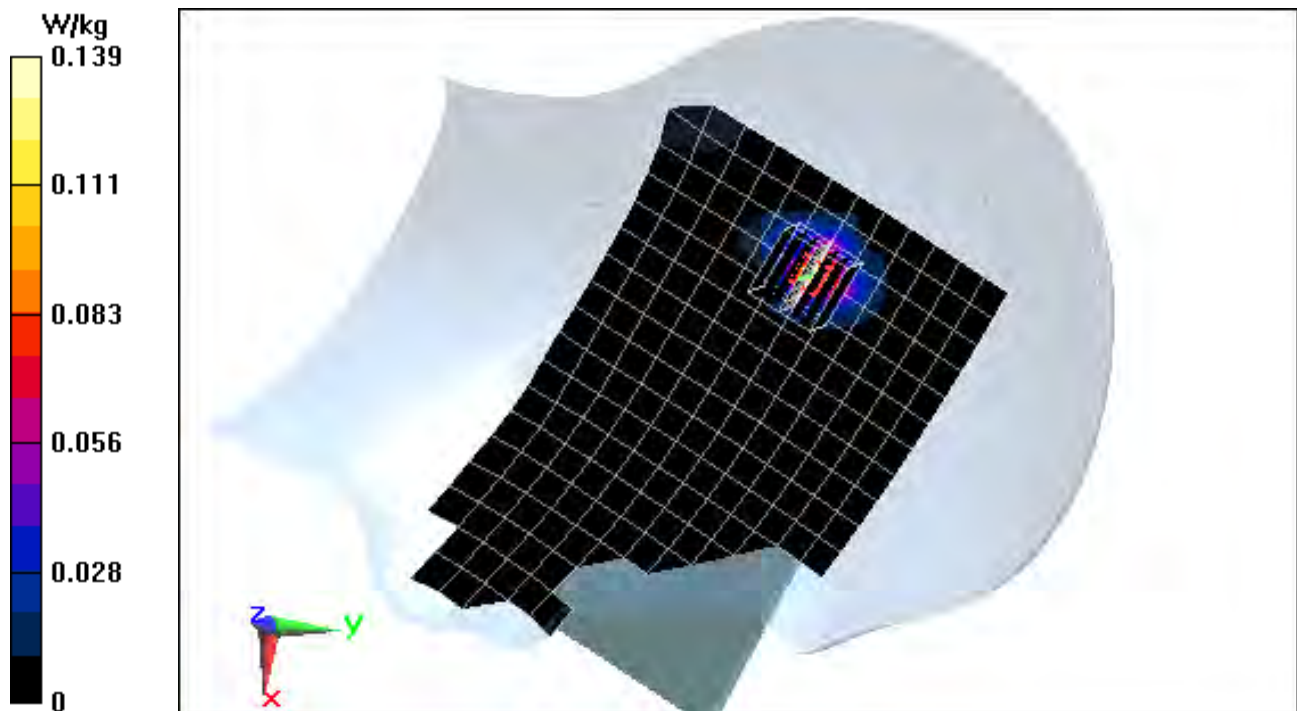

PCTEST ENGINEERING LABORATORY, INC.

DUT: A3LSMG890A; Type: Portable Handset; Serial: 359356060056374

Communication System: UID 0, GSM; Frequency: 836.6 MHz; Duty Cycle: 1:8.3

Medium: 835 Body Medium parameters used (interpolated):

$f = 836.6 \text{ MHz}$; $\sigma = 1.008 \text{ S/m}$; $\epsilon_r = 54.554$; $\rho = 1000 \text{ kg/m}^3$

Phantom section: Flat Section ; Space: 1.5 cm

Test Date: 04-06-2015; Ambient Temp: 22.5°C; Tissue Temp: 21.8°C

Probe: ES3DV3 - SN3288; ConvF(6.32, 6.32, 6.32); Calibrated: 9/24/2014;

Sensor-Surface: 3mm (Mechanical Surface Detection)

Electronics: DAE4 Sn1364; Calibrated: 9/18/2014

Phantom: ELI v5.0; Type: QDOVA001BB; Serial: 1229

Measurement SW: DASY52, Version 52.8 (8); SEMCAD X Version 14.6.10 (7331)

Mode: GSM 850, Body SAR, Back Side, Mid.ch

Area Scan (9x15x1): Measurement grid: dx=15mm, dy=15mm

Zoom Scan (6x5x7)/Cube 0: Measurement grid: dx=8mm, dy=8mm, dz=5mm

Reference Value = 20.90 V/m; Power Drift = 0.00 dB

Peak SAR (extrapolated) = 0.520 W/kg

SAR(1 g) = 0.414 W/kg

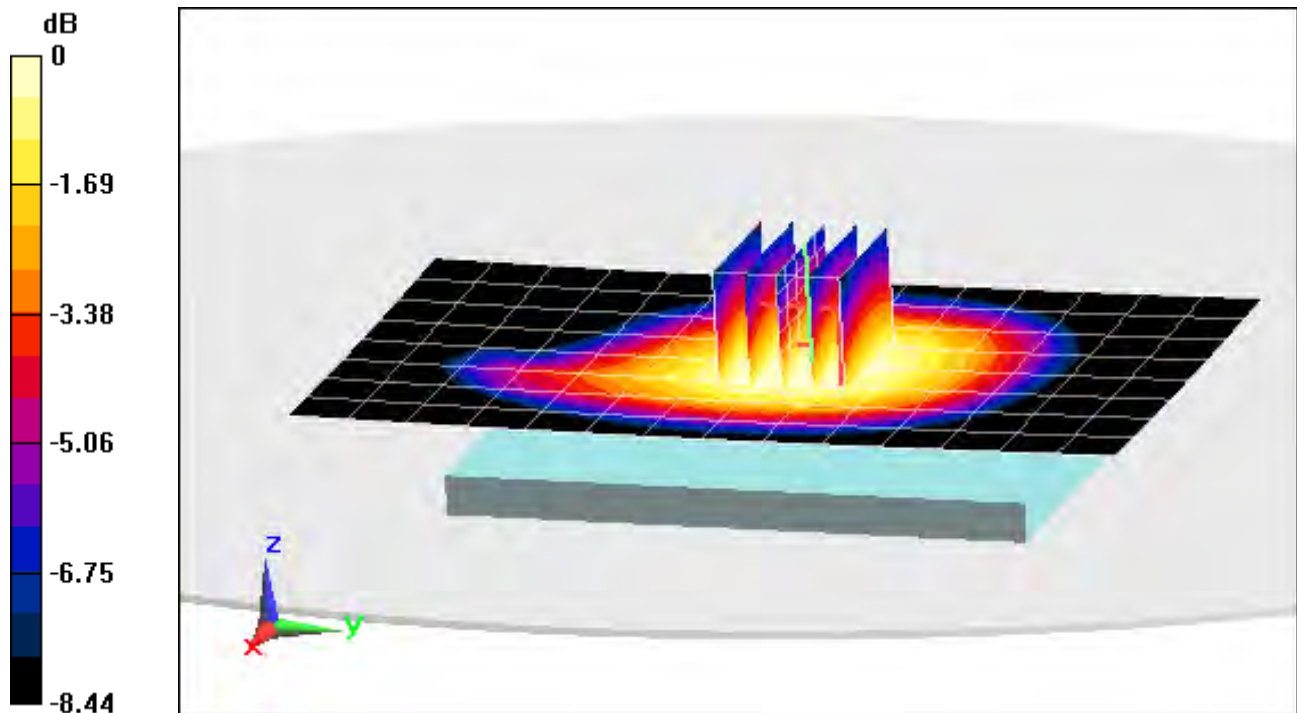

0 dB = 0.453 W/kg = -3.44 dBW/kg

PCTEST ENGINEERING LABORATORY, INC.

DUT: A3LSMG890A; Type: Portable Handset; Serial: 359356060056374

Communication System: UID 0, GSM GPRS; 2 Tx slots, Frequency: 824.2 MHz; Duty Cycle: 1:4.15

Medium: 835 Body Medium parameters used (interpolated):

$f = 824.2$ MHz; $\sigma = 0.995$ S/m; $\epsilon_r = 54.708$; $\rho = 1000$ kg/m³

Phantom section: Flat Section ; Space: 1.0 cm

Test Date: 04-06-2015; Ambient Temp: 22.5°C; Tissue Temp: 21.8°C

Probe: ES3DV3 - SN3288; ConvF(6.32, 6.32, 6.32); Calibrated: 9/24/2014;

Sensor-Surface: 3mm (Mechanical Surface Detection)

Electronics: DAE4 Sn1364; Calibrated: 9/18/2014

Phantom: ELI v5.0; Type: QDOVA001BB; Serial: 1229

Measurement SW: DASY52, Version 52.8 (8);SEMCAD X Version 14.6.10 (7331)

Mode: GPRS 850, Body SAR, Back Side, Low.ch, 2 Tx Slots

Area Scan (9x15x1): Measurement grid: dx=15mm, dy=15mm

Zoom Scan (6x6x7)/Cube 0: Measurement grid: dx=8mm, dy=8mm, dz=5mm

Reference Value = 29.70 V/m; Power Drift = 0.10 dB

Peak SAR (extrapolated) = 1.08 W/kg

SAR(1 g) = 0.813 W/kg

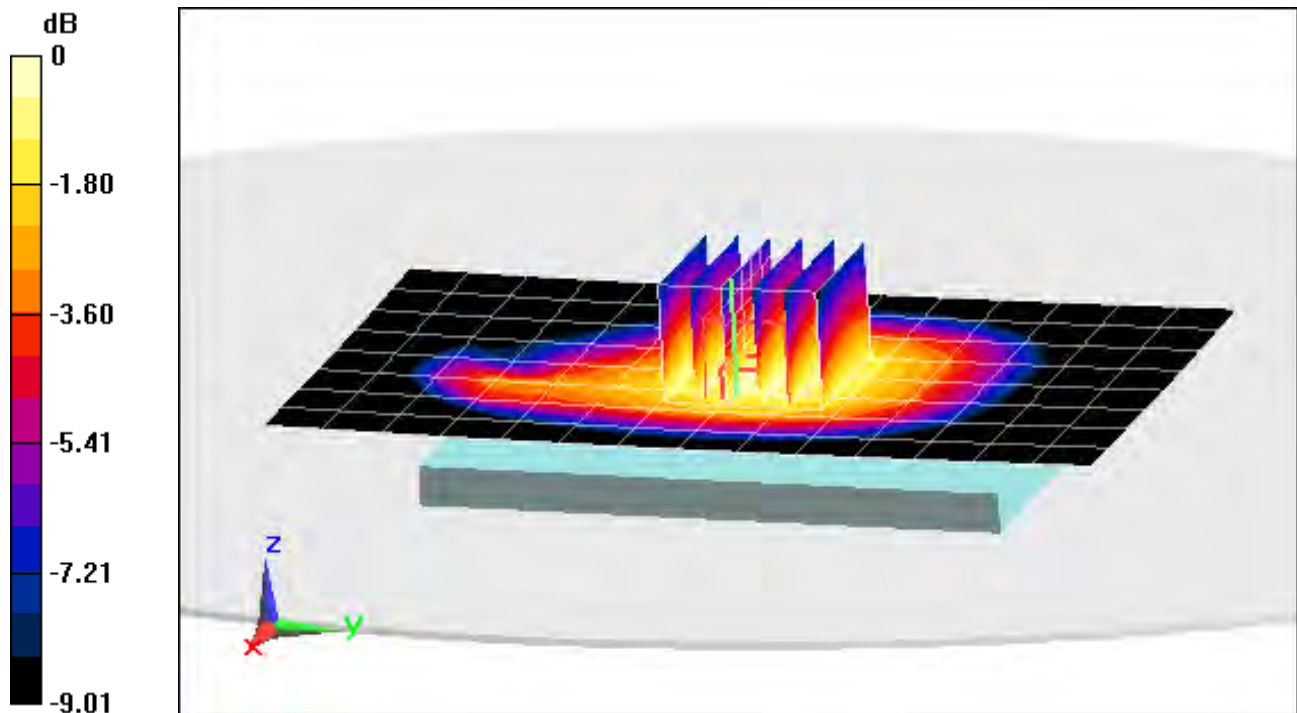

0 dB = 0.892 W/kg = -0.50 dBW/kg

PCTEST ENGINEERING LABORATORY, INC.

DUT: A3LSMG890A; Type: Portable Handset; Serial: 359356060056374

Communication System: UID 0, GSM; Frequency: 1880 MHz; Duty Cycle: 1:8.3

Medium: 1900 Body Medium parameters used:

$f = 1880 \text{ MHz}$; $\sigma = 1.558 \text{ S/m}$; $\epsilon_r = 53.351$; $\rho = 1000 \text{ kg/m}^3$

Phantom section: Flat Section ; Space: 1.5 cm

Test Date: 04-06-2015; Ambient Temp: 20.5°C; Tissue Temp: 21.0°C

Probe: ES3DV2 - SN3022; ConvF(4.49, 4.49, 4.49); Calibrated: 8/19/2014;

Sensor-Surface: 3mm (Mechanical Surface Detection)

Electronics: DAE4 Sn1322; Calibrated: 8/12/2014

Phantom: ELI v5.0; Type: QDOVA001BB; Serial: 1226

Measurement SW: DASY52, Version 52.8 (8); SEMCAD X Version 14.6.10 (7331)

Mode: GSM 1900, Body SAR, Back side, Mid.ch

Area Scan (9x13x1): Measurement grid: dx=15mm, dy=15mm

Zoom Scan (5x5x7)/Cube 0: Measurement grid: dx=8mm, dy=8mm, dz=5mm

Reference Value = 16.95 V/m; Power Drift = 0.02 dB

Peak SAR (extrapolated) = 0.732 W/kg

SAR(1 g) = 0.455 W/kg

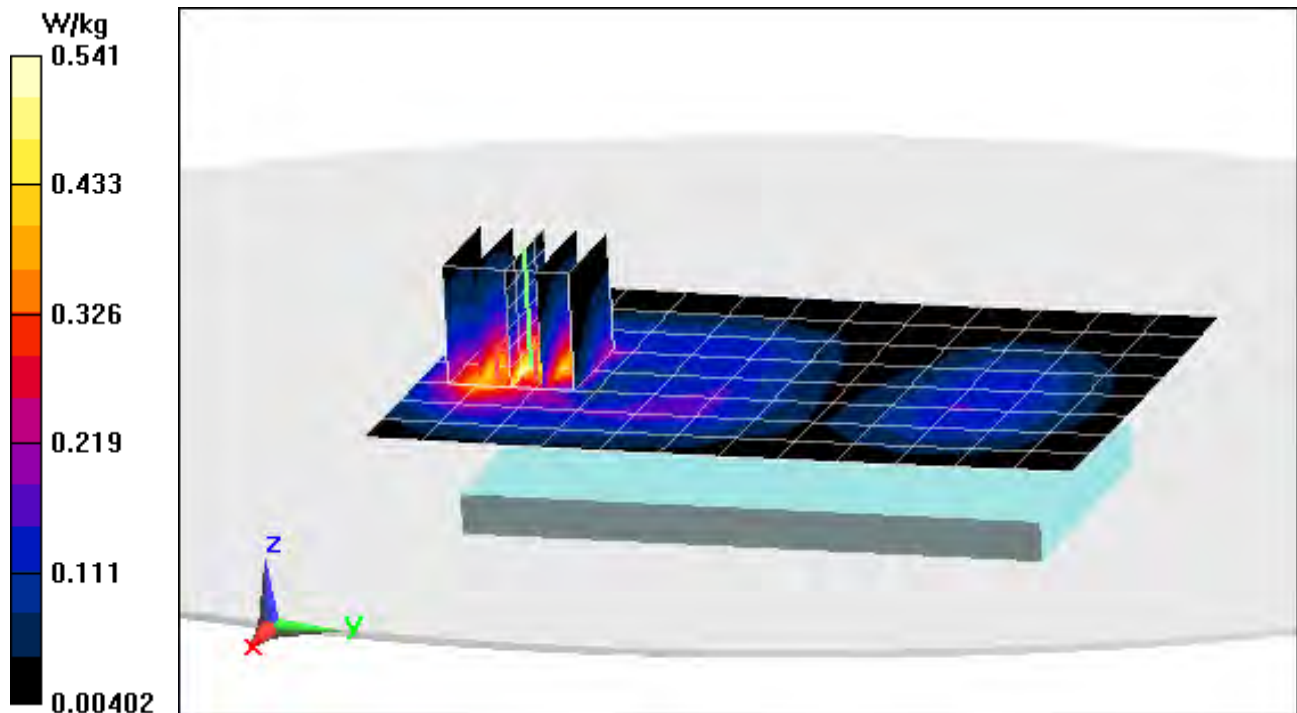

PCTEST ENGINEERING LABORATORY, INC.

DUT: A3LSMG890A; Type: Portable Handset; Serial: 359356060079855

Communication System: UID 0, GSM GPRS; 2 Tx slots; Frequency: 1880 MHz; Duty Cycle: 1:4.15

Medium: 1900 Body Medium parameters used:

$f = 1880 \text{ MHz}$; $\sigma = 1.558 \text{ S/m}$; $\epsilon_r = 52.559$; $\rho = 1000 \text{ kg/m}^3$

Phantom section: Flat Section ; Space: 1.0 cm

Test Date: 05-04-2015; Ambient Temp: 22.4°C; Tissue Temp: 22.4°C

Probe: ES3DV2 - SN3022; ConvF(4.49, 4.49, 4.49); Calibrated: 8/19/2014;

Sensor-Surface: 3mm (Mechanical Surface Detection)

Electronics: DAE4 Sn1322; Calibrated: 8/12/2014

Phantom: ELI v5.0; Type: QDOVA001BB; Serial: 1226

Measurement SW: DASY52, Version 52.8 (8); SEMCAD X Version 14.6.10 (7331)

Mode: GPRS 1900, Body SAR, Back side, Mid.ch, 2 Tx Slots

Area Scan (9x15x1): Measurement grid: dx=15mm, dy=15mm

Zoom Scan (5x5x7)/Cube 0: Measurement grid: dx=8mm, dy=8mm, dz=5mm

Reference Value = 22.21 V/m; Power Drift = -0.19 dB

Peak SAR (extrapolated) = 1.06 W/kg

SAR(1 g) = 0.646 W/kg

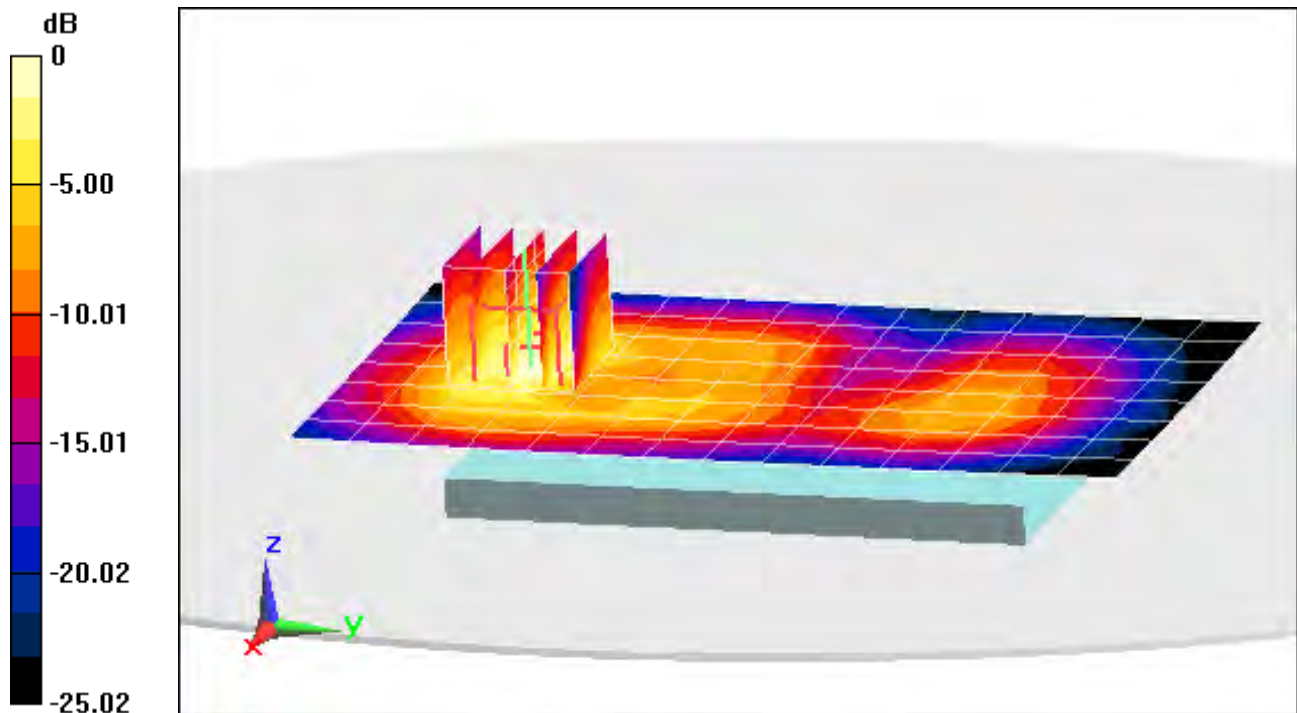

0 dB = 0.782 W/kg = -1.07 dBW/kg

PCTEST ENGINEERING LABORATORY, INC.

DUT: A3LSMG890A; Type: Portable Handset; Serial: 359356060056374

Communication System: UID 0, UMTS; Frequency: 836.6 MHz; Duty Cycle: 1:1

Medium: 835 Body Medium parameters used (interpolated):

$f = 836.6 \text{ MHz}$; $\sigma = 1.008 \text{ S/m}$; $\epsilon_r = 54.554$; $\rho = 1000 \text{ kg/m}^3$

Phantom section: Flat Section ; Space: 1.5 cm

Test Date: 04-06-2015; Ambient Temp: 22.5°C; Tissue Temp: 21.8°C

Probe: ES3DV3 - SN3288; ConvF(6.32, 6.32, 6.32); Calibrated: 9/24/2014;

Sensor-Surface: 3mm (Mechanical Surface Detection)

Electronics: DAE4 Sn1364; Calibrated: 9/18/2014

Phantom: ELI v5.0; Type: QDOVA001BB; Serial: 1229

Measurement SW: DASY52, Version 52.8 (8); SEMCAD X Version 14.6.10 (7331)

Mode: UMTS 850, Body SAR, Back Side, Mid.ch

Area Scan (9x15x1): Measurement grid: dx=15mm, dy=15mm

Zoom Scan (5x5x7)/Cube 0: Measurement grid: dx=8mm, dy=8mm, dz=5mm

Reference Value = 22.06 V/m; Power Drift = 0.00 dB

Peak SAR (extrapolated) = 0.572 W/kg

SAR(1 g) = 0.456 W/kg

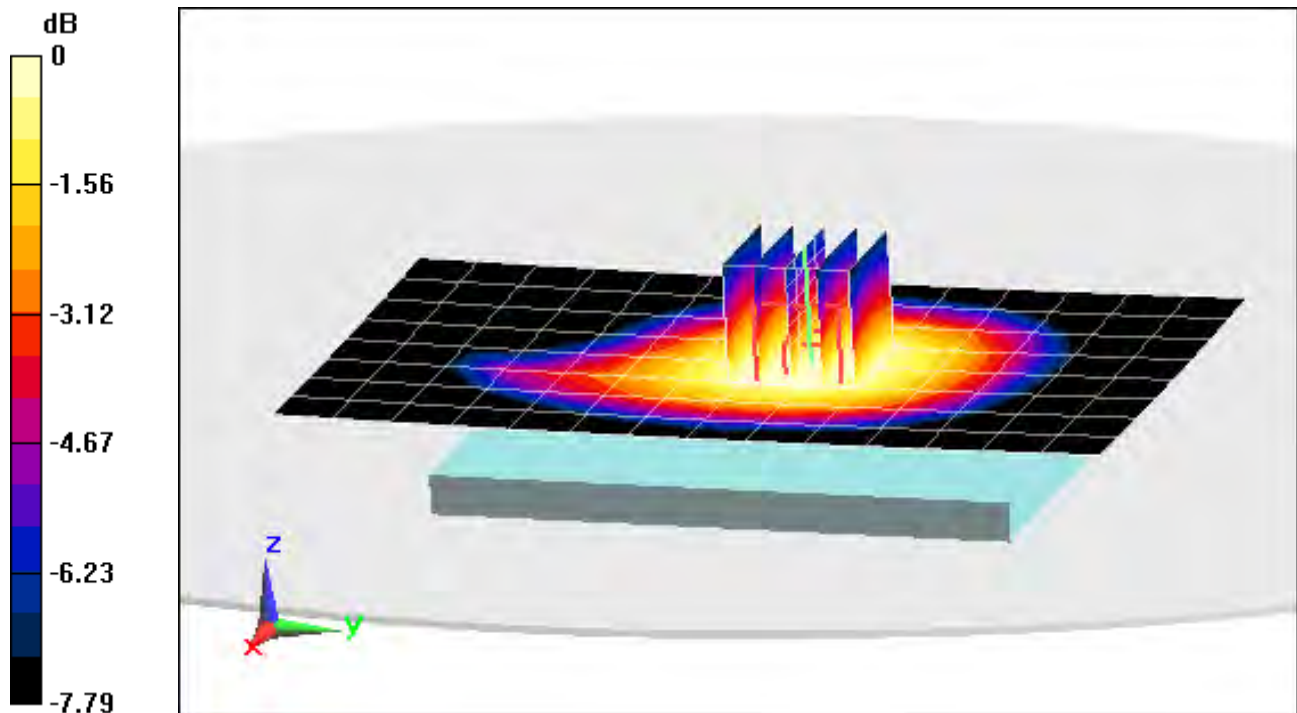

0 dB = 0.501 W/kg = -3.00 dBW/kg

PCTEST ENGINEERING LABORATORY, INC.

DUT: A3LSMG890A; Type: Portable Handset; Serial: 359356060056374

Communication System: UID 0, UMTS; Frequency: 836.6 MHz; Duty Cycle: 1:1

Medium: 835 Body Medium parameters used (interpolated):

$f = 836.6 \text{ MHz}$; $\sigma = 1.008 \text{ S/m}$; $\epsilon_r = 54.554$; $\rho = 1000 \text{ kg/m}^3$

Phantom section: Flat Section ; Space: 1.0 cm

Test Date: 04-06-2015; Ambient Temp: 22.5°C; Tissue Temp: 21.8°C

Probe: ES3DV3 - SN3288; ConvF(6.32, 6.32, 6.32); Calibrated: 9/24/2014;

Sensor-Surface: 3mm (Mechanical Surface Detection)

Electronics: DAE4 Sn1364; Calibrated: 9/18/2014

Phantom: ELI v5.0; Type: QDOVA001BB; Serial: 1229

Measurement SW: DASY52, Version 52.8 (8); SEMCAD X Version 14.6.10 (7331)

Mode: UMTS 850, Body SAR, Back Side, Mid.ch

Area Scan (9x15x1): Measurement grid: dx=15mm, dy=15mm

Zoom Scan (6x5x7)/Cube 0: Measurement grid: dx=8mm, dy=8mm, dz=5mm

Reference Value = 22.92 V/m; Power Drift = 0.01 dB

Peak SAR (extrapolated) = 0.623 W/kg

SAR(1 g) = 0.499 W/kg

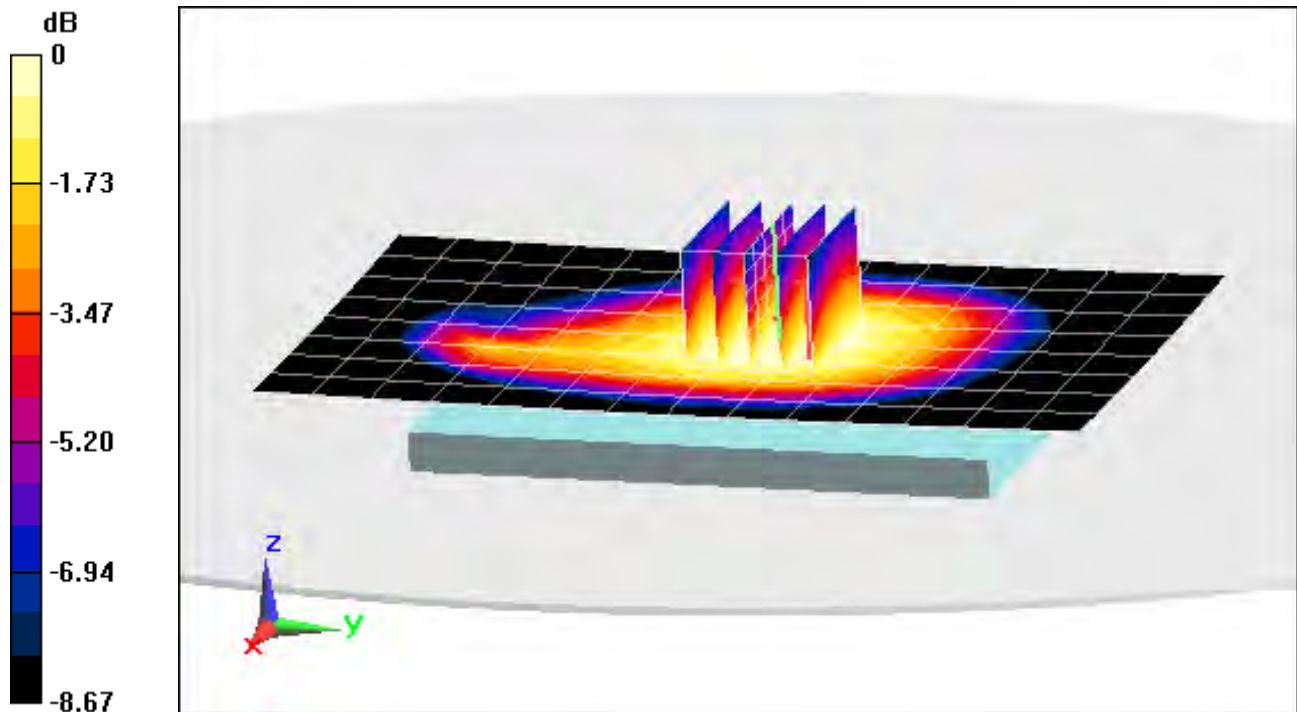

0 dB = 0.544 W/kg = -2.64 dBW/kg

PCTEST ENGINEERING LABORATORY, INC.

DUT: A3LSMG890A; Type: Portable Handset; Serial: 359356060056374

Communication System: UID 0, UMTS; Frequency: 1880 MHz; Duty Cycle: 1:1

Medium: 1900 Body Medium parameters used:

$f = 1880 \text{ MHz}$; $\sigma = 1.558 \text{ S/m}$; $\epsilon_r = 53.351$; $\rho = 1000 \text{ kg/m}^3$

Phantom section: Flat Section ; Space: 1.5 cm

Test Date: 04-06-2015; Ambient Temp: 20.5°C; Tissue Temp: 21.0°C

Probe: ES3DV2 - SN3022; ConvF(4.49, 4.49, 4.49); Calibrated: 8/19/2014;

Sensor-Surface: 3mm (Mechanical Surface Detection)

Electronics: DAE4 Sn1322; Calibrated: 8/12/2014

Phantom: ELI v5.0; Type: QDOVA001BB; Serial: 1226

Measurement SW: DASY52, Version 52.8 (8); SEMCAD X Version 14.6.10 (7331)

Mode: UMTS 1900, Body SAR, Back side, Mid.ch

Area Scan (9x13x1): Measurement grid: dx=15mm, dy=15mm

Zoom Scan (5x5x7)/Cube 0: Measurement grid: dx=8mm, dy=8mm, dz=5mm

Reference Value = 17.75 V/m; Power Drift = 0.05 dB

Peak SAR (extrapolated) = 0.713 W/kg

SAR(1 g) = 0.448 W/kg

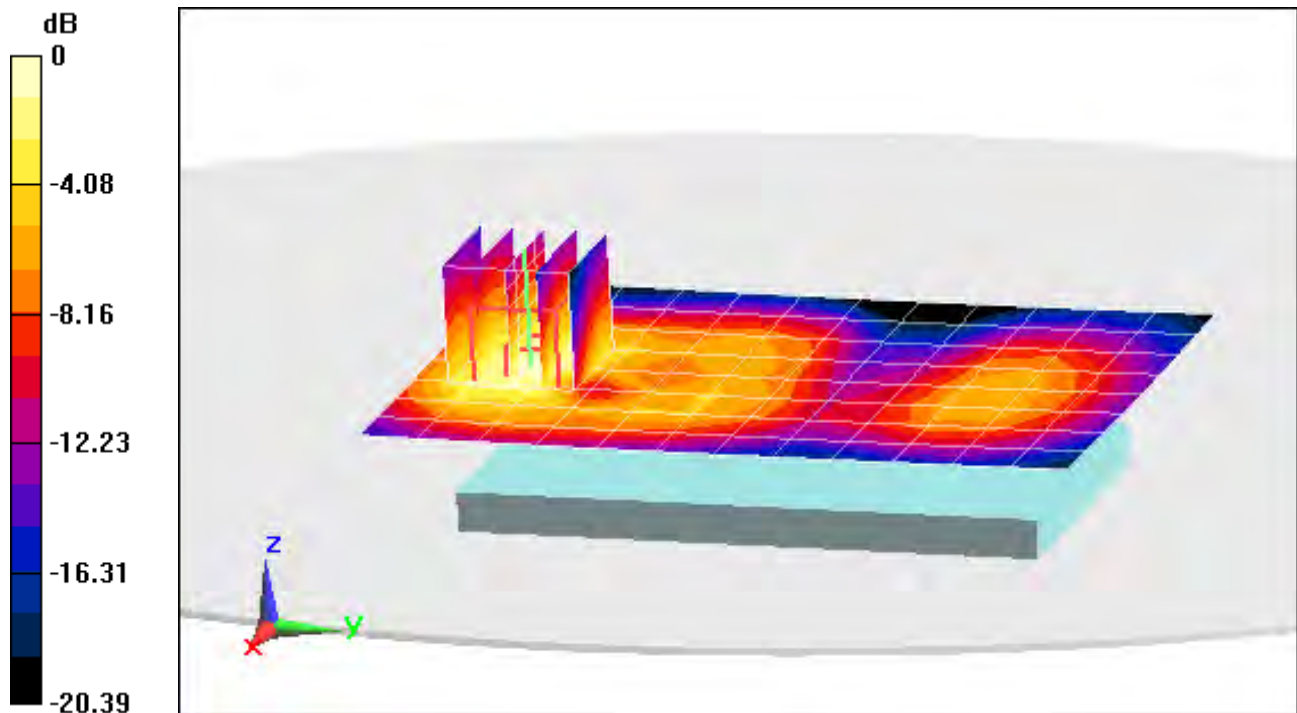

0 dB = 0.532 W/kg = -2.74 dBW/kg

PCTEST ENGINEERING LABORATORY, INC.

DUT: A3LSMG890A; Type: Portable Handset; Serial: 359356060056374

Communication System: UID 0, UMTS; Frequency: 1880 MHz; Duty Cycle: 1:1

Medium: 1900 Body Medium parameters used:

$f = 1880 \text{ MHz}$; $\sigma = 1.558 \text{ S/m}$; $\epsilon_r = 53.351$; $\rho = 1000 \text{ kg/m}^3$

Phantom section: Flat Section ; Space: 1.0 cm

Test Date: 04-06-2015; Ambient Temp: 20.5°C; Tissue Temp: 21.0°C

Probe: ES3DV2 - SN3022; ConvF(4.49, 4.49, 4.49); Calibrated: 8/19/2014;

Sensor-Surface: 3mm (Mechanical Surface Detection)

Electronics: DAE4 Sn1322; Calibrated: 8/12/2014

Phantom: ELI v5.0; Type: QDOVA001BB; Serial: 1226

Measurement SW: DASY52, Version 52.8 (8); SEMCAD X Version 14.6.10 (7331)

Mode: UMTS 1900, Body SAR, Back side, Mid.ch

Area Scan (9x13x1): Measurement grid: dx=15mm, dy=15mm

Zoom Scan (5x5x7)/Cube 0: Measurement grid: dx=8mm, dy=8mm, dz=5mm

Reference Value = 19.73 V/m; Power Drift = 0.10 dB

Peak SAR (extrapolated) = 1.02 W/kg

SAR(1 g) = 0.601 W/kg

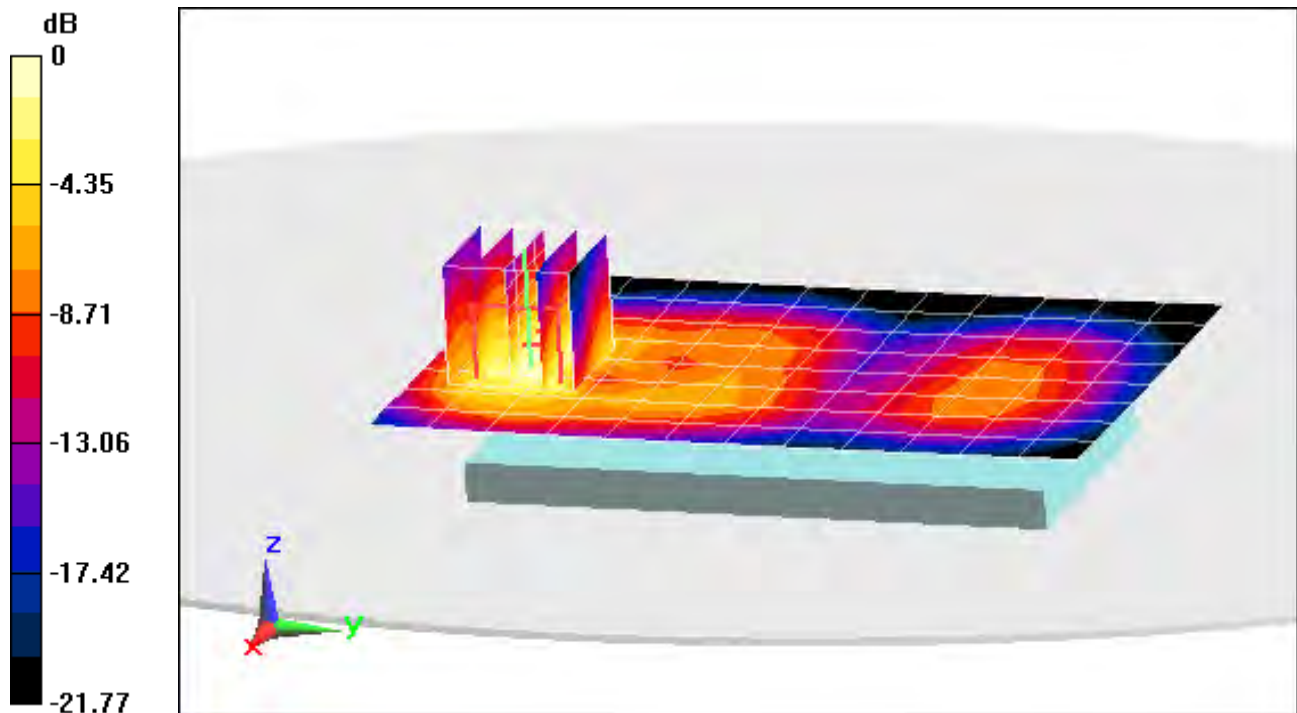

0 dB = 0.731 W/kg = -1.36 dBW/kg

PCTEST ENGINEERING LABORATORY, INC.

DUT: A3LSMG890A; Type: Portable Handset; Serial: 359356060056366

Communication System: UID 0, LTE Band 12; Frequency: 707.5 MHz; Duty Cycle: 1:1

Medium: 750 Body Medium parameters used (interpolated):

$f = 707.5$ MHz; $\sigma = 0.952$ S/m; $\epsilon_r = 56.62$; $\rho = 1000$ kg/m³

Phantom section: Flat Section ; Space: 1.5 cm

Test Date: 04-08-2015; Ambient Temp: 21.3°C; Tissue Temp: 21.4°C

Probe: ES3DV2 - SN3022; ConvF(6.02, 6.02, 6.02); Calibrated: 8/19/2014;

Sensor-Surface: 3mm (Mechanical Surface Detection)

Electronics: DAE4 Sn1322; Calibrated: 8/12/2014

Phantom: ELI v5.0; Type: QDOVA001BB; Serial: 1226

Measurement SW: DASY52, Version 52.8 (8); SEMCAD X Version 14.6.10 (7331)

**Mode: LTE Band 12, Body SAR, Back side, Mid.ch,
10 MHz Bandwidth, QPSK, 1 RB, 25 RB Offset**

Area Scan (9x13x1): Measurement grid: dx=15mm, dy=15mm

Zoom Scan (5x5x7)/Cube 0: Measurement grid: dx=8mm, dy=8mm, dz=5mm

Reference Value = 23.75 V/m; Power Drift = 0.06 dB

Peak SAR (extrapolated) = 0.638 W/kg

SAR(1 g) = 0.513 W/kg

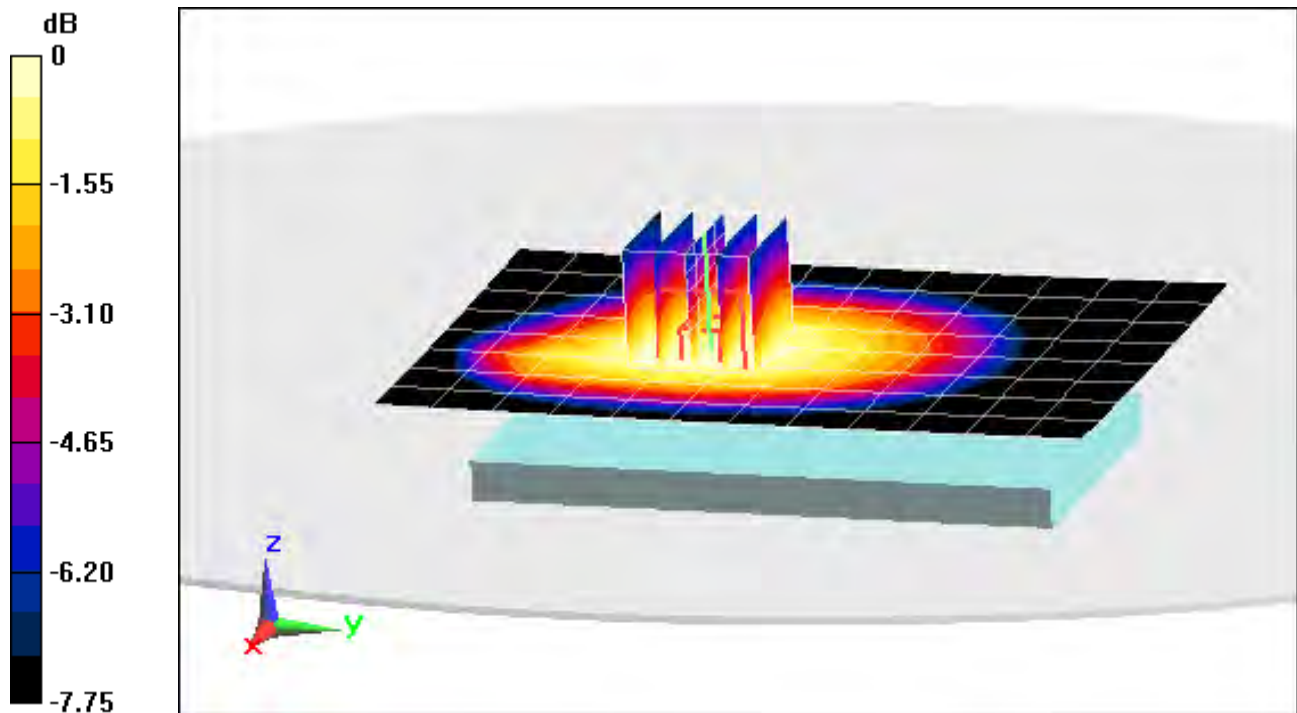

0 dB = 0.562 W/kg = -2.50 dBW/kg

PCTEST ENGINEERING LABORATORY, INC.

DUT: A3LSMG890A; Type: Portable Handset; Serial: 359356060056366

Communication System: UID 0, LTE Band 12; Frequency: 707.5 MHz; Duty Cycle: 1:1

Medium: 750 Body Medium parameters used (interpolated):

$f = 707.5 \text{ MHz}$; $\sigma = 0.952 \text{ S/m}$; $\epsilon_r = 56.62$; $\rho = 1000 \text{ kg/m}^3$

Phantom section: Flat Section ; Space: 1.0 cm

Test Date: 04-08-2015; Ambient Temp: 21.3°C; Tissue Temp: 21.4°C

Probe: ES3DV2 - SN3022; ConvF(6.02, 6.02, 6.02); Calibrated: 8/19/2014;

Sensor-Surface: 3mm (Mechanical Surface Detection)

Electronics: DAE4 Sn1322; Calibrated: 8/12/2014

Phantom: ELI v5.0; Type: QDOVA001BB; Serial: 1226

Measurement SW: DASY52, Version 52.8 (8); SEMCAD X Version 14.6.10 (7331)

**Mode: LTE Band 12, Body SAR, Back side, Mid.ch,
10 MHz Bandwidth, QPSK, 1 RB, 25 RB Offset**

Area Scan (9x13x1): Measurement grid: dx=15mm, dy=15mm

Zoom Scan (5x5x7)/Cube 0: Measurement grid: dx=8mm, dy=8mm, dz=5mm

Reference Value = 25.81 V/m; Power Drift = 0.03 dB

Peak SAR (extrapolated) = 0.789 W/kg

SAR(1 g) = 0.630 W/kg

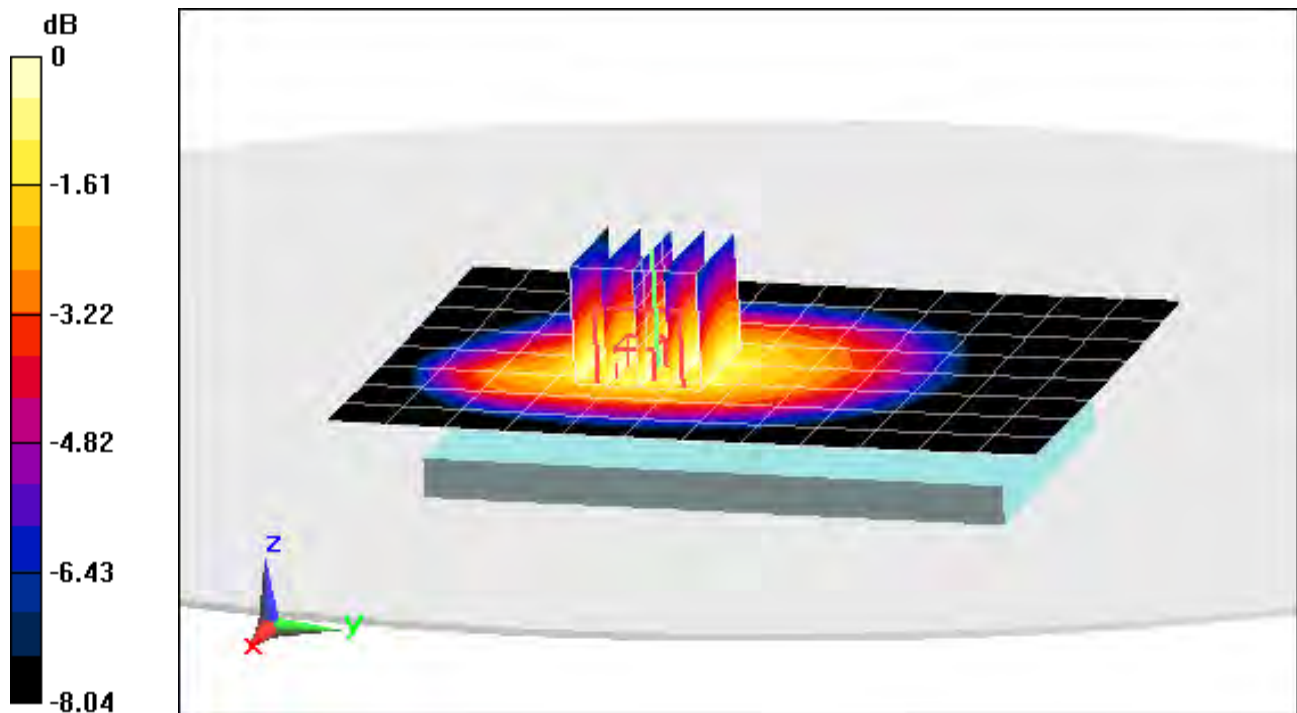

0 dB = 0.683 W/kg = -1.66 dBW/kg

PCTEST ENGINEERING LABORATORY, INC.

DUT: A3LSMG890A; Type: Portable Handset; Serial: 359356060056374

Communication System: UID 0, LTE Band 5; Frequency: 836.5 MHz; Duty Cycle: 1:1

Medium: 835 Body Medium parameters used (interpolated):

$f = 836.5 \text{ MHz}$; $\sigma = 1.008 \text{ S/m}$; $\epsilon_r = 54.555$; $\rho = 1000 \text{ kg/m}^3$

Phantom section: Flat Section ; Space: 1.5 cm

Test Date: 04-06-2015; Ambient Temp: 22.5°C; Tissue Temp: 21.8°C

Probe: ES3DV3 - SN3288; ConvF(6.32, 6.32, 6.32); Calibrated: 9/24/2014;

Sensor-Surface: 3mm (Mechanical Surface Detection)

Electronics: DAE4 Sn1364; Calibrated: 9/18/2014

Phantom: ELI v5.0; Type: QDOVA001BB; Serial: 1229

Measurement SW: DASY52, Version 52.8 (8); SEMCAD X Version 14.6.10 (7331)

**Mode: LTE Band 5 (Cell.), Body SAR, Back Side, Mid.ch,
10 MHz Bandwidth, QPSK, 1 RB, 25 RB Offset**

Area Scan (9x15x1): Measurement grid: dx=15mm, dy=15mm

Zoom Scan (5x5x7)/Cube 0: Measurement grid: dx=8mm, dy=8mm, dz=5mm

Reference Value = 23.26 V/m; Power Drift = 0.01 dB

Peak SAR (extrapolated) = 0.635 W/kg

SAR(1 g) = 0.508 W/kg

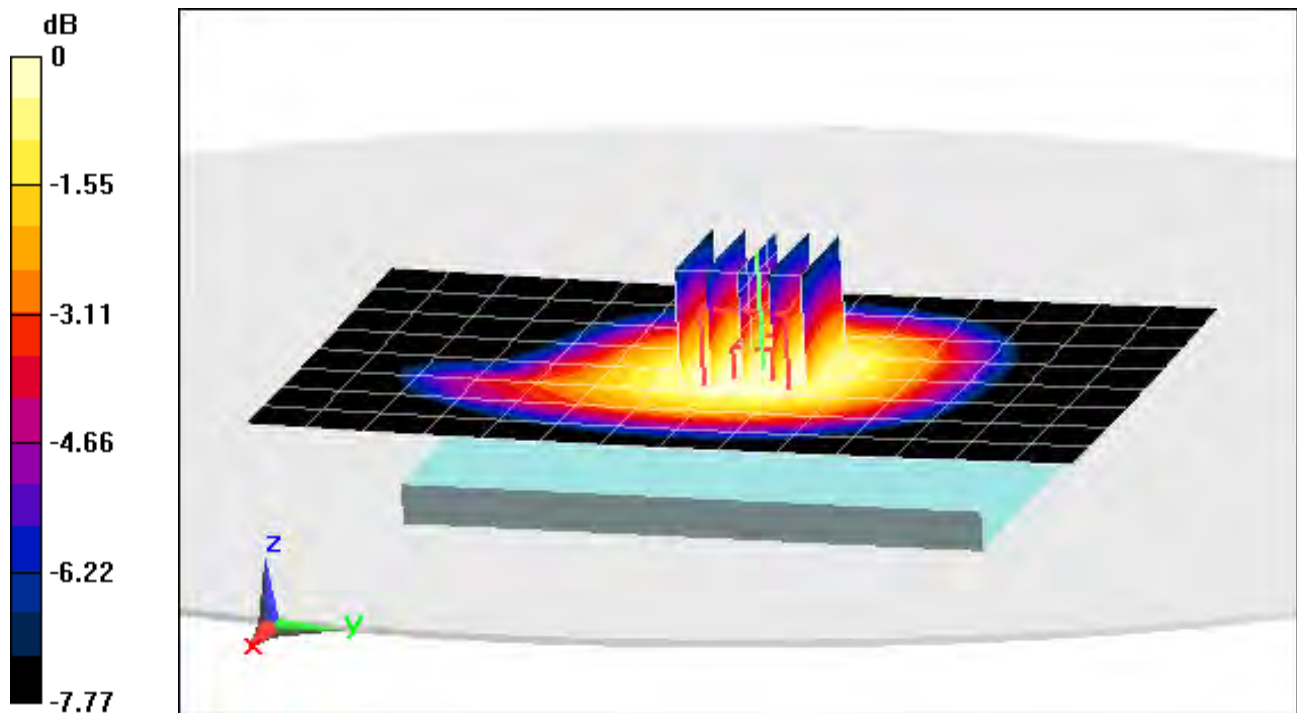

0 dB = 0.557 W/kg = -2.54 dBW/kg

PCTEST ENGINEERING LABORATORY, INC.

DUT: A3LSMG890A; Type: Portable Handset; Serial: 359356060056374

Communication System: UID 0, LTE Band 5; Frequency: 836.5 MHz; Duty Cycle: 1:1

Medium: 835 Body Medium parameters used (interpolated):

$f = 836.5 \text{ MHz}$; $\sigma = 1.008 \text{ S/m}$; $\epsilon_r = 54.555$; $\rho = 1000 \text{ kg/m}^3$

Phantom section: Flat Section ; Space: 1.0 cm

Test Date: 04-06-2015; Ambient Temp: 22.5°C; Tissue Temp: 21.8°C

Probe: ES3DV3 - SN3288; ConvF(6.32, 6.32, 6.32); Calibrated: 9/24/2014;

Sensor-Surface: 3mm (Mechanical Surface Detection)

Electronics: DAE4 Sn1364; Calibrated: 9/18/2014

Phantom: ELI v5.0; Type: QDOVA001BB; Serial: 1229

Measurement SW: DASY52, Version 52.8 (8); SEMCAD X Version 14.6.10 (7331)

**Mode: LTE Band 5 (Cell.), Body SAR, Back Side, Mid.ch,
10 MHz Bandwidth, QPSK, 1 RB, 25 RB Offset**

Area Scan (9x15x1): Measurement grid: dx=15mm, dy=15mm

Zoom Scan (6x6x7)/Cube 0: Measurement grid: dx=8mm, dy=8mm, dz=5mm

Reference Value = 24.23 V/m; Power Drift = 0.17 dB

Peak SAR (extrapolated) = 0.728 W/kg

SAR(1 g) = 0.580 W/kg

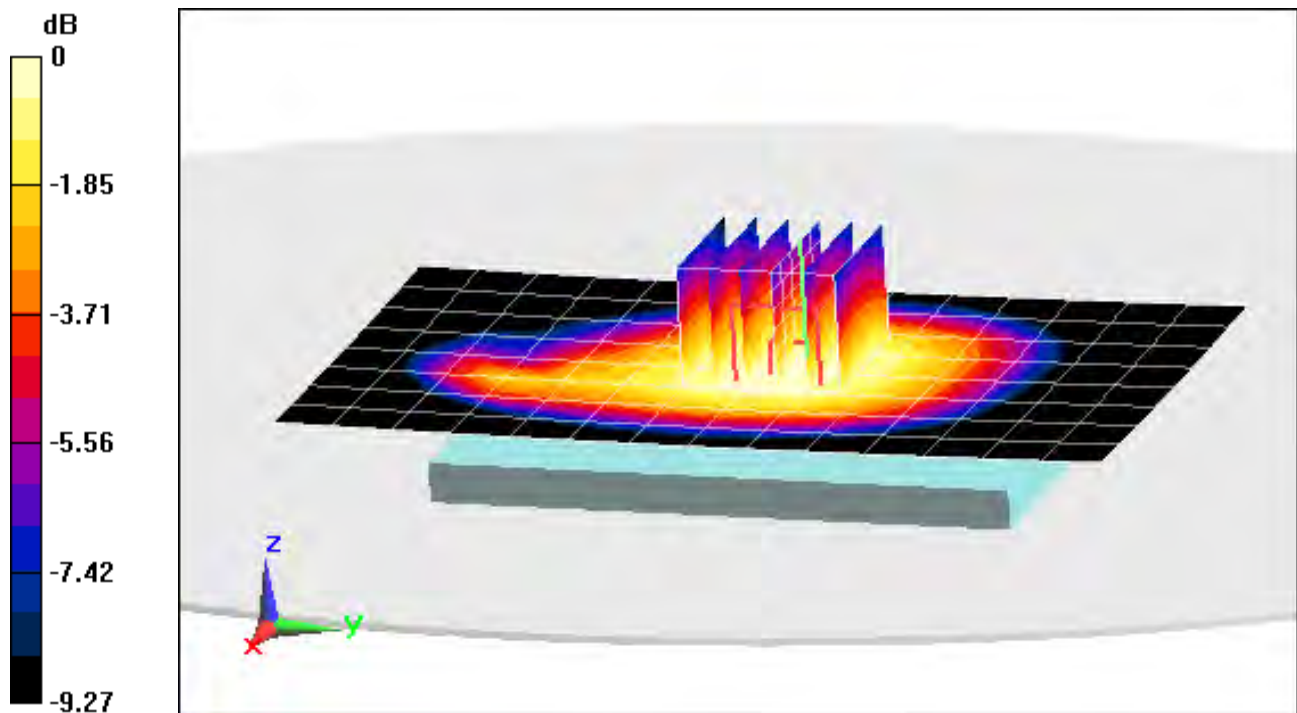

0 dB = 0.634 W/kg = -1.98 dBW/kg

PCTEST ENGINEERING LABORATORY, INC.

DUT: A3LSMG890A; Type: Portable Handset; Serial: 359356060056374

Communication System: UID 0, LTE Band 4 (AWS); Frequency: 1732.5 MHz; Duty Cycle: 1:1

Medium: 1750 Body Medium parameters used (interpolated):

$f = 1732.5 \text{ MHz}$; $\sigma = 1.463 \text{ S/m}$; $\epsilon_r = 52.612$; $\rho = 1000 \text{ kg/m}^3$

Phantom section: Flat Section ; Space: 1.5 cm

Test Date: 04-09-2015; Ambient Temp: 23.8°C; Tissue Temp: 22.0°C

Probe: ES3DV3 - SN3333; ConvF(4.89, 4.89, 4.89); Calibrated: 10/24/2014;

Sensor-Surface: 3mm (Mechanical Surface Detection)

Electronics: DAE4 Sn1408; Calibrated: 10/23/2014

Phantom: Main TWIN SAM; Type: QD000P40CC; Serial: TP-1406

Measurement SW: DASY52, Version 52.8 (8); SEMCAD X Version 14.6.10 (7331)

**Mode: LTE Band 4 (AWS), Body SAR, Back side, Mid.ch,
20 MHz Bandwidth, QPSK, 1 RB, 50 RB Offset**

Area Scan (9x15x1): Measurement grid: dx=15mm, dy=15mm

Zoom Scan (5x5x7)/Cube 0: Measurement grid: dx=8mm, dy=8mm, dz=5mm

Reference Value = 17.22 V/m; Power Drift = 0.00 dB

Peak SAR (extrapolated) = 0.609 W/kg

SAR(1 g) = 0.380 W/kg

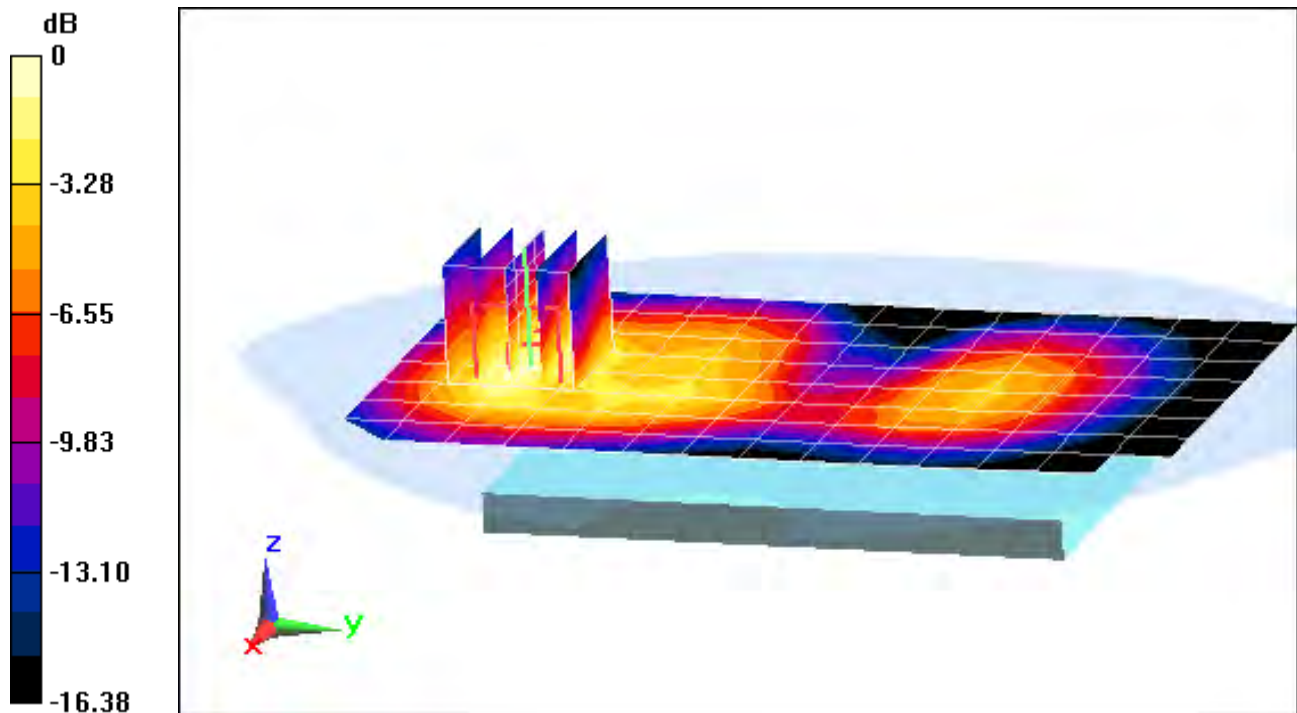

0 dB = 0.457 W/kg = -3.40 dBW/kg

PCTEST ENGINEERING LABORATORY, INC.

DUT: A3LSMG890A; Type: Portable Handset; Serial: 359356060056374

Communication System: UID 0, LTE Band 4 (AWS); Frequency: 1732.5 MHz; Duty Cycle: 1:1

Medium: 1750 Body Medium parameters used (interpolated):

$f = 1732.5 \text{ MHz}$; $\sigma = 1.463 \text{ S/m}$; $\epsilon_r = 52.612$; $\rho = 1000 \text{ kg/m}^3$

Phantom section: Flat Section ; Space: 1.0 cm

Test Date: 04-09-2015; Ambient Temp: 23.8°C; Tissue Temp: 22.0°C

Probe: ES3DV3 - SN3333; ConvF(4.89, 4.89, 4.89); Calibrated: 10/24/2014;

Sensor-Surface: 3mm (Mechanical Surface Detection)

Electronics: DAE4 Sn1408; Calibrated: 10/23/2014

Phantom: Main TWIN SAM; Type: QD000P40CC; Serial: TP-1406

Measurement SW: DASY52, Version 52.8 (8); SEMCAD X Version 14.6.10 (7331)

**Mode: LTE Band 4 (AWS), Body SAR, Front side, Mid.ch,
20 MHz Bandwidth, QPSK, 1 RB, 0 RB Offset**

Area Scan (9x15x1): Measurement grid: dx=15mm, dy=15mm

Zoom Scan (5x5x7)/Cube 0: Measurement grid: dx=8mm, dy=8mm, dz=5mm

Reference Value = 19.87 V/m; Power Drift = 0.01 dB

Peak SAR (extrapolated) = 0.806 W/kg

SAR(1 g) = 0.485 W/kg

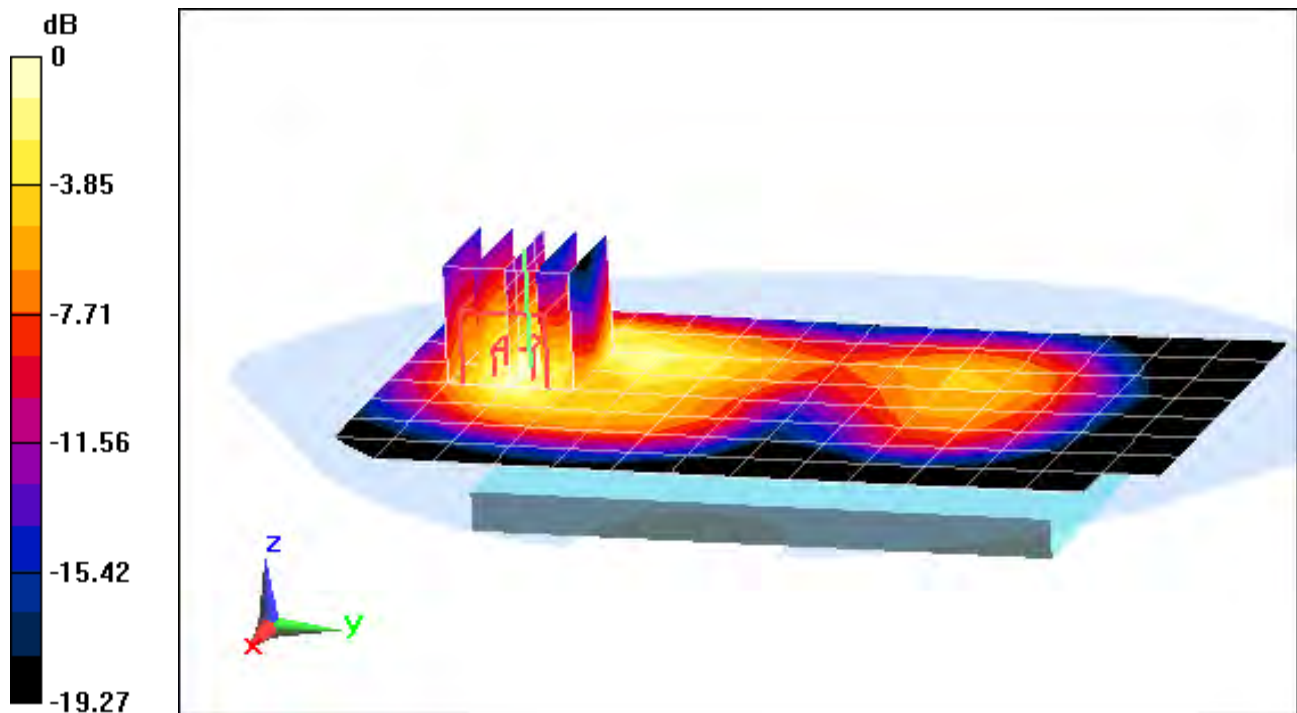

0 dB = 0.600 W/kg = -2.22 dBW/kg

PCTEST ENGINEERING LABORATORY, INC.

DUT: A3LSMG890A; Type: Portable Handset; Serial: 359356060056374

Communication System: UID 0, LTE Band 2 (PCS); Frequency: 1900 MHz; Duty Cycle: 1:1

Medium: 1900 Body Medium parameters used (interpolated):

$f = 1900 \text{ MHz}$; $\sigma = 1.581 \text{ S/m}$; $\epsilon_r = 53.276$; $\rho = 1000 \text{ kg/m}^3$

Phantom section: Flat Section ; Space: 1.5 cm

Test Date: 04-06-2015; Ambient Temp: 20.5°C; Tissue Temp: 21.0°C

Probe: ES3DV2 - SN3022; ConvF(4.49, 4.49, 4.49); Calibrated: 8/19/2014;

Sensor-Surface: 3mm (Mechanical Surface Detection)

Electronics: DAE4 Sn1322; Calibrated: 8/12/2014

Phantom: ELI v5.0; Type: QDOVA001BB; Serial: 1226

Measurement SW: DASY52, Version 52.8 (8); SEMCAD X Version 14.6.10 (7331)

**Mode: LTE Band 2 (PCS), Body SAR, Back side, High.ch,
20 MHz Bandwidth, QPSK, 1 RB, 50 RB Offset**

Area Scan (9x14x1): Measurement grid: dx=15mm, dy=15mm

Zoom Scan (5x5x7)/Cube 0: Measurement grid: dx=8mm, dy=8mm, dz=5mm

Reference Value = 21.39 V/m; Power Drift = 0.07 dB

Peak SAR (extrapolated) = 0.847 W/kg

SAR(1 g) = 0.544 W/kg

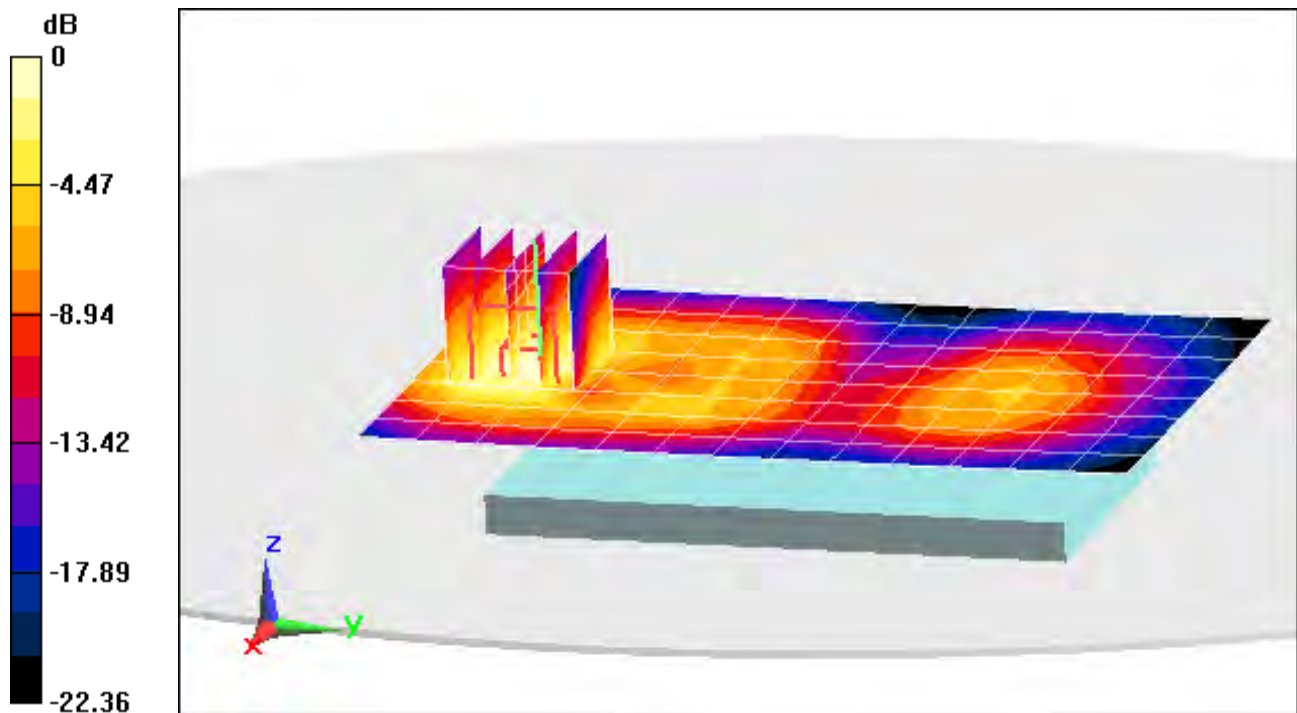

0 dB = 0.644 W/kg = -1.91 dBW/kg

PCTEST ENGINEERING LABORATORY, INC.

DUT: A3LSMG890A; Type: Portable Handset; Serial: 359356060079921

Communication System: UID 0, LTE Band 2 (PCS); Frequency: 1860 MHz; Duty Cycle: 1:1

Medium: 1900 Body Medium parameters used (interpolated):

$f = 1860 \text{ MHz}$; $\sigma = 1.537 \text{ S/m}$; $\epsilon_r = 52.614$; $\rho = 1000 \text{ kg/m}^3$

Phantom section: Flat Section ; Space: 1.0 cm

Test Date: 05-04-2015; Ambient Temp: 22.4°C; Tissue Temp: 22.4°C

Probe: ES3DV2 - SN3022; ConvF(4.49, 4.49, 4.49); Calibrated: 8/19/2014;

Sensor-Surface: 3mm (Mechanical Surface Detection)

Electronics: DAE4 Sn1322; Calibrated: 8/12/2014

Phantom: ELI v5.0; Type: QDOVA001BB; Serial: 1226

Measurement SW: DASY52, Version 52.8 (8); SEMCAD X Version 14.6.10 (7331)

**Mode: LTE Band 2 (PCS), Body SAR, Back side, Low.ch,
20 MHz Bandwidth, QPSK, 1 RB, 0 RB Offset**

Area Scan (8x13x1): Measurement grid: dx=15mm, dy=15mm

Zoom Scan (5x5x7)/Cube 0: Measurement grid: dx=8mm, dy=8mm, dz=5mm

Reference Value = 20.78 V/m; Power Drift = -0.03 dB

Peak SAR (extrapolated) = 0.936 W/kg

SAR(1 g) = 0.568 W/kg

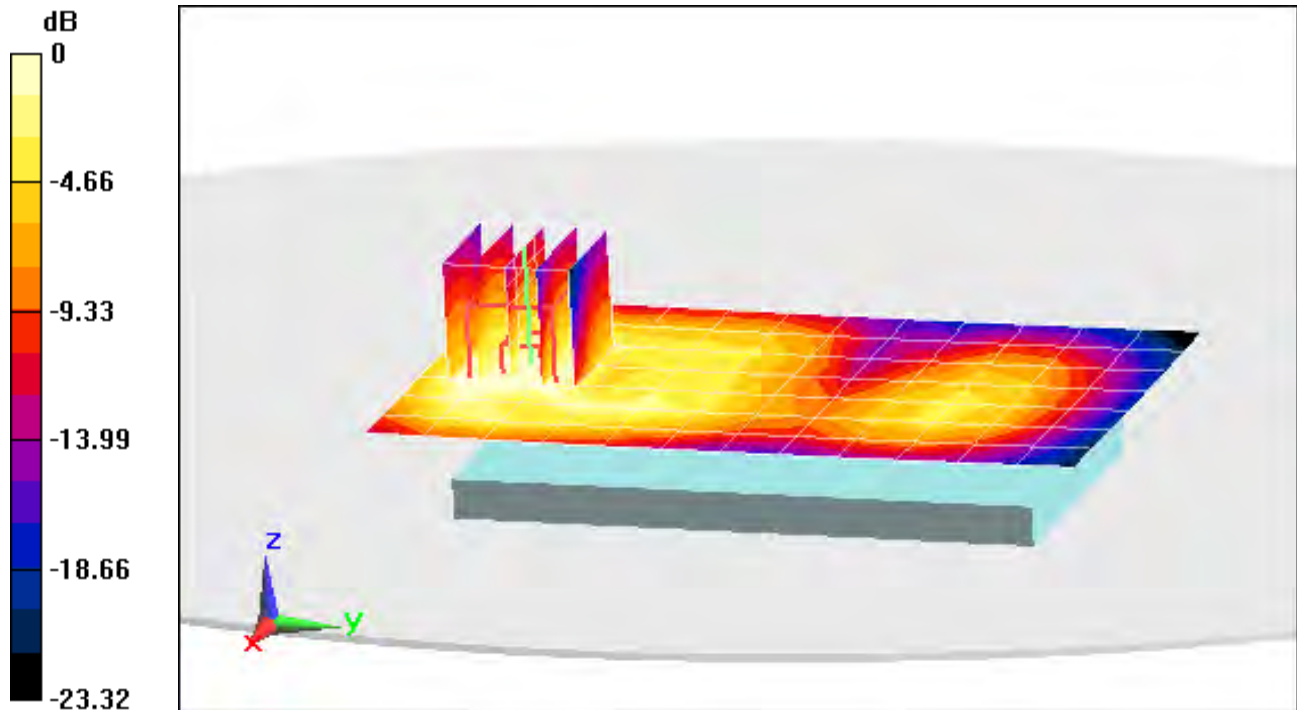

0 dB = 0.688 W/kg = -1.62 dBW/kg

PCTEST ENGINEERING LABORATORY, INC.

DUT: A3LSMG890A; Type: Portable Handset; Serial: 359356060056374

Communication System: UID 0, LTE Band 30; Frequency: 2310 MHz; Duty Cycle: 1:1

Medium: 2300 Body Medium parameters used:

$f = 2310 \text{ MHz}$; $\sigma = 1.763 \text{ S/m}$; $\epsilon_r = 52.824$; $\rho = 1000 \text{ kg/m}^3$

Phantom section: Flat Section ; Space: 1.5 cm

Test Date: 04-09-2015; Ambient Temp: 24.4°C; Tissue Temp: 23.5°C

Probe: ES3DV3 - SN3318; ConvF(4.52, 4.52, 4.52); Calibrated: 1/23/2015;

Sensor-Surface: 3mm (Mechanical Surface Detection)

Electronics: DAE4 Sn1272; Calibrated: 1/14/2015

Phantom: ELI v6.0; Type: QDOVA003AA; Serial: TP:2027

Measurement SW: DASY52, Version 52.8 (8); SEMCAD X Version 14.6.10 (7331)

**Mode: LTE Band 30, Body SAR, Back side, Mid.ch,
10 MHz Bandwidth, QPSK, 1 RB, 25 RB Offset**

Area Scan (9x17x1): Measurement grid: dx=12mm, dy=12mm

Zoom Scan (8x8x7)/Cube 0: Measurement grid: dx=5mm, dy=5mm, dz=5mm

Reference Value = 13.07 V/m; Power Drift = 0.02 dB

Peak SAR (extrapolated) = 0.460 W/kg

SAR(1 g) = 0.272 W/kg

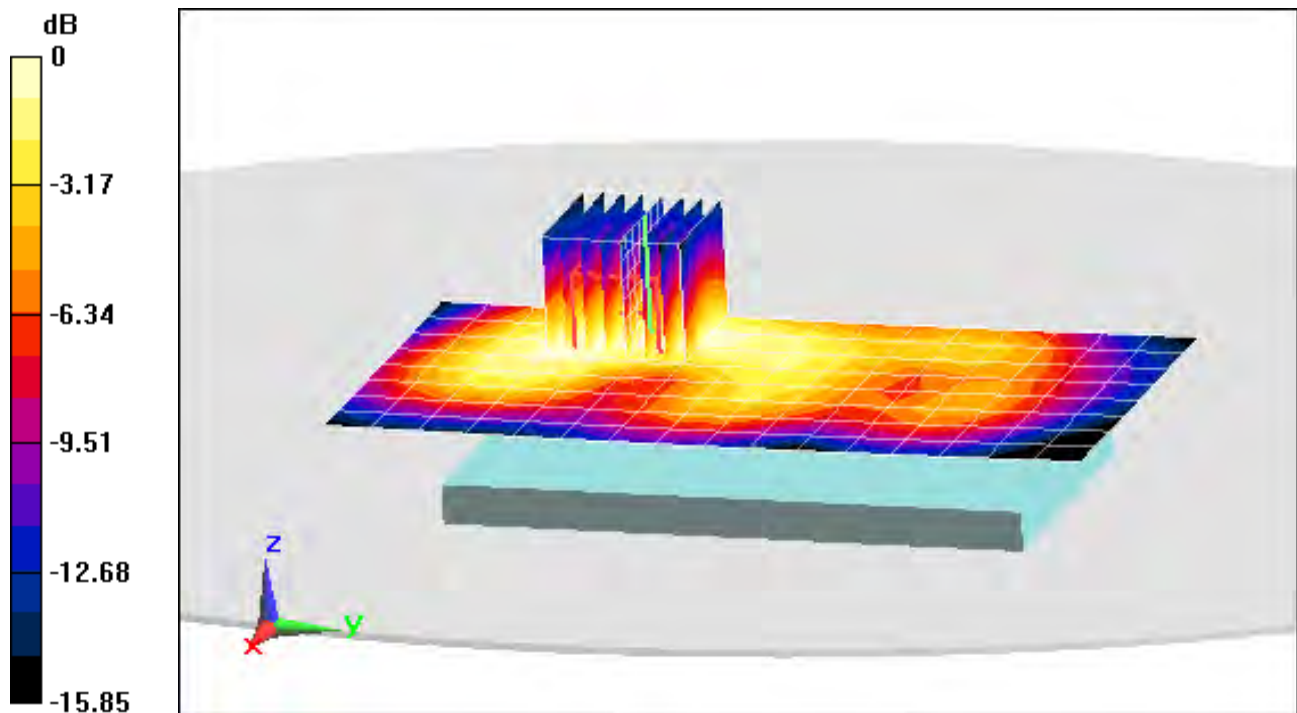

0 dB = 0.323 W/kg = -4.91 dBW/kg

PCTEST ENGINEERING LABORATORY, INC.

DUT: A3LSMG890A; Type: Portable Handset; Serial: 359356060056374

Communication System: UID 0, LTE Band 30; Frequency: 2310 MHz; Duty Cycle: 1:1

Medium: 2300 Body Medium parameters used:

$f = 2310 \text{ MHz}$; $\sigma = 1.763 \text{ S/m}$; $\epsilon_r = 52.824$; $\rho = 1000 \text{ kg/m}^3$

Phantom section: Flat Section ; Space: 1.0 cm

Test Date: 04-09-2015; Ambient Temp: 24.4°C; Tissue Temp: 23.5°C

Probe: ES3DV3 - SN3318; ConvF(4.52, 4.52, 4.52); Calibrated: 1/23/2015;

Sensor-Surface: 3mm (Mechanical Surface Detection)

Electronics: DAE4 Sn1272; Calibrated: 1/14/2015

Phantom: ELI v6.0; Type: QDOVA003AA; Serial: TP:2027

Measurement SW: DASY52, Version 52.8 (8); SEMCAD X Version 14.6.10 (7331)

**Mode: LTE Band 30, Body SAR, Right Edge, Mid.ch,
10 MHz Bandwidth, QPSK, 1 RB, 25 RB Offset**

Area Scan (11x17x1): Measurement grid: dx=5mm, dy=12mm

Zoom Scan (7x7x7)/Cube 0: Measurement grid: dx=5mm, dy=5mm, dz=5mm

Reference Value = 18.05 V/m; Power Drift = 0.03 dB

Peak SAR (extrapolated) = 0.928 W/kg

SAR(1 g) = 0.526 W/kg

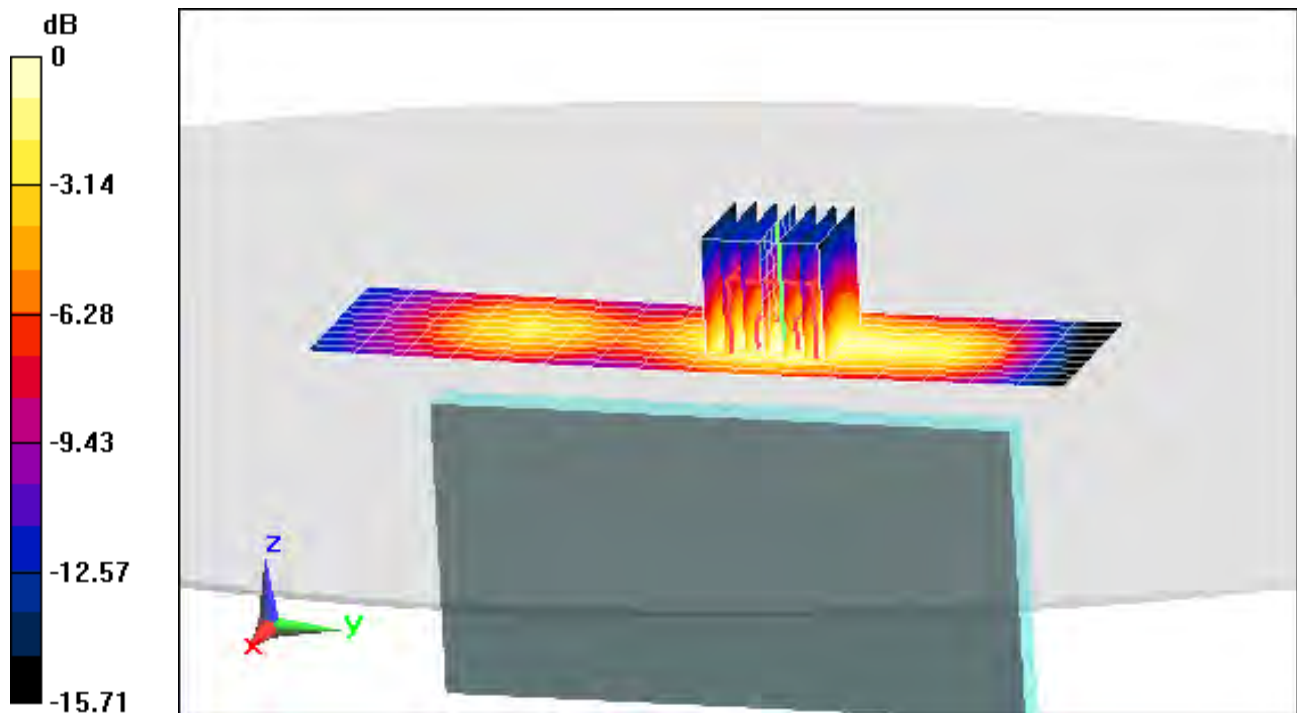

0 dB = 0.642 W/kg = -1.92 dBW/kg

PCTEST ENGINEERING LABORATORY, INC.

DUT: A3LSMG890A; Type: Portable Handset; Serial: 359356060056374

Communication System: UID 0, IEEE 802.11b; Frequency: 2437 MHz; Duty Cycle: 1:1

Medium: 2450 Body Medium parameters used (interpolated):

$f = 2437 \text{ MHz}$; $\sigma = 1.921 \text{ S/m}$; $\epsilon_r = 52.378$; $\rho = 1000 \text{ kg/m}^3$

Phantom section: Flat Section ; Space: 1.5 cm

Test Date: 04-09-2015; Ambient Temp: 22.3°C; Tissue Temp: 22.2°C

Probe: ES3DV3 - SN3318; ConvF(4.37, 4.37, 4.37); Calibrated: 1/23/2015;

Sensor-Surface: 3mm (Mechanical Surface Detection)

Electronics: DAE4 Sn1272; Calibrated: 1/14/2015

Phantom: ELI v6.0; Type: QDOVA003AA; Serial: TP:2027

Measurement SW: DASY52, Version 52.8 (8); SEMCAD X Version 14.6.10 (7331)

**Mode: IEEE 802.11b, Body SAR, Ch 6, 1 Mbps,
22MHz Bandwidth, Back Side, Antenna 1**

Area Scan (11x17x1): Measurement grid: dx=12mm, dy=12mm

Zoom Scan (7x7x7)/Cube 0: Measurement grid: dx=5mm, dy=5mm, dz=5mm

Reference Value = 9.419 V/m; Power Drift = 0.04 dB

Peak SAR (extrapolated) = 0.325 W/kg

SAR(1 g) = 0.169 W/kg

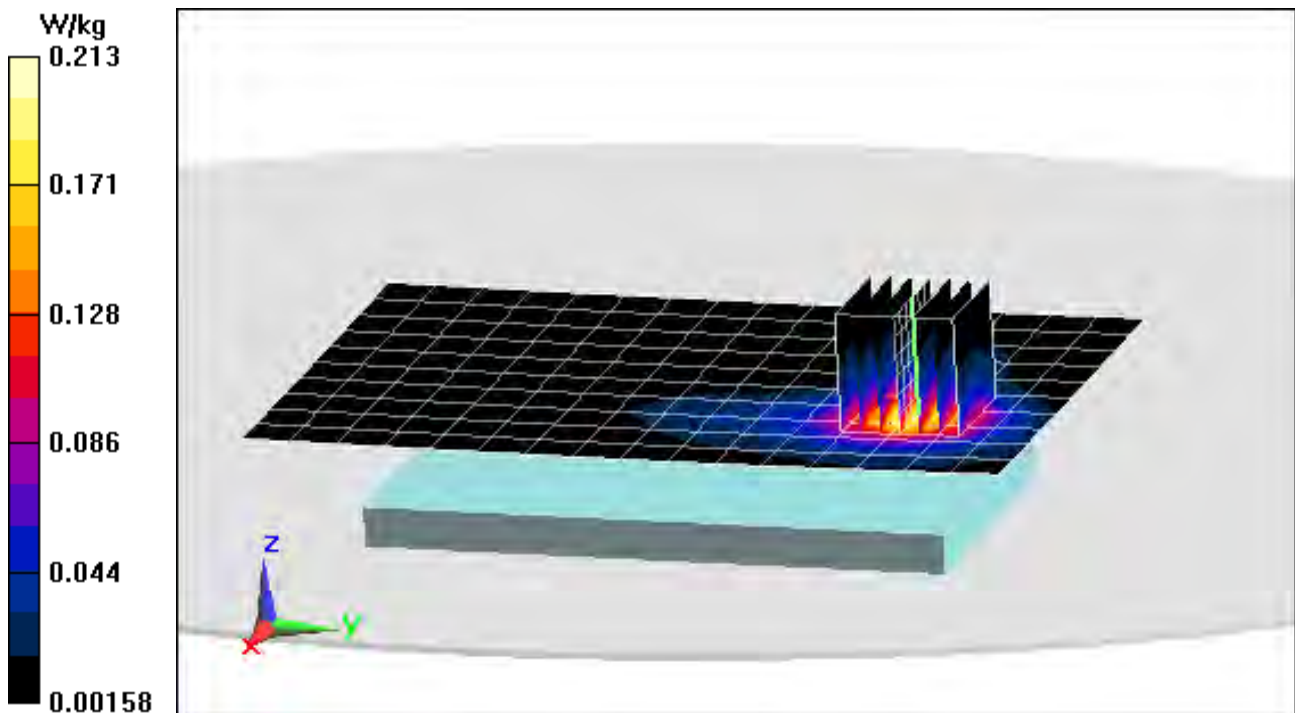

PCTEST ENGINEERING LABORATORY, INC.

DUT: A3LSMG890A; Type: Portable Handset; Serial: 359356060056374

Communication System: UID 0, IEEE 802.11b; Frequency: 2437 MHz; Duty Cycle: 1:1

Medium: 2450 Body Medium parameters used (interpolated):

$f = 2437 \text{ MHz}$; $\sigma = 1.921 \text{ S/m}$; $\epsilon_r = 52.378$; $\rho = 1000 \text{ kg/m}^3$

Phantom section: Flat Section ; Space: 1.0 cm

Test Date: 04-09-2015; Ambient Temp: 22.3°C; Tissue Temp: 22.2°C

Probe: ES3DV3 - SN3318; ConvF(4.37, 4.37, 4.37); Calibrated: 1/23/2015;

Sensor-Surface: 3mm (Mechanical Surface Detection)

Electronics: DAE4 Sn1272; Calibrated: 1/14/2015

Phantom: ELI v6.0; Type: QDOVA003AA; Serial: TP:2027

Measurement SW: DASY52, Version 52.8 (8); SEMCAD X Version 14.6.10 (7331)

**Mode: IEEE 802.11b, Body SAR, Ch 6, 1 Mbps,
22MHz Bandwidth, Back Side, Antenna 1**

Area Scan (11x17x1): Measurement grid: dx=12mm, dy=12mm

Zoom Scan (7x7x7)/Cube 0: Measurement grid: dx=5mm, dy=5mm, dz=5mm

Reference Value = 15.38 V/m; Power Drift = 0.05 dB

Peak SAR (extrapolated) = 0.773 W/kg

SAR(1 g) = 0.390 W/kg

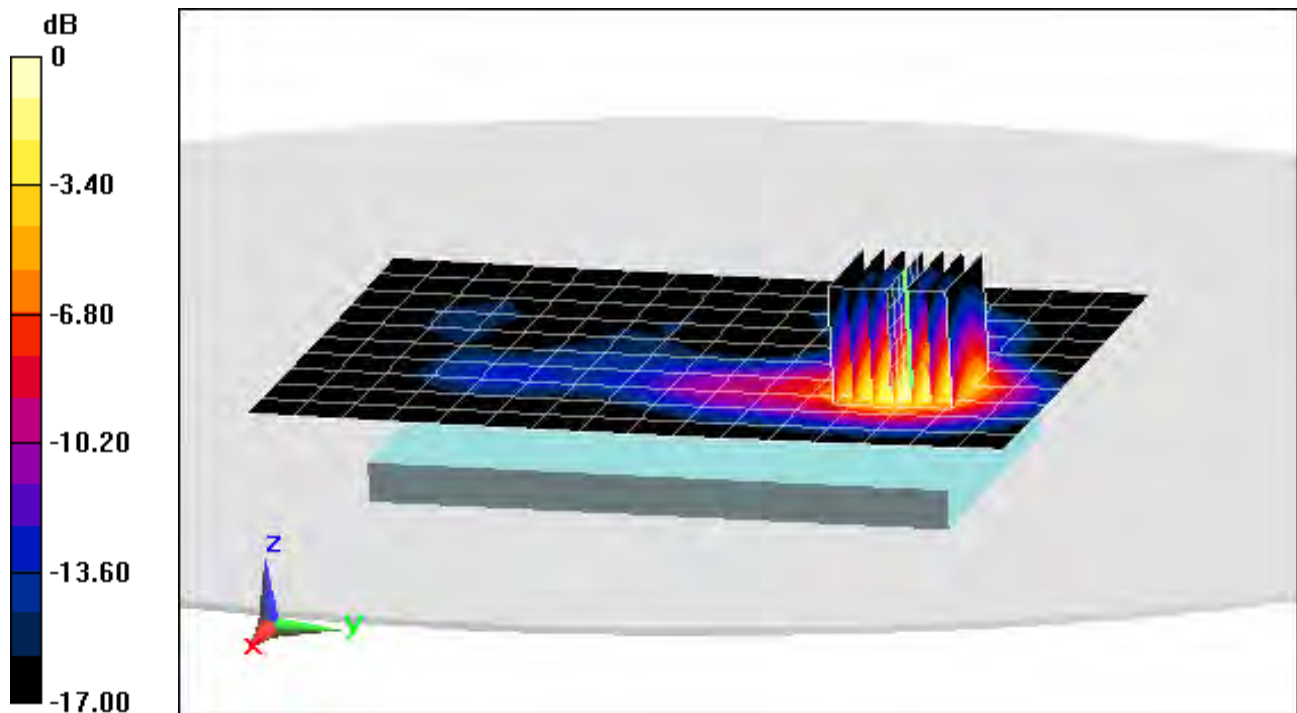

0 dB = 0.488 W/kg = -3.12 dBW/kg

PCTEST ENGINEERING LABORATORY, INC.

DUT: A3LSMG890A; Type: Portable Handset; Serial: 359356060056390

Communication System: UID 0, 802.11a 5.2-5.8 GHz Band; Frequency: 5720 MHz; Duty Cycle: 1:1

Medium: 5GHz Body Medium parameters used (interpolated):

$f = 5720 \text{ MHz}$; $\sigma = 6.031 \text{ S/m}$; $\epsilon_r = 46.049$; $\rho = 1000 \text{ kg/m}^3$

Phantom section: Flat Section ; Space: 1.0 cm

Test Date: 04-06-2015; Ambient Temp: 23.5°C; Tissue Temp: 22.1°C

Probe: EX3DV4 - SN3914; ConvF(4.01, 4.01, 4.01); Calibrated: 2/10/2015;

Sensor-Surface: 1.4mm (Mechanical Surface Detection)

Electronics: DAE4 Sn1333; Calibrated: 10/31/2014

Phantom: SAM Sub ; Type: QD000P40CC; Serial: TP:1357

Measurement SW: DASY52, Version 52.8 (8); SEMCAD X Version 14.6.10 (7331)

**Mode: IEEE 802.11a, 5.5-5.7 GHz, 20 MHz Bandwidth,
Body SAR, Ch 144, 6 Mbps, Back Side, Antenna 2**

Area Scan (13x20x1): Measurement grid: dx=10mm, dy=10mm

Zoom Scan (7x7x7)/Cube 0: Measurement grid: dx=4mm, dy=4mm, dz=1.4mm; Graded Ratio = 1.4

Reference Value = 5.825 V/m; Power Drift = 0.16 dB

Peak SAR (extrapolated) = 0.749 W/kg

SAR(1 g) = 0.187 W/kg

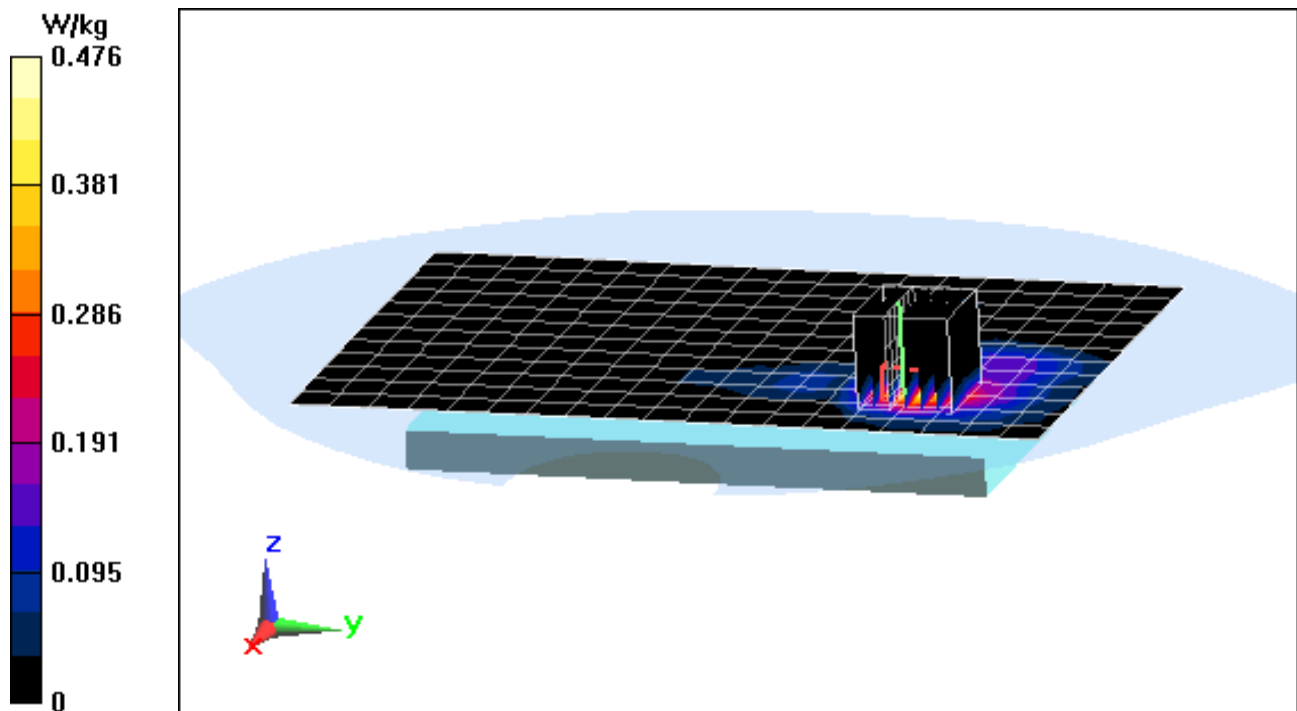

PCTEST ENGINEERING LABORATORY, INC.

DUT: A3LSMG890A; Type: Portable Handset; Serial: 359356060056390

Communication System: UID 0, IEEE 802.11a; Frequency: 5785 MHz; Duty Cycle: 1:1

Medium: 5GHz Body Medium parameters used:

$f = 5785 \text{ MHz}$; $\sigma = 6.122 \text{ S/m}$; $\epsilon_r = 45.898$; $\rho = 1000 \text{ kg/m}^3$

Phantom section: Flat Section ; Space: 1.0 cm

Test Date: 04-06-2015; Ambient Temp: 23.5°C; Tissue Temp: 22.1°C

Probe: EX3DV4 - SN3914; ConvF(4.01, 4.01, 4.01); Calibrated: 2/10/2015;

Sensor-Surface: 1.4mm (Mechanical Surface Detection)

Electronics: DAE4 Sn1333; Calibrated: 10/31/2014

Phantom: SAM Sub ; Type: QD000P40CC; Serial: TP:1357

Measurement SW: DASY52, Version 52.8 (8); SEMCAD X Version 14.6.10 (7331)

**Mode: IEEE 802.11a, 5.8 GHz, 20 MHz Bandwidth,
Body SAR, Ch 157, 6 Mbps, Back Side, Antenna 2**

Area Scan (13x20x1): Measurement grid: dx=10mm, dy=10mm

Zoom Scan (7x7x7)/Cube 0: Measurement grid: dx=4mm, dy=4mm, dz=1.4mm; Graded Ratio = 1.4

Reference Value = 5.838 V/m; Power Drift = 0.01 dB

Peak SAR (extrapolated) = 0.767 W/kg

SAR(1 g) = 0.186 W/kg

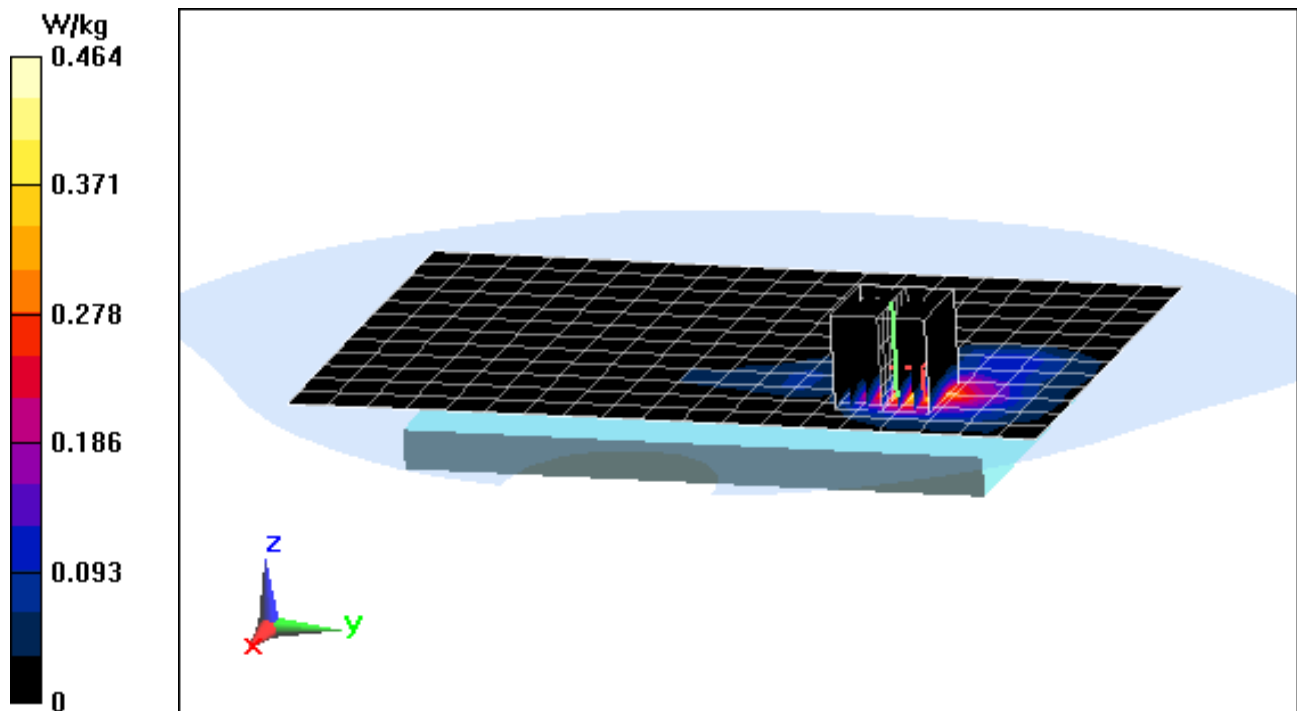

APPENDIX B: SYSTEM VERIFICATION

PCTEST ENGINEERING LABORATORY, INC.

DUT: Dipole 750 MHz; Type: D750V3; Serial: 1003

Communication System: UID 0, CW; Frequency: 750 MHz; Duty Cycle: 1:1

Medium: 750 Head Medium parameters used (interpolated):

$f = 750 \text{ MHz}$; $\sigma = 0.925 \text{ S/m}$; $\epsilon_r = 41.603$; $\rho = 1000 \text{ kg/m}^3$

Phantom section: Flat Section ; Space: 1.5 cm

Test Date: 04-08-2015; Ambient Temp: 21.3°C; Tissue Temp: 21.4°C

Probe: ES3DV2 - SN3022; ConvF(6.39, 6.39, 6.39); Calibrated: 8/19/2014;

Sensor-Surface: 3mm (Mechanical Surface Detection)

Electronics: DAE4 Sn1322; Calibrated: 8/12/2014

Phantom: SAM with CRP v4.0; Type: QD000P40CD; Serial: TP:1800

Measurement SW: DASY52, Version 52.8 (8); SEMCAD X Version 14.6.10 (7331)

750 MHz System Verification

Area Scan (7x15x1): Measurement grid: dx=15mm, dy=15mm

Zoom Scan (5x5x7)/Cube 0: Measurement grid: dx=8mm, dy=8mm, dz=5mm

Input Power = 20 dBm (100 mW)

Peak SAR (extrapolated) = 1.23 W/kg

SAR(1 g) = 0.827 W/kg

Deviation = 2.22%

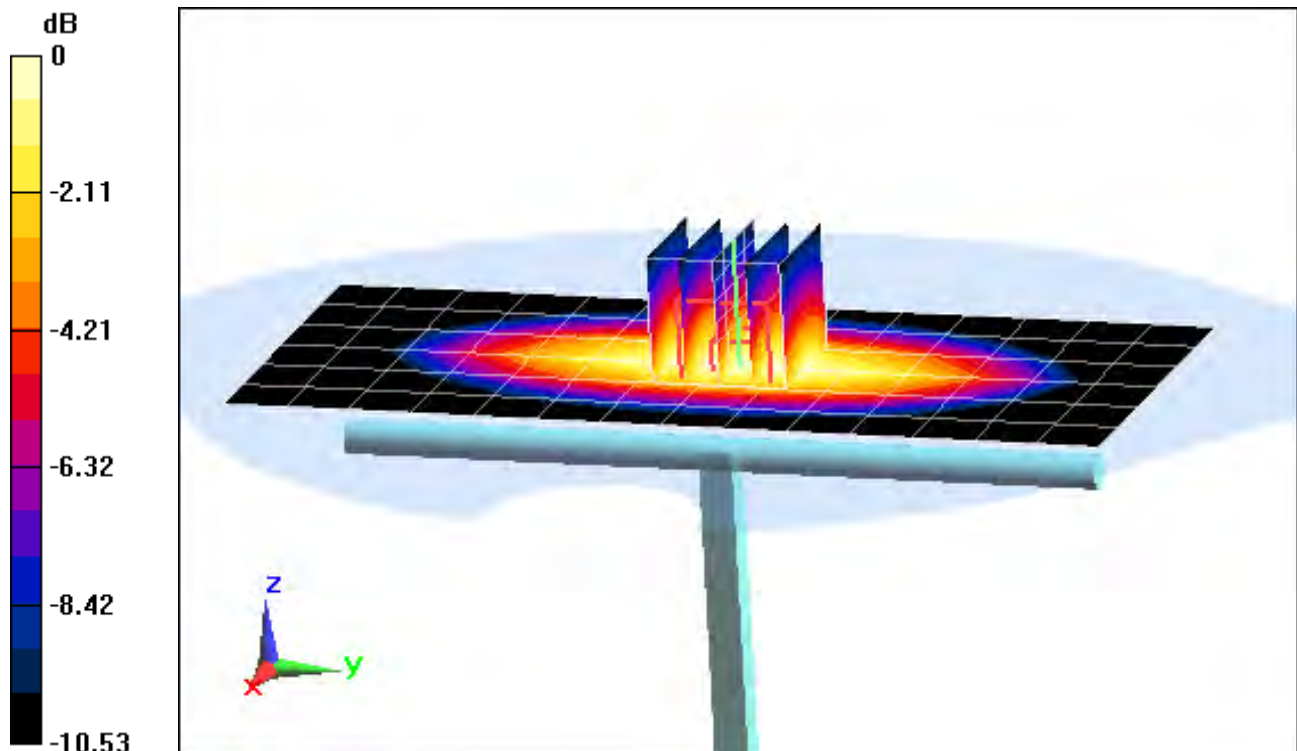

0 dB = 0.967 W/kg = -0.15 dBW/kg

PCTEST ENGINEERING LABORATORY, INC.

DUT: Dipole 835 MHz; Type: D835V2; Serial: 4d133

Communication System: UID 0, CW; Frequency: 835 MHz; Duty Cycle: 1:1

Medium: 835 Head Medium parameters used:

$f = 835 \text{ MHz}$; $\sigma = 0.936 \text{ S/m}$; $\epsilon_r = 43.008$; $\rho = 1000 \text{ kg/m}^3$

Phantom section: Flat Section ; Space: 1.5 cm

Test Date: 04-08-2015; Ambient Temp: 23.8°C; Tissue Temp: 22.0°C

Probe: ES3DV3 - SN3209; ConvF(6.04, 6.04, 6.04); Calibrated: 3/19/2015;

Sensor-Surface: 3mm (Mechanical Surface Detection)

Electronics: DAE4 Sn1334; Calibrated: 3/13/2015

Phantom: SAM v5.0 Left; Type: QD000P40CD; Serial: TP: 1687

Measurement SW: DASY52, Version 52.8 (8); SEMCAD X Version 14.6.10 (7331)

835 MHz System Verification

Area Scan (7x14x1): Measurement grid: dx=15mm, dy=15mm

Zoom Scan (5x5x7)/Cube 0: Measurement grid: dx=8mm, dy=8mm, dz=5mm

Input Power = 20 dBm (100 mW)

Peak SAR (extrapolated) = 1.43 W/kg

SAR(1 g) = 0.981 W/kg

Deviation = 6.63%

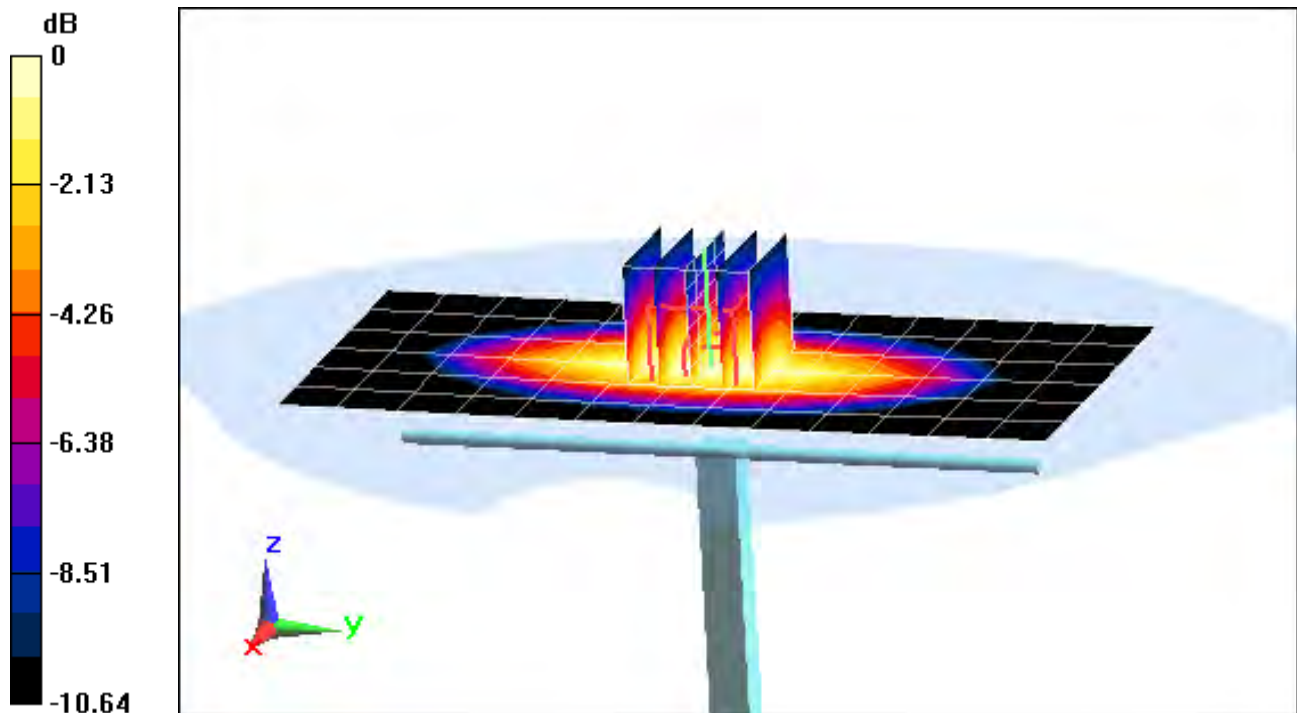

0 dB = 1.15 W/kg = 0.61 dBW/kg

PCTEST ENGINEERING LABORATORY, INC.

DUT: Dipole 1750 MHz; Type: D1765V2; Serial: 1051

Communication System: UID 0, CW; Frequency: 1750 MHz; Duty Cycle: 1:1

Medium: 1750 Head Medium parameters used:

$f = 1750 \text{ MHz}$; $\sigma = 1.326 \text{ S/m}$; $\epsilon_r = 39.028$; $\rho = 1000 \text{ kg/m}^3$

Phantom section: Flat Section ; Space: 1.0 cm

Test Date: 04-07-2015; Ambient Temp: 23.9°C; Tissue Temp: 23.2°C

Probe: ES3DV3 - SN3334; ConvF(5.21, 5.21, 5.21); Calibrated: 12/16/2014;

Sensor-Surface: 3mm (Mechanical Surface Detection)

Electronics: DAE4 Sn1415; Calibrated: 12/12/2014

Phantom: Sub Twin Sam v5.0; Type: QD000P40CD; Serial: TP:1626

Measurement SW: DASY52, Version 52.8 (8); SEMCAD X Version 14.6.10 (7331)

1750 MHz System Verification

Area Scan (7x9x1): Measurement grid: dx=15mm, dy=15mm

Zoom Scan (5x5x7)/Cube 0: Measurement grid: dx=8mm, dy=8mm, dz=5mm

Input Power = 20 dBm (100 mW)

Peak SAR (extrapolated) = 6.11 W/kg

SAR(1 g) = 3.47 W/kg

Deviation = -4.14%

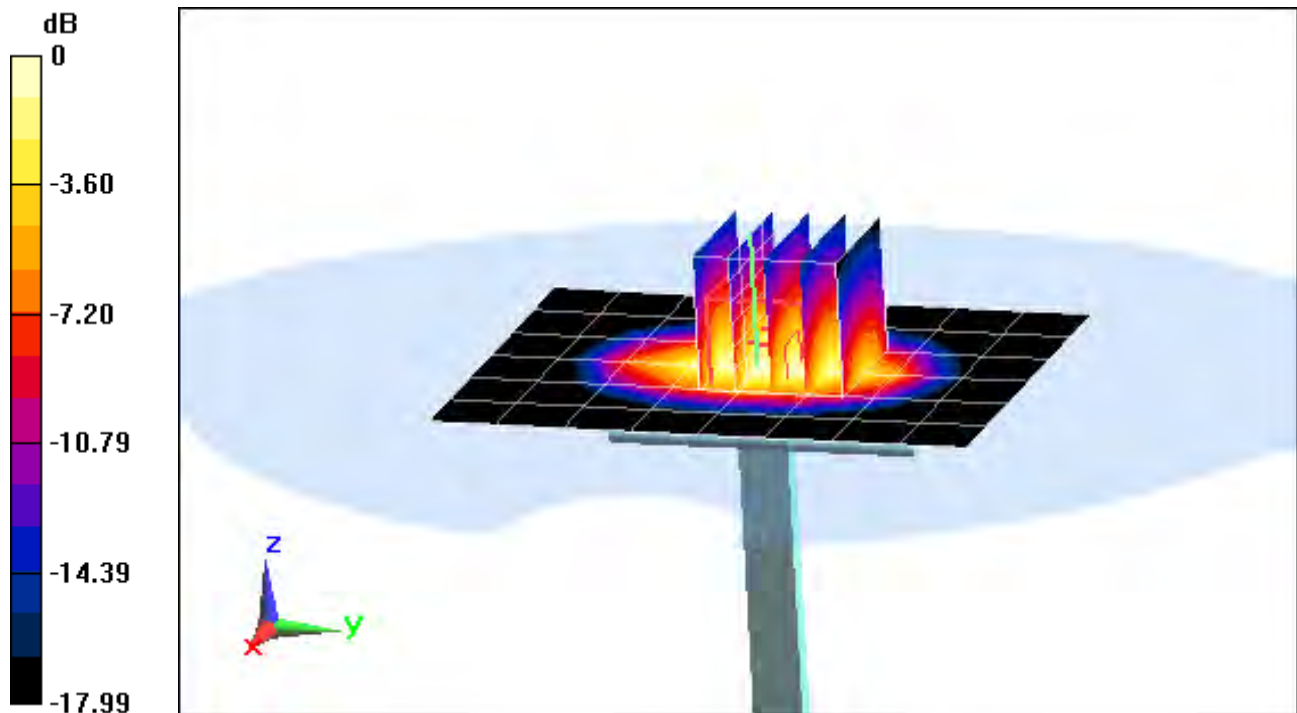

0 dB = 4.36 W/kg = 6.39 dBW/kg

PCTEST ENGINEERING LABORATORY, INC.

DUT: Dipole 1900 MHz; Type: D1900V2; Serial: 5d141

Communication System: UID 0, CW; Frequency: 1900 MHz; Duty Cycle: 1:1

Medium: 1900 Head Medium parameters used (interpolated):

$f = 1900 \text{ MHz}$; $\sigma = 1.447 \text{ S/m}$; $\epsilon_r = 40.154$; $\rho = 1000 \text{ kg/m}^3$

Phantom section: Flat Section ; Space: 1.0 cm

Test Date: 04-06-2015; Ambient Temp: 22.7°C; Tissue Temp: 21.4°C

Probe: ES3DV3 - SN3213; ConvF(5.06, 5.06, 5.06); Calibrated: 1/20/2015;

Sensor-Surface: 3mm (Mechanical Surface Detection)

Electronics: DAE4 Sn1407; Calibrated: 1/19/2015

Phantom: SAM Front; Type: SAM; Serial: 1686

Measurement SW: DASY52, Version 52.8 (8); SEMCAD X Version 14.6.10 (7331)

1900 MHz System Verification

Area Scan (7x10x1): Measurement grid: dx=15mm, dy=15mm

Zoom Scan (5x5x7)/Cube 0: Measurement grid: dx=8mm, dy=8mm, dz=5mm

Input Power = 20 dBm (100 mW)

Peak SAR (extrapolated) = 7.99 W/kg

SAR(1 g) = 4.32 W/kg

Deviation = 7.73%

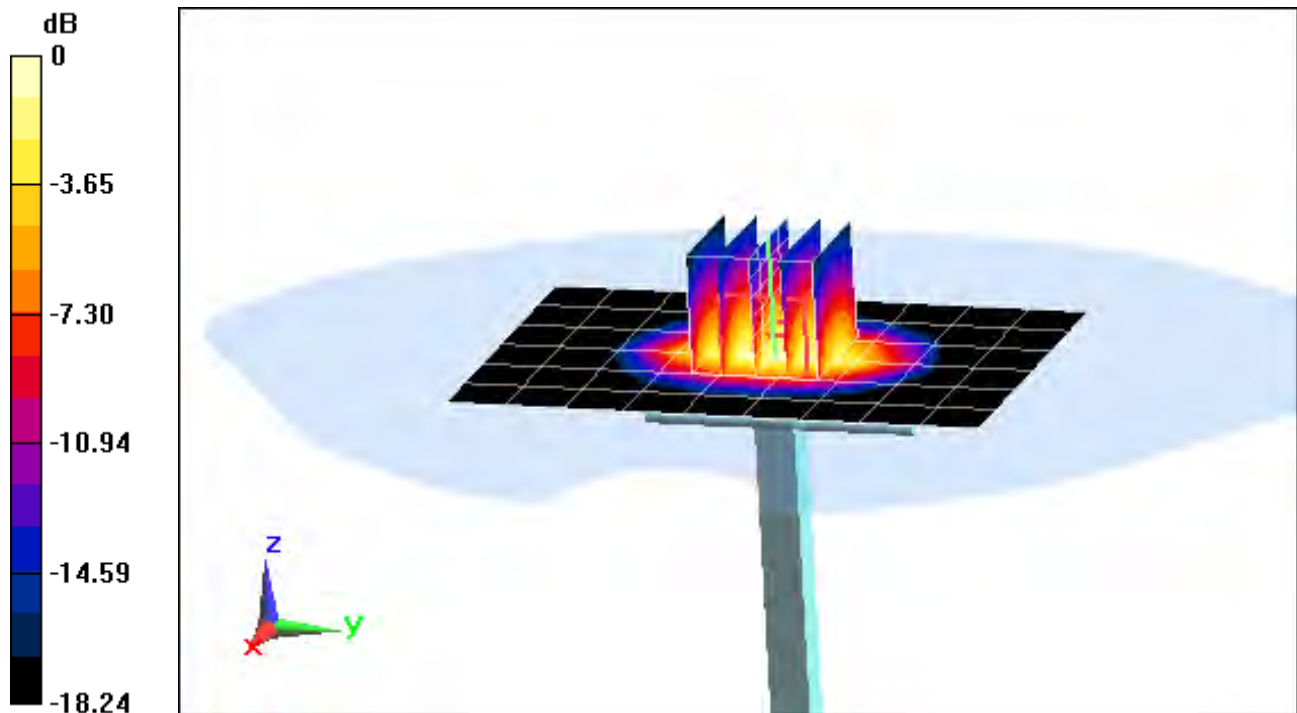

0 dB = 5.51 W/kg = 7.41 dBW/kg

PCTEST ENGINEERING LABORATORY, INC.

DUT: Dipole 2300 MHz; Type: D2300V2; Serial: 1008

Communication System: UID 0, CW; Frequency: 2300 MHz; Duty Cycle: 1:1

Medium: 2300 Head Medium parameters used:

$f = 2300 \text{ MHz}$; $\sigma = 1.672 \text{ S/m}$; $\epsilon_r = 40.966$; $\rho = 1000 \text{ kg/m}^3$

Phantom section: Flat Section ; Space: 1.0 cm

Test Date: 04-14-2015; Ambient Temp: 23.0°C; Tissue Temp: 24.0°C

Probe: ES3DV3 - SN3318; ConvF(4.78, 4.78, 4.78); Calibrated: 1/23/2015;

Sensor-Surface: 3mm (Mechanical Surface Detection)

Electronics: DAE4 Sn1272; Calibrated: 1/14/2015

Phantom: SAM Front; Type: SAM; Serial: 1686

Measurement SW: DASY52, Version 52.8 (8); SEMCAD X Version 14.6.10 (7331)

2300 MHz System Verification

Area Scan (8x9x1): Measurement grid: dx=12mm, dy=12mm

Zoom Scan (7x7x7)/Cube 0: Measurement grid: dx=5mm, dy=5mm, dz=5mm

Input Power = 20 dBm (100 mW)

Peak SAR (extrapolated) = 10.6 W/kg

SAR(1 g) = 5.24 W/kg

Deviation = 5.01%

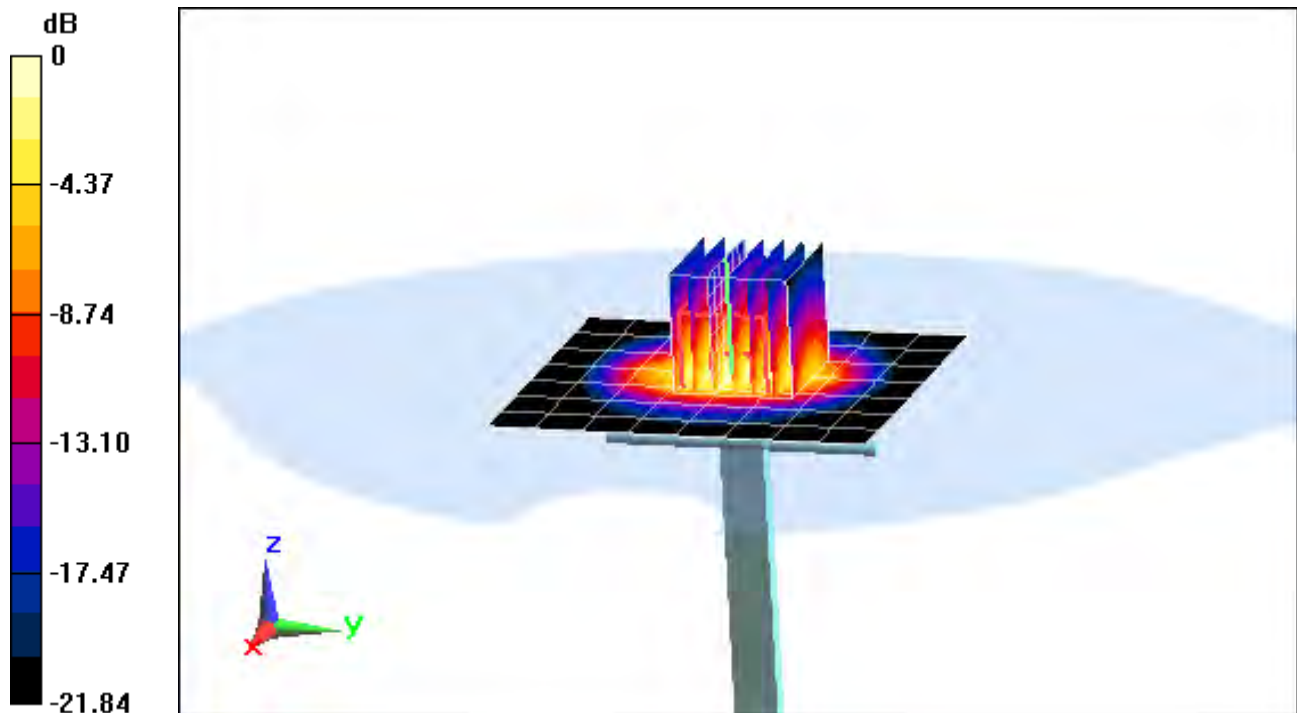

0 dB = 6.88 W/kg = 8.38 dBW/kg

PCTEST ENGINEERING LABORATORY, INC.

DUT: Dipole 2450 MHz; Type: D2450V2; Serial: 719

Communication System: UID 0, CW; Frequency: 2450 MHz; Duty Cycle: 1:1

Medium: 2450 Head Medium parameters used:

$f = 2450 \text{ MHz}$; $\sigma = 1.877 \text{ S/m}$; $\epsilon_r = 38.786$; $\rho = 1000 \text{ kg/m}^3$

Phantom section: Flat Section ; Space: 1.0 cm

Test Date: 04-06-2015; Ambient Temp: 23.2°C; Tissue Temp: 22.1°C

Probe: ES3DV3 - SN3332; ConvF(4.49, 4.49, 4.49); Calibrated: 9/18/2014;

Sensor-Surface: 3mm (Mechanical Surface Detection)

Electronics: DAE4 Sn1323; Calibrated: 9/17/2014

Phantom: SAM V5.0 Right; Type: QD000P40CD; Serial: 1647

Measurement SW: DASY52, Version 52.8 (8); SEMCAD X Version 14.6.10 (7331)

2450 MHz System Verification

Area Scan (8x9x1): Measurement grid: dx=12mm, dy=12mm

Zoom Scan (7x7x7)/Cube 0: Measurement grid: dx=5mm, dy=5mm, dz=5mm

Input Power = 20 dBm (100 mW)

Peak SAR (extrapolated) = 11.6 W/kg

SAR(1 g) = 5.40 W/kg

Deviation = 3.65%

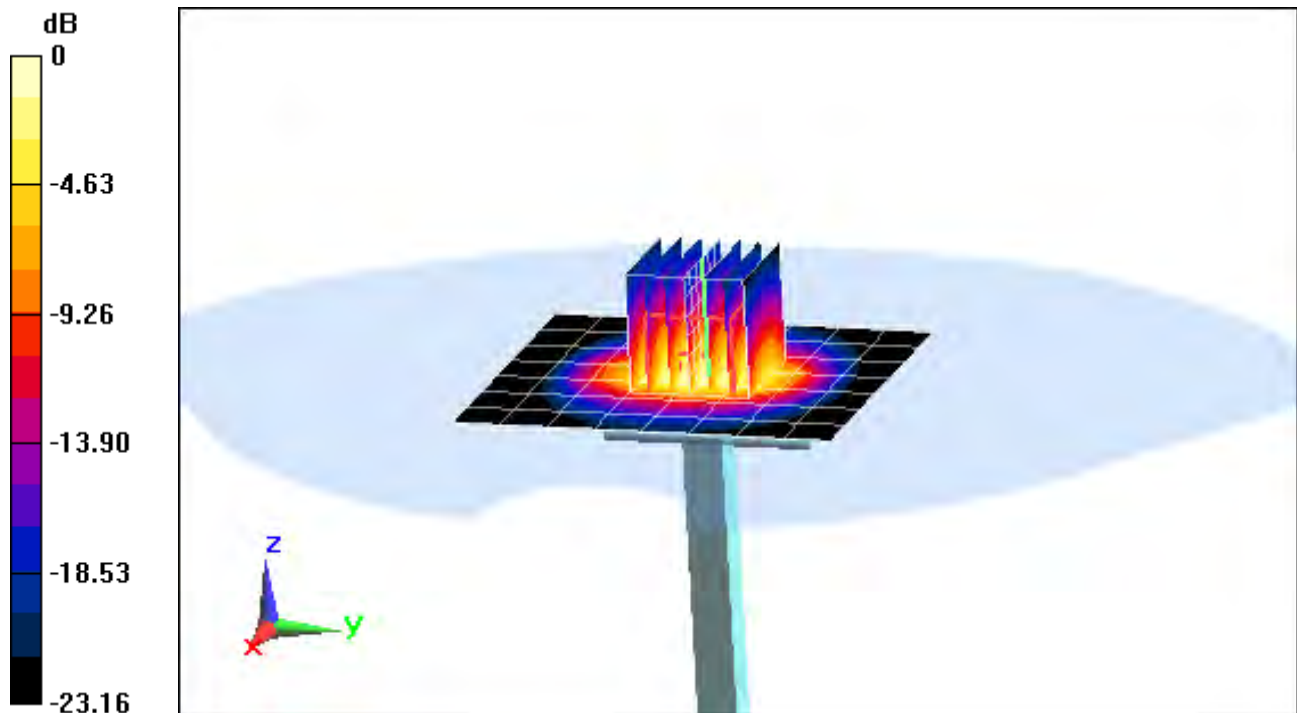

0 dB = 7.15 W/kg = 8.54 dBW/kg

PCTEST ENGINEERING LABORATORY, INC.

DUT: Dipole 5300 MHz; Type: D5GHzV2; Serial: 1191

Communication System: UID 0, CW; Frequency: 5300 MHz; Duty Cycle: 1:1

Medium: 5GHz Head Medium parameters used:

$f = 5300 \text{ MHz}$; $\sigma = 4.834 \text{ S/m}$; $\epsilon_r = 36.168$; $\rho = 1000 \text{ kg/m}^3$

Phantom section: Flat Section ; Space: 1.0 cm

Test Date: 04-08-2015; Ambient Temp: 22.8°C; Tissue Temp: 23.0°C

Probe: EX3DV4 - SN3914; ConvF(5.06, 5.06, 5.06); Calibrated: 2/10/2015;

Sensor-Surface: 1.4mm (Mechanical Surface Detection)

Electronics: DAE4 Sn1333; Calibrated: 10/31/2014

Phantom: SAM Main ; Type: QD000P40CC; Serial: TP 1114

Measurement SW: DASY52, Version 52.8 (8); SEMCAD X Version 14.6.10 (7331)

5300 MHz System Verification

Area Scan (7x8x1): Measurement grid: dx=10mm, dy=10mm

Zoom Scan (8x8x7)/Cube 0: Measurement grid: dx=4mm, dy=4mm, dz=1.4mm; Graded Ratio = 1.4

Input Power = 17 dBm (50 mW)

Peak SAR (extrapolated) = 19.2 W/kg

SAR(1 g) = 4.22 W/kg

Deviation = -1.63%

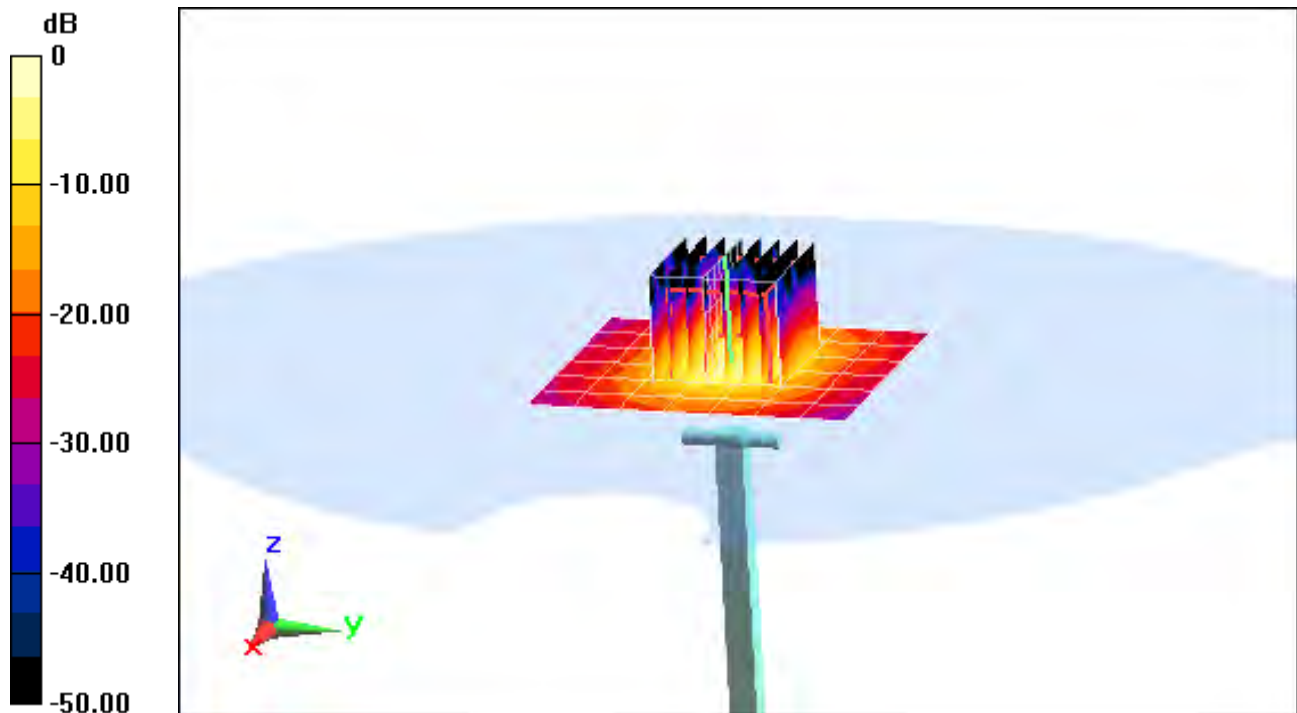

0 dB = 10.1 W/kg = 10.04 dBW/kg

PCTEST ENGINEERING LABORATORY, INC.

DUT: Dipole 5500 MHz; Type: D5GHzV2; Serial: 1191

Communication System: UID 0, CW; Frequency: 5500 MHz; Duty Cycle: 1:1

Medium: 5GHz Head Medium parameters used:

$f = 5500 \text{ MHz}$; $\sigma = 5.048 \text{ S/m}$; $\epsilon_r = 35.593$; $\rho = 1000 \text{ kg/m}^3$

Phantom section: Flat Section ; Space: 1.0 cm

Test Date: 04-08-2015; Ambient Temp: 22.8°C; Tissue Temp: 23.0°C

Probe: EX3DV4 - SN3914; ConvF(4.92, 4.92, 4.92); Calibrated: 2/10/2015;

Sensor-Surface: 1.4mm (Mechanical Surface Detection)

Electronics: DAE4 Sn1333; Calibrated: 10/31/2014

Phantom: SAM Main ; Type: QD000P40CC; Serial: TP 1114

Measurement SW: DASY52, Version 52.8 (8); SEMCAD X Version 14.6.10 (7331)

5500 MHz System Verification

Area Scan (7x7x1): Measurement grid: dx=10mm, dy=10mm

Zoom Scan (8x8x7)/Cube 0: Measurement grid: dx=4mm, dy=4mm, dz=1.4mm; Graded Ratio = 1.4

Input Power = 17 dBm (50 mW)

Peak SAR (extrapolated) = 20.1 W/kg

SAR(1 g) = 4.19 W/kg

Deviation = -5.42%

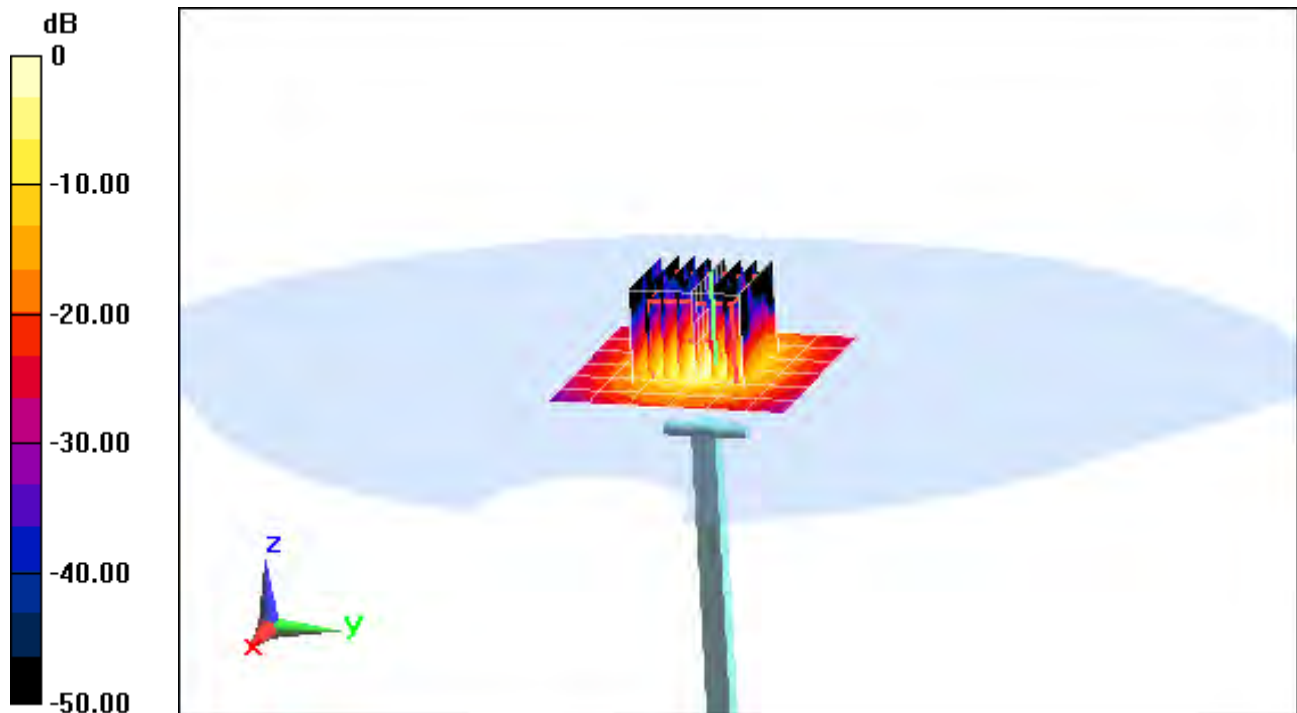

PCTEST ENGINEERING LABORATORY, INC.

DUT: Dipole 5800 MHz; Type: D5GHzV2; Serial: 1191

Communication System: UID 0, CW; Frequency: 5800 MHz; Duty Cycle: 1:1

Medium: 5GHz Head Medium parameters used:

$f = 5800 \text{ MHz}$; $\sigma = 5.46 \text{ S/m}$; $\epsilon_r = 34.752$; $\rho = 1000 \text{ kg/m}^3$

Phantom section: Flat Section ; Space: 1.0 cm

Test Date: 04-08-2015; Ambient Temp: 22.8°C; Tissue Temp: 23.0°C

Probe: EX3DV4 - SN3914; ConvF(4.67, 4.67, 4.67); Calibrated: 2/10/2015;

Sensor-Surface: 1.4mm (Mechanical Surface Detection)

Electronics: DAE4 Sn1333; Calibrated: 10/31/2014

Phantom: SAM Main ; Type: QD000P40CC; Serial: TP 1114

Measurement SW: DASY52, Version 52.8 (8); SEMCAD X Version 14.6.10 (7331)

5800 MHz System Verification

Area Scan (7x7x1): Measurement grid: dx=10mm, dy=10mm

Zoom Scan (8x8x7)/Cube 0: Measurement grid: dx=4mm, dy=4mm, dz=1.4mm; Graded Ratio = 1.4

Input Power = 17 dBm (50 mW)

Peak SAR (extrapolated) = 21.3 W/kg

SAR(1 g) = 4.13 W/kg

Deviation = 0.36%



0 dB = 10.5 W/kg = 10.21 dBW/kg

PCTEST ENGINEERING LABORATORY, INC.

DUT: Dipole 750 MHz; Type: D750V3; Serial: 1003

Communication System: UID 0, CW; Frequency: 750 MHz; Duty Cycle: 1:1

Medium: 750 Body Medium parameters used (interpolated):

$f = 750 \text{ MHz}$; $\sigma = 0.992 \text{ S/m}$; $\epsilon_r = 56.243$; $\rho = 1000 \text{ kg/m}^3$

Phantom section: Flat Section ; Space: 1.5 cm

Test Date: 04-08-2015; Ambient Temp: 21.3°C; Tissue Temp: 21.4°C

Probe: ES3DV2 - SN3022; ConvF(6.02, 6.02, 6.02); Calibrated: 8/19/2014;

Sensor-Surface: 3mm (Mechanical Surface Detection)

Electronics: DAE4 Sn1322; Calibrated: 8/12/2014

Phantom: ELI v5.0; Type: QDOVA001BB; Serial: 1226

Measurement SW: DASY52, Version 52.8 (8); SEMCAD X Version 14.6.10 (7331)

750 MHz System Verification

Area Scan (7x15x1): Measurement grid: dx=15mm, dy=15mm

Zoom Scan (5x5x7)/Cube 0: Measurement grid: dx=8mm, dy=8mm, dz=5mm

Input Power = 20 dBm (100 mW)

Peak SAR (extrapolated) = 1.30 W/kg

SAR(1 g) = 0.893 W/kg

Deviation = 5.56%

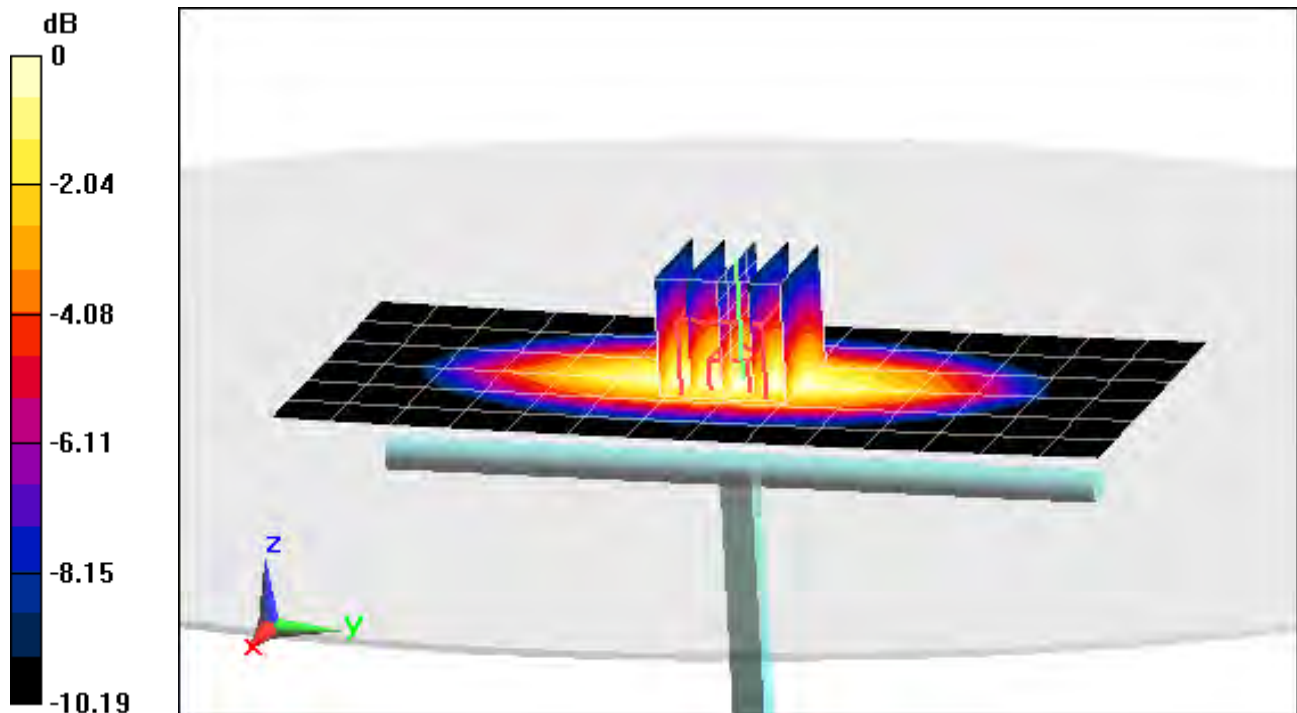

0 dB = 1.02 W/kg = 0.09 dBW/kg

PCTEST ENGINEERING LABORATORY, INC.

DUT: Dipole 835 MHz; Type: D835V2; Serial: 4d133

Communication System: UID 0, CW; Frequency: 835 MHz; Duty Cycle: 1:1

Medium: 835 Body Medium parameters used:

$f = 835 \text{ MHz}$; $\sigma = 1.007 \text{ S/m}$; $\epsilon_r = 54.573$; $\rho = 1000 \text{ kg/m}^3$

Phantom section: Flat Section ; Space: 1.5 cm

Test Date: 04-06-2015; Ambient Temp: 22.5°C; Tissue Temp: 21.8°C

Probe: ES3DV3 - SN3288; ConvF(6.32, 6.32, 6.32); Calibrated: 9/24/2014;

Sensor-Surface: 3mm (Mechanical Surface Detection)

Electronics: DAE4 Sn1364; Calibrated: 9/18/2014

Phantom: ELI v5.0; Type: QDOVA001BB; Serial: 1229

Measurement SW: DASY52, Version 52.8 (8); SEMCAD X Version 14.6.10 (7331)

835 MHz System Verification

Area Scan (7x14x1): Measurement grid: dx=15mm, dy=15mm

Zoom Scan (5x5x7)/Cube 0: Measurement grid: dx=8mm, dy=8mm, dz=5mm

Input Power = 20 dBm (100 mW)

Peak SAR (extrapolated) = 1.42 W/kg

SAR(1 g) = 0.957 W/kg

Deviation = 2.35%

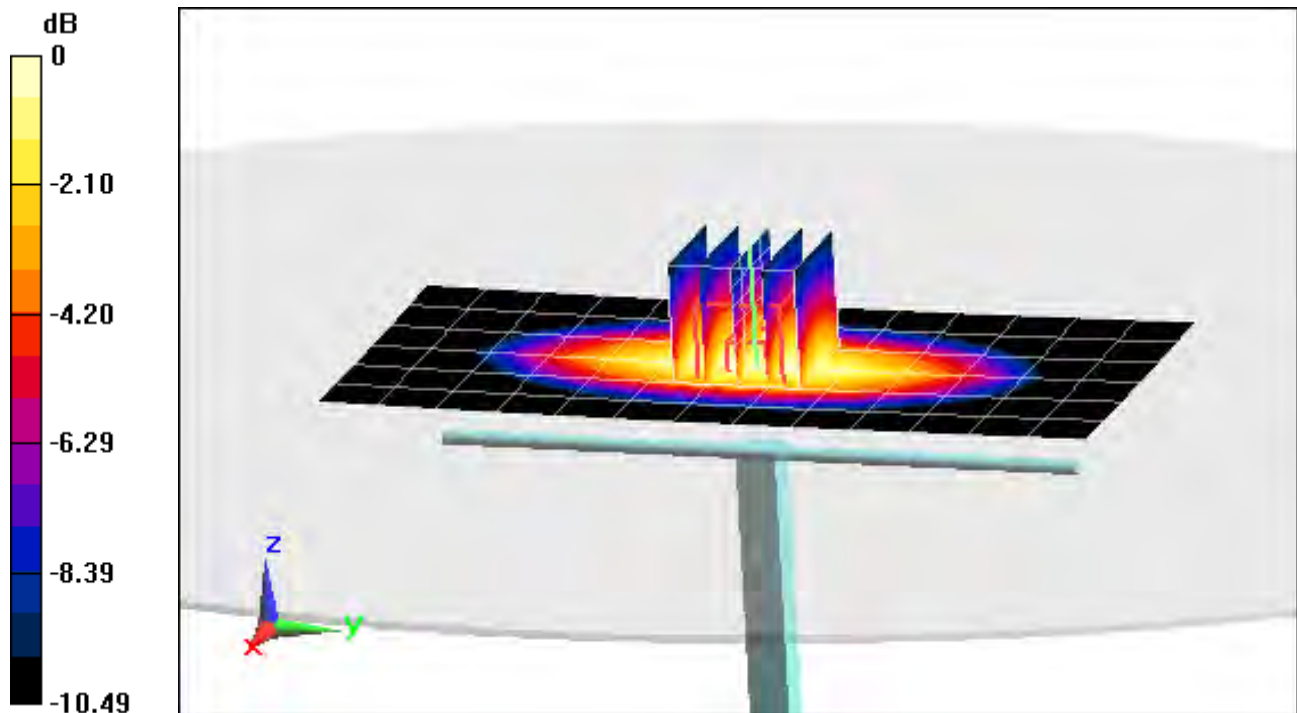

0 dB = 1.12 W/kg = 0.49 dBW/kg

PCTEST ENGINEERING LABORATORY, INC.

DUT: Dipole 835 MHz; Type: D835V2; Serial: 4d133

Communication System: UID 0, CW; Frequency: 835 MHz; Duty Cycle: 1:1

Medium: 835 Body Medium parameters used:

$f = 835 \text{ MHz}$; $\sigma = 0.996 \text{ S/m}$; $\epsilon_r = 53.694$; $\rho = 1000 \text{ kg/m}^3$

Phantom section: Flat Section ; Space: 1.5 cm

Test Date: 04-20-2015; Ambient Temp: 22.5°C; Tissue Temp: 22.0°C

Probe: ES3DV3 - SN3209; ConvF(6.07, 6.07, 6.07); Calibrated: 3/19/2015;

Sensor-Surface: 3mm (Mechanical Surface Detection)

Electronics: DAE4 Sn1334; Calibrated: 3/13/2015

Phantom: SAM v5.0 front; Type: QD000P40CD; Serial: TP-1646

Measurement SW: DASY52, Version 52.8 (8); SEMCAD X Version 14.6.10 (7331)

835 MHz System Verification

Area Scan (7x14x1): Measurement grid: dx=15mm, dy=15mm

Zoom Scan (5x5x7)/Cube 0: Measurement grid: dx=8mm, dy=8mm, dz=5mm

Input Power = 20 dBm (100 mW)

Peak SAR (extrapolated) = 1.51 W/kg

SAR(1 g) = 1.02 W/kg

Deviation = 9.09%

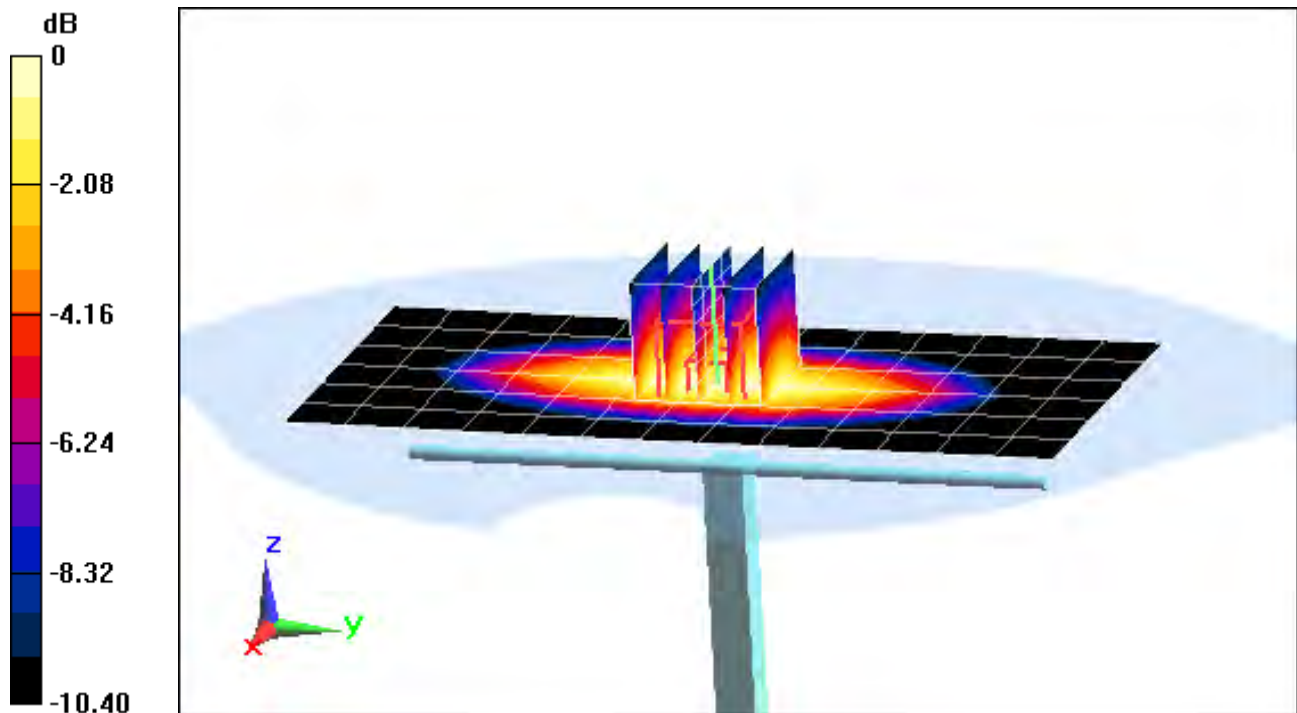

0 dB = 1.19 W/kg = 0.76 dBW/kg

PCTEST ENGINEERING LABORATORY, INC.

DUT: Dipole 1750 MHz; Type: D1765V2; Serial: 1008

Communication System: UID 0, CW; Frequency: 1750 MHz; Duty Cycle: 1:1

Medium: 1750 Body Medium parameters used:

$f = 1750 \text{ MHz}$; $\sigma = 1.481 \text{ S/m}$; $\epsilon_r = 52.546$; $\rho = 1000 \text{ kg/m}^3$

Phantom section: Flat Section ; Space: 1.0 cm

Test Date: 04-09-2015; Ambient Temp: 23.8°C; Tissue Temp: 22.0°C

Probe: ES3DV3 - SN3333; ConvF(4.89, 4.89, 4.89); Calibrated: 10/24/2014;

Sensor-Surface: 3mm (Mechanical Surface Detection)

Electronics: DAE4 Sn1408; Calibrated: 10/23/2014

Phantom: Main TWIN SAM; Type: QD000P40CC; Serial: TP-1406

Measurement SW: DASY52, Version 52.8 (8); SEMCAD X Version 14.6.10 (7331)

1750 MHz System Verification

Area Scan (7x9x1): Measurement grid: dx=15mm, dy=15mm

Zoom Scan (5x5x7)/Cube 0: Measurement grid: dx=8mm, dy=8mm, dz=5mm

Input Power = 20 dBm (100 mW)

Peak SAR (extrapolated) = 6.85 W/kg

SAR(1 g) = 3.95 W/kg

Deviation = 5.05%

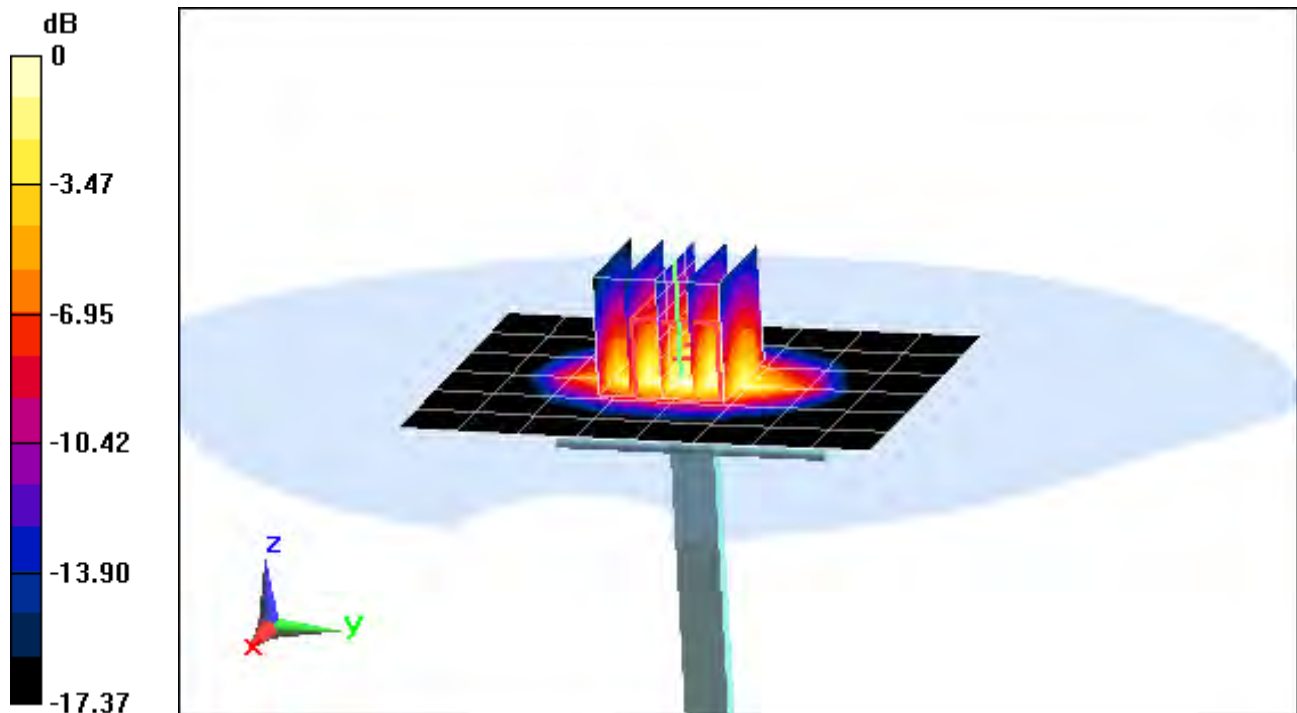

0 dB = 5.02 W/kg = 7.01 dBW/kg

PCTEST ENGINEERING LABORATORY, INC.

DUT: Dipole 1900 MHz; Type: D1900V2; Serial: 5d141

Communication System: UID 0, CW; Frequency: 1900 MHz; Duty Cycle: 1:1

Medium: 1900 Body Medium parameters used (interpolated):

$f = 1900$ MHz; $\sigma = 1.581$ S/m; $\epsilon_r = 53.276$; $\rho = 1000$ kg/m³

Phantom section: Flat Section ; Space: 1.0 cm

Test Date: 04-06-2015; Ambient Temp: 20.5°C; Tissue Temp: 21.0°C

Probe: ES3DV2 - SN3022; ConvF(4.49, 4.49, 4.49); Calibrated: 8/19/2014;

Sensor-Surface: 3mm (Mechanical Surface Detection)

Electronics: DAE4 Sn1322; Calibrated: 8/12/2014

Phantom: ELI v5.0; Type: QDOVA001BB; Serial: 1226

Measurement SW: DASY52, Version 52.8 (8); SEMCAD X Version 14.6.10 (7331)

1900 MHz System Verification

Area Scan (7x10x1): Measurement grid: dx=15mm, dy=15mm

Zoom Scan (5x5x7)/Cube 0: Measurement grid: dx=8mm, dy=8mm, dz=5mm

Input Power = 20 dBm (100 mW)

Peak SAR (extrapolated) = 7.31 W/kg

SAR(1 g) = 4.19 W/kg

Deviation = 3.20%

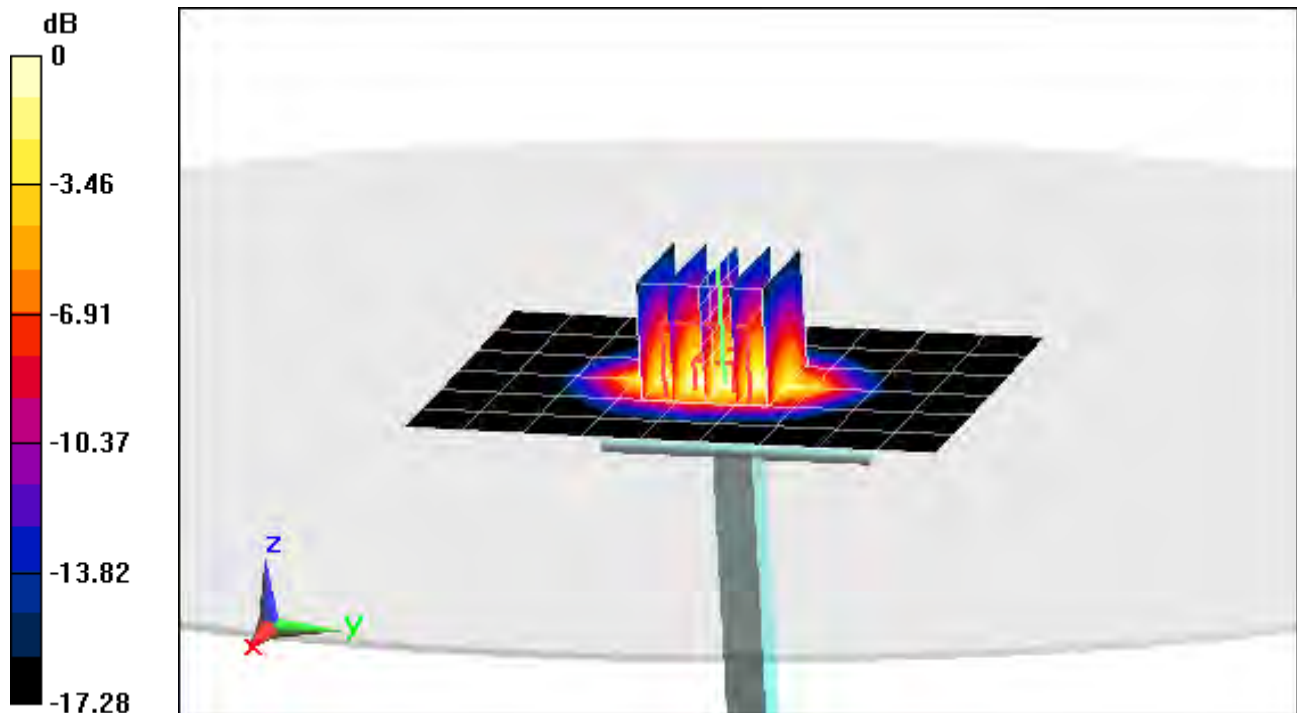

0 dB = 5.30 W/kg = 7.24 dBW/kg

PCTEST ENGINEERING LABORATORY, INC.

DUT: Dipole 1900 MHz; Type: D1900V2; Serial: 5d141

Communication System: UID 0, CW; Frequency: 1900 MHz; Duty Cycle: 1:1

Medium: 1900 Body Medium parameters used (interpolated):

$f = 1900 \text{ MHz}$; $\sigma = 1.581 \text{ S/m}$; $\epsilon_r = 52.482$; $\rho = 1000 \text{ kg/m}^3$

Phantom section: Flat Section ; Space: 1.0 cm

Test Date: 05-04-2015; Ambient Temp: 22.4°C; Tissue Temp: 22.4°C

Probe: ES3DV2 - SN3022; ConvF(4.49, 4.49, 4.49); Calibrated: 8/19/2014;

Sensor-Surface: 3mm (Mechanical Surface Detection)

Electronics: DAE4 Sn1322; Calibrated: 8/12/2014

Phantom: ELI v5.0; Type: QDOVA001BB; Serial: 1226

Measurement SW: DASY52, Version 52.8 (7); SEMCAD X Version 14.6.10 (7331)

1900 MHz System Verification

Area Scan (7x10x1): Measurement grid: dx=15mm, dy=15mm

Zoom Scan (5x5x7)/Cube 0: Measurement grid: dx=8mm, dy=8mm, dz=5mm

Input Power = 20 dBm (100 mW)

Peak SAR (extrapolated) = 7.04 W/kg

SAR(1 g) = 4.03 W/kg

Deviation = -0.74%

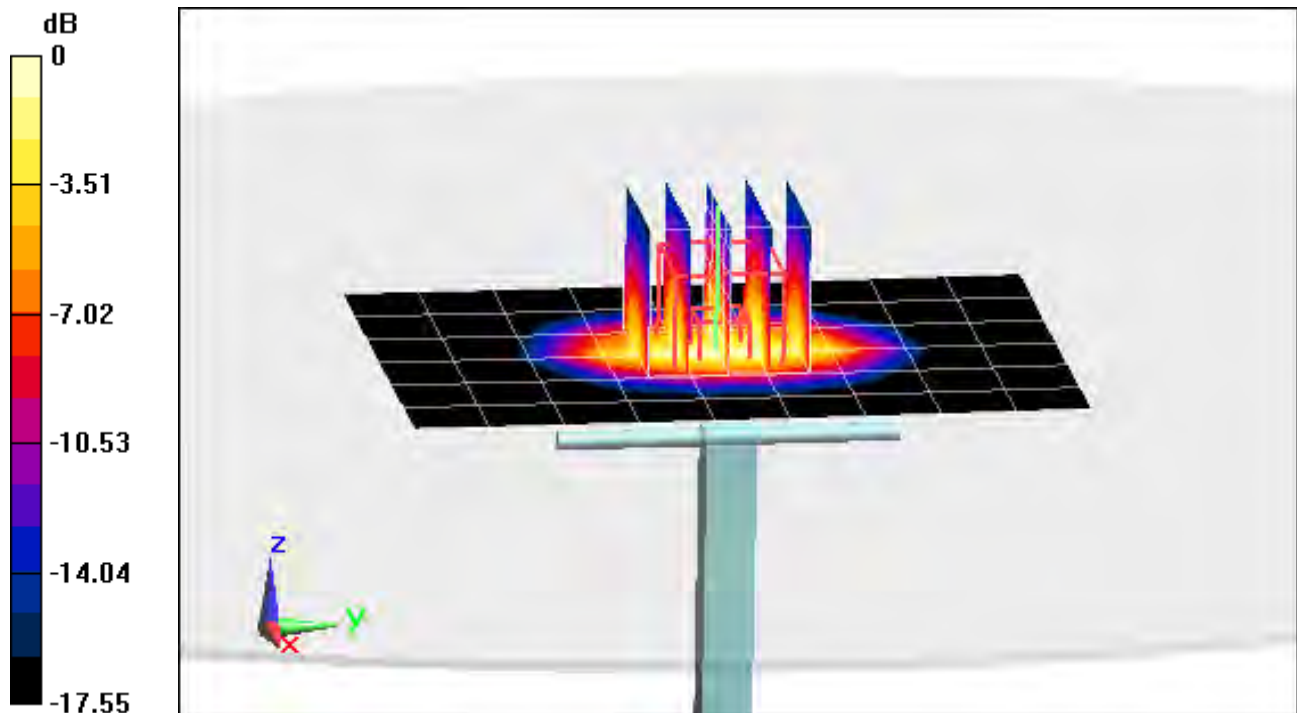

0 dB = 5.08 W/kg = 7.06 dBW/kg

PCTEST ENGINEERING LABORATORY, INC.

DUT: Dipole 2300 MHz; Type: D2300V2; Serial: 1008

Communication System: UID 0, CW; Frequency: 2300 MHz; Duty Cycle: 1:1

Medium: 2300 Body Medium parameters used:

$f = 2300 \text{ MHz}$; $\sigma = 1.752 \text{ S/m}$; $\epsilon_r = 52.878$; $\rho = 1000 \text{ kg/m}^3$

Phantom section: Flat Section ; Space: 1.0 cm

Test Date: 04-09-2015; Ambient Temp: 24.4°C; Tissue Temp: 23.5°C

Probe: ES3DV3 - SN3318; ConvF(4.52, 4.52, 4.52); Calibrated: 1/23/2015;

Sensor-Surface: 3mm (Mechanical Surface Detection)

Electronics: DAE4 Sn1272; Calibrated: 1/14/2015

Phantom: ELI v6.0; Type: QDOVA003AA; Serial: TP:2027

Measurement SW: DASY52, Version 52.8 (8); SEMCAD X Version 14.6.10 (7331)

2300 MHz System Verification

Area Scan (8x9x1): Measurement grid: dx=12mm, dy=12mm

Zoom Scan (7x7x7)/Cube 0: Measurement grid: dx=5mm, dy=5mm, dz=5mm

Input Power = 20 dBm (100 mW)

Peak SAR (extrapolated) = 9.37 W/kg

SAR(1 g) = 4.75 W/kg

Deviation = -1.25%

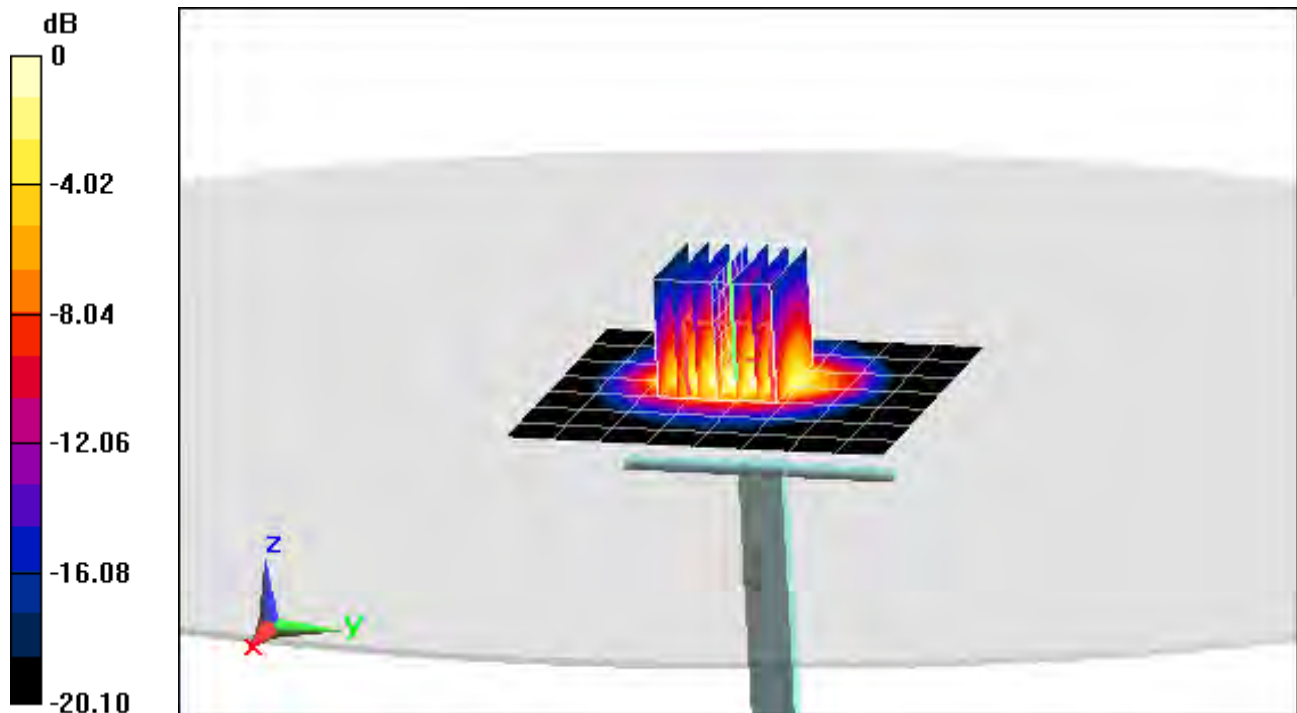

0 dB = 6.15 W/kg = 7.89 dBW/kg

PCTEST ENGINEERING LABORATORY, INC.

DUT: Dipole 2450 MHz; Type: D2450V2; Serial: 719

Communication System: UID 0, CW; Frequency: 2450 MHz; Duty Cycle: 1:1

Medium: 2450 Body Medium parameters used:

$f = 2450 \text{ MHz}$; $\sigma = 1.938 \text{ S/m}$; $\epsilon_r = 52.335$; $\rho = 1000 \text{ kg/m}^3$

Phantom section: Flat Section ; Space: 1.0 cm

Test Date: 04-09-2015; Ambient Temp: 22.3°C; Tissue Temp: 22.2°C

Probe: ES3DV3 - SN3318; ConvF(4.37, 4.37, 4.37); Calibrated: 1/23/2015;

Sensor-Surface: 3mm (Mechanical Surface Detection)

Electronics: DAE4 Sn1272; Calibrated: 1/14/2015

Phantom: ELI v6.0; Type: QDOVA003AA; Serial: TP:2027

Measurement SW: DASY52, Version 52.8 (8); SEMCAD X Version 14.6.10 (7331)

2450 MHz System Verification

Area Scan (8x9x1): Measurement grid: dx=12mm, dy=12mm

Zoom Scan (8x7x7)/Cube 0: Measurement grid: dx=5mm, dy=5mm, dz=5mm

Input Power = 20 dBm (100 mW)

Peak SAR (extrapolated) = 11.4 W/kg

SAR(1 g) = 5.41 W/kg

Deviation = 4.44%

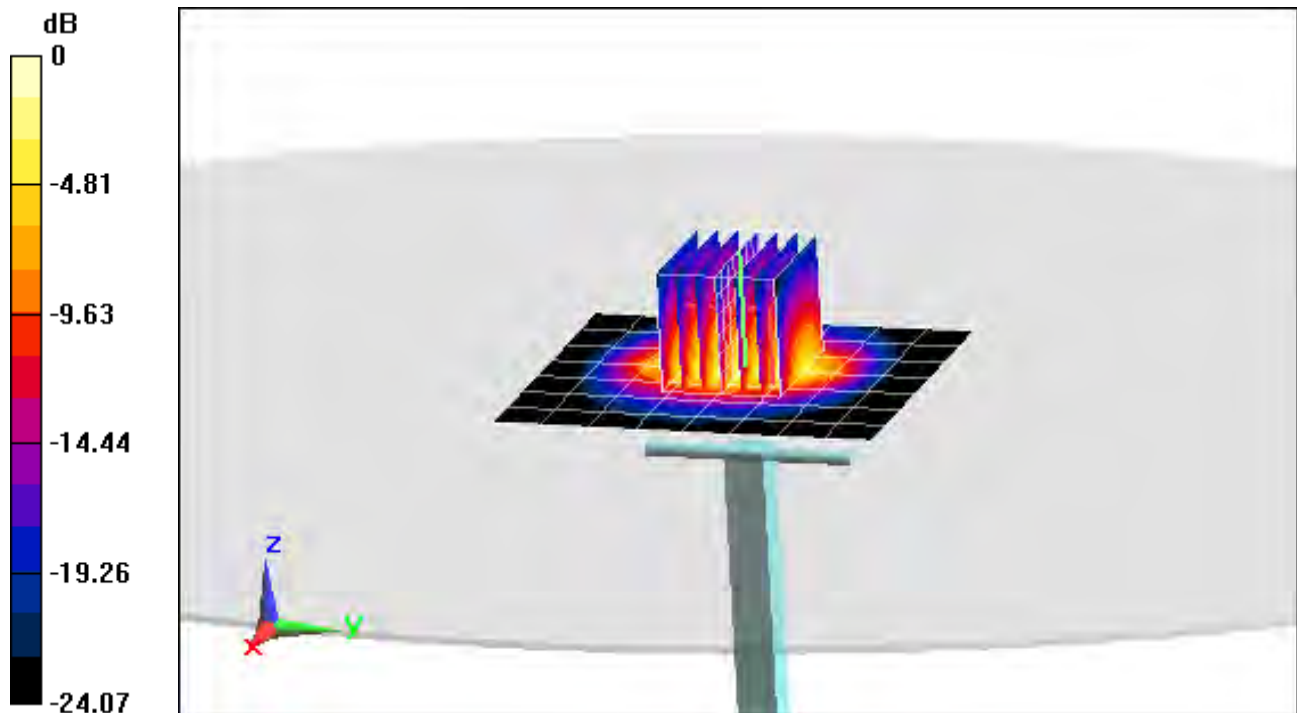

0 dB = 7.12 W/kg = 8.52 dBW/kg

PCTEST ENGINEERING LABORATORY, INC.

DUT: SAR Dipole 5300 MHz; Type: D5GHzV2; Serial: 1191

Communication System: UID 0, CW; Frequency: 5300 MHz; Duty Cycle: 1:1

Medium: 5GHz Body Medium parameters used:

$f = 5300 \text{ MHz}$; $\sigma = 5.496 \text{ S/m}$; $\epsilon_r = 46.663$; $\rho = 1000 \text{ kg/m}^3$

Phantom section: Flat Section ; Space: 1.0 cm

Test Date: 04-06-2015; Ambient Temp: 23.5°C; Tissue Temp: 22.1°C

Probe: EX3DV4 - SN3914; ConvF(4.33, 4.33, 4.33); Calibrated: 2/10/2015;

Sensor-Surface: 1.4mm (Mechanical Surface Detection)

Electronics: DAE4 Sn1333; Calibrated: 10/31/2014

Phantom: SAM Sub ; Type: QD000P40CC; Serial: TP:1357

Measurement SW: DASY52, Version 52.8 (8); SEMCAD X Version 14.6.10 (7331)

5300 MHz System Verification

Area Scan (7x8x1): Measurement grid: dx=10mm, dy=10mm

Zoom Scan (9x8x7)/Cube 0: Measurement grid: dx=4mm, dy=4mm, dz=1.4mm; Graded Ratio = 1.4

Input Power = 17 dBm (50 mW)

Peak SAR (extrapolated) = 18.1 W/kg

SAR(1 g) = 4.18 W/kg

Deviation = 4.63%

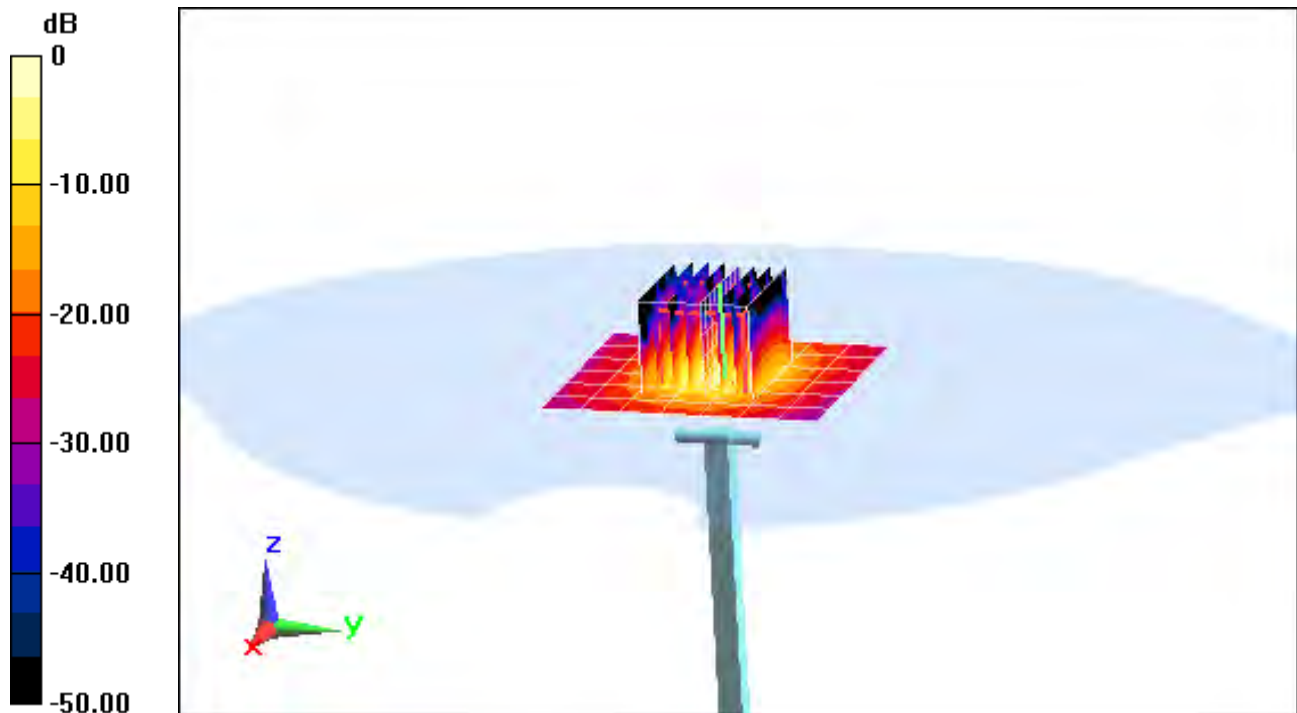

0 dB = 10.4 W/kg = 10.17 dBW/kg

PCTEST ENGINEERING LABORATORY, INC.

DUT: SAR Dipole 5800 MHz; Type: D5GHzV2; Serial: 1191

Communication System: UID 0, CW; Frequency: 5800 MHz; Duty Cycle: 1:1

Medium: 5GHz Body Medium parameters used:

$f = 5800 \text{ MHz}$; $\sigma = 6.135 \text{ S/m}$; $\epsilon_r = 45.874$; $\rho = 1000 \text{ kg/m}^3$

Phantom section: Flat Section ; Space: 1.0 cm

Test Date: 04-06-2015; Ambient Temp: 23.5°C; Tissue Temp: 22.1°C

Probe: EX3DV4 - SN3914; ConvF(4.01, 4.01, 4.01); Calibrated: 2/10/2015;

Sensor-Surface: 1.4mm (Mechanical Surface Detection)

Electronics: DAE4 Sn1333; Calibrated: 10/31/2014

Phantom: SAM Sub ; Type: QD000P40CC; Serial: TP:1357

Measurement SW: DASY52, Version 52.8 (8); SEMCAD X Version 14.6.10 (7331)

5800 MHz System Verification

Area Scan (7x7x1): Measurement grid: dx=10mm, dy=10mm

Zoom Scan (8x8x7)/Cube 0: Measurement grid: dx=4mm, dy=4mm, dz=1.4mm; Graded Ratio = 1.4

Input Power = 17 dBm (50 mW)

Peak SAR (extrapolated) = 17.7 W/kg

SAR(1 g) = 4.03 W/kg

Deviation = 3.33%

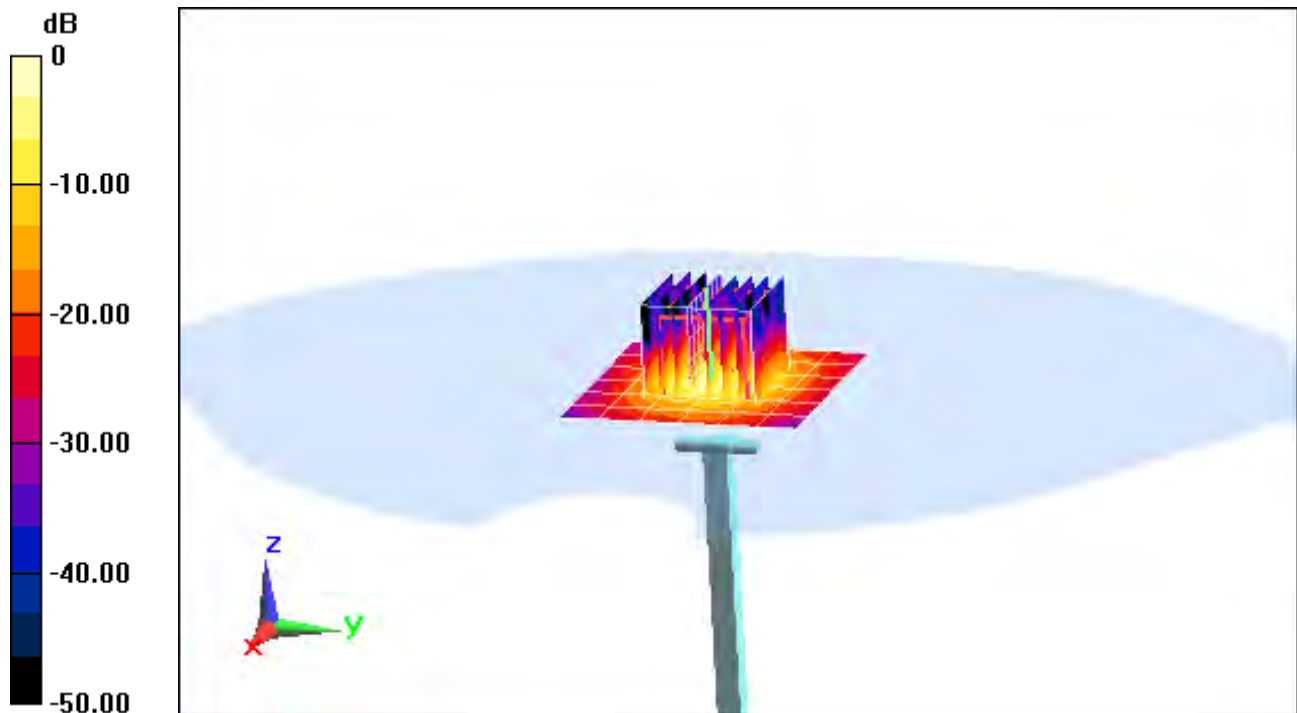

0 dB = 10.1 W/kg = 10.04 dBW/kg

APPENDIX C: PROBE CALIBRATION



Accreditation No.: SCS 0108

Accredited by the Swiss Accreditation Service (SAS)
The Swiss Accreditation Service is one of the signatories to the EA
Multilateral Agreement for the recognition of calibration certificates

Certificate No: D750V3-1003_Jan15

Client **PC Test**

CALIBRATION CERTIFICATE

Object D750V3 - SN: 1003

Calibration procedure(s) QA CAL-05.v9
Calibration procedure for dipole validation kits above 700 MHz

CC
2/3/15

Calibration date: January 16, 2015

This calibration certificate documents the traceability to national standards, which realize the physical units of measurements (SI).
The measurements and the uncertainties with confidence probability are given on the following pages and are part of the certificate.

All calibrations have been conducted in the closed laboratory facility: environment temperature (22 ± 3)°C and humidity < 70%.

Calibration Equipment used (M&TE critical for calibration)

Primary Standards	ID #	Cal Date (Certificate No.)	Scheduled Calibration
Power meter EPM-442A	GB37480704	07-Oct-14 (No. 217-02020)	Oct-15
Power sensor HP 8481A	US37292783	07-Oct-14 (No. 217-02020)	Oct-15
Power sensor HP 8481A	MY41092317	07-Oct-14 (No. 217-02021)	Oct-15
Reference 20 dB Attenuator	SN: 5058 (20k)	03-Apr-14 (No. 217-01918)	Apr-15
Type-N mismatch combination	SN: 5047.2 / 06327	03-Apr-14 (No. 217-01921)	Apr-15
Reference Probe ES3DV3	SN: 3205	30-Dec-14 (No. ES3-3205_Dec14)	Dec-15
DAE4	SN: 601	18-Aug-14 (No. DAE4-601_Aug14)	Aug-15
Secondary Standards	ID #	Check Date (in house)	Scheduled Check
RF generator R&S SMT-06	100005	04-Aug-99 (in house check Oct-13)	In house check: Oct-16
Network Analyzer HP 8753E	US37390585 S4206	18-Oct-01 (in house check Oct-14)	In house check: Oct-15

Calibrated by: Name Michael Weber Function Laboratory Technician

Signature

Approved by: Katja Pokovic Technical Manager

Issued: January 19, 2015

This calibration certificate shall not be reproduced except in full without written approval of the laboratory.



Accredited by the Swiss Accreditation Service (SAS)

The Swiss Accreditation Service is one of the signatories to the EA Multilateral Agreement for the recognition of calibration certificates

Glossary:

TSL	tissue simulating liquid
ConvF	sensitivity in TSL / NORM x,y,z
N/A	not applicable or not measured

Calibration is Performed According to the Following Standards:

- IEEE Std 1528-2013, "IEEE Recommended Practice for Determining the Peak Spatial-Averaged Specific Absorption Rate (SAR) in the Human Head from Wireless Communications Devices: Measurement Techniques", June 2013
- IEC 62209-1, "Procedure to measure the Specific Absorption Rate (SAR) for hand-held devices used in close proximity to the ear (frequency range of 300 MHz to 3 GHz)", February 2005
- KDB 865664, "SAR Measurement Requirements for 100 MHz to 6 GHz"

Additional Documentation:

- DASY4/5 System Handbook

Methods Applied and Interpretation of Parameters:

- Measurement Conditions:** Further details are available from the Validation Report at the end of the certificate. All figures stated in the certificate are valid at the frequency indicated.
- Antenna Parameters with TSL:** The dipole is mounted with the spacer to position its feed point exactly below the center marking of the flat phantom section, with the arms oriented parallel to the body axis.
- Feed Point Impedance and Return Loss:** These parameters are measured with the dipole positioned under the liquid filled phantom. The impedance stated is transformed from the measurement at the SMA connector to the feed point. The Return Loss ensures low reflected power. No uncertainty required.
- Electrical Delay:** One-way delay between the SMA connector and the antenna feed point. No uncertainty required.
- SAR measured:** SAR measured at the stated antenna input power.
- SAR normalized:** SAR as measured, normalized to an input power of 1 W at the antenna connector.
- SAR for nominal TSL parameters:** The measured TSL parameters are used to calculate the nominal SAR result.

The reported uncertainty of measurement is stated as the standard uncertainty of measurement multiplied by the coverage factor $k=2$, which for a normal distribution corresponds to a coverage probability of approximately 95%.

Measurement Conditions

DASY system configuration, as far as not given on page 1.

DASY Version	DASY5	V52.8.8
Extrapolation	Advanced Extrapolation	
Phantom	Modular Flat Phantom	
Distance Dipole Center - TSL	15 mm	with Spacer
Zoom Scan Resolution	dx, dy, dz = 5 mm	
Frequency	750 MHz \pm 1 MHz	

Head TSL parameters

The following parameters and calculations were applied.

	Temperature	Permittivity	Conductivity
Nominal Head TSL parameters	22.0 °C	41.9	0.89 mho/m
Measured Head TSL parameters	(22.0 \pm 0.2) °C	41.7 \pm 6 %	0.91 mho/m \pm 6 %
Head TSL temperature change during test	< 0.5 °C	----	----

SAR result with Head TSL

SAR averaged over 1 cm³ (1 g) of Head TSL	Condition	
SAR measured	250 mW input power	2.06 W/kg
SAR for nominal Head TSL parameters	normalized to 1W	8.09 W/kg \pm 17.0 % (k=2)

SAR averaged over 10 cm³ (10 g) of Head TSL	condition	
SAR measured	250 mW input power	1.35 W/kg
SAR for nominal Head TSL parameters	normalized to 1W	5.32 W/kg \pm 16.5 % (k=2)

Body TSL parameters

The following parameters and calculations were applied.

	Temperature	Permittivity	Conductivity
Nominal Body TSL parameters	22.0 °C	55.5	0.96 mho/m
Measured Body TSL parameters	(22.0 \pm 0.2) °C	56.0 \pm 6 %	0.99 mho/m \pm 6 %
Body TSL temperature change during test	< 0.5 °C	----	----

SAR result with Body TSL

SAR averaged over 1 cm³ (1 g) of Body TSL	Condition	
SAR measured	250 mW input power	2.16 W/kg
SAR for nominal Body TSL parameters	normalized to 1W	8.46 W/kg \pm 17.0 % (k=2)

SAR averaged over 10 cm³ (10 g) of Body TSL	condition	
SAR measured	250 mW input power	1.42 W/kg
SAR for nominal Body TSL parameters	normalized to 1W	5.58 W/kg \pm 16.5 % (k=2)

Appendix (Additional assessments outside the scope of SCS0108)

Antenna Parameters with Head TSL

Impedance, transformed to feed point	53.7 Ω - 1.4 j Ω
Return Loss	- 28.5 dB

Antenna Parameters with Body TSL

Impedance, transformed to feed point	48.3 Ω - 3.8 j Ω
Return Loss	- 27.5 dB

General Antenna Parameters and Design

Electrical Delay (one direction)	1.043 ns
----------------------------------	----------

After long term use with 100W radiated power, only a slight warming of the dipole near the feedpoint can be measured.

The dipole is made of standard semirigid coaxial cable. The center conductor of the feeding line is directly connected to the second arm of the dipole. The antenna is therefore short-circuited for DC-signals. On some of the dipoles, small end caps are added to the dipole arms in order to improve matching when loaded according to the position as explained in the "Measurement Conditions" paragraph. The SAR data are not affected by this change. The overall dipole length is still according to the Standard.

No excessive force must be applied to the dipole arms, because they might bend or the soldered connections near the feedpoint may be damaged.

Additional EUT Data

Manufactured by	SPEAG
Manufactured on	January 21, 2009

DASY5 Validation Report for Head TSL

Date: 16.01.2015

Test Laboratory: SPEAG, Zurich, Switzerland

DUT: Dipole 750 MHz; Type: D750V3; Serial: D750V3 - SN: 1003

Communication System: UID 0 - CW; Frequency: 750 MHz

Medium parameters used: $f = 750 \text{ MHz}$; $\sigma = 0.91 \text{ S/m}$; $\epsilon_r = 41.7$; $\rho = 1000 \text{ kg/m}^3$

Phantom section: Flat Section

Measurement Standard: DASY5 (IEEE/IEC/ANSI C63.19-2011)

DASY52 Configuration:

- Probe: ES3DV3 - SN3205; ConvF(6.44, 6.44, 6.44); Calibrated: 30.12.2014;
- Sensor-Surface: 3mm (Mechanical Surface Detection)
- Electronics: DAE4 Sn601; Calibrated: 18.08.2014
- Phantom: Flat Phantom 4.9L; Type: QD000P49AA; Serial: 1001
- DASY52 52.8.8(1222); SEMCAD X 14.6.10(7331)

Dipole Calibration for Head Tissue/Pin=250 mW, d=15mm/Zoom Scan (7x7x7)/Cube 0:

Measurement grid: $dx=5\text{mm}$, $dy=5\text{mm}$, $dz=5\text{mm}$

Reference Value = 53.08 V/m; Power Drift = 0.00 dB

Peak SAR (extrapolated) = 3.05 W/kg

SAR(1 g) = 2.06 W/kg; SAR(10 g) = 1.35 W/kg

Maximum value of SAR (measured) = 2.41 W/kg

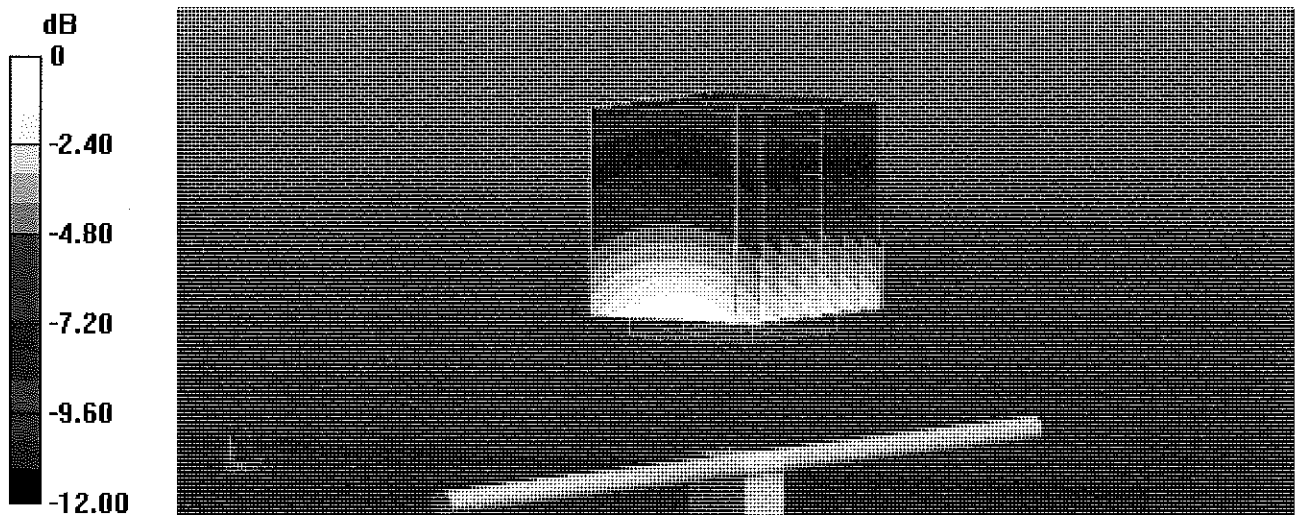

0 dB = 2.41 W/kg = 3.82 dBW/kg

Impedance Measurement Plot for Head TSL

16 Jan 2015 16:07:22
 [CH1] S11 1 U FS 1: 53.666 Ω -1.3730 Δ 154.55 pF 750.000 000 MHz

*
 Del
 CA
 Avg
 16
 H1d

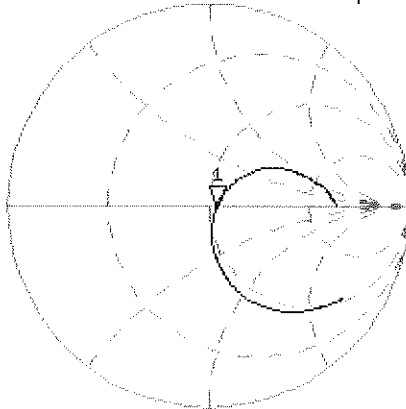

CH2 S11 LOG 5 dB/REF -20 dB 1:-28.456 dB 750.000 000 MHz

CA
 Avg
 16
 H1d

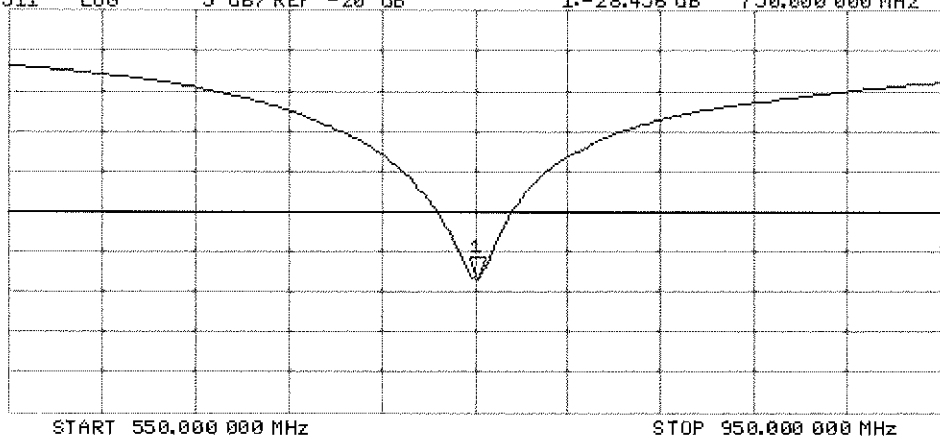

DASY5 Validation Report for Body TSL

Date: 16.01.2015

Test Laboratory: SPEAG, Zurich, Switzerland

DUT: Dipole 750 MHz; Type: D750V3; Serial: D750V3 - SN: 1003

Communication System: UID 0 - CW; Frequency: 750 MHz

Medium parameters used: $f = 750$ MHz; $\sigma = 0.99$ S/m; $\epsilon_r = 56$; $\rho = 1000$ kg/m³

Phantom section: Flat Section

Measurement Standard: DASY5 (IEEE/IEC/ANSI C63.19-2011)

DASY52 Configuration:

- Probe: ES3DV3 - SN3205; ConvF(6.21, 6.21, 6.21); Calibrated: 30.12.2014;
- Sensor-Surface: 3mm (Mechanical Surface Detection)
- Electronics: DAE4 Sn601; Calibrated: 18.08.2014
- Phantom: Flat Phantom 4.9L; Type: QD000P49AA; Serial: 1001
- DASY52 52.8.8(1222); SEMCAD X 14.6.10(7331)

Dipole Calibration for Body Tissue/Pin=250 mW, d=15mm/Zoom Scan (7x7x7)/Cube 0:

Measurement grid: dx=5mm, dy=5mm, dz=5mm

Reference Value = 52.21 V/m; Power Drift = -0.00 dB

Peak SAR (extrapolated) = 3.16 W/kg

SAR(1 g) = 2.16 W/kg; SAR(10 g) = 1.42 W/kg

Maximum value of SAR (measured) = 2.52 W/kg

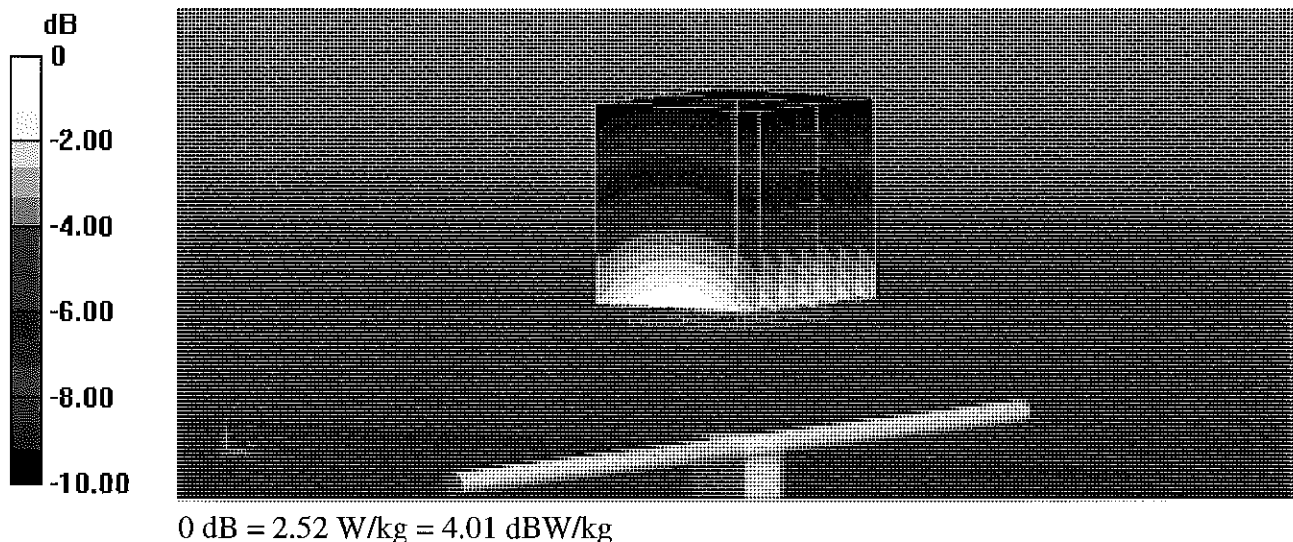

Impedance Measurement Plot for Body TSL

16 Jan 2015 13:37:35

[CH1] S11 1 U FS 1: 48.268 Ω -3.7676 Ω 56.324 μ F 750.000 000 MHz

*
De1
CA

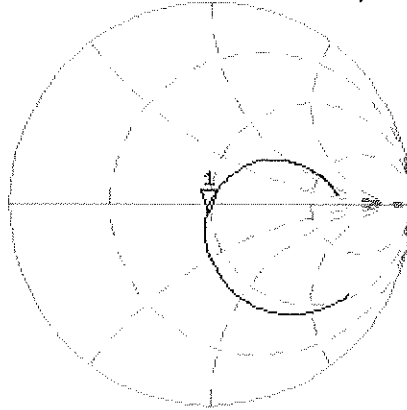

Avg
16

H1d

CH2 S11 LOG 5 dB/REF -20 dB 1:-27.498 dB 750.000 000 MHz

CA

Avg
16

H1d

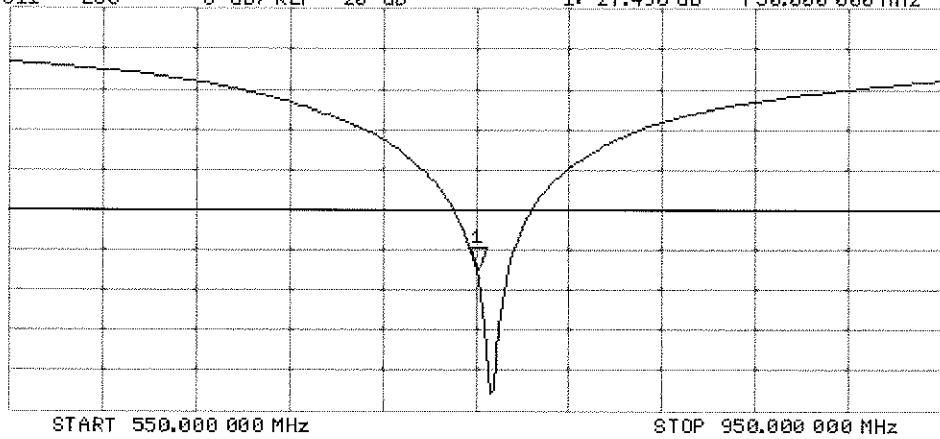

**Calibration Laboratory of
Schmid & Partner
Engineering AG**
Zeughausstrasse 43, 8004 Zurich, Switzerland



S Schweizerischer Kalibrierdienst
S Service suisse d'étalonnage
C Servizio svizzero di taratura
S Swiss Calibration Service

Accredited by the Swiss Accreditation Service (SAS)
The Swiss Accreditation Service is one of the signatories to the EA
Multilateral Agreement for the recognition of calibration certificates

Accreditation No.: **SCS 108**

Client **PC Test**

Certificate No: **D835V2-4d133_Jul14**

CALIBRATION CERTIFICATE

Object **D835V2 - SN: 4d133**

Calibration procedure(s) **QA CAL-05.v9
Calibration procedure for dipole validation kits above 700 MHz**

CC
W/G/M

Calibration date: **July 24, 2014**

This calibration certificate documents the traceability to national standards, which realize the physical units of measurements (SI).
The measurements and the uncertainties with confidence probability are given on the following pages and are part of the certificate.

All calibrations have been conducted in the closed laboratory facility: environment temperature (22 ± 3)°C and humidity < 70%.

Calibration Equipment used (M&TE critical for calibration)

Primary Standards	ID #	Cal Date (Certificate No.)	Scheduled Calibration
Power meter EPM-442A	GB37480704	09-Oct-13 (No. 217-01827)	Oct-14
Power sensor HP 8481A	US37292783	09-Oct-13 (No. 217-01827)	Oct-14
Power sensor HP 8481A	MY41092317	09-Oct-13 (No. 217-01828)	Oct-14
Reference 20 dB Attenuator	SN: 5058 (20k)	03-Apr-14 (No. 217-01918)	Apr-15
Type-N mismatch combination	SN: 5047.2 / 06327	03-Apr-14 (No. 217-01921)	Apr-15
Reference Probe ES3DV3	SN: 3205	30-Dec-13 (No. ES3-3205_Dec13)	Dec-14
DAE4	SN: 601	30-Apr-14 (No. DAE4-601_Apr14)	Apr-15

Secondary Standards	ID #	Check Date (in house)	Scheduled Check
RF generator R&S SMT-06	100005	04-Aug-99 (in house check Oct-13)	In house check: Oct-16
Network Analyzer HP 8763E	US37390585 S4206	18-Oct-01 (in house check Oct-13)	In house check: Oct-14

Calibrated by: **Jeton Kastrali** (Name), **Laboratory Technician** (Function), *[Signature]* (Signature)

Approved by: **Katja Pokovic** (Name), **Technical Manager** (Function), *[Signature]* (Signature)

Issued: July 24, 2014

This calibration certificate shall not be reproduced except in full without written approval of the laboratory.

**Calibration Laboratory of
Schmid & Partner
Engineering AG**
Zeughausstrasse 43, 8004 Zurich, Switzerland



S Schweizerischer Kalibrierdienst
C Service suisse d'étalonnage
S Servizio svizzero di taratura
S Swiss Calibration Service

Accredited by the Swiss Accreditation Service (SAS)
The Swiss Accreditation Service is one of the signatories to the EA
Multilateral Agreement for the recognition of calibration certificates

Accreditation No.: **SCS 108**

Glossary:

TSL	tissue simulating liquid
ConvF	sensitivity in TSL / NORM x,y,z
N/A	not applicable or not measured

Calibration is Performed According to the Following Standards:

- IEEE Std 1528-2013, "IEEE Recommended Practice for Determining the Peak Spatial-Averaged Specific Absorption Rate (SAR) in the Human Head from Wireless Communications Devices: Measurement Techniques", June 2013
- IEC 62209-1, "Procedure to measure the Specific Absorption Rate (SAR) for hand-held devices used in close proximity to the ear (frequency range of 300 MHz to 3 GHz)", February 2005
- KDB 865664, "SAR Measurement Requirements for 100 MHz to 6 GHz"

Additional Documentation:

- DASY4/5 System Handbook

Methods Applied and Interpretation of Parameters:

- Measurement Conditions:* Further details are available from the Validation Report at the end of the certificate. All figures stated in the certificate are valid at the frequency indicated.
- Antenna Parameters with TSL:* The dipole is mounted with the spacer to position its feed point exactly below the center marking of the flat phantom section, with the arms oriented parallel to the body axis.
- Feed Point Impedance and Return Loss:* These parameters are measured with the dipole positioned under the liquid filled phantom. The impedance stated is transformed from the measurement at the SMA connector to the feed point. The Return Loss ensures low reflected power. No uncertainty required.
- Electrical Delay:* One-way delay between the SMA connector and the antenna feed point. No uncertainty required.
- SAR measured:* SAR measured at the stated antenna input power.
- SAR normalized:* SAR as measured, normalized to an input power of 1 W at the antenna connector.
- SAR for nominal TSL parameters:* The measured TSL parameters are used to calculate the nominal SAR result.

The reported uncertainty of measurement is stated as the standard uncertainty of measurement multiplied by the coverage factor $k=2$, which for a normal distribution corresponds to a coverage probability of approximately 95%.

Measurement Conditions

DASY system configuration, as far as not given on page 1.

DASY Version	DASY5	V52.8.8
Extrapolation	Advanced Extrapolation	
Phantom	Modular Flat Phantom	
Distance Dipole Center - TSL	15 mm	with Spacer
Zoom Scan Resolution	dx, dy, dz = 5 mm	
Frequency	835 MHz ± 1 MHz	

Head TSL parameters

The following parameters and calculations were applied.

	Temperature	Permittivity	Conductivity
Nominal Head TSL parameters	22.0 °C	41.5	0.90 mho/m
Measured Head TSL parameters	(22.0 ± 0.2) °C	41.1 ± 6 %	0.94 mho/m ± 6 %
Head TSL temperature change during test	< 0.5 °C	----	----

SAR result with Head TSL

SAR averaged over 1 cm ³ (1 g) of Head TSL	Condition	
SAR measured	250 mW input power	2.38 W/kg
SAR for nominal Head TSL parameters	normalized to 1W	9.20 W/kg ± 17.0 % (k=2)

SAR averaged over 10 cm ³ (10 g) of Head TSL	condition	
SAR measured	250 mW input power	1.53 W/kg
SAR for nominal Head TSL parameters	normalized to 1W	5.96 W/kg ± 16.5 % (k=2)

Body TSL parameters

The following parameters and calculations were applied.

	Temperature	Permittivity	Conductivity
Nominal Body TSL parameters	22.0 °C	55.2	0.97 mho/m
Measured Body TSL parameters	(22.0 ± 0.2) °C	53.8 ± 6 %	1.02 mho/m ± 6 %
Body TSL temperature change during test	< 0.5 °C	----	----

SAR result with Body TSL

SAR averaged over 1 cm ³ (1 g) of Body TSL	Condition	
SAR measured	250 mW input power	2.44 W/kg
SAR for nominal Body TSL parameters	normalized to 1W	9.35 W/kg ± 17.0 % (k=2)

SAR averaged over 10 cm ³ (10 g) of Body TSL	condition	
SAR measured	250 mW input power	1.59 W/kg
SAR for nominal Body TSL parameters	normalized to 1W	6.15 W/kg ± 16.5 % (k=2)

Appendix (Additional assessments outside the scope of SCS108)

Antenna Parameters with Head TSL

Impedance, transformed to feed point	51.6 Ω - 1.0 $j\Omega$
Return Loss	- 34.7 dB

Antenna Parameters with Body TSL

Impedance, transformed to feed point	47.8 Ω - 3.3 $j\Omega$
Return Loss	- 27.8 dB

General Antenna Parameters and Design

Electrical Delay (one direction)	1.395 ns
----------------------------------	----------

After long term use with 100W radiated power, only a slight warming of the dipole near the feedpoint can be measured.

The dipole is made of standard semirigid coaxial cable. The center conductor of the feeding line is directly connected to the second arm of the dipole. The antenna is therefore short-circuited for DC-signals. On some of the dipoles, small end caps are added to the dipole arms in order to improve matching when loaded according to the position as explained in the "Measurement Conditions" paragraph. The SAR data are not affected by this change. The overall dipole length is still according to the Standard.

No excessive force must be applied to the dipole arms, because they might bend or the soldered connections near the feedpoint may be damaged.

Additional EUT Data

Manufactured by	SPEAG
Manufactured on	July 22, 2011

DASY5 Validation Report for Head TSL

Date: 24.07.2014

Test Laboratory: SPEAG, Zurich, Switzerland

DUT: Dipole 835 MHz; Type: D835V2; Serial: D835V2 - SN: 4d133

Communication System: UID 0 - CW; Frequency: 835 MHz

Medium parameters used: $f = 835$ MHz; $\sigma = 0.94$ S/m; $\epsilon_r = 41.1$; $\rho = 1000$ kg/m³

Phantom section: Flat Section

Measurement Standard: DASY5 (IEEE/IEC/ANSI C63.19-2011)

DASY52 Configuration:

- Probe: ES3DV3 - SN3205; ConvF(6.22, 6.22, 6.22); Calibrated: 30.12.2013;
- Sensor-Surface: 3mm (Mechanical Surface Detection)
- Electronics: DAE4 Sn601; Calibrated: 30.04.2014
- Phantom: Flat Phantom 4.9L; Type: QD000P49AA; Serial: 1001
- DASY52 52.8.8(1222); SEMCAD X 14.6.10(7331)

Dipole Calibration for Head Tissue/Pin=250 mW, d=15mm/Zoom Scan (7x7x7)/Cube 0:

Measurement grid: dx=5mm, dy=5mm, dz=5mm

Reference Value = 56.07 V/m; Power Drift = 0.03 dB

Peak SAR (extrapolated) = 3.58 W/kg

SAR(1 g) = 2.38 W/kg; SAR(10 g) = 1.53 W/kg

Maximum value of SAR (measured) = 2.79 W/kg

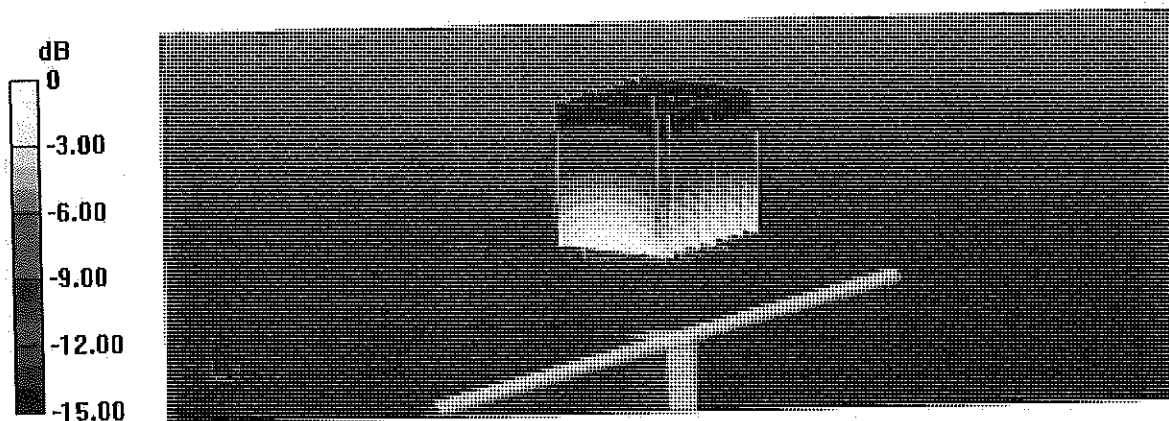

0 dB = 2.79 W/kg = 4.46 dBW/kg

Impedance Measurement Plot for Head TSL

24 Jul 2014 11:33:11

[CHI] S11 1 U F6

Z: 51.553 Ω -1.0293 Ω 105.19 pF 835.000 000 MHz

De1

CA

AVG
16

H1d

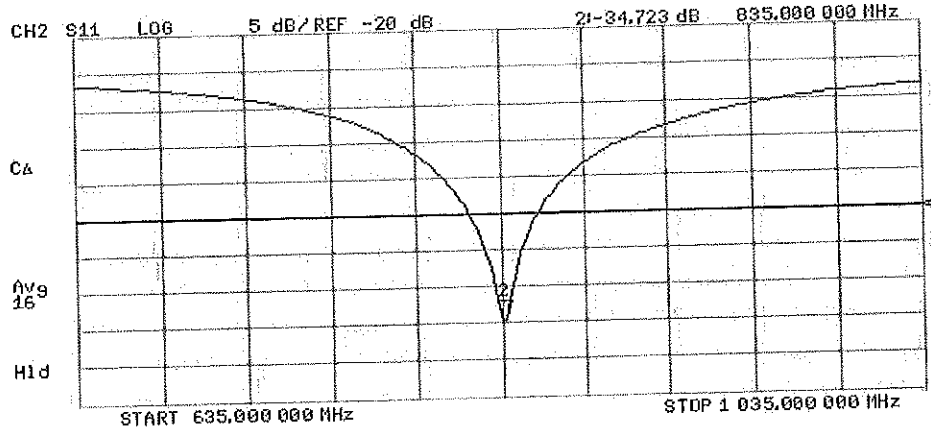
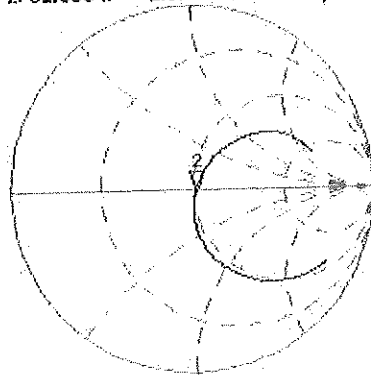

DASY5 Validation Report for Body TSL

Date: 17.07.2014

Test Laboratory: SPEAG, Zurich, Switzerland

DUT: Dipole 835 MHz; Type: D835V2; Serial: D835V2 - SN: 4d133

Communication System: UID 0 - CW; Frequency: 835 MHz
Medium parameters used: $f = 835$ MHz; $\sigma = 1.02$ S/m; $\epsilon_r = 53.8$; $\rho = 1000$ kg/m³
Phantom section: Flat Section
Measurement Standard: DASY5 (IEEE/IEC/ANSI C63.19-2011)

DASY52 Configuration:

- Probe: ES3DV3 - SN3205; ConvF(6.09, 6.09, 6.09); Calibrated: 30.12.2013;
- Sensor-Surface: 3mm (Mechanical Surface Detection)
- Electronics: DAE4 Sn601; Calibrated: 30.04.2014
- Phantom: Flat Phantom 4.9L; Type: QD000P49AA; Serial: 1001
- DASY52 52.8.8(1222); SEMCAD X 14.6.10(7331)

Dipole Calibration for Body Tissue/Pin=250 mW, d=15mm/Zoom Scan (7x7x7)/Cube 0:

Measurement grid: dx=5mm, dy=5mm, dz=5mm
Reference Value = 54.61 V/m; Power Drift = -0.01 dB
Peak SAR (extrapolated) = 3.59 W/kg
SAR(1 g) = 2.44 W/kg; SAR(10 g) = 1.59 W/kg
Maximum value of SAR (measured) = 2.84 W/kg

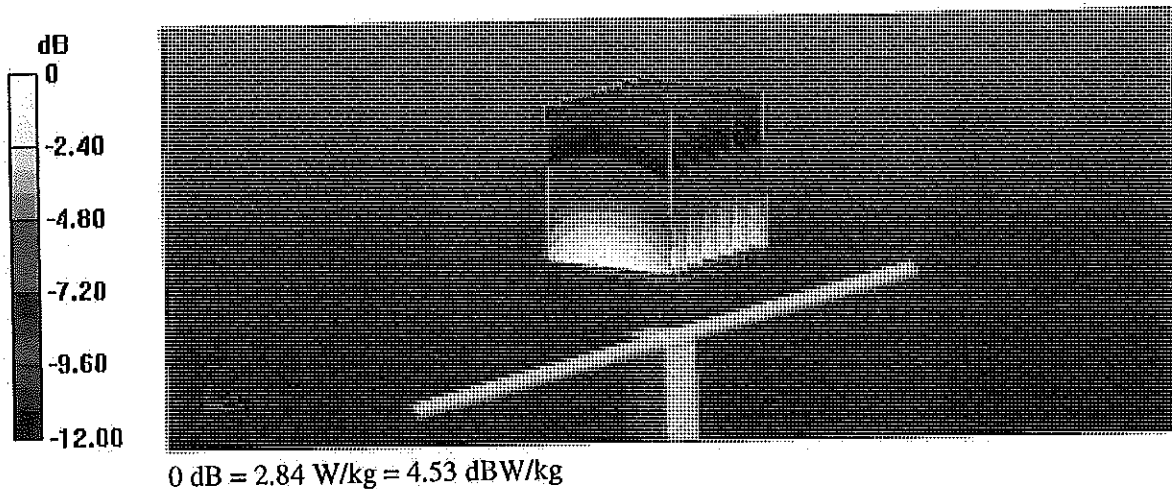

Impedance Measurement Plot for Body TSL

17 Jul 2014 13:43:24

CH1 S11 1 U F8

1: 47.799 Ω -3.3184 Ω 57.439 pF

835.000 000 MHz

*
Del
CA

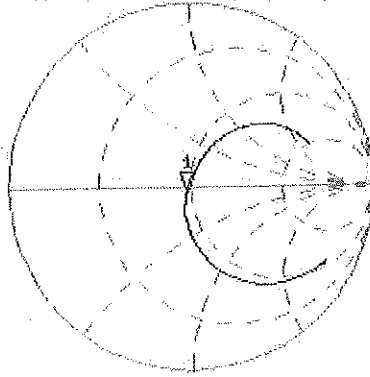

Avg
16

H1d

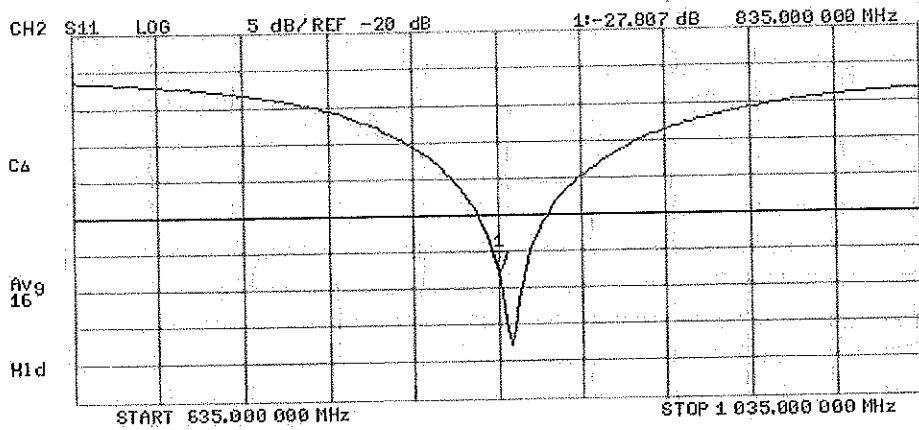

**Calibration Laboratory of
Schmid & Partner
Engineering AG**
Zeughausstrasse 43, 8004 Zurich, Switzerland



S Schweizerischer Kalibrierdienst
C Service suisse d'étalonnage
S Servizio svizzero di taratura
S Swiss Calibration Service

Accredited by the Swiss Accreditation Service (SAS)
The Swiss Accreditation Service is one of the signatories to the EA
Multilateral Agreement for the recognition of calibration certificates

Accreditation No.: **SCS 108**

Client **PC Test**

Certificate No: **D1750V2-1051_Apr14**

CALIBRATION CERTIFICATE

Object **D1750V2 - SN: 1051**

Calibration procedure(s) **QA CAL-05.v9
Calibration procedure for dipole validation kits above 700 MHz**

Calibration date: **April 10, 2014**

*Kok
5/7/14*

This calibration certificate documents the traceability to national standards, which realize the physical units of measurements (SI).
The measurements and the uncertainties with confidence probability are given on the following pages and are part of the certificate.

All calibrations have been conducted in the closed laboratory facility: environment temperature (22 ± 3)°C and humidity < 70%.

Calibration Equipment used (M&TE critical for calibration)

Primary Standards	ID #	Cal Date (Certificate No.)	Scheduled Calibration
Power meter EPM-442A	GB37480704	09-Oct-13 (No. 217-01027)	Oct-14
Power sensor HP 8481A	US37292783	09-Oct-13 (No. 217-01027)	Oct-14
Power sensor HP 8481A	MY41092317	09-Oct-13 (No. 217-01028)	Oct-14
Reference 20 dB Attenuator	SN: 5058 (20k)	03-Apr-14 (No. 217-01018)	Apr-15
Type-N mismatch combination	SN: 5047.2 / 06327	03-Apr-14 (No. 217-01021)	Apr-15
Reference Probe ES3DV3	SN: 3205	30-Dec-13 (No. ES3-3205_Dec13)	Dec-14
DAE4	SN: 601	25-Apr-13 (No. DAE4-601_Apr13)	Apr-14
Secondary Standards	ID #	Check Date (in house)	Scheduled Check
RF generator R&S SMT-06	100005	04-Aug-99 (in house check Oct-13)	In house check: Oct-16
Network Analyzer HP 8753E	US37390585 S4206	18-Oct-01 (in house check Oct-13)	In house check: Oct-14

Calibrated by: **Israe El-Naouq** Function: **Laboratory Technician** Signature: *Israe El-Naouq*

Approved by: **Kalja Pokovic** Technical Manager Signature: *Kalja Pokovic*

Issued: April 10, 2014

This calibration certificate shall not be reproduced except in full without written approval of the laboratory.

**Calibration Laboratory of
Schmid & Partner
Engineering AG**
Zeughausstrasse 43, 8004 Zurich, Switzerland



S Schweizerischer Kalibrierdienst
S Service suisse d'étalonnage
C Servizio svizzero di taratura
S Swiss Calibration Service

Accredited by the Swiss Accreditation Service (SAS)

The Swiss Accreditation Service is one of the signatories to the EA
Multilateral Agreement for the recognition of calibration certificates

Accreditation No.: **SCS 108**

Glossary:

TSL	tissue simulating liquid
ConvF	sensitivity in TSL / NORM x,y,z
N/A	not applicable or not measured

Calibration is Performed According to the Following Standards:

- IEEE Std 1528-2013, "IEEE Recommended Practice for Determining the Peak Spatial-Averaged Specific Absorption Rate (SAR) in the Human Head from Wireless Communications Devices: Measurement Techniques", June 2013
- IEC 62209-1, "Procedure to measure the Specific Absorption Rate (SAR) for hand-held devices used in close proximity to the ear (frequency range of 300 MHz to 3 GHz)", February 2005
- KDB 865664, "SAR Measurement Requirements for 100 MHz to 6 GHz"

Additional Documentation:

- DASY4/5 System Handbook

Methods Applied and Interpretation of Parameters:

- Measurement Conditions:** Further details are available from the Validation Report at the end of the certificate. All figures stated in the certificate are valid at the frequency indicated.
- Antenna Parameters with TSL:** The dipole is mounted with the spacer to position its feed point exactly below the center marking of the flat phantom section, with the arms oriented parallel to the body axis.
- Feed Point Impedance and Return Loss:** These parameters are measured with the dipole positioned under the liquid filled phantom. The impedance stated is transformed from the measurement at the SMA connector to the feed point. The Return Loss ensures low reflected power. No uncertainty required.
- Electrical Delay:** One-way delay between the SMA connector and the antenna feed point. No uncertainty required.
- SAR measured:** SAR measured at the stated antenna input power.
- SAR normalized:** SAR as measured, normalized to an input power of 1 W at the antenna connector.
- SAR for nominal TSL parameters:** The measured TSL parameters are used to calculate the nominal SAR result.

The reported uncertainty of measurement is stated as the standard uncertainty of measurement multiplied by the coverage factor $k=2$, which for a normal distribution corresponds to a coverage probability of approximately 95%.

Measurement Conditions

DASY system configuration, as far as not given on page 1.

DASY Version	DASY5	V52.8.7
Extrapolation	Advanced Extrapolation	
Phantom	Modular Flat Phantom	
Distance Dipole Center - TSL	10 mm	with Spacer
Zoom Scan Resolution	dx, dy, dz = 5 mm	
Frequency	1750 MHz ± 1 MHz	

Head TSL parameters

The following parameters and calculations were applied.

	Temperature	Permittivity	Conductivity
Nominal Head TSL parameters	22.0 °C	40.1	1.37 mho/m
Measured Head TSL parameters	(22.0 ± 0.2) °C	39.1 ± 6 %	1.35 mho/m ± 6 %
Head TSL temperature change during test	< 0.5 °C	----	----

SAR result with Head TSL

SAR averaged over 1 cm ³ (1 g) of Head TSL	Condition	
SAR measured	250 mW input power	9.02 W/kg
SAR for nominal Head TSL parameters	normalized to 1W	36.2 W/kg ± 17.0 % (k=2)

SAR averaged over 10 cm ³ (10 g) of Head TSL	condition	
SAR measured	250 mW input power	4.79 W/kg
SAR for nominal Head TSL parameters	normalized to 1W	19.2 W/kg ± 16.5 % (k=2)

Body TSL parameters

The following parameters and calculations were applied.

	Temperature	Permittivity	Conductivity
Nominal Body TSL parameters	22.0 °C	53.4	1.49 mho/m
Measured Body TSL parameters	(22.0 ± 0.2) °C	52.0 ± 6 %	1.48 mho/m ± 6 %
Body TSL temperature change during test	< 0.5 °C	----	----

SAR result with Body TSL

SAR averaged over 1 cm ³ (1 g) of Body TSL	Condition	
SAR measured	250 mW input power	9.37 W/kg
SAR for nominal Body TSL parameters	normalized to 1W	37.4 W/kg ± 17.0 % (k=2)

SAR averaged over 10 cm ³ (10 g) of Body TSL	condition	
SAR measured	250 mW input power	5.04 W/kg
SAR for nominal Body TSL parameters	normalized to 1W	20.1 W/kg ± 16.5 % (k=2)

Appendix

Antenna Parameters with Head TSL

Impedance, transformed to feed point	$50.7 \Omega + 0.4 j\Omega$
Return Loss	- 41.5 dB

Antenna Parameters with Body TSL

Impedance, transformed to feed point	$46.8 \Omega + 0.8 j\Omega$
Return Loss	- 29,3 dB

General Antenna Parameters and Design

Electrical Delay (one direction)	1.222 ns
----------------------------------	----------

After long term use with 100W radiated power, only a slight warming of the dipole near the feedpoint can be measured.

The dipole is made of standard semirigid coaxial cable. The center conductor of the feeding line is directly connected to the second arm of the dipole. The antenna is therefore short-circuited for DC-signals. On some of the dipoles, small end caps are added to the dipole arms in order to improve matching when loaded according to the position as explained in the "Measurement Conditions" paragraph. The SAR data are not affected by this change. The overall dipole length is still according to the Standard.

No excessive force must be applied to the dipole arms, because they might bend or the soldered connections near the feedpoint may be damaged.

Additional EUT Data

Manufactured by	SPEAG
Manufactured on	February 19, 2010

DASY5 Validation Report for Head TSL

Date: 10.04.2014

Test Laboratory: SPEAG, Zurich, Switzerland

DUT: Dipole 1750 MHz; Type: D1750V2; Serial: D1750V2 - SN: 1051

Communication System: UID 0 - CW; Frequency: 1750 MHz

Medium parameters used: $f = 1750$ MHz; $\sigma = 1.35$ S/m; $\epsilon_r = 39.1$; $\rho = 1000$ kg/m³

Phantom section: Flat Section

Measurement Standard: DASY5 (IEEE/IEC/ANSI C63.19-2007)

DASY52 Configuration:

- Probe: ES3DV3 - SN3205; ConvF(5.23, 5.23, 5.23); Calibrated: 30.12.2013;
- Sensor-Surface: 3mm (Mechanical Surface Detection)
- Electronics: DAE4 Sn601; Calibrated: 25.04.2013
- Phantom: Flat Phantom 5.0 (front); Type: QD000P50AA; Serial: I001
- DASY52 52.8.7(1137); SEMCAD X 14.6.10(7164)

Dipole Calibration for Head Tissue/Pin=250 mW, d=10mm/Zoom Scan (7x7x7)/Cube 0:

Measurement grid: dx=5mm, dy=5mm, dz=5mm

Reference Value = 94.631 V/m; Power Drift = 0.00 dB

Peak SAR (extrapolated) = 16.2 W/kg

SAR(1 g) = 9.02 W/kg; SAR(10 g) = 4.79 W/kg

Maximum value of SAR (measured) = 11.3 W/kg

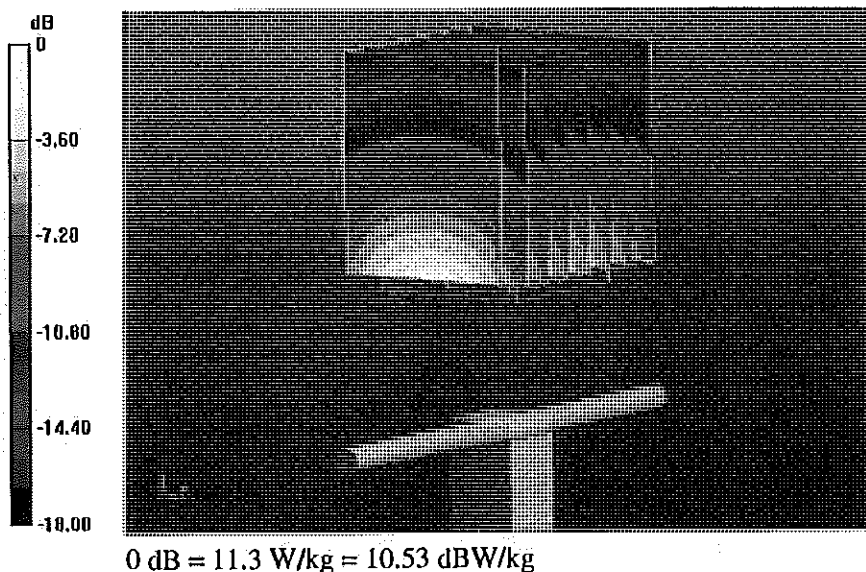

Impedance Measurement Plot for Head TSL

10 Apr 2014 12:21:05

CH1 S11 1 U FS 1: 50.727 Ω 0.4230 μ 38.545 pF 1 750.000 000 MHz

*
Del
CA

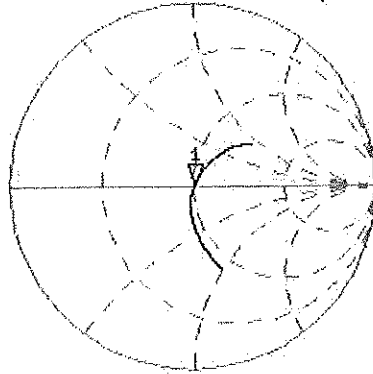

Avg
16

H1d

CH2 S11 LOG 5 dB/REF -20 dB 1: -41.536 dB 1 750.000 000 MHz

CA

Avg
16

H1d

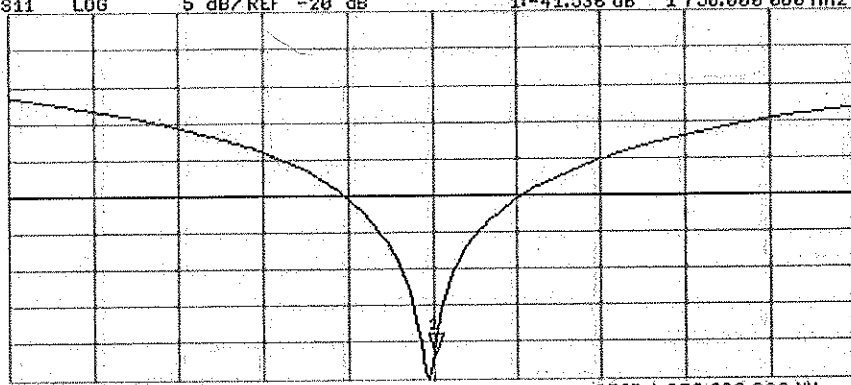

START 1 550.000 000 MHz

STOP 1 950.000 000 MHz

DASY5 Validation Report for Body TSL

Date: 10.04.2014

Test Laboratory: SPEAG, Zurich, Switzerland

DUT: Dipole 1750 MHz; Type: D1750V2; Serial: D1750V2 - SN: 1051

Communication System: UID 0 - CW; Frequency: 1750 MHz

Medium parameters used: $f = 1750$ MHz; $\sigma = 1.48$ S/m; $\epsilon_r = 52$; $\rho = 1000$ kg/m³

Phantom section: Flat Section

Measurement Standard: DASY5 (IEEE/IEC/ANSI C63.19-2007)

DASY52 Configuration:

- Probe: ES3DV3 - SN3205; ConvF(4.89, 4.89, 4.89); Calibrated: 30.12.2013;
- Sensor-Surface: 3mm (Mechanical Surface Detection)
- Electronics: DAE4 Sn601; Calibrated: 25.04.2013
- Phantom: Flat Phantom 5.0 (back); Type: QD000P50AA; Serial: 1002
- DASY52 52.8.7(1137); SEMCAD X 14.6.10(7164)

Dipole Calibration for Body Tissue/Pin=250 mW, d=10mm/Zoom Scan (7x7x7)/Cube 0:

Measurement grid: dx=5mm, dy=5mm, dz=5mm

Reference Value = 93.321 V/m; Power Drift = -0,01 dB

Peak SAR (extrapolated) = 16.1 W/kg

SAR(1 g) = 9.37 W/kg; SAR(10 g) = 5.04 W/kg

Maximum value of SAR (measured) = 11.8 W/kg

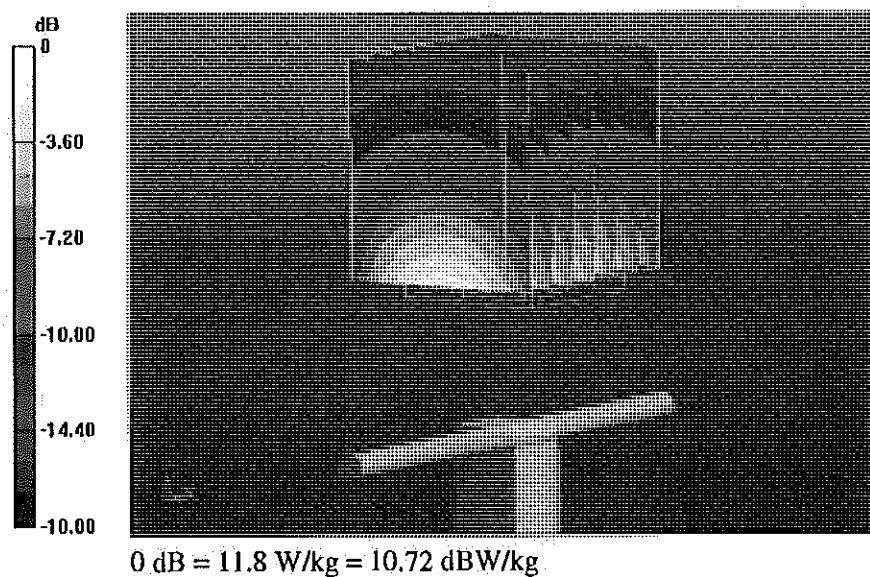

Impedance Measurement Plot for Body TSL

10 Apr 2014 12:20:40

CH1 S11 1 U FS 1: 46.787 Ω 0.8086 Ω 73.538 pF 1 750.000 000 MHz

*
De I
CA

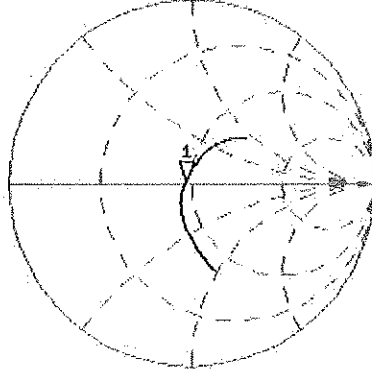

AVG
16

H1 d

CH2 S11 LOG 5 dB/REF -20 dB 1: -29.320 dB 1 750.000 000 MHz

CA

AVG
16

H1 d

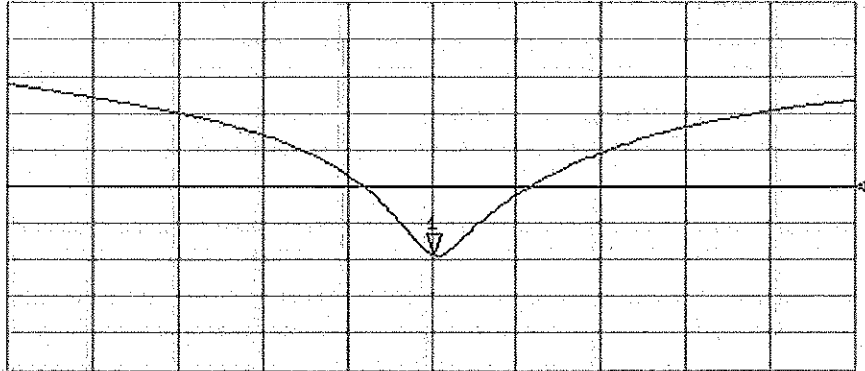



Accredited by the Swiss Accreditation Service (SAS)
The Swiss Accreditation Service is one of the signatories to the EA
Multilateral Agreement for the recognition of calibration certificates

Accreditation No.: **SCS 108**

Client **PC Test**

Certificate No: **D1900V2-5d141_Apr14**

CALIBRATION CERTIFICATE

Object **D1900V2 - SN: 5d141**

Calibration procedure(s) **QA CAL-05.v9
Calibration procedure for dipole validation kits above 700 MHz**

Calibration date: **April 09, 2014**

✓
Kok
5/7/14

This calibration certificate documents the traceability to national standards, which realize the physical units of measurements (SI).
The measurements and the uncertainties with confidence probability are given on the following pages and are part of the certificate.

All calibrations have been conducted in the closed laboratory facility: environment temperature (22 ± 3)°C and humidity < 70%.

Calibration Equipment used (M&TE critical for calibration)

Primary Standards	ID #	Cal Date (Certificate No.)	Scheduled Calibration
Power meter EPM-442A	GB37480704	09-Oct-13 (No. 217-01827)	Oct-14
Power sensor HP 8481A	US37292783	09-Oct-13 (No. 217-01827)	Oct-14
Power sensor HP 8481A	MY41092317	09-Oct-13 (No. 217-01828)	Oct-14
Reference 20 dB Attenuator	SN: 5058 (20k)	03-Apr-14 (No. 217-01918)	Apr-15
Type-N mismatch combination	SN: 5047.2 / 06327	03-Apr-14 (No. 217-01921)	Apr-15
Reference Probe ES3DV3	SN: 3205	30-Dec-13 (No. ES3-3205_Dec13)	Dec-14
DAE4	SN: 801	25-Apr-13 (No. DAE4-801_Apr13)	Apr-14

Secondary Standards	ID #	Check Date (in house)	Scheduled Check
RF generator R&S SMT-06	100005	04-Aug-99 (in house check Oct-13)	In house check: Oct-16
Network Analyzer HP 8753E	US37390585 S4206	18-Oct-01 (in house check Oct-13)	In house check: Oct-14

Calibrated by: **Claudio Leubler** Function: **Laboratory Technician**

Approved by: **Katja Pokovic** Technical Manager

Signature

Issued: April 9, 2014

This calibration certificate shall not be reproduced except in full without written approval of the laboratory.



Accredited by the Swiss Accreditation Service (SAS)
The Swiss Accreditation Service is one of the signatories to the EA
Multilateral Agreement for the recognition of calibration certificates

Accreditation No.: **SCS 108**

Glossary:

TSL	tissue simulating liquid
ConvF	sensitivity in TSL / NORM x,y,z
N/A	not applicable or not measured

Calibration is Performed According to the Following Standards:

- a) IEEE Std 1528-2013, "IEEE Recommended Practice for Determining the Peak Spatial-Averaged Specific Absorption Rate (SAR) in the Human Head from Wireless Communications Devices: Measurement Techniques", June 2013
- b) IEC 62209-1, "Procedure to measure the Specific Absorption Rate (SAR) for hand-held devices used in close proximity to the ear (frequency range of 300 MHz to 3 GHz)", February 2005
- c) KDB 865664, "SAR Measurement Requirements for 100 MHz to 6 GHz"

Additional Documentation:

- d) DASY4/5 System Handbook

Methods Applied and Interpretation of Parameters:

- *Measurement Conditions:* Further details are available from the Validation Report at the end of the certificate. All figures stated in the certificate are valid at the frequency indicated.
- *Antenna Parameters with TSL:* The dipole is mounted with the spacer to position its feed point exactly below the center marking of the flat phantom section, with the arms oriented parallel to the body axis.
- *Feed Point Impedance and Return Loss:* These parameters are measured with the dipole positioned under the liquid filled phantom. The impedance stated is transformed from the measurement at the SMA connector to the feed point. The Return Loss ensures low reflected power. No uncertainty required.
- *Electrical Delay:* One-way delay between the SMA connector and the antenna feed point. No uncertainty required.
- *SAR measured:* SAR measured at the stated antenna input power.
- *SAR normalized:* SAR as measured, normalized to an input power of 1 W at the antenna connector.
- *SAR for nominal TSL parameters:* The measured TSL parameters are used to calculate the nominal SAR result.

The reported uncertainty of measurement is stated as the standard uncertainty of measurement multiplied by the coverage factor $k=2$, which for a normal distribution corresponds to a coverage probability of approximately 95%.

Measurement Conditions

DASY system configuration, as far as not given on page 1.

DASY Version	DASY5	V52.8.7
Extrapolation	Advanced Extrapolation	
Phantom	Modular Flat Phantom	
Distance Dipole Center - TSL	10 mm	with Spacer
Zoom Scan Resolution	dx, dy, dz = 5 mm	
Frequency	1900 MHz \pm 1 MHz	

Head TSL parameters

The following parameters and calculations were applied.

	Temperature	Permittivity	Conductivity
Nominal Head TSL parameters	22.0 °C	40.0	1.40 mho/m
Measured Head TSL parameters	(22.0 \pm 0.2) °C	39.1 \pm 6 %	1.36 mho/m \pm 6 %
Head TSL temperature change during test	< 0.5 °C	----	----

SAR result with Head TSL

SAR averaged over 1 cm ³ (1 g) of Head TSL	Condition	
SAR measured	250 mW input power	9.91 W/kg
SAR for nominal Head TSL parameters	normalized to 1W	40.1 W/kg \pm 17.0 % (k=2)

SAR averaged over 10 cm ³ (10 g) of Head TSL	condition	
SAR measured	250 mW input power	5.17 W/kg
SAR for nominal Head TSL parameters	normalized to 1W	20.8 W/kg \pm 16.5 % (k=2)

Body TSL parameters

The following parameters and calculations were applied.

	Temperature	Permittivity	Conductivity
Nominal Body TSL parameters	22.0 °C	53.3	1.52 mho/m
Measured Body TSL parameters	(22.0 \pm 0.2) °C	52.4 \pm 6 %	1.52 mho/m \pm 6 %
Body TSL temperature change during test	< 0.5 °C	----	----

SAR result with Body TSL

SAR averaged over 1 cm ³ (1 g) of Body TSL	Condition	
SAR measured	250 mW input power	10.2 W/kg
SAR for nominal Body TSL parameters	normalized to 1W	40.6 W/kg \pm 17.0 % (k=2)

SAR averaged over 10 cm ³ (10 g) of Body TSL	condition	
SAR measured	250 mW input power	5.41 W/kg
SAR for nominal Body TSL parameters	normalized to 1W	21.6 W/kg \pm 16.5 % (k=2)

Appendix

Antenna Parameters with Head TSL

Impedance, transformed to feed point	52.8 Ω + 5.5 j Ω
Return Loss	- 24.5 dB

Antenna Parameters with Body TSL

Impedance, transformed to feed point	48.8 Ω + 6.3 j Ω
Return Loss	- 23.7 dB

General Antenna Parameters and Design

Electrical Delay (one direction)	1.199 ns
----------------------------------	----------

After long term use with 100W radiated power, only a slight warming of the dipole near the feedpoint can be measured.

The dipole is made of standard semirigid coaxial cable. The center conductor of the feeding line is directly connected to the second arm of the dipole. The antenna is therefore short-circuited for DC-signals. On some of the dipoles, small end caps are added to the dipole arms in order to improve matching when loaded according to the position as explained in the "Measurement Conditions" paragraph. The SAR data are not affected by this change. The overall dipole length is still according to the Standard.

No excessive force must be applied to the dipole arms, because they might bend or the soldered connections near the feedpoint may be damaged.

Additional EUT Data

Manufactured by	SPEAG
Manufactured on	March 11, 2011

DASY5 Validation Report for Head TSL

Date: 09.04.2014

Test Laboratory: SPEAG, Zurich, Switzerland

DUT: Dipole 1900 MHz; Type: D1900V2; Serial: D1900V2 - SN: 5d141

Communication System: UID 0 - CW; Frequency: 1900 MHz

Medium parameters used: $f = 1900$ MHz; $\sigma = 1.36$ S/m; $\epsilon_r = 39.1$; $\rho = 1000$ kg/m³

Phantom section: Flat Section

Measurement Standard: DASY5 (IEEE/IEC/ANSI C63.19-2007)

DASY52 Configuration:

- Probe: ES3DV3 - SN3205; ConvF(5.06, 5.06, 5.06); Calibrated: 30.12.2013;
- Sensor-Surface: 3mm (Mechanical Surface Detection)
- Electronics: DAE4 Sn601; Calibrated: 25.04.2013
- Phantom: Flat Phantom 5.0 (front); Type: QD000P50AA; Serial: 1001
- DASY52 52.8.7(1137); SEMCAD X 14.6.10(7164)

Dipole Calibration for Head Tissue/ $P_{in}=250$ mW, $d=10$ mm/Zoom Scan (7x7x7)/Cube 0:

Measurement grid: $dx=5$ mm, $dy=5$ mm, $dz=5$ mm

Reference Value = 99.080 V/m; Power Drift = 0.01 dB

Peak SAR (extrapolated) = 18.2 W/kg

SAR(1 g) = 9.91 W/kg; SAR(10 g) = 5.17 W/kg

Maximum value of SAR (measured) = 12.5 W/kg

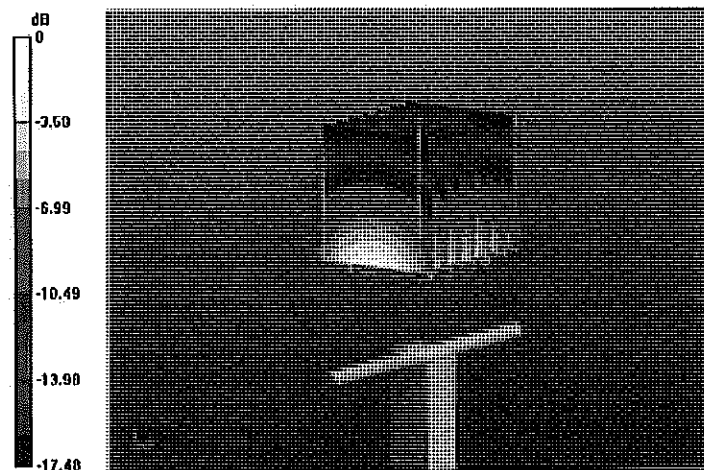

0 dB = 12.5 W/kg = 10.97 dBW/kg

Impedance Measurement Plot for Head TSL

9 Apr 2014 11:03:32

CH1 S11 1 U FS 1: 52.760 n 5.4512 n 456.62 pH 1 900.000 000 MHz

*
Del
CA

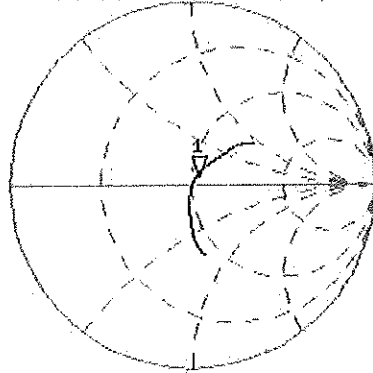

AVG
16

H1d

CH2 S11 LOG 5 dB/REF -20 dB 1:-24.525 dB 1 900.000 000 MHz

CA

AVG
16

H1d

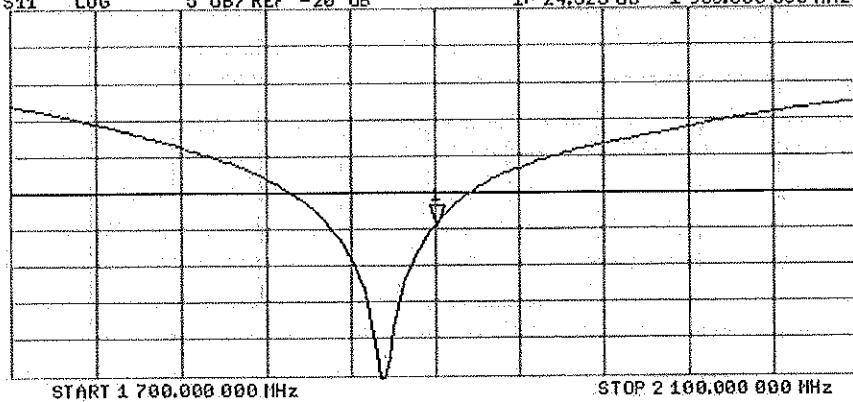

DASY5 Validation Report for Body TSL

Date: 09.04.2014

Test Laboratory: SPEAG, Zurich, Switzerland

DUT: Dipole 1900 MHz; Type: D1900V2; Serial: D1900V2 - SN: 5d141

Communication System: UID 0 - CW; Frequency: 1900 MHz

Medium parameters used: $f = 1900$ MHz; $\sigma = 1.52$ S/m; $\epsilon_r = 52.4$; $\rho = 1000$ kg/m³

Phantom section: Flat Section

Measurement Standard: DASY5 (IEEE/IEC/ANSI C63.19-2007)

DASY52 Configuration:

- Probe: ES3DV3 - SN3205; ConvF(4.76, 4.76, 4.76); Calibrated: 30.12.2013;
- Sensor-Surface: 3mm (Mechanical Surface Detection)
- Electronics: DAE4 Sn601; Calibrated: 25.04.2013
- Phantom: Flat Phantom 5.0 (back); Type: QD000P50AA; Serial: 1002
- DASY52 52.8.7(1137); SEMCAD X 14.6.10(7164)

Dipole Calibration for Body Tissue/Pin=250 mW, d=10mm/Zoom Scan (7x7x7)/Cube 0:

Measurement grid: dx=5mm, dy=5mm, dz=5mm

Reference Value = 95.820 V/m; Power Drift = -0.01 dB

Peak SAR (extrapolated) = 17.9 W/kg

SAR(1 g) = 10.2 W/kg; SAR(10 g) = 5.41 W/kg

Maximum value of SAR (measured) = 12.9 W/kg

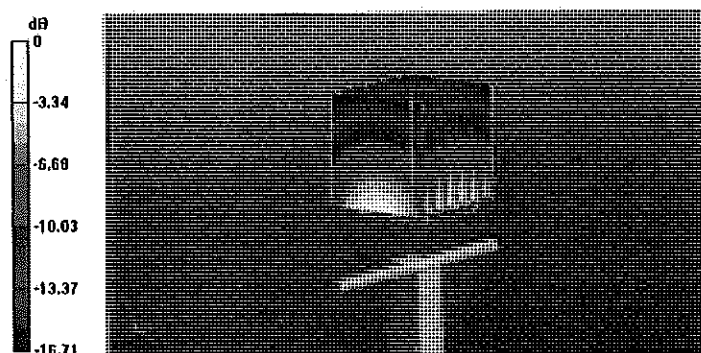

0 dB = 12.9 W/kg = 11.11 dBW/kg

Impedance Measurement Plot for Body TSL

9 Apr 2014 11:02:32

CH1 S11 1 U FS 1: 48.752 Ω 6.3320 Ω 530.41 μ H 1 900.000 000 MHz

*
Del
CA
Avg
16
↑

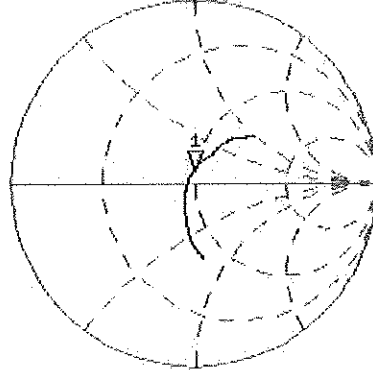

CH2 S11 LOG 5 dB/REF -20 dB 1: -23.715 dB 1 900.000 000 MHz

CA
Avg
16
↑

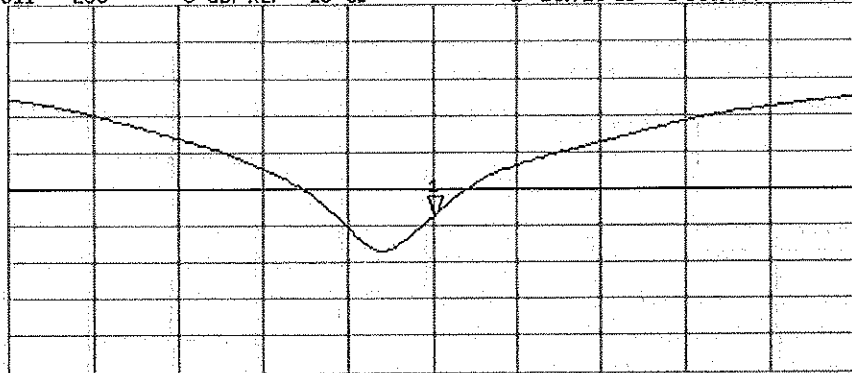



Accredited by the Swiss Accreditation Service (SAS)
The Swiss Accreditation Service is one of the signatories to the EA
Multilateral Agreement for the recognition of calibration certificates

Accreditation No.: **SCS 0108**

Client **PC Test**

Certificate No: **D1900V2-5d141_Apr15**

CALIBRATION CERTIFICATE

Object **D1900V2 - SN:5d141**

Calibration procedure(s) **QA CAL-05.v9
Calibration procedure for dipole validation kits above 700 MHz**

Calibration date: **April 14, 2015**

PM ✓
4/29/15

This calibration certificate documents the traceability to national standards, which realize the physical units of measurements (SI).
The measurements and the uncertainties with confidence probability are given on the following pages and are part of the certificate.

All calibrations have been conducted in the closed laboratory facility: environment temperature (22 ± 3)°C and humidity < 70%.

Calibration Equipment used (M&TE critical for calibration)

Primary Standards	ID #	Cal Date (Certificate No.)	Scheduled Calibration
Power meter EPM-442A	GB37480704	07-Oct-14 (No. 217-02020)	Oct-15
Power sensor HP 8481A	US37292783	07-Oct-14 (No. 217-02020)	Oct-15
Power sensor HP 8481A	MY41092317	07-Oct-14 (No. 217-02021)	Oct-15
Reference 20 dB Attenuator	SN: 5058 (20k)	01-Apr-15 (No. 217-02131)	Mar-16
Type-N mismatch combination	SN: 5047.2 / 06327	01-Apr-15 (No. 217-02134)	Mar-16
Reference Probe ES3DV3	SN: 3205	30-Dec-14 (No. ES3-3205_Dec14)	Dec-15
DAE4	SN: 601	18-Aug-14 (No. DAE4-601_Aug14)	Aug-15
Secondary Standards	ID #	Check Date (in house)	Scheduled Check
RF generator R&S SMT-06	100005	04-Aug-99 (in house check Oct-13)	In house check: Oct-16
Network Analyzer HP 8753E	US37390585 S4206	18-Oct-01 (in house check Oct-14)	In house check: Oct-15

Calibrated by: **Claudio Leubler** (Name), **Laboratory Technician** (Function),  (Signature)

Approved by: **Katja Pokovic** (Name), **Technical Manager** (Function),  (Signature)

Issued: April 14, 2015

This calibration certificate shall not be reproduced except in full without written approval of the laboratory.



Accredited by the Swiss Accreditation Service (SAS)

The Swiss Accreditation Service is one of the signatories to the EA
Multilateral Agreement for the recognition of calibration certificates

Accreditation No.: **SCS 0108**

Glossary:

TSL	tissue simulating liquid
ConvF	sensitivity in TSL / NORM x,y,z
N/A	not applicable or not measured

Calibration is Performed According to the Following Standards:

- IEEE Std 1528-2013, "IEEE Recommended Practice for Determining the Peak Spatial-Averaged Specific Absorption Rate (SAR) in the Human Head from Wireless Communications Devices: Measurement Techniques", June 2013
- IEC 62209-1, "Procedure to measure the Specific Absorption Rate (SAR) for hand-held devices used in close proximity to the ear (frequency range of 300 MHz to 3 GHz)", February 2005
- KDB 865664, "SAR Measurement Requirements for 100 MHz to 6 GHz"

Additional Documentation:

- DASY4/5 System Handbook

Methods Applied and Interpretation of Parameters:

- Measurement Conditions:* Further details are available from the Validation Report at the end of the certificate. All figures stated in the certificate are valid at the frequency indicated.
- Antenna Parameters with TSL:* The dipole is mounted with the spacer to position its feed point exactly below the center marking of the flat phantom section, with the arms oriented parallel to the body axis.
- Feed Point Impedance and Return Loss:* These parameters are measured with the dipole positioned under the liquid filled phantom. The impedance stated is transformed from the measurement at the SMA connector to the feed point. The Return Loss ensures low reflected power. No uncertainty required.
- Electrical Delay:* One-way delay between the SMA connector and the antenna feed point. No uncertainty required.
- SAR measured:* SAR measured at the stated antenna input power.
- SAR normalized:* SAR as measured, normalized to an input power of 1 W at the antenna connector.
- SAR for nominal TSL parameters:* The measured TSL parameters are used to calculate the nominal SAR result.

The reported uncertainty of measurement is stated as the standard uncertainty of measurement multiplied by the coverage factor $k=2$, which for a normal distribution corresponds to a coverage probability of approximately 95%.

Measurement Conditions

DASY system configuration, as far as not given on page 1.

DASY Version	DASY5	V52.8.8
Extrapolation	Advanced Extrapolation	
Phantom	Modular Flat Phantom	
Distance Dipole Center - TSL	10 mm	with Spacer
Zoom Scan Resolution	dx, dy, dz = 5 mm	
Frequency	1900 MHz ± 1 MHz	

Head TSL parameters

The following parameters and calculations were applied.

	Temperature	Permittivity	Conductivity
Nominal Head TSL parameters	22.0 °C	40.0	1.40 mho/m
Measured Head TSL parameters	(22.0 ± 0.2) °C	38.6 ± 6 %	1.37 mho/m ± 6 %
Head TSL temperature change during test	< 0.5 °C	----	----

SAR result with Head TSL

SAR averaged over 1 cm ³ (1 g) of Head TSL	Condition	
SAR measured	250 mW input power	9.93 W/kg
SAR for nominal Head TSL parameters	normalized to 1W	39.9 W/kg ± 17.0 % (k=2)

SAR averaged over 10 cm ³ (10 g) of Head TSL	condition	
SAR measured	250 mW input power	5.20 W/kg
SAR for nominal Head TSL parameters	normalized to 1W	20.9 W/kg ± 16.5 % (k=2)

Body TSL parameters

The following parameters and calculations were applied.

	Temperature	Permittivity	Conductivity
Nominal Body TSL parameters	22.0 °C	53.3	1.52 mho/m
Measured Body TSL parameters	(22.0 ± 0.2) °C	52.8 ± 6 %	1.50 mho/m ± 6 %
Body TSL temperature change during test	< 0.5 °C	----	----

SAR result with Body TSL

SAR averaged over 1 cm ³ (1 g) of Body TSL	Condition	
SAR measured	250 mW input power	9.94 W/kg
SAR for nominal Body TSL parameters	normalized to 1W	40.0 W/kg ± 17.0 % (k=2)

SAR averaged over 10 cm ³ (10 g) of Body TSL	condition	
SAR measured	250 mW input power	5.29 W/kg
SAR for nominal Body TSL parameters	normalized to 1W	21.2 W/kg ± 16.5 % (k=2)

Appendix (Additional assessments outside the scope of SCS 0108)

Antenna Parameters with Head TSL

Impedance, transformed to feed point	53.0 Ω + 4.6 j Ω
Return Loss	- 25.5 dB

Antenna Parameters with Body TSL

Impedance, transformed to feed point	48.2 Ω + 5.6 j Ω
Return Loss	- 24.5 dB

General Antenna Parameters and Design

Electrical Delay (one direction)	1.198 ns
----------------------------------	----------

After long term use with 100W radiated power, only a slight warming of the dipole near the feedpoint can be measured.

The dipole is made of standard semirigid coaxial cable. The center conductor of the feeding line is directly connected to the second arm of the dipole. The antenna is therefore short-circuited for DC-signals. On some of the dipoles, small end caps are added to the dipole arms in order to improve matching when loaded according to the position as explained in the "Measurement Conditions" paragraph. The SAR data are not affected by this change. The overall dipole length is still according to the Standard.

No excessive force must be applied to the dipole arms, because they might bend or the soldered connections near the feedpoint may be damaged.

Additional EUT Data

Manufactured by	SPEAG
Manufactured on	March 11, 2011

DASY5 Validation Report for Head TSL

Date: 14.04.2015

Test Laboratory: SPEAG, Zurich, Switzerland

DUT: Dipole 1900 MHz; Type: D1900V2; Serial: D1900V2 - SN:5d141

Communication System: UID 0 - CW; Frequency: 1900 MHz

Medium parameters used: $f = 1900$ MHz; $\sigma = 1.37$ S/m; $\epsilon_r = 38.6$; $\rho = 1000$ kg/m³

Phantom section: Flat Section

Measurement Standard: DASY5 (IEEE/IEC/ANSI C63.19-2011)

DASY52 Configuration:

- Probe: ES3DV3 - SN3205; ConvF(5, 5, 5); Calibrated: 30.12.2014;
- Sensor-Surface: 3mm (Mechanical Surface Detection)
- Electronics: DAE4 Sn601; Calibrated: 18.08.2014
- Phantom: Flat Phantom 5.0 (front); Type: QD000P50AA; Serial: 1001
- DASY52 52.8.8(1222); SEMCAD X 14.6.10(7331)

Dipole Calibration for Head Tissue/Pin=250 mW, d=10mm/Zoom Scan (7x7x7)/Cube 0:

Measurement grid: dx=5mm, dy=5mm, dz=5mm

Reference Value = 98.18 V/m; Power Drift = 0.04 dB

Peak SAR (extrapolated) = 18.2 W/kg

SAR(1 g) = 9.93 W/kg; SAR(10 g) = 5.2 W/kg

Maximum value of SAR (measured) = 12.5 W/kg

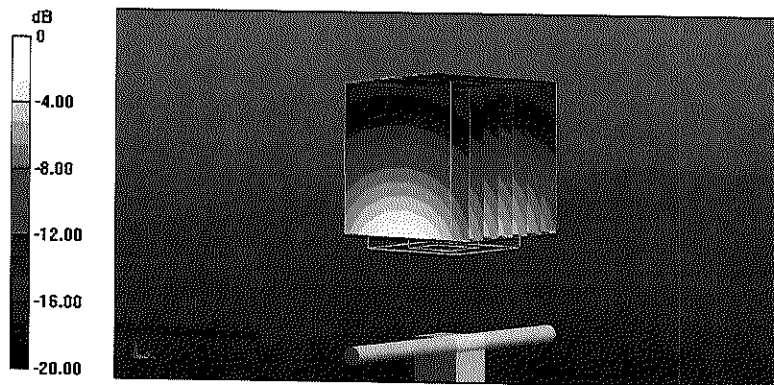

0 dB = 12.5 W/kg = 10.97 dBW/kg

Impedance Measurement Plot for Head TSL

14 Apr 2015 13:39:53

CH1 S11 1 U FS 1: 53.010 Ω 4.5664 Ω 382.51 pF 1 900.000 000 MHz

*
De1
CA
Avg
16
H1d

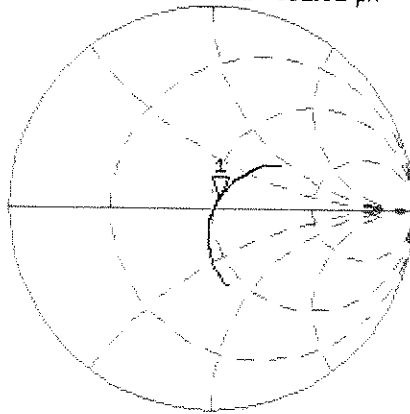

CH2 S11 LOG 5 dB/REF -20 dB 1:-25.507 dB 1 900.000 000 MHz

CA
Avg
16
H1d

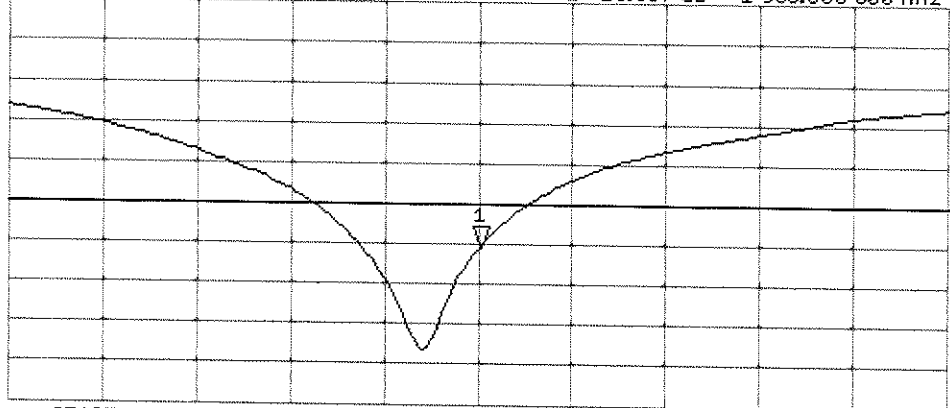

START 1 700.000 000 MHz

STOP 2 100.000 000 MHz

DASY5 Validation Report for Body TSL

Date: 14.04.2015

Test Laboratory: SPEAG, Zurich, Switzerland

DUT: Dipole 1900 MHz; Type: D1900V2; Serial: D1900V2 - SN:5d141

Communication System: UID 0 - CW; Frequency: 1900 MHz

Medium parameters used: $f = 1900$ MHz; $\sigma = 1.5$ S/m; $\epsilon_r = 52.8$; $\rho = 1000$ kg/m³

Phantom section: Flat Section

Measurement Standard: DASY5 (IEEE/IEC/ANSI C63.19-2011)

DASY52 Configuration:

- Probe: ES3DV3 - SN3205; ConvF(4.65, 4.65, 4.65); Calibrated: 30.12.2014;
- Sensor-Surface: 3mm (Mechanical Surface Detection)
- Electronics: DAE4 Sn601; Calibrated: 18.08.2014
- Phantom: Flat Phantom 5.0 (back); Type: QD000P50AA; Serial: 1002
- DASY52 52.8.8(1222); SEMCAD X 14.6.10(7331)

Dipole Calibration for Body Tissue/Pin=250 mW, d=10mm/Zoom Scan (7x7x7)/Cube 0:

Measurement grid: dx=5mm, dy=5mm, dz=5mm

Reference Value = 95.73 V/m; Power Drift = 0.01 dB

Peak SAR (extrapolated) = 16.9 W/kg

SAR(1 g) = 9.94 W/kg; SAR(10 g) = 5.29 W/kg

Maximum value of SAR (measured) = 12.5 W/kg

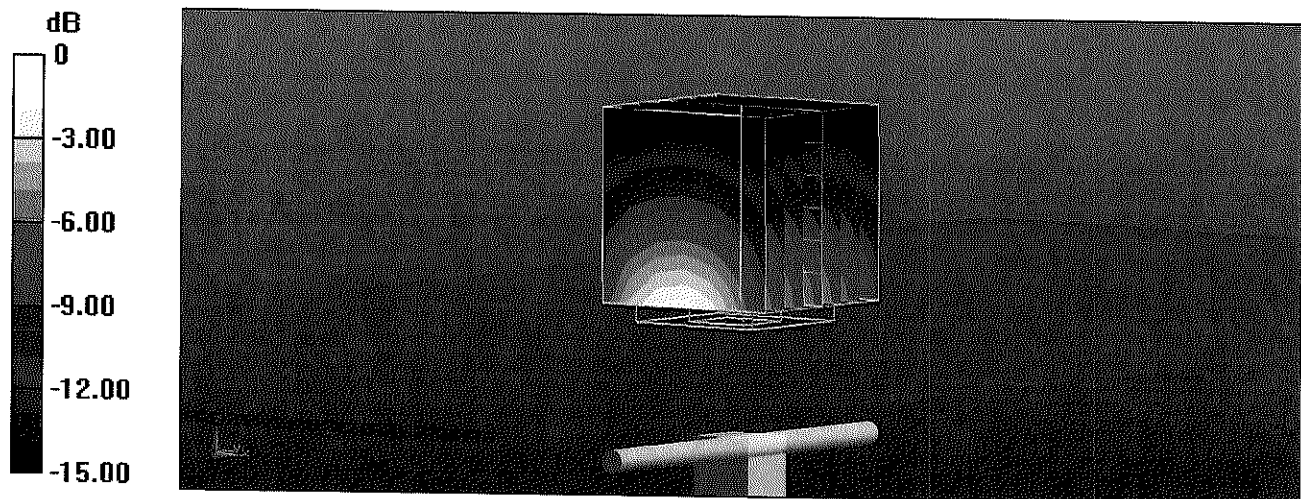

0 dB = 12.5 W/kg = 10.97 dBW/kg

Impedance Measurement Plot for Body TSL

14 Apr 2015 13:39:04

CH1 S11 1 U FS

1: 48.211 Ω 5.5664 Ω 466.27 pF

1 900.000 000 MHz

*
Del
CA

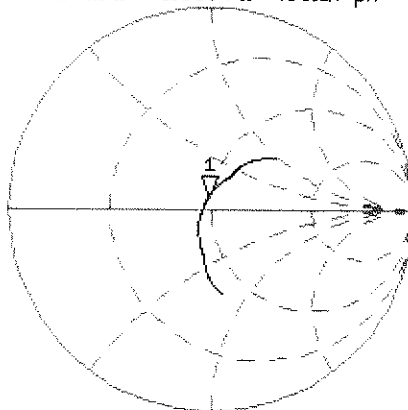

Avg
16

H1d

CH2 S11 LOG 5 dB/REF -20 dB 1:-24,520 dB 1 900.000 000 MHz

CA

Avg
16

H1d

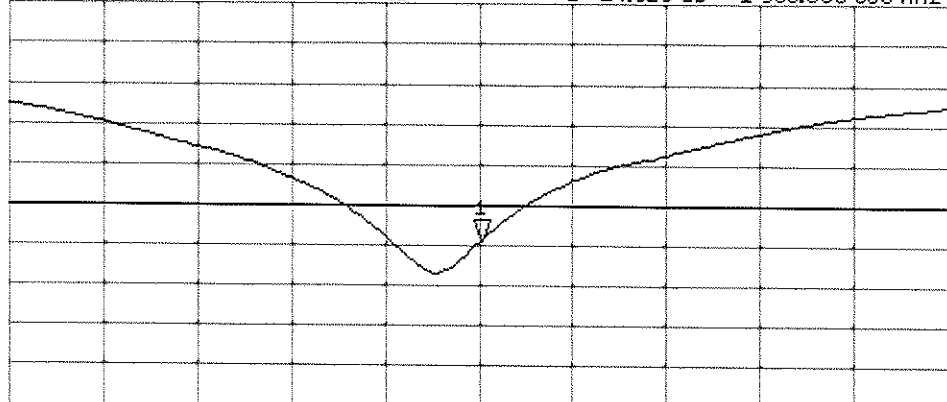

START 1 700.000 000 MHz

STOP 2 100.000 000 MHz



Accredited by the Swiss Accreditation Service (SAS)
The Swiss Accreditation Service is one of the signatories to the EA
Multilateral Agreement for the recognition of calibration certificates

Accreditation No.: **SCS 0108**

Client **PC Test**

Certificate No: **D2300V2-1008_Jan15**

CALIBRATION CERTIFICATE

Object **D2300V2 - SN:1008**

Calibration procedure(s) **QA CAL-05.v9**
Calibration procedure for dipole validation kits above 700 MHz CC
2/3/15

Calibration date: **January 27, 2015**

This calibration certificate documents the traceability to national standards, which realize the physical units of measurements (SI).
The measurements and the uncertainties with confidence probability are given on the following pages and are part of the certificate.

All calibrations have been conducted in the closed laboratory facility: environment temperature (22 ± 3)°C and humidity < 70%.

Calibration Equipment used (M&TE critical for calibration)

Primary Standards	ID #	Cal Date (Certificate No.)	Scheduled Calibration
Power meter EPM-442A	GB37480704	07-Oct-14 (No. 217-02020)	Oct-15
Power sensor HP 8481A	US37292783	07-Oct-14 (No. 217-02020)	Oct-15
Power sensor HP 8481A	MY41092317	07-Oct-14 (No. 217-02021)	Oct-15
Reference 20 dB Attenuator	SN: 5058 (20k)	03-Apr-14 (No. 217-01918)	Apr-15
Type-N mismatch combination	SN: 5047.2 / 06327	03-Apr-14 (No. 217-01921)	Apr-15
Reference Probe ES3DV3	SN: 3205	30-Dec-14 (No. ES3-3205_Dec14)	Dec-15
DAE4	SN: 601	18-Aug-14 (No. DAE4-601_Aug14)	Aug-15

Secondary Standards	ID #	Check Date (in house)	Scheduled Check
RF generator R&S SMT-06	100005	04-Aug-99 (in house check Oct-13)	In house check: Oct-16
Network Analyzer HP 8753E	US37390585 S4206	18-Oct-01 (in house check Oct-14)	In house check: Oct-15

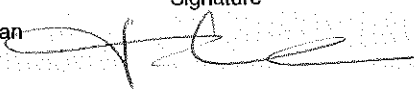
Calibrated by: **Jeton Kastrati** (Name) **Laboratory Technician** (Function)  (Signature)

Approved by: **Katja Pokovic** (Name) **Technical Manager** (Function)  (Signature)

Issued: January 27, 2015

This calibration certificate shall not be reproduced except in full without written approval of the laboratory.



Accredited by the Swiss Accreditation Service (SAS)

The Swiss Accreditation Service is one of the signatories to the EA Multilateral Agreement for the recognition of calibration certificates

Accreditation No.: **SCS 0108**

Glossary:

TSL	tissue simulating liquid
ConvF	sensitivity in TSL / NORM x,y,z
N/A	not applicable or not measured

Calibration is Performed According to the Following Standards:

- IEEE Std 1528-2013, "IEEE Recommended Practice for Determining the Peak Spatial-Averaged Specific Absorption Rate (SAR) in the Human Head from Wireless Communications Devices: Measurement Techniques", June 2013
- IEC 62209-1, "Procedure to measure the Specific Absorption Rate (SAR) for hand-held devices used in close proximity to the ear (frequency range of 300 MHz to 3 GHz)", February 2005
- KDB 865664, "SAR Measurement Requirements for 100 MHz to 6 GHz"

Additional Documentation:

- DASY4/5 System Handbook

Methods Applied and Interpretation of Parameters:

- Measurement Conditions:* Further details are available from the Validation Report at the end of the certificate. All figures stated in the certificate are valid at the frequency indicated.
- Antenna Parameters with TSL:* The dipole is mounted with the spacer to position its feed point exactly below the center marking of the flat phantom section, with the arms oriented parallel to the body axis.
- Feed Point Impedance and Return Loss:* These parameters are measured with the dipole positioned under the liquid filled phantom. The impedance stated is transformed from the measurement at the SMA connector to the feed point. The Return Loss ensures low reflected power. No uncertainty required.
- Electrical Delay:* One-way delay between the SMA connector and the antenna feed point. No uncertainty required.
- SAR measured:* SAR measured at the stated antenna input power.
- SAR normalized:* SAR as measured, normalized to an input power of 1 W at the antenna connector.
- SAR for nominal TSL parameters:* The measured TSL parameters are used to calculate the nominal SAR result.

The reported uncertainty of measurement is stated as the standard uncertainty of measurement multiplied by the coverage factor $k=2$, which for a normal distribution corresponds to a coverage probability of approximately 95%.

Measurement Conditions

DASY system configuration, as far as not given on page 1.

DASY Version	DASY5	V52.8.8
Extrapolation	Advanced Extrapolation	
Phantom	Modular Flat Phantom	
Distance Dipole Center - TSL	10 mm	with Spacer
Zoom Scan Resolution	dx, dy, dz = 5 mm	
Frequency	2300 MHz \pm 1 MHz	

Head TSL parameters

The following parameters and calculations were applied.

	Temperature	Permittivity	Conductivity
Nominal Head TSL parameters	22.0 °C	39.5	1.67 mho/m
Measured Head TSL parameters	(22.0 \pm 0.2) °C	39.9 \pm 6 %	1.71 mho/m \pm 6 %
Head TSL temperature change during test	< 0.5 °C	----	----

SAR result with Head TSL

SAR averaged over 1 cm³ (1 g) of Head TSL	Condition	
SAR measured	250 mW input power	12.6 W/kg
SAR for nominal Head TSL parameters	normalized to 1W	49.9 W/kg \pm 17.0 % (k=2)

SAR averaged over 10 cm³ (10 g) of Head TSL	condition	
SAR measured	250 mW input power	6.04 W/kg
SAR for nominal Head TSL parameters	normalized to 1W	24.0 W/kg \pm 16.5 % (k=2)

Body TSL parameters

The following parameters and calculations were applied.

	Temperature	Permittivity	Conductivity
Nominal Body TSL parameters	22.0 °C	52.9	1.81 mho/m
Measured Body TSL parameters	(22.0 \pm 0.2) °C	52.0 \pm 6 %	1.85 mho/m \pm 6 %
Body TSL temperature change during test	< 0.5 °C	----	----

SAR result with Body TSL

SAR averaged over 1 cm³ (1 g) of Body TSL	Condition	
SAR measured	250 mW input power	12.2 W/kg
SAR for nominal Body TSL parameters	normalized to 1W	48.1 W/kg \pm 17.0 % (k=2)

SAR averaged over 10 cm³ (10 g) of Body TSL	condition	
SAR measured	250 mW input power	5.81 W/kg
SAR for nominal Body TSL parameters	normalized to 1W	23.0 W/kg \pm 16.5 % (k=2)

Appendix (Additional assessments outside the scope of SCS0108)

Antenna Parameters with Head TSL

Impedance, transformed to feed point	48.8 Ω - 2.0 j Ω
Return Loss	- 32.5 dB

Antenna Parameters with Body TSL

Impedance, transformed to feed point	45.8 Ω - 1.5 j Ω
Return Loss	- 26.6 dB

General Antenna Parameters and Design

Electrical Delay (one direction)	1.169 ns
----------------------------------	----------

After long term use with 100W radiated power, only a slight warming of the dipole near the feedpoint can be measured.

The dipole is made of standard semirigid coaxial cable. The center conductor of the feeding line is directly connected to the second arm of the dipole. The antenna is therefore short-circuited for DC-signals. On some of the dipoles, small end caps are added to the dipole arms in order to improve matching when loaded according to the position as explained in the "Measurement Conditions" paragraph. The SAR data are not affected by this change. The overall dipole length is still according to the Standard.

No excessive force must be applied to the dipole arms, because they might bend or the soldered connections near the feedpoint may be damaged.

Additional EUT Data

Manufactured by	SPEAG
Manufactured on	October 30, 2007

DASY5 Validation Report for Head TSL

Date: 27.01.2015

Test Laboratory: SPEAG, Zurich, Switzerland

DUT: Dipole 2300 MHz; Type: D2300V2; Serial: D2300V2 - SN:1008

Communication System: UID 0 - CW; Frequency: 2300 MHz

Medium parameters used: $f = 2300$ MHz; $\sigma = 1.71$ S/m; $\epsilon_r = 39.9$; $\rho = 1000$ kg/m³

Phantom section: Flat Section

Measurement Standard: DASY5 (IEEE/IEC/ANSI C63.19-2011)

DASY52 Configuration:

- Probe: ES3DV3 - SN3205; ConvF(4.75, 4.75, 4.75); Calibrated: 30.12.2014;
- Sensor-Surface: 3mm (Mechanical Surface Detection)
- Electronics: DAE4 Sn601; Calibrated: 18.08.2014
- Phantom: Flat Phantom 5.0 (front); Type: QD000P50AA; Serial: 1001
- DASY52 52.8.8(1222); SEMCAD X 14.6.10(7331)

Dipole Calibration for Head Tissue/d=10mm, Pin=250 mW, dist=3.0mm (ES-Probe)/Zoom

Scan (7x7x7) 2 (7x7x7)/Cube 0: Measurement grid: dx=5mm, dy=5mm, dz=5mm

Reference Value = 101.6 V/m; Power Drift = 0.03 dB

Peak SAR (extrapolated) = 24.1 W/kg

SAR(1 g) = 12.6 W/kg; SAR(10 g) = 6.04 W/kg

Maximum value of SAR (measured) = 16.3 W/kg

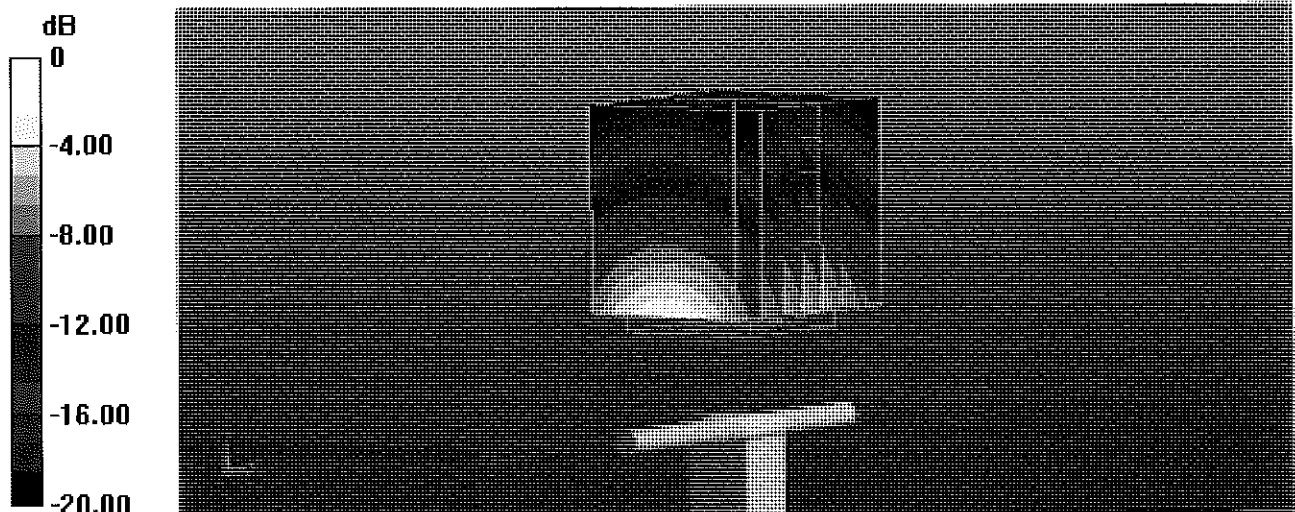

Impedance Measurement Plot for Head TSL

26 Jan 2015 17:09:25

CH1 S11 1 U FS 2: 48.832 Ω -2.0459 Δ 33.807 pF 2 300.000 000 MHz

*
De1
CA
Avg
16
H1d

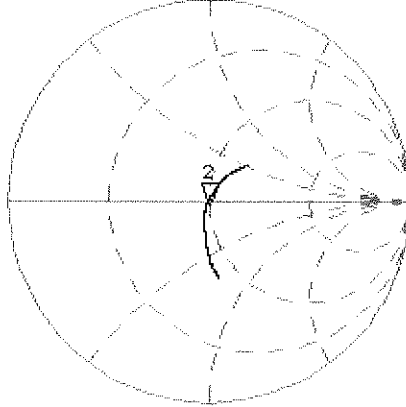

CH2 S11 LOG 5 dB/REF -20 dB 2: -32.452 dB 2 300.000 000 MHz

CA
Avg
16
H1d

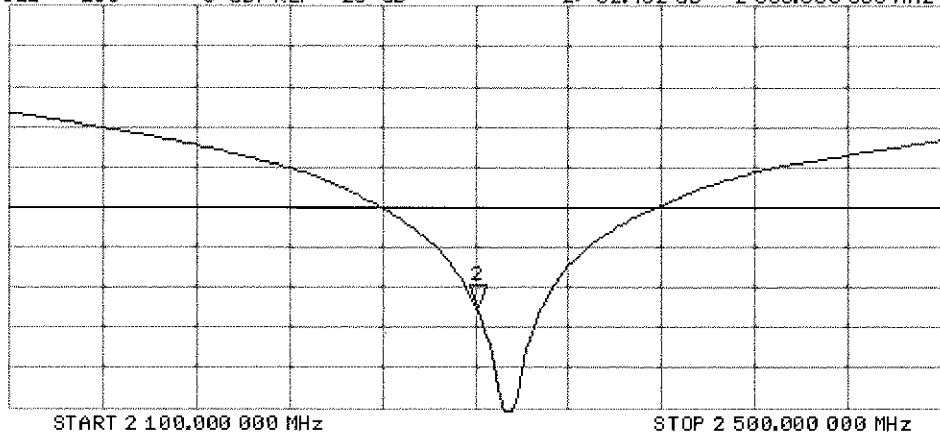

DASY5 Validation Report for Body TSL

Date: 27.01.2015

Test Laboratory: SPEAG, Zurich, Switzerland

DUT: Dipole 2300 MHz; Type: D2300V2; Serial: D2300V2 - SN:1008

Communication System: UID 0 - CW; Frequency: 2300 MHz

Medium parameters used: $f = 2300$ MHz; $\sigma = 1.85$ S/m; $\epsilon_r = 52$; $\rho = 1000$ kg/m³

Phantom section: Flat Section

Measurement Standard: DASY5 (IEEE/IEC/ANSI C63.19-2011)

DASY52 Configuration:

- Probe: ES3DV3 - SN3205; ConvF(4.44, 4.44, 4.44); Calibrated: 30.12.2014;
- Sensor-Surface: 3mm (Mechanical Surface Detection)
- Electronics: DAE4 Sn601; Calibrated: 18.08.2014
- Phantom: Flat Phantom 5.0 (back); Type: QD000P50AA; Serial: 1002
- DASY52 52.8.8(1222); SEMCAD X 14.6.10(7331)

Dipole Calibration for Body Tissue/d=10mm, Pin=250 mW, dist=3.0mm (ES-Probe)/Zoom

Scan (7x7x7) (7x7x7)/Cube 0: Measurement grid: dx=5mm, dy=5mm, dz=5mm

Reference Value = 95.62 V/m; Power Drift = 0.02 dB

Peak SAR (extrapolated) = 24.0 W/kg

SAR(1 g) = 12.2 W/kg; SAR(10 g) = 5.81 W/kg

Maximum value of SAR (measured) = 15.7 W/kg

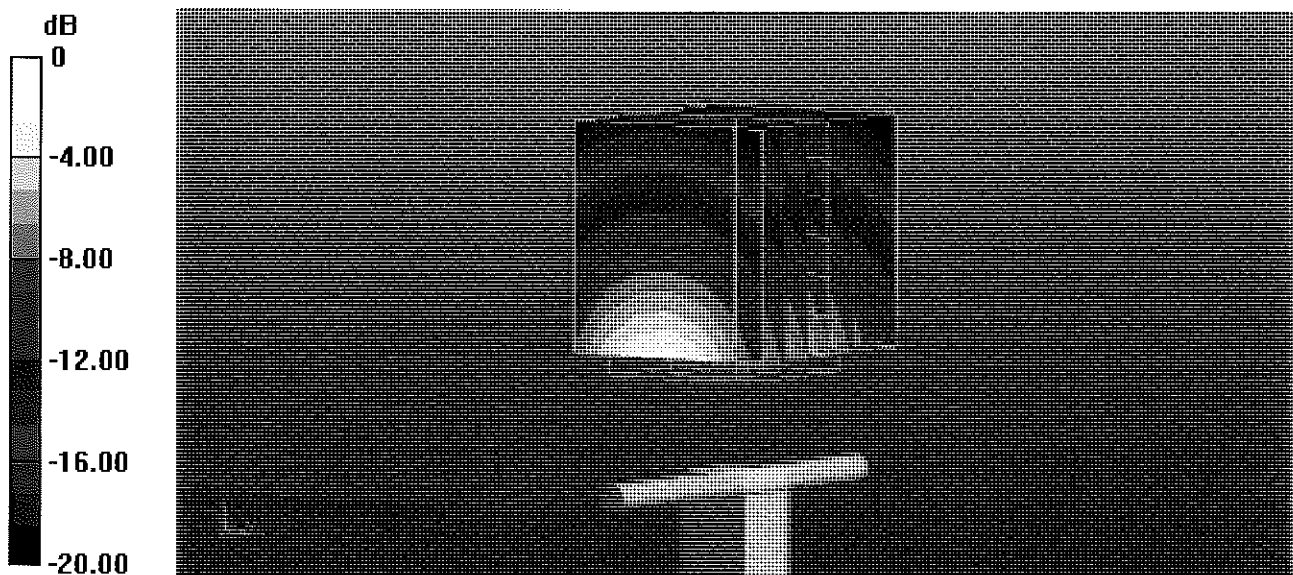

0 dB = 15.7 W/kg = 11.96 dBW/kg

Impedance Measurement Plot for Body TSL

26 Jan 2015 17:08:00

[CH1] S11 1 U FS 2: 45.758 Ω -1.4863 Ω 46.556 μ F 2 300.000 000 MHz

*
De1
C Δ
Avg
16
H1d

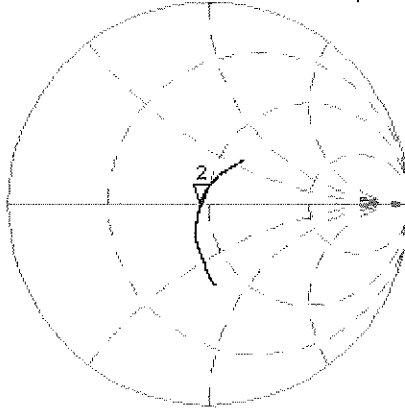

CH2 S11 LOG 5 dB/REF -20 dB 2:-26.571 dB 2 300.000 000 MHz

C Δ
Avg
16
H1d

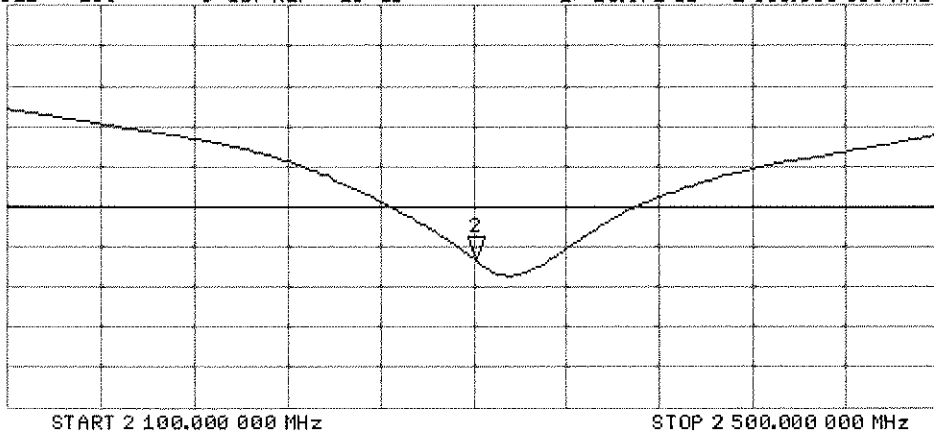



Accredited by the Swiss Accreditation Service (SAS)
The Swiss Accreditation Service is one of the signatories to the EA
Multilateral Agreement for the recognition of calibration certificates

Accreditation No.: **SCS 108**

Client **PC Test**

Certificate No: **D2450V2-719_Aug14**

CALIBRATION CERTIFICATE

Object **D2450V2 - SN: 719**

Calibration procedure(s) **QA CAL-05.v9
Calibration procedure for dipole validation kits above 700 MHz**

Calibration date: **August 11, 2014**

✓ KOK 9/8/14

This calibration certificate documents the traceability to national standards, which realize the physical units of measurements (SI).
The measurements and the uncertainties with confidence probability are given on the following pages and are part of the certificate.

All calibrations have been conducted in the closed laboratory facility: environment temperature (22 ± 3)°C and humidity < 70%.

Calibration Equipment used (M&TE critical for calibration)

Primary Standards	ID #	Cal Date (Certificate No.)	Scheduled Calibration
Power meter EPM-442A	GB37480704	09-Oct-13 (No. 217-01827)	Oct-14
Power sensor HP 8481A	US37292783	09-Oct-13 (No. 217-01827)	Oct-14
Power sensor HP 8481A	MY41092317	09-Oct-13 (No. 217-01828)	Oct-14
Reference 20 dB Attenuator	SN: 5058 (20k)	03-Apr-14 (No. 217-01918)	Apr-15
Type-N mismatch combination	SN: 5047.2 / 06327	03-Apr-14 (No. 217-01921)	Apr-15
Reference Probe ES3DV3	SN: 3205	30-Dec-13 (No. ES3-3205_Dec13)	Dec-14
DAE4	SN: 601	30-Apr-14 (No. DAE4-601_Apr14)	Apr-15
Secondary Standards	ID #	Check Date (in house)	Scheduled Check
RF generator R&S SMT-06	100005	04-Aug-99 (in house check Oct-13)	In house check: Oct-16
Network Analyzer HP 8753E	US37390585 S4206	18-Oct-01 (in house check Oct-13)	In house check: Oct-14

Calibrated by: **Michael Weber** Function: **Laboratory Technician** Signature: *M. Weber*

Approved by: **Katja Pokovic** Technical Manager *[Signature]*

Issued: August 12, 2014

This calibration certificate shall not be reproduced except in full without written approval of the laboratory.



Accredited by the Swiss Accreditation Service (SAS)
The Swiss Accreditation Service is one of the signatories to the EA
Multilateral Agreement for the recognition of calibration certificates

Accreditation No.: **SCS 108**

Glossary:

TSL	tissue simulating liquid
ConvF	sensitivity in TSL / NORM x,y,z
N/A	not applicable or not measured

Calibration is Performed According to the Following Standards:

- a) IEEE Std 1528-2013, "IEEE Recommended Practice for Determining the Peak Spatial-Averaged Specific Absorption Rate (SAR) in the Human Head from Wireless Communications Devices: Measurement Techniques", June 2013
- b) IEC 62209-1, "Procedure to measure the Specific Absorption Rate (SAR) for hand-held devices used in close proximity to the ear (frequency range of 300 MHz to 3 GHz)", February 2005
- c) KDB 865664, "SAR Measurement Requirements for 100 MHz to 6 GHz"

Additional Documentation:

- d) DASY4/5 System Handbook

Methods Applied and Interpretation of Parameters:

- *Measurement Conditions:* Further details are available from the Validation Report at the end of the certificate. All figures stated in the certificate are valid at the frequency indicated.
- *Antenna Parameters with TSL:* The dipole is mounted with the spacer to position its feed point exactly below the center marking of the flat phantom section, with the arms oriented parallel to the body axis.
- *Feed Point Impedance and Return Loss:* These parameters are measured with the dipole positioned under the liquid filled phantom. The impedance stated is transformed from the measurement at the SMA connector to the feed point. The Return Loss ensures low reflected power. No uncertainty required.
- *Electrical Delay:* One-way delay between the SMA connector and the antenna feed point. No uncertainty required.
- *SAR measured:* SAR measured at the stated antenna input power.
- *SAR normalized:* SAR as measured, normalized to an input power of 1 W at the antenna connector.
- *SAR for nominal TSL parameters:* The measured TSL parameters are used to calculate the nominal SAR result.

The reported uncertainty of measurement is stated as the standard uncertainty of measurement multiplied by the coverage factor $k=2$, which for a normal distribution corresponds to a coverage probability of approximately 95%.

Measurement Conditions

DASY system configuration, as far as not given on page 1.

DASY Version	DASY5	V52.8.8
Extrapolation	Advanced Extrapolation	
Phantom	Modular Flat Phantom	
Distance Dipole Center - TSL	10 mm	with Spacer
Zoom Scan Resolution	dx, dy, dz = 5 mm	
Frequency	2450 MHz ± 1 MHz	

Head TSL parameters

The following parameters and calculations were applied.

	Temperature	Permittivity	Conductivity
Nominal Head TSL parameters	22.0 °C	39.2	1.80 mho/m
Measured Head TSL parameters	(22.0 ± 0.2) °C	38.0 ± 6 %	1.82 mho/m ± 6 %
Head TSL temperature change during test	< 0.5 °C	----	----

SAR result with Head TSL

SAR averaged over 1 cm ³ (1 g) of Head TSL	Condition	
SAR measured	250 mW input power	13.2 W/kg
SAR for nominal Head TSL parameters	normalized to 1W	52.1 W/kg ± 17.0 % (k=2)

SAR averaged over 10 cm ³ (10 g) of Head TSL	condition	
SAR measured	250 mW input power	6.09 W/kg
SAR for nominal Head TSL parameters	normalized to 1W	24.2 W/kg ± 16.5 % (k=2)

Body TSL parameters

The following parameters and calculations were applied.

	Temperature	Permittivity	Conductivity
Nominal Body TSL parameters	22.0 °C	52.7	1.95 mho/m
Measured Body TSL parameters	(22.0 ± 0.2) °C	50.5 ± 6 %	2.02 mho/m ± 6 %
Body TSL temperature change during test	< 0.5 °C	----	----

SAR result with Body TSL

SAR averaged over 1 cm ³ (1 g) of Body TSL	Condition	
SAR measured	250 mW input power	13.3 W/kg
SAR for nominal Body TSL parameters	normalized to 1W	51.8 W/kg ± 17.0 % (k=2)

SAR averaged over 10 cm ³ (10 g) of Body TSL	condition	
SAR measured	250 mW input power	6.10 W/kg
SAR for nominal Body TSL parameters	normalized to 1W	24.0 W/kg ± 16.5 % (k=2)

Appendix (Additional assessments outside the scope of SCS108)

Antenna Parameters with Head TSL

Impedance, transformed to feed point	54.9 Ω + 3.0 j Ω
Return Loss	- 25.2 dB

Antenna Parameters with Body TSL

Impedance, transformed to feed point	50.9 Ω + 5.8 j Ω
Return Loss	- 24.7 dB

General Antenna Parameters and Design

Electrical Delay (one direction)	1.149 ns
----------------------------------	----------

After long term use with 100W radiated power, only a slight warming of the dipole near the feedpoint can be measured.

The dipole is made of standard semirigid coaxial cable. The center conductor of the feeding line is directly connected to the second arm of the dipole. The antenna is therefore short-circuited for DC-signals. On some of the dipoles, small end caps are added to the dipole arms in order to improve matching when loaded according to the position as explained in the "Measurement Conditions" paragraph. The SAR data are not affected by this change. The overall dipole length is still according to the Standard.

No excessive force must be applied to the dipole arms, because they might bend or the soldered connections near the feedpoint may be damaged.

Additional EUT Data

Manufactured by	SPEAG
Manufactured on	September 10, 2002

DASY5 Validation Report for Head TSL

Date: 11.08.2014

Test Laboratory: SPEAG, Zurich, Switzerland

DUT: Dipole 2450 MHz; Type: D2450V2; Serial: D2450V2 - SN: 719

Communication System: UID 0 - CW; Frequency: 2450 MHz

Medium parameters used: $f = 2450$ MHz; $\sigma = 1.82$ S/m; $\epsilon_r = 38$; $\rho = 1000$ kg/m³

Phantom section: Flat Section

Measurement Standard: DASY5 (IEEE/IEC/ANSI C63.19-2011)

DASY52 Configuration:

- Probe: ES3DV3 - SN3205; ConvF(4.53, 4.53, 4.53); Calibrated: 30.12.2013;
- Sensor-Surface: 3mm (Mechanical Surface Detection)
- Electronics: DAE4 Sn601; Calibrated: 30.04.2014
- Phantom: Flat Phantom 5.0 (front); Type: QD000P50AA; Serial: 1001
- DASY52 52.8.8(1222); SEMCAD X 14.6.10(7331)

Dipole Calibration for Head Tissue/Pin=250 mW, d=10mm/Zoom Scan (7x7x7)/Cube 0:

Measurement grid: dx=5mm, dy=5mm, dz=5mm

Reference Value = 101.6 V/m; Power Drift = 0.03 dB

Peak SAR (extrapolated) = 27.5 W/kg

SAR(1 g) = 13.2 W/kg; SAR(10 g) = 6.09 W/kg

Maximum value of SAR (measured) = 17.4 W/kg

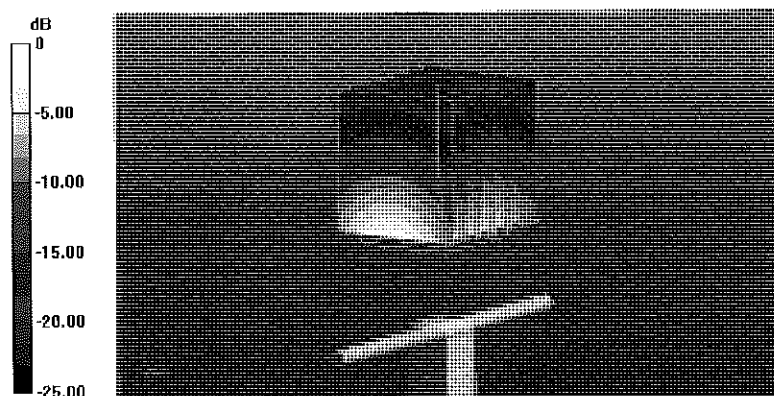

0 dB = 17.4 W/kg = 12.41 dBW/kg

Impedance Measurement Plot for Head TSL

11 Aug 2014 11:49:06
[CH1] S11 1 U FS 1: 54.887 Ω 3.0391 Ω 197.42 pF 2 450.000 000 MHz

Del
C Δ

Avg
16

H1 d

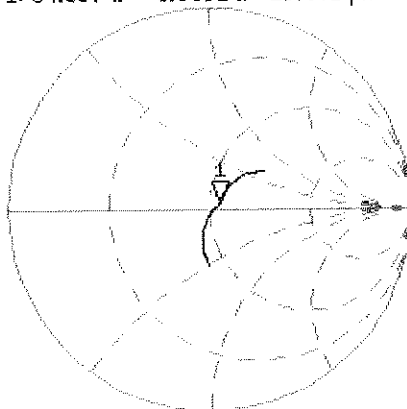

CH2 S11 LOG 5 dB/REF -20 dB 1: -25.212 dB 2 450.000 000 MHz

C Δ

Avg
16

H1 d

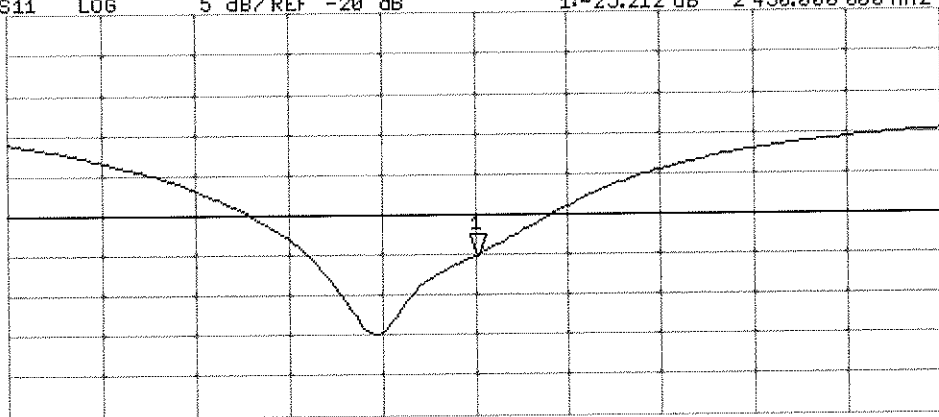

START 2 250.000 000 MHz

STOP 2 650.000 000 MHz

DASY5 Validation Report for Body TSL

Date: 11.08.2014

Test Laboratory: SPEAG, Zurich, Switzerland

DUT: Dipole 2450 MHz; Type: D2450V2; Serial: D2450V2 - SN: 719

Communication System: UID 0 - CW; Frequency: 2450 MHz

Medium parameters used: $f = 2450$ MHz; $\sigma = 2.02$ S/m; $\epsilon_r = 50.5$; $\rho = 1000$ kg/m³

Phantom section: Flat Section

Measurement Standard: DASY5 (IEEE/IEC/ANSI C63.19-2011)

DASY52 Configuration:

- Probe: ES3DV3 - SN3205; ConvF(4.35, 4.35, 4.35); Calibrated: 30.12.2013;
- Sensor-Surface: 3mm (Mechanical Surface Detection)
- Electronics: DAE4 Sn601; Calibrated: 30.04.2014
- Phantom: Flat Phantom 5.0 (back); Type: QD000P50AA; Serial: 1002
- DASY52 52.8.8(1222); SEMCAD X 14.6.10(7331)

Dipole Calibration for Body Tissue/ $P_{in}=250$ mW, $d=10$ mm/Zoom Scan (7x7x7)/Cube 0:

Measurement grid: $dx=5$ mm, $dy=5$ mm, $dz=5$ mm

Reference Value = 96.08 V/m; Power Drift = -0.01 dB

Peak SAR (extrapolated) = 27.9 W/kg

SAR(1 g) = 13.3 W/kg; SAR(10 g) = 6.1 W/kg

Maximum value of SAR (measured) = 17.6 W/kg

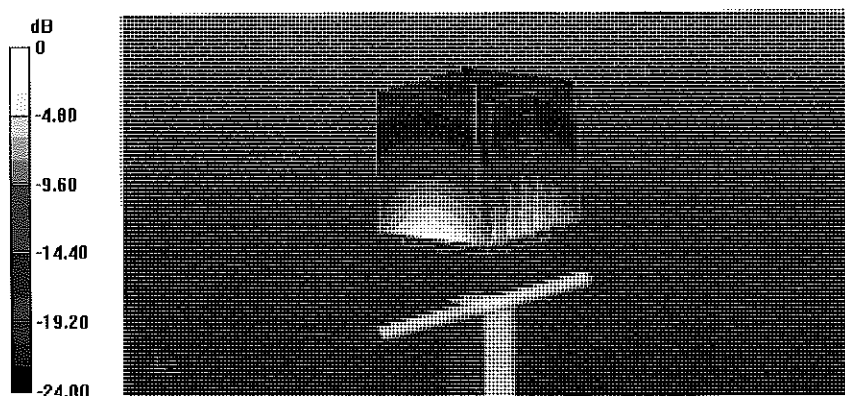

0 dB = 17.6 W/kg = 12.46 dBW/kg

Impedance Measurement Plot for Body TSL

11 Aug 2014 11:48:32

CH1 S11 1 U FS 1: 50.928 Δ 5.8223 Δ 378.22 pF 2 450.000 000 MHz

*
De1
CA

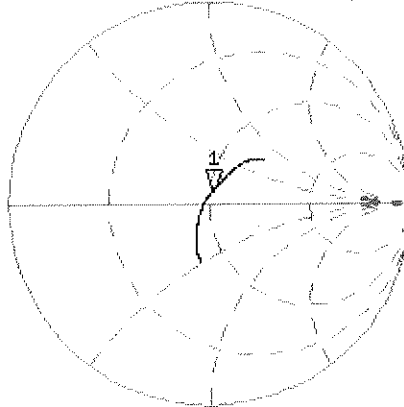

Avg
1E
H1d

CH2 S11 LOG 5 dB/REF -20 dB 1: -24.679 dB 2 450.000 000 MHz

CA
Avg
1E
H1d

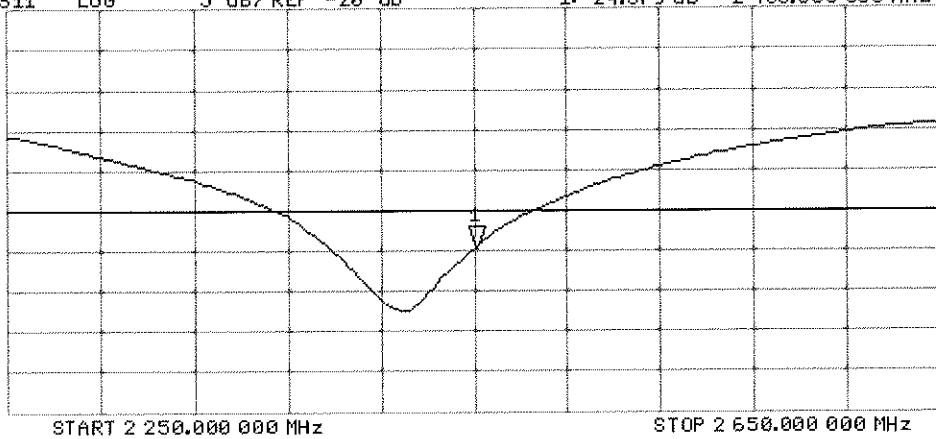



Accredited by the Swiss Accreditation Service (SAS)
The Swiss Accreditation Service is one of the signatories to the EA
Multilateral Agreement for the recognition of calibration certificates

Accreditation No.: **SCS 108**

Client **PC Test**

Certificate No: **D5GHzV2-1191_Sep14**

CALIBRATION CERTIFICATE

Object **D5GHzV2 - SN:1191**

Calibration procedure(s) **QA CAL-22.v2
Calibration procedure for dipole validation kits between 3-6 GHz**

*CC
11/14*

Calibration date: **September 25, 2014**

This calibration certificate documents the traceability to national standards, which realize the physical units of measurements (SI).
The measurements and the uncertainties with confidence probability are given on the following pages and are part of the certificate.

All calibrations have been conducted in the closed laboratory facility: environment temperature (22 ± 3)°C and humidity < 70%.

Calibration Equipment used (M&TE critical for calibration)

Primary Standards	ID #	Cal Date (Certificate No.)	Scheduled Calibration
Power meter EPM-442A	GB37480704	09-Oct-13 (No. 217-01827)	Oct-14
Power sensor HP 8481A	US37292783	09-Oct-13 (No. 217-01827)	Oct-14
Power sensor HP 8481A	MY41092317	09-Oct-13 (No. 217-01828)	Oct-14
Reference 20 dB Attenuator	SN: 5058 (20k)	03-Apr-14 (No. 217-01918)	Apr-15
Type-N mismatch combination	SN: 5047.2 / 06327	03-Apr-14 (No. 217-01921)	Apr-15
Reference Probe EX3DV4	SN: 3503	30-Dec-13 (No. EX3-3503_Dec13)	Dec-14
DAE4	SN: 601	18-Aug-14 (No. DAE4-601_Aug14)	Aug-15
Secondary Standards	ID #	Check Date (in house)	Scheduled Check
RF generator R&S SMT-06	100005	04-Aug-99 (in house check Oct-13)	In house check: Oct-16
Network Analyzer HP 8753E	US37390585 S4206	18-Oct-01 (in house check Oct-13)	In house check: Oct-14

Calibrated by: **Claudio Leubler** Name: Claudio Leubler Function: Laboratory Technician

Signature

Approved by: **Katja Pokovic** Name: Katja Pokovic Technical Manager

Issued: September 25, 2014

This calibration certificate shall not be reproduced except in full without written approval of the laboratory.

**Calibration Laboratory of
Schmid & Partner
Engineering AG**
Zeughausstrasse 43, 8004 Zurich, Switzerland



S Schweizerischer Kalibrierdienst
C Service suisse d'étalonnage
S Servizio svizzero di taratura
S Swiss Calibration Service

Accreditation No.: **SCS 108**

Accredited by the Swiss Accreditation Service (SAS)

The Swiss Accreditation Service is one of the signatories to the EA
Multilateral Agreement for the recognition of calibration certificates

Glossary:

TSL	tissue simulating liquid
ConvF	sensitivity in TSL / NORM x,y,z
N/A	not applicable or not measured

Calibration is Performed According to the Following Standards:

- IEC 62209-2, "Evaluation of Human Exposure to Radio Frequency Fields from Handheld and Body-Mounted Wireless Communication Devices in the Frequency Range of 30 MHz to 6 GHz: Human models, Instrumentation, and Procedures"; Part 2: "Procedure to determine the Specific Absorption Rate (SAR) for including accessories and multiple transmitters", March 2010
- KDB 865664, "SAR Measurement Requirements for 100 MHz to 6 GHz"
- IEEE Std 1528-2013, "IEEE Recommended Practice for Determining the Peak Spatial-Averaged Specific Absorption Rate (SAR) in the Human Head from Wireless Communications Devices: Measurement Techniques", June 2013

Additional Documentation:

- DASY4/5 System Handbook

Methods Applied and Interpretation of Parameters:

- Measurement Conditions:* Further details are available from the Validation Report at the end of the certificate. All figures stated in the certificate are valid at the frequency indicated.
- Antenna Parameters with TSL:* The dipole is mounted with the spacer to position its feed point exactly below the center marking of the flat phantom section, with the arms oriented parallel to the body axis.
- Feed Point Impedance and Return Loss:* These parameters are measured with the dipole positioned under the liquid filled phantom. The impedance stated is transformed from the measurement at the SMA connector to the feed point. The Return Loss ensures low reflected power. No uncertainty required.
- Electrical Delay:* One-way delay between the SMA connector and the antenna feed point. No uncertainty required.
- SAR measured:* SAR measured at the stated antenna input power.
- SAR normalized:* SAR as measured, normalized to an input power of 1 W at the antenna connector.
- SAR for nominal TSL parameters:* The measured TSL parameters are used to calculate the nominal SAR result.

The reported uncertainty of measurement is stated as the standard uncertainty of measurement multiplied by the coverage factor $k=2$, which for a normal distribution corresponds to a coverage probability of approximately 95%.

Measurement Conditions

DASY system configuration, as far as not given on page 1.

DASY Version	DASY5	V52.8.8
Extrapolation	Advanced Extrapolation	
Phantom	Modular Flat Phantom V5.0	
Distance Dipole Center - TSL	10 mm	with Spacer
Zoom Scan Resolution	dx, dy = 4.0 mm, dz = 1.4 mm	Graded Ratio = 1.4 (Z direction)
Frequency	5200 MHz ± 1 MHz 5300 MHz ± 1 MHz 5500 MHz ± 1 MHz 5600 MHz ± 1 MHz 5800 MHz ± 1 MHz	

Head TSL parameters at 5200 MHz

The following parameters and calculations were applied.

	Temperature	Permittivity	Conductivity
Nominal Head TSL parameters	22.0 °C	36.0	4.66 mho/m
Measured Head TSL parameters	(22.0 ± 0.2) °C	34.9 ± 6 %	4.54 mho/m ± 6 %
Head TSL temperature change during test	< 0.5 °C	----	----

SAR result with Head TSL at 5200 MHz

SAR averaged over 1 cm ³ (1 g) of Head TSL	Condition	
SAR measured	100 mW input power	8.17 W/kg
SAR for nominal Head TSL parameters	normalized to 1W	81.1 W/kg ± 19.9 % (k=2)

SAR averaged over 10 cm ³ (10 g) of Head TSL	condition	
SAR measured	100 mW input power	2.33 W/kg
SAR for nominal Head TSL parameters	normalized to 1W	23.1 W/kg ± 19.5 % (k=2)

Head TSL parameters at 5300 MHz

The following parameters and calculations were applied.

	Temperature	Permittivity	Conductivity
Nominal Head TSL parameters	22.0 °C	35.9	4.76 mho/m
Measured Head TSL parameters	(22.0 ± 0.2) °C	34.8 ± 6 %	4.64 mho/m ± 6 %
Head TSL temperature change during test	< 0.5 °C	----	----

SAR result with Head TSL at 5300 MHz

SAR averaged over 1 cm ³ (1 g) of Head TSL	Condition	
SAR measured	100 mW input power	8.64 W/kg
SAR for nominal Head TSL parameters	normalized to 1W	85.8 W / kg ± 19.9 % (k=2)

SAR averaged over 10 cm ³ (10 g) of Head TSL	condition	
SAR measured	100 mW input power	2.47 W/kg
SAR for nominal Head TSL parameters	normalized to 1W	24.5 W/kg ± 19.5 % (k=2)

Head TSL parameters at 5500 MHz

The following parameters and calculations were applied.

	Temperature	Permittivity	Conductivity
Nominal Head TSL parameters	22.0 °C	35.6	4.96 mho/m
Measured Head TSL parameters	(22.0 ± 0.2) °C	34.5 ± 6 %	4.83 mho/m ± 6 %
Head TSL temperature change during test	< 0.5 °C	----	----

SAR result with Head TSL at 5500 MHz

SAR averaged over 1 cm ³ (1 g) of Head TSL	Condition	
SAR measured	100 mW input power	8.93 W/kg
SAR for nominal Head TSL parameters	normalized to 1W	88.6 W/kg ± 19.9 % (k=2)

SAR averaged over 10 cm ³ (10 g) of Head TSL	condition	
SAR measured	100 mW input power	2.54 W/kg
SAR for nominal Head TSL parameters	normalized to 1W	25.2 W/kg ± 19.5 % (k=2)

Head TSL parameters at 5600 MHz

The following parameters and calculations were applied.

	Temperature	Permittivity	Conductivity
Nominal Head TSL parameters	22.0 °C	35.5	5.07 mho/m
Measured Head TSL parameters	(22.0 ± 0.2) °C	34.4 ± 6 %	4.93 mho/m ± 6 %
Head TSL temperature change during test	< 0.5 °C	----	----

SAR result with Head TSL at 5600 MHz

SAR averaged over 1 cm ³ (1 g) of Head TSL	Condition	
SAR measured	100 mW input power	8.76 W/kg
SAR for nominal Head TSL parameters	normalized to 1W	86.9 W/kg ± 19.9 % (k=2)

SAR averaged over 10 cm ³ (10 g) of Head TSL	condition	
SAR measured	100 mW input power	2.49 W/kg
SAR for nominal Head TSL parameters	normalized to 1W	24.7 W/kg ± 19.5 % (k=2)

Head TSL parameters at 5800 MHz

The following parameters and calculations were applied.

	Temperature	Permittivity	Conductivity
Nominal Head TSL parameters	22.0 °C	35.3	5.27 mho/m
Measured Head TSL parameters	(22.0 ± 0.2) °C	34.1 ± 6 %	5.14 mho/m ± 6 %
Head TSL temperature change during test	< 0.5 °C	----	----

SAR result with Head TSL at 5800 MHz

SAR averaged over 1 cm ³ (1 g) of Head TSL	Condition	
SAR measured	100 mW input power	8.30 W/kg
SAR for nominal Head TSL parameters	normalized to 1W	82.3 W/kg ± 19.9 % (k=2)

SAR averaged over 10 cm ³ (10 g) of Head TSL	condition	
SAR measured	100 mW input power	2.35 W/kg
SAR for nominal Head TSL parameters	normalized to 1W	23.3 W/kg ± 19.5 % (k=2)

Body TSL parameters at 5200 MHz

The following parameters and calculations were applied.

	Temperature	Permittivity	Conductivity
Nominal Body TSL parameters	22.0 °C	49.0	5.30 mho/m
Measured Body TSL parameters	(22.0 ± 0.2) °C	47.1 ± 6 %	5.40 mho/m ± 6 %
Body TSL temperature change during test	< 0.5 °C	----	----

SAR result with Body TSL at 5200 MHz

SAR averaged over 1 cm ³ (1 g) of Body TSL	Condition	
SAR measured	100 mW input power	7.84 W/kg
SAR for nominal Body TSL parameters	normalized to 1W	77.8 W/kg ± 19.9 % (k=2)

SAR averaged over 10 cm ³ (10 g) of Body TSL	condition	
SAR measured	100 mW input power	2.18 W/kg
SAR for nominal Body TSL parameters	normalized to 1W	21.6 W/kg ± 19.5 % (k=2)

Body TSL parameters at 5300 MHz

The following parameters and calculations were applied.

	Temperature	Permittivity	Conductivity
Nominal Body TSL parameters	22.0 °C	48.9	5.42 mho/m
Measured Body TSL parameters	(22.0 ± 0.2) °C	46.9 ± 6 %	5.53 mho/m ± 6 %
Body TSL temperature change during test	< 0.5 °C	----	----

SAR result with Body TSL at 5300 MHz

SAR averaged over 1 cm ³ (1 g) of Body TSL	Condition	
SAR measured	100 mW input power	8.05 W/kg
SAR for nominal Body TSL parameters	normalized to 1W	79.9 W/kg ± 19.9 % (k=2)

SAR averaged over 10 cm ³ (10 g) of Body TSL	condition	
SAR measured	100 mW input power	2.25 W/kg
SAR for nominal Body TSL parameters	normalized to 1W	22.3 W/kg ± 19.5 % (k=2)

Body TSL parameters at 5500 MHz

The following parameters and calculations were applied.

	Temperature	Permittivity	Conductivity
Nominal Body TSL parameters	22.0 °C	48.6	5.65 mho/m
Measured Body TSL parameters	(22.0 ± 0.2) °C	46.6 ± 6 %	5.79 mho/m ± 6 %
Body TSL temperature change during test	< 0.5 °C	----	----

SAR result with Body TSL at 5500 MHz

SAR averaged over 1 cm ³ (1 g) of Body TSL	Condition	
SAR measured	100 mW input power	8.37 W/kg
SAR for nominal Body TSL parameters	normalized to 1W	83.1 W/kg ± 19.9 % (k=2)

SAR averaged over 10 cm ³ (10 g) of Body TSL	condition	
SAR measured	100 mW input power	2.32 W/kg
SAR for nominal Body TSL parameters	normalized to 1W	23.0 W/kg ± 19.5 % (k=2)

Body TSL parameters at 5600 MHz

The following parameters and calculations were applied.

	Temperature	Permittivity	Conductivity
Nominal Body TSL parameters	22.0 °C	48.5	5.77 mho/m
Measured Body TSL parameters	(22.0 ± 0.2) °C	46.4 ± 6 %	5.93 mho/m ± 6 %
Body TSL temperature change during test	< 0.5 °C	----	----

SAR result with Body TSL at 5600 MHz

SAR averaged over 1 cm ³ (1 g) of Body TSL	Condition	
SAR measured	100 mW input power	8.48 W/kg
SAR for nominal Body TSL parameters	normalized to 1W	84.1 W/kg ± 19.9 % (k=2)

SAR averaged over 10 cm ³ (10 g) of Body TSL	condition	
SAR measured	100 mW input power	2.35 W/kg
SAR for nominal Body TSL parameters	normalized to 1W	23.3 W/kg ± 19.5 % (k=2)

Body TSL parameters at 5800 MHz

The following parameters and calculations were applied.

	Temperature	Permittivity	Conductivity
Nominal Body TSL parameters	22.0 °C	48.2	6.00 mho/m
Measured Body TSL parameters	(22.0 ± 0.2) °C	46.1 ± 6 %	6.21 mho/m ± 6 %
Body TSL temperature change during test	< 0.5 °C	----	----

SAR result with Body TSL at 5800 MHz

SAR averaged over 1 cm ³ (1 g) of Body TSL	Condition	
SAR measured	100 mW input power	7.86 W/kg
SAR for nominal Body TSL parameters	normalized to 1W	78.0 W/kg ± 19.9 % (k=2)

SAR averaged over 10 cm ³ (10 g) of Body TSL	condition	
SAR measured	100 mW input power	2.17 W/kg
SAR for nominal Body TSL parameters	normalized to 1W	21.5 W/kg ± 19.5 % (k=2)

Appendix (Additional assessments outside the scope of SCS108)

Antenna Parameters with Head TSL at 5200 MHz

Impedance, transformed to feed point	51.8 Ω - 9.9 j Ω
Return Loss	- 20.1 dB

Antenna Parameters with Head TSL at 5300 MHz

Impedance, transformed to feed point	54.5 Ω - 1.5 j Ω
Return Loss	- 26.8 dB

Antenna Parameters with Head TSL at 5500 MHz

Impedance, transformed to feed point	49.6 Ω - 2.0 j Ω
Return Loss	- 33.9 dB

Antenna Parameters with Head TSL at 5600 MHz

Impedance, transformed to feed point	56.5 Ω - 4.4 j Ω
Return Loss	- 22.7 dB

Antenna Parameters with Head TSL at 5800 MHz

Impedance, transformed to feed point	56.6 Ω + 4.4 j Ω
Return Loss	- 22.6 dB

Antenna Parameters with Body TSL at 5200 MHz

Impedance, transformed to feed point	51.9 Ω - 8.1 j Ω
Return Loss	- 21.8 dB

Antenna Parameters with Body TSL at 5300 MHz

Impedance, transformed to feed point	54.5 Ω + 0.1 j Ω
Return Loss	- 27.3 dB

Antenna Parameters with Body TSL at 5500 MHz

Impedance, transformed to feed point	50.2 Ω - 0.6 j Ω
Return Loss	- 43.8 dB

Antenna Parameters with Body TSL at 5600 MHz

Impedance, transformed to feed point	57.5 Ω - 3.2 j Ω
Return Loss	- 22.4 dB

Antenna Parameters with Body TSL at 5800 MHz

Impedance, transformed to feed point	57.2 Ω + 5.2 j Ω
Return Loss	- 21.7 dB

General Antenna Parameters and Design

Electrical Delay (one direction)	1.202 ns
----------------------------------	----------

After long term use with 100W radiated power, only a slight warming of the dipole near the feedpoint can be measured.

The dipole is made of standard semirigid coaxial cable. The center conductor of the feeding line is directly connected to the second arm of the dipole. The antenna is therefore short-circuited for DC-signals. On some of the dipoles, small end caps are added to the dipole arms in order to improve matching when loaded according to the position as explained in the "Measurement Conditions" paragraph. The SAR data are not affected by this change. The overall dipole length is still according to the Standard.

No excessive force must be applied to the dipole arms, because they might bend or the soldered connections near the feedpoint may be damaged.

Additional EUT Data

Manufactured by	SPEAG
Manufactured on	April 01, 2014

DASY5 Validation Report for Head TSL

Date: 25.09.2014

Test Laboratory: SPEAG, Zurich, Switzerland

DUT: Dipole 5GHz; Type: D5GHzV2; Serial: D5GHzV2 - SN:1191

Communication System: UID 0 - CW; Frequency: 5200 MHz, Frequency: 5300 MHz, Frequency: 5500 MHz, Frequency: 5600 MHz, Frequency: 5800 MHz

Medium parameters used: $f = 5200$ MHz; $\sigma = 4.54$ S/m; $\epsilon_r = 34.9$; $\rho = 1000$ kg/m³

Medium parameters used: $f = 5300$ MHz; $\sigma = 4.64$ S/m; $\epsilon_r = 34.8$; $\rho = 1000$ kg/m³

Medium parameters used: $f = 5500$ MHz; $\sigma = 4.83$ S/m; $\epsilon_r = 34.5$; $\rho = 1000$ kg/m³

Medium parameters used: $f = 5600$ MHz; $\sigma = 4.93$ S/m; $\epsilon_r = 34.4$; $\rho = 1000$ kg/m³

Medium parameters used: $f = 5800$ MHz; $\sigma = 5.14$ S/m; $\epsilon_r = 34.1$; $\rho = 1000$ kg/m³

Phantom section: Flat Section

Measurement Standard: DASY5 (IBEE/IEC/ANSI C63.19-2011)

DASY52 Configuration:

- Probe: EX3DV4 - SN3503; ConvF(5.52, 5.52, 5.52); Calibrated: 30.12.2013, ConvF(5.2, 5.2, 5.2); Calibrated: 30.12.2013, ConvF(5.01, 5.01, 5.01); Calibrated: 30.12.2013, ConvF(4.86, 4.86, 4.86); Calibrated: 30.12.2013, ConvF(4.91, 4.91, 4.91); Calibrated: 30.12.2013;
- Sensor-Surface: 1.4mm (Mechanical Surface Detection)
- Electronics: DAE4 Sn601; Calibrated: 18.08.2014
- Phantom: Flat Phantom 5.0 (front); Type: QD000P50AA; Serial: 1001
- DASY52 52.8.8(1222); SEMCAD X 14.6.10(7331)

Dipole Calibration for Head Tissue/Pin=100mW, dist=10mm, f=5200 MHz/Zoom Scan,

dist=1.4mm (8x8x7)/Cube 0: Measurement grid: dx=4mm, dy=4mm, dz=1.4mm

Reference Value = 65.20 V/m; Power Drift = 0.04 dB

Peak SAR (extrapolated) = 30.0 W/kg

SAR(1 g) = 8.17 W/kg; SAR(10 g) = 2.33 W/kg

Maximum value of SAR (measured) = 18.5 W/kg

Dipole Calibration for Head Tissue/Pin=100mW, dist=10mm, f=5300 MHz/Zoom Scan,

dist=1.4mm (8x8x7)/Cube 0: Measurement grid: dx=4mm, dy=4mm, dz=1.4mm

Reference Value = 65.90 V/m; Power Drift = 0.09 dB

Peak SAR (extrapolated) = 32.7 W/kg

SAR(1 g) = 8.64 W/kg; SAR(10 g) = 2.47 W/kg

Maximum value of SAR (measured) = 19.8 W/kg

Dipole Calibration for Head Tissue/Pin=100mW, dist=10mm, f=5500 MHz/Zoom Scan,

dist=1.4mm (8x8x7)/Cube 0: Measurement grid: dx=4mm, dy=4mm, dz=1.4mm

Reference Value = 65.91 V/m; Power Drift = 0.09 dB

Peak SAR (extrapolated) = 35.3 W/kg

SAR(1 g) = 8.93 W/kg; SAR(10 g) = 2.54 W/kg

Maximum value of SAR (measured) = 20.9 W/kg

Dipole Calibration for Head Tissue/Pin=100mW, dist=10mm, f=5600 MHz/Zoom Scan, dist=1.4mm (8x8x7)/Cube 0: Measurement grid: dx=4mm, dy=4mm, dz=1.4mm
Reference Value = 65.29 V/m; Power Drift = 0.07 dB
Peak SAR (extrapolated) = 34.8 W/kg
SAR(1 g) = 8.76 W/kg; SAR(10 g) = 2.49 W/kg
Maximum value of SAR (measured) = 20.7 W/kg

Dipole Calibration for Head Tissue/Pin=100mW, dist=10mm, f=5800 MHz/Zoom Scan, dist=1.4mm (8x8x7)/Cube 0: Measurement grid: dx=4mm, dy=4mm, dz=1.4mm
Reference Value = 62.74 V/m; Power Drift = 0.06 dB
Peak SAR (extrapolated) = 34.4 W/kg
SAR(1 g) = 8.3 W/kg; SAR(10 g) = 2.35 W/kg

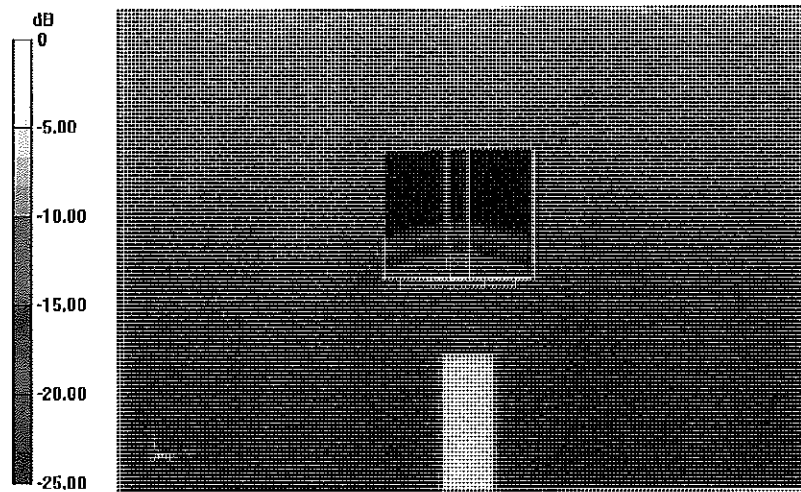

0 dB = 19.8 W/kg = 12.97 dBW/kg

Impedance Measurement Plot for Head TSL

25 Sep 2014 11:07:52

CH1 S11 1 U FS 1: 51.911 Ω -9.9180 Ω 3.0860 pF 5 200.000 000 MHz

*
Del
Cor
Avg
0
H1d

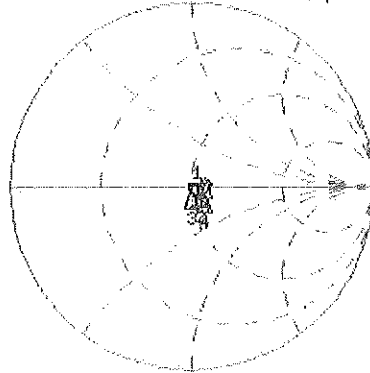

CH1 Markers

2: 54.518 Ω
-1.5078 Ω
5.30000 GHz
3: 49.566 Ω
-1.9707 Ω
5.50000 GHz
4: 56.516 Ω
-4.3633 Ω
5.60000 GHz
5: 56.555 Ω
4.3904 Ω
5.80000 GHz

CH2 S11 LOG 5 dB/REF -20 dB 1: -20.126 dB 5 200.000 000 MHz

Cor
Avg
0
H1d

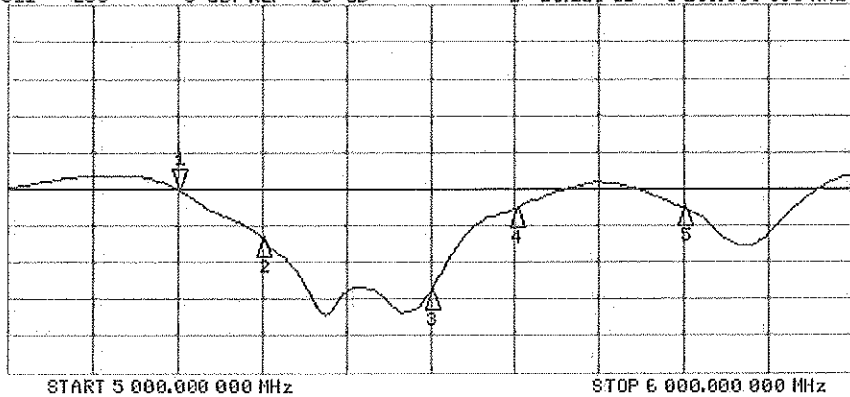

CH2 Markers

2: -26.825 dB
5.30000 GHz
3: -33.870 dB
5.50000 GHz
4: -22.660 dB
5.60000 GHz
5: -22.611 dB
5.80000 GHz

DASY5 Validation Report for Body TSL

Date: 24.09.2014

Test Laboratory: SPEAG, Zurich, Switzerland

DUT: Dipole 5GHz; Type: D5GHzV2; Serial: D5GHzV2 - SN:1191

Communication System: UID 0 - CW; Frequency: 5200 MHz, Frequency: 5300 MHz, Frequency: 5500 MHz, Frequency: 5600 MHz, Frequency: 5800 MHz

Medium parameters used: $f = 5200$ MHz; $\sigma = 5.4$ S/m; $\epsilon_r = 47.1$; $\rho = 1000$ kg/m³

Medium parameters used: $f = 5300$ MHz; $\sigma = 5.53$ S/m; $\epsilon_r = 46.9$; $\rho = 1000$ kg/m³

Medium parameters used: $f = 5500$ MHz; $\sigma = 5.79$ S/m; $\epsilon_r = 46.6$; $\rho = 1000$ kg/m³

Medium parameters used: $f = 5600$ MHz; $\sigma = 5.93$ S/m; $\epsilon_r = 46.4$; $\rho = 1000$ kg/m³

Medium parameters used: $f = 5800$ MHz; $\sigma = 6.21$ S/m; $\epsilon_r = 46.1$; $\rho = 1000$ kg/m³

Phantom section: Flat Section

Measurement Standard: DASY5 (IEBE/IEC/ANSI C63.19-2011)

DASY52 Configuration:

- Probe: EX3DV4 - SN3503; ConvF(5.01, 5.01, 5.01); Calibrated: 30.12.2013, ConvF(4.76, 4.76, 4.76); Calibrated: 30.12.2013, ConvF(4.52, 4.52, 4.52); Calibrated: 30.12.2013, ConvF(4.3, 4.3, 4.3); Calibrated: 30.12.2013, ConvF(4.47, 4.47, 4.47); Calibrated: 30.12.2013;
- Sensor-Surface: 1.4mm (Mechanical Surface Detection)
- Electronics: DAE4 Sn601; Calibrated: 18.08.2014
- Phantom: Flat Phantom 5.0 (back); Type: QD000P50AA; Serial: 1002
- DASY52 52.8.8(1222); SEMCAD X 14.6.10(7331)

Dipole Calibration for Body Tissue/Pin=100mW, dist=10mm, f=5200 MHz/Zoom Scan, dist=1.4mm (8x8x7)/Cube 0: Measurement grid: dx=4mm, dy=4mm, dz=1.4mm

Reference Value = 60.46 V/m; Power Drift = 0.02 dB

Peak SAR (extrapolated) = 30.7 W/kg

SAR(1 g) = 7.84 W/kg; SAR(10 g) = 2.18 W/kg

Maximum value of SAR (measured) = 18.5 W/kg

Dipole Calibration for Body Tissue/Pin=100mW, dist=10mm, f=5300 MHz/Zoom Scan, dist=1.4mm (8x8x7)/Cube 0: Measurement grid: dx=4mm, dy=4mm, dz=1.4mm

Reference Value = 60.42 V/m; Power Drift = 0.03 dB

Peak SAR (extrapolated) = 32.1 W/kg

SAR(1 g) = 8.05 W/kg; SAR(10 g) = 2.25 W/kg

Maximum value of SAR (measured) = 19.1 W/kg

Dipole Calibration for Body Tissue/Pin=100mW, dist=10mm, f=5500 MHz/Zoom Scan, dist=1.4mm (8x8x7)/Cube 0: Measurement grid: dx=4mm, dy=4mm, dz=1.4mm

Reference Value = 60.44 V/m; Power Drift = 0.02 dB

Peak SAR (extrapolated) = 35.8 W/kg

SAR(1 g) = 8.37 W/kg; SAR(10 g) = 2.32 W/kg

Maximum value of SAR (measured) = 20.4 W/kg

Dipole Calibration for Body Tissue/Pin=100mW, dist=10mm, f=5600 MHz/Zoom Scan, dist=1.4mm (8x8x7)/Cube 0: Measurement grid: dx=4mm, dy=4mm, dz=1.4mm
Reference Value = 60.44 V/m; Power Drift = 0.01 dB
Peak SAR (extrapolated) = 37.0 W/kg
SAR(1 g) = 8.48 W/kg; SAR(10 g) = 2.35 W/kg
Maximum value of SAR (measured) = 20.9 W/kg

Dipole Calibration for Body Tissue/Pin=100mW, dist=10mm, f=5800 MHz/Zoom Scan, dist=1.4mm (8x8x7)/Cube 0: Measurement grid: dx=4mm, dy=4mm, dz=1.4mm
Reference Value = 56.69 V/m; Power Drift = 0.01 dB
Peak SAR (extrapolated) = 36.4 W/kg
SAR(1 g) = 7.86 W/kg; SAR(10 g) = 2.17 W/kg
Maximum value of SAR (measured) = 19.7 W/kg

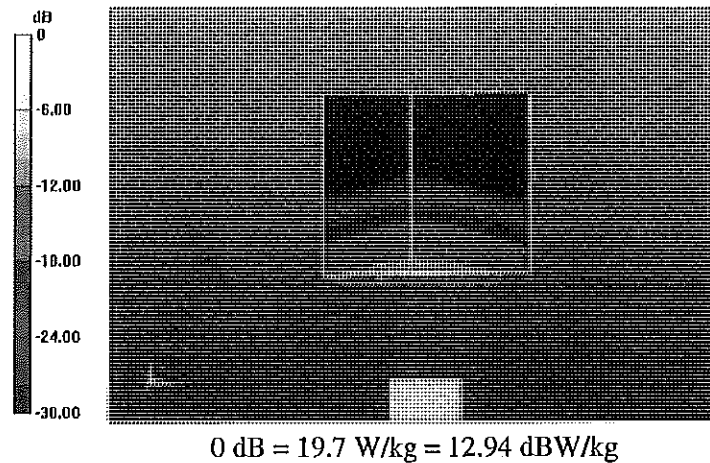

Impedance Measurement Plot for Body TSL

24 Sep 2014 11:05:50

[CH1] S11 1 U FS 1: 51.867 Ω -8.0566 Ω 3.7989 pF 5 200.000 000 MHz

Del
Cor
Avg
16
H1d

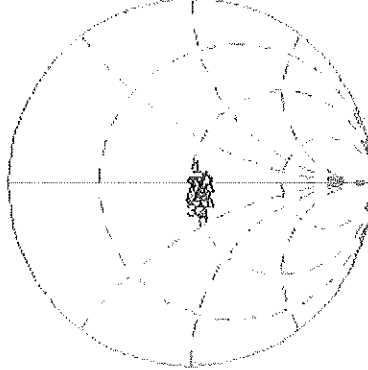

CH1 Markers
2: 54.531 Ω
0.1015 Ω
5.30000 GHz
3: 50.207 Ω
-613.28 pF
5.50000 GHz
4: 57.480 Ω
-3.1563 Ω
5.60000 GHz
5: 57.150 Ω
5.1934 Ω
5.80000 GHz

CH2 S11 LOG 5 dB/REF -20 dB 1: -21.835 dB 5 200.000 000 MHz

Cor
Avg
16
H1d

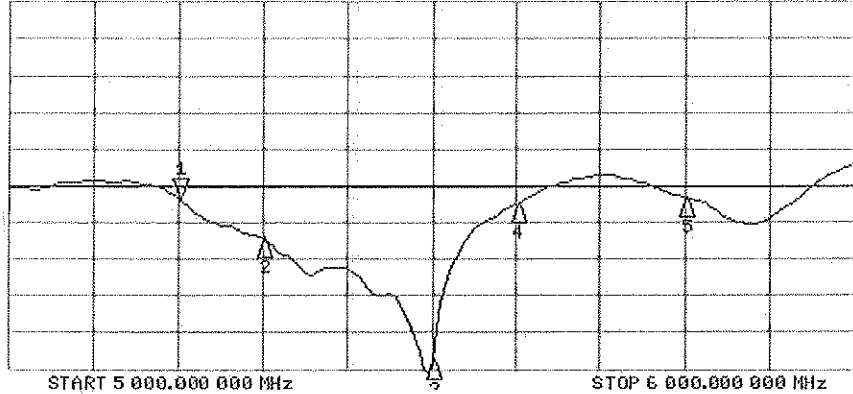

CH2 Markers
2: -27.251 dB
5.30000 GHz
3: -43.776 dB
5.50000 GHz
4: -22.442 dB
5.60000 GHz
5: -21.682 dB
5.80000 GHz



Accredited by the Swiss Accreditation Service (SAS)
The Swiss Accreditation Service is one of the signatories to the EA
Multilateral Agreement for the recognition of calibration certificates

Accreditation No.: **SCS 108**

Client **PC Test**

Certificate No: **D1765V2-1008_May14**

CALIBRATION CERTIFICATE

Object **D1765V2 - SN: 1008**

Calibration procedure(s) **QA CAL-05.v9
Calibration procedure for dipole validation kits above 700 MHz**

*CCV
6/2/14*

Calibration date: **May 07, 2014**

This calibration certificate documents the traceability to national standards, which realize the physical units of measurements (SI).
The measurements and the uncertainties with confidence probability are given on the following pages and are part of the certificate.

All calibrations have been conducted in the closed laboratory facility: environment temperature (22 ± 3)°C and humidity < 70%.

Calibration Equipment used (M&TE critical for calibration)

Primary Standards	ID #	Cal Date (Certificate No.)	Scheduled Calibration
Power meter EPM-442A	GB37480704	09-Oct-13 (No. 217-01827)	Oct-14
Power sensor HP 8481A	US37292783	09-Oct-13 (No. 217-01827)	Oct-14
Power sensor HP 8481A	MY41092317	09-Oct-13 (No. 217-01828)	Oct-14
Reference 20 dB Attenuator	SN: 5058 (20k)	03-Apr-14 (No. 217-01918)	Apr-15
Type-N mismatch combination	SN: 5047.2 / 06327	03-Apr-14 (No. 217-01921)	Apr-15
Reference Probe ES3DV3	SN: 3205	30-Dec-13 (No. ES3-3205_Dec13)	Dec-14
DAE4	SN: 601	30-Apr-14 (No. DAE4-601_Apr14)	Apr-15
Secondary Standards	ID #	Check Date (in house)	Scheduled Check
RF generator R&S SMT-06	100005	04-Aug-99 (in house check Oct-13)	In house check: Oct-16
Network Analyzer HP 8753E	US37390585 S4206	18-Oct-01 (in house check Oct-13)	In house check: Oct-14

Calibrated by: **Name** Jeton Kastrati **Function** Laboratory Technician **Signature** *[Signature]*

Approved by: **Name** Katja Pokovic **Technical Manager** *[Signature]*

Issued: May 12, 2014

This calibration certificate shall not be reproduced except in full without written approval of the laboratory.



Accredited by the Swiss Accreditation Service (SAS)
The Swiss Accreditation Service is one of the signatories to the EA
Multilateral Agreement for the recognition of calibration certificates

Accreditation No.: **SCS 108**

Glossary:

TSL	tissue simulating liquid
ConvF	sensitivity in TSL / NORM x,y,z
N/A	not applicable or not measured

Calibration is Performed According to the Following Standards:

- a) IEEE Std 1528-2013, "IEEE Recommended Practice for Determining the Peak Spatial-Averaged Specific Absorption Rate (SAR) in the Human Head from Wireless Communications Devices: Measurement Techniques", June 2013
- b) IEC 62209-1, "Procedure to measure the Specific Absorption Rate (SAR) for hand-held devices used in close proximity to the ear (frequency range of 300 MHz to 3 GHz)", February 2005
- c) KDB 865664, "SAR Measurement Requirements for 100 MHz to 6 GHz"

Additional Documentation:

- d) DASY4/5 System Handbook

Methods Applied and Interpretation of Parameters:

- *Measurement Conditions:* Further details are available from the Validation Report at the end of the certificate. All figures stated in the certificate are valid at the frequency indicated.
- *Antenna Parameters with TSL:* The dipole is mounted with the spacer to position its feed point exactly below the center marking of the flat phantom section, with the arms oriented parallel to the body axis.
- *Feed Point Impedance and Return Loss:* These parameters are measured with the dipole positioned under the liquid filled phantom. The impedance stated is transformed from the measurement at the SMA connector to the feed point. The Return Loss ensures low reflected power. No uncertainty required.
- *Electrical Delay:* One-way delay between the SMA connector and the antenna feed point. No uncertainty required.
- *SAR measured:* SAR measured at the stated antenna input power.
- *SAR normalized:* SAR as measured, normalized to an input power of 1 W at the antenna connector.
- *SAR for nominal TSL parameters:* The measured TSL parameters are used to calculate the nominal SAR result.

The reported uncertainty of measurement is stated as the standard uncertainty of measurement multiplied by the coverage factor $k=2$, which for a normal distribution corresponds to a coverage probability of approximately 95%.

Measurement Conditions

DASY system configuration, as far as not given on page 1.

DASY Version	DASY5	V52.8.8
Extrapolation	Advanced Extrapolation	
Phantom	Modular Flat Phantom	
Distance Dipole Center - TSL	10 mm	with Spacer
Zoom Scan Resolution	dx, dy, dz = 5 mm	
Frequency	1750 MHz \pm 1 MHz	

Head TSL parameters

The following parameters and calculations were applied.

	Temperature	Permittivity	Conductivity
Nominal Head TSL parameters	22.0 °C	40.1	1.37 mho/m
Measured Head TSL parameters	(22.0 \pm 0.2) °C	39.0 \pm 6 %	1.36 mho/m \pm 6 %
Head TSL temperature change during test	< 0.5 °C	----	----

SAR result with Head TSL

SAR averaged over 1 cm ³ (1 g) of Head TSL	Condition	
SAR measured	250 mW input power	9.23 W/kg
SAR for nominal Head TSL parameters	normalized to 1W	36.9 W/kg \pm 17.0 % (k=2)

SAR averaged over 10 cm ³ (10 g) of Head TSL	condition	
SAR measured	250 mW input power	4.87 W/kg
SAR for nominal Head TSL parameters	normalized to 1W	19.5 W/kg \pm 16.5 % (k=2)

Body TSL parameters

The following parameters and calculations were applied.

	Temperature	Permittivity	Conductivity
Nominal Body TSL parameters	22.0 °C	53.4	1.49 mho/m
Measured Body TSL parameters	(22.0 \pm 0.2) °C	52.2 \pm 6 %	1.48 mho/m \pm 6 %
Body TSL temperature change during test	< 0.5 °C	----	----

SAR result with Body TSL

SAR averaged over 1 cm ³ (1 g) of Body TSL	Condition	
SAR measured	250 mW input power	9.41 W/kg
SAR for nominal Body TSL parameters	normalized to 1W	37.6 W/kg \pm 17.0 % (k=2)

SAR averaged over 10 cm ³ (10 g) of Body TSL	condition	
SAR measured	250 mW input power	5.02 W/kg
SAR for nominal Body TSL parameters	normalized to 1W	20.1 W/kg \pm 16.5 % (k=2)

Appendix

Antenna Parameters with Head TSL

Impedance, transformed to feed point	47.7 Ω - 6.1 j Ω
Return Loss	- 23.6 dB

Antenna Parameters with Body TSL

Impedance, transformed to feed point	43.7 Ω - 6.4 j Ω
Return Loss	- 20.4 dB

General Antenna Parameters and Design

Electrical Delay (one direction)	1.211 ns
----------------------------------	----------

After long term use with 100W radiated power, only a slight warming of the dipole near the feedpoint can be measured.

The dipole is made of standard semirigid coaxial cable. The center conductor of the feeding line is directly connected to the second arm of the dipole. The antenna is therefore short-circuited for DC-signals. On some of the dipoles, small end caps are added to the dipole arms in order to improve matching when loaded according to the position as explained in the "Measurement Conditions" paragraph. The SAR data are not affected by this change. The overall dipole length is still according to the Standard.

No excessive force must be applied to the dipole arms, because they might bend or the soldered connections near the feedpoint may be damaged.

Additional EUT Data

Manufactured by	SPEAG
Manufactured on	October 06, 2005

DASY5 Validation Report for Head TSL

Date: 07.05.2014

Test Laboratory: SPEAG, Zurich, Switzerland

DUT: Dipole 1765 MHz; Type: D1765V2; Serial: D1765V2 - SN: 1008

Communication System: UID 0 - CW; Frequency: 1750 MHz

Medium parameters used: $f = 1750$ MHz; $\sigma = 1.36$ S/m; $\epsilon_r = 39$; $\rho = 1000$ kg/m³

Phantom section: Flat Section

Measurement Standard: DASY5 (IEEE/IEC/ANSI C63.19-2007)

DASY52 Configuration:

- Probe: ES3DV3 - SN3205; ConvF(5.23, 5.23, 5.23); Calibrated: 30.12.2013;
- Sensor-Surface: 3mm (Mechanical Surface Detection)
- Electronics: DAE4 Sn601; Calibrated: 30.04.2014
- Phantom: Flat Phantom 5.0 (front); Type: QD000P50AA; Serial: 1001
- DASY52 52.8.8(1222); SEMCAD X 14.6.10(7331)

Dipole Calibration for Head Tissue/Pin=250 mW, d=10mm/Zoom Scan (7x7x7)/Cube 0:

Measurement grid: dx=5mm, dy=5mm, dz=5mm

Reference Value = 96.06 V/m; Power Drift = 0.01 dB

Peak SAR (extrapolated) = 16.7 W/kg

SAR(1 g) = 9.23 W/kg; SAR(10 g) = 4.87 W/kg

Maximum value of SAR (measured) = 11.7 W/kg

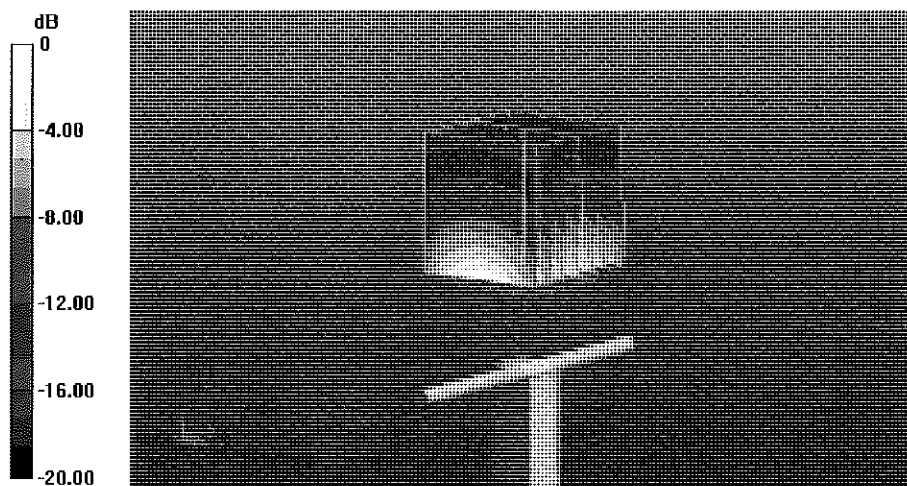

0 dB = 11.7 W/kg = 10.68 dBW/kg

Impedance Measurement Plot for Head TSL

7 May 2014 09:22:35

CH1 S11 1 U FS 1: 47.709 Ω -6.0566 Ω 15.016 pF 1 750.000 000 MHz

*
De1
C Δ
Avg
16
H1 d

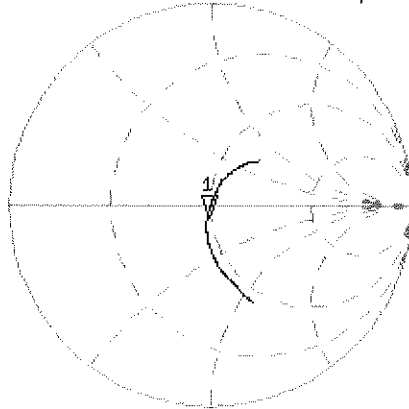

CH2 S11 LOG 5 dB/REF -20 dB 1:-23.588 dB 1 750.000 000 MHz

C Δ
Avg
16
H1 d

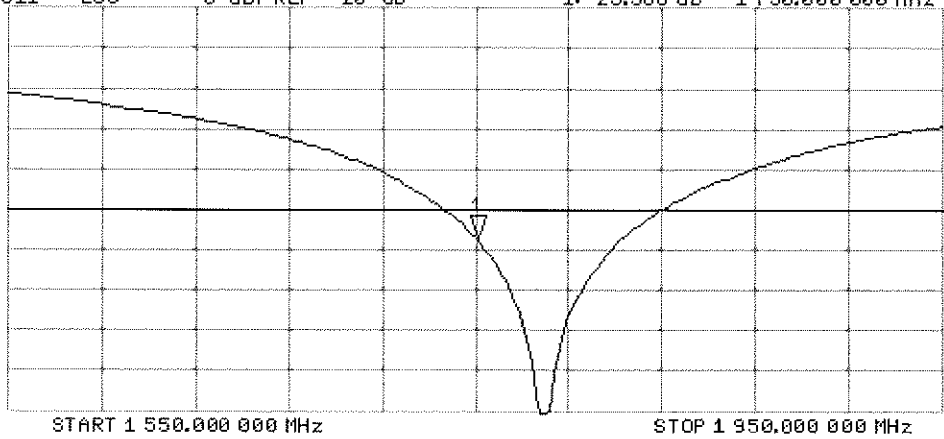

DASY5 Validation Report for Body TSL

Date: 07.05.2014

Test Laboratory: SPEAG, Zurich, Switzerland

DUT: Dipole 1765 MHz; Type: D1765V2; Serial: D1765V2 - SN: 1008

Communication System: UID 0 - CW; Frequency: 1750 MHz

Medium parameters used: $f = 1750$ MHz; $\sigma = 1.48$ S/m; $\epsilon_r = 52.2$; $\rho = 1000$ kg/m³

Phantom section: Flat Section

Measurement Standard: DASY5 (IEEE/IEC/ANSI C63.19-2007)

DASY52 Configuration:

- Probe: ES3DV3 - SN3205; ConvF(4.89, 4.89, 4.89); Calibrated: 30.12.2013;
- Sensor-Surface: 3mm (Mechanical Surface Detection)
- Electronics: DAE4 Sn601; Calibrated: 30.04.2014
- Phantom: Flat Phantom 5.0 (back); Type: QD000P50AA; Serial: 1002
- DASY52 52.8.8(1222); SEMCAD X 14.6.10(7331)

Dipole Calibration for Body Tissue/Pin=250 mW, d=10mm/Zoom Scan (7x7x7)/Cube 0:

Measurement grid: dx=5mm, dy=5mm, dz=5mm

Reference Value = 93.01 V/m; Power Drift = 0.00 dB

Peak SAR (extrapolated) = 16.3 W/kg

SAR(1 g) = 9.41 W/kg; SAR(10 g) = 5.02 W/kg

Maximum value of SAR (measured) = 11.8 W/kg

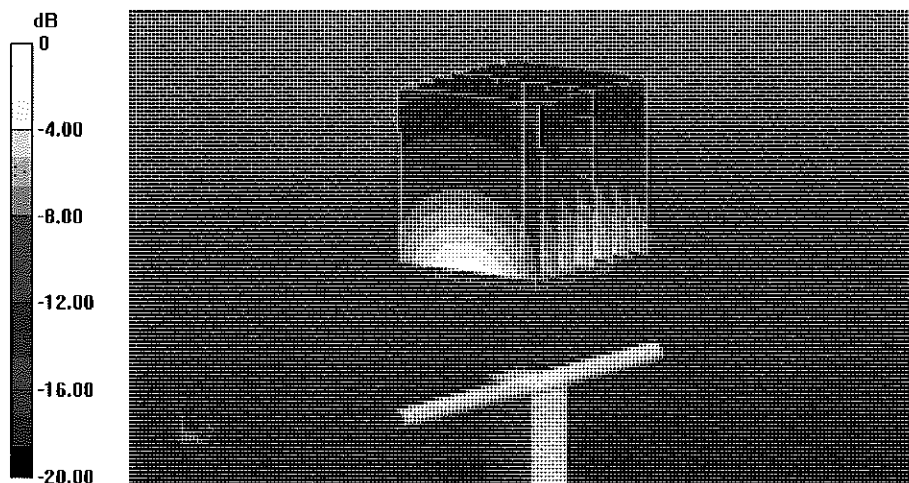

Impedance Measurement Plot for Body TSL

7 May 2014 09:21:55

CH1 S11 1 U FS 1: 43.727 Ω -5.3691 Ω 14.279 pF 1 750.000 000 MHz

*
De1

CA

Avg
16

H1d

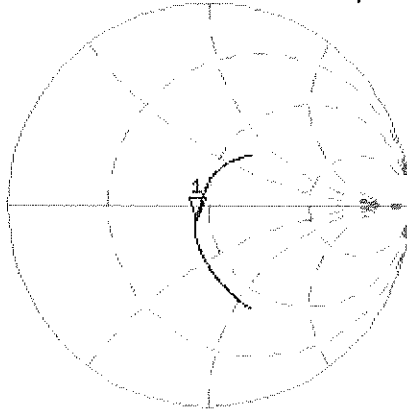

CH2 S11 LOG 5 dB/REF -20 dB 1:-20.429 dB 1 750.000 000 MHz

CA

Avg
16

H1d

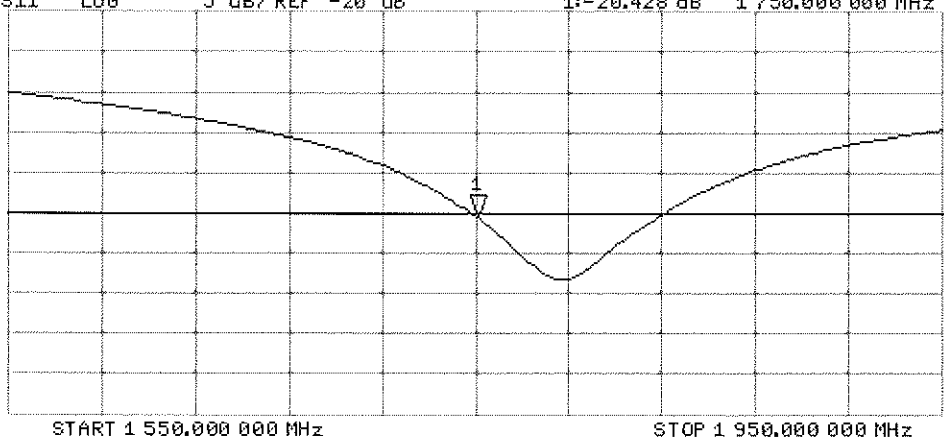

**Calibration Laboratory of
Schmid & Partner
Engineering AG**
Zeughausstrasse 43, 8004 Zurich, Switzerland



S Schweizerischer Kalibrierdienst
C Service suisse d'étalonnage
S Servizio svizzero di taratura
Swiss Calibration Service

Accredited by the Swiss Accreditation Service (SAS)
The Swiss Accreditation Service is one of the signatories to the EA
Multilateral Agreement for the recognition of calibration certificates

Accreditation No.: **SCS 108**

Client **PC Test**

Certificate No: **ES3-3022_Aug14/2**

CALIBRATION CERTIFICATE (Replacement of No: ES3-3022_Aug14)

Object **ES3DV2 - SN:3022**

Calibration procedure(s) **QA CAL-01.v9, QA CAL-12.v9, QA CAL-23.v5, QA CAL-25.v6
Calibration procedure for dosimetric E-field probes** CC
D/M/14

Calibration date: **August 19, 2014**

This calibration certificate documents the traceability to national standards, which realize the physical units of measurements (SI).
The measurements and the uncertainties with confidence probability are given on the following pages and are part of the certificate.

All calibrations have been conducted in the closed laboratory facility: environment temperature (22 ± 3)°C and humidity < 70%.

Calibration Equipment used (M&TE critical for calibration)

Primary Standards	ID	Cal Date (Certificate No.)	Scheduled Calibration
Power meter E4419B	GB41293874	03-Apr-14 (No. 217-01911)	Apr-15
Power sensor E4412A	MY41498087	03-Apr-14 (No. 217-01911)	Apr-15
Reference 3 dB Attenuator	SN: S5054 (3c)	03-Apr-14 (No. 217-01915)	Apr-15
Reference 20 dB Attenuator	SN: S5277 (20x)	03-Apr-14 (No. 217-01919)	Apr-15
Reference 30 dB Attenuator	SN: S5129 (30b)	03-Apr-14 (No. 217-01920)	Apr-15
Reference Probe ES3DV2	SN: 3013	30-Dec-13 (No. ES3-3013_Dec13)	Dec-14
DAE4	SN: 660	13-Dec-13 (No. DAE4-660_Dec13)	Dec-14
Secondary Standards	ID	Check Date (in house)	Scheduled Check
RF generator HP 8648C	US3642U01700	4-Aug-99 (in house check Apr-13)	In house check: Apr-16
Network Analyzer HP 8753E	US37390585	18-Oct-01 (in house check Oct-13)	In house check: Oct-14

Calibrated by:	Name Jeton Kastrali	Function Laboratory Technician	Signature
Approved by:	Name Katja Pokovic	Function Technical Manager	

Issued: November 3, 2014

This calibration certificate shall not be reproduced except in full without written approval of the laboratory.



Accredited by the Swiss Accreditation Service (SAS)
The Swiss Accreditation Service is one of the signatories to the EA
Multilateral Agreement for the recognition of calibration certificates

Accreditation No.: **SCS 108**

Glossary:

TSL	tissue simulating liquid
NORM _{x,y,z}	sensitivity in free space
ConvF	sensitivity in TSL / NORM _{x,y,z}
DCP	diode compression point
CF	crest factor (1/duty_cycle) of the RF signal
A, B, C, D	modulation dependent linearization parameters
Polarization φ	φ rotation around probe axis
Polarization ϑ	ϑ rotation around an axis that is in the plane normal to probe axis (at measurement center), i.e., $\vartheta = 0$ is normal to probe axis
Connector Angle	information used in DASY system to align probe sensor X to the robot coordinate system

Calibration is Performed According to the Following Standards:

- IEEE Std 1528-2013, "IEEE Recommended Practice for Determining the Peak Spatial-Averaged Specific Absorption Rate (SAR) in the Human Head from Wireless Communications Devices: Measurement Techniques", June 2013
- IEC 62209-1, "Procedure to measure the Specific Absorption Rate (SAR) for hand-held devices used in close proximity to the ear (frequency range of 300 MHz to 3 GHz)", February 2005

Methods Applied and Interpretation of Parameters:

- NORM_{x,y,z}**: Assessed for E-field polarization $\vartheta = 0$ ($f \leq 900$ MHz in TEM-cell; $f > 1800$ MHz: R22 waveguide). NORM_{x,y,z} are only intermediate values, i.e., the uncertainties of NORM_{x,y,z} does not affect the E²-field uncertainty inside TSL (see below ConvF).
- NORM(f)_{x,y,z} = NORM_{x,y,z} * frequency_response** (see Frequency Response Chart). This linearization is implemented in DASY4 software versions later than 4.2. The uncertainty of the frequency response is included in the stated uncertainty of ConvF.
- DCP_{x,y,z}**: DCP are numerical linearization parameters assessed based on the data of power sweep with CW signal (no uncertainty required). DCP does not depend on frequency nor media.
- PAR**: PAR is the Peak to Average Ratio that is not calibrated but determined based on the signal characteristics
- A_{x,y,z}; B_{x,y,z}; C_{x,y,z}; D_{x,y,z}; VR_{x,y,z}; A, B, C, D** are numerical linearization parameters assessed based on the data of power sweep for specific modulation signal. The parameters do not depend on frequency nor media. VR is the maximum calibration range expressed in RMS voltage across the diode.
- ConvF and Boundary Effect Parameters**: Assessed in flat phantom using E-field (or Temperature Transfer Standard for $f \leq 800$ MHz) and inside waveguide using analytical field distributions based on power measurements for $f > 800$ MHz. The same setups are used for assessment of the parameters applied for boundary compensation (alpha, depth) of which typical uncertainty values are given. These parameters are used in DASY4 software to improve probe accuracy close to the boundary. The sensitivity in TSL corresponds to NORM_{x,y,z} * ConvF whereby the uncertainty corresponds to that given for ConvF. A frequency dependent ConvF is used in DASY version 4.4 and higher which allows extending the validity from ± 50 MHz to ± 100 MHz.
- Spherical isotropy (3D deviation from isotropy)**: in a field of low gradients realized using a flat phantom exposed by a patch antenna.
- Sensor Offset**: The sensor offset corresponds to the offset of virtual measurement center from the probe tip (on probe axis). No tolerance required.
- Connector Angle**: The angle is assessed using the information gained by determining the NORM_x (no uncertainty required).

Probe ES3DV2

SN:3022

Manufactured: April 15, 2003
Calibrated: August 19, 2014

Calibrated for DASY/EASY Systems
(Note: non-compatible with DASY2 system!)

DASY/EASY - Parameters of Probe: ES3DV2 - SN:3022

Basic Calibration Parameters

	Sensor X	Sensor Y	Sensor Z	Unc (k=2)
Norm ($\mu\text{V}/(\text{V}/\text{m})^2$) ^A	1.00	1.04	0.96	$\pm 10.1\%$
DCP (mV) ^B	103.0	96.3	101.6	

Modulation Calibration Parameters

UID	Communication System Name		A dB	B dB $\sqrt{\mu\text{V}}$	C	D dB	VR mV	Unc ^E (k=2)
0	CW	X	0.0	0.0	1.0	0.00	181.8	$\pm 2.7\%$
		Y	0.0	0.0	1.0		183.0	
		Z	0.0	0.0	1.0		192.3	
10010- CAA	SAR Validation (Square, 100ms, 10ms)	X	2.51	63.1	12.7	10.00	42.6	$\pm 1.9\%$
		Y	2.62	63.1	12.9		42.7	
		Z	3.12	65.7	13.6		40.4	
10011- CAB	UMTS-FDD (WCDMA)	X	3.33	67.8	19.2	2.91	145.9	$\pm 0.9\%$
		Y	3.13	64.9	16.9		147.4	
		Z	3.20	66.4	18.2		139.6	
10012- CAA	IEEE 802.11b WiFi 2.4 GHz (DSSS, 1 Mbps)	X	3.05	70.1	19.8	1.87	147.2	$\pm 0.9\%$
		Y	2.62	65.1	16.2		147.4	
		Z	2.85	68.2	18.4		141.7	
10013- CAA	IEEE 802.11g WiFi 2.4 GHz (DSSS-OFDM, 6 Mbps)	X	11.10	70.9	23.6	9.46	143.9	$\pm 3.0\%$
		Y	11.04	70.2	22.9		144.2	
		Z	10.77	70.2	23.1		134.7	
10021- DAB	GSM-FDD (TDMA, GMSK)	X	19.66	99.7	28.6	9.39	126.0	$\pm 1.9\%$
		Y	11.04	89.6	25.5		138.9	
		Z	10.45	88.8	24.9		137.5	
10023- DAB	GPRS-FDD (TDMA, GMSK, TN 0)	X	20.19	99.6	28.5	9.57	142.0	$\pm 2.5\%$
		Y	10.53	88.4	25.0		145.5	
		Z	15.52	96.5	27.8		147.6	
10024- DAB	GPRS-FDD (TDMA, GMSK, TN 0-1)	X	31.93	99.6	25.2	6.56	149.5	$\pm 1.9\%$
		Y	12.70	87.9	22.2		148.0	
		Z	27.00	99.8	25.7		135.3	
10027- DAB	GPRS-FDD (TDMA, GMSK, TN 0-1-2)	X	38.32	99.8	23.8	4.80	148.1	$\pm 2.2\%$
		Y	9.80	83.2	19.3		138.8	
		Z	31.96	99.9	24.2		128.9	
10028- DAB	GPRS-FDD (TDMA, GMSK, TN 0-1-2-3)	X	40.03	99.5	22.8	3.55	130.5	$\pm 2.2\%$
		Y	40.27	99.6	23.0		148.1	
		Z	43.09	99.7	22.5		140.1	
10032- CAA	IEEE 802.15.1 Bluetooth (GFSK, DH5)	X	38.93	99.4	20.4	1.16	146.7	$\pm 1.9\%$
		Y	32.83	92.5	17.9		139.2	
		Z	31.94	99.5	20.8		133.1	
10039- CAB	CDMA2000 (1xRTT, RC1)	X	4.66	66.8	19.3	4.57	144.5	$\pm 1.2\%$
		Y	4.56	65.3	17.9		137.2	
		Z	4.52	66.1	18.7		131.7	

10081-CAB	CDMA2000 (1xRTT, RC3)	X	3.82	66.0	18.7	3.97	140.3	±0.9 %
		Y	3.77	64.5	17.3		133.6	
		Z	3.79	65.7	18.4		128.2	
10098-CAB	UMTS-FDD (HSUPA, Subtest 2)	X	4.40	66.2	18.5	3.98	130.9	±1.2 %
		Y	4.39	65.0	17.4		131.1	
		Z	4.47	66.3	18.4		140.0	
10100-CAB	LTE-FDD (SC-FDMA, 100% RB, 20 MHz, QPSK)	X	6.30	67.3	19.8	5.67	137.4	±1.7 %
		Y	6.25	66.3	18.9		135.9	
		Z	6.36	67.4	19.7		147.5	
10108-CAB	LTE-FDD (SC-FDMA, 100% RB, 10 MHz, QPSK)	X	6.14	66.8	19.6	5.80	134.6	±1.7 %
		Y	6.17	66.1	18.9		133.9	
		Z	6.24	67.0	19.7		144.5	
10110-CAB	LTE-FDD (SC-FDMA, 100% RB, 6 MHz, QPSK)	X	5.82	66.3	19.4	5.75	131.2	±1.7 %
		Y	5.82	65.4	18.6		130.3	
		Z	5.91	66.5	19.4		140.4	
10114-CAA	IEEE 802.11n (HT Greenfield, 13.5 Mbps, BPSK)	X	10.00	68.5	21.2	8.10	124.3	±2.5 %
		Y	9.89	67.9	20.6		124.0	
		Z	10.05	68.6	21.2		133.2	
10117-CAA	IEEE 802.11n (HT Mixed, 13.5 Mbps, BPSK)	X	10.01	68.6	21.2	8.07	125.8	±2.5 %
		Y	9.91	67.9	20.7		125.8	
		Z	10.09	68.8	21.3		134.7	
10151-CAB	LTE-TDD (SC-FDMA, 50% RB, 20 MHz, QPSK)	X	9.69	75.5	26.4	9.28	144.7	±3.3 %
		Y	9.09	72.7	24.6		143.2	
		Z	8.54	72.0	24.5		124.8	
10154-CAB	LTE-FDD (SC-FDMA, 50% RB, 10 MHz, QPSK)	X	5.82	66.2	19.4	5.75	131.3	±1.9 %
		Y	6.06	66.3	19.1		149.2	
		Z	5.91	66.5	19.4		140.7	
10160-CAB	LTE-FDD (SC-FDMA, 50% RB, 15 MHz, QPSK)	X	6.27	66.9	19.7	5.82	136.5	±1.4 %
		Y	6.19	65.8	18.7		128.4	
		Z	6.33	67.0	19.6		145.4	
10169-CAB	LTE-FDD (SC-FDMA, 1 RB, 20 MHz, QPSK)	X	4.81	66.4	19.7	5.73	134.8	±1.7 %
		Y	4.92	66.1	19.1		149.9	
		Z	4.78	66.4	19.6		141.2	
10172-CAB	LTE-TDD (SC-FDMA, 1 RB, 20 MHz, QPSK)	X	7.83	76.6	27.2	9.21	131.4	±3.5 %
		Y	7.54	74.5	25.8		147.8	
		Z	7.71	76.7	27.4		145.3	
10175-CAB	LTE-FDD (SC-FDMA, 1 RB, 10 MHz, QPSK)	X	4.90	66.9	20.0	5.72	147.6	±1.4 %
		Y	4.90	66.0	19.1		148.0	
		Z	4.78	66.4	19.6		141.6	
10181-CAB	LTE-FDD (SC-FDMA, 1 RB, 15 MHz, QPSK)	X	4.90	66.9	20.0	5.72	148.1	±1.4 %
		Y	4.89	65.9	19.0		146.9	
		Z	4.80	66.5	19.7		142.1	
10193-CAA	IEEE 802.11n (HT Greenfield, 6.5 Mbps, BPSK)	X	9.80	68.7	21.4	8.09	135.1	±2.7 %
		Y	9.78	68.2	20.9		135.5	
		Z	9.70	68.5	21.2		130.2	

10196-CAA	IEEE 802.11n (HT Mixed, 6.5 Mbps, BPSK)	X	9.79	68.7	21.4	8.10	136.4	±2.7 %
		Y	9.81	68.3	20.9		138.0	
		Z	9.72	68.6	21.3		132.8	
10219-CAA	IEEE 802.11n (HT Mixed, 7.2 Mbps, BPSK)	X	9.68	68.6	21.3	8.03	136.0	±2.7 %
		Y	9.74	68.3	21.0		137.4	
		Z	9.62	68.5	21.2		132.6	
10222-CAA	IEEE 802.11n (HT Mixed, 15 Mbps, BPSK)	X	10.20	69.1	21.5	8.06	143.4	±2.5 %
		Y	9.91	60.0	20.7		125.8	
		Z	10.27	69.4	21.6		148.4	
10225-CAB	UMTS-FDD (HSPA+)	X	6.87	66.9	19.6	5.97	139.5	±1.9 %
		Y	7.04	66.9	19.3		149.3	
		Z	6.89	67.0	19.5		143.5	
10237-CAB	LTE-TDD (SC-FDMA, 1 RB, 10 MHz, QPSK)	X	7.66	75.9	26.9	9.21	126.1	±3.0 %
		Y	7.17	73.1	25.1		132.1	
		Z	7.18	74.6	26.3		128.0	
10252-CAB	LTE-TDD (SC-FDMA, 50% RB, 10 MHz, QPSK)	X	8.58	73.1	25.3	9.24	127.6	±3.3 %
		Y	8.22	71.0	23.7		126.9	
		Z	8.83	74.3	26.0		149.8	
10267-CAB	LTE-TDD (SC-FDMA, 100% RB, 10 MHz, QPSK)	X	9.69	75.5	26.5	9.30	143.8	±3.3 %
		Y	8.88	72.0	24.2		135.2	
		Z	8.83	72.9	25.1		131.3	
10274-CAB	UMTS-FDD (HSUPA, Subtest 5, 3GPP Rel8.10)	X	5.87	67.0	19.2	4.87	141.2	±1.4 %
		Y	5.77	65.8	18.1		136.0	
		Z	5.71	66.3	18.6		132.7	
10275-CAB	UMTS-FDD (HSUPA, Subtest 5, 3GPP Rel8.4)	X	4.44	67.2	19.2	3.96	147.3	±0.9 %
		Y	4.29	65.3	17.6		139.2	
		Z	4.31	66.3	18.5		139.6	
10291-AAB	CDMA2000, RC3, SO55, Full Rate	X	3.60	67.1	19.1	3.46	137.8	±0.7 %
		Y	3.44	64.8	17.2		129.6	
		Z	3.48	66.2	18.4		130.5	
10292-AAB	CDMA2000, RC3, SO32, Full Rate	X	3.50	66.9	18.9	3.39	139.5	±0.7 %
		Y	3.38	64.8	17.2		132.0	
		Z	3.48	66.5	18.5		133.1	
10297-AAA	LTE-FDD (SC-FDMA, 50% RB, 20 MHz, QPSK)	X	6.12	66.7	19.6	5.81	133.3	±1.9 %
		Y	6.35	66.7	19.3		149.3	
		Z	6.17	66.8	19.5		132.7	
10311-AAA	LTE-FDD (SC-FDMA, 100% RB, 15 MHz, QPSK)	X	6.72	67.4	20.0	6.06	138.7	±1.7 %
		Y	6.63	66.3	19.1		131.4	
		Z	6.72	67.3	19.9		138.7	
10315-AAA	IEEE 802.11b WiFi 2.4 GHz (DSSS, 1 Mbps, 96pc duty cycle)	X	2.90	69.9	19.8	1.71	146.4	±0.5 %
		Y	2.54	65.2	16.5		139.3	
		Z	2.75	68.1	18.5		146.4	
10316-AAA	IEEE 802.11g WiFi 2.4 GHz (ERP-OFDM, 6 Mbps, 96pc duty cycle)	X	10.12	69.3	21.9	8.36	142.9	±3.0 %
		Y	10.01	68.5	21.3		135.2	
		Z	10.11	69.3	21.9		141.7	

10403-AAB	CDMA2000 (1xEV-DO, Rev. 0)	X	4.59	68.2	19.0	3.76	126.7	±0.7 %
		Y	4.59	67.2	18.0		142.4	
		Z	4.64	68.5	19.0		143.0	
10404-AAB	CDMA2000 (1xEV-DO, Rev. A)	X	4.64	68.8	19.3	3.77	147.1	±0.9 %
		Y	4.47	67.1	17.9		139.6	
		Z	4.54	68.4	18.9		147.2	
10415-AAA	IEEE 802.11b WiFi 2.4 GHz (DSSS, 1 Mbps, 99pc duty cycle)	X	2.66	69.0	19.4	1.54	145.8	±0.5 %
		Y	2.40	64.8	16.2		140.0	
		Z	2.62	67.8	18.4		147.2	
10416-AAA	IEEE 802.11g WiFi 2.4 GHz (ERP-OFDM, 6 Mbps, 99pc duty cycle)	X	9.97	69.1	21.7	8.23	142.0	±3.0 %
		Y	10.08	68.9	21.4		145.8	
		Z	10.01	69.2	21.8		143.3	

The reported uncertainty of measurement is stated as the standard uncertainty of measurement multiplied by the coverage factor $k=2$, which for a normal distribution corresponds to a coverage probability of approximately 95%.

[^] The uncertainties of Norm X, Y, Z do not affect the E^2 -field uncertainty inside TSL (see Pages 8 and 9).

[^] Numerical linearization parameter: uncertainty not required.

[^] Uncertainty is determined using the max. deviation from linear response applying rectangular distribution and is expressed for the square of the field value.

DASY/EASY - Parameters of Probe: ES3DV2 - SN:3022

Calibration Parameter Determined in Head Tissue Simulating Media

f (MHz) ^c	Relative Permittivity ^F	Conductivity (S/m) ^F	ConvF X	ConvF Y	ConvF Z	Alpha ^G	Depth ^G (mm)	Unct. (k=2)
750	41.9	0.89	6.39	6.39	6.39	0.20	2.24	± 12.0 %
835	41.5	0.90	6.18	6.18	6.18	0.23	1.98	± 12.0 %
1750	40.1	1.37	5.04	5.04	5.04	0.51	1.35	± 12.0 %
1900	40.0	1.40	4.85	4.85	4.85	0.38	1.66	± 12.0 %
2450	39.2	1.80	4.31	4.31	4.31	0.66	1.28	± 12.0 %
2600	39.0	1.96	4.13	4.13	4.13	0.76	1.28	± 12.0 %

^c Frequency validity above 300 MHz of ± 100 MHz only applies for DASY v4.4 and higher (see Page 2), else it is restricted to ± 50 MHz. The uncertainty is the RSS of the ConvF uncertainty at calibration frequency and the uncertainty for the indicated frequency band. Frequency validity below 300 MHz is ± 10, 25, 40, 50 and 70 MHz for ConvF assessments at 30, 64, 128, 150 and 220 MHz respectively. Above 5 GHz frequency validity can be extended to ± 110 MHz.

^F At frequencies below 3 GHz, the validity of tissue parameters (ϵ and σ) can be relaxed to ± 10% if liquid compensation formula is applied to measured SAR values. At frequencies above 3 GHz, the validity of tissue parameters (ϵ and σ) is restricted to ± 5%. The uncertainty is the RSS of the ConvF uncertainty for indicated target tissue parameters.

^G Alpha/Depth are determined during calibration. SPEAG warrants that the remaining deviation due to the boundary effect after compensation is always less than ± 1% for frequencies below 3 GHz and below ± 2% for frequencies between 3-6 GHz at any distance larger than half the probe tip diameter from the boundary.

DASY/EASY - Parameters of Probe: ES3DV2 - SN:3022

Calibration Parameter Determined in Body Tissue Simulating Media

f (MHz) ^c	Relative Permittivity ^F	Conductivity (S/m) ^F	ConvF X	ConvF Y	ConvF Z	Alpha ^g	Depth ^g (mm)	Unct. (k=2)
450	56.7	0.94	6.78	6.78	6.78	0.12	1.30	± 13.3 %
600	56.1	0.95	6.72	6.72	6.72	0.05	1.20	± 13.3 %
750	55.5	0.96	6.02	6.02	6.02	0.23	2.05	± 12.0 %
835	55.2	0.97	5.98	5.98	5.98	0.29	1.85	± 12.0 %
1750	53.4	1.49	4.70	4.70	4.70	0.66	1.25	± 12.0 %
1900	53.3	1.52	4.49	4.49	4.49	0.33	2.02	± 12.0 %
2450	52.7	1.95	4.05	4.05	4.05	0.80	1.01	± 12.0 %
2600	52.5	2.16	3.94	3.94	3.94	0.68	1.03	± 12.0 %

^c Frequency validity above 300 MHz of ± 100 MHz only applies for DASY v4.4 and higher (see Page 2), else it is restricted to ± 50 MHz. The uncertainty is the RSS of the ConvF uncertainty at calibration frequency and the uncertainty for the indicated frequency band. Frequency validity below 300 MHz is ± 10, 25, 40, 50 and 70 MHz for ConvF assessments at 30, 64, 128, 150 and 220 MHz respectively. Above 5 GHz frequency validity can be extended to ± 110 MHz.

^F At frequencies below 3 GHz, the validity of tissue parameters (ϵ and σ) can be relaxed to ± 10% if liquid compensation formula is applied to measured SAR values. At frequencies above 3 GHz, the validity of tissue parameters (ϵ and σ) is restricted to ± 5%. The uncertainty is the RSS of the ConvF uncertainty for indicated target tissue parameters.

^g Alpha/Depth are determined during calibration. SPEAG warrants that the remaining deviation due to the boundary effect after compensation is always less than ± 1% for frequencies below 3 GHz and below ± 2% for frequencies between 3-6 GHz at any distance larger than half the probe tip diameter from the boundary.

Frequency Response of E-Field (TEM-Cell:ifi110 EXX, Waveguide: R22)

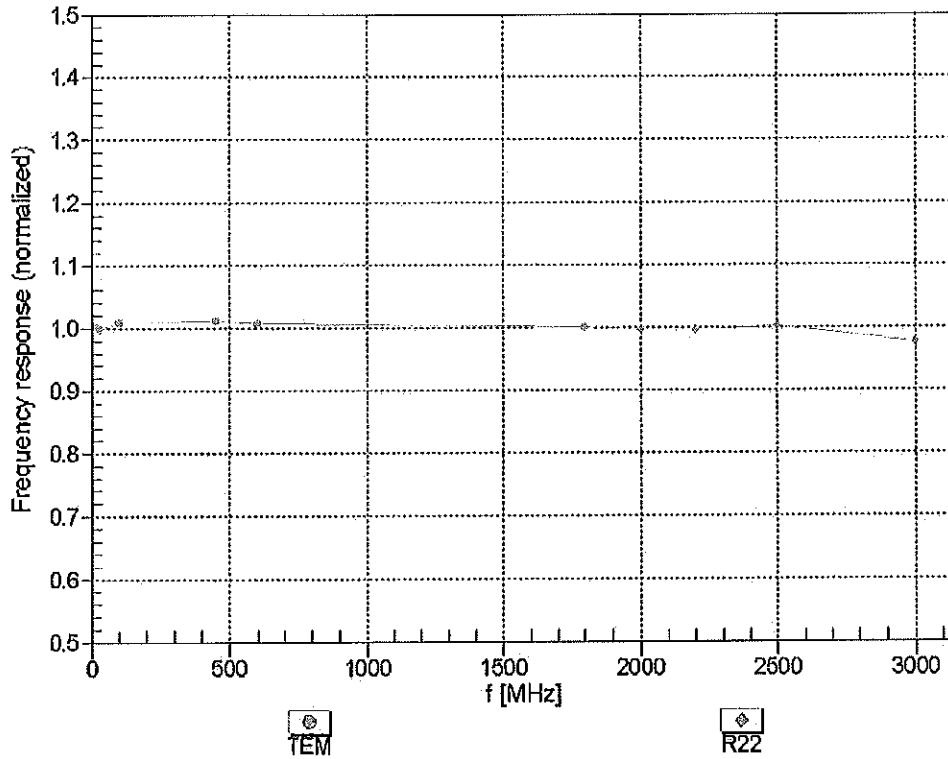

Uncertainty of Frequency Response of E-field: $\pm 6.3\%$ (k=2)

Receiving Pattern (ϕ), $\theta = 0^\circ$

f=600 MHz,TEM

f=1800 MHz,R22

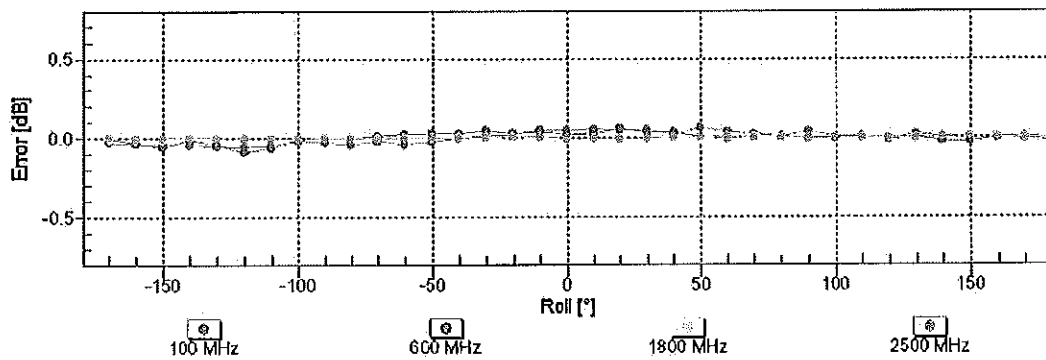
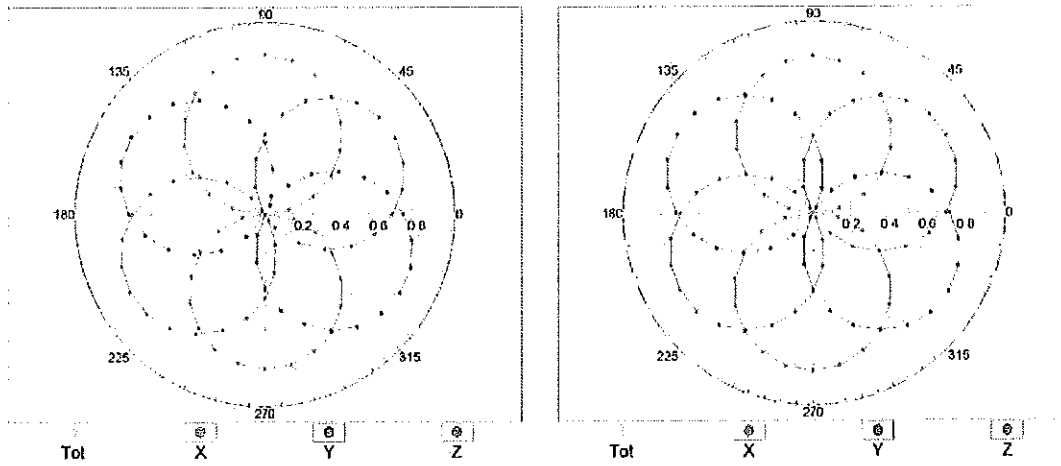

Uncertainty of Axial Isotropy Assessment: $\pm 0.5\%$ (k=2)

Dynamic Range $f(SAR_{head})$ (TEM cell, $f_{eval} = 1900$ MHz)

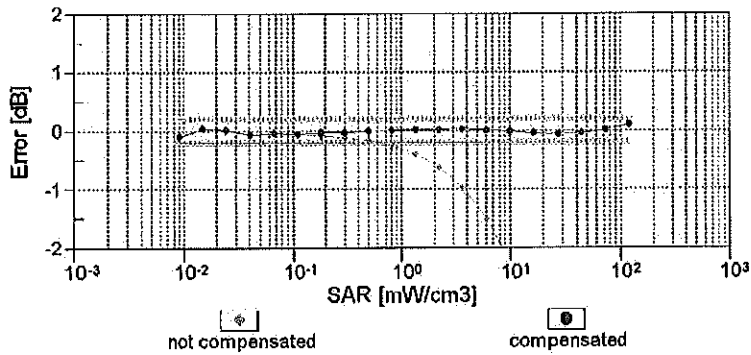
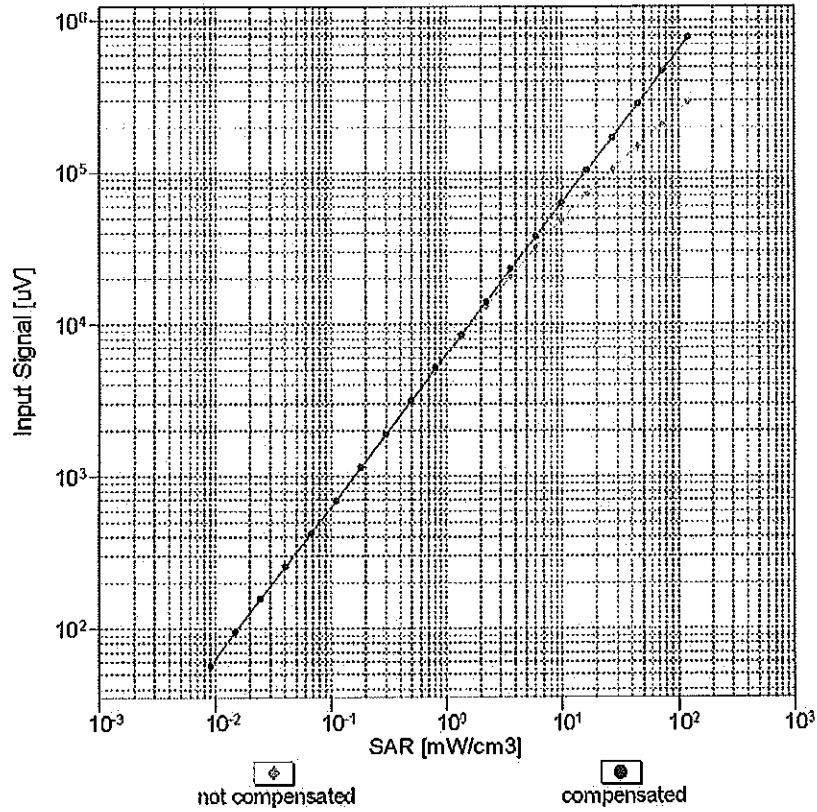

Uncertainty of Linearity Assessment: $\pm 0.6\%$ ($k=2$)

Conversion Factor Assessment

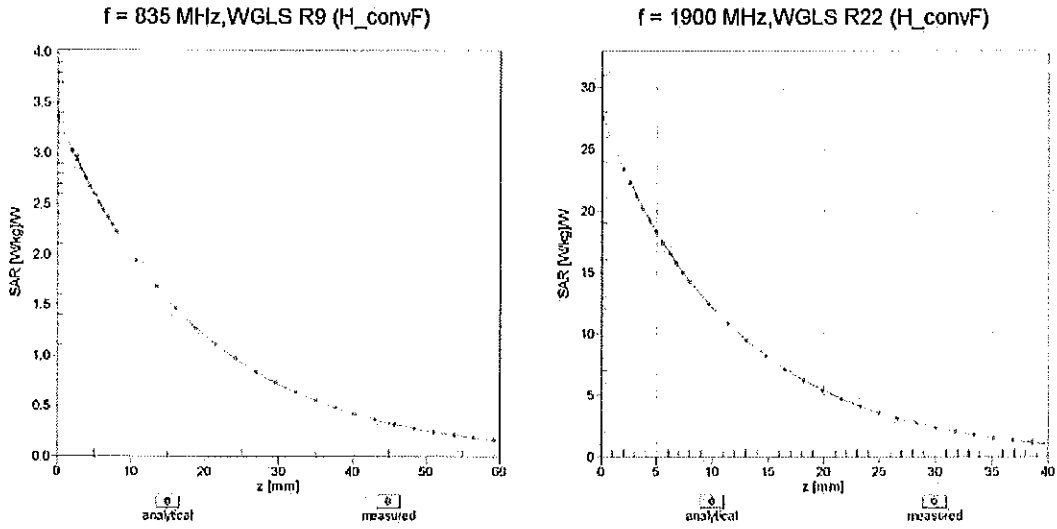

Deviation from Isotropy in Liquid Error (ϕ, ϑ), f = 900 MHz

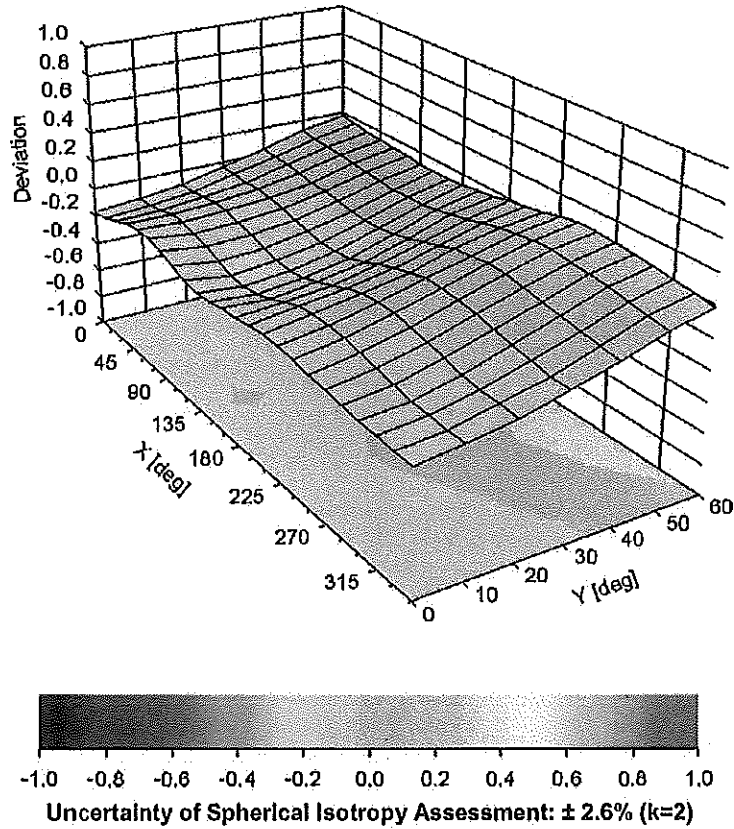

DASY/EASY - Parameters of Probe: ES3DV2 - SN:3022**Other Probe Parameters**

Sensor Arrangement	Triangular
Connector Angle (°)	-80,3
Mechanical Surface Detection Mode	enabled
Optical Surface Detection Mode	disabled
Probe Overall Length	337 mm
Probe Body Diameter	10 mm
Tip Length	10 mm
Tip Diameter	4 mm
Probe Tip to Sensor X Calibration Point	2 mm
Probe Tip to Sensor Y Calibration Point	2 mm
Probe Tip to Sensor Z Calibration Point	2 mm
Recommended Measurement Distance from Surface	3 mm

**Calibration Laboratory of
Schmid & Partner
Engineering AG**
Zeughausstrasse 43, 8004 Zurich, Switzerland



S Schweizerischer Kalibrierdienst
S Service suisse d'étalonnage
S Servizio svizzero di taratura
S Swiss Calibration Service

Accredited by the Swiss Accreditation Service (SAS)
The Swiss Accreditation Service is one of the signatories to the EA
Multilateral Agreement for the recognition of calibration certificates

Accreditation No.: **SCS 0108**

Client **PC Test**

Certificate No: **ES3-3209_Mar15**

CALIBRATION CERTIFICATE

Object **ES3DV3 - SN:3209**

Calibration procedure(s) **QA CAL-01.v9, QA CAL-23.v5, QA CAL-25.v6
Calibration procedure for dosimetric E-field probes**

Calibration date: **March 19, 2015**

BW ✓
3/26

This calibration certificate documents the traceability to national standards, which realize the physical units of measurements (SI).
The measurements and the uncertainties with confidence probability are given on the following pages and are part of the certificate.

All calibrations have been conducted in the closed laboratory facility: environment temperature (22 ± 3)°C and humidity < 70%.

Calibration Equipment used (M&TE critical for calibration)

Primary Standards	ID	Cal Date (Certificate No.)	Scheduled Calibration
Power meter E4419B	GB41293874	03-Apr-14 (No. 217-01911)	Apr-15
Power sensor E4412A	MY41498087	03-Apr-14 (No. 217-01911)	Apr-15
Reference 3 dB Attenuator	SN: S5054 (3c)	03-Apr-14 (No. 217-01915)	Apr-15
Reference 20 dB Attenuator	SN: S5277 (20x)	03-Apr-14 (No. 217-01919)	Apr-15
Reference 30 dB Attenuator	SN: S5129 (30b)	03-Apr-14 (No. 217-01920)	Apr-15
Reference Probe ES3DV2	SN: 3013	30-Dec-14 (No. ES3-3013_Dec14)	Dec-15
DAE4	SN: 660	14-Jan-15 (No. DAE4-660_Jan15)	Jan-16
Secondary Standards	ID	Check Date (in house)	Scheduled Check
RF generator HP 8648C	US3642U01700	4-Aug-99 (in house check Apr-13)	In house check: Apr-16
Network Analyzer HP 8753E	US37390585	18-Oct-01 (in house check Oct-14)	In house check: Oct-15

Calibrated by:	Name Israe Elnaouq	Function Laboratory Technician	Signature <i>Israe Elnaouq</i>
Approved by:	Name Katja Pokovic	Function Technical Manager	<i>Katja Pokovic</i>

Issued: March 19, 2015

This calibration certificate shall not be reproduced except in full without written approval of the laboratory.



Accredited by the Swiss Accreditation Service (SAS)
The Swiss Accreditation Service is one of the signatories to the EA
Multilateral Agreement for the recognition of calibration certificates

Accreditation No.: **SCS 0108**

Glossary:

TSL	tissue simulating liquid
NORM _{x,y,z}	sensitivity in free space
ConvF	sensitivity in TSL / NORM _{x,y,z}
DCP	diode compression point
CF	crest factor (1/duty_cycle) of the RF signal
A, B, C, D	modulation dependent linearization parameters
Polarization φ	φ rotation around probe axis
Polarization ϑ	ϑ rotation around an axis that is in the plane normal to probe axis (at measurement center), i.e., $\vartheta = 0$ is normal to probe axis
Connector Angle	information used in DASY system to align probe sensor X to the robot coordinate system

Calibration is Performed According to the Following Standards:

- a) IEEE Std 1528-2013, "IEEE Recommended Practice for Determining the Peak Spatial-Averaged Specific Absorption Rate (SAR) in the Human Head from Wireless Communications Devices: Measurement Techniques", June 2013
- b) IEC 62209-1, "Procedure to measure the Specific Absorption Rate (SAR) for hand-held devices used in close proximity to the ear (frequency range of 300 MHz to 3 GHz)", February 2005

Methods Applied and Interpretation of Parameters:

- **NORM_{x,y,z}**: Assessed for E-field polarization $\vartheta = 0$ ($f \leq 900$ MHz in TEM-cell; $f > 1800$ MHz: R22 waveguide). NORM_{x,y,z} are only intermediate values, i.e., the uncertainties of NORM_{x,y,z} does not affect the E²-field uncertainty inside TSL (see below *ConvF*).
- **NORM(f)_{x,y,z}** = NORM_{x,y,z} * *frequency_response* (see Frequency Response Chart). This linearization is implemented in DASY4 software versions later than 4.2. The uncertainty of the frequency response is included in the stated uncertainty of *ConvF*.
- **DCP_{x,y,z}**: DCP are numerical linearization parameters assessed based on the data of power sweep with CW signal (no uncertainty required). DCP does not depend on frequency nor media.
- **PAR**: PAR is the Peak to Average Ratio that is not calibrated but determined based on the signal characteristics
- **A_{x,y,z}; B_{x,y,z}; C_{x,y,z}; D_{x,y,z}; VR_{x,y,z}**: A, B, C, D are numerical linearization parameters assessed based on the data of power sweep for specific modulation signal. The parameters do not depend on frequency nor media. VR is the maximum calibration range expressed in RMS voltage across the diode.
- **ConvF and Boundary Effect Parameters**: Assessed in flat phantom using E-field (or Temperature Transfer Standard for $f \leq 800$ MHz) and inside waveguide using analytical field distributions based on power measurements for $f > 800$ MHz. The same setups are used for assessment of the parameters applied for boundary compensation (alpha, depth) of which typical uncertainty values are given. These parameters are used in DASY4 software to improve probe accuracy close to the boundary. The sensitivity in TSL corresponds to NORM_{x,y,z} * *ConvF* whereby the uncertainty corresponds to that given for *ConvF*. A frequency dependent *ConvF* is used in DASY version 4.4 and higher which allows extending the validity from ± 50 MHz to ± 100 MHz.
- **Spherical isotropy (3D deviation from isotropy)**: in a field of low gradients realized using a flat phantom exposed by a patch antenna.
- **Sensor Offset**: The sensor offset corresponds to the offset of virtual measurement center from the probe tip (on probe axis). No tolerance required.
- **Connector Angle**: The angle is assessed using the information gained by determining the NORM_x (no uncertainty required).

Probe ES3DV3

SN:3209

Manufactured: October 14, 2008
Calibrated: March 19, 2015

Calibrated for DASY/EASY Systems
(Note: non-compatible with DASY2 system!)

DASY/EASY - Parameters of Probe: ES3DV3 - SN:3209

Basic Calibration Parameters

	Sensor X	Sensor Y	Sensor Z	Unc (k=2)
Norm ($\mu\text{V}/(\text{V}/\text{m})^2$) ^A	1.35	1.33	1.14	$\pm 10.1\%$
DCP (mV) ^B	102.0	100.9	103.3	

Modulation Calibration Parameters

UID	Communication System Name		A dB	B dB $\sqrt{\mu\text{V}}$	C	D dB	VR mV	Unc ^E (k=2)
0	CW	X	0.0	0.0	1.0	0.00	214.5	$\pm 3.5\%$
		Y	0.0	0.0	1.0		192.6	
		Z	0.0	0.0	1.0		199.1	
10010- CAA	SAR Validation (Square, 100ms, 10ms)	X	2.61	65.1	12.2	10.00	42.3	$\pm 1.7\%$
		Y	1.39	57.8	8.9		42.7	
		Z	4.57	70.3	14.0		38.3	
10011- CAB	UMTS-FDD (WCDMA)	X	3.12	66.3	18.1	2.91	130.3	$\pm 0.7\%$
		Y	3.08	65.6	17.5		132.2	
		Z	3.32	67.7	19.0		137.6	
10012- CAB	IEEE 802.11b WiFi 2.4 GHz (DSSS, 1 Mbps)	X	2.54	66.8	17.8	1.87	131.1	$\pm 0.7\%$
		Y	2.67	67.1	17.7		131.6	
		Z	2.85	69.2	19.1		138.0	
10013- CAB	IEEE 802.11g WiFi 2.4 GHz (DSSS-OFDM, 6 Mbps)	X	10.78	70.5	23.4	9.46	146.9	$\pm 2.7\%$
		Y	10.39	69.2	22.5		123.5	
		Z	10.50	69.9	23.1		128.4	
10021- DAB	GSM-FDD (TDMA, GMSK)	X	3.65	74.2	17.7	9.39	130.0	$\pm 1.9\%$
		Y	6.62	83.5	22.0		149.4	
		Z	4.25	76.8	19.2		136.2	
10023- DAB	GPRS-FDD (TDMA, GMSK, TN 0)	X	3.95	75.3	18.4	9.57	138.8	$\pm 2.5\%$
		Y	4.99	78.2	19.8		143.3	
		Z	4.11	75.8	18.9		129.3	
10024- DAB	GPRS-FDD (TDMA, GMSK, TN 0-1)	X	6.44	80.3	17.7	6.56	135.0	$\pm 1.7\%$
		Y	3.76	73.7	16.0		144.2	
		Z	11.61	88.5	20.7		148.0	
10027- DAB	GPRS-FDD (TDMA, GMSK, TN 0-1-2)	X	43.77	99.9	21.8	4.80	131.8	$\pm 1.7\%$
		Y	13.95	87.5	19.0		142.7	
		Z	39.96	99.9	22.1		145.6	
10028- DAB	GPRS-FDD (TDMA, GMSK, TN 0-1-2-3)	X	62.88	99.8	20.4	3.55	144.5	$\pm 2.2\%$
		Y	2.45	70.4	12.9		130.3	
		Z	80.83	99.9	19.9		135.1	
10032- CAA	IEEE 802.15.1 Bluetooth (GFSK, DH5)	X	0.32	58.4	4.3	1.16	144.1	$\pm 1.9\%$
		Y	16.25	79.9	12.1		129.5	
		Z	95.90	91.1	14.4		134.6	
10100- CAB	LTE-FDD (SC-FDMA, 100% RB, 20 MHz, QPSK)	X	6.32	67.4	19.8	5.67	138.3	$\pm 1.4\%$
		Y	6.35	67.3	19.5		144.4	
		Z	6.20	67.1	19.6		127.7	

10103-CAB	LTE-TDD (SC-FDMA, 100% RB, 20 MHz, QPSK)	X	8.72	73.1	25.3	9.29	138.6	±2.7 %
		Y	8.88	72.9	24.9		147.9	
		Z	8.48	72.3	24.9		127.4	
10108-CAC	LTE-FDD (SC-FDMA, 100% RB, 10 MHz, QPSK)	X	6.14	66.9	19.6	5.80	136.2	±1.7 %
		Y	6.20	66.8	19.4		142.8	
		Z	6.10	66.8	19.6		126.2	
10117-CAB	IEEE 802.11n (HT Mixed, 13.5 Mbps, BPSK)	X	10.05	68.9	21.4	8.07	126.8	±2.2 %
		Y	9.98	68.5	21.1		132.4	
		Z	10.23	69.4	21.7		140.4	
10151-CAB	LTE-TDD (SC-FDMA, 50% RB, 20 MHz, QPSK)	X	8.16	72.2	25.0	9.28	133.6	±2.7 %
		Y	8.33	72.0	24.5		142.6	
		Z	8.40	73.1	25.6		147.5	
10154-CAC	LTE-FDD (SC-FDMA, 50% RB, 10 MHz, QPSK)	X	5.83	66.5	19.4	5.75	133.1	±1.4 %
		Y	5.89	66.3	19.2		139.3	
		Z	6.00	67.2	19.9		146.5	
10160-CAB	LTE-FDD (SC-FDMA, 50% RB, 15 MHz, QPSK)	X	6.26	66.9	19.6	5.82	138.8	±1.7 %
		Y	6.34	67.0	19.5		145.1	
		Z	6.22	66.9	19.7		128.8	
10169-CAB	LTE-FDD (SC-FDMA, 1 RB, 20 MHz, QPSK)	X	4.77	66.7	19.8	5.73	135.9	±1.4 %
		Y	4.89	66.6	19.5		141.8	
		Z	4.85	66.8	19.9		128.3	
10172-CAB	LTE-TDD (SC-FDMA, 1 RB, 20 MHz, QPSK)	X	6.77	75.0	26.9	9.21	144.2	±2.5 %
		Y	6.56	72.6	25.2		131.1	
		Z	6.68	74.0	26.4		137.1	
10175-CAC	LTE-FDD (SC-FDMA, 1 RB, 10 MHz, QPSK)	X	4.80	66.9	19.9	5.72	135.2	±1.4 %
		Y	4.87	66.5	19.5		140.6	
		Z	5.03	67.7	20.4		149.4	
10181-CAB	LTE-FDD (SC-FDMA, 1 RB, 15 MHz, QPSK)	X	4.77	66.7	19.8	5.72	134.7	±1.2 %
		Y	4.88	66.5	19.5		140.6	
		Z	4.84	66.8	19.9		127.8	
10196-CAB	IEEE 802.11n (HT Mixed, 6.5 Mbps, BPSK)	X	9.97	69.5	21.9	8.10	145.2	±2.2 %
		Y	9.60	68.2	21.0		125.1	
		Z	9.80	69.1	21.7		133.9	
10225-CAB	UMTS-FDD (HSPA+)	X	6.95	67.5	19.8	5.97	147.3	±1.4 %
		Y	6.73	66.4	19.1		128.7	
		Z	6.89	67.4	19.8		137.2	
10237-CAB	LTE-TDD (SC-FDMA, 1 RB, 10 MHz, QPSK)	X	6.85	75.4	27.2	9.21	146.0	±2.5 %
		Y	6.54	72.5	25.1		131.6	
		Z	6.76	74.4	26.6		138.2	
10252-CAB	LTE-TDD (SC-FDMA, 50% RB, 10 MHz, QPSK)	X	7.58	71.3	24.6	9.24	126.6	±2.5 %
		Y	7.73	71.1	24.2		133.3	
		Z	7.82	72.4	25.3		139.0	
10267-CAB	LTE-TDD (SC-FDMA, 100% RB, 10 MHz, QPSK)	X	8.18	72.2	25.1	9.30	133.6	±2.7 %
		Y	8.35	72.0	24.6		141.1	
		Z	8.42	73.2	25.6		147.0	

10275-CAB	UMTS-FDD (HSUPA, Subtest 5, 3GPP Rel8.4)	X	4.22	66.1	18.4	3.96	128.8	±0.9 %
		Y	4.24	65.9	18.1		133.8	
		Z	4.39	67.1	19.0		141.7	
10291-AAB	CDMA2000, RC3, SO55, Full Rate	X	3.51	66.7	18.6	3.46	140.9	±0.7 %
		Y	3.52	66.2	18.1		143.4	
		Z	3.58	67.2	19.0		131.7	
10292-AAB	CDMA2000, RC3, SO32, Full Rate	X	3.45	66.7	18.5	3.39	142.0	±0.7 %
		Y	3.50	66.4	18.2		146.9	
		Z	3.61	67.8	19.3		132.2	
10297-AAA	LTE-FDD (SC-FDMA, 50% RB, 20 MHz, QPSK)	X	6.15	66.9	19.6	5.81	136.3	±1.4 %
		Y	6.20	66.8	19.4		140.3	
		Z	6.11	66.8	19.6		126.6	
10311-AAA	LTE-FDD (SC-FDMA, 100% RB, 15 MHz, QPSK)	X	6.80	67.8	20.1	6.06	143.2	±1.7 %
		Y	6.80	67.5	19.9		147.4	
		Z	6.71	67.6	20.1		131.9	
10400-AAB	IEEE 802.11ac WiFi (20MHz, 64-QAM, 99pc duty cycle)	X	10.31	70.0	22.4	8.37	147.9	±3.0 %
		Y	9.88	68.5	21.3		127.2	
		Z	10.13	69.5	22.1		135.8	
10403-AAB	CDMA2000 (1xEV-DO, Rev. 0)	X	4.60	68.6	18.9	3.76	128.2	±0.5 %
		Y	4.58	67.9	18.4		134.2	
		Z	4.86	69.6	19.5		142.6	
10404-AAB	CDMA2000 (1xEV-DO, Rev. A)	X	4.57	68.9	19.1	3.77	149.7	±0.5 %
		Y	4.51	68.0	18.5		132.3	
		Z	4.78	69.6	19.5		140.3	
10415-AAA	IEEE 802.11b WiFi 2.4 GHz (DSSS, 1 Mbps, 99pc duty cycle)	X	2.47	67.0	17.9	1.54	128.1	±0.7 %
		Y	2.46	66.4	17.4		132.5	
		Z	2.72	69.1	19.2		140.6	
10416-AAA	IEEE 802.11g WiFi 2.4 GHz (ERP-OFDM, 6 Mbps, 99pc duty cycle)	X	10.12	69.7	22.1	8.23	146.8	±2.7 %
		Y	9.66	68.2	21.1		125.0	
		Z	9.91	69.2	21.8		134.3	

The reported uncertainty of measurement is stated as the standard uncertainty of measurement multiplied by the coverage factor $k=2$, which for a normal distribution corresponds to a coverage probability of approximately 95%.

^A The uncertainties of NormX,Y,Z do not affect the E^2 -field uncertainty inside TSL (see Pages 7 and 8).

^B Numerical linearization parameter: uncertainty not required.

^E Uncertainty is determined using the max. deviation from linear response applying rectangular distribution and is expressed for the square of the field value.

DASY/EASY - Parameters of Probe: ES3DV3 - SN:3209

Calibration Parameter Determined in Head Tissue Simulating Media

f (MHz) ^C	Relative Permittivity ^F	Conductivity (S/m) ^F	ConvF X	ConvF Y	ConvF Z	Alpha ^G	Depth ^G (mm)	Unct. (k=2)
750	41.9	0.89	6.34	6.34	6.34	0.29	2.02	± 12.0 %
835	41.5	0.90	6.04	6.04	6.04	0.23	2.57	± 12.0 %
1750	40.1	1.37	5.23	5.23	5.23	0.80	1.08	± 12.0 %
1900	40.0	1.40	5.05	5.05	5.05	0.10	2.40	± 12.0 %
2300	39.5	1.67	4.76	4.76	4.76	0.70	1.27	± 12.0 %
2450	39.2	1.80	4.53	4.53	4.53	0.80	1.22	± 12.0 %
2600	39.0	1.96	4.36	4.36	4.36	0.75	1.31	± 12.0 %

^C Frequency validity above 300 MHz of ± 100 MHz only applies for DASY v4.4 and higher (see Page 2), else it is restricted to ± 50 MHz. The uncertainty is the RSS of the ConvF uncertainty at calibration frequency and the uncertainty for the indicated frequency band. Frequency validity below 300 MHz is ± 10, 25, 40, 50 and 70 MHz for ConvF assessments at 30, 64, 128, 150 and 220 MHz respectively. Above 5 GHz frequency validity can be extended to ± 110 MHz.

^F At frequencies below 3 GHz, the validity of tissue parameters (ϵ and σ) can be relaxed to ± 10% if liquid compensation formula is applied to measured SAR values. At frequencies above 3 GHz, the validity of tissue parameters (ϵ and σ) is restricted to ± 5%. The uncertainty is the RSS of the ConvF uncertainty for indicated target tissue parameters.

^G Alpha/Depth are determined during calibration. SPEAG warrants that the remaining deviation due to the boundary effect after compensation is always less than ± 1% for frequencies below 3 GHz and below ± 2% for frequencies between 3-6 GHz at any distance larger than half the probe tip diameter from the boundary.

DASY/EASY - Parameters of Probe: ES3DV3 - SN:3209

Calibration Parameter Determined in Body Tissue Simulating Media

f (MHz) ^C	Relative Permittivity ^F	Conductivity (S/m) ^F	ConvF X	ConvF Y	ConvF Z	Alpha ^G	Depth (mm) ^G	Unct. (k=2)
750	55.5	0.96	6.12	6.12	6.12	0.34	1.81	± 12.0 %
835	55.2	0.97	6.07	6.07	6.07	0.37	1.79	± 12.0 %
1750	53.4	1.49	4.86	4.86	4.86	0.67	1.43	± 12.0 %
1900	53.3	1.52	4.57	4.57	4.57	0.57	1.53	± 12.0 %
2300	52.9	1.81	4.28	4.28	4.28	0.80	1.19	± 12.0 %
2450	52.7	1.95	4.12	4.12	4.12	0.72	1.15	± 12.0 %
2600	52.5	2.16	3.92	3.92	3.92	0.80	1.10	± 12.0 %

^C Frequency validity above 300 MHz of ± 100 MHz only applies for DASY v4.4 and higher (see Page 2), else it is restricted to ± 50 MHz. The uncertainty is the RSS of the ConvF uncertainty at calibration frequency and the uncertainty for the indicated frequency band. Frequency validity below 300 MHz is ± 10, 25, 40, 50 and 70 MHz for ConvF assessments at 30, 64, 128, 150 and 220 MHz respectively. Above 5 GHz frequency validity can be extended to ± 110 MHz.

^F At frequencies below 3 GHz, the validity of tissue parameters (ϵ and σ) can be relaxed to ± 10% if liquid compensation formula is applied to measured SAR values. At frequencies above 3 GHz, the validity of tissue parameters (ϵ and σ) is restricted to ± 5%. The uncertainty is the RSS of the ConvF uncertainty for indicated target tissue parameters.

^G Alpha/Depth are determined during calibration. SPEAG warrants that the remaining deviation due to the boundary effect after compensation is always less than ± 1% for frequencies below 3 GHz and below ± 2% for frequencies between 3-6 GHz at any distance larger than half the probe tip diameter from the boundary.

Frequency Response of E-Field (TEM-Cell:ifi110 EXX, Waveguide: R22)

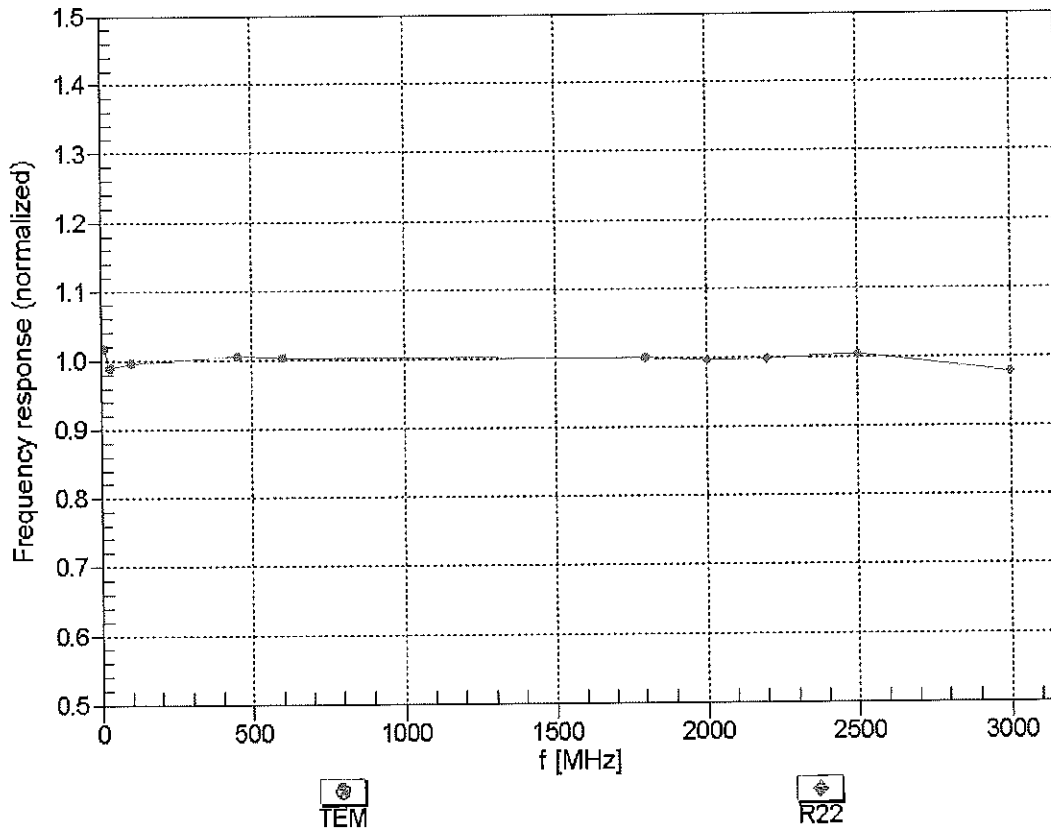

Uncertainty of Frequency Response of E-field: $\pm 6.3\%$ (k=2)

Receiving Pattern (ϕ), $\theta = 0^\circ$

f=600 MHz, TEM

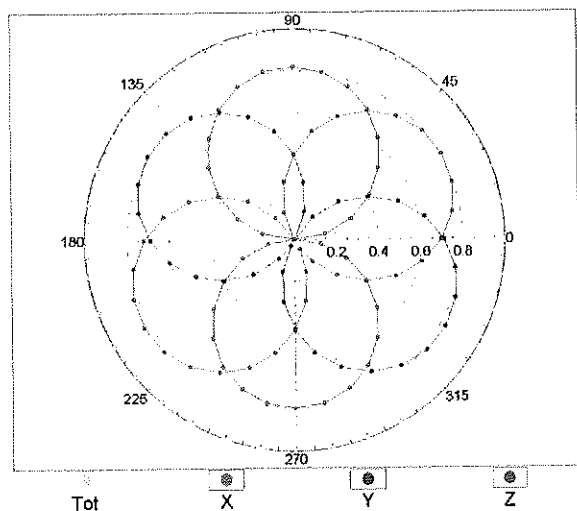

f=1800 MHz, R22

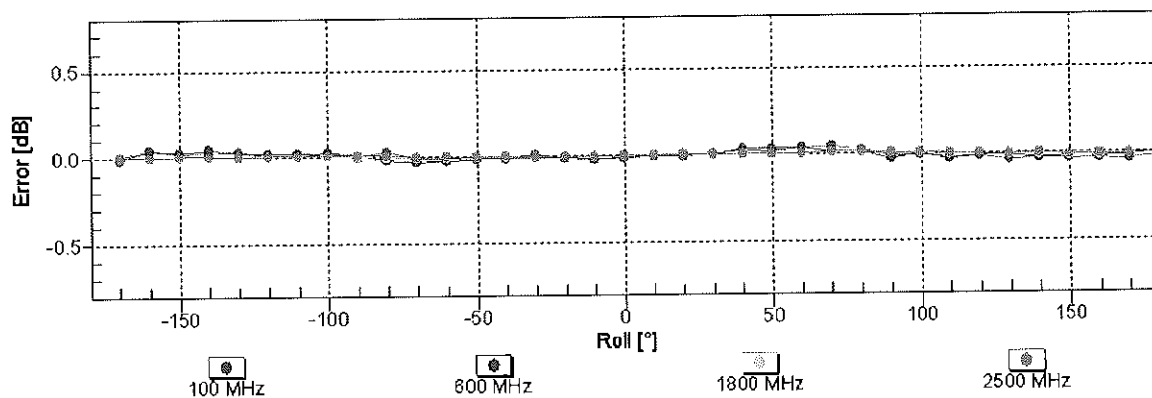
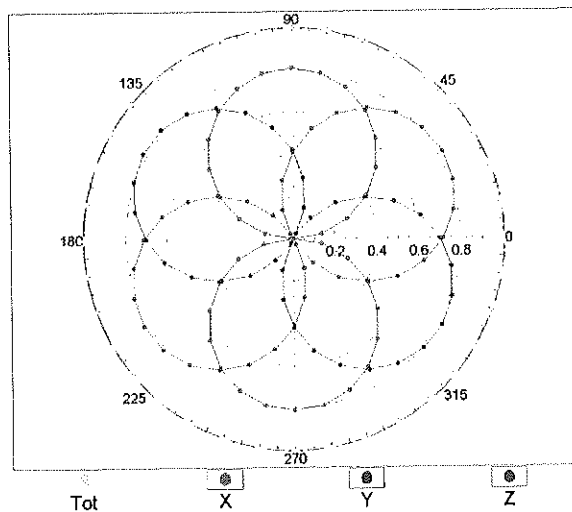

Uncertainty of Axial Isotropy Assessment: $\pm 0.5\%$ ($k=2$)

Dynamic Range $f(SAR_{head})$ (TEM cell , $f_{eval} = 1900$ MHz)

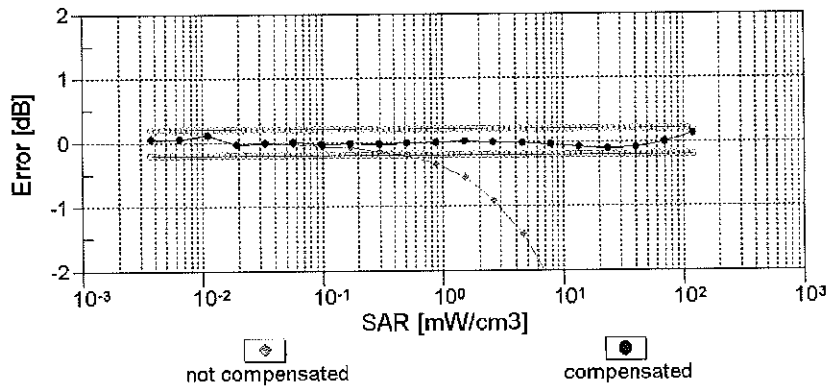
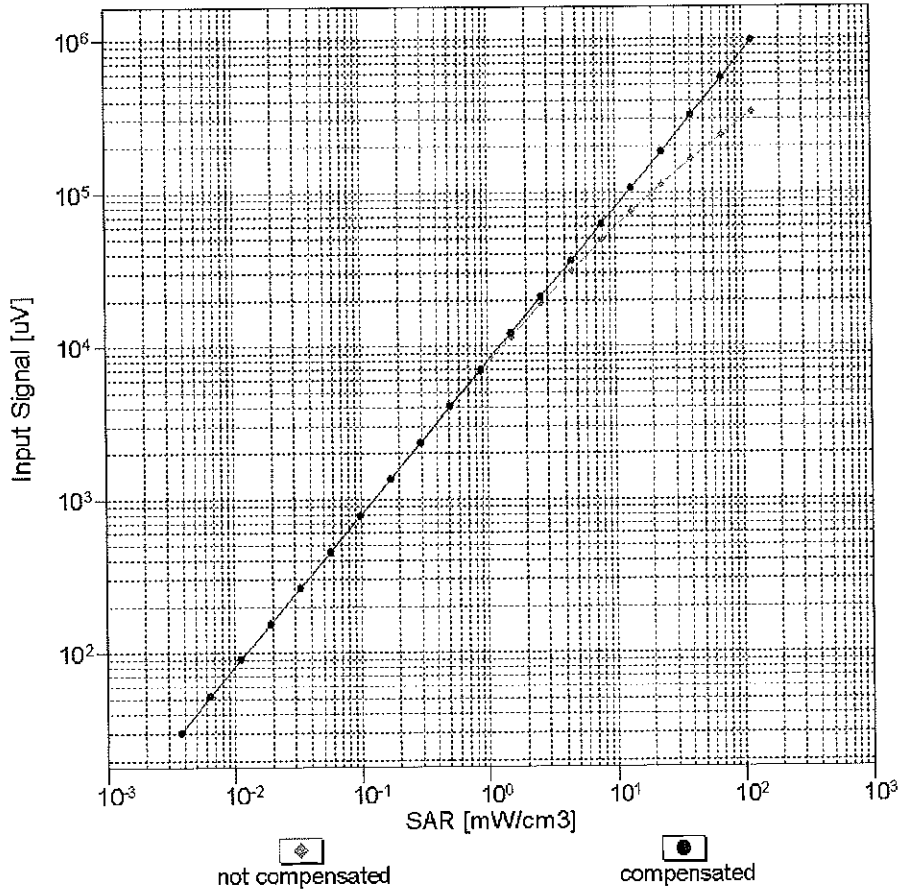

Uncertainty of Linearity Assessment: ± 0.6% (k=2)

Conversion Factor Assessment

f = 835 MHz, WGLS R9 (H_convF)

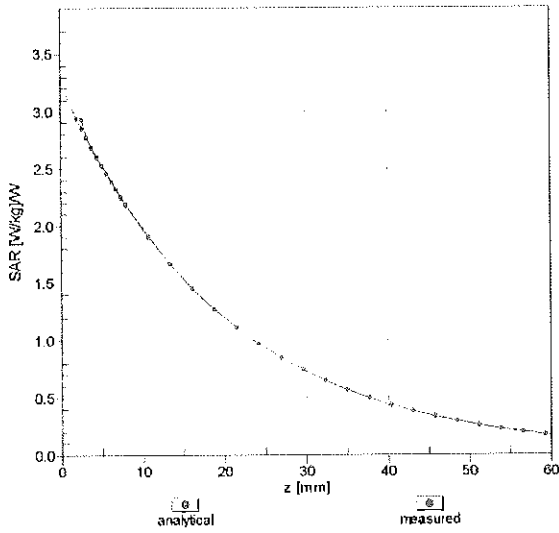

f = 1900 MHz, WGLS R22 (H_convF)

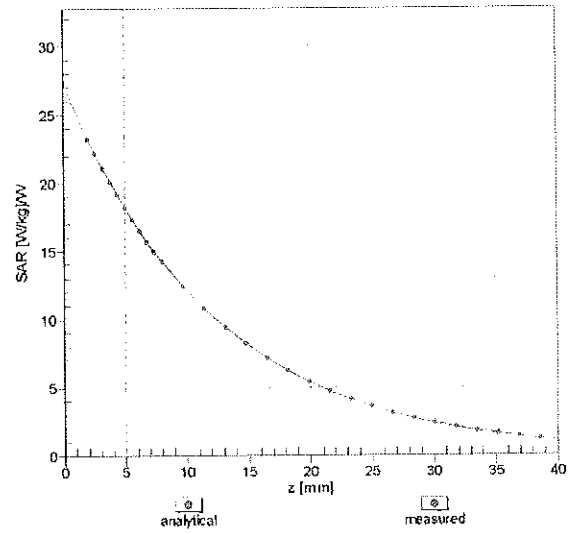

Deviation from Isotropy in Liquid Error (ϕ, θ), f = 900 MHz

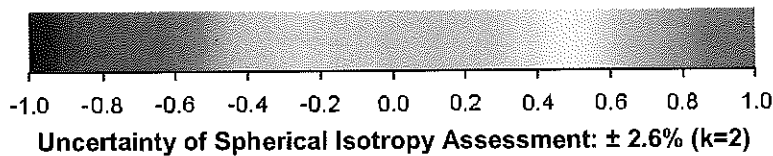
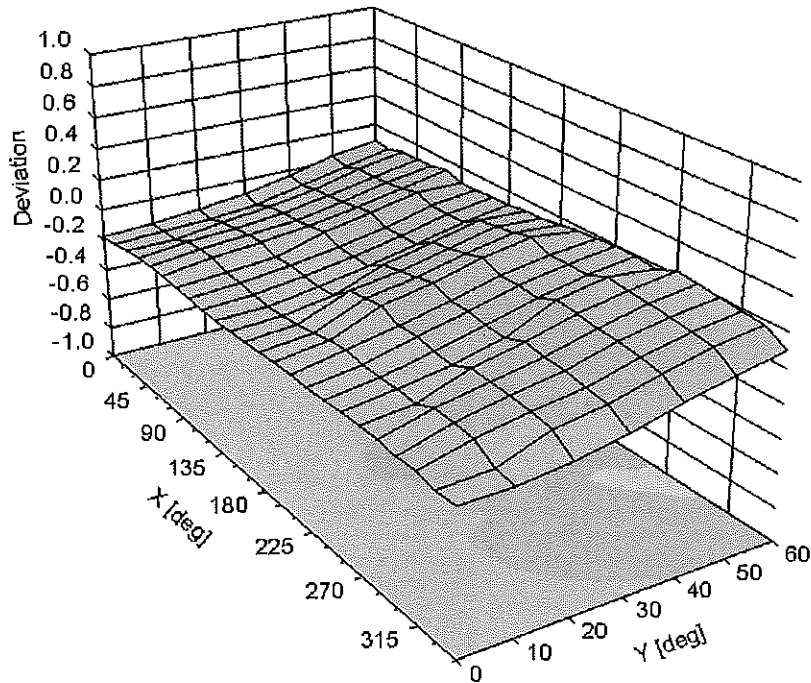

DASY/EASY - Parameters of Probe: ES3DV3 - SN:3209

Other Probe Parameters

Sensor Arrangement	Triangular
Connector Angle (°)	-40.3
Mechanical Surface Detection Mode	enabled
Optical Surface Detection Mode	disabled
Probe Overall Length	337 mm
Probe Body Diameter	10 mm
Tip Length	10 mm
Tip Diameter	4 mm
Probe Tip to Sensor X Calibration Point	2 mm
Probe Tip to Sensor Y Calibration Point	2 mm
Probe Tip to Sensor Z Calibration Point	2 mm
Recommended Measurement Distance from Surface	3 mm

Calibration Laboratory of
Schmid & Partner
Engineering AG
Zeughausstrasse 43, 8004 Zurich, Switzerland



S Schweizerischer Kalibrierdienst
S Service suisse d'étalonnage
S Servizio svizzero di taratura
S Swiss Calibration Service

Accredited by the Swiss Accreditation Service (SAS)
The Swiss Accreditation Service is one of the signatories to the EA
Multilateral Agreement for the recognition of calibration certificates

Accreditation No.: SCS 108

Client PC Test

Certificate No: ES3-3334_Dec14

CALIBRATION CERTIFICATE

Object ES3DV3 - SN:3334

Calibration procedure(s) QA CAL-01.v9, QA CAL-23.v5, QA CAL-25.v6
Calibration procedure for dosimetric E-field probes

CC
12/16/14

Calibration date: December 16, 2014

This calibration certificate documents the traceability to national standards, which realize the physical units of measurements (SI).
The measurements and the uncertainties with confidence probability are given on the following pages and are part of the certificate.

All calibrations have been conducted in the closed laboratory facility: environment temperature (22 ± 3)°C and humidity < 70%.

Calibration Equipment used (M&TE critical for calibration)

Primary Standards	ID	Cal Date (Certificate No.)	Scheduled Calibration
Power meter E4419B	GB41293874	03-Apr-14 (No. 217-01911)	Apr-15
Power sensor E4412A	MY41498087	03-Apr-14 (No. 217-01911)	Apr-15
Reference 3 dB Attenuator	SN: S5054 (3c)	03-Apr-14 (No. 217-01915)	Apr-15
Reference 20 dB Attenuator	SN: S5277 (20x)	03-Apr-14 (No. 217-01919)	Apr-15
Reference 30 dB Attenuator	SN: S5129 (30b)	03-Apr-14 (No. 217-01920)	Apr-15
Reference Probe ES3DV2	SN: 3013	30-Dec-13 (No. ES3-3013_Dec13)	Dec-14
DAE4	SN: 789	30-Apr-14 (No. DAE4-789_Apr14)	Apr-15
Secondary Standards	ID	Check Date (in house)	Scheduled Check
RF generator HP 8648C	US3642U01700	4-Aug-99 (in house check Apr-13)	In house check: Apr-16
Network Analyzer HP 8753E	US37390585	18-Oct-01 (in house check Oct-14)	In house check: Oct-15

	Name	Function	Signature
Calibrated by:	Leif Klysner	Laboratory Technician	
Approved by:	Katja Pokovic	Technical Manager	
			Issued: December 16, 2014

This calibration certificate shall not be reproduced except in full without written approval of the laboratory.



Accredited by the Swiss Accreditation Service (SAS)
The Swiss Accreditation Service is one of the signatories to the EA
Multilateral Agreement for the recognition of calibration certificates

Accreditation No.: **SCS 108**

Glossary:

TSL	tissue simulating liquid
NORM _{x,y,z}	sensitivity in free space
ConvF	sensitivity in TSL / NORM _{x,y,z}
DCP	diode compression point
CF	crest factor (1/duty_cycle) of the RF signal
A, B, C, D	modulation dependent linearization parameters
Polarization ϕ	ϕ rotation around probe axis
Polarization ϑ	ϑ rotation around an axis that is in the plane normal to probe axis (at measurement center), i.e., $\vartheta = 0$ is normal to probe axis
Connector Angle	Information used in DASY system to align probe sensor X to the robot coordinate system

Calibration is Performed According to the Following Standards:

- a) IEEE Std 1528-2013, "IEEE Recommended Practice for Determining the Peak Spatial-Averaged Specific Absorption Rate (SAR) in the Human Head from Wireless Communications Devices: Measurement Techniques", June 2013
- b) IEC 62209-1, "Procedure to measure the Specific Absorption Rate (SAR) for hand-held devices used in close proximity to the ear (frequency range of 300 MHz to 3 GHz)", February 2005

Methods Applied and Interpretation of Parameters:

- **NORM_{x,y,z}:** Assessed for E-field polarization $\vartheta = 0$ ($f \leq 900$ MHz in TEM-cell; $f > 1800$ MHz: R22 waveguide). NORM_{x,y,z} are only intermediate values, i.e., the uncertainties of NORM_{x,y,z} does not affect the E²-field uncertainty inside TSL (see below ConvF).
- **NORM(f)_{x,y,z} = NORM_{x,y,z} * frequency_response** (see Frequency Response Chart). This linearization is implemented in DASY4 software versions later than 4.2. The uncertainty of the frequency response is included in the stated uncertainty of ConvF.
- **DCP_{x,y,z}:** DCP are numerical linearization parameters assessed based on the data of power sweep with CW signal (no uncertainty required). DCP does not depend on frequency nor media.
- **PAR:** PAR is the Peak to Average Ratio that is not calibrated but determined based on the signal characteristics
- **A_{x,y,z}; B_{x,y,z}; C_{x,y,z}; D_{x,y,z}; VR_{x,y,z}:** A, B, C, D are numerical linearization parameters assessed based on the data of power sweep for specific modulation signal. The parameters do not depend on frequency nor media. VR is the maximum calibration range expressed in RMS voltage across the diode.
- **ConvF and Boundary Effect Parameters:** Assessed in flat phantom using E-field (or Temperature Transfer Standard for $f \leq 800$ MHz) and inside waveguide using analytical field distributions based on power measurements for $f > 800$ MHz. The same setups are used for assessment of the parameters applied for boundary compensation (alpha, depth) of which typical uncertainty values are given. These parameters are used in DASY4 software to improve probe accuracy close to the boundary. The sensitivity in TSL corresponds to NORM_{x,y,z} * ConvF whereby the uncertainty corresponds to that given for ConvF. A frequency dependent ConvF is used in DASY version 4.4 and higher which allows extending the validity from ± 50 MHz to ± 100 MHz.
- **Spherical Isotropy (3D deviation from isotropy):** in a field of low gradients realized using a flat phantom exposed by a patch antenna.
- **Sensor Offset:** The sensor offset corresponds to the offset of virtual measurement center from the probe tip (on probe axis). No tolerance required.
- **Connector Angle:** The angle is assessed using the information gained by determining the NORM_x (no uncertainty required).

Probe ES3DV3

SN:3334

Manufactured: January 24, 2012
Repaired: December 9, 2014
Calibrated: December 16, 2014

Calibrated for DASY/EASY Systems
(Note: non-compatible with DASY2 system!)

DASY/EASY - Parameters of Probe: ES3DV3 - SN:3334**Basic Calibration Parameters**

	Sensor X	Sensor Y	Sensor Z	Unc (k=2)
Norm ($\mu\text{V}/(\text{V}/\text{m})^2$) ^A	1.04	1.05	1.01	$\pm 10.1 \%$
DCP (mV) ^B	106.5	105.0	105.6	

Modulation Calibration Parameters

UID	Communication System Name		A dB	B dB $\sqrt{\mu\text{V}}$	C	D dB	VR mV	Unc ^F (k=2)
0	CW	X	0.0	0.0	1.0	0.00	188.0	$\pm 3.0 \%$
		Y	0.0	0.0	1.0		183.2	
		Z	0.0	0.0	1.0		181.8	
10010-CAA	SAR Validation (Square, 100ms, 10ms)	X	4.61	67.2	13.7	10.00	38.4	$\pm 1.4 \%$
		Y	20.36	82.7	18.7		38.0	
		Z	17.55	80.3	17.6		37.0	
10011-CAB	UMTS-FDD (WCDMA)	X	3.56	68.4	19.1	2.91	148.4	$\pm 0.7 \%$
		Y	3.44	68.1	19.2		146.9	
		Z	3.52	68.3	19.1		144.7	
10012-CAB	IEEE 802.11b WIFI 2.4 GHz (DSSS, 1 Mbps)	X	3.54	71.9	20.0	1.87	148.0	$\pm 0.7 \%$
		Y	3.51	72.2	20.5		148.9	
		Z	3.80	73.3	20.6		144.6	
10013-CAB	IEEE 802.11g WIFI 2.4 GHz (DSSS-OFDM, 6 Mbps)	X	11.39	71.1	23.3	9.46	149.8	$\pm 3.8 \%$
		Y	11.54	71.8	24.0		149.5	
		Z	11.11	70.5	23.0		141.6	
10021-DAB	GSM-FDD (TDMA, GMSK)	X	15.29	91.3	25.0	9.39	131.9	$\pm 1.7 \%$
		Y	24.16	100.0	28.4		142.8	
		Z	13.05	89.2	24.5		126.5	
10023-DAB	GPRS-FDD (TDMA, GMSK, TN 0)	X	16.07	91.7	25.1	9.57	144.0	$\pm 2.2 \%$
		Y	19.00	95.3	26.8		136.4	
		Z	13.93	89.8	24.6		141.0	
10024-DAB	GPRS-FDD (TDMA, GMSK, TN 0-1)	X	19.98	91.0	22.4	6.56	134.2	$\pm 1.9 \%$
		Y	34.78	99.7	25.5		145.0	
		Z	29.89	96.8	24.1		129.8	
10027-DAB	GPRS-FDD (TDMA, GMSK, TN 0-1-2)	X	56.30	99.7	22.8	4.80	125.2	$\pm 1.9 \%$
		Y	41.16	99.6	23.9		131.2	
		Z	50.78	99.8	23.1		147.6	
10028-DAB	GPRS-FDD (TDMA, GMSK, TN 0-1-2-3)	X	49.35	99.7	22.5	3.55	133.2	$\pm 2.2 \%$
		Y	46.49	99.6	22.9		139.2	
		Z	58.21	99.7	22.0		129.4	
10032-CAA	IEEE 802.15.1 Bluetooth (GFSK, DH5)	X	56.54	100.0	20.2	1.16	128.0	$\pm 1.7 \%$
		Y	20.03	99.3	22.4		130.3	
		Z	84.01	100.0	19.4		141.0	
10100-CAB	LTE-FDD (SC-FDMA, 100% RB, 20 MHz, QPSK)	X	6.44	67.6	19.6	5.67	138.5	$\pm 1.4 \%$
		Y	6.50	67.9	20.0		142.1	
		Z	6.31	67.2	19.4		129.4	

10103-CAB	LTE-TDD (SC-FDMA, 100% RB, 20 MHz, QPSK)	X	9.77	73.6	24.6	9.29	129.6	±3.3 %
		Y	10.52	76.0	26.3		132.1	
		Z	10.21	75.0	25.4		147.7	
10108-CAC	LTE-FDD (SC-FDMA, 100% RB, 10 MHz, QPSK)	X	6.36	67.2	19.6	5.80	136.8	±1.4 %
		Y	6.31	67.3	19.8		137.2	
		Z	6.20	66.7	19.3		128.8	
10117-CAB	IEEE 802.11n (HT Mixed, 13.5 Mbps, BPSK)	X	9.96	68.3	20.8	8.07	126.5	±2.5 %
		Y	10.12	68.8	21.3		126.6	
		Z	10.22	69.0	21.2		143.7	
10151-CAB	LTE-TDD (SC-FDMA, 50% RB, 20 MHz, QPSK)	X	9.29	73.0	24.4	9.28	125.3	±3.3 %
		Y	9.65	74.5	25.6		124.4	
		Z	9.65	74.3	25.2		141.1	
10154-CAC	LTE-FDD (SC-FDMA, 50% RB, 10 MHz, QPSK)	X	6.03	66.7	19.3	5.75	132.7	±1.4 %
		Y	5.97	66.7	19.5		132.7	
		Z	6.17	67.3	19.7		148.3	
10160-CAB	LTE-FDD (SC-FDMA, 50% RB, 15 MHz, QPSK)	X	6.47	67.2	19.5	5.82	138.1	±1.4 %
		Y	6.44	67.3	19.8		138.2	
		Z	6.27	66.6	19.2		126.8	
10169-CAB	LTE-FDD (SC-FDMA, 1 RB, 20 MHz, QPSK)	X	5.03	66.9	19.6	5.73	137.2	±1.2 %
		Y	4.97	67.0	19.9		135.7	
		Z	4.91	66.5	19.5		127.1	
10172-CAB	LTE-TDD (SC-FDMA, 1 RB, 20 MHz, QPSK)	X	8.53	77.4	26.9	9.21	142.4	±2.7 %
		Y	9.59	81.3	29.3		142.3	
		Z	7.78	75.0	25.7		126.7	
10175-CAC	LTE-FDD (SC-FDMA, 1 RB, 10 MHz, QPSK)	X	5.02	67.0	19.7	5.72	131.8	±1.2 %
		Y	4.98	67.0	19.9		136.1	
		Z	4.95	66.8	19.6		128.1	
10181-CAB	LTE-FDD (SC-FDMA, 1 RB, 15 MHz, QPSK)	X	4.99	66.8	19.6	5.72	131.2	±1.2 %
		Y	4.99	67.1	20.0		136.2	
		Z	4.92	66.6	19.5		127.9	
10196-CAB	IEEE 802.11n (HT Mixed, 6.5 Mbps, BPSK)	X	9.98	68.8	21.2	8.10	141.7	±2.5 %
		Y	10.14	69.5	21.8		147.2	
		Z	9.85	68.6	21.1		137.5	
10225-CAB	UMTS-FDD (HSPA+)	X	7.17	67.5	19.6	5.97	146.0	±1.4 %
		Y	7.13	67.7	19.9		149.9	
		Z	7.12	67.5	19.6		142.9	
10237-CAB	LTE-TDD (SC-FDMA, 1 RB, 10 MHz, QPSK)	X	8.29	76.6	26.5	9.21	136.1	±2.7 %
		Y	9.60	81.4	29.3		142.3	
		Z	7.98	75.8	26.1		132.9	
10252-CAB	LTE-TDD (SC-FDMA, 50% RB, 10 MHz, QPSK)	X	9.27	74.1	25.1	9.24	139.1	±3.3 %
		Y	10.25	77.5	27.4		146.3	
		Z	9.07	73.7	25.0		135.8	
10267-CAB	LTE-TDD (SC-FDMA, 100% RB, 10 MHz, QPSK)	X	9.95	74.9	25.4	9.30	147.0	±3.3 %
		Y	9.80	75.0	25.9		125.9	
		Z	9.74	74.6	25.4		143.8	

10275-CAB	UMTS-FDD (HSUPA, Sublest 5, 3GPP Rel8.4)	X	4.63	67.6	19.0	3.96	147.5	±0.7 %
		Y	4.41	66.9	18.9		129.5	
		Z	4.61	67.6	19.1		148.1	
10291-AAB	CDMA2000, RC3, SO55, Full Rate	X	3.83	67.7	19.0	3.46	133.7	±0.7 %
		Y	3.71	67.4	19.0		139.0	
		Z	3.86	68.1	19.2		133.7	
10292-AAB	CDMA2000, RC3, SO32, Full Rate	X	3.85	68.2	19.2	3.39	136.7	±0.5 %
		Y	3.67	67.5	19.1		141.3	
		Z	3.75	67.8	19.0		136.2	
10297-AAA	LTE-FDD (SC-FDMA, 50% RB, 20 MHz, QPSK)	X	6.31	67.1	19.5	5.81	130.6	±1.4 %
		Y	6.32	67.3	19.8		135.1	
		Z	6.24	66.9	19.4		129.2	
10311-AAA	LTE-FDD (SC-FDMA, 100% RB, 15 MHz, QPSK)	X	6.85	67.5	19.8	6.06	135.1	±1.4 %
		Y	6.90	67.9	20.2		141.5	
		Z	6.82	67.5	19.8		135.1	
10403-AAB	CDMA2000 (1xEV-DO, Rev. 0)	X	5.04	69.1	19.1	3.76	126.0	±0.5 %
		Y	4.90	69.0	19.3		129.6	
		Z	5.11	69.7	19.4		125.8	
10404-AAB	CDMA2000 (1xEV-DO, Rev. A)	X	5.05	69.6	19.4	3.77	147.1	±0.7 %
		Y	4.84	69.2	19.5		127.8	
		Z	5.15	70.1	19.6		143.3	
10415-AAA	IEEE 802.11b WIFI 2.4 GHz (DSSS, 1 Mbps, 99pc duty cycle)	X	3.13	71.2	19.9	1.54	144.5	±0.5 %
		Y	2.93	70.4	19.9		149.8	
		Z	3.18	71.6	20.1		141.4	
10416-AAA	IEEE 802.11g WIFI 2.4 GHz (ERP-OFDM, 6 Mbps, 99pc duty cycle)	X	10.11	69.0	21.4	8.23	144.3	±2.5 %
		Y	10.21	69.6	21.9		148.3	
		Z	9.99	68.9	21.3		141.1	

The reported uncertainty of measurement is stated as the standard uncertainty of measurement multiplied by the coverage factor $k=2$, which for a normal distribution corresponds to a coverage probability of approximately 95%.

^A The uncertainties of NormX,Y,Z do not affect the E²-field uncertainty inside TSL. (see Pages 7 and 8).

^B Numerical linearization parameter: uncertainty not required.

^E Uncertainty is determined using the max. deviation from linear response applying rectangular distribution and is expressed for the square of the field value.

DASY/EASY - Parameters of Probe: ES3DV3 - SN:3334

Calibration Parameter Determined in Head Tissue Simulating Media

f (MHz) ^c	Relative Permittivity ^f	Conductivity (S/m) ^f	ConvF X	ConvF Y	ConvF Z	Alpha ^g	Depth ^g (mm)	Unct. (k=2)
750	41.9	0.89	6.51	6.51	6.51	0.80	1.17	± 12.0 %
835	41.5	0.90	6.25	6.25	6.25	0.38	1.58	± 12.0 %
1750	40.1	1.37	5.21	5.21	5.21	0.43	1.63	± 12.0 %
1900	40.0	1.40	5.03	5.03	5.03	0.53	1.45	± 12.0 %
2450	39.2	1.80	4.51	4.51	4.51	0.80	1.26	± 12.0 %
2600	39.0	1.96	4.31	4.31	4.31	0.79	1.27	± 12.0 %

^c Frequency validity above 300 MHz of ± 100 MHz only applies for DASY v4.4 and higher (see Page 2), else it is restricted to ± 50 MHz. The uncertainty is the RSS of the ConvF uncertainty at calibration frequency and the uncertainty for the indicated frequency band. Frequency validity below 300 MHz is ± 10, 25, 40, 50 and 70 MHz for ConvF assessments at 30, 64, 128, 150 and 220 MHz respectively. Above 5 GHz frequency validity can be extended to ± 110 MHz.

^f At frequencies below 3 GHz, the validity of tissue parameters (ϵ and σ) can be relaxed to ± 10% if liquid compensation formula is applied to measured SAR values. At frequencies above 3 GHz, the validity of tissue parameters (ϵ and σ) is restricted to ± 5%. The uncertainty is the RSS of the ConvF uncertainty for indicated target tissue parameters.

^g Alpha/Depth are determined during calibration. SPEAG warrants that the remaining deviation due to the boundary effect after compensation is always less than ± 1% for frequencies below 3 GHz and below ± 2% for frequencies between 3-6 GHz at any distance larger than half the probe tip diameter from the boundary.

DASY/EASY - Parameters of Probe: ES3DV3 - SN:3334

Calibration Parameter Determined in Body Tissue Simulating Media

f (MHz) ^c	Relative Permittivity ^f	Conductivity (S/m) ^f	ConvF X	ConvF Y	ConvF Z	Alpha ^g	Depth ^d (mm)	Unct. (k=2)
750	55.5	0.96	6.09	6.09	6.09	0.49	1.47	± 12.0 %
835	55.2	0.97	6.14	6.14	6.14	0.69	1.27	± 12.0 %
1750	53.4	1.49	4.94	4.94	4.94	0.80	1.24	± 12.0 %
1900	53.3	1.52	4.73	4.73	4.73	0.62	1.44	± 12.0 %
2450	52.7	1.95	4.28	4.28	4.28	0.80	1.13	± 12.0 %
2600	52.5	2.16	4.16	4.16	4.16	0.75	1.25	± 12.0 %

^c Frequency validity above 300 MHz of ± 100 MHz only applies for DASY v4.4 and higher (see Page 2), else it is restricted to ± 50 MHz. The uncertainty is the RSS of the ConvF uncertainty at calibration frequency and the uncertainty for the indicated frequency band. Frequency validity below 300 MHz is ± 10, 25, 40, 50 and 70 MHz for ConvF assessments at 30, 64, 128, 150 and 220 MHz respectively. Above 5 GHz frequency validity can be extended to ± 110 MHz.

^f At frequencies below 3 GHz, the validity of tissue parameters (ϵ and σ) can be relaxed to ± 10% if liquid compensation formula is applied to measured SAR values. At frequencies above 3 GHz, the validity of tissue parameters (ϵ and σ) is restricted to ± 5%. The uncertainty is the RSS of the ConvF uncertainty for indicated target tissue parameters.

^g Alpha/Depth are determined during calibration. SPEAG warrants that the remaining deviation due to the boundary effect after compensation is always less than ± 1% for frequencies below 3 GHz and below ± 2% for frequencies between 3-6 GHz at any distance larger than half the probe tip diameter from the boundary.

Frequency Response of E-Field (TEM-Cell:ifi110 EXX, Waveguide: R22)

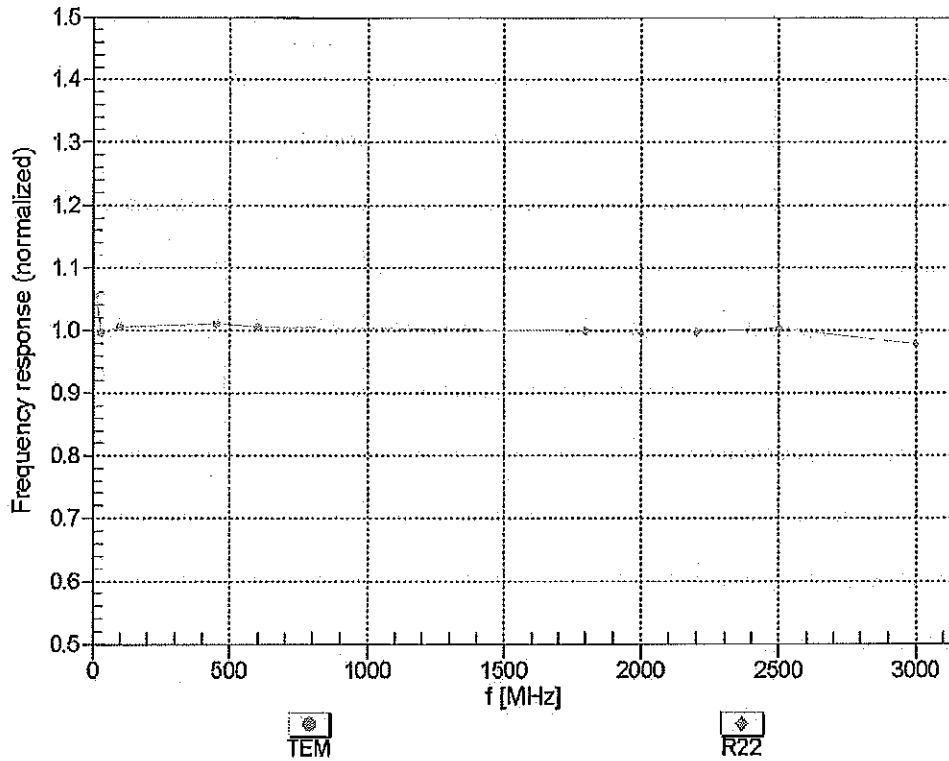

Uncertainty of Frequency Response of E-field: $\pm 6.3\%$ ($k=2$)

Receiving Pattern (ϕ), $\theta = 0^\circ$

f=600 MHz,TEM

f=1800 MHz,R22

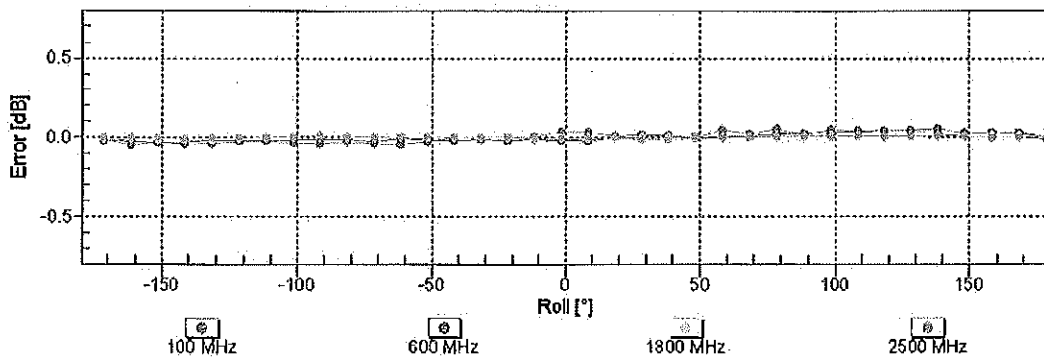
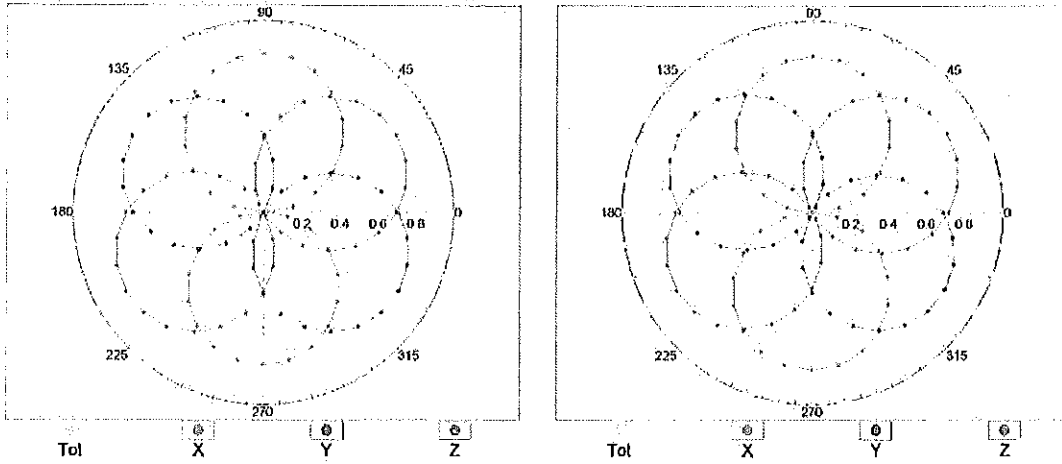

Uncertainty of Axial Isotropy Assessment: $\pm 0.5\%$ (k=2)

Dynamic Range f(SAR_{head}) (TEM cell , f_{eval}= 1900 MHz)

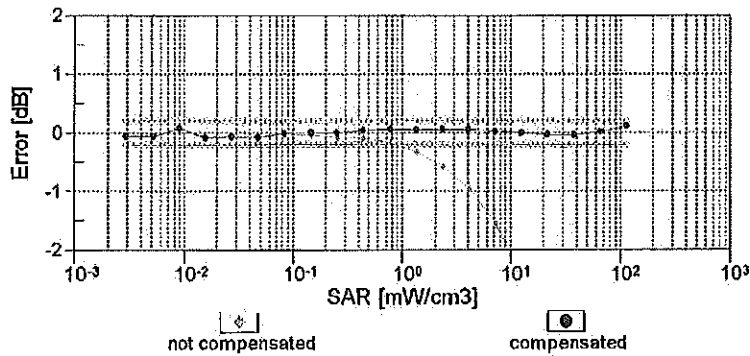
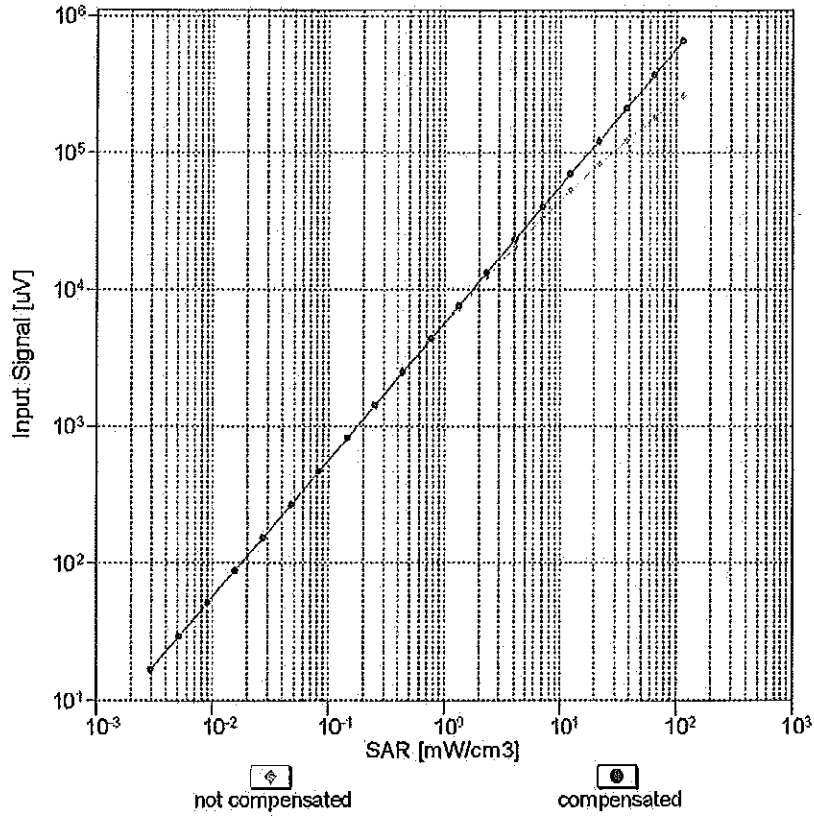

Uncertainty of Linearity Assessment: $\pm 0.6\%$ ($k=2$)

Conversion Factor Assessment

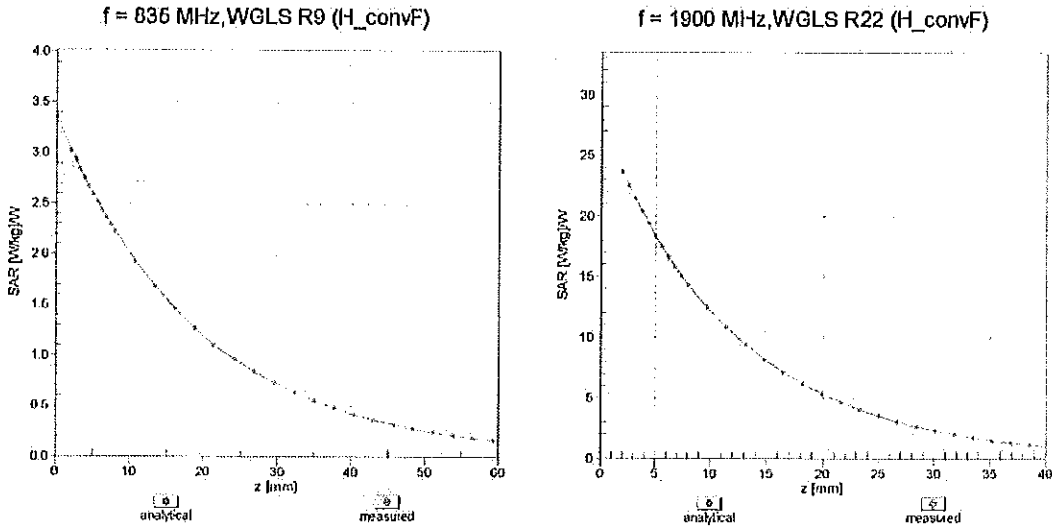

Deviation from Isotropy in Liquid Error (ϕ, θ), f = 900 MHz

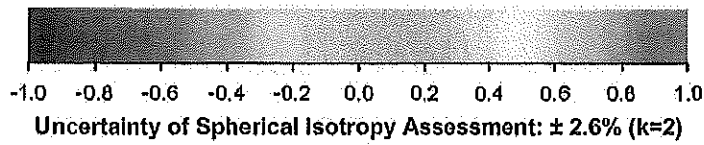
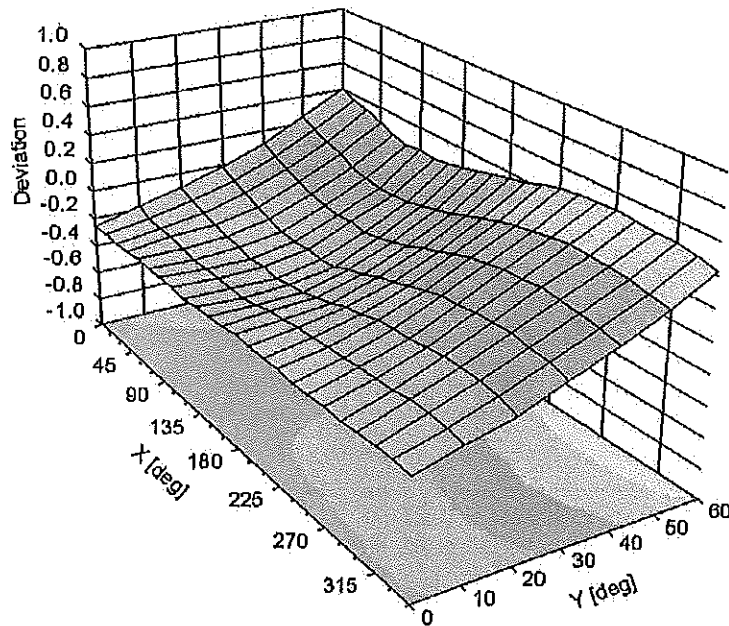

DASY/EASY - Parameters of Probe: ES3DV3 - SN:3334**Other Probe Parameters**

Sensor Arrangement	Triangular
Connector Angle (°)	18.5
Mechanical Surface Detection Mode	enabled
Optical Surface Detection Mode	disabled
Probe Overall Length	337 mm
Probe Body Diameter	10 mm
Tip Length	10 mm
Tip Diameter	4 mm
Probe Tip to Sensor X Calibration Point	2 mm
Probe Tip to Sensor Y Calibration Point	2 mm
Probe Tip to Sensor Z Calibration Point	2 mm
Recommended Measurement Distance from Surface	3 mm

**Calibration Laboratory of
Schmid & Partner
Engineering AG**
Zeughausstrasse 43, 8004 Zurich, Switzerland



S Schweizerischer Kalibrierdienst
C Service suisse d'étalonnage
S Servizio svizzero di taratura
Swiss Calibration Service

Accredited by the Swiss Accreditation Service (SAS)
The Swiss Accreditation Service is one of the signatories to the EA
Multilateral Agreement for the recognition of calibration certificates

Accreditation No.: **SCS 0108**

Client **PC Test**

Certificate No: **ES3-3213_Jan15**

CALIBRATION CERTIFICATE

Object **ES3DV3 - SN:3213**

Calibration procedure(s) **QA CAL-01.v9, QA CAL-23.v5, QA CAL-25.v6
Calibration procedure for dosimetric E-field probes**

CC
1/30/15

Calibration date: **January 20, 2015**

This calibration certificate documents the traceability to national standards, which realize the physical units of measurements (SI).
The measurements and the uncertainties with confidence probability are given on the following pages and are part of the certificate.

All calibrations have been conducted in the closed laboratory facility: environment temperature (22 ± 3)°C and humidity < 70%.

Calibration Equipment used (M&TE critical for calibration)

Primary Standards	ID	Cal Date (Certificate No.)	Scheduled Calibration
Power meter E4419B	GB41293874	03-Apr-14 (No. 217-01911)	Apr-15
Power sensor E4412A	MY41498087	03-Apr-14 (No. 217-01911)	Apr-15
Reference 3 dB Attenuator	SN: S5054 (3c)	03-Apr-14 (No. 217-01915)	Apr-15
Reference 20 dB Attenuator	SN: S5277 (20x)	03-Apr-14 (No. 217-01919)	Apr-15
Reference 30 dB Attenuator	SN: S5129 (30b)	03-Apr-14 (No. 217-01920)	Apr-15
Reference Probe ES3DV2	SN: 3013	30-Dec-14 (No. ES3-3013_Dec14)	Dec-15
DAE4	SN: 660	14-Jan-15 (No. DAE4-660_Jan15)	Jan-16
Secondary Standards	ID	Check Date (in house)	Scheduled Check
RF generator HP 8648C	US3642U01700	4-Aug-99 (in house check Apr-13)	In house check: Apr-16
Network Analyzer HP 8753E	US37390585	18-Oct-01 (in house check Oct-14)	In house check: Oct-15

Calibrated by:	Name Israe Elnaouq	Function Laboratory Technician	Signature
Approved by:	Katja Pokovic	Technical Manager	

Issued: January 22, 2015

This calibration certificate shall not be reproduced except in full without written approval of the laboratory.



Accredited by the Swiss Accreditation Service (SAS)

Accreditation No.: **SCS 0108**

The Swiss Accreditation Service is one of the signatories to the EA
Multilateral Agreement for the recognition of calibration certificates

Glossary:

TSL	tissue simulating liquid
NORM _{x,y,z}	sensitivity in free space
ConvF	sensitivity in TSL / NORM _{x,y,z}
DCP	diode compression point
CF	crest factor (1/duty_cycle) of the RF signal
A, B, C, D	modulation dependent linearization parameters
Polarization φ	φ rotation around probe axis
Polarization ϑ	ϑ rotation around an axis that is in the plane normal to probe axis (at measurement center), i.e., $\vartheta = 0$ is normal to probe axis
Connector Angle	information used in DASY system to align probe sensor X to the robot coordinate system

Calibration is Performed According to the Following Standards:

- a) IEEE Std 1528-2013, "IEEE Recommended Practice for Determining the Peak Spatial-Averaged Specific Absorption Rate (SAR) in the Human Head from Wireless Communications Devices: Measurement Techniques", June 2013
- b) IEC 62209-1, "Procedure to measure the Specific Absorption Rate (SAR) for hand-held devices used in close proximity to the ear (frequency range of 300 MHz to 3 GHz)", February 2005

Methods Applied and Interpretation of Parameters:

- *NORM_{x,y,z}*: Assessed for E-field polarization $\vartheta = 0$ ($f \leq 900$ MHz in TEM-cell; $f > 1800$ MHz: R22 waveguide). *NORM_{x,y,z}* are only intermediate values, i.e., the uncertainties of *NORM_{x,y,z}* does not affect the E^2 -field uncertainty inside TSL (see below *ConvF*).
- *NORM(f)_{x,y,z}* = *NORM_{x,y,z}* * *frequency_response* (see Frequency Response Chart). This linearization is implemented in DASY4 software versions later than 4.2. The uncertainty of the frequency response is included in the stated uncertainty of *ConvF*.
- *DCP_{x,y,z}*: DCP are numerical linearization parameters assessed based on the data of power sweep with CW signal (no uncertainty required). DCP does not depend on frequency nor media.
- *PAR*: PAR is the Peak to Average Ratio that is not calibrated but determined based on the signal characteristics
- *A_{x,y,z}*; *B_{x,y,z}*; *C_{x,y,z}*; *D_{x,y,z}*; *VR_{x,y,z}*; *A, B, C, D* are numerical linearization parameters assessed based on the data of power sweep for specific modulation signal. The parameters do not depend on frequency nor media. *VR* is the maximum calibration range expressed in RMS voltage across the diode.
- *ConvF and Boundary Effect Parameters*: Assessed in flat phantom using E-field (or Temperature Transfer Standard for $f \leq 800$ MHz) and inside waveguide using analytical field distributions based on power measurements for $f > 800$ MHz. The same setups are used for assessment of the parameters applied for boundary compensation (alpha, depth) of which typical uncertainty values are given. These parameters are used in DASY4 software to improve probe accuracy close to the boundary. The sensitivity in TSL corresponds to *NORM_{x,y,z}* * *ConvF* whereby the uncertainty corresponds to that given for *ConvF*. A frequency dependent *ConvF* is used in DASY version 4.4 and higher which allows extending the validity from ± 50 MHz to ± 100 MHz.
- *Spherical isotropy (3D deviation from isotropy)*: in a field of low gradients realized using a flat phantom exposed by a patch antenna.
- *Sensor Offset*: The sensor offset corresponds to the offset of virtual measurement center from the probe tip (on probe axis). No tolerance required.
- *Connector Angle*: The angle is assessed using the information gained by determining the *NORM_x* (no uncertainty required).

Probe ES3DV3

SN:3213

Manufactured: October 14, 2008
Calibrated: January 20, 2015

Calibrated for DASY/EASY Systems
(Note: non-compatible with DASY2 system!)

DASY/EASY - Parameters of Probe: ES3DV3 - SN:3213

Basic Calibration Parameters

	Sensor X	Sensor Y	Sensor Z	Unc (k=2)
Norm ($\mu V/(V/m)^2$) ^A	1.49	1.37	1.34	$\pm 10.1\%$
DCP (mV) ^B	99.9	101.8	101.4	

Modulation Calibration Parameters

UID	Communication System Name		A dB	B dB $\sqrt{\mu V}$	C	D dB	VR mV	Unc ^E (k=2)
0	CW	X	0.0	0.0	1.0	0.00	169.8	$\pm 3.8\%$
		Y	0.0	0.0	1.0		215.4	
		Z	0.0	0.0	1.0		214.5	
10010-CAA	SAR Validation (Square, 100ms, 10ms)	X	1.84	57.8	10.2	10.00	47.4	$\pm 1.9\%$
		Y	1.82	58.6	10.3		44.3	
		Z	1.65	57.3	9.2		44.2	
10011-CAB	UMTS-FDD (WCDMA)	X	3.32	66.8	18.5	2.91	135.8	$\pm 0.5\%$
		Y	3.18	66.4	18.2		127.9	
		Z	3.21	66.5	18.2		128.1	
10012-CAB	IEEE 802.11b WiFi 2.4 GHz (DSSS, 1 Mbps)	X	2.90	68.1	18.4	1.87	137.2	$\pm 0.7\%$
		Y	2.97	69.2	19.0		130.1	
		Z	2.80	68.0	18.4		129.9	
10013-CAB	IEEE 802.11g WiFi 2.4 GHz (DSSS-OFDM, 6 Mbps)	X	11.40	71.2	23.7	9.46	135.1	$\pm 3.8\%$
		Y	11.25	71.3	23.9		124.2	
		Z	10.96	70.3	23.2		124.8	
10021-DAB	GSM-FDD (TDMA, GMSK)	X	18.25	96.6	27.2	9.39	140.4	$\pm 1.7\%$
		Y	21.48	99.9	28.2		133.3	
		Z	11.76	89.4	24.5		127.3	
10023-DAB	GPRS-FDD (TDMA, GMSK, TN 0)	X	13.12	91.7	26.0	9.57	126.4	$\pm 1.9\%$
		Y	17.05	95.2	26.6		127.3	
		Z	8.91	85.2	23.3		118.8	
10024-DAB	GPRS-FDD (TDMA, GMSK, TN 0-1)	X	34.78	100.0	25.2	6.56	116.4	$\pm 1.7\%$
		Y	33.37	99.5	24.8		111.7	
		Z	34.11	99.5	24.6		110.5	
10027-DAB	GPRS-FDD (TDMA, GMSK, TN 0-1-2)	X	37.18	99.7	24.0	4.80	131.2	$\pm 1.7\%$
		Y	44.91	99.8	23.3		127.4	
		Z	41.51	99.7	23.2		125.0	
10028-DAB	GPRS-FDD (TDMA, GMSK, TN 0-1-2-3)	X	48.95	99.5	22.4	3.55	140.9	$\pm 1.7\%$
		Y	67.41	99.8	21.5		137.8	
		Z	56.45	100.0	21.9		135.0	
10032-CAA	IEEE 802.15.1 Bluetooth (GFSK, DH5)	X	20.23	99.3	22.1	1.16	111.3	$\pm 1.2\%$
		Y	32.72	99.5	20.6		109.6	
		Z	48.57	100.0	20.0		108.8	
10100-CAB	LTE-FDD (SC-FDMA, 100% RB, 20 MHz, QPSK)	X	6.60	67.9	20.0	5.67	144.6	$\pm 1.2\%$
		Y	6.55	68.2	20.2		142.7	
		Z	6.50	67.8	19.9		141.5	

10103-CAB	LTE-TDD (SC-FDMA, 100% RB, 20 MHz, QPSK)	X	10.34	75.7	26.2	9.29	133.2	±2.5 %
		Y	10.31	76.5	26.9		128.2	
		Z	9.74	74.5	25.6		127.1	
10108-CAC	LTE-FDD (SC-FDMA, 100% RB, 10 MHz, QPSK)	X	6.50	67.6	20.0	5.80	142.8	±1.2 %
		Y	6.41	67.7	20.1		140.3	
		Z	6.41	67.6	19.9		140.2	
10117-CAB	IEEE 802.11n (HT Mixed, 13.5 Mbps, BPSK)	X	10.36	69.2	21.6	8.07	132.8	±2.7 %
		Y	10.42	69.7	21.9		131.4	
		Z	10.22	69.1	21.4		130.0	
10151-CAB	LTE-TDD (SC-FDMA, 50% RB, 20 MHz, QPSK)	X	9.65	74.6	25.8	9.28	127.9	±2.5 %
		Y	9.66	75.6	26.7		123.7	
		Z	9.14	73.6	25.3		122.7	
10154-CAC	LTE-FDD (SC-FDMA, 50% RB, 10 MHz, QPSK)	X	6.14	66.9	19.6	5.75	139.3	±1.4 %
		Y	6.08	67.2	19.9		138.5	
		Z	6.05	66.9	19.6		137.3	
10160-CAB	LTE-FDD (SC-FDMA, 50% RB, 15 MHz, QPSK)	X	6.58	67.5	19.9	5.82	144.3	±1.4 %
		Y	6.54	67.8	20.1		143.7	
		Z	6.50	67.5	19.8		142.1	
10169-CAB	LTE-FDD (SC-FDMA, 1 RB, 20 MHz, QPSK)	X	4.93	66.1	19.3	5.73	120.6	±0.9 %
		Y	4.93	66.7	19.8		120.9	
		Z	4.85	66.3	19.5		118.9	
10172-CAB	LTE-TDD (SC-FDMA, 1 RB, 20 MHz, QPSK)	X	8.93	79.5	28.6	9.21	140.8	±2.5 %
		Y	9.60	82.9	30.6		139.9	
		Z	8.30	78.2	27.9		136.6	
10175-CAC	LTE-FDD (SC-FDMA, 1 RB, 10 MHz, QPSK)	X	4.90	66.0	19.3	5.72	118.8	±0.9 %
		Y	4.93	66.8	19.8		120.2	
		Z	4.81	66.1	19.3		116.6	
10181-CAB	LTE-FDD (SC-FDMA, 1 RB, 15 MHz, QPSK)	X	4.92	66.1	19.3	5.72	119.0	±0.9 %
		Y	4.92	66.6	19.8		120.5	
		Z	4.77	65.8	19.2		115.8	
10196-CAB	IEEE 802.11n (HT Mixed, 6.5 Mbps, BPSK)	X	9.93	68.7	21.4	8.10	125.0	±2.5 %
		Y	10.06	69.4	21.9		128.3	
		Z	9.78	68.5	21.2		120.5	
10225-CAB	UMTS-FDD (HSPA+)	X	6.66	65.7	18.8	5.97	106.5	±0.9 %
		Y	6.81	66.6	19.3		112.3	
		Z	6.64	66.0	18.9		108.0	
10237-CAB	LTE-TDD (SC-FDMA, 1 RB, 10 MHz, QPSK)	X	8.91	79.4	28.5	9.21	141.4	±2.2 %
		Y	9.39	82.3	30.4		146.7	
		Z	8.40	78.5	28.2		141.2	
10252-CAB	LTE-TDD (SC-FDMA, 50% RB, 10 MHz, QPSK)	X	8.84	73.3	25.2	9.24	119.1	±2.7 %
		Y	8.94	74.6	26.3		118.6	
		Z	8.39	72.4	24.7		114.0	
10267-CAB	LTE-TDD (SC-FDMA, 100% RB, 10 MHz, QPSK)	X	9.62	74.6	25.8	9.30	126.2	±2.7 %
		Y	9.77	76.0	26.9		126.1	
		Z	9.10	73.4	25.2		121.4	

10275-CAB	UMTS-FDD (HSUPA, Subtest 5, 3GPP Rel8.4)	X	4.43	66.4	18.5	3.96	132.5	±0.7 %
		Y	4.37	66.6	18.6		134.1	
		Z	4.40	66.7	18.6		130.5	
10291-AAB	CDMA2000, RC3, SO55, Full Rate	X	3.63	66.4	18.4	3.46	122.5	±0.5 %
		Y	3.54	66.5	18.5		124.9	
		Z	3.55	66.3	18.3		121.4	
10292-AAB	CDMA2000, RC3, SO32, Full Rate	X	3.49	65.9	18.1	3.39	125.1	±0.5 %
		Y	3.52	66.7	18.6		126.1	
		Z	3.51	66.5	18.4		123.8	
10297-AAA	LTE-FDD (SC-FDMA, 50% RB, 20 MHz, QPSK)	X	6.49	67.6	19.9	5.81	143.1	±1.4 %
		Y	6.49	68.0	20.3		142.3	
		Z	6.42	67.6	19.9		144.3	
10311-AAA	LTE-FDD (SC-FDMA, 100% RB, 15 MHz, QPSK)	X	7.06	68.1	20.2	6.06	147.6	±1.7 %
		Y	7.09	68.7	20.7		148.2	
		Z	7.03	68.3	20.4		149.8	
10403-AAB	CDMA2000 (1xEV-DO, Rev. 0)	X	4.66	67.4	18.4	3.76	135.3	±0.5 %
		Y	4.69	68.1	18.7		134.9	
		Z	4.72	68.2	18.7		136.5	
10404-AAB	CDMA2000 (1xEV-DO, Rev. A)	X	4.58	67.4	18.3	3.77	133.4	±0.5 %
		Y	4.68	68.4	18.9		132.8	
		Z	4.58	67.9	18.5		135.4	
10415-AAA	IEEE 802.11b WiFi 2.4 GHz (DSSS, 1 Mbps, 99pc duty cycle)	X	2.41	65.7	17.2	1.54	131.4	±0.7 %
		Y	2.42	66.4	17.7		131.3	
		Z	2.59	67.7	18.2		134.1	
10416-AAA	IEEE 802.11g WiFi 2.4 GHz (ERP-OFDM, 6 Mbps, 99pc duty cycle)	X	10.06	68.9	21.5	8.23	127.6	±2.7 %
		Y	10.12	69.5	22.0		126.3	
		Z	10.04	69.1	21.7		129.7	

The reported uncertainty of measurement is stated as the standard uncertainty of measurement multiplied by the coverage factor $k=2$, which for a normal distribution corresponds to a coverage probability of approximately 95%.

^A The uncertainties of NormX,Y,Z do not affect the E^2 -field uncertainty inside TSL (see Pages 7 and 8).

^B Numerical linearization parameter: uncertainty not required.

^E Uncertainty is determined using the max. deviation from linear response applying rectangular distribution and is expressed for the square of the field value.

DASY/EASY - Parameters of Probe: ES3DV3 - SN:3213

Calibration Parameter Determined in Head Tissue Simulating Media

f (MHz) ^c	Relative Permittivity ^F	Conductivity (S/m) ^F	ConvF X	ConvF Y	ConvF Z	Alpha ^G	Depth ^G (mm)	Unct. (k=2)
750	41.9	0.89	6.45	6.45	6.45	0.57	1.37	± 12.0 %
835	41.5	0.90	6.26	6.26	6.26	0.65	1.26	± 12.0 %
1750	40.1	1.37	5.22	5.22	5.22	0.47	1.47	± 12.0 %
1900	40.0	1.40	5.06	5.06	5.06	0.80	1.14	± 12.0 %
2450	39.2	1.80	4.54	4.54	4.54	0.78	1.22	± 12.0 %
2600	39.0	1.96	4.33	4.33	4.33	0.80	1.28	± 12.0 %

^c Frequency validity above 300 MHz of ± 100 MHz only applies for DASY v4.4 and higher (see Page 2), else it is restricted to ± 50 MHz. The uncertainty is the RSS of the ConvF uncertainty at calibration frequency and the uncertainty for the indicated frequency band. Frequency validity below 300 MHz is ± 10, 25, 40, 50 and 70 MHz for ConvF assessments at 30, 64, 128, 150 and 220 MHz respectively. Above 5 GHz frequency validity can be extended to ± 110 MHz.

^F At frequencies below 3 GHz, the validity of tissue parameters (ϵ and σ) can be relaxed to ± 10% if liquid compensation formula is applied to measured SAR values. At frequencies above 3 GHz, the validity of tissue parameters (ϵ and σ) is restricted to ± 5%. The uncertainty is the RSS of the ConvF uncertainty for indicated target tissue parameters.

^G Alpha/Depth are determined during calibration. SPEAG warrants that the remaining deviation due to the boundary effect after compensation is always less than ± 1% for frequencies below 3 GHz and below ± 2% for frequencies between 3-6 GHz at any distance larger than half the probe tip diameter from the boundary.

DASY/EASY - Parameters of Probe: ES3DV3 - SN:3213

Calibration Parameter Determined in Body Tissue Simulating Media

f (MHz) ^C	Relative Permittivity ^F	Conductivity (S/m) ^F	ConvF X	ConvF Y	ConvF Z	Alpha ^G	Depth ^G (mm)	Unct. (k=2)
750	55.5	0.96	6.11	6.11	6.11	0.71	1.24	± 12.0 %
835	55.2	0.97	6.07	6.07	6.07	0.35	1.86	± 12.0 %
1750	53.4	1.49	4.93	4.93	4.93	0.51	1.47	± 12.0 %
1900	53.3	1.52	4.72	4.72	4.72	0.80	1.20	± 12.0 %
2450	52.7	1.95	4.37	4.37	4.37	0.71	1.12	± 12.0 %
2600	52.5	2.16	4.20	4.20	4.20	0.66	0.95	± 12.0 %

^C Frequency validity above 300 MHz of ± 100 MHz only applies for DASY v4.4 and higher (see Page 2), else it is restricted to ± 50 MHz. The uncertainty is the RSS of the ConvF uncertainty at calibration frequency and the uncertainty for the indicated frequency band. Frequency validity below 300 MHz is ± 10, 25, 40, 50 and 70 MHz for ConvF assessments at 30, 64, 128, 150 and 220 MHz respectively. Above 5 GHz frequency validity can be extended to ± 110 MHz.

^F At frequencies below 3 GHz, the validity of tissue parameters (ϵ and σ) can be relaxed to ± 10% if liquid compensation formula is applied to measured SAR values. At frequencies above 3 GHz, the validity of tissue parameters (ϵ and σ) is restricted to ± 5%. The uncertainty is the RSS of the ConvF uncertainty for indicated target tissue parameters.

^G Alpha/Depth are determined during calibration. SPEAG warrants that the remaining deviation due to the boundary effect after compensation is always less than ± 1% for frequencies below 3 GHz and below ± 2% for frequencies between 3-6 GHz at any distance larger than half the probe tip diameter from the boundary.

Frequency Response of E-Field (TEM-Cell:ifi110 EXX, Waveguide: R22)

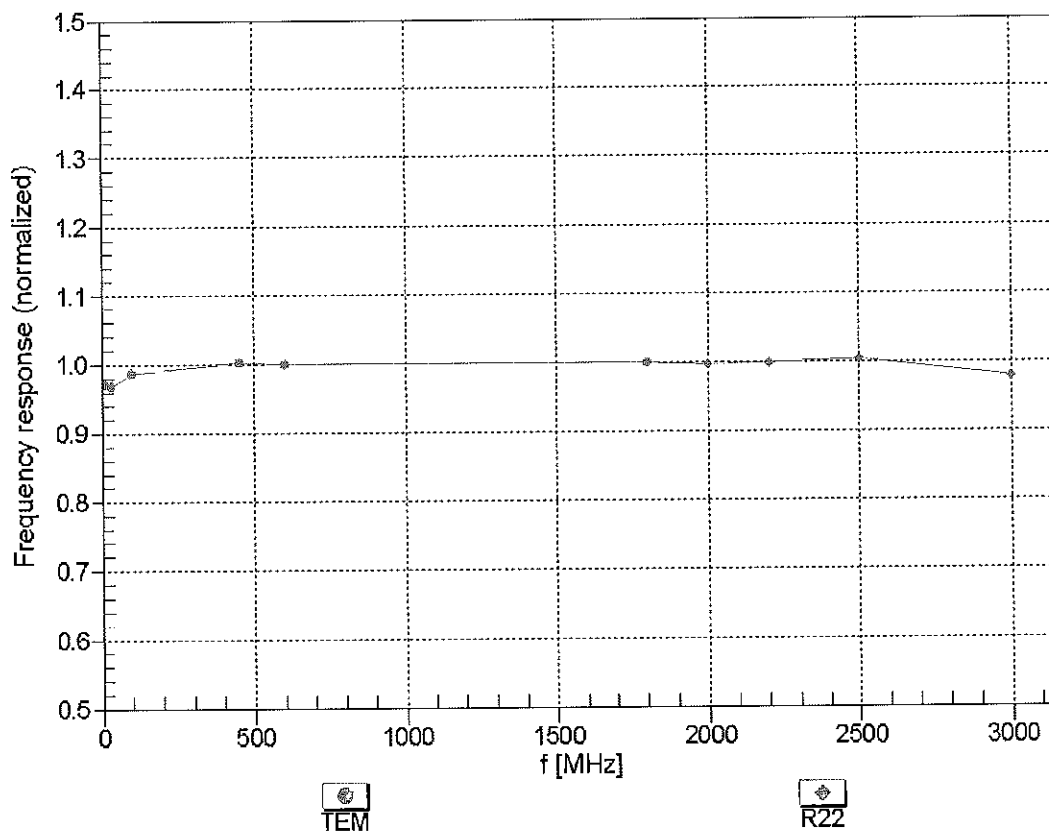

Uncertainty of Frequency Response of E-field: $\pm 6.3\%$ (k=2)

Receiving Pattern (ϕ), $\theta = 0^\circ$

f=600 MHz, TEM

f=1800 MHz, R22

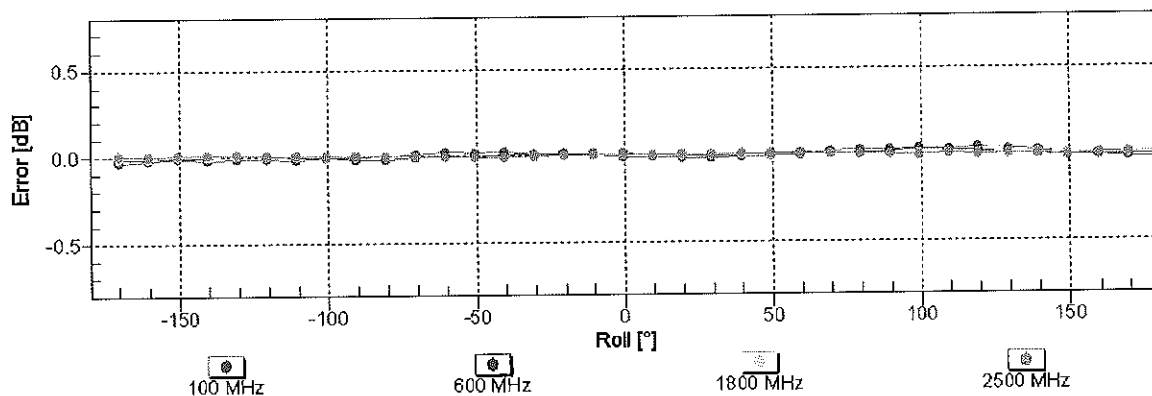
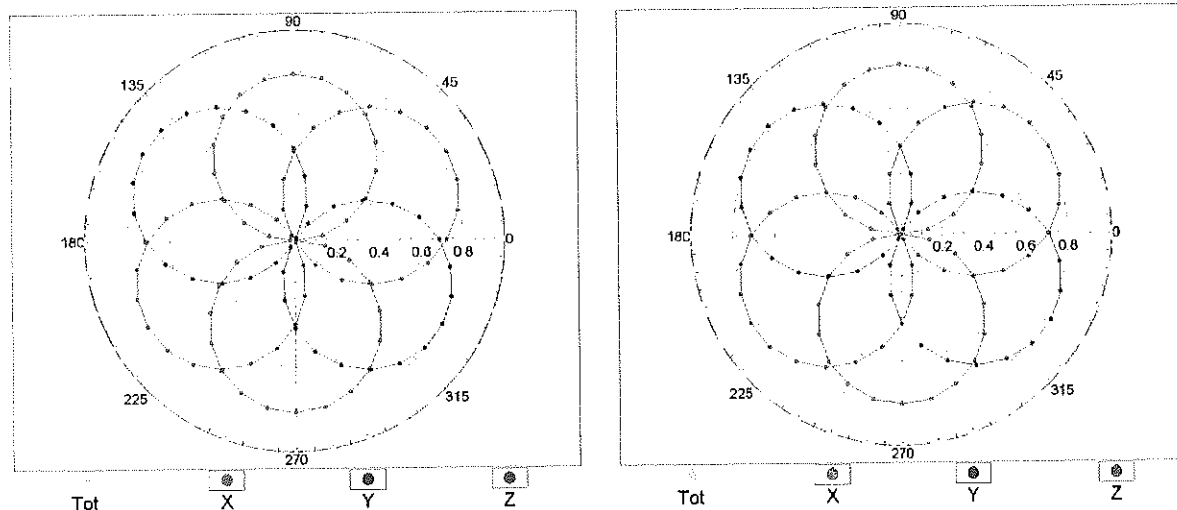

Uncertainty of Axial Isotropy Assessment: $\pm 0.5\%$ (k=2)

Dynamic Range f(SAR_{head}) (TEM cell , f_{eval}= 1900 MHz)

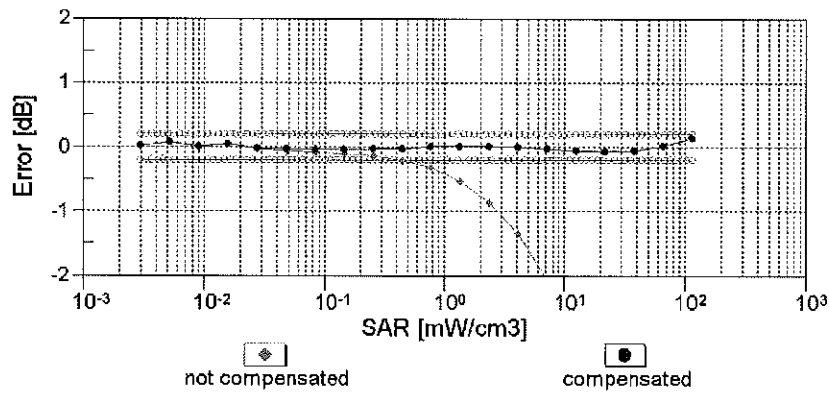
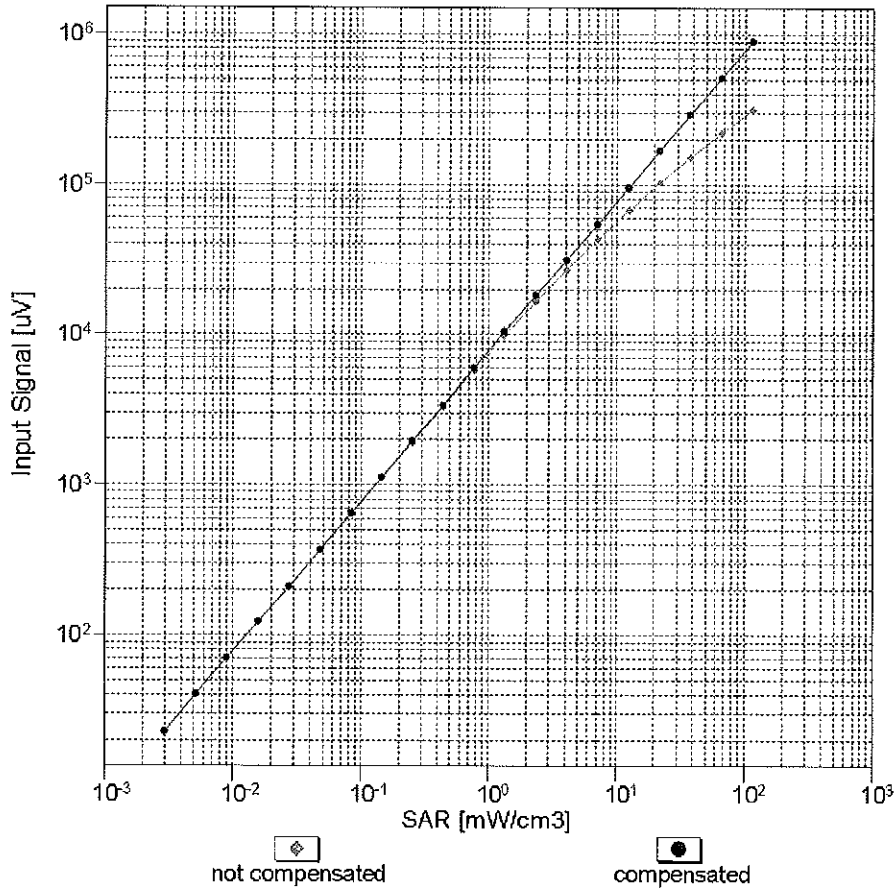

Uncertainty of Linearity Assessment: ± 0.6% (k=2)

Conversion Factor Assessment

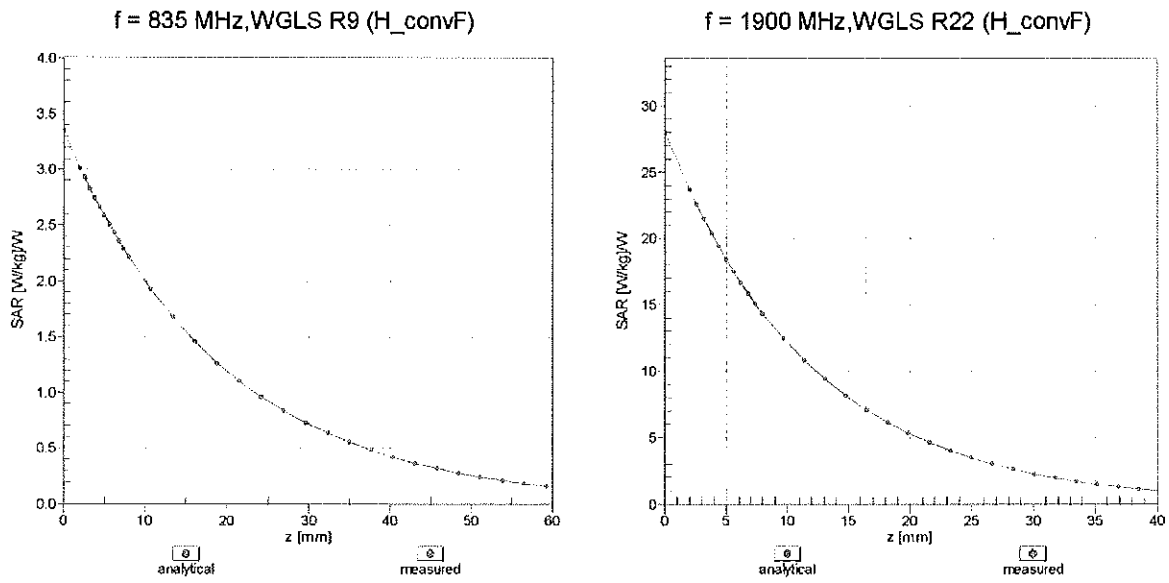

Deviation from Isotropy in Liquid Error (ϕ, θ), f = 900 MHz

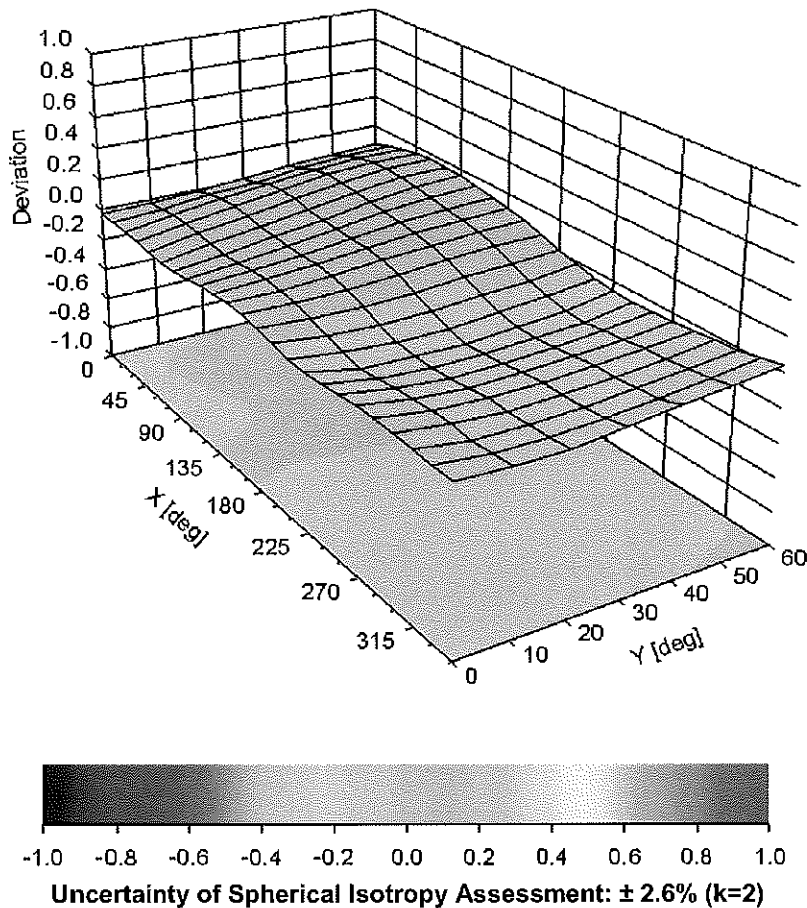

DASY/EASY - Parameters of Probe: ES3DV3 - SN:3213

Other Probe Parameters

Sensor Arrangement	Triangular
Connector Angle (°)	-70.6
Mechanical Surface Detection Mode	enabled
Optical Surface Detection Mode	disabled
Probe Overall Length	337 mm
Probe Body Diameter	10 mm
Tip Length	10 mm
Tip Diameter	4 mm
Probe Tip to Sensor X Calibration Point	2 mm
Probe Tip to Sensor Y Calibration Point	2 mm
Probe Tip to Sensor Z Calibration Point	2 mm
Recommended Measurement Distance from Surface	3 mm



Accredited by the Swiss Accreditation Service (SAS)
The Swiss Accreditation Service is one of the signatories to the EA
Multilateral Agreement for the recognition of calibration certificates

Accreditation No.: **SCS 0108**

Client **PC Test**

Certificate No: **ES3-3318_Jan15**

CALIBRATION CERTIFICATE

Object **ES3DV3 - SN:3318**

Calibration procedure(s) **QA CAL-01.v9, QA CAL-23.v5, QA CAL-25.v6
Calibration procedure for dosimetric E-field probes**

CC
1/30/15

Calibration date: **January 23, 2015**

This calibration certificate documents the traceability to national standards, which realize the physical units of measurements (SI).
The measurements and the uncertainties with confidence probability are given on the following pages and are part of the certificate.

All calibrations have been conducted in the closed laboratory facility: environment temperature (22 ± 3)°C and humidity < 70%.

Calibration Equipment used (M&TE critical for calibration)

Primary Standards	ID	Cal Date (Certificate No.)	Scheduled Calibration
Power meter E4419B	GB41293874	03-Apr-14 (No. 217-01911)	Apr-15
Power sensor E4412A	MY41498087	03-Apr-14 (No. 217-01911)	Apr-15
Reference 3 dB Attenuator	SN: S5054 (3c)	03-Apr-14 (No. 217-01915)	Apr-15
Reference 20 dB Attenuator	SN: S5277 (20x)	03-Apr-14 (No. 217-01919)	Apr-15
Reference 30 dB Attenuator	SN: S5129 (30b)	03-Apr-14 (No. 217-01920)	Apr-15
Reference Probe ES3DV2	SN: 3013	30-Dec-14 (No. ES3-3013_Dec14)	Dec-15
DAE4	SN: 660	14-Jan-15 (No. DAE4-660_Jan15)	Jan-16
Secondary Standards	ID	Check Date (in house)	Scheduled Check
RF generator HP 8648C	US3642U01700	4-Aug-99 (in house check Apr-13)	In house check: Apr-16
Network Analyzer HP 8753E	US37390585	18-Oct-01 (in house check Oct-14)	In house check: Oct-15

	Name	Function	Signature
Calibrated by:	Israe Elnaouq	Laboratory Technician	
Approved by:	Katja Pokovic	Technical Manager	

Issued: January 26, 2015

This calibration certificate shall not be reproduced except in full without written approval of the laboratory.



Accredited by the Swiss Accreditation Service (SAS)

Accreditation No.: **SCS 0108**

The Swiss Accreditation Service is one of the signatories to the EA
Multilateral Agreement for the recognition of calibration certificates

Glossary:

TSL	tissue simulating liquid
NORM _{x,y,z}	sensitivity in free space
ConvF	sensitivity in TSL / NORM _{x,y,z}
DCP	diode compression point
CF	crest factor (1/duty_cycle) of the RF signal
A, B, C, D	modulation dependent linearization parameters
Polarization ϕ	ϕ rotation around probe axis
Polarization ϑ	ϑ rotation around an axis that is in the plane normal to probe axis (at measurement center), i.e., $\vartheta = 0$ is normal to probe axis
Connector Angle	information used in DASY system to align probe sensor X to the robot coordinate system

Calibration is Performed According to the Following Standards:

- a) IEEE Std 1528-2013, "IEEE Recommended Practice for Determining the Peak Spatial-Averaged Specific Absorption Rate (SAR) in the Human Head from Wireless Communications Devices: Measurement Techniques", June 2013
- b) IEC 62209-1, "Procedure to measure the Specific Absorption Rate (SAR) for hand-held devices used in close proximity to the ear (frequency range of 300 MHz to 3 GHz)", February 2005

Methods Applied and Interpretation of Parameters:

- *NORM_{x,y,z}*: Assessed for E-field polarization $\vartheta = 0$ ($f \leq 900$ MHz in TEM-cell; $f > 1800$ MHz: R22 waveguide). *NORM_{x,y,z}* are only intermediate values, i.e., the uncertainties of *NORM_{x,y,z}* does not affect the E^2 -field uncertainty inside TSL (see below *ConvF*).
- *NORM(f)_{x,y,z}* = *NORM_{x,y,z}* * *frequency_response* (see Frequency Response Chart). This linearization is implemented in DASY4 software versions later than 4.2. The uncertainty of the frequency response is included in the stated uncertainty of *ConvF*.
- *DCP_{x,y,z}*: DCP are numerical linearization parameters assessed based on the data of power sweep with CW signal (no uncertainty required). DCP does not depend on frequency nor media.
- *PAR*: PAR is the Peak to Average Ratio that is not calibrated but determined based on the signal characteristics
- *A_{x,y,z}*; *B_{x,y,z}*; *C_{x,y,z}*; *D_{x,y,z}*; *VR_{x,y,z}*; *A, B, C, D* are numerical linearization parameters assessed based on the data of power sweep for specific modulation signal. The parameters do not depend on frequency nor media. *VR* is the maximum calibration range expressed in RMS voltage across the diode.
- *ConvF and Boundary Effect Parameters*: Assessed in flat phantom using E-field (or Temperature Transfer Standard for $f \leq 800$ MHz) and inside waveguide using analytical field distributions based on power measurements for $f > 800$ MHz. The same setups are used for assessment of the parameters applied for boundary compensation (alpha, depth) of which typical uncertainty values are given. These parameters are used in DASY4 software to improve probe accuracy close to the boundary. The sensitivity in TSL corresponds to *NORM_{x,y,z}* * *ConvF* whereby the uncertainty corresponds to that given for *ConvF*. A frequency dependent *ConvF* is used in DASY version 4.4 and higher which allows extending the validity from ± 50 MHz to ± 100 MHz.
- *Spherical isotropy (3D deviation from isotropy)*: in a field of low gradients realized using a flat phantom exposed by a patch antenna.
- *Sensor Offset*: The sensor offset corresponds to the offset of virtual measurement center from the probe tip (on probe axis). No tolerance required.
- *Connector Angle*: The angle is assessed using the information gained by determining the *NORM_x* (no uncertainty required).

Probe ES3DV3

SN:3318

Manufactured: January 10, 2012
Calibrated: January 23, 2015

Calibrated for DASY/EASY Systems
(Note: non-compatible with DASY2 system!)

DASY/EASY - Parameters of Probe: ES3DV3 - SN:3318

Basic Calibration Parameters

	Sensor X	Sensor Y	Sensor Z	Unc (k=2)
Norm ($\mu V/(V/m)^2$) ^A	1.15	0.92	1.28	$\pm 10.1 \%$
DCP (mV) ^B	106.4	109.2	103.4	

Modulation Calibration Parameters

UID	Communication System Name		A dB	B dB $\sqrt{\mu V}$	C	D dB	VR mV	Unc ^E (k=2)
0	CW	X	0.0	0.0	1.0	0.00	200.6	$\pm 3.5 \%$
		Y	0.0	0.0	1.0		185.3	
		Z	0.0	0.0	1.0		207.7	
10010-CAA	SAR Validation (Square, 100ms, 10ms)	X	3.26	66.4	14.0	10.00	41.4	$\pm 1.2 \%$
		Y	1.76	59.6	9.8		36.1	
		Z	1.82	57.7	9.6		43.6	
10011-CAB	UMTS-FDD (WCDMA)	X	3.48	68.9	19.9	2.91	120.2	$\pm 0.5 \%$
		Y	3.76	70.1	19.9		146.0	
		Z	3.11	66.0	17.9		124.4	
10012-CAB	IEEE 802.11b WiFi 2.4 GHz (DSSS, 1 Mbps)	X	3.71	74.2	21.7	1.87	121.7	$\pm 0.7 \%$
		Y	3.65	73.3	20.7		147.5	
		Z	2.77	67.4	17.8		126.6	
10013-CAB	IEEE 802.11g WiFi 2.4 GHz (DSSS-OFDM, 6 Mbps)	X	10.68	69.5	22.7	9.46	114.7	$\pm 2.5 \%$
		Y	10.82	70.4	23.0		139.8	
		Z	11.22	71.1	23.7		122.2	
10021-DAB	GSM-FDD (TDMA, GMSK)	X	16.13	95.0	26.6	9.39	122.7	$\pm 2.2 \%$
		Y	4.61	73.1	17.2		130.8	
		Z	15.10	92.0	25.4		135.9	
10023-DAB	GPRS-FDD (TDMA, GMSK, TN 0)	X	17.03	96.8	27.5	9.57	113.0	$\pm 1.9 \%$
		Y	4.15	71.7	16.8		119.9	
		Z	21.50	98.0	27.5		130.9	
10024-DAB	GPRS-FDD (TDMA, GMSK, TN 0-1)	X	35.51	99.5	24.5	6.56	147.6	$\pm 2.7 \%$
		Y	6.12	77.2	17.1		118.1	
		Z	38.50	99.7	24.7		114.0	
10027-DAB	GPRS-FDD (TDMA, GMSK, TN 0-1-2)	X	45.57	99.9	23.2	4.80	113.3	$\pm 1.7 \%$
		Y	2.73	68.4	12.6		133.3	
		Z	54.59	99.9	22.9		131.0	
10028-DAB	GPRS-FDD (TDMA, GMSK, TN 0-1-2-3)	X	53.68	99.5	21.9	3.55	123.0	$\pm 3.0 \%$
		Y	60.05	99.8	21.1		144.9	
		Z	66.60	99.6	21.6		140.7	
10032-CAA	IEEE 802.15.1 Bluetooth (GFSK, DH5)	X	20.92	99.4	21.8	1.16	136.6	$\pm 2.2 \%$
		Y	95.40	88.3	13.8		117.6	
		Z	100.00	99.5	18.7		110.1	
10100-CAB	LTE-FDD (SC-FDMA, 100% RB, 20 MHz, QPSK)	X	6.50	68.1	20.2	5.67	130.5	$\pm 1.2 \%$
		Y	6.11	66.7	19.2		107.2	
		Z	6.55	68.2	20.1		142.7	

10103-CAB	LTE-TDD (SC-FDMA, 100% RB, 20 MHz, QPSK)	X	9.76	74.8	25.9	9.29	116.0	±2.5 %
		Y	8.85	72.2	24.1		134.9	
		Z	10.83	77.4	27.2		131.5	
10108-CAC	LTE-FDD (SC-FDMA, 100% RB, 10 MHz, QPSK)	X	6.36	67.7	20.1	5.80	128.7	±1.2 %
		Y	5.92	66.1	19.0		106.6	
		Z	6.42	67.7	20.0		140.4	
10117-CAB	IEEE 802.11n (HT Mixed, 13.5 Mbps, BPSK)	X	10.20	69.1	21.6	8.07	118.1	±2.5 %
		Y	10.27	69.3	21.4		143.9	
		Z	10.43	69.7	21.8		131.0	
10151-CAB	LTE-TDD (SC-FDMA, 50% RB, 20 MHz, QPSK)	X	9.09	73.7	25.5	9.28	112.0	±2.7 %
		Y	8.35	71.5	23.9		131.1	
		Z	9.58	74.4	25.6		126.8	
10154-CAC	LTE-FDD (SC-FDMA, 50% RB, 10 MHz, QPSK)	X	6.01	67.0	19.8	5.75	126.4	±1.2 %
		Y	6.17	67.7	19.9		148.9	
		Z	6.07	67.1	19.7		137.2	
10160-CAB	LTE-FDD (SC-FDMA, 50% RB, 15 MHz, QPSK)	X	6.41	67.4	19.9	5.82	130.9	±0.9 %
		Y	6.06	66.2	19.0		109.1	
		Z	6.54	67.7	20.0		142.6	
10169-CAB	LTE-FDD (SC-FDMA, 1 RB, 20 MHz, QPSK)	X	4.79	66.5	19.8	5.73	109.4	±0.9 %
		Y	4.82	67.1	19.8		128.8	
		Z	4.85	66.4	19.5		119.0	
10172-CAB	LTE-TDD (SC-FDMA, 1 RB, 20 MHz, QPSK)	X	8.44	79.3	28.7	9.21	125.1	±2.5 %
		Y	7.15	75.0	26.0		144.0	
		Z	10.13	83.8	30.8		141.9	
10175-CAC	LTE-FDD (SC-FDMA, 1 RB, 10 MHz, QPSK)	X	5.13	68.2	20.8	5.72	146.5	±0.9 %
		Y	4.77	66.8	19.6		125.2	
		Z	4.81	66.2	19.4		118.5	
10181-CAB	LTE-FDD (SC-FDMA, 1 RB, 15 MHz, QPSK)	X	5.11	68.1	20.7	5.72	146.4	±0.9 %
		Y	4.79	67.0	19.7		126.0	
		Z	4.88	66.6	19.7		118.9	
10196-CAB	IEEE 802.11n (HT Mixed, 6.5 Mbps, BPSK)	X	9.63	68.3	21.2	8.10	108.2	±2.5 %
		Y	9.84	68.9	21.3		135.5	
		Z	9.99	69.2	21.7		124.0	
10225-CAB	UMTS-FDD (HSPA+)	X	6.99	67.3	19.7	5.97	134.8	±0.9 %
		Y	6.73	66.8	19.2		115.9	
		Z	6.71	66.2	19.0		106.3	
10237-CAB	LTE-TDD (SC-FDMA, 1 RB, 10 MHz, QPSK)	X	7.79	76.4	27.0	9.21	126.4	±2.5 %
		Y	7.19	75.1	26.1		144.7	
		Z	10.12	83.9	30.9		142.0	
10252-CAB	LTE-TDD (SC-FDMA, 50% RB, 10 MHz, QPSK)	X	8.19	71.9	24.7	9.24	103.3	±2.2 %
		Y	7.76	70.8	23.6		122.0	
		Z	9.31	75.2	26.4		119.1	
10267-CAB	LTE-TDD (SC-FDMA, 100% RB, 10 MHz, QPSK)	X	8.90	73.0	25.1	9.30	108.7	±2.2 %
		Y	8.38	71.6	24.0		129.7	
		Z	10.15	76.5	26.9		126.1	

10275-CAB	UMTS-FDD (HSUPA, Subtest 5, 3GPP Rel8.4)	X	4.42	67.2	19.2	3.96	119.1	±0.7 %
		Y	4.71	68.5	19.5		143.8	
		Z	4.39	66.7	18.6		131.7	
10291-AAB	CDMA2000, RC3, SO55, Full Rate	X	3.65	67.5	19.3	3.46	111.3	±0.5 %
		Y	3.89	69.0	19.6		130.9	
		Z	3.49	66.1	18.2		122.4	
10292-AAB	CDMA2000, RC3, SO32, Full Rate	X	3.60	67.6	19.3	3.39	114.4	±0.5 %
		Y	3.85	69.1	19.7		133.4	
		Z	3.45	66.2	18.2		123.7	
10297-AAA	LTE-FDD (SC-FDMA, 50% RB, 20 MHz, QPSK)	X	6.36	67.6	20.1	5.81	128.7	±1.2 %
		Y	5.95	66.1	19.0		106.5	
		Z	6.39	67.6	19.9		140.7	
10311-AAA	LTE-FDD (SC-FDMA, 100% RB, 15 MHz, QPSK)	X	6.98	68.4	20.6	6.06	134.9	±1.2 %
		Y	6.52	66.7	19.3		111.3	
		Z	7.06	68.6	20.5		146.2	
10403-AAB	CDMA2000 (1xEV-DO, Rev. 0)	X	4.97	69.7	19.7	3.76	122.2	±0.5 %
		Y	5.31	71.6	20.2		143.6	
		Z	4.54	67.3	18.2		133.0	
10404-AAB	CDMA2000 (1xEV-DO, Rev. A)	X	4.77	69.4	19.6	3.77	120.8	±0.5 %
		Y	5.40	72.4	20.6		141.3	
		Z	4.71	68.5	18.9		131.5	
10415-AAA	IEEE 802.11b WiFi 2.4 GHz (DSSS, 1 Mbps, 99pc duty cycle)	X	3.07	71.7	20.7	1.54	120.5	±0.7 %
		Y	3.52	73.8	21.0		142.0	
		Z	2.38	66.1	17.4		129.6	
10416-AAA	IEEE 802.11g WiFi 2.4 GHz (ERP-OFDM, 6 Mbps, 99pc duty cycle)	X	9.73	68.3	21.2	8.23	114.7	±2.5 %
		Y	9.99	69.2	21.5		138.0	
		Z	10.10	69.4	21.9		125.3	

The reported uncertainty of measurement is stated as the standard uncertainty of measurement multiplied by the coverage factor $k=2$, which for a normal distribution corresponds to a coverage probability of approximately 95%.

^A The uncertainties of NormX,Y,Z do not affect the E^2 -field uncertainty inside TSL (see Pages 7 and 8).

^B Numerical linearization parameter: uncertainty not required.

^E Uncertainty is determined using the max. deviation from linear response applying rectangular distribution and is expressed for the square of the field value.

DASY/EASY - Parameters of Probe: ES3DV3 - SN:3318

Calibration Parameter Determined in Head Tissue Simulating Media

f (MHz) ^C	Relative Permittivity ^F	Conductivity (S/m) ^F	ConvF X	ConvF Y	ConvF Z	Alpha ^G	Depth ^G (mm)	Unct. (k=2)
750	41.9	0.89	6.58	6.58	6.58	0.36	1.73	± 12.0 %
835	41.5	0.90	6.39	6.39	6.39	0.80	1.14	± 12.0 %
1750	40.1	1.37	5.27	5.27	5.27	0.76	1.19	± 12.0 %
1900	40.0	1.40	5.05	5.05	5.05	0.44	1.55	± 12.0 %
2300	39.5	1.67	4.78	4.78	4.78	0.80	1.23	± 12.0 %
2450	39.2	1.80	4.50	4.50	4.50	0.55	1.49	± 12.0 %
2600	39.0	1.96	4.34	4.34	4.34	0.76	1.32	± 12.0 %

^C Frequency validity above 300 MHz of ± 100 MHz only applies for DASY v4.4 and higher (see Page 2), else it is restricted to ± 50 MHz. The uncertainty is the RSS of the ConvF uncertainty at calibration frequency and the uncertainty for the indicated frequency band. Frequency validity below 300 MHz is ± 10, 25, 40, 50 and 70 MHz for ConvF assessments at 30, 64, 128, 150 and 220 MHz respectively. Above 5 GHz frequency validity can be extended to ± 110 MHz.

^F At frequencies below 3 GHz, the validity of tissue parameters (ϵ and σ) can be relaxed to ± 10% if liquid compensation formula is applied to measured SAR values. At frequencies above 3 GHz, the validity of tissue parameters (ϵ and σ) is restricted to ± 5%. The uncertainty is the RSS of the ConvF uncertainty for indicated target tissue parameters.

^G Alpha/Depth are determined during calibration. SPEAG warrants that the remaining deviation due to the boundary effect after compensation is always less than ± 1% for frequencies below 3 GHz and below ± 2% for frequencies between 3-6 GHz at any distance larger than half the probe tip diameter from the boundary.

DASY/EASY - Parameters of Probe: ES3DV3 - SN:3318

Calibration Parameter Determined in Body Tissue Simulating Media

f (MHz) ^C	Relative Permittivity ^F	Conductivity (S/m) ^F	ConvF X	ConvF Y	ConvF Z	Alpha ^G	Depth (mm) ^G	Unct. (k=2)
750	55.5	0.96	6.22	6.22	6.22	0.67	1.28	± 12.0 %
835	55.2	0.97	6.23	6.23	6.23	0.80	1.19	± 12.0 %
1750	53.4	1.49	4.95	4.95	4.95	0.40	1.77	± 12.0 %
1900	53.3	1.52	4.76	4.76	4.76	0.60	1.48	± 12.0 %
2300	52.9	1.81	4.52	4.52	4.52	0.80	1.19	± 12.0 %
2450	52.7	1.95	4.37	4.37	4.37	0.72	1.23	± 12.0 %
2600	52.5	2.16	4.17	4.17	4.17	0.80	1.00	± 12.0 %

^C Frequency validity above 300 MHz of ± 100 MHz only applies for DASY v4.4 and higher (see Page 2), else it is restricted to ± 50 MHz. The uncertainty is the RSS of the ConvF uncertainty at calibration frequency and the uncertainty for the indicated frequency band. Frequency validity below 300 MHz is ± 10, 25, 40, 50 and 70 MHz for ConvF assessments at 30, 64, 128, 150 and 220 MHz respectively. Above 5 GHz frequency validity can be extended to ± 110 MHz.

^F At frequencies below 3 GHz, the validity of tissue parameters (ϵ and σ) can be relaxed to ± 10% if liquid compensation formula is applied to measured SAR values. At frequencies above 3 GHz, the validity of tissue parameters (ϵ and σ) is restricted to ± 5%. The uncertainty is the RSS of the ConvF uncertainty for indicated target tissue parameters.

^G Alpha/Depth are determined during calibration. SPEAG warrants that the remaining deviation due to the boundary effect after compensation is always less than ± 1% for frequencies below 3 GHz and below ± 2% for frequencies between 3-6 GHz at any distance larger than half the probe tip diameter from the boundary.

Frequency Response of E-Field (TEM-Cell:ifi110 EXX, Waveguide: R22)

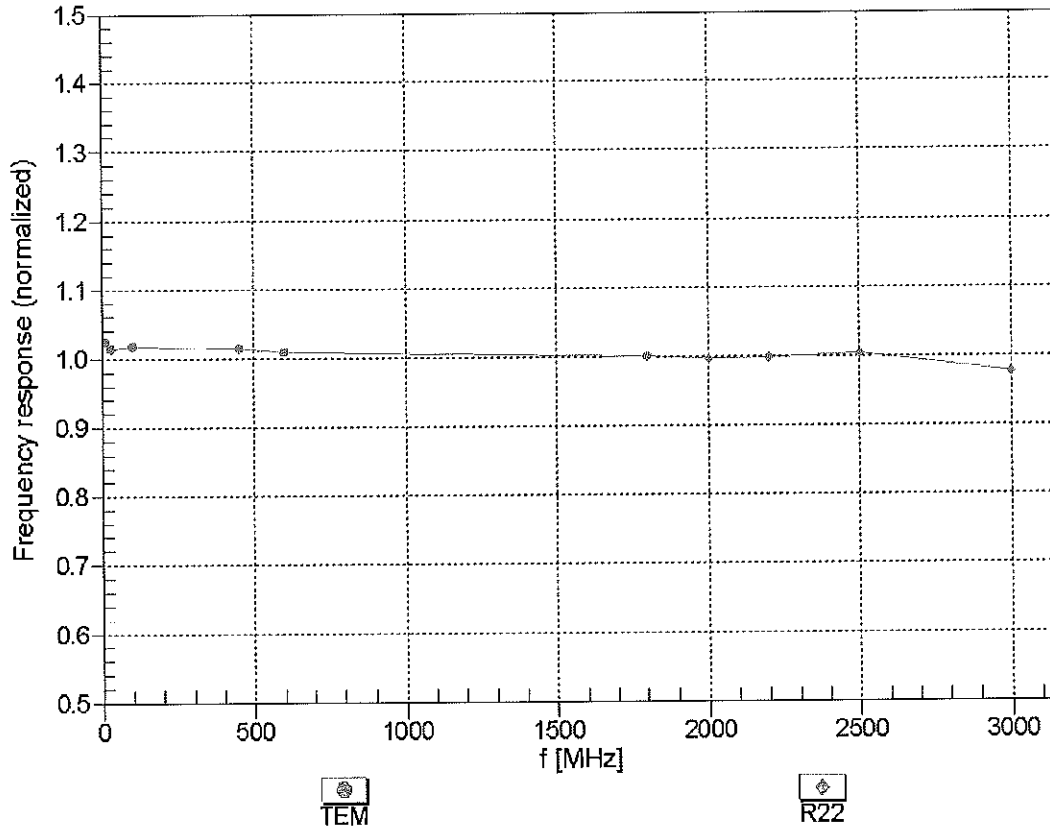

Uncertainty of Frequency Response of E-field: $\pm 6.3\%$ ($k=2$)

Receiving Pattern (ϕ), $\theta = 0^\circ$

f=600 MHz,TEM

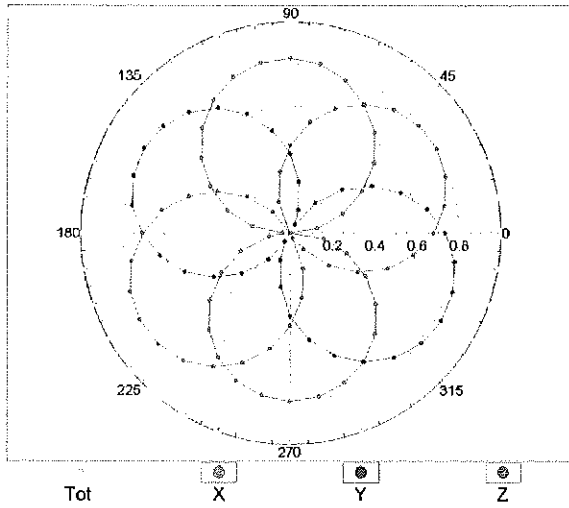

f=1800 MHz,R22

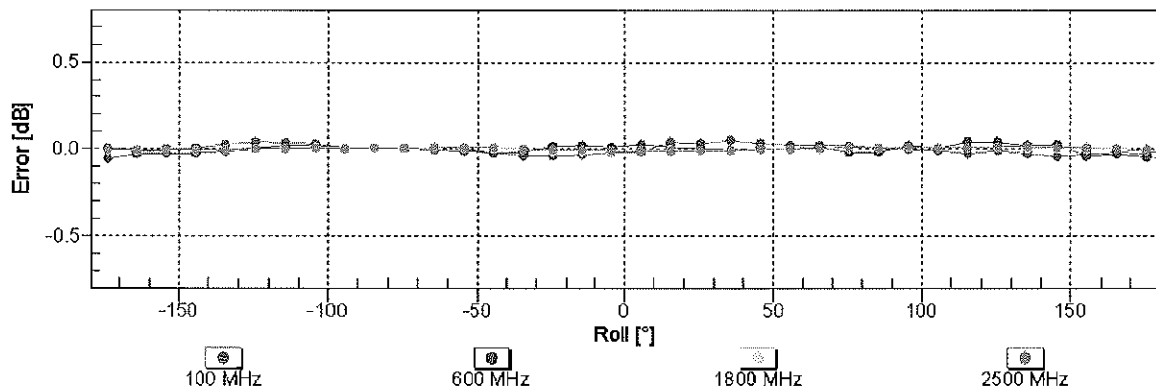
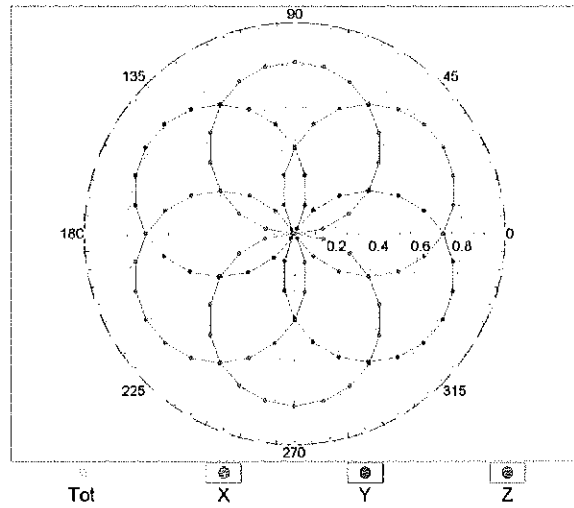

Uncertainty of Axial Isotropy Assessment: $\pm 0.5\%$ ($k=2$)

Dynamic Range f(SAR_{head}) (TEM cell , f_{eval}= 1900 MHz)

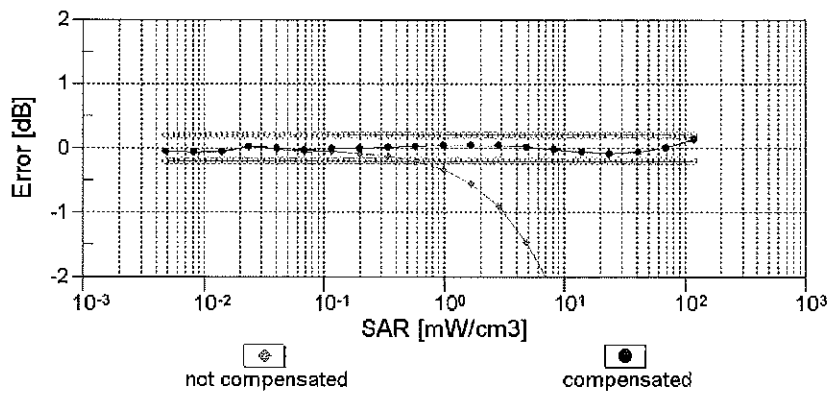
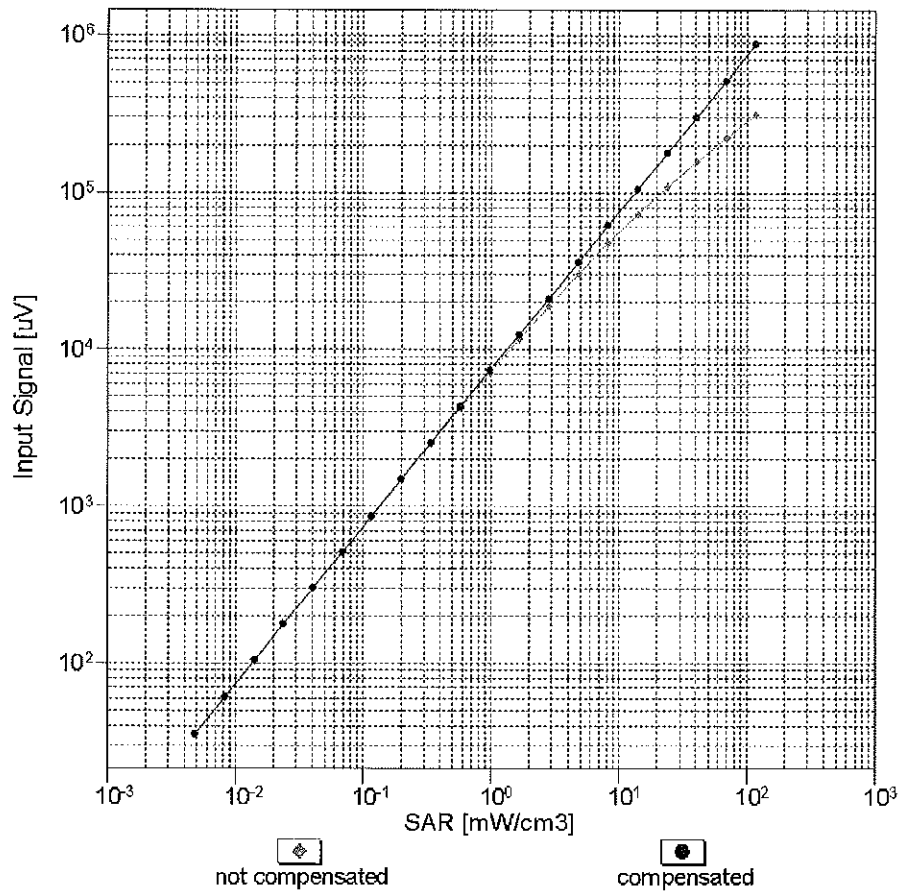

Uncertainty of Linearity Assessment: ± 0.6% (k=2)

Conversion Factor Assessment

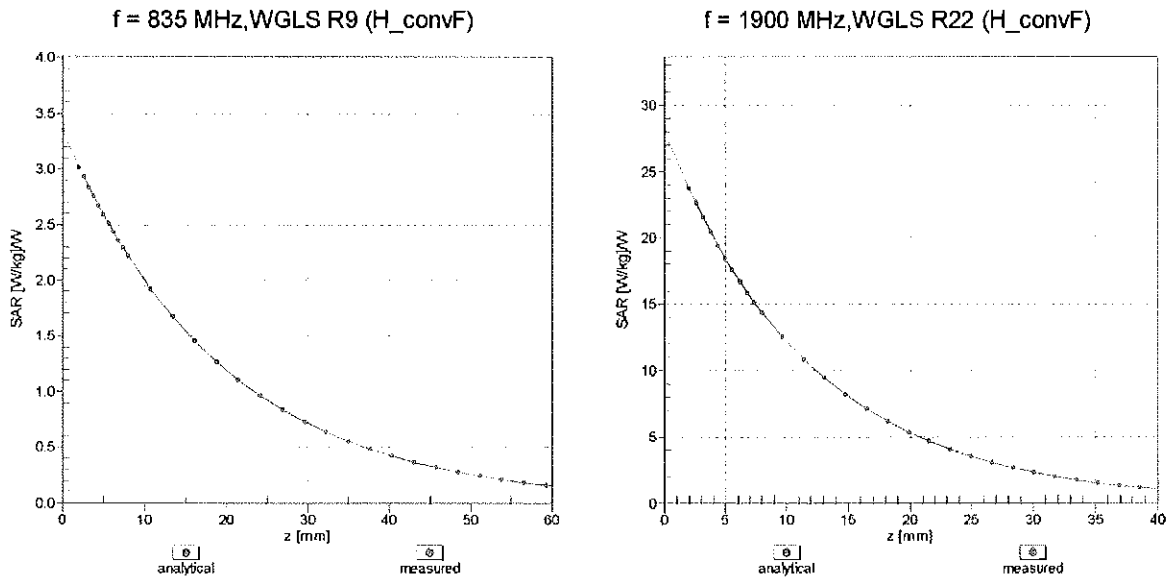

Deviation from Isotropy in Liquid Error (ϕ, θ), f = 900 MHz

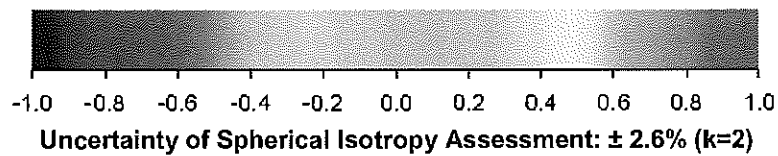
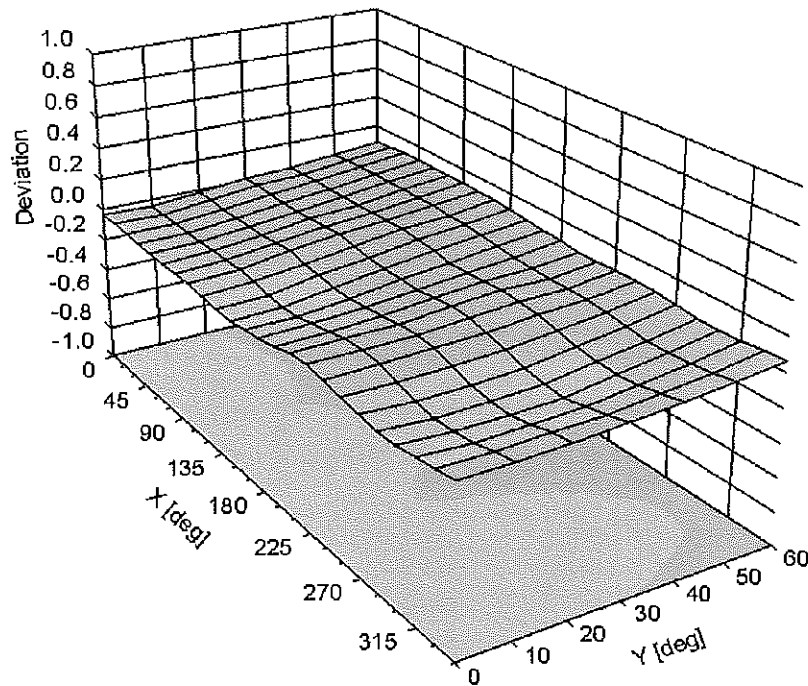

DASY/EASY - Parameters of Probe: ES3DV3 - SN:3318

Other Probe Parameters

Sensor Arrangement	Triangular
Connector Angle (°)	-104.4
Mechanical Surface Detection Mode	enabled
Optical Surface Detection Mode	disabled
Probe Overall Length	337 mm
Probe Body Diameter	10 mm
Tip Length	10 mm
Tip Diameter	4 mm
Probe Tip to Sensor X Calibration Point	2 mm
Probe Tip to Sensor Y Calibration Point	2 mm
Probe Tip to Sensor Z Calibration Point	2 mm
Recommended Measurement Distance from Surface	3 mm

**Calibration Laboratory of
Schmid & Partner
Engineering AG**
Zeughausstrasse 43, 8004 Zurich, Switzerland



S Schweizerischer Kalibrierdienst
C Service suisse d'étalonnage
S Servizio svizzero di taratura
Swiss Calibration Service

Accredited by the Swiss Accreditation Service (SAS)
The Swiss Accreditation Service is one of the signatories to the EA
Multilateral Agreement for the recognition of calibration certificates

Accreditation No.: **SCS 108**

Client **PC Test**

Certificate No: **ES3-3332_Sep14/2**

CALIBRATION CERTIFICATE (Replacement of No: ES3-3332_Sep14)

Object **ES3DV3 - SN:3332**

Calibration procedure(s) **QA CAL-01.v9, QA CAL-23.v5, QA CAL-25.v6**
Calibration procedure for dosimetric E-field probes CC
12/12/14

Calibration date: **September 18, 2014**

This calibration certificate documents the traceability to national standards, which realize the physical units of measurements (SI).
The measurements and the uncertainties with confidence probability are given on the following pages and are part of the certificate.

All calibrations have been conducted in the closed laboratory facility: environment temperature (22 ± 3)°C and humidity < 70%.

Calibration Equipment used (M&TE critical for calibration)

Primary Standards	ID	Cal Date (Certificate No.)	Scheduled Calibration
Power meter E4419B	GB41293874	03-Apr-14 (No. 217-01911)	Apr-15
Power sensor E4412A	MY41498087	03-Apr-14 (No. 217-01911)	Apr-15
Reference 3 dB Attenuator	SN: S5054 (3c)	03-Apr-14 (No. 217-01915)	Apr-15
Reference 20 dB Attenuator	SN: S5277 (20x)	03-Apr-14 (No. 217-01919)	Apr-15
Reference 30 dB Attenuator	SN: S5129 (30b)	03-Apr-14 (No. 217-01920)	Apr-15
Reference Probe ES3DV2	SN: 3013	30-Dec-13 (No. ES3-3013_Dec13)	Dec-14
DAE4	SN: 660	13-Dec-13 (No. DAE4-660_Dec13)	Dec-14
Secondary Standards	ID	Check Date (in house)	Scheduled Check
RF generator HP 8648C	US3642U01700	4-Aug-99 (in house check Apr-13)	in house check: Apr-16
Network Analyzer HP 8753E	US37390585	18-Oct-01 (in house check Oct-13)	in house check: Oct-14

	Name	Function	Signature
Calibrated by:	Israe El-Naouq	Laboratory Technician	
Approved by:	Katja Pokovic	Technical Manager	
			Issued: November 3, 2014

This calibration certificate shall not be reproduced except in full without written approval of the laboratory.



Accredited by the Swiss Accreditation Service (SAS)
The Swiss Accreditation Service is one of the signatories to the EA
Multilateral Agreement for the recognition of calibration certificates

Accreditation No.: **SCS 108**

Glossary:

TSL	tissue simulating liquid
NORM _{x,y,z}	sensitivity in free space
ConvF	sensitivity in TSL / NORM _{x,y,z}
DCP	diode compression point
CF	crest factor (1/duty_cycle) of the RF signal
A, B, C, D	modulation dependent linearization parameters
Polarization φ	φ rotation around probe axis
Polarization ϑ	ϑ rotation around an axis that is in the plane normal to probe axis (at measurement center), i.e., $\vartheta = 0$ is normal to probe axis
Connector Angle	information used in DASY system to align probe sensor X to the robot coordinate system

Calibration is Performed According to the Following Standards:

- IEEE Std 1528-2013, "IEEE Recommended Practice for Determining the Peak Spatial-Averaged Specific Absorption Rate (SAR) in the Human Head from Wireless Communications Devices: Measurement Techniques", June 2013
- IEC 62209-1, "Procedure to measure the Specific Absorption Rate (SAR) for hand-held devices used in close proximity to the ear (frequency range of 300 MHz to 3 GHz)", February 2005

Methods Applied and Interpretation of Parameters:

- NORM_{x,y,z}**: Assessed for E-field polarization $\vartheta = 0$ ($f \leq 900$ MHz in TEM-cell; $f > 1800$ MHz: R22 waveguide). NORM_{x,y,z} are only intermediate values, i.e., the uncertainties of NORM_{x,y,z} does not affect the E²-field uncertainty inside TSL (see below ConvF).
- NORM(f)_{x,y,z} = NORM_{x,y,z} * frequency_response** (see Frequency Response Chart). This linearization is implemented in DASY4 software versions later than 4.2. The uncertainty of the frequency response is included in the stated uncertainty of ConvF.
- DCP_{x,y,z}**: DCP are numerical linearization parameters assessed based on the data of power sweep with CW signal (no uncertainty required). DCP does not depend on frequency nor media.
- PAR**: PAR is the Peak to Average Ratio that is not calibrated but determined based on the signal characteristics
- A_{x,y,z}; B_{x,y,z}; C_{x,y,z}; D_{x,y,z}; VR_{x,y,z}**: A, B, C, D are numerical linearization parameters assessed based on the data of power sweep for specific modulation signal. The parameters do not depend on frequency nor media. VR is the maximum calibration range expressed in RMS voltage across the diode.
- ConvF and Boundary Effect Parameters**: Assessed in flat phantom using E-field (or Temperature Transfer Standard for $f \leq 800$ MHz) and inside waveguide using analytical field distributions based on power measurements for $f > 800$ MHz. The same setups are used for assessment of the parameters applied for boundary compensation (alpha, depth) of which typical uncertainty values are given. These parameters are used in DASY4 software to improve probe accuracy close to the boundary. The sensitivity in TSL corresponds to NORM_{x,y,z} * ConvF whereby the uncertainty corresponds to that given for ConvF. A frequency dependent ConvF is used in DASY version 4.4 and higher which allows extending the validity from ± 50 MHz to ± 100 MHz.
- Spherical Isotropy (3D deviation from Isotropy)**: in a field of low gradients realized using a flat phantom exposed by a patch antenna.
- Sensor Offset**: The sensor offset corresponds to the offset of virtual measurement center from the probe tip (on probe axis). No tolerance required.
- Connector Angle**: The angle is assessed using the information gained by determining the NORM_x (no uncertainty required).

Probe ES3DV3

SN:3332

Manufactured: January 24, 2012
Calibrated: September 18, 2014

Calibrated for DASY/EASY Systems
(Note: non-compatible with DASY2 system!)

DASY/EASY - Parameters of Probe: ES3DV3 - SN:3332

Basic Calibration Parameters

	Sensor X	Sensor Y	Sensor Z	Unc (k=2)
Norm ($\mu\text{V}/(\text{V}/\text{m})^2$) ^A	0.94	1.15	0.98	$\pm 10.1 \%$
DCP (mV) ^B	105.8	103.8	112.4	

Modulation Calibration Parameters

UID	Communication System Name		A dB	B dB $\sqrt{\mu\text{V}}$	C	D dB	VR mV	Unc ^F (k=2)
0	CW	X	0.0	0.0	1.0	0.00	178.7	$\pm 3.0 \%$
		Y	0.0	0.0	1.0		199.5	
		Z	0.0	0.0	1.0		186.5	
10010- CAA	SAR Validation (Square, 100ms, 10ms)	X	55.60	92.4	20.6	10.00	35.7	$\pm 1.7 \%$
		Y	2.80	61.2	11.6		42.9	
		Z	10.49	80.1	18.0		36.1	
10011- CAB	UMTS-FDD (WCDMA)	X	3.47	67.9	18.8	2.91	141.3	$\pm 0.7 \%$
		Y	3.29	67.0	18.4		138.2	
		Z	3.78	70.4	20.1		147.9	
10012- CAA	IEEE 802.11b WiFi 2.4 GHz (DSSS, 1 Mbps)	X	3.53	72.0	20.1	1.87	141.7	$\pm 0.7 \%$
		Y	3.03	69.1	18.8		141.1	
		Z	4.06	75.5	21.6		148.2	
10013- CAA	IEEE 802.11g WiFi 2.4 GHz (DSSS-OFDM, 6 Mbps)	X	10.87	69.8	22.6	9.46	137.3	$\pm 3.5 \%$
		Y	11.63	71.7	23.9		141.9	
		Z	10.51	69.6	22.5		139.2	
10021- DAB	GSM-FDD (TDMA, GMSK)	X	6.92	78.4	20.1	9.39	137.0	$\pm 2.5 \%$
		Y	26.20	99.6	27.8		141.5	
		Z	5.13	78.3	21.1		144.7	
10023- DAB	GPRS-FDD (TDMA, GMSK, TN 0)	X	9.10	83.6	22.5	9.57	144.0	$\pm 2.5 \%$
		Y	26.31	100.0	28.1		136.7	
		Z	6.15	81.6	22.5		139.9	
10024- DAB	GPRS-FDD (TDMA, GMSK, TN 0-1)	X	10.54	84.1	20.4	6.56	141.8	$\pm 2.5 \%$
		Y	40.55	99.6	24.9		142.2	
		Z	6.45	81.5	20.2		145.7	
10027- DAB	GPRS-FDD (TDMA, GMSK, TN 0-1-2)	X	28.34	94.6	21.9	4.80	131.4	$\pm 2.5 \%$
		Y	52.22	99.6	23.3		126.8	
		Z	28.33	99.5	23.9		140.7	
10028- DAB	GPRS-FDD (TDMA, GMSK, TN 0-1-2-3)	X	52.17	100.0	22.2	3.55	147.0	$\pm 1.7 \%$
		Y	57.29	99.6	22.4		133.0	
		Z	25.84	99.5	23.3		126.2	
10032- CAA	IEEE 802.15.1 Bluetooth (GFSK, DH5)	X	59.05	100.0	19.9	1.16	135.5	$\pm 1.9 \%$
		Y	100.00	99.7	19.2		143.5	
		Z	34.97	100.0	20.4		143.1	

10039-CAB	CDMA2000 (1xRTT, RC1)	X	4.78	66.9	18.9	4.57	134.6	±0.9 %
		Y	4.85	67.1	19.1		141.0	
		Z	4.76	67.8	19.4		140.7	
10081-CAB	CDMA2000 (1xRTT, RC3)	X	3.98	66.4	18.6	3.97	130.4	±0.7 %
		Y	3.98	66.5	18.7		136.2	
		Z	4.04	67.7	19.2		137.4	
10098-CAB	UMTS-FDD (HSUPA, Subtest 2)	X	4.75	67.3	18.8	3.98	144.4	±0.7 %
		Y	4.55	66.5	18.5		126.5	
		Z	4.72	67.9	19.0		128.1	
10100-CAB	LTE-FDD (SC-FDMA, 100% RB, 20 MHz, QPSK)	X	6.26	66.9	19.2	5.67	124.5	±1.2 %
		Y	6.38	67.4	19.7		131.7	
		Z	6.36	67.7	19.7		132.3	
10108-CAB	LTE-FDD (SC-FDMA, 100% RB, 10 MHz, QPSK)	X	6.44	67.5	19.7	5.80	147.4	±1.4 %
		Y	6.31	67.2	19.7		130.2	
		Z	6.17	67.2	19.6		130.1	
10110-CAB	LTE-FDD (SC-FDMA, 100% RB, 5 MHz, QPSK)	X	6.08	66.9	19.5	5.75	142.7	±1.4 %
		Y	5.97	66.6	19.4		127.3	
		Z	5.84	66.7	19.3		126.2	
10114-CAA	IEEE 802.11n (HT Greenfield, 13.5 Mbps, BPSK)	X	10.13	68.7	21.0	8.10	136.9	±2.5 %
		Y	10.57	69.9	21.9		146.3	
		Z	10.06	69.0	21.1		143.6	
10117-CAA	IEEE 802.11n (HT Mixed, 13.5 Mbps, BPSK)	X	10.12	68.6	21.0	8.07	138.2	±2.5 %
		Y	10.60	69.9	21.9		148.0	
		Z	10.07	69.0	21.1		146.6	
10151-CAB	LTE-TDD (SC-FDMA, 50% RB, 20 MHz, QPSK)	X	8.76	71.7	23.8	9.28	130.7	±3.0 %
		Y	10.03	75.2	25.9		121.5	
		Z	8.15	70.7	23.5		134.1	
10164-CAB	LTE-FDD (SC-FDMA, 50% RB, 10 MHz, QPSK)	X	6.10	67.0	19.5	5.75	144.4	±1.4 %
		Y	5.98	66.6	19.4		127.8	
		Z	5.84	66.6	19.3		127.2	
10160-CAB	LTE-FDD (SC-FDMA, 50% RB, 15 MHz, QPSK)	X	6.56	67.5	19.7	5.82	149.5	±1.7 %
		Y	6.41	67.1	19.6		132.5	
		Z	6.17	66.8	19.4		130.4	
10169-CAB	LTE-FDD (SC-FDMA, 1 RB, 20 MHz, QPSK)	X	5.01	67.0	19.7	5.73	147.8	±1.2 %
		Y	5.01	66.9	19.8		132.1	
		Z	4.75	66.9	19.7		130.3	
10172-CAB	LTE-TDD (SC-FDMA, 1 RB, 20 MHz, QPSK)	X	7.65	75.0	25.8	9.21	144.9	±2.7 %
		Y	10.17	82.4	29.7		136.4	
		Z	6.53	72.3	24.6		145.6	
10175-CAB	LTE-FDD (SC-FDMA, 1 RB, 10 MHz, QPSK)	X	4.98	66.9	19.6	5.72	141.0	±1.2 %
		Y	4.98	66.7	19.7		130.5	
		Z	4.71	66.7	19.5		128.1	

10181-CAB	LTE-FDD (SC-FDMA, 1 RB, 15 MHz, QPSK)	X	4.95	66.7	19.5	5.72	139.8	±1.2 %
		Y	4.97	66.7	19.7		129.5	
		Z	4.72	66.8	19.6		128.0	
10193-CAA	IEEE 802.11n (HT Greenfield, 6.5 Mbps, BPSK)	X	9.75	68.2	20.9	8.09	131.8	±2.5 %
		Y	10.16	69.4	21.7		139.2	
		Z	9.62	68.6	21.0		137.3	
10196-CAA	IEEE 802.11n (HT Mixed, 6.5 Mbps, BPSK)	X	9.77	68.3	20.9	8.10	133.6	±2.5 %
		Y	10.17	69.4	21.8		140.1	
		Z	9.61	68.5	21.0		140.1	
10219-CAA	IEEE 802.11n (HT Mixed, 7.2 Mbps, BPSK)	X	9.69	68.3	20.9	8.03	133.6	±2.5 %
		Y	10.05	69.3	21.7		139.2	
		Z	9.58	68.7	21.1		139.4	
10222-CAA	IEEE 802.11n (HT Mixed, 15 Mbps, BPSK)	X	10.13	68.7	21.0	8.06	140.7	±2.5 %
		Y	10.61	69.8	21.8		145.1	
		Z	10.11	69.1	21.2		148.4	
10225-CAB	UMTS-FDD (HSPA+)	X	7.03	67.2	19.4	5.97	138.0	±1.4 %
		Y	7.07	67.2	19.6		140.2	
		Z	6.97	67.8	19.7		144.6	
10237-CAB	LTE-TDD (SC-FDMA, 1 RB, 10 MHz, QPSK)	X	7.11	72.9	24.7	9.21	124.6	±2.7 %
		Y	10.04	82.0	29.5		135.7	
		Z	6.29	71.2	24.0		126.2	
10252-CAB	LTE-TDD (SC-FDMA, 50% RB, 10 MHz, QPSK)	X	8.61	72.5	24.3	9.24	145.2	±3.3 %
		Y	10.53	77.8	27.4		136.7	
		Z	7.56	70.0	23.1		126.7	
10267-CAB	LTE-TDD (SC-FDMA, 100% RB, 10 MHz, QPSK)	X	8.74	71.6	23.8	9.30	128.7	±3.3 %
		Y	11.51	79.1	28.0		147.2	
		Z	8.07	70.4	23.2		134.1	
10274-CAB	UMTS-FDD (HSUPA, Subtest 5, 3GPP Rel8.10)	X	5.90	66.7	18.7	4.87	128.0	±0.9 %
		Y	5.93	66.8	18.9		134.5	
		Z	5.92	67.6	19.1		138.2	
10275-CAB	UMTS-FDD (HSUPA, Subtest 5, 3GPP Rel8.4)	X	4.53	67.1	18.8	3.96	133.8	±0.7 %
		Y	4.48	67.0	18.8		139.6	
		Z	4.62	68.3	19.3		145.0	
10291-AAB	CDMA2000, RC3, SO55, Full Rate	X	3.82	67.8	19.0	3.46	147.6	±0.7 %
		Y	3.66	67.0	18.8		131.7	
		Z	3.97	69.6	20.0		135.9	
10292-AAB	CDMA2000, RC3, SO32, Full Rate	X	3.70	67.5	18.8	3.39	128.1	±0.7 %
		Y	3.60	66.9	18.7		132.5	
		Z	3.80	68.9	19.5		139.8	
10297-AAA	LTE-FDD (SC-FDMA, 50% RB, 20 MHz, QPSK)	X	6.47	67.6	19.8	5.81	149.7	±1.7 %
		Y	6.24	66.9	19.5		126.3	
		Z	6.20	67.3	19.6		130.9	

10311-AAA	LTE-FDD (SC-FDMA, 100% RB, 15 MHz, QPSK)	X	6.72	67.1	19.5	6.06	128.8	±1.4 %
		Y	6.85	67.7	20.0		132.4	
		Z	6.75	67.7	19.8		136.6	
10315-AAA	IEEE 802.11b WiFi 2.4 GHz (DSSS, 1 Mbps, 96pc duty cycle)	X	3.27	71.1	19.8	1.71	140.1	±0.7 %
		Y	2.95	69.4	19.1		139.8	
		Z	3.75	74.4	21.2		146.9	
10316-AAA	IEEE 802.11g WiFi 2.4 GHz (ERP-OFDM, 6 Mbps, 96pc duty cycle)	X	10.04	68.7	21.3	8.36	136.3	±2.5 %
		Y	10.42	69.8	22.1		138.1	
		Z	9.84	68.9	21.3		139.7	
10403-AAB	CDMA2000 (1xEV-DO, Rev. 0)	X	5.01	69.3	19.2	3.76	144.3	±0.7 %
		Y	4.79	68.1	18.7		146.3	
		Z	5.40	72.5	20.8		146.7	
10404-AAB	CDMA2000 (1xEV-DO, Rev. A)	X	4.97	69.5	19.3	3.77	141.3	±0.7 %
		Y	4.72	68.2	18.8		143.1	
		Z	5.12	71.8	20.5		144.4	
10415-AAA	IEEE 802.11b WiFi 2.4 GHz (DSSS, 1 Mbps, 99pc duty cycle)	X	3.05	70.5	19.5	1.54	139.7	±0.7 %
		Y	2.71	68.7	18.9		140.2	
		Z	4.22	77.3	22.5		145.9	
10416-AAA	IEEE 802.11g WiFi 2.4 GHz (ERP-OFDM, 6 Mbps, 99pc duty cycle)	X	9.92	68.6	21.1	8.23	136.3	±2.5 %
		Y	10.20	69.4	21.8		138.3	
		Z	9.76	68.8	21.3		138.9	

The reported uncertainty of measurement is stated as the standard uncertainty of measurement multiplied by the coverage factor $k=2$, which for a normal distribution corresponds to a coverage probability of approximately 95%.

^A The uncertainties of NormX,Y,Z do not affect the E²-field uncertainty inside TSL (see Pages 8 and 9).

^B Numerical linearization parameter: uncertainty not required.

^E Uncertainty is determined using the max. deviation from linear response applying rectangular distribution and is expressed for the square of the field value.

DASY/EASY - Parameters of Probe: ES3DV3 - SN:3332

Calibration Parameter Determined in Head Tissue Simulating Media

f (MHz) ^C	Relative Permittivity ^F	Conductivity (S/m) ^F	ConvF X	ConvF Y	ConvF Z	Alpha ^G	Depth ^G (mm)	Unct. (k=2)
750	41.9	0.89	6.56	6.56	6.56	0.50	1.43	± 12.0 %
835	41.5	0.90	6.31	6.31	6.31	0.61	1.31	± 12.0 %
1750	40.1	1.37	5.17	5.17	5.17	0.62	1.33	± 12.0 %
1900	40.0	1.40	5.04	5.04	5.04	0.80	1.17	± 12.0 %
2450	39.2	1.80	4.49	4.49	4.49	0.77	1.24	± 12.0 %
2600	39.0	1.96	4.35	4.35	4.35	0.73	1.38	± 12.0 %

^C Frequency validity above 300 MHz of ± 100 MHz only applies for DASY v4.4 and higher (see Page 2), else it is restricted to ± 50 MHz. The uncertainty is the RSS of the ConvF uncertainty at calibration frequency and the uncertainty for the indicated frequency band. Frequency validity below 300 MHz is ± 10, 25, 40, 50 and 70 MHz for ConvF assessments at 30, 64, 128, 150 and 220 MHz respectively. Above 5 GHz frequency validity can be extended to ± 110 MHz.

^F At frequencies below 3 GHz, the validity of tissue parameters (ϵ and σ) can be relaxed to ± 10% if liquid compensation formula is applied to measured SAR values. At frequencies above 3 GHz, the validity of tissue parameters (ϵ and σ) is restricted to ± 5%. The uncertainty is the RSS of the ConvF uncertainty for indicated target tissue parameters.

^G Alpha/Depth are determined during calibration. SPEAG warrants that the remaining deviation due to the boundary effect after compensation is always less than ± 1% for frequencies below 3 GHz and below ± 2% for frequencies between 3-6 GHz at any distance larger than half the probe tip diameter from the boundary.

DASY/EASY - Parameters of Probe: ES3DV3 - SN:3332

Calibration Parameter Determined in Body Tissue Simulating Media

f (MHz) ^c	Relative Permittivity ^F	Conductivity (S/m) ^F	ConvF X	ConvF Y	ConvF Z	Alpha ^g	Depth ^g (mm)	Unct. (k=2)
750	55.5	0.96	6.24	6.24	6.24	0.50	1.50	± 12.0 %
835	55.2	0.97	6.21	6.21	6.21	0.45	1.59	± 12.0 %
1750	53.4	1.49	4.88	4.88	4.88	0.39	1.78	± 12.0 %
1900	53.3	1.52	4.64	4.64	4.64	0.61	1.47	± 12.0 %
2450	52.7	1.95	4.31	4.31	4.31	0.80	1.18	± 12.0 %
2600	52.5	2.16	4.11	4.11	4.11	0.68	0.99	± 12.0 %

^c Frequency validity above 300 MHz of ± 100 MHz only applies for DASY v4.4 and higher (see Page 2), else it is restricted to ± 50 MHz. The uncertainty is the RSS of the ConvF uncertainty at calibration frequency and the uncertainty for the indicated frequency band. Frequency validity below 300 MHz is ± 10, 25, 40, 50 and 70 MHz for ConvF assessments at 30, 64, 128, 150 and 220 MHz respectively. Above 5 GHz frequency validity can be extended to ± 110 MHz.

^F At frequencies below 3 GHz, the validity of tissue parameters (ϵ and σ) can be relaxed to ± 10% if liquid compensation formula is applied to measured SAR values. At frequencies above 3 GHz, the validity of tissue parameters (ϵ and σ) is restricted to ± 5%. The uncertainty is the RSS of the ConvF uncertainty for indicated target tissue parameters.

^g Alpha/Depth are determined during calibration. SPEAG warrants that the remaining deviation due to the boundary effect after compensation is always less than ± 1% for frequencies below 3 GHz and below ± 2% for frequencies between 3-6 GHz at any distance larger than half the probe lip diameter from the boundary.

Frequency Response of E-Field (TEM-Cell:ifi110 EXX, Waveguide: R22)

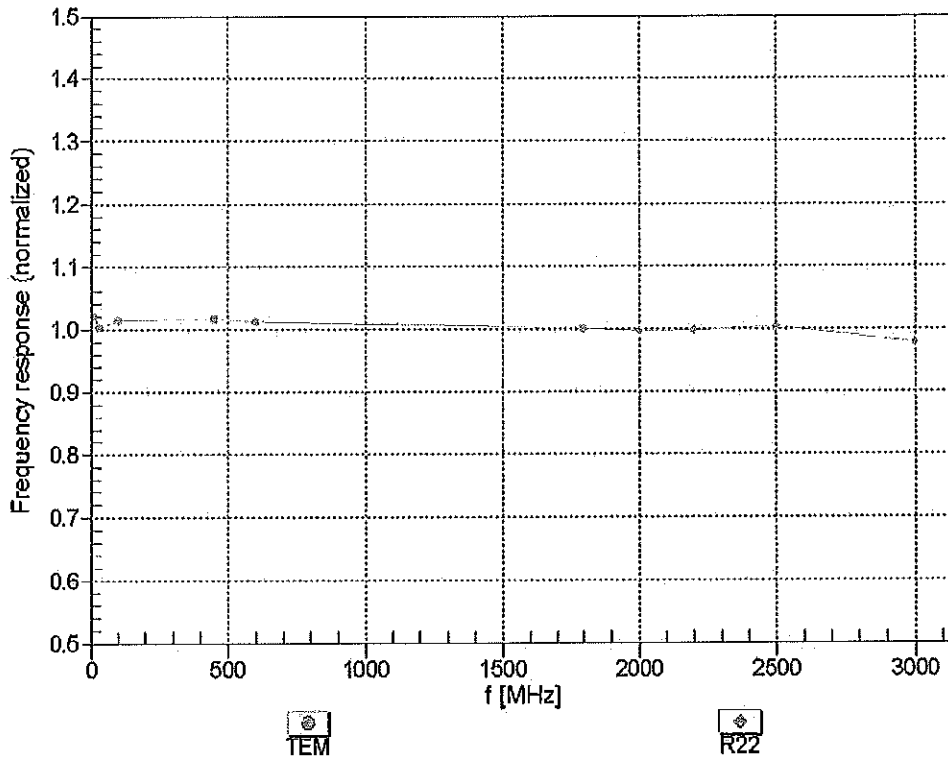

Uncertainty of Frequency Response of E-field: $\pm 6.3\%$ (k=2)

Receiving Pattern (ϕ), $\theta = 0^\circ$

f=600 MHz,TEM

f=1800 MHz,R22

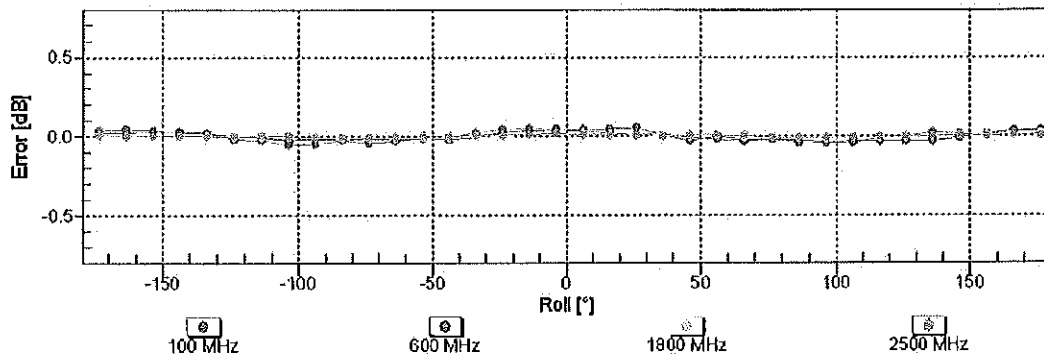
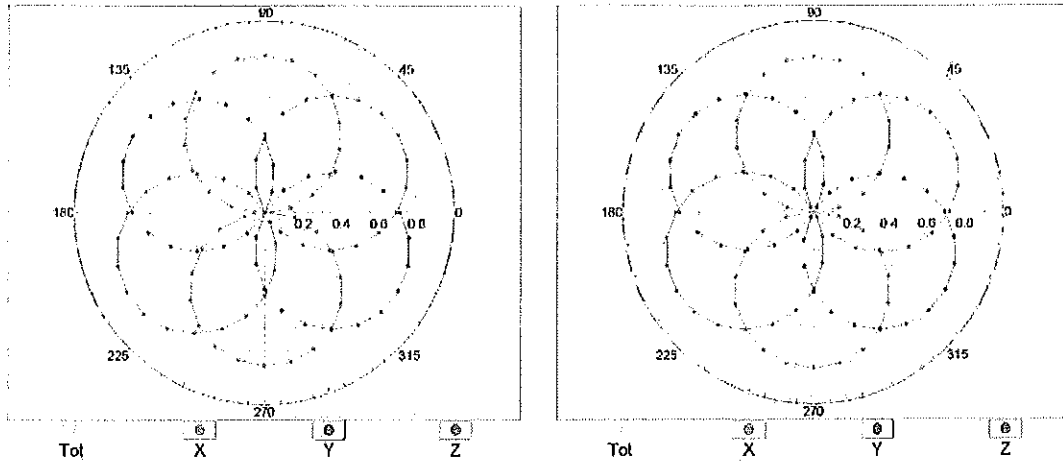

Uncertainty of Axial Isotropy Assessment: $\pm 0.5\%$ ($k=2$)

Dynamic Range $f(SAR_{head})$ (TEM cell , $f_{eval} = 1900$ MHz)

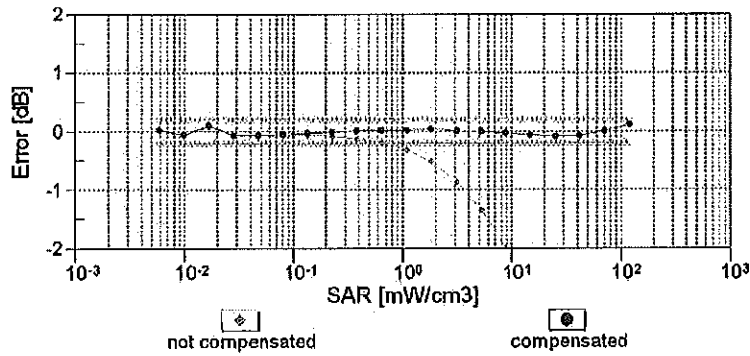
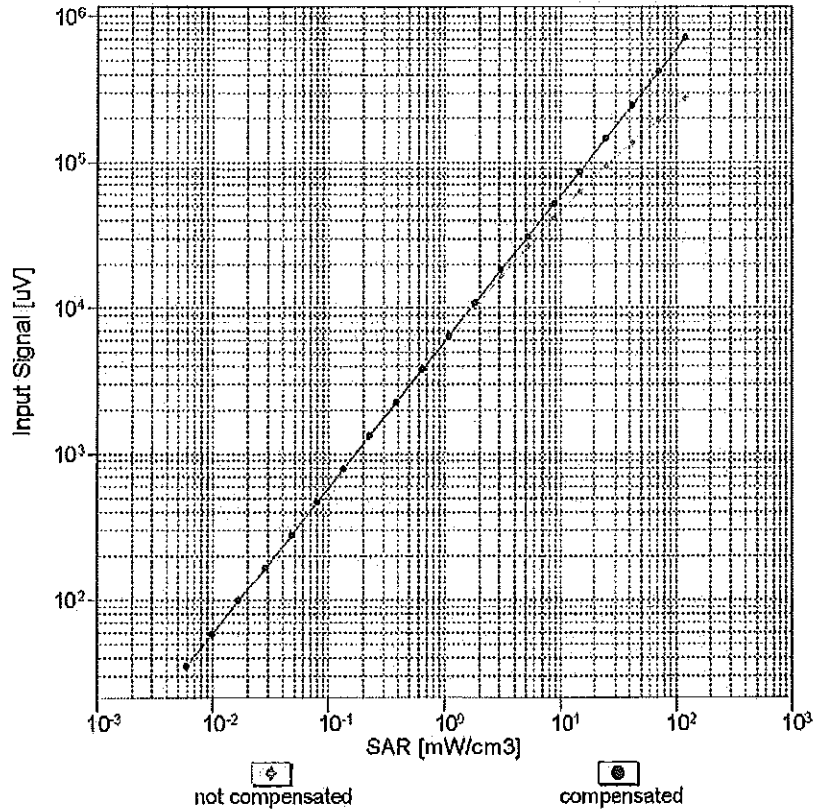

Uncertainty of Linearity Assessment: $\pm 0.6\%$ ($k=2$)

Conversion Factor Assessment

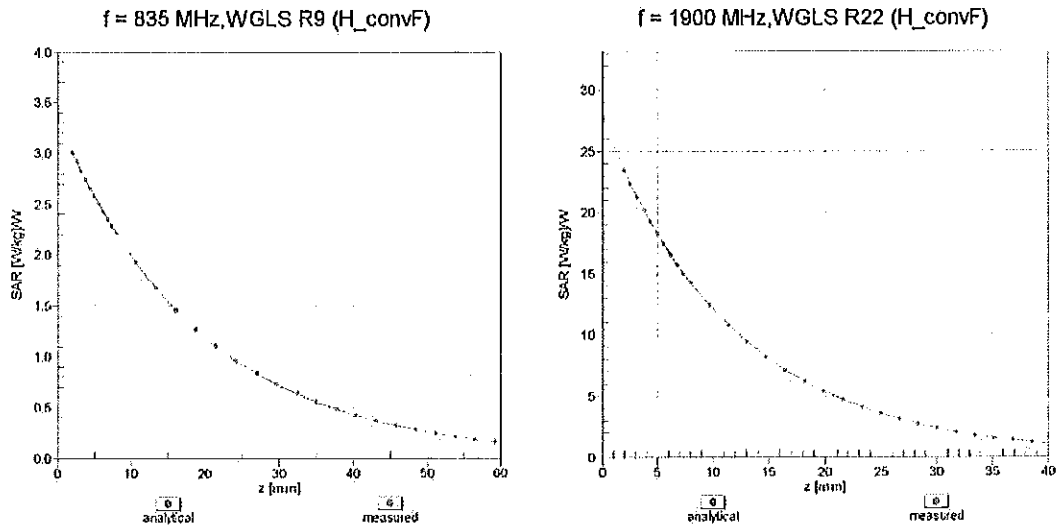

Deviation from Isotropy in Liquid Error (ϕ, θ), f = 900 MHz

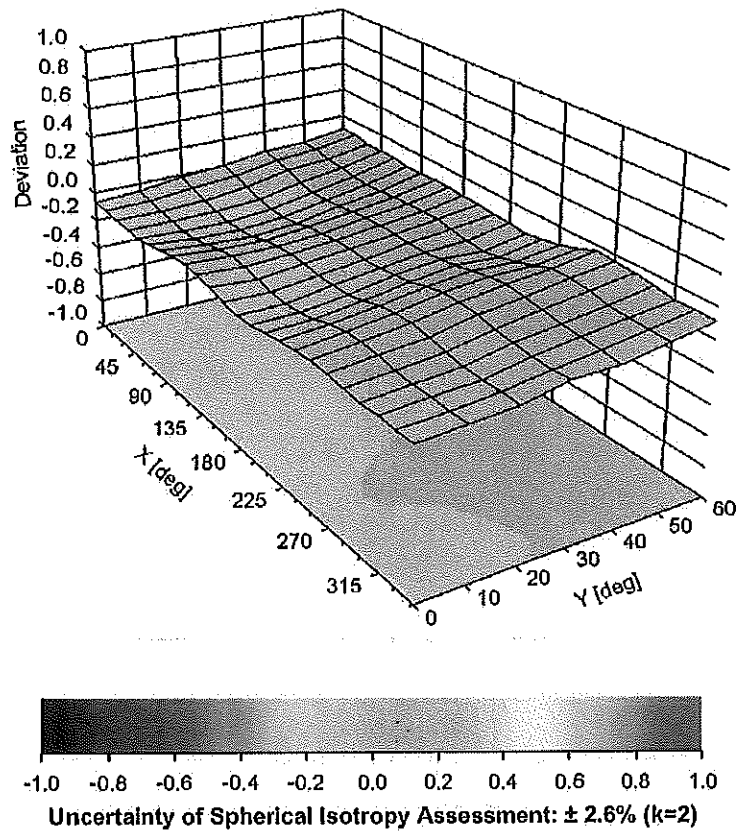

DASY/EASY - Parameters of Probe: ES3DV3 - SN:3332**Other Probe Parameters**

Sensor Arrangement	Triangular
Connector Angle (°)	-3.7
Mechanical Surface Detection Mode	enabled
Optical Surface Detection Mode	disabled
Probe Overall Length	337 mm
Probe Body Diameter	10 mm
Tip Length	10 mm
Tip Diameter	4 mm
Probe Tip to Sensor X Calibration Point	2 mm
Probe Tip to Sensor Y Calibration Point	2 mm
Probe Tip to Sensor Z Calibration Point	2 mm
Recommended Measurement Distance from Surface	3 mm



Accredited by the Swiss Accreditation Service (SAS)
The Swiss Accreditation Service is one of the signatories to the EA
Multilateral Agreement for the recognition of calibration certificates

Accreditation No.: **SCS 0108**

Client **PC Test**

Certificate No: **EX3-3914_Feb15**

CALIBRATION CERTIFICATE

Object **EX3DV4 - SN:3914** CCV
3/6/15

Calibration procedure(s) **QA CAL-01.v9, QA CAL-14.v4, QA CAL-23.v5, QA CAL-25.v6
Calibration procedure for dosimetric E-field probes**

Calibration date: **February 10, 2015**

This calibration certificate documents the traceability to national standards, which realize the physical units of measurements (SI).
The measurements and the uncertainties with confidence probability are given on the following pages and are part of the certificate.

All calibrations have been conducted in the closed laboratory facility: environment temperature (22 ± 3)°C and humidity < 70%.

Calibration Equipment used (M&TE critical for calibration)

Primary Standards	ID	Cal Date (Certificate No.)	Scheduled Calibration
Power meter E4419B	GB41293874	03-Apr-14 (No. 217-01911)	Apr-15
Power sensor E4412A	MY41498087	03-Apr-14 (No. 217-01911)	Apr-15
Reference 3 dB Attenuator	SN: S5054 (3c)	03-Apr-14 (No. 217-01915)	Apr-15
Reference 20 dB Attenuator	SN: S5277 (20x)	03-Apr-14 (No. 217-01919)	Apr-15
Reference 30 dB Attenuator	SN: S5129 (30b)	03-Apr-14 (No. 217-01920)	Apr-15
Reference Probe ES3DV2	SN: 3013	30-Dec-14 (No. ES3-3013_Dec14)	Dec-15
DAE4	SN: 660	14-Jan-15 (No. DAE4-660_Jan15)	Jan-16
Secondary Standards	ID	Check Date (in house)	Scheduled Check
RF generator HP 8648C	US3642U01700	4-Aug-99 (in house check Apr-13)	In house check: Apr-16
Network Analyzer HP 8753E	US37390585	18-Oct-01 (in house check Oct-14)	In house check: Oct-15

Calibrated by:	Name Claudio Leubler	Function Laboratory Technician	Signature
Approved by:	Katja Pokovic	Technical Manager	

Issued: February 10, 2015

This calibration certificate shall not be reproduced except in full without written approval of the laboratory.



Accredited by the Swiss Accreditation Service (SAS)

Accreditation No.: **SCS 0108**

The Swiss Accreditation Service is one of the signatories to the EA Multilateral Agreement for the recognition of calibration certificates

Glossary:

TSL	tissue simulating liquid
NORM _{x,y,z}	sensitivity in free space
ConvF	sensitivity in TSL / NORM _{x,y,z}
DCP	diode compression point
CF	crest factor (1/duty_cycle) of the RF signal
A, B, C, D	modulation dependent linearization parameters
Polarization φ	φ rotation around probe axis
Polarization ϑ	ϑ rotation around an axis that is in the plane normal to probe axis (at measurement center), i.e., $\vartheta = 0$ is normal to probe axis
Connector Angle	information used in DASY system to align probe sensor X to the robot coordinate system

Calibration is Performed According to the Following Standards:

- a) IEEE Std 1528-2013, "IEEE Recommended Practice for Determining the Peak Spatial-Averaged Specific Absorption Rate (SAR) in the Human Head from Wireless Communications Devices: Measurement Techniques", June 2013
- b) IEC 62209-1, "Procedure to measure the Specific Absorption Rate (SAR) for hand-held devices used in close proximity to the ear (frequency range of 300 MHz to 3 GHz)", February 2005

Methods Applied and Interpretation of Parameters:

- **NORM_{x,y,z}:** Assessed for E-field polarization $\vartheta = 0$ ($f \leq 900$ MHz in TEM-cell; $f > 1800$ MHz: R22 waveguide). NORM_{x,y,z} are only intermediate values, i.e., the uncertainties of NORM_{x,y,z} does not affect the E²-field uncertainty inside TSL (see below *ConvF*).
- **NORM(f)_{x,y,z} = NORM_{x,y,z} * frequency_response** (see Frequency Response Chart). This linearization is implemented in DASY4 software versions later than 4.2. The uncertainty of the frequency response is included in the stated uncertainty of *ConvF*.
- **DCP_{x,y,z}:** DCP are numerical linearization parameters assessed based on the data of power sweep with CW signal (no uncertainty required). DCP does not depend on frequency nor media.
- **PAR:** PAR is the Peak to Average Ratio that is not calibrated but determined based on the signal characteristics
- **A_{x,y,z}; B_{x,y,z}; C_{x,y,z}; D_{x,y,z}; VR_{x,y,z}; A, B, C, D** are numerical linearization parameters assessed based on the data of power sweep for specific modulation signal. The parameters do not depend on frequency nor media. VR is the maximum calibration range expressed in RMS voltage across the diode.
- **ConvF and Boundary Effect Parameters:** Assessed in flat phantom using E-field (or Temperature Transfer Standard for $f \leq 800$ MHz) and inside waveguide using analytical field distributions based on power measurements for $f > 800$ MHz. The same setups are used for assessment of the parameters applied for boundary compensation (alpha, depth) of which typical uncertainty values are given. These parameters are used in DASY4 software to improve probe accuracy close to the boundary. The sensitivity in TSL corresponds to NORM_{x,y,z} * ConvF whereby the uncertainty corresponds to that given for ConvF. A frequency dependent ConvF is used in DASY version 4.4 and higher which allows extending the validity from ± 50 MHz to ± 100 MHz.
- **Spherical isotropy (3D deviation from isotropy):** in a field of low gradients realized using a flat phantom exposed by a patch antenna.
- **Sensor Offset:** The sensor offset corresponds to the offset of virtual measurement center from the probe tip (on probe axis). No tolerance required.
- **Connector Angle:** The angle is assessed using the information gained by determining the NORM_x (no uncertainty required).

Probe EX3DV4

SN:3914

Manufactured:	December 18, 2012
Repaired:	January 23, 2015
Calibrated:	February 10, 2015

Calibrated for DASY/EASY Systems
(Note: non-compatible with DASY2 system!)

DASY/EASY - Parameters of Probe: EX3DV4 - SN:3914

Basic Calibration Parameters

	Sensor X	Sensor Y	Sensor Z	Unc (k=2)
Norm ($\mu\text{V}/(\text{V}/\text{m})^2$) ^A	0.48	0.42	0.45	$\pm 10.1\%$
DCP (mV) ^B	102.7	103.2	101.3	

Modulation Calibration Parameters

UID	Communication System Name		A dB	B dB $\sqrt{\mu\text{V}}$	C	D dB	VR mV	Unc ^E (k=2)
0	CW	X	0.0	0.0	1.0	0.00	137.3	$\pm 2.7\%$
		Y	0.0	0.0	1.0		140.8	
		Z	0.0	0.0	1.0		134.6	
10010- CAA	SAR Validation (Square, 100ms, 10ms)	X	1.33	60.3	9.9	10.00	40.4	$\pm 1.2\%$
		Y	1.02	57.7	9.2		42.2	
		Z	1.41	61.3	11.0		39.9	
10011- CAB	UMTS-FDD (WCDMA)	X	3.39	67.3	18.6	2.91	148.9	$\pm 0.5\%$
		Y	3.47	67.6	18.6		130.1	
		Z	3.30	66.5	17.9		145.8	
10012- CAB	IEEE 802.11b WiFi 2.4 GHz (DSSS, 1 Mbps)	X	2.92	68.9	18.9	1.87	149.0	$\pm 0.7\%$
		Y	3.17	70.1	19.2		131.4	
		Z	2.72	67.0	17.6		146.9	
10013- CAB	IEEE 802.11g WiFi 2.4 GHz (DSSS-OFDM, 6 Mbps)	X	10.52	69.1	22.1	9.46	140.7	$\pm 3.3\%$
		Y	10.67	69.8	22.6		146.8	
		Z	10.44	68.9	22.0		136.8	
10021- DAB	GSM-FDD (TDMA, GMSK)	X	1.64	63.4	11.8	9.39	86.2	$\pm 1.7\%$
		Y	2.03	65.7	13.6		105.2	
		Z	1.78	63.6	12.4		85.9	
10023- DAB	GPRS-FDD (TDMA, GMSK, TN 0)	X	1.78	65.0	13.2	9.57	84.0	$\pm 2.2\%$
		Y	1.84	63.8	12.5		101.1	
		Z	1.92	64.9	13.4		83.0	
10024- DAB	GPRS-FDD (TDMA, GMSK, TN 0-1)	X	2.04	68.8	13.2	6.56	141.3	$\pm 1.9\%$
		Y	2.32	70.4	14.4		134.7	
		Z	1.59	65.5	12.3		139.3	
10027- DAB	GPRS-FDD (TDMA, GMSK, TN 0-1-2)	X	1.51	67.3	11.9	4.80	148.8	$\pm 1.9\%$
		Y	1.27	63.7	10.0		136.2	
		Z	3.26	75.5	15.4		148.7	
10028- DAB	GPRS-FDD (TDMA, GMSK, TN 0-1-2-3)	X	52.54	99.9	20.2	3.55	143.3	$\pm 1.7\%$
		Y	2.95	74.0	13.7		149.7	
		Z	32.98	99.9	21.5		141.9	
10032- CAA	IEEE 802.15.1 Bluetooth (GFSK, DH5)	X	96.97	99.5	17.5	1.16	145.3	$\pm 1.2\%$
		Y	83.69	99.7	18.1		128.6	
		Z	0.69	65.4	9.0		143.2	

10062-CAB	IEEE 802.11a/h WiFi 5 GHz (OFDM, 6 Mbps)	X	10.27	68.9	21.5	8.68	145.1	±2.7 %
		Y	9.95	68.4	21.3		123.8	
		Z	10.18	68.8	21.4		140.9	
10100-CAB	LTE-FDD (SC-FDMA, 100% RB, 20 MHz, QPSK)	X	6.38	67.0	19.3	5.67	140.1	±1.4 %
		Y	6.54	67.7	19.6		147.0	
		Z	6.34	66.8	19.1		137.4	
10103-CAB	LTE-TDD (SC-FDMA, 100% RB, 20 MHz, QPSK)	X	7.44	67.6	21.6	9.29	132.4	±1.7 %
		Y	7.78	69.0	22.4		140.2	
		Z	7.40	67.4	21.4		129.5	
10108-CAC	LTE-FDD (SC-FDMA, 100% RB, 10 MHz, QPSK)	X	6.25	66.7	19.2	5.80	137.9	±1.4 %
		Y	6.36	67.2	19.5		143.3	
		Z	6.20	66.4	19.0		135.0	
10117-CAB	IEEE 802.11n (HT Mixed, 13.5 Mbps, BPSK)	X	10.03	68.2	20.7	8.07	128.5	±2.5 %
		Y	10.17	68.7	21.0		134.9	
		Z	9.94	68.0	20.5		125.2	
10151-CAB	LTE-TDD (SC-FDMA, 50% RB, 20 MHz, QPSK)	X	7.21	67.6	21.8	9.28	149.5	±1.9 %
		Y	7.39	68.5	22.3		135.1	
		Z	7.19	67.5	21.7		147.3	
10154-CAC	LTE-FDD (SC-FDMA, 50% RB, 10 MHz, QPSK)	X	5.91	66.2	19.1	5.75	133.8	±1.2 %
		Y	6.04	66.8	19.4		139.4	
		Z	5.88	66.0	18.9		131.1	
10160-CAB	LTE-FDD (SC-FDMA, 50% RB, 15 MHz, QPSK)	X	6.36	66.7	19.3	5.82	139.0	±1.4 %
		Y	6.51	67.4	19.7		145.5	
		Z	6.31	66.4	19.0		136.5	
10169-CAB	LTE-FDD (SC-FDMA, 1 RB, 20 MHz, QPSK)	X	4.79	66.3	19.4	5.73	136.1	±1.2 %
		Y	4.90	67.0	19.8		141.5	
		Z	4.76	66.0	19.1		133.8	
10172-CAB	LTE-TDD (SC-FDMA, 1 RB, 20 MHz, QPSK)	X	5.66	68.8	22.7	9.21	138.2	±2.5 %
		Y	5.93	70.3	23.7		147.0	
		Z	5.68	68.6	22.6		136.7	
10175-CAC	LTE-FDD (SC-FDMA, 1 RB, 10 MHz, QPSK)	X	4.77	66.2	19.3	5.72	135.7	±1.2 %
		Y	4.92	67.1	19.8		141.2	
		Z	4.72	65.8	19.0		133.6	
10181-CAB	LTE-FDD (SC-FDMA, 1 RB, 15 MHz, QPSK)	X	4.77	66.2	19.3	5.72	134.8	±1.2 %
		Y	4.91	67.0	19.7		141.1	
		Z	4.76	66.0	19.1		132.8	
10196-CAB	IEEE 802.11n (HT Mixed, 6.5 Mbps, BPSK)	X	9.99	68.8	21.1	8.10	146.9	±2.5 %
		Y	9.71	68.4	21.0		127.0	
		Z	9.91	68.7	21.0		143.4	
10225-CAB	UMTS-FDD (HSPA+)	X	7.10	67.5	19.5	5.97	149.1	±1.2 %
		Y	6.98	67.4	19.5		128.9	
		Z	7.01	67.2	19.3		145.5	

10237-CAB	LTE-TDD (SC-FDMA, 1 RB, 10 MHz, QPSK)	X	5.68	68.9	22.8	9.21	139.9	±2.2 %
		Y	5.93	70.3	23.6		148.1	
		Z	5.70	68.8	22.7		137.5	
10252-CAB	LTE-TDD (SC-FDMA, 50% RB, 10 MHz, QPSK)	X	6.81	67.4	21.7	9.24	143.4	±2.2 %
		Y	6.93	68.0	22.2		129.3	
		Z	6.79	67.2	21.6		140.3	
10267-CAB	LTE-TDD (SC-FDMA, 100% RB, 10 MHz, QPSK)	X	7.23	67.7	21.9	9.30	149.4	±1.9 %
		Y	7.42	68.6	22.4		135.2	
		Z	7.19	67.4	21.6		146.2	
10275-CAB	UMTS-FDD (HSUPA, Subtest 5, 3GPP Rel8.4)	X	4.44	66.7	18.6	3.96	129.1	±0.7 %
		Y	4.57	67.4	18.9		134.5	
		Z	4.35	66.1	18.1		126.6	
10291-AAB	CDMA2000, RC3, SO55, Full Rate	X	3.64	66.9	18.6	3.46	140.9	±0.7 %
		Y	3.87	68.3	19.3		147.1	
		Z	3.61	66.5	18.2		138.4	
10292-AAB	CDMA2000, RC3, SO32, Full Rate	X	3.64	67.4	18.8	3.39	142.3	±0.5 %
		Y	3.85	68.5	19.3		148.3	
		Z	3.59	66.7	18.3		139.6	
10297-AAA	LTE-FDD (SC-FDMA, 50% RB, 20 MHz, QPSK)	X	6.23	66.6	19.2	5.81	136.3	±1.4 %
		Y	6.42	67.4	19.7		142.8	
		Z	6.19	66.3	19.0		133.9	
10311-AAA	LTE-FDD (SC-FDMA, 100% RB, 15 MHz, QPSK)	X	6.84	67.3	19.6	6.06	142.4	±1.4 %
		Y	6.98	67.8	19.9		149.5	
		Z	6.75	66.8	19.3		140.0	
10317-AAB	IEEE 802.11a WiFi 5 GHz (OFDM, 6 Mbps, 96pc duty cycle)	X	10.13	68.9	21.3	8.36	147.4	±2.7 %
		Y	9.84	68.4	21.1		127.5	
		Z	10.04	68.7	21.2		143.2	
10400-AAB	IEEE 802.11ac WiFi (20MHz, 64-QAM, 99pc duty cycle)	X	10.24	69.0	21.4	8.37	148.6	±2.7 %
		Y	9.92	68.4	21.2		126.6	
		Z	10.14	68.8	21.3		144.6	
10401-AAB	IEEE 802.11ac WiFi (40MHz, 64-QAM, 99pc duty cycle)	X	10.60	68.6	21.2	8.60	129.4	±3.0 %
		Y	10.77	69.1	21.5		136.8	
		Z	10.52	68.4	21.1		125.9	
10402-AAB	IEEE 802.11ac WiFi (80MHz, 64-QAM, 99pc duty cycle)	X	10.60	68.5	20.9	8.53	129.7	±3.0 %
		Y	11.01	69.5	21.5		139.1	
		Z	10.54	68.3	20.8		126.7	
10403-AAB	CDMA2000 (1xEV-DO, Rev. 0)	X	5.07	70.1	19.4	3.76	127.5	±0.5 %
		Y	5.47	71.9	20.2		133.6	
		Z	4.93	69.5	19.0		124.9	
10404-AAB	CDMA2000 (1xEV-DO, Rev. A)	X	5.01	70.2	19.5	3.77	149.3	±0.7 %
		Y	5.38	71.9	20.2		132.0	
		Z	4.94	69.9	19.2		146.4	

10415-AAA	IEEE 802.11b WiFi 2.4 GHz (DSSS, 1 Mbps, 99pc duty cycle)	X	3.20	71.2	19.8	1.54	126.8	±0.7 %
		Y	3.51	72.6	20.4		134.5	
		Z	2.79	68.1	18.1		148.4	
10416-AAA	IEEE 802.11g WiFi 2.4 GHz (ERP-OFDM, 6 Mbps, 99pc duty cycle)	X	10.07	68.8	21.2	8.23	147.8	±2.7 %
		Y	9.81	68.4	21.1		128.4	
		Z	10.00	68.7	21.1		144.0	
10417-AAA	IEEE 802.11a/h WiFi 5 GHz (OFDM, 6 Mbps, 99pc duty cycle)	X	10.07	68.8	21.2	8.23	148.4	±2.7 %
		Y	9.82	68.4	21.1		129.0	
		Z	9.99	68.7	21.1		144.6	

The reported uncertainty of measurement is stated as the standard uncertainty of measurement multiplied by the coverage factor $k=2$, which for a normal distribution corresponds to a coverage probability of approximately 95%.

^A The uncertainties of NormX,Y,Z do not affect the E^2 -field uncertainty inside TSL (see Pages 8 and 9).

^B Numerical linearization parameter: uncertainty not required.

^E Uncertainty is determined using the max. deviation from linear response applying rectangular distribution and is expressed for the square of the field value.

DASY/EASY - Parameters of Probe: EX3DV4 - SN:3914

Calibration Parameter Determined in Head Tissue Simulating Media

f (MHz) ^C	Relative Permittivity ^F	Conductivity (S/m) ^F	ConvF X	ConvF Y	ConvF Z	Alpha ^G	Depth ^G (mm)	Unct. (k=2)
750	41.9	0.89	9.82	9.82	9.82	0.39	0.92	± 12.0 %
835	41.5	0.90	9.50	9.50	9.50	0.43	0.83	± 12.0 %
1750	40.1	1.37	8.04	8.04	8.04	0.30	0.93	± 12.0 %
1900	40.0	1.40	7.86	7.86	7.86	0.35	0.86	± 12.0 %
2450	39.2	1.80	7.02	7.02	7.02	0.28	1.05	± 12.0 %
2600	39.0	1.96	6.82	6.82	6.82	0.26	1.17	± 12.0 %
5200	36.0	4.66	5.26	5.26	5.26	0.35	1.80	± 13.1 %
5300	35.9	4.76	5.06	5.06	5.06	0.35	1.80	± 13.1 %
5500	35.6	4.96	4.92	4.92	4.92	0.40	1.80	± 13.1 %
5600	35.5	5.07	4.73	4.73	4.73	0.40	1.80	± 13.1 %
5800	35.3	5.27	4.67	4.67	4.67	0.40	1.80	± 13.1 %

^C Frequency validity above 300 MHz of ± 100 MHz only applies for DASY v4.4 and higher (see Page 2), else it is restricted to ± 50 MHz. The uncertainty is the RSS of the ConvF uncertainty at calibration frequency and the uncertainty for the indicated frequency band. Frequency validity below 300 MHz is ± 10, 25, 40, 50 and 70 MHz for ConvF assessments at 30, 64, 128, 150 and 220 MHz respectively. Above 5 GHz frequency validity can be extended to ± 110 MHz.

^F At frequencies below 3 GHz, the validity of tissue parameters (ϵ and σ) can be relaxed to ± 10% if liquid compensation formula is applied to measured SAR values. At frequencies above 3 GHz, the validity of tissue parameters (ϵ and σ) is restricted to ± 5%. The uncertainty is the RSS of the ConvF uncertainty for indicated target tissue parameters.

^G Alpha/Depth are determined during calibration. SPEAG warrants that the remaining deviation due to the boundary effect after compensation is always less than ± 1% for frequencies below 3 GHz and below ± 2% for frequencies between 3-6 GHz at any distance larger than half the probe tip diameter from the boundary.

DASY/EASY - Parameters of Probe: EX3DV4 - SN:3914

Calibration Parameter Determined in Body Tissue Simulating Media

f (MHz) ^C	Relative Permittivity ^F	Conductivity (S/m) ^F	ConvF X	ConvF Y	ConvF Z	Alpha ^G	Depth (mm) ^G	Unct. (k=2)
750	55.5	0.96	9.53	9.53	9.53	0.33	1.09	± 12.0 %
835	55.2	0.97	9.49	9.49	9.49	0.27	1.25	± 12.0 %
1750	53.4	1.49	7.78	7.78	7.78	0.51	0.79	± 12.0 %
1900	53.3	1.52	7.49	7.49	7.49	0.73	0.64	± 12.0 %
2450	52.7	1.95	7.15	7.15	7.15	0.69	0.64	± 12.0 %
2600	52.5	2.16	6.84	6.84	6.84	0.80	0.57	± 12.0 %
5200	49.0	5.30	4.50	4.50	4.50	0.45	1.90	± 13.1 %
5300	48.9	5.42	4.33	4.33	4.33	0.45	1.90	± 13.1 %
5500	48.6	5.65	3.91	3.91	3.91	0.50	1.90	± 13.1 %
5600	48.5	5.77	3.89	3.89	3.89	0.50	1.90	± 13.1 %
5800	48.2	6.00	4.01	4.01	4.01	0.55	1.90	± 13.1 %

^C Frequency validity above 300 MHz of ± 100 MHz only applies for DASY v4.4 and higher (see Page 2), else it is restricted to ± 50 MHz. The uncertainty is the RSS of the ConvF uncertainty at calibration frequency and the uncertainty for the indicated frequency band. Frequency validity below 300 MHz is ± 10, 25, 40, 50 and 70 MHz for ConvF assessments at 30, 64, 128, 150 and 220 MHz respectively. Above 5 GHz frequency validity can be extended to ± 110 MHz.

^F At frequencies below 3 GHz, the validity of tissue parameters (ϵ and σ) can be relaxed to ± 10% if liquid compensation formula is applied to measured SAR values. At frequencies above 3 GHz, the validity of tissue parameters (ϵ and σ) is restricted to ± 5%. The uncertainty is the RSS of the ConvF uncertainty for indicated target tissue parameters.

^G Alpha/Depth are determined during calibration. SPEAG warrants that the remaining deviation due to the boundary effect after compensation is always less than ± 1% for frequencies below 3 GHz and below ± 2% for frequencies between 3-6 GHz at any distance larger than half the probe tip diameter from the boundary.

Frequency Response of E-Field (TEM-Cell:ifi110 EXX, Waveguide: R22)

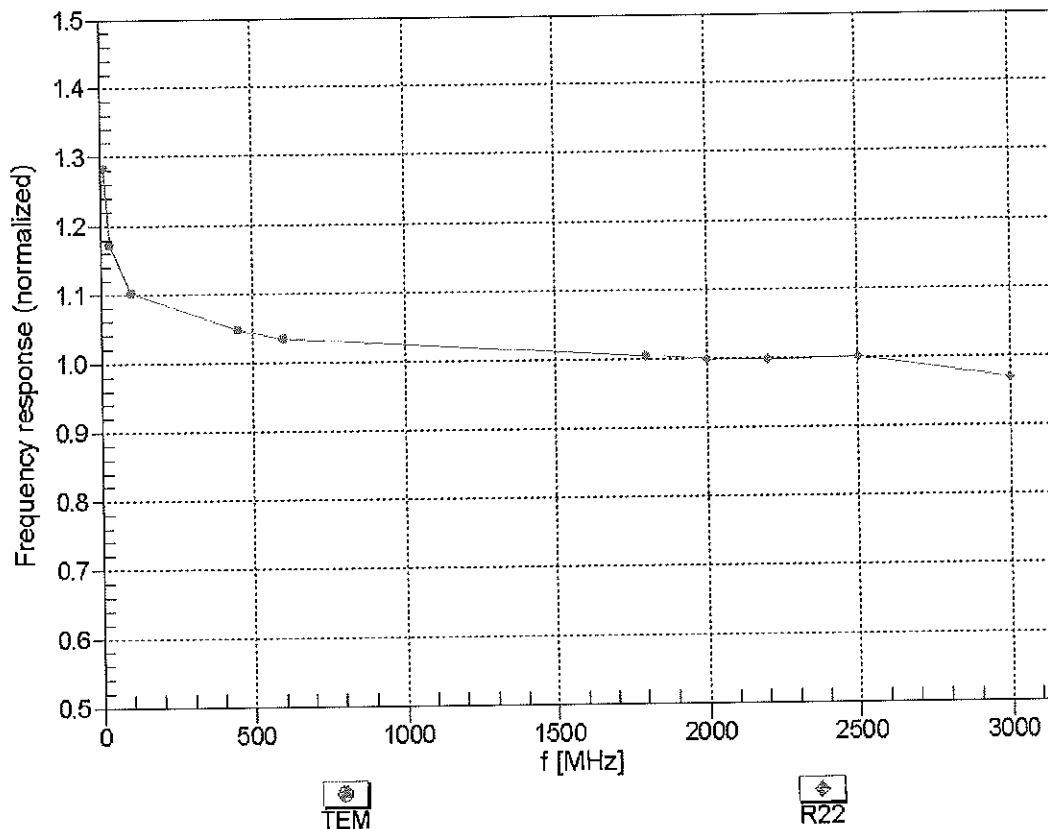

Uncertainty of Frequency Response of E-field: $\pm 6.3\%$ (k=2)

Receiving Pattern (ϕ), $\theta = 0^\circ$

f=600 MHz, TEM

f=1800 MHz, R22

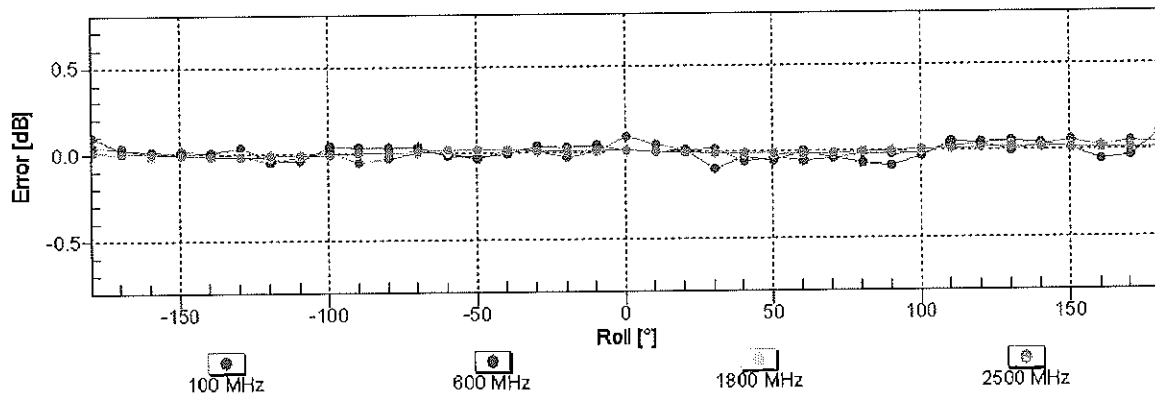
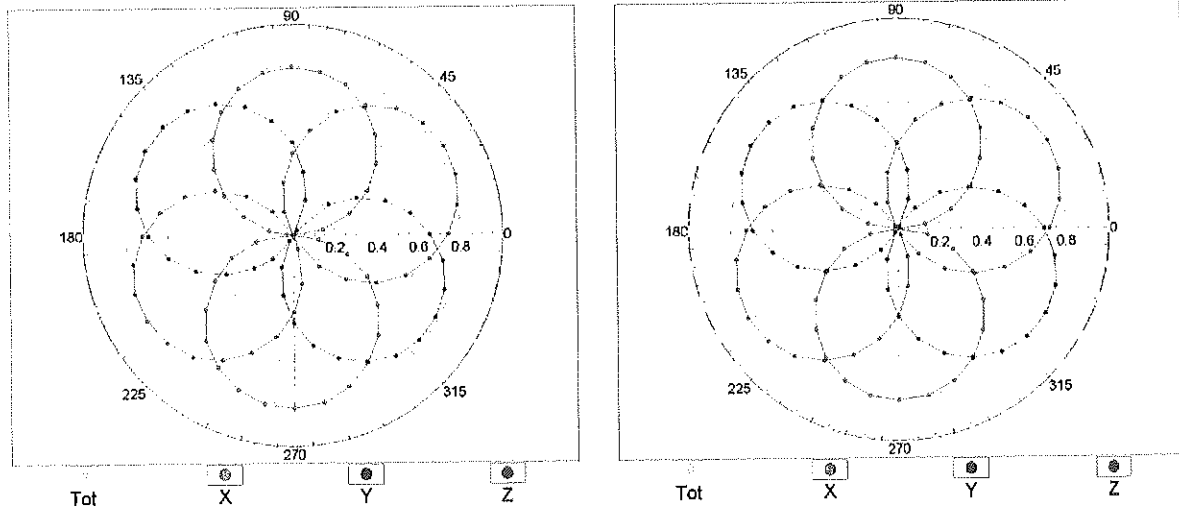

Uncertainty of Axial Isotropy Assessment: $\pm 0.5\%$ ($k=2$)

Dynamic Range f(SAR_{head}) (TEM cell , f_{eval}= 1900 MHz)

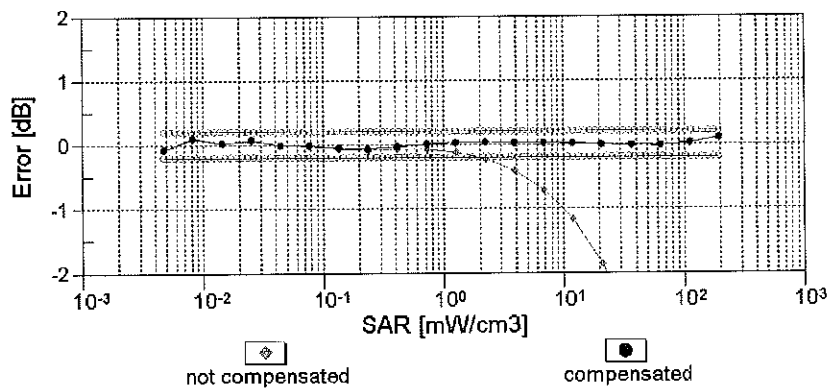
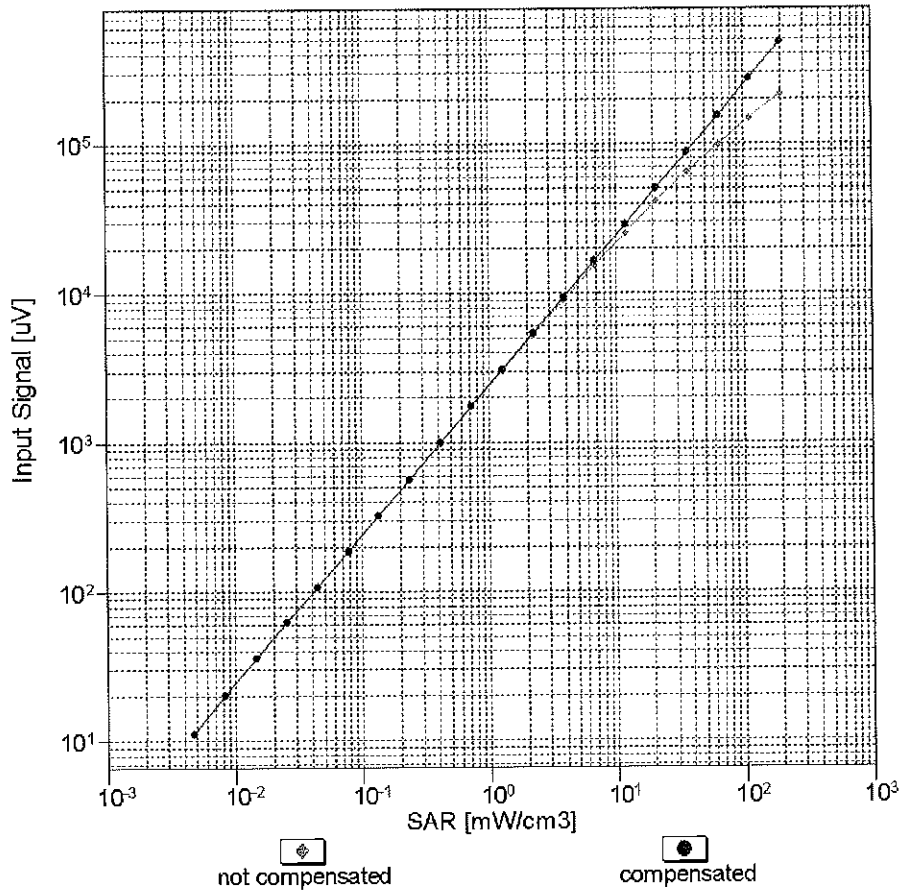

Uncertainty of Linearity Assessment: ± 0.6% (k=2)

Conversion Factor Assessment

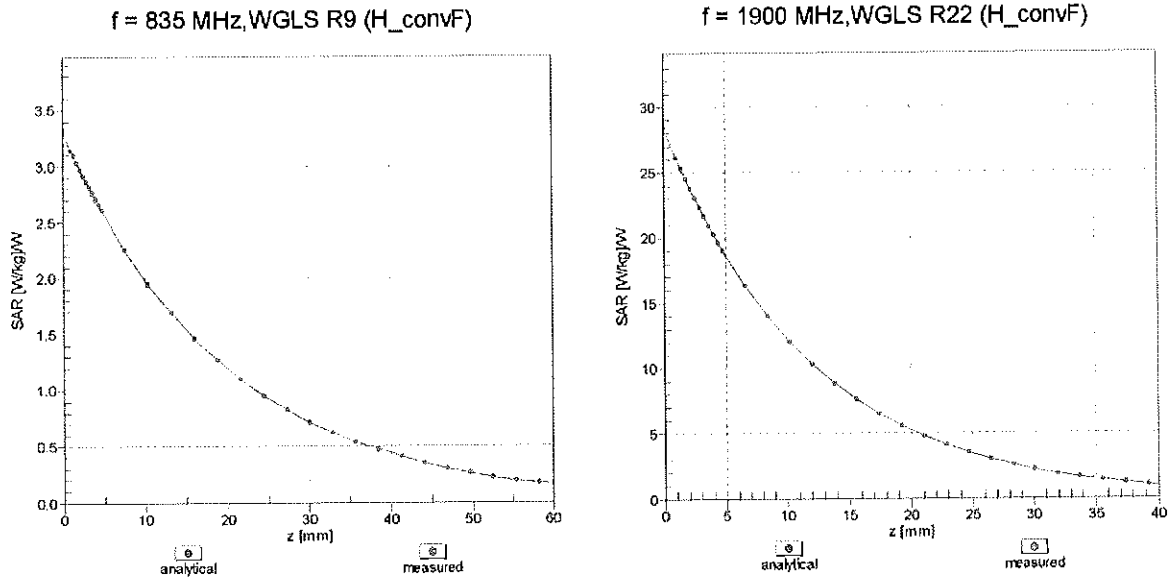

Deviation from Isotropy in Liquid Error (ϕ, θ), f = 900 MHz

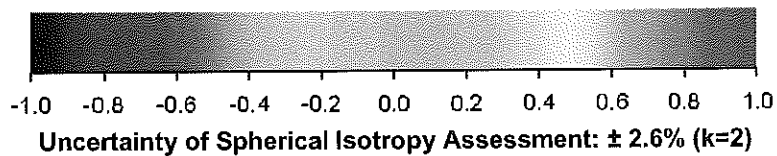
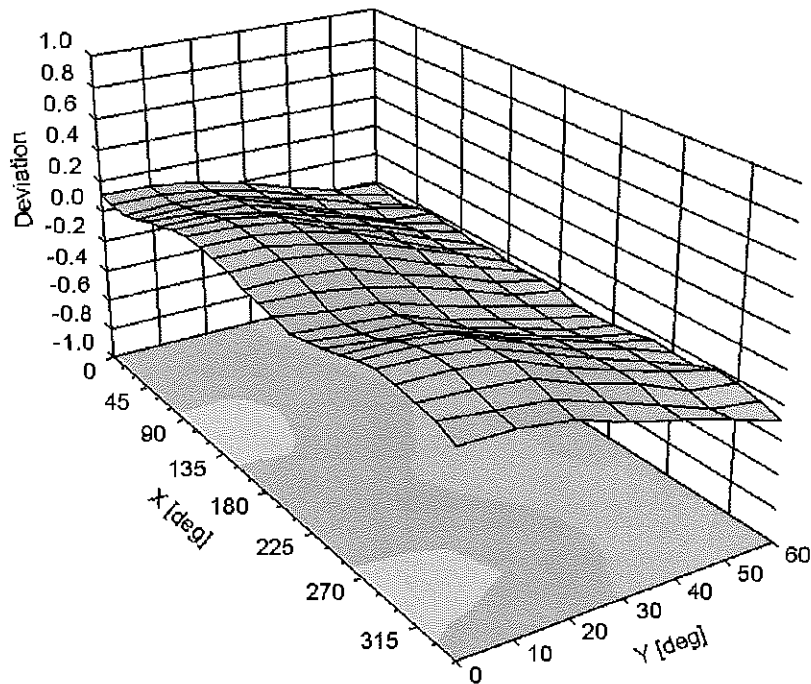

DASY/EASY - Parameters of Probe: EX3DV4 - SN:3914**Other Probe Parameters**

Sensor Arrangement	Triangular
Connector Angle (°)	-49.5
Mechanical Surface Detection Mode	enabled
Optical Surface Detection Mode	disabled
Probe Overall Length	337 mm
Probe Body Diameter	10 mm
Tip Length	9 mm
Tip Diameter	2.5 mm
Probe Tip to Sensor X Calibration Point	1 mm
Probe Tip to Sensor Y Calibration Point	1 mm
Probe Tip to Sensor Z Calibration Point	1 mm
Recommended Measurement Distance from Surface	1.4 mm

**Calibration Laboratory of
Schmid & Partner
Engineering AG**
Zeughausstrasse 43, 8004 Zurich, Switzerland



S Schweizerischer Kalibrierdienst
S Service suisse d'étalonnage
C Servizio svizzero di taratura
S Swiss Calibration Service

Accredited by the Swiss Accreditation Service (SAS)
The Swiss Accreditation Service is one of the signatories to the EA
Multilateral Agreement for the recognition of calibration certificates

Accreditation No.: **SCS 108**

Client **PC Test**

Certificate No: **ES3-3288_Sep14/2**

CALIBRATION CERTIFICATE (Replacement of No:ES3-3288_Sep14)

Object **ES3DV3 - SN:3288**

Calibration procedure(s) **QA CAL-01.v9, QA CAL-23.v5, QA CAL-25.v6
Calibration procedure for dosimetric E-field probes** CC
12/14

Calibration date: **September 24, 2014**

This calibration certificate documents the traceability to national standards, which realize the physical units of measurements (SI).
The measurements and the uncertainties with confidence probability are given on the following pages and are part of the certificate.

All calibrations have been conducted in the closed laboratory facility: environment temperature (22 ± 3)°C and humidity < 70%.

Calibration Equipment used (M&TE critical for calibration)

Primary Standards	ID	Cal Date (Certificate No.)	Scheduled Calibration
Power meter E4419B	GB41293874	03-Apr-14 (No. 217-01911)	Apr-15
Power sensor E4412A	MY41498087	03-Apr-14 (No. 217-01911)	Apr-15
Reference 3 dB Attenuator	SN: S5054 (3c)	03-Apr-14 (No. 217-01915)	Apr-15
Reference 20 dB Attenuator	SN: S5277 (20x)	03-Apr-14 (No. 217-01919)	Apr-15
Reference 30 dB Attenuator	SN: S5129 (30b)	03-Apr-14 (No. 217-01920)	Apr-15
Reference Probe ES3DV2	SN: 3013	30-Dec-13 (No. ES3-3013_Dec13)	Dec-14
DAE4	SN: 660	13-Dec-13 (No. DAE4-660_Dec13)	Dec-14
Secondary Standards	ID	Check Date (in house)	Scheduled Check
RF generator HP 8648C	US3642U01700	4-Aug-99 (in house check Apr-13)	In house check: Apr-16
Network Analyzer HP 8753E	US37390585	18-Oct-01 (in house check Oct-13)	In house check: Oct-14

	Name	Function	Signature
Calibrated by:	Leif Klysner	Laboratory Technician	
Approved by:	Katja Pokovic	Technical Manager	

Issued: November 3, 2014

This calibration certificate shall not be reproduced except in full without written approval of the laboratory.



Accredited by the Swiss Accreditation Service (SAS)
The Swiss Accreditation Service is one of the signatories to the EA
Multilateral Agreement for the recognition of calibration certificates

Accreditation No.: **SCS 108**

Glossary:

TSL	tissue simulating liquid
NORM _{x,y,z}	sensitivity in free space
ConvF	sensitivity in TSL / NORM _{x,y,z}
DCP	diode compression point
CF	crest factor (1/duty_cycle) of the RF signal
A, B, C, D	modulation dependent linearization parameters
Polarization ϕ	ϕ rotation around probe axis
Polarization ϑ	ϑ rotation around an axis that is in the plane normal to probe axis (at measurement center), i.e., $\vartheta = 0$ is normal to probe axis
Connector Angle	information used in DASY system to align probe sensor X to the robot coordinate system

Calibration is Performed According to the Following Standards:

- a) IEEE Std 1528-2013, "IEEE Recommended Practice for Determining the Peak Spatial-Averaged Specific Absorption Rate (SAR) in the Human Head from Wireless Communications Devices: Measurement Techniques", June 2013
- b) IEC 62209-1, "Procedure to measure the Specific Absorption Rate (SAR) for hand-held devices used in close proximity to the ear (frequency range of 300 MHz to 3 GHz)", February 2005

Methods Applied and Interpretation of Parameters:

- *NORM_{x,y,z}*: Assessed for E-field polarization $\vartheta = 0$ ($f \leq 900$ MHz in TEM-cell; $f > 1800$ MHz: R22 waveguide). *NORM_{x,y,z}* are only intermediate values, i.e., the uncertainties of *NORM_{x,y,z}* does not affect the E^2 -field uncertainty inside TSL (see below *ConvF*).
- *NORM(f)_{x,y,z}* = *NORM_{x,y,z}* * *frequency_response* (see Frequency Response Chart). This linearization is implemented in DASY4 software versions later than 4.2. The uncertainty of the frequency response is included in the stated uncertainty of *ConvF*.
- *DCP_{x,y,z}*: DCP are numerical linearization parameters assessed based on the data of power sweep with CW signal (no uncertainty required). DCP does not depend on frequency nor media.
- *PAR*: PAR is the Peak to Average Ratio that is not calibrated but determined based on the signal characteristics
- *A_{x,y,z}*; *B_{x,y,z}*; *C_{x,y,z}*; *D_{x,y,z}*; *VR_{x,y,z}*; *A, B, C, D* are numerical linearization parameters assessed based on the data of power sweep for specific modulation signal. The parameters do not depend on frequency nor media. *VR* is the maximum calibration range expressed in RMS voltage across the diode.
- *ConvF and Boundary Effect Parameters*: Assessed in flat phantom using E-field (or Temperature Transfer Standard for $f \leq 800$ MHz) and inside waveguide using analytical field distributions based on power measurements for $f > 800$ MHz. The same setups are used for assessment of the parameters applied for boundary compensation (alpha, depth) of which typical uncertainty values are given. These parameters are used in DASY4 software to improve probe accuracy close to the boundary. The sensitivity in TSL corresponds to *NORM_{x,y,z}* * *ConvF* whereby the uncertainty corresponds to that given for *ConvF*. A frequency dependent *ConvF* is used in DASY version 4.4 and higher which allows extending the validity from ± 50 MHz to ± 100 MHz.
- *Spherical isotropy (3D deviation from isotropy)*: in a field of low gradients realized using a flat phantom exposed by a patch antenna.
- *Sensor Offset*: The sensor offset corresponds to the offset of virtual measurement center from the probe tip (on probe axis). No tolerance required.
- *Connector Angle*: The angle is assessed using the information gained by determining the *NORM_x* (no uncertainty required).

Probe ES3DV3

SN:3288

Manufactured:	July 6, 2010
Repaired:	September 18, 2014
Calibrated:	September 24, 2014

Calibrated for DASY/EASY Systems
(Note: non-compatible with DASY2 system!)

DASY/EASY - Parameters of Probe: ES3DV3 - SN:3288

Basic Calibration Parameters

	Sensor X	Sensor Y	Sensor Z	Unc (k=2)
Norm ($\mu\text{V}/(\text{V}/\text{m})^2$) ^A	1.05	1.16	0.92	$\pm 10.1 \%$
DCP (mV) ^B	105.1	104.6	106.7	

Modulation Calibration Parameters

UID	Communication System Name		A dB	B dB $\sqrt{\mu\text{V}}$	C	D dB	VR mV	Unc ^E (k=2)
0	CW	X	0.0	0.0	1.0	0.00	195.8	$\pm 3.5 \%$
		Y	0.0	0.0	1.0		175.9	
		Z	0.0	0.0	1.0		177.1	
10010-CAA	SAR Validation (Square, 100ms, 10ms)	X	2.71	61.9	11.4	10.00	40.3	$\pm 2.2 \%$
		Y	2.37	60.2	11.2		42.6	
		Z	1.54	56.6	8.9		41.2	
10011-CAB	UMTS-FDD (WCDMA)	X	3.29	67.1	18.4	2.91	133.8	$\pm 0.5 \%$
		Y	3.43	67.9	18.9		139.5	
		Z	3.45	68.1	18.9		141.3	
10012-CAA	IEEE 802.11b WiFi 2.4 GHz (DSSS, 1 Mbps)	X	2.99	68.9	18.6	1.87	135.1	$\pm 0.7 \%$
		Y	3.59	72.4	20.4		140.7	
		Z	3.54	72.4	20.3		143.0	
10013-CAA	IEEE 802.11g WiFi 2.4 GHz (DSSS-OFDM, 6 Mbps)	X	11.15	70.8	23.3	9.46	132.3	$\pm 3.5 \%$
		Y	11.29	70.8	23.2		141.1	
		Z	11.07	70.7	23.2		139.2	
10021-DAB	GSM-FDD (TDMA, GMSK)	X	14.71	90.5	24.5	9.39	149.0	$\pm 1.9 \%$
		Y	16.40	92.8	26.0		131.3	
		Z	11.34	87.2	23.6		126.1	
10023-DAB	GPRS-FDD (TDMA, GMSK, TN 0)	X	15.91	92.2	25.3	9.57	138.9	$\pm 2.5 \%$
		Y	21.25	96.9	27.2		142.0	
		Z	11.68	87.2	23.5		145.9	
10024-DAB	GPRS-FDD (TDMA, GMSK, TN 0-1)	X	38.62	99.8	24.7	6.56	123.8	$\pm 2.2 \%$
		Y	36.71	99.7	25.2		128.1	
		Z	36.56	99.4	24.5		129.5	
10027-DAB	GPRS-FDD (TDMA, GMSK, TN 0-1-2)	X	56.60	99.6	22.6	4.80	138.8	$\pm 1.9 \%$
		Y	46.94	99.9	23.7		149.9	
		Z	51.17	99.8	22.9		144.9	
10028-DAB	GPRS-FDD (TDMA, GMSK, TN 0-1-2-3)	X	70.88	100.0	21.6	3.55	147.5	$\pm 1.9 \%$
		Y	52.58	99.8	22.6		129.4	
		Z	76.98	99.8	21.2		128.7	
10032-CAA	IEEE 802.15.1 Bluetooth (GFSK, DH5)	X	98.89	99.5	18.9	1.16	135.8	$\pm 1.4 \%$
		Y	78.39	99.6	19.5		141.7	
		Z	95.21	95.5	17.1		143.4	
10039-CAB	CDMA2000 (1xRTT, RC1)	X	4.72	66.7	18.9	4.57	133.7	$\pm 0.9 \%$
		Y	4.85	67.1	19.1		137.7	
		Z	4.81	67.4	19.2		141.9	

10081-CAB	CDMA2000 (1xRTT, RC3)	X	3.91	66.3	18.6	3.97	129.5	±0.7 %
		Y	4.00	66.6	18.7		133.7	
		Z	3.99	66.8	18.8		137.5	
10098-CAB	UMTS-FDD (HSUPA, Subtest 2)	X	4.63	66.9	18.7	3.98	141.4	±0.7 %
		Y	4.78	67.5	19.0		147.7	
		Z	4.57	66.8	18.6		127.8	
10100-CAB	LTE-FDD (SC-FDMA, 100% RB, 20 MHz, QPSK)	X	6.59	68.2	20.1	5.67	149.2	±1.4 %
		Y	6.36	67.3	19.6		130.7	
		Z	6.36	67.5	19.6		133.6	
10108-CAB	LTE-FDD (SC-FDMA, 100% RB, 10 MHz, QPSK)	X	6.44	67.8	20.0	5.80	146.6	±1.4 %
		Y	6.23	66.8	19.4		128.8	
		Z	6.24	67.1	19.6		131.4	
10110-CAB	LTE-FDD (SC-FDMA, 100% RB, 5 MHz, QPSK)	X	6.08	67.1	19.6	5.75	143.2	±1.4 %
		Y	6.20	67.4	19.8		148.0	
		Z	5.92	66.6	19.3		128.5	
10114-CAA	IEEE 802.11n (HT Greenfield, 13.5 Mbps, BPSK)	X	10.32	69.3	21.5	8.10	137.0	±2.2 %
		Y	10.31	69.1	21.4		143.5	
		Z	10.37	69.5	21.6		146.1	
10117-CAA	IEEE 802.11n (HT Mixed, 13.5 Mbps, BPSK)	X	10.35	69.4	21.6	8.07	138.3	±2.2 %
		Y	10.36	69.3	21.4		146.4	
		Z	10.42	69.6	21.6		149.0	
10151-CAB	LTE-TDD (SC-FDMA, 50% RB, 20 MHz, QPSK)	X	9.95	75.7	26.2	9.28	134.9	±3.3 %
		Y	10.37	76.0	26.1		146.6	
		Z	9.77	75.4	26.0		142.5	
10154-CAB	LTE-FDD (SC-FDMA, 50% RB, 10 MHz, QPSK)	X	6.12	67.2	19.7	5.75	144.9	±1.4 %
		Y	6.21	67.4	19.8		148.8	
		Z	5.91	66.5	19.3		128.7	
10160-CAB	LTE-FDD (SC-FDMA, 50% RB, 15 MHz, QPSK)	X	6.28	66.7	19.4	5.82	125.5	±1.2 %
		Y	6.37	66.8	19.4		129.7	
		Z	6.36	67.1	19.6		132.9	
10169-CAB	LTE-FDD (SC-FDMA, 1 RB, 20 MHz, QPSK)	X	5.08	67.6	20.2	5.73	147.0	±1.2 %
		Y	4.95	66.6	19.6		128.6	
		Z	4.91	66.9	19.8		131.2	
10172-CAB	LTE-TDD (SC-FDMA, 1 RB, 20 MHz, QPSK)	X	8.18	77.2	27.2	9.21	123.4	±2.7 %
		Y	8.37	76.6	26.6		129.5	
		Z	7.97	76.7	26.9		128.7	
10175-CAB	LTE-FDD (SC-FDMA, 1 RB, 10 MHz, QPSK)	X	5.05	67.4	20.1	5.72	146.2	±1.4 %
		Y	5.10	67.3	20.0		142.8	
		Z	4.87	66.7	19.6		129.6	
10181-CAB	LTE-FDD (SC-FDMA, 1 RB, 15 MHz, QPSK)	X	5.04	67.4	20.0	5.72	145.5	±1.2 %
		Y	5.12	67.4	20.0		143.4	
		Z	4.87	66.7	19.6		129.9	
10193-CAA	IEEE 802.11n (HT Greenfield, 6.5 Mbps, BPSK)	X	9.92	68.9	21.4	8.09	131.0	±2.2 %
		Y	9.84	68.5	21.1		130.0	
		Z	9.94	69.0	21.4		138.6	

10196-CAA	IEEE 802.11n (HT Mixed, 6.5 Mbps, BPSK)	X	9.90	68.9	21.4	8.10	130.8	±2.2 %
		Y	9.81	68.4	21.0		131.4	
		Z	9.95	69.1	21.5		140.5	
10219-CAA	IEEE 802.11n (HT Mixed, 7.2 Mbps, BPSK)	X	9.81	68.8	21.3	8.03	130.0	±2.2 %
		Y	9.89	68.9	21.3		138.1	
		Z	9.89	69.1	21.5		140.5	
10222-CAA	IEEE 802.11n (HT Mixed, 15 Mbps, BPSK)	X	10.25	69.2	21.4	8.06	137.1	±2.2 %
		Y	10.30	69.2	21.4		144.4	
		Z	10.38	69.6	21.6		148.4	
10225-CAB	UMTS-FDD (HSPA+)	X	6.90	66.8	19.3	5.97	132.8	±1.4 %
		Y	7.09	67.3	19.6		142.0	
		Z	7.04	67.4	19.6		143.5	
10237-CAB	LTE-TDD (SC-FDMA, 1 RB, 10 MHz, QPSK)	X	9.61	81.9	29.6	9.21	149.3	±2.7 %
		Y	8.66	77.6	27.1		133.7	
		Z	8.20	77.5	27.3		132.2	
10252-CAB	LTE-TDD (SC-FDMA, 50% RB, 10 MHz, QPSK)	X	9.16	74.5	25.8	9.24	126.3	±3.0 %
		Y	9.62	75.0	25.8		137.4	
		Z	9.16	74.8	25.9		135.2	
10267-CAB	LTE-TDD (SC-FDMA, 100% RB, 10 MHz, QPSK)	X	9.97	75.7	26.3	9.30	133.7	±3.3 %
		Y	10.38	75.9	26.1		146.1	
		Z	9.91	75.7	26.3		143.8	
10274-CAB	UMTS-FDD (HSUPA, Subtest 5, 3GPP Rel8.10)	X	5.86	66.6	18.7	4.87	129.9	±0.9 %
		Y	6.01	67.1	19.0		135.7	
		Z	5.95	67.1	19.0		139.4	
10275-CAB	UMTS-FDD (HSUPA, Subtest 5, 3GPP Rel8.4)	X	4.40	66.7	18.6	3.96	136.4	±0.7 %
		Y	4.55	67.3	19.0		138.3	
		Z	4.56	67.6	19.1		144.3	
10291-AAB	CDMA2000, RC3, SO55, Full Rate	X	3.64	66.9	18.7	3.46	127.4	±0.5 %
		Y	3.77	67.6	19.1		130.2	
		Z	3.72	67.5	19.0		134.4	
10292-AAB	CDMA2000, RC3, SO32, Full Rate	X	3.58	67.0	18.7	3.39	128.4	±0.5 %
		Y	3.73	67.7	19.1		132.7	
		Z	3.69	67.8	19.1		136.1	
10297-AAA	LTE-FDD (SC-FDMA, 50% RB, 20 MHz, QPSK)	X	6.43	67.7	19.9	5.81	145.5	±1.4 %
		Y	6.49	67.7	19.9		149.5	
		Z	6.23	67.0	19.6		129.5	
10311-AAA	LTE-FDD (SC-FDMA, 100% RB, 15 MHz, QPSK)	X	6.74	67.3	19.8	6.06	126.7	±1.4 %
		Y	6.83	67.5	19.8		132.9	
		Z	6.81	67.6	19.9		135.8	
10315-AAA	IEEE 802.11b WiFi 2.4 GHz (DSSS, 1 Mbps, 96pc duty cycle)	X	3.00	69.9	19.4	1.71	133.9	±0.5 %
		Y	3.30	71.5	20.1		141.0	
		Z	3.22	71.4	20.0		142.9	
10316-AAA	IEEE 802.11g WiFi 2.4 GHz (ERP-OFDM, 6 Mbps, 96pc duty cycle)	X	10.17	69.2	21.8	8.36	130.5	±2.5 %
		Y	10.20	69.1	21.6		138.4	
		Z	10.20	69.4	21.8		140.7	

10403-AAB	CDMA2000 (1xEV-DO, Rev. 0)	X	4.75	68.3	18.8	3.76	138.5	±0.7 %
		Y	5.00	69.1	19.2		146.7	
		Z	4.92	69.2	19.1		148.5	
10404-AAB	CDMA2000 (1xEV-DO, Rev. A)	X	4.73	68.6	18.9	3.77	136.3	±0.7 %
		Y	4.97	69.4	19.4		143.7	
		Z	4.91	69.6	19.3		146.0	
10415-AAA	IEEE 802.11b WiFi 2.4 GHz (DSSS, 1 Mbps, 99pc duty cycle)	X	2.65	68.1	18.5	1.54	135.2	±0.5 %
		Y	3.05	70.8	19.9		140.7	
		Z	2.87	69.8	19.3		144.8	
10416-AAA	IEEE 802.11g WiFi 2.4 GHz (ERP-OFDM, 6 Mbps, 99pc duty cycle)	X	10.00	69.0	21.5	8.23	130.8	±2.2 %
		Y	10.06	68.9	21.4		138.6	
		Z	10.08	69.3	21.7		141.6	

The reported uncertainty of measurement is stated as the standard uncertainty of measurement multiplied by the coverage factor $k=2$, which for a normal distribution corresponds to a coverage probability of approximately 95%.

^A The uncertainties of NormX,Y,Z do not affect the E^2 -field uncertainty inside TSL (see Pages 8 and 9).

^B Numerical linearization parameter: uncertainty not required.

^E Uncertainty is determined using the max. deviation from linear response applying rectangular distribution and is expressed for the square of the field value.

DASY/EASY - Parameters of Probe: ES3DV3 - SN:3288

Calibration Parameter Determined in Head Tissue Simulating Media

f (MHz) ^C	Relative Permittivity ^F	Conductivity (S/m) ^F	ConvF X	ConvF Y	ConvF Z	Alpha ^G	Depth ^G (mm)	Unct. (k=2)
750	41.9	0.89	6.81	6.81	6.81	0.37	1.70	± 12.0 %
835	41.5	0.90	6.51	6.51	6.51	0.45	1.52	± 12.0 %
1750	40.1	1.37	5.38	5.38	5.38	0.44	1.58	± 12.0 %
1900	40.0	1.40	5.17	5.17	5.17	0.80	1.18	± 12.0 %
2450	39.2	1.80	4.56	4.56	4.56	0.80	1.21	± 12.0 %
2600	39.0	1.96	4.44	4.44	4.44	0.80	1.22	± 12.0 %

^C Frequency validity above 300 MHz of ± 100 MHz only applies for DASY v4.4 and higher (see Page 2), else it is restricted to ± 50 MHz. The uncertainty is the RSS of the ConvF uncertainty at calibration frequency and the uncertainty for the indicated frequency band. Frequency validity below 300 MHz is ± 10, 25, 40, 50 and 70 MHz for ConvF assessments at 30, 64, 128, 150 and 220 MHz respectively. Above 5 GHz frequency validity can be extended to ± 110 MHz.

^F At frequencies below 3 GHz, the validity of tissue parameters (ϵ and σ) can be relaxed to ± 10% if liquid compensation formula is applied to measured SAR values. At frequencies above 3 GHz, the validity of tissue parameters (ϵ and σ) is restricted to ± 5%. The uncertainty is the RSS of the ConvF uncertainty for indicated target tissue parameters.

^G Alpha/Depth are determined during calibration. SPEAG warrants that the remaining deviation due to the boundary effect after compensation is always less than ± 1% for frequencies below 3 GHz and below ± 2% for frequencies between 3-6 GHz at any distance larger than half the probe tip diameter from the boundary.

DASY/EASY - Parameters of Probe: ES3DV3 - SN:3288

Calibration Parameter Determined in Body Tissue Simulating Media

f (MHz) ^C	Relative Permittivity ^F	Conductivity (S/m) ^F	ConvF X	ConvF Y	ConvF Z	Alpha ^G	Depth ^G (mm)	Unct. (k=2)
750	55.5	0.96	6.38	6.38	6.38	0.31	1.89	± 12.0 %
835	55.2	0.97	6.32	6.32	6.32	0.55	1.39	± 12.0 %
1750	53.4	1.49	5.03	5.03	5.03	0.57	1.44	± 12.0 %
1900	53.3	1.52	4.82	4.82	4.82	0.51	1.54	± 12.0 %
2450	52.7	1.95	4.36	4.36	4.36	0.71	1.07	± 12.0 %
2600	52.5	2.16	4.22	4.22	4.22	0.80	1.07	± 12.0 %

^C Frequency validity above 300 MHz of ± 100 MHz only applies for DASY v4.4 and higher (see Page 2), else it is restricted to ± 50 MHz. The uncertainty is the RSS of the ConvF uncertainty at calibration frequency and the uncertainty for the indicated frequency band. Frequency validity below 300 MHz is ± 10, 25, 40, 50 and 70 MHz for ConvF assessments at 30, 64, 128, 150 and 220 MHz respectively. Above 5 GHz frequency validity can be extended to ± 110 MHz.

^F At frequencies below 3 GHz, the validity of tissue parameters (ϵ and σ) can be relaxed to ± 10% if liquid compensation formula is applied to measured SAR values. At frequencies above 3 GHz, the validity of tissue parameters (ϵ and σ) is restricted to ± 5%. The uncertainty is the RSS of the ConvF uncertainty for indicated target tissue parameters.

^G Alpha/Depth are determined during calibration. SPEAG warrants that the remaining deviation due to the boundary effect after compensation is always less than ± 1% for frequencies below 3 GHz and below ± 2% for frequencies between 3-6 GHz at any distance larger than half the probe tip diameter from the boundary.

Frequency Response of E-Field

(TEM-Cell:ifi1110 EXX, Waveguide: R22)

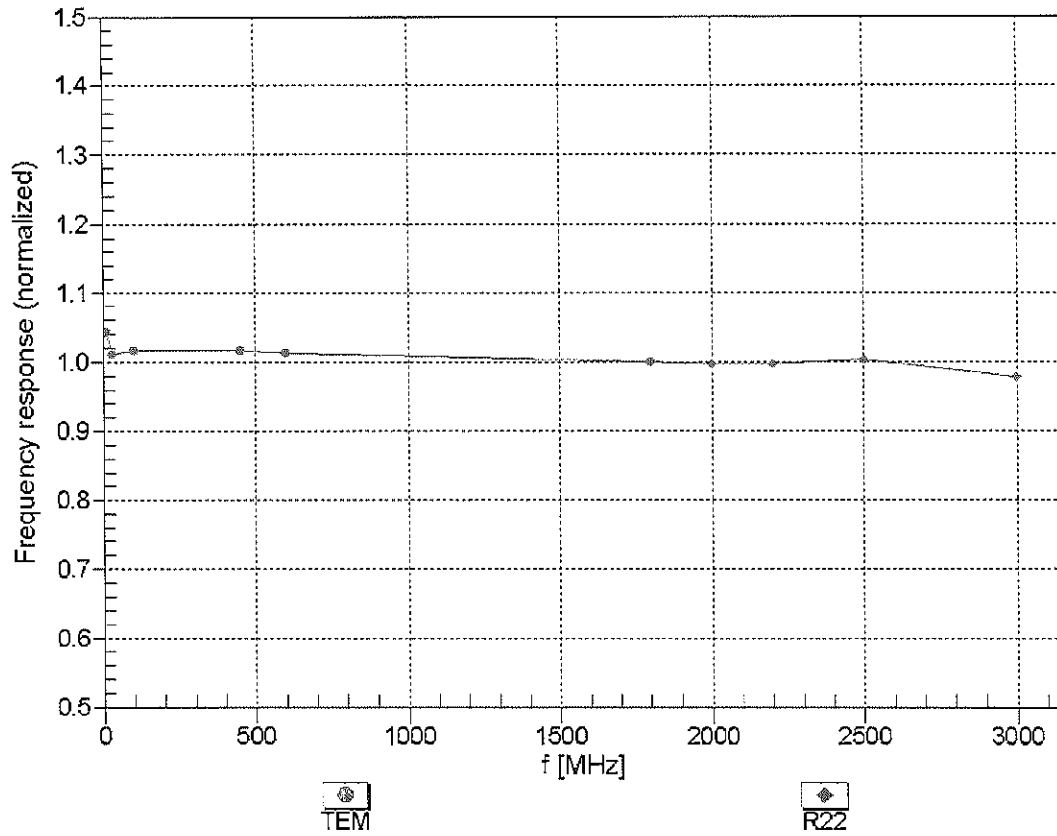

Uncertainty of Frequency Response of E-field: $\pm 6.3\%$ (k=2)

Receiving Pattern (ϕ), $\vartheta = 0^\circ$

f=600 MHz, TEM

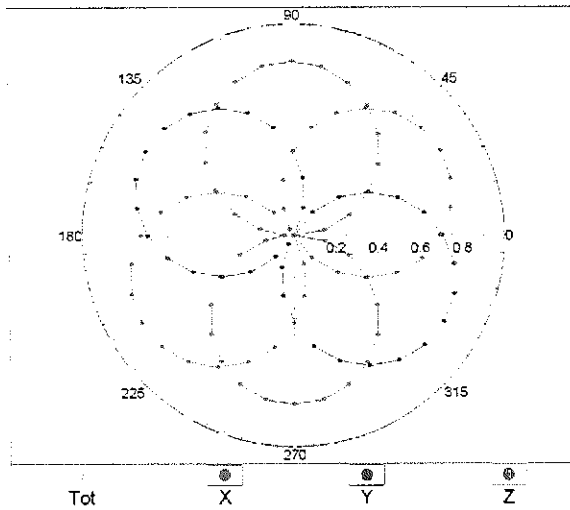

f=1800 MHz, R22

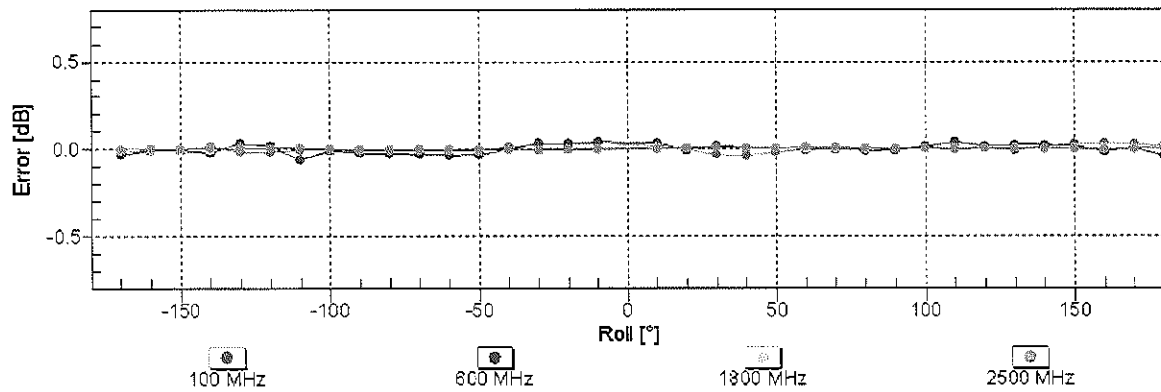
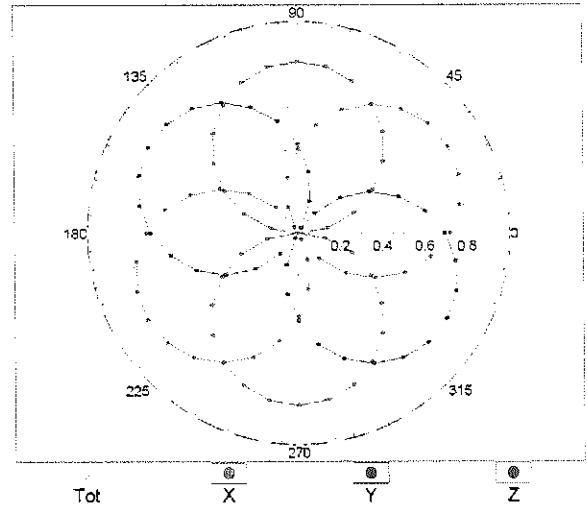

Uncertainty of Axial Isotropy Assessment: $\pm 0.5\%$ ($k=2$)

Dynamic Range $f(\text{SAR}_{\text{head}})$ (TEM cell , $f_{\text{eval}}= 1900 \text{ MHz}$)

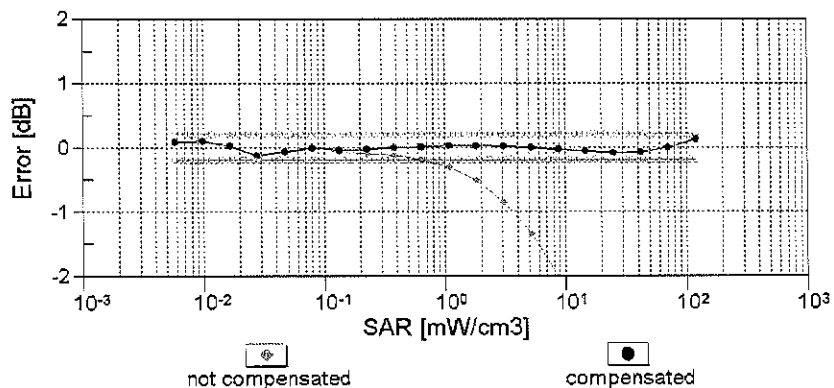
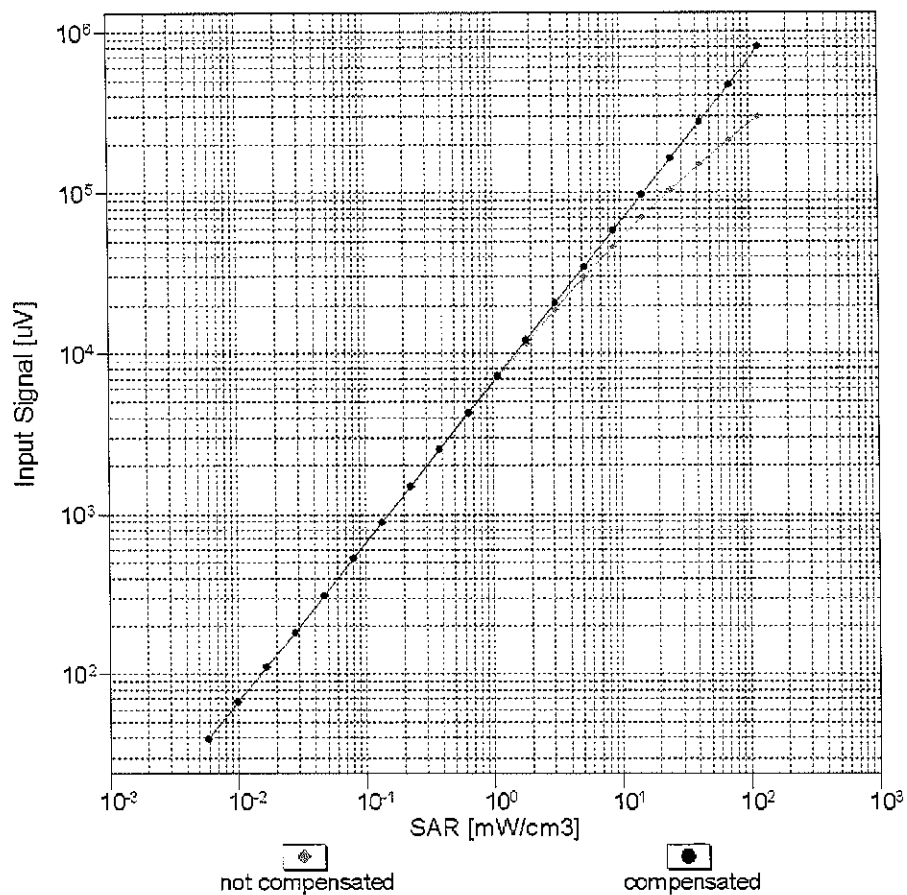

Uncertainty of Linearity Assessment: $\pm 0.6\%$ ($k=2$)

Conversion Factor Assessment

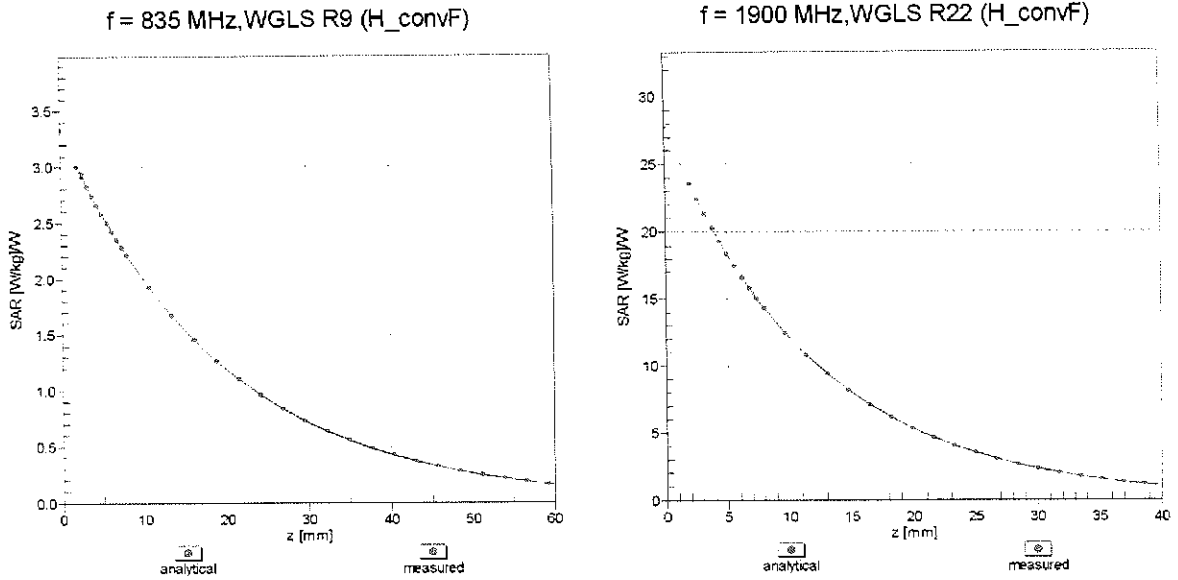

Deviation from Isotropy in Liquid

Error (ϕ, θ), f = 900 MHz

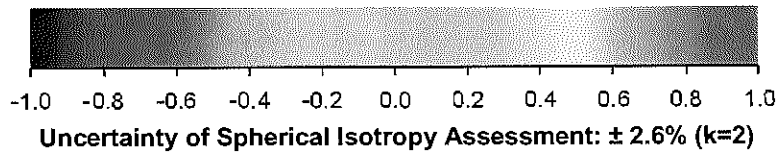
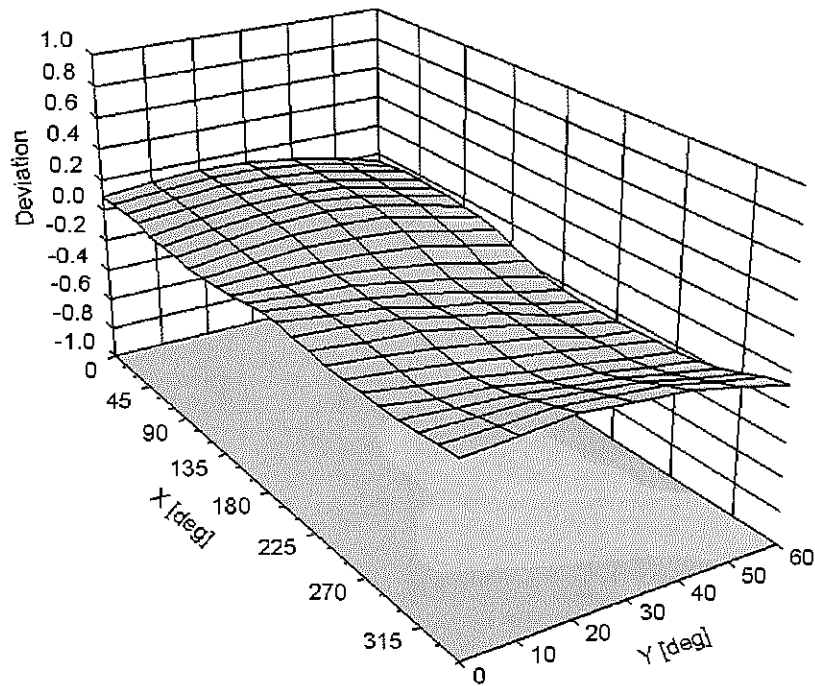

DASY/EASY - Parameters of Probe: ES3DV3 - SN:3288

Other Probe Parameters

Sensor Arrangement	Triangular
Connector Angle (°)	-110
Mechanical Surface Detection Mode	enabled
Optical Surface Detection Mode	disabled
Probe Overall Length	337 mm
Probe Body Diameter	10 mm
Tip Length	10 mm
Tip Diameter	4 mm
Probe Tip to Sensor X Calibration Point	2 mm
Probe Tip to Sensor Y Calibration Point	2 mm
Probe Tip to Sensor Z Calibration Point	2 mm
Recommended Measurement Distance from Surface	3 mm

**Calibration Laboratory of
Schmid & Partner
Engineering AG**
Zeughausstrasse 43, 8004 Zurich, Switzerland



S Schweizerischer Kalibrierdienst
C Service suisse d'étalonnage
S Servizio svizzero di taratura
Swiss Calibration Service

Accredited by the Swiss Accreditation Service (SAS)
The Swiss Accreditation Service is one of the signatories to the EA
Multilateral Agreement for the recognition of calibration certificates

Accreditation No.: **SCS 108**

Client **PC Test**

Certificate No: **ES3-3333_Oct14**

CALIBRATION CERTIFICATE

Object **ES3DV3 - SN:3333**

Calibration procedure(s) **QA CAL-01.v9, QA CAL-23.v5, QA CAL-25.v6
Calibration procedure for dosimetric E-field probes**

CC
10/31/14

Calibration date: **October 24, 2014**

This calibration certificate documents the traceability to national standards, which realize the physical units of measurements (SI).
The measurements and the uncertainties with confidence probability are given on the following pages and are part of the certificate.

All calibrations have been conducted in the closed laboratory facility: environment temperature (22 ± 3)°C and humidity < 70%.

Calibration Equipment used (M&TE critical for calibration)

Primary Standards	ID	Cal Date (Certificate No.)	Scheduled Calibration
Power meter E4419B	GB41293874	03-Apr-14 (No. 217-01911)	Apr-15
Power sensor E4412A	MY41498087	03-Apr-14 (No. 217-01911)	Apr-15
Reference 3 dB Attenuator	SN: S5054 (3c)	03-Apr-14 (No. 217-01915)	Apr-15
Reference 20 dB Attenuator	SN: S5277 (20x)	03-Apr-14 (No. 217-01919)	Apr-15
Reference 30 dB Attenuator	SN: S5129 (30b)	03-Apr-14 (No. 217-01920)	Apr-15
Reference Probe ES3DV2	SN: 3013	30-Dec-13 (No. ES3-3013_Dec13)	Dec-14
DAE4	SN: 660	13-Dec-13 (No. DAE4-660_Dec13)	Dec-14
Secondary Standards	ID	Check Date (in house)	Scheduled Check
RF generator HP 8648C	US3642U01700	4-Aug-99 (in house check Apr-13)	In house check: Apr-16
Network Analyzer HP 8753E	US37390585	18-Oct-01 (in house check Oct-14)	In house check: Oct-15

	Name	Function	Signature
Calibrated by:	Leif Klysner	Laboratory Technician	
Approved by:	Kalja Pokovic	Technical Manager	
			Issued: October 24, 2014

This calibration certificate shall not be reproduced except in full without written approval of the laboratory.



Accredited by the Swiss Accreditation Service (SAS)
The Swiss Accreditation Service is one of the signatories to the EA
Multilateral Agreement for the recognition of calibration certificates

Accreditation No.: **SCS 108**

Glossary:

TSL	tissue simulating liquid
NORM _{x,y,z}	sensitivity in free space
ConvF	sensitivity in TSL / NORM _{x,y,z}
DCP	diode compression point
CF	crest factor (1/duty_cycle) of the RF signal
A, B, C, D	modulation dependent linearization parameters
Polarization φ	φ rotation around probe axis
Polarization ϑ	ϑ rotation around an axis that is in the plane normal to probe axis (at measurement center), i.e., $\vartheta = 0$ is normal to probe axis
Connector Angle	information used in DASY system to align probe sensor X to the robot coordinate system

Calibration is Performed According to the Following Standards:

- a) IEEE Std 1528-2013, "IEEE Recommended Practice for Determining the Peak Spatial-Averaged Specific Absorption Rate (SAR) in the Human Head from Wireless Communications Devices: Measurement Techniques", June 2013
- b) IEC 62209-1, "Procedure to measure the Specific Absorption Rate (SAR) for hand-held devices used in close proximity to the ear (frequency range of 300 MHz to 3 GHz)", February 2005

Methods Applied and Interpretation of Parameters:

- **NORM_{x,y,z}**: Assessed for E-field polarization $\vartheta = 0$ ($f \leq 900$ MHz in TEM-cell; $f > 1800$ MHz: R22 waveguide). NORM_{x,y,z} are only intermediate values, i.e., the uncertainties of NORM_{x,y,z} does not affect the E²-field uncertainty inside TSL (see below ConvF).
- **NORM(f)_{x,y,z} = NORM_{x,y,z} * frequency_response** (see Frequency Response Chart). This linearization is implemented in DASY4 software versions later than 4.2. The uncertainty of the frequency response is included in the stated uncertainty of ConvF.
- **DCP_{x,y,z}**: DCP are numerical linearization parameters assessed based on the data of power sweep with CW signal (no uncertainty required). DCP does not depend on frequency nor media.
- **PAR**: PAR is the Peak to Average Ratio that is not calibrated but determined based on the signal characteristics
- **A_{x,y,z}; B_{x,y,z}; C_{x,y,z}; D_{x,y,z}; VR_{x,y,z}; A, B, C, D** are numerical linearization parameters assessed based on the data of power sweep for specific modulation signal. The parameters do not depend on frequency nor media. VR is the maximum calibration range expressed in RMS voltage across the diode.
- **ConvF and Boundary Effect Parameters**: Assessed in flat phantom using E-field (or Temperature Transfer Standard for $f \leq 800$ MHz) and inside waveguide using analytical field distributions based on power measurements for $f > 800$ MHz. The same setups are used for assessment of the parameters applied for boundary compensation (alpha, depth) of which typical uncertainty values are given. These parameters are used in DASY4 software to improve probe accuracy close to the boundary. The sensitivity in TSL corresponds to NORM_{x,y,z} * ConvF whereby the uncertainty corresponds to that given for ConvF. A frequency dependent ConvF is used in DASY version 4.4 and higher which allows extending the validity from ± 50 MHz to ± 100 MHz.
- **Spherical Isotropy (3D deviation from isotropy)**: in a field of low gradients realized using a flat phantom exposed by a patch antenna.
- **Sensor Offset**: The sensor offset corresponds to the offset of virtual measurement center from the probe tip (on probe axis). No tolerance required.
- **Connector Angle**: The angle is assessed using the information gained by determining the NORM_x (no uncertainty required).

Probe ES3DV3

SN:3333

Manufactured: January 24, 2012
Calibrated: October 24, 2014

Calibrated for DASY/EASY Systems
(Note: non-compatible with DASY2 system!)

DASY/EASY - Parameters of Probe: ES3DV3 - SN:3333

Basic Calibration Parameters

	Sensor X	Sensor Y	Sensor Z	Unc (k=2)
Norm ($\mu\text{V}/(\text{V}/\text{m})^2$) ^A	1.08	0.90	0.88	$\pm 10.1\%$
DCP (mV) ^B	102.7	107.7	106.3	

Modulation Calibration Parameters

UID	Communication System Name		A dB	B dB $\sqrt{\mu\text{V}}$	C	D dB	VR mV	Unc ^E (k=2)
0	CW	X	0.0	0.0	1.0	0.00	190.7	$\pm 2.5\%$
		Y	0.0	0.0	1.0		183.3	
		Z	0.0	0.0	1.0		197.9	
10010- CAA	SAR Validation (Square, 100ms, 10ms)	X	3.17	61.7	12.2	10.00	42.4	$\pm 1.9\%$
		Y	3.16	63.7	12.4		38.0	
		Z	1.84	59.2	10.5		39.9	
10011- CAB	UMTS-FDD (WCDMA)	X	3.22	65.9	17.6	2.91	128.5	$\pm 0.5\%$
		Y	3.60	69.3	19.8		146.7	
		Z	3.51	68.1	18.8		133.7	
10012- CAA	IEEE 802.11b WIFI 2.4 GHz (DSSS, 1 Mbps)	X	3.14	68.6	18.2	1.87	132.6	$\pm 0.7\%$
		Y	3.64	73.3	21.1		127.5	
		Z	3.50	71.4	19.6		136.4	
10013- CAA	IEEE 802.11g WIFI 2.4 GHz (DSSS-OFDM, 6 Mbps)	X	11.56	70.8	23.0	9.46	135.8	$\pm 3.5\%$
		Y	10.93	70.2	23.0		122.3	
		Z	10.93	70.0	22.6		132.8	
10021- DAB	GSM-FDD (TDMA, GMSK)	X	24.60	96.9	27.6	9.39	147.6	$\pm 1.9\%$
		Y	19.44	94.3	26.1		148.6	
		Z	9.58	82.7	21.9		138.2	
10023- DAB	GPRS-FDD (TDMA, GMSK, TN 0)	X	20.09	93.0	26.4	9.57	141.7	$\pm 2.7\%$
		Y	24.86	99.0	27.9		143.5	
		Z	11.74	86.4	23.4		134.4	
10024- DAB	GPRS-FDD (TDMA, GMSK, TN 0-1)	X	23.76	91.2	23.1	6.56	147.8	$\pm 2.5\%$
		Y	37.10	99.8	25.3		149.9	
		Z	16.01	88.1	21.6		128.0	
10027- DAB	GPRS-FDD (TDMA, GMSK, TN 0-1-2)	X	36.24	94.5	22.6	4.80	128.6	$\pm 2.5\%$
		Y	47.57	99.9	23.7		133.5	
		Z	44.37	99.7	23.6		140.1	
10028- DAB	GPRS-FDD (TDMA, GMSK, TN 0-1-2-3)	X	65.86	99.7	22.7	3.55	133.1	$\pm 2.7\%$
		Y	55.92	100.0	22.6		142.0	
		Z	59.41	100.0	22.2		125.1	
10032- CAA	IEEE 802.15.1 Bluetooth (GFSK, DH5)	X	85.87	100.0	20.1	1.16	138.3	$\pm 2.2\%$
		Y	14.41	99.2	23.3		130.5	
		Z	85.82	99.8	19.3		135.9	
10100- CAB	LTE-FDD (SC-FDMA, 100% RB, 20 MHz, QPSK)	X	6.49	67.4	19.4	5.67	144.6	$\pm 1.7\%$
		Y	6.49	68.0	20.1		139.9	
		Z	6.54	67.9	19.7		147.3	

10103-CAB	LTE-TDD (SC-FDMA, 100% RB, 20 MHz, QPSK)	X	10.81	74.7	24.9	9.29	122.0	±3.0 %
		Y	10.50	75.9	26.1		131.6	
		Z	9.76	73.5	24.5		138.6	
10108-CAB	LTE-FDD (SC-FDMA, 100% RB, 10 MHz, QPSK)	X	6.43	67.2	19.4	5.80	143.3	±1.7 %
		Y	6.37	67.7	20.0		138.0	
		Z	6.43	67.5	19.7		146.7	
10117-CAA	IEEE 802.11n (HT Mixed, 13.5 Mbps, BPSK)	X	10.19	68.6	20.9	8.07	136.2	±2.5 %
		Y	10.15	68.9	21.4		128.3	
		Z	10.12	68.7	21.0		137.9	
10151-CAB	LTE-TDD (SC-FDMA, 50% RB, 20 MHz, QPSK)	X	11.48	77.0	26.1	9.28	147.5	±3.3 %
		Y	9.81	74.9	25.8		125.7	
		Z	9.22	72.8	24.3		133.2	
10154-CAB	LTE-FDD (SC-FDMA, 50% RB, 10 MHz, QPSK)	X	6.10	66.5	19.1	5.75	140.0	±1.7 %
		Y	6.04	67.1	19.8		134.8	
		Z	6.12	67.1	19.5		143.2	
10160-CAB	LTE-FDD (SC-FDMA, 50% RB, 15 MHz, QPSK)	X	6.57	67.2	19.4	5.82	146.3	±1.7 %
		Y	6.47	67.6	20.0		139.6	
		Z	6.56	67.6	19.7		148.5	
10169-CAB	LTE-FDD (SC-FDMA, 1 RB, 20 MHz, QPSK)	X	5.16	66.7	19.4	5.73	145.8	±1.4 %
		Y	5.02	67.5	20.2		137.5	
		Z	5.07	67.2	19.7		147.1	
10172-CAB	LTE-TDD (SC-FDMA, 1 RB, 20 MHz, QPSK)	X	10.07	79.2	27.3	9.21	136.5	±3.0 %
		Y	9.70	81.5	29.3		142.5	
		Z	7.63	74.3	25.3		125.0	
10175-CAB	LTE-FDD (SC-FDMA, 1 RB, 10 MHz, QPSK)	X	5.13	66.6	19.3	5.72	145.9	±1.4 %
		Y	5.01	67.4	20.1		137.5	
		Z	5.04	67.1	19.7		146.3	
10181-CAB	LTE-FDD (SC-FDMA, 1 RB, 15 MHz, QPSK)	X	5.14	66.6	19.3	5.72	145.7	±1.4 %
		Y	5.03	67.5	20.3		137.4	
		Z	5.06	67.2	19.7		146.6	
10196-CAA	IEEE 802.11n (HT Mixed, 6.5 Mbps, BPSK)	X	9.88	68.3	20.8	8.10	130.9	±2.5 %
		Y	10.13	69.6	21.8		149.0	
		Z	9.77	68.4	20.9		131.6	
10225-CAB	UMTS-FDD (HSPA+)	X	6.98	66.5	19.0	5.97	132.9	±1.7 %
		Y	7.14	67.8	20.0		149.7	
		Z	7.02	67.2	19.4		134.3	
10237-CAB	LTE-TDD (SC-FDMA, 1 RB, 10 MHz, QPSK)	X	10.13	79.4	27.4	9.21	137.5	±3.0 %
		Y	9.73	81.6	29.3		143.3	
		Z	7.59	74.1	25.1		125.6	
10252-CAB	LTE-TDD (SC-FDMA, 50% RB, 10 MHz, QPSK)	X	10.80	76.4	25.9	9.24	140.0	±3.3 %
		Y	10.19	77.2	27.1		147.2	
		Z	8.55	71.8	23.9		124.9	
10267-CAB	LTE-TDD (SC-FDMA, 100% RB, 10 MHz, QPSK)	X	11.59	77.3	26.3	9.30	148.4	±3.5 %
		Y	9.87	75.1	25.9		126.0	
		Z	9.21	72.7	24.2		133.6	

10275-CAB	UMTS-FDD (HSUPA, Subtest 5, 3GPP Rel8.4)	X	4.40	66.1	18.1	3.96	134.1	±0.7 %
		Y	4.48	67.4	19.2		129.7	
		Z	4.54	67.2	18.7		137.4	
10291-AAB	CDMA2000, RC3, SO55, Full Rate	X	3.59	65.7	17.7	3.46	127.5	±0.7 %
		Y	3.85	68.4	19.7		143.4	
		Z	3.78	67.6	18.8		129.7	
10292-AAB	CDMA2000, RC3, SO32, Full Rate	X	3.56	65.9	17.8	3.39	127.9	±0.7 %
		Y	3.81	68.6	19.8		144.2	
		Z	3.71	67.5	18.8		130.7	
10297-AAA	LTE-FDD (SC-FDMA, 50% RB, 20 MHz, QPSK)	X	6.44	67.1	19.4	5.81	143.0	±1.7 %
		Y	6.37	67.6	20.0		137.9	
		Z	6.43	67.5	19.7		146.5	
10311-AAA	LTE-FDD (SC-FDMA, 100% RB, 15 MHz, QPSK)	X	7.02	67.8	19.8	6.06	148.7	±1.9 %
		Y	6.96	68.2	20.4		143.6	
		Z	6.72	67.1	19.5		126.9	
10403-AAB	CDMA2000 (1xEV-DO, Rev. 0)	X	4.73	67.0	17.9	3.76	140.2	±0.7 %
		Y	4.96	69.4	19.5		130.7	
		Z	5.05	69.3	19.1		140.9	
10404-AAB	CDMA2000 (1xEV-DO, Rev. A)	X	4.70	67.2	18.1	3.77	138.1	±0.7 %
		Y	4.85	69.5	19.6		129.6	
		Z	5.14	70.1	19.5		139.3	
10415-AAA	IEEE 802.11b WiFi 2.4 GHz (DSSS, 1 Mbps, 99pc duty cycle)	X	2.47	66.1	17.1	1.54	133.2	±0.7 %
		Y	3.15	72.2	20.9		127.9	
		Z	3.32	72.0	20.1		137.2	
10416-AAA	IEEE 802.11g WiFi 2.4 GHz (ERP-OFDM, 6 Mbps, 99pc duty cycle)	X	9.99	68.4	21.0	8.23	131.6	±2.5 %
		Y	9.84	68.6	21.4		123.3	
		Z	9.89	68.6	21.1		133.4	

The reported uncertainty of measurement is stated as the standard uncertainty of measurement multiplied by the coverage factor $k=2$, which for a normal distribution corresponds to a coverage probability of approximately 95%.

^A The uncertainties of NormX,Y,Z do not affect the E^2 -field uncertainty inside TSL (see Pages 7 and 8).

^B Numerical linearization parameter: uncertainty not required.

^E Uncertainty is determined using the max. deviation from linear response applying rectangular distribution and is expressed for the square of the field value.

DASY/EASY - Parameters of Probe: ES3DV3 - SN:3333

Calibration Parameter Determined in Head Tissue Simulating Media

f (MHz) ^C	Relative Permittivity ^F	Conductivity (S/m) ^F	ConvF X	ConvF Y	ConvF Z	Alpha ^G	Depth ^G (mm)	Unct. (k=2)
750	41.9	0.89	6.55	6.55	6.55	0.34	1.74	± 12.0 %
835	41.5	0.90	6.33	6.33	6.33	0.44	1.48	± 12.0 %
1750	40.1	1.37	5.26	5.26	5.26	0.73	1.21	± 12.0 %
1900	40.0	1.40	5.11	5.11	5.11	0.66	1.32	± 12.0 %
2450	39.2	1.80	4.53	4.53	4.53	0.62	1.40	± 12.0 %
2600	39.0	1.96	4.40	4.40	4.40	0.68	1.38	± 12.0 %

^C Frequency validity above 300 MHz of ± 100 MHz only applies for DASY v4.4 and higher (see Page 2), else it is restricted to ± 50 MHz. The uncertainty is the RSS of the ConvF uncertainty at calibration frequency and the uncertainty for the indicated frequency band. Frequency validity below 300 MHz is ± 10, 25, 40, 50 and 70 MHz for ConvF assessments at 30, 64, 128, 150 and 220 MHz respectively. Above 5 GHz frequency validity can be extended to ± 110 MHz.

^F At frequencies below 3 GHz, the validity of tissue parameters (ϵ and σ) can be relaxed to ± 10% if liquid compensation formula is applied to measured SAR values. At frequencies above 3 GHz, the validity of tissue parameters (ϵ and σ) is restricted to ± 5%. The uncertainty is the RSS of the ConvF uncertainty for indicated target tissue parameters.

^G Alpha/Depth are determined during calibration. SPEAG warrants that the remaining deviation due to the boundary effect after compensation is always less than ± 1% for frequencies below 3 GHz and below ± 2% for frequencies between 3-6 GHz at any distance larger than half the probe tip diameter from the boundary.

DASY/EASY - Parameters of Probe: ES3DV3 - SN:3333

Calibration Parameter Determined in Body Tissue Simulating Media

f (MHz) ^C	Relative Permittivity ^F	Conductivity (S/m) ^F	ConvF X	ConvF Y	ConvF Z	Alpha ^G	Depth (mm)	Uct. (k=2)
750	55.5	0.96	6.14	6.14	6.14	0.35	1.76	± 12.0 %
835	55.2	0.97	6.12	6.12	6.12	0.57	1.37	± 12.0 %
1750	53.4	1.49	4.89	4.89	4.89	0.80	1.24	± 12.0 %
1900	53.3	1.52	4.67	4.67	4.67	0.75	1.29	± 12.0 %
2450	52.7	1.95	4.26	4.26	4.26	0.80	1.01	± 12.0 %
2600	52.5	2.16	4.13	4.13	4.13	0.80	0.99	± 12.0 %

^C Frequency validity above 300 MHz of ± 100 MHz only applies for DASY v4.4 and higher (see Page 2), else it is restricted to ± 50 MHz. The uncertainty is the RSS of the ConvF uncertainty at calibration frequency and the uncertainty for the indicated frequency band. Frequency validity below 300 MHz is ± 10, 25, 40, 50 and 70 MHz for ConvF assessments at 30, 64, 128, 150 and 220 MHz respectively. Above 5 GHz frequency validity can be extended to ± 110 MHz.

^F At frequencies below 3 GHz, the validity of tissue parameters (ϵ and σ) can be relaxed to ± 10% if liquid compensation formula is applied to measured SAR values. At frequencies above 3 GHz, the validity of tissue parameters (ϵ and σ) is restricted to ± 5%. The uncertainty is the RSS of the ConvF uncertainty for indicated target tissue parameters.

^G Alpha/Depth are determined during calibration. SPEAG warrants that the remaining deviation due to the boundary effect after compensation is always less than ± 1% for frequencies below 3 GHz and below ± 2% for frequencies between 3-6 GHz at any distance larger than half the probe tip diameter from the boundary.

Frequency Response of E-Field (TEM-Cell: ifi110 EXX, Waveguide: R22)

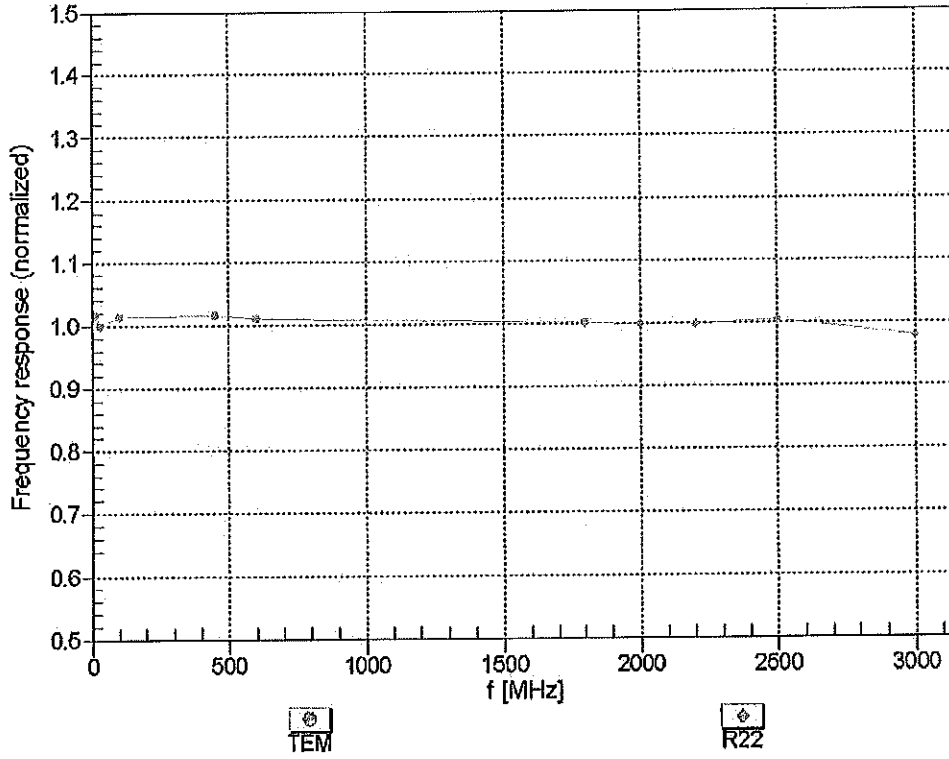

Uncertainty of Frequency Response of E-field: $\pm 6.3\%$ (k=2)

Receiving Pattern (ϕ), $\theta = 0^\circ$

f=600 MHz,TEM

f=1800 MHz,R22

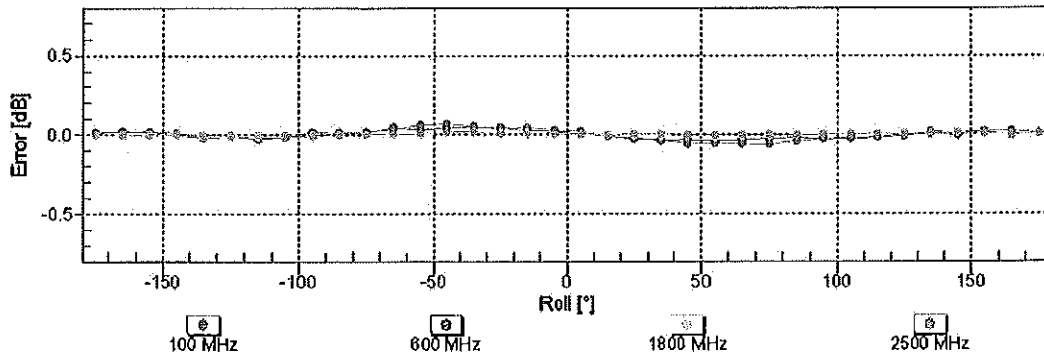
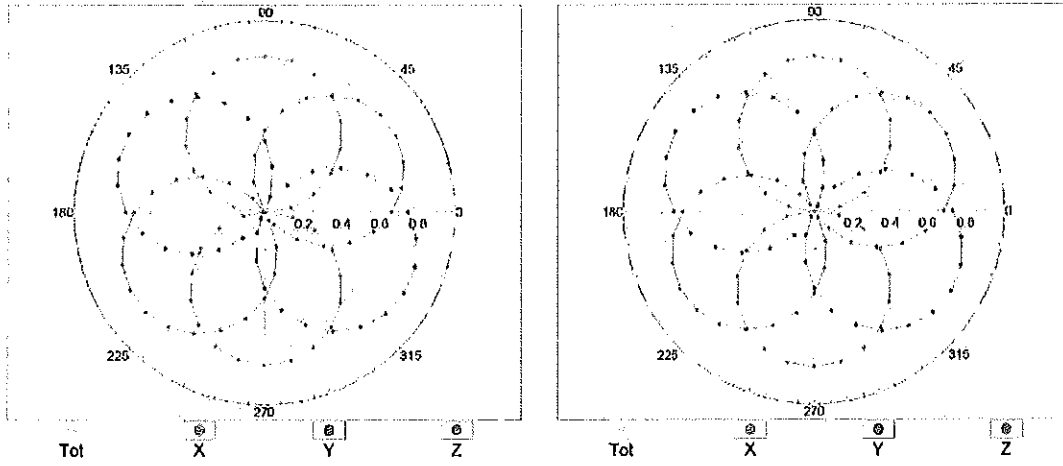

Uncertainty of Axial Isotropy Assessment: $\pm 0.5\%$ (k=2)

Dynamic Range $f(SAR_{head})$ (TEM cell, $f_{eval} = 1900$ MHz)

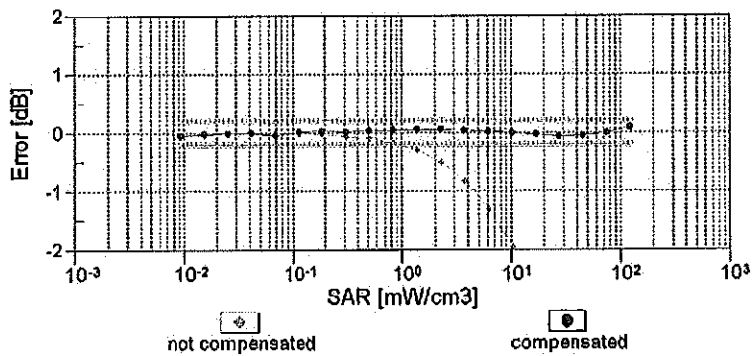
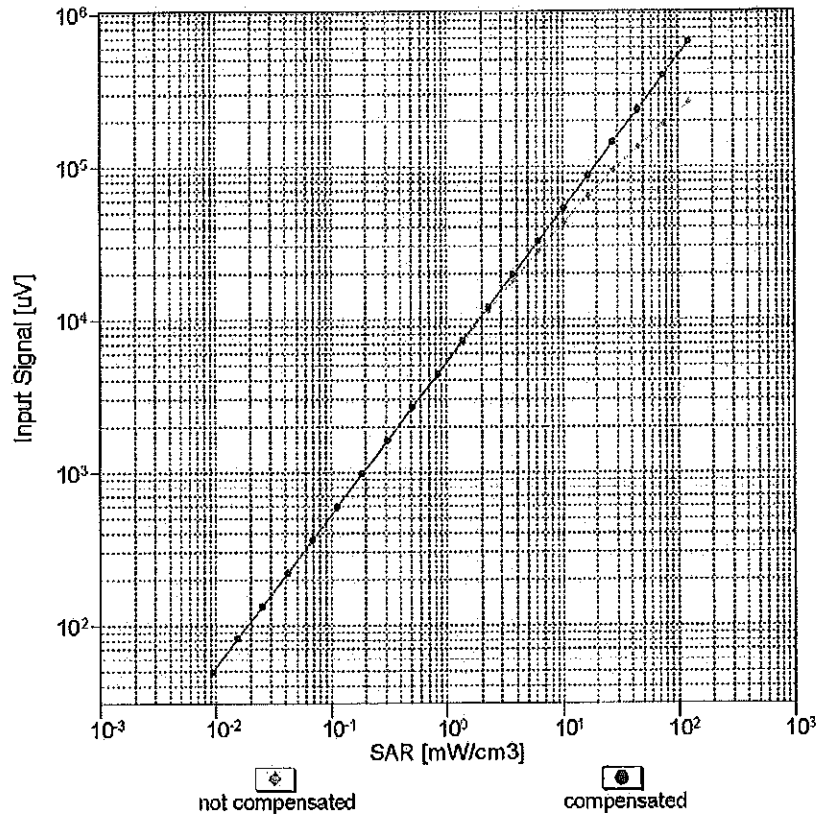

Uncertainty of Linearity Assessment: $\pm 0.6\%$ ($k=2$)

Conversion Factor Assessment

f = 835 MHz, WGLS R9 (H_convF)

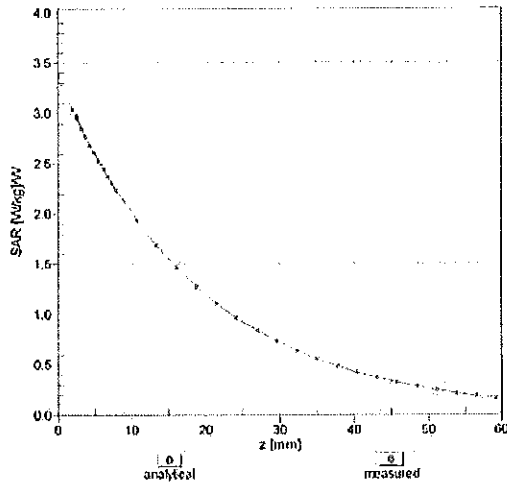

f = 1900 MHz, WGLS R22 (H_convF)

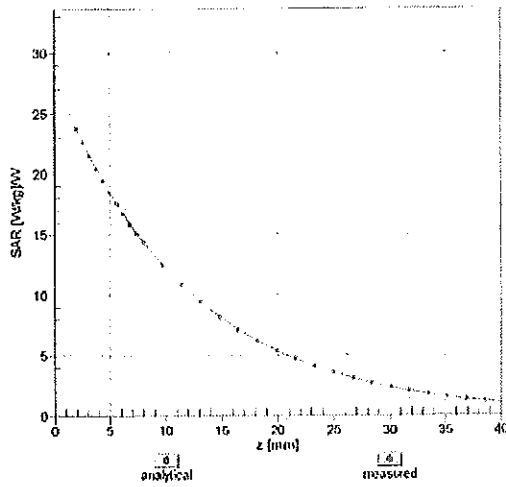

Deviation from Isotropy in Liquid

Error (ϕ, θ), f = 900 MHz

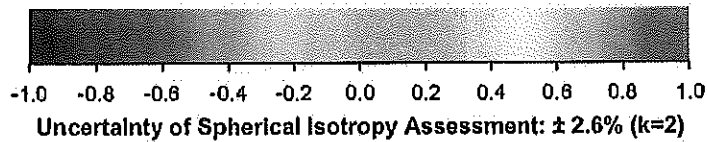
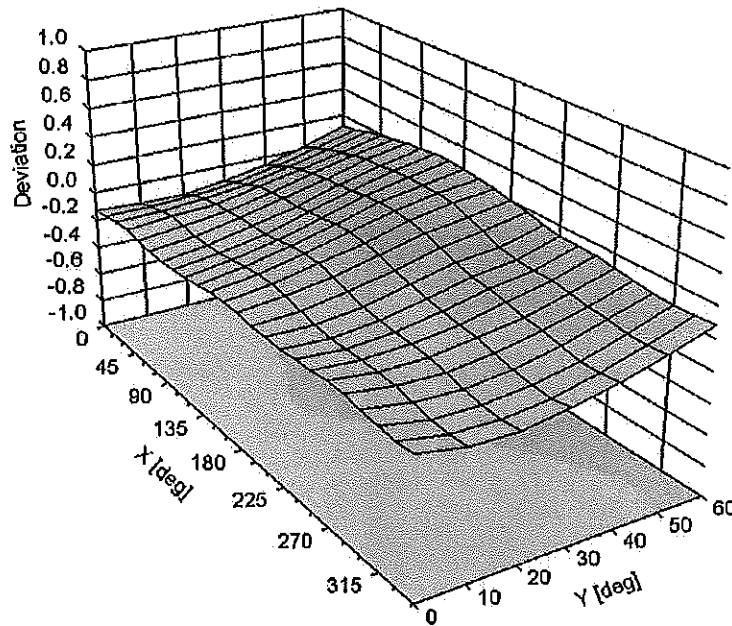

DASY/EASY - Parameters of Probe: ES3DV3 - SN:3333**Other Probe Parameters**

Sensor Arrangement	Triangular
Connector Angle (°)	-34.9
Mechanical Surface Detection Mode	enabled
Optical Surface Detection Mode	disabled
Probe Overall Length	337 mm
Probe Body Diameter	10 mm
Tip Length	10 mm
Tip Diameter	4 mm
Probe Tip to Sensor X Calibration Point	2 mm
Probe Tip to Sensor Y Calibration Point	2 mm
Probe Tip to Sensor Z Calibration Point	2 mm
Recommended Measurement Distance from Surface	3 mm

APPENDIX D: SAR TISSUE SPECIFICATIONS

Measurement Procedure for Tissue verification:



- 1) The network analyzer and probe system was configured and calibrated.
- 2) The probe was immersed in the tissue. The tissue was placed in a nonmetallic container. Trapped air bubbles beneath the flange were minimized by placing the probe at a slight angle.
- 3) The complex admittance with respect to the probe aperture was measured
- 4) The complex relative permittivity ϵ can be calculated from the below equation (Pournaropoulos and Misra):

$$Y = \frac{j2\omega\epsilon_r\epsilon_0}{[\ln(b/a)]^2} \int_a^b \int_a^b \int_0^\pi \cos\phi' \frac{\exp[-j\omega r(\mu_0\epsilon_r'\epsilon_0)^{1/2}]}{r} d\phi' d\rho' d\rho$$

where Y is the admittance of the probe in contact with the sample, the primed and unprimed coordinates refer to source and observation points, respectively, $r^2 = \rho^2 + \rho'^2 - 2\rho\rho' \cos\phi'$, ω is the angular frequency, and $j = \sqrt{-1}$.

**Table D-1
Composition of the Tissue Equivalent Matter**

Frequency (MHz)	750	750	835	835	1750	1750	1900	1900	2300-2450	2300-2450	5200-5800	5200-5800
Tissue	Head	Body	Head	Body	Head	Body	Head	Body	Head	Body	Head	Body
Ingredients (% by weight)												
Bactericide			0.1	0.1								
DGBE					47	31	44.92	29.44		26.7		
HEC			1	1								
NaCl	See page 2-3	See page 2	1.45	0.94	0.4	0.2	0.18	0.39	See page 4	0.1	See page 5	
Sucrose			57	44.9								
Polysorbate (Tween) 80												20
Water			40.45	53.06	52.6	68.8	54.9	70.17		73.2		80

FCC ID: A3LSMG890A		SAR EVALUATION REPORT		Reviewed by: Quality Manager
Test Dates: 04/06/15 - 05/04/15	DUT Type: Portable Handset			APPENDIX D: Page 1 of 5

2 Composition / Information on ingredients

The Item is composed of the following ingredients:

H ₂ O	Water, 35 – 58%
Sucrose	Sugar, white, refined, 40 – 60%
NaCl	Sodium Chloride, 0 – 6%
Hydroxyethyl-cellulose	Medium Viscosity (CAS# 9004-62-0), <0.3%
Preventol-D7	Preservative: aqueous preparation, (CAS# 55965-84-9), containing 5-chloro-2-methyl-3(2H)-isothiazolone and 2-methyl-3(2H)-isothiazolone, 0.1 – 0.7%

Relevant for safety; Refer to the respective Safety Data Sheet*.

Figure D-1
Composition of 750 MHz Head and Body Tissue Equivalent Matter

Note: 750MHz liquid recipes are proprietary SPEAG. Since the composition is approximate to the actual liquids utilized, the manufacturer tissue-equivalent liquid data sheets are provided below.

Measurement Certificate / Material Test

Item Name	Body Tissue Simulating Liquid (MSL750V2)
Product No.	SL AAM 075 AA (Charge: 130828-1)
Manufacturer	SPEAG

Measurement Method

TSL dielectric parameters measured using calibrated OCP probe.

Setup Validation

Validation results were within $\pm 2.5\%$ towards the target values of Methanol.

Target Parameters

Target parameters as defined in the IEEE 1528 and IEC 62209 compliance standards.

Test Condition

Ambient	Environment temperatur (22 ± 3)°C and humidity < 70%.
TSL Temperature	22°C
Test Date	28-Aug-13
Operator	IEN

Additional Information

TSL Density	1.212 g/cm ³
TSL Heat-capacity	3.006 kJ/(kg*K)

f (MHz)	Measured			Target		Diff.to Target [%]	
	HP-e'	HP-e''	sigma	eps	sigma	Δ-eps	Δ-sigma
600	57.4	24.76	0.83	56.1	0.95	2.3	-13.2
625	57.1	24.42	0.85	56.0	0.95	2.0	-11.0
650	56.8	24.09	0.87	55.9	0.96	1.6	-8.9
675	56.6	23.80	0.89	55.8	0.96	1.3	-6.7
700	56.3	23.52	0.92	55.7	0.96	1.0	-4.5
725	56.1	23.27	0.94	55.6	0.96	0.8	-2.4
750	55.8	23.03	0.96	55.5	0.96	0.5	-0.3
775	55.6	22.87	0.99	55.4	0.97	0.2	2.1
800	55.3	22.71	1.01	55.3	0.97	-0.1	4.5
825	55.1	22.54	1.03	55.2	0.98	-0.3	5.8
838	54.9	22.45	1.05	55.2	0.98	-0.5	6.4
850	54.8	22.37	1.06	55.2	0.99	-0.6	7.0
875	54.6	22.25	1.06	55.1	1.02	-0.9	6.2
900	54.4	22.13	1.11	55.0	1.05	-1.1	5.5
925	54.2	22.02	1.13	55.0	1.06	-1.5	6.6
950	53.9	21.91	1.18	54.9	1.08	-1.8	7.7
975	53.7	21.84	1.18	54.9	1.09	-2.2	9.0
1000	53.5	21.77	1.21	54.8	1.10	-2.5	10.3

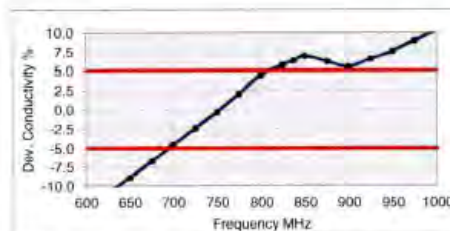
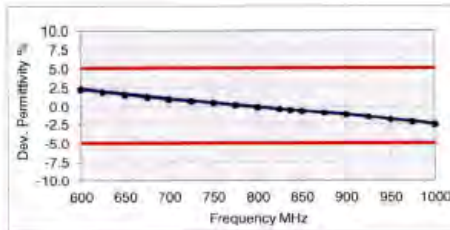



Figure D-2
750MHz Body Tissue Equivalent Matter

FCC ID: A3LSMG890A		SAR EVALUATION REPORT		Reviewed by: Quality Manager
Test Dates: 04/06/15 - 05/04/15	DUT Type: Portable Handset			APPENDIX D: Page 2 of 5

Measurement Certificate / Material Test

Item Name **Head Tissue Simulating Liquid (HSL750V2)**
 Product No. SL AAH 075 AA (Charge: 130826-2)
 Manufacturer SPEAG

Measurement Method

TSL dielectric parameters measured using calibrated OCP probe.

Setup Validation

Validation results were within $\pm 2.5\%$ towards the target values of Methanol.

Target Parameters

Target parameters as defined in the IEEE 1528 and IEC 62209 compliance standards.

Test Condition

Ambient Environment temperatur (22 ± 3)°C and humidity < 70%.
 TSL Temperature 22°C
 Test Date 28-Aug-13
 Operator IEN

Additional Information

TSL Density 1.284 g/cm³
 TSL Heat-capacity 2.701 kJ/(kg*K)

f [MHz]	Measured			Target		Diff.to Target [%]	
	HP-e'	HP-e''	sigma	eps	sigma	Δ -eps	Δ -sigma
600	44.4	23.32	0.78	42.7	0.88	3.9	-11.7
625	44.0	23.05	0.80	42.6	0.88	3.4	-9.3
650	43.6	22.78	0.82	42.5	0.89	2.8	-7.0
675	43.3	22.54	0.85	42.3	0.89	2.2	-4.7
700	42.9	22.30	0.87	42.2	0.89	1.6	-2.4
725	42.6	22.10	0.89	42.1	0.89	1.2	0.0
750	42.3	21.90	0.91	41.9	0.89	0.8	2.3
775	41.9	21.74	0.94	41.8	0.90	0.2	4.6
800	41.6	21.57	0.96	41.7	0.90	-0.3	7.0
825	41.3	21.42	0.98	41.6	0.91	-0.8	8.4
838	41.1	21.35	0.99	41.5	0.91	-1.0	9.1
850	41.0	21.27	1.01	41.5	0.92	-1.3	9.8
875	40.7	21.14	1.03	41.5	0.94	-2.0	9.1
900	40.4	21.00	1.05	41.5	0.97	-2.6	8.4
925	40.1	20.89	1.07	41.5	0.98	-3.2	9.4
950	39.9	20.78	1.10	41.4	0.99	-3.8	10.4
975	39.6	20.69	1.12	41.4	1.00	-4.4	11.7
1000	39.3	20.60	1.15	41.3	1.01	-4.9	12.9

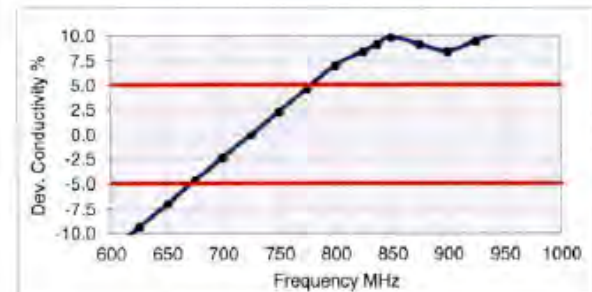
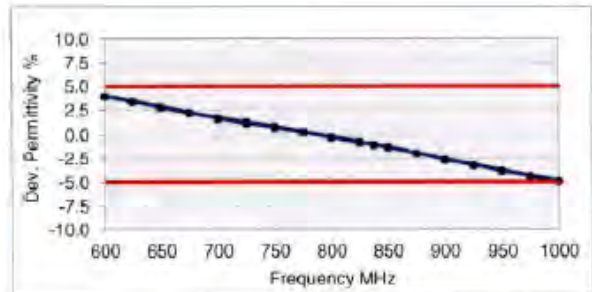



Figure D-3
750MHz Head Tissue Equivalent Matter

FCC ID: A3LSMG890A		SAR EVALUATION REPORT		Reviewed by: Quality Manager
Test Dates: 04/06/15 - 05/04/15	DUT Type: Portable Handset			APPENDIX D: Page 3 of 5

2 Composition / Information on ingredients

The Item is composed of the following ingredients:

H2O	Water, 52 – 75%
C8H18O3	Diethylene glycol monobutyl ether (DGBE), 25 – 48% (CAS-No. 112-34-5, EC-No. 203-961-6, EC-index-No. 603-096-00-8) Relevant for safety; Refer to the respective Safety Data Sheet*.
NaCl	Sodium Chloride, <1.0%

Figure D-4
Composition of 2.4 GHz Head Tissue Equivalent Matter

Note: 2.4 GHz head liquid recipes are proprietary SPEAG. Since the composition is approximate to the actual liquids utilized, the manufacturer tissue-equivalent liquid data sheets are provided below.

Measurement Certificate / Material Test

Item Name	Head Tissue Simulating Liquid (HSL2450V2)
Product No.	SL AAH 245 BA (Charge: 130926-1)
Manufacturer	SPEAG

Measurement Method

TSL dielectric parameters measured using calibrated OCP probe.

Setup Validation

Validation results were within $\pm 2.5\%$ towards the target values of Methanol.

Target Parameters

Target parameters as defined in the IEEE 1528 and IEC 62209 compliance standards.

Test Condition

Ambient	Environment temperatur (22 ± 3)°C and humidity < 70%.
TSL Temperature	23°C
Test Date	2-Oct-13
Operator	CL

Additional Information

TSL Density	0.988 g/cm ³
TSL Heat-capacity	3.680 kJ/(kg·K)

f (MHz)	Measured			Target		Diff. to Target [%]	
	HP-e'	HP-e''	sigma	eps	sigma	Δ -eps	Δ -sigma
1900	40.3	11.88	1.26	40.0	1.40	0.9	-10.3
1925	40.3	11.98	1.28	40.0	1.40	0.6	-8.3
1950	40.2	12.08	1.31	40.0	1.40	0.4	-6.4
1975	40.1	12.15	1.34	40.0	1.40	0.2	-4.6
2000	40.0	12.23	1.36	40.0	1.40	-0.1	-2.8
2025	39.9	12.34	1.39	40.0	1.42	-0.2	-2.3
2050	39.8	12.45	1.42	39.9	1.44	-0.3	-1.7
2075	39.7	12.54	1.45	39.9	1.47	-0.4	-1.3
2100	39.6	12.64	1.48	39.8	1.49	-0.5	-0.8
2125	39.5	12.69	1.50	39.8	1.51	-0.7	-0.7
2150	39.4	12.75	1.52	39.7	1.53	-0.8	-0.6
2175	39.3	12.84	1.55	39.7	1.56	-1.0	-0.1
2200	39.2	12.94	1.58	39.6	1.58	-1.2	0.4
2225	39.1	13.00	1.61	39.6	1.60	-1.3	0.6
2250	39.0	13.07	1.64	39.6	1.62	-1.4	0.8
2275	38.9	13.15	1.66	39.5	1.64	-1.5	1.2
2300	38.8	13.22	1.69	39.5	1.67	-1.7	1.5
2325	38.7	13.32	1.72	39.4	1.69	-1.9	2.0
2350	38.6	13.42	1.75	39.4	1.71	-2.0	2.5
2375	38.5	13.49	1.78	39.3	1.73	-2.1	2.8
2400	38.4	13.56	1.81	39.3	1.76	-2.3	3.1
2425	38.3	13.63	1.84	39.2	1.78	-2.5	3.5
2450	38.2	13.71	1.87	39.2	1.80	-2.6	3.6
2475	38.1	13.79	1.90	39.2	1.83	-2.8	3.9
2500	38.0	13.87	1.93	39.1	1.85	-3.0	4.0
2525	37.9	13.96	1.96	39.1	1.88	-3.1	4.2
2550	37.8	14.05	1.99	39.1	1.91	-3.3	4.4
2575	37.7	14.11	2.02	39.0	1.94	-3.5	4.4
2600	37.5	14.17	2.05	39.0	1.96	-3.8	4.4
2625	37.4	14.23	2.08	39.0	1.99	-4.0	4.4
2650	37.3	14.30	2.11	38.9	2.02	-4.2	4.5
2675	37.2	14.37	2.14	38.9	2.05	-4.4	4.6
2700	37.1	14.45	2.17	38.9	2.07	-4.6	4.7

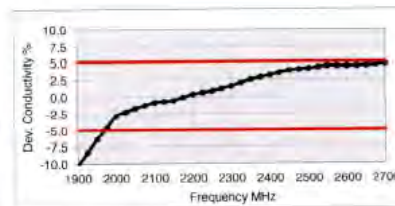
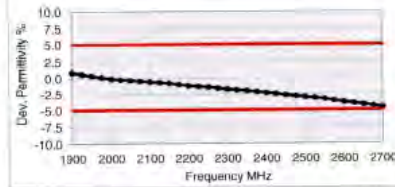



Figure D-5
2.4 GHz Head Tissue Equivalent Matter

FCC ID: A3LSMG890A		SAR EVALUATION REPORT		Reviewed by: Quality Manager
Test Dates: 04/06/15 - 05/04/15	DUT Type: Portable Handset			APPENDIX D: Page 4 of 5

2 Composition / Information on ingredients

The Item is composed of the following ingredients:

Water	50 – 65%
Mineral oil	10 – 30%
Emulsifiers	8 – 25%
Sodium salt	0 – 1.5%

Figure D-6
Composition of 5 GHz Head Tissue Equivalent Matter

Note: 5GHz head liquid recipes are proprietary SPEAG. Since the composition is approximate to the actual liquids utilized, the manufacturer tissue-equivalent liquid data sheets are provided below.

Measurement Certificate / Material Test

Item Name	Head Tissue Simulating Liquid (HBBL3500-5800V5)
Product No.	SL AAH 502 AC (Charge: 130903-1)
Manufacturer	SPEAG
Measurement Method	
TSL dielectric parameters measured using calibrated OCP probe	
Setup Validation	
Validation results were within $\pm 2.5\%$ towards the target values of Methanol.	
Target Parameters	
Target parameters as defined in the IEEE 1528 and IEC 62209 compliance standards.	
Test Condition	
Ambient	Environment temperatur (22 \pm 3)°C and humidity < 70%.
TSL Temperature	22°C
Test Date	4-Sep-13
Operator	IEN
Additional Information	
TSL Density	0.985 g/cm ³
TSL Heat-capacity	3.383 kJ/(kg*K)

f (MHz)	Measured			Target			Diff to Target [%]	
	HP-e'	HP-e''	sigma	eps	sigma	delta-eps	delta-sigma	
3400	38.7	15.01	2.84	38.0	2.81	1.7	1.1	
3500	38.5	14.98	2.92	37.9	2.91	1.5	0.3	
3600	38.4	14.98	3.00	37.8	3.02	1.5	-0.5	
3700	38.3	14.97	3.08	37.7	3.12	1.6	-1.2	
3800	38.2	14.95	3.16	37.6	3.22	1.6	-1.9	
3900	38.1	14.96	3.25	37.5	3.32	1.7	-2.2	
4000	37.9	14.98	3.33	37.4	3.43	1.5	-2.8	
4100	37.8	15.00	3.42	37.2	3.53	1.5	-3.0	
4200	37.7	15.04	3.51	37.1	3.63	1.5	-3.3	
4300	37.6	15.10	3.61	37.0	3.73	1.6	-3.3	
4400	37.4	15.16	3.71	36.9	3.84	1.4	-3.3	
4500	37.3	15.22	3.81	36.8	3.94	1.4	-3.2	
4600	37.2	15.29	3.91	36.7	4.04	1.4	-3.2	
4700	37.0	15.34	4.01	36.6	4.14	1.2	-3.2	
4800	36.9	15.41	4.11	36.4	4.25	1.3	-3.2	
4850	36.8	15.43	4.16	36.4	4.30	1.1	-3.2	
4900	36.8	15.47	4.22	36.3	4.35	1.3	-2.9	
4950	36.7	15.49	4.26	36.3	4.40	1.2	-3.2	
5000	36.6	15.52	4.32	36.2	4.46	1.1	-2.9	
5050	36.5	15.55	4.37	36.2	4.50	0.9	-2.9	
5100	36.5	15.59	4.42	36.1	4.55	1.1	-2.9	
5150	36.4	15.62	4.47	36.0	4.60	1.0	-2.9	
5200	36.3	15.65	4.53	36.0	4.66	0.9	-2.7	
5250	36.2	15.67	4.58	35.9	4.71	0.8	-2.7	
5300	36.2	15.71	4.63	35.9	4.76	0.9	-2.7	
5350	36.1	15.73	4.68	35.8	4.81	0.8	-2.7	
5400	36.0	15.75	4.73	35.8	4.86	0.7	-2.7	
5450	35.9	15.78	4.78	35.7	4.91	0.6	-2.7	
5500	35.8	15.79	4.83	35.6	4.96	0.7	-2.7	
5550	35.8	15.83	4.89	35.6	5.01	0.6	-2.5	
5600	35.7	15.86	4.94	35.5	5.07	0.5	-2.5	
5650	35.7	15.89	5.00	35.5	5.12	0.6	-2.3	
5700	35.6	15.92	5.05	35.4	5.17	0.5	-2.3	
5750	35.5	15.96	5.11	35.4	5.22	0.4	-2.1	
5800	35.5	15.97	5.15	35.3	5.27	0.6	-2.3	
5850	35.4	16.02	5.21	35.3	5.34	0.3	-2.3	
5900	35.3	16.03	5.26	35.3	5.40	0.0	-2.6	

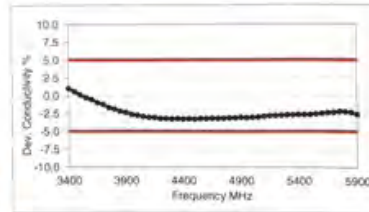
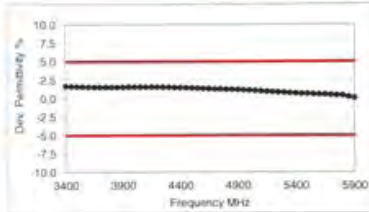



Figure D-7
5GHz Head Tissue Equivalent Matter

FCC ID: A3LSMG890A		SAR EVALUATION REPORT		Reviewed by: Quality Manager
Test Dates: 04/06/15 - 05/04/15	DUT Type: Portable Handset			APPENDIX D: Page 5 of 5

APPENDIX E: SAR SYSTEM VALIDATION



Per FCC KDB 865664 D02v01, SAR system validation status should be documented to confirm measurement accuracy. The SAR systems (including SAR probes, system components and software versions) used for this device were validated against its performance specifications prior to the SAR measurements. Reference dipoles were used with the required tissue- equivalent media for system validation, according to the procedures outlined in FCC KDB 865664 D01 v01 and IEEE 1528-2013. Since SAR probe calibrations are frequency dependent, each probe calibration point was validated at a frequency within the valid frequency range of the probe calibration point, using the system that normally operates with the probe for routine SAR measurements and according to the required tissue-equivalent media.

A tabulated summary of the system validation status including the validation date(s), measurement frequencies, SAR probes and tissue dielectric parameters has been included.

Table E-I
SAR System Validation Summary

SAR SYSTEM #	FREQ. [MHz]	DATE	PROBE SN	PROBE TYPE	PROBE CAL. POINT		COND.	PERM.	CW VALIDATION			MOD. VALIDATION		
							(σ)	(ϵ_r)	SENSI- TIVITY	PROBE LINEARITY	PROBE ISOTROPY	MOD. TYPE	DUTY FACTOR	PAR
J	750	9/26/2014	3022	ES3DV2	750	Head	0.916	40.24	PASS	PASS	PASS	N/A	N/A	N/A
D	835	4/8/2015	3209	ES3DV3	835	Head	0.936	43.01	PASS	PASS	PASS	GMSK	PASS	N/A
B	1750	1/4/2015	3334	ES3DV3	1750	Head	1.369	39.91	PASS	PASS	PASS	N/A	N/A	N/A
G	1900	3/23/2015	3213	ES3DV3	1900	Head	1.432	39.95	PASS	PASS	PASS	GMSK	PASS	N/A
G	2300	4/14/2015	3318	ES3DV3	2300	Head	1.672	40.97	PASS	PASS	PASS	N/A	N/A	N/A
E	2450	11/5/2014	3332	ES3DV3	2450	Head	1.868	39.67	PASS	PASS	PASS	OFDM/TDD	PASS	PASS
A	5300	3/2/2015	3914	EX3DV4	5300	Head	4.931	36.29	PASS	PASS	PASS	OFDM	N/A	PASS
A	5500	3/2/2015	3914	EX3DV4	5500	Head	5.144	35.86	PASS	PASS	PASS	OFDM	N/A	PASS
A	5800	3/2/2015	3914	EX3DV4	5800	Head	5.110	35.10	PASS	PASS	PASS	OFDM	N/A	PASS
J	750	9/29/2014	3022	ES3DV2	750	Body	0.955	53.59	PASS	PASS	PASS	N/A	N/A	N/A
K	835	10/13/2014	3288	ES3DV3	835	Body	0.998	52.95	PASS	PASS	PASS	GMSK	PASS	N/A
D	835	4/8/2015	3209	ES3DV3	835	Body	1.007	54.13	PASS	PASS	PASS	GMSK	PASS	N/A
C	1750	11/17/2014	3333	ES3DV3	1750	Body	1.525	52.44	PASS	PASS	PASS	N/A	N/A	N/A
J	1900	9/4/2014	3022	ES3DV2	1900	Body	1.555	52.66	PASS	PASS	PASS	GMSK	PASS	N/A
G	2300	4/9/2015	3318	ES3DV3	2300	Body	1.752	52.88	PASS	PASS	PASS	N/A	N/A	N/A
G	2450	4/9/2015	3318	ES3DV3	2450	Body	1.938	52.34	PASS	PASS	PASS	OFDM/TDD	PASS	PASS
A	5300	2/19/2015	3914	EX3DV4	5300	Body	5.181	47.44	PASS	PASS	PASS	OFDM	N/A	PASS
A	5800	2/19/2015	3914	EX3DV4	5800	Body	5.942	46.31	PASS	PASS	PASS	OFDM	N/A	PASS

NOTE: While the probes have been calibrated for both CW and modulated signals, all measurements were performed using communication systems calibrated for CW signals only. Modulations in the table above represent test configurations for which the measurement system has been validated per FCC KDB Publication 865664 D01v01 for scenarios when CW probe calibrations are used with other signal types. SAR systems were validated for modulated signals with a periodic duty cycle, such as GMSK, or with a high peak to average ratio (>5 dB), such as OFDM according to KDB 865664.

FCC ID: A3LSMG890A	 SAR EVALUATION REPORT 	Reviewed by: Quality Manager
Test Dates: 04/06/15 - 05/04/15	DUT Type: Portable Handset	APPENDIX E: Page 1 of 1