



FCC CFR47 PART 15 SUBPART C

Bluetooth

CERTIFICATION TEST REPORT

FOR

GSM/WCDMA/LTE Phone + BT/BLE, DTS/UNII a/b/g/n/ac, ANT+ and NFC

MODEL NUMBER : SM-G889A

FCC ID: A3LSMG889A

REPORT NUMBER: 4788768228-E4V1

ISSUE DATE: APR 26, 2019

Prepared for
SAMSUNG ELECTRONICS CO., LTD.
129 SAMSUNG-RO, YEONGTONG-GU, SUWON-SI,
GYEONGGI-DO, 16677, KOREA

Prepared by
UL Korea, Ltd.
26th floor, 152, Teheran-ro, Gangnam-gu Seoul, 06236, Korea

Suwon Test Site: UL Korea, Ltd. Suwon Laboratory
218 Maeyeong-ro, Yeongtong-gu,
Suwon-si, Gyeonggi-do, 16675, Korea
TEL: (031) 337-9902
FAX: (031) 213-5433



Testing
Laboratory

TL-637

Revision History

<u>Rev.</u>	<u>Issue Date</u>	<u>Revisions</u>	<u>Revised By</u>
V1	04/26/19	Initial issue	Hyunsik Yun

TABLE OF CONTENTS

1. ATTESTATION OF TEST RESULTS	5
2. TEST METHODOLOGY	6
3. FACILITIES AND ACCREDITATION	6
4. CALIBRATION AND UNCERTAINTY	6
4.1. MEASURING INSTRUMENT CALIBRATION.....	6
4.2. SAMPLE CALCULATION.....	6
4.3. MEASUREMENT UNCERTAINTY	7
5. EQUIPMENT UNDER TEST	8
5.1. DESCRIPTION OF EUT.....	8
5.1. MAXIMUM OUTPUT POWER.....	8
5.2. DESCRIPTION OF AVAILABLE ANTENNAS	8
5.3. WORST-CASE CONFIGURATION AND MODE	8
5.4. DESCRIPTION OF TEST SETUP	9
6. MEASUREMENT METHODS	11
7. TEST AND MEASUREMENT EQUIPMENT	12
8. REFERENCE MEASUREMENT RESULTS.....	13
8.1. ON TIME AND DUTY CYCLE RESULTS.....	13
8.2. 20 dB AND 99% BANDWIDTH.....	14
8.2.1. BASIC DATA RATE GFSK MODULATION.....	14
8.2.2. ENHANCED DATA RATE Pi/4-DQPSK MODULATION.....	14
8.2.3. ENHANCED DATA RATE 8PSK MODULATION	14
8.2.4. 20 dB AND 99% BANDWIDTH PLOTS.....	15
9. SUMMARY TABLE	18
10. ANTENNA PORT TEST RESULTS	19
10.1. HOPPING FREQUENCY SEPARATION	19
10.2. NUMBER OF HOPPING CHANNELS.....	20
10.3. AVERAGE TIME OF OCCUPANCY.....	24
10.4. OUTPUT POWER.....	32
10.4.1. BASIC DATA RATE GFSK MODULATION.....	32
10.4.2. ENHANCED DATA RATE Pi/4-DPSK MODULATION	32
10.4.3. ENHANCED DATA RATE 8PSK MODULATION	32
10.4.4. OUTPUT POWER PLOTS.....	33
10.5. AVERAGE POWER.....	36

10.5.1.	BASIC DATA RATE GFSK MODULATION.....	36
10.5.2.	ENHANCED DATA RATE PI/4-DQPSK MODULATION	36
10.5.3.	ENHANCED DATA RATE 8PSK MODULATION	36
10.6.	CONDUCTED SPURIOUS EMISSIONS.....	37
10.6.1.	BASIC DATA RATE GFSK MODULATION.....	38
10.6.2.	ENHANCED DATA RATE PI/4-DQPSK MODULATION	42
10.6.3.	ENHANCED DATA RATE 8PSK MODULATION	46
11.	RADIATED TEST RESULTS	50
11.1.	LIMITS AND PROCEDURE	50
11.1.	TRANSMITTER ABOVE 1 GHz	52
11.1.1.	BASIC DATA RATE GFSK MODULATION.....	52
11.1.2.	ENHANCED DATA RATE 8PSK MODULATION	62
11.2.	WORST-CASE BELOW 1 GHz.....	72
12.	AC POWER LINE CONDUCTED EMISSIONS	74
13.	SETUP PHOTOS	77

1. ATTESTATION OF TEST RESULTS

COMPANY NAME: SAMSUNG ELECTRONICS CO., LTD.
EUT DESCRIPTION: GSM/WCDMA/LTE Phone + BT/BLE, DTS/UNII a/b/g/n/ac, ANT+ and NFC
MODEL NUMBER: SM-G889A
SERIAL NUMBER: R38M109WC2T (RADIATED);
R38KC03K3LM (CONDUCTED)
DATE TESTED: MAR 06, 2019 - MAR 14, 2019

APPLICABLE STANDARDS	
STANDARD	TEST RESULTS
CFR 47 Part 15 Subpart C	Pass

UL Korea, Ltd. tested the above equipment in accordance with the requirements set forth in the above standards. All indications of Pass/Fail in this report are opinions expressed by UL Korea, Ltd. based on interpretations and/or observations of test results. Measurement Uncertainties were not taken into account and are published for informational purposes only. The test results show that the equipment tested is capable of demonstrating compliance with the requirements as documented in this report.

Note: The results documented in this report apply only to the tested sample, under the conditions and modes of operation as described herein. This document may not be altered or revised in any way unless done so by UL Korea, Ltd. and all revisions are duly noted in the revisions section. Any alteration of this document not carried out by UL Korea, Ltd. will constitute fraud and shall nullify the document. This report must not be used by the client to claim product certification, approval, or endorsement by IAS, any agency of the Federal Government, or any agency of any government.

Approved & Released For
UL Korea, Ltd. By:



SungGil Park
Suwon Lab Engineer
UL Korea, Ltd.

Tested By:



HyunSik Yun
Suwon Lab Engineer
UL Korea, Ltd.

2. TEST METHODOLOGY

The tests documented in this report were performed in accordance with following methods.

1. FCC CFR 47 Part 2.
2. FCC CFR 47 Part 15.
3. 558074 D01 15.247 Meas Guidance v05r01
4. ANSI C63.10-2013.

3. FACILITIES AND ACCREDITATION

The test sites and measurement facilities used to collect data are located at 218 Maeyeong-ro, Yeongtong-gu, Suwon-si, Gyeonggi-do, 16675, Korea. Line conducted emissions are measured only at the 218 address. The following table identifies which facilities were utilized for radiated emission measurements documented in this report. Specific facilities are also identified in the test results sections.

218 Maeyeong-ro	
<input checked="" type="checkbox"/>	Chamber 1
<input type="checkbox"/>	Chamber 2
<input type="checkbox"/>	Chamber 3

UL Korea, Ltd. is accredited by IAS, Laboratory Code TL-637. The full scope of accreditation can be viewed at <http://www.iasonline.org/PDF/TL/TL-637.pdf>.

4. CALIBRATION AND UNCERTAINTY

4.1. MEASURING INSTRUMENT CALIBRATION

The measuring equipment utilized to perform the tests documented in this report has been calibrated in accordance with the manufacturer's recommendations, and is traceable to recognized national standards.

4.2. SAMPLE CALCULATION

Where relevant, the following sample calculation is provided:

$$\begin{aligned} \text{Field Strength (dBuV/m)} &= \text{Measured Voltage (dBuV)} + \text{Antenna Factor (dB/m)} + \\ &\text{Cable Loss (dB)} - \text{Preamplifier Gain (dB)} \\ 36.5 \text{ dBuV} + 18.7 \text{ dB/m} + 0.6 \text{ dB} - 26.9 \text{ dB} &= 28.9 \text{ dBuV/m} \end{aligned}$$

4.3. MEASUREMENT UNCERTAINTY

Where relevant, the following measurement uncertainty levels have been estimated for tests performed on the apparatus:

PARAMETER	UNCERTAINTY
Conducted Disturbance, 0.15 to 30 MHz	2.32 dB
Radiated Disturbance, Below 1GHz	3.86 dB
Radiated Disturbance, Above 1 GHz	5.97 dB

Uncertainty figures are valid to a confidence level of 95%.

5. EQUIPMENT UNDER TEST

5.1.DESCRPTION OF EUT

The EUT is a GSM/WCDMA/LTE Phone + BT/BLE, DTS/UNII a/b/g/n/ac, ANT+ and NFC.
 This test report addresses the DSS (BT) operational mode.

5.1.MAXIMUM OUTPUT POWER

The transmitter has a maximum conducted output power as follows:

Frequency Range [MHz]	Mode	Power Mode	Output Power [dBm]	Output Power [mW]
2 402 ~ 2 480	Basic GFSK	Average	13.371	21.73
		Peak	13.559	22.69
	Enhanced Pi/4-DPSK	Average	6.629	4.60
		Peak	9.182	8.28
	Enhanced 8PSK	Average	6.740	4.72
		Peak	9.801	9.55

5.2.DESCRPTION OF AVAILABLE ANTENNAS

The radio utilizes an internal antenna, with a maximum gain of -3.94 dBi.

5.3.WORST-CASE CONFIGURATION AND MODE

Radiated emission below 1GHz and power line conducted emission were performed with the EUT set to transmit at the channel with highest output power as worst-case scenario.

Radiated emission above 1GHz was performed with the EUT set to transmit low/mid/high channels.

The fundamental of the EUT was investigated in three orthogonal orientations X, Y and Z it was determined that Y orientation was worst-case orientation; therefore, all final radiated testing was performed with the EUT in Y orientation.

Note: GFSK, Pi/4-DQPSK, 8PSK average Power are all investigated, The GFSK & 8PSK Power are the worst case. Testing is based on this mode to showing compliance. For average power data please refer to section 9.5. All radiated and power line conducted tests were performed connected with earphone and charger for evaluation of worst case mode.

5.4.DESCRPTION OF TEST SETUP

SUPPORT EQUIPMENT

Support Equipment List				
Description	Manufacturer	Model	Serial Number	FCC ID
Charger	SAMSUNG	EP-TA300	R37KACB0KE3SE3	N/A
Data Cable	SAMSUNG	EP-DN930CWE	N/A	N/A
Earphone	SAMSUNG	GH59-15097A	N/A	N/A

I/O CABLE

I/O Cable List						
Cable No	Port	# of identical ports	Connector Type	Cable Type	Cable Length (m)	Remarks
1	DC Power	1	C Type	Shielded	1.2m	N/A
2	Audio	2	Mini-Jack	Unshielded	1.6m	N/A

TEST SETUP

The EUT is continuously communicating to the Bluetooth tester during the tests.
Test software enable BT communications.

SETUP DIAGRAM FOR TESTS (CONDUCTED TEST SETUP)

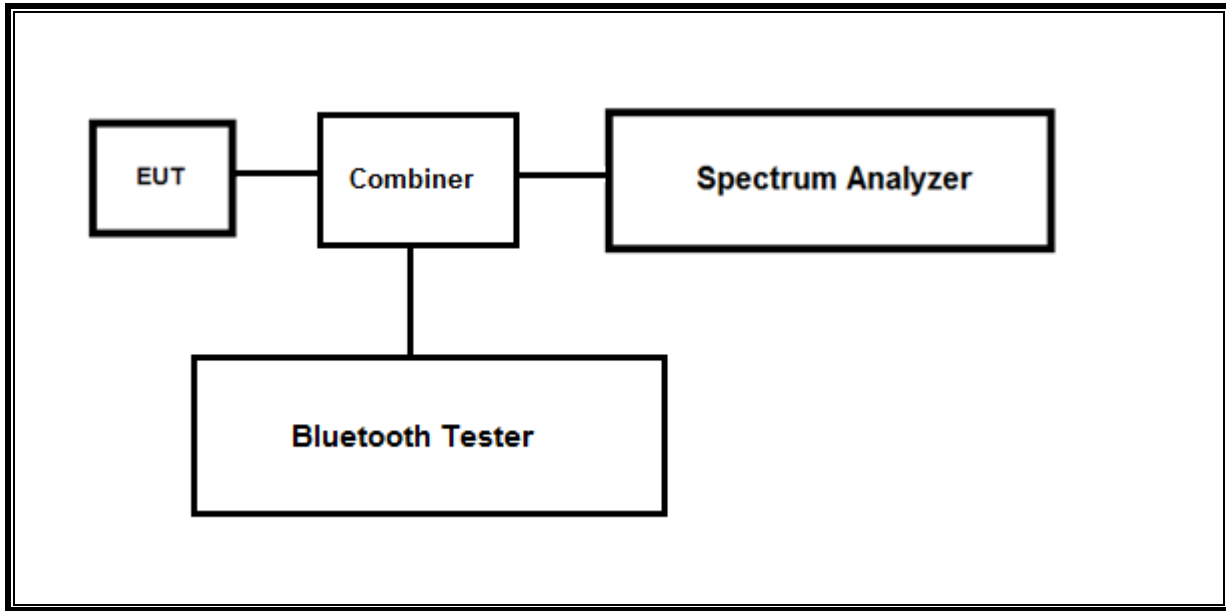

SETUP DIAGRAM FOR TESTS (RADIATED TEST SETUP)

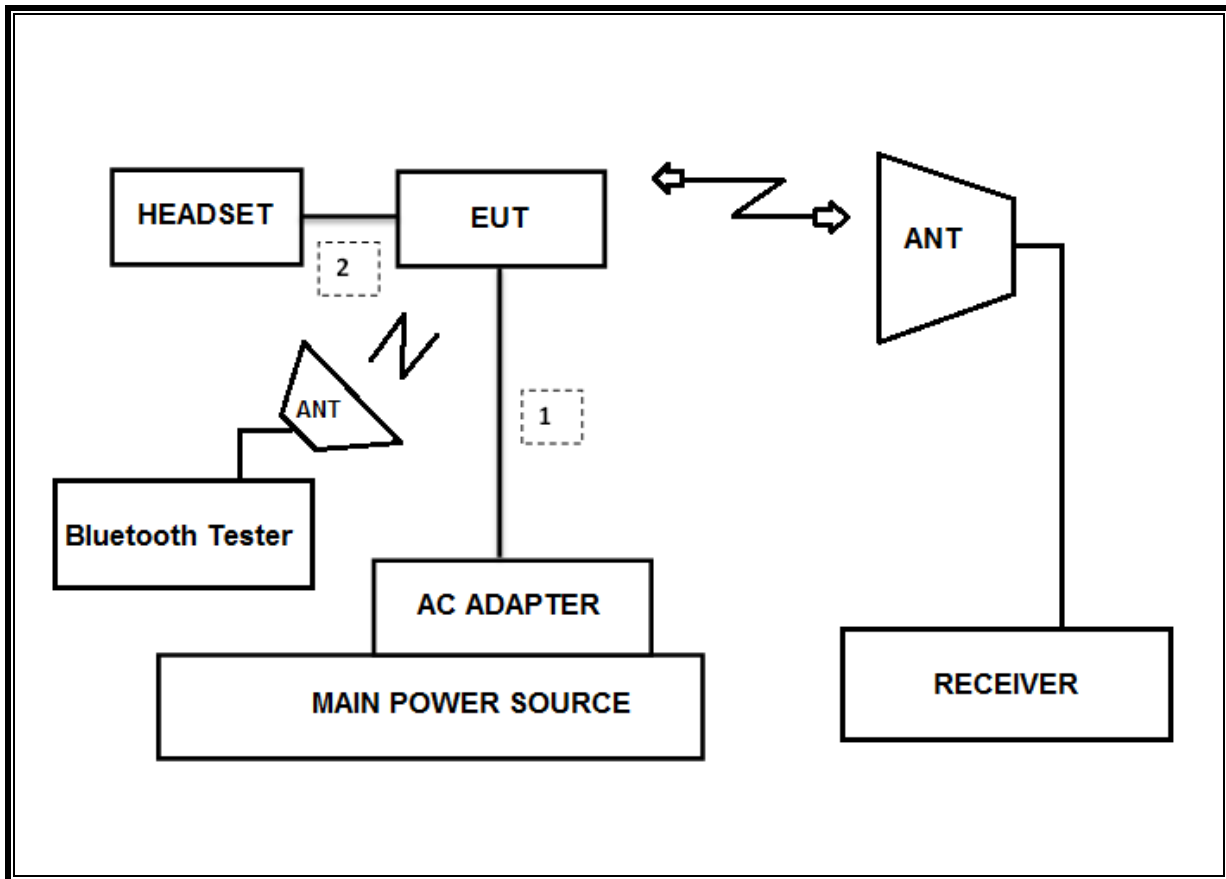

6. MEASUREMENT METHODS

20dB BW : ANSI C63.10, Section 6.9.2

99% BW : ANSI C63.10, Section 6.9.3

HOPPING FREQUENCY SEPARATION : ANSI C63.10, Section 7.8.2

NUMBER OF HOPPING CHANNELS : ANSI C63.10, Section 7.8.3

AVERAGE TIME OF OCCUPANCY : ANSI C63.10, Section 7.8.4

OUTPUT POWER : ANSI C63.10, Section 7.8.5.

Out-of-band EMISSIONS (Conducted) : ANSI C63.10, Section 7.8.6, 7.8.8

Out-of-band EMISSIONS IN NON-RESTRICTED BANDS: ANSI C63.10, Section 6.

Out-of-band EMISSIONS IN RESTRICTED BANDS : ANSI C63.10, Section 6.

AC Power Line Conducted Emission : ANSI C63.10-2013, Section 6.2.

7. TEST AND MEASUREMENT EQUIPMENT

The following test and measurement equipment was utilized for the tests documented in this report:

Test Equipment List				
Description	Manufacturer	Model	S/N	Cal Due
Antenna, Bilog, 30MHz-1GHz	SCHWARZBECK	VULB9163	750	08-04-20
Antenna, Bilog, 30MHz-1GHz	SCHWARZBECK	VULB9163	749	08-04-20
Antenna, Bilog, 30MHz-1GHz	SCHWARZBECK	VULB9163	845	08-04-20
Antenna, Horn, 18 GHz	ETS	3115	00167211	08-04-20
Antenna, Horn, 18 GHz	ETS	3115	00161451	08-04-20
Antenna, Horn, 18 GHz	ETS	3117	00168724	08-04-20
Antenna, Horn, 18 GHz	ETS	3117	00168717	08-04-20
Antenna, Horn, 18 GHz	ETS	3117	00205959	08-04-20
Antenna, Horn, 40 GHz	ETS	3116C	00166155	08-14-20
Antenna, Horn, 40 GHz	ETS	3116C	00168645	12-04-19
Antenna, Horn, 40 GHz	ETS	3116C-PA	00168841	08-09-19
Preamplifier, 1000 MHz	Sonoma	310N	341282	08-07-19
Preamplifier, 1000 MHz	Sonoma	310N	351741	08-07-19
Preamplifier, 1000 MHz	Sonoma	310N	370599	08-06-19
Preamplifier, 18 GHz	Miteq	AFS42-00101800-25-S-42	1876511	08-07-19
Preamplifier, 18 GHz	Miteq	AFS42-00101800-25-S-42	1896138	08-07-19
Preamplifier, 18 GHz	Miteq	AFS42-00101800-25-S-42	2029169	08-07-19
Spectrum Analyzer, 44 GHz	Agilent / HP	N9030A	MY54170614	08-07-19
Spectrum Analyzer, 44 GHz	Agilent / HP	N9030A	MY54490312	08-06-19
Average Power Sensor	Agilent / HP	U2000	MY54270007	08-07-19
Bluetooth Tester	TESCOM	TC-3000C	3000C000546	08-07-19
Combiner	WEINCHEL	1575	2150	08-08-19
Attenuator	PASTERNAK	PE7087-10	A001	08-08-19
Attenuator	PASTERNAK	PE7087-10	A008	08-08-19
Attenuator	PASTERNAK	PE7087-10	2	08-07-19
EMI Test Receive, 40 GHz	R&S	ESU40	100439	08-06-19
EMI Test Receive, 40 GHz	R&S	ESU40	100457	08-06-19
EMI Test Receive, 44 GHz	R&S	ESW44	101590	08-06-19
EMI Test Receive, 3 GHz	R&S	ESR3	101832	08-06-19
Low Pass Filter 5GHz	Micro-Tronics	LPS17541	009	08-07-19
Low Pass Filter 5GHz	Micro-Tronics	LPS17541	015	08-07-19
Low Pass Filter 5GHz	Micro-Tronics	LPS17541	020	08-06-19
High Pass Filter 3GHz	Micro-Tronics	HPM17543	010	08-07-19
High Pass Filter 3GHz	Micro-Tronics	HPM17543	015	08-07-19
High Pass Filter 3GHz	Micro-Tronics	HPM17543	020	08-06-19
High Pass Filter 6GHz	Micro-Tronics	HPS17542	009	08-07-19
High Pass Filter 6GHz	Micro-Tronics	HPS17542	016	08-07-19
High Pass Filter 6GHz	Micro-Tronics	HPS17542	021	08-06-19
LISN	R&S	ENV-216	101837	08-09-19
UL Software				
Description	Manufacturer	Model	Version	
Radiated software	UL	UL EMC	Ver 9.5	
AC Line Conducted software	UL	UL EMC	Ver 9.5	

8. REFERENCE MEASUREMENT RESULTS

8.1.ON TIME AND DUTY CYCLE RESULTS

LIMITS

None: for reporting purposes only.

Mode	ON Time B [msec]	Period [msec]	Duty Cycle x [linear]	Duty Cycle [%]	Duty Cycle Correction Factor [dB]	1/T Minimum VBW [kHz]
2400MHz Bands						
BT	2.882	3.750	0.769	76.9%	1.14	0.347

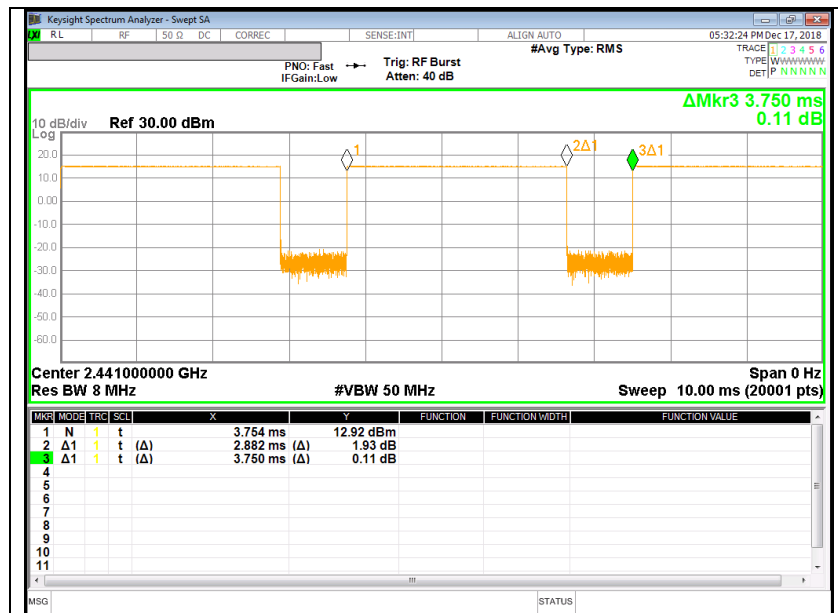

8.2.20 dB AND 99% BANDWIDTH

LIMITS

None; for reporting purposes only.

TEST PROCEDURE

The transmitter output is connected to a spectrum analyzer. The RBW is set to $\geq 1\%$ of the 20 dB bandwidth. The VBW is set to \geq RBW. The sweep time is coupled.

RESULTS

8.2.1. BASIC DATA RATE GFSK MODULATION

Channel	Frequency [MHz]	20 dB Bandwidth [MHz]	99% Bandwidth [kHz]
Low	2 402	1.031	863.190
Mid	2 440	1.036	894.560
High	2 480	1.032	866.740
Worst		1.036	894.560

8.2.2. ENHANCED DATA RATE Pi/4-DQPSK MODULATION

Channel	Frequency [MHz]	20 dB Bandwidth [MHz]	99% Bandwidth [kHz]
Low	2 402	1.349	1165.400
Mid	2 440	1.350	1165.500
High	2 480	1.352	1165.300
Worst		1.352	1165.500

8.2.3. ENHANCED DATA RATE 8PSK MODULATION

Channel	Frequency [MHz]	20 dB Bandwidth [MHz]	99% Bandwidth [kHz]
Low	2 402	1.311	1194.500
Mid	2 440	1.314	1194.700
High	2 480	1.314	1165.100
Worst		1.314	1194.700

8.2.4. 20 dB AND 99% BANDWIDTH PLOTS

GFSK BANDWIDTH

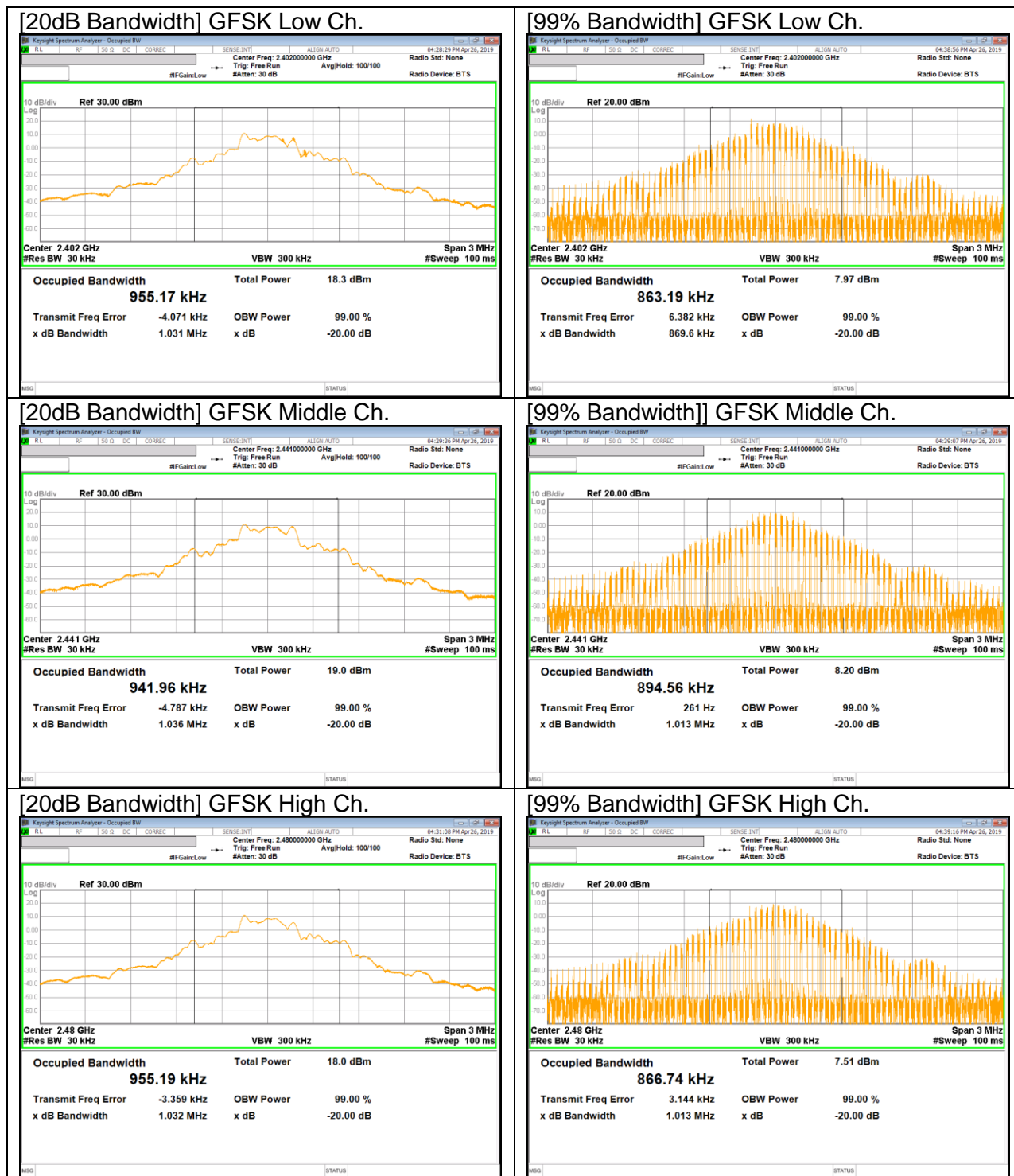

Pi/4-DQPSK BANDWIDTH

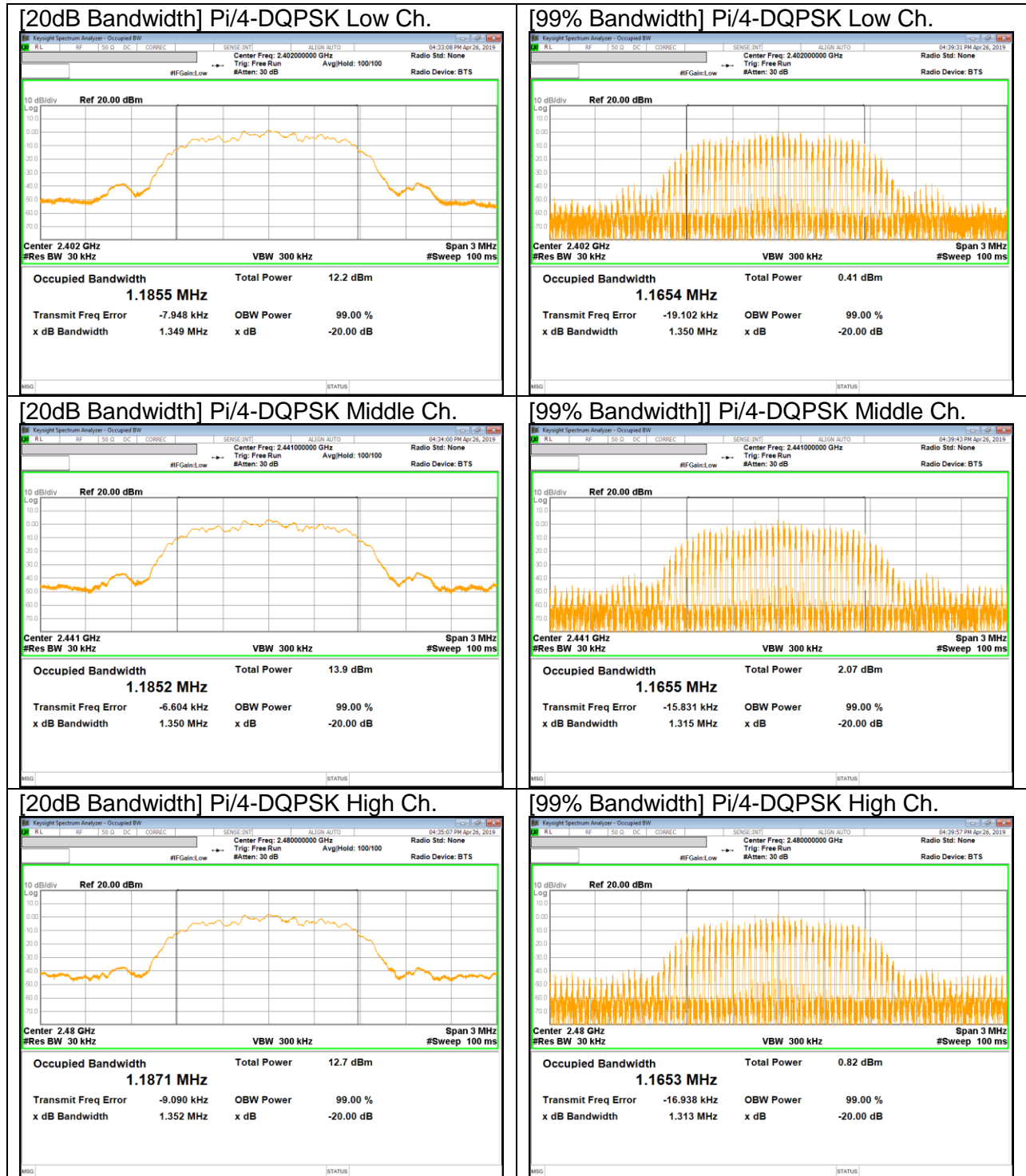

8PSK BANDWIDTH

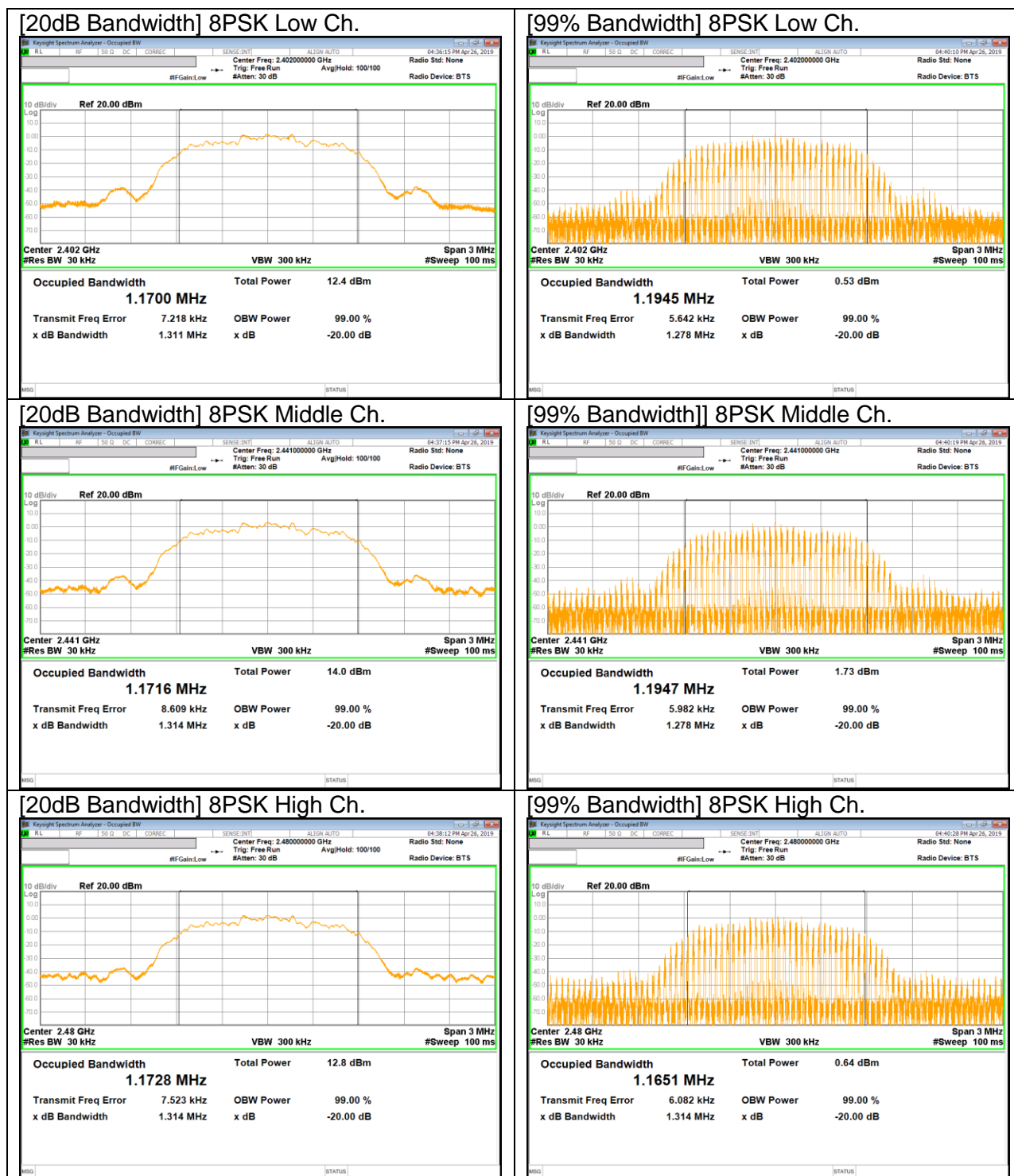

9. SUMMARY TABLE

FCC Part Section	Test Description	Test Limit	Test Condition	Test Result
2.1051, 15.247 (d)	Band Edge / Conducted Spurious Emission	-20dBc	Conducted	Pass
15.247 (b)(1)	TX conducted output power	<30dBm		Pass
15.247 (a)(1)	Hopping frequency separation	> two-thirds of the 20 dB bandwidth		Pass
15.247 (a)(1)(iii)	Number of Hopping channels	More than 15 non-overlapping channels		Pass
15.247 (a)(1)(iii)	Avg Time of Occupancy	< 0.4sec		Pass
15.207 (a)	AC Power Line conducted emissions	Section 10	Power Line conducted	Pass
15.205, 15.209	Radiated Spurious Emission	< 54dBuV/m	Radiated	Pass

10. ANTENNA PORT TEST RESULTS

10.1. HOPPING FREQUENCY SEPARATION

LIMIT

FCC §15.247 (a) (1)

Frequency hopping systems shall have hopping channel carrier frequencies separated by a minimum of 25 kHz or the 20 dB bandwidth of the hopping channel, whichever is greater.

Alternatively, frequency hopping systems operating in the 2400-2483.5 MHz band may have hopping channel carrier frequencies that are separated by 25 kHz or two-thirds of the 20 dB bandwidth of the hopping channel, whichever is greater, provided the systems operate with an output power no greater than 125 mW.

TEST PROCEDURE

The transmitter output is connected to a spectrum analyzer. The RBW is set to 300 kHz and the VBW is set to 300 kHz. The sweep time is coupled.

RESULTS

HOPPING FREQUENCY SEPARATION PLOT

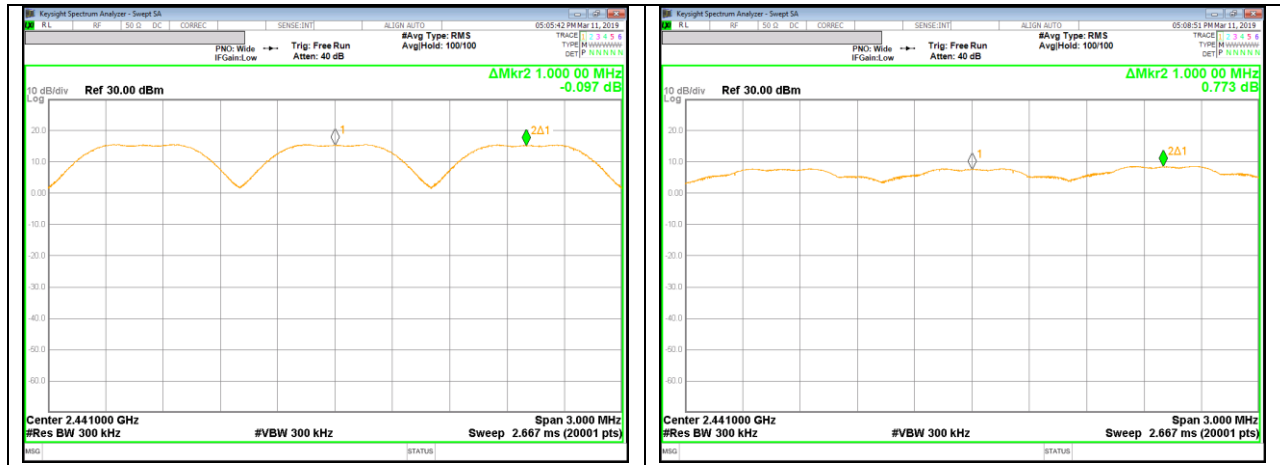

[GFSK]

[8PSK]

10.2. NUMBER OF HOPPING CHANNELS

LIMIT

FCC §15.247 (a) (1) (iii)

Frequency hopping systems in the 2400 – 2483.5 MHz band shall use at least 15 non-overlapping channels.

TEST PROCEDURE

The transmitter output is connected to a spectrum analyzer. The span is set to cover the entire authorized band, in either a single sweep or in multiple contiguous sweeps. The RBW is set to a maximum of 1 % of the span. The analyzer is set to Max Hold.

RESULTS

Normal Mode: 79 Channels observed.

NUMBER OF HOPPING CHANNELS (100 MHz SPAN)

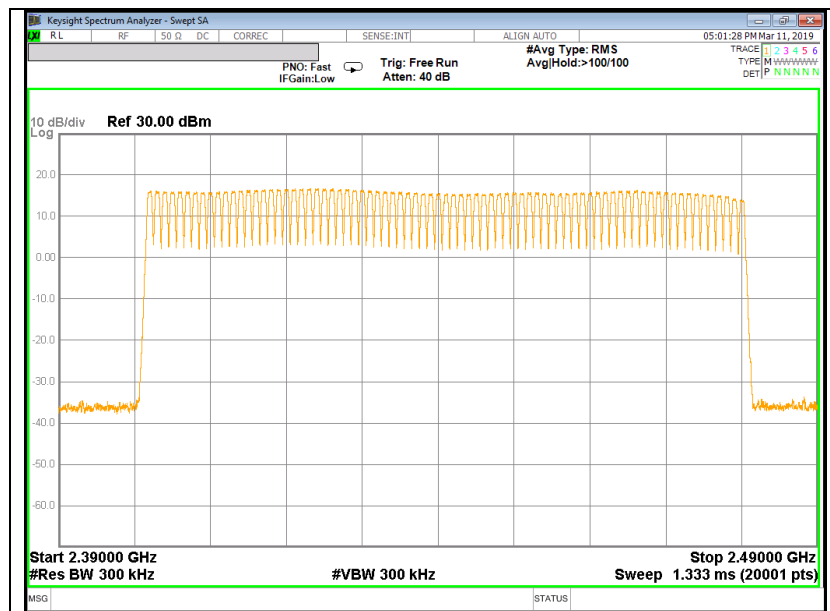

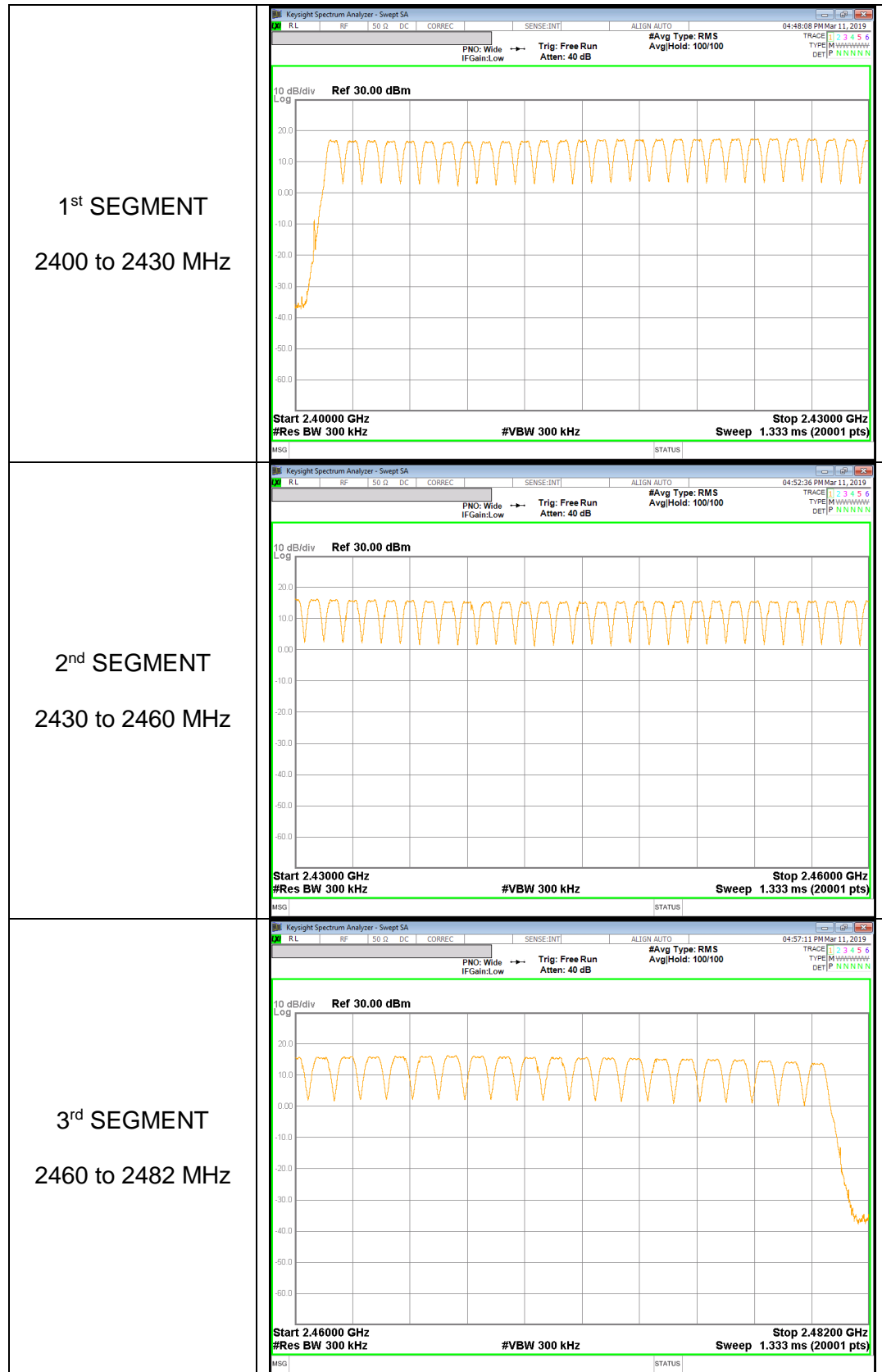

NUMBER OF HOPPING CHANNELS PLOTS[8PSK]

NUMBER OF HOPPING CHANNELS (100 MHZ SPAN)

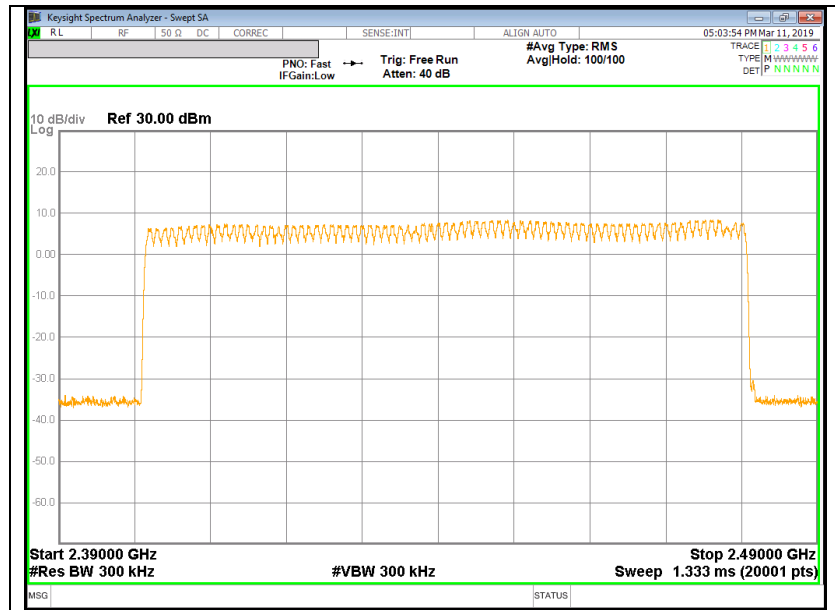

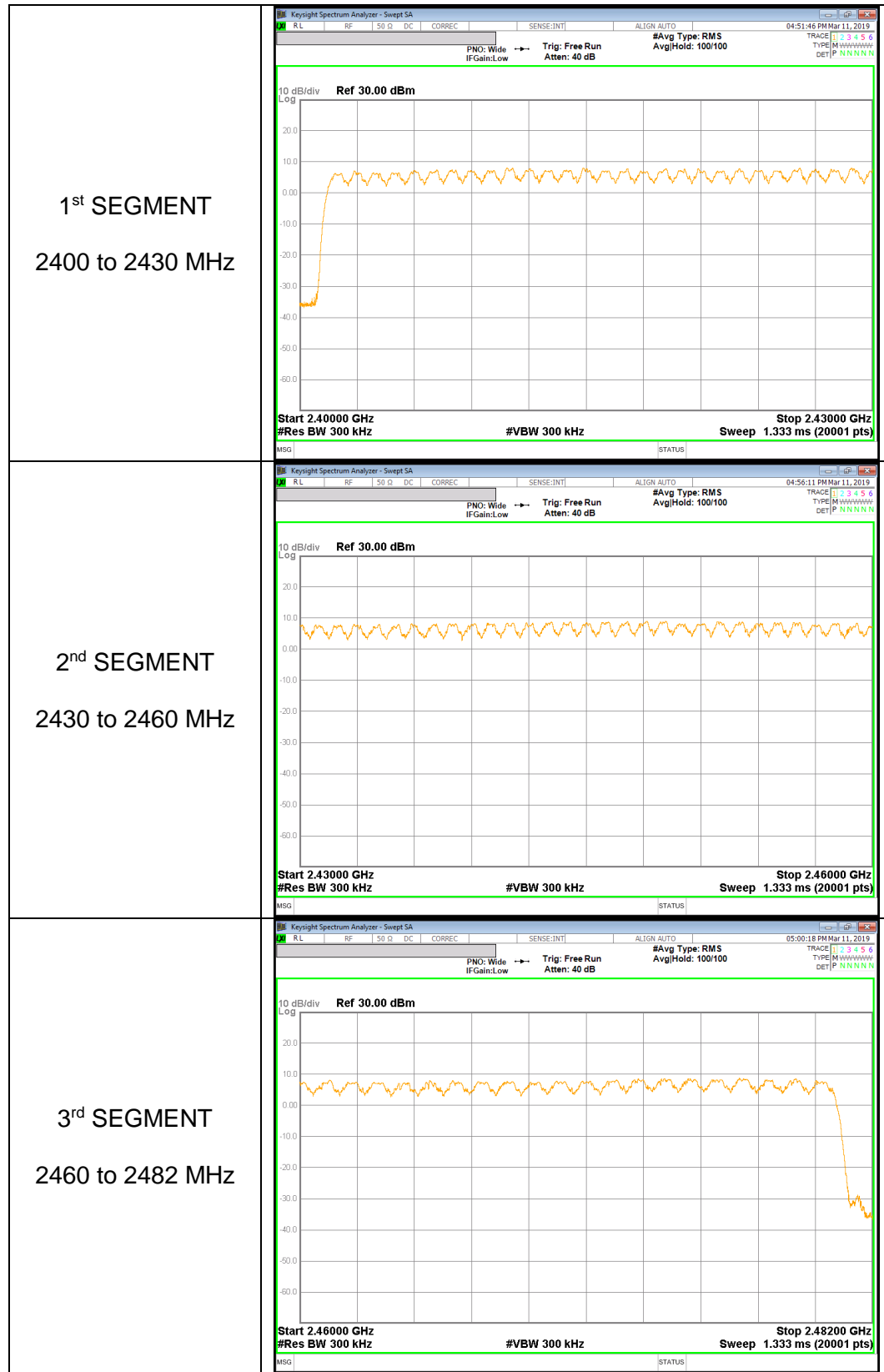

10.3. AVERAGE TIME OF OCCUPANCY

LIMIT

FCC §15.247 (a) (1) (iii)

The average time of occupancy on any channel shall not be greater than 0.4 seconds within a period of 0.4 seconds multiplied by the number of hopping channels employed.

TEST PROCEDURE

The transmitter output is connected to a spectrum analyzer. The span is set to 0 Hz, centered on a single, selected hopping channel. The width of a single pulse is measured in a fast scan. The number of pulses is measured in a 3.16 second scan, to enable resolution of each occurrence.

The average time of occupancy in the specified 31.6 second period (79 channels * 0.4 s) is equal to $10 * (\# \text{ of pulses in } 3.16 \text{ s}) * \text{ pulse width}$.

For AFH mode, the average time of occupancy in the specified 8 second period (20 channels * 0.4 seconds) is equal to $10 * (\# \text{ of pulses in } 0.8 \text{ s}) * \text{ pulse width}$.

RESULTS[GFSK]

DH Packet	Pulse Width [msec]	Number of Pulses in 3.16 seconds	Average Time of Occupancy [sec]	Limit [sec]	Margin [sec]
GFSK Normal					
DH1	0.380	32	0.121568	0.4	-0.2784
DH3	1.635	16	0.261600	0.4	-0.1384
DH5	2.882	12	0.345840	0.4	-0.0542
GFSK AFH					
DH Packet	Pulse Width [msec]	Number of Pulses in 0.8 seconds	Average Time of Occupancy [sec]	Limit [sec]	Margin [sec]
GFSK AFH					
DH1	0.380	8	0.030392	0.4	-0.3696
DH3	1.635	4	0.065400	0.4	-0.3346
DH5	2.882	3	0.086460	0.4	-0.3135

DH1

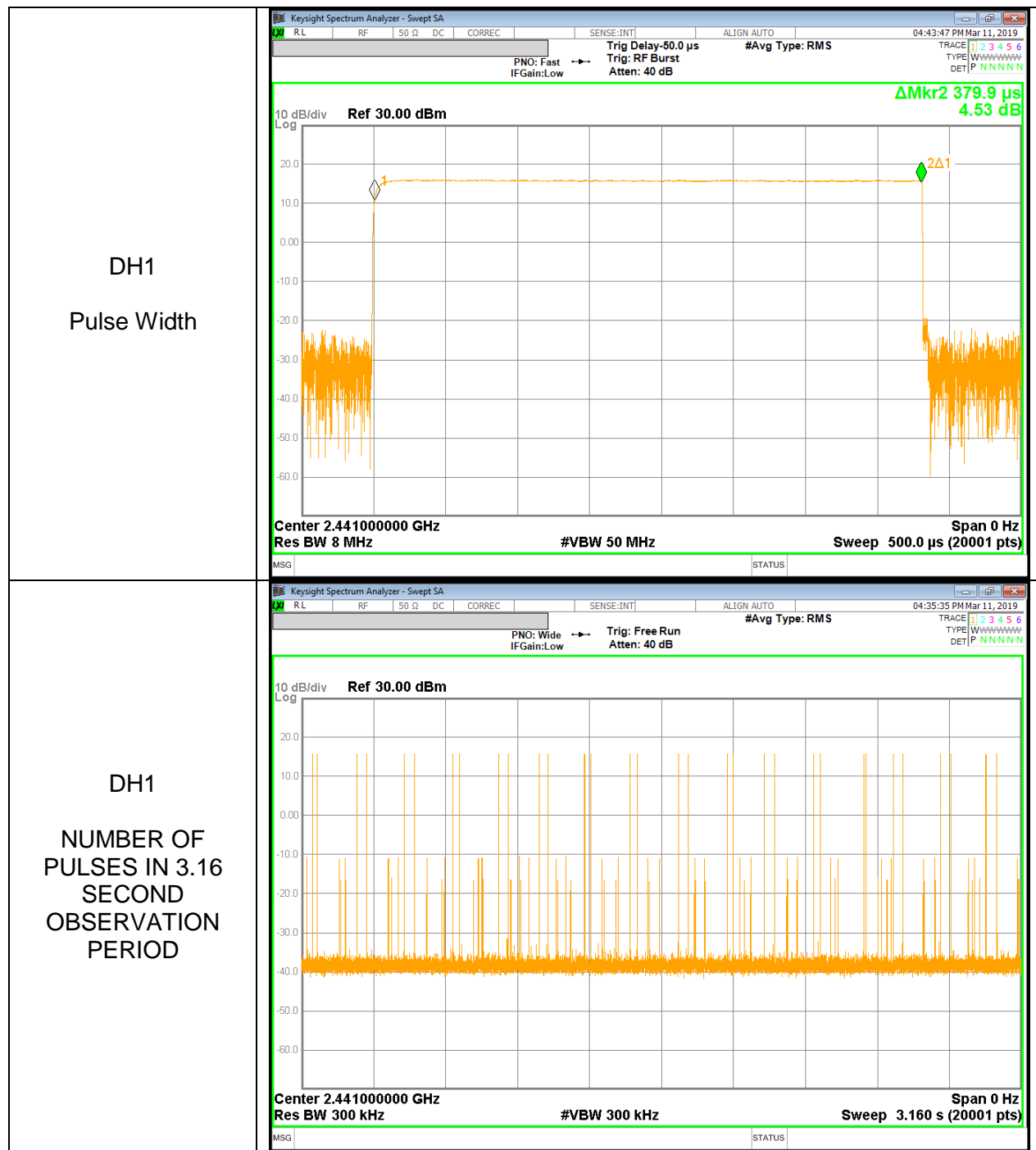

DH3

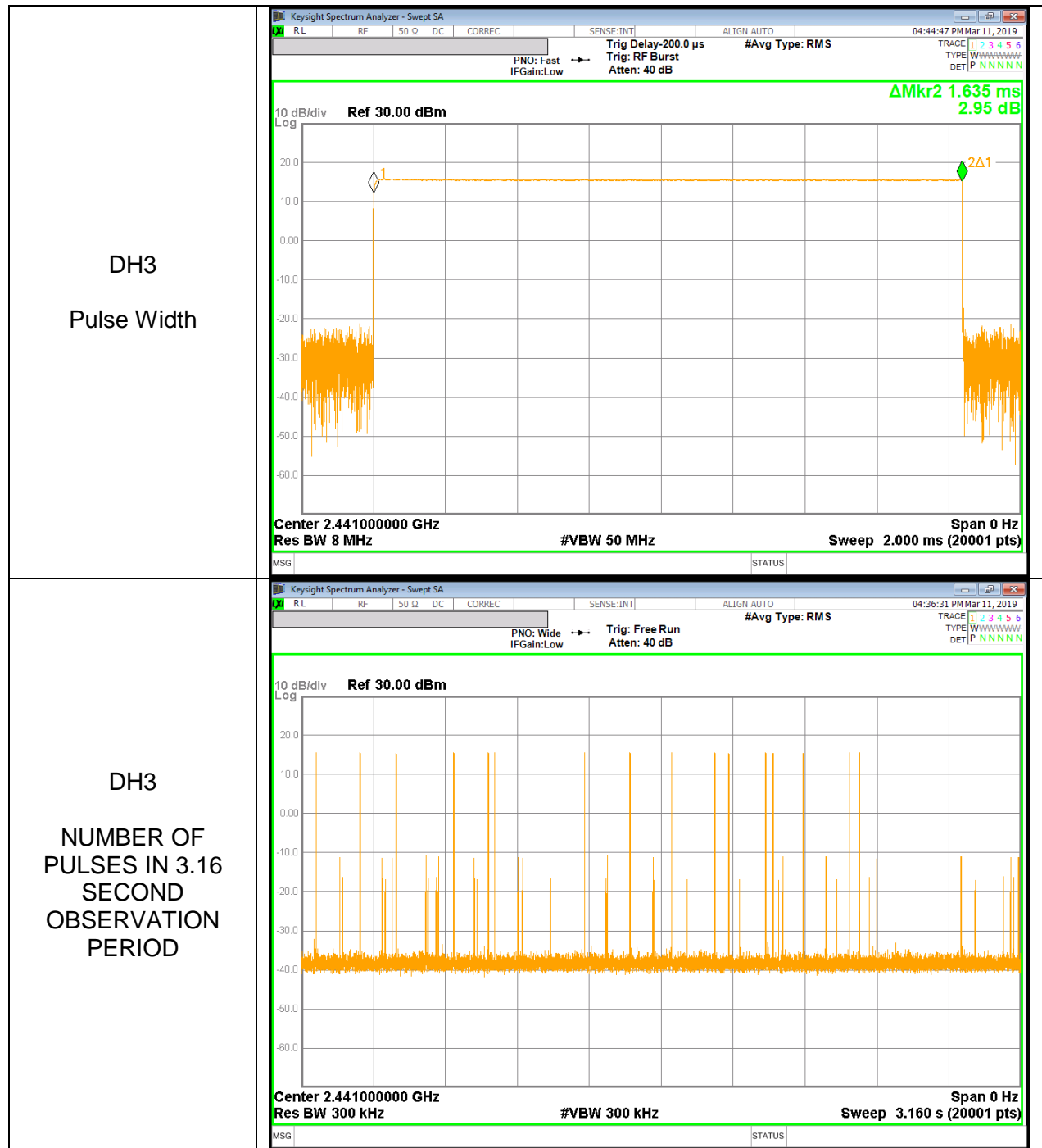

DH5

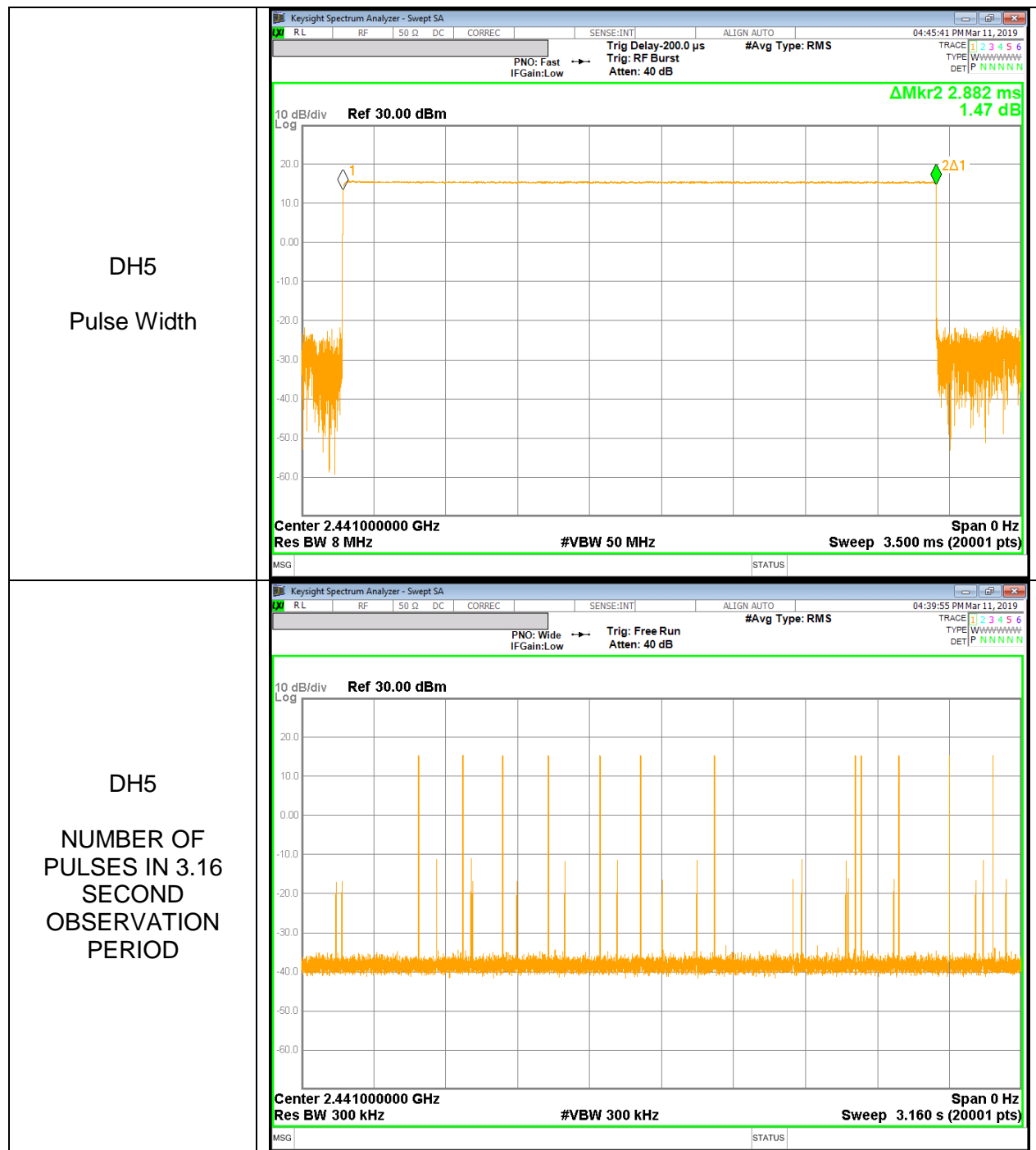

RESULTS[8PSK]

DH Packet	Pulse Width [msec]	Number of Pulses in 3.16 seconds	Average Time of Occupancy [sec]	Limit [sec]	Margin [sec]
GFSK Normal					
DH1	0.387	32	0.123904	0.4	-0.2761
DH3	1.638	16	0.262080	0.4	-0.1379
DH5	2.889	12	0.346680	0.4	-0.0533
DH Packet	Pulse Width [msec]	Number of Pulses in 0.8 seconds	Average Time of Occupancy [sec]	Limit [sec]	Margin [sec]
GFSK AFH					
DH1	0.387	8	0.030976	0.4	-0.369024
DH3	1.638	4	0.065520	0.4	-0.33448
DH5	2.889	3	0.086670	0.4	-0.31333

DH1

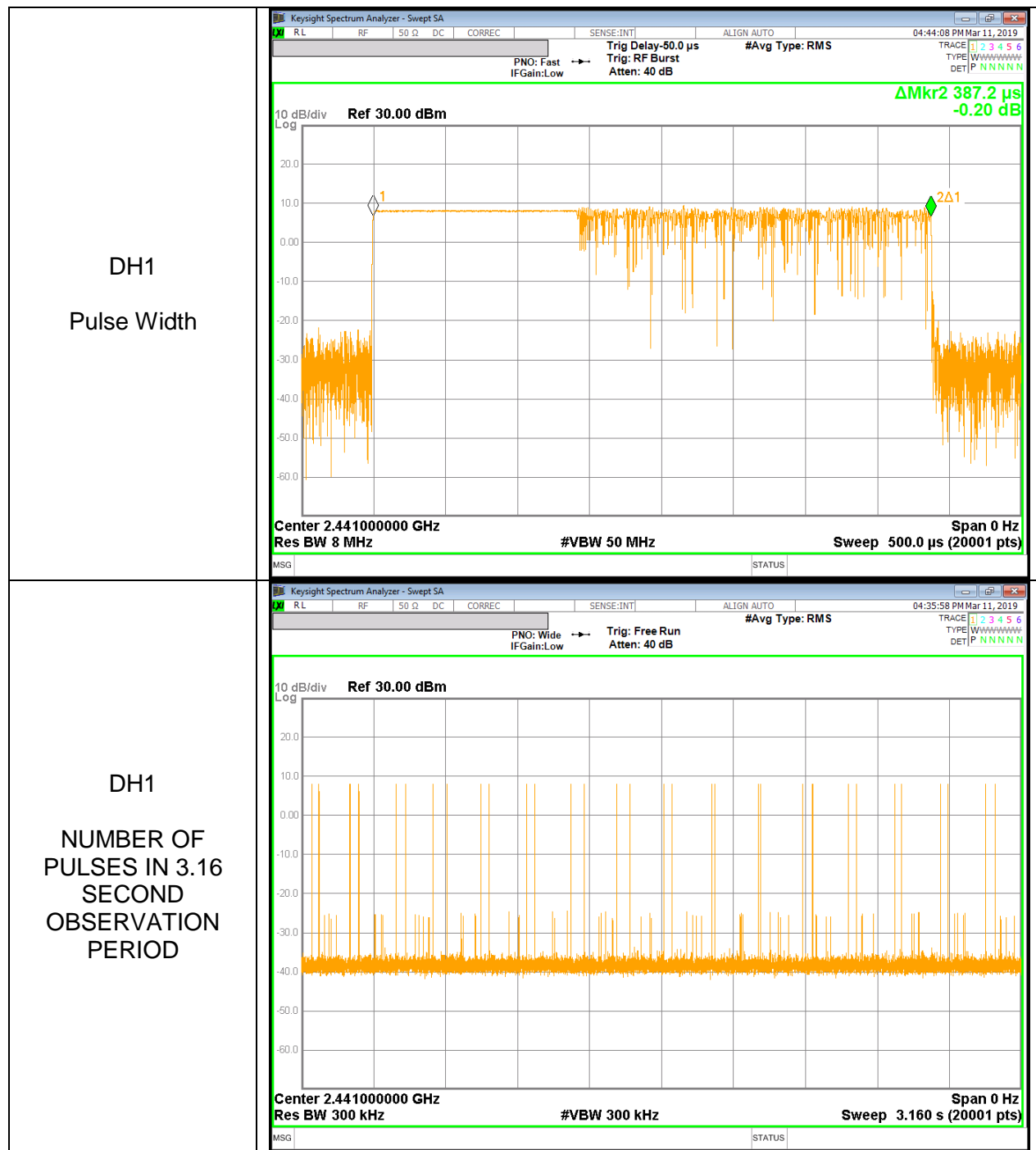

DH3

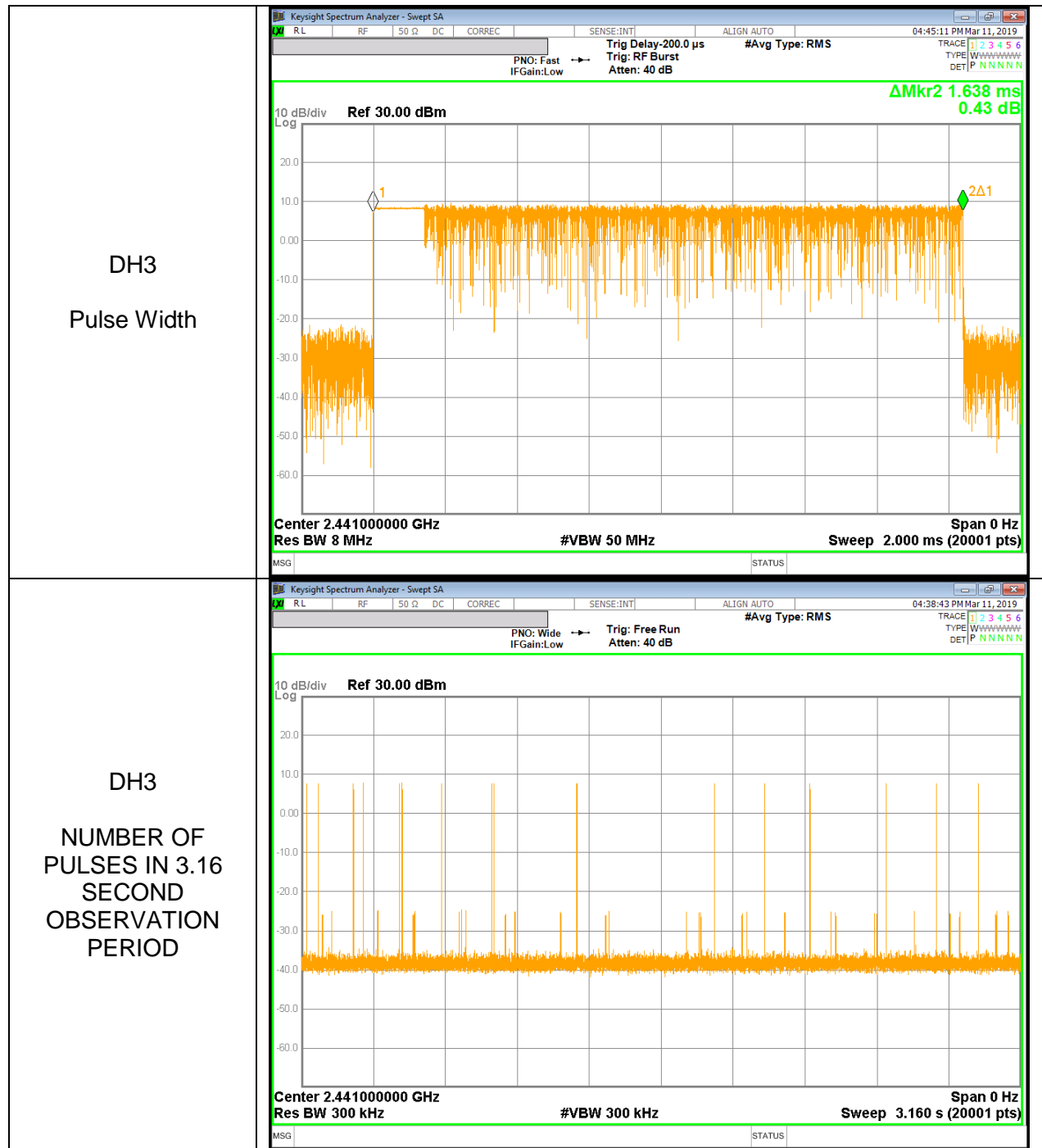

DH5

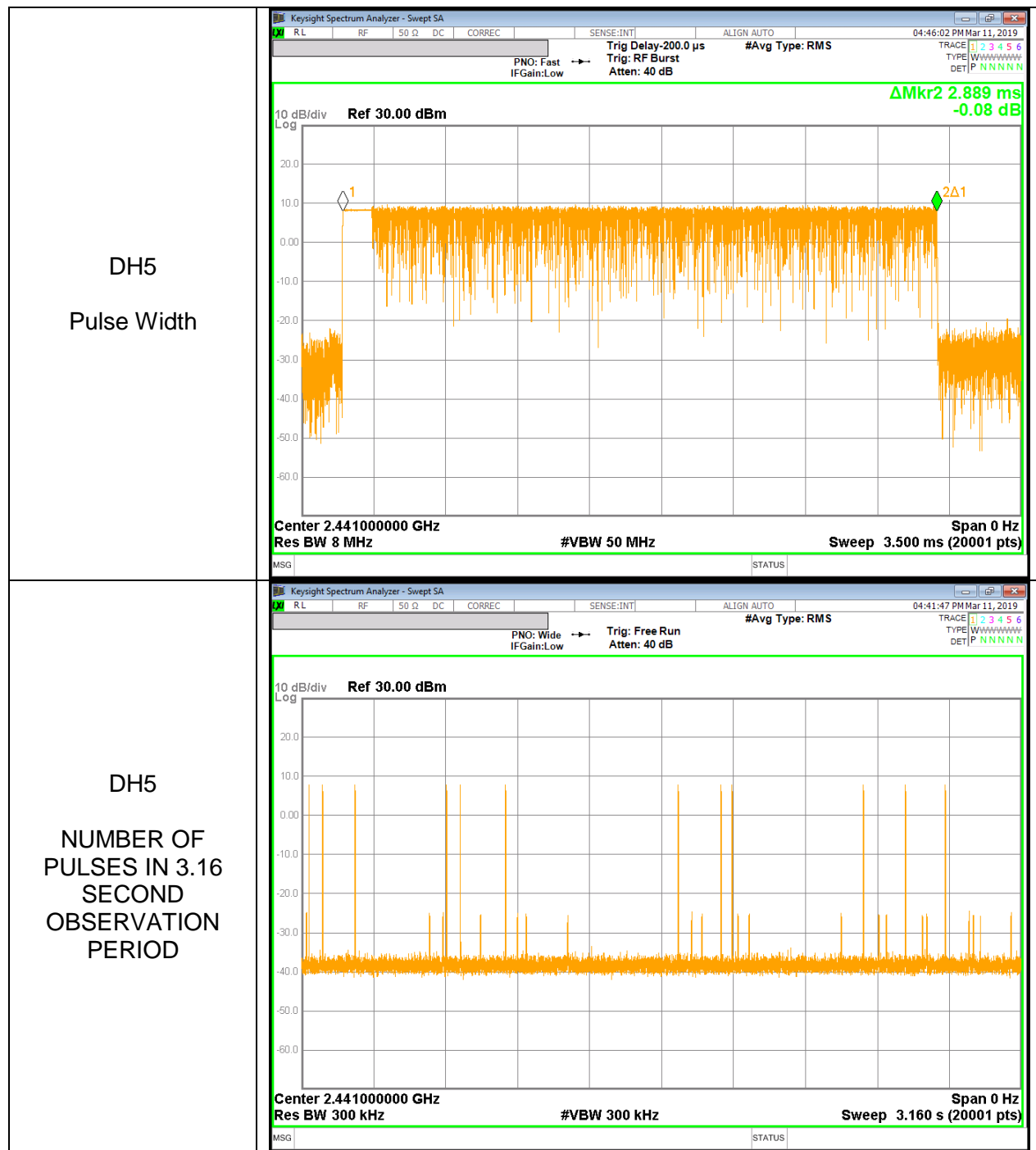

10.4. OUTPUT POWER

LIMIT

§15.247 (b) (1)

The maximum antenna gain is less than 6 dBi, therefore the limit is 21 dBm.

TEST PROCEDURE

The transmitter output is connected to a spectrum analyzer the analyzer bandwidth is set to a value greater than the 20 dB bandwidth of the EUT.

RESULTS

10.4.1. BASIC DATA RATE GFSK MODULATION

Channel	Frequency [MHz]	Output Power [dBm]	Limit [dBm]	Margin [dB]
Low	2 402	13.142	21.000	-7.858
Mid	2 441	13.559	21.000	-7.441
High	2 480	12.926	21.000	-8.074
Worst		13.559	21.000	-7.441

10.4.2. ENHANCED DATA RATE Pi/4-DPSK MODULATION

Channel	Frequency [MHz]	Output Power [dBm]	Limit [dBm]	Margin [dB]
Low	2 402	7.686	21.000	-13.314
Mid	2 441	9.182	21.000	-11.818
High	2 480	7.969	21.000	-13.031
Worst		9.182	21.000	-11.818

10.4.3. ENHANCED DATA RATE 8PSK MODULATION



Channel	Frequency [MHz]	Output Power [dBm]	Limit [dBm]	Margin [dB]
Low	2 402	8.356	21.000	-12.644
Mid	2 441	9.801	21.000	-11.199
High	2 480	8.525	21.000	-12.475
Worst		9.801	21.000	-11.199

10.4.4. OUTPUT POWER PLOTS

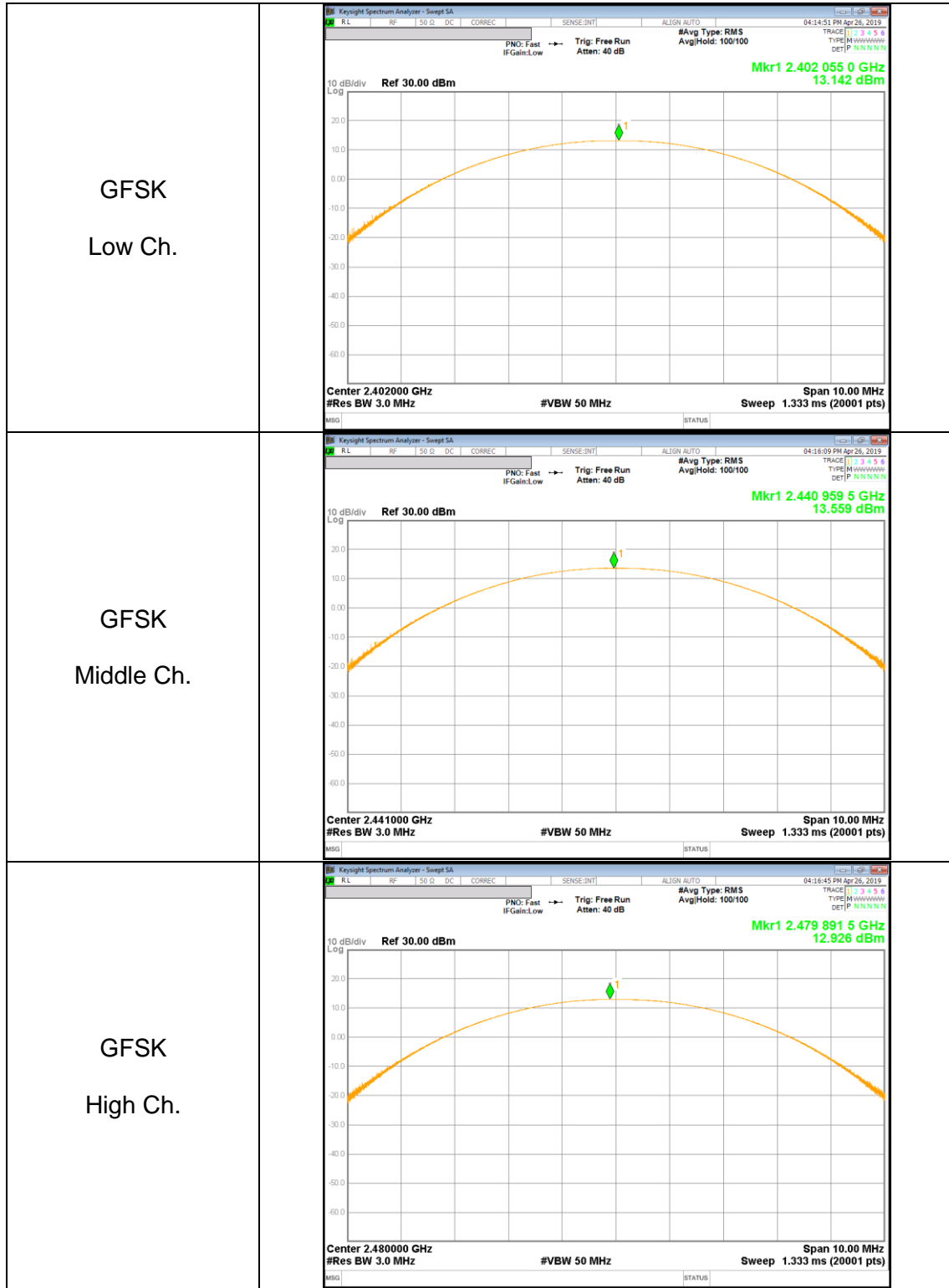
GFSK OUTPUT POWER

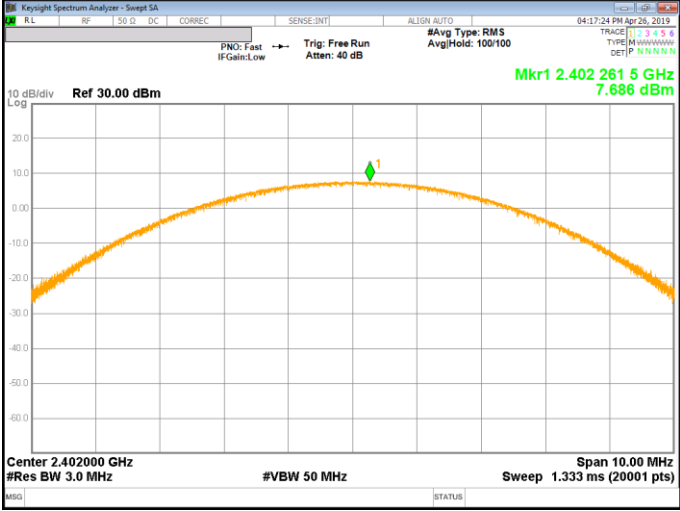

Pi/4-DPSK OUTPUT POWER

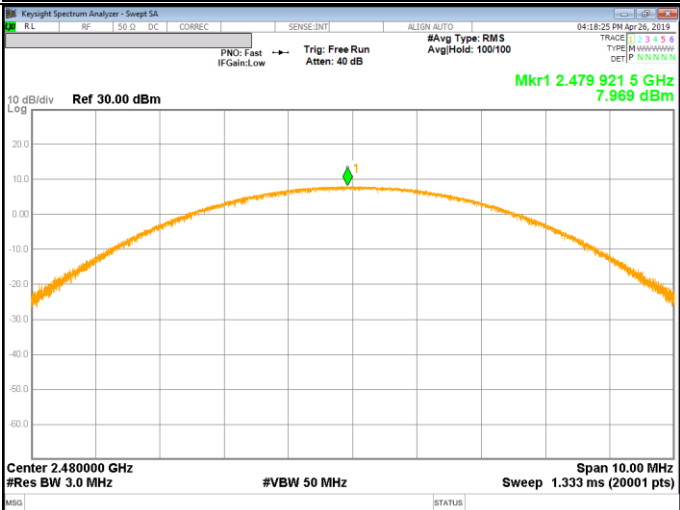
<p>Pi/4-DPSK Low Ch.</p>	 <p>Keyight Spectrum Analyzer - Swept SA PNO: Fast IF Gain: Low Trig: Free Run Atten: 40 dB #Avg Type: RMS Avg Hold: 100/100 Ref 30.00 dBm Mkr1 2.402 261 5 GHz 7.686 dBm 10 dB/div LOG Center 2.402000 GHz #Res BW 3.0 MHz #VBW 50 MHz Span 10.00 MHz Sweep 1.333 ms (20001 pts)</p>
<p>Pi/4-DPSK Middle Ch.</p>	 <p>Keyight Spectrum Analyzer - Swept SA PNO: Fast IF Gain: Low Trig: Free Run Atten: 40 dB #Avg Type: RMS Avg Hold: 100/100 Ref 30.00 dBm Mkr1 2.441 265 5 GHz 9.182 dBm 10 dB/div LOG Center 2.441000 GHz #Res BW 3.0 MHz #VBW 50 MHz Span 10.00 MHz Sweep 1.333 ms (20001 pts)</p>
<p>Pi/4-DPSK High Ch.</p>	 <p>Keyight Spectrum Analyzer - Swept SA PNO: Fast IF Gain: Low Trig: Free Run Atten: 40 dB #Avg Type: RMS Avg Hold: 100/100 Ref 30.00 dBm Mkr1 2.479 921 5 GHz 7.969 dBm 10 dB/div LOG Center 2.480000 GHz #Res BW 3.0 MHz #VBW 50 MHz Span 10.00 MHz Sweep 1.333 ms (20001 pts)</p>

8PSK OUTPUT POWER

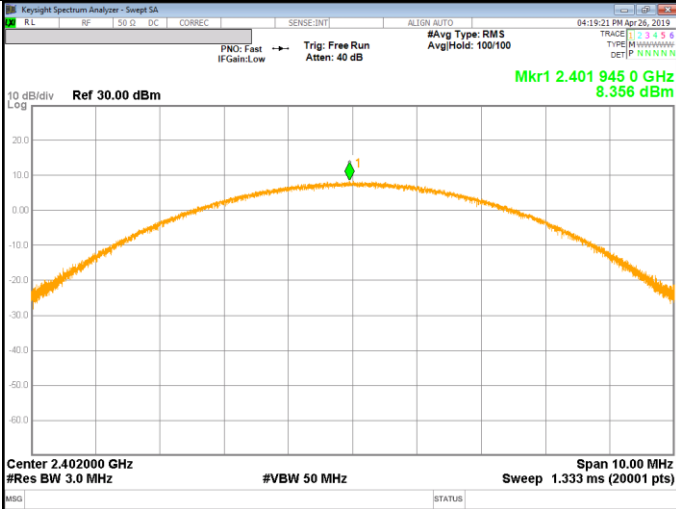
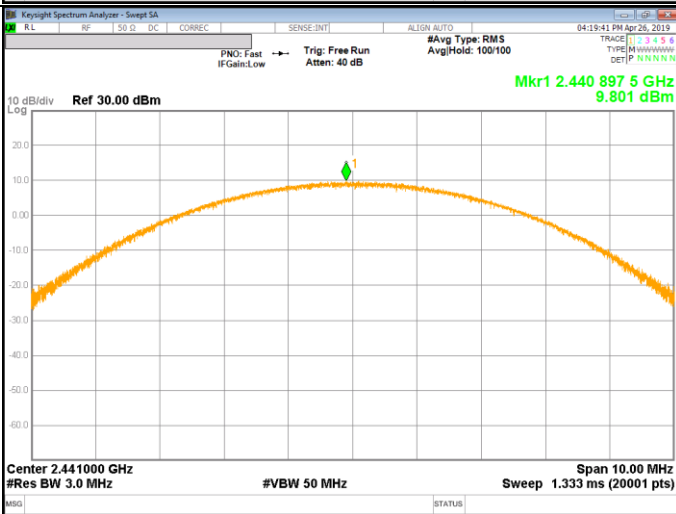
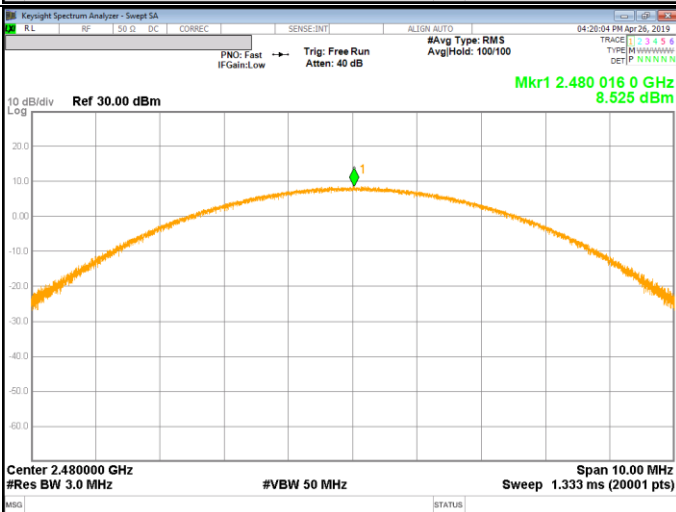
<p>8PSK Low Ch.</p>	 <p>Keyight Spectrum Analyzer - Swept SA PNO: Fast IF Gain: Low Trig: Free Run Atten: 40 dB #Avg Type: RMS AvgHold: 100/100 04:19:21 PM Apr 26, 2019 Ref 30.00 dBm Mkr1 2.401 945 0 GHz 8.356 dBm 10 dB/div LOG Center 2.402000 GHz #Res BW 3.0 MHz #VBW 50 MHz Span 10.00 MHz Sweep 1.333 ms (20001 pts)</p>
<p>8PSK Middle Ch.</p>	 <p>Keyight Spectrum Analyzer - Swept SA PNO: Fast IF Gain: Low Trig: Free Run Atten: 40 dB #Avg Type: RMS AvgHold: 100/100 04:19:41 PM Apr 26, 2019 Ref 30.00 dBm Mkr1 2.440 897 5 GHz 9.801 dBm 10 dB/div LOG Center 2.441000 GHz #Res BW 3.0 MHz #VBW 50 MHz Span 10.00 MHz Sweep 1.333 ms (20001 pts)</p>
<p>8PSK High Ch.</p>	 <p>Keyight Spectrum Analyzer - Swept SA PNO: Fast IF Gain: Low Trig: Free Run Atten: 40 dB #Avg Type: RMS AvgHold: 100/100 04:20:04 PM Apr 26, 2019 Ref 30.00 dBm Mkr1 2.480 016 0 GHz 8.525 dBm 10 dB/div LOG Center 2.480000 GHz #Res BW 3.0 MHz #VBW 50 MHz Span 10.00 MHz Sweep 1.333 ms (20001 pts)</p>

10.5. AVERAGE POWER

LIMIT

None; for reporting purposes only.

TEST PROCEDURE

The transmitter output is connected to a power meter.

RESULTS

The cable assembly insertion loss was entered as an offset in the power meter to allow for direct reading of power.

10.5.1. BASIC DATA RATE GFSK MODULATION

Channel	Frequency [MHz]	AV power [dBm]	AV power [mW]
Low	2 402	12.950	19.724
Middle	2 441	13.371	21.732
High	2 480	12.709	18.659

10.5.2. ENHANCED DATA RATE PI/4-DQPSK MODULATION

Channel	Frequency [MHz]	AV power [dBm]	AV power [mW]
Low	2 402	5.222	3.328
Middle	2 441	6.629	4.601
High	2 480	5.566	3.602

10.5.3. ENHANCED DATA RATE 8PSK MODULATION

Channel	Frequency [MHz]	AV power [dBm]	AV power [mW]
Low	2 402	5.092	3.230
Middle	2 441	6.740	4.721
High	2 480	5.624	3.651

10.6. CONDUCTED SPURIOUS EMISSIONS

LIMITS

FCC §15.247 (d)

Limit = -20 dBc

TEST PROCEDURE

The transmitter output is connected to a spectrum analyzer. The resolution bandwidth is set to 100 kHz. The video bandwidth is set to 300 kHz.

The spectrum from 30 MHz to 26 GHz is investigated with the transmitter set to the lowest, middle, and highest channels.

The bandedges at 2.4 and 2.4835 GHz are investigated with the transmitter set to the normal hopping mode.

RESULTS

10.6.1. BASIC DATA RATE GFSK MODULATION

GFSK Mode

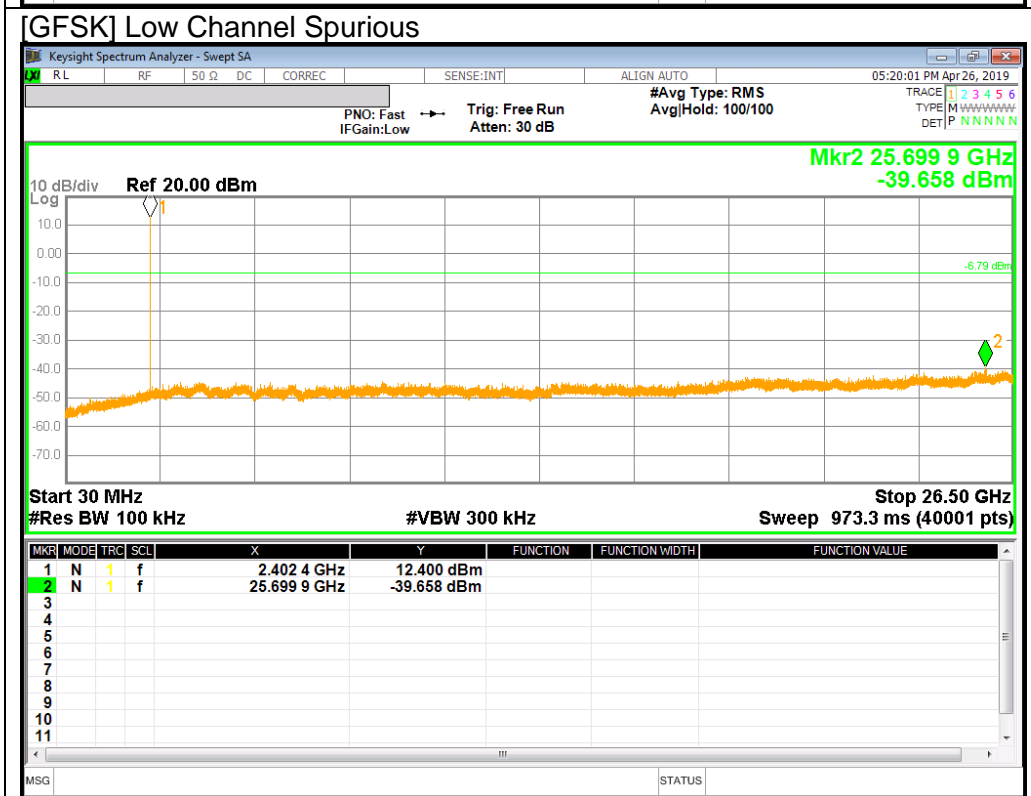
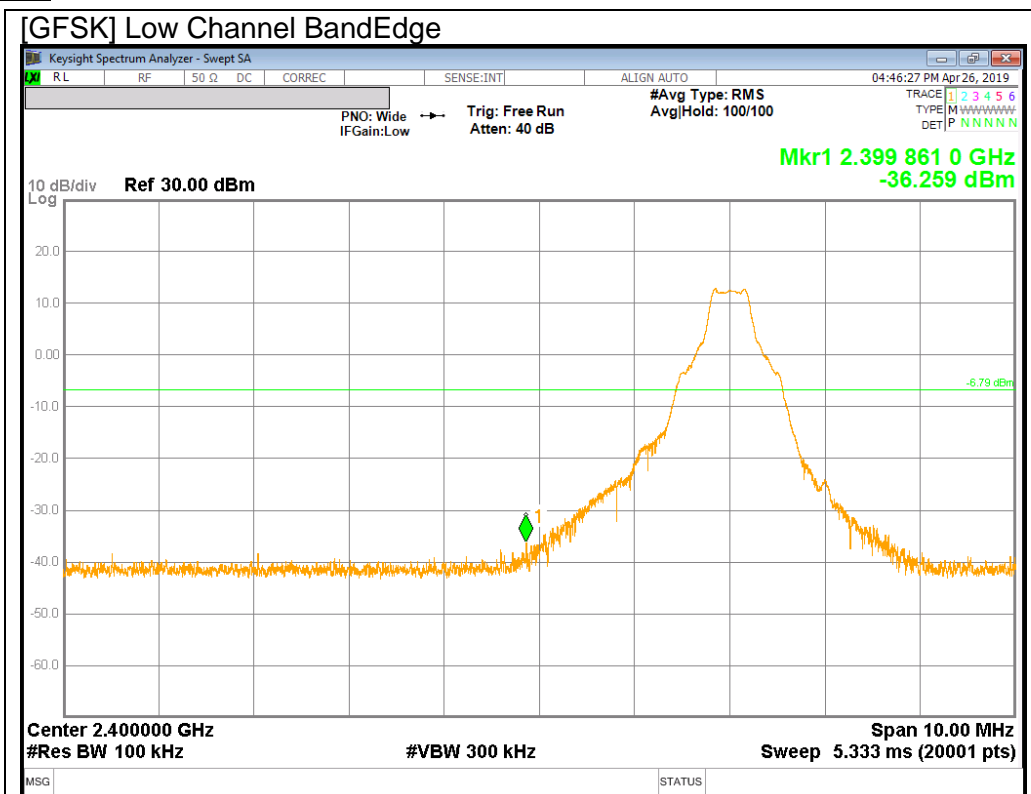

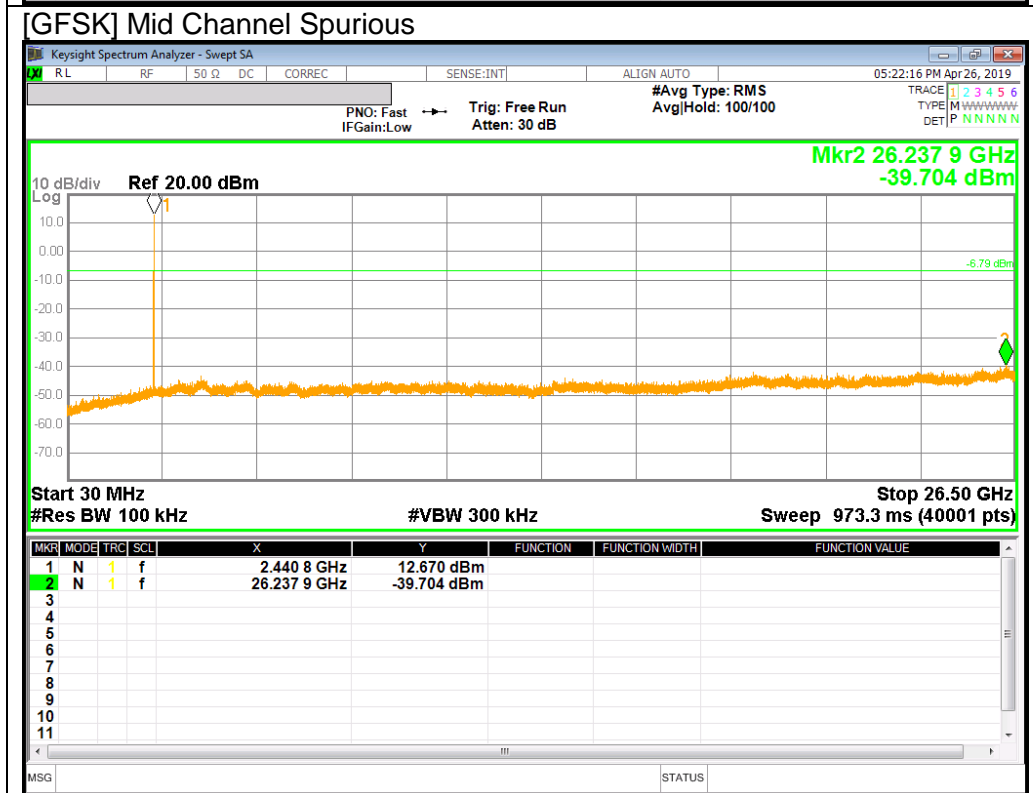
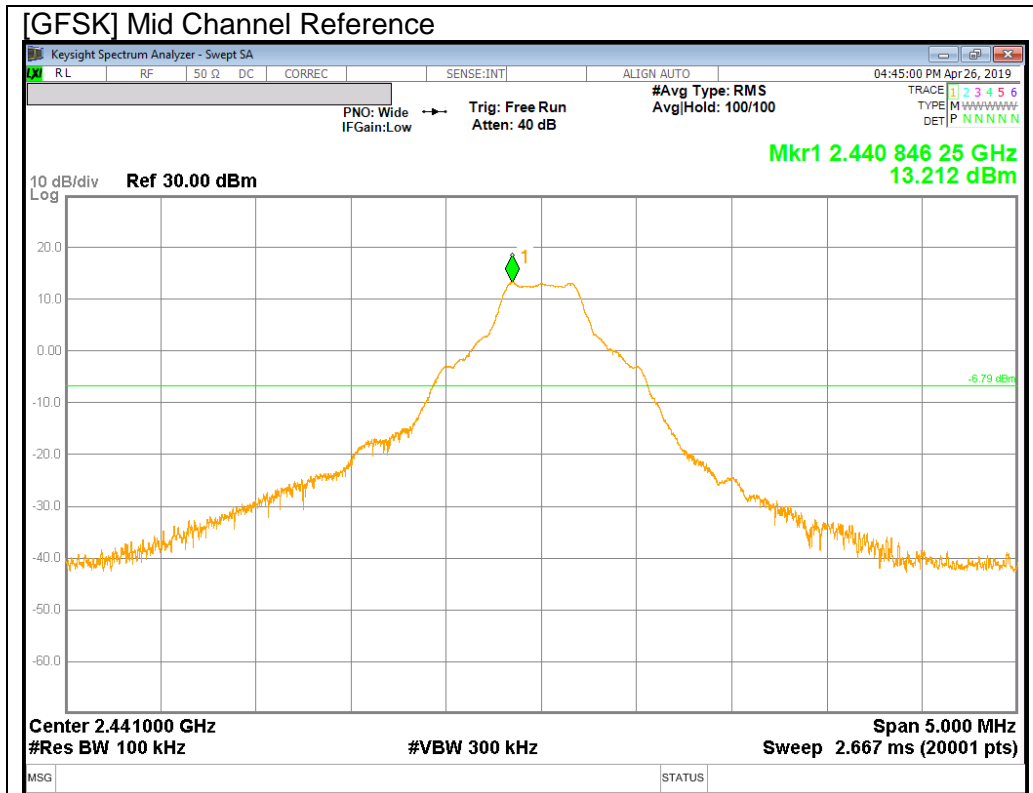

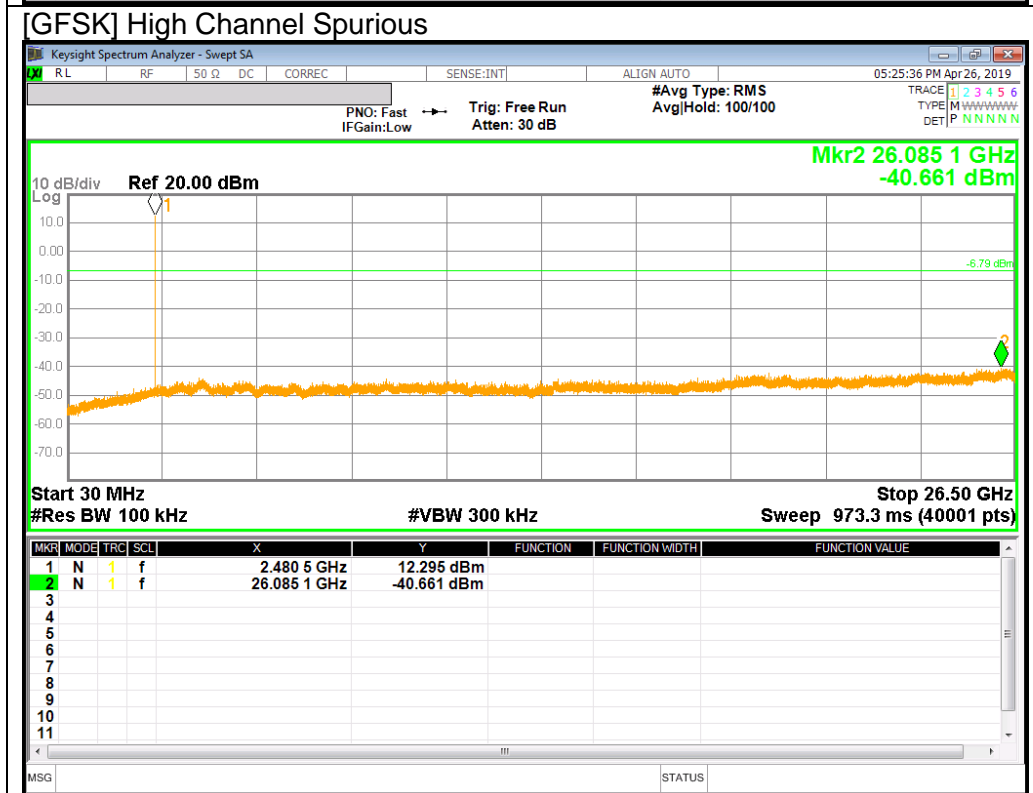
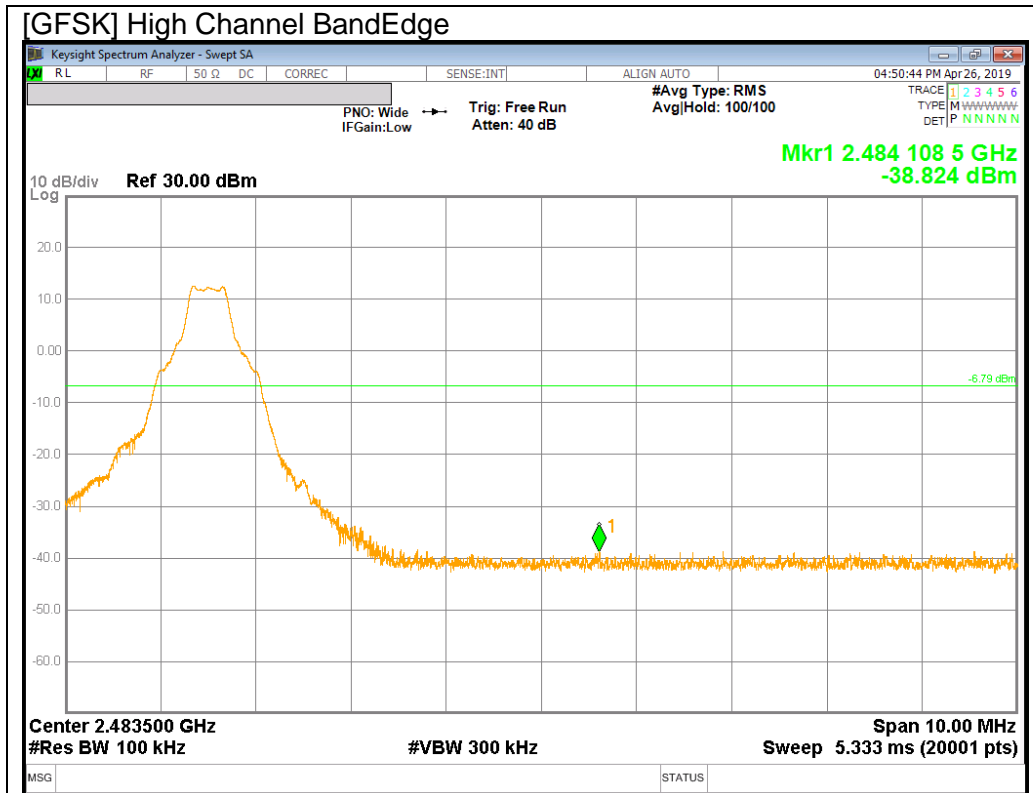

BandEdge Emission at GFSK Hopping Mode

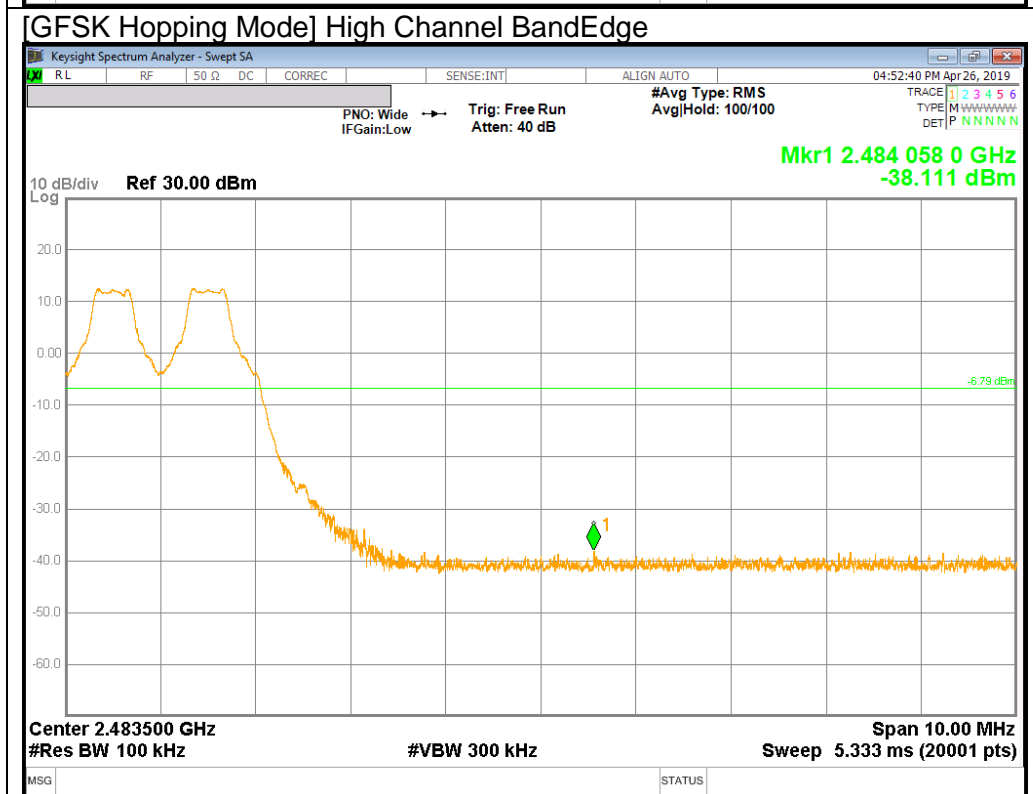
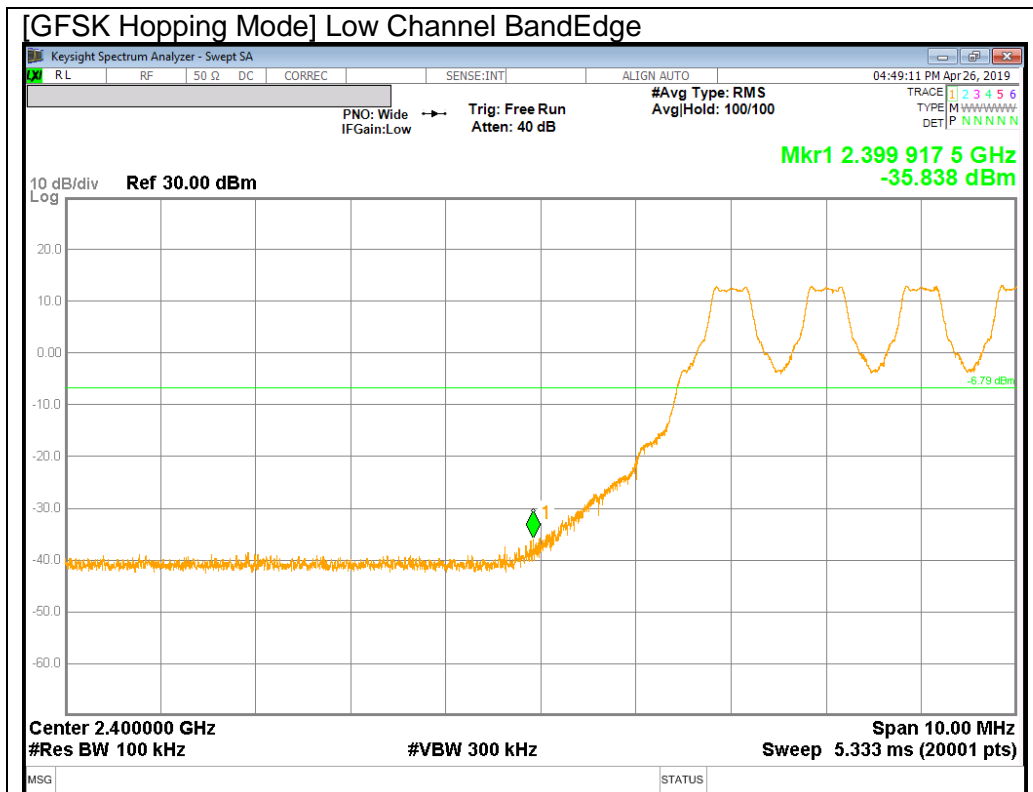

10.6.2. ENHANCED DATA RATE PI/4-DQPSK MODULATION

PI/4-DQPSK Mode

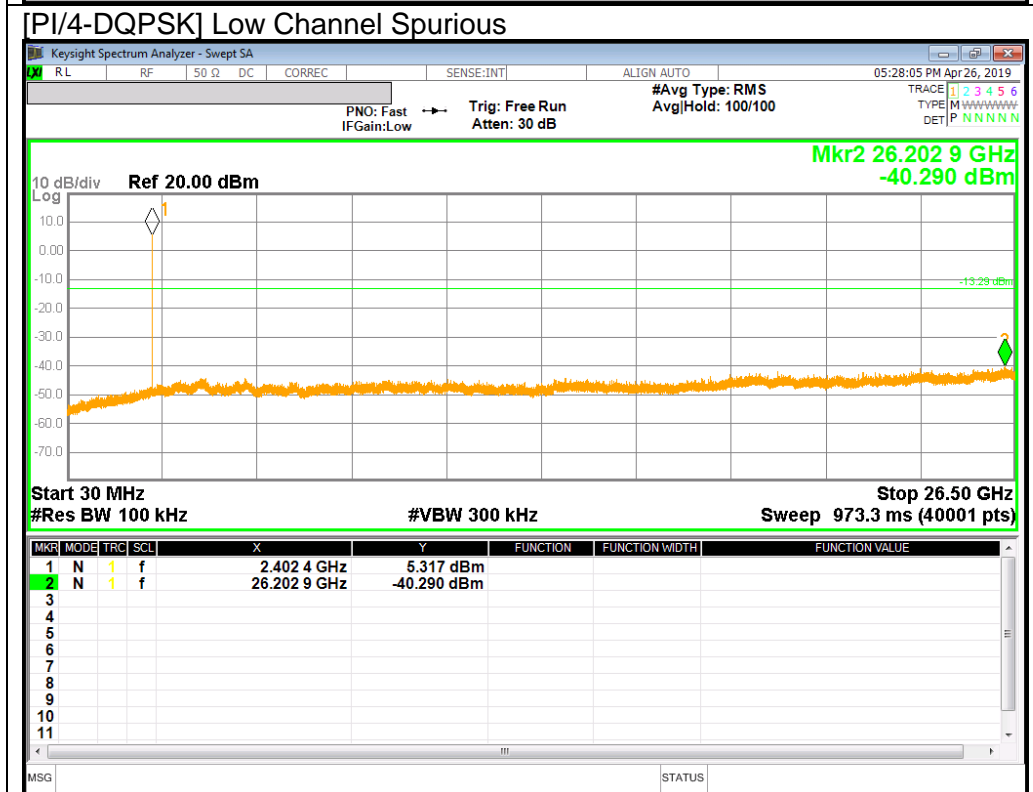
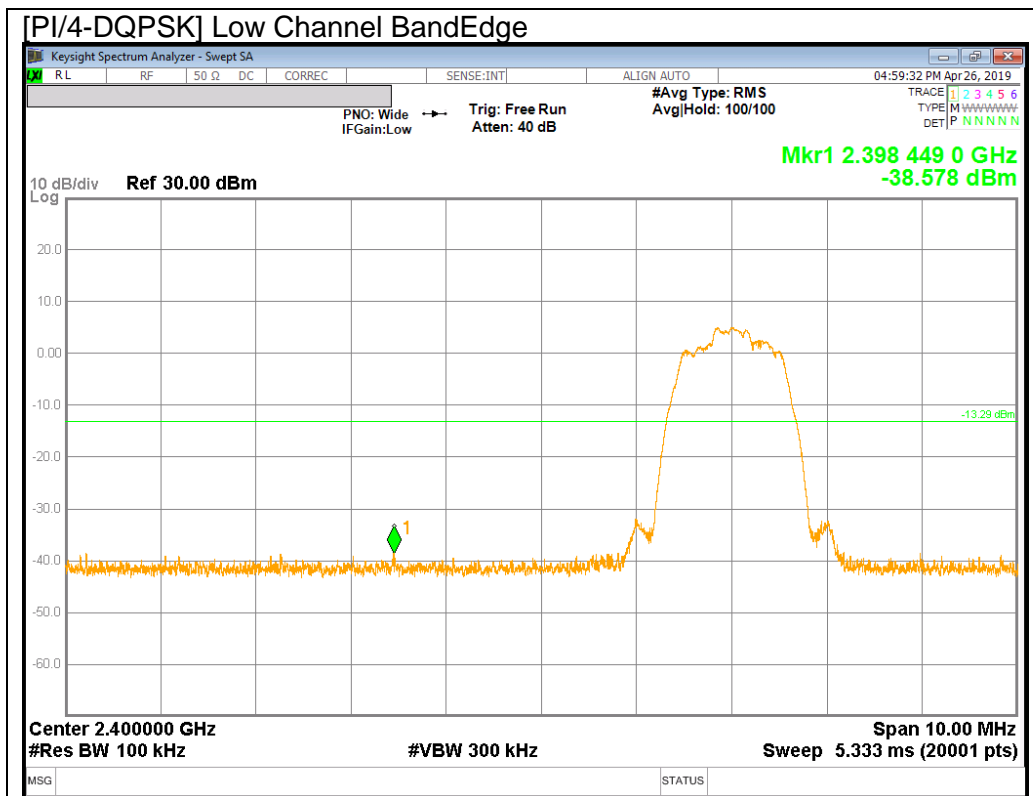

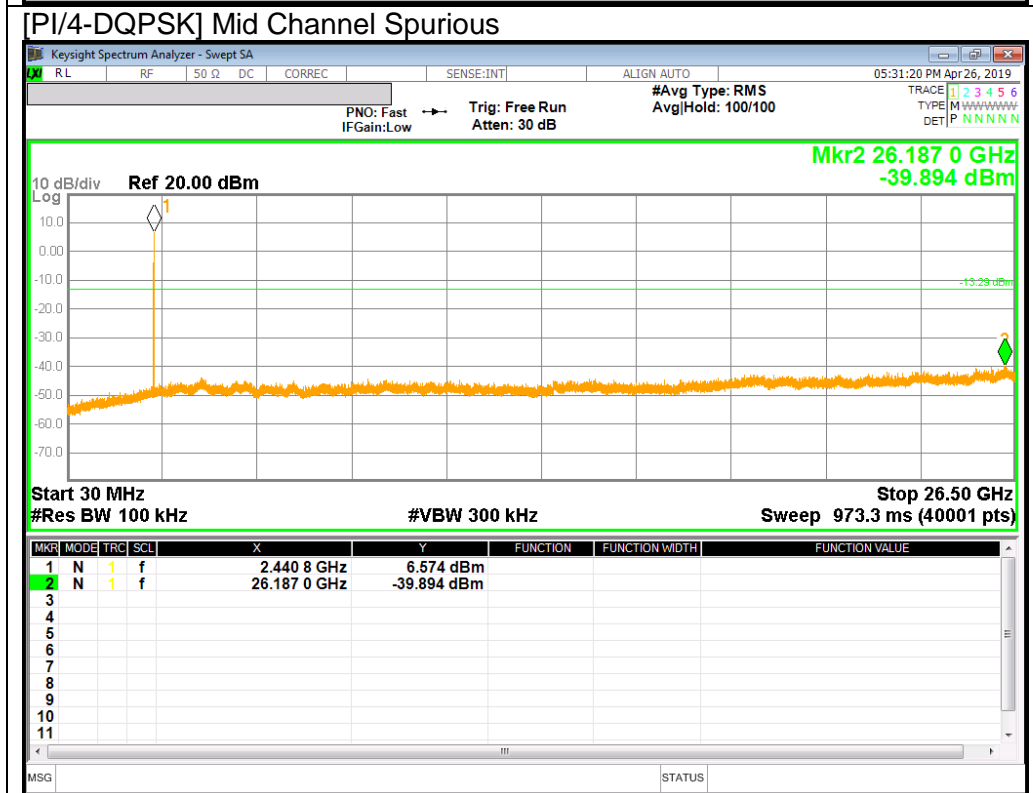
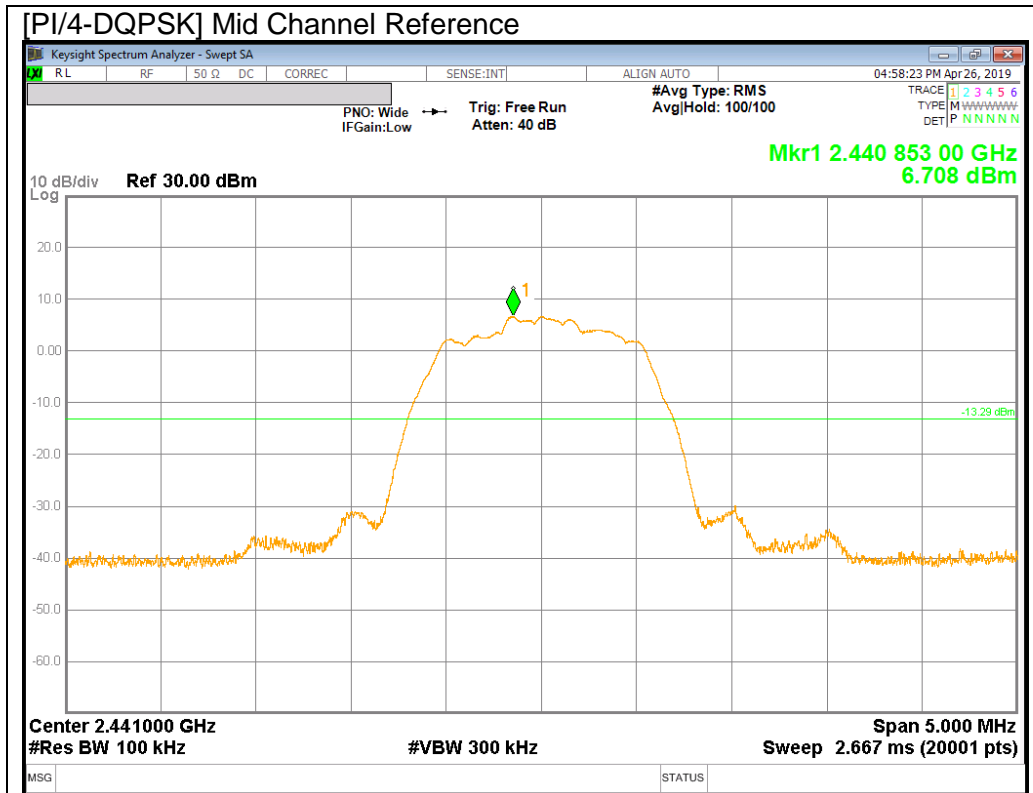

10.6.3. ENHANCED DATA RATE 8PSK MODULATION

8PSK Mode

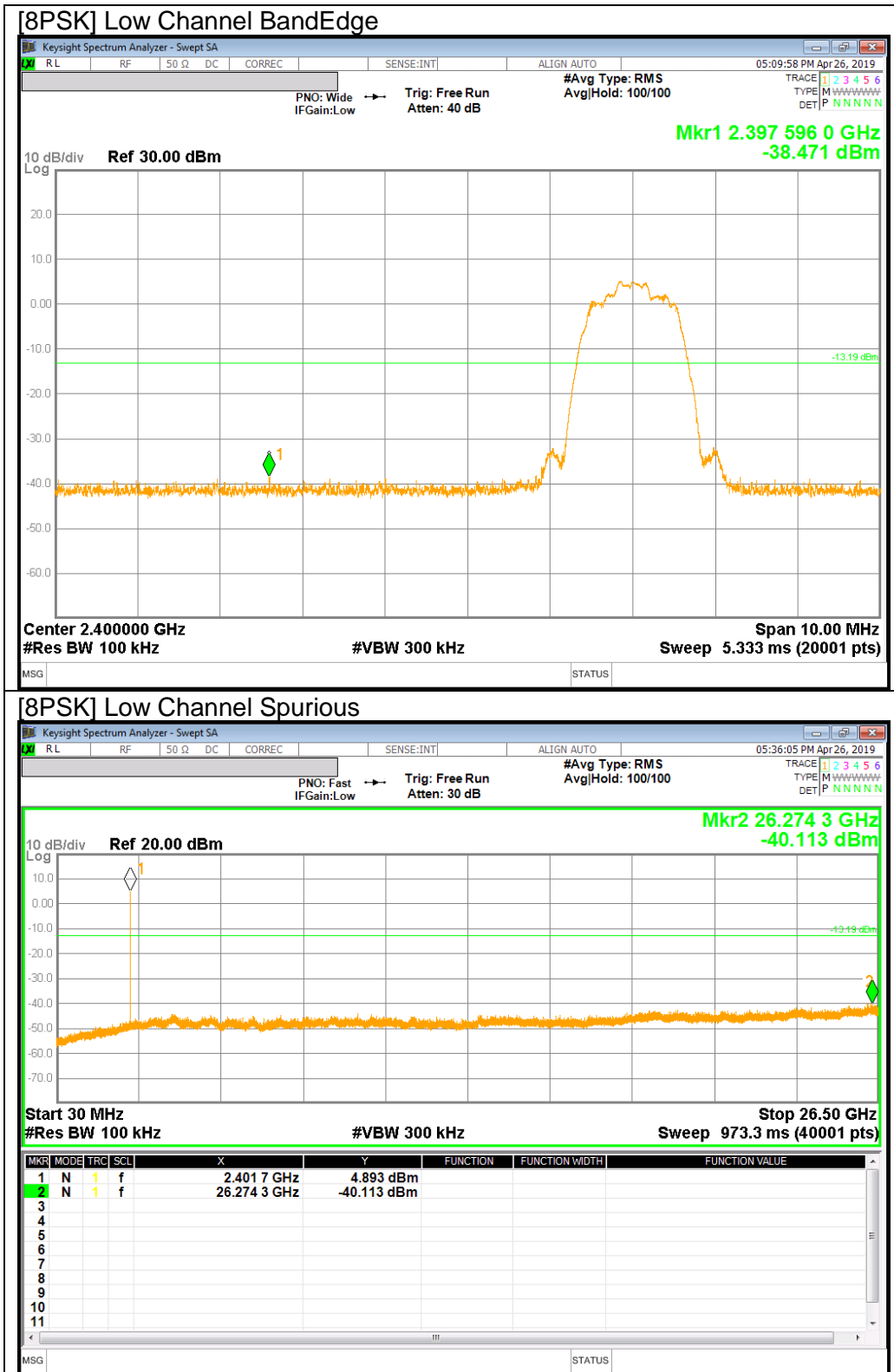

11. RADIATED TEST RESULTS

11.1. LIMITS AND PROCEDURE

LIMITS

FCC §15.205 and §15.209

Limits for radiated disturbance of an intentional radiator		
Frequency range (MHz)	Limits (µV/m)	Measurement Distance (m)
0.009 – 0.490	2400 / F (kHz)	300
0.490 – 1.705	24000 / F (kHz)	30
1.705 – 30.0	30	30
30 – 88	100**	3
88 - 216	150**	3
216 – 960	200**	3
Above 960	500	3

** Except as provided in paragraph (g), fundamental emissions from intentional radiators operating under this section shall not be located in the frequency bands 54-72 MHz, 76-88 MHz, 174-216 MHz or 470-806 MHz. However, operation within these frequency bands is permitted under other sections of this part, e.g. §§ 15.231 and 15.241.

TEST PROCEDURE

The EUT is placed on a non-conducting table 80 cm above the ground plane for below 1GHz and 150 cm for above 1GHz. The EUT is configured in accordance with ANSI C63.10. The EUT is set to transmit in a continuous mode.

For measurements below 1 GHz the resolution bandwidth is set to 100 kHz for peak detection measurements or 120 kHz for quasi-peak detection measurements. Peak detection is used unless otherwise noted as quasi-peak.

For measurements above 1 GHz the resolution bandwidth is set to 1 MHz; the video bandwidth is set to 3 MHz for peak measurements.(Pre-scans to detect harmonic and spurious emissions, the resolution bandwidth is set to 1 MHz; the video bandwidth is set to 30 KHz for peak measurements.)

For band edge measurements above 1 GHz the resolution bandwidth is set to 1 MHz, then the video bandwidth is set to 3 MHz for peak measurements and 1/T (on time) for average measurement.

$$\text{GFSK} = 1/T = 1 / 0.002882\text{S} = 347\text{Hz}.$$

The minimum VBW was 347Hz, but test receiver(ESU40) couldn't set value 347Hz. Due to this reason, testing VBW was set to 500Hz(Worst cases).

The spectrum from 1GHz to 26 GHz is investigated with the transmitter set to the lowest, middle, and highest channels in the 2.4 GHz band.
(From 30MHz to 1GHz, test was performed with the EUT set to transmit at the channel with highest output power)

The frequency range of interest is monitored at a fixed antenna height and EUT azimuth. The EUT is rotated through 360 degrees to maximize emissions received. The antenna is scanned from 1 to 4 meters above the ground plane to further maximize the emission. Measurements are made with the antenna polarized in both the vertical and the horizontal positions.

Note : Emission was pre-scanned from 9KHz to 30MHz; No emissions were detected which was at least 20dB below the specification limit (consider distance correction factor).
Per FCC part 15.31(o), test results were not reported.

Although these tests were performed other than open field test site, adequate comparison measurements were confirmed against 30 m open are test site.
Therefore sufficient tests were made to demonstrate that the alternative site produces results that correlate with the one of tests made in an open field based on KDB 414788.

11.1. TRANSMITTER ABOVE 1 GHz

11.1.1. BASIC DATA RATE GFSK MODULATION

RESTRICTED BANDEDGE (LOW CHANNEL)

HORIZONTAL PEAK AND AVERAGE PLOT

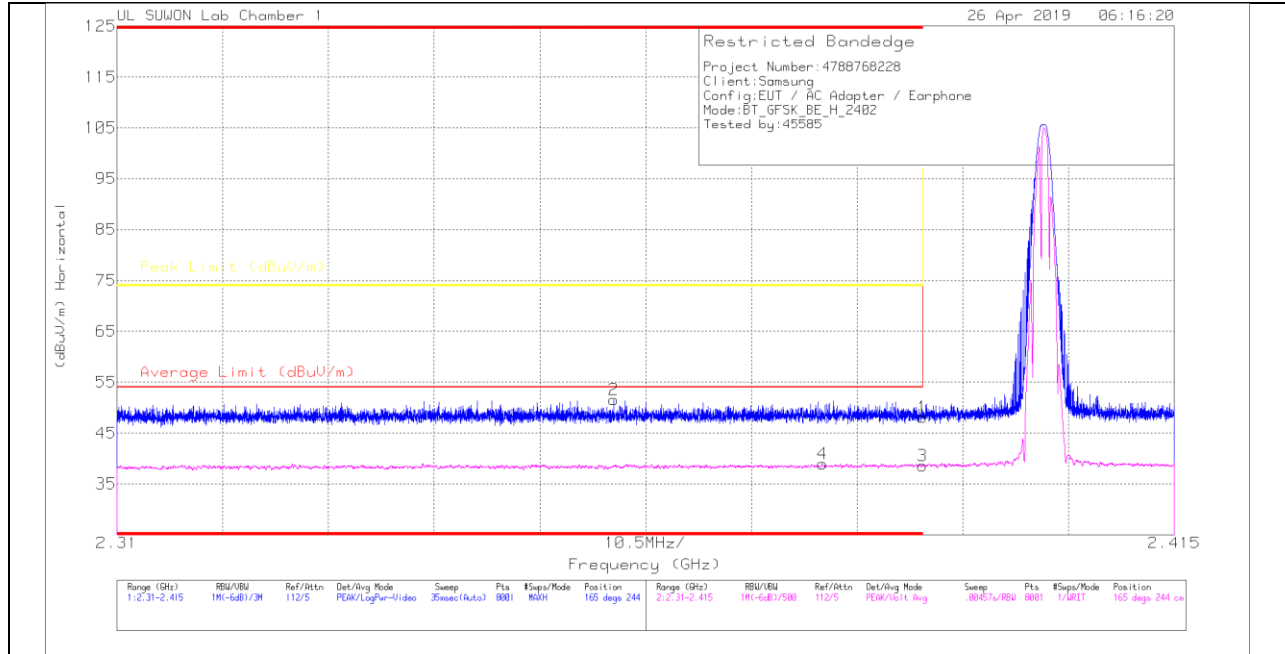

HORIZONTAL DATA

Trace Markers

Marker	Frequency (GHz)	Meter Reading (dBuV)	Det	3117_00168717	10dB[dB]	Corrected Reading (dBuV/m)	Average Limit (dBuV/m)	Margin (dB)	Peak Limit (dBuV/m)	PK Margin (dB)	Azimuth (Degs)	Height (cm)	Polarity
1	* 2.39	41.92	Pk	31.7	-25.5	48.12	-	-	74	-25.88	165	244	H
2	* 2.359	45.66	Pk	31.6	-25.7	51.56	-	-	74	-22.44	165	244	H
3	* 2.39	32.39	VA1T	31.7	-25.5	38.59	54	-15.41	-	-	165	244	H
4	* 2.38	32.87	VA1T	31.6	-25.5	38.97	54	-15.03	-	-	165	244	H

* - indicates frequency in CFR47 Pt 15 / IC RSS-Restricted Band

Pk - Peak detector

VA1T - FHSS: Linear Voltage Average VB=1/Ton where: Ton is transmit duration

VERTICAL PEAK AND AVERAGE PLOT

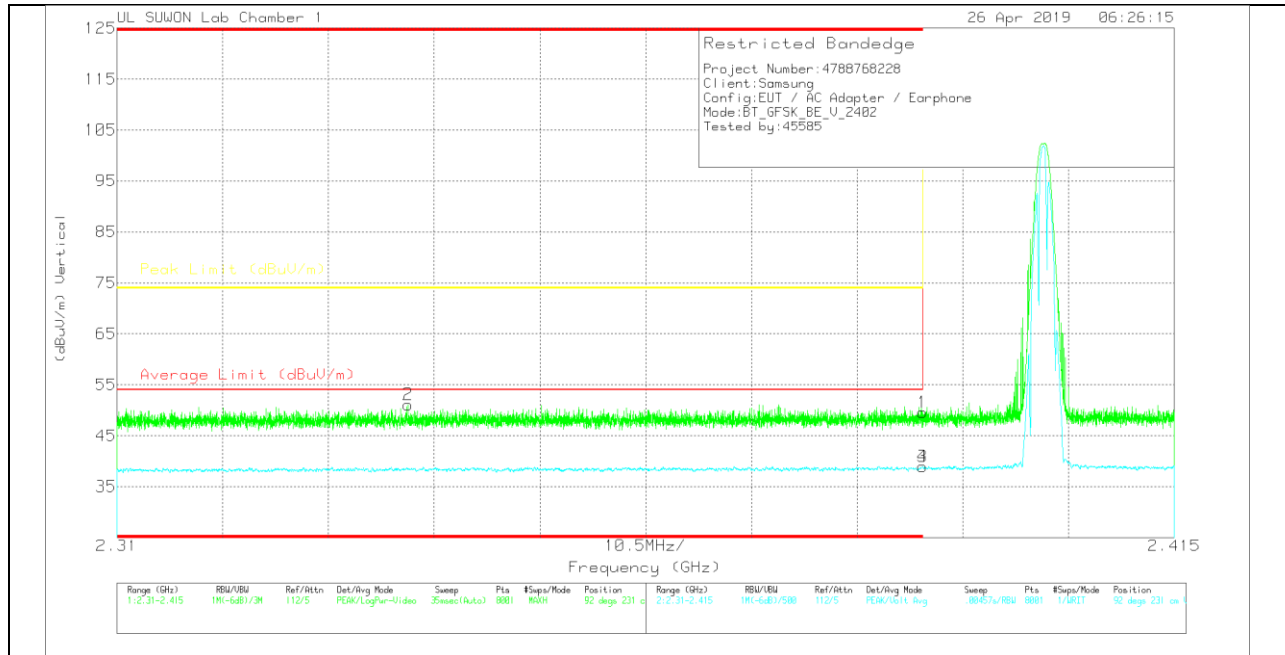

VERTICAL DATA

Trace Markers

Marker	Frequency (GHz)	Meter Reading (dBuV)	Det	3117_00168717	10dB[dB]	Corrected Reading (dBuV/m)	Average Limit (dBuV/m)	Margin (dB)	Peak Limit (dBuV/m)	PK Margin (dB)	Azimuth (Degs)	Height (cm)	Polarity
1	* 2.39	43.33	Pk	31.7	-25.5	49.53	-	-	74	-24.47	92	231	V
2	* 2.339	45.33	Pk	31.5	-25.7	51.13	-	-	74	-22.87	92	231	V
3	* 2.39	32.73	VA1T	31.7	-25.5	38.93	54	-15.07	-	-	92	231	V
4	* 2.39	32.75	VA1T	31.7	-25.5	38.95	54	-15.05	-	-	92	231	V

* - indicates frequency in CFR47 Pt 15 / IC RSS-Restricted Band

Pk - Peak detector

VA1T - FHSS: Linear Voltage Average $V_B=1/T_{on}$ where: T_{on} is transmit duration

AUTHORIZED BANDEDGE (HIGH CHANNEL)

HORIZONTAL PEAK AND AVERAGE PLOT

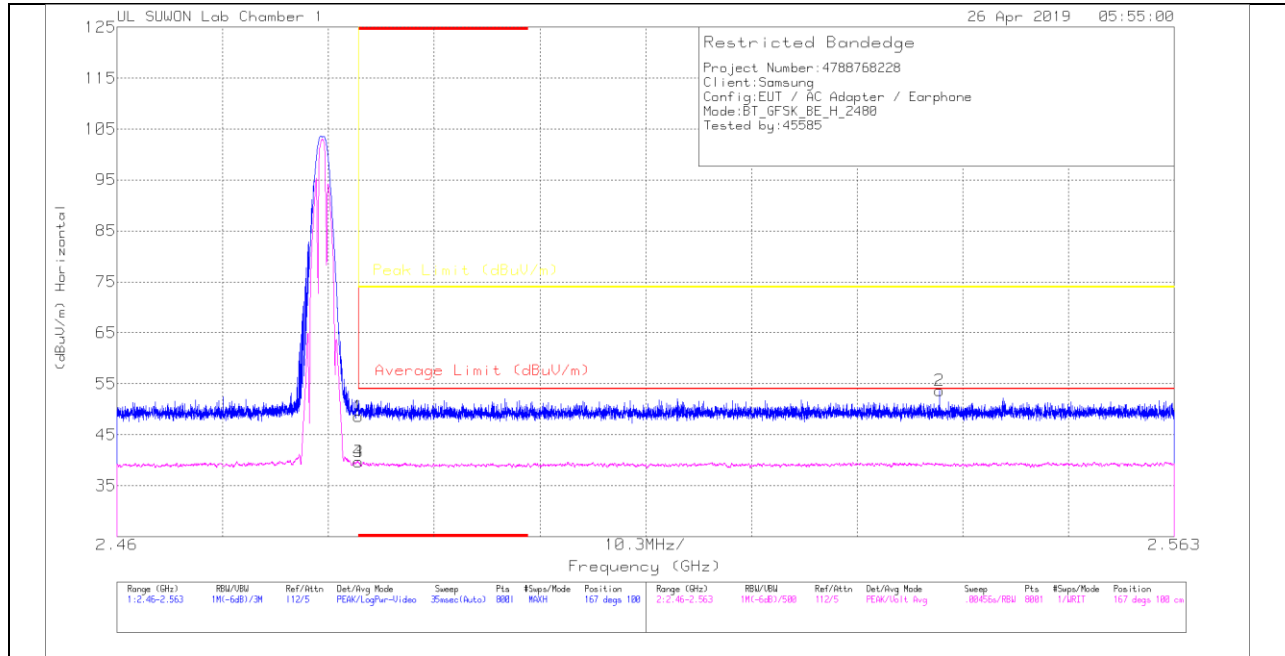

HORIZONTAL DATA

Trace Markers

Marker	Frequency (GHz)	Meter Reading (dBuV)	Det	3117_00168717	10dB(dB)	Corrected Reading (dBuV/m)	Average Limit (dBuV/m)	Margin (dB)	Peak Limit (dBuV/m)	PK Margin (dB)	Azimuth (Degs)	Height (cm)	Polarity
1	* 2.484	41.97	PK	31.9	-25.3	48.57	-	-	74	-25.43	167	100	H
2	2.54	46.82	PK	32	-25.2	53.62	-	-	74	-20.38	167	100	H
3	* 2.484	33.08	VA1T	31.9	-25.3	39.68	54	-14.32	-	-	167	100	H
4	* 2.484	33.08	VA1T	31.9	-25.3	39.68	54	-14.32	-	-	167	100	H

* - indicates frequency in CFR47 Pt 15 / IC RSS-Restricted Band

PK - Peak detector

VA1T - FHSS: Linear Voltage Average VB=1/Ton where: Ton is transmit duration

VERTICAL PEAK AND AVERAGE PLOT

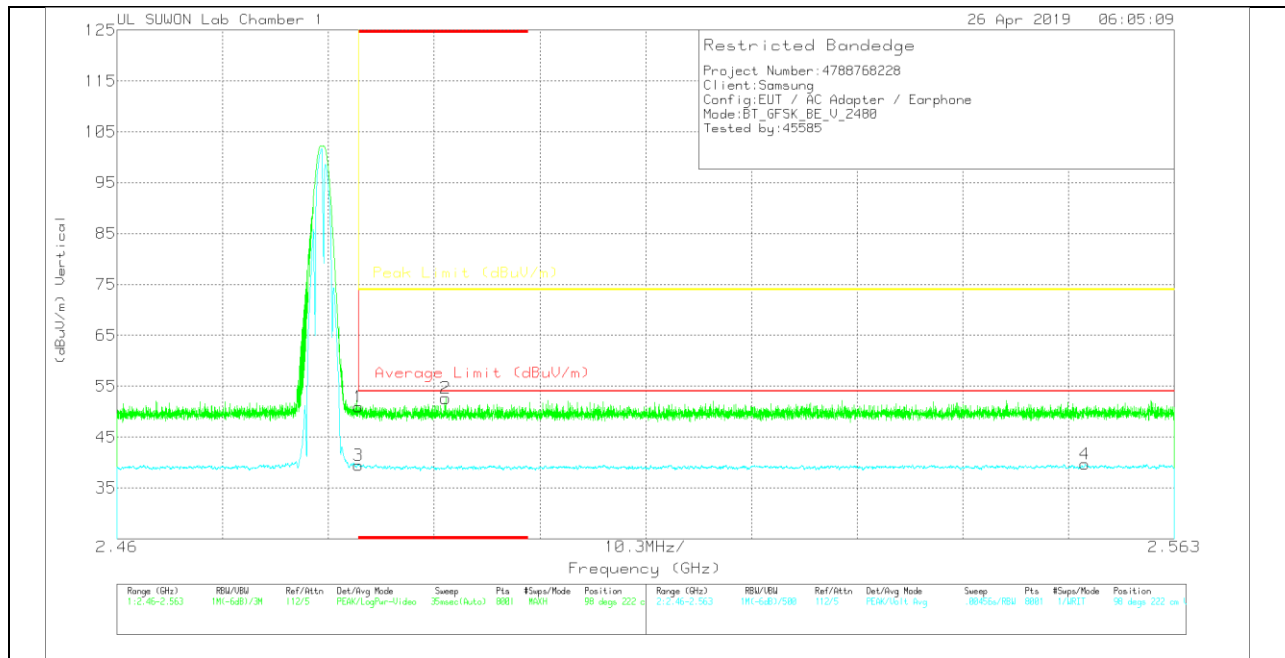

VERTICAL DATA

Trace Markers

Marker	Frequency (GHz)	Meter Reading (dBuV)	Det	3117_00168717	10dB(dB)	Corrected Reading (dBuV/m)	Average Limit (dBuV/m)	Margin (dB)	Peak Limit (dBuV/m)	PK Margin (dB)	Azimuth (Degs)	Height (cm)	Polarity
1	* 2.484	44.4	Pk	31.9	-25.3	51	-	-	74	-23	98	222	V
2	* 2.492	45.92	Pk	31.9	-25.2	52.62	-	-	74	-21.38	98	222	V
3	* 2.484	32.89	VA1T	31.9	-25.3	39.49	54	-14.51	-	-	98	222	V
4	2.554	32.74	VA1T	32	-25.1	39.64	54	-14.36	-	-	98	222	V

* - indicates frequency in CFR47 Pt 15 / IC RSS-Restricted Band

Pk - Peak detector

VA1T - FHSS: Linear Voltage Average $VB=1/Ton$ where: Ton is transmit duration

HARMONICS AND SPURIOUS EMISSIONS

LOW CHANNEL HORIZONTAL

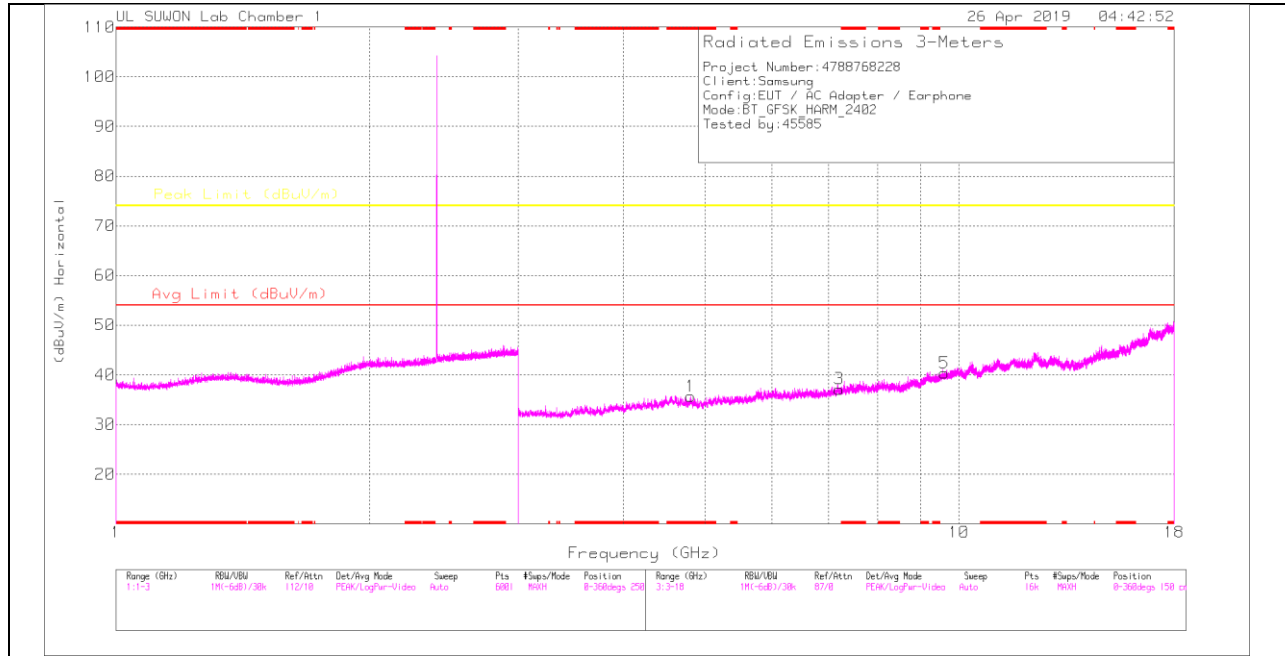

LOW CHANNEL VERTICAL

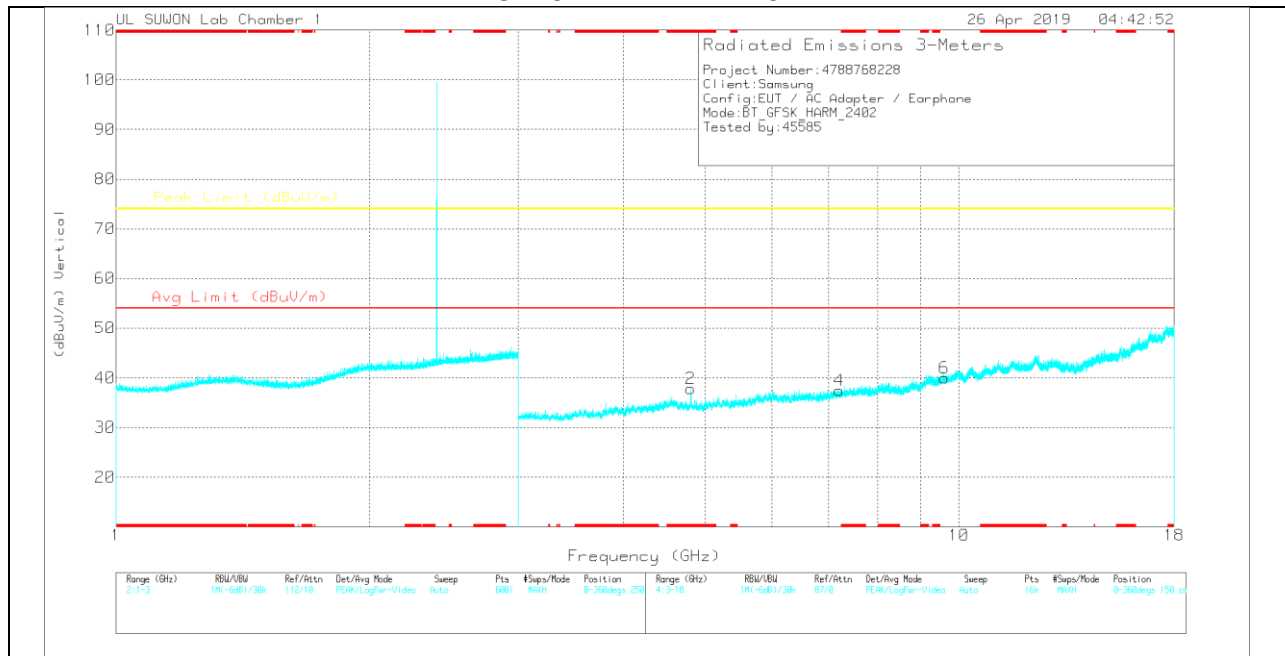

Note: Emission was scanned up to 26GHz; No emissions were detected above the noise floor which was at least 20dB below the specification limit.

LOW CHANNEL DATA

Trace Markers

Marker	Frequency (GHz)	Meter Reading (dBuV)	Det	3117_00168717	3GHz_HP[dB]	Corrected Reading (dBuV/m)	Avg Limit (dBuV/m)	Margin (dB)	Peak Limit (dBuV/m)	Margin (dB)	Azimuth (Degs)	Height (cm)	Polarity
1	* 4.804	32.88	PK	34.2	-31.4	35.68	-	-	74	-38.32	0-360	250	H
3	7.214	29.14	PK	35.8	-27.8	37.14	-	-	74	-36.86	0-360	250	H
5	9.608	26.45	PK	37	-23.1	40.35	-	-	74	-33.65	0-360	150	H
2	* 4.804	35.05	PK	34.2	-31.4	37.85	-	-	74	-36.15	0-360	150	V
4	7.209	29.59	PK	35.8	-27.9	37.49	-	-	74	-36.51	0-360	250	V
6	9.612	26.07	PK	37	-23.1	39.97	-	-	74	-34.03	0-360	250	V

* - indicates frequency in CFR47 Pt 15 / IC RSS-Restricted Band
 PK – Peak Detector

Radiated Emissions

Frequency (GHz)	Meter Reading (dBuV)	Det	3117_00168717	3GHz_HP[dB]	Corrected Reading (dBuV/m)	Avg Limit (dBuV/m)	Margin (dB)	Peak Limit (dBuV/m)	Margin (dB)	Azimuth (Degs)	Height (cm)	Polarity
* 4.804	41.04	PKFH	34.2	-31.4	43.84	-	-	74	-30.16	289	106	H
* 4.804	31.18	VA1T	34.2	-31.4	33.98	54	-20.02	-	-	289	106	H
* 4.804	41.95	PKFH	34.2	-31.4	44.75	-	-	74	-29.25	18	106	V
* 4.804	34.06	VA1T	34.2	-31.4	36.86	54	-17.14	-	-	18	106	V

* - indicates frequency in CFR47 Pt 15 / IC RSS-Restricted Band
 PKFH - FHSS: RB=100k/1MHz VB=3 x RB, Peak
 VA1T - FHSS: Linear Voltage Average VB=1/Ton where: Ton is transmit duration

MID CHANNEL HORIZONTAL

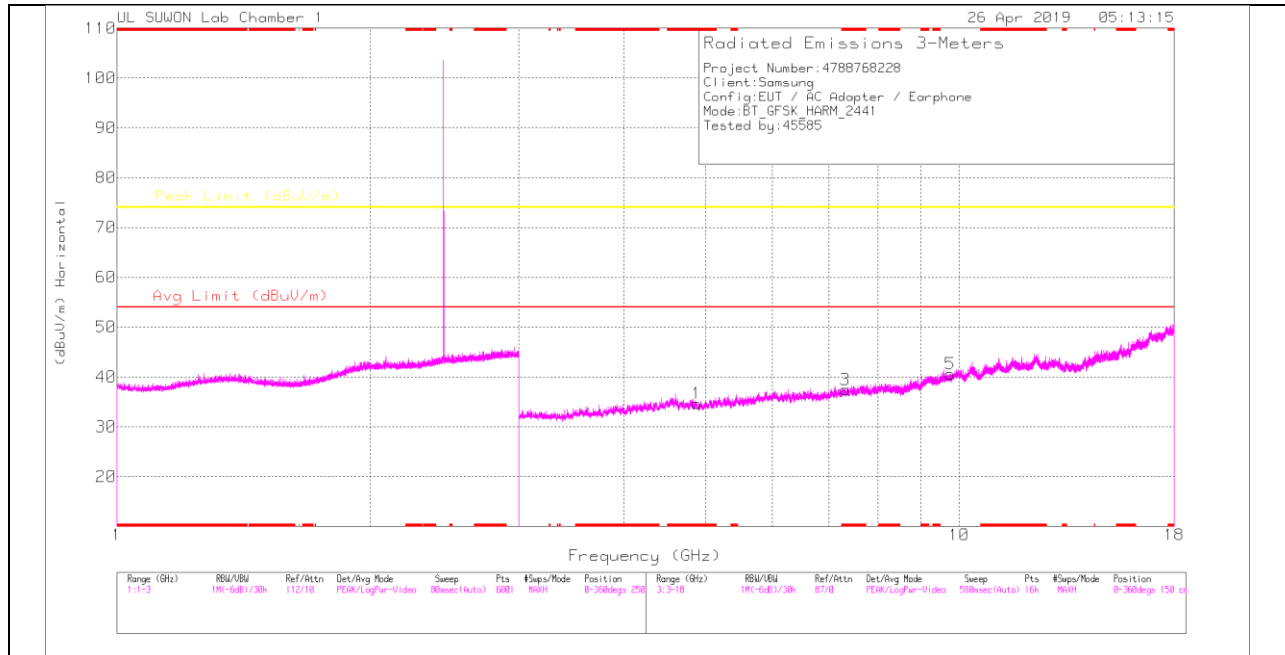

MID CHANNEL VERTICAL

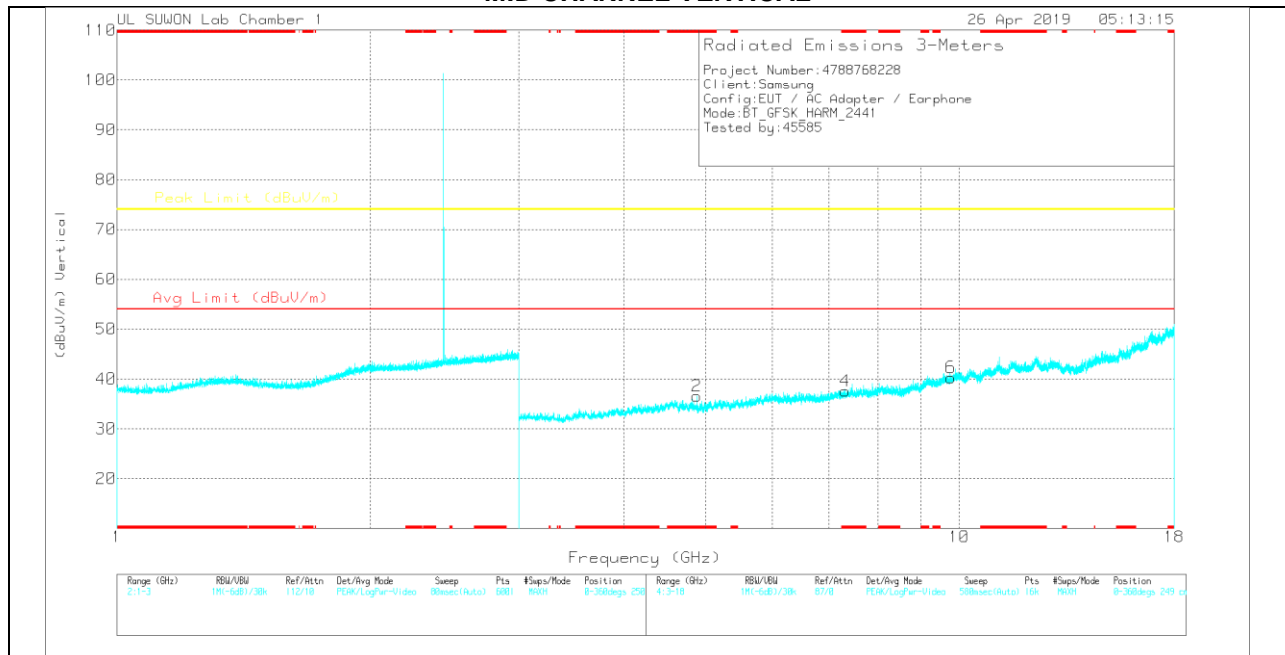

Note: Emission was scanned up to 26GHz; No emissions were detected above the noise floor which was at least 20dB below the specification limit.

MID CHANNEL DATA

Trace Markers

Marker	Frequency (GHz)	Meter Reading (dBuV)	Det	3117_00168717	3GHz_HP[dB]	Corrected Reading (dBuV/m)	Avg Limit (dBuV/m)	Margin (dB)	Peak Limit (dBuV/m)	Margin (dB)	Azimuth (Degs)	Height (cm)	Polarity
1	* 4.881	31.94	PK	34.2	-31.5	34.64	-	-	74	-39.36	0-360	249	H
3	* 7.323	29	PK	35.8	-27.3	37.5	-	-	74	-36.5	0-360	249	H
5	9.764	27.32	PK	37.2	-23.9	40.62	-	-	74	-33.38	0-360	150	H
2	* 4.881	33.88	PK	34.2	-31.5	36.58	-	-	74	-37.42	0-360	150	V
4	* 7.323	29.06	PK	35.8	-27.3	37.56	-	-	74	-36.44	0-360	150	V
6	9.768	26.9	PK	37.3	-23.9	40.3	-	-	74	-33.7	0-360	150	V

* - indicates frequency in CFR47 Pt 15 / IC RSS-Restricted Band
 PK – Peak Detector

HIGH CHANNEL HORIZONTAL

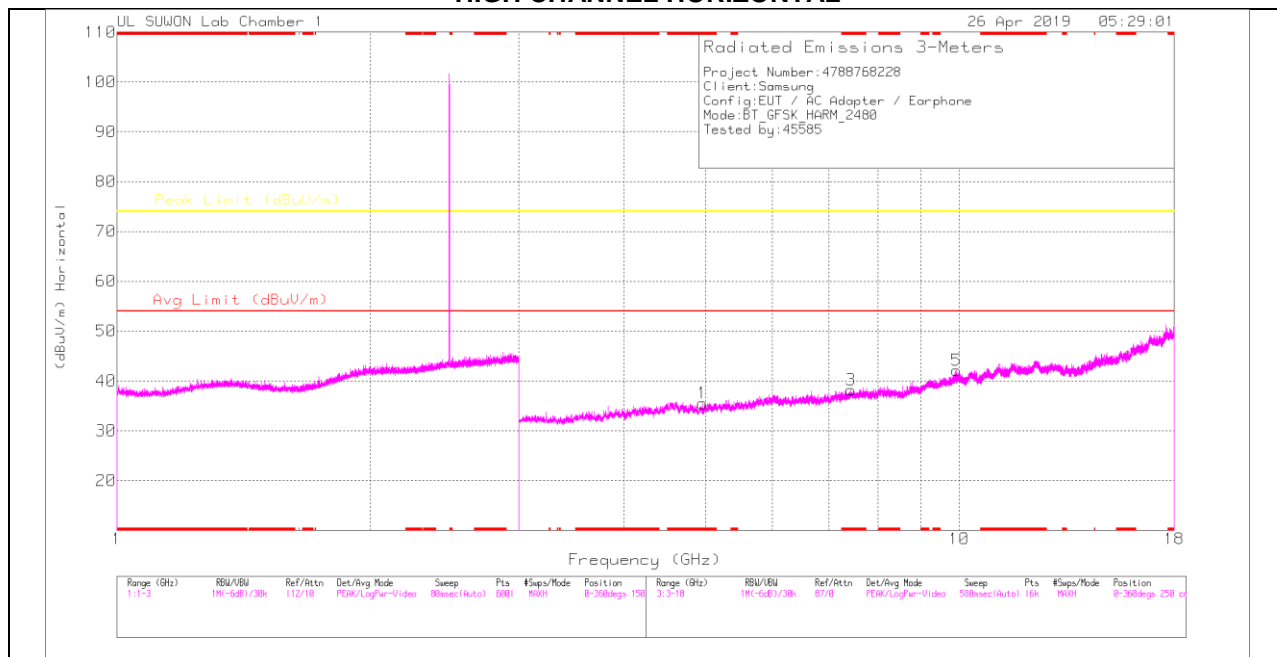

HIGH CHANNEL VERTICAL

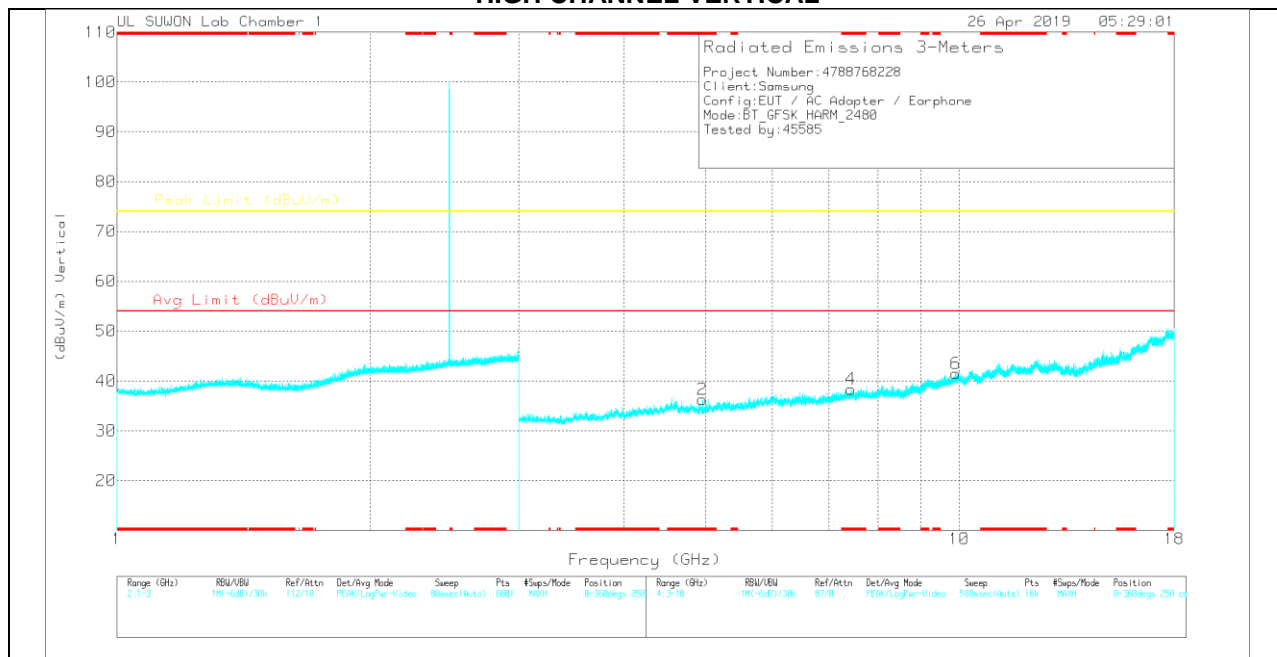

Note: Emission was scanned up to 26GHz; No emissions were detected above the noise floor which was at least 20dB below the specification limit.

HIGH CHANNEL DATA

Trace Markers

Marker	Frequency (GHz)	Meter Reading (dBuV)	Det	3117_00168717	3GHz_HP[dB]	Corrected Reading (dBuV/m)	Avg Limit (dBuV/m)	Margin (dB)	Peak Limit (dBuV/m)	Margin (dB)	Azimuth (Degs)	Height (cm)	Polarity
1	* 4.956	32.7	PK	34.2	-31.4	35.5	-	-	74	-38.5	0-360	150	H
3	* 7.439	29.45	PK	35.8	-27	38.25	-	-	74	-35.75	0-360	250	H
5	9.918	26.89	PK	37.5	-22.3	42.09	-	-	74	-31.91	0-360	150	H
2	* 4.959	33.51	PK	34.2	-31.4	36.31	-	-	74	-37.69	0-360	150	V
4	* 7.435	29.5	PK	35.8	-26.9	38.4	-	-	74	-35.6	0-360	150	V
6	9.917	26.33	PK	37.5	-22.3	41.53	-	-	74	-32.47	0-360	150	V

* - indicates frequency in CFR47 Pt 15 / IC RSS-Restricted Band
 PK – Peak Detector

11.1.2. ENHANCED DATA RATE 8PSK MODULATION RESTRICTED BANDEDGE (LOW CHANNEL)

HORIZONTAL PEAK AND AVERAGE PLOT

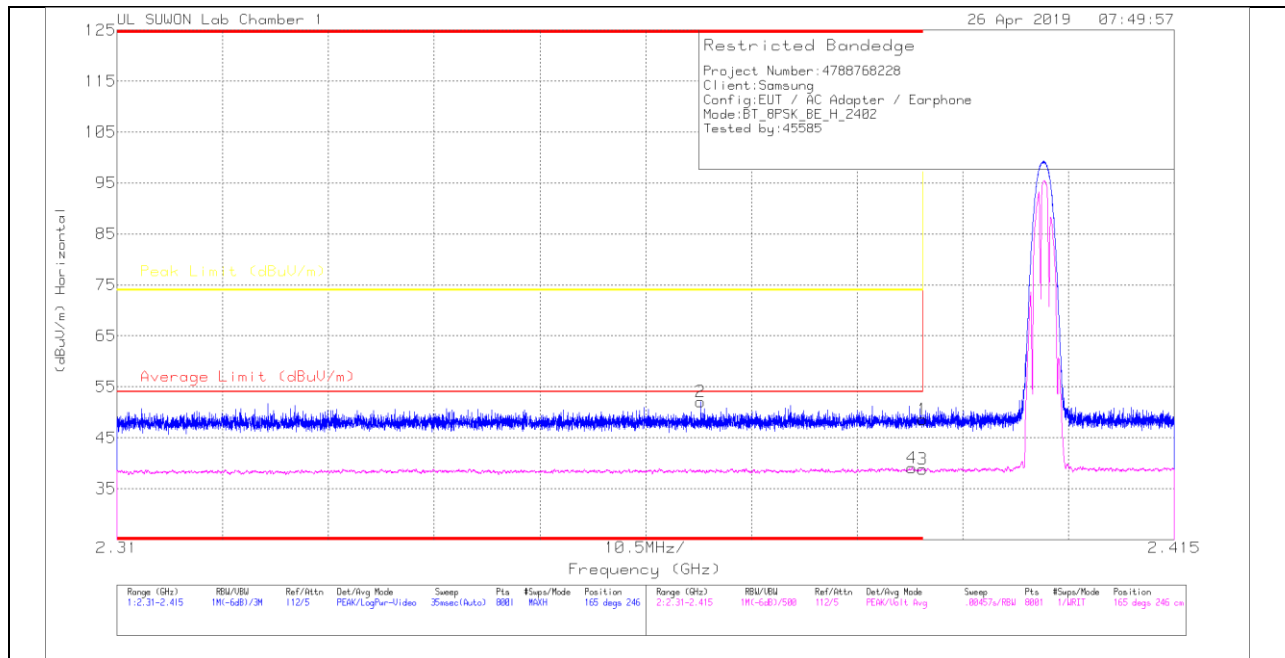

HORIZONTAL DATA

Trace Markers

Marker	Frequency (GHz)	Meter Reading (dBuV)	Det	3117_00168717	10dB(dB)	Corrected Reading (dBuV/m)	Average Limit (dBuV/m)	Margin (dB)	Peak Limit (dBuV/m)	PK Margin (dB)	Azimuth (Degs)	Height (cm)	Polarity
1	* 2.39	42.4	Pk	31.7	-25.5	48.6	-	-	74	-25.4	165	246	H
2	* 2.368	46.08	Pk	31.6	-25.6	52.08	-	-	74	-21.92	165	246	H
3	* 2.39	32.6	VA1T	31.7	-25.5	38.8	54	-15.2	-	-	165	246	H
4	* 2.389	32.89	VA1T	31.7	-25.5	39.09	54	-14.91	-	-	165	246	H

* - indicates frequency in CFR47 Pt 15 / IC RSS-Restricted Band

Pk - Peak detector

VA1T - FHSS: Linear Voltage Average $V_B=1/T_{on}$ where: T_{on} is transmit duration

VERTICAL PEAK AND AVERAGE PLOT

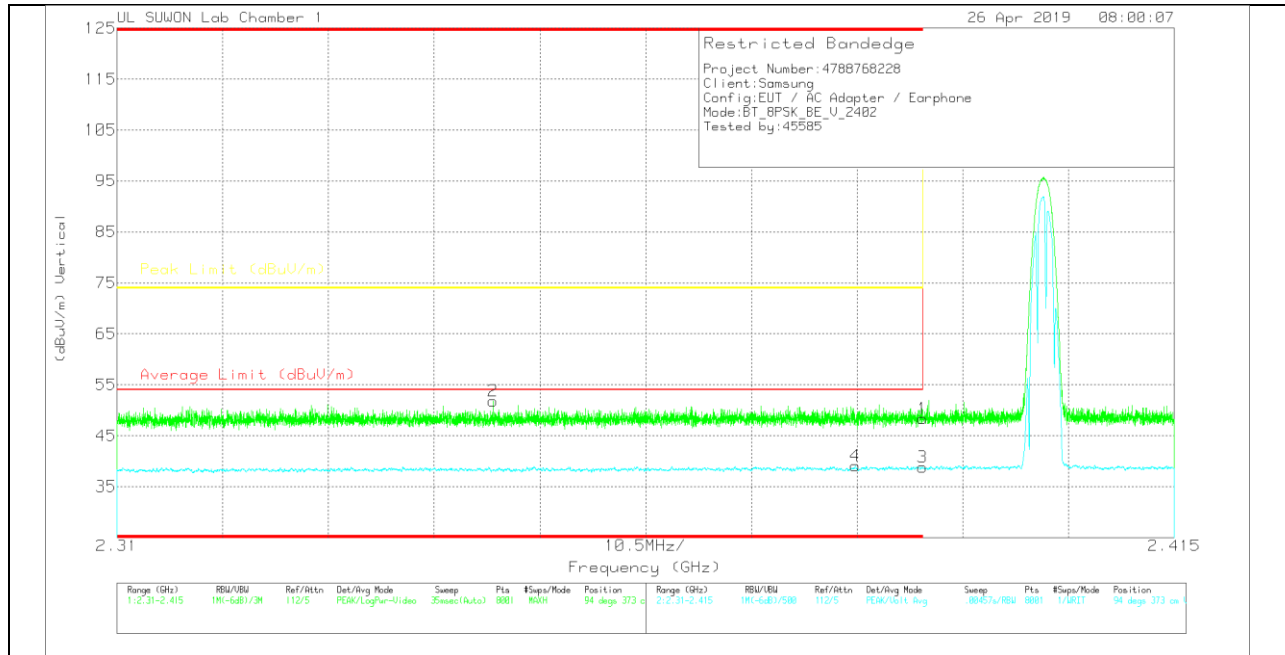

VERTICAL DATA

Trace Markers

Marker	Frequency (GHz)	Meter Reading (dBuV)	Det	3117_00168717	10dB(dB)	Corrected Reading (dBuV/m)	Average Limit (dBuV/m)	Margin (dB)	Peak Limit (dBuV/m)	PK Margin (dB)	Azimuth (Degs)	Height (cm)	Polarity
1	* 2.39	42.2	Pk	31.7	-25.5	48.4	-	-	74	-25.6	94	373	V
2	* 2.347	45.94	Pk	31.6	-25.7	51.84	-	-	74	-22.16	94	373	V
3	* 2.39	32.58	VA1T	31.7	-25.5	38.78	54	-15.22	-	-	94	373	V
4	* 2.383	32.99	VA1T	31.7	-25.6	39.09	54	-14.91	-	-	94	373	V

* - indicates frequency in CFR47 Pt 15 / IC RSS-Restricted Band

Pk - Peak detector

VA1T - FHSS: Linear Voltage Average VB=1/Ton where: Ton is transmit duration

AUTHORIZED BANDEDGE (HIGH CHANNEL)

HORIZONTAL PEAK AND AVERAGE PLOT

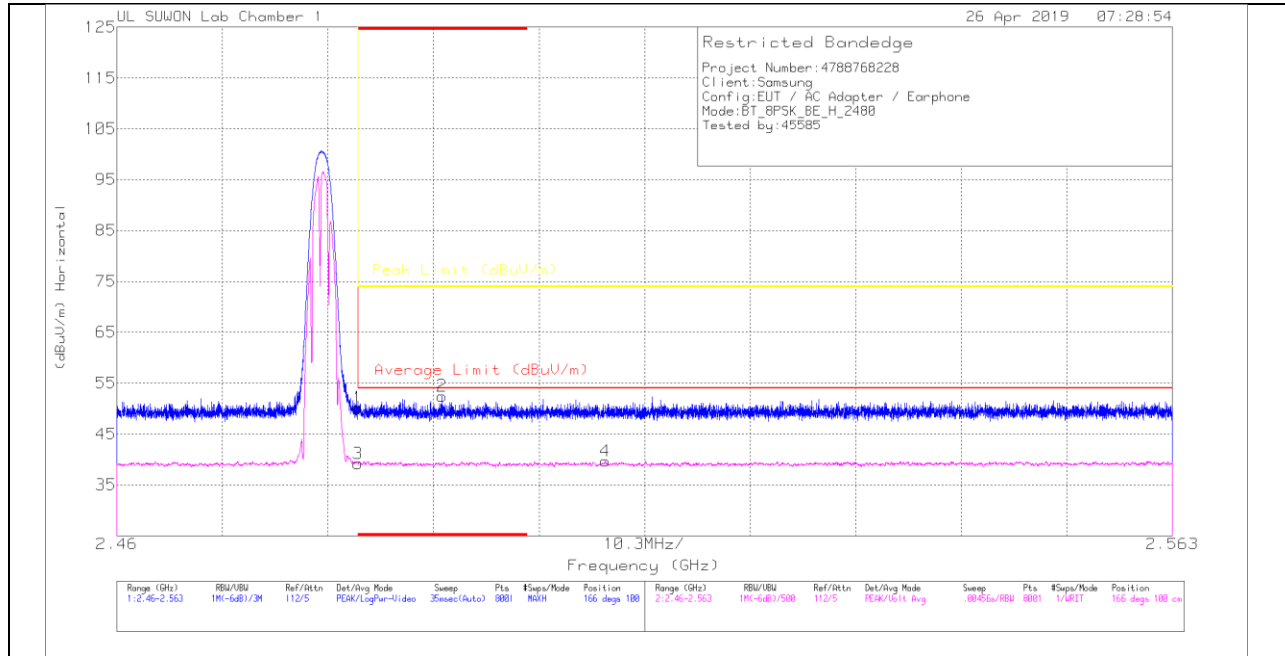

HORIZONTAL DATA

Trace Markers

Marker	Frequency (GHz)	Meter Reading (dBuV)	Det	3117_00168717	10dB(dB)	Corrected Reading (dBuV/m)	Average Limit (dBuV/m)	Margin (dB)	Peak Limit (dBuV/m)	PK Margin (dB)	Azimuth (Degs)	Height (cm)	Polarity
1	* 2.484	43.64	Pk		-25.3	50.24	-	-	74	-23.76	166	100	H
2	* 2.492	45.79	Pk		-25.2	52.49	-	-	74	-21.51	166	100	H
3	* 2.484	32.54	VA1T		-25.3	39.14	54	-14.86	-	-	166	100	H
4	2.508	32.85	VA1T		-25.2	39.65	54	-14.35	-	-	166	100	H

* - indicates frequency in CFR47 Pt 15 / IC RSS-Restricted Band

Pk - Peak detector

VA1T - FHSS: Linear Voltage Average VB=1/Ton where: Ton is transmit duration

VERTICAL PEAK AND AVERAGE PLOT

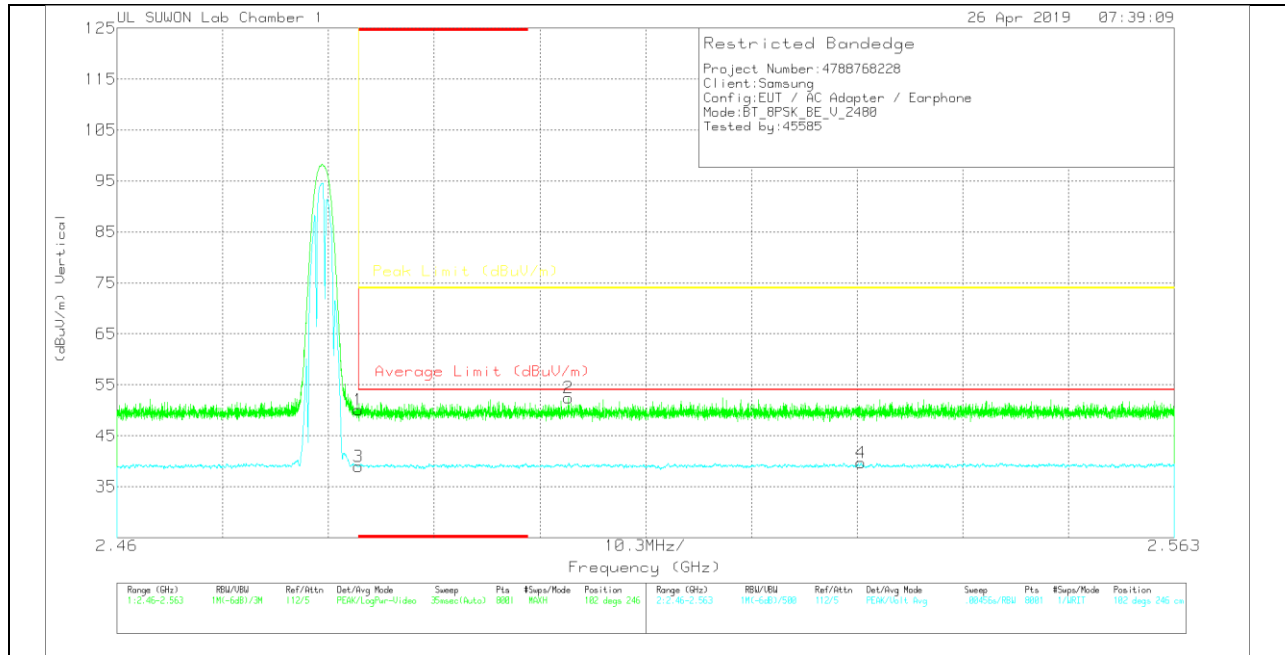

VERTICAL DATA

Trace Markers

Marker	Frequency (GHz)	Meter Reading (dBuV)	Det	3117_00168717	10dB(dB)	Corrected Reading (dBuV/m)	Average Limit (dBuV/m)	Margin (dB)	Peak Limit (dBuV/m)	PK Margin (dB)	Azimuth (Degs)	Height (cm)	Polarity
1	* 2.484	43.43	Pk	31.9	-25.3	50.03	-	-	74	-23.97	102	246	V
2	2.504	45.67	Pk	32	-25.2	52.47	-	-	74	-21.53	102	246	V
3	* 2.484	32.36	VA1T	31.9	-25.3	38.96	54	-15.04	-	-	102	246	V
4	2.532	32.86	VA1T	32	-25.2	39.66	54	-14.34	-	-	102	246	V

* - indicates frequency in CFR47 Pt 15 / IC RSS-Restricted Band

Pk - Peak detector

VA1T - FHSS: Linear Voltage Average $V_B=1/T_{on}$ where: T_{on} is transmit duration

HARMONICS AND SPURIOUS EMISSIONS

LOW CHANNEL HORIZONTAL

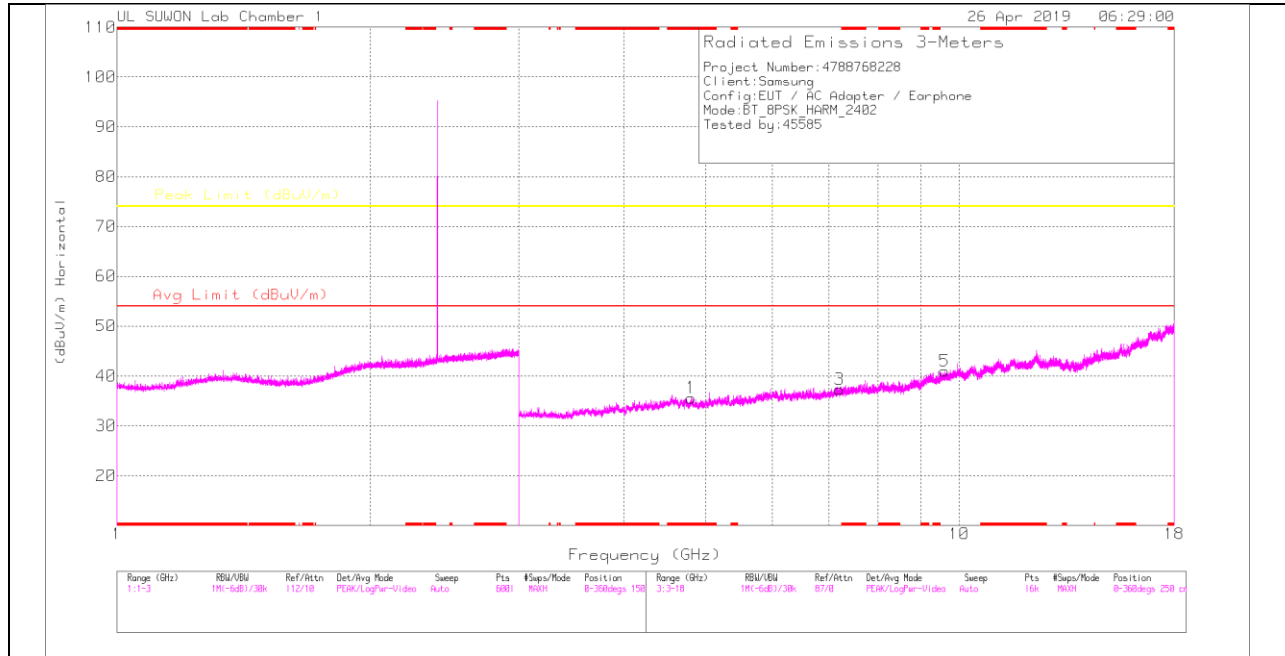

LOW CHANNEL VERTICAL

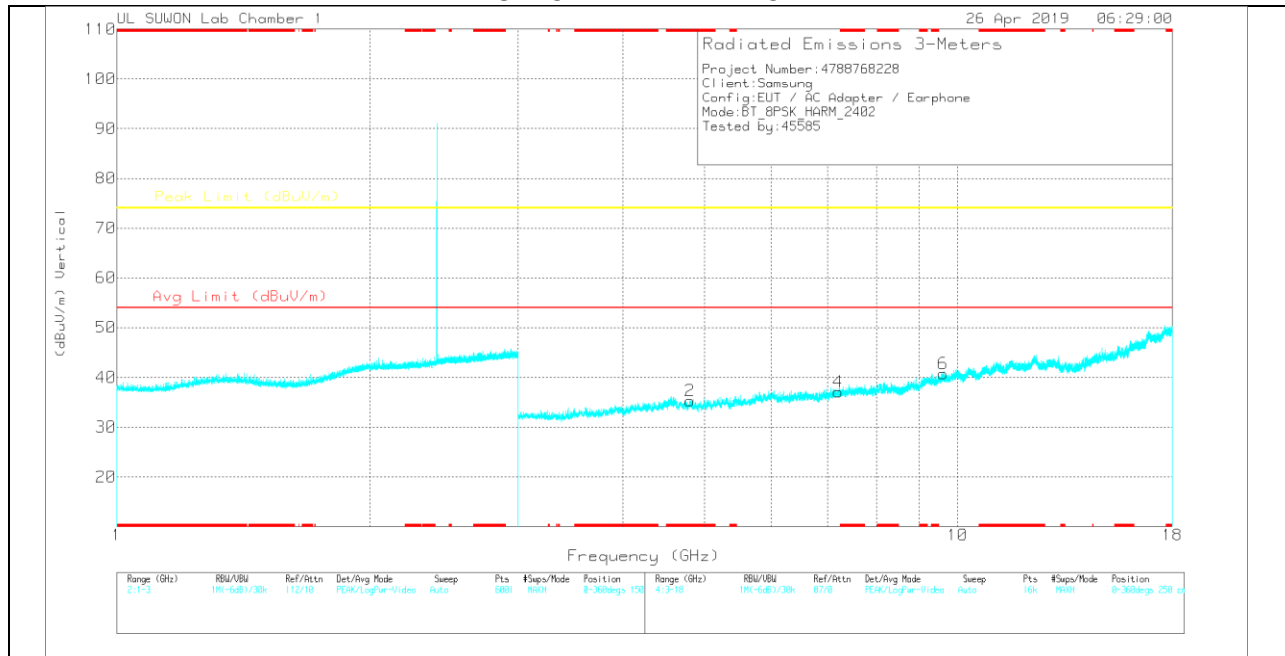

Note: Emission was scanned up to 26GHz; No emissions were detected above the noise floor which was at least 20dB below the specification limit.

LOW CHANNEL DATA

Trace Markers

Marker	Frequency (GHz)	Meter Reading (dBuV)	Det	3117_00168717	3GHz_HP[dB]	Corrected Reading (dBuV/m)	Avg Limit (dBuV/m)	Margin (dB)	Peak Limit (dBuV/m)	Margin (dB)	Azimuth (Degs)	Height (cm)	Polarity
1	* 4.802	32.82	PK	34.2	-31.4	35.62	-	-	74	-38.38	0-360	250	H
3	7.206	29.47	PK	35.8	-27.9	37.37	-	-	74	-36.63	0-360	250	H
5	9.602	27.15	PK	37	-23.1	41.05	-	-	74	-32.95	0-360	150	H
2	* 4.806	32.49	PK	34.2	-31.4	35.29	-	-	74	-38.71	0-360	150	V
4	7.211	29.12	PK	35.8	-27.9	37.02	-	-	74	-36.98	0-360	250	V
6	9.605	26.82	PK	37	-23.1	40.72	-	-	74	-33.28	0-360	150	V

* - indicates frequency in CFR47 Pt 15 / IC RSS-Restricted Band
 PK – Peak Detector

MID CHANNEL HORIZONTAL

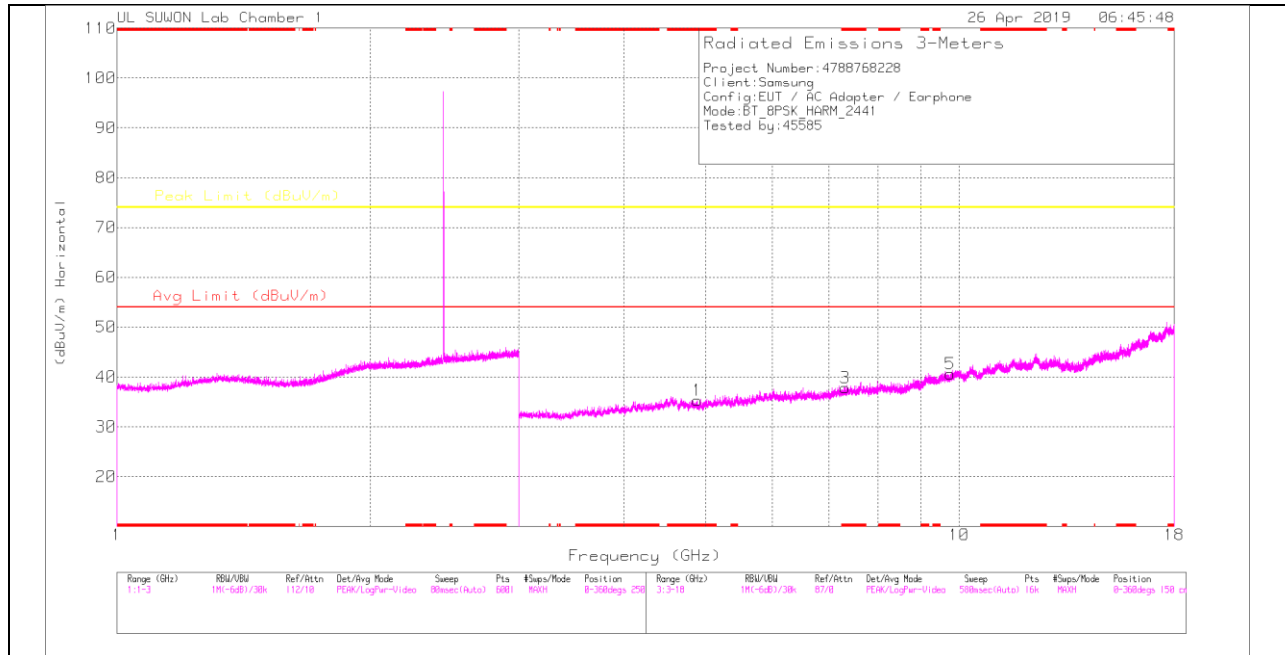

MID CHANNEL VERTICAL

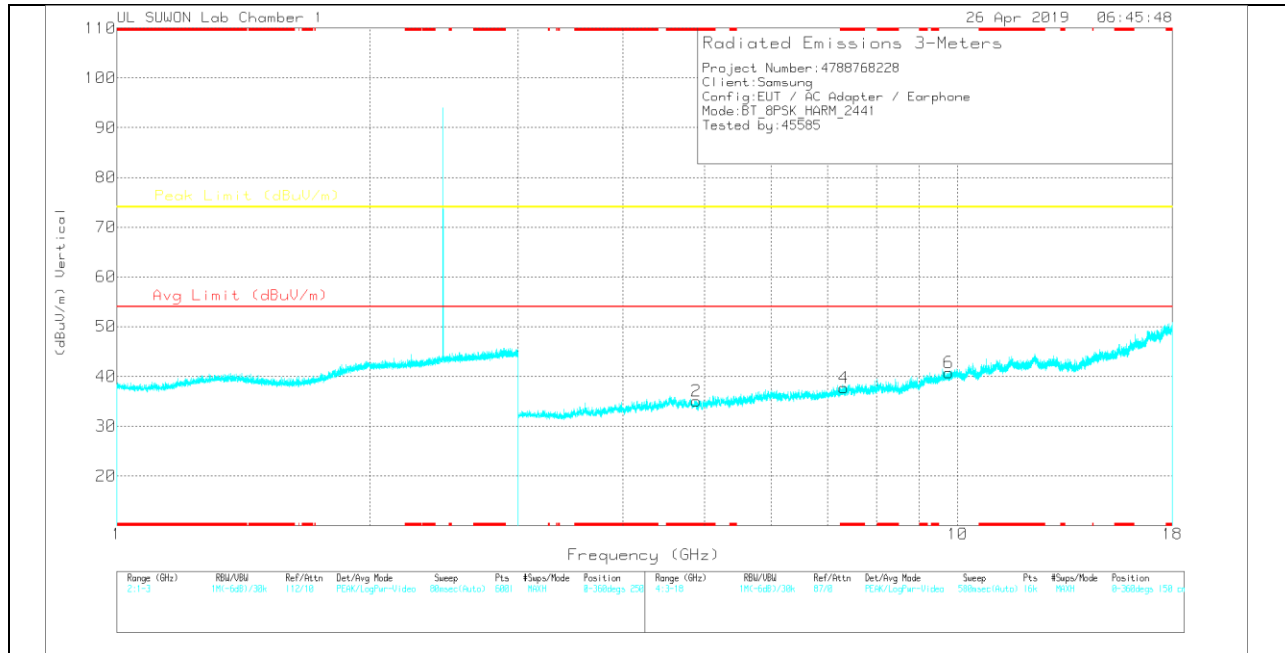

Note: Emission was scanned up to 26GHz; No emissions were detected above the noise floor which was at least 20dB below the specification limit.

MID CHANNEL DATA

Trace Markers

Marker	Frequency (GHz)	Meter Reading (dBuV)	Det	3117_00168717	3GHz_HP[dB]	Corrected Reading (dBuV/m)	Avg Limit (dBuV/m)	Margin (dB)	Peak Limit (dBuV/m)	Margin (dB)	Azimuth (Degs)	Height (cm)	Polarity
1	* 4.885	32.58	PK	34.2	-31.5	35.28	-	-	74	-38.72	0-360	150	H
3	* 7.325	29.31	PK	35.8	-27.3	37.81	-	-	74	-36.19	0-360	150	H
5	9.758	27.31	PK	37.2	-23.9	40.61	-	-	74	-33.39	0-360	250	H
2	* 4.886	32.32	PK	34.2	-31.5	35.02	-	-	74	-38.98	0-360	150	V
4	* 7.32	29.25	PK	35.8	-27.3	37.75	-	-	74	-36.25	0-360	250	V
6	9.764	27.42	PK	37.2	-23.9	40.72	-	-	74	-33.28	0-360	250	V

* - indicates frequency in CFR47 Pt 15 / IC RSS-Restricted Band

PK – Peak Detector

HIGH CHANNEL HORIZONTAL

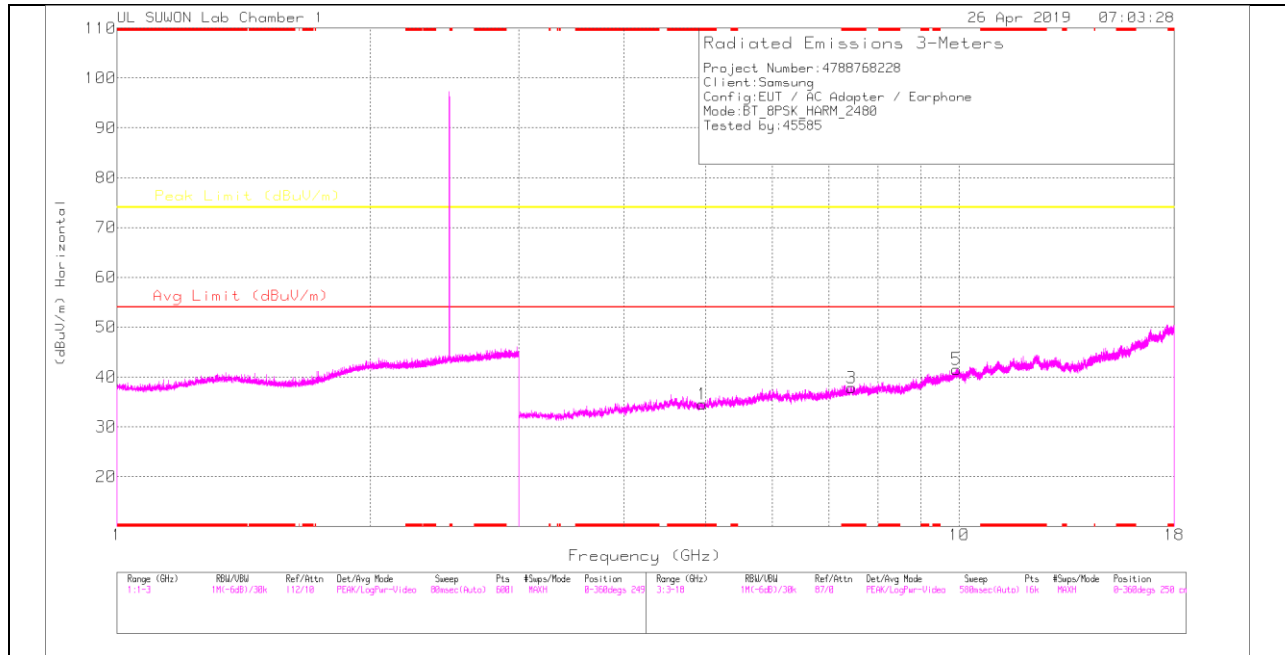

HIGH CHANNEL VERTICAL

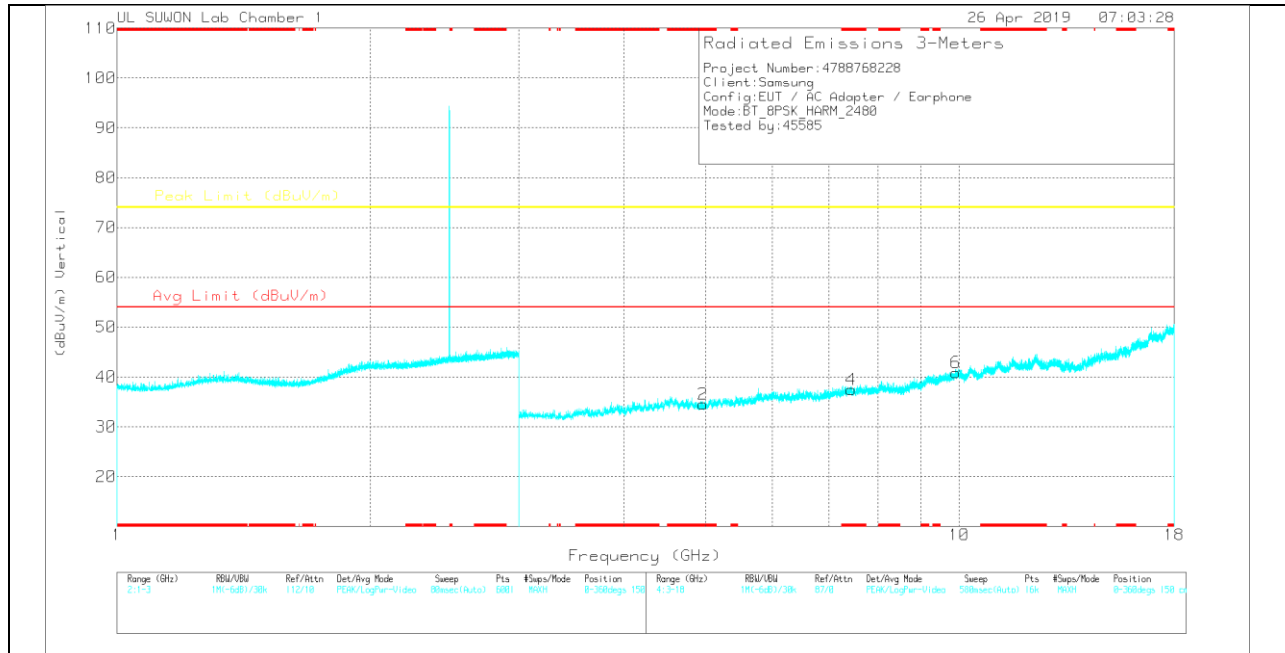

Note: Emission was scanned up to 26GHz; No emissions were detected above the noise floor which was at least 20dB below the specification limit.

HIGH CHANNEL DATA

Trace Markers

Marker	Frequency (GHz)	Meter Reading (dBuV)	Det	3117_00168717	3GHz_HP[dB]	Corrected Reading (dBuV/m)	Avg Limit (dBuV/m)	Margin (dB)	Peak Limit (dBuV/m)	Margin (dB)	Azimuth (Degs)	Height (cm)	Polarity
1	* 4.957	31.79	PK	34.2	-31.4	34.59	-	-	74	-39.41	0-360	250	H
3	* 7.445	29.17	PK	35.8	-27.1	37.87	-	-	74	-36.13	0-360	250	H
5	9.925	26.36	PK	37.5	-22.3	41.56	-	-	74	-32.44	0-360	150	H
2	* 4.963	31.71	PK	34.2	-31.4	34.51	-	-	74	-39.49	0-360	150	V
4	* 7.443	28.68	PK	35.8	-27	37.48	-	-	74	-36.52	0-360	150	V
6	9.915	25.7	PK	37.5	-22.3	40.9	-	-	74	-33.1	0-360	250	V

* - indicates frequency in CFR47 Pt 15 / IC RSS-Restricted Band
 PK – Peak Detector