



# CERTIFICATION TEST REPORT

**Report Number.** : 4790047196-E10V1

**Applicant** : SAMSUNG ELECTRONICS CO., LTD.  
129 SAMSUNG-RO, YEONGTONG-GU, SUWON-SI,  
GYEONGGI-DO, 16677, KOREA

**Model** : SM-G780G/DSM, SM-G780G/DS, SM-G780G

**FCC ID** : A3LSMG780G1

**EUT Description** : GSM/WCDMA/LTE Phone + BT/BLE, DTS/UNII a/b/g/n/ac/ax,  
WPT and NFC

**Test Standard(s)** : FCC 47 CFR PART 15 SUBPART B

**Date Of Issue:**

2021-08-18

**Prepared by:**

UL Korea, Ltd.

26th floor, 152, Teheran-ro, Gangnam-gu Seoul, 06236, Korea

Suwon Test Site: UL Korea, Ltd. Suwon Laboratory

218 Maeyeong-ro, Yeongtong-gu,  
Suwon-si, Gyeonggi-do, 16675, Korea

TEL: (031) 337-9902

FAX: (031) 213-5433



ACCREDITED

**Testing Laboratory**

**TL-637**

Revision History

<u>Rev.</u>	<u>Issue Date</u>	<u>Revisions</u>	<u>Revised By</u>
V1	2021-08-18	Initial issue	Steven(Sangyun) Kim

## TABLE OF CONTENTS

<b>1. ATTESTATION OF TEST RESULTS .....</b>	<b>4</b>
<b>2. TEST METHODOLOGY .....</b>	<b>5</b>
<b>3. FACILITIES AND ACCREDITATION .....</b>	<b>5</b>
<b>4. CALIBRATION AND UNCERTAINTY .....</b>	<b>6</b>
4.1. MEASURING INSTRUMENT CALIBRATION.....	6
4.2. SAMPLE CALCULATION.....	6
4.3. MEASUREMENT UNCERTAINTY .....	6
4.4. DECISION RULE .....	6
<b>5. EQUIPMENT UNDER TEST .....</b>	<b>7</b>
5.1. DESCRIPTION OF EUT.....	7
5.2. TEST MODE.....	7
5.3. WORST-CASE ORIENTATION AND MODE.....	7
5.4. MODIFICATIONS.....	8
5.5. DETAILS OF TESTED SYSTEM.....	8
<b>6. TEST AND MEASUREMENT EQUIPMENT .....</b>	<b>12</b>
<b>7. TEST RESULTS.....</b>	<b>13</b>
7.1. RADIATED EMISSIONS.....	13
7.1.1. RADIATED EMISSIONS 30 TO 1000 MHz.....	14
7.1.2. RADIATED EMISSIONS 1 GHz to 18 GHz.....	22
7.1.3. RADIATED EMISSIONS Above 18 GHz.....	30
7.2. CONDUCTED EMISSIONS.....	38
7.2.1. CONDUCTED EMISSIONS .....	39

# 1. ATTESTATION OF TEST RESULTS

**COMPANY NAME:** SAMSUNG ELECTRONICS CO., LTD.  
**EUT DESCRIPTION:** GSM/WCDMA/LTE Phone + BT/BLE, DTS/UNII a/b/g/n/ac/ax, WPT and NFC  
**MODEL NUMBER:** SM-G780G/DSM, SM-G780G/DS, SM-G780G  
**SERIAL NUMBER:** R38R301JR3B (RADIATED)  
**DATE TESTED:** 2021-08-10 ~ 2021-08-18;

APPLICABLE STANDARDS	
STANDARD	TEST RESULTS
FCC PART 15B	Pass

UL Korea, Ltd. tested the above equipment in accordance with the requirements set forth in the above standards. All indications of Pass/Fail in this report are opinions expressed by UL Korea, Ltd. based on interpretations and/or observations of test results. Measurement Uncertainties were not taken into account and are published for informational purposes only. The test results show that the equipment tested is capable of demonstrating compliance with the requirements as documented in this report.

**Note:** The results documented in this report apply only to the tested sample, under the conditions and modes of operation as described herein. This document may not be altered or revised in any way unless done so by UL Korea, Ltd. and all revisions are duly noted in the revisions section. Any alteration of this document not carried out by UL Korea, Ltd. will constitute fraud and shall nullify the document. This report must not be used by the client to claim product certification, approval, or endorsement by IAS, any agency of the Federal Government, or any agency of any government.

Approved & Released For  
UL Korea, Ltd. By:



Junwhan Lee  
Suwon Lab Engineer  
UL Korea, Ltd.

Tested By:



Steven(Sangyun) Kim  
Suwon Lab Engineer  
UL Korea, Ltd.

## 2. TEST METHODOLOGY

The tests documented in this report were performed in accordance with following methods.

1. FCC CFR 47 Part 2.
2. FCC CFR 47 Part 15.
3. ANSI C63.4-2014

## 3. FACILITIES AND ACCREDITATION

The test sites and measurement facilities used to collect data are located at 218 Maeyeong-ro, Yeongtong-gu, Suwon-si, Gyeonggi-do, 16675, Korea. Line conducted emissions are measured only at the 218 address. The following table identifies which facilities were utilized for radiated emission measurements documented in this report. Specific facilities are also identified in the test results sections.

218 Maeyeong-ro	
<input checked="" type="checkbox"/>	Chamber 1
<input type="checkbox"/>	Chamber 2
<input type="checkbox"/>	Chamber 3

UL Korea, Ltd. is accredited by IAS, Laboratory Code TL-637. The full scope of accreditation can be viewed at <https://www.iasonline.org/wp-content/uploads/2017/05/TL-637-cert-New.pdf>.

## 4. CALIBRATION AND UNCERTAINTY

### 4.1. MEASURING INSTRUMENT CALIBRATION

The measuring equipment utilized to perform the tests documented in this report has been calibrated in accordance with the manufacturer's recommendations, and is traceable to recognized national standards.

### 4.2. SAMPLE CALCULATION

Where relevant, the following sample calculation is provided:

$EIRP = \text{PSA reading with EUT worst orientation (dBm)} + \text{Path loss (dB)} - \text{cable loss (between the SG and substitution antenna)} + \text{Substitution Antenna Factor (dBi)}$

$ERP = \text{PSA reading with EUT worst orientation (dBm)} + \text{Path loss (dB)} - \text{cable loss (between the SG and substitution antenna)}$

(Path loss = Signal generator output – PSA reading with substitution antenna)

### 4.3. MEASUREMENT UNCERTAINTY

Where relevant, the following measurement uncertainty levels have been estimated for tests performed on the apparatus:

PARAMETER	UNCERTAINTY
Radiated Disturbance, 30 MHz to 1 GHz	4.26 dB
Radiated Disturbance, 1 GHz to 18 GHz	5.90 dB
Radiated Disturbance, Above 18 GHz	5.49 dB

Uncertainty figures are valid to a confidence level of 95%.

### 4.4. DECISION RULE

Decision rule for statement(s) of conformity is based on Procedure 2, Clause 4.4.3 in IEC Guide 115:2007.

## 5. EQUIPMENT UNDER TEST

### 5.1. DESCRIPTION OF EUT

GSM/WCDMA/LTE Phone + BT/BLE, DTS/UNII a/b/g/n/ac/ax, WPT and NFC.

#### GENERAL INFORMATION

Type of device	Class B personal computers and peripherals Other Class B digital devices & peripherals
Personal Computer power requirements	100-240 VAC / 50-60 Hz, 1.8 A
Travel Adapter power requirements	100-240 VAC / 50-60 Hz, 0.7 A
List of frequencies generated or used by the EUT	30 GHz (5th harmonic of the frequency of 5GHz UNII)

### 5.2. TEST MODE

Mode	Description
Test Case 1	Camera(Front) + Charging
Test Case 2	Video and Audio Play + Earphone
Test Case 3	Video and Audio Play + Display Out
Test Case 4	USB Data Communication with PC

Note: All descriptions were tested under simultaneous operation.  
 Receiver Mode (Licensed Band within 30-960MHz) test result refer to FCC Report Receiver mode(CXX).

### 5.3. WORST-CASE ORIENTATION AND MODE

The EUT was investigated in three orthogonal orientations X, Y, Z it was determined that X orientation with data transfer was worst-case; therefore, all final radiated testing was performed with the EUT in X orientation with data transfer.

## 5.1. MODIFICATIONS

No modifications were made during testing.

## 5.2. DETAILS OF TESTED SYSTEM

### SUPPORT EQUIPMENT & PERIPHERALS

Support Equipment List				
Description	Manufacturer	Model	Serial Number	FCC ID/DoC
Laptop PC	Lenovo	T480s	PC0VHHJR	DoC
AC/DC Adapter	Lenovo	ADLX65YDC3A	8SSA10M13946D1SG862021R	N/A
Mouse	SAMSUNG	AA-MW1D5WB	CN57BA5904489BDV8JN9W1756	N/A
Data Cable	SAMSUNG	-	EP-DR140AWE	N/A
Charger	SAMSUNG	EP-TA200	R37M194GPM1SE3	N/A
Earphone	SAMSUNG	-	GH59-15252ARYBN3	N/A
Micro SD Card	SAMSUNG	MB-MC256GA	-	-
Monitor	DELL	U2417H	CN-0767T7-WS200-74M-C4SL-A03	N/A



**I/O CABLES**

[DIAGRAM 1]

I/O Cable List						
Cable No	Port	# of identical ports	Connect or Type	Cable Type	Cable Length(m)	Remarks
1	AC Power	1	Power	-	Direct	From AC/DC Adapter to AC Main
2	Type C	1	Power	Unshielded	0.7m	From AD/DC Adapter to EUT
3	Micro SD Slot	1	-	-	Direct	Fitted In EUT

[DIAGRAM 2]

I/O Cable List						
Cable No	Port	# of identical ports	Connect or Type	Cable Type	Cable Length(m)	Remarks
1	Earphone	1	Type C	Shielded	0.7m	From Earphone to EUT
2	Micro SD Slot	1	-	-	Direct	Fitted In EUT

\* Radiated Test Only

[DIAGRAM 3]

I/O Cable List						
Cable No	Port	# of identical ports	Connect or Type	Cable Type	Cable Length(m)	Remarks
1	Type C	1	DP	Shielded	1.5m	From LCD Monitor to EUT
2	Micro SD Slot	1	-	-	Direct	Fitted In EUT

\* Radiated Test Only

[DIAGRAM 4]

I/O Cable List						
Cable No	Port	# of identical ports	Connect or Type	Cable Type	Cable Length(m)	Remarks
1	AC Power	1	Power	Unshielded	1.5m	From AD/DC Adapter to AC Main
2	DC Power	1	Type C	Shielded	0.7m	From Laptop to AC/DC Adapter
3	USB	1	USB	Shielded	1.5m	From Laptop to EUT
4	AC Power	1	Type C	Unshielded	1.0m	From Mouse to Laptop
5	Micro SD Slot	1	-	-	Direct	Fitted In EUT
6	Ethernet	1	RJ45	Unshielded	1.5m	From Laptop to Router in out of test site

**TEST SETUP**

The EUT is installed in a typical configuration. Copy files from PC to EUT fitted Micro sd card.  
Video and sound on EUT send to the LCD Monitor from DP cable.

**TEST SETUP DIAGRAM 1 for Test Case 1**

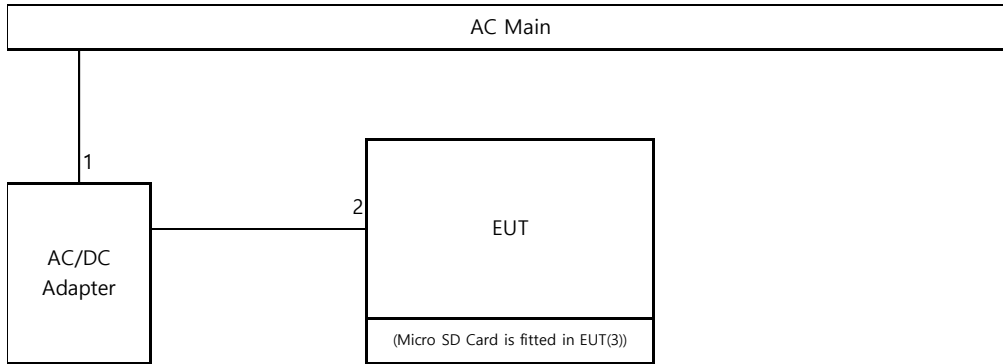

**TEST SETUP DIAGRAM 2 for Test Case 2**

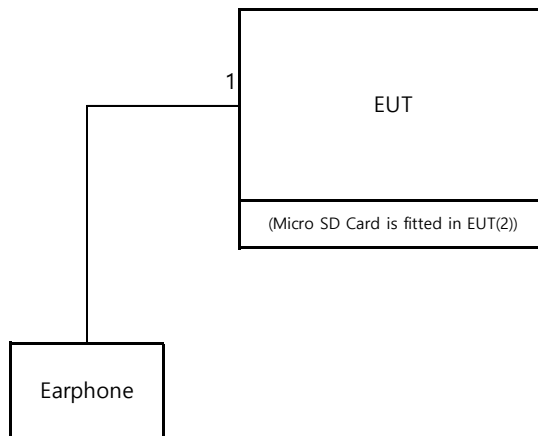

**TEST SETUP DIAGRAM 3 for Test case 3**

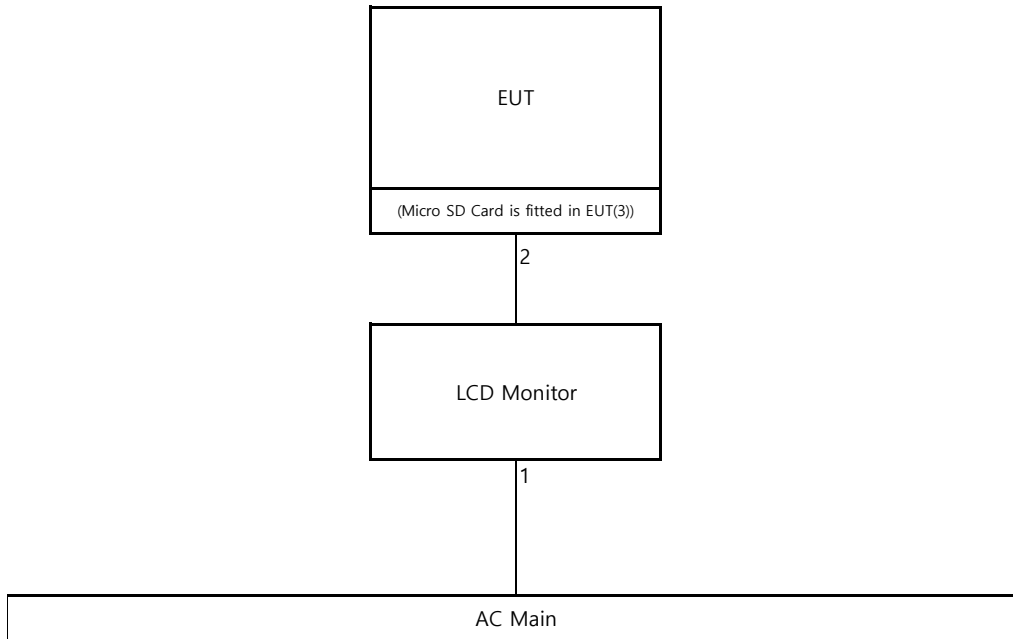

**TEST SETUP DIAGRAM 4 for Test case 4**

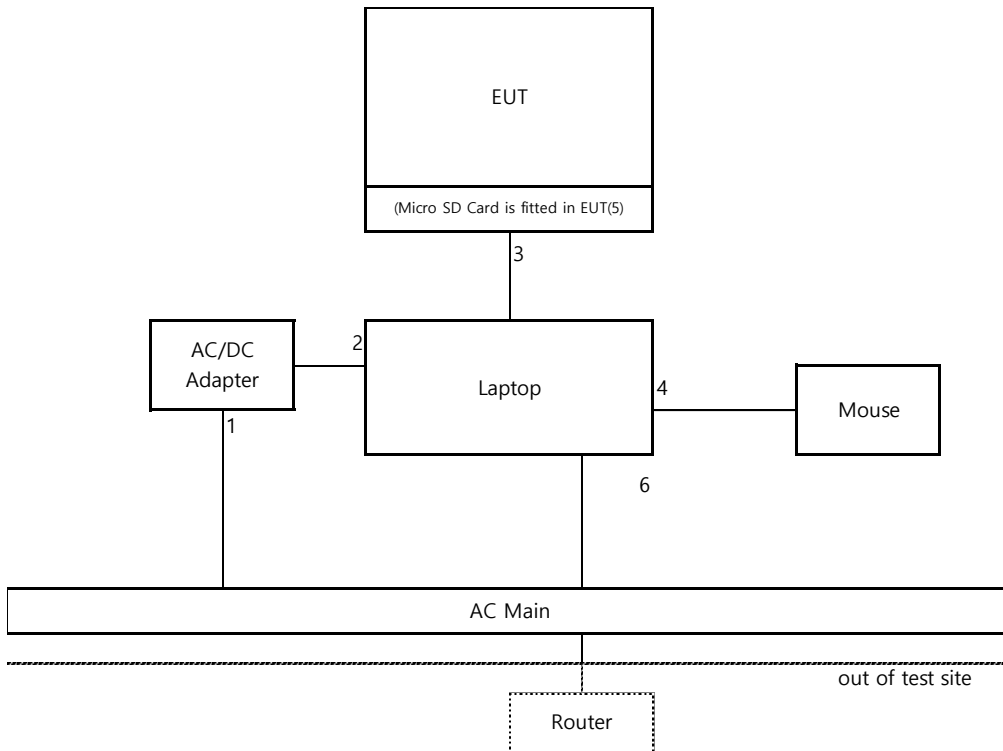

## 6. TEST AND MEASUREMENT EQUIPMENT

The following test and measurement equipment was utilized for the tests documented in this report:

Test Equipment List				
Description	Manufacturer	Model	S/N	Cal Due
Antenna, Horn, 40 GHz	ETS	3116C	00166155	2022-08-04
Antenna, Horn, 40 GHz	ETS	3116C	00168645	2022-08-04
Preamplifier	ETS	3116C-PA	00168841	2022-08-04
Antenna, Bilog, 30MHz-1GHz	SCHWARZBECK	VULB9163	750	2022-08-19
Antenna, Bilog, 30MHz-1GHz	SCHWARZBECK	VULB9163	845	2022-08-13
Antenna, Bilog, 30MHz-1GHz	SCHWARZBECK	VULB9163	749	2022-08-13
Antenna, Horn, 18 GHz	ETS	3115	00167211	2022-07-27
Antenna, Horn, 18 GHz	ETS	3115	00161451	2022-08-15
Antenna, Horn, 18 GHz	ETS	3117	00168724	2022-07-27
Antenna, Horn, 18 GHz	ETS	3117	00168717	2022-08-15
Preamplifier, 1000 MHz	Sonoma	310N	341282	2022-08-02
Preamplifier, 1000 MHz	Sonoma	310N	370599	2022-08-02
Preamplifier, 1000 MHz	Sonoma	310N	351741	2022-08-02
Preamplifier, 18 GHz	Miteq	AFS42-00101800-25-S-42	1876511	2022-08-02
Preamplifier, 18 GHz	Miteq	AFS42-00101800-25-S-42	2029168	2022-08-02
Preamplifier, 18 GHz	Miteq	AFS42-00101800-25-S-42	1896138	2022-08-02
EMI Test Receive, 40 GHz	R&S	ESU40	100439	2022-08-02
EMI Test Receive, 40 GHz	R&S	ESU40	100457	2022-08-02
EMI Test Receive, 3 GHz	R&S	ESR3	101832	2022-08-02
LISN	R&S	ENV-216	101836	2022-08-05
LISN	R&S	ENV-216	101837	2022-08-05
UL Software				
Description	Manufacturer	Model	Version	
Radiated software	UL	UL EMC	Ver 9.5	
AC Line Conducted software	UL	UL EMC	Ver 9.5	

## 7. TEST RESULTS

### 7.1. RADIATED EMISSIONS

#### TEST PROCEDURE

ANSI C63.4-2014

The highest clock frequency generated or used in the EUT is 40 GHz therefore the frequency range was investigated from 30 MHz to 40 GHz.

#### LIMIT

§15.109 (a) Except for Class A digital devices, the field strength of radiated emissions from unintentional radiators at a distance of 3 meters shall not exceed the following values:

Limits for radiated disturbance of Class B ITE at measuring distance of 3 m	
Frequency range (MHz)	Quasi-peak limits (dB $\mu$ V/m)
30 to 88	40
88 to 216	43.5
216 to 960	46
Above 960 MHz	54

Note: The lower limit shall apply at the transition frequency.

### 7.1.1. RADIATED EMISSIONS 30 TO 1000 MHz [Test case 1]

#### HORIZONTAL PEAK PLOT

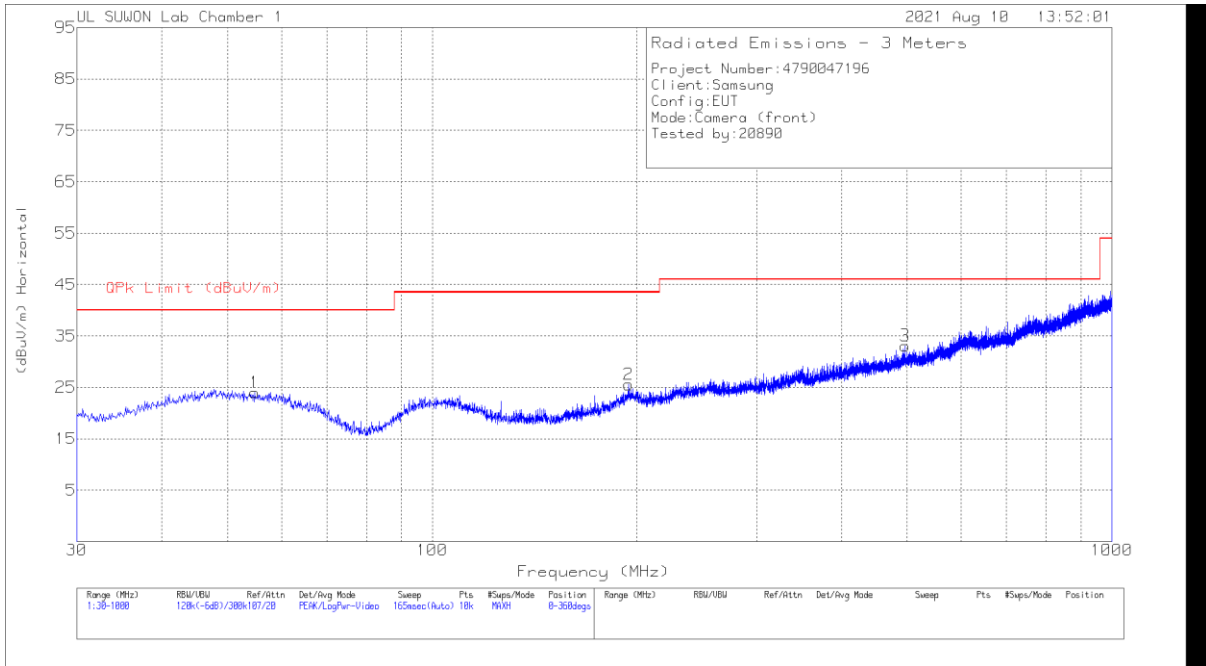

#### VERTICAL PEAK PLOT

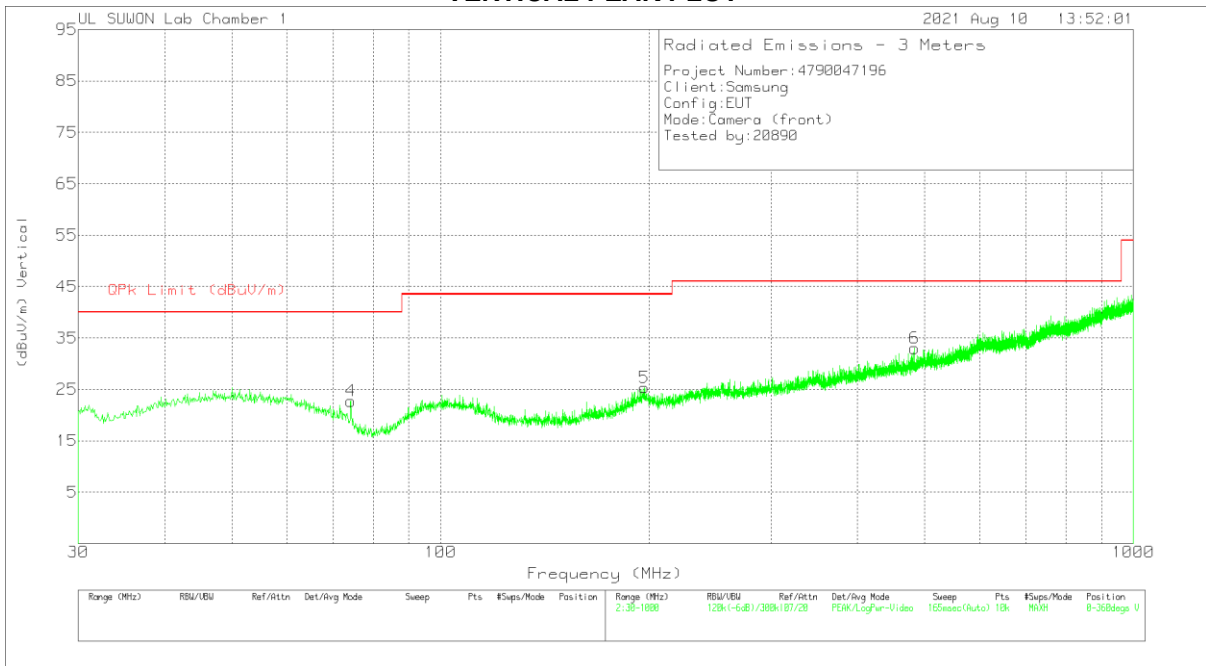

**DATA**

Trace Markers

Marker	Frequency (MHz)	Meter Reading (dBuV)	Det	VULB9163_750	Below_1G[dB]	Corrected Reading (dBuV/m)	QPk Limit (dBuV/m)	Margin (dB)	Azimuth (Degs)	Height (cm)	Polarity
1	54.832	33.97	Pk	19.4	-29.4	23.97	40	-16.03	0-360	400	H
2	194.318	35.16	Pk	17.9	-27.5	25.56	43.52	-17.96	0-360	400	H
3	496.57	35.48	Pk	23.3	-25.7	33.08	46.02	-12.94	0-360	200	H
4	74.232	38.23	Pk	13.8	-29.3	22.73	40	-17.27	0-360	100	V
5	196.937	34.82	Pk	18.2	-27.7	25.32	43.52	-18.2	0-360	100	V
6	483.572	36.01	Pk	22.8	-25.8	33.01	46.02	-13.01	0-360	100	V

Pk - Peak detector

[Test case 2]

**HORIZONTAL PEAK PLOT**

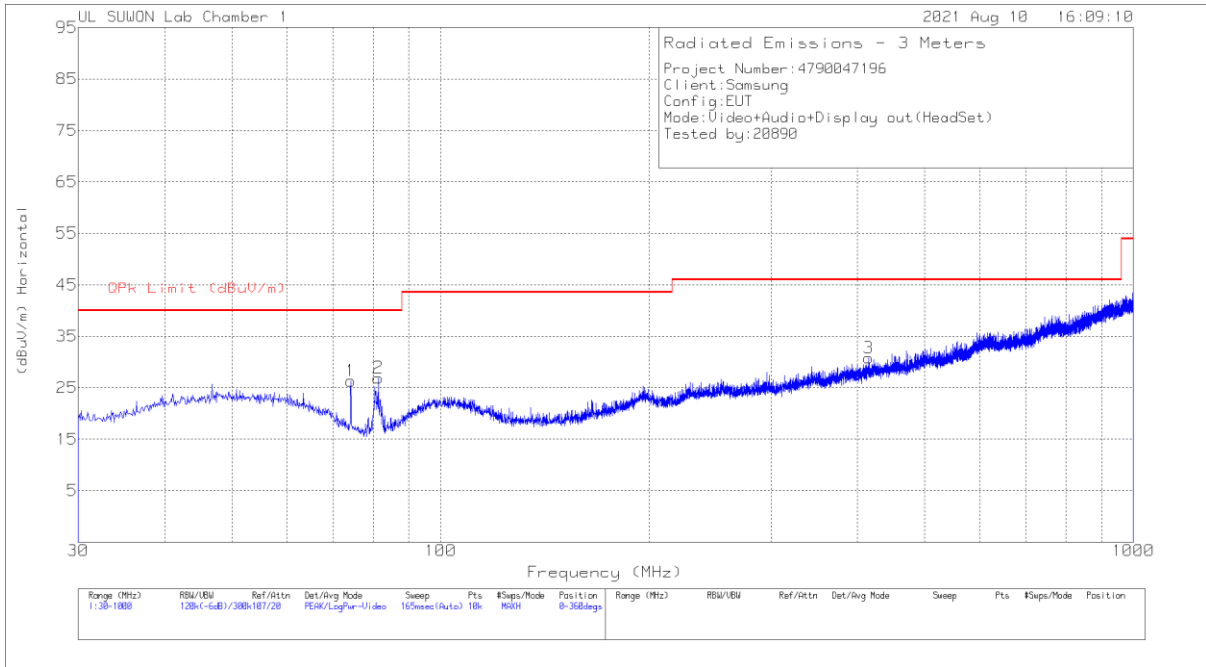

**VERTICAL PEAK PLOT**

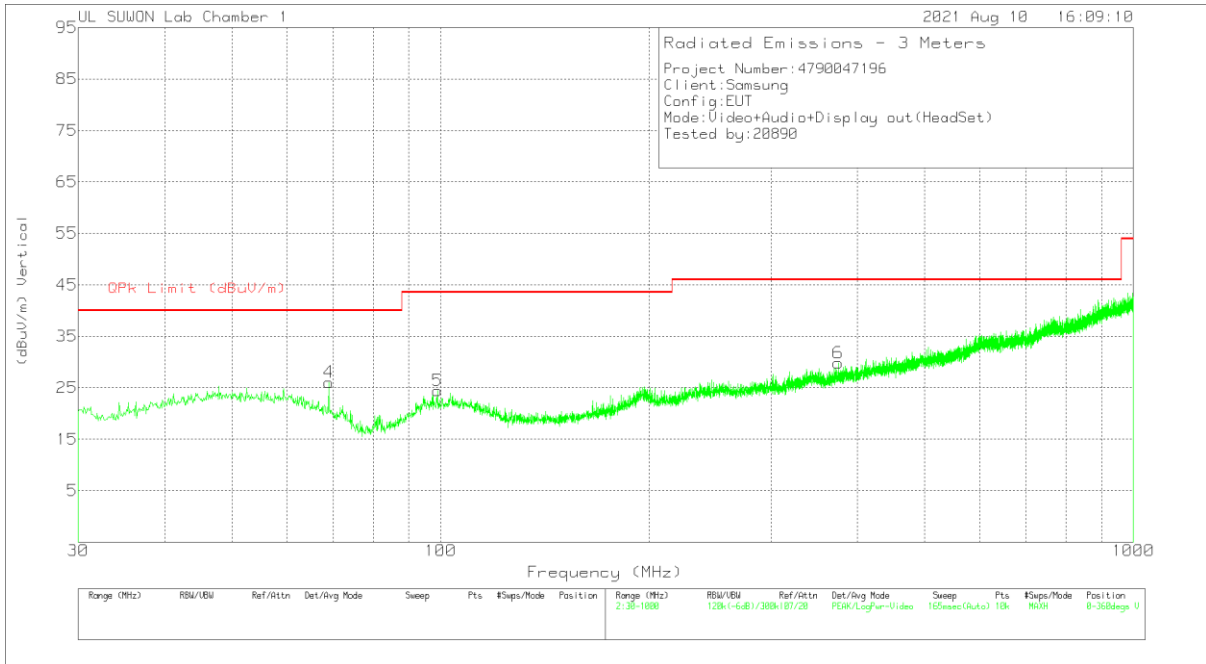



**DATA**

Trace Markers

Marker	Frequency (MHz)	Meter Reading (dBuV)	Det	VULB9163_750	Below_1G[dB]	Corrected Reading (dBuV/m)	QPk Limit (dBuV/m)	Margin (dB)	Azimuth (Degs)	Height (cm)	Polarity
1	74.232	41.84	Pk	13.8	-29.3	26.34	40	-13.66	0-360	300	H
2	81.313	43.13	Pk	12.8	-29	26.93	40	-13.07	0-360	300	H
3	415.187	34.99	Pk	21.9	-26.1	30.79	46.02	-15.23	0-360	100	H
4	68.994	39.24	Pk	15.9	-29.1	26.04	40	-13.96	0-360	400	V
5	98.967	35.33	Pk	17.8	-28.7	24.43	43.52	-19.09	0-360	100	V
6	375.029	35.22	Pk	21	-26.4	29.82	46.02	-16.2	0-360	100	V

Pk - Peak detector

[Test case 3]

**HORIZONTAL PEAK PLOT**

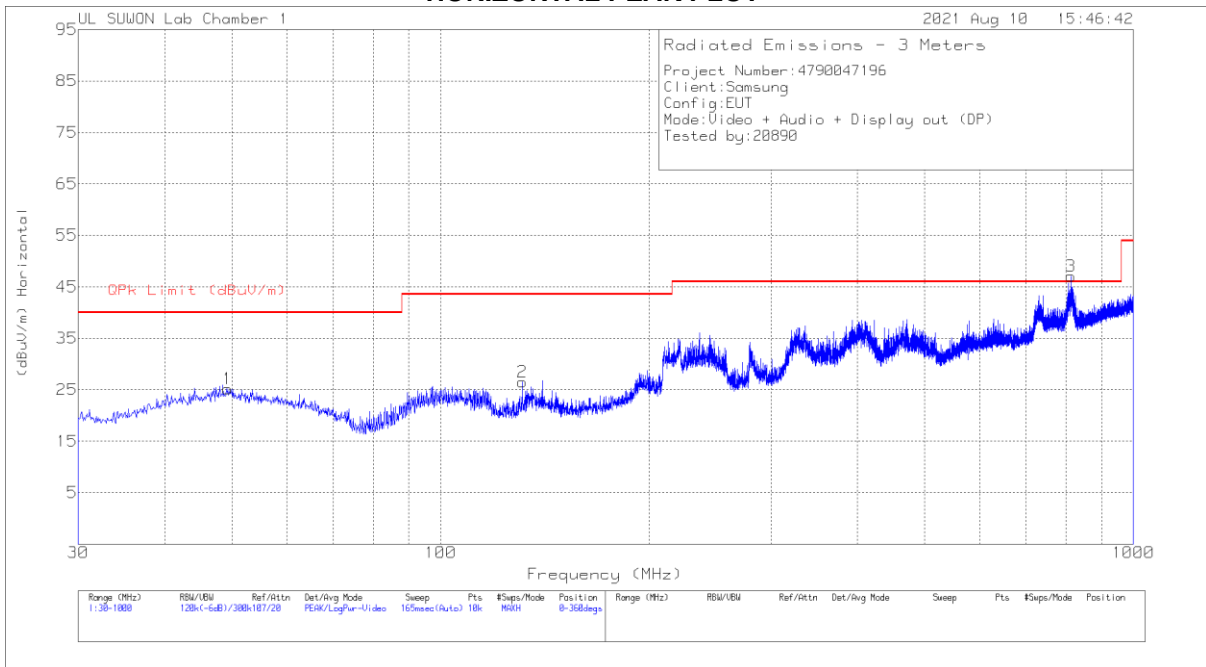

**VERTICAL PEAK PLOT**



**DATA**

Trace Markers

Marker	Frequency (MHz)	Meter Reading (dBuV)	Det	VULB9163_750	Below_1G[dB]	Corrected Reading (dBuV/m)	QPk Limit (dBuV/m)	Margin (dB)	Azimuth (Degs)	Height (cm)	Polarity
1	49.303	35.07	Pk	19.7	-29.6	25.17	40	-14.83	0-360	300	H
2	131.268	40.59	Pk	14.2	-28.3	26.49	43.52	-17.03	0-360	200	H
3	813.081	44.15	Pk	27	-24.1	47.05	<b>46.02</b>	<b>1.03</b>	0-360	100	H
4	48.042	45.25	Pk	19.8	-29.6	35.45	40	-4.55	0-360	100	V
5	135.051	48.67	Pk	14.2	-28.3	34.57	43.52	-8.95	0-360	100	V
6	811.044	38.37	Pk	27	-24.1	41.27	46.02	-4.75	0-360	100	V

Pk - Peak detector

Radiated Emissions

Frequency (MHz)	Meter Reading (dBuV)	Det	VULB9163_750	Below_1G[dB]	Corrected Reading (dBuV/m)	QPk Limit (dBuV/m)	Margin (dB)	Azimuth (Degs)	Height (cm)	Polarity
812.129	39.83	Qp	27	-24.1	42.73	46.02	-3.29	294	100	H

Qp - Quasi-Peak detector

[Test case 4]

HORIZONTAL PEAK PLOT

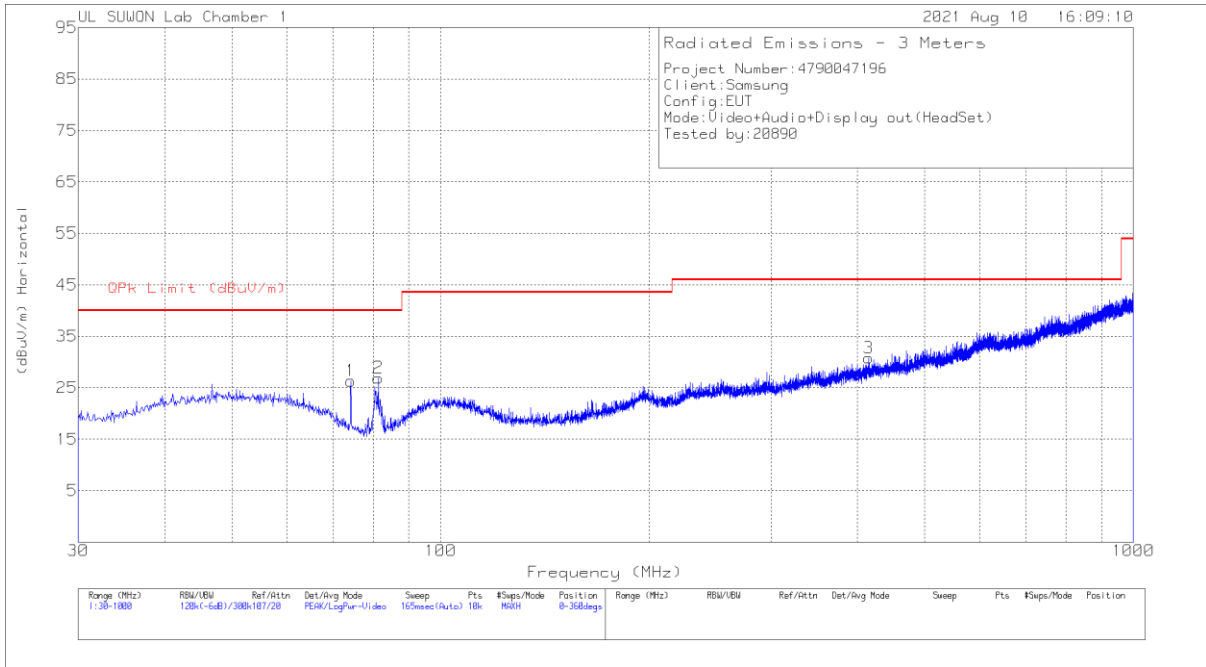

VERTICAL PEAK PLOT

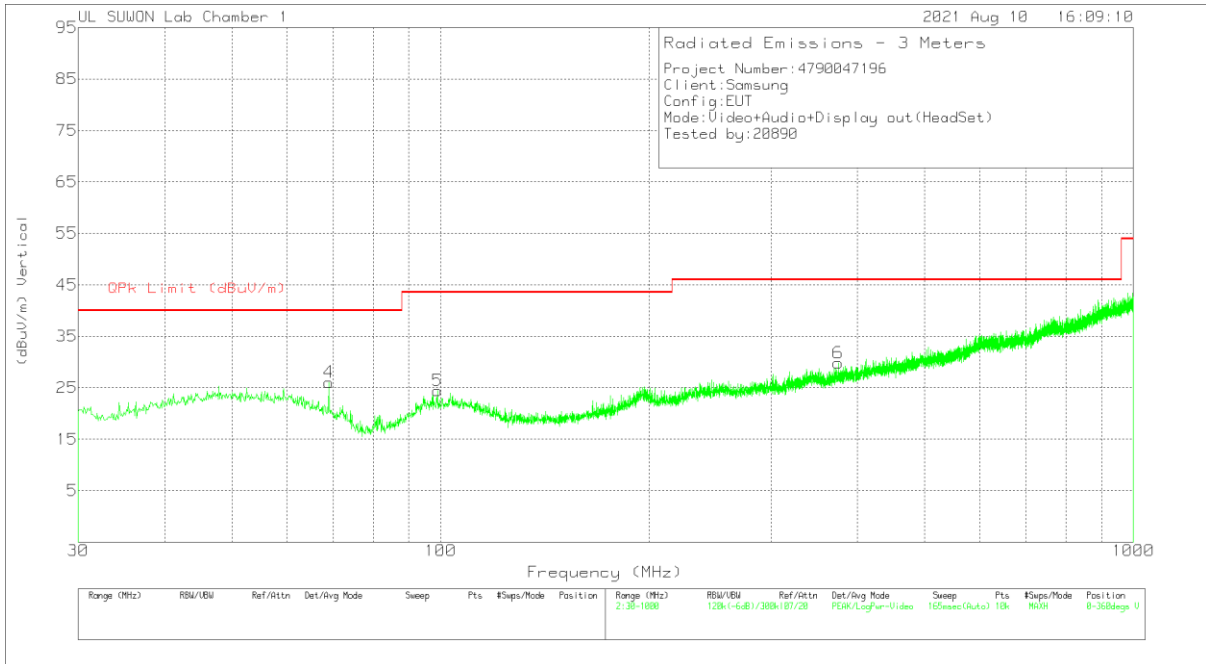

**DATA**

Trace Markers

Marker	Frequency (MHz)	Meter Reading (dBuV)	Det	VULB9163_750	Below_1G[dB]	Corrected Reading (dBuV/m)	QPk Limit (dBuV/m)	Margin (dB)	Azimuth (Degs)	Height (cm)	Polarity
1	74.232	41.84	Pk	13.8	-29.3	26.34	40	-13.66	0-360	300	H
2	81.313	43.13	Pk	12.8	-29	26.93	40	-13.07	0-360	300	H
3	415.187	34.99	Pk	21.9	-26.1	30.79	46.02	-15.23	0-360	100	H
4	68.994	39.24	Pk	15.9	-29.1	26.04	40	-13.96	0-360	400	V
5	98.967	35.33	Pk	17.8	-28.7	24.43	43.52	-19.09	0-360	100	V
6	375.029	35.22	Pk	21	-26.4	29.82	46.02	-16.2	0-360	100	V

Pk - Peak detector

## 7.1.2. RADIATED EMISSIONS 1 GHz to 18 GHz [Test case 1]

### HORIZONTAL PEAK PLOT

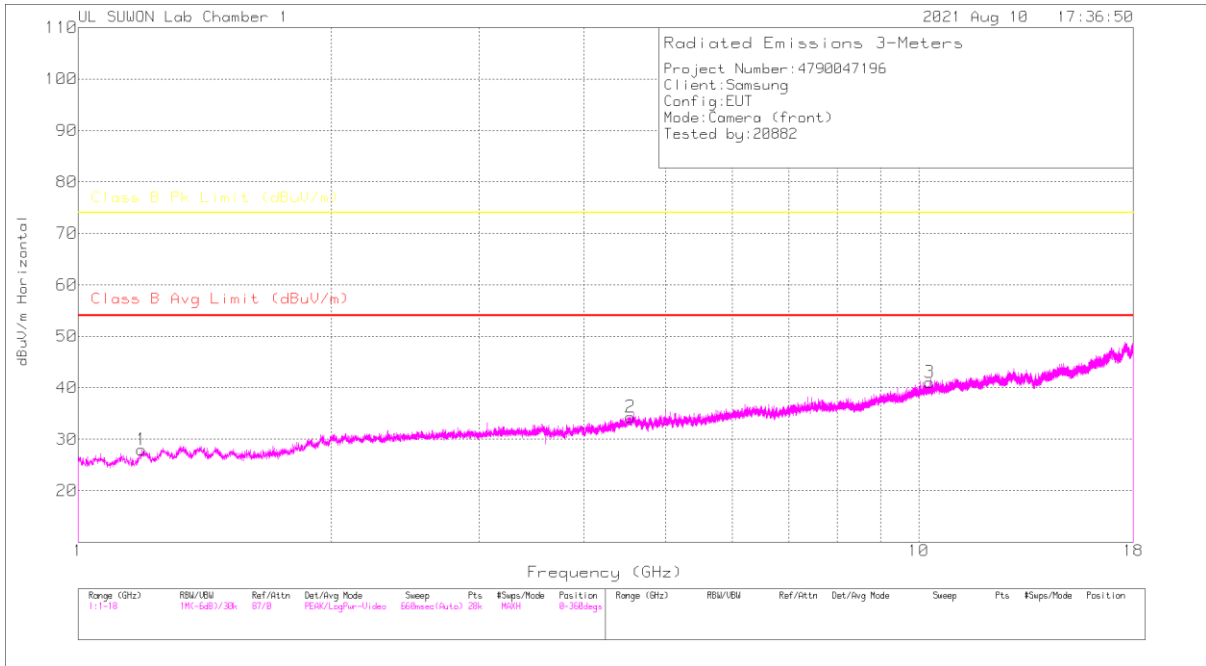

### VERTICAL PEAK PLOT

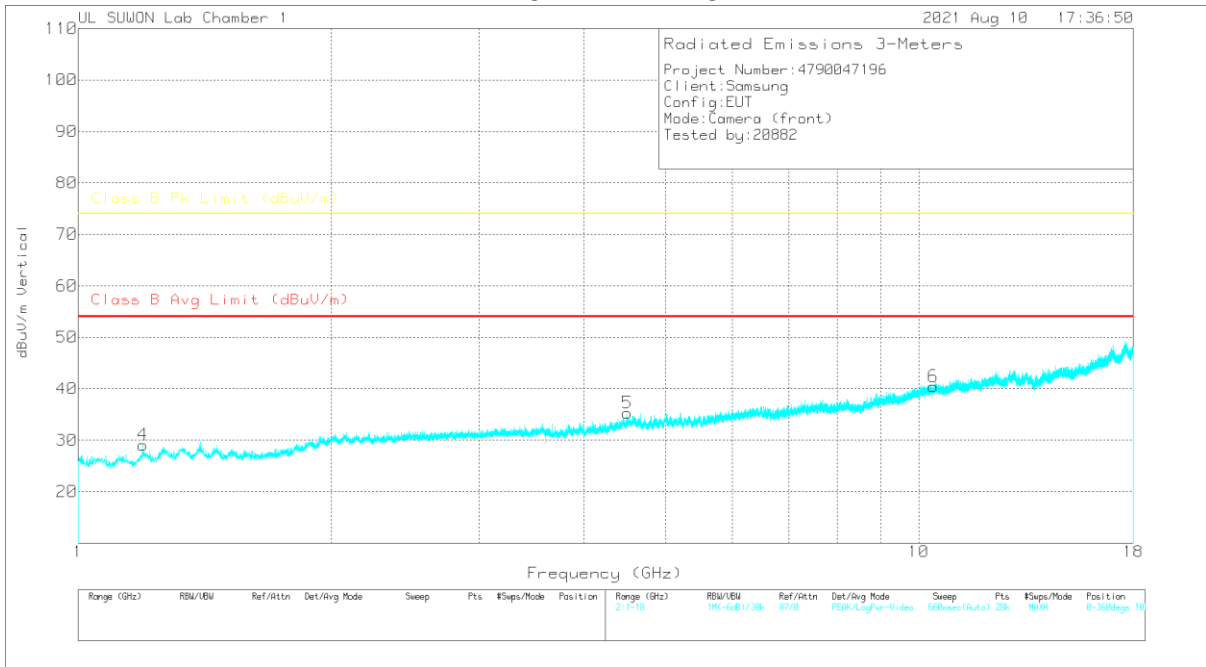

**DATA**

**Trace Markers**

Marker	Frequency (GHz)	Meter Reading (dBuV)	Det	3117_00168717	1-18GHz[dB]	Corrected Reading dBuV/m	Class B Avg Limit (dBuV/m)	Av(CISPR)Marg in (dB)	Class B Pk Limit (dBuV/m)	Margin (dB)	Azimuth (Degs)	Height (cm)	Polarity
1	1.19002	36.97	PK	28.4	-37.4	27.97	-	-	74	-46.03	0-360	200	H
2	4.54109	32.42	PK	34.2	-32.3	34.32	-	-	74	-39.68	0-360	100	H
3	10.29861	26.67	PK	37.8	-23.4	41.07	-	-	74	-32.93	0-360	200	H
4	1.19305	38.09	PK	28.4	-37.4	29.09	-	-	74	-44.91	0-360	200	V
5	4.50223	33.29	PK	34.2	-32.2	35.29	-	-	74	-38.71	0-360	200	V
6	10.40425	25.64	PK	37.8	-23	40.44	-	-	74	-33.56	0-360	100	V

PK – Peak Detector

[Test case 2]

**HORIZONTAL PEAK PLOT**

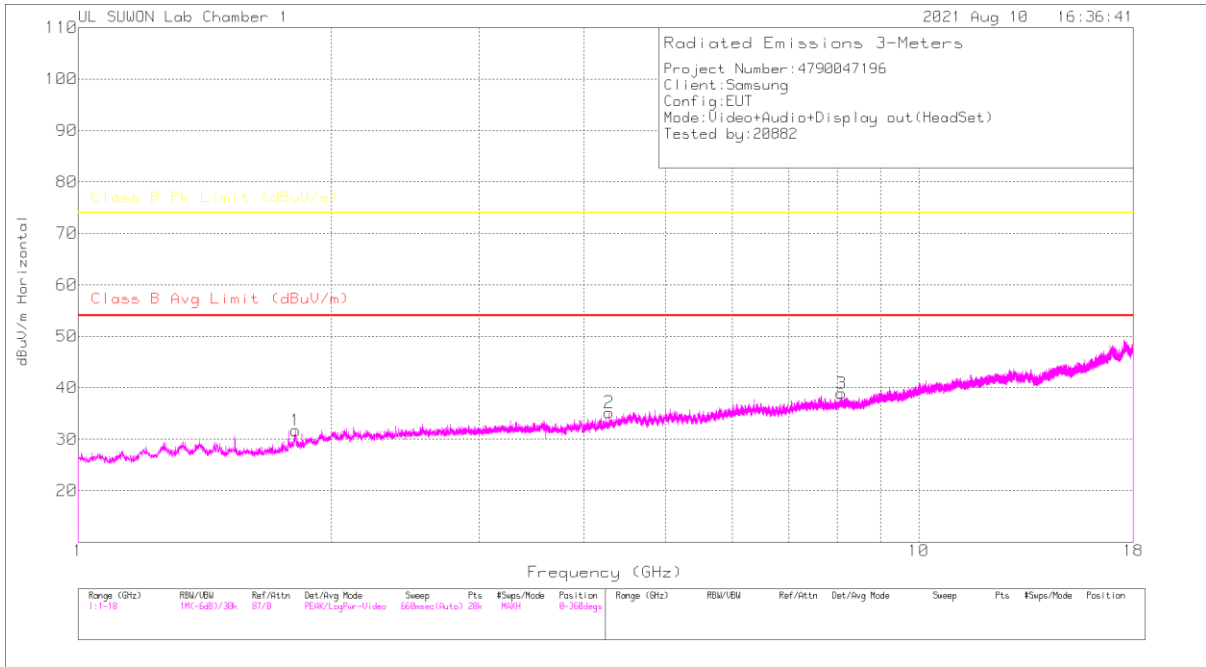

**VERTICAL PEAK PLOT**

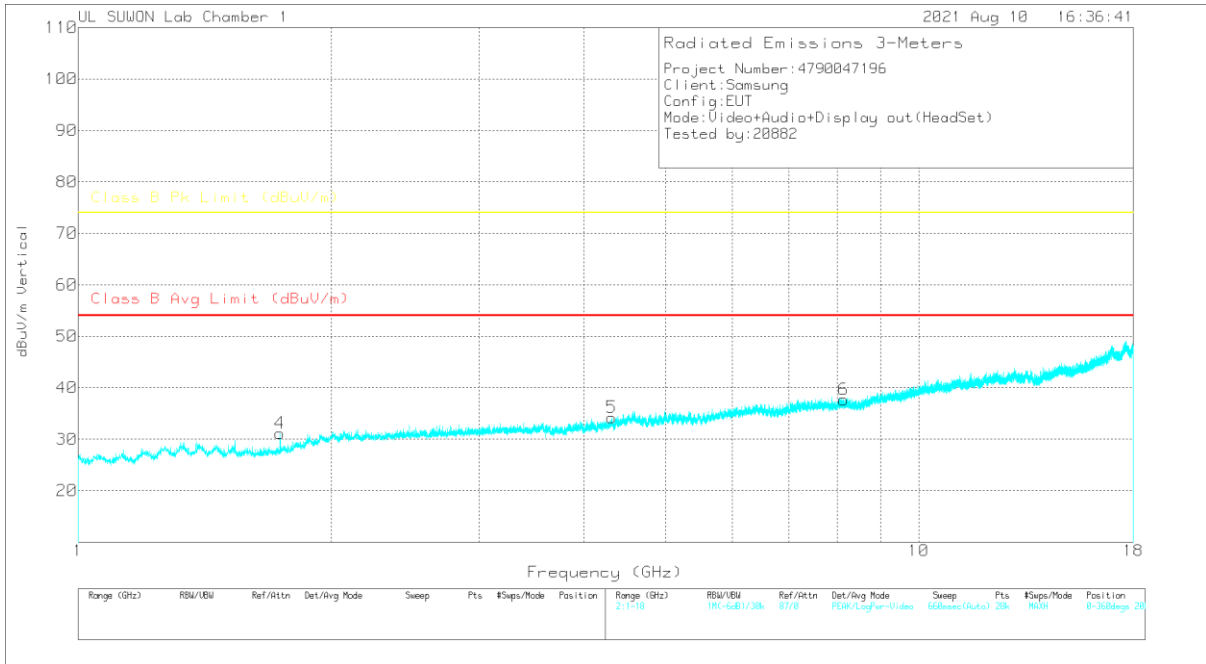



**DATA**

Trace Markers

Marker	Frequency (GHz)	Meter Reading (dBuV)	Det	3117_00168717	1-18GHz(dB)	Corrected Reading dBuV/m	Class B Avg Limit (dBuV/m)	Av(CISPR)Margin (dB)	Class B Pk Limit (dBuV/m)	Margin (dB)	Azimuth (Degs)	Height (cm)	Polarity
1	1.81348	38.19	PK	29.7	-36.2	31.69	-	-	74	-42.31	0-360	100	H
2	4.28429	34.08	PK	33.8	-32.7	35.18	-	-	74	-38.82	0-360	100	H
3	8.08885	29.65	PK	36.2	-26.9	38.95	-	-	74	-35.05	0-360	100	H
4	1.73821	38.54	PK	28.9	-36.3	31.14	-	-	74	-42.86	0-360	100	V
5	4.31161	33.12	PK	33.8	-32.7	34.22	-	-	74	-39.78	0-360	100	V
6	8.13984	28.09	PK	36.2	-26.6	37.69	-	-	74	-36.31	0-360	100	V

PK – Peak Detector

[Test case 3]

**HORIZONTAL PEAK PLOT**

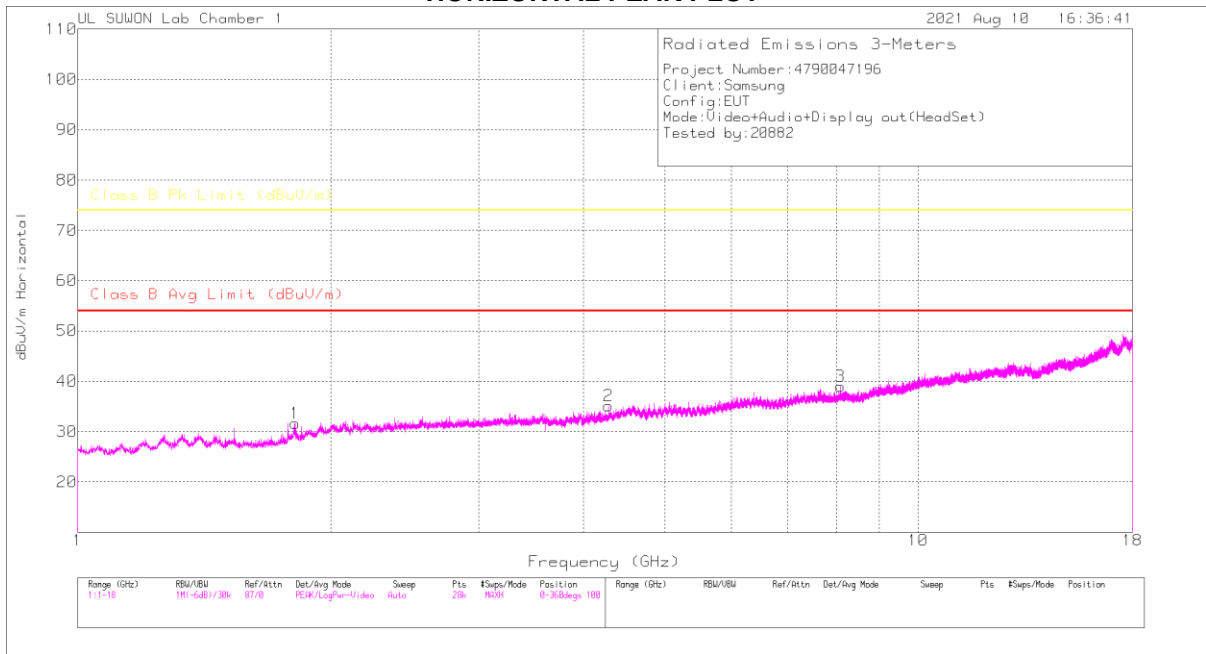

**VERTICAL PEAK PLOT**

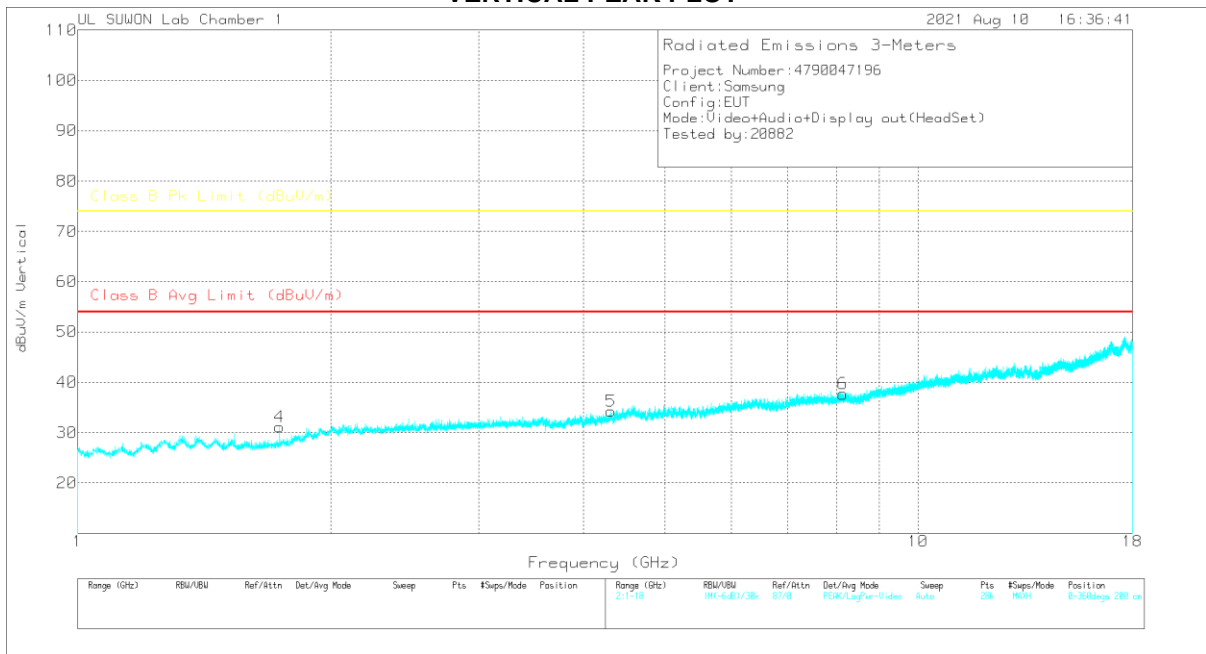

**DATA**

Trace Markers

Marker	Frequency (GHz)	Meter Reading (dBuV)	Det	3117_00168717	1-18GHz[dB]	Corrected Reading dBuV/m	Class B Avg Limit (dBuV/m)	Av(CISPR)Margin (dB)	Class B Pk Limit (dBuV/m)	Margin (dB)	Azimuth (Degs)	Height (cm)	Polarity
1	1.81348	38.19	PK	29.7	-36.2	31.69	-	-	74	-42.31	0-360	100	H
2	4.28429	34.08	PK	33.8	-32.7	35.18	-	-	74	-38.82	0-360	100	H
3	8.08885	29.65	PK	36.2	-26.9	38.95	-	-	74	-35.05	0-360	100	H
4	1.73821	38.54	PK	28.9	-36.3	31.14	-	-	74	-42.86	0-360	100	V
5	4.31161	33.12	PK	33.8	-32.7	34.22	-	-	74	-39.78	0-360	100	V
6	8.13984	28.09	PK	36.2	-26.6	37.69	-	-	74	-36.31	0-360	100	V

PK – Peak Detector

Radiated Emissions

Frequency (GHz)	Meter Reading (dBuV)	Det	3117_00168717	1-18GHz[dB]	Corrected Reading dBuV/m	Class B Avg Limit (dBuV/m)	Av(CISPR)Margin (dB)	Class B Pk Limit (dBuV/m)	Margin (dB)	Azimuth (Degs)	Height (cm)	Polarity
1.8134	43.48	Pk	29.7	-36.2	36.98	-	-	74	-37.02	0	100	H
4.28229	31.49	Pk	33.8	-32.7	32.59	-	-	74	-41.41	0	100	H
8.08685	30.94	Pk	36.2	-26.9	40.24	-	-	74	-33.76	0	100	H
1.74021	36.13	Pk	28.9	-36.3	28.73	-	-	74	-45.27	0	100	V
4.30961	38.32	Pk	33.8	-32.7	39.42	-	-	74	-34.58	0	100	V
8.13784	29.3	Pk	36.2	-26.6	38.9	-	-	74	-35.1	0	100	V

Pk - Peak detector

[Test case 4]

**HORIZONTAL PEAK PLOT**

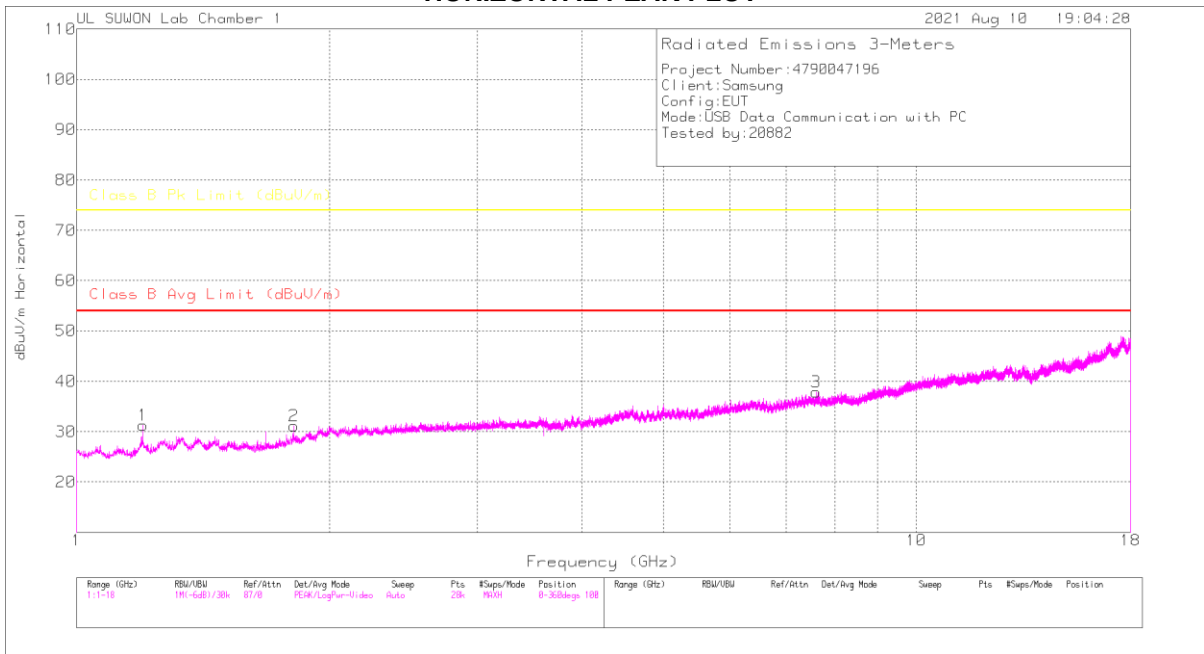

**VERTICAL PEAK PLOT**

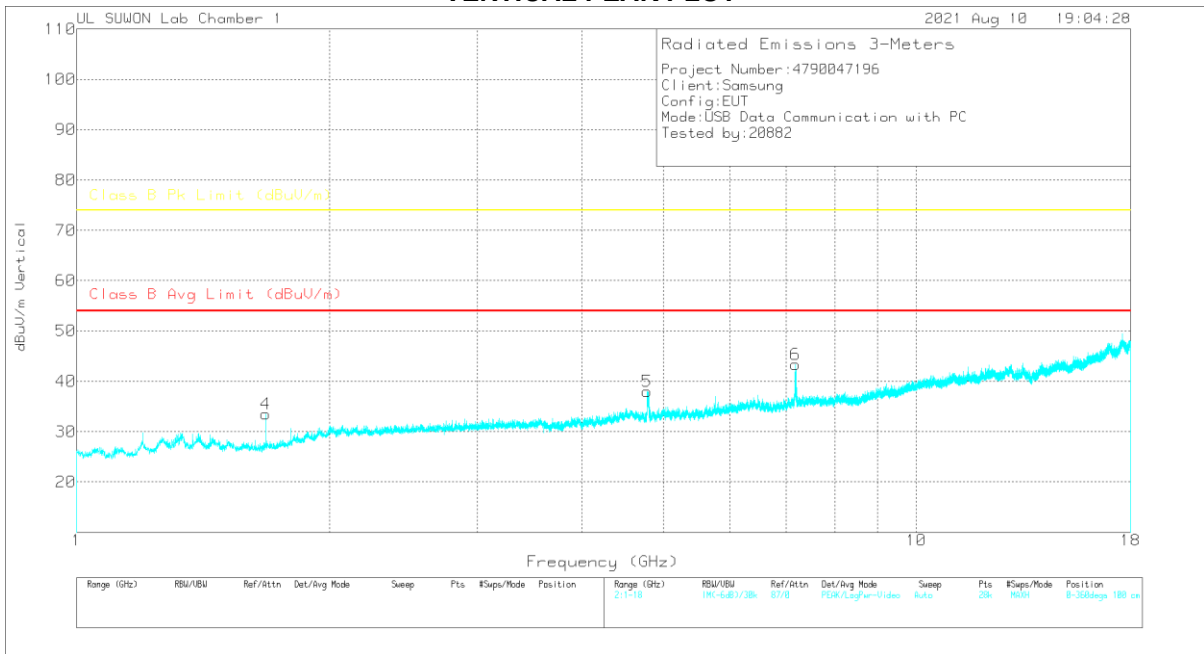

**DATA**

**Trace Markers**

Marker	Frequency (GHz)	Meter Reading (dBuV)	Det	3117_00168717	1-18GHz[dB]	Corrected Reading dBuV/m	Class B Avg Limit (dBuV/m)	Av(CISPR)Margin (dB)	Class B Pk Limit (dBuV/m)	Margin (dB)	Azimuth (Degs)	Height (cm)	Polarity
1	1.19973	40.19	PK	28.5	-37.4	31.29	-	-	74	-42.71	0-360	100	H
2	1.81348	37.64	PK	29.7	-36.2	31.14	-	-	74	-42.86	0-360	100	H
3	7.59712	29.67	PK	35.8	-27.6	37.87	-	-	74	-36.13	0-360	100	H
4	1.67993	41.52	PK	28.5	-36.5	33.52	-	-	74	-40.48	0-360	100	V
5	4.78027	35.97	PK	34.1	-32.1	37.97	-	-	74	-36.03	0-360	200	V
6	7.18552	35.76	PK	35.9	-28.3	43.36	-	-	74	-30.64	0-360	200	V

PK – Peak Detector

**Radiated Emissions**

Frequency (GHz)	Meter Reading (dBuV)	Det	3117_00168717	1-18GHz[dB]	Corrected Reading dBuV/m	Class B Avg Limit (dBuV/m)	Av(CISPR)Margin (dB)	Class B Pk Limit (dBuV/m)	Margin (dB)	Azimuth (Degs)	Height (cm)	Polarity
1.19947	44.25	Pk	28.5	-37.4	35.35	-	-	74	-38.65	335	151	H
1.19973	32.41	Ca	28.5	-37.4	23.51	54	-30.49	-	-	335	150	H
1.81148	38.41	Pk	29.7	-36.2	31.91	-	-	74	-42.09	360	100	H
7.59648	35.69	Pk	35.8	-27.6	43.89	-	-	74	-30.11	360	100	H
1.68193	44.93	Pk	28.5	-36.5	36.93	-	-	74	-37.07	341	317	V
1.68193	31.02	Ca	28.5	-36.5	23.02	54	-30.98	-	-	341	317	V
4.78027	41.35	Pk	34.1	-32.1	43.35	-	-	74	-30.65	95	110	V
4.78027	28.25	Ca	34.1	-32.1	30.25	54	-23.75	-	-	95	110	V
7.18552	48.38	Pk	35.9	-28.3	55.98	-	-	74	-18.02	0	149	V
7.18552	25.71	Ca	35.9	-28.3	33.31	54	-20.69	-	-	0	149	V

Pk - Peak detector

Ca - CISPR average detection

### 7.1.3. RADIATED EMISSIONS Above 18 GHz [Test case 1]

#### HORIZONTAL PEAK PLOT

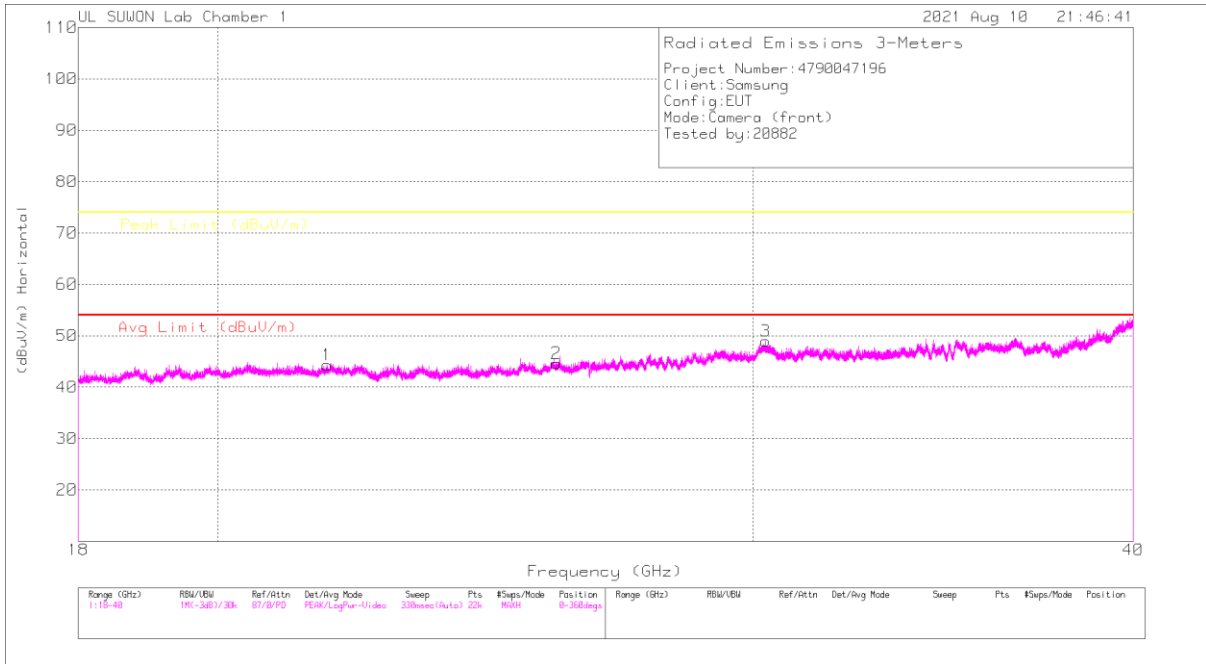

#### VERTICAL PEAK PLOT

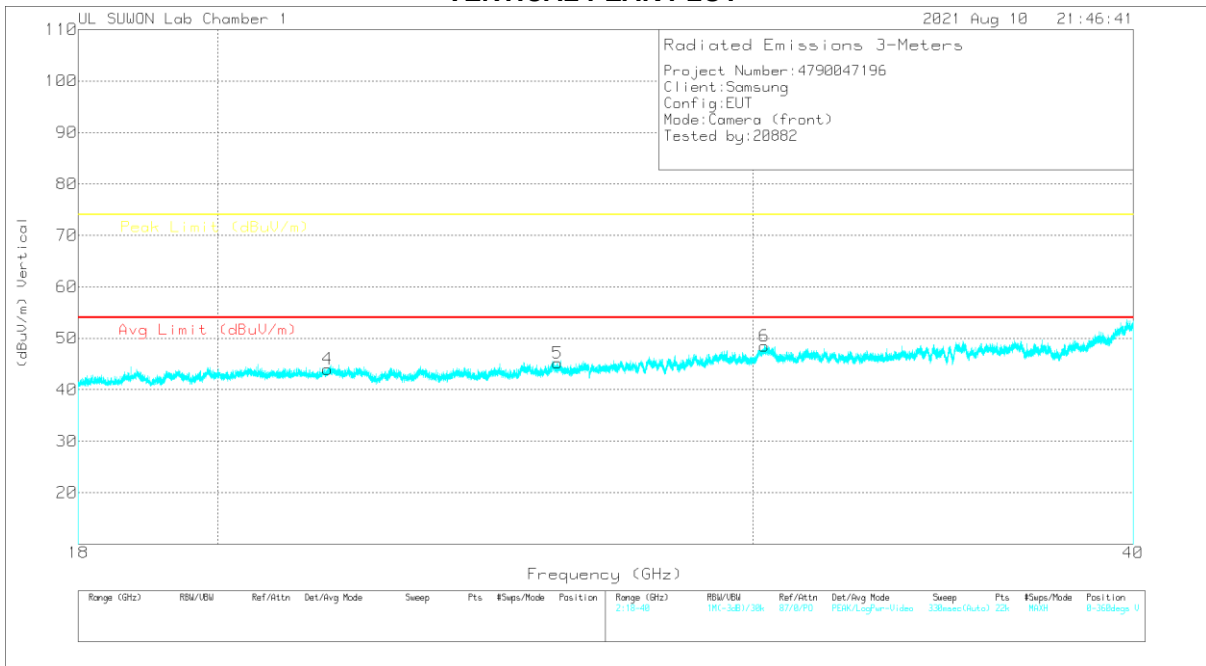

**DATA**

**Trace Markers**

Marker	Frequency (GHz)	Meter Reading (dBuV)	Det	3116C-PA	18-40GHz[dB]	Corrected Reading (dBuV/m)	Avg Limit (dBuV/m)	Margin (dB)	Peak Limit (dBuV/m)	Margin (dB)	Azimuth (Degs)	Height (cm)	Polarity
1	21.73283	17.9	PK	10	16.4	44.3	-	-	74	-29.7	0-360	100	H
2	25.84965	19.5	PK	7.1	18	44.6	-	-	74	-29.4	0-360	100	H
3	30.27945	15.87	PK	13.4	19.7	48.97	-	-	74	-25.03	0-360	100	H
4	21.73683	17.61	PK	10	16.4	44.01	-	-	74	-29.99	0-360	100	V
5	25.87565	20.07	PK	7.1	18	45.17	-	-	74	-28.83	0-360	100	V
6	30.25045	15.39	PK	13.4	19.7	48.49	-	-	74	-25.51	0-360	100	V

PK – Peak Detector

[Test case 2]

**HORIZONTAL PEAK PLOT**



**VERTICAL PEAK PLOT**

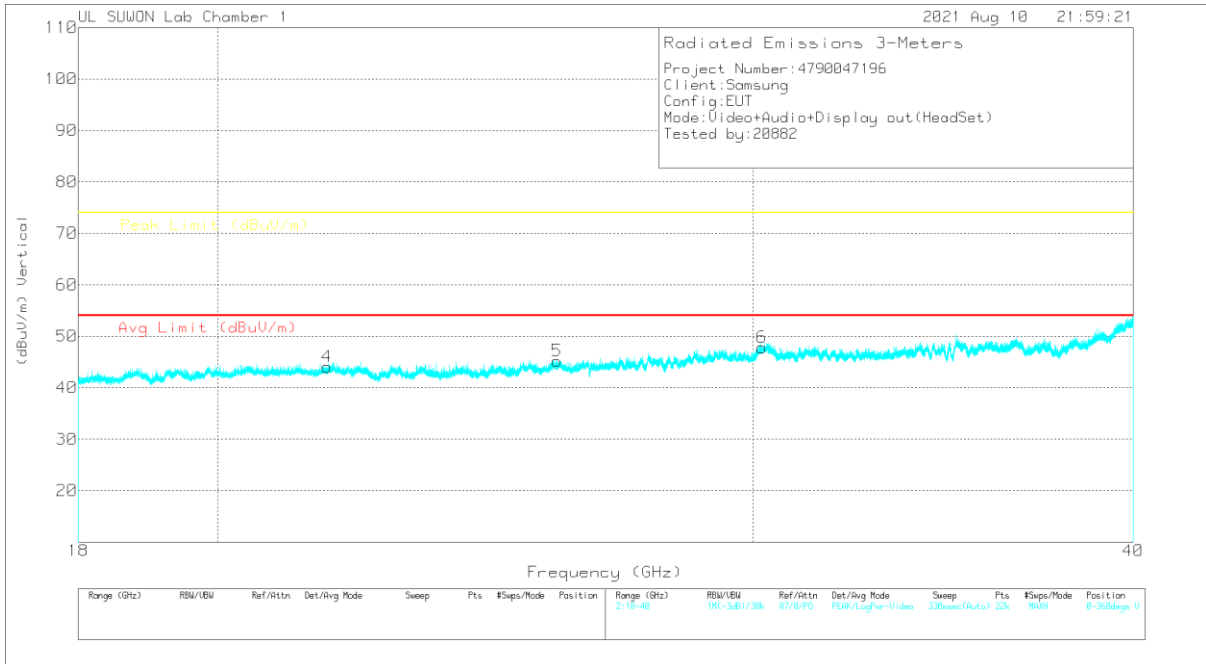



**DATA**

**Trace Markers**

Marker	Frequency (GHz)	Meter Reading (dBuV)	Det	3116C-PA	18-40GHz[dB]	Corrected Reading (dBuV/m)	Avg Limit (dBuV/m)	Margin (dB)	Peak Limit (dBuV/m)	Margin (dB)	Azimuth (Degs)	Height (cm)	Polarity
1	21.76483	17.74	PK	10	16.4	44.14	-	-	74	-29.86	0-360	100	H
2	25.84665	20	PK	7.1	18	45.1	-	-	74	-28.9	0-360	100	H
3	30.23845	15.04	PK	13.4	19.7	48.14	-	-	74	-25.86	0-360	100	H
4	21.72583	17.65	PK	10	16.4	44.05	-	-	74	-29.95	0-360	100	V
5	25.86065	20.1	PK	7.1	18	45.2	-	-	74	-28.8	0-360	100	V
6	30.19645	14.84	PK	13.4	19.6	47.84	-	-	74	-26.16	0-360	100	V

PK – Peak Detector

**Radiated Emissions**

Frequency (GHz)	Meter Reading (dBuV)	Det	3116C-PA	18-40GHz[dB]	Corrected Reading (dBuV/m)	Avg Limit (dBuV/m)	Margin (dB)	Peak Limit (dBuV/m)	Margin (dB)	Azimuth (Degs)	Height (cm)	Polarity
21.76483	25.7	Pk	10	16.4	52.1	-	-	74	-21.9	360	100	H
21.76483	12.66	Ca	10	16.4	39.06	54	-14.94	-	-	360	100	H
25.84665	26.84	Pk	7.1	18	51.94	-	-	74	-22.06	360	100	H
25.84665	14.41	Ca	7.1	18	39.51	54	-14.49	-	-	360	100	H
30.23845	22.79	Pk	13.4	19.7	55.89	-	-	74	-18.11	360	100	H
30.23845	9.8	Ca	13.4	19.7	42.9	54	-11.1	-	-	360	100	H
21.76683	25.53	Pk	10	16.4	51.93	-	-	74	-22.07	360	100	V
21.76683	12.58	Ca	10	16.4	38.98	54	-15.02	-	-	360	100	V
25.84501	18.86	Pk	7.1	18	51.96	-	-	74	-30.04	360	100	V
25.84501	14.37	Ca	7.1	18	39.47	54	-14.53	-	-	360	100	V
30.23845	22.6	Pk	13.4	19.7	55.7	-	-	74	-18.3	360	100	V
30.23845	9.78	Ca	13.4	19.7	42.88	54	-11.12	-	-	360	100	V

Pk - Peak detector

Ca - CISPR average detection

[Test case 3]

**HORIZONTAL PEAK PLOT**



**VERTICAL PEAK PLOT**

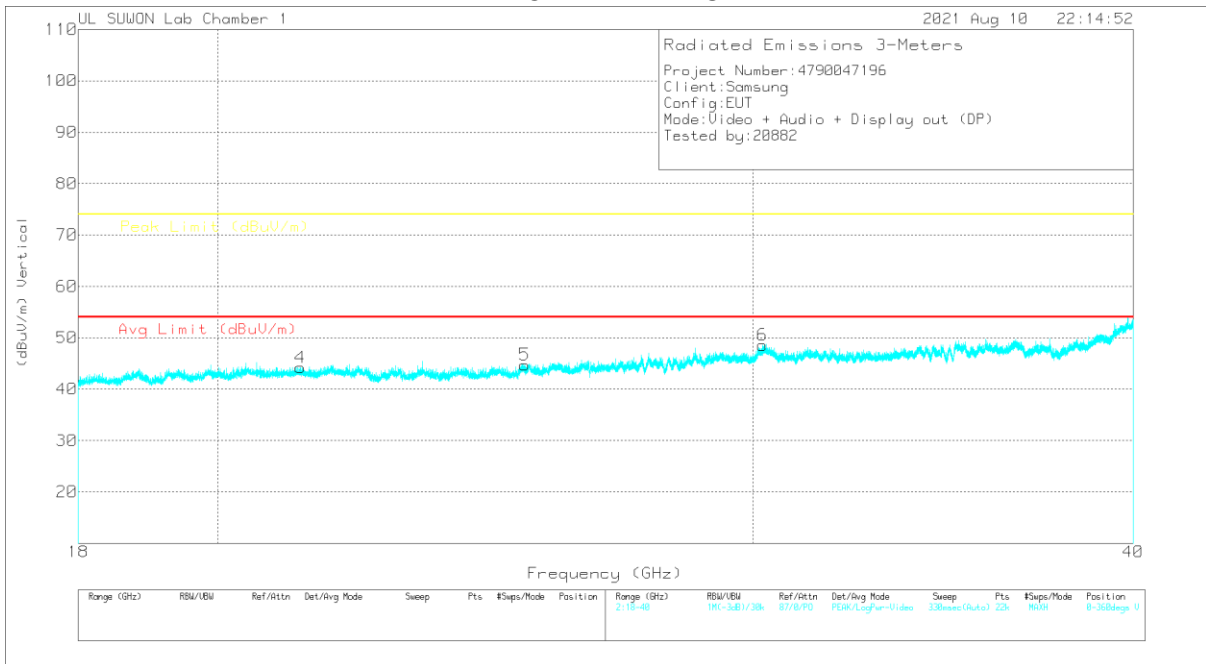

**DATA**

**Trace Markers**

Marker	Frequency (GHz)	Meter Reading (dBuV)	Det	3116C-PA	18-40GHz[dB]	Corrected Reading (dBuV/m)	Avg Limit (dBuV/m)	Margin (dB)	Peak Limit (dBuV/m)	Margin (dB)	Azimuth (Degs)	Height (cm)	Polarity
1	21.30985	17.9	PK	9.5	16.2	43.6	-	-	74	-30.4	0-360	100	H
2	25.30367	19.24	PK	7.5	17.8	44.54	-	-	74	-29.46	0-360	100	H
3	30.24745	15.32	PK	13.4	19.7	48.42	-	-	74	-25.58	0-360	100	H
4	21.29485	18.49	PK	9.4	16.3	44.19	-	-	74	-29.81	0-360	100	V
5	25.23567	19.43	PK	7.5	17.8	44.73	-	-	74	-29.27	0-360	100	V
6	30.21545	15.46	PK	13.4	19.7	48.56	-	-	74	-25.44	0-360	100	V

PK – Peak Detector

**Radiated Emissions**

Frequency (GHz)	Meter Reading (dBuV)	Det	3116C-PA	18-40GHz[dB]	Corrected Reading (dBuV/m)	Avg Limit (dBuV/m)	Margin (dB)	Peak Limit (dBuV/m)	Margin (dB)	Azimuth (Degs)	Height (cm)	Polarity
21.30985	26.18	Pk	9.5	16.2	51.88	-	-	74	-22.12	360	100	H
21.30985	13.32	Ca	9.5	16.2	39.02	54	-14.98	-	-	360	100	H
25.30367	27.89	Pk	7.5	17.8	53.19	-	-	74	-20.81	360	100	H
25.30367	14.43	Ca	7.5	17.8	39.73	54	-14.27	-	-	360	100	H
30.24545	22.82	Pk	13.4	19.7	55.92	-	-	74	-18.08	360	100	H
30.24545	10.1	Ca	13.4	19.7	43.2	54	-10.8	-	-	360	100	H
21.30985	26.14	Pk	9.5	16.2	51.84	-	-	74	-22.16	360	100	V
21.30985	13.19	Ca	9.5	16.2	38.89	54	-15.11	-	-	360	100	V
25.30367	27.05	Pk	7.5	17.8	52.35	-	-	74	-21.65	360	100	V
25.30367	14.41	Ca	7.5	17.8	39.71	54	-14.29	-	-	360	100	V
30.24745	23.38	Pk	13.4	19.7	56.48	-	-	74	-17.52	360	100	V
30.24745	10.05	Ca	13.4	19.7	43.15	54	-10.85	-	-	360	100	V

Pk - Peak detector

Ca - CISPR average detection

[Test case 4]

**HORIZONTAL PEAK PLOT**



**VERTICAL PEAK PLOT**

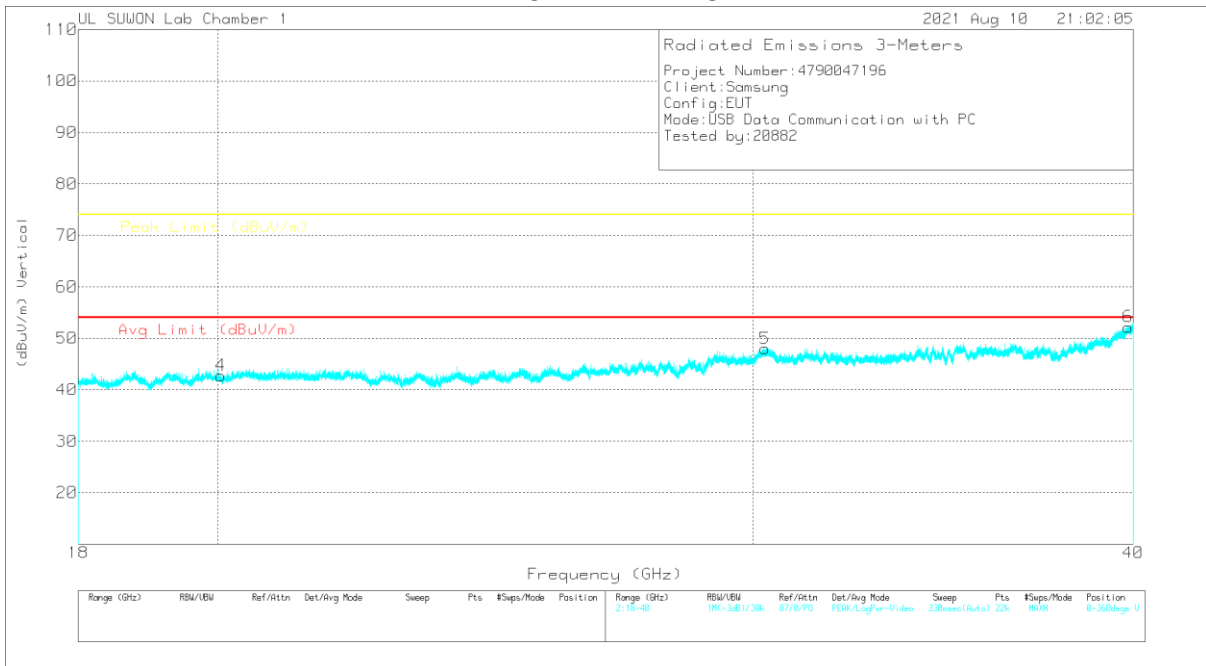

**DATA**

**Trace Markers**

Marker	Frequency (GHz)	Meter Reading (dBuV)	Det	3116C-PA	18-40GHz[dB]	Corrected Reading (dBuV/m)	Avg Limit (dBuV/m)	Margin (dB)	Peak Limit (dBuV/m)	Margin (dB)	Azimuth (Degs)	Height (cm)	Polarity
1	20.08891	20.21	PK	6.8	15.7	42.71	-	-	74	-31.29	0-360	100	H
2	30.32345	14.87	PK	13.4	19.7	47.97	-	-	74	-26.03	0-360	100	H
3	39.97601	16.25	PK	13.2	23.1	52.55	-	-	74	-21.45	0-360	100	H
4	20.04991	20.36	PK	6.7	15.7	42.76	-	-	74	-31.24	0-360	100	V
5	30.26545	14.88	PK	13.4	19.7	47.98	-	-	74	-26.02	0-360	100	V
6	39.84602	16.22	PK	13	23	52.22	-	-	74	-21.78	0-360	100	V

PK – Peak Detector

**Radiated Emissions**

Frequency (GHz)	Meter Reading (dBuV)	Det	3116C-PA	18-40GHz[dB]	Corrected Reading (dBuV/m)	Avg Limit (dBuV/m)	Margin (dB)	Peak Limit (dBuV/m)	Margin (dB)	Azimuth (Degs)	Height (cm)	Polarity
20.08891	28.78	Pk	6.8	15.7	51.28	-	-	74	-22.72	360	100	H
20.08891	15.86	Ca	6.8	15.7	38.36	54	-15.64	-	-	360	100	H
30.32345	22.67	Pk	13.4	19.7	55.77	-	-	74	-18.23	360	100	H
30.32345	9.87	Ca	13.4	19.7	42.97	54	-11.03	-	-	360	100	H
39.97601	24.43	Pk	13.2	23.1	60.73	-	-	74	-13.27	360	100	H
39.97601	11.12	Ca	13.2	23.1	47.42	54	-6.58	-	-	360	100	H
20.08891	28.64	Pk	6.8	15.7	51.14	-	-	74	-22.86	360	100	V
20.08891	15.71	Ca	6.8	15.7	38.21	54	-15.79	-	-	360	100	V
30.32345	22.72	Pk	13.4	19.7	55.82	-	-	74	-18.18	360	100	V
30.32345	9.85	Ca	13.4	19.7	42.95	54	-11.05	-	-	360	100	V
39.97601	24.17	Pk	13.2	23.1	60.47	-	-	74	-13.53	360	100	V
39.97601	11.11	Ca	13.2	23.1	47.41	54	-6.59	-	-	360	100	V

Pk - Peak detector

Ca - CISPR average detection

## 7.2. CONDUCTED EMISSIONS

### TEST PROCEDURE

ANSI C63.4-2014

### LIMIT

§15.107 (a) Except for Class A digital devices, for equipment that is designed to be connected to the public utility (AC) power line, the radio frequency voltage that is conducted back onto the AC power line on any frequency or frequencies within the band 150 kHz to 30 MHz shall not exceed the limits in the following table, as measured using a 50  $\mu$ H/50 ohms line impedance stabilization network (LISN). Compliance with the provisions of this paragraph shall be based on the measurement of the radio frequency voltage between each power line and ground at the power terminal. The lower limit applies at the band edges.

Frequency range (MHz)	Limits (dB $\mu$ V)	
	Quasi-peak	Average
0.15 to 0.50	66 to 56	56 to 46
0.50 to 5	56	46
5 to 30	60	50

Notes:  
 1. The lower limit shall apply at the transition frequencies  
 2. The limit decreases linearly with the logarithm of the frequency in the range 0.15 MHz to 0.50 MHz.

## 7.2.1. CONDUCTED EMISSIONS

[Test case 1]

### 6 WORST EMISSIONS

Line-L1 .15 – 30 MHz

### LINE 1 RESULTS

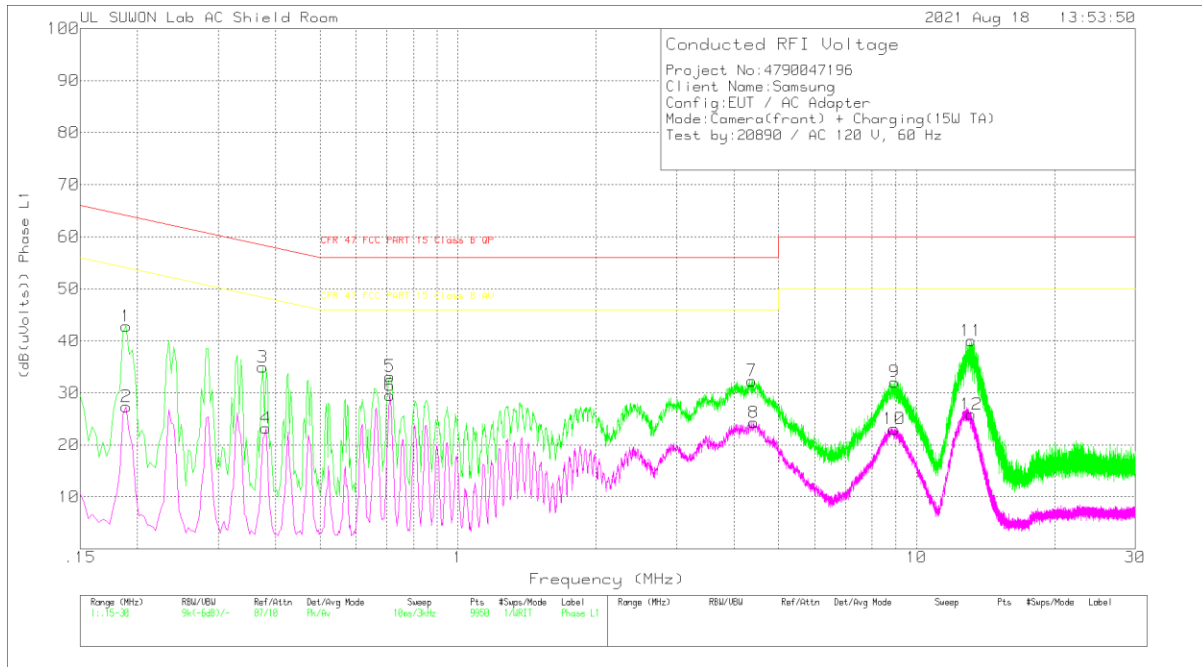

Trace Markers

Range 1: Phase L1 .15 - 30MHz

Marker	Frequency (MHz)	Meter Reading (dBuV)	Det	101836_Wit h EX_L1[dB]	CABLELOS S(dB)	Corrected Reading (dB(uVolts))	CFR 47 FCC PART 15 Class B QP	Margin (dB)	CFR 47 FCC PART 15 Class B AV	Margin (dB)
1	.189	32.57	Pk	10	.2	42.77	64.08	-21.31	-	-
2	.189	17.14	Av	10	.2	27.34	-	-	54.08	-26.74
3	.375	24.84	Pk	9.9	.2	34.94	58.39	-23.45	-	-
4	.381	13.11	Av	9.9	.2	23.21	-	-	48.26	-25.05
5	.711	23.05	Pk	9.9	.2	33.15	56	-22.85	-	-
6	.711	19.42	Av	9.9	.2	29.52	-	-	46	-16.48
7	4.38	22.2	Pk	9.8	.3	32.3	56	-23.7	-	-
8	4.416	14.19	Av	9.8	.3	24.29	-	-	46	-21.71
9	8.946	21.8	Pk	9.9	.4	32.1	60	-27.9	-	-
10	8.94	12.75	Av	9.9	.4	23.05	-	-	50	-26.95
11	13.155	29.61	Pk	10	.4	40.01	60	-19.99	-	-
12	13.173	15.46	Av	10	.4	25.86	-	-	50	-24.14

Pk - Peak detector

Av - Average detection



**Line-L2 .15 – 30 MHz**

**LINE 2 RESULTS**

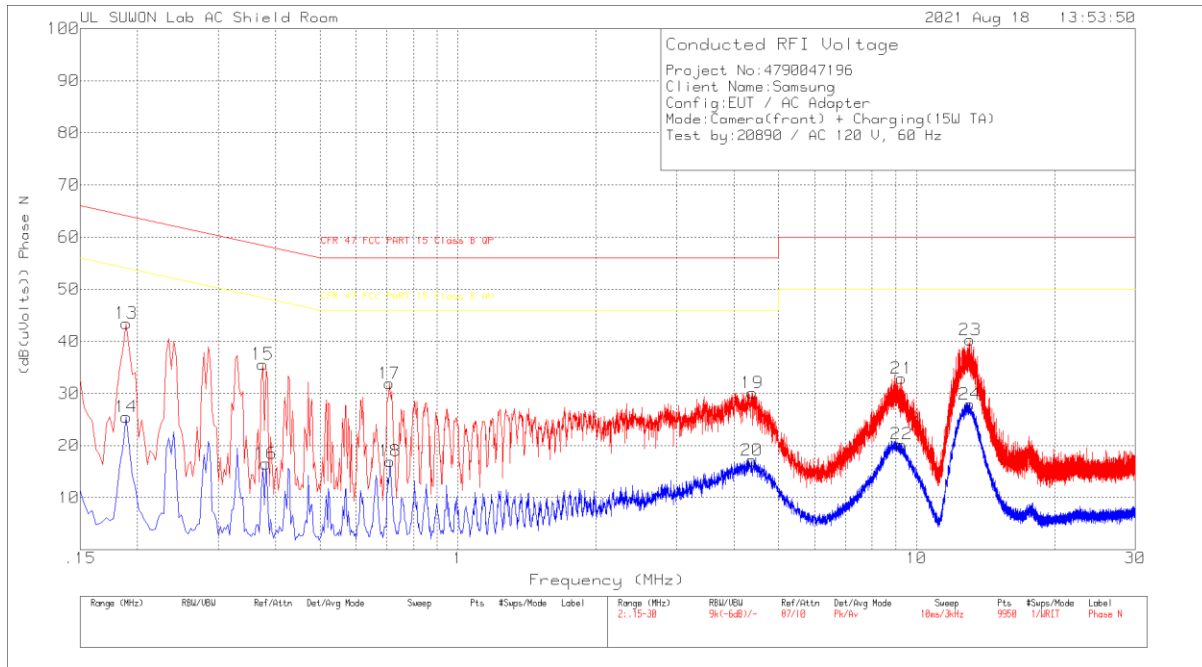

Trace Markers

Range 2: Phase N .15 - 30MHz

Marker	Frequency (MHz)	Meter Reading (dBuV)	Det	101836_Wit h EX_N[dB]	CABLELOS S(dB)	Corrected Reading (dB(uVolts))	CFR 47 FCC PART 15 Class B QP	Margin (dB)	CFR 47 FCC PART 15 Class B AV	Margin (dB)
13	.189	33.25	Pk	10	.2	43.45	64.08	-20.63	-	-
14	.189	15.26	Av	10	.2	25.46	-	-	54.08	-28.62
15	.375	25.47	Pk	9.9	.2	35.57	58.39	-22.82	-	-
16	.381	6.42	Av	9.9	.2	16.52	-	-	48.26	-31.74
17	.708	21.79	Pk	9.9	.2	31.89	56	-24.11	-	-
18	.711	6.88	Av	9.9	.2	16.98	-	-	46	-29.02
19	4.383	19.99	Pk	9.8	.3	30.09	56	-25.91	-	-
20	4.374	7.02	Av	9.8	.3	17.12	-	-	46	-28.88
21	9.282	22.58	Pk	9.9	.4	32.88	60	-27.12	-	-
22	9.282	9.95	Av	9.9	.4	20.25	-	-	50	-29.75
23	13.089	29.74	Pk	10.1	.4	40.24	60	-19.76	-	-
24	13.065	17.38	Av	10.1	.4	27.88	-	-	50	-22.12

Pk - Peak detector

Av - Average detection

[Test case 4]

**6 WORST EMISSIONS**

**Line-L1 .15 – 30 MHz**

**LINE 1 RESULTS**

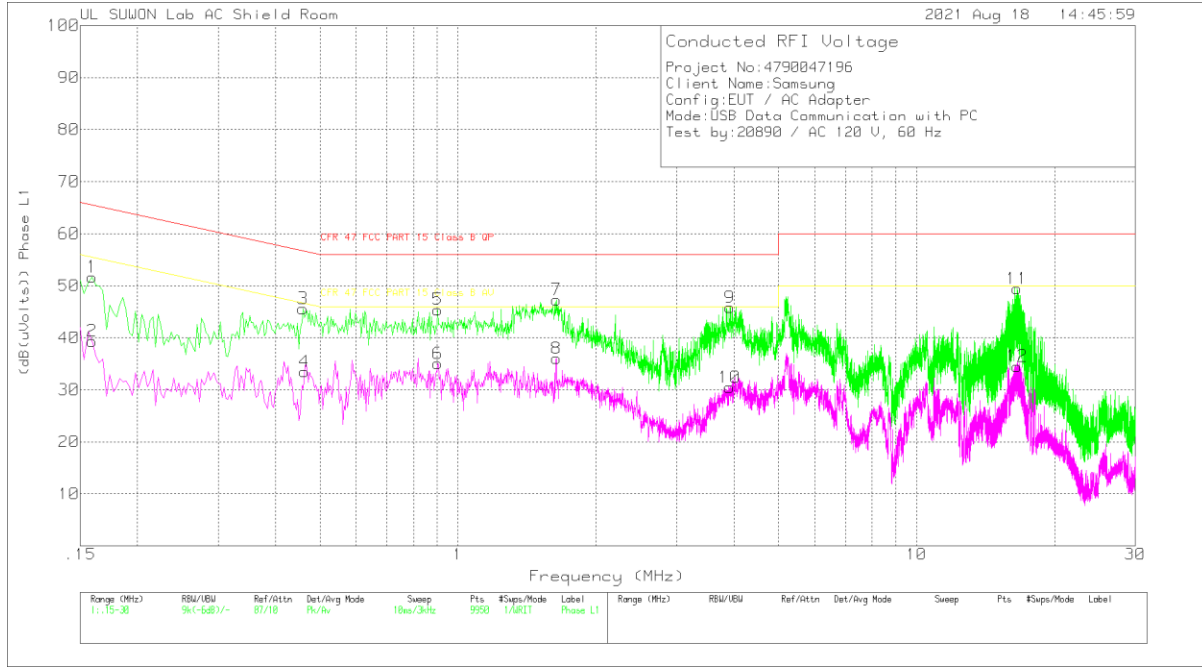

Trace Markers

Range 1: Phase L1 .15 - 30MHz

Marker	Frequency (MHz)	Meter Reading (dBuV)	Det	101836_L1[ dB]	CABLELOS S(dB)	Corrected Reading (dB(uVolts))	CFR 47 FCC PART 15 Class B QP	Margin (dB)	CFR 47 FCC PART 15 Class B AV	Margin (dB)
1	.159	41.76	Pk	9.8	.1	51.66	65.52	-13.86	-	-
2	.159	29.46	Av	9.8	.1	39.36	-	-	55.52	-16.16
3	.459	35.59	Pk	9.8	.2	45.59	56.71	-11.12	-	-
4	.462	23.49	Av	9.8	.2	33.49	-	-	46.66	-13.17
5	.903	35.39	Pk	9.7	.3	45.39	56	-10.61	-	-
6	.903	25.03	Av	9.7	.3	35.03	-	-	46	-10.97
7	1.638	37.28	Pk	9.7	.3	47.28	56	-8.72	-	-
8	1.638	26.02	Av	9.7	.3	36.02	-	-	46	-9.98
9	3.921	35.92	Pk	9.6	.3	45.82	56	-10.18	-	-
10	3.912	20.55	Av	9.6	.3	30.45	-	-	46	-15.55
11	16.572	39.35	Pk	9.7	.4	49.45	60	-10.55	-	-
12	16.572	24.4	Av	9.7	.4	34.5	-	-	50	-15.5

Pk - Peak detector

Av - Average detection

Quasi-Peak Emissions

Range 1: Phase L1 .15 - 30MHz

Frequency (MHz)	Meter Reading (dBuV)	Det	101836_L1[ dB]	CABLELOS S(dB)	Corrected Reading (dB(uVolts))	CFR 47 FCC PART 15 Class B QP	Margin (dB)	CFR 47 FCC PART 15 Class B AV	Margin (dB)
1.63725	32.58	Qp	9.7	.3	42.58	56	-13.42	-	-

**Line-L2 .15 – 30 MHz**

**LINE 2 RESULTS**

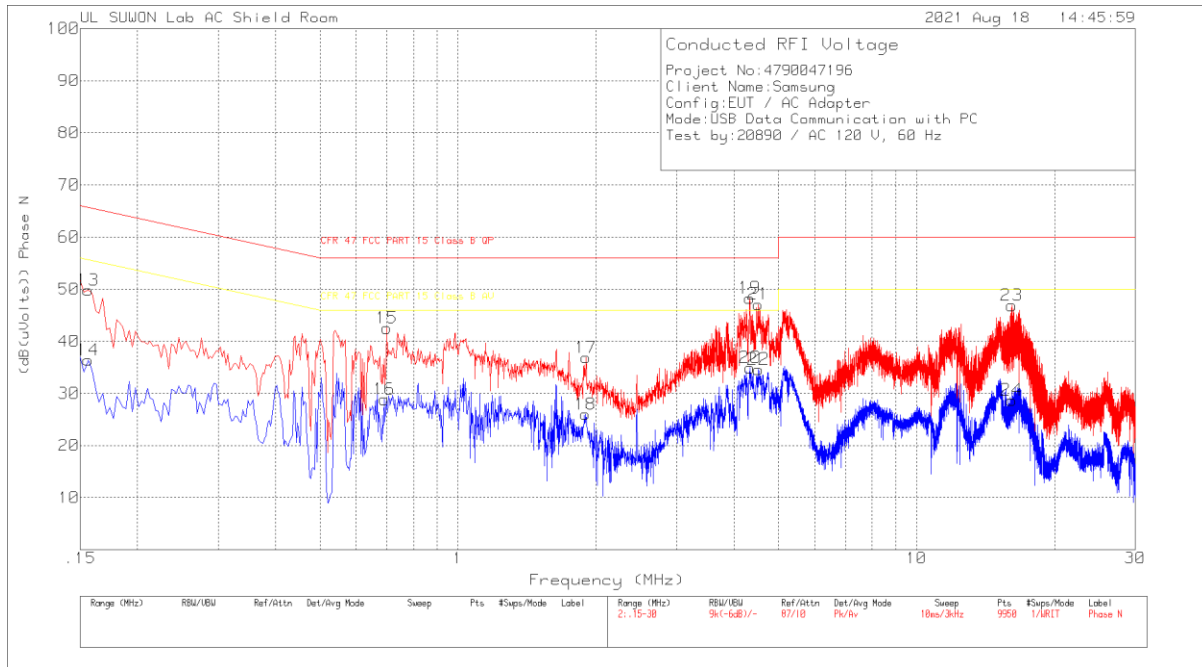

Trace Markers

Range 2: Phase N .15 - 30MHz

Marker	Frequency (MHz)	Meter Reading (dBuV)	Det	101836_N[dB]	CABLELOS S(dB)	Corrected Reading (dB(uVolts))	CFR 47 FCC PART 15 Class B QP	Margin (dB)	CFR 47 FCC PART 15 Class B AV	Margin (dB)
13	.156	39.9	Pk	9.8	.1	49.8	65.67	-15.87	-	-
14	.156	26.49	Av	9.8	.1	36.39	-	-	55.67	-19.28
15	.699	32.52	Pk	9.8	.2	42.52	56	-13.48	-	-
16	.69	18.86	Av	9.8	.2	28.86	-	-	46	-17.14
17	1.902	26.95	Pk	9.6	.3	36.85	56	-19.15	-	-
18	1.896	16.07	Av	9.6	.3	25.97	-	-	46	-20.03
19	4.326	38.37	Pk	9.6	.3	48.27	56	-7.73	-	-
20	4.338	25	Av	9.6	.3	34.9	-	-	46	-11.1
21	4.518	37.19	Pk	9.6	.3	47.09	56	-8.91	-	-
22	4.521	24.69	Av	9.6	.3	34.59	-	-	46	-11.41
23	16.134	36.76	Pk	9.7	.4	46.86	60	-13.14	-	-
24	16.128	18.58	Av	9.7	.4	28.68	-	-	50	-21.32

Pk - Peak detector

Av - Average detection

Quasi-Peak Emissions

Range 2: Phase N .15 - 30MHz

Frequency (MHz)	Meter Reading (dBuV)	Det	101836_N[dB]	CABLELOS S(dB)	Corrected Reading (dB(uVolts))	CFR 47 FCC PART 15 Class B QP	Margin (dB)	CFR 47 FCC PART 15 Class B AV	Margin (dB)
4.32525	21.87	Qp	9.6	.3	31.77	56	-24.23	-	-
4.51725	20.73	Qp	9.6	.3	30.63	56	-25.37	-	-

Qp - Quasi-Peak detector

**END OF TEST REPORT**