



SAR EVALUATION REPORT

Applicant Name:
 Samsung Electronics, Co. Ltd.
 129, Samsung-ro, Maetan dong,
 Yeongtong-gu, Suwon-si
 Gyeonggi-do 443-742, Korea

Date of Testing:
 12/01/14 - 12/08/14
Test Site/Location:
 PCTEST Lab, Columbia, MD, USA
Document Serial No.:
 0Y1412012187.A3L

FCC ID: A3LSMG720AX

APPLICANT: SAMSUNG ELECTRONICS, CO. LTD.

DUT Type: Portable Handset
Application Type: Certification
FCC Rule Part(s): CFR §2.1093
Model(s): SM-G720AX

Equipment Class	Band & Mode	Tx Frequency	SAR		
			1 gm Head (W/kg)	1 gm Body-Worn (W/kg)	1 gm Hotspot (W/kg)
PCE	GSM/GPRS/EDGE 850	824.20 - 848.80 MHz	0.25	0.38	0.51
PCE	UMTS 850	826.40 - 846.60 MHz	0.22	0.33	0.33
PCE	GSM/GPRS/EDGE 1900	1850.20 - 1909.80 MHz	0.13	0.42	0.49
PCE	UMTS 1900	1852.4 - 1907.6 MHz	0.22	0.72	0.72
PCE	LTE Band 17	706.5 - 713.5 MHz	< 0.1	< 0.1	< 0.1
PCE	LTE Band 4 (AWS)	1710.7 - 1754.3 MHz	0.17	0.59	0.59
PCE	LTE Band 2 (PCS)	1850.7 - 1909.3 MHz	0.18	0.64	0.64
DTS	2.4 GHz WLAN	2412 - 2462 MHz	0.16	0.23	0.23
DSS/DTS	Bluetooth	2402 - 2480 MHz		N/A	
Simultaneous SAR per KDB 690783 D01v01r03:			0.35	0.96	0.96



This wireless portable device has been shown to be capable of compliance for localized specific absorption rate (SAR) for uncontrolled environment/general population exposure limits specified in ANSI/IEEE C95.1-1992 and has been tested in accordance with the measurement procedures specified in Section 1.7 of this report; for North American frequency bands only.

I attest to the accuracy of data. All measurements reported herein were performed by me or were made under my supervision and are correct to the best of my knowledge and belief. I assume full responsibility for the completeness of these measurements and vouch for the qualifications of all persons taking them. Test results reported herein relate only to the item(s) tested.

 Randy Ortanez
 President





The SAR Tick is an initiative of the Mobile Manufacturers Forum (MMF). While a product may be considered eligible, use of the SAR Tick logo requires an agreement with the MMF. Further details can be obtained by emailing: sartick@mmfai.info.

FCC ID: A3LSMG720AX		SAR EVALUATION REPORT		Reviewed by: Quality Manager
Document S/N: 0Y1412012187.A3L	Test Dates: 12/01/14 - 12/08/14	DUT Type: Portable Handset	Page 1 of 48	

T A B L E O F C O N T E N T S

1	DEVICE UNDER TEST	3
2	LTE INFORMATION	8
3	INTRODUCTION	9
4	DOSIMETRIC ASSESSMENT	10
5	DEFINITION OF REFERENCE POINTS	11
6	TEST CONFIGURATION POSITIONS FOR HANDSETS	12
7	RF EXPOSURE LIMITS	15
8	FCC MEASUREMENT PROCEDURES.....	16
9	RF CONDUCTED POWERS.....	20
10	SYSTEM VERIFICATION.....	30
11	SAR DATA SUMMARY	32
12	FCC MULTI-TX AND ANTENNA SAR CONSIDERATIONS.....	40
13	SAR MEASUREMENT VARIABILITY	43
14	EQUIPMENT LIST.....	44
15	MEASUREMENT UNCERTAINTIES	45
16	CONCLUSION.....	46
17	REFERENCES	47
APPENDIX A: SAR TEST PLOTS		
APPENDIX B: SAR DIPOLE VERIFICATION PLOTS		
APPENDIX C: PROBE AND DIPOLE CALIBRATION CERTIFICATES		
APPENDIX D: SAR TISSUE SPECIFICATIONS		
APPENDIX E: SAR SYSTEM VALIDATION		
APPENDIX F: SAR TEST SETUP PHOTOGRAPHS		

FCC ID: A3LSMG720AX		SAR EVALUATION REPORT		Reviewed by: Quality Manager
Document S/N: OY1412012187.A3L	Test Dates: 12/01/14 - 12/08/14	DUT Type: Portable Handset		Page 2 of 48

1 DEVICE UNDER TEST

1.1 Device Overview

Band & Mode	Operating Modes	Tx Frequency
GSM/GPRS/EDGE 850	Voice/Data	824.20 - 848.80 MHz
UMTS 850	Voice/Data	826.40 - 846.60 MHz
GSM/GPRS/EDGE 1900	Voice/Data	1850.20 - 1909.80 MHz
UMTS 1900	Voice/Data	1852.4 - 1907.6 MHz
LTE Band 17	Data	706.5 - 713.5 MHz
LTE Band 4 (AWS)	Data	1710.7 - 1754.3 MHz
LTE Band 2 (PCS)	Data	1850.7 - 1909.3 MHz
2.4 GHz WLAN	Data	2412 - 2462 MHz
Bluetooth	Data	2402 - 2480 MHz
ANT+	Data	2402 - 2480 MHz



1.2 Nominal and Maximum Output Power Specifications

This device operates using the following maximum and nominal output power specifications. SAR values were scaled to the maximum allowed power to determine compliance per KDB Publication 447498 D01v05.

Mode / Band		Voice (dBm)	Burst Average GMSK (dBm)				Burst Average 8-PSK (dBm)			
		1 TX Slot	1 TX Slots	2 TX Slots	3 TX Slots	4 TX Slots	1 TX Slots	2 TX Slots	3 TX Slots	4 TX Slots
GSM/GPRS/EDGE 850	Maximum	32.8	32.8	30.1	29.2	26.5	27.3	26.4	23.5	23.5
	Nominal	32.3	32.3	29.6	28.7	26.0	26.8	25.9	23.0	23.0
GSM/GPRS/EDGE 1900	Maximum	30.3	30.3	27.7	25.5	23.1	25.8	25.0	20.3	20.2
	Nominal	29.8	29.8	27.2	25.0	22.6	25.3	24.5	19.8	19.7

Mode / Band		Modulated Average (dBm)			
		3GPP WCDMA Rel 99	3GPP HSDPA Rel 5	3GPP HSUPA Rel 6	3GPP DC-HSDPA Rel 8
UMTS Band 5 (850 MHz)	Maximum	23.1	21.9	21.7	22.0
	Nominal	22.6	21.4	21.2	21.5
UMTS Band 2 (1900 MHz)	Maximum	22.8	21.8	21.7	22.0
	Nominal	22.3	21.3	21.2	21.5

Mode / Band	Modulated Average (dBm)	
LTE Band 17	Maximum	23.7
	Nominal	23.2
LTE Band 4 (AWS)	Maximum	23.7
	Nominal	23.2
LTE Band 2 (PCS)	Maximum	22.7
	Nominal	22.2

FCC ID: A3LSMG720AX	 PCTEST ENGINEERING LABORATORY, INC.	SAR EVALUATION REPORT		Reviewed by: Quality Manager
Document S/N: OY1412012187.A3L	Test Dates: 12/01/14 - 12/08/14	DUT Type: Portable Handset	Page 3 of 48	

Mode / Band		Modulated Average (dBm)
IEEE 802.11b (2.4 GHz)	Maximum	17.5
	Nominal	17.0
IEEE 802.11g (2.4 GHz)	Maximum	14.5
	Nominal	14.0
IEEE 802.11n (2.4 GHz)	Maximum	13.5
	Nominal	13.0
Bluetooth	Maximum	10.0
	Nominal	9.5
Bluetooth LE	Maximum	0.5
	Nominal	0.0



1.3 Antenna Specifications

The overall dimensions of this device are > 9x5 cm. The overall diagonal dimension of the device is <160 mm and the diagonal display is <150 mm. Exact antenna dimensions and separation distances are shown in the Technical Descriptions in the FCC filing.

**Table 1-1
Sides for SAR Testing**

Mode	Back	Front	Top	Bottom	Right	Left
GPRS 850	Yes	Yes	No	Yes	Yes	Yes
UMTS 850	Yes	Yes	No	Yes	Yes	Yes
GPRS 1900	Yes	Yes	No	Yes	Yes	Yes
UMTS 1900	Yes	Yes	No	Yes	Yes	Yes
LTE Band 17	Yes	Yes	No	Yes	Yes	Yes
LTE Band 4 (AWS)	Yes	Yes	No	Yes	Yes	Yes
LTE Band 2 (PCS)	Yes	Yes	No	Yes	Yes	Yes
2.4 GHz WLAN	Yes	Yes	Yes	No	No	Yes

Note: Particular DUT edges were not required to be evaluated for Wireless Router SAR if the edges were greater than 2.5 cm from the transmitting antenna according to FCC KDB Publication 941225 D06v01 guidance, page 2. The distances between the transmit antennas and the edges of the device are included in the filing.

FCC ID: A3LSMG720AX		SAR EVALUATION REPORT		Reviewed by: Quality Manager
Document S/N: 0Y1412012187.A3L	Test Dates: 12/01/14 - 12/08/14	DUT Type: Portable Handset	Page 4 of 48	

1.4 Simultaneous Transmission Capabilities

According to FCC KDB Publication 447498 D05v01, transmitters are considered to be transmitting simultaneously when there is overlapping transmission, with the exception of transmissions during network hand-offs with maximum hand-off duration less than 30 seconds. Possible transmission paths for the DUT are shown in Figure 1-1 and are color-coded to indicate communication modes which share the same path. Modes which share the same transmission path cannot transmit simultaneously with one another.

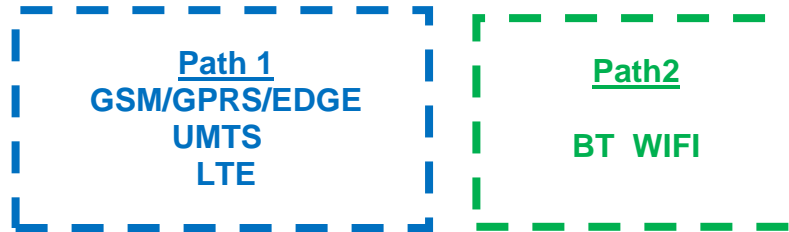



Figure 1-1
Simultaneous Transmission Paths

This device contains multiple transmitters that may operate simultaneously, and therefore requires a simultaneous transmission analysis according to FCC KDB Publication 447498 D01v05 3) procedures.

Table 1-2
Simultaneous Transmission Scenarios

No.	Capable Transmit Configuration	Head	Body-Worn Accessory	Wireless Router
1	GSM voice + 2.4 GHz WI-FI	Yes	Yes	N/A
2	GSM voice + 2.4 GHz Bluetooth	N/A	Yes	N/A
3	UMTS + 2.4 GHz WI-FI	Yes	Yes	Yes
4	UMTS + 2.4 GHz Bluetooth	N/A	Yes	N/A
5	LTE + 2.4 GHz WI-FI	Yes*	Yes*	Yes
6	LTE + 2.4 GHz Bluetooth	N/A	Yes*	N/A
7	GPRS/EDGE + 2.4 GHz WI-FI	N/A	N/A	Yes

- 2.4 GHz WLAN, and 2.4 GHz Bluetooth share the same antenna path and cannot transmit simultaneously.
- All licensed modes share the same antenna path and cannot transmit simultaneously.
- (*) = for VOIP applications possibly used by the end-user
- When the user utilizes multiple services in UMTS 3G mode it uses multi-Radio Access Bearer or multi-RAB. The power control is based on a physical control channel (Dedicated Physical Control Channel [DPCCH]) and power control will be adjusted to meet the needs of both services. Therefore, the UMTS+WLAN scenario also represents the UMTS Voice/DATA + WLAN Hotspot scenario.
- Per the manufacturer, WIFI Direct is not expected to be used in conjunction with a held-to-ear or body-worn accessory voice call. Therefore, there are no simultaneous transmission scenarios involving WIFI direct beyond that listed in the above table.

FCC ID: A3LSMG720AX		SAR EVALUATION REPORT		Reviewed by: Quality Manager
Document S/N: OY1412012187.A3L	Test Dates: 12/01/14 - 12/08/14	DUT Type: Portable Handset	Page 5 of 48	

1.5 SAR Test Exclusions Applied

(A) WIFI/BT

Per FCC KDB 447498 D01v05, the 1g SAR exclusion threshold for distances <50mm is defined by the following equation:

$$\frac{\text{Max Power of Channel (mW)}}{\text{Test Separation Dist (mm)}} * \sqrt{\text{Frequency(GHz)}} \leq 3.0$$

Based on the maximum conducted power of Bluetooth (rounded to the nearest mW) and the antenna to user separation distance, body-worn Bluetooth SAR was not required; $[(10/10) * \sqrt{2.480}] = 1.6 < 3.0$. Per KDB Publication 447498 D01v05, the maximum power of the channel was rounded to the nearest mW before calculation.

(B) Licensed Transmitter(s)

GSM/GPRS/EDGE DTM is not supported for US bands. Therefore, the GSM Voice modes in this report do not transmit simultaneously with GPRS/EDGE Data.

This device is only capable of QPSK HSUPA in the uplink. Therefore, no additional SAR tests are required beyond that described for devices with HSUPA in KDB 941225 D01v02.



LTE SAR for the higher modulations and lower bandwidths were not tested since the maximum average output power of all required channels and configurations was not more than 0.5 dB higher than the highest bandwidth; and the reported LTE SAR for the highest bandwidth was less than 1.45 W/kg for all configurations according to FCC KDB 941225 D05v02.

1.6 Power Reduction for SAR

There is no power reduction used for any band/mode implemented in this device for SAR purposes.

1.7 Guidance Applied



- IEEE 1528-2003
- FCC KDB Publication 941225 D01, D05, D06 (2G/3G/4G and Hotspot)
- FCC KDB Publication 248227 D01v01r02 (SAR Considerations for 802.11 Devices)
- FCC KDB Publication 447498 D01v05r02 (General SAR Guidance)
- FCC KDB Publication 865664 D01v01r03, D02v01r01 (SAR Measurements up to 6 GHz)
- October 2013 TCB Workshop Notes (GPRS Testing Considerations)

FCC ID: A3LSMG720AX		SAR EVALUATION REPORT		Reviewed by: Quality Manager
Document S/N: OY1412012187.A3L	Test Dates: 12/01/14 - 12/08/14	DUT Type: Portable Handset		Page 6 of 48

1.8 Device Serial Numbers

Several samples were used with identical hardware to support SAR testing. The manufacturer has confirmed that the device(s) tested have the same physical, mechanical and thermal characteristics and are within operational tolerances expected for production units.



	Head Serial Number	Body-Worn Serial Number	Hotspot Serial Number
GSM/GPRS/EDGE 850	96	96	96
UMTS 850	96	96	96
GSM/GPRS/EDGE 1900	100	100	100
UMTS 1900	100	100	100
LTE Band 17	100	96	96
LTE Band 4 (AWS)	96	96	96
LTE Band 2 (PCS)	100	100	100
2.4 GHz WLAN	100	100	100

FCC ID: A3LSMG720AX		SAR EVALUATION REPORT		Reviewed by: Quality Manager
Document S/N: 0Y1412012187.A3L	Test Dates: 12/01/14 - 12/08/14	DUT Type: Portable Handset	Page 7 of 48	

2

LTE INFORMATION

LTE Information			
FCC ID	A3LSMG720AX		
Form Factor	Portable Handset		
Frequency Range of each LTE transmission band	LTE Band 17 (706.5 - 713.5 MHz)		
	LTE Band 4 (AWS) (1710.7 - 1754.3 MHz)		
	LTE Band 2 (PCS) (1850.7 - 1909.3 MHz)		
Channel Bandwidths	LTE Band 17: 5 MHz, 10 MHz		
	LTE Band 4 (AWS): 1.4 MHz, 3 MHz, 5 MHz, 10 MHz, 15 MHz, 20 MHz		
	LTE Band 2 (PCS): 1.4 MHz, 3 MHz, 5 MHz, 10 MHz, 15 MHz, 20 MHz		
Channel Numbers and Frequencies (MHz)	Low	Mid	High
LTE Band 17: 5 MHz	706.5 (23755)	710 (23790)	713.5 (23825)
LTE Band 17: 10 MHz	709 (23780)	710 (23790)	711 (23800)
LTE Band 4 (AWS): 1.4 MHz	1710.7 (19957)	1732.5 (20175)	1754.3 (20393)
LTE Band 4 (AWS): 3 MHz	1711.5 (19965)	1732.5 (20175)	1753.5 (20385)
LTE Band 4 (AWS): 5 MHz	1712.5 (19975)	1732.5 (20175)	1752.5 (20375)
LTE Band 4 (AWS): 10 MHz	1715 (20000)	1732.5 (20175)	1750 (20350)
LTE Band 4 (AWS): 15 MHz	1717.5 (20025)	1732.5 (20175)	1747.5 (20325)
LTE Band 4 (AWS): 20 MHz	1720 (20050)	1732.5 (20175)	1745 (20300)
LTE Band 2 (PCS): 1.4 MHz	1850.7 (18607)	1880 (18900)	1909.3 (19193)
LTE Band 2 (PCS): 3 MHz	1851.5 (18615)	1880 (18900)	1908.5 (19185)
LTE Band 2 (PCS): 5 MHz	1852.5 (18625)	1880 (18900)	1907.5 (19175)
LTE Band 2 (PCS): 10 MHz	1855 (18650)	1880 (18900)	1905 (19150)
LTE Band 2 (PCS): 15 MHz	1857.5 (18675)	1880 (18900)	1902.5 (19125)
LTE Band 2 (PCS): 20 MHz	1860 (18700)	1880 (18900)	1900 (19100)
UE Category	3		
Modulations Supported in UL	QPSK, 16QAM		
LTE MPR Permanently implemented per 3GPP TS 36.101 section 6.2.3~6.2.5? (manufacturer attestation to be provided)	YES		
A-MPR (Additional MPR) disabled for SAR Testing?	YES		

FCC ID: A3LSMG720AX		SAR EVALUATION REPORT		Reviewed by: Quality Manager
Document S/N: OY1412012187.A3L	Test Dates: 12/01/14 - 12/08/14	DUT Type: Portable Handset	Page 8 of 48	

3 INTRODUCTION

The FCC and Industry Canada have adopted the guidelines for evaluating the environmental effects of radio frequency (RF) radiation in ET Docket 93-62 on Aug. 6, 1996 and Health Canada Safety Code 6 to protect the public and workers from the potential hazards of RF emissions due to FCC-regulated portable devices. [1]

The safety limits used for the environmental evaluation measurements are based on the criteria published by the American National Standards Institute (ANSI) for localized specific absorption rate (SAR) in IEEE/ANSI C95.1-1992 Standard for Safety Levels with Respect to Human Exposure to Radio Frequency Electromagnetic Fields, 3 kHz to 300 GHz [3] and Health Canada RF Exposure Guidelines Safety Code 6 [22]. The measurement procedure described in IEEE/ANSI C95.3-2002 Recommended Practice for the Measurement of Potentially Hazardous Electromagnetic Fields - RF and Microwave [4] is used for guidance in measuring the Specific Absorption Rate (SAR) due to the RF radiation exposure from the Equipment Under Test (EUT). These criteria for SAR evaluation are similar to those recommended by the International Committee for Non-Ionizing Radiation Protection (ICNIRP) in "Biological Effects and Exposure Criteria for Radiofrequency Electromagnetic Fields," Report No. Vol 74. SAR is a measure of the rate of energy absorption due to exposure to an RF transmitting source. SAR values have been related to threshold levels for potential biological hazards.

3.1 SAR Definition

Specific Absorption Rate is defined as the time derivative (rate) of the incremental energy (dU) absorbed by (dissipated in) an incremental mass (dm) contained in a volume element (dV) of a given density (ρ). It is also defined as the rate of RF energy absorption per unit mass at a point in an absorbing body (see Equation 3-1).

Equation 3-1
SAR Mathematical Equation

$$SAR = \frac{d}{dt} \left(\frac{dU}{dm} \right) = \frac{d}{dt} \left(\frac{dU}{\rho dv} \right)$$



SAR is expressed in units of Watts per Kilogram (W/kg).

$$SAR = \frac{\sigma \cdot E^2}{\rho}$$

where:

- σ = conductivity of the tissue-simulating material (S/m)
- ρ = mass density of the tissue-simulating material (kg/m³)
- E = Total RMS electric field strength (V/m)

NOTE: The primary factors that control rate of energy absorption were found to be the wavelength of the incident field in relation to the dimensions and geometry of the irradiated organism, the orientation of the organism in relation to the polarity of field vectors, the presence of reflecting surfaces, and whether conductive contact is made by the organism with a ground plane.[6]

FCC ID: A3LSMG720AX		SAR EVALUATION REPORT		Reviewed by: Quality Manager
Document S/N: 0Y1412012187.A3L	Test Dates: 12/01/14 - 12/08/14	DUT Type: Portable Handset	Page 9 of 48	

4 DOSIMETRIC ASSESSMENT

4.1 Measurement Procedure

The evaluation was performed using the following procedure compliant to FCC KDB Publication 865664 D01v01 and IEEE 1528-2013:

1. The SAR distribution at the exposed side of the head or body was measured at a distance no greater than 5.0 mm from the inner surface of the shell. The area covered the entire dimension of the device-head and body interface and the horizontal grid resolution was determined per FCC KDB Publication 865664 D01v01 (See Table 4-1) and IEEE 1528-2013.
2. The point SAR measurement was taken at the maximum SAR region determined from Step 1 to enable the monitoring of SAR fluctuations/drifts during the 1g/10g cube evaluation. SAR at this fixed point was measured and used as a reference value.
3. Based on the area scan data, the peak of the region with maximum SAR was determined by spline interpolation. Around this point, a volume was assessed according to the measurement resolution and volume size requirements of FCC KDB Publication 865664 D01v01 (See Table 4-1) and IEEE 1528-2013. On the basis of this data set, the spatial peak SAR value was evaluated with the following procedure (see references or the DASy manual online for more details):
 - a. SAR values at the inner surface of the phantom are extrapolated from the measured values along the line away from the surface with spacing no greater than that in Table 4-1. The extrapolation was based on a least-squares algorithm. A polynomial of the fourth order was calculated through the points in the z-axis (normal to the phantom shell).
 - b. After the maximum interpolated values were calculated between the points in the cube, the SAR was averaged over the spatial volume (1g or 10g) using a 3D-Spline interpolation algorithm. The 3D-spline is composed of three one-dimensional splines with the “Not a knot” condition (in x, y, and z directions). The volume was then integrated with the trapezoidal algorithm. One thousand points (10 x 10 x 10) were obtained through interpolation, in order to calculate the averaged SAR.
 - c. All neighboring volumes were evaluated until no neighboring volume with a higher average value was found.
4. The SAR reference value, at the same location as step 2, was re-measured after the zoom scan was complete to calculate the SAR drift. If the drift deviated by more than 5%, the SAR test and drift measurements were repeated.

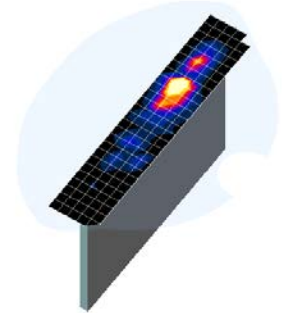



Figure 4-1
Sample SAR Area Scan

Table 4-1
Area and Zoom Scan Resolutions per FCC KDB Publication 865664 D01v01*

Frequency	Maximum Area Scan Resolution (mm) ($\Delta x_{area}, \Delta y_{area}$)	Maximum Zoom Scan Resolution (mm) ($\Delta x_{zoom}, \Delta y_{zoom}$)	Maximum Zoom Scan Spatial Resolution (mm)			Minimum Zoom Scan Volume (mm) (x,y,z)
			Uniform Grid $\Delta z_{zoom}(n)$	Graded Grid		
				$\Delta z_{zoom}(1)^*$	$\Delta z_{zoom}(n>1)^*$	
≤ 2 GHz	≤ 15	≤ 8	≤ 5	≤ 4	≤ 1.5* $\Delta z_{zoom}(n-1)$	≥ 30
2-3 GHz	≤ 12	≤ 5	≤ 5	≤ 4	≤ 1.5* $\Delta z_{zoom}(n-1)$	≥ 30
3-4 GHz	≤ 12	≤ 5	≤ 4	≤ 3	≤ 1.5* $\Delta z_{zoom}(n-1)$	≥ 28
4-5 GHz	≤ 10	≤ 4	≤ 3	≤ 2.5	≤ 1.5* $\Delta z_{zoom}(n-1)$	≥ 25
5-6 GHz	≤ 10	≤ 4	≤ 2	≤ 2	≤ 1.5* $\Delta z_{zoom}(n-1)$	≥ 22

*Also compliant to IEEE 1528-2013 Table 6

FCC ID: A3LSMG720AX		SAR EVALUATION REPORT		Reviewed by: Quality Manager
Document S/N: OY1412012187.A3L	Test Dates: 12/01/14 - 12/08/14	DUT Type: Portable Handset		Page 10 of 48

5 DEFINITION OF REFERENCE POINTS

5.1 EAR REFERENCE POINT

Figure 5-2 shows the front, back and side views of the SAM Twin Phantom. The point “M” is the reference point for the center of the mouth, “LE” is the left ear reference point (ERP), and “RE” is the right ERP. The ERP is 15mm posterior to the entrance to the ear canal (EEC) along the B-M line (Back-Mouth), as shown in Figure 5-1. The plane passing through the two ear canals and M is defined as the Reference Plane. The line N-F (Neck-Front), also called the Reference Pivoting Line, is not perpendicular to the reference plane (see Figure 5-1). Line B-M is perpendicular to the N-F line. Both N-F and B-M lines are marked on the external phantom shell to facilitate handset positioning [5].

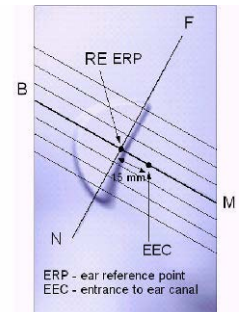

Figure 5-1
Close-Up Side view of ERP

5.2 HANDSET REFERENCE POINTS

Two imaginary lines on the handset were established: the vertical centerline and the horizontal line. The test device was placed in a normal operating position with the acoustic output located along the “vertical centerline” on the front of the device aligned to the “ear reference point” (See Figure 5-3). The acoustic output was then located at the same level as the center of the ear reference point. The test device was positioned so that the “vertical centerline” was bisecting the front surface of the handset at its top and bottom edges, positioning the “ear reference point” on the outer surface of the both the left and right head phantoms on the ear reference point.



Figure 5-2
Front, back and side view of SAM Twin Phantom

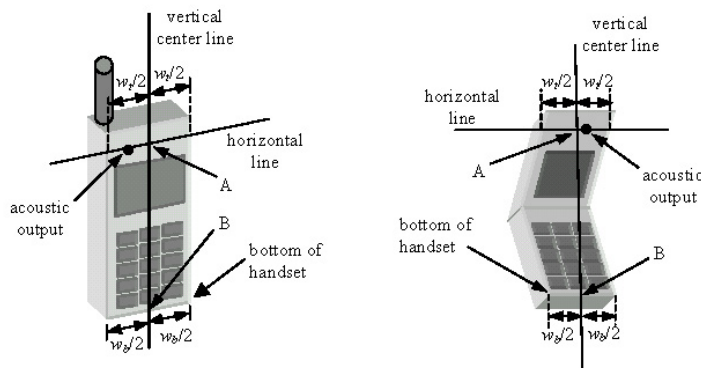



Figure 5-3
Handset Vertical Center & Horizontal Line Reference Points

FCC ID: A3LSMG720AX		SAR EVALUATION REPORT		Reviewed by: Quality Manager
Document S/N: OY1412012187.A3L	Test Dates: 12/01/14 - 12/08/14	DUT Type: Portable Handset		Page 11 of 48

6 TEST CONFIGURATION POSITIONS FOR HANDSETS

6.1 Device Holder

The device holder is made out of low-loss POM material having the following dielectric parameters: relative permittivity $\epsilon = 3$ and loss tangent $\delta = 0.02$.

6.2 Positioning for Cheek

1. The test device was positioned with the device close to the surface of the phantom such that point A is on the (virtual) extension of the line passing through points RE and LE on the phantom (see Figure 6-1), such that the plane defined by the vertical center line and the horizontal line of the phone is approximately parallel to the sagittal plane of the phantom.

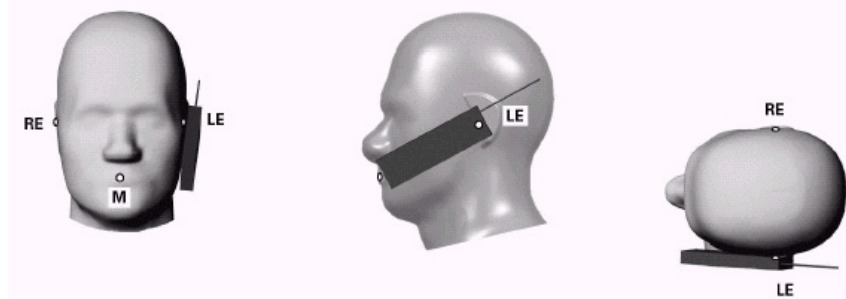



Figure 6-1 Front, Side and Top View of Cheek Position

2. The handset was translated towards the phantom along the line passing through RE & LE until the handset touches the pinna.
3. While maintaining the handset in this plane, the handset was rotated around the LE-RE line until the vertical centerline was in the reference plane.
4. The phone was then rotated around the vertical centerline until the phone (horizontal line) was symmetrical with respect to the line NF.
5. While maintaining the vertical centerline in the reference plane, keeping point A on the line passing through RE and LE, and maintaining the device contact with the ear, the device was rotated about the NF line until any point on the handset made contact with a phantom point below the ear (cheek) (See Figure 6-2).

6.3 Positioning for Ear / 15° Tilt

With the test device aligned in the “Cheek Position”:

1. While maintaining the orientation of the phone, the phone was retracted parallel to the reference plane far enough to enable a rotation of the phone by 15 degrees.
2. The phone was then rotated around the horizontal line by 15 degrees.
3. While maintaining the orientation of the phone, the phone was moved parallel to the reference plane until any part of the handset touched the head. (In this position, point A was located on the line RE-LE). The tilted position is obtained when the contact is on the pinna. If the contact was at any location other than the pinna, the angle of the phone would then be reduced. In this situation, the tilted position was obtained when any part of the phone was in contact of the ear as well as a second part of the phone was in contact with the head (see Figure 6-2).

FCC ID: A3LSMG720AX		SAR EVALUATION REPORT		Reviewed by: Quality Manager
Document S/N: OY1412012187.A3L	Test Dates: 12/01/14 - 12/08/14	DUT Type: Portable Handset		Page 12 of 48

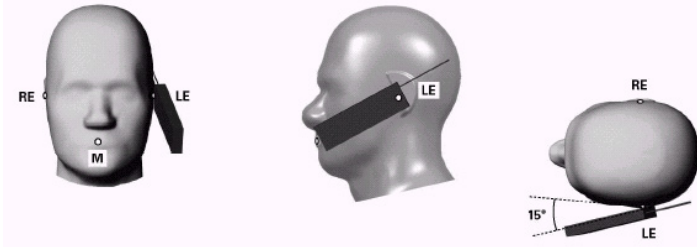

Figure 6-2 Front, Side and Top View of Ear/15° Tilt Position

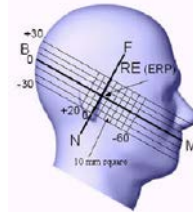

Figure 6-3 Side view w/ relevant markings

6.4 SAR Evaluations near the Mouth/Jaw Regions of the SAM Phantom

Antennas located near the bottom of a phone may require SAR measurements around the mouth and jaw regions of the SAM head phantom. This typically applies to clam-shell style phones that are generally longer in the unfolded normal use positions or to certain older style long rectangular phones. Per IEEE 1528-2013, a rotated SAM phantom is necessary to allow probe access to such regions. Both SAM heads of the TwinSAM-Chin20 are rotated 20 degrees around the NF line. Each head can be removed from the table for emptying and cleaning.

Under these circumstances, the following procedures apply, adopted from the FCC guidance on SAR handsets document FCC KDB Publication 648474 D04_v01. The SAR required in these regions of SAM should be measured using a flat phantom. The phone should be positioned with a separation distance of 4 mm between the ear reference point (ERP) and the outer surface of the flat phantom shell. While maintaining this distance at the ERP location, the low (bottom) edge of the phone should be lowered from the phantom to establish the same separation distance between the peak SAR location identified by the truncated partial SAR distribution measured with the SAM phantom. The distance from the peak SAR location to the phone is determined by the straight line passing perpendicularly through the phantom surface. When it is not feasible to maintain 4 mm separation at the ERP while also establishing the required separation at the peak SAR location, the top edge of the phone will be allowed to touch the phantom with a separation < 4 mm at the ERP. The phone should not be tilted to the left or right while placed in this inclined position to the flat phantom.

6.5 Body-Worn Accessory Configurations

Body-worn operating configurations are tested with the belt-clips and holsters attached to the device and positioned against a flat phantom in a normal use configuration (see Figure 6-4). Per FCC KDB Publication 648474 D04v01, Body-worn accessory exposure is typically related to voice mode operations when handsets are carried in body-worn accessories. The body-worn accessory procedures in FCC KDB Publication 447498 D01v05 should be used to test for body-worn accessory SAR compliance, without a headset connected to it. This enables the test results for such configuration to be compatible with that required for hotspot mode when the body-worn accessory test separation distance is greater than or equal to that required for hotspot mode, when applicable. When the reported SAR for a body-worn accessory, measured without a headset connected to the handset, is > 1.2 W/kg, the highest reported SAR configuration for that wireless mode and frequency band should be repeated for that body-worn accessory with a headset attached to the handset.

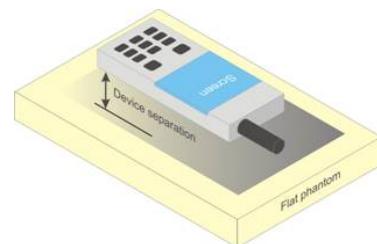



Figure 6-4 Sample Body-Worn Diagram

FCC ID: A3LSMG720AX	 PCTEST ENGINEERING LABORATORY, INC.	SAR EVALUATION REPORT		Reviewed by: Quality Manager
Document S/N: OY1412012187.A3L	Test Dates: 12/01/14 - 12/08/14	DUT Type: Portable Handset		Page 13 of 48

Accessories for Body-worn operation configurations are divided into two categories: those that do not contain metallic components and those that do contain metallic components. When multiple accessories that do not contain metallic components are supplied with the device, the device is tested with only the accessory that dictates the closest spacing to the body. Then multiple accessories that contain metallic components are tested with the device with each accessory. If multiple accessories share an identical metallic component (i.e. the same metallic belt-clip used with different holsters with no other metallic components) only the accessory that dictates the closest spacing to the body is tested.

Body-worn accessories may not always be supplied or available as options for some devices intended to be authorized for body-worn use. In this case, a test configuration with a separation distance between the back of the device and the flat phantom is used. Test position spacing was documented. Transmitters that are designed to operate in front of a person's face, as in push-to-talk configurations, are tested for SAR compliance with the front of the device positioned to face the flat phantom in head fluid. For devices that are carried next to the body such as a shoulder, waist or chest-worn transmitters, SAR compliance is tested with the accessories, including headsets and microphones, attached to the device and positioned against a flat phantom in a normal use configuration.

6.6 Extremity Exposure Configurations



Devices that are designed or intended for use on extremities or mainly operated in extremity only exposure conditions; i.e., hands, wrists, feet and ankles, may require extremity SAR evaluation. When the device also operates in close proximity to the user's body, SAR compliance for the body is also required. The 1-g body and 10-g extremity SAR Exclusion Thresholds found in KDB Publication 44798 D01v05 should be applied to determine SAR test requirements.

Per KDB Publication 447498 D01v05, Cell phones (handsets) are not normally designed to be used on extremities or operated in extremity only exposure conditions. The maximum output power levels of handsets generally do not require extremity SAR testing to show compliance. Therefore, extremity SAR was not evaluated for this device.

6.7 Wireless Router Configurations

Some battery-operated handsets have the capability to transmit and receive user data through simultaneous transmission of WIFI simultaneously with a separate licensed transmitter. The FCC has provided guidance in FCC KDB Publication 941225 D06 v01 where SAR test considerations for handsets ($L \times W \geq 9 \text{ cm} \times 5 \text{ cm}$) are based on a composite test separation distance of 10 mm from the front, back and edges of the device containing transmitting antennas within 2.5 cm of their edges, determined from general mixed use conditions for this type of devices. Since the hotspot SAR results may overlap with the body-worn accessory SAR requirements, the more conservative configurations can be considered, thus excluding some body-worn accessory SAR tests.

When the user enables the personal wireless router functions for the handset, actual operations include simultaneous transmission of both the WIFI transmitter and another licensed transmitter. Both transmitters often do not transmit at the same transmitting frequency and thus cannot be evaluated for SAR under actual use conditions due to the limitations of the SAR assessment probes. Therefore, SAR must be evaluated for each frequency transmission and mode separately and spatially summed with the WIFI transmitter according to FCC KDB Publication 447498 D01v05 publication procedures. The "Portable Hotspot" feature on the handset was NOT activated during SAR assessments, to ensure the SAR measurements were evaluated for a single transmission frequency RF signal at a time.

FCC ID: A3LSMG720AX		SAR EVALUATION REPORT		Reviewed by: Quality Manager
Document S/N: 0Y1412012187.A3L	Test Dates: 12/01/14 - 12/08/14	DUT Type: Portable Handset		Page 14 of 48

7 RF EXPOSURE LIMITS

7.1 Uncontrolled Environment

UNCONTROLLED ENVIRONMENTS are defined as locations where there is the exposure of individuals who have no knowledge or control of their exposure. The general population/uncontrolled exposure limits are applicable to situations in which the general public may be exposed or in which persons who are exposed as a consequence of their employment may not be made fully aware of the potential for exposure or cannot exercise control over their exposure. Members of the general public would come under this category when exposure is not employment-related; for example, in the case of a wireless transmitter that exposes persons in its vicinity.



7.2 Controlled Environment

CONTROLLED ENVIRONMENTS are defined as locations where there is exposure that may be incurred by persons who are aware of the potential for exposure, (i.e. as a result of employment or occupation). In general, occupational/controlled exposure limits are applicable to situations in which persons are exposed as a consequence of their employment, who have been made fully aware of the potential for exposure and can exercise control over their exposure. This exposure category is also applicable when the exposure is of a transient nature due to incidental passage through a location where the exposure levels may be higher than the general population/uncontrolled limits, but the exposed person is fully aware of the potential for exposure and can exercise control over his or her exposure by leaving the area or by some other appropriate means.

**Table 7-1
SAR Human Exposure Specified in ANSI/IEEE C95.1-1992 and Health Canada Safety Code 6**

HUMAN EXPOSURE LIMITS		
	UNCONTROLLED ENVIRONMENT <i>General Population</i> (W/kg) or (mW/g)	CONTROLLED ENVIRONMENT <i>Occupational</i> (W/kg) or (mW/g)
Peak Spatial Average SAR Head	1.6	8.0
Whole Body SAR	0.08	0.4
Peak Spatial Average SAR Hands, Feet, Ankle, Wrists, etc.	4.0	20

1. The Spatial Peak value of the SAR averaged over any 1 gram of tissue (defined as a tissue volume in the shape of a cube) and over the appropriate averaging time.
2. The Spatial Average value of the SAR averaged over the whole body.
3. The Spatial Peak value of the SAR averaged over any 10 grams of tissue (defined as a tissue volume in the shape of a cube) and over the appropriate averaging time.

FCC ID: A3LSMG720AX	 PCTEST ENGINEERING LABORATORY, INC.	SAR EVALUATION REPORT		Reviewed by: Quality Manager
Document S/N: 0Y1412012187.A3L	Test Dates: 12/01/14 - 12/08/14	DUT Type: Portable Handset	Page 15 of 48	

8 FCC MEASUREMENT PROCEDURES

Power measurements were performed using a base station simulator under digital average power.

8.1 Measured and Reported SAR

Per FCC KDB Publication 447498 D01v05, When SAR is not measured at the maximum power level allowed for production units, the results must be scaled to the maximum tune-up tolerance limit according to the power applied to the individual channels tested to determine compliance. For simultaneous transmission, the measured aggregate SAR must be scaled according to the sum of the differences between the maximum tune-up tolerance and actual power used to test each transmitter. When SAR is measured at or scaled to the maximum tune-up tolerance limit, the results are referred to as *reported* SAR. The highest *reported* SAR results are identified on the grant of equipment authorization according to procedures in KDB 690783 D01v01r02.

8.2 Procedures Used to Establish RF Signal for SAR

The following procedures are according to FCC KDB Publication 941225 D01 "SAR Measurement Procedures for 3G Devices" v02, October 2007.

The device was placed into a simulated call using a base station simulator in a RF shielded chamber. Establishing connections in this manner ensure a consistent means for testing SAR and are recommended for evaluating SAR [4]. Devices under test were evaluated prior to testing, with a fully charged battery and were configured to operate at maximum output power. In order to verify that the device was tested throughout the SAR test at maximum output power, the SAR measurement system measures a "point SAR" at an arbitrary reference point at the start and end of the 1 gram SAR evaluation, to assess for any power drifts during the evaluation. If the power drift deviated by more than 5%, the SAR test and drift measurements were repeated.

8.3 SAR Measurement Conditions for UMTS



8.3.1 Output Power Verification

Maximum output power is measured on the High, Middle and Low channels for each applicable transmission band according to the general descriptions in section 5.2 of 3GPP TS 34.121, using the appropriate RMC or AMR with TPC (transmit power control) set to all "1s".

Maximum output power is verified on the High, Middle and Low channels according to the general descriptions in section 5.2 of 3GPP TS 34.121 (release 5), using the appropriate RMC with TPC (transmit power control) set to all "1s" or applying the required inner loop power control procedures to maintain maximum output power while HSUPA is active. Results for all applicable physical channel configurations (DPCCH, DPDCHn and spreading codes, HS-DPCCH etc) are tabulated in this test report. All configurations that are not supported by the DUT or cannot be measured due to technical or equipment limitations are identified.

8.3.2 Head SAR Measurements for Handsets

SAR for head exposure configurations is measured using the 12.2 kbps RMC with TPC bits configured to all "1s". SAR in AMR configurations is not required when the maximum average output of each RF channel for 12.2 kbps AMR is less than 0.25 dB higher than that measured in 12.2 kbps RMC. Otherwise, SAR is measured on the maximum output channel in 12.2 AMR with a

FCC ID: A3LSMG720AX		SAR EVALUATION REPORT		Reviewed by: Quality Manager
Document S/N: 0Y1412012187.A3L	Test Dates: 12/01/14 - 12/08/14	DUT Type: Portable Handset		Page 16 of 48

3.4 kbps SRB (signaling radio bearer) using the exposure configuration that resulted in the highest SAR for that RF channel in the 12.2 kbps RMC mode.

8.3.3 Body SAR Measurements

SAR for body exposure configurations is measured using the 12.2 kbps RMC with the TPC bits all “1s”.

8.3.4 SAR Measurements for Handsets with Rel 5 HSDPA

Body SAR for HSDPA is not required for handsets with HSDPA capabilities when the maximum average output power of each RF channel with HSDPA active is less than 0.25 dB higher than that measured without HSDPA using 12.2 kbps RMC and the maximum SAR for 12.2 kbps RMC is $\leq 75\%$ of the SAR limit. Otherwise, SAR is measured for HSDPA, using an FRC with H-Set 1 in Sub-test 1 and a 12.2 kbps RMC configured in Test Loop Mode 1, using the highest body SAR configuration measured in 12.2 kbps RMC without HSDPA, on the maximum output channel with the body exposure configuration that resulted in the highest SAR in 12.2 kbps RMC mode for that RF channel.

The H-set used in FRC for HSDPA should be configured according to the UE category of a test device. The number of HS-DSCH/HSPDSCHs, HARQ processes, minimum inter-TTI interval, transport block sizes and RV coding sequence are defined by the applicable H-set. To maintain a consistent test configuration and stable transmission conditions, QPSK is used in the FRC for SAR testing. HS-DPCCH should be configured with a CQI feedback cycle of 2 ms to maintain a constant rate of active CQI slots. DPCCH and DPDCH gain factors of $\beta_c=9$ and $\beta_d=15$, and power offset parameters of $\Delta_{ACK} = \Delta_{NACK} = 5$ and $\Delta_{CQI}=2$ is used. The CQI value is determined by the UE category, transport block size, number of HS-PDSCHs and modulation used in the FRC.

Sub-Test	β_c	β_d	β_d (SF)	β_c/β_d	β_{HS} (Note 1, Note 2)	CM (dB) (Note 3)	MPR (dB) (Note 3)
1	2/15	15/15	64	2/15	4/15	0.0	0.0
2	12/15 (Note 4)	15/15 (Note 4)	64	12/15 (Note 4)	24/15	1.0	0.0
3	15/15	8/15	64	15/8	30/15	1.5	0.5
4	15/15	4/15	64	15/4	30/15	1.5	0.5

Note 1: $\Delta_{ACK}, \Delta_{NACK}$ and $\Delta_{CQI} = 8 \Rightarrow A_{HS} = \beta_{HS}/\beta_c = 30/15 \Rightarrow \beta_{HS} = 30/15 * \beta_c$.
 Note 2: For the HS-DPCCH power mask requirement test in clause 5.2C, 5.7A, and the Error Vector Magnitude (EVM) with HS-DPCCH test in clause 5.13.1A, and HSDPA EVM with phase discontinuity in clause 5.13.1AA, Δ_{ACK} and $\Delta_{NACK} = 8$ ($A_{HS} = 30/15$) with $\beta_{HS} = 30/15 * \beta_c$, and $\Delta_{CQI} = 7$ ($A_{HS} = 24/15$) with $\beta_{HS} = 24/15 * \beta_c$.
 Note 3: CM = 1 for $\beta_c/\beta_d = 12/15$, $\beta_{HS}/\beta_c = 24/15$. For all other combinations of DPDCH, DPCCH and HS-DPCCH the MPR is based on the relative CM difference. This is applicable for only UEs that support HSDPA in release 6 and later releases.



Figure 8-1
Table C.10.1.4 of TS 234.121-1

8.3.5 SAR Measurements for Handsets with Rel 6 HSUPA

Body SAR for HSUPA is not required when the maximum average output of each RF channel with HSUPA/HSDPA active is less than 0.25 dB higher than as measured without HSUPA/HSDPA using 12.2 kbps RMC and maximum SAR for 12.2 kbps RMC is $\leq 75\%$ of the SAR limit.

Otherwise SAR is measured on the maximum output channel for the body exposure configuration produced highest SAR in 12.2 kbps RMC for that RF channel, using the additional procedures under “Release 6 HSPA data devices”

Head SAR for VOIP operations under HSPA is not required when maximum average output of each RF channel with HSPA is less than 0.25 dB higher than as measured using 12.2 kbps RMC. Otherwise SAR is measured using same HSPA configuration as used for body SAR.

FCC ID: A3LSMG720AX		SAR EVALUATION REPORT		Reviewed by: Quality Manager
Document S/N: OY1412012187.A3L	Test Dates: 12/01/14 - 12/08/14	DUT Type: Portable Handset		Page 17 of 48

Sub-test	β_c	β_a	β_a (SF)	β_c/β_a	$\beta_{10}^{(1)}$	β_{ec}	β_{ed}	β_{ed} (SF)	β_{ed} (codes)	CM ⁽²⁾ (dB)	MPR (dB)	AG ⁽⁴⁾ Index	E-TFCI
1	11/15 ⁽³⁾	15/15 ⁽³⁾	64	11/15 ⁽³⁾	22/15	209/225	1039/225	4	1	1.0	0.0	20	75
2	6/15	15/15	64	6/15	12/15	12/15	94/75	4	1	3.0	2.0	12	67
3	15/15	9/15	64	15/9	30/15	30/15	β_{ed} : 47/15 β_{ed} : 47/15	4	2	2.0	1.0	15	92
4	2/15	15/15	64	2/15	4/15	2/15	56/75	4	1	3.0	2.0	17	71
5	15/15 ⁽⁴⁾	15/15 ⁽⁴⁾	64	15/15 ⁽⁴⁾	30/15	24/15	134/15	4	1	1.0	0.0	21	81

Note 1: Δ_{ACK} , Δ_{NACK} and $\Delta_{CQI} = 8 \Leftrightarrow A_{10} = \beta_{10}/\beta_c = 30/15 \Leftrightarrow \beta_{10} = 30/15 * \beta_c$.

Note 2: CM = 1 for $\beta_c/\beta_a = 12/15$, $\beta_{10}/\beta_c = 24/15$. For all other combinations of DPDCH, DPCCH, HS-DPCCH, E-DPDCH and E-DPCCH the MPR is based on the relative CM difference.

Note 3: For subtest 1 the β_c/β_a ratio of 11/15 for the TFC during the measurement period (TF1, TF0) is achieved by setting the signaled gain factors for the reference TFC (TF1, TF1) to $\beta_c = 10/15$ and $\beta_a = 15/15$.

Note 4: For subtest 5 the β_c/β_a ratio of 15/15 for the TFC during the measurement period (TF1, TF0) is achieved by setting the signaled gain factors for the reference TFC (TF1, TF1) to $\beta_c = 14/15$ and $\beta_a = 15/15$.

Note 5: Testing UE using E-DPDCH Physical Layer category 1 Sub-test 3 is not required according to TS 25.306 Table 5.1g.

Note 6: β_{ed} can not be set directly; it is set by Absolute Grant Value.

8.3.6 SAR Measurement Conditions for DC-HSDPA

SAR test exclusion for DC-HSDPA devices is determined by power measurements according to the H-Set 12, Fixed Reference Channel (FRC) configuration in Table C.8.1.12 of 3GPP TS 34.121-1. A primary and a secondary serving HS-DSCH Cell are required to perform the power measurement and for the results to qualify for SAR test exclusion. DC-HSDPA uplink maximum output power measurements using the four Rel. 5 HSDPA subtests in Table C.10.1.4 of TS 234.121-1 is required.

When the maximum average output power of each RF channel with DC-HSDPA active is $\leq 1/4$ dB higher than that measured using 12.2 kbps RMC, or the maximum reported SAR for 12.2 kbps RMC is $\leq 75\%$ of the SAR limit, SAR evaluation for DC-HSDPA is not required.

8.4 SAR Measurement Conditions for LTE

LTE modes were tested according to FCC KDB 941225 D05v02 publication. Please see notes after the tabulated SAR data for required test configurations. Establishing connections with base station simulators ensure a consistent means for testing SAR and are recommended for evaluating SAR [4]. The R&S CMW500 was used for LTE output power measurements and SAR testing. Closed loop power control was used so the UE transmits with maximum output power during SAR testing. SAR tests were performed with the same number of RB and RB offsets transmitting on all TTI frames (maximum TTI).

8.4.1 Spectrum Plots for RB Configurations



A properly configured base station simulator was used for SAR tests and power measurements. Therefore, spectrum plots for RB configurations were not required to be included in this report.

8.4.2 MPR

MPR is permanently implemented for this device by the manufacturer. The specific manufacturer target MPR is indicated alongside the SAR results. MPR is enabled for this device, according to 3GPP TS36.101 Section 6.2.3 – 6.2.5 under Table 6.2.3-1.

8.4.3 A-MPR

A-MPR (Additional MPR) has been disabled for all SAR tests by setting NS=01 on the base station simulator.

FCC ID: A3LSMG720AX	 PCTEST ENGINEERING LABORATORY, INC.	SAR EVALUATION REPORT		Reviewed by: Quality Manager
Document S/N: OY1412012187.A3L	Test Dates: 12/01/14 - 12/08/14	DUT Type: Portable Handset	Page 18 of 48	

8.4.4 Required RB Size and RB Offsets for SAR Testing

According to FCC KDB 941225 D05v02r01:

- a. Per Section 5.2.1, SAR is required for QPSK 1 RB Allocation for the largest bandwidth
 - i. The required channel and offset combination with the highest maximum output power is required for SAR.
 - ii. When the reported SAR is ≤ 0.8 W/kg, testing of the remaining RB offset configurations and required test channels is not required. Otherwise, SAR is required for the remaining required test channels using the RB offset configuration with highest output power for that channel.
 - iii. When the reported SAR for a required test channel is > 1.45 W/kg, SAR is required for all RB offset configurations for that channel.
- b. Per Section 5.2.2, SAR is required for 50% RB allocation using the largest bandwidth following the same procedures outlined in Section 5.2.1.
- c. Per Section 5.2.3, QPSK SAR is not required for the 100% allocation when the highest maximum output power for the 100% allocation is less than the highest maximum output power of the 1 RB and 50% RB allocations and the reported SAR for the 1 RB and 50% RB allocations is < 0.8 W/kg.
- d. Per Section 5.2.4 and 5.3, SAR tests for higher order modulations and lower bandwidths configurations are not required when the conducted power of the required test configurations determined by Sections 5.2.1 through 5.2.3 is less than or equal to $\frac{1}{2}$ dB higher than the equivalent configuration using QPSK modulation and when the QPSK SAR for those configurations is < 1.45 W/kg.

8.5 SAR Testing with 802.11 Transmitters

Normal network operating configurations are not suitable for measuring the SAR of 802.11 b/g/n transmitters. Unpredictable fluctuations in network traffic and antenna diversity conditions can introduce undesirable variations in SAR results. The SAR for these devices should be measured using chipset based test mode software to ensure the results are consistent and reliable. See KDB Publication 248227 D01v01r02 for more details.



8.5.1 General Device Setup

Chipset based test mode software is hardware dependent and generally varies among manufacturers. The device operating parameters established in test mode for SAR measurements must be identical to those programmed in production units, including output power levels, amplifier gain settings and other RF performance tuning parameters. The test frequencies should correspond to actual channel frequencies defined for domestic use. SAR for devices with switched diversity should be measured with only one antenna transmitting at a time during each SAR measurement, according to a fixed modulation and data rate. The same data pattern should be used for all measurements.

8.5.2 Frequency Channel Configurations [24]

For 2.4 GHz, the highest average RF output power channel between the low, mid and high channel at the lowest data rate was selected for SAR evaluation in 802.11b mode. 802.11g/n modes and higher data rates for 802.11b were additionally evaluated for SAR if the output power of the respective mode was 0.25 dB or higher than the powers of the SAR configurations tested in the 802.11b mode.

If the maximum extrapolated peak SAR of the zoom scan for the highest output channel was less than 1.6 W/kg and if the 1g averaged SAR was less than 0.8 W/kg, SAR testing was not required for the other test channels in the band.

FCC ID: A3LSMG720AX		SAR EVALUATION REPORT		Reviewed by: Quality Manager
Document S/N: OY1412012187.A3L	Test Dates: 12/01/14 - 12/08/14	DUT Type: Portable Handset		Page 19 of 48

9 RF CONDUCTED POWERS

9.1 GSM Conducted Powers

		Maximum Burst-Averaged Output Power									
		Voice	GPRS/EDGE Data (GMSK)				EDGE Data (8-PSK)				
Band	Channel	GSM [dBm] CS (1 Slot)	GPRS [dBm] 1 Tx Slot	GPRS [dBm] 2 Tx Slot	GPRS [dBm] 3 Tx Slot	GPRS [dBm] 4 Tx Slot	EDGE [dBm] 1 Tx Slot	EDGE [dBm] 2 Tx Slot	EDGE [dBm] 3 Tx Slot	EDGE [dBm] 4 Tx Slot	
GSM 850	128	32.46	32.47	29.52	28.00	26.06	26.81	25.72	22.57	22.44	
	190	32.49	32.50	29.55	28.12	26.27	26.88	25.68	22.51	22.35	
	251	32.17	32.22	29.23	28.06	25.89	26.71	25.62	22.40	22.23	
GSM 1900	512	29.68	29.67	26.81	24.52	21.67	25.12	24.42	19.47	19.11	
	661	30.01	29.99	27.02	24.79	21.83	25.27	24.58	19.64	19.25	
	810	29.92	29.89	26.97	24.63	21.78	25.22	24.37	19.52	19.07	
		Calculated Maximum Frame-Averaged Output Power									
		Voice	GPRS/EDGE Data (GMSK)				EDGE Data (8-PSK)				
Band	Channel	GSM [dBm] CS (1 Slot)	GPRS [dBm] 1 Tx Slot	GPRS [dBm] 2 Tx Slot	GPRS [dBm] 3 Tx Slot	GPRS [dBm] 4 Tx Slot	EDGE [dBm] 1 Tx Slot	EDGE [dBm] 2 Tx Slot	EDGE [dBm] 3 Tx Slot	EDGE [dBm] 4 Tx Slot	
GSM 850	128	23.43	23.44	23.50	23.74	23.05	17.78	19.70	18.31	19.43	
	190	23.46	23.47	23.53	23.86	23.26	17.85	19.66	18.25	19.34	
	251	23.14	23.19	23.21	23.80	22.88	17.68	19.60	18.14	19.22	
GSM 1900	512	20.65	20.64	20.79	20.26	18.66	16.09	18.40	15.21	16.10	
	661	20.98	20.96	21.00	20.53	18.82	16.24	18.56	15.38	16.24	
	810	20.89	20.86	20.95	20.37	18.77	16.19	18.35	15.26	16.06	
GSM 850	Frame	23.27	23.27	23.58	24.44	22.99	17.77	19.88	18.74	19.99	
GSM 1900	Avg.Targets:	20.77	20.77	21.18	20.74	19.59	16.27	18.48	15.54	16.69	



Note:

- Both burst-averaged and calculated frame-averaged powers are included. Frame-averaged power was calculated from the measured burst-averaged power by converting the slot powers into linear units and calculating the energy over 8 timeslots.
- The source-based frame-averaged output power was evaluated for all GPRS/EDGE slot configurations. The configuration with the highest target frame averaged output power was evaluated for hotspot SAR. When the maximum frame-averaged powers are equivalent across two or more slots (within 0.25 dB), the configuration with the most number of time slots was tested.
- GPRS/EDGE (GMSK) output powers were measured with coding scheme setting of 1 (CS1) on the base station simulator. CS1 was configured to measure GPRS output power measurements and SAR to ensure GMSK modulation in the signal. Our Investigation has shown that CS1 - CS4 settings do not have any impact on the output levels or modulation in the GPRS modes.
- EDGE (8-PSK) output powers were measured with MCS7 on the base station simulator. MCS7 coding scheme was used to measure the output powers for EDGE since investigation has shown that choosing MCS7 coding scheme will ensure 8-PSK modulation. It has been shown that MCS levels that produce 8PSK modulation do not have an impact on output power.

GSM Class: B
GPRS Multislot class: 33 (Max 4 Tx uplink slots)
EDGE Multislot class: 33 (Max 4 Tx uplink slots)
DTM Multislot Class: N/A



Figure 9-1
Power Measurement Setup

FCC ID: A3LSMG720AX		SAR EVALUATION REPORT		Reviewed by: Quality Manager
Document S/N: OY1412012187.A3L	Test Dates: 12/01/14 - 12/08/14	DUT Type: Portable Handset	Page 20 of 48	

9.2 UMTS Conducted Powers

3GPP Release Version	Mode	3GPP 34.121 Subtest	Cellular Band [dBm]			PCS Band [dBm]			3GPP MPR [dB]
			4132	4183	4233	9262	9400	9538	
99	WCDMA	12.2 kbps RMC	22.40	22.31	22.39	22.07	22.27	22.21	-
99		12.2 kbps AMR	22.39	22.37	22.34	22.13	22.26	22.20	-
6	HSDPA	Subtest 1	21.44	21.33	21.38	21.28	21.51	21.36	0
6		Subtest 2	21.35	21.35	21.45	21.17	21.53	21.33	0
6		Subtest 3	21.49	21.31	21.44	21.26	21.38	21.42	0.5
6		Subtest 4	21.40	21.39	21.47	21.25	21.48	21.31	0.5
6	HSUPA	Subtest 1	20.29	20.26	20.46	20.40	20.83	20.20	0
6		Subtest 2	20.20	20.24	20.27	20.01	20.63	20.06	2
6		Subtest 3	20.81	20.60	20.76	20.46	20.82	20.25	1
6		Subtest 4	20.42	20.49	20.55	20.14	20.52	20.40	2
6		Subtest 5	21.23	21.30	21.34	20.99	21.33	21.28	0
8	DC-HSDPA	Subtest 1	21.02	20.99	20.93	21.42	21.60	21.43	0
8		Subtest 2	21.01	20.90	20.96	21.59	21.60	21.63	0
8		Subtest 3	20.70	20.65	20.66	20.89	21.21	21.35	0.5
8		Subtest 4	20.63	20.67	20.61	21.00	21.18	21.12	0.5

UMTS SAR was tested under RMC 12.2 kbps with HSPA Inactive per KDB Publication 941225 D01v02. HSPA SAR was not required since the average output power of the HSPA subtests was not more than 0.25 dB higher than the RMC level and SAR was less than 1.2 W/kg.



DC-HSDPA considerations

- 3GPP Specification 34.121-1 Release 8 Ver 8.10.0 was used for DC-HSDPA guidance
- H-Set 12 (QPSK) was confirmed to be used during DC-HSDPA measurements
- Measured maximum output powers for DC-HSDPA were not greater than 1/4 dB higher than the WCDMA 12.2 kbps RMC maximum output, as a result, SAR is not required for DC-HSDPA
- The DUT supports UE category 24 for HSDPA

It is expected by the manufacturer that MPR for some HSPA subtests may be up to 1 dB more than specified by 3GPP, but also as low as 0 dB according to the chipset implementation in this model.



Figure 9-2
Power Measurement Setup

FCC ID: A3LSMG720AX		SAR EVALUATION REPORT		Reviewed by: Quality Manager
Document S/N: OY1412012187.A3L	Test Dates: 12/01/14 - 12/08/14	DUT Type: Portable Handset		Page 21 of 48

9.3 LTE Conducted Powers

9.3.1 LTE Band 17

**Table 9-1
LTE Band 17 Conducted Powers - 10 MHz Bandwidth**



Frequency [MHz]	Channel	Bandwidth [MHz]	Modulation	RB Size	RB Offset	Conducted Power [dBm]	MPR Allowed per 3GPP [dB]	MPR [dB]
710.0	23790	10	QPSK	1	0	23.40	0	0
			QPSK	1	25	23.37	0	0
			QPSK	1	49	23.16	0	0
			QPSK	25	0	22.23	0-1	1
			QPSK	25	12	22.18	0-1	1
			QPSK	25	25	22.16	0-1	1
			QPSK	50	0	22.22	0-1	1
			16QAM	1	0	22.43	0-1	1
			16QAM	1	25	22.38	0-1	1
			16QAM	1	49	22.19	0-1	1
			16QAM	25	0	21.27	0-2	2
			16QAM	25	12	21.20	0-2	2
			16QAM	25	25	21.29	0-2	2
			16QAM	50	0	21.17	0-2	2

Note: LTE Band 17 at 10 MHz bandwidth does not support three non-overlapping channels. Per KDB Publication 941225 D05v02, when a device supports overlapping channel assignment in a channel bandwidth configuration, the middle channel of the group of overlapping channels should be selected for testing.

**Table 9-2
LTE Band 17 Conducted Powers - 5 MHz Bandwidth**

Frequency [MHz]	Channel	Bandwidth [MHz]	Modulation	RB Size	RB Offset	Conducted Power [dBm]	MPR Allowed per 3GPP [dB]	MPR [dB]
710.0	23790	5	QPSK	1	0	23.21	0	0
			QPSK	1	12	23.07	0	0
			QPSK	1	24	23.33	0	0
			QPSK	12	0	21.97	0-1	1
			QPSK	12	6	21.98	0-1	1
			QPSK	12	13	22.02	0-1	1
			QPSK	25	0	22.07	0-1	1
			16-QAM	1	0	22.09	0-1	1
			16-QAM	1	12	21.93	0-1	1
			16-QAM	1	24	22.12	0-1	1
			16-QAM	12	0	20.92	0-2	2
			16-QAM	12	6	20.82	0-2	2
			16-QAM	12	13	20.93	0-2	2
			16-QAM	25	0	21.08	0-2	2

Note: LTE Band 17 at 5 MHz bandwidth does not support three non-overlapping channels. Per KDB Publication 941225 D05v02, when a device supports overlapping channel assignment in a channel bandwidth configuration, the middle channel of the group of overlapping channels should be selected for testing.

FCC ID: A3LSMG720AX		SAR EVALUATION REPORT		Reviewed by: Quality Manager
Document S/N: OY1412012187.A3L	Test Dates: 12/01/14 - 12/08/14	DUT Type: Portable Handset	Page 22 of 48	

9.3.2

LTE Band 4 (AWS)

Table 9-3
LTE Band 4 (AWS) Conducted Powers - 20 MHz Bandwidth

	Frequency [MHz]	Channel	Bandwidth [MHz]	Modulation	RB Size	RB Offset	Conducted Power [dBm]	MPR Allowed per 3GPP [dB]	MPR [dB]
Mid	1732.5	20175	20	QPSK	1	0	23.47	0	0
	1732.5	20175	20	QPSK	1	50	23.39	0	0
	1732.5	20175	20	QPSK	1	99	23.27	0	0
	1732.5	20175	20	QPSK	50	0	22.30	0-1	1
	1732.5	20175	20	QPSK	50	25	22.17	0-1	1
	1732.5	20175	20	QPSK	50	50	22.09	0-1	1
	1732.5	20175	20	QPSK	100	0	22.24	0-1	1
	1732.5	20175	20	16QAM	1	0	22.50	0-1	1
	1732.5	20175	20	16QAM	1	50	22.16	0-1	1
	1732.5	20175	20	16QAM	1	99	22.30	0-1	1
	1732.5	20175	20	16QAM	50	0	21.24	0-2	2
	1732.5	20175	20	16QAM	50	25	21.10	0-2	2
	1732.5	20175	20	16QAM	50	50	21.06	0-2	2
	1732.5	20175	20	16QAM	100	0	21.18	0-2	2

Note: LTE Band 4 (AWS) at 20 MHz bandwidth does not support three non-overlapping channels. Per KDB Publication 941225 D05v02, when a device supports overlapping channel assignment in a channel bandwidth configuration, the middle channel of the group of overlapping channels should be selected for testing.

Table 9-4
LTE Band 4 (AWS) Conducted Powers - 15 MHz Bandwidth

	Frequency [MHz]	Channel	Bandwidth [MHz]	Modulation	RB Size	RB Offset	Conducted Power [dBm]	MPR Allowed per 3GPP [dB]	MPR [dB]	
Low	1717.5	20025	15	QPSK	1	0	23.51	0	0	
	1717.5	20025	15	QPSK	1	36	23.41	0	0	
	1717.5	20025	15	QPSK	1	74	23.44	0	0	
	1717.5	20025	15	QPSK	36	0	22.25	0-1	1	
	1717.5	20025	15	QPSK	36	18	22.21	0-1	1	
	1717.5	20025	15	QPSK	36	37	22.39	0-1	1	
	1717.5	20025	15	QPSK	75	0	22.16	0-1	1	
	1717.5	20025	15	16QAM	1	0	22.32	0-1	1	
	1717.5	20025	15	16QAM	1	36	21.76	0-1	1	
	1717.5	20025	15	16QAM	1	74	22.05	0-1	1	
	1717.5	20025	15	16QAM	36	0	21.19	0-2	2	
	1717.5	20025	15	16QAM	36	18	21.05	0-2	2	
	1717.5	20025	15	16QAM	36	37	21.02	0-2	2	
	1717.5	20025	15	16QAM	75	0	21.18	0-2	2	
	Mid	1732.5	20175	15	QPSK	1	0	23.55	0	0
		1732.5	20175	15	QPSK	1	36	22.96	0	0
		1732.5	20175	15	QPSK	1	74	23.52	0	0
		1732.5	20175	15	QPSK	36	0	22.26	0-1	1
1732.5		20175	15	QPSK	36	18	22.07	0-1	1	
1732.5		20175	15	QPSK	36	37	22.03	0-1	1	
1732.5		20175	15	QPSK	75	0	22.10	0-1	1	
1732.5		20175	15	16QAM	1	0	22.13	0-1	1	
1732.5		20175	15	16QAM	1	36	22.55	0-1	1	
1732.5		20175	15	16QAM	1	74	22.45	0-1	1	
1732.5		20175	15	16QAM	36	0	21.40	0-2	2	
1732.5		20175	15	16QAM	36	18	21.21	0-2	2	
1732.5		20175	15	16QAM	36	37	21.15	0-2	2	
1732.5		20175	15	16QAM	75	0	21.14	0-2	2	
High		1747.5	20325	15	QPSK	1	0	23.53	0	0
		1747.5	20325	15	QPSK	1	36	23.33	0	0
		1747.5	20325	15	QPSK	1	74	23.28	0	0
		1747.5	20325	15	QPSK	36	0	22.20	0-1	1
	1747.5	20325	15	QPSK	36	18	22.03	0-1	1	
	1747.5	20325	15	QPSK	36	37	22.10	0-1	1	
	1747.5	20325	15	QPSK	75	0	22.11	0-1	1	
	1747.5	20325	15	16QAM	1	0	22.03	0-1	1	
	1747.5	20325	15	16QAM	1	36	21.84	0-1	1	
	1747.5	20325	15	16QAM	1	74	21.76	0-1	1	
	1747.5	20325	15	16QAM	36	0	21.05	0-2	2	
	1747.5	20325	15	16QAM	36	18	20.99	0-2	2	
	1747.5	20325	15	16QAM	36	37	21.06	0-2	2	
	1747.5	20325	15	16QAM	75	0	21.04	0-2	2	



FCC ID: A3LSMG720AX	 PCTEST ENGINEERING LABORATORY, INC.	SAR EVALUATION REPORT		Reviewed by: Quality Manager
Document S/N: OY1412012187.A3L	Test Dates: 12/01/14 - 12/08/14	DUT Type: Portable Handset		Page 23 of 48

Table 9-5
LTE Band 4 (AWS) Conducted Powers - 10 MHz Bandwidth

	Frequency [MHz]	Channel	Bandwidth [MHz]	Modulation	RB Size	RB Offset	Conducted Power [dBm]	MPR Allowed per 3GPP [dB]	MPR [dB]	
Low	1715	20000	10	QPSK	1	0	23.61	0	0	
	1715	20000	10	QPSK	1	25	23.06	0	0	
	1715	20000	10	QPSK	1	49	23.49	0	0	
	1715	20000	10	QPSK	25	0	22.21	0-1	1	
	1715	20000	10	QPSK	25	12	22.11	0-1	1	
	1715	20000	10	QPSK	25	25	22.15	0-1	1	
	1715	20000	10	QPSK	50	0	22.19	0-1	1	
	1715	20000	10	16QAM	1	0	22.35	0-1	1	
	1715	20000	10	16QAM	1	25	22.62	0-1	1	
	1715	20000	10	16QAM	1	49	22.37	0-1	1	
	1715	20000	10	16QAM	25	0	20.96	0-2	2	
	1715	20000	10	16QAM	25	12	21.18	0-2	2	
	1715	20000	10	16QAM	25	25	21.00	0-2	2	
	1715	20000	10	16QAM	50	0	21.02	0-2	2	
	Mid	1732.5	20175	10	QPSK	1	0	23.30	0	0
		1732.5	20175	10	QPSK	1	25	23.44	0	0
1732.5		20175	10	QPSK	1	49	23.22	0	0	
1732.5		20175	10	QPSK	25	0	22.20	0-1	1	
1732.5		20175	10	QPSK	25	12	22.13	0-1	1	
1732.5		20175	10	QPSK	25	25	22.17	0-1	1	
1732.5		20175	10	QPSK	50	0	22.10	0-1	1	
1732.5		20175	10	16QAM	1	0	22.44	0-1	1	
1732.5		20175	10	16QAM	1	25	22.33	0-1	1	
1732.5		20175	10	16QAM	1	49	22.16	0-1	1	
1732.5		20175	10	16QAM	25	0	21.22	0-2	2	
1732.5		20175	10	16QAM	25	12	21.15	0-2	2	
1732.5		20175	10	16QAM	25	25	21.01	0-2	2	
1732.5		20175	10	16QAM	50	0	21.01	0-2	2	
High		1750	20350	10	QPSK	1	0	23.35	0	0
		1750	20350	10	QPSK	1	25	23.50	0	0
	1750	20350	10	QPSK	1	49	23.39	0	0	
	1750	20350	10	QPSK	25	0	22.18	0-1	1	
	1750	20350	10	QPSK	25	12	22.10	0-1	1	
	1750	20350	10	QPSK	25	25	22.09	0-1	1	
	1750	20350	10	QPSK	50	0	22.14	0-1	1	
	1750	20350	10	16QAM	1	0	22.14	0-1	1	
	1750	20350	10	16QAM	1	25	22.44	0-1	1	
	1750	20350	10	16QAM	1	49	21.85	0-1	1	
	1750	20350	10	16QAM	25	0	21.15	0-2	2	
	1750	20350	10	16QAM	25	12	21.18	0-2	2	
	1750	20350	10	16QAM	25	25	21.10	0-2	2	
	1750	20350	10	16QAM	50	0	21.16	0-2	2	

Table 9-6
LTE Band 4 (AWS) Conducted Powers - 5 MHz Bandwidth

	Frequency [MHz]	Channel	Bandwidth [MHz]	Modulation	RB Size	RB Offset	Conducted Power [dBm]	MPR Allowed per 3GPP [dB]	MPR [dB]	
Low	1712.5	19975	5	QPSK	1	0	23.25	0	0	
	1712.5	19975	5	QPSK	1	12	23.38	0	0	
	1712.5	19975	5	QPSK	1	24	23.40	0	0	
	1712.5	19975	5	QPSK	12	0	22.16	0-1	1	
	1712.5	19975	5	QPSK	12	6	22.08	0-1	1	
	1712.5	19975	5	QPSK	12	13	22.11	0-1	1	
	1712.5	19975	5	QPSK	25	0	22.03	0-1	1	
	1712.5	19975	5	16-QAM	1	0	22.31	0-1	1	
	1712.5	19975	5	16-QAM	1	12	22.46	0-1	1	
	1712.5	19975	5	16-QAM	1	24	22.31	0-1	1	
	1712.5	19975	5	16-QAM	12	0	21.14	0-2	2	
	1712.5	19975	5	16-QAM	12	6	20.95	0-2	2	
	1712.5	19975	5	16-QAM	12	13	21.08	0-2	2	
	1712.5	19975	5	16-QAM	25	0	21.15	0-2	2	
	Mid	1732.5	20175	5	QPSK	1	0	22.93	0	0
		1732.5	20175	5	QPSK	1	12	23.20	0	0
1732.5		20175	5	QPSK	1	24	23.21	0	0	
1732.5		20175	5	QPSK	12	0	22.04	0-1	1	
1732.5		20175	5	QPSK	12	6	22.05	0-1	1	
1732.5		20175	5	QPSK	12	13	22.13	0-1	1	
1732.5		20175	5	QPSK	25	0	22.03	0-1	1	
1732.5		20175	5	16-QAM	1	0	22.41	0-1	1	
1732.5		20175	5	16-QAM	1	12	22.00	0-1	1	
1732.5		20175	5	16-QAM	1	24	21.84	0-1	1	
1732.5		20175	5	16-QAM	12	0	20.91	0-2	2	
1732.5		20175	5	16-QAM	12	6	20.94	0-2	2	
1732.5		20175	5	16-QAM	12	13	21.01	0-2	2	
1732.5		20175	5	16-QAM	25	0	20.93	0-2	2	
High		1752.5	20375	5	QPSK	1	0	23.14	0	0
		1752.5	20375	5	QPSK	1	12	23.13	0	0
	1752.5	20375	5	QPSK	1	24	23.38	0	0	
	1752.5	20375	5	QPSK	12	0	22.13	0-1	1	
	1752.5	20375	5	QPSK	12	6	22.19	0-1	1	
	1752.5	20375	5	QPSK	12	13	22.14	0-1	1	
	1752.5	20375	5	QPSK	25	0	22.10	0-1	1	
	1752.5	20375	5	16-QAM	1	0	22.05	0-1	1	
	1752.5	20375	5	16-QAM	1	12	22.25	0-1	1	
	1752.5	20375	5	16-QAM	1	24	22.41	0-1	1	
	1752.5	20375	5	16-QAM	12	0	21.00	0-2	2	
	1752.5	20375	5	16-QAM	12	6	21.06	0-2	2	
	1752.5	20375	5	16-QAM	12	13	21.11	0-2	2	
	1752.5	20375	5	16-QAM	25	0	21.00	0-2	2	

Table 9-7
LTE Band 4 (AWS) Conducted Powers - 3 MHz Bandwidth

	Frequency [MHz]	Channel	Bandwidth [MHz]	Modulation	RB Size	RB Offset	Conducted Power [dBm]	MPR Allowed per 3GPP [dB]	MPR [dB]
Low	1711.5	19965	3	QPSK	1	0	23.43	0	0
	1711.5	19965	3	QPSK	1	7	23.43	0	0
	1711.5	19965	3	QPSK	1	14	23.06	0	0
	1711.5	19965	3	QPSK	8	0	22.20	0-1	1
	1711.5	19965	3	QPSK	8	4	22.15	0-1	1
	1711.5	19965	3	QPSK	8	7	22.09	0-1	1
	1711.5	19965	3	QPSK	15	0	22.13	0-1	1
	1711.5	19965	3	16-QAM	1	0	22.31	0-1	1
	1711.5	19965	3	16-QAM	1	7	22.37	0-1	1
	1711.5	19965	3	16-QAM	1	14	21.90	0-1	1
	1711.5	19965	3	16-QAM	8	0	20.93	0-2	2
	1711.5	19965	3	16-QAM	8	4	21.01	0-2	2
	1711.5	19965	3	16-QAM	8	7	21.39	0-2	2
	1711.5	19965	3	16-QAM	15	0	21.31	0-2	2
	1732.5	20175	3	QPSK	1	0	23.31	0	0
1732.5	20175	3	QPSK	1	7	23.28	0	0	
1732.5	20175	3	QPSK	1	14	23.28	0	0	
1732.5	20175	3	QPSK	8	0	22.14	0-1	1	
1732.5	20175	3	QPSK	8	4	22.07	0-1	1	
1732.5	20175	3	QPSK	8	7	22.12	0-1	1	
1732.5	20175	3	QPSK	15	0	22.11	0-1	1	
1732.5	20175	3	16-QAM	1	0	22.47	0-1	1	
1732.5	20175	3	16-QAM	1	7	22.65	0-1	1	
1732.5	20175	3	16-QAM	1	14	22.49	0-1	1	
1732.5	20175	3	16-QAM	8	0	20.91	0-2	2	
1732.5	20175	3	16-QAM	8	4	21.10	0-2	2	
1732.5	20175	3	16-QAM	8	7	21.23	0-2	2	
1732.5	20175	3	16-QAM	15	0	21.13	0-2	2	
Mid	1753.5	20385	3	QPSK	1	0	23.52	0	0
	1753.5	20385	3	QPSK	1	7	23.40	0	0
	1753.5	20385	3	QPSK	1	14	23.41	0	0
	1753.5	20385	3	QPSK	8	0	22.21	0-1	1
	1753.5	20385	3	QPSK	8	4	22.10	0-1	1
	1753.5	20385	3	QPSK	8	7	22.10	0-1	1
	1753.5	20385	3	QPSK	15	0	22.14	0-1	1
	1753.5	20385	3	16-QAM	1	0	21.93	0-1	1
	1753.5	20385	3	16-QAM	1	7	22.10	0-1	1
	1753.5	20385	3	16-QAM	1	14	22.13	0-1	1
	1753.5	20385	3	16-QAM	8	0	21.23	0-2	2
	1753.5	20385	3	16-QAM	8	4	20.91	0-2	2
	1753.5	20385	3	16-QAM	8	7	21.12	0-2	2
	1753.5	20385	3	16-QAM	15	0	21.16	0-2	2
	High	1753.5	20385	3	QPSK	1	0	23.52	0
1753.5		20385	3	QPSK	1	7	23.40	0	0
1753.5		20385	3	QPSK	1	14	23.41	0	0
1753.5		20385	3	QPSK	8	0	22.21	0-1	1
1753.5		20385	3	QPSK	8	4	22.10	0-1	1
1753.5		20385	3	QPSK	8	7	22.10	0-1	1
1753.5		20385	3	QPSK	15	0	22.14	0-1	1
1753.5		20385	3	16-QAM	1	0	21.93	0-1	1
1753.5		20385	3	16-QAM	1	7	22.10	0-1	1
1753.5		20385	3	16-QAM	1	14	22.13	0-1	1
1753.5		20385	3	16-QAM	8	0	21.23	0-2	2
1753.5		20385	3	16-QAM	8	4	20.91	0-2	2
1753.5		20385	3	16-QAM	8	7	21.12	0-2	2
1753.5		20385	3	16-QAM	15	0	21.16	0-2	2

Table 9-8
LTE Band 4 (AWS) Conducted Powers -1.4 MHz Bandwidth

	Frequency [MHz]	Channel	Bandwidth [MHz]	Modulation	RB Size	RB Offset	Conducted Power [dBm]	MPR Allowed per 3GPP [dB]	MPR [dB]
Low	1710.7	19967	1.4	QPSK	1	0	23.54	0	0
	1710.7	19967	1.4	QPSK	1	2	23.61	0	0
	1710.7	19967	1.4	QPSK	1	5	23.50	0	0
	1710.7	19967	1.4	QPSK	3	0	23.22	0	0
	1710.7	19967	1.4	QPSK	3	2	23.34	0	0
	1710.7	19967	1.4	QPSK	3	3	23.30	0	0
	1710.7	19967	1.4	QPSK	6	0	22.18	0-1	1
	1710.7	19967	1.4	16-QAM	1	0	22.47	0-1	1
	1710.7	19967	1.4	16-QAM	1	2	22.25	0-1	1
	1710.7	19967	1.4	16-QAM	1	5	21.77	0-1	1
	1710.7	19967	1.4	16-QAM	3	0	21.93	0-1	1
	1710.7	19967	1.4	16-QAM	3	2	22.01	0-1	1
	1710.7	19967	1.4	16-QAM	3	3	22.17	0-1	1
	1710.7	19967	1.4	16-QAM	6	0	21.33	0-2	2
	1732.5	20175	1.4	QPSK	1	0	23.09	0	0
1732.5	20175	1.4	QPSK	1	2	23.11	0	0	
1732.5	20175	1.4	QPSK	1	5	23.07	0	0	
1732.5	20175	1.4	QPSK	3	0	23.04	0	0	
1732.5	20175	1.4	QPSK	3	2	23.01	0	0	
1732.5	20175	1.4	QPSK	3	3	23.19	0	0	
1732.5	20175	1.4	QPSK	6	0	22.05	0-1	1	
1732.5	20175	1.4	16-QAM	1	0	22.69	0-1	1	
1732.5	20175	1.4	16-QAM	1	2	22.42	0-1	1	
1732.5	20175	1.4	16-QAM	1	5	22.61	0-1	1	
1732.5	20175	1.4	16-QAM	3	0	22.46	0-1	1	
1732.5	20175	1.4	16-QAM	3	2	22.22	0-1	1	
1732.5	20175	1.4	16-QAM	3	3	21.96	0-1	1	
1732.5	20175	1.4	16-QAM	6	0	20.72	0-2	2	
Mid	1754.3	20393	1.4	QPSK	1	0	23.15	0	0
	1754.3	20393	1.4	QPSK	1	2	23.23	0	0
	1754.3	20393	1.4	QPSK	1	5	23.49	0	0
	1754.3	20393	1.4	QPSK	3	0	23.02	0	0
	1754.3	20393	1.4	QPSK	3	2	23.09	0	0
	1754.3	20393	1.4	QPSK	3	3	23.04	0	0
	1754.3	20393	1.4	QPSK	6	0	22.24	0-1	1
	1754.3	20393	1.4	16-QAM	1	0	22.21	0-1	1
	1754.3	20393	1.4	16-QAM	1	2	22.63	0-1	1
	1754.3	20393	1.4	16-QAM	1	5	22.18	0-1	1
	1754.3	20393	1.4	16-QAM	3	0	22.25	0-1	1
	1754.3	20393	1.4	16-QAM	3	2	22.10	0-1	1
	1754.3	20393	1.4	16-QAM	3	3	22.05	0-1	1
	1754.3	20393	1.4	16-QAM	6	0	21.13	0-2	2

9.3.3

LTE Band 2 (PCS)

Table 9-9
LTE Band 2 (PCS) Conducted Powers - 20 MHz Bandwidth

	Frequency [MHz]	Channel	Bandwidth [MHz]	Modulation	RB Size	RB Offset	Conducted Power [dBm]	MPR Allowed per 3GPP [dB]	MPR [dB]
Low	1860	18700	20	QPSK	1	0	22.30	0	0
	1860	18700	20	QPSK	1	50	22.26	0	0
	1860	18700	20	QPSK	1	99	22.31	0	0
	1860	18700	20	QPSK	50	0	21.27	-0.1	1
	1860	18700	20	QPSK	50	25	21.12	-0.1	1
	1860	18700	20	QPSK	50	50	21.19	-0.1	1
	1860	18700	20	QPSK	100	0	21.25	-0.1	1
	1860	18700	20	16QAM	1	0	21.37	-0.1	1
	1860	18700	20	16QAM	1	50	21.50	-0.1	1
	1860	18700	20	16QAM	1	99	21.34	-0.1	1
	1860	18700	20	16QAM	50	0	20.34	-0.2	2
	1860	18700	20	16QAM	50	25	20.24	-0.2	2
	1860	18700	20	16QAM	50	50	20.36	-0.2	2
	1860	18700	20	16QAM	100	0	20.26	-0.2	2
	1880.0	18900	20	QPSK	1	0	22.54	0	0
	1880.0	18900	20	QPSK	1	50	22.57	0	0
	1880.0	18900	20	QPSK	1	99	22.51	0	0
	1880.0	18900	20	QPSK	50	0	21.38	-0.1	1
1880.0	18900	20	QPSK	50	25	21.43	-0.1	1	
1880.0	18900	20	QPSK	50	50	21.33	-0.1	1	
1880.0	18900	20	QPSK	100	0	21.37	-0.1	1	
1880.0	18900	20	16QAM	1	0	21.30	-0.1	1	
1880.0	18900	20	16QAM	1	50	21.41	-0.1	1	
1880.0	18900	20	16QAM	1	99	21.51	-0.1	1	
1880.0	18900	20	16QAM	50	0	20.45	-0.2	2	
1880.0	18900	20	16QAM	50	25	20.46	-0.2	2	
1880.0	18900	20	16QAM	50	50	20.38	-0.2	2	
1880.0	18900	20	16QAM	100	0	20.39	-0.2	2	
High	1900	19100	20	QPSK	1	0	22.42	0	0
	1900	19100	20	QPSK	1	50	22.58	0	0
	1900	19100	20	QPSK	1	99	22.37	0	0
	1900	19100	20	QPSK	50	0	21.38	-0.1	1
	1900	19100	20	QPSK	50	25	21.29	-0.1	1
	1900	19100	20	QPSK	50	50	21.34	-0.1	1
	1900	19100	20	QPSK	100	0	21.28	-0.1	1
	1900	19100	20	16QAM	1	0	21.70	-0.1	1
	1900	19100	20	16QAM	1	50	21.67	-0.1	1
	1900	19100	20	16QAM	1	99	21.48	-0.1	1
	1900	19100	20	16QAM	50	0	20.47	-0.2	2
	1900	19100	20	16QAM	50	25	20.38	-0.2	2
	1900	19100	20	16QAM	50	50	20.46	-0.2	2
	1900	19100	20	16QAM	100	0	20.30	-0.2	2

Table 9-10
LTE Band 2 (PCS) Conducted Powers - 15 MHz Bandwidth

	Frequency [MHz]	Channel	Bandwidth [MHz]	Modulation	RB Size	RB Offset	Conducted Power [dBm]	MPR Allowed per 3GPP [dB]	MPR [dB]
Low	1857.5	18675	15	QPSK	1	0	22.25	0	0
	1857.5	18675	15	QPSK	1	36	22.06	0	0
	1857.5	18675	15	QPSK	1	74	22.13	0	0
	1857.5	18675	15	QPSK	36	0	21.11	-0.1	1
	1857.5	18675	15	QPSK	36	18	21.03	-0.1	1
	1857.5	18675	15	QPSK	36	37	21.07	-0.1	1
	1857.5	18675	15	QPSK	75	0	20.99	-0.1	1
	1857.5	18675	15	16QAM	1	0	20.87	-0.1	1
	1857.5	18675	15	16QAM	1	36	21.00	-0.1	1
	1857.5	18675	15	16QAM	1	74	21.46	-0.1	1
	1857.5	18675	15	16QAM	36	0	20.25	-0.2	2
	1857.5	18675	15	16QAM	36	18	20.13	-0.2	2
	1857.5	18675	15	16QAM	36	37	19.99	-0.2	2
	1857.5	18675	15	16QAM	75	0	20.04	-0.2	2
	1880.0	18900	15	QPSK	1	0	22.26	0	0
	1880.0	18900	15	QPSK	1	36	22.37	0	0
	1880.0	18900	15	QPSK	1	74	22.35	0	0
	1880.0	18900	15	QPSK	36	0	21.32	-0.1	1
1880.0	18900	15	QPSK	36	18	21.34	-0.1	1	
1880.0	18900	15	QPSK	36	37	21.36	-0.1	1	
1880.0	18900	15	QPSK	75	0	21.24	-0.1	1	
1880.0	18900	15	16QAM	1	0	21.65	-0.1	1	
1880.0	18900	15	16QAM	1	36	21.35	-0.1	1	
1880.0	18900	15	16QAM	1	74	21.35	-0.1	1	
1880.0	18900	15	16QAM	36	0	20.30	-0.2	2	
1880.0	18900	15	16QAM	36	18	20.28	-0.2	2	
1880.0	18900	15	16QAM	36	37	20.35	-0.2	2	
1880.0	18900	15	16QAM	75	0	20.29	-0.2	2	
High	1902.5	19125	15	QPSK	1	0	22.30	0	0
	1902.5	19125	15	QPSK	1	36	22.40	0	0
	1902.5	19125	15	QPSK	1	74	22.38	0	0
	1902.5	19125	15	QPSK	36	0	21.23	-0.1	1
	1902.5	19125	15	QPSK	36	18	21.29	-0.1	1
	1902.5	19125	15	QPSK	36	37	21.22	-0.1	1
	1902.5	19125	15	QPSK	75	0	21.20	-0.1	1
	1902.5	19125	15	16QAM	1	0	21.53	-0.1	1
	1902.5	19125	15	16QAM	1	36	20.93	-0.1	1
	1902.5	19125	15	16QAM	1	74	20.99	-0.1	1
	1902.5	19125	15	16QAM	36	0	20.21	-0.2	2
	1902.5	19125	15	16QAM	36	18	20.22	-0.2	2
	1902.5	19125	15	16QAM	36	37	20.25	-0.2	2
	1902.5	19125	15	16QAM	75	0	20.21	-0.2	2

Table 9-11
LTE Band 2 (PCS) Conducted Powers - 10 MHz Bandwidth

	Frequency [MHz]	Channel	Bandwidth [MHz]	Modulation	RB Size	RB Offset	Conducted Power [dBm]	MPR Allowed per 3GPP [dB]	MPR [dB]	
Low	1855	18650	10	QPSK	1	0	22.35	0	0	
	1855	18650	10	QPSK	1	25	22.08	0	0	
	1855	18650	10	QPSK	1	49	22.37	0	0	
	1855	18650	10	QPSK	25	0	21.16	-0.1	1	
	1855	18650	10	QPSK	25	12	21.11	-0.1	1	
	1855	18650	10	QPSK	25	25	21.06	-0.1	1	
	1855	18650	10	QPSK	50	0	21.19	-0.1	1	
	1855	18650	10	16QAM	1	0	21.36	-0.1	1	
	1855	18650	10	16QAM	1	25	21.32	-0.1	1	
	1855	18650	10	16QAM	1	49	21.54	-0.1	1	
	1855	18650	10	16QAM	25	0	20.26	-0.2	2	
	1855	18650	10	16QAM	25	12	20.03	-0.2	2	
	1855	18650	10	16QAM	25	25	20.26	-0.2	2	
	1855	18650	10	16QAM	50	0	20.17	-0.2	2	
	Mid	1880.0	18900	10	QPSK	1	0	22.31	0	0
		1880.0	18900	10	QPSK	1	25	22.65	0	0
		1880.0	18900	10	QPSK	1	49	22.44	0	0
		1880.0	18900	10	QPSK	25	0	21.37	-0.1	1
1880.0		18900	10	QPSK	25	12	21.27	-0.1	1	
1880.0		18900	10	QPSK	25	25	21.33	-0.1	1	
1880.0		18900	10	QPSK	50	0	21.37	-0.1	1	
1880.0		18900	10	16QAM	1	0	21.48	-0.1	1	
1880.0		18900	10	16QAM	1	25	21.65	-0.1	1	
1880.0		18900	10	16QAM	1	49	21.47	-0.1	1	
1880.0		18900	10	16QAM	25	0	20.42	-0.2	2	
1880.0		18900	10	16QAM	25	12	20.43	-0.2	2	
1880.0		18900	10	16QAM	25	25	20.28	-0.2	2	
1880.0		18900	10	16QAM	50	0	20.51	-0.2	2	
High		1905	19150	10	QPSK	1	0	22.48	0	0
		1905	19150	10	QPSK	1	25	22.39	0	0
		1905	19150	10	QPSK	1	49	22.35	0	0
		1905	19150	10	QPSK	25	0	21.28	-0.1	1
	1905	19150	10	QPSK	25	12	21.22	-0.1	1	
	1905	19150	10	QPSK	25	25	21.24	-0.1	1	
	1905	19150	10	QPSK	50	0	21.25	-0.1	1	
	1905	19150	10	16QAM	1	0	21.24	-0.1	1	
	1905	19150	10	16QAM	1	25	21.48	-0.1	1	
	1905	19150	10	16QAM	1	49	21.57	-0.1	1	
	1905	19150	10	16QAM	25	0	20.39	-0.2	2	
	1905	19150	10	16QAM	25	12	20.25	-0.2	2	
	1905	19150	10	16QAM	25	25	20.08	-0.2	2	
	1905	19150	10	16QAM	50	0	20.10	-0.2	2	

Table 9-12
LTE Band 2 (PCS) Conducted Powers - 5 MHz Bandwidth

	Frequency [MHz]	Channel	Bandwidth [MHz]	Modulation	RB Size	RB Offset	Conducted Power [dBm]	MPR Allowed per 3GPP [dB]	MPR [dB]	
Low	1852.5	18625	5	QPSK	1	0	22.28	0	0	
	1852.5	18625	5	QPSK	1	12	22.18	0	0	
	1852.5	18625	5	QPSK	1	24	22.35	0	0	
	1852.5	18625	5	QPSK	12	0	21.10	-0.1	1	
	1852.5	18625	5	QPSK	12	6	21.11	-0.1	1	
	1852.5	18625	5	QPSK	12	13	21.14	-0.1	1	
	1852.5	18625	5	QPSK	25	0	21.12	-0.1	1	
	1852.5	18625	5	16-QAM	1	0	21.52	-0.1	1	
	1852.5	18625	5	16-QAM	1	12	21.27	-0.1	1	
	1852.5	18625	5	16-QAM	1	24	21.14	-0.1	1	
	1852.5	18625	5	16-QAM	12	0	20.00	-0.2	2	
	1852.5	18625	5	16-QAM	12	6	20.04	-0.2	2	
	1852.5	18625	5	16-QAM	12	13	20.27	-0.2	2	
	1852.5	18625	5	16-QAM	25	0	20.24	-0.2	2	
	Mid	1880.0	18900	5	QPSK	1	0	22.28	0	0
		1880.0	18900	5	QPSK	1	12	22.52	0	0
		1880.0	18900	5	QPSK	1	24	22.25	0	0
		1880.0	18900	5	QPSK	12	0	21.37	-0.1	1
1880.0		18900	5	QPSK	12	6	21.32	-0.1	1	
1880.0		18900	5	QPSK	12	13	21.49	-0.1	1	
1880.0		18900	5	QPSK	25	0	21.41	-0.1	1	
1880.0		18900	5	16-QAM	1	0	21.14	-0.1	1	
1880.0		18900	5	16-QAM	1	12	21.12	-0.1	1	
1880.0		18900	5	16-QAM	1	24	21.60	-0.1	1	
1880.0		18900	5	16-QAM	12	0	20.21	-0.2	2	
1880.0		18900	5	16-QAM	12	6	20.41	-0.2	2	
1880.0		18900	5	16-QAM	12	13	20.29	-0.2	2	
1880.0		18900	5	16-QAM	25	0	20.41	-0.2	2	
High		1907.5	19175	5	QPSK	1	0	22.54	0	0
		1907.5	19175	5	QPSK	1	12	22.44	0	0
		1907.5	19175	5	QPSK	1	24	22.28	0	0
		1907.5	19175	5	QPSK	12	0	21.23	-0.1	1
	1907.5	19175	5	QPSK	12	6	21.07	-0.1	1	
	1907.5	19175	5	QPSK	12	13	21.02	-0.1	1	
	1907.5	19175	5	QPSK	25	0	21.11	-0.1	1	
	1907.5	19175	5	16-QAM	1	0	21.42	-0.1	1	
	1907.5	19175	5	16-QAM	1	12	21.40	-0.1	1	
	1907.5	19175	5	16-QAM	1	24	21.34	-0.1	1	
	1907.5	19175	5	16-QAM	12	0	20.09	-0.2	2	
	1907.5	19175	5	16-QAM	12	6	20.05	-0.2	2	
	1907.5	19175	5	16-QAM	12	13	20.04	-0.2	2	
	1907.5	19175	5	16-QAM	25	0	20.04	-0.2	2	

Table 9-13



LTE Band 2 (PCS) Conducted Powers - 3 MHz Bandwidth

	Frequency [MHz]	Channel	Bandwidth [MHz]	Modulation	RB Size	RB Offset	Conducted Power [dBm]	MPR Allowed per 3GPP [dB]	MPR [dB]	
Low	1851.5	18615	3	QPSK	1	0	22.27	0	0	
	1851.5	18615	3	QPSK	1	7	22.30	0	0	
	1851.5	18615	3	QPSK	1	14	22.54	0	0	
	1851.5	18615	3	QPSK	8	0	21.04	0-1	1	
	1851.5	18615	3	QPSK	8	4	21.06	0-1	1	
	1851.5	18615	3	QPSK	8	7	21.04	0-1	1	
	1851.5	18615	3	QPSK	15	0	21.09	0-1	1	
	1851.5	18615	3	16-QAM	1	0	20.81	0-1	1	
	1851.5	18615	3	16-QAM	1	7	21.17	0-1	1	
	1851.5	18615	3	16-QAM	1	14	21.12	0-1	1	
	1851.5	18615	3	16-QAM	8	0	20.21	0-2	2	
	1851.5	18615	3	16-QAM	8	4	19.90	0-2	2	
	1851.5	18615	3	16-QAM	8	7	20.21	0-2	2	
	1851.5	18615	3	16-QAM	15	0	20.11	0-2	2	
	Mid	1890.0	18900	3	QPSK	1	0	22.23	0	0
		1890.0	18900	3	QPSK	1	7	22.31	0	0
		1890.0	18900	3	QPSK	1	14	22.28	0	0
		1890.0	18900	3	QPSK	8	0	21.26	0-1	1
1890.0		18900	3	QPSK	8	4	21.35	0-1	1	
1890.0		18900	3	QPSK	8	7	21.38	0-1	1	
1890.0		18900	3	QPSK	15	0	21.37	0-1	1	
1890.0		18900	3	16-QAM	1	0	21.40	0-1	1	
1890.0		18900	3	16-QAM	1	7	21.44	0-1	1	
1890.0		18900	3	16-QAM	1	14	21.42	0-1	1	
1890.0		18900	3	16-QAM	8	0	20.68	0-2	2	
1890.0		18900	3	16-QAM	8	4	20.30	0-2	2	
1890.0		18900	3	16-QAM	8	7	20.31	0-2	2	
1890.0		18900	3	16-QAM	15	0	20.53	0-2	2	
High		1908.5	19185	3	QPSK	1	0	22.14	0	0
		1908.5	19185	3	QPSK	1	7	22.42	0	0
		1908.5	19185	3	QPSK	1	14	22.19	0	0
		1908.5	19185	3	QPSK	8	0	21.20	0-1	1
	1908.5	19185	3	QPSK	8	4	21.04	0-1	1	
	1908.5	19185	3	QPSK	8	7	21.16	0-1	1	
	1908.5	19185	3	QPSK	15	0	21.05	0-1	1	
	1908.5	19185	3	16-QAM	1	0	21.52	0-1	1	
	1908.5	19185	3	16-QAM	1	7	21.61	0-1	1	
	1908.5	19185	3	16-QAM	1	14	21.46	0-1	1	
	1908.5	19185	3	16-QAM	8	0	20.12	0-2	2	
	1908.5	19185	3	16-QAM	8	4	19.80	0-2	2	
	1908.5	19185	3	16-QAM	8	7	20.09	0-2	2	
	1908.5	19185	3	16-QAM	15	0	19.99	0-2	2	

Table 9-14

LTE Band 2 (PCS) Conducted Powers -1.4 MHz Bandwidth

	Frequency [MHz]	Channel	Bandwidth [MHz]	Modulation	RB Size	RB Offset	Conducted Power [dBm]	MPR Allowed per 3GPP [dB]	MPR [dB]	
Low	1850.7	18607	1.4	QPSK	1	0	22.49	0	0	
	1850.7	18607	1.4	QPSK	1	2	22.56	0	0	
	1850.7	18607	1.4	QPSK	1	5	22.51	0	0	
	1850.7	18607	1.4	QPSK	3	0	22.36	0	0	
	1850.7	18607	1.4	QPSK	3	2	22.30	0	0	
	1850.7	18607	1.4	QPSK	3	3	22.21	0	0	
	1850.7	18607	1.4	QPSK	6	0	20.94	0-1	1	
	1850.7	18607	1.4	16-QAM	1	0	21.14	0-1	1	
	1850.7	18607	1.4	16-QAM	1	2	21.48	0-1	1	
	1850.7	18607	1.4	16-QAM	1	5	21.05	0-1	1	
	1850.7	18607	1.4	16-QAM	3	0	21.07	0-1	1	
	1850.7	18607	1.4	16-QAM	3	2	21.24	0-1	1	
	1850.7	18607	1.4	16-QAM	3	3	20.88	0-1	1	
	1850.7	18607	1.4	16-QAM	6	0	20.27	0-2	2	
	Mid	1890.0	18900	1.4	QPSK	1	0	22.35	0	0
		1890.0	18900	1.4	QPSK	1	2	22.24	0	0
		1890.0	18900	1.4	QPSK	1	5	22.21	0	0
		1890.0	18900	1.4	QPSK	3	0	22.27	0	0
1890.0		18900	1.4	QPSK	3	2	22.31	0	0	
1890.0		18900	1.4	QPSK	3	3	22.35	0	0	
1890.0		18900	1.4	QPSK	6	0	21.37	0-1	1	
1890.0		18900	1.4	16-QAM	1	0	21.09	0-1	1	
1890.0		18900	1.4	16-QAM	1	2	21.25	0-1	1	
1890.0		18900	1.4	16-QAM	1	5	21.04	0-1	1	
1890.0		18900	1.4	16-QAM	3	0	21.60	0-1	1	
1890.0		18900	1.4	16-QAM	3	2	21.37	0-1	1	
1890.0		18900	1.4	16-QAM	3	3	21.31	0-1	1	
1890.0		18900	1.4	16-QAM	6	0	20.54	0-2	2	
High		1909.3	19193	1.4	QPSK	1	0	22.29	0	0
		1909.3	19193	1.4	QPSK	1	2	22.43	0	0
		1909.3	19193	1.4	QPSK	1	5	22.32	0	0
		1909.3	19193	1.4	QPSK	3	0	22.31	0	0
	1909.3	19193	1.4	QPSK	3	2	22.22	0	0	
	1909.3	19193	1.4	QPSK	3	3	22.23	0	0	
	1909.3	19193	1.4	QPSK	6	0	21.06	0-1	1	
	1909.3	19193	1.4	16-QAM	1	0	20.76	0-1	1	
	1909.3	19193	1.4	16-QAM	1	2	21.60	0-1	1	
	1909.3	19193	1.4	16-QAM	1	5	21.35	0-1	1	
	1909.3	19193	1.4	16-QAM	3	0	21.47	0-1	1	
	1909.3	19193	1.4	16-QAM	3	2	20.81	0-1	1	
	1909.3	19193	1.4	16-QAM	3	3	21.22	0-1	1	
	1909.3	19193	1.4	16-QAM	6	0	20.11	0-2	2	

FCC ID: A3LSMG720AX		SAR EVALUATION REPORT		Reviewed by: Quality Manager
Document S/N: OY1412012187.A3L	Test Dates: 12/01/14 - 12/08/14	DUT Type: Portable Handset	Page 28 of 48	

9.4 WLAN Conducted Powers

Table 9-15
IEEE 802.11b Average RF Power

Mode	Freq [MHz]	Channel	802.11b (2.4 GHz) Conducted Power [dBm]			
			Data Rate [Mbps]			
	1	2	5.5	11		
802.11b	2412	1*	16.12	16.11	16.26	16.27
802.11b	2437	6*	16.28	16.29	16.34	16.32
802.11b	2462	11*	17.32	17.38	17.39	17.38

Table 9-16
IEEE 802.11g Average RF Power

Mode	Freq [MHz]	Channel	802.11g (2.4 GHz) Conducted Power [dBm]							
			Data Rate [Mbps]							
	6	9	12	18	24	36	48	54		
802.11g	2412	1	12.68	12.56	12.54	12.55	12.51	12.51	12.54	12.52
802.11g	2437	6	13.01	13.15	13.35	13.34	13.29	13.27	13.26	13.34
802.11g	2462	11	13.85	13.89	13.89	13.90	13.86	13.88	13.80	13.91

Table 9-17
IEEE 802.11n Average RF Power

Mode	Freq [MHz]	Channel	802.11n (2.4 GHz) Conducted Power [dBm]							
			Data Rate [Mbps]							
	6.5	13	20	26	39	52	58	65		
802.11n	2412	1	12.95	12.45	12.75	12.72	12.67	12.66	12.77	12.45
802.11n	2437	6	12.27	12.56	12.52	12.44	12.53	12.43	12.46	12.43
802.11n	2462	11	12.93	12.98	12.89	12.87	12.83	12.83	12.86	12.82

Justification for reduced test configurations for WIFI channels per KDB Publication 248227 D01v01r02 and October 2012/April 2013 FCC/TCB Meeting Notes:

- For 2.4 GHz operations, highest average RF output power channel for the lowest data rate for IEEE 802.11b were selected for SAR evaluation. Other IEEE 802.11 modes (including 802.11g/n) were not investigated since the average output powers over all channels and data rates were not more than 0.25 dB higher than the tested channel in the lowest data rate of IEEE 802.11b mode.
- When the maximum extrapolated peak SAR of the zoom scan for the maximum output channel is <1.6 W/kg and the reported 1g averaged SAR is <0.8 W/kg, SAR testing on other channels is not required. Otherwise, the other default (or corresponding required) test channels were additionally tested using the lowest data rate.
- The bolded data rate and channel above were tested for SAR.

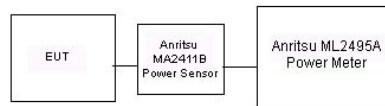



Figure 9-3

FCC ID: A3LSMG720AX		SAR EVALUATION REPORT		Reviewed by: Quality Manager
Document S/N: OY1412012187.A3L	Test Dates: 12/01/14 - 12/08/14	DUT Type: Portable Handset	Page 29 of 48	



10 SYSTEM VERIFICATION

10.1 Tissue Verification

**Table 10-1
Measured Tissue Properties**

Calibrated for Tests Performed on:	Tissue Type	Tissue Temp During Calibration (C°)	Measured Frequency (MHz)	Measured Conductivity, σ (S/m)	Measured Dielectric Constant, ϵ	TARGET Conductivity, σ (S/m)	TARGET Dielectric Constant, ϵ	% dev σ	% dev ϵ
12/8/2014	750H	21.0	710	0.899	42.740	0.890	42.149	1.01%	1.40%
			725	0.912	42.574	0.891	42.071	2.36%	1.20%
			740	0.924	42.382	0.893	41.994	3.47%	0.92%
			755	0.937	42.184	0.894	41.916	4.81%	0.64%
12/3/2014	835H	22.5	820	0.924	40.398	0.899	41.578	2.78%	-2.84%
			835	0.937	40.218	0.900	41.500	4.11%	-3.09%
			850	0.951	40.013	0.916	41.500	3.82%	-3.58%
12/1/2014	1750H	22.0	1710	1.342	39.128	1.348	40.142	-0.45%	-2.53%
			1750	1.382	38.946	1.371	40.079	0.80%	-2.83%
			1790	1.418	38.758	1.394	40.016	1.72%	-3.14%
12/4/2014	1900H	22.3	1850	1.376	39.884	1.400	40.000	-1.71%	-0.29%
			1880	1.409	39.754	1.400	40.000	0.64%	-0.62%
			1910	1.440	39.690	1.400	40.000	2.86%	-0.78%
12/8/2014	2450H	22.8	2401	1.821	39.077	1.756	39.287	3.70%	-0.53%
			2450	1.876	38.853	1.800	39.200	4.22%	-0.89%
			2499	1.933	38.648	1.853	39.138	4.32%	-1.25%
			710	0.955	55.749	0.960	55.687	-0.52%	0.11%
12/4/2014	750B	22.8	725	0.968	55.595	0.961	55.629	0.73%	-0.06%
			740	0.981	55.482	0.963	55.570	1.87%	-0.16%
			755	0.995	55.305	0.964	55.512	3.22%	-0.37%
			820	0.973	54.526	0.969	55.258	0.41%	-1.32%
12/1/2014	835B	21.4	835	0.985	54.302	0.970	55.200	1.55%	-1.63%
			850	0.998	54.135	0.988	55.154	1.01%	-1.85%
			820	0.988	53.377	0.969	55.258	1.96%	-3.40%
12/3/2014	835B	22.1	835	1.000	53.180	0.970	55.200	3.09%	-3.66%
			850	1.013	52.998	0.988	55.154	2.53%	-3.91%
			1710	1.462	51.787	1.463	53.537	-0.07%	-3.27%
12/1/2014	1750B	21.4	1750	1.508	51.603	1.488	53.432	1.34%	-3.42%
			1790	1.551	51.499	1.514	53.326	2.44%	-3.43%
			1850	1.519	52.095	1.520	53.300	-0.07%	-2.26%
12/1/2014	1900B	21.4	1880	1.558	52.024	1.520	53.300	2.50%	-2.39%
			1910	1.595	51.906	1.520	53.300	4.93%	-2.62%
			2401	1.981	53.583	1.903	52.765	4.10%	1.55%
12/1/2014	2450B	23.1	2450	2.045	53.371	1.950	52.700	4.87%	1.27%
			2499	2.111	53.199	2.019	52.638	4.56%	1.07%

The above measured tissue parameters were used in the DASY software. The DASY software was used to perform interpolation to determine the dielectric parameters at the SAR test device frequencies (per KDB Publication 865664 and IEEE 1528-2013 6.6.1.2). The tissue parameters listed in the SAR test plots may slightly differ from the table above due to significant digit rounding in the software.

FCC ID: A3LSMG720AX	 PCTEST ENGINEERING LABORATORY, INC.	SAR EVALUATION REPORT		Reviewed by: Quality Manager
Document S/N: OY1412012187.A3L	Test Dates: 12/01/14 - 12/08/14	DUT Type: Portable Handset		Page 30 of 48

10.2 Test System Verification

Prior to SAR assessment, the system is verified to $\pm 10\%$ of the SAR measurement on the reference dipole at the time of calibration by the calibration facility. Full system validation status and result summary can be found in Appendix E.

Table 10-2
System Verification Results

System Verification TARGET & MEASURED												
SAR System #	Tissue Frequency (MHz)	Tissue Type	Date:	Amb. Temp (°C)	Liquid Temp (°C)	Input Power (W)	Dipole SN	Probe SN	Measured SAR _{1g} (W/kg)	1 W Target SAR _{1g} (W/kg)	1 W Normalized SAR _{1g} (W/kg)	Deviation _{1g} (%)
K	750	HEAD	12/08/2014	23.0	21.3	0.100	1003	3288	0.814	8.370	8.140	-2.75%
E	835	HEAD	12/03/2014	23.6	22.5	0.100	4d119	3332	0.884	9.220	8.840	-4.12%
J	1750	HEAD	12/01/2014	24.0	22.0	0.100	1008	3022	3.480	36.900	34.800	-5.69%
D	1900	HEAD	12/04/2014	23.9	22.7	0.100	5d149	3263	4.260	40.200	42.600	5.97%
G	2450	HEAD	12/08/2014	23.7	22.8	0.100	797	3258	5.130	51.800	51.300	-0.97%
G	750	BODY	12/04/2014	23.3	22.8	0.100	1003	3258	0.879	8.770	8.790	0.23%
I	835	BODY	12/01/2014	23.4	21.4	0.100	4d119	3209	0.951	9.340	9.510	1.82%
K	835	BODY	12/03/2014	23.1	22.1	0.100	4d119	3288	0.981	9.340	9.810	5.03%
J	1750	BODY	12/01/2014	22.9	22.2	0.100	1008	3022	3.640	37.600	36.400	-3.19%
G	1900	BODY	12/01/2014	24.5	22.8	0.100	5d141	3258	4.230	40.600	42.300	4.19%
H	2450	BODY	12/01/2014	23.1	23.1	0.100	797	3319	5.210	49.400	52.100	5.47%

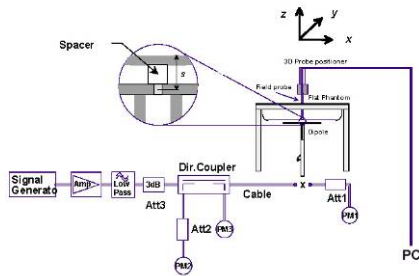



Figure 10-1
System Verification Setup Diagram



Figure 10-2
System Verification Setup Photo

FCC ID: A3LSMG720AX	 PCTEST ENGINEERING LABORATORY, INC.	SAR EVALUATION REPORT	 SAMSUNG	Reviewed by: Quality Manager
Document S/N: OY1412012187.A3L	Test Dates: 12/01/14 - 12/08/14	DUT Type: Portable Handset	Page 31 of 48	

11 SAR DATA SUMMARY

11.1 Standalone Head SAR Data

**Table 11-1
GSM 850 Head SAR**



MEASUREMENT RESULTS														
FREQUENCY		Mode/Band	Service	Maximum Allowed Power [dBm]	Conducted Power [dBm]	Power Drift [dB]	Side	Test Position	Device Serial Number	Duty Cycle	SAR (1g)	Scaling Factor	Scaled SAR (1g)	Plot #
MHz	Ch.										(W/kg)		(W/kg)	
836.60	190	GSM850	GSM	32.8	32.49	0.12	Right	Cheek	96	1:8.3	0.171	1.074	0.184	
836.60	190	GSM850	GSM	32.8	32.49	-0.01	Right	Tilt	96	1:8.3	0.117	1.074	0.126	
836.60	190	GSM850	GSM	32.8	32.49	0.07	Left	Cheek	96	1:8.3	0.229	1.074	0.246	A1
836.60	190	GSM850	GSM	32.8	32.49	0.06	Left	Tilt	96	1:8.3	0.131	1.074	0.141	
ANSI / IEEE C95.1 1992 - SAFETY LIMIT Spatial Peak Uncontrolled Exposure/General Population							Head 1.6 W/kg (mW/g) averaged over 1 gram							

**Table 11-2
UMTS 850 Head SAR**

MEASUREMENT RESULTS														
FREQUENCY		Mode/Band	Service	Maximum Allowed Power [dBm]	Conducted Power [dBm]	Power Drift [dB]	Side	Test Position	Device Serial Number	Duty Cycle	SAR (1g)	Scaling Factor	Scaled SAR (1g)	Plot #
MHz	Ch.										(W/kg)		(W/kg)	
836.60	4183	UMTS 850	RMC	23.1	22.31	0.10	Right	Cheek	96	1:1	0.128	1.199	0.153	
836.60	4183	UMTS 850	RMC	23.1	22.31	0.09	Right	Tilt	96	1:1	0.084	1.199	0.101	
836.60	4183	UMTS 850	RMC	23.1	22.31	0.06	Left	Cheek	96	1:1	0.187	1.199	0.224	A2
836.60	4183	UMTS 850	RMC	23.1	22.31	0.20	Left	Tilt	96	1:1	0.099	1.199	0.119	
ANSI / IEEE C95.1 1992 - SAFETY LIMIT Spatial Peak Uncontrolled Exposure/General Population							Head 1.6 W/kg (mW/g) averaged over 1 gram							

**Table 11-3
GSM 1900 Head SAR**

MEASUREMENT RESULTS														
FREQUENCY		Mode/Band	Service	Maximum Allowed Power [dBm]	Conducted Power [dBm]	Power Drift [dB]	Side	Test Position	Device Serial Number	Duty Cycle	SAR (1g)	Scaling Factor	Scaled SAR (1g)	Plot #
MHz	Ch.										(W/kg)		(W/kg)	
1880.00	661	GSM1900	GSM	30.3	30.01	0.05	Right	Cheek	100	1:8.3	0.109	1.069	0.117	
1880.00	661	GSM1900	GSM	30.3	30.01	0.17	Right	Tilt	100	1:8.3	0.063	1.069	0.067	
1880.00	661	GSM1900	GSM	30.3	30.01	0.12	Left	Cheek	100	1:8.3	0.122	1.069	0.130	A3
1880.00	661	GSM1900	GSM	30.3	30.01	0.14	Left	Tilt	100	1:8.3	0.060	1.069	0.064	
ANSI / IEEE C95.1 1992 - SAFETY LIMIT Spatial Peak Uncontrolled Exposure/General Population							Head 1.6 W/kg (mW/g) averaged over 1 gram							

FCC ID: A3LSMG720AX		SAR EVALUATION REPORT		Reviewed by: Quality Manager
Document S/N: OY1412012187.A3L	Test Dates: 12/01/14 - 12/08/14	DUT Type: Portable Handset		Page 32 of 48

**Table 11-4
UMTS 1900 Head SAR**



MEASUREMENT RESULTS														
FREQUENCY		Mode/Band	Service	Maximum Allowed Power [dBm]	Conducted Power [dBm]	Power Drift [dB]	Side	Test Position	Device Serial Number	Duty Cycle	SAR (1g)	Scaling Factor	Scaled SAR (1g)	Plot #
MHz	Ch.										(W/kg)		(W/kg)	
1880.00	9400	UMTS 1900	RMC	22.8	22.27	0.03	Right	Cheek	100	1:1	0.145	1.130	0.164	
1880.00	9400	UMTS 1900	RMC	22.8	22.27	0.07	Right	Tilt	100	1:1	0.094	1.130	0.106	
1880.00	9400	UMTS 1900	RMC	22.8	22.27	-0.04	Left	Cheek	100	1:1	0.191	1.130	0.216	A4
1880.00	9400	UMTS 1900	RMC	22.8	22.27	0.05	Left	Tilt	100	1:1	0.091	1.130	0.103	
ANSI / IEEE C95.1 1992 - SAFETY LIMIT Spatial Peak Uncontrolled Exposure/General Population								Head 1.6 W/kg (mW/g) averaged over 1 gram						

**Table 11-5
LTE Band 17 Head SAR**

MEASUREMENT RESULTS																			
FREQUENCY		Mode	Bandwidth [MHz]	Maximum Allowed Power [dBm]	Conducted Power [dBm]	Power Drift [dB]	MPR [dB]	Side	Test Position	Modulation	RB Size	RB Offset	Device Serial Number	Duty Cycle	SAR (1g)	Scaling Factor	Scaled SAR (1g)	Plot #	
MHz	Ch.														(W/kg)		(W/kg)		
710.00	23790	Mid	LTE Band 17	10	23.7	23.40	0.16	0	Right	Cheek	QPSK	1	0	100	1:1	0.033	1.072	0.035	
710.00	23790	Mid	LTE Band 17	10	22.7	22.23	0.18	1	Right	Cheek	QPSK	25	0	100	1:1	0.025	1.114	0.028	
710.00	23790	Mid	LTE Band 17	10	23.7	23.40	0.07	0	Right	Tilt	QPSK	1	0	100	1:1	0.020	1.072	0.021	
710.00	23790	Mid	LTE Band 17	10	22.7	22.23	0.04	1	Right	Tilt	QPSK	25	0	100	1:1	0.015	1.114	0.017	
710.00	23790	Mid	LTE Band 17	10	23.7	23.40	0.11	0	Left	Cheek	QPSK	1	0	100	1:1	0.045	1.072	0.048	A5
710.00	23790	Mid	LTE Band 17	10	22.7	22.23	0.04	1	Left	Cheek	QPSK	25	0	100	1:1	0.037	1.114	0.041	
710.00	23790	Mid	LTE Band 17	10	23.7	23.40	-0.07	0	Left	Tilt	QPSK	1	0	100	1:1	0.023	1.072	0.025	
710.00	23790	Mid	LTE Band 17	10	22.7	22.23	0.04	1	Left	Tilt	QPSK	25	0	100	1:1	0.020	1.114	0.022	
ANSI / IEEE C95.1 1992 - SAFETY LIMIT Spatial Peak Uncontrolled Exposure/General Population								Head 1.6 W/kg (mW/g) averaged over 1 gram											

**Table 11-6
LTE Band 4 (AWS) Head SAR**

MEASUREMENT RESULTS																			
FREQUENCY		Mode	Bandwidth [MHz]	Maximum Allowed Power [dBm]	Conducted Power [dBm]	Power Drift [dB]	MPR [dB]	Side	Test Position	Modulation	RB Size	RB Offset	Device Serial Number	Duty Cycle	SAR (1g)	Scaling Factor	Scaled SAR (1g)	Plot #	
MHz	Ch.														(W/kg)		(W/kg)		
1732.50	20175	Mid	LTE Band 4 (AWS)	20	23.7	23.47	-0.04	0	Right	Cheek	QPSK	1	0	96	1:1	0.120	1.054	0.126	
1732.50	20175	Mid	LTE Band 4 (AWS)	20	22.7	22.30	-0.09	1	Right	Cheek	QPSK	50	0	96	1:1	0.076	1.096	0.083	
1732.50	20175	Mid	LTE Band 4 (AWS)	20	23.7	23.47	-0.05	0	Right	Tilt	QPSK	1	0	96	1:1	0.055	1.054	0.058	
1732.50	20175	Mid	LTE Band 4 (AWS)	20	22.7	22.30	0.11	1	Right	Tilt	QPSK	50	0	96	1:1	0.043	1.096	0.047	
1732.50	20175	Mid	LTE Band 4 (AWS)	20	23.7	23.47	0.03	0	Left	Cheek	QPSK	1	0	96	1:1	0.158	1.054	0.167	A6
1732.50	20175	Mid	LTE Band 4 (AWS)	20	22.7	22.30	0.03	1	Left	Cheek	QPSK	50	0	96	1:1	0.124	1.096	0.136	
1732.50	20175	Mid	LTE Band 4 (AWS)	20	23.7	23.47	-0.05	0	Left	Tilt	QPSK	1	0	96	1:1	0.053	1.054	0.056	
1732.50	20175	Mid	LTE Band 4 (AWS)	20	22.7	22.30	0.05	1	Left	Tilt	QPSK	50	0	96	1:1	0.040	1.096	0.044	
ANSI / IEEE C95.1 1992 - SAFETY LIMIT Spatial Peak Uncontrolled Exposure/General Population								Head 1.6 W/kg (mW/g) averaged over 1 gram											

FCC ID: A3LSMG720AX		SAR EVALUATION REPORT		Reviewed by: Quality Manager
Document S/N: OY1412012187.A3L	Test Dates: 12/01/14 - 12/08/14	DUT Type: Portable Handset	Page 33 of 48	

**Table 11-7
LTE Band 2 (PCS) Head SAR**

MEASUREMENT RESULTS																			
FREQUENCY		Mode	Bandwidth [MHz]	Maximum Allowed Power [dBm]	Conducted Power [dBm]	Power Drift [dB]	MPR [dB]	Side	Test Position	Modulation	RB Size	RB Offset	Device Serial Number	Duty Cycle	SAR (1g)	Scaling Factor	Scaled SAR (1g) (W/kg)	Plot #	
MHz	Ch.														(W/kg)				
1900.00	19100	High	LTE Band 2 (PCS)	20	22.7	22.58	0.03	0	Right	Cheek	QPSK	1	50	100	1:1	0.159	1.028	0.163	
1880.00	18900	Mid	LTE Band 2 (PCS)	20	21.7	21.43	0.08	1	Right	Cheek	QPSK	50	25	100	1:1	0.115	1.064	0.122	
1900.00	19100	High	LTE Band 2 (PCS)	20	22.7	22.58	0.18	0	Right	Tilt	QPSK	1	50	100	1:1	0.114	1.028	0.117	
1880.00	18900	Mid	LTE Band 2 (PCS)	20	21.7	21.43	0.13	1	Right	Tilt	QPSK	50	25	100	1:1	0.081	1.064	0.086	
1900.00	19100	High	LTE Band 2 (PCS)	20	22.7	22.58	0.04	0	Left	Cheek	QPSK	1	50	100	1:1	0.176	1.028	0.181	A7
1880.00	18900	Mid	LTE Band 2 (PCS)	20	21.7	21.43	0.11	1	Left	Cheek	QPSK	50	25	100	1:1	0.153	1.064	0.163	
1900.00	19100	High	LTE Band 2 (PCS)	20	22.7	22.58	0.09	0	Left	Tilt	QPSK	1	50	100	1:1	0.112	1.028	0.115	
1880.00	18900	Mid	LTE Band 2 (PCS)	20	21.7	21.43	0.03	1	Left	Tilt	QPSK	50	25	100	1:1	0.075	1.064	0.080	
ANSI / IEEE C95.1 1992 - SAFETY LIMIT Spatial Peak Uncontrolled Exposure/General Population										Head 1.6 W/kg (mW/g) averaged over 1 gram									



**Table 11-8
DTS Head SAR**

MEASUREMENT RESULTS															
FREQUENCY		Mode	Service	Maximum Allowed Power [dBm]	Conducted Power [dBm]	Power Drift [dB]	Side	Test Position	Device Serial Number	Data Rate (Mbps)	Duty Cycle	SAR (1g)	Scaling Factor	Scaled SAR (1g) (W/kg)	Plot #
MHz	Ch.											(W/kg)			
2462	11	IEEE 802.11b	DSSS	17.5	17.32	-0.05	Right	Cheek	100	1	1:1	0.156	1.042	0.163	A8
2462	11	IEEE 802.11b	DSSS	17.5	17.32	-0.06	Right	Tilt	100	1	1:1	0.063	1.042	0.066	
2462	11	IEEE 802.11b	DSSS	17.5	17.32	0.19	Left	Cheek	100	1	1:1	0.058	1.042	0.060	
2462	11	IEEE 802.11b	DSSS	17.5	17.32	0.07	Left	Tilt	100	1	1:1	0.042	1.042	0.044	
ANSI / IEEE C95.1 1992 - SAFETY LIMIT Spatial Peak Uncontrolled Exposure/General Population										Head 1.6 W/kg (mW/g) averaged over 1 gram					

11.2 Standalone Body-Worn SAR Data

**Table 11-9
GSM/UMTS Body-Worn SAR Data**

MEASUREMENT RESULTS															
FREQUENCY		Mode	Service	Maximum Allowed Power [dBm]	Conducted Power [dBm]	Power Drift [dB]	Spacing	Device Serial Number	# of Time Slots	Duty Cycle	Side	SAR (1g)	Scaling Factor	Scaled SAR (1g) (W/kg)	Plot #
MHz	Ch.											(W/kg)			
836.60	190	GSM 850	GSM	32.8	32.49	-0.01	10 mm	96	1	1:8.3	back	0.358	1.074	0.384	A9
836.60	4183	UMTS 850	RMC	23.1	22.31	-0.01	10 mm	96	N/A	1:1	back	0.272	1.199	0.326	A11
1880.00	661	GSM 1900	GSM	30.3	30.01	0.00	10 mm	100	1	1:8.3	back	0.390	1.069	0.417	A12
1880.00	9400	UMTS 1900	RMC	22.8	22.27	-0.02	10 mm	100	N/A	1:1	back	0.641	1.130	0.724	A14
ANSI / IEEE C95.1 1992 - SAFETY LIMIT Spatial Peak Uncontrolled Exposure/General Population										Body 1.6 W/kg (mW/g) averaged over 1 gram					



FCC ID: A3LSMG720AX		SAR EVALUATION REPORT		Reviewed by: Quality Manager
Document S/N: OY1412012187.A3L	Test Dates: 12/01/14 - 12/08/14	DUT Type: Portable Handset		Page 34 of 48

**Table 11-10
LTE Body-Worn SAR**

MEASUREMENT RESULTS																			
FREQUENCY		Mode	Bandwidth [MHz]	Maximum Allowed Power [dBm]	Conducted Power [dBm]	Power Drift [dB]	MPR [dB]	Device Serial Number	Modulation	RB Size	RB Offset	Spacing	Side	Duty Cycle	SAR (1g) (W/kg)	Scaling Factor	Scaled SAR (1g) (W/kg)	Plot #	
MHz	Ch.																		
710.00	23790	Md	LTE Band 17	10	23.7	23.40	0.11	0	96	QPSK	1	0	10 mm	back	1:1	0.079	1.072	0.085	A15
710.00	23790	Md	LTE Band 17	10	22.7	22.23	-0.06	1	96	QPSK	25	0	10 mm	back	1:1	0.065	1.114	0.072	
1732.50	20175	Md	LTE Band 4 (AWS)	20	23.7	23.47	-0.03	0	96	QPSK	1	0	10 mm	back	1:1	0.564	1.054	0.594	A16
1732.50	20175	Md	LTE Band 4 (AWS)	20	22.7	22.30	0.00	1	96	QPSK	50	0	10 mm	back	1:1	0.401	1.096	0.439	
1900.00	19100	High	LTE Band 2 (PCS)	20	22.7	22.58	0.01	0	100	QPSK	1	50	10 mm	back	1:1	0.625	1.028	0.643	A17
1880.00	18900	Md	LTE Band 2 (PCS)	20	21.7	21.43	0.04	1	100	QPSK	50	25	10 mm	back	1:1	0.467	1.064	0.497	
ANSI / IEEE C95.1 1992 - SAFETY LIMIT Spatial Peak Uncontrolled Exposure/General Population									Body 1.6 W/kg (mW/g) averaged over 1 gram										

**Table 11-11
DTS Body-Worn SAR**



MEASUREMENT RESULTS															
FREQUENCY		Mode	Service	Maximum Allowed Power [dBm]	Conducted Power [dBm]	Power Drift [dB]	Spacing	Device Serial Number	Data Rate (Mbps)	Side	Duty Cycle	SAR (1g) (W/kg)	Scaling Factor	Scaled SAR (1g) (W/kg)	Plot #
MHz	Ch.														
2462	11	IEEE 802.11b	DSSS	17.5	17.32	-0.05	10 mm	100	1	back	1:1	0.225	1.042	0.234	A18
ANSI / IEEE C95.1 1992 - SAFETY LIMIT Spatial Peak Uncontrolled Exposure/General Population									Body 1.6 W/kg (mW/g) averaged over 1 gram						

FCC ID: A3LSMG720AX		SAR EVALUATION REPORT		Reviewed by: Quality Manager
Document S/N: OY1412012187.A3L	Test Dates: 12/01/14 - 12/08/14	DUT Type: Portable Handset		Page 35 of 48

11.3 Standalone Wireless Router SAR Data

Table 11-12
GPRS/UMTS Hotspot SAR Data

MEASUREMENT RESULTS															
FREQUENCY		Mode	Service	Maximum Allowed Power [dBm]	Conducted Power [dBm]	Power Drift [dB]	Spacing	Device Serial Number	# of GPRS Slots	Duty Cycle	Side	SAR (1g)	Scaling Factor	Scaled SAR (1g)	Plot #
MHz	Ch.											(W/kg)		(W/kg)	
836.60	190	GSM 850	GPRS	29.2	28.12	0.01	10 mm	96	3	1:2.76	back	0.394	1.282	0.505	A10
836.60	190	GSM 850	GPRS	29.2	28.12	0.01	10 mm	96	3	1:2.76	front	0.299	1.282	0.383	
836.60	190	GSM 850	GPRS	29.2	28.12	0.19	10 mm	96	3	1:2.76	bottom	0.152	1.282	0.195	
836.60	190	GSM 850	GPRS	29.2	28.12	0.03	10 mm	96	3	1:2.76	right	0.225	1.282	0.288	
836.60	190	GSM 850	GPRS	29.2	28.12	-0.02	10 mm	96	3	1:2.76	left	0.387	1.282	0.496	
836.60	4183	UMTS 850	RMC	23.1	22.31	-0.01	10 mm	96	N/A	1:1	back	0.272	1.199	0.326	A11
836.60	4183	UMTS 850	RMC	23.1	22.31	0.01	10 mm	96	N/A	1:1	front	0.231	1.199	0.277	
836.60	4183	UMTS 850	RMC	23.1	22.31	-0.06	10 mm	96	N/A	1:1	bottom	0.118	1.199	0.141	
836.60	4183	UMTS 850	RMC	23.1	22.31	0.06	10 mm	96	N/A	1:1	right	0.131	1.199	0.157	
836.60	4183	UMTS 850	RMC	23.1	22.31	-0.01	10 mm	96	N/A	1:1	left	0.243	1.199	0.291	
1880.00	661	GSM 1900	GPRS	27.7	27.02	-0.10	10 mm	100	2	1:4.15	back	0.417	1.169	0.487	A13
1880.00	661	GSM 1900	GPRS	27.7	27.02	-0.14	10 mm	100	2	1:4.15	front	0.402	1.169	0.470	
1880.00	661	GSM 1900	GPRS	27.7	27.02	-0.10	10 mm	100	2	1:4.15	bottom	0.275	1.169	0.321	
1880.00	661	GSM 1900	GPRS	27.7	27.02	0.05	10 mm	100	2	1:4.15	right	0.050	1.169	0.058	
1880.00	661	GSM 1900	GPRS	27.7	27.02	-0.05	10 mm	100	2	1:4.15	left	0.103	1.169	0.120	
1880.00	9400	UMTS 1900	RMC	22.8	22.27	-0.02	10 mm	100	N/A	1:1	back	0.641	1.130	0.724	A14
1880.00	9400	UMTS 1900	RMC	22.8	22.27	-0.06	10 mm	100	N/A	1:1	front	0.542	1.130	0.612	
1880.00	9400	UMTS 1900	RMC	22.8	22.27	-0.06	10 mm	100	N/A	1:1	bottom	0.449	1.130	0.507	
1880.00	9400	UMTS 1900	RMC	22.8	22.27	0.04	10 mm	100	N/A	1:1	right	0.073	1.130	0.082	
1880.00	9400	UMTS 1900	RMC	22.8	22.27	0.01	10 mm	100	N/A	1:1	left	0.154	1.130	0.174	
ANSI / IEEE C95.1 1992 - SAFETY LIMIT Spatial Peak Uncontrolled Exposure/General Population							Body 1.6 W/kg (mW/g) averaged over 1 gram								

FCC ID: A3LSMG720AX		SAR EVALUATION REPORT		Reviewed by: Quality Manager
Document S/N: OY1412012187.A3L	Test Dates: 12/01/14 - 12/08/14	DUT Type: Portable Handset		Page 36 of 48

**Table 11-13
LTE Band 17 Hotspot SAR**



MEASUREMENT RESULTS																			
FREQUENCY		Mode	Bandwidth [MHz]	Maximum Allowed Power [dBm]	Conducted Power [dBm]	Power Drift [dB]	MPR [dB]	Device Serial Number	Modulation	RB Size	RB Offset	Spacing	Side	Duty Cycle	SAR (1g)	Scaling Factor	Scaled SAR (1g)	Plot #	
MHz	Ch.														(W/kg)		(W/kg)		
710.00	23790	Mid	LTE Band 17	10	23.7	23.40	0.11	0	96	QPSK	1	0	10 mm	back	1:1	0.079	1.072	0.085	A15
710.00	23790	Mid	LTE Band 17	10	22.7	22.23	-0.06	1	96	QPSK	25	0	10 mm	back	1:1	0.085	1.114	0.072	
710.00	23790	Mid	LTE Band 17	10	23.7	23.40	-0.10	0	96	QPSK	1	0	10 mm	front	1:1	0.079	1.072	0.085	
710.00	23790	Mid	LTE Band 17	10	22.7	22.23	0.01	1	96	QPSK	25	0	10 mm	front	1:1	0.060	1.114	0.067	
710.00	23790	Mid	LTE Band 17	10	23.7	23.40	0.03	0	96	QPSK	1	0	10 mm	bottom	1:1	0.028	1.072	0.030	
710.00	23790	Mid	LTE Band 17	10	22.7	22.23	0.03	1	96	QPSK	25	0	10 mm	bottom	1:1	0.021	1.114	0.023	
710.00	23790	Mid	LTE Band 17	10	23.7	23.40	0.04	0	96	QPSK	1	0	10 mm	right	1:1	0.017	1.072	0.018	
710.00	23790	Mid	LTE Band 17	10	22.7	22.23	-0.03	1	96	QPSK	25	0	10 mm	right	1:1	0.016	1.114	0.018	
710.00	23790	Mid	LTE Band 17	10	23.7	23.40	-0.12	0	96	QPSK	1	0	10 mm	left	1:1	0.046	1.072	0.049	
710.00	23790	Mid	LTE Band 17	10	22.7	22.23	0.03	1	96	QPSK	25	0	10 mm	left	1:1	0.041	1.114	0.046	
ANSI / IEEE C95.1 1992 - SAFETY LIMIT Spatial Peak Uncontrolled Exposure/General Population								Body 1.6 W/kg (mW/g) averaged over 1 gram											

**Table 11-14
LTE Band 4 (AWS) Hotspot SAR**

MEASUREMENT RESULTS																			
FREQUENCY		Mode	Bandwidth [MHz]	Maximum Allowed Power [dBm]	Conducted Power [dBm]	Power Drift [dB]	MPR [dB]	Device Serial Number	Modulation	RB Size	RB Offset	Spacing	Side	Duty Cycle	SAR (1g)	Scaling Factor	Scaled SAR (1g)	Plot #	
MHz	Ch.														(W/kg)		(W/kg)		
1732.50	20175	Mid	LTE Band 4 (AWS)	20	23.7	23.47	-0.03	0	96	QPSK	1	0	10 mm	back	1:1	0.564	1.054	0.594	A16
1732.50	20175	Mid	LTE Band 4 (AWS)	20	22.7	22.30	0.00	1	96	QPSK	50	0	10 mm	back	1:1	0.401	1.096	0.439	
1732.50	20175	Mid	LTE Band 4 (AWS)	20	23.7	23.47	-0.20	0	96	QPSK	1	0	10 mm	front	1:1	0.519	1.054	0.547	
1732.50	20175	Mid	LTE Band 4 (AWS)	20	22.7	22.30	-0.01	1	96	QPSK	50	0	10 mm	front	1:1	0.361	1.096	0.396	
1732.50	20175	Mid	LTE Band 4 (AWS)	20	23.7	23.47	-0.16	0	96	QPSK	1	0	10 mm	bottom	1:1	0.415	1.054	0.437	
1732.50	20175	Mid	LTE Band 4 (AWS)	20	22.7	22.30	-0.08	1	96	QPSK	50	0	10 mm	bottom	1:1	0.315	1.096	0.345	
1732.50	20175	Mid	LTE Band 4 (AWS)	20	23.7	23.47	-0.04	0	96	QPSK	1	0	10 mm	right	1:1	0.052	1.054	0.055	
1732.50	20175	Mid	LTE Band 4 (AWS)	20	22.7	22.30	0.12	1	96	QPSK	50	0	10 mm	right	1:1	0.042	1.096	0.046	
1732.50	20175	Mid	LTE Band 4 (AWS)	20	23.7	23.47	0.05	0	96	QPSK	1	0	10 mm	left	1:1	0.148	1.054	0.156	
1732.50	20175	Mid	LTE Band 4 (AWS)	20	22.7	22.30	0.07	1	96	QPSK	50	0	10 mm	left	1:1	0.110	1.096	0.121	
ANSI / IEEE C95.1 1992 - SAFETY LIMIT Spatial Peak Uncontrolled Exposure/General Population								Body 1.6 W/kg (mW/g) averaged over 1 gram											

**Table 11-15
LTE Band 2 (PCS) Hotspot SAR**

MEASUREMENT RESULTS																			
FREQUENCY		Mode	Bandwidth [MHz]	Maximum Allowed Power [dBm]	Conducted Power [dBm]	Power Drift [dB]	MPR [dB]	Device Serial Number	Modulation	RB Size	RB Offset	Spacing	Side	Duty Cycle	SAR (1g)	Scaling Factor	Scaled SAR (1g)	Plot #	
MHz	Ch.														(W/kg)		(W/kg)		
1900.00	19100	High	LTE Band 2 (PCS)	20	22.7	22.58	0.01	0	100	QPSK	1	50	10 mm	back	1:1	0.625	1.028	0.643	A17
1880.00	18900	Mid	LTE Band 2 (PCS)	20	21.7	21.43	0.04	1	100	QPSK	50	25	10 mm	back	1:1	0.467	1.064	0.497	
1900.00	19100	High	LTE Band 2 (PCS)	20	22.7	22.58	0.04	0	100	QPSK	1	50	10 mm	front	1:1	0.572	1.028	0.588	
1880.00	18900	Mid	LTE Band 2 (PCS)	20	21.7	21.43	-0.06	1	100	QPSK	50	25	10 mm	front	1:1	0.445	1.064	0.473	
1900.00	19100	High	LTE Band 2 (PCS)	20	22.7	22.58	0.02	0	100	QPSK	1	50	10 mm	bottom	1:1	0.438	1.028	0.450	
1880.00	18900	Mid	LTE Band 2 (PCS)	20	21.7	21.43	0.00	1	100	QPSK	50	25	10 mm	bottom	1:1	0.324	1.064	0.345	
1900.00	19100	High	LTE Band 2 (PCS)	20	22.7	22.58	-0.02	0	100	QPSK	1	50	10 mm	right	1:1	0.066	1.028	0.068	
1880.00	18900	Mid	LTE Band 2 (PCS)	20	21.7	21.43	0.01	1	100	QPSK	50	25	10 mm	right	1:1	0.046	1.064	0.049	
1900.00	19100	High	LTE Band 2 (PCS)	20	22.7	22.58	-0.07	0	100	QPSK	1	50	10 mm	left	1:1	0.155	1.028	0.159	
1880.00	18900	Mid	LTE Band 2 (PCS)	20	21.7	21.43	0.03	1	100	QPSK	50	25	10 mm	left	1:1	0.105	1.064	0.112	
ANSI / IEEE C95.1 1992 - SAFETY LIMIT Spatial Peak Uncontrolled Exposure/General Population								Body 1.6 W/kg (mW/g) averaged over 1 gram											

FCC ID: A3LSMG720AX		SAR EVALUATION REPORT		Reviewed by: Quality Manager
Document S/N: OY1412012187.A3L	Test Dates: 12/01/14 - 12/08/14	DUT Type: Portable Handset	Page 37 of 48	

**Table 11-16
WLAN Hotspot SAR**

MEASUREMENT RESULTS															
FREQUENCY		Mode	Service	Maximum Allowed Power [dBm]	Conducted Power [dBm]	Power Drift [dB]	Spacing	Device Serial Number	Data Rate (Mbps)	Side	Duty Cycle	SAR (1g)	Scaling Factor	Scaled SAR (1g)	Plot #
MHz	Ch.											(W/kg)		(W/kg)	
2462	11	IEEE 802.11b	DSSS	17.5	17.32	-0.05	10 mm	100	1	back	1:1	0.225	1.042	0.234	A18
2462	11	IEEE 802.11b	DSSS	17.5	17.32	0.04	10 mm	100	1	front	1:1	0.047	1.042	0.049	
2462	11	IEEE 802.11b	DSSS	17.5	17.32	-0.01	10 mm	100	1	top	1:1	0.024	1.042	0.025	
2462	11	IEEE 802.11b	DSSS	17.5	17.32	0.00	10 mm	100	1	left	1:1	0.121	1.042	0.126	
ANSI / IEEE C95.1 1992 - SAFETY LIMIT Spatial Peak Uncontrolled Exposure/General Population							Body 1.6 W/kg (mW/g) averaged over 1 gram								



11.4 SAR Test Notes

General Notes:

1. The test data reported are the worst-case SAR values according to test procedures specified in IEEE 1528-2003, and FCC KDB Publication 447498 D01v05.
2. Batteries are fully charged at the beginning of the SAR measurements.
3. Liquid tissue depth was at least 15.0 cm for all frequencies.
4. The manufacturer has confirmed that the device(s) tested have the same physical, mechanical and thermal characteristics and are within operational tolerances expected for production units.
5. SAR results were scaled to the maximum allowed power to demonstrate compliance per FCC KDB Publication 447498 D01v05.
6. Device was tested using a fixed spacing for body-worn accessory testing. A separation distance of 10 mm was considered because the manufacturer has determined that there will be body-worn accessories available in the marketplace for users to support this separation distance.
7. Per FCC KDB Publication 648474 D04v01, body-worn SAR was evaluated without a headset connected to the device. Since the standalone reported body-worn SAR was ≤ 1.2 W/kg, no additional body-worn SAR evaluations using a headset cable were required.
8. Per FCC KDB 865664 D01 v01, variability SAR tests were not performed since the measured SAR results for a frequency band were less than 0.8 W/kg. Please see Section 13 for variability analysis.
9. During SAR Testing for the Wireless Router conditions per FCC KDB Publication 941225 D06v01, the actual Portable Hotspot operation (with actual simultaneous transmission of a transmitter with WIFI) was not activated (See Section 6.7 for more details).

GSM Test Notes:

1. Body-Worn accessory testing is typically associated with voice operations. Therefore, GSM voice was evaluated for body-worn SAR.
2. Justification for reduced test configurations per KDB Publication 941225 D03v01 and October 2013 TCB Workshop Notes: The source-based frame-averaged output power was evaluated for all GPRS/EDGE slot configurations. The configuration with the highest target frame averaged output power was evaluated for hotspot SAR. When the maximum frame-averaged powers are equivalent across two or more slots (within 0.25 dB), the configuration with the most number of time slots was tested.
3. Per FCC KDB Publication 447498 D01v05, if the reported (scaled) SAR measured at the middle channel or highest output power channel for each test configuration is ≤ 0.8 W/kg then testing at the other channels is not required for such test configuration(s). When the maximum output power variation across the required test channels is $> \frac{1}{2}$ dB, instead of the middle channel, the highest output power channel was used.

FCC ID: A3LSMG720AX		SAR EVALUATION REPORT		Reviewed by: Quality Manager
Document S/N: OY1412012187.A3L	Test Dates: 12/01/14 - 12/08/14	DUT Type: Portable Handset	Page 38 of 48	

UMTS Notes:



1. UMTS mode in was tested under RMC 12.2 kbps with HSPA Inactive per KDB Publication 941225 D01v02. HSPA SAR was not required since the average output power of the HSPA subtests was not more than 0.25 dB higher than the RMC level and SAR was less than 1.2 W/kg.
2. Per FCC KDB Publication 447498 D01v05, if the reported (scaled) SAR measured at the middle channel or highest output power channel for each test configuration is ≤ 0.8 W/kg then testing at the other channels is not required for such test configuration(s). When the maximum output power variation across the required test channels is $> \frac{1}{2}$ dB, instead of the middle channel, the highest output power channel was used.

LTE Notes:

1. LTE Considerations: LTE test configurations are determined according to SAR Evaluation Considerations for LTE Devices in FCC KDB Publication 941225 D05v02r01. The general test procedures used for testing can be found in Section 8.4.4.
2. MPR is permanently implemented for this device by the manufacturer. The specific manufacturer target MPR is indicated alongside the SAR results. MPR is enabled for this device, according to 3GPP TS36.101 Section 6.2.3 – 6.2.5 under Table 6.2.3-1.
3. A-MPR was disabled for all SAR tests by setting NS=01 on the base station simulator. SAR tests were performed with the same number of RB and RB offsets transmitting on all TTI frames (maximum TTI).

WLAN Notes:

1. Justification for reduced test configurations for WIFI channels per KDB Publication 248227 D01v01r02 and October 2012 FCC/TCB Meeting Notes for 2.4 GHz WIFI operations: Highest average RF output power channel for the lowest data rate was selected for SAR evaluation in 802.11b. Other IEEE 802.11 modes (including 802.11g/n) were not investigated since the average output powers over all channels and data rates were not more than 0.25 dB higher than the tested channel in the lowest data rate of IEEE 802.11b mode.
2. WIFI transmission was verified using an uncalibrated spectrum analyzer.
3. When the maximum extrapolated peak SAR of the zoom scan for the maximum output channel is < 1.6 W/kg or the reported 1g averaged SAR is < 0.8 W/kg, SAR testing on other default channels was required.

FCC ID: A3LSMG720AX		SAR EVALUATION REPORT		Reviewed by: Quality Manager
Document S/N: 0Y1412012187.A3L	Test Dates: 12/01/14 - 12/08/14	DUT Type: Portable Handset	Page 39 of 48	

12 FCC MULTI-TX AND ANTENNA SAR CONSIDERATIONS

12.1 Introduction

The following procedures adopted from FCC KDB Publication 447498 D01v05 are applicable to handsets with built-in unlicensed transmitters such as 802.11b/g/n and Bluetooth devices which may simultaneously transmit with the licensed transmitter.

12.2 Simultaneous Transmission Procedures

This device contains transmitters that may operate simultaneously. Therefore simultaneous transmission analysis is required. Per FCC KDB 447498 D01v05 IV.C.1.iii and IEEE 1528-2013 Section 6.3.4.1.2, simultaneous transmission SAR test exclusion may be applied when the sum of the 1-g SAR for all the simultaneous transmitting antennas in a specific physical test configuration is ≤ 1.6 W/kg. When standalone SAR is not required to be measured, per FCC KDB 447498 D01v05 4.3.2 2), the following equation must be used to estimate the standalone 1g SAR for simultaneous transmission assessment involving that transmitter.

$$\text{Estimated SAR} = \frac{\sqrt{f(\text{GHz})}}{7.5} * \frac{(\text{Max Power of channel, mW})}{\text{Min. Separation Distance, mm}}$$

**Table 12-1
Estimated SAR**



Mode	Frequency	Maximum Allowed Power	Separation Distance (Body)	Estimated SAR (Body)
	[MHz]	[dBm]	[mm]	[W/kg]
Bluetooth	2480	10.00	10	0.210

Note: Held-to ear configurations are not applicable to Bluetooth operations and therefore were not considered for simultaneous transmission. Per KDB Publication 447498 D01v05, the maximum power of the channel was rounded to the nearest mW before calculation.

12.3 Head SAR Simultaneous Transmission Analysis

**Table 12-2
Simultaneous Transmission Scenario with 2.4 GHz WLAN (Held to Ear)**

Simult Tx	Configuration	GSM 850 SAR (W/kg)	2.4 GHz WLAN SAR (W/kg)	Σ SAR (W/kg)	Simult Tx	Configuration	UMTS 850 SAR (W/kg)	2.4 GHz WLAN SAR (W/kg)	Σ SAR (W/kg)
Head SAR	Right Cheek	0.184	0.163	0.347	Head SAR	Right Cheek	0.153	0.163	0.316
	Right Till	0.126	0.066	0.192		Right Till	0.101	0.066	0.167
	Left Cheek	0.246	0.060	0.306		Left Cheek	0.224	0.060	0.284
	Left Till	0.141	0.044	0.185		Left Till	0.119	0.044	0.163

FCC ID: A3LSMG720AX		SAR EVALUATION REPORT		Reviewed by: Quality Manager
Document S/N: OY1412012187.A3L	Test Dates: 12/01/14 - 12/08/14	DUT Type: Portable Handset	Page 40 of 48	

Simult Tx	Configuration	GSM 1900 SAR (W/kg)	2.4 GHz WLAN SAR (W/kg)	Σ SAR (W/kg)	Simult Tx	Configuration	UMTS 1900 SAR (W/kg)	2.4 GHz WLAN SAR (W/kg)	Σ SAR (W/kg)
Head SAR	Right Cheek	0.117	0.163	0.280	Head SAR	Right Cheek	0.164	0.163	0.327
	Right Tilt	0.067	0.066	0.133		Right Tilt	0.106	0.066	0.172
	Left Cheek	0.130	0.060	0.190		Left Cheek	0.216	0.060	0.276
	Left Tilt	0.064	0.044	0.108		Left Tilt	0.103	0.044	0.147
Simult Tx	Configuration	LTE Band 17 SAR (W/kg)	2.4 GHz WLAN SAR (W/kg)	Σ SAR (W/kg)	Simult Tx	Configuration	LTE Band 4 (AWS) SAR (W/kg)	2.4 GHz WLAN SAR (W/kg)	Σ SAR (W/kg)
Head SAR	Right Cheek	0.035	0.163	0.198	Head SAR	Right Cheek	0.126	0.163	0.289
	Right Tilt	0.021	0.066	0.087		Right Tilt	0.058	0.066	0.124
	Left Cheek	0.048	0.060	0.108		Left Cheek	0.167	0.060	0.227
	Left Tilt	0.025	0.044	0.069		Left Tilt	0.056	0.044	0.100
Simult Tx	Configuration	LTE Band 2 (PCS) SAR (W/kg)	2.4 GHz WLAN SAR (W/kg)	Σ SAR (W/kg)					
Head SAR	Right Cheek	0.163	0.163	0.326					
	Right Tilt	0.117	0.066	0.183					
	Left Cheek	0.181	0.060	0.241					
	Left Tilt	0.115	0.044	0.159					

12.4 Body-Worn Simultaneous Transmission Analysis



Table 12-3
Simultaneous Transmission Scenario with 2.4 GHz WLAN (Body-Worn at 1.0 cm)

Configuration	Mode	2G/3G/4G SAR (W/kg)	2.4 GHz WLAN SAR (W/kg)	Σ SAR (W/kg)
Back Side	GSM 850	0.384	0.234	0.618
Back Side	UMTS 850	0.326	0.234	0.560
Back Side	GSM 1900	0.417	0.234	0.651
Back Side	UMTS 1900	0.724	0.234	0.958
Back Side	LTE Band 17	0.085	0.234	0.319
Back Side	LTE Band 4 (AWS)	0.594	0.234	0.828
Back Side	LTE Band 2 (PCS)	0.643	0.234	0.877

Table 12-4
Simultaneous Transmission Scenario with Bluetooth (Body-Worn at 1.0 cm)

Configuration	Mode	2G/3G/4G SAR (W/kg)	Bluetooth SAR (W/kg)	Σ SAR (W/kg)
Back Side	GSM 850	0.384	0.210	0.594
Back Side	UMTS 850	0.326	0.210	0.536
Back Side	GSM 1900	0.417	0.210	0.627
Back Side	UMTS 1900	0.724	0.210	0.934
Back Side	LTE Band 17	0.085	0.210	0.295
Back Side	LTE Band 4 (AWS)	0.594	0.210	0.804
Back Side	LTE Band 2 (PCS)	0.643	0.210	0.853

Note: Bluetooth SAR was not required to be measured per FCC KDB 447498. Estimated SAR results were used in the above table to determine simultaneous transmission SAR test exclusion.

FCC ID: A3LSMG720AX	 PCTEST ENGINEERING LABORATORY, INC.	SAR EVALUATION REPORT		Reviewed by: Quality Manager
Document S/N: OY1412012187.A3L	Test Dates: 12/01/14 - 12/08/14	DUT Type: Portable Handset	Page 41 of 48	

12.5 Hotspot SAR Simultaneous Transmission Analysis



Per FCC KDB Publication 941225 D06v01, the devices edges with antennas more than 2.5 cm from edge are not required to be evaluated for SAR (“-”).

**Table 12-5
Simultaneous Transmission Scenario (2.4 GHz Hotspot at 1.0 cm)**

Simult Tx	Configuration	GPRS 850 SAR (W/kg)	2.4 GHz WLAN SAR (W/kg)	Σ SAR (W/kg)	Simult Tx	Configuration	UMTS 850 SAR (W/kg)	2.4 GHz WLAN SAR (W/kg)	Σ SAR (W/kg)
Body SAR	Back	0.505	0.234	0.739	Body SAR	Back	0.326	0.234	0.560
	Front	0.383	0.049	0.432		Front	0.277	0.049	0.326
	Top	-	0.025	0.025		Top	-	0.025	0.025
	Bottom	0.195	-	0.195		Bottom	0.141	-	0.141
	Right	0.288	-	0.288		Right	0.157	-	0.157
	Left	0.496	0.126	0.622		Left	0.291	0.126	0.417
Simult Tx	Configuration	GPRS 1900 SAR (W/kg)	2.4 GHz WLAN SAR (W/kg)	Σ SAR (W/kg)	Simult Tx	Configuration	UMTS 1900 SAR (W/kg)	2.4 GHz WLAN SAR (W/kg)	Σ SAR (W/kg)
Body SAR	Back	0.487	0.234	0.721	Body SAR	Back	0.724	0.234	0.958
	Front	0.470	0.049	0.519		Front	0.612	0.049	0.661
	Top	-	0.025	0.025		Top	-	0.025	0.025
	Bottom	0.321	-	0.321		Bottom	0.507	-	0.507
	Right	0.058	-	0.058		Right	0.082	-	0.082
	Left	0.120	0.126	0.246		Left	0.174	0.126	0.300
Simult Tx	Configuration	LTE Band 17 SAR (W/kg)	2.4 GHz WLAN SAR (W/kg)	Σ SAR (W/kg)	Simult Tx	Configuration	LTE Band 4 (AWS) SAR (W/kg)	2.4 GHz WLAN SAR (W/kg)	Σ SAR (W/kg)
Body SAR	Back	0.085	0.234	0.319	Body SAR	Back	0.594	0.234	0.828
	Front	0.085	0.049	0.134		Front	0.547	0.049	0.596
	Top	-	0.025	0.025		Top	-	0.025	0.025
	Bottom	0.030	-	0.030		Bottom	0.437	-	0.437
	Right	0.018	-	0.018		Right	0.055	-	0.055
	Left	0.049	0.126	0.175		Left	0.156	0.126	0.282
Simult Tx	Configuration	LTE Band 2 (PCS) SAR (W/kg)	2.4 GHz WLAN SAR (W/kg)	Σ SAR (W/kg)					
Body SAR	Back	0.643	0.234	0.877					
	Front	0.588	0.049	0.637					
	Top	-	0.025	0.025					
	Bottom	0.450	-	0.450					
	Right	0.068	-	0.068					
	Left	0.159	0.126	0.285					

12.6 Simultaneous Transmission Conclusion

The above numerical summed SAR results for all the worst-case simultaneous transmission conditions were below the SAR limit. Therefore, the above analysis is sufficient to determine that simultaneous transmission cases will not exceed the SAR limit and therefore no measured volumetric simultaneous SAR summation is required per FCC KDB Publication 447498 D01v05 and IEEE 1528-2013 Section 6.3.4.1.2.

FCC ID: A3LSMG720AX	 PCTEST ENGINEERING LABORATORY, INC.	SAR EVALUATION REPORT		Reviewed by: Quality Manager
Document S/N: OY1412012187.A3L	Test Dates: 12/01/14 - 12/08/14	DUT Type: Portable Handset	Page 42 of 48	



13 SAR MEASUREMENT VARIABILITY

13.1 Measurement Variability

Per FCC KDB Publication 865664 D01v01, SAR measurement variability was not assessed since measured 1g SAR each frequency band was below 0.8 W/kg.

13.2 Measurement Uncertainty



The measured SAR was <1.5 W/kg for all frequency bands. Therefore, per KDB Publication 865664 D01v01, the extended measurement uncertainty analysis per IEEE 1528-2003 was not required.

FCC ID: A3LSMG720AX		SAR EVALUATION REPORT		Reviewed by: Quality Manager
Document S/N: 0Y1412012187.A3L	Test Dates: 12/01/14 - 12/08/14	DUT Type: Portable Handset		Page 43 of 48

14 EQUIPMENT LIST

Manufacturer	Model	Description	Cal Date	Cal Interval	Cal Due	Serial Number
Agilent	E8257D	(250kHz-20GHz) Signal Generator	4/15/2014	Annual	4/15/2015	MY45470194
Agilent	8594A	(9kHz-2.9GHz) Spectrum Analyzer	N/A	N/A	N/A	3051A00187
Agilent	8648D	(9kHz-4GHz) Signal Generator	4/15/2014	Annual	4/15/2015	3629U00687
Agilent	E4438C	ESG Vector Signal Generator	4/1/2014	Annual	4/1/2015	MY47270002
Agilent	N5182A	MXG Vector Signal Generator	4/15/2014	Annual	4/15/2015	MY47420800
Agilent	8753ES	S-Parameter Network Analyzer	5/22/2014	Annual	5/22/2015	US39170118
Amplifier Research	15S1G6	Amplifier	CBT	N/A	CBT	433971
Anritsu	ML2469A	Power Meter	3/14/2014	Annual	3/14/2015	1306009
Anritsu	ML2495A	Power Meter	10/31/2013	Biennial	10/31/2015	941001
Anritsu	MA2411B	Pulse Power Sensor	2/3/2014	Annual	2/3/2015	1339018
Anritsu	MT8820C	Radio Communication Analyzer	8/28/2014	Annual	8/28/2015	6201240328
Anritsu	MA24106A	USB Power Sensor	5/15/2014	Annual	5/15/2015	1244512
Anritsu	MA24106A	USB Power Sensor	1/3/2014	Annual	1/3/2015	1344554
COMTech	AR85729-5	Solid State Amplifier	CBT	N/A	CBT	M155A00-009
COMTECH	AR85729-5/5759B	Solid State Amplifier	CBT	N/A	CBT	M3W1A00-1002
Control Company	61220-416	Long-Stem Thermometer	4/29/2014	Biennial	4/29/2016	111331323
Fisher Scientific	S97611	Thermometer	4/12/2013	Biennial	4/12/2015	130219304
MCL	BW-N6W5+	6dB Attenuator	CBT	N/A	CBT	1139
MiniCircuits	SLP-2400+	Low Pass Filter	CBT	N/A	CBT	R8979500903
Mini-Circuits	BW-N20W5+	DC to 18 GHz Precision Fixed 20 dB Attenuator	CBT	N/A	CBT	N/A
Mini-Circuits	NLP-1200+	Low Pass Filter DC to 1000 MHz	CBT	N/A	CBT	N/A
Mini-Circuits	NLP-2950+	Low Pass Filter DC to 2700 MHz	CBT	N/A	CBT	N/A
Mini-Circuits	BW-N20W5	Power Attenuator	CBT	N/A	CBT	1226
Mitutoyo	CD-6"CSX	Digital Caliper	5/8/2014	Biennial	5/8/2016	13264162
Narda	4014C-6	4 - 8 GHz SMA 6 dB Directional Coupler	CBT	N/A	CBT	N/A
Narda	BW-S3W2	Attenuator (3dB)	CBT	N/A	CBT	120
Pasternack	PE2208-6	Bidirectional Coupler	CBT	N/A	CBT	N/A
Pasternack	PE2209-10	Bidirectional Coupler	CBT	N/A	CBT	N/A
Rohde & Schwarz	CMU200	Base Station Simulator	6/6/2014	Annual	6/6/2015	109892
Rohde & Schwarz	CMW500	Radio Communication Tester	10/4/2013	Biennial	10/4/2015	108798
Seekonk	NC-100	Torque Wrench	3/18/2014	Biennial	3/18/2016	N/A
Seekonk	NC-100	Torque Wrench 5/16", 8" lbs	3/18/2014	Biennial	3/18/2016	N/A
SPEAG	DAK-3.5	Dielectric Assessment Kit	5/6/2014	Annual	5/6/2015	1070
Tektronix	RSA6114A	Real Time Spectrum Analyzer	4/16/2014	Annual	4/16/2015	B010177
VWR	36934-158	Wall-Mounted Thermometer	8/8/2013	Biennial	8/8/2015	130477877
SPEAG	D750V3	750 MHz Dipole	1/20/2014	Annual	1/20/2015	1003
SPEAG	D835V2	835 MHz SAR Dipole	4/7/2014	Annual	4/7/2015	4d119
SPEAG	D1765V2	1765 MHz SAR Dipole	5/7/2014	Annual	5/7/2015	1008
SPEAG	D1900V2	1900 MHz SAR Dipole	7/23/2014	Annual	7/23/2015	5d149
SPEAG	D2450V2	2450 MHz SAR Dipole	1/21/2014	Annual	1/21/2015	797
SPEAG	D1900V2	1900 MHz SAR Dipole	4/9/2014	Annual	4/9/2015	5d141
SPEAG	ES3DV3	SAR Probe	9/24/2014	Annual	9/24/2015	3288
SPEAG	ES3DV3	SAR Probe	9/18/2014	Annual	9/18/2015	3332
SPEAG	ES3DV2	SAR Probe	8/19/2014	Annual	8/19/2015	3022
SPEAG	ES3DV3	SAR Probe	5/15/2014	Annual	5/15/2015	3263
SPEAG	ES3DV3	SAR Probe	2/25/2014	Annual	2/25/2015	3258
SPEAG	ES3DV3	SAR Probe	3/19/2014	Annual	3/19/2015	3209
SPEAG	ES3DV3	SAR Probe	4/17/2014	Annual	4/17/2015	3319
SPEAG	DAE4	Dasy Data Acquisition Electronics	9/18/2014	Annual	9/18/2015	1364
SPEAG	DAE4	Dasy Data Acquisition Electronics	9/17/2014	Annual	9/17/2015	1323
SPEAG	DAE4	Dasy Data Acquisition Electronics	8/12/2014	Annual	8/12/2015	1322
SPEAG	DAE4	Dasy Data Acquisition Electronics	5/14/2014	Annual	5/14/2015	859
SPEAG	DAE4	Dasy Data Acquisition Electronics	2/26/2014	Annual	2/26/2015	665
SPEAG	DAE4	Dasy Data Acquisition Electronics	3/17/2014	Annual	3/17/2015	1334
SPEAG	DAE4	Dasy Data Acquisition Electronics	4/11/2014	Annual	4/11/2015	1368



Note: CBT (Calibrated Before Testing). Prior to testing, the measurement paths containing a cable, amplifier, attenuator, coupler or filter were connected to a calibrated source (i.e. a signal generator) to determine the losses of the measurement path. The power meter offset was then adjusted to compensate for the measurement system losses. This level offset is stored within the power meter before measurements are made. This calibration verification procedure applies to the system verification and output power measurements. The calibrated reading is then taken directly from the power meter after compensation of the losses for all final power measurements.

FCC ID: A3LSMG720AX	 PCTEST ENGINEERING LABORATORY, INC.	SAR EVALUATION REPORT		Reviewed by: Quality Manager
Document S/N: OY1412012187.A3L	Test Dates: 12/01/14 - 12/08/14	DUT Type: Portable Handset	Page 44 of 48	

15 MEASUREMENT UNCERTAINTIES

a	b	c	d	e= f(d,k)	f	g	h = c x f/e	i = c x g/e	k
Uncertainty Component	IEEE 1528 Sec.	Tol. (± %)	Prob. Dist.	Div.	c _i 1gm	c _i 10 gms	1gm u _i (± %)	10gms u _i (± %)	v _i
Measurement System									
Probe Calibration	E.2.1	6.0	N	1	1.0	1.0	6.0	6.0	∞
Axial Isotropy	E.2.2	0.25	N	1	0.7	0.7	0.2	0.2	∞
Hemishperical Isotropy	E.2.2	1.3	N	1	1.0	1.0	1.3	1.3	∞
Boundary Effect	E.2.3	0.4	N	1	1.0	1.0	0.4	0.4	∞
Linearity	E.2.4	0.3	N	1	1.0	1.0	0.3	0.3	∞
System Detection Limits	E.2.5	5.1	N	1	1.0	1.0	5.1	5.1	∞
Readout Electronics	E.2.6	1.0	N	1	1.0	1.0	1.0	1.0	∞
Response Time	E.2.7	0.8	R	1.73	1.0	1.0	0.5	0.5	∞
Integration Time	E.2.8	2.6	R	1.73	1.0	1.0	1.5	1.5	∞
RF Ambient Conditions	E.6.1	3.0	R	1.73	1.0	1.0	1.7	1.7	∞
Probe Positioner Mechanical Tolerance	E.6.2	0.4	R	1.73	1.0	1.0	0.2	0.2	∞
Probe Positioning w/ respect to Phantom	E.6.3	2.9	R	1.73	1.0	1.0	1.7	1.7	∞
Extrapolation, Interpolation & Integration algorithms for Max. SAR Evaluation	E.5	1.0	R	1.73	1.0	1.0	0.6	0.6	∞
Test Sample Related									
Test Sample Positioning	E.4.2	6.0	N	1	1.0	1.0	6.0	6.0	287
Device Holder Uncertainty	E.4.1	3.32	R	1.73	1.0	1.0	1.9	1.9	∞
Output Power Variation - SAR drift measurement	6.6.2	5.0	R	1.73	1.0	1.0	2.9	2.9	∞
Phantom & Tissue Parameters									
Phantom Uncertainty (Shape & Thickness tolerances)	E.3.1	4.0	R	1.73	1.0	1.0	2.3	2.3	∞
Liquid Conductivity - deviation from target values	E.3.2	5.0	R	1.73	0.64	0.43	1.8	1.2	∞
Liquid Conductivity - measurement uncertainty	E.3.3	3.8	N	1	0.64	0.43	2.4	1.6	6
Liquid Permittivity - deviation from target values	E.3.2	5.0	R	1.73	0.60	0.49	1.7	1.4	∞
Liquid Permittivity - measurement uncertainty	E.3.3	4.5	N	1	0.60	0.49	2.7	2.2	6
Combined Standard Uncertainty (k=1)	RSS						12.1	11.7	299
Expanded Uncertainty (95% CONFIDENCE LEVEL)	k=2						24.2	23.5	

The above measurement uncertainties are according to IEEE Std. 1528-2003



FCC ID: A3LSMG720AX		SAR EVALUATION REPORT		Reviewed by: Quality Manager
Document S/N: OY1412012187.A3L	Test Dates: 12/01/14 - 12/08/14	DUT Type: Portable Handset	Page 45 of 48	

16 CONCLUSION

16.1 Measurement Conclusion



The SAR evaluation indicates that the EUT complies with the RF radiation exposure limits of the FCC and Industry Canada, with respect to all parameters subject to this test. These measurements were taken to simulate the RF effects of RF exposure under worst-case conditions. Precise laboratory measures were taken to assure repeatability of the tests. The results and statements relate only to the item(s) tested.

Please note that the absorption and distribution of electromagnetic energy in the body are very complex phenomena that depend on the mass, shape, and size of the body, the orientation of the body with respect to the field vectors, and the electrical properties of both the body and the environment. Other variables that may play a substantial role in possible biological effects are those that characterize the environment (e.g. ambient temperature, air velocity, relative humidity, and body insulation) and those that characterize the individual (e.g. age, gender, activity level, debilitation, or disease). Because various factors may interact with one another to vary the specific biological outcome of an exposure to electromagnetic fields, any protection guide should consider maximal amplification of biological effects as a result of field-body interactions, environmental conditions, and physiological variables. [3]



FCC ID: A3LSMG720AX		SAR EVALUATION REPORT		Reviewed by: Quality Manager
Document S/N: 0Y1412012187.A3L	Test Dates: 12/01/14 - 12/08/14	DUT Type: Portable Handset		Page 46 of 48

17 REFERENCES

- [1] Federal Communications Commission, ET Docket 93-62, Guidelines for Evaluating the Environmental Effects of Radiofrequency Radiation, Aug. 1996.
- [2] ANSI/IEEE C95.1-2005, American National Standard safety levels with respect to human exposure to radio frequency electromagnetic fields, 3kHz to 300GHz, New York: IEEE, 2006.
- [3] ANSI/IEEE C95.1-1992, American National Standard safety levels with respect to human exposure to radio frequency electromagnetic fields, 3kHz to 300GHz, New York: IEEE, Sept. 1992.
- [4] ANSI/IEEE C95.3-2002, IEEE Recommended Practice for the Measurement of Potentially Hazardous Electromagnetic Fields - RF and Microwave, New York: IEEE, December 2002.
- [5] IEEE Standards Coordinating Committee 39 –Standards Coordinating Committee 34 – IEEE Std. 1528-2003, Recommended Practice for Determining the Peak Spatial-Average Specific Absorption Rate (SAR) in the Human Head Due to Wireless Communications Devices: Measurement Techniques.
- [6] NCRP, National Council on Radiation Protection and Measurements, Biological Effects and Exposure Criteria for RadioFrequency Electromagnetic Fields, NCRP Report No. 86, 1986. Reprinted Feb. 1995.
- [7] T. Schmid, O. Egger, N. Kuster, Automated E-field scanning system for dosimetric assessments, IEEE Transaction on Microwave Theory and Techniques, vol. 44, Jan. 1996, pp. 105-113.
- [8] K. Pokovic, T. Schmid, N. Kuster, Robust setup for precise calibration of E-field probes in tissue simulating liquids at mobile communications frequencies, ICECOM97, Oct. 1997, pp. -124.
- [9] K. Pokovic, T. Schmid, and N. Kuster, E-field Probe with improved isotropy in brain simulating liquids, Proceedings of the ELMAR, Zadar, Croatia, June 23-25, 1996, pp. 172-175.
- [10] Schmid & Partner Engineering AG, Application Note: Data Storage and Evaluation, June 1998, p2.
- [11] V. Hombach, K. Meier, M. Burkhardt, E. Kuhn, N. Kuster, The Dependence of EM Energy Absorption upon Human Modeling at 900 MHz, IEEE Transaction on Microwave Theory and Techniques, vol. 44 no. 10, Oct. 1996, pp. 1865-1873.
- [12] N. Kuster and Q. Balzano, Energy absorption mechanism by biological bodies in the near field of dipole antennas above 300MHz, IEEE Transaction on Vehicular Technology, vol. 41, no. 1, Feb. 1992, pp. 17-23.
- [13] G. Hartsgrove, A. Kraszewski, A. Surowiec, Simulated Biological Materials for Electromagnetic Radiation Absorption Studies, University of Ottawa, Bioelectromagnetics, Canada: 1987, pp. 29-36.
- [14] Q. Balzano, O. Garay, T. Manning Jr., Electromagnetic Energy Exposure of Simulated Users of Portable Cellular Telephones, IEEE Transactions on Vehicular Technology, vol. 44, no.3, Aug. 1995.
- [15] W. Gander, Computermathematick, Birkhaeuser, Basel, 1992.
- [16] W.H. Press, S.A. Teukolsky, W.T. Vetterling, and B.P. Flannery, Numerical Recipes in C, The Art of Scientific Computing, Second edition, Cambridge University Press, 1992.
- [17] N. Kuster, R. Kastle, T. Schmid, Dosimetric evaluation of mobile communications equipment with known precision, IEEE Transaction on Communications, vol. E80-B, no. 5, May 1997, pp. 645-652.

FCC ID: A3LSMG720AX		SAR EVALUATION REPORT	 Reviewed by: Quality Manager
Document S/N: OY1412012187.A3L	Test Dates: 12/01/14 - 12/08/14	DUT Type: Portable Handset	Page 47 of 48

- [18] CENELEC CLC/SC111B, European Prestandard (prENV 50166-2), Human Exposure to Electromagnetic Fields High-frequency: 10kHz-300GHz, Jan. 1995.
- [19] Prof. Dr. Niels Kuster, ETH, Eidgenössische Technische Hochschule Zürich, Dosimetric Evaluation of the Cellular Phone.
- [20] IEC 62209-1, Human exposure to radio frequency fields from hand-held and body-mounted wireless communication devices - Human models, instrumentation, and procedures - Part 1: Procedure to determine the specific absorption rate (SAR) for hand-held devices used in close proximity to the ear (frequency range of 300 MHz to 3 GHz), Feb. 2005.
- [21] Industry Canada RSS-102 Radio Frequency Exposure Compliance of Radiocommunication Apparatus (All Frequency Bands) Issue 4, March 2010.
- [22] Health Canada Safety Code 6 Limits of Human Exposure to Radio Frequency Electromagnetic Fields in the Frequency Range from 3 kHz – 300 GHz, 2009
- [23] FCC SAR Test Procedures for 2G-3G Devices, Mobile Hotspot and UMPC Devices KDB Publications 941225, D01-D07
- [24] SAR Measurement procedures for IEEE 802.11a/b/g KDB Publication 248227 D01v01r02
- [25] FCC SAR Considerations for Handsets with Multiple Transmitters and Antennas, KDB Publications 648474 D02-D04
- [26] FCC SAR Evaluation Considerations for Laptop, Notebook, Netbook and Tablet Computers, FCC KDB Publication 616217 D04
- [27] FCC SAR Measurement and Reporting Requirements for 100MHz – 6 GHz, KDB Publications 865664 D01-D02
- [28] FCC General RF Exposure Guidance and SAR Procedures for Dongles, KDB Publication 447498, D01-D02
- [29] Anexo à Resolução No. 533, de 10 de Setembro de 2009.
- [30] IEC 62209-2, Human exposure to radio frequency fields from hand-held and body-mounted wireless communication devices - Human models, instrumentation, and procedures - Part 2: Procedure to determine the specific absorption rate (SAR) for wireless communication devices used in close proximity to the human body (frequency range of 30 MHz to 6 GHz), Mar. 2010.

FCC ID: A3LSMG720AX		SAR EVALUATION REPORT		Reviewed by: Quality Manager
Document S/N: 0Y1412012187.A3L	Test Dates: 12/01/14 - 12/08/14	DUT Type: Portable Handset	Page 48 of 48	

APPENDIX A: SAR TEST DATA

PCTEST ENGINEERING LABORATORY, INC.

DUT: A3LSMG720AX; Type: Portable Handset; Serial: 96

Communication System: UID 0, GSM; Frequency: 836.6 MHz; Duty Cycle: 1:8.3
Medium: 835 Head, Medium parameters used (interpolated):
 $f = 836.6 \text{ MHz}$; $\sigma = 0.938 \text{ S/m}$; $\epsilon_r = 40.196$; $\rho = 1000 \text{ kg/m}^3$
Phantom section: Left Section

Test Date: 12-03-2014; Ambient Temp: 23.6°C; Tissue Temp: 22.5°C

Probe: ES3DV3 - SN3332; ConvF(6.31, 6.31, 6.31); Calibrated: 9/18/2014;
Sensor-Surface: 3mm (Mechanical Surface Detection)
Electronics: DAE4 Sn1323; Calibrated: 9/17/2014
Phantom: SAM V5.0 Right; Type: QD000P40CD; Serial: 1647
Measurement SW: DASY52, Version 52.8 (8); SEMCAD X Version 14.6.10 (7331)

Mode: GSM 850, Left Head, Cheek, Mid.ch

Area Scan (9x15x1): Measurement grid: dx=15mm, dy=15mm
Zoom Scan (5x5x7)/Cube 0: Measurement grid: dx=8mm, dy=8mm, dz=5mm
Reference Value = 15.81 V/m; Power Drift = 0.07 dB
Peak SAR (extrapolated) = 0.286 W/kg
SAR(1 g) = 0.229 W/kg

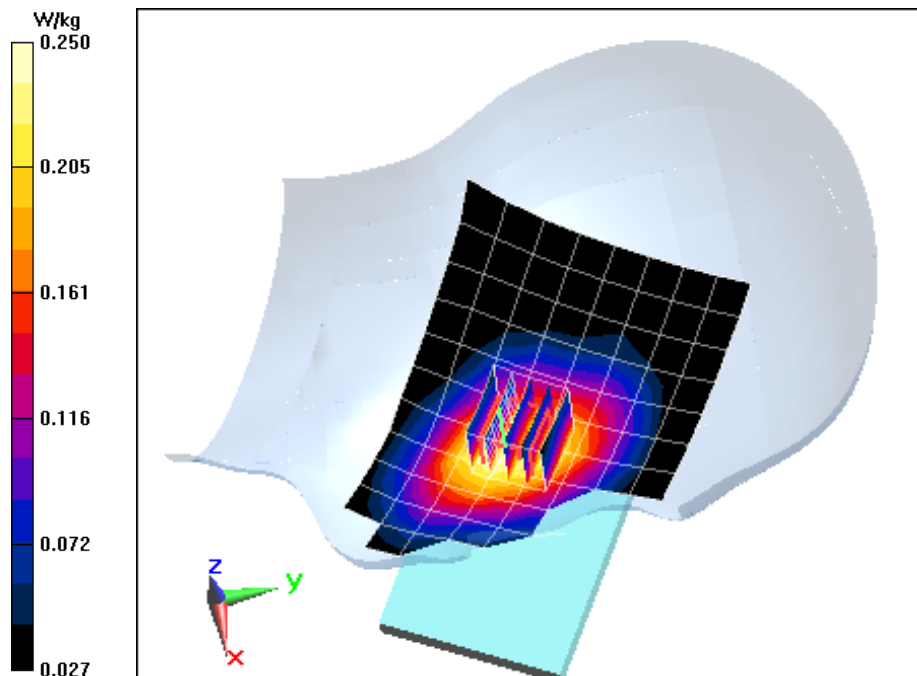

PCTEST ENGINEERING LABORATORY, INC.

DUT: A3LSMG720AX; Type: Portable Handset; Serial: 96

Communication System: UID 0, UMTS; Frequency: 836.6 MHz; Duty Cycle: 1:1
Medium: 835 Head, Medium parameters used (interpolated):
 $f = 836.6 \text{ MHz}$; $\sigma = 0.938 \text{ S/m}$; $\epsilon_r = 40.196$; $\rho = 1000 \text{ kg/m}^3$
Phantom section: Left Section

Test Date: 12-03-2014; Ambient Temp: 23.6°C; Tissue Temp: 22.5°C

Probe: ES3DV3 - SN3332; ConvF(6.31, 6.31, 6.31); Calibrated: 9/18/2014;
Sensor-Surface: 3mm (Mechanical Surface Detection)
Electronics: DAE4 Sn1323; Calibrated: 9/17/2014
Phantom: SAM V5.0 Right; Type: QD000P40CD; Serial: 1647
Measurement SW: DASY52, Version 52.8 (8); SEMCAD X Version 14.6.10 (7331)

Mode: UMTS 850, Left Head, Cheek, Mid.ch

Area Scan (9x15x1): Measurement grid: dx=15mm, dy=15mm
Zoom Scan (5x5x7)/Cube 0: Measurement grid: dx=8mm, dy=8mm, dz=5mm
Reference Value = 14.64 V/m; Power Drift = 0.06 dB
Peak SAR (extrapolated) = 0.234 W/kg
SAR(1 g) = 0.187 W/kg

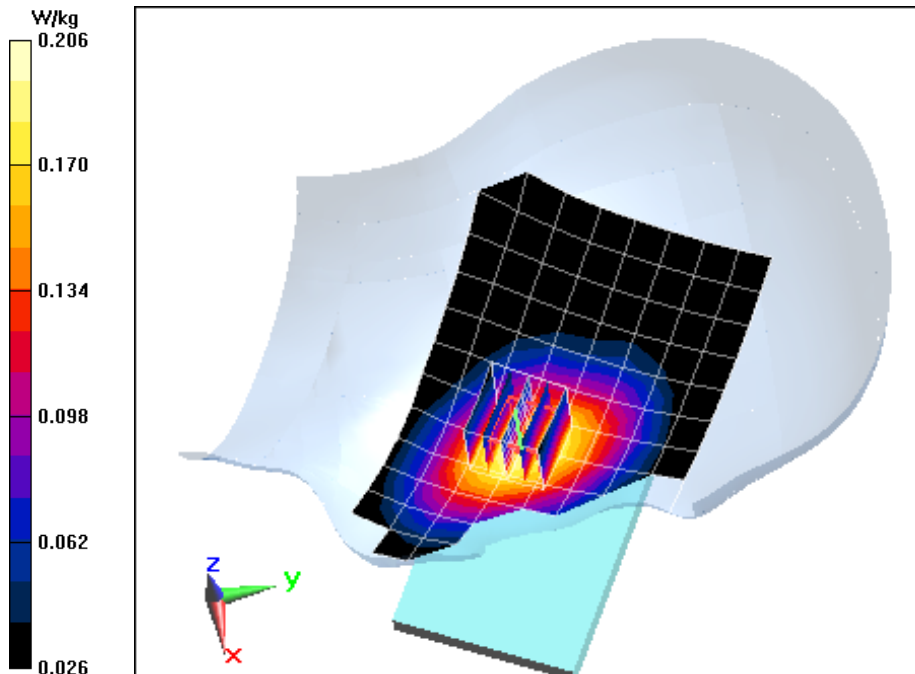

PCTEST ENGINEERING LABORATORY, INC.

DUT: A3LSMG720AX; Type: Portable Handset; Serial: 100

Communication System: UID 0, GSM1900; Frequency: 1880 MHz; Duty Cycle: 1:8.3

Medium: 1900 Head, Medium parameters used:

$f = 1880 \text{ MHz}$; $\sigma = 1.409 \text{ S/m}$; $\epsilon_r = 39.754$; $\rho = 1000 \text{ kg/m}^3$

Phantom section: Left Section

Test Date: 12-04-2014; Ambient Temp: 23.9°C; Tissue Temp: 22.7°C

Probe: ES3DV3 - SN3263; ConvF(5.08, 5.08, 5.08); Calibrated: 5/15/2014;

Sensor-Surface: 3mm (Mechanical Surface Detection)

Electronics: DAE4 Sn859; Calibrated: 5/14/2014

Phantom: SAM v5.0 Left; Type: QD000P40CD; Serial: TP: 1687

Measurement SW: DASY52, Version 52.8 (8); SEMCAD X Version 14.6.10 (7331)

Mode: GSM 1900, Left Head, Cheek, Mid.ch

Area Scan (9x15x1): Measurement grid: dx=15mm, dy=15mm

Zoom Scan (5x5x7)/Cube 0: Measurement grid: dx=8mm, dy=8mm, dz=5mm

Reference Value = 9.794 V/m; Power Drift = 0.12 dB

Peak SAR (extrapolated) = 0.190 W/kg

SAR(1 g) = 0.122 W/kg

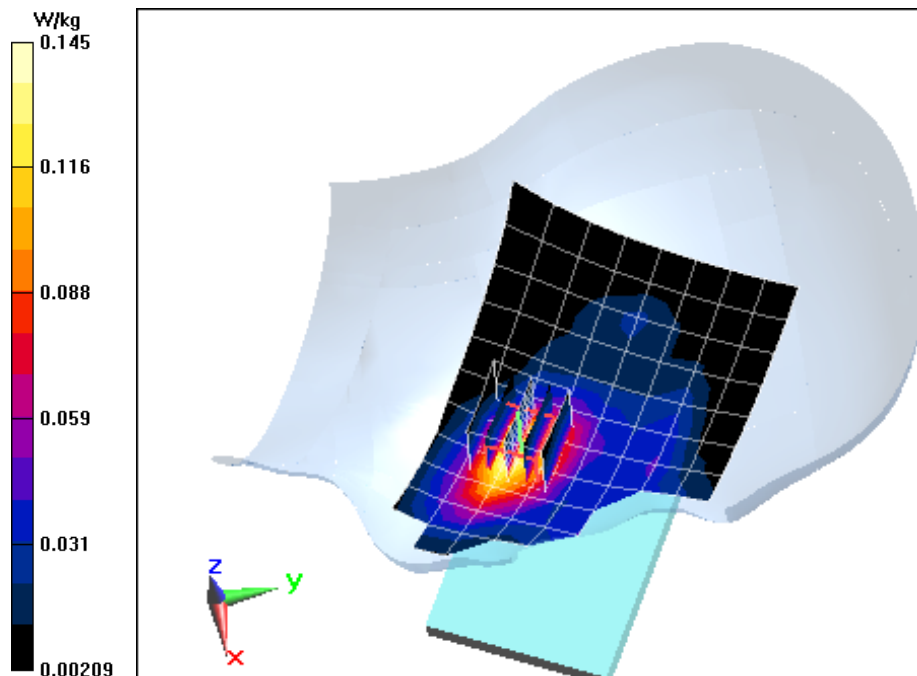

PCTEST ENGINEERING LABORATORY, INC.

DUT: A3LSMG720AX; Type: Portable Handset; Serial: 100

Communication System: UID 0, UMTS; Frequency: 1880 MHz; Duty Cycle: 1:1
Medium: 1900 Head, Medium parameters used:
 $f = 1880 \text{ MHz}$; $\sigma = 1.409 \text{ S/m}$; $\epsilon_r = 39.754$; $\rho = 1000 \text{ kg/m}^3$
Phantom section: Left Section

Test Date: 12-04-2014; Ambient Temp: 23.9°C; Tissue Temp: 22.7°C

Probe: ES3DV3 - SN3263; ConvF(5.08, 5.08, 5.08); Calibrated: 5/15/2014;
Sensor-Surface: 3mm (Mechanical Surface Detection)
Electronics: DAE4 Sn859; Calibrated: 5/14/2014
Phantom: SAM v5.0 Left; Type: QD000P40CD; Serial: TP: 1687
Measurement SW: DASY52, Version 52.8 (8); SEMCAD X Version 14.6.10 (7331)

Mode: UMTS 1900, Left Head, Cheek, Mid.ch

Area Scan (9x15x1): Measurement grid: dx=15mm, dy=15mm
Zoom Scan (5x5x7)/Cube 0: Measurement grid: dx=8mm, dy=8mm, dz=5mm
Reference Value = 12.05 V/m; Power Drift = -0.04 dB
Peak SAR (extrapolated) = 0.292 W/kg
SAR(1 g) = 0.191 W/kg

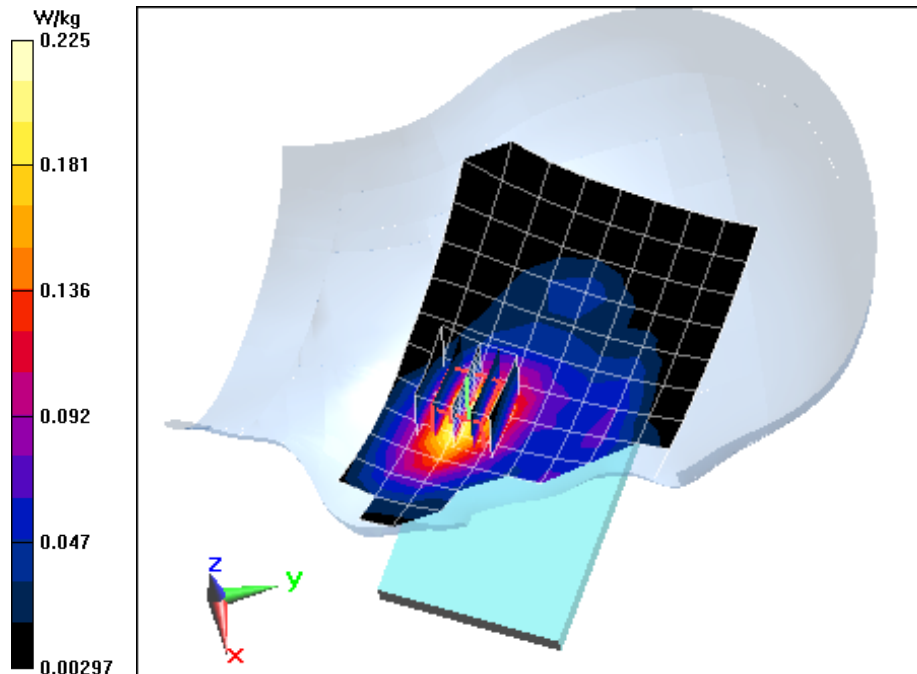

PCTEST ENGINEERING LABORATORY, INC.

DUT: A3LSMG720AX; Type: Portable Handset; Serial: 100

Communication System: UID 0, LTE Band 17; Frequency: 710 MHz; Duty Cycle: 1:1

Medium: 750 Head, Medium parameters used:

$f = 710 \text{ MHz}$; $\sigma = 0.899 \text{ S/m}$; $\epsilon_r = 42.74$; $\rho = 1000 \text{ kg/m}^3$

Phantom section: Left Section

Test Date: 12-08-2014; Ambient Temp: 23.0°C; Tissue Temp: 21.3°C

Probe: ES3DV3 - SN3288; ConvF(6.81, 6.81, 6.81); Calibrated: 9/24/2014;

Sensor-Surface: 3mm (Mechanical Surface Detection)

Electronics: DAE4 Sn1364; Calibrated: 9/18/2014

Phantom: SAM with CRP v4.0; Type: QD000P40CD; Serial: TP:1797

Measurement SW: DASY52, Version 52.8 (8); SEMCAD X Version 14.6.10 (7331)

**Mode: LTE Band 17, Left Head, Cheek, Mid.ch,
QPSK, 10 MHz Bandwidth, 1 RB, 0 RB Offset**

Area Scan (8x13x1): Measurement grid: dx=15mm, dy=15mm

Zoom Scan (6x6x7)/Cube 0: Measurement grid: dx=8mm, dy=8mm, dz=5mm

Reference Value = 7.267 V/m; Power Drift = 0.11 dB

Peak SAR (extrapolated) = 0.0610 W/kg

SAR(1 g) = 0.045 W/kg

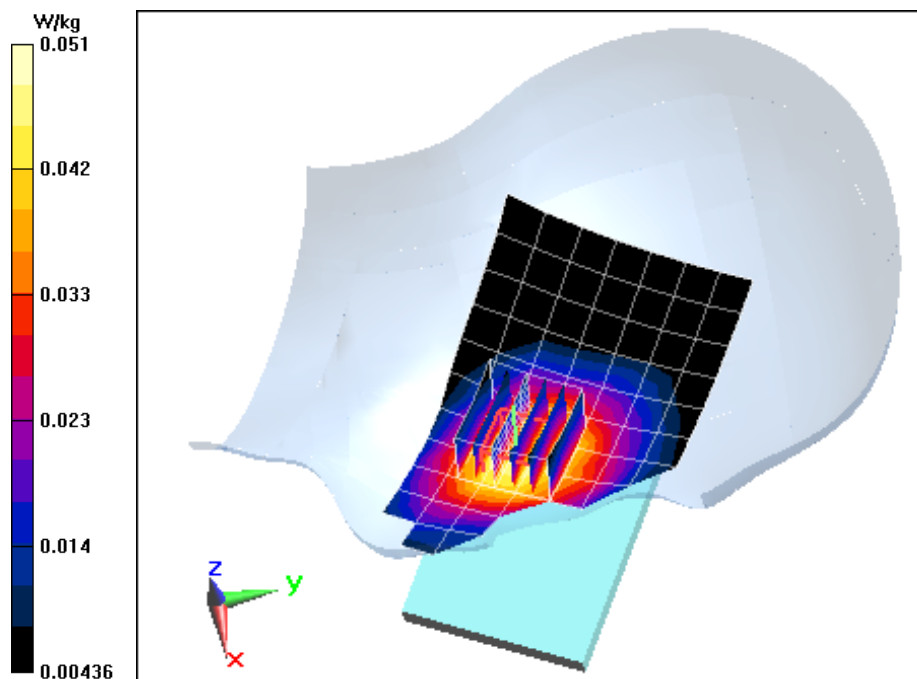

PCTEST ENGINEERING LABORATORY, INC.

DUT: A3LSMG720AX; Type: Portable Handset; Serial: 96

Communication System: UID 0, LTE Band 4 (AWS); Frequency: 1732.5 MHz; Duty Cycle: 1:1
Medium: 1750 Head, Medium parameters used (interpolated):
 $f = 1732.5 \text{ MHz}$; $\sigma = 1.365 \text{ S/m}$; $\epsilon_r = 39.026$; $\rho = 1000 \text{ kg/m}^3$
Phantom section: Left Section

Test Date: 12-01-2014; Ambient Temp: 24.0°C; Tissue Temp: 22.0°C

Probe: ES3DV2 - SN3022; ConvF(5.04, 5.04, 5.04); Calibrated: 8/19/2014;
Sensor-Surface: 3mm (Mechanical Surface Detection)
Electronics: DAE4 Sn1322; Calibrated: 8/12/2014
Phantom: SAM with CRP v4.0; Type: QD000P40CD; Serial: TP:1800
Measurement SW: DASY52, Version 52.8 (8); SEMCAD X Version 14.6.10 (7331)

**Mode: LTE Band 4 (AWS), Left Head, Cheek, Mid.ch,
QPSK, 20 MHz Bandwidth, 1 RB, 0 RB Offset**

Area Scan (9x14x1): Measurement grid: $dx=15\text{mm}$, $dy=15\text{mm}$
Zoom Scan (5x5x7)/Cube 0: Measurement grid: $dx=8\text{mm}$, $dy=8\text{mm}$, $dz=5\text{mm}$
Reference Value = 11.75 V/m; Power Drift = 0.03 dB
Peak SAR (extrapolated) = 0.246 W/kg
SAR(1 g) = 0.158 W/kg

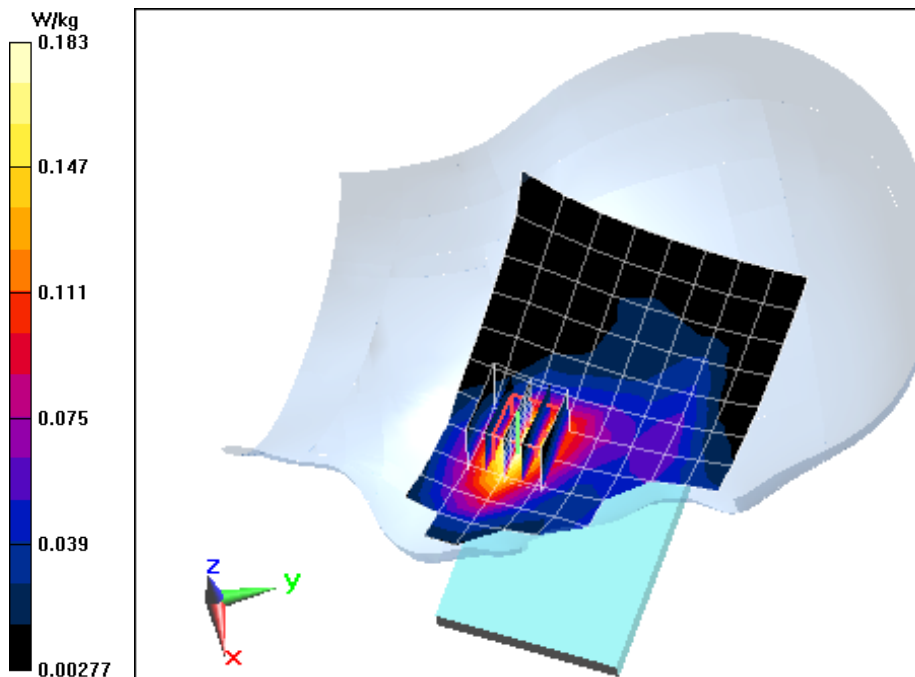

PCTEST ENGINEERING LABORATORY, INC.

DUT: A3LSMG720AX; Type: Portable Handset; Serial: 100

Communication System: UID 0, LTE Band 2 (PCS); Frequency: 1900 MHz; Duty Cycle: 1:1
Medium: 1900 Head, Medium parameters used (interpolated):
 $f = 1900 \text{ MHz}$; $\sigma = 1.43 \text{ S/m}$; $\epsilon_r = 39.711$; $\rho = 1000 \text{ kg/m}^3$
Phantom section: Left Section

Test Date: 12-04-2014; Ambient Temp: 23.9°C; Tissue Temp: 22.7°C

Probe: ES3DV3 - SN3263; ConvF(5.08, 5.08, 5.08); Calibrated: 5/15/2014;
Sensor-Surface: 3mm (Mechanical Surface Detection)
Electronics: DAE4 Sn859; Calibrated: 5/14/2014
Phantom: SAM v5.0 Left; Type: QD000P40CD; Serial: TP: 1687
Measurement SW: DASY52, Version 52.8 (8); SEMCAD X Version 14.6.10 (7331)

**Mode: LTE Band 2 (PCS), Left Head, Cheek, High.ch,
QPSK, 20 MHz Bandwidth, 1 RB, 50 RB Offset**

Area Scan (9x15x1): Measurement grid: $dx=15\text{mm}$, $dy=15\text{mm}$
Zoom Scan (5x5x7)/Cube 0: Measurement grid: $dx=8\text{mm}$, $dy=8\text{mm}$, $dz=5\text{mm}$
Reference Value = 12.93 V/m; Power Drift = 0.04 dB
Peak SAR (extrapolated) = 0.268 W/kg
SAR(1 g) = 0.176 W/kg

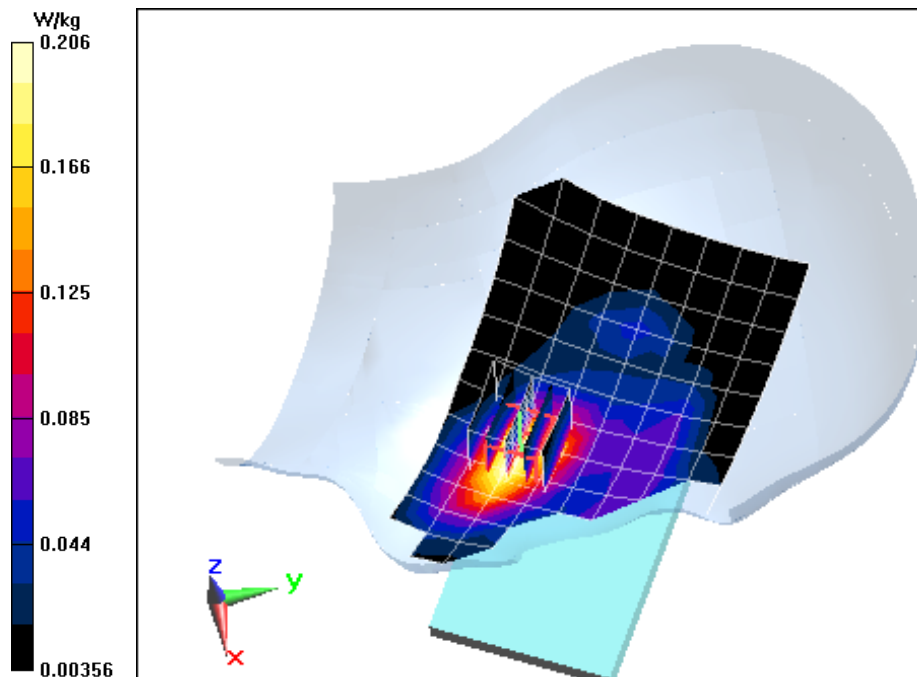

PCTEST ENGINEERING LABORATORY, INC.

DUT: A3LSMG720AX; Type: Portable Handset; Serial: 100

Communication System: UID 0, IEEE 802.11b; Frequency: 2462 MHz; Duty Cycle: 1:1
Medium: 2450 Head, Medium parameters used (interpolated):
 $f = 2462 \text{ MHz}$; $\sigma = 1.89 \text{ S/m}$; $\epsilon_r = 38.803$; $\rho = 1000 \text{ kg/m}^3$
Phantom section: Right Section

Test Date: 12-08-2014; Ambient Temp: 23.7°C; Tissue Temp: 22.8°C

Probe: ES3DV3 - SN3258; ConvF(4.52, 4.52, 4.52); Calibrated: 2/25/2014;
Sensor-Surface: 3mm (Mechanical Surface Detection)
Electronics: DAE4 Sn665; Calibrated: 2/26/2014
Phantom: SAM Front; Type: SAM; Serial: 1686
Measurement SW: DASY52, Version 52.8 (8); SEMCAD X Version 14.6.10 (7331)

Mode: IEEE 802.11b, Right Head, Cheek, Ch 11, 1 Mbps

Area Scan (10x16x1): Measurement grid: dx=12mm, dy=12mm
Zoom Scan (7x7x7)/Cube 0: Measurement grid: dx=5mm, dy=5mm, dz=5mm
Reference Value = 8.769 V/m; Power Drift = -0.05 dB
Peak SAR (extrapolated) = 0.380 W/kg
SAR(1 g) = 0.156 W/kg

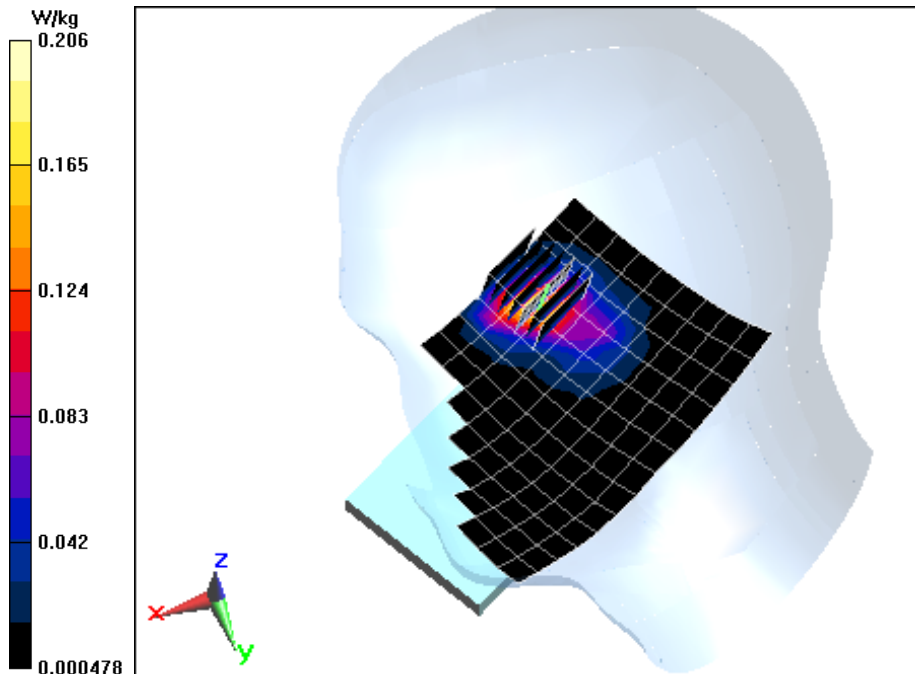

PCTEST ENGINEERING LABORATORY, INC.

DUT: A3LSMG720AX; Type: Portable Handset; Serial: 96

Communication System: UID 0, GSM; Frequency: 836.6 MHz; Duty Cycle: 1:8.3
Medium: 835 Body, Medium parameters used (interpolated):
 $f = 836.6 \text{ MHz}$; $\sigma = 0.986 \text{ S/m}$; $\epsilon_r = 54.284$; $\rho = 1000 \text{ kg/m}^3$
Phantom section: Flat Section; Space: 1.0 cm

Test Date: 12-01-2014; Ambient Temp: 23.4°C; Tissue Temp: 21.4°C

Probe: ES3DV3 - SN3209; ConvF(6.14, 6.14, 6.14); Calibrated: 3/19/2014;
Sensor-Surface: 3mm (Mechanical Surface Detection)
Electronics: DAE4 Sn1334; Calibrated: 3/17/2014
Phantom: SAM front; Type: QD000P40CD; Serial: TP:1759
Measurement SW: DASY52, Version 52.8 (8); SEMCAD X Version 14.6.10 (7331)

Mode: GSM 850, Body SAR, Back side, Mid.ch

Area Scan (9x14x1): Measurement grid: dx=15mm, dy=15mm
Zoom Scan (5x5x7)/Cube 0: Measurement grid: dx=8mm, dy=8mm, dz=5mm
Reference Value = 19.99 V/m; Power Drift = -0.01 dB
Peak SAR (extrapolated) = 0.404 W/kg
SAR(1 g) = 0.358 W/kg

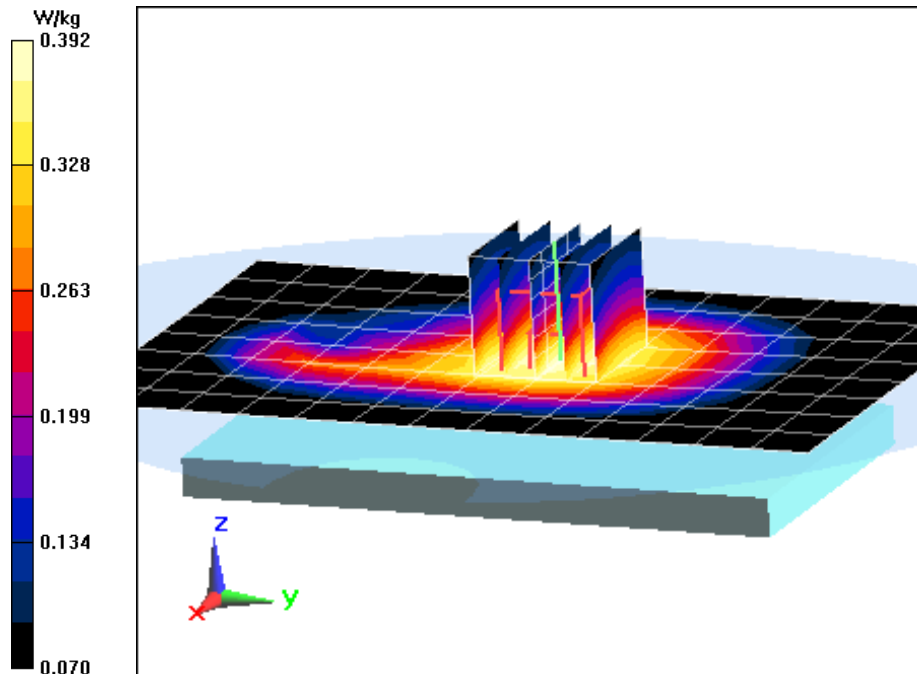

PCTEST ENGINEERING LABORATORY, INC.

DUT: A3LSMG720AX; Type: Portable Handset; Serial: 96

Communication System: UID 0, GSM GPRS; 3 Tx slots; Frequency: 836.6 MHz; Duty Cycle: 1:2.76
Medium: 835 Body, Medium parameters used (interpolated):
 $f = 836.6 \text{ MHz}$; $\sigma = 0.986 \text{ S/m}$; $\epsilon_r = 54.284$; $\rho = 1000 \text{ kg/m}^3$
Phantom section: Flat Section; Space: 1.0 cm

Test Date: 12-01-2014; Ambient Temp: 23.4°C; Tissue Temp: 21.4°C

Probe: ES3DV3 - SN3209; ConvF(6.14, 6.14, 6.14); Calibrated: 3/19/2014;
Sensor-Surface: 3mm (Mechanical Surface Detection)
Electronics: DAE4 Sn1334; Calibrated: 3/17/2014
Phantom: SAM front; Type: QD000P40CD; Serial: TP:1759
Measurement SW: DASY52, Version 52.8 (8); SEMCAD X Version 14.6.10 (7331)

Mode: GPRS 850, Body SAR, Back side, Mid.ch, 3 Tx Slots

Area Scan (9x15x1): Measurement grid: dx=15mm, dy=15mm
Zoom Scan (6x5x7)/Cube 0: Measurement grid: dx=8mm, dy=8mm, dz=5mm
Reference Value = 20.58 V/m; Power Drift = 0.01 dB
Peak SAR (extrapolated) = 0.501 W/kg
SAR(1 g) = 0.394 W/kg

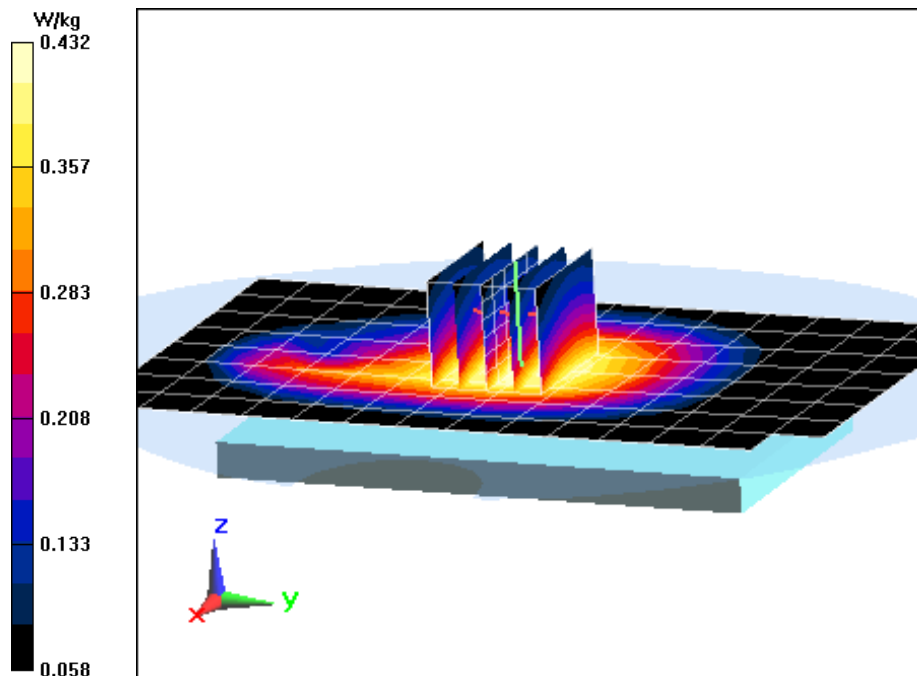

PCTEST ENGINEERING LABORATORY, INC.

DUT: A3LSMG720AX; Type: Portable Handset; Serial: 96

Communication System: UID 0, UMTS; Frequency: 836.6 MHz; Duty Cycle: 1:1
Medium: 835 Body, Medium parameters used (interpolated):
 $f = 836.6 \text{ MHz}$; $\sigma = 1.001 \text{ S/m}$; $\epsilon_r = 53.161$; $\rho = 1000 \text{ kg/m}^3$
Phantom section: Flat Section; Space: 1.0 cm

Test Date: 12-03-2014; Ambient Temp: 23.1°C; Tissue Temp: 22.1°C

Probe: ES3DV3 - SN3288; ConvF(6.32, 6.32, 6.32); Calibrated: 9/24/2014;
Sensor-Surface: 3mm (Mechanical Surface Detection)
Electronics: DAE4 Sn1364; Calibrated: 9/18/2014
Phantom: ELI v5.0; Type: QDOVA001BB; Serial: 1229
Measurement SW: DASY52, Version 52.8 (8); SEMCAD X Version 14.6.10 (7331)

Mode: UMTS 850, Body SAR, Back side, Mid.ch

Area Scan (9x15x1): Measurement grid: dx=15mm, dy=15mm
Zoom Scan (6x5x7)/Cube 0: Measurement grid: dx=8mm, dy=8mm, dz=5mm
Reference Value = 16.90 V/m; Power Drift = -0.01 dB
Peak SAR (extrapolated) = 0.349 W/kg
SAR(1 g) = 0.272 W/kg

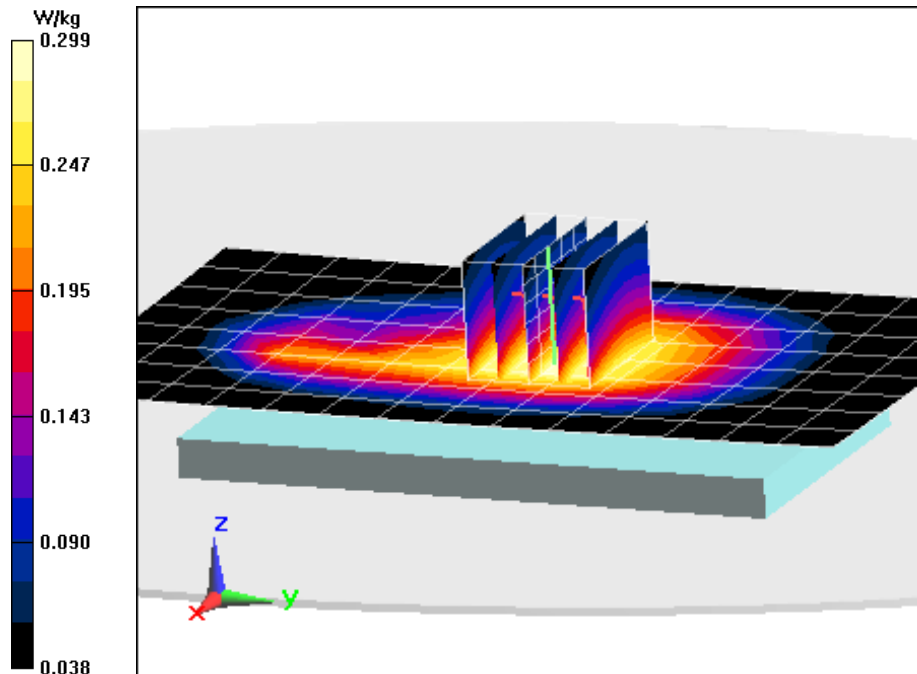

PCTEST ENGINEERING LABORATORY, INC.

DUT: A3LSMG720AX; Type: Portable Handset; Serial: 100

Communication System: UID 0, GSM; Frequency: 1880 MHz; Duty Cycle: 1:8.3
Medium: 1900 Body, Medium parameters used:
 $f = 1880 \text{ MHz}$; $\sigma = 1.558 \text{ S/m}$; $\epsilon_r = 52.024$; $\rho = 1000 \text{ kg/m}^3$
Phantom section: Flat Section; Space: 1.0 cm

Test Date: 12-01-2014; Ambient Temp: 24.5°C; Tissue Temp: 22.8°C

Probe: ES3DV3 - SN3258; ConvF(4.61, 4.61, 4.61); Calibrated: 2/25/2014;
Sensor-Surface: 3mm (Mechanical Surface Detection)
Electronics: DAE4 Sn665; Calibrated: 2/26/2014
Phantom: ELI v5.0; Type: QDOVA002AA; Serial: TP-1158
Measurement SW: DASY52, Version 52.8 (8); SEMCAD X Version 14.6.10 (7331)

Mode: GSM 1900, Body SAR, Back side, Mid.ch

Area Scan (9x15x1): Measurement grid: dx=15mm, dy=15mm
Zoom Scan (5x5x7)/Cube 0: Measurement grid: dx=8mm, dy=8mm, dz=5mm
Reference Value = 14.96 V/m; Power Drift = 0.00 dB
Peak SAR (extrapolated) = 0.639 W/kg
SAR(1 g) = 0.390 W/kg

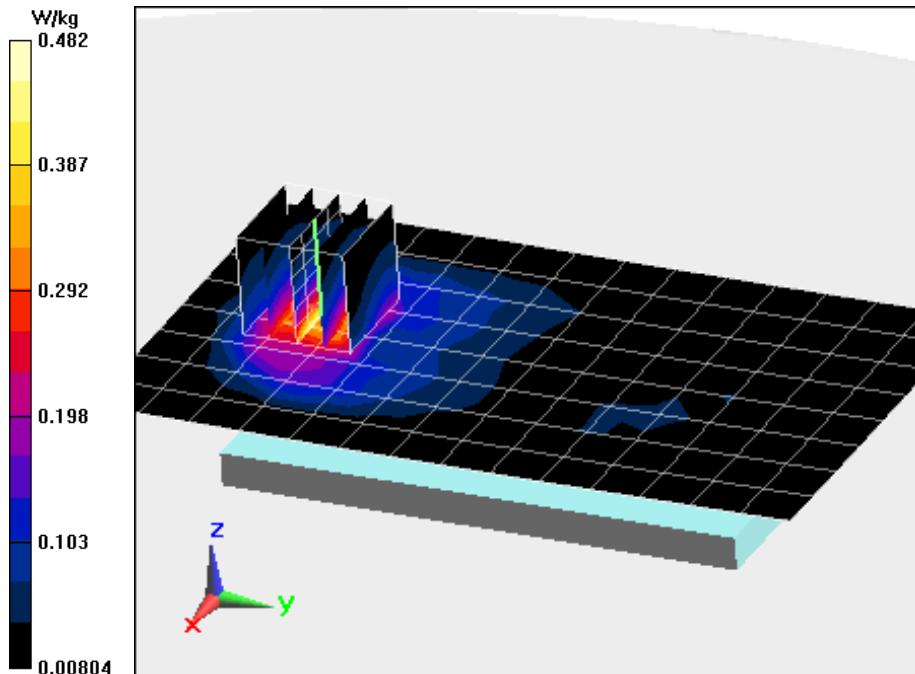

PCTEST ENGINEERING LABORATORY, INC.

DUT: A3LSMG720AX; Type: Portable Handset; Serial: 100

Communication System: UID 0, GSM GPRS; 2 Tx slots; Frequency: 1880 MHz; Duty Cycle: 1:4.15

Medium: 1900 Body, Medium parameters used:

$f = 1880 \text{ MHz}$; $\sigma = 1.558 \text{ S/m}$; $\epsilon_r = 52.024$; $\rho = 1000 \text{ kg/m}^3$

Phantom section: Flat Section; Space: 1.0 cm

Test Date: 12-01-2014; Ambient Temp: 24.5°C; Tissue Temp: 22.8°C

Probe: ES3DV3 - SN3258; ConvF(4.61, 4.61, 4.61); Calibrated: 2/25/2014;

Sensor-Surface: 3mm (Mechanical Surface Detection)

Electronics: DAE4 Sn665; Calibrated: 2/26/2014

Phantom: ELI v5.0; Type: QDOVA002AA; Serial: TP-1158

Measurement SW: DASY52, Version 52.8 (8); SEMCAD X Version 14.6.10 (7331)

Mode: GPRS 1900, Body SAR, Back side, Mid.ch, 2 Tx Slots

Area Scan (9x15x1): Measurement grid: dx=15mm, dy=15mm

Zoom Scan (5x5x7)/Cube 0: Measurement grid: dx=8mm, dy=8mm, dz=5mm

Reference Value = 15.69 V/m; Power Drift = -0.10 dB

Peak SAR (extrapolated) = 0.689 W/kg

SAR(1 g) = 0.417 W/kg

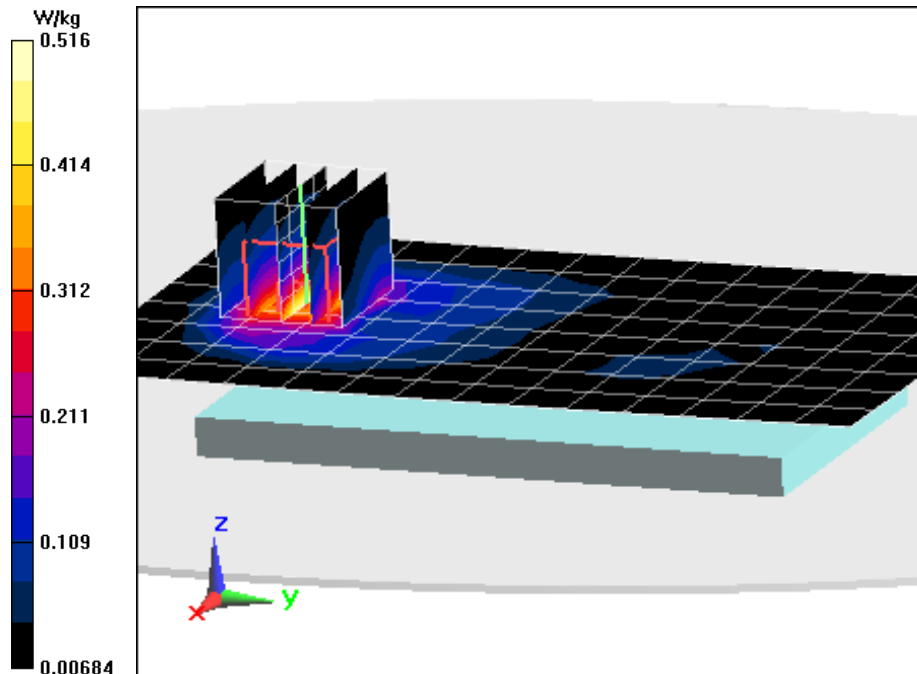

PCTEST ENGINEERING LABORATORY, INC.

DUT: A3LSMG720AX; Type: Portable Handset; Serial: 100

Communication System: UID 0, UMTS; Frequency: 1880 MHz; Duty Cycle: 1:1
Medium: 1900 Body, Medium parameters used:
 $f = 1880 \text{ MHz}$; $\sigma = 1.558 \text{ S/m}$; $\epsilon_r = 52.024$; $\rho = 1000 \text{ kg/m}^3$
Phantom section: Flat Section; Space: 1.0 cm

Test Date: 12-01-2014; Ambient Temp: 24.5°C; Tissue Temp: 22.8°C

Probe: ES3DV3 - SN3258; ConvF(4.61, 4.61, 4.61); Calibrated: 2/25/2014;
Sensor-Surface: 3mm (Mechanical Surface Detection)
Electronics: DAE4 Sn665; Calibrated: 2/26/2014
Phantom: ELI v5.0; Type: QDOVA002AA; Serial: TP-1158
Measurement SW: DASY52, Version 52.8 (8); SEMCAD X Version 14.6.10 (7331)

Mode: UMTS 1900, Body SAR, Back side, Mid.ch

Area Scan (9x14x1): Measurement grid: dx=15mm, dy=15mm
Zoom Scan (5x5x7)/Cube 0: Measurement grid: dx=8mm, dy=8mm, dz=5mm
Reference Value = 21.06 V/m; Power Drift = -0.02 dB
Peak SAR (extrapolated) = 1.05 W/kg
SAR(1 g) = 0.641 W/kg

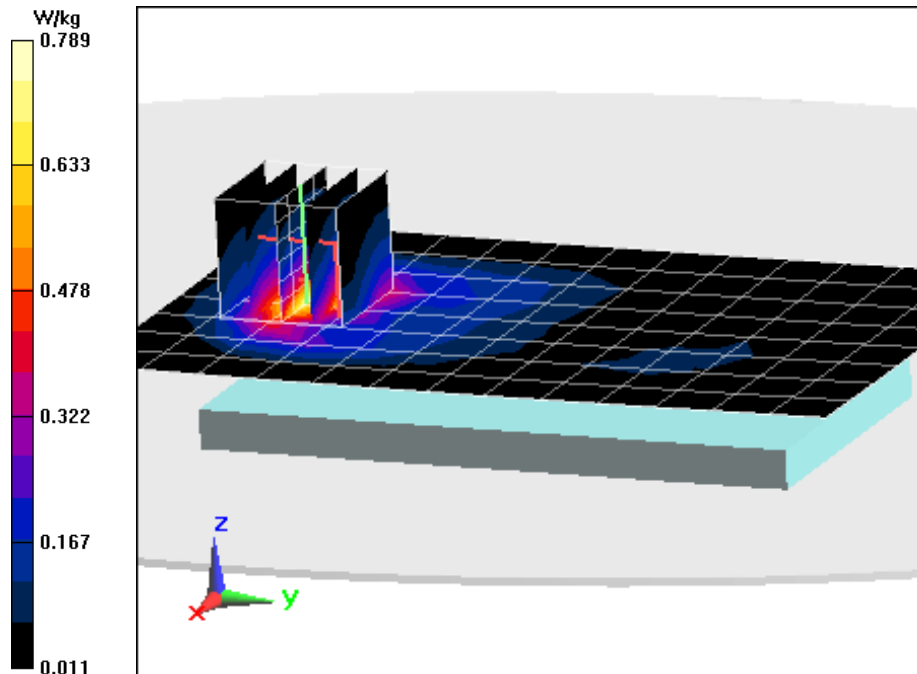

PCTEST ENGINEERING LABORATORY, INC.

DUT: A3LSMG720AX; Type: Portable Handset; Serial: 96

Communication System: UID 0, LTE Band 17; Frequency: 710 MHz; Duty Cycle: 1:1

Medium: 750 Body, Medium parameters used:

$f = 710 \text{ MHz}$; $\sigma = 0.955 \text{ S/m}$; $\epsilon_r = 55.749$; $\rho = 1000 \text{ kg/m}^3$

Phantom section: Flat Section; Space: 1.0 cm

Test Date: 12-04-2014; Ambient Temp: 23.3°C; Tissue Temp: 22.8°C

Probe: ES3DV3 - SN3258; ConvF(6.15, 6.15, 6.15); Calibrated: 2/25/2014;

Sensor-Surface: 3mm (Mechanical Surface Detection)

Electronics: DAE4 Sn665; Calibrated: 2/26/2014

Phantom: ELI v5.0; Type: QDOVA002AA; Serial: TP-1158

Measurement SW: DASY52, Version 52.8 (8); SEMCAD X Version 14.6.10 (7331)

**Mode: LTE Band 17, Body SAR, Back side, Mid.ch, 10 MHz Bandwidth,
QPSK, 1 RB, 0 RB Offset**

Area Scan (8x13x1): Measurement grid: dx=15mm, dy=15mm

Zoom Scan (5x6x7)/Cube 0: Measurement grid: dx=8mm, dy=8mm, dz=5mm

Reference Value = 9.088 V/m; Power Drift = 0.11 dB

Peak SAR (extrapolated) = 0.133 W/kg

SAR(1 g) = 0.079 W/kg

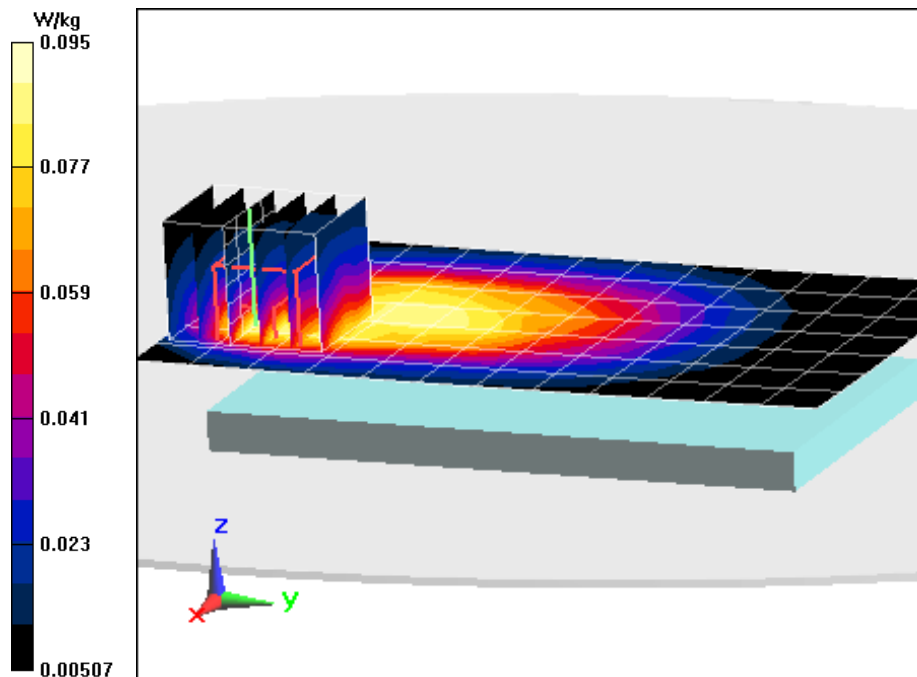

PCTEST ENGINEERING LABORATORY, INC.

DUT: A3LSMG720AX; Type: Portable Handset; Serial: 96

Communication System: UID 0, LTE Band 4 (AWS); Frequency: 1732.5 MHz; Duty Cycle: 1:1
Medium: 1750 Body, Medium parameters used (interpolated):
 $f = 1732.5 \text{ MHz}$; $\sigma = 1.488 \text{ S/m}$; $\epsilon_r = 51.684$; $\rho = 1000 \text{ kg/m}^3$
Phantom section: Flat Section; Space: 1.0 cm

Test Date: 12-01-2014; Ambient Temp: 22.9°C; Tissue Temp: 22.2°C

Probe: ES3DV2 - SN3022; ConvF(4.7, 4.7, 4.7); Calibrated: 8/19/2014;

Sensor-Surface: 3mm (Mechanical Surface Detection)

Electronics: DAE4 Sn1322; Calibrated: 8/12/2014

Phantom: ELI v5.0; Type: QDOVA001BB; Serial: 1226

Measurement SW: DASY52, Version 52.8 (8); SEMCAD X Version 14.6.10 (7331)

**Mode: LTE Band 4 (AWS), Body SAR, Back side, Mid.ch, 20 MHz Bandwidth,
QPSK, 1 RB, 0 RB Offset**

Area Scan (9x13x1): Measurement grid: $dx=15\text{mm}$, $dy=15\text{mm}$

Zoom Scan (5x5x7)/Cube 0: Measurement grid: $dx=8\text{mm}$, $dy=8\text{mm}$, $dz=5\text{mm}$

Reference Value = 20.52 V/m; Power Drift = -0.03 dB

Peak SAR (extrapolated) = 0.927 W/kg

SAR(1 g) = 0.564 W/kg

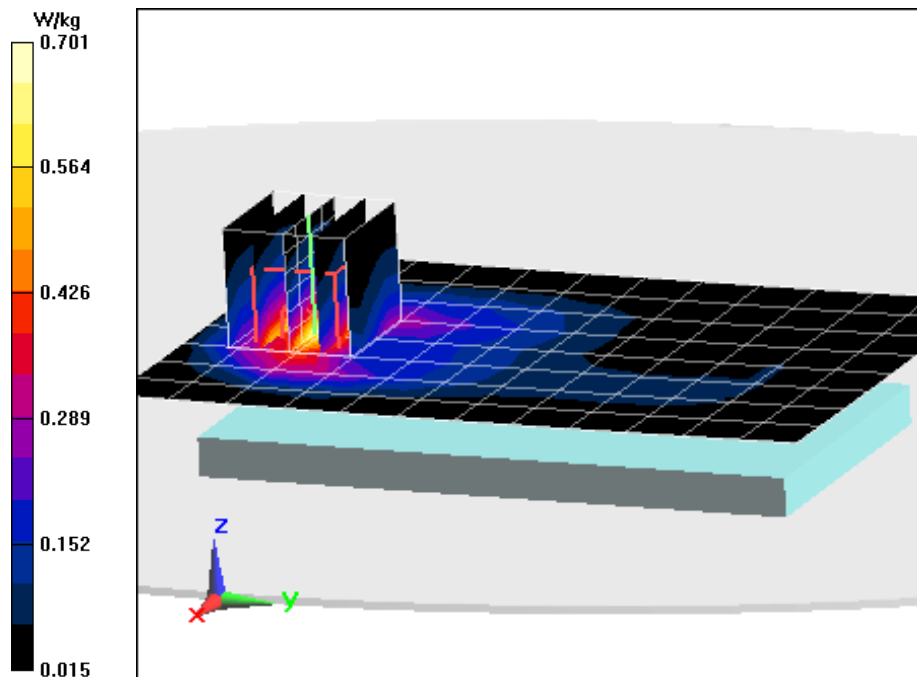

PCTEST ENGINEERING LABORATORY, INC.

DUT: A3LSMG720AX; Type: Portable Handset; Serial: 100

Communication System: UID 0, LTE Band 2 (PCS); Frequency: 1900 MHz; Duty Cycle: 1:1
Medium: 1900 Body, Medium parameters used (interpolated):
 $f = 1900 \text{ MHz}$; $\sigma = 1.583 \text{ S/m}$; $\epsilon_r = 51.945$; $\rho = 1000 \text{ kg/m}^3$
Phantom section: Flat Section; Space: 1.0 cm

Test Date: 12-01-2014; Ambient Temp: 24.5°C; Tissue Temp: 22.8°C

Probe: ES3DV3 - SN3258; ConvF(4.61, 4.61, 4.61); Calibrated: 2/25/2014;
Sensor-Surface: 3mm (Mechanical Surface Detection)
Electronics: DAE4 Sn665; Calibrated: 2/26/2014
Phantom: ELI v5.0; Type: QDOVA002AA; Serial: TP-1158
Measurement SW: DASY52, Version 52.8 (8); SEMCAD X Version 14.6.10 (7331)

**Mode: LTE Band 2 (PCS), Body SAR, Back side, High.ch, 20 MHz Bandwidth,
QPSK, 1 RB, 50 RB Offset**

Area Scan (8x13x1): Measurement grid: dx=15mm, dy=15mm
Zoom Scan (5x5x7)/Cube 0: Measurement grid: dx=8mm, dy=8mm, dz=5mm
Reference Value = 20.82 V/m; Power Drift = 0.01 dB
Peak SAR (extrapolated) = 1.02 W/kg
SAR(1 g) = 0.625 W/kg

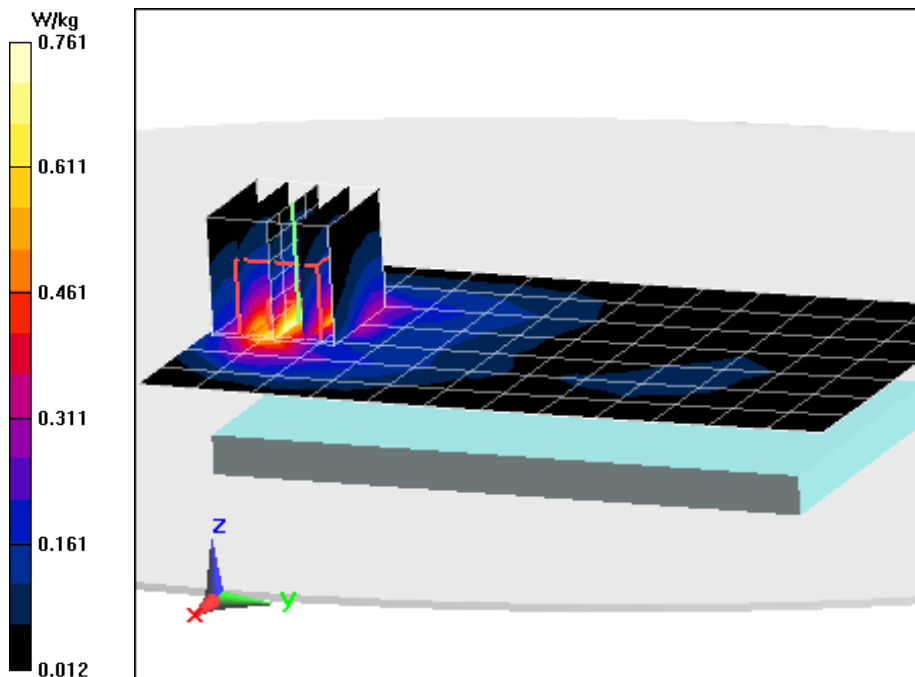

PCTEST ENGINEERING LABORATORY, INC.

DUT: A3LSMG720AX; Type: Portable Handset; Serial: 100

Communication System: UID 0, IEEE 802.11b; Frequency: 2462 MHz; Duty Cycle: 1:1
Medium: 2450 Body, Medium parameters used (interpolated):
 $f = 2462 \text{ MHz}$; $\sigma = 2.061 \text{ S/m}$; $\epsilon_r = 53.329$; $\rho = 1000 \text{ kg/m}^3$
Phantom section: Flat Section; Space: 1.0 cm

Test Date: 12-01-2014; Ambient Temp: 23.1°C; Tissue Temp: 23.1°C

Probe: ES3DV3 - SN3319; ConvF(4.24, 4.24, 4.24); Calibrated: 4/17/2014;
Sensor-Surface: 3mm (Mechanical Surface Detection)
Electronics: DAE4 Sn1368; Calibrated: 4/11/2014
Phantom: SAM; Type: QD000P40CD; Serial: TP:1758
Measurement SW: DASY52, Version 52.8 (8); SEMCAD X Version 14.6.10 (7331)

Mode: IEEE 802.11b, Body SAR, Ch 11, 1 Mbps, Back Side

Area Scan (11x18x1): Measurement grid: dx=12mm, dy=12mm
Zoom Scan (7x7x7)/Cube 0: Measurement grid: dx=5mm, dy=5mm, dz=5mm
Reference Value = 11.19 V/m; Power Drift = -0.05 dB
Peak SAR (extrapolated) = 0.486 W/kg
SAR(1 g) = 0.225 W/kg

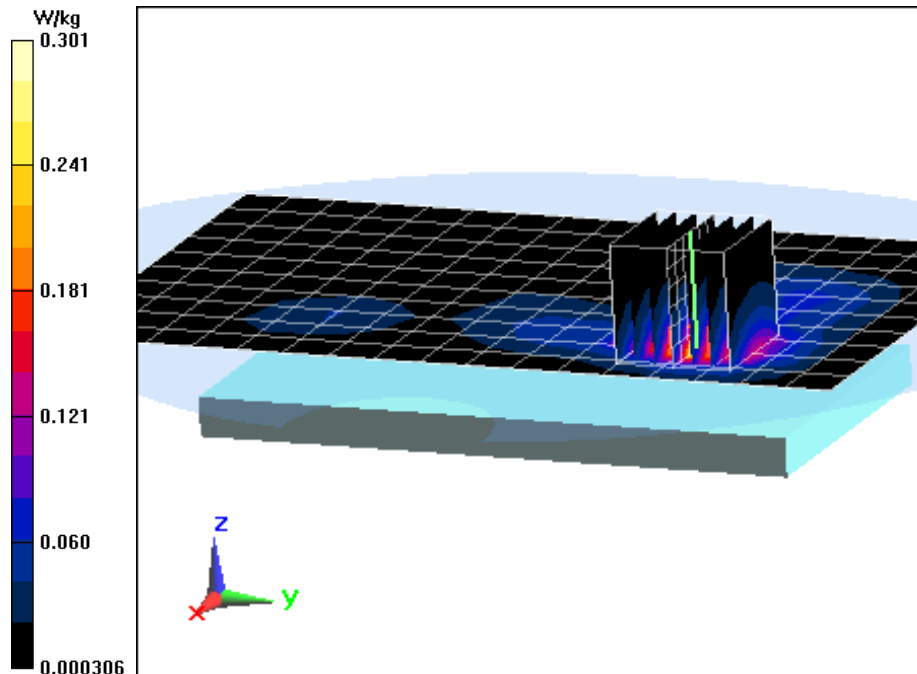

APPENDIX B: SYSTEM VERIFICATION

PCTEST ENGINEERING LABORATORY, INC.

DUT: Dipole 750 MHz; Type: D750V3; Serial: 1003

Communication System: UID 0, CW; Frequency: 750 MHz; Duty Cycle: 1:1

Medium: 750 Head, Medium parameters used (interpolated):

$f = 750 \text{ MHz}$; $\sigma = 0.933 \text{ S/m}$; $\epsilon_r = 42.25$; $\rho = 1000 \text{ kg/m}^3$

Phantom section: Flat Section; Space: 1.5 cm

Test Date: 12-08-2014; Ambient Temp: 23.0°C; Tissue Temp: 21.3°C

Probe: ES3DV3 - SN3288; ConvF(6.81, 6.81, 6.81); Calibrated: 9/24/2014;

Sensor-Surface: 3mm (Mechanical Surface Detection)

Electronics: DAE4 Sn1364; Calibrated: 9/18/2014

Phantom: SAM with CRP v4.0; Type: QD000P40CD; Serial: TP:1797

Measurement SW: DASY52, Version 52.8 (8); SEMCAD X Version 14.6.10 (7331)

750 MHz System Verification

Area Scan (7x15x1): Measurement grid: dx=15mm, dy=15mm

Zoom Scan (5x5x7)/Cube 0: Measurement grid: dx=8mm, dy=8mm, dz=5mm

Input Power = 20.0 dBm (100 mW)

Peak SAR (extrapolated) = 1.23 W/kg

SAR(1 g) = 0.814 W/kg

Deviation = -2.75%

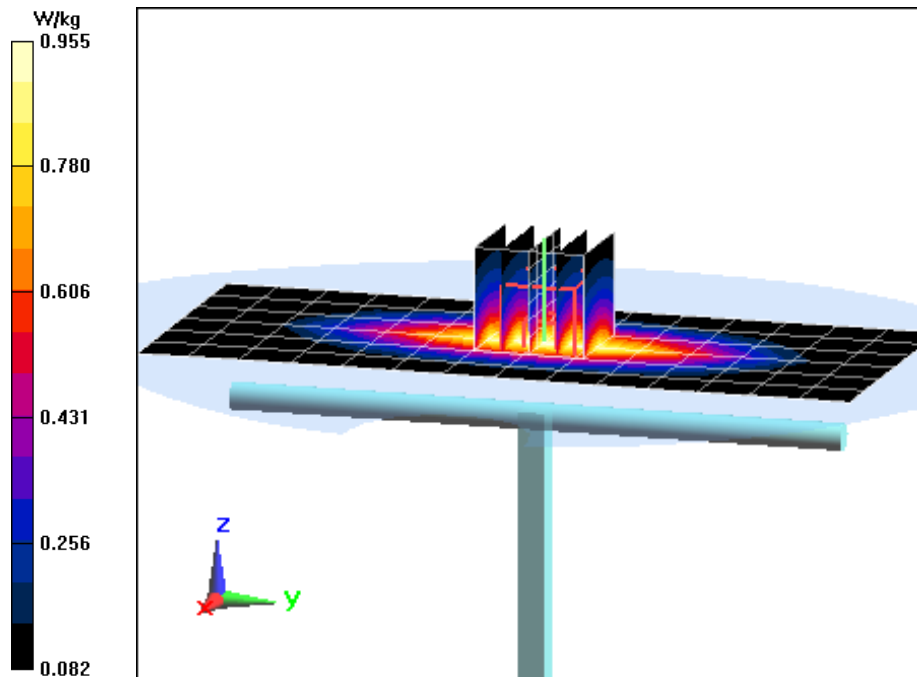

PCTEST ENGINEERING LABORATORY, INC.

DUT: Dipole 835 MHz; Type: D835V2; Serial: 4d119

Communication System: UID 0, CW; Frequency: 835 MHz; Duty Cycle: 1:1

Medium: 835 Head, Medium parameters used:

$f = 835 \text{ MHz}$; $\sigma = 0.937 \text{ S/m}$; $\epsilon_r = 40.218$; $\rho = 1000 \text{ kg/m}^3$

Phantom section: Flat Section; Space: 1.5 cm

Test Date: 12-03-2014; Ambient Temp: 23.6°C; Tissue Temp: 22.5°C

Probe: ES3DV3 - SN3332; ConvF(6.31, 6.31, 6.31); Calibrated: 9/18/2014;

Sensor-Surface: 3mm (Mechanical Surface Detection)

Electronics: DAE4 Sn1323; Calibrated: 9/17/2014

Phantom: SAM V5.0 Right; Type: QD000P40CD; Serial: 1647

Measurement SW: DASY52, Version 52.8 (8); SEMCAD X Version 14.6.10 (7331)

835 MHz System Verification

Area Scan (7x14x1): Measurement grid: dx=15mm, dy=15mm

Zoom Scan (5x5x7)/Cube 0: Measurement grid: dx=8mm, dy=8mm, dz=5mm

Input Power = 20.0 dBm (100 mW)

Peak SAR (extrapolated) = 1.31 W/kg

SAR(1 g) = 0.884 W/kg

Deviation = -4.12%

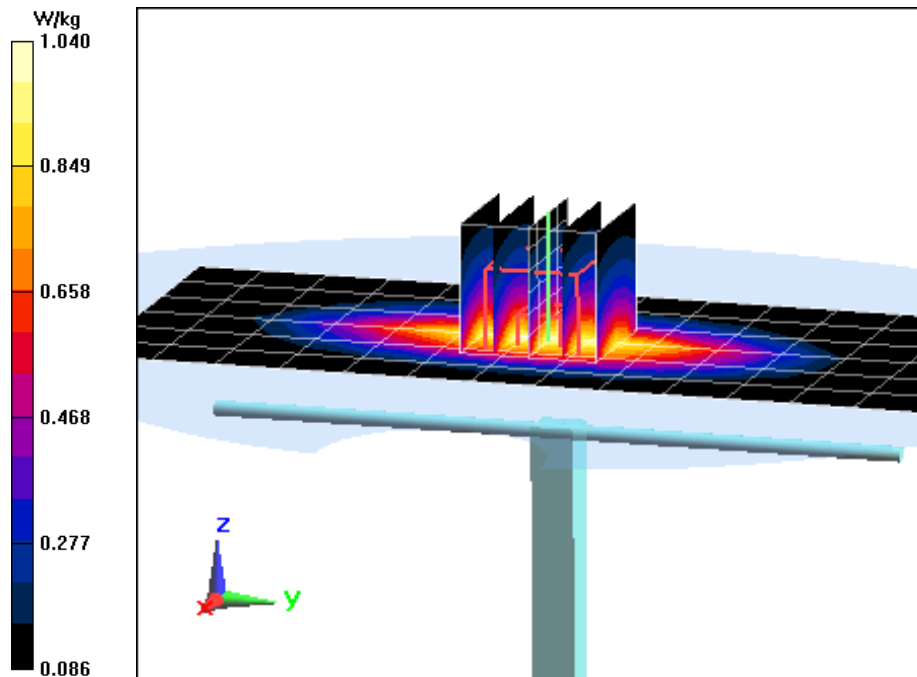

PCTEST ENGINEERING LABORATORY, INC.

DUT: Dipole 1750 MHz; Type: D1765V2; Serial: 1008

Communication System: UID 0, CW; Frequency: 1750 MHz; Duty Cycle: 1:1

Medium: 1750 Head, Medium parameters used:

$f = 1750 \text{ MHz}$; $\sigma = 1.382 \text{ S/m}$; $\epsilon_r = 38.946$; $\rho = 1000 \text{ kg/m}^3$

Phantom section: Flat Section; Space: 1.0 cm

Test Date: 12-01-2014; Ambient Temp: 24.0°C; Tissue Temp: 22.0°C

Probe: ES3DV2 - SN3022; ConvF(5.04, 5.04, 5.04); Calibrated: 8/19/2014;

Sensor-Surface: 3mm (Mechanical Surface Detection)

Electronics: DAE4 Sn1322; Calibrated: 8/12/2014

Phantom: SAM with CRP v4.0; Type: QD000P40CD; Serial: TP:1800

Measurement SW: DASY52, Version 52.8 (8); SEMCAD X Version 14.6.10 (7331)

1750 MHz System Verification

Area Scan (7x9x1): Measurement grid: dx=15mm, dy=15mm

Zoom Scan (5x5x7)/Cube 0: Measurement grid: dx=8mm, dy=8mm, dz=5mm

Input Power = 20.0 dBm (100 mW)

Peak SAR (extrapolated) = 6.17 W/kg

SAR(1 g) = 3.48 W/kg

Deviation = -5.69%

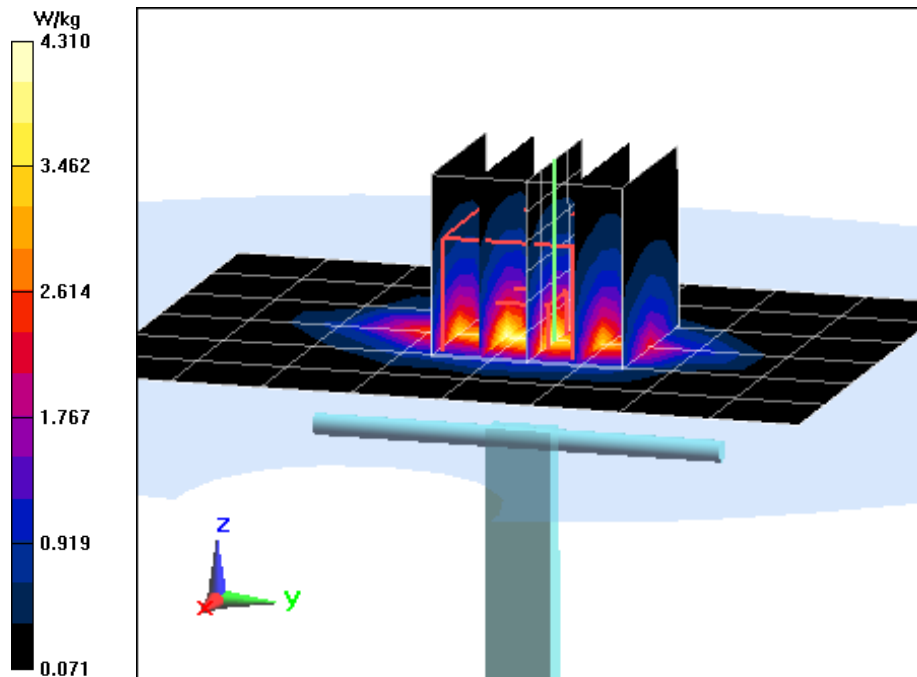

PCTEST ENGINEERING LABORATORY, INC.

DUT: Dipole 1900 MHz; Type: D1900V2; Serial: 5d149

Communication System: UID 0, CW; Frequency: 1900 MHz; Duty Cycle: 1:1

Medium: 1900 Head, Medium parameters used (interpolated):

$f = 1900 \text{ MHz}$; $\sigma = 1.43 \text{ S/m}$; $\epsilon_r = 39.711$; $\rho = 1000 \text{ kg/m}^3$

Phantom section: Flat Section; Space: 1.0 cm

Test Date: 12-04-2014; Ambient Temp: 23.9°C; Tissue Temp: 22.7°C

Probe: ES3DV3 - SN3263; ConvF(5.08, 5.08, 5.08); Calibrated: 5/15/2014;

Sensor-Surface: 3mm (Mechanical Surface Detection)

Electronics: DAE4 Sn859; Calibrated: 5/14/2014

Phantom: SAM v5.0 Left; Type: QD000P40CD; Serial: TP: 1687

Measurement SW: DASY52, Version 52.8 (8); SEMCAD X Version 14.6.10 (7331)

1900 MHz System Verification

Area Scan (7x10x1): Measurement grid: dx=15mm, dy=15mm

Zoom Scan (5x5x7)/Cube 0: Measurement grid: dx=8mm, dy=8mm, dz=5mm

Input Power = 20.0 dBm (100 mW)

Peak SAR (extrapolated) = 7.91 W/kg

SAR(1 g) = 4.26 W/kg

Deviation = 5.97%

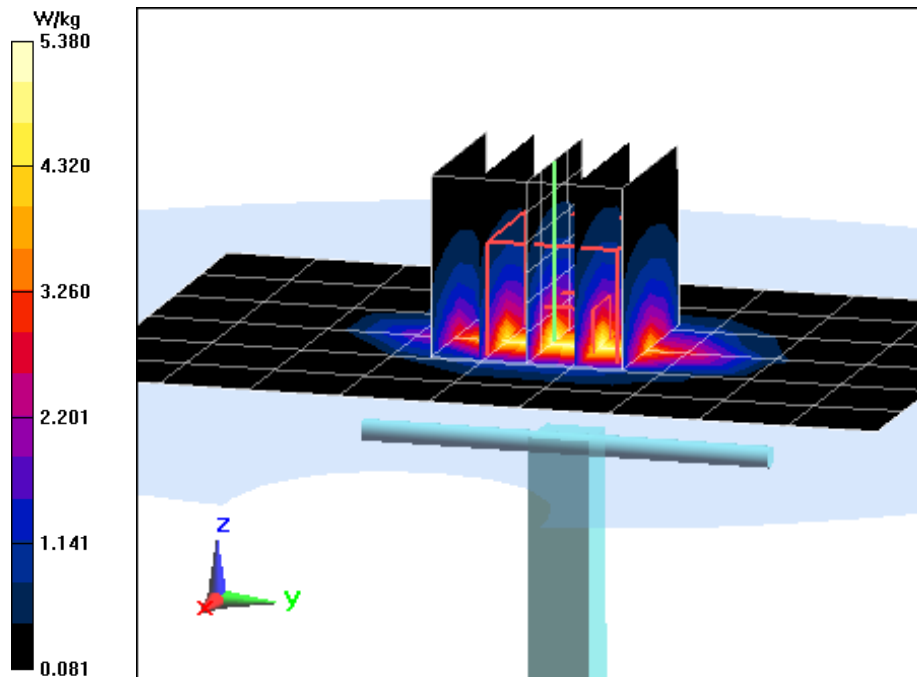

PCTEST ENGINEERING LABORATORY, INC.

DUT: Dipole 2450 MHz; Type: D2450V2; Serial: 797

Communication System: UID 0, CW; Frequency: 2450 MHz; Duty Cycle: 1:1

Medium: 2450 Head, Medium parameters used:

$f = 2450 \text{ MHz}$; $\sigma = 1.876 \text{ S/m}$; $\epsilon_r = 38.853$; $\rho = 1000 \text{ kg/m}^3$

Phantom section: Flat Section; Space: 1.0 cm

Test Date: 12-08-2014; Ambient Temp: 23.7°C; Tissue Temp: 22.8°C

Probe: ES3DV3 - SN3258; ConvF(4.52, 4.52, 4.52); Calibrated: 2/25/2014;

Sensor-Surface: 3mm (Mechanical Surface Detection)

Electronics: DAE4 Sn665; Calibrated: 2/26/2014

Phantom: SAM Front; Type: SAM; Serial: 1686

Measurement SW: DASY52, Version 52.8 (8); SEMCAD X Version 14.6.10 (7331)

2450 MHz System Verification

Area Scan (8x9x1): Measurement grid: dx=12mm, dy=12mm

Zoom Scan (7x7x7)/Cube 0: Measurement grid: dx=5mm, dy=5mm, dz=5mm

Input Power = 20.0 dBm (100 mW)

Peak SAR (extrapolated) = 11.1 W/kg

SAR(1 g) = 5.13 W/kg

Deviation = -0.97%

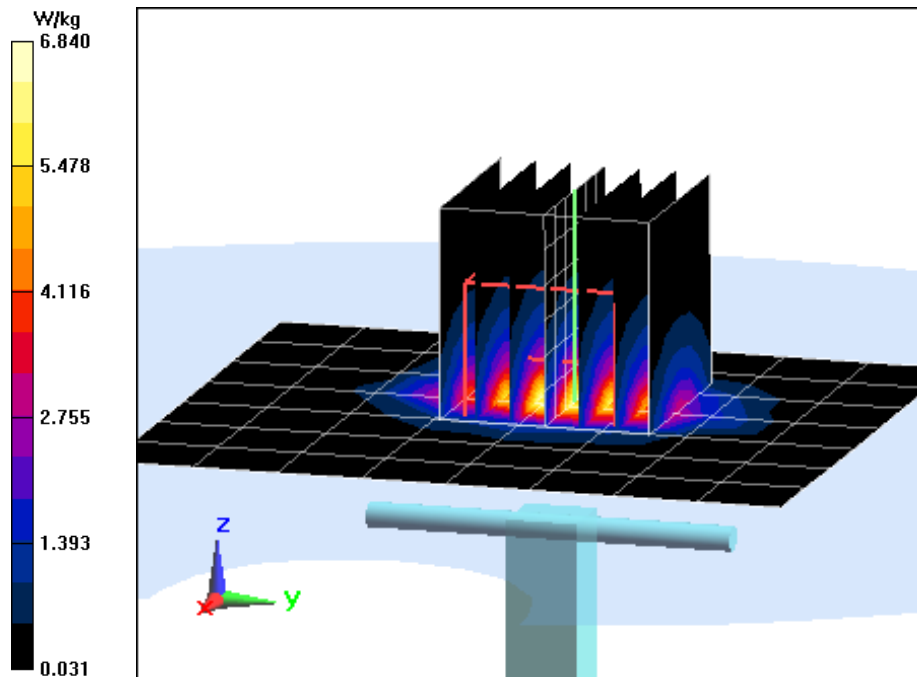

PCTEST ENGINEERING LABORATORY, INC.

DUT: Dipole 750 MHz; Type: D750V3; Serial: 1003

Communication System: UID 0, CW; Frequency: 750 MHz; Duty Cycle: 1:1

Medium: 750 Body, Medium parameters used (interpolated):

$f = 750 \text{ MHz}$; $\sigma = 0.99 \text{ S/m}$; $\epsilon_r = 55.364$; $\rho = 1000 \text{ kg/m}^3$

Phantom section: Flat Section; Space: 1.5 cm

Test Date: 12-04-2014; Ambient Temp: 23.3°C; Tissue Temp: 22.8°C

Probe: ES3DV3 - SN3258; ConvF(6.15, 6.15, 6.15); Calibrated: 2/25/2014;

Sensor-Surface: 3mm (Mechanical Surface Detection)

Electronics: DAE4 Sn665; Calibrated: 2/26/2014

Phantom: ELI v5.0; Type: QDOVA002AA; Serial: TP-1158

Measurement SW: DASY52, Version 52.8 (8); SEMCAD X Version 14.6.10 (7331)

750 MHz System Verification

Area Scan (7x15x1): Measurement grid: dx=15mm, dy=15mm

Zoom Scan (5x5x7)/Cube 0: Measurement grid: dx=8mm, dy=8mm, dz=5mm

Input Power = 20.0 dBm (100 mW)

Peak SAR (extrapolated) = 1.28 W/kg

SAR(1 g) = 0.879 W/kg

Deviation = 0.23%

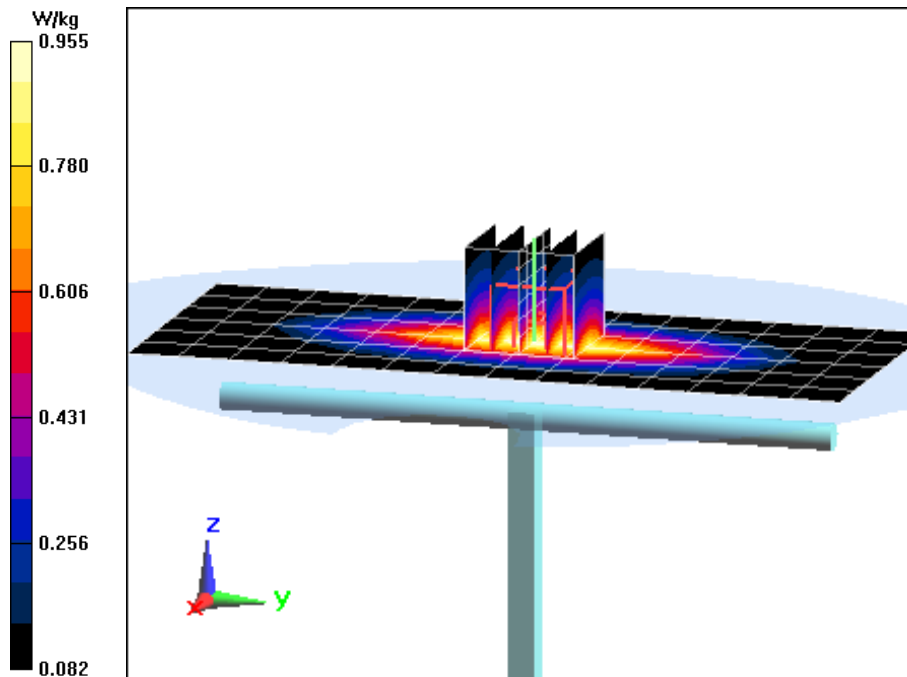

PCTEST ENGINEERING LABORATORY, INC.

DUT: Dipole 835 MHz; Type: D835V2; Serial: 4d119

Communication System: UID 0, CW; Frequency: 835 MHz; Duty Cycle: 1:1

Medium: 835 Body, Medium parameters used:

$f = 835 \text{ MHz}$; $\sigma = 0.985 \text{ S/m}$; $\epsilon_r = 54.302$; $\rho = 1000 \text{ kg/m}^3$

Phantom section: Flat Section; Space: 1.5 cm

Test Date: 12-01-2014; Ambient Temp: 23.4°C; Tissue Temp: 21.4°C

Probe: ES3DV3 - SN3209; ConvF(6.14, 6.14, 6.14); Calibrated: 3/19/2014;

Sensor-Surface: 3mm (Mechanical Surface Detection)

Electronics: DAE4 Sn1334; Calibrated: 3/17/2014

Phantom: SAM front; Type: QD000P40CD; Serial: TP:1759

Measurement SW: DASY52, Version 52.8 (8); SEMCAD X Version 14.6.10 (7331)

835 MHz System Verification

Area Scan (7x14x1): Measurement grid: dx=15mm, dy=15mm

Zoom Scan (5x5x7)/Cube 0: Measurement grid: dx=8mm, dy=8mm, dz=5mm

Input Power = 20.0 dBm (100 mW)

Peak SAR (extrapolated) = 1.43 W/kg

SAR(1 g) = 0.951 W/kg

Deviation = 1.82%

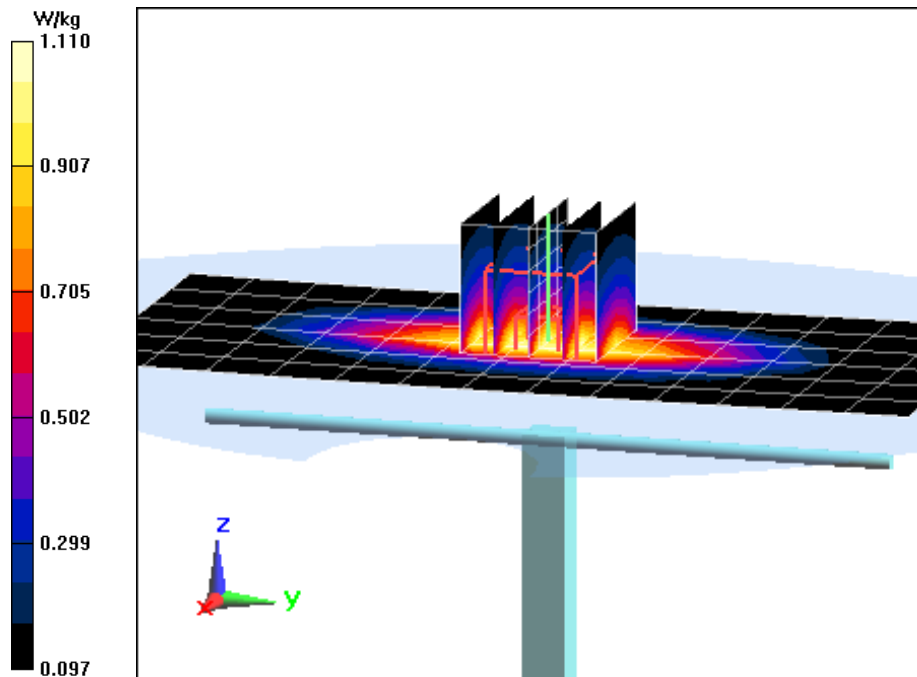

PCTEST ENGINEERING LABORATORY, INC.

DUT: Dipole 835 MHz; Type: D835V2; Serial: 4d119

Communication System: UID 0, CW; Frequency: 835 MHz; Duty Cycle: 1:1

Medium: 835 Body, Medium parameters used:

$f = 835 \text{ MHz}$; $\sigma = 1 \text{ S/m}$; $\epsilon_r = 53.18$; $\rho = 1000 \text{ kg/m}^3$

Phantom section: Flat Section; Space: 1.5 cm

Test Date: 12-03-2014; Ambient Temp: 23.1°C; Tissue Temp: 22.1°C

Probe: ES3DV3 - SN3288; ConvF(6.32, 6.32, 6.32); Calibrated: 9/24/2014;

Sensor-Surface: 3mm (Mechanical Surface Detection)

Electronics: DAE4 Sn1364; Calibrated: 9/18/2014

Phantom: ELI v5.0; Type: QDOVA001BB; Serial: 1229

Measurement SW: DASY52, Version 52.8 (8); SEMCAD X Version 14.6.10 (7331)

835 MHz System Verification

Area Scan (7x14x1): Measurement grid: dx=15mm, dy=15mm

Zoom Scan (5x5x7)/Cube 0: Measurement grid: dx=8mm, dy=8mm, dz=5mm

Input Power = 20.0 dBm (100 mW)

Peak SAR (extrapolated) = 1.44 W/kg

SAR(1 g) = 0.981 W/kg

Deviation = 5.03%

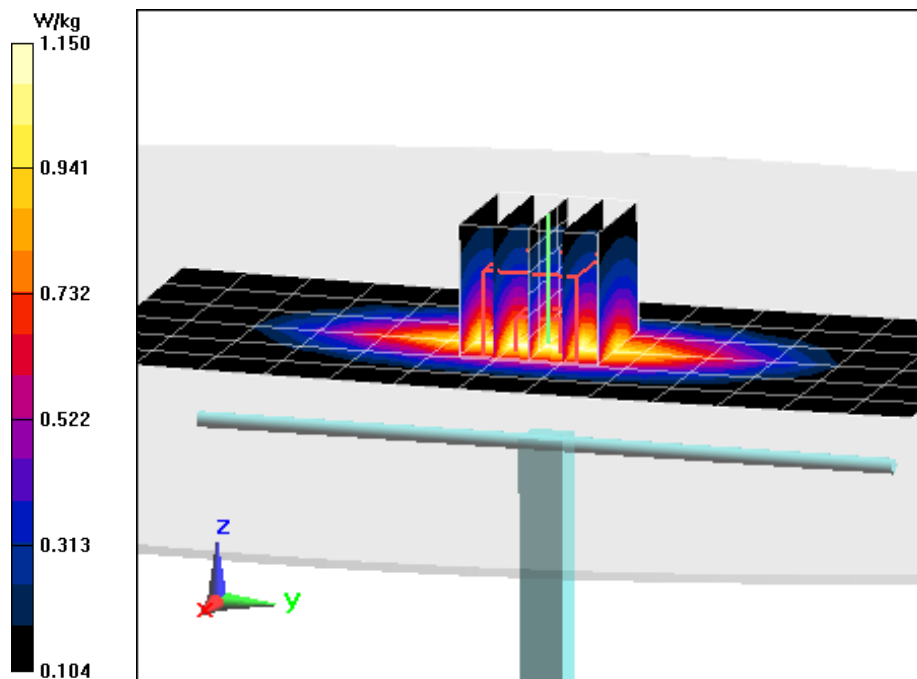

PCTEST ENGINEERING LABORATORY, INC.

DUT: Dipole 1750 MHz; Type: D1765V2; Serial: 1008

Communication System: UID 0, CW; Frequency: 1750 MHz; Duty Cycle: 1:1

Medium: 1750 Body, Medium parameters used:

$f = 1750 \text{ MHz}$; $\sigma = 1.508 \text{ S/m}$; $\epsilon_r = 51.603$; $\rho = 1000 \text{ kg/m}^3$

Phantom section: Flat Section; Space: 1.0 cm

Test Date: 12-01-2014; Ambient Temp: 22.9°C; Tissue Temp: 22.2°C

Probe: ES3DV2 - SN3022; ConvF(4.7, 4.7, 4.7); Calibrated: 8/19/2014;

Sensor-Surface: 3mm (Mechanical Surface Detection)

Electronics: DAE4 Sn1322; Calibrated: 8/12/2014

Phantom: ELI v5.0; Type: QDOVA001BB; Serial: 1226

Measurement SW: DASY52, Version 52.8 (8); SEMCAD X Version 14.6.10 (7331)

1750 MHz System Verification

Area Scan (7x9x1): Measurement grid: dx=15mm, dy=15mm

Zoom Scan (5x5x7)/Cube 0: Measurement grid: dx=8mm, dy=8mm, dz=5mm

Input Power = 20.0 dBm (100 mW)

Peak SAR (extrapolated) = 6.41 W/kg

SAR(1 g) = 3.64 W/kg

Deviation = -3.19%

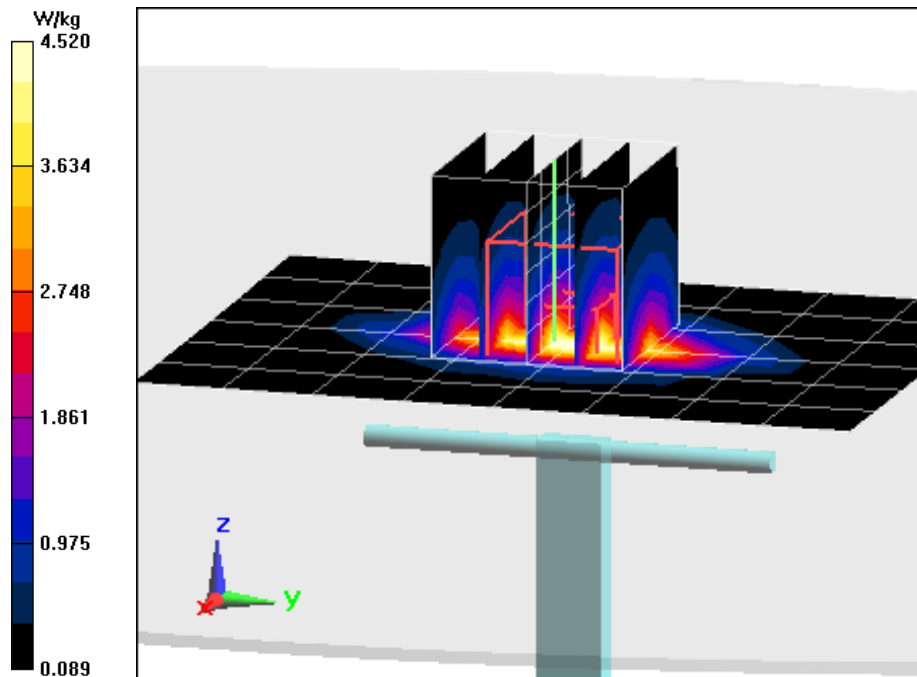

PCTEST ENGINEERING LABORATORY, INC.

DUT: Dipole 1900 MHz; Type: D1900V2; Serial: 5d141

Communication System: UID 0, CW; Frequency: 1900 MHz; Duty Cycle: 1:1

Medium: 1900 Body, Medium parameters used (interpolated):

$f = 1900 \text{ MHz}$; $\sigma = 1.583 \text{ S/m}$; $\epsilon_r = 51.945$; $\rho = 1000 \text{ kg/m}^3$

Phantom section: Flat Section; Space: 1.0 cm

Test Date: 12-01-2014; Ambient Temp: 24.5°C; Tissue Temp: 22.8°C

Probe: ES3DV3 - SN3258; ConvF(4.61, 4.61, 4.61); Calibrated: 2/25/2014;

Sensor-Surface: 3mm (Mechanical Surface Detection)

Electronics: DAE4 Sn665; Calibrated: 2/26/2014

Phantom: ELI v5.0; Type: QDOVA002AA; Serial: TP-1158

Measurement SW: DASY52, Version 52.8 (8); SEMCAD X Version 14.6.10 (7331)

1900 MHz System Verification

Area Scan (7x10x1): Measurement grid: dx=15mm, dy=15mm

Zoom Scan (5x5x7)/Cube 0: Measurement grid: dx=8mm, dy=8mm, dz=5mm

Input Power = 20.0 dBm (100 mW)

Peak SAR (extrapolated) = 7.30 W/kg

SAR(1 g) = 4.23 W/kg

Deviation = 4.19%

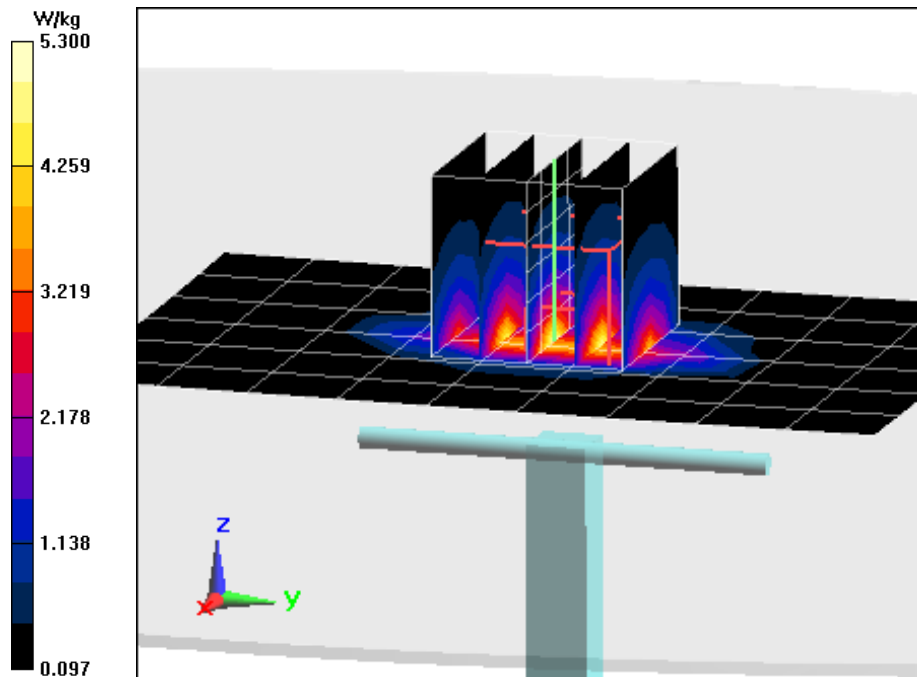

PCTEST ENGINEERING LABORATORY, INC.

DUT: Dipole 2450 MHz; Type: D2450V2; Serial: 797

Communication System: UID 0, CW; Frequency: 2450 MHz; Duty Cycle: 1:1

Medium: 2450 Body, Medium parameters used:

$f = 2450$ MHz; $\sigma = 2.045$ S/m; $\epsilon_r = 53.371$; $\rho = 1000$ kg/m³

Phantom section: Flat Section; Space: 1.0 cm

Test Date: 12-01-2014; Ambient Temp: 23.1°C; Tissue Temp: 23.1°C

Probe: ES3DV3 - SN3319; ConvF(4.24, 4.24, 4.24); Calibrated: 4/17/2014;

Sensor-Surface: 3mm (Mechanical Surface Detection)

Electronics: DAE4 Sn1368; Calibrated: 4/11/2014

Phantom: SAM; Type: QD000P40CD; Serial: TP:1758

Measurement SW: DASY52, Version 52.8 (8); SEMCAD X Version 14.6.10 (7331)

2450 MHz System Verification

Area Scan (8x9x1): Measurement grid: dx=12mm, dy=12mm

Zoom Scan (7x7x7)/Cube 0: Measurement grid: dx=5mm, dy=5mm, dz=5mm

Input Power = 20.0 dBm (100 mW)

Peak SAR (extrapolated) = 11.0 W/kg

SAR(1 g) = 5.21 W/kg

Deviation = 5.47%

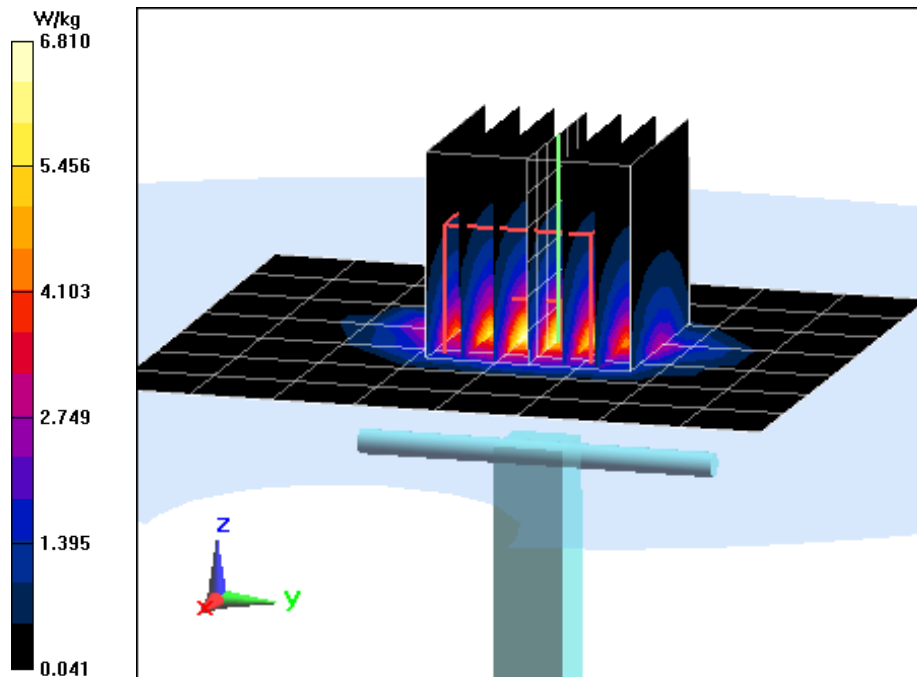

APPENDIX C: PROBE CALIBRATION



Accredited by the Swiss Accreditation Service (SAS)
The Swiss Accreditation Service is one of the signatories to the EA
Multilateral Agreement for the recognition of calibration certificates

Accreditation No.: **SCS 108**

Client **PC Test**

Certificate No: **ES3-3288_Sep14**

CALIBRATION CERTIFICATE

Object **ES3DV3 - SN:3288**

Calibration procedure(s) **QA CAL-01.v9, QA CAL-23.v5, QA CAL-25.v6
Calibration procedure for dosimetric E-field probes**

Calibration date: **September 24, 2014**

*✓
KOK
19/10/14*

This calibration certificate documents the traceability to national standards, which realize the physical units of measurements (SI).
The measurements and the uncertainties with confidence probability are given on the following pages and are part of the certificate.

All calibrations have been conducted in the closed laboratory facility: environment temperature (22 ± 3)°C and humidity < 70%.

Calibration Equipment used (M&TE critical for calibration)

Primary Standards	ID	Cal Date (Certificate No.)	Scheduled Calibration
Power meter E4419B	GB41293874	03-Apr-14 (No. 217-01911)	Apr-15
Power sensor E4412A	MY41498087	03-Apr-14 (No. 217-01911)	Apr-15
Reference 3 dB Attenuator	SN: S5054 (3c)	03-Apr-14 (No. 217-01915)	Apr-15
Reference 20 dB Attenuator	SN: S5277 (20x)	03-Apr-14 (No. 217-01919)	Apr-15
Reference 30 dB Attenuator	SN: S5129 (30b)	03-Apr-14 (No. 217-01920)	Apr-15
Reference Probe ES3DV2	SN: 3013	30-Dec-13 (No. ES3-3013_Dec13)	Dec-14
DAE4	SN: 660	13-Dec-13 (No. DAE4-660_Dec13)	Dec-14
Secondary Standards	ID	Check Date (in house)	Scheduled Check
RF generator HP 8648C	US3642U01700	4-Aug-99 (in house check Apr-13)	In house check: Apr-16
Network Analyzer HP 8753E	US37390585	18-Oct-01 (in house check Oct-13)	In house check: Oct-14

	Name	Function	Signature
Calibrated by:	Leif Klysner	Laboratory Technician	<i>Leif Klysner</i>
Approved by:	Katja Pokovic	Technical Manager	<i>Katja Pokovic</i>

Issued: September 24, 2014

This calibration certificate shall not be reproduced except in full without written approval of the laboratory.



Accredited by the Swiss Accreditation Service (SAS)

Accreditation No.: **SCS 108**

The Swiss Accreditation Service is one of the signatories to the EA
Multilateral Agreement for the recognition of calibration certificates

Glossary:

TSL	tissue simulating liquid
NORM _{x,y,z}	sensitivity in free space
ConvF	sensitivity in TSL / NORM _{x,y,z}
DCP	diode compression point
CF	crest factor (1/duty_cycle) of the RF signal
A, B, C, D	modulation dependent linearization parameters
Polarization φ	φ rotation around probe axis
Polarization ϑ	ϑ rotation around an axis that is in the plane normal to probe axis (at measurement center), i.e., $\vartheta = 0$ is normal to probe axis
Connector Angle	information used in DASY system to align probe sensor X to the robot coordinate system

Calibration is Performed According to the Following Standards:

- IEEE Std 1528-2013, "IEEE Recommended Practice for Determining the Peak Spatial-Averaged Specific Absorption Rate (SAR) in the Human Head from Wireless Communications Devices: Measurement Techniques", June 2013
- IEC 62209-1, "Procedure to measure the Specific Absorption Rate (SAR) for hand-held devices used in close proximity to the ear (frequency range of 300 MHz to 3 GHz)", February 2005

Methods Applied and Interpretation of Parameters:

- NORM_{x,y,z}**: Assessed for E-field polarization $\vartheta = 0$ ($f \leq 900$ MHz in TEM-cell; $f > 1800$ MHz: R22 waveguide). NORM_{x,y,z} are only intermediate values, i.e., the uncertainties of NORM_{x,y,z} does not affect the E²-field uncertainty inside TSL (see below ConvF).
- NORM(f)_{x,y,z} = NORM_{x,y,z} * frequency_response** (see Frequency Response Chart). This linearization is implemented in DASY4 software versions later than 4.2. The uncertainty of the frequency response is included in the stated uncertainty of ConvF.
- DCP_{x,y,z}**: DCP are numerical linearization parameters assessed based on the data of power sweep with CW signal (no uncertainty required). DCP does not depend on frequency nor media.
- PAR**: PAR is the Peak to Average Ratio that is not calibrated but determined based on the signal characteristics
- A_{x,y,z}; B_{x,y,z}; C_{x,y,z}; D_{x,y,z}; VR_{x,y,z}**: A, B, C, D are numerical linearization parameters assessed based on the data of power sweep for specific modulation signal. The parameters do not depend on frequency nor media. VR is the maximum calibration range expressed in RMS voltage across the diode.
- ConvF and Boundary Effect Parameters**: Assessed in flat phantom using E-field (or Temperature Transfer Standard for $f \leq 800$ MHz) and inside waveguide using analytical field distributions based on power measurements for $f > 800$ MHz. The same setups are used for assessment of the parameters applied for boundary compensation (alpha, depth) of which typical uncertainty values are given. These parameters are used in DASY4 software to improve probe accuracy close to the boundary. The sensitivity in TSL corresponds to NORM_{x,y,z} * ConvF whereby the uncertainty corresponds to that given for ConvF. A frequency dependent ConvF is used in DASY version 4.4 and higher which allows extending the validity from ± 50 MHz to ± 100 MHz.
- Spherical isotropy (3D deviation from isotropy)**: in a field of low gradients realized using a flat phantom exposed by a patch antenna.
- Sensor Offset**: The sensor offset corresponds to the offset of virtual measurement center from the probe tip (on probe axis). No tolerance required.
- Connector Angle**: The angle is assessed using the information gained by determining the NORM_x (no uncertainty required).

Probe ES3DV3

SN:3288

Manufactured:	July 6, 2010
Repaired:	September 18, 2014
Calibrated:	September 24, 2014

Calibrated for DASY/EASY Systems

(Note: non-compatible with DASY2 system!)

DASY/EASY - Parameters of Probe: ES3DV3 - SN:3288

Basic Calibration Parameters

	Sensor X	Sensor Y	Sensor Z	Unc (k=2)
Norm ($\mu\text{V}/(\text{V}/\text{m})^2$) ^A	1.05	1.16	0.92	$\pm 10.1\%$
DCP (mV) ^B	105.1	104.6	106.7	

Modulation Calibration Parameters

UID	Communication System Name		A dB	B dB $\sqrt{\mu\text{V}}$	C	D dB	VR mV	Unc ^E (k=2)
0	CW	X	0.0	0.0	1.0	0.00	195.8	$\pm 3.5\%$
		Y	0.0	0.0	1.0		175.9	
		Z	0.0	0.0	1.0		177.1	
10010-CAA	SAR Validation (Square, 100ms, 10ms)	X	2.71	61.9	11.4	10.00	40.3	$\pm 2.2\%$
		Y	2.37	60.2	11.2		42.6	
		Z	1.54	56.6	8.9		41.2	
10011-CAB	UMTS-FDD (WCDMA)	X	3.29	67.1	18.4	2.91	133.8	$\pm 0.5\%$
		Y	3.43	67.9	18.9		139.5	
		Z	3.45	68.1	18.9		141.3	
10012-CAA	IEEE 802.11b WiFi 2.4 GHz (DSSS, 1 Mbps)	X	2.99	68.9	18.6	1.87	135.1	$\pm 0.7\%$
		Y	3.59	72.4	20.4		140.7	
		Z	3.54	72.4	20.3		143.0	
10013-CAA	IEEE 802.11g WiFi 2.4 GHz (DSSS-OFDM, 6 Mbps)	X	11.15	70.8	23.3	9.46	132.3	$\pm 3.5\%$
		Y	11.29	70.8	23.2		141.1	
		Z	11.07	70.7	23.2		139.2	
10021-DAB	GSM-FDD (TDMA, GMSK)	X	14.71	90.5	24.5	9.39	149.0	$\pm 1.9\%$
		Y	16.40	92.8	26.0		131.3	
		Z	11.34	87.2	23.6		126.1	
10023-DAB	GPRS-FDD (TDMA, GMSK, TN 0)	X	15.91	92.2	25.3	9.57	138.9	$\pm 2.5\%$
		Y	21.25	96.9	27.2		142.0	
		Z	11.68	87.2	23.5		145.9	
10024-DAB	GPRS-FDD (TDMA, GMSK, TN 0-1)	X	38.62	99.8	24.7	6.56	123.8	$\pm 2.2\%$
		Y	36.71	99.7	25.2		128.1	
		Z	36.56	99.4	24.5		129.5	
10027-DAB	GPRS-FDD (TDMA, GMSK, TN 0-1-2)	X	56.60	99.6	22.6	4.80	138.8	$\pm 1.9\%$
		Y	46.94	99.9	23.7		149.9	
		Z	51.17	99.8	22.9		144.9	
10028-DAB	GPRS-FDD (TDMA, GMSK, TN 0-1-2-3)	X	70.88	100.0	21.6	3.55	147.5	$\pm 1.9\%$
		Y	52.58	99.8	22.6		129.4	
		Z	76.98	99.8	21.2		128.7	
10032-CAA	IEEE 802.15.1 Bluetooth (GFSK, DH5)	X	98.89	99.5	18.9	1.16	135.8	$\pm 1.4\%$
		Y	78.39	99.6	19.5		141.7	
		Z	95.21	95.5	17.1		143.4	
10039-CAB	CDMA2000 (1xRTT, RC1)	X	4.72	66.7	18.9	4.57	133.7	$\pm 0.9\%$
		Y	4.85	67.1	19.1		137.7	
		Z	4.81	67.4	19.2		141.9	

10081-CAB	CDMA2000 (1xRTT, RC3)	X	3.91	66.3	18.6	3.97	129.5	±0.7 %
		Y	4.00	66.6	18.7		133.7	
		Z	3.99	66.8	18.8		137.5	
10098-CAB	UMTS-FDD (HSUPA, Subtest 2)	X	4.63	66.9	18.7	3.98	141.4	±0.7 %
		Y	4.78	67.5	19.0		147.7	
		Z	4.57	66.8	18.6		127.8	
10100-CAB	LTE-FDD (SC-FDMA, 100% RB, 20 MHz, QPSK)	X	6.59	68.2	20.1	5.67	149.2	±1.4 %
		Y	6.36	67.3	19.6		130.7	
		Z	6.36	67.5	19.6		133.6	
10108-CAB	LTE-FDD (SC-FDMA, 100% RB, 10 MHz, QPSK)	X	6.44	67.8	20.0	5.80	146.6	±1.4 %
		Y	6.23	66.8	19.4		128.8	
		Z	6.24	67.1	19.6		131.4	
10110-CAB	LTE-FDD (SC-FDMA, 100% RB, 5 MHz, QPSK)	X	6.08	67.1	19.6	5.75	143.2	±1.4 %
		Y	6.20	67.4	19.8		148.0	
		Z	5.92	66.6	19.3		128.5	
10114-CAA	IEEE 802.11n (HT Greenfield, 13.5 Mbps, BPSK)	X	10.32	69.3	21.5	8.10	137.0	±2.2 %
		Y	10.31	69.1	21.4		143.5	
		Z	10.37	69.5	21.6		146.1	
10117-CAA	IEEE 802.11n (HT Mixed, 13.5 Mbps, BPSK)	X	10.35	69.4	21.6	8.07	138.3	±2.2 %
		Y	10.36	69.3	21.4		146.4	
		Z	10.42	69.6	21.6		149.0	
10151-CAB	LTE-TDD (SC-FDMA, 50% RB, 20 MHz, QPSK)	X	9.95	75.7	26.2	9.28	134.9	±3.3 %
		Y	10.37	76.0	26.1		146.6	
		Z	9.77	75.4	26.0		142.5	
10154-CAB	LTE-FDD (SC-FDMA, 50% RB, 10 MHz, QPSK)	X	6.12	67.2	19.7	5.75	144.9	±1.4 %
		Y	6.21	67.4	19.8		148.8	
		Z	5.91	66.5	19.3		128.7	
10160-CAB	LTE-FDD (SC-FDMA, 50% RB, 15 MHz, QPSK)	X	6.28	66.7	19.4	5.82	125.5	±1.2 %
		Y	6.37	66.8	19.4		129.7	
		Z	6.36	67.1	19.6		132.9	
10169-CAB	LTE-FDD (SC-FDMA, 1 RB, 20 MHz, QPSK)	X	5.08	67.6	20.2	5.73	147.0	±1.2 %
		Y	4.95	66.6	19.6		128.6	
		Z	4.91	66.9	19.8		131.2	
10172-CAB	LTE-TDD (SC-FDMA, 1 RB, 20 MHz, QPSK)	X	8.18	77.2	27.2	9.21	123.4	±2.7 %
		Y	8.37	76.6	26.6		129.5	
		Z	7.97	76.7	26.9		128.7	
10175-CAB	LTE-FDD (SC-FDMA, 1 RB, 10 MHz, QPSK)	X	5.05	67.4	20.1	5.72	146.2	±1.4 %
		Y	5.10	67.3	20.0		142.8	
		Z	4.87	66.7	19.6		129.6	
10181-CAB	LTE-FDD (SC-FDMA, 1 RB, 15 MHz, QPSK)	X	5.04	67.4	20.0	5.72	145.5	±1.2 %
		Y	5.12	67.4	20.0		143.4	
		Z	4.87	66.7	19.6		129.9	
10193-CAA	IEEE 802.11n (HT Greenfield, 6.5 Mbps, BPSK)	X	9.92	68.9	21.4	8.09	131.0	±2.2 %
		Y	9.84	68.5	21.1		130.0	
		Z	9.94	69.0	21.4		138.6	

10196-CAA	IEEE 802.11n (HT Mixed, 6.5 Mbps, BPSK)	X	9.90	68.9	21.4	8.10	130.8	±2.2 %
		Y	9.81	68.4	21.0		131.4	
		Z	9.95	69.1	21.5		140.5	
10219-CAA	IEEE 802.11n (HT Mixed, 7.2 Mbps, BPSK)	X	9.81	68.8	21.3	8.03	130.0	±2.2 %
		Y	9.89	68.9	21.3		138.1	
		Z	9.89	69.1	21.5		140.5	
10222-CAA	IEEE 802.11n (HT Mixed, 15 Mbps, BPSK)	X	10.25	69.2	21.4	8.06	137.1	±2.2 %
		Y	10.30	69.2	21.4		144.4	
		Z	10.38	69.6	21.6		148.4	
10225-CAB	UMTS-FDD (HSPA+)	X	6.90	66.8	19.3	5.97	132.8	±1.4 %
		Y	7.09	67.3	19.6		142.0	
		Z	7.04	67.4	19.6		143.5	
10237-CAB	LTE-TDD (SC-FDMA, 1 RB, 10 MHz, QPSK)	X	9.61	81.9	29.6	9.21	149.3	±2.7 %
		Y	8.66	77.6	27.1		133.7	
		Z	8.20	77.5	27.3		132.2	
10252-CAB	LTE-TDD (SC-FDMA, 50% RB, 10 MHz, QPSK)	X	9.16	74.5	25.8	9.24	126.3	±3.0 %
		Y	9.62	75.0	25.8		137.4	
		Z	9.16	74.8	25.9		135.2	
10267-CAB	LTE-TDD (SC-FDMA, 100% RB, 10 MHz, QPSK)	X	9.97	75.7	26.3	9.30	133.7	±3.3 %
		Y	10.38	75.9	26.1		146.1	
		Z	9.91	75.7	26.3		143.8	
10274-CAB	UMTS-FDD (HSUPA, Subtest 5, 3GPP Rel8.10)	X	5.86	66.6	18.7	4.87	129.9	±0.9 %
		Y	6.01	67.1	19.0		135.7	
		Z	5.95	67.1	19.0		139.4	
10275-CAB	UMTS-FDD (HSUPA, Subtest 5, 3GPP Rel8.4)	X	4.40	66.7	18.6	3.96	136.4	±0.7 %
		Y	4.55	67.3	19.0		138.3	
		Z	4.56	67.6	19.1		144.3	
10291-AAB	CDMA2000, RC3, SO55, Full Rate	X	3.64	66.9	18.7	3.46	127.4	±0.5 %
		Y	3.77	67.6	19.1		130.2	
		Z	3.72	67.5	19.0		134.4	
10292-AAB	CDMA2000, RC3, SO32, Full Rate	X	3.58	67.0	18.7	3.39	128.4	±0.5 %
		Y	3.73	67.7	19.1		132.7	
		Z	3.69	67.8	19.1		136.1	
10297-AAA	LTE-FDD (SC-FDMA, 50% RB, 20 MHz, QPSK)	X	6.43	67.7	19.9	5.81	145.5	±1.4 %
		Y	6.49	67.7	19.9		149.5	
		Z	6.23	67.0	19.6		129.5	
10311-AAA	LTE-FDD (SC-FDMA, 100% RB, 15 MHz, QPSK)	X	6.74	67.3	19.8	6.06	126.7	±1.4 %
		Y	6.83	67.5	19.8		132.9	
		Z	6.81	67.6	19.9		135.8	
10315-AAA	IEEE 802.11b WiFi 2.4 GHz (DSSS, 1 Mbps, 96pc duty cycle)	X	3.00	69.9	19.4	1.71	133.9	±0.5 %
		Y	3.30	71.5	20.1		141.0	
		Z	3.22	71.4	20.0		142.9	
10316-AAA	IEEE 802.11g WiFi 2.4 GHz (ERP-OFDM, 6 Mbps, 96pc duty cycle)	X	10.17	69.2	21.8	8.36	130.5	±2.5 %
		Y	10.20	69.1	21.6		138.4	
		Z	10.20	69.4	21.8		140.7	

10403-AAB	CDMA2000 (1xEV-DO, Rev. 0)	X	4.75	68.3	18.8	3.76	138.5	±0.7 %
		Y	5.00	69.1	19.2		146.7	
		Z	4.92	69.2	19.1		148.5	
10404-AAB	CDMA2000 (1xEV-DO, Rev. A)	X	4.73	68.6	18.9	3.77	136.3	±0.7 %
		Y	4.97	69.4	19.4		143.7	
		Z	4.91	69.6	19.3		146.0	
10415-AAA	IEEE 802.11b WiFi 2.4 GHz (DSSS, 1 Mbps, 99pc duty cycle)	X	2.65	68.1	18.5	1.54	135.2	±0.5 %
		Y	3.05	70.8	19.9		140.7	
		Z	2.87	69.8	19.3		144.8	
10416-AAA	IEEE 802.11g WiFi 2.4 GHz (ERP-OFDM, 6 Mbps, 99pc duty cycle)	X	10.00	69.0	21.5	8.23	130.8	±2.2 %
		Y	10.06	68.9	21.4		138.6	
		Z	10.08	69.3	21.7		141.6	

The reported uncertainty of measurement is stated as the standard uncertainty of measurement multiplied by the coverage factor $k=2$, which for a normal distribution corresponds to a coverage probability of approximately 95%.

^A The uncertainties of NormX,Y,Z do not affect the E^2 -field uncertainty inside TSL. (see Pages 8 and 9).

^B Numerical linearization parameter: uncertainty not required.

^E Uncertainty is determined using the max. deviation from linear response applying rectangular distribution and is expressed for the square of the field value.

DASY/EASY - Parameters of Probe: ES3DV3 - SN:3288

Calibration Parameter Determined in Head Tissue Simulating Media

f (MHz) ^C	Relative Permittivity ^F	Conductivity (S/m) ^F	ConvF X	ConvF Y	ConvF Z	Alpha ^G	Depth (mm) ^G	Unct. (k=2)
750	41.9	0.89	6.81	6.81	6.81	0.37	1.70	± 12.0 %
835	41.5	0.90	6.51	6.51	6.51	0.45	1.52	± 12.0 %
1750	40.1	1.37	5.38	5.38	5.38	0.44	1.58	± 12.0 %
1900	40.0	1.40	5.17	5.17	5.17	0.80	1.18	± 12.0 %
2450	39.2	1.80	4.56	4.56	4.56	0.80	1.21	± 12.0 %
2600	39.0	1.96	4.44	4.44	4.44	0.80	1.22	± 12.0 %

^C Frequency validity above 300 MHz of ± 100 MHz only applies for DASY v4.4 and higher (see Page 2), else it is restricted to ± 50 MHz. The uncertainty is the RSS of the ConvF uncertainty at calibration frequency and the uncertainty for the indicated frequency band. Frequency validity below 300 MHz is ± 10, 25, 40, 50 and 70 MHz for ConvF assessments at 30, 64, 128, 150 and 220 MHz respectively. Above 5 GHz frequency validity can be extended to ± 110 MHz.

^F At frequencies below 3 GHz, the validity of tissue parameters (ϵ and σ) can be relaxed to ± 10% if liquid compensation formula is applied to measured SAR values. At frequencies above 3 GHz, the validity of tissue parameters (ϵ and σ) is restricted to ± 5%. The uncertainty is the RSS of the ConvF uncertainty for indicated target tissue parameters.

^G Alpha/Depth are determined during calibration. SPEAG warrants that the remaining deviation due to the boundary effect after compensation is always less than ± 1% for frequencies below 3 GHz and below ± 2% for frequencies between 3-6 GHz at any distance larger than half the probe tip diameter from the boundary.

DASY/EASY - Parameters of Probe: ES3DV3 - SN:3288

Calibration Parameter Determined in Body Tissue Simulating Media

f (MHz) ^C	Relative Permittivity ^F	Conductivity (S/m) ^F	ConvF X	ConvF Y	ConvF Z	Alpha ^G	Depth ^G (mm)	Unct. (k=2)
750	55.5	0.96	6.38	6.38	6.38	0.31	1.89	± 12.0 %
835	55.2	0.97	6.32	6.32	6.32	0.55	1.39	± 12.0 %
1750	53.4	1.49	5.03	5.03	5.03	0.57	1.44	± 12.0 %
1900	53.3	1.52	4.82	4.82	4.82	0.51	1.54	± 12.0 %
2450	52.7	1.95	4.36	4.36	4.36	0.71	1.07	± 12.0 %
2600	52.5	2.16	4.22	4.22	4.22	0.80	1.07	± 12.0 %

^C Frequency validity above 300 MHz of ± 100 MHz only applies for DASY v4.4 and higher (see Page 2), else it is restricted to ± 50 MHz. The uncertainty is the RSS of the ConvF uncertainty at calibration frequency and the uncertainty for the indicated frequency band. Frequency validity below 300 MHz is ± 10, 25, 40, 50 and 70 MHz for ConvF assessments at 30, 64, 128, 150 and 220 MHz respectively. Above 5 GHz frequency validity can be extended to ± 110 MHz.

^F At frequencies below 3 GHz, the validity of tissue parameters (ϵ and σ) can be relaxed to ± 10% if liquid compensation formula is applied to measured SAR values. At frequencies above 3 GHz, the validity of tissue parameters (ϵ and σ) is restricted to ± 5%. The uncertainty is the RSS of the ConvF uncertainty for indicated target tissue parameters.

^G Alpha/Depth are determined during calibration. SPEAG warrants that the remaining deviation due to the boundary effect after compensation is always less than ± 1% for frequencies below 3 GHz and below ± 2% for frequencies between 3-6 GHz at any distance larger than half the probe tip diameter from the boundary.

Frequency Response of E-Field (TEM-Cell:ifi1110 EXX, Waveguide: R22)

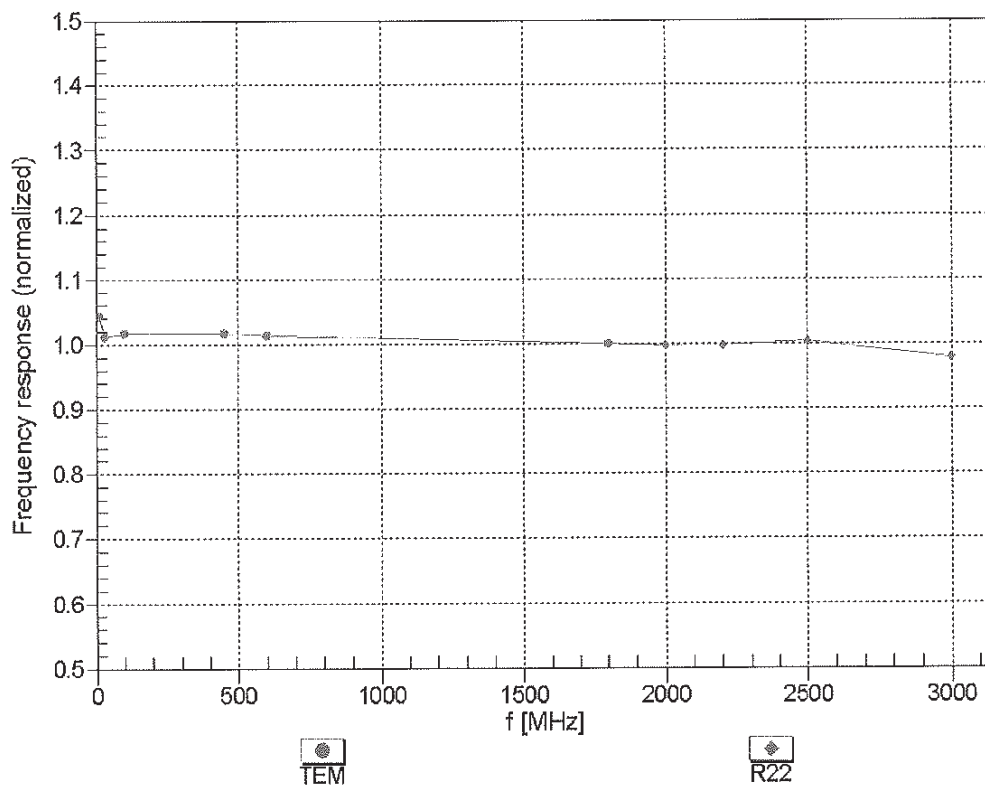

Uncertainty of Frequency Response of E-field: $\pm 6.3\%$ (k=2)

Receiving Pattern (ϕ), $\vartheta = 0^\circ$

f=600 MHz,TEM

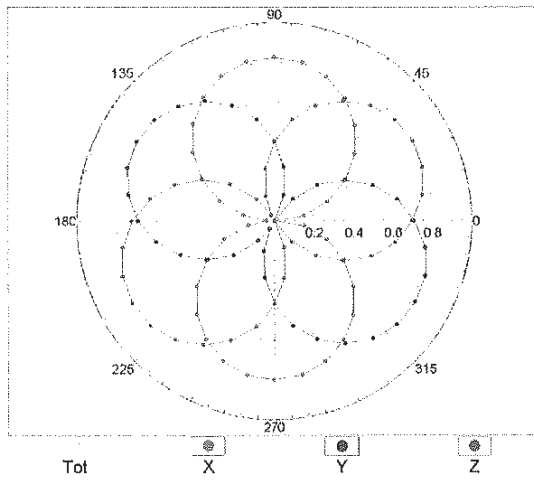

f=1800 MHz,R22

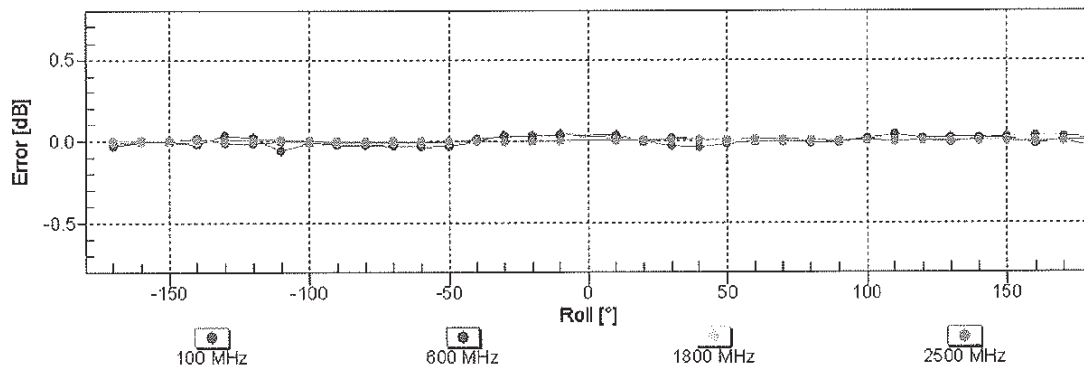
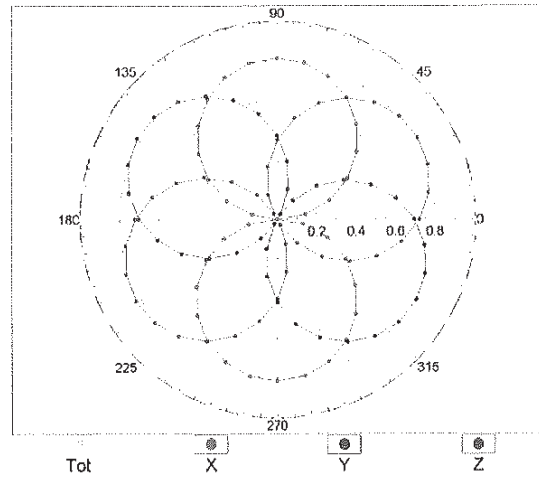

Uncertainty of Axial Isotropy Assessment: $\pm 0.5\%$ (k=2)

Dynamic Range f(SAR_{head}) (TEM cell , f_{eval}= 1900 MHz)

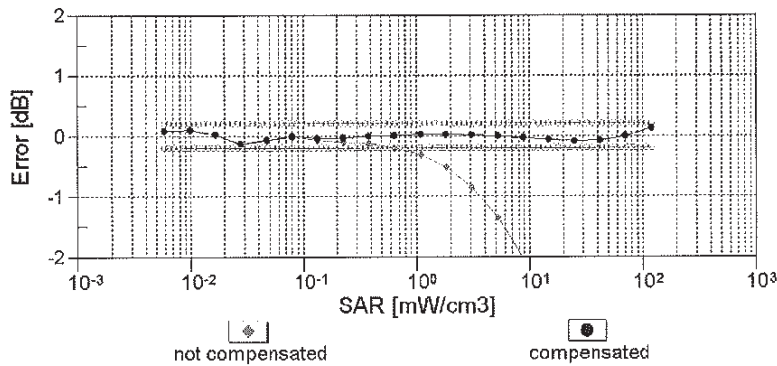
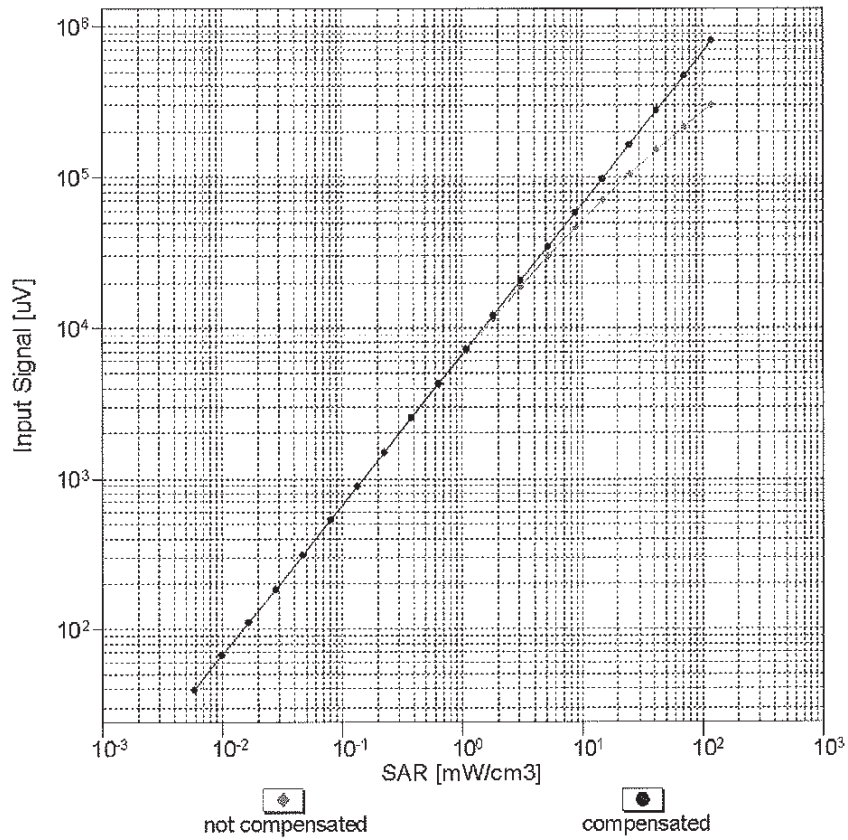

Uncertainty of Linearity Assessment: ± 0.6% (k=2)

Conversion Factor Assessment

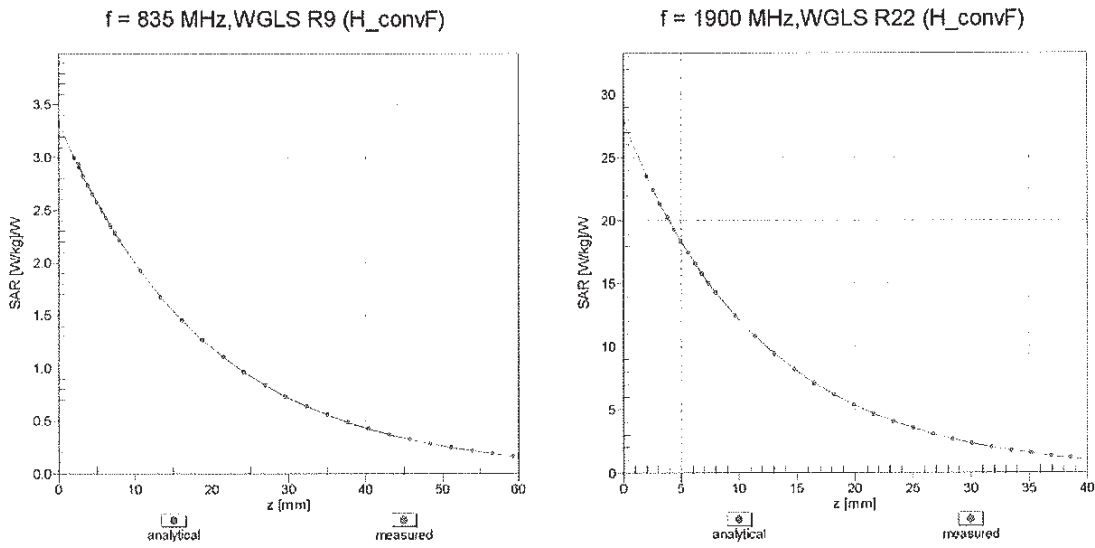

Deviation from Isotropy in Liquid Error (ϕ, θ), f = 900 MHz

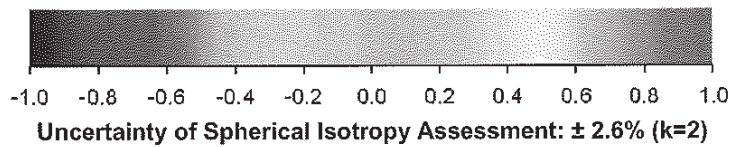
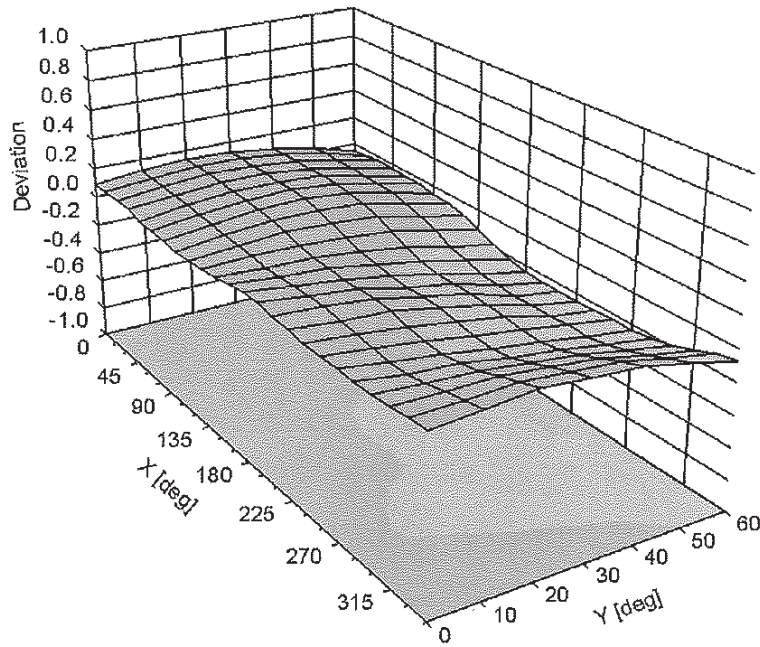

DASY/EASY - Parameters of Probe: ES3DV3 - SN:3288

Other Probe Parameters

Sensor Arrangement	Triangular
Connector Angle (°)	-110
Mechanical Surface Detection Mode	enabled
Optical Surface Detection Mode	disabled
Probe Overall Length	337 mm
Probe Body Diameter	10 mm
Tip Length	10 mm
Tip Diameter	4 mm
Probe Tip to Sensor X Calibration Point	2 mm
Probe Tip to Sensor Y Calibration Point	2 mm
Probe Tip to Sensor Z Calibration Point	2 mm
Recommended Measurement Distance from Surface	2 mm



Accredited by the Swiss Accreditation Service (SAS)
The Swiss Accreditation Service is one of the signatories to the EA
Multilateral Agreement for the recognition of calibration certificates

Accreditation No.: **SCS 108**

Client **PC Test**

Certificate No: **ES3-3332_Sep14**

CALIBRATION CERTIFICATE

Object **ES3DV3 - SN:3332**

Calibration procedure(s) **QA CAL-01.v9, QA CAL-23.v5, QA CAL-25.v6
Calibration procedure for dosimetric E-field probes**

Calibration date: **September 18, 2014**

This calibration certificate documents the traceability to national standards, which realize the physical units of measurements (SI).
The measurements and the uncertainties with confidence probability are given on the following pages and are part of the certificate.

All calibrations have been conducted in the closed laboratory facility: environment temperature (22 ± 3)°C and humidity < 70%.

Calibration Equipment used (M&TE critical for calibration)

✓
KOK
19/09/14

Primary Standards	ID	Cal Date (Certificate No.)	Scheduled Calibration
Power meter E4419B	GB41293874	03-Apr-14 (No. 217-01911)	Apr-15
Power sensor E4412A	MY41498087	03-Apr-14 (No. 217-01911)	Apr-15
Reference 3 dB Attenuator	SN: S5054 (3c)	03-Apr-14 (No. 217-01915)	Apr-15
Reference 20 dB Attenuator	SN: S5277 (20x)	03-Apr-14 (No. 217-01919)	Apr-15
Reference 30 dB Attenuator	SN: S5129 (30b)	03-Apr-14 (No. 217-01920)	Apr-15
Reference Probe ES3DV2	SN: 3013	30-Dec-13 (No. ES3-3013_Dec13)	Dec-14
DAE4	SN: 660	13-Dec-13 (No. DAE4-660_Dec13)	Dec-14
Secondary Standards	ID	Check Date (in house)	Scheduled Check
RF generator HP 8648C	US3642U01700	4-Aug-99 (in house check Apr-13)	In house check: Apr-16
Network Analyzer HP 8753E	US37390585	18-Oct-01 (in house check Oct-13)	In house check: Oct-14

	Name	Function	Signature
Calibrated by:	Israe El-Naouq	Laboratory Technician	
Approved by:	Katja Pokovic	Technical Manager	
			Issued: September 18, 2014
This calibration certificate shall not be reproduced except in full without written approval of the laboratory.			



Accredited by the Swiss Accreditation Service (SAS)

Accreditation No.: **SCS 108**

The Swiss Accreditation Service is one of the signatories to the EA Multilateral Agreement for the recognition of calibration certificates

Glossary:

TSL	tissue simulating liquid
NORM _{x,y,z}	sensitivity in free space
ConvF	sensitivity in TSL / NORM _{x,y,z}
DCP	diode compression point
CF	crest factor (1/duty_cycle) of the RF signal
A, B, C, D	modulation dependent linearization parameters
Polarization φ	φ rotation around probe axis
Polarization ϑ	ϑ rotation around an axis that is in the plane normal to probe axis (at measurement center), i.e., $\vartheta = 0$ is normal to probe axis
Connector Angle	information used in DASY system to align probe sensor X to the robot coordinate system

Calibration is Performed According to the Following Standards:

- IEEE Std 1528-2013, "IEEE Recommended Practice for Determining the Peak Spatial-Averaged Specific Absorption Rate (SAR) in the Human Head from Wireless Communications Devices: Measurement Techniques", June 2013
- IEC 62209-1, "Procedure to measure the Specific Absorption Rate (SAR) for hand-held devices used in close proximity to the ear (frequency range of 300 MHz to 3 GHz)", February 2005

Methods Applied and Interpretation of Parameters:

- NORM_{x,y,z}**: Assessed for E-field polarization $\vartheta = 0$ ($f \leq 900$ MHz in TEM-cell; $f > 1800$ MHz: R22 waveguide). NORM_{x,y,z} are only intermediate values, i.e., the uncertainties of NORM_{x,y,z} does not affect the E²-field uncertainty inside TSL (see below ConvF).
- NORM(f)_{x,y,z}** = NORM_{x,y,z} * frequency_response (see Frequency Response Chart). This linearization is implemented in DASY4 software versions later than 4.2. The uncertainty of the frequency response is included in the stated uncertainty of ConvF.
- DCP_{x,y,z}**: DCP are numerical linearization parameters assessed based on the data of power sweep with CW signal (no uncertainty required). DCP does not depend on frequency nor media.
- PAR**: PAR is the Peak to Average Ratio that is not calibrated but determined based on the signal characteristics
- A_{x,y,z}; B_{x,y,z}; C_{x,y,z}; D_{x,y,z}; VR_{x,y,z}**: A, B, C, D are numerical linearization parameters assessed based on the data of power sweep for specific modulation signal. The parameters do not depend on frequency nor media. VR is the maximum calibration range expressed in RMS voltage across the diode.
- ConvF and Boundary Effect Parameters**: Assessed in flat phantom using E-field (or Temperature Transfer Standard for $f \leq 800$ MHz) and inside waveguide using analytical field distributions based on power measurements for $f > 800$ MHz. The same setups are used for assessment of the parameters applied for boundary compensation (alpha, depth) of which typical uncertainty values are given. These parameters are used in DASY4 software to improve probe accuracy close to the boundary. The sensitivity in TSL corresponds to NORM_{x,y,z} * ConvF whereby the uncertainty corresponds to that given for ConvF. A frequency dependent ConvF is used in DASY version 4.4 and higher which allows extending the validity from ± 50 MHz to ± 100 MHz.
- Spherical isotropy (3D deviation from isotropy)**: in a field of low gradients realized using a flat phantom exposed by a patch antenna.
- Sensor Offset**: The sensor offset corresponds to the offset of virtual measurement center from the probe tip (on probe axis). No tolerance required.
- Connector Angle**: The angle is assessed using the information gained by determining the NORM_x (no uncertainty required).

Probe ES3DV3

SN:3332

Manufactured: January 24, 2012
Calibrated: September 18, 2014

Calibrated for DASY/EASY Systems
(Note: non-compatible with DASY2 system!)

DASY/EASY - Parameters of Probe: ES3DV3 - SN:3332

Basic Calibration Parameters

	Sensor X	Sensor Y	Sensor Z	Unc (k=2)
Norm ($\mu V/(V/m)^2$) ^A	0.94	1.15	0.98	$\pm 10.1\%$
DCP (mV) ^B	105.8	103.8	112.4	

Modulation Calibration Parameters

UID	Communication System Name		A dB	B dB $\sqrt{\mu V}$	C	D dB	VR mV	Unc ^L (k=2)
0	CW	X	0.0	0.0	1.0	0.00	178.7	$\pm 3.0\%$
		Y	0.0	0.0	1.0		199.5	
		Z	0.0	0.0	1.0		186.5	
10010- CAA	SAR Validation (Square, 100ms, 10ms)	X	55.60	92.4	20.6	10.00	35.7	$\pm 1.7\%$
		Y	2.80	61.2	11.6		42.9	
		Z	10.49	80.1	18.0		36.1	
10011- CAB	UMTS-FDD (WCDMA)	X	3.47	67.9	18.8	2.91	141.3	$\pm 0.7\%$
		Y	3.29	67.0	18.4		138.2	
		Z	3.78	70.4	20.1		147.9	
10012- CAA	IEEE 802.11b WiFi 2.4 GHz (DSSS, 1 Mbps)	X	3.53	72.0	20.1	1.87	141.7	$\pm 0.7\%$
		Y	3.03	69.1	18.8		141.1	
		Z	4.06	75.5	21.6		148.2	
10013- CAA	IEEE 802.11g WiFi 2.4 GHz (DSSS-OFDM, 6 Mbps)	X	10.87	69.8	22.6	9.46	137.3	$\pm 3.5\%$
		Y	11.63	71.7	23.9		141.9	
		Z	10.51	69.6	22.5		139.2	
10021- DAB	GSM-FDD (TDMA, GMSK)	X	6.92	78.4	20.1	9.39	137.0	$\pm 2.5\%$
		Y	26.20	99.6	27.8		141.5	
		Z	5.13	78.3	21.1		144.7	
10023- DAB	GPRS-FDD (TDMA, GMSK, TN 0)	X	9.10	83.6	22.5	9.57	144.0	$\pm 2.5\%$
		Y	26.31	100.0	28.1		136.7	
		Z	6.15	81.6	22.5		139.9	
10024- DAB	GPRS-FDD (TDMA, GMSK, TN 0-1)	X	10.54	84.1	20.4	6.56	141.8	$\pm 2.5\%$
		Y	40.55	99.6	24.9		142.2	
		Z	6.45	81.5	20.2		145.7	
10027- DAB	GPRS-FDD (TDMA, GMSK, TN 0-1-2)	X	28.34	94.6	21.9	4.80	131.4	$\pm 2.5\%$
		Y	52.22	99.6	23.3		126.8	
		Z	28.33	99.5	23.9		140.7	
10028- DAB	GPRS-FDD (TDMA, GMSK, TN 0-1-2-3)	X	52.17	100.0	22.2	3.55	147.0	$\pm 1.7\%$
		Y	57.29	99.6	22.4		133.0	
		Z	25.84	99.5	23.3		126.2	
10032- CAA	IEEE 802.15.1 Bluetooth (GFSK, DH5)	X	59.05	100.0	19.9	1.16	135.5	$\pm 1.9\%$
		Y	100.00	99.7	19.2		143.5	
		Z	34.97	100.0	20.4		143.1	

10039-CAB	CDMA2000 (1xRTT, RC1)	X	4.78	66.9	18.9	4.57	134.6	±0.9 %
		Y	4.85	67.1	19.1		141.0	
		Z	4.76	67.8	19.4		140.7	
10081-CAB	CDMA2000 (1xRTT, RC3)	X	3.98	66.4	18.6	3.97	130.4	±0.7 %
		Y	3.98	66.5	18.7		136.2	
		Z	4.04	67.7	19.2		137.4	
10098-CAB	UMTS-FDD (HSUPA, Subtest 2)	X	4.75	67.3	18.8	3.98	144.4	±0.7 %
		Y	4.55	66.5	18.5		126.5	
		Z	4.72	67.9	19.0		128.1	
10100-CAB	LTE-FDD (SC-FDMA, 100% RB, 20 MHz, QPSK)	X	6.26	66.9	19.2	5.67	124.5	±1.2 %
		Y	6.38	67.4	19.7		131.7	
		Z	6.36	67.7	19.7		132.3	
10108-CAB	LTE-FDD (SC-FDMA, 100% RB, 10 MHz, QPSK)	X	6.44	67.5	19.7	5.80	147.4	±1.4 %
		Y	6.31	67.2	19.7		130.2	
		Z	6.17	67.2	19.6		130.1	
10110-CAB	LTE-FDD (SC-FDMA, 100% RB, 5 MHz, QPSK)	X	6.08	66.9	19.5	5.75	142.7	±1.4 %
		Y	5.97	66.6	19.4		127.3	
		Z	5.84	66.7	19.3		126.2	
10114-CAA	IEEE 802.11n (HT Greenfield, 13.5 Mbps, BPSK)	X	10.13	68.7	21.0	8.10	136.9	±2.5 %
		Y	10.57	69.9	21.9		146.3	
		Z	10.06	69.0	21.1		143.6	
10117-CAA	IEEE 802.11n (HT Mixed, 13.5 Mbps, BPSK)	X	10.12	68.6	21.0	8.07	138.2	±2.5 %
		Y	10.60	69.9	21.9		148.0	
		Z	10.07	69.0	21.1		146.6	
10151-CAB	LTE-TDD (SC-FDMA, 50% RB, 20 MHz, QPSK)	X	8.76	71.7	23.8	9.28	130.7	±3.0 %
		Y	10.03	75.2	25.9		121.5	
		Z	8.15	70.7	23.5		134.1	
10154-CAB	LTE-FDD (SC-FDMA, 50% RB, 10 MHz, QPSK)	X	6.10	67.0	19.5	5.75	144.4	±1.4 %
		Y	5.98	66.6	19.4		127.8	
		Z	5.84	66.6	19.3		127.2	
10160-CAB	LTE-FDD (SC-FDMA, 50% RB, 15 MHz, QPSK)	X	6.56	67.5	19.7	5.82	149.5	±1.7 %
		Y	6.41	67.1	19.6		132.5	
		Z	6.17	66.8	19.4		130.4	
10169-CAB	LTE-FDD (SC-FDMA, 1 RB, 20 MHz, QPSK)	X	5.01	67.0	19.7	5.73	147.8	±1.2 %
		Y	5.01	66.9	19.8		132.1	
		Z	4.75	66.9	19.7		130.3	
10172-CAB	LTE-TDD (SC-FDMA, 1 RB, 20 MHz, QPSK)	X	7.65	75.0	25.8	9.21	144.9	±2.7 %
		Y	10.17	82.4	29.7		136.4	
		Z	6.53	72.3	24.6		145.6	
10175-CAB	LTE-FDD (SC-FDMA, 1 RB, 10 MHz, QPSK)	X	4.98	66.9	19.6	5.72	141.0	±1.2 %
		Y	4.98	66.7	19.7		130.5	
		Z	4.71	66.7	19.5		128.1	

10181-CAB	LTE-FDD (SC-FDMA, 1 RB, 15 MHz, QPSK)	X	4.95	66.7	19.5	5.72	139.8	±1.2 %
		Y	4.97	66.7	19.7		129.5	
		Z	4.72	66.8	19.6		128.0	
10193-CAA	IEEE 802.11n (HT Greenfield, 6.5 Mbps, BPSK)	X	9.75	68.2	20.9	8.09	131.8	±2.5 %
		Y	10.16	69.4	21.7		139.2	
		Z	9.62	68.6	21.0		137.3	
10196-CAA	IEEE 802.11n (HT Mixed, 6.5 Mbps, BPSK)	X	9.77	68.3	20.9	8.10	133.6	±2.5 %
		Y	10.17	69.4	21.8		140.1	
		Z	9.61	68.5	21.0		140.1	
10219-CAA	IEEE 802.11n (HT Mixed, 7.2 Mbps, BPSK)	X	9.69	68.3	20.9	8.03	133.6	±2.5 %
		Y	10.05	69.3	21.7		139.2	
		Z	9.58	68.7	21.1		139.4	
10222-CAA	IEEE 802.11n (HT Mixed, 15 Mbps, BPSK)	X	10.13	68.7	21.0	8.06	140.7	±2.5 %
		Y	10.51	69.8	21.8		145.1	
		Z	10.11	69.1	21.2		148.4	
10225-CAB	UMTS-FDD (HSPA+)	X	7.03	67.2	19.4	5.97	138.0	±1.4 %
		Y	7.07	67.2	19.6		140.2	
		Z	6.97	67.8	19.7		144.6	
10237-CAB	LTE-TDD (SC-FDMA, 1 RB, 10 MHz, QPSK)	X	7.11	72.9	24.7	9.21	124.6	±2.7 %
		Y	10.04	82.0	29.5		135.7	
		Z	6.29	71.2	24.0		126.2	
10252-CAB	LTE-TDD (SC-FDMA, 50% RB, 10 MHz, QPSK)	X	8.61	72.5	24.3	9.24	145.2	±3.3 %
		Y	10.53	77.8	27.4		136.7	
		Z	7.56	70.0	23.1		126.7	
10267-CAB	LTE-TDD (SC-FDMA, 100% RB, 10 MHz, QPSK)	X	8.74	71.6	23.8	9.30	128.7	±3.3 %
		Y	11.51	79.1	28.0		147.2	
		Z	8.07	70.4	23.2		134.1	
10274-CAB	UMTS-FDD (HSUPA, Subtest 5, 3GPP Rel8.10)	X	5.90	66.7	18.7	4.87	128.0	±0.9 %
		Y	5.93	66.8	18.9		134.5	
		Z	5.92	67.6	19.1		138.2	
10275-CAB	UMTS-FDD (HSUPA, Subtest 5, 3GPP Rel8.4)	X	4.53	67.1	18.8	3.96	133.8	±0.7 %
		Y	4.48	67.0	18.8		139.6	
		Z	4.62	68.3	19.3		145.0	
10291-AAB	CDMA2000, RC3, SO55, Full Rate	X	3.82	67.8	19.0	3.46	147.6	±0.7 %
		Y	3.66	67.0	18.8		131.7	
		Z	3.97	69.6	20.0		135.9	
10292-AAB	CDMA2000, RC3, SO32, Full Rate	X	3.70	67.5	18.8	3.39	128.1	±0.7 %
		Y	3.60	66.9	18.7		132.5	
		Z	3.80	68.9	19.5		139.8	
10297-AAA	LTE-FDD (SC-FDMA, 50% RB, 20 MHz, QPSK)	X	6.47	67.6	19.8	5.81	149.7	±1.7 %
		Y	6.24	66.9	19.5		126.3	
		Z	6.20	67.3	19.6		130.9	

10311-AAA	LTE-FDD (SC-FDMA, 100% RB, 15 MHz, QPSK)	X	6.72	67.1	19.5	6.06	128.8	±1.4 %
		Y	6.85	67.7	20.0		132.4	
		Z	6.75	67.7	19.8		136.6	
10315-AAA	IEEE 802.11b WiFi 2.4 GHz (DSSS, 1 Mbps, 96pc duty cycle)	X	3.27	71.1	19.8	1.71	140.1	±0.7 %
		Y	2.95	69.4	19.1		139.8	
		Z	3.75	74.4	21.2		146.9	
10316-AAA	IEEE 802.11g WiFi 2.4 GHz (ERP-OFDM, 6 Mbps, 96pc duty cycle)	X	10.04	68.7	21.3	8.36	136.3	±2.5 %
		Y	10.42	69.8	22.1		138.1	
		Z	9.84	68.9	21.3		139.7	
10403-AAB	CDMA2000 (1xEV-DO, Rev. 0)	X	5.01	69.3	19.2	3.76	144.3	±0.7 %
		Y	4.79	68.1	18.7		146.3	
		Z	5.40	72.5	20.8		146.7	
10404-AAB	CDMA2000 (1xEV-DO, Rev. A)	X	4.97	69.5	19.3	3.77	141.3	±0.7 %
		Y	4.72	68.2	18.8		143.1	
		Z	5.12	71.8	20.5		144.4	
10415-AAA	IEEE 802.11b WiFi 2.4 GHz (DSSS, 1 Mbps, 99pc duty cycle)	X	3.05	70.5	19.5	1.54	139.7	±0.7 %
		Y	2.71	68.7	18.9		140.2	
		Z	4.22	77.3	22.5		145.9	
10416-AAA	IEEE 802.11g WiFi 2.4 GHz (ERP-OFDM, 6 Mbps, 99pc duty cycle)	X	9.92	68.6	21.1	8.23	136.3	±2.5 %
		Y	10.20	69.4	21.8		138.3	
		Z	9.76	68.8	21.3		138.9	

The reported uncertainty of measurement is stated as the standard uncertainty of measurement multiplied by the coverage factor $k=2$, which for a normal distribution corresponds to a coverage probability of approximately 95%.

^A The uncertainties of NormX,Y,Z do not affect the E^2 -field uncertainty inside TSL (see Pages 8 and 9).

^B Numerical linearization parameter: uncertainty not required.

^E Uncertainty is determined using the max. deviation from linear response applying rectangular distribution and is expressed for the square of the field value.

DASY/EASY - Parameters of Probe: ES3DV3 - SN:3332

Calibration Parameter Determined in Head Tissue Simulating Media

f (MHz) ^C	Relative Permittivity ^F	Conductivity (S/m) ^F	ConvF X	ConvF Y	ConvF Z	Alpha ^G	Depth ^G (mm)	Unct. (k=2)
750	41.9	0.89	6.56	6.56	6.56	0.50	1.43	± 12.0 %
835	41.5	0.90	6.31	6.31	6.31	0.61	1.31	± 12.0 %
1750	40.1	1.37	5.17	5.17	5.17	0.62	1.33	± 12.0 %
1900	40.0	1.40	5.04	5.04	5.04	0.80	1.17	± 12.0 %
2450	39.2	1.80	4.49	4.49	4.49	0.77	1.24	± 12.0 %
2600	39.0	1.96	4.35	4.35	4.35	0.73	1.38	± 12.0 %

^C Frequency validity above 300 MHz of ± 100 MHz only applies for DASY v4.4 and higher (see Page 2), else it is restricted to ± 50 MHz. The uncertainty is the RSS of the ConvF uncertainty at calibration frequency and the uncertainty for the indicated frequency band. Frequency validity below 300 MHz is ± 10, 25, 40, 50 and 70 MHz for ConvF assessments at 30, 64, 128, 150 and 220 MHz respectively. Above 5 GHz frequency validity can be extended to ± 110 MHz.

^F At frequencies below 3 GHz, the validity of tissue parameters (ϵ and σ) can be relaxed to ± 10% if liquid compensation formula is applied to measured SAR values. At frequencies above 3 GHz, the validity of tissue parameters (ϵ and σ) is restricted to ± 5%. The uncertainty is the RSS of the ConvF uncertainty for indicated target tissue parameters.

^G Alpha/Depth are determined during calibration. SPEAG warrants that the remaining deviation due to the boundary effect after compensation is always less than ± 1% for frequencies below 3 GHz and below ± 2% for frequencies between 3-6 GHz at any distance larger than half the probe tip diameter from the boundary.

DASY/EASY - Parameters of Probe: ES3DV3 - SN:3332

Calibration Parameter Determined in Body Tissue Simulating Media

f (MHz) ^C	Relative Permittivity ^F	Conductivity (S/m) ^F	ConvF X	ConvF Y	ConvF Z	Alpha ^G	Depth ^G (mm)	Unct. (k=2)
750	55.5	0.96	6.24	6.24	6.24	0.50	1.50	± 12.0 %
835	55.2	0.97	6.21	6.21	6.21	0.45	1.59	± 12.0 %
1750	53.4	1.49	4.88	4.88	4.88	0.39	1.78	± 12.0 %
1900	53.3	1.52	4.64	4.64	4.64	0.61	1.47	± 12.0 %
2450	52.7	1.95	4.31	4.31	4.31	0.80	1.18	± 12.0 %
2600	52.5	2.16	4.11	4.11	4.11	0.68	0.99	± 12.0 %

^C Frequency validity above 300 MHz of ± 100 MHz only applies for DASY v4.4 and higher (see Page 2), else it is restricted to ± 50 MHz. The uncertainty is the RSS of the ConvF uncertainty at calibration frequency and the uncertainty for the indicated frequency band. Frequency validity below 300 MHz is ± 10 , 25, 40, 50 and 70 MHz for ConvF assessments at 30, 64, 128, 150 and 220 MHz respectively. Above 5 GHz frequency validity can be extended to ± 110 MHz.

^F At frequencies below 3 GHz, the validity of tissue parameters (ϵ and σ) can be relaxed to $\pm 10\%$ if liquid compensation formula is applied to measured SAR values. At frequencies above 3 GHz, the validity of tissue parameters (ϵ and σ) is restricted to $\pm 5\%$. The uncertainty is the RSS of the ConvF uncertainty for indicated target tissue parameters.

^G Alpha/Depth are determined during calibration. SPEAG warrants that the remaining deviation due to the boundary effect after compensation is always less than $\pm 1\%$ for frequencies below 3 GHz and below $\pm 2\%$ for frequencies between 3-6 GHz at any distance larger than half the probe tip diameter from the boundary.

Frequency Response of E-Field (TEM-Cell:ifi110 EXX, Waveguide: R22)

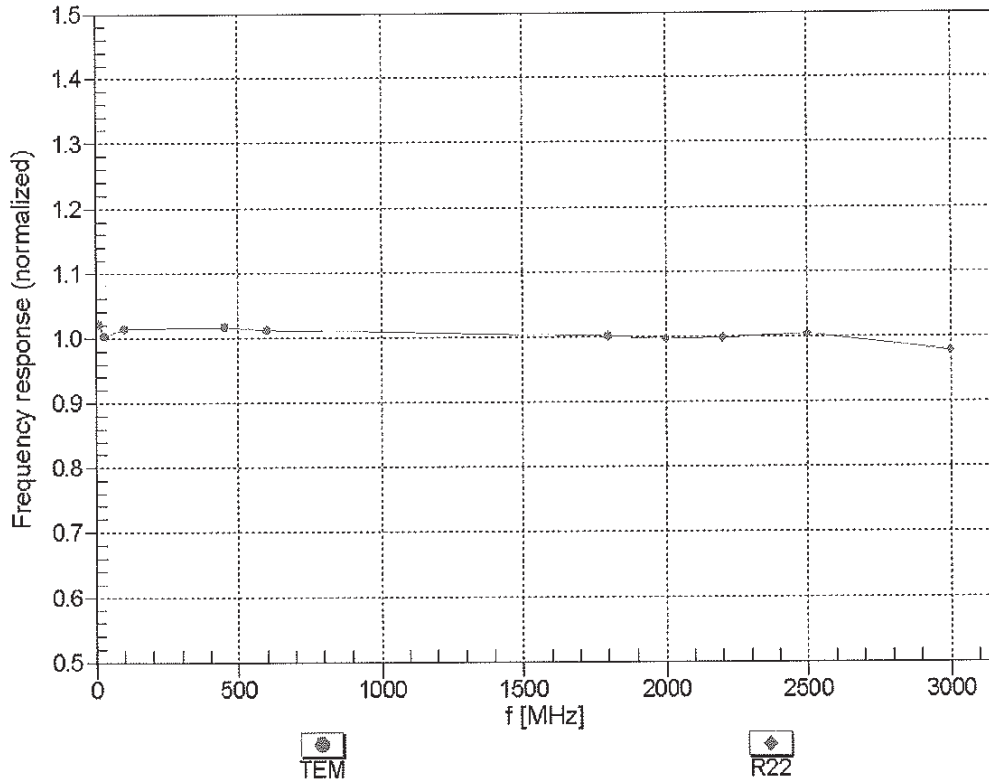

Uncertainty of Frequency Response of E-field: $\pm 6.3\%$ (k=2)

Receiving Pattern (ϕ), $\theta = 0^\circ$

f=600 MHz,TEM

f=1800 MHz,R22

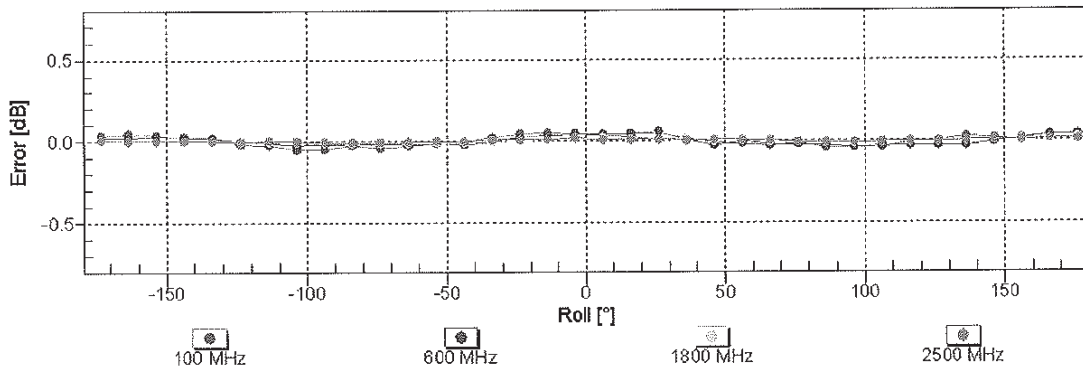
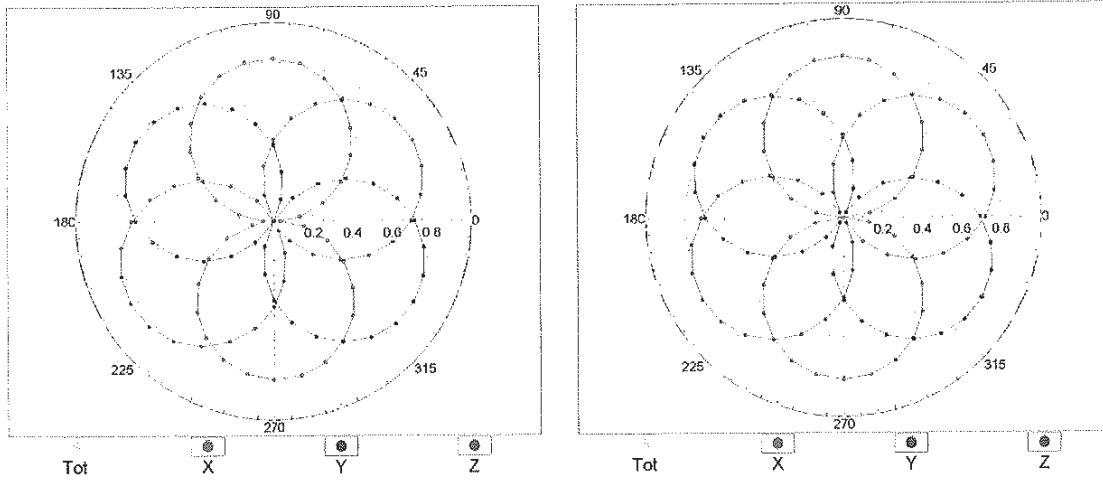

Uncertainty of Axial Isotropy Assessment: $\pm 0.5\%$ ($k=2$)

Dynamic Range $f(SAR_{head})$ (TEM cell , $f_{eval}= 1900$ MHz)

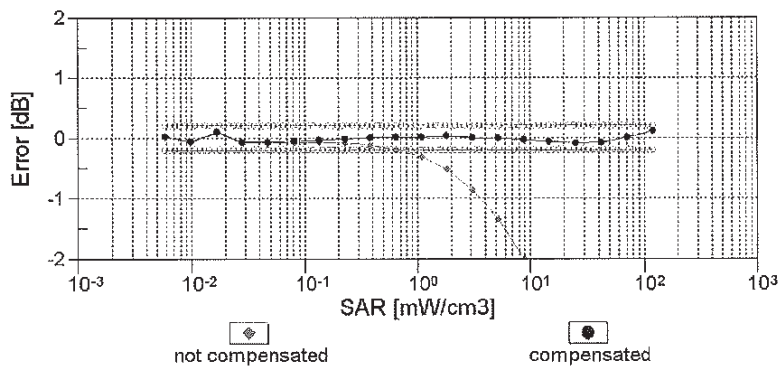
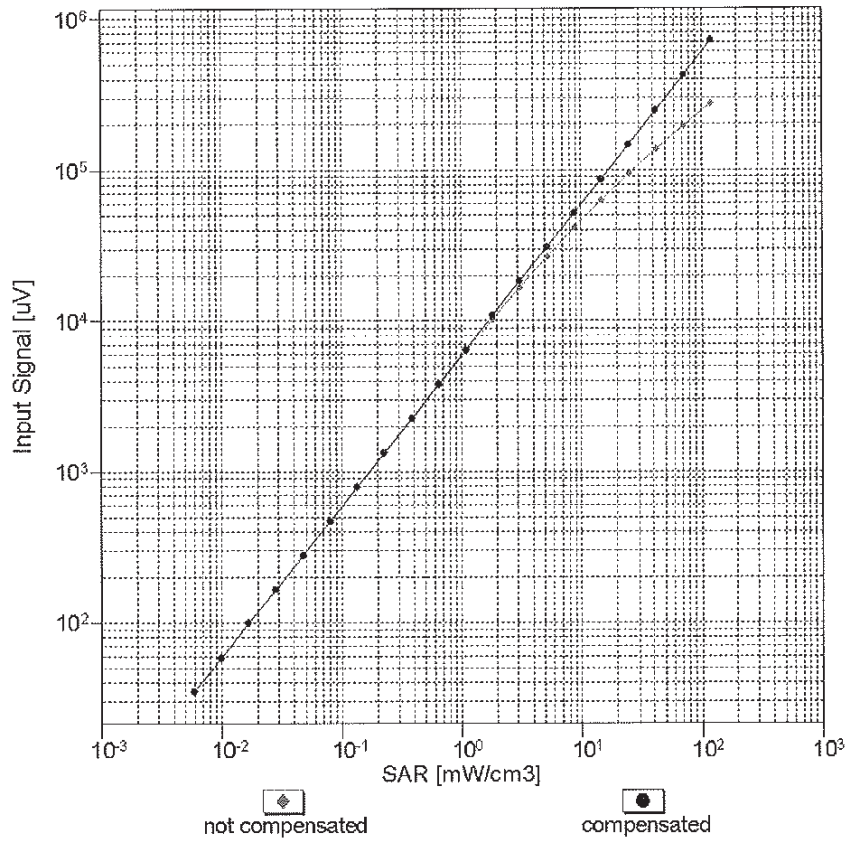

Uncertainty of Linearity Assessment: $\pm 0.6\%$ ($k=2$)

Conversion Factor Assessment

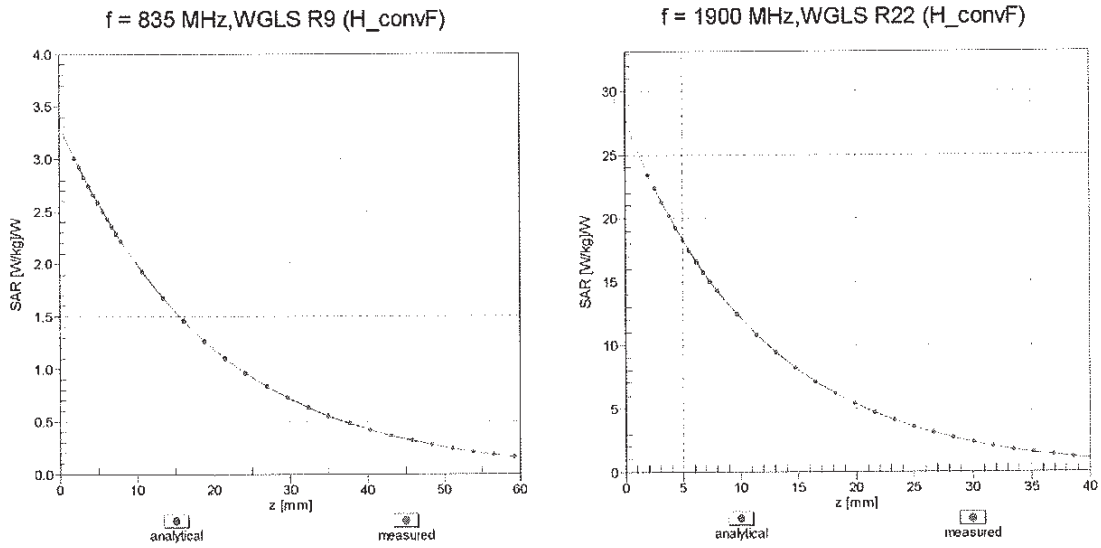

Deviation from Isotropy in Liquid Error (ϕ, θ), f = 900 MHz

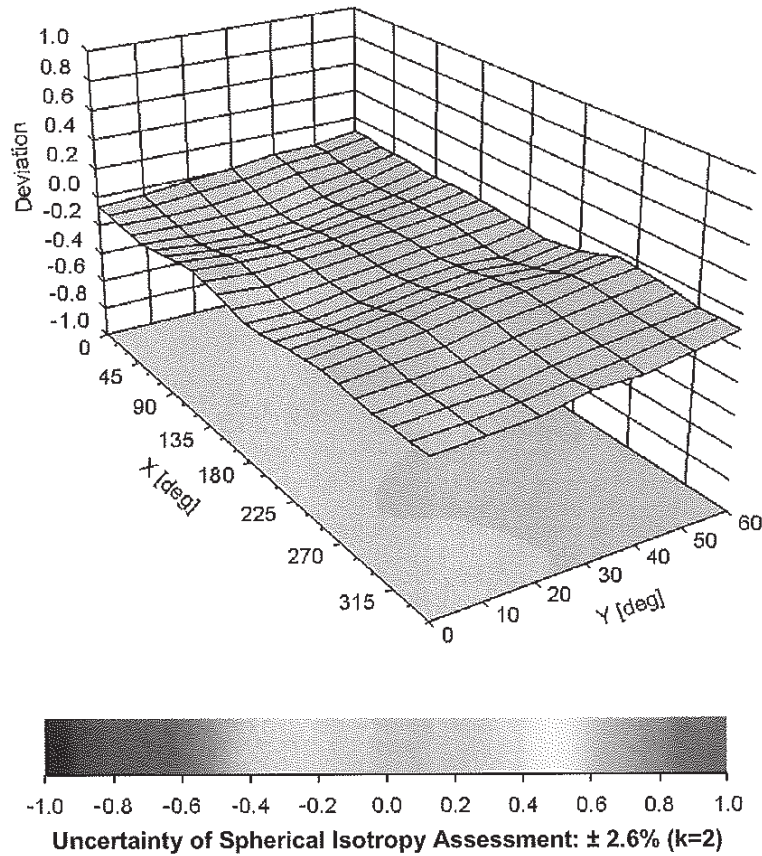

DASY/EASY - Parameters of Probe: ES3DV3 - SN:3332**Other Probe Parameters**

Sensor Arrangement	Triangular
Connector Angle (°)	-3.7
Mechanical Surface Detection Mode	enabled
Optical Surface Detection Mode	disabled
Probe Overall Length	337 mm
Probe Body Diameter	10 mm
Tip Length	10 mm
Tip Diameter	4 mm
Probe Tip to Sensor X Calibration Point	2 mm
Probe Tip to Sensor Y Calibration Point	2 mm
Probe Tip to Sensor Z Calibration Point	2 mm
Recommended Measurement Distance from Surface	2 mm



Accredited by the Swiss Accreditation Service (SAS)
The Swiss Accreditation Service is one of the signatories to the EA
Multilateral Agreement for the recognition of calibration certificates

Accreditation No.: **SCS 108**

Client **PC Test**

Certificate No: **ES3-3022_Aug14**

CALIBRATION CERTIFICATE

Object **ES3DV2 - SN:3022**

Calibration procedure(s) **QA CAL-01.v9, QA CAL-12.v9, QA CAL-23.v5, QA CAL-25.v6
Calibration procedure for dosimetric E-field probes**

Calibration date: **August 19, 2014**

This calibration certificate documents the traceability to national standards, which realize the physical units of measurements (SI).
The measurements and the uncertainties with confidence probability are given on the following pages and are part of the certificate.

All calibrations have been conducted in the closed laboratory facility: environment temperature (22 ± 3)°C and humidity < 70%.

Calibration Equipment used (M&TE critical for calibration)

*✓ KOK
9/2/14*

Primary Standards	ID	Cal Date (Certificate No.)	Scheduled Calibration
Power meter E4419B	GB41293874	03-Apr-14 (No. 217-01911)	Apr-15
Power sensor E4412A	MY41498087	03-Apr-14 (No. 217-01911)	Apr-15
Reference 3 dB Attenuator	SN: S5054 (3c)	03-Apr-14 (No. 217-01915)	Apr-15
Reference 20 dB Attenuator	SN: S5277 (20x)	03-Apr-14 (No. 217-01919)	Apr-15
Reference 30 dB Attenuator	SN: S5129 (30b)	03-Apr-14 (No. 217-01920)	Apr-15
Reference Probe ES3DV2	SN: 3013	30-Dec-13 (No. ES3-3013_Dec13)	Dec-14
DAE4	SN: 660	13-Dec-13 (No. DAE4-660_Dec13)	Dec-14
Secondary Standards	ID	Check Date (in house)	Scheduled Check
RF generator HP 8648C	US3642U01700	4-Aug-99 (in house check Apr-13)	In house check: Apr-16
Network Analyzer HP 8753E	US37390585	18-Oct-01 (in house check Oct-13)	In house check: Oct-14

Calibrated by:	Name Jeton Kastrati	Function Laboratory Technician	Signature
Approved by:	Name Katja Pokovic	Function Technical Manager	Signature

Issued: August 20, 2014

This calibration certificate shall not be reproduced except in full without written approval of the laboratory.



Accredited by the Swiss Accreditation Service (SAS)

Accreditation No.: **SCS 108**

The Swiss Accreditation Service is one of the signatories to the EA
Multilateral Agreement for the recognition of calibration certificates

Glossary:

TSL	tissue simulating liquid
NORM _{x,y,z}	sensitivity in free space
ConvF	sensitivity in TSL / NORM _{x,y,z}
DCP	diode compression point
CF	crest factor (1/duty_cycle) of the RF signal
A, B, C, D	modulation dependent linearization parameters
Polarization φ	φ rotation around probe axis
Polarization ϑ	ϑ rotation around an axis that is in the plane normal to probe axis (at measurement center), i.e., $\vartheta = 0$ is normal to probe axis
Connector Angle	information used in DASY system to align probe sensor X to the robot coordinate system

Calibration is Performed According to the Following Standards:

- IEEE Std 1528-2013, "IEEE Recommended Practice for Determining the Peak Spatial-Averaged Specific Absorption Rate (SAR) in the Human Head from Wireless Communications Devices: Measurement Techniques", June 2013
- IEC 62209-1, "Procedure to measure the Specific Absorption Rate (SAR) for hand-held devices used in close proximity to the ear (frequency range of 300 MHz to 3 GHz)", February 2005

Methods Applied and Interpretation of Parameters:

- NORM_{x,y,z}**: Assessed for E-field polarization $\vartheta = 0$ ($f \leq 900$ MHz in TEM-cell; $f > 1800$ MHz: R22 waveguide). NORM_{x,y,z} are only intermediate values, i.e., the uncertainties of NORM_{x,y,z} does not affect the E²-field uncertainty inside TSL (see below ConvF).
- NORM(f)_{x,y,z}** = NORM_{x,y,z} * frequency_response (see Frequency Response Chart). This linearization is implemented in DASY4 software versions later than 4.2. The uncertainty of the frequency response is included in the stated uncertainty of ConvF.
- DCP_{x,y,z}**: DCP are numerical linearization parameters assessed based on the data of power sweep with CW signal (no uncertainty required). DCP does not depend on frequency nor media.
- PAR**: PAR is the Peak to Average Ratio that is not calibrated but determined based on the signal characteristics
- A_{x,y,z}; B_{x,y,z}; C_{x,y,z}; D_{x,y,z}; VR_{x,y,z}; A, B, C, D** are numerical linearization parameters assessed based on the data of power sweep for specific modulation signal. The parameters do not depend on frequency nor media. VR is the maximum calibration range expressed in RMS voltage across the diode.
- ConvF and Boundary Effect Parameters**: Assessed in flat phantom using E-field (or Temperature Transfer Standard for $f \leq 800$ MHz) and inside waveguide using analytical field distributions based on power measurements for $f > 800$ MHz. The same setups are used for assessment of the parameters applied for boundary compensation (alpha, depth) of which typical uncertainty values are given. These parameters are used in DASY4 software to improve probe accuracy close to the boundary. The sensitivity in TSL corresponds to NORM_{x,y,z} * ConvF whereby the uncertainty corresponds to that given for ConvF. A frequency dependent ConvF is used in DASY version 4.4 and higher which allows extending the validity from ± 50 MHz to ± 100 MHz.
- Spherical isotropy (3D deviation from isotropy)**: in a field of low gradients realized using a flat phantom exposed by a patch antenna.
- Sensor Offset**: The sensor offset corresponds to the offset of virtual measurement center from the probe tip (on probe axis). No tolerance required.
- Connector Angle**: The angle is assessed using the information gained by determining the NORM_x (no uncertainty required).

Probe ES3DV2

SN:3022

Manufactured: April 15, 2003
Calibrated: August 19, 2014

Calibrated for DASY/EASY Systems
(Note: non-compatible with DASY2 system!)

DASY/EASY - Parameters of Probe: ES3DV2 - SN:3022

Basic Calibration Parameters

	Sensor X	Sensor Y	Sensor Z	Unc (k=2)
Norm ($\mu\text{V}/(\text{V/m})^2$) ^A	1.00	1.04	0.96	$\pm 10.1\%$
DCP (mV) ^B	103.0	96.3	101.6	

Modulation Calibration Parameters

UID	Communication System Name		A dB	B dB $\sqrt{\mu\text{V}}$	C	D dB	VR mV	Unc ^E (k=2)
0	CW	X	0.0	0.0	1.0	0.00	181.8	$\pm 2.7\%$
		Y	0.0	0.0	1.0		183.0	
		Z	0.0	0.0	1.0		192.3	
10010-CAA	SAR Validation (Square, 100ms, 10ms)	X	2.51	63.1	12.7	10.00	42.6	$\pm 1.9\%$
		Y	2.62	63.1	12.9		42.7	
		Z	3.12	65.7	13.6		40.4	
10011-CAB	UMTS-FDD (WCDMA)	X	3.33	67.8	19.2	2.91	145.9	$\pm 0.9\%$
		Y	3.13	64.9	16.9		147.4	
		Z	3.20	66.4	18.2		139.6	
10012-CAA	IEEE 802.11b WiFi 2.4 GHz (DSSS, 1 Mbps)	X	3.05	70.1	19.8	1.87	147.2	$\pm 0.9\%$
		Y	2.62	65.1	16.2		147.4	
		Z	2.85	68.2	18.4		141.7	
10013-CAA	IEEE 802.11g WiFi 2.4 GHz (DSSS-OFDM, 6 Mbps)	X	11.10	70.9	23.6	9.46	143.9	$\pm 3.0\%$
		Y	11.04	70.2	22.9		144.2	
		Z	10.77	70.2	23.1		134.7	
10021-DAB	GSM-FDD (TDMA, GMSK)	X	19.66	99.7	28.6	9.39	126.0	$\pm 1.9\%$
		Y	11.04	89.6	25.5		138.9	
		Z	10.45	88.8	24.9		137.5	
10023-DAB	GPRS-FDD (TDMA, GMSK, TN 0)	X	20.19	99.6	28.5	9.57	142.0	$\pm 2.5\%$
		Y	10.53	88.4	25.0		145.5	
		Z	15.52	96.5	27.8		147.6	
10024-DAB	GPRS-FDD (TDMA, GMSK, TN 0-1)	X	31.93	99.6	25.2	6.56	149.5	$\pm 1.9\%$
		Y	12.70	87.9	22.2		148.0	
		Z	27.00	99.8	25.7		135.3	
10027-DAB	GPRS-FDD (TDMA, GMSK, TN 0-1-2)	X	38.32	99.8	23.8	4.80	148.1	$\pm 2.2\%$
		Y	9.80	83.2	19.3		138.8	
		Z	31.96	99.9	24.2		128.9	
10028-DAB	GPRS-FDD (TDMA, GMSK, TN 0-1-2-3)	X	40.03	99.5	22.8	3.55	130.5	$\pm 2.2\%$
		Y	40.27	99.6	23.0		148.1	
		Z	43.09	99.7	22.5		140.1	
10032-CAA	IEEE 802.15.1 Bluetooth (GFSK, DH5)	X	38.93	99.4	20.4	1.16	146.7	$\pm 1.9\%$
		Y	32.83	92.5	17.9		139.2	
		Z	31.94	99.5	20.8		133.1	
10039-CAB	CDMA2000 (1xRTT, RC1)	X	4.66	66.8	19.3	4.57	144.5	$\pm 1.2\%$
		Y	4.56	65.3	17.9		137.2	
		Z	4.52	66.1	18.7		131.7	

10081-CAB	CDMA2000 (1xRTT, RC3)	X	3.82	66.0	18.7	3.97	140.3	±0.9 %
		Y	3.77	64.5	17.3		133.6	
		Z	3.79	65.7	18.4		128.2	
10098-CAB	UMTS-FDD (HSUPA, Subtest 2)	X	4.40	66.2	18.5	3.98	130.9	±1.2 %
		Y	4.39	65.0	17.4		131.1	
		Z	4.47	66.3	18.4		140.0	
10100-CAB	LTE-FDD (SC-FDMA, 100% RB, 20 MHz, QPSK)	X	6.30	67.3	19.8	5.67	137.4	±1.7 %
		Y	6.25	66.3	18.9		135.9	
		Z	6.36	67.4	19.7		147.5	
10108-CAB	LTE-FDD (SC-FDMA, 100% RB, 10 MHz, QPSK)	X	6.14	66.8	19.6	5.80	134.6	±1.7 %
		Y	6.17	66.1	18.9		133.9	
		Z	6.24	67.0	19.7		144.5	
10110-CAB	LTE-FDD (SC-FDMA, 100% RB, 5 MHz, QPSK)	X	5.82	66.3	19.4	5.75	131.2	±1.7 %
		Y	5.82	65.4	18.6		130.3	
		Z	5.91	66.5	19.4		140.4	
10114-CAA	IEEE 802.11n (HT Greenfield, 13.5 Mbps, BPSK)	X	10.00	68.5	21.2	8.10	124.3	±2.5 %
		Y	9.89	67.9	20.6		124.0	
		Z	10.05	68.6	21.2		133.2	
10117-CAA	IEEE 802.11n (HT Mixed, 13.5 Mbps, BPSK)	X	10.01	68.6	21.2	8.07	125.8	±2.5 %
		Y	9.91	67.9	20.7		125.8	
		Z	10.09	68.8	21.3		134.7	
10151-CAB	LTE-TDD (SC-FDMA, 50% RB, 20 MHz, QPSK)	X	9.69	75.5	26.4	9.28	144.7	±3.3 %
		Y	9.09	72.7	24.6		143.2	
		Z	8.54	72.0	24.5		124.8	
10154-CAB	LTE-FDD (SC-FDMA, 50% RB, 10 MHz, QPSK)	X	5.82	66.2	19.4	5.75	131.3	±1.9 %
		Y	6.06	66.3	19.1		149.2	
		Z	5.91	66.5	19.4		140.7	
10160-CAB	LTE-FDD (SC-FDMA, 50% RB, 15 MHz, QPSK)	X	6.27	66.9	19.7	5.82	136.5	±1.4 %
		Y	6.19	65.8	18.7		128.4	
		Z	6.33	67.0	19.6		145.4	
10169-CAB	LTE-FDD (SC-FDMA, 1 RB, 20 MHz, QPSK)	X	4.81	66.4	19.7	5.73	134.8	±1.7 %
		Y	4.92	66.1	19.1		149.9	
		Z	4.78	66.4	19.6		141.2	
10172-CAB	LTE-TDD (SC-FDMA, 1 RB, 20 MHz, QPSK)	X	7.83	76.6	27.2	9.21	131.4	±3.5 %
		Y	7.54	74.5	25.8		147.8	
		Z	7.71	76.7	27.4		145.3	
10175-CAB	LTE-FDD (SC-FDMA, 1 RB, 10 MHz, QPSK)	X	4.90	66.9	20.0	5.72	147.6	±1.4 %
		Y	4.90	66.0	19.1		148.0	
		Z	4.78	66.4	19.6		141.6	
10181-CAB	LTE-FDD (SC-FDMA, 1 RB, 15 MHz, QPSK)	X	4.90	66.9	20.0	5.72	148.1	±1.4 %
		Y	4.89	65.9	19.0		146.9	
		Z	4.80	66.5	19.7		142.1	
10193-CAA	IEEE 802.11n (HT Greenfield, 6.5 Mbps, BPSK)	X	9.80	68.7	21.4	8.09	135.1	±2.7 %
		Y	9.78	68.2	20.9		135.5	
		Z	9.70	68.5	21.2		130.2	

10196-CAA	IEEE 802.11n (HT Mixed, 6.5 Mbps, BPSK)	X	9.79	68.7	21.4	8.10	136.4	±2.7 %
		Y	9.81	68.3	20.9		138.0	
		Z	9.72	68.6	21.3		132.8	
10219-CAA	IEEE 802.11n (HT Mixed, 7.2 Mbps, BPSK)	X	9.68	68.6	21.3	8.03	136.0	±2.7 %
		Y	9.74	68.3	21.0		137.4	
		Z	9.62	68.5	21.2		132.6	
10222-CAA	IEEE 802.11n (HT Mixed, 15 Mbps, BPSK)	X	10.20	69.1	21.5	8.06	143.4	±2.5 %
		Y	9.91	68.0	20.7		125.8	
		Z	10.27	69.4	21.6		148.4	
10225-CAB	UMTS-FDD (HSPA+)	X	6.87	66.9	19.6	5.97	139.5	±1.9 %
		Y	7.04	66.9	19.3		149.3	
		Z	6.89	67.0	19.5		143.5	
10237-CAB	LTE-TDD (SC-FDMA, 1 RB, 10 MHz, QPSK)	X	7.66	75.9	26.9	9.21	126.1	±3.0 %
		Y	7.17	73.1	25.1		132.1	
		Z	7.18	74.6	26.3		128.0	
10252-CAB	LTE-TDD (SC-FDMA, 50% RB, 10 MHz, QPSK)	X	8.58	73.1	25.3	9.24	127.6	±3.3 %
		Y	8.22	71.0	23.7		126.9	
		Z	8.83	74.3	26.0		149.8	
10267-CAB	LTE-TDD (SC-FDMA, 100% RB, 10 MHz, QPSK)	X	9.69	75.5	26.5	9.30	143.8	±3.3 %
		Y	8.88	72.0	24.2		135.2	
		Z	8.83	72.9	25.1		131.3	
10274-CAB	UMTS-FDD (HSUPA, Subtest 5, 3GPP Rel8.10)	X	5.87	67.0	19.2	4.87	141.2	±1.4 %
		Y	5.77	65.8	18.1		136.0	
		Z	5.71	66.3	18.6		132.7	
10275-CAB	UMTS-FDD (HSUPA, Subtest 5, 3GPP Rel8.4)	X	4.44	67.2	19.2	3.96	147.3	±0.9 %
		Y	4.29	65.3	17.6		139.2	
		Z	4.31	66.3	18.5		139.6	
10291-AAB	CDMA2000, RC3, SO55, Full Rate	X	3.60	67.1	19.1	3.46	137.8	±0.7 %
		Y	3.44	64.8	17.2		129.6	
		Z	3.48	66.2	18.4		130.5	
10292-AAB	CDMA2000, RC3, SO32, Full Rate	X	3.50	66.9	18.9	3.39	139.5	±0.7 %
		Y	3.38	64.8	17.2		132.0	
		Z	3.48	66.5	18.5		133.1	
10297-AAA	LTE-FDD (SC-FDMA, 50% RB, 20 MHz, QPSK)	X	6.12	66.7	19.6	5.81	133.3	±1.9 %
		Y	6.35	66.7	19.3		149.3	
		Z	6.17	66.8	19.5		132.7	
10311-AAA	LTE-FDD (SC-FDMA, 100% RB, 15 MHz, QPSK)	X	6.72	67.4	20.0	6.06	138.7	±1.7 %
		Y	6.63	66.3	19.1		131.4	
		Z	6.72	67.3	19.9		138.7	
10315-AAA	IEEE 802.11b WiFi 2.4 GHz (DSSS, 1 Mbps, 96pc duty cycle)	X	2.90	69.9	19.8	1.71	146.4	±0.5 %
		Y	2.54	65.2	16.5		139.3	
		Z	2.75	68.1	18.5		146.4	
10316-AAA	IEEE 802.11g WiFi 2.4 GHz (ERP-OFDM, 6 Mbps, 96pc duty cycle)	X	10.12	69.3	21.9	8.36	142.9	±3.0 %
		Y	10.01	68.5	21.3		135.2	
		Z	10.11	69.3	21.9		141.7	

10403-AAB	CDMA2000 (1xEV-DO, Rev. 0)	X	4.59	68.2	19.0	3.76	126.7	±0.7 %
		Y	4.59	67.2	18.0		142.4	
		Z	4.64	68.5	19.0		143.0	
10404-AAB	CDMA2000 (1xEV-DO, Rev. A)	X	4.64	68.8	19.3	3.77	147.1	±0.9 %
		Y	4.47	67.1	17.9		139.6	
		Z	4.54	68.4	18.9		147.2	
10415-AAA	IEEE 802.11b WiFi 2.4 GHz (DSSS, 1 Mbps, 99pc duty cycle)	X	2.66	69.0	19.4	1.54	145.8	±0.5 %
		Y	2.40	64.8	16.2		140.0	
		Z	2.62	67.8	18.4		147.2	
10416-AAA	IEEE 802.11g WiFi 2.4 GHz (ERP-OFDM, 6 Mbps, 99pc duty cycle)	X	9.97	69.1	21.7	8.23	142.0	±3.0 %
		Y	10.08	68.9	21.4		145.8	
		Z	10.01	69.2	21.8		143.3	

The reported uncertainty of measurement is stated as the standard uncertainty of measurement multiplied by the coverage factor k=2, which for a normal distribution corresponds to a coverage probability of approximately 95%.

^A The uncertainties of NormX,Y,Z do not affect the E²-field uncertainty inside TSL (see Pages 8 and 9).

^B Numerical linearization parameter: uncertainty not required.

^C Uncertainty is determined using the max. deviation from linear response applying rectangular distribution and is expressed for the square of the field value.

DASY/EASY - Parameters of Probe: ES3DV2 - SN:3022

Calibration Parameter Determined in Head Tissue Simulating Media

f (MHz) ^C	Relative Permittivity ^F	Conductivity (S/m) ^F	ConvF X	ConvF Y	ConvF Z	Alpha ^G	Depth (mm) ^G	Unct. (k=2)
750	41.9	0.89	6.39	6.39	6.39	0.20	2.24	± 12.0 %
835	41.5	0.90	6.18	6.18	6.18	0.23	1.98	± 12.0 %
1750	40.1	1.37	5.04	5.04	5.04	0.51	1.35	± 12.0 %
1900	40.0	1.40	4.85	4.85	4.85	0.38	1.66	± 12.0 %
2450	39.2	1.80	4.31	4.31	4.31	0.66	1.28	± 12.0 %
2600	39.0	1.96	4.13	4.13	4.13	0.76	1.28	± 12.0 %

^C Frequency validity above 300 MHz of ± 100 MHz only applies for DASY v4.4 and higher (see Page 2), else it is restricted to ± 50 MHz. The uncertainty is the RSS of the ConvF uncertainty at calibration frequency and the uncertainty for the indicated frequency band. Frequency validity below 300 MHz is ± 10, 25, 40, 50 and 70 MHz for ConvF assessments at 30, 64, 128, 150 and 220 MHz respectively. Above 5 GHz frequency validity can be extended to ± 110 MHz.

^F At frequencies below 3 GHz, the validity of tissue parameters (ϵ and σ) can be relaxed to ± 10% if liquid compensation formula is applied to measured SAR values. At frequencies above 3 GHz, the validity of tissue parameters (ϵ and σ) is restricted to ± 5%. The uncertainty is the RSS of the ConvF uncertainty for indicated target tissue parameters.

^G Alpha/Depth are determined during calibration. SPEAG warrants that the remaining deviation due to the boundary effect after compensation is always less than ± 1% for frequencies below 3 GHz and below ± 2% for frequencies between 3-6 GHz at any distance larger than half the probe tip diameter from the boundary.

DASY/EASY - Parameters of Probe: ES3DV2 - SN:3022

Calibration Parameter Determined in Body Tissue Simulating Media

f (MHz) ^C	Relative Permittivity ^F	Conductivity (S/m) ^F	ConvF X	ConvF Y	ConvF Z	Alpha ^G	Depth (mm) ^G	Unct. (k=2)
450	56.7	0.94	6.78	6.78	6.78	0.12	1.30	± 13.3 %
600	56.1	0.95	6.72	6.72	6.72	0.05	1.20	± 13.3 %
750	55.5	0.96	6.02	6.02	6.02	0.23	2.05	± 12.0 %
835	55.2	0.97	5.98	5.98	5.98	0.29	1.85	± 12.0 %
1750	53.4	1.49	4.70	4.70	4.70	0.66	1.25	± 12.0 %
1900	53.3	1.52	4.49	4.49	4.49	0.33	2.02	± 12.0 %
2450	52.7	1.95	4.05	4.05	4.05	0.80	1.01	± 12.0 %
2600	52.5	2.16	3.94	3.94	3.94	0.68	1.03	± 12.0 %

^C Frequency validity above 300 MHz of ± 100 MHz only applies for DASY v4.4 and higher (see Page 2), else it is restricted to ± 50 MHz. The uncertainty is the RSS of the ConvF uncertainty at calibration frequency and the uncertainty for the indicated frequency band. Frequency validity below 300 MHz is ± 10, 25, 40, 50 and 70 MHz for ConvF assessments at 30, 64, 128, 150 and 220 MHz respectively. Above 5 GHz frequency validity can be extended to ± 110 MHz.

^F At frequencies below 3 GHz, the validity of tissue parameters (ϵ and σ) can be relaxed to ± 10% if liquid compensation formula is applied to measured SAR values. At frequencies above 3 GHz, the validity of tissue parameters (ϵ and σ) is restricted to ± 5%. The uncertainty is the RSS of the ConvF uncertainty for indicated target tissue parameters.

^G Alpha/Depth are determined during calibration. SPEAG warrants that the remaining deviation due to the boundary effect after compensation is always less than ± 1% for frequencies below 3 GHz and below ± 2% for frequencies between 3-6 GHz at any distance larger than half the probe tip diameter from the boundary.

Frequency Response of E-Field (TEM-Cell:ifi110 EXX, Waveguide: R22)

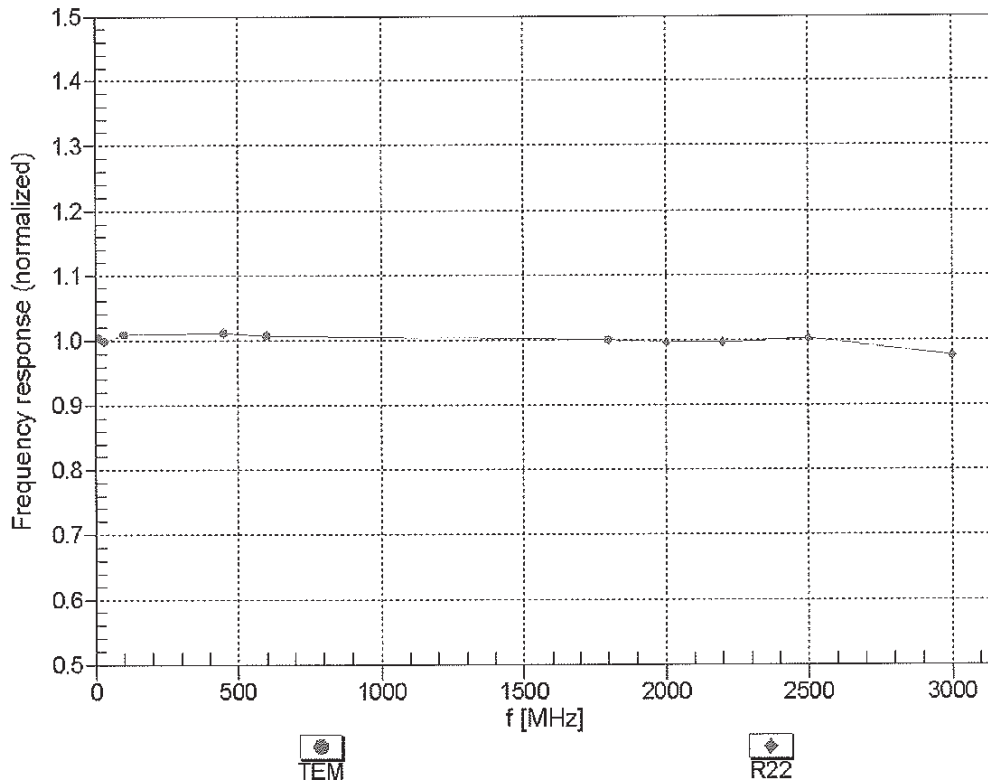

Uncertainty of Frequency Response of E-field: $\pm 6.3\%$ (k=2)

Receiving Pattern (ϕ), $\theta = 0^\circ$

f=600 MHz, TEM

f=1800 MHz, R22

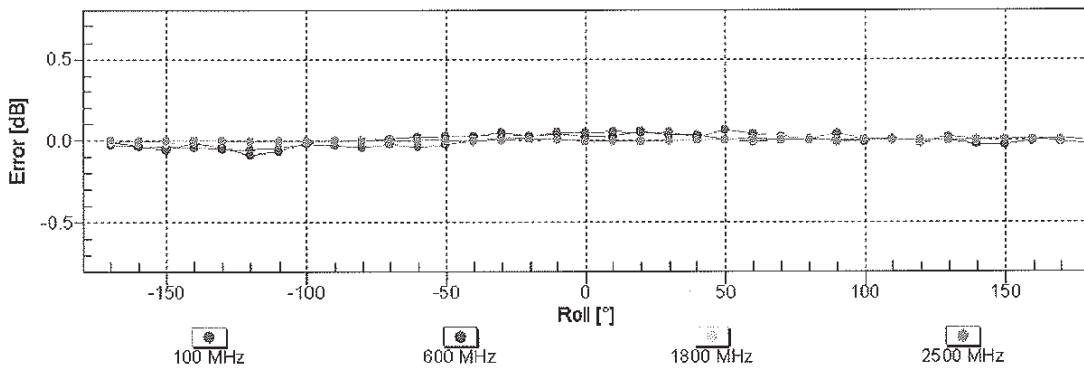
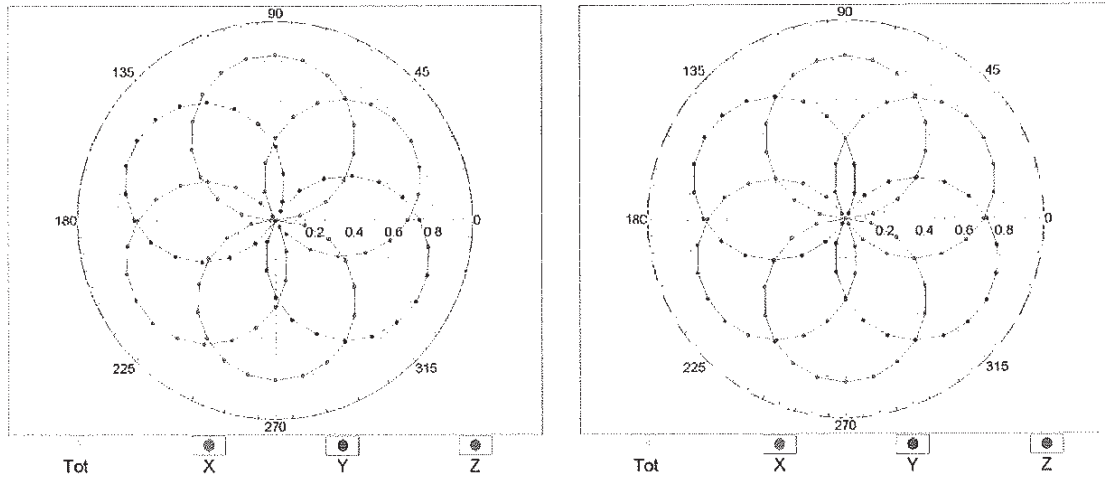

Uncertainty of Axial Isotropy Assessment: $\pm 0.5\%$ ($k=2$)

Dynamic Range f(SAR_{head}) (TEM cell , f_{eval}= 1900 MHz)

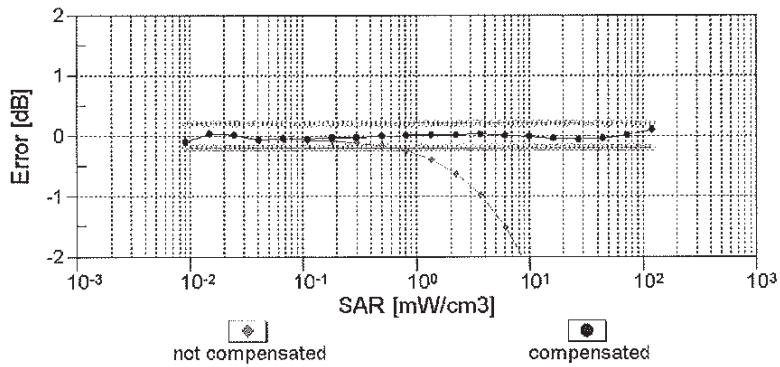
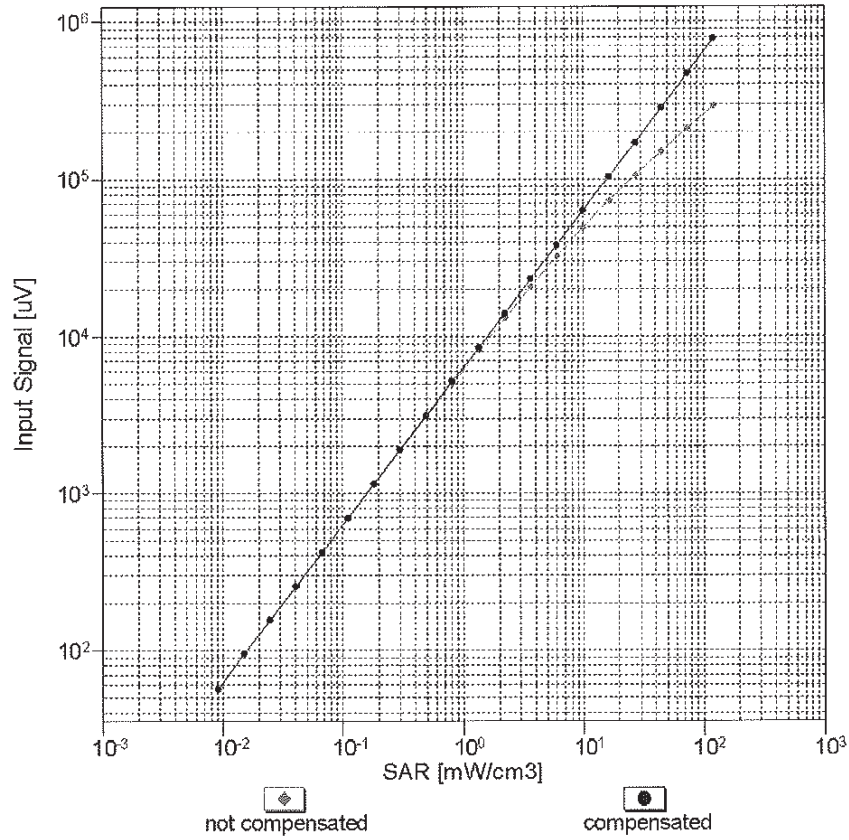

Uncertainty of Linearity Assessment: ± 0.6% (k=2)

Conversion Factor Assessment

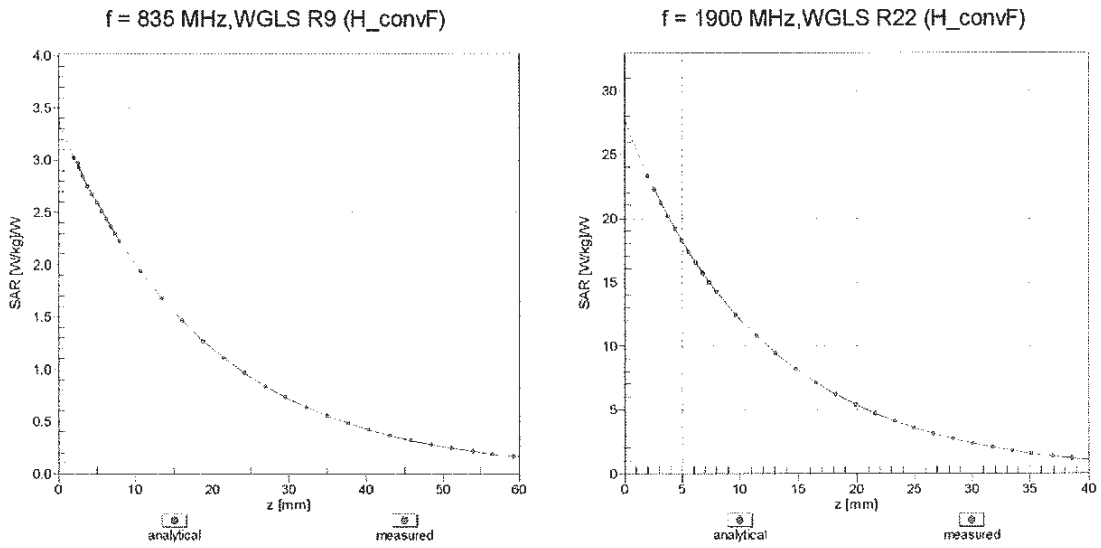

Deviation from Isotropy in Liquid Error (ϕ, θ), f = 900 MHz

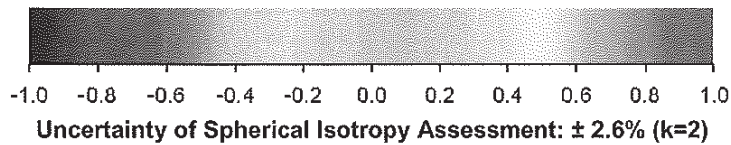
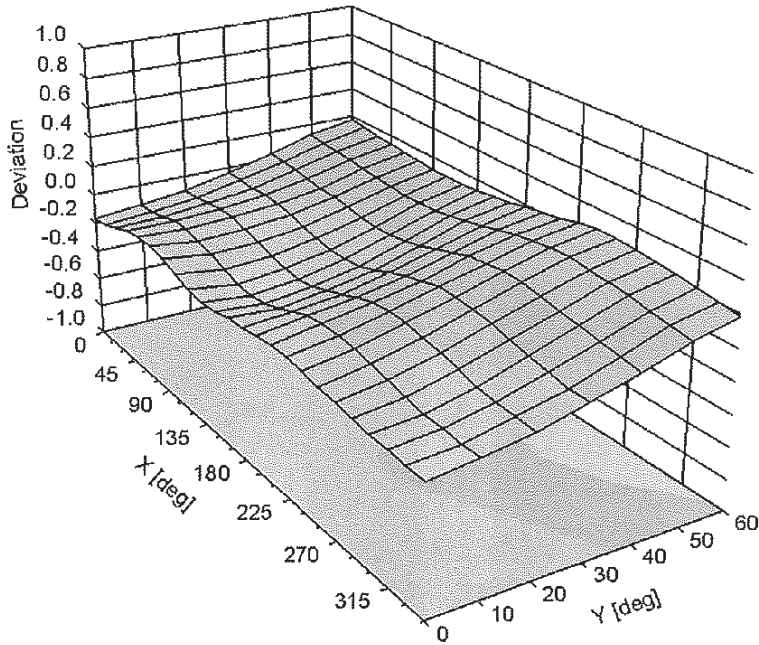

DASY/EASY - Parameters of Probe: ES3DV2 - SN:3022

Other Probe Parameters

Sensor Arrangement	Triangular
Connector Angle (°)	-80.3
Mechanical Surface Detection Mode	enabled
Optical Surface Detection Mode	disabled
Probe Overall Length	337 mm
Probe Body Diameter	10 mm
Tip Length	10 mm
Tip Diameter	4 mm
Probe Tip to Sensor X Calibration Point	2 mm
Probe Tip to Sensor Y Calibration Point	2 mm
Probe Tip to Sensor Z Calibration Point	2 mm
Recommended Measurement Distance from Surface	2 mm