



**FCC CFR47 PART 24 SUBPART E
FCC CFR47 PART 22 SUBPART H**

CERTIFICATION TEST REPORT

FOR

GSM/WCDMA Phone + Bluetooth and WLAN 2.4GHz b/g/n

MODEL NUMBER: SM-G530BT

FCC ID: A3LSMG530BT

REPORT NUMBER: 14I18664-E1

ISSUE DATE: September 5, 2014

Prepared for

**SAMSUNG ELECTRONICS CO., LTD.
416, MAETAN 3-DONG, YEONGTONG-GU
SUWON-CITY, GYEONGGI-DO 443-742, SOUTH KOREA**

Prepared by

**UL VERIFICATION SERVICES INC.
47173 BENICIA STREET
FREMONT, CA 94538, U.S.A.
TEL: (510) 771-1000
FAX: (510) 661-0888**



NVLAP LAB CODE 200065-0

Revision History

Rev.	Date	Revisions	Revised By
--	9/5/14	Initial issue	P. Zhang

TABLE OF CONTENTS

1.	ATTESTATION OF TEST RESULTS	5
2.	TEST METHODOLOGY	6
3.	FACILITIES AND ACCREDITATION	6
4.	CALIBRATION AND UNCERTAINTY	6
4.1.	<i>MEASURING INSTRUMENT CALIBRATION</i>	<i>6</i>
4.2.	<i>SAMPLE CALCULATION</i>	<i>6</i>
4.3.	<i>MEASUREMENT UNCERTAINTY</i>	<i>7</i>
5.	EQUIPMENT UNDER TEST	8
5.1.	<i>DESCRIPTION OF EUT</i>	<i>8</i>
5.2.	<i>MAXIMUM OUTPUT POWER.....</i>	<i>8</i>
5.3.	<i>DESCRIPTION OF AVAILABLE ANTENNAS</i>	<i>9</i>
5.4.	<i>DESCRIPTION OF TEST SETUP.....</i>	<i>10</i>
6.	TEST AND MEASUREMENT EQUIPMENT	13
7.	Summary Table.....	14
8.	RF POWER OUTPUT VERIFICATION.....	15
8.1.	<i>GSM/GPRS/EDGE</i>	<i>15</i>
8.1.1.	<i>GSM OUTPUT POWER RESULT.....</i>	<i>16</i>
8.2.	<i>UMTS REL 99.....</i>	<i>17</i>
8.2.1.	<i>UMTS REL 99 OUTPUT POWER RESULT</i>	<i>17</i>
8.3.	<i>UMTS HSDPA</i>	<i>18</i>
8.3.1.	<i>UMTS HSDPA OUTPUT POWER RESULT.....</i>	<i>18</i>
8.3.2.	<i>UMTS HSUPA</i>	<i>20</i>
8.3.3.	<i>UMTS HSUPA OUTPUT POWER RESULT.....</i>	<i>21</i>
9.	PEAK TO AVERAGE RATIO	23
9.1.	<i>CONDUCTED PEAK TO AVERAGE RESULT.....</i>	<i>23</i>
10.	LIMITS AND CONDUCTED RESULTS.....	26
10.1.	<i>OCCUPIED BANDWIDTH.....</i>	<i>26</i>
10.1.1.	<i>OCCUPIED BANDWIDTH RESULTS.....</i>	<i>27</i>
10.1.2.	<i>OCCUPIED BANDWIDTH PLOTS</i>	<i>29</i>
10.2.	<i>BAND EDGE EMISSIONS</i>	<i>34</i>

10.2.1. BAND EDGE PLOTS35

10.3. OUT OF BAND EMISSIONS40

10.3.1. OUT OF BAND EMISSIONS RESULT41

10.3.2. OUT OF BAND EMISSIONS PLOTS.....43

10.4. FREQUENCY STABILITY46

10.4.1. FREQUENCY STABILITY RESULTS47

11. RADIATED TEST RESULTS49

11.1. RADIATED POWER (ERP & EIRP).....49

11.1.1. ERP/EIRP Results.....49

11.1.2. ERP/EIRP DATA.....51

11.2. FIELD STRENGTH OF SPURIOUS RADIATION59

11.2.1. SPURIOUS RADIATION DATA.....60

12. SETUP PHOTOS68

1. ATTESTATION OF TEST RESULTS

COMPANY NAME: SAMSUNG ELECTRONICS CO., LTD.
EUT DESCRIPTION: GSM/WCDMA Phone + Bluetooth and WLAN 2.4GHz b/g/n
MODEL: SM-G530BT
SERIAL NUMBER: R31F800SN4W (RADIATED), R31F800SN2M (CONDUCTED)
DATE TESTED: AUG 27-SEP 5, 2014

APPLICABLE STANDARDS	
STANDARD	TEST RESULTS
FCC PART 22H, 24E	PASS

UL Verification Services Inc. tested the above equipment in accordance with the requirements set forth in the above standards. All indications of Pass/Fail in this report are opinions expressed by UL Verification Services Inc. based on interpretations and/or observations of test results. Measurement Uncertainties were not taken into account and are published for informational purposes only. The test results show that the equipment tested is capable of demonstrating compliance with the requirements as documented in this report.

Note: The results documented in this report apply only to the tested sample, under the conditions and modes of operation as described herein. This document may not be altered or revised in any way unless done so by UL Verification Services Inc. and all revisions are duly noted in the revisions section. Any alteration of this document not carried out by UL Verification Services Inc. will constitute fraud and shall nullify the document. This report must not be used by the client to claim product certification, approval, or endorsement by NVLAP, NIST, any agency of the Federal Government, or any agency of any government.

Approved & Released For
UL Verification Services Inc. By:

Tested By:



PENG ZHANG
CONSUMER TECHNOLOGY DIVISION
PROJECT LEAD
UL Verification Services Inc.

Daniel Soper
CONSUMER TECHNOLOGY DIVISION
EMC ENGINEER
UL Verification Services Inc.

2. TEST METHODOLOGY

The tests documented in this report were performed in accordance with TIA-603-C, FCC CFR 47 Part 22, FCC CFR Part 24

3. FACILITIES AND ACCREDITATION

The test sites and measurement facilities used to collect data are located at 47173 and 47266 Benicia Street, Fremont, California, USA. Line conducted emissions are measured only at the 47173 address. The following table identifies which facilities were utilized for radiated emission measurements documented in this report. Specific facilities are also identified in the test results sections.

47173 Benicia Street	47266 Benicia Street
<input checked="" type="checkbox"/> Chamber A(IC: 2324B-1)	<input type="checkbox"/> Chamber D(IC: 2324B-4)
<input checked="" type="checkbox"/> Chamber B(IC: 2324B-2)	<input type="checkbox"/> Chamber E(IC: 2324B-5)
<input checked="" type="checkbox"/> Chamber C(IC: 2324B-3)	<input type="checkbox"/> Chamber F(IC: 2324B-6)
	<input type="checkbox"/> Chamber G(IC: 2324B-7)
	<input type="checkbox"/> Chamber H(IC: 2324B-8)

UL Verification Services Inc. is accredited by NVLAP, Laboratory Code 200065-0. The full scope of accreditation can be viewed at <http://ts.nist.gov/standards/scopes/2000650.htm>.

4. CALIBRATION AND UNCERTAINTY

4.1. MEASURING INSTRUMENT CALIBRATION

The measuring equipment utilized to perform the tests documented in this report has been calibrated in accordance with the manufacturer's recommendations, and is traceable to recognized national standards

4.2. SAMPLE CALCULATION

Where relevant, the following sample calculation is provided:

$$\text{EIRP} = \text{PSA reading with EUT worst orientation (dBm)} + \text{Path loss (dB)} - \text{cable loss(between the SG and substitution antenna)} + \text{Substitution Antenna Factor (dBi)}$$

ERP = PSA reading with EUT worst orientation (dBm) + Path loss (dB) – cable loss(between the SG and substitution antenna)

(Path loss = Signal generator output – PSA reading with substitution antenna)

4.3. MEASUREMENT UNCERTAINTY

Where relevant, the following measurement uncertainty levels have been estimated for tests performed on the apparatus:

PARAMETER	UNCERTAINTY
Conducted Disturbance, 0.15 to 30 MHz	3.52 dB
Radiated Disturbance, 30 to 27000 MHz	4.94 dB

Uncertainty figures are valid to a confidence level of 95%.

5. EQUIPMENT UNDER TEST

5.1. DESCRIPTION OF EUT

The EUT is a GSM/WCDMA Phone + Bluetooth and WLAN 2.4GHz b/g/n

5.2. MAXIMUM OUTPUT POWER

The transmitter has a maximum peak conducted and radiated ERP / EIRP output powers as follows:

FCC Part 22/24						
Band	Frequency Range(MHz)	Modulation Peak	Conducted		Radiated	
			Peak (dBm)	Peak (mW)	Peak (dBm)	Peak (mW)
GSM850	824~849	GMSK	32.7	1862.1		
	824~849	GPRS	32.8	1905.5	28.3	676.1
	824~849	EGPRS	27.9	616.6	25.4	346.7
GSM1900	1850~1910	GMSK	30.0	1000.0		
	1850~1910	GPRS	30.0	1000.0	28.9	767.4
	1850~1910	EGPRS	26.5	446.7	26.47	443.6

FCC Part 22/24						
Band	Frequency Range(MHz)	Modulation Peak	Conducted		Radiated	
			Avg (dBm)	Avg (mW)	Avg (dBm)	Avg (mW)
Band 5	824~849	REL99	22.3	169.8	19.5	89.1
	824~849	HSDPA	21.9	154.9	18.3	68.3
	824~849	HSUPA	21.5	141.3		
Band 2	1850~1910	REL99	22.5	177.8	22.8	188.5
	1850~1910	HSDPA	21.4	138.0	21.9	154.5
	1850~1910	HSUPA	21.3	134.9		

5.3. DESCRIPTION OF AVAILABLE ANTENNAS

The radio utilizes a PIFA antenna for the [List the bands supported] with a maximum peak gain as follow:

Frequency (MHz)	Peak Gain (dBi)
Band 5, 824~849MHz	-2.26
Band 2, 1850~1910MHz	0.54

5.4. DESCRIPTION OF TEST SETUP

SUPPORT EQUIPMENT

Support Equipment List				
Description	Manufacturer	Model	Serial Number	FCC ID
AC Adapter	Samsung	ETA0U83BWB	N/A	N/A
Earphone	Samsung	EHS61ASFWE	N/A	N/A

I/O CABLES (CONDUCTED SETUP)

I/O Cable List						
Cable No	Port	# of identical ports	Connector Type	Cable Type	Cable Length (m)	Remarks
1	RF Out	1	Spectrum Analyzer	Shielded	None	NA
2	Antenna Port	1	EUT	Shielded	0.1m	NA
3	RF In/Out	1	Communication Test Set	Shielded	1m	NA

I/O CABLES (RADIATED SETUP)

I/O CABLE LIST						
Cable No.	Port	# of Identical Ports	Connector Type	Cable Type	Cable Length	Remarks
1	USB	1	AC Adapter	Un-shielded	1.2m	No
2	Jack	1	Headset	Shielded	1m	No
3	RF In/out	1	Communication Test Set	Un-shielded	2m	Yes

TEST SETUP

The EUT is continuously communicated to the call box during the tests.

SETUP DIAGRAM FOR TESTS (CONDUCTED TEST SETUP)

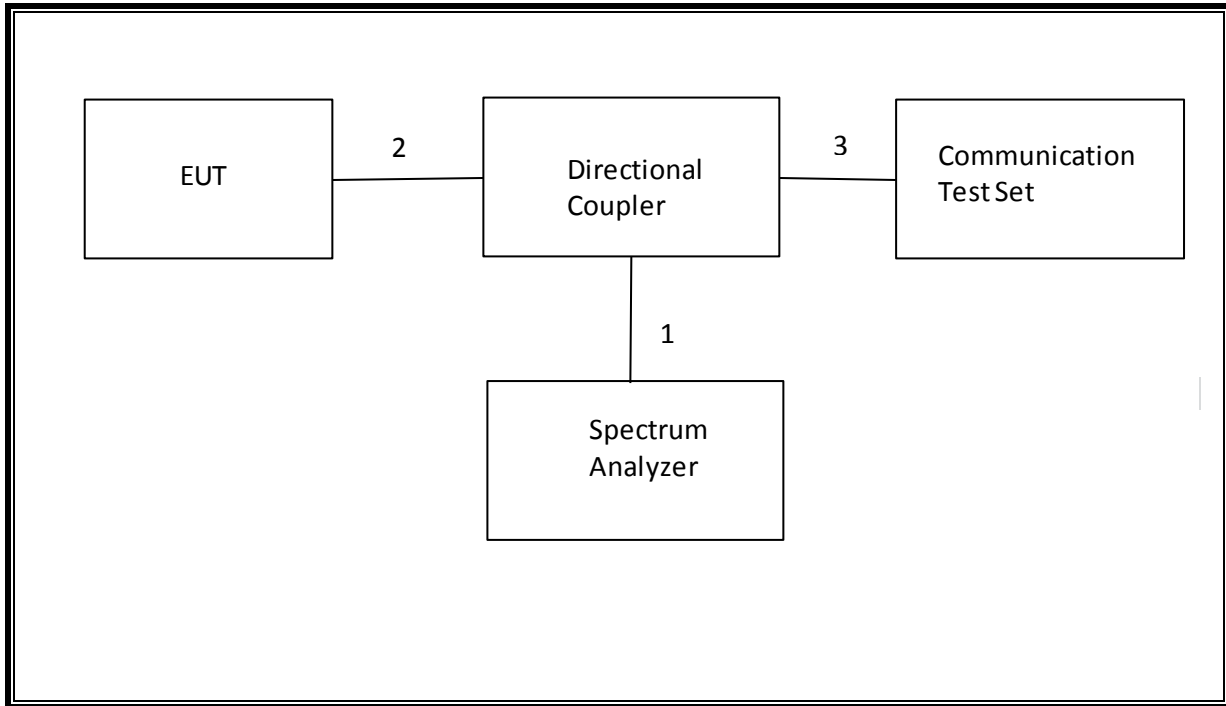

SETUP DIAGRAM FOR TESTS (RADIATED TEST SETUP)

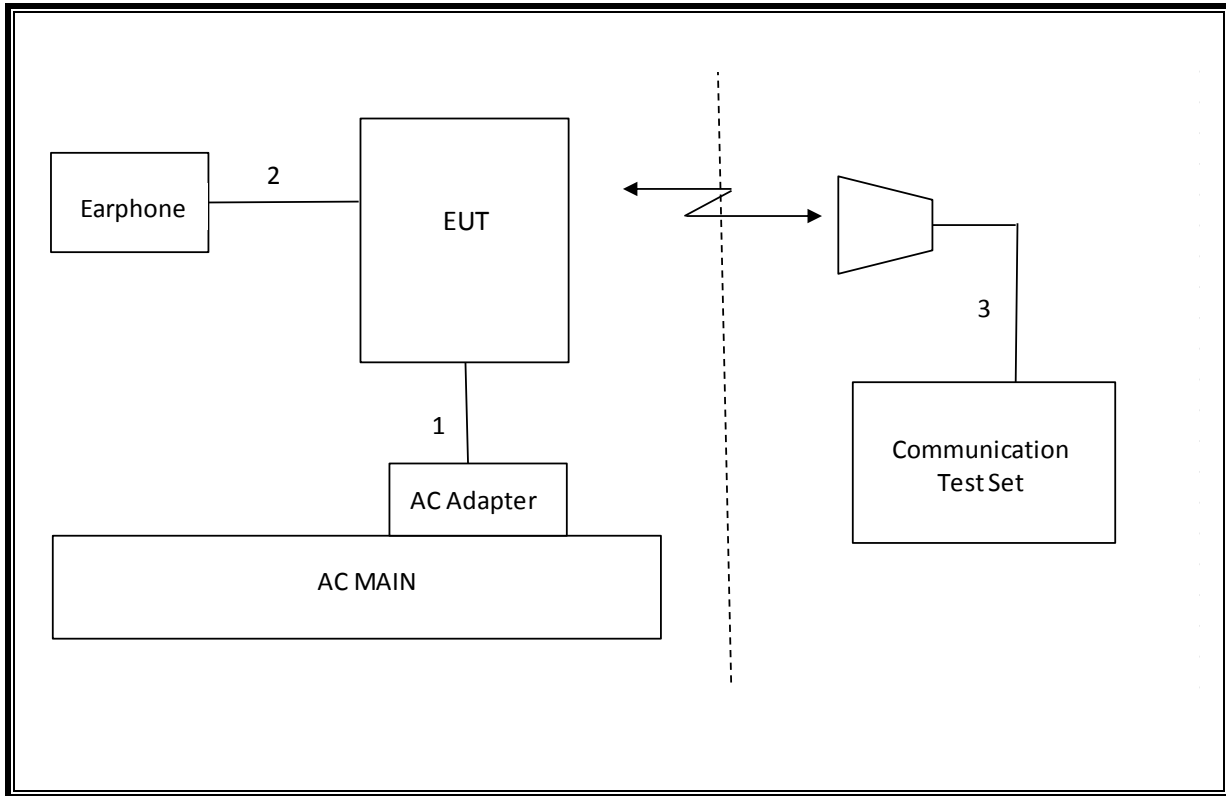

6. TEST AND MEASUREMENT EQUIPMENT

The following test and measurement equipment was utilized for the tests documented in this report:

TEST EQUIPMENT LIST				
Description	Manufacturer	Model	Asset	Cal Due
Spectrum Analyzer, 44 GHz	Agilent / HP	E4446A	C01179	02/26/15
Antenna, Bilog, 2 GHz	Sunol Sciences	JB1	C01011	08/14/15
Antenna, Horn, 18 GHz	EMCO	3115	C00783	10/25/14
Antenna, Horn, 18 GHz	EMCO	3115	C00784	10/25/14
Highpass Filter, 2.7 GHz	Micro-Tronics	HPM13194	N02687	CNR
Highpass Filter, 1.5 GHz	Micro-Tronics	HPM13193	N02688	CNR
Temperature / Humidity Chamber	Thermotron	SE 600-10-10	C00930	01/09/15
Communications Test Set	R&S	CMW500	T159	07/02/15
DC power supply, 8 V @ 3 A or 15 V	Agilent / HP	E3610A	None	CNR
Vector signal generator, 6 GHz	Agilent / HP	E4438C	None	07/06/15
Antenna, Tuned Dipole 400~1000	ETS	3121C DB4	C00993	02/14/15
Directional Coupler	RF-Lambda	RFDC5M06G15	None	CNR
Antenna, Horn, 26.5 GHz	ARA	MWH-1826/B	C00589	12/17/14

7. Summary Table

FCC Part Section	RSS Section(s)	Test Description	Test Limit	Test Condition	Test Result	Note
2.1049	N/A	Occupied Band width (99%)	N/A	Conducted	Pass	4.201 Mhz
22.917(a) 24.238(a) 27.53(g) 90.691	RSS-132(4.5.1) RSS-133(6.5.1) RSS-139(6.5.1)	Band Edge / Conducted Spurious Emission	-13dBm		Pass	-14.206dBm
2.1046	N/A	Conducted output power	N/A		Pass	32.8dBm
22.355 24.235 27.54 90.213	RSS-132(4.3) RSS-133(6.3) RSS-139(6.3) RSS-199(4.3)	Frequency Stability	2.5PPM		Pass	.043 PPM
22.913(a)(2)	RSS-132(4.4)	Effective Radiated Power	38 dBm	Radiated	Pass	28.3dBm
24.232(c) 27.50(h)(2)	RSS-133(6.4) RSS-199(4.4)	Equivalent Isotropic Radiated Power	33dBm		Pass	28.9dBm
22.917(a) 24.238(a) 27.53(g)	RSS-132(4.5.1) RSS-133(6.5.1) RSS-139(6.5.1)	Radiated Spurious Emission	-13dBm		Pass	-36dBm

8. RF POWER OUTPUT VERIFICATION

8.1. GSM/GPRS/EDGE

Function: Menu select > GSM Mobile Station > GSM 850/900/1800/1900
Press Connection control to choose the different menus
Press RESET > choose all to reset all settings
Connection Press Signal Off to turn off the signal and change settings
Network Support > GSM+GPRS or GSM+EGPRS
Main Service > Packet Data
Service selection > Test Mode A – Auto Slot Config. off
MS Signal Press Slot Config bottom on the right twice to select and change the number of time slots and power setting
 > Slot configuration > Uplink/Gamma
 > 33 dBm for GPRS 850/900
 > 30 dBm for GPRS1800/1900
BS Signal Enter the same channel number for TCH channel (test channel) and BCCH channel
Frequency Offset > + 0 Hz
Mode > BCCH and TCH
BCCH Level > -85 dBm (May need to adjust if link is not stable)
BCCH Channel > choose desire test channel [Enter the same channel number for TCH channel (test channel) and BCCH channel]
Channel Type > Off
P0> 4 dB
Slot Config > Unchanged (if already set under MS Signal)
TCH > choose desired test channel
Hopping > Off
Main Timeslot > 3 (Default)
Network Coding Scheme > CS4 (GPRS) and MCS5 ~ MCS9 (EGPRS)
Bit Stream > 2E9-1PSR Bit Pattern
AF/RF Enter appropriate offsets for Ext. Att. Output and Ext. Att. Input
Connection Press Signal On to turn on the signal and change settings

8.1.1. GSM OUTPUT POWER RESULT

Band	Mode	Ch.	f(MHz)	1 time slot	2 time slot	3 time slot	4 time slot
				Peak (dBm)	Peak (dBm)	Peak (dBm)	Peak (dBm)
GSM850	GMSK	128	824.2	32.4			
		190	836.6	32.5			
		251	848.8	32.7			
	GPRS	128	824.2	32.4	30.4	28.4	27.5
		190	836.6	32.5	30.4	28.5	27.5
		251	848.8	32.8	30.5	28.7	27.7
	EGPRS	128	824.2	27.8	26.4	25.5	24.2
		190	836.6	27.8	26.5	25.3	24.2
		251	848.8	27.9	26.6	25.6	24.4
GSM1900	GMSK	512	1850.2	30.0			
		661	1880	29.5			
		810	1909.8	29.6			
	GPRS	512	1850.2	30.0	27.5	25.5	24.5
		661	1880	29.5	27.4	25.4	24.5
		810	1909.8	29.6	27.5	25.5	24.5
	EGPRS	512	1850.2	26.5	25.5	24.5	23.5
		661	1880	26.4	25.1	24.1	23.1
		810	1909.8	26.5	25.2	24.3	23.4

8.2. UMTS REL 99

TEST PROCEDURE

The following summary of these settings are illustrated below:

	Mode	Rel99
	Subtest	-
WCDMA General Settings	Loopback Mode	Test Mode 1
	Rel99 RMC	12.2kbps RMC
	HSDPA FRC	Not Applicable
	HSUPA Test	Not Applicable
	Power Control Algorithm	Algorithm2
	β_c	Not Applicable
	β_d	Not Applicable
	β_{ec}	Not Applicable
	β_c/β_d	8/15
	β_{hs}	Not Applicable
	β_{ed}	Not Applicable

8.2.1. UMTS REL 99 OUTPUT POWER RESULT

Band	Mode	Ch.	f(MHz)	Conducted Power (dBm)
				Avg (dBm)
Band 5	REL99	4132	826.4	22.2
		4183	836.6	22.2
		4233	846.6	22.3
Band 2	REL99	9262	1852.4	22.5
		9400	1880	22.2
		9538	1907.6	22.2

8.3. UMTS HSDPA

The following 4 Sub-tests were completed according to Release 5 procedures in section 5.2 of 3GPP TS34.121. A summary of these settings are illustrated below:

	Mode	Rel5 HSDPA			
	Subtest	1	2	3	4
WCDMA General Settings	Loopback Mode	Test Mode 1			
	Rel99 RMC	12.2kbps RMC			
	HSDPA FRC	H-Set1			
	Power Control Algorithm	Algorithm 2			
	β_c	2/15	12/15	15/15	15/15
	β_d	15/15	15/15	8/15	4/15
	Bd (SF)	64			
	β_c/β_d	2/15	12/15	15/8	15/4
	β_{hs}	4/15	24/15	30/15	30/15
MPR (dB)	0	0	0.5	0.5	
HSDPA Specific Settings	D_{ACK}	8			
	D_{NAK}	8			
	DCQI	8			
	Ack-Nack repetition factor	3			
	CQI Feedback (Table 5.2B.4)	4ms			
	CQI Repetition Factor (Table 5.2B.4)	2			
	$A_{hs} = \beta_{hs}/\beta_c$	30/15			

8.3.1. UMTS HSDPA OUTPUT POWER RESULT

Band	Mode	Subset	Ch.	f(MHz)	Conducted Power (dBm)
					Avg (dBm)
Band 5	HSDPA	1	4132	826.4	21.3
			4183	836.6	21.1
			4233	846.6	21.2
		2	4132	826.4	21.8
			4183	836.6	21.9
			4233	846.6	21.7
		3	4132	826.4	20.7
			4183	836.6	20.5
			4233	846.6	20.6
		4	4132	826.4	20.5
			4183	836.6	20.8
			4233	846.6	20.9
Band 2	HSDPA	1	9262	1852.4	21.4

			9400	1880	21.2
			9538	1907.6	21.2
		2	9262	1852.4	20.5
			9400	1880	20.5
			9538	1907.6	20.5
		3	9262	1852.4	20.0
			9400	1880	20.0
			9538	1907.6	20.1
		4	9262	1852.4	20.8
			9400	1880	20.8
			9538	1907.6	21.0

8.3.2. UMTS HSUPA

TEST PROCEDURE

The following summary of these settings are illustrated below: (ETSI TS 134.121-1 Table C.11.1)

	Mode	Rel6 HSUPA	Rel6 HSUPA	Rel6 HSUPA	Rel6 HSUPA	Rel6 HSUPA
	Subtest	1	2	3	4	5
WCDMA General Settings	Loopback Mode	Test Mode 1				
	P-CPICH (dB)	-10				
	P-CCPCH (dB)	-12				
	SCH (dB)	-12				
	PICH(dB)	-15				
	DPCH (dB)	-9				
	HS-SCCH_1 (dB)	-8				
	HS-PDSCH (dB)	-3				
	Rel99 RMC	12.2kbps RMC				
	HSDPA FRC	H-Set1				
	HSUPA Test	HSUPA Loopback				
	Power Control Algorithm	Algorithm2				
	Bc	11/15	6/15	15/15	2/15	15/15
	Bd	15/15	15/15	9/15	15/15	15/15
	Bec	209/225	12/15	30/15	2/15	5/15
	β_c/β_d	11/15	6/15	15/9	2/15	15/15
	Bhs	22/15	12/15	30/15	4/15	30/15
β_{ed} (note1)	1309/225	94/75	47/15 47/15	56/75	134/15	
MPR	0	2	1	2	0	
HSDPA Specific Settings	DACK	8				
	DNAK	8				
	DCQI	8				
	Ack-Nack repetition factor	3				
	CQI Feedback (Table 5.2B.4)	4ms				
	CQI Repetition Factor (Table 5.2B.4)	2				
Ahs = β_{hs}/β_c	30/15					
HSUPA Specific Settings	D E-DPCCH	6	8	8	5	7
	DHARQ	0	0	0	0	0
	AG Index	20	12	15	17	21
	Reference E-TFCIs	5	5	2	5	5
	ETFCI (from 34.121 Table C.11.1.3)	75	67	92	71	81
	Associated Max UL Data Rate kbps	242.1	174.9	482.8	205.8	308.9
	Reference E_TFCIs	E-TFCI 11 E-TFCI PO 4 E-TFCI 67 E-TFCI PO 18 E-TFCI 71 E-TFCI PO 23 E-TFCI 75 E-TFCI PO 26 E-TFCI 81 E-TFCI PO 27		E-TFCI 11 E-TFCI PO 4 E-TFCI 92 E-TFCI PO 18		E-TFCI 11 E-TFCI PO 4 E-TFCI 67 E-TFCI PO 18 E-TFCI 71 E-TFCI PO 23 E-TFCI 75 E-TFCI PO 26 E-TFCI 81 E-TFCI PO 27

Note1: β ed cannot be set directly, it is set by Absolute Grant Value.

8.3.3. UMTS HSUPA OUTPUT POWER RESULT

Band	Mode	Subset	Ch.	f(MHz)	Conducted Power
					(dBm) Avg (dBm)
Band 5	HSUPA	1	4132	826.4	21.3
			4183	836.6	21.5
			4233	846.6	21.4
		2	4132	826.4	19.7
			4183	836.6	20.3
			4233	846.6	20.1
		3	4132	826.4	20.8
			4183	836.6	20.2
			4233	846.6	20.4
		4	4132	826.4	20.8
			4183	836.6	20.9
			4233	846.6	20.4
		5	4132	826.4	21.3
			4183	836.6	21.5
			4233	846.6	21.4
Band 2	HSUPA	1	9262	1852.4	21.0
			9400	1880	21.3
			9538	1907.6	21.0
		2	9262	1852.4	20.3
			9400	1880	20.2
			9538	1907.6	20.1
		3	9262	1852.4	20.3
			9400	1880	20.0
			9538	1907.6	20.1
		4	9262	1852.4	20.3
			9400	1880	19.9

REPORT NO: 14118664-E1
MODEL NUMER: SM-G530BT

DATE: September 5, 2014
FCC ID: A3LSMG530BT

			9538	1907.6	20.2
		5	9262	1852.4	21.6
			9400	1880	21.2
			9538	1907.6	21.2

9. PEAK TO AVERAGE RATIO

Test Procedure

Per KDB 971168 D01 Power Meas License Digital Systems v02r01

Test Spec

In addition, when the transmitter power is measured in terms of average value, the peak-to-average ratio of the power shall not exceed 13 dB.

9.1. CONDUCTED PEAK TO AVERAGE RESULT

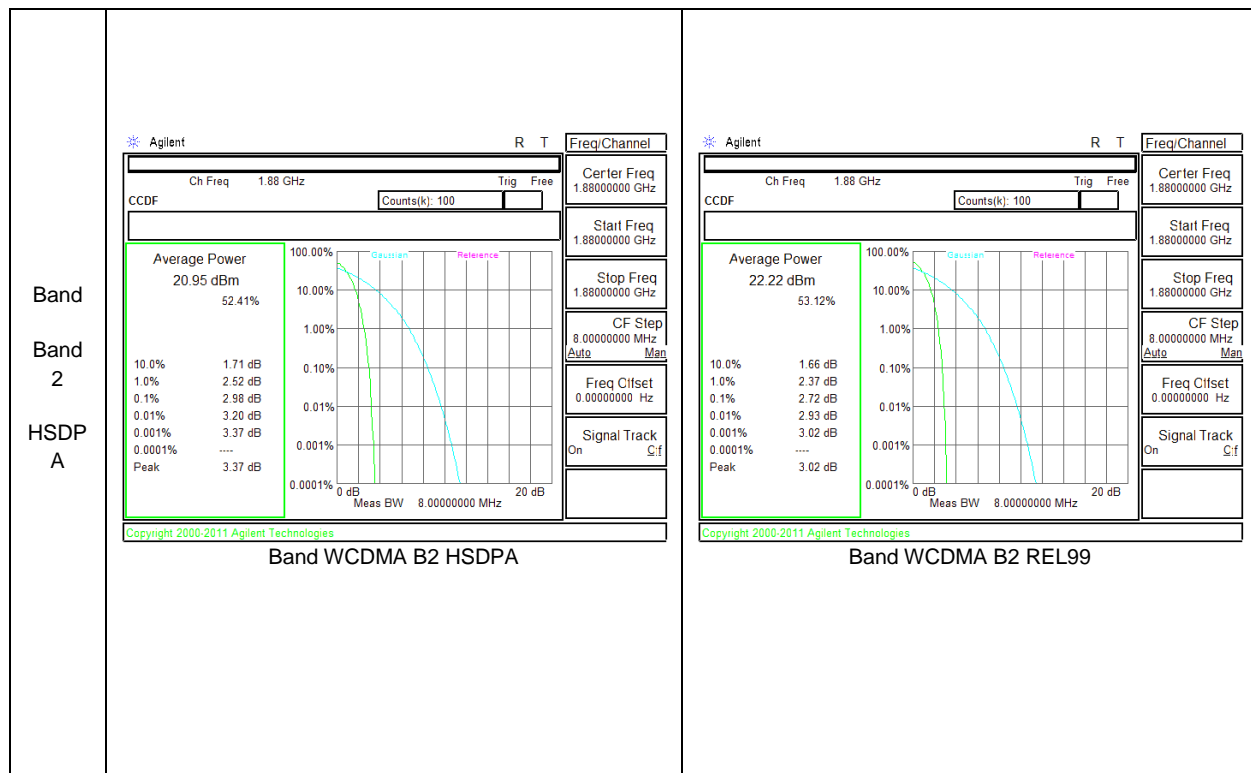

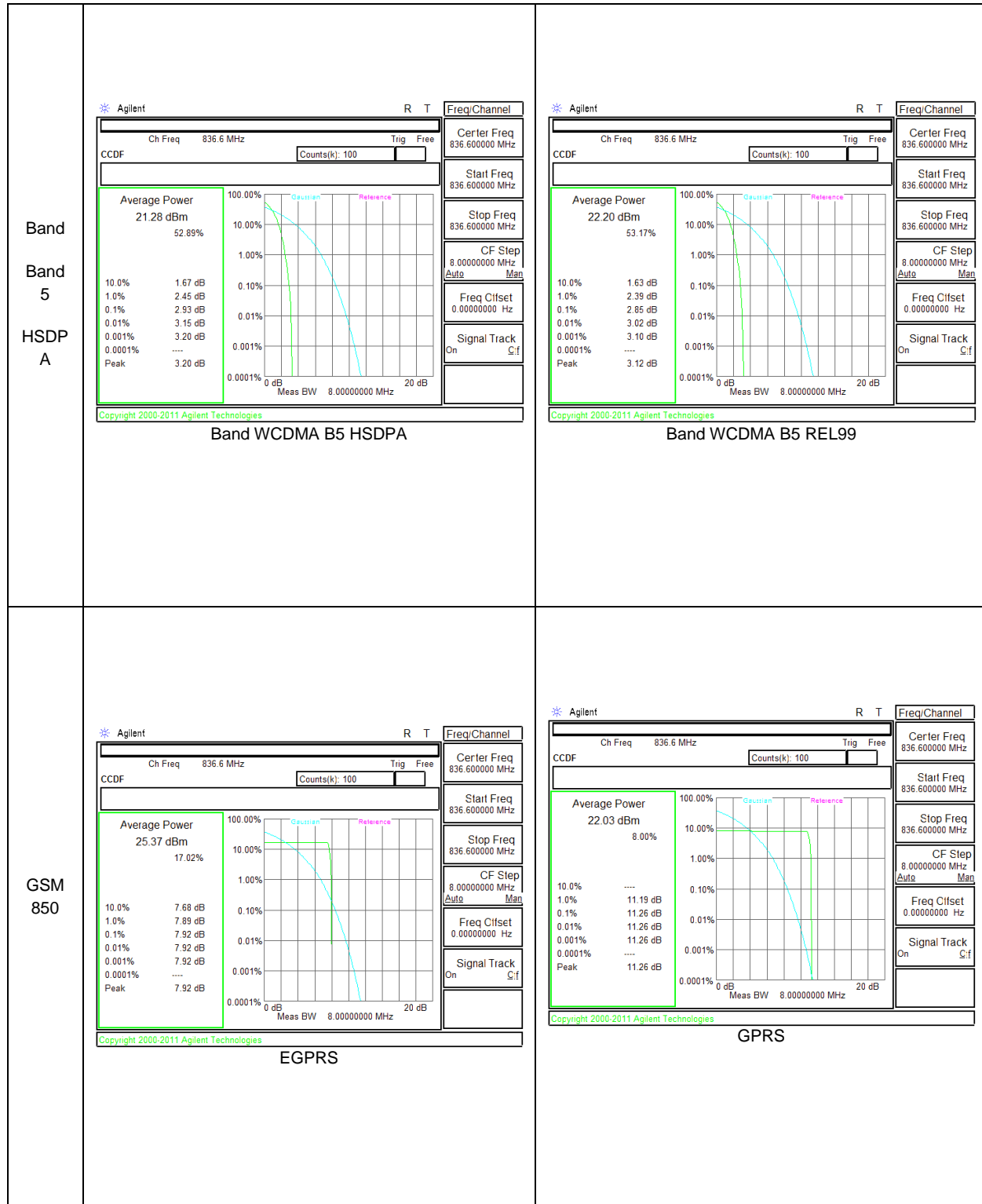

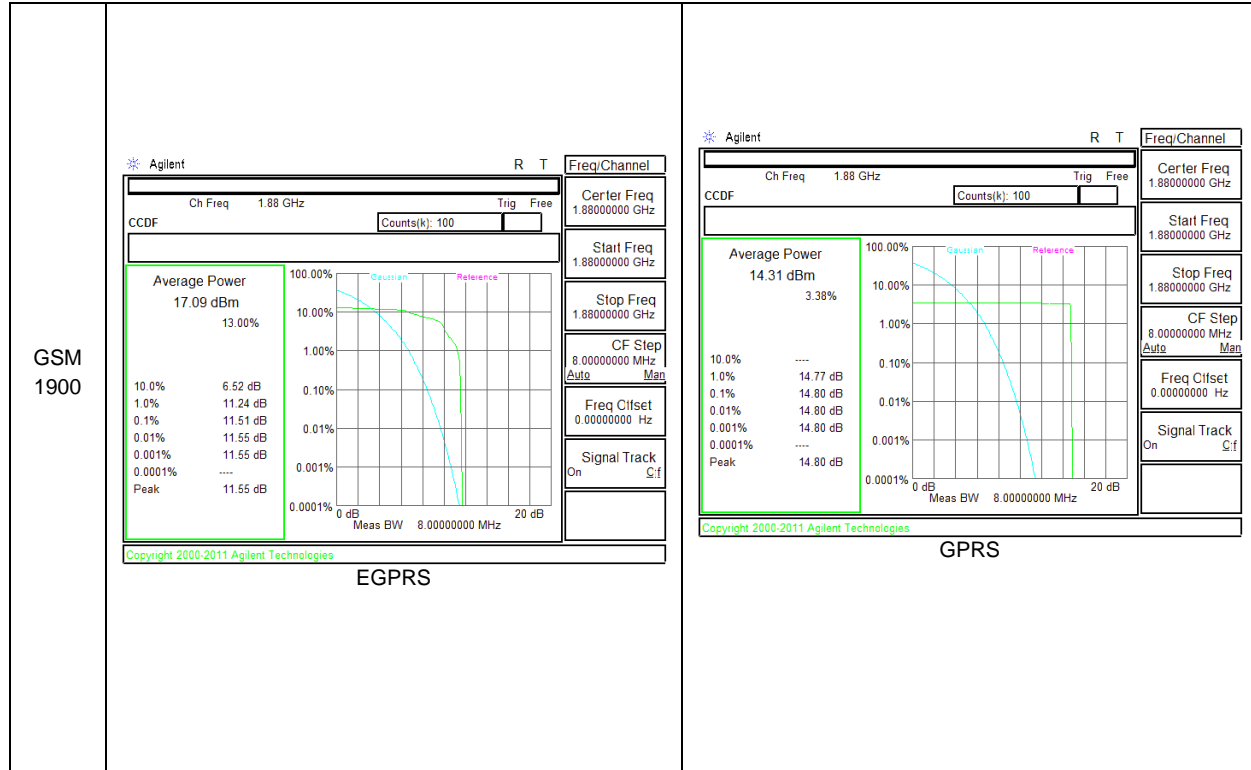

10. LIMITS AND CONDUCTED RESULTS

10.1. OCCUPIED BANDWIDTH

RULE PART(S)

FCC: §2.1049
IC: RSS-132, 4.5; RSS-133, 6.5

LIMITS

For reporting purposes only

TEST PROCEDURE

The transmitter output was connected to a calibrated coaxial cable and coupler, the other end of which was connected to a spectrum analyzer. The occupied bandwidth was measured with the spectrum analyzer at the low, middle and high channel in each band. The -26dB bandwidth was also measured and recorded.

(KDB 971168 D01 Power Meas License Digital Systems v02r01 - 06/07/2013)

10.1.1. OCCUPIED BANDWIDTH RESULTS
GSM OCCUPIED BANDWIDTH RESULTS

Band	Mode	Channel	f (MHz)	99% BW (MHz)	-26dB BW (MHz)
GSM850	GMSK	128	824.2		
		190	836.6		
		251	848.8		
	GPRS	128	824.2	0.2654	0.3576
		190	836.6	0.2646	0.3589
		251	848.8	0.2662	0.3638
	EGPRS	128	824.2	0.2645	0.3625
		190	836.6	0.2669	0.3616
		251	848.8	0.2668	0.3594
GSM1900	GMSK	512	1850.2		
		661	1880		
		810	1909.8		
	GPRS	512	1850.2	0.2429	0.3128
		661	1880	0.2439	0.317
		810	1909.8	0.2394	0.308
	EGPRS	512	1850.2	0.2652	0.363
		661	1880	0.2639	0.3568
		810	1909.8	0.2626	0.3575

WCDMA OCCUPIED BANDWIDTH RESULTS

Band	Mode	Channel	f (MHz)	99% BW (MHz)	-26dB BW (MHz)
Band 5	REL99	4132	826.4	4.183	4.651
		4183	836.6	4.174	4.655
		4233	846.6	4.174	4.634
	HSDPA	4132	826.4	4.17	4.654
		4183	836.6	4.164	4.638
		4233	846.6	4.164	4.638
	HSUPA	4132	826.4		
		4183	836.6		
		4233	846.6		
Band 2	REL99	9262	1852.4	4.201	4.684
		9400	1880	4.169	4.684
		9538	1907.6	4.177	4.695
	HSDPA	9262	1852.4	4.185	4.618
		9400	1880	4.157	4.635
		9538	1907.6	4.181	4.625
	HSUPA	9262	1852.4		
		9400	1880		
		9538	1907.6		

10.1.2. OCCUPIED BANDWIDTH PLOTS

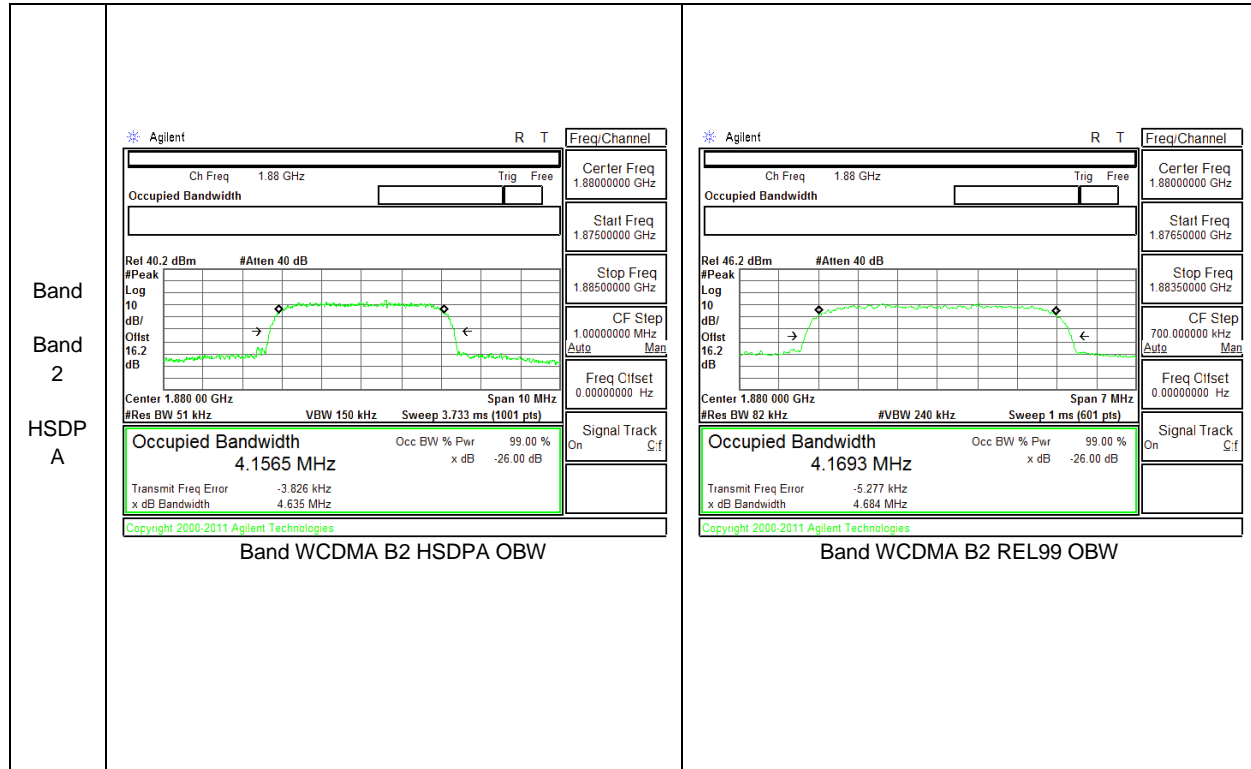

Band Band 2 HSDPA A	<p>Copyright 2000-2011 Agilent Technologies</p> <p style="text-align: center;">Band WCDMA B2 HSDPA OBW</p>	<p>Copyright 2000-2011 Agilent Technologies</p> <p style="text-align: center;">Band WCDMA B2 REL99 OBW</p>
	<p>Copyright 2000-2011 Agilent Technologies</p> <p style="text-align: center;">Band WCDMA B5 HSDPA OBW</p>	<p>Copyright 2000-2011 Agilent Technologies</p> <p style="text-align: center;">Band WCDMA B5 REL99 OBW</p>

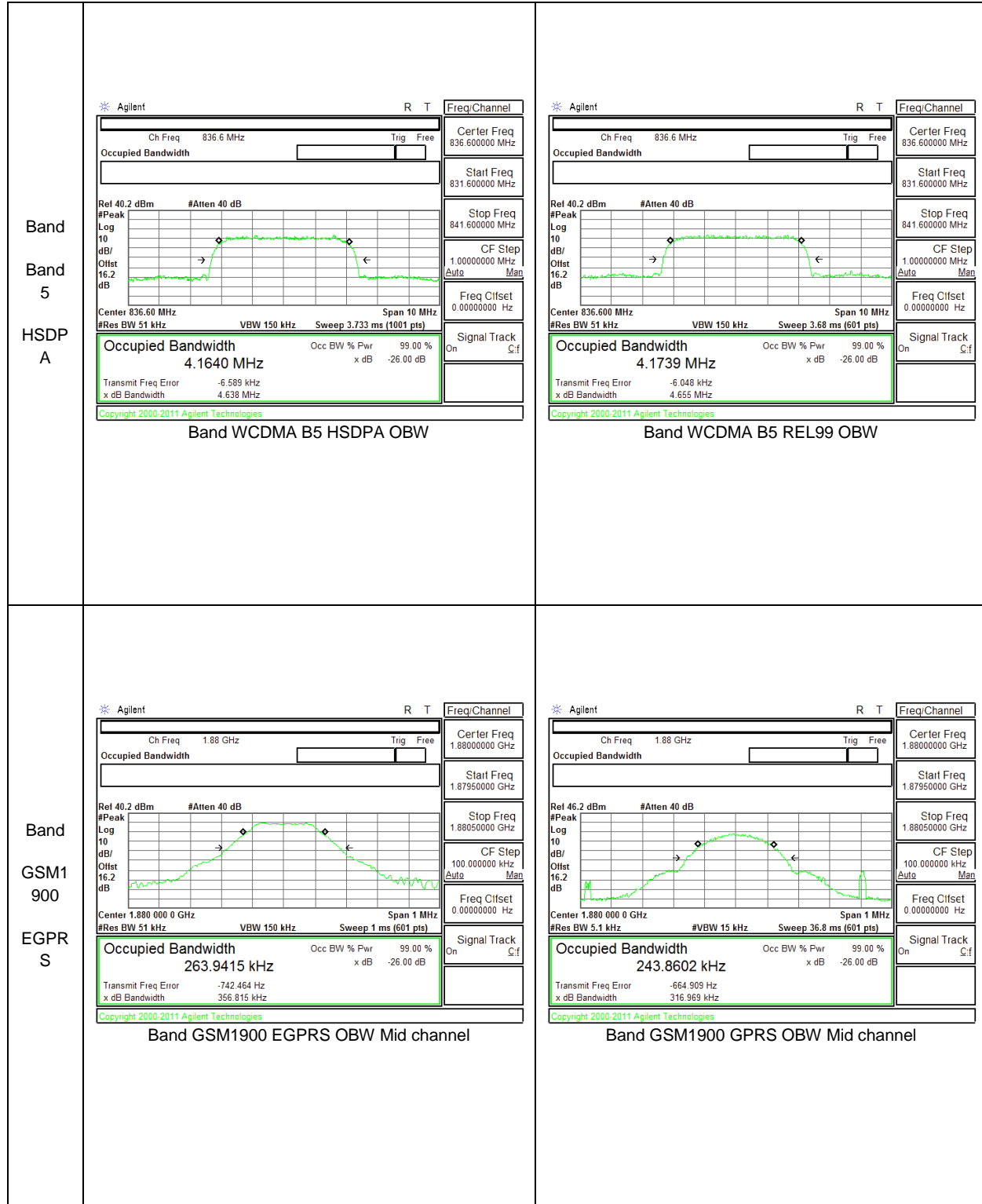

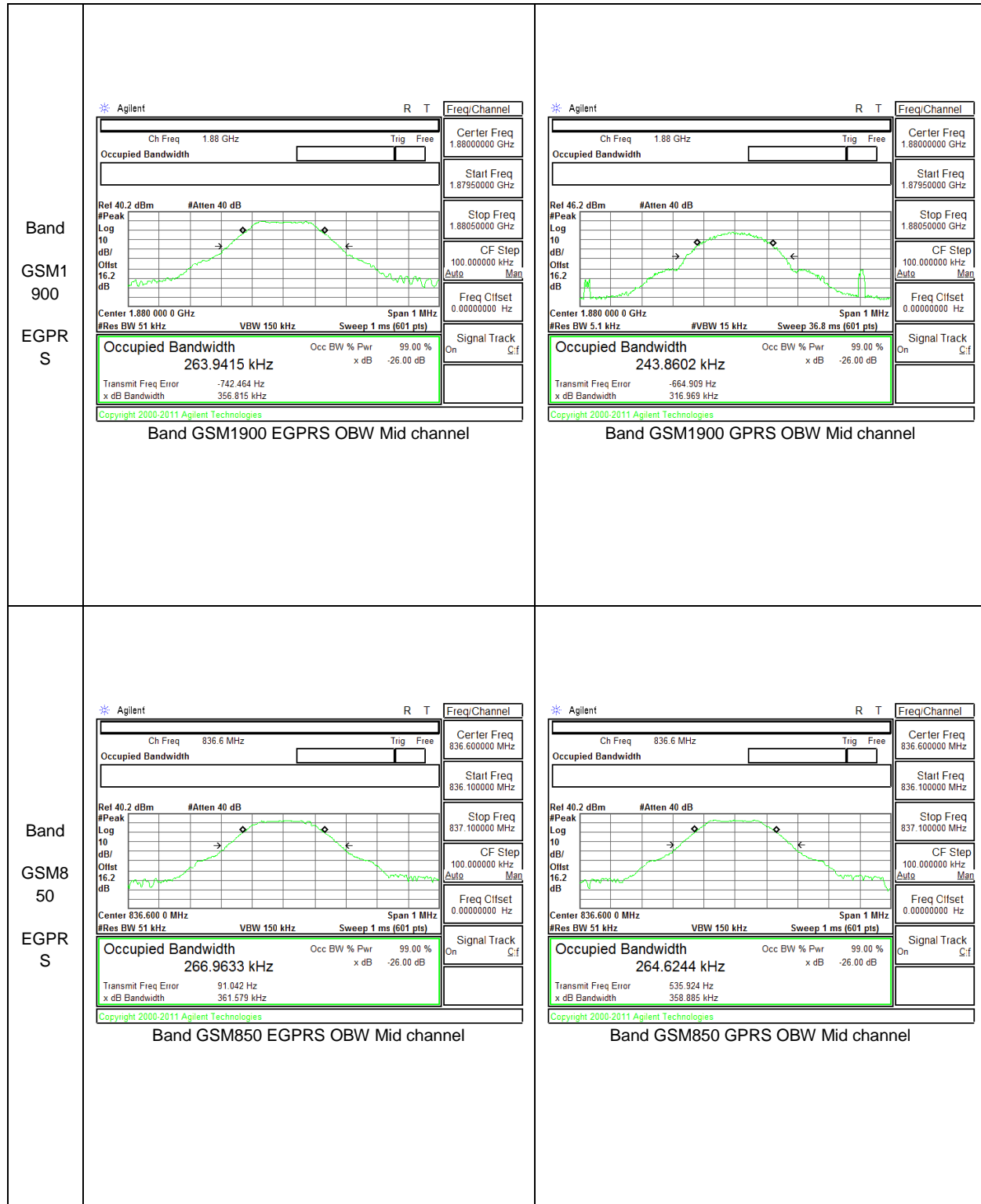

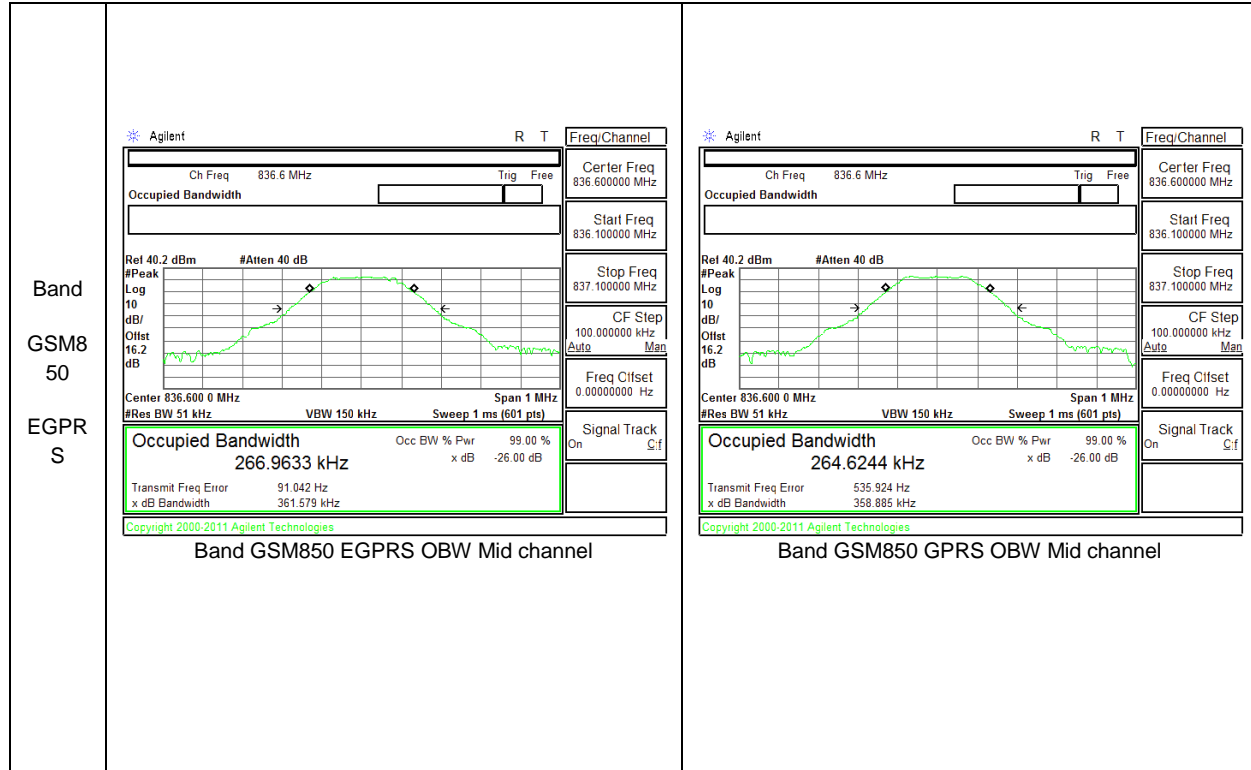

10.2. BAND EDGE EMISSIONS

RULE PART(S)

FCC: §22.359, §24.238

LIMITS

The power of any emission outside of the authorized operating frequency ranges must be attenuated below the transmitting power (P) by a factor of at least $43 + 10 \log (P)$ dB.

TEST PROCEDURE

Per KDB 971168 D01 Power Meas License Digital Systems v02r01

The transmitter output was connected to an Agilent 8960 or a CMW500 Test Set and configured to operate at maximum power. The band edge emissions were measured at the required operating frequencies in each band on the Spectrum Analyzer.

RESULTS

10.2.1. BAND EDGE PLOTS

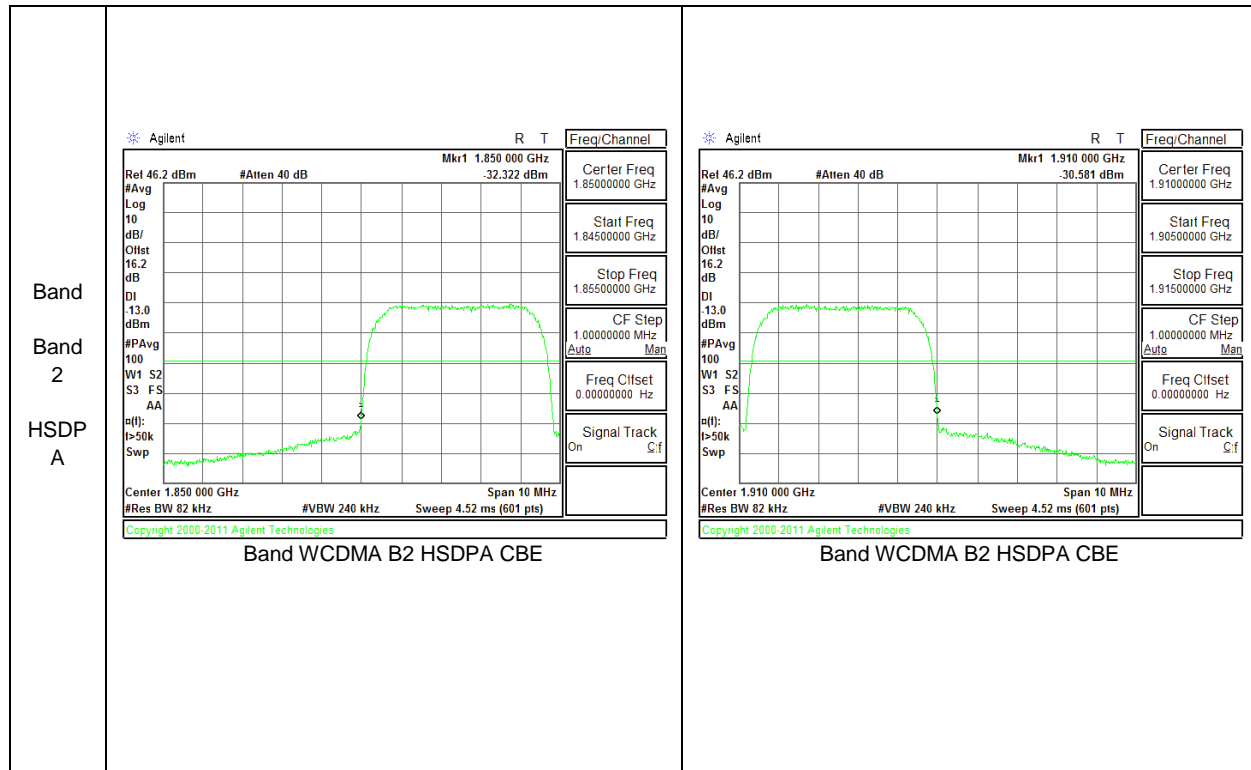

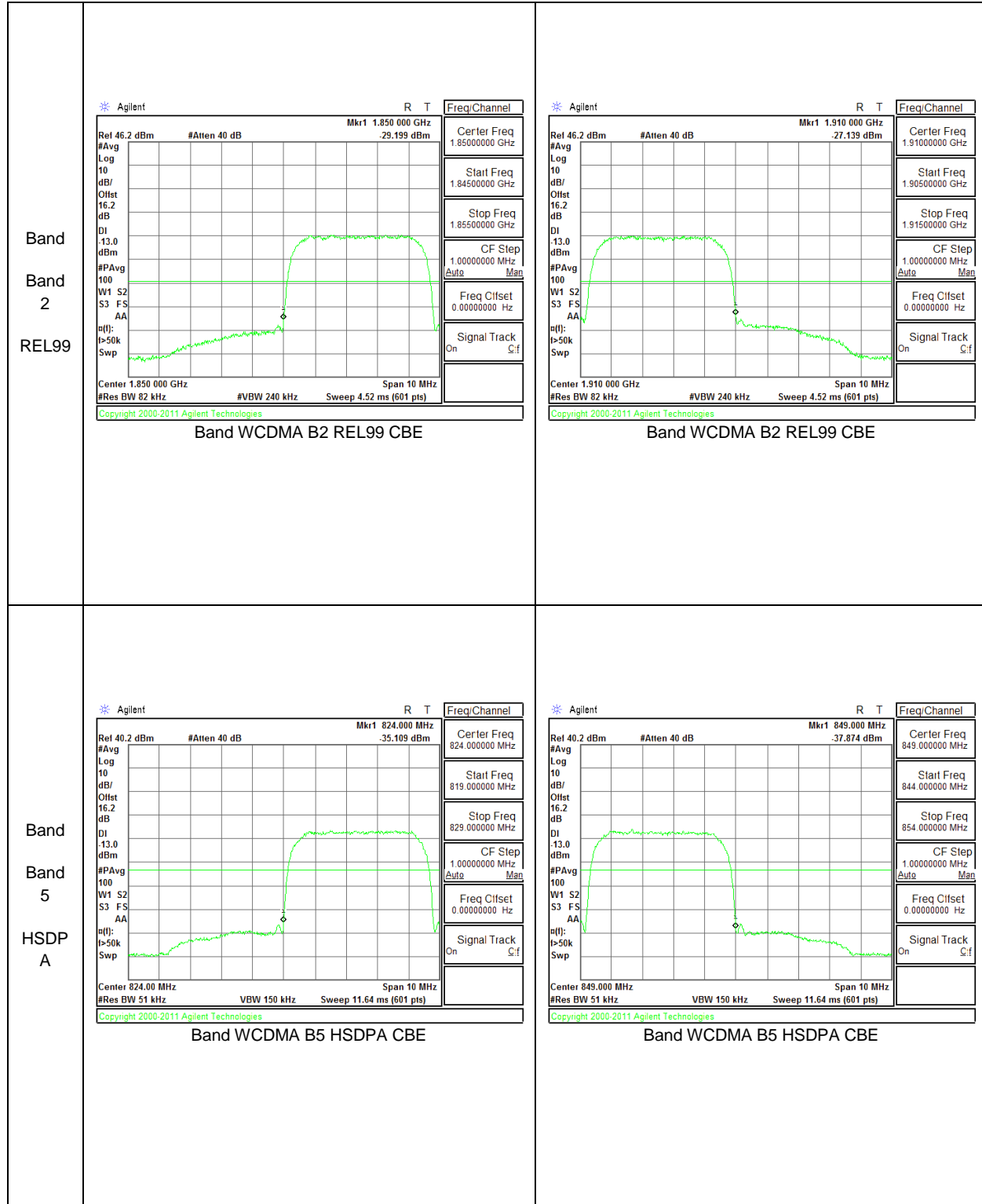

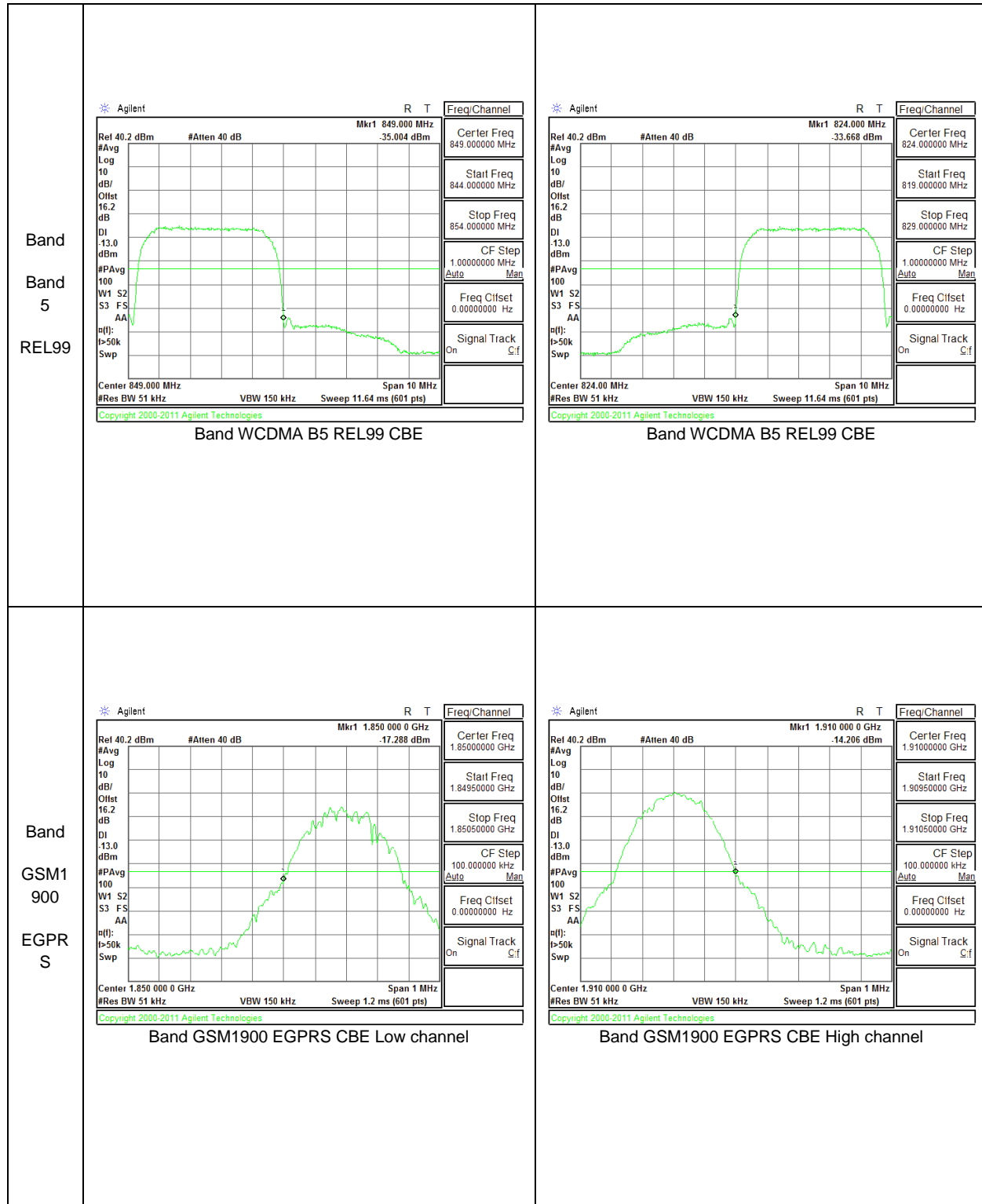

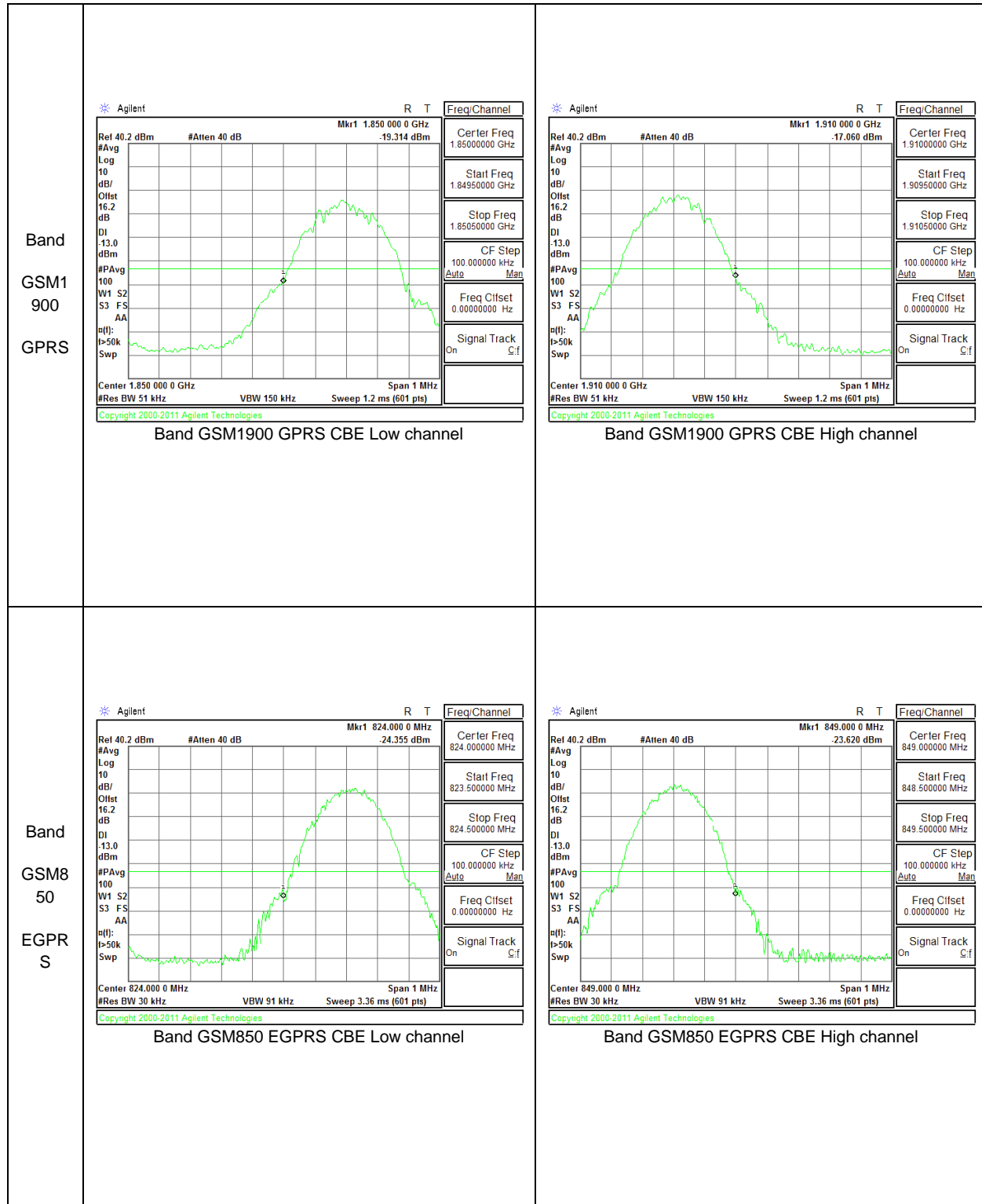

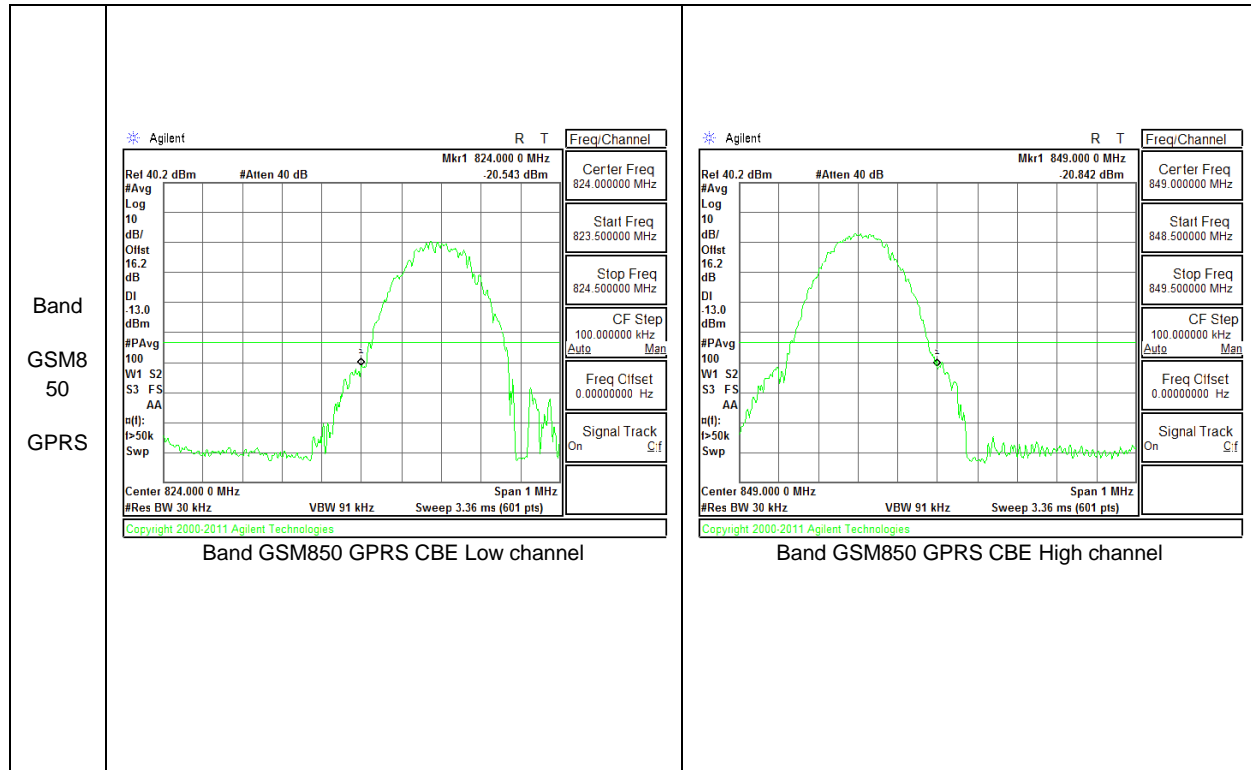

10.3. OUT OF BAND EMISSIONS

RULE PART(S)

FCC: §2.1051, §22.901, §22.917, §24.238

LIMITS

The power of any emission outside of the authorized operating frequency ranges must be attenuated below the transmitting power (P) by a factor of at least $43 + 10 \log (P)$ dB.

TEST PROCEDURE

Per KDB 971168 D01 Power Meas License Digital Systems v02r01

The RF output of the transmitter was connected to a spectrum analyzer through a calibrated coaxial cable. Sufficient scans were taken to show the out-of-band Emissions, if any, up to 10th harmonic. Multiple sweeps were recorded in maximum hold mode using a peak detector to ensure that the worst-case emissions were caught.

RESULTS

10.3.1. OUT OF BAND EMISSIONS RESULT

Band	Mode	f (MHz)	Spur (dBm)	Spec (dBm)	Delta (dB)
GSM850	GMSK	824.2			
		836.6			
		848.8			
	GPRS	824.2	-17.93	-13	-4.93
		836.6	-17.36	-13	-4.36
		848.8	-18.65	-13	-5.65
	EGPRS	824.2	-17.81	-13	-4.81
		836.6	-17.31	-13	-4.31
		848.8	-17.23	-13	-4.23
GSM1900	GMSK	1850.2			
		1880			
		1909.8			
	GPRS	1850.2	-17.53	-13	-4.53
		1880	-17.65	-13	-4.65
		1909.8	-18.09	-13	-5.09
	EGPRS	1850.2	-17.45	-13	-4.45
		1880	-17.31	-13	-4.31
		1909.8	-16.73	-13	-3.73

Band	Mode	f (MHz)	Spur (dBm)	Spec (dBm)	Delta (dB)
Band 5	REL99	826.4	-17.87	-13	-4.87
		836.6	-17.83	-13	-4.83
		846.6	-17.16	-13	-4.16
	HSDPA	826.4	-18.27	-13	-5.27
		836.6	-17.33	-13	-4.33
		846.6	-17.4	-13	-4.4
Band 2	REL99	1852.4	-16.88	-13	-3.88
		1880	-17.07	-13	-4.07
		1907.6	-17.61	-13	-4.61
	HSDPA	1852.4	-17.22	-13	-4.22
		1880	-17.27	-13	-4.27
		1907.6	-18.15	-13	-5.15

10.3.2. OUT OF BAND EMISSIONS PLOTS

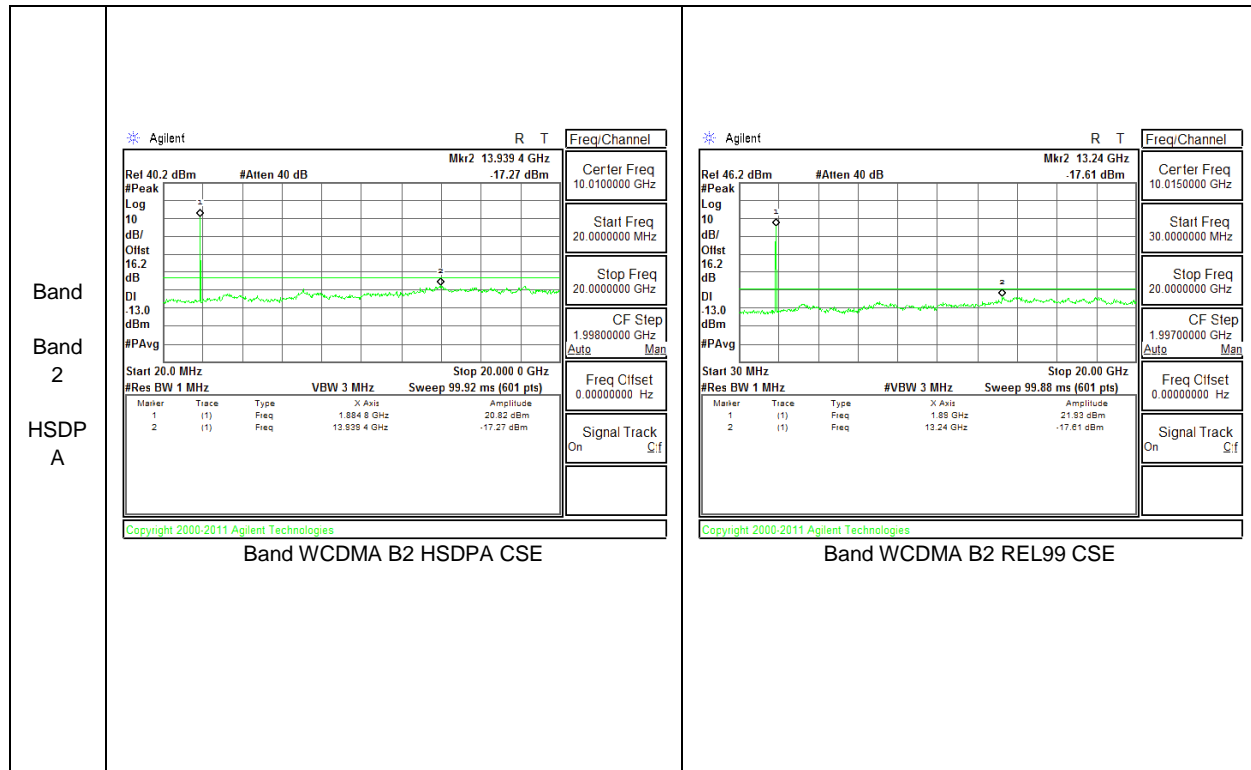

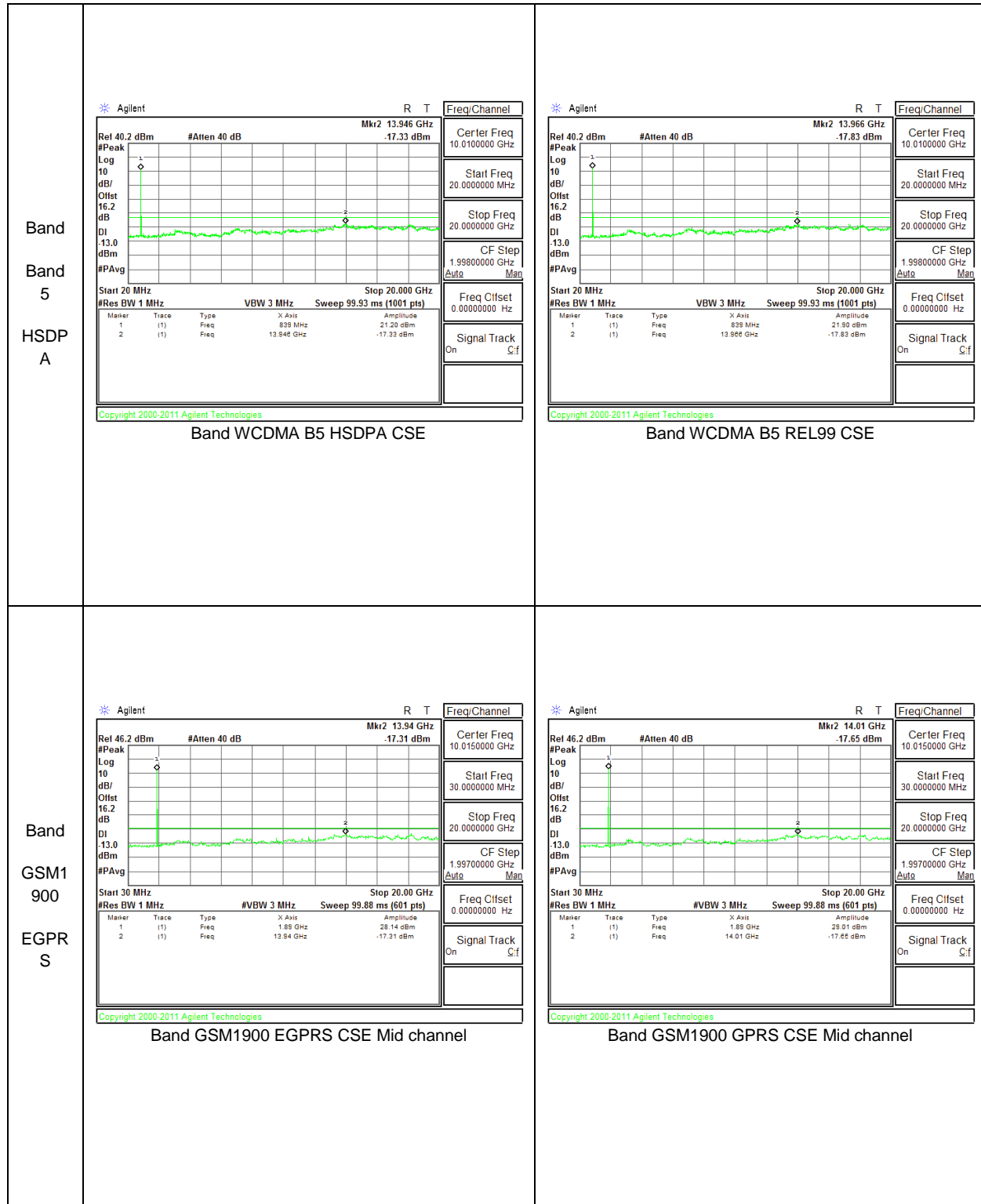

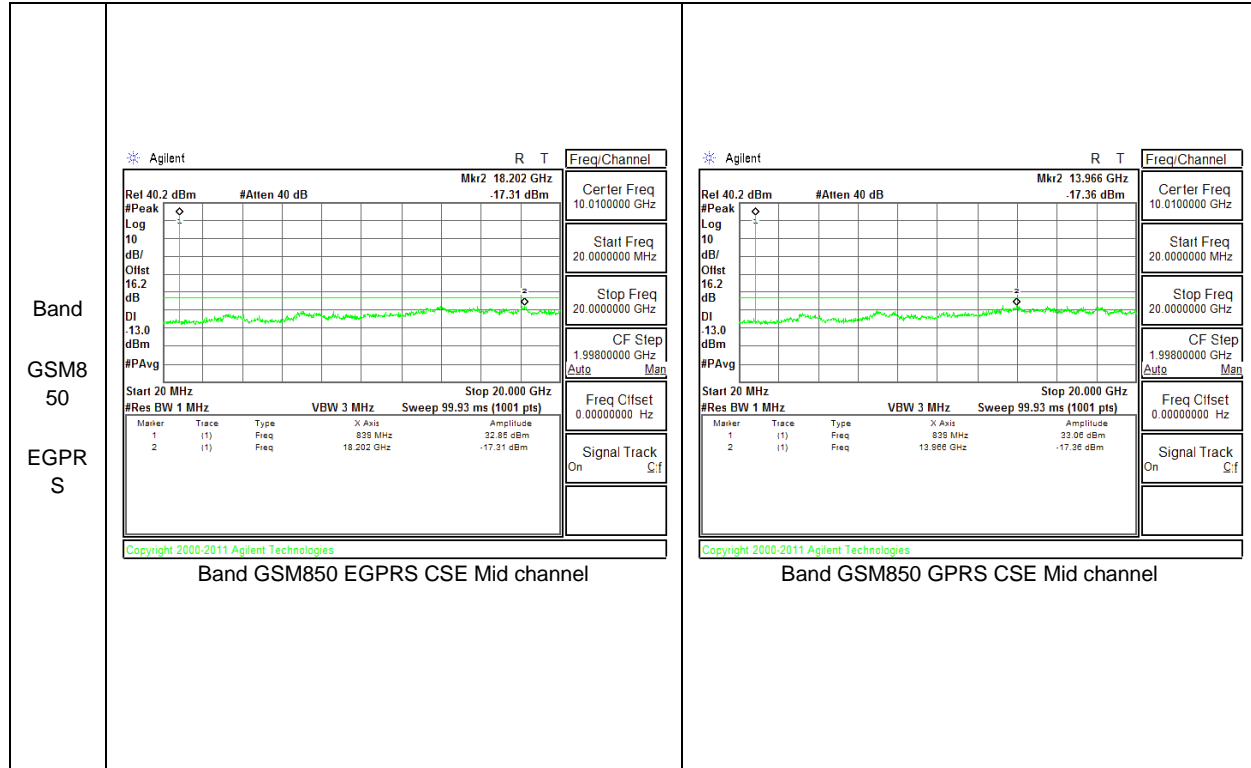

10.4. FREQUENCY STABILITY

RULE PART(S)

FCC: §2.1055, §22.355, §24.235

LIMITS

§22.355 - The carrier frequency shall not depart from the reference frequency in excess of ± 2.5 ppm for mobile stations.

§24.235 - The frequency stability shall be sufficient to ensure that the fundamental emission stays within the authorized frequency block.

TEST PROCEDURE

Per KDB 971168 D01 Power Meas License Digital Systems v02r01

RESULTS

See the following pages.

10.4.1. FREQUENCY STABILITY RESULTS

GPRS 1900, Channel 661 Freq: 1880MHz– MID CHANNEL

Reference Frequency: PCS Mid Channel		1880	MHz @ 20°C	
Limit: to stay +/- 2.5 ppm =		4700.000	Hz	
Power Supply (Vdc)	Environment Temperature (°C)	Frequency Deviation Measured with Time Elapse		
		(MHz)	Delta (ppm)	Limit (ppm)
3.80	50	1879.999984	0.017	2.5
3.80	40	1879.999986	0.016	2.5
3.80	30	1880.000015	0.001	2.5
3.80	20	1880.000017	0	2.5
3.80	10	1880.000013	0.002	2.5
3.80	0	1880.000020	-0.002	2.5
3.80	-10	1880.000018	-0.001	2.5
3.80	-20	1880.000016	0.000	2.5
3.80	-30	1880.000021	-0.003	2.5

Reference Frequency: PCS Mid Channel		1880	MHz @ 20°C	
Limit: to stay +/- 2.5 ppm =		4700.000	Hz	
Power Supply (Vdc)	Environment Temperature (°C)	Frequency Deviation Measured with Time Elapse		
		(MHz)	Delta (ppm)	Limit (ppm)
3.80	20	1880.000021	0	2.5
4.30	20	1880.000025	-0.004	2.5
3.20	20	1880.000024	-0.004	2.5

GPRS 850 CELL BAND, – MID CHANNEL190, Frequency 836.6MHz

Reference Frequency: PCS Mid Channel		836.6	MHz @ 20°C	
Limit: to stay +/- 2.5 ppm =		2091.500	Hz	
Power Supply (Vdc)	Environment Temperature (°C)	Frequency Deviation Measured with Time Elapse		
		(MHz)	Delta (ppm)	Limit (ppm)
3.80	50	836.600009	0.015	2.5
3.80	40	836.599991	0.037	2.5
3.80	30	836.599992	0.036	2.5
3.80	20	836.600022	0	2.5
3.80	10	836.599994	0.034	2.5
3.80	0	836.599992	0.036	2.5
3.80	-10	836.599990	0.038	2.5
3.80	-20	836.599988	0.041	2.5
3.80	-30	836.599986	0.043	2.5

Reference Frequency: PCS Mid Channel		836.6	MHz @ 20°C	
Limit: to stay +/- 2.5 ppm =		2091.500	Hz	
Power Supply (Vdc)	Environment Temperature (°C)	Frequency Deviation Measured with Time Elapse		
		(MHz)	Delta (ppm)	Limit (ppm)
3.80	20	836.600009	0	2.5
4.30	20	836.5999885	0.040	2.5
3.20	20	836.6000125	0.011	2.5

11. RADIATED TEST RESULTS

11.1. RADIATED POWER (ERP & EIRP)

RULE PART(S)

FCC: §2.1046, §22.913, §24.232

LIMITS

22.913(a) - The ERP of mobile transmitters and auxiliary test transmitters must not exceed 7 Watts.

24.232(c) - Mobile/portable stations are limited to 2 watts e.i.r.p. peak power and the equipment must employ means to limit the power to the minimum necessary for successful communications.

In addition, when the transmitter power is measured in terms of average value, the peak-to-average ratio of the power shall not exceed 13dB.

TEST PROCEDURE

ANSI / TIA / EIA 603C Clause 2.2.17; PSA setting reference to 971168 D01 v02r01

For peak power measurement with a PSA:

a) Set the RBW \geq OBW; b) Set VBW $\geq 3 \times$ RBW; c) Set span $\geq 2 \times$ RBW; d) Sweep time = auto couple; e) Detector = peak; f) Ensure that the number of measurement points \geq span/RBW; g) Trace mode = max hold;

For average power measurement with a PSA:

a) Set span to at least 1.5 times the OBW; b) Set RBW = 1-5% of the OBW, not to exceed 1 MHz; c) Set VBW $\geq 3 \times$ RBW; d) Set number of points in sweep $\geq 2 \times$ span / RBW; e) Sweep time = auto-couple; f) Detector = RMS (power averaging); g) Use free run trigger If burst duty cycle ≥ 98 ; h) Use trigger to capture bursts If burst duty cycle < 98 ; i) Trace average at least 100 traces in power averaging (*i.e.*, RMS) mode. j) Compute the power by integrating the spectrum across the OBW of the signal using the instrument's band power measurement function.

TEST RESULTS

11.1.1. ERP/EIRP Results

Band	Mode	Channel	f(MHz)	ERP / EIRP	
				dBm	mW
Band 2	REL99	9262	1852.4	22.3	168.1
		9400	1880	21.3	135.8
		9538	1907.6	22.8	188.5
	HSDPA	9262	1852.4	21.6	143.3
		9400	1880	21.6	145.6
		9538	1907.6	21.9	154.5

Band	Mode	Channel	f(MHz)	ERP / EIRP	
				dBm	mW
Band 5	REL99	4132	826.4	18.5	70.0
		4183	836.6	19.5	89.1
		4233	846.6	17.5	56.6
	HSDPA	4132	826.4	17.7	58.9
		4183	836.6	18.3	68.3
		4233	846.6	17.1	51.2

Band	Mode	Channel	f(MHz)	ERP / EIRP	
				dBm	mW
GSM1900	GPRS	512	1850.2	28.9	767.4
		661	1880	28.4	693.4
		810	1909.8	28.3	677.6
	EGPRS	512	1850.2	26.5	443.6
		661	1880	26.4	437.5
		810	1909.8	26.6	452.9

Band	Mode	Channel	f(MHz)	ERP / EIRP	
				dBm	mW
GSM850	GPRS	128	824.2	28.3	676.1
		190	836.6	27.3	537.0
		251	848.8	27.6	575.4
	EGPRS	128	824.2	25.4	346.7
		190	836.6	24.2	263.0
		251	848.8	25.4	346.7

11.1.2. ERP/EIRP DATA

Band 2 HSDP A	High Frequency Substitution Measurement UL Verification Services, Inc. Chamber A																																																																																																	
	Company:		Samsung																																																																																															
	Project #:		14118664																																																																																															
	Date:		08/29/14																																																																																															
	Test Engineer:		O. Stoelting																																																																																															
	Configuration:		X-pos EUT																																																																																															
	Mode:		HSDPA B2																																																																																															
	Test Equipment:																																																																																																	
	Receiving: Horn T136, and Chamber A SMA Cables																																																																																																	
	Substitution: Horn T962, 8ft SMA Cable (SN # 245185 003) Warehouse.																																																																																																	
<table border="1"> <thead> <tr> <th>f MHz</th> <th>SG reading (dBm)</th> <th>Ant. Pol. (H/V)</th> <th>Cable Loss (dB)</th> <th>Antenna Gain (dBi)</th> <th>EIRP (dBm)</th> <th>Limit (dBm)</th> <th>Margin (dB)</th> <th>Notes</th> </tr> </thead> <tbody> <tr> <td colspan="9">Low Ch</td> </tr> <tr> <td>1852.40</td> <td>8.29</td> <td>V</td> <td>0.9</td> <td>7.9</td> <td>15.29</td> <td>33.0</td> <td>-17.7</td> <td></td> </tr> <tr> <td>1852.40</td> <td>14.56</td> <td>H</td> <td>0.9</td> <td>7.9</td> <td>21.56</td> <td>33.0</td> <td>-11.4</td> <td></td> </tr> <tr> <td colspan="9">Mid Ch</td> </tr> <tr> <td>1880.00</td> <td>11.24</td> <td>V</td> <td>0.9</td> <td>7.9</td> <td>18.24</td> <td>33.0</td> <td>-14.8</td> <td></td> </tr> <tr> <td>1880.00</td> <td>14.63</td> <td>H</td> <td>0.9</td> <td>7.9</td> <td>21.63</td> <td>33.0</td> <td>-11.4</td> <td></td> </tr> <tr> <td colspan="9">High Ch</td> </tr> <tr> <td>1907.60</td> <td>11.24</td> <td>V</td> <td>0.9</td> <td>7.9</td> <td>18.24</td> <td>33.0</td> <td>-14.8</td> <td></td> </tr> <tr> <td>1907.60</td> <td>14.89</td> <td>H</td> <td>0.9</td> <td>7.9</td> <td>21.89</td> <td>33.0</td> <td>-11.1</td> <td></td> </tr> </tbody> </table>									f MHz	SG reading (dBm)	Ant. Pol. (H/V)	Cable Loss (dB)	Antenna Gain (dBi)	EIRP (dBm)	Limit (dBm)	Margin (dB)	Notes	Low Ch									1852.40	8.29	V	0.9	7.9	15.29	33.0	-17.7		1852.40	14.56	H	0.9	7.9	21.56	33.0	-11.4		Mid Ch									1880.00	11.24	V	0.9	7.9	18.24	33.0	-14.8		1880.00	14.63	H	0.9	7.9	21.63	33.0	-11.4		High Ch									1907.60	11.24	V	0.9	7.9	18.24	33.0	-14.8		1907.60	14.89	H	0.9	7.9	21.89	33.0	-11.1	
f MHz	SG reading (dBm)	Ant. Pol. (H/V)	Cable Loss (dB)	Antenna Gain (dBi)	EIRP (dBm)	Limit (dBm)	Margin (dB)	Notes																																																																																										
Low Ch																																																																																																		
1852.40	8.29	V	0.9	7.9	15.29	33.0	-17.7																																																																																											
1852.40	14.56	H	0.9	7.9	21.56	33.0	-11.4																																																																																											
Mid Ch																																																																																																		
1880.00	11.24	V	0.9	7.9	18.24	33.0	-14.8																																																																																											
1880.00	14.63	H	0.9	7.9	21.63	33.0	-11.4																																																																																											
High Ch																																																																																																		
1907.60	11.24	V	0.9	7.9	18.24	33.0	-14.8																																																																																											
1907.60	14.89	H	0.9	7.9	21.89	33.0	-11.1																																																																																											
Rev. 3.17.11																																																																																																		
Note: For Band 4 EIRP limit is 30dBm																																																																																																		

		High Frequency Substitution Measurement Compliance Certification Services Chamber A							
Band 2 REL99	Company: Samsung Project #: 14118664 Date: 08/29/14 Test Engineer: O. Stoelting Configuration: X-pos EUT Mode: WCDMA_1900 MHz_Rel 99 Test Equipment: Receiving: Horn T136, and Chamber A SMA Cables Substitution: Horn T962, 8ft SMA Cable (SN # 245185 003) Warehouse.								
	f MHz	SG reading (dBm)	Ant. Pol. (H/V)	Cable Loss (dB)	Antenna Gain (dBi)	EIRP (dBm)	Limit (dBm)	Margin (dB)	Notes
	Low Ch								
	1852.40	8.80	V	0.85	10.41	18.36	33.0	-14.6	
	1852.40	12.70	H	0.85	10.41	22.26	33.0	-10.7	
	Mid Ch								
	1880.00	3.94	V	0.85	10.81	13.90	33.0	-19.1	
	1880.00	11.37	H	0.85	10.81	21.33	33.0	-11.7	
	High Ch								
	1907.60	10.44	V	0.85	11.15	20.74	33.0	-12.3	
1907.60	12.45	H	0.85	11.15	22.75	33.0	-10.2		
Rev. 3.17.11 Note: For Band 4 EIRP limit is 30dBm									

Band Band 5 HSDP A	High Frequency Substitution Measurement UL Verification Services, Inc. Chamber A																																																																																																	
	Company:		Samsung																																																																																															
	Project #:		14118664																																																																																															
	Date:		08/29/14																																																																																															
	Test Engineer:		O. Stoelting																																																																																															
	Configuration:		X-pos EUT																																																																																															
	Mode:		WCDMA_HSDPA_850																																																																																															
	Test Equipment:																																																																																																	
	Receiving: Hybrid T477, and Chamber A SMA Cables																																																																																																	
	Substitution: Dipole T416, 8ft SMA Cable (SN # 245185 003) Warehouse.																																																																																																	
<table border="1"> <thead> <tr> <th>f MHz</th> <th>SG reading (dBm)</th> <th>Ant. Pol. (H/V)</th> <th>Cable Loss (dB)</th> <th>Antenna Gain (dBd)</th> <th>ERP (dBm)</th> <th>Limit (dBm)</th> <th>Margin (dB)</th> <th>No</th> </tr> </thead> <tbody> <tr> <td colspan="9">Low Ch</td> </tr> <tr> <td>826.60</td> <td>11.23</td> <td>V</td> <td>0.9</td> <td>0.0</td> <td>10.33</td> <td>38.5</td> <td>-28.1</td> <td></td> </tr> <tr> <td>826.60</td> <td>18.60</td> <td>H</td> <td>0.9</td> <td>0.0</td> <td>17.70</td> <td>38.5</td> <td>-20.7</td> <td></td> </tr> <tr> <td colspan="9">Mid Ch</td> </tr> <tr> <td>836.60</td> <td>10.32</td> <td>V</td> <td>0.9</td> <td>0.0</td> <td>9.42</td> <td>38.5</td> <td>-29.0</td> <td></td> </tr> <tr> <td>836.60</td> <td>19.24</td> <td>H</td> <td>0.9</td> <td>0.0</td> <td>18.34</td> <td>38.5</td> <td>-20.1</td> <td></td> </tr> <tr> <td colspan="9">High Ch</td> </tr> <tr> <td>846.60</td> <td>10.78</td> <td>V</td> <td>0.9</td> <td>0.0</td> <td>9.88</td> <td>38.5</td> <td>-28.6</td> <td></td> </tr> <tr> <td>846.60</td> <td>17.99</td> <td>H</td> <td>0.9</td> <td>0.0</td> <td>17.09</td> <td>38.5</td> <td>-21.4</td> <td></td> </tr> </tbody> </table>									f MHz	SG reading (dBm)	Ant. Pol. (H/V)	Cable Loss (dB)	Antenna Gain (dBd)	ERP (dBm)	Limit (dBm)	Margin (dB)	No	Low Ch									826.60	11.23	V	0.9	0.0	10.33	38.5	-28.1		826.60	18.60	H	0.9	0.0	17.70	38.5	-20.7		Mid Ch									836.60	10.32	V	0.9	0.0	9.42	38.5	-29.0		836.60	19.24	H	0.9	0.0	18.34	38.5	-20.1		High Ch									846.60	10.78	V	0.9	0.0	9.88	38.5	-28.6		846.60	17.99	H	0.9	0.0	17.09	38.5	-21.4	
f MHz	SG reading (dBm)	Ant. Pol. (H/V)	Cable Loss (dB)	Antenna Gain (dBd)	ERP (dBm)	Limit (dBm)	Margin (dB)	No																																																																																										
Low Ch																																																																																																		
826.60	11.23	V	0.9	0.0	10.33	38.5	-28.1																																																																																											
826.60	18.60	H	0.9	0.0	17.70	38.5	-20.7																																																																																											
Mid Ch																																																																																																		
836.60	10.32	V	0.9	0.0	9.42	38.5	-29.0																																																																																											
836.60	19.24	H	0.9	0.0	18.34	38.5	-20.1																																																																																											
High Ch																																																																																																		
846.60	10.78	V	0.9	0.0	9.88	38.5	-28.6																																																																																											
846.60	17.99	H	0.9	0.0	17.09	38.5	-21.4																																																																																											
Rev. 3.17.11																																																																																																		
Note: For Band 13/17 ERP limit is 34.77dBm; For Band 26 limit is 50dBm																																																																																																		

		High Frequency Substitution Measurement UL Verification Services, Inc. Chamber A								
		Company:	Samsung							
		Project #:	14118664							
		Date:	08/29/14							
		Test Engineer:	O. Stoelting							
		Configuration:	X-pos EUT							
		Mode:	WCDMA_Rel99_850							
		Test Equipment:	Receiving: Hybrid T477, and Chamber A SMA Cables Substitution: Dipole T416, 8ft SMA Cable (SN # 245185 003) Warehouse.							
Band		f	SG reading	Ant. Pol.	Cable Loss	Antenna Gain	ERP	Limit	Margin	Note
Band		MHz	(dBm)	(H/V)	(dB)	(dBd)	(dBm)	(dBm)	(dB)	
5										
REL99		Low Ch								
		826.60	11.96	V	0.9	0.0	11.06	38.5	-27.4	
		826.60	19.35	H	0.9	0.0	18.45	38.5	-20.0	
		Mid Ch								
		836.60	12.03	V	0.9	0.0	11.14	38.5	-27.3	
		836.60	20.40	H	0.9	0.0	19.50	38.5	-18.9	
		High Ch								
		846.60	11.94	V	0.9	0.0	11.04	38.5	-27.4	
		846.60	18.43	H	0.9	0.0	17.53	38.5	-20.9	
		Rev. 3.17.11 Note: For Band 13/17 ERP limit is 34.77dBm; For Band 26 limit is 50dBm								

		High Frequency Substitution Measurement UL Verification Services, Inc. Chamber B								
		Company:	Samsung							
		Project #:	14118664							
		Date:	08/28/14							
		Test Engineer:	L. Lara							
		Configuration:	EUT X position							
		Mode:	GPRS 1900							
		Test Equipment:								
		Receiving: Horn T345, and Chamber B SMA Cables								
		Substitution: Horn T59 Substitution, 4ft SMA Cable Warehouse								
Band		f	SG reading	Ant. Pol.	Cable Loss	Antenna Gain	EIRP	Limit	Margin	Notes
GSM1		MHz	(dBm)	(H/V)	(dB)	(dBi)	(dBm)	(dBm)	(dB)	
900		Low								
		1850.20	17.32	V	0.9	7.9	24.32	33.0	-8.7	
		1850.20	21.85	H	0.9	7.9	28.85	33.0	-4.2	
		Mid								
		1880.00	16.57	V	0.9	7.9	23.57	33.0	-9.4	
		1880.00	21.41	H	0.9	7.9	28.41	33.0	-4.6	
		High								
		1909.80	17.80	V	0.9	7.9	24.80	33.0	-8.2	
		1909.80	21.31	H	0.9	7.9	28.31	33.0	-4.7	
GPRS		Rev. 3.17.11								
		Note: For Band 4 EIRP limit is 30dBm								

Band GSM8 50 EGPR S	High Frequency Substitution Measurement UL Verification Services, Inc. Chamber B																																																																																																					
	Company:		Samsung																																																																																																			
	Project #:		14118664																																																																																																			
	Date:		08/28/14																																																																																																			
	Test Engineer:		L. Lara																																																																																																			
	Configuration:		EUT X position																																																																																																			
	Mode:		EGPRS850																																																																																																			
	Test Equipment:																																																																																																					
	Receiving: Sunol T243, and 3m Chamber B																																																																																																					
	Substitution: Dipole S/N: 00022117, 4ft SMA Cable (SN # 245200 001) Warehouse.																																																																																																					
<table border="1"> <thead> <tr> <th>f MHz</th> <th>SG reading (dBm)</th> <th>Ant. Pol. (H/V)</th> <th>Cable Loss (dB)</th> <th>Antenna Gain (dBd)</th> <th>ERP (dBm)</th> <th>Limit (dBm)</th> <th>Margin (dB)</th> <th>Notes</th> </tr> </thead> <tbody> <tr> <td colspan="10">Low</td> </tr> <tr> <td>824.20</td> <td>19.02</td> <td>V</td> <td>0.9</td> <td>0.0</td> <td>18.12</td> <td>38.5</td> <td>-20.3</td> <td></td> </tr> <tr> <td>824.20</td> <td>26.29</td> <td>H</td> <td>0.9</td> <td>0.0</td> <td>25.39</td> <td>38.5</td> <td>-13.1</td> <td></td> </tr> <tr> <td colspan="10">Mid</td> </tr> <tr> <td>836.60</td> <td>17.82</td> <td>V</td> <td>0.9</td> <td>0.0</td> <td>16.92</td> <td>38.5</td> <td>-21.5</td> <td></td> </tr> <tr> <td>836.60</td> <td>25.05</td> <td>H</td> <td>0.9</td> <td>0.0</td> <td>24.16</td> <td>38.5</td> <td>-14.3</td> <td></td> </tr> <tr> <td colspan="10">High</td> </tr> <tr> <td>848.80</td> <td>19.38</td> <td>V</td> <td>0.9</td> <td>0.0</td> <td>18.48</td> <td>38.5</td> <td>-20.0</td> <td></td> </tr> <tr> <td>848.80</td> <td>26.28</td> <td>H</td> <td>0.9</td> <td>0.0</td> <td>25.38</td> <td>38.5</td> <td>-13.1</td> <td></td> </tr> </tbody> </table>										f MHz	SG reading (dBm)	Ant. Pol. (H/V)	Cable Loss (dB)	Antenna Gain (dBd)	ERP (dBm)	Limit (dBm)	Margin (dB)	Notes	Low										824.20	19.02	V	0.9	0.0	18.12	38.5	-20.3		824.20	26.29	H	0.9	0.0	25.39	38.5	-13.1		Mid										836.60	17.82	V	0.9	0.0	16.92	38.5	-21.5		836.60	25.05	H	0.9	0.0	24.16	38.5	-14.3		High										848.80	19.38	V	0.9	0.0	18.48	38.5	-20.0		848.80	26.28	H	0.9	0.0	25.38	38.5	-13.1	
f MHz	SG reading (dBm)	Ant. Pol. (H/V)	Cable Loss (dB)	Antenna Gain (dBd)	ERP (dBm)	Limit (dBm)	Margin (dB)	Notes																																																																																														
Low																																																																																																						
824.20	19.02	V	0.9	0.0	18.12	38.5	-20.3																																																																																															
824.20	26.29	H	0.9	0.0	25.39	38.5	-13.1																																																																																															
Mid																																																																																																						
836.60	17.82	V	0.9	0.0	16.92	38.5	-21.5																																																																																															
836.60	25.05	H	0.9	0.0	24.16	38.5	-14.3																																																																																															
High																																																																																																						
848.80	19.38	V	0.9	0.0	18.48	38.5	-20.0																																																																																															
848.80	26.28	H	0.9	0.0	25.38	38.5	-13.1																																																																																															
Rev. 3.17.11 Note: For Band 13/17 ERP limit is 34.77dBm; For Band 26 limit is 50dBm																																																																																																						

Band 50 GSM8 GPRS	High Frequency Substitution Measurement UL Verification Services, Inc. Chamber B								
	Company:		Samsung						
	Project #:		14118664						
	Date:		08/28/14						
	Test Engineer:		L. Lara						
	Configuration:		EUT X position						
	Mode:		GPRS850						
	Test Equipment:								
	Receiving: Sunol T243, and 3m Chamber B								
	Substitution: Dipole S/N: 00022117, 4ft SMA Cable (SN # 245200 001) Warehouse.								
	f	SG reading	Ant. Pol.	Cable Loss	Antenna Gain	ERP	Limit	Margin	Notes
	MHz	(dBm)	(H/V)	(dB)	(dBd)	(dBm)	(dBm)	(dB)	
	Low								
	824.20	19.61	V	0.9	0.0	18.71	38.5	-19.7	
	824.20	29.15	H	0.9	0.0	28.25	38.5	-10.2	
	Mid								
	836.60	18.88	V	0.9	0.0	17.98	38.5	-20.5	
	836.60	28.20	H	0.9	0.0	27.30	38.5	-11.1	
	High								
	848.80	19.24	V	0.9	0.0	18.34	38.5	-20.1	
	848.80	28.47	H	0.9	0.0	27.57	38.5	-10.9	
	Rev. 3.17.11								
	Note: For Band 13/17 ERP limit is 34.77dBm; For Band 26 limit is 50dBm								

Band GSM1 900 EGPRS	High Frequency Substitution Measurement UL Verification Services, Inc. Chamber B																																																																																																
	Company:		Samsung																																																																																														
	Project #:		14118664																																																																																														
	Date:		08/28/14																																																																																														
	Test Engineer:		L. Lara																																																																																														
	Configuration:		EUT X position																																																																																														
	Mode:		EGPRS 1900																																																																																														
	Test Equipment:																																																																																																
	Receiving: Horn T345, and Chamber B SMA Cables																																																																																																
	Substitution: Horn T59 Substitution, 4ft SMA Cable Warehouse																																																																																																
<table border="1"> <thead> <tr> <th>f MHz</th> <th>SG reading (dBm)</th> <th>Ant. Pol. (H/V)</th> <th>Cable Loss (dB)</th> <th>Antenna Gain (dBi)</th> <th>EIRP (dBm)</th> <th>Limit (dBm)</th> <th>Margin (dB)</th> <th>Notes</th> </tr> </thead> <tbody> <tr> <td colspan="9">Low</td> </tr> <tr> <td>1850.20</td> <td>16.32</td> <td>V</td> <td>0.9</td> <td>7.9</td> <td>23.32</td> <td>33.0</td> <td>-9.7</td> <td></td> </tr> <tr> <td>1850.20</td> <td>20.20</td> <td>H</td> <td>0.9</td> <td>7.9</td> <td>26.47</td> <td>33.0</td> <td>-6.5</td> <td></td> </tr> <tr> <td colspan="9">Mid</td> </tr> <tr> <td>1880.00</td> <td>15.47</td> <td>V</td> <td>0.9</td> <td>7.9</td> <td>22.47</td> <td>33.0</td> <td>-10.5</td> <td></td> </tr> <tr> <td>1880.00</td> <td>19.41</td> <td>H</td> <td>0.9</td> <td>7.9</td> <td>26.41</td> <td>33.0</td> <td>-6.6</td> <td></td> </tr> <tr> <td colspan="9">High</td> </tr> <tr> <td>1909.80</td> <td>15.91</td> <td>V</td> <td>0.9</td> <td>7.9</td> <td>22.91</td> <td>33.0</td> <td>-10.1</td> <td></td> </tr> <tr> <td>1909.80</td> <td>19.56</td> <td>H</td> <td>0.9</td> <td>7.9</td> <td>26.56</td> <td>33.0</td> <td>-6.4</td> <td></td> </tr> </tbody> </table>								f MHz	SG reading (dBm)	Ant. Pol. (H/V)	Cable Loss (dB)	Antenna Gain (dBi)	EIRP (dBm)	Limit (dBm)	Margin (dB)	Notes	Low									1850.20	16.32	V	0.9	7.9	23.32	33.0	-9.7		1850.20	20.20	H	0.9	7.9	26.47	33.0	-6.5		Mid									1880.00	15.47	V	0.9	7.9	22.47	33.0	-10.5		1880.00	19.41	H	0.9	7.9	26.41	33.0	-6.6		High									1909.80	15.91	V	0.9	7.9	22.91	33.0	-10.1		1909.80	19.56	H	0.9	7.9	26.56	33.0	-6.4	
f MHz	SG reading (dBm)	Ant. Pol. (H/V)	Cable Loss (dB)	Antenna Gain (dBi)	EIRP (dBm)	Limit (dBm)	Margin (dB)	Notes																																																																																									
Low																																																																																																	
1850.20	16.32	V	0.9	7.9	23.32	33.0	-9.7																																																																																										
1850.20	20.20	H	0.9	7.9	26.47	33.0	-6.5																																																																																										
Mid																																																																																																	
1880.00	15.47	V	0.9	7.9	22.47	33.0	-10.5																																																																																										
1880.00	19.41	H	0.9	7.9	26.41	33.0	-6.6																																																																																										
High																																																																																																	
1909.80	15.91	V	0.9	7.9	22.91	33.0	-10.1																																																																																										
1909.80	19.56	H	0.9	7.9	26.56	33.0	-6.4																																																																																										
Rev. 3.17.11 Note: For Band 4 EIRP limit is 30dBm																																																																																																	

11.2. FIELD STRENGTH OF SPURIOUS RADIATION

RULE PART(S)

FCC: §2.1053, §22.917, §24.238

LIMIT

The power of any emission outside of the authorized operating frequency ranges must be attenuated below the transmitting power (P) by a factor of at least $43 + 10 \log (P)$ dB.

TEST PROCEDURE

For Cellular equipment - Compliance with these rules is based on the use of measurement instrumentation employing a resolution bandwidth of 100 kHz or greater. In the 1 MHz bands immediately outside and adjacent to the frequency block a resolution bandwidth of at least one percent of the emission bandwidth of the fundamental emission of the transmitter may be employed. A narrower resolution bandwidth is permitted in all cases to improve measurement accuracy provided the measured power is integrated over the full required measurement bandwidth (i.e. 100 kHz or 1 percent of emission bandwidth, as specified). The emission bandwidth is defined as the width of the signal between two points, one below the carrier center frequency and one above the carrier center frequency, outside of which all emissions are attenuated at least 26 dB below the transmitter power.

For PCS equipment - Compliance with these rules is based on the use of measurement instrumentation employing a resolution bandwidth of 1 MHz or greater. However, in the 1 MHz bands immediately outside and adjacent to the frequency block a resolution bandwidth of at least one percent of the emission bandwidth of the fundamental emission of the transmitter may be employed. A narrower resolution bandwidth is permitted in all cases to improve measurement accuracy provided the measured power is integrated over the full required measurement bandwidth (i.e. 1 MHz or 1 percent of emission bandwidth, as specified). The emission bandwidth is defined as the width of the signal between two points, one below the carrier center frequency and one above the carrier center frequency, outside of which all emissions are attenuated at least 26 dB below the transmitter power.

RESULTS

11.2.1. SPURIOUS RADIATION DATA

Compliance Certification Services Above 1GHz High Frequency Substitution Measurement										
Company:		Samsung								
Project #:		14118664								
Date:		08/29/14								
Test Engineer:		O. Stoelting								
Configuration:		X-Pos EUT w/ AC Charger and HS								
Mode:		HSDPA B2								
Chamber		Pre-amplifier		Filter		Limit				
5m Chamber A		T34 8449B		Filter 1		Part 24				
Band	f GHz	SG reading (dBm)	Ant. Pol. (H/V)	Distance (m)	Preamp (dB)	Filter (dB)	EIRP (dBm)	Limit (dBm)	Delta (dB)	Notes
Low Ch, 1852.4MHz										
Band 2	3.705	-16.6	V	3.0	35.4	1.0	-51.0	-13.0	-38.0	
	5.557	-16.7	V	3.0	34.7	1.0	-50.5	-13.0	-37.5	
	7.410	-16.4	V	3.0	34.9	1.0	-50.3	-13.0	-37.3	
HSDPA	3.705	-19.0	H	3.0	35.4	1.0	-53.4	-13.0	-40.4	
	5.557	-16.3	H	3.0	34.7	1.0	-50.0	-13.0	-37.0	
	7.410	-14.9	H	3.0	34.9	1.0	-48.8	-13.0	-35.8	
Mid Ch, 1880MHz										
	3.760	-17.1	V	3.0	35.3	1.0	-51.5	-13.0	-38.5	
	5.640	-17.4	V	3.0	34.7	1.0	-51.1	-13.0	-38.1	
	7.520	-15.2	V	3.0	34.9	1.0	-49.1	-13.0	-36.1	
	3.760	-18.0	H	3.0	35.3	1.0	-52.4	-13.0	-39.4	
	5.640	-16.4	H	3.0	34.7	1.0	-50.1	-13.0	-37.1	
	7.520	-13.6	H	3.0	34.9	1.0	-47.5	-13.0	-34.5	
High Ch, 1907.6MHz										
	3.815	-17.8	V	3.0	35.3	1.0	-52.1	-13.0	-39.1	
	5.723	-15.9	V	3.0	34.7	1.0	-49.6	-13.0	-36.6	
	7.630	-15.2	V	3.0	34.9	1.0	-49.1	-13.0	-36.1	
	3.815	-16.8	H	3.0	35.3	1.0	-51.1	-13.0	-38.1	
	5.723	-15.4	H	3.0	34.7	1.0	-49.2	-13.0	-36.2	
	7.630	-14.5	H	3.0	34.9	1.0	-48.4	-13.0	-35.4	
Rev. 03.03.09										
Note: No other emissions were detected above the system noise floor.										

Compliance Certification Services Above 1GHz High Frequency Substitution Measurement									
Company:		Samsung							
Project #:		14118664							
Date:		08/29/14							
Test Engineer:		O. Stoelting							
Configuration:		X-Pos EUT w/ AC Charger and HS							
Mode:		REL99 Band 2							
Chamber		Pre-amplifer			Filter		Limit		
5m Chamber A		T34 8449B			Filter 1		Part 22		
f GHz	SG reading (dBm)	Ant. Pol. (H/V)	Distance (m)	Preamp (dB)	Filter (dB)	EIRP (dBm)	Limit (dBm)	Delta (dB)	Notes
Low Ch, 1852.4MHz									
3.705	-17.9	V	3.0	35.4	1.0	-52.3	-13.0	-39.3	
5.557	-16.3	V	3.0	34.7	1.0	-50.1	-13.0	-37.1	
7.410	-16.4	V	3.0	34.9	1.0	-50.3	-13.0	-37.3	
REL99									
3.705	-18.7	H	3.0	35.4	1.0	-53.1	-13.0	-40.1	
5.557	-15.5	H	3.0	34.7	1.0	-49.2	-13.0	-36.2	
7.410	-14.8	H	3.0	34.9	1.0	-48.7	-13.0	-35.7	
Mid Ch, 1880MHz									
3.760	-15.7	V	3.0	35.3	1.0	-50.1	-13.0	-37.1	
5.640	-16.4	V	3.0	34.7	1.0	-50.2	-13.0	-37.2	
7.520	-15.0	V	3.0	34.9	1.0	-48.9	-13.0	-35.9	
3.760	-19.0	H	3.0	35.3	1.0	-53.3	-13.0	-40.3	
5.640	-17.0	H	3.0	34.7	1.0	-50.7	-13.0	-37.7	
7.520	-13.6	H	3.0	34.9	1.0	-47.6	-13.0	-34.6	
High Ch, 1907.6MHz									
3.815	-18.7	V	3.0	35.3	1.0	-53.0	-13.0	-40.0	
5.723	-15.8	V	3.0	34.7	1.0	-49.5	-13.0	-36.5	
7.630	-15.0	V	3.0	34.9	1.0	-49.0	-13.0	-36.0	
3.815	-18.5	H	3.0	35.3	1.0	-52.8	-13.0	-39.8	
5.723	-15.1	H	3.0	34.7	1.0	-48.9	-13.0	-35.9	
7.630	-14.7	H	3.0	34.9	1.0	-48.6	-13.0	-35.6	
Rev. 03.03.09									
Note: No other emissions were detected above the system noise floor.									

Compliance Certification Services Above 1GHz High Frequency Substitution Measurement										
Company:		Samsung								
Project #:		14118664								
Date:		08/29/14								
Test Engineer:		O. Stoelting								
Configuration:		X-Pos EUT w/ AC Charger and HS								
Mode:		HSDPA B5								
Chamber		Pre-amplifer			Filter		Limit			
5m Chamber A		T34 8449B			Filter 1		Part 22			
Band	f GHz	SG reading (dBm)	Ant. Pol. (H/V)	Distance (m)	Preamp (dB)	Filter (dB)	EIRP (dBm)	Limit (dBm)	Delta (dB)	Notes
Band 5 HSDP A	Low Ch, 826.4MHz									
	1.653	-19.5	V	3.0	37.4	1.0	-55.9	-13.0	-42.9	
	2.479	-22.9	V	3.0	36.4	1.0	-58.3	-13.0	-45.3	
	3.306	-21.6	V	3.0	35.8	1.0	-56.4	-13.0	-43.4	
	1.653	-18.0	H	3.0	37.4	1.0	-54.3	-13.0	-41.3	
	2.479	-25.3	H	3.0	36.4	1.0	-60.7	-13.0	-47.7	
	3.306	-22.0	H	3.0	35.8	1.0	-56.8	-13.0	-43.8	
	Mid Ch, 836.6MHz									
	1.673	-23.6	V	3.0	37.3	1.0	-59.9	-13.0	-46.9	
2.510	-23.3	V	3.0	36.4	1.0	-58.6	-13.0	-45.6		
3.346	-22.7	V	3.0	35.8	1.0	-57.5	-13.0	-44.5		
1.673	-18.1	H	3.0	37.3	1.0	-54.4	-13.0	-41.4		
2.510	-25.0	H	3.0	36.4	1.0	-60.4	-13.0	-47.4		
3.346	-20.8	H	3.0	35.8	1.0	-55.6	-13.0	-42.6		
High Ch, 846.6MHz										
1.693	-24.0	V	3.0	37.3	1.0	-60.3	-13.0	-47.3		
2.540	-22.5	V	3.0	36.3	1.0	-57.8	-13.0	-44.8		
3.386	-20.0	V	3.0	35.7	1.0	-54.7	-13.0	-41.7		
1.693	-20.3	H	3.0	37.3	1.0	-56.6	-13.0	-43.6		
2.540	-24.6	H	3.0	36.3	1.0	-60.0	-13.0	-47.0		
3.386	-20.6	H	3.0	35.7	1.0	-55.3	-13.0	-42.3		
Rev. 03.03.09										
Note: No other emissions were detected above the system noise floor.										

Compliance Certification Services
Above 1GHz High Frequency Substitution Measurement

Company: Samsung
Project #: 14118664
Date: 08/29/14
Test Engineer: O. Stoelting
Configuration: X-Pos EUT w/ AC Charger and HS
Mode: REL99 B5

Chamber
 5m Chamber A

Pre-amplifer
 T34 8449B

Filter
 Filter 1

Limit
 Part 22

	f GHz	SG reading (dBm)	Ant. Pol. (H/V)	Distance (m)	Preamp (dB)	Filter (dB)	EIRP (dBm)	Limit (dBm)	Delta (dB)	Notes	
Band Band 5 REL99	Low Ch, 826.4MHz										
	1.653	-16.4	V	3.0	37.4	1.0	-52.8	-13.0	-39.8		
	2.479	-22.6	V	3.0	36.4	1.0	-58.0	-13.0	-45.0		
	3.306	-20.1	V	3.0	35.8	1.0	-54.9	-13.0	-41.9		
	1.653	-16.7	H	3.0	37.4	1.0	-53.1	-13.0	-40.1		
	2.479	-24.5	H	3.0	36.4	1.0	-59.9	-13.0	-46.9		
	3.306	-20.5	H	3.0	35.8	1.0	-55.3	-13.0	-42.3		
	Mid Ch, 836.6MHz										
	1.673	-22.2	V	3.0	37.3	1.0	-58.6	-13.0	-45.6		
	2.510	-22.2	V	3.0	36.4	1.0	-57.6	-13.0	-44.6		
	3.346	-20.8	V	3.0	35.8	1.0	-55.5	-13.0	-42.5		
	1.673	-17.5	H	3.0	37.3	1.0	-53.8	-13.0	-40.8		
	2.510	-24.5	H	3.0	36.4	1.0	-59.9	-13.0	-46.9		
	3.346	-21.8	H	3.0	35.8	1.0	-56.5	-13.0	-43.5		
	High Ch, 846.6MHz										
	1.693	-18.5	V	3.0	37.3	1.0	-54.8	-13.0	-41.8		
	2.540	-22.7	V	3.0	36.3	1.0	-58.0	-13.0	-45.0		
	3.386	-20.6	V	3.0	35.7	1.0	-55.3	-13.0	-42.3		
1.693	-18.7	H	3.0	37.3	1.0	-55.0	-13.0	-42.0			
2.540	-23.7	H	3.0	36.3	1.0	-59.0	-13.0	-46.0			
3.386	-19.9	H	3.0	35.7	1.0	-54.6	-13.0	-41.6			

Rev. 03.03.09
 Note: No other emissions were detected above the system noise floor.

Compliance Certification Services Above 1GHz High Frequency Substitution Measurement										
Company:		Samsung								
Project #:		14118664								
Date:		09/05/14								
Test Engineer:		Jude Semana								
Configuration:		Y-Pos EUT w/ AC Charger + HS								
Mode:		EGPRS 1900								
Chamber		Pre-amplifier			Filter		Limit			
5m Chamber B		T34 8449B			Filter 1		Part 24			
Band	f GHz	SG reading (dBm)	Ant. Pol. (H/V)	Distance (m)	Preamp (dB)	Filter (dB)	EIRP (dBm)	Limit (dBm)	Delta (dB)	Not
GSM1 900 EGPRS	Low Ch, 1850.2MHz									
	3.700	-19.4	V	3.0	35.4	1.0	-53.8	-13.0	-40.8	
	5.551	-19.9	V	3.0	34.7	1.0	-53.6	-13.0	-40.6	
	7.401	-17.5	V	3.0	34.9	1.0	-51.4	-13.0	-38.4	
	3.700	-20.4	H	3.0	35.4	1.0	-54.8	-13.0	-41.8	
	5.551	-18.5	H	3.0	34.7	1.0	-52.2	-13.0	-39.2	
	7.401	-15.5	H	3.0	34.9	1.0	-49.4	-13.0	-36.4	
	Mid Ch, 1880.0MHz									
	3.760	-22.1	V	3.0	35.3	1.0	-56.5	-13.0	-43.5	
	5.640	-18.6	V	3.0	34.7	1.0	-52.4	-13.0	-39.4	
	7.520	-17.3	V	3.0	34.9	1.0	-51.2	-13.0	-38.2	
	3.760	-21.3	H	3.0	35.3	1.0	-55.7	-13.0	-42.7	
5.640	-18.6	H	3.0	34.7	1.0	-52.4	-13.0	-39.4		
7.520	-15.5	H	3.0	34.9	1.0	-49.5	-13.0	-36.5		
High Ch, 1909.8MHz										
3.820	-20.5	V	3.0	35.3	1.0	-54.8	-13.0	-41.8		
5.729	-18.4	V	3.0	34.7	1.0	-52.2	-13.0	-39.2		
7.639	-18.6	V	3.0	35.0	1.0	-52.6	-13.0	-39.6		
3.820	-22.1	H	3.0	35.3	1.0	-56.4	-13.0	-43.4		
5.729	-17.4	H	3.0	34.7	1.0	-51.1	-13.0	-38.1		
7.639	-16.3	H	3.0	35.0	1.0	-50.2	-13.0	-37.2		
Rev. 03.03.09										
Note: No other emissions were detected above the system noise floor.										

**Compliance Certification Services
 Above 1GHz High Frequency Substitution Measurement**

Company: Samsung
Project #: 14118664
Date: 09/05/14
Test Engineer: Jude Semana
Configuration: Y-Pos EUT w/ AC Charger + HS
Mode: GPRS 1900

Chamber	Pre-amplifier	Filter	Limit
5m Chamber B	T34 8449B	Filter 1	Part 24

Band	f GHz	SG reading (dBm)	Ant. Pol. (H/V)	Distance (m)	Preamp (dB)	Filter (dB)	EIRP (dBm)	Limit (dBm)	Delta (dB)	Not
	Low Ch, 1850.2MHz									
	3.700	-19.3	V	3.0	35.4	1.0	-53.7	-13.0	-40.7	
GSM1	5.551	-19.1	V	3.0	34.7	1.0	-52.8	-13.0	-39.8	
900	7.401	-17.2	V	3.0	34.9	1.0	-51.1	-13.0	-38.1	
	3.700	-18.4	H	3.0	35.4	1.0	-52.8	-13.0	-39.8	
GPRS	5.551	-17.6	H	3.0	34.7	1.0	-51.3	-13.0	-38.3	
	7.401	-14.3	H	3.0	34.9	1.0	-48.2	-13.0	-35.2	
	Mid Ch, 1880.0MHz									
	3.760	-21.3	V	3.0	35.3	1.0	-55.6	-13.0	-42.6	
	5.640	-20.2	V	3.0	34.7	1.0	-54.0	-13.0	-41.0	
	7.520	-17.1	V	3.0	34.9	1.0	-51.0	-13.0	-38.0	
	3.760	-24.6	H	3.0	35.3	1.0	-58.9	-13.0	-45.9	
	5.640	-19.2	H	3.0	34.7	1.0	-52.9	-13.0	-39.9	
	7.520	-16.1	H	3.0	34.9	1.0	-50.0	-13.0	-37.0	
	High Ch, 1909.8MHz									
	3.820	-19.9	V	3.0	35.3	1.0	-54.2	-13.0	-41.2	
	5.729	-18.1	V	3.0	34.7	1.0	-51.9	-13.0	-38.9	
	7.639	-18.3	V	3.0	35.0	1.0	-52.2	-13.0	-39.2	
	3.820	-22.9	H	3.0	35.3	1.0	-57.1	-13.0	-44.1	
	5.729	-16.9	H	3.0	34.7	1.0	-50.6	-13.0	-37.6	
	7.639	-16.3	H	3.0	35.0	1.0	-50.2	-13.0	-37.2	

Rev. 03.03.09

Note: No other emissions were detected above the system noise floor.

Compliance Certification Services Above 1GHz High Frequency Substitution Measurement										
Company:		Samsung								
Project #:		14118664								
Date:		08/28/14								
Test Engineer:		Jude Semana								
Configuration:		Y-Pos EUT w/ AC Charger + HS								
Mode:		EGPRS 850								
Chamber		Pre-amplifer			Filter		Limit			
5m Chamber B		T34 8449B			Filter 1		Part 22			
Band	f GHz	SG reading (dBm)	Ant. Pol. (H/V)	Distance (m)	Preamp (dB)	Filter (dB)	EIRP (dBm)	Limit (dBm)	Delta (dB)	Notes
GSM850 EGPRS	Low Ch, 824.2MHz									
	1.648	-11.1	V	3.0	37.4	1.5	-47.0	-13.0	-34.0	
	2.473	-5.5	V	3.0	36.4	1.5	-40.4	-13.0	-27.4	
	3.297	-3.1	V	3.0	35.8	1.5	-37.4	-13.0	-24.4	
	1.648	-12.1	H	3.0	37.4	1.5	-48.0	-13.0	-35.0	
	2.473	-7.1	H	3.0	36.4	1.5	-42.0	-13.0	-29.0	
	3.297	-2.0	H	3.0	35.8	1.5	-36.3	-13.0	-23.3	
	Mid Ch, 836.6MHz									
	1.673	-14.5	V	3.0	37.3	1.5	-50.3	-13.0	-37.3	
2.510	-8.1	V	3.0	36.4	1.5	-43.0	-13.0	-30.0		
3.346	-6.2	V	3.0	35.8	1.5	-40.4	-13.0	-27.4		
1.673	-13.7	H	3.0	37.3	1.5	-49.5	-13.0	-36.5		
2.510	-9.5	H	3.0	36.4	1.5	-44.3	-13.0	-31.3		
3.346	-6.1	H	3.0	35.8	1.5	-40.3	-13.0	-27.3		
High Ch, 848.8MHz										
1.698	-8.5	V	3.0	37.3	1.5	-44.3	-13.0	-31.3		
2.547	-5.3	V	3.0	36.3	1.5	-40.2	-13.0	-27.2		
3.395	-3.2	V	3.0	35.7	1.5	-37.4	-13.0	-24.4		
1.698	-10.7	H	3.0	37.3	1.5	-46.5	-13.0	-33.5		
2.547	-6.8	H	3.0	36.3	1.5	-41.7	-13.0	-28.7		
3.395	-3.7	H	3.0	35.7	1.5	-37.9	-13.0	-24.9		
Rev. 03.03.09										
Note: No other emissions were detected above the system noise floor.										

Compliance Certification Services Above 1GHz High Frequency Substitution Measurement										
Company:		Samsung								
Project #:		14118664								
Date:		08/28/14								
Test Engineer:		Jude Semana								
Configuration:		Y-Pos EUT w/ AC Charger + HS								
Mode:		GPRS 850								
Chamber		Pre-amplifer			Filter		Limit			
5m Chamber B		T34 8449B			Filter 1		Part 22			
Band	f GHz	SG reading (dBm)	Ant. Pol. (H/V)	Distance (m)	Preamp (dB)	Filter (dB)	EIRP (dBm)	Limit (dBm)	Delta (dB)	Note
Low Ch, 824.2MHz										
GSM850	1.648	-11.7	V	3.0	37.4	1.5	-47.6	-13.0	-34.6	
	2.473	-5.8	V	3.0	36.4	1.5	-40.7	-13.0	-27.7	
	3.297	-1.7	V	3.0	35.8	1.5	-36.0	-13.0	-23.0	
GPRS	1.648	-11.9	H	3.0	37.4	1.5	-47.8	-13.0	-34.8	
	2.473	-7.4	H	3.0	36.4	1.5	-42.3	-13.0	-29.3	
	3.297	-2.6	H	3.0	35.8	1.5	-36.9	-13.0	-23.9	
Mid Ch, 836.6MHz										
	1.673	-13.1	V	3.0	37.3	1.5	-48.9	-13.0	-35.9	
	2.510	-8.0	V	3.0	36.4	1.5	-42.8	-13.0	-29.8	
	3.346	-5.6	V	3.0	35.8	1.5	-39.8	-13.0	-26.8	
	1.673	-12.1	H	3.0	37.3	1.5	-48.0	-13.0	-35.0	
	2.510	-9.4	H	3.0	36.4	1.5	-44.2	-13.0	-31.2	
	3.346	-6.2	H	3.0	35.8	1.5	-40.4	-13.0	-27.4	
High Ch, 848.8MHz										
	1.698	-9.1	V	3.0	37.3	1.5	-44.9	-13.0	-31.9	
	2.547	-5.2	V	3.0	36.3	1.5	-40.0	-13.0	-27.0	
	3.395	-2.1	V	3.0	35.7	1.5	-36.3	-13.0	-23.3	
	1.698	-10.0	H	3.0	37.3	1.5	-45.8	-13.0	-32.8	
	2.547	-6.2	H	3.0	36.3	1.5	-41.0	-13.0	-28.0	
	3.395	-3.4	H	3.0	35.7	1.5	-37.6	-13.0	-24.6	
Rev. 03.03.09										
Note: No other emissions were detected above the system noise floor.										