





TEST REPORT

<p>KCTL KCTL Inc. 65, Sinwon-ro, Yeongtong-gu, Suwon-si, Gyeonggi-do, 16677, Korea TEL: 82-31-285-0894 FAX: 82-505-299-8311 www.kctl.co.kr</p>	<p>Report No.: KR21-SRF0019 Page (1) of (59)</p>	
<p>1. Client</p> <ul style="list-style-type: none"> ◦ Name : Samsung Electronics Co., Ltd. ◦ Address : 129, Samsung-ro, Yeongtong-gu, Suwon-si, Gyeonggi-do, 16677, Rep. of Korea ◦ Date of Receipt : 2020-12-03 <p>2. Use of Report : Certification</p> <p>3. Name of Product / Model : Mobile phone / SM-G525F/DS</p> <p>4. Manufacturer / Country of Origin : Samsung Electronics Co., Ltd. / Vietnam</p> <p>5. FCC ID : A3LSMG525F</p> <p>6. Date of Test : 2020-12-11 to 2021-01-11</p> <p>7. Location of Test : <input checked="" type="checkbox"/> Permanent Testing Lab <input type="checkbox"/> On Site Testing (Address: Address of testing location)</p> <p>8. Test method used : FCC Part 2 FCC Part 90 subpart S</p> <p>9. Test Results : Refer to the test result in the test report</p>		
<p>Affirmation</p>	<p>Tested by Name : Taeyoung Kim </p>	<p>Technical Manager Name : Seungyong Kim </p>
<p style="text-align: right;">2021-01-14</p> <p style="text-align: center;">KCTL Inc.</p> <p>As a test result of the sample which was submitted from the client, this report does not guarantee the whole product quality. This test report should not be used and copied without a written agreement by KCTL Inc.</p>		

REPORT REVISION HISTORY

Date	Revision	Page No
2021-01-14	Originally issued	-

This report shall not be reproduced except in full, without the written approval of KCTL Inc. This document may be altered or revised by KCTL Inc. personnel only, and shall be noted in the revision section of the document. Any alteration of this document not carried out by KCTL Inc. will constitute fraud and shall nullify the document. This test report is a general report that does not use the KOLAS accreditation mark and is not related to KS Q ISO/IEC 17025 and KOLAS accreditation.

General remarks for test reports

Nothing significant to report.

CONTENTS

1.	General information	4
2.	Device information	4
2.1.	Frequency/channel operations.....	6
3.	Maximum ERP/EIRP power.....	7
4.	Summary of tests	8
4.1.	Worst case orientation	8
5.	Measurement uncertainty	9
6.	Measurement results explanation example	10
7.	Test results	11
7.1.	Conducted output power.....	11
7.2.	99% Occupied Bandwidth & 26 dB Bandwidth.....	16
7.3.	Spurious Emissions at Antenna Terminal.....	31
7.4.	Band Edge Emissions at Antenna Terminal	36
7.5.	Frequency stability.....	48
7.6.	Radiated Power (ERP/EIRP)	51
7.7.	Radiated Spurious Emissions.....	55
8.	Measurement equipment	59

1. General information

Client : Samsung Electronics Co., Ltd.
Address : 129, Samsung-ro, Yeongtong-gu, Suwon-si, Gyeonggi-do, 16677,
Rep. of Korea
Manufacturer : Samsung Electronics Co., Ltd.
Address : 129, Samsung-ro, Yeongtong-gu, Suwon-si, Gyeonggi-do, 16677,
Rep. of Korea
Factory : Samsung Electronics Vietnam Thai Nguyen Co., Ltd.
Address : KCN Yen Binh I, Pho Yen, Thai Nguyen, VNM, Thai Nguyen Thai Nguyen, VNM
Laboratory : KCTL Inc.
Address : 65, Sinwon-ro, Yeongtong-gu, Suwon-si, Gyeonggi-do, 16677, Korea
Accreditations : FCC Site Designation No: KR0040, FCC Site Registration No: 687132
VCCI Registration No. : R-20080, G-20078, C-20059, T-20056
Industry Canada Registration No. : 8035A
KOLAS No.: KT231

2. Device information

Equipment under test : Mobile phone
Model : SM-G525F/DS
Derivative model : SM-G525F
Modulation technique : Bluetooth(BDR/EDR)_GFSK, $\pi/4$ DQPSK, 8DPSK
Bluetooth(BLE)_GFSK
WIFI(802.11a/b/g/n/ac)_DSSS, OFDM
LTE_QPSK, 16QAM
WCDMA_QPSK
GSM_GMSK, 8-PSK
NFC_ASK
Number of channels : Bluetooth(BDR/EDR)_79 ch / Bluetooth(BLE)_40 ch
802.11b/g/n_HT20 : 13 ch
UNII-1: 4 ch (20 MHz), 2 ch (40 MHz), 1 ch (80 MHz)
UNII-2A: 4 ch (20 MHz), 2 ch (40 MHz), 1 ch (80 MHz)
UNII-2C: 12 ch (20 MHz), 6 ch (40 MHz), 3 ch (80 MHz)
UNII-3: 5 ch (20 MHz), 2 ch (40 MHz), 1 ch (80 MHz)
NFC: 1 ch
Power source : DC 3.85 V
Antenna specification : LTE/WCDMA/GSM_SCI Antenna
WIFI/Bluetooth(BDR/EDR/BLE)_SCI Antenna
NFC_FPCB Antenna

Antenna gain : WIFI/Bluetooth(BDR/EDR/BLE)_-4.00 dBi
UNII-1 : -4.30 dBi
UNII-2A : -4.50 dBi
UNII-2C : -4.30 dBi
UNII-3 : -4.70 dBi

Frequency range : Bluetooth(BDR/EDR/BLE)_2 402 MHz ~ 2 480 MHz
2 412 MHz ~ 2 472 MHz (802.11b/g/n_HT20)
UNII-1: 5 180 MHz ~ 5 240 MHz (802.11a/n/ac_HT20/VHT20)
UNII-1: 5 190 MHz ~ 5 230 MHz (802.11n/ac_HT40/VHT40)
UNII-1: 5 210 MHz (802.11ac_VHT80)
UNII-2A: 5 260 MHz ~ 5 320 MHz (802.11a/n/ac_HT20/VHT20)
UNII-2A: 5 270 MHz ~ 5 310 MHz (802.11n/ac_HT40/VHT40)
UNII-2A: 5 290 MHz (802.11ac_VHT80)
UNII-2C: 5 500 MHz ~ 5 720 MHz (802.11a/n/ac_HT20/VHT20)
UNII-2C: 5 510 MHz ~ 5 710 MHz (802.11n/ac_HT40/VHT40)
UNII-2C: 5 530 MHz ~ 5 690 MHz (802.11ac_VHT80)
UNII-3: 5 745 MHz ~ 5 825 MHz (802.11a/n/ac_HT20/VHT20)
UNII-3: 5 755 MHz ~ 5 795 MHz (802.11n/ac_HT40/VHT40)
UNII-3: 5 775 MHz (802.11ac_VHT80)
LTE Band 2_1 850.7 MHz ~ 1 909.3 MHz
LTE Band 4_1 710.7 MHz ~ 1 754.3 MHz
LTE Band 5_824.7 MHz ~ 848.3 MHz
LTE Band 12_699.7 MHz ~ 715.3 MHz
LTE Band 17_706.5 MHz ~ 713.5 MHz
LTE Band 26_824.7 MHz ~ 848.3 MHz, 814.7 MHz ~ 823.3 MHz
LTE Band 41_2 498.5 MHz ~ 2 687.5 MHz
LTE Band 66_1 710.7 MHz ~ 1 779.3 MHz
GSM 850_824.2 MHz ~ 848.8 MHz
GSM 1900_1 850.2 MHz ~ 1 909.8 MHz
WCDMA 850_826.4 MHz ~ 846.6 MHz
WCDMA 1700_1 712.4 MHz ~ 1 752.6 MHz
WCDMA 1900_1 852.4 MHz ~ 1 907.6 MHz
NFC_13.56 MHz

Software version : G525F.001
Hardware version : REV0.1
Test device serial No. : Conducted(R38NB03HNYF. R38NB03HNBK)
Radiated(R38NB03HNMW)

Operation temperature : -30 °C ~ 50 °C

Note. The Product equality letter includes detailed information about the differences between basic and derivative model.

2.1. Frequency/channel operations

This device contains the following capabilities:

WiFi (802.11a/b/g/n/ac), Bluetooth (BDR/EDR/BLE), NFC

LTE Band 2, LTE Band 4, LTE Band 5, LTE Band 12, LTE Band 17, LTE Band 26, LTE Band 41,
LTE Band 66, GSM 850, GSM 1900, WCDMA 850, WCDMA 1700, WCDMA 1900

LTE Band 26

Ch.	Frequency (MHz)
26697	814.7
26783	823.3
26790	824.0

Table 2.2.1. 1.4M BW

Ch.	Frequency (MHz)
26705	815.5
26775	822.5
26790	824.0

Table 2.2.2. 3M BW

Ch.	Frequency (MHz)
26715	816.5
26765	821.5
26790	824.0

Table 2.2.3. 5M BW

Ch.	Frequency (MHz)
26740	819.0
26790	824.0

Table 2.2.4. 10M BW

Ch.	Frequency (MHz)
26765	821.5
26790	824.0

Table 2.2.5. 15M BW

3. Maximum ERP/EIRP power**LTE Band 26 (Part 90)**

Mode	Tx frequency (MHz)	Emission designator	Conducted	
			Max. power (dBm)	Max. power (W)
LTE Band 26	814.7 ~ 823.3	1M10G7D	24.36	0.273
		1M10W7D	23.45	0.221
	815.5 ~ 822.5	2M71G7D	24.27	0.267
		2M71W7D	23.31	0.214
	816.5 ~ 821.5	4M55G7D	24.36	0.273
		4M53W7D	23.33	0.215
	819.0	9M02G7D	24.36	0.273
		8M99W7D	23.21	0.209
	821.5	13M5G7D	24.37	0.274
		13M5W7D	23.33	0.215
Straddle channel	824.0	1M10G7D	24.16	0.261
		1M10W7D	23.42	0.220
		2M71G7D	24.16	0.261
		2M70W7D	23.35	0.216
		4M52G7D	24.34	0.272
		4M53W7D	23.18	0.208
		8M99G7D	24.24	0.265
		8M99W7D	23.14	0.206
		13M5G7D	24.32	0.270
		13M4W7D	23.35	0.216

4. Summary of tests

FCC Part section(s)	Parameter	Test Limit	Test Condition	Test results
2.1046 90.635	Conducted Output Power	< 100 Watts	Conducted	Pass
2.1049	Occupied Bandwidth & 26 dB Bandwidth	N/A		Pass
2.1051 90.691(a)	Band Edge Emissions at Antenna Terminal	<43 + 10Log ₁₀ (P) dB, <50 10Log ₁₀ (P) dB at Band Edge and for all out-of-band emissions within 37.5kHz of Block Edge		Pass
	Spurious Emissions at Antenna Terminal			Pass
2.1055 90.213	Frequency stability	< 2.5 ppm		Pass
90.635(b)	Effective Radiated Power	< 100 Watts max. ERP	Radiated	Pass
2.1053 90.691(a)	Radiated Spurious Emissions	<43 + 10Log ₁₀ (P) dB		Pass

Notes:

1. The test procedure(s) in this report were performed in accordance as following.
 - ◆ ANSI C63.26-2015
 - ◆ ANSI/TIA-603-E-2016
 - ◆ KDB 971168 D01 v03r01

4.1. Worst case orientation

1. All modes of operation were investigated and the worst case emissions are reported with the EUT positioning, modulations, RB sizes and offsets, and channel bandwidth configurations in the test data.
2. All final radiated testing was performed with the EUT in worst case orientation.
3. For Band 26 (Part 90), The fundamental of the EUT was investigated in three orthogonal orientations X, Y and Z. It was determined that Y orientation was worst-case orientation. Therefore, all final radiated testing was performed with the EUT in Y orientation.
4. All the radiated tests have been performed several case.

(Stand-alone, with accessories (TA etc.))

Worst case : Stand-alone

Test condition	LTE Band	Modulation	Bandwidth (MHz)	RB size	RB offset
Radiated	B26 (Part90)	QPSK	15	1	0, 38, 74
Conducted		QPSK, 16QAM	1.4, 3, 5, 10, 15	1	0, 5, 14, 24, 49, 74
		Full	0		

5. Measurement uncertainty

The measurement uncertainties shown below were calculated in accordance with the requirements of ANSI C63.4-2014.

All measurement uncertainty values are shown with a coverage factor of $k=2$ to indicate a 95 % level of confidence. The measurement data shown herein meets or exceeds the U_{CISPR} measurement uncertainty values specified in CISPR 16-4-2 and thus, can be compared directly to specified limits to determine compliance.

Parameter	Expanded uncertainty (\pm)	
Conducted RF power	1.3 dB	
Conducted spurious emissions	1.3 dB	
Radiated spurious emissions	30 MHz ~ 1 GHz	3.7 dB
	Above 1 GHz	5.7 dB

6. Measurement results explanation example

Frequency (MHz)	Factor(dB)	Frequency (MHz)	Factor(dB)
30	5.73	11 000	9.45
50	6.17	12 000	9.27
100	6.35	13 000	9.71
200	6.48	14 000	9.69
300	6.58	15 000	9.99
400	6.67	16 000	10.41
500	6.74	17 000	9.85
600	6.79	18 000	10.68
700	6.85	19 000	10.39
800	6.90	20 000	10.79
900	6.96	21 000	10.89
1 000	6.98	22 000	10.84
2 000	7.32	23 000	11.36
3 000	7.59	24 000	10.89
4 000	7.92	25 000	11.26
5 000	8.11	26 000	10.92
6 000	8.32	26 500	11.67
7 000	8.32	27 000	11.70
8 000	8.58	28 000	11.77
9 000	8.79	29 000	11.04
10 000	8.95	30 000	12.00

Note.

Offset(dB) = RF cable loss(dB) + Divider (dB)

7. Test results

7.1. Conducted output power

Test setup

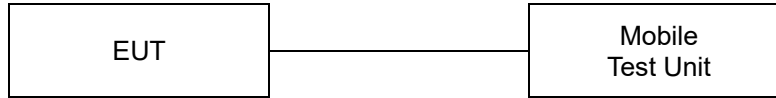

Test procedure

971168 D01 v03r01 – Section 5.2
ANSI C63.26-2015 – Section 5.2.4.2
CFR 47, - Section §2.1046

Test settings

When an average power meter is used to perform RF output power measurements, the fundamental condition that measurement be performed only over durations of active transmissions at maximum output power level applies. Thus, an average power meter can always be used to perform the measurement when the EUT can be configured to transmit continuously.

If the EUT cannot be configured to transmit continuously (i.e., burst duty cycle < 98%), then the following options can be implemented to facilitate measurement of the average power with an average power meter:

- a) A gated average power meter can be used to perform the measurement if the gating parameters can be adjusted such that the power is measured only during active transmission bursts at maximum output power levels.
- b) A conventional average power meter with no signal gating capability can also be used if the measured burst duty cycle is constant (i.e., duty cycle variations are less than or equal to $\pm 2\%$) by performing the measurement over the on/off burst cycles and then correcting (increasing) the measured level by a factor equal to $[10\log(1/\text{duty cycle})]$. See 5.2.4.3.4 for guidance with respect to measuring the transmitter duty cycle.

See item r) of 4.1 for more information regarding power meter functional requirements and limitations, and consult the instrumentation-specific application literature for proper set-up and use.

Notes:

Offset(dB) = RF cable loss(dB)

Test results

Test Band	Bandwidth (MHz)	Test mode	RB size	RB offset	MPR	Maximum power			
						Frequency (MHz)			
						Low	Middle	High	
LTE Band 26	1.4	QPSK	1	0	0	24.36	-	24.22	
			1	3	0	24.30	-	24.15	
			1	5	0	24.24	-	24.19	
			3	0	0	24.23	-	24.17	
			3	1	0	24.24	-	24.20	
			3	3	0	24.28	-	24.18	
		6	0	1	23.29	-	23.25		
		16QAM	1	0	1	23.36	-	23.45	
			1	3	1	23.34	-	23.38	
			1	5	1	23.29	-	23.44	
			3	0	1	23.32	-	23.17	
			3	1	1	23.28	-	23.16	
			3	3	1	23.41	-	23.18	
		6	0	2	22.37	-	22.28		
		3	QPSK	1	0	0	24.16	-	24.11
				1	8	0	24.20	-	24.09
				1	14	0	24.27	-	24.08
				8	0	1	23.26	-	23.18
	8			4	1	23.26	-	23.15	
	8			7	1	23.20	-	23.15	
	15		0	1	23.32	-	23.23		
	16QAM		1	0	1	23.19	-	23.29	
			1	8	1	23.31	-	23.01	
			1	14	1	23.13	-	22.89	
			8	0	2	22.43	-	22.15	
			8	4	2	22.37	-	22.18	
			8	7	2	22.40	-	22.17	
	15		0	2	22.39	-	22.19		
	5		QPSK	1	0	0	24.36	-	24.21
				1	12	0	24.31	-	24.22
				1	24	0	24.27	-	24.24
				12	0	1	23.28	-	23.22
		12		7	1	23.28	-	23.25	
		12		13	1	23.27	-	23.21	
		25	0	1	23.31	-	23.25		
		16QAM	1	0	1	23.33	-	23.09	
			1	12	1	23.29	-	23.09	
			1	24	1	23.24	-	23.06	
			12	0	2	22.18	-	22.05	
			12	7	2	22.15	-	22.06	
			12	13	2	22.12	-	22.04	
		25	0	2	22.29	-	22.15		

Test Band	Bandwidth (MHz)	Test mode	RB size	RB offset	MPR	Maximum power		
						Frequency (MHz)		
						Low	Middle	High
LTE Band 26	10	QPSK	1	0	0	-	24.36	-
			1	25	0	-	24.29	-
			1	49	0	-	24.24	-
			25	0	1	-	23.32	-
			25	12	1	-	23.28	-
			25	25	1	-	23.24	-
			50	0	1	-	23.35	-
		16QAM	1	0	1	-	23.21	-
			1	25	1	-	23.21	-
			1	49	1	-	23.04	-
			25	0	2	-	22.27	-
			25	12	2	-	22.27	-
			25	25	2	-	22.26	-
			50	0	2	-	22.33	-
			15	QPSK	1	0	0	-
	1	36			0	-	24.24	-
	1	74			0	-	24.21	-
	36	0			1	-	23.40	-
	36	18			1	-	23.39	-
	36	37			1	-	23.33	-
	75	0			1	-	23.41	-
	16QAM	1		0	1	-	23.33	-
		1		36	1	-	23.25	-
		1		74	1	-	23.15	-
		36		0	2	-	22.31	-
		36		18	2	-	22.26	-
		36		37	2	-	22.24	-
		75		0	2	-	22.38	-

Straddle channel

Test Band	Bandwidth (MHz)	Test mode	RB size	RB offset	MPR	Maximum power
LTE Band 26	1.4	QPSK	1	0	0	24.11
			1	3	0	24.13
			1	5	0	24.08
			3	0	0	24.07
			3	1	0	24.09
			3	3	0	24.16
		6	0	1	23.20	
		16QAM	1	0	1	23.42
			1	3	1	23.34
			1	5	1	23.42
			3	0	1	23.05
			3	1	1	23.09
	3		3	1	23.05	
	6	0	2	22.15		
	3	QPSK	1	0	0	24.09
			1	8	0	24.16
			1	14	0	24.08
			8	0	1	23.17
			8	4	1	23.16
			8	7	1	23.18
		15	0	1	23.25	
		16QAM	1	0	1	23.35
			1	8	1	23.08
			1	14	1	22.95
			8	0	2	22.15
			8	4	2	22.18
	8		7	2	22.18	
	15	0	2	22.22		
	5	QPSK	1	0	0	24.32
			1	12	0	24.25
			1	24	0	24.34
			12	0	1	23.27
			12	7	1	23.31
			12	13	1	23.27
		25	0	1	23.32	
		16QAM	1	0	1	23.15
1			12	1	23.18	
1			24	1	23.14	
12			0	2	22.14	
12			7	2	22.12	
12	13		2	22.12		
25	0	2	22.24			

Test Band	Bandwidth (MHz)	Test mode	RB size	RB offset	MPR	Maximum power
LTE Band 26	10	QPSK	1	0	0	24.24
			1	25	0	24.14
			1	49	0	24.08
			25	0	1	23.17
			25	12	1	23.17
			25	25	1	23.16
			50	0	1	23.26
		16QAM	1	0	1	23.11
			1	25	1	23.14
			1	49	1	22.99
			25	0	2	22.11
			25	12	2	22.15
			25	25	2	22.20
			50	0	2	22.22
	15	QPSK	1	0	0	24.32
			1	36	0	24.21
			1	74	0	24.16
			36	0	1	23.29
			36	18	1	23.29
			36	37	1	23.26
			75	0	1	23.24
		16QAM	1	0	1	23.35
			1	36	1	23.25
			1	74	1	23.19
	36	0	2	22.27		
	36	18	2	22.27		
	36	37	2	22.21		
	75	0	2	22.25		

7.2. 99% Occupied Bandwidth & 26 dB Bandwidth

Test setup

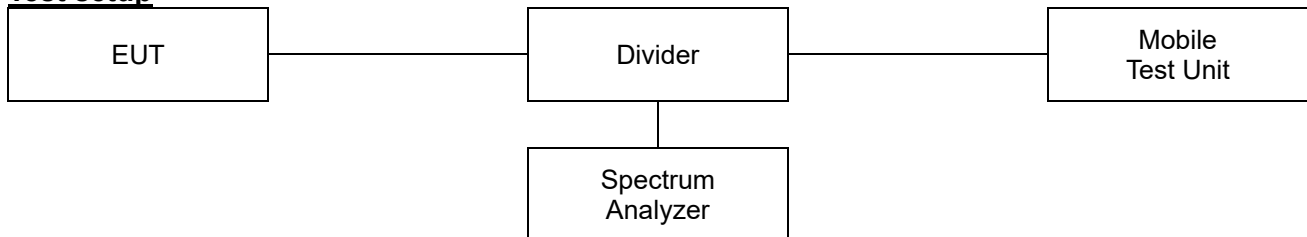

Limit

According to §2.1049, the occupied bandwidth, that is the frequency bandwidth such that, below its lower and above its upper frequency limits, the mean powers radiated are each equal to 0.5 percent of the total mean power radiated by a given emission shall be measured.

Test procedure

971168 D01 v03r01 – Section 4.2 and 4.3
ANSI C63.26-2015 – Section 5.4.3 and 5.4.4

Test settings

◆ 26dB Bandwidth

- c) The spectrum analyzer center frequency is set to the nominal EUT channel center frequency. The span range for the spectrum analyzer shall be wide enough to see sufficient roll off of the signal to make the measurement.
- d) The nominal RBW shall be in the range of 1% to 5% of the anticipated OBW, and the VBW shall be set $\geq 3 \times$ RBW.
- e) Set the reference level of the instrument as required to prevent the signal amplitude from exceeding the maximum spectrum analyzer input mixer level for linear operation. See guidance provided in 4.2.3.
- d) The dynamic range of the spectrum analyzer at the selected RBW shall be more than 10 dB below the target “-X dB” requirement, i.e., if the requirement calls for measuring the -26 dB OBW, the spectrum analyzer noise floor at the selected RBW shall be at least 36 dB below the reference level.
- e) Set spectrum analyzer detection mode to peak, and the trace mode to max hold.
- f) Determine the reference value by either of the following:
 - 1) Set the EUT to transmit a modulated signal. Allow the trace to stabilize. Set the spectrum analyzer marker to the highest level of the displayed trace (this is the reference value).
 - 2) Set the EUT to transmit an unmodulated carrier. Set the spectrum analyzer marker to the level of the carrier.
- g) Determine the “-X dB amplitude” as equal to (Reference Value - X). Alternatively, this calculation can be performed on the spectrum analyzer using the delta-marker measurement function.
- h) If the reference value was determined using an unmodulated carrier, turn the EUT modulation on, then either clear the existing trace or start a new trace on the spectrum analyzer and allow the new trace to stabilize. Otherwise the trace from step f) shall be used

for step i).

- i) Place two markers, one at the lowest and the other at the highest frequency of the envelope of the spectral display such that each marker is at or slightly below the “-X dB amplitude” determined in step f). If a marker is below this “-X dB amplitude” value it should be as close as possible to this value. The OBW is the positive frequency difference between the two markers.
- j) The spectral envelope can cross the “-X dB amplitude” at multiple points. The lowest or highest frequency shall be selected as the frequencies that are the farthest away from the center frequency at which the spectral envelope crosses the “-X dB amplitude.”
- j) The OBW shall be reported by providing plot(s) of the measuring instrument display, to include markers depicting the relevant frequency and amplitude information (e.g., marker table). The frequency and amplitude axis and scale shall be clearly labeled. Tabular data may be reported in addition to the plot(s).

◆ 99% Occupied Bandwidth

- a) The spectrum analyzer center frequency is set to the nominal EUT channel center frequency. The frequency span for the spectrum analyzer shall be set wide enough to capture all modulation products including the emission skirts (typically a span of $1.5 \times \text{OBW}$ is sufficient).
- b) The nominal IF filter 3 dB bandwidth (RBW) shall be in the range of 1% to 5% of the anticipated OBW, and the VBW shall be set $\geq 3 \times \text{RBW}$.
- c) Set the reference level of the instrument as required to prevent the signal amplitude from exceeding the maximum spectrum analyzer input mixer level for linear operation. See guidance provided in 4.2.3.
- d) Set the detection mode to peak, and the trace mode to max-hold.
- e) If the instrument does not have a 99% OBW function, recover the trace data points and sum directly in linear power terms. Place the recovered amplitude data points, beginning at the lowest frequency, in a running sum until 0.5% of the total is reached. Record that frequency as the lower OBW frequency. Repeat the process until 99.5% of the total is reached and record that frequency as the upper OBW frequency. The 99% power OBW can be determined by computing the difference these two frequencies.
- f) The OBW shall be reported and plot(s) of the measuring instrument display shall be provided with the test report. The frequency and amplitude axis and scale shall be clearly labeled. Tabular data can be reported in addition to the plot(s).

Notes:

1. The EUT was setup to maximum output power as its lowest and highest channel with all bandwidth, Modulation.

Test results

Test Band	Bandwidth (MHz)	Frequency (MHz)	Test mode	26dB bandwidth (MHz)	99 % bandwidth (MHz)
LTE Band 26	1.4	814.7	QPSK	1.31	1.10
			16QAM	1.33	1.10
		823.3	QPSK	1.34	1.10
			16QAM	1.35	1.10
	3	815.5	QPSK	3.09	2.70
			16QAM	3.09	2.71
		822.5	QPSK	3.12	2.71
			16QAM	3.11	2.70
	5	816.5	QPSK	5.35	4.55
			16QAM	5.27	4.53
		821.5	QPSK	5.32	4.55
			16QAM	5.26	4.52
	10	819.0	QPSK	10.34	9.02
			16QAM	10.19	8.99
	15	821.5	QPSK	14.91	13.45
			16QAM	15.21	13.49

Straddle channel

Test Band	Bandwidth (MHz)	Frequency (MHz)	Test mode	26dB bandwidth (MHz)	99 % bandwidth (MHz)
LTE Band 26	1.4	824	QPSK	1.31	1.10
			16QAM	1.34	1.10
	3	824	QPSK	3.09	2.71
			16QAM	3.10	2.70
	5	824	QPSK	5.40	4.52
			16QAM	5.36	4.53
	10	824	QPSK	10.34	8.99
			16QAM	10.24	8.99
	15	824	QPSK	15.21	13.49
			16QAM	14.95	13.41

26dB Bandwidth

Test mode: LTE Band 26

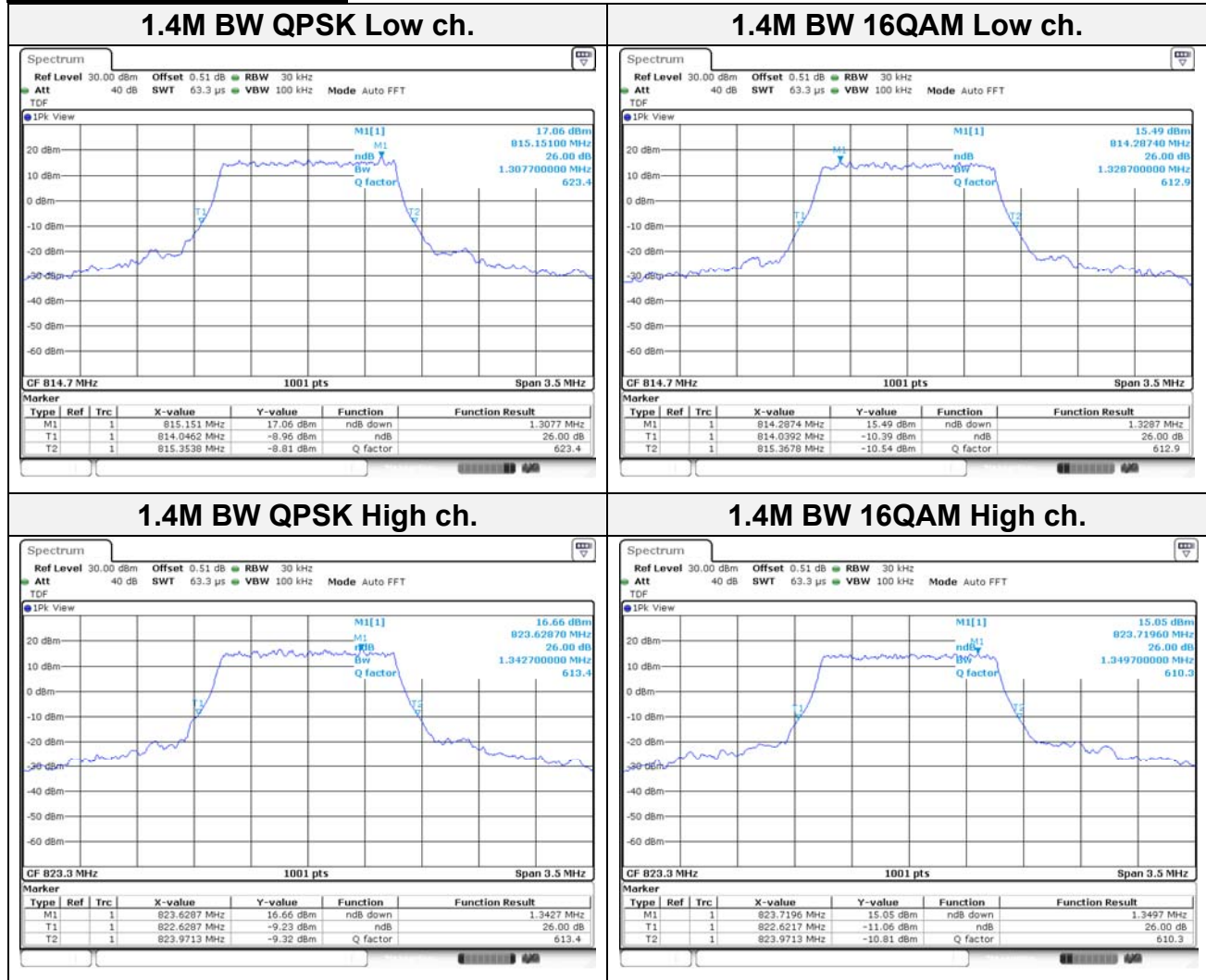

3M BW QPSK Low ch.

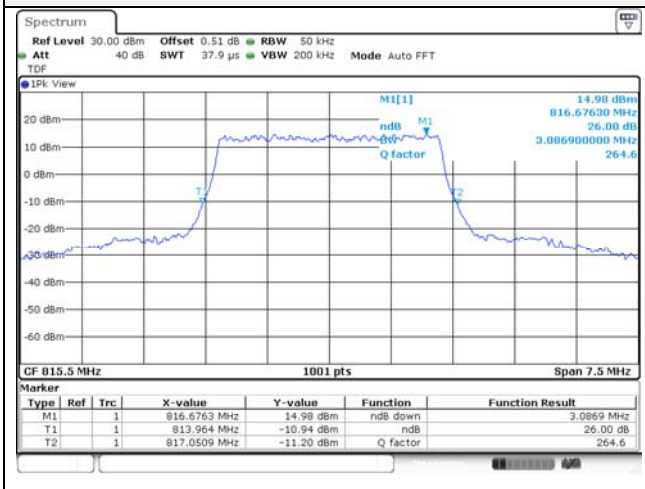

3M BW 16QAM Low ch.

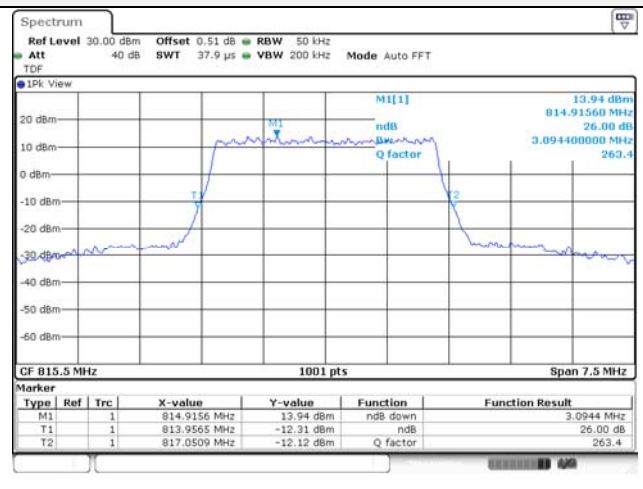

3M BW QPSK High ch.

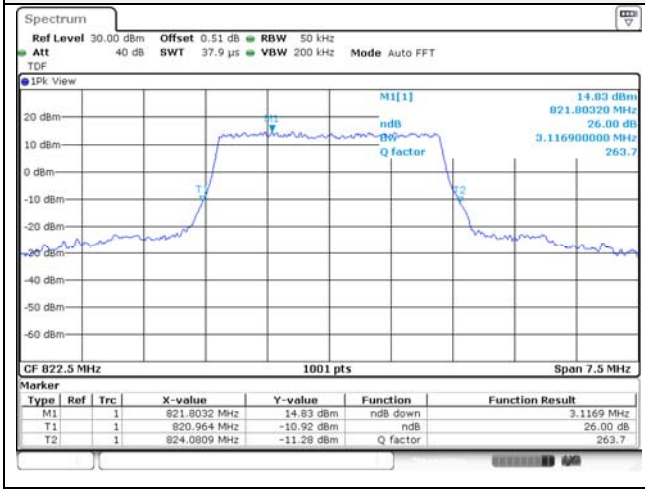

3M BW 16QAM High ch.

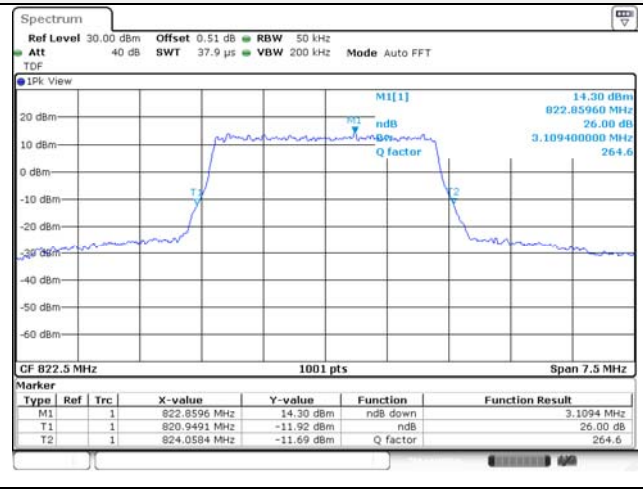

5M BW QPSK Low ch.

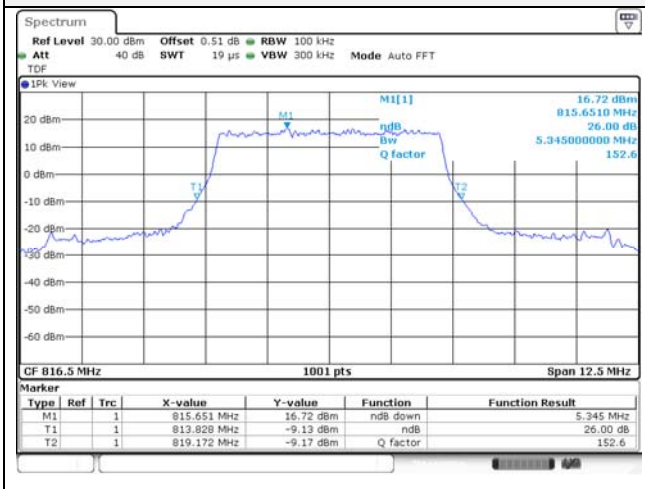

5M BW 16QAM Low ch.

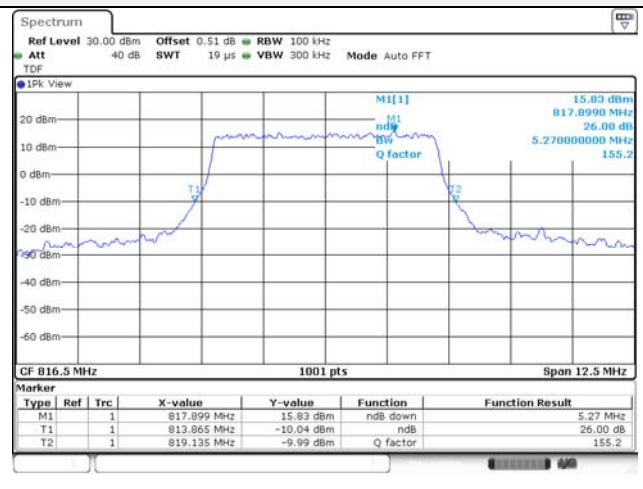

5M BW QPSK High ch.

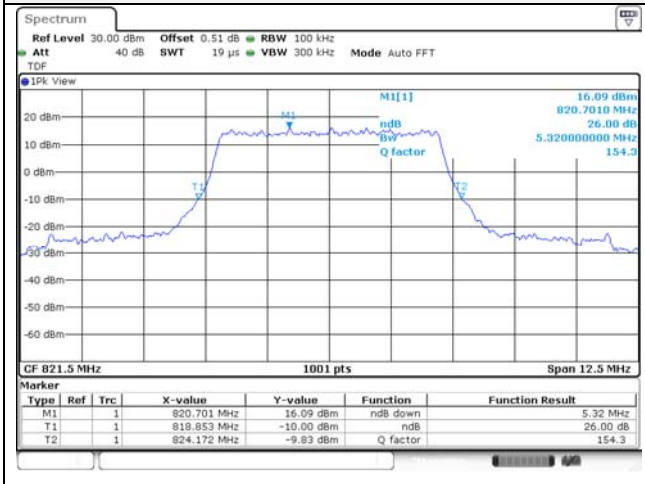

5M BW 16QAM High ch.

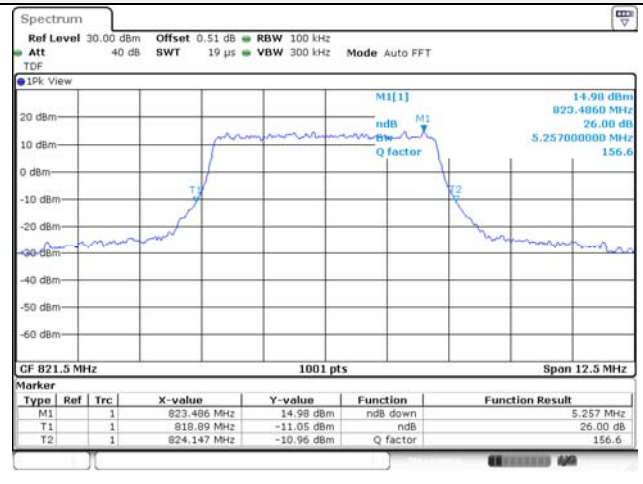

10M BW QPSK Mid ch.

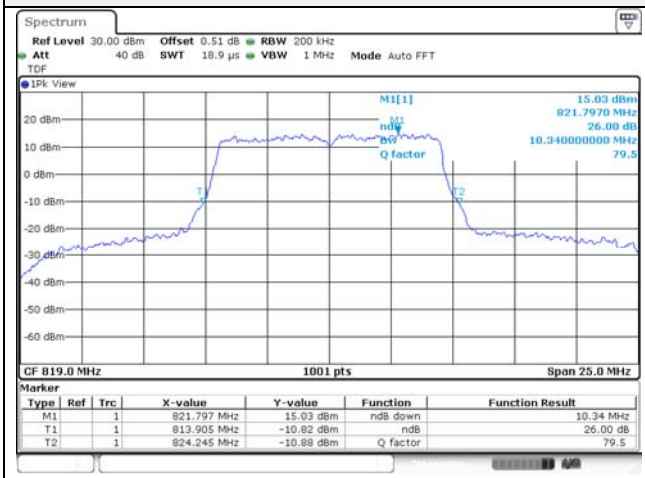

10M BW 16QAM Mid ch.

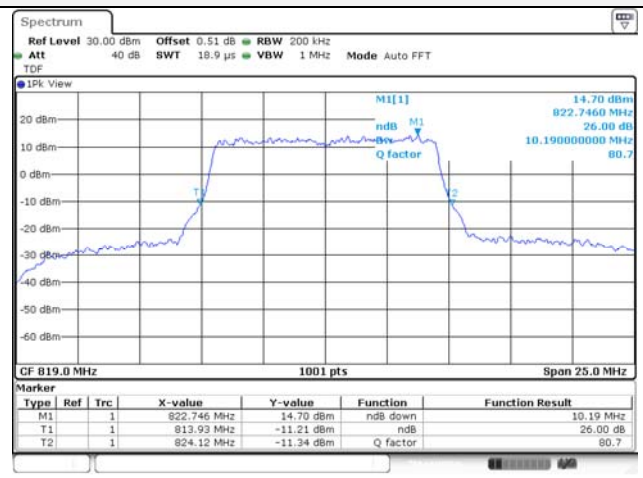

15M BW QPSK Mid ch.

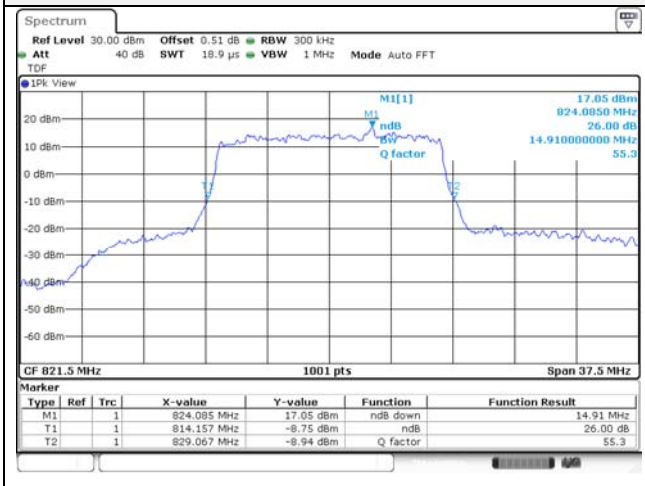

15M BW 16QAM Mid ch.

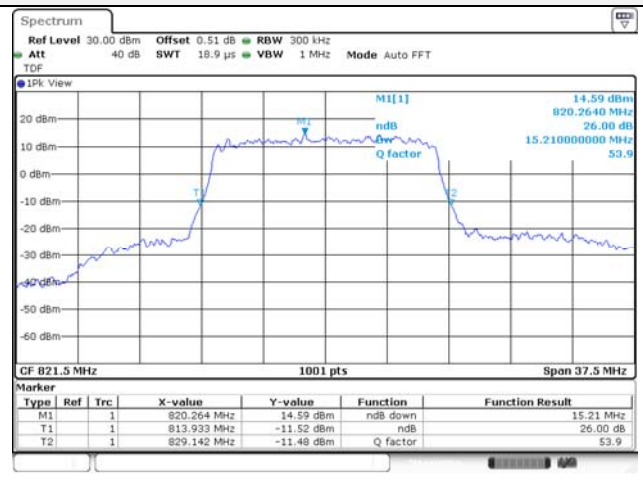

Straddle channel

1.4M BW QPSK

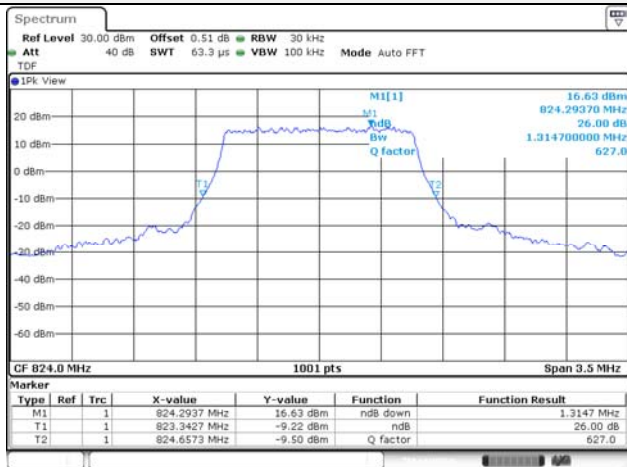

1.4M BW 16QAM

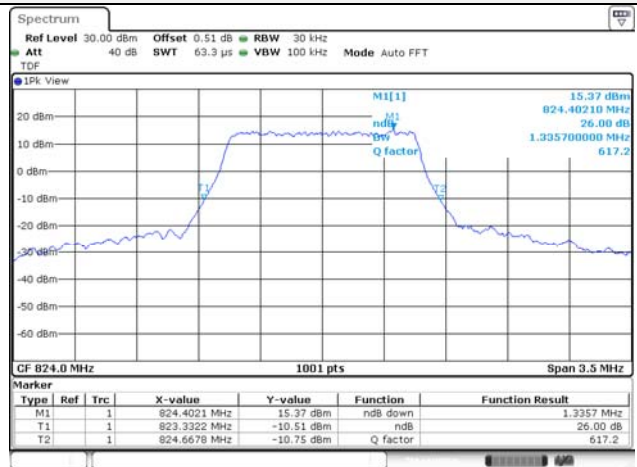

3M BW QPSK

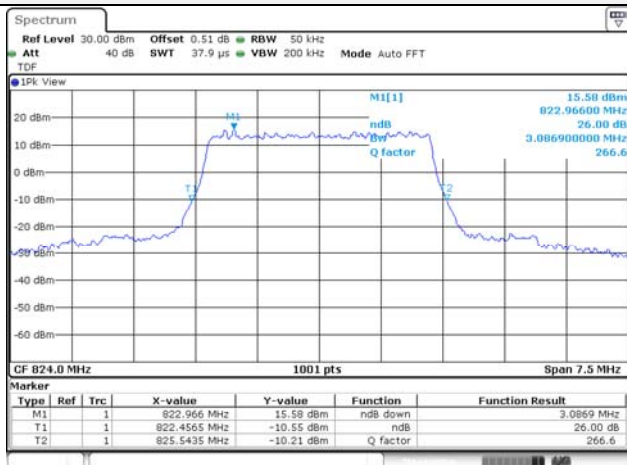

3M BW 16QAM

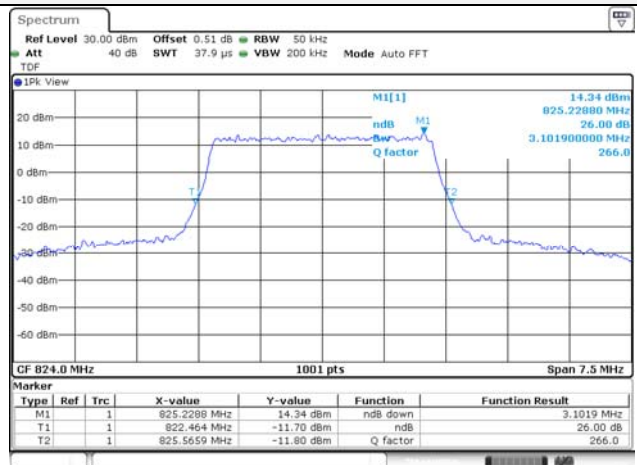

5M BW QPSK

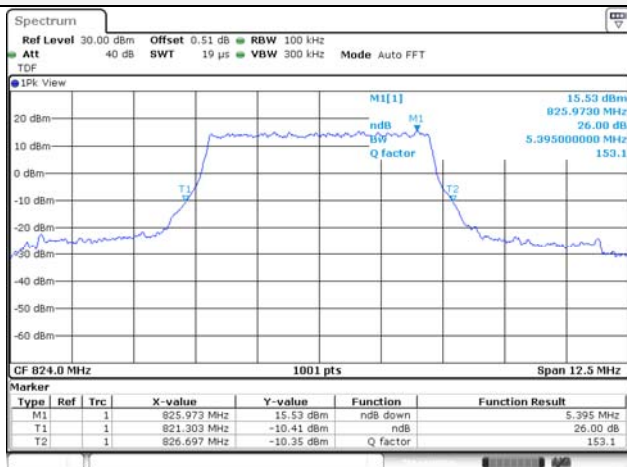

5M BW 16QAM

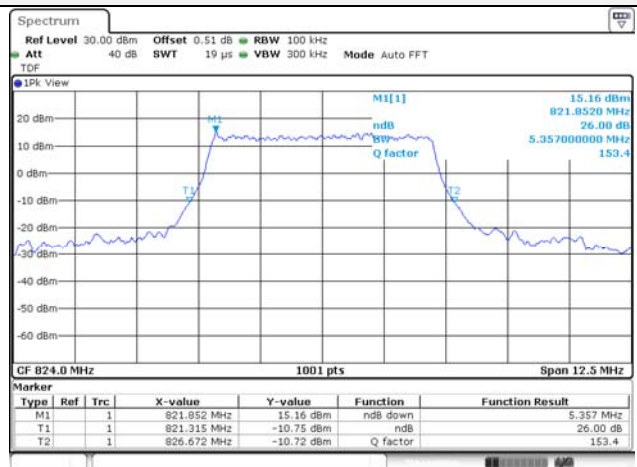

10M BW QPSK

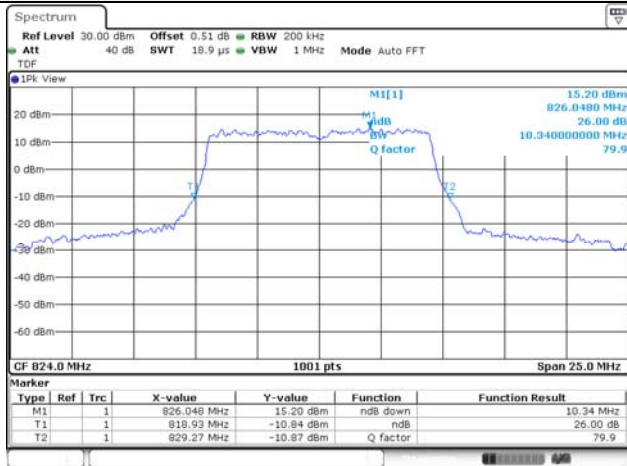

10M BW 16QAM

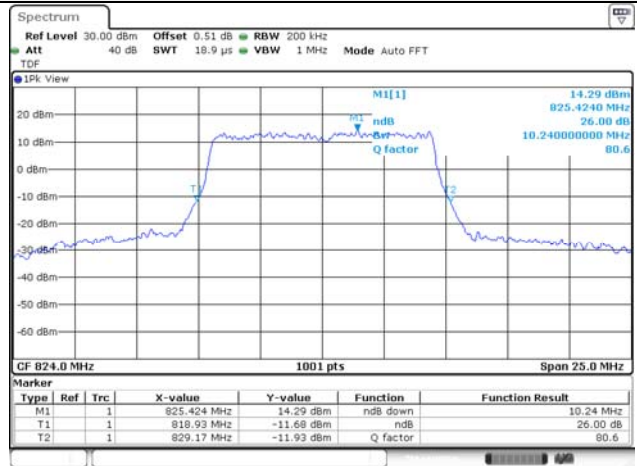

15M BW QPSK

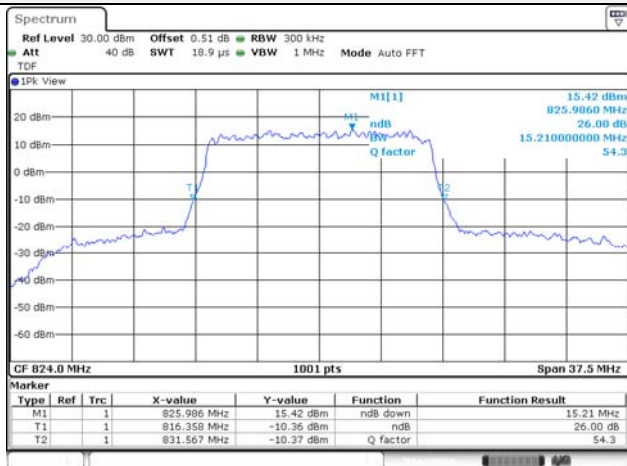

15M BW 16QAM

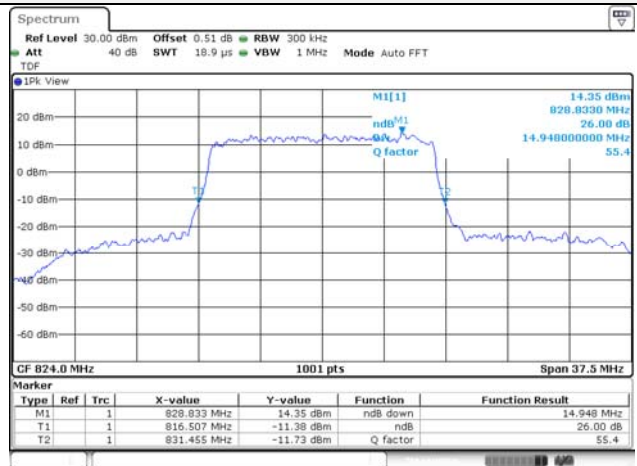

99% Occupied Bandwidth
Test mode: LTE Band 26

1.4M BW QPSK Low ch.

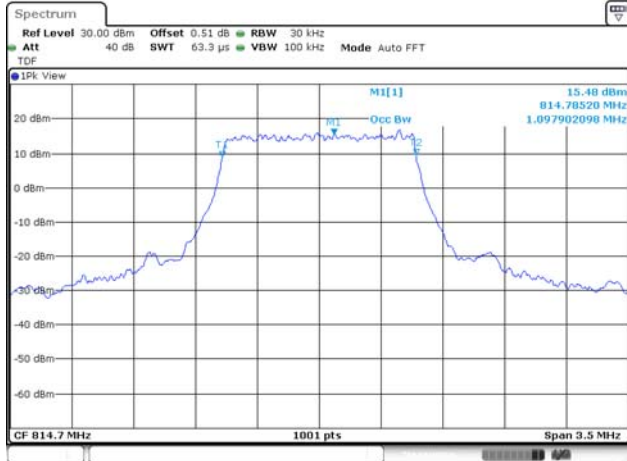

1.4M BW 16QAM Low ch.



1.4M BW QPSK High ch.



1.4M BW 16QAM High ch.



3M BW QPSK Low ch.

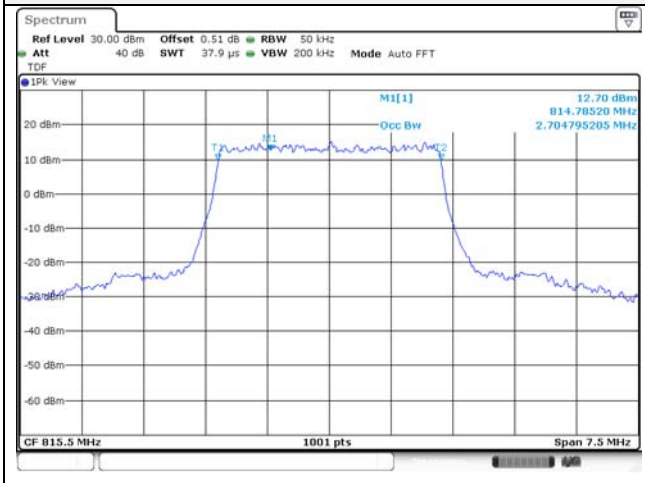

3M BW 16QAM Low ch.

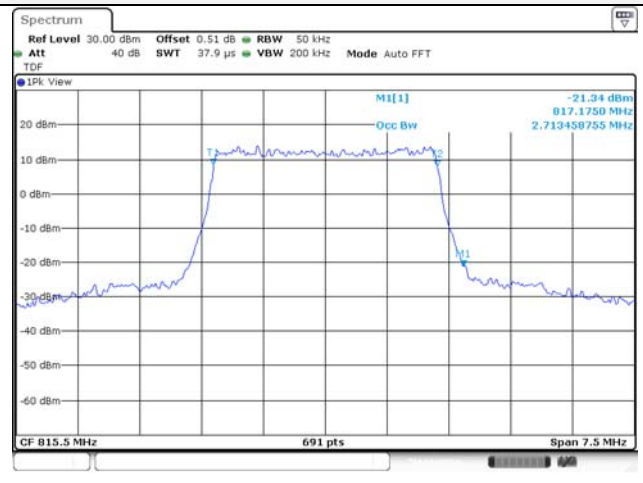

3M BW QPSK High ch.

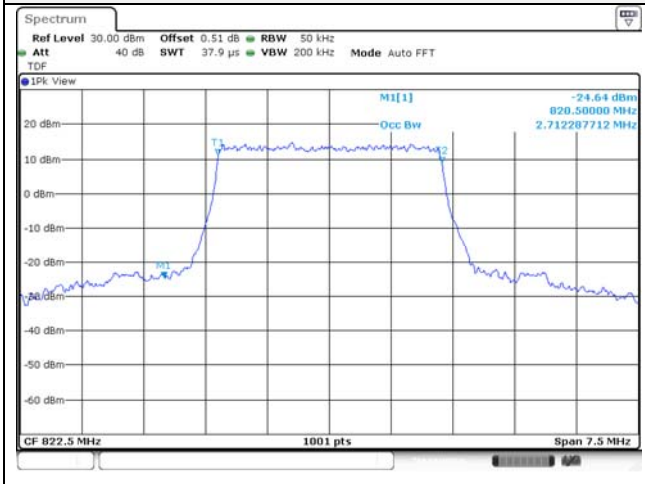

3M BW 16QAM High ch.

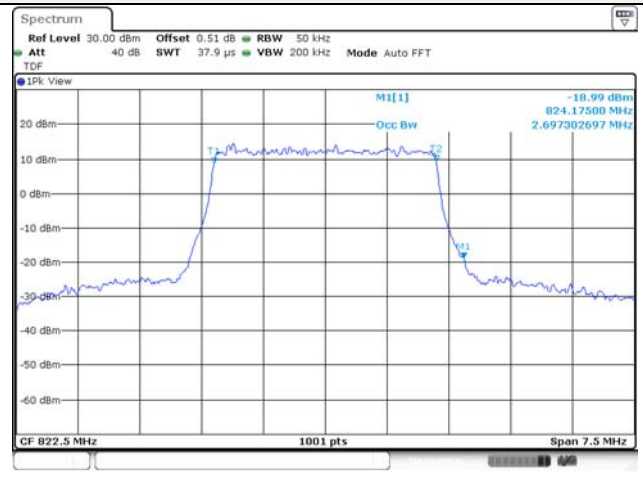

5M BW QPSK Low ch.

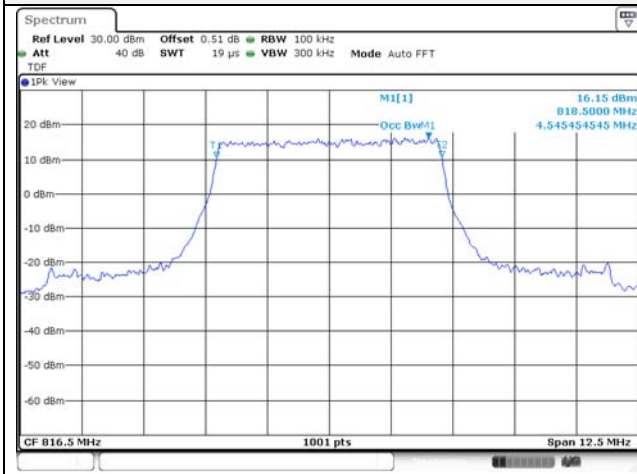

5M BW 16QAM Low ch.

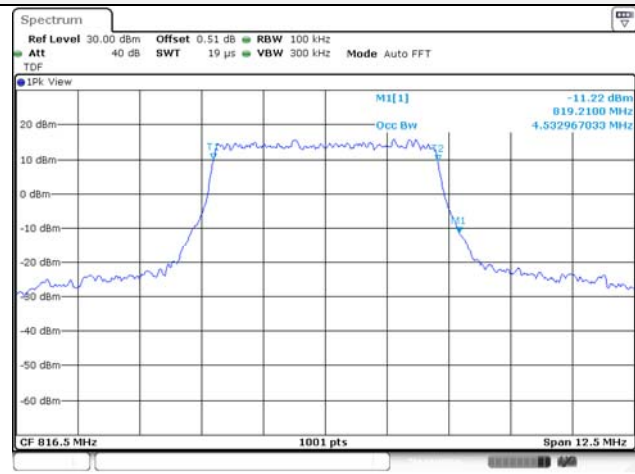

5M BW QPSK High ch.

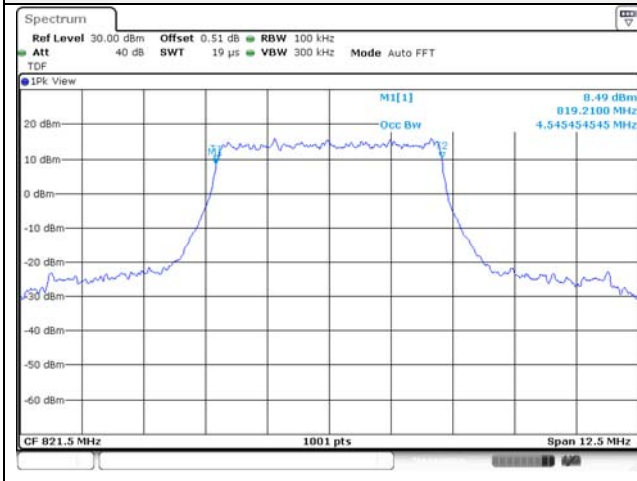

5M BW 16QAM High ch.

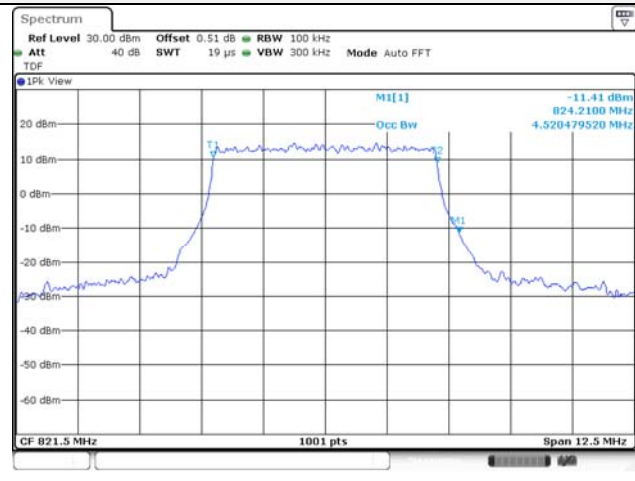

10M BW QPSK Mid ch.

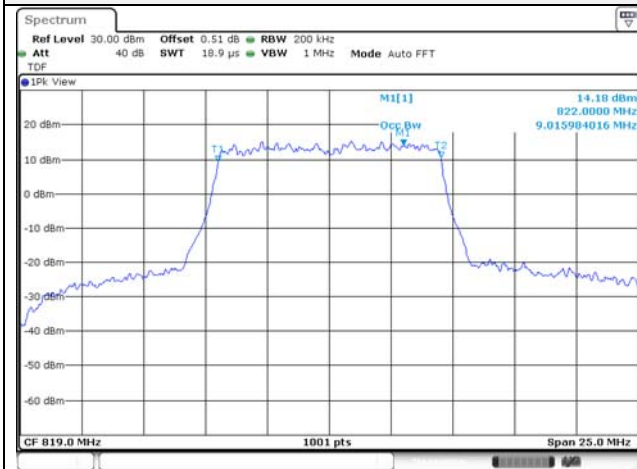

10M BW 16QAM Mid ch.

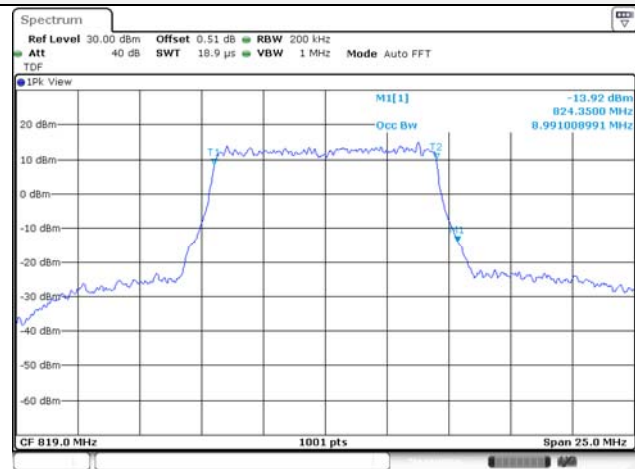

15M BW QPSK Mid ch.

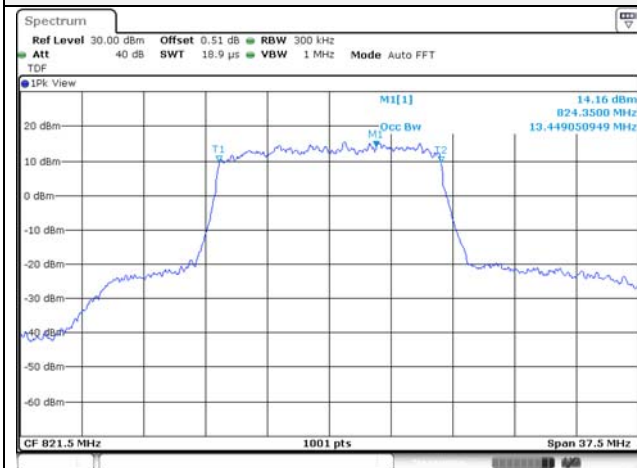

15M BW 16QAM Mid ch.



Straddle channel

1.4M BW QPSK



1.4M BW 16QAM



3M BW QPSK

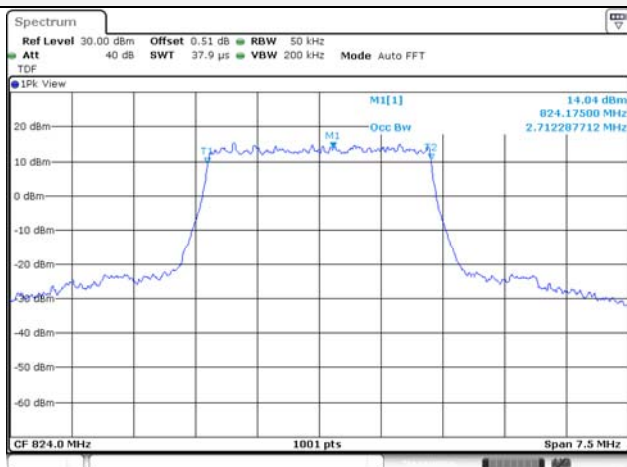

3M BW 16QAM

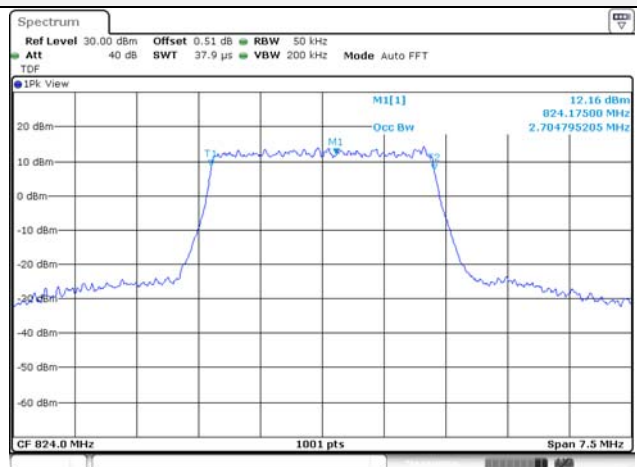

5M BW QPSK

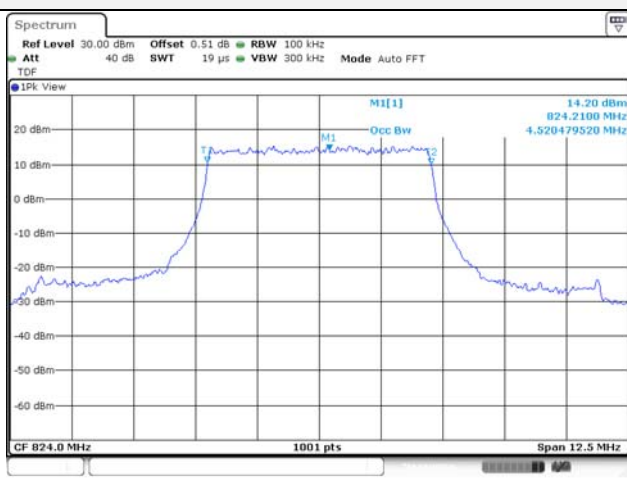

5M BW 16QAM

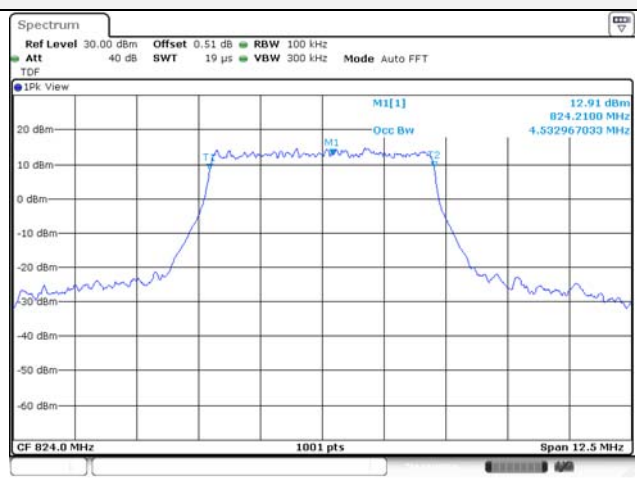

10M BW QPSK

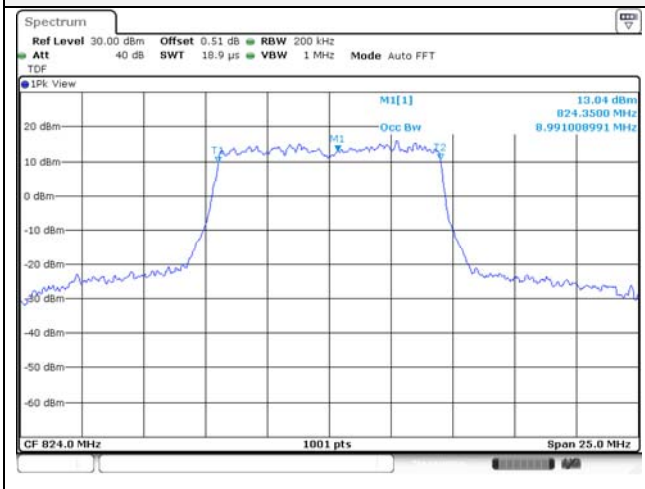

10M BW 16QAM

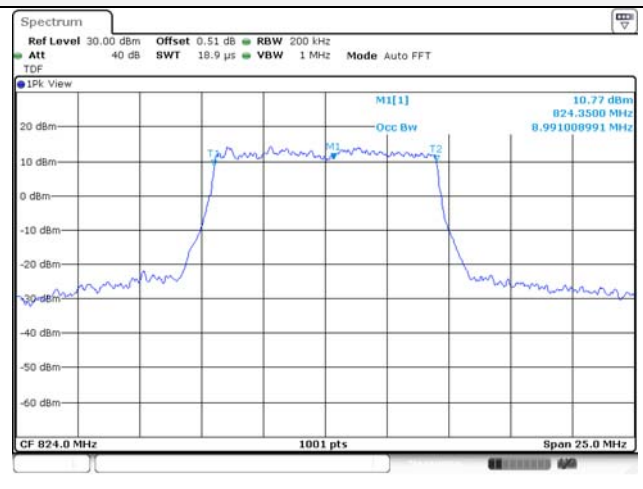

15M BW QPSK

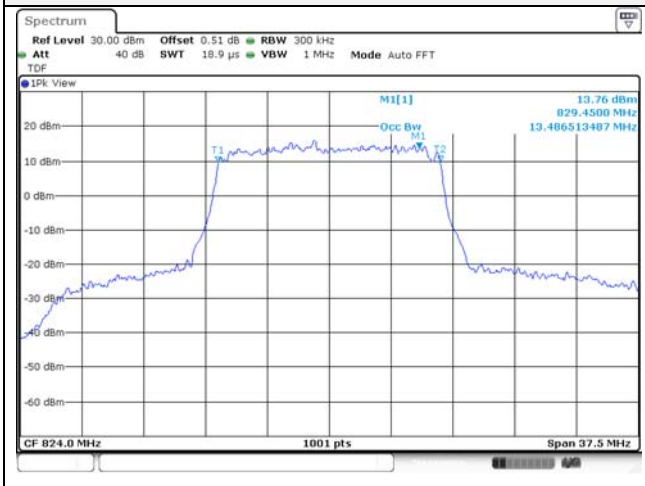

15M BW 16QAM

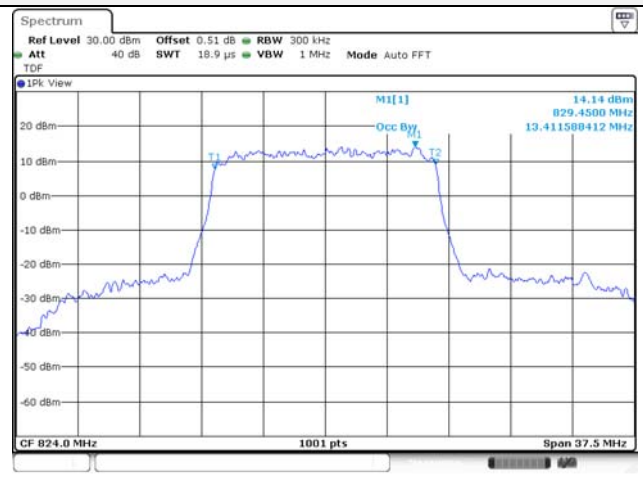

7.3. Spurious Emissions at Antenna Terminal

Test setup

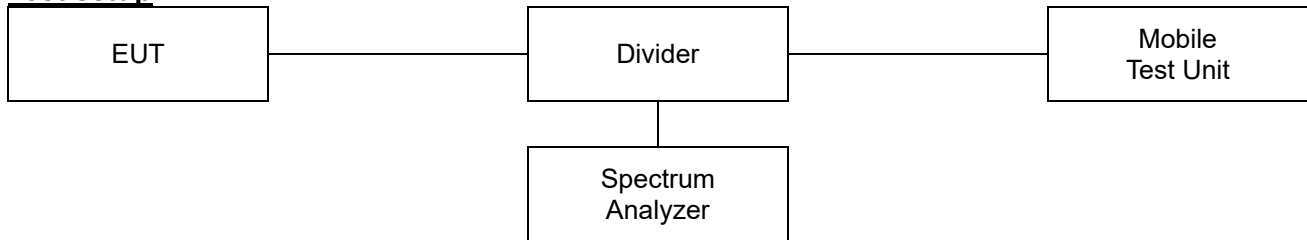

Limit

According to §90.691(a), Out-of-band emission requirement shall apply only to the “outer” channels included in an EA license and to spectrum adjacent to interior channels used by incumbent licensees. The emission limits are as follows:

(1) For any frequency removed from the EA licensee’s frequency block by up to and including 37.5 kHz, the power of any emission shall be attenuated below the transmitter power (P) in watts by at least $116 \log_{10}(f/6.1)$ decibels or $50 + 10\log_{10}(P)$ decibels or 80 decibels, whichever is the lesser attenuation, where f is the frequency removed from the center of the outer channel in the block in kilohertz where f is greater than 12.5 kHz.

(2) For any frequency removed from the EA licensee’s frequency block greater than 37.5 kHz, the power of any emission shall be attenuated below the transmitter power (P) in watts by at least $43 + 10\log_{10}(P)$ decibels or 80 decibels, whichever is the lesser attenuation, where f is the frequency removed from the center of the outer channel in the block in kilohertz and where f is greater than 37.5 kHz.

Test procedure

971168 D01 v03r01 - Section 6
ANSI 63.26-2015 – Section 5.7

Test settings

- 1) Start frequency was set to 30 MHz and stop frequency was set to at least 10th the fundamental frequency.
- 2) Detector = RMS
- 3) Sweep time = auto couple.
- 4) Trace mode = trace average
- 5) Allow trace to fully stabilize.
- 6) Please see test notes below RBW and VBW settings.

Notes:

1. Compliance with these provisions is based on the use of measurement instrumentation employing a resolution bandwidth of 100 kHz or greater for frequencies less than 1 GHz and 1 MHz or greater for frequencies greater than 1 GHz.

The emission bandwidth is defined as the width of the signal between two points, one below the carrier center frequency and one above the carrier center frequency, outside of which all emissions are attenuated at least 26 dB below the transmitter power.

Test results

Test mode: LTE Band 26

1.4M BW QPSK Low ch.

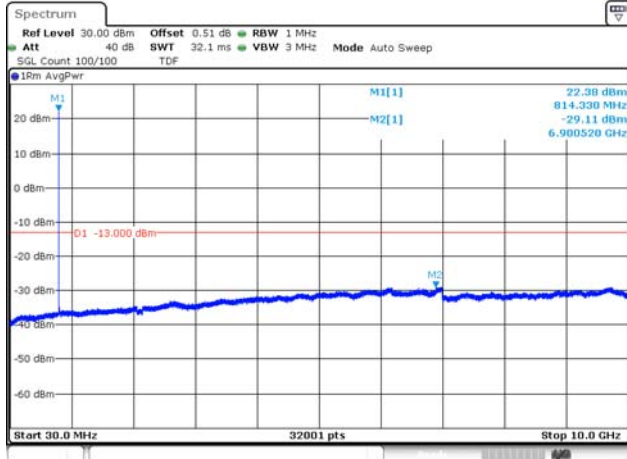

1.4M BW 16QAM Low ch.

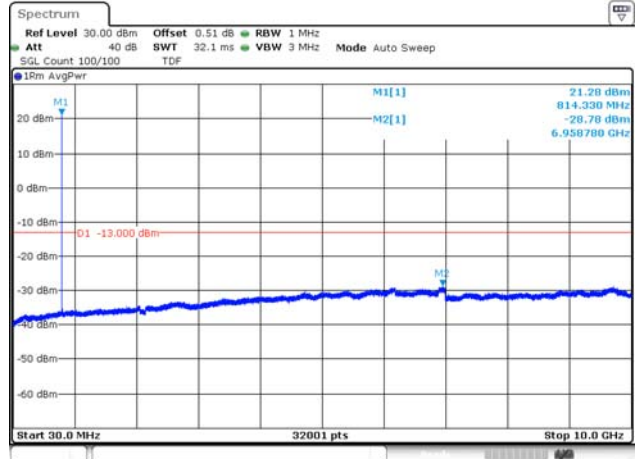

1.4M BW QPSK High ch.

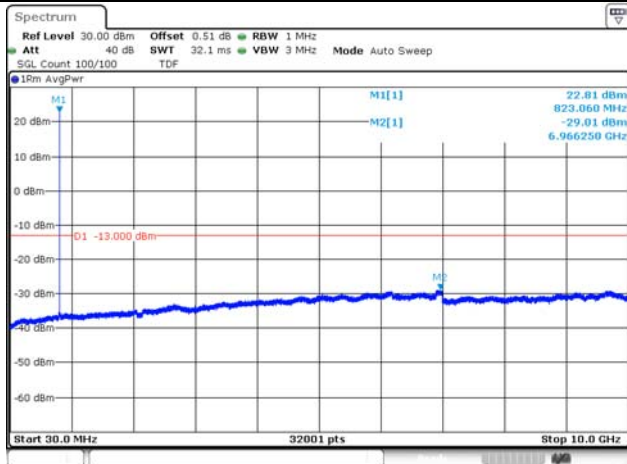

1.4M BW 16QAM High ch.

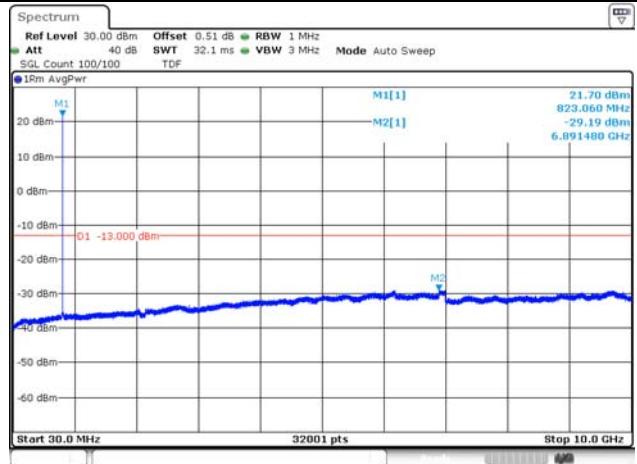

3M BW QPSK Low ch.

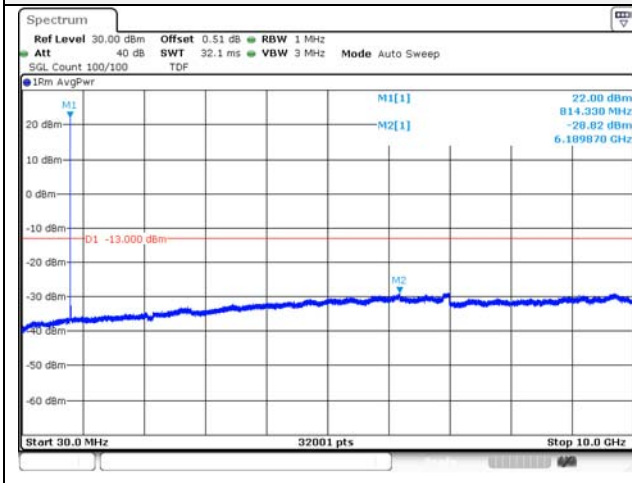

3M BW 16QAM Low ch.

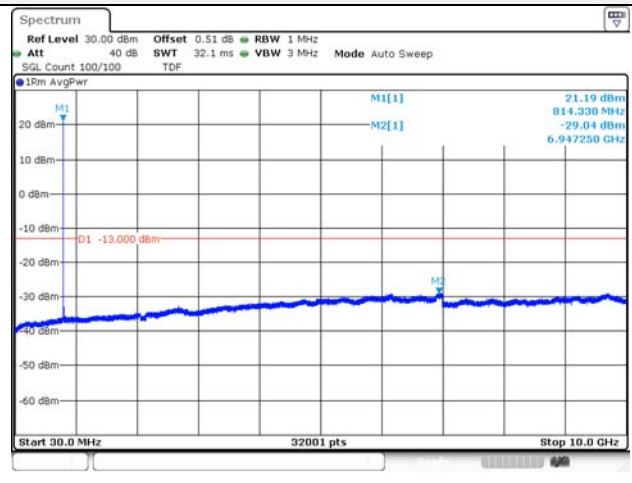

3M BW QPSK High ch.

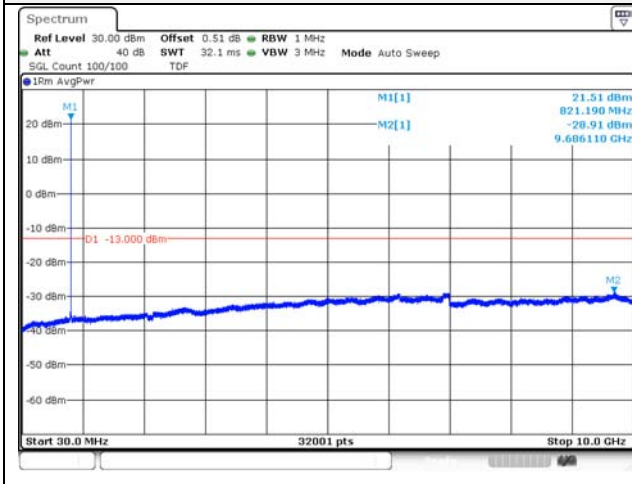

3M BW 16QAM High ch.

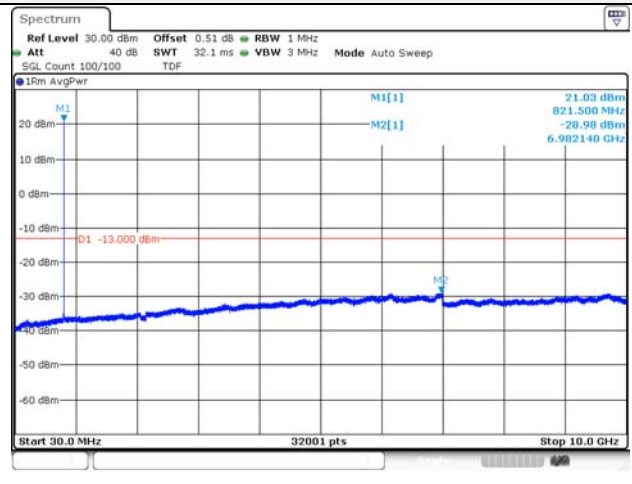

5M BW QPSK Low ch.

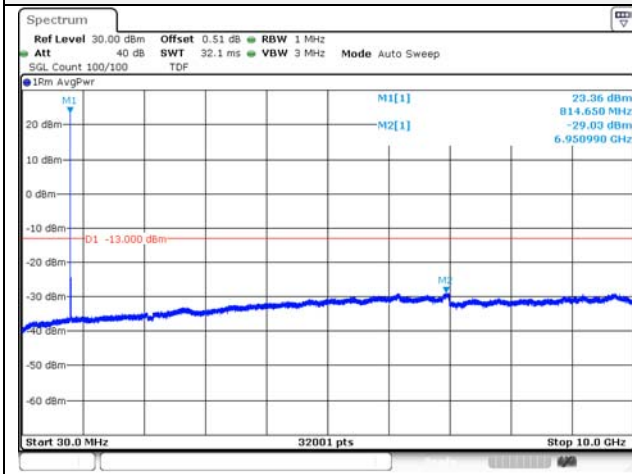

5M BW 16QAM Low ch.

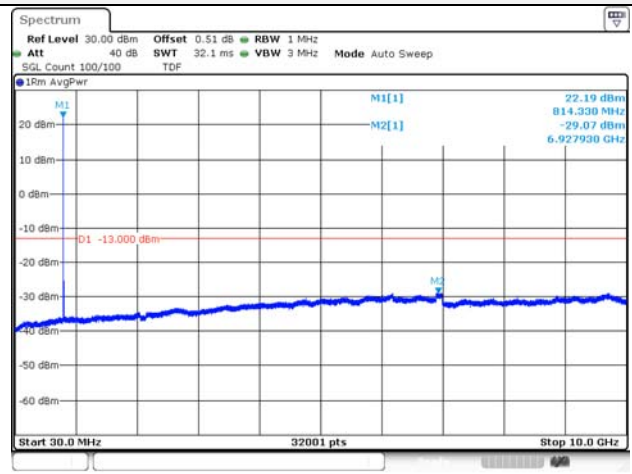

5M BW QPSK High ch.

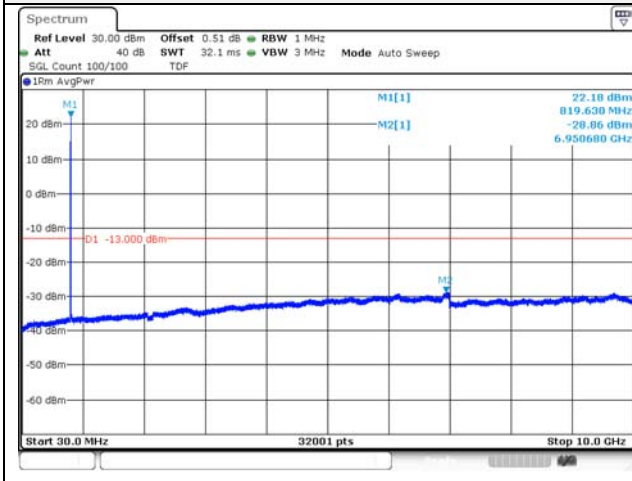

5M BW 16QAM High ch.

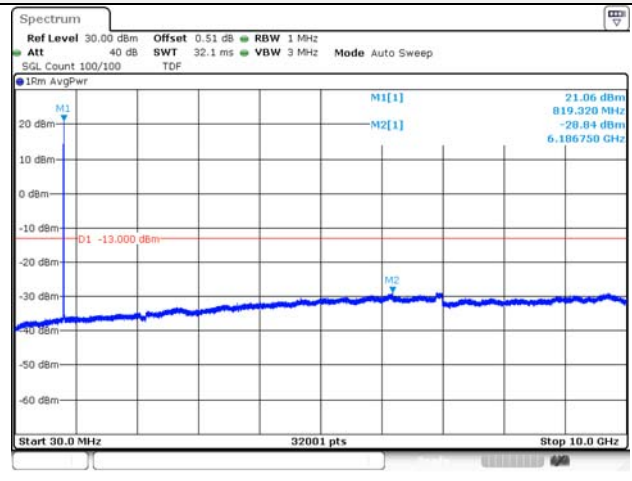

10M BW QPSK Mid ch.

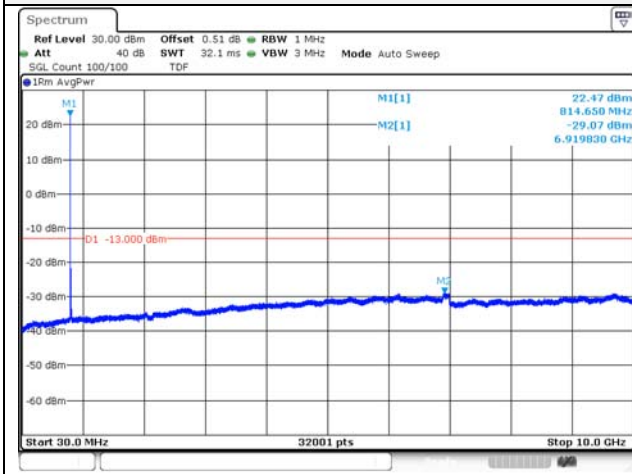

10M BW 16QAM Mid ch.

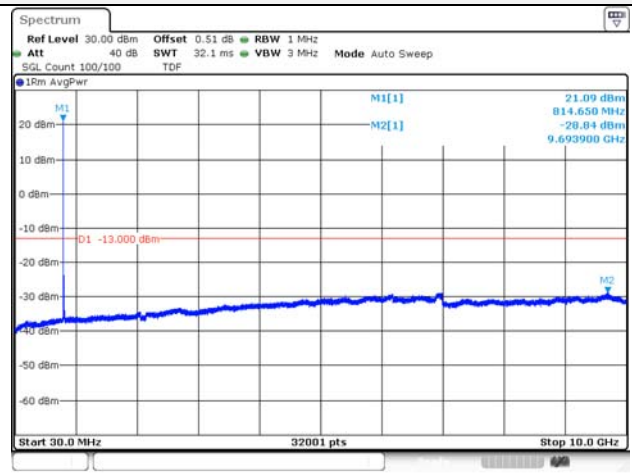

15M BW QPSK Mid ch.

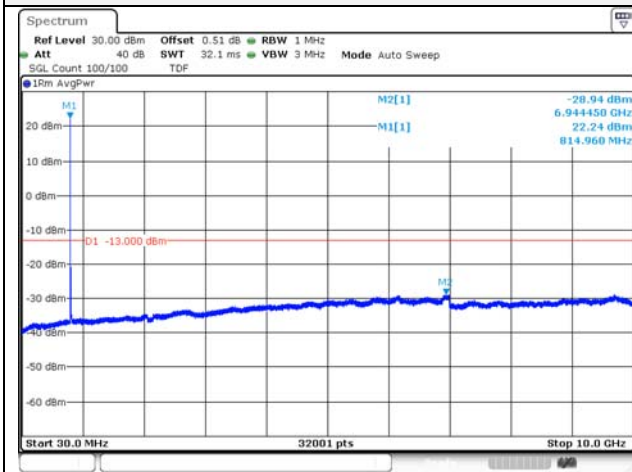

15M BW 16QAM Mid ch.

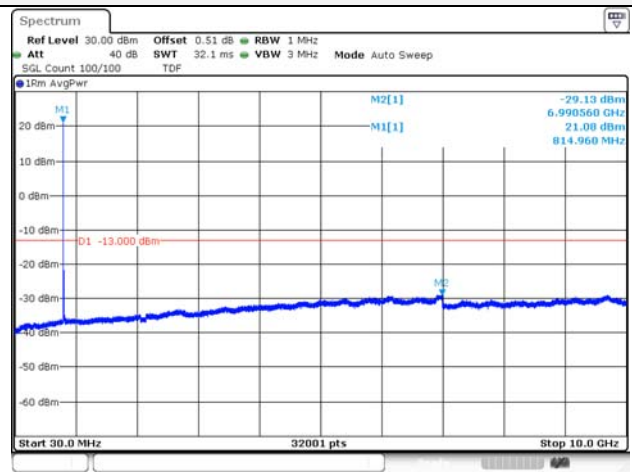

7.4. Band Edge Emissions at Antenna Terminal

Test setup

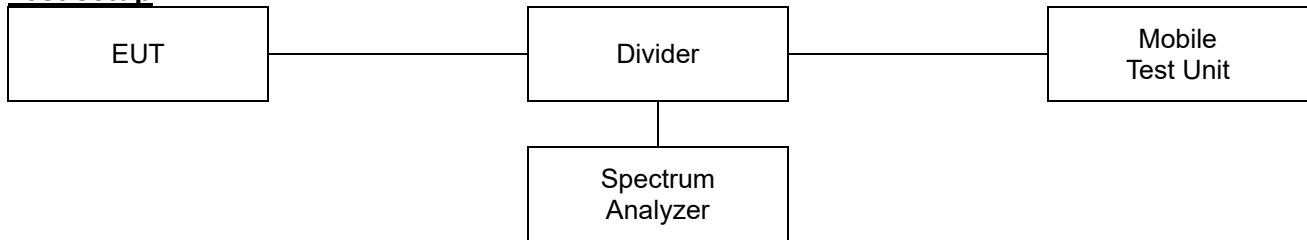

Limit

According to §90.691(a), Out-of-band emission requirement shall apply only to the “outer” channels included in an EA license and to spectrum adjacent to interior channels used by incumbent licensees. The emission limits are as follows:

(1) For any frequency removed from the EA licensee’s frequency block by up to and including 37.5 kHz, the power of any emission shall be attenuated below the transmitter power (P) in watts by at least $116 \log_{10}(f/6.1)$ decibels or $50 + 10\log_{10}(P)$ decibels or 80 decibels, whichever is the lesser attenuation, where f is the frequency removed from the center of the outer channel in the block in kilohertz where f is greater than 12.5 kHz.

(2) For any frequency removed from the EA licensee’s frequency block greater than 37.5 kHz, the power of any emission shall be attenuated below the transmitter power (P) in watts by at least $43 + 10\log_{10}(P)$ decibels or 80 decibels, whichever is the lesser attenuation, where f is the frequency removed from the center of the outer channel in the block in kilohertz and where f is greater than 37.5 kHz.

Test procedure

971168 D01 v03r01 - Section 6

ANSI C63.26-2015 – Section 5.7

Test settings

- 1) Start frequency was set to 30 MHz and stop frequency was set to at least 10th the fundamental frequency.
- 2) Span was set large enough so as to capture all out of band emissions near the band edge.
- 3) Set the RBW > 1% of the emission bandwidth.
- 4) Set the VBW ≥ 3 x RBW.
- 5) Set the number of sweep points ≥ 2 x Span/RBW
- 6) Detector = RMS
- 7) Trace mode = trace average
- 8) Sweep time should be auto for peak detection. For RMS detection the sweep time should be set as follows:
 - a) If the device can be configured to transmit continuously (duty cycle ≥ 98%), set the (sweep time) > (number of points in sweep) x (symbol period) (e.g., by a factor of 10 x symbol period x number of points) Increasing the sweep time (i.e., slowing the sweep speed) will allow for averaging over multiple symbols.
 - b) If the device cannot transmit continuously (duty cycle < 98%), a gated sweep

shall be used when possible (i.e., gate triggered such that the analyzer only sweeps when the device is transmitting at full power), set the sweep time $>$ (number of points in sweep) \times (symbol period) but the sweep time shall always be maintained at a value that is less than or equal to the minimum transmission time

- c) If the device cannot be configured to transmit continuously (duty cycle $>$ 98%), and a free-running sweep must be used, set the sweep time so that the averaging is performed over multiple on/off cycles by setting the sweep time $>$ (number of points in sweep) \times (transmitter period) (i.e., the transmit on-time + the off-time). The spectrum analyzer readings shall subsequently be corrected by $[10 \log (1/\text{duty cycle})]$. This assumes that the transmission period and duty cycle is relatively constant (duty cycle variation $\leq \pm 2\%$).
- d) If the device cannot be configured to transmit continuously and a free-running sweep must be used, and if the transmissions exhibit a non-constant duty cycle (duty cycle variations $>$ $\pm 2\%$), set the sweep time so that the averaging is performed over the on-period by setting the sweep time $>$ (symbol period) \times (number of points), while also maintaining the sweep time $<$ (transmitter on-time). The trace mode shall be set to max hold, since not every display point will be averaged only over just the on-time. Thus, multiple sweeps (e.g., 100) in maximum hold are necessary to ensure that the maximum power is measured.

- 9) Allow trace to fully stabilize.

Notes:

1. Compliance with these rules is based on the use of measurement instrumentation employing a resolution bandwidth of 1 MHz or greater. However, in the 1 MHz bands immediately outside and adjacent to the frequency block a resolution bandwidth of at least one percent of the emission bandwidth of the fundamental emission of the transmitter may be employed. The emission bandwidth is defined as the width of the signal between two points, one below the carrier center frequency and one above the carrier center frequency, outside of which all emissions are attenuated at least 26 dB below the transmitter power.
2. The EUT was setup to maximum output power as its lowest and highest channel with all bandwidth, modulation and RB configurations.

Test results

Test mode: LTE Band 26

1.4M BW QPSK Low ch. 1RB

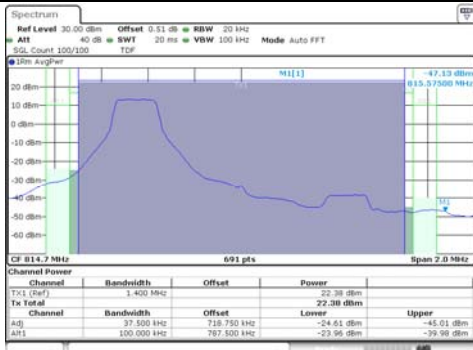

1.4M BW QPSK High ch. 1RB

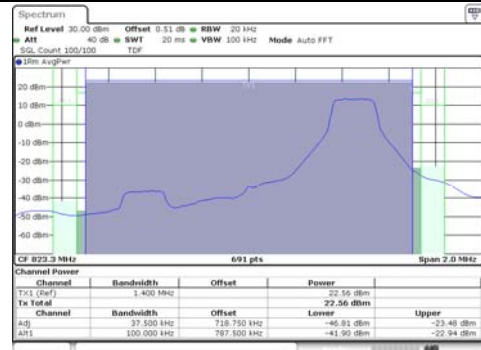

1.4M BW QPSK Low ch. FRB

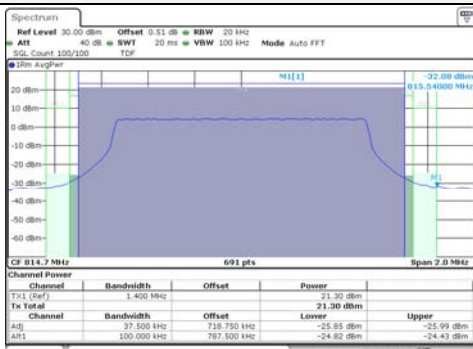

1.4M BW QPSK High ch. FRB

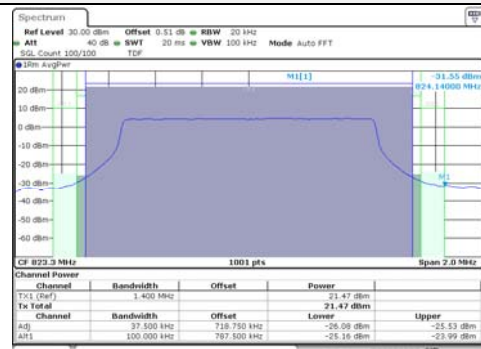

1.4M BW 16QAM Low ch. 1RB

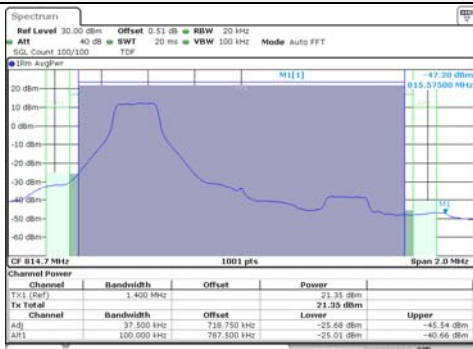

1.4M BW 16QAM High ch. 1RB

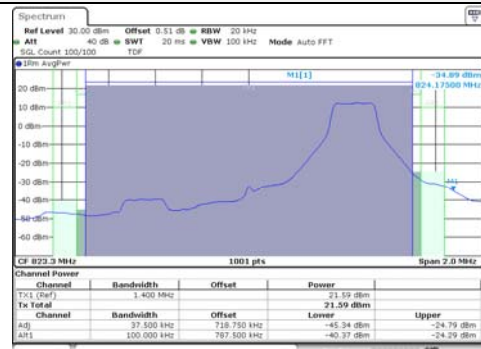

1.4M BW 16QAM Low ch. FRB

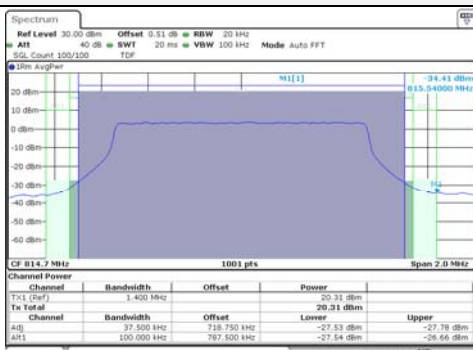

1.4M BW 16QAM High ch. FRB

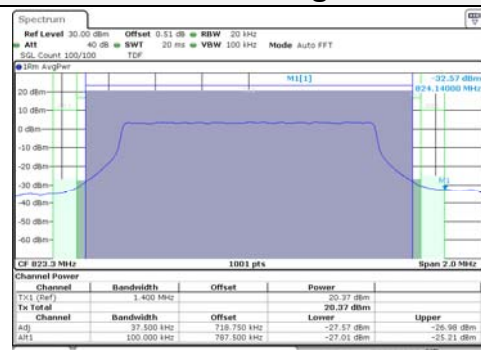

3M BW QPSK Low ch. 1RB

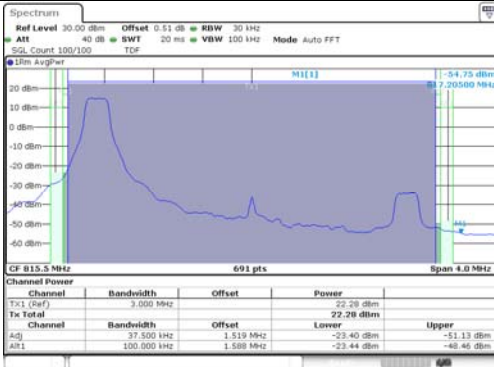

3M BW QPSK High ch. 1RB

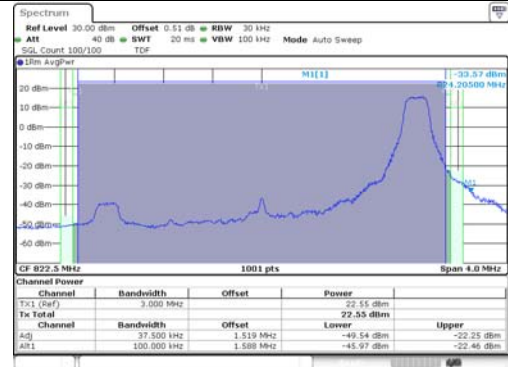

3M BW QPSK Low ch. FRB

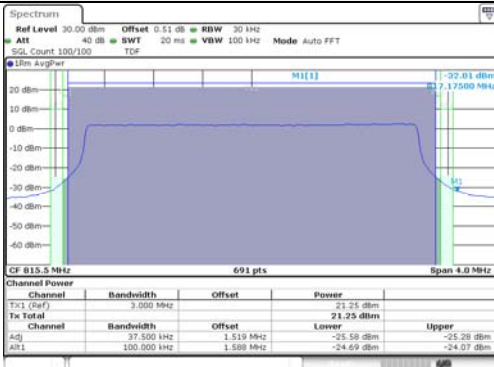

3M BW QPSK High ch. FRB

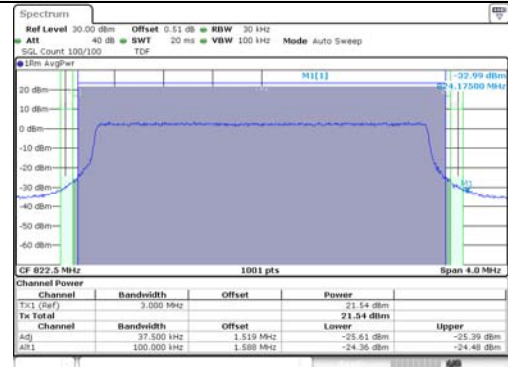

3M BW 16QAM Low ch. 1RB

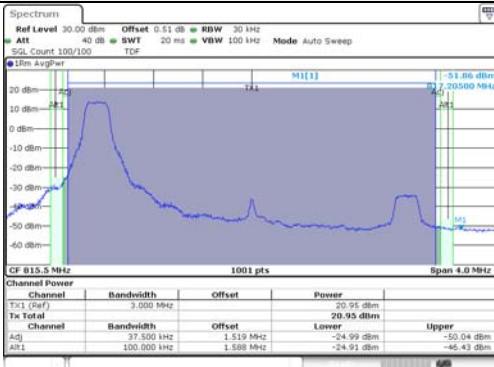

3M BW 16QAM High ch. 1RB

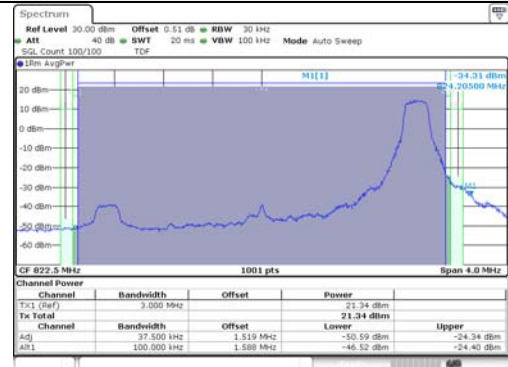

3M BW 16QAM Low ch. FRB

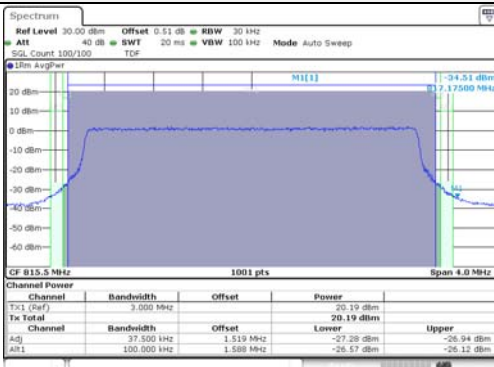

3M BW 16QAM High ch. FRB

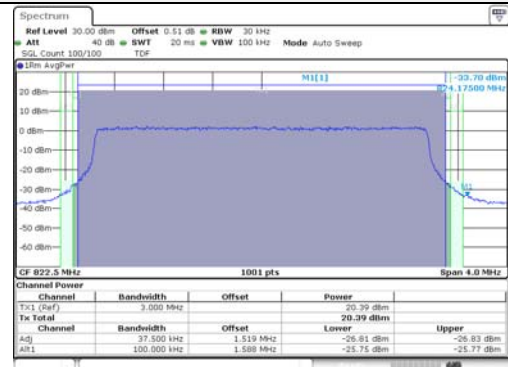

5M BW QPSK Low ch. 1RB

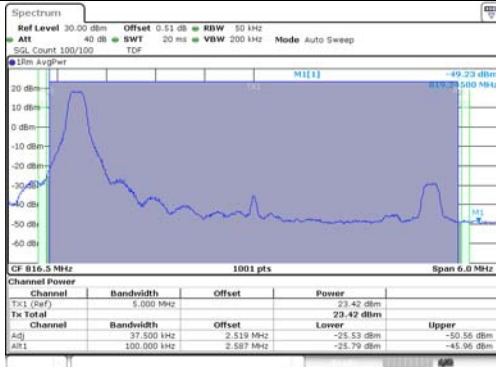

5M BW QPSK High ch. 1RB

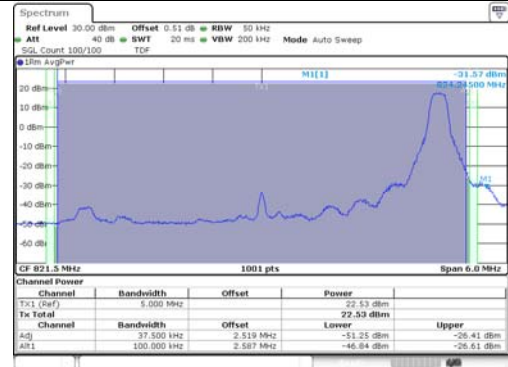

5M BW QPSK Low ch. FRB

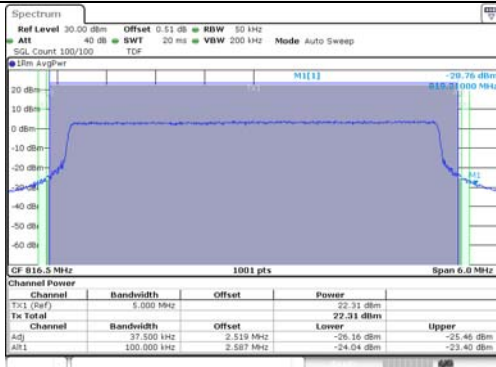

5M BW QPSK High ch. FRB

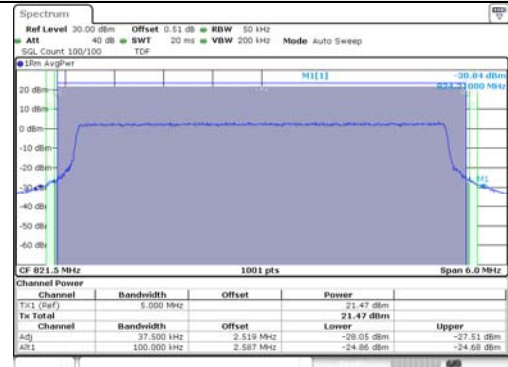

5M BW 16QAM Low ch. 1RB

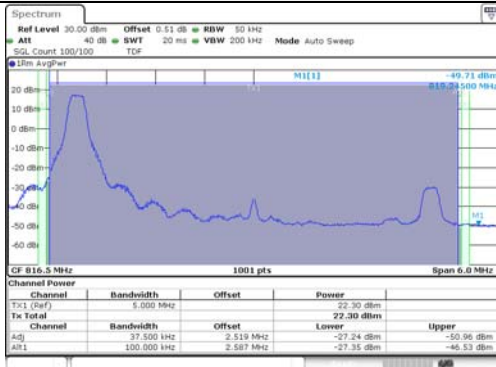

5M BW 16QAM High ch. 1RB

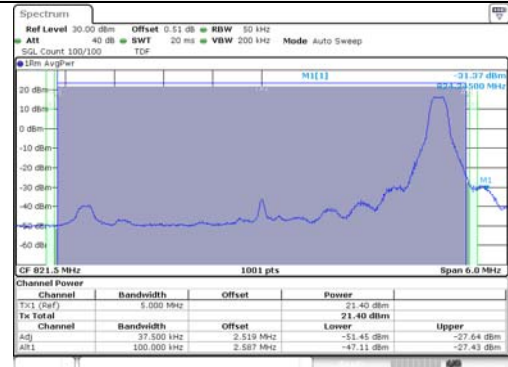

5M BW 16QAM Low ch. FRB

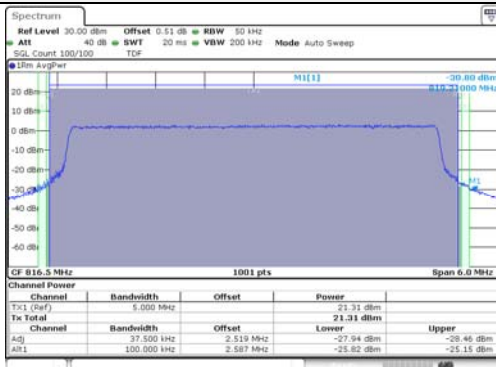

5M BW 16QAM High ch. FRB

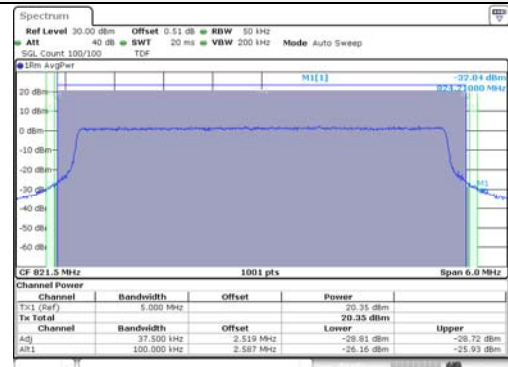

10M BW QPSK Mid ch. Lower 1RB

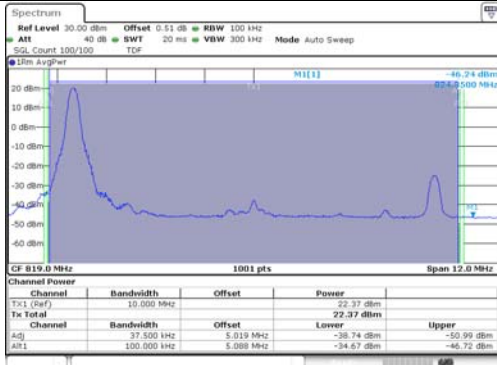

10M BW QPSK Mid ch. Upper 1RB

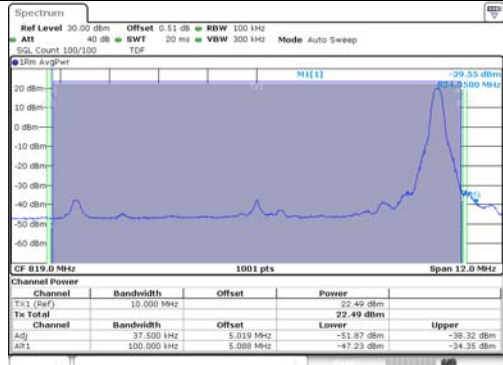

10M BW QPSK Mid ch. Lower FRB

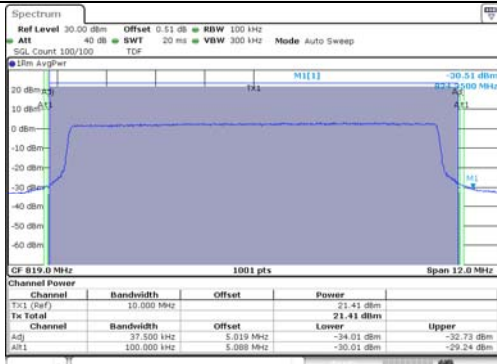

10M BW QPSK Mid ch. Upper FRB

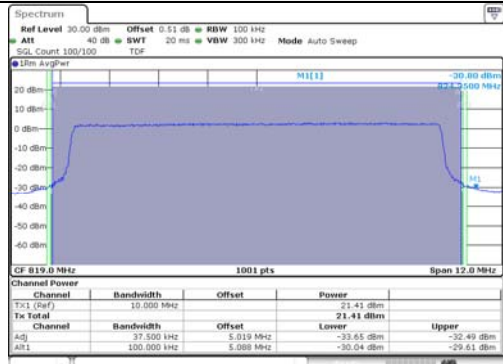

10M BW 16QAM Mid ch. Lower 1RB

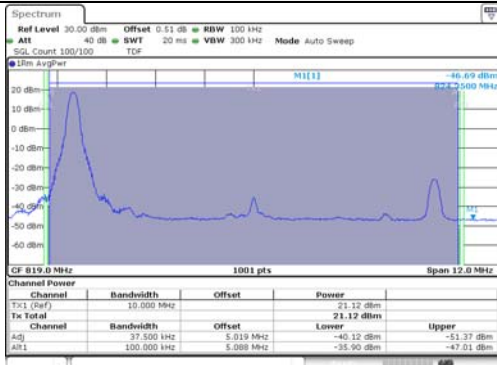

10M BW 16QAM Mid ch. Upper 1RB

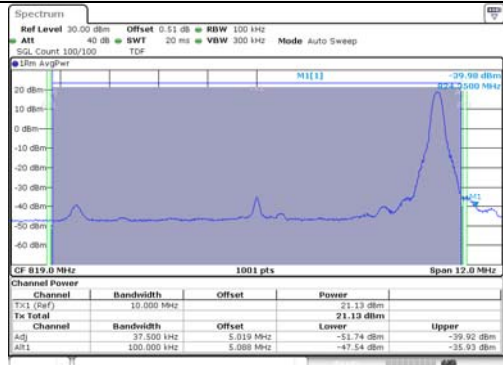

10M BW 16QAM Mid ch. Lower FRB

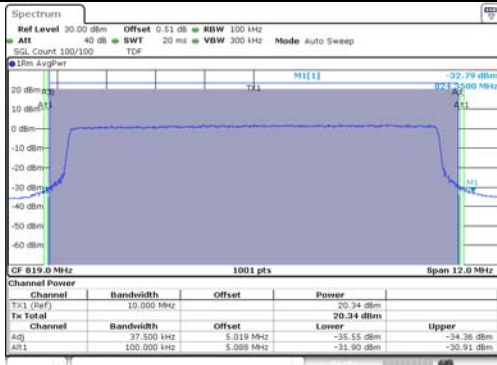

10M BW 16QAM Mid ch. Upper FRB

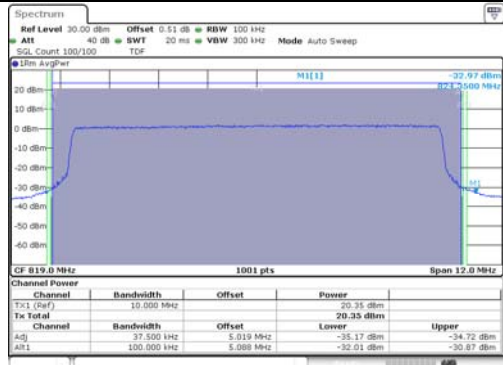

15M BW QPSK Mid ch. Lower 1RB

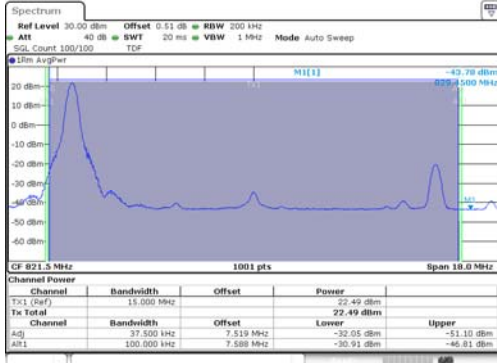

15M BW QPSK Mid ch. Upper 1RB

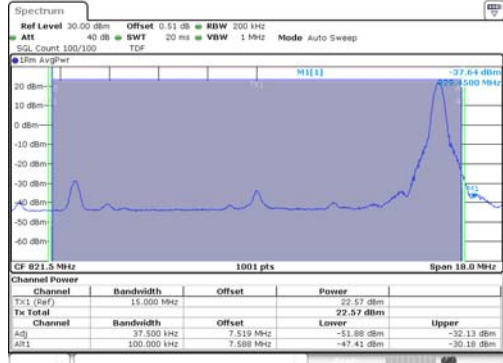

15M BW QPSK Mid ch. Lower FRB

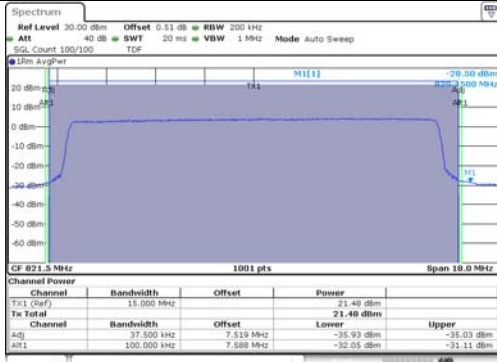

15M BW QPSK Mid ch. Upper FRB

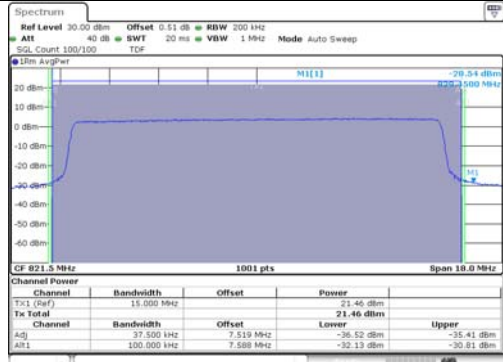

15M BW 16QAM Mid ch. Lower 1RB

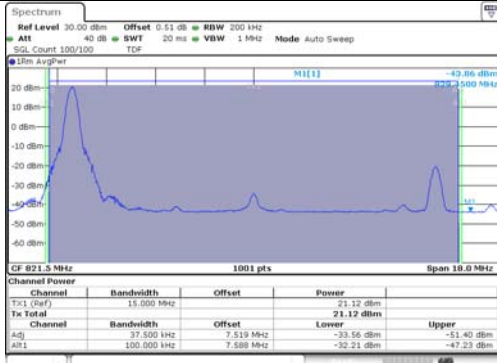

15M BW 16QAM Mid ch. Upper 1RB

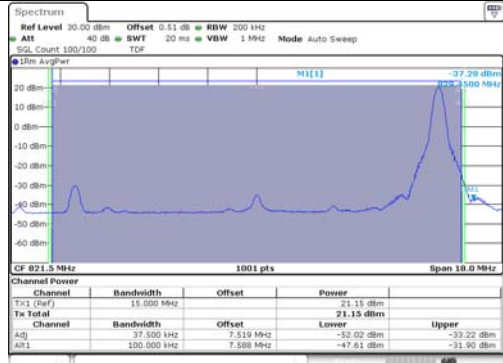

15M BW 16QAM Mid ch. Lower FRB

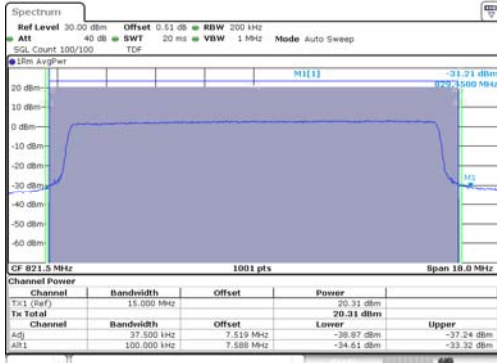

15M BW 16QAM Mid ch. Upper FRB

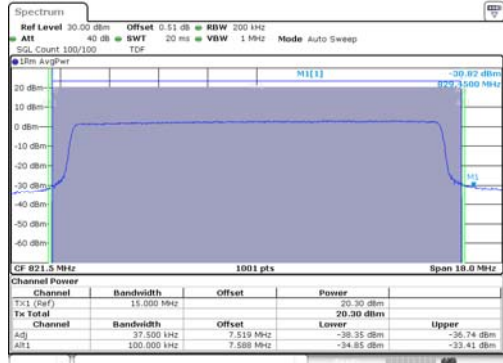

Straddle channel

1.4M BW QPSK Low ch. 1RB

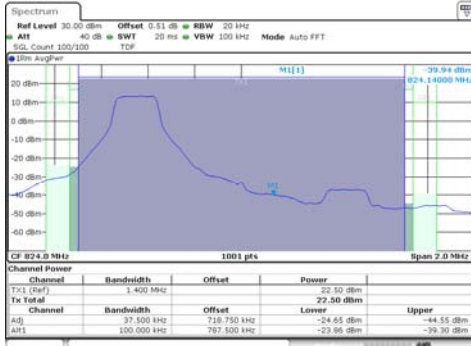

1.4M BW QPSK High ch. 1RB

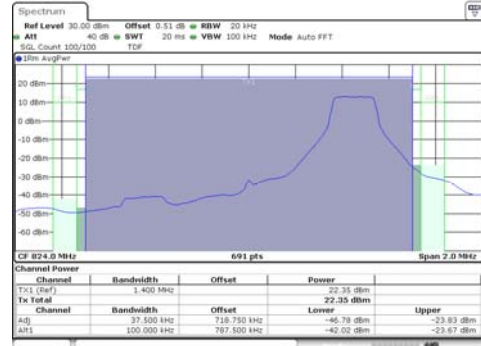

1.4M BW QPSK Low ch. FRB

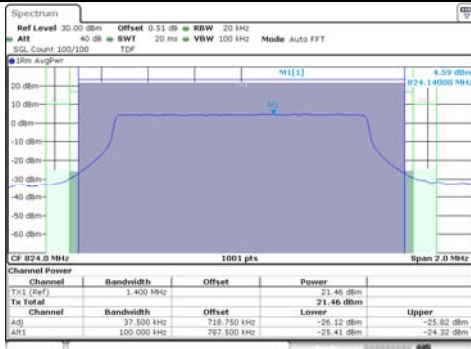

1.4M BW QPSK High ch. FRB

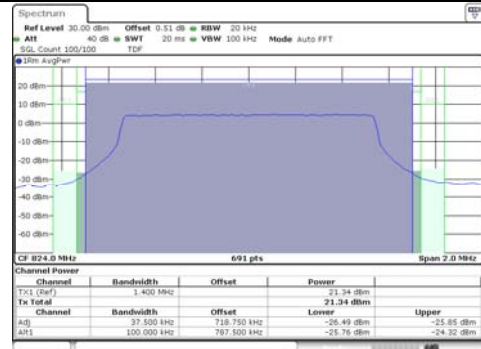

1.4M BW 16QAM Low ch. 1RB

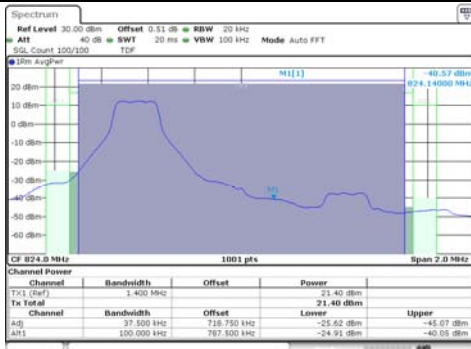

1.4M BW 16QAM High ch. 1RB

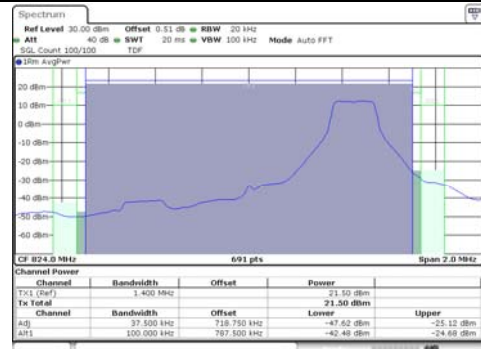

1.4M BW 16QAM Low ch. FRB

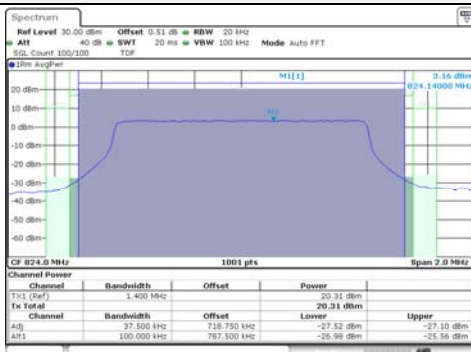

1.4M BW 16QAM High ch. FRB

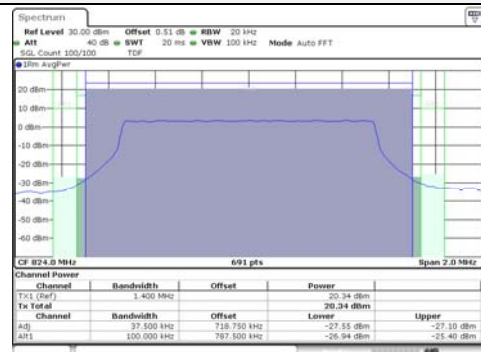

3M BW QPSK Low ch. 1RB

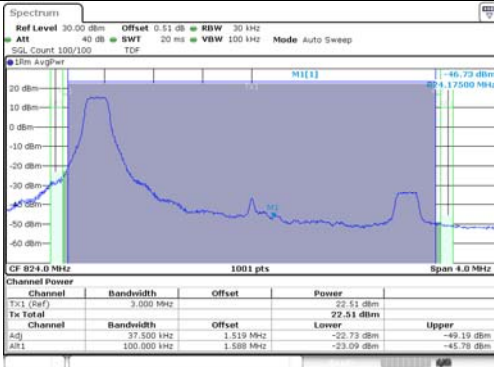

3M BW QPSK High ch. 1RB

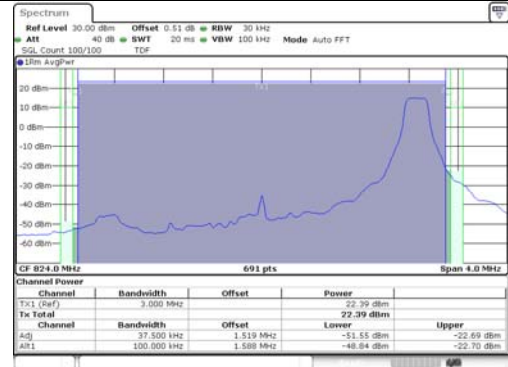

3M BW QPSK Low ch. FRB

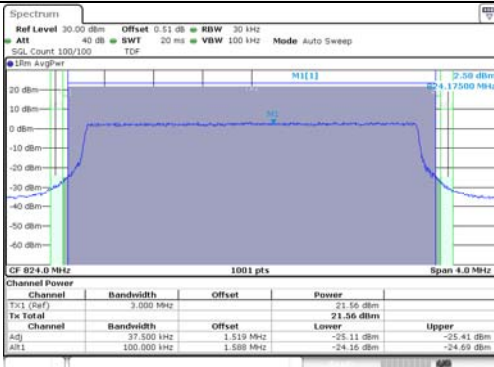

3M BW QPSK High ch. FRB

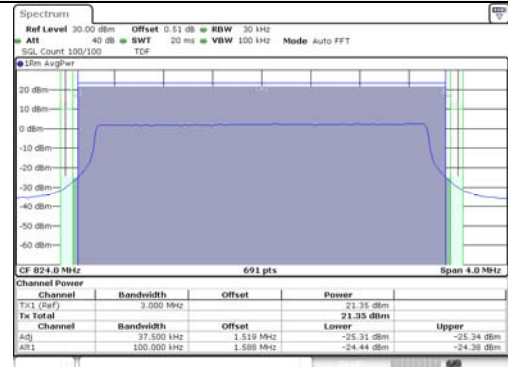

3M BW 16QAM Low ch. 1RB

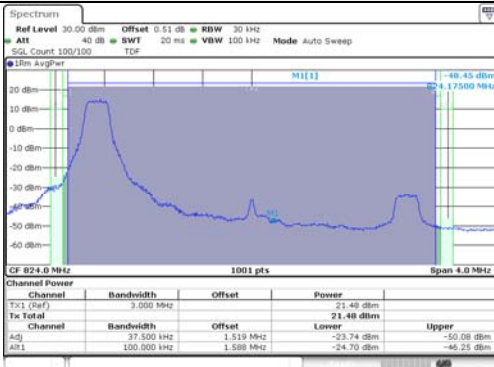

3M BW 16QAM High ch. 1RB

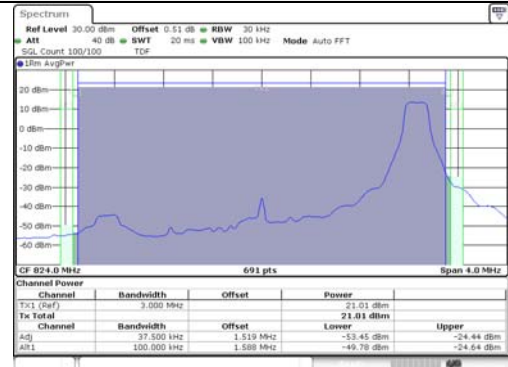

3M BW 16QAM Low ch. FRB

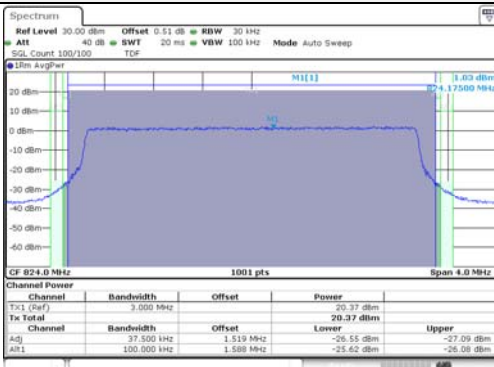

3M BW 16QAM High ch. FRB

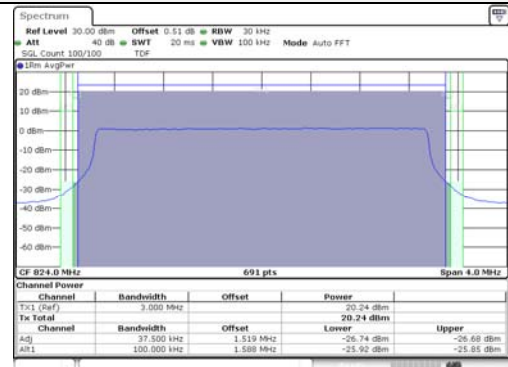

5M BW QPSK Low ch. 1RB

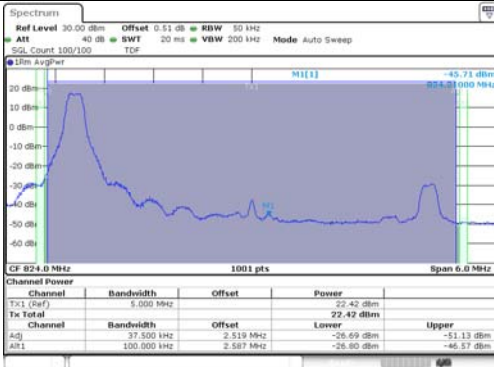

5M BW QPSK High ch. 1RB

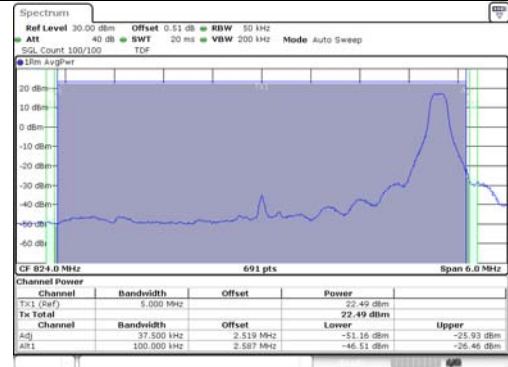

5M BW QPSK Low ch. FRB

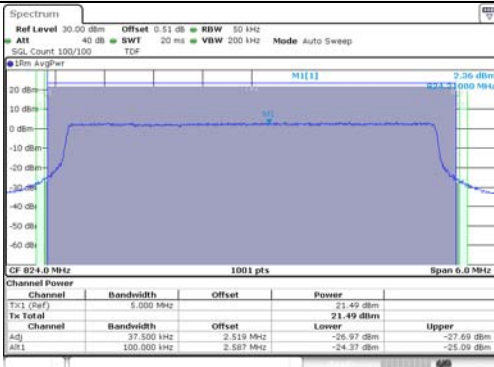

5M BW QPSK High ch. FRB

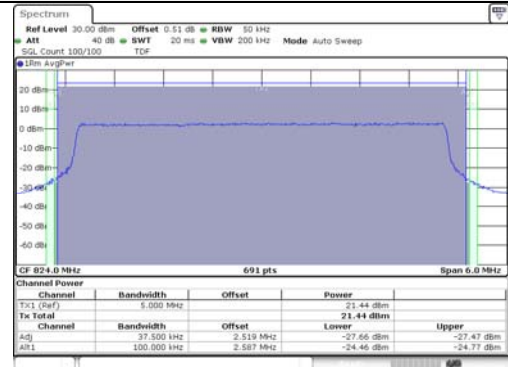

5M BW 16QAM Low ch. 1RB

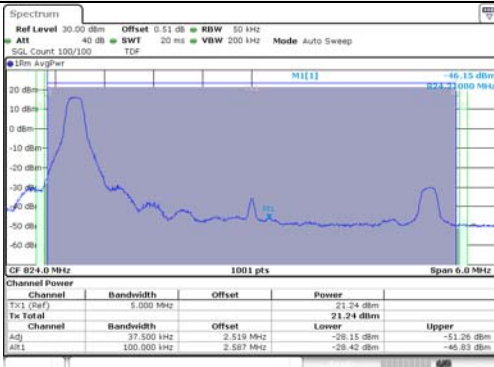

5M BW 16QAM High ch. 1RB

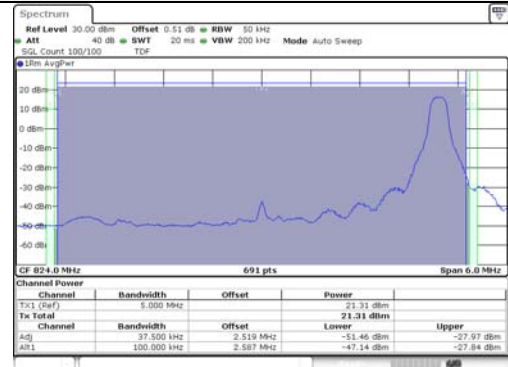

5M BW 16QAM Low ch. FRB

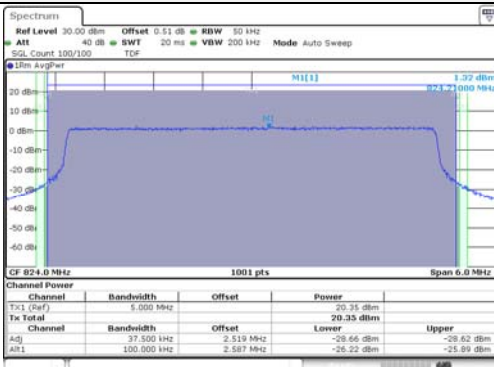

5M BW 16QAM High ch. FRB

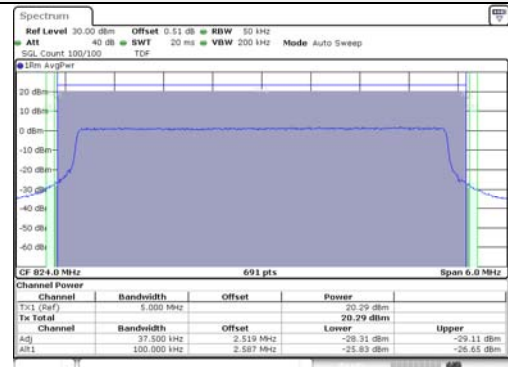

10M BW QPSK Mid ch. Lower 1RB

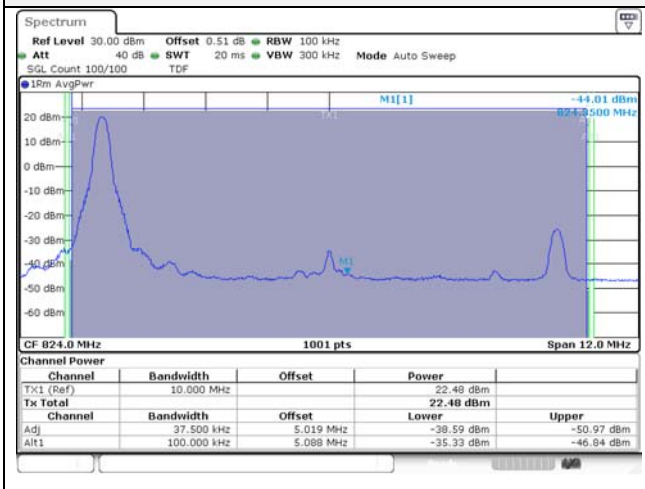

10M BW 16QAM Mid ch. Lower 1RB

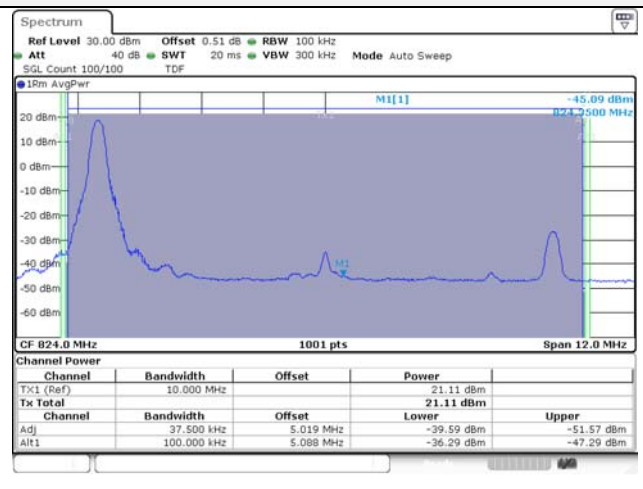

10M BW QPSK Mid ch. Upper 1RB

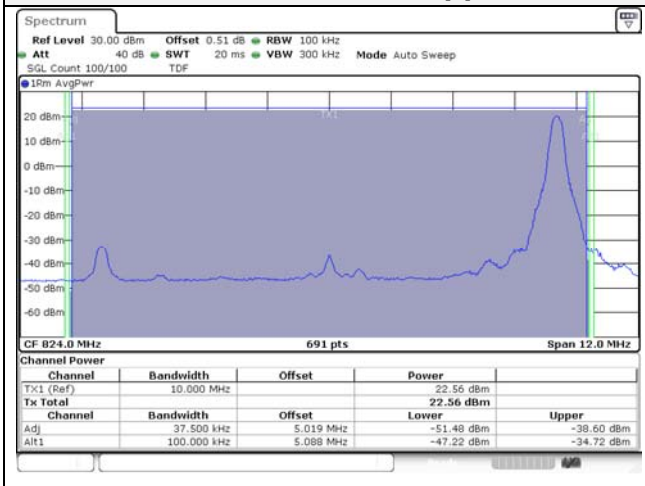

10M BW 16QAM Mid ch. Upper 1RB

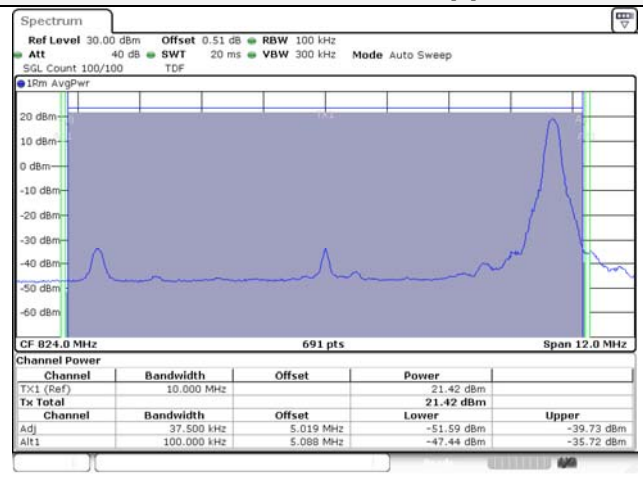

10M BW QPSK Mid ch. FRB

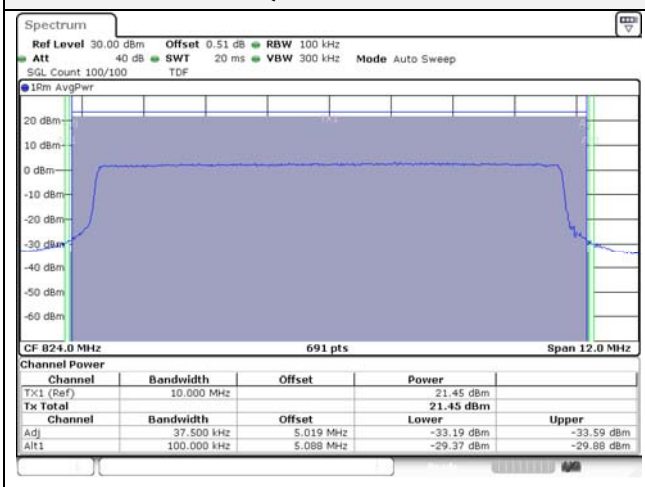

10M BW 16QAM Mid ch. FRB

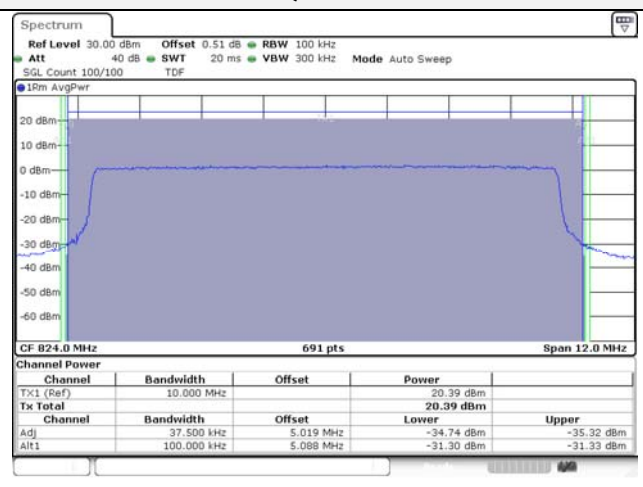

15M BW QPSK Mid ch. Lower 1RB

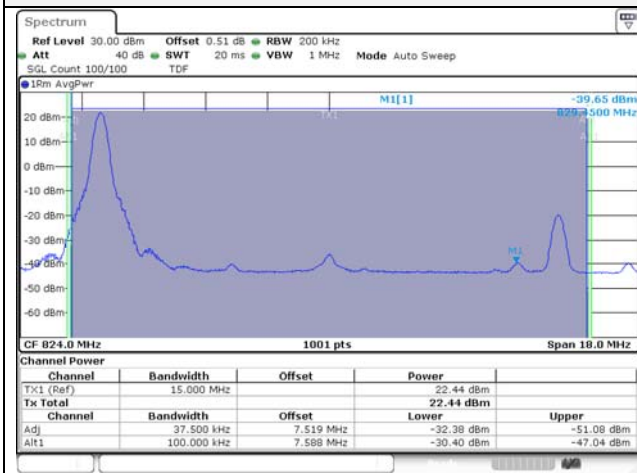

15M BW 16QAM Mid ch. Lower 1RB

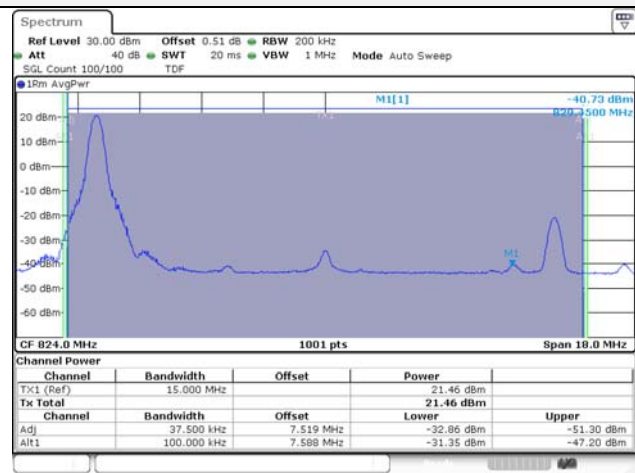

15M BW QPSK Mid ch. Upper 1RB

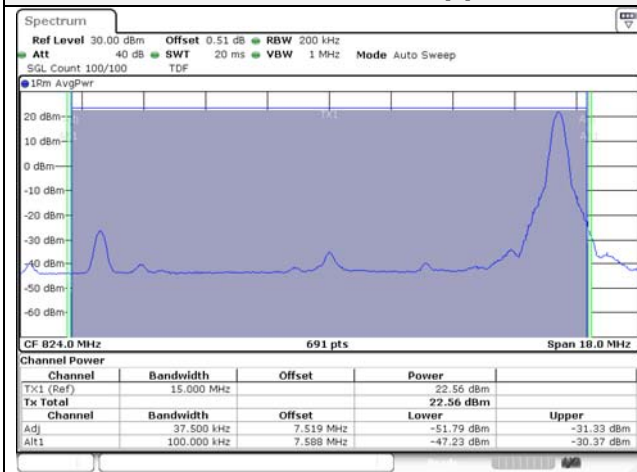

15M BW 16QAM Mid ch. Upper 1RB

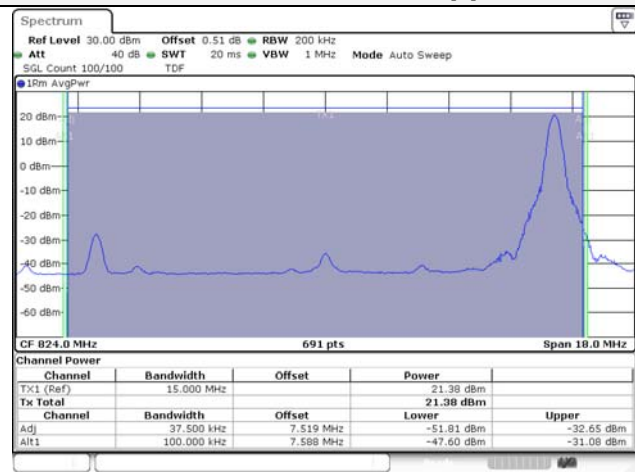

15M BW QPSK Mid ch. FRB

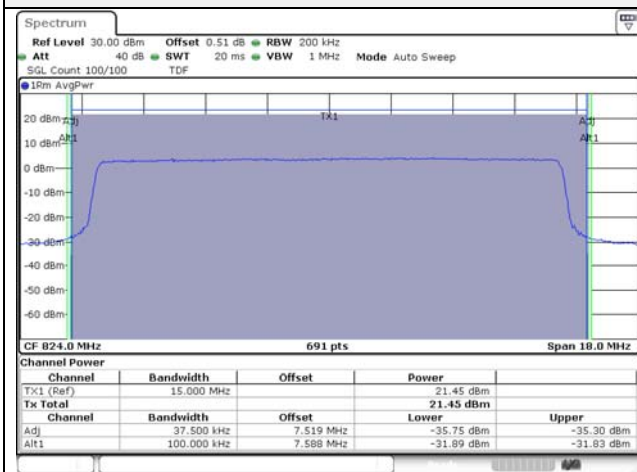

15M BW 16QAM Mid ch. FRB

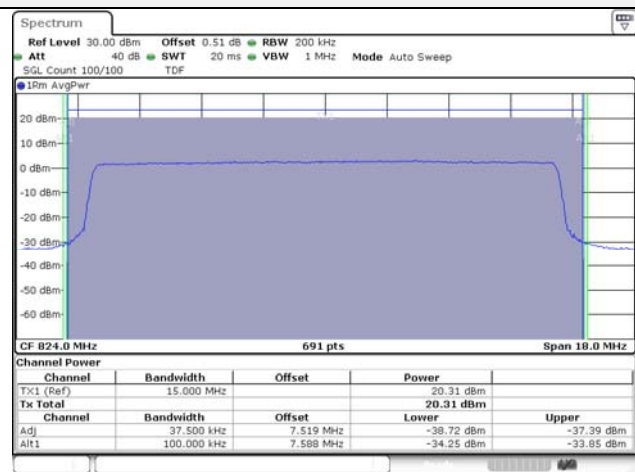

7.5. Frequency stability

Test setup

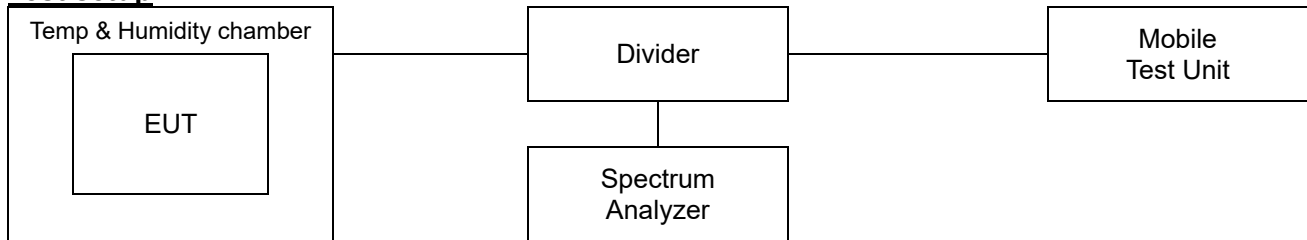

Limit

According to §2.1055(a),

The frequency stability shall be measured with variation of ambient temperature as follows:

- 1) From -30° to $+50^{\circ}$ centigrade for all equipment except that specified in paragraphs (a) (2) and (3) of this section.
- 2) From -20° to $+50^{\circ}$ centigrade for equipment to be licensed for use in the maritime services under part 80 of this chapter, except for class A, B, and S emergency position indicating radiobeacons (EPIRBS), and equipment to be licensed for use above 952 MHz at operational fixed stations in all services, stations in the local television transmission service and point-to-point microwave radio service under part 21 of this chapter, equipment licensed for use aboard aircraft in the aviation services under part 87 of this chapter, and equipment authorized for use in the family radio service under part 95 of this chapter.
- 3) From 0° to $+50^{\circ}$ centigrade for equipment to be licensed for use in the radio broadcast Services under part 73 of this chapter.

According to §2.1055(d),

The frequency stability shall be measured with variation of primary supply Voltage as follows:

- 1) Vary primary supply voltage from 85 to 115 percent of the nominal value for other than hand carried battery equipment.
- 2) For hand carried, battery powered equipment, reduce primary supply voltage to the battery operating and point which shall be specified by the manufacturer.
- 3) The supply voltage shall be measured at the input to the cable normally provided with the equipment, or at the power supply terminals if cables are not normally provided. Effects on frequency of transmitter keying (except for broadcast transmitters) and any heating element cycling at the nominal supply voltage and at each extreme also shall be shown.

According to §90.213

For mobile devices operating in the 809 to 824 MHz band at a power level 2 Watts or less, the limit specified in Table is ± 2.5 ppm.

Test procedure

ANSI 63.26-2015 – Section 5.6

Test settings

- 1) The carrier frequency of the transmitter is measured at room temperature. (20°C to provide a reference)
- 2) The equipment is turned on in a “standby” condition for one minute before applying power to the transmitter. Measurement of the carrier frequency of the transmitter is made within one minute after applying power to the transmitter.
- 3) Frequency measurements are made at 10°C intervals ranging from -30°C to +50°C. A period of at least one half-hour is provided to allow stabilization of the equipment at each Temperature level.

Test results

Test mode : LTE Band 26
 Frequency (Hz) : 823 300 000
 Channel : 26783
 Deviation limit(FCC) : ±0.00025% or 2.5ppm

Voltage (%)	Power (V)	Temp. (°C)	Frequency (Hz)	Frequency error (Hz)	Deviation	
					(ppm)	(%)
100%	3.85	+22(Ref)	823,299,995	-4.98	0.0	-0.000001
		-30	823,299,994	-5.67	0.0	-0.000001
		-20	823,299,995	-5.17	0.0	-0.000001
		-10	823,299,995	-4.93	0.0	-0.000001
		0	823,299,995	-4.57	0.0	-0.000001
		+10	823,299,996	-3.63	0.0	0.000000
		+20	823,299,997	-2.72	0.0	0.000000
		+30	823,299,996	-3.84	0.0	0.000000
		+40	823,299,996	-4.18	0.0	-0.000001
		+50	823,299,995	-5.32	0.0	-0.000001
115%	4.43	+22(Ref)	823,299,996	-3.72	0.0	0.000000
End point	3.40	+22(Ref)	823,299,995	-5.05	0.0	-0.000001

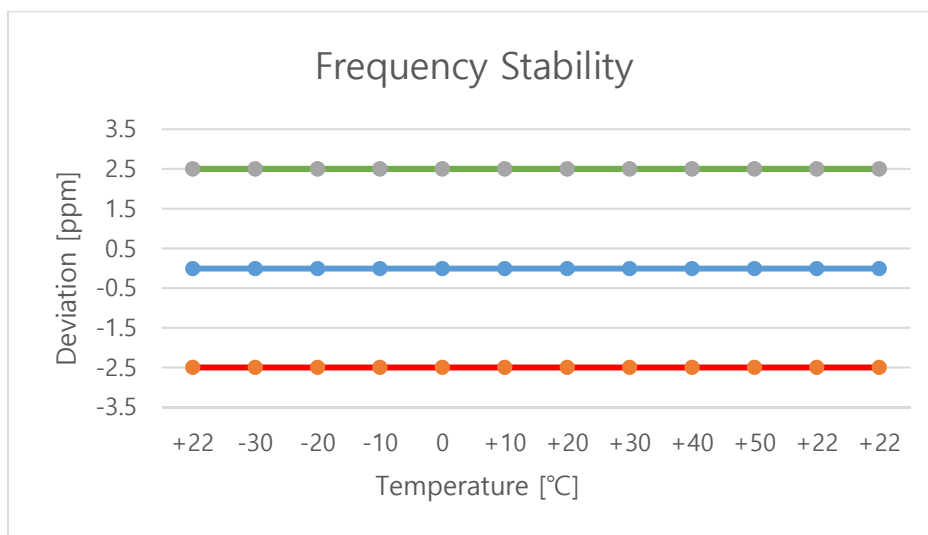

7.6. Radiated Power (ERP/EIRP)

Test setup

The diagram below shows the test setup that is utilized to make the measurements for emission from 30 MHz to 1 GHz emissions.

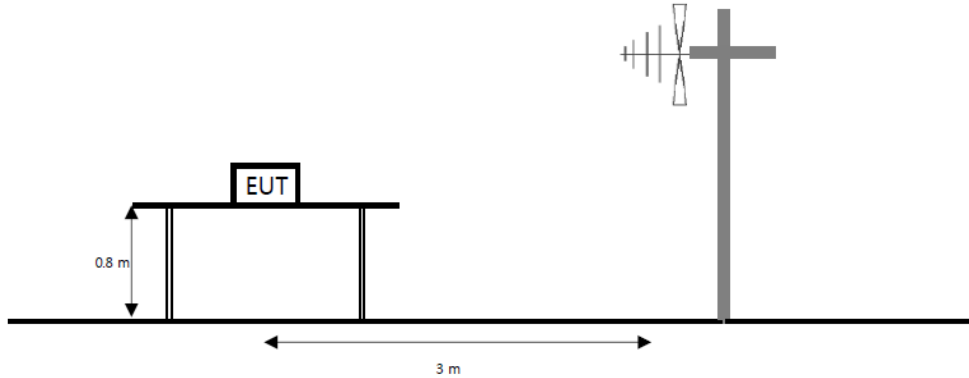

The diagram below shows the test setup that is utilized to make the measurements for emission from 1 GHz to the tenth harmonic of the highest fundamental frequency or to 40 GHz emissions, whichever is lower.

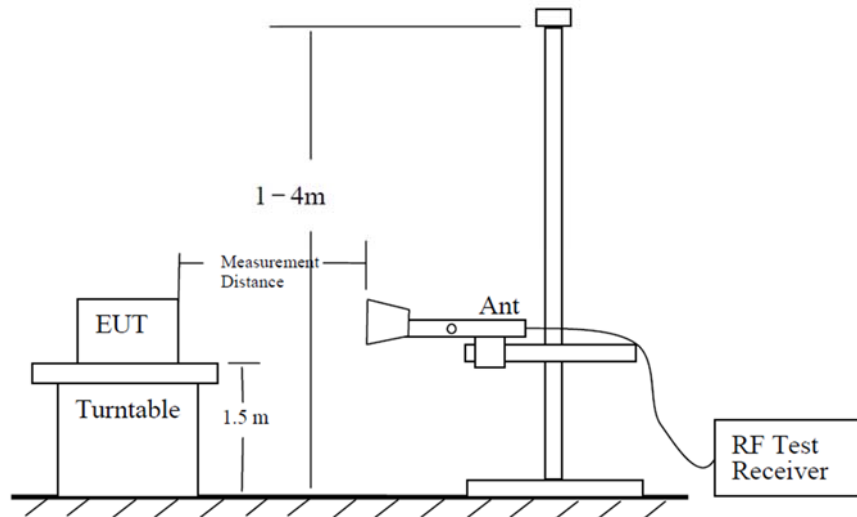

The diagram below shows the test setup for substituted method.

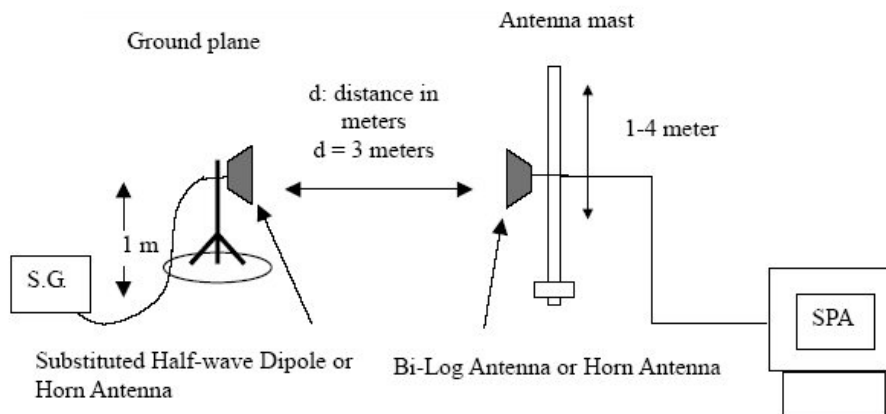

Limit

According to §90.635(b), the maximum output power of the transmitter for mobile stations is 100 watts(20 dBw).

Test procedure

971168 D01 v03r01 - Section 5.2 and 5.8

ANSI 63.26-2015 – Section 5.2

ANSI/TIA-603-E-2016 - Section 2.2.17

Test settings

- 1) RBW = 1 % to 5 % of the OBW.
- 2) VBW $\geq 3 \times$ RBW.
- 3) SPAN = 2 \times to 3 \times the OBW.
- 4) Number of measurement points in sweep $\geq 2 \times$ span / RBW.
- 5) Sweep time :
 - 1) Auto couple, or
 - 2) $\geq [10 \times (\text{number of points in sweep}) \times (\text{transmission period})]$ for single sweep (automation-compatible) measurement. Transmission period is the on and off time of the transmitter.
- 6) Detector = RMS
- 7) If the EUT can be configured to transmit continuously, then set the trigger to free run.
- 8) If the EUT cannot be configured to transmit continuously, then use a sweep trigger with the level set to enable triggering only on full power bursts and configure the EUT to transmit at full power for the entire duration of each sweep. Verify that the sweep time is less than or equal to the transmission burst duration. Time gating can also be used under similar constraints (i.e., configured such that measurement data is collected only during active full-power transmissions).
- 9) Trace mode = trace averaging (RMS) over 100 sweeps.
- 10) Compute the power by integrating the spectrum across the OBW of the signal using the instrument's band or channel power measurement function, with the band/channel limits set equal to the OBW band edges. If the instrument does not have a band or channel power function, then sum the spectrum levels (in linear power units) at intervals equal to the RBW extending across the entire OBW of the spectrum.
- 11) Allow trace to fully stabilize.

Notes:

1. On a test site, the EUT shall be placed at 80 cm height on a turn table, and in the position close To normal use as declared by the applicant.
2. The test antenna shall be oriented initially for vertical polarization located 3 m from EUT to Correspond to the fundamental frequency of the transmitter.
3. The turntable is rotated through 360°, and the receiving antenna scans in order to determine the Level of the maximized emission.
4. The test antenna shall be raised and lowered again through the specified range of height until the maximum signal level is detected by the measuring receiver.
5. The maximum signal level detected by the measuring receiver shall be noted.
6. The EUT was replaced by half-wave dipole (1 GHz below) or horn antenna (1 GHz above) connected to a signal generator.
The power is calculated by the following formula;
$$Pd(\text{dBm}) = Pg(\text{dBm}) - \text{Cable loss (dB)} + \text{Antenna gain (dB)}$$

Note. Pd is the dipole equivalent power and Pg is the generator output power into the substitution antenna.
7. The test antenna shall be raised and lowered through the specified range of height to ensure that The maximum signal is received.
8. The input signal to the substitution antenna shall be adjusted to the level that produces a level Detected by the measuring corrected for the change of input attenuator setting of the measuring Receiver.
9. The input level to the substitution antenna shall be recorded as power level in dBm, corrected for Any change of input attenuator setting of the measuring receiver.
10. The measurement shall be repeated with the test antenna and the substitution antenna Orientated for horizontal polarization.

Test results**Test mode: LTE Band 26**

Bandwidth	Modulation	Frequency	Pol.	Antenna Gain	C.L	Substitute Level	ERP	
		[MHz]	[V/H]	[dBi]	[dB]	[dBm]	[dBm]	[W]
1.4 M	QPSK	814.7	V	0.40	5.14	26.64	21.90	0.155
		823.3	V	-0.30	5.20	27.23	21.73	0.149
	16QAM	814.7	V	0.40	5.14	25.39	20.65	0.116
		823.3	V	-0.30	5.20	26.00	20.50	0.112
3 M	QPSK	815.5	V	0.40	5.15	26.70	21.95	0.157
		822.5	V	-0.30	5.19	27.13	21.64	0.146
	16QAM	815.5	V	0.40	5.15	25.31	20.56	0.114
		822.5	V	-0.30	5.19	26.25	20.76	0.119
5 M	QPSK	816.5	V	0.40	5.15	26.61	21.86	0.153
		821.5	V	-0.30	5.17	27.15	21.68	0.147
	16QAM	816.5	V	0.40	5.15	25.37	20.62	0.115
		821.5	V	-0.30	5.17	26.29	20.82	0.121
10 M	QPSK	819.0	V	-0.30	5.18	27.20	21.72	0.149
	16QAM	819.0	V	-0.30	5.18	25.79	20.31	0.107
15 M	QPSK	821.5	V	-0.30	5.17	27.25	21.78	0.151
	16QAM	821.5	V	-0.30	5.17	26.11	20.64	0.116

Straddle channel

Bandwidth	Modulation	Frequency	Pol.	Antenna Gain	C.L	Substitute Level	ERP	
		[MHz]	[V/H]	[dBi]	[dB]	[dBm]	[dBm]	[W]
1.4 M	QPSK	824	V	-0.30	5.21	27.32	21.81	0.152
	16QAM		V	-0.30	5.21	26.34	20.83	0.121
3 M	QPSK		V	-0.30	5.21	27.46	21.95	0.157
	16QAM		V	-0.30	5.21	26.26	20.75	0.119
5 M	QPSK		V	-0.30	5.21	27.37	21.86	0.153
	16QAM		V	-0.30	5.21	26.22	20.71	0.118
10 M	QPSK		V	-0.30	5.21	27.51	22.00	0.158
	16QAM		V	-0.30	5.21	26.54	21.03	0.127
15 M	QPSK		V	-0.30	5.21	27.67	22.16	0.164
	16QAM		V	-0.30	5.21	26.82	21.31	0.135

Note.

1. ERP & EIRP(dBm) = Substitute Level(dB) + Antenna gain(dBi) - C.L(Cable loss) (dB)

7.7. Radiated Spurious Emissions

Test setup

The diagram below shows the test setup that is utilized to make the measurements for emission from 30 MHz to 1 GHz emissions.

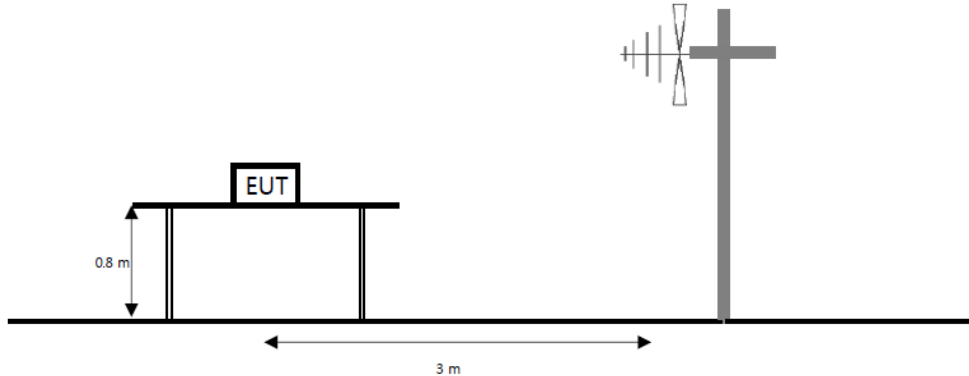

The diagram below shows the test setup that is utilized to make the measurements for emission from 1 GHz to the tenth harmonic of the highest fundamental frequency or to 40 GHz emissions, whichever is lower.

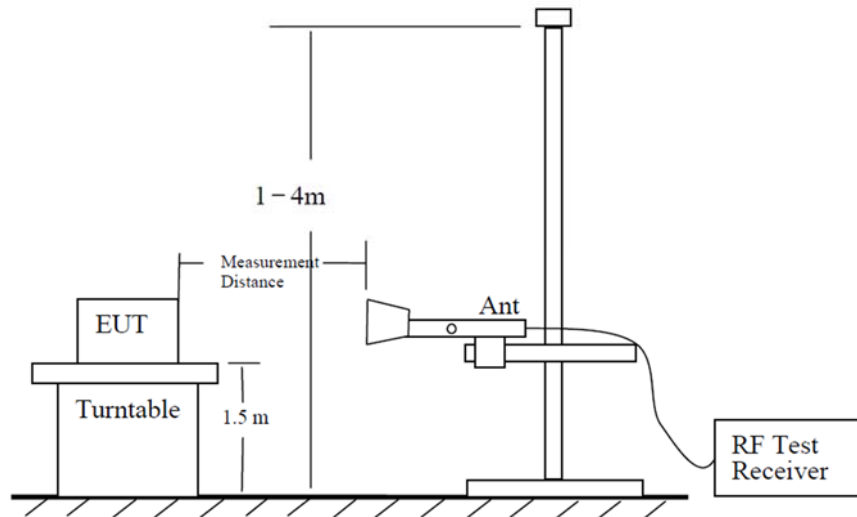

The diagram below shows the test setup for substituted method.

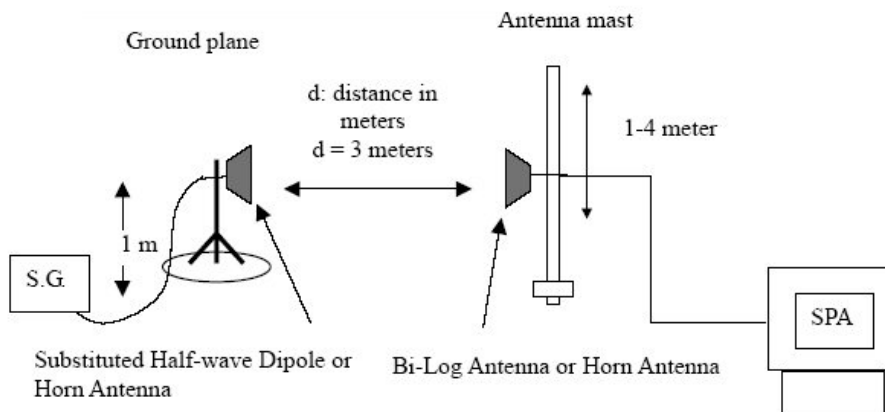

Limit

According to §90.691(a), Out-of-band emission requirement shall apply only to the “outer” channels included in an EA license and to spectrum adjacent to interior channels used by incumbent licensees. The emission limits are as follows:

(1) For any frequency removed from the EA licensee’s frequency block by up to and including 37.5 kHz, the power of any emission shall be attenuated below the transmitter power (P) in watts by at least $116 \log_{10}(f/6.1)$ decibels or $50 + 10\log_{10}(P)$ decibels or 80 decibels, whichever is the lesser attenuation, where f is the frequency removed from the center of the outer channel in the block in kilohertz where f is greater than 12.5 kHz.

(2) For any frequency removed from the EA licensee’s frequency block greater than 37.5 kHz, the power of any emission shall be attenuated below the transmitter power (P) in watts by at least $43 + 10\log_{10}(P)$ decibels or 80 decibels, whichever is the lesser attenuation, where f is the frequency removed from the center of the outer channel in the block in kilohertz and where f is greater than 37.5 kHz.

Test procedure

971168 D01 v03r01 - Section 6.2

ANSI 63.26-2015 – Section 5.5

ANSI/TIA-603-E-2016 - Section 2.2.12

Test settings

- 1) RBW = 1 kHz for below 1 GHz and 1 MHz for above 1 GHz.
- 2) VBW $\geq 3 \times$ RBW.
- 3) Detector = RMS
- 4) Trace mode = Max hold
- 5) Sweep time = Auto couple
- 6) Number of sweep points $\geq 2 \times$ span / RBW
- 7) Allow trace to fully stabilize.

Notes:

1. On a test site, the EUT shall be placed at 80 cm height on a turn table, and in the position close to normal use as declared by the applicant.
2. The test antenna shall be oriented initially for vertical polarization located 3 m from EUT to correspond to the fundamental frequency of the transmitter.
3. The turntable is rotated through 360°, and the receiving antenna scans in order to determine the level of the maximized emission.
4. The test antenna shall be raised and lowered again through the specified range of height until the maximum signal level is detected by the measuring receiver.
5. The maximum signal level detected by the measuring receiver shall be noted.
6. The EUT was replaced by half-wave dipole (1 GHz below) or horn antenna (1 GHz above) connected to a signal generator.
7. The test antenna shall be raised and lowered through the specified range of height to ensure that the maximum signal is received.
8. The input signal to the substitution antenna shall be adjusted to the level that produces a level detected by the measuring corrected for the change of input attenuator setting of the measuring receiver.
9. The input level to the substitution antenna shall be recorded as power level in dBm, corrected for any change of input attenuator setting of the measuring receiver.
10. The measurement shall be repeated with the test antenna and the substitution antenna orientated for horizontal polarization.

Test results (Above 1 000 MHz)Test mode : LTE Band 26Frequency(MHz) : 821.5Channel : 26765Bandwidth(MHz) : 15

Mode	Frequency	Pol.	Antenna Gain	Cable loss	Substitute Level	Level	Limit	Margin
	[MHz]	[V/H]	[dBi]	[dB]	[dBm]	[dBm]	[dBm]	[dB]
QPSK	1 628.20	H	8.01	7.34	-60.27	-59.60	-30.00	29.60
	2 442.40	H	9.66	9.02	-56.84	-56.20	-30.00	26.20
	3 256.00	H	9.55	10.65	-52.30	-53.40	-30.00	23.40
	4 070.20	H	9.88	11.98	-50.80	-52.90	-30.00	22.90

Test mode : LTE Band 26Frequency(MHz) : 824Channel : 26790Bandwidth(MHz) : 15

Mode	Frequency	Pol.	Antenna Gain	Cable loss	Substitute Level	Level	Limit	Margin
	[MHz]	[V/H]	[dBi]	[dB]	[dBm]	[dBm]	[dBm]	[dB]
QPSK	1 633.00	H	8.01	7.35	-61.46	-60.80	-30.00	30.80
	2 449.60	H	9.68	9.04	-56.64	-56.00	-30.00	26.00
	3 266.20	H	9.55	10.67	-53.78	-54.90	-30.00	24.90
	4 082.20	H	9.91	12.00	-51.71	-53.80	-30.00	23.80

Note.

1. Limit Calculation(dBm)= 43 + 10log(P_[Watts])

8. Measurement equipment

Equipment Name	Manufacturer	Model No.	Serial No.	Next Cal. Date
Biconical VHF-UHF Broadband Antenna	SCHWARZBECK	VUBA9117	275	22.04.09
Bilog Antenna	ETS.LINDGREN	3143B	00228420	21.09.30
Horn Antenna	ETS.lindgren	3115	62589	21.07.16
Horn Antenna	ETS.LINDGREN	3117	00227509	21.09.23
Horn Antenna	ETS.lindgren	3116	00086632	21.02.17
Horn Antenna	ETS.lindgren	3116	00086635	21.05.12
High pass Filter	Wainwright Instruments GmbH	WHKX12-2805-3000-18000-40SS	32	21.08.20
High pass Filter	Wainwright Instruments GmbH	WHKX10-900-1000-15000-40SS	11	21.08.20
Attenuator	Weinschel ENGINEERING	10	AJ1239	21.05.15
Broadband Amplifier	SONOMA INSTRUMENT	310N	186280	21.04.03
Amplifier	L-3 Narda-MITEQ	AFS5-00101800-25-S-5	2054571	21.08.28
Amplifier	L-3 Narda-MITEQ	JS44-18004000-33-8P	2000996	21.01.22
Spectrum Analyzer	KEYSIGHT	N9040B	US55230151	21.07.29
Spectrum Analyzer	R&S	FSV40	100988	21.12.23*
Spectrum Analyzer	R&S	FSV30	100807	21.07.29
Power Divider	AGILENT	11636B	54456	21.12.31*
Vector Signal Generator	R&S	SMBV100A	257566	21.07.13
Signal Generator	R&S	SMB100A	176206	21.01.21
Wideband Radio Communication Tester	R&S	CMW500	132423	21.03.12
Wideband Radio Communication Tester	R&S	CMW500	141780	21.04.16
Antenna Stand	innco systems GmbH	AS1500-EP-10kg	N/A	N/A
Antenna Stand	innco systems GmbH	AS1500-EP-10kg	N/A	N/A
Turn Device	innco systems GmbH	DE3700-RH	N/A	N/A

* Tests related to this equipment were progressed after the calibration was completed.

End of test report