

**UNII 5.8 GHz IEEE 802.11a mode**

11a Mode Low Channel

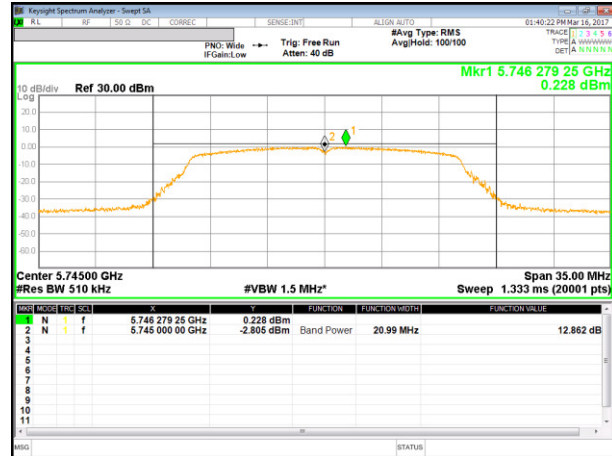

11a Mode Middle Channel

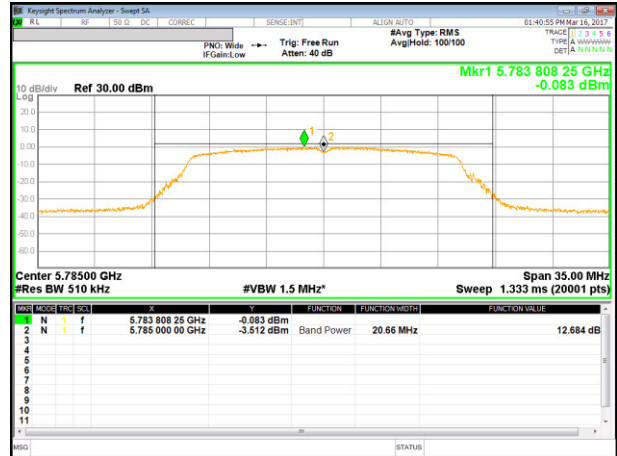

11a Mode High Channel

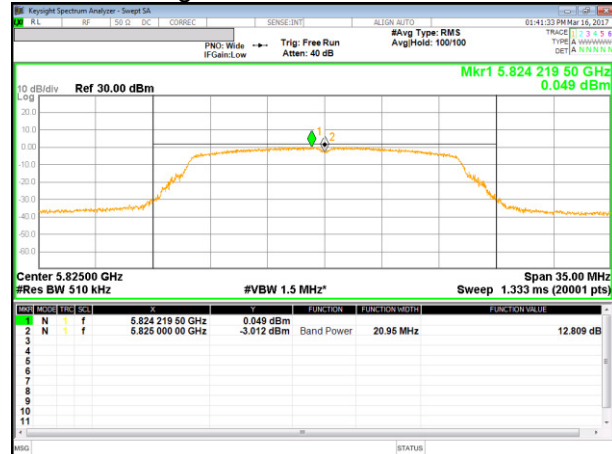

**UNII 5.8 GHz IEEE 802.11n HT20 mode**

11n HT20 Mode Low Channel

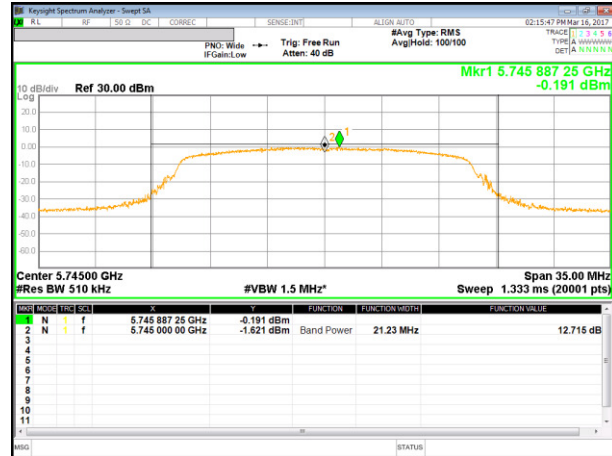

11n HT20 Mode Middle Channel

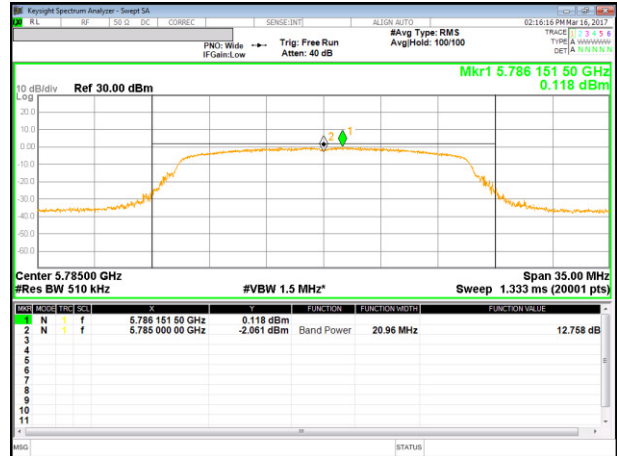

11n HT20 Mode High Channel

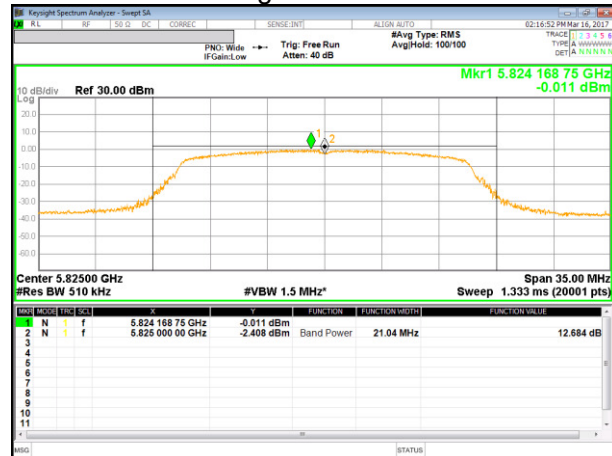

**UNII 5.8 GHz IEEE 802.11n HT40 mode**

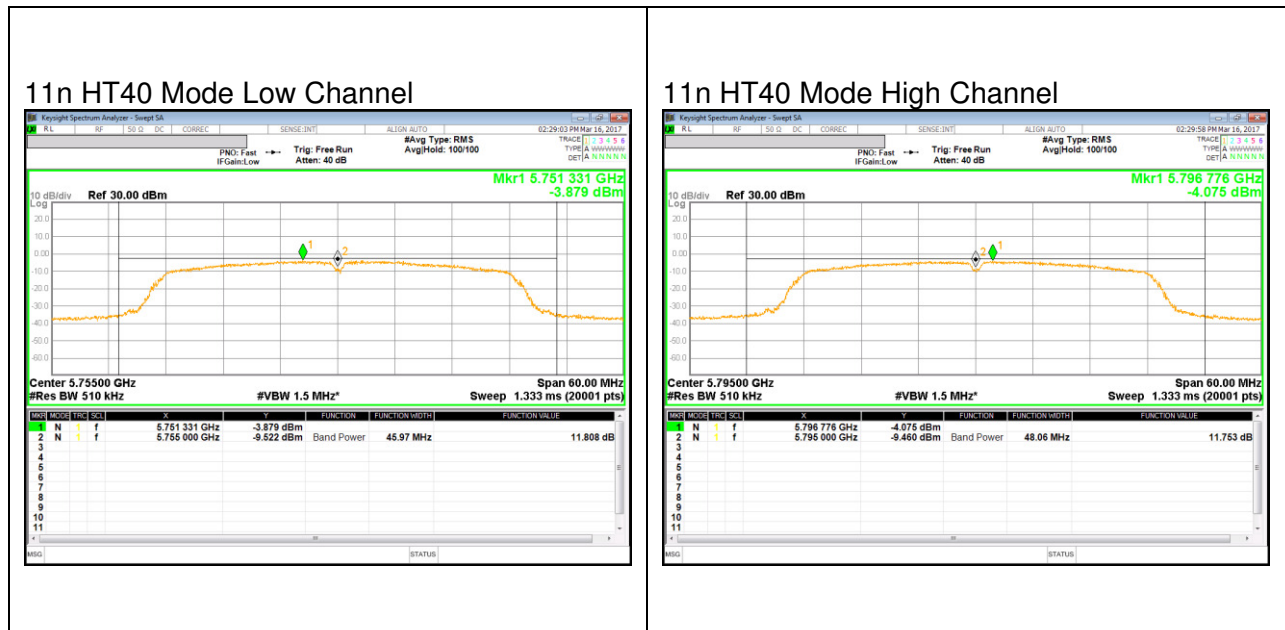

## 10. TRANSMITTER ABOVE 1 GHz

### LIMITS

FCC §15.205 and §15.209

Limits for radiated disturbance of an intentional radiator		
Frequency range (MHz)	Limits (µV/m)	Measurement Distance (m)
0.009 – 0.490	2400 / F (kHz)	300
0.490 – 1.705	24000 / F (kHz)	30
1.705 – 30.0	30	30
30 – 88	100**	3
88 - 216	150**	3
216 – 960	200**	3
Above 960	500	3

\*\* Except as provided in paragraph (g), fundamental emissions from intentional radiators operating under this section shall not be located in the frequency bands 54-72 MHz, 76-88 MHz, 174-216 MHz or 470-806 MHz. However, operation within these frequency bands is permitted under other sections of this part, e.g. §§ 15.231 and 15.241.

FCC §15.407 (b)

(b) Undesirable emission limits. Except as shown in paragraph (b)(7) of this section, the maximum emissions outside of the frequency bands of operation shall be attenuated in accordance with the following limits:

- (1) For transmitters operating in the 5.15-5.25 GHz band: All emissions outside of the 5.15-5.35 GHz band shall not exceed an e.i.r.p. of -27 dBm/MHz.
- (2) For transmitters operating in the 5.25-5.35 GHz band: All emissions outside of the 5.15-5.35 GHz band shall not exceed an e.i.r.p. of -27 dBm/MHz.
- (3) For transmitters operating in the 5.47-5.725 GHz band: All emissions outside of the 5.47-5.725 GHz band shall not exceed an e.i.r.p. of -27 dBm/MHz.
- (4) For transmitters operating in the 5.725-5.85 GHz band:
  - (i) All emissions shall be limited to a level of -27 dBm/MHz at 75 MHz or more above or below the band edge increasing linearly to 10 dBm/MHz at 25 MHz above or below the band edge, and from 25 MHz above or below the band edge increasing linearly to a level of 15.6 dBm/MHz at 5 MHz above or below the band edge, and from 5 MHz above or below the band edge increasing linearly to a level of 27 dBm/MHz at the band edge.
- (5) The emission measurements shall be performed using a minimum resolution bandwidth of 1 MHz. A lower resolution bandwidth may be employed near the band edge, when necessary, provided the measured energy is integrated to show the total power over 1 MHz.
- (6) Unwanted emissions below 1 GHz must comply with the general field strength limits set forth

in §15.209. Further, any U-NII devices using an AC power line are required to comply also with the conducted limits set forth in §15.207.

(7) The provisions of §15.205 apply to intentional radiators operating under this section.

(8) When measuring the emission limits, the nominal carrier frequency shall be adjusted as close to the upper and lower frequency band edges as the design of the equipment permits.

**Note**

- Limit translation to field strength level (FCC §15.407)

$$E[\text{dBuV/m}] = \text{EIRP}[\text{dBm}] + 95.2 = -27\text{dBm} + 95.2 = 68.2\text{dBuV/m}$$

$$E[\text{dBuV/m}] = \text{EIRP}[\text{dBm}] + 95.2 = -17\text{dBm} + 95.2 = 78.2\text{dBuV/m}$$

**TEST PROCEDURE**

The EUT is placed on a non-conducting table 80 cm above the ground plane for below 1GHz and 150 cm for above 1GHz. The antenna to EUT distance is 3 meters. The EUT is configured in accordance with ANSI C63.10. The EUT is set to transmit in a continuous mode.

For measurements below 1 GHz the resolution bandwidth is set to 100 kHz for peak detection measurements or 120 kHz for quasi-peak detection measurements. Peak detection is used unless otherwise noted as quasi-peak.

Reference to KDB 789033 D02 v01r03 UNII part G) 6) c) Method AD:

For measurements above 1 GHz the resolution bandwidth is set to 1 MHz; the video bandwidth is set to 3 MHz for peak measurements and add duty cycle factor to the reading offset for average measurements.

Pre-scans to detect harmonic and spurious emissions, the resolution bandwidth is set to 1 MHz; the video bandwidth is set to 30 KHz for peak measurements.

The spectrum from 1 GHz to 40 GHz is investigated with the transmitter set to the lowest, middle, and highest channels in each applicable band.

(From 30MHz to 1GHz, test was performed with the EUT set to transmit at the channel with highest output power)

The frequency range of interest is monitored at a fixed antenna height and EUT azimuth. The EUT is rotated through 360 degrees to maximize emissions received. The antenna is scanned from 1 to 4 meters above the ground plane to further maximize the emission. Measurements are made with the antenna polarized in both the vertical and the horizontal positions.

Note : Emission was pre-scanned from 9KHz to 30MHz; No emissions were detected which was at least 20dB below the specification limit (consider distance correction factor).

Per FCC part 15.31(o), test results were not reported.

Formula for converting the filed strength from uV/m to dBuV/m is:

$$\text{Limit (dBuV/m)} = 20 \log \text{limit (uV/m)}$$

Although these tests were performed other than open area test site, adequate comparison measurements were confirmed against 30 m open are test site.

Therefore sufficient tests were made to demonstrate that the alternative site produces results that correlate with the one of tests made in an open field based on KDB 937606.

### 10.1. 5.2 GHz

#### 10.1.1. TX Above 1GHz 802.11a MODE IN THE 5.2GHz BAND

### RESTRICTED BANDEDGE (LOW CHANNEL)

#### HORIZONTAL PEAK AND AVERAGE PLOT

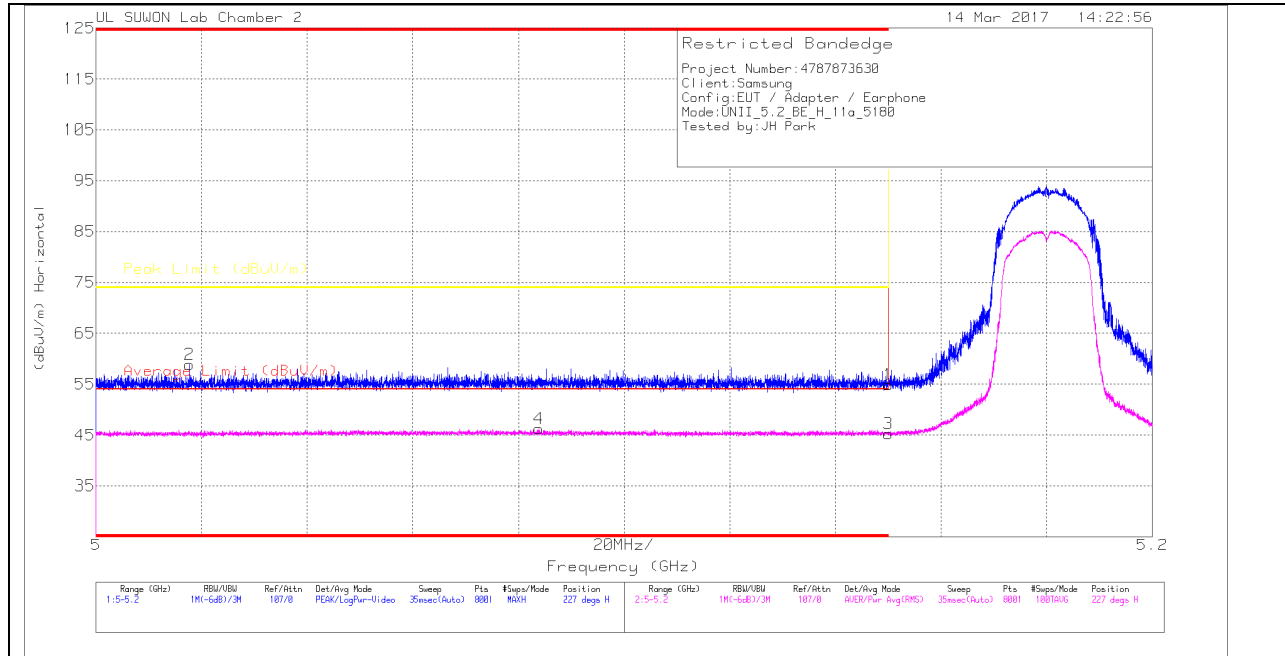

#### HORIZONTAL DATA

##### Trace Markers

Marker	Frequency (GHz)	Meter Reading (dBuV)	Det	3117(001687 24)_150619	10dB(dB)	DC Corr (dB)	Corrected Reading (dBuV/m)	Average Limit (dBuV/m)	Margin (dB)	Peak Limit (dBuV/m)	PK Margin (dB)	Azimuth (Degs)	Height (cm)	Polarity
1	* 5.15	36.07	Pk	34.1	-15.3	0	54.87	-	-	74	-19.13	227	129	H
2	* 5.018	40.01	Pk	34	-15.2	0	58.81	-	-	74	-15.19	227	129	H
3	* 5.15	26.27	RMS	34.1	-15.3	.18	45.25	54	-8.75	-	-	227	129	H
4	* 5.084	27.25	RMS	34	-15.2	.18	46.23	54	-7.77	-	-	227	129	H

\* - indicates frequency in CFR15.205/IC7.2.2 Restricted Band

Pk - Peak detector

RMS - RMS detection

**VERTICAL PEAK AND AVERAGE PLOT**

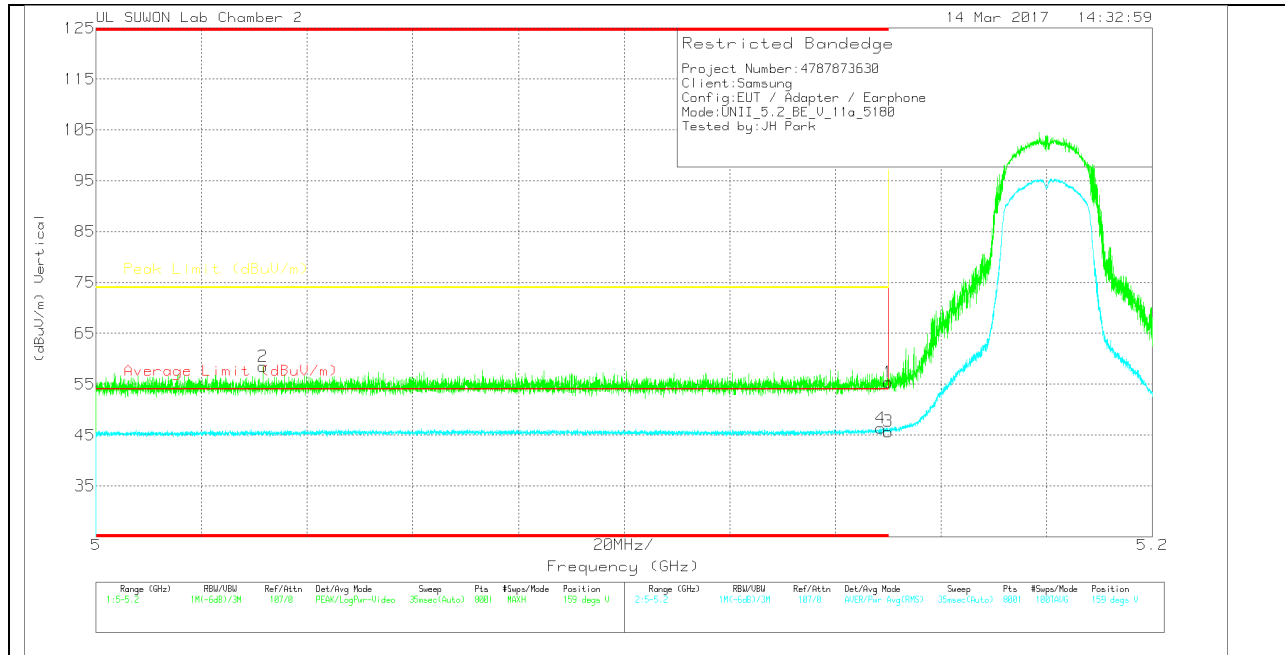

**VERTICAL DATA**

**Trace Markers**

Marker	Frequency (GHz)	Meter Reading (dBuV)	Det	3117(001687 24)_150619	10dB(dB)	DC Corr (dB)	Corrected Reading (dBuV/m)	Average Limit (dBuV/m)	Margin (dB)	Peak Limit (dBuV/m)	PK Margin (dB)	Azimuth (Degs)	Height (cm)	Polarity
1	* 5.15	36.62	PK	34.1	-15.3	0	55.42	-	-	74	-18.58	159	135	V
2	* 5.032	39.7	PK	34	-15.2	0	58.5	-	-	74	-15.5	159	135	V
3	* 5.15	26.71	RMS	34.1	-15.3	.18	45.69	54	-8.31	-	-	159	135	V
4	* 5.149	27.44	RMS	34.1	-15.3	.18	46.42	54	-7.58	-	-	159	135	V

\* - indicates frequency in CFR15.205/IC7.2.2 Restricted Band

PK - Peak detector

RMS - RMS detection

## HARMONICS AND SPURIOUS EMISSIONS

### LOW CHANNEL HORIZONTAL

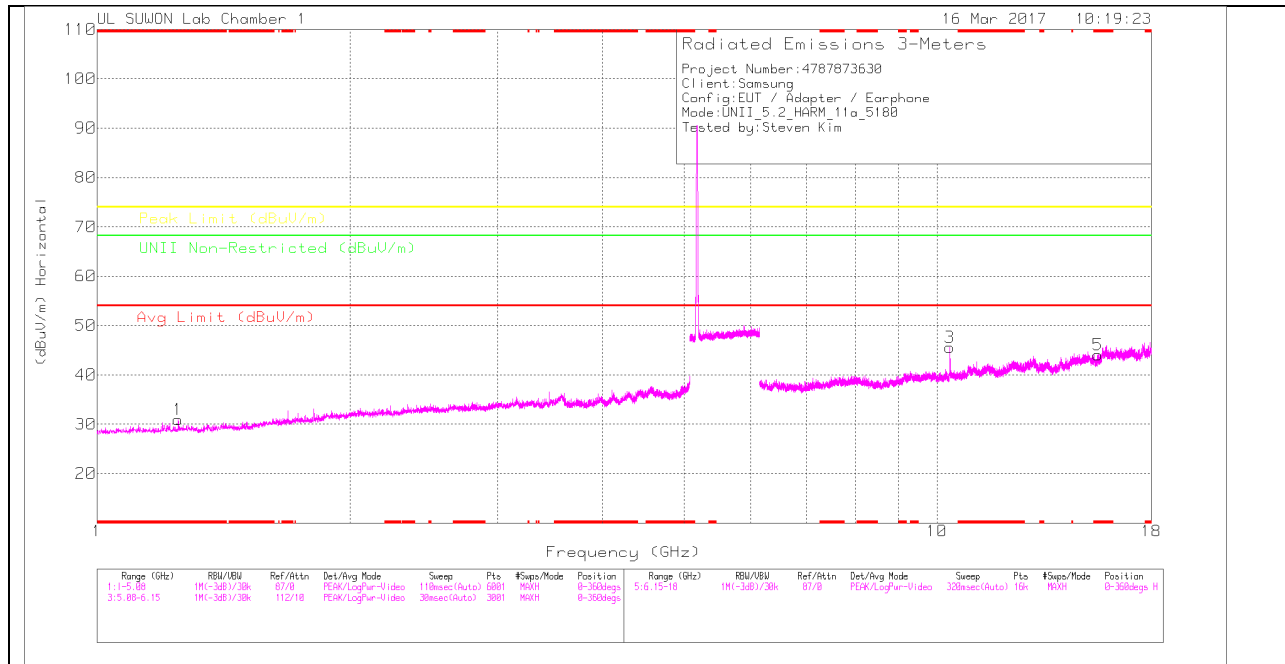

### LOW CHANNEL VERTICAL

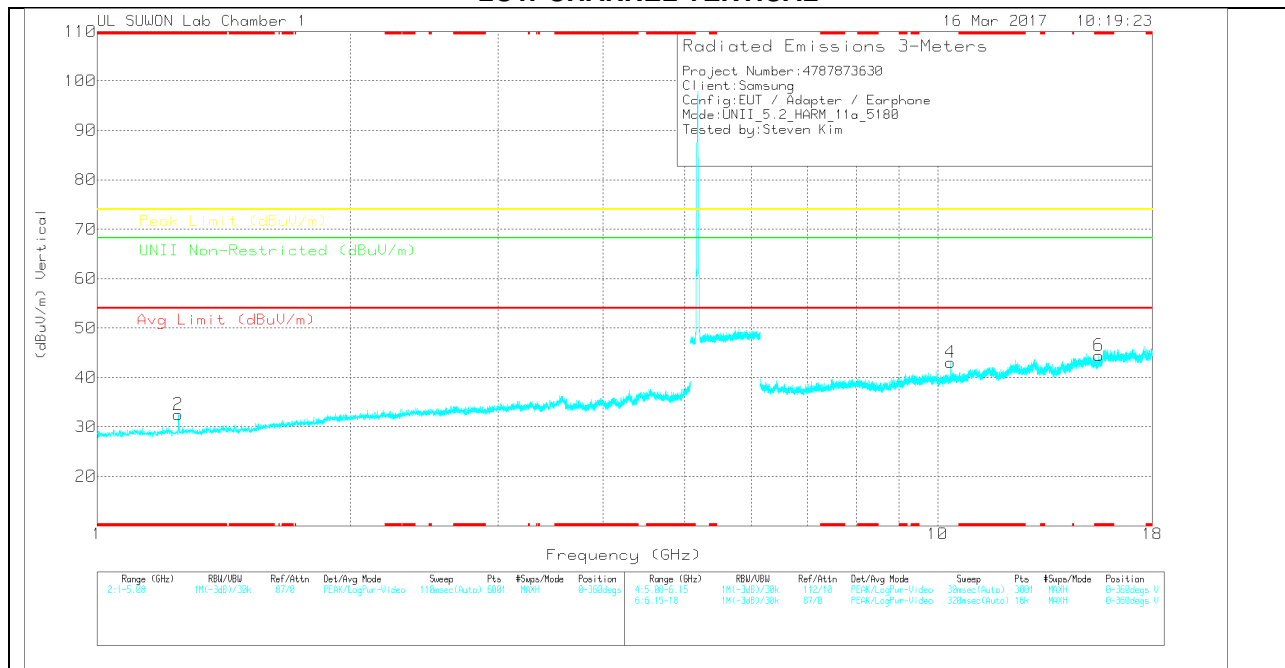

Note: Emission was scanned up to 40GHz; No emissions were detected above the noise floor which was at least 20dB below the specification limit.

**LOW CHANNEL DATA**

Trace Markers

Marker	Frequency (GHz)	Meter Reading (dBuV)	Det	3117(0016 8717)_150 619	5Ghz_LP(d B)	DC Corr (dB)	Corrected Reading (dBuV/m)	Avg Limit (dBuV/m)	Margin (dB)	Peak Limit (dBuV/m)	Margin (dB)	UNII Non-Restricted (dBuV/m)	Margin (dB)	Azimuth (Degs)	Height (cm)	Polarity
1	* 1.25	42.21	PK	28.3	-39.6	0	30.91	-	-	74	-43.09	-	-	0-360	150	H
2	* 1.25	43.82	PK	28.3	-39.6	0	32.52	-	-	74	-41.48	-	-	0-360	250	V
3	10.361	36.06	PK	37.8	-28.3	0	45.56	-	-	-	-	68.2	-22.64	0-360	150	H
5	* 15.539	24.04	PK	40.3	-20.3	0	44.04	-	-	74	-29.96	-	-	0-360	150	H
4	10.36	33.57	PK	37.8	-28.3	0	43.07	-	-	-	-	68.2	-25.13	0-360	150	V
6	* 15.542	24.38	PK	40.3	-20.2	0	44.48	-	-	74	-29.52	-	-	0-360	250	V

\* - indicates frequency in CFR15.205/IC7.2.2 Restricted Band

PK – Peak Detector

Radiated Emissions

Frequency (GHz)	Meter Reading (dBuV)	Det	3117(001687 17)_150619	6Ghz_HP(dB)	DC Corr (dB)	Corrected Reading (dBuV/m)	Avg Limit (dBuV/m)	Margin (dB)	Peak Limit (dBuV/m)	Margin (dB)	UNII Non-Restricted (dBuV/m)	Margin (dB)	Azimuth (Degs)	Height (cm)	Polarity
10.365	46.31	PK-U	37.8	-28.2	0	55.91	-	-	-	-	68.2	-12.29	184	144	H
10.36	45.32	PK-U	37.8	-28.3	0	54.82	-	-	-	-	68.2	-13.38	158	123	V

\* - indicates frequency in CFR15.205/IC7.2.2 Restricted Band

PK-U - U-NII: Maximum Peak

MID CHANNEL HORIZONTAL

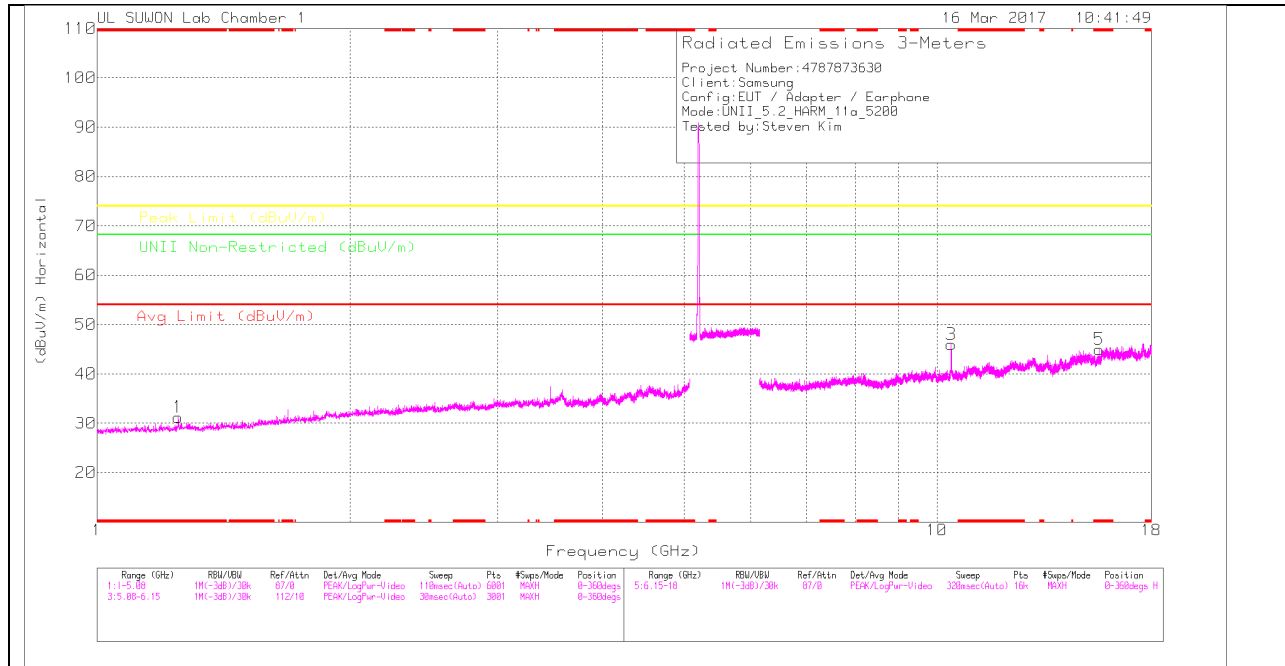

MID CHANNEL VERTICAL

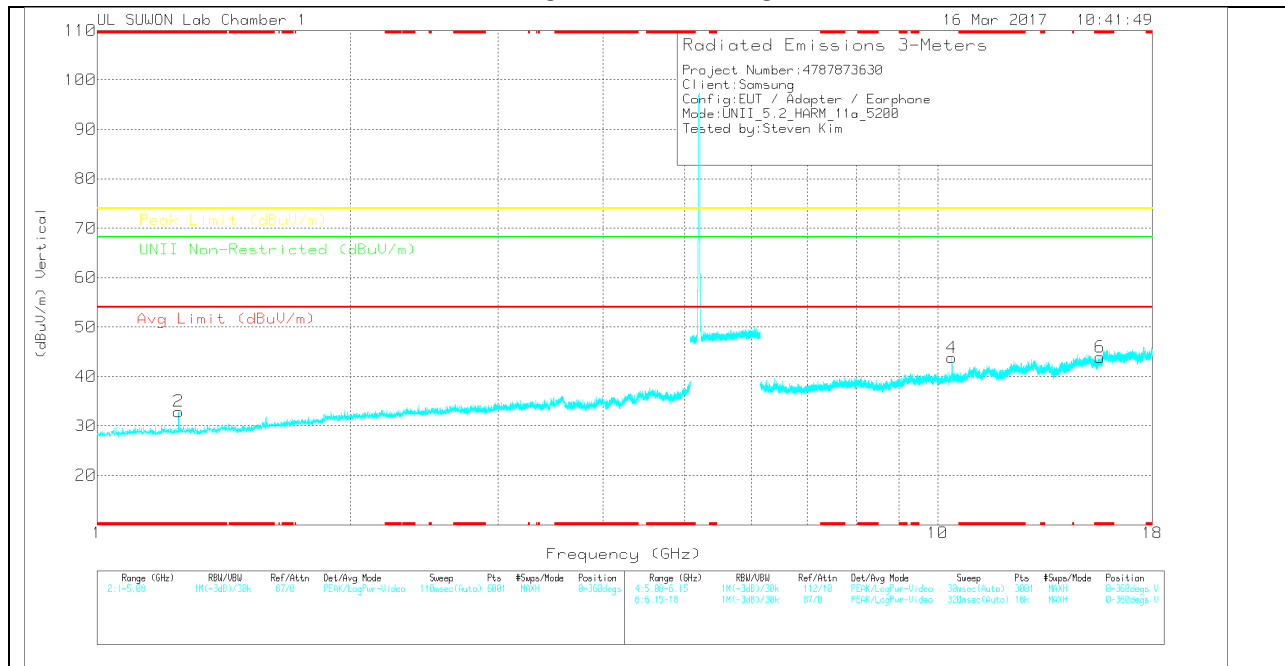

Note: Emission was scanned up to 40GHz; No emissions were detected above the noise floor which was at least 20dB below the specification limit.

**MID CHANNEL DATA**

Trace Markers

Marker	Frequency (GHz)	Meter Reading (dBuV)	Det	3117(0016 8717)_150 619	5Ghz_LP(d B)	DC Corr (dB)	Corrected Reading (dBuV/m)	Avg Limit (dBuV/m)	Margin (dB)	Peak Limit (dBuV/m)	Margin (dB)	UNII Non-Restricted (dBuV/m)	Margin (dB)	Azimuth (Degs)	Height (cm)	Polarity
1	* 1.25	42.55	PK	28.3	-39.6	0	31.25	-	-	74	-42.75	-	-	0-360	150	H
2	* 1.25	44.21	PK	28.3	-39.6	0	32.91	-	-	74	-41.09	-	-	0-360	250	V
3	10.4	35.99	PK	37.8	-27.8	0	45.99	-	-	-	-	68.2	-22.21	0-360	150	H
5	* 15.6	23.17	PK	40.3	-18.5	0	44.97	-	-	74	-29.03	-	-	0-360	250	H
4	10.399	33.79	PK	37.8	-27.8	0	43.79	-	-	-	-	68.2	-24.41	0-360	150	V
6	* 15.6	22.08	PK	40.3	-18.5	0	43.88	-	-	74	-30.12	-	-	0-360	250	V

\* - indicates frequency in CFR15.205/IC7.2.2 Restricted Band

PK – Peak Detector

Radiated Emissions

Frequency (GHz)	Meter Reading (dBuV)	Det	3117(001687 17)_150619	6Ghz_HP(dB)	DC Corr (dB)	Corrected Reading (dBuV/m)	Avg Limit (dBuV/m)	Margin (dB)	Peak Limit (dBuV/m)	Margin (dB)	UNII Non-Restricted (dBuV/m)	Margin (dB)	Azimuth (Degs)	Height (cm)	Polarity
10.397	43.07	PK-U	37.8	-27.8	0	53.07	-	-	-	-	68.2	-15.13	180	400	H
10.403	44.37	PK-U	37.8	-27.8	0	54.37	-	-	-	-	68.2	-13.83	156	121	V

\* - indicates frequency in CFR15.205/IC7.2.2 Restricted Band

PK-U - U-NII: Maximum Peak

**HIGH CHANNEL HORIZONTAL**

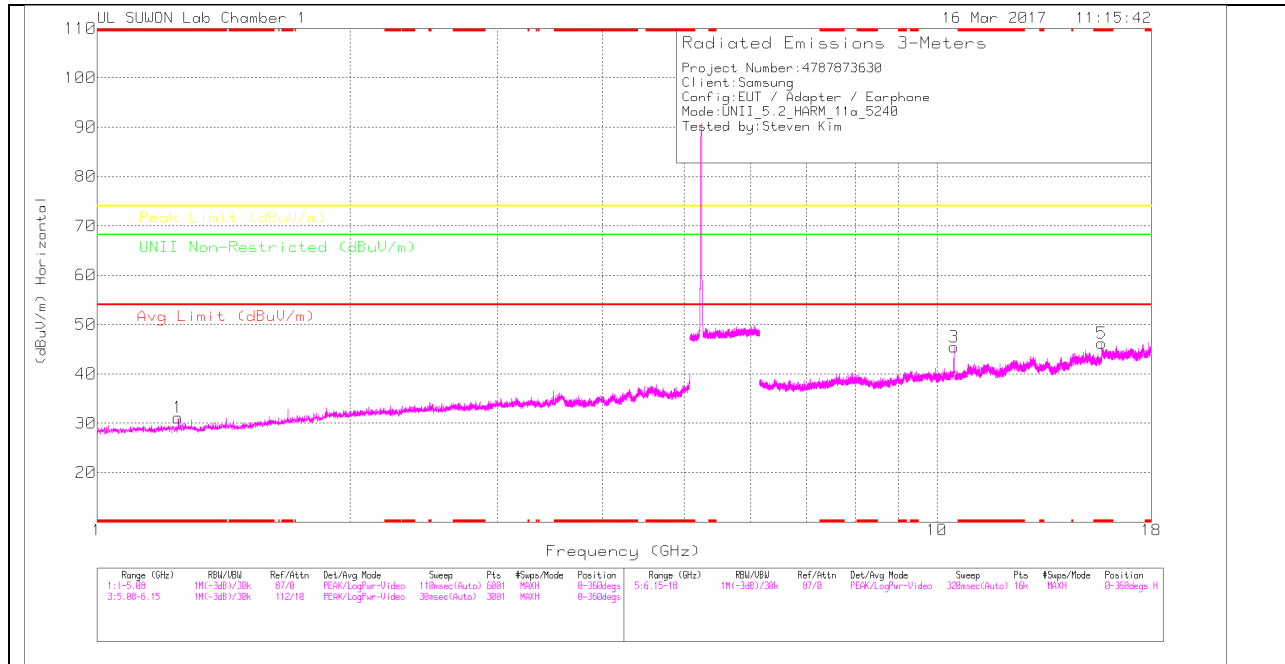

**HIGH CHANNEL VERTICAL**

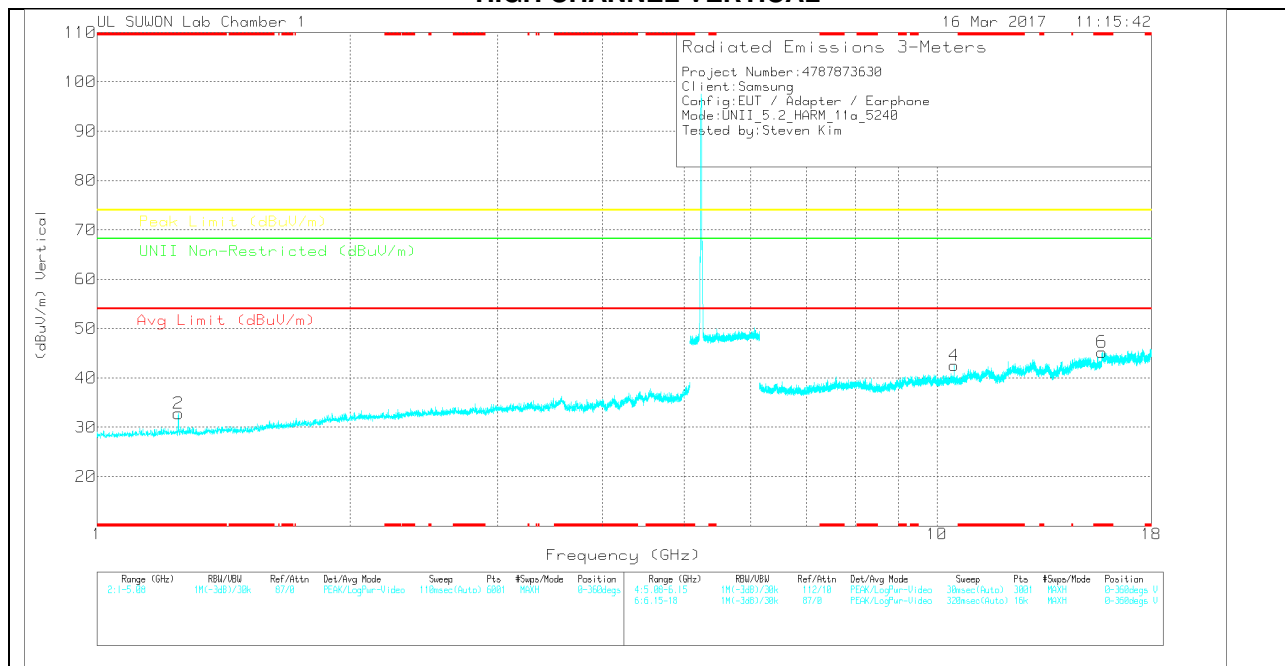

Note: Emission was scanned up to 40GHz; No emissions were detected above the noise floor which was at least 20dB below the specification limit.

**HIGH CHANNEL DATA**

Trace Markers

Marker	Frequency (GHz)	Meter Reading (dBuV)	Det	3117(0016 8717_150 619)	5Ghz_LP(d B)	DC Corr (dB)	Corrected Reading (dBuV/m)	Avg Limit (dBuV/m)	Margin (dB)	Peak Limit (dBuV/m)	Margin (dB)	UNII Non-Restricted (dBuV/m)	Margin (dB)	Azimuth (Degs)	Height (cm)	Polarity
1	* 1.25	42.44	PK	28.3	-39.6	0	31.14	-	-	74	-42.86	-	-	0-360	150	H
2	* 1.25	44.1	PK	28.3	-39.6	0	32.8	-	-	74	-41.2	-	-	0-360	250	V
3	10.48	36.43	PK	37.8	-28.8	0	45.43	-	-	-	-	68.2	-22.77	0-360	150	H
5	* 15.719	23.69	PK	40.4	-17.9	0	46.19	-	-	74	-27.81	-	-	0-360	250	H
4	10.48	33.53	PK	37.8	-28.8	0	42.53	-	-	-	-	68.2	-25.67	0-360	150	V
6	* 15.723	22.55	PK	40.4	-17.7	0	45.25	-	-	74	-28.75	-	-	0-360	250	V

\* - indicates frequency in CFR15.205/IC7.2.2 Restricted Band

PK – Peak Detector

Radiated Emissions

Frequency (GHz)	Meter Reading (dBuV)	Det	3117(001687 17_150619)	6Ghz_HP(dB)	DC Corr (dB)	Corrected Reading (dBuV/m)	Avg Limit (dBuV/m)	Margin (dB)	Peak Limit (dBuV/m)	Margin (dB)	UNII Non-Restricted (dBuV/m)	Margin (dB)	Azimuth (Degs)	Height (cm)	Polarity
10.483	46.84	PK-U	37.8	-28.7	0	55.94	-	-	-	-	68.2	-12.26	184	178	H
10.482	45.39	PK-U	37.8	-28.7	0	54.49	-	-	-	-	68.2	-13.71	155	139	V

\* - indicates frequency in CFR15.205/IC7.2.2 Restricted Band

PK-U - U-NII: Maximum Peak

### 10.1.2. TX Above 1GHz 802.11n HT20 MODE IN THE 5.2GHz BAND RESTRICTED BANDEDGE (LOW CHANNEL)

#### HORIZONTAL PEAK AND AVERAGE PLOT

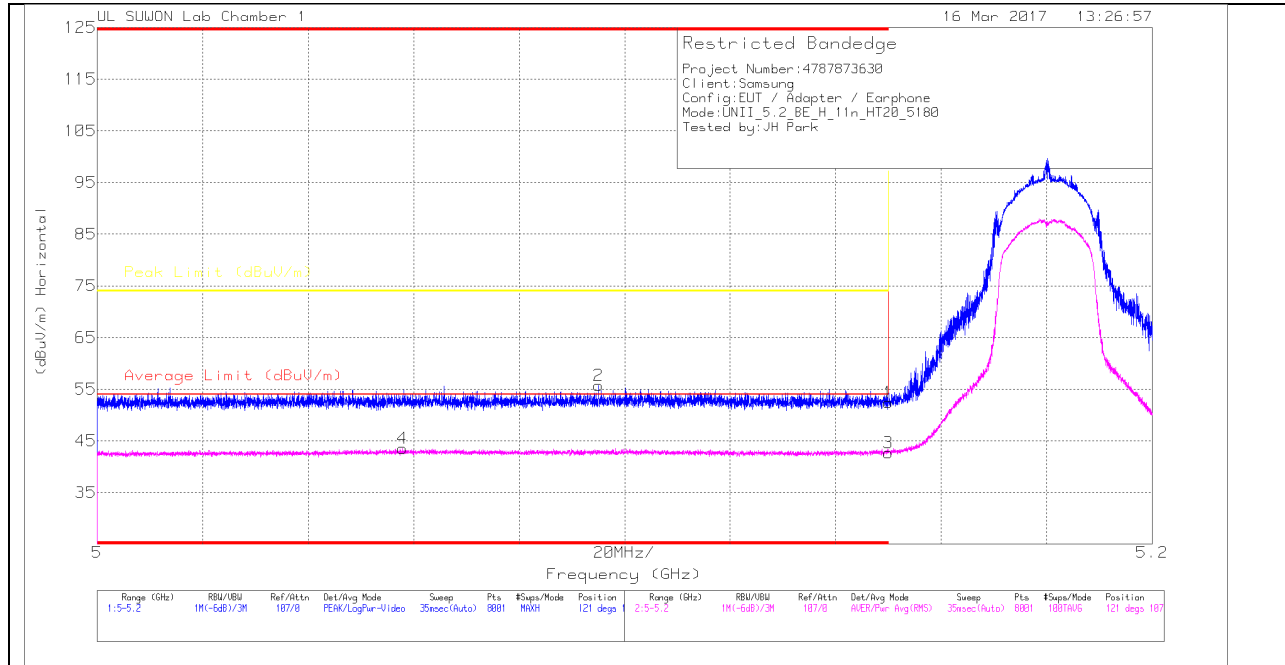

#### HORIZONTAL DATA

##### Trace Markers

Marker	Frequency (GHz)	Meter Reading (dBuV)	Det	3117(00168 717)_150619	10dB_Att(dB)	DC Corr (dB)	Corrected Reading (dBuV/m)	Average Limit (dBuV/m)	Margin (dB)	Peak Limit (dBuV/m)	PK Margin (dB)	Azimuth (Degs)	Height (cm)	Polarity
1	* 5.15	42.4	Pk	34.2	-24.2	0	52.4	-	-	74	-21.6	121	107	H
2	* 5.095	45.72	Pk	34.2	-24.2	0	55.72	-	-	74	-18.28	121	107	H
3	* 5.15	32.39	RMS	34.2	-24.1	.17	42.66	54	-11.34	-	-	121	107	H
4	* 5.058	33.48	RMS	34.1	-24.2	.17	43.55	54	-10.45	-	-	121	107	H

\* - indicates frequency in CFR15.205/IC7.2.2 Restricted Band

Pk - Peak detector

RMS - RMS detection

**VERTICAL PEAK AND AVERAGE PLOT**

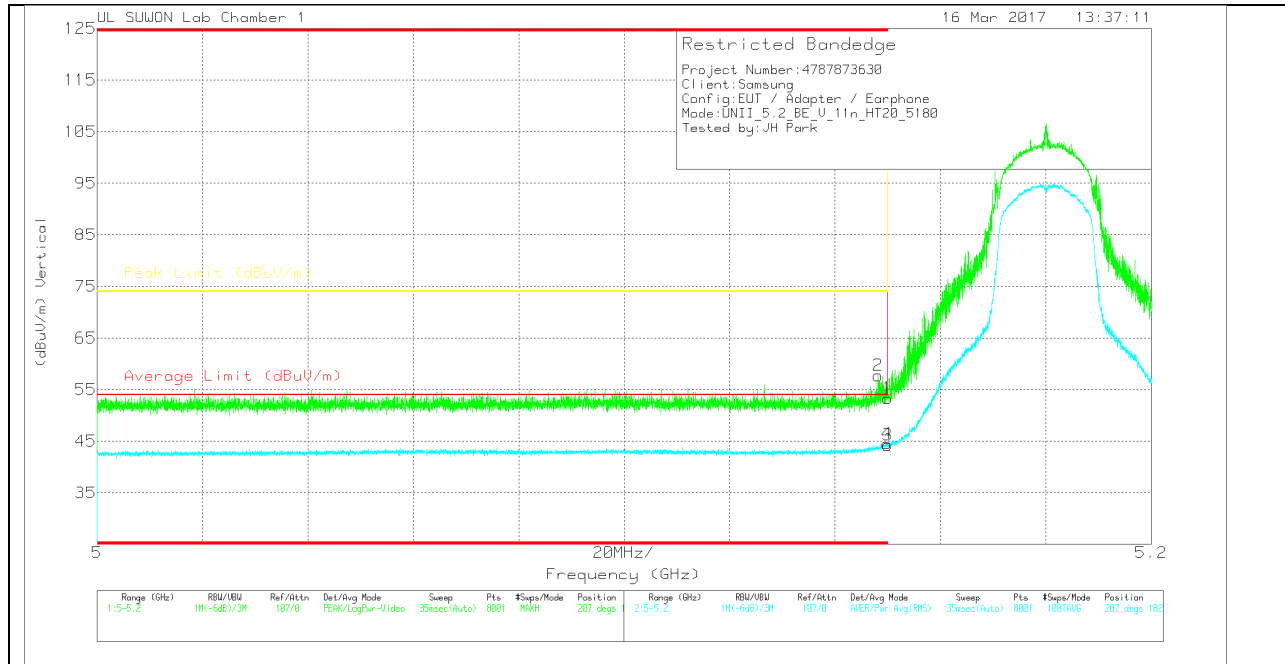

**VERTICAL DATA**

Trace Markers

Marker	Frequency (GHz)	Meter Reading (dBuV)	Det	3117(001687 17)_150619	10dB_Att(dB)	DC Corr (dB)	Corrected Reading (dBuV/m)	Average Limit (dBuV/m)	Margin (dB)	Peak Limit (dBuV/m)	PK Margin (dB)	Azimuth (Degs)	Height (cm)	Polarity
1	* 5.15	43.33	Pk	34.2	-24.2	0	53.33	-	-	74	-20.67	207	182	V
2	* 5.148	47.63	Pk	34.2	-24.1	0	57.73	-	-	74	-16.27	207	182	V
3	* 5.15	33.97	RMS	34.2	-24.1	.17	44.24	54	-9.76	-	-	207	182	V
4	* 5.15	34.25	RMS	34.2	-24.1	.17	44.52	54	-9.48	-	-	207	182	V

\* - indicates frequency in CFR15.205/IC7.2.2 Restricted Band

Pk - Peak detector

RMS - RMS detection

## HARMONICS AND SPURIOUS EMISSIONS

### LOW CHANNEL HORIZONTAL

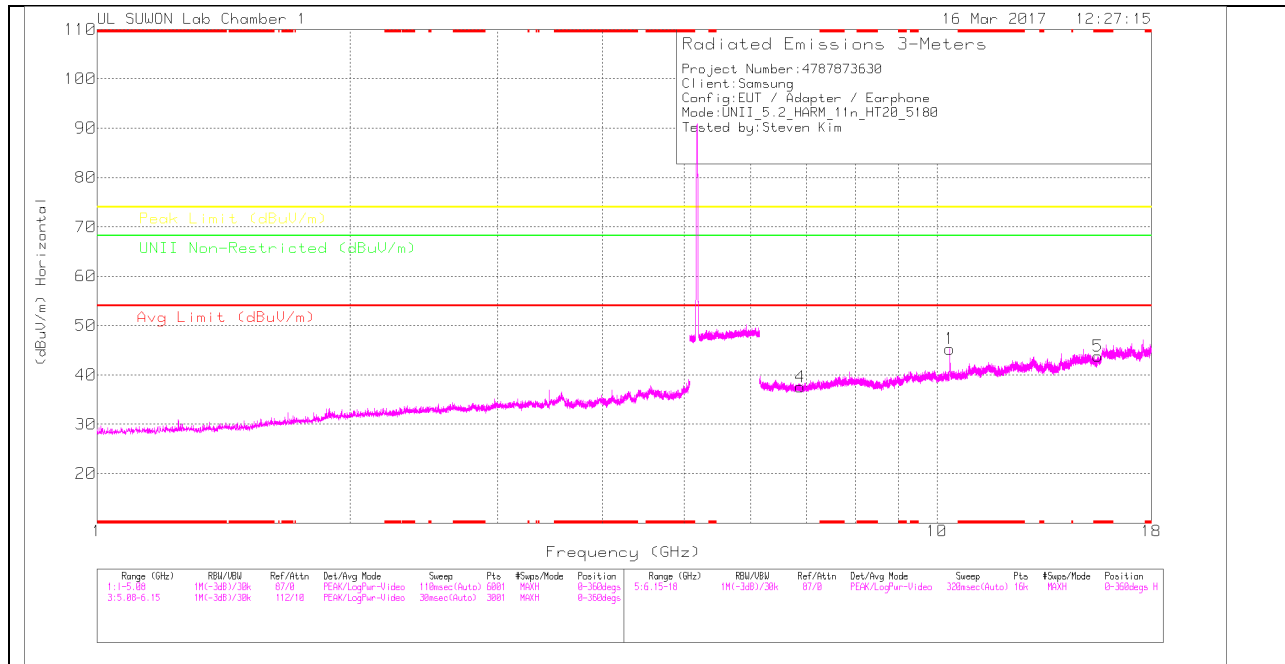

### LOW CHANNEL VERTICAL

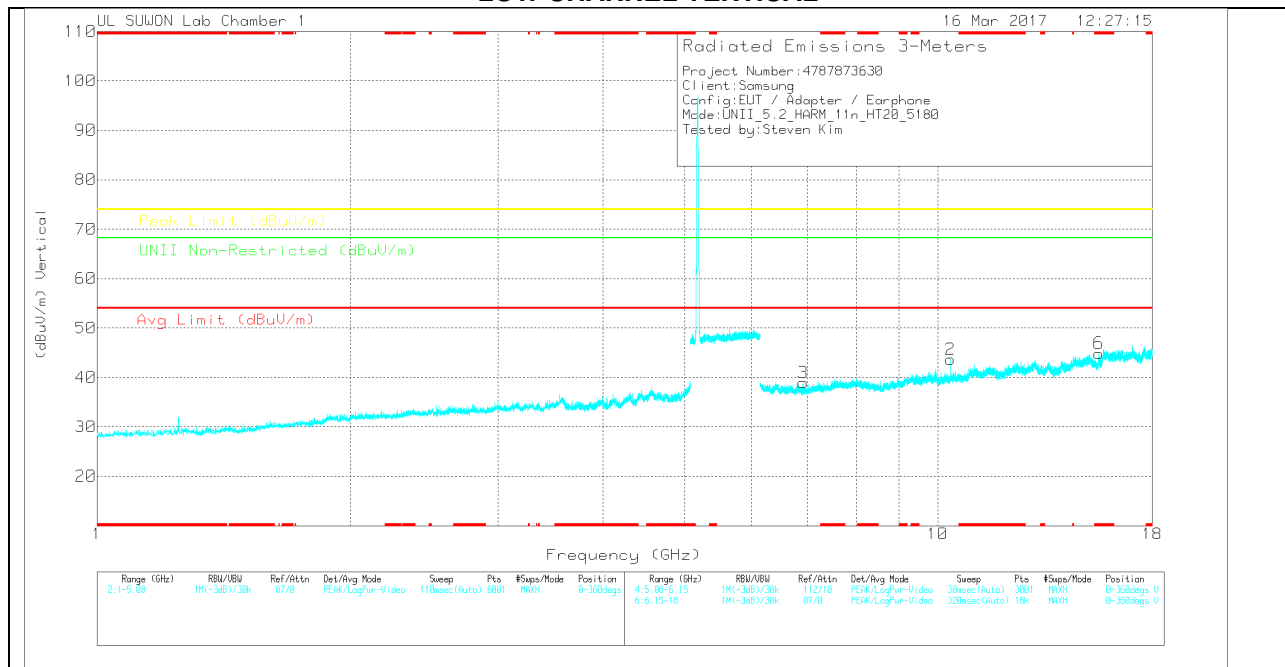

Note: Emission was scanned up to 40GHz; No emissions were detected above the noise floor which was at least 20dB below the specification limit.

**LOW CHANNEL DATA**

Trace Markers

Marker	Frequency (GHz)	Meter Reading (dBuV)	Det	3117(0016 8717)_150 619	6Ghz_HP(d B)	DC Corr (dB)	Corrected Reading (dBuV/m)	Avg Limit (dBuV/m)	Margin (dB)	Peak Limit (dBuV/m)	Margin (dB)	UNII Non-Restricted (dBuV/m)	Margin (dB)	Azimuth (Degs)	Height (cm)	Polarity
1	10.361	35.78	PK	37.8	-28.3	0	45.28	-	-	-	-	68.2	-22.92	0-360	150	H
4	6.874	33.17	PK	35.6	-31.2	0	37.57	-	-	-	-	68.2	-30.63	0-360	250	H
5	* 15.543	23.58	PK	40.3	-20.1	0	43.78	-	-	74	-30.22	-	-	0-360	250	H
2	10.36	34.18	PK	37.8	-28.3	0	43.68	-	-	-	-	68.2	-24.52	0-360	150	V
3	6.917	34.46	PK	35.7	-31.2	0	38.96	-	-	-	-	68.2	-29.24	0-360	150	V
6	* 15.544	24.56	PK	40.3	-20	0	44.86	-	-	74	-29.14	-	-	0-360	150	V

\* - indicates frequency in CFR15.205/IC7.2.2 Restricted Band

PK – Peak Detector

Radiated Emissions

Frequency (GHz)	Meter Reading (dBuV)	Det	3117(001687 17)_150619	6Ghz_HP(dB)	DC Corr (dB)	Corrected Reading (dBuV/m)	Avg Limit (dBuV/m)	Margin (dB)	Peak Limit (dBuV/m)	Margin (dB)	UNII Non-Restricted (dBuV/m)	Margin (dB)	Azimuth (Degs)	Height (cm)	Polarity
10.36	47.67	PK-U	37.8	-28.3	0	57.17	-	-	-	-	68.2	-11.03	176	169	H
10.36	46.86	PK-U	37.8	-28.3	0	56.36	-	-	-	-	68.2	-11.84	158	130	V

\* - indicates frequency in CFR15.205/IC7.2.2 Restricted Band

PK-U - U-NII: Maximum Peak

MID CHANNEL HORIZONTAL

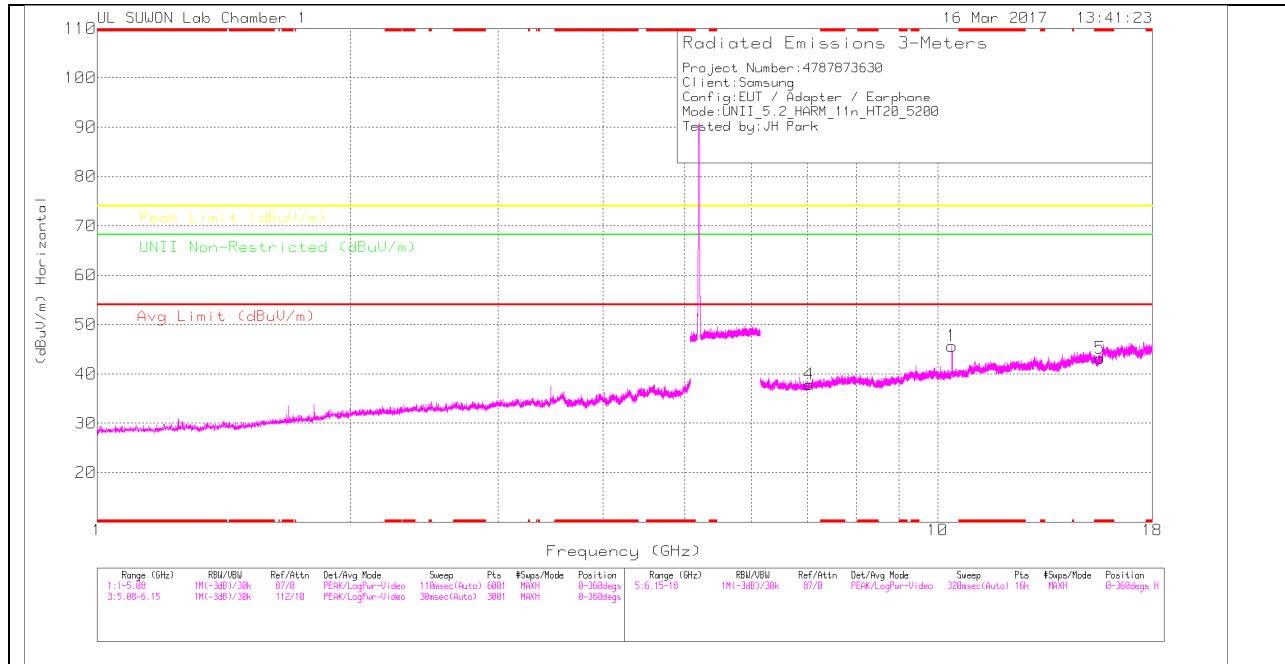

MID CHANNEL VERTICAL

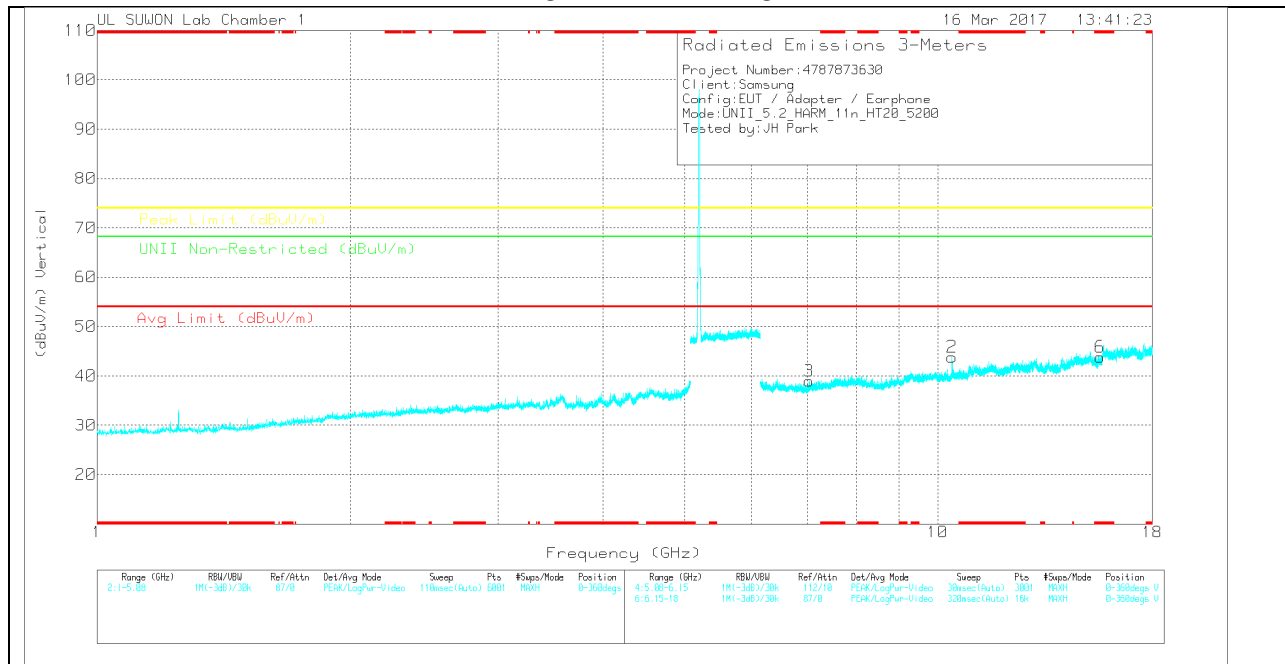

Note: Emission was scanned up to 40GHz; No emissions were detected above the noise floor which was at least 20dB below the specification limit.

**MID CHANNEL DATA**

Trace Markers

Marker	Frequency (GHz)	Meter Reading (dBuV)	Det	3117/0016 8717_150 619	6Ghz_HP(dB)	DC Corr (dB)	Corrected Reading (dBuV/m)	Avg Limit (dBuV/m)	Margin (dB)	Peak Limit (dBuV/m)	Margin (dB)	UNII Non-Restricted (dBuV/m)	Margin (dB)	Azimuth (Degs)	Height (cm)	Polarity
1	10.4	35.66	PK	37.8	-27.8	0	45.66	-	-	-	-	68.2	-22.54	0-360	250	H
4	7.032	33.17	PK	35.7	-31	0	37.87	-	-	-	-	68.2	-30.33	0-360	250	H
5	* 15.603	21.29	PK	40.3	-18.4	0	43.19	-	-	74	-30.81	-	-	0-360	150	H
2	10.4	33.82	PK	37.8	-27.8	0	43.82	-	-	-	-	68.2	-24.38	0-360	150	V
3	7.028	34.23	PK	35.7	-31	0	38.93	-	-	-	-	68.2	-29.27	0-360	250	V
6	* 15.598	22.01	PK	40.3	-18.5	0	43.81	-	-	74	-30.19	-	-	0-360	250	V

\* - indicates frequency in CFR15.205/IC7.2.2 Restricted Band

PK – Peak Detector

Radiated Emissions

Frequency (GHz)	Meter Reading (dBuV)	Det	3117/001687 17_150619	6Ghz_HP(dB)	DC Corr (dB)	Corrected Reading (dBuV/m)	Avg Limit (dBuV/m)	Margin (dB)	Peak Limit (dBuV/m)	Margin (dB)	UNII Non-Restricted (dBuV/m)	Margin (dB)	Azimuth (Degs)	Height (cm)	Polarity
10.401	46.85	PK-U	37.8	-27.8	0	56.85	-	-	-	-	68.2	-11.35	228	122	H
10.4	46.14	PK-U	37.8	-27.8	0	56.14	-	-	-	-	68.2	-12.06	155	136	V

\* - indicates frequency in CFR15.205/IC7.2.2 Restricted Band

PK-U - U-NII: Maximum Peak

### HIGH CHANNEL HORIZONTAL

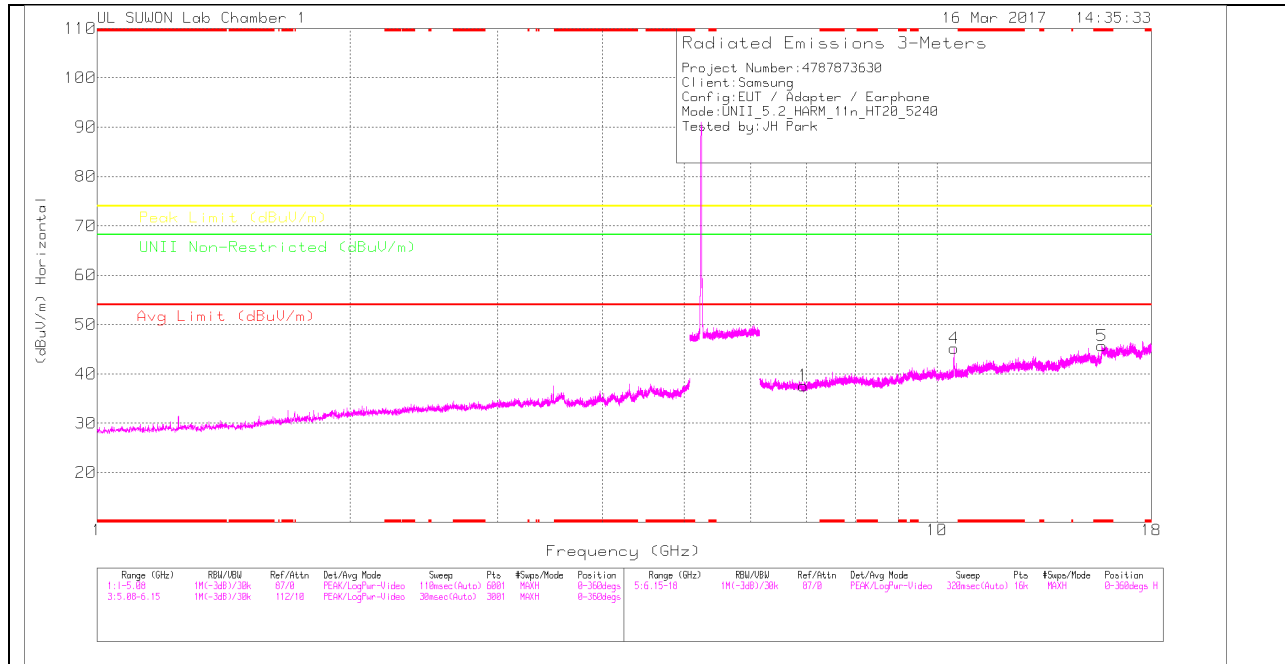

### HIGH CHANNEL VERTICAL

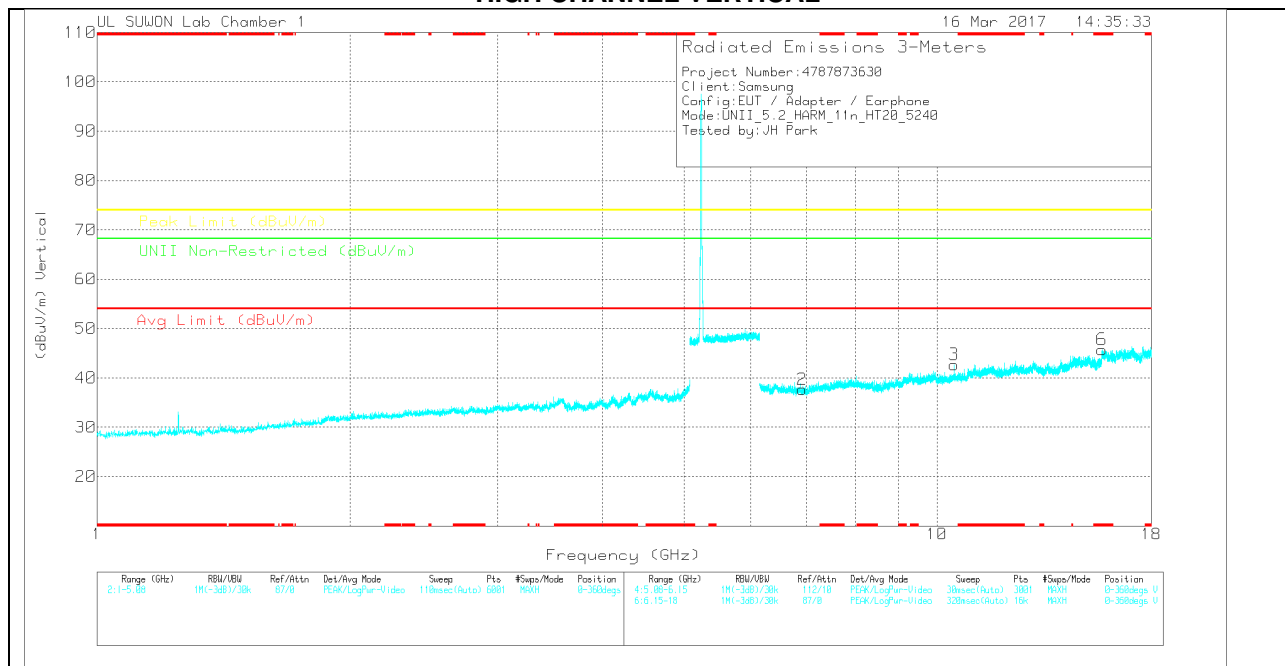

Note: Emission was scanned up to 40GHz; No emissions were detected above the noise floor which was at least 20dB below the specification limit.

**HIGH CHANNEL DATA**

Trace Markers

Marker	Frequency (GHz)	Meter Reading (dBuV)	Det	3117(0016 8717)_150 619	6Ghz_HP(d B)	DC Corr (dB)	Corrected Reading (dBuV/m)	Avg Limit (dBuV/m)	Margin (dB)	Peak Limit (dBuV/m)	Margin (dB)	UNII Non-Restricted (dBuV/m)	Margin (dB)	Azimuth (Degs)	Height (cm)	Polarity
1	6.936	32.89	PK	35.7	-31	0	37.59	-	-	-	-	68.2	-30.61	0-360	150	H
4	10.48	36.17	PK	37.8	-28.8	0	45.17	-	-	-	-	68.2	-23.03	0-360	150	H
5	* 15.721	23.07	PK	40.4	-17.8	0	45.67	-	-	74	-28.33	-	-	0-360	150	H
2	6.915	33.29	PK	35.7	-31.3	0	37.69	-	-	-	-	68.2	-30.51	0-360	150	V
3	10.481	33.6	PK	37.8	-28.7	0	42.7	-	-	-	-	68.2	-25.5	0-360	150	V
6	* 15.722	23.03	PK	40.4	-17.7	0	45.73	-	-	74	-28.27	-	-	0-360	250	V

\* - indicates frequency in CFR15.205/IC7.2.2 Restricted Band

PK – Peak Detector

Radiated Emissions

Frequency (GHz)	Meter Reading (dBuV)	Det	3117(001687 17)_150619	6Ghz_HP(dB)	DC Corr (dB)	Corrected Reading (dBuV/m)	Avg Limit (dBuV/m)	Margin (dB)	Peak Limit (dBuV/m)	Margin (dB)	UNII Non-Restricted (dBuV/m)	Margin (dB)	Azimuth (Degs)	Height (cm)	Polarity
10.48	47.28	PK-U	37.8	-28.8	0	56.28	-	-	-	-	68.2	-11.92	176	198	H
10.481	45.04	PK-U	37.8	-28.7	0	54.14	-	-	-	-	68.2	-14.06	158	161	V

\* - indicates frequency in CFR15.205/IC7.2.2 Restricted Band

PK-U - U-NII: Maximum Peak

### 10.1.3. TX Above 1GHz 802.11n HT40 MODE IN THE 5.2GHz BAND RESTRICTED BANDEDGE (LOW CHANNEL)

#### HORIZONTAL PEAK AND AVERAGE PLOT

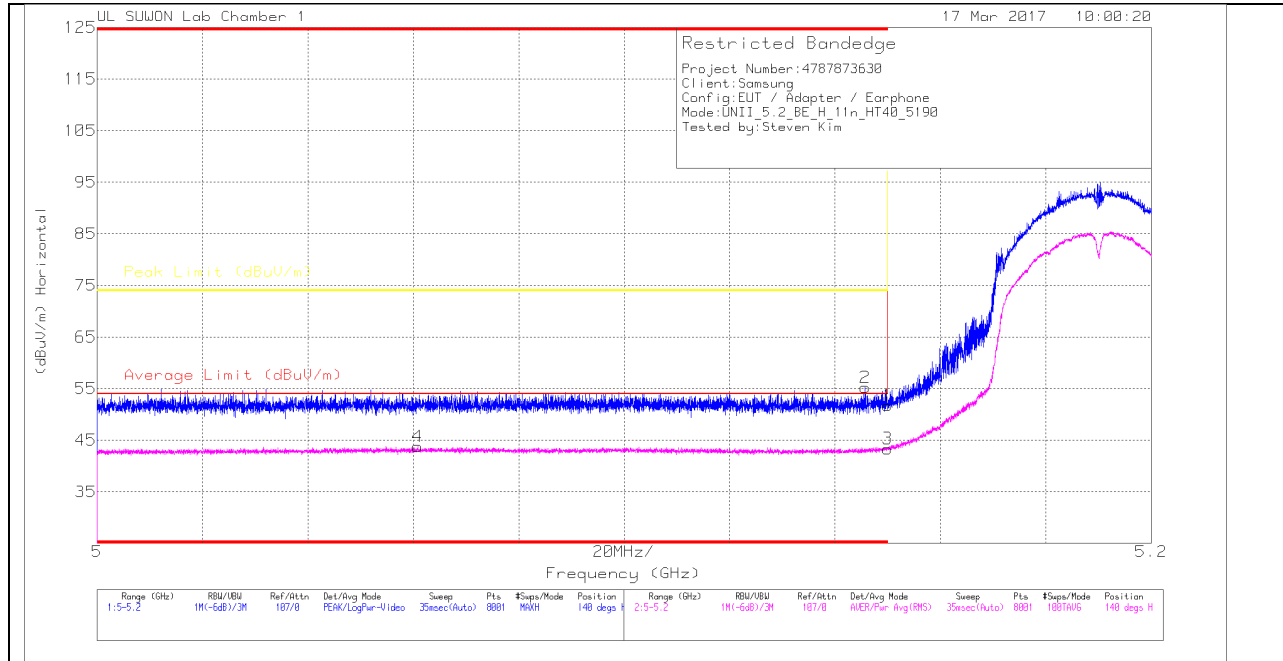

#### HORIZONTAL DATA

##### Trace Markers

Marker	Frequency (GHz)	Meter Reading (dBuV)	Det	3117(00168717)_150619	10dB_Att(dB)	DC Corr (dB)	Corrected Reading (dBuV/m)	Average Limit (dBuV/m)	Margin (dB)	Peak Limit (dBuV/m)	PK Margin (dB)	Azimuth (Degs)	Height (cm)	Polarity
1	* 5.15	41.74	Pk	34.2	-24.2	0	51.74	-	-	74	-22.26	140	391	H
2	* 5.146	45.2	Pk	34.2	-24.2	0	55.2	-	-	74	-18.8	140	391	H
3	* 5.15	32.87	RMS	34.2	-24.1	.38	43.35	54	-10.65	-	-	140	391	H
4	* 5.061	33.52	RMS	34.1	-24.2	.38	43.8	54	-10.2	-	-	140	391	H

\* - indicates frequency in CFR15.205/IC7.2.2 Restricted Band

Pk - Peak detector

RMS - RMS detection

**VERTICAL PEAK AND AVERAGE PLOT**

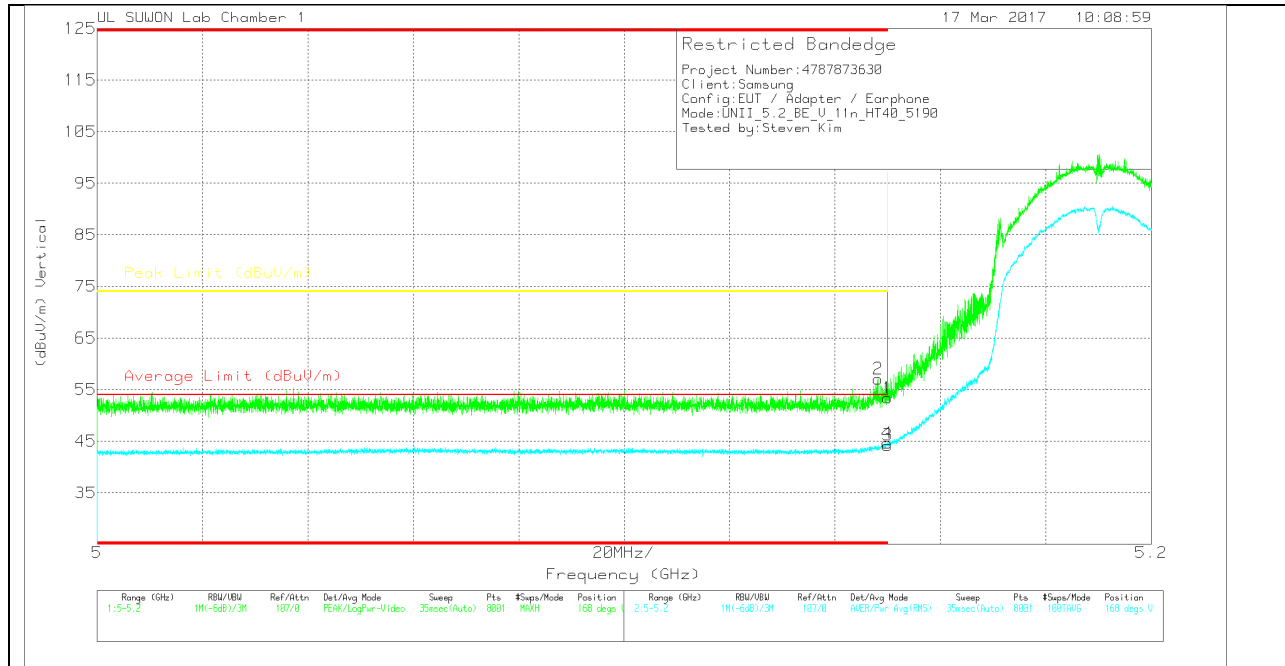

**VERTICAL DATA**

**Trace Markers**

Marker	Frequency (GHz)	Meter Reading (dBuV)	Det	3117(001687 17)_150619	10dB_Att(dB )	DC Corr (dB)	Corrected Reading (dBuV/m)	Average Limit (dBuV/m)	Margin (dB)	Peak Limit (dBuV/m)	PK Margin (dB)	Azimuth (Degs)	Height (cm)	Polarity
1	* 5.15	43.38	Pk	34.2	-24.2	0	53.38	-	-	74	-20.62	168	163	V
2	* 5.148	46.97	Pk	34.2	-24.1	0	57.07	-	-	74	-16.93	168	163	V
3	* 5.15	33.73	RMS	34.2	-24.1	.38	44.21	54	-9.79	-	-	168	163	V
4	* 5.15	34.14	RMS	34.2	-24.1	.38	44.62	54	-9.38	-	-	168	163	V

\* - indicates frequency in CFR15.205/IC7.2.2 Restricted Band

Pk - Peak detector

RMS - RMS detection

## HARMONICS AND SPURIOUS EMISSIONS

### LOW CHANNEL HORIZONTAL

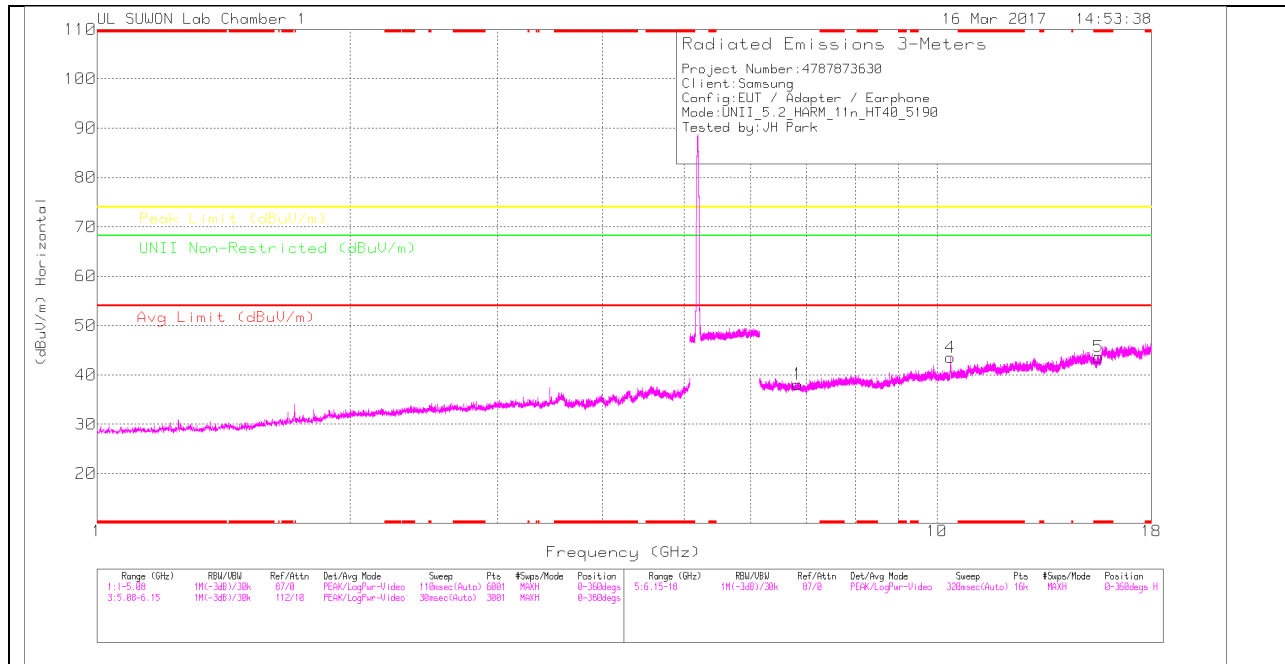

### LOW CHANNEL VERTICAL

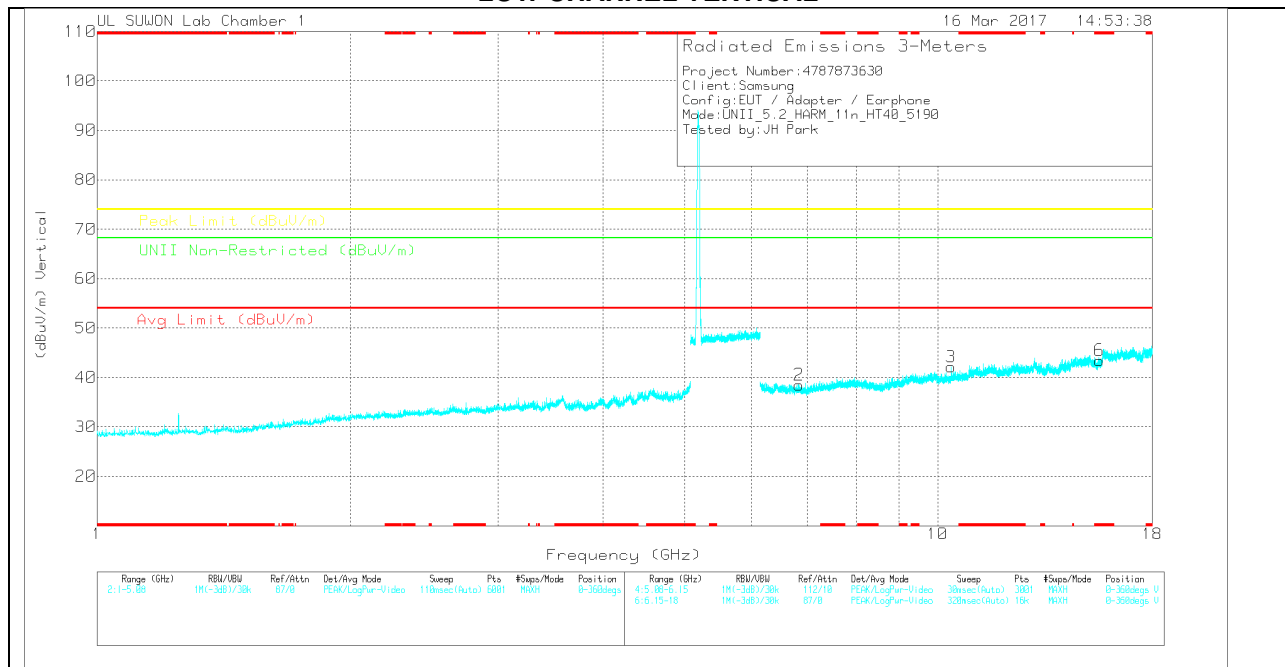

Note: Emission was scanned up to 40GHz; No emissions were detected above the noise floor which was at least 20dB below the specification limit.

**LOW CHANNEL DATA**

Trace Markers

Marker	Frequency (GHz)	Meter Reading (dBuV)	Det	3117(0016 8717)_150 519	6Ghz_HP(d B)	DC Corr (dB)	Corrected Reading (dBuV/m)	Avg Limit (dBuV/m)	Margin (dB)	Peak Limit (dBuV/m)	Margin (dB)	UNII Non-Restricted (dBuV/m)	Margin (dB)	Azimuth (Degs)	Height (cm)	Polarity
1	6.826	33.59	PK	35.6	-31.1	0	38.09	-	-	-	-	68.2	-30.11	0-360	150	H
4	10.379	33.52	PK	37.8	-27.8	0	43.52	-	-	-	-	68.2	-24.68	0-360	150	H
5	* 15.572	22.31	PK	40.3	-19	0	43.61	-	-	74	-30.39	-	-	0-360	250	H
2	6.842	33.98	PK	35.6	-31.1	0	38.48	-	-	-	-	68.2	-29.72	0-360	250	V
3	10.379	32.14	PK	37.8	-27.8	0	42.14	-	-	-	-	68.2	-26.06	0-360	150	V
6	* 15.568	22.24	PK	40.3	-19.1	0	43.44	-	-	74	-30.56	-	-	0-360	150	V

\* - indicates frequency in CFR15.205/IC7.2.2 Restricted Band

PK – Peak Detector

Radiated Emissions

Frequency (GHz)	Meter Reading (dBuV)	Det	3117(001687 17)_150619	6Ghz_HP(dB)	DC Corr (dB)	Corrected Reading (dBuV/m)	Avg Limit (dBuV/m)	Margin (dB)	Peak Limit (dBuV/m)	Margin (dB)	UNII Non-Restricted (dBuV/m)	Margin (dB)	Azimuth (Degs)	Height (cm)	Polarity
10.38	45.26	PK-U	37.8	-27.8	0	55.26	-	-	-	-	68.2	-12.94	175	216	H
10.38	44.49	PK-U	37.8	-27.8	0	54.49	-	-	-	-	68.2	-13.71	152	131	V

\* - indicates frequency in CFR15.205/IC7.2.2 Restricted Band

PK-U - U-NII: Maximum Peak

**HIGH CHANNEL HORIZONTAL**

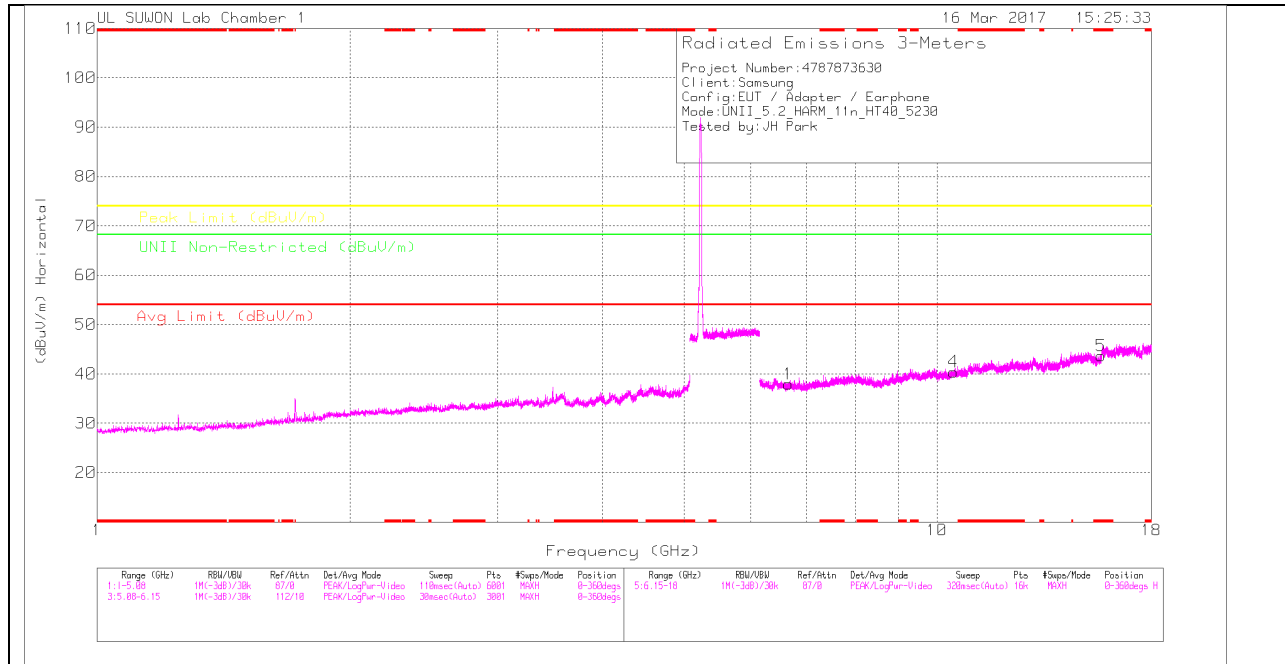

**HIGH CHANNEL VERTICAL**

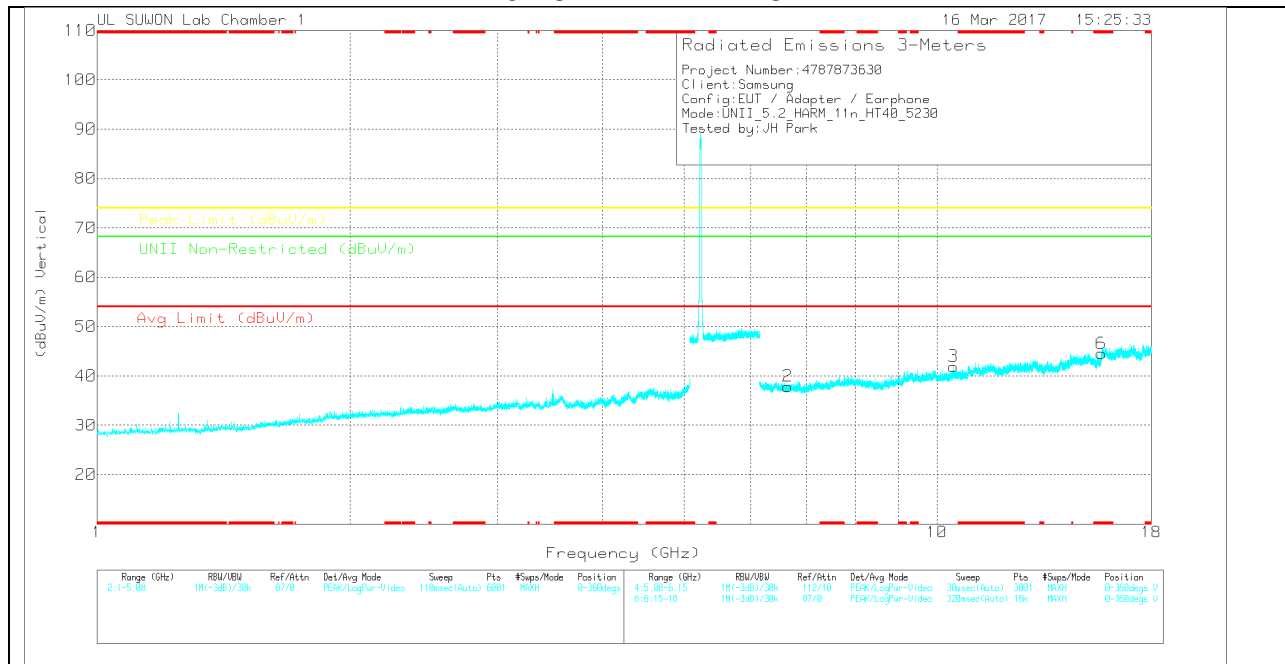

Note: Emission was scanned up to 40GHz; No emissions were detected above the noise floor which was at least 20dB below the specification limit.

**HIGH CHANNEL DATA**

Trace Markers

Marker	Frequency (GHz)	Meter Reading (dBuV)	Det	3117(0016 8717)_150 619	6Ghz_HP(d B)	DC Corr (dB)	Corrected Reading (dBuV/m)	Avg Limit (dBuV/m)	Margin (dB)	Peak Limit (dBuV/m)	Margin (dB)	UNII Non-Restricted (dBuV/m)	Margin (dB)	Azimuth (Degs)	Height (cm)	Polarity
1	6.652	33.61	PK	35.5	-31.2	0	37.91	-	-	-	-	68.2	-30.29	0-360	250	H
4	10.46	31.1	PK	37.8	-28.5	0	40.4	-	-	-	-	68.2	-27.8	0-360	150	H
5	* 15.691	22.17	PK	40.4	-18.9	0	43.67	-	-	74	-30.33	-	-	0-360	150	H
2	6.64	33.57	PK	35.5	-31.2	0	37.87	-	-	-	-	68.2	-30.33	0-360	250	V
3	10.46	32.62	PK	37.8	-28.5	0	41.92	-	-	-	-	68.2	-26.28	0-360	150	V
6	* 15.693	23.03	PK	40.4	-18.9	0	44.53	-	-	74	-29.47	-	-	0-360	150	V

\* - indicates frequency in CFR15.205/IC7.2.2 Restricted Band

PK – Peak Detector

Note: Only peak measurement was performed. Because peak measurement result of unwanted emission is less than average limit (54dBuV/m).

## 10.2. 5.3 GHz

### 10.2.1. TX ABOVE 1 GHz 802.11a MODE IN THE 5.3 GHz BAND AUTHORIZED BANDEDGE (HIGH CHANNEL)

#### HORIZONTAL PEAK AND AVERAGE PLOT

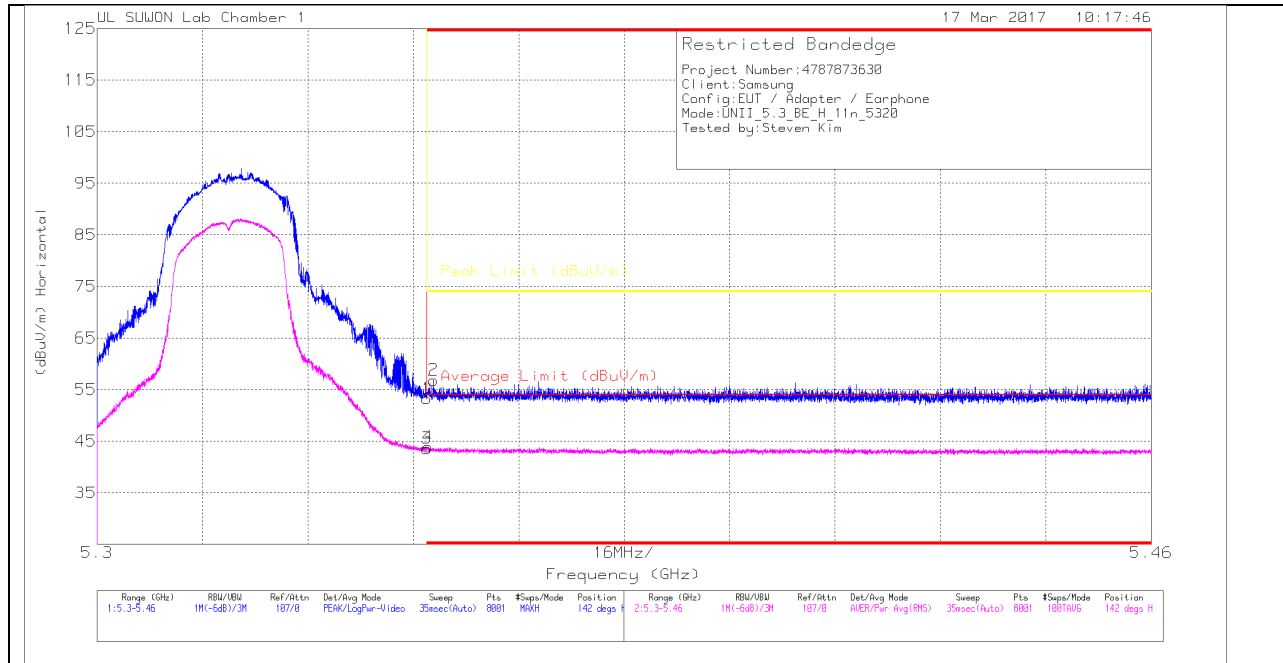

#### HORIZONTAL DATA

##### Trace Markers

Marker	Frequency (GHz)	Meter Reading (dBuV)	Det	3117(00168717)_150619	10dB_Att(dB)	DC Corr (dB)	Corrected Reading (dBuV/m)	Average Limit (dBuV/m)	Margin (dB)	Peak Limit (dBuV/m)	PK Margin (dB)	Azimuth (Degs)	Height (cm)	Polarity
1	* 5.35	42.29	Pk		-23.5	0	53.29	-	-	74	-20.71	142	367	H
2	* 5.351	45.86	Pk		-23.5	0	56.86	-	-	74	-17.14	142	367	H
3	* 5.35	32.72	RMS		-23.8	.18	43.6	54	-10.4	-	-	142	367	H
4	* 5.35	33.01	RMS		-23.8	.18	43.89	54	-10.11	-	-	142	367	H

\* - indicates frequency in CFR15.205/IC7.2.2 Restricted Band

Pk - Peak detector

RMS - RMS detection

**VERTICAL PEAK AND AVERAGE PLOT**

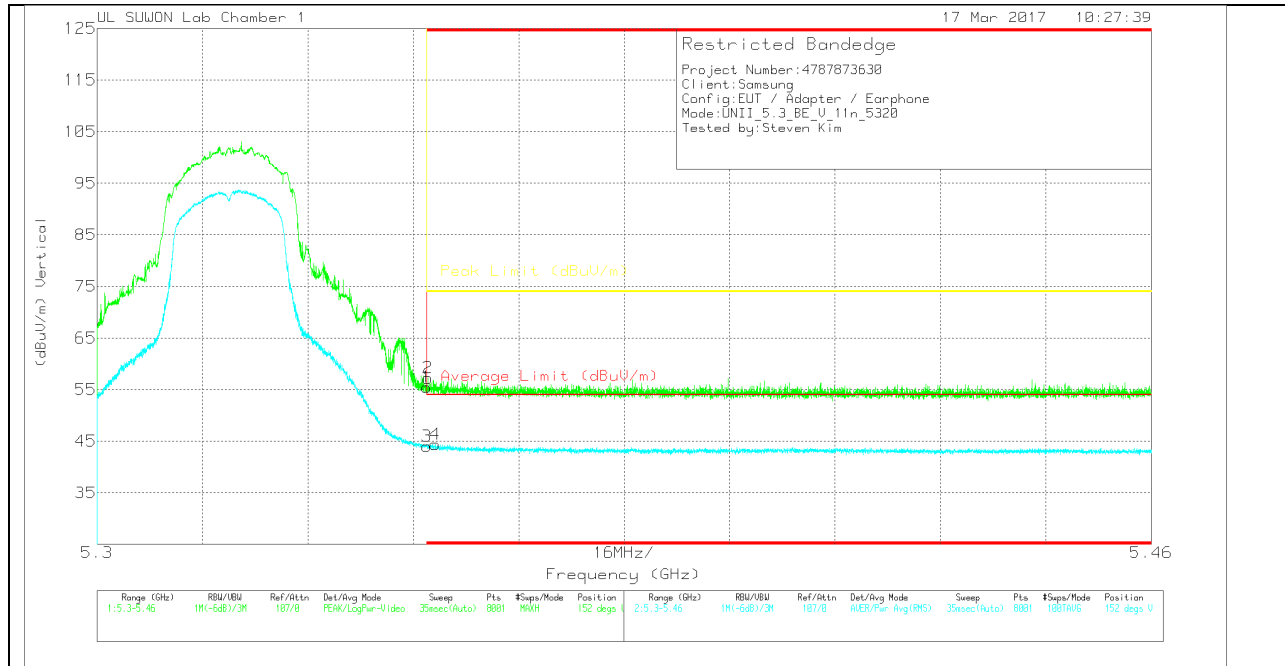

**VERTICAL DATA**

**Trace Markers**

Marker	Frequency (GHz)	Meter Reading (dBuV)	Det	3117(001687 17)_150619	10dB_Att(dB)	DC Corr (dB)	Corrected Reading (dBuV/m)	Average Limit (dBuV/m)	Margin (dB)	Peak Limit (dBuV/m)	PK Margin (dB)	Azimuth (Degs)	Height (cm)	Polarity
1	* 5.35	44.46	Pk		-23.5	0	55.46	-	-	74	-18.54	152	175	V
2	* 5.35	46.16	Pk		-23.4	0	57.26	-	-	74	-16.74	152	175	V
3	* 5.35	33.13	RMS		-23.8	.18	44.01	54	-9.99	-	-	152	175	V
4	* 5.351	33.53	RMS		-23.8	.18	44.41	54	-9.59	-	-	152	175	V

\* - indicates frequency in CFR15.205/IC7.2.2 Restricted Band

Pk - Peak detector

RMS - RMS detection

## HARMONICS AND SPURIOUS EMISSIONS

### LOW CHANNEL HORIZONTAL

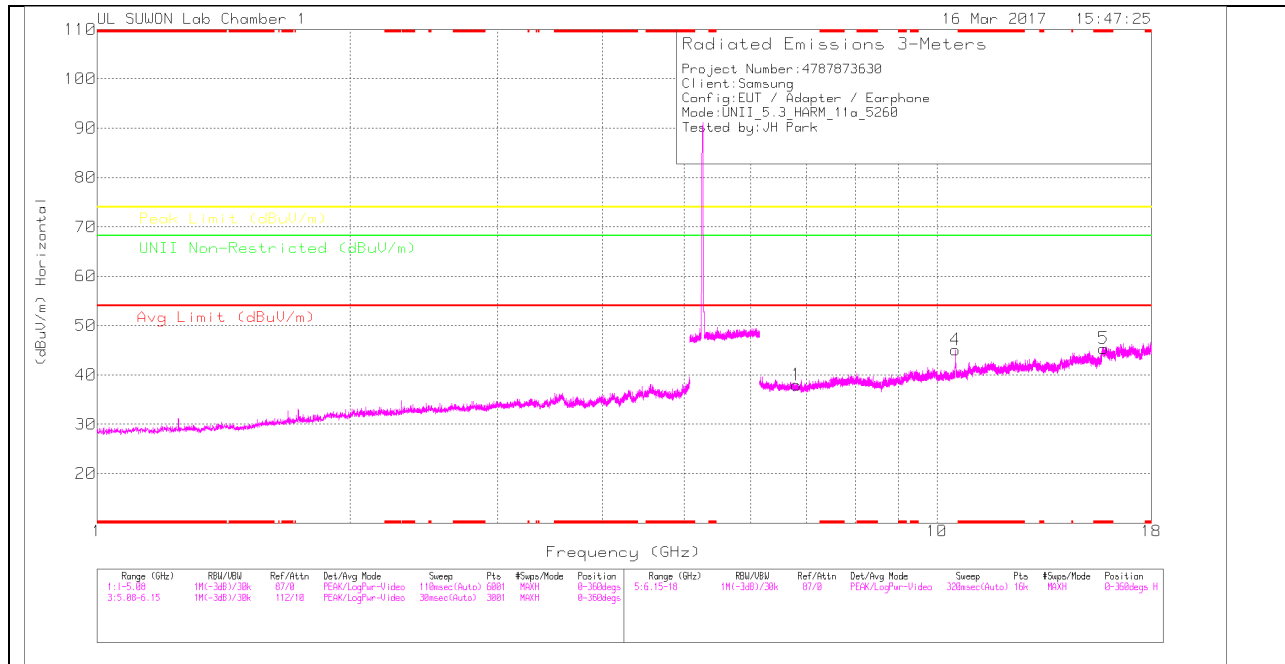

### LOW CHANNEL VERTICAL

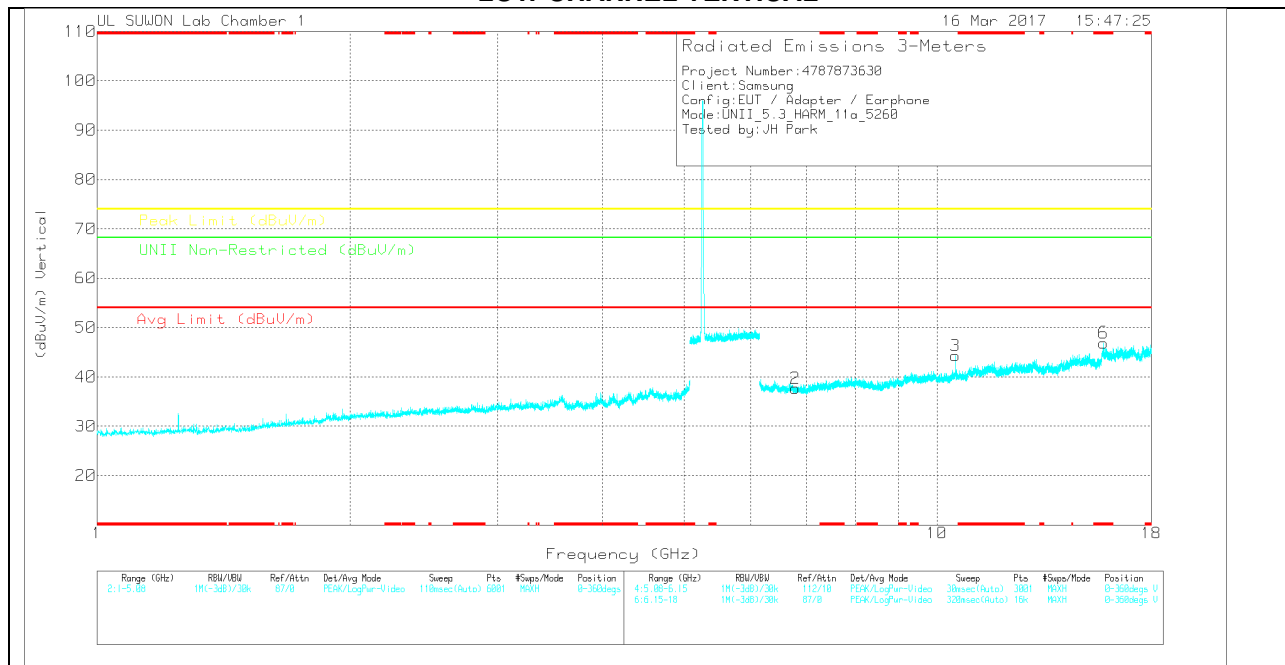

Note: Emission was scanned up to 40GHz; No emissions were detected above the noise floor which was at least 20dB below the specification limit.

**LOW CHANNEL DATA**

Trace Markers

Marker	Frequency (GHz)	Meter Reading (dBuV)	Det	3117(0016 8717)_150 519	6Ghz_HP(d B)	DC Corr (dB)	Corrected Reading (dBuV/m)	Avg Limit (dBuV/m)	Margin (dB)	Peak Limit (dBuV/m)	Margin (dB)	UNII Non-Restricted (dBuV/m)	Margin (dB)	Azimuth (Degs)	Height (cm)	Polarity
1	6.804	33.38	PK	35.6	-31	0	37.98	-	-	-	-	68.2	-30.22	0-360	250	H
4	10.519	35.39	PK	37.9	-28.2	0	45.09	-	-	-	-	68.2	-23.11	0-360	250	H
5	* 15.78	21.77	PK	40.4	-16.8	0	45.37	-	-	74	-28.63	-	-	0-360	250	H
2	6.785	33.07	PK	35.6	-31	0	37.67	-	-	-	-	68.2	-30.53	0-360	250	V
3	10.519	34.61	PK	37.9	-28.2	0	44.31	-	-	-	-	68.2	-23.89	0-360	150	V
6	* 15.782	23.27	PK	40.4	-16.8	0	46.87	-	-	74	-27.13	-	-	0-360	250	V

\* - indicates frequency in CFR15.205/IC7.2.2 Restricted Band

PK – Peak Detector

Radiated Emissions

Frequency (GHz)	Meter Reading (dBuV)	Det	3117(001687 17)_150619	6Ghz_HP(dB)	DC Corr (dB)	Corrected Reading (dBuV/m)	Avg Limit (dBuV/m)	Margin (dB)	Peak Limit (dBuV/m)	Margin (dB)	UNII Non-Restricted (dBuV/m)	Margin (dB)	Azimuth (Degs)	Height (cm)	Polarity
10.522	46.35	PK-U	37.9	-28.3	0	55.95	-	-	-	-	68.2	-12.25	178	136	H
10.521	45.73	PK-U	37.9	-28.3	0	55.33	-	-	-	-	68.2	-12.87	153	180	V

\* - indicates frequency in CFR15.205/IC7.2.2 Restricted Band

PK-U - U-NII: Maximum Peak

MID CHANNEL HORIZONTAL

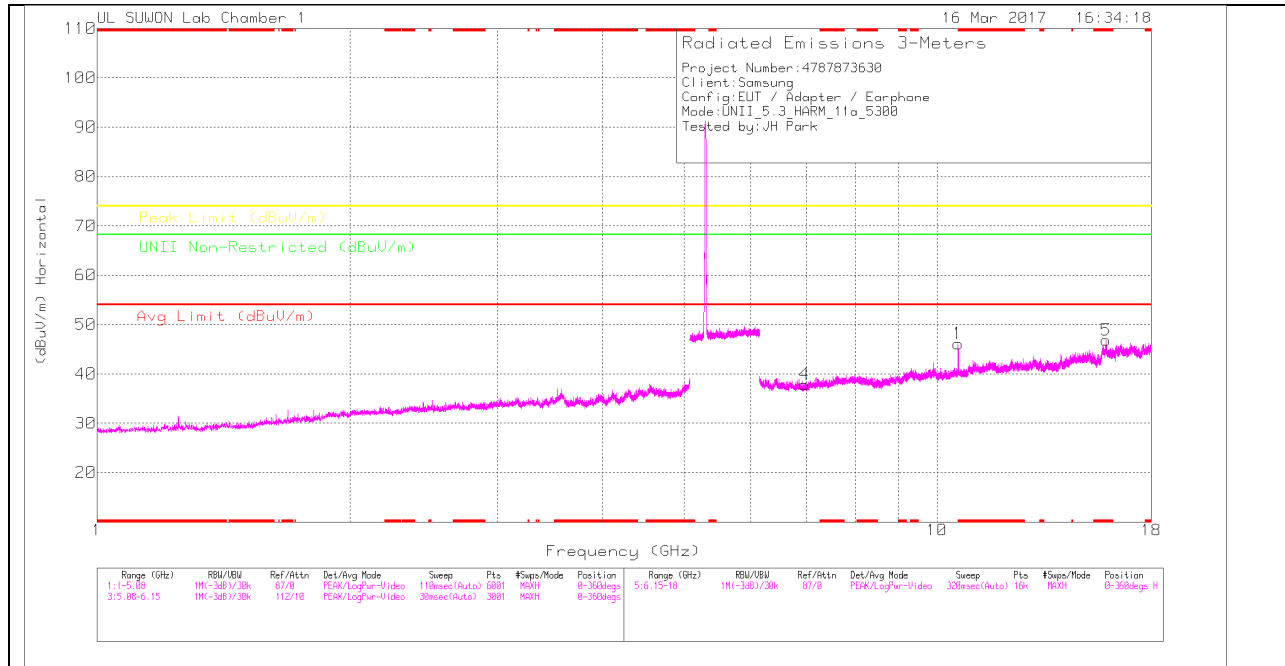

MID CHANNEL VERTICAL

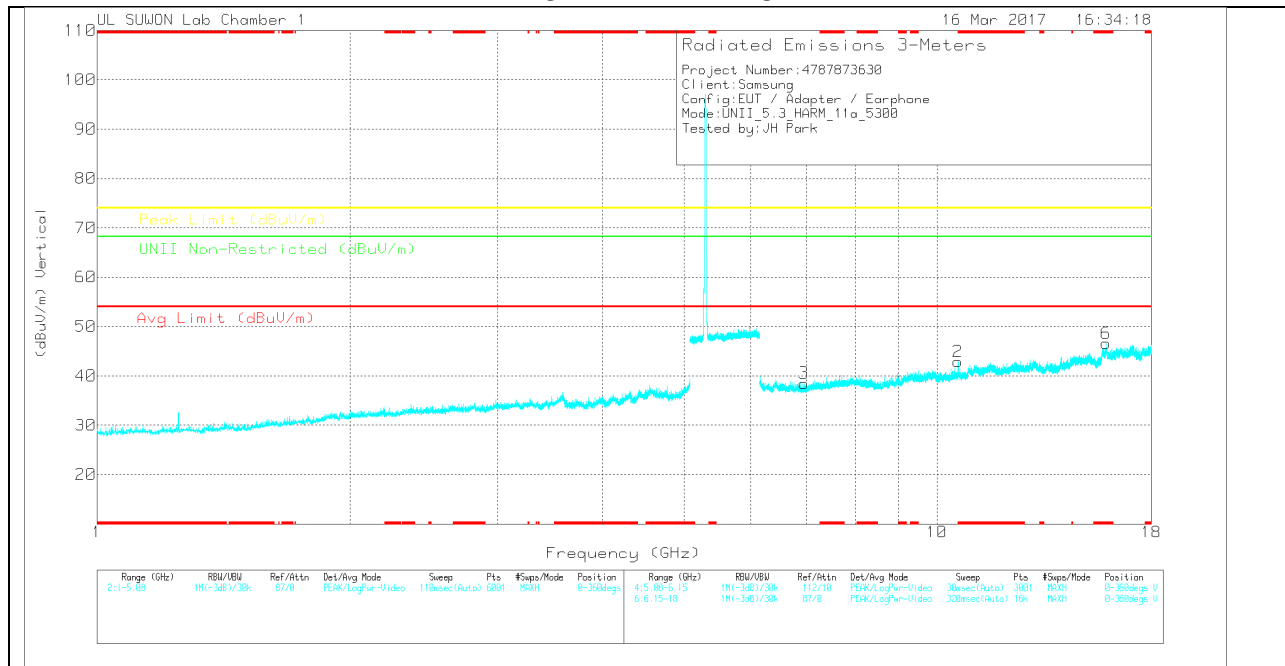

Note: Emission was scanned up to 40GHz; No emissions were detected above the noise floor which was at least 20dB below the specification limit.

**MID CHANNEL DATA**

Trace Markers

Marker	Frequency (GHz)	Meter Reading (dBuV)	Det	3117(0016 8717)_150 619	6Ghz_HP(d B)	DC Corr (dB)	Corrected Reading (dBuV/m)	Avg Limit (dBuV/m)	Margin (dB)	Peak Limit (dBuV/m)	Margin (dB)	UNII Non-Restricted (dBuV/m)	Margin (dB)	Azimuth (Degs)	Height (cm)	Polarity
1	10.599	36.11	PK	37.9	-27.9	0	46.11	-	-	-	-	68.2	-22.09	0-360	150	H
4	6.958	33.16	PK	35.7	-31	0	37.86	-	-	-	-	68.2	-30.34	0-360	250	H
5	* 15.901	25.56	PK	40.5	-19.2	0	46.86	-	-	74	-27.14	-	-	0-360	250	H
2	10.599	32.77	PK	37.9	-27.8	0	42.87	-	-	-	-	68.2	-25.33	0-360	150	V
3	6.944	33.8	PK	35.7	-31	0	38.5	-	-	-	-	68.2	-29.7	0-360	250	V
6	* 15.903	25.29	PK	40.5	-19.2	0	46.59	-	-	74	-27.41	-	-	0-360	250	V

\* - indicates frequency in CFR15.205/IC7.2.2 Restricted Band

PK – Peak Detector

Radiated Emissions

Frequency (GHz)	Meter Reading (dBuV)	Det	3117(001687 17)_150619	6Ghz_HP(dB)	DC Corr (dB)	Corrected Reading (dBuV/m)	Avg Limit (dBuV/m)	Margin (dB)	Peak Limit (dBuV/m)	Margin (dB)	UNII Non-Restricted (dBuV/m)	Margin (dB)	Azimuth (Degs)	Height (cm)	Polarity
* 10.6	45.67	PK-U	37.9	-27.9	0	55.67	-	-	74	-18.33	-	-	179	149	H
* 10.6	33.24	ADR	37.9	-27.9	.18	43.42	54	-10.58	-	-	-	-	179	149	H
* 10.601	44.29	PK-U	37.9	-27.8	0	54.39	-	-	74	-19.61	-	-	155	161	V
* 10.6	32.27	ADR	37.9	-27.9	.18	42.45	54	-11.55	-	-	-	-	155	161	V

\* - indicates frequency in CFR15.205/IC7.2.2 Restricted Band

PK-U - U-NII: Maximum Peak

ADR - U-NII AD primary method, RMS average

### HIGH CHANNEL HORIZONTAL

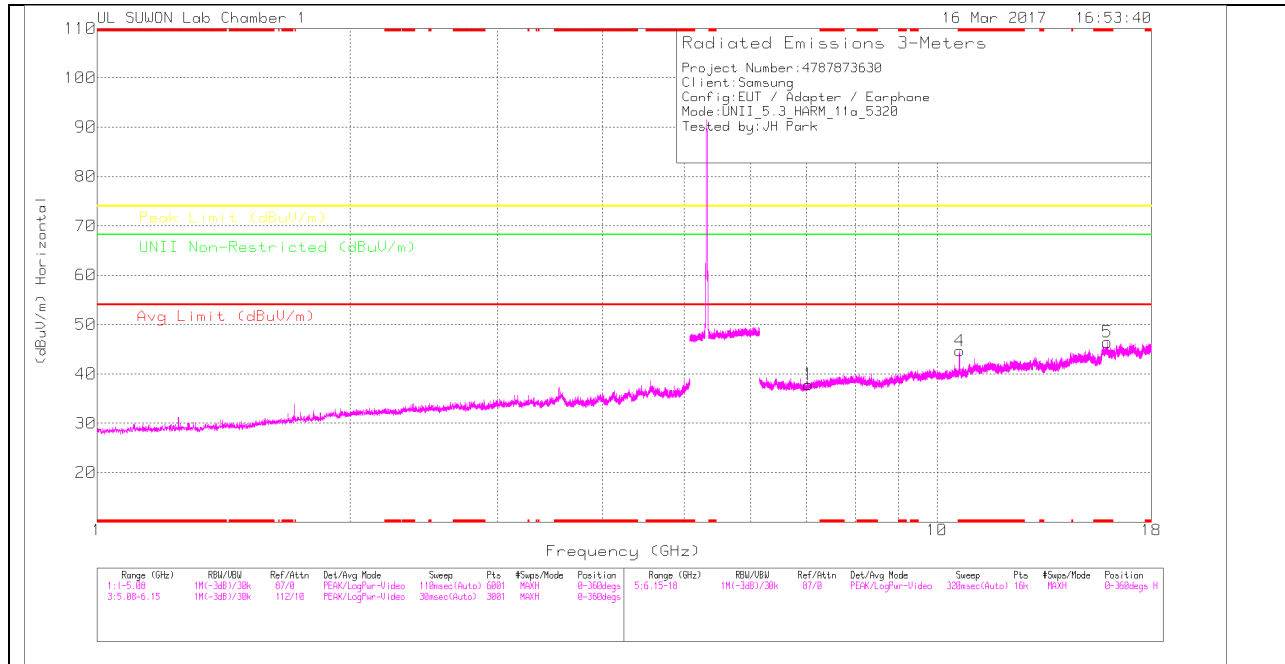

### HIGH CHANNEL VERTICAL

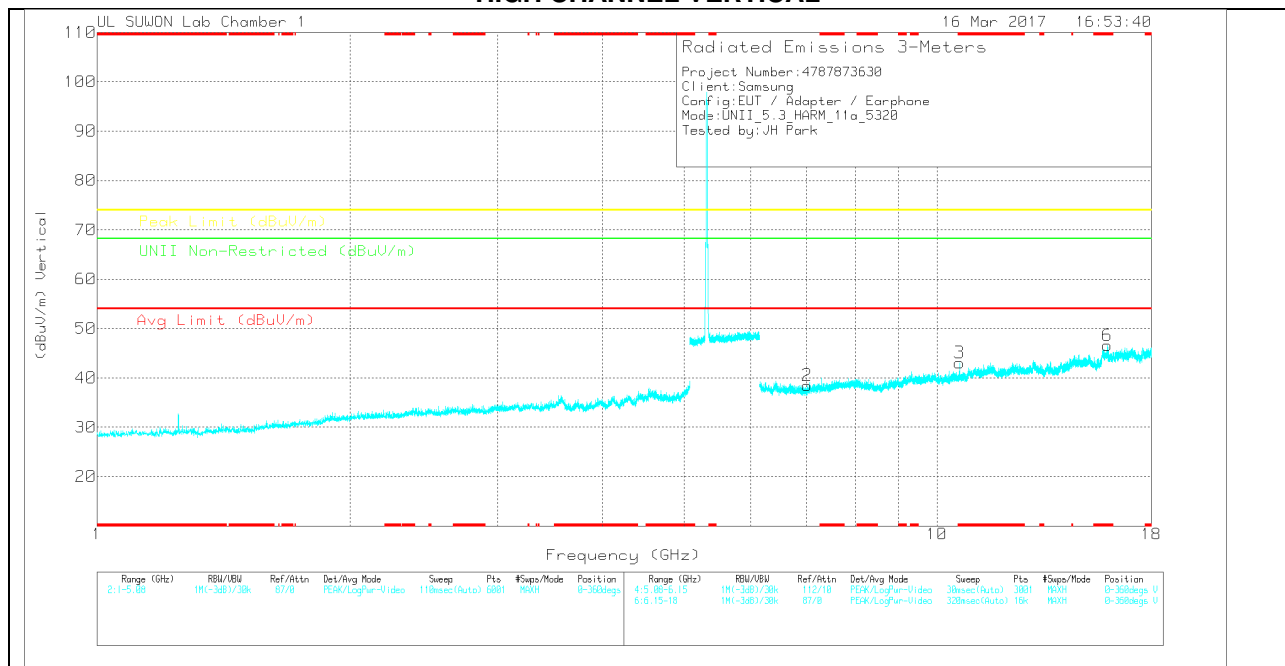

Note: Emission was scanned up to 40GHz; No emissions were detected above the noise floor which was at least 20dB below the specification limit.

**HIGH CHANNEL DATA**

Trace Markers

Marker	Frequency (GHz)	Meter Reading (dBuV)	Det	3117(0016 8717)_150 519	6Ghz_HP(d B)	DC Corr (dB)	Corrected Reading (dBuV/m)	Avg Limit (dBuV/m)	Margin (dB)	Peak Limit (dBuV/m)	Margin (dB)	UNII Non-Restricted (dBuV/m)	Margin (dB)	Azimuth (Degs)	Height (cm)	Polarity
1	7.028	33.24	PK	35.7	-31.1	0	37.84	-	-	-	-	68.2	-30.36	0-360	150	H
4	* 10.639	35.39	PK	37.9	-28.6	0	44.69	-	-	74	-29.31	-	-	0-360	150	H
5	* 15.961	25.72	PK	40.6	-19.9	0	46.42	-	-	74	-27.58	-	-	0-360	250	H
2	7.008	33.98	PK	35.7	-31.2	0	38.48	-	-	-	-	68.2	-29.72	0-360	150	V
3	* 10.638	33.77	PK	37.9	-28.6	0	43.07	-	-	74	-30.93	-	-	0-360	150	V
6	* 15.961	25.86	PK	40.6	-19.9	0	46.56	-	-	74	-27.44	-	-	0-360	250	V

\* - indicates frequency in CFR15.205/IC7.2.2 Restricted Band

PK – Peak Detector

Radiated Emissions

Frequency (GHz)	Meter Reading (dBuV)	Det	3117(001687 17)_150619	6Ghz_HP(dB)	DC Corr (dB)	Corrected Reading (dBuV/m)	Avg Limit (dBuV/m)	Margin (dB)	Peak Limit (dBuV/m)	Margin (dB)	UNII Non-Restricted (dBuV/m)	Margin (dB)	Azimuth (Degs)	Height (cm)	Polarity
* 10.642	46.55	PK-U	38	-28.6	0	55.95	-	-	74	-18.05	-	-	217	173	H
* 10.64	32.93	ADR	37.9	-28.6	.18	42.41	54	-11.59	-	-	-	-	217	173	H
* 10.64	44.77	PK-U	37.9	-28.6	0	54.07	-	-	74	-19.93	-	-	155	170	V
* 10.64	32.34	ADR	37.9	-28.6	.18	41.82	54	-12.18	-	-	-	-	155	170	V

\* - indicates frequency in CFR15.205/IC7.2.2 Restricted Band

PK-U - U-NII: Maximum Peak

ADR - U-NII AD primary method, RMS average

10.2.2. TX ABOVE 1GHz 802.11n HT20 MODE IN THE 5.3GHz BAND

AUTHORIZED BANDEDGE (HIGH CHANNEL)

HORIZONTAL PEAK AND AVERAGE PLOT

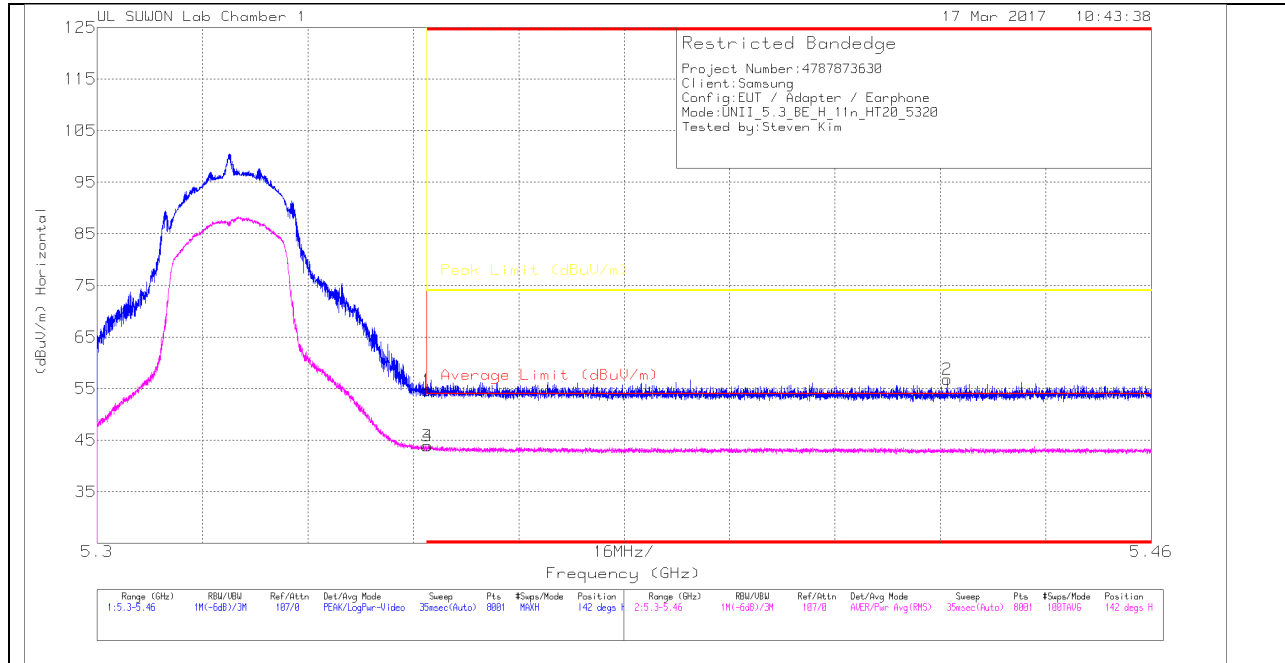

HORIZONTAL DATA

Trace Markers

Marker	Frequency (GHz)	Meter Reading (dBuV)	Det	3117(00168717)_150619	10dB_Att(dB)	DC Corr (dB)	Corrected Reading (dBuV/m)	Average Limit (dBuV/m)	Margin (dB)	Peak Limit (dBuV/m)	PK Margin (dB)	Azimuth (Degs)	Height (cm)	Polarity
1	* 5.35	43.64	Pk	34.5	-23.5	0	54.64	-	-	74	-19.36	142	366	H
2	* 5.429	45.59	Pk	34.6	-23.4	0	56.79	-	-	74	-17.21	142	366	H
3	* 5.35	33.01	RMS	34.5	-23.8	.17	43.88	54	-10.12	-	-	142	366	H
4	* 5.35	33.04	RMS	34.5	-23.8	.17	43.91	54	-10.09	-	-	142	366	H

\* - indicates frequency in CFR15.205/IC7.2.2 Restricted Band

Pk - Peak detector

RMS - RMS detection

**VERTICAL PEAK AND AVERAGE PLOT**

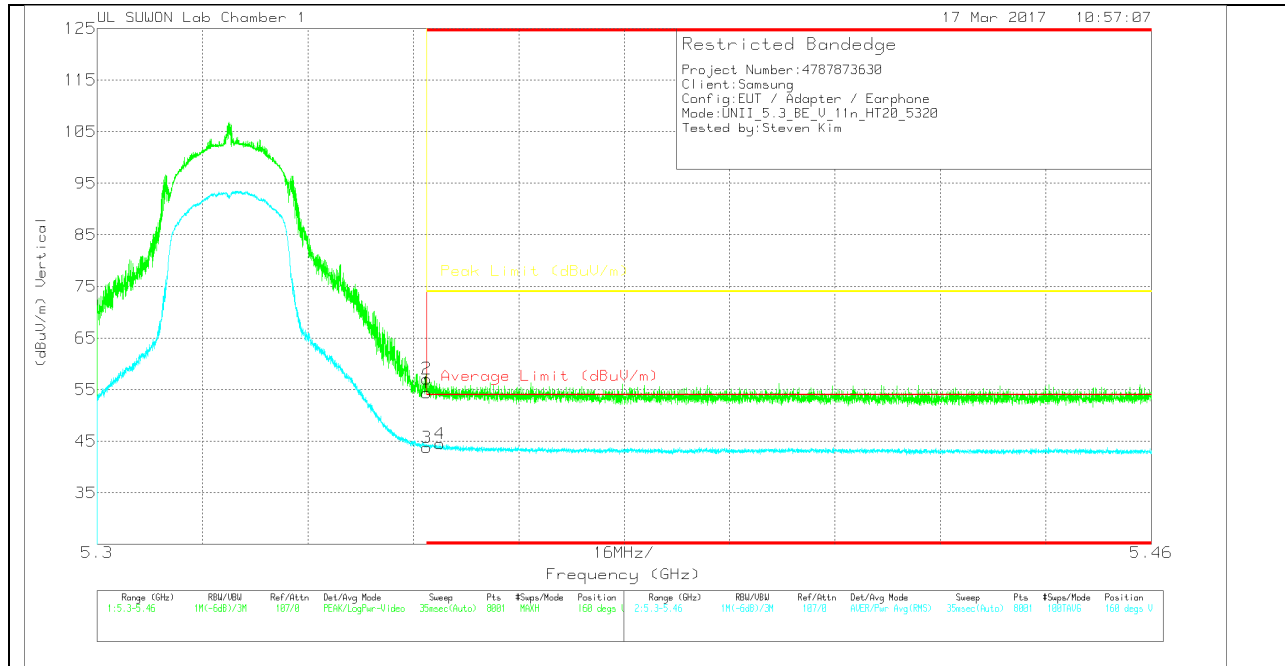

**VERTICAL DATA**

**Trace Markers**

Marker	Frequency (GHz)	Meter Reading (dBuV)	Det	3117(00168 717)_15061 9	10dB_Att(dB )	DC Corr (dB)	Corrected Reading (dBuV/m)	Average Limit (dBuV/m)	Margin (dB)	Peak Limit (dBuV/m)	PK Margin (dB)	Azimuth (Degs)	Height (cm)	Polarity
1	* 5.35	43.37	Pk		-23.5	0	54.37	-	-	74	-19.63	160	174	V
2	* 5.35	46	Pk		-23.4	0	57.1	-	-	74	-16.9	160	174	V
3	* 5.35	32.89	RMS		-23.8	.17	43.76	54	-10.24	-	-	160	174	V
4	* 5.352	33.62	RMS		-23.8	.17	44.49	54	-9.51	-	-	160	174	V

\* - indicates frequency in CFR15.205/IC7.2.2 Restricted Band

Pk - Peak detector

RMS - RMS detection

## HARMONICS AND SPURIOUS EMISSIONS

### LOW CHANNEL HORIZONTAL

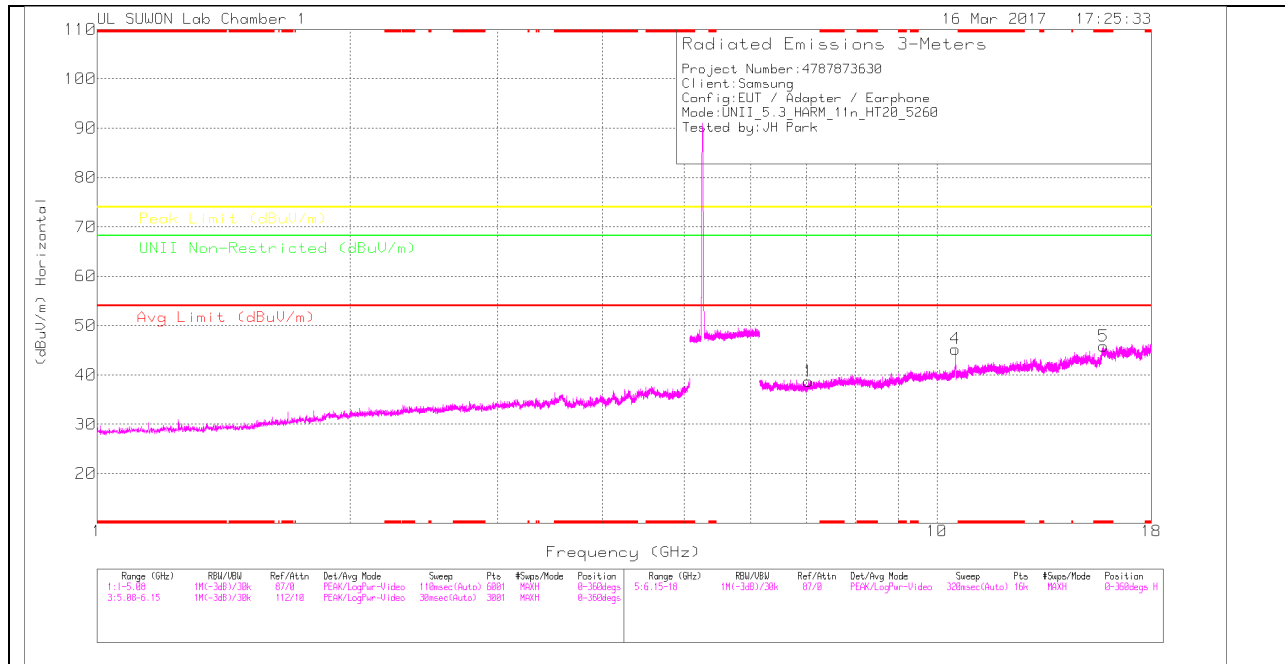

### LOW CHANNEL VERTICAL

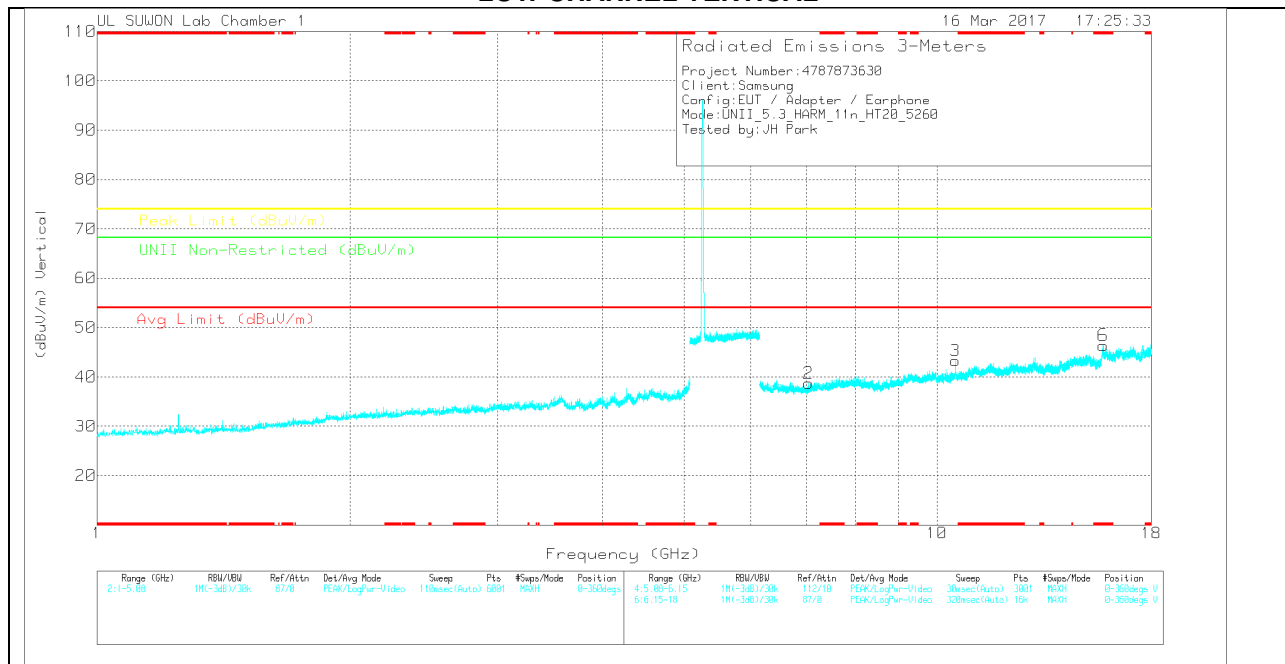

Note: Emission was scanned up to 40GHz; No emissions were detected above the noise floor which was at least 20dB below the specification limit.

**LOW CHANNEL DATA**

Trace Markers

Marker	Frequency (GHz)	Meter Reading (dBuV)	Det	3117(0016 8717)_150 619	6Ghz_HP(d B)	DC Corr (dB)	Corrected Reading (dBuV/m)	Avg Limit (dBuV/m)	Margin (dB)	Peak Limit (dBuV/m)	Margin (dB)	UNII Non-Restricted (dBuV/m)	Margin (dB)	Azimuth (Degs)	Height (cm)	Polarity
1	7.035	33.98	PK	35.7	-31	0	38.68	-	-	-	-	68.2	-29.52	0-360	150	H
4	10.519	35.56	PK	37.9	-28.2	0	45.26	-	-	-	-	68.2	-22.94	0-360	150	H
5	* 15.78	22.21	PK	40.4	-16.8	0	45.81	-	-	74	-28.19	-	-	0-360	250	H
2	7.035	34.02	PK	35.7	-31	0	38.72	-	-	-	-	68.2	-29.48	0-360	150	V
3	10.519	33.6	PK	37.9	-28.2	0	43.3	-	-	-	-	68.2	-24.9	0-360	150	V
6	* 15.777	22.77	PK	40.4	-16.8	0	46.37	-	-	74	-27.63	-	-	0-360	250	V

\* - indicates frequency in CFR15.205/IC7.2.2 Restricted Band

PK – Peak Detector

Radiated Emissions

Frequency (GHz)	Meter Reading (dBuV)	Det	3117(001687 17)_150619	6Ghz_HP(dB)	DC Corr (dB)	Corrected Reading (dBuV/m)	Avg Limit (dBuV/m)	Margin (dB)	Peak Limit (dBuV/m)	Margin (dB)	UNII Non-Restricted (dBuV/m)	Margin (dB)	Azimuth (Degs)	Height (cm)	Polarity
10.52	47.38	PK-U	37.9	-28.3	0	56.98	-	-	-	-	68.2	-11.22	214	151	H
10.52	45	PK-U	37.9	-28.3	0	54.6	-	-	-	-	68.2	-13.6	156	136	V

\* - indicates frequency in CFR15.205/IC7.2.2 Restricted Band

PK-U - U-NII: Maximum Peak

MID CHANNEL HORIZONTAL

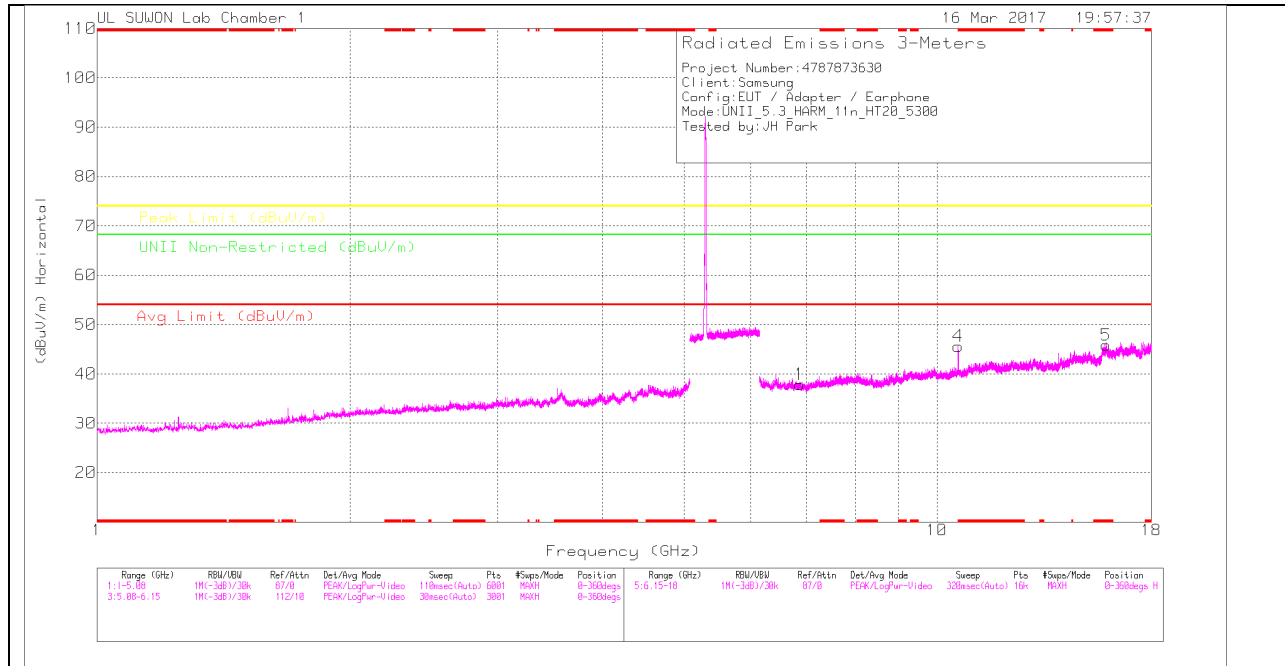

MID CHANNEL VERTICAL

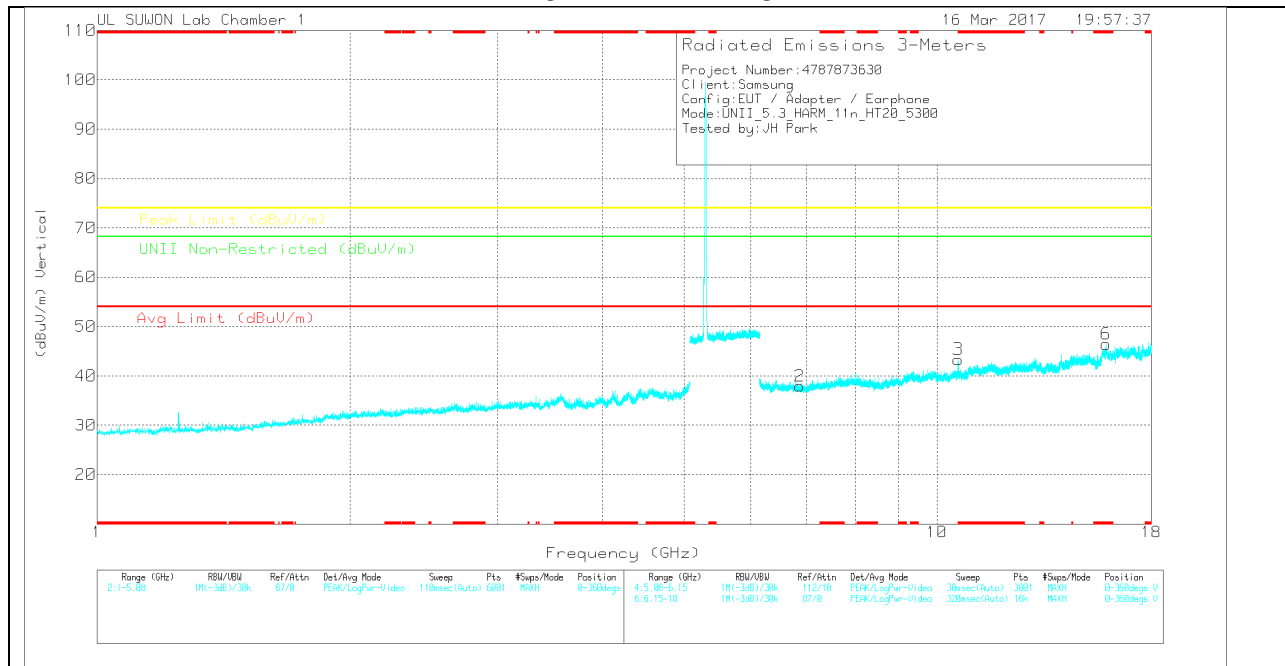

Note: Emission was scanned up to 40GHz; No emissions were detected above the noise floor which was at least 20dB below the specification limit.

**MID CHANNEL DATA**

Trace Markers

Marker	Frequency (GHz)	Meter Reading (dBuV)	Det	3117/0016 8717_150 619	6Ghz_HP(d B)	DC Corr (dB)	Corrected Reading (dBuV/m)	Avg Limit (dBuV/m)	Margin (dB)	Peak Limit (dBuV/m)	Margin (dB)	UNII Non-Restricted (dBuV/m)	Margin (dB)	Azimuth (Degs)	Height (cm)	Polarity
1	6.867	33.44	PK	35.6	-31.2	0	37.84	-	-	-	-	68.2	-30.36	0-360	250	H
4	10.599	35.61	PK	37.9	-27.9	0	45.61	-	-	-	-	68.2	-22.59	0-360	150	H
5	* 15.902	24.5	PK	40.5	-19.2	0	45.8	-	-	74	-28.2	-	-	0-360	250	H
2	6.865	33.43	PK	35.6	-31.1	0	37.93	-	-	-	-	68.2	-30.27	0-360	250	V
3	10.599	33.33	PK	37.9	-27.9	0	43.33	-	-	-	-	68.2	-24.87	0-360	150	V
6	* 15.899	25.12	PK	40.5	-19.2	0	46.42	-	-	74	-27.58	-	-	0-360	250	V

\* - indicates frequency in CFR15.205/IC7.2.2 Restricted Band

PK – Peak Detector

Radiated Emissions

Frequency (GHz)	Meter Reading (dBuV)	Det	3117/001687 17_150619	6Ghz_HP(dB)	DC Corr (dB)	Corrected Reading (dBuV/m)	Avg Limit (dBuV/m)	Margin (dB)	Peak Limit (dBuV/m)	Margin (dB)	UNII Non-Restricted (dBuV/m)	Margin (dB)	Azimuth (Degs)	Height (cm)	Polarity
* 10.6	42.62	PK-U	37.9	-27.9	0	52.62	-	-	74	-21.38	-	-	251	168	H
* 10.6	29.44	ADR	37.9	-27.9	.17	39.61	54	-14.39	-	-	-	-	251	168	H
* 10.601	44.31	PK-U	37.9	-27.9	0	54.31	-	-	74	-19.69	-	-	153	134	V
* 10.6	32.25	ADR	37.9	-27.9	.17	42.42	54	-11.58	-	-	-	-	153	134	V

\* - indicates frequency in CFR15.205/IC7.2.2 Restricted Band

PK-U - U-NII: Maximum Peak

ADR - U-NII AD primary method, RMS average

### HIGH CHANNEL HORIZONTAL

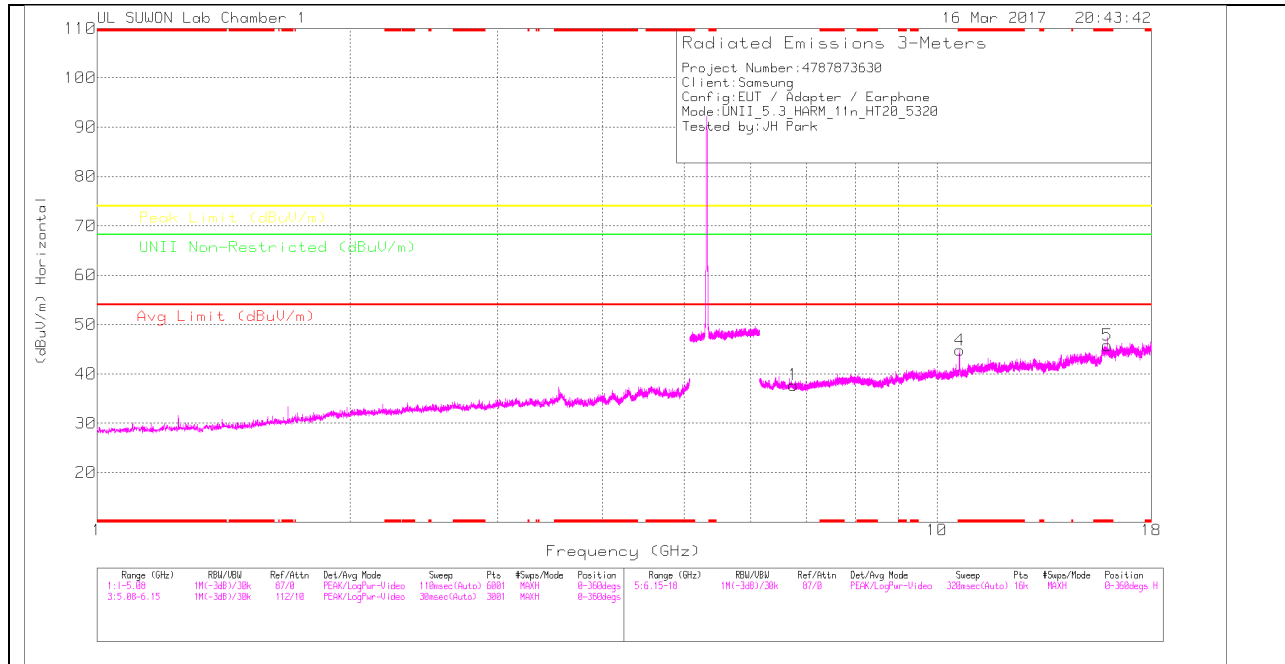

### HIGH CHANNEL VERTICAL

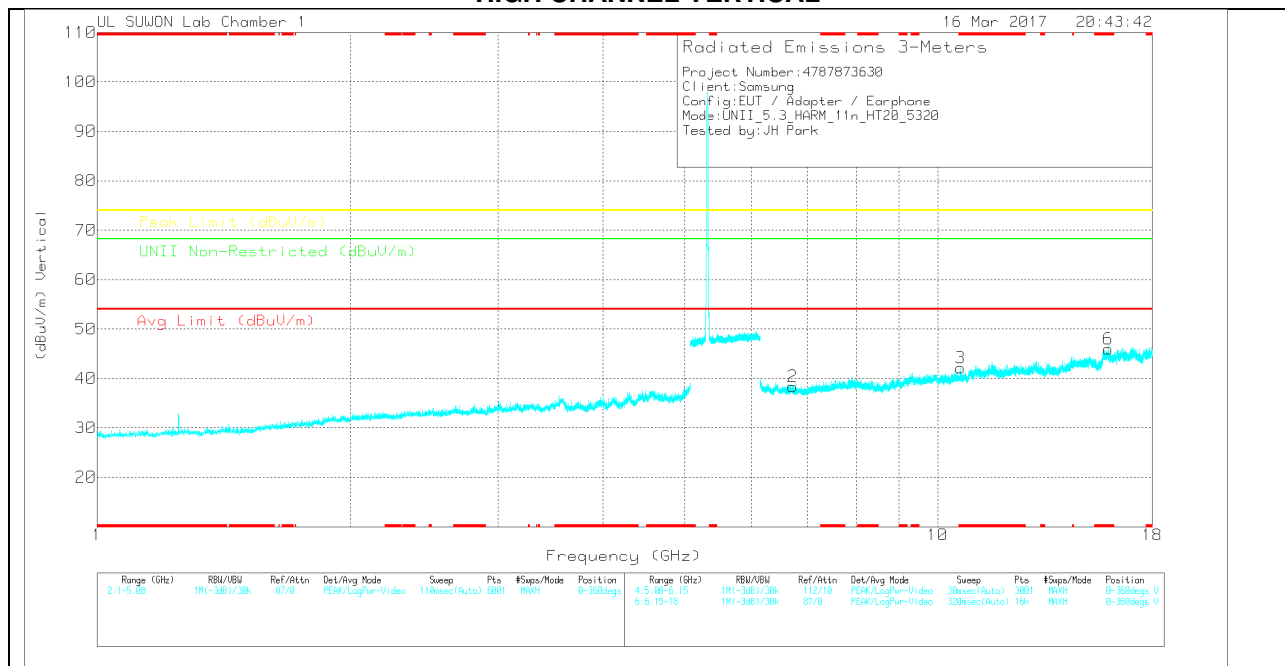

Note: Emission was scanned up to 40GHz; No emissions were detected above the noise floor which was at least 20dB below the specification limit.

**HIGH CHANNEL DATA**

Trace Markers

Marker	Frequency (GHz)	Meter Reading (dBuV)	Det	3117(0016 8717)_150 519	6Ghz_HP(d B)	DC Corr (dB)	Corrected Reading (dBuV/m)	Avg Limit (dBuV/m)	Margin (dB)	Peak Limit (dBuV/m)	Margin (dB)	UNII Non-Restricted (dBuV/m)	Margin (dB)	Azimuth (Degs)	Height (cm)	Polarity
1	6.749	33.55	PK	35.6	-31.4	0	37.75	-	-	-	-	68.2	-30.45	0-360	150	H
4	*10.64	35.5	PK	37.9	-28.6	0	44.8	-	-	74	-29.2	-	-	0-360	150	H
5	*15.96	25.09	PK	40.6	-19.9	0	45.79	-	-	74	-28.21	-	-	0-360	250	H
2	6.72	34.14	PK	35.5	-31.3	0	38.34	-	-	-	-	68.2	-29.86	0-360	150	V
3	*10.64	32.83	PK	37.9	-28.6	0	42.13	-	-	74	-31.87	-	-	0-360	150	V
6	*15.957	25.15	PK	40.6	-19.8	0	45.95	-	-	74	-28.05	-	-	0-360	250	V

\* - indicates frequency in CFR15.205/IC7.2.2 Restricted Band

PK – Peak Detector

Radiated Emissions

Frequency (GHz)	Meter Reading (dBuV)	Det	3117(001687 17)_150619	6Ghz_HP(dB)	DC Corr (dB)	Corrected Reading (dBuV/m)	Avg Limit (dBuV/m)	Margin (dB)	Peak Limit (dBuV/m)	Margin (dB)	UNII Non-Restricted (dBuV/m)	Margin (dB)	Azimuth (Degs)	Height (cm)	Polarity
*10.64	47.73	PK-U	37.9	-28.6	0	57.03	-	-	74	-16.97	-	-	217	162	H
*10.64	34.25	ADR	37.9	-28.6	.17	43.72	54	-10.28	-	-	-	-	217	162	H
*10.64	44.7	PK-U	37.9	-28.6	0	54	-	-	74	-20	-	-	153	141	V
*10.64	31.7	ADR	37.9	-28.6	.17	41.17	54	-12.83	-	-	-	-	153	141	V

\* - indicates frequency in CFR15.205/IC7.2.2 Restricted Band

PK-U - U-NII: Maximum Peak

ADR - U-NII AD primary method, RMS average

### 10.2.3. TX ABOVE 1GHz 802.11n HT40 MODE IN THE 5.3GHz BAND AUTHORIZED BANDEDGE (HIGH CHANNEL)

#### HORIZONTAL PEAK AND AVERAGE PLOT

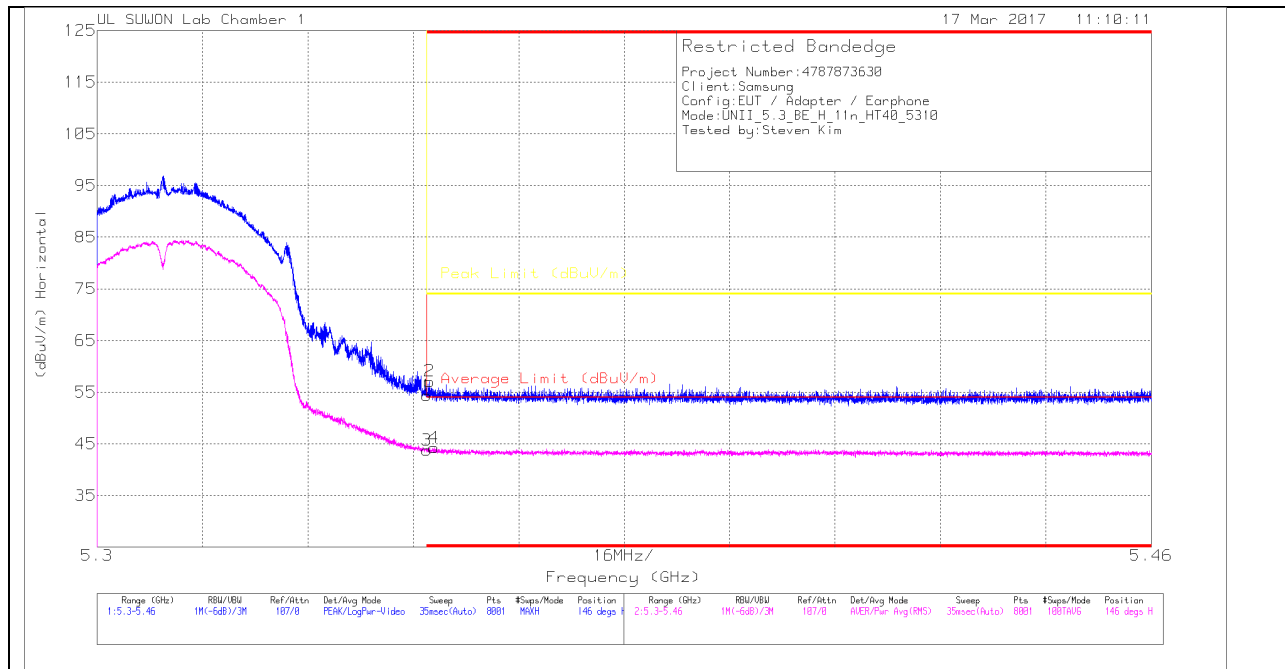

#### HORIZONTAL DATA

##### Trace Markers

Marker	Frequency (GHz)	Meter Reading (dBuV)	Det	3117(00168 717)_150619	10dB_Att(dB)	DC Corr (dB)	Corrected Reading (dBuV/m)	Average Limit (dBuV/m)	Margin (dB)	Peak Limit (dBuV/m)	PK Margin (dB)	Azimuth (Degs)	Height (cm)	Polarity
1	* 5.35	43.35	Pk		-23.5	0	54.35	-	-	74	-19.65	146	333	H
2	* 5.35	46.02	Pk		-23.4	0	57.12	-	-	74	-16.88	146	333	H
3	* 5.35	32.69	RMS		-23.8	.38	43.77	54	-10.23	-	-	146	333	H
4	* 5.351	33.18	RMS		-23.8	.38	44.26	54	-9.74	-	-	146	333	H

\* - indicates frequency in CFR15.205/IC7.2.2 Restricted Band

Pk - Peak detector

RMS - RMS detection

**VERTICAL PEAK AND AVERAGE PLOT**

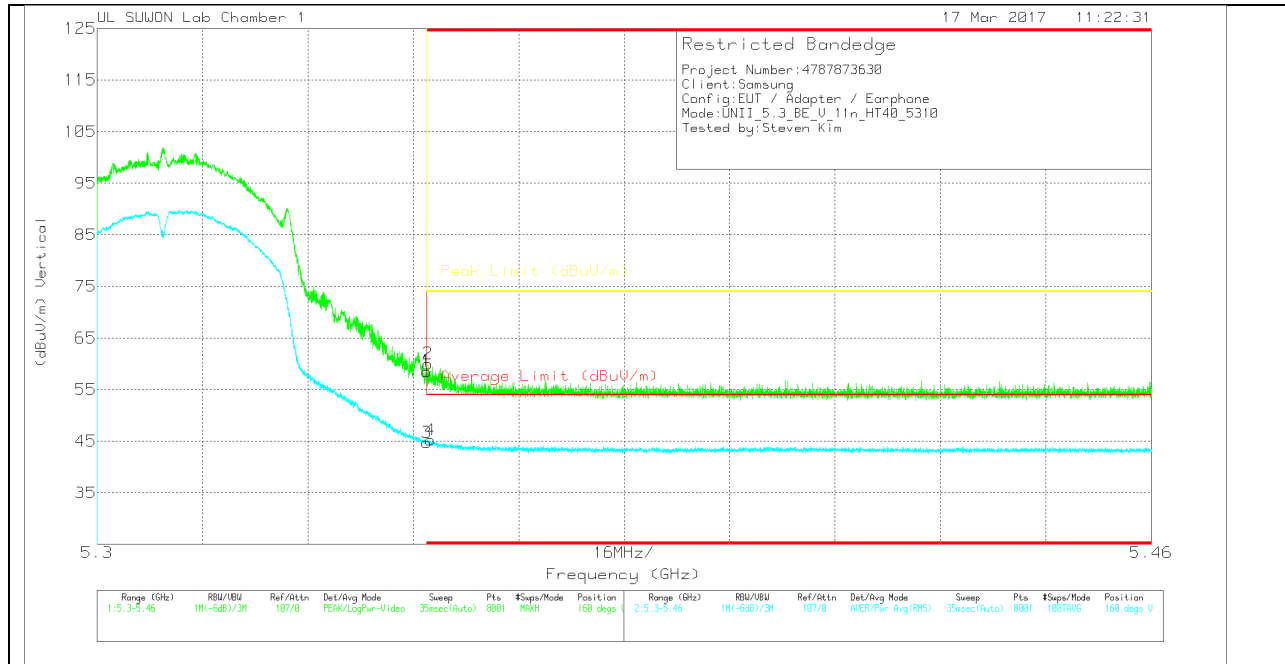

**VERTICAL DATA**

**Trace Markers**

Marker	Frequency (GHz)	Meter Reading (dBuV)	Det	3117(001687 17)_150619	10dB_Att(dB )	DC Corr (dB)	Corrected Reading (dBuV/m)	Average Limit (dBuV/m)	Margin (dB)	Peak Limit (dBuV/m)	PK Margin (dB)	Azimuth (Degs)	Height (cm)	Polarity
1	* 5.35	47.56	Pk	34.5	-23.5	0	58.56	-	-	74	-15.44	160	174	V
2	* 5.35	48.91	Pk	34.5	-23.4	0	60.01	-	-	74	-13.99	160	174	V
3	* 5.35	33.69	RMS	34.5	-23.8	.38	44.77	54	-9.23	-	-	160	174	V
4	* 5.351	34.18	RMS	34.5	-23.8	.38	45.26	54	-8.74	-	-	160	174	V

\* - indicates frequency in CFR15.205/IC7.2.2 Restricted Band

Pk - Peak detector

RMS - RMS detection

## HARMONICS AND SPURIOUS EMISSIONS

### LOW CHANNEL HORIZONTAL

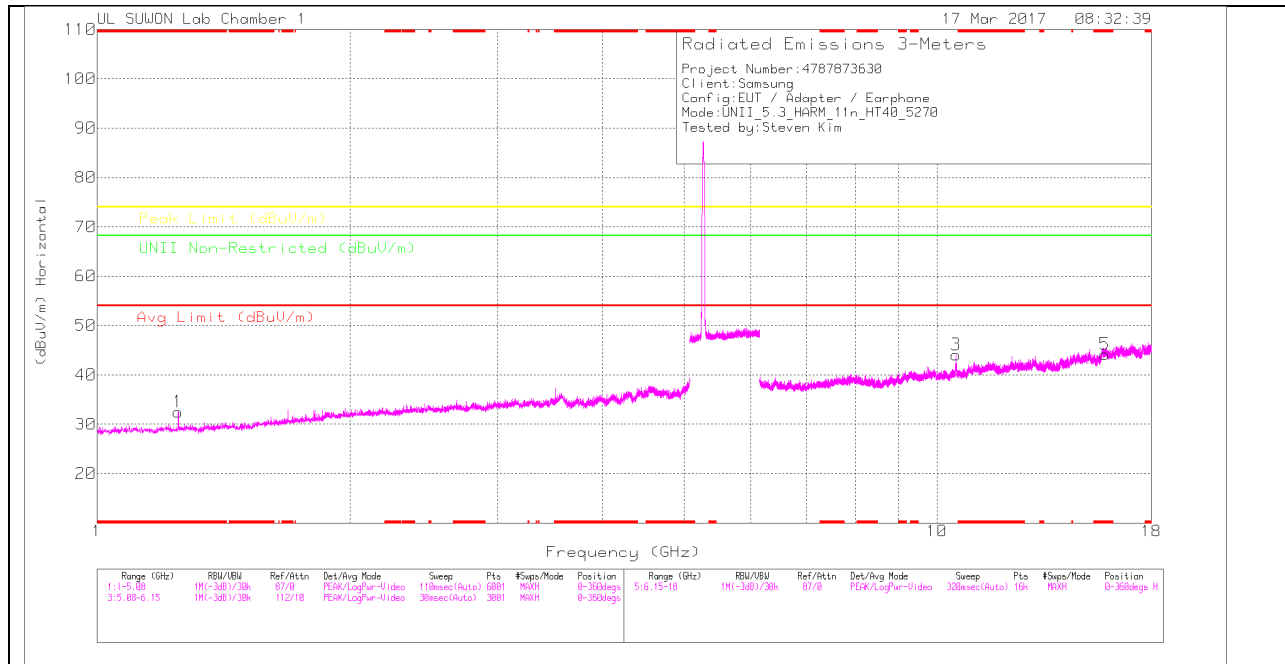

### LOW CHANNEL VERTICAL

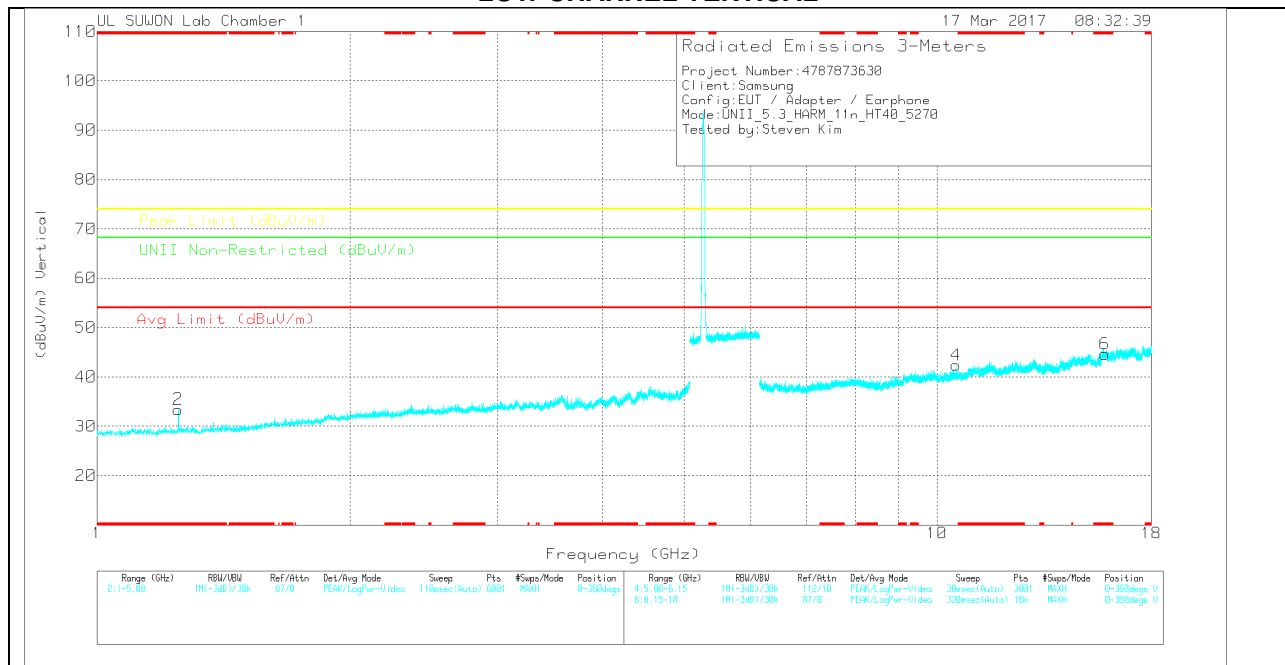

Note: Emission was scanned up to 40GHz; No emissions were detected above the noise floor which was at least 20dB below the specification limit.

**LOW CHANNEL DATA**

Trace Markers

Marker	Frequency (GHz)	Meter Reading (dBuV)	Det	3117(0016 8717)_150 619	5Ghz_LP(d B)	DC Corr (dB)	Corrected Reading (dBuV/m)	Avg Limit (dBuV/m)	Margin (dB)	Peak Limit (dBuV/m)	Margin (dB)	UNII Non-Restricted (dBuV/m)	Margin (dB)	Azimuth (Degs)	Height (cm)	Polarity
1	* 1.25	43.81	PK	28.3	-39.6	0	32.51	-	-	74	-41.49	-	-	0-360	150	H
2	* 1.25	44.7	PK	28.3	-39.6	0	33.4	-	-	74	-40.6	-	-	0-360	250	V
3	10.539	34.29	PK	37.9	-28.1	0	44.09	-	-	-	-	68.2	-24.11	0-360	150	H
5	* 15.84	22.6	PK	40.5	-18.9	0	44.2	-	-	74	-29.8	-	-	0-360	150	H
4	10.54	32.57	PK	37.9	-28.1	0	42.37	-	-	-	-	68.2	-25.83	0-360	150	V
6	* 15.839	23.04	PK	40.5	-18.9	0	44.64	-	-	74	-29.36	-	-	0-360	250	V

\* - indicates frequency in CFR15.205/IC7.2.2 Restricted Band

PK – Peak Detector

Radiated Emissions

Frequency (GHz)	Meter Reading (dBuV)	Det	3117(001687 17)_150619	6Ghz_HP(dB)	DC Corr (dB)	Corrected Reading (dBuV/m)	Avg Limit (dBuV/m)	Margin (dB)	Peak Limit (dBuV/m)	Margin (dB)	UNII Non-Restricted (dBuV/m)	Margin (dB)	Azimuth (Degs)	Height (cm)	Polarity
10.54	45.53	PK-U	37.9	-28.1	0	55.33	-	-	-	-	68.2	-12.87	187	140	H
10.54	43.44	PK-U	37.9	-28.1	0	53.24	-	-	-	-	68.2	-14.96	161	139	V

\* - indicates frequency in CFR15.205/IC7.2.2 Restricted Band

PK-U - U-NII: Maximum Peak

### HIGH CHANNEL HORIZONTAL

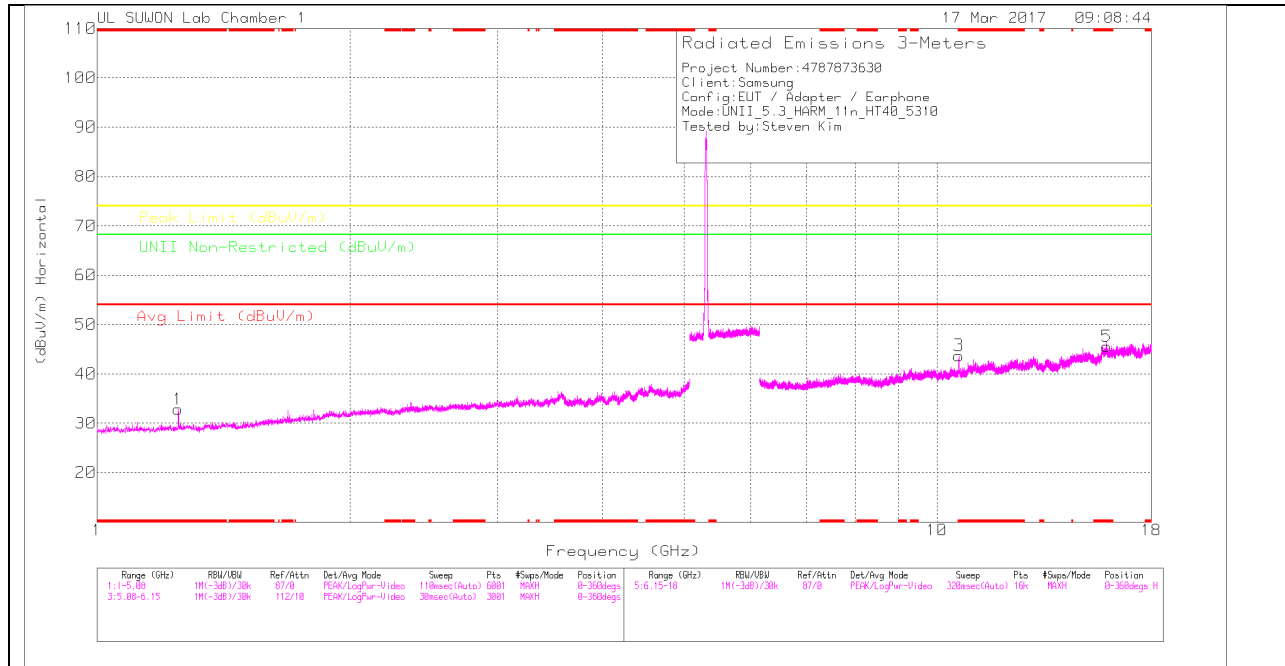

### HIGH CHANNEL VERTICAL

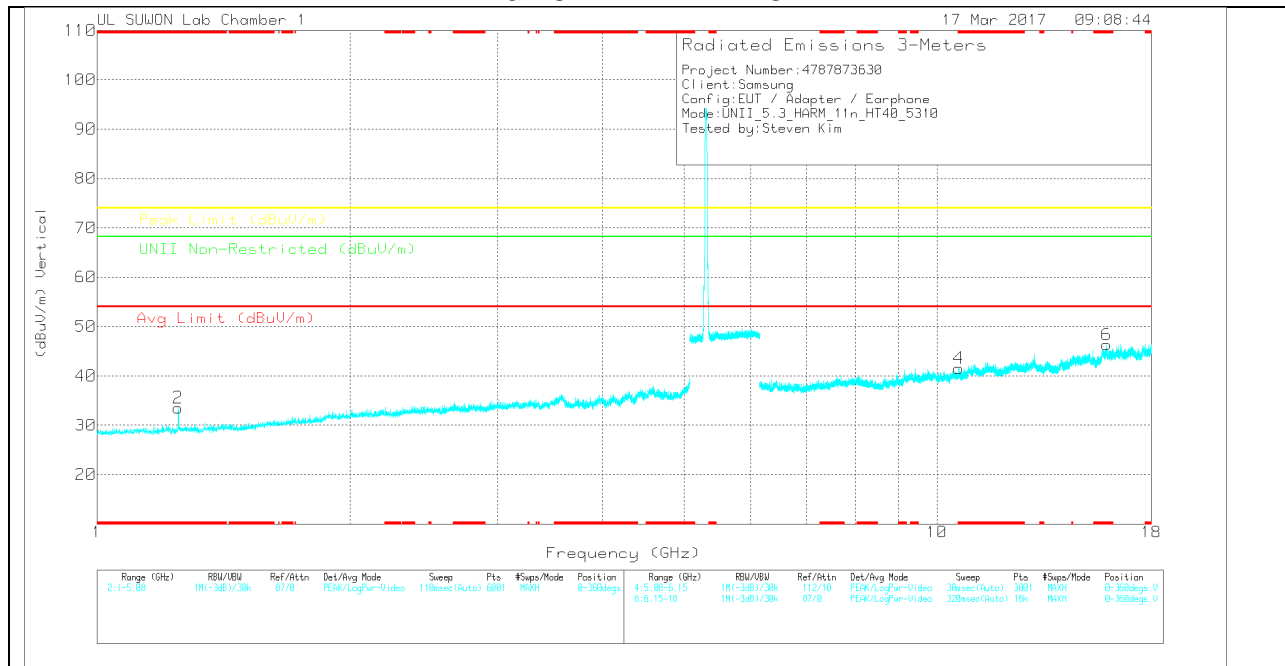

Note: Emission was scanned up to 40GHz; No emissions were detected above the noise floor which was at least 20dB below the specification limit.

**HIGH CHANNEL DATA**

Trace Markers

Marker	Frequency (GHz)	Meter Reading (dBuV)	Det	3117(0016 8717)_150 619	5Ghz_LP(d B)	DC Corr (dB)	Corrected Reading (dBuV/m)	Avg Limit (dBuV/m)	Margin (dB)	Peak Limit (dBuV/m)	Margin (dB)	UNII Non-Restricted (dBuV/m)	Margin (dB)	Azimuth (Degs)	Height (cm)	Polarity
1	* 1.25	44.15	PK	28.3	-39.6	0	32.85	-	-	74	-41.15	-	-	0-360	150	H
2	* 1.25	44.81	PK	28.3	-39.6	0	33.51	-	-	74	-40.49	-	-	0-360	250	V
3	* 10.619	33.91	PK	37.9	-28.1	0	43.71	-	-	74	-30.29	-	-	0-360	150	H
5	* 15.926	24.28	PK	40.6	-19.3	0	45.58	-	-	74	-28.42	-	-	0-360	250	H
4	* 10.62	31.83	PK	37.9	-28.2	0	41.53	-	-	74	-32.47	-	-	0-360	150	V
6	* 15.924	24.85	PK	40.6	-19.1	0	46.35	-	-	74	-27.65	-	-	0-360	250	V

\* - indicates frequency in CFR15.205/IC7.2.2 Restricted Band

PK – Peak Detector

Radiated Emissions

Frequency (GHz)	Meter Reading (dBuV)	Det	3117(001687 17)_150619	6Ghz_HP(dB)	DC Corr (dB)	Corrected Reading (dBuV/m)	Avg Limit (dBuV/m)	Margin (dB)	Peak Limit (dBuV/m)	Margin (dB)	UNII Non-Restricted (dBuV/m)	Margin (dB)	Azimuth (Degs)	Height (cm)	Polarity
* 10.62	46.34	PK-U	37.9	-28.2	0	56.04	-	-	74	-17.96	-	-	223	153	H
* 10.62	32.94	ADR	37.9	-28.2	.38	43.02	54	-10.98	-	-	-	-	223	153	H
* 10.62	43.34	PK-U	37.9	-28.2	0	53.04	-	-	74	-20.96	-	-	158	142	V
* 10.62	32.08	ADR	37.9	-28.2	.38	42.16	54	-11.84	-	-	-	-	158	142	V

\* - indicates frequency in CFR15.205/IC7.2.2 Restricted Band

PK-U - U-NII: Maximum Peak

ADR - U-NII AD primary method, RMS average

### 10.3. 5.5-5.6 GHz

#### 10.3.1. TX ABOVE 1 GHz 802.11a MODE IN THE 5.5 GHz BAND

#### RESTRICTED BANDEDGE (LOW CHANNEL)

#### HORIZONTAL PEAK AND AVERAGE PLOT

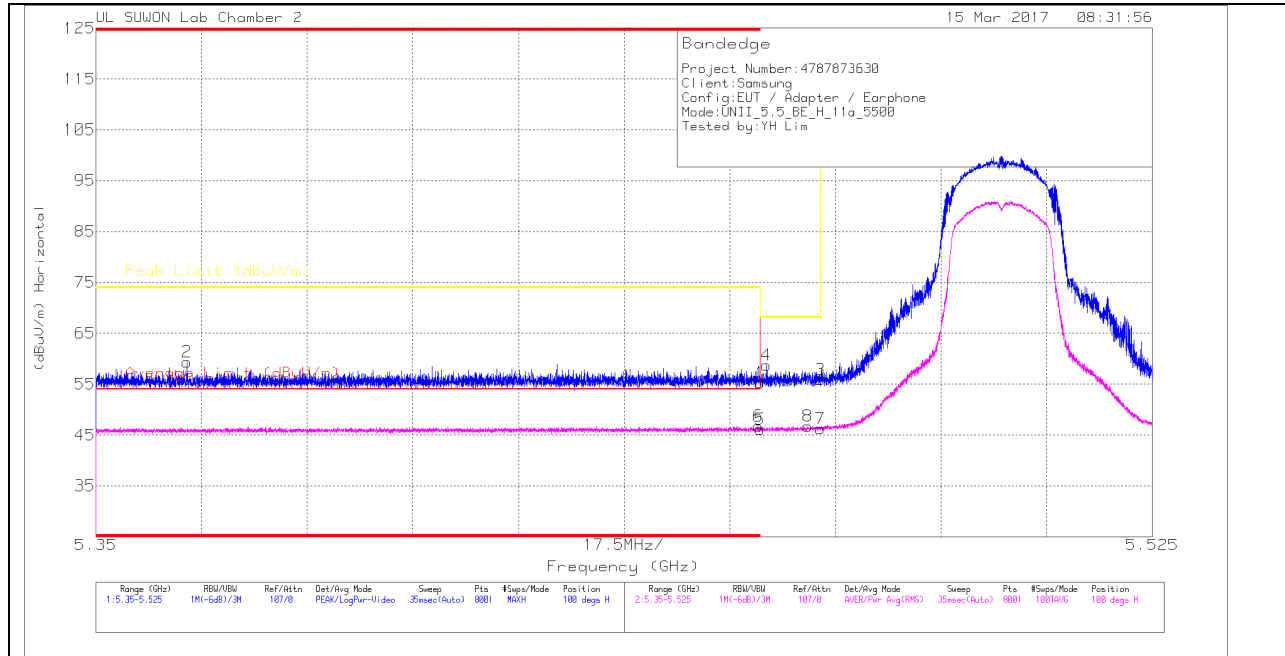

#### HORIZONTAL DATA

#### Trace Markers

Marker	Frequency (GHz)	Meter Reading (dBuV)	Det	3117(001687 24)_150619	10dB(dB)	DC Corr (dB)	Corrected Reading (dBuV/m)	Average Limit (dBuV/m)	Margin (dB)	Peak Limit (dBuV/m)	PK Margin (dB)	Azimuth (Degs)	Height (cm)	Polarity
1	* 5.46	35.79	Pk	34.5	-15	0	55.29	-	-	74	-18.71	100	231	H
2	* 5.365	40.13	Pk	34.4	-15.2	0	59.33	-	-	74	-14.67	100	231	H
3	5.47	36.41	Pk	34.5	-15	0	55.91	-	-	68.2	-12.29	100	231	H
4	5.461	39.22	Pk	34.5	-15	0	58.72	-	-	68.2	-9.48	100	231	H
5	* 5.46	26.44	RMS	34.5	-15	.18	46.12	54	-7.88	-	-	100	231	H
6	* 5.46	27.06	RMS	34.5	-15	.18	46.74	54	-7.26	-	-	100	231	H

\* - indicates frequency in CFR15.205/IC7.2.2 Restricted Band

Pk - Peak detector

RMS - RMS detection

**VERTICAL PEAK AND AVERAGE PLOT**

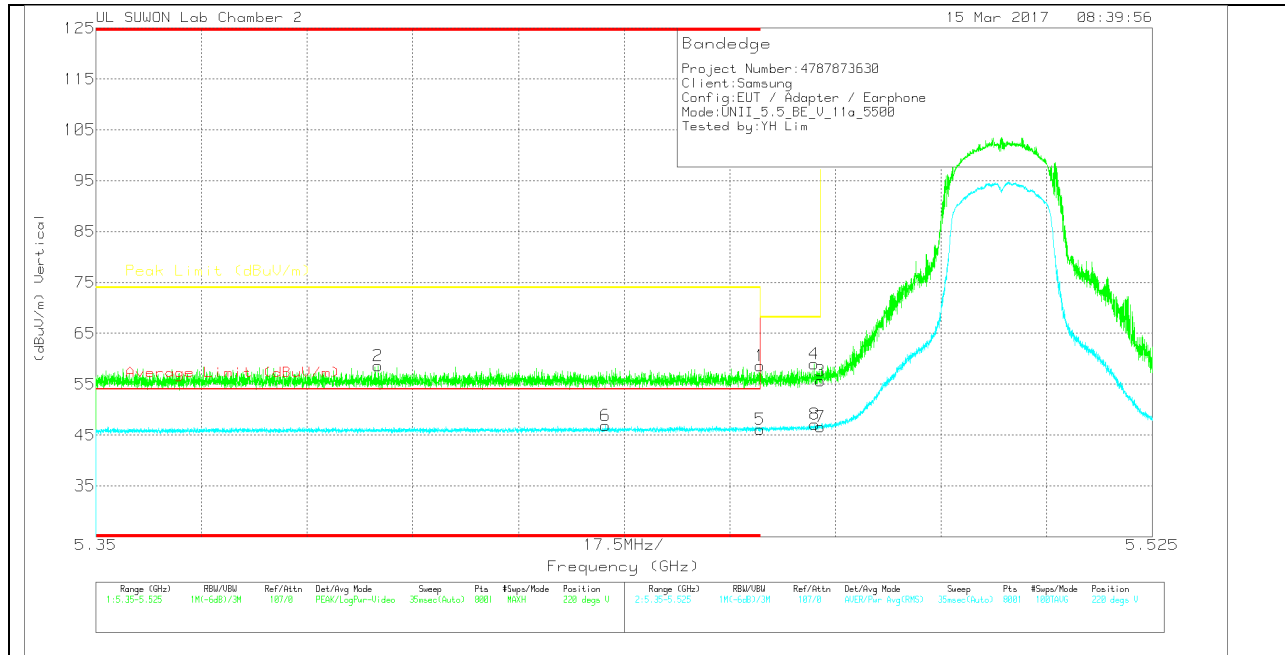

**VERTICAL DATA**

**Trace Markers**

Marker	Frequency (GHz)	Meter Reading (dBuV)	Det	3117(001687 24)_150619	10dB(dB)	DC Corr (dB)	Corrected Reading (dBuV/m)	Average Limit (dBuV/m)	Margin (dB)	Peak Limit (dBuV/m)	PK Margin (dB)	Azimuth (Degs)	Height (cm)	Polarity
1	* 5.46	39.06	Pk	34.5	-15	0	58.56	-	-	74	-15.44	220	148	V
2	* 5.397	39.44	Pk	34.4	-15.2	0	58.64	-	-	74	-15.36	220	148	V
3	5.47	36.13	Pk	34.5	-15	0	55.63	-	-	68.2	-12.57	220	148	V
4	5.469	39.44	Pk	34.5	-15	0	58.94	-	-	68.2	-9.26	220	148	V
5	* 5.46	26.47	RMS	34.5	-15	.18	46.15	54	-7.85	-	-	220	148	V
6	* 5.434	27.26	RMS	34.5	-15.1	.18	46.84	54	-7.16	-	-	220	148	V

\* - indicates frequency in CFR15.205/IC7.2.2 Restricted Band

Pk - Peak detector

RMS - RMS detection

## AUTHORIZED BANDEDGE (HIGH CHANNEL)

### HORIZONTAL PEAK AND AVERAGE PLOT

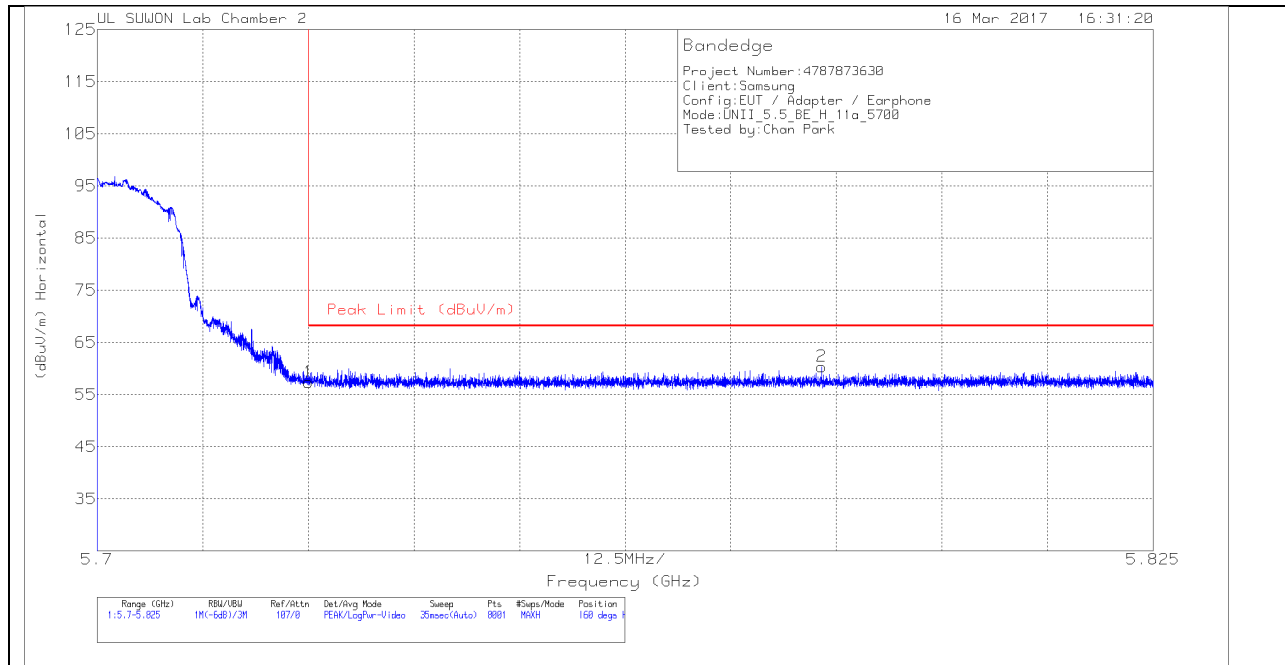

### HORIZONTAL DATA

Trace Markers

Marker	Frequency (GHz)	Meter Reading (dBuV)	Det	3117(0016 8724)_150 619	10dB[dB]	DC Corr (dB)	Corrected Reading (dBuV/m)	Peak Limit (dBuV/m)	PK Margin (dB)	Azimuth (Degs)	Height (cm)	Polarity
1	5.725	37.19	Pk		-14.5	0	57.39	68.2	-10.81	160	109	H
2	5.786	40.07	Pk		-14.4	0	60.37	68.2	-7.83	160	109	H

Pk - Peak detector

**VERTICAL PEAK AND AVERAGE PLOT**

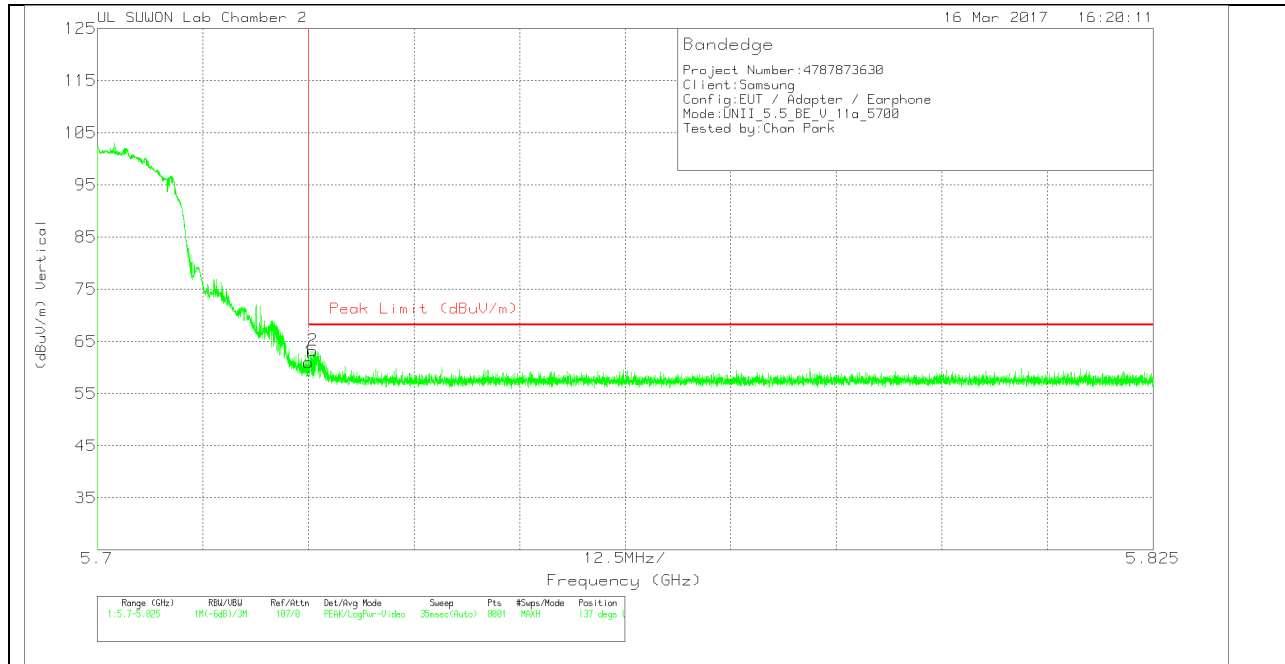

**VERTICAL DATA**

Trace Markers

Marker	Frequency (GHz)	Meter Reading (dBuV)	Det	3117(0016 8724)_150 619	10dB[dB]	DC Corr (dB)	Corrected Reading (dBuV/m)	Peak Limit (dBuV/m)	PK Margin (dB)	Azimuth (Degs)	Height (cm)	Polarity
1	5.725	40.8	Pk	34.7	-14.5	0	61	68.2	-7.2	137	136	V
2	5.726	43.07	Pk	34.7	-14.5	0	63.27	68.2	-4.93	137	136	V

Pk - Peak detector

## HARMONICS AND SPURIOUS EMISSIONS

### LOW CHANNEL HORIZONTAL

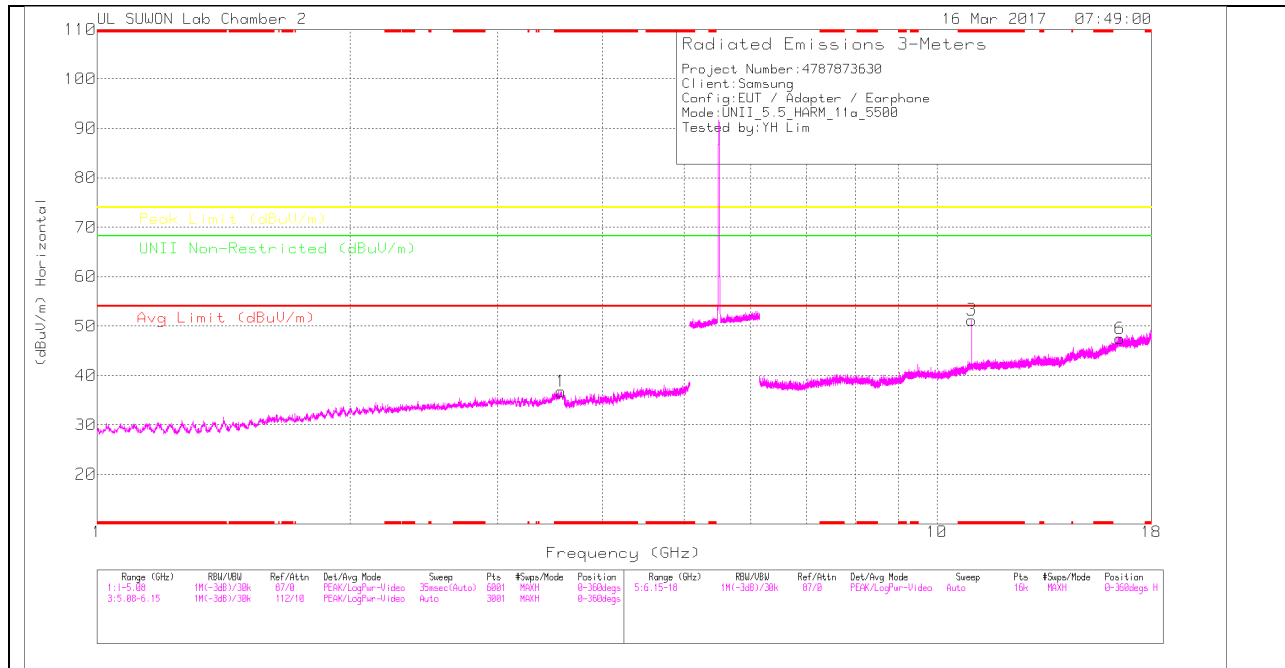

### LOW CHANNEL VERTICAL

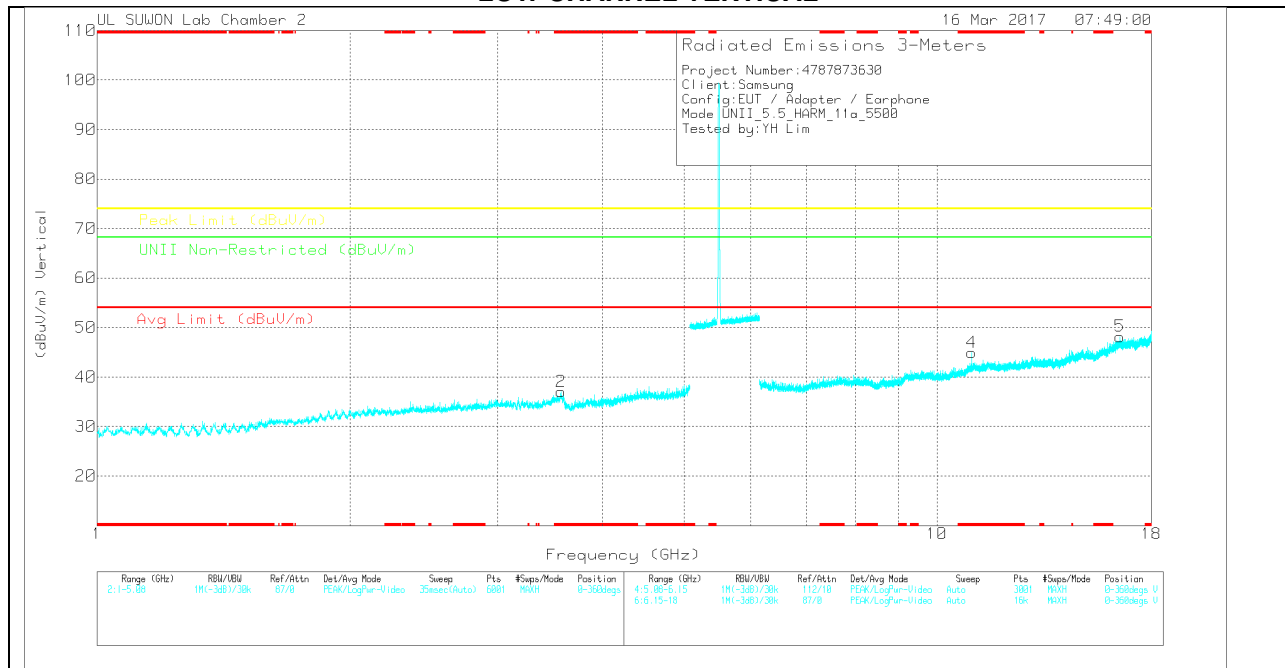

Note: Emission was scanned up to 40GHz; No emissions were detected above the noise floor which was at least 20dB below the specification limit.

**LOW CHANNEL DATA**

Trace Markers

Marker	Frequency (GHz)	Meter Reading (dBuV)	Det	3117(0016 8724)_150 619	5GHz_LP[d B]	DC Corr (dB)	Corrected Reading (dBuV/m)	Avg Limit (dBuV/m)	Margin (dB)	Peak Limit (dBuV/m)	Margin (dB)	UNII Non-Restricted (dBuV/m)	Margin (dB)	Azimuth (Degs)	Height (cm)	Polarity
1	* 3.57	28.86	PK	32.8	-24.9	0	36.76	-	-	74	-37.24	-	-	0-360	150	H
2	* 3.57	29.16	PK	32.8	-24.9	0	37.06	-	-	74	-36.94	-	-	0-360	250	V
3	* 11	29.23	PK	38	-16	0	51.23	-	-	74	-22.77	-	-	0-360	250	H
6	16.503	20.87	PK	41	-14.4	0	47.47	-	-	-	-	68.2	-20.73	0-360	250	H
4	* 11	22.93	PK	38	-16	0	44.93	-	-	74	-29.07	-	-	0-360	250	V
5	16.506	21.59	PK	41	-14.4	0	48.19	-	-	-	-	68.2	-20.01	0-360	150	V

\* - indicates frequency in CFR15.205/IC7.2.2 Restricted Band

PK – Peak detector

Radiated Emissions

Frequency (GHz)	Meter Reading (dBuV)	Det	3117(001687 24)_150619	6GHz_HP[dB]	DC Corr (dB)	Corrected Reading (dBuV/m)	Avg Limit (dBuV/m)	Margin (dB)	Peak Limit (dBuV/m)	Margin (dB)	UNII Non-Restricted (dBuV/m)	Margin (dB)	Azimuth (Degs)	Height (cm)	Polarity
* 11	35.38	PK-U	38	-16	0	57.38	-	-	74	-16.62	-	-	148	244	H
* 11	28.5	ADR	38	-16	.18	50.68	54	-3.32	-	-	-	-	148	244	H
* 11	32.63	PK-U	38	-16	0	54.63	-	-	74	-19.37	-	-	204	154	V
* 11	21.74	ADR	38	-16	.18	43.92	54	-10.08	-	-	-	-	204	154	V

\* - indicates frequency in CFR15.205/IC7.2.2 Restricted Band

PK-U - U-NII: Maximum Peak

ADR - U-NII AD primary method, RMS average

MID CHANNEL HORIZONTAL

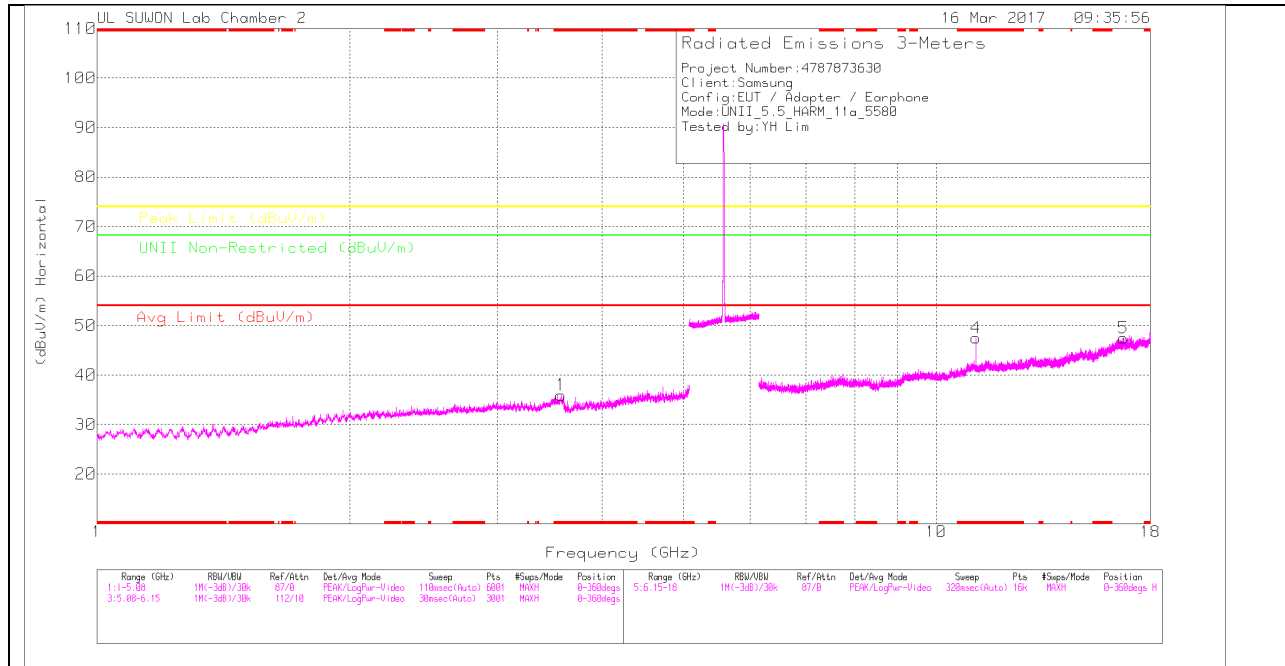

MID CHANNEL VERTICAL

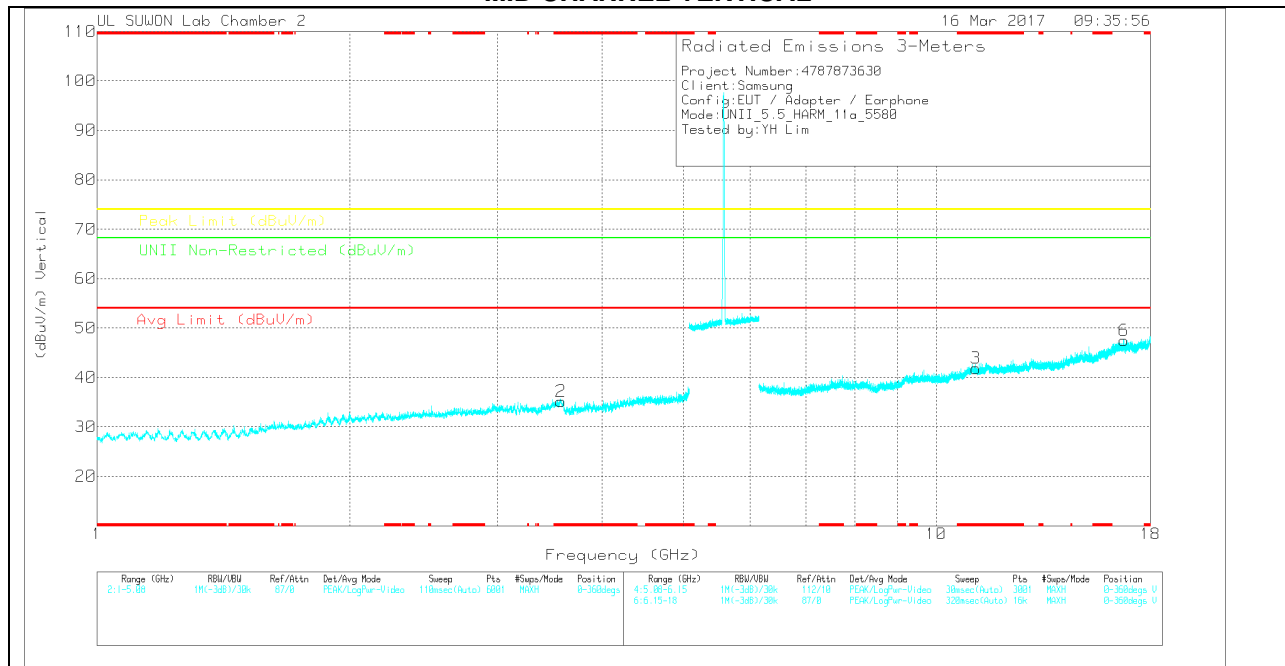

Note: Emission was scanned up to 40GHz; No emissions were detected above the noise floor which was at least 20dB below the specification limit.

**MID CHANNEL DATA**

Trace Markers

Marker	Frequency (GHz)	Meter Reading (dBuV)	Det	3117(0016 8724)_150 619	5GHz_LP[d B]	DC Corr (dB)	Corrected Reading (dBuV/m)	Avg Limit (dBuV/m)	Margin (dB)	Peak Limit (dBuV/m)	Margin (dB)	UNII Non-Restricted (dBuV/m)	Margin (dB)	Azimuth (Degs)	Height (cm)	Polarity
1	* 3.572	28.15	PK	32.8	-25	0	35.95	-	-	74	-38.05	-	-	0-360	150	H
2	* 3.572	27.36	PK	32.8	-25	0	35.16	-	-	74	-38.84	-	-	0-360	250	V
4	* 11.16	25.58	PK	38.1	-16.2	0	47.48	-	-	74	-26.52	-	-	0-360	250	H
5	16.719	20.27	PK	41	-13.8	0	47.47	-	-	-	-	68.2	-20.73	0-360	150	H
3	* 11.16	19.93	PK	38.1	-16.2	0	41.83	-	-	74	-32.17	-	-	0-360	150	V
6	16.745	20.08	PK	41	-13.6	0	47.48	-	-	-	-	68.2	-20.72	0-360	250	V

\* - indicates frequency in CFR15.205/IC7.2.2 Restricted Band

PK – Peak detector

Radiated Emissions

Frequency (GHz)	Meter Reading (dBuV)	Det	3117(001687 24)_150619	6GHz_HP[dB]	DC Corr (dB)	Corrected Reading (dBuV/m)	Avg Limit (dBuV/m)	Margin (dB)	Peak Limit (dBuV/m)	Margin (dB)	UNII Non-Restricted (dBuV/m)	Margin (dB)	Azimuth (Degs)	Height (cm)	Polarity
* 11.16	32.98	PK-U	38.1	-16.2	0	54.88	-	-	74	-19.12	-	-	156	101	H
* 11.16	23.11	ADR	38.1	-16.2	.18	45.19	54	-8.81	-	-	-	-	156	101	H
* 11.16	31.23	PK-U	38.1	-16.2	0	53.13	-	-	74	-20.87	-	-	210	161	V
* 11.16	18.95	ADR	38.1	-16.2	.18	41.03	54	-12.97	-	-	-	-	210	161	V

\* - indicates frequency in CFR15.205/IC7.2.2 Restricted Band

PK-U - U-NII: Maximum Peak

ADR - U-NII AD primary method, RMS average

### HIGH CHANNEL HORIZONTAL

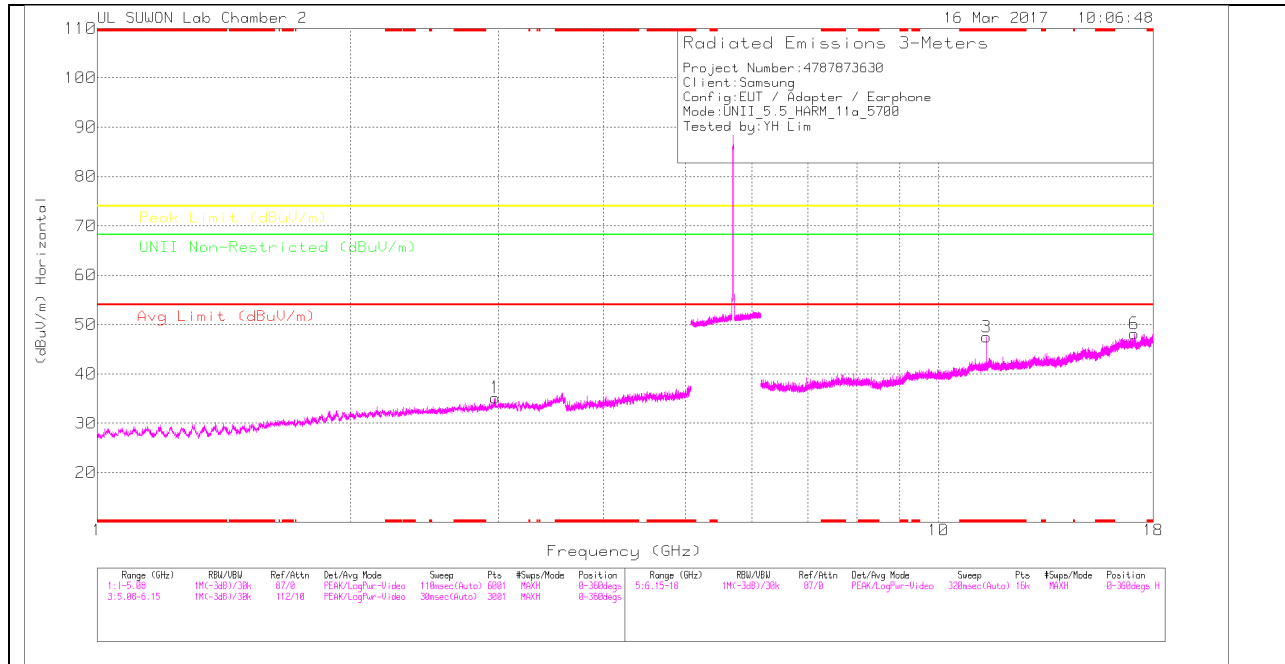

### HIGH CHANNEL VERTICAL

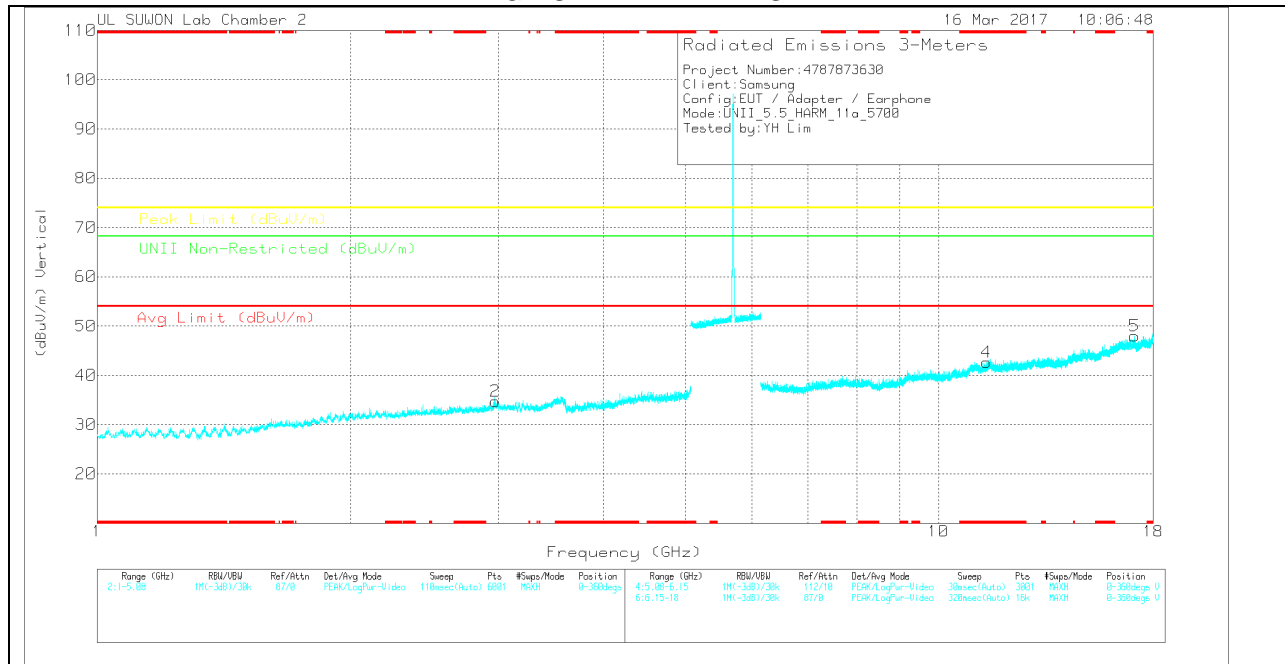

Note: Emission was scanned up to 40GHz; No emissions were detected above the noise floor which was at least 20dB below the specification limit.

**HIGH CHANNEL DATA**

Trace Markers

Marker	Frequency (GHz)	Meter Reading (dBuV)	Det	3117/0016 8724_150 619	5GHz_LP[d B]	DC Corr (dB)	Corrected Reading (dBuV/m)	Avg Limit (dBuV/m)	Margin (dB)	Peak Limit (dBuV/m)	Margin (dB)	UNII Non-Restricted (dBuV/m)	Margin (dB)	Azimuth (Degs)	Height (cm)	Polarity
1	2.973	28.49	PK	32.4	-25.7	0	35.19	-	-	-	-	68.2	-33.01	0-360	250	H
2	2.975	28.02	PK	32.4	-25.7	0	34.72	-	-	-	-	68.2	-33.48	0-360	150	V
3	* 11.4	24.77	PK	38.3	-15.6	0	47.47	-	-	74	-26.53	-	-	0-360	250	H
6	17.102	20.55	PK	41.1	-13.5	0	48.15	-	-	-	-	68.2	-20.05	0-360	250	H
4	* 11.4	19.92	PK	38.3	-15.6	0	42.62	-	-	74	-31.38	-	-	0-360	250	V
5	17.103	20.37	PK	41.1	-13.5	0	47.97	-	-	-	-	68.2	-20.23	0-360	150	V

\* - indicates frequency in CFR15.205/IC7.2.2 Restricted Band

Avg - Video bandwidth < Resolution bandwidth

Radiated Emissions

Frequency (GHz)	Meter Reading (dBuV)	Det	3117/001687 24_150619	6GHz_HP[dB]	DC Corr (dB)	Corrected Reading (dBuV/m)	Avg Limit (dBuV/m)	Margin (dB)	Peak Limit (dBuV/m)	Margin (dB)	UNII Non-Restricted (dBuV/m)	Margin (dB)	Azimuth (Degs)	Height (cm)	Polarity
* 11.4	33.57	PK-U	38.3	-15.6	0	56.27	-	-	74	-17.73	-	-	155	189	H
* 11.4	23.76	ADR	38.3	-15.6	.18	46.64	54	-7.36	-	-	-	-	155	189	H
* 11.398	31.27	PK-U	38.3	-15.6	0	53.97	-	-	74	-20.03	-	-	208	216	V
* 11.4	20.36	ADR	38.3	-15.6	.18	43.24	54	-10.76	-	-	-	-	208	216	V

\* - indicates frequency in CFR15.205/IC7.2.2 Restricted Band

PK-U - U-NII: Maximum Peak

ADR - U-NII AD primary method, RMS average

**STRADDLE CHANNEL HORIZONTAL**

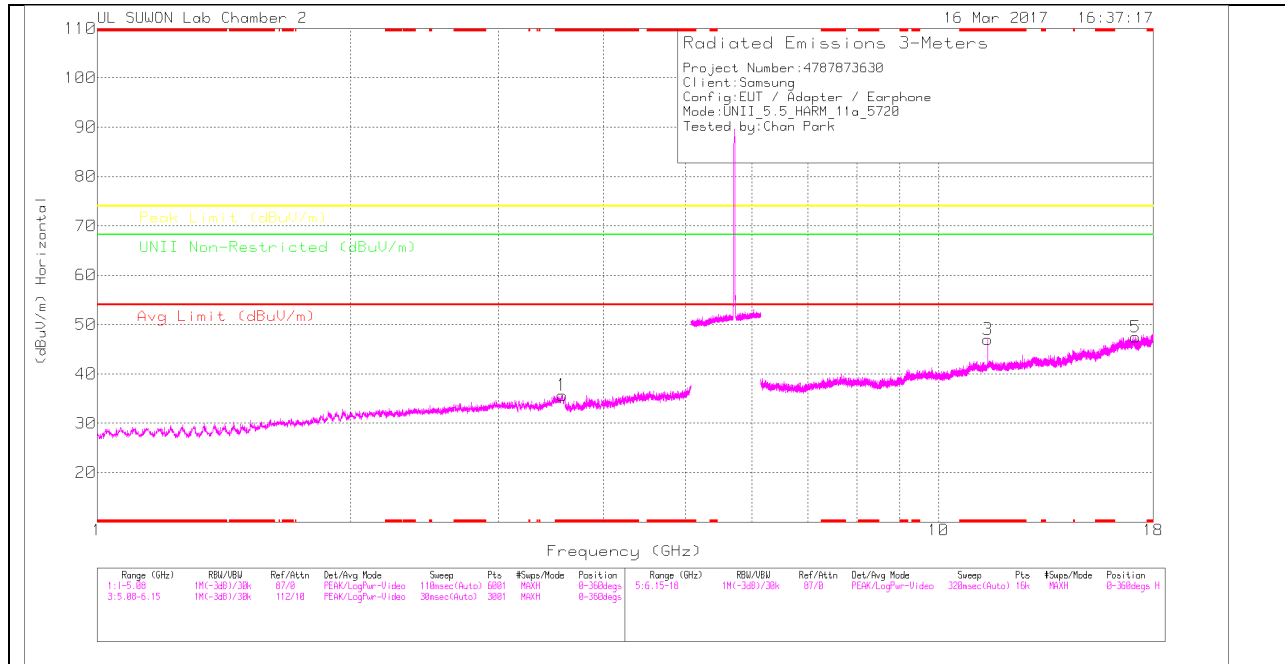

**STRADDLE CHANNEL VERTICAL**

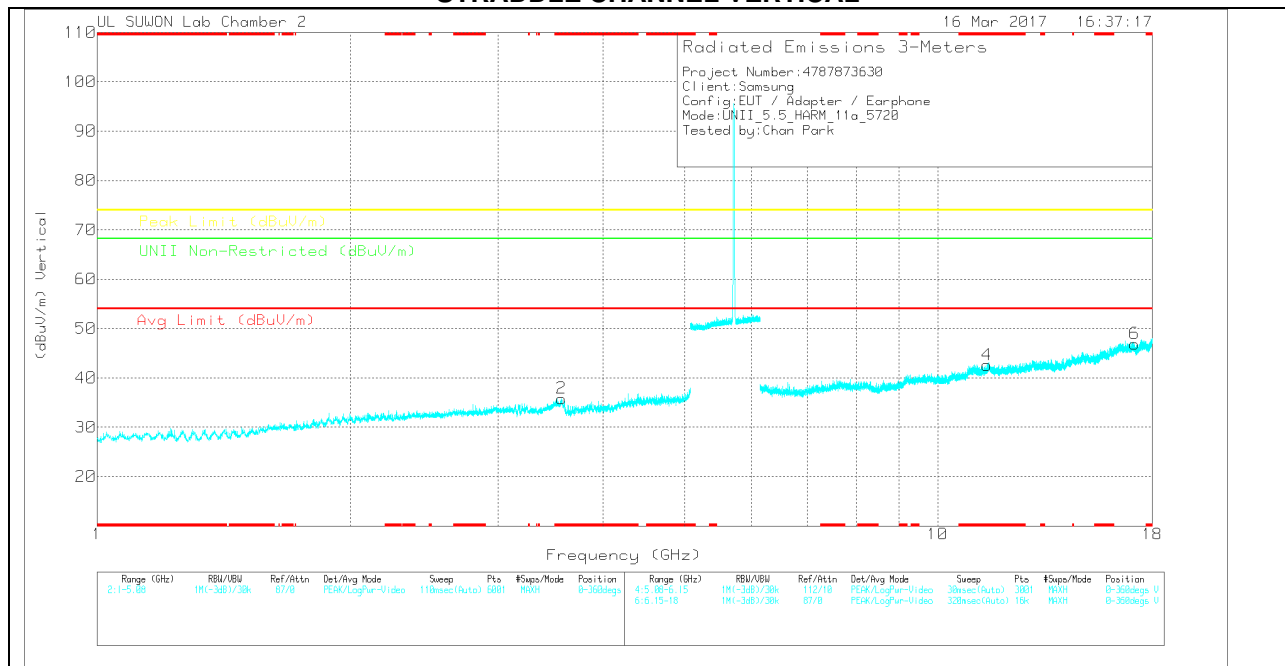

Note: Emission was scanned up to 40GHz; No emissions were detected above the noise floor which was at least 20dB below the specification limit.

**STRADDLE CHANNEL DATA**

Trace Markers

Marker	Frequency (GHz)	Meter Reading (dBuV)	Det	3117(0016 8724)_150 619	5GHz_LP[d B]	DC Corr (dB)	Corrected Reading (dBuV/m)	Avg Limit (dBuV/m)	Margin (dB)	Peak Limit (dBuV/m)	Margin (dB)	UNII Non-Restricted (dBuV/m)	Margin (dB)	Azimuth (Degs)	Height (cm)	Polarity
1	* 3.572	27.79	PK	32.8	-24.9	0	35.69	-	-	74	-38.31	-	-	0-360	150	H
2	* 3.567	27.94	PK	32.8	-24.9	0	35.84	-	-	74	-38.16	-	-	0-360	250	V
3	* 11.44	24.6	PK	38.3	-15.9	0	47	-	-	74	-27	-	-	0-360	250	H
5	17.158	19.87	PK	41.1	-13.5	0	47.47	-	-	-	-	68.2	-20.73	0-360	150	H
4	* 11.439	20.2	PK	38.3	-15.9	0	42.6	-	-	74	-31.4	-	-	0-360	250	V
6	17.159	19.31	PK	41.1	-13.5	0	46.91	-	-	-	-	68.2	-21.29	0-360	150	V

\* - indicates frequency in CFR15.205/IC7.2.2 Restricted Band

PK – Peak detector

Radiated Emissions

Frequency (GHz)	Meter Reading (dBuV)	Det	3117(001687 24)_150619	6GHz_HP[dB]	DC Corr (dB)	Corrected Reading (dBuV/m)	Avg Limit (dBuV/m)	Margin (dB)	Peak Limit (dBuV/m)	Margin (dB)	UNII Non-Restricted (dBuV/m)	Margin (dB)	Azimuth (Degs)	Height (cm)	Polarity
* 11.44	34.59	PK-U	38.3	-15.9	0	56.99	-	-	74	-17.01	-	-	155	207	H
* 11.44	25.67	ADR	38.3	-15.9	0	48.07	54	-5.93	-	-	-	-	155	207	H

\* - indicates frequency in CFR15.205/IC7.2.2 Restricted Band

PK-U - U-NII: Maximum Peak

ADR - U-NII AD primary method, RMS average

### 10.3.2. TX ABOVE 1GHz 802.11n HT20 MODE IN THE 5.5GHz BAND RESTRICTED BANDEDGE (LOW CHANNEL)

#### HORIZONTAL PEAK AND AVERAGE PLOT

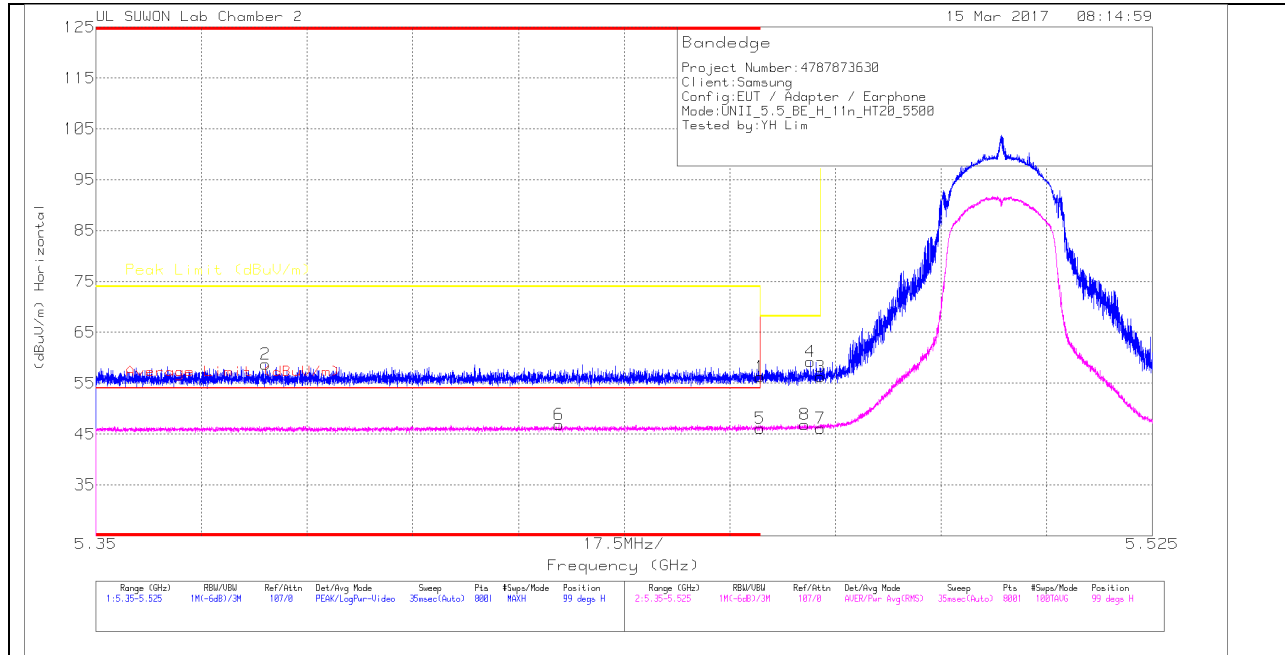

#### HORIZONTAL DATA

##### Trace Markers

Marker	Frequency (GHz)	Meter Reading (dBuV)	Det	3117(001687 24)_150619	10dB(dB)	DC Corr (dB)	Corrected Reading (dBuV/m)	Average Limit (dBuV/m)	Margin (dB)	Peak Limit (dBuV/m)	PK Margin (dB)	Azimuth (Degs)	Height (cm)	Polarity
1	* 5.46	36.74	Pk	34.5	-15	0	56.24	-	-	74	-17.76	99	189	H
2	* 5.378	39.5	Pk	34.4	-15.2	0	58.7	-	-	74	-15.3	99	189	H
3	5.47	36.82	Pk	34.5	-15	0	56.32	-	-	68.2	-11.88	99	189	H
4	5.468	39.71	Pk	34.5	-15	0	59.21	-	-	68.2	-8.99	99	189	H
5	* 5.46	26.4	RMS	34.5	-15	.17	46.07	54	-7.93	-	-	99	189	H
6	* 5.427	27.3	RMS	34.5	-15.1	.17	46.87	54	-7.13	-	-	99	189	H

\* - indicates frequency in CFR15.205/IC7.2.2 Restricted Band

Pk - Peak detector

RMS - RMS detection

**VERTICAL PEAK AND AVERAGE PLOT**

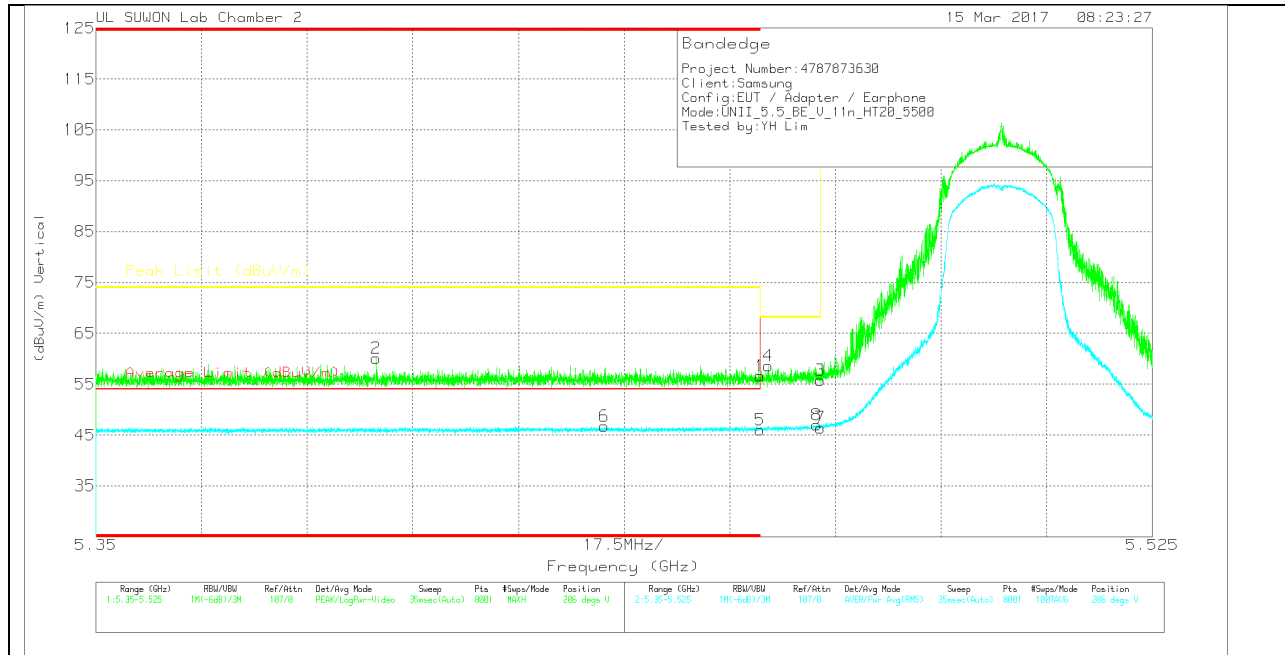

**VERTICAL DATA**

Trace Markers

Marker	Frequency (GHz)	Meter Reading (dBuV)	Det	3117(001687 24)_150619	10dB(dB)	DC Corr (dB)	Corrected Reading (dBuV/m)	Average Limit (dBuV/m)	Margin (dB)	Peak Limit (dBuV/m)	PK Margin (dB)	Azimuth (Degs)	Height (cm)	Polarity
1	* 5.46	37.11	Pk	34.5	-15	0	56.61	-	-	74	-17.39	206	140	V
2	* 5.396	40.91	Pk	34.4	-15.2	0	60.11	-	-	74	-13.89	206	140	V
3	5.47	36.24	Pk	34.5	-15	0	55.74	-	-	68.2	-12.46	206	140	V
4	5.461	39.16	Pk	34.5	-15	0	58.66	-	-	68.2	-9.54	206	140	V
5	* 5.46	26.37	RMS	34.5	-15	.17	46.04	54	-7.96	-	-	206	140	V
6	* 5.434	27.15	RMS	34.5	-15.1	.17	46.72	54	-7.28	-	-	206	140	V

\* - indicates frequency in CFR15.205/IC7.2.2 Restricted Band

Pk - Peak detector

RMS - RMS detection

## AUTHORIZED BANDEDGE (HIGH CHANNEL)

### HORIZONTAL PEAK AND AVERAGE PLOT

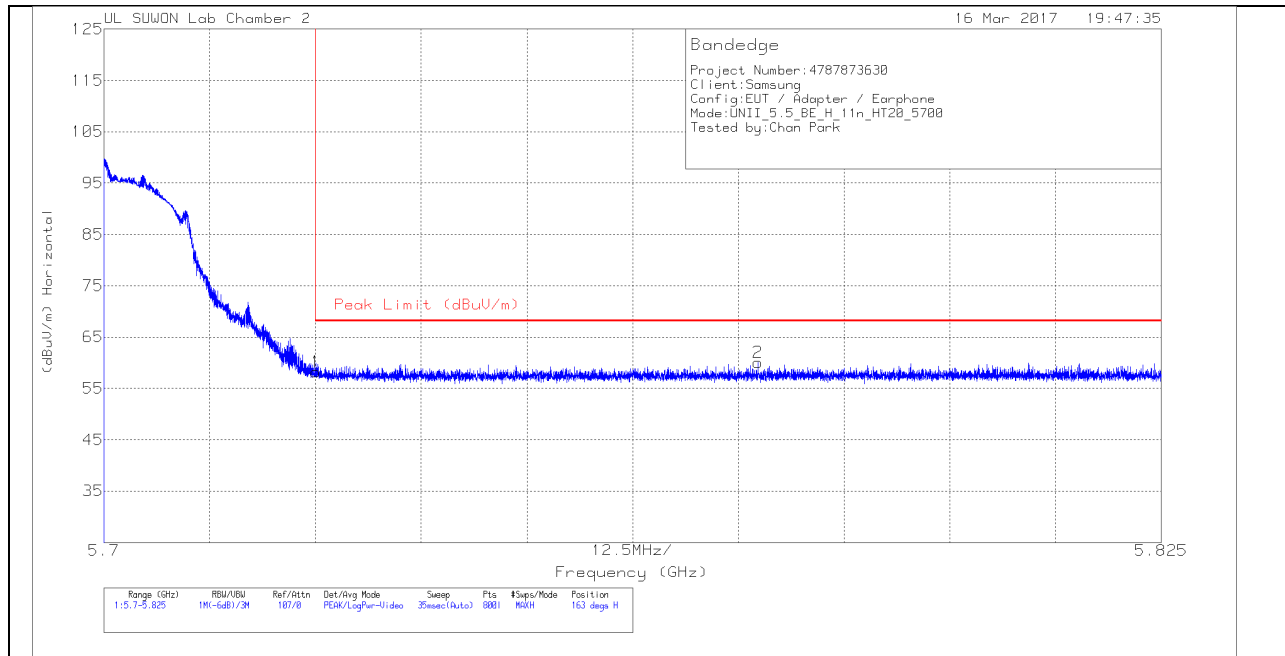

### HORIZONTAL DATA

#### Trace Markers

Marker	Frequency (GHz)	Meter Reading (dBuV)	Det	3117(0016 8724)_150 619	10dB[dB]	DC Corr (dB)	Corrected Reading (dBuV/m)	Peak Limit (dBuV/m)	PK Margin (dB)	Azimuth (Degs)	Height (cm)	Polarity
1	5.725	38.03	Pk	34.7	-14.5	0	58.23	68.2	-9.97	163	129	H
2	5.777	39.72	Pk	34.7	-14.4	0	60.02	68.2	-8.18	163	129	H

Pk - Peak detector

**VERTICAL PEAK AND AVERAGE PLOT**

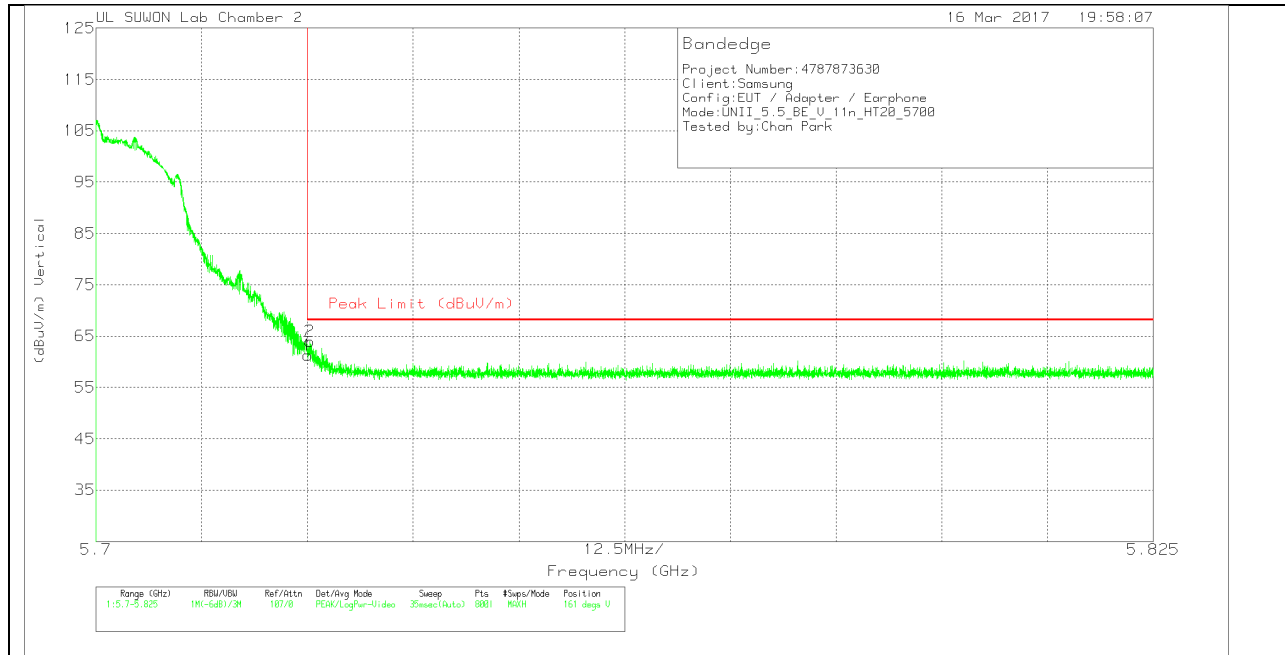

**VERTICAL DATA**

Trace Markers

Marker	Frequency (GHz)	Meter Reading (dBuV)	Det	3117(0016 8724)_150 619	10dB[dB]	DC Corr (dB)	Corrected Reading (dBuV/m)	Peak Limit (dBuV/m)	PK Margin (dB)	Azimuth (Degs)	Height (cm)	Polarity
1	5.725	41.13	Pk	34.7	-14.5	0	61.33	68.2	-6.87	161	202	V
2	5.725	43.76	PK	34.7	-14.5	0	63.96	68.2	-4.24	161	202	V

Pk - Peak detector

## HARMONICS AND SPURIOUS EMISSIONS

### LOW CHANNEL HORIZONTAL

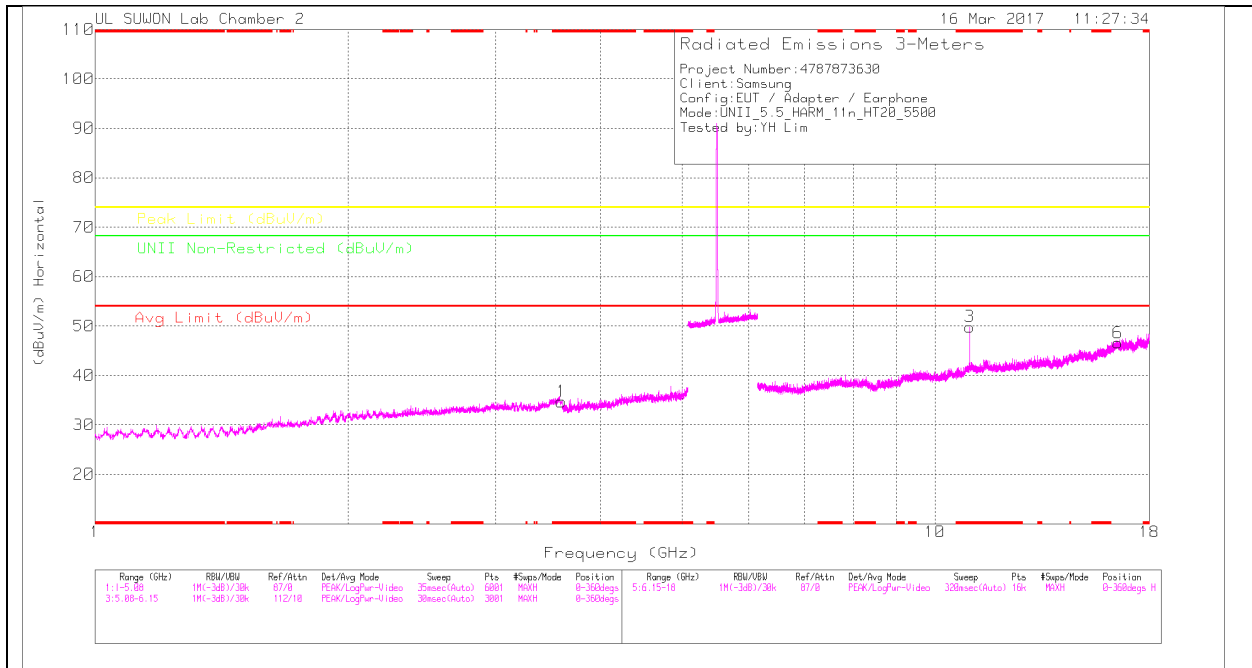

### LOW CHANNEL VERTICAL

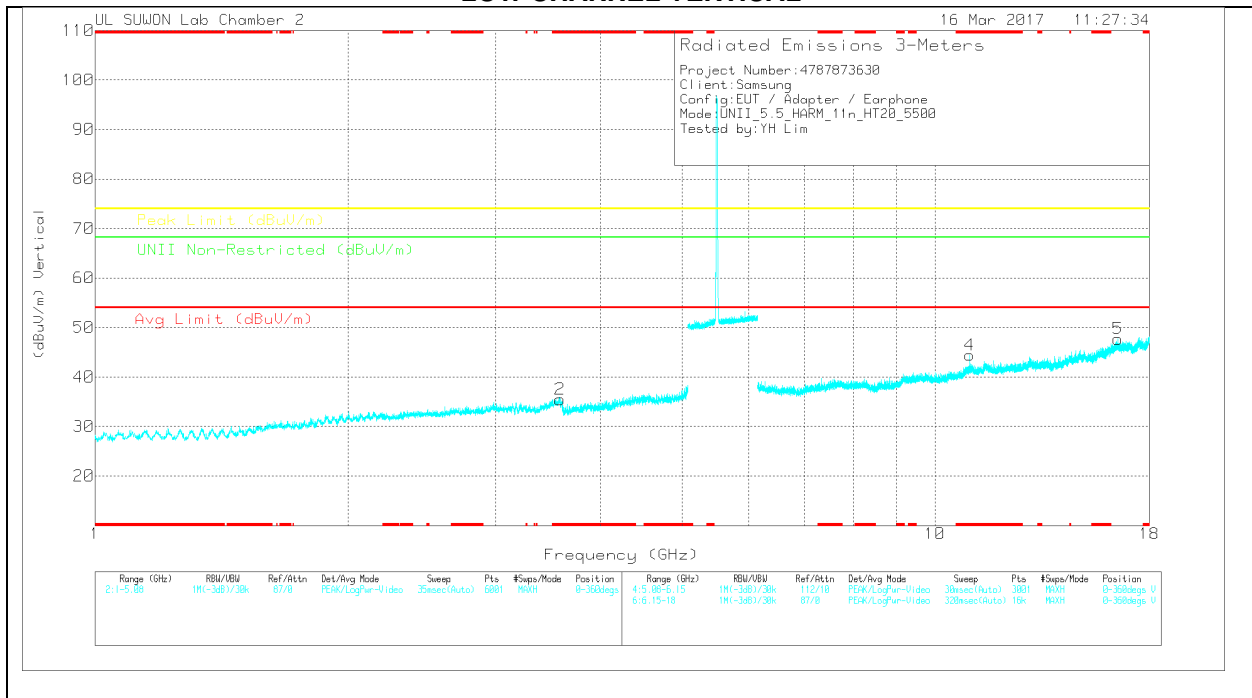

Note: Emission was scanned up to 40GHz; No emissions were detected above the noise floor which was at least 20dB below the specification limit.

**LOW CHANNEL DATA**

Trace Markers

Marker	Frequency (GHz)	Meter Reading (dBuV)	Det	3117(0016 8724)_150 619	5GHz_LP[d B]	DC Corr (dB)	Corrected Reading (dBuV/m)	Avg Limit (dBuV/m)	Margin (dB)	Peak Limit (dBuV/m)	Margin (dB)	UNII Non-Restricted (dBuV/m)	Margin (dB)	Azimuth (Degs)	Height (cm)	Polarity
1	* 3.591	27.22	PK	32.8	-25.3	0	34.72	-	-	74	-39.28	-	-	0-360	150	H
2	* 3.579	27.77	PK	32.8	-25.1	0	35.47	-	-	74	-38.53	-	-	0-360	250	V
3	* 11	27.84	PK	38	-16	0	49.84	-	-	74	-24.16	-	-	0-360	250	H
6	16.511	19.98	PK	41	-14.4	0	46.58	-	-	-	-	68.2	-21.62	0-360	150	H
4	* 11	22.44	PK	38	-16	0	44.44	-	-	74	-29.56	-	-	0-360	250	V
5	16.514	20.99	PK	41	-14.3	0	47.69	-	-	-	-	68.2	-20.51	0-360	150	V

\* - indicates frequency in CFR15.205/IC7.2.2 Restricted Band

PK – Peak detector

Radiated Emissions

Frequency (GHz)	Meter Reading (dBuV)	Det	3117(001687 24)_150619	6GHz_HP[dB]	DC Corr (dB)	Corrected Reading (dBuV/m)	Avg Limit (dBuV/m)	Margin (dB)	Peak Limit (dBuV/m)	Margin (dB)	UNII Non-Restricted (dBuV/m)	Margin (dB)	Azimuth (Degs)	Height (cm)	Polarity
* 11	34.53	PK-U	38	-16	0	56.53	-	-	74	-17.47	-	-	217	202	H
* 11	27.63	ADR	38	-16	.17	49.8	54	-4.2	-	-	-	-	217	202	H
* 11	31.22	PK-U	38	-16	0	53.22	-	-	74	-20.78	-	-	204	209	V
* 11	21.72	ADR	38	-16	.17	43.89	54	-10.11	-	-	-	-	204	209	V

\* - indicates frequency in CFR15.205/IC7.2.2 Restricted Band

PK-U - U-NII: Maximum Peak

ADR - U-NII AD primary method, RMS average

MID CHANNEL HORIZONTAL

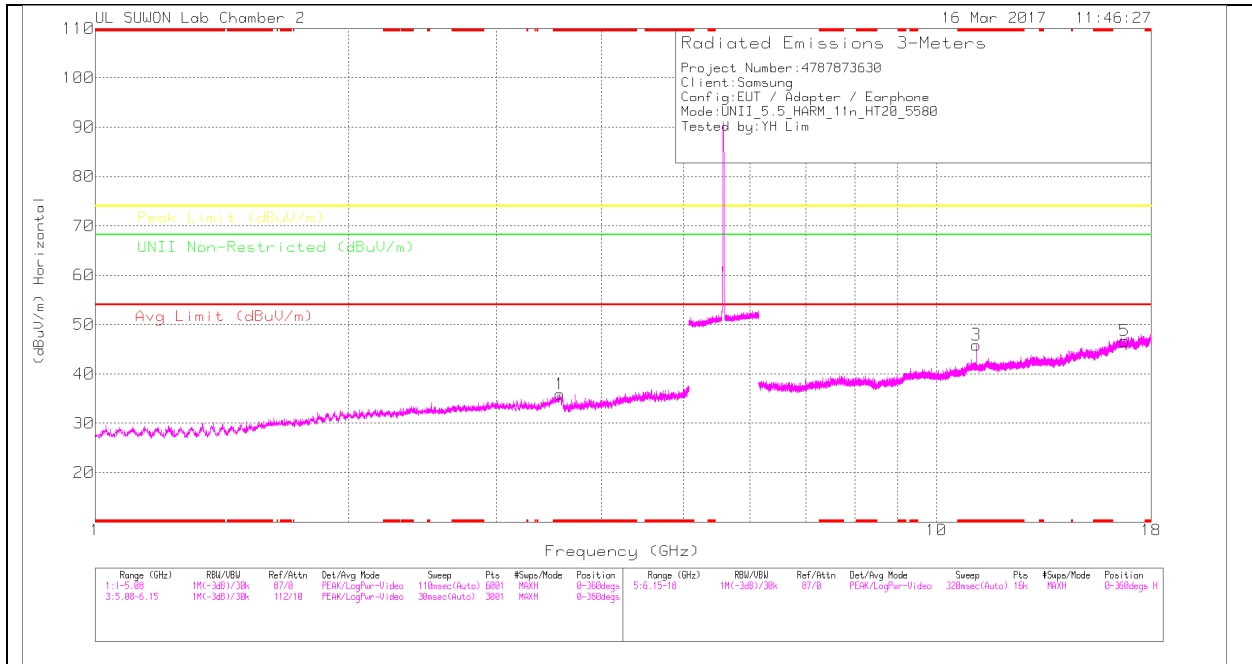

MID CHANNEL VERTICAL

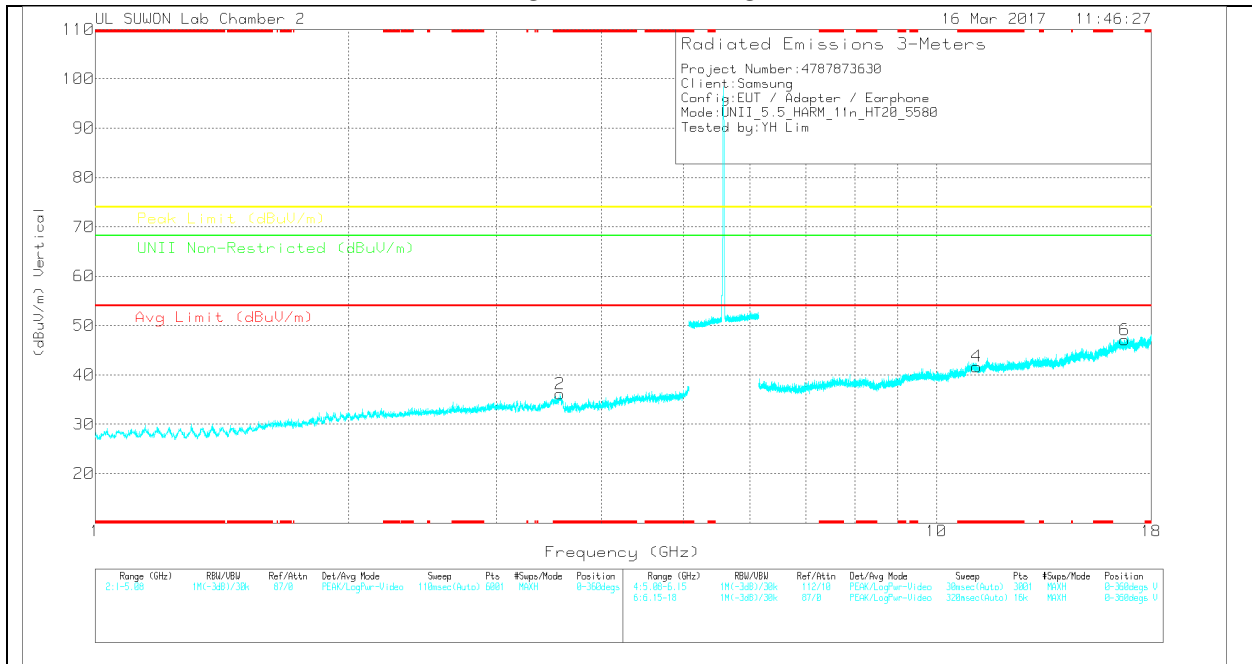

Note: Emission was scanned up to 40GHz; No emissions were detected above the noise floor which was at least 20dB below the specification limit.

**MID CHANNEL DATA**

Trace Markers

Marker	Frequency (GHz)	Meter Reading (dBuV)	Det	3117(0016 8724)_150 619	5GHz_LP[d B]	DC Corr (dB)	Corrected Reading (dBuV/m)	Avg Limit (dBuV/m)	Margin (dB)	Peak Limit (dBuV/m)	Margin (dB)	UNII Non-Restricted (dBuV/m)	Margin (dB)	Azimuth (Degs)	Height (cm)	Polarity
1	* 3.57	27.97	PK	32.8	-24.9	0	35.87	-	-	74	-38.13	-	-	0-360	250	H
2	* 3.57	28.27	PK	32.8	-24.9	0	36.17	-	-	74	-37.83	-	-	0-360	250	V
3	* 11.16	23.96	PK	38.1	-16.2	0	45.86	-	-	74	-28.14	-	-	0-360	250	H
5	16.74	19.48	PK	41	-13.8	0	46.68	-	-	-	-	68.2	-21.52	0-360	150	H
4	* 11.161	19.8	PK	38.1	-16.2	0	41.7	-	-	74	-32.3	-	-	0-360	150	V
6	16.741	19.81	PK	41	-13.7	0	47.11	-	-	-	-	68.2	-21.09	0-360	250	V

\* - indicates frequency in CFR15.205/IC7.2.2 Restricted Band

PK – Peak detector

Radiated Emissions

Frequency (GHz)	Meter Reading (dBuV)	Det	3117(001687 24)_150619	6GHz_HP[dB]	DC Corr (dB)	Corrected Reading (dBuV/m)	Avg Limit (dBuV/m)	Margin (dB)	Peak Limit (dBuV/m)	Margin (dB)	UNII Non-Restricted (dBuV/m)	Margin (dB)	Azimuth (Degs)	Height (cm)	Polarity
* 11.16	33.68	PK-U	38.1	-16.2	0	55.58	-	-	74	-18.42	-	-	152	207	H
* 11.16	25.15	ADR	38.1	-16.2	.17	47.22	54	-6.78	-	-	-	-	152	207	H

\* - indicates frequency in CFR15.205/IC7.2.2 Restricted Band

PK-U - U-NII: Maximum Peak

ADR - U-NII AD primary method, RMS average

### HIGH CHANNEL HORIZONTAL

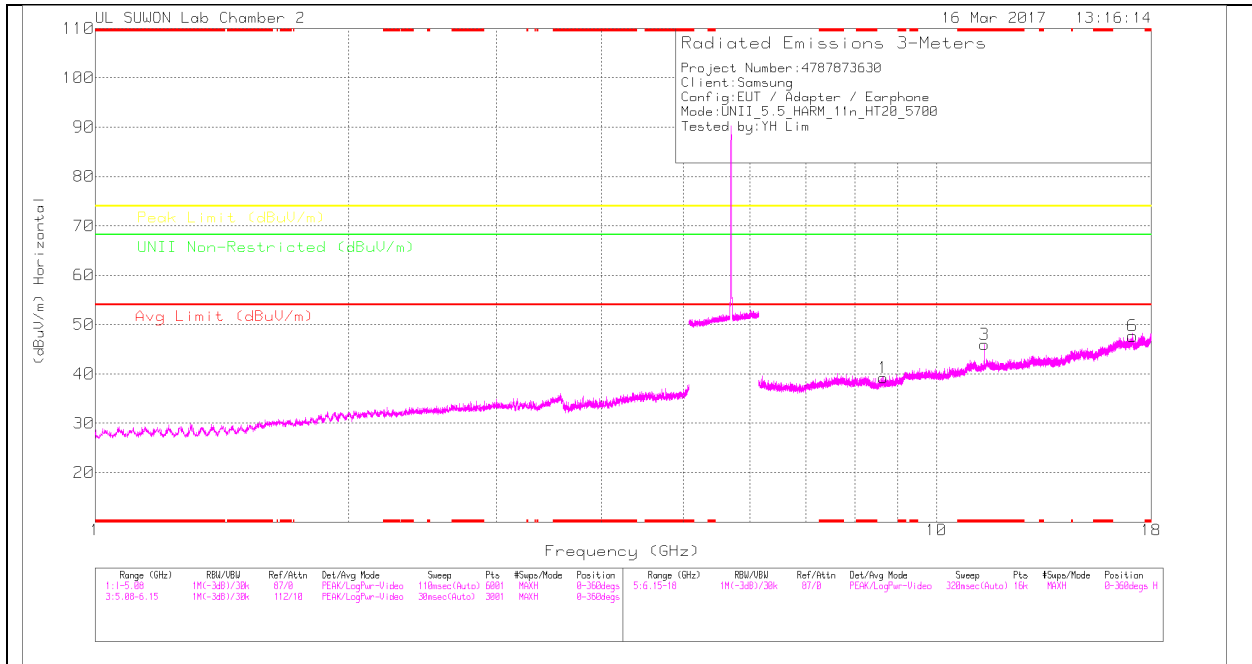

### HIGH CHANNEL VERTICAL

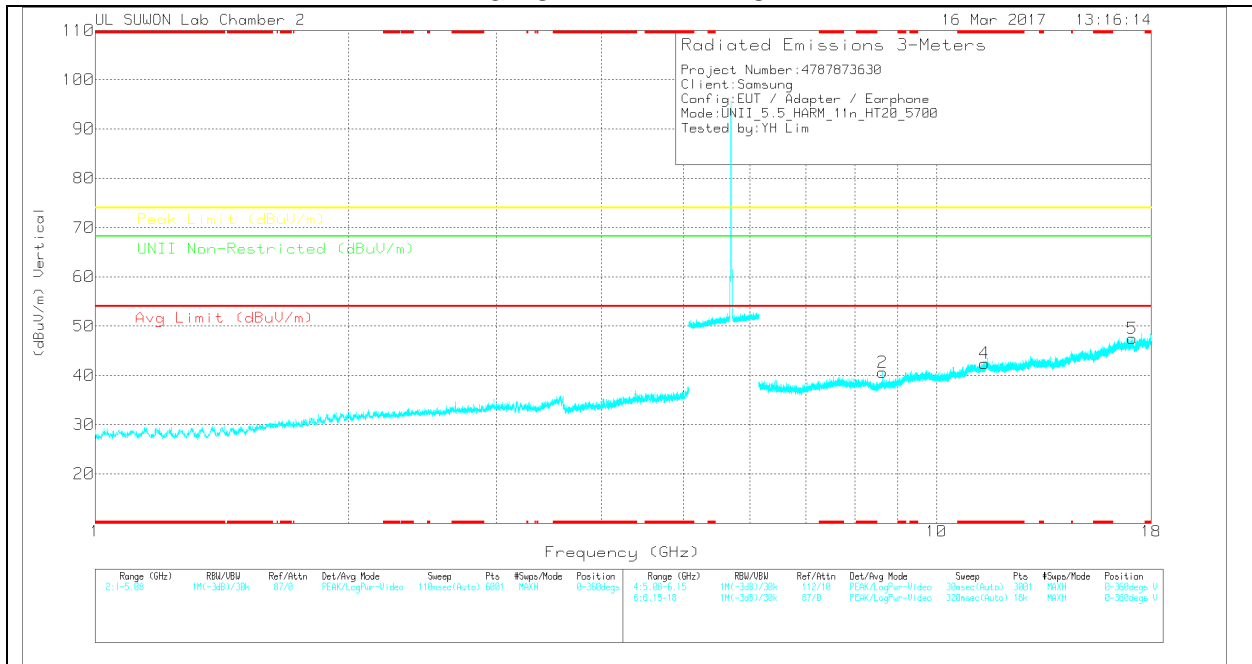

Note: Emission was scanned up to 40GHz; No emissions were detected above the noise floor which was at least 20dB below the specification limit.

**HIGH CHANNEL DATA**

Trace Markers

Marker	Frequency (GHz)	Meter Reading (dBuV)	Det	3117(0016 8724)_150 619	6GHz_HP[dB]	DC Corr (dB)	Corrected Reading (dBuV/m)	Avg Limit (dBuV/m)	Margin (dB)	Peak Limit (dBuV/m)	Margin (dB)	UNII Non-Restricted (dBuV/m)	Margin (dB)	Azimuth (Degs)	Height (cm)	Polarity
1	8.646	21.62	PK	36	-18.4	0	39.22	-	-	-	-	68.2	-28.98	0-360	250	H
3	* 11.4	23.23	PK	38.3	-15.6	0	45.93	-	-	74	-28.07	-	-	0-360	250	H
6	17.105	20.09	PK	41.1	-13.5	0	47.69	-	-	-	-	68.2	-20.51	0-360	150	H
2	8.635	22.79	PK	36	-18.2	0	40.59	-	-	-	-	68.2	-27.61	0-360	250	V
4	* 11.399	19.71	PK	38.3	-15.6	0	42.41	-	-	74	-31.59	-	-	0-360	250	V
5	17.102	19.86	PK	41.1	-13.5	0	47.46	-	-	-	-	68.2	-20.74	0-360	250	V

\* - indicates frequency in CFR15.205/IC7.2.2 Restricted Band

PK – Peak detector

Radiated Emissions

Frequency (GHz)	Meter Reading (dBuV)	Det	3117(001687 24)_150619	6GHz_HP[dB]	DC Corr (dB)	Corrected Reading (dBuV/m)	Avg Limit (dBuV/m)	Margin (dB)	Peak Limit (dBuV/m)	Margin (dB)	UNII Non-Restricted (dBuV/m)	Margin (dB)	Azimuth (Degs)	Height (cm)	Polarity
* 11.4	34.32	PK-U	38.3	-15.6	0	57.02	-	-	74	-16.98	-	-	153	204	H
* 11.4	24.82	ADR	38.3	-15.6	.17	47.69	54	-6.31	-	-	-	-	153	204	H
* 11.399	30.78	PK-U	38.3	-15.6	0	53.48	-	-	74	-20.52	-	-	204	171	V
* 11.4	18.96	ADR	38.3	-15.6	.17	41.83	54	-12.17	-	-	-	-	204	171	V

\* - indicates frequency in CFR15.205/IC7.2.2 Restricted Band

PK-U - U-NII: Maximum Peak

ADR - U-NII AD primary method, RMS average

### STRADDLE CHANNEL HORIZONTAL

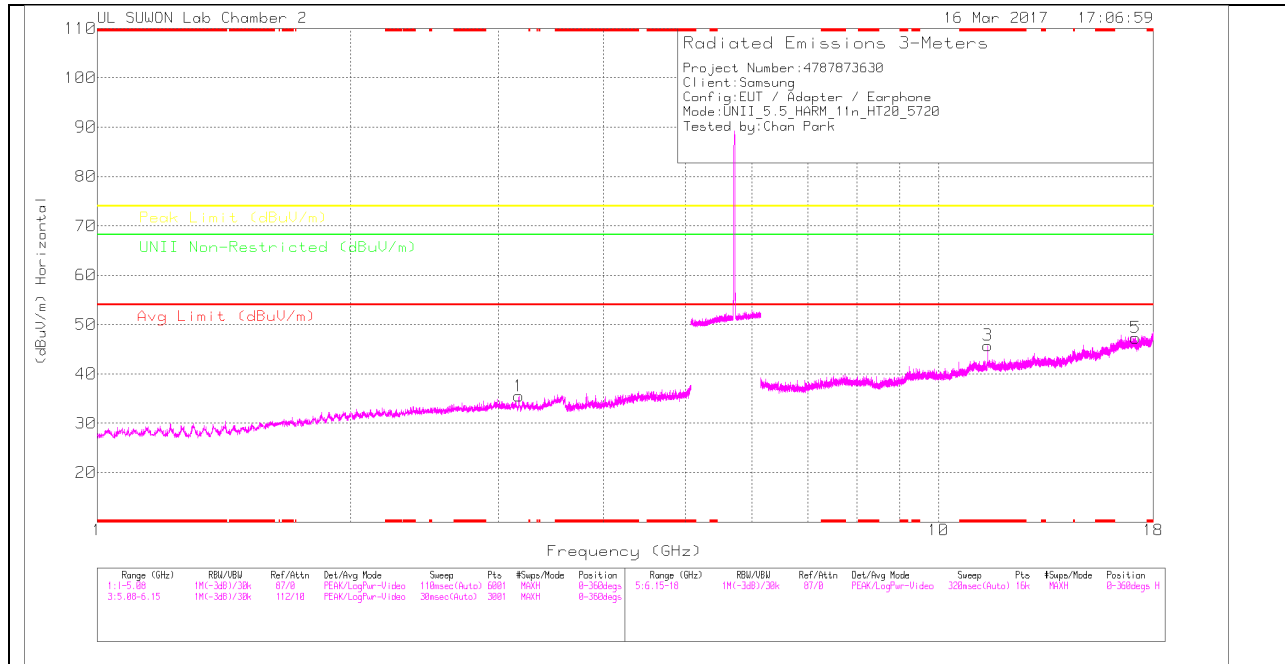

### STRADDLE CHANNEL VERTICAL

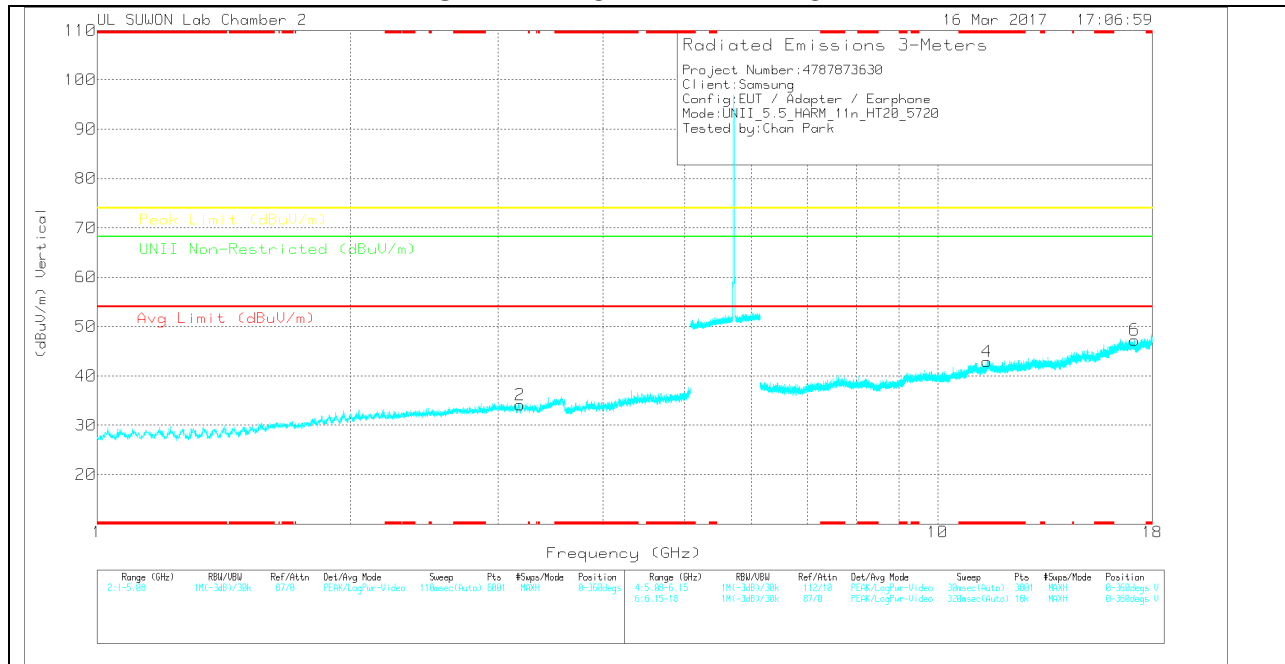

Note: Emission was scanned up to 40GHz; No emissions were detected above the noise floor which was at least 20dB below the specification limit.

**STRADDLE CHANNEL DATA**

Trace Markers

Marker	Frequency (GHz)	Meter Reading (dBuV)	Det	3117(00168724)_150619	5GHz_LP[dB]	DC Corr (dB)	Corrected Reading (dBuV/m)	Avg Limit (dBuV/m)	Margin (dB)	Peak Limit (dBuV/m)	Margin (dB)	UNII Non-Restricted (dBuV/m)	Margin (dB)	Azimuth (Degs)	Height (cm)	Polarity
1	3.172	28.79	PK	32.5	-25.8	0	35.49	-	-	-	-	68.2	-32.71	0-360	150	H
2	3.185	27.19	PK	32.6	-25.7	0	34.09	-	-	-	-	68.2	-34.11	0-360	150	V
3	* 11.44	23.36	PK	38.3	-15.9	0	45.76	-	-	74	-28.24	-	-	0-360	150	H
5	17.159	19.71	PK	41.1	-13.5	0	47.31	-	-	-	-	68.2	-20.89	0-360	150	H
4	* 11.44	20.5	PK	38.3	-15.9	0	42.9	-	-	74	-31.1	-	-	0-360	250	V
6	17.158	19.68	PK	41.1	-13.5	0	47.28	-	-	-	-	68.2	-20.92	0-360	250	V

\* - indicates frequency in CFR15.205/IC7.2.2 Restricted Band

PK – Peak detector

Radiated Emissions

Frequency (GHz)	Meter Reading (dBuV)	Det	3117(00168724)_150619	6GHz_HP[dB]	DC Corr (dB)	Corrected Reading (dBuV/m)	Avg Limit (dBuV/m)	Margin (dB)	Peak Limit (dBuV/m)	Margin (dB)	UNII Non-Restricted (dBuV/m)	Margin (dB)	Azimuth (Degs)	Height (cm)	Polarity
* 11.401	30.11	PK-U	38.3	-15.7	0	52.71	-	-	74	-21.29	-	-	52	131	H
* 11.401	16.96	ADR	38.3	-15.7	0	39.56	54	-14.44	-	-	-	-	52	131	H

\* - indicates frequency in CFR15.205/IC7.2.2 Restricted Band

PK-U - U-NII: Maximum Peak

ADR - U-NII AD primary method, RMS average

### 10.3.3. TX ABOVE 1GHz 802.11n HT40 MODE IN THE 5.5GHz BAND RESTRICTED BANDEDGE (LOW CHANNEL)

#### HORIZONTAL PEAK AND AVERAGE PLOT

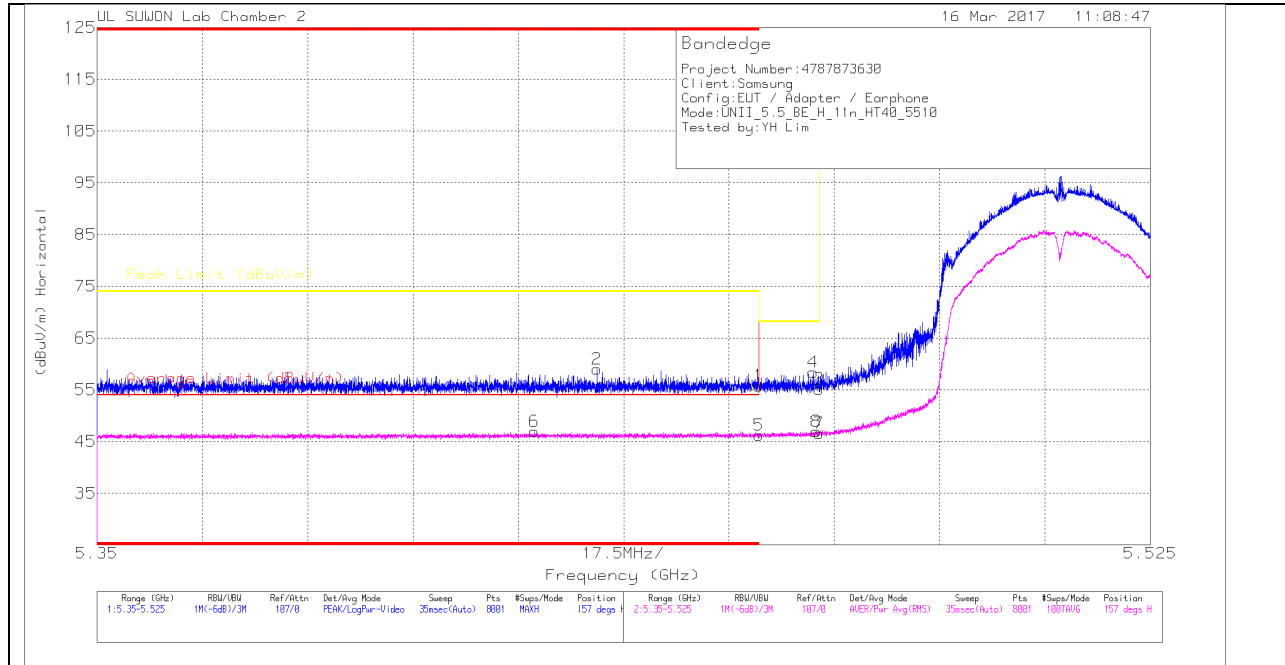

#### HORIZONTAL DATA

##### Trace Markers

Marker	Frequency (GHz)	Meter Reading (dBuV)	Det	3117(001687 24)_150619	10dB(dB)	DC Corr (dB)	Corrected Reading (dBuV/m)	Average Limit (dBuV/m)	Margin (dB)	Peak Limit (dBuV/m)	PK Margin (dB)	Azimuth (Degs)	Height (cm)	Polarity
1	* 5.46	36.3	Pk	34.5	-15	0	55.8	-	-	74	-18.2	157	262	H
2	* 5.433	39.61	Pk	34.5	-15.1	0	59.01	-	-	74	-14.99	157	262	H
3	5.47	35.64	Pk	34.5	-15	0	55.14	-	-	68.2	-13.06	157	262	H
4	5.469	38.89	Pk	34.5	-15	0	58.39	-	-	68.2	-9.81	157	262	H
5	* 5.46	26.35	RMS	34.5	-15	.38	46.23	54	-7.77	-	-	157	262	H
6	* 5.423	27.26	RMS	34.4	-15.1	.38	46.94	54	-7.06	-	-	157	262	H

\* - indicates frequency in CFR15.205/IC7.2.2 Restricted Band

Pk - Peak detector

RMS - RMS detection

**VERTICAL PEAK AND AVERAGE PLOT**

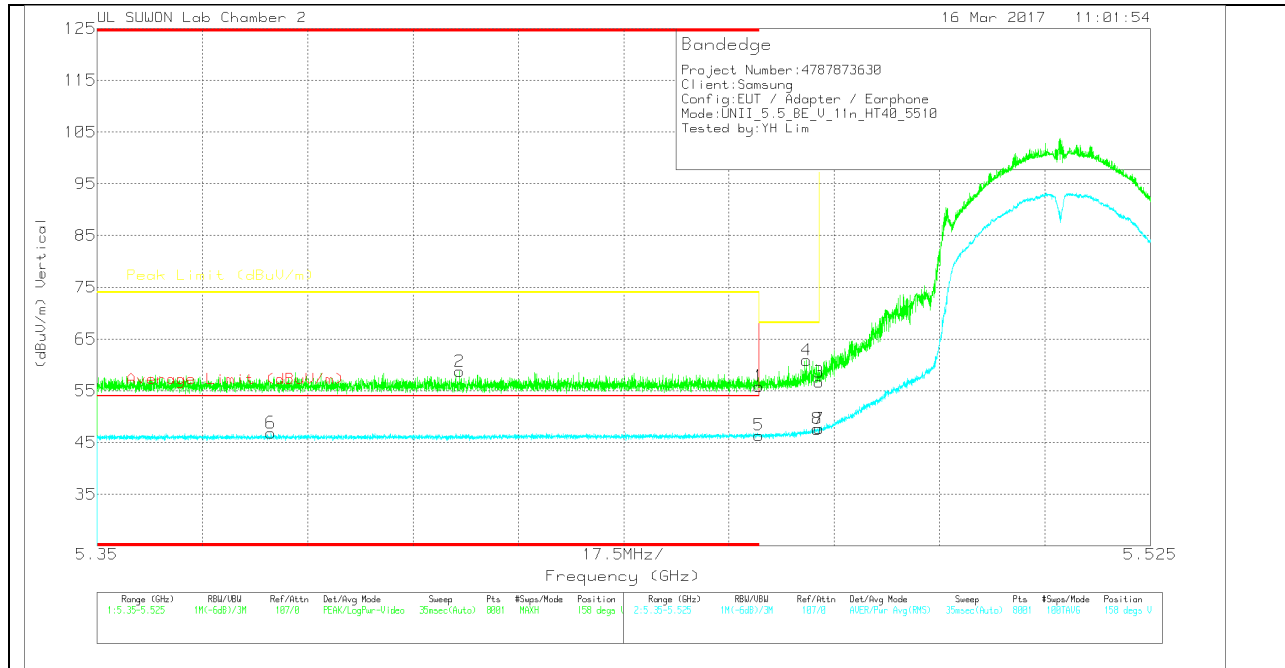

**VERTICAL DATA**

Trace Markers

Marker	Frequency (GHz)	Meter Reading (dBuV)	Det	3117(001687 24)_150619	10dB(dB)	DC Corr (dB)	Corrected Reading (dBuV/m)	Average Limit (dBuV/m)	Margin (dB)	Peak Limit (dBuV/m)	PK Margin (dB)	Azimuth (Degs)	Height (cm)	Polarity
1	* 5.46	36.39	Pk	34.5	-15	0	55.89	-	-	74	-18.11	158	189	V
2	* 5.41	39.53	Pk	34.4	-15.2	0	58.73	-	-	74	-15.27	158	189	V
3	5.47	37.16	Pk	34.5	-15	0	56.66	-	-	68.2	-11.54	158	189	V
4	5.468	41.41	Pk	34.5	-15	0	60.91	-	-	68.2	-7.29	158	189	V
5	* 5.46	26.52	RMS	34.5	-15	.38	46.4	54	-7.6	-	-	158	189	V
6	* 5.379	27.28	RMS	34.4	-15.2	.38	46.86	54	-7.14	-	-	158	189	V

\* - indicates frequency in CFR15.205/IC7.2.2 Restricted Band

Pk - Peak detector

RMS - RMS detection

## AUTHORIZED BANDEDGE (HIGH CHANNEL)

### HORIZONTAL PEAK AND AVERAGE PLOT

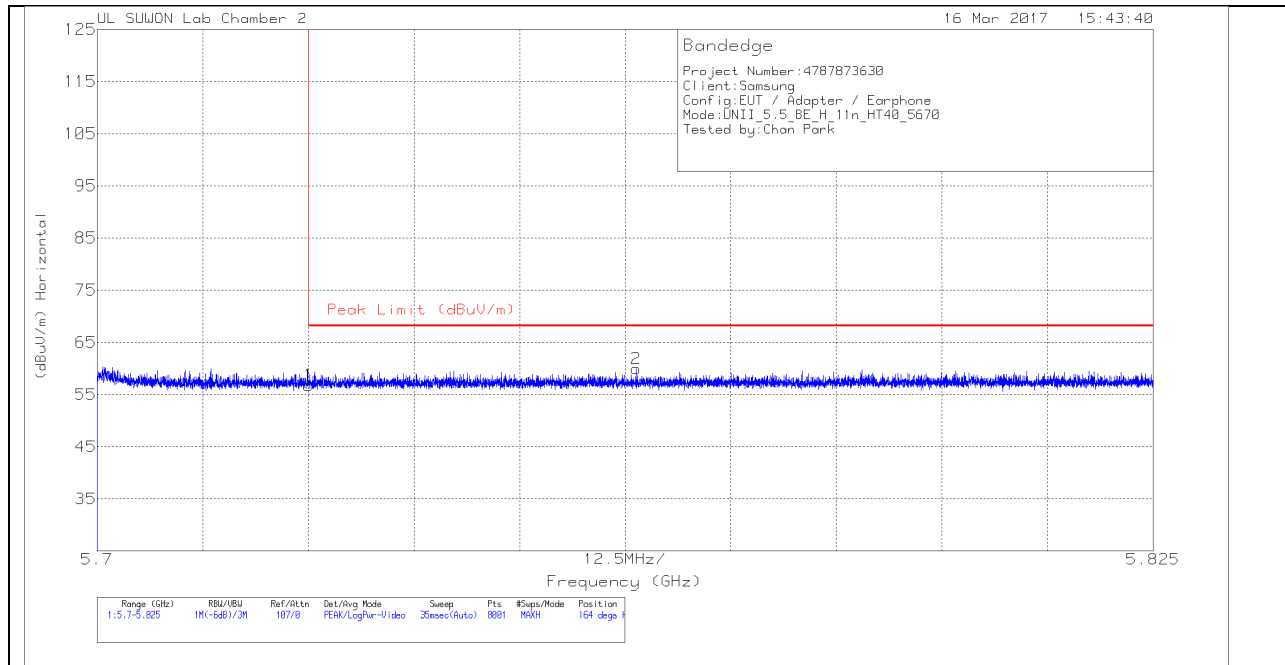

### HORIZONTAL DATA

Trace Markers

Marker	Frequency (GHz)	Meter Reading (dBuV)	Det	3117(0016 8724)_150 619	10dB[dB]	DC Corr (dB)	Corrected Reading (dBuV/m)	Peak Limit (dBuV/m)	PK Margin (dB)	Azimuth (Degs)	Height (cm)	Polarity
1	5.725	36.58	Pk	34.7	-14.5	0	56.78	68.2	-11.42	164	132	H
2	5.764	39.66	Pk	34.7	-14.4	0	59.96	68.2	-8.24	164	132	H

Pk - Peak detector

**VERTICAL PEAK AND AVERAGE PLOT**

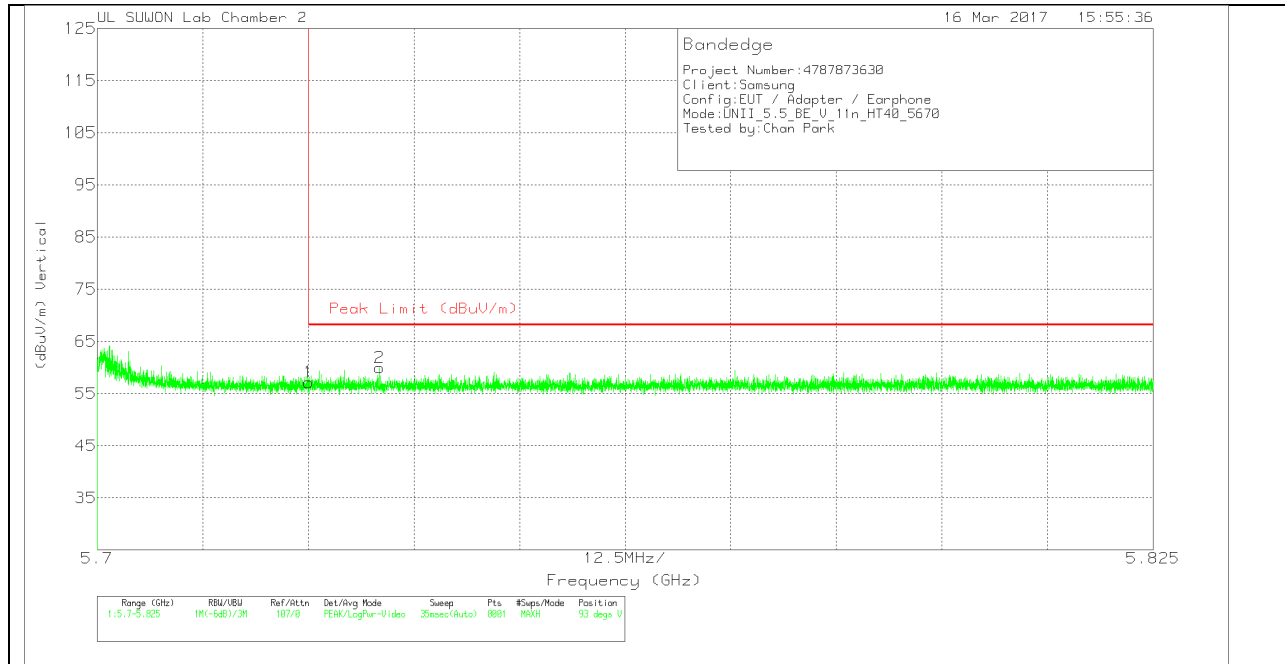

**VERTICAL DATA**

Trace Markers

Marker	Frequency (GHz)	Meter Reading (dBuV)	Det	3117(0016 8724)_150 619	10dB[dB]	DC Corr (dB)	Corrected Reading (dBuV/m)	Peak Limit (dBuV/m)	PK Margin (dB)	Azimuth (Degs)	Height (cm)	Polarity
1	5.725	36.95	Pk	34.7	-14.5	0	57.15	68.2	-11.05	93	127	V
2	5.733	39.65	Pk	34.7	-14.4	0	59.95	68.2	-8.25	93	127	V

Pk - Peak detector

## HARMONICS AND SPURIOUS EMISSIONS

### LOW CHANNEL HORIZONTAL

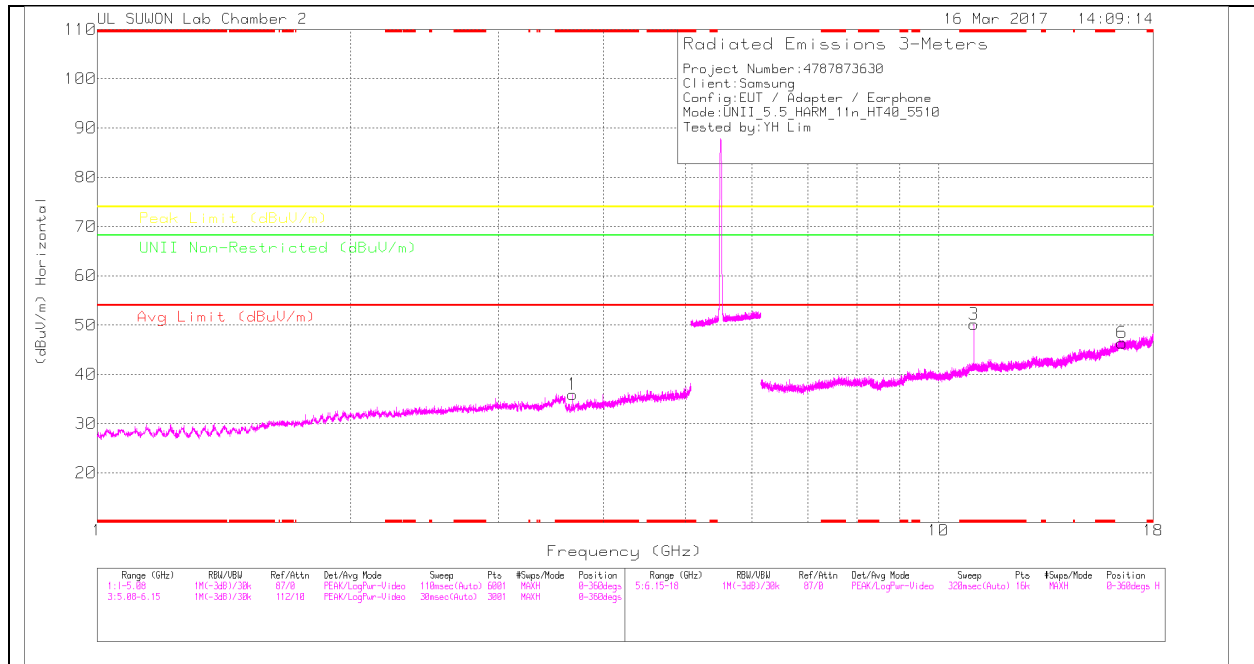

### LOW CHANNEL VERTICAL

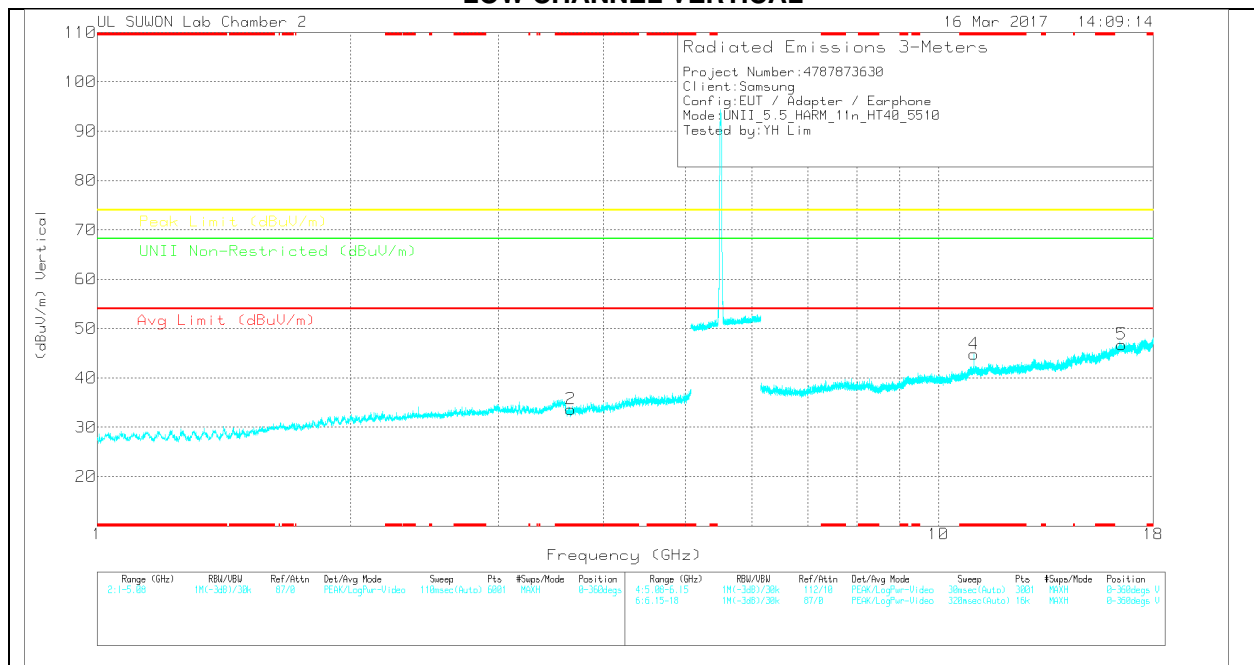

Note: Emission was scanned up to 40GHz; No emissions were detected above the noise floor which was at least 20dB below the specification limit.

**LOW CHANNEL DATA**

Trace Markers

Marker	Frequency (GHz)	Meter Reading (dBuV)	Det	3117(0016 8724)_150 619	5GHz_LP[d B]	DC Corr (dB)	Corrected Reading (dBuV/m)	Avg Limit (dBuV/m)	Margin (dB)	Peak Limit (dBuV/m)	Margin (dB)	UNII Non-Restricted (dBuV/m)	Margin (dB)	Azimuth (Degs)	Height (cm)	Polarity
1	* 3.674	28.64	PK	32.9	-25.6	0	35.94	-	-	74	-38.06	-	-	0-360	250	H
2	* 3.658	26.47	PK	32.9	-25.7	0	33.67	-	-	74	-40.33	-	-	0-360	150	V
3	* 11.02	28.28	PK	38	-16.1	0	50.18	-	-	74	-23.82	-	-	0-360	250	H
6	16.526	19.8	PK	41	-14.4	0	46.4	-	-	-	-	68.2	-21.8	0-360	150	H
4	* 11.02	22.95	PK	38	-16.1	0	44.85	-	-	74	-29.15	-	-	0-360	250	V
5	16.509	20.19	PK	41	-14.4	0	46.79	-	-	-	-	68.2	-21.41	0-360	150	V

\* - indicates frequency in CFR15.205/IC7.2.2 Restricted Band

PK – Peak detector

Radiated Emissions

Frequency (GHz)	Meter Reading (dBuV)	Det	3117(001687 24)_150619	6GHz_HP[dB]	DC Corr (dB)	Corrected Reading (dBuV/m)	Avg Limit (dBuV/m)	Margin (dB)	Peak Limit (dBuV/m)	Margin (dB)	UNII Non-Restricted (dBuV/m)	Margin (dB)	Azimuth (Degs)	Height (cm)	Polarity
* 11.02	33.89	PK-U	38	-16.1	0	55.79	-	-	74	-18.21	-	-	213	200	H
* 11.02	27.57	ADR	38	-16.1	.38	49.85	54	-4.15	-	-	-	-	213	200	H
* 11.02	31.87	PK-U	38	-16.1	0	53.77	-	-	74	-20.23	-	-	209	222	V
* 11.02	21.68	ADR	38	-16.1	.38	43.96	54	-10.04	-	-	-	-	209	222	V

\* - indicates frequency in CFR15.205/IC7.2.2 Restricted Band

PK-U - U-NII: Maximum Peak

ADR - U-NII AD primary method, RMS average

MID CHANNEL HORIZONTAL

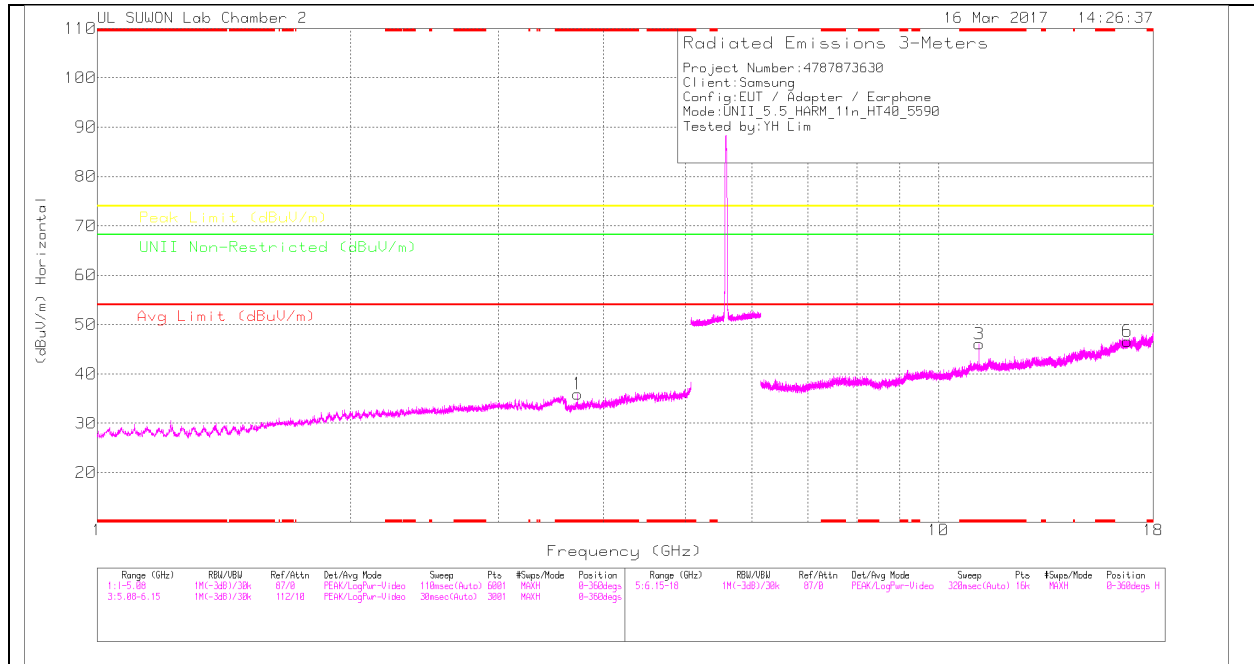

MID CHANNEL VERTICAL

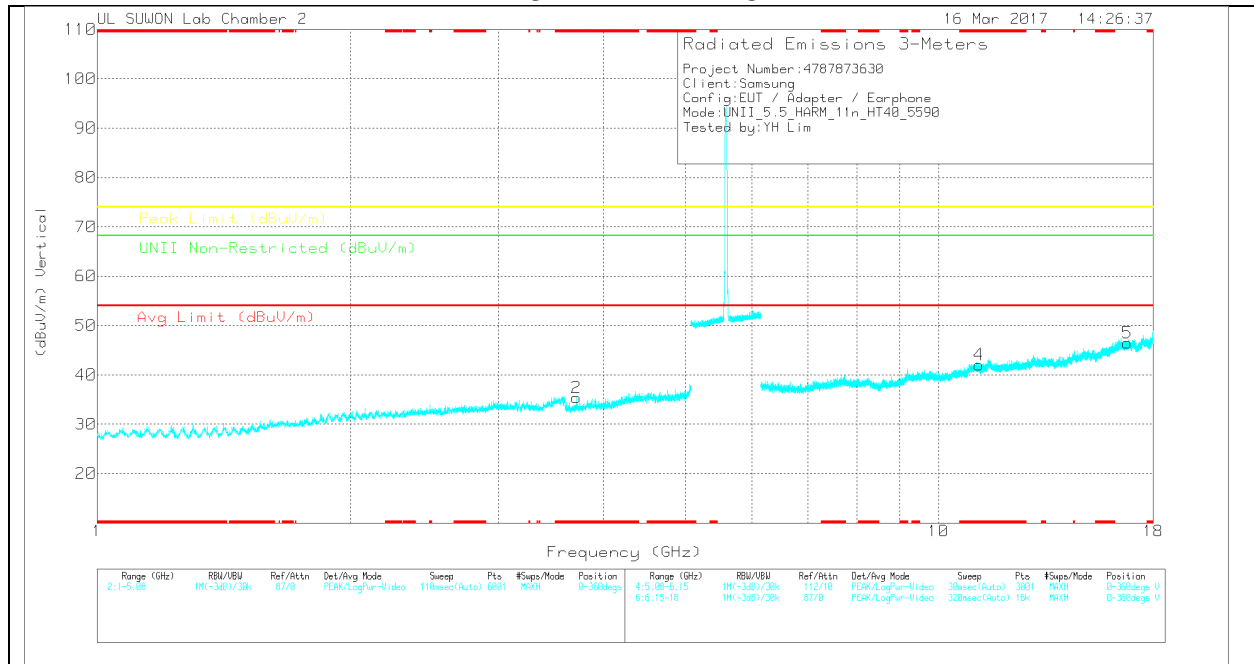

Note: Emission was scanned up to 40GHz; No emissions were detected above the noise floor which was at least 20dB below the specification limit.

**MID CHANNEL DATA**

Trace Markers

Marker	Frequency (GHz)	Meter Reading (dBuV)	Det	3117(0016 8724)_150 619	5GHz_LP[d B]	DC Corr (dB)	Corrected Reading (dBuV/m)	Avg Limit (dBuV/m)	Margin (dB)	Peak Limit (dBuV/m)	Margin (dB)	UNII Non-Restricted (dBuV/m)	Margin (dB)	Azimuth (Degs)	Height (cm)	Polarity
1	* 3.727	28.45	PK	33	-25.5	0	35.95	-	-	74	-38.05	-	-	0-360	250	H
2	* 3.715	27.87	PK	33	-25.5	0	35.37	-	-	74	-38.63	-	-	0-360	150	V
3	* 11.18	24.26	PK	38.1	-16.3	0	46.06	-	-	74	-27.94	-	-	0-360	250	H
6	16.768	19.24	PK	41	-13.6	0	46.64	-	-	-	-	68.2	-21.56	0-360	250	H
4	* 11.179	20.15	PK	38.1	-16.2	0	42.05	-	-	74	-31.95	-	-	0-360	250	V
5	16.771	18.98	PK	41	-13.5	0	46.48	-	-	-	-	68.2	-21.72	0-360	250	V

\* - indicates frequency in CFR15.205/IC7.2.2 Restricted Band

PK – Peak detector

Radiated Emissions

Frequency (GHz)	Meter Reading (dBuV)	Det	3117(001687 24)_150619	6GHz_HP[dB]	DC Corr (dB)	Corrected Reading (dBuV/m)	Avg Limit (dBuV/m)	Margin (dB)	Peak Limit (dBuV/m)	Margin (dB)	UNII Non-Restricted (dBuV/m)	Margin (dB)	Azimuth (Degs)	Height (cm)	Polarity
* 11.18	33.56	PK-U	38.1	-16.2	0	55.46	-	-	74	-18.54	-	-	156	196	H
* 11.18	24.55	ADR	38.1	-16.3	.38	46.73	54	-7.27	-	-	-	-	156	196	H
* 11.18	31.19	PK-U	38.1	-16.3	0	52.99	-	-	74	-21.01	-	-	204	211	V
* 11.18	19.76	ADR	38.1	-16.3	.38	41.94	54	-12.06	-	-	-	-	204	211	V

\* - indicates frequency in CFR15.205/IC7.2.2 Restricted Band

PK-U - U-NII: Maximum Peak

ADR - U-NII AD primary method, RMS average

### HIGH CHANNEL HORIZONTAL

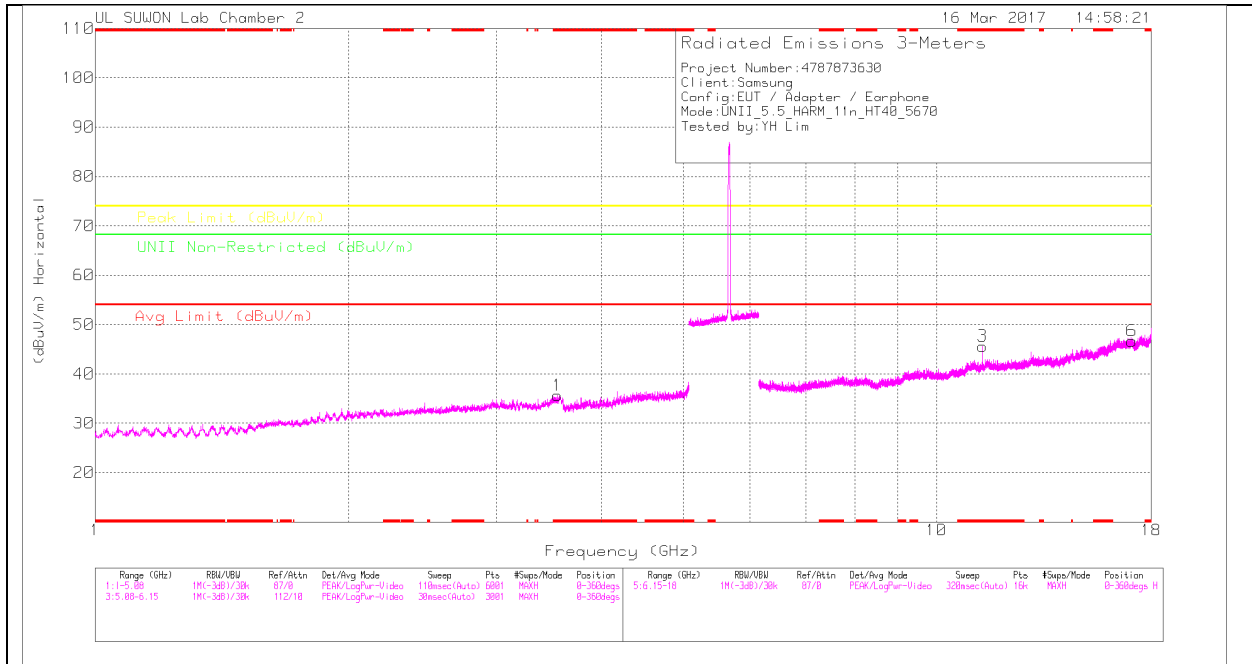

### HIGH CHANNEL VERTICAL

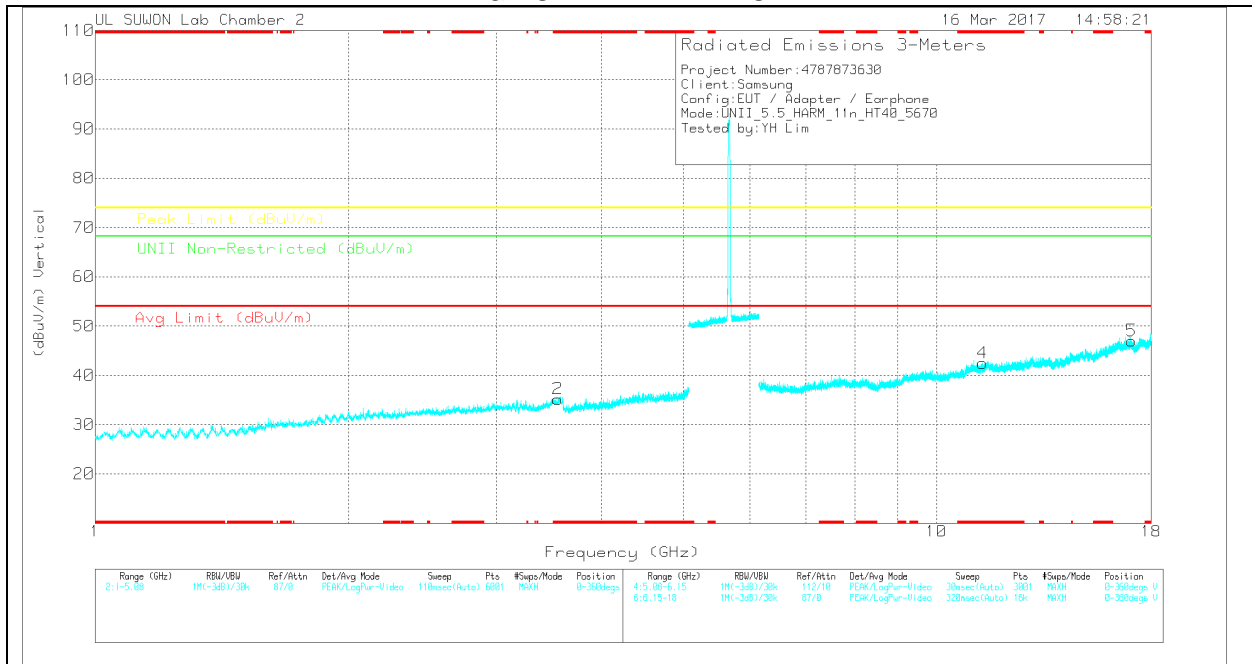

Note: Emission was scanned up to 40GHz; No emissions were detected above the noise floor which was at least 20dB below the specification limit.

**HIGH CHANNEL DATA**

Trace Markers

Marker	Frequency (GHz)	Meter Reading (dBuV)	Det	3117(00168724)_150619	5GHz_LP[dB]	DC Corr (dB)	Corrected Reading (dBuV/m)	Avg Limit (dBuV/m)	Margin (dB)	Peak Limit (dBuV/m)	Margin (dB)	UNII Non-Restricted (dBuV/m)	Margin (dB)	Azimuth (Degs)	Height (cm)	Polarity
1	* 3.543	27.44	PK	32.8	-24.6	0	35.64	-	-	74	-38.36	-	-	0-360	150	H
2	* 3.548	27.1	PK	32.8	-24.7	0	35.2	-	-	74	-38.8	-	-	0-360	150	V
3	* 11.34	23.03	PK	38.2	-15.6	0	45.63	-	-	74	-28.37	-	-	0-360	250	H
6	17.074	18.97	PK	41.1	-13.4	0	46.67	-	-	-	-	68.2	-21.53	0-360	150	H
4	* 11.34	19.88	PK	38.2	-15.6	0	42.48	-	-	74	-31.52	-	-	0-360	250	V
5	17.072	19.3	PK	41.1	-13.4	0	47	-	-	-	-	68.2	-21.2	0-360	250	V

\* - indicates frequency in CFR15.205/IC7.2.2 Restricted Band

PK – Peak detector

Radiated Emissions

Frequency (GHz)	Meter Reading (dBuV)	Det	3117(00168724)_150619	6GHz_HP[dB]	DC Corr (dB)	Corrected Reading (dBuV/m)	Avg Limit (dBuV/m)	Margin (dB)	Peak Limit (dBuV/m)	Margin (dB)	UNII Non-Restricted (dBuV/m)	Margin (dB)	Azimuth (Degs)	Height (cm)	Polarity
* 11.34	33.09	PK-U	38.2	-15.5	0	55.79	-	-	74	-18.21	-	-	156	187	H
* 11.34	23.97	ADR	38.2	-15.5	.38	47.05	54	-6.95	-	-	-	-	156	187	H
* 11.34	30.66	PK-U	38.2	-15.6	0	53.26	-	-	74	-20.74	-	-	206	209	V
* 11.34	19.11	ADR	38.2	-15.6	.38	42.09	54	-11.91	-	-	-	-	206	209	V

\* - indicates frequency in CFR15.205/IC7.2.2 Restricted Band

PK-U - U-NII: Maximum Peak

ADR - U-NII AD primary method, RMS average

**STRADDLE CHANNEL HORIZONTAL**

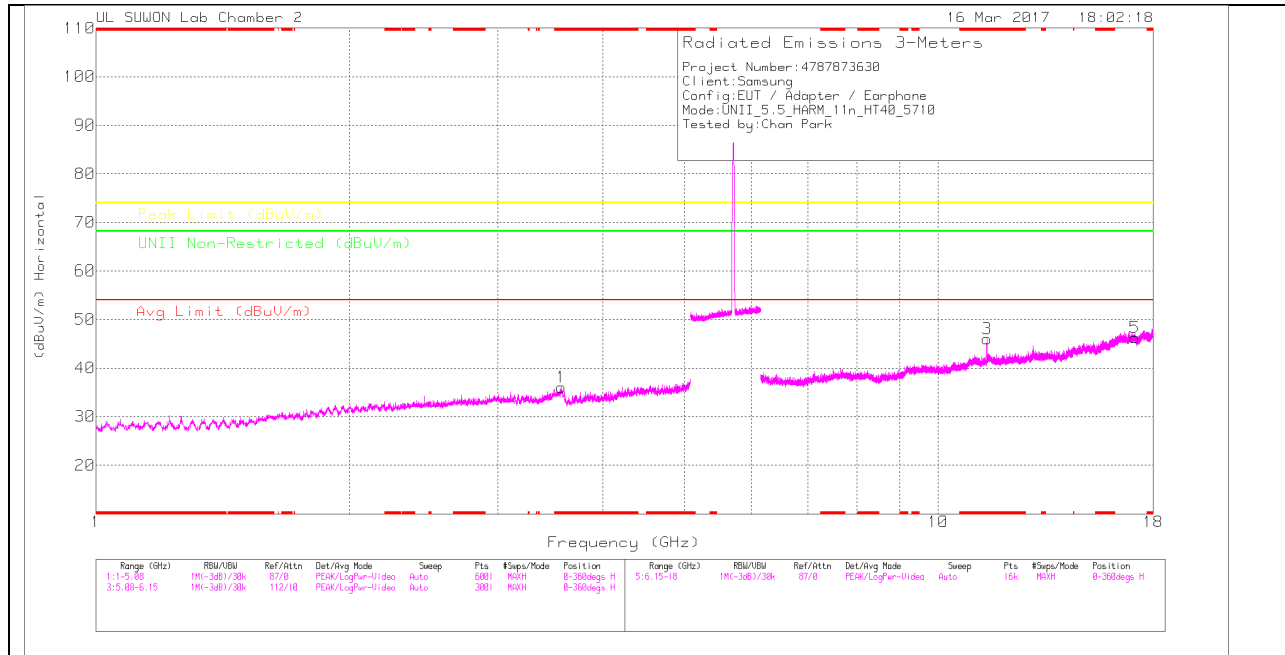

**STRADDLE CHANNEL VERTICAL**

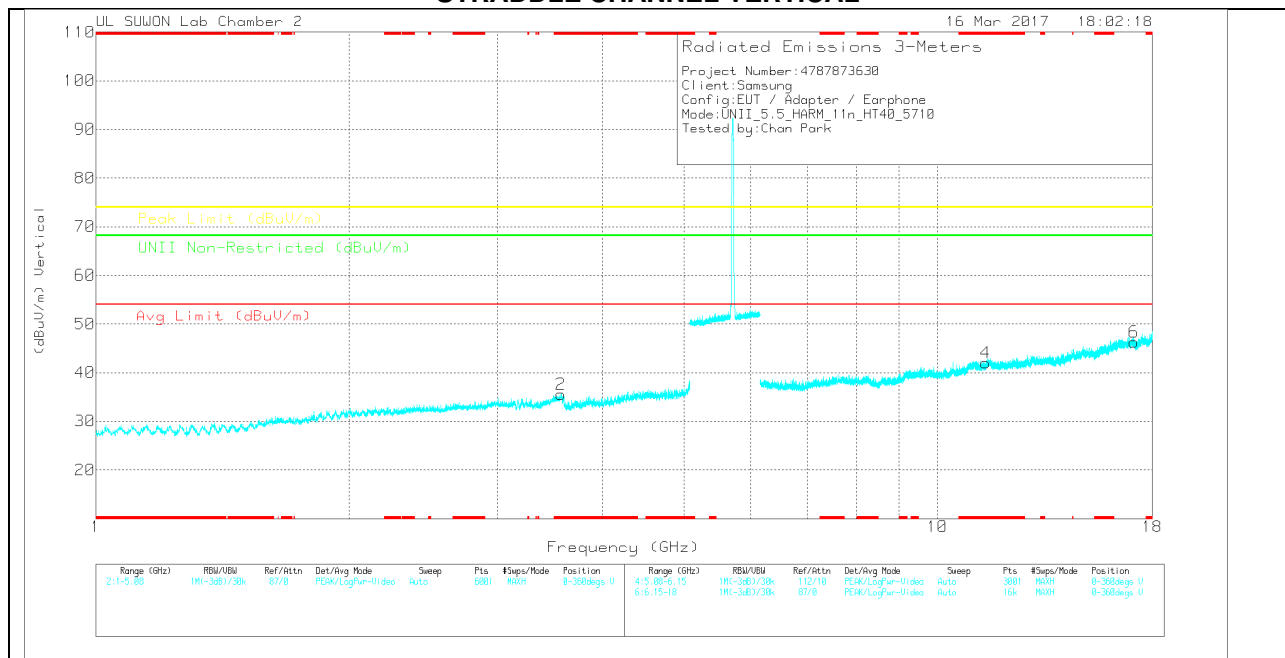

Note: Emission was scanned up to 40GHz; No emissions were detected above the noise floor which was at least 20dB below the specification limit.

**STRADDLE CHANNEL DATA**

Trace Markers

Marker	Frequency (GHz)	Meter Reading (dBuV)	Det	3117(0016 8724)_150 619	5GHz_LPF(d B)	DC Corr (dB)	Corrected Reading (dBuV/m)	Avg Limit (dBuV/m)	Margin (dB)	Peak Limit (dBuV/m)	Margin (dB)	UNII Non-Restricted (dBuV/m)	Margin (dB)	Azimuth (Degs)	Height (cm)	Polarity
1	* 3.57	28.18	Pk	32.8	-24.9	0	36.08	-	-	74	-37.92	-	-	0-360	250	H
2	* 3.571	27.66	Pk	32.8	-24.9	0	35.56	-	-	74	-38.44	-	-	0-360	150	V
3	* 11.42	23.5	Pk	38.3	-15.8	0	46	-	-	74	-28	-	-	0-360	250	H
5	17.128	18.77	Pk	41.1	-13.6	0	46.27	-	-	-	-	68.2	-21.93	0-360	150	H
4	* 11.418	19.52	Pk	38.3	-15.8	0	42.02	-	-	74	-31.98	-	-	0-360	150	V
6	17.127	18.69	Pk	41.1	-13.5	0	46.29	-	-	-	-	68.2	-21.91	0-360	150	V

\* - indicates frequency in CFR15.205/IC7.2.2 Restricted Band

Pk – Peak detector

Radiated Emissions

Frequency (GHz)	Meter Reading (dBuV)	Det	3117(001687 24)_150619	6GHz_HP[dB]	DC Corr (dB)	Corrected Reading (dBuV/m)	Avg Limit (dBuV/m)	Margin (dB)	Peak Limit (dBuV/m)	Margin (dB)	UNII Non-Restricted (dBuV/m)	Margin (dB)	Azimuth (Degs)	Height (cm)	Polarity
* 11.42	32.74	PK-U	38.3	-15.8	0	55.24	-	-	74	-18.76	-	-	151	248	H
* 11.42	23.07	ADR	38.3	-15.8	.38	45.95	54	-8.05	-	-	-	-	151	248	H

\* - indicates frequency in CFR15.205/IC7.2.2 Restricted Band

PK-U - U-NII: Maximum Peak

ADR - U-NII AD primary method, RMS average

### 10.4. 5.8 GHz

#### 10.4.1. TX ABOVE 1GHz 802.11a MODE IN THE 5.8GHz BAND BANDEDGE (LOW CHANNEL)

##### HORIZONTAL PEAK PLOT

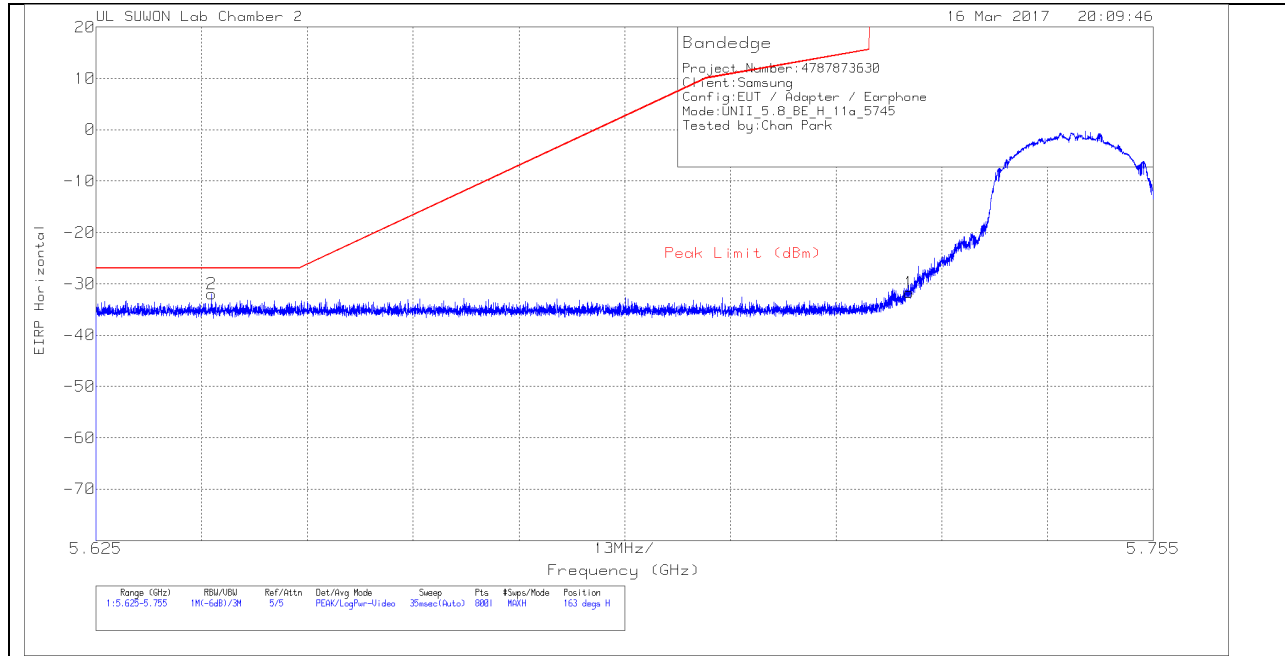

##### HORIZONTAL DATA

###### Trace Markers

Marker	Frequency (GHz)	Meter Reading (dBm)	Det	3117(0016 8724)_150 619	Path_2_10 dB	Conversion Factor (dB)	DC Corr (dB)	Corrected Reading EIRP	Peak Limit (dBm)	PK Margin (dB)	Azimuth (Degs)	Height (cm)	Polarity
1	5.725	-62.6	Pk	34.7	-15.6	11.8	0	-31.7	278.26	-309.96	163	136	H
2	5.639	-62.71	Pk	34.6	-15.7	11.8	0	-32.01	-27	-5.01	163	136	H

Pk - Peak detector

**VERTICAL PEAK PLOT**

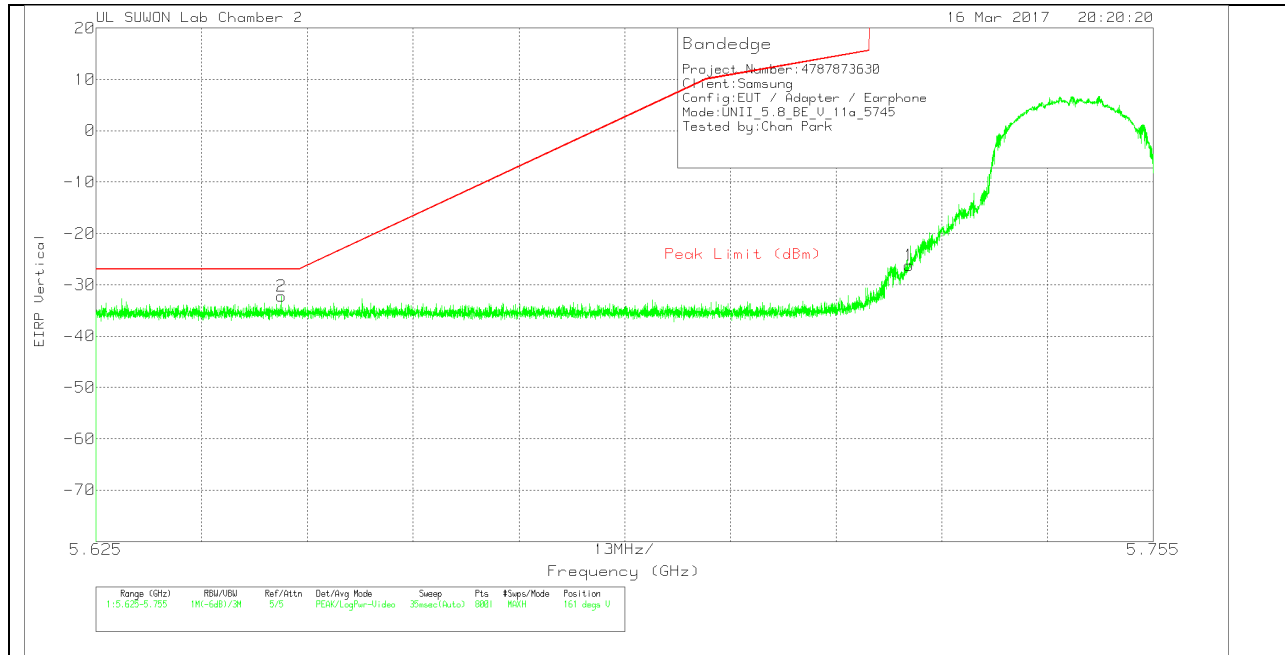

**VERTICAL DATA**

Trace Markers

Marker	Frequency (GHz)	Meter Reading (dBm)	Det	3117(0016 8724)_150 619	Path_2_10 dB	Conversion Factor (dB)	DC Corr (dB)	Corrected Reading EIRP	Peak Limit (dBm)	PK Margin (dB)	Azimuth (Degs)	Height (cm)	Polarity
1	5.725	-57.09	Pk	34.7	-15.6	11.8	0	-26.19	278.26	-304.45	161	213	V
2	5.648	-62.91	Pk	34.6	-15.7	11.8	0	-32.21	-27	-5.21	161	213	V

Pk - Peak detector

### BANDEDGE (HIGH CHANNEL)

#### HORIZONTAL PEAK PLOT

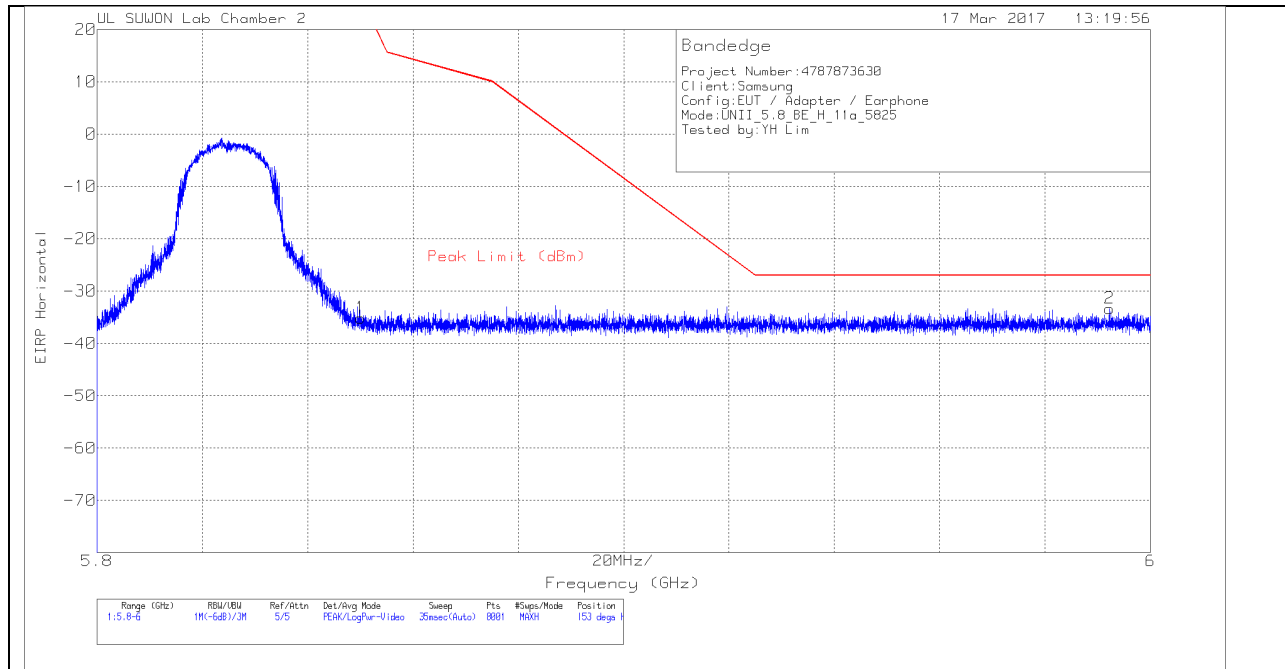

#### HORIZONTAL DATA

##### Trace Markers

Marker	Frequency (GHz)	Meter Reading (dBm)	Det	3117(0016 8724)_150 619	Path_2_10 dB	Conversion Factor (dB)	DC Corr (dB)	Corrected Reading EIRP	Peak Limit (dBm)	PK Margin (dB)	Azimuth (Degs)	Height (cm)	Polarity
1	5.85	-66.13	Pk	34.7	-15.5	11.8	0	-35.13	26.94	-62.07	153	262	H
2	5.992	-64.51	Pk	34.8	-15.4	11.8	0	-33.31	-27	-6.31	153	262	H

Pk - Peak detector

**VERTICAL PEAK PLOT**

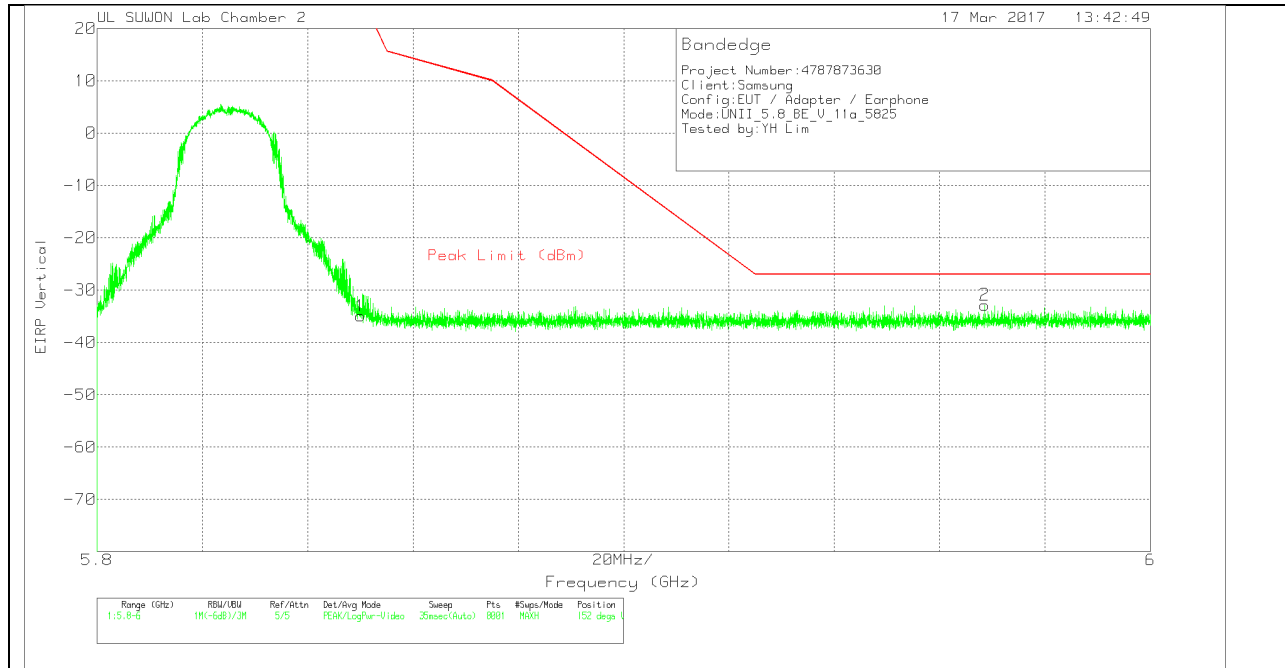

**VERTICAL DATA**

Trace Markers

Marker	Frequency (GHz)	Meter Reading (dBm)	Det	3117(0016 8724)_150 619	Path_2_10 dB	Conversion Factor (dB)	DC Corr (dB)	Corrected Reading EIRP	Peak Limit (dBm)	PK Margin (dB)	Azimuth (Degs)	Height (cm)	Polarity
1	5.85	-65.96	Pk	34.7	-15.5	11.8	0	-34.96	26.94	-61.9	152	142	V
2	5.969	-64.04	Pk	34.8	-15.4	11.8	0	-32.84	-27	-5.84	152	142	V

Pk - Peak detector

**LOW CHANNEL HORIZONTAL**

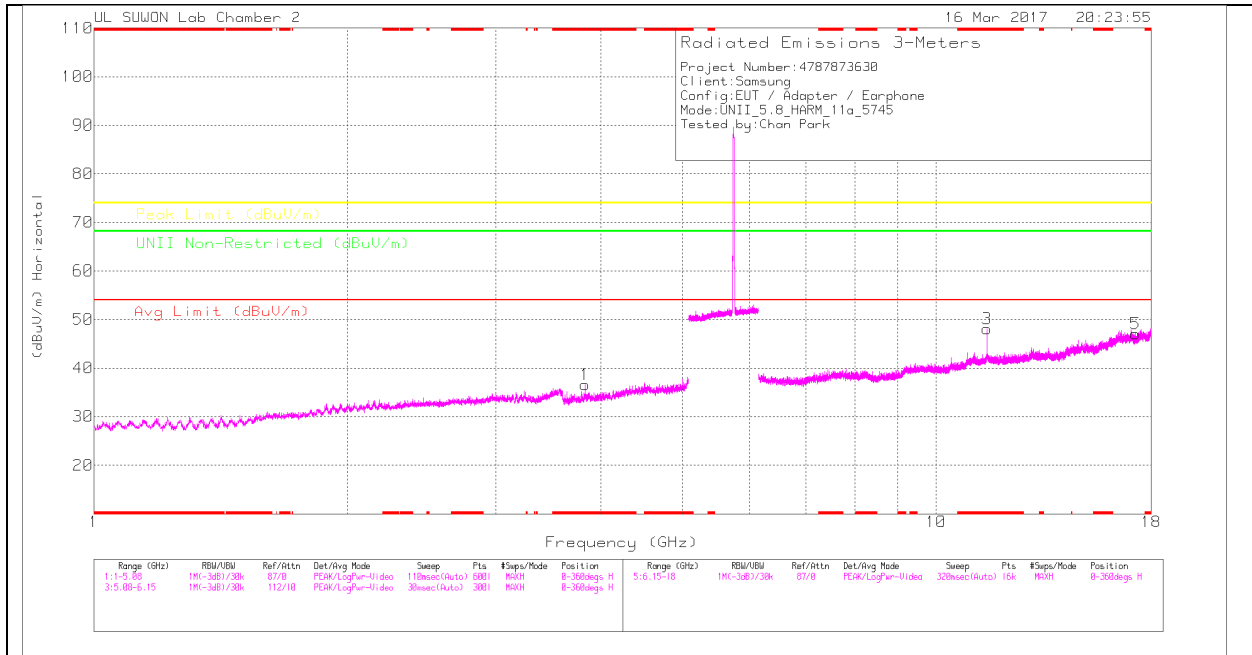

**LOW CHANNEL VERTICAL**

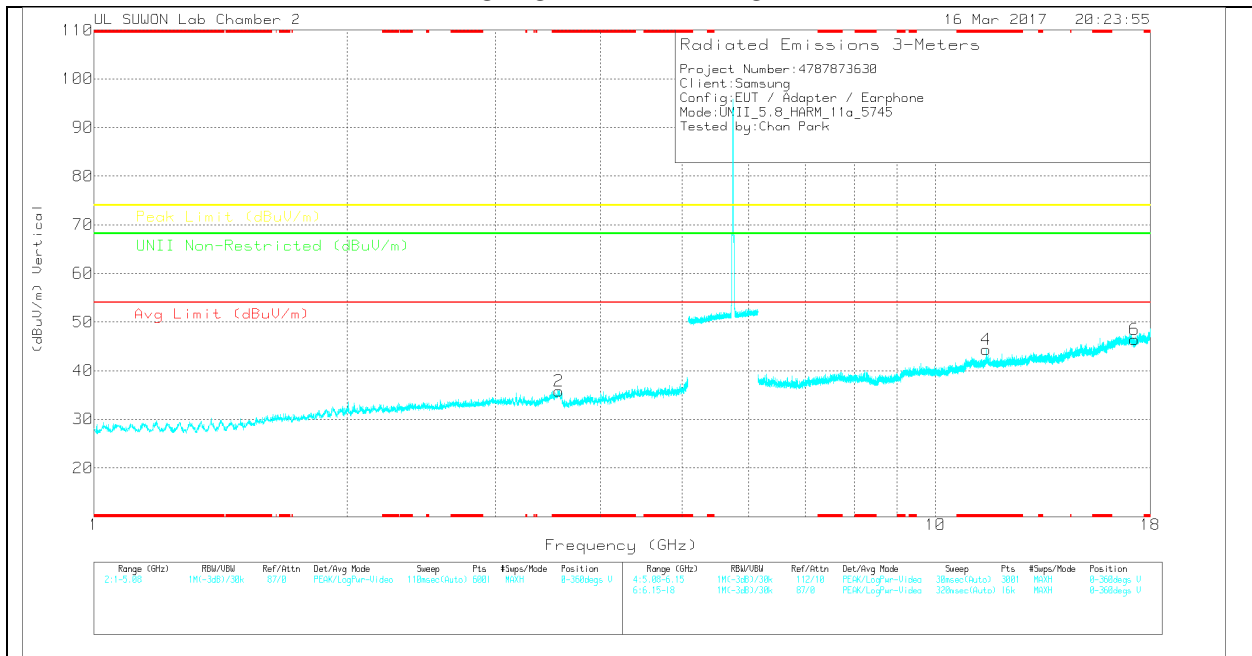

Note: Emission was scanned up to 40GHz; No emissions were detected above the noise floor which was at least 20dB below the specification limit.

**LOW CHANNEL DATA**

Trace Markers

Marker	Frequency (GHz)	Meter Reading (dBuV)	Det	3117(0016 8724)_150 619	5GHz_LP(d B)	DC Corr (dB)	Corrected Reading (dBuV/m)	Avg Limit (dBuV/m)	Margin (dB)	Peak Limit (dBuV/m)	Margin (dB)	UNII Non-Restricted (dBuV/m)	Margin (dB)	Azimuth (Degs)	Height (cm)	Polarity
1	* 3.829	28.53	PK	33.1	-25	0	36.63	-	-	74	-37.37	-	-	0-360	150	H
2	* 3.57	27.95	PK	32.8	-24.9	0	35.85	-	-	74	-38.15	-	-	0-360	250	V
3	* 11.49	25.7	PK	38.3	-15.9	0	48.1	-	-	74	-25.9	-	-	0-360	250	H
5	17.235	19.33	PK	41.2	-13.5	0	47.03	-	-	-	-	68.2	-21.17	0-360	150	H
4	* 11.49	21.98	PK	38.3	-15.9	0	44.38	-	-	74	-29.62	-	-	0-360	150	V
6	17.239	18.62	PK	41.2	-13.4	0	46.42	-	-	-	-	68.2	-21.78	0-360	150	V

\* - indicates frequency in CFR15.205/IC7.2.2 Restricted Band

PK – Peak detector

Radiated Emissions

Frequency (GHz)	Meter Reading (dBuV)	Det	3117(001687 24)_150619	6GHz_HP[dB]	DC Corr (dB)	Corrected Reading (dBuV/m)	Avg Limit (dBuV/m)	Margin (dB)	Peak Limit (dBuV/m)	Margin (dB)	UNII Non-Restricted (dBuV/m)	Margin (dB)	Azimuth (Degs)	Height (cm)	Polarity
* 11.49	34.39	PK-U	38.3	-15.9	0	56.79	-	-	74	-17.21	-	-	152	234	H
* 11.49	25.24	ADR	38.3	-15.9	.18	47.82	54	-6.18	-	-	-	-	152	234	H
* 11.49	31.35	PK-U	38.3	-15.9	0	53.75	-	-	74	-20.25	-	-	207	201	V
* 11.49	21.22	ADR	38.3	-15.9	.18	43.8	54	-10.2	-	-	-	-	207	201	V

\* - indicates frequency in CFR15.205/IC7.2.2 Restricted Band

PK-U - U-NII: Maximum Peak

ADR - U-NII AD primary method, RMS average

**MID CHANNEL HORIZONTAL**

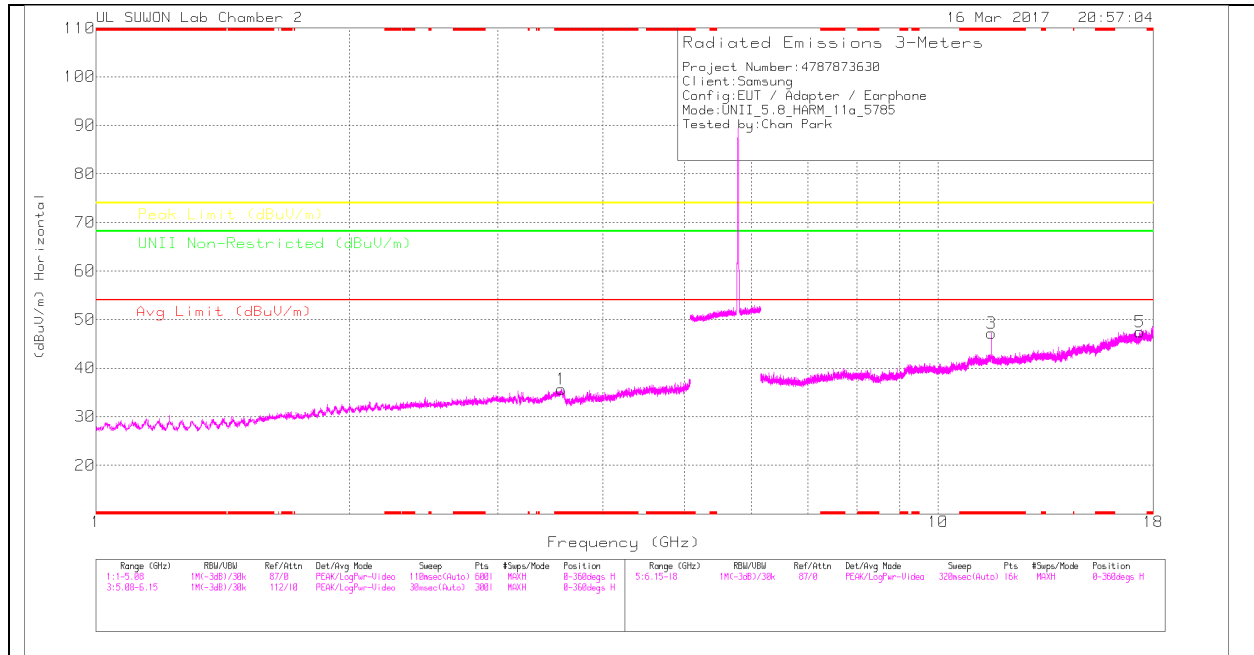

**MID CHANNEL VERTICAL**

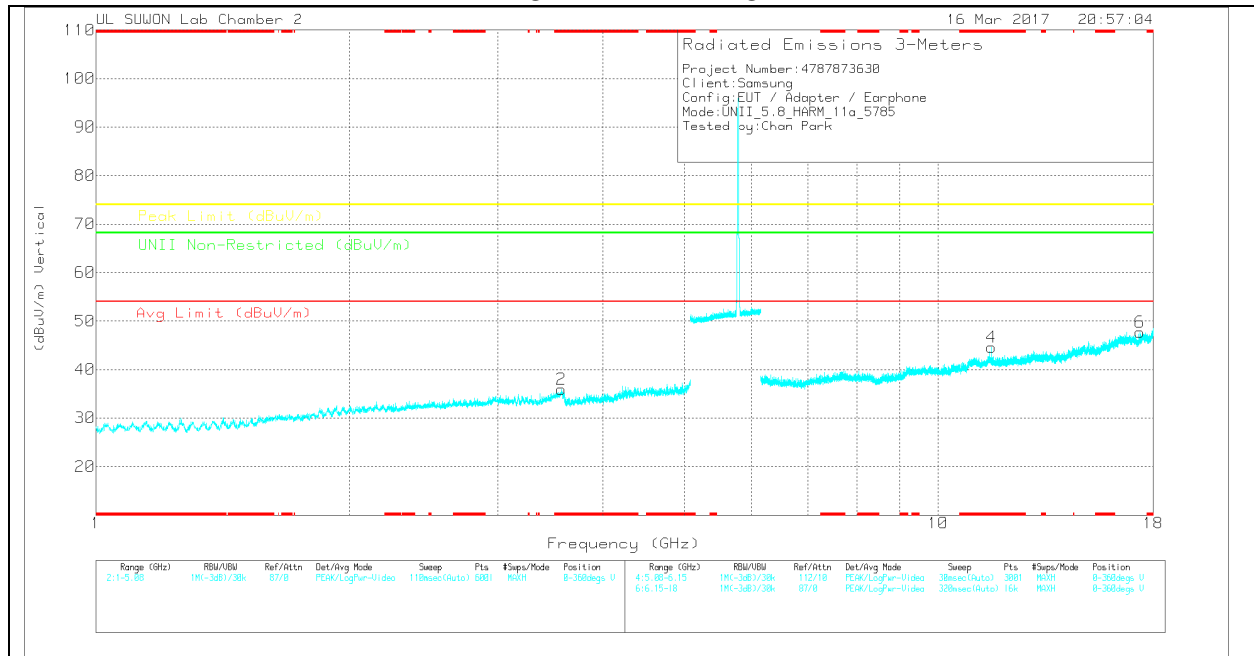

Note: Emission was scanned up to 40GHz; No emissions were detected above the noise floor which was at least 20dB below the specification limit.

**MID CHANNEL DATA**

Trace Markers

Marker	Frequency (GHz)	Meter Reading (dBuV)	Det	3117(0016 8724)_150 619	5GHz_LP[d B]	DC Corr (dB)	Corrected Reading (dBuV/m)	Avg Limit (dBuV/m)	Margin (dB)	Peak Limit (dBuV/m)	Margin (dB)	UNII Non-Restricted (dBuV/m)	Margin (dB)	Azimuth (Degs)	Height (cm)	Polarity
1	* 3.568	27.77	PK	32.8	-24.9	0	35.67	-	-	74	-38.33	-	-	0-360	150	H
2	* 3.571	27.99	PK	32.8	-24.9	0	35.89	-	-	74	-38.11	-	-	0-360	250	V
3	* 11.57	24.71	PK	38.4	-15.9	0	47.21	-	-	74	-26.79	-	-	0-360	150	H
5	17.356	19.57	PK	41.2	-13.3	0	47.47	-	-	-	-	68.2	-20.73	0-360	150	H
4	* 11.57	22.13	PK	38.4	-15.9	0	44.63	-	-	74	-29.37	-	-	0-360	250	V
6	17.356	19.81	PK	41.2	-13.3	0	47.71	-	-	-	-	68.2	-20.49	0-360	150	V

\* - indicates frequency in CFR15.205/IC7.2.2 Restricted Band

PK – Peak Detector

Radiated Emissions

Frequency (GHz)	Meter Reading (dBuV)	Det	3117(001687 24)_150619	6GHz_HP[dB]	DC Corr (dB)	Corrected Reading (dBuV/m)	Avg Limit (dBuV/m)	Margin (dB)	Peak Limit (dBuV/m)	Margin (dB)	UNII Non-Restricted (dBuV/m)	Margin (dB)	Azimuth (Degs)	Height (cm)	Polarity
* 11.57	36.38	PK-U	38.4	-15.9	0	58.88	-	-	74	-15.12	-	-	155	204	H
* 11.57	26.26	ADR	38.4	-15.9	.18	48.94	54	-5.06	-	-	-	-	155	204	H
* 11.57	33.21	PK-U	38.4	-15.9	0	55.71	-	-	74	-18.29	-	-	208	202	V
* 11.57	21.69	ADR	38.4	-15.9	.18	44.37	54	-9.63	-	-	-	-	208	202	V

\* - indicates frequency in CFR15.205/IC7.2.2 Restricted Band

PK-U - U-NII: Maximum Peak

ADR - U-NII AD primary method, RMS average

### HIGH CHANNEL HORIZONTAL

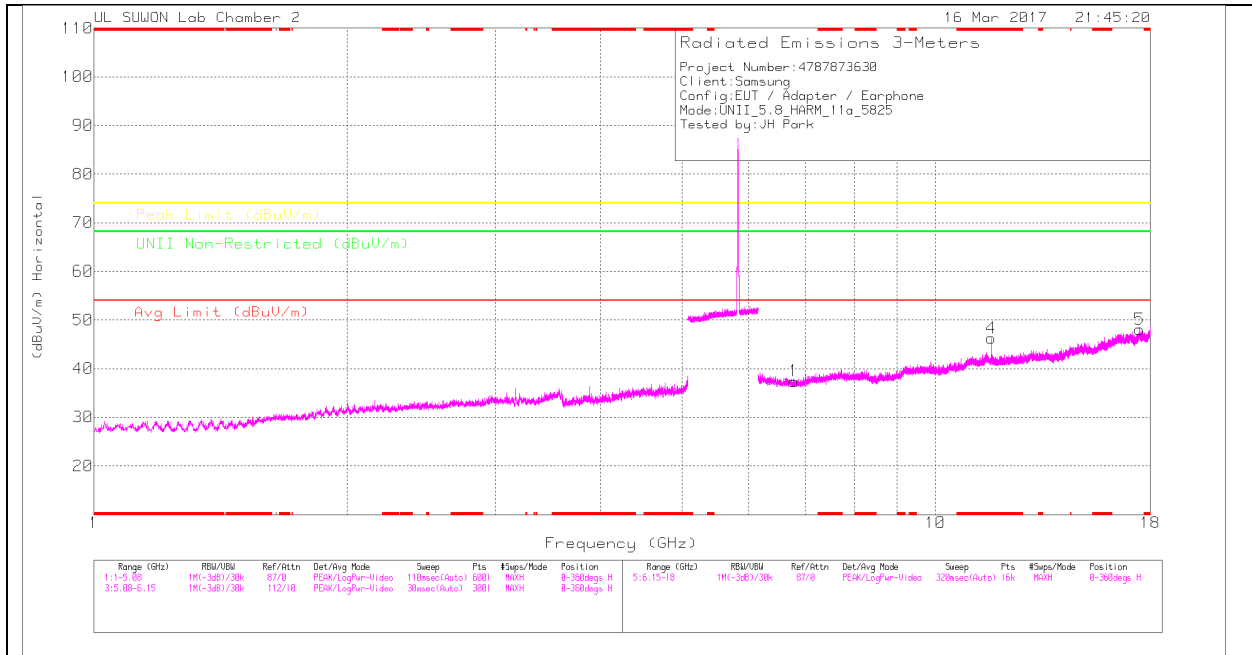

### HIGH CHANNEL VERTICAL

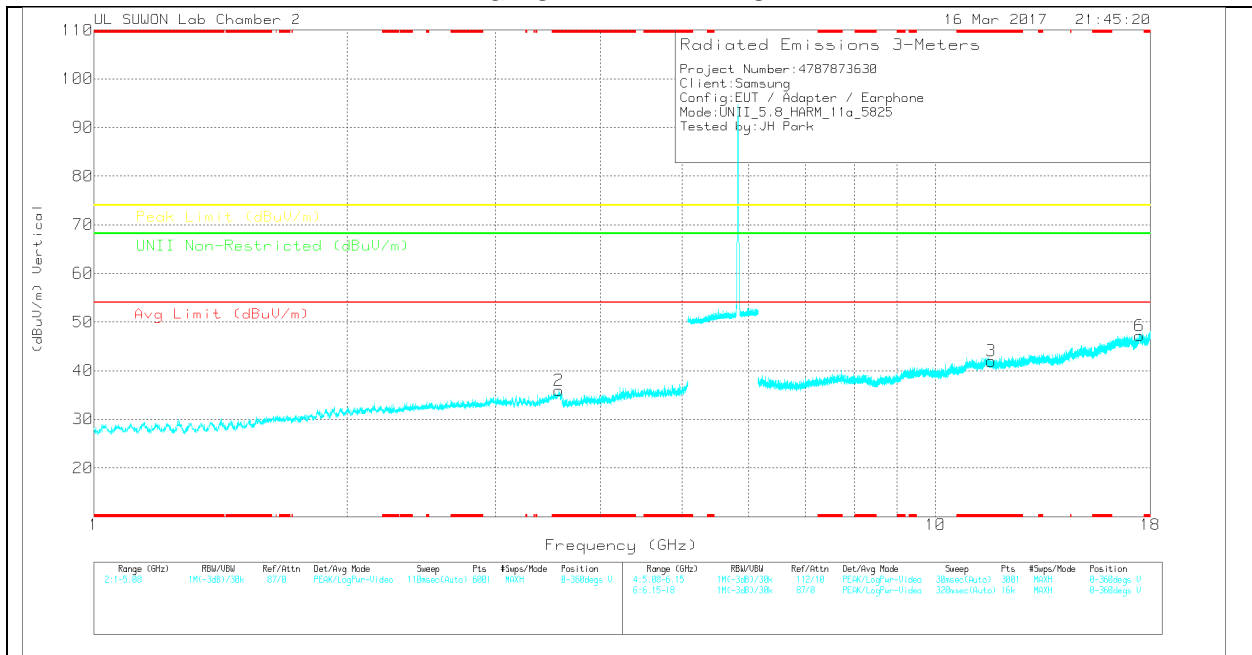

Note: Emission was scanned up to 40GHz; No emissions were detected above the noise floor which was at least 20dB below the specification limit.

**HIGH CHANNEL DATA**

Trace Markers

Marker	Frequency (GHz)	Meter Reading (dBuV)	Det	3117(0016 8724)_150 619	5GHz_LP[d B]	DC Corr (dB)	Corrected Reading (dBuV/m)	Avg Limit (dBuV/m)	Margin (dB)	Peak Limit (dBuV/m)	Margin (dB)	UNII Non-Restricted (dBuV/m)	Margin (dB)	Azimuth (Degs)	Height (cm)	Polarity
2	* 3.571	27.99	PK	32.8	-24.9	0	35.89	-	-	74	-38.11	-	-	0-360	250	V
1	6.79	23.72	PK	35.4	-21.7	0	37.42	-	-	-	-	68.2	-30.78	0-360	250	H
4	* 11.65	23.53	PK	38.4	-15.7	0	46.23	-	-	74	-27.77	-	-	0-360	250	H
5	17.477	18.98	PK	41.3	-12.2	0	48.08	-	-	-	-	68.2	-20.12	0-360	150	H
3	* 11.653	19.35	PK	38.4	-15.8	0	41.95	-	-	74	-32.05	-	-	0-360	150	V
6	17.473	18.09	PK	41.3	-12.2	0	47.19	-	-	-	-	68.2	-21.01	0-360	150	V

\* - indicates frequency in CFR15.205/IC7.2.2 Restricted Band

PK – Peak Detector

Radiated Emissions

Frequency (GHz)	Meter Reading (dBuV)	Det	3117(0016 8724)_150 619	6GHz_HP[ dB]	DC Corr (dB)	Corrected Reading (dBuV/m)	Avg Limit (dBuV/m)	Margin (dB)	Peak Limit (dBuV/m)	Margin (dB)	UNII Non-Restricted (dBuV/m)	Margin (dB)	Azimuth (Degs)	Height (cm)	Polarity
* 11.65	34.21	PK-U	38.4	-15.7	0	56.91	-	-	74	-17.09	-	-	160	104	H
* 11.65	24.45	ADR	38.4	-15.7	.18	47.33	54	-6.67	-	-	-	-	160	104	H

\* - indicates frequency in CFR15.205/IC7.2.2 Restricted Band

PK-U - U-NII: Maximum Peak

ADR - U-NII AD primary method, RMS average

### 10.4.2. TX ABOVE 1GHz 802.11n HT20 MODE IN THE 5.8GHz BAND BANDEDGE (LOW CHANNEL)

#### HORIZONTAL PEAK PLOT

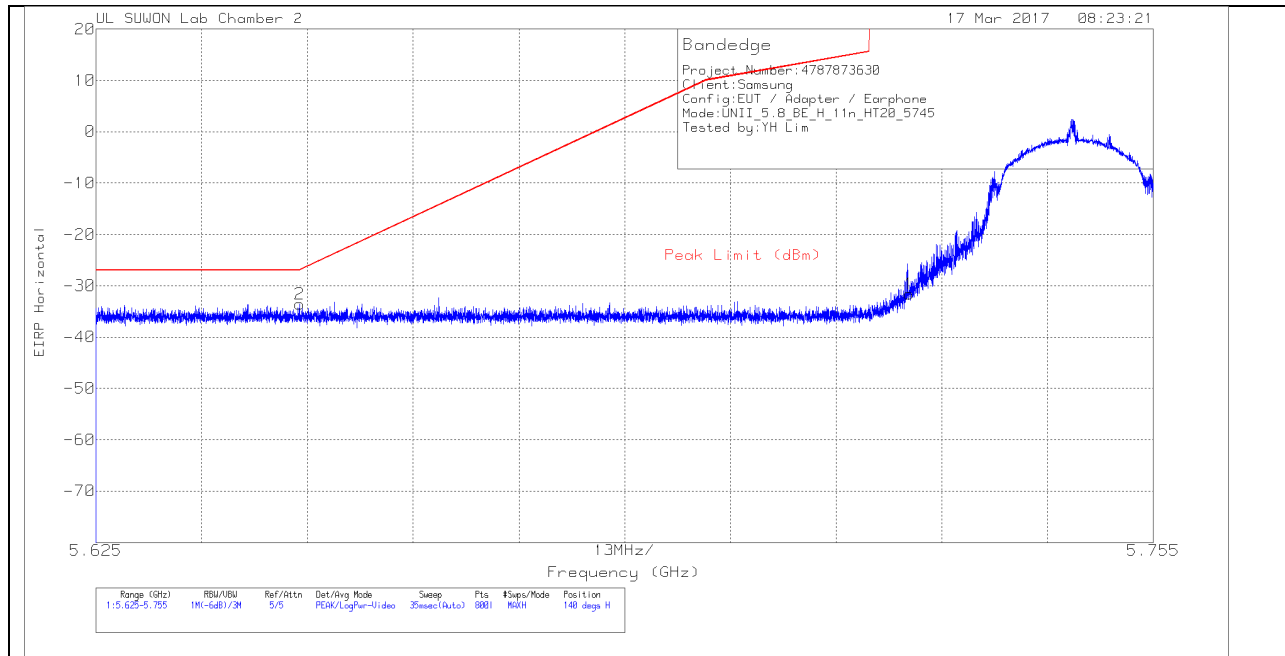

#### HORIZONTAL DATA

##### Trace Markers

Marker	Frequency (GHz)	Meter Reading (dBm)	Det	3117(0016 8724)_150 619	Path_2_10 dB	Conversion Factor (dB)	DC Corr (dB)	Corrected Reading EIRP	Peak Limit (dBm)	PK Margin (dB)	Azimuth (Degs)	Height (cm)	Polarity
1	5.725	-62.51	Pk	34.7	-15.6	11.8	0	-31.61	278.26	-309.87	140	270	H
2	5.65	-64.27	Pk	34.6	-15.7	11.8	0	-33.57	-26.97	-6.6	140	270	H

Pk - Peak detector

**VERTICAL PEAK PLOT**

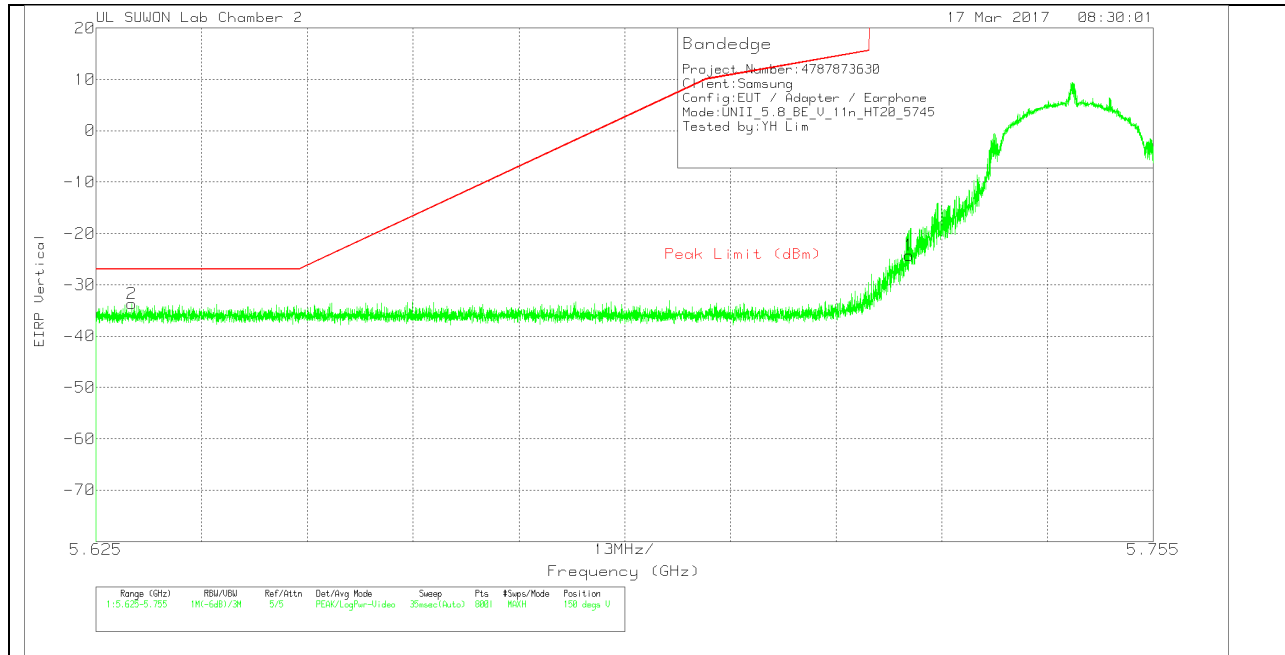

**VERTICAL DATA**

Trace Markers

Marker	Frequency (GHz)	Meter Reading (dBm)	Det	3117(0016 8724)_150 619	Path_2_10 dB	Conversion Factor (dB)	DC Corr (dB)	Corrected Reading EIRP	Peak Limit (dBm)	PK Margin (dB)	Azimuth (Degs)	Height (cm)	Polarity
1	5.725	-55.11	Pk	34.7	-15.6	11.8	0	-24.21	278.26	-302.47	150	225	V
2	5.629	-64.39	Pk	34.6	-15.7	11.8	0	-33.69	-27	-6.69	150	225	V

Pk - Peak detector

### BANDEDGE (HIGH CHANNEL)

#### HORIZONTAL PEAK AND AVERAGE PLOT

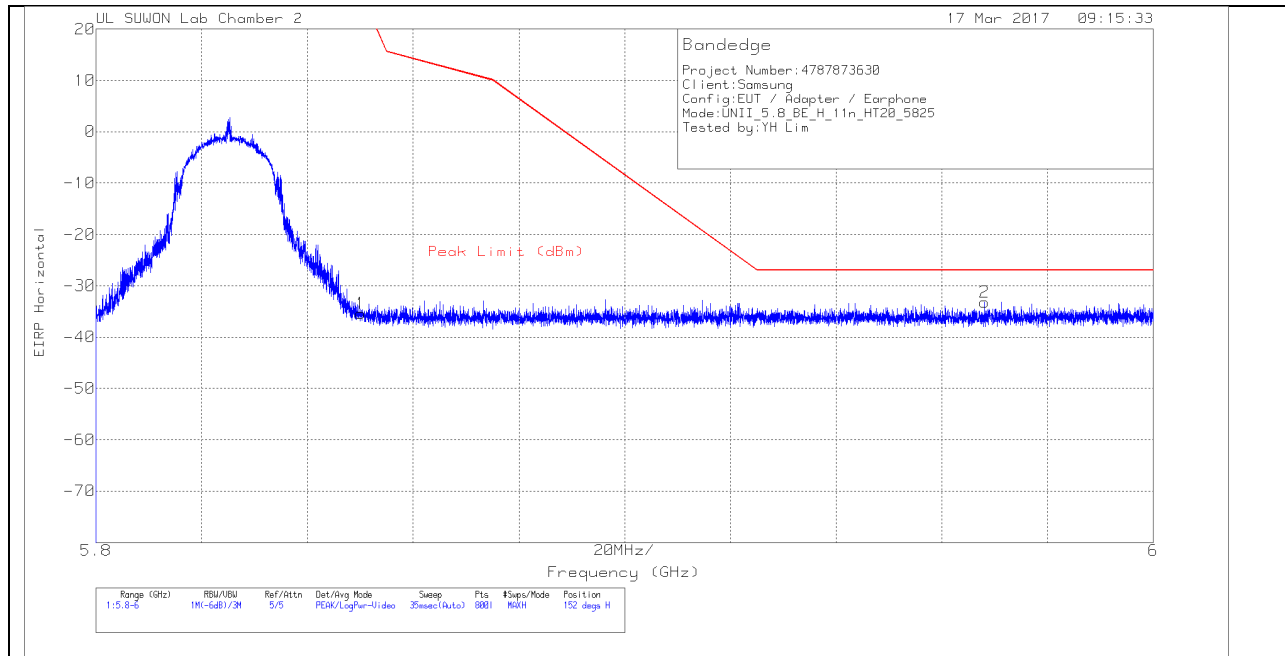

#### HORIZONTAL DATA

##### Trace Markers

Marker	Frequency (GHz)	Meter Reading (dBm)	Det	3117(0016 8724)_150 619	Path_2_10 dB	Conversion Factor (dB)	DC Corr (dB)	Corrected Reading EIRP	Peak Limit (dBm)	PK Margin (dB)	Azimuth (Degs)	Height (cm)	Polarity
1	5.85	-66.34	Pk	34.7	-15.5	11.8	0	-35.34	26.94	-62.28	152	263	H
2	5.968	-64.41	Pk	34.8	-15.4	11.8	0	-33.21	-27	-6.21	152	263	H

Pk - Peak detector

**VERTICAL PEAK PLOT**

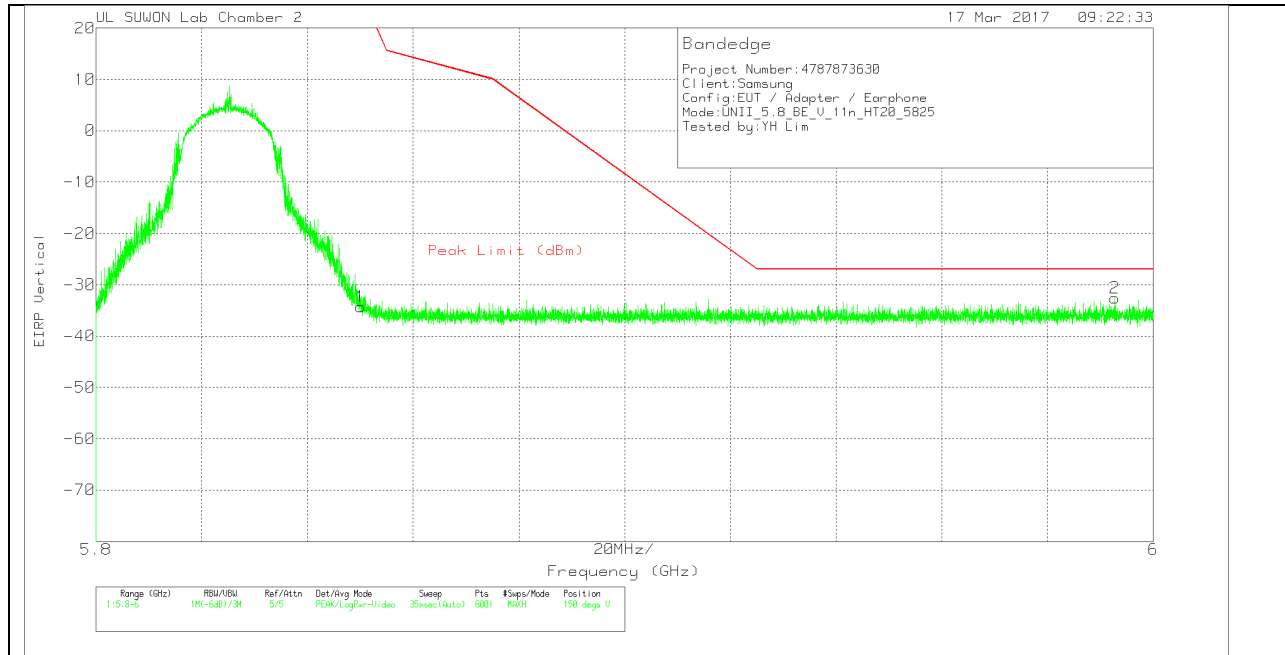

**VERTICAL DATA**

Trace Markers

Marker	Frequency (GHz)	Meter Reading (dBm)	Det	3117(0016 8724)_150 619	Path_2_10 dB	Conversion Factor (dB)	DC Corr (dB)	Corrected Reading EIRP	Peak Limit (dBm)	PK Margin (dB)	Azimuth (Degs)	Height (cm)	Polarity
1	5.85	-65.32	Pk	34.7	-15.5	11.8	0	-34.32	26.94	-61.26	150	119	V
2	5.993	-63.75	Pk	34.8	-15.4	11.8	0	-32.55	-27	-5.55	150	119	V

Pk - Peak detector

**LOW CHANNEL HORIZONTAL**

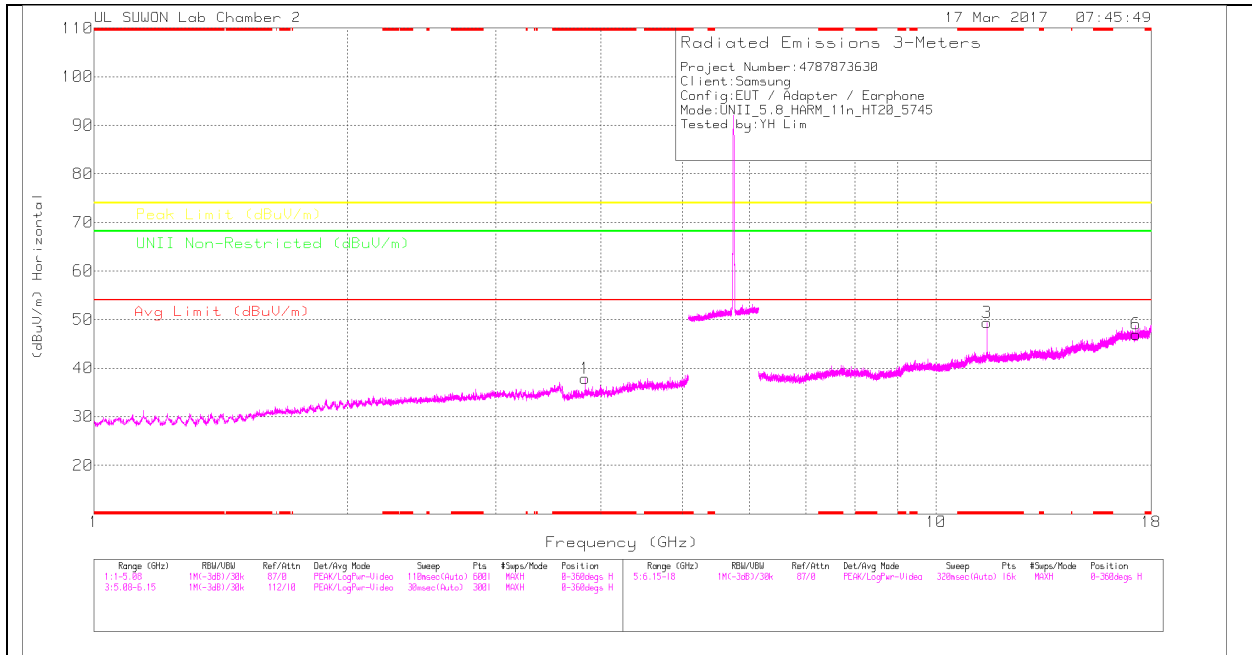

**LOW CHANNEL VERTICAL**

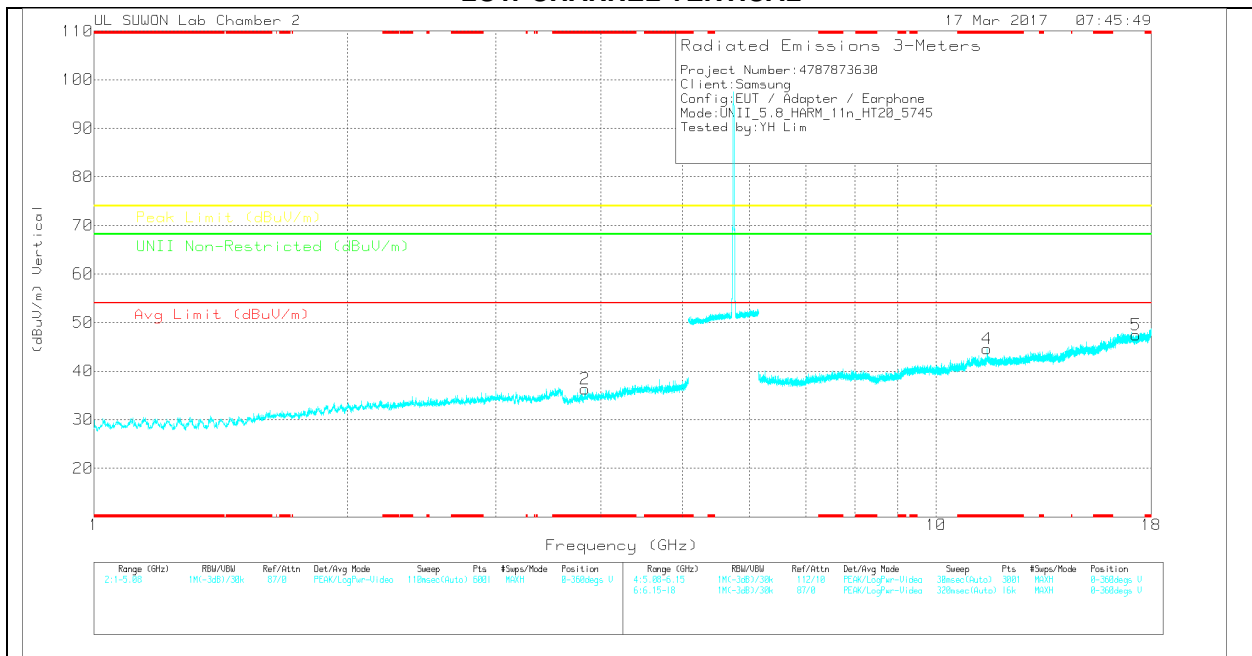

Note: Emission was scanned up to 40GHz; No emissions were detected above the noise floor which was at least 20dB below the specification limit.

**LOW CHANNEL DATA**

Trace Markers

Marker	Frequency (GHz)	Meter Reading (dBuV)	Det	3117(0016 8724)_150 619	5GHz_LP[d B]	DC Corr (dB)	Corrected Reading (dBuV/m)	Avg Limit (dBuV/m)	Margin (dB)	Peak Limit (dBuV/m)	Margin (dB)	UNII Non-Restricted (dBuV/m)	Margin (dB)	Azimuth (Degs)	Height (cm)	Polarity
1	* 3.83	29.72	PK	33.1	-24.9	0	37.92	-	-	74	-36.08	-	-	0-360	250	H
2	* 3.83	28.06	PK	33.1	-24.9	0	36.26	-	-	74	-37.74	-	-	0-360	250	V
3	* 11.49	27.02	PK	38.3	-15.9	0	49.42	-	-	74	-24.58	-	-	0-360	150	H
6	17.274	19.19	PK	41.2	-13.4	0	46.99	-	-	-	-	68.2	-21.21	0-360	150	H
4	* 11.49	22.19	PK	38.3	-15.9	0	44.59	-	-	74	-29.41	-	-	0-360	150	V
5	17.263	19.64	PK	41.2	-13.4	0	47.44	-	-	-	-	68.2	-20.76	0-360	150	V

\* - indicates frequency in CFR15.205/IC7.2.2 Restricted Band

PK – Peak detector

Radiated Emissions

Frequency (GHz)	Meter Reading (dBuV)	Det	3117(001687 24)_150619	6GHz_HP[dB]	DC Corr (dB)	Corrected Reading (dBuV/m)	Avg Limit (dBuV/m)	Margin (dB)	Peak Limit (dBuV/m)	Margin (dB)	UNII Non-Restricted (dBuV/m)	Margin (dB)	Azimuth (Degs)	Height (cm)	Polarity
* 11.49	36.84	PK-U	38.3	-15.9	0	59.24	-	-	74	-14.76	-	-	155	195	H
* 11.49	26.97	ADR	38.3	-15.9	.17	49.54	54	-4.46	-	-	-	-	155	195	H
* 11.49	30.6	PK-U	38.3	-15.9	0	53	-	-	74	-21	-	-	212	387	V
* 11.49	19.21	ADR	38.3	-15.9	.17	41.78	54	-12.22	-	-	-	-	212	387	V

\* - indicates frequency in CFR15.205/IC7.2.2 Restricted Band

PK-U - U-NII: Maximum Peak

ADR - U-NII AD primary method, RMS average

**MID CHANNEL HORIZONTAL**

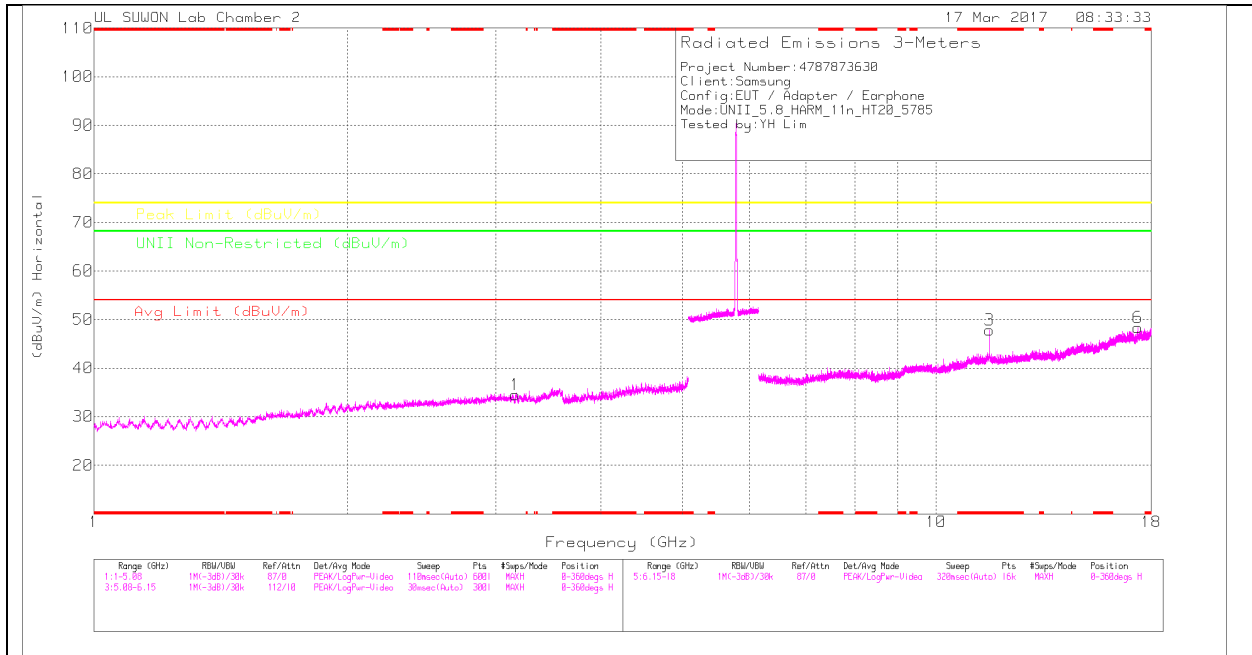

**MID CHANNEL VERTICAL**

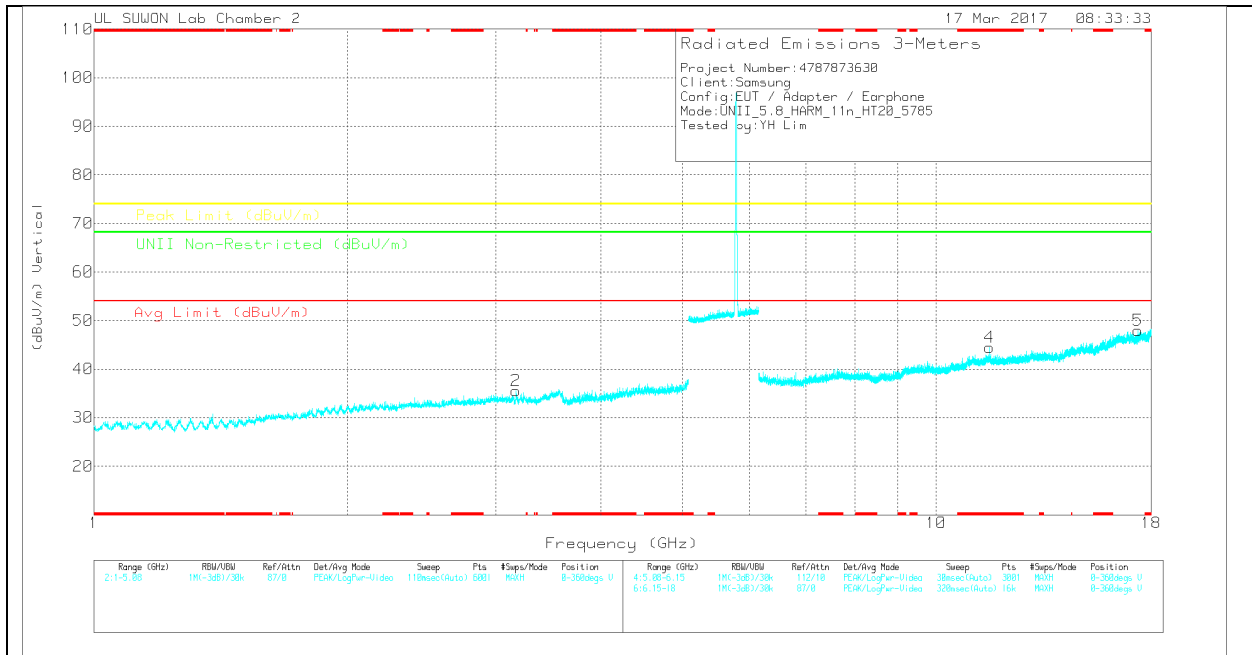

Note: Emission was scanned up to 40GHz; No emissions were detected above the noise floor which was at least 20dB below the specification limit.

**MID CHANNEL DATA**

Trace Markers

Marker	Frequency (GHz)	Meter Reading (dBuV)	Det	3117(0016 8724)_150 619	5GHz_LP[d B]	DC Corr (dB)	Corrected Reading (dBuV/m)	Avg Limit (dBuV/m)	Margin (dB)	Peak Limit (dBuV/m)	Margin (dB)	UNII Non-Restricted (dBuV/m)	Margin (dB)	Azimuth (Degs)	Height (cm)	Polarity
1	3.164	27.85	PK	32.5	-25.9	0	34.45	-	-	-	-	68.2	-33.75	0-360	250	H
2	3.172	28.8	PK	32.5	-25.8	0	35.5	-	-	-	-	68.2	-32.7	0-360	250	V
3	* 11.57	25.35	PK	38.4	-15.9	0	47.85	-	-	74	-26.15	-	-	0-360	150	H
6	17.355	20.42	PK	41.2	-13.3	0	48.32	-	-	-	-	68.2	-19.88	0-360	250	H
4	* 11.57	21.92	PK	38.4	-15.9	0	44.42	-	-	74	-29.58	-	-	0-360	250	V
5	17.371	19.92	PK	41.2	-13.2	0	47.92	-	-	-	-	68.2	-20.28	0-360	150	V

\* - indicates frequency in CFR15.205/IC7.2.2 Restricted Band

PK – Peak detector

Radiated Emissions

Frequency (GHz)	Meter Reading (dBuV)	Det	3117(001687 24)_150619	6GHz_HP[dB]	DC Corr (dB)	Corrected Reading (dBuV/m)	Avg Limit (dBuV/m)	Margin (dB)	Peak Limit (dBuV/m)	Margin (dB)	UNII Non-Restricted (dBuV/m)	Margin (dB)	Azimuth (Degs)	Height (cm)	Polarity
* 11.57	36.99	PK-U	38.4	-15.9	0	59.49	-	-	74	-14.51	-	-	155	205	H
* 11.57	26.43	ADR	38.4	-15.9	.17	49.1	54	-4.9	-	-	-	-	155	205	H
* 11.57	36.84	PK-U	38.4	-15.9	0	59.34	-	-	74	-14.66	-	-	155	198	H
* 11.57	26.69	ADR	38.4	-15.9	.17	49.36	54	-4.64	-	-	-	-	155	198	H

\* - indicates frequency in CFR15.205/IC7.2.2 Restricted Band

PK-U - U-NII: Maximum Peak

ADR - U-NII AD primary method, RMS average

### HIGH CHANNEL HORIZONTAL

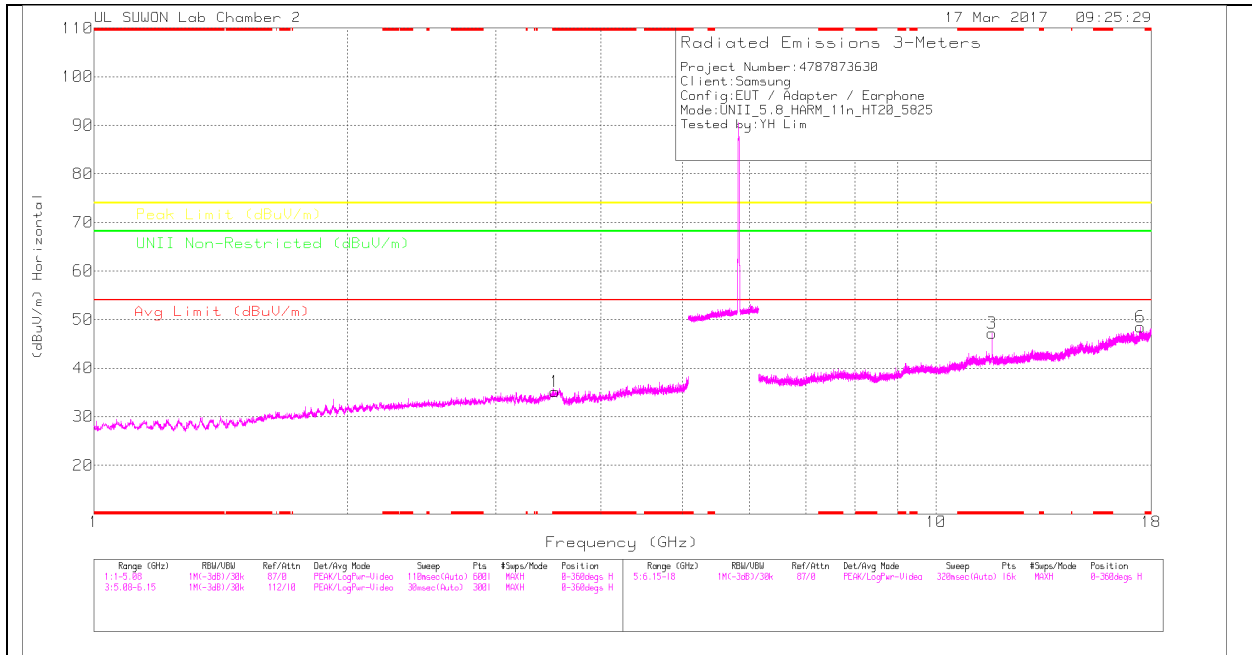

### HIGH CHANNEL VERTICAL

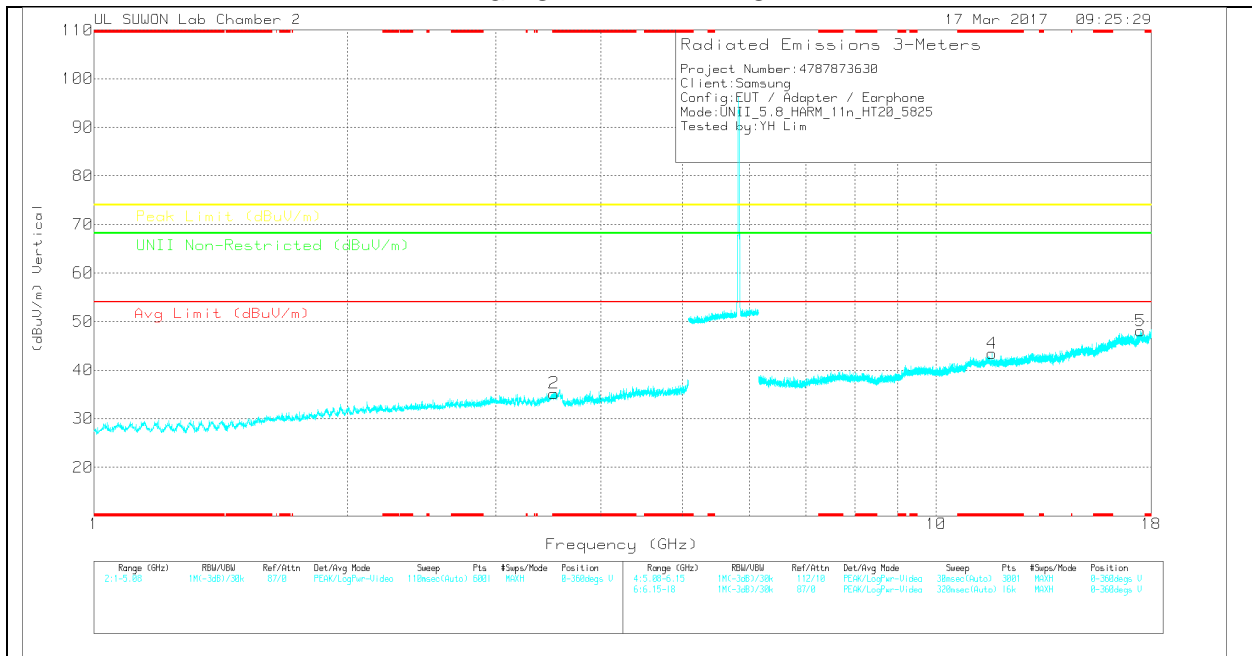

Note: Emission was scanned up to 40GHz; No emissions were detected above the noise floor which was at least 20dB below the specification limit.

**HIGH CHANNEL DATA**

Trace Markers

Marker	Frequency (GHz)	Meter Reading (dBuV)	Det	3117(00168724)_150619	5GHz_LP[dB]	DC Corr (dB)	Corrected Reading (dBuV/m)	Avg Limit (dBuV/m)	Margin (dB)	Peak Limit (dBuV/m)	Margin (dB)	UNII Non-Restricted (dBuV/m)	Margin (dB)	Azimuth (Degs)	Height (cm)	Polarity
1	* 3.524	26.87	PK	32.7	-24.4	0	35.17	-	-	74	-38.83	-	-	0-360	250	H
2	* 3.517	27.02	PK	32.7	-24.5	0	35.22	-	-	74	-38.78	-	-	0-360	250	V
3	* 11.65	24.54	PK	38.4	-15.7	0	47.24	-	-	74	-26.76	-	-	0-360	150	H
6	17.476	19.41	PK	41.3	-12.2	0	48.51	-	-	-	-	68.2	-19.69	0-360	150	H
4	* 11.65	20.75	PK	38.4	-15.7	0	43.45	-	-	74	-30.55	-	-	0-360	150	V
5	17.474	18.98	PK	41.3	-12.2	0	48.08	-	-	-	-	68.2	-20.12	0-360	150	V

\* - indicates frequency in CFR15.205/IC7.2.2 Restricted Band

PK – Peak detector

Radiated Emissions

Frequency (GHz)	Meter Reading (dBuV)	Det	3117(00168724)_150619	6GHz_HP[dB]	DC Corr (dB)	Corrected Reading (dBuV/m)	Avg Limit (dBuV/m)	Margin (dB)	Peak Limit (dBuV/m)	Margin (dB)	UNII Non-Restricted (dBuV/m)	Margin (dB)	Azimuth (Degs)	Height (cm)	Polarity
* 11.65	35.47	PK-U	38.4	-15.7	0	58.17	-	-	74	-15.83	-	-	155	191	H
* 11.65	25.28	ADR	38.4	-15.7	.17	48.15	54	-5.85	-	-	-	-	155	191	H
* 11.65	30.8	PK-U	38.4	-15.7	0	53.5	-	-	74	-20.5	-	-	207	358	V
* 11.65	19.82	ADR	38.4	-15.7	.17	42.69	54	-11.31	-	-	-	-	207	358	V

\* - indicates frequency in CFR15.205/IC7.2.2 Restricted Band

PK-U - U-NII: Maximum Peak

ADR - U-NII AD primary method, RMS average

### 10.4.3. TX ABOVE 1GHz 802.11n HT40 MODE IN THE 5.8GHz BAND BANDEDGE (LOW CHANNEL)

#### HORIZONTAL PEAK PLOT

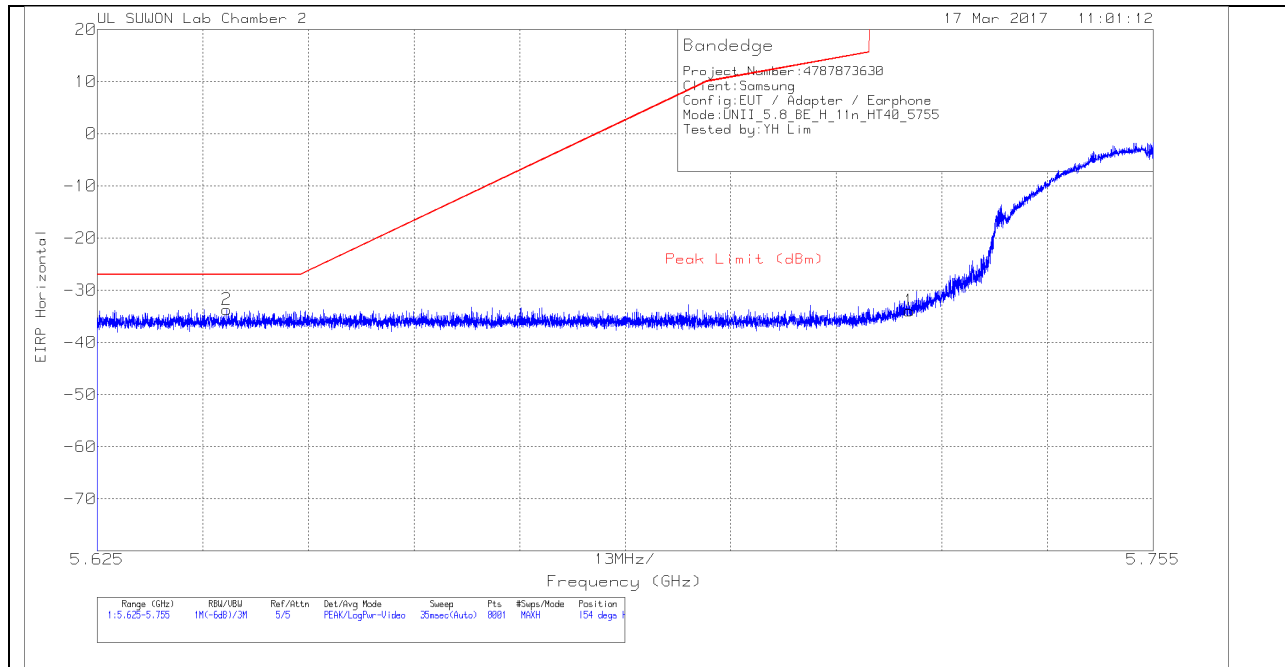

#### HORIZONTAL DATA

##### Trace Markers

Marker	Frequency (GHz)	Meter Reading (dBm)	Det	3117(0016 8724)_150 619	Path_2_10 dB	Conversion Factor (dB)	DC Corr (dB)	Corrected Reading EIRP	Peak Limit (dBm)	PK Margin (dB)	Azimuth (Degs)	Height (cm)	Polarity
1	5.725	-64.81	Pk	34.7	-15.6	11.8	0	-33.91	278.26	-312.17	154	253	H
2	5.641	-64.38	Pk	34.6	-15.7	11.8	0	-33.68	-27	-6.68	154	253	H

Pk - Peak detector

**VERTICAL PEAK PLOT**

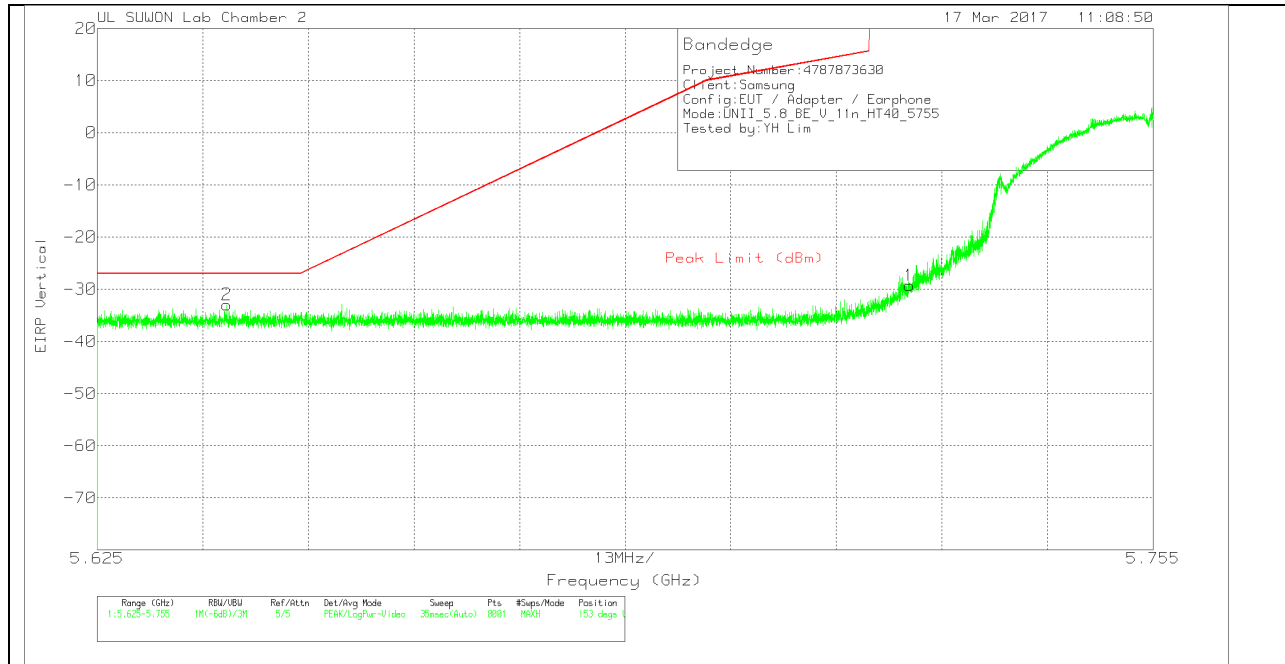

**VERTICAL DATA**

Trace Markers

Marker	Frequency (GHz)	Meter Reading (dBm)	Det	3117/0016 8724)_150 619	Path_2_10 dB	Conversion Factor (dB)	DC Corr (dB)	Corrected Reading EIRP	Peak Limit (dBm)	PK Margin (dB)	Azimuth (Degs)	Height (cm)	Polarity
1	5.725	-60.2	Pk	34.7	-15.6	11.8	0	-29.3	278.26	-307.56	153	129	V
2	5.641	-63.67	Pk	34.6	-15.7	11.8	0	-32.97	-27	-5.97	153	129	V

Pk - Peak detector

### BANDEDGE (HIGH CHANNEL)

#### HORIZONTAL PEAK PLOT

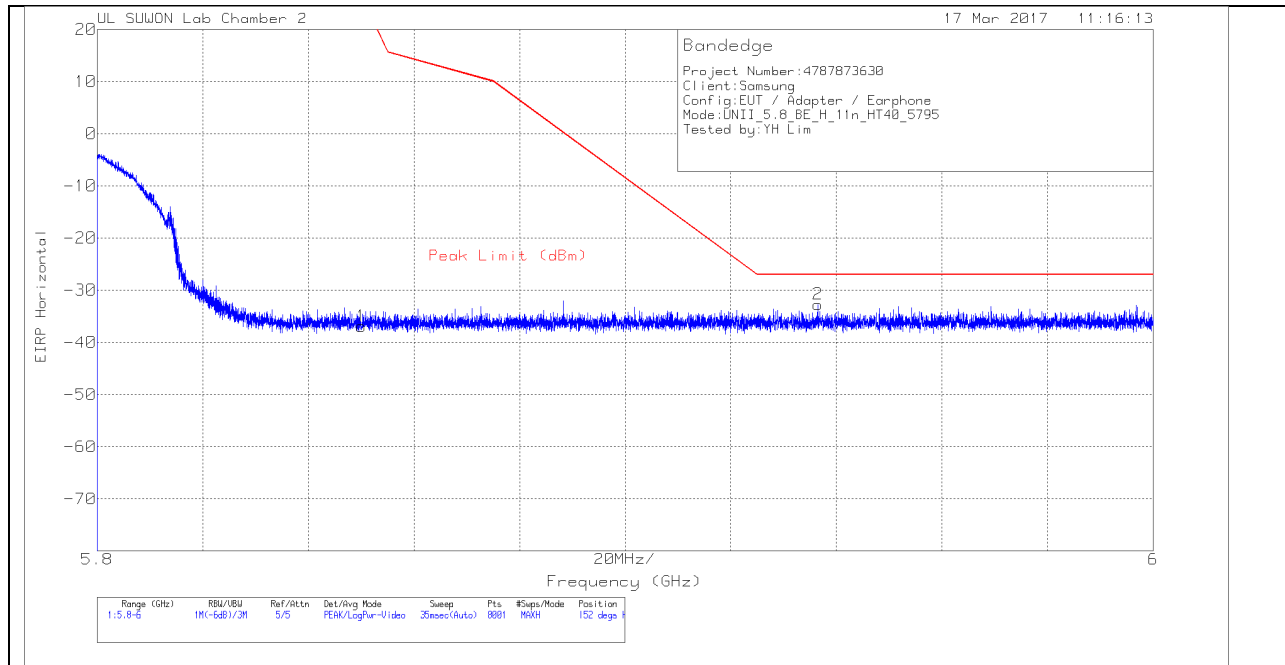

#### HORIZONTAL DATA

##### Trace Markers

Marker	Frequency (GHz)	Meter Reading (dBm)	Det	3117(0016 8724)_150 619	Path_2_10 dB	Conversion Factor (dB)	DC Corr (dB)	Corrected Reading EIRP	Peak Limit (dBm)	PK Margin (dB)	Azimuth (Degs)	Height (cm)	Polarity
1	5.85	-67.91	Pk	34.7	-15.5	11.8	0	-36.91	26.94	-63.85	152	249	H
2	5.936	-63.8	Pk	34.8	-15.5	11.8	0	-32.7	-27	-5.7	152	249	H

Pk - Peak detector

**VERTICAL PEAK PLOT**

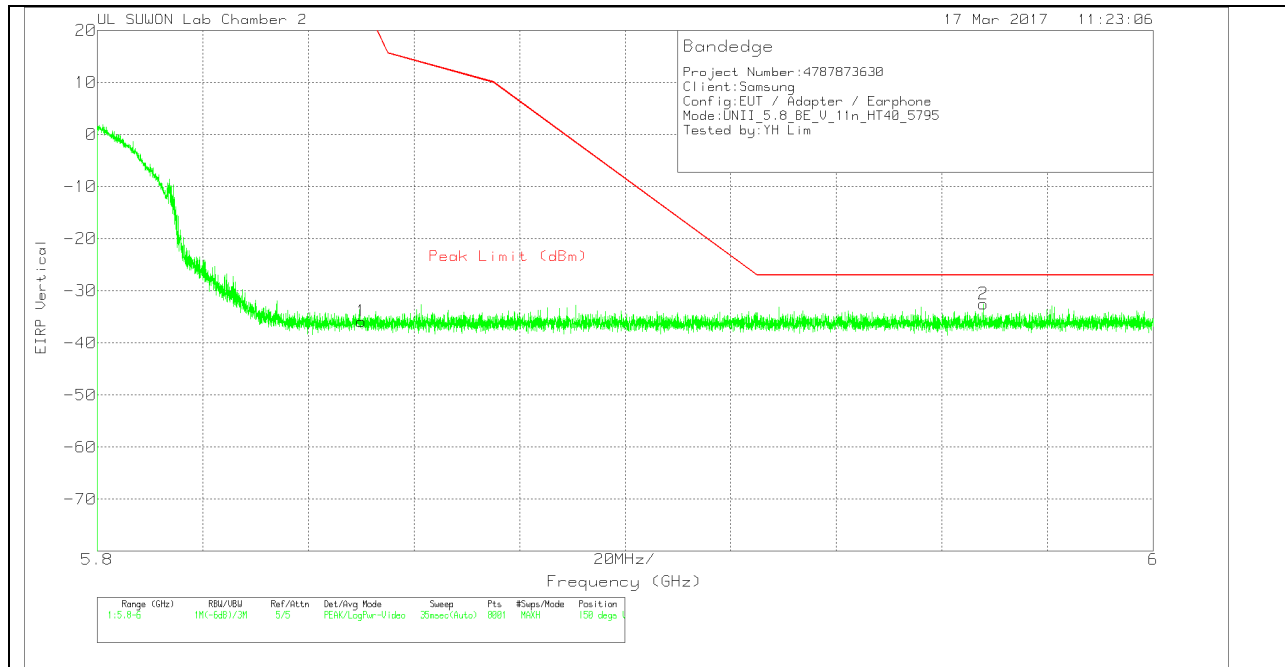

**VERTICAL DATA**

Trace Markers

Marker	Frequency (GHz)	Meter Reading (dBm)	Det	3117(0016 8724)_150 619	Path_2_10 dB	Conversion Factor (dB)	DC Corr (dB)	Corrected Reading EIRP	Peak Limit (dBm)	PK Margin (dB)	Azimuth (Degs)	Height (cm)	Polarity
1	5.85	-66.83	Pk	34.7	-15.5	11.8	0	-35.83	26.94	-62.77	150	120	V
2	5.968	-63.7	Pk	34.8	-15.4	11.8	0	-32.5	-27	-5.5	150	120	V

Pk - Peak detector

**LOW CHANNEL HORIZONTAL**

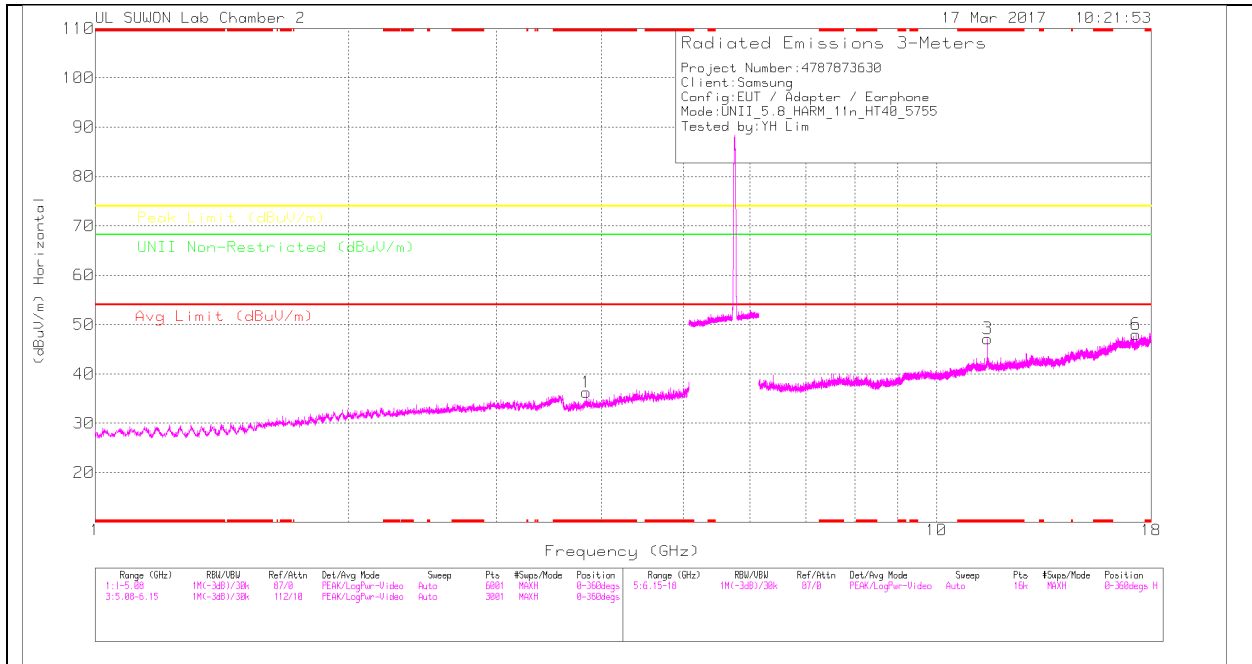

**LOW CHANNEL VERTICAL**

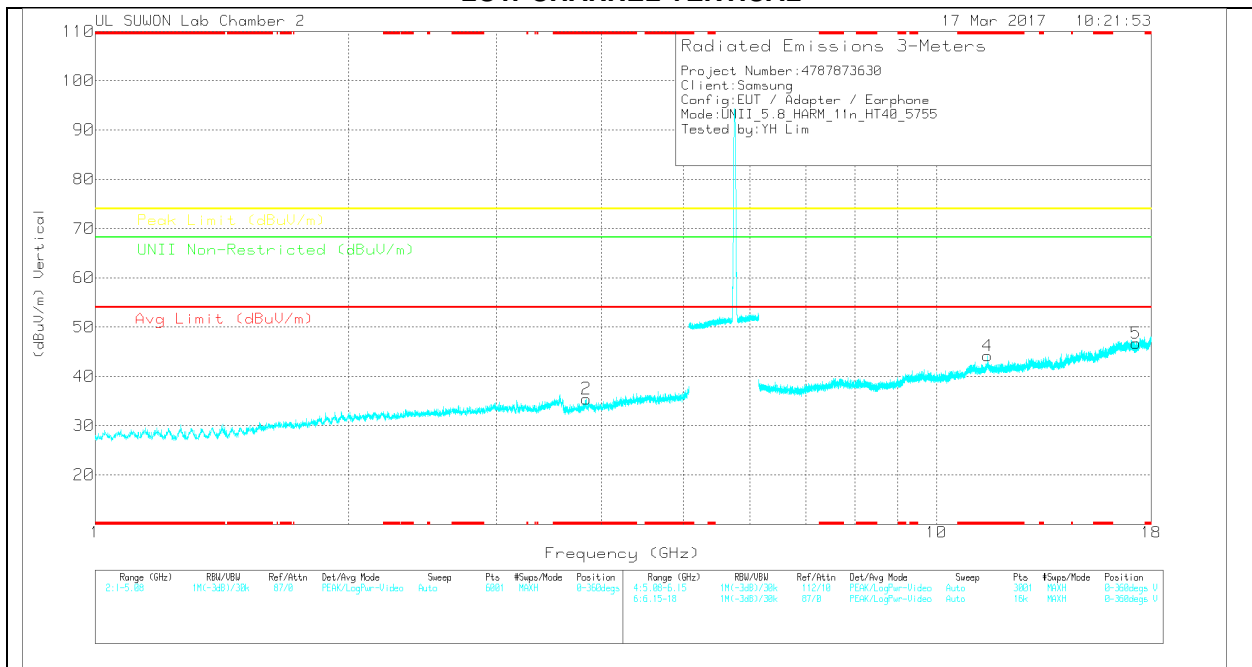

Note: Emission was scanned up to 40GHz; No emissions were detected above the noise floor which was at least 20dB below the specification limit.

**LOW CHANNEL DATA**

Trace Markers

Marker	Frequency (GHz)	Meter Reading (dBuV)	Det	3117(00168724)_150619	5GHz_LP[dB]	DC Corr (dB)	Corrected Reading (dBuV/m)	Avg Limit (dBuV/m)	Margin (dB)	Peak Limit (dBuV/m)	Margin (dB)	UNII Non-Restricted (dBuV/m)	Margin (dB)	Azimuth (Degs)	Height (cm)	Polarity
1	* 3.837	28.07	PK	33.1	-24.9	0	36.27	-	-	74	-37.73	-	-	0-360	250	H
2	* 3.836	27.24	PK	33.1	-24.9	0	35.44	-	-	74	-38.56	-	-	0-360	150	V
3	* 11.51	24.75	PK	38.3	-15.9	0	47.15	-	-	74	-26.85	-	-	0-360	250	H
6	17.271	20.23	PK	41.2	-13.4	0	48.03	-	-	-	-	68.2	-20.17	0-360	150	H
4	* 11.51	21.78	PK	38.3	-15.9	0	44.18	-	-	74	-29.82	-	-	0-360	250	V
5	17.262	18.92	PK	41.2	-13.4	0	46.72	-	-	-	-	68.2	-21.48	0-360	150	V

\* - indicates frequency in CFR15.205/IC7.2.2 Restricted Band

PK – Peak detector

Radiated Emissions

Frequency (GHz)	Meter Reading (dBuV)	Det	3117(00168724)_150619	6GHz_HP[dB]	DC Corr (dB)	Corrected Reading (dBuV/m)	Avg Limit (dBuV/m)	Margin (dB)	Peak Limit (dBuV/m)	Margin (dB)	UNII Non-Restricted (dBuV/m)	Margin (dB)	Azimuth (Degs)	Height (cm)	Polarity
* 11.51	34.16	PK-U	38.3	-15.9	0	56.56	-	-	74	-17.44	-	-	156	200	H
* 11.51	25.24	ADR	38.3	-15.9	.38	48.02	54	-5.98	-	-	-	-	156	200	H
* 11.51	30.55	PK-U	38.3	-15.9	0	52.95	-	-	74	-21.05	-	-	210	385	V
* 11.51	18.47	ADR	38.3	-15.9	.38	41.25	54	-12.75	-	-	-	-	210	385	V

\* - indicates frequency in CFR15.205/IC7.2.2 Restricted Band

PK-U - U-NII: Maximum Peak

ADR - U-NII AD primary method, RMS average

### HIGH CHANNEL HORIZONTAL

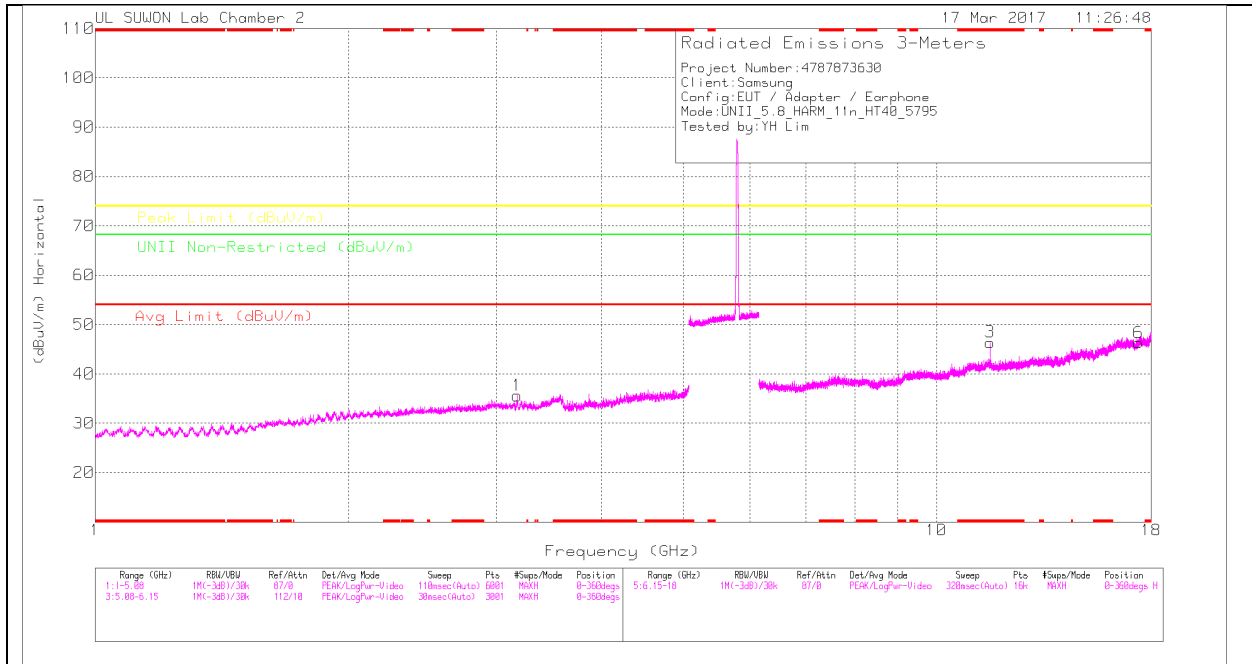

### HIGH CHANNEL VERTICAL

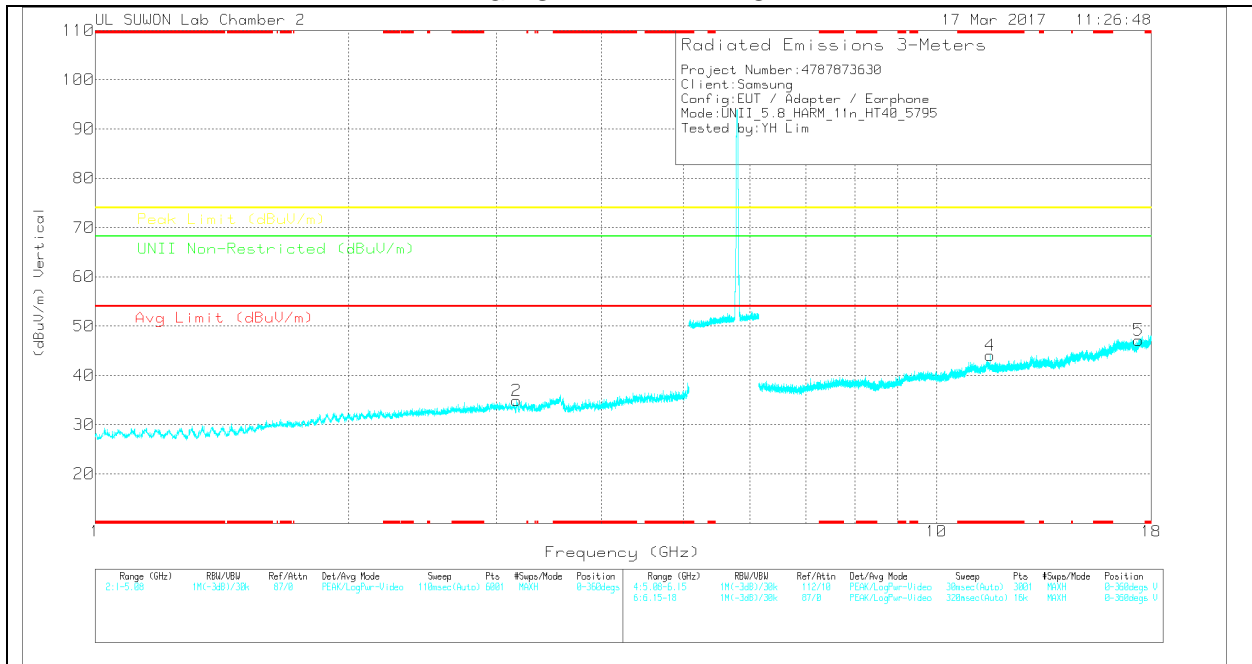

Note: Emission was scanned up to 40GHz; No emissions were detected above the noise floor which was at least 20dB below the specification limit.

**HIGH CHANNEL DATA**

Trace Markers

Marker	Frequency (GHz)	Meter Reading (dBuV)	Det	3117/0016 87241_150 619	5GHz_LP[dB]	DC Corr (dB)	Corrected Reading (dBuV/m)	Avg Limit (dBuV/m)	Margin (dB)	Peak Limit (dBuV/m)	Margin (dB)	UNII Non-Restricted (dBuV/m)	Margin (dB)	Azimuth (Degs)	Height (cm)	Polarity
1	3.174	28.8	PK	32.6	-25.8	0	35.6	-	-	-	-	68.2	-32.6	0-360	250	H
2	3.171	28.2	PK	32.5	-25.8	0	34.9	-	-	-	-	68.2	-33.3	0-360	250	V
3	* 11.59	23.9	PK	38.4	-15.9	0	46.4	-	-	74	-27.6	-	-	0-360	150	H
6	17.377	18.21	PK	41.2	-13.1	0	46.31	-	-	-	-	68.2	-21.89	0-360	150	H
4	* 11.59	21.54	PK	38.4	-15.9	0	44.04	-	-	74	-29.96	-	-	0-360	250	V
5	17.388	18.92	PK	41.2	-13	0	47.12	-	-	-	-	68.2	-21.08	0-360	250	V

\* - indicates frequency in CFR15.205/IC7.2.2 Restricted Band

PK – Peak detector

Radiated Emissions

Frequency (GHz)	Meter Reading (dBuV)	Det	3117/001687 241_150619	6GHz_HP[dB]	DC Corr (dB)	Corrected Reading (dBuV/m)	Avg Limit (dBuV/m)	Margin (dB)	Peak Limit (dBuV/m)	Margin (dB)	UNII Non-Restricted (dBuV/m)	Margin (dB)	Azimuth (Degs)	Height (cm)	Polarity
* 11.59	35.14	PK-U	38.4	-15.9	0	57.64	-	-	74	-16.36	-	-	155	202	H
* 11.59	25.6	ADR	38.4	-15.9	.38	48.48	54	-5.52	-	-	-	-	155	202	H
* 11.59	30.42	PK-U	38.4	-15.9	0	52.92	-	-	74	-21.08	-	-	209	361	V
* 11.59	18.97	ADR	38.4	-15.9	.38	41.85	54	-12.15	-	-	-	-	209	361	V

\* - indicates frequency in CFR15.205/IC7.2.2 Restricted Band

PK-U - U-NII: Maximum Peak

ADR - U-NII AD primary method, RMS average

# 11. WORST-CASE BELOW 1 GHz (in the 5.3 GHz Band)

## SPURIOUS EMISSIONS 30 TO 1000 MHz (WORST-CASE CONFIGURATION, HORIZONTAL)

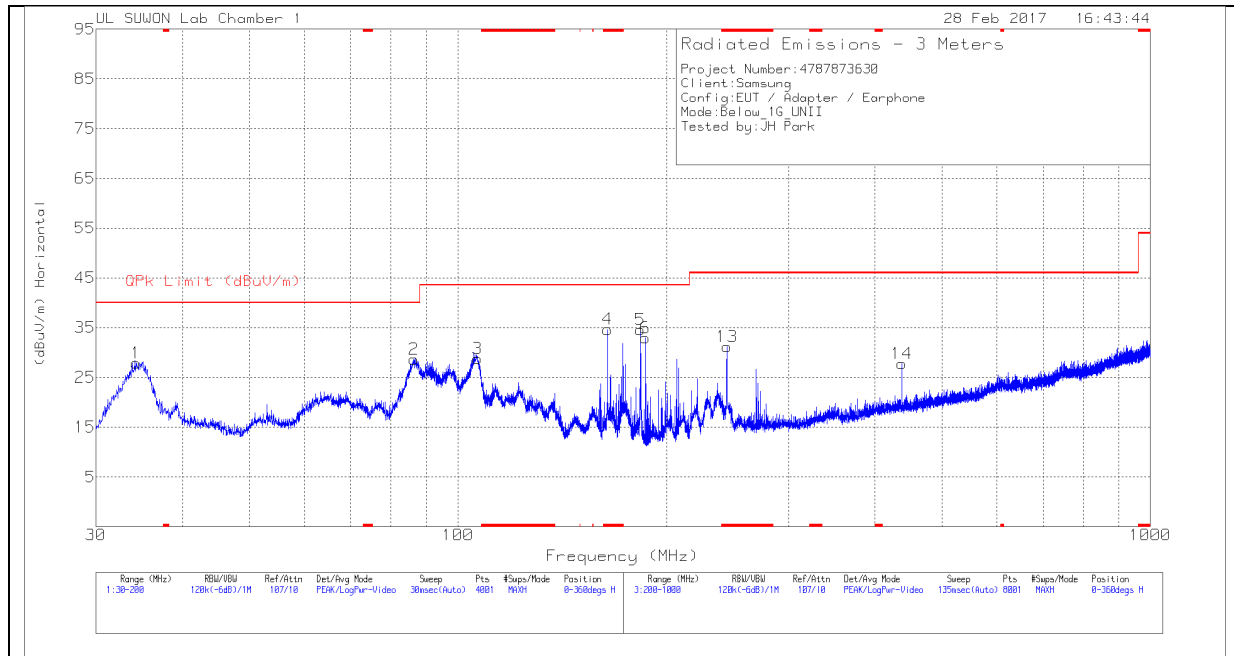

## SPURIOUS EMISSIONS 30 TO 1000 MHz (WORST-CASE CONFIGURATION, VERTICAL)

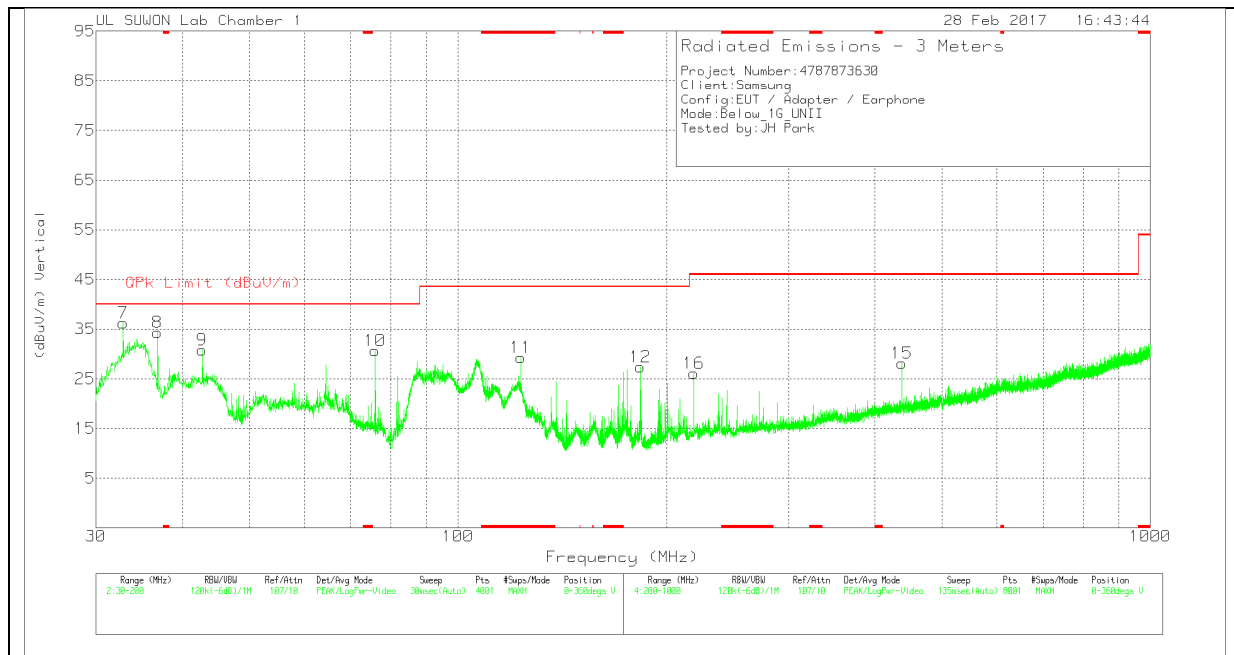

**Below 1G Data**

Trace Markers

Marker	Frequency (MHz)	Meter Reading (dBuV)	Det	VULB9163_7 50(dB)	30-1000MHz(dB )	Corrected Reading (dBuV/m)	QPk Limit (dBuV/m)	Margin (dB)	Azimuth (Degs)	Height (cm)	Polarity
1	34.2925	45.73	Pk	10.6	-28.4	27.93	40	-12.07	0-360	300	H
2	86.3975	47.9	Pk	8.6	-27.8	28.7	40	-11.3	0-360	200	H
3	106.7975	44.42	Pk	11.6	-27.2	28.82	43.52	-14.7	0-360	300	H
4	* 164.4275	52.66	Pk	8.7	-26.7	34.66	43.52	-8.86	0-360	200	H
5	183.425	51.35	Pk	9.7	-26.5	34.55	43.52	-8.97	0-360	200	H
6	186.6125	49.64	Pk	10	-26.7	32.94	43.52	-10.58	0-360	100	H
7	32.8475	54.01	Pk	10.5	-28.3	36.21	40	-3.79	0-360	100	V
8	36.8425	52.29	Pk	11.4	-29.4	34.29	40	-5.71	0-360	200	V
9	42.7075	45.78	Pk	13.1	-28.1	30.78	40	-9.22	0-360	200	V
10	75.9425	50.64	Pk	7.6	-27.6	30.64	40	-9.36	0-360	200	V
11	* 123.33	47.02	Pk	9.4	-27.1	29.32	43.52	-14.2	0-360	200	V
12	183.425	44.14	Pk	9.7	-26.5	27.34	43.52	-16.18	0-360	100	V
13	* 244.5	45.55	Pk	12.2	-26.6	31.15	46.02	-14.87	0-360	100	H
14	437.5	36.66	Pk	15.9	-24.8	27.76	46.02	-18.26	0-360	200	H
15	437.5	37.06	Pk	15.9	-24.8	28.16	46.02	-17.86	0-360	200	V
16	218.9	41.62	Pk	11.2	-26.7	26.12	46.02	-19.9	0-360	100	V

\* - indicates frequency in CFR15.205/IC7.2.2 Restricted Band

Pk - Peak detector

## 12. AC POWER LINE CONDUCTED EMISSIONS

### LIMITS

FCC §15.207 (a)

Frequency of Emission (MHz)	Conducted Limit (dBuV)	
	Quasi-peak	Average
0.15-0.5	66 to 56	56 to 46
0.5-5	56	46
5-30	60	50

\*Decreases with the logarithm of the frequency.

### TEST PROCEDURE

The EUT is placed on a non-conducting table 40 cm from the vertical ground plane and 80 cm above the horizontal ground plane. The EUT is configured in accordance with ANSI C63.10.

The receiver is set to a resolution bandwidth of 9 kHz. Peak detection is used unless otherwise noted as quasi-peak or average.

Line conducted data is recorded for both NEUTRAL and HOT lines.

### RESULTS

**6 WORST EMISSIONS**

**LINE 1 PLOT**

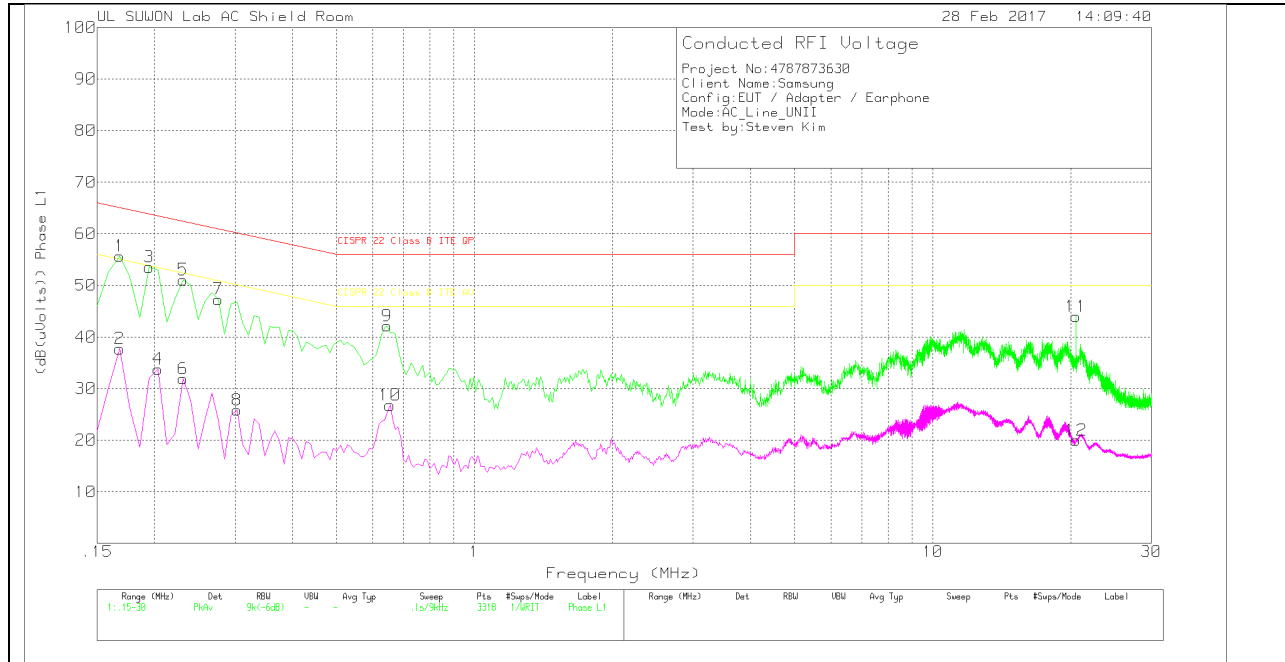

**LINE 1 RESULTS**

Trace Markers

Phase L1 .15 - 30MHz

Marker	Frequency (MHz)	Meter Reading (dBuV)	Det	101837_w ith ex- cord_L1	CABLELOSS (dB)	Corrected Reading (dB(uVolts))	CISPR 22 Class B ITE QP	Margin (dB)	CISPR 22 Class B ITE AV	Margin (dB)
1	.168	45.59	Pk	10	.1	55.69	65.06	-9.37	-	-
2	.168	27.63	Av	10	.1	37.73	-	-	55.06	-17.33
3	.195	43.46	Pk	9.9	.2	53.56	63.82	-10.26	-	-
4	.204	23.71	Av	9.9	.2	33.81	-	-	53.45	-19.64
5	.231	41.17	Pk	9.7	.2	51.07	62.41	-11.34	-	-
6	.231	22.02	Av	9.7	.2	31.92	-	-	52.41	-20.49
7	.276	37.43	Pk	9.7	.2	47.33	60.94	-13.61	-	-
8	.303	15.95	Av	9.7	.2	25.85	-	-	50.16	-24.31
9	.645	32.03	Pk	9.9	.2	42.13	56	-13.87	-	-
10	.654	16.67	Av	9.9	.2	26.77	-	-	46	-19.23
11	20.553	33.19	Pk	10.4	.4	43.99	60	-16.01	-	-
12	20.562	9.21	Av	10.4	.4	20.01	-	-	50	-29.99

Pk - Peak detector

Av - Average detection

Quasi-Peak Emissions

Phase L1 .15 - 30MHz

Frequency (MHz)	Meter Reading (dBuV)	Det	101837_wit h ex-cord_L1	CABLELOSS(dB)	Corrected Reading (dB(uVolts))	CISPR 22 Class B ITE QP	Margin (dB)	CISPR 22 Class B ITE AV	Margin (dB)
.1644	44.77	Qp	9.9	.1	54.77	65.24	-10.47	-	-
.1968	42.26	Qp	9.9	.2	52.36	63.74	-11.38	-	-

Qp – Quasi-peak detector

LINE 2 PLOT

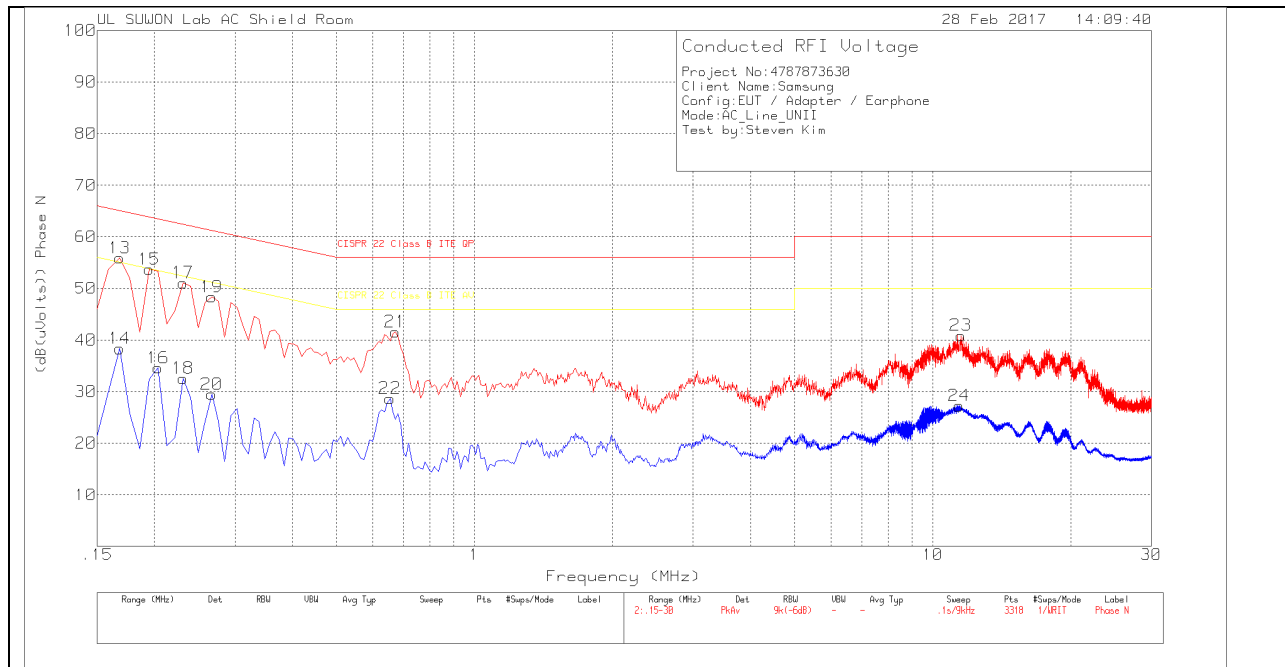

**LINE 2 RESULTS**

Trace Markers

Phase N .15 - 30MHz

Marker	Frequency (MHz)	Meter Reading (dBuV)	Det	101837_w ith ex- cord_N	CABLELOSS (dB)	Corrected Reading (dB(uVolts))	CISPR 22 Class B ITE QP	Margin (dB)	CISPR 22 Class B ITE AV	Margin (dB)
13	.168	45.79	Pk	10	.1	55.89	65.06	-9.17	-	-
14	.168	28.25	Av	10	.1	38.35	-	-	55.06	-16.71
15	.195	43.63	Pk	9.9	.2	53.73	63.82	-10.09	-	-
16	.204	24.52	Av	9.9	.2	34.62	-	-	53.45	-18.83
17	.231	41.17	Pk	9.7	.2	51.07	62.41	-11.34	-	-
18	.231	22.69	Av	9.7	.2	32.59	-	-	52.41	-19.82
19	.267	38.45	Pk	9.7	.2	48.35	61.21	-12.86	-	-
20	.267	19.6	Av	9.7	.2	29.5	-	-	51.21	-21.71
21	.672	31.49	Pk	9.9	.2	41.59	56	-14.41	-	-
22	.654	18.57	Av	9.9	.2	28.67	-	-	46	-17.33
23	11.517	30.38	Pk	10.2	.3	40.88	60	-19.12	-	-
24	11.427	16.76	Av	10.2	.3	27.26	-	-	50	-22.74

Pk - Peak detector

Av - Average detection

Quasi-Peak Emissions

Phase N .15 - 30MHz

Frequency (MHz)	Meter Reading (dBuV)	Det	101837_wit h ex-cord_N	CABLELOSS (dB)	Corrected Reading (dB(uVolts))	CISPR 22 Class B ITE QP	Margin (dB)	CISPR 22 Class B ITE AV	Margin (dB)
.1644	44.76	Qp	9.9	.1	54.76	65.24	-10.48	-	-
.1968	42.26	Qp	9.9	.2	52.36	63.74	-11.38	-	-

Qp – Quasi-peak detector

## 13. DYNAMIC FREQUENCY SELECTION

### 13.1. OVERVIEW

#### 13.1.1. LIMITS

##### FCC

§15.407 (h), FCC KDB 905462 D02 "COMPLIANCE MEASUREMENT PROCEDURES FOR UNLICENSED-NATIONAL INFORMATION INFRASTRUCTURE DEVICES OPERATING IN THE 5250-5350 MHz AND 5470-5725 MHz BANDS INCORPORATING DYNAMIC FREQUENCY SELECTION" and KDB 905462 D03 "U-NII CLIENT DEVICES WITHOUT RADAR DETECTION CAPABILITY".

**Table 1: Applicability of DFS requirements prior to use of a channel**

Requirement	Operational Mode		
	Master	Client (without radar detection)	Client (with radar detection)
Non-Occupancy Period	Yes	Not required	Yes
DFS Detection Threshold	Yes	Not required	Yes
Channel Availability Check Time	Yes	Not required	Not required
U-NII Detection Bandwidth	Yes	Not required	Yes

**Table 2: Applicability of DFS requirements during normal operation**

Requirement	Operational Mode		
	Master	Client (without DFS)	Client (with DFS)
DFS Detection Threshold	Yes	Not required	Yes
Channel Closing Transmission Time	Yes	Yes	Yes
Channel Move Time	Yes	Yes	Yes
U-NII Detection Bandwidth	Yes	Not required	Yes

Additional requirements for devices with multiple bandwidth modes	Master Device or Client with Radar DFS	Client (without DFS)
U-NII Detection Bandwidth and Statistical Performance Check	All BW modes must be tested	Not required
Channel Move Time and Channel Closing Transmission Time	Test using widest BW mode available	Test using the widest BW mode available for the link
All other tests	Any single BW mode	Not required
<b>Note:</b> Frequencies selected for statistical performance check (Section 7.8.4) should include several frequencies within the radar detection bandwidth and frequencies near the edge of the radar detection bandwidth. For 802.11 devices it is suggested to select frequencies in all 20 MHz channel blocks and a null frequency between the bonded 20 MHz channel blocks.		

**Table 3: Interference Threshold values, Master or Client incorporating In-Service Monitoring**

Maximum Transmit Power	Value (see notes)
E.I.R.P. $\geq$ 200 mill watt	-64 dBm
E.I.R.P. < 200 mill watt and power spectral density < 10 dBm/MHz	-62 dBm
E.I.R.P. < 200 mill watt that do not meet power spectral density requirement	-64 dBm
<p><b>Note 1:</b> This is the level at the input of the receiver assuming a 0 dBi receive antenna</p> <p><b>Note 2:</b> Throughout these test procedures an additional 1 dB has been added to the amplitude of the test transmission waveforms to account for variations in measurement equipment. This will ensure that the test signal is at or above the detection threshold level to trigger a DFS response.</p> <p><b>Note 3:</b> E.I.R.P. is based on the highest antenna gain. For MIMO devices refer to KDB publication 662911 D01.</p>	

**Table 4: DFS Response requirement values**

Parameter	Value
<i>Non-occupancy period</i>	30 minutes
<i>Channel Availability Check Time</i>	60 seconds
<i>Channel Move Time</i>	10 seconds (See Note 1)
<i>Channel Closing Transmission Time</i>	200 milliseconds + approx. 60 milliseconds over remaining 10 second period. (See Notes 1 and 2)
<i>U-NII Detection Bandwidth</i>	Minimum 100% of the U-NII 99% transmission power bandwidth. (See Note 3)
<p><b>Note 1:</b> <i>Channel Move Time</i> and the <i>Channel Closing Transmission Time</i> should be performed with Radar Type 0. The measurement timing begins at the end of the Radar Type 0 burst.</p> <p><b>Note 2:</b> The <i>Channel Closing Transmission Time</i> is comprised of 200 milliseconds starting at the beginning of the <i>Channel Move Time</i> plus any additional intermittent control signals required to facilitate a <i>Channel</i> move (an aggregate of 60 milliseconds) during the remainder of the 10 second period. The aggregate duration of control signals will not count quiet periods in between transmissions.</p> <p><b>Note 3:</b> During the <i>U-NII Detection Bandwidth</i> detection test, radar type 0 should be used. For each frequency step the minimum percentage of detection is 90 percent. Measurements are performed with no data traffic.</p>	

**Table 5 – Short Pulse Radar Test Waveforms**

Radar Type	Pulse Width (usec)	PRI (usec)	Pulses	Minimum Percentage of Successful Detection	Minimum Trials
0	1	1428	18	See Note 1	See Note 1
1	1	Test A: 15 unique PRI values randomly selected from the list of 23 PRI values in table 5a	Roundup: $\{(1/360) \times (19 \times 10^6 \text{ PRI}_{\text{usec}})\}$	60%	30
		Test B: 15 unique PRI values randomly selected within the range of 518-3066 usec. With a minimum increment of 1 usec, excluding PRI values selected in Test A			
2	1-5	150-230	23-29	60%	30
3	6-10	200-500	16-18	60%	30
4	11-20	200-500	12-16	60%	30
Aggregate (Radar Types 1-4)				80%	120
<b>Note 1:</b> Short Pulse Radar Type 0 should be used for the <i>Detection Bandwidth</i> test, <i>Channel Move Time</i> , and <i>Channel Closing Time</i> tests.					

**Table 6 – Long Pulse Radar Test Signal**

Radar Waveform Type	Pulse Width (μsec)	Chirp Width (MHz)	PRI (μsec)	Pulses per Burst	Number of Bursts	Minimum Percentage of Successful Detection	Minimum Trials
5	50-100	5-20	1000-2000	1-3	8-20	80%	30

**Table 7 – Frequency Hopping Radar Test Signal**

Radar Waveform Type	Pulse Width (μsec)	PRI (μsec)	Pulses per Hop	Hopping Rate (kHz)	Hopping Sequence Length (msec)	Minimum Percentage of Successful Detection	Minimum Trials
6	1	333	9	0.333	300	70%	30

### 13.1.1. TEST AND MEASUREMENT SYSTEM

#### CONDUCTED METHOD SYSTEM BLOCK DIAGRAM

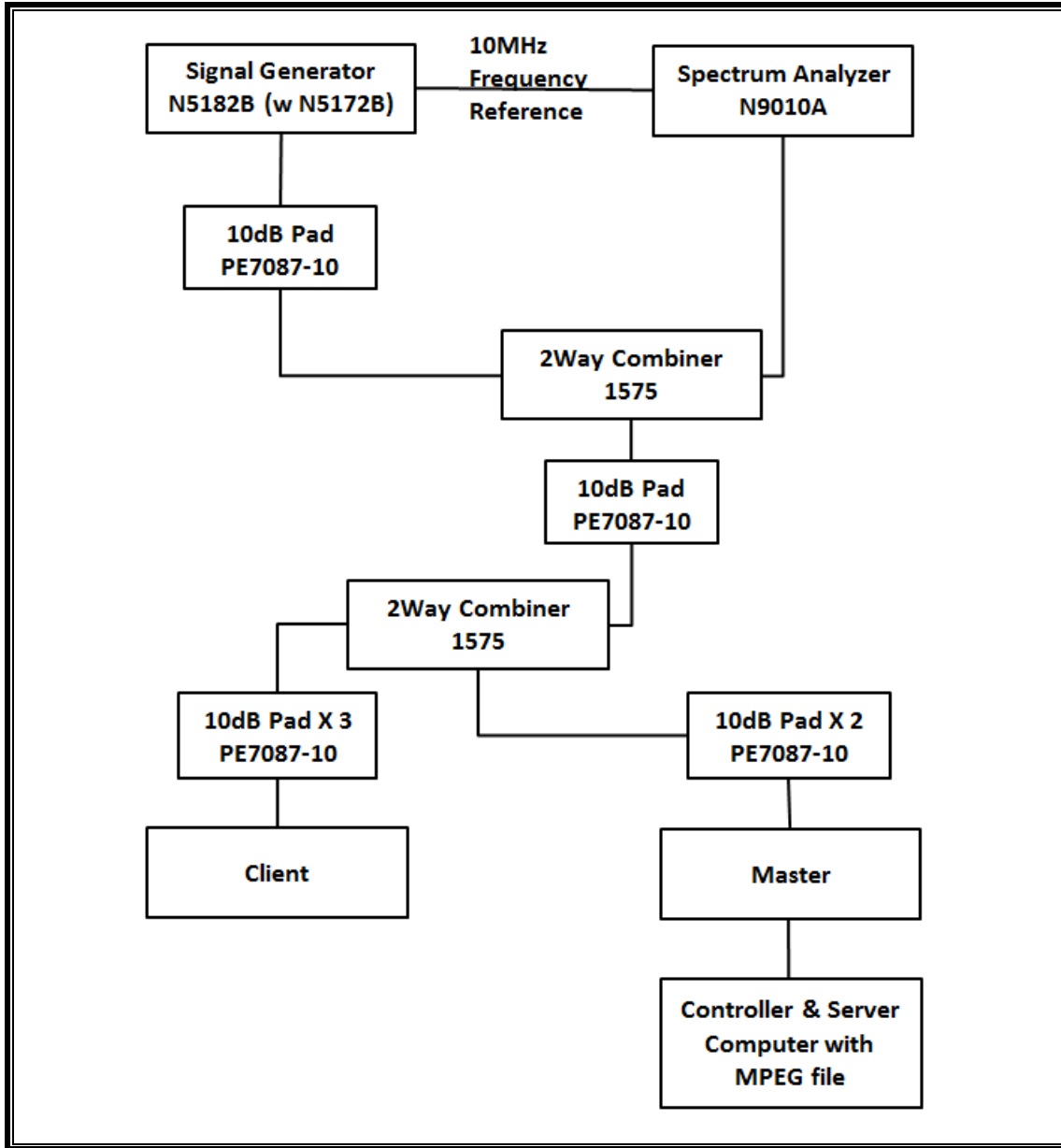

## **SYSTEM OVERVIEW**

The short pulse and long pulse signal generating system utilizes the Keysite Signal Studio for Pulse Building as N5172B. The Vector Signal Generator has been validated by the NTIA. The hopping signal generating system utilizes the CCS simulated hopping method and system, which has been validated by the DoD, FCC and NTIA. The software selects waveform parameters from within the bounds of the signal type on a random basis using uniform distribution.

The short pulse types 1, 2, 3 and 4, and the long pulse type 5 parameters are randomized at run-time.

The hopping type 6 pulse parameters are fixed while the hopping sequence is based on the August 2005 NTIA Hopping Frequency List. The initial starting point randomized at run-time and each subsequent starting point is incremented by 475. Each frequency in the 100-length segment is compared to the boundaries of the EUT Detection Bandwidth and the software creates a hopping burst pattern in accordance with Section 7.4.1.3 Method #2 Simulated Frequency Hopping Radar Waveform Generating Subsystem of KDB 905462 D02. The frequency of the signal generator is incremented in 1 MHz steps from  $F_L$  to  $F_H$  for each successive trial. This incremental sequence is repeated as required to generate a minimum of 30 total trials and to maintain a uniform frequency distribution over the entire Detection Bandwidth.

The signal monitoring equipment consists of a spectrum analyzer. The aggregate ON time is calculated by multiplying the number of bins above a threshold during a particular observation period by the dwell time per bin, with the analyzer set to peak detection and max hold.

## **SYSTEM CALIBRATION**

A 50-ohm load is connected in place of the spectrum analyzer, and the spectrum analyzer is connected to a horn antenna via a coaxial cable, with the reference level offset set to (horn antenna gain – coaxial cable loss). The signal generator is set to CW mode. The amplitude of the signal generator is adjusted to yield a level of –64 dBm as measured on the spectrum analyzer.

Without changing any of the instrument settings, the spectrum analyzer is reconnected to the Common port of the Spectrum Analyzer Combiner/Divider. The Reference Level Offset of the spectrum analyzer is adjusted so that the displayed amplitude of the signal is –64 dBm.

The spectrum analyzer displays the level of the signal generator as received at the antenna ports of the Master Device. The interference detection threshold may be varied from the calibrated value of –64 dBm and the spectrum analyzer will still indicate the level as received by the Master Device.

**ADJUSTMENT OF DISPLAYED TRAFFIC LEVEL**

A link is established between the Master and Slave and the distance between the units is adjusted as needed to provide a suitable received level at the Master and Slave devices. The video test file is streamed to generate WLAN traffic. The monitoring antenna is adjusted so that the WLAN traffic level, as displayed on the spectrum analyzer, is at lower amplitude than the radar detection threshold.

**TEST AND MEASUREMENT EQUIPMENT**

The following test and measurement equipment was utilized for the DFS tests documented in this report:

<b>TEST EQUIPMENT LIST</b>				
<b>Description</b>	<b>Manufacturer</b>	<b>Model</b>	<b>S/N</b>	<b>Cal Due</b>
Spectrum Analyzer, 7 GHz	Agilent / HP	N9010A	MY54200580	08-17-17
Vector Signal Generator, 6GHz	Agilent / HP	N5182B	MY53051241	08-16-17

### 13.1.2. SETUP OF EUT

#### CONDUCTED METHOD EUT TEST SETUP

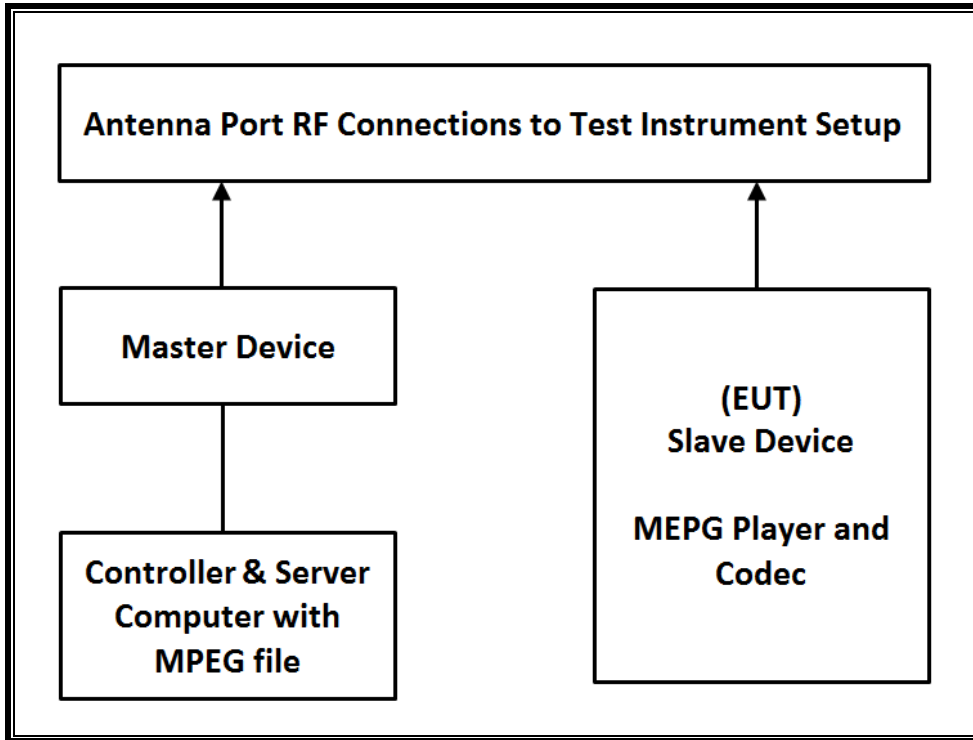

#### SUPPORT EQUIPMENT

The following support equipment was utilized for the DFS tests documented in this report:

PERIPHERAL SUPPORT EQUIPMENT LIST				
Description	Manufacturer	Model	Serial Number	FCC ID
Wireless Access Point	Cisco	AIR-CAP3702E-A-K9	FTX182276QX	LDK102087
PC (Controller/Server)	HP	HP EliteDesk 800 G1 TWR	CZC4125J25	DoC

### **13.1.3. DESCRIPTION OF EUT**

The EUT operates over the 5250-5350 MHz and 5470-5725 MHz ranges.

The EUT is a Slave Device without Radar Detection.

The highest power level within these bands is 13.42 dBm in the 5250-5350 MHz band and 13.322 dBm in the 5470-5725 MHz band.

The antenna gain assembly utilized with the EUT are -0.25dBi(for UNII-2A) and -2.76dBi(UNII-2C) .

The rated output power of the Master unit is > 23dBm (EIRP). Therefore the required interference threshold level is -64 dBm. After correction for procedural adjustments, the required conducted threshold at the antenna port is  $-64 + 1 = -63$  dBm.

The calibrated radiated DFS Detection Threshold level is set to -64 dBm. The tested level is lower than the required level hence it provides a margin to the limit.

The EUT uses one transmitter/receiver chain connected to an antenna to perform radiated tests.

WLAN traffic that meets or exceeds the minimum required loading was generated by transferring a data stream from the controller/server PC to the EUT using iPerf version 2.0.5 software package.

TPC is not required since the maximum EIRP is less than 500 mW (27 dBm).

The EUT utilizes the 802.11a, 802.11n architecture. Two nominal channel bandwidths are implemented: 20 MHz and 40 MHz.

The software installed in the access point is 12.4(25d)JA1.

### **UNIFORM CHANNEL SPREADING**

This requirement is not applicable to Slave radio devices.

### **OVERVIEW OF MASTER DEVICE WITH RESPECT TO §15.407 (h) REQUIREMENTS**

The Master Device is a Cisco Access Point, FCC ID: LDK102087. The minimum antenna gain for the Master Device is 6 dBi.

The rated output power of the Master unit is > 23dBm (EIRP). Therefore the required interference threshold level is -64 dBm. After correction for procedural adjustments, the required radiated threshold at the antenna port is  $-64 + 1 = -63$  dBm.

The calibrated radiated DFS Detection Threshold level is set to -64 dBm. The tested level is lower than the required level hence it provides a margin to the limit.

## 13.2. RESULTS FOR 20 MHz BANDWIDTH

### 13.2.1. TEST CHANNEL

All tests were performed at a channel center frequency of 5500 MHz.

### 13.2.2. RADAR WAVEFORM AND TRAFFIC

#### RADAR WAVEFORM

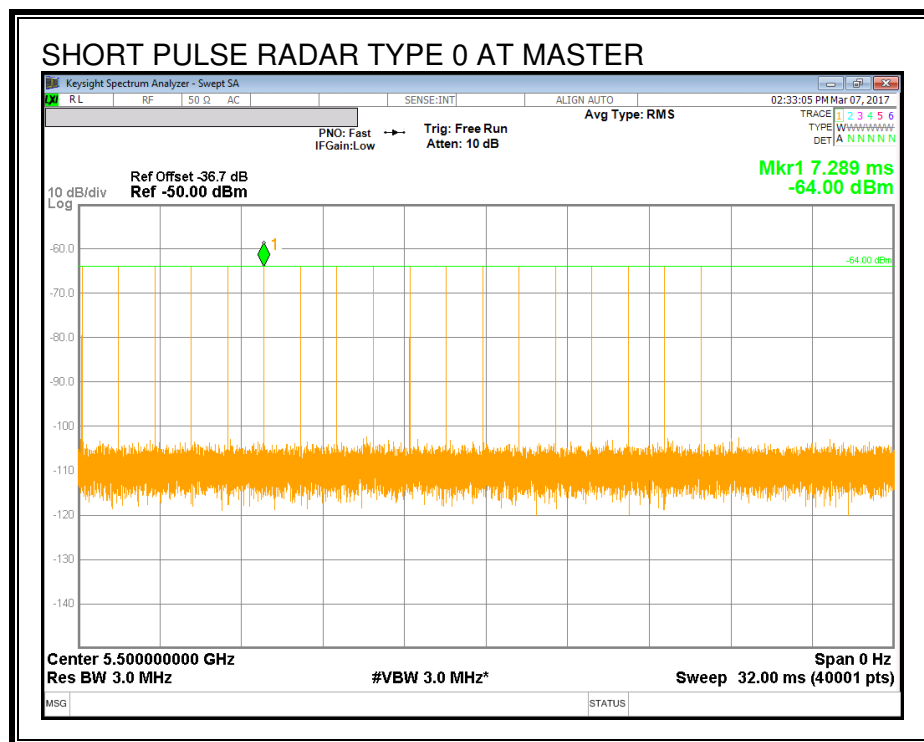

**TRAFFIC**

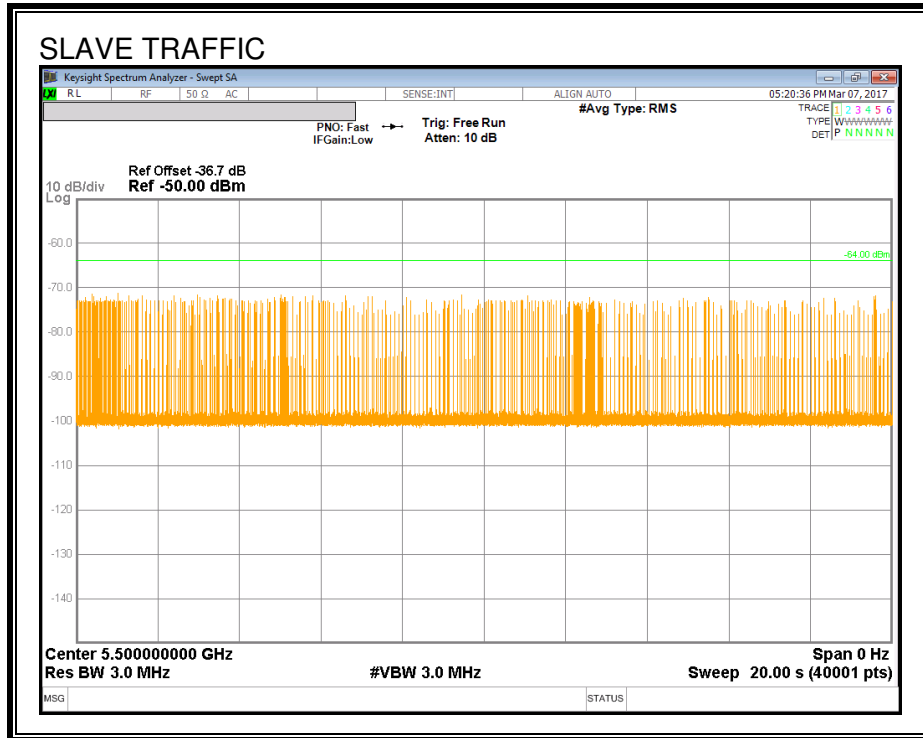

### 13.2.3. OVERLAPPING CHANNEL TESTS

#### RESULTS

These tests are not applicable.

### 13.2.4. MOVE AND CLOSING TIME

#### REPORTING NOTES

The reference marker is set at the end of last radar pulse.

The delta marker is set at the end of the last WLAN transmission following the radar pulse. This delta is the channel move time.

The aggregate channel closing transmission time is calculated as follows:

Aggregate Transmission Time =  
(Number of analyzer bins showing transmission) \* (dwell time per bin)

The observation period over which the aggregate time is calculated begins at (Reference Marker + 200 msec) and ends no earlier than (Reference Marker + 10 sec).

#### RESULTS

Channel Move Time (sec)	Limit (sec)
0.592	10

Aggregate Channel Closing Transmission Time (msec)	Limit (msec)
3.000	60

**MOVE TIME & CHANNEL CLOSING TIME**

**AGGREGATE CHANNEL CLOSING TRANSMISSION TIME**

No transmissions are observed during the aggregate monitoring period.

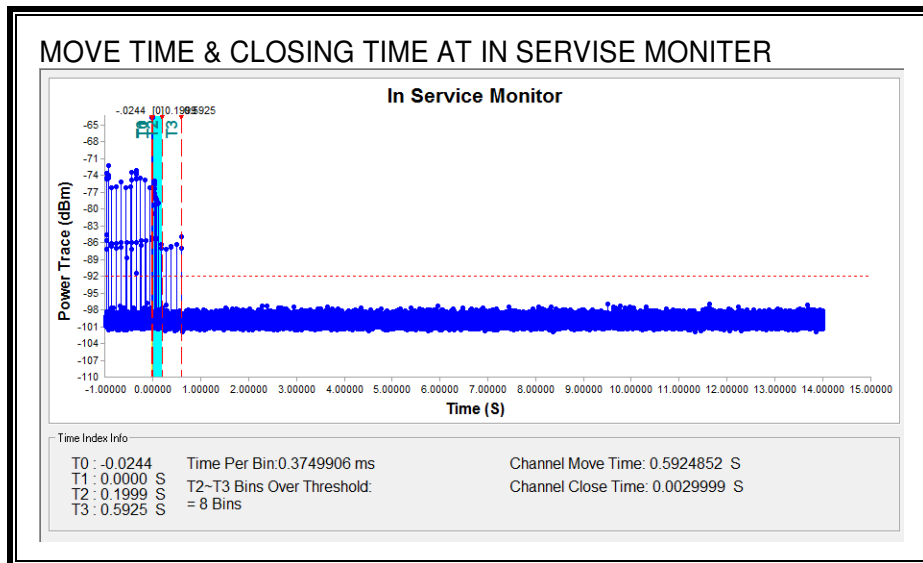
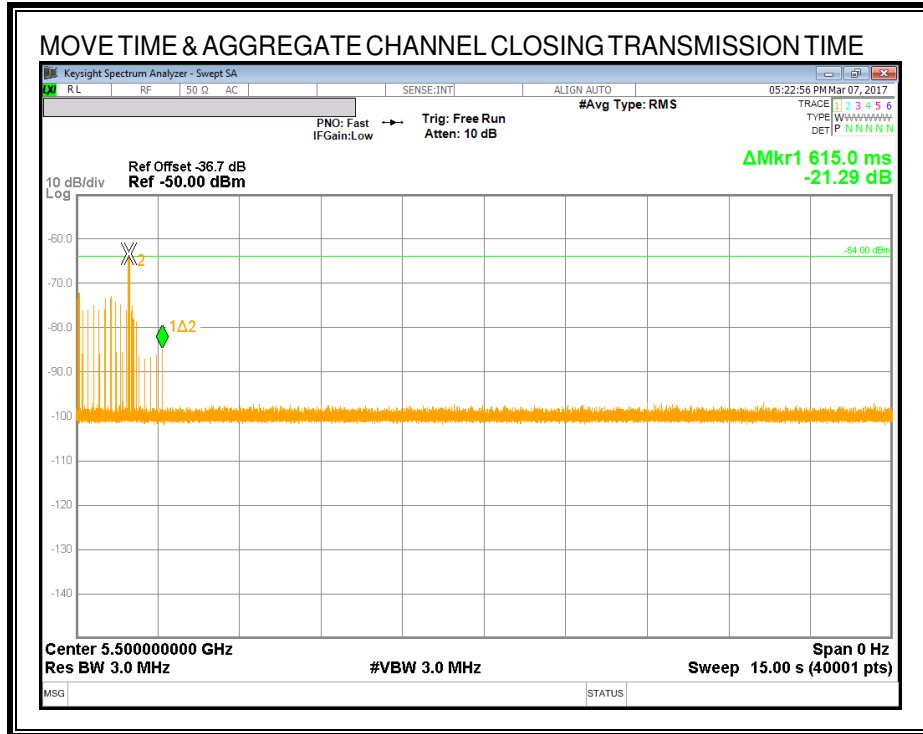



### 13.3. RESULTS FOR 40 MHz BANDWIDTH

#### 13.3.1. TEST CHANNEL

All tests were performed at a channel center frequency of 5510 MHz.

#### 13.3.2. RADAR WAVEFORM AND TRAFFIC

##### RADAR WAVEFORM

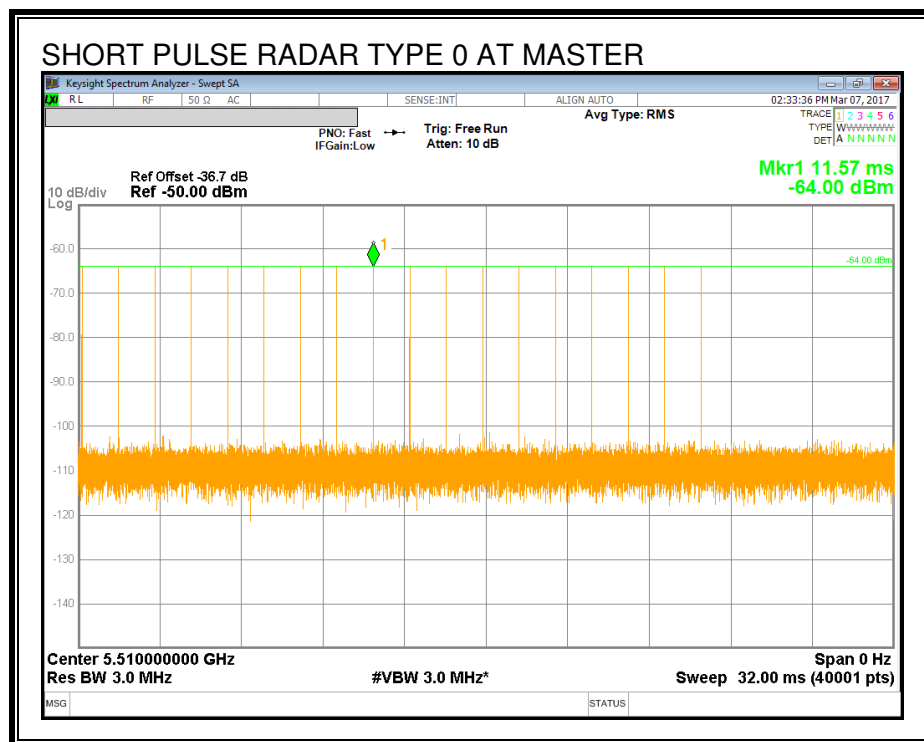

**TRAFFIC**

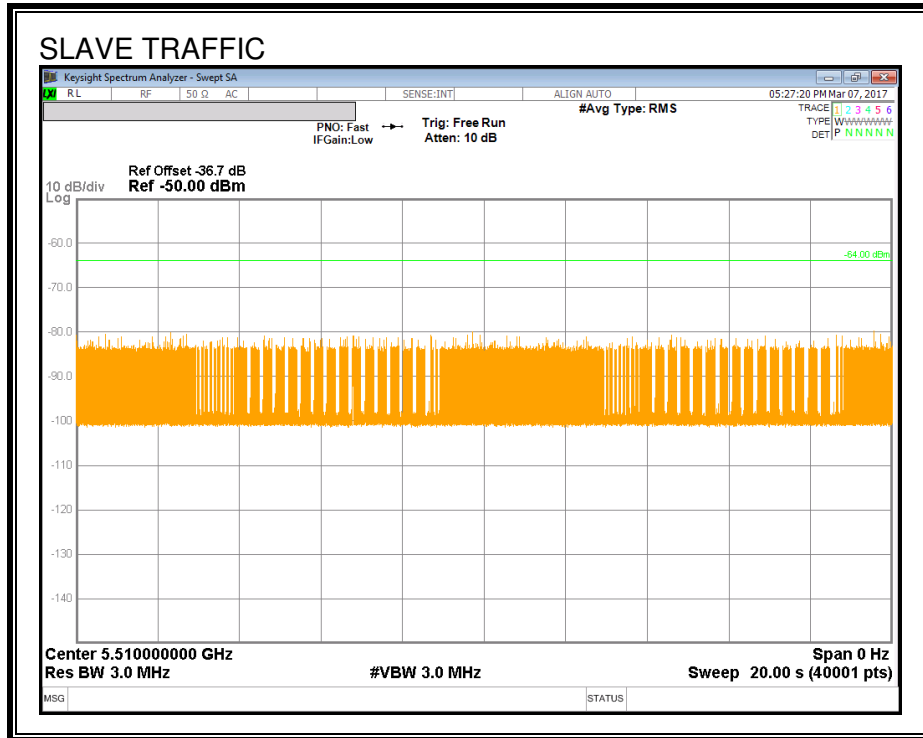

### 13.3.3. OVERLAPPING CHANNEL TESTS

#### RESULTS

These tests are not applicable.

### 13.3.4. MOVE AND CLOSING TIME

#### REPORTING NOTES

The reference marker is set at the end of last radar pulse.

The delta marker is set at the end of the last WLAN transmission following the radar pulse. This delta is the channel move time.

The aggregate channel closing transmission time is calculated as follows:

Aggregate Transmission Time =  
(Number of analyzer bins showing transmission) \* (dwell time per bin)

The observation period over which the aggregate time is calculated begins at (Reference Marker + 200 msec) and ends no earlier than (Reference Marker + 10 sec).

#### RESULTS

Channel Move Time (sec)	Limit (sec)
0.631	10

Aggregate Channel Closing Transmission Time (msec)	Limit (msec)
3.000	60

**MOVE TIME & CHANNEL CLOSING TIME**

**AGGREGATE CHANNEL CLOSING TRANSMISSION TIME**

No transmissions are observed during the aggregate monitoring period.

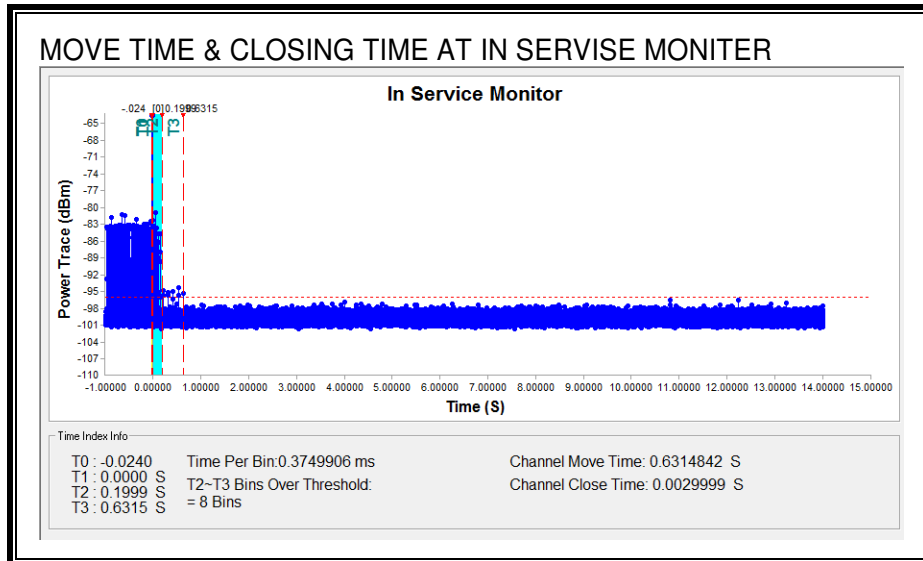
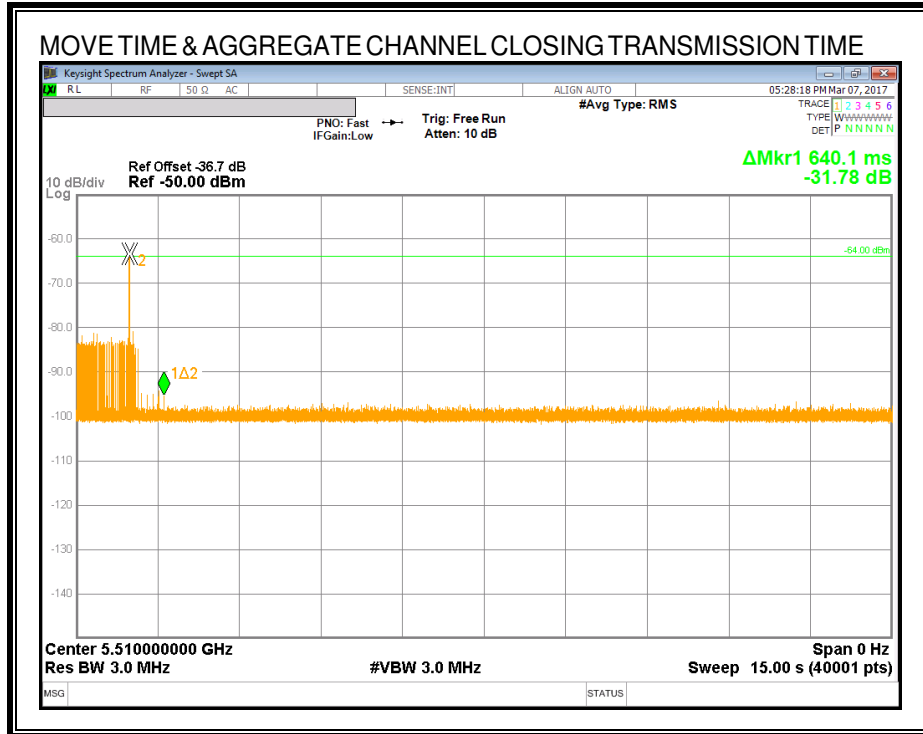

**NON-OCCUPANCY PERIOD**

**RESULTS**

No EUT transmissions were observed on the test channel during the 10-minute observation time.

