



**FCC CFR47 PART 22 SUBPART H
FCC CFR47 PART 24 SUBPART E**

WWAN

CERTIFICATION TEST REPORT

FOR

GSM/WCDMA/LTE Phone + BT/BLE, DTS/UNII a/b/g/n and NFC

MODEL NUMBER : SM-G390F

FCC ID: A3LSMG390F

REPORT NUMBER: 4787833362-E6V1

ISSUE DATE: FEB 22, 2017

Prepared for
**SAMSUNG ELECTRONICS CO., LTD.
129 SAMSUNG-RO, YEONGTONG-GU, SUWON-SI,
GYEONGGI-DO, 16677, KOREA**

Prepared by
**UL Korea, Ltd. Suwon Laboratory
218 Maeyeong-ro, Yeongtong-gu,
Suwon-si, Gyeonggi-do, 16675, Korea
TEL: (031) 337-9902
FAX: (031) 213-5433**



Revision History

<u>Rev.</u>	<u>Issue Date</u>	<u>Revisions</u>	<u>Revised By</u>
V1	02/22/17	Initial issue	Junwhan Lee

TABLE OF CONTENTS

1. ATTESTATION OF TEST RESULTS	5
2. TEST METHODOLOGY	6
3. FACILITIES AND ACCREDITATION	6
4. CALIBRATION AND UNCERTAINTY	6
4.1. <i>MEASURING INSTRUMENT CALIBRATION</i>	6
4.2. <i>SAMPLE CALCULATION</i>	6
4.3. <i>MEASUREMENT UNCERTAINTY</i>	6
5. EQUIPMENT UNDER TEST	7
5.1. <i>DESCRIPTION OF EUT</i>	7
5.2. <i>MAXIMUM OUTPUT POWER (GSM)</i>	7
5.3. <i>MAXIMUM OUTPUT POWER (WCDMA)</i>	8
5.4. <i>MAXIMUM OUTPUT POWER (LTE)</i>	8
5.5. <i>DESCRIPTION OF AVAILABLE ANTENNAS</i>	9
5.6. <i>DESCRIPTION OF TEST SETUP</i>	10
6. TEST AND MEASUREMENT EQUIPMENT	12
7. Summary Table	13
8. RF POWER OUTPUT VERIFICATION	14
8.1. <i>GSM/GPRS/EDGE</i>	14
8.1.1. <i>GSM OUTPUT POWER RESULT</i>	15
8.2. <i>UMTS REL 99</i>	17
8.2.1. <i>WCDMA OUTPUT POWER RESULT</i>	21
8.3. <i>LTE OUTPUT VERIFICATION</i>	23
8.3.1. <i>LTE OUTPUT POWER RESULT</i>	24
9. PEAK TO AVERAGE RATIO	25
9.1. <i>CONDUCTED PEAK TO AVERAGE RESULT</i>	25
9.2. <i>CONDUCTED PEAK TO AVERAGE PLOTS</i>	27
10. LIMITS AND CONDUCTED RESULTS	30
10.1. <i>OCCUPIED BANDWIDTH</i>	30
10.1.1. <i>OCCUPIED BANDWIDTH RESULTS</i>	30
10.1.2. <i>OCCUPIED BANDWIDTH PLOTS</i>	33
10.2. <i>BAND EDGE EMISSIONS</i>	41
10.2.1. <i>BAND EDGE PLOTS</i>	44

10.3	OUT OF BAND EMISSIONS	50
10.3.1.	OUT OF BAND EMISSIONS PLOTS.....	53
10.4.	FREQUENCY STABILITY	61
10.4.1.	FREQUENCY STABILITY RESULTS.....	62
11.	RADIATED TEST RESULTS.....	67
11.1.	RADIATED POWER (ERP & EIRP).....	67
11.1.1.	ERP/EIRP Results	68
11.1.2.	ERP/EIRP DATA	70
11.2.	FIELD STRENGTH OF SPURIOUS RADIATION.....	78
11.2.1.	SPURIOUS RADIATION PLOTS.....	79
12.	SETUP PHOTOS	87

1. ATTESTATION OF TEST RESULTS

COMPANY NAME: SAMSUNG ELECTRONICS CO., LTD.
EUT DESCRIPTION: GSM/WCDMA/LTE Phone + BT/BLE, DTS/UNII a/b/g/n and NFC
MODEL NUMBER: SM-G390F
SERIAL NUMBER: R38HC02374V (RADIATED);
R38HC02391M (CONDUCTED)
DATE TESTED: JAN 18, 2017 – JAN 25, 2017

APPLICABLE STANDARDS	
STANDARD	TEST RESULTS
FCC PART 22H and 24E	Pass

UL Korea, Ltd. tested the above equipment in accordance with the requirements set forth in the above standards. All indications of Pass/Fail in this report are opinions expressed by UL Korea, Ltd. based on interpretations and/or observations of test results. Measurement Uncertainties were not taken into account and are published for informational purposes only. The test results show that the equipment tested is capable of demonstrating compliance with the requirements as documented in this report.

Note: The results documented in this report apply only to the tested sample, under the conditions and modes of operation as described herein. This document may not be altered or revised in any way unless done so by UL Korea, Ltd. and all revisions are duly noted in the revisions section. Any alteration of this document not carried out by UL Korea, Ltd. will constitute fraud and shall nullify the document. This report must not be used by the client to claim product certification, approval, or endorsement by IAS, any agency of the Federal Government, or any agency of any government.

Approved & Released For
UL Korea, Ltd. By:



SungGil Park
Suwon Lab Engineer
UL Korea, Ltd.

Tested By:



Junwhan Lee
Suwon Lab Engineer
UL Korea, Ltd.

2. TEST METHODOLOGY

The tests documented in this report were performed in accordance with following methods.

1. FCC CFR 47 Part 2.
2. FCC CFR 47 Part 22.
3. FCC CFR 47 Part 24.
4. ANSI TIA-603-D

3. FACILITIES AND ACCREDITATION

The test sites and measurement facilities used to collect data are located at 218 Maeyeong-ro, Yeongtong-gu, Suwon-si, Gyeonggi-do, 16675, Korea. Line conducted emissions are measured only at the 218 address. The following table identifies which facilities were utilized for radiated emission measurements documented in this report. Specific facilities are also identified in the test results sections.

218 Maeyeong-ro	
<input type="checkbox"/>	Chamber 1
<input checked="" type="checkbox"/>	Chamber 2

UL Korea, Ltd. is accredited by IAS, Laboratory Code TL-637. The full scope of accreditation can be viewed at <http://www.iasonline.org/PDF/TL/TL-637.pdf>.

4. CALIBRATION AND UNCERTAINTY

4.1. MEASURING INSTRUMENT CALIBRATION

The measuring equipment utilized to perform the tests documented in this report has been calibrated in accordance with the manufacturer's recommendations, and is traceable to recognized national standards.

4.2. SAMPLE CALCULATION

Where relevant, the following sample calculation is provided:

$EIRP = \text{PSA reading with EUT worst orientation (dBm)} + \text{Path loss (dB)} - \text{cable loss (between the SG and substitution antenna)} + \text{Substitution Antenna Factor (dBi)}$

$ERP = \text{PSA reading with EUT worst orientation (dBm)} + \text{Path loss (dB)} - \text{cable loss (between the SG and substitution antenna)}$

(Path loss = Signal generator output – PSA reading with substitution antenna)

4.3. MEASUREMENT UNCERTAINTY

Where relevant, the following measurement uncertainty levels have been estimated for tests performed on the apparatus:

PARAMETER	UNCERTAINTY
Conducted Disturbance, 0.15 to 30 MHz	2.32 dB
Radiated Disturbance, Below 1GHz	4.14 dB
Radiated Disturbance, Above 1 GHz	5.97 dB

Uncertainty figures are valid to a confidence level of 95%.

5. EQUIPMENT UNDER TEST

5.1. DESCRIPTION OF EUT

The EUT is a GSM/WCDMA/LTE Phone + BT/BLE, DTS/UNII a/b/g/n and NFC.

5.2. MAXIMUM OUTPUT POWER (GSM)

The transmitter has a maximum peak conducted and radiated ERP / EIRP output powers as follows:

FCC Part 22/24						
Band	Frequency Range	Modulation	Conducted		Radiated	
	[MHz]		Peak	Avg [dBm]	Avg [mW]	Avg [dBm]
GSM850	824~849	GMSK	31.63	1455.46		
		GPRS	31.66	1465.55	28.58	721.11
		EGPRS	26.58	454.99	24.36	272.90
GSM1900	1850~1910	GMSK	28.55	716.14		
		GPRS	28.61	726.11	29.63	918.33
		EGPRS	25.00	316.23	26.78	476.43

5.3. MAXIMUM OUTPUT POWER (WCDMA)

The transmitter has a maximum peak conducted and radiated ERP / EIRP output powers as follows:

FCC Part 22/24						
Band	Frequency Range	Modulation	Conducted		Radiated	
	[MHz]		Peak	Avg [dBm]	Avg [mW]	Avg [dBm]
Band 5	824~849	REL99	23.22	209.89	19.75	94.41
		HSDPA	22.12	162.93	20.29	106.91
		HSUPA	23.18	207.97		
Band 2	1850~1910	REL99	22.04	159.96	23.38	217.77
		HSDPA	21.98	157.76	23.13	205.59
		HSUPA	22.00	158.49		

5.4. MAXIMUM OUTPUT POWER (LTE)

The transmitter has a maximum peak conducted and radiated ERP / EIRP output powers as follows:

LTE Band 5

FCC Part 22							
Band	Frequency Range [MHz]	BandWidth [MHz]	Modulation	Conducted		Radiated	
				Peak	Avg [dBm]	Avg [mW]	Avg [dBm]
Band 5	824 ~ 849	10	QPSK	23.08	203.24	17.14	51.76
			16QAM	21.68	147.23	16.18	41.50
		5	QPSK	23.13	205.59	18.04	63.68
			16QAM	21.39	137.72	17.04	50.58
		3	QPSK	23.10	204.17	17.77	59.84
			16QAM	21.57	143.55	16.79	47.75
		1.4	QPSK	23.16	207.01	16.34	43.05
			16QAM	21.71	148.25	15.35	34.28

5.5. DESCRIPTION OF AVAILABLE ANTENNAS

The radio utilizes a internal antenna for the [List the bands supported] with a maximum peak gain as follow:

Frequency (MHz)	Peak Gain (dBi)
GSM850 / WCDMA Band 5 / LTE Band 5 824 ~ 849 MHz	-1.9
GSM1900 / WCDMA Band 2 1850 ~ 1910 MHz	0.3

5.6. DESCRIPTION OF TEST SETUP

SUPPORT EQUIPMENT

Support Equipment List				
Description	Manufacturer	Model	Serial Number	FCC ID
Charger	SAMSUNG	EP-TA50EWE	DK1H822VS/A-E	N/A
Data Cable	SAMSUNG	ECB-DU68WE	N/A	N/A
Earphone	SAMSUNG	EHS64AVFWE	N/A	N/A

I/O CABLES

I/O Cable List						
Cable No	Port	# of identical ports	Connector Type	Cable Type	Cable Length (m)	Remarks
1	DC Power	1	Mini-USB	Shielded	0.8m	N/A
2	Audio	2	Mini-Jack	Unshielded	1.0m	N/A

TEST SETUP

The EUT is continuously communicated to the call box during the tests.

SETUP DIAGRAM FOR TESTS (CONDUCTED TEST SETUP)

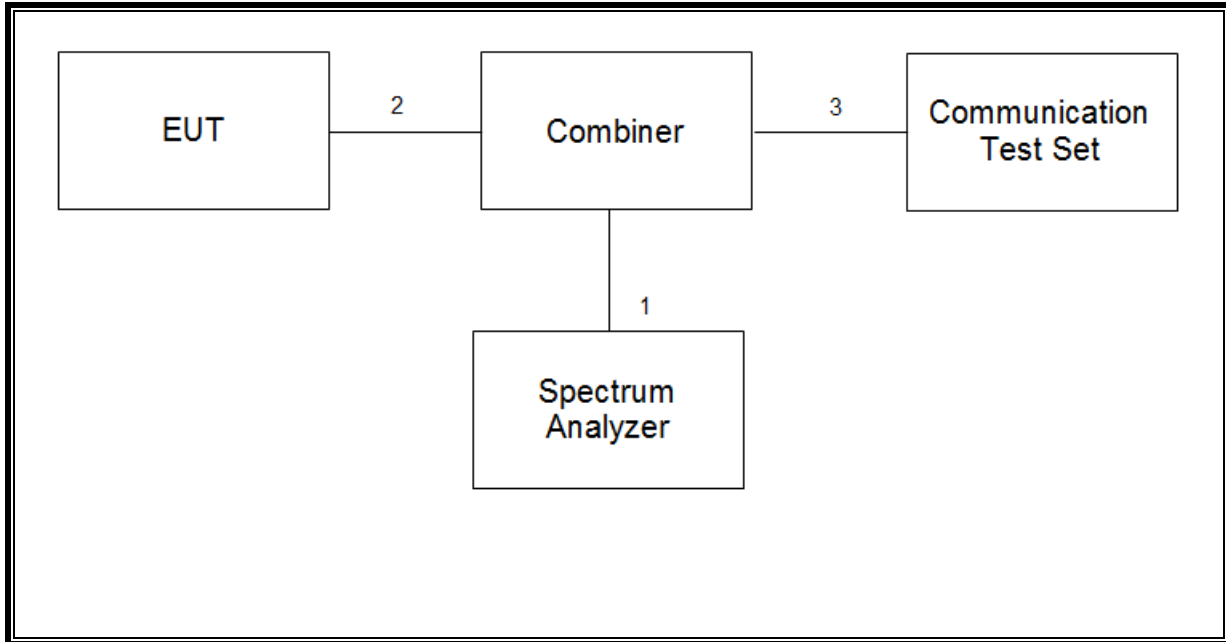

SETUP DIAGRAM FOR TESTS (RADIATED TEST SETUP)

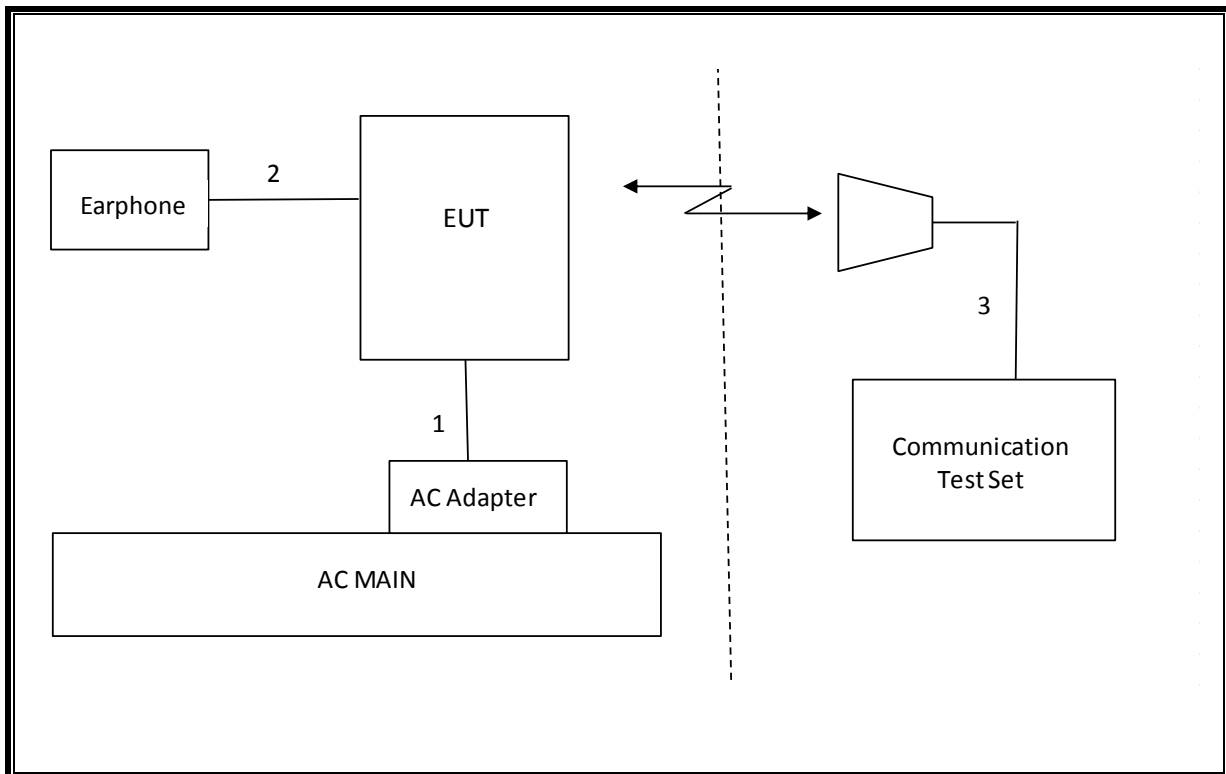

6. TEST AND MEASUREMENT EQUIPMENT

The following test and measurement equipment was utilized for the tests documented in this report:

Test Equipment List				
Description	Manufacturer	Model	S/N	Cal Due
Antenna, Tuned Dipole 400~1000 MHz	ETS	3121D DB4	00164753	07-28-17
Antenna, Horn, 40 GHz	ETS	3116C	00166155	11-30-17
Antenna, Horn, 40 GHz	ETS	3116C-PA	00168841	12-15-17
Antenna, Bilog, 30MHz-1GHz	SCHWARZBECK	VULB9163	750	10-14-18
Antenna, Bilog, 30MHz-1GHz	SCHWARZBECK	VULB9163	749	04-25-17
Antenna, Horn, 18 GHz	ETS	3115	00161451	03-17-17
Antenna, Horn, 18 GHz	ETS	3115	00167211	10-14-18
Antenna, Horn, 18 GHz	ETS	3117	00168724	06-17-17
Antenna, Horn, 18 GHz	ETS	3117	00168717	06-17-17
Combiner	WEINSCHEL	1575	2150	08-16-17
Communications Test Set	R&S	CMW500	150312	08-17-17
Communications Test Set	R&S	CMW500	115331	08-17-17
DC Power Supply	Agilent / HP	E3640A	MY54226395	08-16-17
Preamplifier, 1000 MHz	Sonoma	310N	341282	08-17-17
Preamplifier, 1000 MHz	Sonoma	310N	351741	08-16-17
Preamplifier	ETS	3115-PA	00167475	08-17-17
Preamplifier, 18 GHz	Miteq	AFS42-00101800-25-S-42	1896138	08-16-17
Spectrum Analyzer, 44 GHz	Agilent / HP	N9030A	MY54170614	08-17-17
Spectrum Analyzer, 44 GHz	Agilent / HP	N9030A	MY54490312	08-16-17
EMI Test Receive, 40 GHz	R&S	ESU40	100439	08-17-17
EMI Test Receive, 40 GHz	R&S	ESU40	100457	08-16-17
High Pass Filter 1.2GHz	Micro-Tronics	HPM50108-02	G005	08-17-17
High Pass Filter 1.2GHz	Micro-Tronics	HPM50108-02	G006	08-17-17
High Pass Filter 2.8GHz	Micro-Tronics	HPM50111-02	010	08-17-17
High Pass Filter 2.8GHz	Micro-Tronics	HPM50111-02	011	08-17-17
High Pass Filter 4GHz	Micro-Tronics	HPM50118-02	G001	08-17-17
High Pass Filter 4GHz	Micro-Tronics	HPM50118-02	G002	08-17-17
Attenuator	PASTERNAK	PE7087-10	A009	08-16-17
Temperature Chamber	ESPEC	SH-642	93001109	08-17-17
UL Software				
Description	Manufacturer	Model	Version	
Antenna port test software	UL	CLT	Ver 1.6	

7. Summary Table

FCC Part Section	Test Description	Test Limit	Test Condition	Test Result	Note
2.1049	Occupied Band width (99%)	N/A	Conducted	Pass	8.9769 MHz
22.917(a) 24.238(a)	Band Edge / Conducted Spurious Emission	-13dBm		Pass	-15.789 dBm
2.1046	Conducted output power	N/A		Pass	31.66dBm
22.355 24.235	Frequency Stability	2.5PPM		Pass	-0.012 PPM
22.913(a)(2)	Effective Radiated Power	38.5 dBm	Radiated	Pass	28.58 dBm
24.232(c)	Equivalent Isotropic Radiated Power	33dBm		Pass	29.63 dBm
22.917(a) 24.238(a)	Radiated Spurious Emission	-13dBm		Pass	-30.6 dBm

FCC Rule Part	Frequency Range [MHz]	Output Power [W]	Frequency Tolerance	Emission Designator	Emission Bandwidth [MHz]	Communication Type
GSM						
22H	824.2 - 848.8	0.721	2.5 ppm	241KGXW		GSM850
22H	824.2 - 848.8	0.273	2.5 ppm	248KG7W		EDGE850
24E	1850.2 - 1909.8	0.918	2.5 ppm	242KGXW		GSM1900
24E	1850.2 - 1909.8	0.476	2.5 ppm	242KG7W		EDGE1900
WCDMA						
22H	826.4 - 846.6	0.107	2.5 ppm	4M14F9W		WCDMA B5
24E	1852.4 - 1907.6	0.218	2.5 ppm	4M14F9W		WCDMA B2
LTE Band 5						
22H	829.0 - 844.0	0.052	2.5 ppm	8M96G7W	10	QPSK
22H	829.0 - 844.0	0.042	2.5 ppm	8M98D7W	10	16QAM
22H	826.5 - 846.5	0.064	2.5 ppm	4M50G7W	5	QPSK
22H	826.5 - 846.5	0.051	2.5 ppm	4M50D7W	5	16QAM

8. RF POWER OUTPUT VERIFICATION

8.1. GSM/GPRS/EDGE

Function: Menu select > GSM Mobile Station > GSM 850/900/1800/1900
Press Connection control to choose the different menus
Press RESET > choose all to reset all settings
Connection Press Signal Off to turn off the signal and change settings
Network Support > GSM+GPRS or GSM+EGPRS
Main Service > Packet Data
Service selection > Test Mode A – Auto Slot Config. off
MS Signal Press Slot Config bottom on the right twice to select and change the number of time slots and power setting
 > Slot configuration > Uplink/Gamma
 > 33 dBm for GPRS 850/900
 > 30 dBm for GPRS1800/1900
BS Signal Enter the same channel number for TCH channel (test channel) and BCCH channel
Frequency Offset > + 0 Hz
Mode > BCCH and TCH
BCCH Level > -85 dBm (May need to adjust if link is not stable)
BCCH Channel > choose desire test channel [Enter the same channel number for TCH channel (test channel) and BCCH channel]
Channel Type > Off
P0> 4 dB
Slot Config > Unchanged (if already set under MS Signal)
TCH > choose desired test channel
Hopping > Off
Main Timeslot >3 (Default)
Network Coding Scheme > CS4 (GPRS) and MCS5 ~ MCS9 (EGPRS)
Bit Stream > 2E9-1PSR Bit Pattern
AF/RF Enter appropriate offsets for Ext. Att. Output and Ext. Att. Input
Connection Press Signal On to turn on the signal and change settings

8.1.1. GSM OUTPUT POWER RESULT

GSM850 Measured Results

Band	Mode	Coding Scheme	Time Slots	Ch No.	Freq. [MHz]	Max. Power		
						Burst Pwr [dBm]	Frame Pwr [dBm]	
850	GSM (Voice)	CS1	1	128	824.2	31.31	22.27	
				190	836.6	31.51	22.48	
				251	848.8	31.63	22.60	
	GPRS (GMSK)	CS1	1	1	128	824.2	31.35	22.32
					190	836.6	31.53	22.50
					251	848.8	31.66	22.63
					128	824.2	30.70	24.68
					190	836.6	30.86	24.84
					251	848.8	30.98	24.96
			2	1	128	824.2	29.63	25.37
					190	836.6	29.76	25.50
					251	848.8	29.87	25.61
			3	1	128	824.2	28.56	25.55
					190	836.6	28.66	25.65
					251	848.8	28.75	25.74
	EGPRS (8PSK)	MCS5	1	1	128	824.2	26.57	17.54
					190	836.6	26.45	17.42
					251	848.8	26.58	17.55
			2	1	128	824.2	25.24	19.22
					190	836.6	25.33	19.31
					251	848.8	25.42	19.40
			3	1	128	824.2	24.00	19.74
					190	836.6	24.08	19.82
					251	848.8	24.15	19.89
4			1	128	824.2	22.65	19.64	
				190	836.6	22.73	19.72	
				251	848.8	22.79	19.78	

GSM1900 Measured Results

Band	Mode	Coding Scheme	Time Slots	Ch No.	Freq. [MHz]	Max. Power	
						Burst Pwr [dBm]	Frame Pwr [dBm]
1900	GSM (Voice)	CS1	1	512	1850.2	28.55	19.52
				661	1880.0	28.30	19.27
				810	1909.8	28.39	19.36
	GPRS (GMSK)	CS1	1	512	1850.2	28.61	19.58
				661	1880.0	28.27	19.24
				810	1909.8	28.44	19.40
			2	512	1850.2	26.70	20.68
				661	1880.0	26.71	20.69
				810	1909.8	27.17	21.14
			3	512	1850.2	25.20	20.94
				661	1880.0	25.10	20.84
				810	1909.8	25.50	21.24
			4	512	1850.2	23.82	20.81
				661	1880.0	23.80	20.79
				810	1909.8	24.20	21.19
	EGPRS (8PSK)	MCS5	1	512	1850.2	24.56	15.52
				661	1880.0	24.61	15.57
				810	1909.8	25.00	15.97
			2	512	1850.2	22.63	16.61
				661	1880.0	22.70	16.68
				810	1909.8	23.20	17.18
			3	512	1850.2	21.47	17.21
				661	1880.0	21.53	17.27
				810	1909.8	22.26	18.00
4			512	1850.2	20.17	17.16	
			661	1880.0	20.20	17.19	
			810	1909.8	21.00	17.99	

8.2. UMTS REL 99

Release 99 Setup Procedures used to establish the test signals

The following tests were completed according to the test requirements outlined in section 5.2 of the 3GPP TS34.121-1 specification. The DUT supports power Class 3, which has a nominal maximum output power of 24 dBm (+1.7/-3.7).

Mode	Subtest	Rel99
WCDMA General Settings	Loopback Mode	Test Mode 2
	Rel99 RMC	12.2kbps RMC
	Power Control Algorithm	Algorithm2
	β_c/β_d	8/15

HSDPA Setup Procedures used to establish the test signals

The following 4 Sub-tests were completed according to Release 5 procedures in section 5.2 of 3GPP TS34.121. A summary of these settings are illustrated below:

	Mode	HSDPA	HSDPA	HSDPA	HSDPA
	Subtest	1	2	3	4
W-CDMA General Settings	Loopback Mode	Test Mode 1			
	Rel99 RMC	12.2kbps RMC			
	HSDPA FRC	H-Set 1			
	Power Control Algorithm	Algorithm 2			
	β_c	2/15	11/15	15/15	15/15
	β_d	15/15	15/15	8/15	4/15
	Bd (SF)	64			
	β_c/β_d	2/15	11/15	15/8	15/4
	β_{hs}	4/15	24/15	30/15	30/15
MPR (dB)	0	0	0.5	0.5	
HSDPA Specific Settings	D_{ACK}	8			
	D_{NAK}	8			
	DCQI	8			
	Ack-Nack repetition factor	3			
	CQI Feedback (Table 5.2B.4)	4ms			
	CQI Repetition Factor (Table 5.2B.4)	2			
	$A_{hs}=\beta_{hs}/\beta_c$	30/15			

HSPA (HSDPA & HSUPA) Setup Procedures used to establish the test signals

The following 5 Sub-tests were completed according to Release 6 procedures in section 5.2 of 3GPP TS34.121. A summary of these settings are illustrated below:

	Mode	HSPA				
	Subtest	1	2	3	4	5
WCDMA General Settings	Loopback Mode	Test Mode 1				
	Rel99 RMC	12.2 kbps RMC				
	HSDPA FRC	H-Set 1				
	HSUPA Test	HSPA				
	Power Control Algorithm	Algorithm 2				Algorithm 1
	β_c	11/15	6/15	15/15	2/15	15/15
	β_d	15/15	15/15	9/15	15/15	0
	β_{ec}	209/225	12/15	30/15	2/15	5/15
	β_c/β_d	11/15	6/15	15/9	2/15	15/1
	β_{hs}	22/15	12/15	30/15	4/15	5/15
	β_{ed}	1309/225	94/75	47/15	56/75	47/15
	CM (dB)	1	3	2	3	1
MPR (dB)	0	2	1	2	0	
HSDPA Specific Settings	DACK	8				0
	DNAK	8				0
	DCQI	8				0
	Ack-Nack repetition factor	3				
	CQI Feedback (Table 5.2B.4)	4ms				
	CQI Repetition Factor (Table 5.2B.4)	2				
	$A_{hs} = \beta_{hs}/\beta_c$	30/15				
HSUPA Specific Settings	E-DPDCCH	6	8	8	5	7
	DHARQ	0	0	0	0	0
	AG Index	20	12	15	17	21
	ETFCI (from 34.121 Table C.11.1.3)	75	67	92	71	81
	Associated Max UL Data Rate kbps	242.1	174.9	482.8	205.8	308.9
	Reference E-TFCIs	5	5	2	5	1
	Reference E-TFCI	11	11	11	11	67
	Reference E-TFCI PO	4	4	4	4	18
	Reference E-TFCI	67	67	92	67	67
	Reference E-TFCI PO	18	18	18	18	18
	Reference E-TFCI	71	71	71	71	71
	Reference E-TFCI PO	23	23	23	23	23
	Reference E-TFCI	75	75	75	75	75
	Reference E-TFCI PO	26	26	26	26	26
	Reference E-TFCI	81	81	81	81	81
Reference E-TFCI PO	27	27	27	27	27	
Maximum Channelisation Codes	2xSF2				SF4	

DC-HSDPA Setup Procedures used to establish the test signals

The following tests were completed according to procedures in section 7.3.13 of 3GPP TS34.108 v9.5.0. A summary of these settings are illustrated below:

Downlink Physical Channels are set as per 3GPP TS34.121-1 v9.0.0 E.5.0

Table E.5.0: Levels for HSDPA connection setup

Parameter During Connection setup	Unit	Value
P-CPICH_Ec/Ior	dB	-10
P-CCPCH and SCH_Ec/Ior	dB	-12
PICH_Ec/Ior	dB	-15
HS-PDSCH	dB	off
HS-SCCH_1	dB	off
DPCH_Ec/Ior	dB	-5
OCNS_Ec/Ior	dB	-3.1

Call is set up as per 3GPP TS34.108 v9.5.0 sub clause 7.3.13

The configurations of the fixed reference channels for HSDPA RF tests are described in 3GPP TS 34.121, annex C for FDD and 3GPP TS 34.122.

Table C.8.1.12: Fixed Reference Channel H-Set 12

Parameter	Unit	Value
Nominal Avg. Inf. Bit Rate	kbps	60
Inter-TTI Distance	TTI's	1
Number of HARQ Processes	Processes	6
Information Bit Payload (N_{INF})	Bits	120
Number Code Blocks	Blocks	1
Binary Channel Bits Per TTI	Bits	960
Total Available SML's in UE	SML's	19200
Number of SML's per HARQ Proc.	SML's	3200
Coding Rate		0.15
Number of Physical Channel Codes	Codes	1
Modulation		QPSK
Note 1: The RMC is intended to be used for DC-HSDPA mode and both cells shall transmit with identical parameters as listed in the table.		
Note 2: Maximum number of transmission is limited to 1, i.e., retransmission is not allowed. The redundancy and constellation version 0 shall be used.		

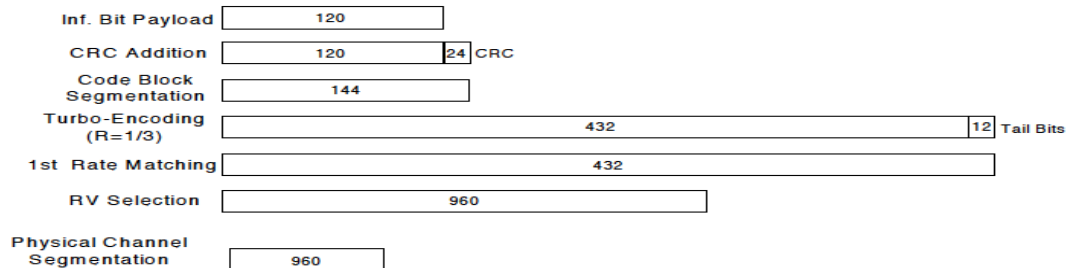

Figure C.8.19: Coding rate for Fixed reference Channel H-Set 12 (QPSK)

The following 4 Sub-tests for HSDPA were completed according to Release 8 procedures in section 5.2 of 3GPP TS34.121. A summary of subtest settings are illustrated below:

Mode	HSDPA	HSDPA	HSDPA	HSDPA
Subtest	1	2	3	4
WCDMA General Settings	Loopback Mode			
	Test Mode 1			
	Rel99 RMC			
	12.2kbps RMC			
	HSDPA FRC			
	H-Set 1			
	Power Control Algorithm			
	Algorithm2			
	β_c	2/15	11/15	15/15
β_d	15/15	15/15	8/15	4/15
β_d (SF)	64			
β_c/β_d	2/15	11/15	15/8	15/4
β_{hs}	4/15	24/15	30/15	30/15
MPR (dB)	0	0	0.5	0.5
HSDPA Specific Settings	DACK			
	8			
	DNAK			
	8			
	DCQI			
	8			
	Ack-Nack Repetition factor			
3				
CQI Feedback				
4ms				
CQI Repetition Factor				
2				
A _{hs} = β_{hs} / β_c				
30/15				

HSPA+

Since 16QAM is not used for uplink, the uplink Category and release is same as HSUPA, i.e., CAT 6 Rel 6. Therefore, the RF conducted power is not measured.

8.2.1. WCDMA OUTPUT POWER RESULT

WCDMA Band 5 Measured Results

Band	Mode		UL Ch No.	Freq. [MHz]	MPR [dB]	Avg Pwr [dBm]
W-CDMA Band V	Rel 99	RMC, 12.2 kbps	4132	826.4	0	23.15
			4183	836.6	0	23.22
			4233	846.6	0	23.14
	HSDPA	Subtest 1	4132	826.4	0	21.90
			4183	836.6	0	22.10
			4233	846.6	0	22.00
		Subtest 2	4132	826.4	0	21.30
			4183	836.6	0	21.50
			4233	846.6	0	21.40
		Subtest 3	4132	826.4	0.5	21.80
			4183	836.6	0.5	22.00
			4233	846.6	0.5	21.90
		Subtest 4	4132	826.4	0.5	20.10
			4183	836.6	0.5	20.30
			4233	846.6	0.5	20.20
	HSUPA	Subtest 1	4132	826.4	0	21.19
			4183	836.6	0	21.29
			4233	846.6	0	21.23
		Subtest 2	4132	826.4	2	19.13
			4183	836.6	2	19.20
			4233	846.6	2	19.14
		Subtest 3	4132	826.4	1	19.66
			4183	836.6	1	19.77
			4233	846.6	1	19.70
		Subtest 4	4132	826.4	2	19.10
			4183	836.6	2	19.21
			4233	846.6	2	19.13
		Subtest 5	4132	826.4	0	21.60
			4183	836.6	0	21.68
			4233	846.6	0	21.62

WCDMA Band 2 Measured Results

Band	Mode		UL Ch No.	Freq. [MHz]	MPR [dB]	Avg Pwr [dBm]
W-CDMA Band II	Rel 99	RMC, 12.2 kbps	9262	1852.4	0	21.85
			9400	1880.0	0	21.66
			9538	1907.6	0	22.04
	HSDPA	Subtest 1	9262	1852.4	0	21.79
			9400	1880.0	0	21.60
			9538	1907.6	0	21.98
		Subtest 2	9262	1852.4	0	21.54
			9400	1880.0	0	21.42
			9538	1907.6	0	21.74
		Subtest 3	9262	1852.4	0.5	21.50
			9400	1880.0	0.5	21.06
			9538	1907.6	0.5	21.44
		Subtest 4	9262	1852.4	0.5	20.11
			9400	1880.0	0.5	19.70
			9538	1907.6	0.5	20.06
	HSUPA	Subtest 1	9262	1852.4	0	20.99
			9400	1880.0	0	20.69
			9538	1907.6	0	21.18
		Subtest 2	9262	1852.4	2	18.91
			9400	1880.0	2	18.66
			9538	1907.6	2	18.96
		Subtest 3	9262	1852.4	1	20.98
			9400	1880.0	1	20.66
			9538	1907.6	1	21.00
		Subtest 4	9262	1852.4	2	18.91
			9400	1880.0	2	18.64
			9538	1907.6	2	19.00
		Subtest 5	9262	1852.4	0	21.84
			9400	1880.0	0	21.57
			9538	1907.6	0	22.00

8.3. LTE OUTPUT VERIFICATION

The following tests were conducted according to the test requirements outlined in section 6.2 of the 3GPP TS36.101 specification.

UE Power Class: 3 (23 +/- 2dBm). The allowed Maximum Power Reduction (MPR) for the maximum output power due to higher order modulation and transmit bandwidth configuration (resource blocks) is specified in Table 6.2.3-1 of the 3GPP TS36.101.

Table 6.2.3-1: Maximum Power Reduction (MPR) for Power Class 3

Modulation	Channel bandwidth / Transmission bandwidth (RB)						MPR (dB)
	1.4 MHz	3.0 MHz	5 MHz	10 MHz	15 MHz	20 MHz	
QPSK	> 5	> 4	> 8	> 12	> 16	> 18	≤ 1
16 QAM	≤ 5	≤ 4	≤ 8	≤ 12	≤ 16	≤ 18	≤ 1
16 QAM	> 5	> 4	> 8	> 12	> 16	> 18	≤ 2

The allowed A-MPR values specified below in Table 6.2.4.-1 of 3GPP TS36.101 are in addition to the allowed MPR requirements. All the measurements below were performed with A-MPR disabled, by using Network Signalling Value of "NS_01".

Table 6.2.4-1: Additional Maximum Power Reduction (A-MPR)

Network Signalling value	Requirements (sub-clause)	E-UTRA Band	Channel bandwidth (MHz)	Resources Blocks (N_{RB})	A-MPR (dB)
NS_01	6.6.2.1.1	Table 5.5-1	1.4, 3, 5, 10, 15, 20	Table 5.6-1	NA
NS_03	6.6.2.2.1	2, 4, 10, 23, 25, 35, 36	3	>5	≤ 1
			5	>6	≤ 1
			10	>6	≤ 1
			15	>8	≤ 1
			20	>10	≤ 1
NS_04	6.6.2.2.2	41	5	>6	≤ 1
			10, 15, 20	See Table 6.2.4-4	
NS_05	6.6.3.3.1	1	10, 15, 20	≥ 50	≤ 1
NS_06	6.6.2.2.3	12, 13, 14, 17	1.4, 3, 5, 10	Table 5.6-1	n/a
NS_07	6.6.2.2.3	13	10	Table 6.2.4-2	Table 6.2.4-2
	6.6.3.3.2				
NS_08	6.6.3.3.3	19	10, 15	> 44	≤ 3
NS_09	6.6.3.3.4	21	10, 15	> 40	≤ 1
				> 55	≤ 2
NS_10		20	15, 20	Table 6.2.4-3	Table 6.2.4-3
NS_11	6.6.2.2.1	23 ¹	1.4, 3, 5, 10	Table 6.2.4-5	Table 6.2.4-5
..					
NS_32	-	-	-	-	-

Note 1: Applies to the lower block of Band 23, i.e. a carrier placed in the 2000-2010 MHz region.

8.3.1. LTE OUTPUT POWER RESULT

LTE Band 5 Measured Results

Band	BW (MHz)	Mode	RB Allocation	RB offset	Target MPR	Avg Pwr [dBm]		
						Max. Power		
						829 MHz	836.5 MHz	844 MHz
LTE Band 5	10	QPSK	1	0	0	23.01	23.00	23.08
			1	25	0	22.97	22.91	22.99
			1	49	0	22.98	22.92	22.99
			25	0	1	21.11	21.07	21.08
			25	12	1	21.05	21.00	21.01
			25	25	1	21.04	21.03	21.02
		16QAM	50	0	1	21.09	21.05	21.07
			1	0	1	21.21	21.68	21.50
			1	25	1	21.10	21.58	21.43
			1	49	1	21.13	21.61	21.42
			25	0	2	20.05	20.12	20.10
			25	12	2	20.00	20.07	20.07
			25	25	2	19.99	20.07	20.03
			50	0	2	20.02	20.03	20.04
Band	BW (MHz)	Mode	RB Allocation	RB offset	Target MPR	Avg Pwr [dBm]		
						Max. Power		
						826.5 MHz	836.5 MHz	846.5 MHz
LTE Band 5	5	QPSK	1	0	0	22.91	23.13	22.89
			1	12	0	22.87	23.04	22.80
			1	24	0	22.92	23.05	22.83
			12	0	1	22.11	22.09	22.05
			12	7	1	22.10	22.08	22.03
			12	13	1	22.11	22.05	22.03
		16QAM	25	0	1	22.10	22.06	22.03
			1	0	1	21.19	21.25	21.39
			1	12	1	21.11	21.18	21.31
			1	24	1	21.13	21.23	21.36
			12	0	2	20.96	21.05	20.90
			12	7	2	20.96	21.01	20.90
			12	13	2	20.94	21.01	20.89
			25	0	2	21.11	20.98	20.99
Band	BW (MHz)	Mode	RB Allocation	RB offset	Target MPR	Avg Pwr [dBm]		
						Max. Power		
						825.5 MHz	836.5 MHz	847.5 MHz
LTE Band 5	3	QPSK	1	0	0	23.06	23.00	23.09
			1	8	0	23.04	22.91	23.03
			1	14	0	23.10	22.98	23.08
			8	0	1	22.12	22.09	22.03
			8	4	1	22.14	22.09	22.05
			8	7	1	22.13	22.07	22.03
		16QAM	15	0	1	22.13	22.08	22.06
			1	0	1	21.16	21.57	21.28
			1	8	1	21.03	21.49	21.17
			1	14	1	21.10	21.52	21.22
			8	0	2	21.00	20.78	20.90
			8	4	2	21.01	20.78	20.91
			8	7	2	21.00	20.77	20.89
			15	0	2	20.99	21.01	20.89
Band	BW (MHz)	Mode	RB Allocation	RB offset	Target MPR	Avg Pwr [dBm]		
						Max. Power		
						824.7 MHz	836.5 MHz	848.3 MHz
LTE Band 5	1.4	QPSK	1	0	0	23.11	23.12	23.05
			1	3	0	23.10	23.10	23.02
			1	5	0	23.16	23.13	23.04
			3	0	1	23.04	22.97	22.96
			3	1	1	23.04	23.01	22.98
			3	3	1	23.05	22.96	22.97
		16QAM	6	0	1	22.07	22.05	22.02
			1	0	1	21.54	21.69	21.53
			1	3	1	21.52	21.66	21.49
			1	5	1	21.56	21.71	21.52
			3	0	2	21.41	21.46	21.56
			3	1	2	21.31	21.44	21.49
			3	3	2	21.30	21.44	21.49
			6	0	2	21.10	20.86	20.90

9. PEAK TO AVERAGE RATIO

Test Procedure

Per KDB 971168 D01 Power Meas License Digital Systems v02r02;

The transmitter output was connected to a CMW500 Test Set and configured to operate at maximum power. The PAR were measured on the Spectrum Analyzer.

Test Spec

In addition, when the transmitter power is measured in terms of average value, the peak-to-average ratio of the power shall not exceed 13 dB.

9.1. CONDUCTED PEAK TO AVERAGE RESULT

GSM

Band	Channel	f [MHz]	Mode	Ratio [dB]	Limit [dB]
GSM850	190	836.6	GPRS	0.22	13.00
			EGPRS	2.77	
GSM1900	661	1880.0	GPRS	0.19	
			EGPRS	3.67	

WCDMA

Band	Channel	f [MHz]	Mode	Ratio [dB]	Limit [dB]
Band 5	4183	836.6	REL99	2.95	13.00
			HSDPA	3.10	
Band 2	9400	1880.0	REL99	3.03	
			HSDPA	3.14	

LTE

Band	BW [MHz]	Channel	f [MHz]	Mode	Ratio [dB]	Limit [dB]
Band 5	10	20525	836.5	QPSK	4.92	13.00
				16QAM	6.51	
	5			QPSK	5.03	
				16QAM	6.54	
	3			QPSK	5.05	
				16QAM	6.74	
	1.4			QPSK	5.07	
				16QAM	6.64	

9.2. CONDUCTED PEAK TO AVERAGE PLOTS

GSM

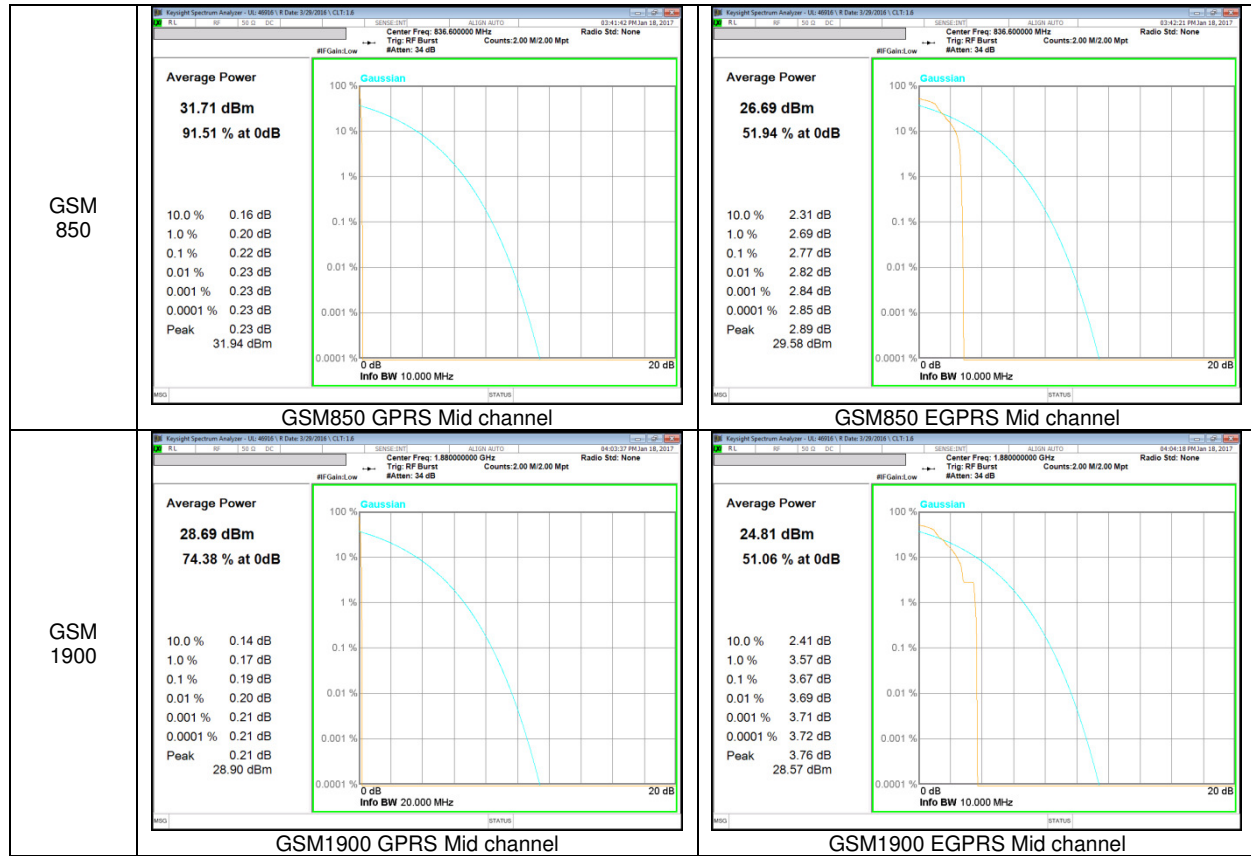

WCDMA

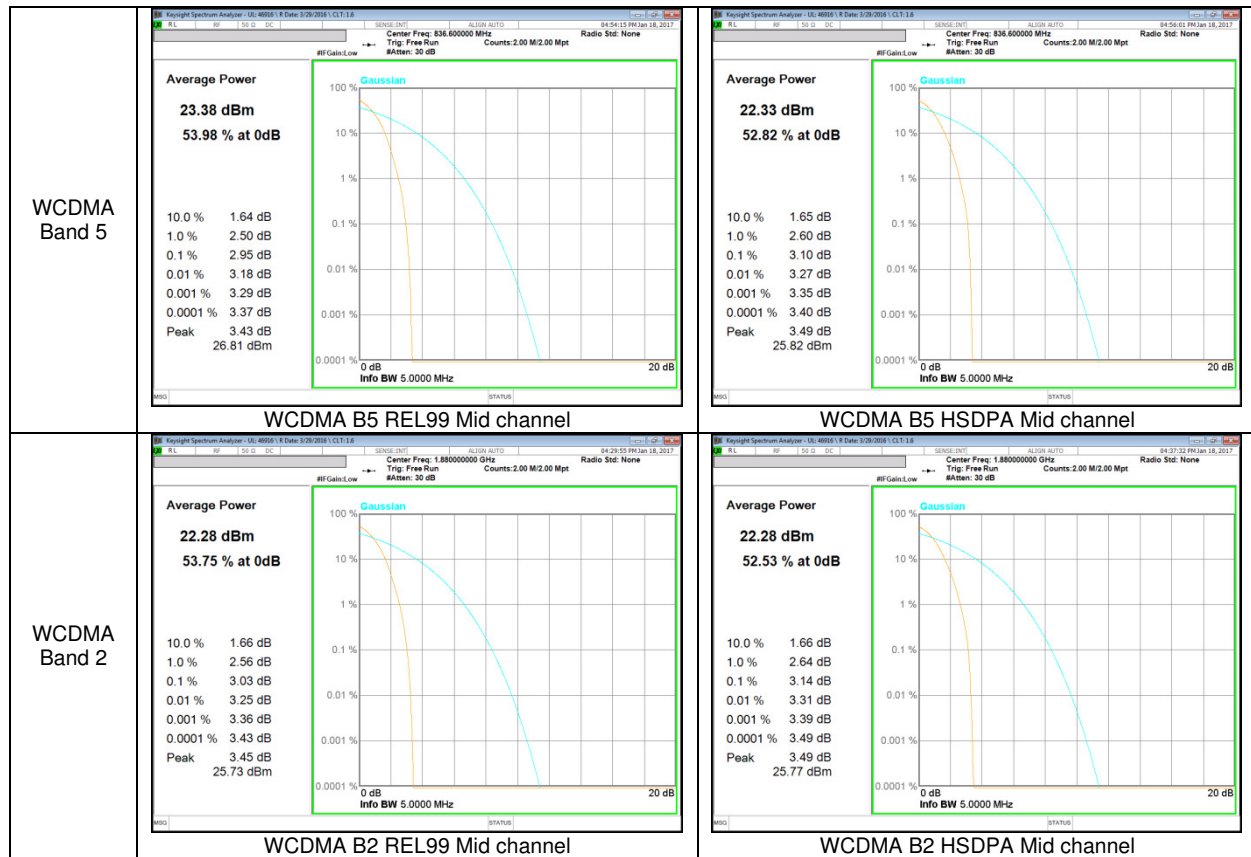

LTE Band 5

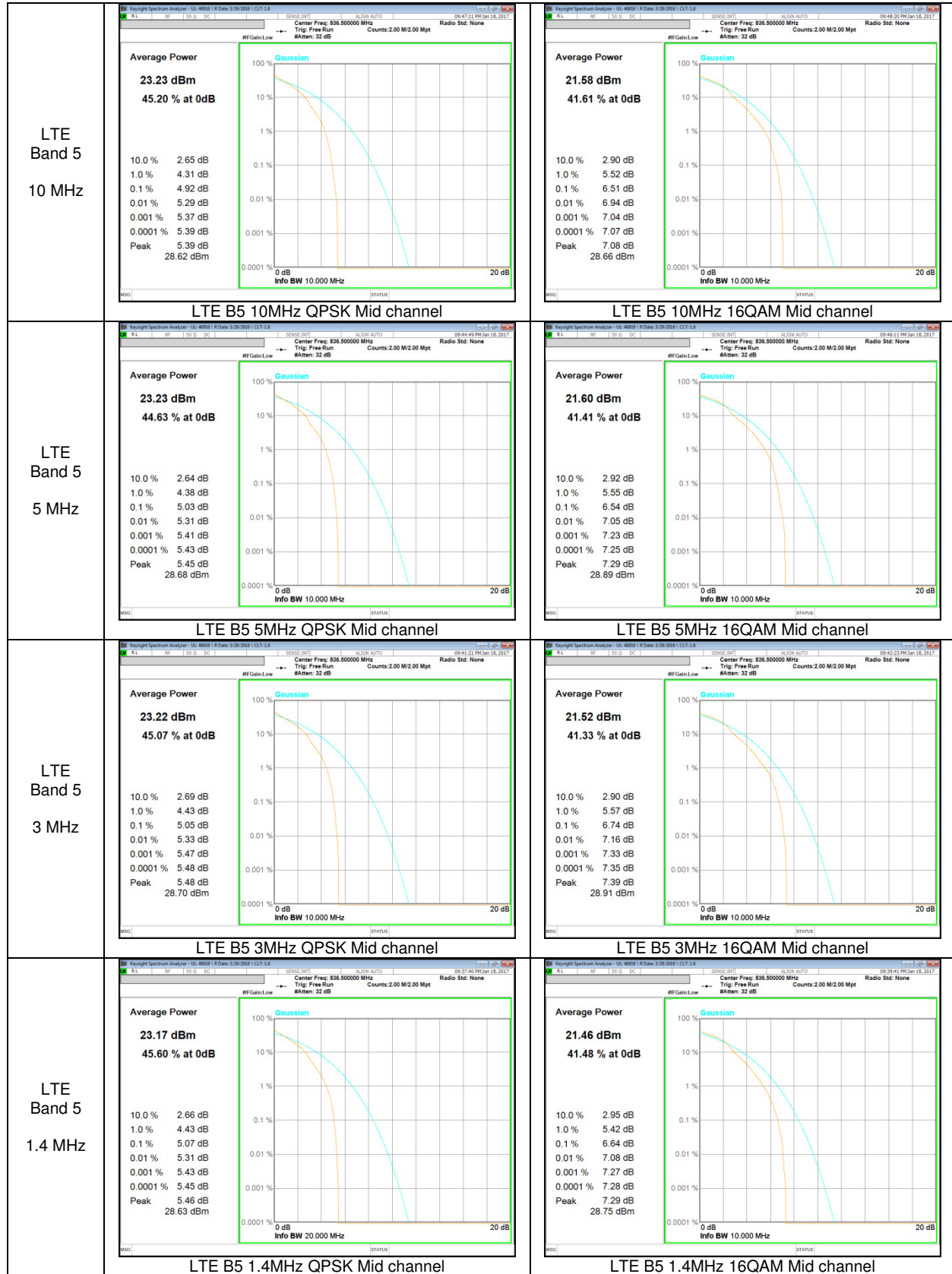

10. LIMITS AND CONDUCTED RESULTS

10.1. OCCUPIED BANDWIDTH

RULE PART(S)

FCC: §2.1049

LIMITS

For reporting purposes only

TEST PROCEDURE

The transmitter output was connected to a calibrated coaxial cable and coupler, the other end of which was connected to a spectrum analyzer. The occupied bandwidth was measured with the spectrum analyzer at the low, middle and high channel in each band. The -26dB bandwidth was also measured and recorded.

(KDB 971168 D01 Power Meas License Digital Systems v02r02)

10.1.1. OCCUPIED BANDWIDTH RESULTS

GSM

Band	Mode	Channel	f [MHz]	99% BW [KHz]	26dB BW [KHz]
GSM850	GPRS	128	824.2	240.80	317.0
		190	836.6	238.88	310.8
		251	848.8	242.75	310.7
	EGPRS	128	824.2	243.56	315.1
		190	836.6	247.52	311.1
		251	848.8	247.09	315.4
GSM1900	GPRS	512	1850.2	236.32	301.6
		661	1880.0	239.71	306.8
		810	1909.8	241.95	307.2
	EGPRS	512	1850.2	242.06	304.6
		661	1880.0	242.12	301.8
		810	1909.8	237.12	308.4

WCDMA

Band	Mode	Channel	f [MHz]	99% BW [MHz]	26dB BW [MHz]
Band 5	REL99	4132	826.4	4.1310	4.702
		4183	836.6	4.1397	4.706
		4233	846.6	4.1373	4.687
	HSDPA	4132	826.4	4.1413	4.703
		4183	836.6	4.1434	4.698
		4233	846.6	4.1429	4.684
Band 2	REL99	9262	1852.4	4.1290	4.675
		9400	1880.0	4.1449	4.695
		9538	1907.6	4.1325	4.698
	HSDPA	9262	1852.4	4.1319	4.685
		9400	1880.0	4.1415	4.678
		9538	1907.6	4.1307	4.678

LTE Band 5

Band	BW [MHz]	Channel	f [MHz]	Mode	99% BW [MHz]	26dB BW [MHz]
Band 5	10	20450	829.0	QPSK	8.9255	10.02
				16QAM	8.9276	10.22
		20524	836.5	QPSK	8.9615	10.25
				16QAM	8.9769	10.09
		20599	844.0	QPSK	8.9183	10.12
				16QAM	8.9448	10.20
	5	20425	826.5	QPSK	4.4969	5.208
				16QAM	4.4849	5.197
		20524	836.5	QPSK	4.4927	5.240
				16QAM	4.5005	5.176
		20624	846.5	QPSK	4.5036	5.251
				16QAM	4.4945	5.273
	3	20415	825.5	QPSK	2.6941	3.074
				16QAM	2.7000	3.101
		20524	836.5	QPSK	2.7013	3.085
				16QAM	2.6970	3.056
		20634	847.5	QPSK	2.6922	3.049
				16QAM	2.6975	3.079
	1.4	20407	824.7	QPSK	1.0881	1.341
				16QAM	1.0871	1.335
		20524	836.5	QPSK	1.0915	1.373
				16QAM	1.0931	1.384
		20624	848.3	QPSK	1.0916	1.351
				16QAM	1.0944	1.385

10.1.2. OCCUPIED BANDWIDTH PLOTS

GSM 850

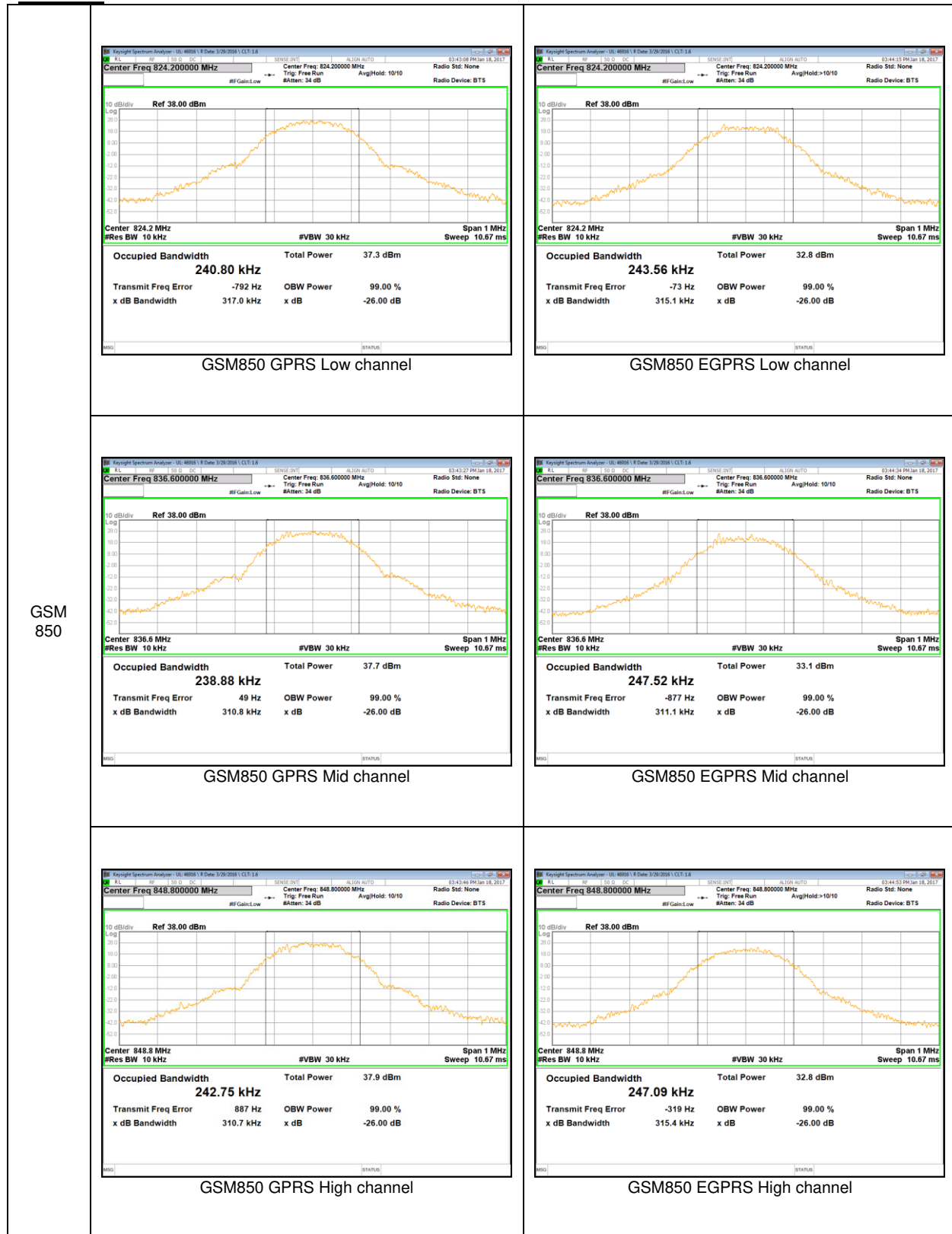

GSM 1900



WCDMA Band 5

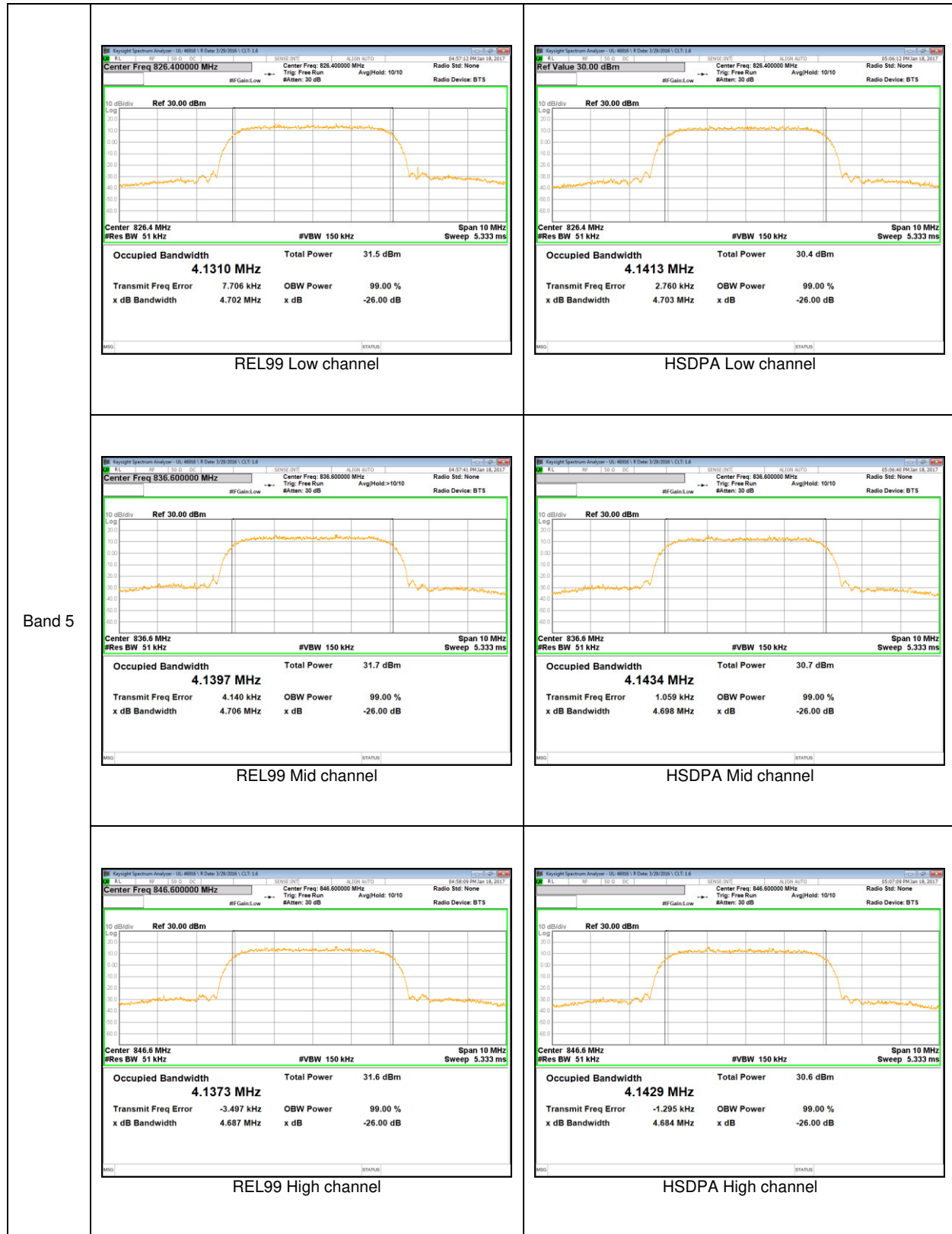

WCDMA Band 2

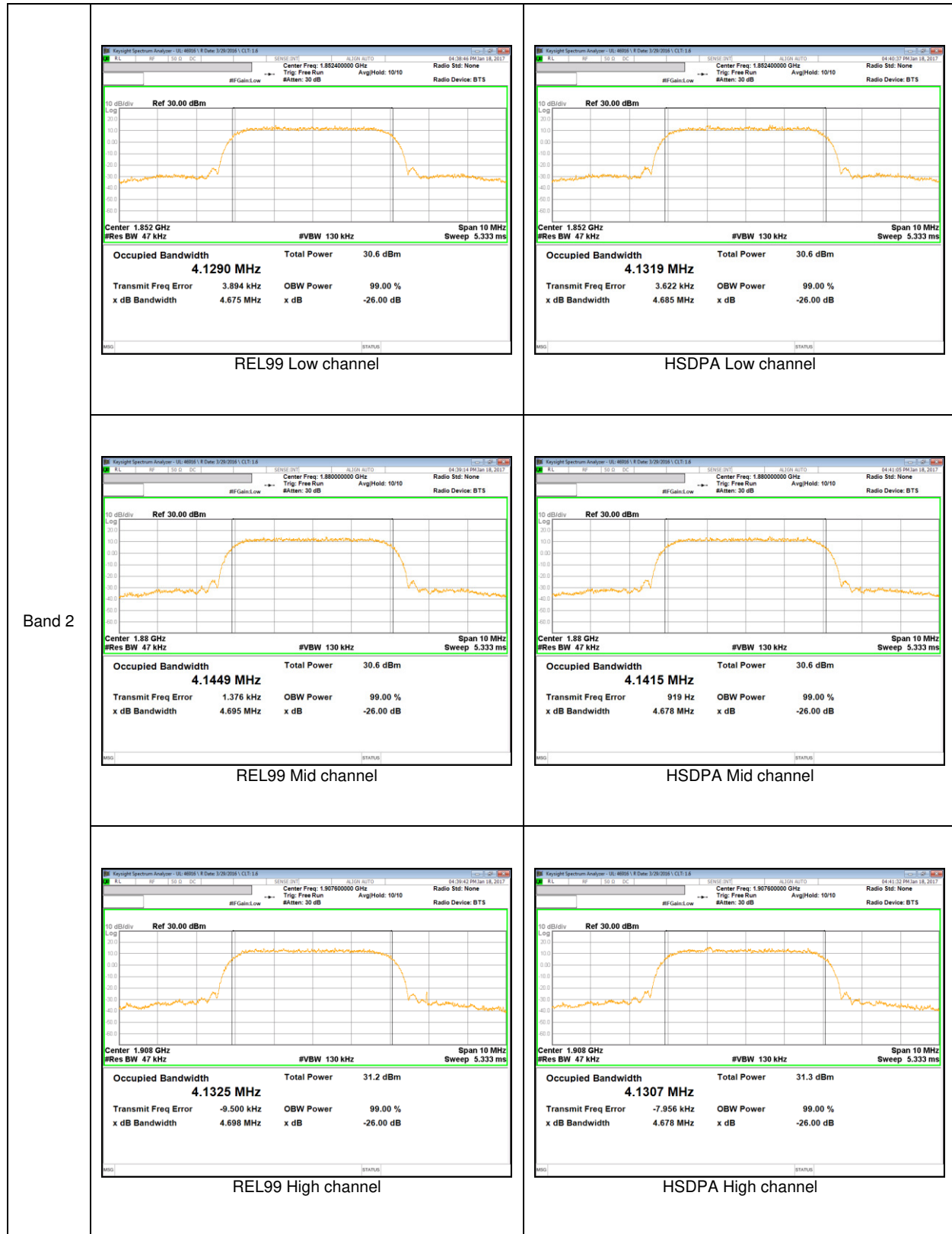

LTE Band 5

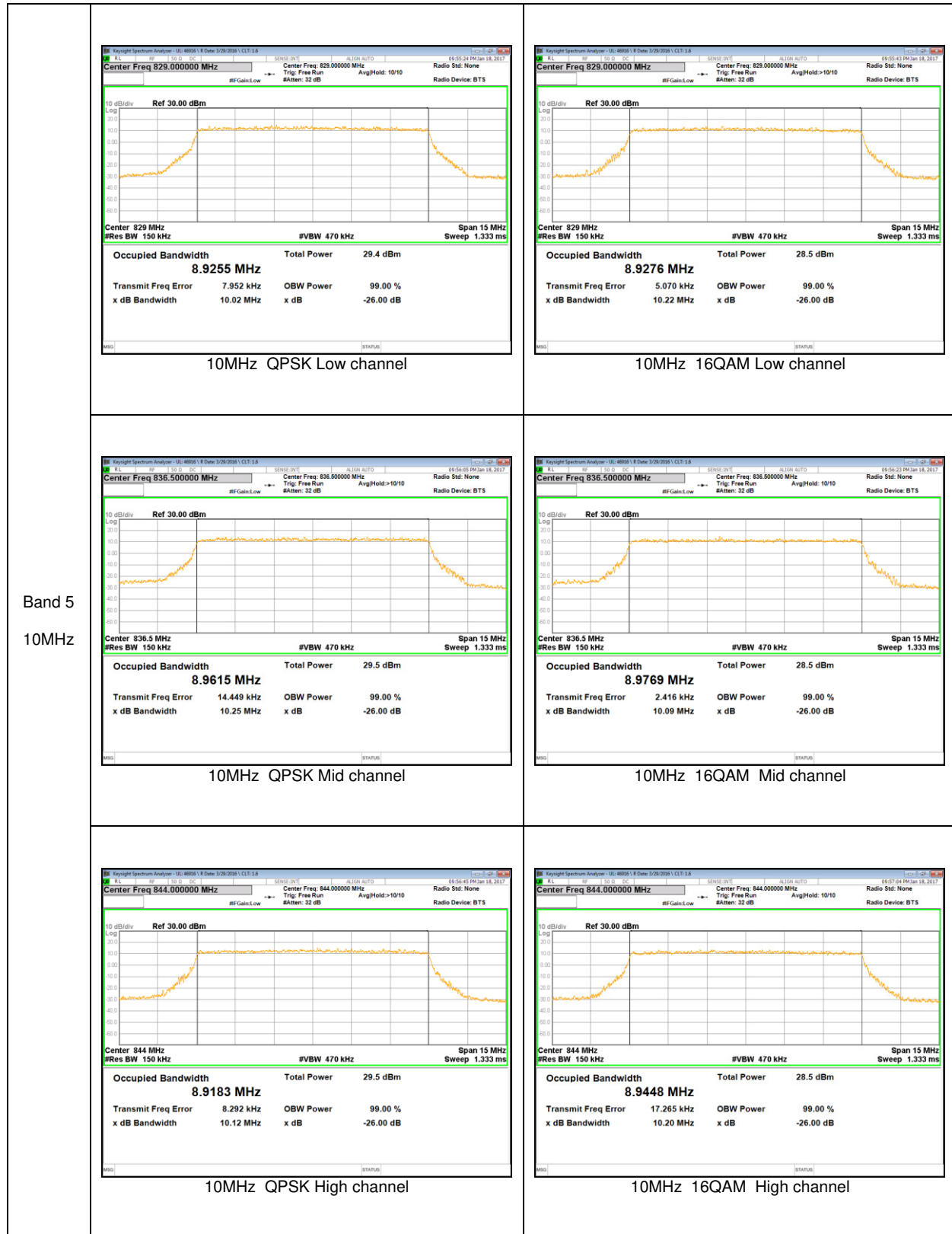

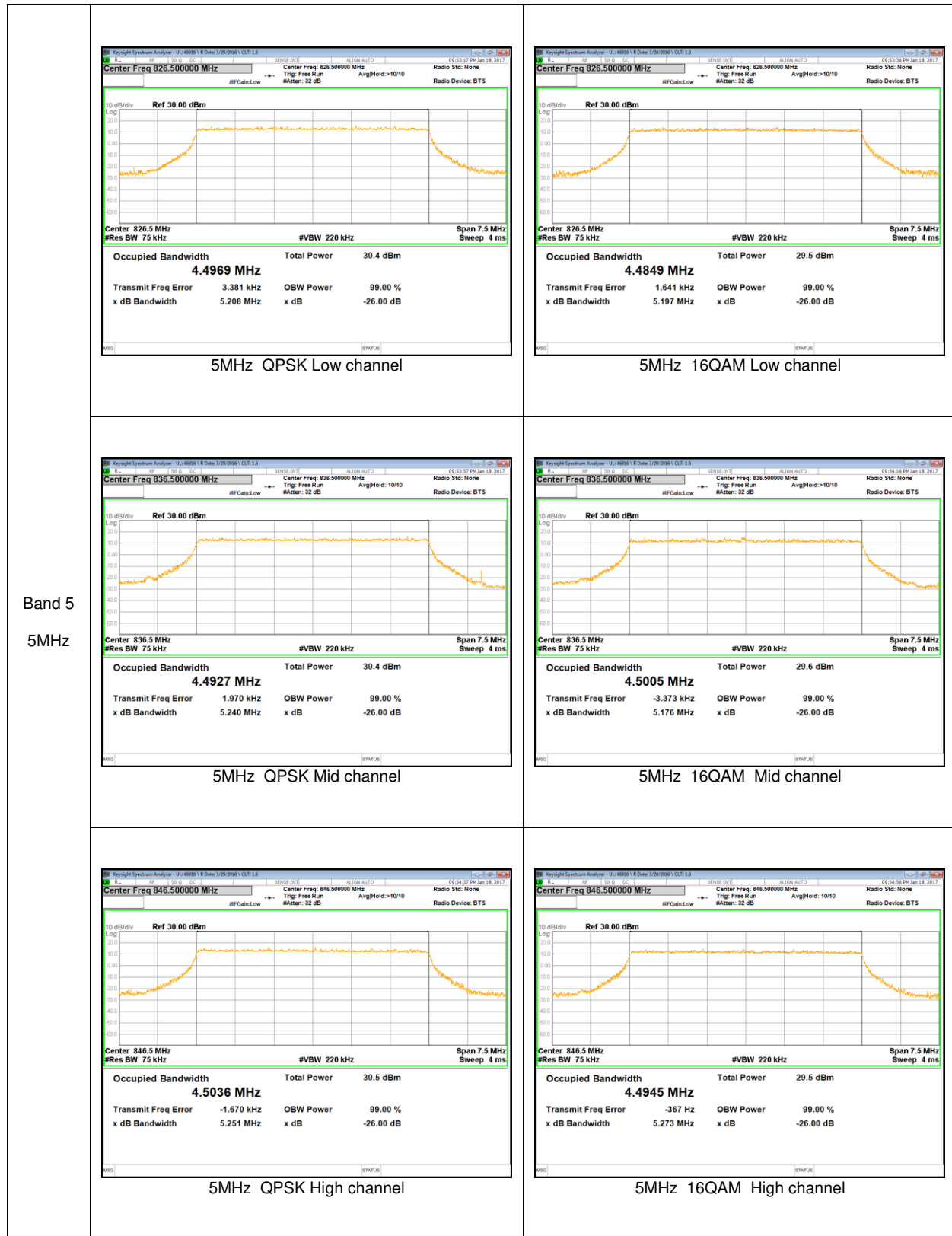

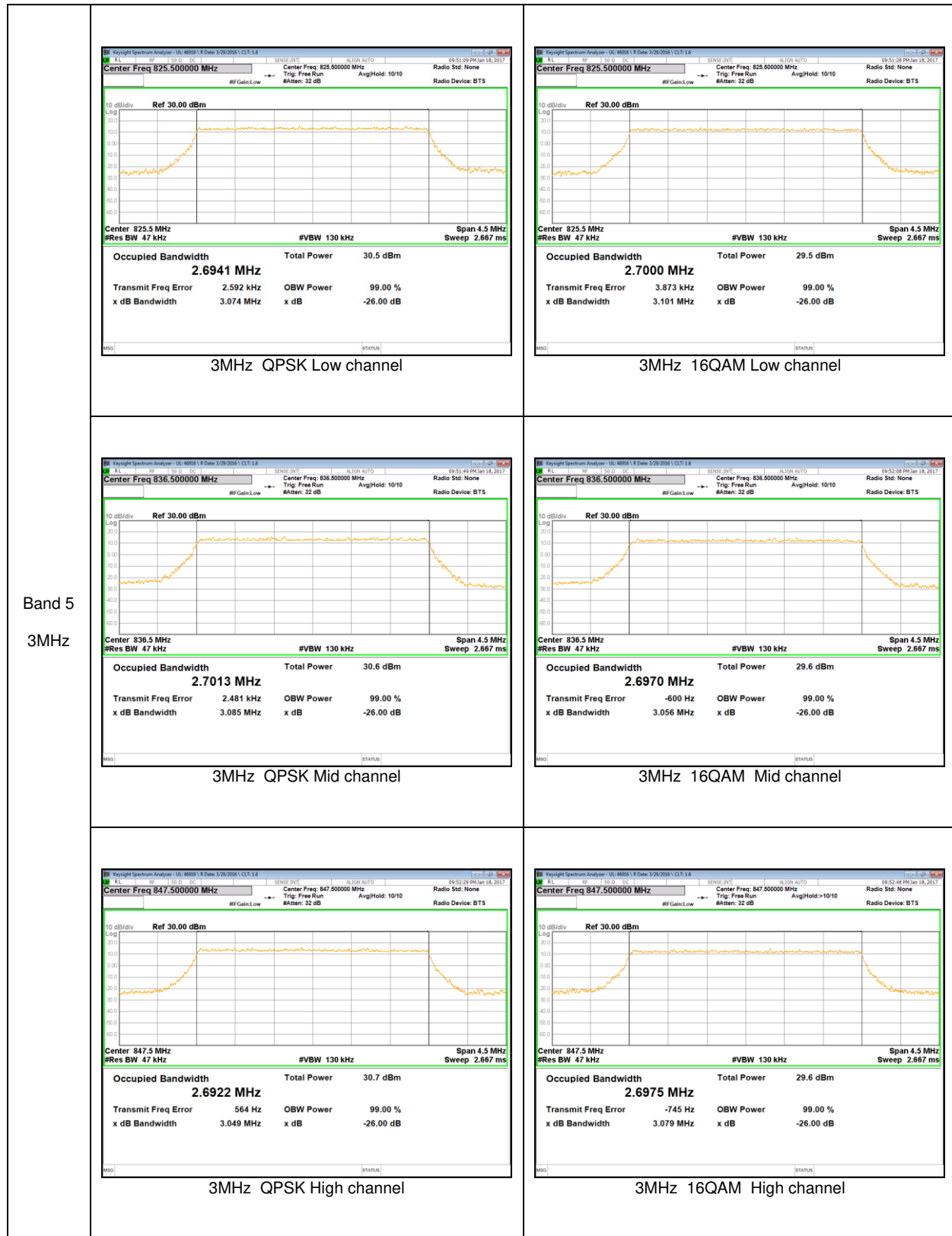

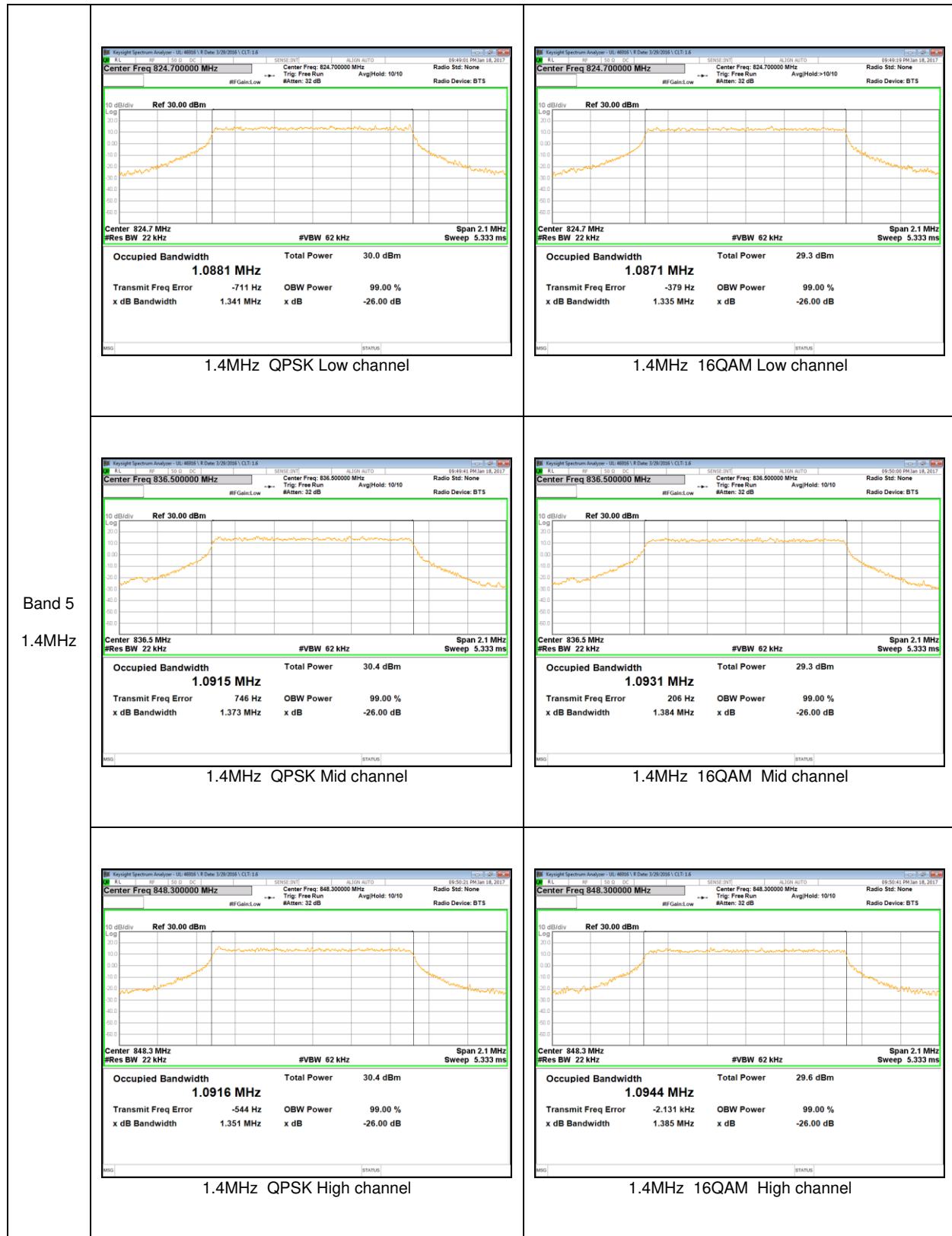

10.2. BAND EDGE EMISSIONS

RULE PART(S)

FCC: §22.359 and §24.238

LIMITS

The power of any emission outside of the authorized operating frequency ranges must be attenuated below the transmitting power (P) by a factor of at least $43 + 10 \log (P)$ dB.

TEST PROCEDURE

Per KDB 971168 D01 Power Meas License Digital Systems v02r02

The transmitter output was connected to a CMW500 Test Set and configured to operate at maximum power. The band edge emissions were measured at the required operating frequencies in each band on the Spectrum Analyzer.

GSM

- a) Set the RBW = 1 ~ 5% of OBW(GSM850 – 8.2KHz, GSM1900 – 9.1KHz)
- b) Set VBW $\geq 3 \times$ RBW;
- c) Set span ≥ 1.5 times the OBW;
- d) Sweep time = 1S ;
- e) Detector = RMS;
- f) Ensure that the number of measurement points $\geq 2 \times$ Span/RBW;
- g) Trace mode = Average(100);
- h) Add duty cycle correction factor (9dB)

WCDMA/LTE

- b) Set the RBW = 1 ~ 1.5 % of OBW(Typically limited to a minimum RBW of 1% of the OBW)
- b) Set VBW $\geq 3 \times$ RBW;
- c) Set span ≥ 1.5 times the OBW;
- d) Sweep time = Auto;
- e) Detector = RMS;
- f) Ensure that the number of measurement points $\geq 2 \times$ Span/RBW;
- g) Trace mode = Average (100);

RESULTS

GSM

Band	Mode	Side	f [MHz]	Level [dBm]	Limit [dBm]
GSM850	GPRS	Lower	823.997	-17.717	-13.00
		Upper	849.018	-17.066	
	EGPRS	Lower	824.000	-24.197	
		Upper	849.000	-25.507	
GSM1900	GPRS	Lower	1849.982	-20.242	
		Upper	1910.018	-19.560	
	EGPRS	Lower	1849.967	-28.268	
		Upper	1910.008	-27.432	

WCDMA

Band	Mode	Side	f [MHz]	Level [dBm]	Limit [dBm]
Band 5	REL99	Lower	824	-25.586	-13.00
		Upper	849	-24.761	
	HSDPA	Lower	824	-26.997	
		Upper	849	-27.049	
Band 2	REL99	Lower	1850	-27.337	
		Upper	1910	-28.182	
	HSDPA	Lower	1850	-29.070	
		Upper	1910	-27.639	

LTE 5

Bandwidth	Mode	Side	RB Status	f [MHz]	Level [dBm]	Limit [dBm]
10 MHz	QPSK	Lower	1RB	824.000	-32.354	-13.00
			FRB	824.000	-31.806	
		Upper	1RB	849.000	-26.250	
			FRB	849.000	-29.880	
	16QAM	Lower	1RB	824.000	-33.871	
			FRB	824.000	-33.242	
		Upper	1RB	849.000	-28.385	
			FRB	849.000	-27.685	
5 MHz	QPSK	Lower	1RB	824.000	-17.843	
			FRB	824.000	-22.250	
		Upper	1RB	849.000	-18.922	
			FRB	849.000	-21.080	
	16QAM	Lower	1RB	824.000	-19.045	
			FRB	824.000	-24.593	
		Upper	1RB	849.000	-19.910	
			FRB	849.000	-25.517	
3 MHz	QPSK	Lower	1RB	824.000	-15.789	
			FRB	824.000	-23.294	
		Upper	1RB	849.000	-16.201	
			FRB	849.000	-23.058	
	16QAM	Lower	1RB	824.000	-19.020	
			FRB	824.000	-25.294	
		Upper	1RB	849.000	-16.807	
			FRB	849.000	-23.242	
1.4 MHz	QPSK	Lower	1RB	824.000	-21.841	
			FRB	824.000	-21.347	
		Upper	1RB	849.000	-20.461	
			FRB	849.000	-23.140	
	16QAM	Lower	1RB	824.000	-25.443	
			FRB	824.000	-25.948	
		Upper	1RB	849.000	-22.804	
			FRB	849.000	-23.584	

10.2.1. BAND EDGE PLOTS

GSM

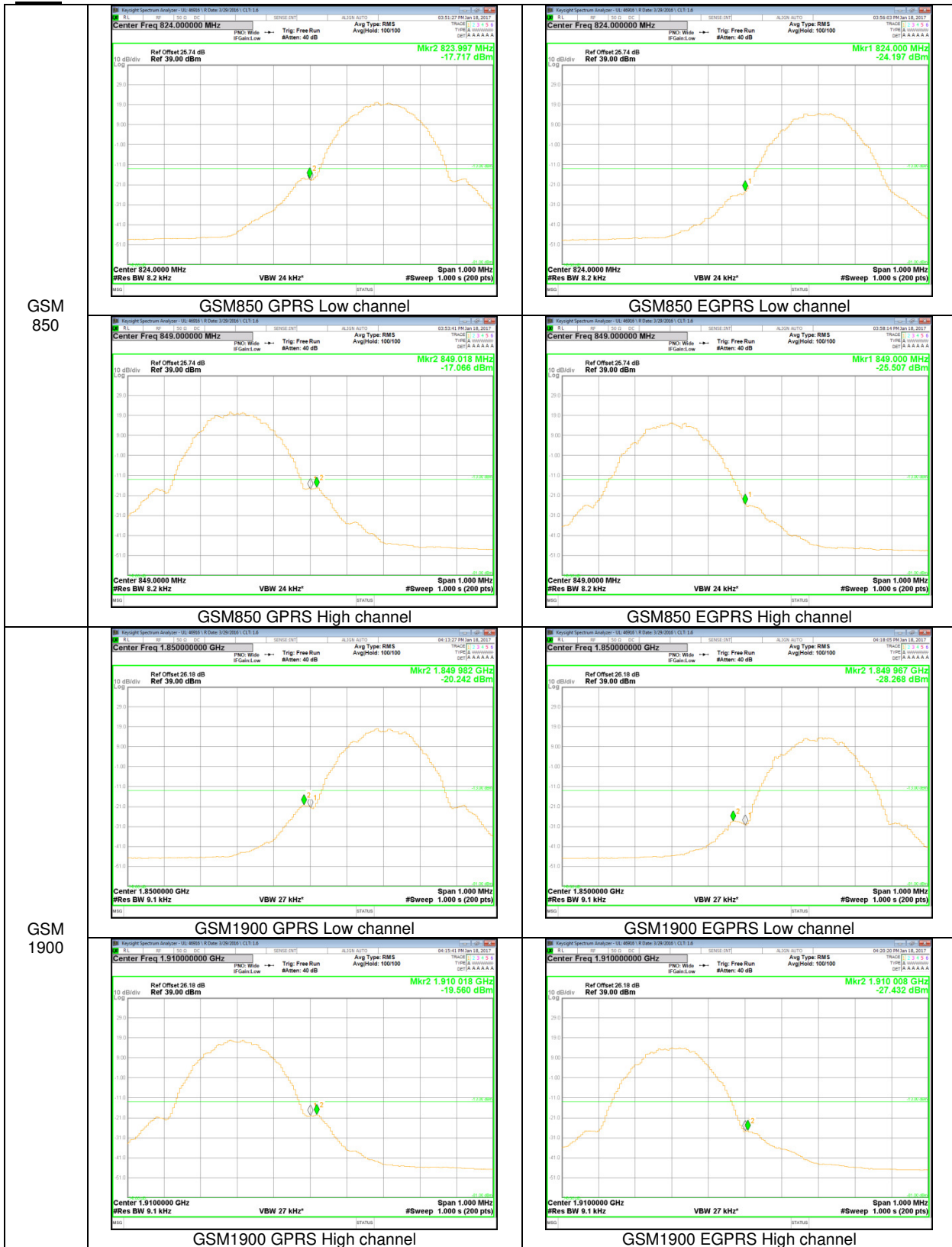

GSM
850

GSM
1900

WCDMA

Band 5

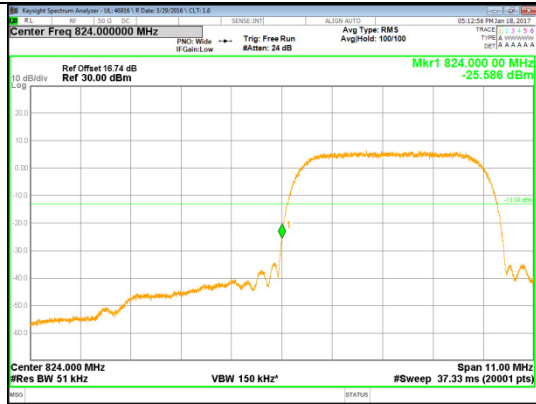

REL99 Low channel

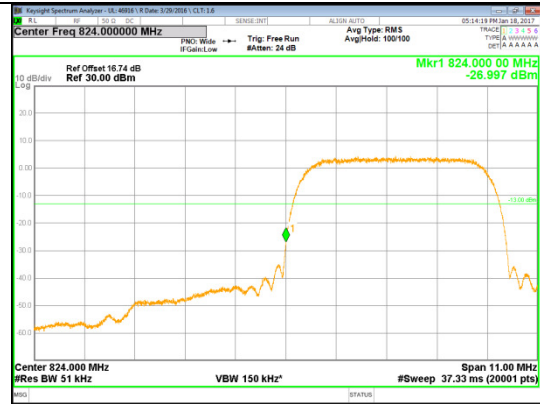

HSDPA Low channel

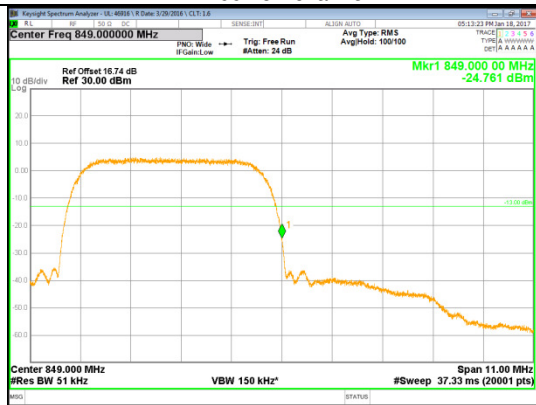

REL99 High channel

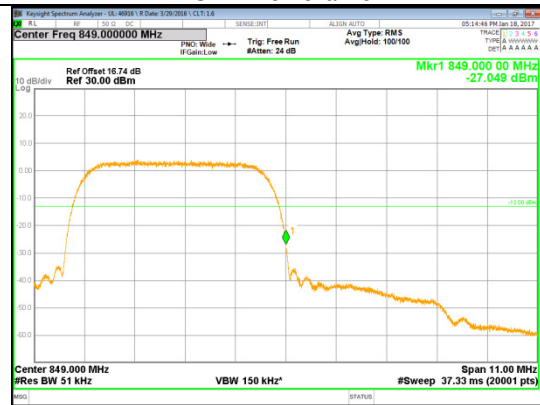

HSDPA High channel

Band 2

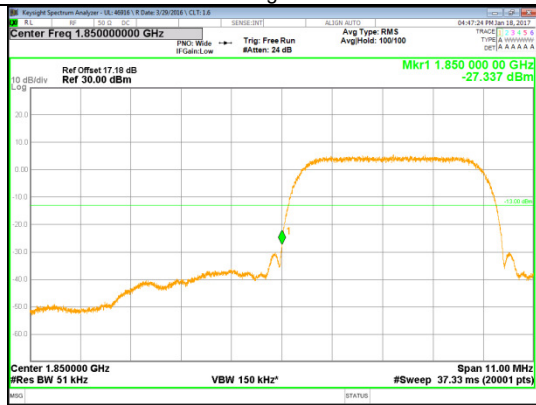

REL99 Low channel

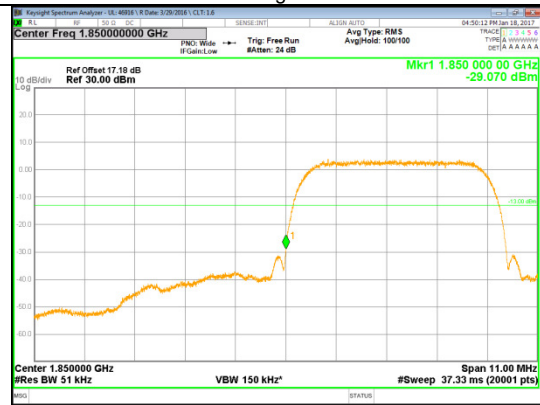

HSDPA Low channel

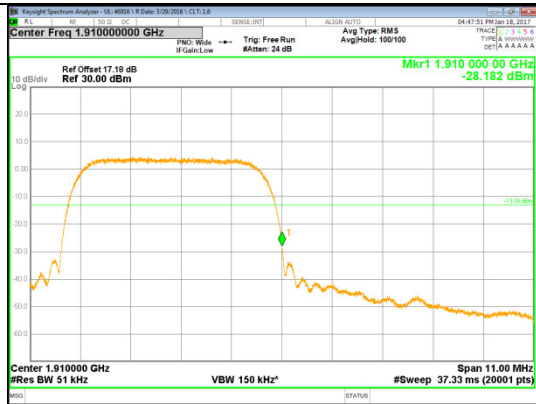

REL99 High channel

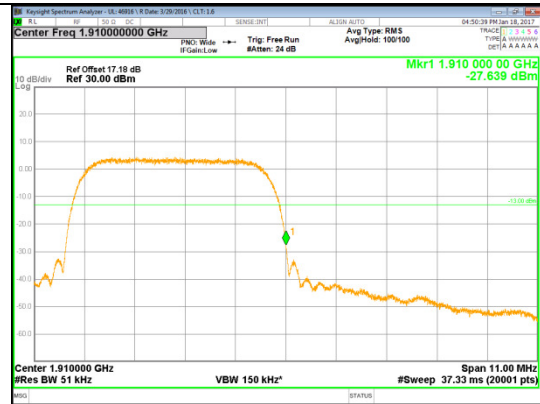

HSDPA High channel

LTE Band 5

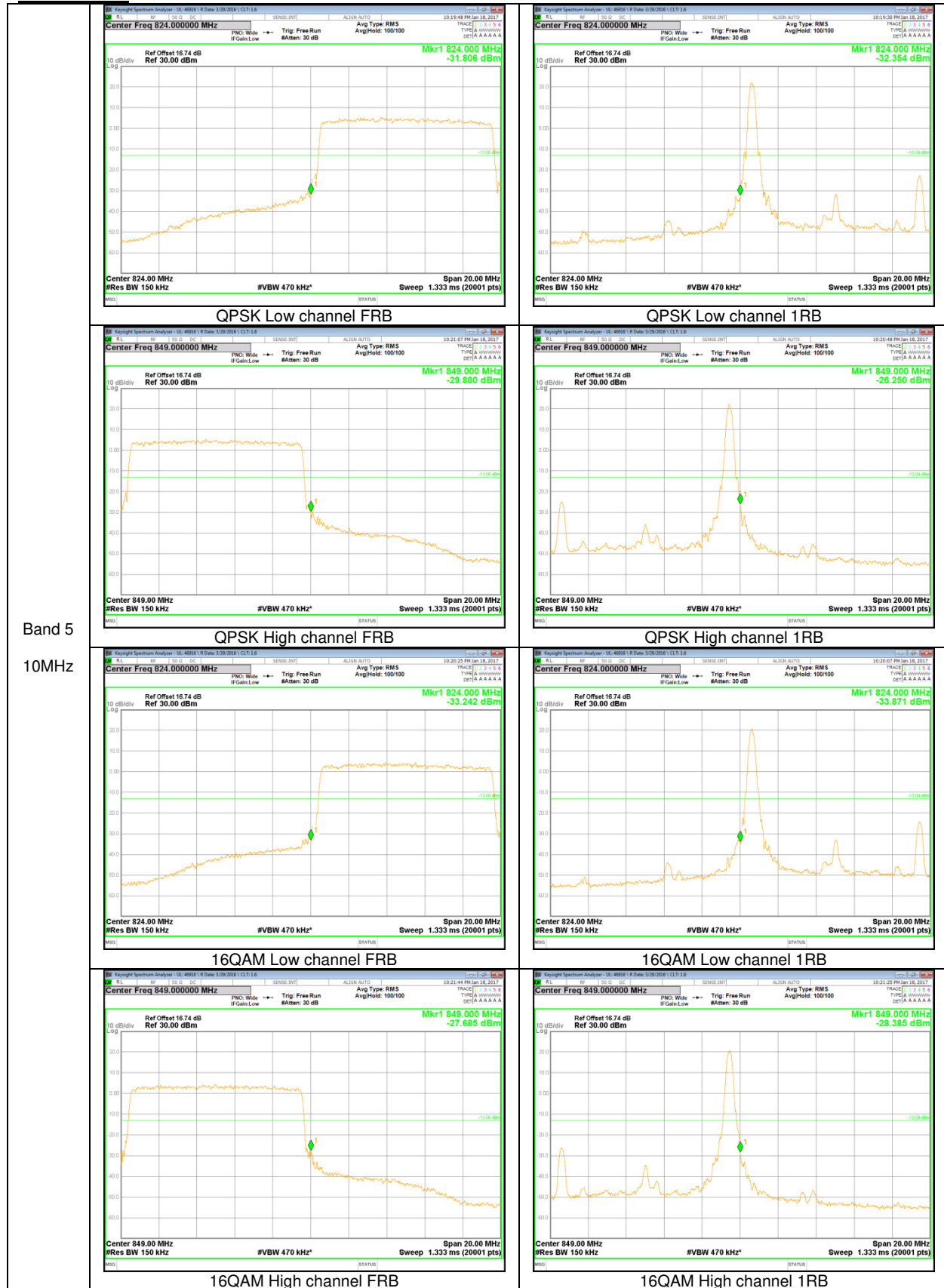

Band 5
 10MHz