

UNII 5.8 GHz IEEE 802.11n HT20 mode

11n HT20 Mode Low Channel

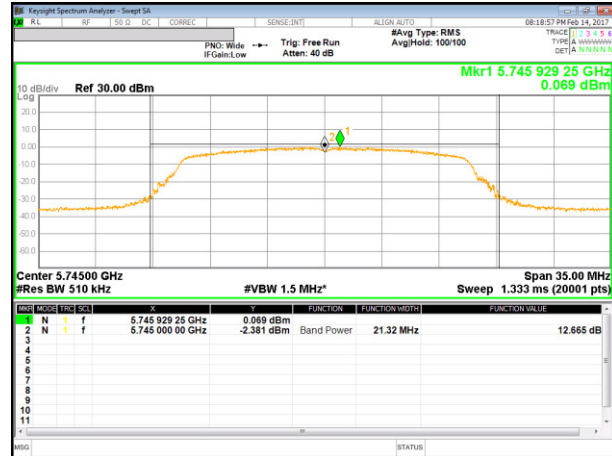

11n HT20 Mode Middle Channel

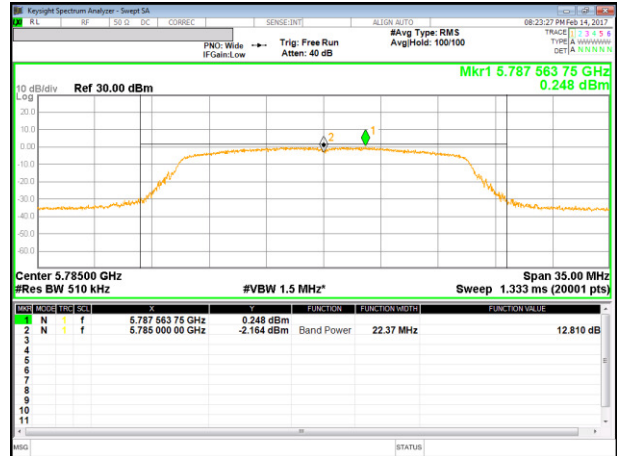

11n HT20 Mode High Channel

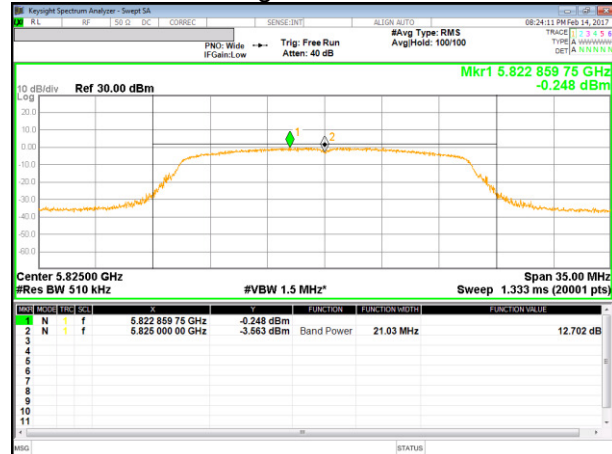

UNII 5.8 GHz IEEE 802.11n HT40 mode

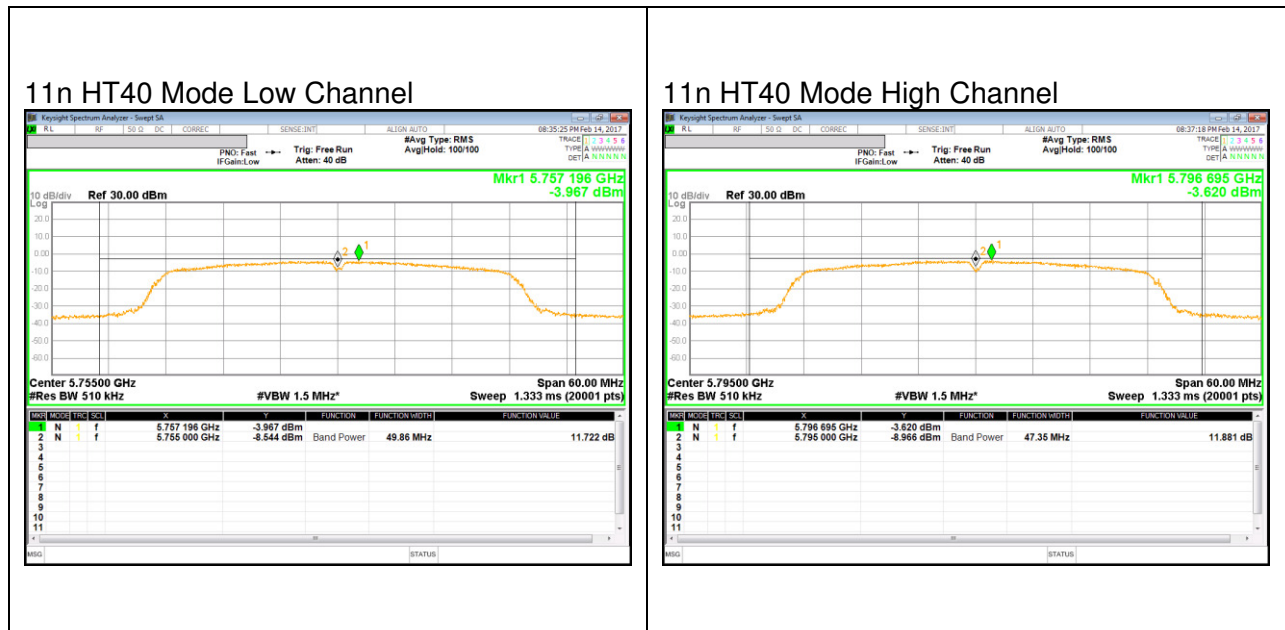

10. TRANSMITTER ABOVE 1 GHz

LIMITS

FCC §15.205 and §15.209

Limits for radiated disturbance of an intentional radiator		
Frequency range (MHz)	Limits (µV/m)	Measurement Distance (m)
0.009 – 0.490	2400 / F (kHz)	300
0.490 – 1.705	24000 / F (kHz)	30
1.705 – 30.0	30	30
30 – 88	100**	3
88 - 216	150**	3
216 – 960	200**	3
Above 960	500	3

** Except as provided in paragraph (g), fundamental emissions from intentional radiators operating under this section shall not be located in the frequency bands 54-72 MHz, 76-88 MHz, 174-216 MHz or 470-806 MHz. However, operation within these frequency bands is permitted under other sections of this part, e.g. §§ 15.231 and 15.241.

FCC §15.407 (b)

(b) Undesirable emission limits. Except as shown in paragraph (b)(7) of this section, the maximum emissions outside of the frequency bands of operation shall be attenuated in accordance with the following limits:

- (1) For transmitters operating in the 5.15-5.25 GHz band: All emissions outside of the 5.15-5.35 GHz band shall not exceed an e.i.r.p. of -27 dBm/MHz.
- (2) For transmitters operating in the 5.25-5.35 GHz band: All emissions outside of the 5.15-5.35 GHz band shall not exceed an e.i.r.p. of -27 dBm/MHz.
- (3) For transmitters operating in the 5.47-5.725 GHz band: All emissions outside of the 5.47-5.725 GHz band shall not exceed an e.i.r.p. of -27 dBm/MHz.
- (4) For transmitters operating in the 5.725-5.85 GHz band:
 - (i) All emissions shall be limited to a level of -27 dBm/MHz at 75 MHz or more above or below the band edge increasing linearly to 10 dBm/MHz at 25 MHz above or below the band edge, and from 25 MHz above or below the band edge increasing linearly to a level of 15.6 dBm/MHz at 5 MHz above or below the band edge, and from 5 MHz above or below the band edge increasing linearly to a level of 27 dBm/MHz at the band edge.
- (5) The emission measurements shall be performed using a minimum resolution bandwidth of 1 MHz. A lower resolution bandwidth may be employed near the band edge, when necessary, provided the measured energy is integrated to show the total power over 1 MHz.
- (6) Unwanted emissions below 1 GHz must comply with the general field strength limits set forth

in §15.209. Further, any U-NII devices using an AC power line are required to comply also with the conducted limits set forth in §15.207.

(7) The provisions of §15.205 apply to intentional radiators operating under this section.

(8) When measuring the emission limits, the nominal carrier frequency shall be adjusted as close to the upper and lower frequency band edges as the design of the equipment permits.

Note

- Limit translation to field strength level (FCC §15.407)

$$E[\text{dBuV/m}] = \text{EIRP}[\text{dBm}] + 95.2 = -27\text{dBm} + 95.2 = 68.2\text{dBuV/m}$$

$$E[\text{dBuV/m}] = \text{EIRP}[\text{dBm}] + 95.2 = -17\text{dBm} + 95.2 = 78.2\text{dBuV/m}$$

TEST PROCEDURE

The EUT is placed on a non-conducting table 80 cm above the ground plane for below 1GHz and 150 cm for above 1GHz. The antenna to EUT distance is 3 meters. The EUT is configured in accordance with ANSI C63.10. The EUT is set to transmit in a continuous mode.

For measurements below 1 GHz the resolution bandwidth is set to 100 kHz for peak detection measurements or 120 kHz for quasi-peak detection measurements. Peak detection is used unless otherwise noted as quasi-peak.

Reference to KDB 789033 D02 v01r03 UNII part G) 6) c) Method AD:

For measurements above 1 GHz the resolution bandwidth is set to 1 MHz; the video bandwidth is set to 3 MHz for peak measurements and add duty cycle factor to the reading offset for average measurements.

Pre-scans to detect harmonic and spurious emissions, the resolution bandwidth is set to 1 MHz; the video bandwidth is set to 30 KHz for peak measurements.

The spectrum from 1 GHz to 40 GHz is investigated with the transmitter set to the lowest, middle, and highest channels in each applicable band.

(From 30MHz to 1GHz, test was performed with the EUT set to transmit at the channel with highest output power)

The frequency range of interest is monitored at a fixed antenna height and EUT azimuth. The EUT is rotated through 360 degrees to maximize emissions received. The antenna is scanned from 1 to 4 meters above the ground plane to further maximize the emission. Measurements are made with the antenna polarized in both the vertical and the horizontal positions.

Note : Emission was pre-scanned from 9KHz to 30MHz; No emissions were detected which was at least 20dB below the specification limit (consider distance correction factor).

Per FCC part 15.31(o), test results were not reported.

Formula for converting the filed strength from uV/m to dBuV/m is:

$$\text{Limit (dBuV/m)} = 20 \log \text{limit (uV/m)}$$

Although these tests were performed other than open area test site, adequate comparison measurements were confirmed against 30 m open are test site.

Therefore sufficient tests were made to demonstrate that the alternative site produces results that correlate with the one of tests made in an open field based on KDB 937606.

10.1. 5.2 GHz

10.1.1. TX Above 1GHz 802.11a MODE IN THE 5.2GHz BAND

RESTRICTED BANDEDGE (LOW CHANNEL)

HORIZONTAL PEAK AND AVERAGE PLOT

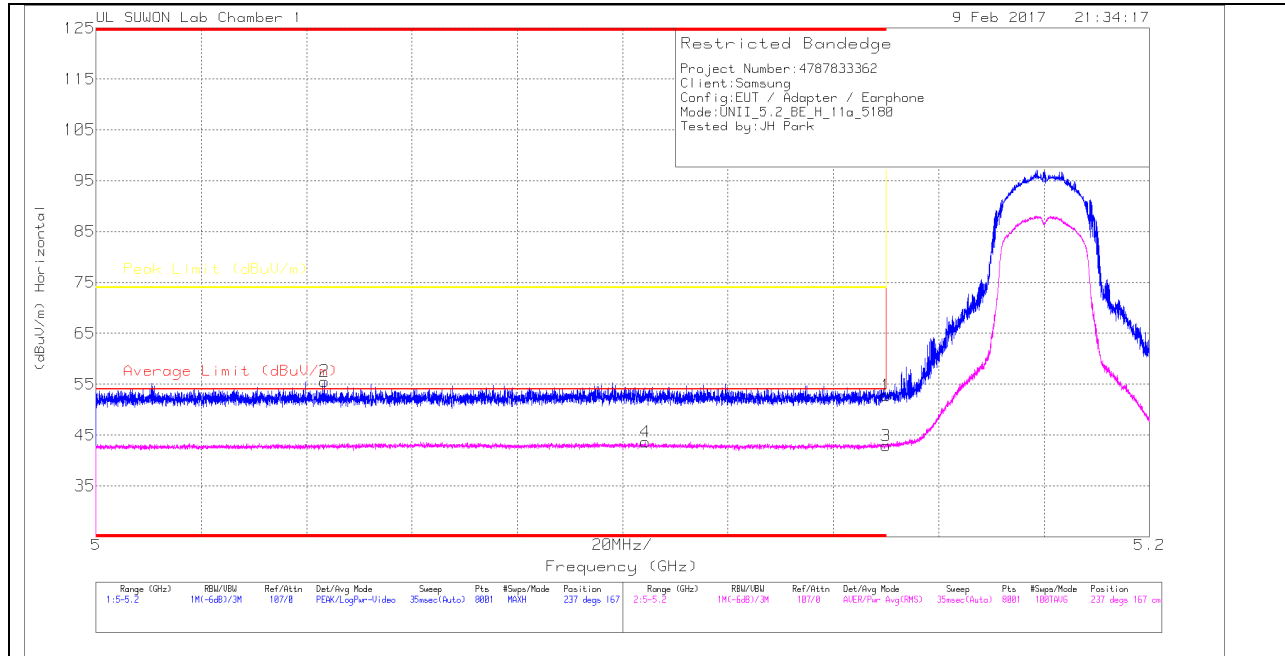

HORIZONTAL DATA

Trace Markers

Marker	Frequency (GHz)	Meter Reading (dBuV)	Det	3117(00168 717)_150619	10dB_Att(dB)	DC Corr (dB)	Corrected Reading (dBuV/m)	Average Limit (dBuV/m)	Margin (dB)	Peak Limit (dBuV/m)	PK Margin (dB)	Azimuth (Degs)	Height (cm)	Polarity
1	* 5.15	42.79	Pk	34.2	-24.2	0	52.79	-	-	74	-21.21	237	167	H
2	* 5.043	45.68	Pk	34.1	-24.2	0	55.58	-	-	74	-18.42	237	167	H
3	* 5.15	32.58	RMS	34.2	-24.1	.18	42.86	54	-11.14	-	-	237	167	H
4	* 5.104	33.41	RMS	34.2	-24.1	.18	43.69	54	-10.31	-	-	237	167	H

* - indicates frequency in CFR15.205/IC7.2.2 Restricted Band

Pk - Peak detector

RMS - RMS detection

VERTICAL PEAK AND AVERAGE PLOT

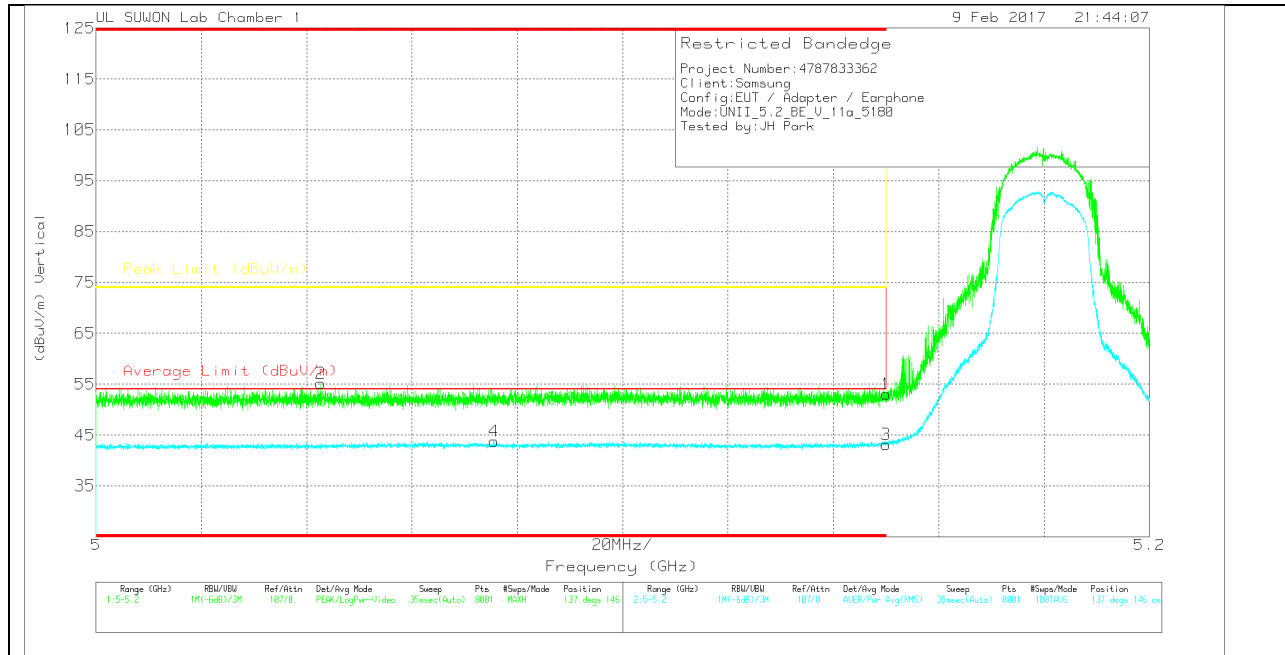

VERTICAL DATA

Trace Markers

Marker	Frequency (GHz)	Meter Reading (dBuV)	Det	3117(00168 717)_15061 9	10dB_Att(dB)	DC Corr (dB)	Corrected Reading (dBuV/m)	Average Limit (dBuV/m)	Margin (dB)	Peak Limit (dBuV/m)	PK Margin (dB)	Azimuth (Degs)	Height (cm)	Polarity
1	* 5.15	43.05	Pk		-24.2	0	53.05	-	-	74	-20.95	137	146	V
2	* 5.043	45.21	Pk		-24.2	0	55.11	-	-	74	-18.89	137	146	V
3	* 5.15	32.87	RMS		-24.1	.18	43.15	54	-10.85	-	-	137	146	V
4	* 5.076	33.58	RMS		-24.2	.18	43.76	54	-10.24	-	-	137	146	V

* - indicates frequency in CFR15.205/IC7.2.2 Restricted Band

Pk - Peak detector

RMS - RMS detection

HARMONICS AND SPURIOUS EMISSIONS

LOW CHANNEL HORIZONTAL

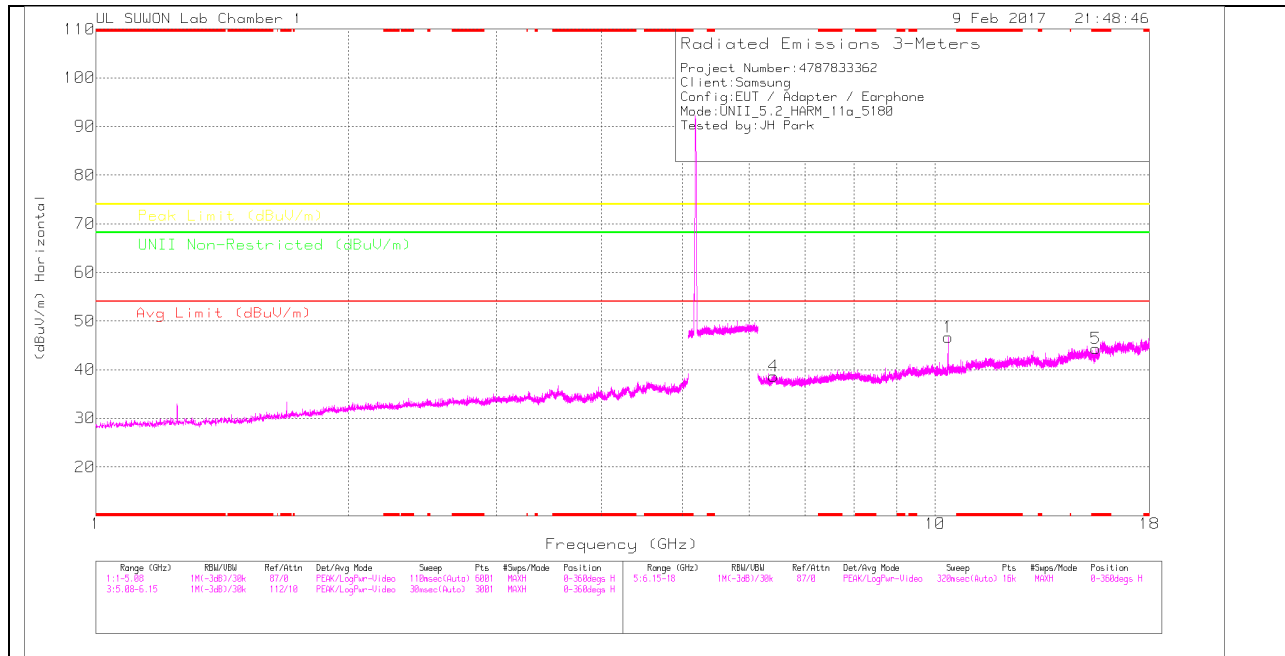

LOW CHANNEL VERTICAL

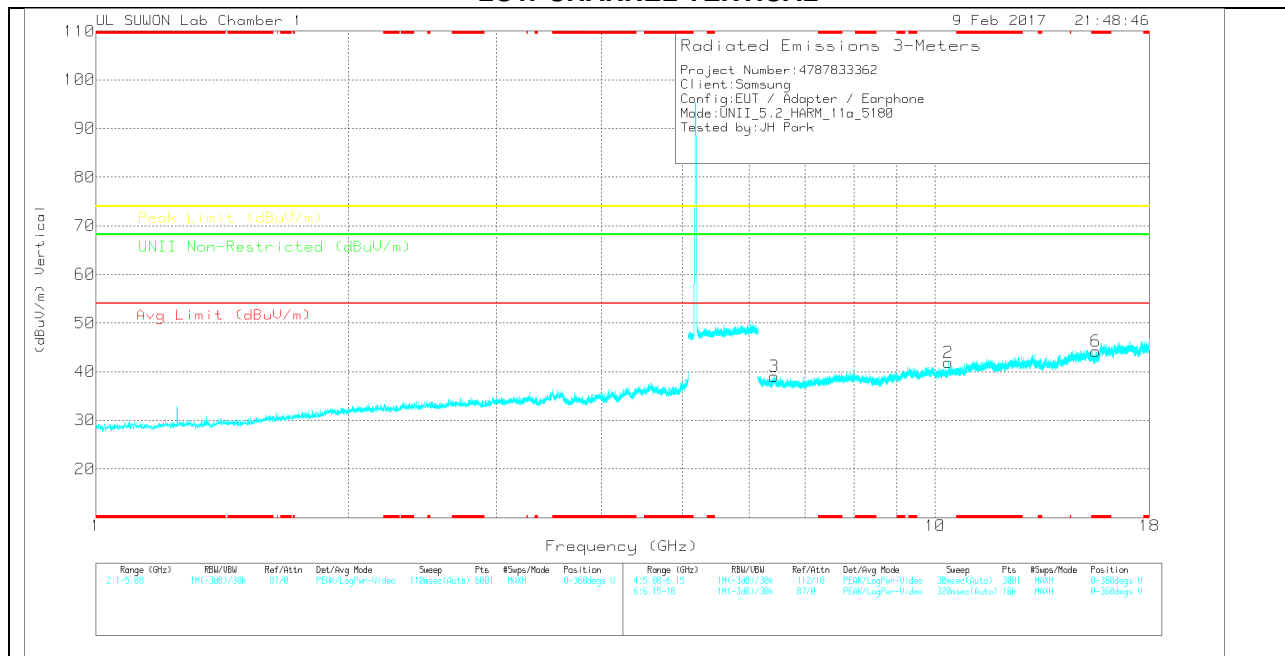

Note: Emission was scanned up to 40GHz; No emissions were detected above the noise floor which was at least 20dB below the specification limit.

LOW CHANNEL DATA

Trace Markers

Marker	Frequency (GHz)	Meter Reading (dBuV)	Det	3117(0016 8717)_150 519	6Ghz_HP(d B)	DC Corr (dB)	Corrected Reading (dBuV/m)	Avg Limit (dBuV/m)	Margin (dB)	Peak Limit (dBuV/m)	Margin (dB)	UNII Non-Restricted (dBuV/m)	Margin (dB)	Azimuth (Degs)	Height (cm)	Polarity
1	10.36	37.11	PK	37.8	-28.3	0	46.61	-	-	-	-	68.2	-21.59	0-360	250	H
4	6.422	33.74	PK	35.4	-30.5	0	38.64	-	-	-	-	68.2	-29.56	0-360	250	H
5	* 15.542	24.19	PK	40.3	-20.2	0	44.29	-	-	74	-29.71	-	-	0-360	250	H
2	10.359	32.43	PK	37.8	-28.3	0	41.93	-	-	-	-	68.2	-26.27	0-360	250	V
3	6.428	34.05	PK	35.4	-30.4	0	39.05	-	-	-	-	68.2	-29.15	0-360	250	V
6	* 15.542	24.11	PK	40.3	-20.2	0	44.21	-	-	74	-29.79	-	-	0-360	250	V

* - indicates frequency in CFR15.205/IC7.2.2 Restricted Band

PK – Peak Detector

Radiated Emissions

Frequency (GHz)	Meter Reading (dBuV)	Det	3117(001687 17)_150619	6Ghz_HP(dB)	DC Corr (dB)	Corrected Reading (dBuV/m)	Avg Limit (dBuV/m)	Margin (dB)	Peak Limit (dBuV/m)	Margin (dB)	UNII Non-Restricted (dBuV/m)	Margin (dB)	Azimuth (Degs)	Height (cm)	Polarity
10.36	47.46	PK-U	37.8	-28.3	0	56.96	-	-	-	-	68.2	-11.24	137	229	H
10.36	43.89	PK-U	37.8	-28.3	0	53.39	-	-	-	-	68.2	-14.81	201	251	V

* - indicates frequency in CFR15.205/IC7.2.2 Restricted Band

PK-U - U-NII: Maximum Peak

MID CHANNEL HORIZONTAL

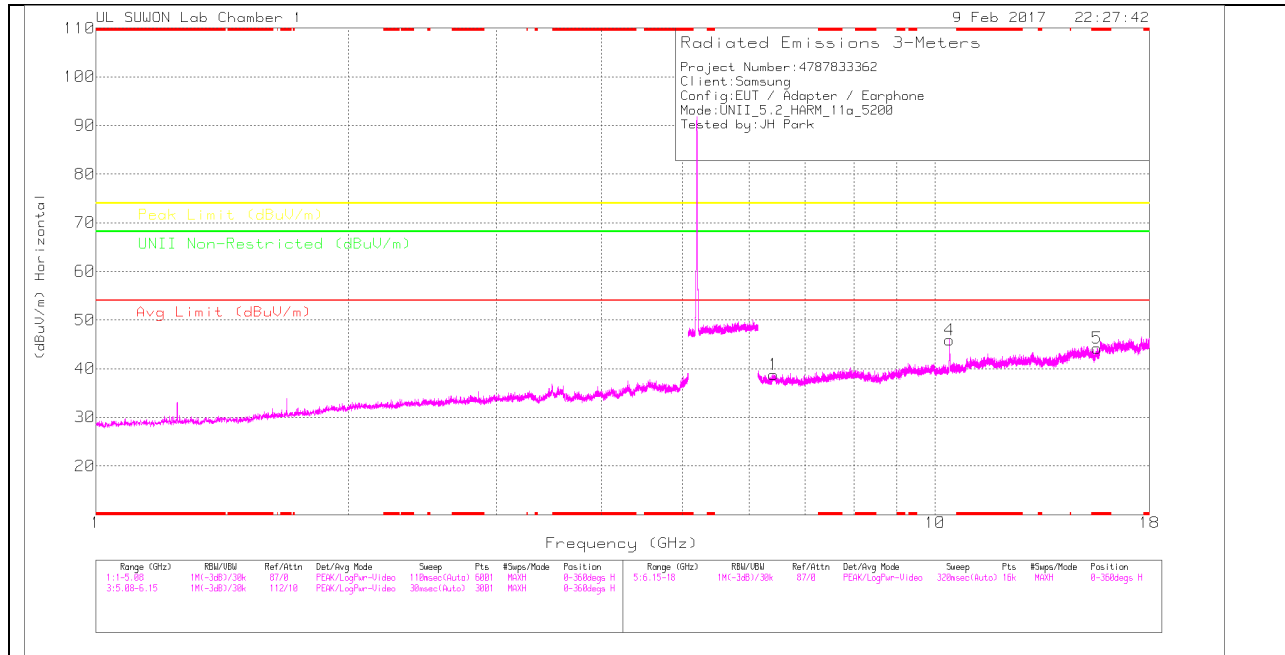

MID CHANNEL VERTICAL

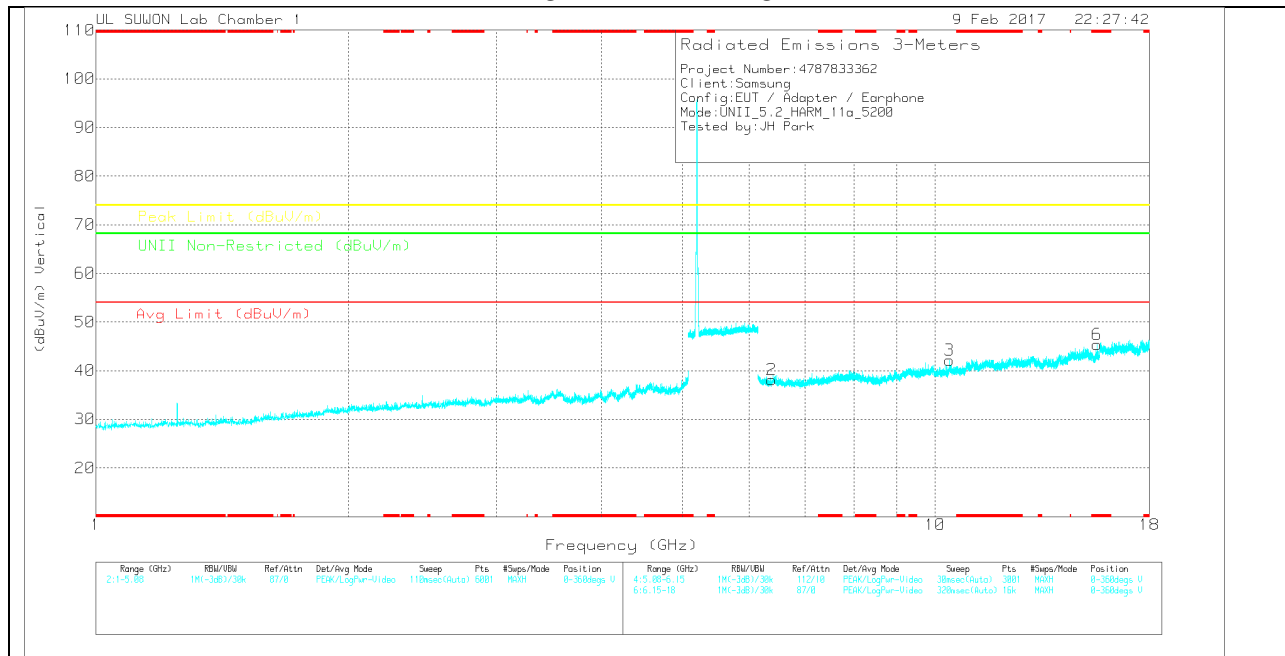

Note: Emission was scanned up to 40GHz; No emissions were detected above the noise floor which was at least 20dB below the specification limit.

MID CHANNEL DATA

Trace Markers

Marker	Frequency (GHz)	Meter Reading (dBuV)	Det	3117(0016 8717)_150 619	6Ghz_HP(d B)	DC Corr (dB)	Corrected Reading (dBuV/m)	Avg Limit (dBuV/m)	Margin (dB)	Peak Limit (dBuV/m)	Margin (dB)	UNII Non-Restricted (dBuV/m)	Margin (dB)	Azimuth (Degs)	Height (cm)	Polarity
1	6.421	33.79	PK	35.4	-30.4	0	38.79	-	-	-	-	68.2	-29.41	0-360	250	H
4	10.399	35.86	PK	37.8	-27.8	0	45.86	-	-	-	-	68.2	-22.34	0-360	250	H
5	* 15.603	22.26	PK	40.3	-18.4	0	44.16	-	-	74	-29.84	-	-	0-360	150	H
2	6.385	33.89	PK	35.3	-31.1	0	38.09	-	-	-	-	68.2	-30.11	0-360	250	V
3	10.403	32.11	PK	37.8	-27.8	0	42.11	-	-	-	-	68.2	-26.09	0-360	250	V
6	* 15.601	23.45	PK	40.3	-18.4	0	45.35	-	-	74	-28.65	-	-	0-360	250	V

* - indicates frequency in CFR15.205/IC7.2.2 Restricted Band

PK – Peak Detector

Radiated Emissions

Frequency (GHz)	Meter Reading (dBuV)	Det	3117(001687 17)_150619	6Ghz_HP(dB)	DC Corr (dB)	Corrected Reading (dBuV/m)	Avg Limit (dBuV/m)	Margin (dB)	Peak Limit (dBuV/m)	Margin (dB)	UNII Non-Restricted (dBuV/m)	Margin (dB)	Azimuth (Degs)	Height (cm)	Polarity
10.402	46.8	PK-U	37.8	-27.8	0	56.8	-	-	-	-	68.2	-11.4	225	211	H
10.4	42.83	PK-U	37.8	-27.8	0	52.83	-	-	-	-	68.2	-15.37	207	286	V

* - indicates frequency in CFR15.205/IC7.2.2 Restricted Band

PK-U - U-NII: Maximum Peak

HIGH CHANNEL HORIZONTAL

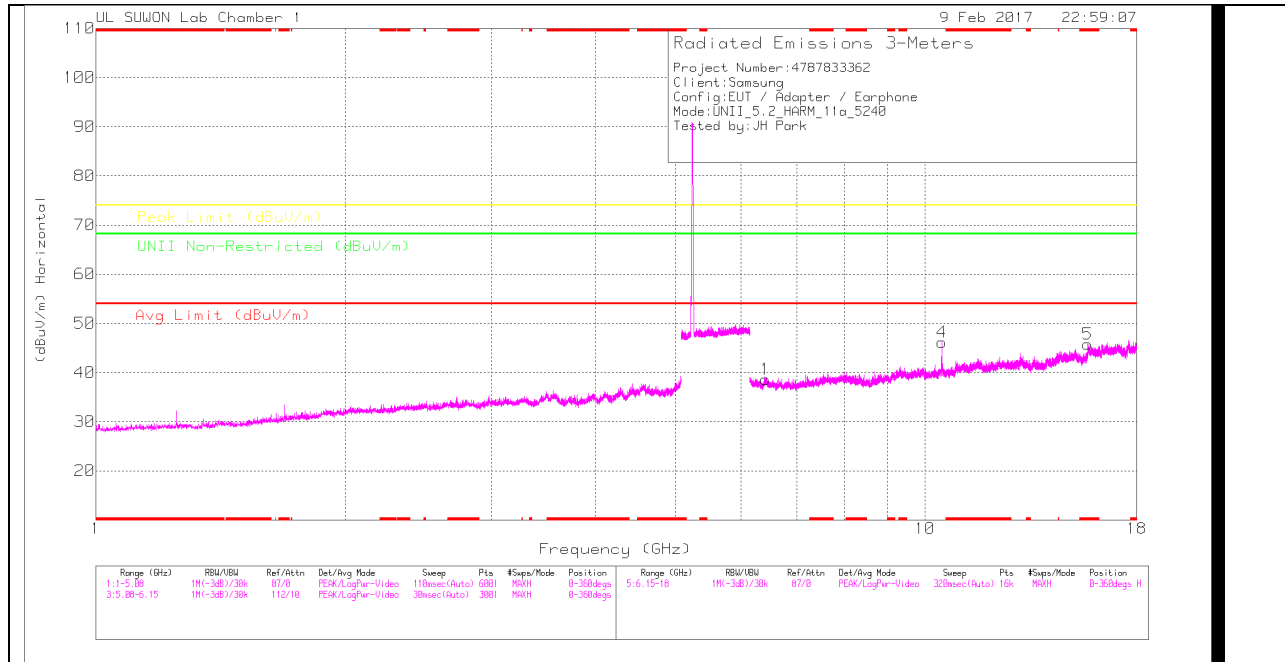

HIGH CHANNEL VERTICAL

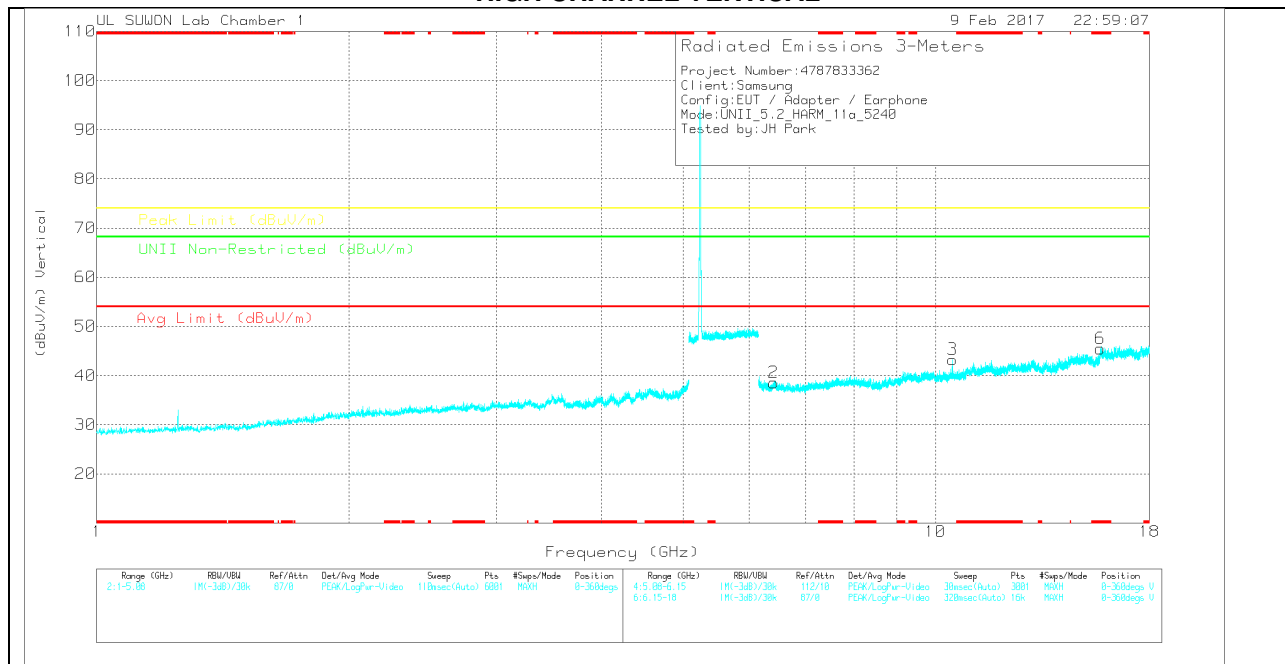

Note: Emission was scanned up to 40GHz; No emissions were detected above the noise floor which was at least 20dB below the specification limit.

HIGH CHANNEL DATA

Trace Markers

Marker	Frequency (GHz)	Meter Reading (dBuV)	Det	3117(0016 8717)_150 519	6Ghz_HP(d B)	DC Corr (dB)	Corrected Reading (dBuV/m)	Avg Limit (dBuV/m)	Margin (dB)	Peak Limit (dBuV/m)	Margin (dB)	UNII Non-Restricted (dBuV/m)	Margin (dB)	Azimuth (Degs)	Height (cm)	Polarity
1	6.418	33.81	PK	35.3	-30.5	0	38.61	-	-	-	-	68.2	-29.59	0-360	150	H
4	10.479	37.12	PK	37.8	-28.8	0	46.12	-	-	-	-	68.2	-22.08	0-360	250	H
5	* 15.721	23.17	PK	40.4	-17.8	0	45.77	-	-	74	-28.23	-	-	0-360	250	H
2	6.411	33.86	PK	35.3	-30.6	0	38.56	-	-	-	-	68.2	-29.64	0-360	250	V
3	10.479	34.26	PK	37.8	-28.8	0	43.26	-	-	-	-	68.2	-24.94	0-360	250	V
6	* 15.715	23.27	PK	40.4	-18.2	0	45.47	-	-	74	-28.53	-	-	0-360	250	V

* - indicates frequency in CFR15.205/IC7.2.2 Restricted Band

PK – Peak Detector

Radiated Emissions

Frequency (GHz)	Meter Reading (dBuV)	Det	3117(001687 17)_150619	6Ghz_HP(dB)	DC Corr (dB)	Corrected Reading (dBuV/m)	Avg Limit (dBuV/m)	Margin (dB)	Peak Limit (dBuV/m)	Margin (dB)	UNII Non-Restricted (dBuV/m)	Margin (dB)	Azimuth (Degs)	Height (cm)	Polarity
10.482	47.66	PK-U	37.8	-28.7	0	56.76	-	-	-	-	68.2	-11.44	223	220	H
10.482	43.38	PK-U	37.8	-28.7	0	52.48	-	-	-	-	68.2	-15.72	207	130	V

* - indicates frequency in CFR15.205/IC7.2.2 Restricted Band

PK-U - U-NII: Maximum Peak

**10.1.2. TX Above 1GHz 802.11n HT20 MODE IN THE 5.2GHz BAND
 RESTRICTED BANDEDGE (LOW CHANNEL)**

HORIZONTAL PEAK AND AVERAGE PLOT

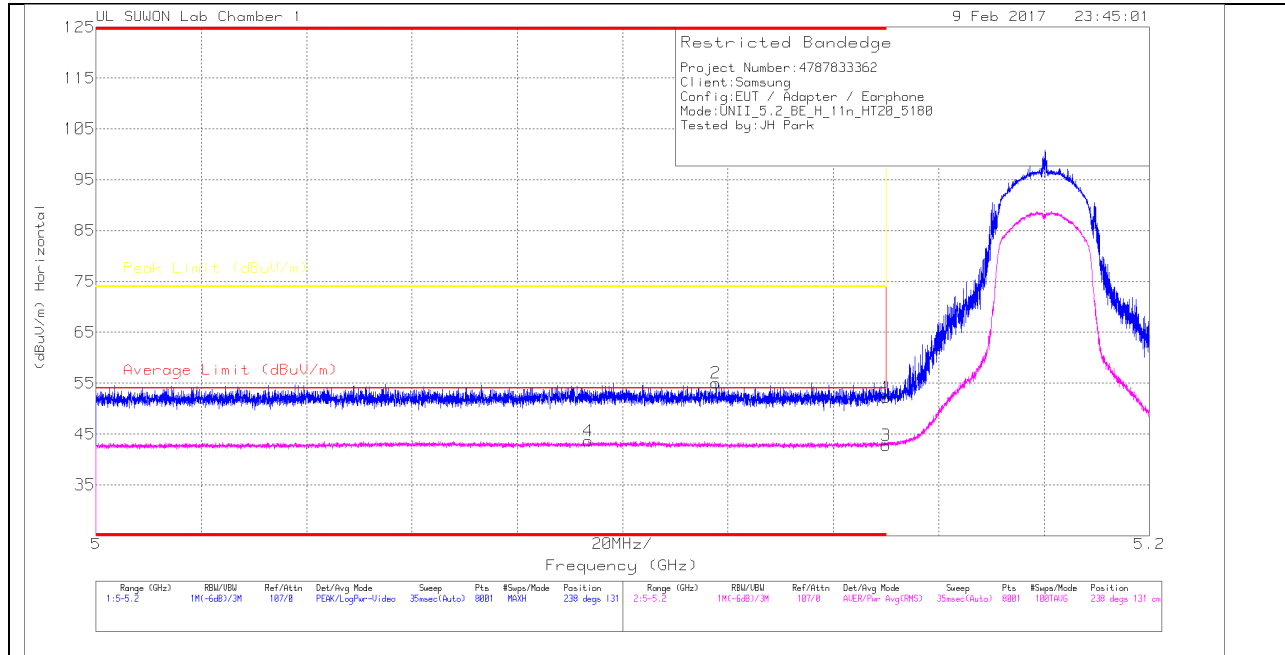

HORIZONTAL DATA

Trace Markers

Marker	Frequency (GHz)	Meter Reading (dBuV)	Det	3117(00168 717)_15061 9	10dB_Att(dB)	DC Corr (dB)	Corrected Reading (dBuV/m)	Average Limit (dBuV/m)	Margin (dB)	Peak Limit (dBuV/m)	PK Margin (dB)	Azimuth (Degs)	Height (cm)	Polarity
1	* 5.15	42.15	Pk		-24.2	0	52.15	-	-	74	-21.85	238	131	H
2	* 5.118	44.94	Pk		-24.1	0	55.04	-	-	74	-18.96	238	131	H
3	* 5.15	32.52	RMS		-24.1	.17	42.79	54	-11.21	-	-	238	131	H
4	* 5.093	33.38	RMS		-24.1	.17	43.65	54	-10.35	-	-	238	131	H

* - indicates frequency in CFR15.205/IC7.2.2 Restricted Band

Pk - Peak detector

RMS - RMS detection

VERTICAL PEAK AND AVERAGE PLOT

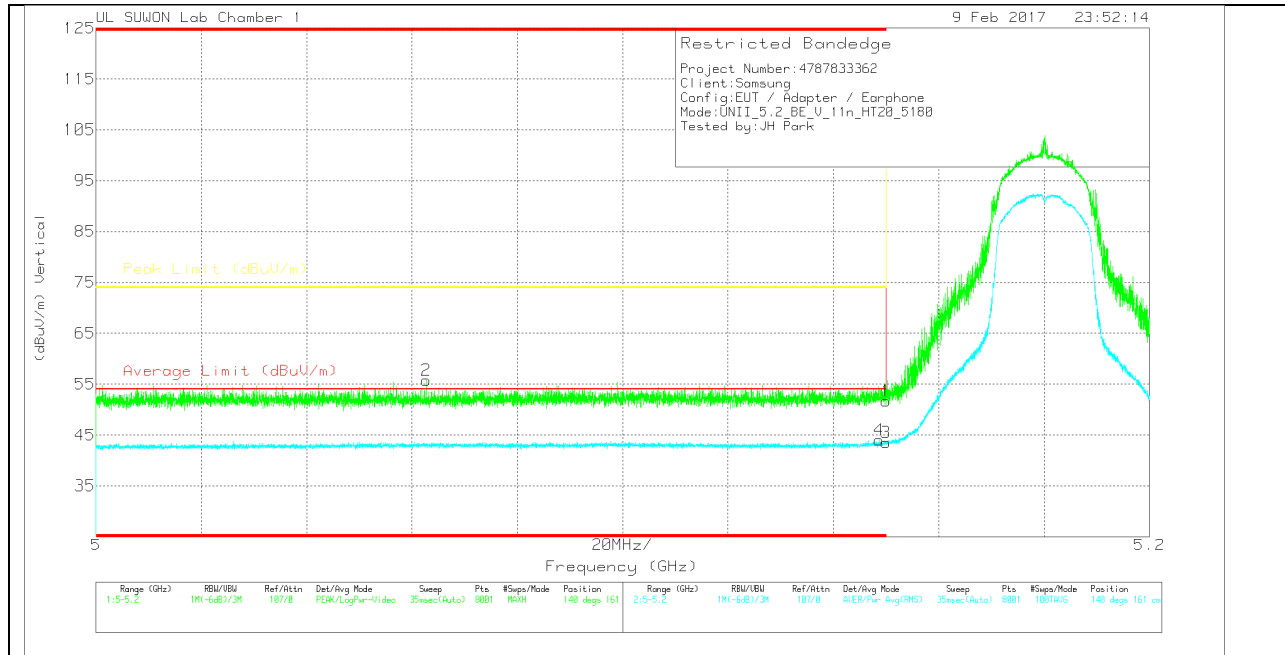

VERTICAL DATA

Trace Markers

Marker	Frequency (GHz)	Meter Reading (dBuV)	Det	3117(00168 717)_15061 9	10dB_Att(dB)	DC Corr (dB)	Corrected Reading (dBuV/m)	Average Limit (dBuV/m)	Margin (dB)	Peak Limit (dBuV/m)	PK Margin (dB)	Azimuth (Degs)	Height (cm)	Polarity
1	* 5.15	41.74	Pk	34.2	-24.2	0	51.74	-	-	74	-22.26	140	161	V
2	* 5.063	46.07	Pk	34.1	-24.4	0	55.77	-	-	74	-18.23	140	161	V
3	* 5.15	33.21	RMS	34.2	-24.1	.17	43.48	54	-10.52	-	-	140	161	V
4	* 5.149	33.78	RMS	34.2	-24.1	.17	44.05	54	-9.95	-	-	140	161	V

* - indicates frequency in CFR15.205/IC7.2.2 Restricted Band

Pk - Peak detector

RMS - RMS detection

HARMONICS AND SPURIOUS EMISSIONS

LOW CHANNEL HORIZONTAL

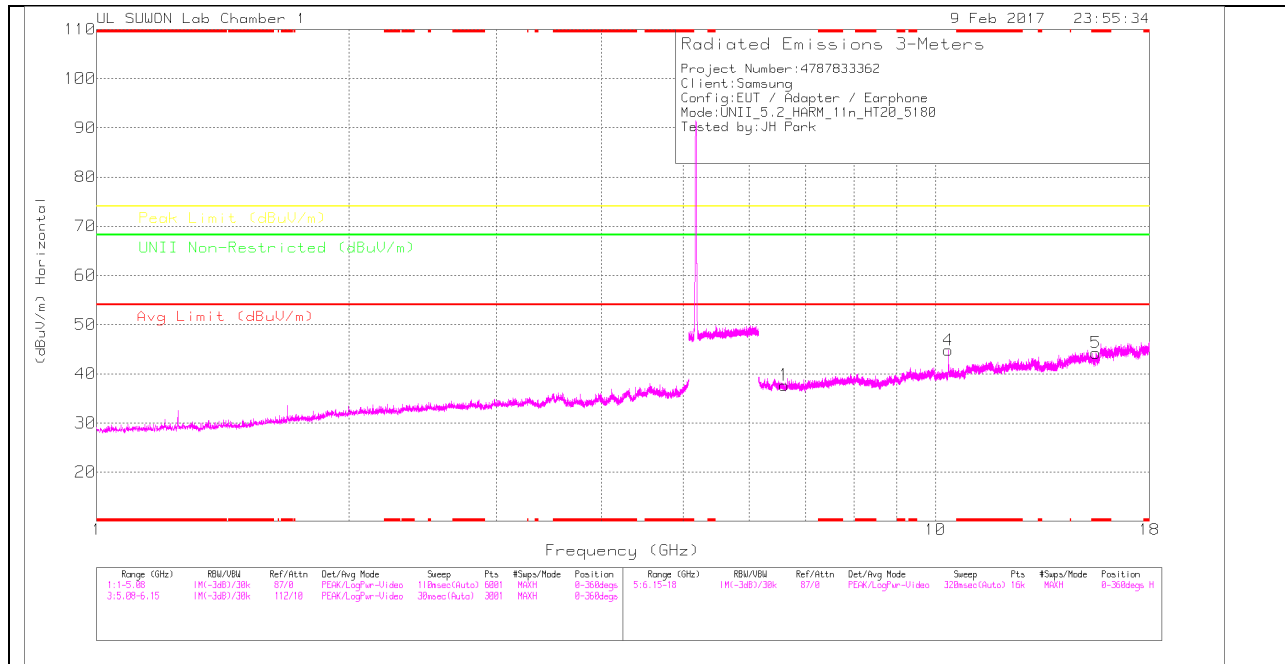

LOW CHANNEL VERTICAL

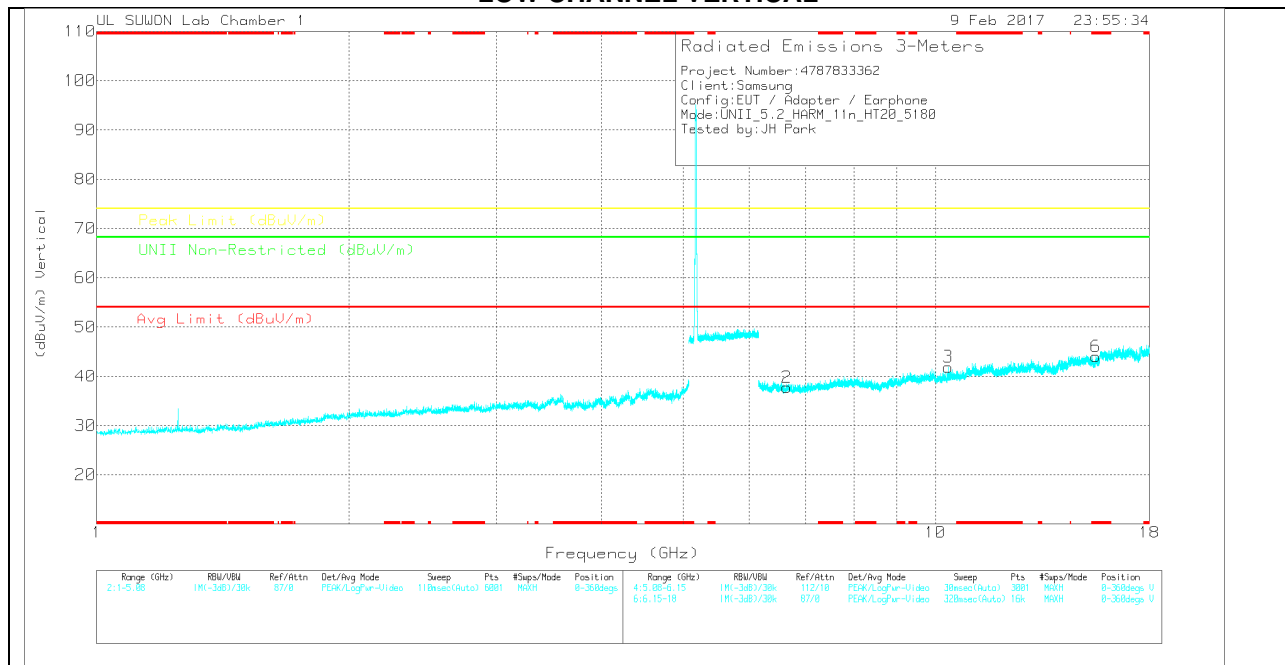

Note: Emission was scanned up to 40GHz; No emissions were detected above the noise floor which was at least 20dB below the specification limit.

LOW CHANNEL DATA

Trace Markers

Marker	Frequency (GHz)	Meter Reading (dBuV)	Det	3117(0016 8717)_150 619	6Ghz_HP(d B)	DC Corr (dB)	Corrected Reading (dBuV/m)	Avg Limit (dBuV/m)	Margin (dB)	Peak Limit (dBuV/m)	Margin (dB)	UNII Non-Restricted (dBuV/m)	Margin (dB)	Azimuth (Degs)	Height (cm)	Polarity
1	6.608	33.19	PK	35.5	-31	0	37.69	-	-	-	-	68.2	-30.51	0-360	150	H
4	10.36	35.3	PK	37.8	-28.3	0	44.8	-	-	-	-	68.2	-23.4	0-360	250	H
5	* 15.541	24.03	PK	40.3	-20.1	0	44.23	-	-	74	-29.77	-	-	0-360	150	H
2	6.654	33.44	PK	35.5	-31.2	0	37.74	-	-	-	-	68.2	-30.46	0-360	150	V
3	10.359	32.4	PK	37.8	-28.3	0	41.9	-	-	-	-	68.2	-26.3	0-360	250	V
6	* 15.536	24.32	PK	40.2	-20.5	0	44.02	-	-	74	-29.98	-	-	0-360	150	V

* - indicates frequency in CFR15.205/IC7.2.2 Restricted Band

PK – Peak Detector

Radiated Emissions

Frequency (GHz)	Meter Reading (dBuV)	Det	3117(001687 17_150619	6Ghz_HP(dB)	DC Corr (dB)	Corrected Reading (dBuV/m)	Avg Limit (dBuV/m)	Margin (dB)	Peak Limit (dBuV/m)	Margin (dB)	UNII Non-Restricted (dBuV/m)	Margin (dB)	Azimuth (Degs)	Height (cm)	Polarity
10.36	48.48	PK-U	37.8	-28.3	0	57.98	-	-	-	-	68.2	-10.22	219	212	H
10.36	44.25	PK-U	37.8	-28.3	0	53.75	-	-	-	-	68.2	-14.45	207	366	V

* - indicates frequency in CFR15.205/IC7.2.2 Restricted Band

PK-U - U-NII: Maximum Peak

MID CHANNEL HORIZONTAL

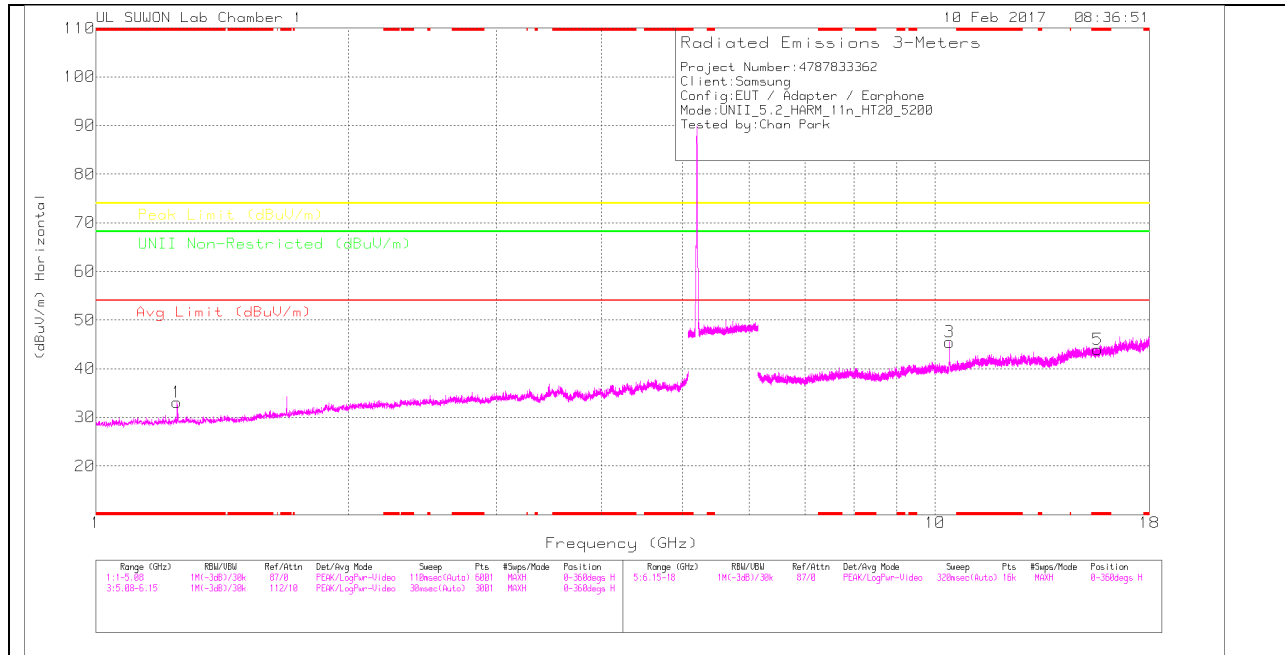

MID CHANNEL VERTICAL

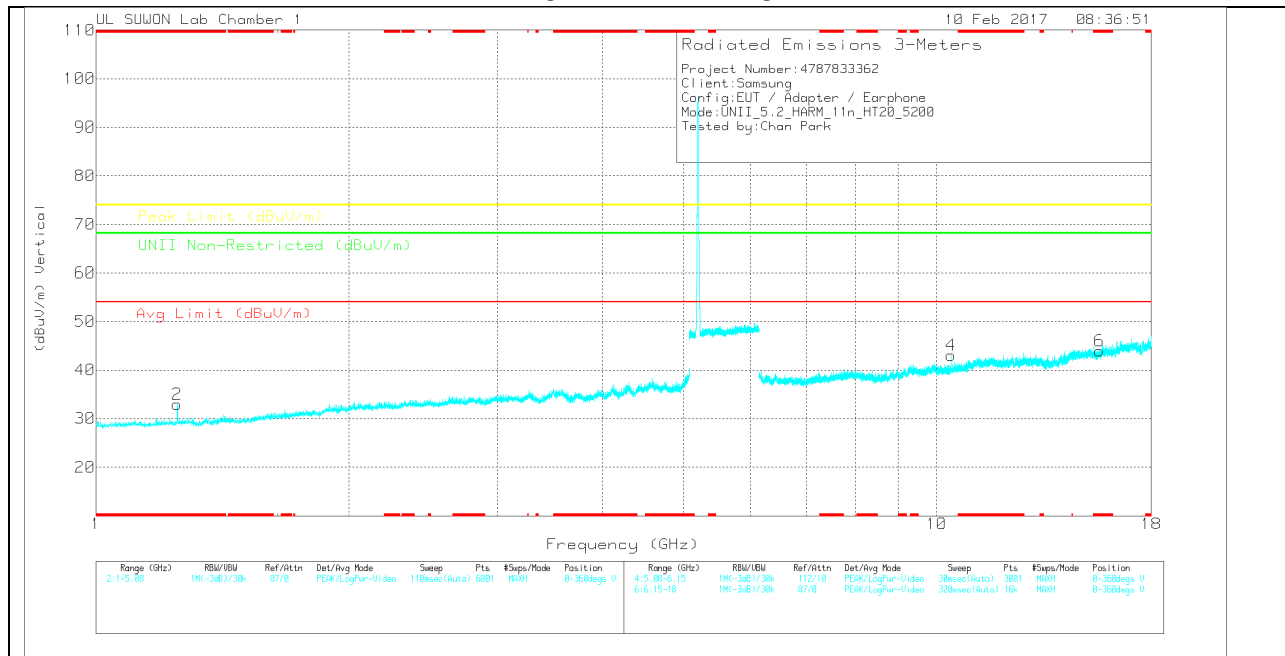

Note: Emission was scanned up to 40GHz; No emissions were detected above the noise floor which was at least 20dB below the specification limit.

MID CHANNEL DATA

Trace Markers

Marker	Frequency (GHz)	Meter Reading (dBuV)	Det	3117(0016 8717)_150 619	5Ghz_LP(d B)	DC Corr (dB)	Corrected Reading (dBuV/m)	Avg Limit (dBuV/m)	Margin (dB)	Peak Limit (dBuV/m)	Margin (dB)	UNII Non-Restricted (dBuV/m)	Margin (dB)	Azimuth (Degs)	Height (cm)	Polarity
1	* 1.25	44.39	Pk	28.3	-39.6	0	33.09	-	-	74	-40.91	-	-	0-360	250	H
2	* 1.25	44.28	Pk	28.3	-39.6	0	32.98	-	-	74	-41.02	-	-	0-360	250	V
3	10.399	35.44	Pk	37.8	-27.8	0	45.44	-	-	-	-	68.2	-22.76	0-360	250	H
5	* 15.607	21.89	Pk	40.3	-18.3	0	43.89	-	-	74	-30.11	-	-	0-360	250	H
4	10.4	33.05	Pk	37.8	-27.8	0	43.05	-	-	-	-	68.2	-25.15	0-360	250	V
6	* 15.606	21.9	Pk	40.3	-18.3	0	43.9	-	-	74	-30.1	-	-	0-360	250	V

* - indicates frequency in CFR15.205/IC7.2.2 Restricted Band

Pk – Peak detector

Radiated Emissions

Frequency (GHz)	Meter Reading (dBuV)	Det	3117(001687 17)_150619	6Ghz_HP(dB)	DC Corr (dB)	Corrected Reading (dBuV/m)	Avg Limit (dBuV/m)	Margin (dB)	Peak Limit (dBuV/m)	Margin (dB)	UNII Non-Restricted (dBuV/m)	Margin (dB)	Azimuth (Degs)	Height (cm)	Polarity
10.4	46.19	PK-U	37.8	-27.8	0	56.19	-	-	-	-	68.2	-12.01	189	218	H
10.4	42.84	PK-U	37.8	-27.8	0	52.84	-	-	-	-	68.2	-15.36	161	245	V

* - indicates frequency in CFR15.205/IC7.2.2 Restricted Band

PK-U - U-NII: Maximum Peak

HIGH CHANNEL HORIZONTAL

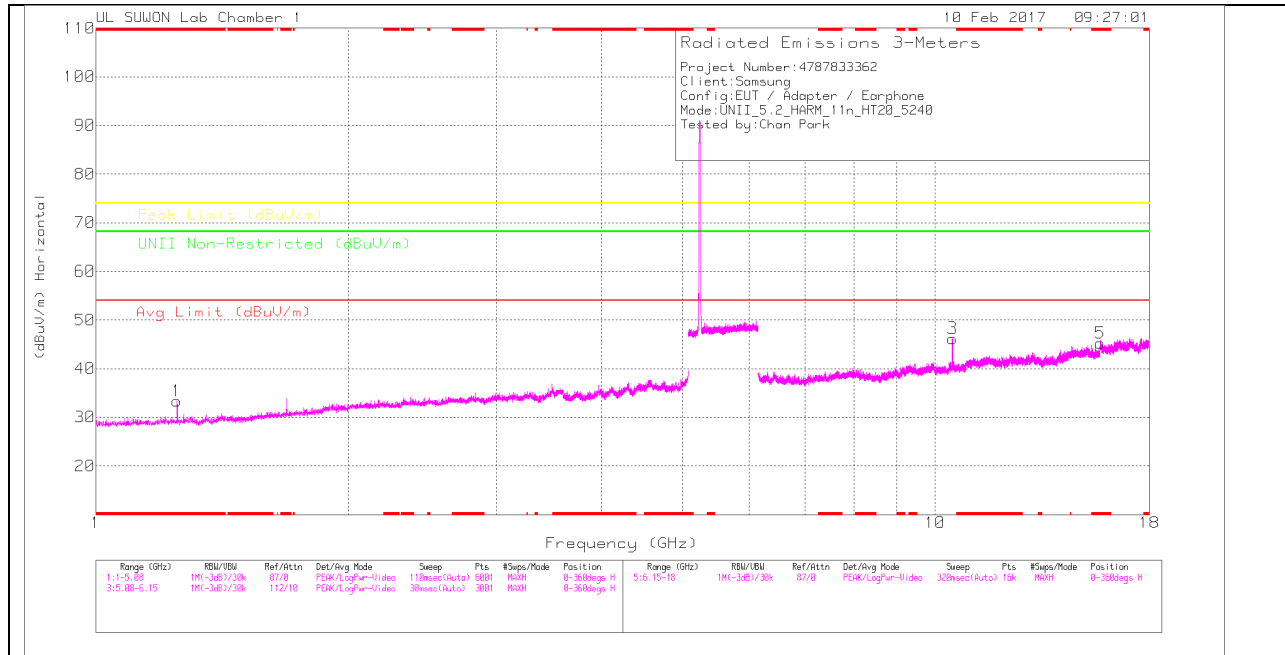

HIGH CHANNEL VERTICAL

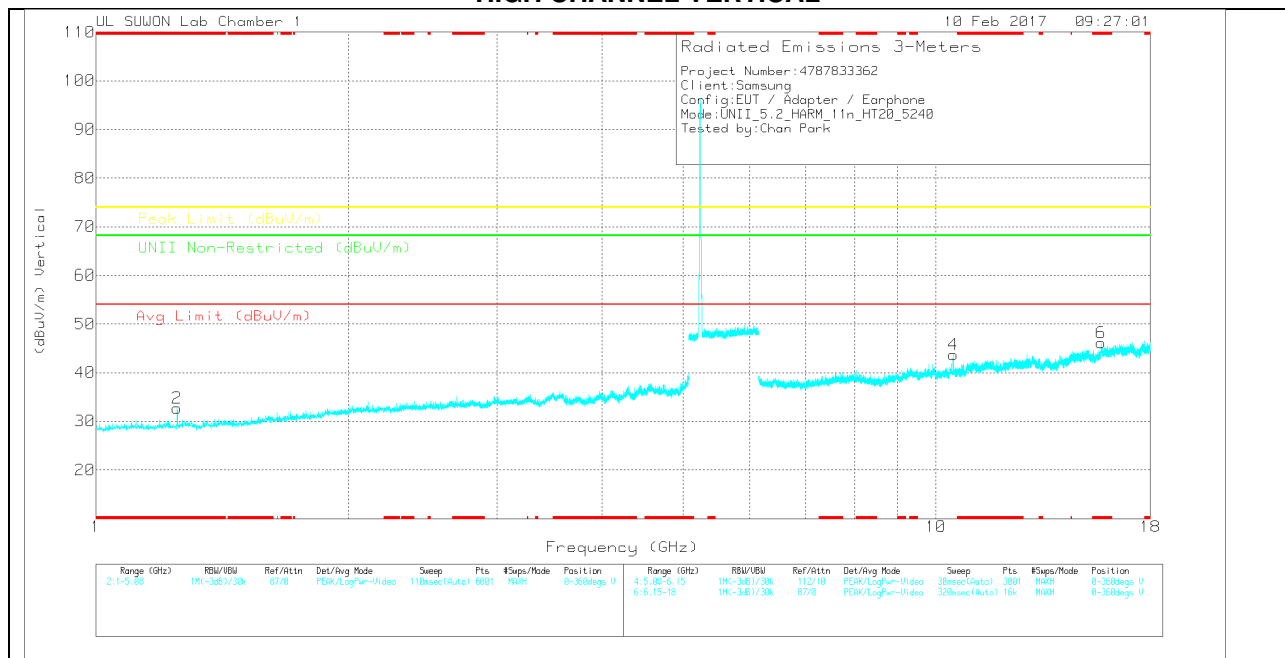

Note: Emission was scanned up to 40GHz; No emissions were detected above the noise floor which was at least 20dB below the specification limit.

HIGH CHANNEL DATA

Trace Markers

Marker	Frequency (GHz)	Meter Reading (dBuV)	Det	3117(0016 8717)_150 619	5Ghz_LP(d B)	DC Corr (dB)	Corrected Reading (dBuV/m)	Avg Limit (dBuV/m)	Margin (dB)	Peak Limit (dBuV/m)	Margin (dB)	UNII Non-Restricted (dBuV/m)	Margin (dB)	Azimuth (Degs)	Height (cm)	Polarity
1	* 1.25	44.62	Pk	28.3	-39.6	0	33.32	-	-	74	-40.68	-	-	0-360	250	H
2	* 1.25	44.05	Pk	28.3	-39.6	0	32.75	-	-	74	-41.25	-	-	0-360	250	V
3	10.48	37.21	Pk	37.8	-28.8	0	46.21	-	-	-	-	68.2	-21.99	0-360	150	H
5	* 15.722	22.51	Pk	40.4	-17.7	0	45.21	-	-	74	-28.79	-	-	0-360	250	H
4	10.48	34.67	Pk	37.8	-28.8	0	43.67	-	-	-	-	68.2	-24.53	0-360	250	V
6	* 15.725	23.37	Pk	40.4	-17.6	0	46.17	-	-	74	-27.83	-	-	0-360	150	V

* - indicates frequency in CFR15.205/IC7.2.2 Restricted Band

Pk – Peak detector

Radiated Emissions

Frequency (GHz)	Meter Reading (dBuV)	Det	3117(001687 17)_150619	6Ghz_HP(dB)	DC Corr (dB)	Corrected Reading (dBuV/m)	Avg Limit (dBuV/m)	Margin (dB)	Peak Limit (dBuV/m)	Margin (dB)	UNII Non-Restricted (dBuV/m)	Margin (dB)	Azimuth (Degs)	Height (cm)	Polarity
10.481	48.26	PK-U	37.8	-28.7	0	57.36	-	-	-	-	68.2	-10.84	186	211	H
10.48	43.39	PK-U	37.8	-28.8	0	52.39	-	-	-	-	68.2	-15.81	163	240	V

* - indicates frequency in CFR15.205/IC7.2.2 Restricted Band

PK-U - U-NII: Maximum Peak

10.1.3. TX Above 1GHz 802.11n HT40 MODE IN THE 5.2GHz BAND RESTRICTED BANDEDGE (LOW CHANNEL)

HORIZONTAL PEAK AND AVERAGE PLOT

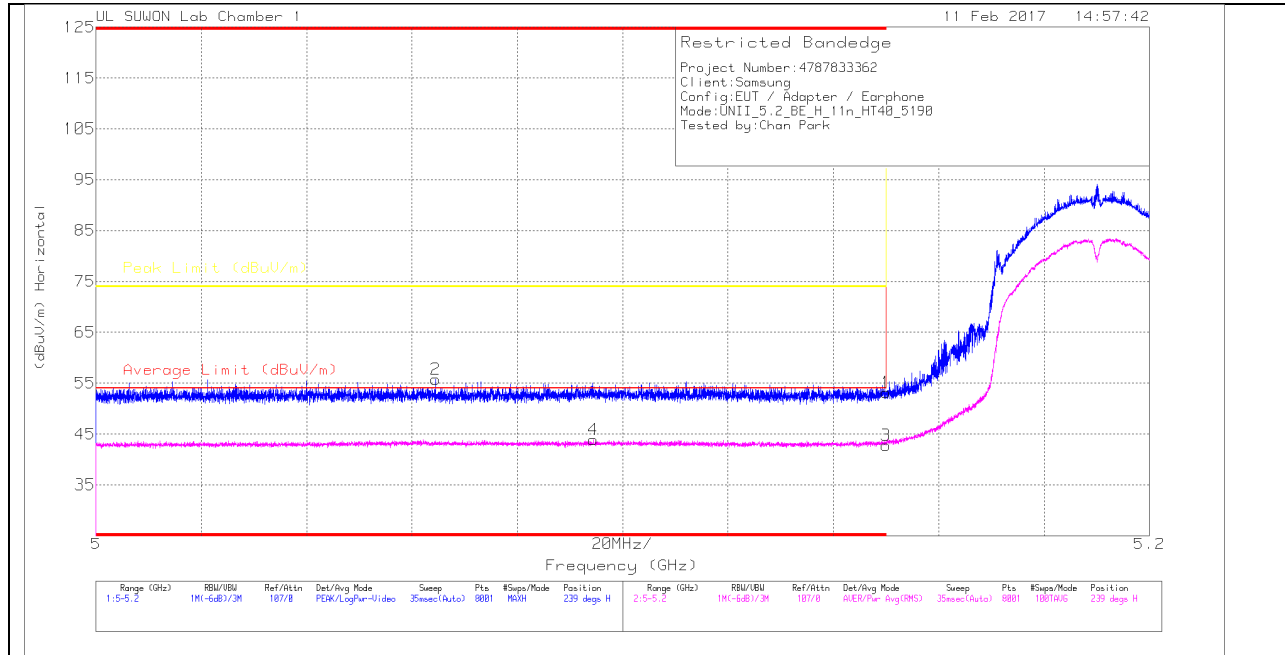

HORIZONTAL DATA

Trace Markers

Marker	Frequency (GHz)	Meter Reading (dBuV)	Det	3117(00168 717)_15061_9	10dB_Att(dB)	DC Corr (dB)	Corrected Reading (dBuV/m)	Average Limit (dBuV/m)	Margin (dB)	Peak Limit (dBuV/m)	PK Margin (dB)	Azimuth (Degs)	Height (cm)	Polarity
1	* 5.15	43.12	Pk	34.2	-24.2	0	53.12	-	-	74	-20.88	239	146	H
2	* 5.064	46.04	Pk	34.1	-24.4	0	55.74	-	-	74	-18.26	239	146	H
3	* 5.15	32.29	RMS	34.2	-24.1	.38	42.77	54	-11.23	-	-	239	146	H
4	* 5.094	33.37	RMS	34.2	-24.1	.38	43.85	54	-10.15	-	-	239	146	H

* - indicates frequency in CFR15.205/IC7.2.2 Restricted Band

Pk - Peak detector

RMS - RMS detection

VERTICAL PEAK AND AVERAGE PLOT

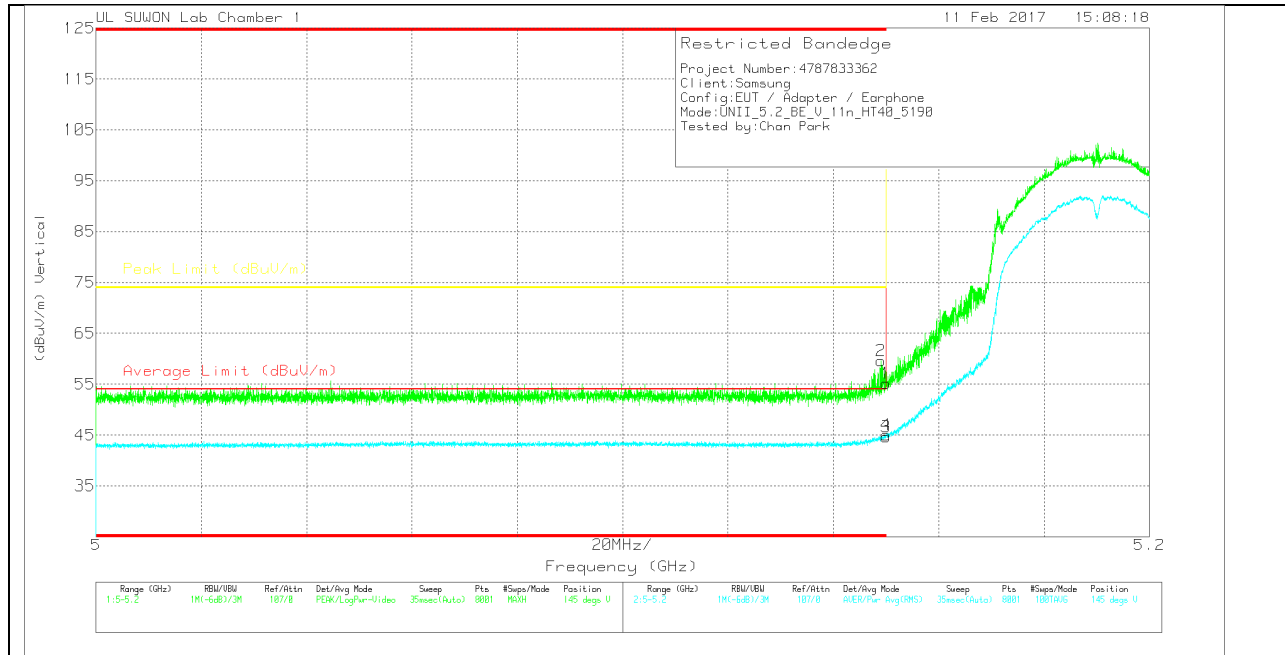

VERTICAL DATA

Trace Markers

Marker	Frequency (GHz)	Meter Reading (dBuV)	Det	3117/001687 17_150619	10dB_Att(dB)	DC Corr (dB)	Corrected Reading (dBuV/m)	Average Limit (dBuV/m)	Margin (dB)	Peak Limit (dBuV/m)	PK Margin (dB)	Azimuth (Degs)	Height (cm)	Polarity
1	* 5.15	45.13	Pk	34.2	-24.2	0	55.13	-	-	74	-18.87	145	342	V
2	* 5.149	49.55	Pk	34.2	-24.1	0	59.65	-	-	74	-14.35	145	342	V
3	* 5.15	34.13	RMS	34.2	-24.1	.38	44.61	54	-9.39	-	-	145	342	V
4	* 5.15	34.56	RMS	34.2	-24.1	.38	45.04	54	-8.96	-	-	145	342	V

* - indicates frequency in CFR15.205/IC7.2.2 Restricted Band

Pk - Peak detector

RMS - RMS detection

HARMONICS AND SPURIOUS EMISSIONS

LOW CHANNEL HORIZONTAL

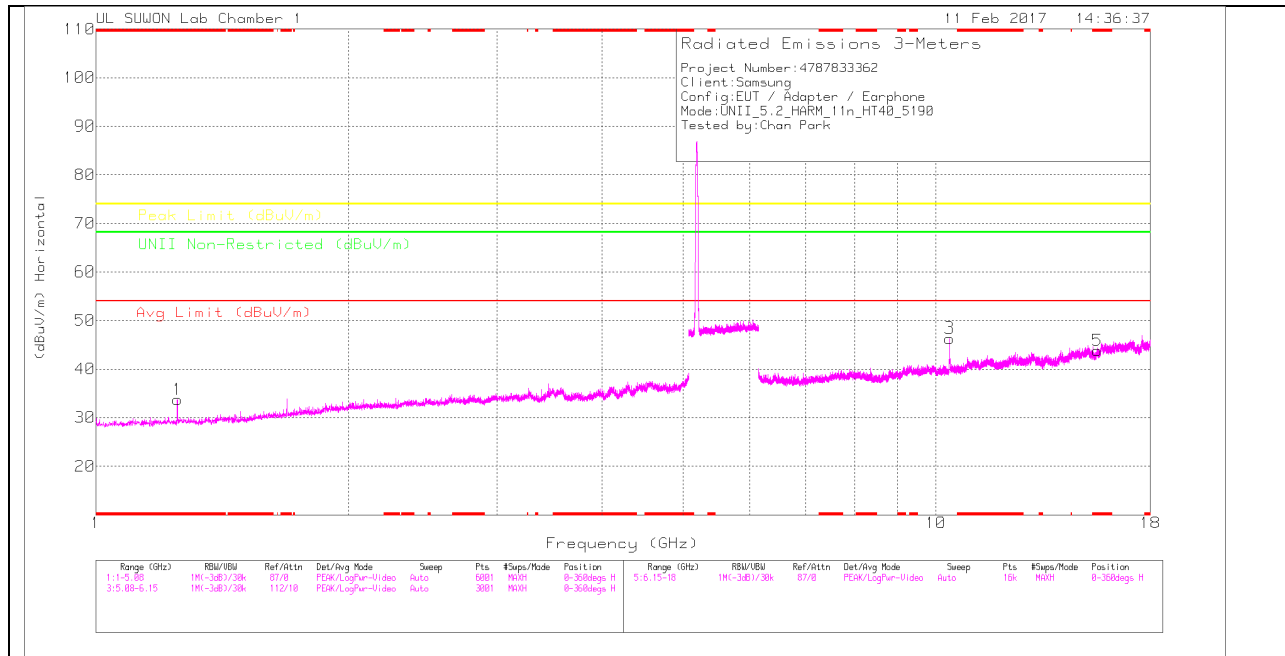

LOW CHANNEL VERTICAL

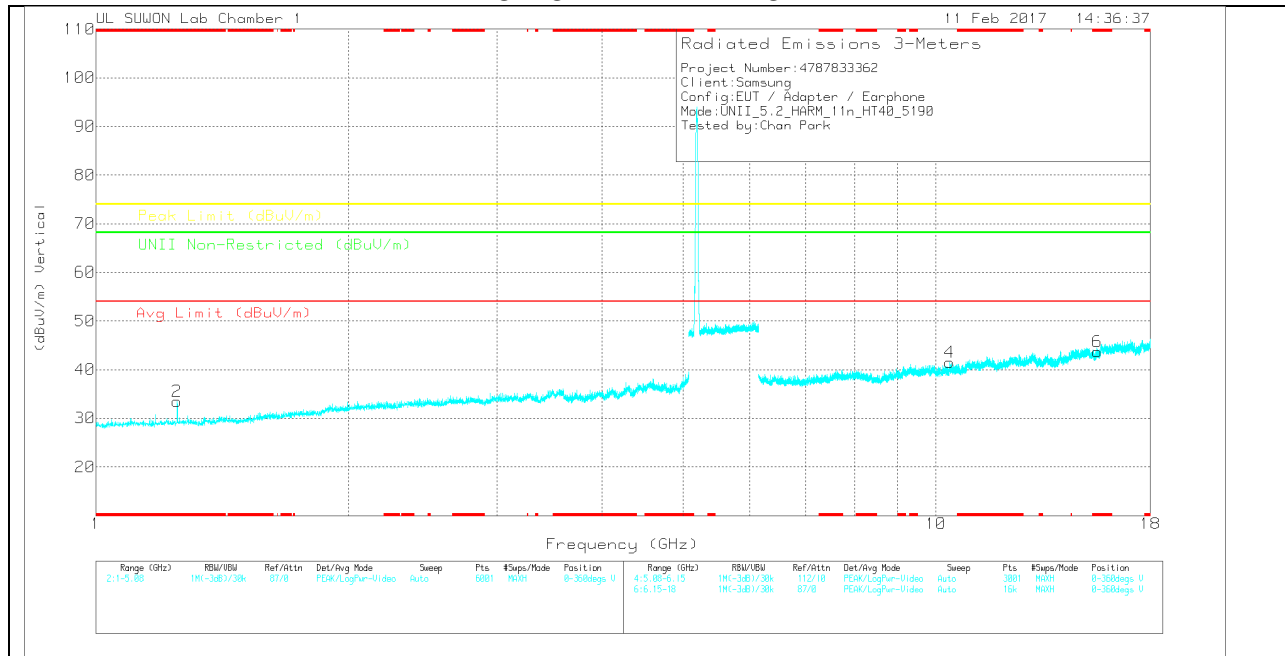

Note: Emission was scanned up to 40GHz; No emissions were detected above the noise floor which was at least 20dB below the specification limit.

LOW CHANNEL DATA

Trace Markers

Marker	Frequency (GHz)	Meter Reading (dBuV)	Det	3117(0016 8717_150 619)	5Ghz_LP(d B)	DC Corr (dB)	Corrected Reading (dBuV/m)	Avg Limit (dBuV/m)	Margin (dB)	Peak Limit (dBuV/m)	Margin (dB)	UNII Non-Restricted (dBuV/m)	Margin (dB)	Azimuth (Degs)	Height (cm)	Polarity
1	* 1.25	44.99	Pk	28.3	-39.6	0	33.69	-	-	74	-40.31	-	-	0-360	250	H
2	* 1.25	44.83	Pk	28.3	-39.6	0	33.53	-	-	74	-40.47	-	-	0-360	250	V
3	10.379	36.34	Pk	37.8	-27.8	0	46.34	-	-	-	-	68.2	-21.86	0-360	250	H
5	* 15.569	22.66	Pk	40.3	-19.1	0	43.86	-	-	74	-30.14	-	-	0-360	250	H
4	10.38	31.55	Pk	37.8	-27.8	0	41.55	-	-	-	-	68.2	-26.65	0-360	250	V
6	* 15.57	22.44	Pk	40.3	-19.1	0	43.64	-	-	74	-30.36	-	-	0-360	250	V

* - indicates frequency in CFR15.205/IC7.2.2 Restricted Band

Pk – Peak detector

Radiated Emissions

Frequency (GHz)	Meter Reading (dBuV)	Det	3117(001687 17_150619)	6Ghz_HP(dB)	DC Corr (dB)	Corrected Reading (dBuV/m)	Avg Limit (dBuV/m)	Margin (dB)	Peak Limit (dBuV/m)	Margin (dB)	UNII Non-Restricted (dBuV/m)	Margin (dB)	Azimuth (Degs)	Height (cm)	Polarity
10.38	47.14	PK-U	37.8	-27.8	0	57.14	-	-	-	-	68.2	-11.06	140	247	H

* - indicates frequency in CFR15.205/IC7.2.2 Restricted Band

PK-U - U-NII: Maximum Peak

HIGH CHANNEL HORIZONTAL

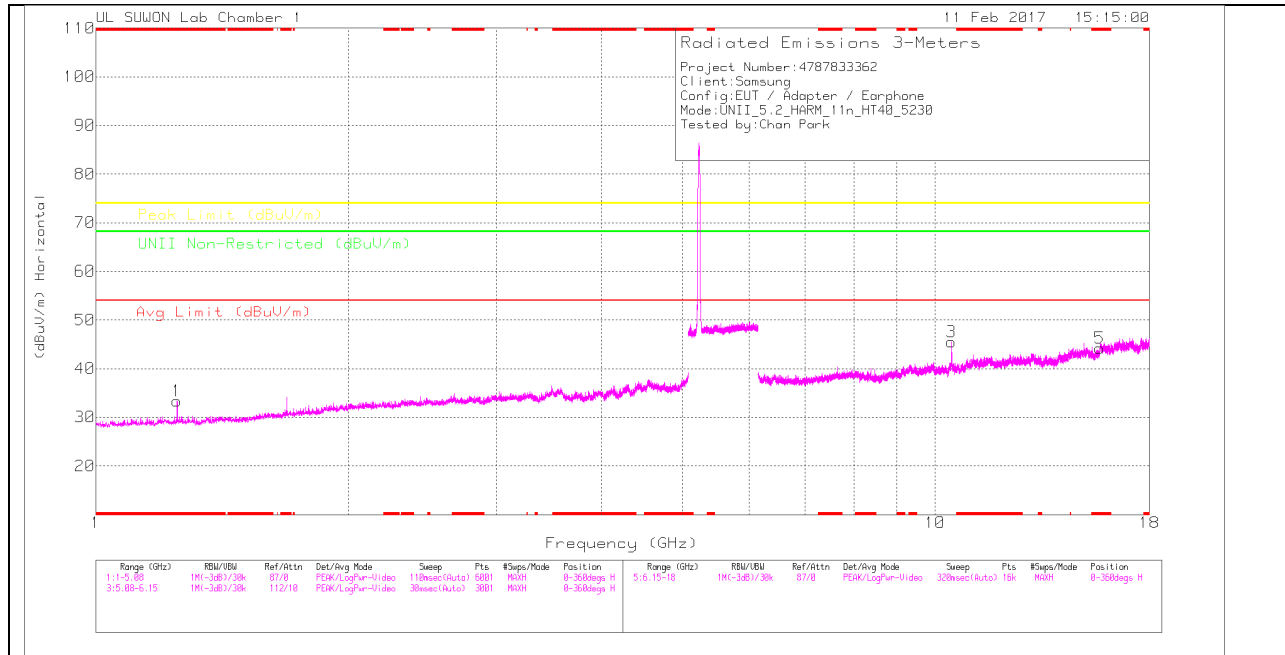

HIGH CHANNEL VERTICAL

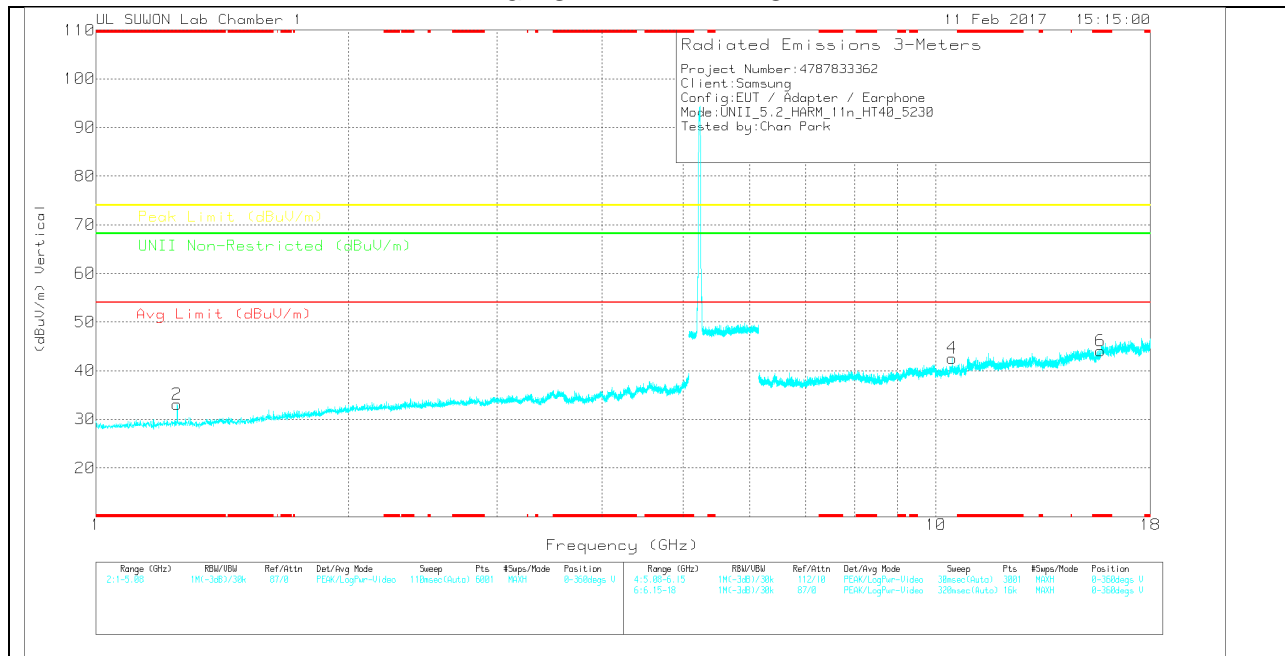

Note: Emission was scanned up to 40GHz; No emissions were detected above the noise floor which was at least 20dB below the specification limit.

HIGH CHANNEL DATA

Trace Markers

Marker	Frequency (GHz)	Meter Reading (dBuV)	Det	3117(0016 8717)_150 619	5Ghz_LP(d B)	DC Corr (dB)	Corrected Reading (dBuV/m)	Avg Limit (dBuV/m)	Margin (dB)	Peak Limit (dBuV/m)	Margin (dB)	UNII Non-Restricted (dBuV/m)	Margin (dB)	Azimuth (Degs)	Height (cm)	Polarity
1	* 1.25	44.7	Pk	28.3	-39.6	0	33.4	-	-	74	-40.6	-	-	0-360	250	H
2	* 1.25	44.35	Pk	28.3	-39.6	0	33.05	-	-	74	-40.95	-	-	0-360	250	V
3	10.459	36.27	Pk	37.8	-28.6	0	45.47	-	-	-	-	68.2	-22.73	0-360	250	H
5	* 15.692	22.66	Pk	40.4	-18.9	0	44.16	-	-	74	-29.84	-	-	0-360	250	H
4	10.46	33.29	Pk	37.8	-28.5	0	42.59	-	-	-	-	68.2	-25.61	0-360	250	V
6	* 15.696	22.52	Pk	40.4	-18.8	0	44.12	-	-	74	-29.88	-	-	0-360	250	V

* - indicates frequency in CFR15.205/IC7.2.2 Restricted Band

Pk – Peak detector

Radiated Emissions

Frequency (GHz)	Meter Reading (dBuV)	Det	3117(001687 17)_150619	6Ghz_HP(dB)	DC Corr (dB)	Corrected Reading (dBuV/m)	Avg Limit (dBuV/m)	Margin (dB)	Peak Limit (dBuV/m)	Margin (dB)	UNII Non-Restricted (dBuV/m)	Margin (dB)	Azimuth (Degs)	Height (cm)	Polarity
10.46	47.3	PK-U	37.8	-28.6	0	56.5	-	-	-	-	68.2	-11.7	142	229	H

* - indicates frequency in CFR15.205/IC7.2.2 Restricted Band

PK-U - U-NII: Maximum Peak

10.2. 5.3 GHz

10.2.1. TX ABOVE 1 GHz 802.11a MODE IN THE 5.3 GHz BAND AUTHORIZED BANDEDGE (HIGH CHANNEL)

HORIZONTAL PEAK AND AVERAGE PLOT

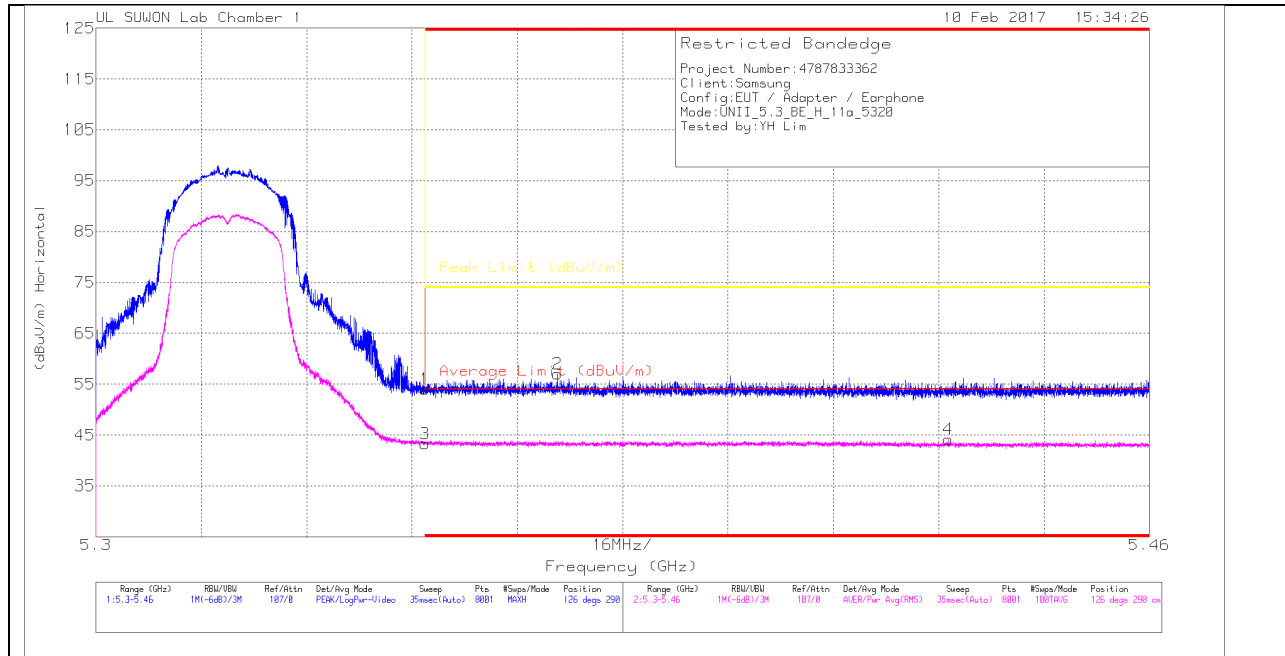

HORIZONTAL DATA

Trace Markers

Marker	Frequency (GHz)	Meter Reading (dBuV)	Det	3117(00168 717_15061 9)	10dB_Att(dB)	DC Corr (dB)	Corrected Reading (dBuV/m)	Average Limit (dBuV/m)	Margin (dB)	Peak Limit (dBuV/m)	PK Margin (dB)	Azimuth (Degs)	Height (cm)	Polarity
1	* 5.35	43.02	Pk		-23.5	0	54.02	-	-	74	-19.98	126	290	H
2	* 5.37	45.79	Pk		-23.3	0	56.99	-	-	74	-17.01	126	290	H
3	* 5.35	32.41	RMS		-23.8	.18	43.29	54	-10.71	-	-	126	290	H
4	* 5.429	33.14	RMS		-23.8	.18	44.12	54	-9.88	-	-	126	290	H

* - indicates frequency in CFR15.205/IC7.2.2 Restricted Band

Pk - Peak detector

RMS - RMS detection

VERTICAL PEAK AND AVERAGE PLOT

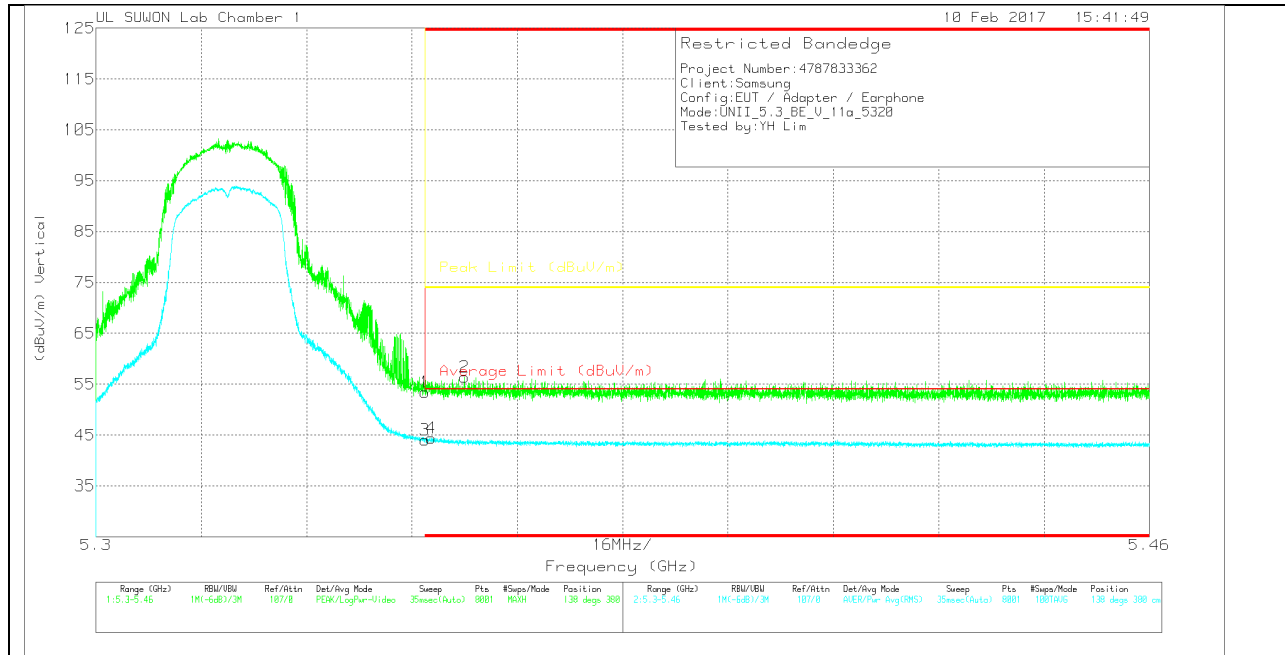

VERTICAL DATA

Trace Markers

Marker	Frequency (GHz)	Meter Reading (dBuV)	Det	3117(001687 17)_150619	10dB_Att(dB)	DC Corr (dB)	Corrected Reading (dBuV/m)	Average Limit (dBuV/m)	Margin (dB)	Peak Limit (dBuV/m)	PK Margin (dB)	Azimuth (Degs)	Height (cm)	Polarity
1	* 5.35	42.4	Pk	34.5	-23.5	0	53.4	-	-	74	-20.6	138	380	V
2	* 5.356	45.22	Pk	34.5	-23.3	0	56.42	-	-	74	-17.58	138	380	V
3	* 5.35	33.17	RMS	34.5	-23.8	.18	44.05	54	-9.95	-	-	138	380	V
4	* 5.351	33.55	RMS	34.5	-23.8	.18	44.43	54	-9.57	-	-	138	380	V

* - indicates frequency in CFR15.205/IC7.2.2 Restricted Band

Pk - Peak detector

RMS - RMS detection

HARMONICS AND SPURIOUS EMISSIONS

LOW CHANNEL HORIZONTAL

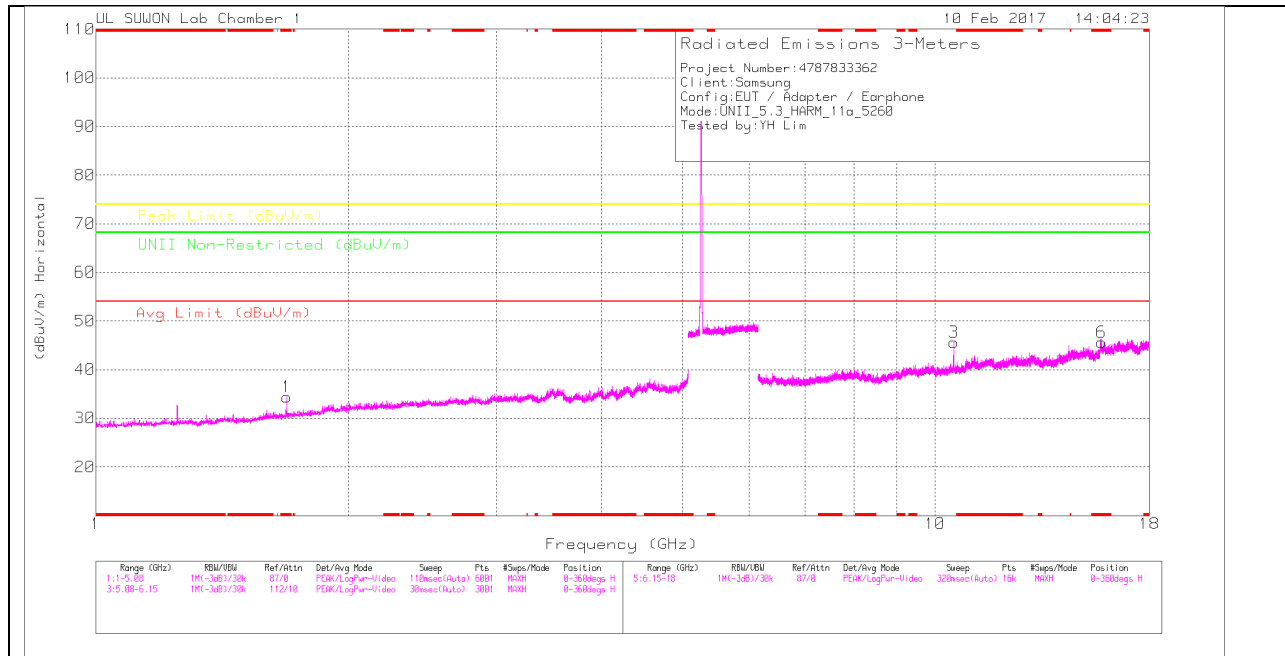

LOW CHANNEL VERTICAL

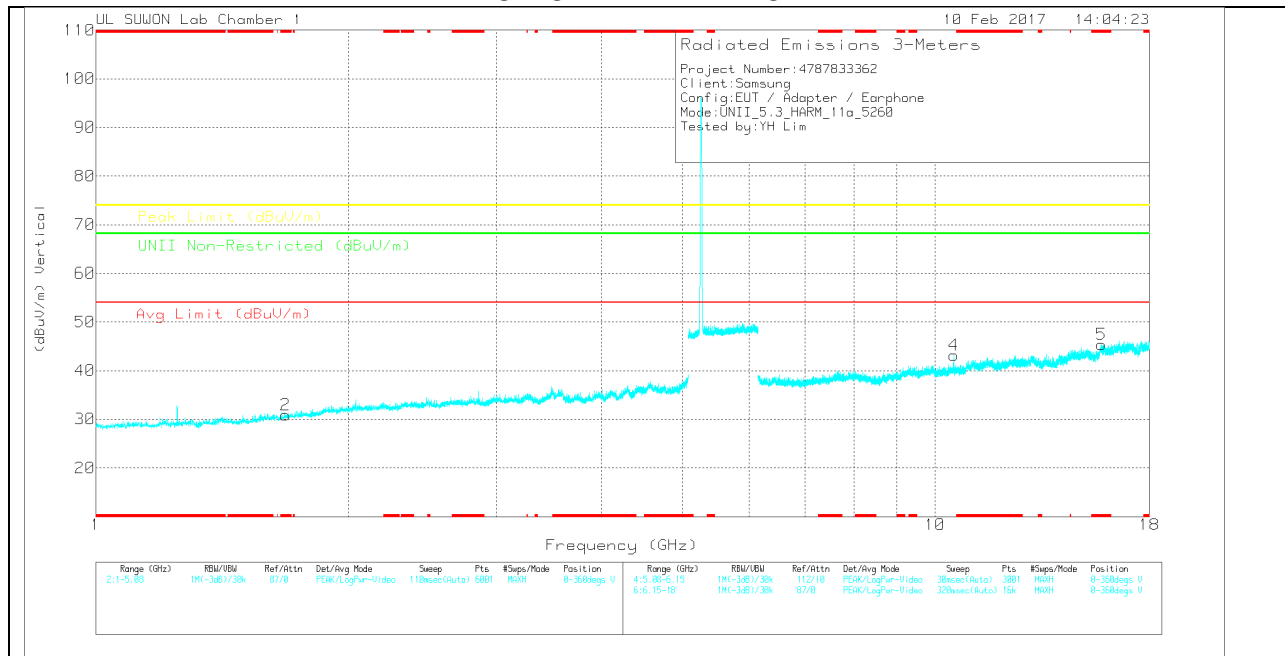

Note: Emission was scanned up to 40GHz; No emissions were detected above the noise floor which was at least 20dB below the specification limit.

LOW CHANNEL DATA

Trace Markers

Marker	Frequency (GHz)	Meter Reading (dBuV)	Det	3117(0016 8717_150 619)	5Ghz_LP(d B)	DC Corr (dB)	Corrected Reading (dBuV/m)	Avg Limit (dBuV/m)	Margin (dB)	Peak Limit (dBuV/m)	Margin (dB)	UNII Non-Restricted (dBuV/m)	Margin (dB)	Azimuth (Degs)	Height (cm)	Polarity
1	* 1.687	43.92	Pk	29.5	-39	0	34.42	-	-	74	-39.58	-	-	0-360	150	H
2	* 1.683	40.54	Pk	29.5	-39.1	0	30.94	-	-	74	-43.06	-	-	0-360	150	V
3	10.519	35.89	Pk	37.9	-28.2	0	45.59	-	-	-	-	68.2	-22.61	0-360	150	H
6	* 15.778	22.01	Pk	40.4	-16.8	0	45.61	-	-	74	-28.39	-	-	0-360	250	H
4	10.52	33.58	Pk	37.9	-28.3	0	43.18	-	-	-	-	68.2	-25.02	0-360	250	V
5	* 15.784	21.73	Pk	40.4	-16.8	0	45.33	-	-	74	-28.67	-	-	0-360	250	V

* - indicates frequency in CFR15.205/IC7.2.2 Restricted Band

Pk – Peak detector

Radiated Emissions

Frequency (GHz)	Meter Reading (dBuV)	Det	3117(001687 17_150619)	6Ghz_HP(dB)	DC Corr (dB)	Corrected Reading (dBuV/m)	Avg Limit (dBuV/m)	Margin (dB)	Peak Limit (dBuV/m)	Margin (dB)	UNII Non-Restricted (dBuV/m)	Margin (dB)	Azimuth (Degs)	Height (cm)	Polarity
10.522	47.06	PK-U	37.9	-28.3	0	56.66	-	-	-	-	68.2	-11.54	185	222	H
10.52	34.98	ADR	37.9	-28.3	.18	44.76	54	-9.24	-	-	-	-	185	222	H
10.521	43.3	PK-U	37.9	-28.3	0	52.9	-	-	-	-	68.2	-15.3	158	345	V
10.52	31.21	ADR	37.9	-28.3	.18	40.99	54	-13.01	-	-	-	-	158	345	V

* - indicates frequency in CFR15.205/IC7.2.2 Restricted Band

PK-U - U-NII: Maximum Peak

ADR - U-NII AD primary method, RMS average

MID CHANNEL HORIZONTAL

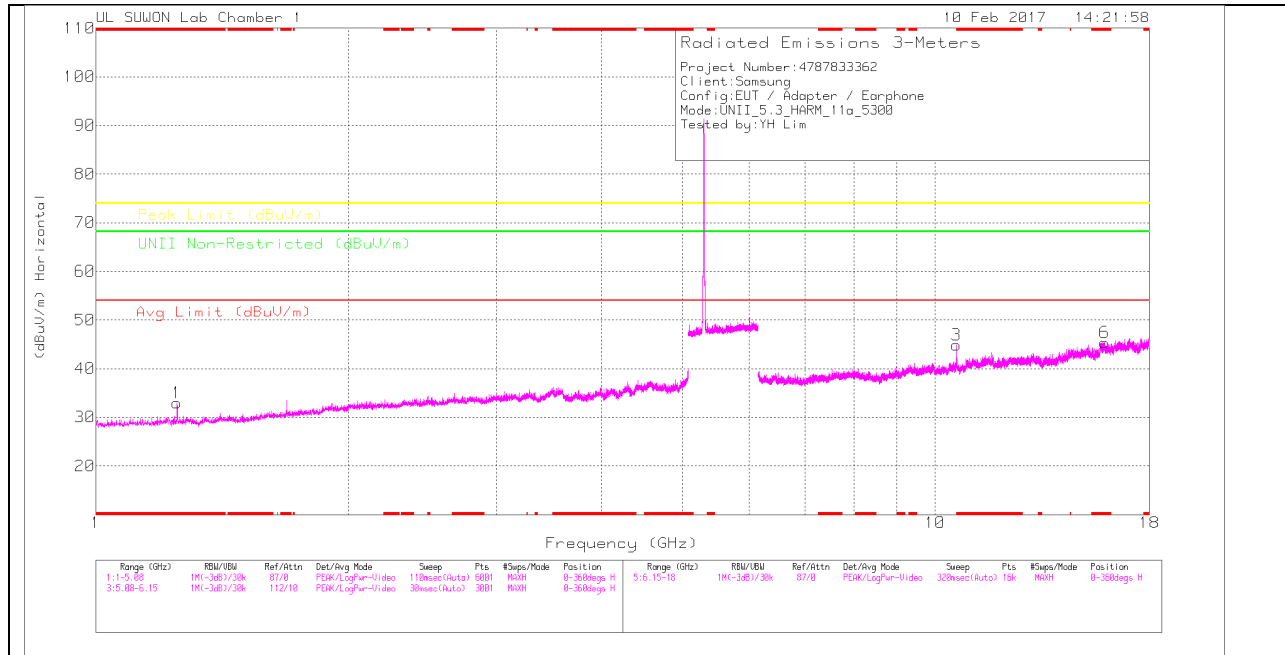

MID CHANNEL VERTICAL

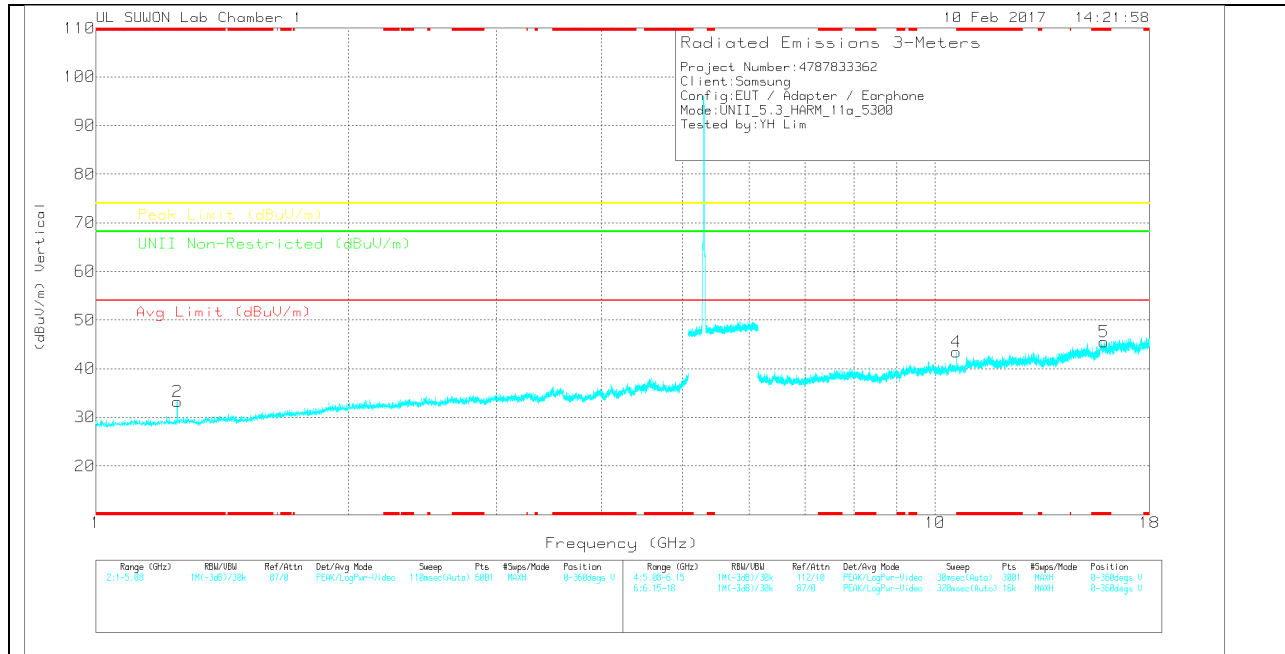

Note: Emission was scanned up to 40GHz; No emissions were detected above the noise floor which was at least 20dB below the specification limit.

MID CHANNEL DATA

Trace Markers

Marker	Frequency (GHz)	Meter Reading (dBuV)	Det	3117(00168717)_150619	5Ghz_LP(dB)	DC Corr (dB)	Corrected Reading (dBuV/m)	Avg Limit (dBuV/m)	Margin (dB)	Peak Limit (dBuV/m)	Margin (dB)	UNII Non-Restricted (dBuV/m)	Margin (dB)	Azimuth (Degs)	Height (cm)	Polarity
1	* 1.25	44.26	Pk	28.3	-39.6	0	32.96	-	-	74	-41.04	-	-	0-360	250	H
2	* 1.25	44.49	Pk	28.3	-39.6	0	33.19	-	-	74	-40.81	-	-	0-360	250	V
3	* 10.6	34.8	Pk	37.9	-27.9	0	44.8	-	-	74	-29.2	-	-	0-360	250	H
6	* 15.91	24.02	Pk	40.5	-19.2	0	45.32	-	-	74	-28.68	-	-	0-360	250	H
4	10.599	33.43	Pk	37.9	-27.9	0	43.43	-	-	-	-	68.2	-24.77	0-360	250	V
5	* 15.895	24.25	Pk	40.5	-19.2	0	45.55	-	-	74	-28.45	-	-	0-360	250	V

* - indicates frequency in CFR15.205/IC7.2.2 Restricted Band

Pk – Peak detector

Radiated Emissions

Frequency (GHz)	Meter Reading (dBuV)	Det	3117(00168717)_150619	6Ghz_HP(dB)	DC Corr (dB)	Corrected Reading (dBuV/m)	Avg Limit (dBuV/m)	Margin (dB)	Peak Limit (dBuV/m)	Margin (dB)	UNII Non-Restricted (dBuV/m)	Margin (dB)	Azimuth (Degs)	Height (cm)	Polarity
10.6	45.9	PK-U	37.9	-27.9	0	55.9	-	-	-	-	68.2	-12.3	171	233	H
10.6	34.53	ADR	37.9	-27.9	.18	44.71	54	-9.29	-	-	-	-	171	233	H
* 10.601	42.83	PK-U	37.9	-27.9	0	52.83	-	-	74	-21.17	-	-	199	198	V
* 10.6	30.32	ADR	37.9	-27.9	.18	40.5	54	-13.5	-	-	-	-	199	198	V

* - indicates frequency in CFR15.205/IC7.2.2 Restricted Band

PK-U - U-NII: Maximum Peak

ADR - U-NII AD primary method, RMS average

HIGH CHANNEL HORIZONTAL

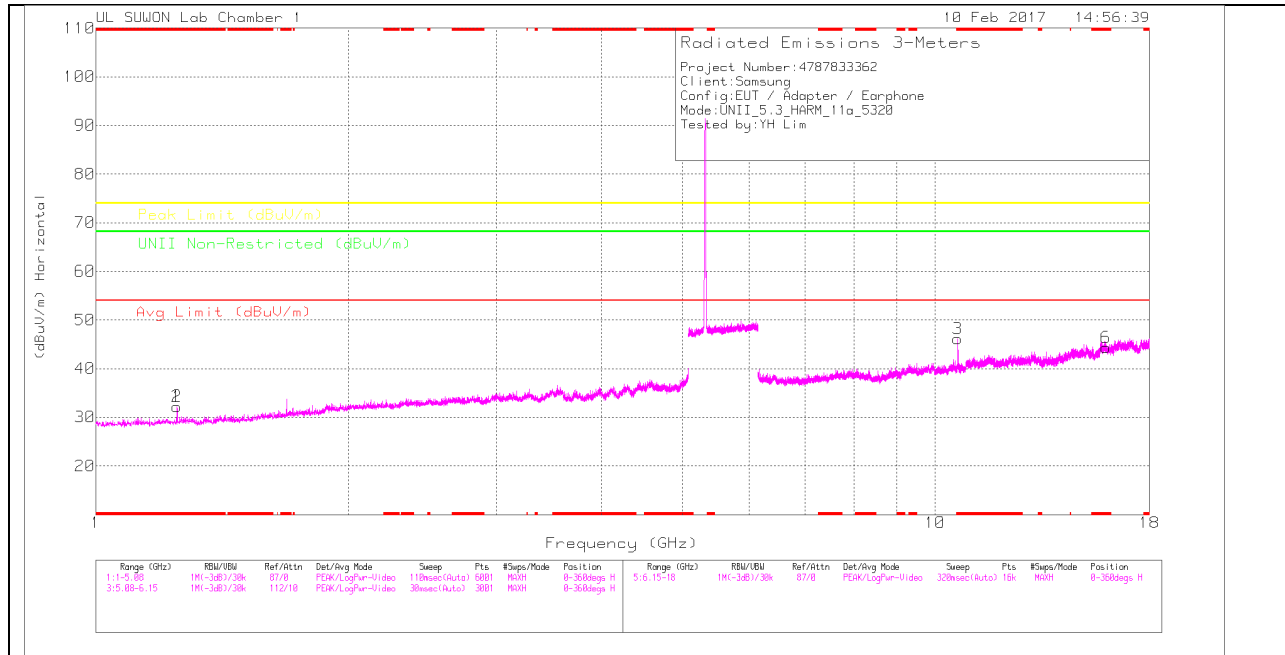

HIGH CHANNEL VERTICAL

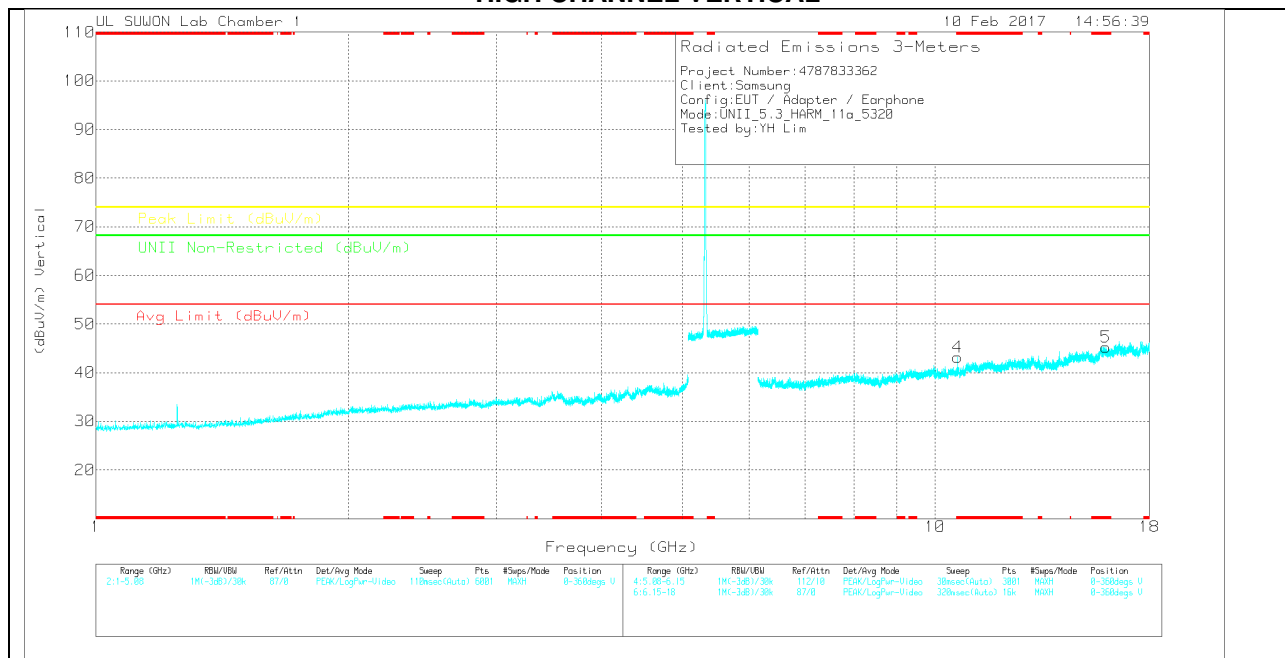

Note: Emission was scanned up to 40GHz; No emissions were detected above the noise floor which was at least 20dB below the specification limit.

HIGH CHANNEL DATA

Trace Markers

Marker	Frequency (GHz)	Meter Reading (dBuV)	Det	3117(0016 8717)_150 619	5Ghz_LP(d B)	DC Corr (dB)	Corrected Reading (dBuV/m)	Avg Limit (dBuV/m)	Margin (dB)	Peak Limit (dBuV/m)	Margin (dB)	UNII Non-Restricted (dBuV/m)	Margin (dB)	Azimuth (Degs)	Height (cm)	Polarity
1	* 1.25	43.54	Pk	28.3	-39.6	0	32.24	-	-	74	-41.76	-	-	0-360	250	H
2	* 1.25	43.54	Pk	28.3	-39.6	0	32.24	-	-	74	-41.76	-	-	0-360	250	H
3	* 10.64	36.81	Pk	37.9	-28.6	0	46.11	-	-	74	-27.89	-	-	0-360	250	H
6	* 15.968	23.73	Pk	40.6	-20	0	44.33	-	-	74	-29.67	-	-	0-360	150	H
4	* 10.639	33.91	Pk	37.9	-28.6	0	43.21	-	-	74	-30.79	-	-	0-360	250	V
5	* 15.966	24.64	Pk	40.6	-20	0	45.24	-	-	74	-28.76	-	-	0-360	250	V

* - indicates frequency in CFR15.205/IC7.2.2 Restricted Band

Pk – Peak detector

Radiated Emissions

Frequency (GHz)	Meter Reading (dBuV)	Det	3117(001687 17)_150619	6Ghz_HP(dB)	DC Corr (dB)	Corrected Reading (dBuV/m)	Avg Limit (dBuV/m)	Margin (dB)	Peak Limit (dBuV/m)	Margin (dB)	UNII Non-Restricted (dBuV/m)	Margin (dB)	Azimuth (Degs)	Height (cm)	Polarity
* 10.638	47.45	PK-U	37.9	-28.6	0	56.75	-	-	74	-17.25	-	-	189	216	H
* 10.64	35.5	ADR	37.9	-28.6	.18	44.98	54	-9.02	-	-	-	-	189	216	H
* 10.641	44.08	PK-U	38	-28.6	0	53.48	-	-	74	-20.52	-	-	52	269	V
* 10.64	30.6	ADR	37.9	-28.6	.18	40.08	54	-13.92	-	-	-	-	52	269	V

* - indicates frequency in CFR15.205/IC7.2.2 Restricted Band

PK-U - U-NII: Maximum Peak

ADR - U-NII AD primary method, RMS average

10.2.2. TX ABOVE 1GHz 802.11n HT20 MODE IN THE 5.3GHz BAND

AUTHORIZED BANDEDGE (HIGH CHANNEL)

HORIZONTAL PEAK AND AVERAGE PLOT

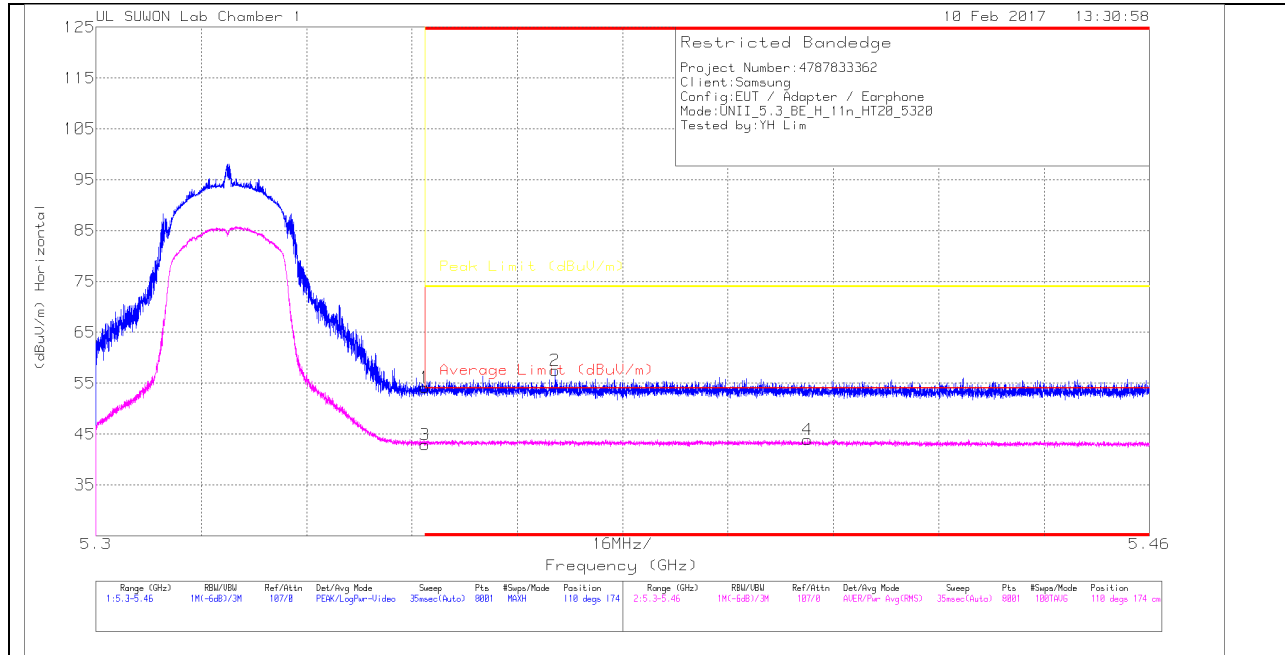

HORIZONTAL DATA

Trace Markers

Marker	Frequency (GHz)	Meter Reading (dBuV)	Det	3117(00168 717)_15061 9	10dB_Att(dB)	DC Corr (dB)	Corrected Reading (dBuV/m)	Average Limit (dBuV/m)	Margin (dB)	Peak Limit (dBuV/m)	PK Margin (dB)	Azimuth (Degs)	Height (cm)	Polarity
1	* 5.35	43.18	Pk		-23.5	0	54.18	-	-	74	-19.82	110	174	H
2	* 5.37	46.33	Pk		-23.3	0	57.53	-	-	74	-16.47	110	174	H
3	* 5.35	32.02	RMS		-23.8	.17	42.89	54	-11.11	-	-	110	174	H
4	* 5.408	32.96	RMS		-23.8	.17	43.93	54	-10.07	-	-	110	174	H

* - indicates frequency in CFR15.205/IC7.2.2 Restricted Band

Pk - Peak detector

RMS - RMS detection

VERTICAL PEAK AND AVERAGE PLOT

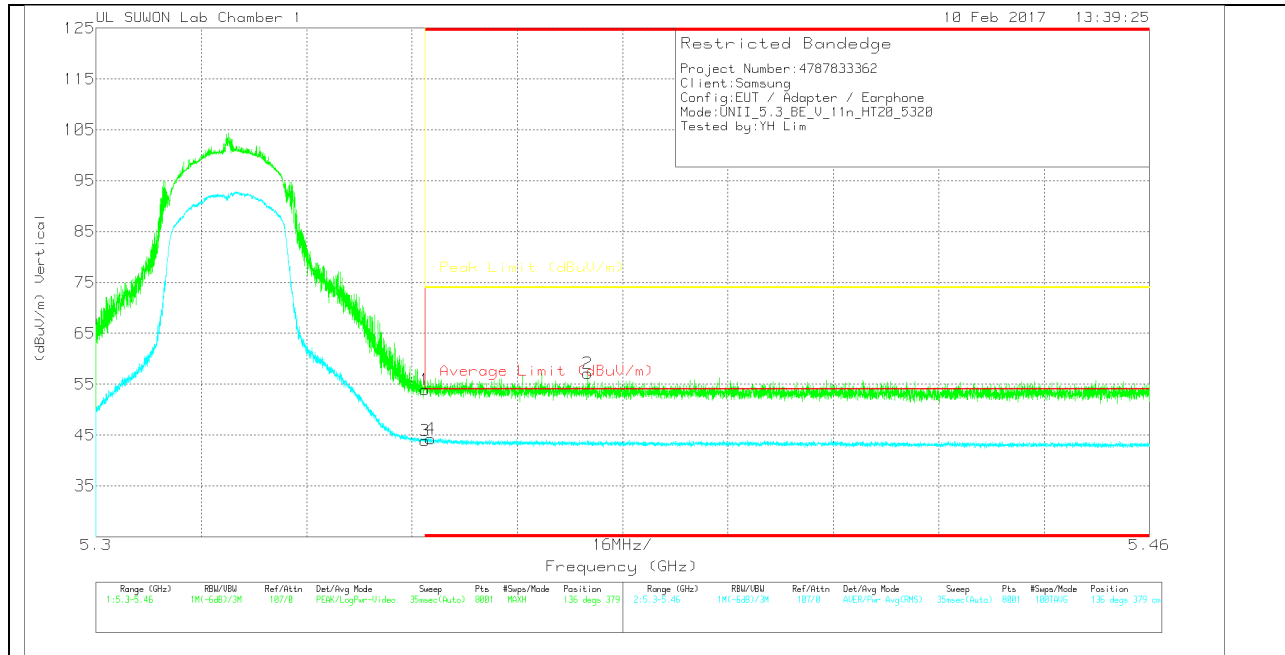

VERTICAL DATA

Trace Markers

Marker	Frequency (GHz)	Meter Reading (dBuV)	Det	3117(00168 717)_15061 9	10dB_Att(dB)	DC Corr (dB)	Corrected Reading (dBuV/m)	Average Limit (dBuV/m)	Margin (dB)	Peak Limit (dBuV/m)	PK Margin (dB)	Azimuth (Degs)	Height (cm)	Polarity
1	* 5.35	42.88	Pk	34.5	-23.5	0	53.88	-	-	74	-20.12	136	379	V
2	* 5.375	45.99	Pk	34.5	-23.4	0	57.09	-	-	74	-16.91	136	379	V
3	* 5.35	32.97	RMS	34.5	-23.8	.17	43.84	54	-10.16	-	-	136	379	V
4	* 5.351	33.45	RMS	34.5	-23.8	.17	44.32	54	-9.68	-	-	136	379	V

* - indicates frequency in CFR15.205/IC7.2.2 Restricted Band

Pk - Peak detector

RMS - RMS detection

HARMONICS AND SPURIOUS EMISSIONS

LOW CHANNEL HORIZONTAL

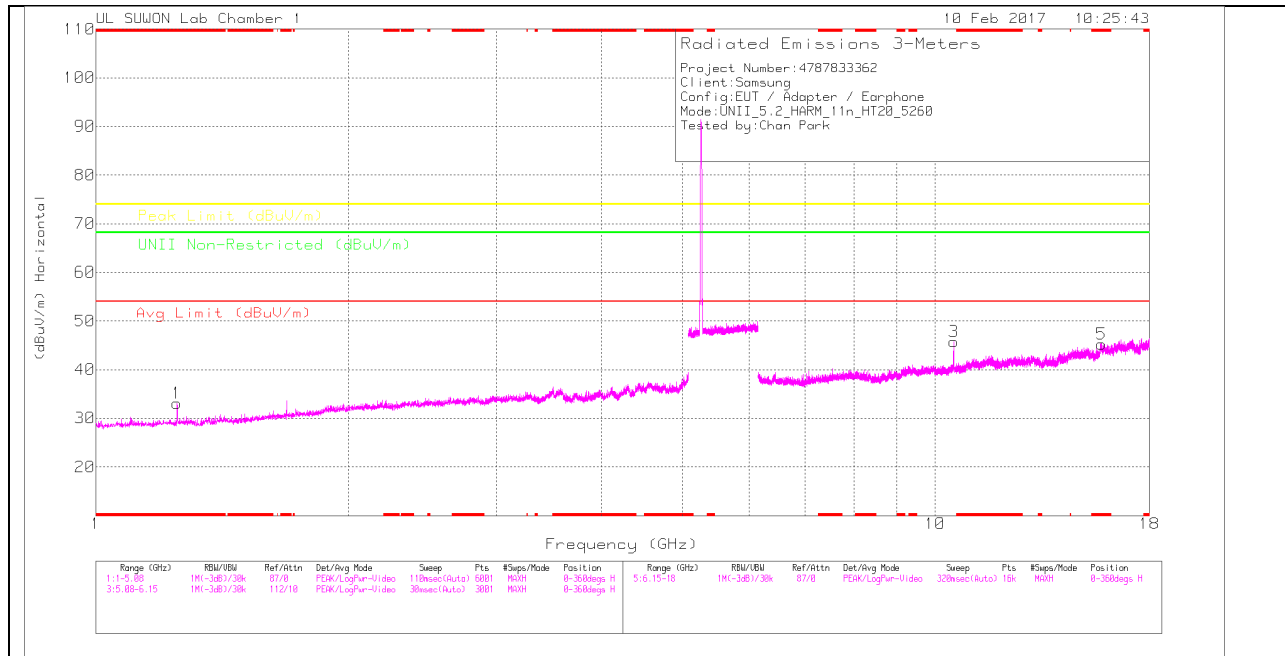

LOW CHANNEL VERTICAL

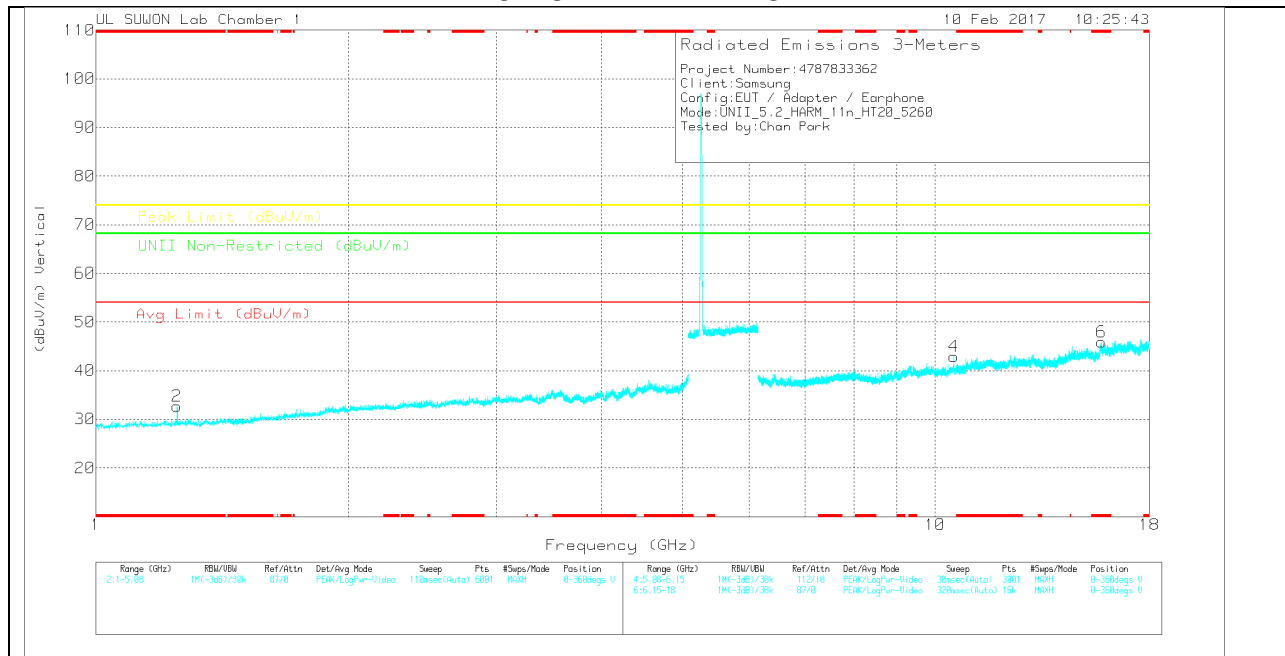

Note: Emission was scanned up to 40GHz; No emissions were detected above the noise floor which was at least 20dB below the specification limit.

LOW CHANNEL DATA

Trace Markers

Marker	Frequency (GHz)	Meter Reading (dBuV)	Det	3117(0016 8717)_150 619	5GHz_LP[d B]	DC Corr (dB)	Corrected Reading (dBuV/m)	Avg Limit (dBuV/m)	Margin (dB)	Peak Limit (dBuV/m)	Margin (dB)	UNII Non-Restricted (dBuV/m)	Margin (dB)	Azimuth (Degs)	Height (cm)	Polarity
1	* 1.25	44.33	Pk	28.3	-39.6	0	33.03	-	-	74	-40.97	-	-	0-360	250	H
2	* 1.25	43.98	Pk	28.3	-39.6	0	32.68	-	-	74	-41.32	-	-	0-360	250	V
3	10.52	36.16	Pk	37.9	-28.3	0	45.76	-	-	-	-	68.2	-22.44	0-360	250	H
5	* 15.78	21.7	Pk	40.4	-16.8	0	45.3	-	-	74	-28.7	-	-	0-360	250	H
4	10.52	33.3	Pk	37.9	-28.3	0	42.9	-	-	-	-	68.2	-25.3	0-360	250	V
6	* 15.78	22.29	Pk	40.4	-16.8	0	45.89	-	-	74	-28.11	-	-	0-360	250	V

* - indicates frequency in CFR15.205/IC7.2.2 Restricted Band

Pk – Peak detector

Note: Only peak measurement was performed. Because peak measurement result of unwanted emission is less than average limit (54dBuV/m).

MID CHANNEL HORIZONTAL

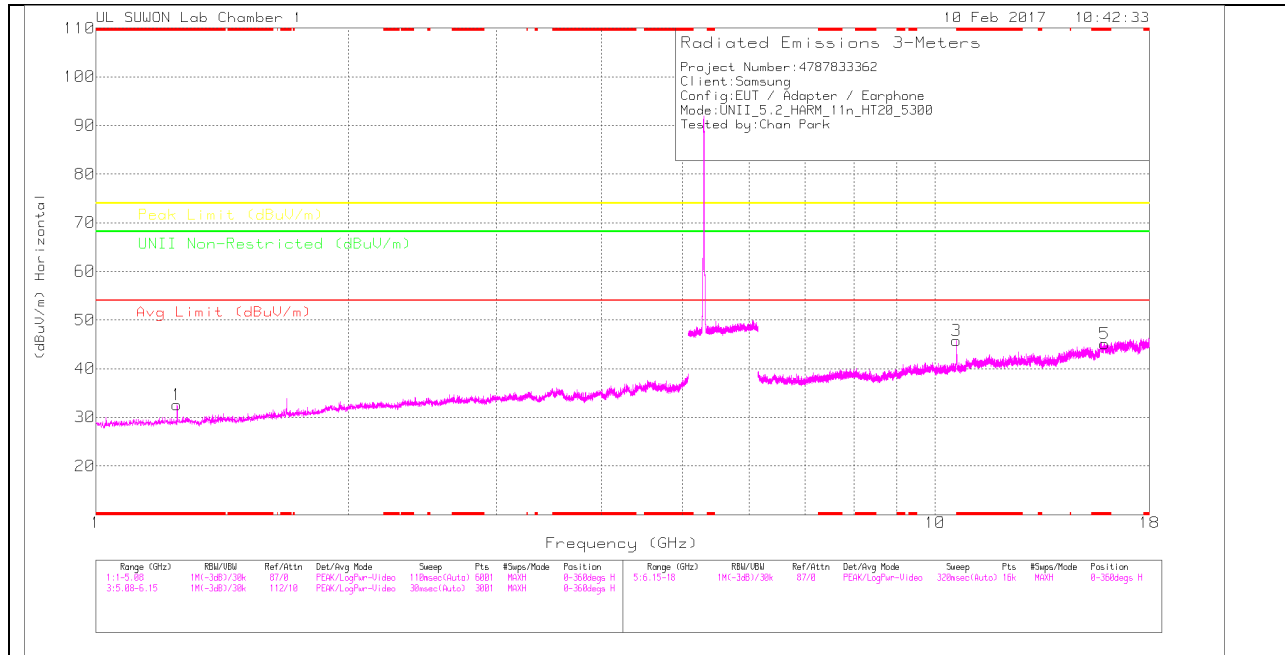

MID CHANNEL VERTICAL

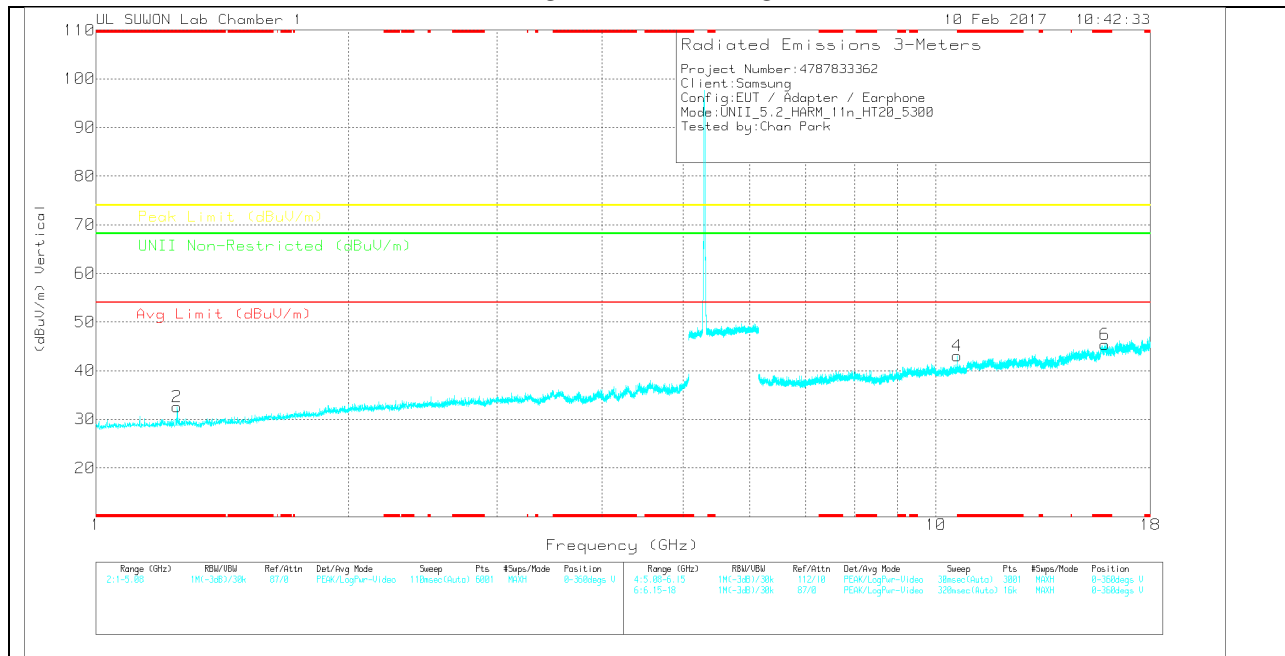

Note: Emission was scanned up to 40GHz; No emissions were detected above the noise floor which was at least 20dB below the specification limit.

MID CHANNEL DATA

Trace Markers

Marker	Frequency (GHz)	Meter Reading (dBuV)	Det	3117(0016 8717)_150 619	5Ghz_LP(d B)	DC Corr (dB)	Corrected Reading (dBuV/m)	Avg Limit (dBuV/m)	Margin (dB)	Peak Limit (dBuV/m)	Margin (dB)	UNII Non-Restricted (dBuV/m)	Margin (dB)	Azimuth (Degs)	Height (cm)	Polarity
1	* 1.25	43.91	Pk	28.3	-39.6	0	32.61	-	-	74	-41.39	-	-	0-360	250	H
2	* 1.25	43.91	Pk	28.3	-39.6	0	32.61	-	-	74	-41.39	-	-	0-360	250	V
3	* 10.6	35.75	Pk	37.9	-27.9	0	45.75	-	-	74	-28.25	-	-	0-360	250	H
5	* 15.903	23.81	Pk	40.5	-19.2	0	45.11	-	-	74	-28.89	-	-	0-360	150	H
4	* 10.6	33.03	Pk	37.9	-27.9	0	43.03	-	-	74	-30.97	-	-	0-360	250	V
6	* 15.9	24.11	Pk	40.5	-19.2	0	45.41	-	-	74	-28.59	-	-	0-360	150	V

* - indicates frequency in CFR15.205/IC7.2.2 Restricted Band

Pk – Peak detector

Radiated Emissions

Frequency (GHz)	Meter Reading (dBuV)	Det	3117(001687 17)_150619	6Ghz_HP(dB)	DC Corr (dB)	Corrected Reading (dBuV/m)	Avg Limit (dBuV/m)	Margin (dB)	Peak Limit (dBuV/m)	Margin (dB)	UNII Non-Restricted (dBuV/m)	Margin (dB)	Azimuth (Degs)	Height (cm)	Polarity
* 10.601	47.34	PK-U	37.9	-27.8	0	57.44	-	-	74	-16.56	-	-	186	215	H
* 10.6	35.25	ADR	37.9	-27.9	.17	45.42	54	-8.58	-	-	-	-	186	215	H
* 10.601	43.01	PK-U	37.9	-27.8	0	53.11	-	-	74	-20.89	-	-	171	233	V
* 10.6	31.48	ADR	37.9	-27.9	.17	41.65	54	-12.35	-	-	-	-	171	233	V

* - indicates frequency in CFR15.205/IC7.2.2 Restricted Band

PK-U - U-NII: Maximum Peak

ADR - U-NII AD primary method, RMS average

HIGH CHANNEL HORIZONTAL

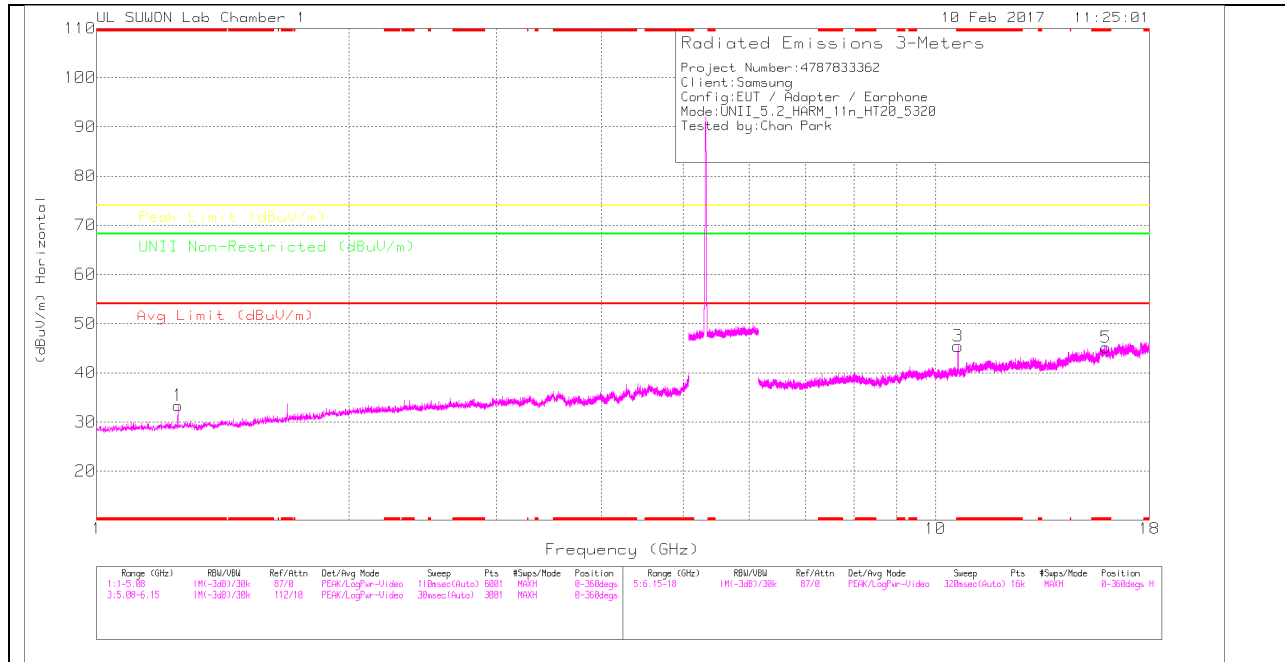

HIGH CHANNEL VERTICAL

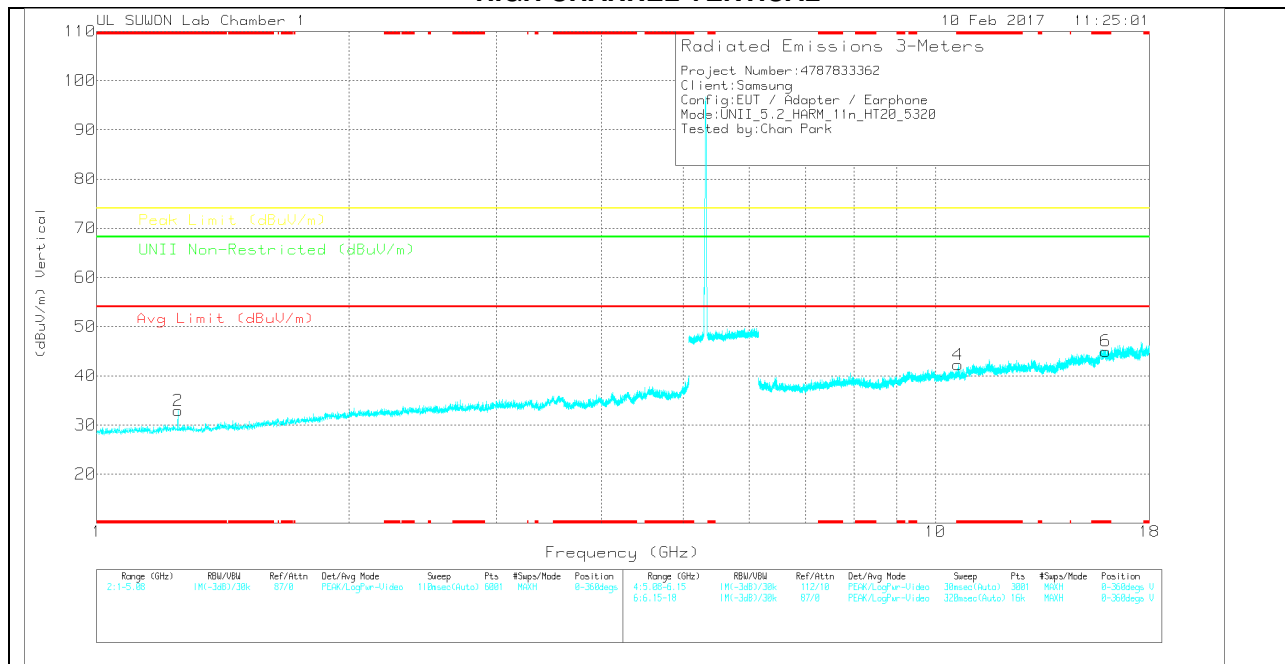

Note: Emission was scanned up to 40GHz; No emissions were detected above the noise floor which was at least 20dB below the specification limit.

HIGH CHANNEL DATA

Trace Markers

Marker	Frequency (GHz)	Meter Reading (dBuV)	Det	3117(0016 8717)_150 619	5Ghz_LP(d B)	DC Corr (dB)	Corrected Reading (dBuV/m)	Avg Limit (dBuV/m)	Margin (dB)	Peak Limit (dBuV/m)	Margin (dB)	UNII Non-Restricted (dBuV/m)	Margin (dB)	Azimuth (Degs)	Height (cm)	Polarity
1	* 1.25	44.63	Pk	28.3	-39.6	0	33.33	-	-	74	-40.67	-	-	0-360	250	H
2	* 1.25	44.2	Pk	28.3	-39.6	0	32.9	-	-	74	-41.1	-	-	0-360	250	V
3	* 10.64	36.08	Pk	37.9	-28.6	0	45.38	-	-	74	-28.62	-	-	0-360	250	H
5	* 15.963	24.49	Pk	40.6	-19.9	0	45.19	-	-	74	-28.81	-	-	0-360	250	H
4	* 10.64	32.94	Pk	37.9	-28.6	0	42.24	-	-	74	-31.76	-	-	0-360	250	V
6	* 15.959	24.28	Pk	40.6	-19.9	0	44.98	-	-	74	-29.02	-	-	0-360	250	V

* - indicates frequency in CFR15.205/IC7.2.2 Restricted Band

PK – Peak detector

Radiated Emissions

Frequency (GHz)	Meter Reading (dBuV)	Det	3117(001687 17)_150619	6Ghz_HP(dB)	DC Corr (dB)	Corrected Reading (dBuV/m)	Avg Limit (dBuV/m)	Margin (dB)	Peak Limit (dBuV/m)	Margin (dB)	UNII Non-Restricted (dBuV/m)	Margin (dB)	Azimuth (Degs)	Height (cm)	Polarity
* 10.641	47.19	PK-U	38	-28.6	0	56.59	-	-	74	-17.41	-	-	195	295	H
* 10.64	35.07	ADR	37.9	-28.6	.17	44.54	54	-9.46	-	-	-	-	195	295	H
* 10.64	43.52	PK-U	37.9	-28.6	0	52.82	-	-	74	-21.18	-	-	158	331	V
* 10.64	31.6	ADR	37.9	-28.6	.17	41.07	54	-12.93	-	-	-	-	158	331	V

* - indicates frequency in CFR15.205/IC7.2.2 Restricted Band

PK-U - U-NII: Maximum Peak

ADR - U-NII AD primary method, RMS average

**10.2.3. TX ABOVE 1GHz 802.11n HT40 MODE IN THE 5.3GHz BAND
 AUTHORIZED BANDEDGE (HIGH CHANNEL)**

HORIZONTAL PEAK AND AVERAGE PLOT

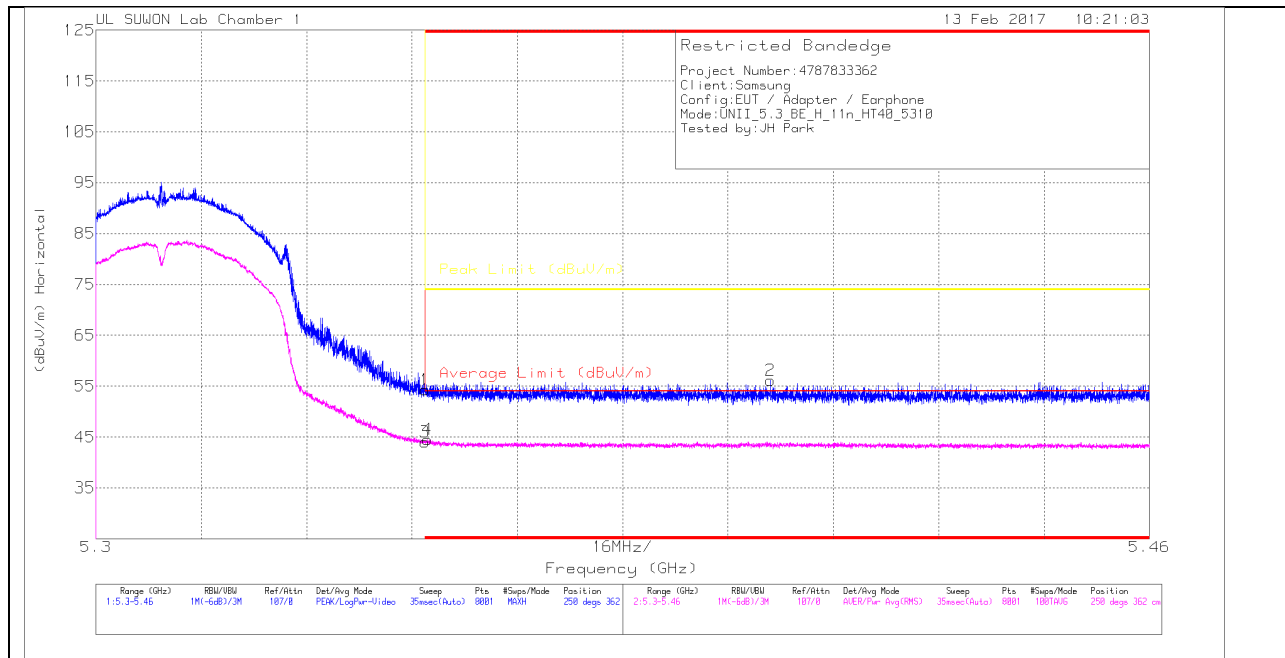

HORIZONTAL DATA

Trace Markers

Marker	Frequency (GHz)	Meter Reading (dBuV)	Det	3117(00168717)_150619	10dB_Att(dB)	DC Corr (dB)	Corrected Reading (dBuV/m)	Average Limit (dBuV/m)	Margin (dB)	Peak Limit (dBuV/m)	PK Margin (dB)	Azimuth (Degs)	Height (cm)	Polarity
1	* 5.35	43.26	Pk		-23.5	0	54.26	-	-	74	-19.74	250	362	H
2	* 5.402	45.09	Pk		-23.5	0	56.19	-	-	74	-17.81	250	362	H
3	* 5.35	32.91	RMS		-23.8	.38	43.99	54	-10.01	-	-	250	362	H
4	* 5.35	33.4	RMS		-23.8	.38	44.48	54	-9.52	-	-	250	362	H

* - indicates frequency in CFR15.205/IC7.2.2 Restricted Band

Pk - Peak detector

RMS - RMS detection

VERTICAL PEAK AND AVERAGE PLOT

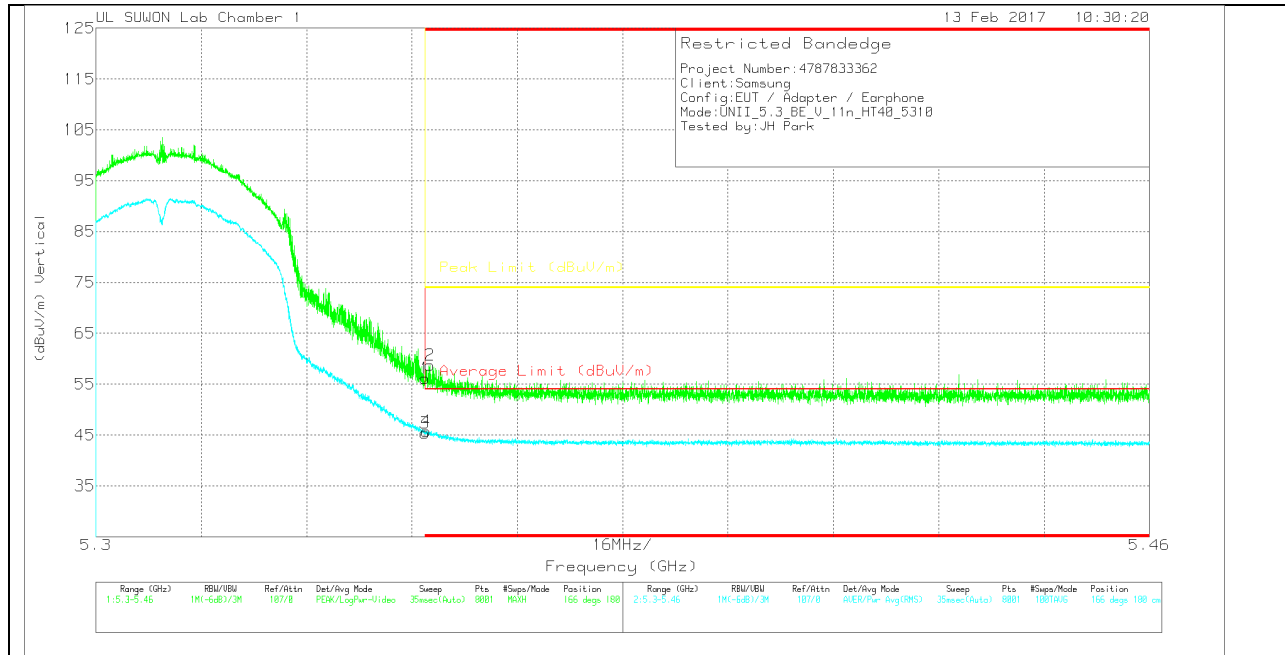

VERTICAL DATA

Trace Markers

Marker	Frequency (GHz)	Meter Reading (dBuV)	Det	3117/001687 17_150619	10dB_Att(dB)	DC Corr (dB)	Corrected Reading (dBuV/m)	Average Limit (dBuV/m)	Margin (dB)	Peak Limit (dBuV/m)	PK Margin (dB)	Azimuth (Degs)	Height (cm)	Polarity
1	* 5.35	45.18	Pk	34.5	-23.5	0	56.18	-	-	74	-17.82	166	180	V
2	* 5.351	47.6	Pk	34.5	-23.4	0	58.7	-	-	74	-15.3	166	180	V
3	* 5.35	34.31	RMS	34.5	-23.8	.38	45.39	54	-8.61	-	-	166	180	V
4	* 5.35	34.68	RMS	34.5	-23.8	.38	45.76	54	-8.24	-	-	166	180	V

* - indicates frequency in CFR15.205/IC7.2.2 Restricted Band

Pk - Peak detector

RMS - RMS detection

HARMONICS AND SPURIOUS EMISSIONS

LOW CHANNEL HORIZONTAL

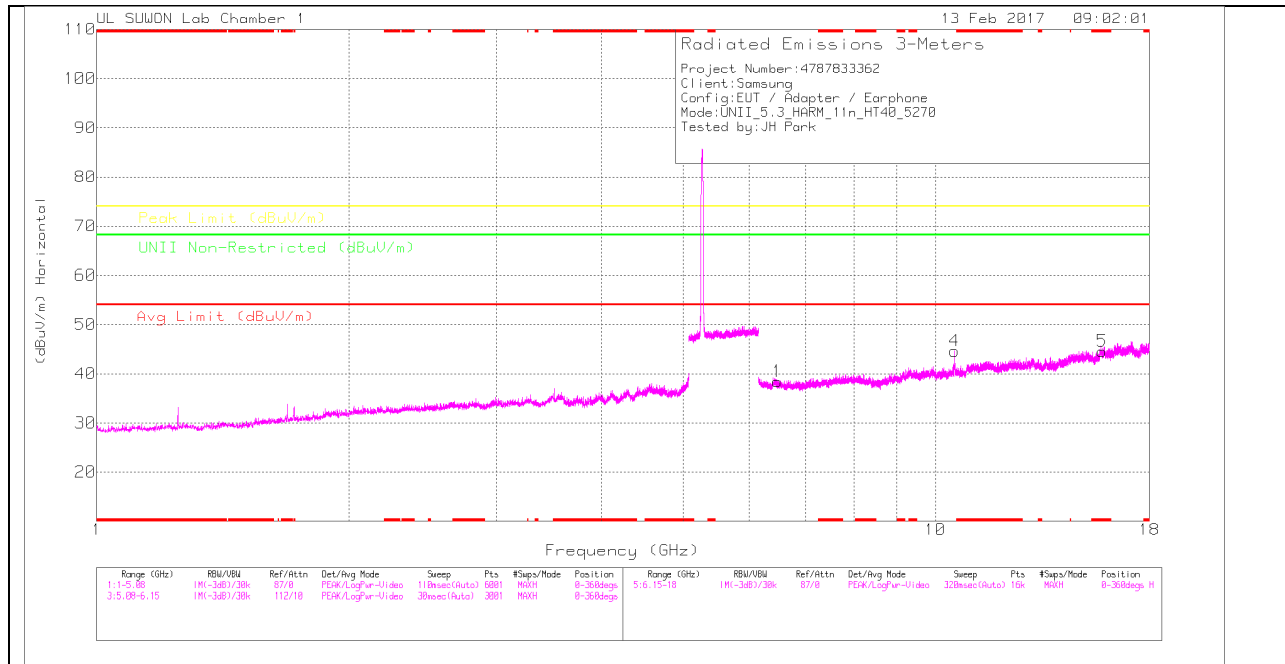

LOW CHANNEL VERTICAL

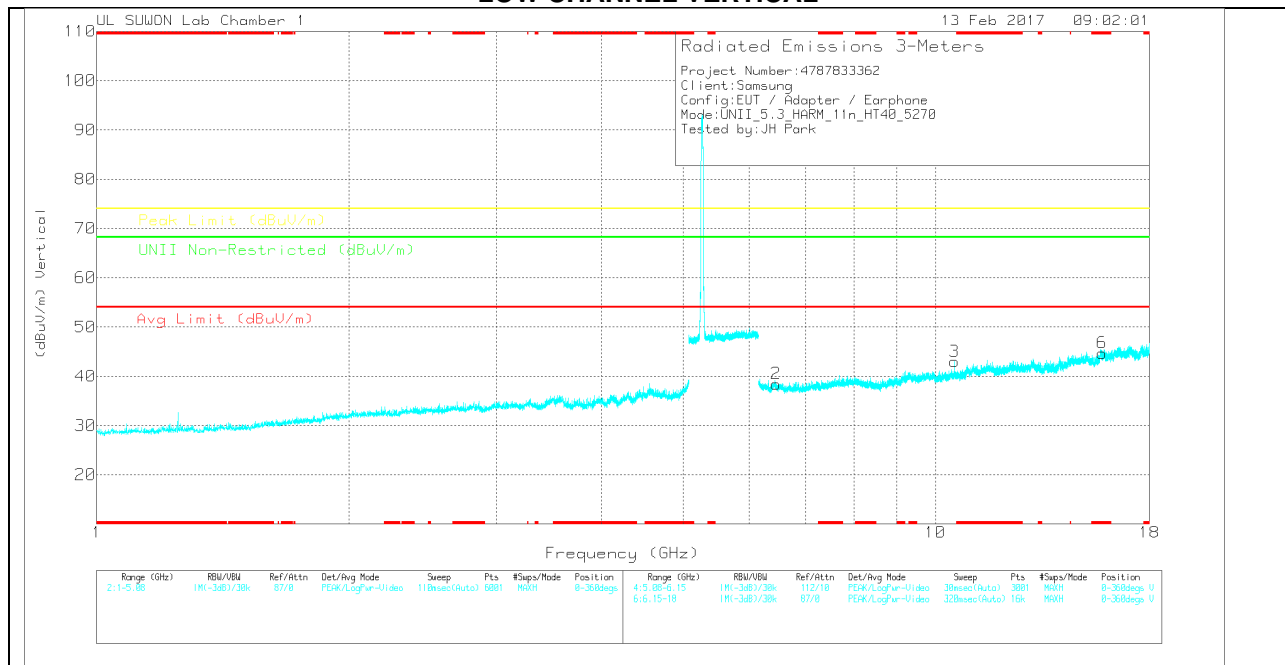

Note: Emission was scanned up to 40GHz; No emissions were detected above the noise floor which was at least 20dB below the specification limit.

LOW CHANNEL DATA

Trace Markers

Marker	Frequency (GHz)	Meter Reading (dBuV)	Det	3117(0016 8717)_150 519	6Ghz_HP(d B)	DC Corr (dB)	Corrected Reading (dBuV/m)	Avg Limit (dBuV/m)	Margin (dB)	Peak Limit (dBuV/m)	Margin (dB)	UNII Non-Restricted (dBuV/m)	Margin (dB)	Azimuth (Degs)	Height (cm)	Polarity
1	6.479	34.23	PK	35.4	-31.2	0	38.43	-	-	-	-	68.2	-29.77	0-360	150	H
4	10.54	34.82	PK	37.9	-28.1	0	44.62	-	-	-	-	68.2	-23.58	0-360	250	H
5	* 15.812	21.69	PK	40.5	-17.6	0	44.59	-	-	74	-29.41	-	-	0-360	150	H
2	6.454	33.77	PK	35.4	-30.7	0	38.47	-	-	-	-	68.2	-29.73	0-360	150	V
3	10.54	33.2	PK	37.9	-28.1	0	43	-	-	-	-	68.2	-25.2	0-360	250	V
6	* 15.814	22.03	PK	40.5	-17.8	0	44.73	-	-	74	-29.27	-	-	0-360	150	V

* - indicates frequency in CFR15.205/IC7.2.2 Restricted Band

PK – Peak Detector

Radiated Emissions

Frequency (GHz)	Meter Reading (dBuV)	Det	3117(001687 17)_150619	6Ghz_HP(dB)	DC Corr (dB)	Corrected Reading (dBuV/m)	Avg Limit (dBuV/m)	Margin (dB)	Peak Limit (dBuV/m)	Margin (dB)	UNII Non-Restricted (dBuV/m)	Margin (dB)	Azimuth (Degs)	Height (cm)	Polarity
10.54	46.64	PK-U	37.9	-28.1	0	56.44	-	-	-	-	68.2	-11.76	140	221	H
10.54	43.76	PK-U	37.9	-28.1	0	53.56	-	-	-	-	68.2	-14.64	161	238	V

* - indicates frequency in CFR15.205/IC7.2.2 Restricted Band

PK-U - U-NII: Maximum Peak

HIGH CHANNEL HORIZONTAL

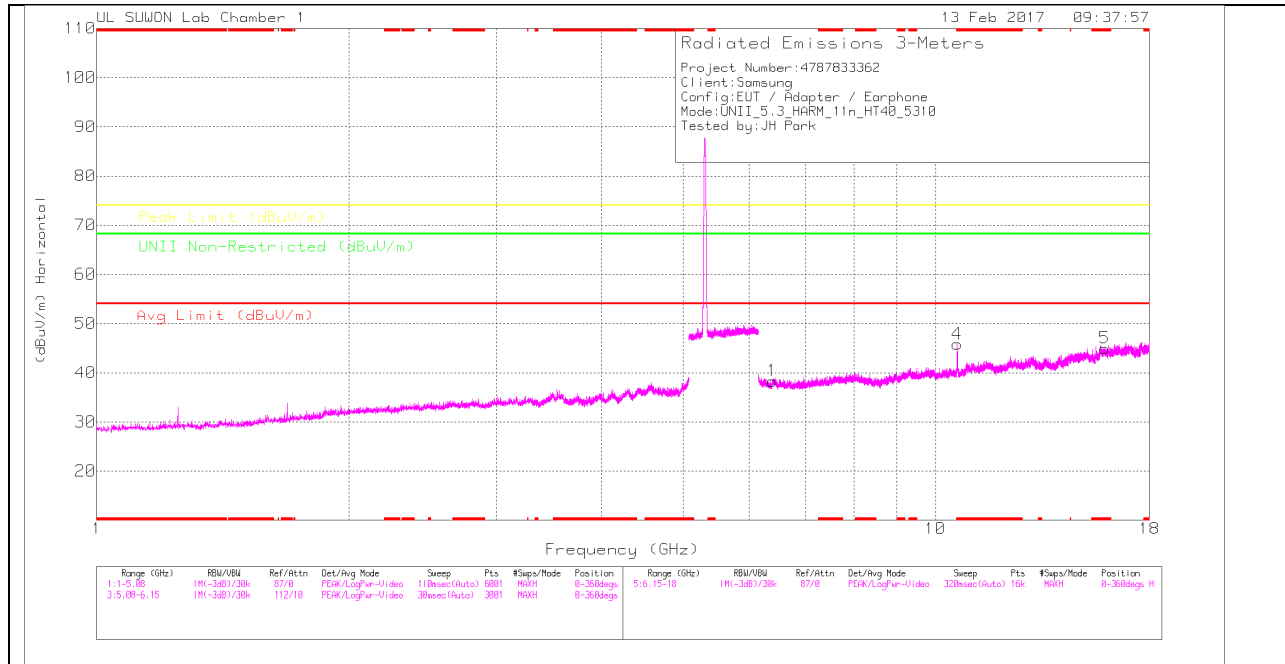

HIGH CHANNEL VERTICAL

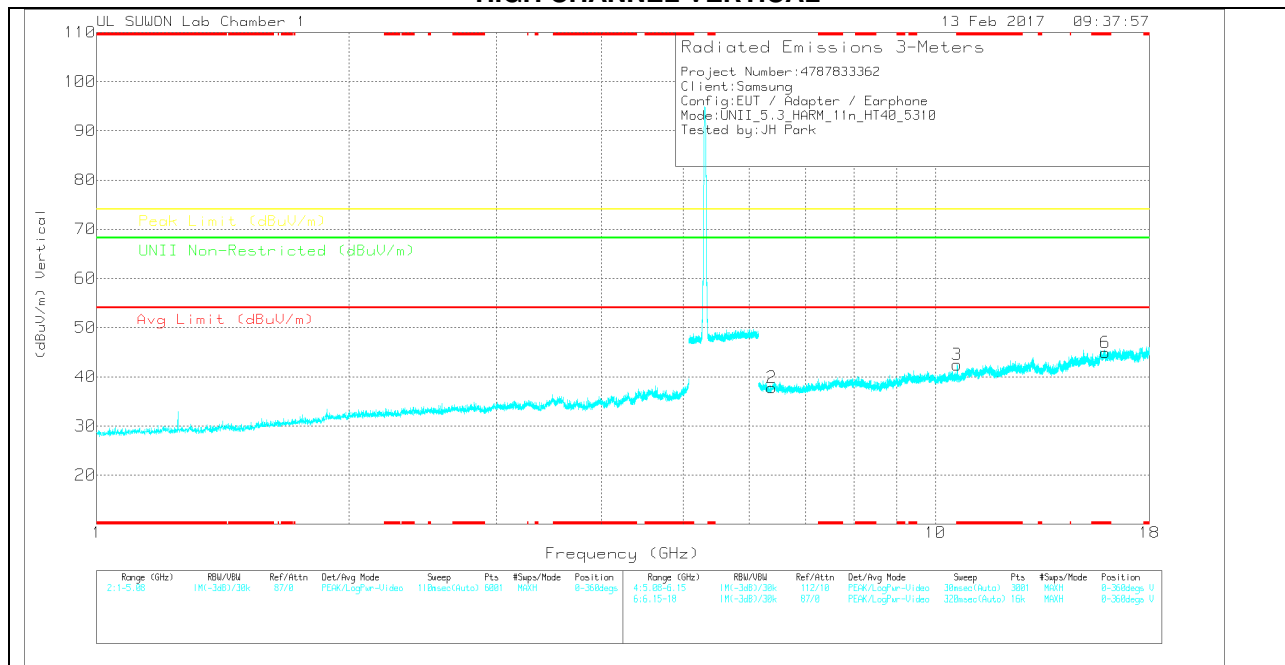

Note: Emission was scanned up to 40GHz; No emissions were detected above the noise floor which was at least 20dB below the specification limit.

HIGH CHANNEL DATA

Trace Markers

Marker	Frequency (GHz)	Meter Reading (dBuV)	Det	3117(0016 8717)_150 619	6Ghz_HP(d B)	DC Corr (dB)	Corrected Reading (dBuV/m)	Avg Limit (dBuV/m)	Margin (dB)	Peak Limit (dBuV/m)	Margin (dB)	UNII Non-Restricted (dBuV/m)	Margin (dB)	Azimuth (Degs)	Height (cm)	Polarity
1	6.388	34.14	PK	35.3	-31.1	0	38.34	-	-	-	-	68.2	-29.86	0-360	250	H
4	* 10.62	36.15	PK	37.9	-28.2	0	45.85	-	-	74	-28.15	-	-	0-360	250	H
5	* 15.924	23.48	PK	40.6	-19.1	0	44.98	-	-	74	-29.02	-	-	0-360	250	H
2	6.381	33.59	PK	35.3	-31.1	0	37.79	-	-	-	-	68.2	-30.41	0-360	150	V
3	* 10.619	32.65	PK	37.9	-28.1	0	42.45	-	-	74	-31.55	-	-	0-360	250	V
6	* 15.943	23.99	PK	40.6	-19.7	0	44.89	-	-	74	-29.11	-	-	0-360	250	V

* - indicates frequency in CFR15.205/IC7.2.2 Restricted Band

PK – Peak Detector

Radiated Emissions

Frequency (GHz)	Meter Reading (dBuV)	Det	3117(001687 17)_150619	6Ghz_HP(dB)	DC Corr (dB)	Corrected Reading (dBuV/m)	Avg Limit (dBuV/m)	Margin (dB)	Peak Limit (dBuV/m)	Margin (dB)	UNII Non-Restricted (dBuV/m)	Margin (dB)	Azimuth (Degs)	Height (cm)	Polarity
* 10.62	46.27	PK-U	37.9	-28.2	0	55.97	-	-	74	-18.03	-	-	142	272	H
* 10.62	33.09	ADR	37.9	-28.2	.38	43.17	54	-10.83	-	-	-	-	142	272	H
* 10.62	42.83	PK-U	37.9	-28.1	0	52.63	-	-	74	-21.37	-	-	141	229	V
* 10.62	31.52	ADR	37.9	-28.2	.38	41.6	54	-12.4	-	-	-	-	141	229	V

* - indicates frequency in CFR15.205/IC7.2.2 Restricted Band

PK-U - U-NII: Maximum Peak

ADR - U-NII AD primary method, RMS average

10.3. 5.5-5.6 GHz

10.3.1. TX ABOVE 1 GHz 802.11a MODE IN THE 5.5 GHz BAND

RESTRICTED BANDEDGE (LOW CHANNEL)

HORIZONTAL PEAK AND AVERAGE PLOT

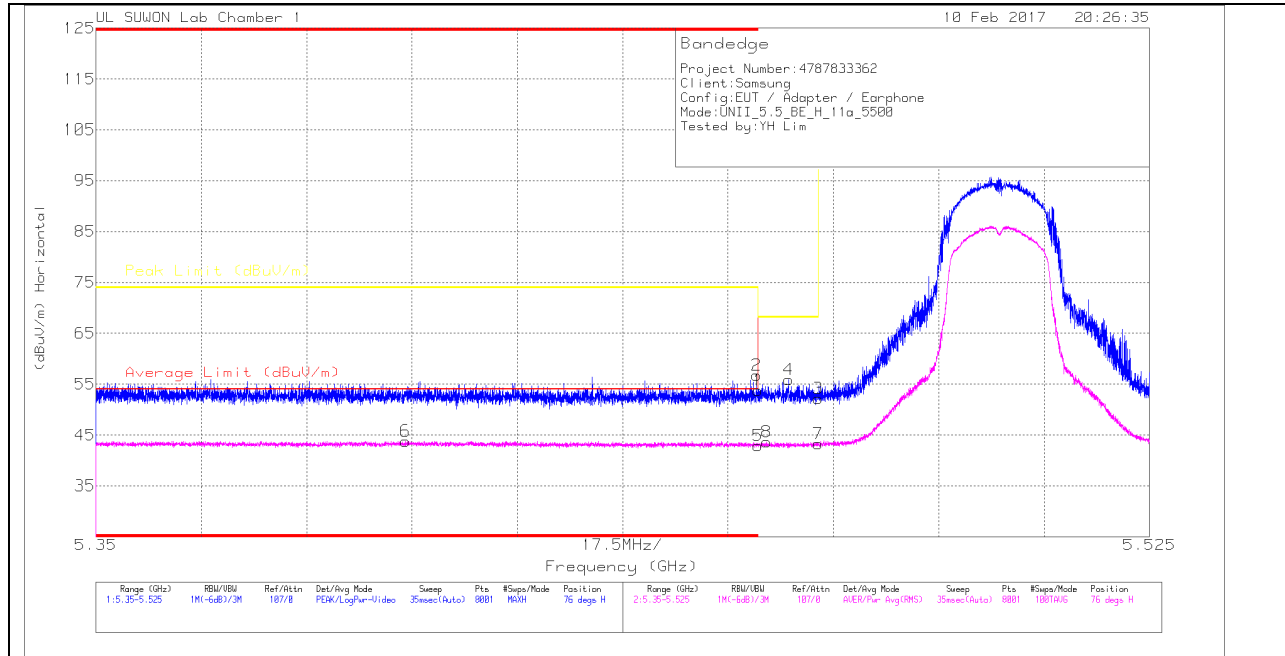

HORIZONTAL DATA

Trace Markers

Marker	Frequency (GHz)	Meter Reading (dBuV)	Det	3117(00168 717)_150619	10dB_Att(dB)	DC Corr (dB)	Corrected Reading (dBuV/m)	Average Limit (dBuV/m)	Margin (dB)	Peak Limit (dBuV/m)	PK Margin (dB)	Azimuth (Degs)	Height (cm)	Polarity
1	* 5.46	42.27	Pk	34.6	-23.1	0	53.77	-	-	74	-20.23	76	242	H
2	* 5.46	45.27	Pk	34.6	-23.1	0	56.77	-	-	74	-17.23	76	242	H
3	5.47	40.73	Pk	34.6	-23.1	0	52.23	-	-	68.2	-15.97	76	242	H
4	5.465	44.24	Pk	34.6	-23	0	55.84	-	-	68.2	-12.36	76	242	H
5	* 5.46	31.85	RMS	34.6	-23.7	.18	42.93	54	-11.07	-	-	76	242	H
6	* 5.401	32.85	RMS	34.6	-23.8	.18	43.83	54	-10.17	-	-	76	242	H

* - indicates frequency in CFR15.205/IC7.2.2 Restricted Band

Pk - Peak detector

RMS - RMS detection

VERTICAL PEAK AND AVERAGE PLOT

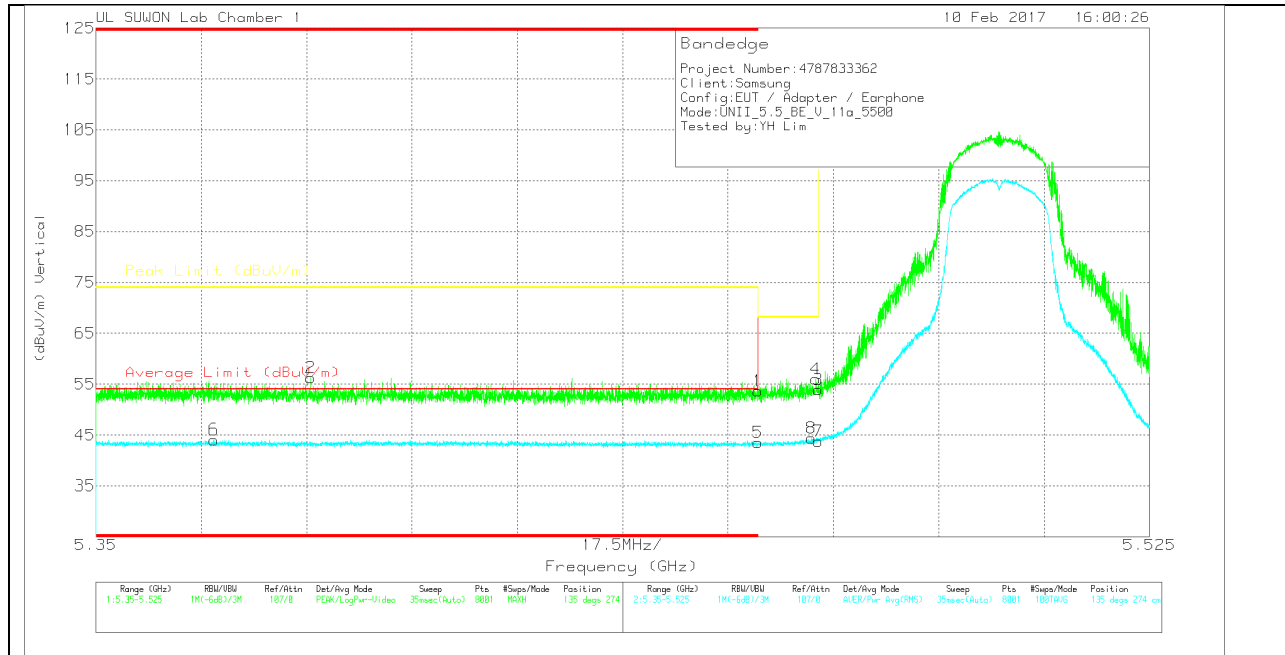

VERTICAL DATA

Trace Markers

Marker	Frequency (GHz)	Meter Reading (dBuV)	Det	3117(00168 717)_15061 9	10dB_Att(dB)	DC Corr (dB)	Corrected Reading (dBuV/m)	Average Limit (dBuV/m)	Margin (dB)	Peak Limit (dBuV/m)	PK Margin (dB)	Azimuth (Degs)	Height (cm)	Polarity
1	* 5.46	42.18	Pk	34.6	-23.1	0	53.68	-	-	74	-20.32	135	274	V
2	* 5.386	45.1	Pk	34.5	-23.3	0	56.3	-	-	74	-17.7	135	274	V
3	5.47	42.44	Pk	34.6	-23.1	0	53.94	-	-	68.2	-14.26	135	274	V
4	5.47	44.5	Pk	34.6	-23.1	0	56	-	-	68.2	-12.2	135	274	V
5	* 5.46	32.45	RMS	34.6	-23.7	.18	43.53	54	-10.47	-	-	135	274	V
6	* 5.37	33.2	RMS	34.5	-23.8	.18	44.08	54	-9.92	-	-	135	274	V

* - indicates frequency in CFR15.205/IC7.2.2 Restricted Band

Pk - Peak detector

RMS - RMS detection

AUTHORIZED BANDEDGE (HIGH CHANNEL)

HORIZONTAL PEAK AND AVERAGE PLOT

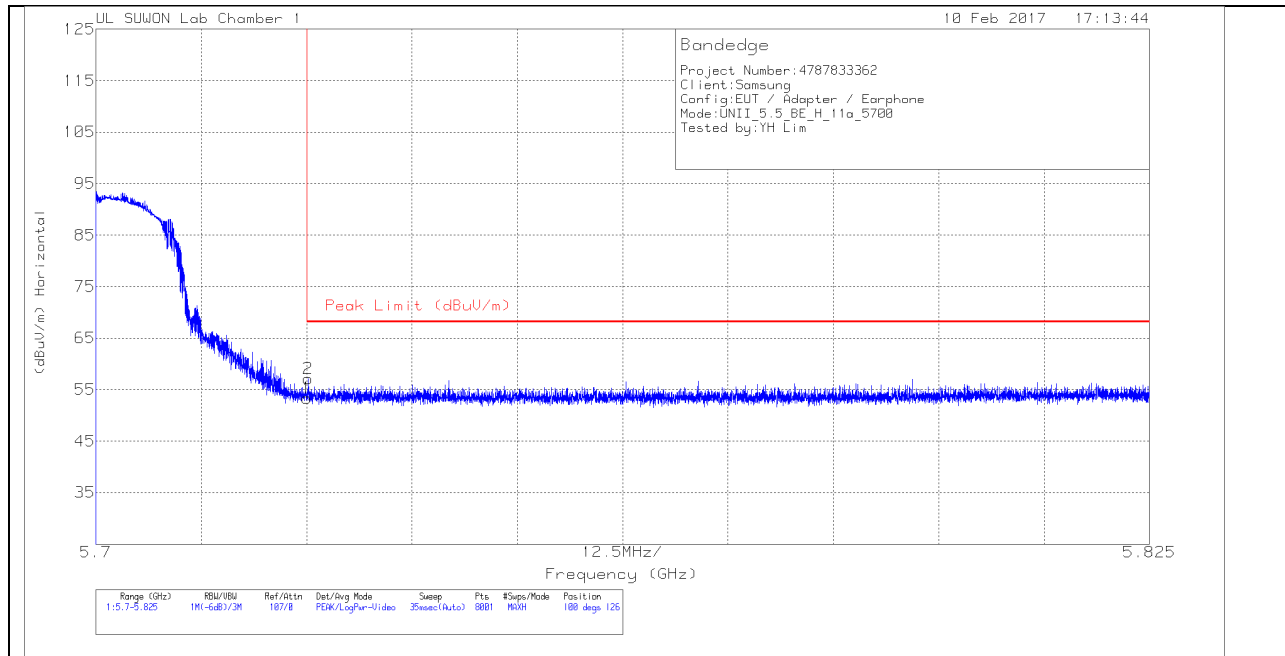

HORIZONTAL DATA

Trace Markers

Marker	Frequency (GHz)	Meter Reading (dBuV)	Det	3117(0016 8717)_150 619	10dB_Att(d B)	DC Corr (dB)	Corrected Reading (dBuV/m)	Peak Limit (dBuV/m)	PK Margin (dB)	Azimuth (Degs)	Height (cm)	Polarity
1	5.725	41.4	Pk		-22.9	0	53.3	68.2	-14.9	100	126	H
2	5.725	45.24	Pk		-22.9	0	57.14	68.2	-11.06	100	126	H

Pk - Peak detector

VERTICAL PEAK AND AVERAGE PLOT

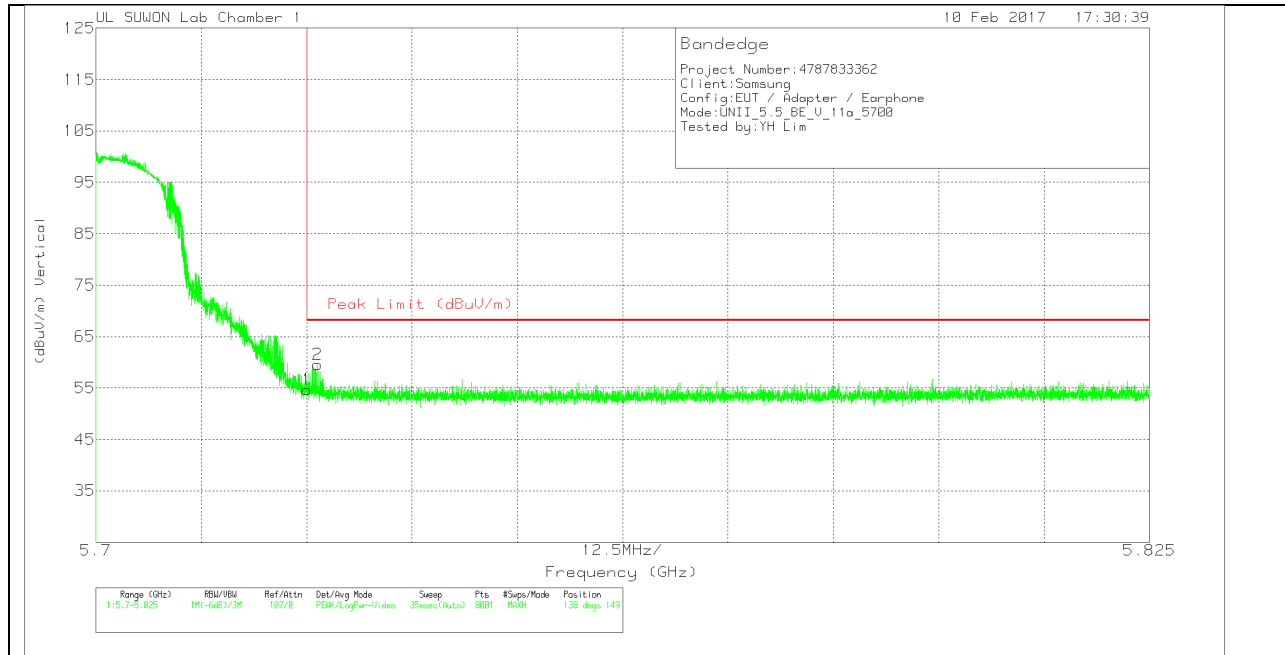

VERTICAL DATA

Trace Markers

Marker	Frequency (GHz)	Meter Reading (dBuV)	Det	3117(0016 8717)_150 619	10dB_Att(d B)	DC Corr (dB)	Corrected Reading (dBuV/m)	Peak Limit (dBuV/m)	PK Margin (dB)	Azimuth (Degs)	Height (cm)	Polarity
1	5.725	42.77	Pk	34.8	-22.9	0	54.67	68.2	-13.53	138	149	V
2	5.726	47.57	Pk	34.8	-22.8	0	59.57	68.2	-8.63	138	149	V

Pk - Peak detector

HARMONICS AND SPURIOUS EMISSIONS

LOW CHANNEL HORIZONTAL

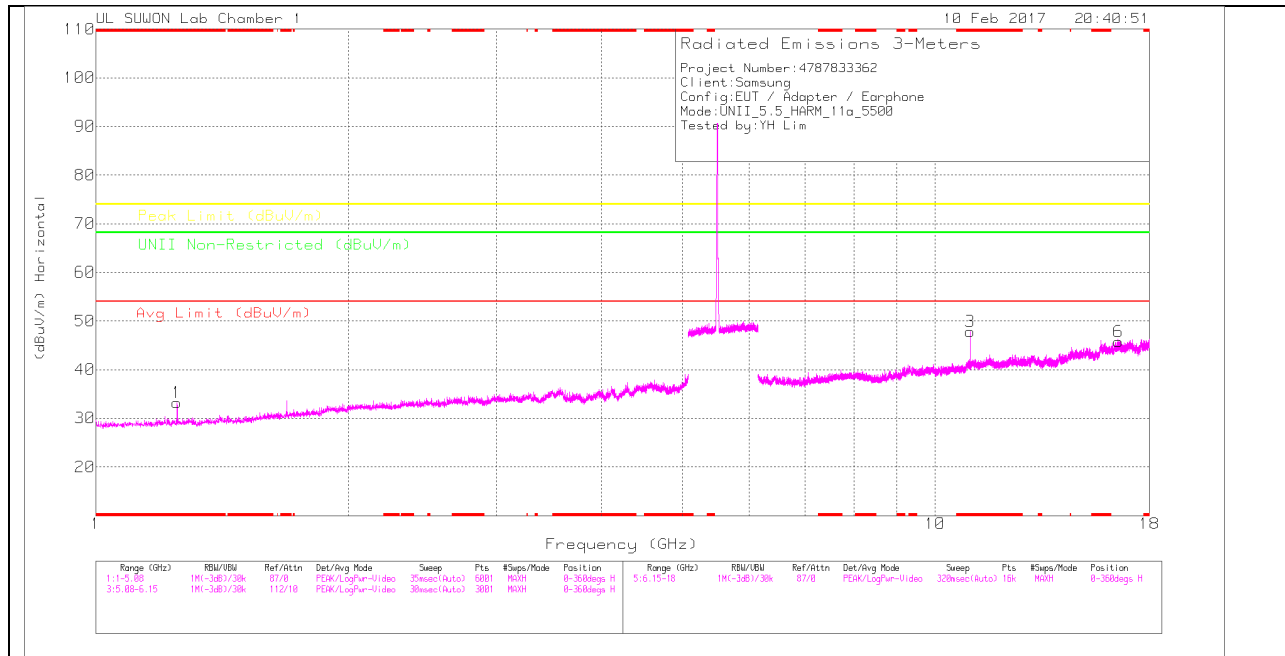

LOW CHANNEL VERTICAL

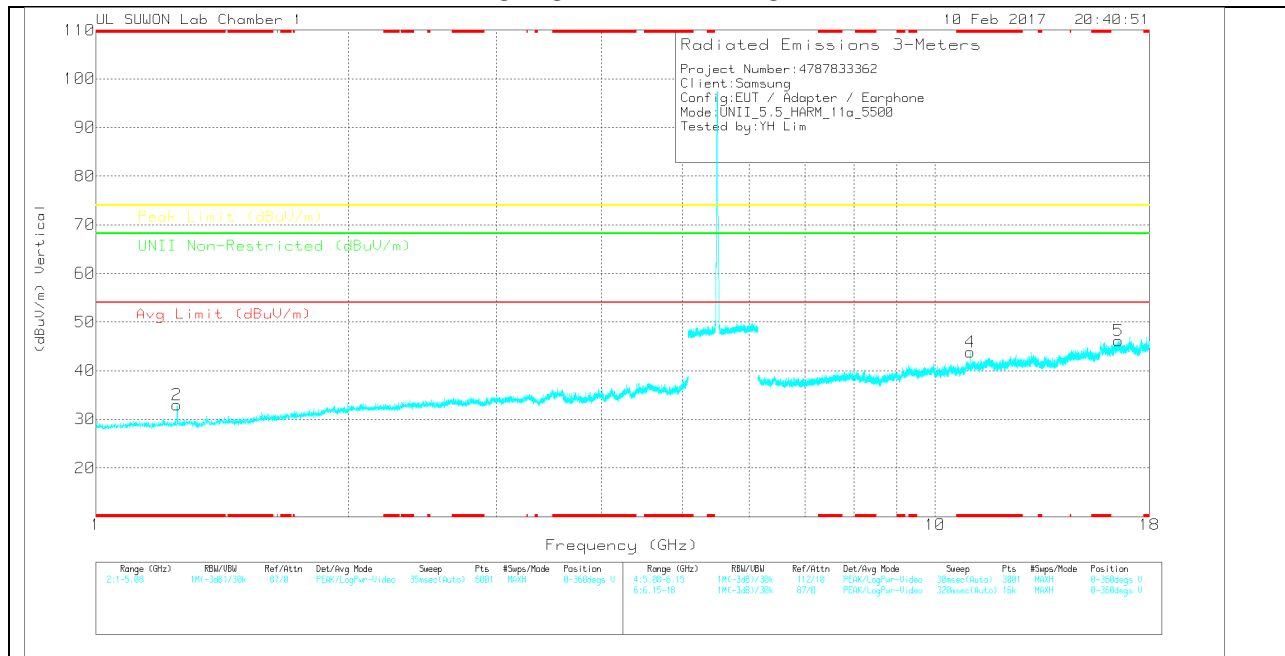

Note: Emission was scanned up to 40GHz; No emissions were detected above the noise floor which was at least 20dB below the specification limit.

LOW CHANNEL DATA

Trace Markers

Marker	Frequency (GHz)	Meter Reading (dBuV)	Det	3117(0016 8717)_150 619	5Ghz_LP(d B)	DC Corr (dB)	Corrected Reading (dBuV/m)	Avg Limit (dBuV/m)	Margin (dB)	Peak Limit (dBuV/m)	Margin (dB)	UNII Non-Restricted (dBuV/m)	Margin (dB)	Azimuth (Degs)	Height (cm)	Polarity
1	* 1.25	44.57	Pk	28.3	-39.6	0	33.27	-	-	74	-40.73	-	-	0-360	250	H
2	* 1.25	44.25	Pk	28.3	-39.6	0	32.95	-	-	74	-41.05	-	-	0-360	250	V
3	* 11	37.64	Pk	38.2	-28	0	47.84	-	-	74	-26.16	-	-	0-360	250	H
6	16.525	27.83	Pk	41.2	-23.3	0	45.73	-	-	-	-	68.2	-22.47	0-360	150	H
4	* 11	33.59	Pk	38.2	-28	0	43.79	-	-	74	-30.21	-	-	0-360	250	V
5	16.53	28.11	Pk	41.2	-23.2	0	46.11	-	-	-	-	68.2	-22.09	0-360	250	V

* - indicates frequency in CFR15.205/IC7.2.2 Restricted Band

Pk – Peak detector

Radiated Emissions

Frequency (GHz)	Meter Reading (dBuV)	Det	3117(001687 17)_150619	6Ghz_HP(dB)	DC Corr (dB)	Corrected Reading (dBuV/m)	Avg Limit (dBuV/m)	Margin (dB)	Peak Limit (dBuV/m)	Margin (dB)	UNII Non-Restricted (dBuV/m)	Margin (dB)	Azimuth (Degs)	Height (cm)	Polarity
* 11	45.25	PK-U	38.2	-28	0	55.45	-	-	74	-18.55	-	-	191	280	H
* 11	36.4	ADR	38.2	-28	.18	46.78	54	-7.22	-	-	-	-	191	280	H
* 11	43.17	PK-U	38.2	-28	0	53.37	-	-	74	-20.63	-	-	199	209	V
* 11	33.18	ADR	38.2	-28	.18	43.56	54	-10.44	-	-	-	-	199	209	V

* - indicates frequency in CFR15.205/IC7.2.2 Restricted Band

PK-U - U-NII: Maximum Peak

ADR - U-NII AD primary method, RMS average

MID CHANNEL HORIZONTAL

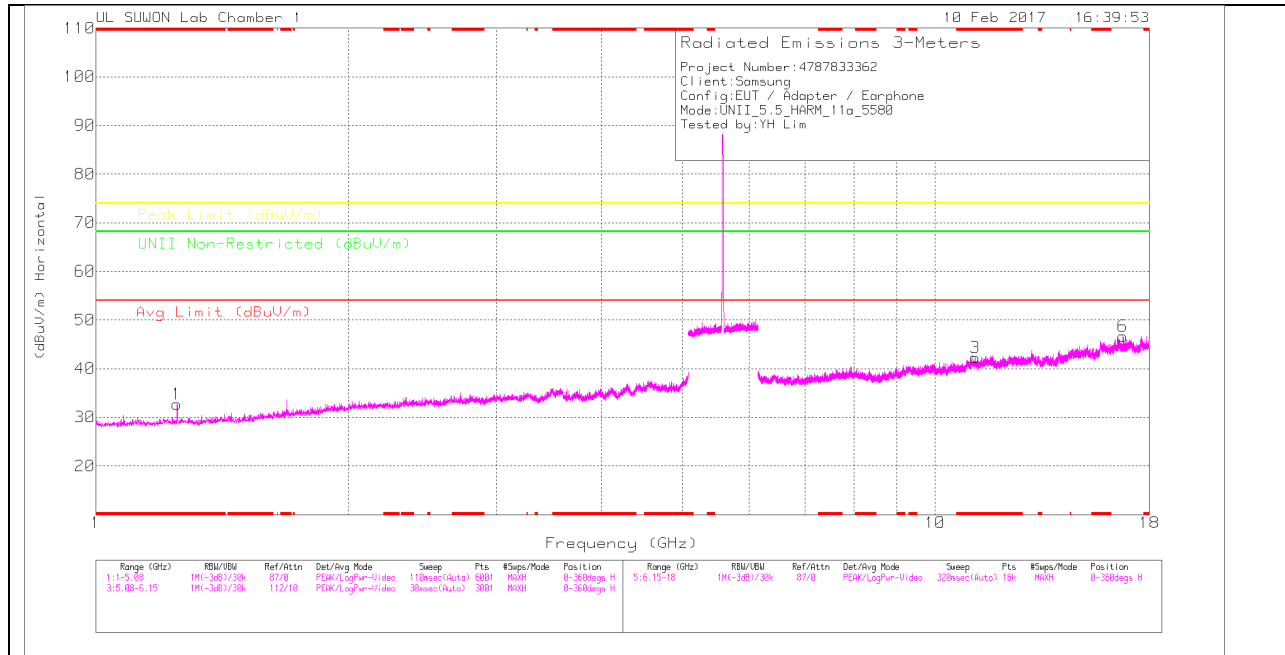

MID CHANNEL VERTICAL

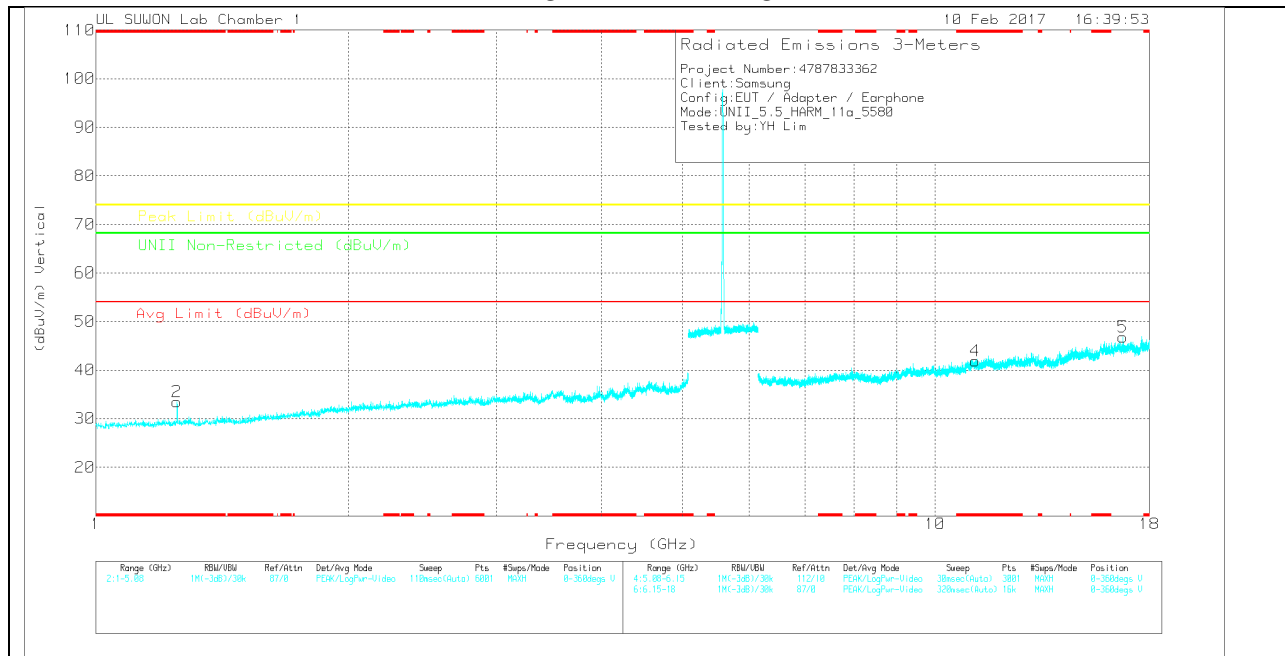

Note: Emission was scanned up to 40GHz; No emissions were detected above the noise floor which was at least 20dB below the specification limit.

MID CHANNEL DATA

Trace Markers

Marker	Frequency (GHz)	Meter Reading (dBuV)	Det	3117(0016 8717)_150 619	5Ghz_LP(d B)	DC Corr (dB)	Corrected Reading (dBuV/m)	Avg Limit (dBuV/m)	Margin (dB)	Peak Limit (dBuV/m)	Margin (dB)	UNII Non-Restricted (dBuV/m)	Margin (dB)	Azimuth (Degs)	Height (cm)	Polarity
1	* 1.25	43.96	Pk	28.3	-39.6	0	32.66	-	-	74	-41.34	-	-	0-360	250	H
2	* 1.25	44.76	Pk	28.3	-39.6	0	33.46	-	-	74	-40.54	-	-	0-360	250	V
3	* 11.164	31.55	Pk	38.3	-27.6	0	42.25	-	-	74	-31.75	-	-	0-360	250	H
6	16.742	28.54	Pk	41.3	-23.2	0	46.64	-	-	-	-	68.2	-21.56	0-360	250	H
4	* 11.159	31.32	Pk	38.3	-27.7	0	41.92	-	-	74	-32.08	-	-	0-360	250	V
5	16.738	28.88	Pk	41.2	-23.3	0	46.78	-	-	-	-	68.2	-21.42	0-360	250	V

* - indicates frequency in CFR15.205/IC7.2.2 Restricted Band

Pk – Peak detector

Note: Only peak measurement was performed. Because peak measurement result of unwanted emission is less than average limit (54dBuV/m).

HIGH CHANNEL HORIZONTAL

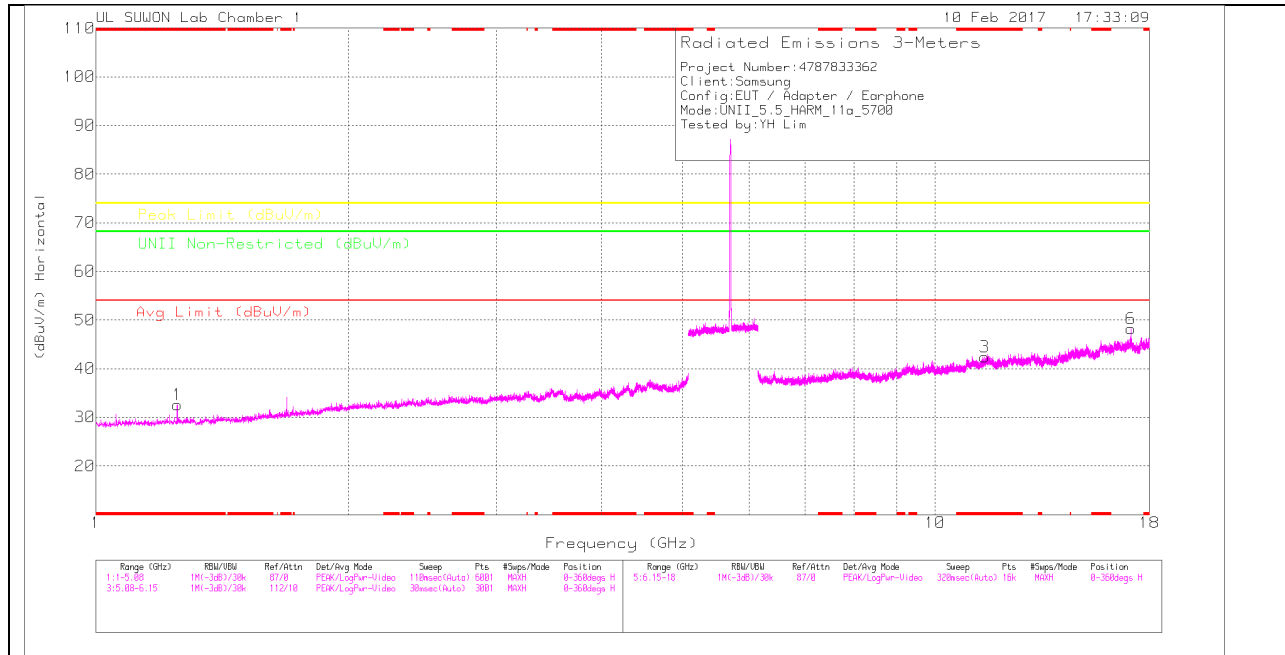

HIGH CHANNEL VERTICAL

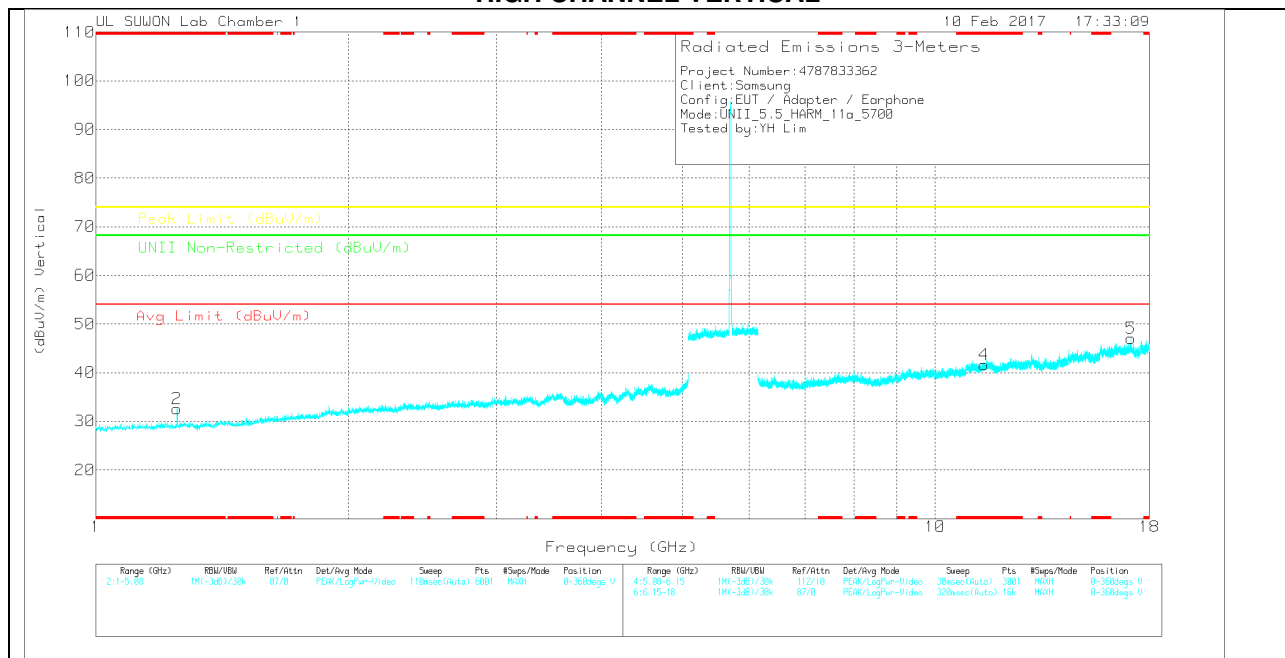

Note: Emission was scanned up to 40GHz; No emissions were detected above the noise floor which was at least 20dB below the specification limit.

HIGH CHANNEL DATA

Trace Markers

Marker	Frequency (GHz)	Meter Reading (dBuV)	Det	3117(0016 8717_150 619)	5Ghz_LP(d B)	DC Corr (dB)	Corrected Reading (dBuV/m)	Avg Limit (dBuV/m)	Margin (dB)	Peak Limit (dBuV/m)	Margin (dB)	UNII Non-Restricted (dBuV/m)	Margin (dB)	Azimuth (Degs)	Height (cm)	Polarity
1	* 1.25	43.92	Pk	28.3	-39.6	0	32.62	-	-	74	-41.38	-	-	0-360	250	H
2	* 1.25	43.92	Pk	28.3	-39.6	0	32.62	-	-	74	-41.38	-	-	0-360	250	V
3	* 11.445	32.12	Pk	38.6	-28.3	0	42.42	-	-	74	-31.58	-	-	0-360	250	H
6	17.096	30.04	Pk	41.3	-23.1	0	48.24	-	-	-	-	68.2	-19.96	0-360	250	H
4	* 11.433	31.44	Pk	38.6	-28.4	0	41.64	-	-	74	-32.36	-	-	0-360	150	V
5	17.099	28.92	Pk	41.3	-23.2	0	47.02	-	-	-	-	68.2	-21.18	0-360	150	V

* - indicates frequency in CFR15.205/IC7.2.2 Restricted Band

Pk – Peak detector

Radiated Emissions

Frequency (GHz)	Meter Reading (dBuV)	Det	3117(001687 17_150619)	6Ghz_HP(dB)	DC Corr (dB)	Corrected Reading (dBuV/m)	Avg Limit (dBuV/m)	Margin (dB)	Peak Limit (dBuV/m)	Margin (dB)	UNII Non-Restricted (dBuV/m)	Margin (dB)	Azimuth (Degs)	Height (cm)	Polarity
17.105	45.09	PK-U	41.3	-23.3	0	63.09	-	-	-	-	68.2	-5.11	242	184	H
17.104	43.2	PK-U	41.3	-23.2	0	61.3	-	-	-	-	68.2	-6.9	199	190	V

* - indicates frequency in CFR15.205/IC7.2.2 Restricted Band

PK-U - U-NII: Maximum Peak

STRADDLE CHANNEL HORIZONTAL

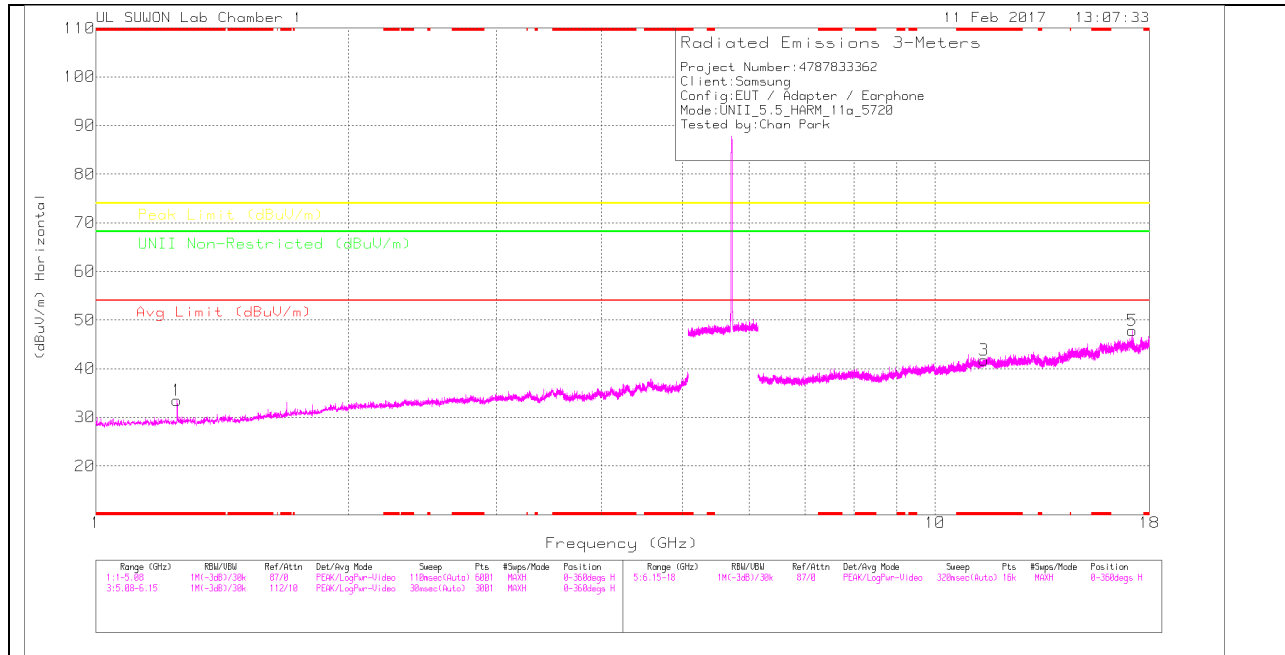

STRADDLE CHANNEL VERTICAL

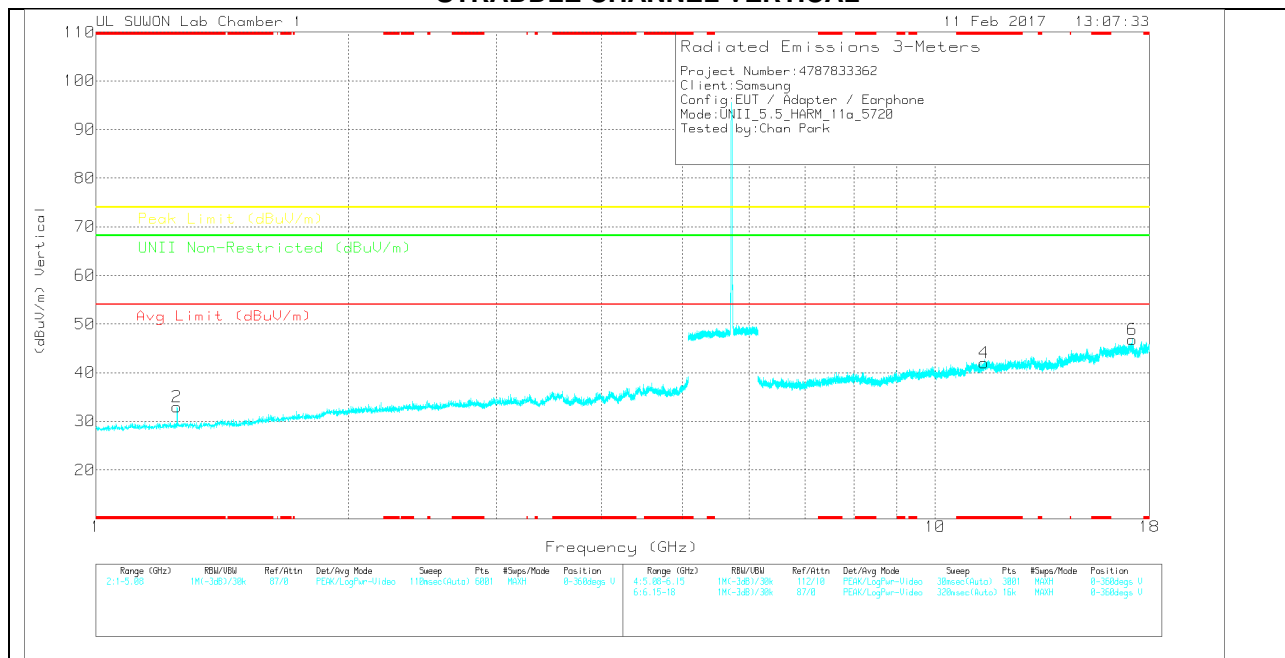

Note: Emission was scanned up to 40GHz; No emissions were detected above the noise floor which was at least 20dB below the specification limit.

STRADDLE CHANNEL DATA

Trace Markers

Marker	Frequency (GHz)	Meter Reading (dBuV)	Det	3117(0016 8717)_150 619	5Ghz_LP(d B)	DC Corr (dB)	Corrected Reading (dBuV/m)	Avg Limit (dBuV/m)	Margin (dB)	Peak Limit (dBuV/m)	Margin (dB)	UNII Non-Restricted (dBuV/m)	Margin (dB)	Azimuth (Degs)	Height (cm)	Polarity
1	* 1.25	44.78	Pk	28.3	-39.6	0	33.48	-	-	74	-40.52	-	-	0-360	250	H
2	* 1.25	44.2	Pk	28.3	-39.6	0	32.9	-	-	74	-41.1	-	-	0-360	250	V
3	* 11.441	31.4	Pk	38.6	-28.3	0	41.7	-	-	74	-32.3	-	-	0-360	250	H
5	17.157	29.41	Pk	41.3	-22.9	0	47.81	-	-	-	-	68.2	-20.39	0-360	250	H
4	* 11.441	31.66	Pk	38.6	-28.3	0	41.96	-	-	74	-32.04	-	-	0-360	250	V
6	17.159	28.26	Pk	41.3	-22.8	0	46.76	-	-	-	-	68.2	-21.44	0-360	150	V

* - indicates frequency in CFR15.205/IC7.2.2 Restricted Band

Pk – Peak detector

Note: Only peak measurement was performed. Because peak measurement result of unwanted emission is less than average limit (54dBuV/m).

10.3.2. TX ABOVE 1GHz 802.11n HT20 MODE IN THE 5.5GHz BAND RESTRICTED BANDEDGE (LOW CHANNEL)

HORIZONTAL PEAK AND AVERAGE PLOT

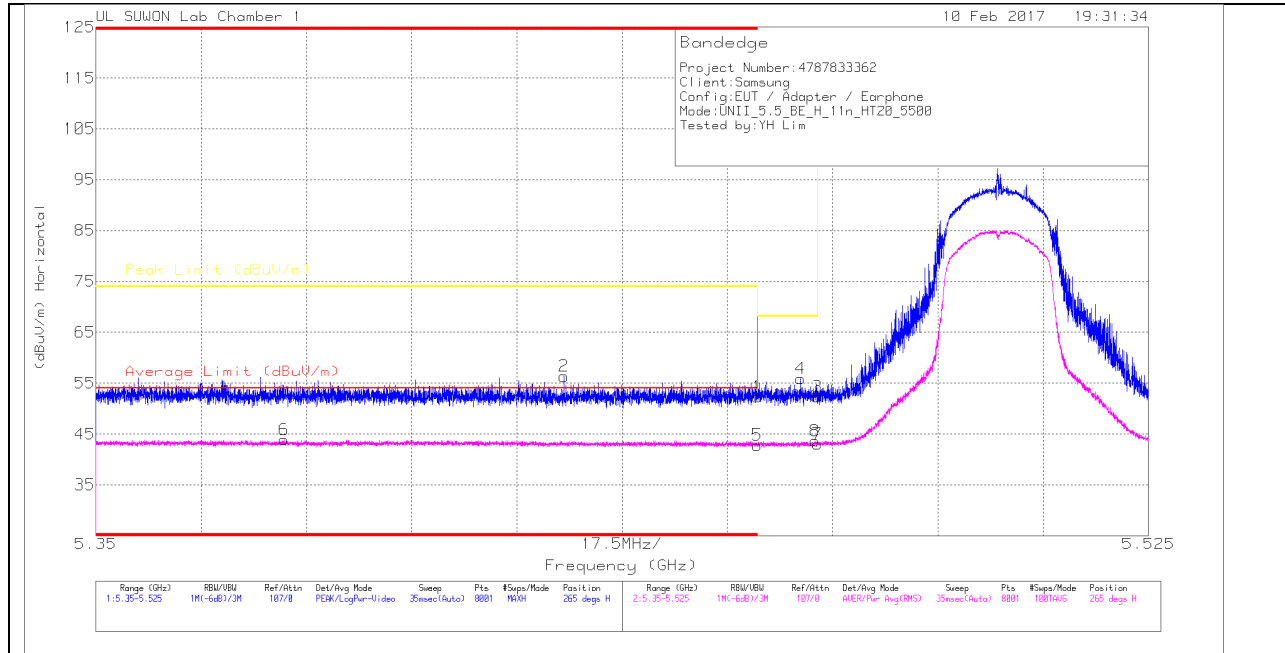

HORIZONTAL DATA

Trace Markers

Marker	Frequency (GHz)	Meter Reading (dBuV)	Det	3117(00168 717)_150619	10dB_Att(dB)	DC Corr (dB)	Corrected Reading (dBuV/m)	Average Limit (dBuV/m)	Margin (dB)	Peak Limit (dBuV/m)	PK Margin (dB)	Azimuth (Degs)	Height (cm)	Polarity
1	* 5.46	40.8	Pk		-23.1	0	52.3	-	-	74	-21.7	265	304	H
2	* 5.428	45.23	Pk		-23.5	0	56.33	-	-	74	-17.67	265	304	H
3	5.47	40.84	Pk		-23.1	0	52.34	-	-	68.2	-15.86	265	304	H
4	5.467	44.36	Pk		-23.1	0	55.86	-	-	68.2	-12.34	265	304	H
5	* 5.46	31.77	RMS		-23.7	.17	42.84	54	-11.16	-	-	265	304	H
6	* 5.381	33.04	RMS		-23.8	.17	43.91	54	-10.09	-	-	265	304	H

* - indicates frequency in CFR15.205/IC7.2.2 Restricted Band

Pk - Peak detector

RMS - RMS detection

VERTICAL PEAK AND AVERAGE PLOT

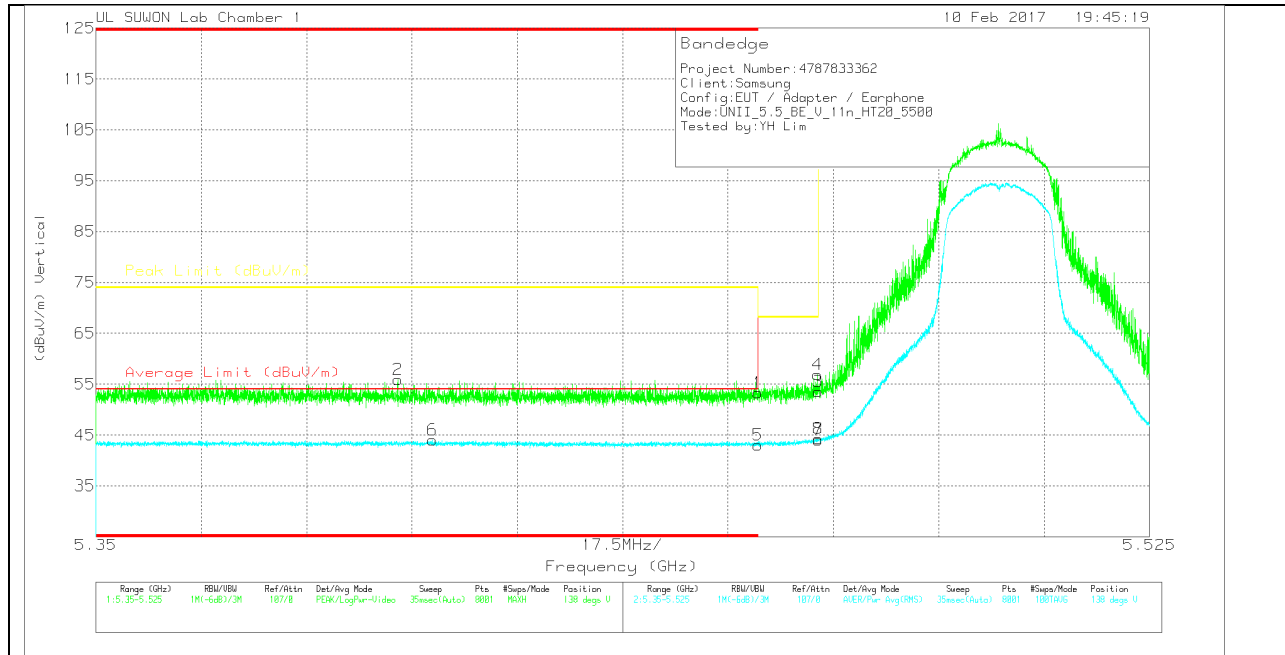

VERTICAL DATA

Trace Markers

Marker	Frequency (GHz)	Meter Reading (dBuV)	Det	3117(00168 717)_15061 9	10dB_Att(dB)	DC Corr (dB)	Corrected Reading (dBuV/m)	Average Limit (dBuV/m)	Margin (dB)	Peak Limit (dBuV/m)	PK Margin (dB)	Azimuth (Degs)	Height (cm)	Polarity
1	* 5.46	41.82	Pk	34.6	-23.1	0	53.32	-	-	74	-20.68	138	121	V
2	* 5.4	44.73	Pk	34.6	-23.4	0	55.93	-	-	74	-18.07	138	121	V
3	5.47	42.01	Pk	34.6	-23.1	0	53.51	-	-	68.2	-14.69	138	121	V
4	5.47	45.37	Pk	34.6	-23.1	0	56.87	-	-	68.2	-11.33	138	121	V
5	* 5.46	31.91	RMS	34.6	-23.7	.17	42.98	54	-11.02	-	-	138	121	V
6	* 5.406	33.04	RMS	34.6	-23.8	.17	44.01	54	-9.99	-	-	138	121	V

* - indicates frequency in CFR15.205/IC7.2.2 Restricted Band

Pk - Peak detector

RMS - RMS detection

AUTHORIZED BANDEDGE (HIGH CHANNEL)

HORIZONTAL PEAK AND AVERAGE PLOT

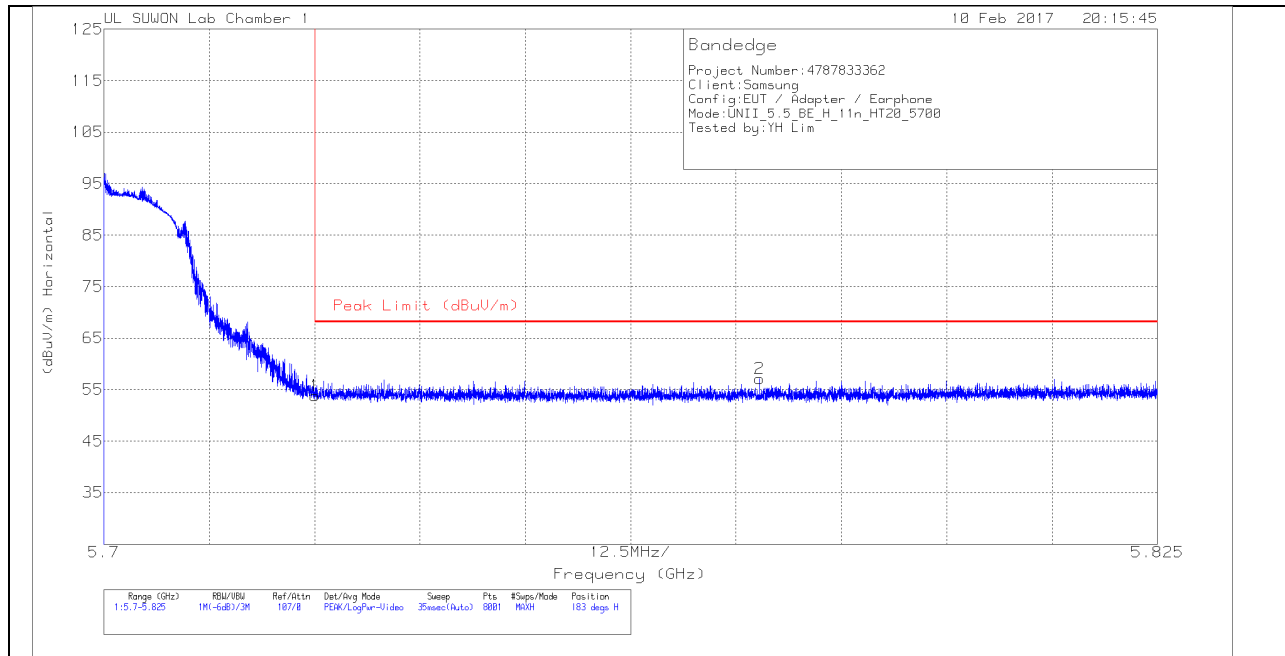

HORIZONTAL DATA

Trace Markers

Marker	Frequency (GHz)	Meter Reading (dBuV)	Det	3117(0016 8717)_150 619	10dB_Att(d B)	DC Corr (dB)	Corrected Reading (dBuV/m)	Peak Limit (dBuV/m)	PK Margin (dB)	Azimuth (Degs)	Height (cm)	Polarity
1	5.725	41.95	Pk	34.8	-22.9	0	53.85	68.2	-14.35	183	387	H
2	5.778	45.25	Pk	34.8	-22.9	0	57.15	68.2	-11.05	183	387	H

Pk - Peak detector

VERTICAL PEAK AND AVERAGE PLOT

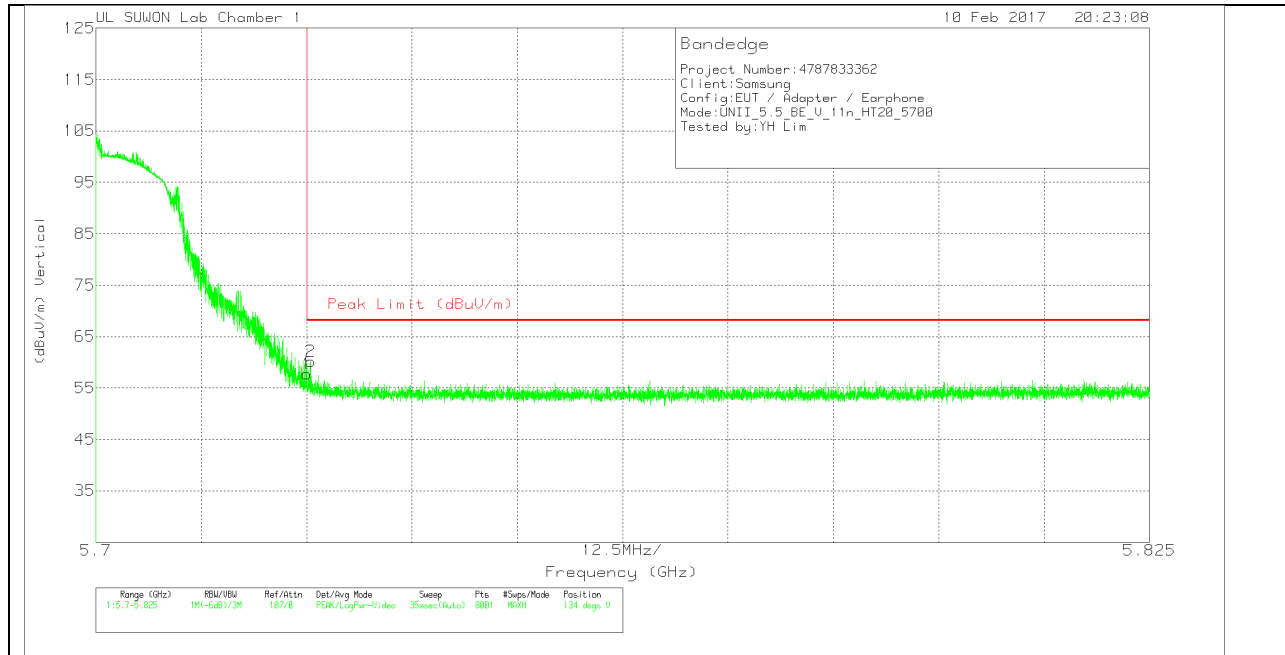

VERTICAL DATA

Trace Markers

Marker	Frequency (GHz)	Meter Reading (dBuV)	Det	3117(0016 8717)_150 619	10dB_Att(d B)	DC Corr (dB)	Corrected Reading (dBuV/m)	Peak Limit (dBuV/m)	PK Margin (dB)	Azimuth (Degs)	Height (cm)	Polarity
1	5.725	45.88	Pk	34.8	-22.9	0	57.78	68.2	-10.42	134	149	V
2	5.725	48.27	Pk	34.8	-22.9	0	60.17	68.2	-8.03	134	149	V

Pk - Peak detector

HARMONICS AND SPURIOUS EMISSIONS

LOW CHANNEL HORIZONTAL

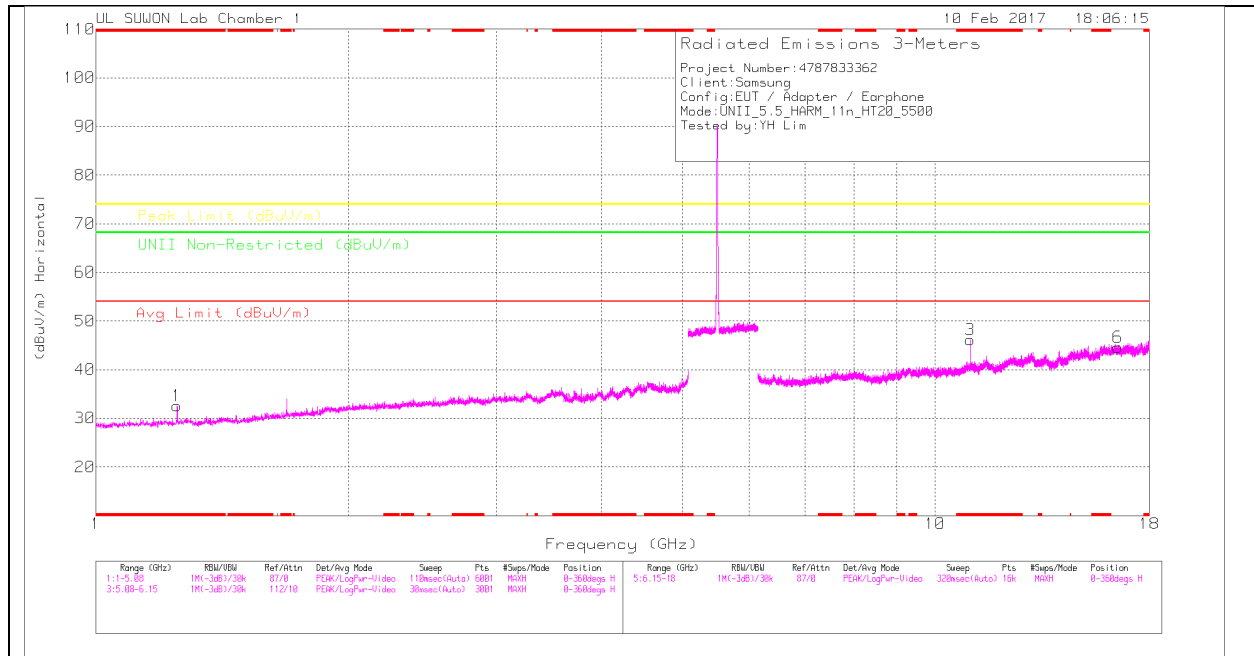

LOW CHANNEL VERTICAL

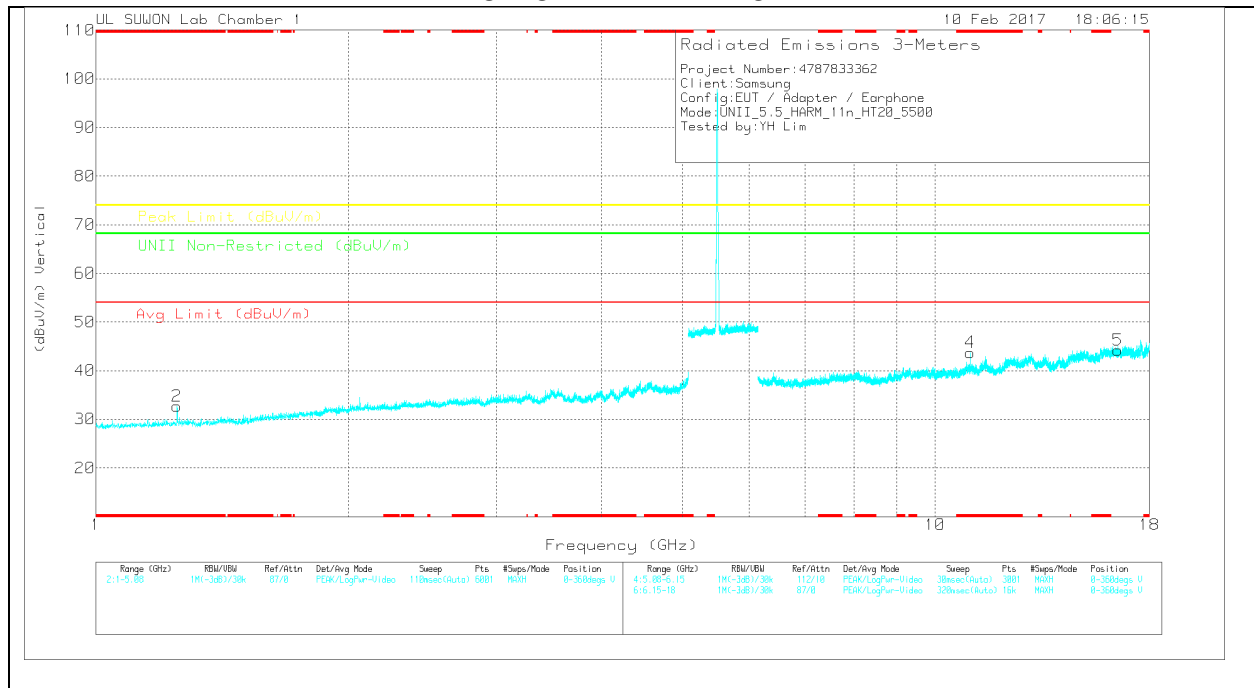

Note: Emission was scanned up to 40GHz; No emissions were detected above the noise floor which was at least 20dB below the specification limit.

LOW CHANNEL DATA

Trace Markers

Marker	Frequency (GHz)	Meter Reading (dBuV)	Det	3117(0016 8717_150 619)	5Ghz_LP(d B)	DC Corr (dB)	Corrected Reading (dBuV/m)	Avg Limit (dBuV/m)	Margin (dB)	Peak Limit (dBuV/m)	Margin (dB)	UNII Non-Restricted (dBuV/m)	Margin (dB)	Azimuth (Degs)	Height (cm)	Polarity
1	* 1.25	43.9	Pk	28.3	-39.6	0	32.6	-	-	74	-41.4	-	-	0-360	250	H
2	* 1.25	43.97	Pk	28.3	-39.6	0	32.67	-	-	74	-41.33	-	-	0-360	250	V
3	* 11	35.93	Pk	38.2	-28	0	46.13	-	-	74	-27.87	-	-	0-360	250	H
6	16.5	27.04	Pk	41.1	-23.6	0	44.54	-	-	-	-	68.2	-23.66	0-360	250	H
4	* 11	33.55	Pk	38.2	-28	0	43.75	-	-	74	-30.25	-	-	0-360	250	V
5	16.503	26.69	Pk	41.1	-23.6	0	44.19	-	-	-	-	68.2	-24.01	0-360	250	V

* - indicates frequency in CFR15.205/IC7.2.2 Restricted Band

Pk – Peak detector

Radiated Emissions

Frequency (GHz)	Meter Reading (dBuV)	Det	3117(001687 17_150619)	6Ghz_HP(dB)	DC Corr (dB)	Corrected Reading (dBuV/m)	Avg Limit (dBuV/m)	Margin (dB)	Peak Limit (dBuV/m)	Margin (dB)	UNII Non-Restricted (dBuV/m)	Margin (dB)	Azimuth (Degs)	Height (cm)	Polarity
* 11	45.61	PK-U	38.2	-28	0	55.81	-	-	74	-18.19	-	-	230	201	H
* 11	36.74	ADR	38.2	-28	.17	47.11	54	-6.89	-	-	-	-	230	201	H
* 11	43.38	PK-U	38.2	-28	0	53.58	-	-	74	-20.42	-	-	202	197	V
* 11	32.62	ADR	38.2	-28	.17	42.99	54	-11.01	-	-	-	-	202	197	V

* - indicates frequency in CFR15.205/IC7.2.2 Restricted Band

PK-U - U-NII: Maximum Peak

ADR - U-NII AD primary method, RMS average

MID CHANNEL HORIZONTAL

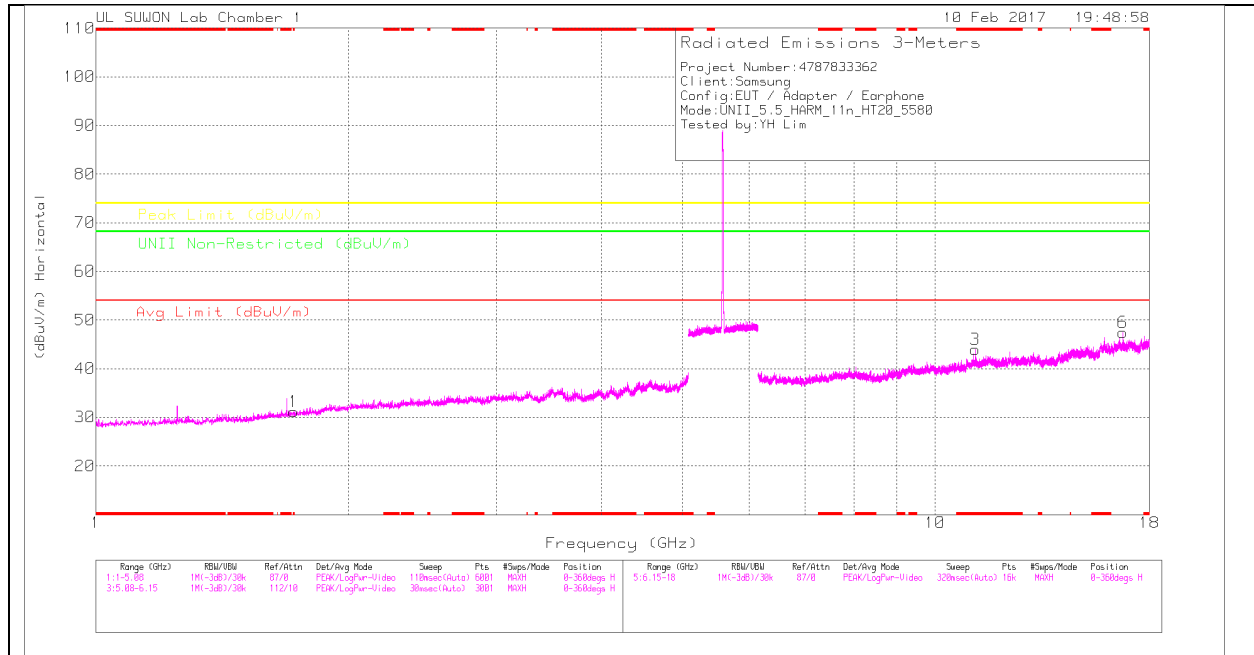

MID CHANNEL VERTICAL

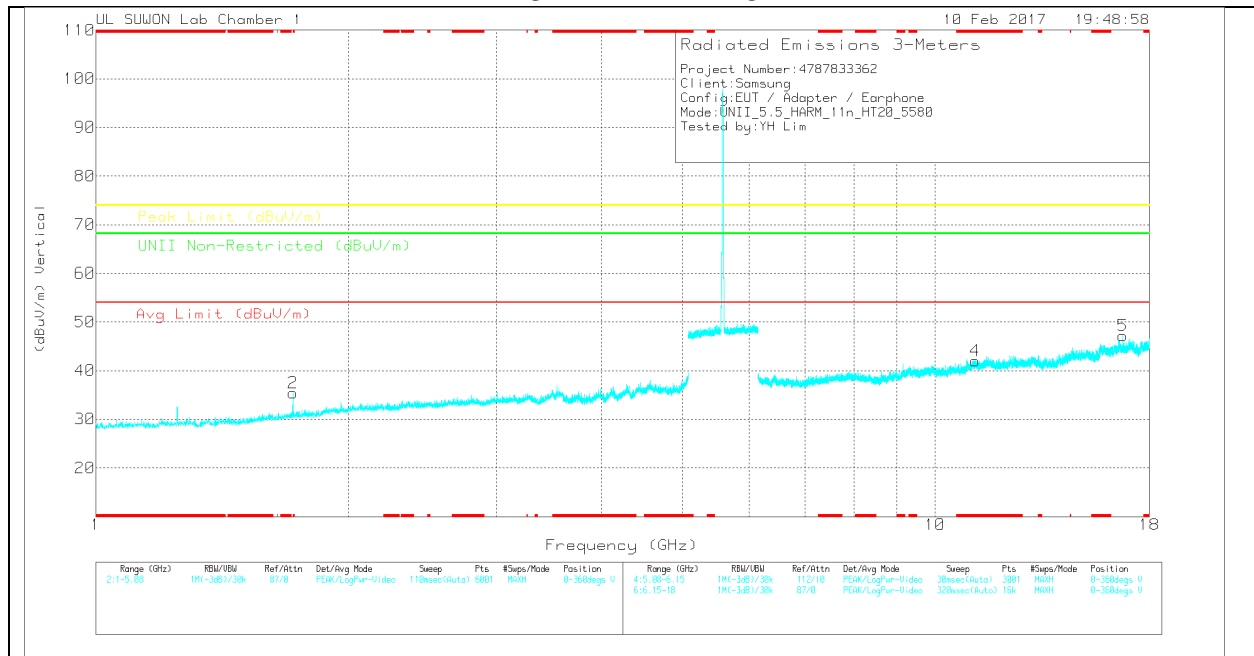

Note: Emission was scanned up to 40GHz; No emissions were detected above the noise floor which was at least 20dB below the specification limit.

MID CHANNEL DATA

Trace Markers

Marker	Frequency (GHz)	Meter Reading (dBuV)	Det	3117(0016 8717)_150 619	5Ghz_LP(d B)	DC Corr (dB)	Corrected Reading (dBuV/m)	Avg Limit (dBuV/m)	Margin (dB)	Peak Limit (dBuV/m)	Margin (dB)	UNII Non-Restricted (dBuV/m)	Margin (dB)	Azimuth (Degs)	Height (cm)	Polarity
1	* 1.72	40.39	Pk	29.7	-38.9	0	31.19	-	-	74	-42.81	-	-	0-360	250	H
2	1.717	44.6	Pk	29.7	-38.9	0	35.4	-	-	-	-	68.2	-32.8	0-360	250	V
3	* 11.16	33.36	Pk	38.3	-27.7	0	43.96	-	-	74	-30.04	-	-	0-360	250	H
6	16.743	29.3	Pk	41.3	-23.1	0	47.5	-	-	-	-	68.2	-20.7	0-360	250	H
4	* 11.16	31.39	Pk	38.3	-27.7	0	41.99	-	-	74	-32.01	-	-	0-360	250	V
5	16.744	29.11	Pk	41.3	-23.2	0	47.21	-	-	-	-	68.2	-20.99	0-360	250	V

* - indicates frequency in CFR15.205/IC7.2.2 Restricted Band

Pk – Peak detector

Note: Only peak measurement was performed. Because peak measurement result of unwanted emission is less than average limit (54dBuV/m).

HIGH CHANNEL HORIZONTAL

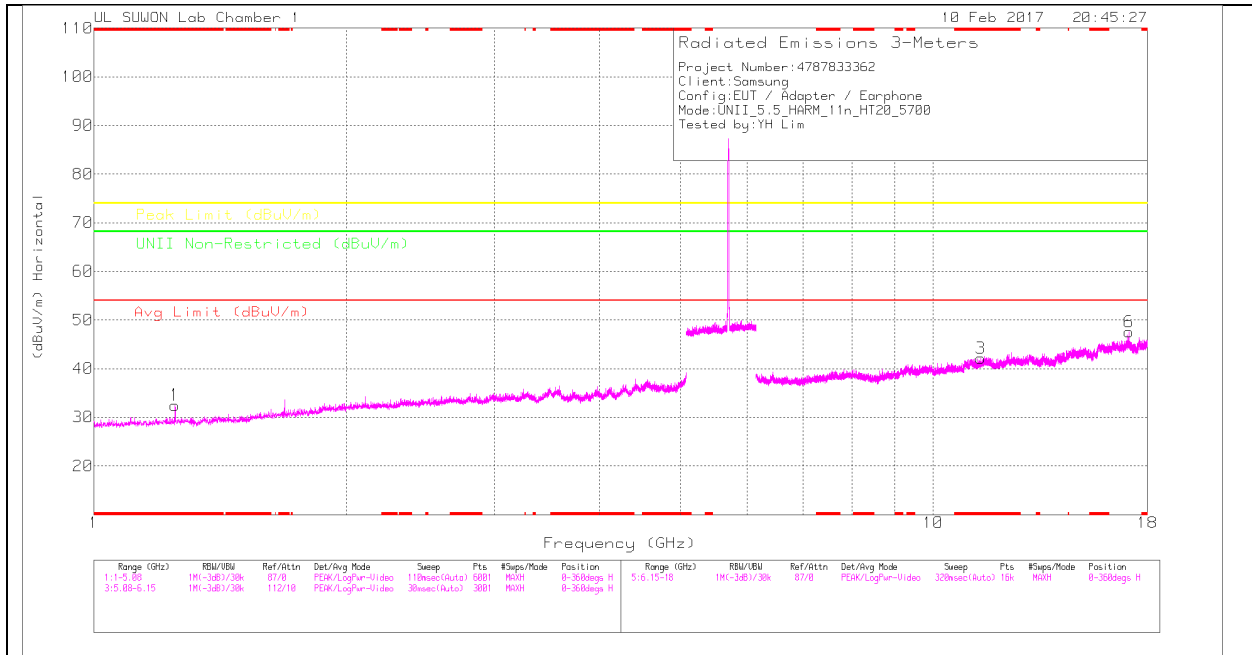

HIGH CHANNEL VERTICAL

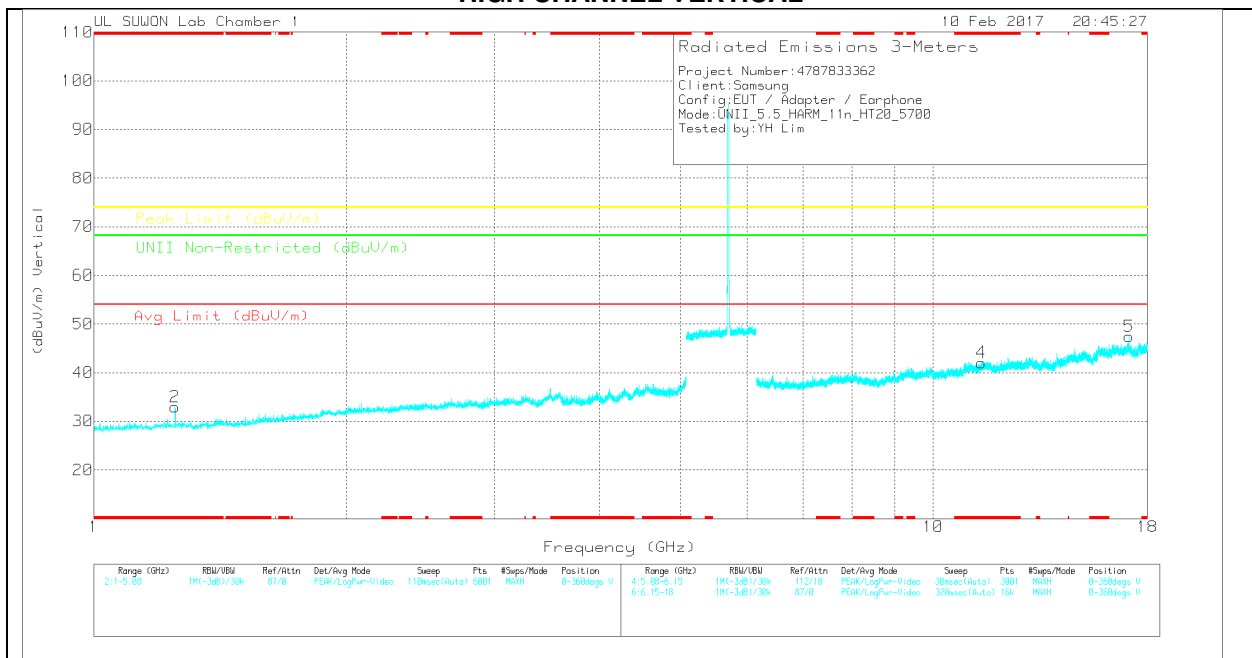

Note: Emission was scanned up to 40GHz; No emissions were detected above the noise floor which was at least 20dB below the specification limit.

HIGH CHANNEL DATA

Trace Markers

Marker	Frequency (GHz)	Meter Reading (dBuV)	Det	3117(0016 8717)_150 619	5Ghz_LP(d B)	DC Corr (dB)	Corrected Reading (dBuV/m)	Avg Limit (dBuV/m)	Margin (dB)	Peak Limit (dBuV/m)	Margin (dB)	UNII Non-Restricted (dBuV/m)	Margin (dB)	Azimuth (Degs)	Height (cm)	Polarity
1	* 1.25	43.8	Pk	28.3	-39.6	0	32.5	-	-	74	-41.5	-	-	0-360	250	H
2	* 1.25	44.31	Pk	28.3	-39.6	0	33.01	-	-	74	-40.99	-	-	0-360	250	V
3	* 11.4	31.75	Pk	38.5	-28.1	0	42.15	-	-	74	-31.85	-	-	0-360	150	H
6	17.102	29.42	Pk	41.3	-23.2	0	47.52	-	-	-	-	68.2	-20.68	0-360	250	H
4	* 11.404	31.67	Pk	38.5	-28.1	0	42.07	-	-	74	-31.93	-	-	0-360	150	V
5	17.103	29.4	Pk	41.3	-23.3	0	47.4	-	-	-	-	68.2	-20.8	0-360	250	V

* - indicates frequency in CFR15.205/IC7.2.2 Restricted Band

Pk – Peak detector

Note: Only peak measurement was performed. Because peak measurement result of unwanted emission is less than average limit (54dBuV/m).

STRADDLE CHANNEL HORIZONTAL

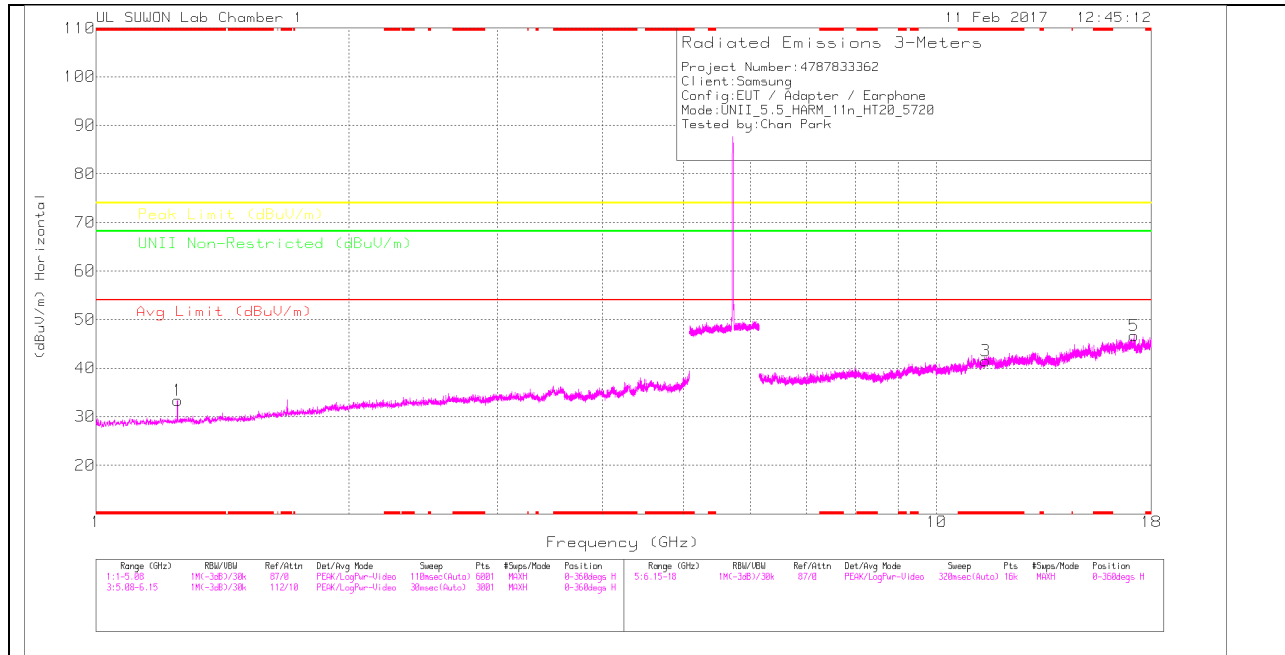

STRADDLE CHANNEL VERTICAL

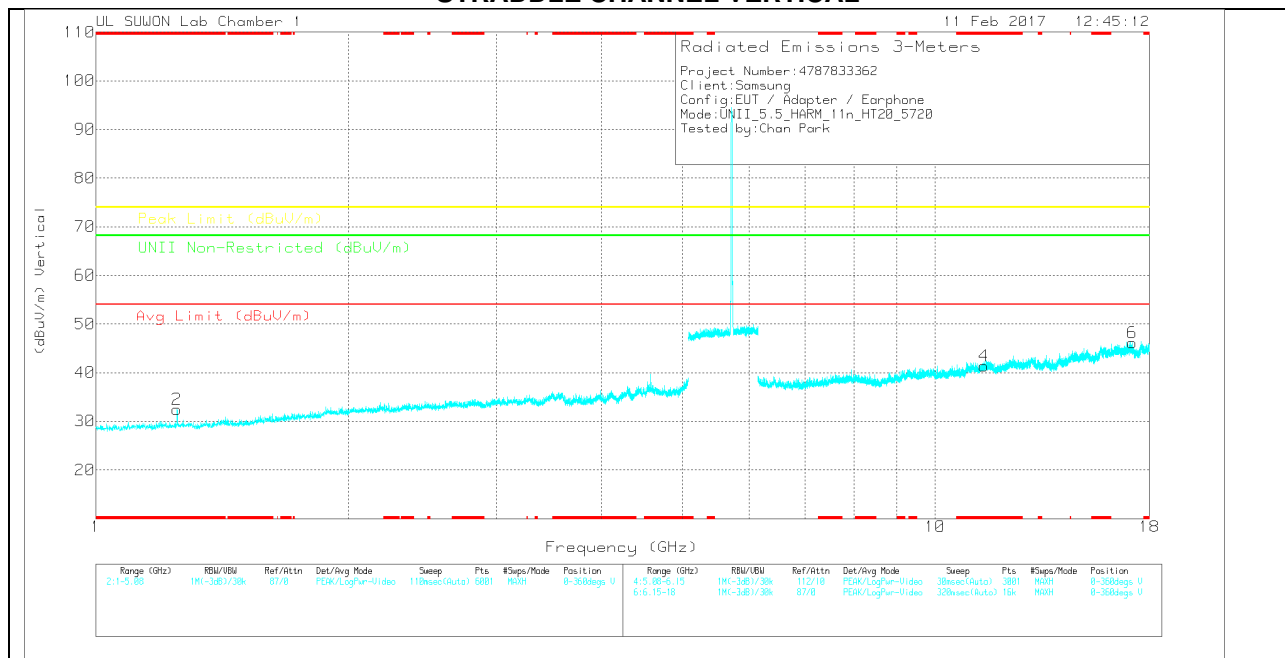

Note: Emission was scanned up to 40GHz; No emissions were detected above the noise floor which was at least 20dB below the specification limit.

STRADDLE CHANNEL DATA

Trace Markers

Marker	Frequency (GHz)	Meter Reading (dBuV)	Det	3117(0016 8717)_150 619	5Ghz_LP(d B)	DC Corr (dB)	Corrected Reading (dBuV/m)	Avg Limit (dBuV/m)	Margin (dB)	Peak Limit (dBuV/m)	Margin (dB)	UNII Non-Restricted (dBuV/m)	Margin (dB)	Azimuth (Degs)	Height (cm)	Polarity
1	* 1.25	44.61	Pk	28.3	-39.6	0	33.31	-	-	74	-40.69	-	-	0-360	250	H
2	* 1.25	43.71	Pk	28.3	-39.6	0	32.41	-	-	74	-41.59	-	-	0-360	250	V
3	* 11.436	31.17	Pk	38.6	-28.3	0	41.47	-	-	74	-32.53	-	-	0-360	250	H
5	17.158	28.27	Pk	41.3	-22.9	0	46.67	-	-	-	-	68.2	-21.53	0-360	250	H
4	* 11.437	31.09	Pk	38.6	-28.3	0	41.39	-	-	74	-32.61	-	-	0-360	250	V
6	17.163	27.58	Pk	41.3	-22.7	0	46.18	-	-	-	-	68.2	-22.02	0-360	250	V

* - indicates frequency in CFR15.205/IC7.2.2 Restricted Band

Pk – Peak detector

Note: Only peak measurement was performed. Because peak measurement result of unwanted emission is less than average limit (54dBuV/m).

10.3.3. TX ABOVE 1GHz 802.11n HT40 MODE IN THE 5.5GHz BAND RESTRICTED BANDEDGE (LOW CHANNEL)

HORIZONTAL PEAK AND AVERAGE PLOT

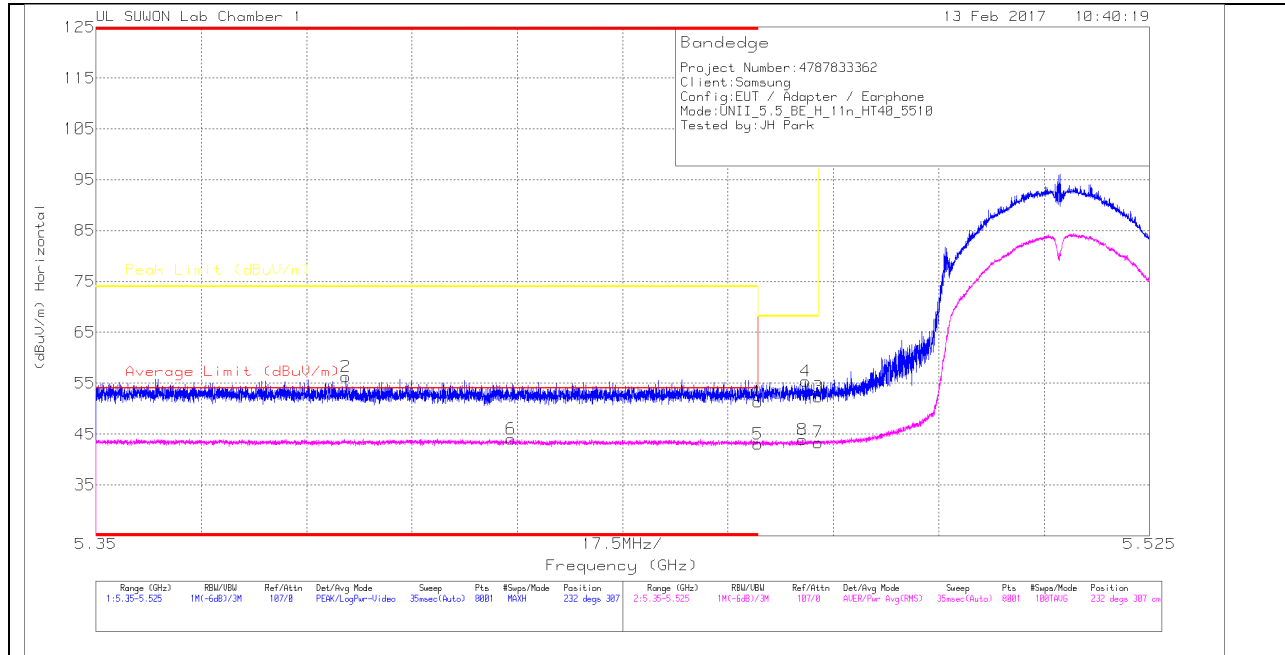

HORIZONTAL DATA

Trace Markers

Marker	Frequency (GHz)	Meter Reading (dBuV)	Det	3117(00168 717)_15061 9	10dB_Att(dB)	DC Corr (dB)	Corrected Reading (dBuV/m)	Average Limit (dBuV/m)	Margin (dB)	Peak Limit (dBuV/m)	PK Margin (dB)	Azimuth (Degs)	Height (cm)	Polarity
1	* 5.46	39.88	Pk		-23.1	0	51.38	-	-	74	-22.62	232	307	H
2	* 5.392	45.13	Pk		-23.4	0	56.23	-	-	74	-17.77	232	307	H
3	5.47	40.75	Pk		-23.1	0	52.25	-	-	68.2	-15.95	232	307	H
4	5.468	43.92	Pk		-23.1	0	55.42	-	-	68.2	-12.78	232	307	H
5	* 5.46	31.74	RMS		-23.7	.38	43.02	54	-10.98	-	-	232	307	H
6	* 5.419	32.88	RMS		-23.8	.38	44.06	54	-9.94	-	-	232	307	H

* - indicates frequency in CFR15.205/IC7.2.2 Restricted Band

Pk - Peak detector

RMS - RMS detection

VERTICAL PEAK AND AVERAGE PLOT

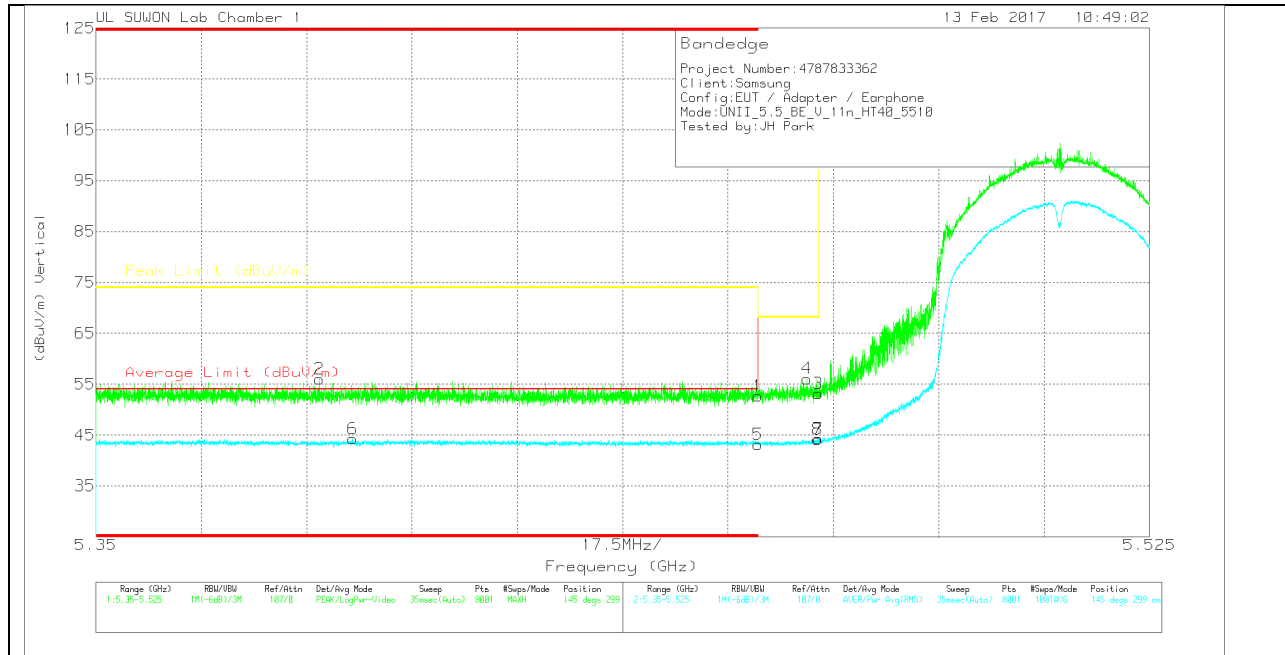

VERTICAL DATA

Trace Markers

Marker	Frequency (GHz)	Meter Reading (dBuV)	Det	3117(00168 717)_15061 9	10dB_Att(dB)	DC Corr (dB)	Corrected Reading (dBuV/m)	Average Limit (dBuV/m)	Margin (dB)	Peak Limit (dBuV/m)	PK Margin (dB)	Azimuth (Degs)	Height (cm)	Polarity
1	* 5.46	41.2	Pk	34.6	-23.1	0	52.7	-	-	74	-21.3	145	299	V
2	* 5.387	44.87	Pk	34.5	-23.3	0	56.07	-	-	74	-17.93	145	299	V
3	5.47	41.66	Pk	34.6	-23.1	0	53.16	-	-	68.2	-15.04	145	299	V
4	5.468	44.58	Pk	34.6	-23.1	0	56.08	-	-	68.2	-12.12	145	299	V
5	* 5.46	31.85	RMS	34.6	-23.7	.38	43.13	54	-10.87	-	-	145	299	V
6	* 5.393	33.14	RMS	34.5	-23.8	.38	44.22	54	-9.78	-	-	145	299	V

* - indicates frequency in CFR15.205/IC7.2.2 Restricted Band

Pk - Peak detector

RMS - RMS detection

AUTHORIZED BANDEDGE (HIGH CHANNEL)

HORIZONTAL PEAK AND AVERAGE PLOT

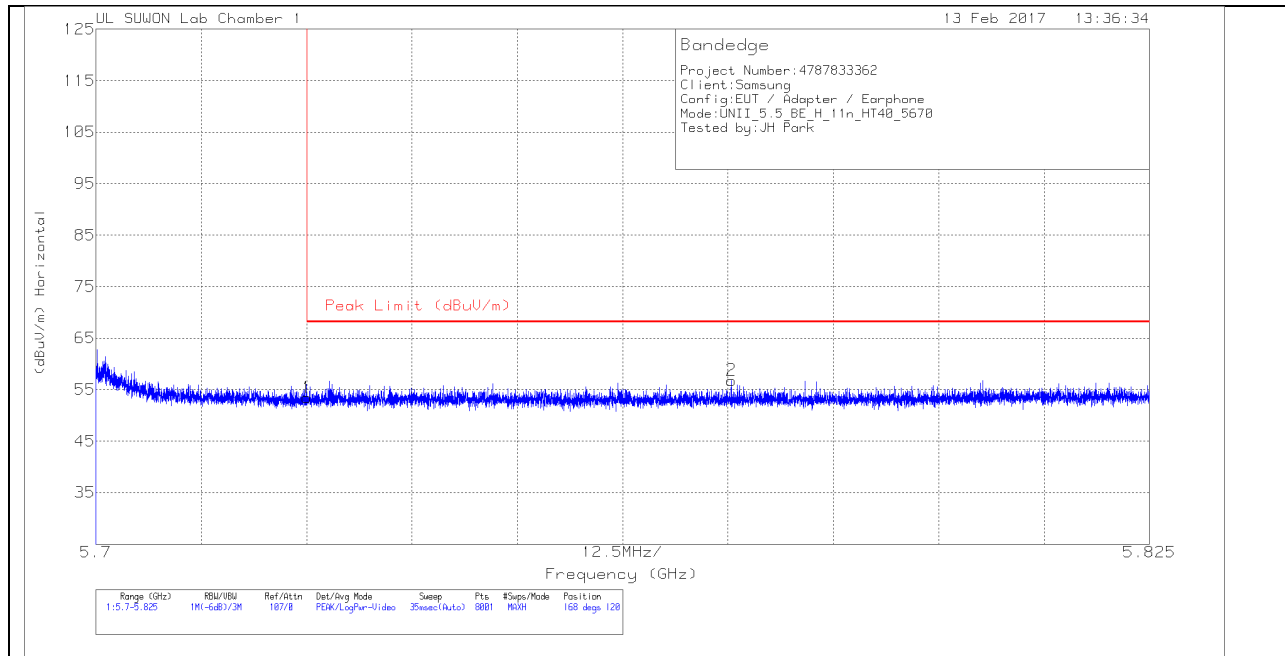

HORIZONTAL DATA

Trace Markers

Marker	Frequency (GHz)	Meter Reading (dBuV)	Det	3117(0016 8717)_150 619	10dB_Att(d B)	DC Corr (dB)	Corrected Reading (dBuV/m)	Peak Limit (dBuV/m)	PK Margin (dB)	Azimuth (Degs)	Height (cm)	Polarity
1	5.725	41.54	Pk		34.8	-22.9	53.44	68.2	-14.76	168	120	H
2	5.775	44.92	Pk		34.8	-22.9	56.82	68.2	-11.38	168	120	H

Pk - Peak detector

VERTICAL PEAK AND AVERAGE PLOT

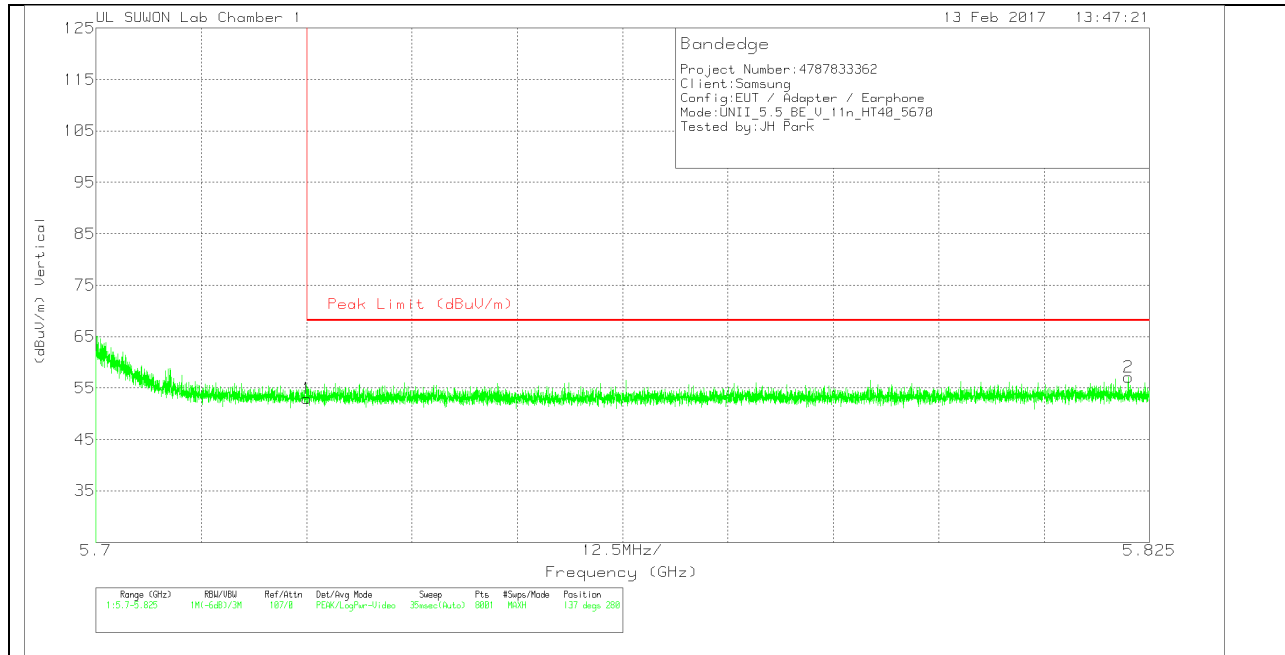

VERTICAL DATA

Trace Markers

Marker	Frequency (GHz)	Meter Reading (dBuV)	Det	3117(0016 8717)_150 619	10dB_Att(d B)	DC Corr (dB)	Corrected Reading (dBuV/m)	Peak Limit (dBuV/m)	PK Margin (dB)	Azimuth (Degs)	Height (cm)	Polarity
1	5.725	41.04	Pk	34.8	-22.9	0	52.94	68.2	-15.26	137	280	V
2	5.822	44.76	Pk	34.8	-22.4	0	57.16	68.2	-11.04	137	280	V

Pk - Peak detector

HARMONICS AND SPURIOUS EMISSIONS

LOW CHANNEL HORIZONTAL

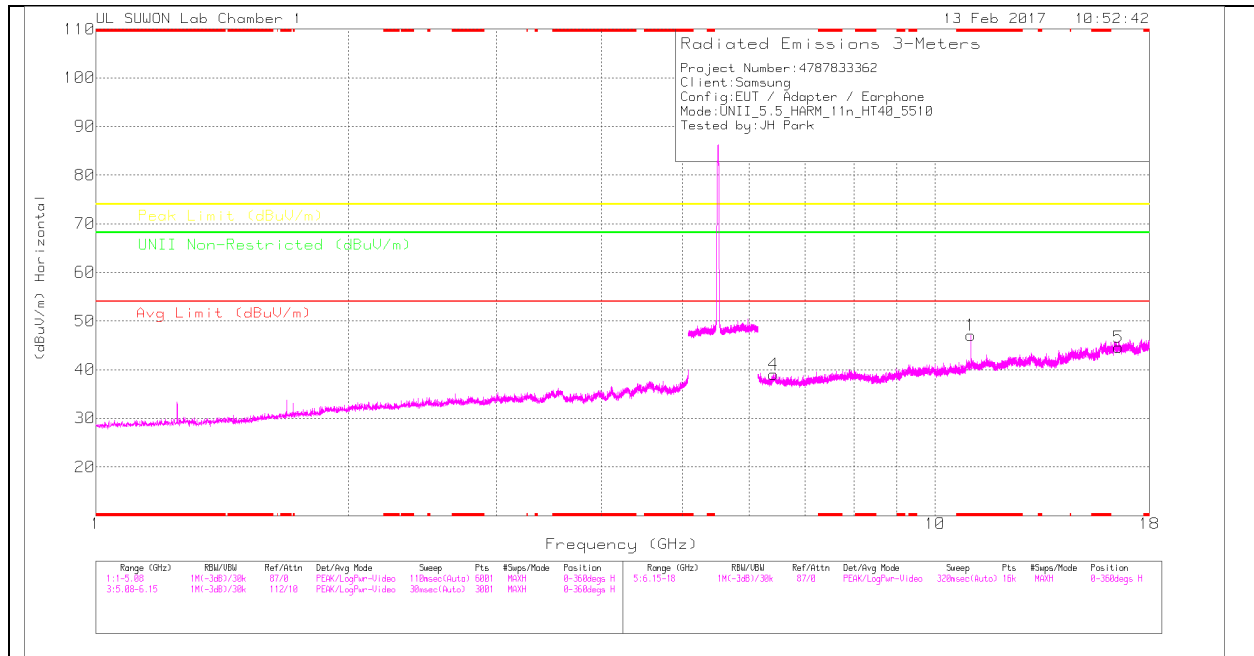

LOW CHANNEL VERTICAL

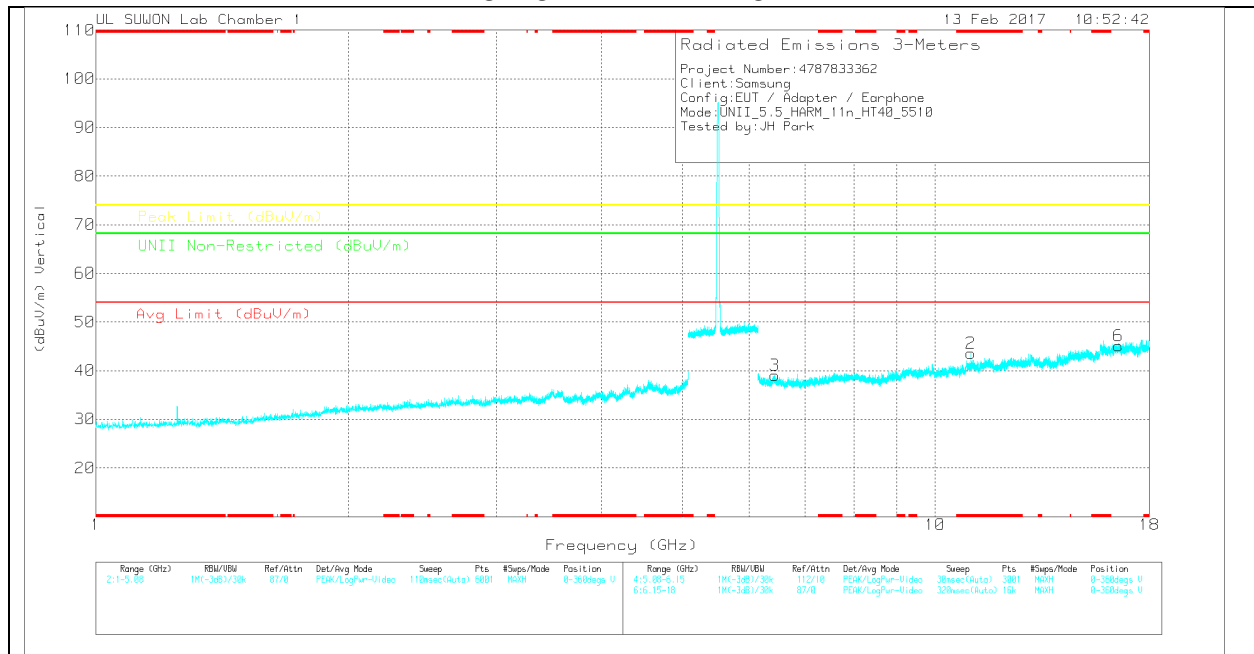

Note: Emission was scanned up to 40GHz; No emissions were detected above the noise floor which was at least 20dB below the specification limit.

LOW CHANNEL DATA

Trace Markers

Marker	Frequency (GHz)	Meter Reading (dBuV)	Det	3117(0016 8717)_150 539	6Ghz_HP(d B)	DC Corr (dB)	Corrected Reading (dBuV/m)	Avg Limit (dBuV/m)	Margin (dB)	Peak Limit (dBuV/m)	Margin (dB)	UNII Non-Restricted (dBuV/m)	Margin (dB)	Azimuth (Degs)	Height (cm)	Polarity
1	* 11.02	37.07	PK	38.2	-28.2	0	47.07	-	-	74	-26.93	-	-	0-360	250	H
4	6.417	34.19	PK	35.3	-30.5	0	38.99	-	-	-	-	68.2	-29.21	0-360	250	H
5	16.53	26.58	PK	41.2	-23.2	0	44.58	-	-	-	-	68.2	-23.62	0-360	250	H
2	* 11.02	33.54	PK	38.2	-28.2	0	43.54	-	-	74	-30.46	-	-	0-360	250	V
3	6.439	34.14	PK	35.4	-30.5	0	39.04	-	-	-	-	68.2	-29.16	0-360	250	V
6	16.533	27.25	PK	41.2	-23.3	0	45.15	-	-	-	-	68.2	-23.05	0-360	150	V

* - indicates frequency in CFR15.205/IC7.2.2 Restricted Band

PK – Peak Detector

Radiated Emissions

Frequency (GHz)	Meter Reading (dBuV)	Det	3117(001687 17)_150619	6Ghz_HP(dB)	DC Corr (dB)	Corrected Reading (dBuV/m)	Avg Limit (dBuV/m)	Margin (dB)	Peak Limit (dBuV/m)	Margin (dB)	UNII Non-Restricted (dBuV/m)	Margin (dB)	Azimuth (Degs)	Height (cm)	Polarity
* 11.02	44.15	PK-U	38.2	-28.2	0	54.15	-	-	74	-19.85	-	-	224	198	H
* 11.02	35.77	ADR	38.2	-28.2	.38	46.15	54	-7.85	-	-	-	-	224	198	H
* 11.02	43.77	PK-U	38.2	-28.2	0	53.77	-	-	74	-20.23	-	-	145	229	V
* 11.02	32.59	ADR	38.2	-28.2	.38	42.97	54	-11.03	-	-	-	-	145	229	V

* - indicates frequency in CFR15.205/IC7.2.2 Restricted Band

PK-U - U-NII: Maximum Peak

ADR - U-NII AD primary method, RMS average

MID CHANNEL HORIZONTAL

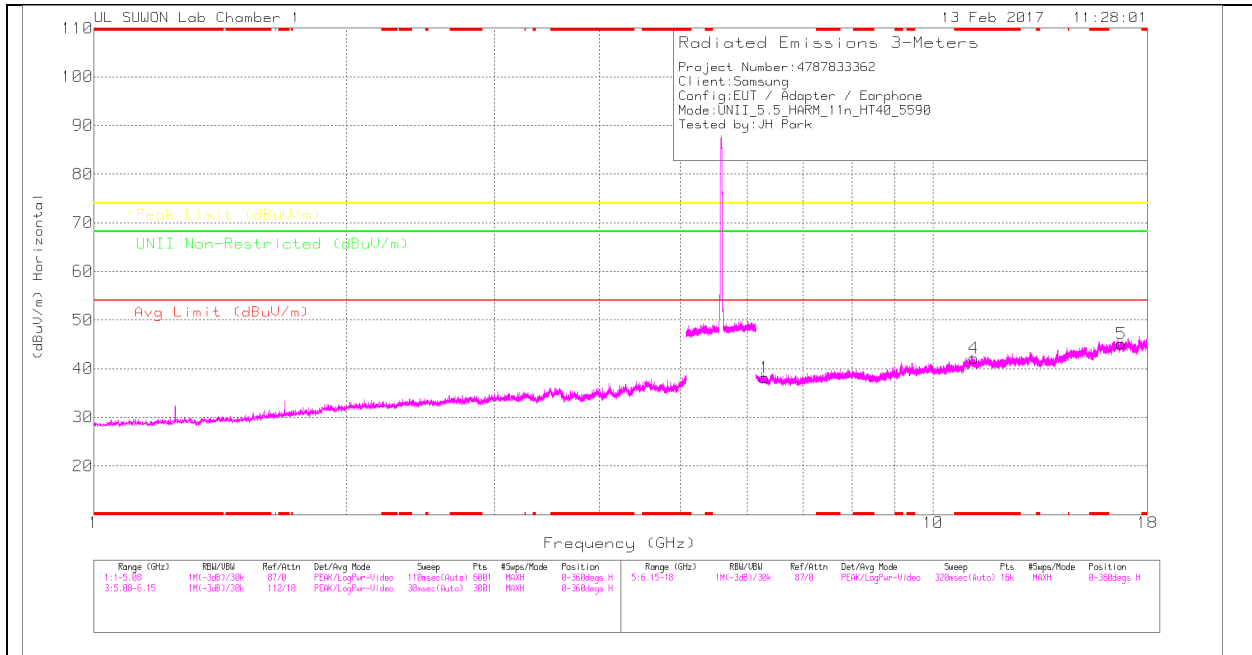

MID CHANNEL VERTICAL

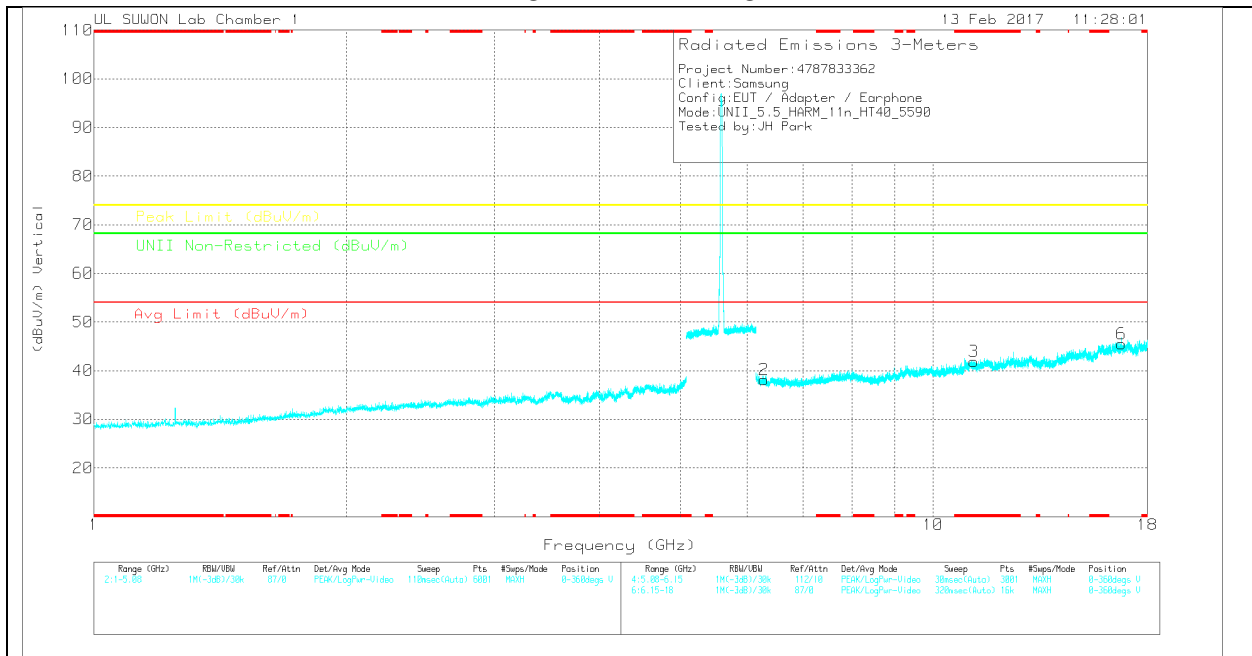

Note: Emission was scanned up to 40GHz; No emissions were detected above the noise floor which was at least 20dB below the specification limit.

MID CHANNEL DATA

Trace Markers

Marker	Frequency (GHz)	Meter Reading (dBuV)	Det	3117(0016 8717)_150 619	6Ghz_HP(d B)	DC Corr (dB)	Corrected Reading (dBuV/m)	Avg Limit (dBuV/m)	Margin (dB)	Peak Limit (dBuV/m)	Margin (dB)	UNII Non-Restricted (dBuV/m)	Margin (dB)	Azimuth (Degs)	Height (cm)	Polarity
1	6.3	34.04	PK	35.2	-31.1	0	38.14	-	-	-	-	68.2	-30.06	0-360	250	H
4	* 11.18	31.49	PK	38.3	-27.7	0	42.09	-	-	74	-31.91	-	-	0-360	150	H
5	16.771	26.86	PK	41.3	-23	0	45.16	-	-	-	-	68.2	-23.04	0-360	250	H
2	6.291	34.09	PK	35.2	-31.2	0	38.09	-	-	-	-	68.2	-30.11	0-360	250	V
3	* 11.18	31.26	PK	38.3	-27.7	0	41.86	-	-	74	-32.14	-	-	0-360	150	V
6	16.77	27.27	PK	41.3	-23.1	0	45.47	-	-	-	-	68.2	-22.73	0-360	150	V

* - indicates frequency in CFR15.205/IC7.2.2 Restricted Band

PK – Peak Detector

Note: Only peak measurement was performed. Because peak measurement result of unwanted emission is less than average limit (54dBuV/m).

HIGH CHANNEL HORIZONTAL

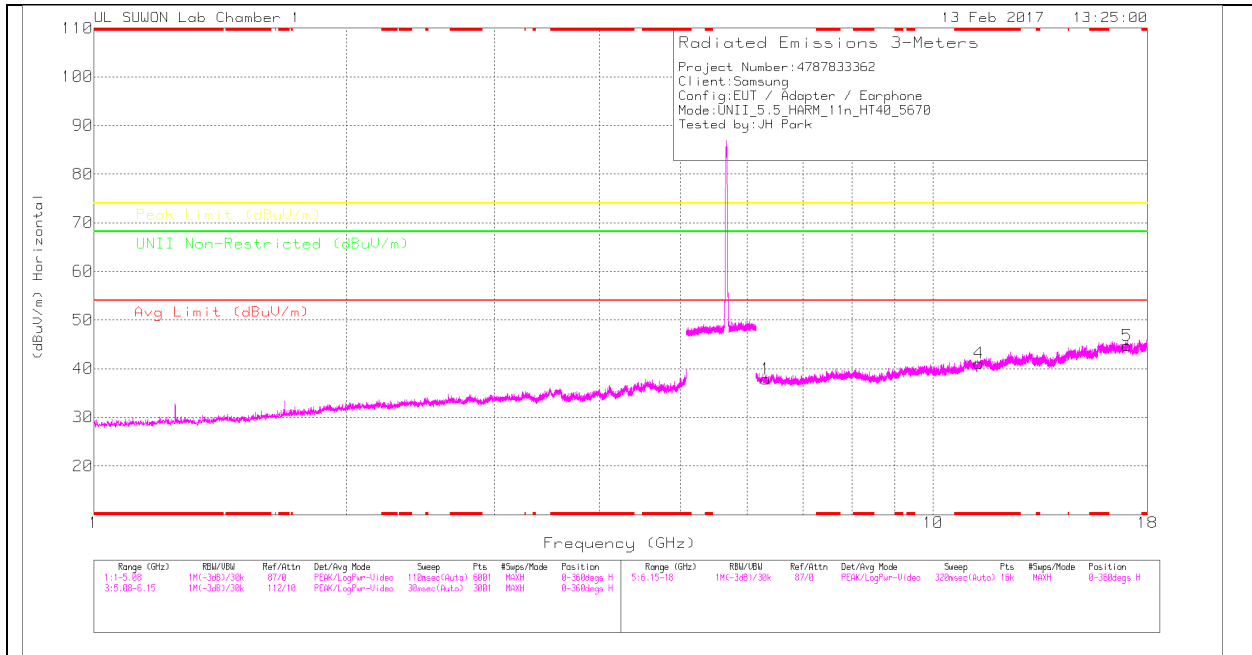

HIGH CHANNEL VERTICAL

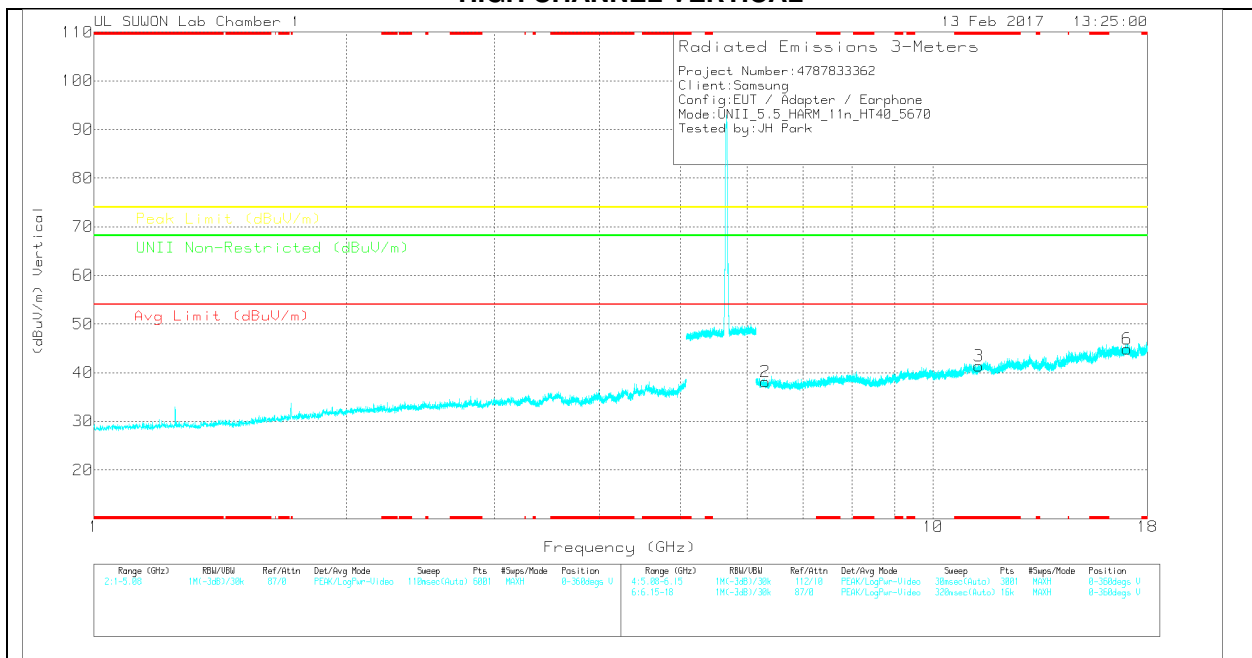

Note: Emission was scanned up to 40GHz; No emissions were detected above the noise floor which was at least 20dB below the specification limit.

HIGH CHANNEL DATA

Trace Markers

Marker	Frequency (GHz)	Meter Reading (dBuV)	Det	3117(0016 8717)_150 519	6Ghz_HP(d B)	DC Corr (dB)	Corrected Reading (dBuV/m)	Avg Limit (dBuV/m)	Margin (dB)	Peak Limit (dBuV/m)	Margin (dB)	UNII Non-Restricted (dBuV/m)	Margin (dB)	Azimuth (Degs)	Height (cm)	Polarity
1	6.323	33.77	PK	35.3	-31.2	0	37.87	-	-	-	-	68.2	-30.33	0-360	150	H
4	* 11.343	29.95	PK	38.5	-27.4	0	41.05	-	-	74	-32.95	-	-	0-360	150	H
5	17.009	26.4	PK	41.4	-23.1	0	44.7	-	-	-	-	68.2	-23.5	0-360	250	H
2	6.308	34.08	PK	35.2	-31.1	0	38.18	-	-	-	-	68.2	-30.02	0-360	250	V
3	* 11.339	30.22	PK	38.5	-27.3	0	41.42	-	-	74	-32.58	-	-	0-360	250	V
6	17.011	26.53	PK	41.4	-23.1	0	44.83	-	-	-	-	68.2	-23.37	0-360	250	V

* - indicates frequency in CFR15.205/IC7.2.2 Restricted Band

PK – Peak Detector

Note: Only peak measurement was performed. Because peak measurement result of unwanted emission is less than average limit (54dBuV/m).

STRADDLE CHANNEL HORIZONTAL

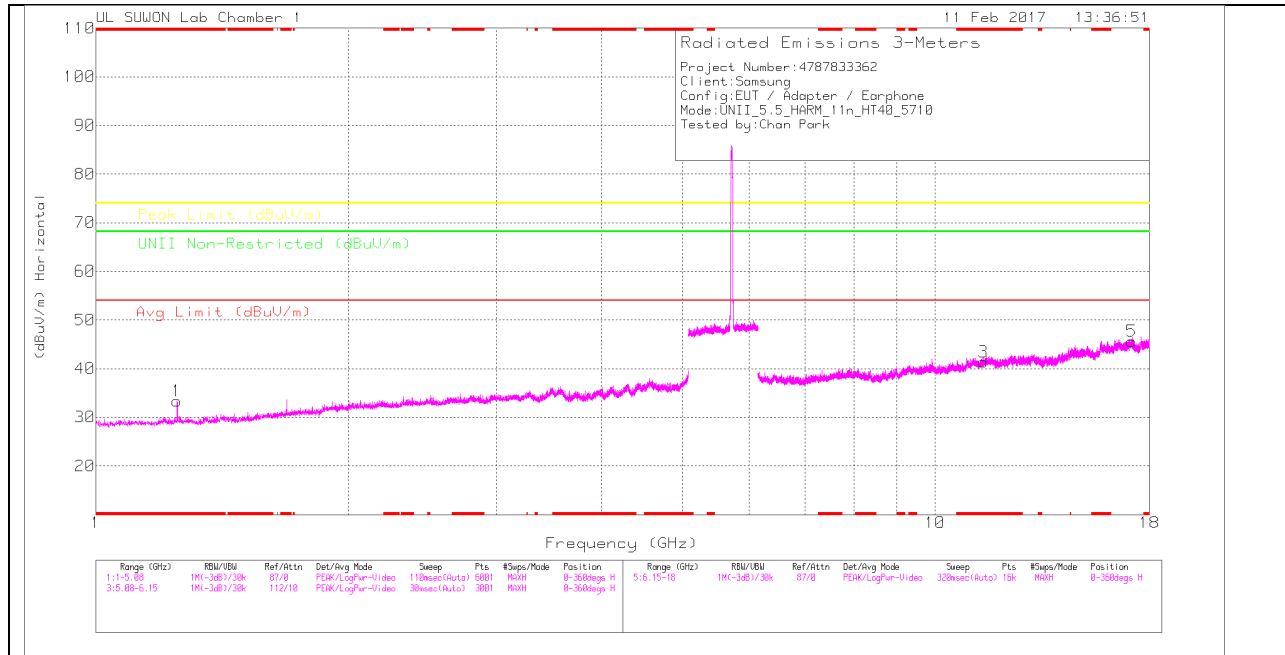

STRADDLE CHANNEL VERTICAL

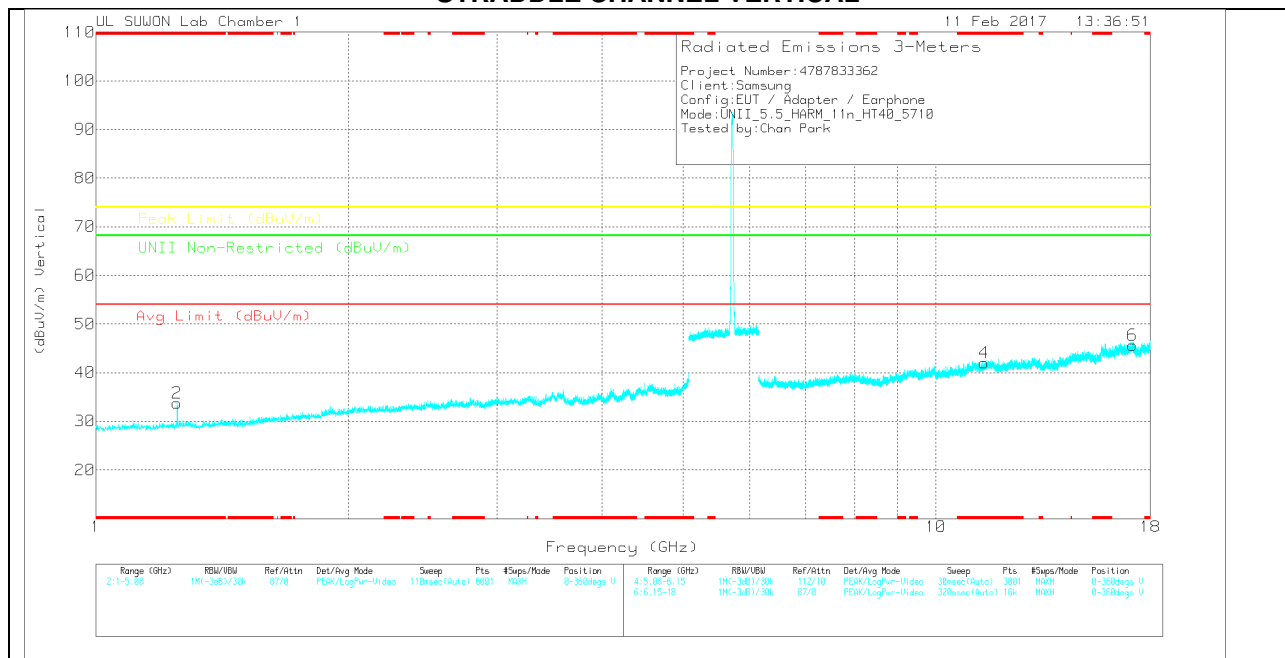

Note: Emission was scanned up to 40GHz; No emissions were detected above the noise floor which was at least 20dB below the specification limit.

STRADDLE CHANNEL DATA

Trace Markers

Marker	Frequency (GHz)	Meter Reading (dBuV)	Det	3117(0016 8717)_150 619	5Ghz_LP(d B)	DC Corr (dB)	Corrected Reading (dBuV/m)	Avg Limit (dBuV/m)	Margin (dB)	Peak Limit (dBuV/m)	Margin (dB)	UNII Non-Restricted (dBuV/m)	Margin (dB)	Azimuth (Degs)	Height (cm)	Polarity
1	* 1.25	44.63	Pk	28.3	-39.6	0	33.33	-	-	74	-40.67	-	-	0-360	250	H
2	* 1.25	45.06	Pk	28.3	-39.6	0	33.76	-	-	74	-40.24	-	-	0-360	250	V
3	* 11.422	31.07	Pk	38.6	-28.3	0	41.37	-	-	74	-32.63	-	-	0-360	150	H
5	17.136	27.4	Pk	41.3	-23.1	0	45.6	-	-	-	-	68.2	-22.6	0-360	250	H
4	* 11.417	31.87	Pk	38.5	-28.4	0	41.97	-	-	74	-32.03	-	-	0-360	150	V
6	17.135	27.49	Pk	41.3	-23.2	0	45.59	-	-	-	-	68.2	-22.61	0-360	250	V

* - indicates frequency in CFR15.205/IC7.2.2 Restricted Band

Pk – Peak detector

Note: Only peak measurement was performed. Because peak measurement result of unwanted emission is less than average limit (54dBuV/m).

10.4. 5.8 GHz

10.4.1. TX ABOVE 1GHz 802.11a MODE IN THE 5.8GHz BAND BANDEDGE (LOW CHANNEL)

HORIZONTAL PEAK PLOT

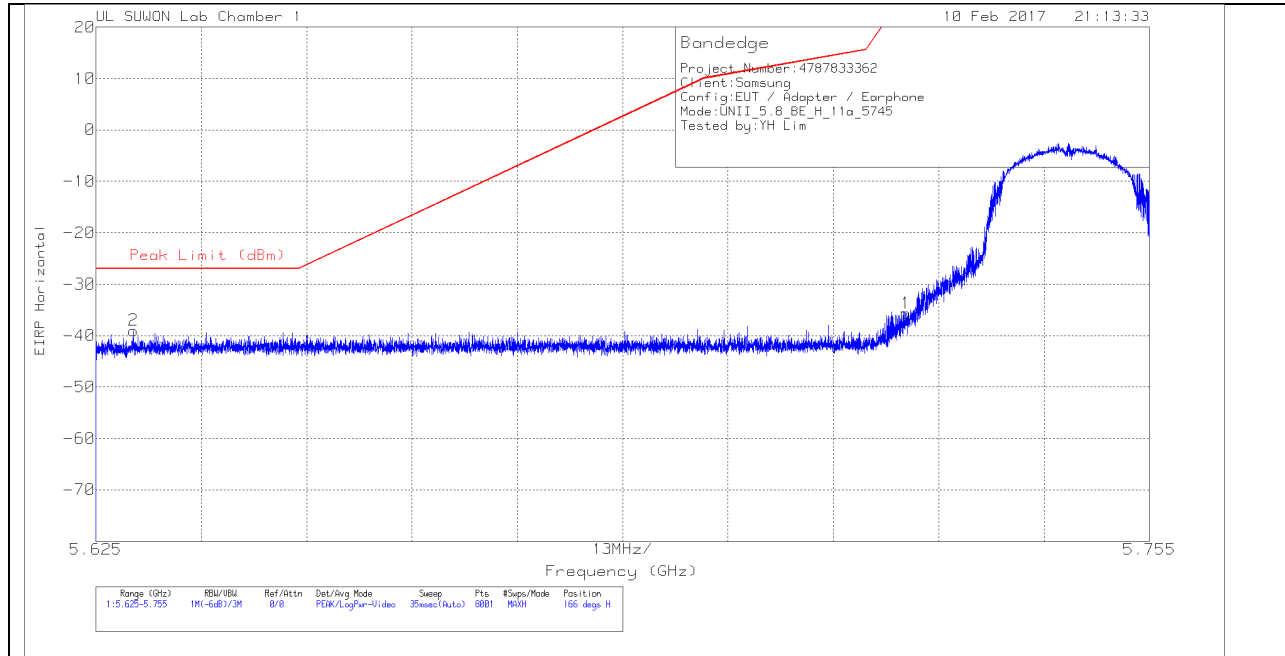

HORIZONTAL DATA

Trace Markers

Marker	Frequency (GHz)	Meter Reading (dBm)	Det	3117(0016 8717)_150 619	10dB_Att(dB)	Conversion Factor (dB)	DC Corr (dB)	Corrected Reading EIRP	Peak Limit (dBm)	PK Margin (dB)	Azimuth (Degs)	Height (cm)	Polarity
1	5.725	-59.31	PK		-22.9	11.8	0	-35.61	26.97	-62.58	166	118	H
2	5.63	-62.3	PK		-23.2	11.8	0	-39	-27	-12	166	118	H

Pk - Peak detector

VERTICAL PEAK PLOT

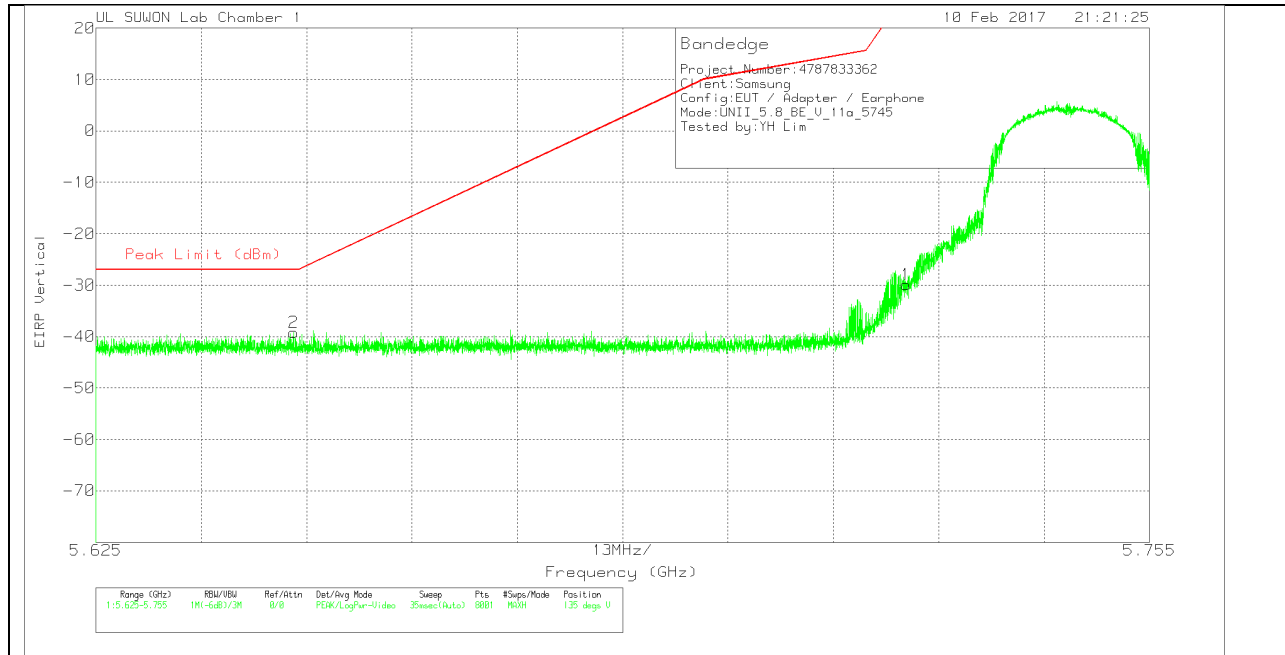

VERTICAL DATA

Trace Markers

Marker	Frequency (GHz)	Meter Reading (dBm)	Det	3117(0016 8717)_150 619	10dB_Att(dB)	Conversion Factor (dB)	DC Corr (dB)	Corrected Reading EIRP	Peak Limit (dBm)	PK Margin (dB)	Azimuth (Degs)	Height (cm)	Polarity
1	5.725	-53.59	PK	34.8	-22.9	11.8	0	-29.89	26.97	-56.86	135	149	V
2	5.649	-62.73	PK	34.8	-23.1	11.8	0	-39.23	-27	-12.23	135	149	V

Pk - Peak detector

BANDEDGE (HIGH CHANNEL)

HORIZONTAL PEAK PLOT

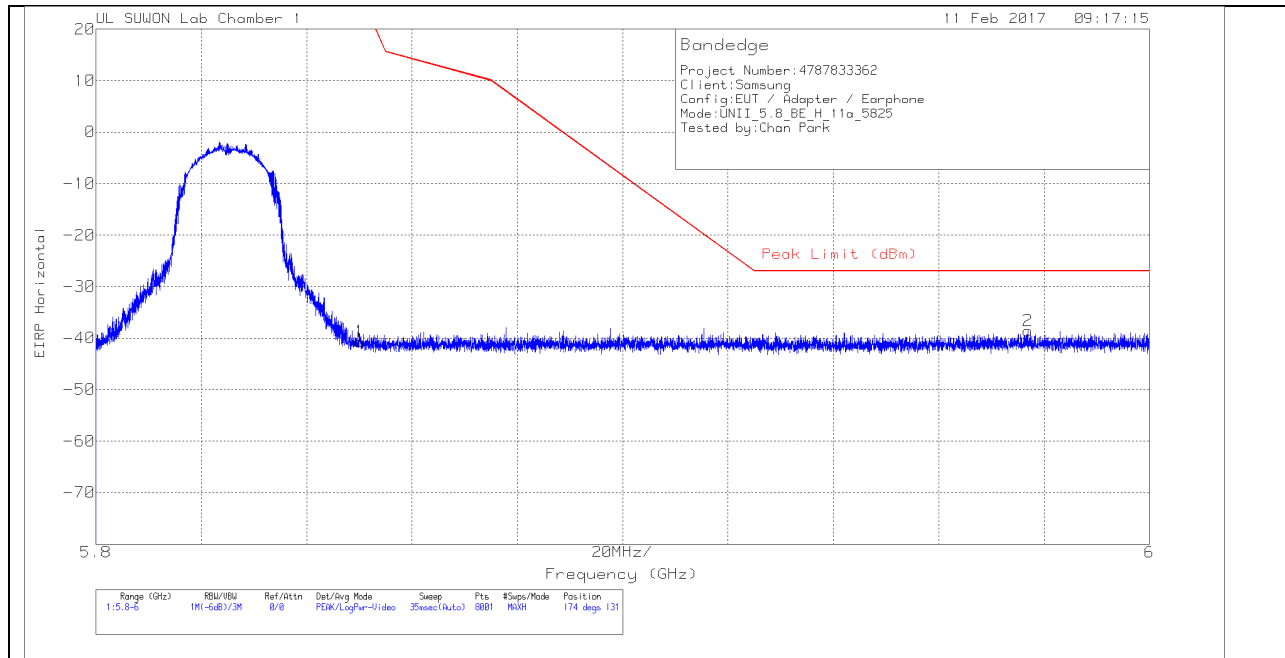

HORIZONTAL DATA

Trace Markers

Marker	Frequency (GHz)	Meter Reading (dBm)	Det	3117(0016 8717)_150 619	10dB_Att (dB)	Conversion Factor (dB)	DC Corr (dB)	Corrected Reading EIRP	Peak Limit (dBm)	PK Margin (dB)	Azimuth (Degs)	Height (cm)	Polarity
1	5.85	-65.09	Pk	34.9	-22.3	11.8	0	-40.69	26.94	-67.63	174	131	H
2	5.977	-62.92	Pk	34.9	-22.4	11.8	0	-38.62	-27	-11.62	174	131	H

Pk - Peak detector

VERTICAL PEAK PLOT

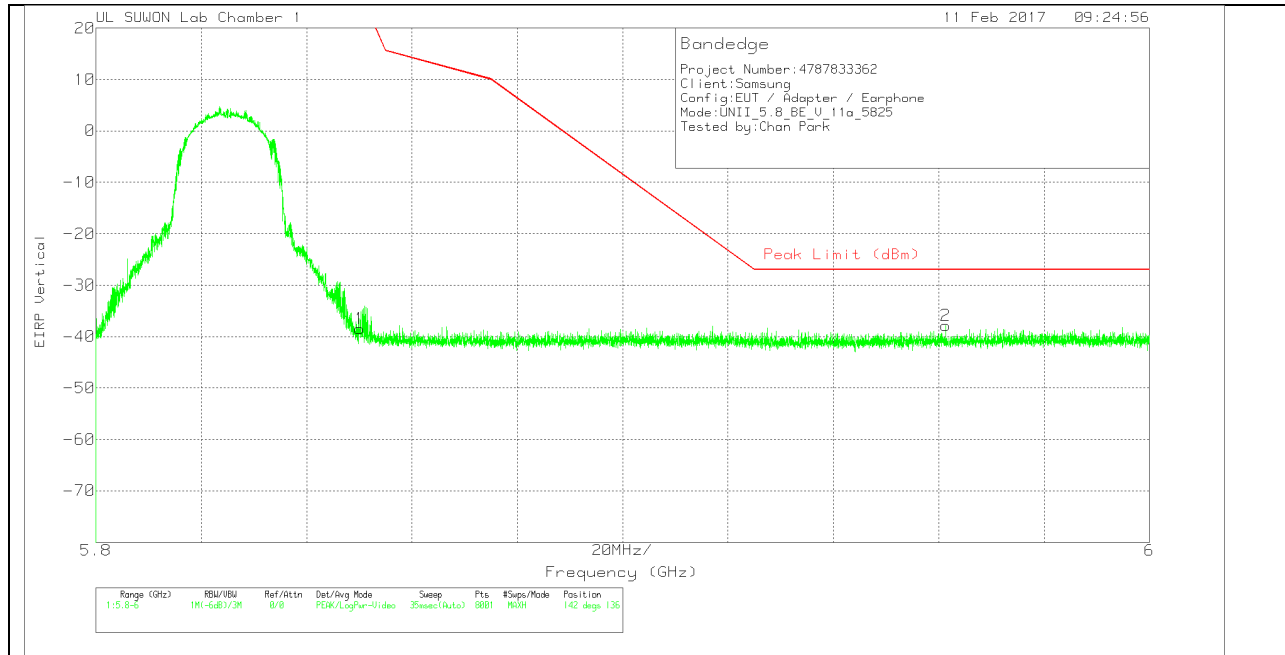

VERTICAL DATA

Trace Markers

Marker	Frequency (GHz)	Meter Reading (dBm)	Det	3117(0016 8717)_150 619	10dB_Att(dB)	Conversion Factor (dB)	DC Corr (dB)	Corrected Reading EIRP	Peak Limit (dBm)	PK Margin (dB)	Azimuth (Degs)	Height (cm)	Polarity
1	5.85	-62.85	PK	34.9	-22.3	11.8	0	-38.45	26.94	-65.39	142	136	V
2	5.961	-61.94	PK	34.9	-22.6	11.8	0	-37.84	-27	-10.84	142	136	V

Pk - Peak detector

LOW CHANNEL HORIZONTAL

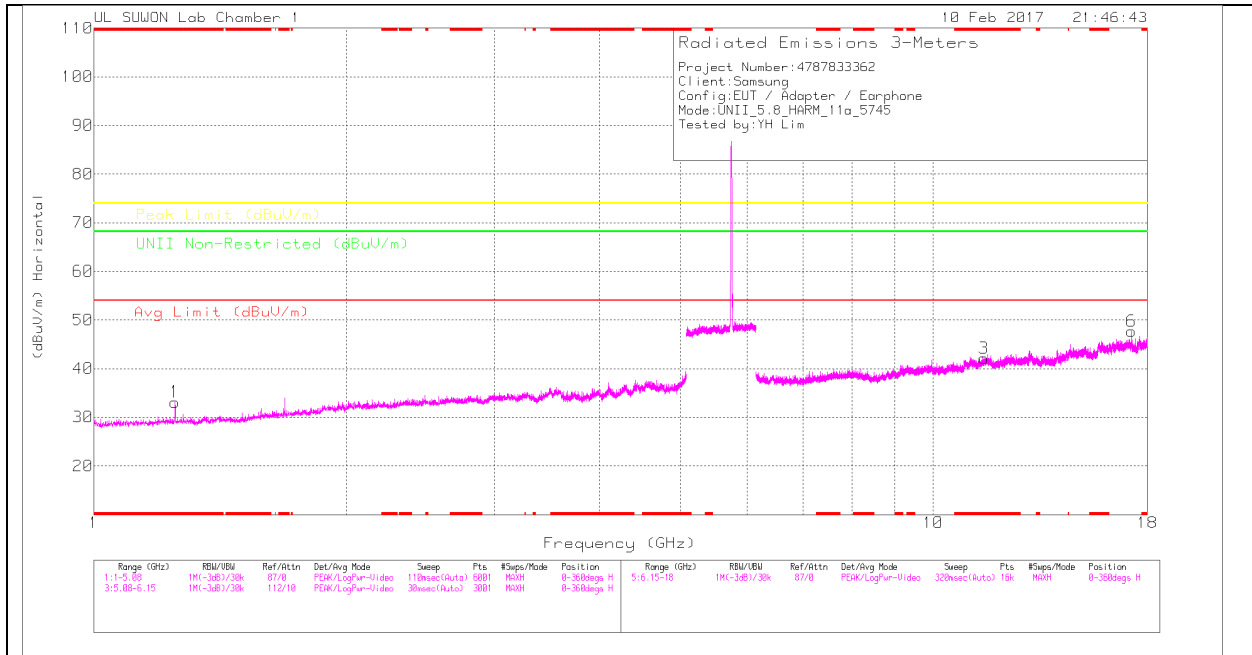

LOW CHANNEL VERTICAL

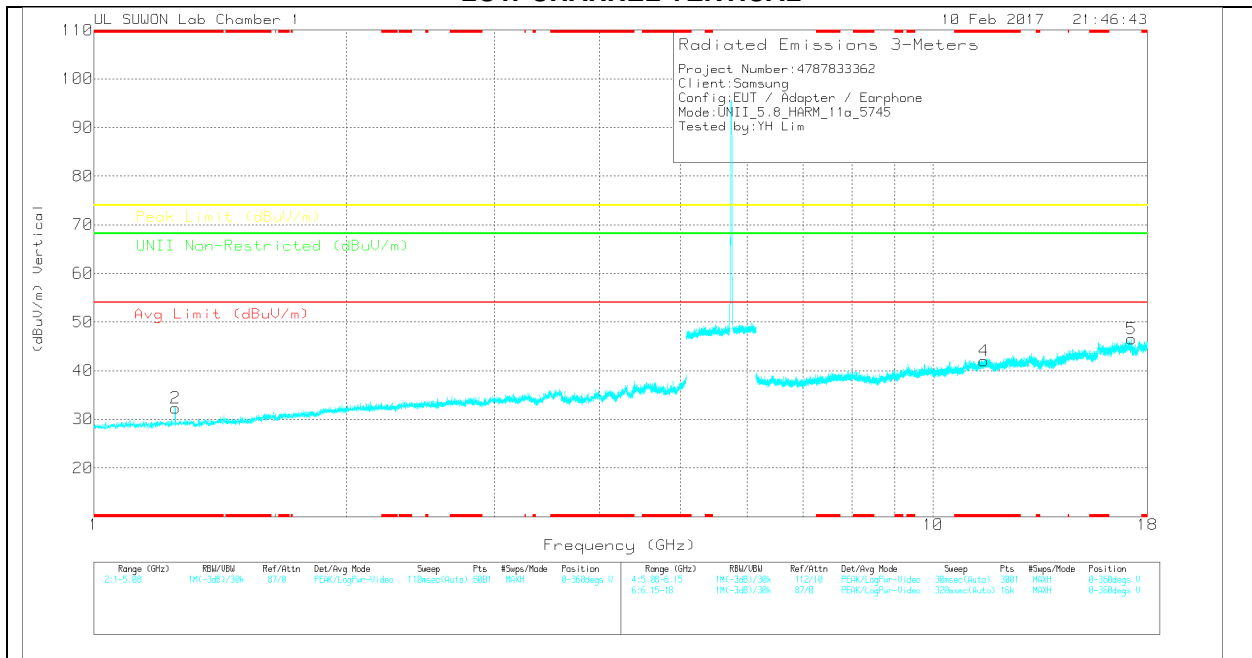

Note: Emission was scanned up to 40GHz; No emissions were detected above the noise floor which was at least 20dB below the specification limit.

LOW CHANNEL DATA

Trace Markers

Marker	Frequency (GHz)	Meter Reading (dBuV)	Det	3117(0016 8717)_150 619	5Ghz_LP(d B)	DC Corr (dB)	Corrected Reading (dBuV/m)	Avg Limit (dBuV/m)	Margin (dB)	Peak Limit (dBuV/m)	Margin (dB)	UNII Non-Restricted (dBuV/m)	Margin (dB)	Azimuth (Degs)	Height (cm)	Polarity
1	* 1.25	44.45	Pk	28.3	-39.6	0	33.15	-	-	74	-40.85	-	-	0-360	250	H
2	* 1.25	43.57	Pk	28.3	-39.6	0	32.27	-	-	74	-41.73	-	-	0-360	250	V
3	* 11.495	31.4	Pk	38.6	-27.9	0	42.1	-	-	74	-31.9	-	-	0-360	250	H
6	17.236	29	Pk	41.2	-22.5	0	47.7	-	-	-	-	68.2	-20.5	0-360	150	H
4	* 11.495	31.35	Pk	38.6	-27.9	0	42.05	-	-	74	-31.95	-	-	0-360	250	V
5	17.233	27.69	Pk	41.2	-22.4	0	46.49	-	-	-	-	68.2	-21.71	0-360	250	V

* - indicates frequency in CFR15.205/IC7.2.2 Restricted Band

Pk – Peak detector

Note: Only peak measurement was performed. Because peak measurement result of unwanted emission is less than average limit (54dBuV/m).

MID CHANNEL HORIZONTAL

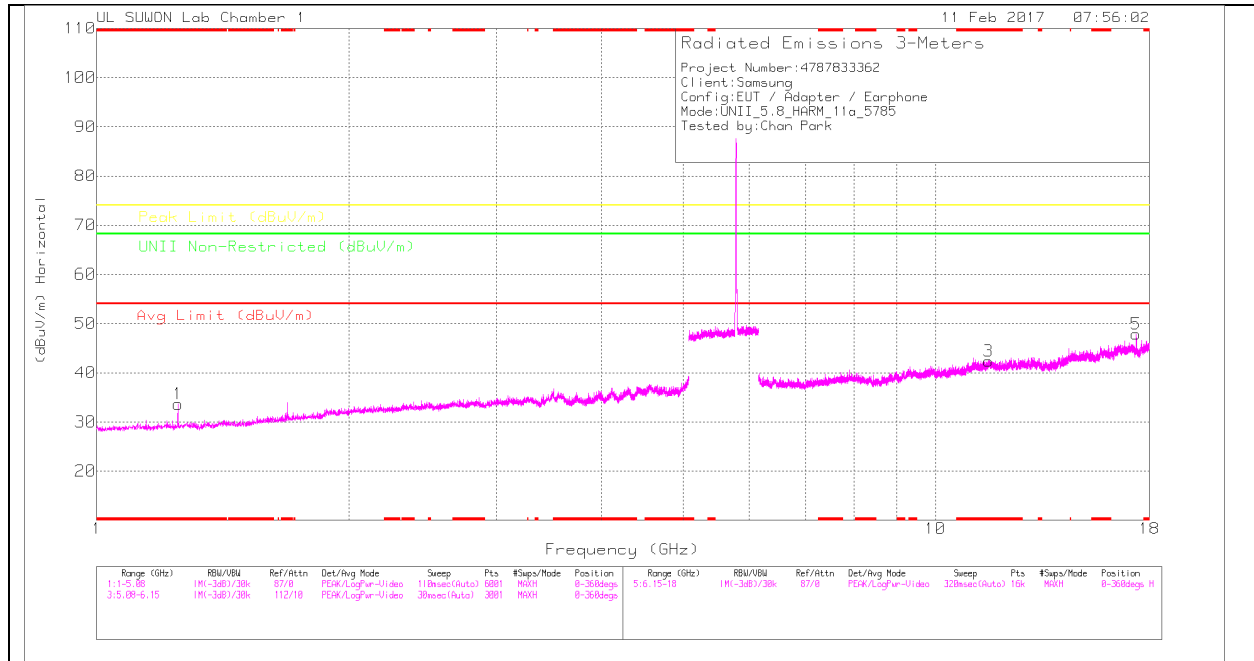

MID CHANNEL VERTICAL

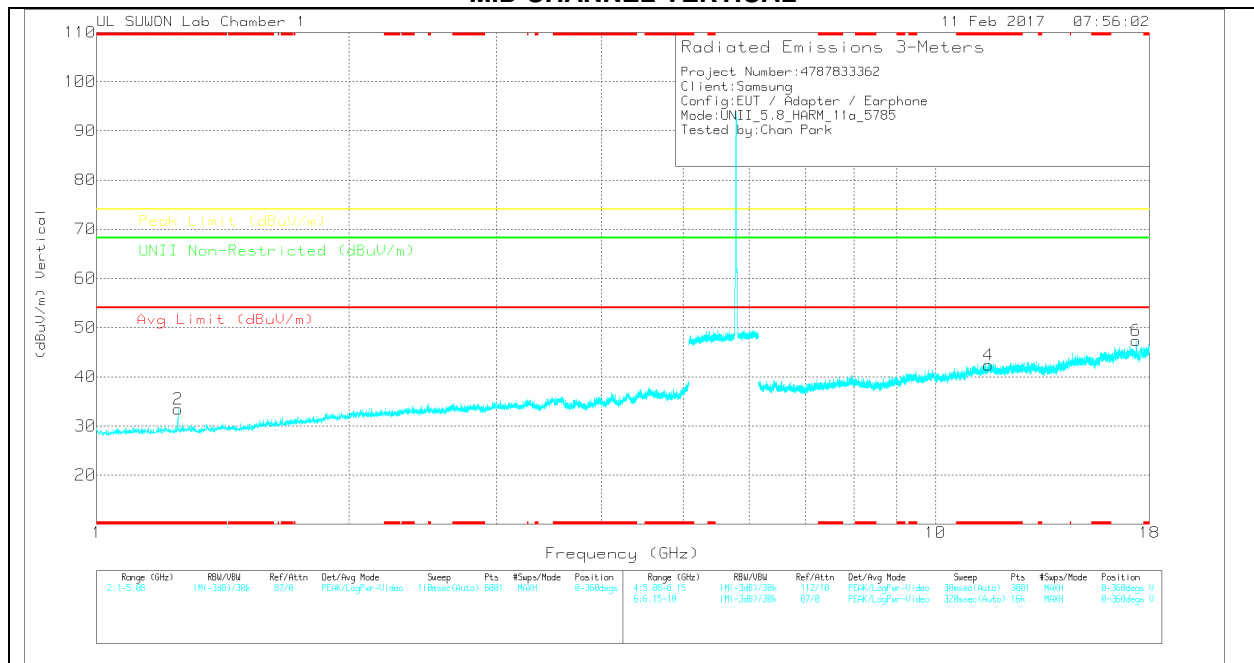

Note: Emission was scanned up to 40GHz; No emissions were detected above the noise floor which was at least 20dB below the specification limit.

MID CHANNEL DATA

Trace Markers

Marker	Frequency (GHz)	Meter Reading (dBuV)	Det	3117(0016 8717)_150 619	5Ghz_LP(d B)	DC Corr (dB)	Corrected Reading (dBuV/m)	Avg Limit (dBuV/m)	Margin (dB)	Peak Limit (dBuV/m)	Margin (dB)	UNII Non-Restricted (dBuV/m)	Margin (dB)	Azimuth (Degs)	Height (cm)	Polarity
1	* 1.25	44.93	Pk	28.3	-39.6	0	33.63	-	-	74	-40.37	-	-	0-360	250	H
2	* 1.25	44.73	Pk	28.3	-39.6	0	33.43	-	-	74	-40.57	-	-	0-360	250	V
3	* 11.567	31.47	Pk	38.7	-27.8	0	42.37	-	-	74	-31.63	-	-	0-360	250	H
5	17.356	29.33	Pk	41.2	-22.7	0	47.83	-	-	-	-	68.2	-20.37	0-360	250	H
4	* 11.57	31.53	Pk	38.7	-27.9	0	42.33	-	-	74	-31.67	-	-	0-360	250	V
6	17.356	28.75	Pk	41.2	-22.6	0	47.35	-	-	-	-	68.2	-20.85	0-360	250	V

* - indicates frequency in CFR15.205/IC7.2.2 Restricted Band

Pk – Peak detector

Radiated Emissions

Frequency (GHz)	Meter Reading (dBuV)	Det	3117(001687 17)_150619	6Ghz_HP(dB)	DC Corr (dB)	Corrected Reading (dBuV/m)	Avg Limit (dBuV/m)	Margin (dB)	Peak Limit (dBuV/m)	Margin (dB)	UNII Non-Restricted (dBuV/m)	Margin (dB)	Azimuth (Degs)	Height (cm)	Polarity
17.36	46.39	PK-U	41.2	-22.6	0	64.99	-	-	-	-	68.2	-3.21	242	190	H
17.36	44.05	PK-U	41.2	-22.6	0	62.65	-	-	-	-	68.2	-5.55	205	206	V

* - indicates frequency in CFR15.205/IC7.2.2 Restricted Band

PK-U - U-NII: Maximum Peak

HIGH CHANNEL HORIZONTAL

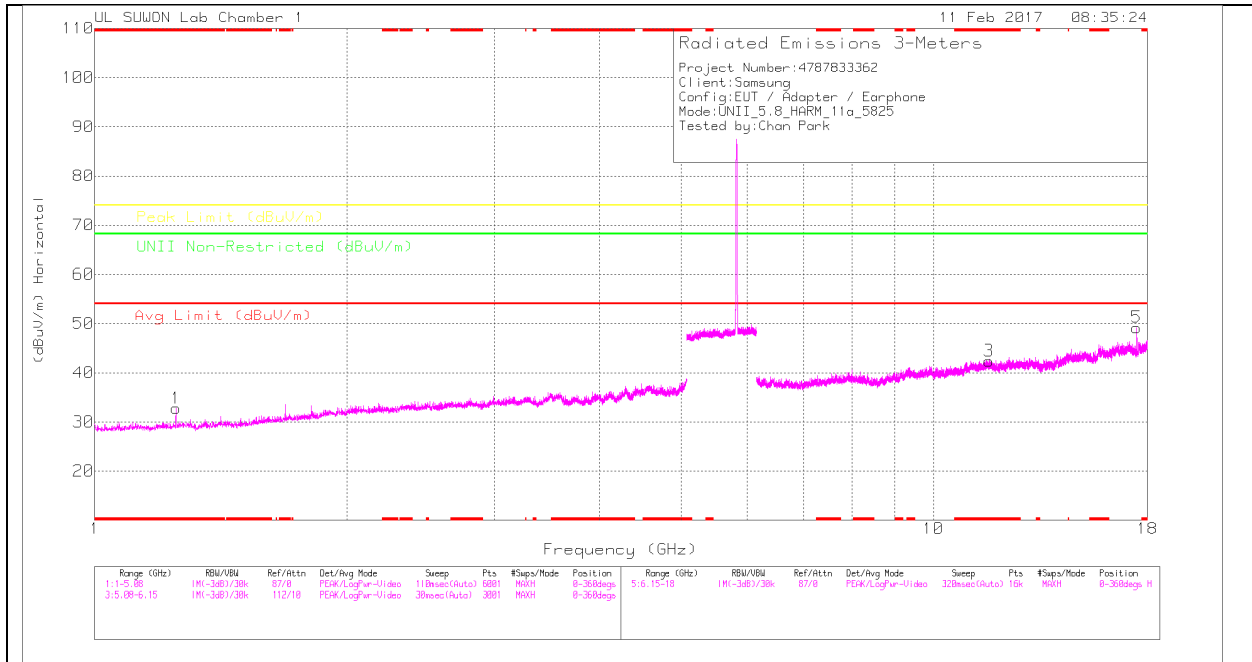

HIGH CHANNEL VERTICAL

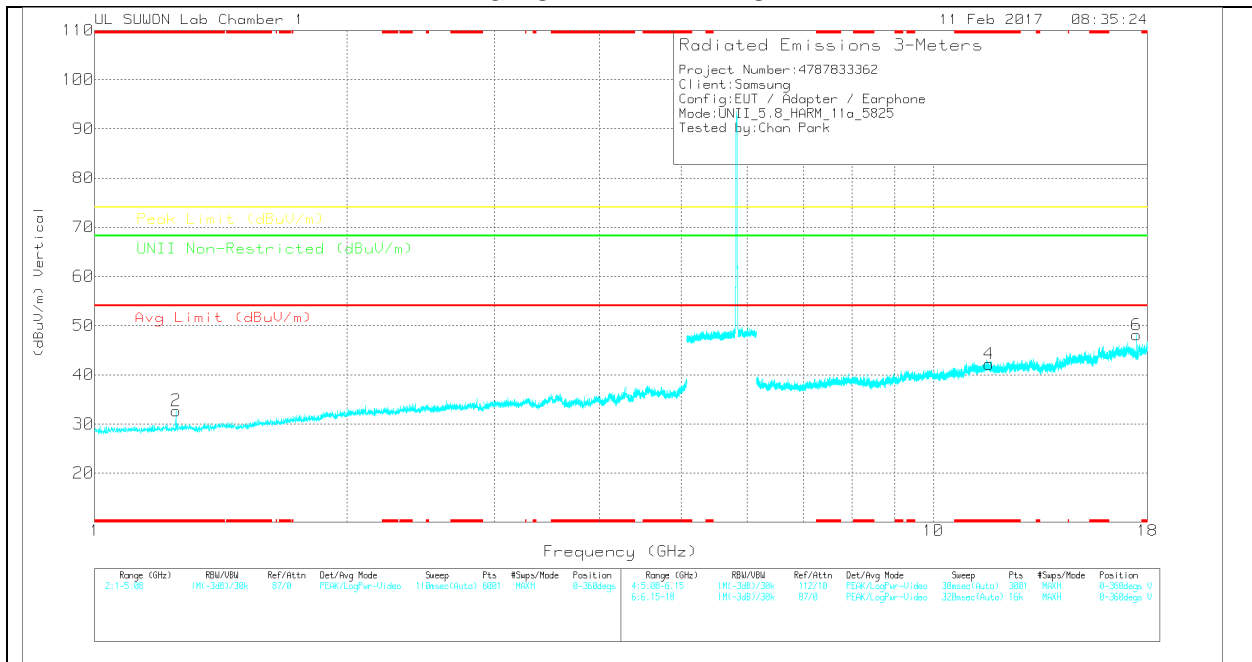

Note: Emission was scanned up to 40GHz; No emissions were detected above the noise floor which was at least 20dB below the specification limit.

HIGH CHANNEL DATA

Trace Markers

Marker	Frequency (GHz)	Meter Reading (dBuV)	Det	3117(0016 8717_150 619)	5Ghz_LP(d B)	DC Corr (dB)	Corrected Reading (dBuV/m)	Avg Limit (dBuV/m)	Margin (dB)	Peak Limit (dBuV/m)	Margin (dB)	UNII Non-Restricted (dBuV/m)	Margin (dB)	Azimuth (Degs)	Height (cm)	Polarity
1	* 1.25	44.09	Pk	28.3	-39.6	0	32.79	-	-	74	-41.21	-	-	0-360	250	H
2	* 1.25	44.01	Pk	28.3	-39.6	0	32.71	-	-	74	-41.29	-	-	0-360	250	V
3	* 11.652	32.3	Pk	38.7	-28.6	0	42.4	-	-	74	-31.6	-	-	0-360	150	H
5	17.476	31.1	Pk	41.1	-23	0	49.2	-	-	-	-	68.2	-19	0-360	150	H
4	* 11.655	31.98	Pk	38.7	-28.5	0	42.18	-	-	74	-31.82	-	-	0-360	250	V
6	17.478	30.03	Pk	41.1	-23	0	48.13	-	-	-	-	68.2	-20.07	0-360	150	V

* - indicates frequency in CFR15.205/IC7.2.2 Restricted Band

Pk – Peak detector

Radiated Emissions

Frequency (GHz)	Meter Reading (dBuV)	Det	3117(001687 17_150619)	6Ghz_HP(dB)	DC Corr (dB)	Corrected Reading (dBuV/m)	Avg Limit (dBuV/m)	Margin (dB)	Peak Limit (dBuV/m)	Margin (dB)	UNII Non-Restricted (dBuV/m)	Margin (dB)	Azimuth (Degs)	Height (cm)	Polarity
17.479	46.77	PK-U	41.1	-23.1	0	64.77	-	-	-	-	68.2	-3.43	244	187	H
17.479	44.51	PK-U	41.1	-23.1	0	62.51	-	-	-	-	68.2	-5.69	213	191	V

* - indicates frequency in CFR15.205/IC7.2.2 Restricted Band

PK-U - U-NII: Maximum Peak

10.4.2. TX ABOVE 1GHz 802.11n HT20 MODE IN THE 5.8GHz BAND BANDEDGE (LOW CHANNEL)

HORIZONTAL PEAK PLOT

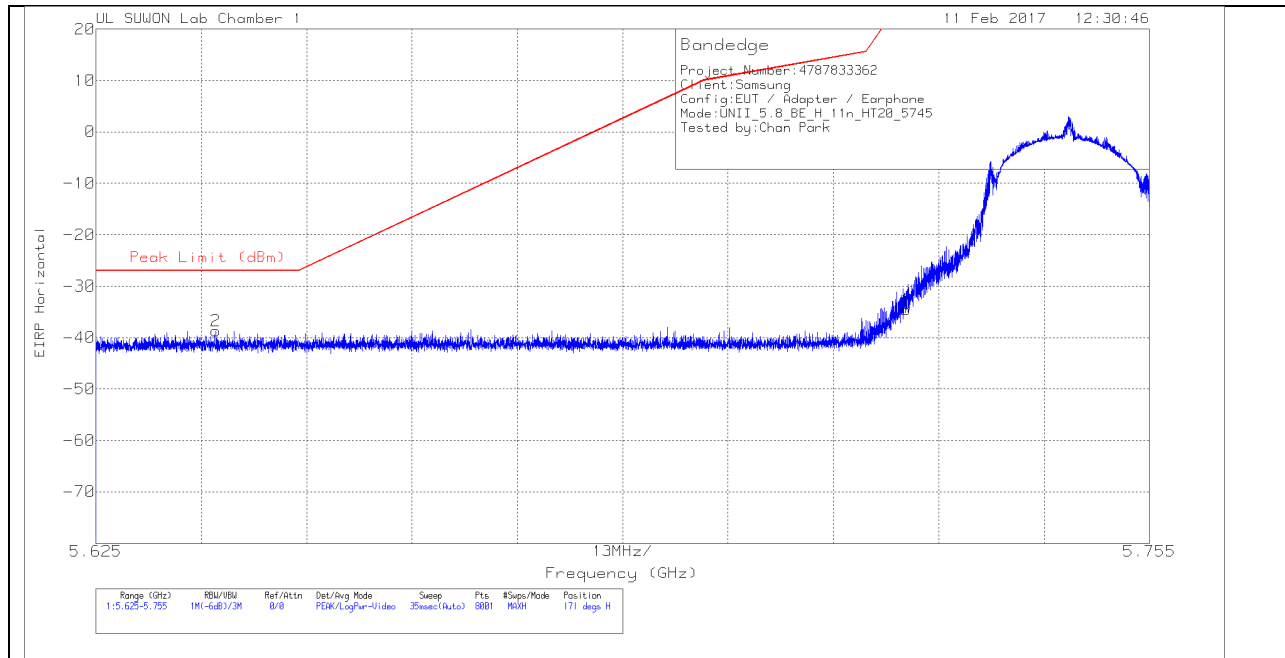

HORIZONTAL DATA

Trace Markers

Marker	Frequency (GHz)	Meter Reading (dBm)	Det	3117(0016 8717)_150 619	10dB_Att (dB)	Conversion Factor (dB)	DC Corr (dB)	Corrected Reading EIRP	Peak Limit (dBm)	PK Margin (dB)	Azimuth (Degs)	Height (cm)	Polarity
1	5.725	-58.18	PK	34.8	-22.9	11.8	0	-34.48	26.97	-61.45	171	109	H
2	5.64	-62.31	PK	34.8	-23	11.8	0	-38.71	-27	-11.71	171	109	H

Pk - Peak detector

VERTICAL PEAK PLOT

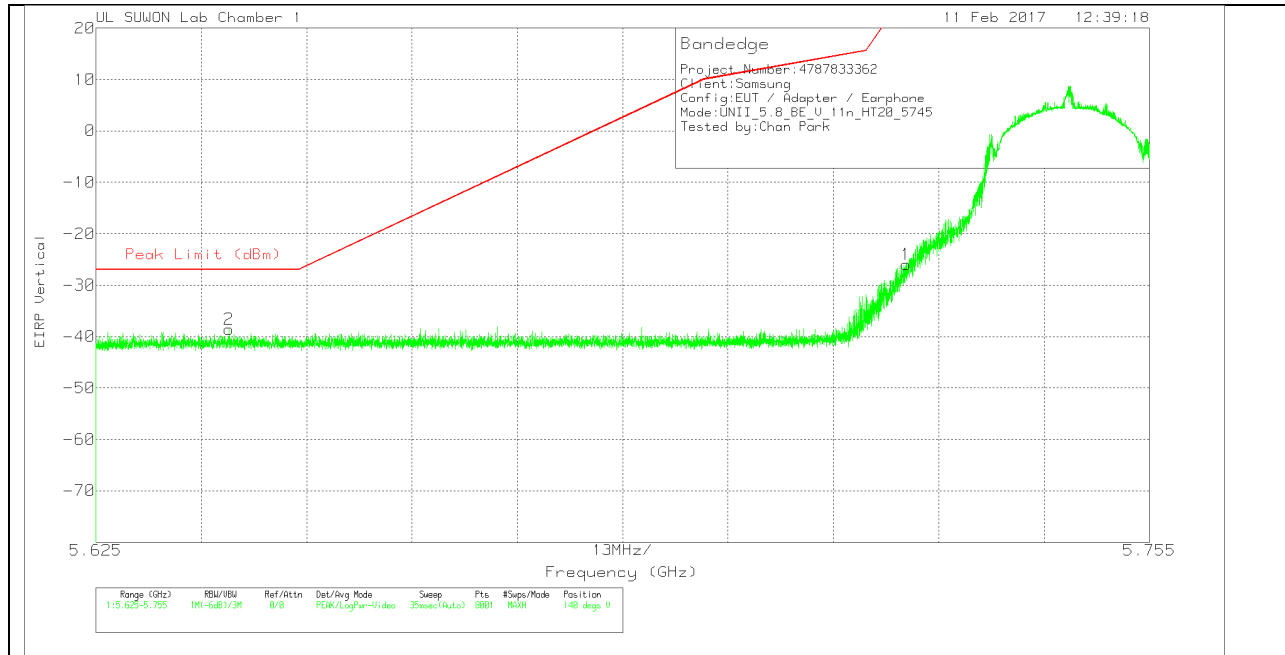

VERTICAL DATA

Trace Markers

Marker	Frequency (GHz)	Meter Reading (dBm)	Det	3117(0016 8717)_150 619	10dB_Att(dB)	Conversion Factor (dB)	DC Corr (dB)	Corrected Reading EIRP	Peak Limit (dBm)	PK Margin (dB)	Azimuth (Degs)	Height (cm)	Polarity
1	5.725	-49.69	PK	34.8	-22.9	11.8	0	-25.99	26.97	-52.96	140	396	V
2	5.641	-62.08	PK	34.8	-23.1	11.8	0	-38.58	-27	-11.58	140	396	V

Pk - Peak detector

BANDEDGE (HIGH CHANNEL)

HORIZONTAL PEAK AND AVERAGE PLOT

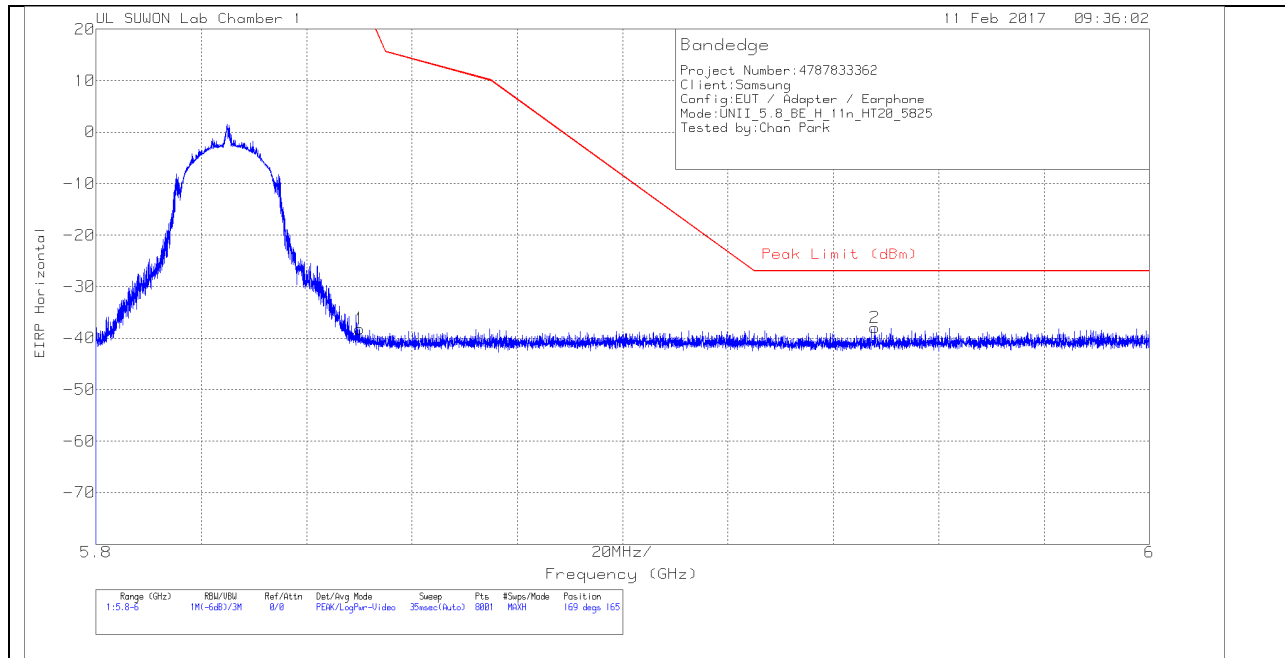

HORIZONTAL DATA

Trace Markers

Marker	Frequency (GHz)	Meter Reading (dBm)	Det	3117(0016 8717)_150 619	10dB_Att (dB)	Conversion Factor (dB)	DC Corr (dB)	Corrected Reading EIRP	Peak Limit (dBm)	PK Margin (dB)	Azimuth (Degs)	Height (cm)	Polarity
1	5.85	-62.55	Pk	34.9	-22.3	11.8	0	-38.15	26.94	-65.09	169	165	H
2	5.948	-62.02	Pk	34.9	-22.6	11.8	0	-37.92	-27	-10.92	169	165	H

Pk - Peak detector

VERTICAL PEAK PLOT

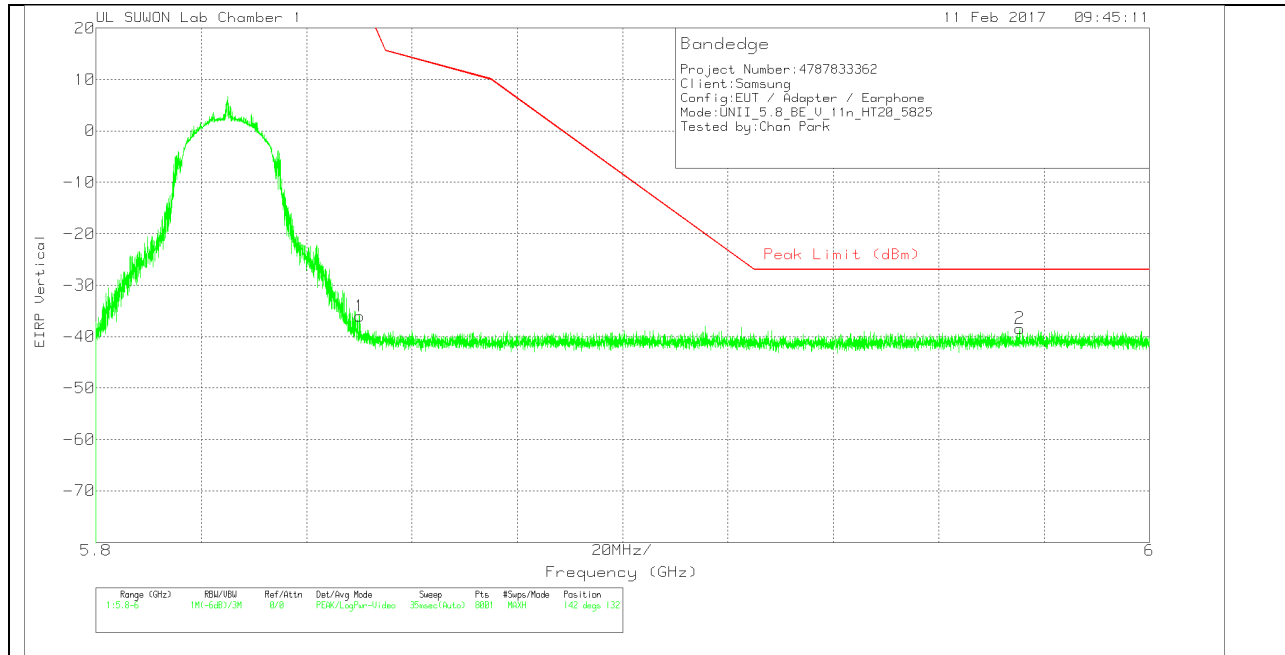

VERTICAL DATA

Trace Markers

Marker	Frequency (GHz)	Meter Reading (dBm)	Det	3117(0016 8717)_150 619	10dB_Att(dB)	Conversion Factor (dB)	DC Corr (dB)	Corrected Reading EIRP	Peak Limit (dBm)	PK Margin (dB)	Azimuth (Degs)	Height (cm)	Polarity
1	5.85	-60.4	PK	34.9	-22.3	11.8	0	-36	26.94	-62.94	142	132	V
2	5.975	-62.69	PK	34.9	-22.4	11.8	0	-38.39	-27	-11.39	142	132	V

Pk - Peak detector

LOW CHANNEL HORIZONTAL

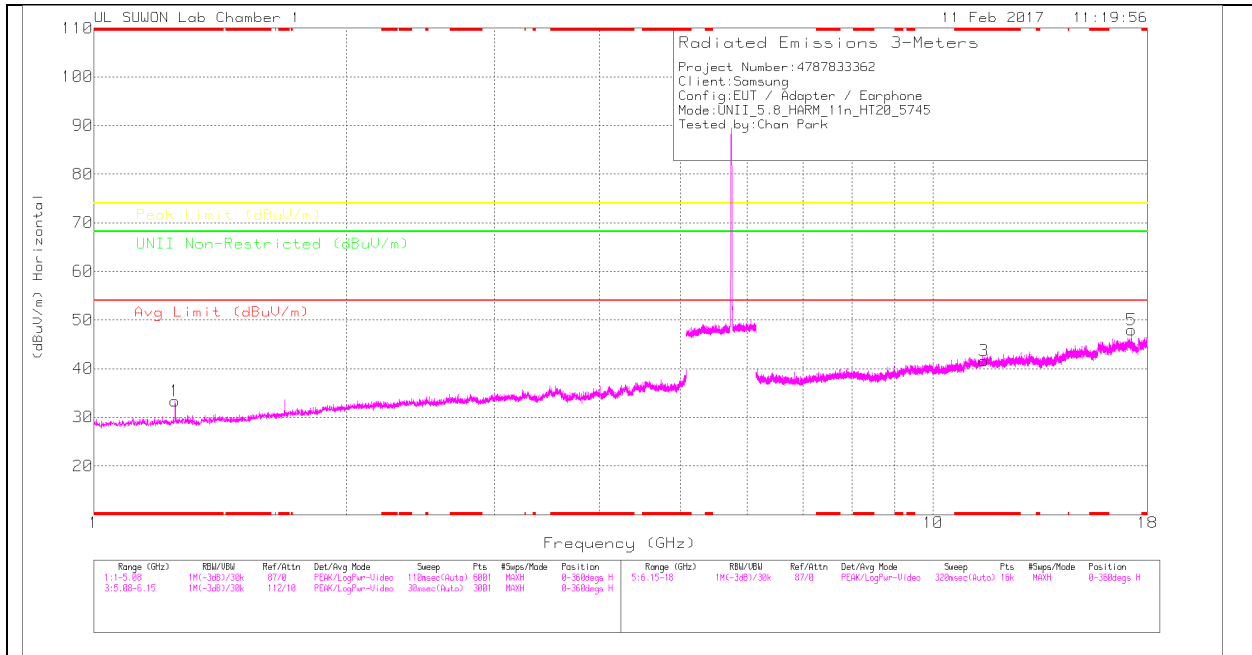

LOW CHANNEL VERTICAL

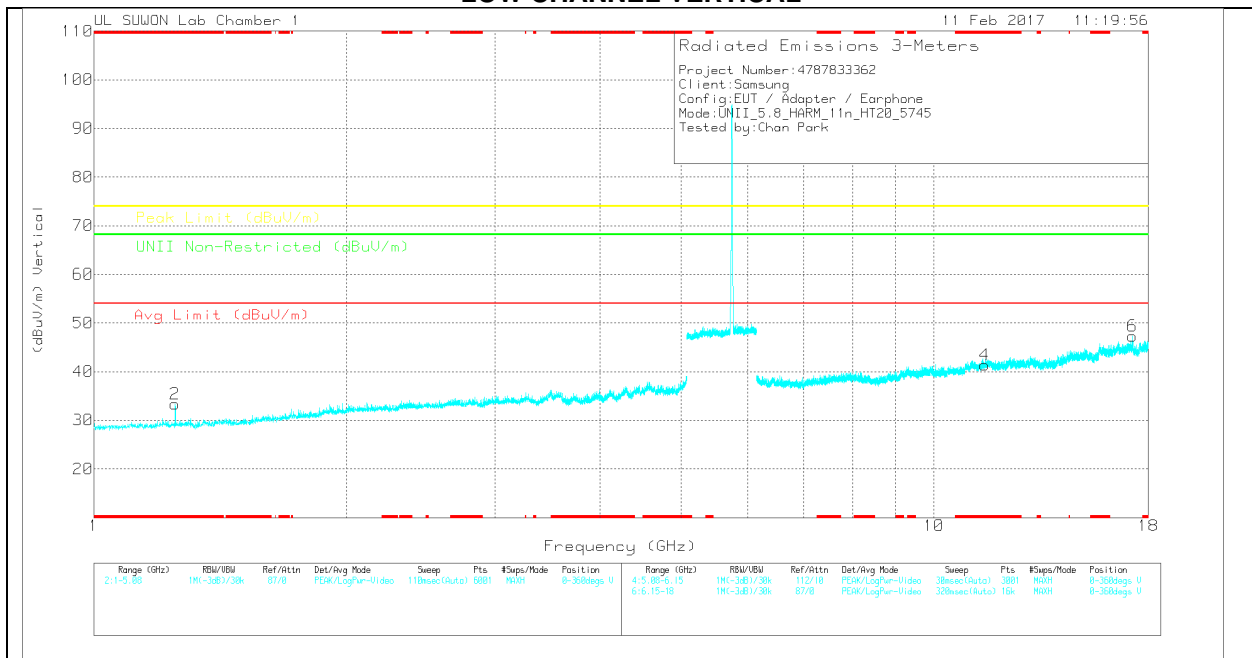

Note: Emission was scanned up to 40GHz; No emissions were detected above the noise floor which was at least 20dB below the specification limit.

LOW CHANNEL DATA

Trace Markers

Marker	Frequency (GHz)	Meter Reading (dBuV)	Det	3117(0016 8717)_150 619	5Ghz_LP(d B)	DC Corr (dB)	Corrected Reading (dBuV/m)	Avg Limit (dBuV/m)	Margin (dB)	Peak Limit (dBuV/m)	Margin (dB)	UNII Non-Restricted (dBuV/m)	Margin (dB)	Azimuth (Degs)	Height (cm)	Polarity
1	* 1.25	44.61	Pk	28.3	-39.6	0	33.31	-	-	74	-40.69	-	-	0-360	250	H
2	* 1.25	44.63	Pk	28.3	-39.6	0	33.33	-	-	74	-40.67	-	-	0-360	250	V
3	* 11.493	31.16	Pk	38.6	-28.1	0	41.66	-	-	74	-32.34	-	-	0-360	150	H
5	17.241	29.31	Pk	41.2	-22.6	0	47.91	-	-	-	-	68.2	-20.29	0-360	250	H
4	* 11.493	30.81	Pk	38.6	-28.1	0	41.31	-	-	74	-32.69	-	-	0-360	250	V
6	17.236	28.6	Pk	41.2	-22.5	0	47.3	-	-	-	-	68.2	-20.9	0-360	250	V

* - indicates frequency in CFR15.205/IC7.2.2 Restricted Band

Pk – Peak detector

Note: Only peak measurement was performed. Because peak measurement result of unwanted emission is less than average limit (54dBuV/m).

MID CHANNEL HORIZONTAL

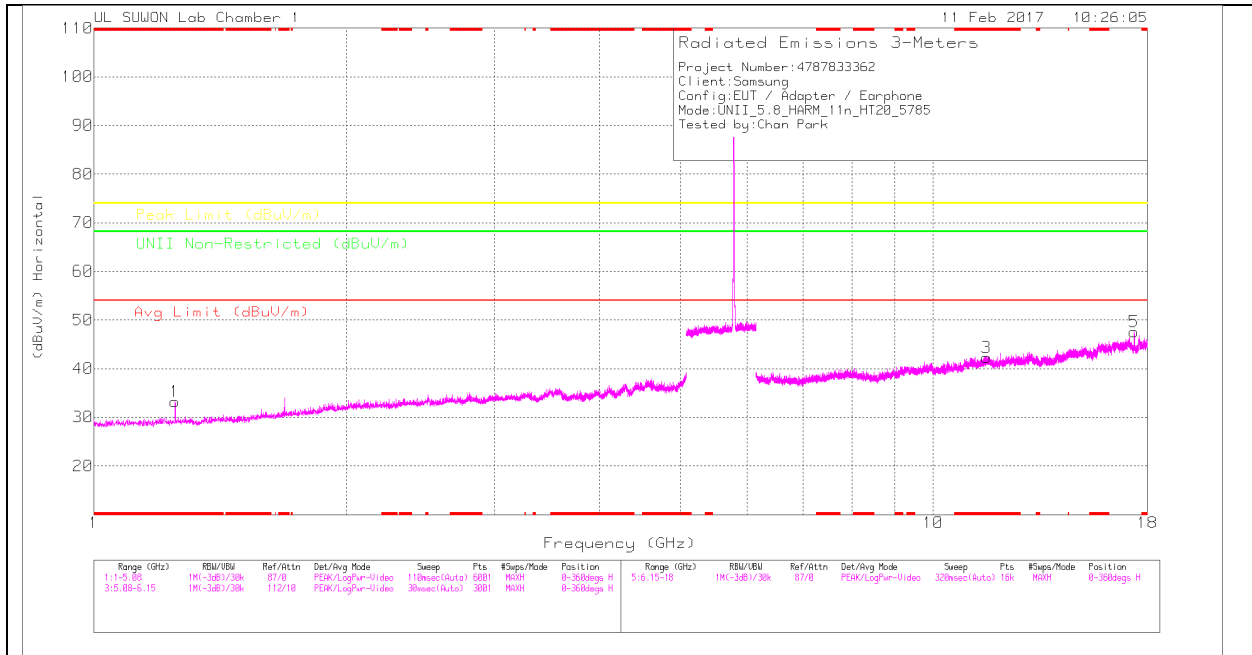

MID CHANNEL VERTICAL

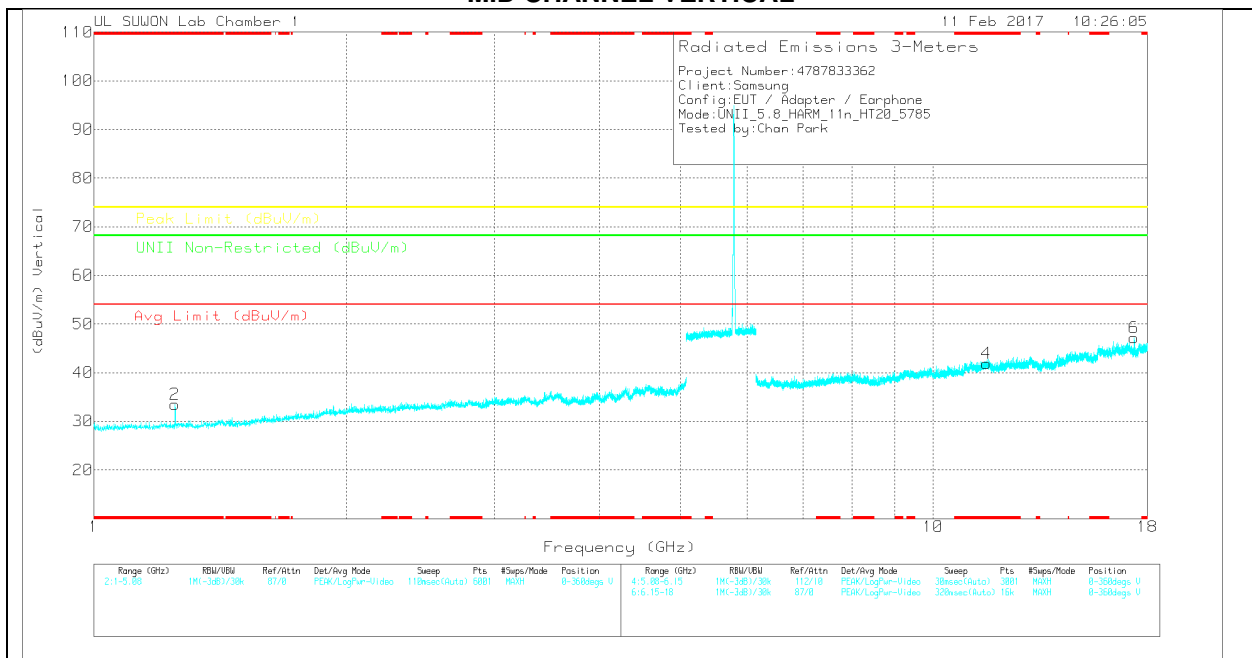

Note: Emission was scanned up to 40GHz; No emissions were detected above the noise floor which was at least 20dB below the specification limit.

MID CHANNEL DATA

Trace Markers

Marker	Frequency (GHz)	Meter Reading (dBuV)	Det	3117(0016 8717)_150 619	5Ghz_LP(d B)	DC Corr (dB)	Corrected Reading (dBuV/m)	Avg Limit (dBuV/m)	Margin (dB)	Peak Limit (dBuV/m)	Margin (dB)	UNII Non-Restricted (dBuV/m)	Margin (dB)	Azimuth (Degs)	Height (cm)	Polarity
1	* 1.25	44.47	Pk	28.3	-39.6	0	33.17	-	-	74	-40.83	-	-	0-360	250	H
2	* 1.25	44.73	Pk	28.3	-39.6	0	33.43	-	-	74	-40.57	-	-	0-360	250	V
3	* 11.568	31.48	Pk	38.7	-27.9	0	42.28	-	-	74	-31.72	-	-	0-360	250	H
5	17.356	28.96	Pk	41.2	-22.6	0	47.56	-	-	-	-	68.2	-20.64	0-360	250	H
4	* 11.57	31.1	Pk	38.7	-27.9	0	41.9	-	-	74	-32.1	-	-	0-360	150	V
6	17.358	28.6	Pk	41.2	-22.6	0	47.2	-	-	-	-	68.2	-21	0-360	150	V

* - indicates frequency in CFR15.205/IC7.2.2 Restricted Band

Pk – Peak detector

Radiated Emissions

Frequency (GHz)	Meter Reading (dBuV)	Det	3117(001687 17)_150619	6Ghz_HP(dB)	DC Corr (dB)	Corrected Reading (dBuV/m)	Avg Limit (dBuV/m)	Margin (dB)	Peak Limit (dBuV/m)	Margin (dB)	UNII Non-Restricted (dBuV/m)	Margin (dB)	Azimuth (Degs)	Height (cm)	Polarity
17.352	45.88	PK-U	41.2	-22.7	0	64.38	-	-	-	-	68.2	-3.82	246	194	H
17.355	43.09	PK-U	41.2	-22.7	0	61.59	-	-	-	-	68.2	-6.61	212	194	V

* - indicates frequency in CFR15.205/IC7.2.2 Restricted Band

PK-U - U-NII: Maximum Peak

HIGH CHANNEL HORIZONTAL

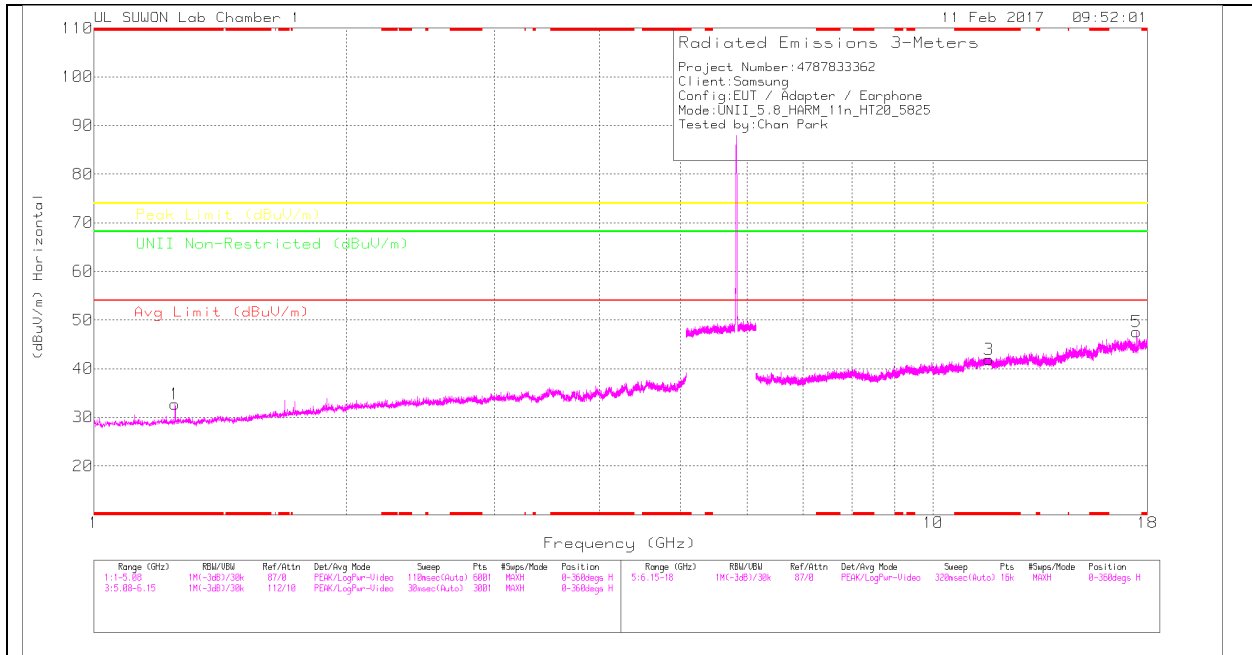

HIGH CHANNEL VERTICAL

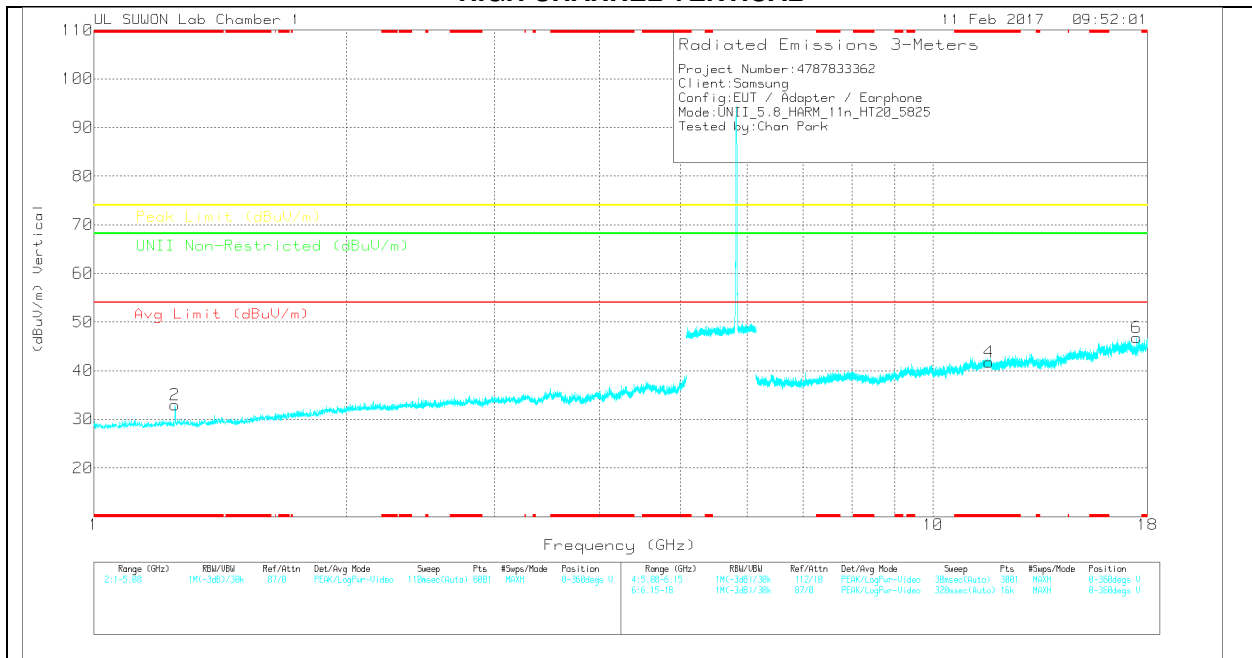

Note: Emission was scanned up to 40GHz; No emissions were detected above the noise floor which was at least 20dB below the specification limit.

HIGH CHANNEL DATA

Trace Markers

Marker	Frequency (GHz)	Meter Reading (dBuV)	Det	3117(0016 8717_150 619)	5Ghz_LP(d B)	DC Corr (dB)	Corrected Reading (dBuV/m)	Avg Limit (dBuV/m)	Margin (dB)	Peak Limit (dBuV/m)	Margin (dB)	UNII Non-Restricted (dBuV/m)	Margin (dB)	Azimuth (Degs)	Height (cm)	Polarity
1	* 1.25	43.99	Pk	28.3	-39.6	0	32.69	-	-	74	-41.31	-	-	0-360	250	H
2	* 1.25	44.2	Pk	28.3	-39.6	0	32.9	-	-	74	-41.1	-	-	0-360	250	V
3	* 11.651	31.77	Pk	38.7	-28.6	0	41.87	-	-	74	-32.13	-	-	0-360	150	H
5	17.472	29.49	Pk	41.1	-23	0	47.59	-	-	-	-	68.2	-20.61	0-360	150	H
4	* 11.655	31.56	Pk	38.7	-28.5	0	41.76	-	-	74	-32.24	-	-	0-360	250	V
6	17.473	28.61	Pk	41.1	-22.9	0	46.81	-	-	-	-	68.2	-21.39	0-360	250	V

* - indicates frequency in CFR15.205/IC7.2.2 Restricted Band

Pk – Peak detector

Radiated Emissions

Frequency (GHz)	Meter Reading (dBuV)	Det	3117(001687 17_150619)	6Ghz_HP(dB)	DC Corr (dB)	Corrected Reading (dBuV/m)	Avg Limit (dBuV/m)	Margin (dB)	Peak Limit (dBuV/m)	Margin (dB)	UNII Non-Restricted (dBuV/m)	Margin (dB)	Azimuth (Degs)	Height (cm)	Polarity
17.474	46.83	PK-U	41.1	-22.9	0	65.03	-	-	-	-	68.2	-3.17	242	185	H
17.474	44.59	PK-U	41.1	-22.9	0	62.79	-	-	-	-	68.2	-5.41	213	189	V

* - indicates frequency in CFR15.205/IC7.2.2 Restricted Band

PK-U - U-NII: Maximum Peak

10.4.3. TX ABOVE 1GHz 802.11n HT40 MODE IN THE 5.8GHz BAND BANDEDGE (LOW CHANNEL)

HORIZONTAL PEAK PLOT

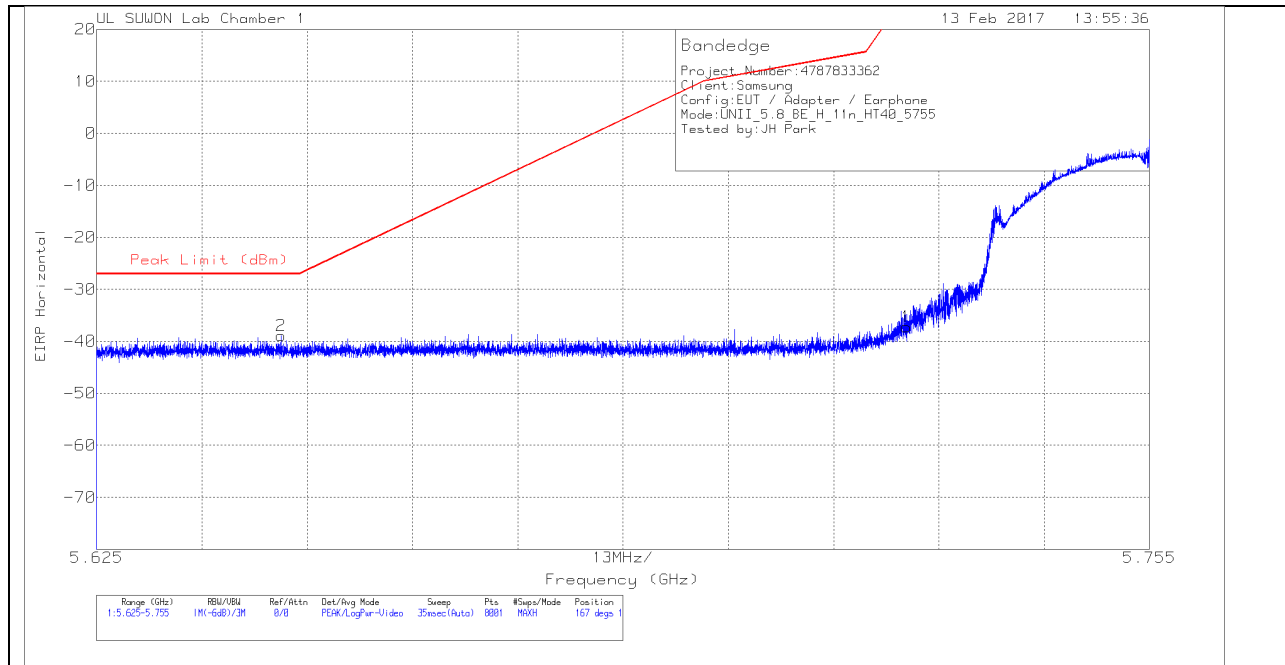

HORIZONTAL DATA

Trace Markers

Marker	Frequency (GHz)	Meter Reading (dBm)	Det	3117(0016 8717)_150 619	10dB_Att(dB)	Conversion Factor (dB)	DC Corr (dB)	Corrected Reading EIRP	Peak Limit (dBm)	PK Margin (dB)	Azimuth (Degs)	Height (cm)	Polarity
1	5.725	-60.96	Pk	34.8	-22.9	11.8	0	-37.26	26.97	-64.23	167	128	H
2	5.648	-62.5	Pk	34.8	-23	11.8	0	-38.9	-27	-11.9	167	128	H

Pk - Peak detector

VERTICAL PEAK PLOT

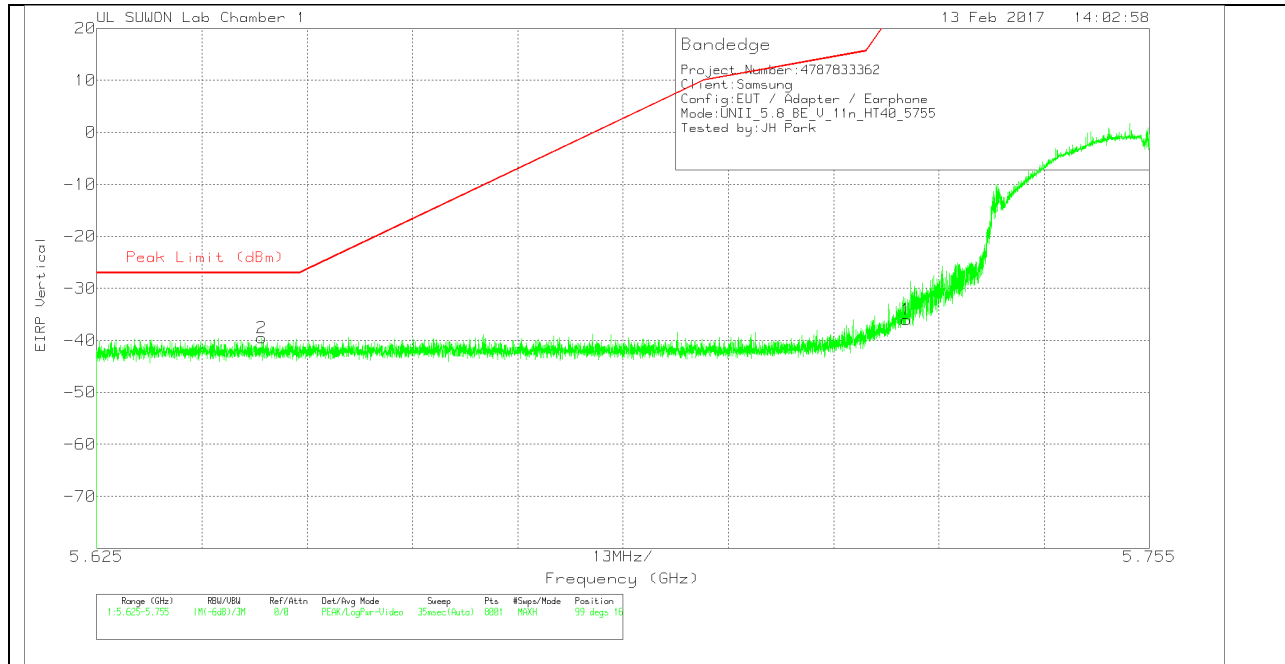

VERTICAL DATA

Trace Markers

Marker	Frequency (GHz)	Meter Reading (dBm)	Det	3117(0016 8717)_150 619	10dB_Att (dB)	Conversion Factor (dB)	DC Corr (dB)	Corrected Reading EIRP	Peak Limit (dBm)	PK Margin (dB)	Azimuth (Degs)	Height (cm)	Polarity
1	5.725	-59.72	PK	34.8	-22.9	11.8	0	-36.02	26.97	-62.99	99	161	V
2	5.645	-63.04	PK	34.8	-23.1	11.8	0	-39.54	-27	-12.54	99	161	V

Pk - Peak detector

BANDEDGE (HIGH CHANNEL)

HORIZONTAL PEAK PLOT

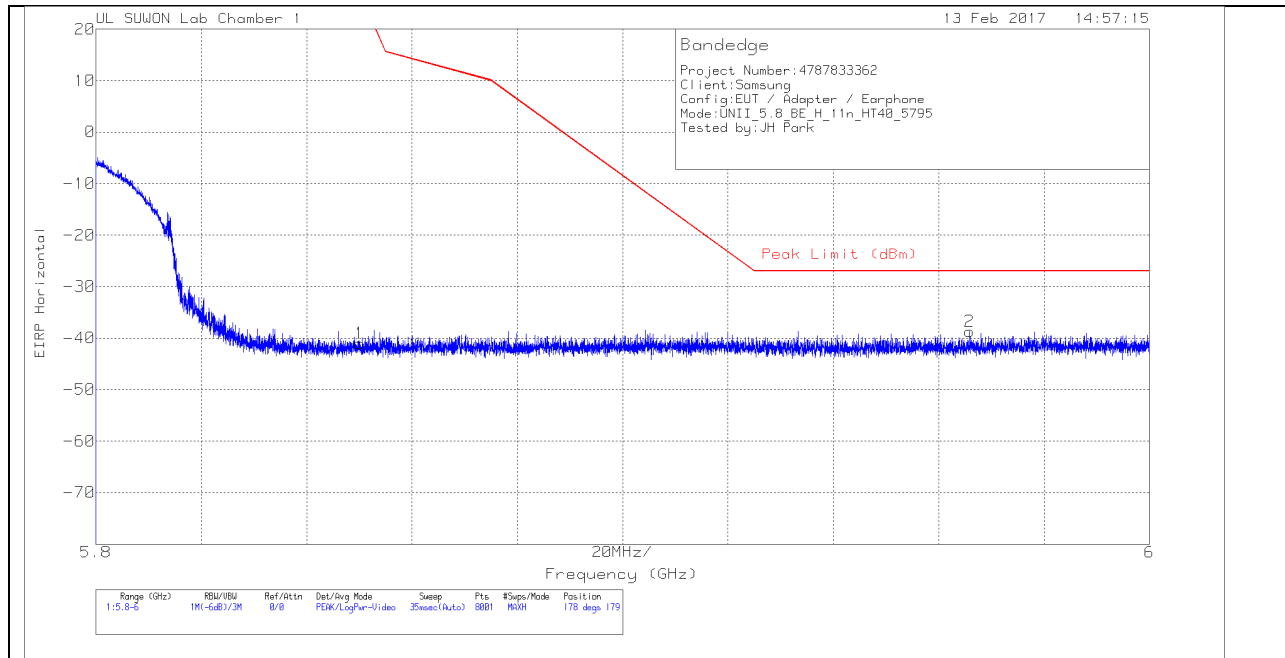

HORIZONTAL DATA

Trace Markers

Marker	Frequency (GHz)	Meter Reading (dBm)	Det	3117(0016 8717)_150 619	10dB_Att (dB)	Conversion Factor (dB)	DC Corr (dB)	Corrected Reading EIRP	Peak Limit (dBm)	PK Margin (dB)	Azimuth (Degs)	Height (cm)	Polarity
1	5.85	-65.45	Pk	34.9	-22.3	11.8	0	-41.05	26.94	-67.99	178	179	H
2	5.966	-62.75	Pk	34.9	-22.6	11.8	0	-38.65	-27	-11.65	178	179	H

Pk - Peak detector

VERTICAL PEAK PLOT

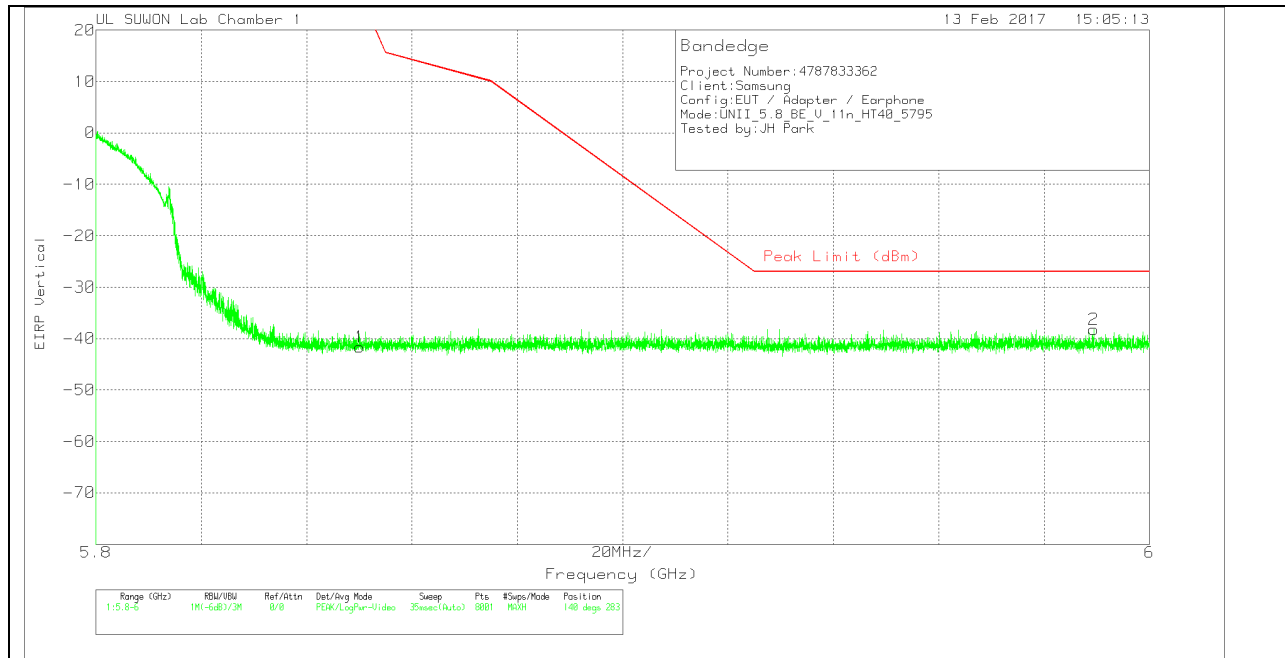

VERTICAL DATA

Trace Markers

Marker	Frequency (GHz)	Meter Reading (dBm)	Det	3117(0016 8717)_150 619	10dB_Att(dB)	Conversion Factor (dB)	DC Corr (dB)	Corrected Reading EIRP	Peak Limit (dBm)	PK Margin (dB)	Azimuth (Degs)	Height (cm)	Polarity
1	5.85	-66.04	Pk	34.9	-22.3	11.8	0	-41.64	26.94	-68.58	140	283	V
2	5.989	-62.46	Pk	34.9	-22.4	11.8	0	-38.16	-27	-11.16	140	283	V

Pk - Peak detector

LOW CHANNEL HORIZONTAL

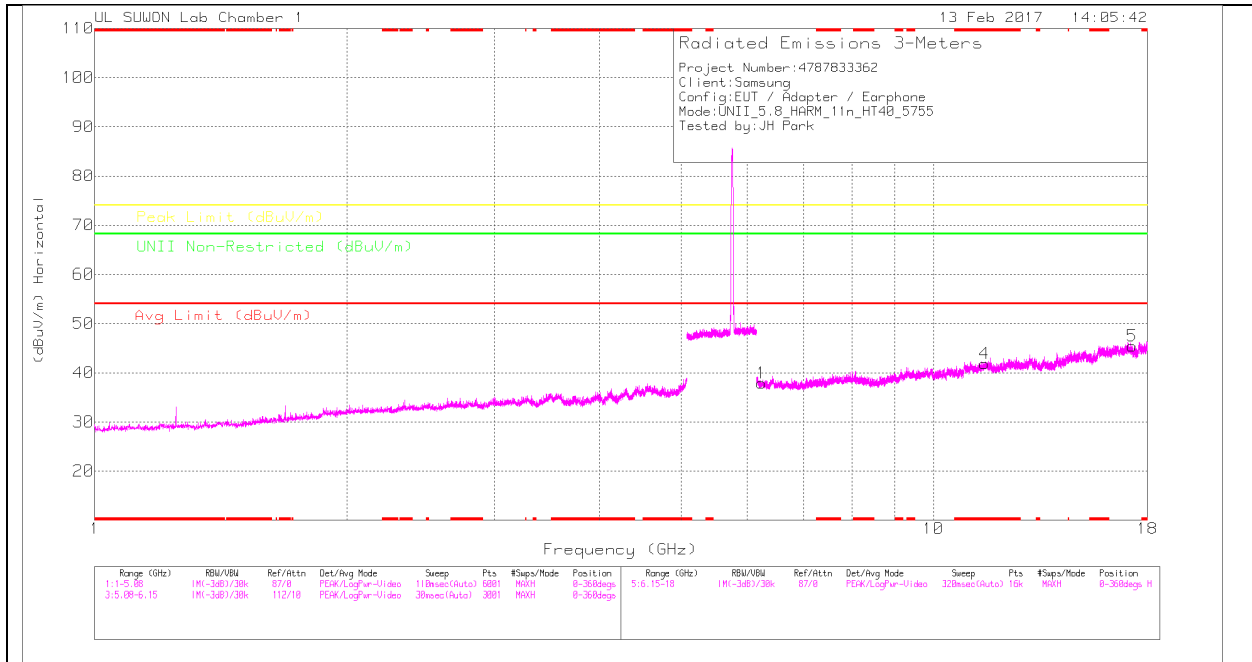

LOW CHANNEL VERTICAL

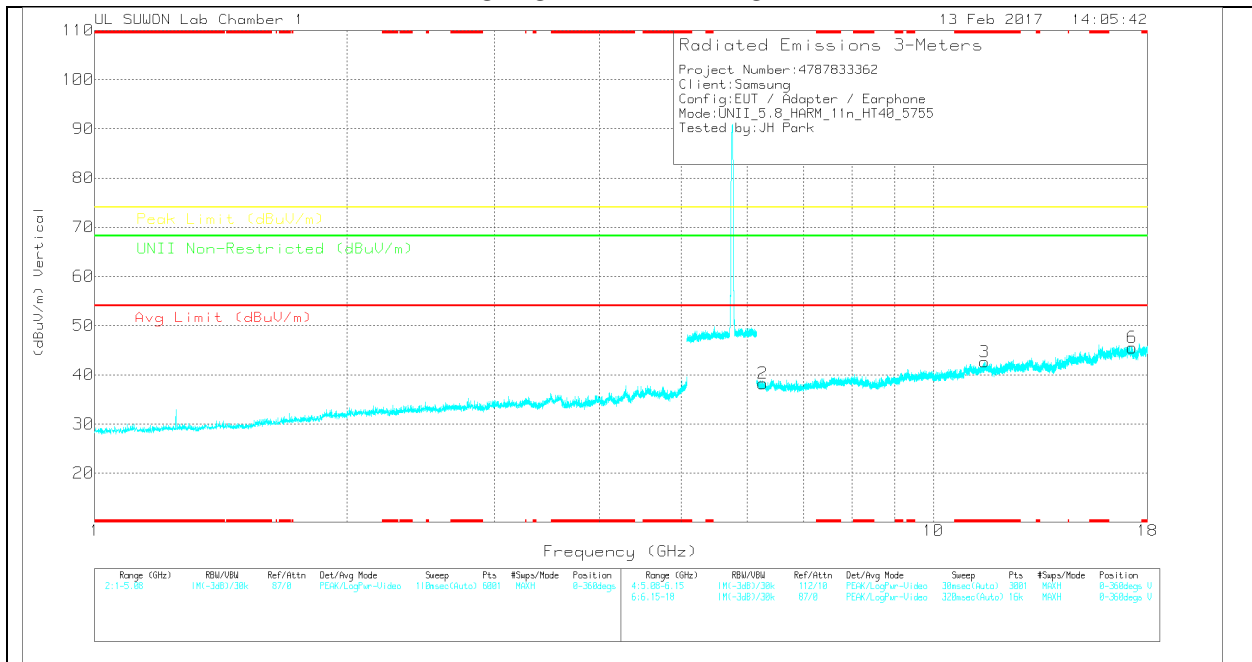

Note: Emission was scanned up to 40GHz; No emissions were detected above the noise floor which was at least 20dB below the specification limit.

LOW CHANNEL DATA

Trace Markers

Marker	Frequency (GHz)	Meter Reading (dBuV)	Det	3117(0016 8717)_150 519	6Ghz_HP(d B)	DC Corr (dB)	Corrected Reading (dBuV/m)	Avg Limit (dBuV/m)	Margin (dB)	Peak Limit (dBuV/m)	Margin (dB)	UNII Non-Restricted (dBuV/m)	Margin (dB)	Azimuth (Degs)	Height (cm)	Polarity
1	6.235	33.89	PK	35.2	-31.2	0	37.89	-	-	-	-	68.2	-30.31	0-360	150	H
4	*11.51	30.92	PK	38.6	-27.7	0	41.82	-	-	74	-32.18	-	-	0-360	250	H
5	17.268	27.44	PK	41.2	-23.2	0	45.44	-	-	-	-	68.2	-22.76	0-360	150	H
2	6.263	34.03	PK	35.2	-31	0	38.23	-	-	-	-	68.2	-29.97	0-360	250	V
3	*11.508	31.74	PK	38.6	-27.7	0	42.64	-	-	74	-31.36	-	-	0-360	250	V
6	17.27	27.51	PK	41.2	-23.2	0	45.51	-	-	-	-	68.2	-22.69	0-360	250	V

* - indicates frequency in CFR15.205/IC7.2.2 Restricted Band

PK – Peak Detector

Note: Only peak measurement was performed. Because peak measurement result of unwanted emission is less than average limit (54dBuV/m).

HIGH CHANNEL HORIZONTAL

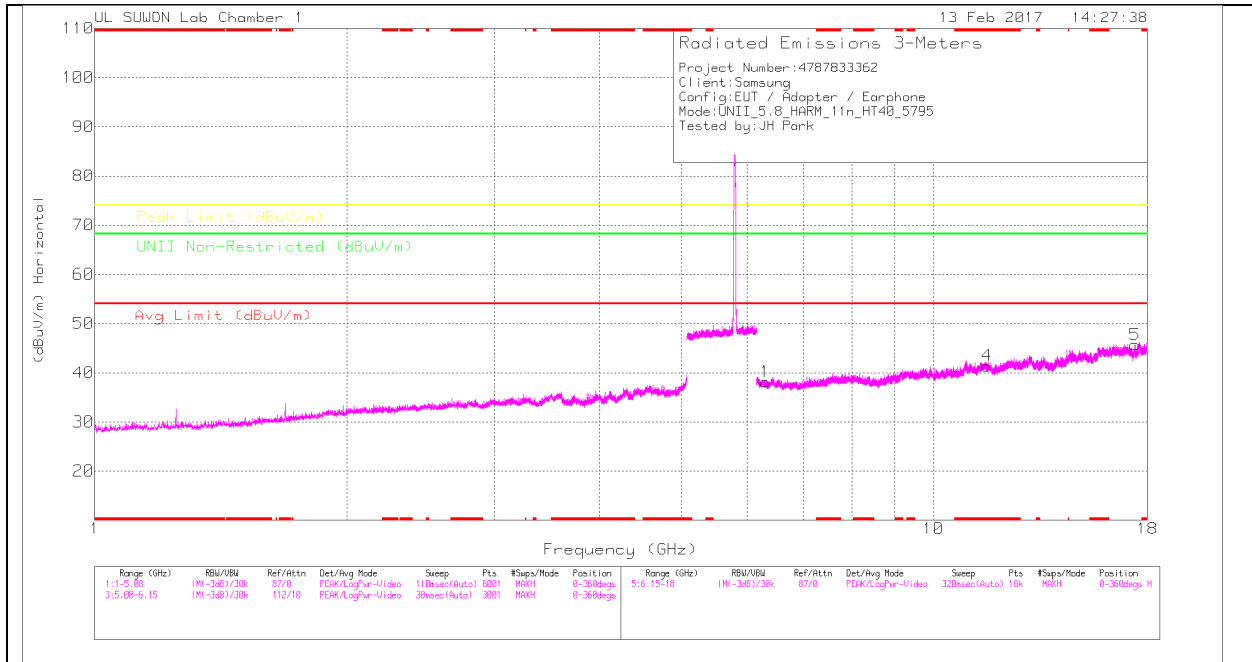

HIGH CHANNEL VERTICAL

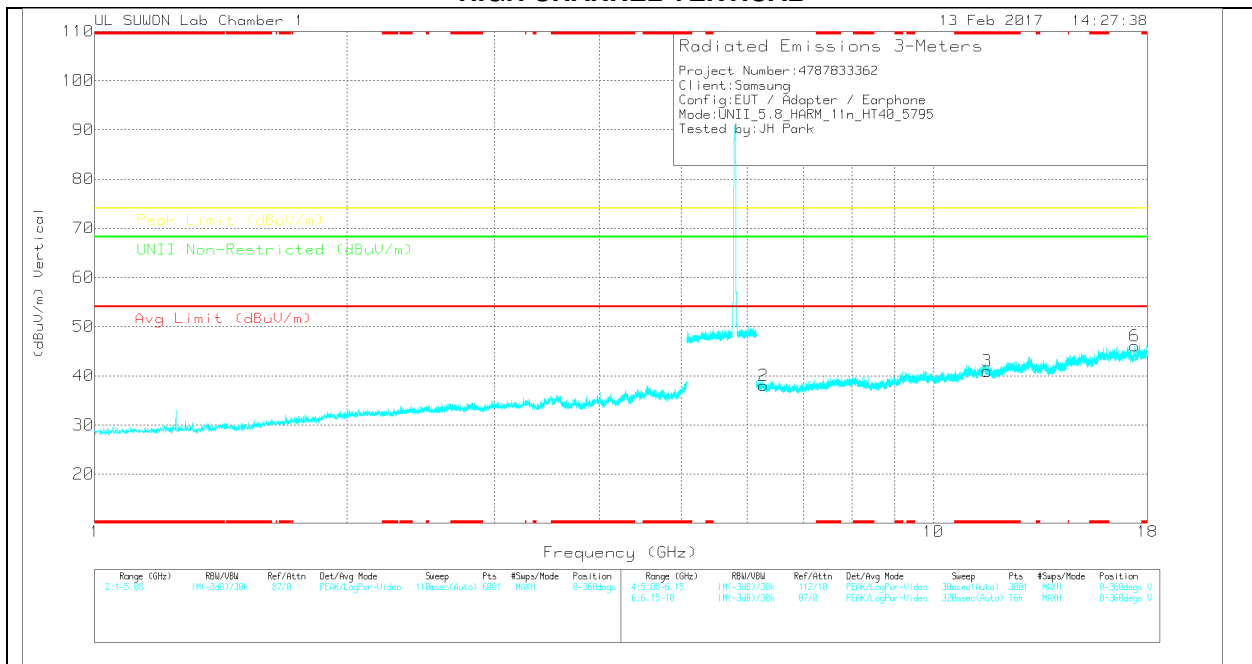

Note: Emission was scanned up to 40GHz; No emissions were detected above the noise floor which was at least 20dB below the specification limit.

HIGH CHANNEL DATA

Trace Markers

Marker	Frequency (GHz)	Meter Reading (dBuV)	Det	3117(0016 8717)_150 519	6Ghz_HP(d B)	DC Corr (dB)	Corrected Reading (dBuV/m)	Avg Limit (dBuV/m)	Margin (dB)	Peak Limit (dBuV/m)	Margin (dB)	UNII Non-Restricted (dBuV/m)	Margin (dB)	Azimuth (Degs)	Height (cm)	Polarity
1	6.305	34.03	PK	35.2	-31.1	0	38.13	-	-	-	-	68.2	-30.07	0-360	250	H
4	* 11.593	30.7	PK	38.7	-28	0	41.4	-	-	74	-32.6	-	-	0-360	150	H
5	17.393	26.25	PK	41.2	-21.8	0	45.65	-	-	-	-	68.2	-22.55	0-360	250	H
2	6.268	33.83	PK	35.2	-31	0	38.03	-	-	-	-	68.2	-30.17	0-360	150	V
3	* 11.589	30.21	PK	38.7	-28	0	40.91	-	-	74	-33.09	-	-	0-360	250	V
6	17.382	26.89	PK	41.2	-22	0	46.09	-	-	-	-	68.2	-22.11	0-360	250	V

* - indicates frequency in CFR15.205/IC7.2.2 Restricted Band

PK – Peak Detector

Note: Only peak measurement was performed. Because peak measurement result of unwanted emission is less than average limit (54dBuV/m).

11. WORST-CASE BELOW 1 GHz (in the 5.3 GHz Band)

SPURIOUS EMISSIONS 30 TO 1000 MHz (WORST-CASE CONFIGURATION, HORIZONTAL)

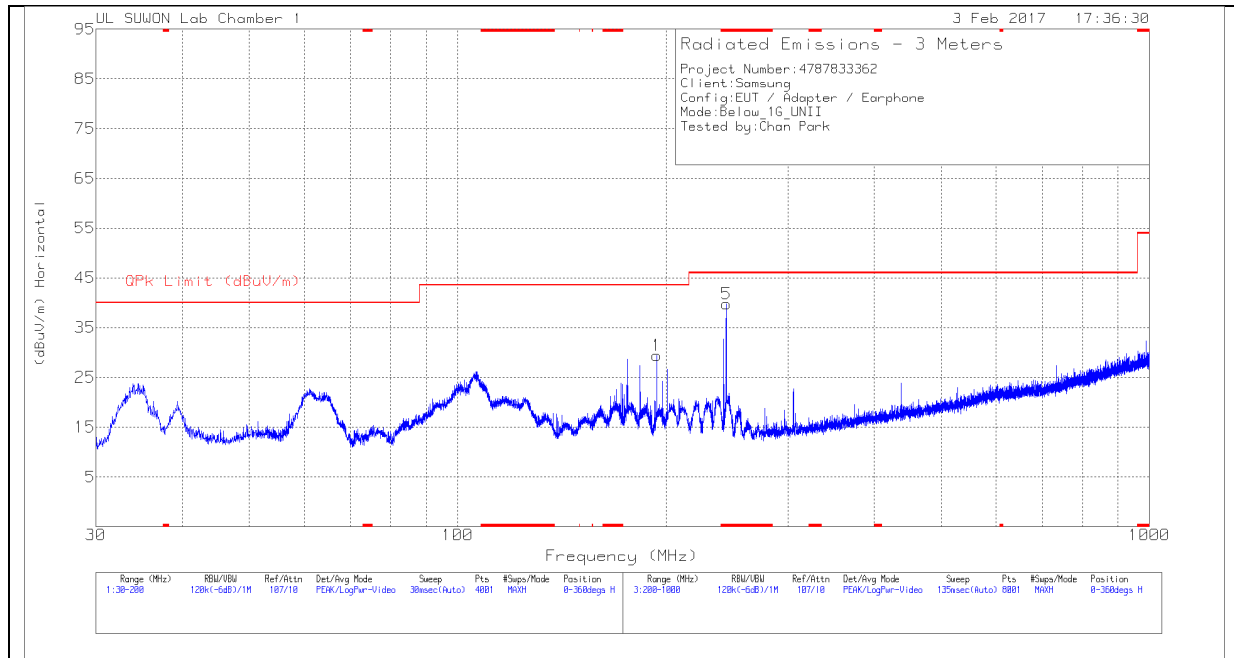

SPURIOUS EMISSIONS 30 TO 1000 MHz (WORST-CASE CONFIGURATION, VERTICAL)

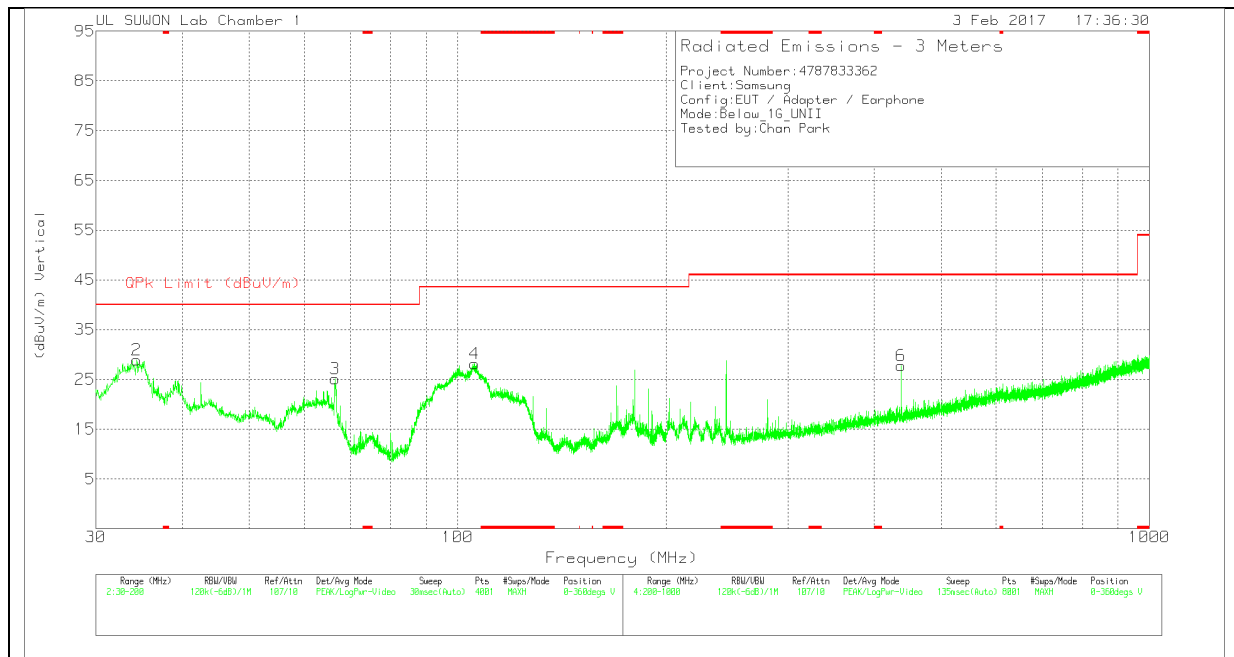

Below 1G Data

Trace Markers

Marker	Frequency (MHz)	Meter Reading (dBuV)	Det	VULB9163-750	Bi-Log	Corrected Reading (dBuV/m)	QPk Limit (dBuV/m)	Margin (dB)	Azimuth (Degs)	Height (cm)	Polarity
1	194.05	46.77	Pk	10.8	-28.2	29.37	43.52	-14.15	0-360	200	H
2	34.3775	48.75	Pk	10.5	-30.4	28.85	40	-11.15	0-360	100	V
3	66.465	44.18	Pk	10.7	-29.8	25.08	40	-14.92	0-360	100	V
4	105.7775	46.26	Pk	11.1	-29.2	28.16	43.52	-15.36	0-360	100	V
5	* 244.5	55.44	Pk	12.2	-27.9	39.74	46.02	-6.28	0-360	100	H
6	437.5	38.27	Pk	16.1	-26.6	27.77	46.02	-18.25	0-360	100	V

* - indicates frequency in CFR15.205/IC7.2.2 Restricted Band

Pk - Peak detector

Radiated Emissions

Frequency (MHz)	Meter Reading (dBuV)	Det	VULB9163-750	Bi-Log	Corrected Reading (dBuV/m)	QPk Limit (dBuV/m)	Margin (dB)	Azimuth (Degs)	Height (cm)	Polarity
* 244.5606	54.91	Qp	12.2	-27.8	39.31	46.02	-6.71	32	115	H

* - indicates frequency in CFR15.205/IC7.2.2 Restricted Band

Qp - Quasi-Peak detector

12. AC POWER LINE CONDUCTED EMISSIONS

LIMITS

FCC §15.207 (a)

Frequency of Emission (MHz)	Conducted Limit (dBuV)	
	Quasi-peak	Average
0.15-0.5	66 to 56	56 to 46
0.5-5	56	46
5-30	60	50

*Decreases with the logarithm of the frequency.

TEST PROCEDURE

The EUT is placed on a non-conducting table 40 cm from the vertical ground plane and 80 cm above the horizontal ground plane. The EUT is configured in accordance with ANSI C63.10.

The receiver is set to a resolution bandwidth of 9 kHz. Peak detection is used unless otherwise noted as quasi-peak or average.

Line conducted data is recorded for both NEUTRAL and HOT lines.

RESULTS

6 WORST EMISSIONS

LINE 1 PLOT

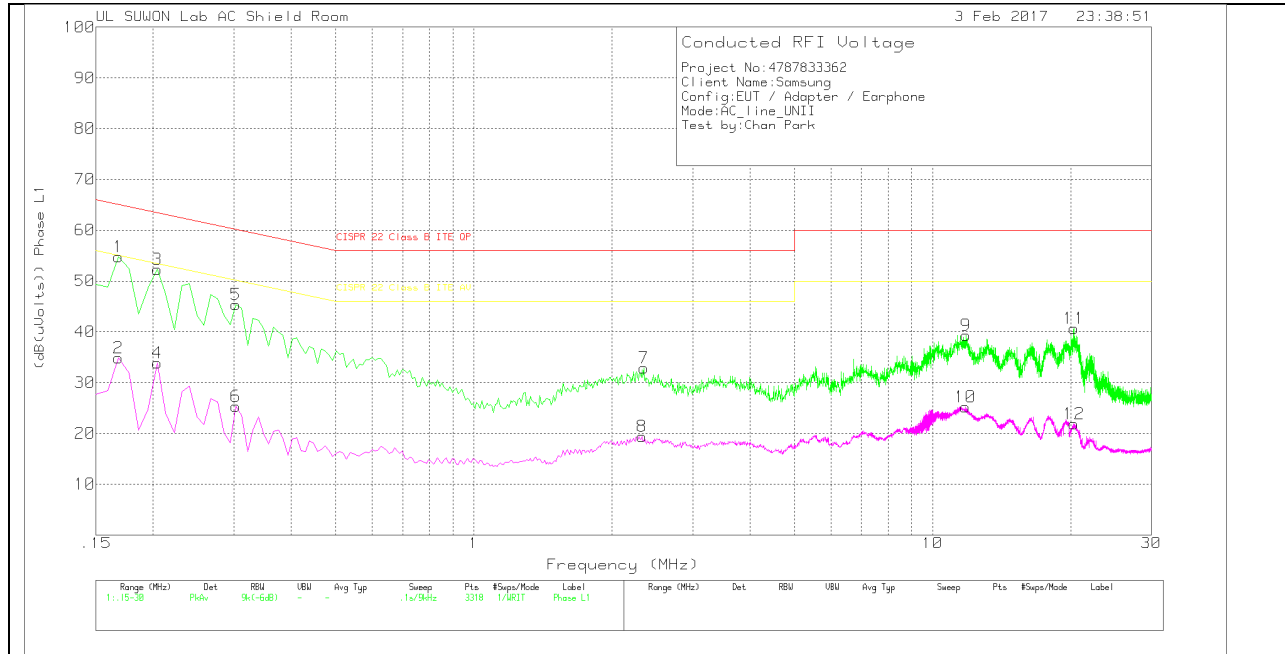

LINE 1 RESULTS

Trace Markers

Phase L1 .15 - 30MHz

Marker	Frequency (MHz)	Meter Reading (dBuV)	Det	101837_w ith ex-cord_L1	CE Shield Room	Corrected Reading (dB(uVolts))	CISPR 22 Class B ITE QP	Margin (dB)	CISPR 22 Class B ITE AV	Margin (dB)
1	.168	44.8	Pk	10	0	54.8	65.06	-10.26	-	-
2	.168	24.89	Av	10	0	34.89	-	-	55.06	-20.17
3	.204	42.4	Pk	9.9	0	52.3	63.45	-11.15	-	-
4	.204	23.91	Av	9.9	0	33.81	-	-	53.45	-19.64
5	.303	35.62	Pk	9.7	0	45.32	60.16	-14.84	-	-
6	.303	15.63	Av	9.7	0	25.33	-	-	50.16	-24.83
7	2.346	23.11	Pk	9.7	.1	32.91	56	-23.09	-	-
8	2.328	9.6	Av	9.7	.1	19.4	-	-	46	-26.6
9	11.832	29.12	Pk	10	.2	39.32	60	-20.68	-	-
10	11.787	15.05	Av	10	.2	25.25	-	-	50	-24.75
11	20.319	30.02	Pk	10.4	.2	40.62	60	-19.38	-	-
12	20.319	11.31	Av	10.4	.2	21.91	-	-	50	-28.09

Pk - Peak detector

Av - Average detection

LINE 2 PLOT

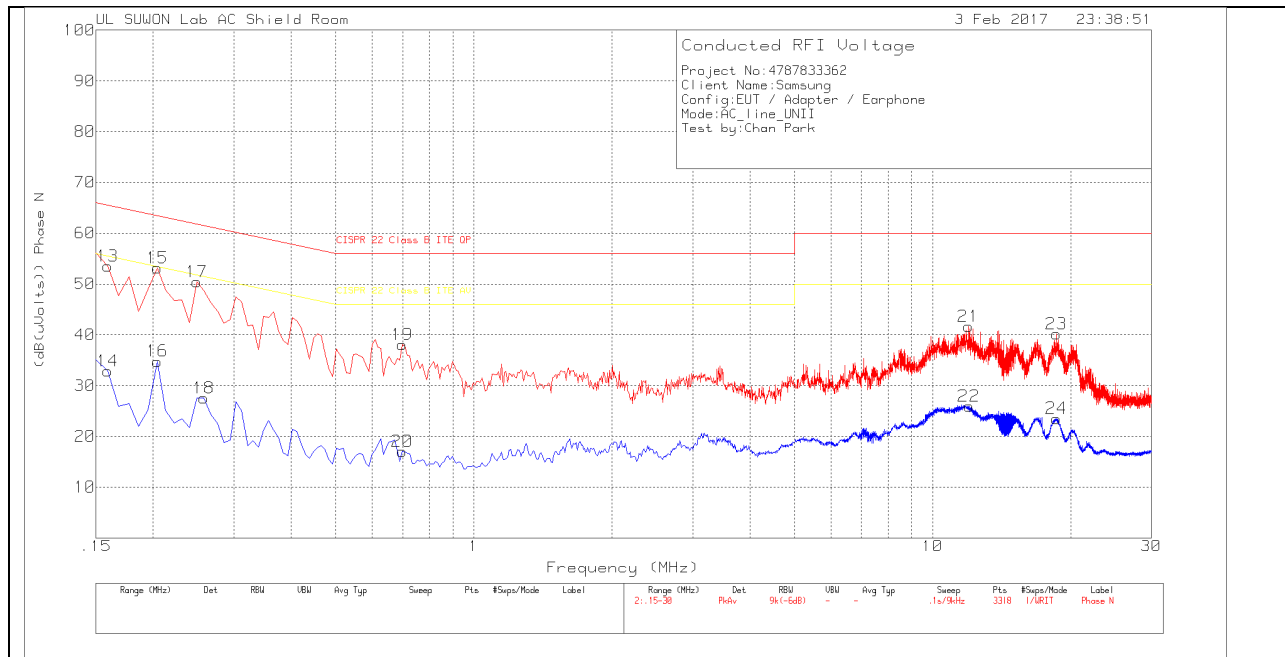

LINE 2 RESULTS

Trace Markers

Phase N .15 - 30MHz

Marker	Frequency (MHz)	Meter Reading (dBuV)	Det	101837_w ith ex-cord_N	CE Shield Room	Corrected Reading (dB(uVolts))	CISPR 22 Class B ITE QP	Margin (dB)	CISPR 22 Class B ITE AV	Margin (dB)
13	.159	43.65	Pk	9.9	0	53.55	65.52	-11.97	-	-
14	.159	22.93	Av	9.9	0	32.83	-	-	55.52	-22.69
15	.204	43.25	Pk	9.9	0	53.15	63.45	-10.3	-	-
16	.204	24.89	Av	9.9	0	34.79	-	-	53.45	-18.66
17	.249	40.77	Pk	9.7	0	50.47	61.79	-11.32	-	-
18	.258	17.86	Av	9.7	0	27.56	-	-	51.5	-23.94
19	.699	28.21	Pk	9.9	0	38.11	56	-17.89	-	-
20	.699	7.16	Av	9.9	0	17.06	-	-	46	-28.94
21	11.994	31.31	Pk	10.2	.2	41.71	60	-18.29	-	-
22	12.003	15.6	Av	10.2	.2	26	-	-	50	-24
23	18.645	29.35	Pk	10.6	.2	40.15	60	-19.85	-	-
24	18.636	12.73	Av	10.6	.2	23.53	-	-	50	-26.47

Pk - Peak detector

Av - Average detection

13. DYNAMIC FREQUENCY SELECTION

13.1. OVERVIEW

13.1.1. LIMITS

FCC

§15.407 (h), FCC KDB 905462 D02 "COMPLIANCE MEASUREMENT PROCEDURES FOR UNLICENSED-NATIONAL INFORMATION INFRASTRUCTURE DEVICES OPERATING IN THE 5250-5350 MHz AND 5470-5725 MHz BANDS INCORPORATING DYNAMIC FREQUENCY SELECTION" and KDB 905462 D03 "U-NII CLIENT DEVICES WITHOUT RADAR DETECTION CAPABILITY".

Table 1: Applicability of DFS requirements prior to use of a channel

Requirement	Operational Mode		
	Master	Client (without radar detection)	Client (with radar detection)
Non-Occupancy Period	Yes	Not required	Yes
DFS Detection Threshold	Yes	Not required	Yes
Channel Availability Check Time	Yes	Not required	Not required
U-NII Detection Bandwidth	Yes	Not required	Yes

Table 2: Applicability of DFS requirements during normal operation

Requirement	Operational Mode		
	Master	Client (without DFS)	Client (with DFS)
DFS Detection Threshold	Yes	Not required	Yes
Channel Closing Transmission Time	Yes	Yes	Yes
Channel Move Time	Yes	Yes	Yes
U-NII Detection Bandwidth	Yes	Not required	Yes

Additional requirements for devices with multiple bandwidth modes	Master Device or Client with Radar DFS	Client (without DFS)
U-NII Detection Bandwidth and Statistical Performance Check	All BW modes must be tested	Not required
Channel Move Time and Channel Closing Transmission Time	Test using widest BW mode available	Test using the widest BW mode available for the link
All other tests	Any single BW mode	Not required
Note: Frequencies selected for statistical performance check (Section 7.8.4) should include several frequencies within the radar detection bandwidth and frequencies near the edge of the radar detection bandwidth. For 802.11 devices it is suggested to select frequencies in all 20 MHz channel blocks and a null frequency between the bonded 20 MHz channel blocks.		

Table 3: Interference Threshold values, Master or Client incorporating In-Service Monitoring

Maximum Transmit Power	Value (see notes)
E.I.R.P. \geq 200 mill watt	-64 dBm
E.I.R.P. < 200 mill watt and power spectral density < 10 dBm/MHz	-62 dBm
E.I.R.P. < 200 mill watt that do not meet power spectral density requirement	-64 dBm
<p>Note 1: This is the level at the input of the receiver assuming a 0 dBi receive antenna</p> <p>Note 2: Throughout these test procedures an additional 1 dB has been added to the amplitude of the test transmission waveforms to account for variations in measurement equipment. This will ensure that the test signal is at or above the detection threshold level to trigger a DFS response.</p> <p>Note 3: E.I.R.P. is based on the highest antenna gain. For MIMO devices refer to KDB publication 662911 D01.</p>	

Table 4: DFS Response requirement values

Parameter	Value
<i>Non-occupancy period</i>	30 minutes
<i>Channel Availability Check Time</i>	60 seconds
<i>Channel Move Time</i>	10 seconds (See Note 1)
<i>Channel Closing Transmission Time</i>	200 milliseconds + approx. 60 milliseconds over remaining 10 second period. (See Notes 1 and 2)
<i>U-NII Detection Bandwidth</i>	Minimum 100% of the U-NII 99% transmission power bandwidth. (See Note 3)
<p>Note 1: <i>Channel Move Time</i> and the <i>Channel Closing Transmission Time</i> should be performed with Radar Type 0. The measurement timing begins at the end of the Radar Type 0 burst.</p> <p>Note 2: The <i>Channel Closing Transmission Time</i> is comprised of 200 milliseconds starting at the beginning of the <i>Channel Move Time</i> plus any additional intermittent control signals required to facilitate a <i>Channel</i> move (an aggregate of 60 milliseconds) during the remainder of the 10 second period. The aggregate duration of control signals will not count quiet periods in between transmissions.</p> <p>Note 3: During the <i>U-NII Detection Bandwidth</i> detection test, radar type 0 should be used. For each frequency step the minimum percentage of detection is 90 percent. Measurements are performed with no data traffic.</p>	

Table 5 – Short Pulse Radar Test Waveforms

Radar Type	Pulse Width (usec)	PRI (usec)	Pulses	Minimum Percentage of Successful Detection	Minimum Trials
0	1	1428	18	See Note 1	See Note 1
1	1	Test A: 15 unique PRI values randomly selected from the list of 23 PRI values in table 5a	Roundup: $\{(1/360) \times (19 \times 10^6 \text{ PRI}_{\text{usec}})\}$	60%	30
		Test B: 15 unique PRI values randomly selected within the range of 518-3066 usec. With a minimum increment of 1 usec, excluding PRI values selected in Test A			
2	1-5	150-230	23-29	60%	30
3	6-10	200-500	16-18	60%	30
4	11-20	200-500	12-16	60%	30
Aggregate (Radar Types 1-4)				80%	120
Note 1: Short Pulse Radar Type 0 should be used for the <i>Detection Bandwidth</i> test, <i>Channel Move Time</i> , and <i>Channel Closing Time</i> tests.					

Table 6 – Long Pulse Radar Test Signal

Radar Waveform Type	Pulse Width (μsec)	Chirp Width (MHz)	PRI (μsec)	Pulses per Burst	Number of Bursts	Minimum Percentage of Successful Detection	Minimum Trials
5	50-100	5-20	1000-2000	1-3	8-20	80%	30

Table 7 – Frequency Hopping Radar Test Signal

Radar Waveform Type	Pulse Width (μsec)	PRI (μsec)	Pulses per Hop	Hopping Rate (kHz)	Hopping Sequence Length (msec)	Minimum Percentage of Successful Detection	Minimum Trials
6	1	333	9	0.333	300	70%	30

13.1.1. TEST AND MEASUREMENT SYSTEM

CONDUCTED METHOD SYSTEM BLOCK DIAGRAM

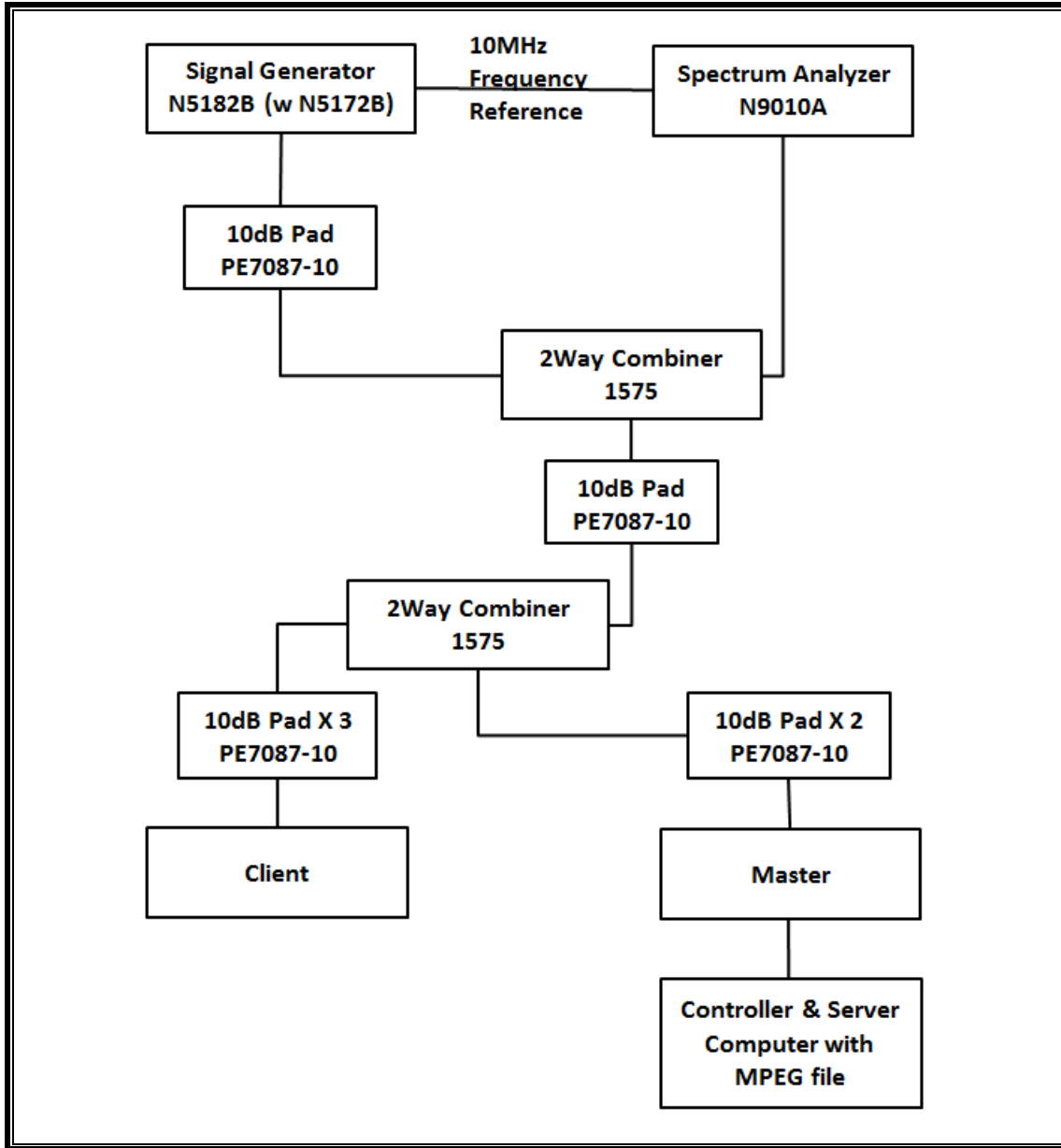

SYSTEM OVERVIEW

The short pulse and long pulse signal generating system utilizes the Keysite Signal Studio for Pulse Building as N5172B. The Vector Signal Generator has been validated by the NTIA. The hopping signal generating system utilizes the CCS simulated hopping method and system, which has been validated by the DoD, FCC and NTIA. The software selects waveform parameters from within the bounds of the signal type on a random basis using uniform distribution.

The short pulse types 1, 2, 3 and 4, and the long pulse type 5 parameters are randomized at run-time.

The hopping type 6 pulse parameters are fixed while the hopping sequence is based on the August 2005 NTIA Hopping Frequency List. The initial starting point randomized at run-time and each subsequent starting point is incremented by 475. Each frequency in the 100-length segment is compared to the boundaries of the EUT Detection Bandwidth and the software creates a hopping burst pattern in accordance with Section 7.4.1.3 Method #2 Simulated Frequency Hopping Radar Waveform Generating Subsystem of KDB 905462 D02. The frequency of the signal generator is incremented in 1 MHz steps from F_L to F_H for each successive trial. This incremental sequence is repeated as required to generate a minimum of 30 total trials and to maintain a uniform frequency distribution over the entire Detection Bandwidth.

The signal monitoring equipment consists of a spectrum analyzer. The aggregate ON time is calculated by multiplying the number of bins above a threshold during a particular observation period by the dwell time per bin, with the analyzer set to peak detection and max hold.

SYSTEM CALIBRATION

A 50-ohm load is connected in place of the spectrum analyzer, and the spectrum analyzer is connected to a horn antenna via a coaxial cable, with the reference level offset set to (horn antenna gain – coaxial cable loss). The signal generator is set to CW mode. The amplitude of the signal generator is adjusted to yield a level of –64 dBm as measured on the spectrum analyzer.

Without changing any of the instrument settings, the spectrum analyzer is reconnected to the Common port of the Spectrum Analyzer Combiner/Divider. The Reference Level Offset of the spectrum analyzer is adjusted so that the displayed amplitude of the signal is –64 dBm.

The spectrum analyzer displays the level of the signal generator as received at the antenna ports of the Master Device. The interference detection threshold may be varied from the calibrated value of –64 dBm and the spectrum analyzer will still indicate the level as received by the Master Device.

ADJUSTMENT OF DISPLAYED TRAFFIC LEVEL

A link is established between the Master and Slave and the distance between the units is adjusted as needed to provide a suitable received level at the Master and Slave devices. The video test file is streamed to generate WLAN traffic. The monitoring antenna is adjusted so that the WLAN traffic level, as displayed on the spectrum analyzer, is at lower amplitude than the radar detection threshold.

TEST AND MEASUREMENT EQUIPMENT

The following test and measurement equipment was utilized for the DFS tests documented in this report:

TEST EQUIPMENT LIST				
Description	Manufacturer	Model	S/N	Cal Due
Spectrum Analyzer, 7 GHz	Agilent / HP	N9010A	MY54200580	08-17-17
Vector Signal Generator, 6GHz	Agilent / HP	N5182B	MY53051241	08-16-17

13.1.2. SETUP OF EUT

CONDUCTED METHOD EUT TEST SETUP

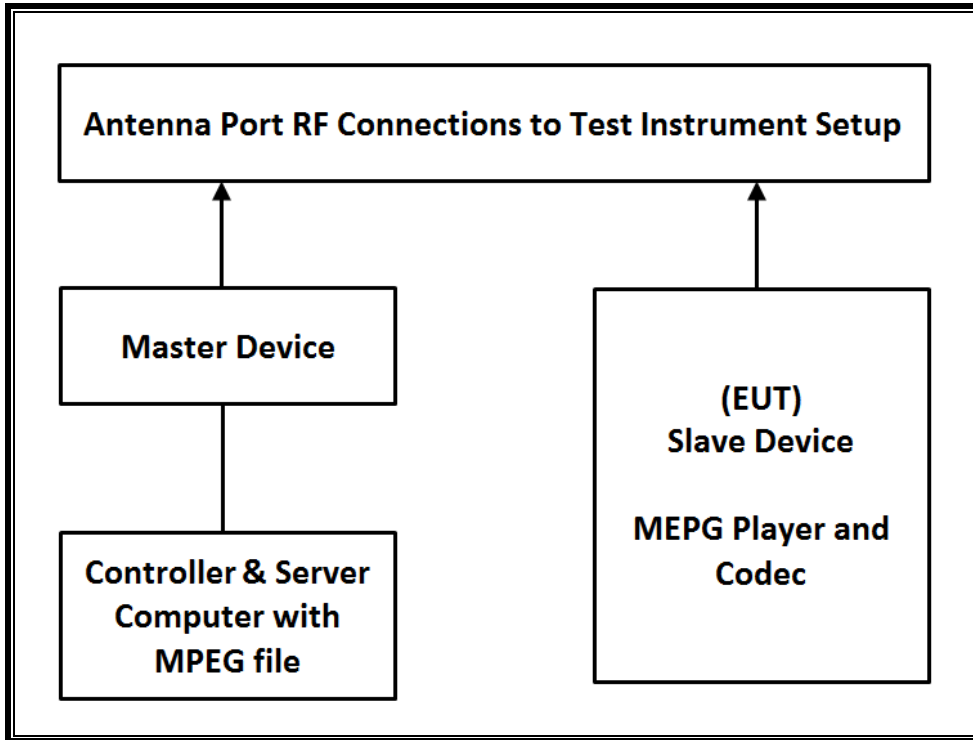

SUPPORT EQUIPMENT

The following support equipment was utilized for the DFS tests documented in this report:

PERIPHERAL SUPPORT EQUIPMENT LIST				
Description	Manufacturer	Model	Serial Number	FCC ID
Wireless Access Point	Cisco	AIR-CAP3702E-A-K9	FTX182276QX	LDK102087
PC (Controller/Server)	HP	HP EliteDesk 800 G1 TWR	CZC4125J25	DoC

13.1.3. DESCRIPTION OF EUT

The EUT operates over the 5250-5350 MHz and 5470-5725 MHz ranges.

The EUT is a Slave Device without Radar Detection.

The highest power level within these bands is 13.474 dBm in the 5250-5350 MHz band and 13.447 dBm in the 5470-5725 MHz band.

The antenna gain assembly utilized with the EUT is -0.25 dBi.

The rated output power of the Master unit is > 23dBm (EIRP). Therefore the required interference threshold level is -64 dBm. After correction for procedural adjustments, the required conducted threshold at the antenna port is $-64 + 1 = -63$ dBm.

The calibrated radiated DFS Detection Threshold level is set to -64 dBm. The tested level is lower than the required level hence it provides a margin to the limit.

The EUT uses one transmitter/receiver chain connected to an antenna to perform radiated tests.

WLAN traffic that meets or exceeds the minimum required loading was generated by transferring a data stream from the controller/server PC to the EUT using iPerf version 2.0.5 software package.

TPC is not required since the maximum EIRP is less than 500 mW (27 dBm).

The EUT utilizes the 802.11ac architecture. Two nominal channel bandwidths are implemented: 20 MHz and 40 MHz.

The software installed in the access point is 12.4(25d)JA1.

UNIFORM CHANNEL SPREADING

This requirement is not applicable to Slave radio devices.

OVERVIEW OF MASTER DEVICE WITH RESPECT TO §15.407 (h) REQUIREMENTS

The Master Device is a Cisco Access Point, FCC ID: LDK102087. The minimum antenna gain for the Master Device is 6 dBi.

The rated output power of the Master unit is > 23dBm (EIRP). Therefore the required interference threshold level is -64 dBm. After correction for procedural adjustments, the required radiated threshold at the antenna port is $-64 + 1 = -63$ dBm.

The calibrated radiated DFS Detection Threshold level is set to -64 dBm. The tested level is lower than the required level hence it provides a margin to the limit.

13.2. RESULTS FOR 20 MHz BANDWIDTH

13.2.1. TEST CHANNEL

All tests were performed at a channel center frequency of 5500 MHz.

13.2.2. RADAR WAVEFORM AND TRAFFIC

RADAR WAVEFORM

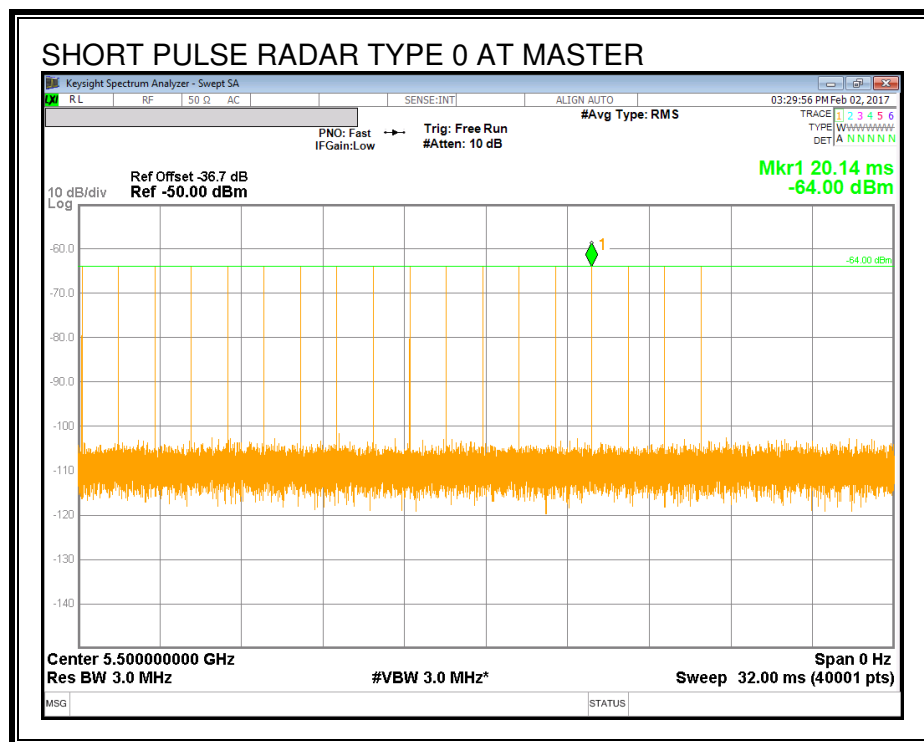

TRAFFIC

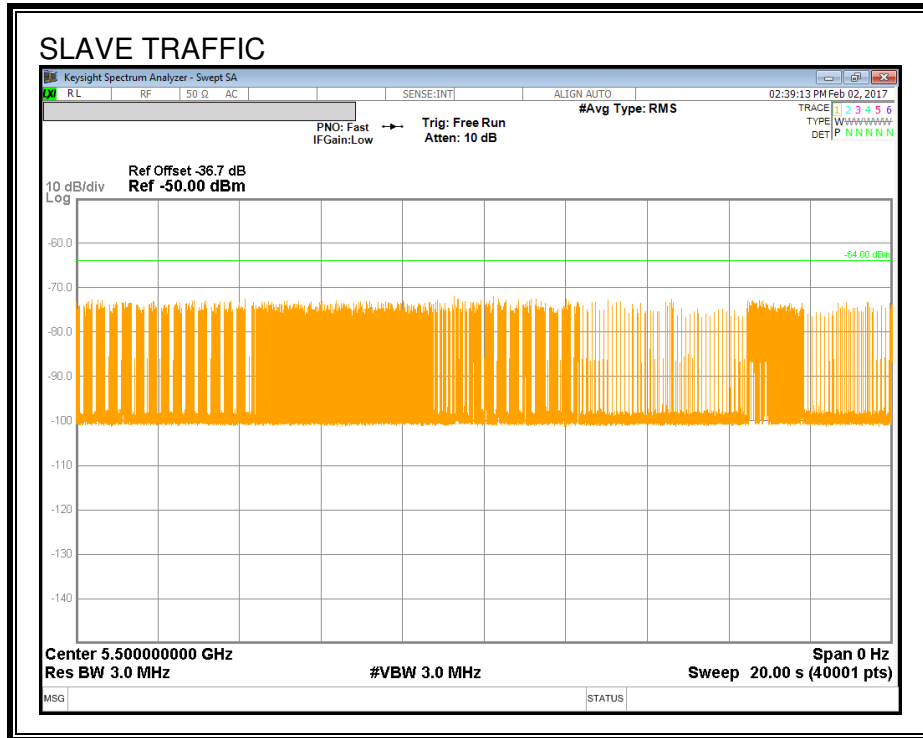

13.2.3. OVERLAPPING CHANNEL TESTS

RESULTS

These tests are not applicable.

13.2.4. MOVE AND CLOSING TIME

REPORTING NOTES

The reference marker is set at the end of last radar pulse.

The delta marker is set at the end of the last WLAN transmission following the radar pulse. This delta is the channel move time.

The aggregate channel closing transmission time is calculated as follows:

Aggregate Transmission Time =
(Number of analyzer bins showing transmission) * (dwell time per bin)

The observation period over which the aggregate time is calculated begins at (Reference Marker + 200 msec) and ends no earlier than (Reference Marker + 10 sec).

RESULTS

Channel Move Time (sec)	Limit (sec)
0.690	10

Aggregate Channel Closing Transmission Time (msec)	Limit (msec)
4.125	60

MOVE TIME & CHANNEL CLOSING TIME

AGGREGATE CHANNEL CLOSING TRANSMISSION TIME

No transmissions are observed during the aggregate monitoring period.

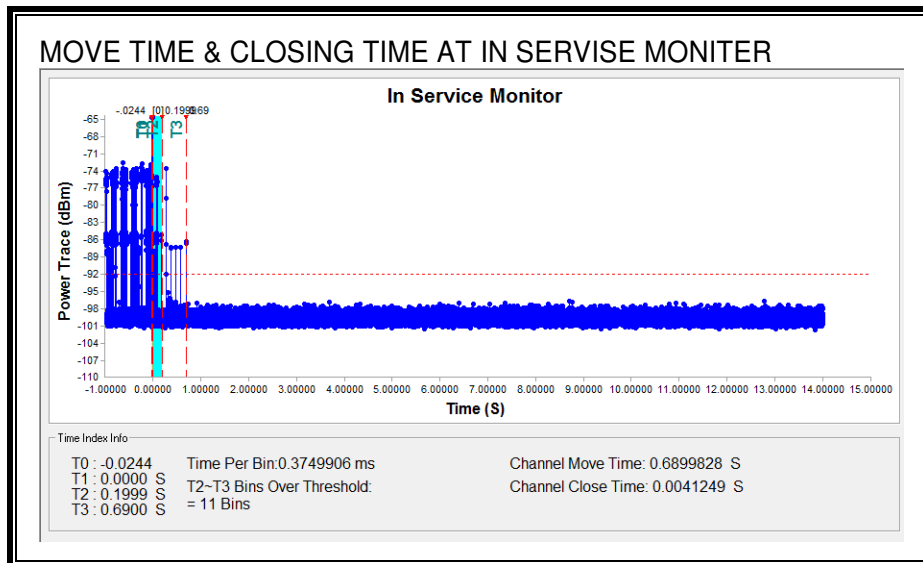
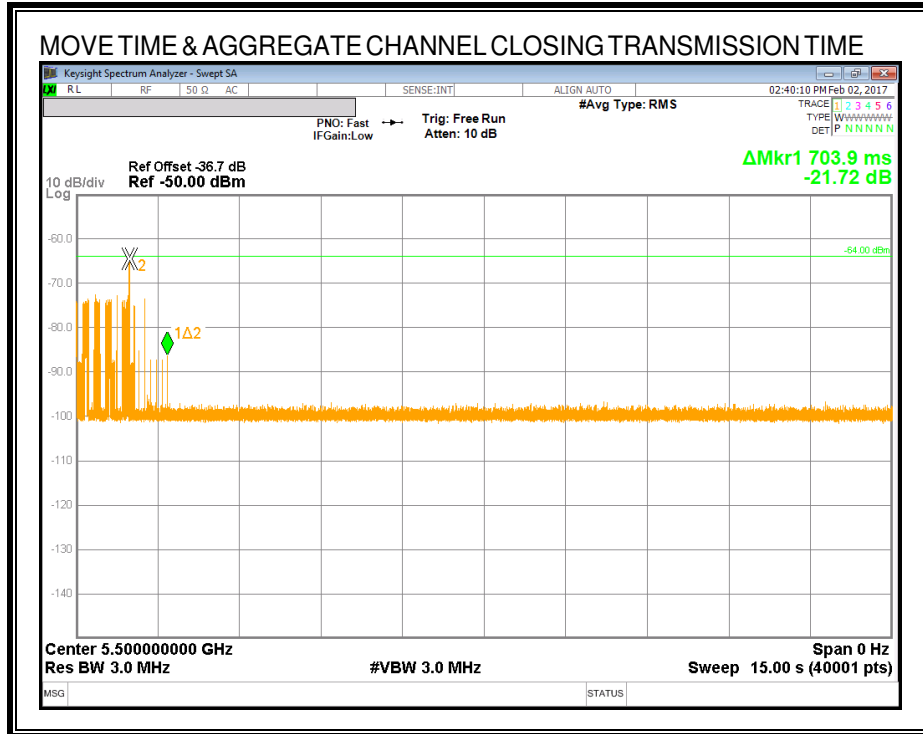

13.3. RESULTS FOR 40 MHz BANDWIDTH

13.3.1. TEST CHANNEL

All tests were performed at a channel center frequency of 5510 MHz.

13.3.2. RADAR WAVEFORM AND TRAFFIC

RADAR WAVEFORM

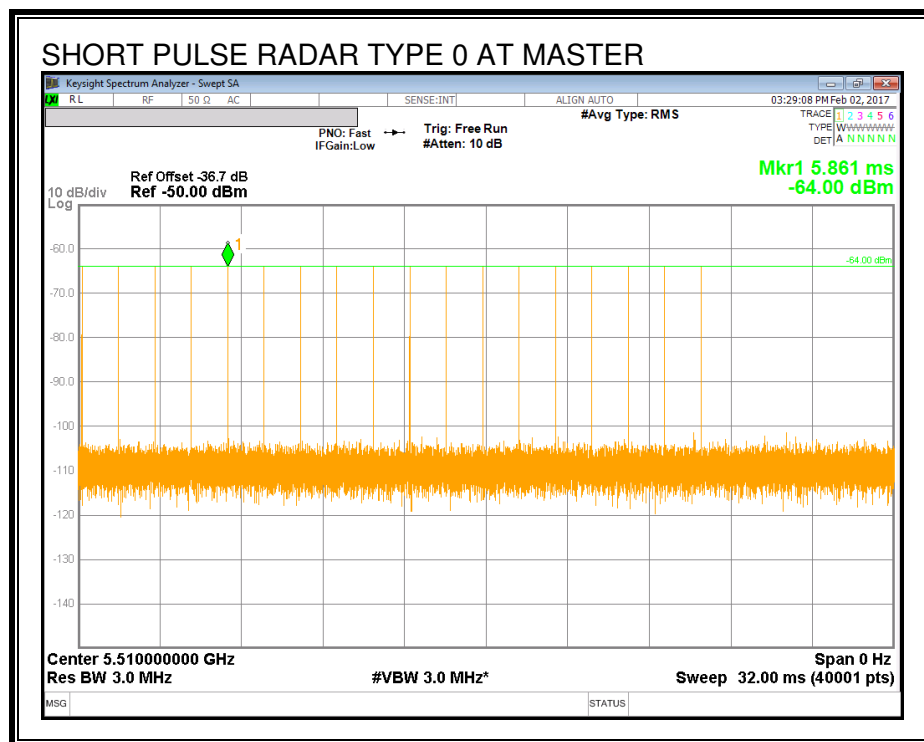

TRAFFIC

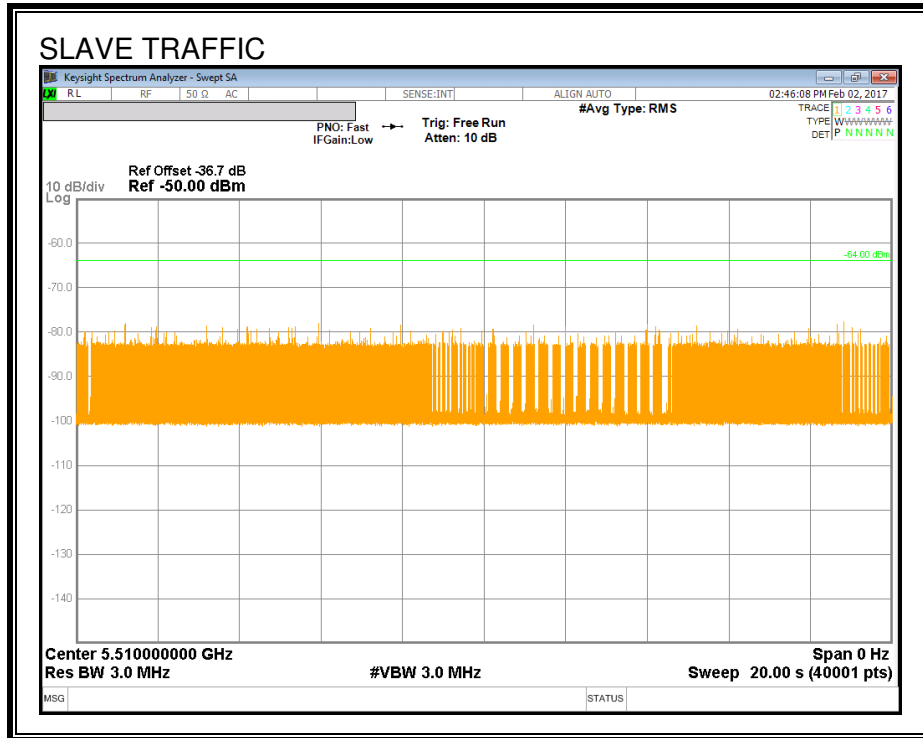

13.3.3. OVERLAPPING CHANNEL TESTS

RESULTS

These tests are not applicable.

13.3.4. MOVE AND CLOSING TIME

REPORTING NOTES

The reference marker is set at the end of last radar pulse.

The delta marker is set at the end of the last WLAN transmission following the radar pulse. This delta is the channel move time.

The aggregate channel closing transmission time is calculated as follows:

Aggregate Transmission Time =
(Number of analyzer bins showing transmission) * (dwell time per bin)

The observation period over which the aggregate time is calculated begins at (Reference Marker + 200 msec) and ends no earlier than (Reference Marker + 10 sec).

RESULTS

Channel Move Time (sec)	Limit (sec)
0.587	10

Aggregate Channel Closing Transmission Time (msec)	Limit (msec)
6.750	60

MOVE TIME & CHANNEL CLOSING TIME

AGGREGATE CHANNEL CLOSING TRANSMISSION TIME

No transmissions are observed during the aggregate monitoring period.

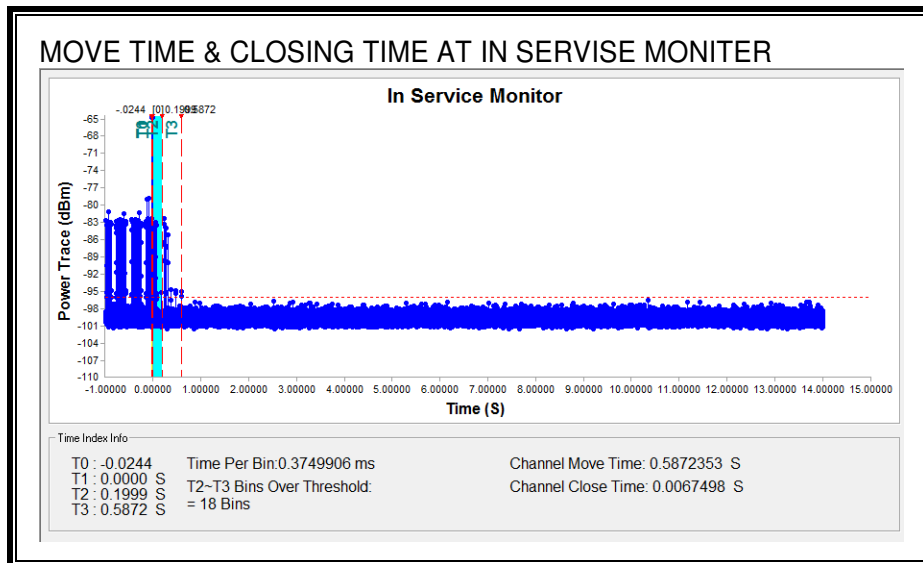
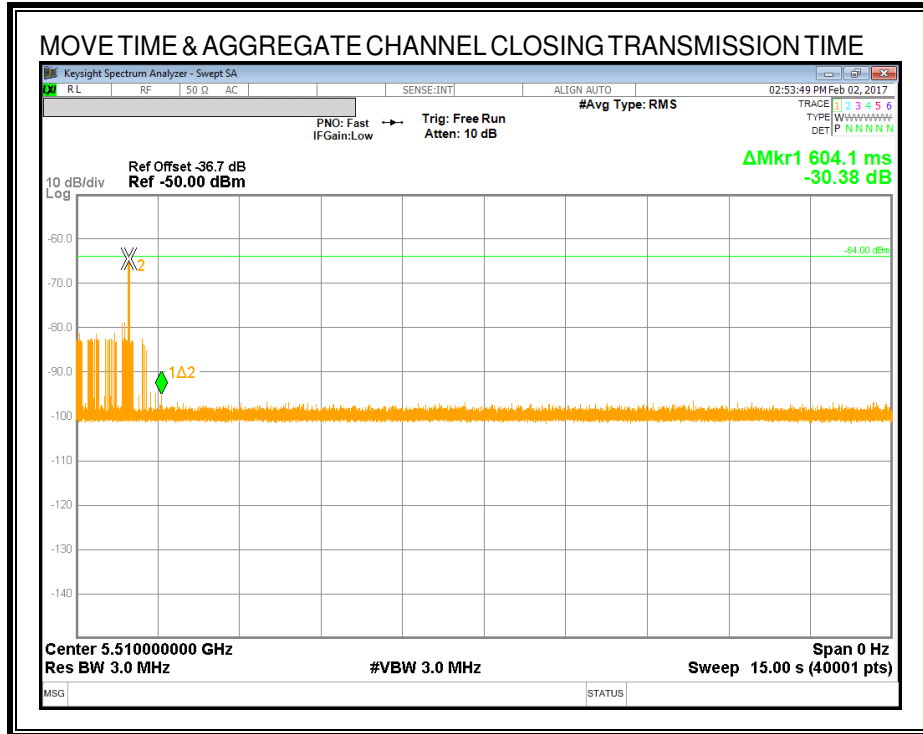

NON-OCCUPANCY PERIOD

RESULTS

No EUT transmissions were observed on the test channel during the 10-minute observation time.

