



**FCC CFR47 PART 22 SUBPART H  
FCC CFR47 PART 24 SUBPART E**

**CERTIFICATION TEST REPORT**

**FOR**

**GSM/WCDMA Phone + Bluetooth/BLE and DTS b/g/n**

**MODEL NUMBER : SM-G361HU/DS**

**FCC ID: A3LSMG361HU**

**REPORT NUMBER: 15K20970-E4**

**ISSUE DATE: JUN 11, 2015**

*Prepared for*  
**SAMSUNG ELECTRONICS CO., LTD.  
129 SAMSUNG-RO, YEONGTONG-GU, SUWON-SI,  
GYEONGGI-DO, 443-742, KOREA**

*Prepared by*  
**UL Korea, Ltd. Suwon Laboratory  
218 Maeyeong-ro, Yeongtong-gu,  
Suwon-si, Gyeonggi-do, 443-823, Korea  
TEL: (031) 337-9902  
FAX: (031) 213-5433**



Revision History

<u>Rev.</u>	<u>Issue Date</u>	<u>Revisions</u>	<u>Revised By</u>
--	06/11/15	Initial issue	Junwhan Lee

## TABLE OF CONTENTS

<b>1. ATTESTATION OF TEST RESULTS .....</b>	<b>5</b>
<b>2. TEST METHODOLOGY .....</b>	<b>6</b>
<b>3. FACILITIES AND ACCREDITATION .....</b>	<b>6</b>
<b>4. CALIBRATION AND UNCERTAINTY .....</b>	<b>6</b>
4.1. MEASURING INSTRUMENT CALIBRATION .....	6
4.2. SAMPLE CALCULATION .....	6
4.3. MEASUREMENT UNCERTAINTY.....	6
<b>5. EQUIPMENT UNDER TEST.....</b>	<b>7</b>
5.1. DESCRIPTION OF EUT .....	7
5.2. MAXIMUM OUTPUT POWER (GSM) .....	7
5.3. MAXIMUM OUTPUT POWER (WCDMA) .....	7
5.4. DESCRIPTION OF TEST SETUP.....	9
<b>6. TEST AND MEASUREMENT EQUIPMENT .....</b>	<b>11</b>
<b>7. Summary Table .....</b>	<b>12</b>
<b>8. RF POWER OUTPUT VERIFICATION .....</b>	<b>13</b>
8.1. GSM/GPRS/EDGE .....	13
8.1.1. GSM OUTPUT POWER RESULT.....	13
8.2. UMTS REL 99.....	14
8.2.1. WCDMA OUTPUT POWER RESULT .....	18
<b>9. PEAK TO AVERAGE RATIO .....</b>	<b>19</b>
9.1. CONDUCTED PEAK TO AVERAGE RESULT.....	19
9.2. CONDUCTED PEAK TO AVERAGE PLOTS.....	19
<b>10. LIMITS AND CONDUCTED RESULTS.....</b>	<b>20</b>
10.1. OCCUPIED BANDWIDTH.....	20
10.1.1. OCCUPIED BANDWIDTH RESULTS.....	20
10.1.2. OCCUPIED BANDWIDTH PLOTS .....	20
10.2. BAND EDGE EMISSIONS .....	22
10.2.1. BAND EDGE PLOTS .....	23
10.3. OUT OF BAND EMISSIONS.....	24
10.3.1. OUT OF BAND EMISSIONS RESULT .....	24
10.3.2. OUT OF BAND EMISSIONS PLOTS.....	25
10.4. FREQUENCY STABILITY.....	27
10.4.1. FREQUENCY STABILITY RESULTS.....	28

---

<b>11. RADIATED TEST RESULTS .....</b>	<b>29</b>
11.1. RADIATED POWER (ERP & EIRP).....	29
11.1.1. ERP/EIRP Results.....	30
11.1.2. ERP/EIRP DATA.....	31
11.2. FIELD STRENGTH OF SPURIOUS RADIATION.....	33
11.2.1. SPURIOUS RADIATION PLOTS.....	34
<b>12. SETUP PHOTOS .....</b>	<b>36</b>

# 1. ATTESTATION OF TEST RESULTS

**COMPANY NAME:** SAMSUNG ELECTRONICS CO., LTD.  
**EUT DESCRIPTION:** GSM/WCDMA Phone +Bluetooth/BLE and DTS b/g/n  
**MODEL NUMBER:** SM-G361HU/DS  
**SERIAL NUMBER:** R31G401L8VT, R31G5002V5M (RADIATED);  
R31G401LD7E, R31G5002TGV (CONDUCTED)  
**DATE TESTED:** MAY 11 - JUNE 05, 2015

APPLICABLE STANDARDS	
STANDARD	TEST RESULTS
FCC PART 22H, 24E	Pass

UL Korea, Ltd. tested the above equipment in accordance with the requirements set forth in the above standards. All indications of Pass/Fail in this report are opinions expressed by UL Korea, Ltd. based on interpretations and/or observations of test results. Measurement Uncertainties were not taken into account and are published for informational purposes only. The test results show that the equipment tested is capable of demonstrating compliance with the requirements as documented in this report.

**Note:** The results documented in this report apply only to the tested sample, under the conditions and modes of operation as described herein. This document may not be altered or revised in any way unless done so by UL Korea, Ltd. and all revisions are duly noted in the revisions section. Any alteration of this document not carried out by UL Korea, Ltd. will constitute fraud and shall nullify the document. This report must not be used by the client to claim product certification, approval, or endorsement by IAS, any agency of the Federal Government, or any agency of any government.

Approved & Released For  
UL Korea, Ltd. By:



CY Choi  
Suwon Lab Engineer  
UL Korea, Ltd.

Tested By:



Junwhan Lee  
Suwon Lab Engineer  
UL Korea, Ltd.

## 2. TEST METHODOLOGY

The tests documented in this report were performed in accordance with TIA-603-C, FCC CFR 47 Part 22 and FCC CFR Part24.

## 3. FACILITIES AND ACCREDITATION

The test sites and measurement facilities used to collect data are located at 218 Maeyeong-ro, Yeongtong-gu, Suwon-si, Gyeonggi-do, 443-823, Korea. Line conducted emissions are measured only at the 218 address. The following table identifies which facilities were utilized for radiated emission measurements documented in this report. Specific facilities are also identified in the test results sections.

218 Maeyeong-ro	
<input checked="" type="checkbox"/>	Chamber 1
<input type="checkbox"/>	Chamber 2

UL Korea, Ltd. is accredited by IAS, Laboratory Code TL-637. The full scope of accreditation can be viewed at <http://www.iasonline.org/PDF/TL/TL-637.pdf>.

## 4. CALIBRATION AND UNCERTAINTY

### 4.1. MEASURING INSTRUMENT CALIBRATION

The measuring equipment utilized to perform the tests documented in this report has been calibrated in accordance with the manufacturer's recommendations, and is traceable to recognized national standards.

### 4.2. SAMPLE CALCULATION

Where relevant, the following sample calculation is provided:

$EIRP = PSA \text{ reading with EUT worst orientation (dBm)} + \text{Path loss (dB)} - \text{cable loss (between the SG and substitution antenna)} + \text{Substitution Antenna Factor (dBi)}$

$ERP = PSA \text{ reading with EUT worst orientation (dBm)} + \text{Path loss (dB)} - \text{cable loss (between the SG and substitution antenna)}$

(Path loss = Signal generator output – PSA reading with substitution antenna)

### 4.3. MEASUREMENT UNCERTAINTY

Where relevant, the following measurement uncertainty levels have been estimated for tests performed on the apparatus:

PARAMETER	UNCERTAINTY
Conducted Disturbance, 0.15 to 30 MHz	2.32 dB
Radiated Disturbance, Below 1GHz	4.14 dB
Radiated Disturbance, Above 1 GHz	5.97 dB

Uncertainty figures are valid to a confidence level of 95%.

## 5. EQUIPMENT UNDER TEST

### 5.1. DESCRIPTION OF EUT

The EUT is a GSM/WCDMA Phone + Bluetooth/BLE and DTS b/g/n.

### 5.2. MAXIMUM OUTPUT POWER (GSM)

The transmitter has a maximum peak conducted and radiated ERP / EIRP output powers as follows:

FCC Part 22/24						
Band	Frequency Range [MHz]	Modulation Peak	Conducted		Radiated	
			Avg [dBm]	Avg [mW]	Avg [dBm]	Avg [mW]
GSM850	824~849	GMSK	32.66	1845.02		
		GPRS	32.68	1853.53	30.00	1000.00
		EGPRS	Rx only			
GSM1900	1850~1910	GMSK	29.22	835.60		
		GPRS	29.24	839.46	31.58	1438.80
		EGPRS	Rx only			

### 5.3. MAXIMUM OUTPUT POWER (WCDMA)

The transmitter has a maximum peak conducted and radiated ERP output powers as follows:

FCC Part 22						
Band	Frequency Range [MHz]	Modulation Peak	Conducted		Radiated	
			Avg [dBm]	Avg [mW]	Avg [dBm]	Avg [mW]
Band 5	824~849	REL99	22.71	186.57	15.34	34.20
		HSDPA	22.50	177.83	15.58	36.14
		HSUPA	21.43	138.87		

**DESCRIPTION OF AVAILABLE ANTENNAS**

The radio utilizes a FPCB antenna for the [List the bands supported] with a maximum peak gain as follow:

Frequency (MHz)	Peak Gain (dBi)
GSM 850 / WCDMA Band 5 824 ~ 849 MHz	-2.15
GSM 1900 1850 ~ 1910 MHz	0.87

## 5.4. DESCRIPTION OF TEST SETUP

### SUPPORT EQUIPMENT

Support Equipment List				
Description	Manufacturer	Model	Serial Number	FCC ID
Charger	SAMSUNG	ETA0U10EWE	N/A	N/A
Data Cable	SAMSUNG	ECB-DU28WE	N/A	N/A
Earphone	SAMSUNG	EHS61ASFWE	N/A	N/A

### I/O CABLES

I/O Cable List						
Cable No	Port	# of identical ports	Connector Type	Cable Type	Cable Length (m)	Remarks
1	DC Power	1	Mini-USB	Shielded	0.8m	N/A
2	Audio	1	Mini-Jack	Unshielded	1.0m	N/A

### TEST SETUP

The EUT is continuously communicated to the call box during the tests.

**SETUP DIAGRAM FOR TESTS (CONDUCTED TEST SETUP)**

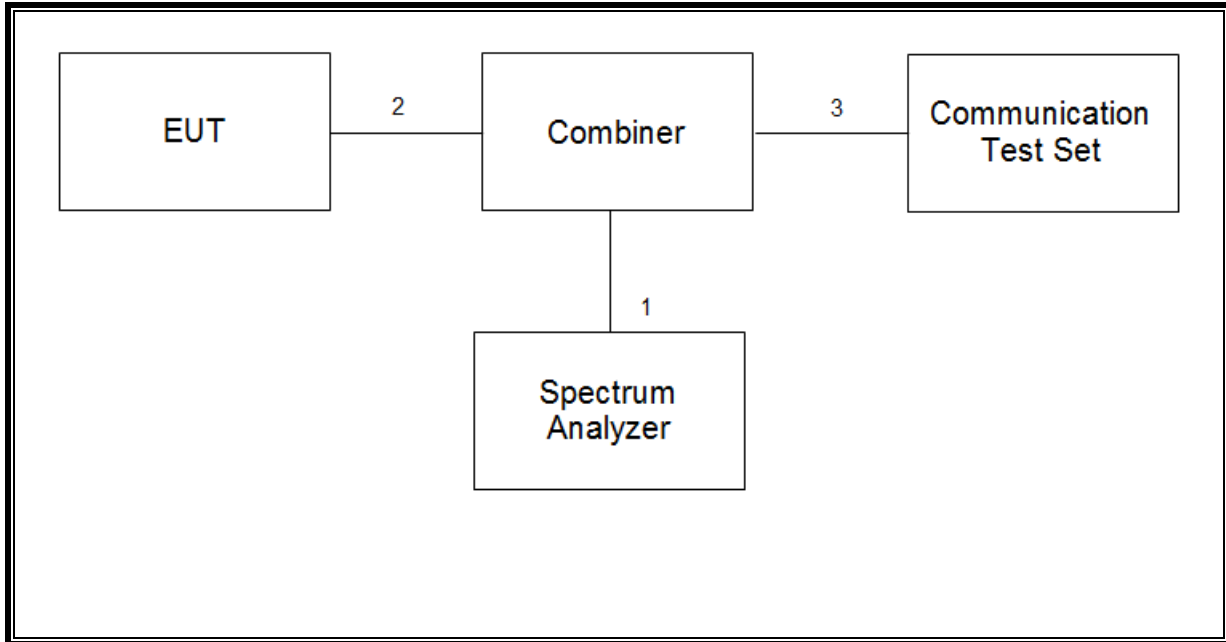

**SETUP DIAGRAM FOR TESTS (RADIATED TEST SETUP)**

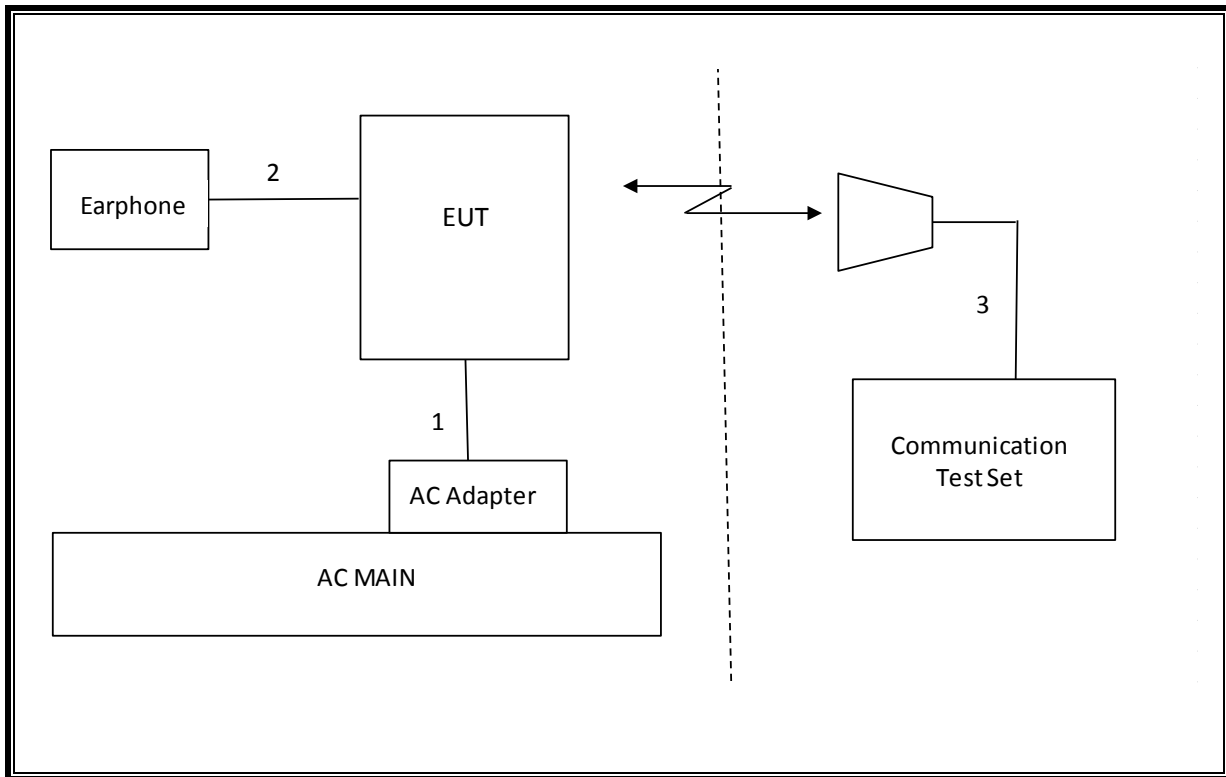

## 6. TEST AND MEASUREMENT EQUIPMENT

The following test and measurement equipment was utilized for the tests documented in this report:

Test Equipment List				
Description	Manufacturer	Model	S/N	Cal Due
Antenna, Tuned Dipole 400~1000 MHz	ETS	3121D DB4	00164753	07-29-15
Antenna, Bilog, 30MHz-1GHz	SCHWARZBECK	VULB9163	950	11-17-15
Antenna, Horn, 18 GHz	ETS	3115	00167211	09-20-15
Antenna, Horn, 40 GHz	ETS	3116C	00166255	09-23-15
Antenna, Horn, 40 GHz	ETS	3116C-PA	00168841	09-29-15
Preamplifier, 1000 MHz	Sonoma	310N	341282	11-17-15
Preamplifier, 18 GHz	Miteq	AFS42-00101800-25-S-42	1876511	11-18-15
Spectrum Analyzer, 44 GHz	Agilent / HP	N9030A	MY54170614	09-23-15
Communications Test Set	R&S	CMW500	150312	08-13-15
Average Power Sensor	R&S	NRZ-Z91	102681	11-17-15
Average Power Sensor	Agilent / HP	U2000	MY54270007	09-23-15
EMI Test Receive, 40 GHz	R&S	ESU40	100439	11-17-15
EMI Test Receive, 3 GHz	R&S	ESR3	101832	11-17-15
Attenuator / Switch driver	HP	11713A	3748A04272	N/A
Low Pass Filter 3GHz	Micro-Tronics	LPS17541	009	11-17-15
High Pass Filter 5GHz	Micro-Tronics	HPS17542	009	11-17-15
High Pass Filter 6GHz	Micro-Tronics	HPM17543	010	11-17-15
Combiner	WEINSCHEL	1575	2153	11-17-15
Temperature Chamber	ESPEC	SH-642	93001109	11-13-15
DC Power Supply	Agilent / HP	E3640A	MY54226395	09-23-15

## 7. Summary Table

The FCC ID:A3LSMG361HU and A3LSMG361H have the same PCB design, all the chipset, component including antennas are same.

A3LSMG361HU supports WCDMA Band 5.

After confirming through preliminary radiated emissions that the performance of the FDD ID : A3LSMG361H remains representative of FCC ID : A3LSMG361HU, test data for FDD ID : A3LSMG361H is being submitted for this application to cover GSM850, GSM1900 features.

FCC Part Section	Test Description	Test Limit	Test Condition	Test Result	Note
2.1049	Occupied Band width (99%)	N/A	Conducted	Pass	4.0921MHz
22.917(a) 24.238(a)	Band Edge / Conducted Spurious Emission	-13dBm		Pass	-22.24dBm
2.1046	Conducted output power	N/A		Pass	32.68dBm
22.355 24.235	Frequency Stability	2.5PPM		Pass	0.081PPM
22.913(a)(2)	Effective Radiated Power	38dBm	Radiated	Pass	30dBm
24.232(c)	Equivalent Isotropic Radiated Power	33dBm		Pass	31.58dBm
22.917(a) 24.238(a)	Radiated Spurious Emission	-13dBm		Pass	-39.7dBm

FCC Rule Part	Frequency Range [MHz]	Output Power [W]	Frequency Tolerance	Emission Designator	Emission Bandwidth	Communication Type
<b>GSM</b>						
22H	824.2 - 848.8	1.000	2.5 ppm	244KGXW	244KHz	GSM850
24E	1850.2 - 1909.8	1.439	2.5 ppm	244KGXW	244KHz	GSM1900
<b>WCDMA</b>						
22H	826.4 - 846.6	0.036	2.5 ppm	4M09F9W	4.092MHz	WCDMA BAND5

## 8. RF POWER OUTPUT VERIFICATION

### 8.1. GSM/GPRS/EDGE

Function: Menu select > GSM Mobile Station > GSM 850/900/1800/1900  
Press Connection control to choose the different menus  
Press RESET > choose all to reset all settings  
Connection Press Signal Off to turn off the signal and change settings  
Network Support > GSM+GPRS or GSM+EGPRS  
Main Service > Packet Data  
Service selection > Test Mode A – Auto Slot Config. off  
MS Signal Press Slot Config bottom on the right twice to select and change the number of time slots and power setting  
    > Slot configuration      > Uplink/Gamma  
    > 33 dBm for GPRS 850/900  
    > 30 dBm for GPRS1800/1900  
BS Signal Enter the same channel number for TCH channel (test channel) and BCCH channel  
Frequency Offset > + 0 Hz  
Mode > BCCH and TCH  
BCCH Level > -85 dBm (May need to adjust if link is not stable)  
BCCH Channel > choose desire test channel [Enter the same channel number for TCH channel (test channel) and BCCH channel]  
Channel Type > Off  
P0> 4 dB  
Slot Config > Unchanged (if already set under MS Signal)  
TCH > choose desired test channel  
Hopping > Off  
Main Timeslot > 3 (Default)  
Network Coding Scheme > CS4 (GPRS) and MCS5 ~ MCS9 (EGPRS)  
    Bit Stream > 2E9-1PSR Bit Pattern  
AF/RF Enter appropriate offsets for Ext. Att. Output and Ext. Att. Input  
Connection Press Signal On to turn on the signal and change settings

#### 8.1.1. GSM OUTPUT POWER RESULT

##### GSM850 Measured Results

Please refer to WWAN test report of FCC ID : A3LSMG361H

##### GSM1900 Measured Results

Please refer to WWAN test report of FCC ID : A3LSMG361H

## 8.2. UMTS REL 99

### Release 99 Setup Procedures used to establish the test signals

The following tests were completed according to the test requirements outlined in section 5.2 of the 3GPP TS34.121-1 specification. The DUT supports power Class 3, which has a nominal maximum output power of 24 dBm (+1.7/-3.7).

Mode	Subtest	Rel99
WCDMA General Settings	Loopback Mode	Test Mode 2
	Rel99 RMC	12.2kbps RMC
	Power Control Algorithm	Algorithm2
	$\beta c/\beta d$	8/15

### HSDPA Setup Procedures used to establish the test signals

The following 4 Sub-tests were completed according to Release 7 procedures in section 5.2 of 3GPP TS34.121. A summary of these settings are illustrated below:

	Mode	HSDPA	HSDPA	HSDPA	HSDPA
	Subtest	1	2	3	4
W-CDMA General Settings	Loopback Mode	Test Mode 1			
	Rel99 RMC	12.2kbps RMC			
	HSDPA FRC	H-Set 1			
	Power Control Algorithm	Algorithm 2			
	$\beta c$	2/15	11/15	15/15	15/15
	$\beta d$	15/15	15/15	8/15	4/15
	Bd (SF)	64			
	$\beta c/\beta d$	2/15	12/15	15/8	15/4
	$\beta hs$	4/15	24/15	30/15	30/15
MPR (dB)	0	0	0.5	0.5	
HSDPA Specific Settings	$D_{ACK}$	8			
	$D_{NAK}$	8			
	DCQI	8			
	Ack-Nack repetition factor	3			
	CQI Feedback (Table 5.2B.4)	4ms			
	CQI Repetition Factor (Table 5.2B.4)	2			
	$A_{hs}=\beta hs/\beta c$	30/15			

**HSPA (HSDPA & HSUPA) Setup Procedures used to establish the test signals**

The following 5 Sub-tests were completed according to Release 6 procedures in section 5.2 of 3GPP TS34.121. A summary of these settings are illustrated below:

	Mode	HSPA				
	Subtest	1	2	3	4	5
WCDMA General Settings	Loopback Mode	Test Mode 1				
	Rel99 RMC	12.2 kbps RMC				
	HSDPA FRC	H-Set 1				
	HSUPA Test	HSPA				
	Power Control Algorithm	Algorithm 2				Algorithm 1
	$\beta_c$	11/15	6/15	15/15	2/15	15/15
	$\beta_d$	15/15	15/15	9/15	15/15	0
	$\beta_{ec}$	209/225	12/15	30/15	2/15	5/15
	$\beta_c/\beta_d$	11/15	6/15	15/9	2/15	15/1
	$\beta_{hs}$	22/15	12/15	30/15	4/15	5/15
	$\beta_{ed}$	1309/225	94/75	47/15	56/75	47/15
	CM (dB)	1	3	2	3	1
MPR (dB)	0	2	1	2	0	
HSDPA Specific Settings	DACK	8				0
	DNAK	8				0
	DCQI	8				0
	Ack-Nack repetition factor	3				
	CQI Feedback (Table 5.2B.4)	4ms				
	CQI Repetition Factor (Table 5.2B.4)	2				
	A <sub>hs</sub> = $\beta_{hs}/\beta_c$	30/15				
HSUPA Specific Settings	E-DPDCCH	6	8	8	5	7
	DHARQ	0	0	0	0	0
	AG Index	20	12	15	17	21
	ETFCI (from 34.121 Table C.11.1.3)	75	67	92	71	81
	Associated Max UL Data Rate kbps	242.1	174.9	482.8	205.8	308.9
	Reference E-TFCIs	5	5	2	5	1
	Reference E-TFCI	11	11	11	11	67
	Reference E-TFCI PO	4	4	4	4	18
	Reference E-TFCI	67	67	92	67	67
	Reference E-TFCI PO	18	18	18	18	18
	Reference E-TFCI	71	71	71	71	71
	Reference E-TFCI PO	23	23	23	23	23
	Reference E-TFCI	75	75	75	75	75
	Reference E-TFCI PO	26	26	26	26	26
	Reference E-TFCI	81	81	81	81	81
Reference E-TFCI PO	27	27	27	27	27	
Maximum Channelisation Codes	2xSF2				SF4	

**DC-HSDPA Setup Procedures used to establish the test signals**

The following tests were completed according to procedures in section 7.3.13 of 3GPP TS34.108 v9.5.0. A summary of these settings are illustrated below:

Downlink Physical Channels are set as per 3GPP TS34.121-1 v9.0.0 E.5.0

Table E.5.0: Levels for HSDPA connection setup

Parameter During Connection setup	Unit	Value
P-CPICH_Ec/Ior	dB	-10
P-CCPCH and SCH_Ec/Ior	dB	-12
PICH_Ec/Ior	dB	-15
HS-PDSCH	dB	off
HS-SCCH_1	dB	off
DPCH_Ec/Ior	dB	-5
OCNS_Ec/Ior	dB	-3.1

Call is set up as per 3GPP TS34.108 v9.5.0 sub clause 7.3.13

The configurations of the fixed reference channels for HSDPA RF tests are described in 3GPP TS 34.121, annex C for FDD and 3GPP TS 34.122.

Table C.8.1.12: Fixed Reference Channel H-Set 12

Parameter	Unit	Value
Nominal Avg. Inf. Bit Rate	kbps	60
inter-TTI Distance	TTI's	1
Number of HARQ Processes	Processes	6
Information Bit Payload ( $N_{INF}$ )	Bits	120
Number Code Blocks	Blocks	1
Binary Channel Bits Per TTI	Bits	960
Total Available SML's in UE	SML's	19200
Number of SML's per HARQ Proc.	SML's	3200
Coding Rate		0.15
Number of Physical Channel Codes	Codes	1
Modulation		QPSK
Note 1: The RMC is intended to be used for DC-HSDPA mode and both cells shall transmit with identical parameters as listed in the table.		
Note 2: Maximum number of transmission is limited to 1, i.e., retransmission is not allowed. The redundancy and constellation version 0 shall be used.		

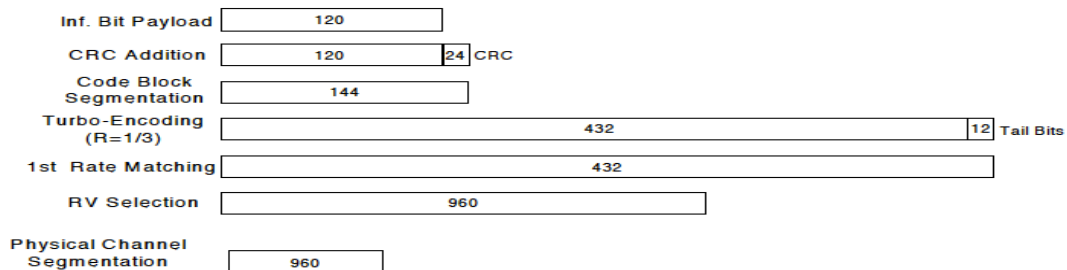

Figure C.8.19: Coding rate for Fixed reference Channel H-Set 12 (QPSK)

The following 4 Sub-tests for HSDPA were completed according to Release 8 procedures in section 5.2 of 3GPP TS34.121. A summary of subtest settings are illustrated below:

Mode	HSDPA	HSDPA	HSDPA	HSDPA
Subtest	1	2	3	4
WCDMA General Settings	Loopback Mode			
	Test Mode 1			
	Rel99 RMC			
	12.2kbps RMC			
	HSDPA FRC			
	H-Set 1			
	Power Control Algorithm			
	Algorithm2			
	$\beta_c$	2/15	11/15	15/15
$\beta_d$	15/15	15/15	8/15	4/15
$\beta_d$ (SF)	64			
$\beta_c/\beta_d$	2/15	11/15	15/8	15/4
$\beta_{hs}$	4/15	24/15	30/15	30/15
MPR (dB)	0	0	0.5	0.5
HSDPA Specific Settings	DACK			
	8			
	DNAK			
	8			
	DCQI			
	8			
	Ack-Nack Repetition factor			
3				
CQI Feedback				
4ms				
CQI Repetition Factor				
2				
A <sub>hs</sub> = $\beta_{hs} / \beta_c$				
30/15				

**HSPA+**

Since 16QAM is not used for uplink, the uplink Category and release is same as HSUPA, i.e., CAT 6 Rel 6. Therefore, the RF conducted power is not measured.

### 8.2.1. WCDMA OUTPUT POWER RESULT

#### WCDMA Band 5 Measured Results

Band	Mode		UL Ch No.	Freq. [MHz]	MPR [dB]	Avg Pwr [dBm]	
W-CDMA Band V	Rel 99	RMC, 12.2 kbps	4132	826.4	0	22.71	
			4183	836.6	0	22.61	
			4233	846.6	0	22.53	
	HSDPA	Subtest 1	4132	826.4	0	22.50	
			4183	836.6	0	22.50	
			4233	846.6	0	22.38	
		Subtest 2	4132	826.4	0	22.50	
			4183	836.6	0	22.50	
			4233	846.6	0	22.33	
		Subtest 3	4132	826.4	0.5	22.50	
			4183	836.6	0.5	22.50	
			4233	846.6	0.5	22.38	
		Subtest 4	4132	826.4	0.5	22.36	
			4183	836.6	0.5	22.40	
			4233	846.6	0.5	22.32	
		HSUPA	Subtest 1	4132	826.4	0	20.56
				4183	836.6	0	20.91
				4233	846.6	0	20.83
	Subtest 2		4132	826.4	2	19.11	
			4183	836.6	2	19.21	
			4233	846.6	2	18.90	
	Subtest 3		4132	826.4	1	20.42	
			4183	836.6	1	20.57	
			4233	846.6	1	20.26	
	Subtest 4		4132	826.4	2	19.90	
			4183	836.6	2	19.98	
			4233	846.6	2	19.72	
	Subtest 5		4132	826.4	0	21.22	
			4183	836.6	0	21.43	
			4233	846.6	0	21.14	

## 9. PEAK TO AVERAGE RATIO

### Test Procedure

Per KDB 971168 D01 Power Meas License Digital Systems v02r02;

The transmitter output was connected to a CMW500 Test Set and configured to operate at maximum power. The PAR were measured on the Spectrum Analyzer.

### Test Spec

In addition, when the transmitter power is measured in terms of average value, the peak-to-average ratio of the power shall not exceed 13 dB.

### 9.1. CONDUCTED PEAK TO AVERAGE RESULT

#### GSM

Please refer to WWAN test report of FCC ID : A3LSMG361H

#### WCDMA

Band	Channel	f [MHz]	Mode	Ratio [dB]	Limit [dB]
Band 5	4183	836.6	REL99	2.95	13.00
			HSDPA	2.99	

### 9.2. CONDUCTED PEAK TO AVERAGE PLOTS

#### GSM

Please refer to WWAN test report of FCC ID : A3LSMG361H

#### WCDMA

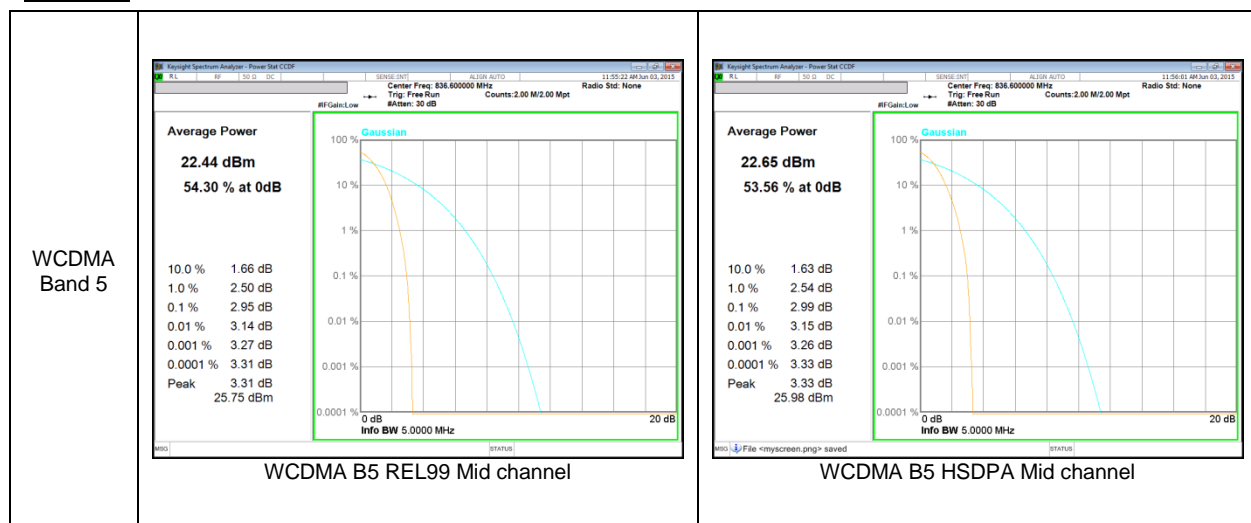

## 10. LIMITS AND CONDUCTED RESULTS

### 10.1. OCCUPIED BANDWIDTH

#### RULE PART(S)

FCC: §2.1049

#### LIMITS

For reporting purposes only

#### TEST PROCEDURE

The transmitter output was connected to a calibrated coaxial cable and coupler, the other end of which was connected to a spectrum analyzer. The occupied bandwidth was measured with the spectrum analyzer at the low, middle and high channel in each band. The -26dB bandwidth was also measured and recorded.

(KDB 971168 D01 Power Meas License Digital Systems v02r02)

#### 10.1.1. OCCUPIED BANDWIDTH RESULTS

##### GSM

Please refer to WWAN test report of FCC ID : A3LSMG361H

##### WCDMA

Band	Mode	Channel	f [MHz]	99% BW [MHz]	26dB BW [MHz]
Band 5	REL99	4132	826.4	4.067	4.607
		4183	836.6	4.083	4.645
		4233	846.6	4.075	4.601
	HSDPA	4132	826.4	4.073	4.608
		4183	836.6	4.092	4.618
		4233	846.6	4.082	4.613

#### 10.1.2. OCCUPIED BANDWIDTH PLOTS

##### GSM 850

Please refer to WWAN test report of FCC ID : A3LSMG361H

##### GSM 1900

Please refer to WWAN test report of FCC ID : A3LSMG361H

**WCDMA Band 5**

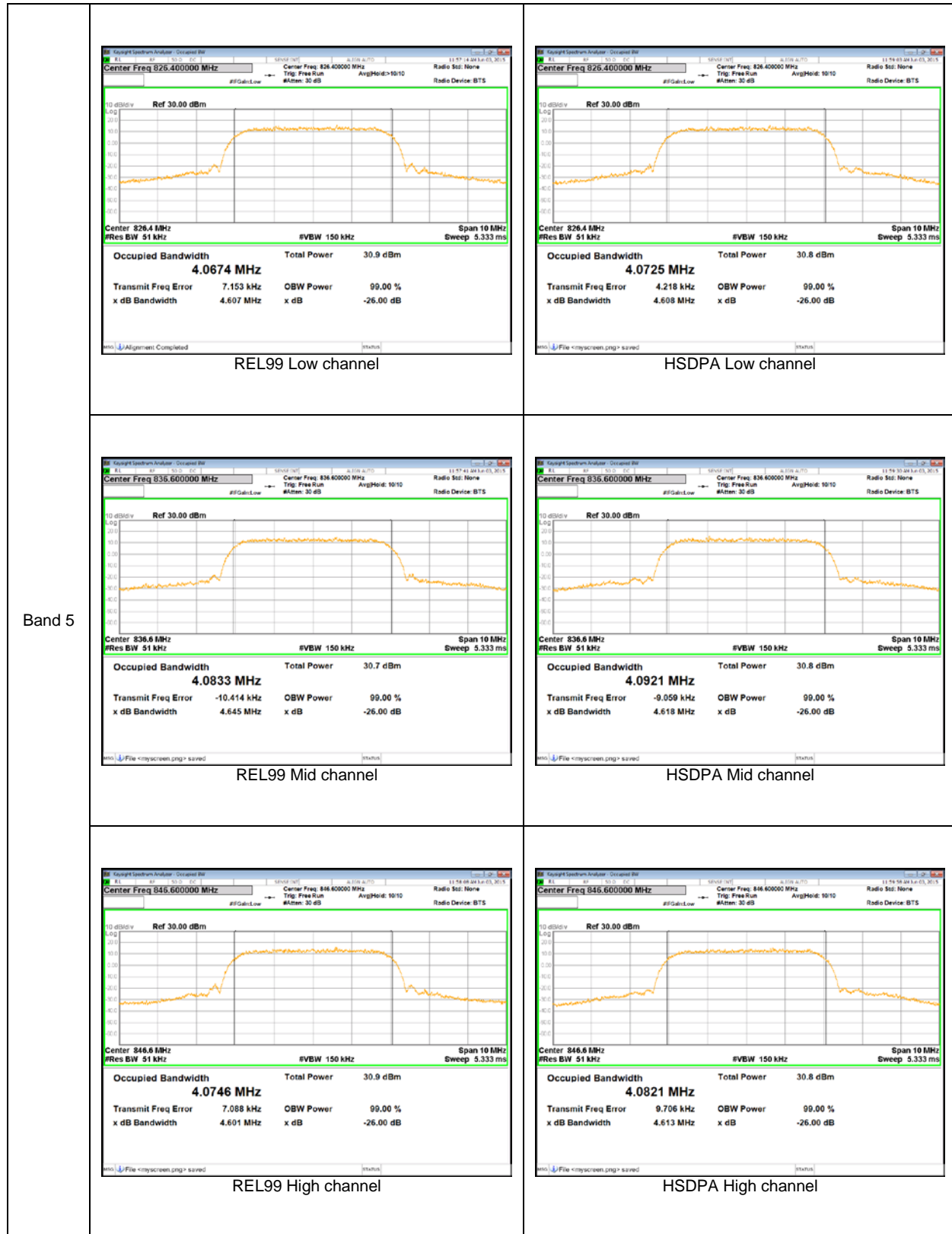

## 10.2. BAND EDGE EMISSIONS

### RULE PART(S)

FCC: §22.359, §24.238

### LIMITS

The power of any emission outside of the authorized operating frequency ranges must be attenuated below the transmitting power (P) by a factor of at least  $43 + 10 \log (P)$  dB.

### TEST PROCEDURE

Per KDB 971168 D01 Power Meas License Digital Systems v02r02

The transmitter output was connected to a CMW500 Test Set and configured to operate at maximum power. The band edge emissions were measured at the required operating frequencies in each band on the Spectrum Analyzer.

### RESULTS

#### GSM

Please refer to WWAN test report of FCC ID : A3LSMG361H

#### WCDMA

Band	Mode	Side	f [MHz]	Level [dBm]	Limit [dBm]
Band 5	REL99	Lower	824	-33.28	-13.00
		Upper	849	-32.27	
	HSDPA	Lower	824	-31.89	
		Upper	849	-31.38	

## 10.2.1. BAND EDGE PLOTS

### GSM

Please refer to WWAN test report of FCC ID : A3LSMG361H

### WCDMA

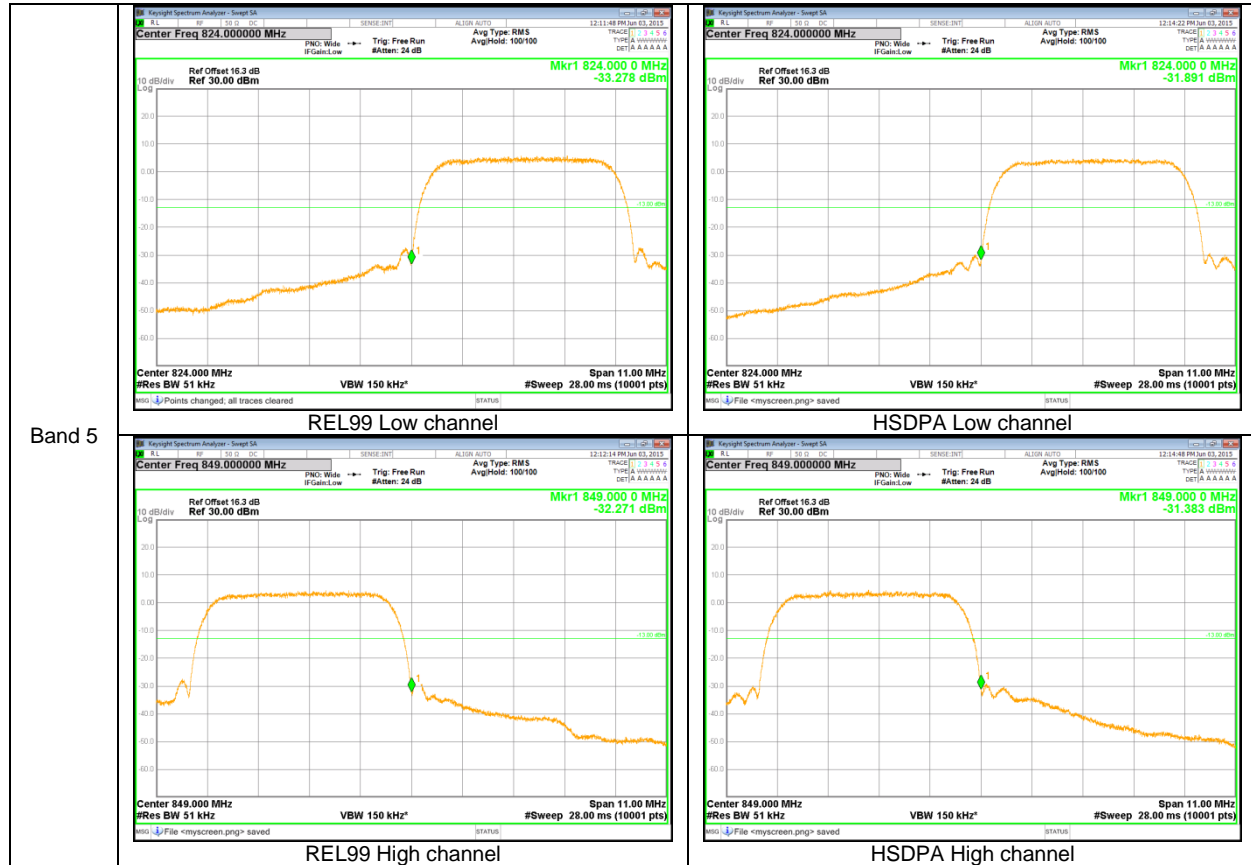

### 10.3. OUT OF BAND EMISSIONS

#### RULE PART(S)

FCC: §2.1051, §22.901, §22.917, §24.238

#### LIMITS

The power of any emission outside of the authorized operating frequency ranges must be attenuated below the transmitting power (P) by a factor of at least 43 + 10 log (P) dB.

#### TEST PROCEDURE

Per KDB 971168 D01 Power Meas License Digital Systems v02r02

The RF output of the transmitter was connected to a spectrum analyzer through a calibrated coaxial cable. Sufficient scans were taken to show the out-of-band Emissions, if any, up to 10th harmonic. Multiple sweeps were recorded in maximum hold mode using a peak detector to ensure that the worst-case emissions were caught.

#### RESULTS

##### 10.3.1. OUT OF BAND EMISSIONS RESULT

#### GSM

Please refer to WWAN test report of FCC ID : A3LSMG361H

#### WCDMA

Band	Mode	f [MHz]	Spurious [dBm]	Limit [dBm]	Margin [dB]
Band 5	REL99	826.4	-32.58	-13.00	19.58
		836.6	-32.85		19.85
		846.6	-32.95		19.95
	HSDPA	826.4	-32.62		19.62
		836.6	-33.28		20.28
		846.6	-33.39		20.39

### **10.3.2. OUT OF BAND EMISSIONS PLOTS**

#### **GSM 850**

Please refer to WWAN test report of FCC ID : A3LSMG361H

#### **GSM 1900**

Please refer to WWAN test report of FCC ID : A3LSMG361H

**WCDMA Band 5**

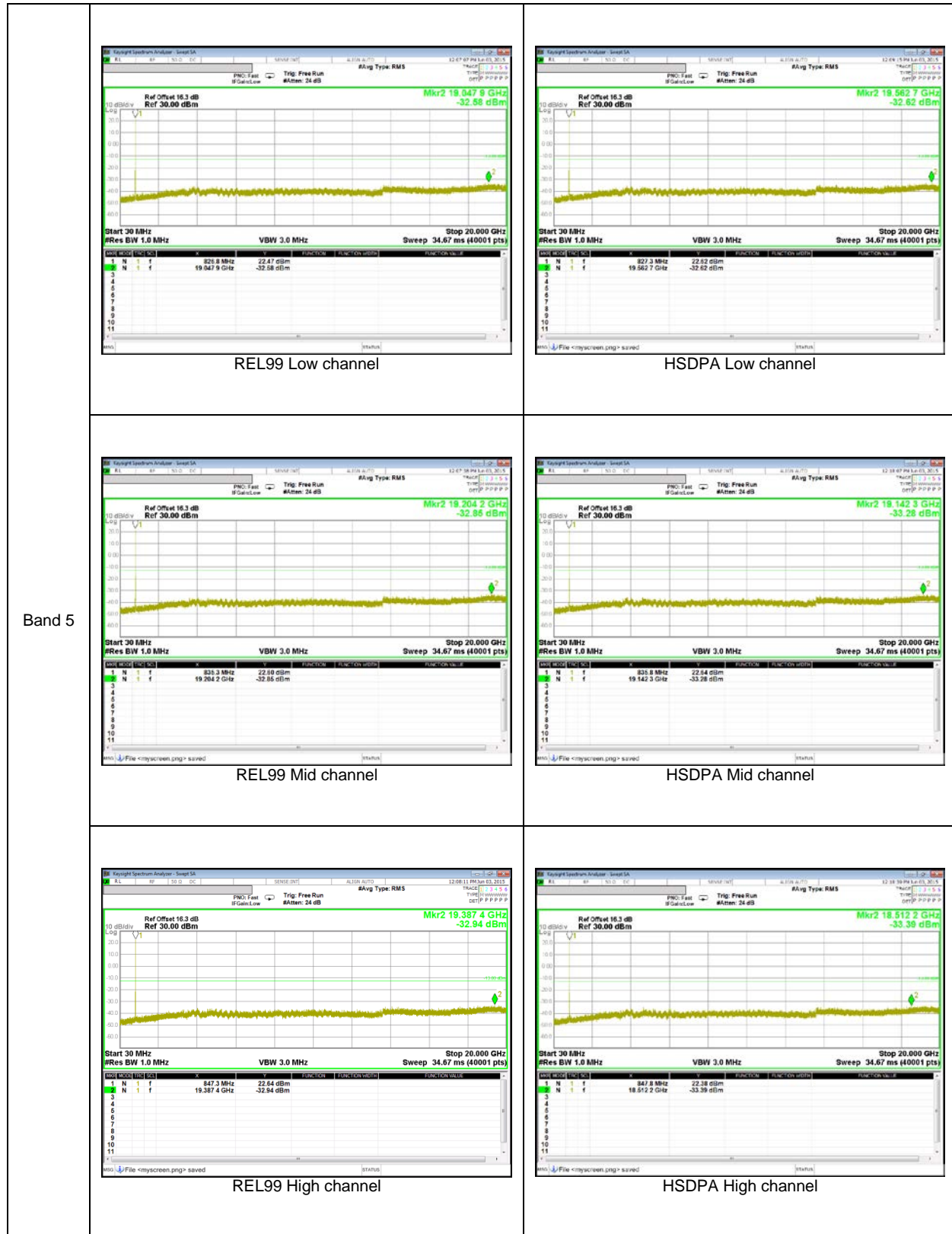

## **10.4. FREQUENCY STABILITY**

### **RULE PART(S)**

FCC: §2.1055, §22.355, §24.235

### **LIMITS**

§22.355 - The carrier frequency shall not depart from the reference frequency in excess of  $\pm 2.5$  ppm for mobile stations.

§24.235 - The frequency stability shall be sufficient to ensure that the fundamental emission stays within the authorized frequency block.

### **TEST PROCEDURE**

Per KDB 971168 D01 Power Meas License Digital Systems v02r02

### **RESULTS**

See the following pages.

**10.4.1. FREQUENCY STABILITY RESULTS**

**WCDMA Band 5, Channel 4183, Frequency 836.6 MHz**

Reference Frequency: Cell Mid Channel 836.6 MHz @ 20°C				
Limit: ± 2.5 ppm = 2091.500 Hz				
Power Supply (Vdc)	Environment Temperature (*C)	Frequency Deviation Measured with Time Elapse		
		(MHz)	Delta (ppm)	Limit (ppm)
3.80	50	836.60000996	-0.023	2.5
3.80	40	836.59999196	-0.001	2.5
3.80	30	836.60000819	-0.020	2.5
<b>3.80</b>	<b>20</b>	<b>836.59999112</b>	<b>0</b>	<b>2.5</b>
3.80	10	836.59999029	0.001	2.5
3.80	0	836.59999161	-0.001	2.5
3.80	-10	836.59999066	0.001	2.5
3.80	-20	836.60000844	-0.021	2.5
3.80	-30	836.59999174	-0.001	2.5

Reference Frequency: WCDMA Band5 Mid Channel 836.6 MHz @ 20°C				
Limit: ± 2.5 ppm = 2091.500 Hz				
Power Supply (Vdc)	Environment Temperature (*C)	Frequency Deviation Measured with Time Elapse		
		(MHz)	Delta (ppm)	Limit (ppm)
<b>3.80</b>	<b>20</b>	<b>836.59999112</b>	<b>0</b>	<b>2.5</b>
4.20	20	836.60000708	-0.019	2.5
3.40	20	836.60000848	-0.021	2.5

**GSM 850, Channel 190, Frequency 836.6 MHz**

Please refer to WWAN test report of FCC ID : A3LSMG361H

**GSM 1900, Channel 661, Frequency 1880.0 MHz**

Please refer to WWAN test report of FCC ID : A3LSMG361H

## 11. RADIATED TEST RESULTS

### 11.1. RADIATED POWER (ERP & EIRP)

#### RULE PART(S)

FCC: §2.1046, §22.913, §24.232

#### LIMITS

22.913(a) - The ERP of mobile transmitters and auxiliary test transmitters must not exceed 7 Watts.

24.232(c) - Mobile/portable stations are limited to 2 watts e.i.r.p. peak power and the equipment must employ means to limit the power to the minimum necessary for successful communications.

In addition, when the transmitter power is measured in terms of average value, the peak-to-average ratio of the power shall not exceed 13dB.

#### TEST PROCEDURE

ANSI / TIA / EIA 603C Clause 2.2.17; MXA setting reference to 971168 D01 v02r02

For peak power measurement with a MXA:

a) Set the RBW  $\geq$  OBW; b) Set VBW  $\geq 3 \times$  RBW; c) Set span  $\geq 2 \times$  RBW; d) Sweep time = auto couple; e) Detector = peak; f) Ensure that the number of measurement points  $\geq$  span/RBW; g) Trace mode = max hold;

For average power measurement with a MXA:

a) Set span to at least 1.5 times the OBW; b) Set RBW = 1-5% of the OBW, not to exceed 1 MHz; c) Set VBW  $\geq 3 \times$  RBW; d) Set number of points in sweep  $\geq 2 \times$  span / RBW; e) Sweep time = auto-couple; f) Detector = RMS (power averaging); g) Use free run trigger If burst duty cycle  $\geq 98$ ; h) Use trigger to capture bursts If burst duty cycle  $< 98$ ; i) Trace average at least 100 traces in power averaging (*i.e.*, RMS) mode. j) Compute the power by integrating the spectrum across the OBW of the signal using the instrument's band power measurement function.

#### TEST RESULTS

**11.1.1. ERP/EIRP Results**

**GSM**

Please refer to WWAN test report of FCC ID : A3LSMG361H

**WCDMA**

Band	Mode	Channel	f [MHz]	ERP / EIRP	
				[dBm]	[mW]
Band 5	REL99	4132	826.4	14.41	27.61
		4183	836.6	15.34	34.20
		4233	846.6	14.95	31.26
	HSDPA	4132	826.4	12.99	19.91
		4183	836.6	15.58	36.14
		4233	846.6	14.33	27.10

## 11.1.2. ERP/EIRP DATA

### **GSM 850**

Please refer to WWAN test report of FCC ID : A3LSMG361H

### **GSM 1900**

Please refer to WWAN test report of FCC ID : A3LSMG361H

**WCDMA Band 5**

High Frequency Substitution Measurement UL Korea, Ltd. Suwon Laboratory Chamber 1									
WCDMA Band 5 REL99	<b>Company:</b> Samsung								
	<b>Project #:</b> 15K20970								
	<b>Date:</b> 06-02-15								
	<b>Test Engineer:</b> Steven Kim								
	<b>Configuration:</b> EUT ONLY, Y Position								
	<b>Mode:</b> Rel 99_850 MHz								
	<b>Test Equipment:</b>								
	Receiving: VULB9163-750, and 3m Chamber N-type Cable (Setup this one for testing EUT)								
	Substitution: Dipole S/N: 00164753, 3m SMA Cable Warehouse.								
	f MHz	SG reading (dBm)	Ant. Pol. (H/V)	Cable Loss (dB)	Antenna Gain (dBd)	ERP (dBm)	Limit (dBm)	Margin (dB)	Notes
Low Ch									
826.40	7.37	V	1.1	-1.5	4.76	38.5	-33.7		
826.40	17.02	H	1.1	-1.5	14.41	38.5	-24.0		
Mid Ch									
836.60	8.89	V	1.1	-1.4	6.40	38.5	-32.1		
836.60	17.83	H	1.1	-1.4	15.34	38.5	-23.1		
High Ch									
846.60	7.93	V	1.1	-1.3	5.55	38.5	-32.9		
846.60	17.33	H	1.1	-1.3	14.95	38.5	-23.5		
Rev. 3.17.11									

High Frequency Substitution Measurement UL Korea, Ltd. Suwon Laboratory Chamber 1									
WCDMA Band 5 HSDPA	<b>Company:</b> Samsung								
	<b>Project #:</b> 15K20970								
	<b>Date:</b> 06-02-15								
	<b>Test Engineer:</b> Steven Kim								
	<b>Configuration:</b> EUT ONLY, Y Position								
	<b>Mode:</b> HSDPA_850 MHz								
	<b>Test Equipment:</b>								
	Receiving: VULB9163-750, and 3m Chamber N-type Cable (Setup this one for testing EUT)								
	Substitution: Dipole S/N: 00164753, 3m SMA Cable Warehouse.								
	f MHz	SG reading (dBm)	Ant. Pol. (H/V)	Cable Loss (dB)	Antenna Gain (dBd)	ERP (dBm)	Limit (dBm)	Margin (dB)	Notes
Low Ch									
826.40	6.26	V	1.1	-1.5	3.65	38.5	-34.8		
826.40	15.60	H	1.1	-1.5	12.99	38.5	-25.5		
Mid Ch									
836.60	9.18	V	1.1	-1.4	6.69	38.5	-31.8		
836.60	18.07	H	1.1	-1.4	15.58	38.5	-22.9		
High Ch									
846.60	6.82	V	1.1	-1.3	4.44	38.5	-34.0		
846.60	16.71	H	1.1	-1.3	14.33	38.5	-24.1		
Rev. 3.17.11									

## 11.2. FIELD STRENGTH OF SPURIOUS RADIATION

### RULE PART(S)

FCC: §2.1053, §22.917, §24.238

### LIMIT

Part 22.917(a) & Part 24.238(a) The power of any emission outside of the authorized operating frequency ranges must be attenuated below the transmitting power (P) by a factor of at least  $43 + 10 \log (P)$  dB.

### TEST PROCEDURE

For Cellular equipment - Compliance with these rules is based on the use of measurement instrumentation employing a resolution bandwidth of 100 kHz or greater. In the 1 MHz bands immediately outside and adjacent to the frequency block a resolution bandwidth of at least one percent of the emission bandwidth of the fundamental emission of the transmitter may be employed. A narrower resolution bandwidth is permitted in all cases to improve measurement accuracy provided the measured power is integrated over the full required measurement bandwidth (i.e. 100 kHz or 1 percent of emission bandwidth, as specified). The emission bandwidth is defined as the width of the signal between two points, one below the carrier center frequency and one above the carrier center frequency, outside of which all emissions are attenuated at least 26 dB below the transmitter power.

For PCS equipment - Compliance with these rules is based on the use of measurement instrumentation employing a resolution bandwidth of 1 MHz or greater. However, in the 1 MHz bands immediately outside and adjacent to the frequency block a resolution bandwidth of at least one percent of the emission bandwidth of the fundamental emission of the transmitter may be employed. A narrower resolution bandwidth is permitted in all cases to improve measurement accuracy provided the measured power is integrated over the full required measurement bandwidth (i.e. 1 MHz or 1 percent of emission bandwidth, as specified). The emission bandwidth is defined as the width of the signal between two points, one below the carrier center frequency and one above the carrier center frequency, outside of which all emissions are attenuated at least 26 dB below the transmitter power.

### RESULTS

### **11.2.1. SPURIOUS RADIATION PLOTS**

#### **GSM 850**

Please refer to WWAN test report of FCC ID : A3LSMG361H

#### **GSM 1900**

Please refer to WWAN test report of FCC ID : A3LSMG361H

**WCDMA Band 5**

		UL Korea, Ltd Suwon Laboratory Above 1GHz High Frequency Substitution Measurement										
WCDMA	Band 5 REL99	Company: Samsung										
		Project #: 15K20970										
		Date: 06-02-15										
		Test Engineer: Steven Kim										
		Configuration: EUT / AC Adapter / Earphone / Y Position										
		Mode: Tx, REL99,850MHz										
		Chamber: Chamber 1		Pre-amplifier: AFS42		Filter: Filter 1		Limit: Part 22				
f GHz	SG reading (dBm)	Ant. Pol. (H/V)	Distance (m)	Preamp (dB)	Filter (dB)	EIRP (dBm)	Limit (dBm)	Delta (dB)	Notes			
<b>Low Ch, 826.40MHz</b>												
1.6520	-11.4	V	3.0	40.2	1.0	-50.6	-13.0	-37.6				
2.4790	-19.8	V	3.0	40.1	1.0	-58.9	-13.0	-45.9				
3.3056	-23.1	V	3.0	39.6	1.0	-61.7	-13.0	-48.7				
1.6520	-8.5	H	3.0	40.2	1.0	-47.6	-13.0	-34.6				
2.4790	-15.8	H	3.0	40.1	1.0	-54.8	-13.0	-41.8				
3.3056	-22.3	H	3.0	39.6	1.0	-60.9	-13.0	-47.9				
<b>Mid Ch, 836.6MHz</b>												
1.6732	-13.4	V	3.0	40.2	1.0	-52.5	-13.0	-39.5				
2.5098	-20.5	V	3.0	40.1	1.0	-59.6	-13.0	-46.6				
3.3464	-21.4	V	3.0	39.6	1.0	-60.0	-13.0	-47.0				
1.6732	-13.0	H	3.0	40.2	1.0	-52.1	-13.0	-39.1				
2.5098	-19.9	H	3.0	40.1	1.0	-58.9	-13.0	-45.9				
3.3464	-20.2	H	3.0	39.6	1.0	-58.7	-13.0	-45.7				
<b>High Ch, 846.6MHz</b>												
1.6932	-8.0	V	3.0	40.2	1.0	-47.2	-13.0	-34.2				
2.5390	-19.1	V	3.0	40.1	1.0	-58.1	-13.0	-45.1				
3.3860	-19.9	V	3.0	39.5	1.0	-58.4	-13.0	-45.4				
1.6932	-9.6	H	3.0	40.2	1.0	-48.7	-13.0	-35.7				
2.5390	-20.5	H	3.0	40.1	1.0	-59.5	-13.0	-46.5				
3.3860	-18.8	H	3.0	39.5	1.0	-57.3	-13.0	-44.3				
Rev. 03.03.09 Note: No other emissions were detected above the system noise floor.												
WCDMA	Band 5 HSDPA	Company: Samsung										
		Project #: 15K20970										
		Date: 06-02-15										
		Test Engineer: Steven Kim										
		Configuration: EUT / AC Adapter / Earphone / Y Position										
		Mode: Tx, HSDPA,850MHz										
		Chamber: Chamber 1		Pre-amplifier: AFS42		Filter: Filter 1		Limit: Part 22				
f GHz	SG reading (dBm)	Ant. Pol. (H/V)	Distance (m)	Preamp (dB)	Filter (dB)	EIRP (dBm)	Limit (dBm)	Delta (dB)	Notes			
<b>Low Ch, 826.40MHz</b>												
1.6520	-8.2	V	3.0	40.2	1.0	-47.4	-13.0	-34.4				
2.4790	-17.5	V	3.0	40.1	1.0	-56.6	-13.0	-43.6				
3.3056	-23.1	V	3.0	39.6	1.0	-61.7	-13.0	-48.7				
1.6520	-10.6	H	3.0	40.2	1.0	-49.7	-13.0	-36.7				
2.4790	-19.4	H	3.0	40.1	1.0	-58.4	-13.0	-45.4				
3.3056	-22.6	H	3.0	39.6	1.0	-61.2	-13.0	-48.2				
<b>Mid Ch, 836.6MHz</b>												
1.6732	-8.8	V	3.0	40.2	1.0	-48.0	-13.0	-35.0				
2.5098	-17.1	V	3.0	40.1	1.0	-56.2	-13.0	-43.2				
3.3464	-19.1	V	3.0	39.6	1.0	-57.7	-13.0	-44.7				
1.6732	-11.9	H	3.0	40.2	1.0	-51.1	-13.0	-38.1				
2.5098	-19.3	H	3.0	40.1	1.0	-58.4	-13.0	-45.4				
3.3464	-19.5	H	3.0	39.6	1.0	-58.1	-13.0	-45.1				
<b>High Ch, 846.6MHz</b>												
1.6932	-8.5	V	3.0	40.2	1.0	-47.7	-13.0	-34.7				
2.5390	-19.3	V	3.0	40.1	1.0	-58.4	-13.0	-45.4				
3.3860	-20.9	V	3.0	39.5	1.0	-59.4	-13.0	-46.4				
1.6932	-12.1	H	3.0	40.2	1.0	-51.2	-13.0	-38.2				
2.5390	-20.7	H	3.0	40.1	1.0	-59.8	-13.0	-46.8				
3.3860	-20.3	H	3.0	39.5	1.0	-58.8	-13.0	-45.8				
Rev. 03.03.09 Note: No other emissions were detected above the system noise floor.												