



**FCC CFR47 PART 22 SUBPART H
FCC CFR47 PART 24 SUBPART E**

CERTIFICATION TEST REPORT

FOR

GSM/WCDMA/LTE Phone + Bluetooth, WLAN b/g/n & NFC

MODEL NUMBER: SM-G360G

FCC ID: A3LSMG360G

REPORT NUMBER: 14I18853-E1

ISSUE DATE: SEPTEMBER 18, 2014

Prepared for

**SAMSUNG ELECTRONICS CO., LTD.
416, MAETAN 3-DONG, YEONGTONG-GU
SUWON-CITY, GYEONGGI-DO 443-742, SOUTH KOREA**

Prepared by

**UL VERIFICATION SERVICES INC.
47173 BENICIA STREET
FREMONT, CA 94538, U.S.A.
TEL: (510) 771-1000
FAX: (510) 661-0888**



NVLAP LAB CODE 200065-0

Revision History

<u>Rev.</u>	<u>Issue Date</u>	<u>Revisions</u>	<u>Revised By</u>
--	9/18/14	Initial Issue	P. Zhang

TABLE OF CONTENTS

1.	ATTESTATION OF TEST RESULTS	5
2.	TEST METHODOLOGY	6
3.	FACILITIES AND ACCREDITATION	6
4.	CALIBRATION AND UNCERTAINTY	6
4.1.	<i>MEASURING INSTRUMENT CALIBRATION</i>	6
4.2.	<i>SAMPLE CALCULATION</i>	6
4.3.	<i>MEASUREMENT UNCERTAINTY.....</i>	7
5.	EQUIPMENT UNDER TEST	8
5.1.	<i>DESCRIPTION OF EUT</i>	8
5.2.	<i>MAXIMUM OUTPUT POWER.....</i>	8
5.3.	<i>MAXIMUM OUTPUT POWER (LTE).....</i>	9
5.4.	<i>DESCRIPTION OF AVAILABLE ANTENNAS</i>	10
5.5.	<i>DESCRIPTION OF TEST SETUP.....</i>	11
6.	TEST AND MEASUREMENT EQUIPMENT.....	14
7.	Summary Table.....	15
8.	RF POWER OUTPUT VERIFICATION.....	16
8.1.	<i>GSM/GPRS/EDGE</i>	16
8.1.1.	<i>GSM OUTPUT POWER RESULT.....</i>	17
8.2.	<i>UMTS REL 99.....</i>	19
8.2.1.	<i>UMTS REL 99 OUTPUT POWER RESULT.....</i>	19
8.3.	<i>UMTS HSDPA</i>	20
8.3.1.	<i>UMTS HSDPA OUTPUT POWER RESULT.....</i>	20
8.3.2.	<i>UMTS HSUPA</i>	21
8.3.3.	<i>UMTS HSUPA OUTPUT POWER RESULT.....</i>	22
8.3.4.	<i>DC-HSDPA.....</i>	23
8.3.1.	<i>UMTS DC-HSDPA OUTPUT POWER RESULT</i>	25
LTE OUTPUT VERIFICATION.....		26
8.3.2.	<i>LTE OUTPUT RESULT</i>	26
9.	PEAK TO AVERAGE RATIO.....	28

9.1. CONDUCTED PEAK TO AVERAGE RESULT.....28

10. LIMITS AND CONDUCTED RESULTS.....35

10.1. OCCUPIED BANDWIDTH.....35

10.1.1. OCCUPIED BANDWIDTH RESULTS.....36

10.1.2. LTE OCCUPIED BANDWIDTH RESULTS37

10.1.3. OCCUPIED BANDWIDTH PLOTS38

10.2. BAND EDGE EMISSIONS44

10.2.1. BAND EDGE PLOTS45

10.3. OUT OF BAND EMISSIONS58

10.3.1. OUT OF BAND EMISSIONS RESULT59

10.3.2. OUT OF BAND EMISSIONS PLOTS.....61

10.4. FREQUENCY STABILITY66

10.4.1. FREQUENCY STABILITY RESULTS.....67

11. RADIATED TEST RESULTS69

11.1. RADIATED POWER (ERP & EIRP).....69

11.1.1. ERP/EIRP Results.....70

11.1.2. LTE ERP/EIRP Results71

11.1.3. ERP/EIRP PLOTS.....73

11.2. FIELD STRENGTH OF SPURIOUS RADIATION.....87

11.2.1. SPURIOUS RADIATION PLOTS.....88

12. SETUP PHOTOS102

1. ATTESTATION OF TEST RESULTS

COMPANY NAME: SAMSUNG ELECTRONICS CO., LTD.
EUT DESCRIPTION: GSM/WCDMA/LTE Phone + Bluetooth, WLAN 2.4GHz b/g/n, & NFC
MODEL: SM-G360G
SERIAL NUMBER: 1958413 (Radiated), 1958409 (Conducted)
DATE TESTED: September 16 - 17, 2014

APPLICABLE STANDARDS	
STANDARD	TEST RESULTS
FCC PART 22H & 24E	PASS

UL Verification Services Inc. tested the above equipment in accordance with the requirements set forth in the above standards. All indications of Pass/Fail in this report are opinions expressed by UL Verification Services Inc. based on interpretations and/or observations of test results. Measurement Uncertainties were not taken into account and are published for informational purposes only. The test results show that the equipment tested is capable of demonstrating compliance with the requirements as documented in this report.

Note: The results documented in this report apply only to the tested sample, under the conditions and modes of operation as described herein. This document may not be altered or revised in any way unless done so by UL Verification Services Inc. and all revisions are duly noted in the revisions section. Any alteration of this document not carried out by UL Verification Services Inc. will constitute fraud and shall nullify the document. This report must not be used by the client to claim product certification, approval, or endorsement by NVLAP, NIST, any agency of the Federal Government, or any agency of any government.

Approved & Released For
UL Verification Services Inc. By:



PENG ZHANG
CONSUMER TECHNOLOGY DIVISION
PROJECT LEAD
UL Verification Services Inc.

Tested By:



R. ALEGRE
CONSUMER TECHNOLOGY DIVISION
LAB ENGINEER
UL Verification Services Inc.

2. TEST METHODOLOGY

The tests documented in this report were performed in accordance with TIA-603-C, FCC CFR 47 Part 22, FCC CFR Part 24.

3. FACILITIES AND ACCREDITATION

The test sites and measurement facilities used to collect data are located at 47173 and 47266 Benicia Street, Fremont, California, USA. Line conducted emissions are measured only at the 47173 address. The following table identifies which facilities were utilized for radiated emission measurements documented in this report. Specific facilities are also identified in the test results sections.

47173 Benicia Street	47266 Benicia Street
<input type="checkbox"/> Chamber A(IC: 2324B-1)	<input type="checkbox"/> Chamber D(IC: 2324B-4)
<input checked="" type="checkbox"/> Chamber B(IC: 2324B-2)	<input type="checkbox"/> Chamber E(IC: 2324B-5)
<input type="checkbox"/> Chamber C(IC: 2324B-3)	<input type="checkbox"/> Chamber F(IC: 2324B-6)
	<input type="checkbox"/> Chamber G(IC: 2324B-7)
	<input type="checkbox"/> Chamber H(IC: 2324B-8)

UL Verification Services Inc. is accredited by NVLAP, Laboratory Code 200065-0. The full scope of accreditation can be viewed at <http://ts.nist.gov/standards/scopes/2000650.htm>.

4. CALIBRATION AND UNCERTAINTY

4.1. MEASURING INSTRUMENT CALIBRATION

The measuring equipment utilized to perform the tests documented in this report has been calibrated in accordance with the manufacturer's recommendations, and is traceable to recognized national standards

4.2. SAMPLE CALCULATION

Where relevant, the following sample calculation is provided:

$EIRP = \text{PSA reading with EUT worst orientation (dBm)} + \text{Path loss (dB)} - \text{cable loss(between the SG and substitution antenna)} + \text{Substitution Antenna Factor (dBi)}$

$ERP = \text{PSA reading with EUT worst orientation (dBm)} + \text{Path loss (dB)} - \text{cable loss(between the SG and substitution antenna)}$

(Path loss = Signal generator output – PSA reading with substitution antenna)

4.3. MEASUREMENT UNCERTAINTY

Where relevant, the following measurement uncertainty levels have been estimated for tests performed on the apparatus:

PARAMETER	UNCERTAINTY
Conducted Disturbance, 0.15 to 30 MHz	3.52 dB
Radiated Disturbance, 30 to 1000 MHz	4.94 dB

Uncertainty figures are valid to a confidence level of 95%.

5. EQUIPMENT UNDER TEST

5.1. DESCRIPTION OF EUT

The EUT is a GSM/WCDMA/LTE Phone + Bluetooth, WLAN b/g/n & NFC

5.2. MAXIMUM OUTPUT POWER

The transmitter has a maximum peak conducted and radiated ERP / EIRP output powers as follows:

FCC Part 22/24						
Band	Frequency Range(MHz)	Modulation	Conducted		Radiated	
			AVG (dBm)	AVG (mW)	AVG(dBm)	AVG (mW)
GSM850	824~849	GMSK	33	1995.3		
	824~849	GPRS	33	1995.3	28.32	679.2
	824~849	EGPRS	27.2	524.8	25.61	363.9
GSM1900	1850~1910	GMSK	30	1000.0		
	1850~1910	GPRS	30	1000.0	28.85	767.4
	1850~1910	EGPRS	25.8	380.2	25.88	387.3
Band 5	824~849	REL99	22.1	162.2	18.20	66.1
	824~849	HSDPA	21.1	128.8	17.22	52.7
	824~849	HSUPA	21	125.9		

5.3. MAXIMUM OUTPUT POWER (LTE)

The transmitter has a maximum peak conducted and radiated ERP/EIRP output powers as follows:

FCC Part 22							
Band	Frequency Range(MHz)	BandWidth (MHz)	Modulation mW	Conducted		Radiated	
				AVG (dBm)	AVG (mW)	AVG (dBm)	AVG (mW)
LTE5	824~849	10MHz	QPSK	22.8	190.5	18.70	74.1
	824~849	10MHz	16QAM	21.7	147.9	17.72	59.2

FCC Part 22							
Band	Frequency Range(MHz)	BandWidth (MHz)	Modulation mW	Conducted		Radiated	
				AVG (dBm)	AVG (mW)	AVG (dBm)	AVG (mW)
LTE5	824~849	5MHz	QPSK	22.88	194.1	18.56	71.8
	824~849	5MHz	16QAM	22.00	158.5	17.47	55.8

FCC Part 22							
Band	Frequency Range(MHz)	BandWidth (MHz)	Modulation mW	Conducted		Radiated	
				AVG (dBm)	AVG (mW)	AVG (dBm)	AVG (mW)
LTE5	824~849	3MHz	QPSK	22.80	190.5	18.71	74.3
	824~849	3MHz	16QAM	21.81	151.7	17.52	56.5

FCC Part 22							
Band	Frequency Range(MHz)	BandWidth (MHz)	Modulation mW	Conducted		Radiated	
				AVG (dBm)	AVG (mW)	AVG (dBm)	AVG (mW)
LTE5	824~849	1.4MHz	QPSK	22.89	194.5	18.91	77.8
	824~849	1.4MHz	16QAM	21.99	158.1	17.88	61.4

5.4. DESCRIPTION OF AVAILABLE ANTENNAS

The radio utilizes a PIFA antenna for the [List the bands supported] with a maximum peak gain as follow:

Frequency (MHz)	Peak Gain (dBi)
GSM850, 824~849MHz	-2.28
GSM1900, 1850~1910MHz	1.76
Band 5, 824~849MHz	-2.28
LTE5, 824~849MHz	-2.28

5.5. DESCRIPTION OF TEST SETUP

SUPPORT EQUIPMENT

Support Equipment List				
Description	Manufacturer	Model	Serial Number	FCC ID
AC Adapter	SAMSUNG	ETA0U10HBE	N/A	N/A
Earphone	SAMSUNG	N/A	N/A	N/A

I/O CABLES (CONDUCTED SETUP)

I/O Cable List						
Cable No	Port	# of identical ports	Connector Type	Cable Type	Cable Length (m)	Remarks
1	RF Out	1	Spectrum Analyzer	Shielded	None	NA
2	Antenna Port	1	EUT	Shielded	0.1m	NA
3	RF In/Out	1	Communication Test Set	Shielded	1m	NA

I/O CABLES (RADIATED SETUP)

I/O CABLE LIST						
Cable No.	Port	# of Identical Ports	Connector Type	Cable Type	Cable Length	Remarks
1	USB	1	AC Adapter	Un-shielded	1.2m	No
2	Jack	1	Headset	Shielded	1m	No
3	RF In/out	1	Communication Test Set	Un-shielded	2m	Yes

TEST SETUP

The EUT is continuously communicated to the call box during the tests.

SETUP DIAGRAM FOR TESTS (CONDUCTED TEST SETUP)

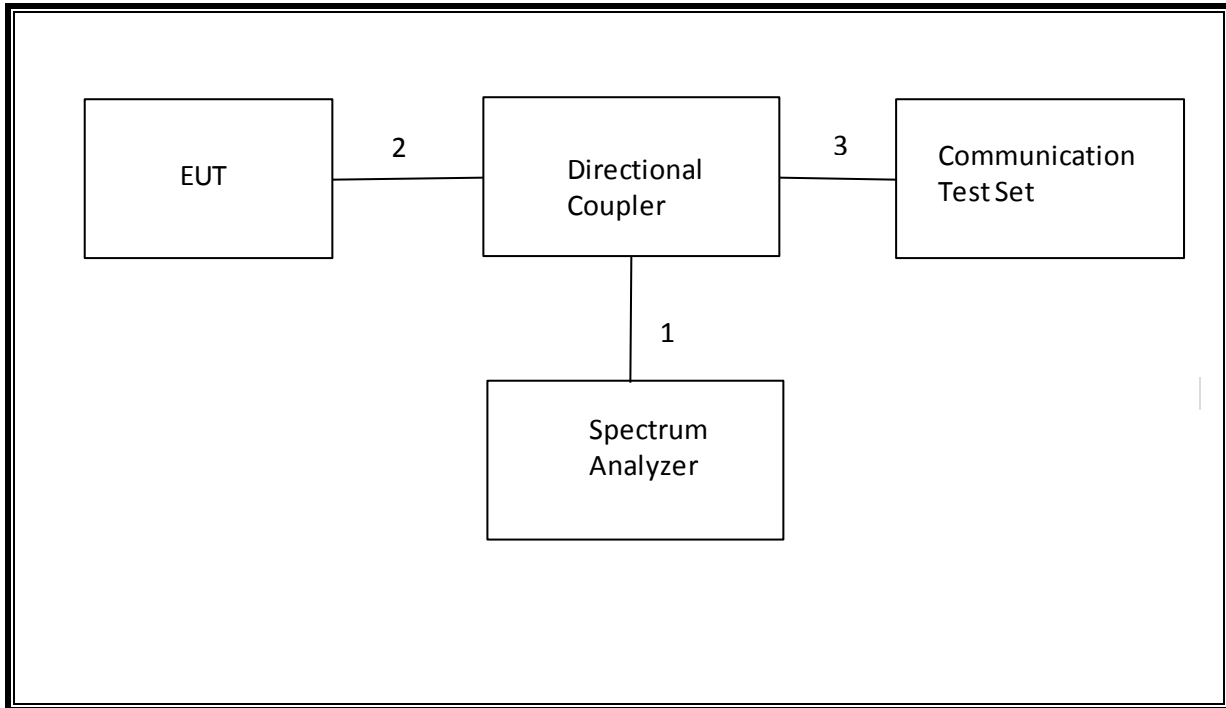

SETUP DIAGRAM FOR TESTS (RADIATED TEST SETUP)

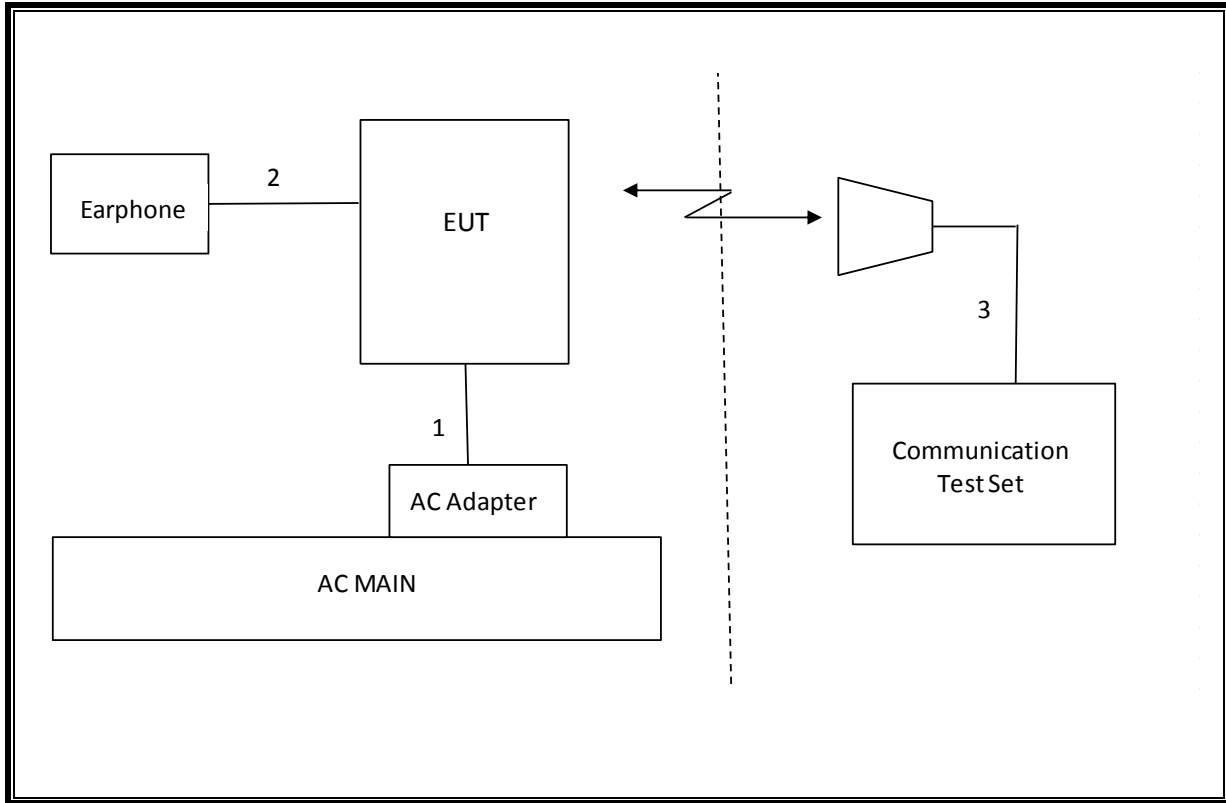

6. TEST AND MEASUREMENT EQUIPMENT

The following test and measurement equipment was utilized for the tests documented in this report:

TEST EQUIPMENT LIST				
Description	Manufacturer	Model	Asset	Cal Due
Spectrum Analyzer, 44 GHz	Agilent / HP	E4446A	C01179	02/26/15
Antenna, Bilog, 2 GHz	Sunol Sciences	JB1	C01011	08/14/15
Antenna, Horn, 18 GHz	EMCO	3115	C00783	10/25/14
Antenna, Horn, 18 GHz	EMCO	3115	C00784	10/25/14
Highpass Filter, 2.7 GHz	Micro-Tronics	HPM13194	N02687	CNR
Highpass Filter, 1.5 GHz	Micro-Tronics	HPM13193	N02688	CNR
Temperature / Humidity Chamber	Thermotron	SE 600-10-10	C00930	01/09/15
Communications Test Set	R&S	CMW500	T159	07/02/15
DC power supply, 8 V @ 3 A or 15 V	Agilent / HP	E3610A	None	CNR
Vector signal generator, 6 GHz	Agilent / HP	E4438C	None	07/06/15
Antenna, Tuned Dipole 400~1000	ETS	3121C DB4	C00993	02/14/15
Directional Coupler	RF-Lambda	RFDC5M06G15	None	CNR
Antenna, Horn, 26.5 GHz	ARA	MWH-1826/B	C00589	12/17/14

7. Summary Table

FCC Part Section	RSS Section(s)	Test Description	Test Limit	Test Condition	Test Result	Worst Case
2.1049	N/A	Occupied Band width (99%)	N/A	Conducted	Pass	8.9617 MHz
22.917(a) 24.238(a)	RSS-132(4.5.1) RSS-133(6.5.1)	Band Edge / Conducted Spurious Emission	-13dBm		Pass	-23.88dBm
2.1046	N/A	Conducted output power	N/A		Pass	33dBm
22.355 24.235	RSS-132(4.3) RSS-133(6.3)	Frequency Stability	2.5PPM		Pass	0.003 PPM
22.913(a)(2)	RSS-132(4.4)	Effective Radiated Power	38 dBm	Radiated	Pass	28.32 dBm
24.232(c)	RSS-133(6.4)	Equivalent Isotropic Radiated Power	33dBm		Pass	28.85 dBm
22.917(a) 24.238(a)	RSS-132(4.5.1) RSS-133(6.5.1)	Radiated Spurious Emission	-13dBm		Pass	-34.6 dBm

8. RF POWER OUTPUT VERIFICATION

8.1. GSM/GPRS/EDGE

Function: Menu select > GSM Mobile Station > GSM 850/900/1800/1900
Press Connection control to choose the different menus
Press RESET > choose all to reset all settings
Connection Press Signal Off to turn off the signal and change settings
Network Support > GSM+GPRS or GSM+EGPRS
Main Service > Packet Data
Service selection > Test Mode A – Auto Slot Config. off
MS Signal Press Slot Config bottom on the right twice to select and change the number of time slots and power setting
 > Slot configuration > Uplink/Gamma
 > 33 dBm for GPRS 850/900
 > 30 dBm for GPRS1800/1900
BS Signal Enter the same channel number for TCH channel (test channel) and BCCH channel
Frequency Offset > + 0 Hz
Mode > BCCH and TCH
BCCH Level > -85 dBm (May need to adjust if link is not stable)
BCCH Channel > choose desire test channel [Enter the same channel number for TCH channel (test channel) and BCCH channel]
Channel Type > Off
P0> 4 dB
Slot Config > Unchanged (if already set under MS Signal)
TCH > choose desired test channel
Hopping > Off
Main Timeslot > 3 (Default)
Network Coding Scheme > CS4 (GPRS) and MCS5 ~ MCS9 (EGPRS)
 Bit Stream > 2E9-1PSR Bit Pattern
AF/RF Enter appropriate offsets for Ext. Att. Output and Ext. Att. Input
Connection Press Signal On to turn on the signal and change settings

8.1.1. GSM OUTPUT POWER RESULT

Mode	Coding Scheme	Time Slots	Ch No.	Freq. (MHz)	Burst Pwr (dBm)
GSM (Voice)	CS1	1	128	824.2	33.0
			190	836.6	32.5
			251	848.8	32.5
GPRS (GMSK)	CS1	1	128	824.2	33.0
			190	836.6	32.5
			251	848.8	32.4
		2	128	824.2	31.5
			190	836.6	31.4
			251	848.8	31.4
		3	128	824.2	29.7
			190	836.6	29.7
			251	848.8	29.6
		4	128	824.2	28.2
			190	836.6	28.2
			251	848.8	28.1
EGPRS (8PSK)	MCS5	1	128	824.2	27.2
			190	836.6	27.0
			251	848.8	26.9
		2	128	824.2	26.5
			190	836.6	26.5
			251	848.8	26.2
		3	128	824.2	21.5
			190	836.6	21.5
			251	848.8	21.5
		4	128	824.2	21.2
			190	836.6	21.2
			251	848.8	21.2

Mode	Coding Scheme	Time Slots	Ch No.	Freq. (MHz)	Burst Pwr (dBm)
GSM (Voice)	CS1	1	512	1850.2	30.0
			661	1880.0	29.8
			810	1909.8	30.0
GPRS (GMSK)	CS1	1	512	1850.2	30.0
			661	1880.0	29.8
			810	1909.8	30.0
		2	512	1850.2	28.7
			661	1880.0	28.6
			810	1909.8	28.9
		3	512	1850.2	26.9
			661	1880.0	26.9
			810	1909.8	27.0
		4	512	1850.2	25.3
			661	1880.0	25.4
			810	1909.8	25.5
EGPRS (8PSK)	MCS5	1	512	1850.2	25.7
			661	1880.0	25.7
			810	1909.8	25.8
		2	512	1850.2	25.2
			661	1880.0	25.3
			810	1909.8	25.3
		3	512	1850.2	20.9
			661	1880.0	21.0
			810	1909.8	21.2
		4	512	1850.2	19.5
			661	1880.0	19.5
			810	1909.8	19.5

8.2. UMTS REL 99

TEST PROCEDURE

The following summary of these settings are illustrated below:

	Mode	Rel99
	Subtest	-
WCDMA General Settings	Loopback Mode	Test Mode 1
	Rel99 RMC	12.2kbps RMC
	HSDPA FRC	Not Applicable
	HSUPA Test	Not Applicable
	Power Control Algorithm	Algorithm2
	β_c	Not Applicable
	β_d	Not Applicable
	β_{ec}	Not Applicable
	β_c/β_d	8/15
	β_{hs}	Not Applicable
	β_{ed}	Not Applicable

8.2.1. UMTS REL 99 OUTPUT POWER RESULT

Release 99				Tune-up Tolerance (dB):		0.5		-1.5
Band	Mode	UL Ch No.	Freq. (MHz)	MPR	Avg Pwr (dBm)	Output Power Tolerance (dBm)		
						Maximum	Target	Minimum
W-CDMA Band V	Rel 99 (RMC, 12.2 kbps)	4132	826.4	0	22.1	22.5	22.0	20.5
		4183	836.6	0	22.1			
		4233	846.6	0	22.1			

8.3. UMTS HSDPA

The following 4 Sub-tests were completed according to Release 5 procedures in section 5.2 of 3GPP TS34.121. A summary of these settings are illustrated below:

	Mode	Rel5 HSDPA			
	Subtest	1	2	3	4
WCDMA General Settings	Loopback Mode	Test Mode 1			
	Rel99 RMC	12.2kbps RMC			
	HSDPA FRC	H-Set1			
	Power Control Algorithm	Algorithm 2			
	β_c	2/15	12/15	15/15	15/15
	β_d	15/15	15/15	8/15	4/15
	Bd (SF)	64			
	β_c/β_d	2/15	12/15	15/8	15/4
	β_{hs}	4/15	24/15	30/15	30/15
MPR (dB)	0	0	0.5	0.5	
HSDPA Specific Settings	D_{ACK}	8			
	D_{NAK}	8			
	DCQI	8			
	Ack-Nack repetition factor	3			
	CQI Feedback (Table 5.2B.4)	4ms			
	CQI Repetition Factor (Table 5.2B.4)	2			
	$A_{hs} = \beta_{hs}/\beta_c$	30/15			

8.3.1. UMTS HSDPA OUTPUT POWER RESULT

HSDPA

Band	Mode	UL Ch No.	Freq. (MHz)	MPR	Avg Pwr (dBm)	Output Power Tolerance (dBm)		
						Maximum	Target	Minimum
W-CDMA Band V	Subtest 1	4132	826.4	0	21.0	21.5	21.0	19.5
		4183	836.6	0	21.1			
		4233	846.6	0	21.1			
	Subtest 2	4132	826.4	0	21.0	21.5	21.0	19.5
		4183	836.6	0	20.9			
		4233	846.6	0	20.8			
	Subtest 3	4132	826.4	0.5	20.4	21.0	20.5	19.0
		4183	836.6	0.5	20.4			
		4233	846.6	0.5	20.3			
	Subtest 4	4132	826.4	0.5	20.1	21.0	20.5	19.0
		4183	836.6	0.5	20.1			
		4233	846.6	0.5	20.0			

8.3.2. UMTS HSUPA

TEST PROCEDURE

The following summary of these settings are illustrated below: (ETSI TS 134.121-1 Table C.11.1)

Mode	Rel6 HSUPA	Rel6 HSUPA	Rel6 HSUPA	Rel6 HSUPA	Rel6 HSUPA	
Subtest	1	2	3	4	5	
WCDMA General Settings	Loopback Mode	Test Mode 1				
	P-CPICH (dB)	-10				
	P-CCPCH (dB)	-12				
	SCH (dB)	-12				
	PICH(dB)	-15				
	DPCH (dB)	-9				
	HS-SCCH_1 (dB)	-8				
	HS-PDSCH (dB)	-3				
	Rel99 RMC	12.2kbps RMC				
	HSDPA FRC	H-Set1				
	HSUPA Test	HSUPA Loopback				
	Power Control Algorithm	Algorithm2				
	Bc	11/15	6/15	15/15	2/15	15/15
	Bd	15/15	15/15	9/15	15/15	15/15
	Bec	209/225	12/15	30/15	2/15	5/15
	β_c/β_d	11/15	6/15	15/9	2/15	15/15
	Bhs	22/15	12/15	30/15	4/15	30/15
β_{ed} (note1)	1309/225	94/75	47/15 47/15	56/75	134/15	
MPR	0	2	1	2	0	
HSDPA Specific Settings	DACK	8				
	DNAK	8				
	DCQI	8				
	Ack-Nack repetition factor	3				
	CQI Feedback (Table 5.2B.4)	4ms				
	CQI Repetition Factor (Table 5.2B.4)	2				
	$A_{hs} = \beta_{hs}/\beta_c$	30/15				
HSUPA Specific Settings	D E-DPCCH	6	8	8	5	7
	DHARQ	0	0	0	0	0
	AG Index	20	12	15	17	21
	Reference E-TFCIs	5	5	2	5	5
	E-TFCI (from 34.121 Table C.11.1.3)	75	67	92	71	81
	Associated Max UL Data Rate kbps	242.1	174.9	482.8	205.8	308.9
	Reference E_TFCIs	E-TFCI 11 E-TFCI PO 4 E-TFCI 67 E-TFCI PO 18 E-TFCI 71 E-TFCI PO 23 E-TFCI 75 E-TFCI PO 26 E-TFCI 81 E-TFCI PO 27		E-TFCI 11 E-TFCI PO 4 E-TFCI 92 E-TFCI PO 18	E-TFCI 11 E-TFCI PO 4 E-TFCI 67 E-TFCI PO 18 E-TFCI 71 E-TFCI PO 23 E-TFCI 75 E-TFCI PO 26 E-TFCI 81 E-TFCI PO 27	

Note1: β_{ed} cannot be set directly, it is set by Absolute Grant Value.

8.3.3. UMTS HSUPA OUTPUT POWER RESULT

HSUPA

Band	Mode	UL Ch No.	Freq. (MHz)	MPR	Avg Pwr (dBm)	Output Power Tolerance (dBm)		
						Maximum	Target	Minimum
W-CDMA Band V	Subtest 1	4132	826.4	0	20.2	22.0	21.5	20.0
		4183	836.6	0	20.6			
		4233	846.6	0	20.3			
	Subtest 2	4132	826.4	2	19.5	20.0	19.5	18.0
		4183	836.6	2	19.4			
		4233	846.6	2	19.8			
	Subtest 3	4132	826.4	1	19.7	21.0	20.5	19.0
		4183	836.6	1	19.6			
		4233	846.6	1	19.8			
	Subtest 4	4132	826.4	2	20.0	20.0	19.5	18.0
		4183	836.6	2	19.9			
		4233	846.6	2	20.0			
	Subtest 5	4132	826.4	0	21.0	22.0	21.5	20.0
		4183	836.6	0	20.9			
		4233	846.6	0	21.0			

8.3.4. DC-HSDPA

The following tests were completed according to procedures in section 7.3.13 of 3GPP TS34.108 v9.5.0. A summary of these settings are illustrated below:

Downlink Physical Channels are set as per 3GPP TS34.121-1 v9.0.0 E.5.0

Table E.5.0: Levels for HSDPA connection setup

Parameter During Connection setup	Unit	Value
P-CPICH_Ec/Ior	dB	-10
P-CCPCH and SCH_Ec/Ior	dB	-12
PICH_Ec/Ior	dB	-15
HS-PDSCH	dB	off
HS-SCCH_1	dB	off
DPCH_Ec/Ior	dB	-5
OCNS_Ec/Ior	dB	-3.1

Call is set up as per 3GPP TS34.108 v9.5.0 sub clause 7.3.13

The configurations of the fixed reference channels for HSDPA RF tests are described in 3GPP TS 34.121, annex C for FDD and 3GPP TS 34.122.

Table C.8.1.12: Fixed Reference Channel H-Set 12

Parameter	Unit	Value
Nominal Avg. Inf. Bit Rate	kbps	60
Inter-TTI Distance	TTI's	1
Number of HARQ Processes	Processes	6
Information Bit Payload (N_{INF})	Bits	120
Number Code Blocks	Blocks	1
Binary Channel Bits Per TTI	Bits	960
Total Available SML's in UE	SML's	19200
Number of SML's per HARQ Proc.	SML's	3200
Coding Rate		0.15
Number of Physical Channel Codes	Codes	1
Modulation		QPSK
Note 1: The RMC is intended to be used for DC-HSDPA mode and both cells shall transmit with identical parameters as listed in the table. Note 2: Maximum number of transmission is limited to 1, i.e., retransmission is not allowed. The redundancy and constellation version 0 shall be used.		

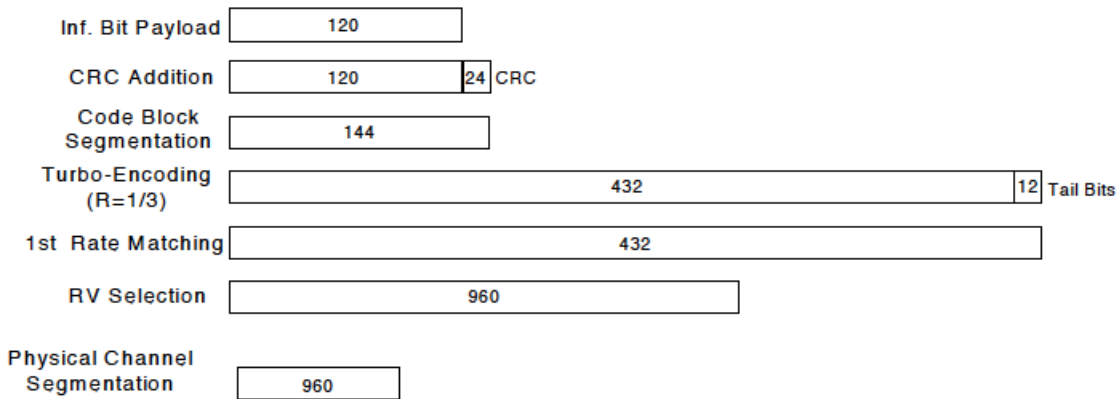

Figure C.8.19: Coding rate for Fixed reference Channel H-Set 12 (QPSK)

The following 4 Sub-tests for HSDPA were completed according to Release 6 procedures in section 5.2 of 3GPP TS34.121. A summary of subtest settings are illustrated below:

	Mode	Rel6 HSDPA	Rel6 HSDPA	Rel6 HSDPA	Rel6 HSDPA
	Subtest	1	2	3	4
WCDMA General Settings	Loopback Mode	Test Mode 1			
	Rel99 RMC	12.2kbps RMC			
	HSDPA FRC	H-Set1			
	Power Control Algorithm	Algorithm2			
	β_c	2/15	12/15	15/15	15/15
	β_d	15/15	15/15	8/15	4/15
	β_d (SF)	64			
	β_c/β_d	2/15	12/15	15/8	15/4
	β_{hs}	4/15	24/15	30/15	30/15
MPR	0	0	0.5	0.5	
HSDPA Specific Settings	DACK	8			
	DNAK	8			
	DCQI	8			
	Ack-Nack Repetition factor	3			
	CQI Feedback	4ms			
	CQI Repetition Factor	2			
	Ahs = β_{hs}/β_c	30/15			

Up commands are set continuously to set the UE to Max power.

8.3.1. UMTS DC-HSDPA OUTPUT POWER RESULT

DC-HSDPA								
Band	Mode	UL Ch No.	Freq. (MHz)	MPR	Avg Pwr (dBm)	Output Power Tolerance (dBm)		
						Maximum	Target	Minimum
W-CDMA Band V	Subtest 1	4132	826.4	0	21.1	21.5	21	19.5
		4183	836.6	0	21.3			
		4233	846.6	0	21.2			
	Subtest 2	4132	826.4	0	21.0	21.5	21	19.5
		4183	836.6	0	21.2			
		4233	846.6	0	21.0			
	Subtest 3	4132	826.4	0.5	20.4	21.5	21	19.5
		4183	836.6	0.5	20.5			
		4233	846.6	0.5	20.5			
	Subtest 4	4132	826.4	0.5	20.4	21.5	21	19.5
		4183	836.6	0.5	20.7			
		4233	846.6	0.5	20.7			

LTE OUTPUT VERIFICATION

8.3.2. LTE OUTPUT RESULT

Band	BW (MHz)	Mode	RB Allocation	RB offset	Target MPR	Avg Pwr (dBm)		
						20450	20525	20600
						829 MHz	836.5 MHz	844 MHz
LTE Band 5	10	QPSK	1	0	0	22.8	22.6	22.7
			1	25	0	22.5	22.6	22.7
			1	49	0	22.5	22.7	22.6
			25	0	1	21.5	21.4	21.6
			25	12	1	21.4	21.6	21.7
			25	25	1	21.5	21.6	21.7
		16QAM	50	0	1	21.4	21.4	21.5
			1	0	1	21.4	21.7	21.2
			1	25	1	21.1	21.9	21.2
			1	49	1	21.1	21.9	21.2
			25	0	2	20.6	20.5	20.7
			25	12	2	20.5	20.6	20.7
			25	25	2	20.5	20.6	20.7
			50	0	2	20.4	20.4	20.6
Band	BW (MHz)	Mode	RB Allocation	RB offset	Target MPR	Avg Pwr (dBm)		
						20425	20525	20625
						826.5 MHz	836.5 MHz	846.5 MHz
LTE Band 5	5	QPSK	1	0	0	22.78	22.64	22.88
			1	12	0	22.65	22.69	22.78
			1	24	0	22.54	22.75	22.78
			12	0	1	21.62	21.58	21.83
			12	7	1	21.61	21.57	21.73
			12	13	1	21.60	21.65	21.81
		16QAM	25	0	1	21.49	21.55	21.70
			1	0	1	21.28	21.70	22.00
			1	12	1	21.13	21.78	22.00
			1	24	1	21.05	21.86	22.00
			12	0	2	20.64	20.66	20.81
			12	7	2	20.61	20.62	20.71
			12	13	2	20.63	20.68	20.75
			25	0	2	20.60	20.59	20.55

Band	BW (MHz)	Mode	RB Allocation	RB offset	Target MPR	Avg Pwr (dBm)		
						20415	20525	20635
						825.5 MHz	836.5 MHz	847.5 MHz
LTE Band 5	3	QPSK	1	0	0	22.80	22.65	22.78
			1	8	0	22.62	22.68	22.66
			1	14	0	22.59	22.77	22.70
			8	0	1	21.73	21.64	21.81
			8	4	1	21.71	21.57	21.80
			8	7	1	21.70	21.66	21.71
			15	0	1	21.62	21.61	21.73
		16QAM	1	0	1	21.39	21.81	21.31
			1	8	1	21.24	21.89	21.19
			1	14	1	21.18	21.96	21.27
			8	0	2	20.74	20.45	20.93
			8	4	2	20.71	20.44	20.92
			8	7	2	20.72	20.50	20.85
			15	0	2	20.70	20.66	20.63
Band	BW (MHz)	Mode	RB Allocation	RB offset	Target MPR	Avg Pwr (dBm)		
						20407	20525	20643
						824.7 MHz	836.5 MHz	848.3 MHz
LTE Band 5	1.4	QPSK	1	0	0	22.89	22.62	22.74
			1	3	0	22.84	22.66	22.72
			1	5	0	22.77	22.71	22.75
			3	0	0	22.91	22.64	22.75
			3	1	0	22.90	22.72	22.78
			3	3	0	22.80	22.71	22.75
			6	0	1	21.71	21.67	21.78
		16QAM	1	0	1	21.61	21.39	21.91
			1	3	1	21.58	21.41	21.92
			1	5	1	21.48	21.45	21.99
			3	0	1	21.79	21.59	21.71
			3	1	1	21.78	21.68	21.66
			3	3	1	21.66	21.65	21.69
			6	0	2	20.77	20.73	20.59

9. PEAK TO AVERAGE RATIO

Test Procedure

Per KDB 971168 D01 Power Meas License Digital Systems v02r01

Test Spec

In addition, when the transmitter power is measured in terms of average value, the peak-to-average ratio of the power shall not exceed 13 dB.

9.1. CONDUCTED PEAK TO AVERAGE RESULT

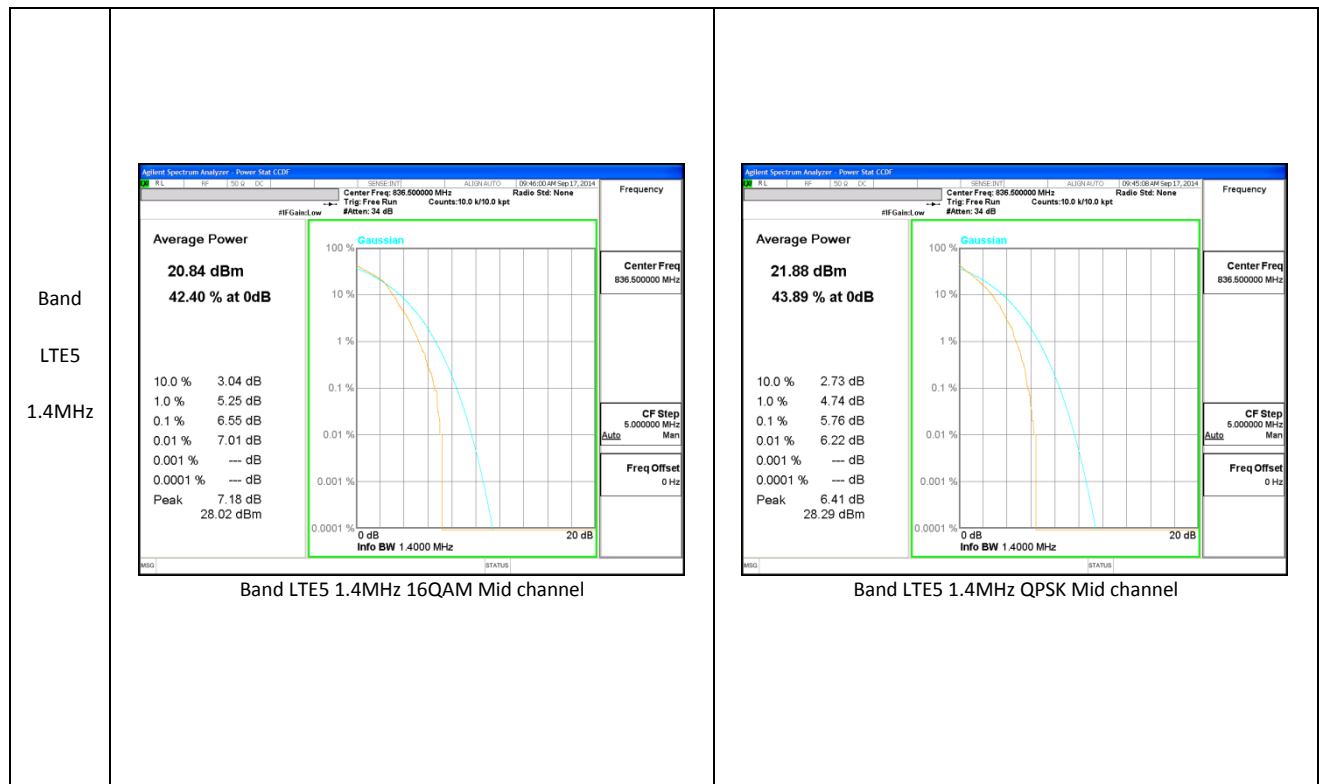

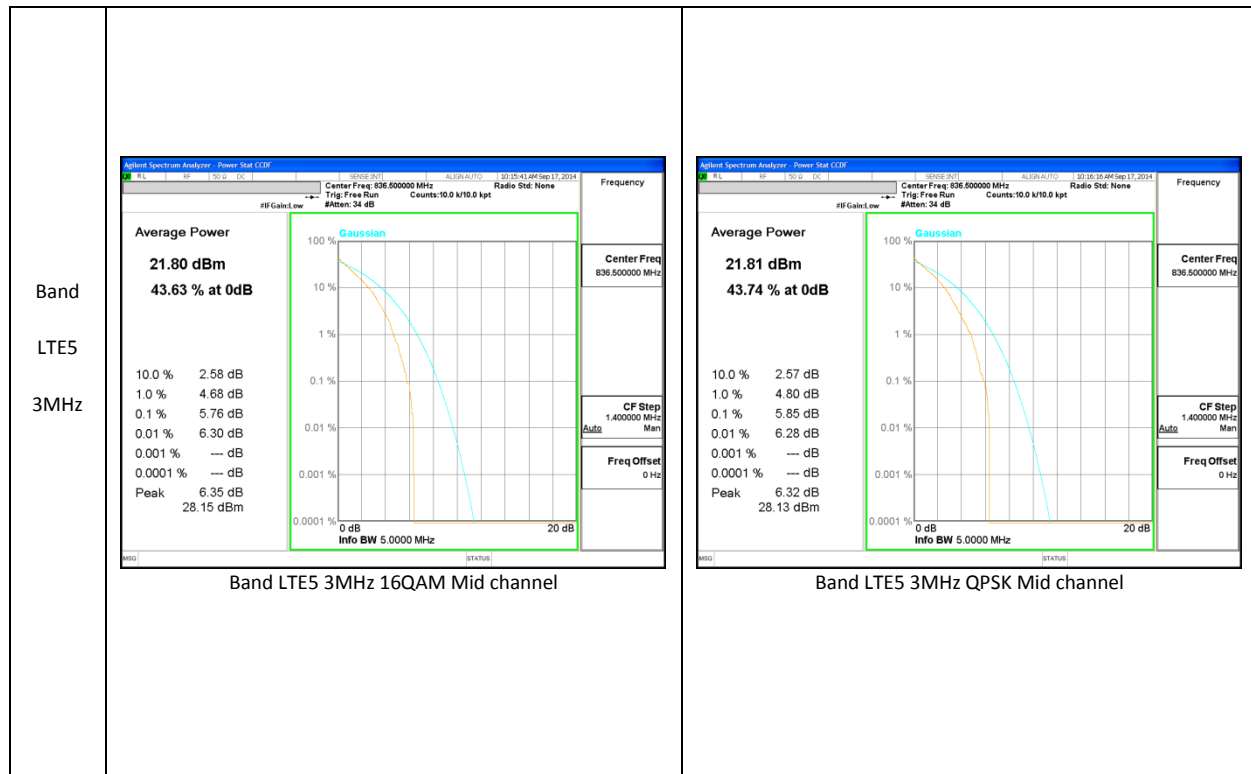

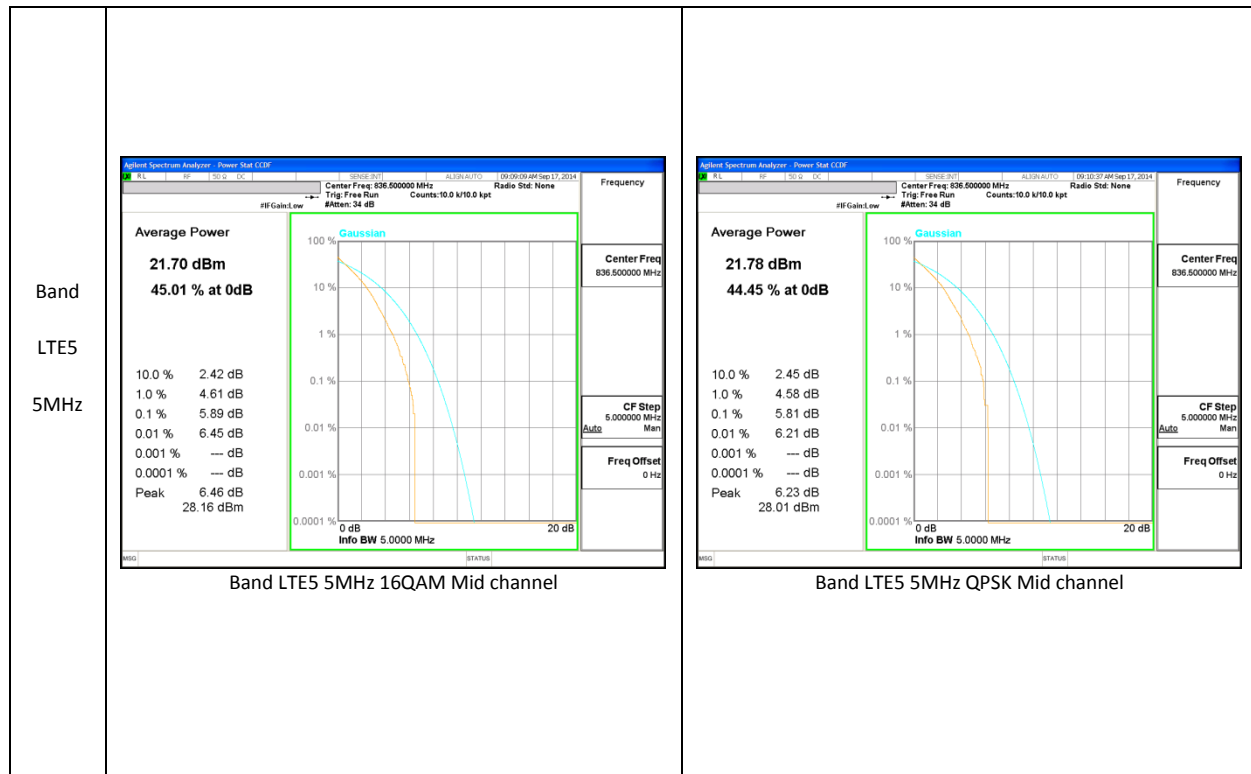

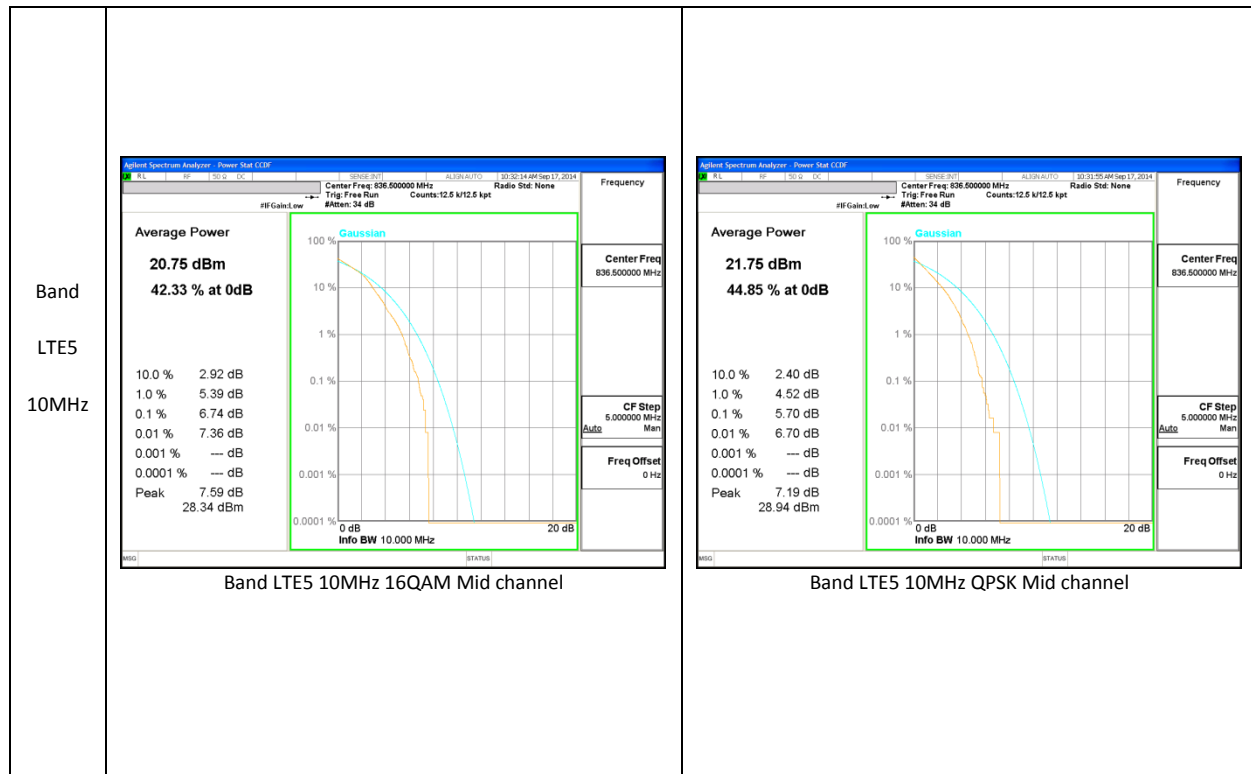

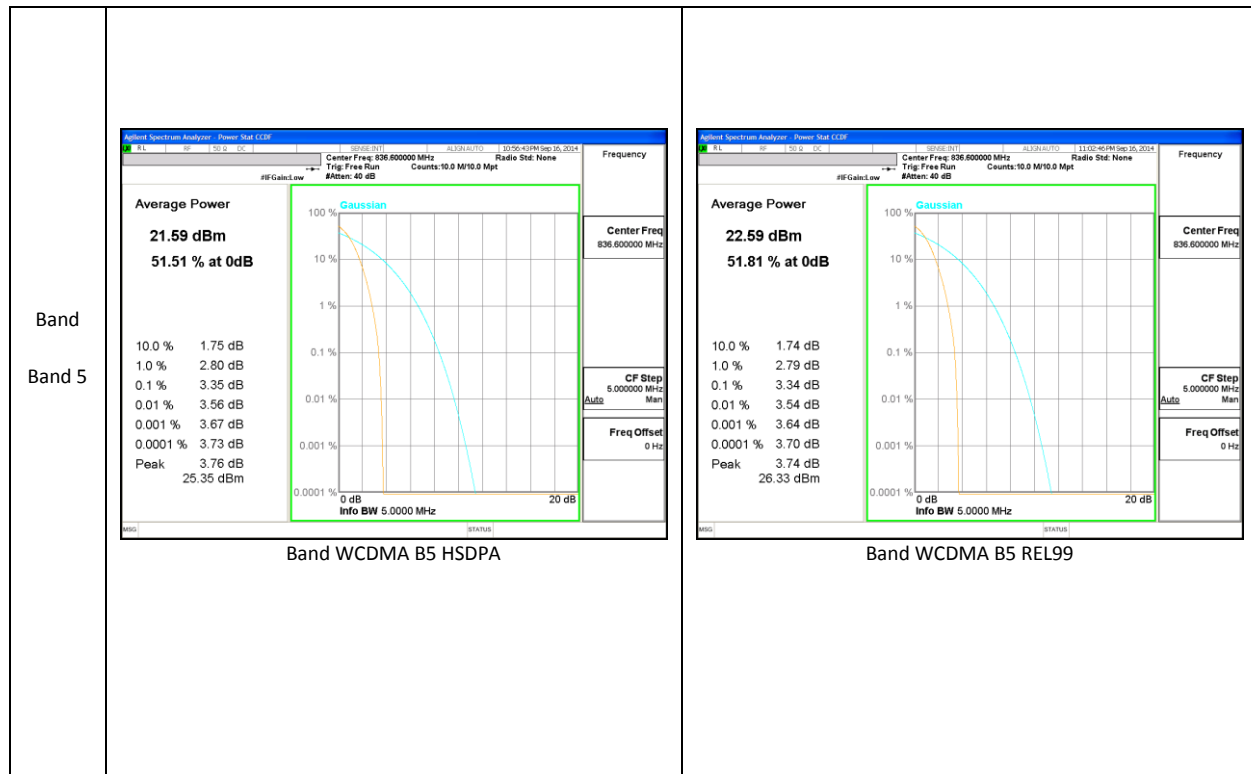

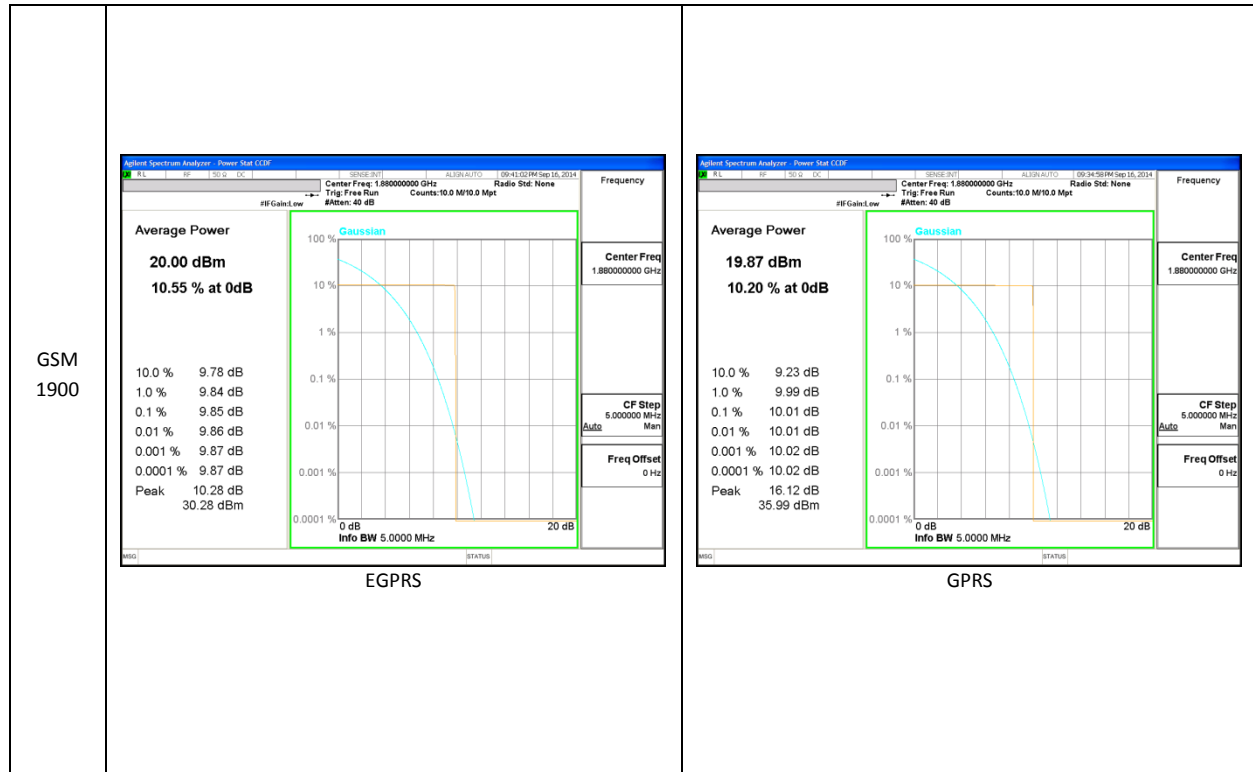

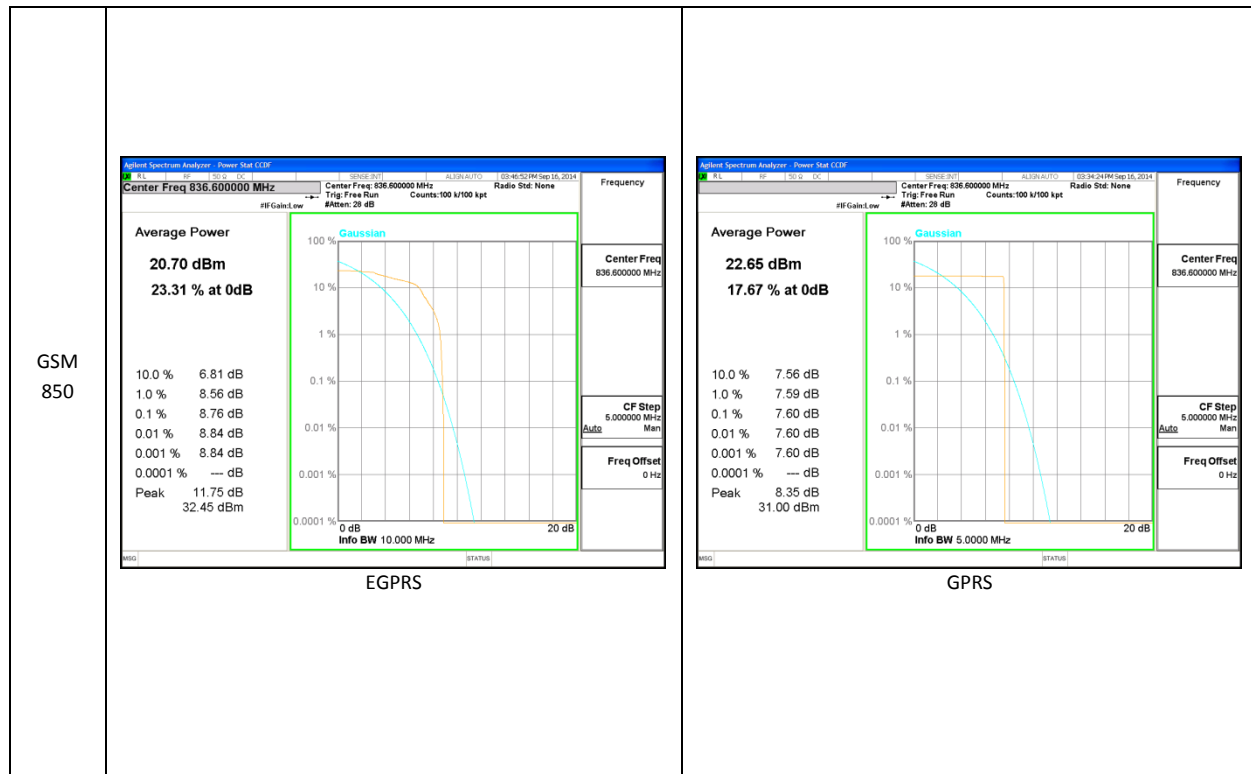

10. LIMITS AND CONDUCTED RESULTS

10.1. OCCUPIED BANDWIDTH

RULE PART(S)

FCC: §2.1049

LIMITS

For reporting purposes only

TEST PROCEDURE

The transmitter output was connected to a calibrated coaxial cable and coupler, the other end of which was connected to a spectrum analyzer. The occupied bandwidth was measured with the spectrum analyzer at the low, middle and high channel in each band. The -26dB bandwidth was also measured and recorded.

(KDB 971168 D01 Power Meas License Digital Systems v02r01 - 06/07/2013)

10.1.1. OCCUPIED BANDWIDTH RESULTS

Band	Mode	Channel	f (MHz)	99% BW (kHz)	-26dB BW (kHz)
GSM850	GPRS	128	824.2	246.28	327.6
		190	836.6	243.69	325.1
		251	848.8	245.6	326.8
	EGPRS	128	824.2	241.62	323.3
		190	836.6	248.42	322.3
		251	848.8	245.89	316.7
GSM1900	GPRS	512	1850.2	245.93	325.4
		661	1880	245.26	326.0
		810	1909.8	246.65	331.4
	EGPRS	512	1850.2	244.69	330.7
		661	1880	248.00	328.2
		810	1909.8	247.6	330.0
Band 5	REL99	4132	826.4	4158.6	4611.0
		4183	836.6	4162.1	4607.0
		4233	846.6	4151.9	4597.0
	HSDPA	4132	826.4	4146.8	4607.0
		4183	836.6	4160.9	4612.0
		4233	846.6	4142.3	4608.0

10.1.2. LTE OCCUPIED BANDWIDTH RESULTS

Band	BW(MHz)	Mode	RB/RB Size	f (MHz)	99% BW (MHz)	-26dB BW (MHz)
LTE5	10	QPSK	50/0	829	8.9314	9.730
			50/0	836.5	8.9617	9.711
			50/0	844	8.9291	9.676
		16QAM	50/0	829	8.9170	9.651
			50/0	836.5	8.9388	9.797
			50/0	844	8.9306	9.672

Band	BW(MHz)	Mode	RB/RB Size	f (MHz)	99% BW (MHz)	-26dB BW (MHz)
LTE5	5	QPSK	25/0	826.5	4.4774	4.898
			25/0	836.5	4.4816	4.912
			25/0	846.5	4.4782	4.886
		16QAM	25/0	826.5	4.4800	4.884
			25/0	836.5	4.4756	4.929
			25/0	846.5	4.4727	4.909

Band	BW(MHz)	Mode	RB/RB Size	f (MHz)	99% BW (MHz)	-26dB BW (MHz)
LTE5	3	QPSK	15/0	825.5	2.6887	2.928
			15/0	836.5	2.6865	2.952
			15/0	847.5	2.6888	2.931
		16QAM	15/0	825.5	2.6855	2.953
			15/0	836.5	2.6860	2.948
			15/0	847.5	2.6834	2.943

Band	BW(MHz)	Mode	RB/RB Size	f (MHz)	99% BW (MHz)	-26dB BW (MHz)
LTE5	1.4	QPSK	6/0	824.7	1.0858	1.249
			6/0	836.5	1.0818	1.259
			6/0	848.3	1.0785	1.258
		16QAM	6/0	824.7	1.0820	1.253
			6/0	836.5	1.0817	1.260
			6/0	848.3	1.0834	1.270

10.1.3. OCCUPIED BANDWIDTH PLOTS

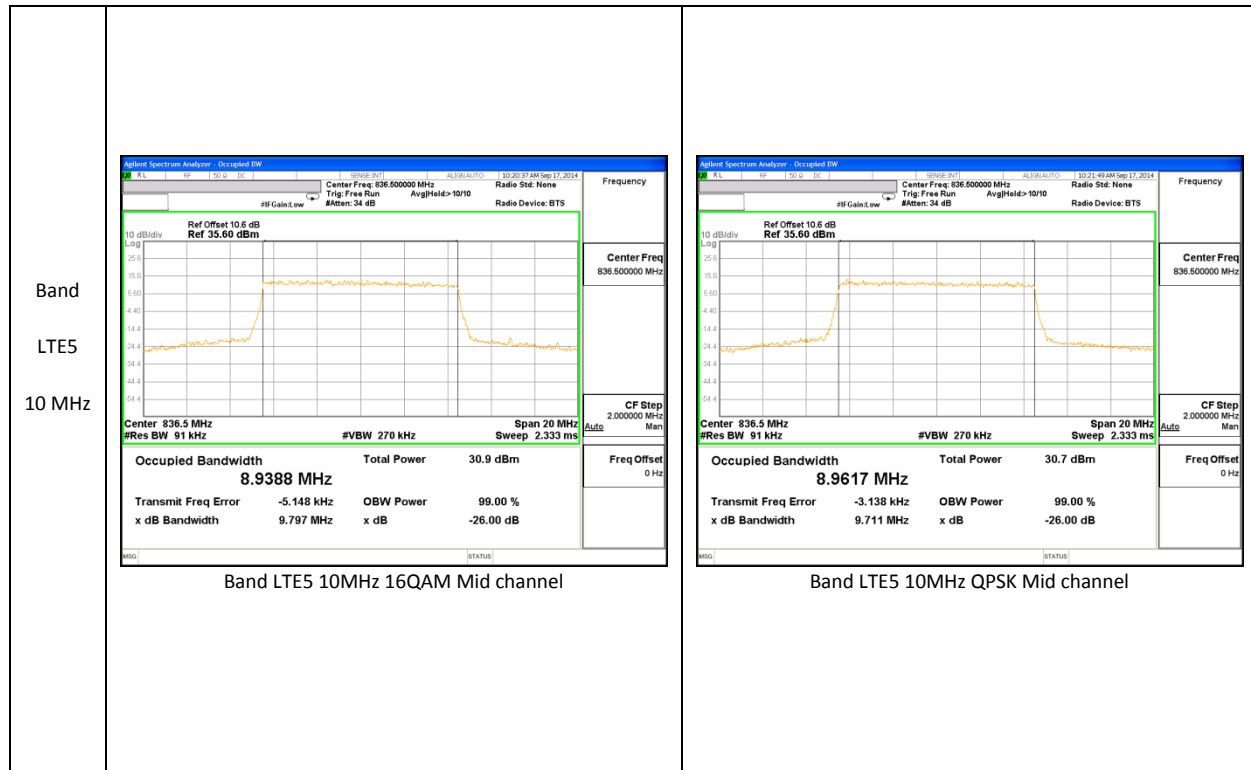



<p>Band LTE5 3 MHz</p>	 <p style="text-align: center;">Band LTE5 3MHz 16QAM Mid channel</p>	 <p style="text-align: center;">Band LTE5 3MHz QPSK Mid channel</p>
<p>Band LTE5 1.4MHz</p>	 <p style="text-align: center;">Band LTE5 1.4MHz 16QAM Mid channel</p>	 <p style="text-align: center;">Band LTE5 1.4MHz QPSK Mid channel</p>





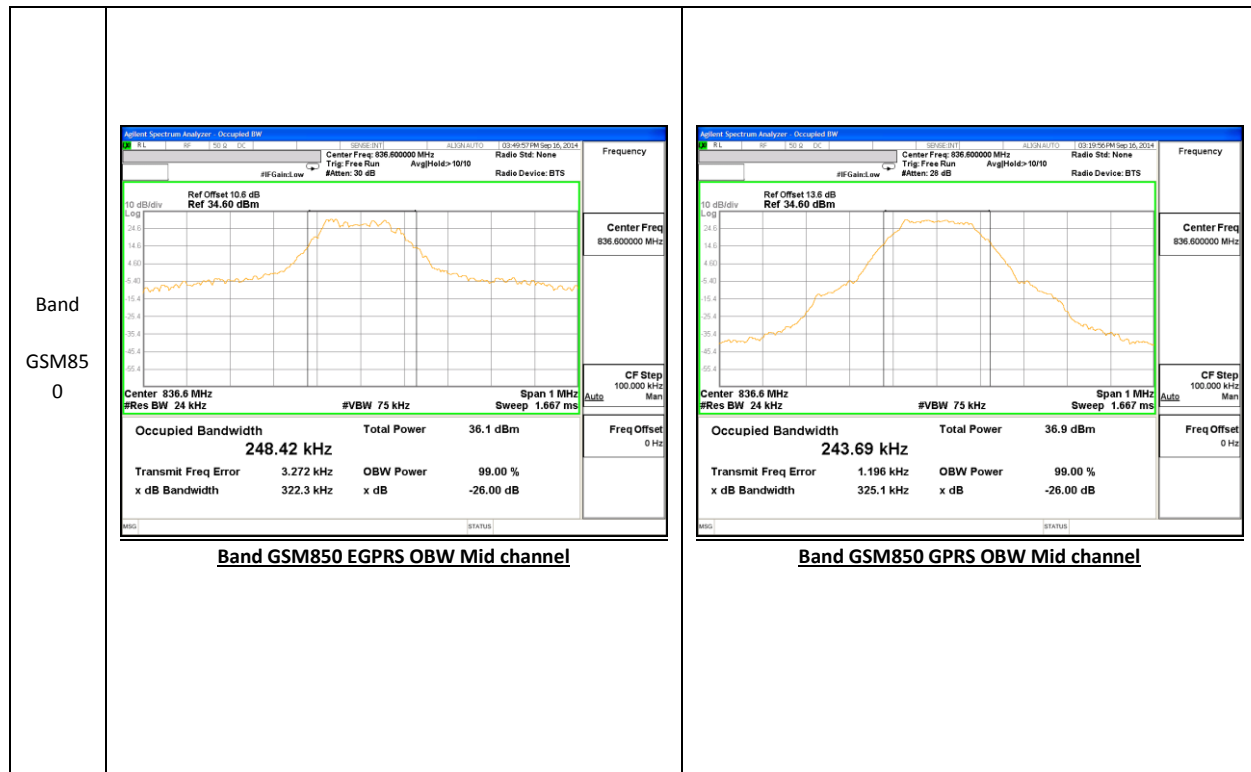

10.2. BAND EDGE EMISSIONS

RULE PART(S)

FCC: §22.359, §24.238

LIMITS

The power of any emission outside of the authorized operating frequency ranges must be attenuated below the transmitting power (P) by a factor of at least $43 + 10 \log (P)$ dB.

TEST PROCEDURE

Per KDB 971168 D01 Power Meas License Digital Systems v02r01

The transmitter output was connected to an Agilent 8960 or a CMW500 Test Set and configured to operate at maximum power. The band edge emissions were measured at the required operating frequencies in each band on the Spectrum Analyzer.

RESULTS

10.2.1. BAND EDGE PLOTS

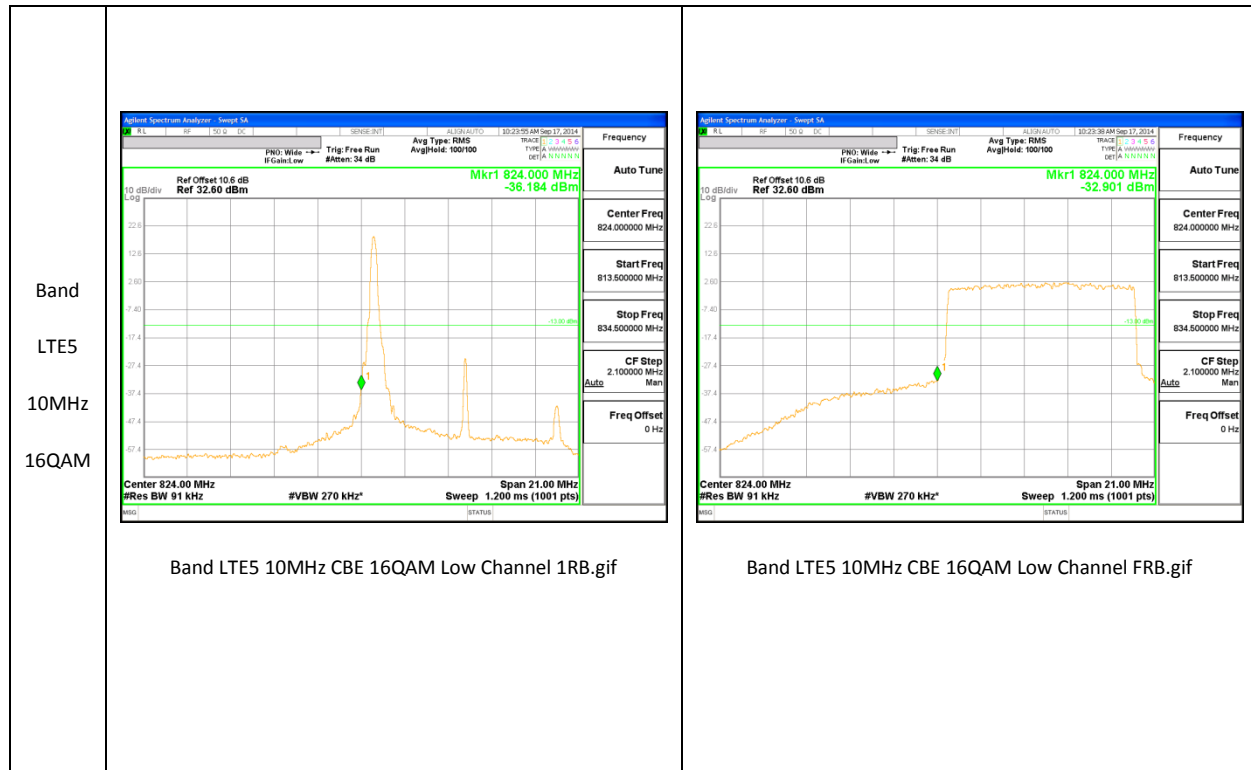

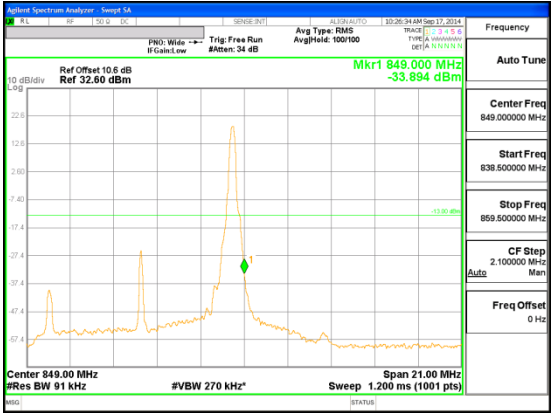
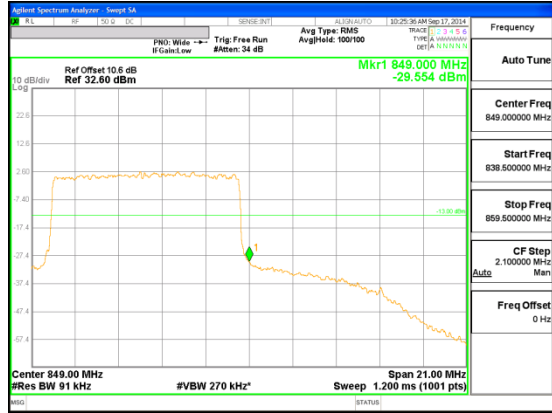
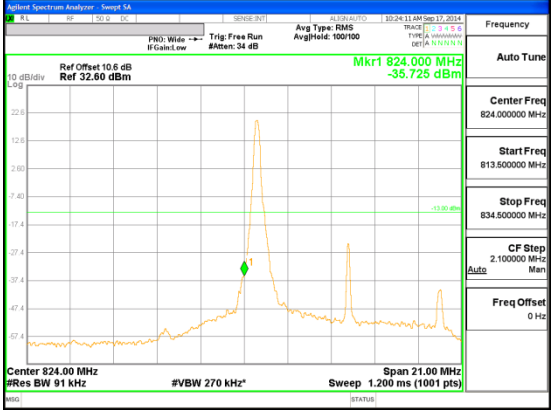
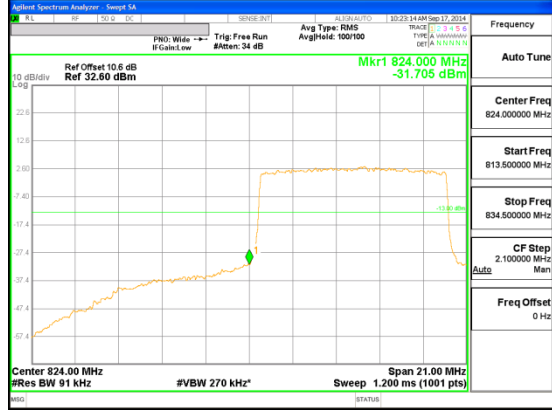
<p>Band LTE5 10MHz 16QAM</p>	 <p>Band LTE5 10MHz CBE 16QAM High Channel 1RB.gif</p>	 <p>Band LTE5 10MHz CBE 16QAM High Channel FRB.gif</p>
<p>Band LTE5 10MHz QPSK</p>	 <p>Band LTE5 10MHz CBE QPSK Low Channel 1RB.gif</p>	 <p>Band LTE5 10MHz CBE QPSK Low Channel FRB.gif</p>
<p>Band LTE5</p>		

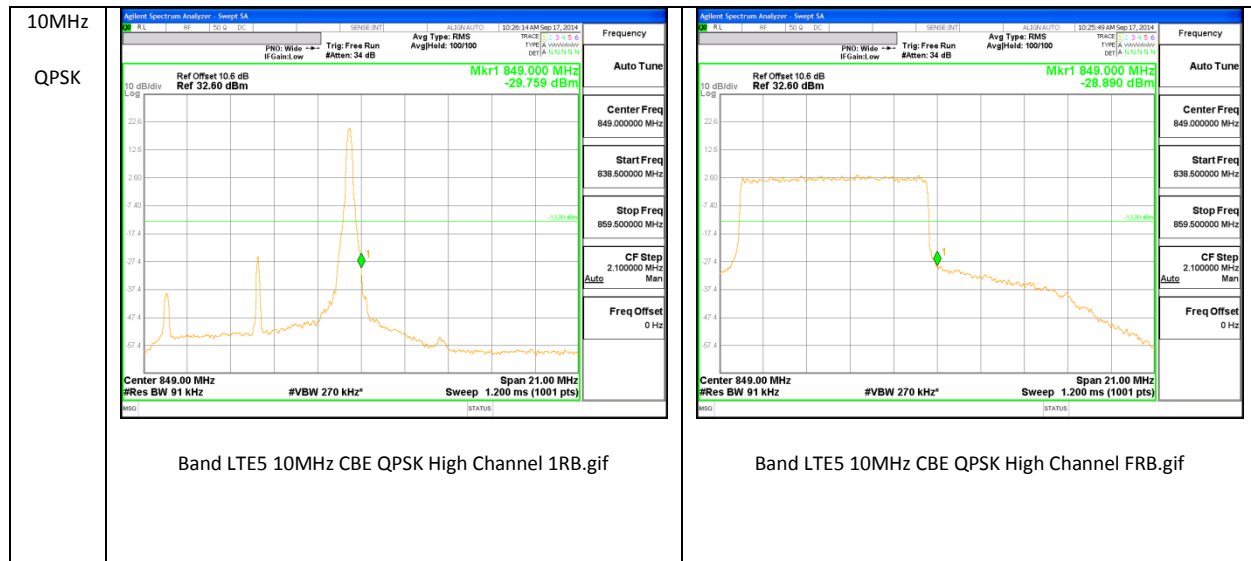

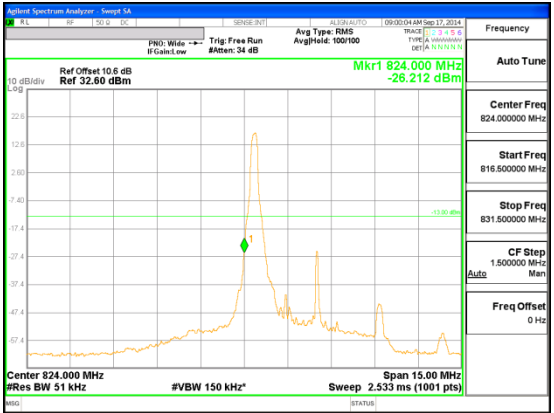
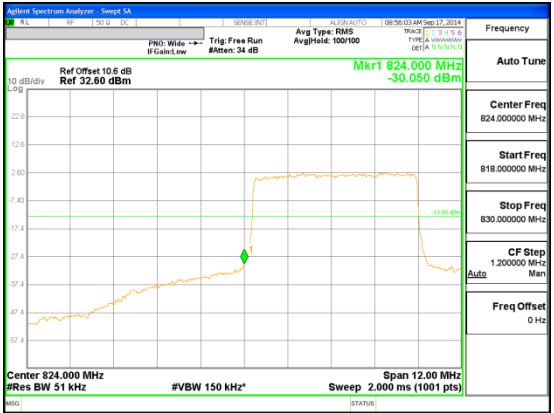
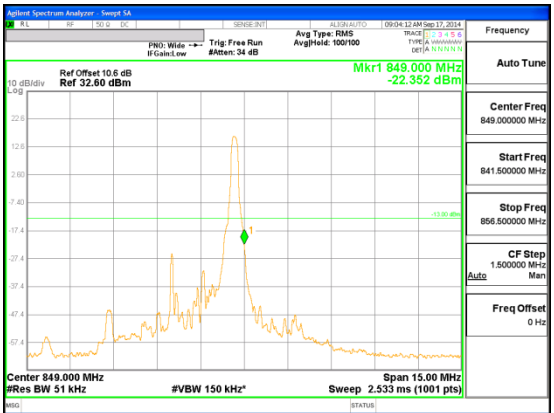
<p>Band LTE5 5MHz 16QAM</p>	 <p>Band LTE5 5MHz CBE 16QAM Low Channel 1RB.gif</p>	 <p>Band LTE5 5MHz CBE 16QAM Low Channel FRB.gif</p>
<p>Band LTE5 5MHz 16QAM</p>	 <p>Band LTE5 5MHz CBE 16QAM High Channel 1RB.gif</p>	 <p>Band LTE5 5MHz CBE 16QAM High Channel FRB.gif</p>

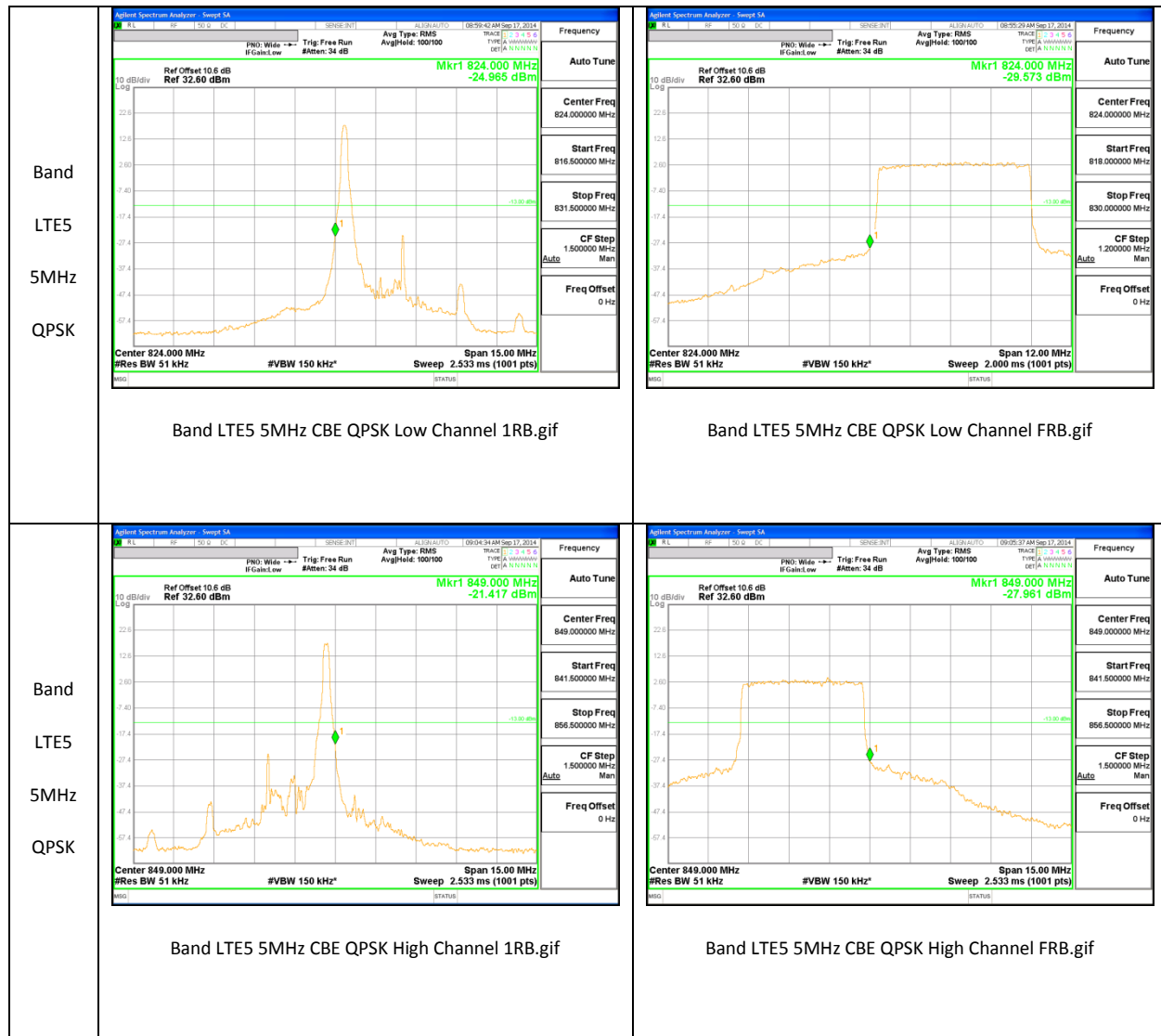

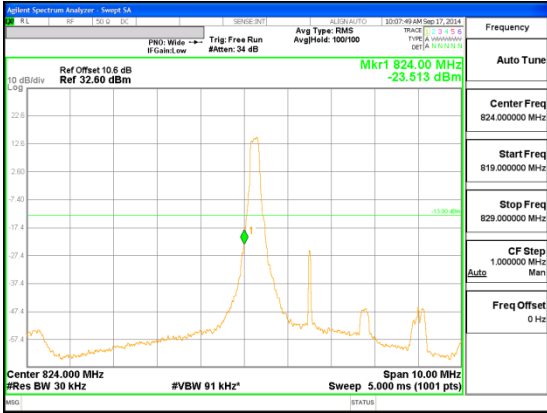
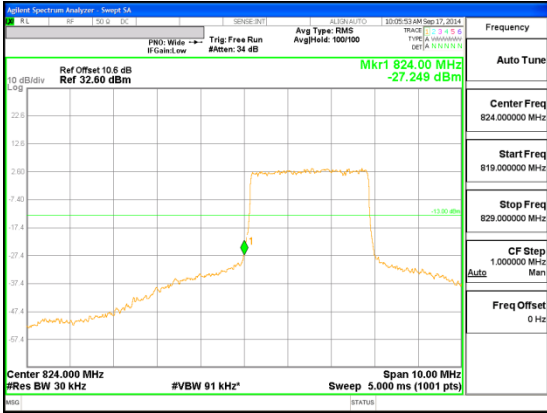
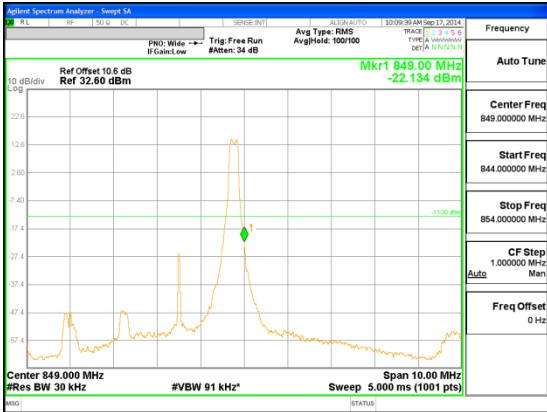
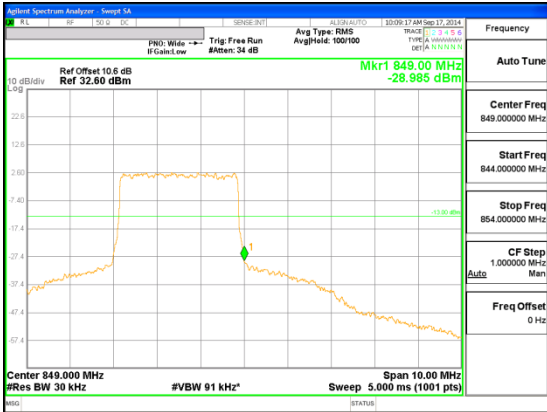
<p>Band LTE5 3MHz 16QAM</p>	 <p>Band LTE5 3MHz CBE 16QAM Low Channel 1RB.gif</p>	 <p>Band LTE5 3MHz CBE 16QAM Low Channel FRB.gif</p>
<p>Band LTE5 3MHz 16QAM</p>	 <p>Band LTE5 3MHz CBE 16QAM High Channel 1RB.gif</p>	 <p>Band LTE5 3MHz CBE 16QAM High Channel FRB.gif</p>

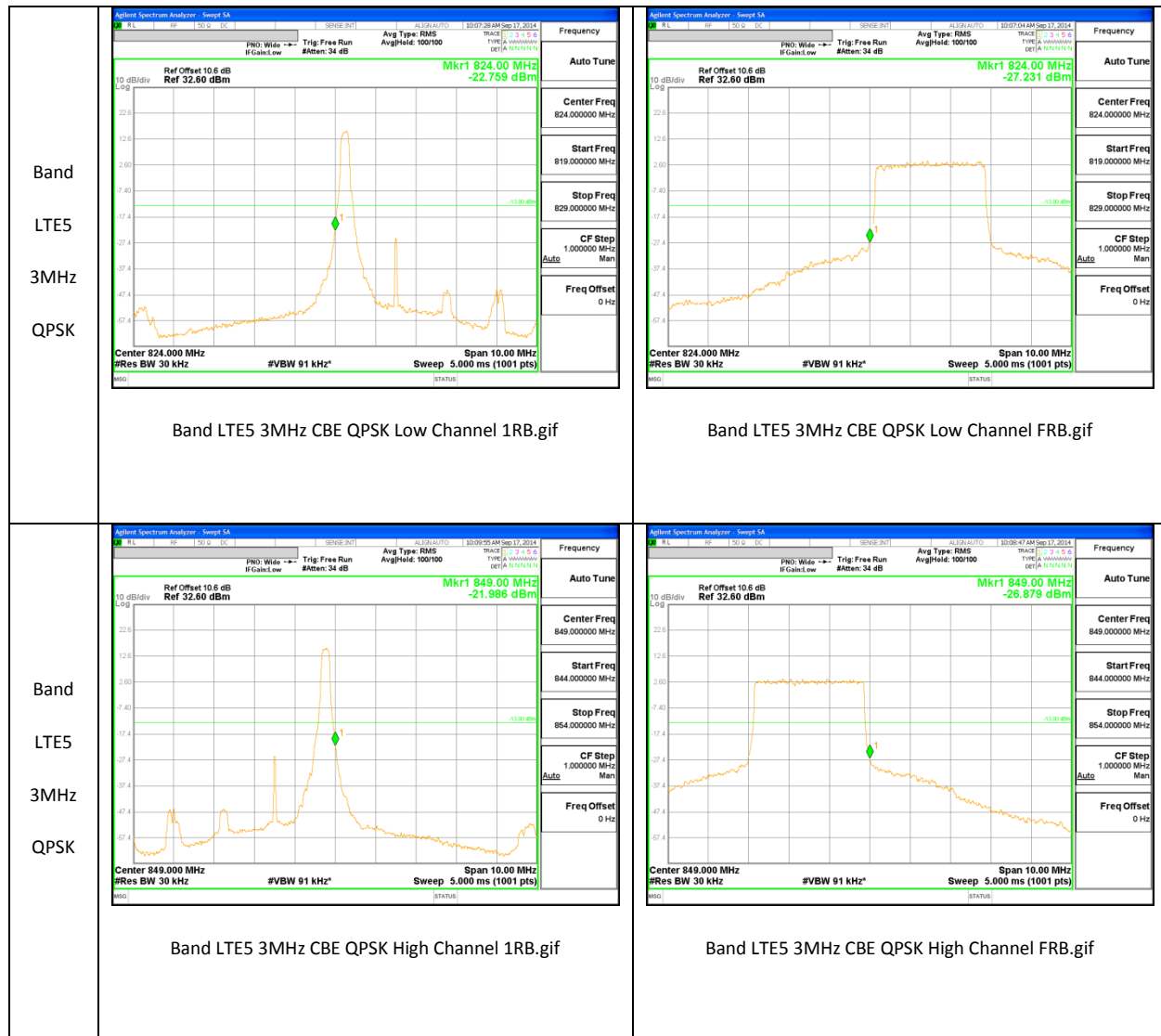

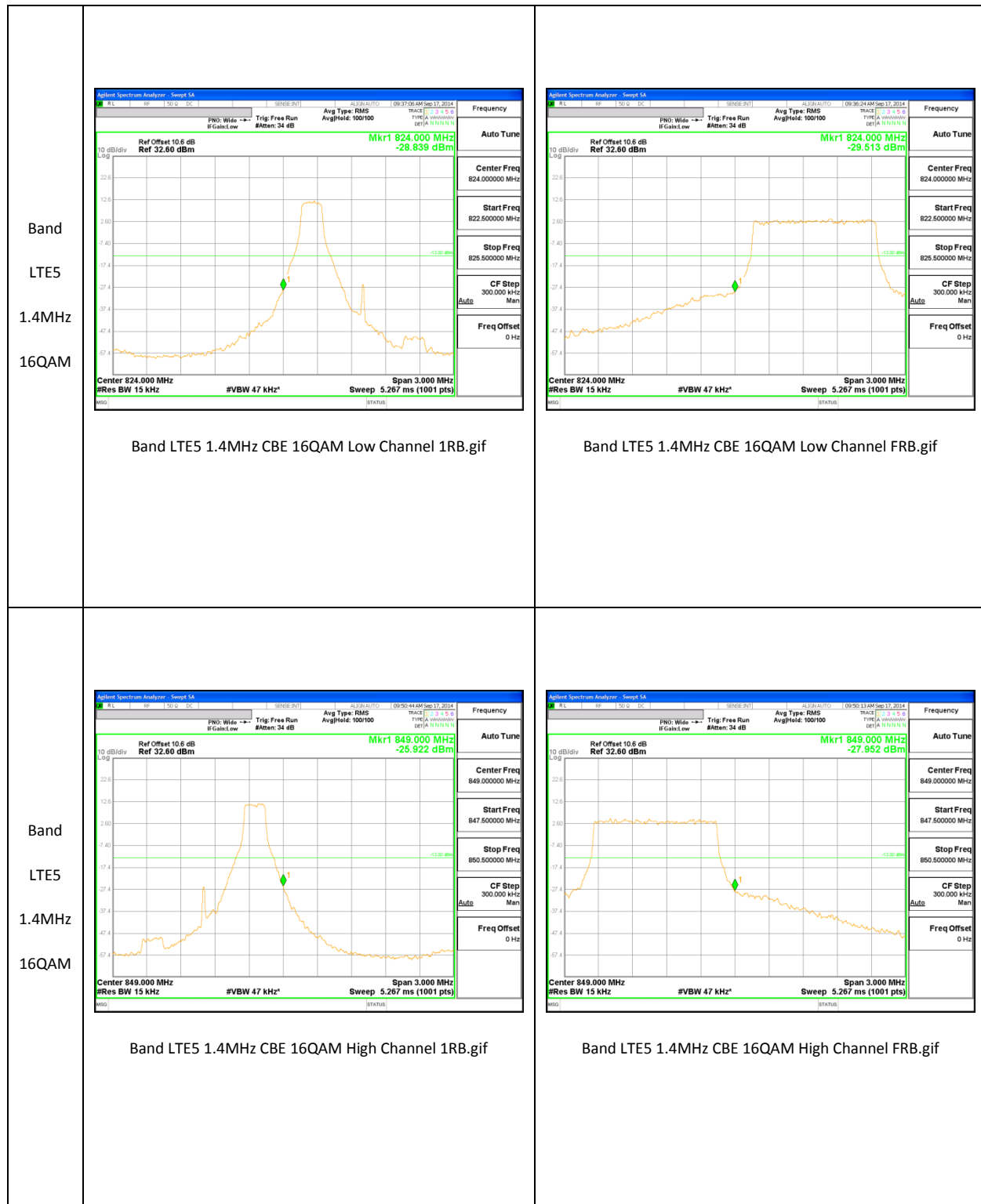

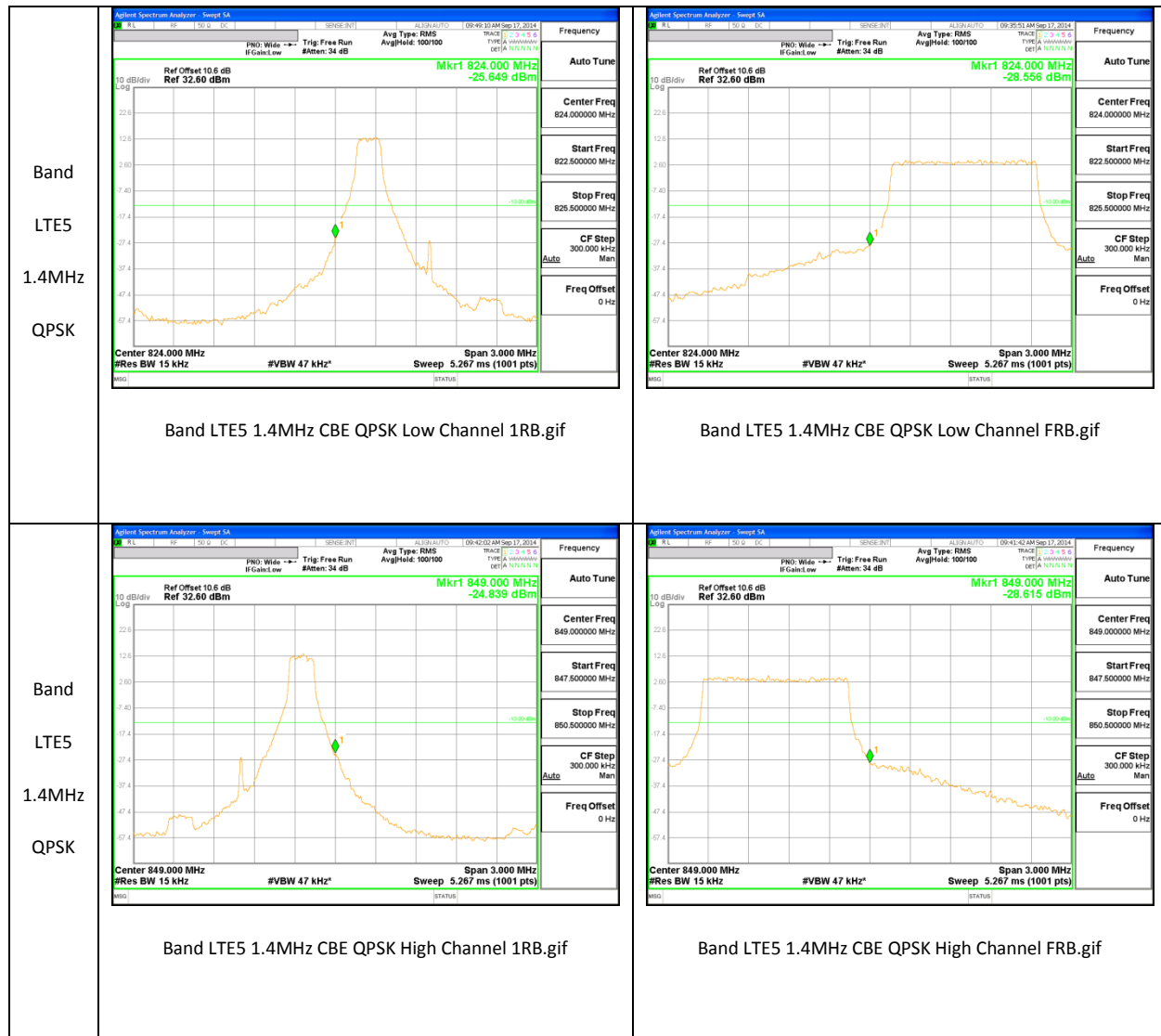

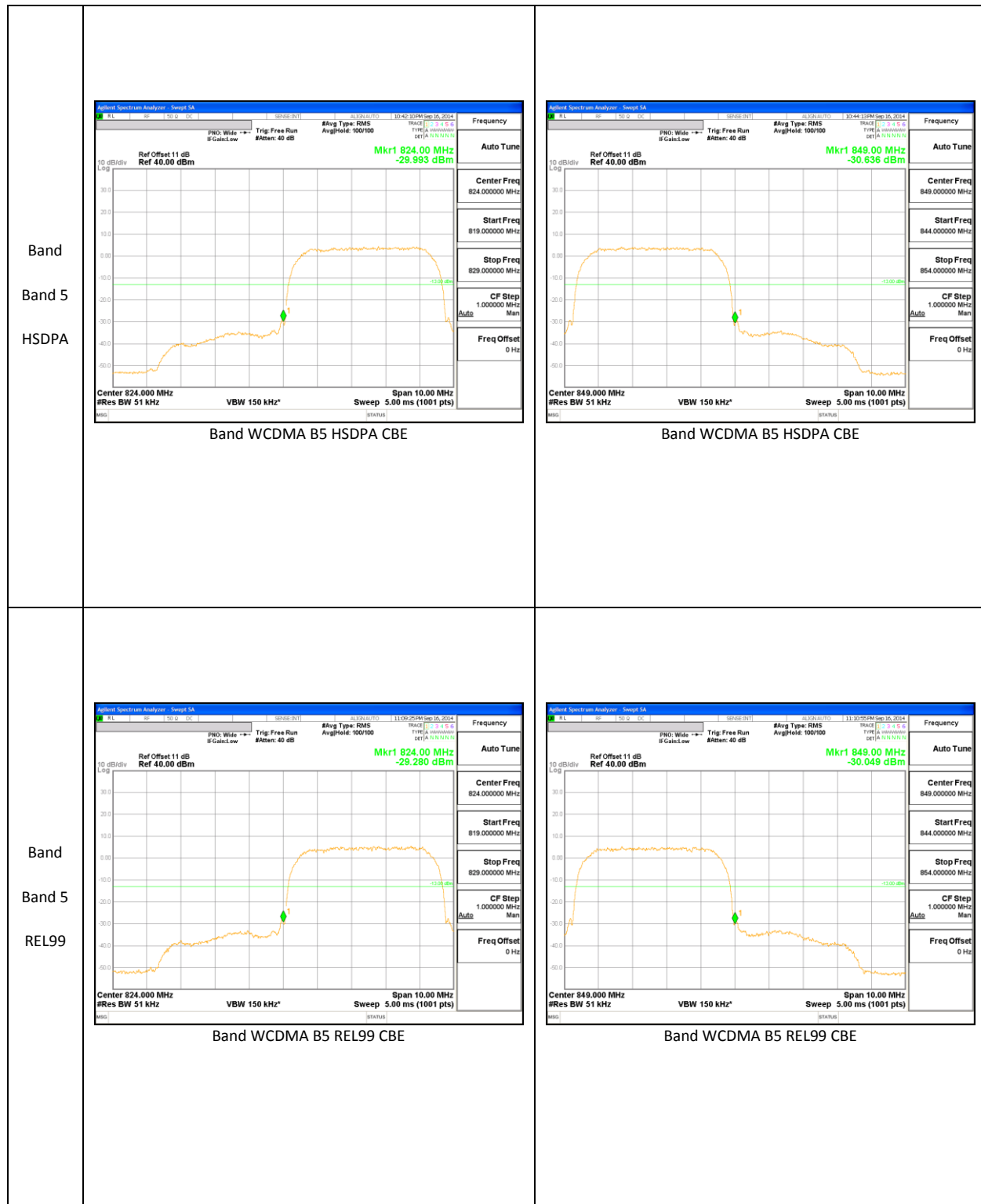

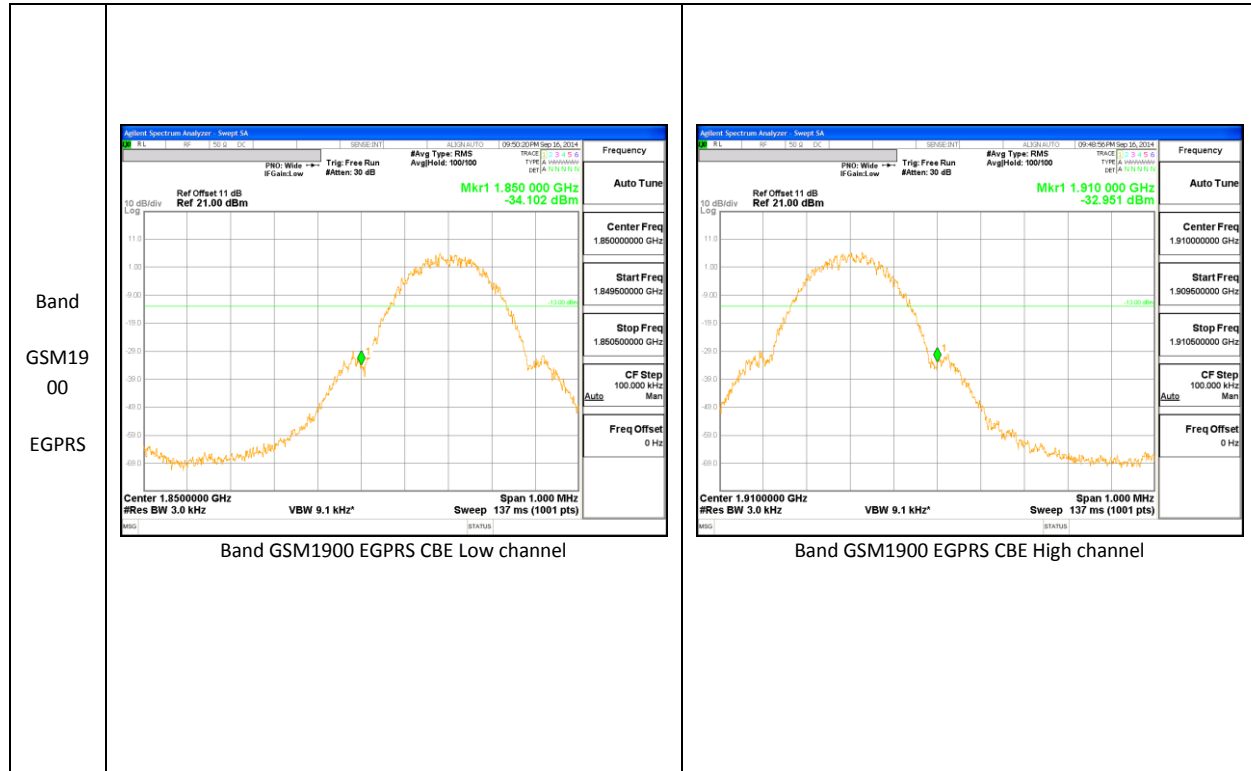

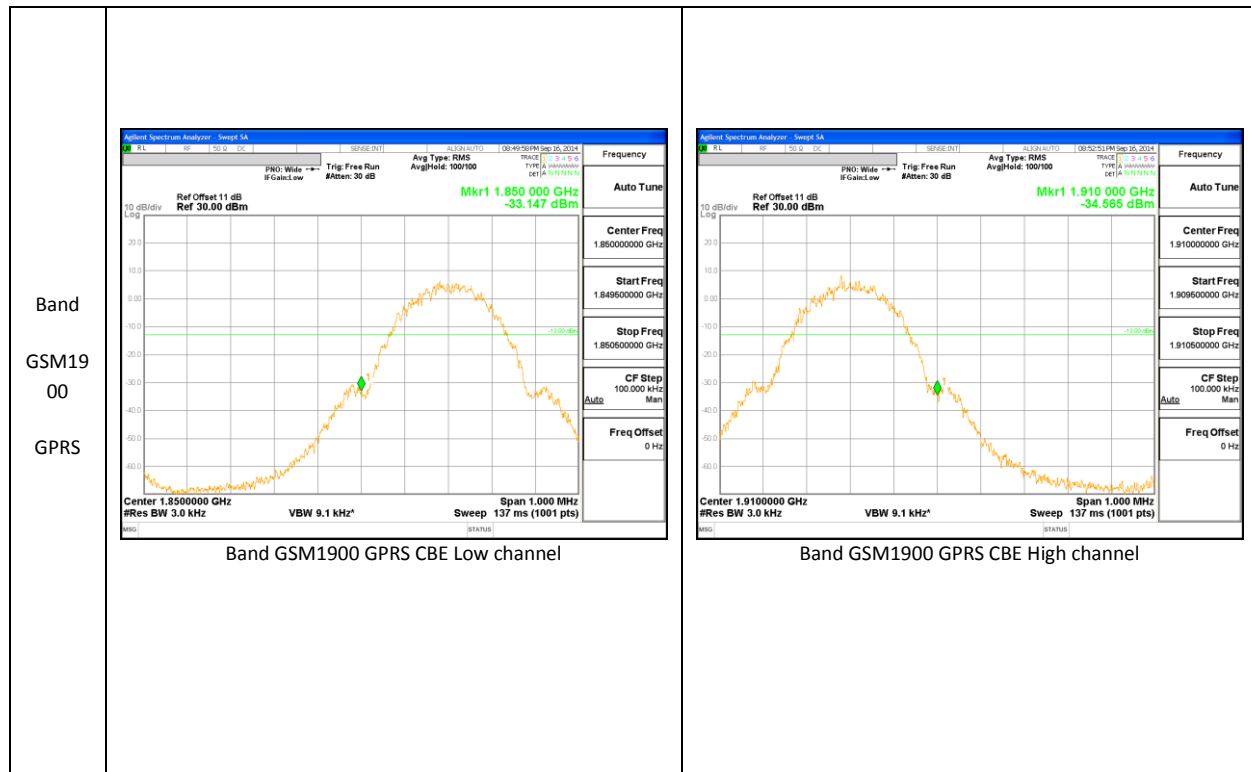

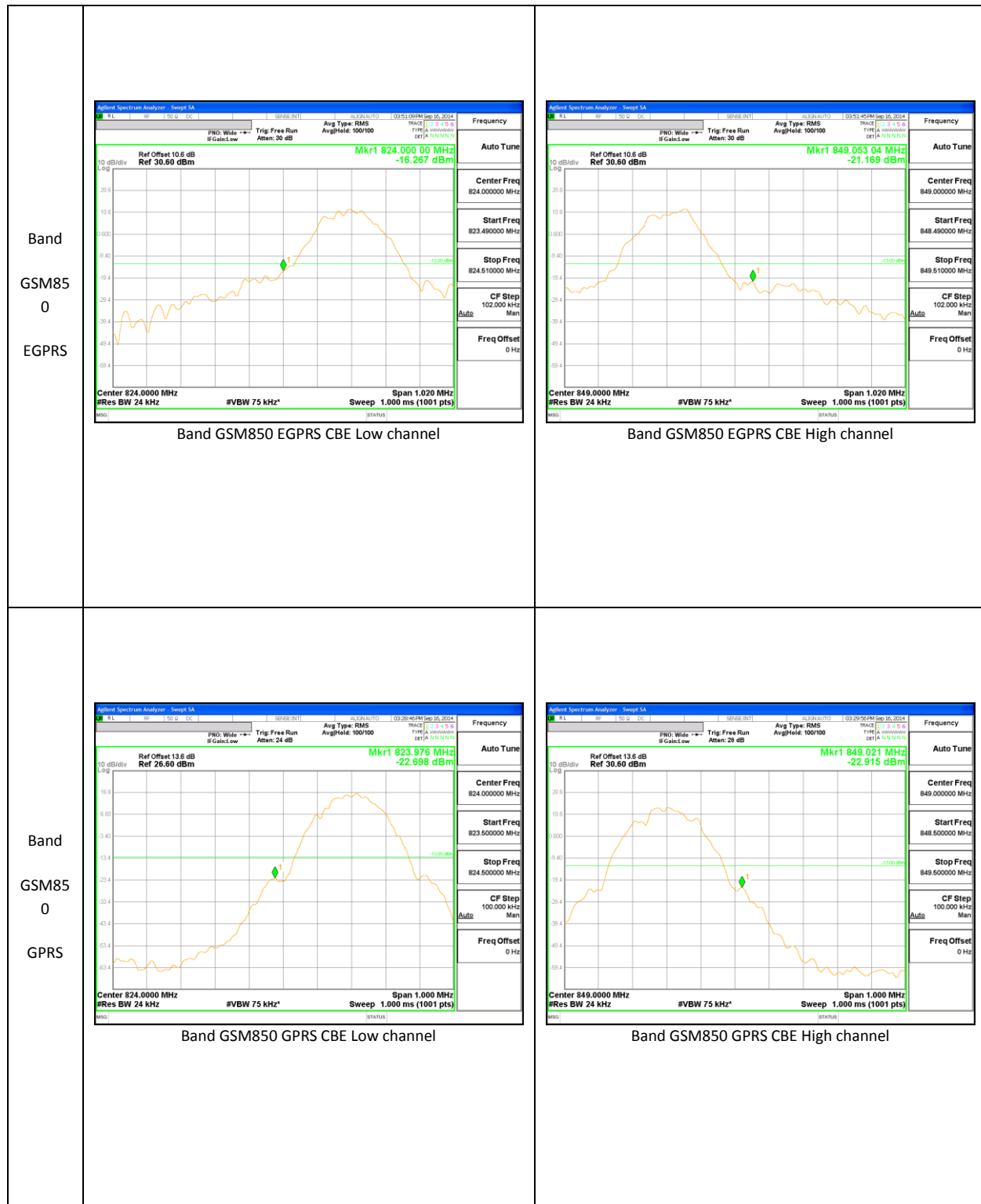

10.3. OUT OF BAND EMISSIONS

RULE PART(S)

FCC: §2.1051, §22.901, §22.917, §24.238

LIMITS

The power of any emission outside of the authorized operating frequency ranges must be attenuated below the transmitting power (P) by a factor of at least $43 + 10 \log (P)$ dB.

TEST PROCEDURE

Per KDB 971168 D01 Power Meas License Digital Systems v02r01

The RF output of the transmitter was connected to a spectrum analyzer through a calibrated coaxial cable. Sufficient scans were taken to show the out-of-band Emissions, if any, up to 10th harmonic. Multiple sweeps were recorded in maximum hold mode using a peak detector to ensure that the worst-case emissions were caught.

RESULTS

10.3.1. OUT OF BAND EMISSIONS RESULT

Band	BW (MHz)	Mode	f (MHz)	Spur (dBm)	Spec (dBm)	Delta (dB)
LTE5	10	QPSK	829	-27.361	-13	-14.361
			836.5	-26.501	-13	-13.501
			844	-26.846	-13	-13.846
		16QAM	829	-26.836	-13	-13.836
			836.5	-26.042	-13	-13.042
			844	-27.346	-13	-14.346

Band	BW (MHz)	Mode	f (MHz)	Spur (dBm)	Spec (dBm)	Delta (dB)
LTE5	5	QPSK	826.5	-29.39	-13	-16.390
			836.5	-27.78	-13	-14.780
			846.5	-28.42	-13	-15.420
		16QAM	826.5	-30.93	-13	-17.930
			836.5	-29.89	-13	-16.890
			846.5	-28.414	-13	-15.414

Band	BW (MHz)	Mode	f (MHz)	Spur (dBm)	Spec (dBm)	Delta (dB)
LTE5	3	QPSK	825.5	-26.201	-13	-13.201
			836.5	-25.989	-13	-12.989
			847.5	-28.419	-13	-15.419
		16QAM	825.5	-28.617	-13	-15.617
			836.5	-26.612	-13	-13.612
			847.5	-26.843	-13	-13.843

Band	BW (MHz)	Mode	f (MHz)	Spur (dBm)	Spec (dBm)	Delta (dB)
LTE5	1.4	QPSK	824.7	-29.28	-13	-16.280
			836.5	-28.753	-13	-15.753
			848.3	-28.595	-13	-15.595
		16QAM	824.7	-29.81	-13	-16.810
			836.5	-30.47	-13	-17.470
			848.3	-30.41	-13	-17.410

Band	Mode	f (MHz)	Spur (dBm)	Spec (dBm)	Delta (dB)
GSM850	GPRS	824.2	-26.340	-13	-13.340
		836.6	-29.851	-13	-16.851
		848.8	-25.401	-13	-12.401
	EGPRS	824.2	-27.529	-13	-14.529
		836.6	-24.941	-13	-11.941
		848.8	-27.113	-13	-14.113
GSM1900	GPRS	1850.2	-23.880	-13	-10.880
		1880	-23.920	-13	-10.920
		1909.8	-24.460	-13	-11.460
	EGPRS	1850.2	-24.950	-13	-11.950
		1880	-25.830	-13	-12.830
		1909.8	-25.630	-13	-12.630
Band 5	REL99	826.4	-24.740	-13	-11.740
		836.6	-25.200	-13	-12.200
		846.6	-25.500	-13	-12.500
Band 5	HSDPA	826.4	-26.090	-13	-13.090
		836.6	-24.440	-13	-11.440
		846.6	-24.420	-13	-11.420

10.3.2. OUT OF BAND EMISSIONS PLOTS

