



**FCC CFR47 PART 22 SUBPART H  
FCC CFR47 PART 24 SUBPART E**

**CERTIFICATION TEST REPORT**

**FOR**

**GSM/WCDMA Phone + Bluetooth, WLAN 2.4GHz b/g/n & NFC**

**MODEL NUMBER: SM-G355HN**

**FCC ID: A3LSMG355HN**

**REPORT NUMBER: 14I17986-1 REVISION A**

**ISSUE DATE: June 19, 2014**

*Prepared for*

**SAMSUNG ELECTRONICS CO., LTD.  
416, MAETAN 3-DONG, YEONGTONG-GU  
SUWON-CITY, GYEONGGI-DO 443-742, SOUTH KOREA**

*Prepared by*

**UL VERIFICATION SERVICES INC.  
47173 BENICIA STREET  
FREMONT, CA 94538, U.S.A.  
TEL: (510) 771-1000  
FAX: (510) 661-0888**

---

**Revision History**

Rev.	Date	Revisions	Revised By
--	6/18/14	Initial issue	P. Zhang
A	6/19/14	Updated statement	P. Zhang

**TABLE OF CONTENTS**

**1. ATTESTATION OF TEST RESULTS ..... 5**

**2. TEST METHODOLOGY ..... 6**

**3. FACILITIES AND ACCREDITATION ..... 6**

**4. CALIBRATION AND UNCERTAINTY ..... 6**

    4.1. *MEASURING INSTRUMENT CALIBRATION* ..... 6

    4.2. *SAMPLE CALCULATION* ..... 6

    4.3. *MEASUREMENT UNCERTAINTY*..... 6

**5. EQUIPMENT UNDER TEST ..... 7**

    5.1. *DESCRIPTION OF EUT* ..... 7

    5.2. *MAXIMUM OUTPUT POWER*..... 7

    5.3. *DESCRIPTION OF AVAILABLE ANTENNAS* ..... 8

    5.4. *DESCRIPTION OF TEST SETUP*..... 9

**6. TEST AND MEASUREMENT EQUIPMENT .....12**

**7. Summary Table.....13**

**8. RF POWER OUTPUT VERIFICATION.....14**

    8.1. *GSM/GPRS/EDGE* ..... 14

        8.1.1. *GSM OUTPUT POWER RESULT*.....15

    8.2. *UMTS REL 99*.....16

        8.2.1. *UMTS REL 99 OUTPUT POWER RESULT* .....16

    8.3. *UMTS HSDPA* .....17

        8.3.1. *UMTS HSDPA OUTPUT POWER RESULT*.....17

        8.3.2. *UMTS HSUPA* .....18

        8.3.3. *UMTS HSUPA OUTPUT POWER RESULT*.....19

**9. PEAK TO AVERAGE RATIO .....20**

    9.1. *CONDUCTED PEAK TO AVERAGE RESULT*.....20

**10. LIMITS AND CONDUCTED RESULTS .....22**

    10.1. *OCCUPIED BANDWIDTH*.....22

        10.1.1. *OCCUPIED BANDWIDTH RESULTS*.....23

        10.1.1. *OCCUPIED BANDWIDTH PLOTS* .....24

    10.2. *BAND EDGE EMISSIONS* .....26

        10.2.1. *BAND EDGE PLOTS* .....27

---

10.3.	<i>OUT OF BAND EMISSIONS</i> .....	29
10.3.1.	OUT OF BAND EMISSIONS RESULT .....	31
10.3.2.	OUT OF BAND EMISSIONS PLOTS.....	32
10.4.	<i>FREQUENCY STABILITY</i> .....	34
10.4.1.	FREQUENCY STABILITY RESULTS.....	35
<b>11.</b>	<b>RADIATED TEST RESULTS</b> .....	<b>37</b>
11.1.	<i>RADIATED POWER (ERP &amp; EIRP)</i> .....	37
11.1.1.	ERP/EIRP Results.....	38
11.1.2.	ERP/EIRP Data.....	39
11.2.	<i>FIELD STRENGTH OF SPURIOUS RADIATION</i> .....	43
11.2.1.	SPURIOUS RADIATION DATA.....	44
<b>12.</b>	<b>SETUP PHOTOS</b> .....	<b>48</b>

# 1. ATTESTATION OF TEST RESULTS

**COMPANY NAME:** SAMSUNG ELECTRONICS CO., LTD.  
416, MAETAN 3-DONG, YEONGTONG-GU  
SUWON-CITY, GYEONGGI-DO 443-742, SOUTH KOREA

**EUT DESCRIPTION:** GSM/WCDMA Phone + Bluetooth, WLAN 2.4GHz b/g/n & NFC

**MODEL:** SM-G355HN

**SERIAL NUMBER:** FL-164-C, FL-230-A

**DATE TESTED:** April 25 – June 18, 2014

APPLICABLE STANDARDS	
STANDARD	TEST RESULTS
FCC PART 22H, 24E	PASS

UL Verification Services Inc. tested the above equipment in accordance with the requirements set forth in the above standards. All indications of Pass/Fail in this report are opinions expressed by UL Verification Services Inc. based on interpretations and/or observations of test results. Measurement Uncertainties were not taken into account and are published for informational purposes only. The test results show that the equipment tested is capable of demonstrating compliance with the requirements as documented in this report.

**Note:** The results documented in this report apply only to the tested sample, under the conditions and modes of operation as described herein. This document may not be altered or revised in any way unless done so by UL Verification Services Inc. and all revisions are duly noted in the revisions section. Any alteration of this document not carried out by UL Verification Services Inc. will constitute fraud and shall nullify the document. This report must not be used by the client to claim product certification, approval, or endorsement by NVLAP, NIST, any agency of the Federal Government, or any agency of any government.

Approved & Released For

UL Verification Services Inc. By:

Tested By:



---

PENG ZHANG  
CONSUMER TECHNOLOGY DIVISION  
PROJECT LEAD  
UL Verification Services Inc.

---

STEVEN TRAN  
CONSUMER TECHNOLOGY DIVISION  
LAB ENGINEER  
UL Verification Services Inc.

## 2. TEST METHODOLOGY

The tests documented in this report were performed in accordance with TIA-603-C, FCC CFR 47 Part 22, FCC CFR Part 24

## 3. FACILITIES AND ACCREDITATION

The test sites and measurement facilities used to collect data are located at 47173 Benicia Street, Fremont, California, USA.

UL Verification Services Inc. is accredited by NVLAP, Laboratory Code 200065-0. The full scope of accreditation can be viewed at <http://www.ul.com>

## 4. CALIBRATION AND UNCERTAINTY

### 4.1. MEASURING INSTRUMENT CALIBRATION

The measuring equipment utilized to perform the tests documented in this report has been calibrated in accordance with the manufacturer's recommendations, and is traceable to recognized national standards

### 4.2. SAMPLE CALCULATION

Where relevant, the following sample calculation is provided:

$$\text{EIRP} = \text{PSA reading with EUT worst orientation (dBm)} + \text{Path loss (dB)} - \text{cable loss (between the SG and substitution antenna)} + \text{Substitution Antenna Factor (dBi)}$$
$$\text{ERP} = \text{PSA reading with EUT worst orientation (dBm)} + \text{Path loss (dB)} - \text{cable loss (between the SG and substitution antenna)}$$
$$(\text{Path loss} = \text{Signal generator output} - \text{PSA reading with substitution antenna})$$

### 4.3. MEASUREMENT UNCERTAINTY

Where relevant, the following measurement uncertainty levels have been estimated for tests performed on the apparatus:

PARAMETER	UNCERTAINTY
Conducted Disturbance, 0.15 to 30 MHz	3.52 dB
Radiated Disturbance, 30 to 18000 MHz	4.94 dB

Uncertainty figures are valid to a confidence level of 95%.

## 5. EQUIPMENT UNDER TEST

### 5.1. DESCRIPTION OF EUT

The EUT is a GSM/WCDMA Phone + Bluetooth, WLAN 2.4GHz b/g/n & NFC.

The model FCC ID: A3LSMG355HN shares the same enclosure and circuit board as mode FCC ID: A3LSMG355H. The WWAN/WLAN/Bluetooth/WWAN circuitry and layout, are almost identical between the two units. The WLAN/Bluetooth antenna and surrounding circuitry is the same between these two units.

Conducted test results have been re-used for A3LSMG355HN after confirming the performance is the same.

Radiated emissions were fully re-evaluated since Main Antenna pattern have been changed for A3LSMG355HN. Other differences between the two FCC IDs are NFC chipset being added for A3LSMG355HN. NFC has been fully tested for FCC ID: A3LSMG355HN.

### 5.2. MAXIMUM OUTPUT POWER

The transmitter has a maximum peak conducted and radiated ERP / EIRP output powers as follows:

FCC Part 22/24						
Band	Frequency Range(MHz)	Modulation Peak	Conducted		Radiated	
			Peak (dBm)	Peak (mW)	Peak (dBm)	Peak (mW)
GSM850	824~849	GMSK	32.9	1949.84		
	824~849	GPRS	32.9	1949.84	28.38	688.65
GSM1900	1850~1910	GMSK	29.4	870.96		
	1850~1910	GPRS	29.4	870.96	27.54	567.54

FCC Part 2 4						
Band	Frequency Range(MHz)	Modulation Peak	Conducted		Radiated	
			Avg (dBm)	Avg (mW)	Avg (dBm)	Avg (mW)
Band 2	1850~1910	REL99	21.9	154.88	20.18	104.23
	1850~1910	HSDPA	21.9	154.88	18.90	77.62
	1850~1910	HSUPA	21.9	154.88		

### 5.3. DESCRIPTION OF AVAILABLE ANTENNAS

The radio utilizes a PIFA antenna for the [List the bands supported] with a maximum peak gain as follow:

Frequency (MHz)	Peak Gain (dBi)
GSM850, 824~849MHz	-3.27
Band 2, 1850~1910MHz	3.36

## 5.4. DESCRIPTION OF TEST SETUP

### SUPPORT EQUIPMENT

Support Equipment List				
Description	Manufacturer	Model	Serial Number	FCC ID
AC Adapter	Samsung	G355H	N/A	N/A
Earphone	Samsung	G355H	N/A	N/A

### I/O CABLES (CONDUCTED SETUP)

I/O Cable List						
Cable No	Port	# of identical ports	Connector Type	Cable Type	Cable Length (m)	Remarks
1	RF Out	1	Spectrum Analyzer	Shielded	None	NA
2	Antenna Port	1	EUT	Shielded	0.1m	NA
3	RF In/Out	1	Communication Test Set	Shielded	1m	NA

### I/O CABLES (RADIATED SETUP)

I/O CABLE LIST						
Cable No.	Port	# of Identical Ports	Connector Type	Cable Type	Cable Length	Remarks
1	USB	1	AC Adapter	Un-shielded	1.2m	No
2	Jack	1	Headset	Shielded	1m	No
3	RF In/out	1	Communication Test Set	Un-shielded	2m	Yes

### TEST SETUP

The EUT is continuously communicated to the call box during the tests.

**SETUP DIAGRAM FOR TESTS (CONDUCTED TEST SETUP)**

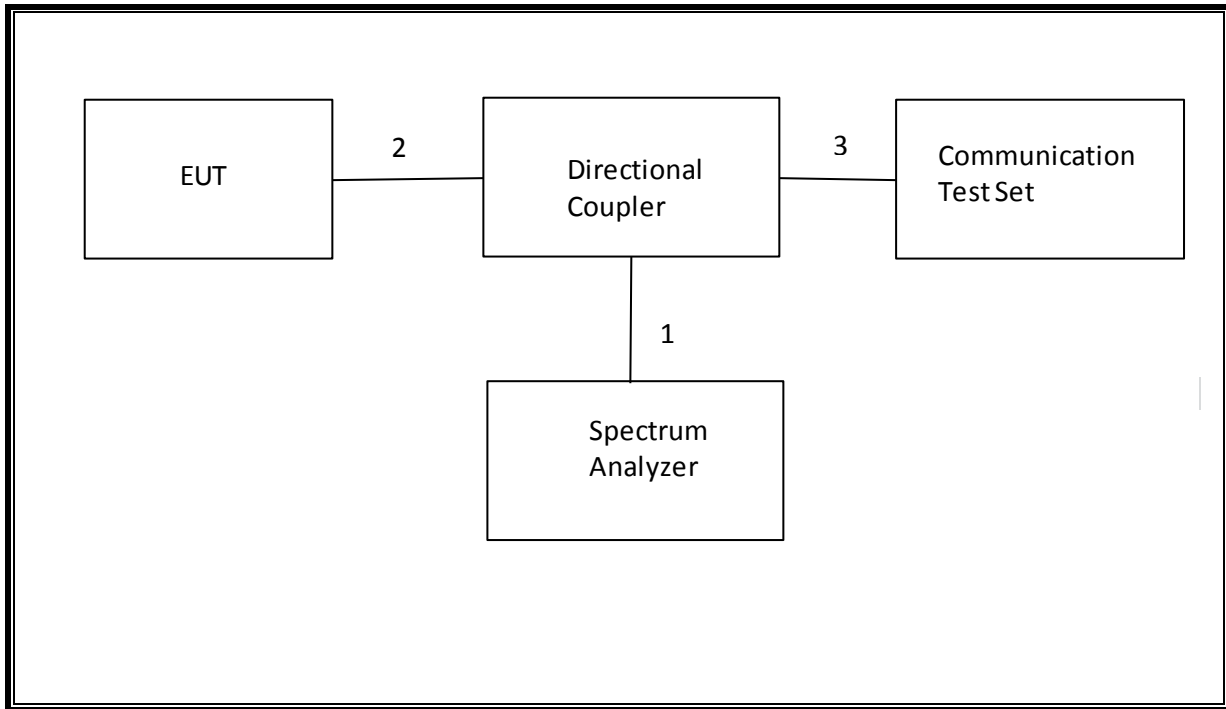

**SETUP DIAGRAM FOR TESTS (RADIATED TEST SETUP)**

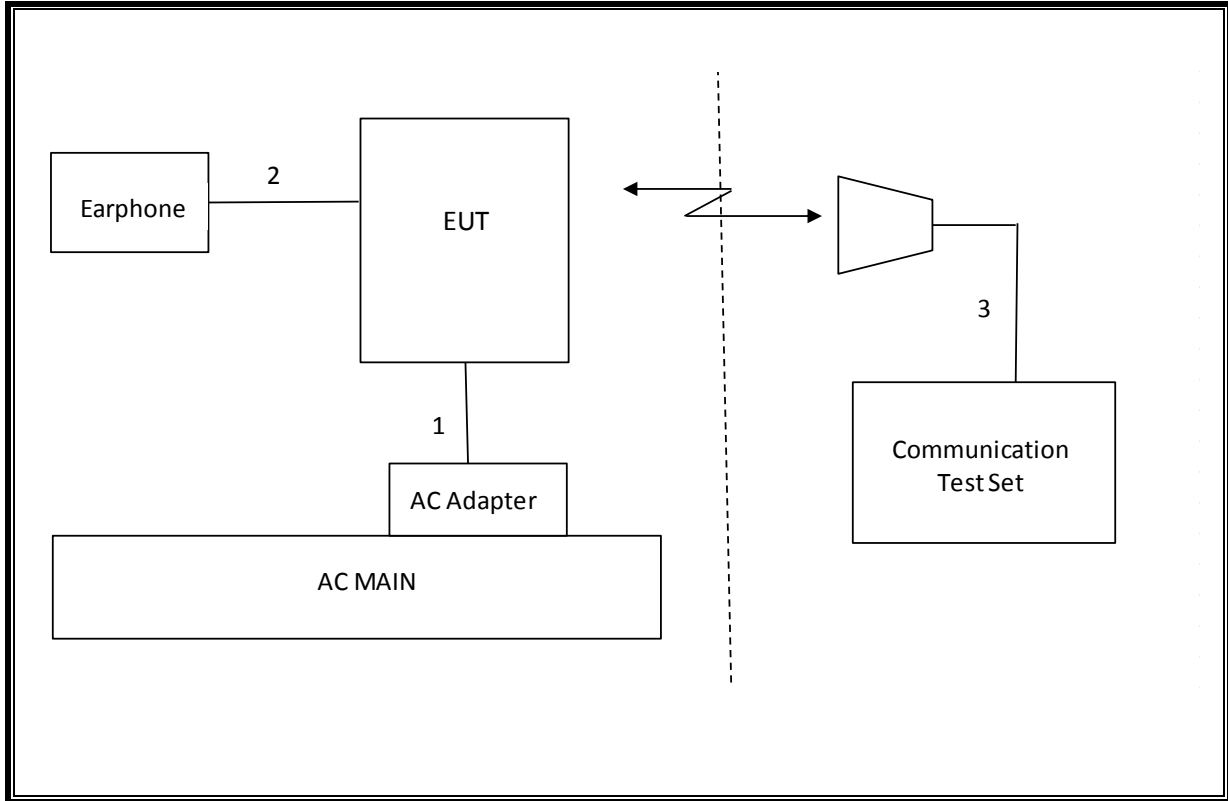

## 6. TEST AND MEASUREMENT EQUIPMENT

The following test and measurement equipment was utilized for the tests documented in this report:

TEST EQUIPMENT LIST				
Description	Manufacturer	Model	Asset	Cal Due
Spectrum Analyzer, 44 GHz	Agilent / HP	E4446A	C01179	02/26/15
Antenna, Bilog, 2 GHz	Sunol Sciences	JB1	C01011	08/14/14
Antenna, Horn, 18 GHz	EMCO	3115	C00783	10/25/14
Antenna, Horn, 18 GHz	EMCO	3115	C00784	10/25/14
Highpass Filter, 2.7 GHz	Micro-Tronics	HPM13194	N02687	CNR
Highpass Filter, 1.5 GHz	Micro-Tronics	HPM13193	N02688	CNR
Temperature / Humidity Chamber	Thermotron	SE 600-10-10	C00930	01/09/15
Communications Test Set	R&S	CMW500	T159	07/02/14
DC power supply, 8 V @ 3 A or 15 V	Agilent / HP	E3610A	None	CNR
Vector signal generator, 6 GHz	Agilent / HP	E4438C	None	07/06/14
Antenna, Tuned Dipole 400~1000	ETS	3121C DB4	C00993	02/14/15
Directional Coupler	RF-Lambda	RFDC5M06G15	None	CNR
Antenna, Horn, 18- 26 GHz	ARA	MWH-1826/B	C00946	11/12/14

## 7. Summary Table

FCC Part Section	RSS Section(s)	Test Description	Test Limit	Test Condition	Test Result	Worst Case
2.1049	N/A	Occupied Band width (99%)	N/A	Conducted	Pass	4.1MHz
22.917(a) 24.238(a)	RSS-132(4.5.1) RSS-133(6.5.1)	Band Edge / Conducted Spurious Emission	-13dBm		Pass	-21.86dBm
2.1046	N/A	Conducted output power	N/A		Pass	32.2dBm
22.355 24.235	RSS-132(4.3) RSS-133(6.3)	Frequency Stability	2.5PPM		Pass	0.012PPM
22.913(a)(2)	RSS-132(4.4)	Effective Radiated Power	38 dBm	Radiated	Pass	28.38dBm
24.232(c )	RSS-133(6.4)	Equivalent Isotropic Radiated Power	33dBm		Pass	27.54dBm
22.917(a) 24.238(a)	RSS-132(4.5.1) RSS-133(6.5.1)	Radiated Spurious Emission	-13dBm		Pass	-37.8dBm

## 8. RF POWER OUTPUT VERIFICATION

### 8.1. GSM/GPRS/EDGE

Function: Menu select > GSM Mobile Station > GSM 850/900/1800/1900  
Press Connection control to choose the different menus  
Press RESET > choose all to reset all settings  
Connection Press Signal Off to turn off the signal and change settings  
Network Support > GSM+GPRS or GSM+EGPRS  
Main Service > Packet Data  
Service selection > Test Mode A – Auto Slot Config. off  
MS Signal Press Slot Config bottom on the right twice to select and change the number of time slots and power setting  
    > Slot configuration      > Uplink/Gamma  
    > 33 dBm for GPRS 850/900  
    > 30 dBm for GPRS1800/1900  
BS Signal Enter the same channel number for TCH channel (test channel) and BCCH channel  
Frequency Offset > + 0 Hz  
Mode > BCCH and TCH  
BCCH Level > -85 dBm (May need to adjust if link is not stable)  
BCCH Channel > choose desire test channel [Enter the same channel number for TCH channel (test channel) and BCCH channel]  
Channel Type > Off  
P0> 4 dB  
Slot Config > Unchanged (if already set under MS Signal)  
TCH > choose desired test channel  
Hopping > Off  
Main Timeslot > 3 (Default)  
Network Coding Scheme > CS4 (GPRS) and MCS5 ~ MCS9 (EGPRS)  
    Bit Stream > 2E9-1PSR Bit Pattern  
AF/RF Enter appropriate offsets for Ext. Att. Output and Ext. Att. Input  
Connection Press Signal On to turn on the signal and change settings

**8.1.1. GSM OUTPUT POWER RESULT**

Band	Mode	Ch.	f(MHz)	1 time slot	2 time slot	3 time slot	4 time slot
				Peak (dBm)	Peak (dBm)	Peak (dBm)	Peak (dBm)
GSM850	GMSK	128	824.2	32.7			
		190	836.6	32.9			
		251	848.8	32.9			
	GPRS	128	824.2	32.6	30.8	28.8	26.9
		190	836.6	32.9	30.9	28.9	27.0
		251	848.8	32.8	31.0	28.9	27.0
GSM1900	GMSK	512	1850.2	29.3			
		661	1880	29.4			
		810	1909.8	29.4			
	GPRS	512	1850.2	29.3	28.5	26.5	24.4
		661	1880	29.4	28.5	26.5	24.3
		810	1909.8	29.3	28.5	26.5	24.2

## 8.2. UMTS REL 99

### TEST PROCEDURE

The following summary of these settings are illustrated below:

	Mode	Rel99
	Subtest	-
WCDMA General Settings	Loopback Mode	Test Mode 1
	Rel99 RMC	12.2kbps RMC
	HSDPA FRC	Not Applicable
	HSUPA Test	Not Applicable
	Power Control Algorithm	Algorithm2
	$\beta_c$	Not Applicable
	$\beta_d$	Not Applicable
	$\beta_{ec}$	Not Applicable
	$\beta_c/\beta_d$	8/15
	$\beta_{hs}$	Not Applicable
	$\beta_{ed}$	Not Applicable

### 8.2.1. UMTS REL 99 OUTPUT POWER RESULT

Band	Mode	Ch.	f(MHz)	Conducted Power (dBm)
				Avg (dBm)
Band 2	REL99	9262	1852.4	21.9
		9400	1880	21.9
		9538	1907.6	21.6

### 8.3. UMTS HSDPA

The following 4 Sub-tests were completed according to Release 5 procedures in section 5.2 of 3GPP TS34.121. A summary of these settings are illustrated below:

	Mode	Rel5 HSDPA			
	Subtest	1	2	3	4
WCDMA General Settings	Loopback Mode	Test Mode 1			
	Rel99 RMC	12.2kbps RMC			
	HSDPA FRC	H-Set1			
	Power Control Algorithm	Algorithm 2			
	$\beta_c$	2/15	12/15	15/15	15/15
	$\beta_d$	15/15	15/15	8/15	4/15
	Bd (SF)	64			
	$\beta_c/\beta_d$	2/15	12/15	15/8	15/4
	$\beta_{hs}$	4/15	24/15	30/15	30/15
MPR (dB)	0	0	0.5	0.5	
HSDPA Specific Settings	$D_{ACK}$	8			
	$D_{NAK}$	8			
	DCQI	8			
	Ack-Nack repetition factor	3			
	CQI Feedback (Table 5.2B.4)	4ms			
	CQI Repetition Factor (Table 5.2B.4)	2			
$A_{hs} = \beta_{hs}/\beta_c$	30/15				

#### 8.3.1. UMTS HSDPA OUTPUT POWER RESULT

Band	Mode	Subset	Ch.	f(MHz)	Conducted Power (dBm)
					Avg (dBm)
Band 2	HSDPA	1	9262	1852.4	21.9
			9400	1880	21.4
			9538	1907.6	21.1
		2	9262	1852.4	21.7
			9400	1880	21.5
			9538	1907.6	21.0
		3	9262	1852.4	21.6
			9400	1880	21.5
			9538	1907.6	21.1
		4	9262	1852.4	21.6
			9400	1880	21.5
			9538	1907.6	21.1

### 8.3.2. UMTS HSUPA

#### TEST PROCEDURE

The following summary of these settings are illustrated below: (ETSI TS 134.121-1 Table C.11.1)

	Mode	Rel6 HSUPA	Rel6 HSUPA	Rel6 HSUPA	Rel6 HSUPA	Rel6 HSUPA
	Subtest	1	2	3	4	5
WCDMA General Settings	Loopback Mode	Test Mode 1				
	P-CPICH (dB)	-10				
	P-CCPCH (dB)	-12				
	SCH (dB)	-12				
	PICH(dB)	-15				
	DPCH (dB)	-9				
	HS-SCCH_1 (dB)	-8				
	HS-PDSCH (dB)	-3				
	Rel99 RMC	12.2kbps RMC				
	HSDPA FRC	H-Set1				
	HSUPA Test	HSUPA Loopback				
	Power Control Algorithm	Algorithm2				
	Bc	11/15	6/15	15/15	2/15	15/15
	Bd	15/15	15/15	9/15	15/15	15/15
	Bec	209/225	12/15	30/15	2/15	5/15
	$\beta_c/\beta_d$	11/15	6/15	15/9	2/15	15/15
Bhs	22/15	12/15	30/15	4/15	30/15	
$\beta_{ed}$ (note1)	1309/225	94/75	47/15 47/15	56/75	134/15	
MPR	0	2	1	2	0	
HSDPA Specific Settings	DACK	8				
	DNAK	8				
	DCQI	8				
	Ack-Nack repetition factor	3				
	CQI Feedback (Table 5.2B.4)	4ms				
	CQI Repetition Factor (Table 5.2B.4)	2				
	Ahs = $\beta_{hs}/\beta_c$	30/15				
HSUPA Specific Settings	D E-DPCCH	6	8	8	5	7
	DHARQ	0	0	0	0	0
	AG Index	20	12	15	17	21
	Reference E-TFCIs	5	5	2	5	5
	ETFCI (from 34.121 Table C.11.1.3)	75	67	92	71	81
	Associated Max UL Data Rate kbps	242.1	174.9	482.8	205.8	308.9
	Reference E_TFCIs	E-TFCI 11 E-TFCI PO 4 E-TFCI 67 E-TFCI PO 18 E-TFCI 71 E-TFCI PO 23 E-TFCI 75 E-TFCI PO 26 E-TFCI 81 E-TFCI PO 27		E-TFCI 11 E-TFCI PO 4 E-TFCI 92 E-TFCI PO 18		E-TFCI 11 E-TFCI PO 4 E-TFCI 67 E-TFCI PO 18 E-TFCI 71 E-TFCI PO 23 E-TFCI 75 E-TFCI PO 26 E-TFCI 81 E-TFCI PO 27

Note1:  $\beta_{ed}$  cannot be set directly, it is set by Absolute Grant Value.

**8.3.3. UMTS HSUPA OUTPUT POWER RESULT**

Band	Mode	Subset	Ch.	f(MHz)	Conducted Power (dBm)
					Avg (dBm)
Band 2	HSUPA	1	9262	1852.4	21.9
			9400	1880	21.8
			9538	1907.6	21.4
		2	9262	1852.4	19.6
			9400	1880	19.4
			9538	1907.6	19.2
		3	9262	1852.4	20.8
			9400	1880	20.7
			9538	1907.6	20.4
		4	9262	1852.4	20.5
			9400	1880	20.2
			9538	1907.6	20.0
		5	9262	1852.4	21.9
			9400	1880	21.8
			9538	1907.6	21.5

## 9. PEAK TO AVERAGE RATIO

### Test Procedure

Per KDB 971168 D01 Power Meas License Digital Systems v02r01

### Test Spec

In addition, when the transmitter power is measured in terms of average value, the peak-to-average ratio of the power shall not exceed 13 dB.

### 9.1. CONDUCTED PEAK TO AVERAGE RESULT

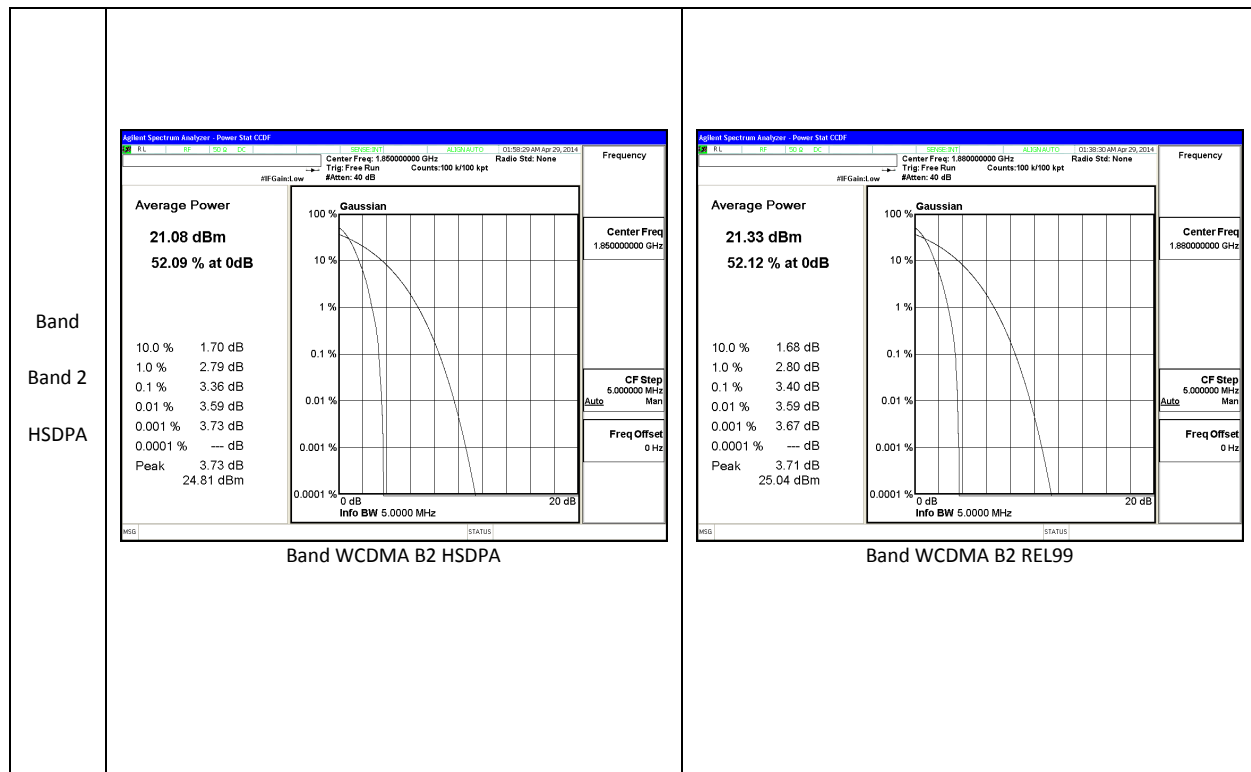

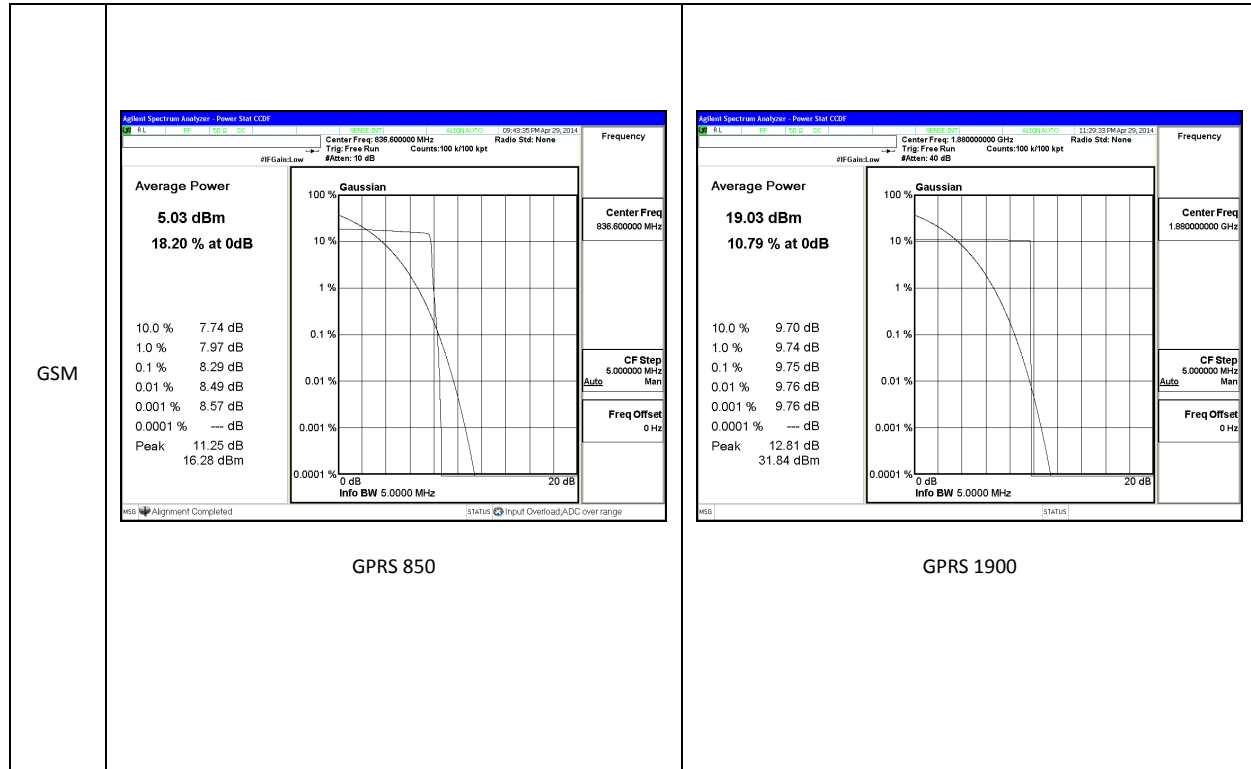

## 10. LIMITS AND CONDUCTED RESULTS

### 10.1. OCCUPIED BANDWIDTH

#### **RULE PART(S)**

FCC: §2.1049

IC: RSS-132, 4.5; RSS-133, 6.5

#### **LIMITS**

For reporting purposes only

#### **TEST PROCEDURE**

The transmitter output was connected to a calibrated coaxial cable and coupler, the other end of which was connected to a spectrum analyzer. The occupied bandwidth was measured with the spectrum analyzer at the low, middle and high channel in each band. The -26dB bandwidth was also measured and recorded.

(KDB 971168 D01 Power Meas License Digital Systems v02r01 - 06/07/2013)

#### **MODES TESTED**

GSM 850, GSM1900, WCDMA Band 2

**10.1.1. OCCUPIED BANDWIDTH RESULTS**

Band	Mode	Channel	f (MHz)	99% BW (KHz)	-26dB BW (KHz)
GSM850	GPRS	128	824.2	244.79	246.75
		190	836.6	246.75	317.1
		251	848.8	248.58	322.3
GSM1900	GPRS	512	1850.2	242.61	314.9
		661	1880	241.5	313.4
		810	1909.8	244.35	313.5
Band	Mode	Channel	f (MHz)	99% BW (MHz)	-26dB BW (MHz)
Band 2	REL99	9262	1852.4	4.09	4.61
		9400	1880	4.09	4.62
		9538	1907.6	4.09	4.62
	HSDPA	9262	1852.4	4.08	4.62
		9400	1880	4.09	4.63
		9538	1907.6	4.1	4.62

### 10.1.1. OCCUPIED BANDWIDTH PLOTS

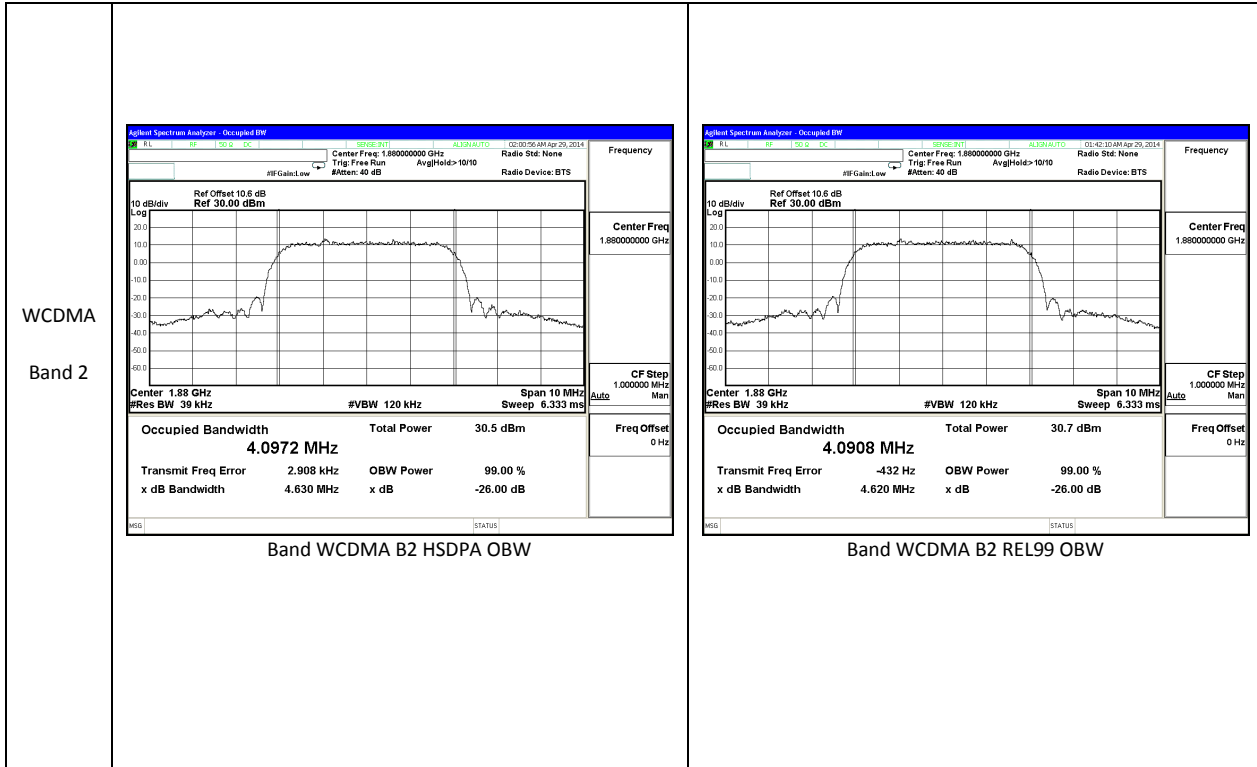

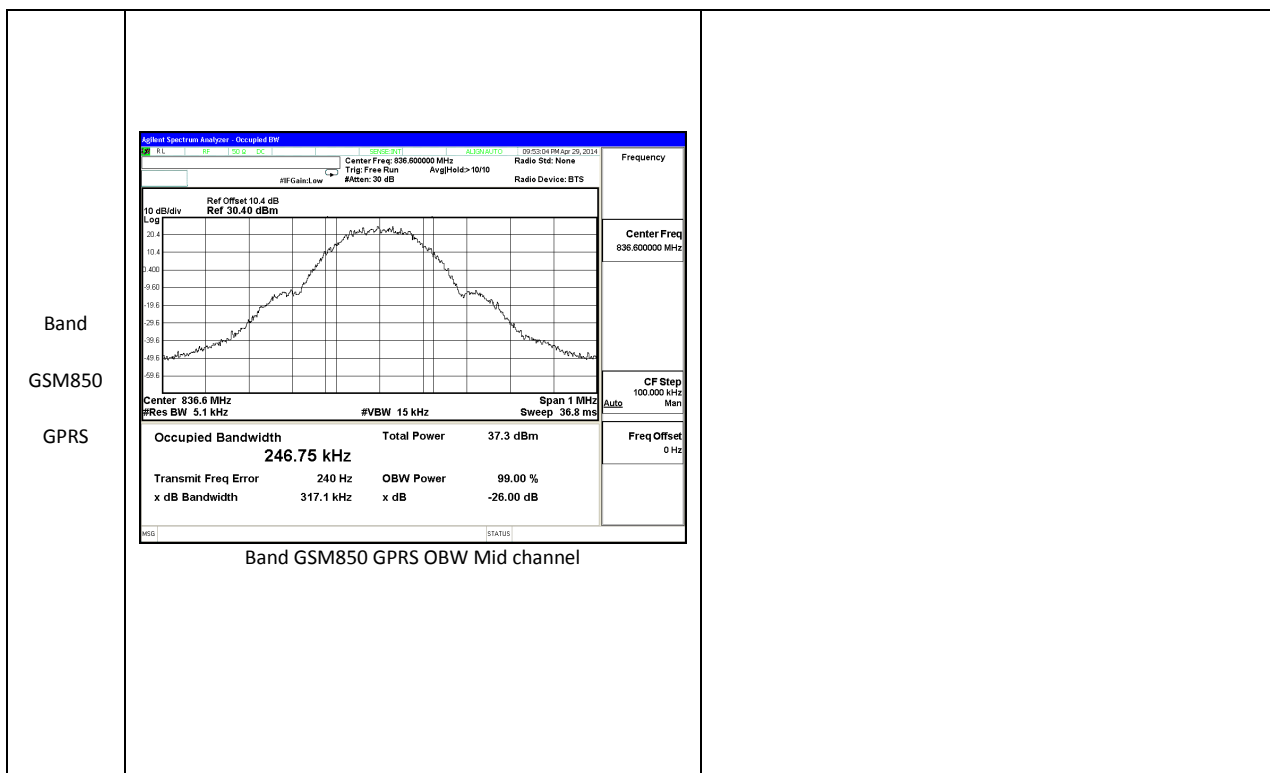
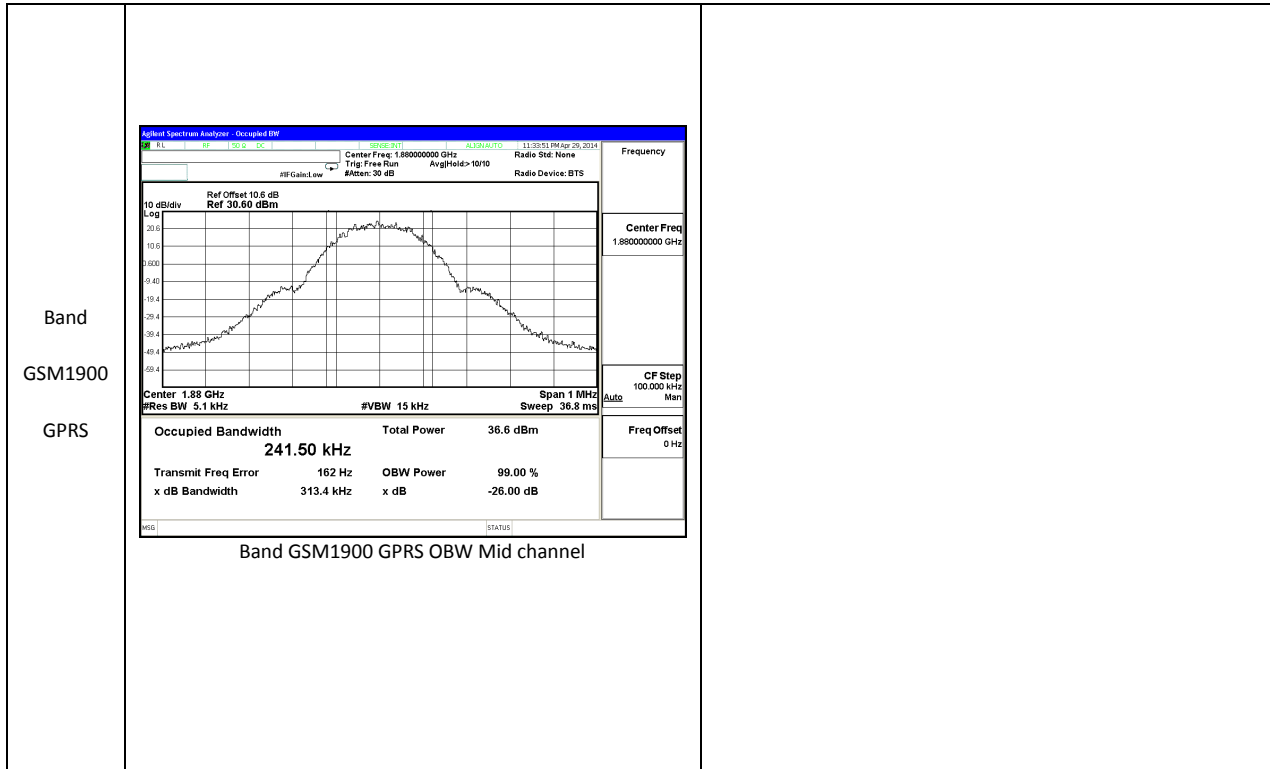

## **10.2. BAND EDGE EMISSIONS**

### **RULE PART(S)**

FCC: §22.359, §24.238

### **LIMITS**

The power of any emission outside of the authorized operating frequency ranges must be attenuated below the transmitting power (P) by a factor of at least  $43 + 10 \log (P)$  dB.

### **TEST PROCEDURE**

Per KDB 971168 D01 Power Meas License Digital Systems v02r01

The transmitter output was connected to an Agilent 8960 or a CMW500 Test Set and configured to operate at maximum power. The band edge emissions were measured at the required operating frequencies in each band on the Spectrum Analyzer.

### **MODES TESTED**

GSM 850, GSM 1900, WCDMA Band 2

### **RESULTS**

10.2.1. BAND EDGE PLOTS

<p>Band Band 2 HSDPA</p>	<p>Band WCDMA B2 HSDPA CBE</p>	<p>Band WCDMA B2 HSDPA CBE</p>
<p>Band Band 2 REL99</p>	<p>Band WCDMA B2 REL99 CBE</p>	<p>Band WCDMA B2 REL99 CBE</p>

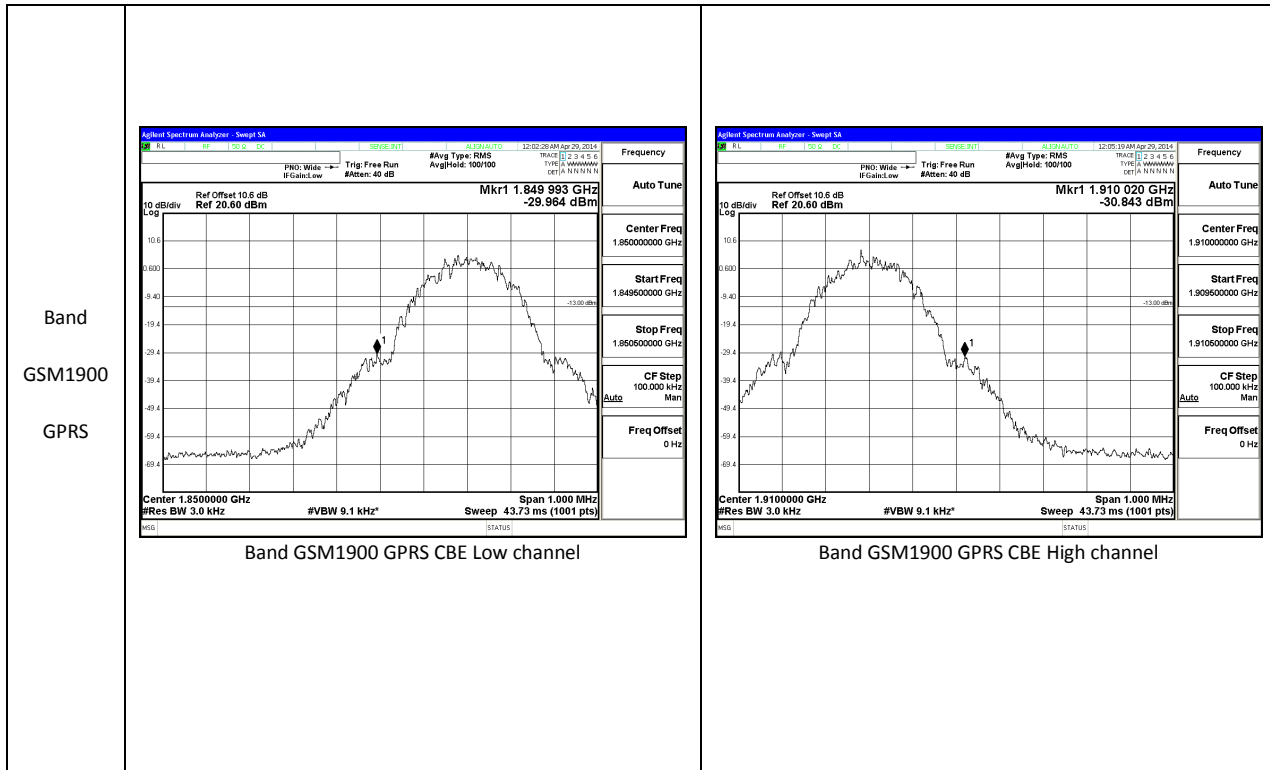

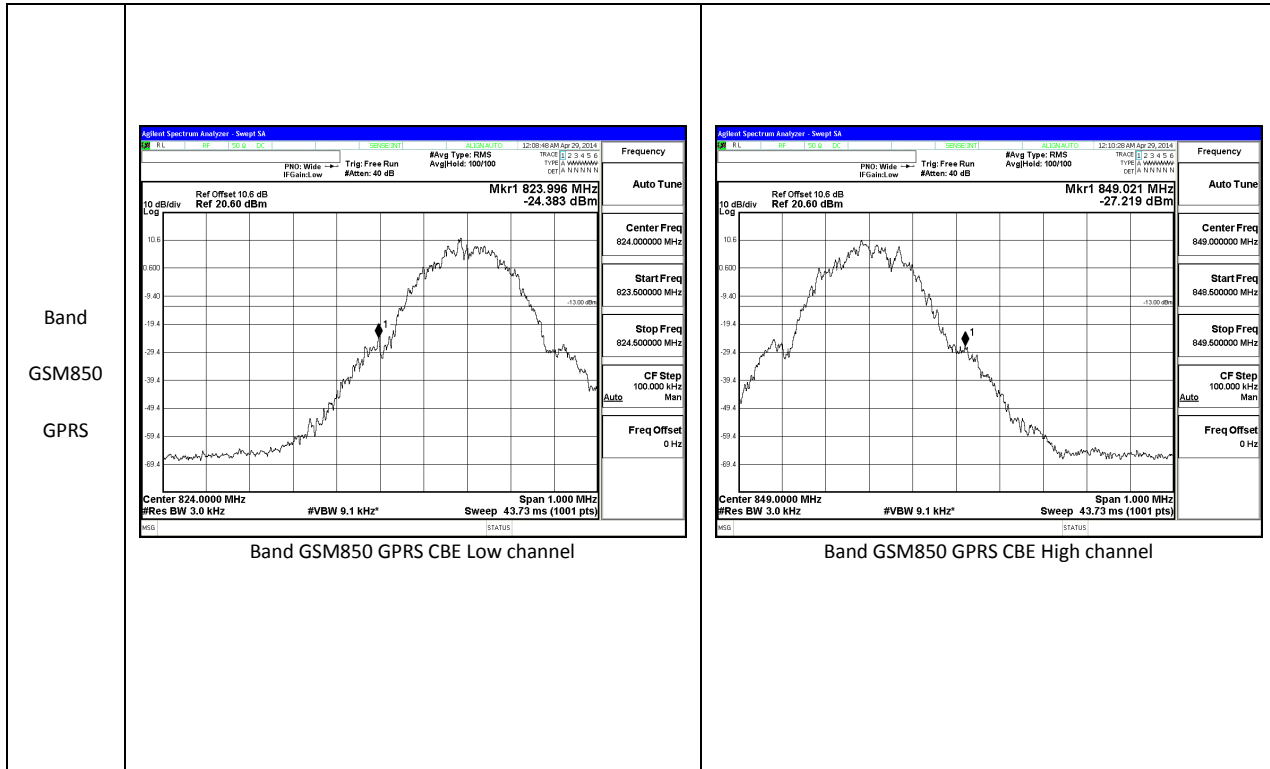

### 10.3. OUT OF BAND EMISSIONS

#### RULE PART(S)

FCC: §2.1051, §22.901, §22.917, §24.238

#### LIMITS

The power of any emission outside of the authorized operating frequency ranges must be attenuated below the transmitting power (P) by a factor of at least  $43 + 10 \log (P)$  dB.

#### TEST PROCEDURE

Per KDB 971168 D01 Power Meas License Digital Systems v02r01

The RF output of the transmitter was connected to a spectrum analyzer through a calibrated coaxial cable. Sufficient scans were taken to show the out-of-band Emissions, if any, up to 10th harmonic. Multiple sweeps were recorded in maximum hold mode using a peak detector to ensure that the worst-case emissions were caught.

#### MODES TESTED

GSM850, GSM1900, WCDMA Band 2

**RESULTS**

**10.3.1. OUT OF BAND EMISSIONS RESULT**

Band	Mode	f (MHz)	Spur (dBm)	Spec (dBm)	Delta (dB)
GSM	850 GPRS	824.2	-23.18	-13	-10.18
		836.6	-22.76	-13	-9.76
		848.8	-23.08	-13	-10.08
	1900 GPRS	1850.2	-23.37	-13	-10.37
		1880	-21.86	-13	-8.86
		1909.8	-22.95	-13	-9.95
WCDMA Band 2	REL99	1852.4	-23.33	-13	-10.33
		1880	-22.95	-13	-9.95
		1907.6	-23.33	-13	-10.33
	HSDPA	1852.4	-22.32	-13	-9.32
		1880	-22.72	-13	-9.72
		1907.6	-21.97	-13	-8.97

### 10.3.2. OUT OF BAND EMISSIONS PLOTS

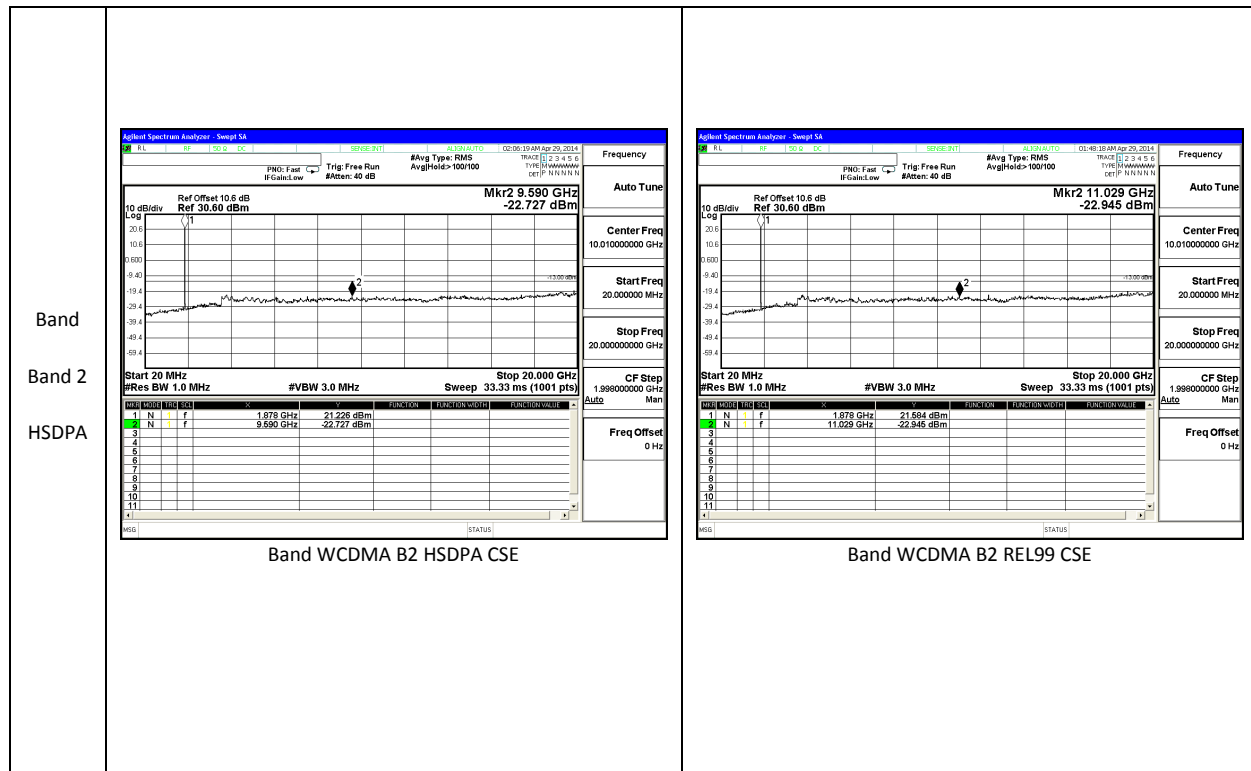

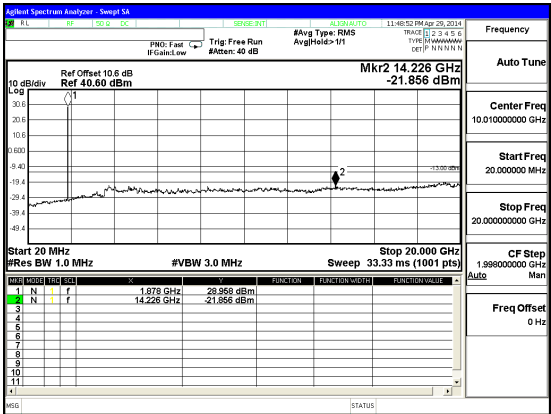
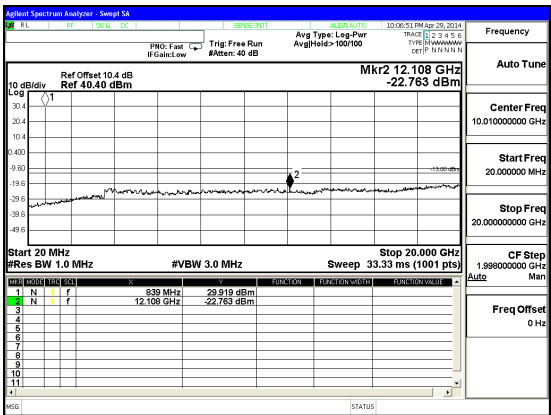
<p>Band GSM1900 GPRS</p>	 <p style="text-align: center;">Band GSM1900 GPRS CSE Mid channel</p>	
<p>Band GSM850 GPRS</p>	 <p style="text-align: center;">Band GSM850 GPRS CSE Mid channel</p>	

## **10.4. FREQUENCY STABILITY**

### **RULE PART(S)**

FCC: §2.1055, §22.355, §24.235

### **LIMITS**

§22.355 - The carrier frequency shall not depart from the reference frequency in excess of  $\pm 2.5$  ppm for mobile stations.

§24.235 - The frequency stability shall be sufficient to ensure that the fundamental emission stays within the authorized frequency block.

### **TEST PROCEDURE**

Per KDB 971168 D01 Power Meas License Digital Systems v02r01

### **RESULTS**

See the following pages.

### 10.4.1. FREQUENCY STABILITY RESULTS

**GSM850, – MID CHANNEL190, Frequency 836.6MHz**

Reference Frequency: Cell Mid Channel 836.6 MHz @ 20°C Limit: +- 2.5 ppm = 2091.500 Hz				
Power Supply (Vdc)	Environment Temperature (°C)	Frequency Deviation Measured with Time Elapse		
		(MHz)	Delta (ppm)	Limit (ppm)
3.80	50	836.600003	0.012	2.5
3.80	40	836.600005	0.010	2.5
3.80	30	836.600007	0.007	2.5
3.80	<b>20</b>	<b>836.600013</b>	<b>0</b>	<b>2.5</b>
3.80	10	836.600010	0.004	2.5
3.80	0	836.600008	0.006	2.5
3.80	-10	836.600009	0.005	2.5
3.80	-20	836.600012	0.001	2.5
3.80	-30	836.600014	-0.001	2.5

Reference Frequency: Cell Mid Channel 836.6 MHz @ 20°C Limit: +- 2.5 ppm = 2091.500 Hz				
Power Supply (Vdc)	Environment Temperature (°C)	Frequency Deviation Measured with Time Elapse		
		(MHz)	Delta (ppm)	Limit (ppm)
<b>3.80</b>	<b>20</b>	<b>836.600013</b>	<b>0.00000</b>	<b>2.5</b>
4.30	20	836.600014	-0.00120	2.5
3.4 (end volt)	20	836.600012	0.00120	2.5

**BAND II, Channel 9400 Freq: 1880MHz– MID CHANNEL**

Reference Frequency: PC S Mid Channel 1880MHz @ 20°C				
Limit: to stay +/- 2.5 ppm = 4700.000 Hz				
Power Supply (Vdc)	Environment Temperature (°C)	Frequency Deviation Measured with Time Elapse		
		(MHz)	Delta (ppm)	Limit (ppm)
3.80	50	1880.000001	0.002	2.5
3.80	40	1880.000002	0.002	2.5
3.80	30	1880.000004	0.001	2.5
<b>3.80</b>	<b>20</b>	<b>1880.000005</b>	<b>0</b>	<b>2.5</b>
3.80	10	1880.000004	0.001	2.5
3.80	0	1880.000003	0.001	2.5
3.80	-10	1880.000004	0.001	2.5
3.80	-20	1880.000005	0.000	2.5
3.80	-30	1880.000006	-0.001	2.5

Reference Frequency: PCS Mid Channel 1880 MHz @ 20°C				
Limit: to stay +/- 2.5 ppm = 4700.000 Hz				
Power Supply (Vdc)	Environment Temperature (°C)	Frequency Deviation Measured with Time Elapse		
		(MHz)	Delta (ppm)	Limit (ppm)
<b>3.80</b>	<b>20</b>	<b>1880.000005</b>	<b>0</b>	<b>2.5</b>
4.30	20	1880.000006	-0.001	2.5
3.4 ( end volt)	20	1880.000004	0.001	2.5

## **11. RADIATED TEST RESULTS**

### **11.1. RADIATED POWER (ERP & EIRP)**

#### **RULE PART(S)**

FCC: §2.1046, §22.913, §24.232

#### **LIMITS**

22.913(a) - The ERP of mobile transmitters and auxiliary test transmitters must not exceed 7 Watts.

24.232(c) - Mobile/portable stations are limited to 2 watts e.i.r.p. peak power and the equipment must employ means to limit the power to the minimum necessary for successful communications.

In addition, when the transmitter power is measured in terms of average value, the peak-to-average ratio of the power shall not exceed 13dB.

#### **TEST PROCEDURE**

ANSI / TIA / EIA 603C Clause 2.2.17

#### **MODES TESTED**

GSM850, GSM1900, WCDMA Band 2

#### **TEST RESULTS**

**11.1.1. ERP/EIRP Results**

Band	Mode	Channel	f(MHz)	ERP / EIRP	
				dBm	mW
Band 2	REL99	9262	1852.4	17.60	57.54
		9400	1880	20.05	101.16
		9538	1907.6	20.18	104.23
	HSDPA	9262	1852.4	17.98	62.81
		9400	1880	18.40	69.18
		9538	1907.6	18.90	77.62
GSM 1900	Mode	Channel	f(MHz)	ERP / EIRP	
				dBm	mW
	GPRS	512	1850.2	26.97	497.74
		661	1880	27.54	567.54
810		1909.8	27.53	566.24	
Band	Mode	Channel	f(MHz)	ERP / EIRP	
				dBm	mW
GSM850	GPRS	128	824.2	26.60	457.09
		190	836.6	27.27	533.33
		251	848.8	28.38	688.65

**11.1.2. ERP/EIRP Data**

Band Band 2 HSDPA	<b>High Frequency Fundamental Measurement Compliance Certification Services Chamber A</b>								
	<b>Company:</b>		Samsung						
	<b>Project #:</b>		14I17986						
	<b>Date:</b>		06/18/14						
	<b>Test Engineer:</b>		R. Alegre/ D. Sblendorio/ N. Sheridan						
	<b>Configuration:</b>		EUT ONLY, Y Position						
	<b>Mode:</b>		HSDPA 99 B2 1900Mhz						
	<b>Test Equipment:</b>								
	Receiving: T136, and Chamber A SMA Cables								
	Substitution: Horn T59 Substitution, 4ft SMA Cable (244639001) Warehouse								
	<b>f</b>	<b>SG reading</b>	<b>Ant. Pol.</b>	<b>Cable Loss</b>	<b>Antenna Gain</b>	<b>EIRP</b>	<b>Limit</b>	<b>Delta</b>	<b>Notes</b>
	<b>MHz</b>	<b>(dBm)</b>	<b>(H/V)</b>	<b>(dB)</b>	<b>(dBi)</b>	<b>(dBm)</b>	<b>(dBm)</b>	<b>(dB)</b>	
	Low Ch								
	1852.40	10.3	V	0.85	7.85	17.34	33.0	-15.7	
	1852.40	11.0	H	0.85	7.85	17.98	33.0	-15.0	
	Mid Ch								
	1880.00	9.6	V	0.85	7.85	16.64	33.0	-16.4	
	1880.00	11.4	H	0.85	7.85	18.40	33.0	-14.6	
	High Ch								
	1907.60	10.8	V	0.85	7.90	17.88	33.0	-15.1	
	1907.60	11.9	H	0.85	7.90	18.90	33.0	-14.1	
	Rev. 3.17.11								

Band Band 2 REL99	<b>High Frequency Fundamental Measurement                  Compliance Certification Services Chamber A</b>																																																																																																	
	<b>Company:</b>		Samsung																																																																																															
	<b>Project #:</b>		14I17986																																																																																															
	<b>Date:</b>		06/18/14																																																																																															
	<b>Test Engineer:</b>		R. Alegre/D. Sblendorio/N. Sheridan																																																																																															
	<b>Configuration:</b>		EUT ONLY, Y Position																																																																																															
	<b>Mode:</b>		REL 99 B2 1900Mhz																																																																																															
	<b>Test Equipment:</b>																																																																																																	
	<b>Receiving:</b>		T136, and Chamber A SMA Cables																																																																																															
	<b>Substitution:</b>		Horn T59 Substitution, 4ft SMA Cable (244639001) Warehouse																																																																																															
<table border="1"> <thead> <tr> <th>f MHz</th> <th>SG reading (dBm)</th> <th>Ant. Pol. (H/V)</th> <th>Cable Loss (dB)</th> <th>Antenna Gain (dBi)</th> <th>EIRP (dBm)</th> <th>Limit (dBm)</th> <th>Delta (dB)</th> <th>Notes</th> </tr> </thead> <tbody> <tr> <td colspan="9">Low Ch</td> </tr> <tr> <td>1852.40</td> <td>7.1</td> <td>V</td> <td>0.85</td> <td>7.85</td> <td>14.06</td> <td>33.0</td> <td>-18.9</td> <td></td> </tr> <tr> <td>1852.40</td> <td>10.6</td> <td>H</td> <td>0.85</td> <td>7.85</td> <td>17.60</td> <td>33.0</td> <td>-15.4</td> <td></td> </tr> <tr> <td colspan="9">Mid Ch</td> </tr> <tr> <td>1880.00</td> <td>9.7</td> <td>V</td> <td>0.85</td> <td>7.85</td> <td>16.68</td> <td>33.0</td> <td>-16.3</td> <td></td> </tr> <tr> <td>1880.00</td> <td>13.1</td> <td>H</td> <td>0.85</td> <td>7.85</td> <td>20.05</td> <td>33.0</td> <td>-13.0</td> <td></td> </tr> <tr> <td colspan="9">High Ch</td> </tr> <tr> <td>1907.60</td> <td>8.5</td> <td>V</td> <td>0.85</td> <td>7.90</td> <td>15.59</td> <td>33.0</td> <td>-17.4</td> <td></td> </tr> <tr> <td>1907.60</td> <td>13.1</td> <td>H</td> <td>0.85</td> <td>7.90</td> <td>20.18</td> <td>33.0</td> <td>-12.8</td> <td></td> </tr> </tbody> </table>									f MHz	SG reading (dBm)	Ant. Pol. (H/V)	Cable Loss (dB)	Antenna Gain (dBi)	EIRP (dBm)	Limit (dBm)	Delta (dB)	Notes	Low Ch									1852.40	7.1	V	0.85	7.85	14.06	33.0	-18.9		1852.40	10.6	H	0.85	7.85	17.60	33.0	-15.4		Mid Ch									1880.00	9.7	V	0.85	7.85	16.68	33.0	-16.3		1880.00	13.1	H	0.85	7.85	20.05	33.0	-13.0		High Ch									1907.60	8.5	V	0.85	7.90	15.59	33.0	-17.4		1907.60	13.1	H	0.85	7.90	20.18	33.0	-12.8	
f MHz	SG reading (dBm)	Ant. Pol. (H/V)	Cable Loss (dB)	Antenna Gain (dBi)	EIRP (dBm)	Limit (dBm)	Delta (dB)	Notes																																																																																										
Low Ch																																																																																																		
1852.40	7.1	V	0.85	7.85	14.06	33.0	-18.9																																																																																											
1852.40	10.6	H	0.85	7.85	17.60	33.0	-15.4																																																																																											
Mid Ch																																																																																																		
1880.00	9.7	V	0.85	7.85	16.68	33.0	-16.3																																																																																											
1880.00	13.1	H	0.85	7.85	20.05	33.0	-13.0																																																																																											
High Ch																																																																																																		
1907.60	8.5	V	0.85	7.90	15.59	33.0	-17.4																																																																																											
1907.60	13.1	H	0.85	7.90	20.18	33.0	-12.8																																																																																											
Rev. 3.17.11																																																																																																		

Band  
GSM1900  
GPRS

**High Frequency Fundamental Measurement  
Compliance Certification Services Chamber A**

**Company:** Samsung  
**Project #:** 14I17986  
**Date:** 06/18/14  
**Test Engineer:** R.Alegre/Nick/Dante  
**Configuration:** EUT ONLY, Y Position  
**Mode:** GPRS 1900MHz

**Test Equipment:**

**Receiving:** T136, and Chamber A SMA Cables  
**Substitution:** Horn T59 Substitution, 4ft SMA Cable (244639001) Warehouse

f GHz	SG reading (dBm)	Ant. Pol. (H/V)	Cable Loss (dB)	Antenna Gain (dBi)	EIRP (dBm)	Limit (dBm)	Delta (dB)	Notes
<b>Low Ch</b>								
1.850	19.9	V	0.85	7.90	26.97	33.0	-6.0	
1.850	17.9	H	0.85	7.90	24.96	33.0	-8.0	
<b>Mid Ch</b>								
1.880	19.3	V	0.85	7.90	26.38	33.0	-6.6	
1.880	20.5	H	0.85	7.90	27.54	33.0	-5.5	
<b>High Ch</b>								
1.910	20.0	V	0.85	7.80	26.94	33.0	-6.1	
1.910	20.6	H	0.85	7.80	27.53	33.0	-5.5	

Rev. 3.17.11

		<b>High Frequency Substitution Measurement</b>							
		<b>UL Verification Services, Inc. Chamber A</b>							
	<b>Company:</b>	Samsung							
	<b>Project #:</b>	14I17986							
	<b>Date:</b>	06/18/14							
	<b>Test Engineer:</b>	R. Alegre/Nick/Dante							
	<b>Configuration:</b>	EUT ONLY							
	<b>Mode:</b>	GPRS 850MHz							
	<b>Test Equipment:</b>								
Band		<b>Receiving: Sunol T1130, and 3m Chamber N-type Cable (Setup this one for testing EUT)</b>							
GSM850		<b>Substitution: Dipole S/N: 00022117, 4ft SMA Cable (SN # 245200 001) Warehouse.</b>							
GPRS									
f MHz	SG reading (dBm)	Ant. Pol. (H/V)	Cable Loss (dB)	Antenna Gain (dBd)	ERP (dBm)	Limit (dBm)	Margin (dB)	Notes	
<b>Low Ch</b>									
824.20	27.10	V	0.5	0.0	26.60	38.5	-11.8		
824.20	14.00	H	0.5	0.0	13.50	38.5	-24.9		
<b>Mid Ch</b>									
836.60	27.77	V	0.5	0.0	27.27	38.5	-11.2		
836.60	15.45	H	0.5	0.0	14.95	38.5	-23.5		
<b>High Ch</b>									
848.80	28.88	V	0.5	0.0	28.38	38.5	-10.1		
848.80	15.86	H	0.5	0.0	15.36	38.5	-23.1		
Rev. 3.17.11									
Note: For Band 13/17 ERP limit is 34.77dBm; For Band 26 limit is 50dBm									

## 11.2. FIELD STRENGTH OF SPURIOUS RADIATION

### RULE PART(S)

FCC: §2.1053, §22.917, §24.238

### LIMIT

§22.917 (e) and §24.238 (a): Out of band emissions. The power of any emission outside of the authorized operating frequency ranges must be attenuated below the transmitting power (P) by a factor of at least  $43 + 10 \log(P)$  dB

### TEST PROCEDURE

For Cellular equipment - Compliance with these rules is based on the use of measurement instrumentation employing a resolution bandwidth of 100 kHz or greater. In the 1 MHz bands immediately outside and adjacent to the frequency block a resolution bandwidth of at least one percent of the emission bandwidth of the fundamental emission of the transmitter may be employed. A narrower resolution bandwidth is permitted in all cases to improve measurement accuracy provided the measured power is integrated over the full required measurement bandwidth (i.e. 100 kHz or 1 percent of emission bandwidth, as specified). The emission bandwidth is defined as the width of the signal between two points, one below the carrier center frequency and one above the carrier center frequency, outside of which all emissions are attenuated at least 26 dB below the transmitter power.

For PCS equipment - Compliance with these rules is based on the use of measurement instrumentation employing a resolution bandwidth of 1 MHz or greater. However, in the 1 MHz bands immediately outside and adjacent to the frequency block a resolution bandwidth of at least one percent of the emission bandwidth of the fundamental emission of the transmitter may be employed. A narrower resolution bandwidth is permitted in all cases to improve measurement accuracy provided the measured power is integrated over the full required measurement bandwidth (i.e. 1 MHz or 1 percent of emission bandwidth, as specified). The emission bandwidth is defined as the width of the signal between two points, one below the carrier center frequency and one above the carrier center frequency, outside of which all emissions are attenuated at least 26 dB below the transmitter power.

### RESULTS

### 11.2.1. SPURIOUS RADIATION DATA

Compliance Certification Services Above 1GHz High Frequency Substitution Measurement										
Company:		Samsung								
Project #:		14I17986								
Date:		06/18/14								
Test Engineer:		O. Stoelting, D. Sblendorio								
Configuration:		X-pos EUT, Charger, HS								
Mode:		WCDMA_HSDPA 1900								
Chamber		Pre-amplifer		Filter		Limit				
5m Chamber B		T343 8449B		Filter 1		Part 24				
Band	f GHz	SG reading (dBm)	Ant. Pol. (H/V)	Distance (m)	Preamp (dB)	Filter (dB)	EIRP (dBm)	Limit (dBm)	Delta (dB)	Notes
Low Ch, 1852.4MHz										
Band 2	3.705	-21.4	V	3.0	35.4	1.0	-55.8	-13.0	-42.8	
	5.557	-17.0	V	3.0	34.7	1.0	-50.7	-13.0	-37.7	
	7.409	-3.9	V	3.0	34.9	1.0	-37.8	-13.0	-24.8	
HSDPA	3.705	-21.7	H	3.0	35.4	1.0	-56.1	-13.0	-43.1	
	5.557	-17.3	H	3.0	34.7	1.0	-51.1	-13.0	-38.1	
	7.409	-12.0	H	3.0	34.9	1.0	-45.9	-13.0	-32.9	
Mid Ch, 1880.0MHz										
	3.760	-17.3	V	3.0	35.3	1.0	-51.7	-13.0	-38.7	
	5.640	-15.6	V	3.0	34.7	1.0	-49.3	-13.0	-36.3	
	7.520	-15.1	V	3.0	34.9	1.0	-49.1	-13.0	-36.1	
	3.760	-17.1	H	3.0	35.3	1.0	-51.5	-13.0	-38.5	
	5.640	-14.7	H	3.0	34.7	1.0	-48.5	-13.0	-35.5	
	7.520	-13.4	H	3.0	34.9	1.0	-47.3	-13.0	-34.3	
High Ch, 1907.6 MHz										
	3.820	-22.0	V	3.0	35.3	1.0	-56.2	-13.0	-43.2	
	5.723	-18.6	V	3.0	34.7	1.0	-52.3	-13.0	-39.3	
	7.630	-13.6	V	3.0	34.9	1.0	-47.5	-13.0	-34.5	
	3.820	-21.3	H	3.0	35.3	1.0	-55.6	-13.0	-42.6	
	5.723	-15.9	H	3.0	34.7	1.0	-49.7	-13.0	-36.7	
	7.630	-11.9	H	3.0	34.9	1.0	-45.8	-13.0	-32.8	
Rev. 03.03.09										
Note: No other emissions were detected above the system noise floor.										

**Compliance Certification Services**  
**Above 1GHz High Frequency Substitution Measurement**

**Company:** Samsung  
**Project #:** 14I17986  
**Date:** 06/18/14  
**Test Engineer:** O. Stoelting, D. Sblendorio  
**Configuration:** X-pos EUT, Charger, HS  
**Mode:** WCDMA\_Rel 1900

<b>Chamber</b>	<b>Pre-amplifer</b>	<b>Filter</b>	<b>Limit</b>
5m Chamber B	T343 8449B	Filter 1	Part 24

Band	f GHz	SG reading (dBm)	Ant. Pol. (H/V)	Distance (m)	Preamp (dB)	Filter (dB)	EIRP (dBm)	Limit (dBm)	Delta (dB)	Notes
	<b>Low Ch, 1852.4MHz</b>									
Band 2	3.705	-21.6	V	3.0	35.4	1.0	-56.0	-13.0	-43.0	
	5.557	-17.7	V	3.0	34.7	1.0	-51.4	-13.0	-38.4	
REL99	7.409	-13.8	V	3.0	34.9	1.0	-47.7	-13.0	-34.7	
	3.705	-23.9	H	3.0	35.4	1.0	-58.3	-13.0	-45.3	
	5.557	-16.4	H	3.0	34.7	1.0	-50.1	-13.0	-37.1	
	7.409	-12.2	H	3.0	34.9	1.0	-46.1	-13.0	-33.1	
	<b>Mid Ch, 1880.0MHz</b>									
	3.760	-17.4	V	3.0	35.3	1.0	-51.8	-13.0	-38.8	
	5.640	-15.5	V	3.0	34.7	1.0	-49.3	-13.0	-36.3	
	7.520	-15.0	V	3.0	34.9	1.0	-48.9	-13.0	-35.9	
	3.760	-17.5	H	3.0	35.3	1.0	-51.8	-13.0	-38.8	
	5.640	-14.7	H	3.0	34.7	1.0	-48.4	-13.0	-35.4	
	7.520	-13.5	H	3.0	34.9	1.0	-47.4	-13.0	-34.4	
	<b>High Ch, 1907.6 MHz</b>									
	3.820	-21.3	V	3.0	35.3	1.0	-55.6	-13.0	-42.6	
	5.723	-16.8	V	3.0	34.7	1.0	-50.6	-13.0	-37.6	
	7.630	-13.4	V	3.0	34.9	1.0	-47.3	-13.0	-34.3	
	3.820	-20.2	H	3.0	35.3	1.0	-54.5	-13.0	-41.5	
	5.723	-15.7	H	3.0	34.7	1.0	-49.4	-13.0	-36.4	
	7.630	-11.7	H	3.0	34.9	1.0	-45.6	-13.0	-32.6	

Rev. 03.03.09  
 Note: No other emissions were detected above the system noise floor.

Compliance Certification Services Above 1GHz High Frequency Substitution Measurement										
<b>Company:</b>		Samsung								
<b>Project #:</b>		14I17986								
<b>Date:</b>		06/18/14								
<b>Test Engineer:</b>		O. Stoelting, D. Sblendorio								
<b>Configuration:</b>		X-pos EUT, Charger, HS								
<b>Mode:</b>		GPRS 1900								
Chamber		Pre-amplifer			Filter		Limit			
5m Chamber B		T343 8449B			Filter 1		Part 24			
Band	f GHz	SG reading (dBm)	Ant. Pol. (H/V)	Distance (m)	Preamp (dB)	Filter (dB)	EIRP (dBm)	Limit (dBm)	Delta (dB)	Notes
<b>Low Ch, 1850MHz</b>										
GSM1900	3.700	-11.2	V	3.0	35.4	1.0	-45.6	-13.0	-32.6	
	5.550	-9.8	V	3.0	34.7	1.0	-43.5	-13.0	-30.5	
	7.400	-8.9	V	3.0	34.9	1.0	-42.8	-13.0	-29.8	
GPRS	3.700	-16.8	H	3.0	35.4	1.0	-51.2	-13.0	-38.2	
	5.550	-14.0	H	3.0	34.7	1.0	-47.7	-13.0	-34.7	
	7.400	-12.5	H	3.0	34.9	1.0	-46.4	-13.0	-33.4	
<b>Mid Ch, 1880.0MHz</b>										
	3.760	-21.4	V	3.0	35.3	1.0	-55.8	-13.0	-42.8	
	5.640	-18.0	V	3.0	34.7	1.0	-51.7	-13.0	-38.7	
	7.520	-20.1	V	3.0	34.9	1.0	-54.1	-13.0	-41.1	
	3.760	-19.2	H	3.0	35.3	1.0	-53.5	-13.0	-40.5	
	5.640	-19.1	H	3.0	34.7	1.0	-52.8	-13.0	-39.8	
	7.520	-18.5	H	3.0	34.9	1.0	-52.4	-13.0	-39.4	
<b>High Ch, 1909.8 MHz</b>										
	3.820	-17.5	V	3.0	35.3	1.0	-51.8	-13.0	-38.8	
	5.729	-21.8	V	3.0	34.7	1.0	-55.5	-13.0	-42.5	
	7.639	-20.7	V	3.0	35.0	1.0	-54.7	-13.0	-41.7	
	3.820	-18.6	H	3.0	35.3	1.0	-52.9	-13.0	-39.9	
	5.729	-20.7	H	3.0	34.7	1.0	-54.4	-13.0	-41.4	
	7.639	-19.1	H	3.0	35.0	1.0	-53.1	-13.0	-40.1	
Rev. 03.03.09										
Note: No other emissions were detected above the system noise floor.										

Compliance Certification Services Above 1GHz High Frequency Substitution Measurement										
<b>Company:</b>		Samsung								
<b>Project #:</b>		14I17986								
<b>Date:</b>		06/18/14								
<b>Test Engineer:</b>		O. Stoelting, D. Sblendorio (and S. Her, K. Ros, E. Black)								
<b>Configuration:</b>		X-pos EUT, Charger, HS								
<b>Mode:</b>		GPRS 850								
Chamber		Pre-amplifer			Filter		Limit			
3m Chamber		T34 8449B			Filter 1		Part 22			
Band	f GHz	SG reading (dBm)	Ant. Pol. (H/V)	Distance (m)	Preamp (dB)	Filter (dB)	EIRP (dBm)	Limit (dBm)	Delta (dB)	Notes
	<b>Low Ch, 824.2MHz</b>									
GSM850	1.648	-26.5	V	3.0	37.4	1.0	-62.9	-13.0	-49.9	
	2.743	-19.3	V	3.0	36.2	1.0	-54.6	-13.0	-41.6	
	3.297	-20.3	V	3.0	35.8	1.0	-55.1	-13.0	-42.1	
GPRS	1.648	-25.4	H	3.0	37.4	1.0	-61.8	-13.0	-48.8	
	2.473	-21.4	H	3.0	36.4	1.0	-56.8	-13.0	-43.8	
	3.297	-20.2	H	3.0	35.8	1.0	-55.0	-13.0	-42.0	
	<b>Mid Ch, 836.6MHz</b>									
	1.673	-25.7	V	3.0	37.3	1.0	-62.0	-13.0	-49.0	
	2.510	-20.2	V	3.0	36.4	1.0	-55.5	-13.0	-42.5	
	3.346	-20.4	V	3.0	35.8	1.0	-55.1	-13.0	-42.1	
	1.673	-26.3	H	3.0	37.3	1.0	-62.7	-13.0	-49.7	
	2.510	-22.0	H	3.0	36.4	1.0	-57.4	-13.0	-44.4	
	3.346	-20.4	H	3.0	35.8	1.0	-55.1	-13.0	-42.1	
	<b>High Ch, 848.8MHz</b>									
	1.698	-25.6	V	3.0	37.3	1.0	-61.9	-13.0	-48.9	
	2.547	-20.1	V	3.0	36.3	1.0	-55.4	-13.0	-42.4	
	3.395	-19.6	V	3.0	35.7	1.0	-54.3	-13.0	-41.3	
	1.698	-25.3	H	3.0	37.3	1.0	-61.6	-13.0	-48.6	
	2.547	-22.0	H	3.0	36.3	1.0	-57.4	-13.0	-44.4	
	3.395	-20.0	H	3.0	35.7	1.0	-54.7	-13.0	-41.7	
Rev. 03.03.09										
Note: No other emissions were detected above the system noise floor.										