



**FCC CFR47 PART 22 SUBPART H
FCC CFR47 PART 24 SUBPART E**

CERTIFICATION TEST REPORT

For

GSM 850/1900 Phone + Bluetooth, WLAN 2.4GHz b/g/n & NFC

MODEL NUMBER: SM-G310HN

FCC ID: A3LSMG310HN

REPORT NUMBER: 14I17192-1, Revision A

ISSUE DATE: March 13, 2014

Prepared for

**SAMSUNG ELECTRONICS CO., LTD.
416, MAETAN 3-DONG, YEONGTONG-GU
SUWON-CITY, GYEONGGI-DO 443-742, SOUTH KOREA**

Prepared by

**UL VERIFICATION SERVICES INC.
47173 BENICIA STREET
FREMONT, CA 94538, U.S.A.
TEL: (510) 771-1000
FAX: (510) 661-0888**



NVLAP LAB CODE 200065-0

Revision History

Rev.	Date	Revisions	Revised By
--	2/24/14	Initial Issue	P. Kim
A	3/13/14	Updated summary table	P. Kim

TABLE OF CONTENTS

1.	ATTESTATION OF TEST RESULTS	5
2.	TEST METHODOLOGY	6
3.	FACILITIES AND ACCREDITATION	6
4.	CALIBRATION AND UNCERTAINTY	6
4.1.	MEASURING INSTRUMENT CALIBRATION	6
4.2.	SAMPLE CALCULATION.....	6
4.3.	MEASUREMENT UNCERTAINTY	6
5.	EQUIPMENT UNDER TEST	7
5.1.	DESCRIPTION OF EUT.....	7
5.2.	MAXIMUM OUTPUT POWER.....	7
5.3.	DESCRIPTION OF AVAILABLE ANTENNAS	7
5.4.	DESCRIPTION OF TEST SETUP.....	8
6.	TEST AND MEASUREMENT EQUIPMENT	11
7.	Summary Table	12
8.	RF POWER OUTPUT VERIFICATION.....	13
8.1.	GSM/GPRS/EDGE.....	13
8.1.1.	GSM OUTPUT POWER RESULT.....	14
9.	LIMITS AND CONDUCTED RESULTS.....	15
9.1.	OCCUPIED BANDWIDTH.....	15
9.1.1.	OCCUPIED BANDWIDTH RESULTS	16
9.1.2.	OCCUPIED BANDWIDTH PLOTS.....	17
9.2.	BAND EDGE EMISSIONS	18
9.2.1.	BAND EDGE PLOTS	19
9.3.	OUT OF BAND EMISSIONS.....	20
9.3.1.	OUT OF BAND EMISSIONS RESULT.....	21
9.3.2.	OUT OF BAND EMISSIONS PLOTS	22
9.4.	FREQUENCY STABILITY.....	23
9.4.1.	FREQUENCY STABILITY RESULTS	24
10.	RADIATED TEST RESULTS.....	25
10.1.	RADIATED POWER (ERP & EIRP).....	25
10.1.1.	ERP/EIRP Results	26

10.1.2. ERP/EIRP PLOTS27
10.2. FIELD STRENGTH OF SPURIOUS RADIATION.....29
10.2.1. SPURIOUS RADIATION PLOTS.....30
11. SETUP PHOTOS32

1. ATTESTATION OF TEST RESULTS

COMPANY NAME: SAMSUNG ELECTRONICS CO., LTD.
EUT DESCRIPTION: GSM 850/1900 Phone + Bluetooth, WLAN 2.4GHz b/g/n & NFC
MODEL: SM-G310HN
SERIAL NUMBER: FL-082-C (Radiated & Conducted)
DATE TESTED: JANUARY 8-13, 2014

APPLICABLE STANDARDS	
STANDARD	TEST RESULTS
FCC PART 22H and 24E	PASS

UL Verification Services Inc. tested the above equipment in accordance with the requirements set forth in the above standards. All indications of Pass/Fail in this report are opinions expressed by UL Verification Services Inc. based on interpretations and/or observations of test results. Measurement Uncertainties were not taken into account and are published for informational purposes only. The test results show that the equipment tested is capable of demonstrating compliance with the requirements as documented in this report.

Note: The results documented in this report apply only to the tested sample, under the conditions and modes of operation as described herein. This document may not be altered or revised in any way unless done so by UL Verification Services Inc. and all revisions are duly noted in the revisions section. Any alteration of this document not carried out by UL Verification Services Inc. will constitute fraud and shall nullify the document. This report must not be used by the client to claim product certification, approval, or endorsement by NVLAP, NIST, any agency of the Federal Government, or any agency of any government.

Approved & Released For

UL Verification Services Inc. By:

Tested By:



PHILIP KIM
WiSE OPERATIONS MANAGER
UL VERIFICATION SERVICES INC.

STEVEN TRAN
WiSE LAB TECHNICIAN
UL VERIFICATION SERVICES INC.

2. TEST METHODOLOGY

The tests documented in this report were performed in accordance with TIA-603-C, FCC CFR 47 Part 22, FCC CFR Part 24.

3. FACILITIES AND ACCREDITATION

The test sites and measurement facilities used to collect data are located at 47173 Benicia Street, Fremont, California, USA.

UL Verification Services Inc. is accredited by NVLAP, Laboratory Code 200065-0. The full scope of accreditation can be viewed at <http://www.ccsemc.com>.

4. CALIBRATION AND UNCERTAINTY

4.1. MEASURING INSTRUMENT CALIBRATION

The measuring equipment utilized to perform the tests documented in this report has been calibrated in accordance with the manufacturer's recommendations, and is traceable to recognized national standards

4.2. SAMPLE CALCULATION

Where relevant, the following sample calculation is provided:

$$\text{EIRP} = \text{PSA reading with EUT worst orientation (dBm)} + \text{Path loss (dB)} - \text{cable loss(between the SG and substitution antenna)} + \text{Substitution Antenna Factor (dBi)}$$
$$\text{ERP} = \text{PSA reading with EUT worst orientation (dBm)} + \text{Path loss (dB)} - \text{cable loss(between the SG and substitution antenna)}$$

(Path loss = Signal generator output – PSA reading with substitution antenna)

4.3. MEASUREMENT UNCERTAINTY

Where relevant, the following measurement uncertainty levels have been estimated for tests performed on the apparatus:

PARAMETER	UNCERTAINTY
Conducted Disturbance, 0.15 to 30 MHz	3.52 dB
Radiated Disturbance, 30 to 18000 MHz	4.94 dB

Uncertainty figures are valid to a confidence level of 95%.

5. EQUIPMENT UNDER TEST

5.1. DESCRIPTION OF EUT

The EUT is a GSM 850/1900 Phone + Bluetooth, WLAN 2.4GHz b/g/n & NFC.

5.2. MAXIMUM OUTPUT POWER

The transmitter has a maximum peak conducted and radiated ERP / EIRP output powers as follows:

FCC Part 22/2 4						
Band	Frequency Range(MHz)	Modulation Peak	Conducted		Radiated	
			Peak (dBm)	Peak (mW)	Peak (dBm)	Peak (mW)
GSM850	824~849	GMSK	32.0	1584.89		
	824~849	GPRS	32.0	1584.89	25.77	377.6
GSM1900	1850~1910	GMSK	29.0	794.33		
	1850~1910	GPRS	29.0	794.33	31.15	1303

5.3. DESCRIPTION OF AVAILABLE ANTENNAS

The radio utilizes a PIFA antenna for the [List the bands supported] with a maximum peak gain as follow:

Frequency (MHz)	Peak Gain (dBi)
GSM850, 824~849MHz	-3.19
GSM1900, 1850~1910MHz	1.66

5.4. DESCRIPTION OF TEST SETUP

SUPPORT EQUIPMENT

Support Equipment List				
Description	Manufacturer	Model	Serial Number	FCC ID
AC Adapter	Samsung	SM-G310H	DK4DA09TS	N/A
Earphone	Samsung	SM-G310H	N/A	N/A

I/O CABLES (CONDUCTED SETUP)

I/O Cable List						
Cable No	Port	# of identical ports	Connector Type	Cable Type	Cable Length (m)	Remarks
1	RF Out	1	Spectrum Analyzer	Shielded	None	NA
2	Antenna Port	1	EUT	Shielded	0.1m	NA
3	RF In/Out	1	Communication Test Set	Shielded	1m	NA

I/O CABLES (RADIATED SETUP)

I/O CABLE LIST						
Cable No.	Port	# of Identical Ports	Connector Type	Cable Type	Cable Length	Remarks
1	USB	1	AC Adapter	Un-shielded	1.2m	No
2	Jack	1	Headset	Shielded	1m	No
3	RF In/out	1	Communication Test Set	Un-shielded	2m	Yes

TEST SETUP

The EUT is continuously communicated to the call box during the tests.

SETUP DIAGRAM FOR TESTS (CONDUCTED TEST SETUP)

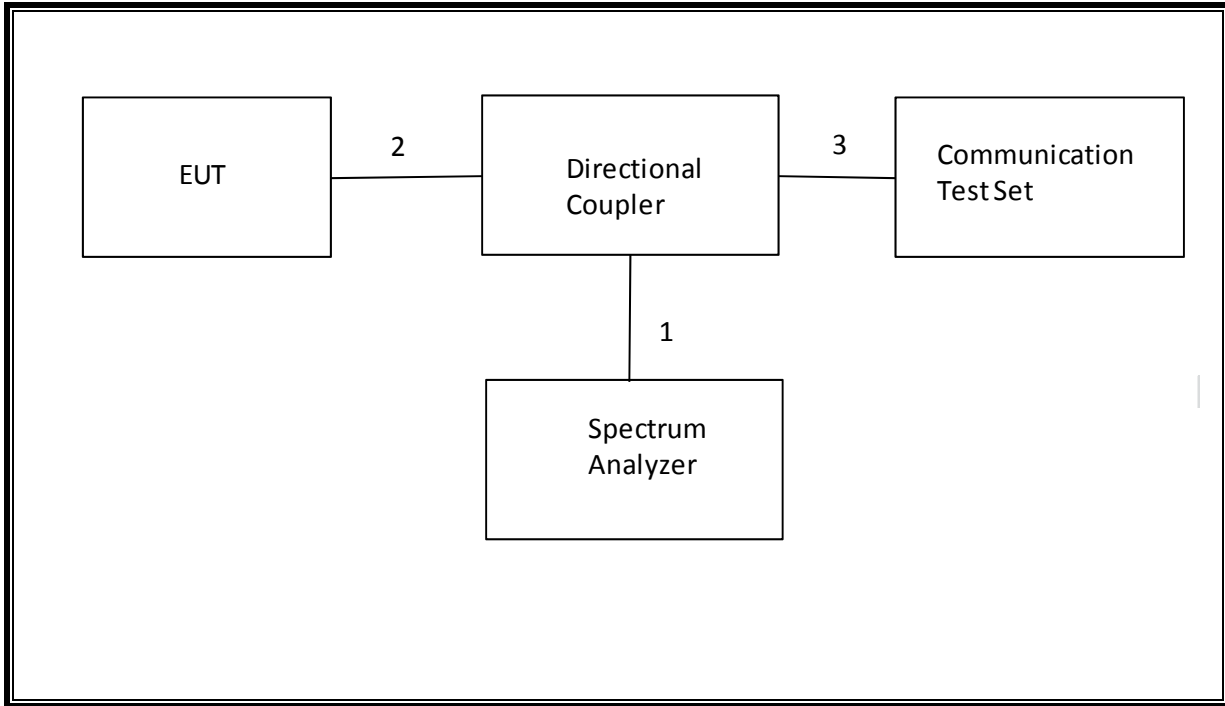

SETUP DIAGRAM FOR TESTS (RADIATED TEST SETUP)

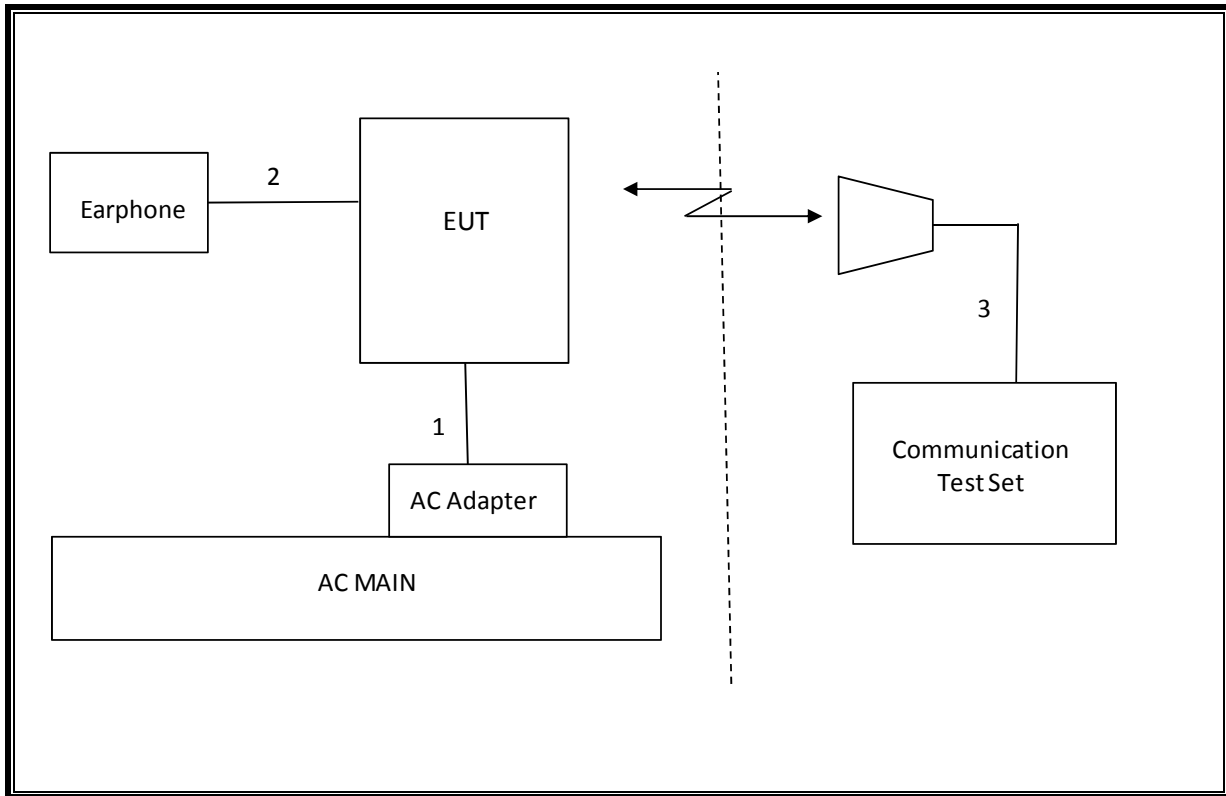

6. TEST AND MEASUREMENT EQUIPMENT

The following test and measurement equipment was utilized for the tests documented in this report:

TEST EQUIPMENT LIST				
Description	Manufacturer	Model	Asset	Cal Due
Spectrum Analyzer, 44 GHz	Agilent / HP	E4446A	C01179	02/26/14
Antenna, Bilog, 2 GHz	Sunol Sciences	JB1	C01011	08/14/14
Antenna, Horn, 18 GHz	EMCO	3115	C00783	10/25/14
Antenna, Horn, 18 GHz	EMCO	3115	C00825	09/25/14
Highpass Filter, 2.7 GHz	Micro-Tronics	HPM13194	N02687	CNR
Highpass Filter, 1.5 GHz	Micro-Tronics	HPM13193	N02688	CNR
Temperature / Humidity Chamber	Thermotron	SE 600-10-10	C00930	01/09/15
Communications Test Set	R&S	CMW500	T159	07/02/14
DC power supply, 8 V @ 3 A or 15 V	Agilent / HP	E3610A	None	CNR
Vector signal generator, 6 GHz	Agilent / HP	E4438C	None	07/06/14
Antenna, Tuned Dipole 400~1000	ETS	3121C DB4	C00993	02/14/14
Directional Coupler	RF-Lambda	RFDC5M06G15	None	CNR

7. Summary Table

FCC Part Section	RSS Section(s)	Test Description	Test Limit	Test Condition	Test Result	Worst Case
2.1049	RSS Gen	Occupied Band width (99%)	N/A	Conducted	Pass	0.247MHz
22.917(a) 24.238(a)	RSS-132(4.5.1) RSS-133(6.5.1)	Band Edge / Conducted Spurious Emission	-13dBm		Pass	-21.75dBm
2.1046	N/A	Conducted output power	N/A		Pass	32dBm
22.355 24.235	RSS-132(4.3) RSS-133(6.3)	Frequency Stability	2.5PPM		Pass	0.01PPM
22.913(a)(2)	RSS-132(4.4)	Effective Radiated Power	38 dBm	Radiated	Pass	25.77dBm
24.232(c)	RSS-133(6.4)	Equivalent Isotropic Radiated Power	33dBm		Pass	31.15dBm
22.917(a) 24.238(a)	RSS-132(4.5.1) RSS-133(6.5.1)	Radiated Spurious Emission	-13dBm		Pass	-17.8dBm

8. RF POWER OUTPUT VERIFICATION

8.1. GSM/GPRS/EDGE

Function: Menu select > GSM Mobile Station > GSM 850/900/1800/1900
Press Connection control to choose the different menus
Press RESET > choose all to reset all settings
Connection Press Signal Off to turn off the signal and change settings
Network Support > GSM+GPRS or GSM+EGPRS
Main Service > Packet Data
Service selection > Test Mode A – Auto Slot Config. off
MS Signal Press Slot Config bottom on the right twice to select and change the number of time slots and power setting
 > Slot configuration > Uplink/Gamma
 > 33 dBm for GPRS 850/900
 > 30 dBm for GPRS1800/1900
BS Signal Enter the same channel number for TCH channel (test channel) and BCCH channel
Frequency Offset > + 0 Hz
Mode > BCCH and TCH
BCCH Level > -85 dBm (May need to adjust if link is not stable)
BCCH Channel > choose desire test channel [Enter the same channel number for TCH channel (test channel) and BCCH channel]
Channel Type > Off
P0> 4 dB
Slot Config > Unchanged (if already set under MS Signal)
TCH > choose desired test channel
Hopping > Off
Main Timeslot > 3 (Default)
Network Coding Scheme > CS4 (GPRS) and MCS9 (EGPRS)
Bit Stream > 2E9-1PSR Bit Pattern
AF/RF Enter appropriate offsets for Ext. Att. Output and Ext. Att. Input
Connection Press Signal On to turn on the signal and change settings

8.1.1. GSM OUTPUT POWER RESULT

Band	Mode	Ch.	f(MHz)	1 time slot	2 time slot	3 time slot	4 time slot
				Peak (dBm)	Peak (dBm)	Peak (dBm)	Peak (dBm)
GSM850	GMSK	128	824.2	32.0			
		190	836.6	32.0			
		251	848.8	32.0			
	GPRS	128	824.2	32.0	29.0	28.0	25.9
		190	836.6	32.0	29.0	27.9	25.9
		251	848.8	32.0	29.0	27.9	25.9
GSM1900	GMSK	512	1850.2	28.9			
		661	1880	29.0			
		810	1909.8	29.0			
	GPRS	512	1850.2	28.9	25.8	24.8	22.8
		661	1880	29.0	26.0	24.9	23.0
		810	1909.8	29.0	26.1	25.1	23.3

9. LIMITS AND CONDUCTED RESULTS

9.1. OCCUPIED BANDWIDTH

RULE PART(S)

FCC: §2.1049

IC: RSS-132, 4.5; RSS-133, 6.5

LIMITS

For reporting purposes only

TEST PROCEDURE

The transmitter output was connected to a calibrated coaxial cable and coupler, the other end of which was connected to a spectrum analyzer. The occupied bandwidth was measured with the spectrum analyzer at the low, middle and high channel in each band. The -26dB bandwidth was also measured and recorded.

(KDB 971168 D01 Power Meas License Digital Systems v02r01 - 06/07/2013)

9.1.1. OCCUPIED BANDWIDTH RESULTS

Band	Mode	Channel	f (MHz)	99% BW (MHz)	-26dB BW (MHz)
GSM850	GPRS	128	824.2	0.242	0.316
		190	836.6	0.242	0.31
		251	848.8	0.241	0.319
GSM1900	GPRS	512	1850.2	0.247	0.323
		661	1880	0.243	0.315
		810	1909.8	0.245	0.318

9.1.2. OCCUPIED BANDWIDTH PLOTS

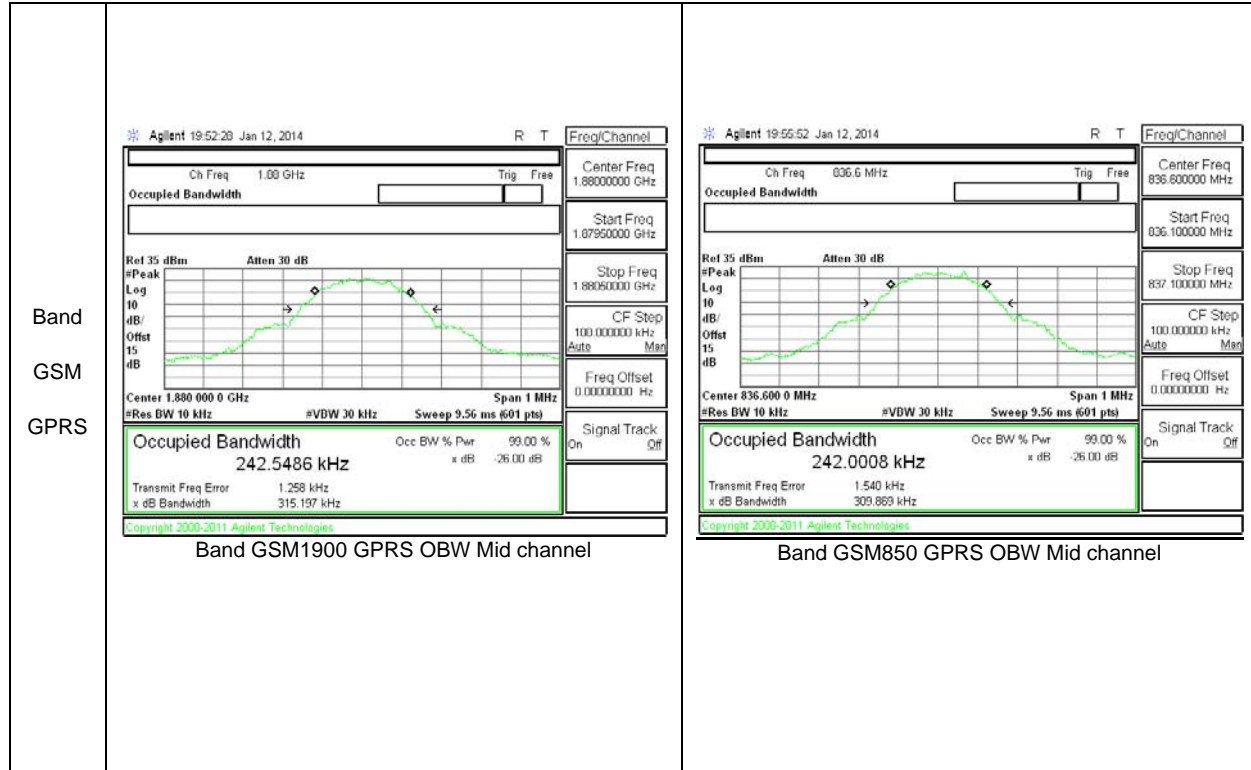

9.2. BAND EDGE EMISSIONS

RULE PART(S)

FCC: §22.359, §24.238

LIMITS

The power of any emission outside of the authorized operating frequency ranges must be attenuated below the transmitting power (P) by a factor of at least $43 + 10 \log (P)$ dB.

TEST PROCEDURE

Per KDB 971168 D01 Power Meas License Digital Systems v02r01

The transmitter output was connected to an Agilent 8960 or a CMW500 Test Set and configured to operate at maximum power. The band edge emissions were measured at the required operating frequencies in each band on the Spectrum Analyzer.

For each band edge measurement:

- Set the spectrum analyzer span to include the block edge frequency (824, 849, 1850, 1910 and 1915MHz)
- Set a marker to point the corresponding band edge frequency in each test case.
- Set display line at -13 dBm.
- Set resolution bandwidth to at least 1% of emission bandwidth.
- (m)(6) Compliance with these rules is based on the user of measurement instrumentation employing a resolution bandwidth of 1MHz or greater. However, in the 1MHz bands immediately outside and adjacent to the frequency block a resolution bandwidth of at least 1 percent of the emission bandwidth may be employed.

MODES TESTED

GSM 850/1900

RESULTS

9.2.1.BAND EDGE PLOTS

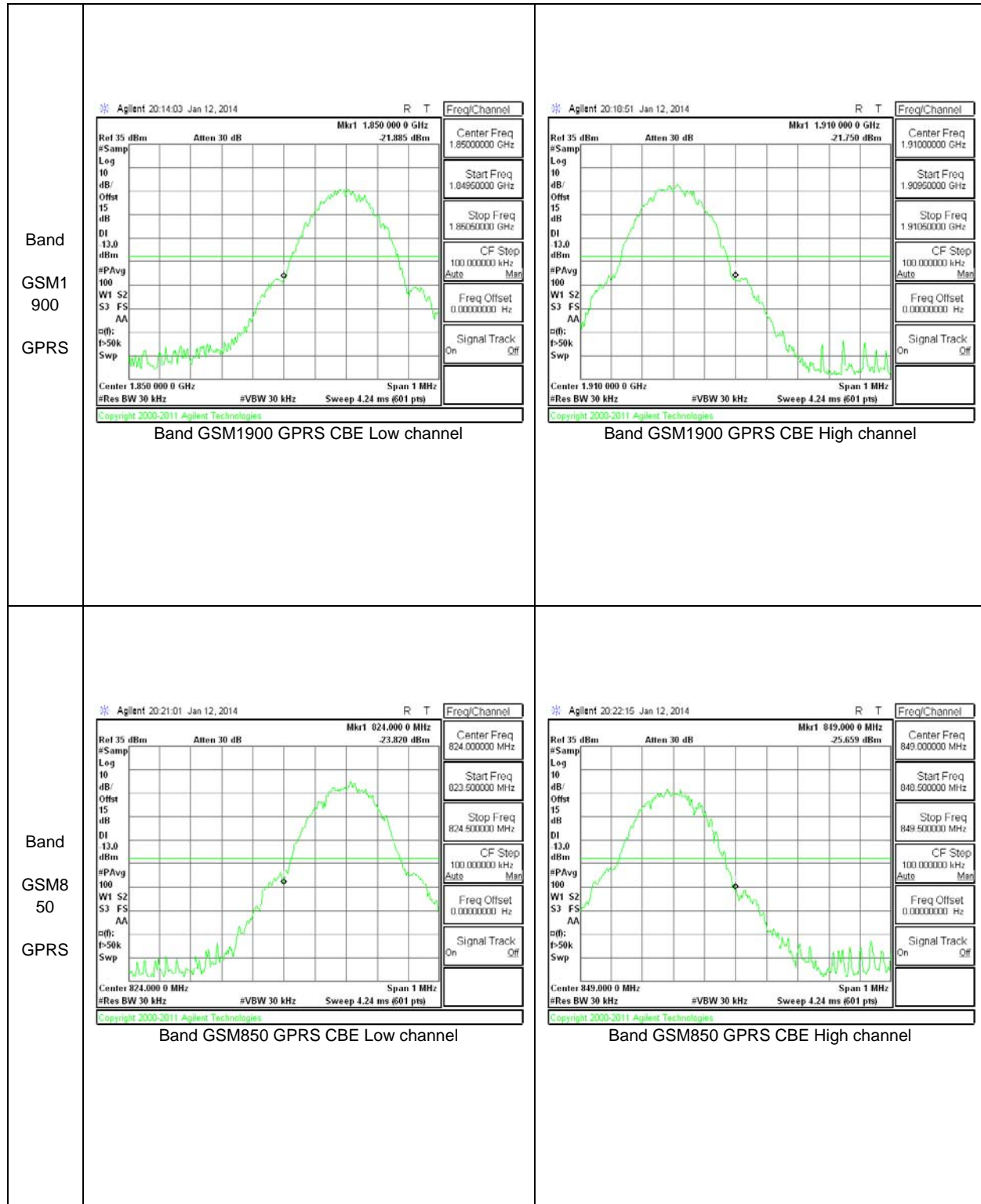

9.3. OUT OF BAND EMISSIONS

RULE PART(S)

FCC: §2.1051, §22.901, §22.917, §24.238

LIMITS

The power of any emission outside of the authorized operating frequency ranges must be attenuated below the transmitting power (P) by a factor of at least $43 + 10 \log (P)$ dB.

TEST PROCEDURE

Per KDB 971168 D01 Power Meas License Digital Systems v02r01

The RF output of the transmitter was connected to a spectrum analyzer through a calibrated coaxial cable. Sufficient scans were taken to show the out-of-band Emissions, if any, up to 10th harmonic. Multiple sweeps were recorded in maximum hold mode using a peak detector to ensure that the worst-case emissions were caught.

For each out of band emissions measurement:

- Set display line at -13 dBm
- Set RBW & VBW to 100 kHz for the measurement below 1 GHz, and 1 MHz for the measurement above 1 GHz.

MODES TESTED

GSM 850/1900

RESULTS

9.3.1. OUT OF BAND EMISSIONS RESULT

Band	Mode	f (MHz)	Spur (dBm)	Spec (dBm)	Delta (dB)
GSM850	GPRS	824.2	-34.52	-13	-21.52
		836.6	-34.86	-13	-21.86
		848.8	-39.52	-13	-26.52
GSM1900	GPRS	1850.2	-28.07	-13	-15.07
		1880	-27.98	-13	-14.98
		1909.8	-30.81	-13	-17.81

9.3.2. OUT OF BAND EMISSIONS PLOTS

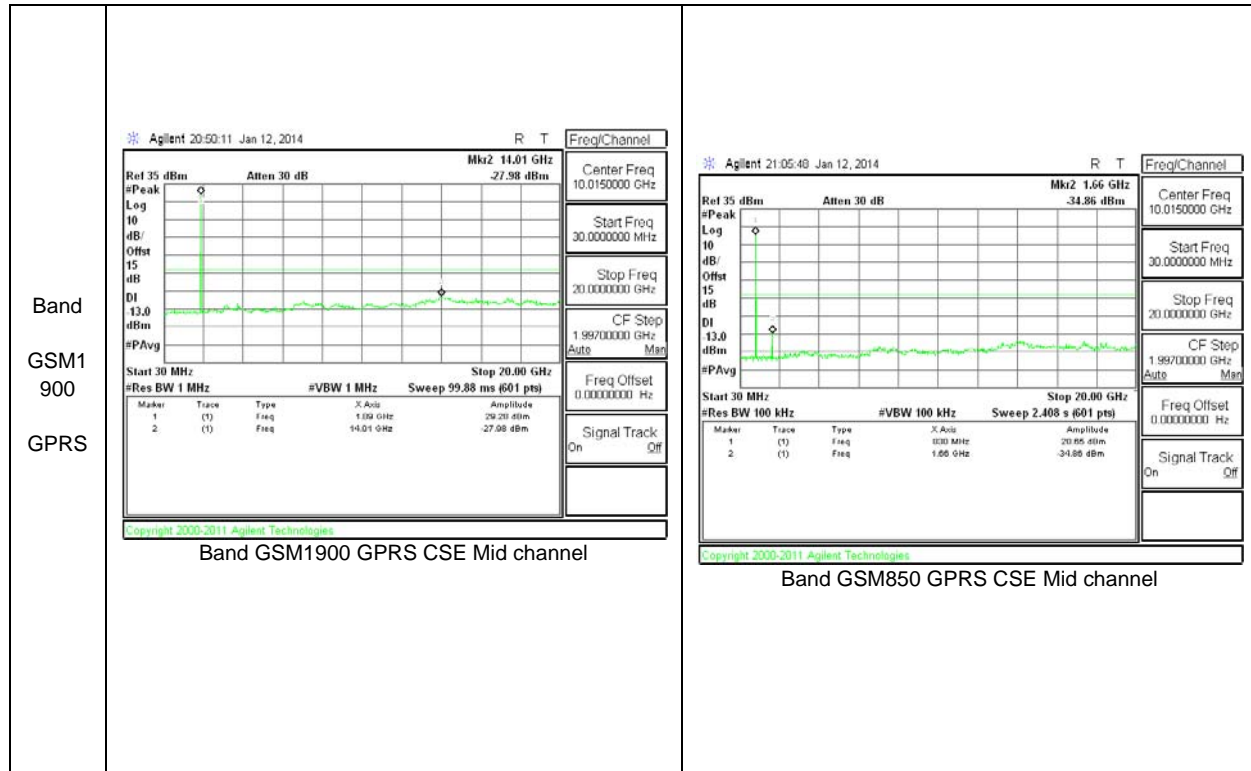

9.4. FREQUENCY STABILITY

RULE PART(S)

FCC: §2.1055, §22.355, §24.235

LIMITS

§22.355 - The carrier frequency shall not depart from the reference frequency in excess of ± 2.5 ppm for mobile stations.

§24.235 - The frequency stability shall be sufficient to ensure that the fundamental emission stays within the authorized frequency block.

TEST PROCEDURE

Per KDB 971168 D01 Power Meas License Digital Systems v02r01

Frequency Stability vs Temperature:

The EUT is placed inside a temperature chamber. The temperature is set to 20°C and allowed to stabilize. After sufficient soak time, the transmitting frequency error is measured. The temperature is increased by 10 degrees, allowed to stabilize and soak, and then the measurement is repeated. This is repeated until +50°C is reached. Reference power supply voltage for these tests is 3.7Vdc.

Frequency Stability vs Voltage:

The peak frequency error is recorded (worst-case). The test voltage ranges from 3.50 to 4.26 VDC.

MODES TESTED

GSM 850/1900

RESULTS

See the following pages.

9.4.1. FREQUENCY STABILITY RESULTS

GSM 850 – MID CHANNEL

Reference Frequency: Mid Channel 836.600000 MHz @ 20°C				
Limit: within the authorized block or +/- 2.5 ppm = 2091.500 Hz				
Power Supply (Vdc)	Environment Temperature (*C)	Frequency Deviation Measured with Time Elapse		
		(MHz)	Delta (ppm)	Limit (ppm)
3.70	50	836.599980	0.046	2.5
3.70	40	836.599975	0.052	2.5
3.70	30	836.599979	0.048	2.5
3.70	20	836.600019	0	2.5
3.70	10	836.600016	0.003	2.5
3.70	0	836.600018	0.001	2.5
3.70	-10	836.600018	0.000	2.5
3.70	-20	836.599980	0.046	2.5
3.70	-30	836.599977	0.050	2.5

Reference Frequency: Mid Channel 836.600000 MHz @ 20°C				
Limit: within the authorized block or +/- 2.5 ppm = 2091.500 Hz				
Power Supply (Vdc)	Environment Temperature (*C)	Frequency Deviation Measured with Time Elapse		
		(MHz)	Delta (ppm)	Limit (ppm)
3.70	20	836.599983	0.00000	2.5
4.20	20	836.599979	0.00544	2.5
3.30	20	836.600015	-0.03719	2.5
End Volt(3.2)	20	836.600015	-0.03808	2.5

GSM 1900 – MID CHANNEL

Reference Frequency: Mid Channel 1880.000000 MHz @ 20°C				
Limit: within the authorized block or +/- 2.5 ppm = 4700.000 Hz				
Power Supply (Vdc)	Environment Temperature (*C)	Frequency Deviation Measured with Time Elapse		
		(MHz)	Delta (ppm)	Limit (ppm)
3.70	50	1879.999966	0.004	2.5
3.70	40	1879.999970	0.002	2.5
3.70	30	1879.999975	0.000	2.5
3.70	20	1879.999974	0	2.5
3.70	10	1879.999978	-0.002	2.5
3.70	0	1879.999970	0.002	2.5
3.70	-10	1880.000024	-0.026	2.5
3.70	-20	1880.000025	-0.027	2.5
3.70	-30	1879.999970	0.002	2.5

Reference Frequency: Mid Channel 836.600000 MHz @ 20°C				
Limit: within the authorized block or +/- 2.5 ppm = 4700.000 Hz				
Power Supply (Vdc)	Environment Temperature (*C)	Frequency Deviation Measured with Time Elapse		
		(MHz)	Delta (ppm)	Limit (ppm)
3.70	20	1879.999978	0.00000	2.5
4.20	20	1879.999972	0.00292	2.5
3.30	20	1880.000019	-0.02167	2.5
End Volt(3.2)	20	1879.999982	-0.00234	2.5

10. RADIATED TEST RESULTS

10.1. RADIATED POWER (ERP & EIRP)

RULE PART(S)

FCC: §2.1046, §22.913, §24.232.

LIMITS

22.913(a) - The ERP of mobile transmitters and auxiliary test transmitters must not exceed 7 Watts.

24.232(c) - Mobile/portable stations are limited to 2 watts e.i.r.p. peak power and the equipment must employ means to limit the power to the minimum necessary for successful communications.

In addition, when the transmitter power is measured in terms of average value, the peak-to-average ratio of the power shall not exceed 13dB.

TEST PROCEDURE

ANSI / TIA / EIA 603C Clause 2.2.17

MODES TESTED

GSM 850/1900

TEST RESULTS

10.1.1. ERP/EIRP Results

Band	Mode	Channel	f(MHz)	ERP / EIRP	
				dBm	mW
GSM1900	GPRS	512	1850.2	31.15	1303.17
		661	1880	30.79	1199.5
		810	1909.8	30.608	1150.27

Band	Mode	Channel	f(MHz)	ERP / EIRP	
				dBm	mW
GSM850	GPRS	128	824.2	23.98	250.0
		190	836.6	24.99	315.5
		251	848.8	25.77	377.6

10.1.2. ERP/EIRP PLOTS

Band GSM1 900 GPRS	High Frequency Fundamental Measurement Compliance Certification Services Chamber C																																																																																																
	Company:		Samsung																																																																																														
	Project #:		13I16774																																																																																														
	Date:		01/09/13																																																																																														
	Test Engineer:		Kiya Kedida																																																																																														
	Configuration:		X, EUT only																																																																																														
	Mode:		GPRS 1900MHz																																																																																														
	Test Equipment:																																																																																																
	Receiving: Horn T119, and Chamber C SMA Cables																																																																																																
	Substitution: Horn T711 Substitution, 4ft SMA Cable (244639001) Warehouse																																																																																																
<table border="1"> <thead> <tr> <th>f GHz</th> <th>SG reading (dBm)</th> <th>Ant. Pol. (H/V)</th> <th>Cable Loss (dB)</th> <th>Antenna Gain (dBi)</th> <th>EIRP (dBm)</th> <th>Limit (dBm)</th> <th>Delta (dB)</th> <th>Notes</th> </tr> </thead> <tbody> <tr> <td colspan="9">Low Ch</td> </tr> <tr> <td>1.850</td> <td>24.0</td> <td>V</td> <td>0.85</td> <td>5.58</td> <td>28.70</td> <td>33.0</td> <td>-4.3</td> <td></td> </tr> <tr> <td>1.850</td> <td>26.4</td> <td>H</td> <td>0.85</td> <td>5.58</td> <td>31.15</td> <td>33.0</td> <td>-1.9</td> <td></td> </tr> <tr> <td colspan="9">Mid Ch</td> </tr> <tr> <td>1.880</td> <td>22.4</td> <td>V</td> <td>0.85</td> <td>5.60</td> <td>27.14</td> <td>33.0</td> <td>-5.9</td> <td></td> </tr> <tr> <td>1.880</td> <td>26.0</td> <td>H</td> <td>0.85</td> <td>5.60</td> <td>30.79</td> <td>33.0</td> <td>-2.2</td> <td></td> </tr> <tr> <td colspan="9">High Ch</td> </tr> <tr> <td>1.910</td> <td>22.4</td> <td>V</td> <td>0.85</td> <td>5.63</td> <td>27.22</td> <td>33.0</td> <td>-5.8</td> <td></td> </tr> <tr> <td>1.910</td> <td>25.8</td> <td>H</td> <td>0.85</td> <td>5.63</td> <td>30.61</td> <td>33.0</td> <td>-2.4</td> <td></td> </tr> </tbody> </table>								f GHz	SG reading (dBm)	Ant. Pol. (H/V)	Cable Loss (dB)	Antenna Gain (dBi)	EIRP (dBm)	Limit (dBm)	Delta (dB)	Notes	Low Ch									1.850	24.0	V	0.85	5.58	28.70	33.0	-4.3		1.850	26.4	H	0.85	5.58	31.15	33.0	-1.9		Mid Ch									1.880	22.4	V	0.85	5.60	27.14	33.0	-5.9		1.880	26.0	H	0.85	5.60	30.79	33.0	-2.2		High Ch									1.910	22.4	V	0.85	5.63	27.22	33.0	-5.8		1.910	25.8	H	0.85	5.63	30.61	33.0	-2.4	
f GHz	SG reading (dBm)	Ant. Pol. (H/V)	Cable Loss (dB)	Antenna Gain (dBi)	EIRP (dBm)	Limit (dBm)	Delta (dB)	Notes																																																																																									
Low Ch																																																																																																	
1.850	24.0	V	0.85	5.58	28.70	33.0	-4.3																																																																																										
1.850	26.4	H	0.85	5.58	31.15	33.0	-1.9																																																																																										
Mid Ch																																																																																																	
1.880	22.4	V	0.85	5.60	27.14	33.0	-5.9																																																																																										
1.880	26.0	H	0.85	5.60	30.79	33.0	-2.2																																																																																										
High Ch																																																																																																	
1.910	22.4	V	0.85	5.63	27.22	33.0	-5.8																																																																																										
1.910	25.8	H	0.85	5.63	30.61	33.0	-2.4																																																																																										
Rev. 3.17.11																																																																																																	

Band GSM8 50 GPRS	High Frequency Substitution Measurement Compliance Certification Services Chamber C								
	Company:		Samsung						
	Project #:		13116774						
	Date:		01/13/14						
	Test Engineer:		Kiya Kedida						
	Configuration:		X Position, EUT only						
	Mode:		GRPS 850MHz						
	Test Equipment:								
	Receiving: Sunol T185, and 3m Chamber N-type Cable (Setup this one for testing EUT)								
	Substitution: Dipole S/N: 00022117, 4ft SMA Cable (SN # 245200 001) Warehouse.								
	f	SG reading	Ant. Pol.	Cable Loss	Antenna Gain	ERP	Limit	Margin	Notes
	MHz	(dBm)	(H/V)	(dB)	(dBd)	(dBm)	(dBm)	(dB)	
	Low Ch								
	824.20	15.13	V	0.9	0.0	14.23	38.5	-24.2	
	824.20	24.88	H	0.9	0.0	23.98	38.5	-14.5	
	Mid Ch								
	836.60	16.96	V	0.9	0.0	16.06	38.5	-22.4	
	836.60	25.89	H	0.9	0.0	24.99	38.5	-13.5	
	High Ch								
	848.80	18.00	V	0.9	0.0	17.10	38.5	-21.3	
	848.80	26.67	H	0.9	0.0	25.77	38.5	-12.7	
	Rev. 3.17.11								

10.2. FIELD STRENGTH OF SPURIOUS RADIATION

RULE PART(S)

FCC: §2.1053, §22.917, §24.238

LIMIT

§22.917 (e) and §24.238 (a): Out of band emissions. The power of any emission outside of the authorized operating frequency ranges must be attenuated below the transmitting power (P) by a factor of at least $43 + 10 \log (P)$ dB

TEST PROCEDURE

For Cellular equipment - Compliance with these rules is based on the use of measurement instrumentation employing a resolution bandwidth of 100 kHz or greater. In the 1 MHz bands immediately outside and adjacent to the frequency block a resolution bandwidth of at least one percent of the emission bandwidth of the fundamental emission of the transmitter may be employed. A narrower resolution bandwidth is permitted in all cases to improve measurement accuracy provided the measured power is integrated over the full required measurement bandwidth (i.e. 100 kHz or 1 percent of emission bandwidth, as specified). The emission bandwidth is defined as the width of the signal between two points, one below the carrier center frequency and one above the carrier center frequency, outside of which all emissions are attenuated at least 26 dB below the transmitter power.

For PCS equipment - Compliance with these rules is based on the use of measurement instrumentation employing a resolution bandwidth of 1 MHz or greater. However, in the 1 MHz bands immediately outside and adjacent to the frequency block a resolution bandwidth of at least one percent of the emission bandwidth of the fundamental emission of the transmitter may be employed. A narrower resolution bandwidth is permitted in all cases to improve measurement accuracy provided the measured power is integrated over the full required measurement bandwidth (i.e. 1 MHz or 1 percent of emission bandwidth, as specified). The emission bandwidth is defined as the width of the signal between two points, one below the carrier center frequency and one above the carrier center frequency, outside of which all emissions are attenuated at least 26 dB below the transmitter power.

MODES TESTED

GSM 850/1900

RESULTS

10.2.1. SPURIOUS RADIATION PLOTS

Compliance Certification Services
Above 1GHz High Frequency Substitution Measurement

Company: Samsung
Project #: 13116774
Date: 01/09/14
Test Engineer: I. Netto
Configuration: X + AC + HS
Mode: GPRS 1900

Chamber

Pre-amplifier

Filter

Limit

3m Chamber

T343 8449B

Filter 1

Part 24

Band	f GHz	SG reading (dBm)	Ant. Pol. (H/V)	Distance (m)	Preamp (dB)	Filter (dB)	EIRP (dBm)	Limit (dBm)	Delta (dB)	Notes
	Low Ch, 1850.2MHz									
	3.700	-7.4	V	3.0	35.4	1.0	-41.8	-13.0	-28.8	
GSM1	5.550	-16.9	V	3.0	34.7	1.0	-50.6	-13.0	-37.6	
900	7.400	-18.2	V	3.0	34.9	1.0	-52.2	-13.0	-39.2	
	GPRS									
	3.700	-4.2	H	3.0	35.4	1.0	-38.6	-13.0	-25.6	
	5.550	-17.5	H	3.0	34.7	1.0	-51.3	-13.0	-38.3	
	7.400		H	3.0	34.9	1.0	-33.9	-13.0	-20.9	
	Mid Ch, 1880.0MHz									
	3.760	2.8	V	3.0	35.3	1.0	-31.5	-13.0	-18.5	
	5.640	-17.3	V	3.0	34.7	1.0	-51.0	-13.0	-38.0	
	7.520	-18.2	V	3.0	34.9	1.0	-52.1	-13.0	-39.1	
	3.760	5.6	H	3.0	35.3	1.0	-28.8	-13.0	-15.8	
	5.640	-12.4	H	3.0	34.7	1.0	-46.2	-13.0	-33.2	
	7.520	-20.7	H	3.0	34.9	1.0	-54.6	-13.0	-41.6	
	High Ch, 1909.8 MHz									
	3.820	12.7	V	3.0	35.3	1.0	-21.6	-13.0	-8.6	
	5.729	-7.1	V	3.0	34.7	1.0	-40.9	-13.0	-27.9	
	7.640	-12.8	V	3.0	35.0	1.0	-46.8	-13.0	-33.8	
	3.820	16.5	H	3.0	35.3	1.0	-17.8	-13.0	-4.8	
	5.729	0.4	H	3.0	34.7	1.0	-33.3	-13.0	-20.3	
	7.640	-17.6	H	3.0	35.0	1.0	-51.6	-13.0	-38.6	

Rev. 03.03.09
 Note: No other emissions were detected above the system noise floor.

Compliance Certification Services Above 1GHz High Frequency Substitution Measurement										
Company:		Samsung								
Project #:		13116774								
Date:		01/09/14								
Test Engineer:		I. Netto								
Configuration:		X only								
Mode:		GPRS 850								
Chamber		Pre-amplifier			Filter		Limit			
3m Chamber		T343 8449B			Filter 1		Part 24			
Band	f GHz	SG reading (dBm)	Ant. Pol. (H/V)	Distance (m)	Preamp (dB)	Filter (dB)	EIRP (dBm)	Limit (dBm)	Delta (dB)	Notes
GSM8 50 GPRS	Low Ch, 824.2MHz									
	1.648	-17.7	V	3.0	37.4	1.0	-54.1	-13.0	-41.1	
	2.473	-14.9	V	3.0	36.4	1.0	-50.3	-13.0	-37.3	
	3.297	-30.0	V	3.0	35.8	1.0	-64.8	-13.0	-51.8	
	1.648	-13.2	H	3.0	37.4	1.0	-49.5	-13.0	-36.5	
	2.473	-15.4	H	3.0	36.4	1.0	-50.8	-13.0	-37.8	
	3.297	-33.1	H	3.0	35.8	1.0	-67.9	-13.0	-54.9	
	Mid Ch, 836.6MHz									
	1.673	-22.4	V	3.0	37.3	1.0	-58.7	-13.0	-45.7	
2.510	-14.6	V	3.0	36.4	1.0	-50.0	-13.0	-37.0		
3.346	-27.1	V	3.0	35.8	1.0	-61.8	-13.0	-48.8		
1.673	-16.7	H	3.0	37.3	1.0	-53.0	-13.0	-40.0		
2.510	-14.2	H	3.0	36.4	1.0	-49.5	-13.0	-36.5		
3.346	-34.1	H	3.0	35.8	1.0	-68.9	-13.0	-55.9		
High Ch, 848.8 MHz										
1.698	-24.0	V	3.0	37.3	1.0	-60.3	-13.0	-47.3		
2.546	-19.1	V	3.0	36.3	1.0	-54.5	-13.0	-41.5		
3.395	-31.2	V	3.0	35.7	1.0	-65.9	-13.0	-52.9		
1.698	-20.6	H	3.0	37.3	1.0	-56.9	-13.0	-43.9		
2.546	-18.1	H	3.0	36.3	1.0	-53.4	-13.0	-40.4		
3.395	-32.5	H	3.0	35.7	1.0	-67.2	-13.0	-54.2		
Rev. 03.03.09										
Note: No other emissions were detected above the system noise floor.										