



FCC 47 CFR § 2.1093

RF EVALUATION REPORT (Digitizer)

FOR

GSM/WCDMA/LTE/5G NR Phone + BT/BLE, DTS/UNII a/b/g/n/ac/ax, NFC, WPT and UWB

MODEL NUMBER: SM-F956U, SM-F956U1

FCC ID: A3LSMF956U

REPORT NUMBER: 4791196575-S5V2

ISSUE DATE: 5/8/2024

Prepared for
SAMSUNG ELECTRONICS CO., LTD.
129 SAMSUNG-RO, YEONGTONG-GU, SUWON-SI,
GYEONGGI-DO, 16677, KOREA

Prepared by

UL Korea, Ltd.

26th floor, 152, Teheran-ro, Gangnam-gu Seoul, 06236, Korea

Suwon Test Site: UL Korea, Ltd. Suwon Laboratory
218 Maeyeong-ro, Yeongtong-gu,
Suwon-si, Gyeonggi-do, 16675, Korea
TEL: (031) 337-9902
FAX: (031) 213-5433



Testing Laboratory

TL-637

Revision History

Rev.	Date	Revisions	Revised By
V1	4/26/2024	Initial Issue	--
V2	5/8/2024	Revised test date in Sec.8	Sunghoon Kim

Table of Contents

1. **Attestation of SAR Characterization** 4

2. **Test Specification, Methods and Procedures**..... 5

3. **Facilities and Accreditation**..... 5

4. **H-field Measurement System & Test Equipment**..... 6

4.1. **H-field Measurement System**..... 6

4.2. **H-field measurement & extrapolation using MAGPy probe**..... 9

4.3. **Test Equipment** 9

5. **Measurement Uncertainty**..... 10

6. **DUT Informations** 10

7. **RF Exposure Conditions (Test Configurations)** 10

8. **System verification** 11

9. **Test results** 12

10. **TER analysis results** 12

Appendixes 13

4791196575-S5 FCC Report Digitizer evaluation _App A_ Test setup photos 13

4791196575-S5 FCC Report Digitizer evaluation _App B_ Highest Magnetic field strength Test Plots 13

4791196575-S5 FCC Report Digitizer evaluation _App C_ System verification Plots..... 13

4791196575-S5 FCC Report Digitizer evaluation _App D_ Probe Cal. Certificates..... 13



4791196575-S5 FCC Report Digitizer evaluation _App E_ Verification Source Cal. Certificates..... 13

1. Attestation of SAR Characterization

Applicant Name	SAMSUNG ELECTRONICS CO.,LTD.
FCC ID	A3LSMF956U
Model Number	SM-F956U, SM-F956U1
Applicable Standards	FCC 47 CFR § 2.1093
Exposure Category	Magnetic field strength limit (A/m)
General population / Uncontrolled exposure	1.63
RF Exposure Conditions	The Highest Magnetic field strength (A/m)
	0.05
TER	0.99
Date Tested	4/4/2024
Test Results	Pass

UL Korea, Ltd. tested the above equipment in accordance with the requirements set forth in the above standards. All indications of Pass/Fail in this report are opinions expressed by UL Korea, Ltd. based on interpretations and/or observations of test results. Measurement Uncertainties were not taken into account and are published for informational purposes only. The test results show that the equipment tested is capable of demonstrating compliance with the requirements as documented in this report.

Note: The results documented in this report apply only to the tested sample, under the conditions and modes of operation as described herein. This document may not be altered or revised in any way unless done so by UL Korea, Ltd. and all revisions are duly noted in the revisions section. Any alteration of this document not carried out by UL Korea, Ltd. will constitute fraud and shall nullify the document. This report must not be used by the client to claim product certification, approval, or endorsement by IAS, any agency of the Federal Government, or any agency of any government

Approved & Released By: 	Prepared By: 
Justin Park Operations Leader UL Korea, Ltd. Suwon Laboratory	Sunghoon Kim Senior Laboratory Engineer UL Korea, Ltd. Suwon Laboratory

2. Test Specification, Methods and Procedures

The tests documented in this report were performed in accordance with FCC 47 CFR § 2.1093.

- 447498 D04 Interim General RF Exposure Guidance v01
- 680106 D01 Wireless Power Transfer v04

In addition to the above, the following information was used:

- [TCB workshop](#) October, 2023; 4.2 Wireless Power Transfer
- DASY6 MODULE WPT SYSTEM HANDBOOK
- DASY8/6 Module WPT and SAR Application note

3. Facilities and Accreditation

The test sites and measurement facilities used to collect data are located at

Suwon
SAR 1 Room

UL Korea, Ltd. is accredited by IAS, Laboratory Code TL-637.

The full scope of accreditation can be viewed at;

<https://www.iasonline.org/wp-content/uploads/2017/05/TL-637-cert-New.pdf>.

4. H-field Measurement System & Test Equipment

4.1. H-field Measurement System

DASY system Module WPT - MAGPy Probe is optimized for evaluation of compliance for wireless power transfer (WPT) systems and any other sources operating in the 3kHz - 10MHz frequency range. Module WPT V2.4+ is compatible with the DASY 8/6 systems and in addition has been extended for easy evaluations of pulsed sources.

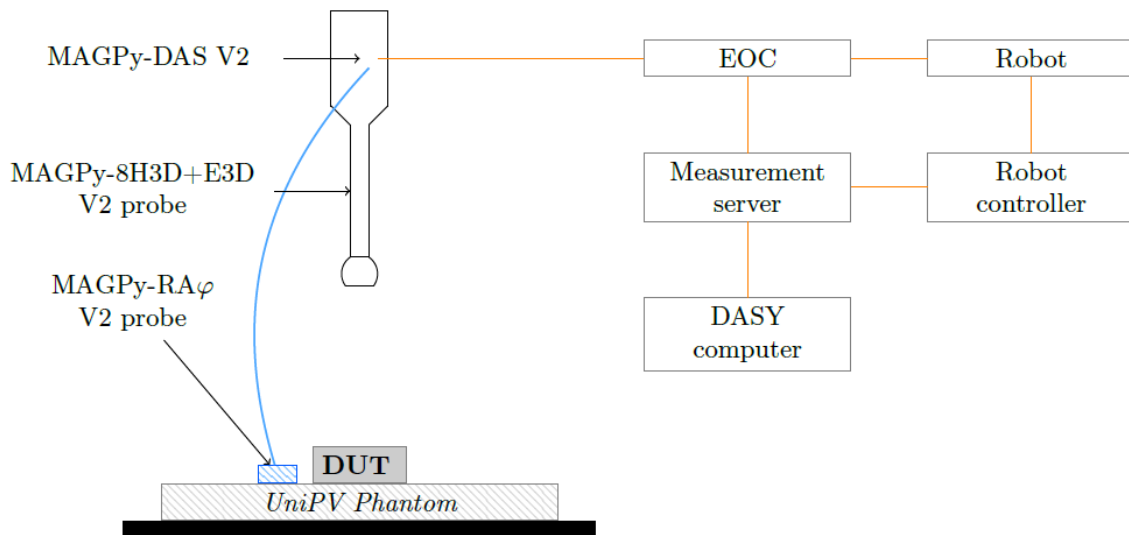

Figure : Typical measurement setup with DASY system Module WPT-MAGPy

DASYsystem Module WPT – MAGPy’s Specifications

<p>System</p>	<p>DASY8/6 Module WPT is composed of the isotropic probe MAGPy-8H3D+E3D Version 2, the reference probe (MAGPy-RAφ), and the data acquisition system (MAGPy-DAS) mounted to the DASY8 robot via the emergency stop (MAGPy-ES). It measures the incident electric and magnetic fields (E-Field, H-Field) in a volume from the surface of the DUT using advanced field reconstructions to obtain a high-resolution (mm range) field distribution. The induced electric (E-) field distributions and specific absorption rate (SAR) are assessed with Sim4Life’s Quasi-Static EM Solver (P-EM-QS) using only the measured data. At each probe location, eight sets of isotropic H-field values and one set of isotropic E-field values are acquired in parallel. The dedicated graphical user interface (GUI) fully automates the testing workflow.</p>
<p>Applications</p>	<p>Laboratory evaluation of WPT systems and any other local electromagnetic source not requiring magnetic (H-) field volume scans exceeding 2000 mm × 1000 mm × 1500 mm:</p> <ul style="list-style-type: none"> Assessment of high-resolution H-field distribution (3 kHz – 10 MHz) <ul style="list-style-type: none"> • Assessment of high-resolution E-field distribution (3 kHz – 10 MHz) • Determination of the induced field and SAR distribution in the standard phantom (3 kHz – 4 MHz) • Demonstration of compliance (3 kHz – 4 MHz) with international standards and national regulations, e.g., ISED Canada SPR-002
<p>Basic Components</p>	<p>The basic components of DASY8/6 Module WPT are:</p> <p>Platform and DASY8/6 TX2-90XL Robot</p> <ul style="list-style-type: none"> • DASY8/6 Measurement Server • EOC8 • Light-Beam Unit • Quick Adapter Change System (QACSV1) • DASY8/6 PC
<p>MAGPy-DAS</p>	<p>The MAGPy-DAS includes:</p> <ul style="list-style-type: none"> • 27 14-bit ADC channels with 25 MSPs • Peak detection stage • Hardware supervising unit • Data transfer to the backend • 22 tap FIR filter
<p>MAGPy-RAφV2</p>	<p>Specifications of the MAGPy-RAφ reference amplitude and phase probe:</p> <ul style="list-style-type: none"> • Frequency range: 3 kHz – 10 MHz • Dynamic range: 0.1 A/m – 3200 A/m (0.12 μT – 4 mT) • Loop coil area: 18.9 cm² • Sensor size: 51 mm x 51 mm x 0.2 mm

<p>MAGPy-8H3D+E3D V2</p>	<p>The MAGPy-8H3D+E3D probe consists of eight isotropic H-field sensors and one isotropic E-field sensor:</p> <p>Probe design:</p> <ul style="list-style-type: none"> • Probe length: 335 mm • Probe tip diameter: 60 mm • 8H3D: eight isotropic 1 cm²-H-field sensors, arranged at the corners of a 22 mm cube • First H-field sensor plane: 7.5 mm from the probe tip • E3D: one isotropic E-field sensor (dipole / monopole) (arm length: 50mm) <p>Sensor specifications:</p> <ul style="list-style-type: none"> • Frequency range: 3 kHz – 10 MHz • H-field dynamic range: 0.1 A/m – 3200 A/m (0.12 μT – 4 mT) • H-field extrapolation uncertainty: 0.6 dB ($k = 2$) • E-field dynamic range: 0.08 V/m – 2000 V/m
<p>Software</p>	<p>Software components:</p> <ul style="list-style-type: none"> • DASY8 Module WPT application programming interface (API) • WPT /6backend • Jupyter Notebook GUI • Sim4Life plugin (vector potential reconstruction, P-EM-QS solver)

4.2. H-field measurement & extrapolation using MAGPy probe.

MAGPy probe v2.4+ can measured H-field strength at 8.5 mm distance from Probe sensor to DUT’s surface. And it is possible to Extrapolated the H-field strength of 0.0 mm using Sim4Life WPT software. So we can use this function for MAGPy probe to measure H-field strength radiating of digitizer’s coil and check the 0mm H-field strength.

In order to additionally apply to estimated 0mm test data, we referred to Section 3.3 of KDB 680106 D01 v04 and compared to both measured data and estimated data at 8.5mm.

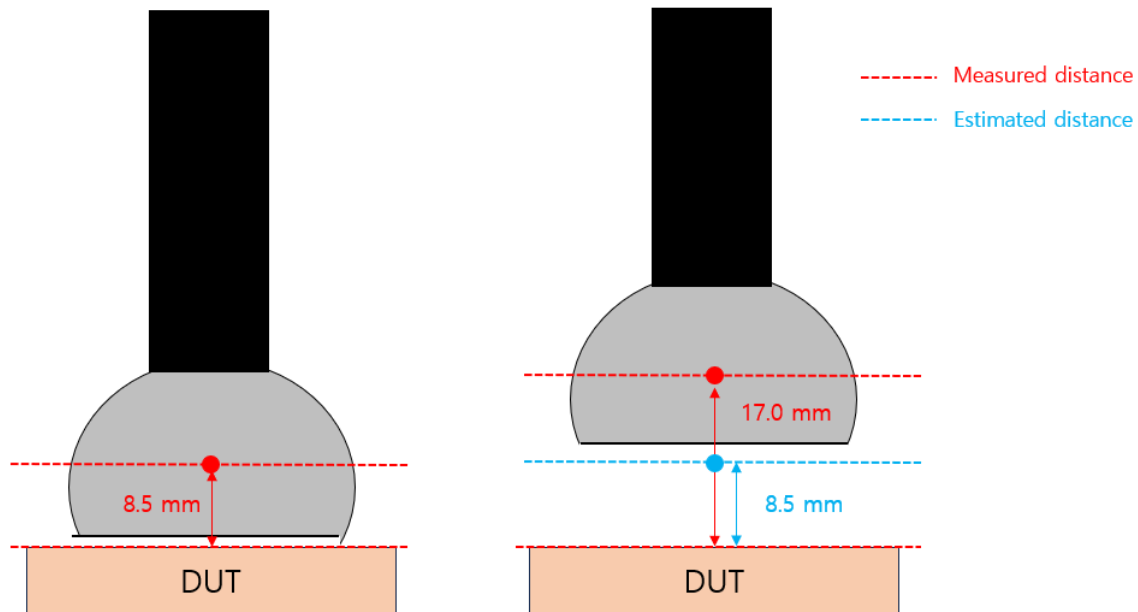

Both results should be within 30% at 8.5 mm distance according to KDB 680106 D01v04 guide.

4.3. Test Equipment

Name of Equipment	Manufacturer	Type/Model	Serial No.	Cal Date	Cal. Due Date
Probe	SPEAG	MAGPy-8H3D+E3D	3071	6-22-2023	6-22-2024
	SPEAG	MAGPy-DAS	2050	6-22-2023	6-22-2024
System verification Source	SPEAG	V-Coil50/400	1014	10-10-2023	10-10-2024

5. Measurement Uncertainty

Measurement uncertainty of Incident H-field (3 kHz to 10 MHz)

Error Description	Unc. Value (± dB)	Prob. Distr.	Div.	<i>ci</i>	Std. Unc. (± dB)
Probe uncertainty					
Amplitude calibration uncertainty	0.35	Normal	1	1	0.35
Probe anisotropy	0.60	Rectangular	1.732	1	0.35
Probe dynamic linearity	0.20	Rectangular	1.732	1	0.12
Probe frequency domain response	0.30	Rectangular	1.732	1	0.17
Probe frequency linear interp. Fit	0.15	Rectangular	1.732	1	0.09
Spatial averaging	0.10	Rectangular	1.732	1	0.06
Parasitic E-field sensitivity	0.10	Rectangular	1.732	1	0.06
Detection limit	0.15	Rectangular	1.732	1	0.09
Readout electronics	0.00	Normal	1	1	0.00
Probe positioning	0.19	Normal	1	1	0.19
Repeatability	0.10	Normal	1	1	0.10
Surface field reconstruction	0.30	Normal	1	1	0.30
Combined Standard Uncertainty (k = 1)					0.67
Expanded Uncertainty U, Coverage Factor = 2, > 95 % Confidence =					1.33

6. DUT Informations

The manufacturer implemented the FTM(Factory Test mode) with 100% duty cycle in both Hover mode(593kHz) and Press Pen's Button(531kHz) that forcedly operates one coil among the X-Y axis coils of Digitizer built into the DUT, We tested using this FTM.

However, in reality, the digitizer coils does not operate at 100% duty. According to Operational description provided by the manufacturer, the maximum operating duty cycle is 2.5%. Therefore, we reflected the duty cycle in the FTM test results.

7. RF Exposure Conditions (Test Configurations)

RF Exposure Conditions	DUT configuration	Mode (Scanning)	Separation distance of DUT's surface-to-Probe's element
Standalone (Body-1g)	Folder Open condition	FTM mode A (Press Pen's Button)	8.5 mm
Standalone (Body-1g)	Folder Open condition	FTM mode B (Hover mode)	8.5 mm

Notes:

- Digitizer feature has only implemented at display on Folder open condition. So test considered only Folder Open condition. And Digitizer's coils operates to radiated to display of DUT. So other surface or edges are not considered.
- Test distance 8.5 mm means that distance between DUT's surface to Probe's element.

8. System verification



System check performed using 400kHz verification source according to test system and procedures for Frequencies from 100kHz to 4Mz in Manufacturer guide(DASY8/6 Modules WPT and SAR APPLICATION NOTE (Module WPT V2.4+)). And The deviation of measured values from the target values of calibration report should be less than the expanded uncertainty(H-field $\pm 1.33\text{dB}$)

Reference Target SAR Values

The reference SAR values can be obtained from the calibration certificate of system validation dipoles.

Verification Source	Serial No.	Cal. Date	Cal.due date	Target field strength
				H-field (A/m)
				Extrapolated at 2mm
V-coil50/400	1014	10-10-2023	10-10-2024	245.00

System verification Results

SAR 1 Room

Date Tested	System Source		H-field Results(A/m) -Extrapolated at 2mm-		Delta ($\pm\%$)	Delta ($\pm\text{dB}$)
	Type	Serial #	Test results	Target		
4-4-2024	V-coil50/400	1014	217.00	245.00	-11.43	-0.53

Notes:

The deviation of measured values from the target values of calibration report should be less than the expanded uncertainty(H-field $\pm 1.33\text{dB}$)

9. Test results

Test mode	DUT Test positon	Operating Frequency (KHz)	Duty factor	Magnetic field strength results (A/m)				Note	Plot No.
				Measured at 8.5 mm	Estimated at 0.0 mm	Measured x Dutyfactor at 8.5 mm	Estimated x Dutyfactor at 0.0 mm		
FTM mode A (Press Pen's Button)	Front	531	0.025	0.85	2.08	0.021	0.052	1	1
FTM mode B (Hover mode)	Front	593	0.025	0.83	1.93	0.021	0.048		2

Additional test for Estimated method verification

Test mode	Test positon	Test distance	Magnetic field strength results (A/m)		Deviation (%)	Note	Plot No.
			Measured Result at 8.5 mm	Extrapolated Result at 8.5 mm			
FTM mode A (Press Pen's Button)	Front	8.5 mm	0.85		-16.5	2	1
	Front	17.0 mm		0.71			3
FTM mode B (Hover mode)	Front	8.5 mm	0.83		-16.6		2
	Front	17.0 mm		0.69			4

Notes:

1. For Estimated Results at 0.0 mm, The result are estimated based on the measured Magnetic field strength at 8.5 mm. and Duty factor was compensated for the measured/estimated results.
2. For Additional test Guidance, It was confirmed that the deviation between Measured H-field and Estimated H-field was within 30% at 8.5mm test distance according to KDB 680106 D01v04 guide.

10. TER analysis results

The Digitizer's ER is 0.03 (0.052 / 1.63). So this ER value considered TER with other transmitters on Front test results.

Test Position	Digitizer's ER	Other transmitter's ER	TER
Front	0.03	0.96	0.99

Notes:

1. Other transmitter's ER refer to Section 12.2.2 Extremity 10-g exposure TER analysis in SAR part.1 report.
2. TER(Total Exposure Ratio) result is not exceed to 1.0.

Appendixes

Refer to separated files for the following appendixes.

4791196575-S5 FCC Report Digitizer evaluation _App A_ Test setup photos

4791196575-S5 FCC Report Digitizer evaluation _App B_ Highest Magnetic field strength Test Plots

4791196575-S5 FCC Report Digitizer evaluation _App C_ System verification Plots

4791196575-S5 FCC Report Digitizer evaluation _App D_ Probe Cal. Certificates

4791196575-S5 FCC Report Digitizer evaluation _App E_ Verification Source Cal. Certificates

END OF REPORT