

- LPI

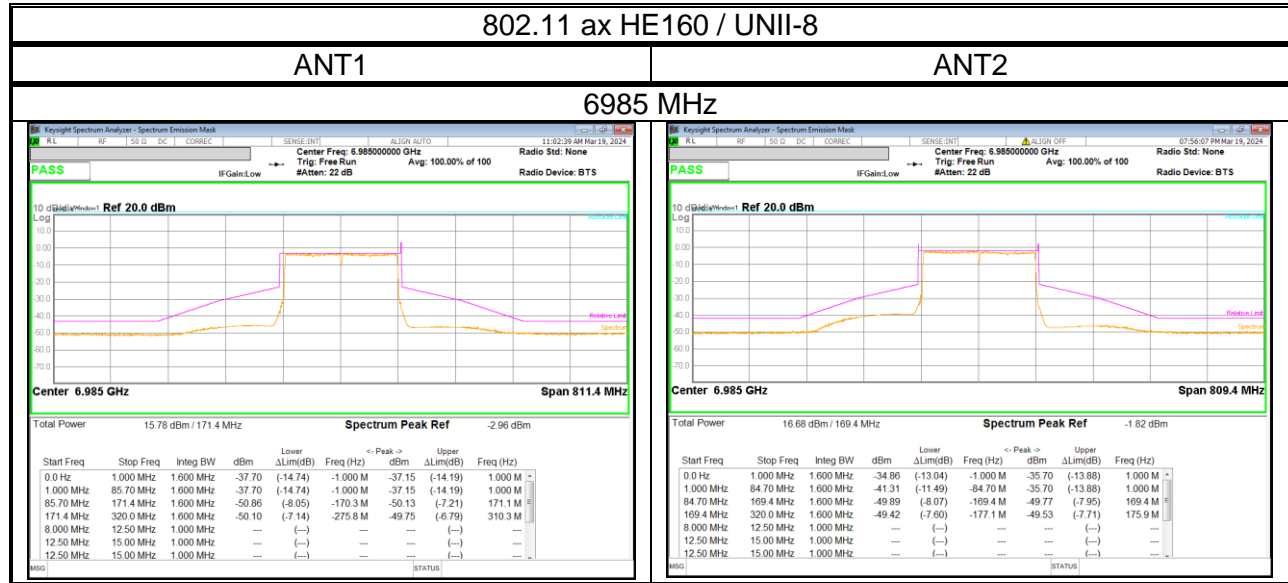

10.2.6. 802.11 ax HE20 RU MODE (WORST CASE)

- SP

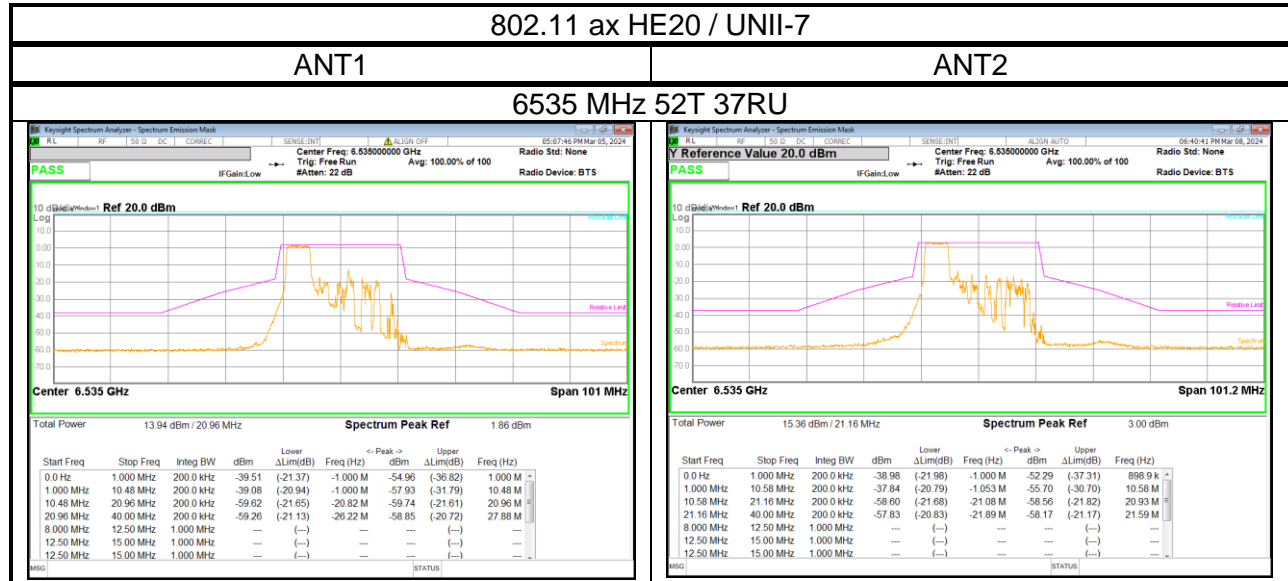

-LPI

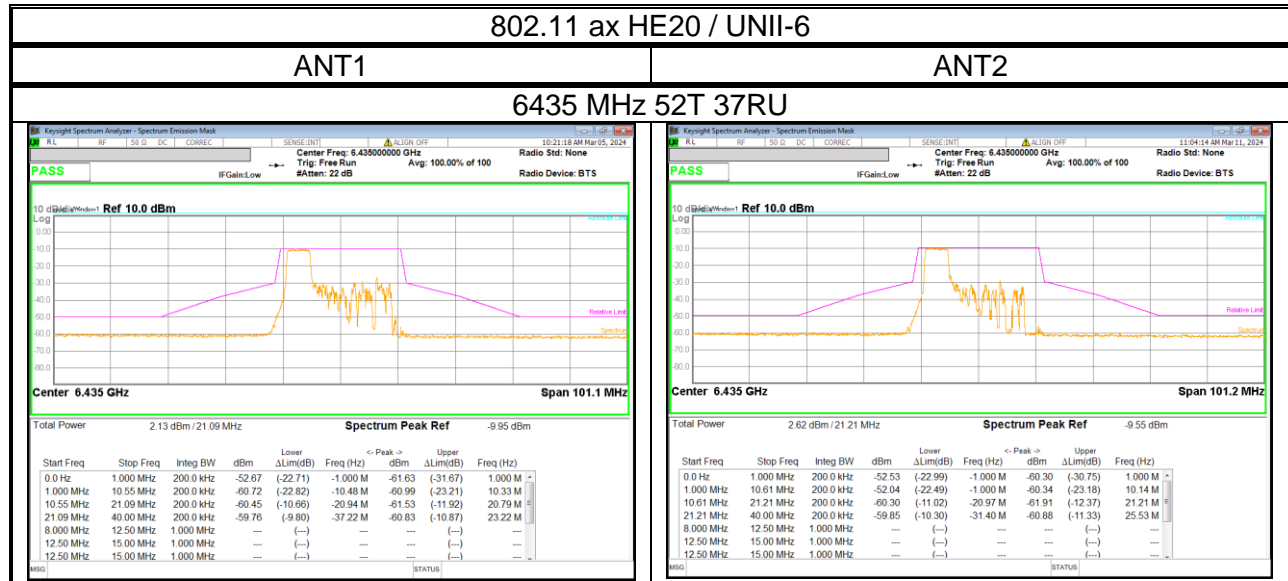

10.2.7. 802.11 ax HE40 RU MODE (WORST CASE)

- SP

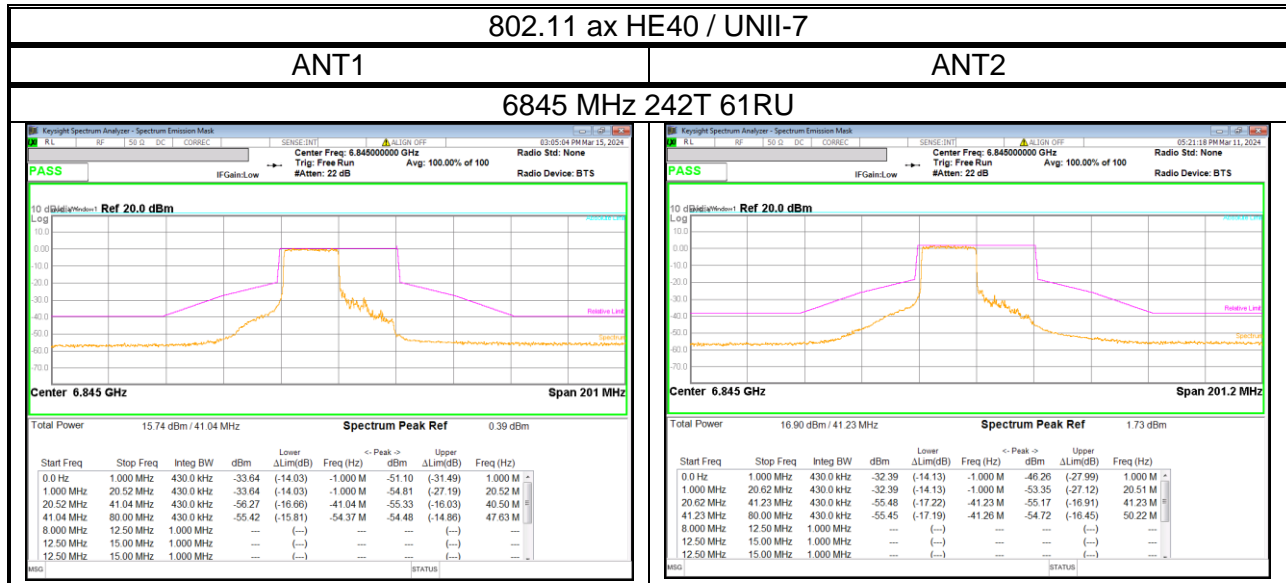

- LPI

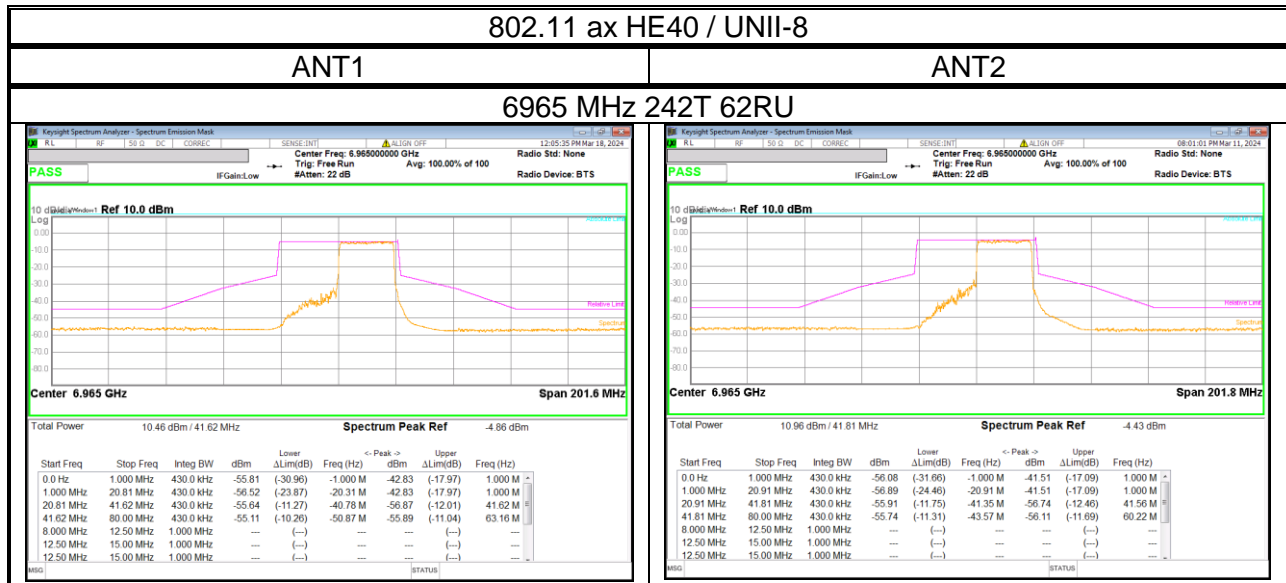

10.2.8. 802.11 ax HE80 RU MODE (WORST CASE)

- SP

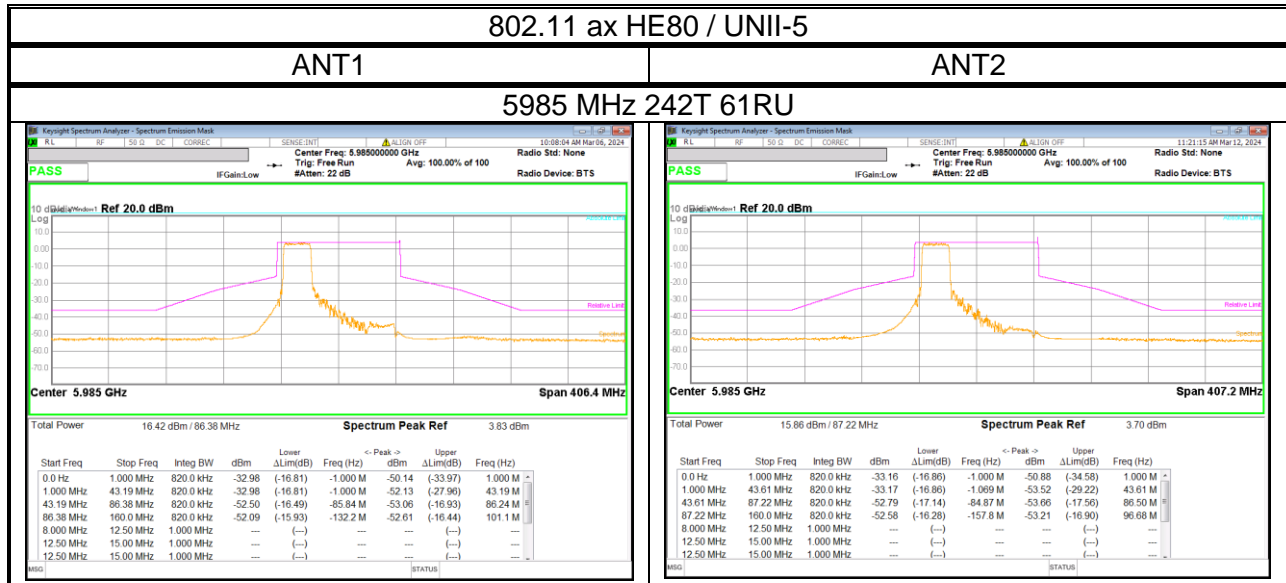

- LPI

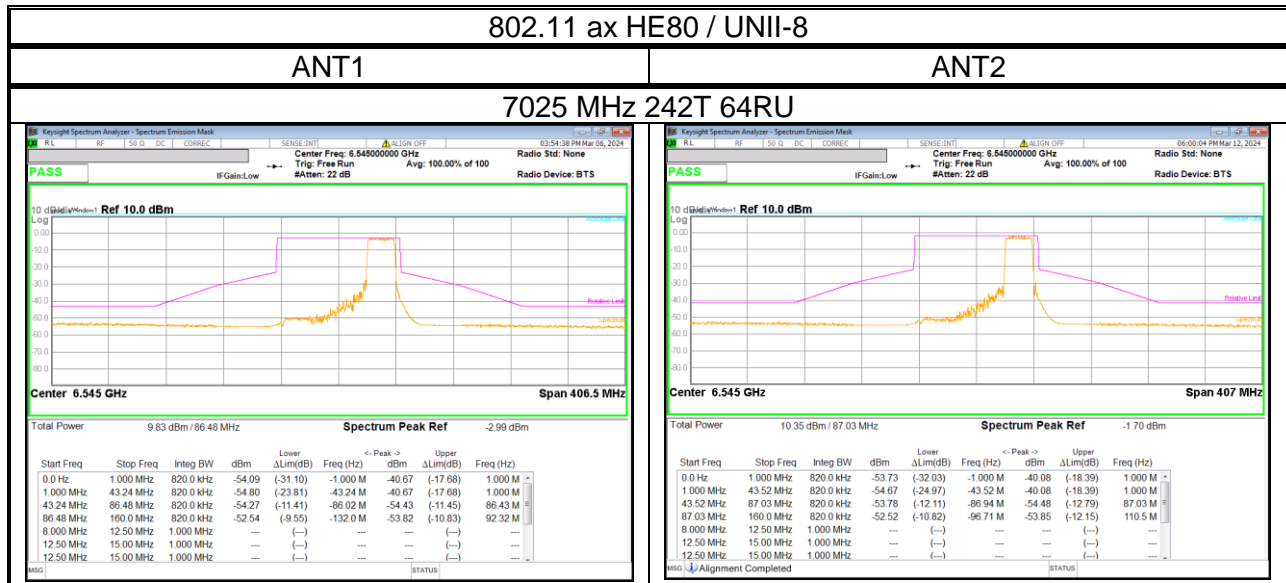

10.2.9. 802.11 ax HE160 RU MODE (WORST CASE)

- SP

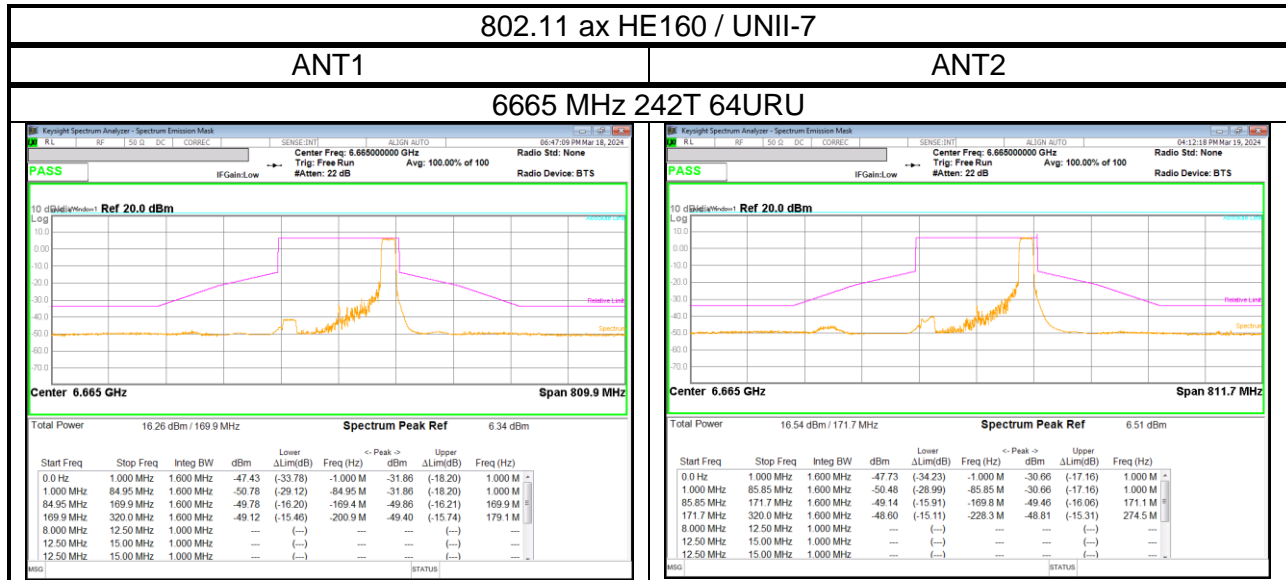

- LPI

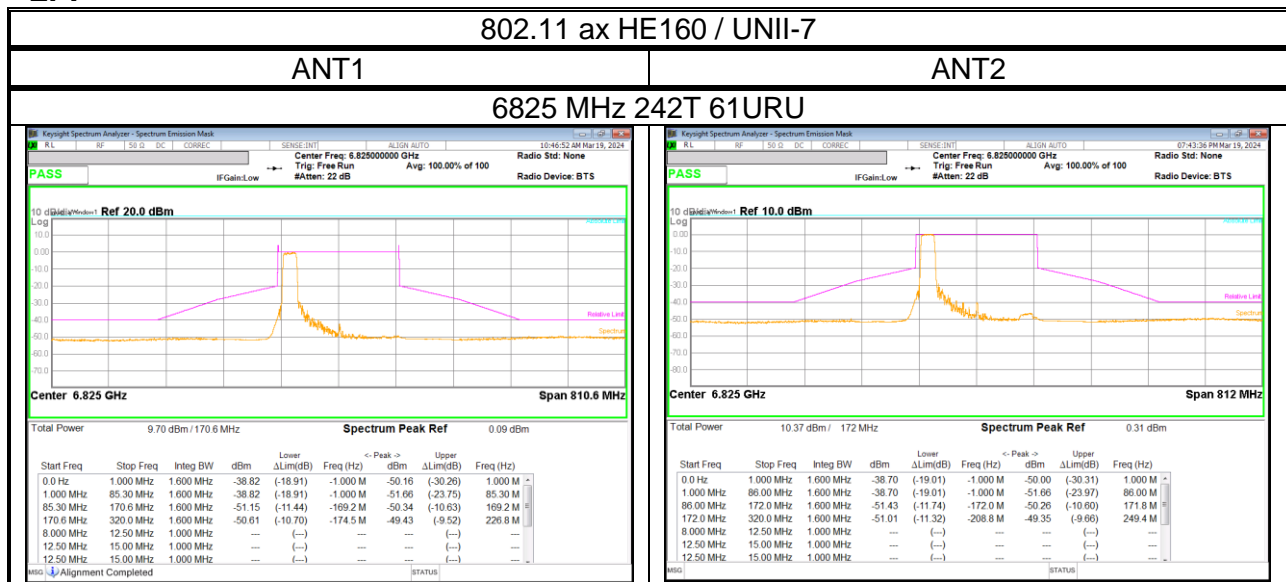

11. TRANSMITTER ABOVE 1 GHz

LIMITS

FCC §15.205 and §15.209

Limits for radiated disturbance of an intentional radiator		
Frequency range (MHz)	Limits (µV/m)	Measurement Distance (m)
0.009 – 0.490	2400 / F (kHz)	300
0.490 – 1.705	24000 / F (kHz)	30
1.705 – 30.0	30	30
30 – 88	100**	3
88 - 216	150**	3
216 – 960	200**	3
Above 960	500	3

** Except as provided in paragraph (g), fundamental emissions from intentional radiators operating under this section shall not be located in the frequency bands 54-72 MHz, 76-88 MHz, 174-216 MHz or 470-806 MHz. However, operation within these frequency bands is permitted under other sections of this part, e.g. §§ 15.231 and 15.241.

FCC Part 15.205 (a) : Only spurious emissions are permitted in any of the frequency bands listed below :

MHz	MHz	MHz	MHz	GHz	GHz
0.009 ~ 0.110	8.41425 ~ 8.41475	108 ~ 121.94	1300 ~ 1427	4.5 ~ 5.15	14.47 ~ 14.5
0.495 ~ 0.505	12.29 ~ 12.293	123 ~ 138	1435 ~ 1626.5	5.35 ~ 5.46	15.35 ~ 16.2
2.1735 ~ 2.1905	12.51975 ~ 12.52025	149.9 ~ 150.05	1645.5 ~ 1646.5	7.25 ~ 7.75	17.7 ~ 21.4
4.125 ~ 4.128	12.57675 ~ 12.57725	156.52475 ~ 156.52525	1660 ~ 1710	8.025 ~ 8.5	22.01 ~ 23.12
4.17725 ~ 4.17775	13.36 ~ 13.41	156.7 ~ 156.9	1718.8 ~ 1722.2	9.0 ~ 9.2	23.6 ~ 24.0
4.20725 ~ 4.20775	16.42 ~ 16.423	162.0125 ~ 167.17	2200 ~ 2300	9.3 ~ 9.5	31.2 ~ 31.8
6.215 ~ 6.218	16.69475 ~ 16.69525	167.72 ~ 173.2	2310 ~ 2390	10.6 ~ 12.7	36.43 ~ 36.5
6.26775 ~ 6.26825	16.80425 ~ 16.80475	240 ~ 285	2483.5 ~ 2500	13.25 ~ 13.4	Above 38.6
6.31175 ~ 6.31225	25.5 ~ 25.67	322 ~ 335.4	2655 ~ 2900		
8.291 ~ 8.294	37.5 ~ 38.25	399.90 ~ 410	3260 ~ 3267		
8.362 ~ 8.366	73 ~ 74.6	608 ~ 614	3332 ~ 3339		
8.37625 ~ 8.38675	74.8 ~ 75.2	960 ~ 1240	3345.8 ~ 3358 3600 ~ 4400		

▪ FCC Part 15.205(b) : The field strength of emissions appearing within these frequency bands shall not exceed the limits shown in §15.209. At frequencies equal to or less than 1000 MHz, compliance with the limits in §15.209 shall be demonstrated using measurement instrumentation employing a CISPR quasi-peak detector. Above 1000 MHz, compliance with the emission limits in §15.209 shall be demonstrated based on the average value of the measured emissions. The provisions in §15.35 apply to these measurements.

FCC §15.407 (b)

(6) For transmitters operating within the 5.925-7.125 GHz band: Any emissions outside of the 5.925-7.125 GHz band must not exceed an e.i.r.p. of -27 dBm/MHz.

(8) The emission measurements shall be performed using a minimum resolution bandwidth of 1 MHz. A lower resolution bandwidth may be employed near the band edge, when necessary, provided the measured energy is integrated to show the total power over 1 MHz.

(9) Unwanted emissions below 1 GHz must comply with the general field strength limits set forth in §15.209. Further, any U-NII devices using an AC power line are required to comply also with the conducted limits set forth in §15.207.

(10) The provisions of §15.205 apply to intentional radiators operating under this section.

(11) When measuring the emission limits, the nominal carrier frequency shall be adjusted as close to the upper and lower frequency band edges as the design of the equipment permits.

Note

- Limit translation to field strength level (FCC §15.407)

$$E[\text{dBuV/m}] = \text{EIRP}[\text{dBm}] + 95.2 = -27\text{dBm} + 95.2 = 68.2\text{dBuV/m}$$

TEST PROCEDURE

The EUT is placed on a non-conducting table 80 cm above the ground plane for below 1GHz and 100 cm for above 1GHz. EUT is set 3 meters away from the receiving antenna and scan from 1m to 4m to find out the highest emission.

The EUT is configured in accordance with ANSI C63.10. The EUT is set to transmit in a continuous mode.

For measurements below 1 GHz the resolution bandwidth is set to 100 kHz for peak detection measurements or 120 kHz for quasi-peak detection measurements. Peak detection is used unless otherwise noted as quasi-peak.

Reference to KDB 789033 D02 v02r01 UNII part G) 6) c) Method AD:

For measurements above 1 GHz the resolution bandwidth is set to 1 MHz; the video bandwidth is set to 3 MHz for peak measurements and add duty cycle factor to the reading offset for average measurements.

Pre-scans to detect harmonic and spurious emissions, the resolution bandwidth is set to 1 MHz; the video bandwidth is set to 30 kHz for peak measurements.

Radiated harmonics spurious 1~18 GHz Low/Mid/High channels, 18-40GHz were performed with the EUT set at the 2TX MIMO mode.

(From 30MHz to 1GHz, test was performed with the EUT set to transmit at the channel with highest output power)

The frequency range of interest is monitored at a fixed antenna height and EUT azimuth. The EUT is rotated through 360 degrees to maximize emissions received. The antenna is scanned from 1 to 4 meters above the ground plane to further maximize the emission. Measurements are made with the antenna polarized in both the vertical and the horizontal positions.

Note : Emission was pre-scanned from 9kHz to 30MHz; No emissions were detected which was at least 20dB below the specification limit (consider distance correction factor).

Per FCC part 15.31(o), test results were not reported.

Although these tests were performed other than open field test site, adequate comparison measurements were confirmed against 30 m open are test site.

Therefore sufficient tests were made to demonstrate that the alternative site produces results that correlate with the one of tests made in an open field based on KDB 414788.

11.1. TX ABOVE 1GHz 2Tx MODE IN U-NII-5 BAND

BANDEDGE (WORST CASE: 802.11ax HE160 / 6025 MHz / SU)

HORIZONTAL PEAK AND AVERAGE DATA

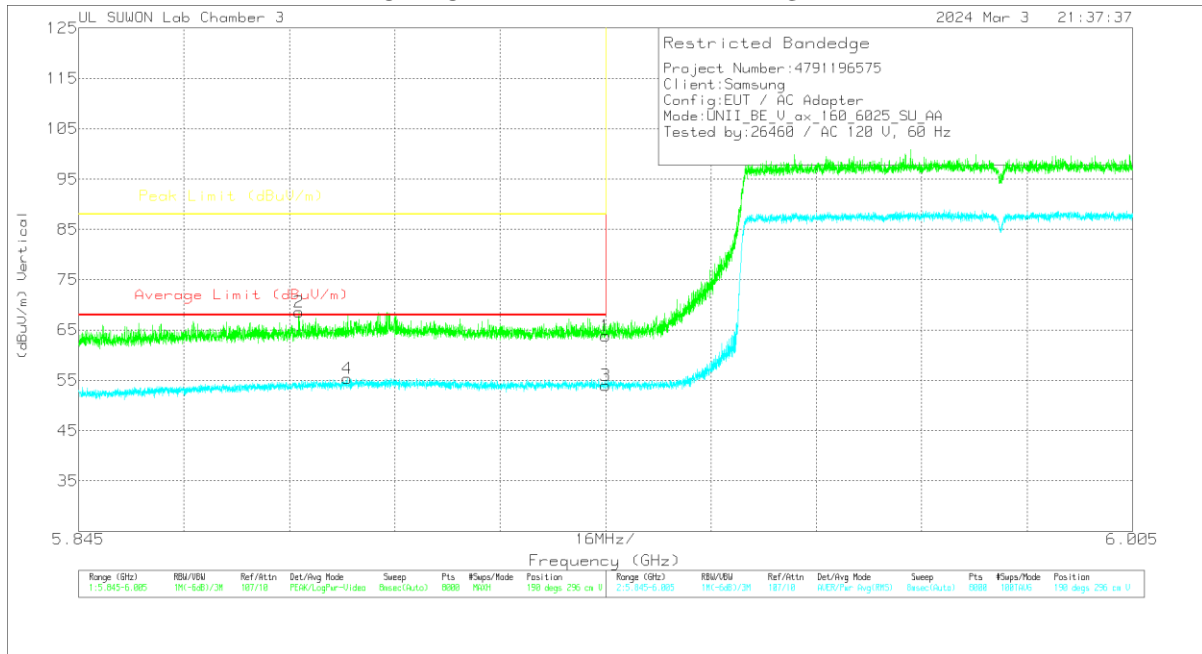

Trace Markers

Marker	Frequency (GHz)	Meter Reading (dBuV)	Det	Antenna_S27_Factor(dB)	10dB_Path Loss(dB)	DC Corr (dB)	Corrected Reading (dBuV/m)	Average Limit (dBuV/m)	Margin (dB)	Peak Limit (dBuV/m)	PK Margin (dB)	Azimuth (Degs)	Height (cm)	Polarity
1	5.92499	47.69	Pk	35.5	-19.4	0	63.79	-	-	88	-24.21	190	296	V
2	5.87843	52.79	Pk	35.3	-19.5	0	68.59	-	-	88	-19.41	190	296	V
3	5.92499	37.84	RMS	35.5	-19.4	0	53.94	68	-14.06	-	-	190	296	V
4	5.88575	39.59	RMS	35.3	-19.5	0	55.39	68	-12.61	-	-	190	296	V

Pk - Peak detector
 RMS - RMS detection

BANDEDGE TEST DATA

Mode	Freq. [MHz]	Antenna	Frequency [GHz]	Reading [dBuV]	Detector Mode	ANT Factor [dB/m]	Loss [dB]	DC Corr [dB]	Result dBuV/m	AV Limit dBuV/m	AV Margin [dB]	PK Limit dBuV/m	PK Margin [dB]	Azimuth [Degs]	Height [cm]	Polarity
802.11a	5955	MIMO	5.92499	38.70	Pk	35.50	-19.40	0.00	54.80	-	-	88.00	-33.20	338	113	H
			5.89969	40.70	Pk	35.40	-19.40	0.00	56.70	-	-	88.00	-31.30	338	113	H
			5.92499	28.57	RMS	35.50	-19.40	0.15	44.82	68.00	-23.18	-	-	338	113	H
			5.92267	29.22	RMS	35.50	-19.40	0.15	45.47	68.00	-22.53	-	-	338	113	H
			5.92499	38.09	Pk	35.50	-19.40	0.00	54.19	-	-	88.00	-33.81	102	311	V
			5.91533	39.41	Pk	35.50	-19.40	0.00	55.51	-	-	88.00	-32.49	102	311	V
			5.92499	27.84	RMS	35.50	-19.40	0.15	44.09	68.00	-23.91	-	-	102	311	V
			5.91719	28.59	RMS	35.50	-19.40	0.15	44.84	68.00	-23.16	-	-	102	311	V
			5.92499	44.18	Pk	35.50	-19.40	0.00	60.28	-	-	88.00	-27.72	216	113	H
			5.92467	45.71	Pk	35.50	-19.40	0.00	61.81	-	-	88.00	-26.19	216	113	H
802.11ax HE20 SU mode	5955	MIMO	5.92499	32.24	RMS	35.50	-19.40	0.00	48.34	68.00	-19.66	-	-	216	113	H
			5.92465	33.61	RMS	35.50	-19.40	0.00	49.71	68.00	-18.29	-	-	216	113	H
			5.92499	40.38	Pk	35.50	-19.40	0.00	56.48	-	-	88.00	-31.52	193	381	V
			5.92373	43.20	Pk	35.50	-19.40	0.00	59.30	-	-	88.00	-28.70	193	381	V
			5.92499	28.89	RMS	35.50	-19.40	0.00	44.99	68.00	-23.01	-	-	193	381	V
			5.92493	29.97	RMS	35.50	-19.40	0.00	46.07	68.00	-21.93	-	-	193	381	V
			5.92499	40.95	Pk	35.50	-19.40	0.00	57.05	-	-	88.00	-30.95	211	100	H
			5.92465	43.28	Pk	35.50	-19.40	0.00	59.38	-	-	88.00	-28.62	211	100	H
			5.92499	31.30	RMS	35.50	-19.40	0.00	47.40	68.00	-20.60	-	-	211	100	H
			5.92473	32.11	RMS	35.50	-19.40	0.00	48.21	68.00	-19.79	-	-	211	100	H
802.11ax HE40 SU mode	5965	MIMO	5.92499	37.78	Pk	35.50	-19.40	0.00	53.88	-	-	88.00	-34.12	128	110	V
			5.90709	39.48	Pk	35.40	-19.40	0.00	55.48	-	-	88.00	-32.52	128	110	V
			5.92499	27.72	RMS	35.50	-19.40	0.00	43.82	68.00	-24.18	-	-	128	110	V
			5.92197	28.67	RMS	35.50	-19.30	0.00	44.87	68.00	-23.13	-	-	128	110	V
			5.92499	46.73	Pk	35.50	-19.40	0.00	62.83	-	-	88.00	-25.17	206	105	H
			5.91985	47.81	Pk	35.50	-19.40	0.00	63.91	-	-	88.00	-24.09	206	105	H
			5.92499	34.29	RMS	35.50	-19.40	0.00	50.39	68.00	-17.61	-	-	206	105	H
			5.92411	35.65	RMS	35.50	-19.40	0.00	51.75	68.00	-16.25	-	-	206	105	H
			5.92499	41.36	Pk	35.50	-19.40	0.00	57.46	-	-	88.00	-30.54	80	383	V
			5.91559	43.40	Pk	35.50	-19.40	0.00	59.50	-	-	88.00	-28.50	80	383	V
802.11ax HE80 SU mode	5985	MIMO	5.92499	30.55	RMS	35.50	-19.40	0.00	46.65	68.00	-21.35	-	-	80	383	V
			5.92169	31.15	RMS	35.50	-19.30	0.00	47.35	68.00	-20.65	-	-	80	383	V
			5.92499	44.42	Pk	35.50	-19.40	0.00	60.52	-	-	88.00	-27.48	218	114	H
			5.91927	49.58	Pk	35.50	-19.40	0.00	65.68	-	-	88.00	-22.32	218	114	H
			5.92499	35.06	RMS	35.50	-19.40	0.00	51.16	68.00	-16.84	-	-	218	114	H
			5.92025	35.84	RMS	35.50	-19.40	0.00	51.94	68.00	-16.06	-	-	218	114	H
			5.92499	47.69	Pk	35.50	-19.40	0.00	63.79	-	-	88.00	-24.21	190	296	V
			5.87843	52.79	Pk	35.30	-19.50	0.00	68.59	-	-	88.00	-19.41	190	296	V
			5.92499	37.84	RMS	35.50	-19.40	0.00	53.94	68.00	-14.06	-	-	190	296	V
			5.88575	39.59	RMS	35.30	-19.50	0.00	55.39	68.00	-12.61	-	-	190	296	V

Note1. Pk - Peak detector, RMS - RMS detector
 Note2. * - indicates frequency in CFR47 Pt 15 / IC RSS-Restricted Band

HARMONICS AND SPURIOUS EMISSIONS(WORST CASE: 802.11ax HE20 6175 MHz / 52T / 37RU)

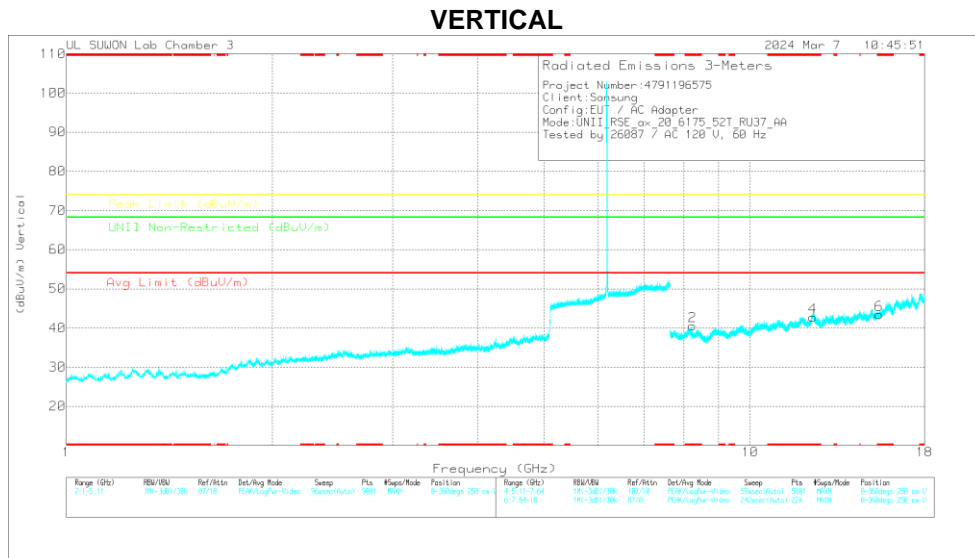
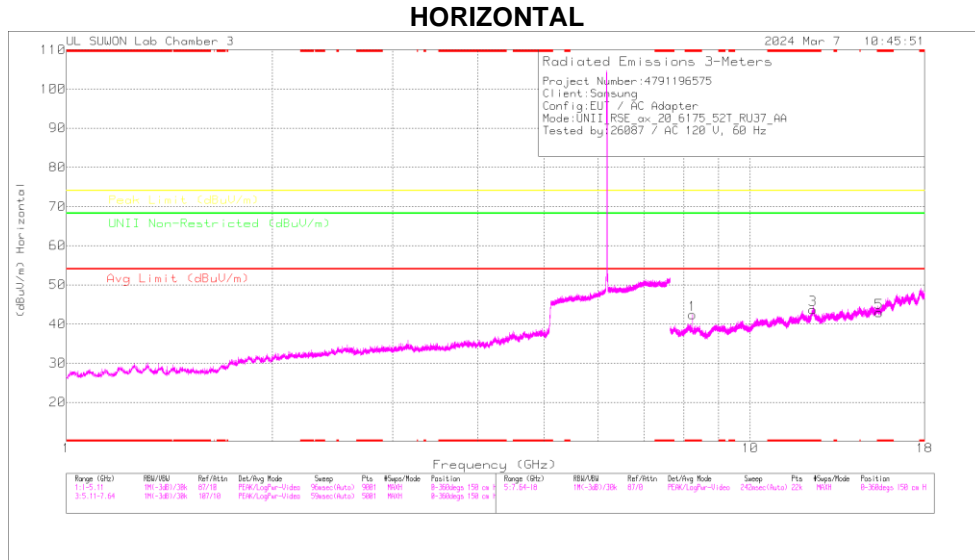

Note: Emission was scanned up to 40GHz; No emissions were detected above the noise floor which was at least 20dB below the specification limit.

Radiated Emissions

Frequency (GHz)	Meas Reading (dBuV)	Det	Antenna_567_Factor(dB)	RGD_HP_Path Loss(dB)	DC Corr (dB)	Corrected Reading (dBuV/m)	Avg Limit (dBuV/m)	Margin (dB)	Peak Limit (dBuV/m)	Margin (dB)	UNII Non-Restricted (dBuV/m)	Margin (dB)	Acimh (dBi)	Height (m)	Polarity	
* 8.23344	38.39	PK-U	36	-23.2	0	51.19	-	-	74	-22.81	-	-	-	205	103	H
* 8.23333	31.16	ADR	36	-23.2	0	43.96	54	-10.04	-	-	-	-	-	205	103	H
* 8.23336	36.98	PK-U	36	-23.2	0	49.78	-	-	74	-24.22	-	-	-	174	263	V
* 8.23334	28.74	ADR	36	-23.2	0	41.54	54	-12.46	-	-	-	-	-	174	263	V
* 12.37239	35.37	PK-U	39.2	-21.8	0	52.77	-	-	74	-21.23	-	-	-	0	100	H
* 12.33598	36.32	PK-U	39.2	-21.8	0	53.92	-	-	74	-20.08	-	-	-	89	103	V
* 12.33462	24.63	ADR	39.2	-21.8	0	42.23	54	-11.77	-	-	-	-	-	89	103	V
* 15.441	34.55	PK-U	40	-21.5	0	53.05	-	-	74	-20.95	-	-	-	0	100	H
* 15.43424	34.79	PK-U	40	-21.4	0	53.39	-	-	74	-20.61	-	-	-	0	100	V

* - indicates frequency in CFR47 Pt 15 / IC RSS-Restricted Band
 PK-U - U-NII: Maximum Peak
 ADR - U-NII AD primary method, RMS average

HARMONICS AND SPURIOUS EMISSIONS TEST DATA

Mode	Freq. [MHz]	Antenna	Frequency [GHz]	Reading [dBuV]	Detector Mode	ANT Factor [dB/m]	Loss [dB]	DC Corr [dB]	Result [dBuV/m]	AV Limit [dBuV/m]	AV Margin [dB]	PK Limit [dBuV/m]	PK Margin [dB]	Non-Restricted [dBuV/m]	Margin [dB]	Azimuth [Degs]	Height [cm]	Polarity		
802.11a	5955	MIMO	7.93987	41.11	PK-U	36.90	-24.10	0.00	52.91	-	-	-	-	68.20	-15.29	202	100	H		
			7.94008	39.16	PK-U	36.90	-24.10	0.00	50.96	-	-	-	-	68.20	-17.24	201	100	V		
			*11.91061	33.96	PK-U	38.60	-22.00	0.00	50.56	-	-	74.00	-23.44	-	-	0	100	H		
			*11.90784	34.30	PK-U	38.60	-22.00	0.00	50.90	-	-	74.00	-23.10	-	-	0	100	V		
			14.89207	33.97	PK-U	39.80	-22.00	0.00	51.77	-	-	-	-	-	-	68.20	-16.43	0	100	H
			14.88834	34.01	PK-U	39.80	-22.10	0.00	51.71	-	-	-	-	-	-	68.20	-16.49	0	100	V
	6175	MIMO	8.233	36.86	PK-U	36.00	-23.20	0.00	49.66	-	-	74.00	-24.34	-	-	-	203	101	H	
			*8.2332	28.14	ADR	36.00	-23.20	0.15	41.09	54.00	-12.91	-	-	-	-	-	203	101	H	
			*8.23323	35.91	PK-U	36.00	-23.20	0.00	48.71	-	-	74.00	-25.29	-	-	-	158	100	V	
			*8.23336	25.73	ADR	36.00	-23.20	0.15	38.68	54.00	-15.32	-	-	-	-	-	158	100	V	
			*12.34769	34.56	PK-U	39.20	-21.70	0.00	52.06	-	-	74.00	-21.94	-	-	-	0	100	H	
			*12.36028	36.02	PK-U	39.20	-21.70	0.00	53.52	-	-	74.00	-20.48	-	-	-	119	104	V	
			*12.35024	24.49	ADR	39.20	-21.70	0.15	42.14	54.00	-11.86	-	-	-	-	-	119	104	V	
			*15.42999	34.11	PK-U	40.00	-21.50	0.00	52.61	-	-	74.00	-21.39	-	-	-	0	100	H	
			*15.45552	34.61	PK-U	40.00	-21.40	0.00	53.21	-	-	74.00	-20.79	-	-	-	0	100	V	
			8.55315	35.56	PK-U	36.00	-23.40	0.00	48.16	-	-	-	-	-	-	68.20	-20.04	204	103	H
			8.55272	34.91	PK-U	36.00	-23.40	0.00	47.51	-	-	-	-	-	-	68.20	-20.69	159	100	V
			12.82555	35.03	PK-U	39.30	-22.70	0.00	51.63	-	-	-	-	-	-	68.20	-16.57	0	100	H
	12.83469	36.26	PK-U	39.30	-22.70	0.00	52.86	-	-	-	-	-	-	68.20	-15.34	110	100	V		
	16.0431	33.64	PK-U	41.10	-19.90	0.00	54.84	-	-	74.00	-19.16	-	-	-	0	100	H			
	*16.03749	33.88	PK-U	41.10	-19.80	0.00	55.18	-	-	74.00	-18.82	-	-	-	0	100	V			
	16.0431	21.03	ADR	41.10	-19.90	0.00	42.23	54.00	-11.77	-	-	-	-	-	0	100	H			
	*16.03749	21.22	ADR	41.10	-19.80	0.00	42.52	54.00	-11.48	-	-	-	-	-	0	100	V			
	802.11ax HE20 RU mode 52 Tone offset 37 Spot-check	6175	MIMO	*8.23944	38.39	PK-U	36.00	-23.20	0.00	51.19	-	-	74.00	-22.61	-	-	205	103	H	
*8.23333				31.16	ADR	36.00	-23.20	0.00	43.96	54.00	-10.04	-	-	-	-	205	103	H		
*8.23336				36.98	PK-U	36.00	-23.20	0.00	49.78	-	-	74.00	-24.22	-	-	-	174	263	V	
*8.2334				28.74	ADR	36.00	-23.20	0.00	41.54	54.00	-12.46	-	-	-	-	-	174	263	V	
*12.37239				35.37	PK-U	39.20	-21.80	0.00	52.77	-	-	74.00	-21.23	-	-	-	0	100	H	
*12.33596				36.32	PK-U	39.20	-21.60	0.00	53.92	-	-	74.00	-20.08	-	-	-	89	103	V	
*12.33462				24.63	ADR	39.20	-21.60	0.00	42.23	54.00	-11.77	-	-	-	-	-	89	103	V	
*15.441				34.55	PK-U	40.00	-21.50	0.00	53.05	-	-	74.00	-20.95	-	-	-	0	100	H	
*15.43424				34.79	PK-U	40.00	-21.40	0.00	53.39	-	-	74.00	-20.61	-	-	-	0	100	V	

Note1. PK-U - U-NII: Maximum Peak, ADR - U-NII AD primary method, RMS average
 Note2. * - indicates frequency in CFR47 Pt 15 / IC RSS-Restricted Band

11.2. TX ABOVE 1GHz 2Tx MODE IN U-NII-6 BAND

HARMONICS AND SPURIOUS EMISSIONS(WORST CASE: 802.11a / 5955 MHz)

HORIZONTAL

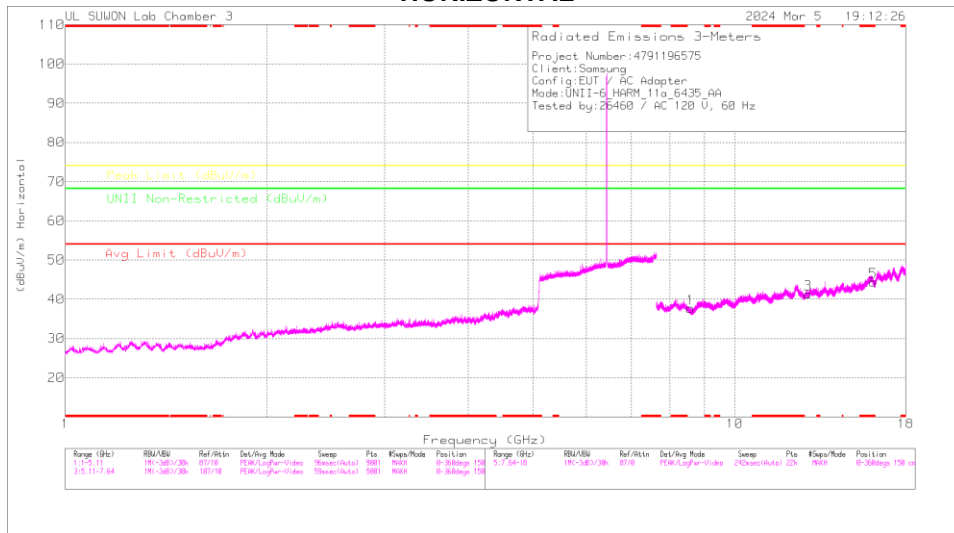

VERTICAL

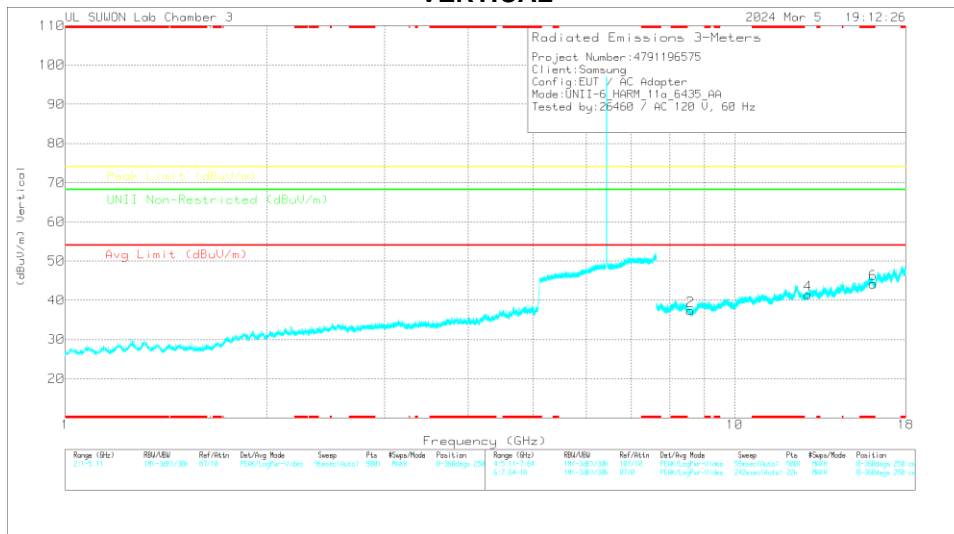

Note: Emission was scanned up to 40GHz; No emissions were detected above the noise floor which was at least 20dB below the specification limit.

Radiated Emissions

Frequency (GHz)	Major Reading (dBuV)	Dir	Antenna_Sett_Factor(dB)	RDP2_HP_Path Loss(dB)	DC Corr (dB)	Corrected Reading (dBuV/m)	Avg Limit (dBuV/m)	Margin (dB)	Peak Limit (dBuV/m)	Margin (dB)	UNII Non-Restricted (dBuV/m)	Margin (dB)	Azimuth (Degs)	Height (cm)	Polarity
8.57983	35.52	PK-U	36	-23.3	0	48.22	-	-	-	-	68.2	-19.98	203	100	H
8.57944	34.46	PK-U	36	-23.3	0	47.16	-	-	-	-	68.2	-21.04	324	101	V
12.8697	35.51	PK-U	39.3	-22.4	0	52.41	-	-	-	-	68.2	-15.79	0	100	H
12.87155	35.22	PK-U	39.3	-22.5	0	52.02	-	-	-	-	68.2	-16.18	0	100	V
* 16.08817	33.19	PK-U	41.1	-19.9	0	54.39	-	-	74	-19.61	-	-	0	100	H
* 16.0886	33.03	PK-U	41.1	-19.9	0	54.23	-	-	74	-19.77	-	-	0	100	V

* - indicates frequency in CFR47 Pt 15 / IC RSS-Restricted Band
 PK-U - U-NII: Maximum Peak

HARMONICS AND SPURIOUS EMISSIONS TEST DATA

Mode	Freq. [MHz]	Antenna	Frequency [GHz]	Reading [dBuV]	Detector Mode	ANT Factor [dB/m]	Loss [dB]	DC Corr [dB]	Result [dBuV/m]	AV Limit [dBuV/m]	AV Margin [dB]	PK Limit [dBuV/m]	PK Margin [dB]	Non-Restricted [dBuV/m]	Margin [dB]	Azimuth [Degs]	Height [cm]	Polarity	
802.11a	6435	MIMO	8.57983	35.52	PK-U	36.00	-23.30	0.00	48.22	-	-	-	-	68.20	-19.98	203	100	H	
			8.57944	34.46	PK-U	36.00	-23.30	0.00	47.16	-	-	-	-	68.20	-21.04	324	101	V	
			12.86970	35.51	PK-U	39.30	-22.40	0.00	52.41	-	-	-	-	68.20	-15.79	0	100	H	
			12.87155	35.22	PK-U	39.30	-22.50	0.00	52.02	-	-	-	-	68.20	-16.18	0	100	V	
			*16.08817	33.19	PK-U	41.10	-19.90	0.00	54.39	-	-	74.00	-19.61	-	-	0	100	H	
			*16.086	33.03	PK-U	41.10	-19.90	0.00	54.23	-	-	74.00	-19.77	-	-	0	100	V	
			*16.08817	21.04	ADR	41.10	-19.90	0.00	42.24	-	-	54.00	-11.76	-	-	0	100	H	
			*16.086	21.11	ADR	41.10	-19.90	0.00	42.31	-	-	54.00	-11.69	-	-	0	100	V	
	6475	MIMO	8.63316	34.77	PK-U	36.10	-23.40	0.00	47.47	-	-	-	-	68.20	-20.73	207	125	H	
			8.63312	34.40	PK-U	36.10	-23.40	0.00	47.10	-	-	-	-	68.20	-21.10	159	100	V	
			12.94981	35.17	PK-U	39.30	-22.10	0.00	52.37	-	-	-	-	68.20	-15.83	0	100	H	
			12.94967	35.22	PK-U	39.30	-22.10	0.00	52.42	-	-	-	-	68.20	-15.78	0	100	V	
			*16.18617	32.52	PK-U	41.20	-19.90	0.00	53.82	-	-	74.00	-20.18	-	-	0	100	H	
			*16.18601	32.96	PK-U	41.20	-19.90	0.00	54.26	-	-	74.00	-19.74	-	-	0	100	V	
			*16.18617	20.06	ADR	41.20	-19.90	0.00	41.36	-	-	54.00	-12.64	-	-	0	100	H	
			*16.18601	20.32	ADR	41.20	-19.90	0.00	41.62	-	-	54.00	-12.38	-	-	0	100	V	
	6515	MIMO	8.68663	34.63	PK-U	36.10	-23.20	0.00	47.53	-	-	-	-	68.20	-20.67	204	105	H	
			8.68650	34.37	PK-U	36.10	-23.20	0.00	47.27	-	-	-	-	68.20	-20.93	115	106	V	
			13.02910	35.39	PK-U	39.20	-22.30	0.00	52.29	-	-	-	-	68.20	-15.91	0	100	H	
			13.02918	35.74	PK-U	39.20	-22.30	0.00	52.64	-	-	-	-	68.20	-15.56	93	101	V	
			16.28506	33.28	PK-U	41.30	-19.50	0.00	55.08	-	-	-	-	68.20	-13.12	0	100	H	
			16.28539	33.69	PK-U	41.30	-19.50	0.00	55.49	-	-	-	-	68.20	-12.71	0	100	V	
	802.11ax HE20 RU mode 52 Tone offset 37 Spot-check	6475	MIMO	8.63341	35.79	PK-U	36.10	-23.40	0.00	48.49	-	-	-	-	68.20	-19.71	207	101	H
				8.63307	34.75	PK-U	36.10	-23.40	0.00	47.45	-	-	-	-	68.20	-20.75	129	100	V
12.97365				35.14	PK-U	39.30	-22.00	0.00	52.44	-	-	-	-	68.20	-15.76	0	100	H	
12.96950				35.09	PK-U	39.30	-22.00	0.00	52.39	-	-	-	-	68.20	-15.81	0	100	V	
*16.19531				32.71	PK-U	41.20	-19.90	0.00	54.01	-	-	74.00	-19.99	-	-	0	100	H	
*16.19636				33.20	PK-U	41.20	-19.90	0.00	54.50	-	-	74.00	-19.50	-	-	0	100	V	
*16.19531				20.14	ADR	41.20	-19.90	0.00	41.44	-	-	54.00	-12.56	-	-	0	100	H	
*16.19636				20.81	ADR	41.20	-19.90	0.00	42.11	-	-	54.00	-11.89	-	-	0	100	V	

Note1. PK-U - U-NII: Maximum Peak / ADR - U-NII AD primary method, RMS average
 Note2. * - indicates frequency in CFR47 Pt 15 / IC RSS-Restricted Band

11.3. TX ABOVE 1GHz 2Tx MODE IN U-NII-7 BAND

HARMONICS AND SPURIOUS EMISSIONS(WORST CASE: 802.11ax HE20 6855 MHz / 52T / 37RU)

HORIZONTAL

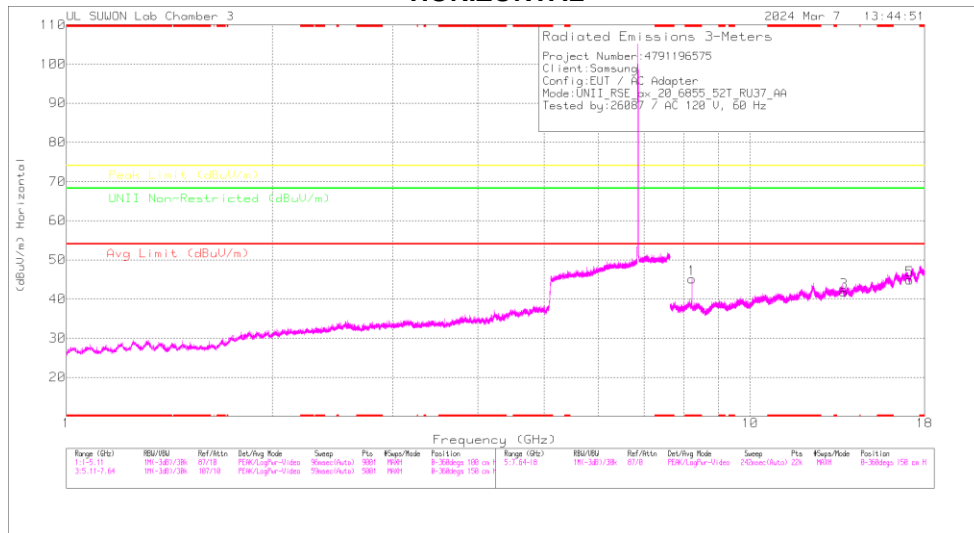

VERTICAL

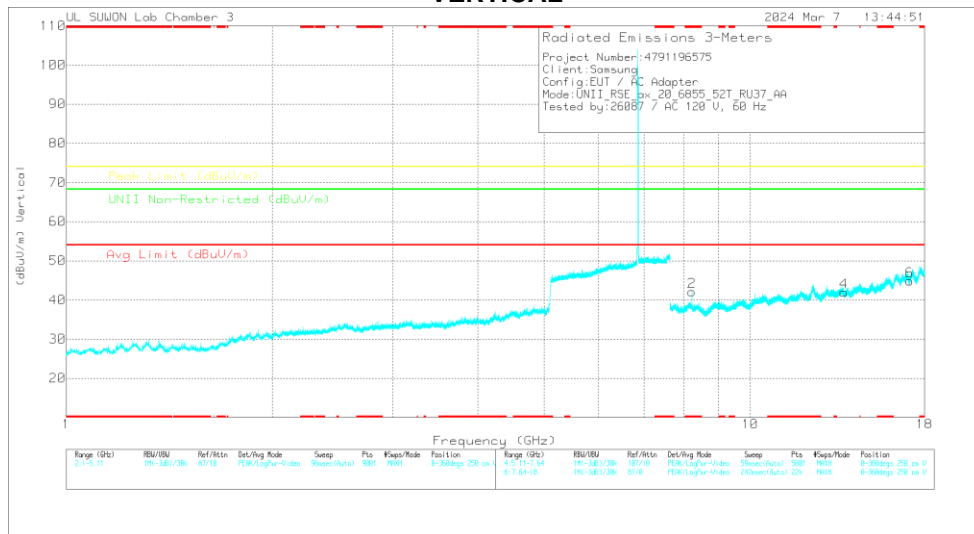

Note. Emission was scanned up to 40GHz; No emissions were detected above the noise floor which was at least 20dB below the specification limit.

Radiated Emissions

Frequency (GHz)	Mask Reading (dBuV)	Det	Antenna (dBi Factor)(dB)	ISRL HP_Path Loss(dB)	DC Corr (dB)	Corrected Reading (dBuV/m)	Avg Limit (dBuV/m)	Margin (dB)	Peak Limit (dBuV/m)	Margin (dB)	UNII Non-Restricted (dBuV/m)	Margin (dB)	Azimuth (Degs)	Height (cm)	Polarity
* 8.226	39.34	PK-U	36	-23.2	0	52.14	-	-	74	-21.86	-	-	207	120	H
* 8.22596	33.38	ADR	36	-23.2	0	46.18	54	-7.82	74	-23.24	-	-	207	120	H
* 8.22634	37.96	PK-U	36	-23.2	0	50.76	-	-	74	-	-	-	165	100	V
* 8.22595	30.02	ADR	36	-23.2	0	42.82	54	-11.18	-	-	-	-	165	100	V
13.72	36.16	PK-U	38.7	-23.2	0	51.66	-	-	-	-	68.2	-16.54	0	100	H
13.69298	36.85	PK-U	38.7	-23	0	52.55	-	-	-	-	68.2	-15.65	105	101	V
17.13558	33.35	PK-U	41.3	-17.5	0	57.15	-	-	-	-	68.2	-11.05	0	100	H
17.13799	33.1	PK-U	41.3	-17.5	0	56.9	-	-	-	-	68.2	-11.3	0	100	V

* - indicates frequency in CFR47 Pt 15 / IC RSS-Restricted Band
 PK-U - U-NII: Maximum Peak
 ADR - U-NII AD primary method, RMS average

HARMONICS AND SPURIOUS EMISSIONS TEST DATA

Mode	Freq. [MHz]	Antenna	Frequency [GHz]	Reading [dBuV]	Detector Mode	ANT Factor [dB/m]	Loss [dB]	DC Corr [dB]	Result [dBuV/m]	AV Limit [dBuV/m]	AV Margin [dB]	PK Limit [dBuV/m]	PK Margin [dB]	Non-Restricted [dBuV/m]	Margin [dB]	Azimuth [Degs]	Height [cm]	Polarity	
802.11a	6535	MIMO	8.71318	34.90	PK-U	36.10	-23.00	0.00	48.00	-	-	-	-	68.20	-20.20	207	124	H	
			8.71352	34.59	PK-U	36.10	-23.00	0.00	47.69	-	-	-	-	68.20	-20.51	128	100	V	
			13.07019	35.13	PK-U	39.20	-22.40	0.00	51.93	-	-	-	-	68.20	-16.27	57	108	H	
			13.06964	37.11	PK-U	39.20	-22.40	0.00	53.91	-	-	-	-	68.20	-14.29	94	103	V	
			16.33877	33.99	PK-U	41.30	-19.10	0.00	56.19	-	-	-	-	68.20	-12.01	0	100	H	
			16.33723	33.60	PK-U	41.30	-19.10	0.00	55.80	-	-	-	-	68.20	-12.40	0	100	V	
	6695	MIMO	8.92517	36.45	PK-U	36.20	-22.50	0.00	49.15	-	-	-	-	68.20	-19.05	205	100	H	
			8.92633	36.63	PK-U	36.20	-22.50	0.00	49.33	-	-	-	-	68.20	-18.87	124	100	V	
			* 13.39173	34.43	PK-U	39.10	-21.90	0.00	51.63	-	-	74.00	-22.37	-	-	0	100	H	
			* 13.39195	22.38	ADR	39.10	-21.90	0.15	39.73	54.00	-14.27	-	-	-	-	0	100	H	
			* 13.39028	36.55	PK-U	39.10	-21.90	0.00	53.75	-	-	74.00	-20.25	-	-	100	100	V	
			* 13.38981	24.14	ADR	39.10	-21.90	0.15	41.49	54.00	-12.51	-	-	-	-	100	100	V	
			16.73844	32.35	PK-U	41.80	-18.30	0.00	55.85	-	-	-	-	-	68.20	-12.35	0	100	H
			16.73522	32.52	PK-U	41.80	-18.30	0.00	56.02	-	-	-	-	-	68.20	-12.18	0	100	V
			* 8.22618	38.04	PK-U	36.00	-23.20	0.00	50.84	-	-	74.00	-23.16	-	-	201	103	H	
			* 8.22595	29.25	ADR	36.00	-23.20	0.15	42.20	54.00	-11.80	-	-	-	-	201	103	H	
	6855	MIMO	* 8.22636	36.49	PK-U	36.00	-23.20	0.00	49.29	-	-	74.00	-24.71	-	-	167	260	V	
			* 8.22598	26.77	ADR	36.00	-23.20	0.15	39.72	54.00	-14.28	-	-	-	167	260	V		
			13.70999	36.34	PK-U	38.70	-23.20	0.00	51.84	-	-	-	-	68.20	-16.36	0	100	H	
			13.71124	37.47	PK-U	38.70	-23.10	0.00	53.07	-	-	-	-	68.20	-15.13	73	100	V	
			17.13791	32.70	PK-U	41.30	-17.50	0.00	56.50	-	-	-	-	68.20	-11.70	0	100	H	
			17.13954	32.54	PK-U	41.30	-17.50	0.00	56.34	-	-	-	-	68.20	-11.86	0	100	V	
			* 8.226	39.34	PK-U	36.00	-23.20	0.00	52.14	-	-	74.00	-21.86	-	-	207	120	H	
			* 8.22588	33.38	ADR	36.00	-23.20	0.00	46.18	54.00	-7.82	-	-	-	-	207	120	H	
			* 8.22634	37.96	PK-U	36.00	-23.20	0.00	50.76	-	-	74.00	-23.24	-	-	165	100	V	
			* 8.22595	30.02	ADR	36.00	-23.20	0.00	42.82	54.00	-11.18	-	-	-	-	165	100	V	
	802.11ax HE20 RU mode 52 Tone offset 37 Spot-check	6855	MIMO	13.72000	36.16	PK-U	38.70	-23.20	0.00	51.66	-	-	-	-	68.20	-16.54	0	100	H
				13.69298	36.85	PK-U	38.70	-23.00	0.00	52.55	-	-	-	-	68.20	-15.65	105	101	V
				17.13558	33.35	PK-U	41.30	-17.50	0.00	57.15	-	-	-	-	68.20	-11.05	0	100	H
				17.13799	33.10	PK-U	41.30	-17.50	0.00	56.90	-	-	-	-	68.20	-11.30	0	100	V

Note1. PK-U - U-NII: Maximum Peak / ADR - U-NII AD primary method, RMS average
 Note2. * - indicates frequency in CFR47 Pt 15 / IC RSS-Restricted Band

11.4. TX ABOVE 1GHz 2Tx MODE IN U-NII-8 BAND

BANDEDGE (WORST CASE: 802.11ax HE20 SU / 7115 MHz)

VERTICAL

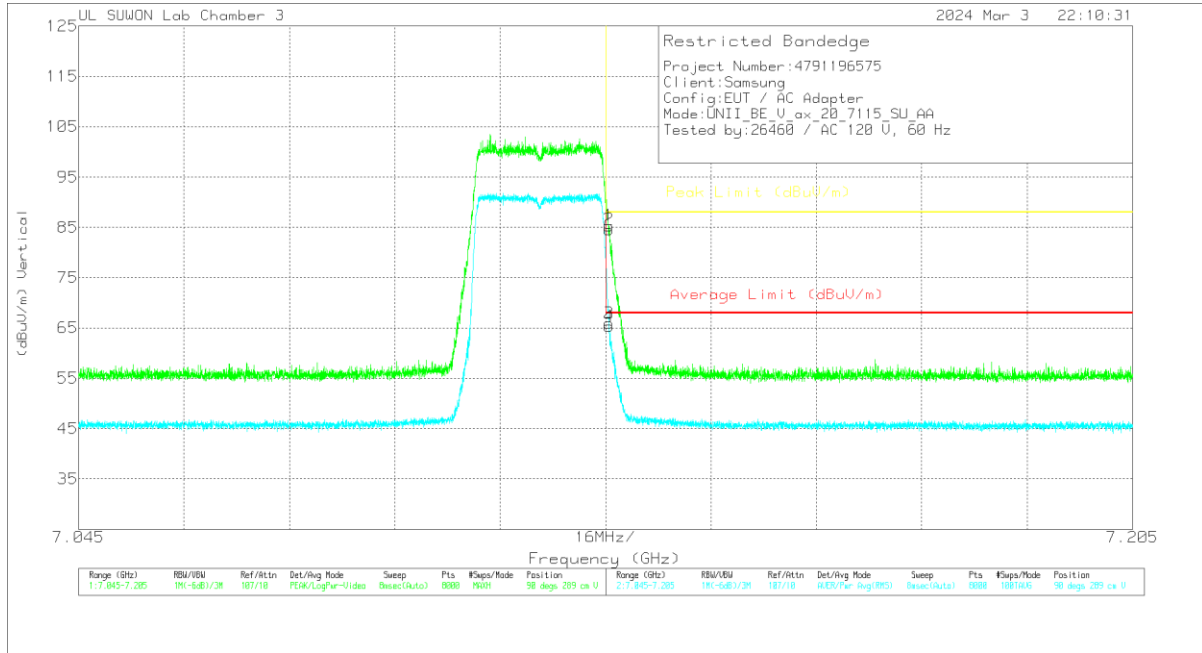

Trace Markers

Marker	Frequency (GHz)	Meter Reading (dBuV)	Det	Antenna_957_Factor(dB)	10dB_Path Loss(dB)	DC Cor (dB)	Corrected Reading (dBuV/m)	Average Limit (dBuV/m)	Margin (dB)	Peak Limit (dBuV/m)	PK Margin (dB)	Azimuth (Degs)	Height (cm)	Polarity
1	7.12549	66.14	PK	35.9	-16.7	0	85.34	-	-	88	-2.66	90	289	V
2	7.12553	65.39	PK	35.9	-16.7	0	84.59	-	-	88	-3.41	90	289	V
3	7.12549	46.76	RMS	35.9	-16.7	0	65.96	68	-2.04	-	-	90	289	V
4	7.12553	46.09	RMS	35.9	-16.7	0	65.29	68	-2.71	-	-	90	289	V

PK - Peak detector
 RMS - RMS detection

BANDEDGE TEST DATA

Mode	Freq. [MHz]	Antenna	Frequency [GHz]	Reading [dBuV]	Detector Mode	ANT Factor [dB/m]	Loss [dB]	DC Corr [dB]	Result dBuV/m	AV Limit dBuV/m	AV Margin [dB]	PK Limit dBuV/m	PK Margin [dB]	Azimuth [Degs]	Height [cm]	Polarity		
802.11a	7115	MIMO	7.12551	60.02	Pk	35.90	-16.70	0.00	79.22	-	-	88.00	-8.78	205	141	H		
			7.12573	62.56	Pk	35.90	-16.70	0.00	81.76	-	-	88.00	-6.24	205	141	H		
			7.12551	44.93	RMS	35.90	-16.70	0.15	64.28	68.00	-3.72	-	-	-	205	141	H	
			7.12557	44.85	RMS	35.90	-16.70	0.15	64.20	68.00	-3.80	-	-	-	205	141	H	
			7.12551	57.88	Pk	35.90	-16.70	0.00	77.08	-	-	88.00	-10.92	-	-	182	302	V
			7.12559	57.05	Pk	35.90	-16.70	0.00	76.25	-	-	88.00	-11.75	-	-	182	302	V
			7.12551	43.53	RMS	35.90	-16.70	0.15	62.88	68.00	-5.12	-	-	-	-	182	302	V
			7.12559	43.41	RMS	35.90	-16.70	0.15	62.76	68.00	-5.24	-	-	-	-	182	302	V
			7.12549	64.55	Pk	35.90	-16.70	0.00	83.75	-	-	88.00	-4.25	-	-	205	184	H
			7.12559	63.85	Pk	35.90	-16.70	0.00	83.05	-	-	88.00	-4.95	-	-	205	184	H
802.11ax HE20 SU mode	7115	MIMO	7.12549	46.56	RMS	35.90	-16.70	0.00	65.76	68.00	-2.24	-	-	205	184	H		
			7.12565	45.01	RMS	35.90	-16.70	0.00	64.21	68.00	-3.79	-	-	-	205	184	H	
			7.12549	66.14	Pk	35.90	-16.70	0.00	85.34	-	-	88.00	-2.66	-	90	289	V	
			7.12553	65.39	Pk	35.90	-16.70	0.00	84.59	-	-	88.00	-3.41	-	90	289	V	
			7.12549	46.76	RMS	35.90	-16.70	0.00	65.96	68.00	-2.04	-	-	-	90	289	V	
			7.12553	46.09	RMS	35.90	-16.70	0.00	65.29	68.00	-2.71	-	-	-	90	289	V	
			7.12501	36.86	Pk	35.90	-16.60	0.00	56.16	-	-	88.00	-31.84	-	-	206	161	H
			7.12811	39.59	Pk	35.90	-16.70	0.00	58.79	-	-	88.00	-29.21	-	-	206	161	H
			7.12501	27.58	RMS	35.90	-16.60	0.00	46.88	68.00	-21.12	-	-	-	-	206	161	H
			7.12529	28.03	RMS	35.90	-16.70	0.00	47.23	68.00	-20.77	-	-	-	-	206	161	H
802.11ax HE40 SU mode	7085	MIMO	7.12501	37.72	Pk	35.90	-16.60	0.00	57.02	-	-	88.00	-30.98	86	292	V		
			7.15336	39.83	Pk	35.90	-16.60	0.00	59.13	-	-	88.00	-28.87	86	292	V		
			7.12501	27.05	RMS	35.90	-16.60	0.00	46.35	68.00	-21.65	-	-	-	86	292	V	
			7.12601	28.06	RMS	35.90	-16.70	0.00	47.26	68.00	-20.74	-	-	-	86	292	V	
			7.12501	37.45	Pk	35.90	-16.60	0.00	56.75	-	-	88.00	-31.25	-	-	201	103	H
			7.20348	38.89	Pk	35.80	-16.40	0.00	58.29	-	-	88.00	-29.71	-	-	201	103	H
			7.12501	27.23	RMS	35.90	-16.60	0.00	46.53	68.00	-21.47	-	-	-	-	201	103	H
			7.13009	27.98	RMS	35.90	-16.60	0.00	47.28	68.00	-20.72	-	-	-	-	201	103	H
			7.12501	36.05	Pk	35.90	-16.60	0.00	55.35	-	-	88.00	-32.65	-	-	91	298	V
			7.15978	39.06	Pk	35.90	-16.60	0.00	58.36	-	-	88.00	-29.64	-	-	91	298	V
802.11ax HE80 SU mode	7025	MIMO	7.12501	26.52	RMS	35.90	-16.60	0.00	45.82	68.00	-22.18	-	-	-	91	298	V	
			7.12569	27.87	RMS	35.90	-16.70	0.00	47.07	68.00	-20.93	-	-	-	91	298	V	
			7.12501	37.00	Pk	35.90	-16.60	0.00	56.30	-	-	88.00	-31.70	-	-	208	107	H
			7.16518	40.96	Pk	35.90	-16.60	0.00	60.26	-	-	88.00	-27.74	-	-	208	107	H
			7.12501	28.16	RMS	35.90	-16.60	0.00	47.46	68.00	-20.54	-	-	-	-	208	107	H
			7.13993	29.01	RMS	35.90	-16.60	0.00	48.31	68.00	-19.69	-	-	-	-	208	107	H
			7.12501	36.12	Pk	35.90	-16.60	0.00	55.42	-	-	88.00	-32.58	-	-	85	296	V
			7.18814	39.90	Pk	35.80	-16.60	0.00	59.10	-	-	88.00	-28.90	-	-	85	296	V
			7.12501	26.94	RMS	35.90	-16.60	0.00	46.24	68.00	-21.76	-	-	-	-	85	296	V
			7.17184	28.33	RMS	35.90	-16.60	0.00	47.63	68.00	-20.37	-	-	-	-	85	296	V

Note1. PK-U - U-NII: Maximum Peak / ADR - U-NII AD primary method, RMS average

HARMONICS AND SPURIOUS EMISSIONS(WORST CASE: 802.11a / 7115 MHz)

HORIZONTAL

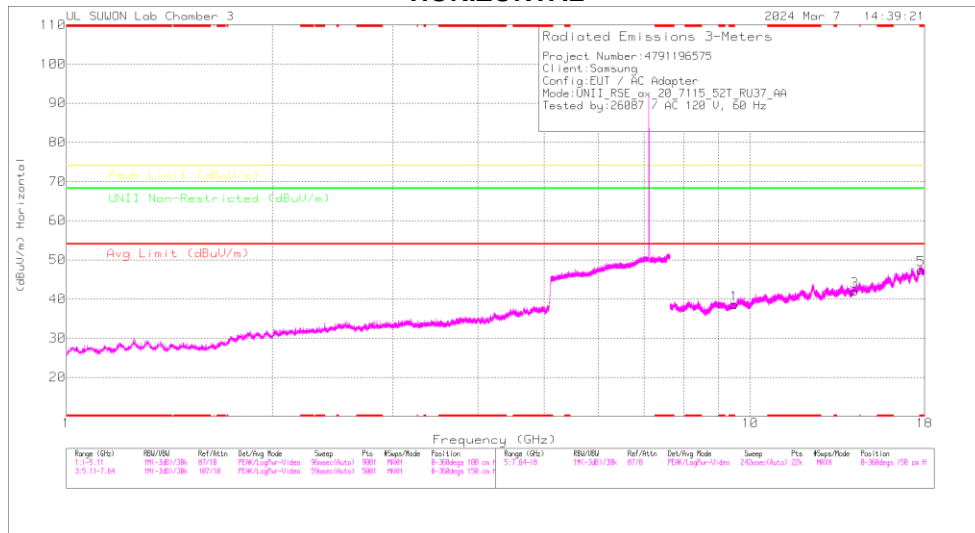

VERTICAL

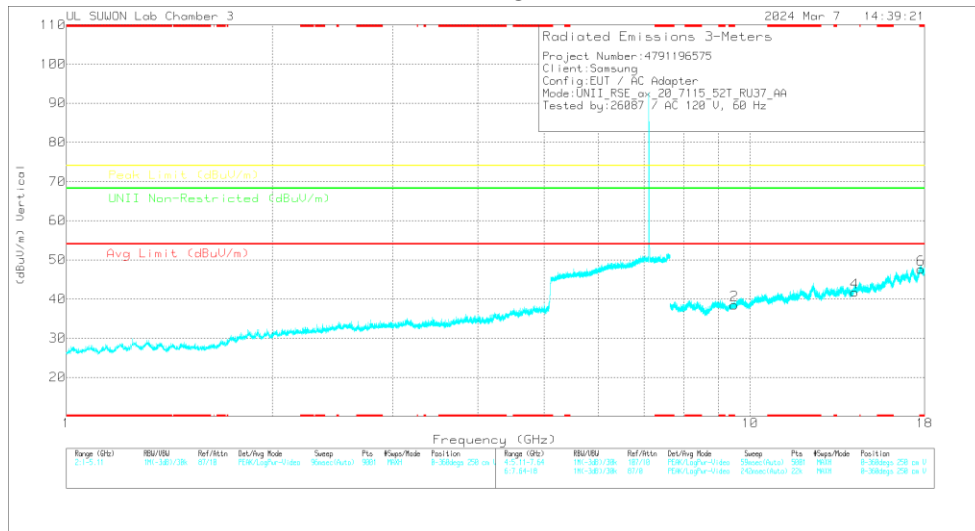

Note: Emission was scanned up to 40GHz; No emissions were detected above the noise floor which was at least 20dB below the specification limit.

Radiated Emissions

Frequency (GHz)	Meter Reading (dBuV)	Det	Antenna_S67_Factor(dB)	8dHz_HP_Path Loss(dB)	DC Cor (dB)	Corrected Reading (dBuV/m)	Avg Limit (dBuV/m)	Margin (dB)	Peak Limit (dBuV/m)	Margin (dB)	UNII Non-Restricted (dBuV/m)	Margin (dB)	Altitude (Meters)	Height (cm)	Polarity
* 9.4831	33.87	PK-U	36.7	-21.9	0	48.67	-	-	74	-25.33	-	-	0	100	H
* 9.48816	33.93	PK-U	36.7	-21.9	0	48.73	-	-	74	-25.27	-	-	133	108	V
* 9.4866	22.43	ADR	36.7	-21.9	0	37.23	54	-16.77	-	-	-	-	133	108	V
14.23259	35.44	PK-U	39.3	-22.4	0	52.34	-	-	-	-	88.2	-15.86	0	100	H
14.23014	36.17	PK-U	39.3	-22.4	0	53.07	-	-	-	-	88.2	-15.13	0	100	V
* 17.78748	31.97	PK-U	41.4	-15.8	0	57.57	-	-	74	-16.43	-	-	0	100	H
* 17.78537	31.9	PK-U	41.4	-15.8	0	57.5	-	-	74	-16.5	-	-	0	100	V

* - indicates frequency in CFR47 Pt 15 / IC RSS-Restricted Band
 PK-U - U-NII: Maximum Peak
 ADR - U-NII AD primary method, RMS average

HARMONICS AND SPURIOUS EMISSIONS TEST DATA

Mode	Freq. [MHz]	Antenna	Frequency [GHz]	Reading [dBuV]	Detector Mode	ANT Factor [dB/m]	Loss [dB]	DC Corr [dB]	Result [dBuV/m]	AV Limit [dBuV/m]	AV Margin [dB]	PK Limit [dBuV/m]	PK Margin [dB]	Non-Restricted [dBuV/m]	Margin [dB]	Azimuth [Degs]	Height [cm]	Polarity	
802.11a	6895	MIMO	10.35260	34.00	PK-U	37.50	-21.10	0.00	50.40	-	-	-	-	68.20	-17.80	0	100	H	
			10.33667	34.47	PK-U	37.50	-21.20	0.00	50.77	-	-	-	-	-	68.20	-17.43	0	100	V
			13.78685	36.59	PK-U	38.70	-23.40	0.00	51.89	-	-	-	-	-	68.20	-16.31	0	100	H
			13.78471	36.00	PK-U	38.70	-23.40	0.00	51.30	-	-	-	-	-	68.20	-16.90	0	100	V
			17.24299	32.34	PK-U	41.10	-16.60	0.00	56.84	-	-	-	-	-	68.20	-11.36	0	100	H
			17.23732	32.19	PK-U	41.10	-16.70	0.00	56.59	-	-	-	-	-	68.20	-11.61	0	100	V
	6995	MIMO	10.49959	33.55	PK-U	37.60	-20.90	0.00	50.25	-	-	-	-	68.20	-17.95	0	100	H	
			10.49480	34.70	PK-U	37.60	-21.00	0.00	51.30	-	-	-	-	68.20	-16.90	0	100	V	
			13.99667	35.94	PK-U	38.80	-23.40	0.00	51.34	-	-	-	-	68.20	-16.86	0	100	H	
			13.98830	36.05	PK-U	38.80	-23.50	0.00	51.35	-	-	-	-	68.20	-16.85	0	100	V	
			17.49439	31.38	PK-U	41.20	-16.70	0.00	55.88	-	-	-	-	68.20	-12.32	0	100	H	
			17.49470	31.46	PK-U	41.20	-16.70	0.00	55.96	-	-	-	-	68.20	-12.24	0	100	V	
	7115	MIMO	* 10.67767	33.24	PK-U	37.80	-21.20	0.00	49.84	-	-	74.00	-24.16	-	-	-	0	100	H
			* 10.6689	33.45	PK-U	37.70	-21.20	0.00	49.95	-	-	74.00	-24.05	-	-	-	0	100	V
			14.23810	35.97	PK-U	39.30	-22.50	0.00	52.77	-	-	-	-	68.20	-15.43	0	100	H	
			14.23877	35.53	PK-U	39.30	-22.40	0.00	52.43	-	-	-	-	68.20	-15.77	0	100	V	
			* 17.78255	32.23	PK-U	41.40	-15.80	0.00	57.83	-	-	74.00	-16.17	-	-	-	0	100	H
			* 17.79026	32.45	PK-U	41.40	-15.80	0.00	58.05	-	-	74.00	-15.95	-	-	-	0	100	V
802.11ax HE20 RU mode 52 Tone offset 37 Spot-check	7115	MIMO	* 9.4831	33.87	PK-U	36.70	-21.90	0.00	48.67	-	-	74.00	-25.33	-	-	0	100	H	
			* 9.48616	33.93	PK-U	36.70	-21.90	0.00	48.73	-	-	74.00	-25.27	-	-	133	108	V	
			* 9.4866	22.43	ADR	36.70	-21.90	0.00	37.23	54.00	-16.77	-	-	-	-	-	-	-	-
			14.23259	35.44	PK-U	39.30	-22.40	0.00	52.34	-	-	-	-	68.20	-15.86	0	100	H	
			14.23014	36.17	PK-U	39.30	-22.40	0.00	53.07	-	-	-	-	68.20	-15.13	0	100	V	
			* 17.78748	31.97	PK-U	41.40	-15.80	0.00	57.57	-	-	74.00	-16.43	-	-	-	0	100	H
			* 17.78537	31.90	PK-U	41.40	-15.80	0.00	57.50	-	-	74.00	-16.50	-	-	-	0	100	V

Note1. PK-U - U-NII: Maximum Peak / ADR - U-NII AD primary method, RMS average

Note2. * - indicates frequency in CFR47 Pt 15 / IC RSS-Restricted Band

12. WORST-CASE BELOW 1 GHz SPURIOUS EMISSIONS 30 TO 1000 MHz (WORST-CASE CONFIGURATION, HORIZONTAL)

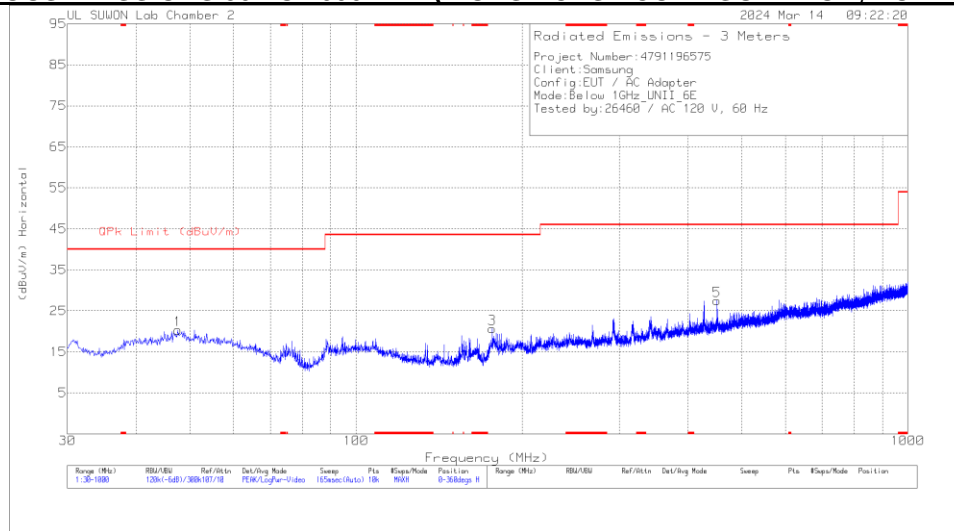

SPURIOUS EMISSIONS 30 TO 1000 MHz (WORST-CASE CONFIGURATION, VERTICAL)

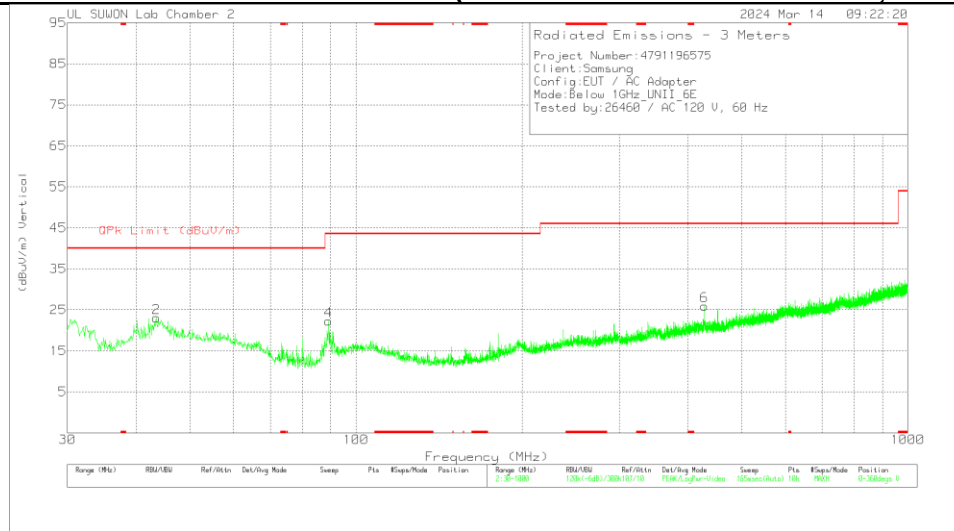

Trace Markers

Marker	Frequency (MHz)	Meter Reading (dBuV)	Det	Antenna_749_Factor(dB)	Below_1G_Path Loss(dB)	DC Corr (dB)	Corrected Reading (dBuV/m)	QPk Limit (dBuV/m)	Margin (dB)	Azimuth (Degs)	Height (cm)	Polarity
1	47.557	31.85	Pk	20.1	-31.6	0	20.35	40	-19.65	0-360	100	H
3	176.664	36.28	Pk	15.1	-30.7	0	20.68	43.52	-22.84	0-360	100	H
5	451.271	35.21	Pk	21.9	-29.6	0	27.51	46.02	-18.51	0-360	100	H
2	43.483	35.25	Pk	19.6	-31.8	0	23.05	40	-16.95	0-360	100	V
4	89.267	37.79	Pk	15.8	-31.3	0	22.29	43.52	-21.23	0-360	100	V
6	428.185	33.96	Pk	21.7	-29.7	0	25.96	46.02	-20.06	0-360	100	V

Pk - Peak detector

13. AC POWER LINE CONDUCTED EMISSIONS

LIMITS

FCC §15.207 (a)
IC RSS-GEN Clause 8.8

Frequency of Emission (MHz)	Conducted Limit (dBuV)	
	Quasi-peak	Average
0.15-0.5	66 to 56 [*]	56 to 46 [*]
0.5-5	56	46
5-30	60	50

^{*}Decreases with the logarithm of the frequency.

TEST PROCEDURE

The EUT is placed on a non-conducting table 40 cm from the vertical ground plane and 80 cm above the horizontal ground plane. The EUT is configured in accordance with ANSI C63.10.

The receiver is set to a resolution bandwidth of 9 kHz. Peak detection is used unless otherwise noted as quasi-peak or average.

Line conducted data is recorded for both NEUTRAL and HOT lines.

RESULTS

WORST EMISSIONS

LINE 1 DATA

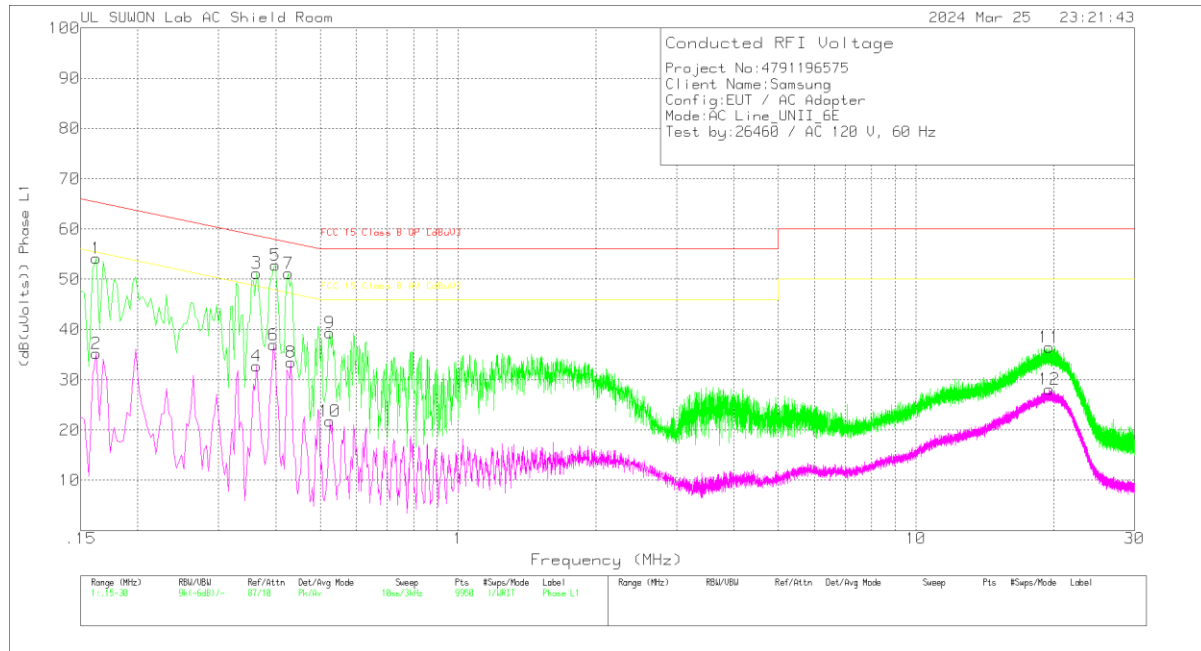

Trace Markers

Range 1: Phase L1 .15 - 30MHz

Marker	Frequency (MHz)	Meter Reading (dBuV)	Det	101836_With EX_L1 [dB]	Cable Loss [dB]	Corrected Reading (dB(uVolts))	FCC 15 Class B QP [dBuV]	Margin (dB)	FCC 15 Class B AV [dBuV]	Margin (dB)
1	.162	44.17	Pk	9.9	.1	54.17	65.36	-11.19	-	-
2	.162	25.24	Av	9.9	.1	35.24	-	-	55.36	-20.12
3	.363	41.34	Pk	9.8	.1	51.24	58.66	-7.42	-	-
4	.363	22.82	Av	9.8	.1	32.72	-	-	48.66	-15.94
5	.399	42.88	Pk	9.8	.1	52.78	57.87	-5.09	-	-
6	.396	27.03	Av	9.8	.1	36.93	-	-	47.94	-11.01
7	.426	41.24	Pk	9.8	.1	51.14	57.33	-6.19	-	-
8	.432	23.53	Av	9.8	.1	33.43	-	-	47.21	-13.78
9	.525	29.35	Pk	9.9	.1	39.35	56	-16.65	-	-
10	.525	11.77	Av	9.9	.1	21.77	-	-	46	-24.23
11	19.575	25.92	Pk	10.2	.3	36.42	60	-23.58	-	-
12	19.569	17.66	Av	10.2	.3	28.16	-	-	50	-21.84

Pk - Peak detector

Av - Average detection

Quasi-Peak Emissions

Range 1: Phase L1 .15 - 30MHz

Frequency (MHz)	Meter Reading (dBuV)	Det	101836_With EX_L1 [dB]	Cable Loss [dB]	Corrected Reading (dB(uVolts))	FCC 15 Class B QP [dBuV]	Margin (dB)	FCC 15 Class B AV [dBuV]	Margin (dB)
.36375	40.07	Qp	9.8	.1	49.97	58.64	-8.67	-	-
.39825	42.31	Qp	9.8	.1	52.21	57.89	-5.68	-	-
.42675	39.84	Qp	9.8	.1	49.74	57.32	-7.58	-	-

Qp - Quasi-Peak detector

LINE 2 DATA

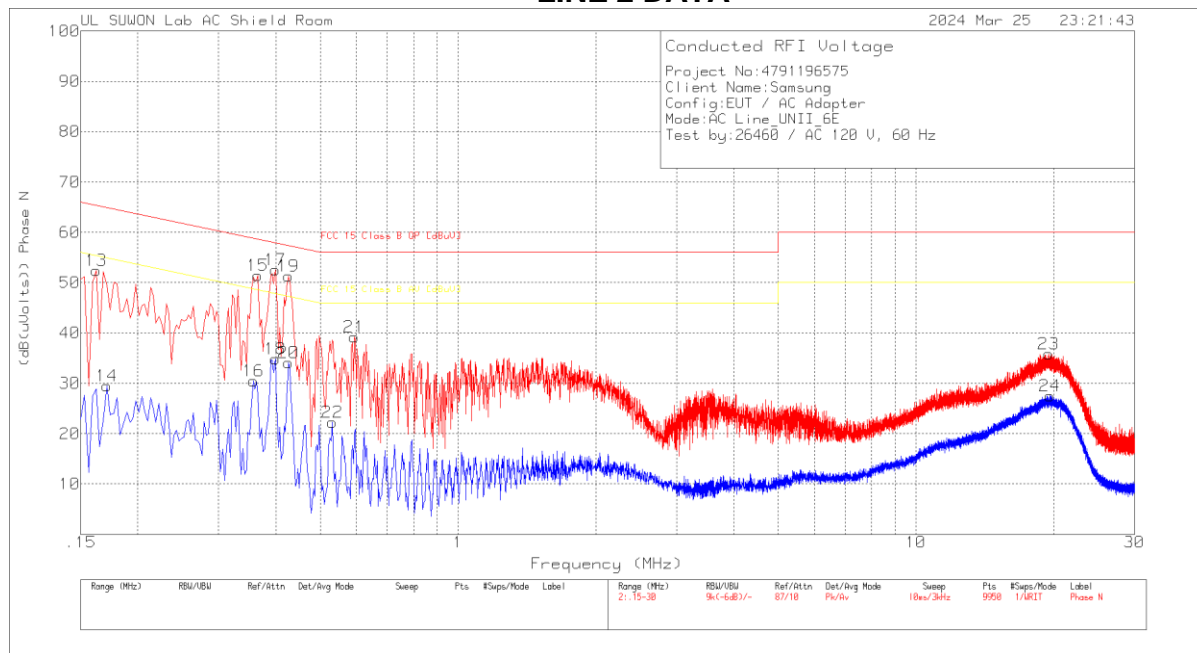

Trace Markers

Range 2: Phase N .15 - 30MHz

Marker	Frequency (MHz)	Meter Reading (dBuV)	Det	101836_With EX_N [dB]	Cable Loss [dB]	Corrected Reading (dB(uVolts))	FCC 15 Class B QP [dBuV]	Margin (dB)	FCC 15 Class B AV [dBuV]	Margin (dB)
13	.162	42.42	Pk	9.9	.1	52.42	65.36	-12.94	-	-
14	.171	19.41	Av	10	.1	29.51	-	-	54.91	-25.4
15	.366	41.5	Pk	9.8	.1	51.4	58.59	-7.19	-	-
16	.357	20.57	Av	9.8	.1	30.47	-	-	48.8	-18.33
17	.399	42.62	Pk	9.8	.1	52.52	57.87	-5.35	-	-
18	.399	24.9	Av	9.8	.1	34.8	-	-	47.87	-13.07
19	.426	41.43	Pk	9.8	.1	51.33	57.33	-6	-	-
20	.426	24.23	Av	9.8	.1	34.13	-	-	47.33	-13.2
21	.594	29.37	Pk	9.8	.1	39.27	56	-16.73	-	-
22	.531	12.21	Av	9.9	.1	22.21	-	-	46	-23.79
23	19.473	25.36	Pk	10.2	.3	35.86	60	-24.14	-	-
24	19.584	17	Av	10.2	.3	27.5	-	-	50	-22.5

Pk - Peak detector

Av - Average detection

Quasi-Peak Emissions

Range 2: Phase N .15 - 30MHz

Frequency (MHz)	Meter Reading (dBuV)	Det	101836_With EX_N [dB]	Cable Loss [dB]	Corrected Reading (dB(uVolts))	FCC 15 Class B QP [dBuV]	Margin (dB)	FCC 15 Class B AV [dBuV]	Margin (dB)
.36525	39.57	Qp	9.8	.1	49.47	58.61	-9.14	-	-
.39825	40.97	Qp	9.8	.1	50.87	57.89	-7.02	-	-
.42675	39.28	Qp	9.8	.1	49.18	57.32	-8.14	-	-

Qp - Quasi-Peak detector

14. Contention Based Protocol

14.1. OVERVIEW

14.1.1. LIMITS

FCC

§15.407 (d) (6)
KDB 987594 D02

Indoor access points, subordinate devices and client devices operating in the 5.925-7.125 GHz band (herein referred to as unlicensed devices) are required to use technologies that include a contention-based protocol to avoid co-channel interference with incumbent devices sharing the band. To ensure incumbent co-channel operations are detected in a technology-agnostic manner, unlicensed devices are required to detect co-channel radio frequency energy (energy detect) and avoid simultaneous transmission.

Unlicensed low-power indoor devices must detect co-channel radio frequency power that is at least -62 dBm or lower. Upon detection of energy in the band, unlicensed low power indoor devices must vacate the channel (in which incumbent signal is transmitted) and stay off the incumbent channel as long as detected radio frequency power is equal to or greater than the threshold (-62 dBm)¹. The -62 dBm (or lower) threshold is referenced to a 0 dBi antenna gain.

To ensure incumbent operations are reliably detected in the band, low power indoor devices must detect RF energy throughout their intended operating channel. For example, an 802.11 device that plans to transmit a 40 MHz- wide signal (on a primary 20 MHz channel and a secondary 20 MHz channel) must detect energy throughout the entire 40 MHz channel. Additionally, low-power indoor devices must detect co-channel energy with 90% or greater certainty.

CHANNEL PUNCTURING AND BANDWIDTH REDUCTION (802.11ax)

This EUT does not support channel puncturing and bandwidth reduction.

14.1.2. TEST AND MEASUREMENT SYSTEM

CONDUCTED METHOD SYSTEM BLOCK DIAGRAM

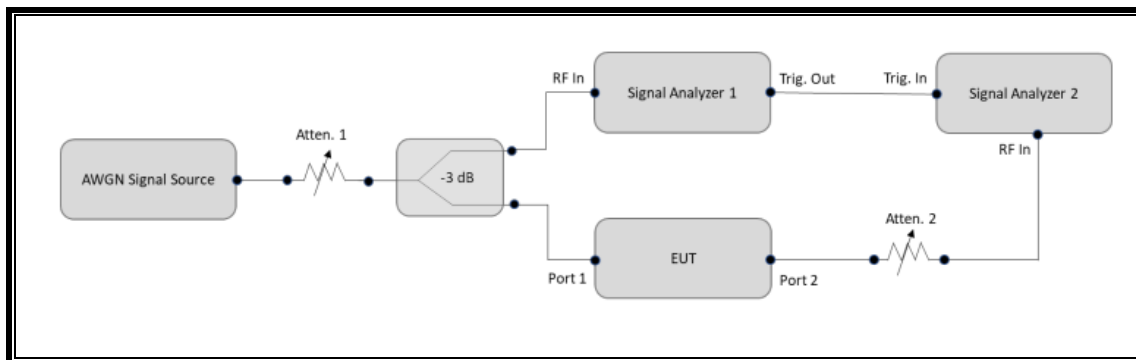

TEST SETTING

- 1) Configure the EUT to transmit with a constant duty cycle.
- 2) Set the operating parameters of the EUT including power level, operating frequency, modulation and bandwidth.
- 3) Set the signal analyzer center frequency to the nominal EUT channel center frequency. The span range of the signal analyzer shall be between two times and five times the OBW of the EUT. Connect the output port of the EUT to the signal analyzer 2, as shown in Figure 2. Ensure that the attenuator 2 provides enough attenuation to not overload the signal analyzer 2 receiver.
- 4) Monitoring the signal analyzer 2, verify the EUT is operating and transmitting with the parameters set at step two.
- 5) Using an AWGN signal source, generate (but do not transmit, i.e., RF OFF) a 10 MHz-wide AWGN signal. Use Table 1 to determine the center frequency of the 10 MHz AWGN signal relative to the EUT's channel bandwidth and center frequency.
- 6) Set the AWGN signal power to an extremely low level (more than 20 dB below the -62 dBm threshold). Connect the AWGN signal source, via a 3-dB splitter, to the signal analyzer 1 and the EUT as shown in Figure 2.
- 7) Transmit the AWGN signal (RF ON) and verify its characteristics on the signal analyzer 1.
- 8) Monitor the signal analyzer 2 to verify if the AWGN signal has been detected and the EUT has ceased transmission. If the EUT continues to transmit, then incrementally increase the AWGN signal power level until the EUT stops transmitting.
- 9) (Including all losses in the RF paths) Determine and record the AWGN signal power level (at the EUT's antenna port) at which the EUT ceased transmission. Repeat the procedure at least 10 times to verify the EUT can detect an AWGN signal with 90% (or better) level of certainty.
- 10) Refer to Table 1 to determine number of times the detection threshold testing needs to be repeated. If testing is required more than once, then go back to step 5, choose a different center frequency for the AWGN signal and repeat the process.

TEST AND MEASUREMENT EQUIPMENT

The following test and measurement equipment was utilized for the tests documented in this report:

TEST EQUIPMENT LIST				
Description	Manufacturer	Model	S/N	Next Cal Due
Spectrum Analyzer	Keysight	N9030B	MY60070693	2025-01-03
Spectrum Analyzer	Agilent	N9030A	MY54170614	2024-07-24
Vector Signal Generator	R&S	SMW200A	110251	2024-07-27
Combiner	WEINSCHTEL	WA1534	UL001	2025-01-16
Combiner	WEINSCHTEL	WA1534	UL003	2025-01-02
Combiner	WEINSCHTEL	WA1534	UL004	2025-01-02
Attenuator	WEINSCHTEL	WA76-30-21	A015	2024-07-24
Attenuator	PASTERNAK	PE7087-10	A001	2024-07-23
Attenuator	PASTERNAK	PE7087-10	A008	2024-07-27

SUPPORT EQUIPMENT

The following support equipment was utilized for the CBP tests documented in this report:

PERIPHERAL SUPPORT EQUIPMENT LIST				
Description	Manufacturer	Model	Serial Number	FCC ID
Wireless Access Point	ASUS	GT-AXE11000	M3IAJF200742	MSQ-RTAXJF00
Notebook PC (Controller/Server)	HP	HP EliteDesk 800 G1 TWR	CZC4125J25	DoC

14.2. TEST RESULTS

14.2.1. AWGN Sample signal

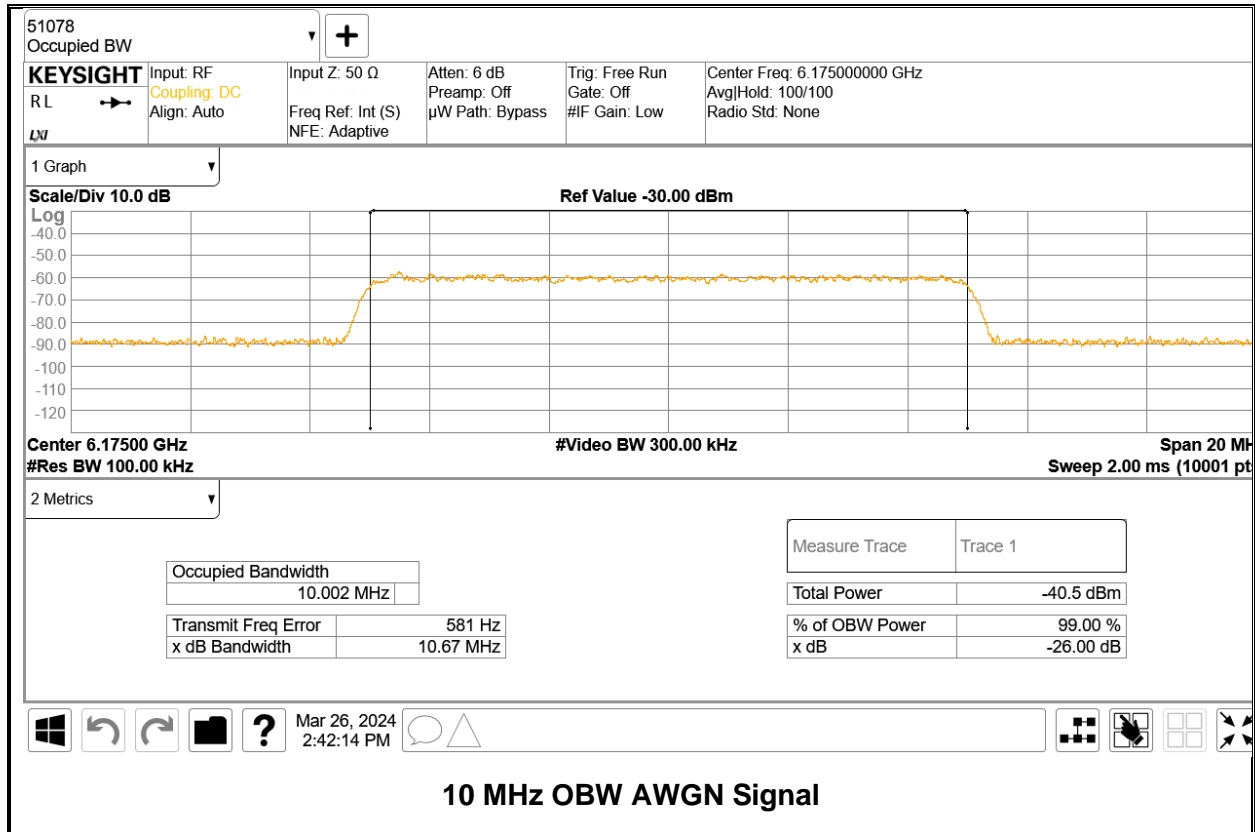

14.2.2. Contention Based Protocol Timing Plot (Measurement Criteria)

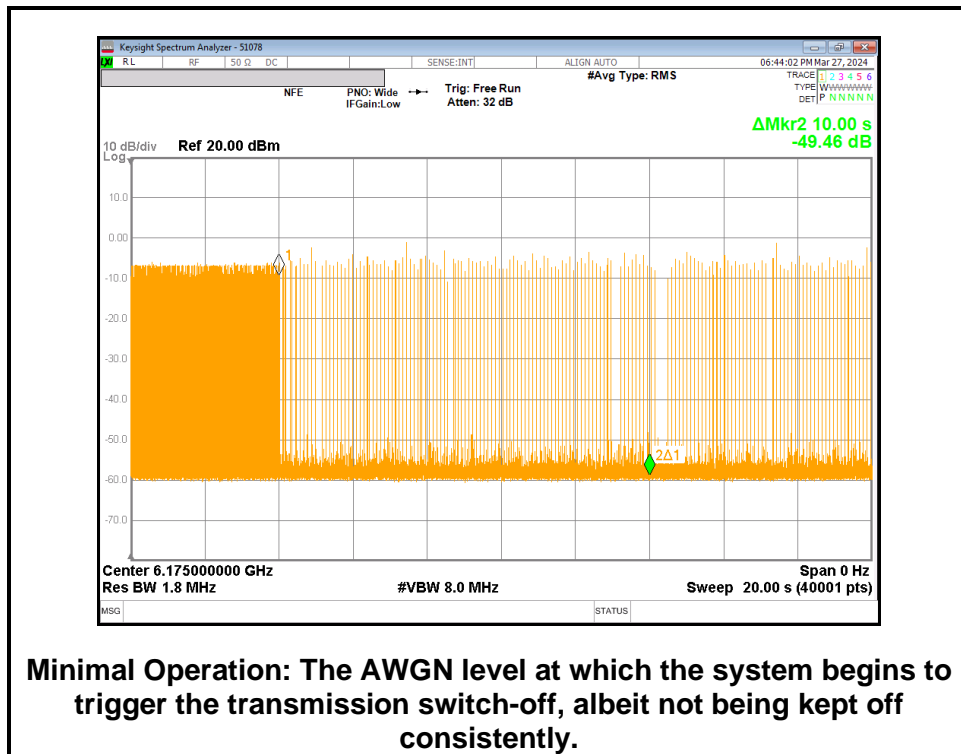
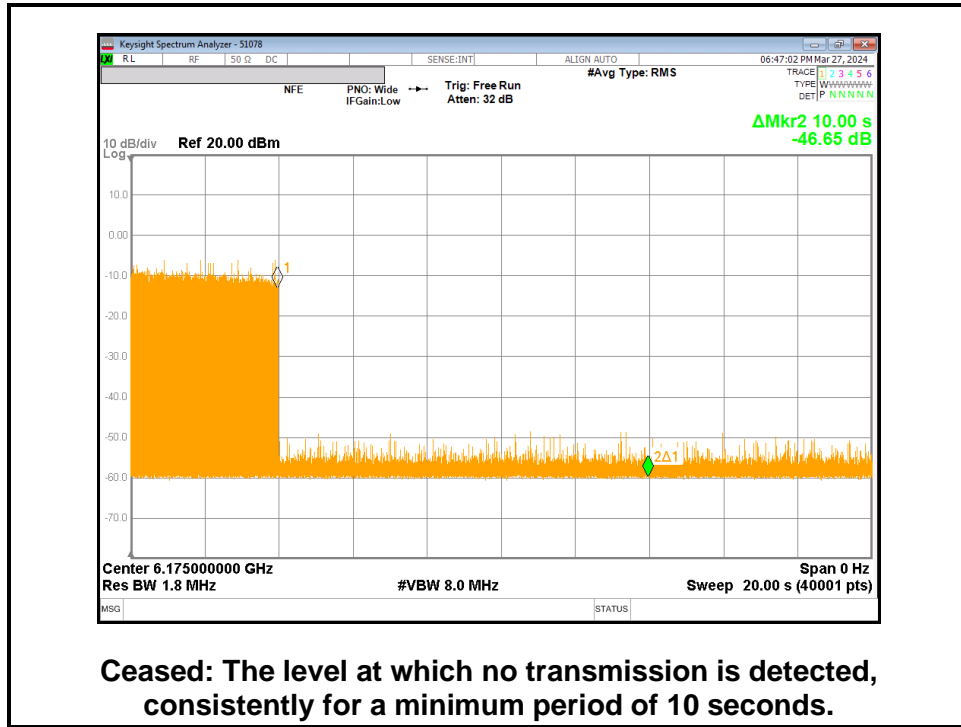

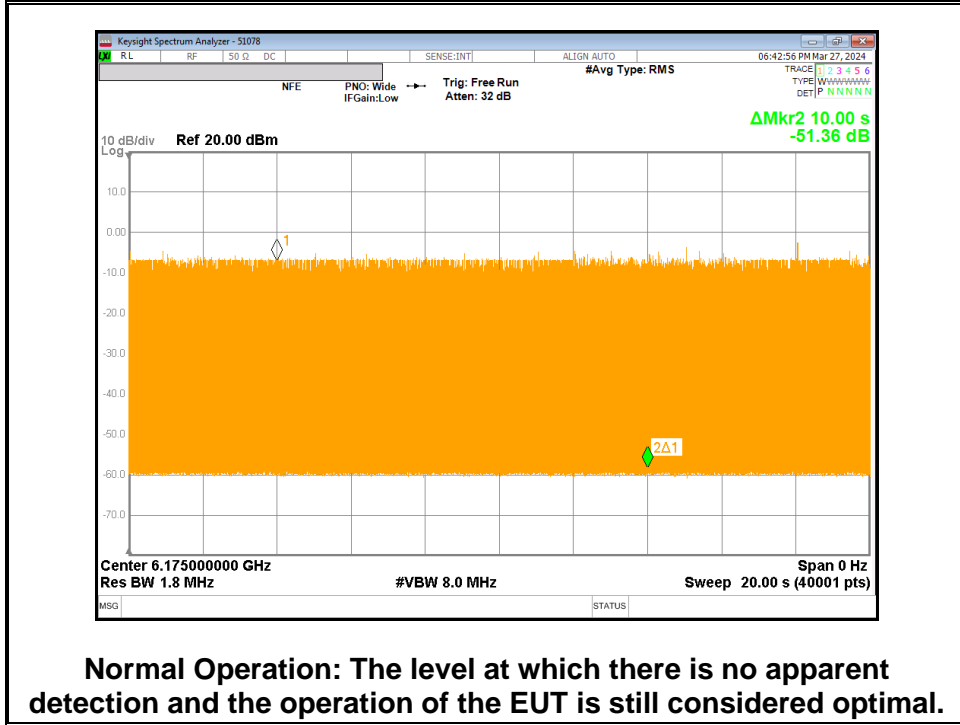

Normal Operation: The level at which there is no apparent detection and the operation of the EUT is still considered optimal.

14.2.3. Contention Based Protocol – Incumbent Detection & Trial Results

Band	Channel	Freq	BW	Inc. Freq	Detection power level (Prior)	Siggen (Prior)	Detection limit	Gain	Detection limit (include Gain)	Margin	Condition	
5	45	6175	20	6175	-73.87	-23.00	-62.00	-9.29	-71.29	-2.58	Ceased	
					-77.84	-27.00	-62.00	-9.29	-71.29	-6.55	Minimal	
					-80.78	-30.00	-62.00	-9.29	-71.29	-9.49	Normal	
	47	6185	160	6110	-71.74	-21.00	-62.00	-9.29	-71.29	-0.45	Ceased	
					-77.75	-27.00	-62.00	-9.29	-71.29	-6.46	Minimal	
					-79.68	-29.00	-62.00	-9.29	-71.29	-8.39	Normal	
				6175	-71.87	-21.00	-62.00	-9.29	-71.29	-0.58	Ceased	
					-76.88	-26.00	-62.00	-9.29	-71.29	-5.59	Minimal	
					-79.85	-29.00	-62.00	-9.29	-71.29	-8.56	Normal	
				6260	-71.78	-21.00	-62.00	-9.29	-71.29	-0.49	Ceased	
					-76.79	-26.00	-62.00	-9.29	-71.29	-5.50	Minimal	
					-78.75	-28.00	-62.00	-9.29	-71.29	-7.46	Normal	
6	105	6475	20	6475	-71.78	-22.00	-62.00	-8.52	-70.52	-1.26	Ceased	
					-78.80	-28.00	-62.00	-8.52	-70.52	-8.28	Minimal	
					-80.75	-30.00	-62.00	-8.52	-70.52	-10.23	Normal	
	111	6505	160	6435	-72.84	-22.00	-62.00	-8.52	-70.52	-2.32	Ceased	
					-77.79	-27.00	-62.00	-8.52	-70.52	-7.27	Minimal	
					-80.75	-30.00	-62.00	-8.52	-70.52	-10.23	Normal	
				6495	-72.88	-22.00	-62.00	-8.52	-70.52	-2.36	Ceased	
					-77.82	-27.00	-62.00	-8.52	-70.52	-7.30	Minimal	
					-80.78	-30.00	-62.00	-8.52	-70.52	-10.26	Normal	
	6575	-72.93	-22.00	-62.00	-8.52	-70.52	-2.41	Ceased				
		-79.94	-29.00	-62.00	-8.52	-70.52	-9.42	Minimal				
		-82.86	-32.00	-62.00	-8.52	-70.52	-12.34	Normal				
	7	149	6695	20	6695	-74.98	-24.00	-62.00	-9.73	-71.73	-3.25	Ceased
						-82.84	-32.00	-62.00	-9.73	-71.73	-11.11	Minimal
						-85.60	-35.00	-62.00	-9.73	-71.73	-13.87	Normal
143		6665	160	6595	-74.92	-24.00	-62.00	-9.73	-71.73	-3.19	Ceased	
					-78.87	-28.00	-62.00	-9.73	-71.73	-7.14	Minimal	
					-81.89	-31.00	-62.00	-9.73	-71.73	-10.16	Normal	
				6655	-75.88	-25.00	-62.00	-9.73	-71.73	-4.15	Ceased	
					-80.88	-30.00	-62.00	-9.73	-71.73	-9.15	Minimal	
					-82.85	-32.00	-62.00	-9.73	-71.73	-11.12	Normal	
				6735	-76.05	-25.00	-62.00	-9.73	-71.73	-4.32	Ceased	
					-81.50	-30.50	-62.00	-9.73	-71.73	-9.77	Minimal	
					-84.01	-33.00	-62.00	-9.73	-71.73	-12.28	Normal	
8		205	6975	20	6975	-74.10	-23.00	-62.00	-8.77	-70.77	-3.33	Ceased
						-82.94	-32.00	-62.00	-8.77	-70.77	-12.17	Minimal
						-84.88	-34.00	-62.00	-8.77	-70.77	-14.11	Normal
	207	6985	160	6915	-72.98	-22.00	-62.00	-8.77	-70.77	-2.21	Ceased	
					-81.85	-31.00	-62.00	-8.77	-70.77	-11.08	Minimal	
					-84.72	-34.00	-62.00	-8.77	-70.77	-13.95	Normal	
				6975	-73.14	-22.00	-62.00	-8.77	-70.77	-2.37	Ceased	
					-81.04	-30.00	-62.00	-8.77	-70.77	-10.27	Minimal	
					-82.97	-32.00	-62.00	-8.77	-70.77	-12.20	Normal	
				7055	-73.20	-22.00	-62.00	-8.77	-70.77	-2.43	Ceased	
					-82.10	-31.00	-62.00	-8.77	-70.77	-11.33	Minimal	
				-84.98	-34.00	-62.00	-8.77	-70.77	-14.21	Normal		

Note. Detection limit (include gain) = Detection limit (-62 dBm) + Antenna Gain (dBi). Detection power threshold is the level of the incumbent at the antenna port and includes all losses between the signal generator and the EUT antenna port.

Band	Channel	Freq	BW	Inc. Freq	1	2	3	4	5	6	7	8	9	10	Detection Rate (%)
5	45	6175	20	6175	O	O	O	O	O	O	X	O	O	O	90
				6110	O	O	O	O	O	O	O	O	O	O	100
	47	6185	160	6175	O	X	O	O	O	O	O	O	O	O	90
				6260	O	O	O	O	O	O	O	O	O	O	100
6	105	6475	20	6475	O	O	O	O	O	O	O	O	O	O	100
				6435	O	O	O	X	O	O	O	O	O	O	90
	111	6505	160	6495	O	O	O	O	O	O	O	O	O	O	100
				6575	O	O	O	O	O	O	O	O	O	O	100
7	149	6695	20	6695	O	O	O	O	O	O	O	O	O	O	100
				6595	O	O	O	O	O	O	X	O	O	O	90
	143	6665	160	6655	X	O	O	O	O	O	O	O	O	O	90
				6735	O	O	O	O	O	O	O	O	O	O	100
8	209	6995	20	6995	O	O	O	O	O	X	O	O	O	O	90
				6915	O	O	O	O	O	O	O	O	O	O	100
	207	6985	160	6975	O	O	X	O	O	O	O	O	O	O	90
				7055	O	O	O	O	O	O	O	O	O	O	100

15. SPOT-CHECK THEST RESULT

BANDEDGE (WORST CASE: 802.11a / 5955 MHz)

HORIZONTAL PEAK AND AVERAGE DATA

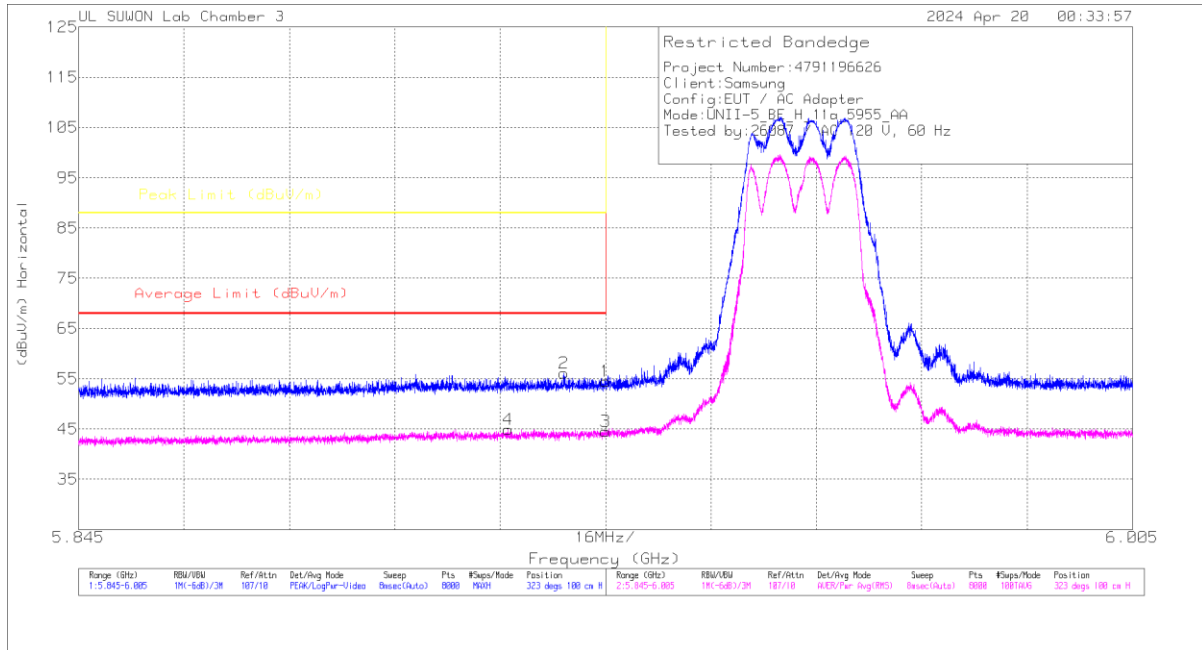

Trace Markers

Marker	Frequency (GHz)	Meter Reading (dBuV)	Det	Antenna_S67_Factor(dB)	10dB_Path Loss(dB)	DC Corr (dB)	Corrected Reading (dBuV/m)	Average Limit (dBuV/m)	Margin (dB)	Peak Limit (dBuV/m)	PK Margin (dB)	Azimuth (Degs)	Height (cm)	Polarity
1	5.92499	38.34	PK	35.5	-19.4	0	54.44	-	-	88	-33.56	323	100	H
2	5.91863	40.02	PK	35.5	-19.4	0	56.12	-	-	88	-31.88	323	100	H
3	5.92499	28.29	RMS	35.5	-19.4	.15	44.54	68	-23.46	-	-	323	100	H
4	5.91017	28.85	RMS	35.4	-19.5	.15	44.9	68	-23.1	-	-	323	100	H

PK - Peak detector
 RMS - RMS detection

HARMONICS AND SPURIOUS EMISSIONS(WORST CASE: 802.11a / 6175 MHz)

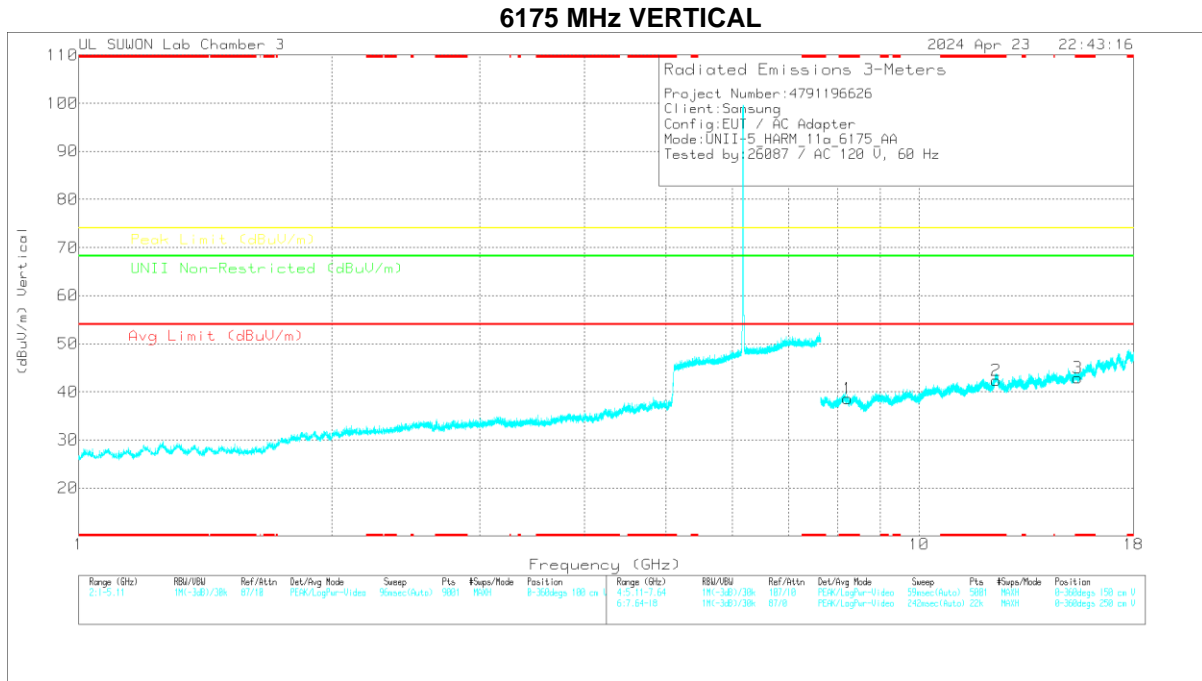

Trace Markers

Marker	Frequency (GHz)	Marker Reading (dBuV)	Det	Antenna_Sett_Factor(dB)	ICM2_HP_Path Loss(dB)	DC Corr (dB)	Corrected Reading (dBuV/m)	Avg Limit (dBuV/m)	Margin (dB)	Peak Limit (dBuV/m)	Margin (dB)	UNII Non-Restricted (dBuV/m)	Margin (dB)	Altitude (Degs)	Height (cm)	Polarity
1	* 8.22955	25.78	PK	36	-23.2	0	38.58	-	-	74	-35.42	-	-	0-360	150	V
2	* 12.35029	24.84	PK	39.2	-21.7	0	42.34	-	-	74	-31.66	-	-	0-360	250	V
3	* 15.43743	24.38	PK	40	-21.5	0	42.88	-	-	74	-31.12	-	-	0-360	250	V

* - indicates frequency in CFR47 Pt 15 / IC RSS-Restricted Band
 PK - Peak Detector

Radiated Emissions

Frequency (GHz)	Marker Reading (dBuV)	Det	Antenna_Sett_Factor(dB)	ICM2_HP_Path Loss(dB)	DC Corr (dB)	Corrected Reading (dBuV/m)	Avg Limit (dBuV/m)	Margin (dB)	Peak Limit (dBuV/m)	Margin (dB)	UNII Non-Restricted (dBuV/m)	Margin (dB)	Altitude (Degs)	Height (cm)	Polarity
* 12.35016	35.54	PK-U	39.2	-21.7	0	53.04	-	-	74	-20.96	-	-	113	104	V
* 12.35028	23.99	ADR	39.2	-21.7	.15	41.54	54	-12.46	-	-	-	-	113	104	V

* - indicates frequency in CFR47 Pt 15 / IC RSS-Restricted Band
 PK-U - U-NII: Maximum Peak
 ADR - U-NII AD primary method, RMS average

HARMONICS AND SPURIOUS EMISSIONS(WORST CASE: 802.11a / 6435 MHz)

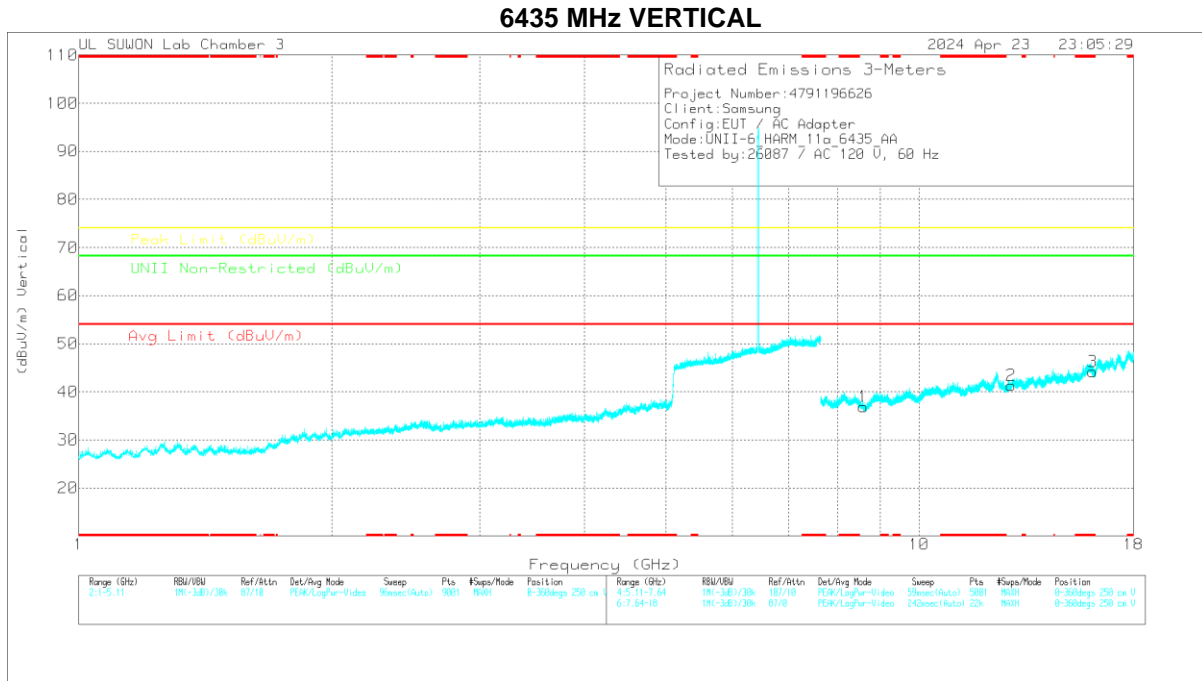

Trace Markers

Marker	Frequency (GHz)	Marker Reading (dBuV)	Det	Antenna_Sef_Factor (dB)	8GHz_HP_Path Loss(dB)	DC Corr (dB)	Corrected Reading (dBuV/m)	Avg Limit (dBuV/m)	Margin (dB)	Peak Limit (dBuV/m)	Margin (dB)	UNII Non-Restricted (dBuV/m)	Margin (dB)	Azimuth (Degs)	Height (cm)	Polarity
1	8.57989	24.24	PK	36	-23.3	0	36.94	-	-	-	-	68.2	-31.26	0-360	250	V
2	12.87015	24.45	PK	39.3	-22.4	0	41.35	-	-	-	-	68.2	-26.85	0-360	150	V
3	* 16.08773	23.04	PK	41.1	-19.9	0	44.24	-	-	74	-29.76	-	-	0-360	150	V

* - indicates frequency in CFR47 Pt 15 / IC RSS-Restricted Band
 PK - Peak Detector

Radiated Emissions

Frequency (GHz)	Marker Reading (dBuV)	Det	Antenna_Sef_Factor (dB)	8GHz_HP_Path Loss(dB)	DC Corr (dB)	Corrected Reading (dBuV/m)	Avg Limit (dBuV/m)	Margin (dB)	Peak Limit (dBuV/m)	Margin (dB)	UNII Non-Restricted (dBuV/m)	Margin (dB)	Azimuth (Degs)	Height (cm)	Polarity
* 16.08961	33.04	PK-U	41.1	-19.9	0	54.24	-	-	74	-19.76	-	-	0	100	V
* 16.09184	21.56	ADR	41.1	-19.8	-15	43.01	54	-10.99	-	-	-	-	0	100	V

* - indicates frequency in CFR47 Pt 15 / IC RSS-Restricted Band
 PK-U - U-NII: Maximum Peak
 ADR - U-NII AD primary method, RMS average

HARMONICS AND SPURIOUS EMISSIONS(WORST CASE: 802.11a / 6855 MHz)

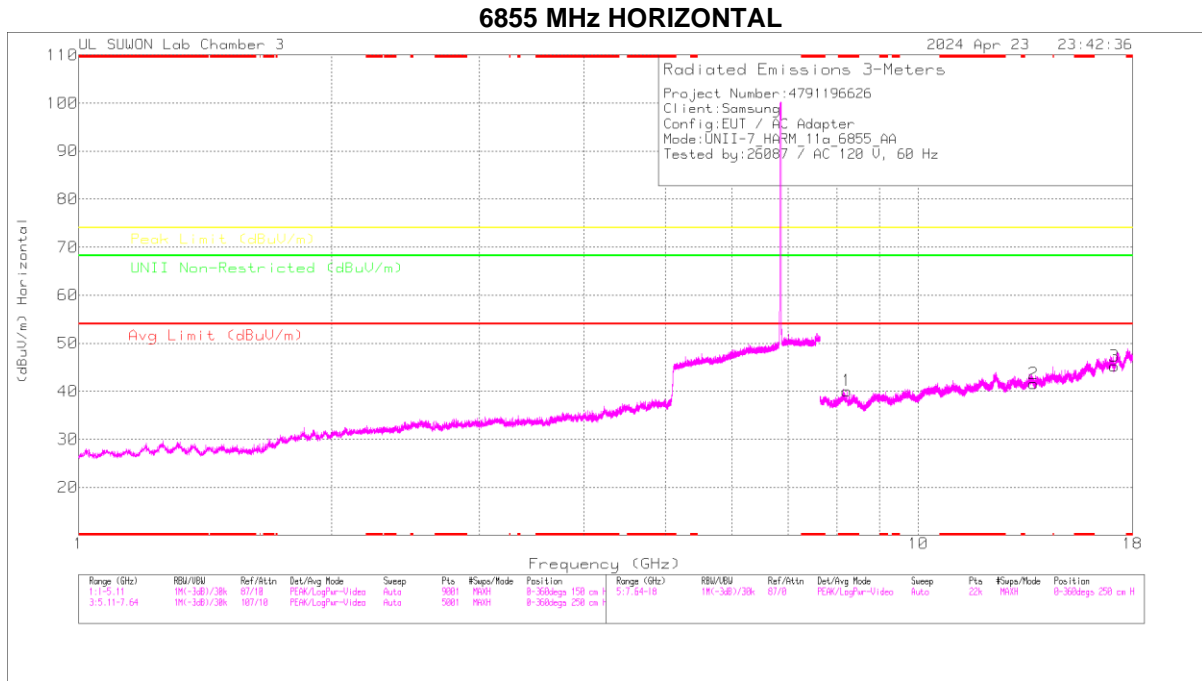

Trace Markers

Marker	Frequency (GHz)	Meter Reading (dBuV)	Det	Antenna_567_Factor(dB)	8GHz_HP_Path Loss(dB)	DC Corr (dB)	Corrected Reading (dBuV/m)	Avg Limit (dBuV/m)	Margin (dB)	Peak Limit (dBuV/m)	Margin (dB)	UNII Non-Restricted (dBuV/m)	Margin (dB)	Altitude (Degs)	Height (cm)	Polarity
1	* 8.22578	27.3	PK	36	-23.2	0	40.1	-	-	74	-33.9	-	-	0-360	250	H
2	13.71022	26.15	PK	36.7	-23.2	0	41.65	-	-	-	-	68.2	-26.55	0-360	250	H
3	17.13734	21.48	PK	41.3	-17.5	0	45.28	-	-	-	-	68.2	-22.92	0-360	250	H

* - indicates frequency in CFR47 Pt 15 / IC RSS-Restricted Band
 PK – Peak Detector

Radiated Emissions

Frequency (GHz)	Meter Reading (dBuV)	Det	Antenna_567_Factor(dB)	8GHz_HP_Path Loss(dB)	DC Corr (dB)	Corrected Reading (dBuV/m)	Avg Limit (dBuV/m)	Margin (dB)	Peak Limit (dBuV/m)	Margin (dB)	UNII Non-Restricted (dBuV/m)	Margin (dB)	Altitude (Degs)	Height (cm)	Polarity
* 8.22622	36.67	PK-U	36	-23.2	0	49.47	-	-	74	-24.53	-	-	195	103	H
* 8.22585	27.14	ADR	36	-23.2	-15	40.09	54	-13.91	-	-	-	-	195	103	H

* - indicates frequency in CFR47 Pt 15 / IC RSS-Restricted Band
 PK-U - U-NII: Maximum Peak

ADR - U-NII AD primary method, RMS average

BANDEDGE (WORST CASE: 802.11a / 7115 MHz)

HORIZONTAL PEAK AND AVERAGE DATA

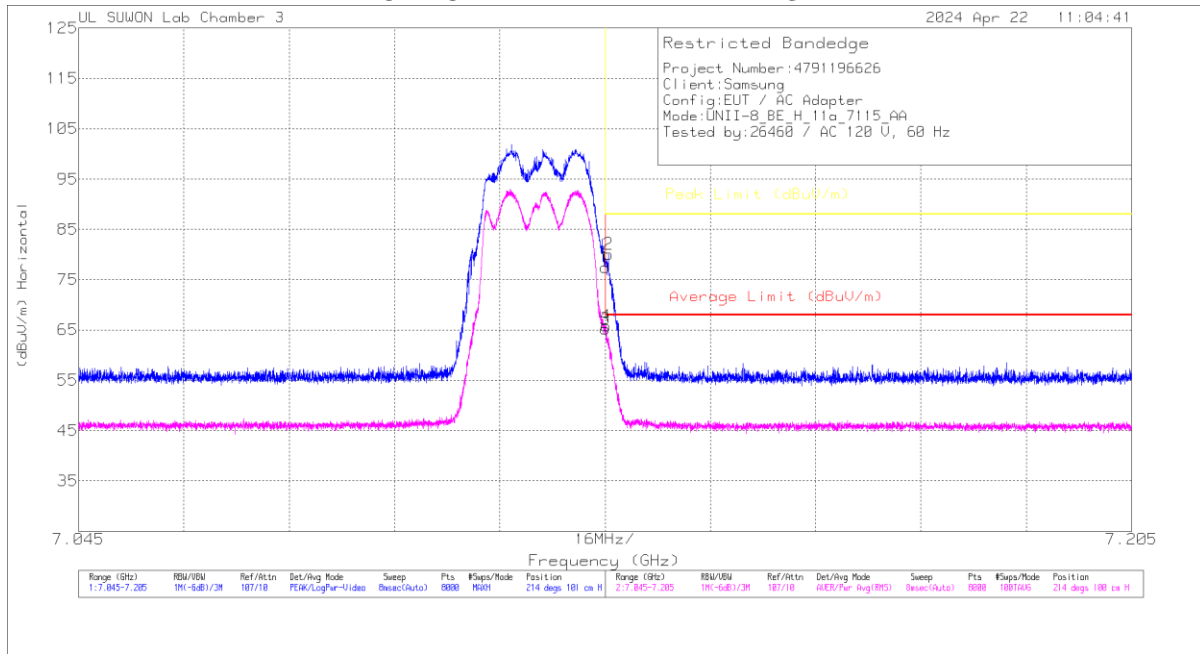

Trace Markers

Marker	Frequency (GHz)	Meter Reading (dBu/m)	Det	Antenna_567_Factor(dB)	10dB_Path Loss(dB)	DC Corr (dB)	Corrected Reading (dBu/m)	Average Limit (dBu/m)	Margin (dB)	Peak Limit (dBu/m)	PK Margin (dB)	Azimuth (Degs)	Height (cm)	Polarity
1	7.12501	58.1	PK	35.9	-16.6	0	77.4	-	-	88	-10.6	214	101	H
2	7.12547	60.9	PK	35.9	-16.7	0	80.1	-	-	88	-7.9	214	101	H
3	7.12501	45.75	RMS	35.9	-16.6	-15	65.2	68	-2.8	-	-	214	100	H
4	7.12509	46.41	RMS	35.9	-16.6	-15	65.86	68	-2.14	-	-	214	100	H

Pk - Peak detector
 RMS - RMS detection

HARMONICS AND SPURIOUS EMISSIONS(WORST CASE: 802.11a / 6895 MHz)

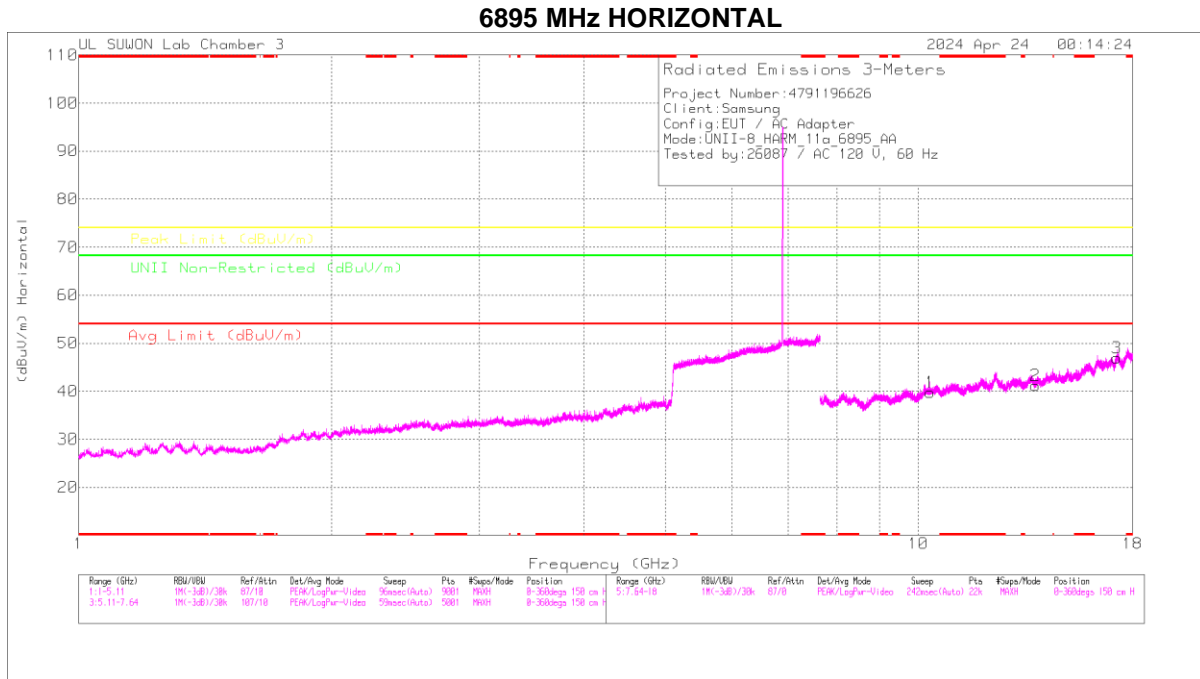

Trace Markers

Marker	Frequency (GHz)	Mask Reading (dBuV)	Det	Antenna_SF7_Factor(dB)	SGHz_HP_Path Loss(dB)	DC Corr (dB)	Corrected Reading (dBuV/m)	Avg Limit (dBuV/m)	Margin (dB)	Peak Limit (dBuV/m)	Margin (dB)	UNII Non-Restricted (dBuV/m)	Margin (dB)	Altitude (Degs)	Height (cm)	Polarity
1	10.34243	23.46	PK	37.5	-21.2	0	39.76	-	-	-	-	68.2	-28.44	0-360	250	H
2	13.79027	25.96	PK	38.7	-23.4	0	41.26	-	-	-	-	68.2	-26.94	0-360	150	H
3	17.23764	22.57	PK	41.1	-16.7	0	48.97	-	-	-	-	68.2	-21.23	0-360	150	H

PK – Peak Detector

Radiated Emissions

Frequency (GHz)	Mask Reading (dBuV)	Det	Antenna_SF7_Factor(dB)	SGHz_HP_Path Loss(dB)	DC Corr (dB)	Corrected Reading (dBuV/m)	Avg Limit (dBuV/m)	Margin (dB)	Peak Limit (dBuV/m)	Margin (dB)	UNII Non-Restricted (dBuV/m)	Margin (dB)	Altitude (Degs)	Height (cm)	Polarity
17.23621	33.16	PK-U	41.1	-16.7	0	57.56	-	-	-	-	68.2	-10.64	0	100	H

PK-U - U-NII: Maximum Peak

BANDEDGE (WORST CASE: 802.11ax HE160 SU / 6025 MHz)

HORIZONTAL PEAK AND AVERAGE DATA

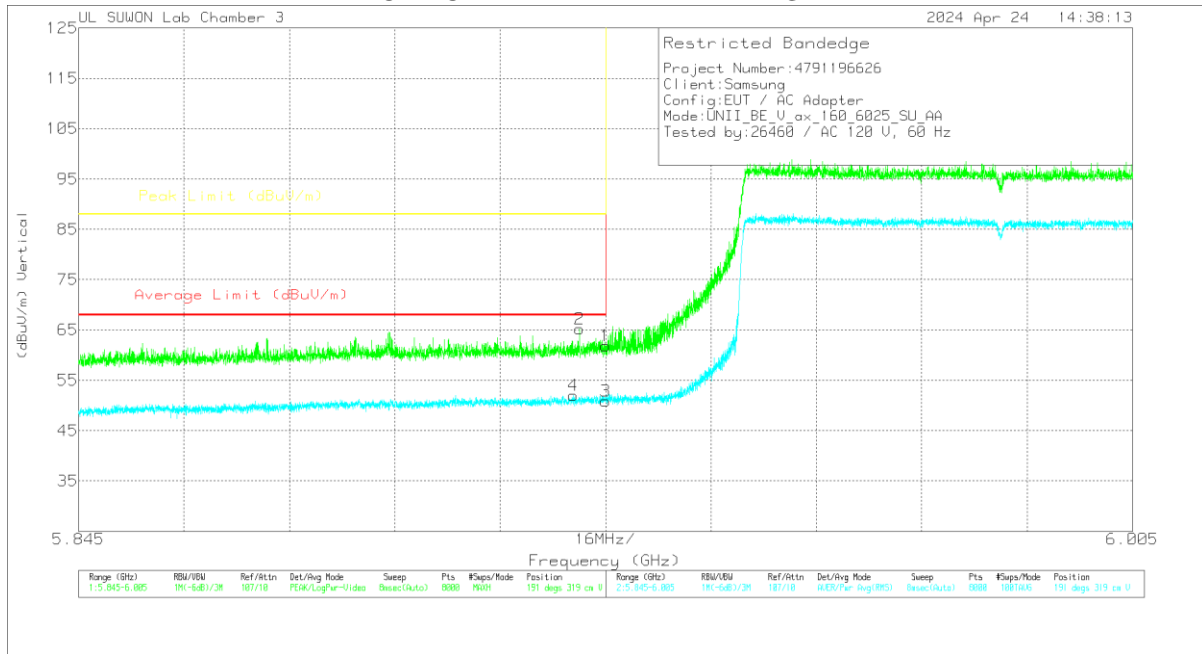

Trace Markers

Marker	Frequency (GHz)	Meter Reading (dBuV)	Det	Antenna_S27_Factor(dB)	10dB_Path Loss(dB)	DC Corr (dB)	Corrected Reading (dBuV/m)	Average Limit (dBuV/m)	Margin (dB)	Peak Limit (dBuV/m)	PK Margin (dB)	Azimuth (Degs)	Height (cm)	Polarity
1	5.92499	45.8	PK	35.5	-19.4	0	61.9	-	-	88	-26.1	191	319	V
2	5.92103	49.16	PK	35.5	-19.4	0	65.26	-	-	88	-22.74	191	319	V
3	5.92499	34.73	RMS	35.5	-19.4	0	50.83	68	-17.17	-	-	191	319	V
4	5.92013	35.88	RMS	35.5	-19.4	0	51.98	68	-16.02	-	-	191	319	V

PK - Peak detector
 RMS - RMS detection

HARMONICS AND SPURIOUS EMISSIONS(WORST CASE: 802.11ax HE20 52T 37RU / 6175 MHz)

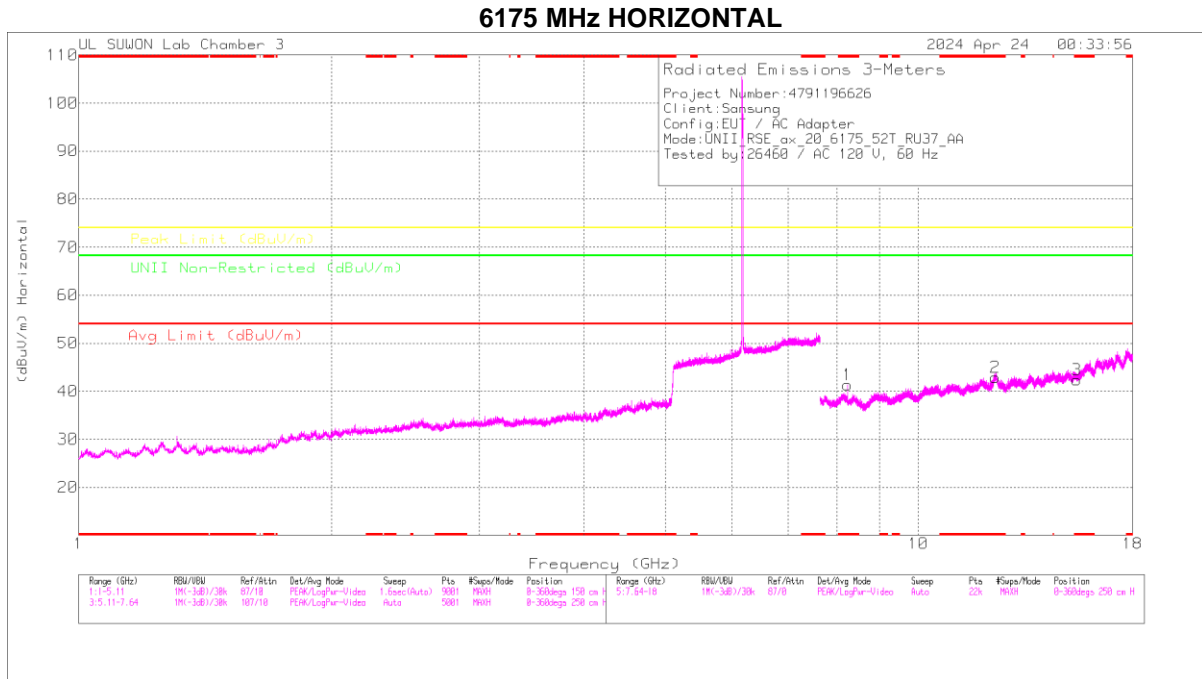

Trace Markers

Marker	Frequency (GHz)	Mask Reading (dBuV)	Det	Antenna_367_Factor(dB)	dBHz_HP_Path Loss(dB)	DC Corr (dB)	Corrected Reading (dBuV/m)	Avg Limit (dBuV/m)	Margin (dB)	Peak Limit (dBuV/m)	Margin (dB)	UNII Non-Restricted (dBuV/m)	Margin (dB)	Azimuth (Degs)	Height (cm)	Polarity
1	* 8.23332	28.48	PK	36	-23.2	0	41.28	-	-	74	-32.72	-	-	0-360	250	H
2	* 12.35029	25.42	PK	36	-21.7	0	42.92	-	-	74	-31.08	-	-	0-360	250	H
3	* 15.43743	23.91	PK	40	-21.5	0	42.41	-	-	74	-31.59	-	-	0-360	250	H

* - indicates frequency in CFR47 Pt 15 / IC RSS-Restricted Band
 PK - Peak Detector

Radiated Emissions

Frequency (GHz)	Mask Reading (dBuV)	Det	Antenna_367_Factor(dB)	dBHz_HP_Path Loss(dB)	DC Corr (dB)	Corrected Reading (dBuV/m)	Avg Limit (dBuV/m)	Margin (dB)	Peak Limit (dBuV/m)	Margin (dB)	UNII Non-Restricted (dBuV/m)	Margin (dB)	Azimuth (Degs)	Height (cm)	Polarity
* 8.23327	38.21	PK-U	36	-23.2	0	51.01	-	-	74	-22.99	-	-	203	118	H
* 8.23329	29.34	ADR	36	-23.2	0	42.14	54	-11.86	-	-	-	-	203	118	H

* - indicates frequency in CFR47 Pt 15 / IC RSS-Restricted Band
 PK-U - U-NII: Maximum Peak
 ADR - U-NII AD primary method, RMS average

HARMONICS AND SPURIOUS EMISSIONS(WORST CASE: 802.11ax HE20 52T 37RU / 6475 MHz)

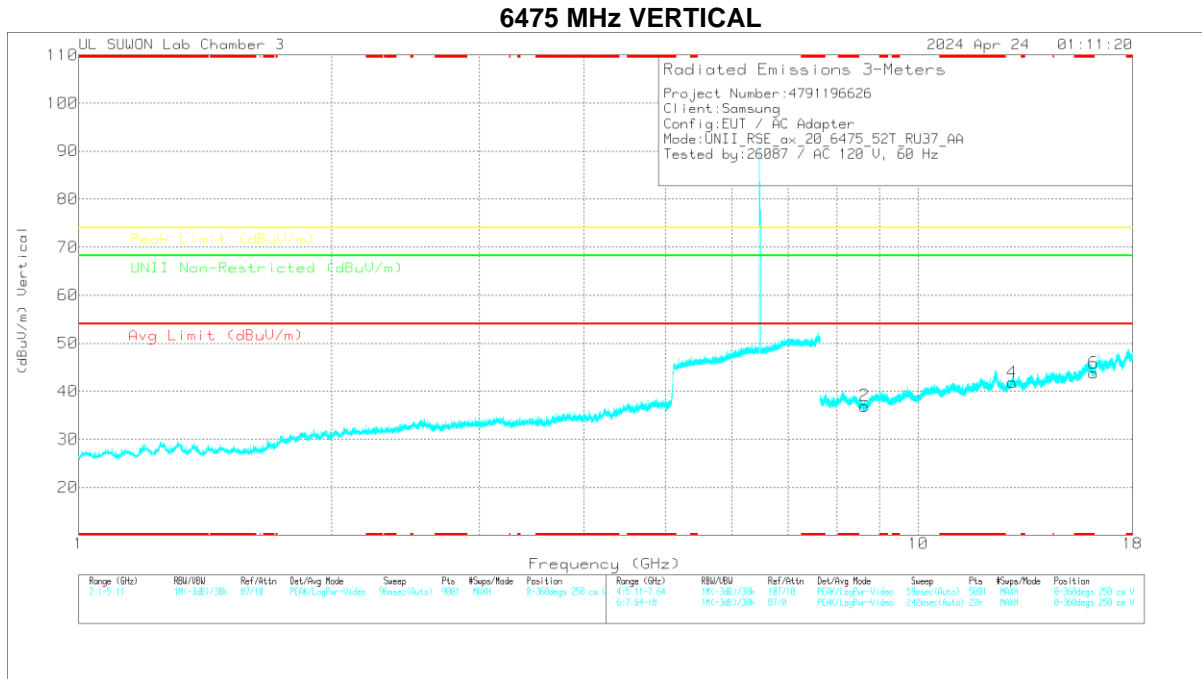

Radiated Emissions

Frequency (GHz)	Meas Reading (dBuV)	Det	Antenna_367_Factor(dB)	ICH2_HP_Path Loss(dB)	DC Corr (dB)	Corrected Reading (dBuV/m)	Avg Limit (dBuV/m)	Margin (dB)	Peak Limit (dBuV/m)	Margin (dB)	UNII Non-Restricted (dBuV/m)	Margin (dB)	Azimuth (Deg)	Height (cm)	Polarity
8.6332	34.66	PK-U	36.1	-23.4	0	47.36	-	-	-	-	68.2	-20.84	198	100	H
* 16.18021	32.66	PK-U	41.2	-19.9	0	53.56	-	-	74	-20.04	-	-	0	100	V
* 16.18839	20.91	ADR	41.2	-19.9	0	42.21	54	-11.79	-	-	-	-	0	100	V

* - indicates frequency in CFR47 Pt 15 / IC RSS-Restricted Band
 PK-U - U-NII: Maximum Peak
 ADR - U-NII AD primary method, RMS average

HARMONICS AND SPURIOUS EMISSIONS(WORST CASE: 802.11ax HE20 52T 37RU/ 6855 MHz)

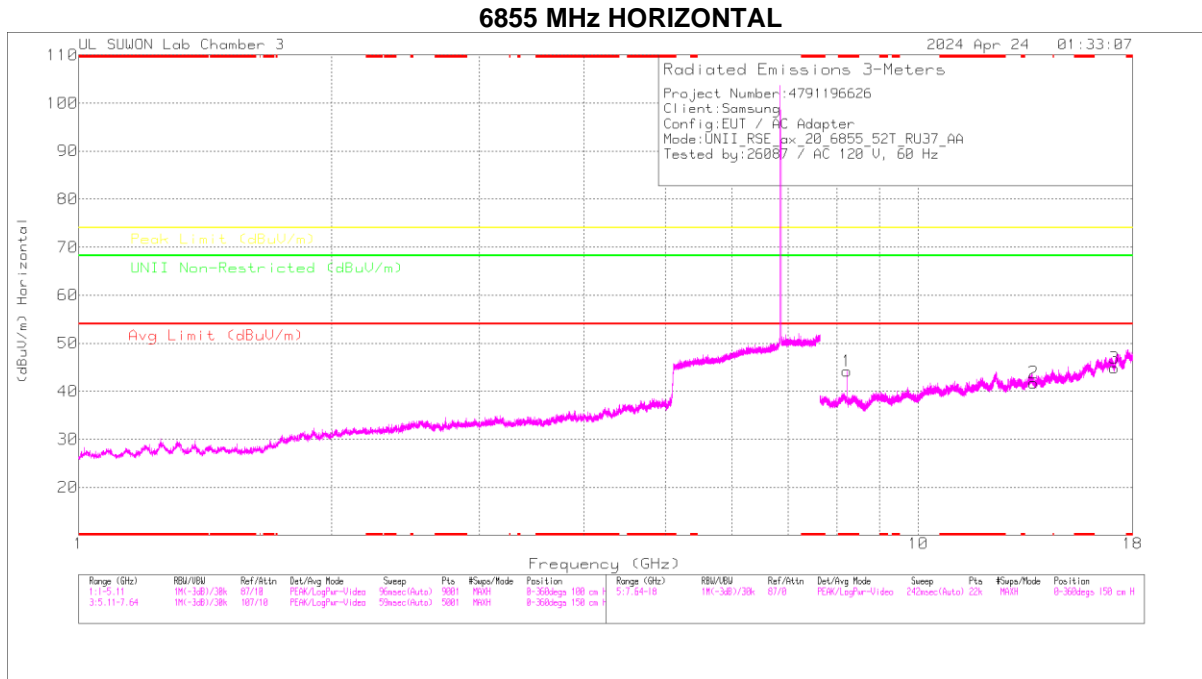

Trace Markers

Marker	Frequency (GHz)	Marker Reading (dBuV)	Det	Antenna_567_Factor(dB)	8GHz_HP_Path Loss(dB)	DC Corr (dB)	Corrected Reading (dBuV/m)	Avg Limit (dBuV/m)	Margin (dB)	Peak Limit (dBuV/m)	Margin (dB)	UNII Non-Restricted (dBuV/m)	Margin (dB)	Altitude (Degs)	Height (cm)	Polarity
1	* 8.22578	31.43	PK	36	-23.2	0	44.23	-	-	74	-29.77	-	-	0-360	250	H
2	13.71022	26.29	PK	38.7	-23.2	0	41.79	-	-	-	-	68.2	-26.41	0-360	250	H
3	17.13734	21.04	PK	41.3	-17.5	0	44.84	-	-	-	-	68.2	-23.38	0-360	150	H

* - indicates frequency in CFR47 Pt 15 / IC RSS-Restricted Band
 PK - Peak Detector

Radiated Emissions

Frequency (GHz)	Marker Reading (dBuV)	Det	Antenna_567_Factor(dB)	8GHz_HP_Path Loss(dB)	DC Corr (dB)	Corrected Reading (dBuV/m)	Avg Limit (dBuV/m)	Margin (dB)	Peak Limit (dBuV/m)	Margin (dB)	UNII Non-Restricted (dBuV/m)	Margin (dB)	Altitude (Degs)	Height (cm)	Polarity
* 8.22611	37.82	PK-U	36	-23.2	0	50.62	-	-	74	-23.38	-	-	198	103	H
* 8.22599	30.42	ADR	36	-23.2	0	43.22	54	-10.78	-	-	-	-	198	103	H

* - indicates frequency in CFR47 Pt 15 / IC RSS-Restricted Band
 PK-U - U-NII: Maximum Peak
 ADR - U-NII AD primary method, RMS average

BANDEDGE (WORST CASE: 802.11ax HE20 SU / 7115 MHz)

HORIZONTAL PEAK AND AVERAGE DATA

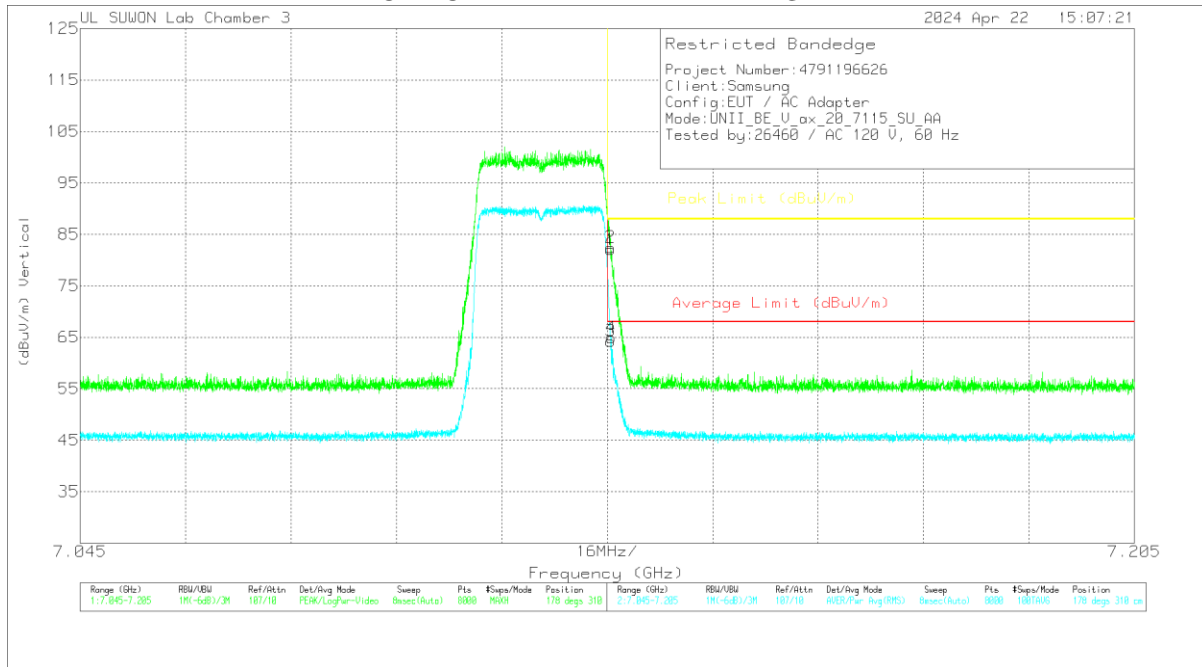

Trace Markers

Marker	Frequency (GHz)	Meter Reading (dBu/m)	Det	Antenna_957_Factor(dB)	10dB_Path Loss(dB)	DC Corr (dB)	Corrected Reading (dBu/m)	Average Limit (dBu/m)	Margin (dB)	Peak Limit (dBu/m)	PK Margin (dB)	Acimsh (Degs)	Height (cm)	Polarity
1	7.12549	62.86	PK	35.9	-16.7	0	82.06	-	-	88	-5.94	178	310	V
2	7.12551	63.27	PK	35.9	-16.7	0	82.47	-	-	88	-5.53	178	310	V
3	7.12549	45.08	RMS	35.9	-16.7	0	64.28	68	-3.72	-	-	178	310	V
4	7.12559	45.74	RMS	35.9	-16.7	0	64.94	68	-3.06	-	-	178	310	V

PK - Peak detector
 RMS - RMS detection

HARMONICS AND SPURIOUS EMISSIONS (WORST CASE: 802.11ax HE20 52T 37RU / 7115 MHz)

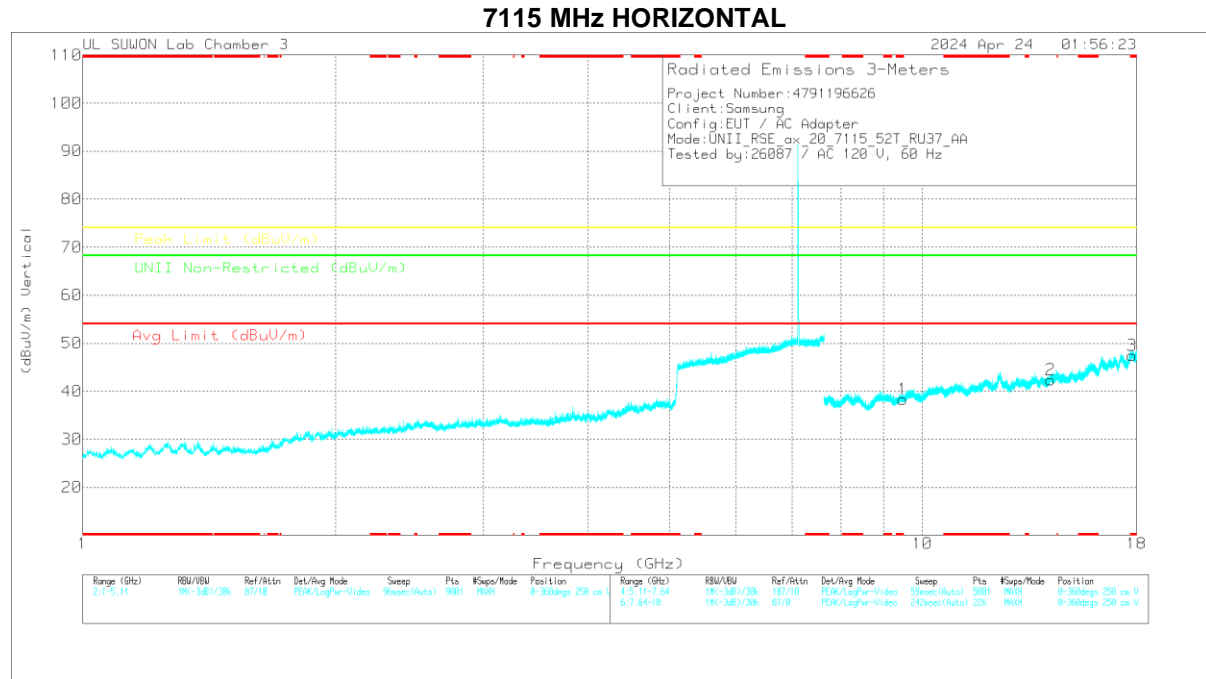

Trace Markers

Marker	Frequency (GHz)	Mask Reading (dBuV)	Det	Antenna_567_Factor (dB)	8GHz_HP_Path Loss (dB)	DC Corr (dB)	Corrected Reading (dBuV/m)	Avg Limit (dBuV/m)	Margin (dB)	Peak Limit (dBuV/m)	Margin (dB)	UNII Non-Restricted (dBuV/m)	Margin (dB)	Azimuth (Degs)	Height (cm)	Polarity
1	* 9.48635	23.55	PK	36.7	-21.9	0	38.35	-	-	74	-35.65	-	-	0-360	150	V
2	14.23008	25.53	PK	39.3	-22.4	0	42.43	-	-	-	-	68.2	-25.77	0-360	150	V
3	* 17.78784	21.73	PK	41.4	-15.7	0	47.43	-	-	74	-26.57	-	-	0-360	250	V

* - indicates frequency in CFR47 Pt 15 / IC RSS-Restricted Band
 PK - Peak Detector

Radiated Emissions

Frequency (GHz)	Mask Reading (dBuV)	Det	Antenna_567_Factor (dB)	8GHz_HP_Path Loss (dB)	DC Corr (dB)	Corrected Reading (dBuV/m)	Avg Limit (dBuV/m)	Margin (dB)	Peak Limit (dBuV/m)	Margin (dB)	UNII Non-Restricted (dBuV/m)	Margin (dB)	Azimuth (Degs)	Height (cm)	Polarity
* 9.48436	33.85	PK-U	36.7	-21.9	0	48.65	-	-	74	-25.35	-	-	308	105	V
* 9.48672	22.48	ADR	36.7	-21.9	0	37.28	54	-16.72	-	-	-	-	308	105	V

* - indicates frequency in CFR47 Pt 15 / IC RSS-Restricted Band
 PK-U - U-NII: Maximum Peak
 ADR - U-NII AD primary method, RMS average

END OF TEST REPORT