

FCC ID: A3LSMF711U

# Power Density Simulation Report

Revision A

June 13, 2021

SAMSUNG ELECTRONICS

## 1. Simulation methodology for Power Density (PD)

### 1.1 Simulation tool

#### 1.1.1 Tool description

For the simulation approach to calculating power density (PD) evaluation for mobile phone with mmWave antenna modules, ANSYS Electromagnetics suite version 2020.R2 (HFSS) is used. ANSYS HFSS is one of several commercial tools for 3D full-wave electromagnetic simulation used for antenna and RF structure design of high frequency component. ANSYS Electromagnetics suite version 2020.R2 (HFSS) is implemented based on Finite Element Method (FEM), which operates in the frequency domain.

#### 1.1.2 Mesh and Convergence criteria

To solve the PD analysis using FEM, volume area containing simulated objects should be subdivided into electrically small parts that are called finite elements as the unknown functions. To subdivide system, the adaptive mesh technique in ANSYS Electromagnetics suite version 2020.R2 (HFSS) is used. ANSYS Electromagnetics suite version 2020.R2 (HFSS) starts to refine the initial mesh based on wavelength and calculate the error to iterative process for adaptive mesh refinement. The determination parameter of the number of iteration in ANSYS Electromagnetics suite version 2020.R2 (HFSS) is defined as convergence criteria, delta S, and the iterative adaptive mesh process repeats until the delta S is met. In ANSYS Electromagnetics suite version 2020.R2 (HFSS), the accuracy of converged results depends on the delta S. Figure 1 is an example of final adaptive mesh of the device (cross-section of top view).

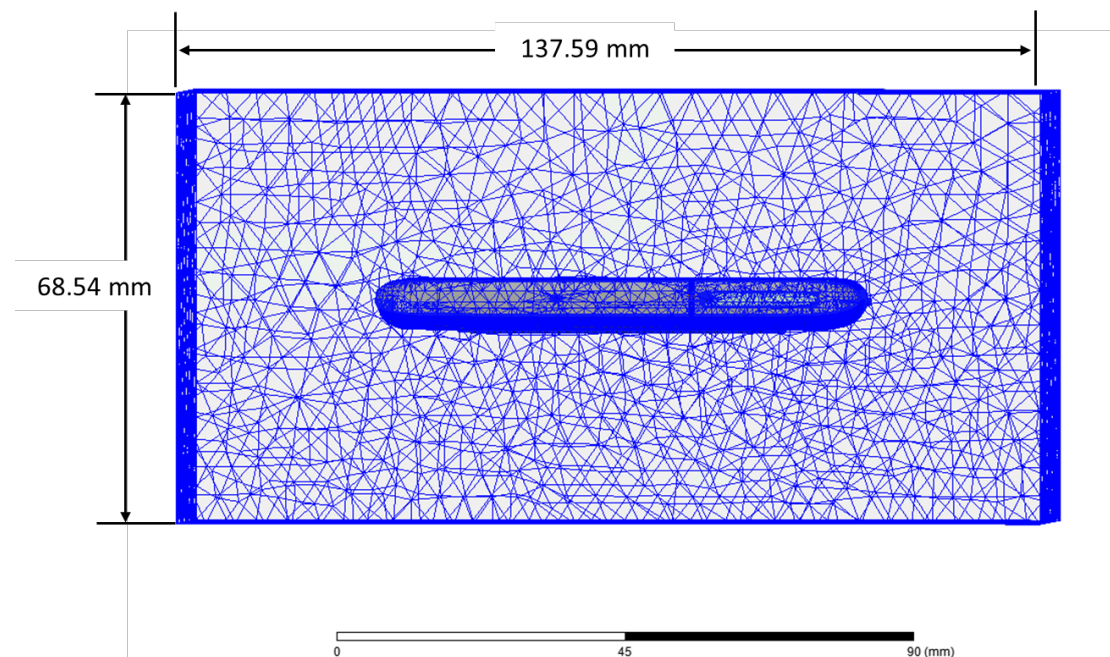

Figure 1 Example of the adaptive mesh technique (Top view)

### 1.1.3 Power density calculation

After solving 3D full-wave electromagnetic simulation, various kinds of physical quantities can be obtained. To calculate PD evaluation, two physical quantities, an electric field ( $\vec{E}$ ) and a magnetic field ( $\vec{H}$ ) are needed. The actual consumption power can be expressed as the real term of the Poynting vector ( $\vec{S}$ ) from the cross product of  $\vec{E}$  and complex conjugation of  $\vec{H}$  as shown below:

$$\langle \vec{S} \rangle = \text{Re} \left( \frac{1}{2} \vec{E} \times \vec{H}^* \right)$$

$\langle \vec{S} \rangle$  can be expressed as point power density based on a peak value of each spatial point on mesh grids, and obtained directly from ANSYS Electromagnetics suite version 2020.R1 (HFSS).

From the point power density  $\langle \vec{S} \rangle$ , the spatial-averaged power density ( $PD_{av}$ ) on an evaluated area ( $A$ ) can be derived as shown below:

$$PD_{av} = \frac{1}{A} \int_A \langle \vec{S} \rangle \cdot ds = \frac{1}{2A_{av}} \iint_{A_{av}} \| \text{Re}\{E \times H^*\} \| dA$$

, where the spatial-averaged power density ( $PD_{av}$ ) is total power density value considering on x, y and z components of point power density  $\langle \vec{S} \rangle$  and the evaluated area ( $A$ ) is  $4\text{cm}^2$ .

## 1.2 Simulation setup

### 1.2.1 3D modeling

Figure 2 shows the simulation model which is mounted two mmWave antenna modules. The simulation modeling includes most of the entire structure of device itself such as PCB, metal frame, battery, cables, and legacy antennas as well as mmWave antenna modules called as Ant K and Ant L. For a folder open status (Fig. 2-1), Ant K is placed on the left side and antennas are facing the left side, and Ant L is placed on the back side and antennas are facing the back side of the device. For a folder close status (Fig. 2-2), Ant K is placed same of the folder open status, and Ant L is placed on the front side and antennas are facing the front side of the device.

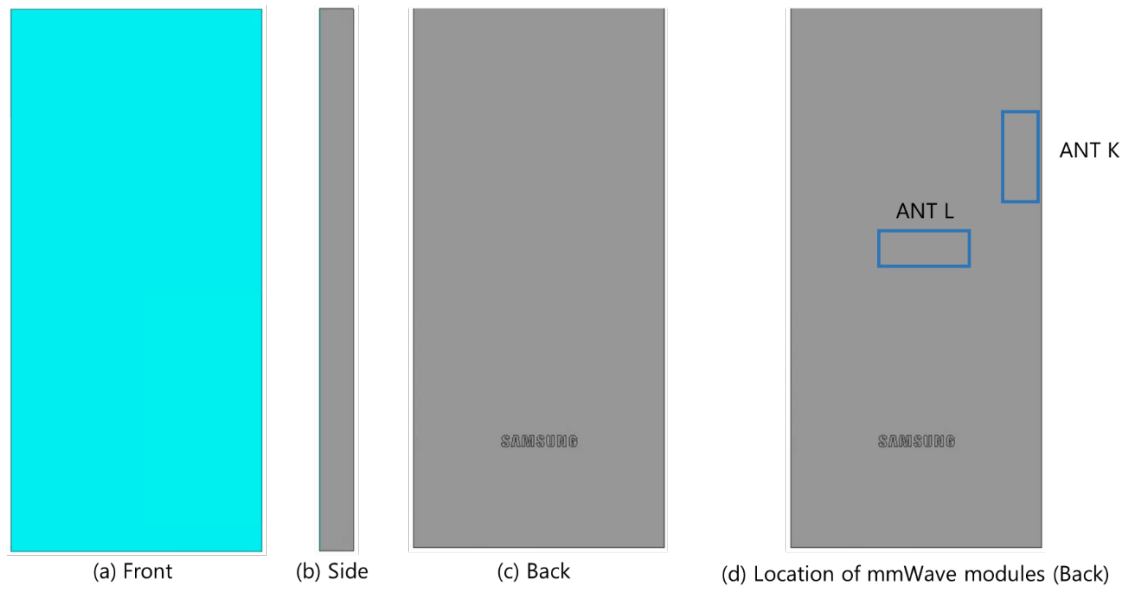

Figure 2-1. Simulation model which is mounted two mmWave antenna modules (Folder Open Status)

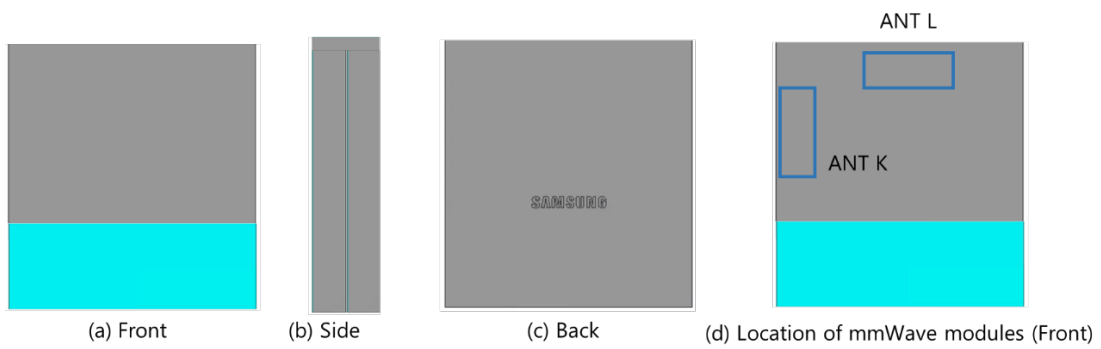

Figure 3-2. Simulation model which is mounted two mmWave antenna modules (Folder Closed Status)

### 1.2.2 PD evaluation planes

Table 1 shows the PD evaluation planes for each mmWave antenna module and Figure 3 shows the PD evaluation planes and whole area of the simulation model to find worst case of beamforming cases.

Please note that the “right” and “left” edge of mentioned in this report are defined from the perspective of looking at the device from the front side.

Table 1. PD evaluation planes

Module	Front	Back	Left From Front View	Right From Front View	Top	Bottom
	S1	S2	S3	S4	S5	S6
Ant K	O	O	O	O	O	O
Ant L	O	O	O	O	O	O

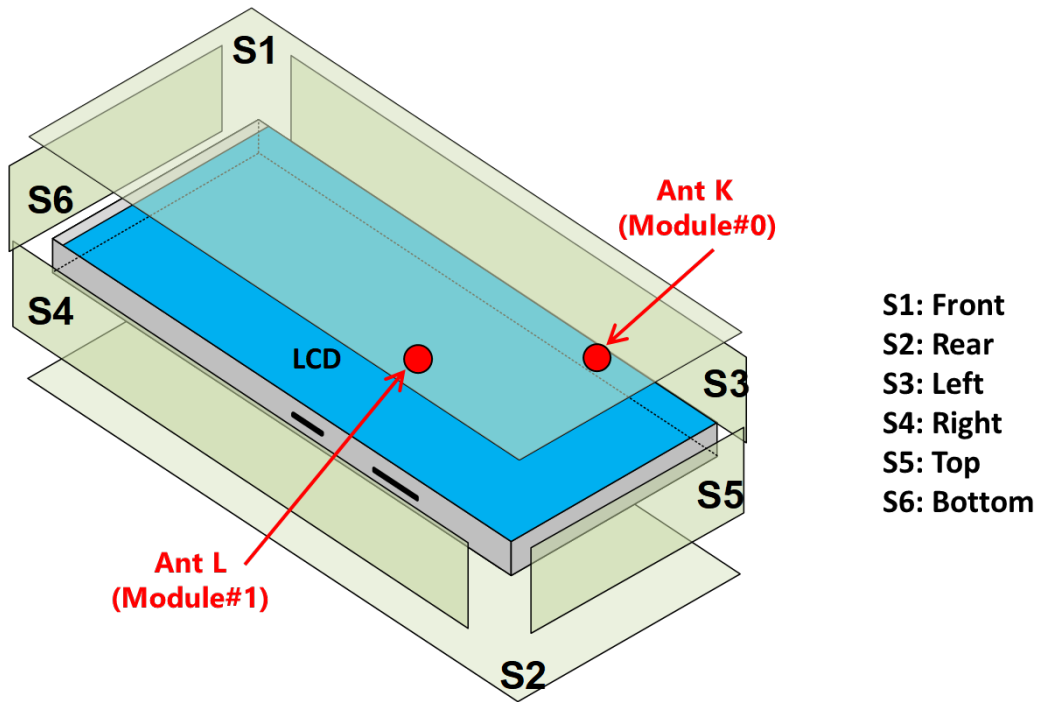

Figure 4. PD evaluation planes

### 1.2.3 Boundary condition

To simulate electromagnetic tool based on FEM, the boundary condition allows electromagnetic waves to be electrically open at the boundary and radiated far away without reflection. ANSYS Electromagnetics suite version 2020.R2 (HFSS) can support the absorbing boundary condition (ABC) for radiation boundary and make normally a quarter wave length from the radiating structure. In this report, to cover all beamforming cases of mmWave antenna modules, 40 mm spacing from each surfaces of the device were used.

### 1.2.4 Source excitation condition

The number of antenna ports of ANT K and ANT L for source excitation are the same. The antenna port of ANT K and L is divided into 10 ports for n261 1 x 5 patch array antennas, 10 ports for n260 1 x 5 patch array antennas. In the 10 ports included in each patch antenna, 5 ports are divided into vertical polarization feeding, and the other 5 ports are divided into horizontal polarization feeding.

Figure 4 shows the ANT K module structure and surrounding structure. The ANT K module is encrypted in the ANSYS Electromagnetics suite (HFSS) and can only check the feeding position.

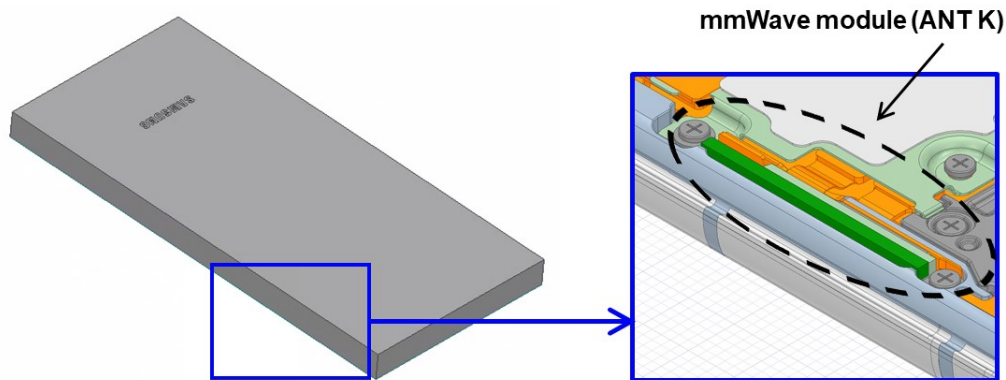

Figure 5. mmWave module (ANT K)

After finishing 3D full wave electromagnetic simulation of modeling structure, the magnitude and phase information can be loaded for each port by using “Edit Sources” function in ANSYS Electromagnetics suite (HFSS). Figure 5 shows an example of antenna port excitations.

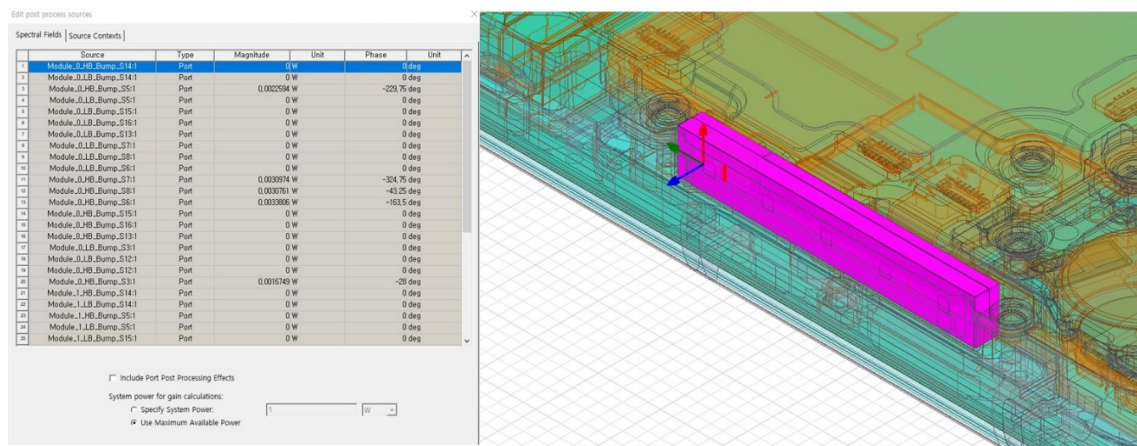

Figure 6. An example of port excitation (ANT K)

Since ANSYS Electromagnetics suite (HFSS) uses FEM solver based on frequency domain analysis method, the input source for the port excitation applies sinusoidal waveform for each frequency.

### 1.2.5 Condition of simulation completion

The simulation completion condition of ANSYS Electromagnetics suite (HFSS) is defined as delta S. The ANSYS Electromagnetics suite (HFSS) calculates the S-parameter for the mesh conditions of each step and determines whether to proceed with the operation of the next step by comparing the difference between the S-parameters in the previous step. A difference between the previous step and the current step of S-parameter is expressed as delta S, and the delta S generally sets 0.02. The simulation result of this report is the result of setting delta S to 0.02.

## 2. Simulation verification

### 2.1 Spatial-averaged power density

As mentioned in the previous chapter, the Poynting vector ( $\vec{S}$ ) can be obtained through cross product of an electric field ( $\vec{E}$ ) and complex conjugate of a magnetic field ( $\vec{H}$ ). The real term of the Poynting vector can be described as the point power density or peak power density. Using the point power density, the spatial-averaged power density can be obtained by the integral of  $4 \text{ cm}^2$  at 2.5 mm intervals of the point power density result. Figure 6 shows examples of the distribution plot of point power density and the averaged power density.

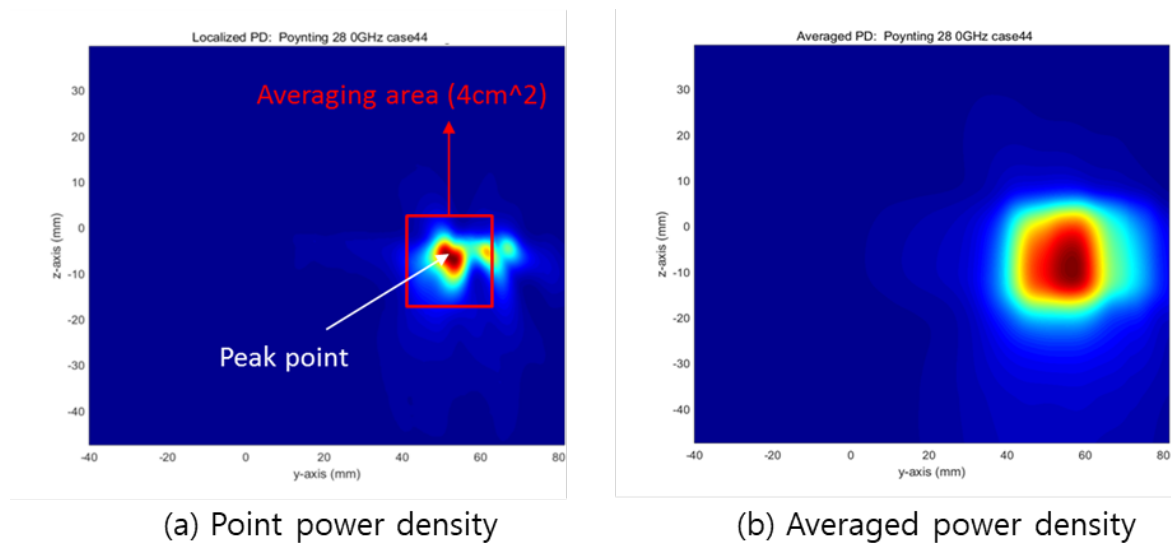

Figure 7. Power density distribution (Example)

### 2.2 Comparison between simulation and measurement

In this section, the simulated-power density distributions and measured-power density distributions are compared to each mmWave antenna.

Based on comparison of power density distributions, simulated power density and measured power density have a good correlation. The discrepancy in amplitude between simulated  $4 \text{ cm}^2$  averaged power density and measured  $4 \text{ cm}^2$  averaged power density is considered as housing influence and used in determining input power limit for each beam for RF exposure compliance.

The input powers per each active port are listed below for both Simulation and Measurement validation and power density characterization. For Simulation, these values were entered directly into HFSS model. For measurement, FTM S/W was used to input these values for each active port also.

Mode/Band	Antenna	Input Power (dBm) SISO	Input Power (dBm) MIMO
5G NR n261	K Patch	6.0	6.0
	L Patch	6.0	6.0
5G NR n260	K Patch	6.0	6.0
	L Patch	6.0	6.0

\* The below simulation and measurement result were performed at 2mm evaluation distance and 28GHz / 38.5GHz. The *input.power.limit* was determined based on below results in RF Exposure Part 0 Report.

Band	Beam ID	Antenna	Surface	Channel	4cm <sup>2</sup> avg. PD (mW/cm <sup>2</sup> )		
					Meas.	Sim	
n261	29	K (patch)	Back (S2)	Mid	0.58	1.11	
			Left (S3)	Mid	0.45	2.2	
	30		Front (S1)	Mid	0.59	1.11	
	157		Back (S2)	Mid	0.71	1.21	
			Left (S3)	Mid	1.04	2.52	
	159		Back (S2)	Mid	0.54	1.44	
	24		L (patch)	Back (S2)	Mid	1.09	1.82
	153			Back (S2)	Mid	1.55	1.99
n260	34	K (patch)	Back (S2)	Mid	0.5	0.96	
	22		Left (S3)	Mid	0.91	1.88	
	34		Front (S1)	Mid	0.78	1.26	
	161		Back (S2)	Mid	0.57	1.15	
	162		Left (S3)	Mid	1.05	1.86	
	152		Front (S1)	Mid	0.56	0.94	
	39		L (patch)	Back (S2)	Mid	0.67	1.24
	159	Back (S2)		Mid	0.6	1.5	

(a) Measured PD for Folder Open Status



Band	Beam ID	Antenna	Surface	Channel	4cm <sup>2</sup> avg. PD (mW/cm <sup>2</sup> )	
					Meas.	Sim
n261	20	K (patch)	Front (S1)	Mid	0.26	0.66
	21		Left (S3)	Mid	0.85	1.18
	149		Front (S1)	Mid	0.47	0.98
	157		Left (S3)	Mid	1.13	2.46
	24	L (patch)	Front (S1)	Mid	1.28	2.23
	161		Front (S1)	Mid	1.4	2.51
	154		Top (S5)	Mid	0.59	1.13
n260	23	K (patch)	Front (S1)	Mid	0.31	0.62
	24		Left (S3)	Mid	1.01	1.56
	161		Front (S1)	Mid	0.45	0.75
	162		Left (S3)	Mid	1.1	1.46
	38	L (patch)	Front (S1)	Mid	0.85	1.25
	157		Front (S1)	Mid	0.72	1.41

(b) Measured PD for Folder Closed Status

[Folder Open Status]

- Table 2-1, n261 ANT K-Patch: Mid Channel, Beam ID 29 and 30 for selected surfaces

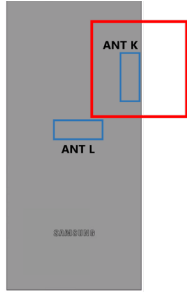
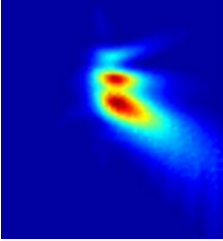
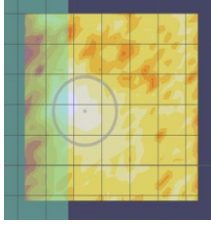
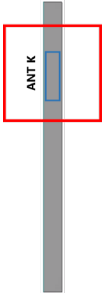
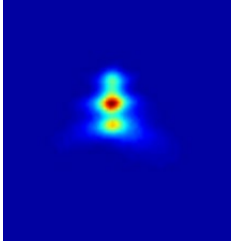
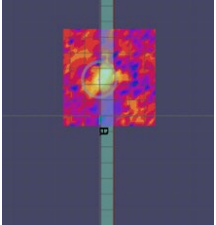
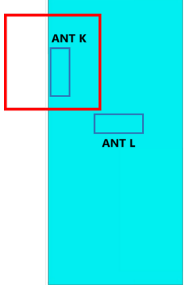
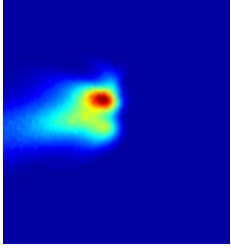
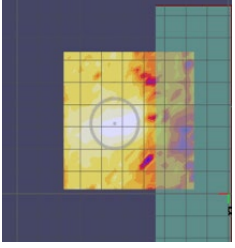
Beam ID	Surface	View	Simulated PD	Measured PD
29	S2 (Rear)			
	S3 (Left)			
30	S1 (Front)			

- Table 2-2, n261 ANT L-Patch: Mid Channel, Beam ID 24 for selected surfaces

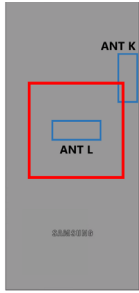
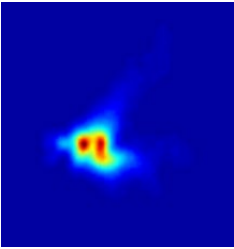
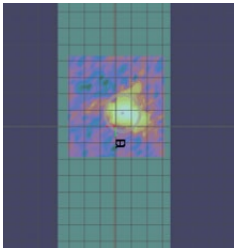
Beam ID	Surface	View	Simulated PD	Measured PD
24	S2 (Rear)			

- Table 2-3, n261 ANT K-Patch: Mid Channel, Beam ID 157 and 159 for selected surfaces

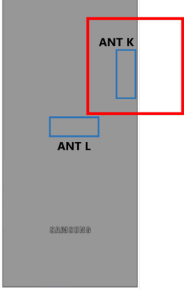
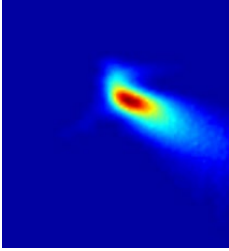
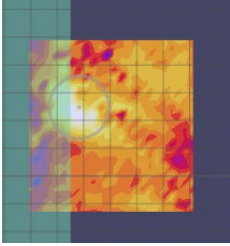
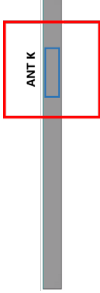
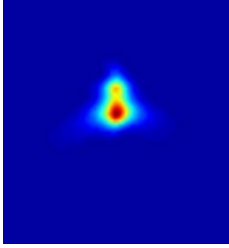
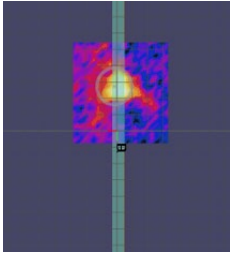
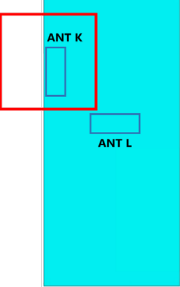
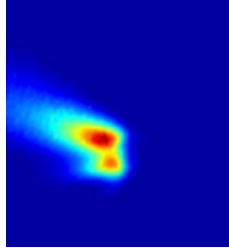
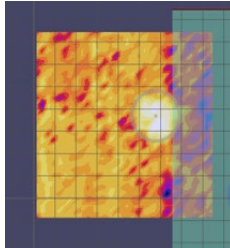
Beam ID	Surface	View	Simulated PD	Measured PD
157	S2 (Rear)			
	S3 (Left)			
159	S1 (Front)			

- Table 2-4, n261 ANT L-Patch: Mid Channel, Beam ID 153 for selected surfaces

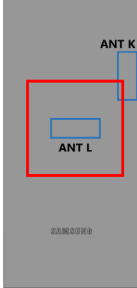
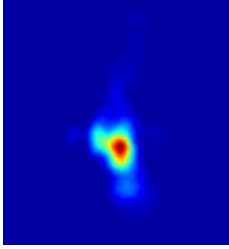
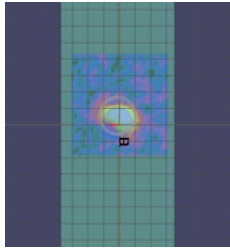
Beam ID	Surface	View	Simulated PD	Measured PD
153	S2 (Rear)			

- Table 2-5, n260 ANT K-Patch: Mid Channel, Beam ID 34 and 22 for selected surfaces

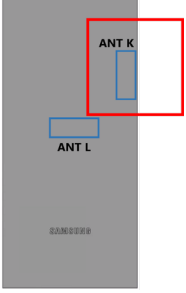
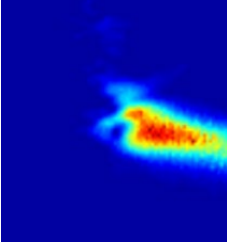
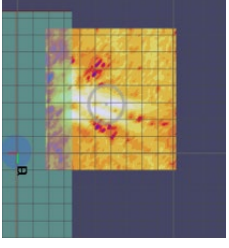
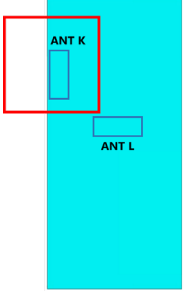
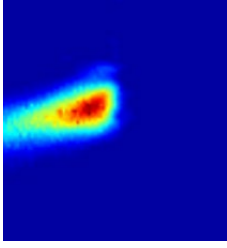
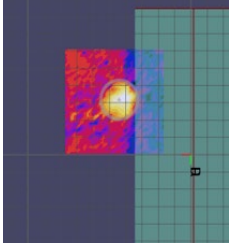
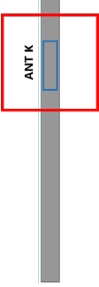
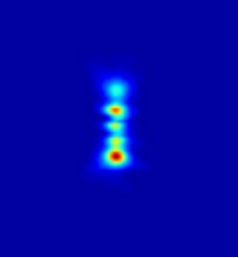
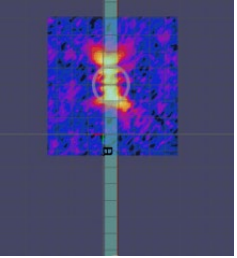
Beam ID	Surface	View	Simulated PD	Measured PD
34	S2 (Rear)			
	S1 (Front)			
22	S3 (Left)			

- Table 2-6, n260 ANT L-Patch: Mid Channel, Beam ID 39 for selected surfaces

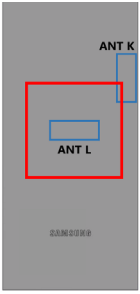
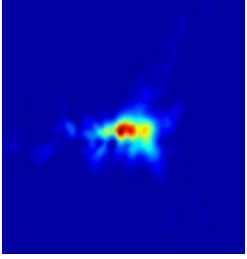
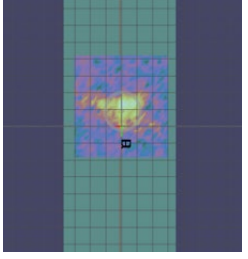
Beam ID	Surface	View	Simulated PD	Measured PD
39	S2 (Rear)			

● Table 2-7, n260 ANT K-Patch: Mid Channel, Beam ID 161, 162 and 152 for selected surfaces

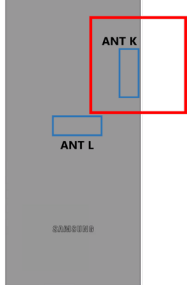
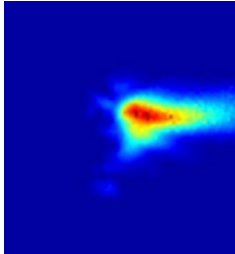
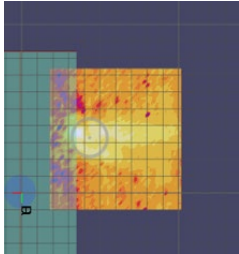
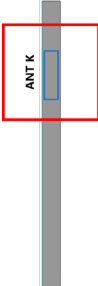
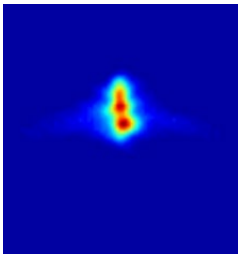
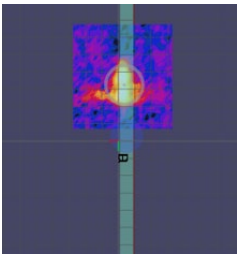
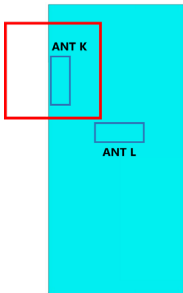
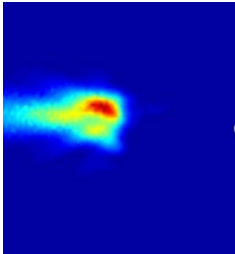
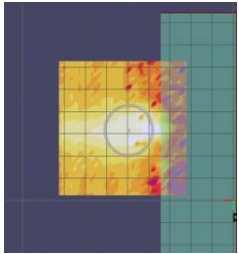
Beam ID	Surface	View	Simulated PD	Measured PD
161	S2 (Rear)			
162	S3 (Left)			
152	S1 (Front)			

● Table 2-8, n260 ANT L-Patch: Mid Channel, Beam ID 159 for selected surfaces

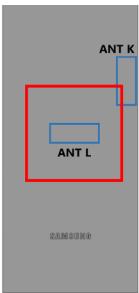
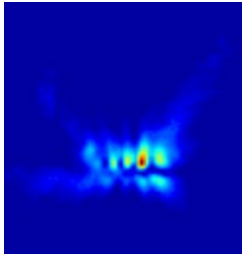
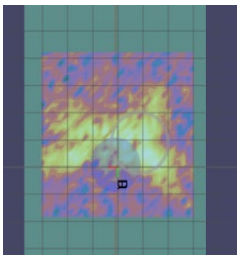
Beam ID	Surface	View	Simulated PD	Measured PD
159	S2 (Rear)			

[Folder Closed Status]

- Table 2-9, n261 ANT K-Patch: Mid Channel, Beam ID 20 and 21 for selected surfaces

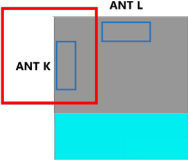
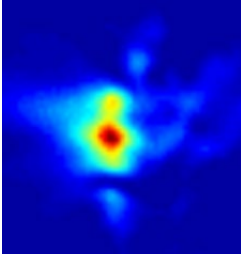
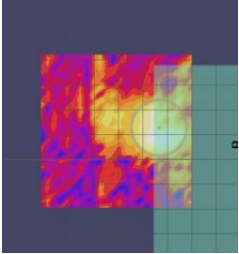
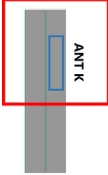
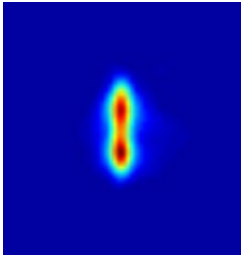
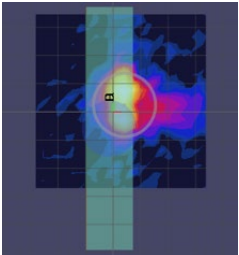
Beam ID	Surface	View	Simulated PD	Measured PD
20	S1 (Front)			
21	S3 (Left)			

- Table 2-10, n261 ANT L-Patch: Mid Channel, Beam ID 24 for selected surfaces

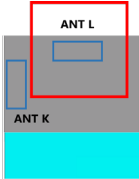
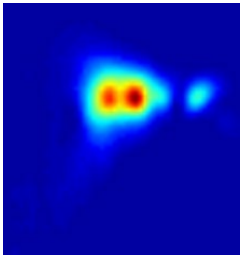
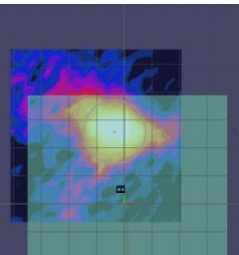
Beam ID	Surface	View	Simulated PD	Measured PD
24	S1 (Front)			

- Table 2-11, n261 ANT K-Patch: Mid Channel, Beam ID 149 and 157 for selected surfaces

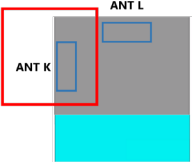
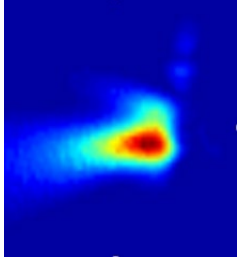
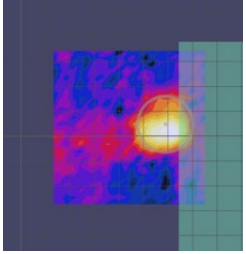
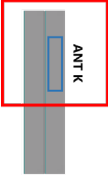
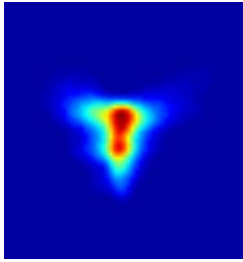
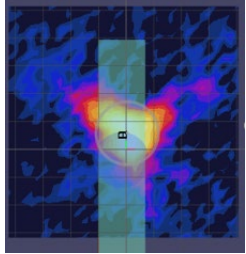
Beam ID	Surface	View	Simulated PD	Measured PD
149	S1 (Front)			
157	S3 (Left)			

- Table 2-12, n261 ANT L-Patch: Mid Channel, Beam ID 161 and 154 for selected surfaces

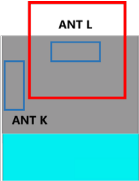
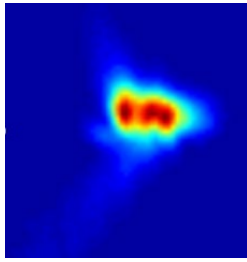
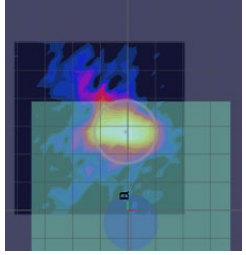
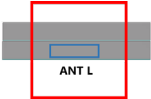
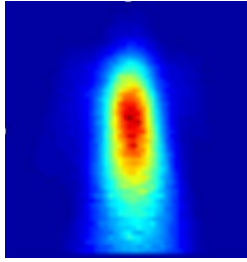
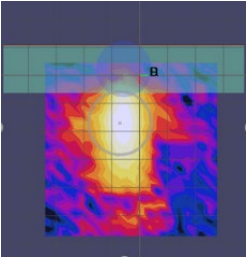
Beam ID	Surface	View	Simulated PD	Measured PD
161	S1 (Front)			
154	S5 (Top)			

- Table 2-13, n260. ANT K-Patch: Mid Channel, Beam ID 23 and 24 for selected surfaces

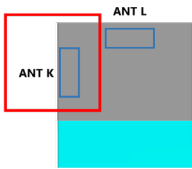
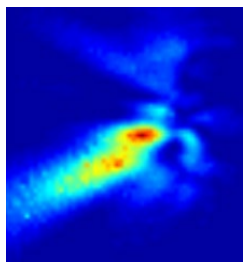
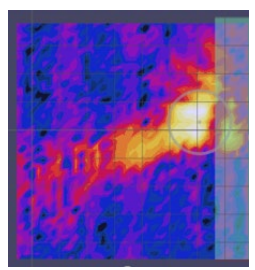
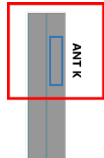
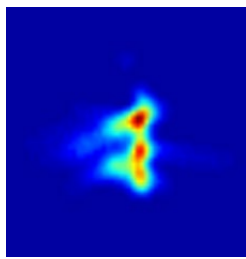
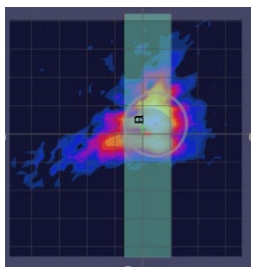
Beam ID	Surface	View	Simulated PD	Measured PD
23	S1 (Front)			
24	S3 (Left)			

- Table 2-14, n260 ANT L-Patch: Mid Channel, Beam ID 38 for selected surfaces

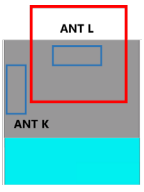
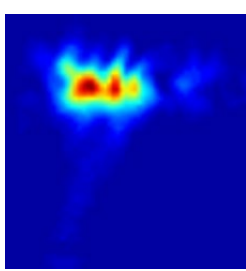
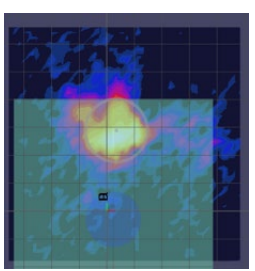
Beam ID	Surface	View	Simulated PD	Measured PD
38	S1 (Front)			

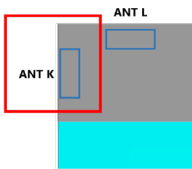
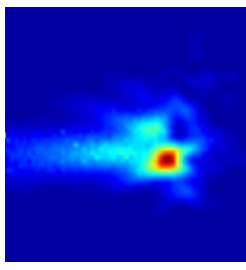
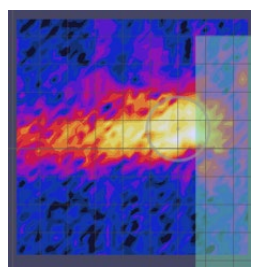
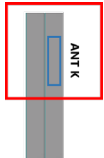
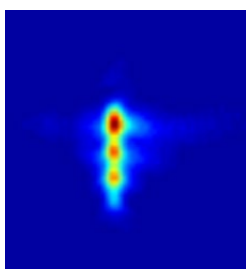
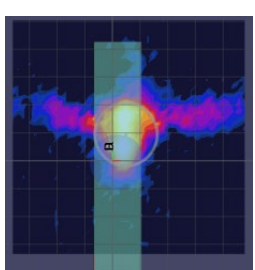

- Table 2-15, n260 ANT K-Patch: Mid Channel, Beam ID 161 and 162 for selected surfaces

Beam ID	Surface	View	Simulated PD	Measured PD
161	S1 (Front)			
162	S3 (Left)			

- Table 2-16, n260 ANT L-Patch: Mid Channel, Beam ID 157 for selected surfaces

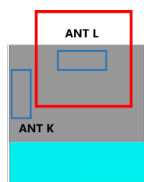
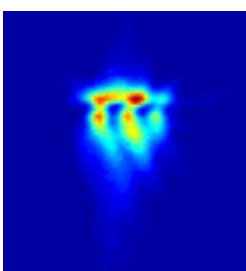
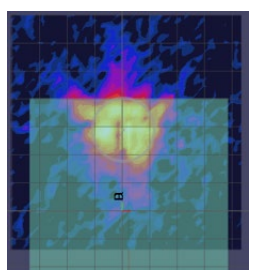
Beam ID	Surface	View	Simulated PD	Measured PD
157	S1 (Front)			

### 3 Simulation results

This section shows the PD simulation results of Ant K and Ant L at 28GHz and 39GHz for each evaluation plane specified in Table 1 at two separation distances of 2mm and 10mm for open condition and 2mm and 5mm for closed conditions. The ratio of PD exposure from front surface to the worst surface at 2mm, and the ratio of PD exposure from 2mm to 10mm (open) or 2mm to 5mm (closed) evaluation distance for each beam are also reported in this section to support RF exposure analysis for simultaneous transmission scenarios performed in the Part 1 Near Field PD report.

The relative phase between beam pairs is not controlled in the chipset design. Therefore, the relative phase between each beam pair was considered mathematically to identify the worst case conditions. The below MIMO results represent the highest reported MIMO simulation results after sweeping across the relative phase between beams a 5° step interval from 0° to 360°.

The worst-case simulated PD determined from the tables in this section were used for conservativeness in *input.power.limit* determination in RF Exposure Part 0 Report.

#### 3.1 PD for Low/Mid/High Channel at 28GHz / 39GHz

##### 3.1.1 Ant K– Patch Antenna

Table 3 & Table 4 show the PD simulation evaluation of Ant K patch antenna at 28GHz / 39GHz for the corresponding evaluation planes specified in Table 1.























Table 6. PD of Ant L – patch antenna (39GHz – n260)

[Folder Open Status]

- L-patch Low CH

Table with columns for No, Module, Type, Beam ID, Bema ID, Feed no, 4om2 PGM(w/cm2), 15.5%, 15.5%, max ratio out of, 1.5%, 1.2%, 4om2 PGM(w/cm2) at 10mm evaluation distance, 50.0%, 11.1%, max ratio out of all beams, 14.2%, 58.9%. Rows include data for various configurations.

- L-patch Mid CH

Table with columns for No, Module, Type, Beam ID, Bema ID, Feed no, 4om2 PGM(w/cm2), 15.5%, 15.4%, max ratio out of, 5.3%, 2.7%, 4om2 PGM(w/cm2) at 10mm evaluation distance, 50.0%, 9.0%, max ratio out of all beams, 58.0%. Rows include data for various configurations.



