

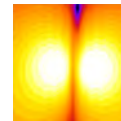

PCTEST

7185 Oakland Mills Road, Columbia, MD 21046 USA
Tel. 410.290.6652 / Fax 410.290.6654
http://www.pctest.com



HEARING AID COMPATIBILITY

Applicant Name:
Samsung Electronics Co., Ltd.
129, Samsung-ro, Maetan dong,
Yeongtong-gu, Suwon-si
Gyeonggi-do 16677, Korea

Date of Testing:
06/15/2020 - 07/02/2020
Test Site/Location:
PCTEST, Columbia, MD, USA
Test Report Serial No.:
1M2005040080-19-R2.A3L
Date of Issue:
07/10/2020

FCC ID: A3LSMF707U

APPLICANT: SAMSUNG ELECTRONICS CO., LTD.

Scope of Test: Audio Band Magnetic Testing (T-Coil)
Application Type: Certification
FCC Rule Part(s): CFR §20.19(b)
HAC Standard: ANSI C63.19-2011
285076 D01 HAC Guidance v05
285076 D02 T-Coil testing for CMRS IP v03
DUT Type: Portable Handset
Model: SM-F707U
Additional Model(s): SM-F707U1, SM-F707W
Test Device Serial No.: Pre-Production Sample [S/N: 0011H]

C63.19-2011 HAC Category: T3 (SIGNAL TO NOISE CATEGORY)

Note: This revised Test Report (S/N: 1M2005040080-19-R2.A3L) supersedes and replaces the previously issued test report on the same subject device for the same type of testing as indicated. Please discard or destroy the previously issued test report(s) and dispose of it accordingly.

This wireless portable device has been shown to be hearing-aid compatible under the above rated category, specified in ANSI/IEEE Std. C63.19-2011 and has been tested in accordance with the specified measurement procedures. Test results reported herein relate only to the item(s) tested. Hearing-Aid Compatibility is based on the assumption that all production units will be designed electrically identical to the device tested in this report. North American Bands only.

I attest to the accuracy of data. All measurements reported herein were performed by me or were made under my supervision and are correct to the best of my knowledge and belief. I assume full responsibility for the completeness of these measurements and vouch for the qualifications of all persons taking them.



Randy Ortanez
President



| | | | | |
|--|---|--------------------------------------|--|--|
| FCC ID: A3LSMF707U | | HAC (T-COIL) TEST REPORT | | Approved by: Quality Manager |
| Filename: 1M2005040080-19-R2.A3L | Test Dates: 06/15/2020 - 07/02/2020 | DUT Type: Portable Handset | | Page 1 of 108 |

TABLE OF CONTENTS

| | | |
|-----|--|-----|
| 1. | INTRODUCTION | 3 |
| 2. | DUT DESCRIPTION..... | 4 |
| 3. | ANSI C63.19-2011 PERFORMANCE CATEGORIES | 7 |
| 4. | METHOD OF MEASUREMENT | 9 |
| 5. | VOLTE TEST SYSTEM SETUP AND DUT CONFIGURATION | 20 |
| 6. | VOWIFI TEST SYSTEM SETUP AND DUT CONFIGURATION | 25 |
| 7. | OTT VOIP TEST SYSTEM AND DUT CONFIGURATION | 29 |
| 8. | FCC 3G MEASUREMENTS | 35 |
| 9. | T-COIL TEST SUMMARY | 37 |
| 10. | MEASUREMENT UNCERTAINTY | 54 |
| 11. | EQUIPMENT LIST | 55 |
| 12. | TEST DATA | 56 |
| 13. | CALIBRATION CERTIFICATES..... | 90 |
| 14. | CONCLUSION..... | 103 |
| 15. | REFERENCES | 104 |
| 16. | TEST SETUP PHOTOGRAPHS | 106 |

| | | | | |
|--|---|--------------------------------------|---|--|
| FCC ID: A3LSMF707U |  | HAC (T-COIL) TEST REPORT |  | Approved by: Quality Manager |
| Filename: 1M2005040080-19-R2.A3L | Test Dates: 06/15/2020 - 07/02/2020 | DUT Type: Portable Handset | | Page 2 of 108 |

1. INTRODUCTION

On July 10, 2003, the Federal Communications Commission (FCC) adopted new rules requiring wireless manufacturers and service providers to provide digital wireless phones that are compatible with hearing aids. The FCC has modified the exemption for wireless phones under the Hearing Aid Compatibility Act of 1998 (HAC Act) in WT Docket 01-309 RM-8658¹ to extend the benefits of wireless telecommunications to individuals with hearing disabilities. These benefits encompass business, social and emergency communications, which increase the value of the wireless network for everyone. An estimated more than 10% of the population in the United States show signs of hearing impairment and of that fraction, almost 80% use hearing aids. Approximately 500 million people worldwide and 30 million people in the United States suffer from hearing loss.

Compatibility Tests Involved:

The standard calls for wireless communications devices to be measured for:

- RF Electric-field emissions
- T-coil mode, magnetic-signal strength in the audio band
- T-coil mode, magnetic-signal frequency response through the audio band
- T-coil mode, magnetic-signal and noise articulation index

The hearing aid must be measured for:

- RF immunity in microphone mode
- RF immunity in T-coil mode

In the following tests and results, this report includes the evaluation for a wireless communications device.

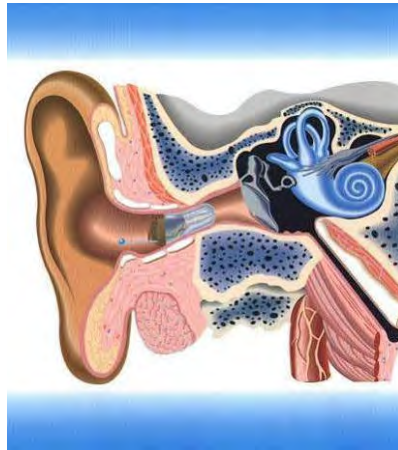



Figure 1-1 Hearing Aid *in-vitu*

¹ FCC Rule & Order, WT Docket 01-309 RM-8658

| | | | | |
|-------------------------------------|---|-------------------------------|---|---------------------------------|
| FCC ID: A3LSMF707U |  | HAC (T-COIL) TEST REPORT |  | Approved by: Quality Manager |
| Filename: 1M2005040080-19-R2.A3L | Test Dates: 06/15/2020 - 07/02/2020 | DUT Type: Portable Handset | | Page 3 of 108 |

2. DUT DESCRIPTION



FCC ID: A3LSMF707U
Applicant: Samsung Electronics Co., Ltd.
129, Samsung-ro, Maetan dong,
Yeongtong-gu, Suwon-si
Gyeonggi-do 16677, Korea
Model: SM-F707U
Additional Model(s): SM-F707U1, SM-F707W
Serial Number: 0011H
HW Version: Rev.1.0
SW Version: F707U.001
Antenna: Internal Antenna
DUT Type: Portable Handset

I. LTE Band Selection

This device supports the following pairs of LTE bands with similar frequencies: LTE B66 & B4 and B41 & B38. These pairs of LTE bands have the same target powers and share the same transmission paths. Since the supported frequency span for the smaller LTE bands are completely covered by the larger LTE bands, only the larger LTE bands (LTE B66 & B41) were evaluated for hearing-aid compliance. LTE B5 and B2 are LTE anchor bands for dual connectivity (EN-DC) scenarios between LTE and NR so they were additionally evaluated as independent LTE bands

II. NR Band Selection

This device supports the following pair of NR bands with similar frequencies: NR n25 & n2. This pair of NR bands has the same target power and shares the same transmission path. Since the supported frequency span for the smaller NR band is completely covered by the larger NR band, only the larger LTE band (NR n25) was evaluated for hearing-aid compliance.



| | | | | |
|-------------------------------------|---|-------------------------------|---|---------------------------------|
| FCC ID: A3LSMF707U |  | HAC (T-COIL) TEST REPORT |  | Approved by: Quality Manager |
| Filename: 1M2005040080-19-R2.A3L | Test Dates: 06/15/2020 - 07/02/2020 | DUT Type: Portable Handset | Page 4 of 108 | |

Table 2-1
SM-F707U & SM-F707U1 HAC Air Interfaces

| Air-Interface | Band (MHz) | Type Transport | HAC Tested | Simultaneous But Not Tested | Name of Voice Service | Audio Codec Evaluated |
|---|-----------------|----------------|---|----------------------------------|---|---|
| CDMA | 835 | VO | Yes | Yes: WIFI or BT | CMRS Voice ¹ | EVRC |
| | 1900 | | | | | |
| GSM | EvDO | VD | Yes | Yes: WIFI or BT | Google Duo ² | OPUS |
| | 850 | VO | Yes | Yes: WIFI or BT | CMRS Voice ¹ | EFR |
| | 1900 | | | | | |
| UMTS | GPRS/EDGE | VD | Yes | Yes: WIFI or BT | Google Duo ² | OPUS |
| | 850 | VD | Yes | Yes: WIFI or BT | CMRS Voice ¹ | NB AMR |
| | 1700 | | | | | |
| | 1900 | | | | | |
| LTE (FDD) | HSPA | VD | Yes | Yes: WIFI or BT | Google Duo ² | OPUS |
| | 680 (B71) | VD | Yes ³ | Yes: WIFI or BT | VoLTE ¹ , Google Duo ² | VoLTE: NB AMR, WB AMR, EVS Google Duo: OPUS |
| | 700 (B12) | | | | | |
| | 780 (B13) | | | | | |
| | 790 (B14) | | | | | |
| | 850 (B5) | | | | | |
| | 850 (B26) | | | | | |
| | 1700 (B4) | | | | | |
| | 1700 (B66) | | | | | |
| | 1900 (B2) | | | | | |
| | 1900 (B25) | | | | | |
| | 2300 (B30) | | | | | |
| 2500 (B7) | | | | | | |
| LTE (TDD) | 2600 (B38) | VD | Yes | Yes: WIFI or BT | VoLTE ¹ , Google Duo ² | VoLTE: NB AMR, WB AMR, EVS Google Duo: OPUS |
| | 2600 (B41) | | | | | |
| | 3600 (B48) | | | | | |
| NR (FDD) | 680 (n71) | VD | Yes ^{3,4} | Yes: WIFI or BT | Google Duo ² | OPUS |
| | 850 (n5) | | | | | |
| | 1700 (n66) | | | | | |
| | 1900 (n2) | | | | | |
| | 1900 (n25) | | | | | |
| NR (TDD) | 2600 (n41) | VD | Yes ⁴ | Yes: WIFI or BT | Google Duo ² | OPUS |
| WIFI | 2450 | VD | Yes | Yes: CDMA, GSM, UMTS, LTE, or NR | VoWIFI ² , Google Duo ² | VoWIFI: NB AMR, WB AMR, EVS Google Duo: OPUS |
| | 5200 (U-NII 1) | | | | | |
| | 5300 (U-NII 2A) | | | | | |
| | 5500 (U-NII 2C) | | | | | |
| | 5800 (U-NII 3) | | | | | |
| BT | 2450 | DT | No | Yes: CDMA, GSM, UMTS, LTE, or NR | N/A | N/A |
| Type Transport VO = Voice Only DT = Digital Data - Not intended for Voice Services VD = CMRS and/or IP Voice over Data Transport | | | Notes: 1. Reference level in accordance with 7.4.2.1 of ANSI C63.19-2011 and July 2012 C63 VoLTE Interpretation. 2. Reference level is -20dBm0 in accordance with FCC KDB 285076 D02 3. LTE B71 and NR n71, while outside the scope of ANSI C63.19 and FCC HAC regulations, were additionally tested according to the existing HAC procedures with currently available test equipment. 4. NR was evaluated using an interim procedure outlined in Section 7.II.5. | | | |





| | | | | |
|--|---|--------------------------------------|---|--|
| FCC ID: A3LSMF707U |  | HAC (T-COIL) TEST REPORT |  | Approved by: Quality Manager |
| Filename: 1M2005040080-19-R2.A3L | Test Dates: 06/15/2020 - 07/02/2020 | DUT Type: Portable Handset | Page 5 of 108 | |

Table 2-2
SM-F707W HAC Air Interfaces

| Air-Interface | Band (MHz) | Type Transport | HAC Tested | Simultaneous But Not Tested | Name of Voice Service | Audio Codec Evaluated |
|---|-----------------|----------------|---|----------------------------------|---|---|
| CDMA | 835 | VO | Yes | Yes: WIFI or BT | CMRS Voice ¹ | EVRC |
| | EvDO | VD | Yes | Yes: WIFI or BT | Google Duo ² | OPUS |
| GSM | 850 | VO | Yes | Yes: WIFI or BT | CMRS Voice ¹ | EFR |
| | 1900 | | | | | |
| | GPRS/EDGE | VD | Yes | Yes: WIFI or BT | Google Duo ² | OPUS |
| UMTS | 850 | VD | Yes | Yes: WIFI or BT | CMRS Voice ¹ | NB AMR |
| | 1700 | | | | | |
| | 1900 | | | | | |
| | HSPA | VD | Yes | Yes: WIFI or BT | Google Duo ² | OPUS |
| LTE (FDD) | 680 (B71) | VD | Yes ³ | Yes: WIFI or BT | VoLTE ¹ , Google Duo ² | VoLTE: NB AMR, WB AMR, EVS Google Duo: OPUS |
| | 700 (B12) | | | | | |
| | 780 (B13) | | | | | |
| | 850 (B5) | | | | | |
| | 1700 (B4) | | | | | |
| | 1700 (B66) | | | | | |
| | 1900 (B2) | | | | | |
| | 1900 (B25) | | | | | |
| | 2300 (B30) | | | | | |
| 2500 (B7) | Yes | | | | | |
| LTE (TDD) | 2600 (B38) | VD | Yes | Yes: WIFI or BT | VoLTE ¹ , Google Duo ² | VoLTE: NB AMR, WB AMR, EVS Google Duo: OPUS |
| | 2600 (B41) | | | | | |
| NR (FDD) | 680 (n71) | VD | Yes ^{3,4} | Yes: WIFI or BT | Google Duo ² | OPUS |
| | 850 (n5) | | | | | |
| | 1700 (n66) | | Yes ⁴ | | | |
| NR (TDD) | 2600 (n41) | VD | Yes ⁴ | Yes: WIFI or BT | Google Duo ² | OPUS |
| WIFI | 2450 | VD | Yes | Yes: CDMA, GSM, UMTS, LTE, or NR | VoWiFi ² , Google Duo ² | VoWiFi: NB AMR, WB AMR, EVS Google Duo: OPUS |
| | 5200 (U-NII 1) | | | | | |
| | 5300 (U-NII 2A) | | | | | |
| | 5500 (U-NII 2C) | | | | | |
| | 5800 (U-NII 3) | | | | | |
| BT | 2450 | DT | No | Yes: CDMA, GSM, UMTS, LTE, or NR | N/A | N/A |
| Type Transport VO = Voice Only DT = Digital Data - Not intended for Voice Services VD = CMRS and/or IP Voice over Data Transport | | | Notes: 1. Reference level in accordance with 7.4.2.1 of ANSI C63.19-2011 and July 2012 C63 VoLTE Interpretation. 2. Reference level is -20dBm0 in accordance with FCC KDB 285076 D02 3. LTE B71 and NR n71, while outside the scope of ANSI C63.19 and FCC HAC regulations, were additionally tested according to the existing HAC procedures with currently available test equipment. 4. NR was evaluated using an interim procedure outlined in Section 7.II.5. | | | |

| | | | | |
|--|---|--------------------------------------|---|--|
| FCC ID: A3L5MF707U |  | HAC (T-COIL) TEST REPORT |  | Approved by: Quality Manager |
| Filename: 1M2005040080-19-R2.A3L | Test Dates: 06/15/2020 - 07/02/2020 | DUT Type: Portable Handset | Page 6 of 108 | |

3. ANSI C63.19-2011 PERFORMANCE CATEGORIES

I. MAGNETIC COUPLING

Axial and Radial Field Intensity

All orientations of the magnetic field, in the axial and radial position along the measurement plane shall be ≥ -18 dB(A/m) at 1 kHz in a 1/3 octave band filter per §8.3.1.

Frequency Response

The frequency response of the axial component of the magnetic field shall follow the response curve specified in EIA RS-504-1983, over the frequency range 300 Hz – 3000 Hz per §8.3.2.

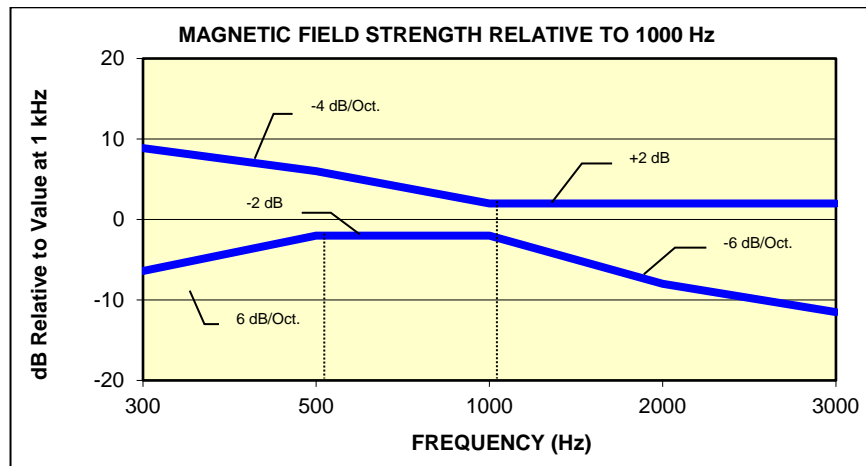

Figure 3-1
Magnetic field frequency response for Wireless Devices with an axial field ≤ -15 dB(A/m) at 1 kHz

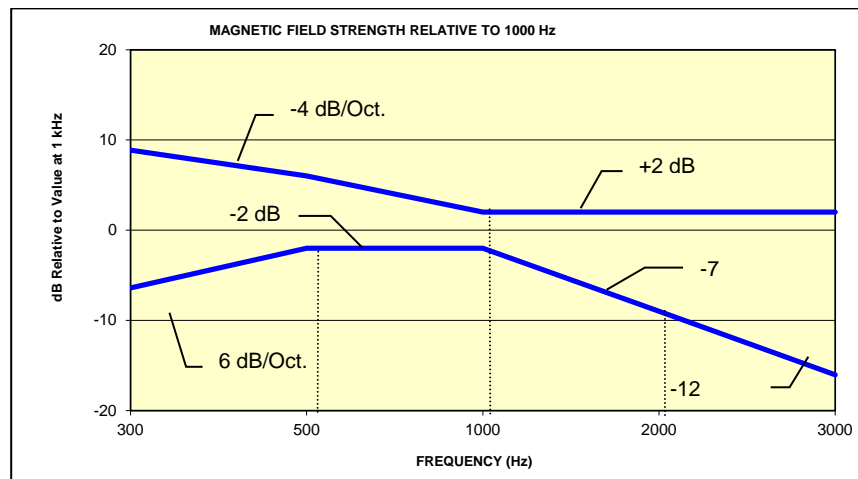



Figure 3-2
Magnetic Field frequency response for wireless devices with an axial field that exceeds -15 dB(A/m) at 1 kHz

| | | | | |
|-------------------------------------|---|-------------------------------|---|---------------------------------|
| FCC ID: A3LSMF707U |  | HAC (T-COIL) TEST REPORT |  | Approved by: Quality Manager |
| Filename: 1M2005040080-19-R2.A3L | Test Dates: 06/15/2020 - 07/02/2020 | DUT Type: Portable Handset | | Page 7 of 108 |

Signal Quality



The table below provides the signal quality requirement for the intended audio magnetic signal from a wireless device. Only the RF immunity of the hearing aid is measured in T-coil mode. It is assumed that a hearing aid can have no immunity to an interference signal in the audio band, which is the intended reception band for this mode. The only criterion that can be measured is the RF immunity in T-coil mode. This is measured using the same procedure as the audio coupling mode at the same levels.

The signal quality of the axial and radial components of the magnetic field was used to determine the T-coil mode category.

| Category | Telephone RF Parameters |
|----------|---|
| | Wireless Device Signal Quality [(Signal + Noise)-to-noise ratio in dB] |
| T1 | 0 to 10 dB |
| T2 | 10 to 20 dB |
| T3 | 20 to 30 dB |
| T4 | > 30 dB |

Table 3-1
Magnetic Coupling Parameters

Note: The FCC limit for SNNR is 20dB and the test data margins will indicate a margin from the FCC limit for compliance.

| | | | | |
|-------------------------------------|---|-------------------------------|---|---------------------------------|
| FCC ID: A3LSMF707U |  | HAC (T-COIL) TEST REPORT |  | Approved by: Quality Manager |
| Filename: 1M2005040080-19-R2.A3L | Test Dates: 06/15/2020 - 07/02/2020 | DUT Type: Portable Handset | Page 8 of 108 | |

4. METHOD OF MEASUREMENT

I. Test Setup

The equipment was connected as shown in an acoustic/RF hemi-anechoic chamber:

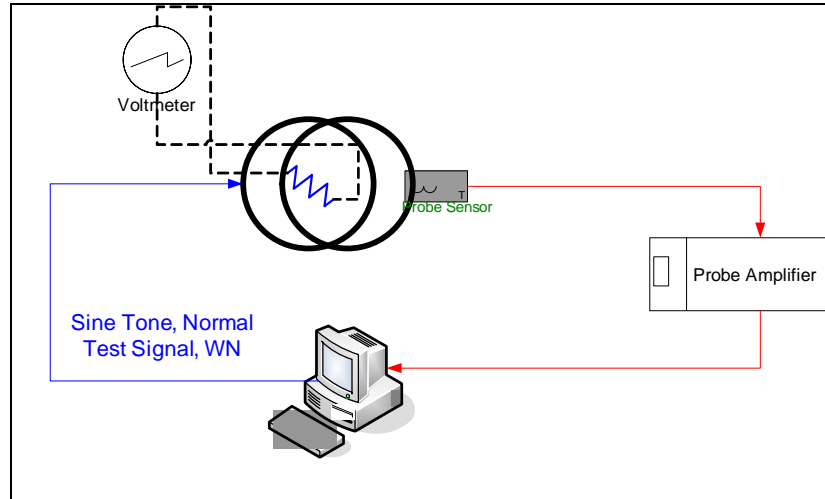

Figure 4-1
Validation Setup with Helmholtz Coil

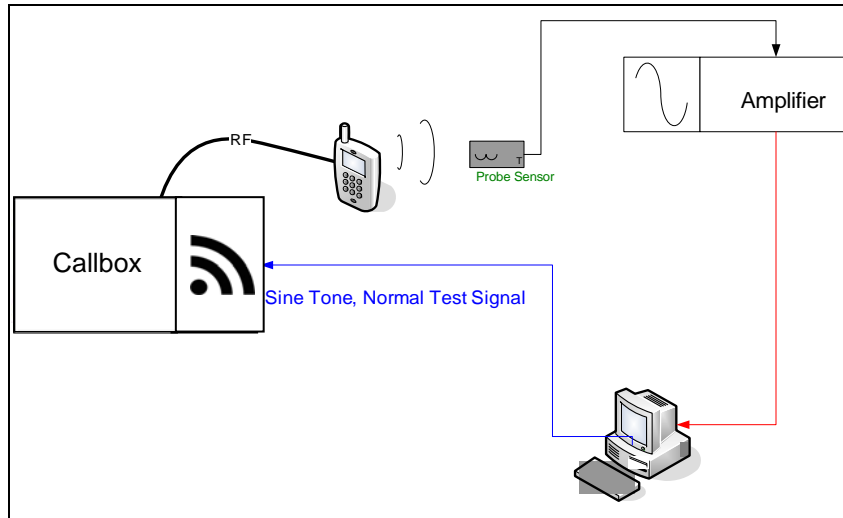



Figure 4-2
T-Coil Test Setup

| | | | | |
|-------------------------------------|---|-------------------------------|---|---------------------------------|
| FCC ID: A3LSMF707U |  | HAC (T-COIL) TEST REPORT |  | Approved by: Quality Manager |
| Filename: 1M2005040080-19-R2.A3L | Test Dates: 06/15/2020 - 07/02/2020 | DUT Type: Portable Handset | | Page 9 of 108 |

II. Scanning Mechanism

| | |
|------------------------|--------------------------------|
| Manufacturer: | TEM |
| Accuracy: | ± 0.83 cm/meter |
| Minimum Step Size: | 0.1 mm |
| Maximum speed | 6.1 cm/sec |
| Line Voltage: | 115 VAC |
| Line Frequency: | 60 Hz |
| Material Composite: | Delrin (Acetal) |
| Data Control: | Parallel Port |
| Dynamic Range (X-Y-Z): | 45 x 31.75 x 47 cm |
| Dimensions: | 36" x 25" x 38" |
| Operating Area: | 36" x 49" x 55" |
| Reflections: | < -20 dB (in anechoic chamber) |

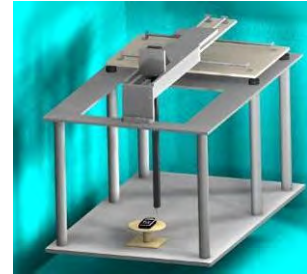

Figure 4-3
RF Near-Field Scanner

III. 3GPP2 Normal Test Signal (Speech)

| | |
|-------------------------|---|
| Manufacturer: | 3GPP2 (TIA 1042 §3.3.1) |
| Stimulus Type: | Modified-IRS weighted, multi-talker speech signal, 4 Male and 4 Female speakers (alternating) |
| Single Sample Duration: | 51.62 seconds |
| Activity Level: | 77.4% |

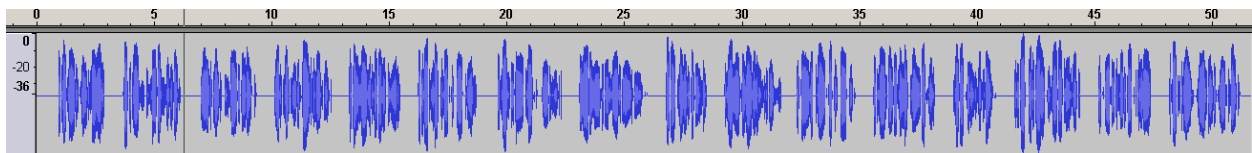



Figure 4-4
Temporal Characteristic of Normal Test Signal

| | | | | |
|-------------------------------------|---|-------------------------------|---|---------------------------------|
| FCC ID: A3LSMF707U |  | HAC (T-COIL) TEST REPORT |  | Approved by: Quality Manager |
| Filename: 1M2005040080-19-R2.A3L | Test Dates: 06/15/2020 - 07/02/2020 | DUT Type: Portable Handset | | Page 10 of 108 |

ABM1 Measurement Block Diagram:



ABM2 Measurement Block Diagram:

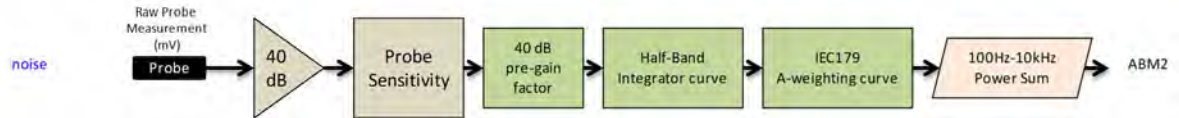

Figure 4-5 Magnetic Measurement Processing Steps

IV. Test Procedure

1. Ambient Noise Check per C63.19 §7.3.1
 - a. Ambient interference was monitored using a Real-Time Analyzer between 100-10,000 Hz with 1/3 octave filtering.
 - b. “A-weighting” and Half-Band Integration was applied to the measurements.
 - c. Since this measurement was measured in the same method as ABM2 measurements, this level was verified to be more than 10 dB below the lowest measurement signal (which is the highest ABM2 measurement for a T4 WD). Therefore the maximum noise level for a T4 WD with an ABM1 = -18 dBA/m is:

$$-18 - 30 - 10 = -58 \text{ dBA/m}$$
2. Measurement System Validation (See Figure 4-1)
 - a. The measurement system including the probe, pre-amplifier and acquisition system were validated as an entire system to ensure the reliability of test measurements.
 - b. ABM1 Validation
 The magnetic field at the center of the Helmholtz coil is given by the equation (per C63.19 Annex D.10.1):

$$H_c = \frac{NI}{r\sqrt{1.25^3}} = \frac{N(\frac{V}{R})}{r\sqrt{1.25^3}}$$



Where H_c = magnetic field strength in amperes per meter

N = number of turns per coil

For the Helmholtz Coil, SN: SBI 1052, $N=20$; $r=0.13\text{m}$; $R=10.193\Omega$ and using $V=29\text{mV}$:

$$H_c = \frac{20 \cdot (\frac{0.029}{10.193})}{0.13 \cdot \sqrt{1.25^3}} = 0.316 \text{ A/m} \approx -10 \text{ dB(A/m)}$$

For the Helmholtz Coil, SN: 925, $N=20$; $r=0.08\text{m}$; $R=10.2\Omega$ and using $V=18\text{mV}$:

| | | | | |
|-------------------------------------|---|-------------------------------|---|---------------------------------|
| FCC ID: A3LSMF707U |  | HAC (T-COIL) TEST REPORT |  | Approved by: Quality Manager |
| Filename: 1M2005040080-19-R2.A3L | Test Dates: 06/15/2020 - 07/02/2020 | DUT Type: Portable Handset | | Page 11 of 108 |

$$H_c = \frac{20 \cdot \left(\frac{0.018}{10.2}\right)}{0.08 \cdot \sqrt{1.25^3}} = 0.316 A/m \approx -10dB(A/m)$$

Therefore a pure tone of 1kHz was applied into the coils such that 29mV or 18mV for SN: SBI 1052 and SN: 925 respectively, was observed across the resistor. The voltmeter used for measurement was verified to be capable of measurements in the audio band range. This theoretically generates an expected field of -10 dB(A/m) in the center of the Helmholtz coil which was used to validate the probe measurement at -10dB(A/m). This was verified to be within ± 0.5 dB of the -10dB(A/m) value (see Page 49 and 50).

c. Frequency Response Validation

The frequency response through the Helmholtz Coil was verified to be within 0.5 dB relative to 1kHz, between 300 – 3000 Hz using the Normal signal as shown below:

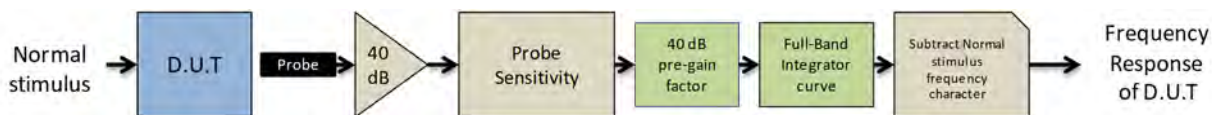



Figure 4-6 Frequency Response Validation

d. ABM2 Measurement Validation

WD noise measurements are filtered with A-weighting and Half-Band Integration over a frequency range of 100Hz – 10kHz to process ABM2 measurements. Below is the verification of the system processing A-weighting and Half-Band integration between system input to output within 0.5 dB of the theoretical result:

| | | | | |
|-------------------------------------|---|-------------------------------|---|---------------------------------|
| FCC ID: A3LSMF707U |  | HAC (T-COIL) TEST REPORT |  | Approved by: Quality Manager |
| Filename: 1M2005040080-19-R2.A3L | Test Dates: 06/15/2020 - 07/02/2020 | DUT Type: Portable Handset | | Page 12 of 108 |

**Table 4-1
ABM2 Frequency Response Validation**

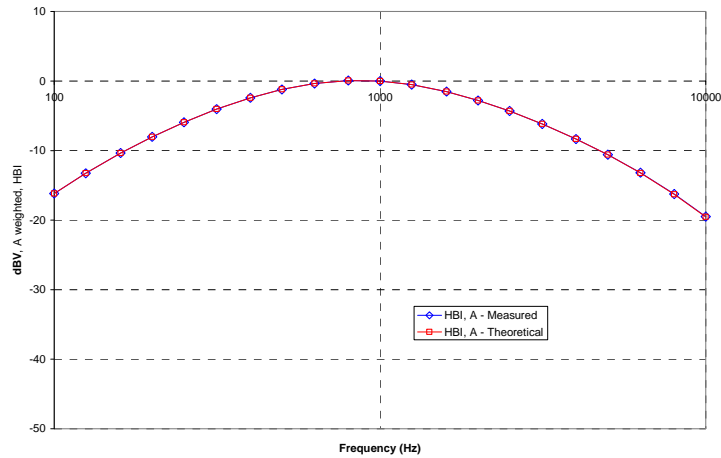

| f (Hz) | HBI, A - Measured (dB re 1kHz) | HBI, A - Theoretical (dB re 1kHz) | dB Var. |
|--------|--------------------------------|-----------------------------------|---------|
| 100 | -16.180 | -16.170 | -0.010 |
| 125 | -13.257 | -13.250 | -0.007 |
| 160 | -10.347 | -10.340 | -0.007 |
| 200 | -8.017 | -8.010 | -0.007 |
| 250 | -5.925 | -5.920 | -0.005 |
| 315 | -4.045 | -4.040 | -0.005 |
| 400 | -2.405 | -2.400 | -0.005 |
| 500 | -1.212 | -1.210 | -0.002 |
| 630 | -0.349 | -0.350 | 0.001 |
| 800 | 0.071 | 0.070 | 0.001 |
| 1000 | 0.000 | 0.000 | 0.000 |
| 1250 | -0.503 | -0.500 | -0.003 |
| 1600 | -1.513 | -1.510 | -0.003 |
| 2000 | -2.778 | -2.780 | 0.002 |
| 2500 | -4.316 | -4.320 | 0.004 |
| 3150 | -6.166 | -6.170 | 0.004 |
| 4000 | -8.322 | -8.330 | 0.008 |
| 5000 | -10.573 | -10.590 | 0.017 |
| 6300 | -13.178 | -13.200 | 0.022 |
| 8000 | -16.241 | -16.270 | 0.029 |
| 10000 | -19.495 | -19.520 | 0.025 |

ABM2 Frequency Response Validation (LISTEN)



**Figure 4-7
ABM2 Frequency Response Validation**

The ABM2 result is a power sum from 100Hz to 10kHz with half-band integration and A-weighting. To verify the power sum measurement, a power sum over the full band was measured and verified to track with the source level (See Figure 4-8). Therefore the

| | | | | |
|-------------------------------------|---|-------------------------------|---|---------------------------------|
| FCC ID: A3LSMF707U |  | HAC (T-COIL) TEST REPORT |  | Approved by: Quality Manager |
| Filename: 1M2005040080-19-R2.A3L | Test Dates: 06/15/2020 - 07/02/2020 | DUT Type: Portable Handset | | Page 13 of 108 |

setup in this step was used to verify the power sum post-processing for ABM2 measurements. See below block diagram:

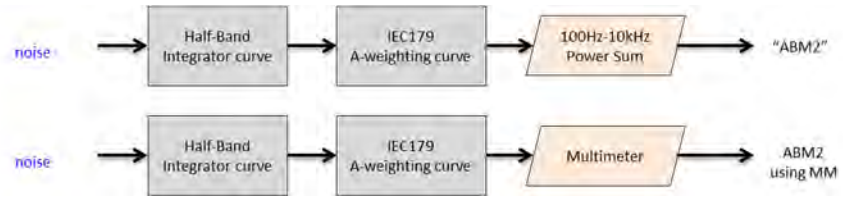

Figure 4-8
ABM2 Validation Block Diagram

The power summed output results for a known input were compared to the multi-meter results to verify any deviation in the post-processing implemented with the power-sum.

Table 4-2
ABM2 Power Sum Validation

| WN Input (dBV) | Power Sum (dBV) | Multimeter-Full (dBV) | Dev (dB) |
|----------------|-----------------|-----------------------|----------|
| -60 | -60.36 | -60.2 | 0.16 |
| -50 | -50.19 | -50.13 | 0.06 |
| -40 | -40.14 | -40.03 | 0.11 |
| -30 | -30.13 | -30.01 | 0.12 |
| -20 | -20.12 | -20 | 0.12 |
| -10 | -10.14 | -10 | 0.14 |

ABM2 Power Sum Validation (LISTEN)

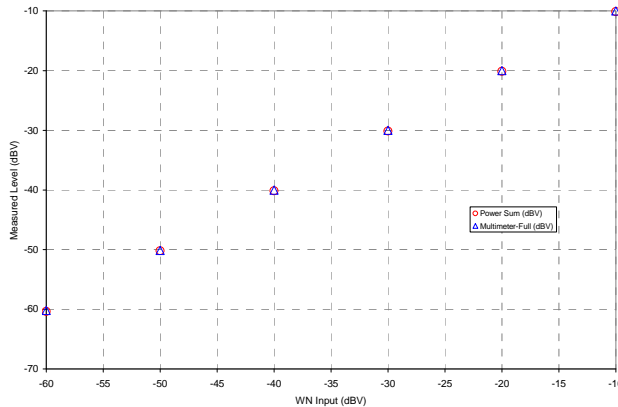



Figure 4-9
ABM2 Power Sum Validation

3. Measurement Test Setup

a. Fine scan above the WD (TEM)

- i. A multitone signal was applied to the handset such that the phone acoustic output was stable within 1dB over the probe settling time and with the acoustic output level at the C63.19 specified levels (below). The measurement step size was in 2 mm increments at a distance of 10 mm between the surface of the

| | | | | |
|-------------------------------------|---|-------------------------------|---|---------------------------------|
| FCC ID: A3LSMF707U |  | HAC (T-COIL) TEST REPORT |  | Approved by: Quality Manager |
| Filename: 1M2005040080-19-R2.A3L | Test Dates: 06/15/2020 - 07/02/2020 | DUT Type: Portable Handset | | Page 14 of 108 |

wireless device as shown below (note that in Figure 4-11, the grid is not to scale but merely a graphical representation of the coordinate system in use):

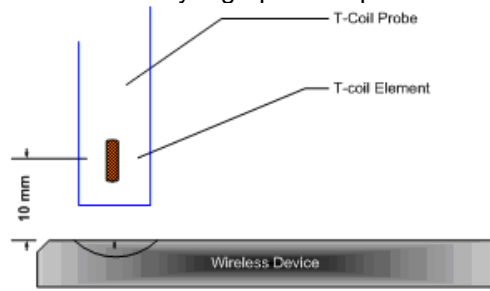

Figure 4-10
Measurement Distance

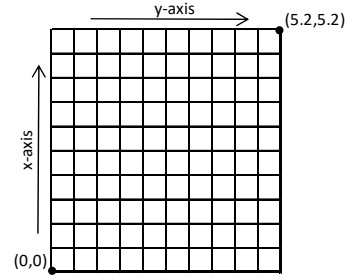



Figure 4-11
Measurement Grid

- ii. After scanning, the planar field maximum point was determined. The position of the probe was moved to this location to setup the test using the SoundCheck system.
- iii. These steps were repeated for all T-coil orientations (axial and radial) per Figure 4-13 after a T-coil orientation was fully measured with the SoundCheck system.
- b. Speech Signal Setup to Base Station Simulator
 - i. C63.19 Table 7-1 states audio reference input levels for various technologies:

| Standard | Technology | Input Level (dBm0) |
|-----------------|---------------------|--------------------|
| TIA/EIA/IS-2000 | CDMA | -18 |
| J-STD-007 | GSM (217) | -16 |
| T1/T1P1/3GPP | UMTS (WCDMA) | -16 |
| iDEN™ | TDMA (22 and 11 Hz) | -18 |

- ii. See Section 5 and 6 for more information regarding CMW500 audio level settings for Voice Over LTE (VoLTE), and Voice Over WIFI (VoWIFI) testing.
- iii. See Section 7 for more information regarding audio level settings for Over-The-Top (OTT) Voice Over IP (VoIP) Testing.
- c. Real-Time Analyzer (RTA)
 - i. The Real-Time Analyzer was configured to analyze measurements using 1/3 Octave band weighted filtering.
- d. WD Radio Configuration Selection
 - i. The device was chosen to be tested in the worst-case ABM2 condition (See Section 8 for more information regarding worst-case configurations for CDMA and UMTS. LTE configuration information can be found in Section 5 and 7. NR configuration information can be found in Section 7. WIFI configuration information can be found in Section 6 and 7.)
 - ii. Supported GSM vocoders were investigated for the worst-case ABM2 condition. GSM-EFR was deemed the worst-case condition for the GSM air interface.
- 4. Signal Quality Data Analysis
 - a. Narrow-band Magnetic Intensity
 - i. The standard specifies a 1kHz 1/3 octave band minimum field intensity for a sine tone. The ABM1 measurements were evaluated at 1kHz with 1/3 octave band filtering over an averaged period of 10 seconds.
 - b. Frequency Response
 - i. The appropriate frequency response curve was measured to curves in Figure 3-1 or Figure 3-2 between 300 – 3000 Hz using digital linear averaging (limit lines chosen according to measurement found in step 4a). A linear average over 3x the

| | | | | |
|-------------------------------------|---|-------------------------------|---|---------------------------------|
| FCC ID: A3LSMF707U |  | HAC (T-COIL) TEST REPORT |  | Approved by: Quality Manager |
| Filename: 1M2005040080-19-R2.A3L | Test Dates: 06/15/2020 - 07/02/2020 | DUT Type: Portable Handset | | Page 15 of 108 |

- length of the artificial voice signal (3x sampling) was performed. A 10 second delay was configured in the measurement process of the stimulus to ensure handset vocoder latency effects and echo cancellation devices (if any) were appropriately stabilized during measurements.
- ii. The appropriate post-processing was applied according to the system processing chain illustrated in Figure 4-6. All R10 frequencies were plotted with respect to OdB at 1kHz value and aligned with respect to the EIA-504 mask.
 - iii. The margin is represented by the closest measured data point on the curve to the EIA-504 limit lines, in dB.
- c. Signal Quality Index
- i. Ensuring the WD was at maximum RF power, maximum volume, backlight off, display on, maximum contrast setting, keypad lights on (when possible) with no audio signal through the vocoder, the WD was measured over at least 100 Hz – 10,000 Hz, maximized over 5 seconds with a 50ms sample time for the ABM2 measurement (5 second time period is used in noise measurements under standards such as IEEE 269, etc.).
 - ii. After applying half-band integration and A-weighting to the result, a power sum was applied over each 1/3 octave bandwidth frequency for an ABM2 value.
 - iii. This result was subtracted from the ABM1 result in step a, to obtain the Signal Quality.

V. Test Setup

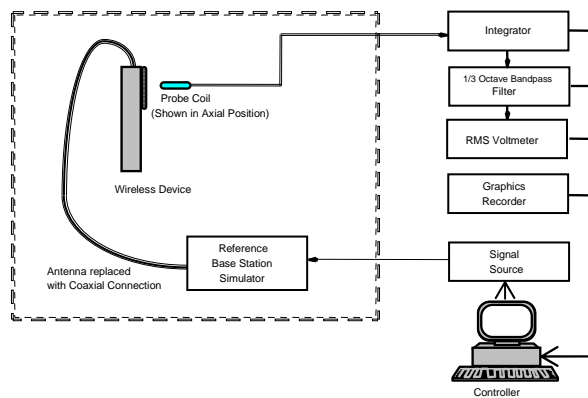



Figure 4-12
Audio Magnetic Field Test Setup

Environmental conditions such as temperature and relative humidity are monitored to ensure there are no impacts on system specifications. Proper voltage and power line frequency conditions are maintained with three phase power sources. Environmental noise and reflections are monitored through system checks.



VI. Deviation from C63.19 Test Procedure

Non-conducted RF connection due to inaccessible RF ports.

VII. Air Interface Technologies Tested

| | | | | |
|-------------------------------------|---|-------------------------------|---|---------------------------------|
| FCC ID: A3LSMF707U |  | HAC (T-COIL) TEST REPORT |  | Approved by: Quality Manager |
| Filename: 1M2005040080-19-R2.A3L | Test Dates: 06/15/2020 - 07/02/2020 | DUT Type: Portable Handset | | Page 16 of 108 |

All air interfaces which support voice capabilities over a managed CMRS or pre-installed OTT VoIP applications were tested for T-coil unless otherwise noted. See Table 2-1 for more details regarding which modes were tested.

| | | | | |
|--|---|--------------------------------------|---|--|
| FCC ID: A3LSMF707U |  | HAC (T-COIL) TEST REPORT |  | Approved by: Quality Manager |
| Filename: 1M2005040080-19-R2.A3L | Test Dates: 06/15/2020 - 07/02/2020 | DUT Type: Portable Handset | Page 17 of 108 | |

© 2020 PCTEST

REV 3.5.M
6/30/2020

© 2020 PCTEST All rights reserved. Unless otherwise specified, no part of this report may be reproduced or utilized in any part, form or by any means, electronic or mechanical, including photocopying and microfilm, without permission in writing from PCTEST. If you have any questions about this international copyright or have an enquiry about obtaining additional rights to this report or assembly of contents thereof, please contact INFO@PCTEST.COM.

VIII. Wireless Device Channels and Frequencies

1. 2G/3G Modes

The frequencies listed in the table below are those that lie in the center of the bands used for cellular telephony. Low, middle and high channels were tested in each band for FCC compliance evaluation to ensure the maximum emission is captured across the entire band. Only middle channels were evaluated for data modes.

**Table 4-3
Center Channels and Frequencies**

| Test frequencies & associated channels | |
|--|-----------------|
| Channel | Frequency (MHz) |
| Secondary Cellular 820 | |
| 564 (CDMA) | 820.10 |
| Cellular 850 | |
| 384 (CDMA) | 836.52 |
| 190 (GSM) | 836.60 |
| 4183 (UMTS) | 836.60 |
| AWS 1750 | |
| 1412 (UMTS) | 1730.40 |
| PCS 1900 | |
| 600 (CDMA) | 1880 |
| 661 (GSM) | 1880 |
| 9400 (UMTS) | 1880 |

2. 4G (LTE) Modes



The middle channel for every band and bandwidth combination was tested for each probe orientation. The band and bandwidth combination from each probe orientation resulting in the worst-case SNNR was additionally tested using low and high channels for that band and bandwidth combination. Low-mid and mid-high channels are additionally tested for LTE TDD. The middle channel and supported bandwidths from the worst-case bands according to Table 7-6 and 7-7 were additionally evaluated with OTT VoIP for each probe orientation. See Tables 9-5 to 9-16 and 9-25 to 9-26 for LTE bandwidths and channels.

3. 5G (NR) Modes

The middle channel and supported bandwidths from the worst-case band according to Table 7-12 in addition to NR TDD n41 was evaluated with OTT VoIP for each probe orientation. The band and bandwidth combination from each probe orientation resulting in the worst-case SNNR was additionally tested using low and high channels for that band and bandwidth combination. See Tables 9-27 and 9-28 for NR bandwidths and channels.

4. WIFI

The middle channel for each IEEE 802.11 standard was tested for each probe orientation. The 2.4GHz IEEE 802.11 standard from each probe orientation resulting in the worst-case SNNR was additionally tested using low and high channels. The 5GHz IEEE 802.11 standard from each probe orientation resulting in the worst-case SNNR was additionally tested on higher U-NII bands as well as applicable low and high channels. See Tables 9-17 to 9-21 and 9-29 to 9-33 for WIFI standards and channels.

| | | | | |
|-------------------------------------|---|-------------------------------|---|---------------------------------|
| FCC ID: A3L3SMF707U |  | HAC (T-COIL) TEST REPORT |  | Approved by: Quality Manager |
| Filename: 1M2005040080-19-R2.A3L | Test Dates: 06/15/2020 - 07/02/2020 | DUT Type: Portable Handset | | Page 18 of 108 |

IX. Test Flow

The flow diagram below was followed (From C63.19):

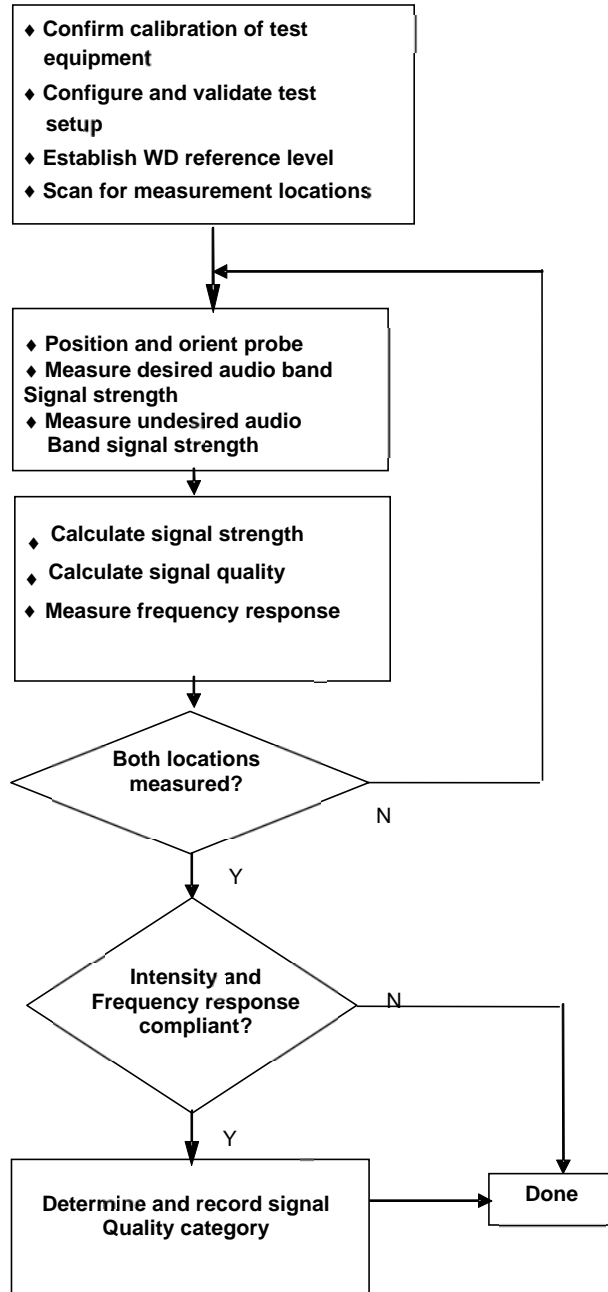



Figure 4-13
C63.19 T-Coil Signal Test Process

| | | | | |
|-------------------------------------|---|-------------------------------|---|---------------------------------|
| FCC ID: A3LSMF707U |  | HAC (T-COIL) TEST REPORT |  | Approved by: Quality Manager |
| Filename: 1M2005040080-19-R2.A3L | Test Dates: 06/15/2020 - 07/02/2020 | DUT Type: Portable Handset | | Page 19 of 108 |

© 2020 PCTEST

REV 3.5.M
6/30/2020

© 2020 PCTEST All rights reserved. Unless otherwise specified, no part of this report may be reproduced or utilized in any part, form or by any means, electronic or mechanical, including photocopying and microfilm, without permission in writing from PCTEST. If you have any questions about this international copyright or have an enquiry about obtaining additional rights to this report or assembly of contents thereof, please contact INFO@PCTEST.COM.

5. VOLTE TEST SYSTEM SETUP AND DUT CONFIGURATION

I. Test System Setup for VoLTE over IMS T-coil Testing

1. Equipment Setup

The general test setup used for VoLTE over IMS is shown below. The callbox used when performing VoLTE over IMS T-coil measurements is a CMW500. The Data Application Unit (DAU) of the CMW500 was used to simulate the IP Multimedia Subsystem (IMS) server.

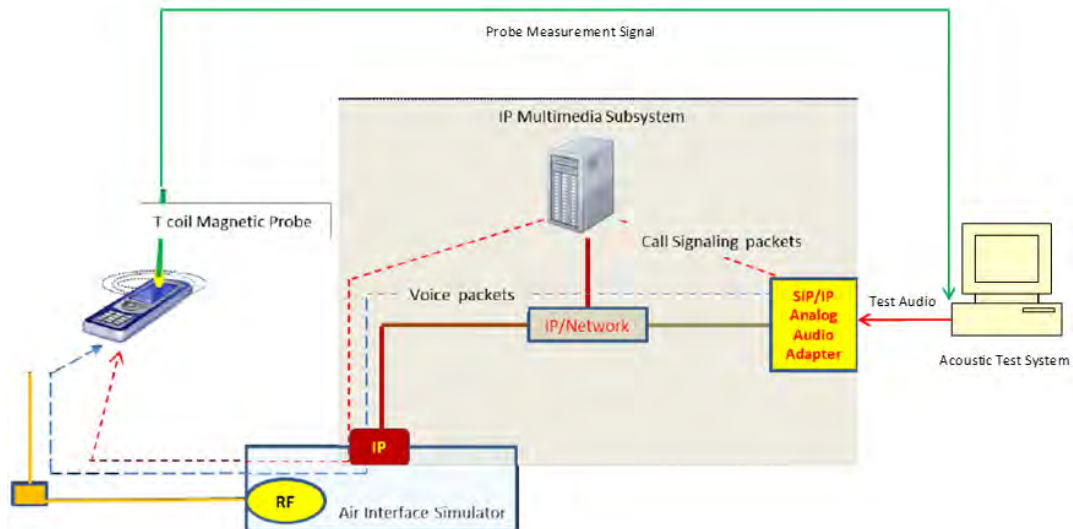



Figure 5-1
Test Setup for VoLTE over IMS T-Coil Measurements

2. Audio Level Settings

According to the July 2012 interpretations by the C63 Committee regarding the appropriate audio levels to be used for VoLTE over IMS T-coil testing, -16dBm0 shall be used for the normal speech input level. The CMW500 base station simulator was manually configured to ensure that the settings for speech input and full scale levels resulted in the -16dBm0 speech input level to the DUT for the VoLTE over IMS connection.

* http://c63.org/documents/misc/posting/new_interpretations.htm

| | | | | |
|-------------------------------------|---|-------------------------------|---|---------------------------------|
| FCC ID: A3L5MF707U |  | HAC (T-COIL) TEST REPORT |  | Approved by: Quality Manager |
| Filename: 1M2005040080-19-R2.A3L | Test Dates: 06/15/2020 - 07/02/2020 | DUT Type: Portable Handset | | Page 20 of 108 |

© 2020 PCTEST

REV 3.5.M

6/30/2020

© 2020 PCTEST All rights reserved. Unless otherwise specified, no part of this report may be reproduced or utilized in any part, form or by any means, electronic or mechanical, including photocopying and microfilm, without permission in writing from PCTEST. If you have any questions about this international copyright or have an enquiry about obtaining additional rights to this report or assembly of contents thereof, please contact INFO@PCTEST.COM.



II. DUT Configuration for VoLTE over IMS T-coil Testing

1. Radio Configuration

An investigation was performed to determine the modulation and RB configuration to be used for testing. The effects of modulation and RB configuration were found to be independent of band and bandwidth; therefore, only one band and bandwidth were used for this investigation. 16QAM, 1 RB, 50% RB offset was used for the testing as the worst-case configuration for the handset. See below table for SNNR comparison between different radio configurations:

Table 5-1
VoLTE over IMS SNNR by Radio Configuration

| Band | Frequency [MHz] | Channel | Bandwidth [MHz] | Modulation | RB Size | RB Offset | ABM1 [dB(A/m)] | ABM2 [dB(A/m)] | SNNR [dB] |
|------|-----------------|---------|-----------------|------------|---------|-----------|----------------|----------------|-----------|
| 66 | 1745.0 | 132322 | 20 | QPSK | 1 | 0 | -0.13 | -41.65 | 41.52 |
| 66 | 1745.0 | 132322 | 20 | QPSK | 1 | 50 | -0.22 | -40.78 | 40.56 |
| 66 | 1745.0 | 132322 | 20 | QPSK | 1 | 99 | -0.19 | -41.13 | 40.94 |
| 66 | 1745.0 | 132322 | 20 | QPSK | 50 | 0 | -0.18 | -44.83 | 44.65 |
| 66 | 1745.0 | 132322 | 20 | QPSK | 50 | 25 | -0.18 | -44.07 | 43.89 |
| 66 | 1745.0 | 132322 | 20 | QPSK | 50 | 50 | -0.21 | -44.20 | 43.99 |
| 66 | 1745.0 | 132322 | 20 | QPSK | 100 | 0 | -0.18 | -43.91 | 43.73 |
| 66 | 1745.0 | 132322 | 20 | 16QAM | 1 | 0 | -0.17 | -36.20 | 36.03 |
| 66 | 1745.0 | 132322 | 20 | 16QAM | 1 | 50 | -0.20 | -35.13 | 34.93 |
| 66 | 1745.0 | 132322 | 20 | 16QAM | 1 | 99 | -0.16 | -35.32 | 35.16 |
| 66 | 1745.0 | 132322 | 20 | 16QAM | 50 | 0 | -0.16 | -44.64 | 44.48 |
| 66 | 1745.0 | 132322 | 20 | 16QAM | 50 | 25 | -0.23 | -44.00 | 43.77 |
| 66 | 1745.0 | 132322 | 20 | 16QAM | 50 | 50 | -0.15 | -43.44 | 43.29 |
| 66 | 1745.0 | 132322 | 20 | 16QAM | 100 | 0 | -0.17 | -44.25 | 44.08 |
| 66 | 1745.0 | 132322 | 20 | 64QAM | 1 | 0 | -0.19 | -38.86 | 38.67 |
| 66 | 1745.0 | 132322 | 20 | 64QAM | 1 | 50 | -0.14 | -37.99 | 37.85 |
| 66 | 1745.0 | 132322 | 20 | 64QAM | 1 | 99 | -0.16 | -38.32 | 38.16 |
| 66 | 1745.0 | 132322 | 20 | 64QAM | 50 | 0 | -0.12 | -44.45 | 44.33 |
| 66 | 1745.0 | 132322 | 20 | 64QAM | 50 | 25 | -0.13 | -44.77 | 44.64 |
| 66 | 1745.0 | 132322 | 20 | 64QAM | 50 | 50 | -0.14 | -43.62 | 43.48 |
| 66 | 1745.0 | 132322 | 20 | 64QAM | 100 | 0 | -0.14 | -44.99 | 44.85 |
| 66 | 1745.0 | 132322 | 20 | 256QAM | 1 | 0 | -0.13 | -44.89 | 44.76 |
| 66 | 1745.0 | 132322 | 20 | 256QAM | 1 | 50 | -0.12 | -45.01 | 44.89 |
| 66 | 1745.0 | 132322 | 20 | 256QAM | 1 | 99 | -0.18 | -42.33 | 42.15 |
| 66 | 1745.0 | 132322 | 20 | 256QAM | 50 | 0 | -0.16 | -42.41 | 42.25 |
| 66 | 1745.0 | 132322 | 20 | 256QAM | 50 | 25 | -0.15 | -42.12 | 41.97 |
| 66 | 1745.0 | 132322 | 20 | 256QAM | 50 | 50 | -0.19 | -42.04 | 41.85 |
| 66 | 1745.0 | 132322 | 20 | 256QAM | 100 | 0 | -0.19 | -41.22 | 41.03 |

| | | | | |
|-------------------------------------|---|-------------------------------|---|---------------------------------|
| FCC ID: A3LSMF707U |  | HAC (T-COIL) TEST REPORT |  | Approved by: Quality Manager |
| Filename: 1M2005040080-19-R2.A3L | Test Dates: 06/15/2020 - 07/02/2020 | DUT Type: Portable Handset | | Page 21 of 108 |

2. Codec Configuration

An investigation was performed to determine the audio codec configuration to be used for testing. The effects of codec configuration were found to be independent of radio configuration; therefore, only one radio configuration was used for this investigation. The EVS Primary SWB 9.6kbps setting was used for the audio codec on the CMW500 for VoLTE over IMS T-coil testing. See below table for comparisons between different codecs and codec data rates:

Table 5-2
AMR Codec Investigation – VoLTE over IMS

| Codec Setting: | WB AMR 23.85kbps | WB AMR 6.60kbps | NB AMR 12.2kbps | NB AMR 4.75kbps | Orientation | Band / BW | Channel |
|--------------------|---------------------|--------------------|--------------------|--------------------|-------------|------------------|---------|
| ABM1 (dBA/m) | 10.10 | 8.91 | 15.42 | 15.25 | Axial | Band 66 20MHz | 132322 |
| ABM2 (dBA/m) | -37.53 | -37.28 | -37.24 | -37.57 | | | |
| Frequency Response | Pass | Pass | Pass | Pass | | | |
| S+N/N (dB) | 47.63 | 46.19 | 52.66 | 52.82 | | | |

Table 5-3
EVS Codec Investigation - VoLTE over IMS

| Codec Setting: | EVS Primary SWB 128kbps | EVS Primary SWB 9.6kbps | EVS Primary WB 128kbps | EVS Primary WB 5.9kbps | EVS Primary NB 24.4kbps | EVS Primary NB 5.9kbps | Orientation | Band / BW | Channel |
|--------------------|----------------------------|----------------------------|---------------------------|---------------------------|----------------------------|---------------------------|-------------|------------------|---------|
| ABM1 (dBA/m) | 0.48 | -0.18 | 10.13 | 10.10 | 15.31 | 13.48 | Axial | Band 66 20MHz | 132322 |
| ABM2 (dBA/m) | -36.64 | -36.36 | -36.82 | -36.90 | -36.71 | -36.31 | | | |
| Frequency Response | Pass | Pass | Pass | Pass | Pass | Pass | | | |
| S+N/N (dB) | 37.12 | 36.18 | 46.95 | 47.00 | 52.02 | 49.79 | | | |

- Mute on; Backlight off; Max Volume; Max Contrast
- TPC = “Max Power”

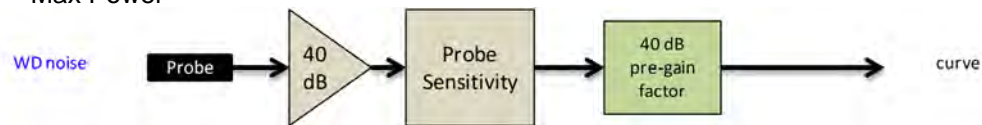



Figure 5-2
Audio Band Magnetic Curve Measurement Block Diagram

| | | | | |
|-------------------------------------|---|-------------------------------|---|---------------------------------|
| FCC ID: A3LSMF707U |  | HAC (T-COIL) TEST REPORT |  | Approved by: Quality Manager |
| Filename: 1M2005040080-19-R2.A3L | Test Dates: 06/15/2020 - 07/02/2020 | DUT Type: Portable Handset | | Page 22 of 108 |

3. LTE TDD Uplink-Downlink Configuration Investigation for VoLTE over IMS

An investigation was performed to determine the worst-case Uplink-Downlink configuration for VoLTE over IMS T-Coil testing.

Per 3GPP TS 36.211, the total frame length for each TDD radio frame of length $T_f = 307200 \cdot T_s = 10$ ms, where T_s is a number of time units equal to $1/(15000 \times 2048)$ seconds. Additionally, each radio frame consists of 10 subframes, each of length $30720 \cdot T_s = 1$ ms, and subframes can be designated as uplink (U), downlink (D), or special subframe (S), depending on the Uplink-Downlink configuration as indicated in Table 4.2-2 of 3GPP TS 36.211. In the transmission duty factor calculation, the special subframe configuration with the shortest UpPTS duration within the special subframe is used and will be applied for measurement. From 3GPP TS 36.211 Table 4.2-1, the shortest UpPTS is $2192 \cdot T_s$ which occurs in the normal cyclic prefix and special subframe configuration 4.

See table below outlining the calculated transmission duty cycles for each Uplink-Downlink configuration:

**Table 5-4
Uplink-Downlink Configurations for Type 2 Frame Structures**



| Uplink-downlink configuration | Downlink-to-Uplink Switch-point periodicity | Subframe number | | | | | | | | | | Calculated Transmission Duty Cycle (%) |
|-------------------------------|---|-----------------|---|---|---|---|---|---|---|---|---|--|
| | | 0 | 1 | 2 | 3 | 4 | 5 | 6 | 7 | 8 | 9 | |
| 0 | 5 ms | D | S | U | U | U | D | S | U | U | U | 61.4% |
| 1 | 5 ms | D | S | U | U | D | D | S | U | U | D | 41.4% |
| 2 | 5 ms | D | S | U | D | D | D | S | U | D | D | 21.4% |
| 3 | 10 ms | D | S | U | U | U | D | D | D | D | D | 30.7% |
| 4 | 10 ms | D | S | U | U | D | D | D | D | D | D | 20.7% |
| 5 | 10 ms | D | S | U | D | D | D | D | D | D | D | 10.7% |
| 6 | 5 ms | D | S | U | U | U | D | S | U | U | D | 51.4% |

a. Power Class 3 Uplink-Downlink Configuration Investigation

Power Class 3 was evaluated with the following radio configuration: channel 40620, 20MHz BW, 16QAM, 1RB, 0RB Offset. For Power Class 3, all configurations (0-6) are supported. The configuration which resulted in the worst SNNR was used for full testing. Uplink-Downlink configuration 1 was used as the worst-case configuration for Power Class 3 VoLTE over IMS T-Coil testing. See table below for the SNNR comparison between each Uplink-Downlink configuration:

**Table 5-5
Power Class 3 VoLTE over IMS SNNR by UL-DL Configuration**

| Frequency [MHz] | Channel | Bandwidth [MHz] | Modulation | RB Size | RB Offset | UL-DL Configuration | ABM1 [dB(A/m)] | ABM2 [dB(A/m)] | SNNR [dB] |
|-----------------|---------|-----------------|------------|---------|-----------|---------------------|----------------|----------------|-----------|
| 2593.0 | 40620 | 20 | 16QAM | 1 | 50 | 0 | -0.27 | -29.90 | 29.63 |
| 2593.0 | 40620 | 20 | 16QAM | 1 | 50 | 1 | -0.23 | -29.64 | 29.41 |
| 2593.0 | 40620 | 20 | 16QAM | 1 | 50 | 2 | -0.28 | -30.56 | 30.28 |
| 2593.0 | 40620 | 20 | 16QAM | 1 | 50 | 3 | -0.36 | -32.17 | 31.81 |
| 2593.0 | 40620 | 20 | 16QAM | 1 | 50 | 4 | -0.30 | -32.21 | 31.91 |
| 2593.0 | 40620 | 20 | 16QAM | 1 | 50 | 5 | -0.37 | -32.91 | 32.54 |
| 2593.0 | 40620 | 20 | 16QAM | 1 | 50 | 6 | -0.34 | -29.87 | 29.53 |

| | | | | |
|-------------------------------------|---|-------------------------------|---|---------------------------------|
| FCC ID: A3LSMF707U |  | HAC (T-COIL) TEST REPORT |  | Approved by: Quality Manager |
| Filename: 1M2005040080-19-R2.A3L | Test Dates: 06/15/2020 - 07/02/2020 | DUT Type: Portable Handset | | Page 23 of 108 |

b. Power Class 2 Uplink-Downlink Configuration Investigation

Power Class 2 was evaluated with the following radio configuration: channel 40620, 20MHz BW, 16QAM, 1RB, 0RB Offset. For Power Class 2, configurations 1-5 are supported. The configuration which resulted in the worst SNNR was used for full testing. Uplink-Downlink configuration 1 was used as the worst-case configuration for Power Class 2 VoLTE over IMS T-Coil testing. See table below for the SNNR comparison between each Uplink-Downlink configuration:



**Table 5-6
Power Class 2 VoLTE over IMS SNNR by UL-DL Configuration**

| Frequency [MHz] | Channel | Bandwidth [MHz] | Modulation | RB Size | RB Offset | UL-DL Configuration | ABM1 [dB(A/m)] | ABM2 [dB(A/m)] | SNNR [dB] |
|-----------------|---------|-----------------|------------|---------|-----------|---------------------|----------------|----------------|-----------|
| 2593.0 | 40620 | 20 | 16QAM | 1 | 50 | 1 | -0.48 | -28.24 | 27.76 |
| 2593.0 | 40620 | 20 | 16QAM | 1 | 50 | 2 | -0.52 | -29.37 | 28.85 |
| 2593.0 | 40620 | 20 | 16QAM | 1 | 50 | 3 | -0.46 | -29.33 | 28.87 |
| 2593.0 | 40620 | 20 | 16QAM | 1 | 50 | 4 | -0.48 | -29.91 | 29.43 |
| 2593.0 | 40620 | 20 | 16QAM | 1 | 50 | 5 | -0.49 | -31.69 | 31.20 |

Note: LTE TDD B41 Power Class 2 only supports UL-DL configurations 1-5, not 0 or 6.

c. Conclusion

Per the investigations above, UL-DL Configuration 1 was used to evaluate Power Class 3 and Power Class 2 VoLTE over IMS.

| | | | | |
|-------------------------------------|---|-------------------------------|---|---------------------------------|
| FCC ID: A3LSMF707U |  | HAC (T-COIL) TEST REPORT |  | Approved by: Quality Manager |
| Filename: 1M2005040080-19-R2.A3L | Test Dates: 06/15/2020 - 07/02/2020 | DUT Type: Portable Handset | | Page 24 of 108 |

6. VOWIFI TEST SYSTEM SETUP AND DUT CONFIGURATION

I. Test System Setup for VoWIFI over IMS T-coil Testing

1. Equipment Setup

The general test setup used for VoWIFI over IMS, or CMRS WIFI Calling, is shown below. The callbox used when performing VoWIFI over IMS T-coil measurements is a CMW500. The Data Application Unit (DAU) of the CMW500 was used to simulate the IP Multimedia Subsystem (IMS) server.

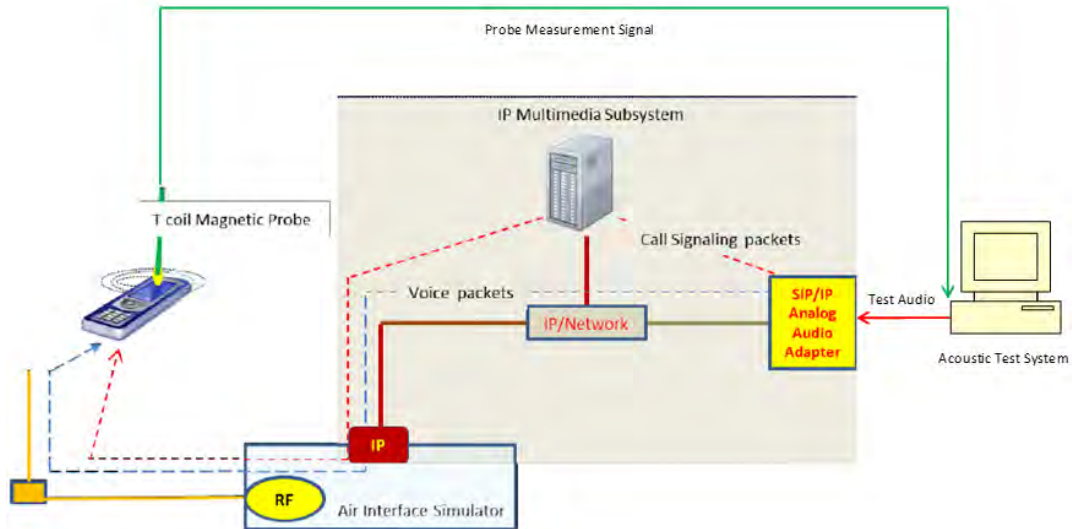



Figure 6-1
Test Setup for VoWIFI over IMS T-Coil Measurements

2. Audio Level Settings

According to KDB 285076 D02 released by the FCC OET regarding the appropriate audio levels to be used for VoWIFI over IMS T-Coil testing, -20dBm0 shall be used for the normal speech input level². The CMW500 base station simulator was manually configured to ensure that the settings for speech input and full scale levels resulted in the -20dBm0 speech input level to the DUT for the VoWIFI over IMS connection.

² FCC Office of Engineering and Technology KDB, "285076 D02 T-Coil Testing for CMRS IP v03," September 13, 2017

| | | | | |
|-------------------------------------|---|-------------------------------|---|---------------------------------|
| FCC ID: A3LSMF707U |  | HAC (T-COIL) TEST REPORT |  | Approved by: Quality Manager |
| Filename: 1M2005040080-19-R2.A3L | Test Dates: 06/15/2020 - 07/02/2020 | DUT Type: Portable Handset | | Page 25 of 108 |

II. DUT Configuration for VoWiFi over IMS T-coil Testing

1. Radio Configuration

An investigation was performed on all applicable data rates and modulations to determine the radio configuration to be used for testing. See tables below for SNNR comparison between radio configurations in each IEEE 802.11 standard:

Table 6-1
IEEE 802.11b SNNR by Radio Configuration

| Mode | Channel | Modulation | Data Rate [Mbps] | ABM1 [dB(A/m)] | ABM2 [dB(A/m)] | SNNR [dB] |
|--------------|---------|------------|------------------|----------------|----------------|-----------|
| IEEE 802.11b | 6 | DSSS | 1 | 1.28 | -37.70 | 38.98 |
| IEEE 802.11b | 6 | DSSS | 2 | 1.47 | -37.28 | 38.75 |
| IEEE 802.11b | 6 | CCK | 5.5 | 1.36 | -37.35 | 38.71 |
| IEEE 802.11b | 6 | CCK | 11 | 1.30 | -39.43 | 40.73 |

Table 6-2
IEEE 802.11g/a SNNR by Radio Configuration

| Mode | Channel | Modulation | Data Rate [Mbps] | ABM1 [dB(A/m)] | ABM2 [dB(A/m)] | SNNR [dB] |
|--------------|---------|------------|------------------|----------------|----------------|-----------|
| IEEE 802.11g | 6 | BPSK | 6 | 1.36 | -36.63 | 37.99 |
| IEEE 802.11g | 6 | BPSK | 9 | 1.09 | -38.33 | 39.42 |
| IEEE 802.11g | 6 | QPSK | 12 | 1.28 | -36.01 | 37.29 |
| IEEE 802.11g | 6 | QPSK | 18 | 1.15 | -38.05 | 39.20 |
| IEEE 802.11g | 6 | 16QAM | 24 | 1.07 | -37.77 | 38.84 |
| IEEE 802.11g | 6 | 16QAM | 36 | 1.07 | -36.66 | 37.73 |
| IEEE 802.11g | 6 | 64QAM | 48 | 1.23 | -37.05 | 38.28 |
| IEEE 802.11g | 6 | 64QAM | 54 | 1.03 | -37.87 | 38.90 |

Table 6-3
IEEE 802.11n/ac 20MHz BW SNNR by Radio Configuration

| Mode | Bandwidth [MHz] | Channel | Modulation | MCS Index | ABM1 [dB(A/m)] | ABM2 [dB(A/m)] | SNNR [dB] |
|---------------|-----------------|---------|------------|-----------|----------------|----------------|-----------|
| IEEE 802.11n | 20 | 40 | BPSK | 0 | 1.51 | -38.67 | 40.18 |
| IEEE 802.11n | 20 | 40 | QPSK | 1 | 1.25 | -38.51 | 39.76 |
| IEEE 802.11n | 20 | 40 | QPSK | 2 | 1.41 | -38.94 | 40.35 |
| IEEE 802.11n | 20 | 40 | 16QAM | 3 | 1.39 | -38.87 | 40.26 |
| IEEE 802.11n | 20 | 40 | 16QAM | 4 | 1.42 | -39.09 | 40.51 |
| IEEE 802.11n | 20 | 40 | 64QAM | 5 | 1.26 | -39.06 | 40.32 |
| IEEE 802.11n | 20 | 40 | 64QAM | 6 | 1.27 | -37.93 | 39.20 |
| IEEE 802.11n | 20 | 40 | 64QAM | 7 | 1.26 | -39.24 | 40.50 |
| IEEE 802.11ac | 20 | 40 | 256QAM | 8 | 1.36 | -38.73 | 40.09 |

Table 6-4
IEEE 802.11ax SU 20MHz BW SNNR by Radio Configuration

| Mode | Bandwidth [MHz] | Channel | Modulation | MCS Index | ABM1 [dB(A/m)] | ABM2 [dB(A/m)] | SNNR [dB] |
|------------------|-----------------|---------|------------|-----------|----------------|----------------|-----------|
| IEEE 802.11ax SU | 20 | 40 | BPSK | 0 | 1.27 | -36.70 | 37.97 |
| IEEE 802.11ax SU | 20 | 40 | QPSK | 1 | 1.28 | -38.11 | 39.39 |
| IEEE 802.11ax SU | 20 | 40 | QPSK | 2 | 1.61 | -38.24 | 39.85 |
| IEEE 802.11ax SU | 20 | 40 | 16QAM | 3 | 1.51 | -38.86 | 40.37 |
| IEEE 802.11ax SU | 20 | 40 | 16QAM | 4 | 1.44 | -38.33 | 39.77 |
| IEEE 802.11ax SU | 20 | 40 | 64QAM | 5 | 1.59 | -38.61 | 40.20 |
| IEEE 802.11ax SU | 20 | 40 | 64QAM | 6 | 1.46 | -38.53 | 39.99 |
| IEEE 802.11ax SU | 20 | 40 | 64QAM | 7 | 1.36 | -39.51 | 40.87 |
| IEEE 802.11ax SU | 20 | 40 | 256QAM | 8 | 1.55 | -39.42 | 40.97 |
| IEEE 802.11ax SU | 20 | 40 | 256QAM | 9 | 1.40 | -38.38 | 39.78 |
| IEEE 802.11ax SU | 20 | 40 | 1024QAM | 10 | 1.38 | -38.60 | 39.98 |
| IEEE 802.11ax SU | 20 | 40 | 1024QAM | 11 | 1.30 | -39.29 | 40.59 |



| | | | | |
|-------------------------------------|---|-------------------------------|---|---------------------------------|
| FCC ID: A3L3SMF707U |  | HAC (T-COIL) TEST REPORT |  | Approved by: Quality Manager |
| Filename: 1M2005040080-19-R2.A3L | Test Dates: 06/15/2020 - 07/02/2020 | DUT Type: Portable Handset | | Page 26 of 108 |

Table 6-5
IEEE 802.11ax RU 20MHz BW SNNR by Radio Configuration

| Mode | Bandwidth [MHz] | Channel | Modulation | MCS Index | RU Index | ABM1 [dB(A/m)] | ABM2 [dB(A/m)] | SNNR [dB] |
|------------------|-----------------|---------|------------|-----------|----------|----------------|----------------|-----------|
| IEEE 802.11ax RU | 20 | 40 | BPSK | 0 | 0 | 1.50 | -38.67 | 40.17 |
| IEEE 802.11ax RU | 20 | 40 | BPSK | 0 | 8 | 1.28 | -38.90 | 40.18 |
| IEEE 802.11ax RU | 20 | 40 | BPSK | 0 | 37 | 1.43 | -38.82 | 40.25 |
| IEEE 802.11ax RU | 20 | 40 | BPSK | 0 | 40 | 1.42 | -38.52 | 39.94 |
| IEEE 802.11ax RU | 20 | 40 | BPSK | 0 | 53 | 1.51 | -38.81 | 40.32 |
| IEEE 802.11ax RU | 20 | 40 | BPSK | 0 | 54 | 1.49 | -38.71 | 40.20 |
| IEEE 802.11ax RU | 20 | 40 | BPSK | 0 | 61 | 1.55 | -38.68 | 40.23 |

Table 6-6
IEEE 802.11n/ac 40MHz BW SNNR by Radio Configuration



| Mode | Bandwidth [MHz] | Channel | Modulation | MCS Index | ABM1 [dB(A/m)] | ABM2 [dB(A/m)] | SNNR [dB] |
|---------------|-----------------|---------|------------|-----------|----------------|----------------|-----------|
| IEEE 802.11n | 40 | 38 | BPSK | 0 | 1.14 | -38.80 | 39.94 |
| IEEE 802.11n | 40 | 38 | QPSK | 1 | 1.29 | -39.18 | 40.47 |
| IEEE 802.11n | 40 | 38 | QPSK | 2 | 1.33 | -39.40 | 40.73 |
| IEEE 802.11n | 40 | 38 | 16QAM | 3 | 1.36 | -38.88 | 40.24 |
| IEEE 802.11n | 40 | 38 | 16QAM | 4 | 1.28 | -39.65 | 40.93 |
| IEEE 802.11n | 40 | 38 | 64QAM | 5 | 1.37 | -39.07 | 40.44 |
| IEEE 802.11n | 40 | 38 | 64QAM | 6 | 1.34 | -39.11 | 40.45 |
| IEEE 802.11n | 40 | 38 | 64QAM | 7 | 1.23 | -39.43 | 40.66 |
| IEEE 802.11ac | 40 | 38 | 256QAM | 8 | 1.21 | -40.67 | 41.88 |
| IEEE 802.11ac | 40 | 38 | 256QAM | 9 | 1.33 | -39.79 | 41.12 |

Table 6-7
IEEE 802.11ax SU 40MHz BW SNNR by Radio Configuration

| Mode | Bandwidth [MHz] | Channel | Modulation | MCS Index | ABM1 [dB(A/m)] | ABM2 [dB(A/m)] | SNNR [dB] |
|------------------|-----------------|---------|------------|-----------|----------------|----------------|-----------|
| IEEE 802.11ax SU | 40 | 38 | BPSK | 0 | 1.31 | -38.21 | 39.52 |
| IEEE 802.11ax SU | 40 | 38 | QPSK | 1 | 1.28 | -38.85 | 40.13 |
| IEEE 802.11ax SU | 40 | 38 | QPSK | 2 | 1.47 | -38.15 | 39.62 |
| IEEE 802.11ax SU | 40 | 38 | 16QAM | 3 | 1.53 | -38.00 | 39.53 |
| IEEE 802.11ax SU | 40 | 38 | 16QAM | 4 | 1.33 | -38.34 | 39.67 |
| IEEE 802.11ax SU | 40 | 38 | 64QAM | 5 | 1.30 | -39.04 | 40.34 |
| IEEE 802.11ax SU | 40 | 38 | 64QAM | 6 | 1.48 | -38.65 | 40.13 |
| IEEE 802.11ax SU | 40 | 38 | 64QAM | 7 | 1.46 | -38.83 | 40.29 |
| IEEE 802.11ax SU | 40 | 38 | 256QAM | 8 | 1.43 | -38.48 | 39.91 |
| IEEE 802.11ax SU | 40 | 38 | 256QAM | 9 | 1.40 | -39.02 | 40.42 |
| IEEE 802.11ax SU | 40 | 38 | 1024QAM | 10 | 1.57 | -37.99 | 39.56 |
| IEEE 802.11ax SU | 40 | 38 | 1024QAM | 11 | 1.53 | -38.63 | 40.16 |

Table 6-8
IEEE 802.11ax RU 40MHz BW SNNR by Radio Configuration

| Mode | Bandwidth [MHz] | Channel | Modulation | MCS Index | RU Index | ABM1 [dB(A/m)] | ABM2 [dB(A/m)] | SNNR [dB] |
|------------------|-----------------|---------|------------|-----------|----------|----------------|----------------|-----------|
| IEEE 802.11ax RU | 40 | 38 | BPSK | 0 | 0 | 1.26 | -38.23 | 39.49 |
| IEEE 802.11ax RU | 40 | 38 | BPSK | 0 | 17 | 1.24 | -38.96 | 40.20 |
| IEEE 802.11ax RU | 40 | 38 | BPSK | 0 | 37 | 1.40 | -38.91 | 40.31 |
| IEEE 802.11ax RU | 40 | 38 | BPSK | 0 | 44 | 1.42 | -38.23 | 39.65 |
| IEEE 802.11ax RU | 40 | 38 | BPSK | 0 | 53 | 1.35 | -38.17 | 39.52 |
| IEEE 802.11ax RU | 40 | 38 | BPSK | 0 | 56 | 1.28 | -38.55 | 39.83 |
| IEEE 802.11ax RU | 40 | 38 | BPSK | 0 | 61 | 1.28 | -38.52 | 39.80 |
| IEEE 802.11ax RU | 40 | 38 | BPSK | 0 | 62 | 1.32 | -38.64 | 39.96 |
| IEEE 802.11ax RU | 40 | 38 | BPSK | 0 | 65 | 1.45 | -38.72 | 40.17 |

| | | | | |
|-------------------------------------|---|-------------------------------|---|---------------------------------|
| FCC ID: A3L5MF707U |  | HAC (T-COIL) TEST REPORT |  | Approved by: Quality Manager |
| Filename: 1M2005040080-19-R2.A3L | Test Dates: 06/15/2020 - 07/02/2020 | DUT Type: Portable Handset | | Page 27 of 108 |

2. Codec Configuration

An investigation was performed to determine the audio codec configuration to be used for testing. The effects of codec configuration were found to be independent of radio configuration; therefore, only one radio configuration was used for this investigation. The EVS Primary SWB 9.6kbps setting was used for the audio codec on the CMW500 for VoWiFi over IMS T-coil testing. See below table for comparisons between different codecs and codec data rates:

Table 6-9
AMR Codec Investigation – VoWiFi over IMS

| Codec Setting: | WB AMR 23.85kbps | WB AMR 6.60kbps | NB AMR 12.2kbps | NB AMR 4.75kbps | Orientation | Band | Standard | Channel |
|--------------------|---------------------|--------------------|--------------------|--------------------|-------------|--------|--------------|---------|
| ABM1 (dBA/m) | 4.58 | 3.80 | 10.98 | 10.75 | Axial | 2.4GHz | IEEE 802.11b | 6 |
| ABM2 (dBA/m) | -38.15 | -37.57 | -38.41 | -37.96 | | | | |
| Frequency Response | Pass | Pass | Pass | Pass | | | | |
| S+N/N (dB) | 42.73 | 41.37 | 49.39 | 48.71 | | | | |

Table 6-10
EVS Codec Investigation – VoWiFi over IMS

| Codec Setting: | EVS Primary SWB 128kbps | EVS Primary SWB 9.6kbps | EVS Primary WB 128kbps | EVS Primary WB 5.9kbps | EVS Primary NB 24.4kbps | EVS Primary NB 5.9kbps | Orientation | Band | Standard | Channel |
|--------------------|----------------------------|----------------------------|---------------------------|---------------------------|----------------------------|---------------------------|-------------|--------|--------------|---------|
| ABM1 (dBA/m) | 1.99 | 1.14 | 4.74 | 4.54 | 10.72 | 11.36 | Axial | 2.4GHz | IEEE 802.11b | 6 |
| ABM2 (dBA/m) | -37.71 | -37.38 | -37.64 | -37.59 | -37.48 | -38.11 | | | | |
| Frequency Response | Pass | Pass | Pass | Pass | Pass | Pass | | | | |
| S+N/N (dB) | 39.70 | 38.52 | 42.38 | 42.13 | 48.20 | 49.47 | | | | |

- Mute on; Backlight off; Max Volume; Max Contrast

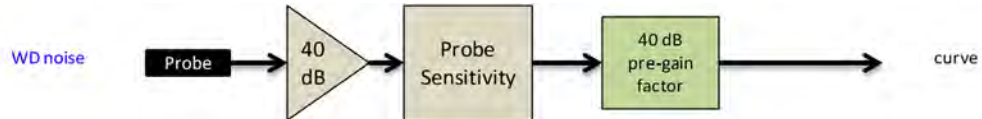



Figure 6-2
Audio Band Magnetic Curve Measurement Block Diagram

| | | | | |
|-------------------------------------|---|-------------------------------|---|---------------------------------|
| FCC ID: A3LSMF707U |  | HAC (T-COIL) TEST REPORT |  | Approved by: Quality Manager |
| Filename: 1M2005040080-19-R2.A3L | Test Dates: 06/15/2020 - 07/02/2020 | DUT Type: Portable Handset | | Page 28 of 108 |

7. OTT VOIP TEST SYSTEM AND DUT CONFIGURATION

I. Test System Setup for OTT VoIP T-Coil Testing

1. OTT VoIP Application

Google Duo is a pre-installed application on the DUT which allows for VoIP calls in a held-to-ear scenario. Duo uses the OPUS audio codec and supports a bitrate range of 6kb/s to 75kb/s. All air interfaces capable of a data connection were evaluated with Google Duo.

2. Equipment Setup

A CMW500 callbox was used to perform OTT VoIP T-coil measurements. The Data Application Unit (DAU) of the CMW500 was connected to the internet and allowed for an IP data connection on the DUT. An auxiliary VoIP unit was used to initiate an OTT VoIP call to the DUT. The auxiliary VoIP unit allowed for the configuration and monitoring of the OTT VoIP codec bitrate during a call. Both high and low bitrate settings were evaluated in to determine the worst-case configuration.

3. Audio Level Settings

According to KDB 285076 D02, the average speech level of -20dBm0 shall be used for protocols not specifically listed in Table 7.1 of ANSI C63.19-2011 or the ANSI C63.19-2011 VoLTE interpretation³. The auxiliary VoIP unit allowed for monitoring the signal input level to ensure that the settings for speech input and full scale levels resulted in the -20dBm0 speech input level to the DUT for the OTT VoIP call.

Note: The green highlighted text is approved by FCC under the TCB PAG Re-Use Policy 388624 D01 IV. D. for T-Coil Testing for WI-FI calling and Google Duo.

II. DUT Configuration for OTT VoIP T-Coil Testing



1. Codec Configuration

An investigation was performed for each applicable data mode to determine the audio codec configuration to be used for testing. The effects of codec configuration were found to be independent of radio configuration; therefore, only one radio configuration for each applicable data mode was used for these investigations. The 6kbps codec setting was used for the audio codec on the auxiliary VoIP unit for OTT VoIP T-Coil testing. See below tables for comparisons between codec data rates on all applicable data modes:

**Table 7-1
Codec Investigation – OTT VoIP (EvDO)**

| Codec Setting: | 75kbps | 6kbps | Orientation | Channel |
|--------------------|--------|--------|-------------|---------|
| ABM1 (dBA/m) | 15.79 | 15.54 | Axial | 600 |
| ABM2 (dBA/m) | -39.60 | -39.45 | | |
| Frequency Response | Pass | Pass | | |
| S+N/N (dB) | 55.39 | 54.99 | | |

³ FCC Office of Engineering and Technology KDB, "285076 D02 T-Coil Testing for CMRS IP v03," September 13, 2017

| | | | | |
|-------------------------------------|---|-------------------------------|---|---------------------------------|
| FCC ID: A3LSMF707U |  | HAC (T-COIL) TEST REPORT |  | Approved by: Quality Manager |
| Filename: 1M2005040080-19-R2.A3L | Test Dates: 06/15/2020 - 07/02/2020 | DUT Type: Portable Handset | | Page 29 of 108 |

**Table 7-2
Codec Investigation – OTT VoIP (EDGE)**

| Codec Setting: | 75kbps | 6kbps | Orientation | Channel |
|--------------------|--------|--------|-------------|---------|
| ABM1 (dBA/m) | 15.23 | 15.00 | Axial | 661 |
| ABM2 (dBA/m) | -24.25 | -23.76 | | |
| Frequency Response | Pass | Pass | | |
| S+N/N (dB) | 39.48 | 38.76 | | |

**Table 7-3
Codec Investigation – OTT VoIP (HSPA)**

| Codec Setting: | 75kbps | 6kbps | Orientation | Channel |
|--------------------|--------|--------|-------------|---------|
| ABM1 (dBA/m) | 15.87 | 15.86 | Axial | 9400 |
| ABM2 (dBA/m) | -41.90 | -41.90 | | |
| Frequency Response | Pass | Pass | | |
| S+N/N (dB) | 57.77 | 57.76 | | |

**Table 7-4
Codec Investigation – OTT VoIP (LTE)**

| Codec Setting: | 75kbps | 6kbps | Orientation | Band / BW | Channel |
|--------------------|--------|--------|-------------|------------------|---------|
| ABM1 (dBA/m) | 15.67 | 15.47 | Axial | Band 66 20MHz | 1323222 |
| ABM2 (dBA/m) | -33.69 | -33.60 | | | |
| Frequency Response | Pass | Pass | | | |
| S+N/N (dB) | 49.36 | 49.07 | | | |

**Table 7-5
Codec Investigation – OTT VoIP (WIFI)**

| Codec Setting: | 75kbps | 6kbps | Orientation | Band | Standard | Channel |
|--------------------|--------|--------|-------------|--------|--------------|---------|
| ABM1 (dBA/m) | 15.42 | 15.11 | Axial | 2.4GHz | IEEE 802.11b | 6 |
| ABM2 (dBA/m) | -35.78 | -35.58 | | | | |
| Frequency Response | Pass | Pass | | | | |
| S+N/N (dB) | 51.20 | 50.69 | | | | |

- Mute on; Backlight off; Max Volume; Max Contrast
- Radio Configurations can be found in Section 9.II.H

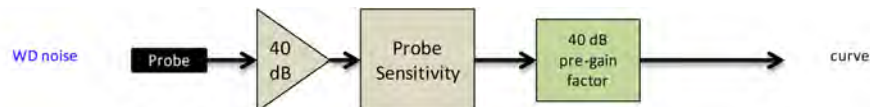

**Figure 7-1
Audio Band Magnetic Curve Measurement Block Diagram**

| | | | | |
|-------------------------------------|--|-------------------------------|--|---------------------------------|
| FCC ID: A3LSMF707U | | HAC (T-COIL) TEST REPORT | | Approved by: Quality Manager |
| Filename: 1M2005040080-19-R2.A3L | Test Dates: 06/15/2020 - 07/02/2020 | DUT Type: Portable Handset | | Page 30 of 108 |

2. Radio Configuration for OTT VoIP (LTE)

An investigation was performed to determine the worst-case LTE FDD band to be used for OTT VoIP testing. LTE FDD Band 14 was used for the testing as the worst-case configuration for the handset. See below table for SNNR comparison between different LTE FDD bands:

Table 7-6
OTT VoIP (LTE FDD) SNNR by LTE Band

| Band | Frequency [MHz] | Channel | Bandwidth [MHz] | Modulation | RB Size | RB Offset | ABM1 [dB(A/m)] | ABM2 [dB(A/m)] | SNNR [dB] |
|------|-----------------|---------|-----------------|------------|---------|-----------|----------------|----------------|-----------|
| 71 | 680.5 | 133297 | 20 | 16QAM | 1 | 50 | 15.59 | -28.96 | 44.55 |
| 12 | 707.5 | 23095 | 10 | 16QAM | 1 | 25 | 15.51 | -29.01 | 44.52 |
| 13 | 782.0 | 23230 | 10 | 16QAM | 1 | 25 | 15.47 | -30.48 | 45.95 |
| 14 | 793.0 | 23330 | 10 | 16QAM | 1 | 25 | 15.42 | -26.82 | 42.24 |
| 26 | 831.5 | 26865 | 15 | 16QAM | 1 | 36 | 15.57 | -27.08 | 42.65 |
| 5 | 836.5 | 20525 | 10 | 16QAM | 1 | 25 | 15.45 | -29.72 | 45.17 |
| 66 | 1745.0 | 132322 | 20 | 16QAM | 1 | 50 | 15.51 | -33.46 | 48.97 |
| 2 | 1880.0 | 18900 | 20 | 16QAM | 1 | 50 | 15.32 | -34.05 | 49.37 |
| 25 | 1882.5 | 26365 | 20 | 16QAM | 1 | 50 | 15.29 | -33.50 | 48.79 |
| 30 | 2310.0 | 27710 | 10 | 16QAM | 1 | 25 | 15.47 | -33.04 | 48.51 |
| 7 | 2535.0 | 21100 | 20 | 16QAM | 1 | 50 | 15.44 | -32.37 | 47.81 |

An investigation was performed to determine the worst-case LTE TDD band to be used for OTT VoIP testing. LTE TDD Band 41 (PC2) was used for the testing as the worst-case configuration for the handset. See below table for SNNR comparison between different LTE TDD bands:

Table 7-7
OTT VoIP (LTE TDD) SNNR by LTE Band



| Band | Frequency [MHz] | Channel | Bandwidth [MHz] | Modulation | RB Size | RB Offset | ABM1 [dB(A/m)] | ABM2 [dB(A/m)] | SNNR [dB] |
|----------|-----------------|---------|-----------------|------------|---------|-----------|----------------|----------------|-----------|
| 41 (PC3) | 2593.0 | 40620 | 20 | 16QAM | 1 | 50 | 15.29 | -29.17 | 44.46 |
| 41 (PC2) | 2593.0 | 40620 | 20 | 16QAM | 1 | 50 | 15.16 | -27.46 | 42.62 |
| 48 | 3625.0 | 55990 | 20 | 16QAM | 1 | 50 | 15.37 | -27.51 | 42.88 |

3. LTE FDD Uplink Carrier Aggregation for OTT VoIP

LTE FDD ULCA was evaluated to ensure LTE FDD standalone was the worst-case scenario. The configurations in Table 7-8 were determined from Table 7-6 and satisfy the configuration requirements as defined in 3GPP 36.101.

Table 7-8
LTE FDD SNNR for OTT VoIP Uplink Carrier Aggregation

| Combination | PCC | | | | | | | | SCC | | | | | | | | ABM1 [dB(A/m)] | ABM2 [dB(A/m)] | SNNR [dB] |
|-------------|----------|---------------------|------------------|--------------------------|------------|------------|------------------|----------|---------------------|------------------|--------------------------|------------|------------|------------------|-------|--------|----------------|----------------|-----------|
| | PCC Band | PCC Bandwidth [MHz] | PCC (UL) Channel | PCC (UL) Frequency [MHz] | Modulation | PCC UL# RB | PCC UL RB Offset | SCC Band | SCC Bandwidth [MHz] | SCC (UL) Channel | SCC (UL) Frequency [MHz] | Modulation | SCC UL# RB | SCC UL RB Offset | | | | | |
| CA_5B | LTE B5 | 10 | 20525 | 836.5 | 16QAM | 1 | 0 | LTE B5 | 5 | 20453 | 829.3 | 16QAM | 1 | 24 | 15.47 | -29.79 | 45.26 | | |
| CA_66B | LTE B66 | 10 | 132322 | 1745.0 | 16QAM | 1 | 0 | LTE B66 | 10 | 132223 | 1735.1 | 16QAM | 1 | 49 | 15.44 | -34.06 | 49.50 | | |
| CA_66C | LTE B66 | 20 | 132322 | 1745.0 | 16QAM | 1 | 0 | LTE B66 | 20 | 132124 | 1725.5 | 16QAM | 1 | 99 | 15.25 | -34.01 | 49.26 | | |

| | | | | |
|-------------------------------------|---|-------------------------------|---|---------------------------------|
| FCC ID: A3LSMF707U |  | HAC (T-COIL) TEST REPORT |  | Approved by: Quality Manager |
| Filename: 1M2005040080-19-R2.A3L | Test Dates: 06/15/2020 - 07/02/2020 | DUT Type: Portable Handset | | Page 31 of 108 |

4. LTE TDD Uplink Carrier Aggregation for OTT VoIP

LTE TDD ULCA was evaluated to ensure LTE TDD standalone was the worst-case scenario. The configurations in Table 7-9 were determined from Table 7-7 and satisfy the configuration requirements as defined in 3GPP 36.101.

Table 7-9
LTE TDD SNNR for OTT VoIP Uplink Carrier Aggregation

| Combination | PCC | | | | | | | SCC | | | | | | | ABM1 [dB(A/m)] | ABM2 [dB(A/m)] | SNNR [dB] |
|--------------|----------|---------------------|---------------------|-----------------------------|------------|------------|------------------|----------|---------------------|---------------------|-----------------------------|------------|------------|------------------|----------------|----------------|-----------|
| | PCC Band | PCC Bandwidth [MHz] | PCC (UL/DL) Channel | PCC (UL/DL) Frequency [MHz] | Modulation | PCC UL# RB | PCC UL RB Offset | SCC Band | SCC Bandwidth [MHz] | SCC (UL/DL) Channel | SCC (UL/DL) Frequency [MHz] | Modulation | SCC UL# RB | SCC UL RB Offset | | | |
| CA_41C (PC3) | LTE B41 | 20 | 40620 | 2593.0 | 16QAM | 1 | 0 | LTE B41 | 20 | 40422 | 2573.2 | 16QAM | 1 | 99 | 15.37 | -29.54 | 44.91 |
| CA_41C (PC2) | LTE B41 | 20 | 40620 | 2593.0 | 16QAM | 1 | 0 | LTE B41 | 20 | 40422 | 2573.2 | 16QAM | 1 | 99 | 15.60 | -27.14 | 42.74 |
| CA_48C | LTE B48 | 20 | 55990 | 3625.0 | 16QAM | 1 | 0 | LTE B48 | 20 | 55792 | 3605.2 | 16QAM | 1 | 99 | 15.18 | -29.49 | 44.67 |



5. Interim Procedure for evaluation OTT VoIP (NR)

The following procedure is used to evaluate OTT VoIP (NR) given equipment limitations.

- a. This procedure is applicable for OTT VoIP (NR) voice calls that use the same protocol, codec(s), and reference level as OTT VoIP (LTE) (i.e. -20dBm0).
- b. Establish the ABM1_{NR} value by using the ABM1_{LTE} magnetic intensity for an LTE call using a correlating LTE band through existing procedures and test equipment.
- c. Establish an ABM2_{NR} value using factory test mode (FTM) to simulate a NR connection for the desired NR band and channel under test.
- d. The following information is documented in Section 9:
 - i. ABM2_{LTE} and ABM2_{NR} for respective tests.
 - ii. Calculate SNNR:
 1. ABM1 = ABM1_{LTE}
 2. ABM2 = ABM2_{NR}
 3. $SNNR_{NR} = [ABM1_{LTE} - ABM2_{NR}] - 3dB$
 - a. A 3dB margin is built in to ensure conservative results with this interim procedure.

The above is only applicable for OTT VoIP scenarios, this device does not support VoNR over IMS.

The manufacturer has confirmed the handset as designed is expected to exhibit similar audio intensity levels between an OTT VoIP call placed over a 4G LTE and a 5G Sub-6GHz data connection.

| | | | | |
|-------------------------------------|---|-------------------------------|---|---------------------------------|
| FCC ID: A3LSMF707U |  | HAC (T-COIL) TEST REPORT |  | Approved by: Quality Manager |
| Filename: 1M2005040080-19-R2.A3L | Test Dates: 06/15/2020 - 07/02/2020 | DUT Type: Portable Handset | | Page 32 of 108 |

6. Radio Configuration for OTT VoIP (NR)

An investigation was performed to determine the waveform, modulation, and RB configuration to be used for testing. Due to equipment limitations, the procedure outlined in 7.II.5 was used to evaluate the SNNR for each radio configuration below. DFT-s-OFDM 16QAM, 1 RB, 50% RB offset was determined to be the worst-case configuration for the handset and will be used for full testing in Section 9.

Table 7-10
NR OTT VoIP SNNR by Radio Configuration (CP-OFDM)

| Band | Frequency [MHz] | Channel | Bandwidth [MHz] | Waveform | Modulation | RB Size | RB Offset | ABM1 _{LTE} [dB(A/m)] | ABM2 _{NR} [dB(A/m)] | SNNR _{NR} [dB] |
|------|-----------------|---------|-----------------|----------|------------|---------|-----------|-------------------------------|------------------------------|-------------------------|
| n66 | 1745.0 | 349000 | 20 | CP-OFDM | QPSK | 1 | 1 | 15.47 | -38.21 | 53.68 |
| n66 | 1745.0 | 349000 | 20 | CP-OFDM | QPSK | 1 | 53 | 15.47 | -36.43 | 51.90 |
| n66 | 1745.0 | 349000 | 20 | CP-OFDM | QPSK | 1 | 104 | 15.47 | -38.23 | 53.70 |
| n66 | 1745.0 | 349000 | 20 | CP-OFDM | QPSK | 53 | 0 | 15.47 | -39.82 | 55.29 |
| n66 | 1745.0 | 349000 | 20 | CP-OFDM | QPSK | 53 | 26 | 15.47 | -40.62 | 56.09 |
| n66 | 1745.0 | 349000 | 20 | CP-OFDM | QPSK | 53 | 53 | 15.47 | -39.96 | 55.43 |
| n66 | 1745.0 | 349000 | 20 | CP-OFDM | QPSK | 106 | 0 | 15.47 | -40.91 | 56.38 |
| n66 | 1745.0 | 349000 | 20 | CP-OFDM | 16QAM | 1 | 1 | 15.47 | -37.19 | 52.66 |
| n66 | 1745.0 | 349000 | 20 | CP-OFDM | 16QAM | 1 | 53 | 15.47 | -37.17 | 52.64 |
| n66 | 1745.0 | 349000 | 20 | CP-OFDM | 16QAM | 1 | 104 | 15.47 | -38.88 | 54.35 |
| n66 | 1745.0 | 349000 | 20 | CP-OFDM | 16QAM | 53 | 0 | 15.47 | -40.99 | 56.46 |
| n66 | 1745.0 | 349000 | 20 | CP-OFDM | 16QAM | 53 | 26 | 15.47 | -39.72 | 55.19 |
| n66 | 1745.0 | 349000 | 20 | CP-OFDM | 16QAM | 53 | 53 | 15.47 | -39.94 | 55.41 |
| n66 | 1745.0 | 349000 | 20 | CP-OFDM | 16QAM | 106 | 0 | 15.47 | -39.72 | 55.19 |
| n66 | 1745.0 | 349000 | 20 | CP-OFDM | 64QAM | 1 | 1 | 15.47 | -38.68 | 54.15 |
| n66 | 1745.0 | 349000 | 20 | CP-OFDM | 64QAM | 1 | 53 | 15.47 | -38.63 | 54.10 |
| n66 | 1745.0 | 349000 | 20 | CP-OFDM | 64QAM | 1 | 104 | 15.47 | -38.99 | 54.46 |
| n66 | 1745.0 | 349000 | 20 | CP-OFDM | 64QAM | 53 | 0 | 15.47 | -40.25 | 55.72 |
| n66 | 1745.0 | 349000 | 20 | CP-OFDM | 64QAM | 53 | 26 | 15.47 | -40.02 | 55.49 |
| n66 | 1745.0 | 349000 | 20 | CP-OFDM | 64QAM | 53 | 53 | 15.47 | -39.74 | 55.21 |
| n66 | 1745.0 | 349000 | 20 | CP-OFDM | 64QAM | 106 | 0 | 15.47 | -40.25 | 55.72 |
| n66 | 1745.0 | 349000 | 20 | CP-OFDM | 256QAM | 1 | 1 | 15.47 | -39.76 | 55.23 |
| n66 | 1745.0 | 349000 | 20 | CP-OFDM | 256QAM | 1 | 53 | 15.47 | -39.72 | 55.19 |
| n66 | 1745.0 | 349000 | 20 | CP-OFDM | 256QAM | 1 | 104 | 15.47 | -37.75 | 53.22 |
| n66 | 1745.0 | 349000 | 20 | CP-OFDM | 256QAM | 53 | 0 | 15.47 | -40.22 | 55.69 |
| n66 | 1745.0 | 349000 | 20 | CP-OFDM | 256QAM | 53 | 26 | 15.47 | -39.81 | 55.28 |
| n66 | 1745.0 | 349000 | 20 | CP-OFDM | 256QAM | 53 | 53 | 15.47 | -39.35 | 54.82 |
| n66 | 1745.0 | 349000 | 20 | CP-OFDM | 256QAM | 106 | 0 | 15.47 | -40.68 | 56.15 |



| | | | | |
|-------------------------------------|---|-------------------------------|---|---------------------------------|
| FCC ID: A3LSMF707U |  | HAC (T-COIL) TEST REPORT |  | Approved by: Quality Manager |
| Filename: 1M2005040080-19-R2.A3L | Test Dates: 06/15/2020 - 07/02/2020 | DUT Type: Portable Handset | | Page 33 of 108 |



Table 7-11
NR OTT VoIP SNNR by Radio Configuration (DFT-s-OFDM)

| Band | Frequency [MHz] | Channel | Bandwidth [MHz] | Waveform | Modulation | RB Size | RB Offset | ABM1 _{LTE} [dB(A/m)] | ABM2 _{NR} [dB(A/m)] | SNNR _{NR} [dB] |
|------|-----------------|---------|-----------------|------------|---------------|---------|-----------|-------------------------------|------------------------------|-------------------------|
| n66 | 1745.0 | 349000 | 20 | DFT-s-OFDM | $\pi/2$ -BPSK | 1 | 1 | 15.47 | -37.06 | 52.53 |
| n66 | 1745.0 | 349000 | 20 | DFT-s-OFDM | $\pi/2$ -BPSK | 1 | 53 | 15.47 | -38.57 | 54.04 |
| n66 | 1745.0 | 349000 | 20 | DFT-s-OFDM | $\pi/2$ -BPSK | 1 | 104 | 15.47 | -36.96 | 52.43 |
| n66 | 1745.0 | 349000 | 20 | DFT-s-OFDM | $\pi/2$ -BPSK | 50 | 0 | 15.47 | -38.92 | 54.39 |
| n66 | 1745.0 | 349000 | 20 | DFT-s-OFDM | $\pi/2$ -BPSK | 50 | 28 | 15.47 | -39.57 | 55.04 |
| n66 | 1745.0 | 349000 | 20 | DFT-s-OFDM | $\pi/2$ -BPSK | 50 | 56 | 15.47 | -40.42 | 55.89 |
| n66 | 1745.0 | 349000 | 20 | DFT-s-OFDM | $\pi/2$ -BPSK | 100 | 0 | 15.47 | -38.17 | 53.64 |
| n66 | 1745.0 | 349000 | 20 | DFT-s-OFDM | QPSK | 1 | 1 | 15.47 | -38.91 | 54.38 |
| n66 | 1745.0 | 349000 | 20 | DFT-s-OFDM | QPSK | 1 | 53 | 15.47 | -38.32 | 53.79 |
| n66 | 1745.0 | 349000 | 20 | DFT-s-OFDM | QPSK | 1 | 104 | 15.47 | -39.27 | 54.74 |
| n66 | 1745.0 | 349000 | 20 | DFT-s-OFDM | QPSK | 50 | 0 | 15.47 | -39.19 | 54.66 |
| n66 | 1745.0 | 349000 | 20 | DFT-s-OFDM | QPSK | 50 | 28 | 15.47 | -39.43 | 54.90 |
| n66 | 1745.0 | 349000 | 20 | DFT-s-OFDM | QPSK | 50 | 56 | 15.47 | -39.68 | 55.15 |
| n66 | 1745.0 | 349000 | 20 | DFT-s-OFDM | QPSK | 100 | 0 | 15.47 | -36.01 | 51.48 |
| n66 | 1745.0 | 349000 | 20 | DFT-s-OFDM | 16QAM | 1 | 1 | 15.47 | -35.53 | 51.00 |
| n66 | 1745.0 | 349000 | 20 | DFT-s-OFDM | 16QAM | 1 | 53 | 15.47 | -34.28 | 49.75 |
| n66 | 1745.0 | 349000 | 20 | DFT-s-OFDM | 16QAM | 1 | 104 | 15.47 | -35.98 | 51.45 |
| n66 | 1745.0 | 349000 | 20 | DFT-s-OFDM | 16QAM | 50 | 0 | 15.47 | -39.36 | 54.83 |
| n66 | 1745.0 | 349000 | 20 | DFT-s-OFDM | 16QAM | 50 | 28 | 15.47 | -39.18 | 54.65 |
| n66 | 1745.0 | 349000 | 20 | DFT-s-OFDM | 16QAM | 50 | 56 | 15.47 | -40.01 | 55.48 |
| n66 | 1745.0 | 349000 | 20 | DFT-s-OFDM | 16QAM | 100 | 0 | 15.47 | -38.32 | 53.79 |
| n66 | 1745.0 | 349000 | 20 | DFT-s-OFDM | 64QAM | 1 | 1 | 15.47 | -38.40 | 53.87 |
| n66 | 1745.0 | 349000 | 20 | DFT-s-OFDM | 64QAM | 1 | 53 | 15.47 | -36.64 | 52.11 |
| n66 | 1745.0 | 349000 | 20 | DFT-s-OFDM | 64QAM | 1 | 104 | 15.47 | -37.94 | 53.41 |
| n66 | 1745.0 | 349000 | 20 | DFT-s-OFDM | 64QAM | 50 | 0 | 15.47 | -39.76 | 55.23 |
| n66 | 1745.0 | 349000 | 20 | DFT-s-OFDM | 64QAM | 50 | 28 | 15.47 | -40.12 | 55.59 |
| n66 | 1745.0 | 349000 | 20 | DFT-s-OFDM | 64QAM | 50 | 56 | 15.47 | -39.26 | 54.73 |
| n66 | 1745.0 | 349000 | 20 | DFT-s-OFDM | 64QAM | 100 | 0 | 15.47 | -39.15 | 54.62 |
| n66 | 1745.0 | 349000 | 20 | DFT-s-OFDM | 256QAM | 1 | 1 | 15.47 | -39.09 | 54.56 |
| n66 | 1745.0 | 349000 | 20 | DFT-s-OFDM | 256QAM | 1 | 53 | 15.47 | -38.81 | 54.28 |
| n66 | 1745.0 | 349000 | 20 | DFT-s-OFDM | 256QAM | 1 | 104 | 15.47 | -37.97 | 53.44 |
| n66 | 1745.0 | 349000 | 20 | DFT-s-OFDM | 256QAM | 50 | 0 | 15.47 | -37.61 | 53.08 |
| n66 | 1745.0 | 349000 | 20 | DFT-s-OFDM | 256QAM | 50 | 28 | 15.47 | -39.65 | 55.12 |
| n66 | 1745.0 | 349000 | 20 | DFT-s-OFDM | 256QAM | 50 | 56 | 15.47 | -38.94 | 54.41 |
| n66 | 1745.0 | 349000 | 20 | DFT-s-OFDM | 256QAM | 100 | 0 | 15.47 | -39.22 | 54.69 |

An investigation was performed to determine the worst-case NR FDD band to be used for OTT VoIP testing. NR n5 was used for the testing as the worst-case configuration for the handset. See below table for SNNR comparison between different NR FDD bands:

Table 7-12
OTT VoIP (NR FDD) SNNR by Band

| Band | Frequency [MHz] | Channel | Bandwidth [MHz] | Waveform | Modulation | RB Size | RB Offset | ABM1 _{LTE} [dB(A/m)] | ABM2 _{NR} [dB(A/m)] | SNNR _{NR} [dB] |
|------|-----------------|---------|-----------------|------------|------------|---------|-----------|-------------------------------|------------------------------|-------------------------|
| n71 | 680.5 | 136100 | 20 | DFT-s-OFDM | 16QAM | 1 | 53 | 15.59 | -30.99 | 46.58 |
| n5 | 836.5 | 167300 | 20 | DFT-s-OFDM | 16QAM | 1 | 53 | 15.45 | -29.31 | 44.76 |
| n66 | 1745.0 | 349000 | 20 | DFT-s-OFDM | 16QAM | 1 | 53 | 15.47 | -34.18 | 49.65 |
| n25 | 1882.5 | 376500 | 20 | DFT-s-OFDM | 16QAM | 1 | 53 | 15.29 | -29.75 | 45.04 |

| | | | | | |
|-------------------------------------|---|---------------------------------|--|---|---------------------------------|
| FCC ID: A3L5MF707U |  | HAC (T-COIL) TEST REPORT | |  | Approved by: Quality Manager |
| Filename: 1M2005040080-19-R2.A3L | Test Dates: 06/15/2020 - 07/02/2020 | DUT Type: Portable Handset | | | Page 34 of 108 |

8. FCC 3G MEASUREMENTS

I. CDMA Test Configurations

Radio Configuration 1, Service Option 3 (thick, green data curve) was used for the testing as the worst-case configuration for the handset due to vocoder gating from the EVRC logic. See below plot for ABM noise comparison between operational field service options and radio configurations for a CDMA2000 handset:

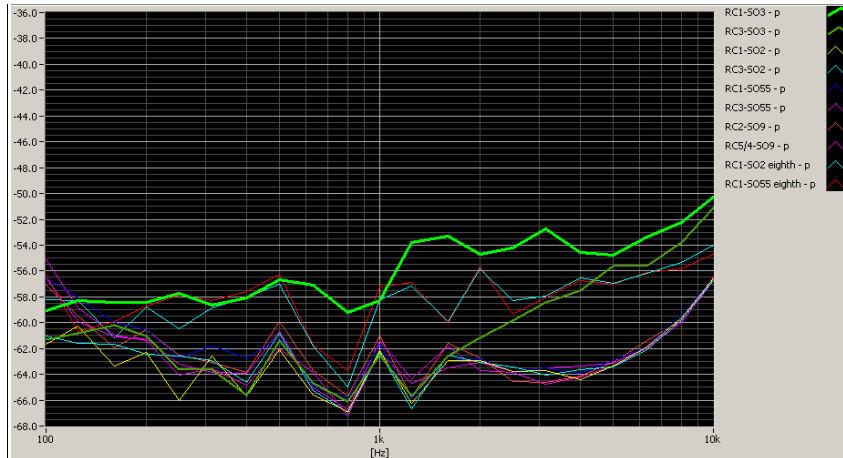

Figure 8-1
CDMA Audio Band Magnetic Noise

Table 8-1
FCC 3G ABM Measurements for A3LSMF707U (CDMA)

| Configuration: | RC1/SO3 | RC3/SO3 | RC4/SO3 | Orientation | Channel |
|--------------------|---------|---------|---------|-------------|---------|
| ABM1 (dBA/m) | 13.50 | 14.03 | 13.80 | Axial | 600 |
| ABM2 (dBA/m) | -36.75 | -46.16 | -46.15 | | |
| Frequency Response | Pass | Pass | Pass | | |
| S+N/N (dB) | 50.25 | 60.19 | 59.95 | | |

- Mute on; Backlight off; Max Volume; Max Contrast
- Power Control Bits = "All Up"

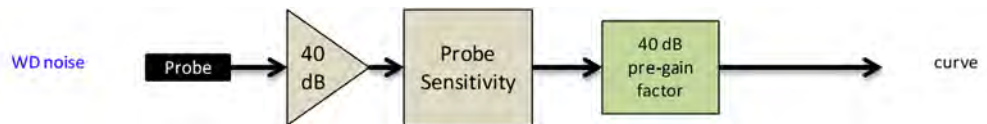

Figure 8-2
Audio Band Magnetic Curve Measurement Block Diagram

| | | | | |
|-------------------------------------|--|-------------------------------|--|---------------------------------|
| FCC ID: A3LSMF707U | | HAC (T-COIL) TEST REPORT | | Approved by: Quality Manager |
| Filename: 1M2005040080-19-R2.A3L | Test Dates: 06/15/2020 - 07/02/2020 | DUT Type: Portable Handset | | Page 35 of 108 |

II. UMTS Test Configurations

AMR at 12.2kbps, 13.6kbps SRB (thick, purple data curve) was used for the testing as the worst-case configuration for the handset. See below plot for ABM noise comparison between vocoder rates:



Figure 8-3
UMTS Audio Band Magnetic Noise

Table 8-2
Codec Investigation - UMTS

| Codec Setting: | AMR 12.2kbps | AMR 7.95kbps | AMR 4.75kbps | Orientation | Channel |
|--------------------|--------------|--------------|--------------|-------------|---------|
| ABM1 (dBA/m) | 14.71 | 15.01 | 14.72 | Axial | 9400 |
| ABM2 (dBA/m) | -45.21 | -45.10 | -45.26 | | |
| Frequency Response | Pass | Pass | Pass | | |
| S+N/N (dB) | 59.92 | 60.11 | 59.98 | | |

- Mute on; Backlight off; Max Volume; Max Contrast
- TPC="All 1s"

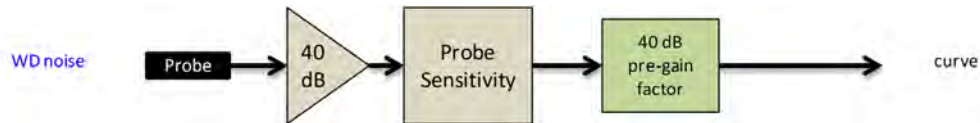



Figure 8-4
Audio Band Magnetic Curve Measurement Block Diagram

| | | | | |
|-------------------------------------|--|-------------------------------|--|---------------------------------|
| FCC ID: A3LSMF707U | | HAC (T-COIL) TEST REPORT | | Approved by: Quality Manager |
| Filename: 1M2005040080-19-R2.A3L | Test Dates: 06/15/2020 - 07/02/2020 | DUT Type: Portable Handset | | Page 36 of 108 |

9. T-COIL TEST SUMMARY

**Table 9-1
Consolidated Tabled Results**

| | | Freq. Response Margin | | Magnetic Intensity Verdict | | FCC SNRR Verdict | | Margin from FCC Limit (dB) | C63.19-2011 Rating |
|--------------------|--------------------|-----------------------|--------|----------------------------|--------|------------------|--------|----------------------------|--------------------|
| | | 8.3.2 | | 8.3.1 | | 8.3.4 | | | |
| C63.19 Section | | Axial | Radial | Axial | Radial | Axial | Radial | | |
| CDMA | Secondary Cellular | PASS | NA | PASS | PASS | PASS | PASS | -13.95 | T4 |
| | Cellular | PASS | NA | PASS | PASS | PASS | PASS | | |
| | PCS | PASS | NA | PASS | PASS | PASS | PASS | | |
| EvDO (OTT VoIP) | Secondary Cellular | PASS | NA | PASS | PASS | PASS | PASS | -25.40 | T4 |
| | Cellular | PASS | NA | PASS | PASS | PASS | PASS | | |
| | PCS | PASS | NA | PASS | PASS | PASS | PASS | | |
| GSM | Cellular | PASS | NA | PASS | PASS | PASS | PASS | -8.84 | T3 |
| | PCS | PASS | NA | PASS | PASS | PASS | PASS | | |
| EDGE (OTT VoIP) | Cellular | PASS | NA | PASS | PASS | PASS | PASS | -11.95 | T4 |
| | PCS | PASS | NA | PASS | PASS | PASS | PASS | | |
| UMTS | Cellular | PASS | NA | PASS | PASS | PASS | PASS | -36.91 | T4 |
| | AWS | PASS | NA | PASS | PASS | PASS | PASS | | |
| | PCS | PASS | NA | PASS | PASS | PASS | PASS | | |
| HSPA (OTT VoIP) | Cellular | PASS | NA | PASS | PASS | PASS | PASS | -35.29 | T4 |
| | AWS | PASS | NA | PASS | PASS | PASS | PASS | | |
| | PCS | PASS | NA | PASS | PASS | PASS | PASS | | |
| LTE FDD | B71 | PASS | NA | PASS | PASS | PASS | PASS | -3.09 | T3 |
| | B12 | PASS | NA | PASS | PASS | PASS | PASS | | |
| | B13 | PASS | NA | PASS | PASS | PASS | PASS | | |
| | B14 | PASS | NA | PASS | PASS | PASS | PASS | | |
| | B26 | PASS | NA | PASS | PASS | PASS | PASS | | |
| | B5 | PASS | NA | PASS | PASS | PASS | PASS | | |
| | B66 | PASS | NA | PASS | PASS | PASS | PASS | | |
| | B2 | PASS | NA | PASS | PASS | PASS | PASS | | |
| | B25 | PASS | NA | PASS | PASS | PASS | PASS | | |
| | B30 | PASS | NA | PASS | PASS | PASS | PASS | | |
| LTE FDD (OTT VoIP) | B14 | PASS | NA | PASS | PASS | PASS | PASS | -18.82 | T4 |
| LTE TDD | B41 (PC3) | PASS | NA | PASS | PASS | PASS | PASS | -3.26 | T3 |
| | B41 (PC2) | PASS | NA | PASS | PASS | PASS | PASS | | |
| | B48 | PASS | NA | PASS | PASS | PASS | PASS | | |
| LTE TDD (OTT VoIP) | B41 (PC2) | PASS | NA | PASS | PASS | PASS | PASS | -18.74 | T4 |
| NR FDD (OTT VoIP) | n5 | NA | NA | PASS | PASS | PASS | PASS | -17.62 | T4 |
| NR TDD (OTT VoIP) | n41 | NA | NA | PASS | PASS | PASS | PASS | -16.59 | T4 |
| WLAN | IEEE 802.11b | PASS | NA | PASS | PASS | PASS | PASS | -18.12 | T4 |
| | IEEE 802.11g | PASS | NA | PASS | PASS | PASS | PASS | | |
| | IEEE 802.11n | PASS | NA | PASS | PASS | PASS | PASS | | |
| | IEEE 802.11ax SU | PASS | NA | PASS | PASS | PASS | PASS | | |
| | IEEE 802.11ax RU | PASS | NA | PASS | PASS | PASS | PASS | | |
| WLAN (OTT VoIP) | IEEE 802.11b | PASS | NA | PASS | PASS | PASS | PASS | -27.80 | T4 |
| | IEEE 802.11g | PASS | NA | PASS | PASS | PASS | PASS | | |
| | IEEE 802.11n | PASS | NA | PASS | PASS | PASS | PASS | | |
| | IEEE 802.11ax SU | PASS | NA | PASS | PASS | PASS | PASS | | |
| | IEEE 802.11ax RU | PASS | NA | PASS | PASS | PASS | PASS | | |
| U-NII | IEEE 802.11a | PASS | NA | PASS | PASS | PASS | PASS | -17.13 | T4 |
| | IEEE 802.11n | PASS | NA | PASS | PASS | PASS | PASS | | |
| | IEEE 802.11ac | PASS | NA | PASS | PASS | PASS | PASS | | |
| | IEEE 802.11ax SU | PASS | NA | PASS | PASS | PASS | PASS | | |
| | IEEE 802.11ax RU | PASS | NA | PASS | PASS | PASS | PASS | | |
| U-NII (OTT VoIP) | IEEE 802.11a | PASS | NA | PASS | PASS | PASS | PASS | -25.98 | T4 |
| | IEEE 802.11n | PASS | NA | PASS | PASS | PASS | PASS | | |
| | IEEE 802.11ac | PASS | NA | PASS | PASS | PASS | PASS | | |
| | IEEE 802.11ax SU | PASS | NA | PASS | PASS | PASS | PASS | | |
| | IEEE 802.11ax RU | PASS | NA | PASS | PASS | PASS | PASS | | |

| | | | | |
|-------------------------------------|---|-------------------------------|---|---------------------------------|
| FCC ID: A3L5MF707U |  | HAC (T-COIL) TEST REPORT |  | Approved by: Quality Manager |
| Filename: 1M2005040080-19-R2.A3L | Test Dates: 06/15/2020 - 07/02/2020 | DUT Type: Portable Handset | | Page 37 of 108 |

I. Raw Handset Data

Table 9-2
Raw Data Results for CDMA

| Mode | Orientation | Channel | ABM1 [dB(A/m)] | ABM2 [dB(A/m)] | Ambient Noise [dB(A/m)] | Frequency Response Margin (dB) | S+N/N (dB) | FCC Limit (dB) | Margin from FCC Limit (dB) | C63.19-2011 Rating | Test Coordinates |
|--------------------|-------------|---------|----------------|----------------|-------------------------|--------------------------------|------------|----------------|----------------------------|--------------------|------------------|
| Secondary Cellular | Axial | 476 | 14.29 | -25.09 | -59.68 | 2.00 | 39.38 | 20.00 | -19.38 | T4 | 1.4, 1.6 |
| | | 564 | 13.86 | -25.69 | | 1.93 | 39.55 | 20.00 | -19.55 | T4 | |
| | | 684 | 14.19 | -25.56 | | 2.00 | 39.75 | 20.00 | -19.75 | T4 | |
| | Radial | 476 | 1.95 | -32.89 | -62.49 | N/A | 34.84 | 20.00 | -14.84 | T4 | 2.0, 2.8 |
| | | 564 | 1.12 | -34.20 | | | 35.32 | 20.00 | -15.32 | T4 | |
| | | 684 | 1.77 | -33.65 | | | 35.42 | 20.00 | -15.42 | T4 | |
| Cellular | Axial | 1013 | 14.20 | -25.08 | -59.68 | 1.95 | 39.28 | 20.00 | -19.28 | T4 | 1.4, 1.6 |
| | | 384 | 13.86 | -26.02 | | 1.94 | 39.88 | 20.00 | -19.88 | T4 | |
| | | 777 | 14.34 | -24.90 | | 1.96 | 39.24 | 20.00 | -19.24 | T4 | |
| | Radial | 1013 | 1.45 | -32.58 | -62.49 | N/A | 34.03 | 20.00 | -14.03 | T4 | 2.0, 2.8 |
| | | 384 | 2.16 | -31.79 | | | 33.95 | 20.00 | -13.95 | T4 | |
| | | 777 | 1.42 | -33.04 | | | 34.46 | 20.00 | -14.46 | T4 | |
| PCS | Axial | 25 | 14.40 | -36.61 | -59.68 | 1.88 | 51.01 | 20.00 | -31.01 | T4 | 1.4, 1.6 |
| | | 600 | 14.02 | -36.42 | | 1.94 | 50.44 | 20.00 | -30.44 | T4 | |
| | | 1175 | 14.09 | -36.00 | | 1.93 | 50.09 | 20.00 | -30.09 | T4 | |
| | Radial | 25 | 1.71 | -44.83 | -62.49 | N/A | 46.54 | 20.00 | -26.54 | T4 | 2.0, 2.8 |
| | | 600 | 1.71 | -44.71 | | | 46.42 | 20.00 | -26.42 | T4 | |
| | | 1175 | 1.58 | -44.00 | | | 45.58 | 20.00 | -25.58 | T4 | |

Table 9-3
Raw Data Results for GSM

| Mode | Orientation | Channel | ABM1 [dB(A/m)] | ABM2 [dB(A/m)] | Ambient Noise [dB(A/m)] | Frequency Response Margin (dB) | S+N/N (dB) | FCC Limit (dB) | Margin from FCC Limit (dB) | C63.19-2011 Rating | Test Coordinates |
|---------|-------------|---------|----------------|----------------|-------------------------|--------------------------------|------------|----------------|----------------------------|--------------------|------------------|
| GSM850 | Axial | 128 | 15.14 | -17.94 | -59.68 | 1.61 | 33.08 | 20.00 | -13.08 | T4 | 1.4, 1.6 |
| | | 190 | 15.05 | -17.45 | | 1.66 | 32.50 | 20.00 | -12.50 | T4 | |
| | | 251 | 15.09 | -17.75 | | 1.61 | 32.84 | 20.00 | -12.84 | T4 | |
| | Radial | 128 | 3.26 | -25.58 | -62.49 | N/A | 28.84 | 20.00 | -8.84 | T3 | 2.0, 2.8 |
| | | 190 | 3.19 | -26.16 | | | 29.35 | 20.00 | -9.35 | T3 | |
| | | 251 | 3.30 | -27.45 | | | 30.75 | 20.00 | -10.75 | T4 | |
| GSM1900 | Axial | 512 | 15.13 | -22.04 | -59.68 | 1.63 | 37.17 | 20.00 | -17.17 | T4 | 1.4, 1.6 |
| | | 661 | 15.12 | -21.29 | | 1.64 | 36.41 | 20.00 | -16.41 | T4 | |
| | | 810 | 15.16 | -22.07 | | 1.57 | 37.23 | 20.00 | -17.23 | T4 | |
| | Radial | 512 | 3.30 | -30.52 | -62.49 | N/A | 33.82 | 20.00 | -13.82 | T4 | 2.0, 2.8 |
| | | 661 | 3.26 | -29.96 | | | 33.22 | 20.00 | -13.22 | T4 | |
| | | 810 | 3.25 | -30.46 | | | 33.71 | 20.00 | -13.71 | T4 | |



| | | | | |
|-------------------------------------|---|-------------------------------|---|---------------------------------|
| FCC ID: A3LSMF707U |  | HAC (T-COIL) TEST REPORT |  | Approved by: Quality Manager |
| Filename: 1M2005040080-19-R2.A3L | Test Dates: 06/15/2020 - 07/02/2020 | DUT Type: Portable Handset | | Page 38 of 108 |

Table 9-4
Raw Data Results for UMTS

| Mode | Orientation | Channel | ABM1 [dB(A/m)] | ABM2 [dB(A/m)] | Ambient Noise [dB(A/m)] | Frequency Response Margin (dB) | S+N/N (dB) | FCC Limit (dB) | Margin from FCC Limit (dB) | C63.19-2011 Rating | Test Coordinates |
|---------|-------------|---------|----------------|----------------|-------------------------|--------------------------------|------------|----------------|----------------------------|--------------------|------------------|
| UMTS V | Axial | 4132 | 14.94 | -44.47 | -59.68 | 1.45 | 59.41 | 20.00 | -39.41 | T4 | 1.4, 1.6 |
| | | 4183 | 14.84 | -44.27 | | 1.46 | 59.11 | 20.00 | -39.11 | T4 | |
| | | 4233 | 14.98 | -44.16 | | 1.53 | 59.14 | 20.00 | -39.14 | T4 | |
| | Radial | 4132 | 3.16 | -53.75 | -62.49 | N/A | 56.91 | 20.00 | -36.91 | T4 | 2.0, 2.8 |
| | | 4183 | 3.15 | -54.79 | | | 57.94 | 20.00 | -37.94 | T4 | |
| | | 4233 | 3.03 | -53.97 | | | 57.00 | 20.00 | -37.00 | T4 | |
| UMTS IV | Axial | 1312 | 14.77 | -44.75 | -59.68 | 1.43 | 59.52 | 20.00 | -39.52 | T4 | 1.4, 1.6 |
| | | 1412 | 14.79 | -45.31 | | 1.43 | 60.10 | 20.00 | -40.10 | T4 | |
| | | 1513 | 14.96 | -44.93 | | 1.48 | 59.89 | 20.00 | -39.89 | T4 | |
| | Radial | 1312 | 3.19 | -55.14 | -62.49 | N/A | 58.33 | 20.00 | -38.33 | T4 | 2.0, 2.8 |
| | | 1412 | 3.17 | -54.87 | | | 58.04 | 20.00 | -38.04 | T4 | |
| | | 1513 | 3.17 | -54.77 | | | 57.94 | 20.00 | -37.94 | T4 | |
| UMTS II | Axial | 9262 | 14.95 | -45.58 | -59.68 | 1.36 | 60.53 | 20.00 | -40.53 | T4 | 1.4, 1.6 |
| | | 9400 | 14.95 | -45.04 | | 1.40 | 59.99 | 20.00 | -39.99 | T4 | |
| | | 9538 | 14.91 | -45.33 | | 1.44 | 60.24 | 20.00 | -40.24 | T4 | |
| | Radial | 9262 | 3.17 | -54.62 | -62.49 | N/A | 57.79 | 20.00 | -37.79 | T4 | 2.0, 2.8 |
| | | 9400 | 3.21 | -54.68 | | | 57.89 | 20.00 | -37.89 | T4 | |
| | | 9538 | 3.19 | -54.77 | | | 57.96 | 20.00 | -37.96 | T4 | |

Table 9-5
Raw Data Results for LTE B71



| Mode | Orientation | Bandwidth | Channel | ABM1 [dB(A/m)] | ABM2 [dB(A/m)] | Ambient Noise [dB(A/m)] | Frequency Response Margin (dB) | S+N/N (dB) | FCC Limit (dB) | Margin from FCC Limit (dB) | C63.19-2011 Rating | Test Coordinates |
|-------------|-------------|-----------|---------|----------------|----------------|-------------------------|--------------------------------|------------|----------------|----------------------------|--------------------|------------------|
| LTE Band 71 | Axial | 20MHz | 133297 | 0.30 | -31.01 | -61.73 | 1.87 | 31.31 | 20.00 | -11.31 | T4 | 1.4, 1.6 |
| | | 15MHz | 133297 | 0.08 | -29.34 | | 1.88 | 29.42 | 20.00 | -9.42 | T3 | |
| | | 10MHz | 133297 | 0.08 | -29.36 | | 1.86 | 29.44 | 20.00 | -9.44 | T3 | |
| | | 5MHz | 133297 | 0.05 | -30.89 | | 1.88 | 30.94 | 20.00 | -10.94 | T4 | |
| | Radial | 20MHz | 133297 | -12.21 | -37.93 | -63.77 | N/A | 25.72 | 20.00 | -5.72 | T3 | 2.0, 2.8 |
| | | 15MHz | 133297 | -12.06 | -38.51 | | | 26.45 | 20.00 | -6.45 | T3 | |
| | | 10MHz | 133297 | -12.06 | -38.15 | | | 26.09 | 20.00 | -6.09 | T3 | |
| | | 5MHz | 133297 | -12.19 | -39.40 | | | 27.21 | 20.00 | -7.21 | T3 | |

Table 9-6
Raw Data Results for LTE B12

| Mode | Orientation | Bandwidth | Channel | ABM1 [dB(A/m)] | ABM2 [dB(A/m)] | Ambient Noise [dB(A/m)] | Frequency Response Margin (dB) | S+N/N (dB) | FCC Limit (dB) | Margin from FCC Limit (dB) | C63.19-2011 Rating | Test Coordinates |
|-------------|-------------|-----------|---------|----------------|----------------|-------------------------|--------------------------------|------------|----------------|----------------------------|--------------------|------------------|
| LTE Band 12 | Axial | 10MHz | 23095 | -0.14 | -33.87 | -61.73 | 1.84 | 33.73 | 20.00 | -13.73 | T4 | 1.4, 1.6 |
| | | 5MHz | 23095 | 0.10 | -32.80 | | 1.86 | 32.90 | 20.00 | -12.90 | T4 | |
| | | 3MHz | 23095 | -0.10 | -33.10 | | 1.87 | 33.00 | 20.00 | -13.00 | T4 | |
| | | 1.4MHz | 23095 | 0.20 | -33.39 | | 1.92 | 33.59 | 20.00 | -13.59 | T4 | |
| | Radial | 10MHz | 23095 | -12.08 | -37.13 | -63.77 | N/A | 25.05 | 20.00 | -5.05 | T3 | 2.0, 2.8 |
| | | 5MHz | 23095 | -12.19 | -37.39 | | | 25.20 | 20.00 | -5.20 | T3 | |
| | | 3MHz | 23095 | -12.14 | -37.56 | | | 25.42 | 20.00 | -5.42 | T3 | |
| | | 1.4MHz | 23095 | -12.19 | -37.99 | | | 25.80 | 20.00 | -5.80 | T3 | |

Table 9-7
Raw Data Results for LTE B13

| Mode | Orientation | Bandwidth | Channel | ABM1 [dB(A/m)] | ABM2 [dB(A/m)] | Ambient Noise [dB(A/m)] | Frequency Response Margin (dB) | S+N/N (dB) | FCC Limit (dB) | Margin from FCC Limit (dB) | C63.19-2011 Rating | Test Coordinates |
|-------------|-------------|-----------|---------|----------------|----------------|-------------------------|--------------------------------|------------|----------------|----------------------------|--------------------|------------------|
| LTE Band 13 | Axial | 10MHz | 23230 | 0.20 | -30.00 | -61.73 | 1.91 | 30.20 | 20.00 | -10.20 | T4 | 1.4, 1.6 |
| | | 5MHz | 23230 | 0.20 | -31.61 | | 1.85 | 31.81 | 20.00 | -11.81 | T4 | |
| | Radial | 10MHz | 23230 | -12.22 | -38.65 | -63.77 | N/A | 26.43 | 20.00 | -6.43 | T3 | 2.0, 2.8 |
| | | 5MHz | 23230 | -12.26 | -40.38 | | | 28.12 | 20.00 | -8.12 | T3 | |

| | | | | | | | |
|-------------------------------------|---|---------------------------------|--|--|--|---|---------------------------------|
| FCC ID: A3LSMF707U |  | HAC (T-COIL) TEST REPORT | | | |  | Approved by: Quality Manager |
| Filename: 1M2005040080-19-R2.A3L | Test Dates: 06/15/2020 - 07/02/2020 | DUT Type: Portable Handset | | | | Page 39 of 108 | |

**Table 9-8
Raw Data Results for LTE B14**

| Mode | Orientation | Bandwidth | Channel | ABM1 [dB(A/m)] | ABM2 [dB(A/m)] | Ambient Noise [dB(A/m)] | Frequency Response Margin (dB) | S+N/N (dB) | FCC Limit (dB) | Margin from FCC Limit (dB) | C63.19-2011 Rating | Test Coordinates |
|-------------|-------------|-----------|---------|----------------|----------------|-------------------------|--------------------------------|------------|----------------|----------------------------|--------------------|------------------|
| LTE Band 14 | Axial | 10MHz | 23330 | 0.10 | -27.72 | -61.73 | 1.80 | 27.82 | 20.00 | -7.82 | T3 | 1.4, 1.6 |
| | | 5MHz | 23355 | 0.09 | -27.46 | | 1.85 | 27.55 | 20.00 | -7.55 | T3 | |
| | | 5MHz | 23330 | -0.01 | -26.45 | | 1.86 | 26.44 | 20.00 | -6.44 | T3 | |
| | | 5MHz | 23305 | 0.07 | -27.74 | | 1.88 | 27.81 | 20.00 | -7.81 | T3 | |
| | Radial | 10MHz | 23330 | -12.11 | -35.79 | -63.77 | N/A | 23.68 | 20.00 | -3.68 | T3 | 2.0, 2.8 |
| | | 5MHz | 23355 | -12.18 | -35.60 | | | 23.42 | 20.00 | -3.42 | T3 | |
| | | 5MHz | 23330 | -12.27 | -35.36 | | | 23.09 | 20.00 | -3.09 | T3 | |
| | | 5MHz | 23305 | -12.21 | -38.52 | | | 26.31 | 20.00 | -6.31 | T3 | |

**Table 9-9
Raw Data Results for LTE B5**

| Mode | Orientation | Bandwidth | Channel | ABM1 [dB(A/m)] | ABM2 [dB(A/m)] | Ambient Noise [dB(A/m)] | Frequency Response Margin (dB) | S+N/N (dB) | FCC Limit (dB) | Margin from FCC Limit (dB) | C63.19-2011 Rating | Test Coordinates |
|------------|-------------|-----------|---------|----------------|----------------|-------------------------|--------------------------------|------------|----------------|----------------------------|--------------------|------------------|
| LTE Band 5 | Axial | 10MHz | 20525 | -0.18 | -28.31 | -61.73 | 1.88 | 28.13 | 20.00 | -8.13 | T3 | 1.4, 1.6 |
| | | 5MHz | 20525 | 0.40 | -29.35 | | 1.89 | 29.75 | 20.00 | -9.75 | T3 | |
| | | 3MHz | 20525 | 0.70 | -29.27 | | 1.82 | 29.97 | 20.00 | -9.97 | T3 | |
| | | 1.4MHz | 20525 | -0.29 | -29.45 | | 1.86 | 29.16 | 20.00 | -9.16 | T3 | |
| | Radial | 10MHz | 20525 | -12.24 | -38.93 | -63.77 | N/A | 26.69 | 20.00 | -6.69 | T3 | 2.0, 2.8 |
| | | 5MHz | 20525 | -12.28 | -39.00 | | | 26.72 | 20.00 | -6.72 | T3 | |
| | | 3MHz | 20525 | -12.17 | -39.08 | | | 26.91 | 20.00 | -6.91 | T3 | |
| | | 1.4MHz | 20525 | -12.17 | -40.01 | | | 27.84 | 20.00 | -7.84 | T3 | |

**Table 9-10
Raw Data Results for LTE B66**

| Mode | Orientation | Bandwidth | Channel | ABM1 [dB(A/m)] | ABM2 [dB(A/m)] | Ambient Noise [dB(A/m)] | Frequency Response Margin (dB) | S+N/N (dB) | FCC Limit (dB) | Margin from FCC Limit (dB) | C63.19-2011 Rating | Test Coordinates |
|-------------|-------------|-----------|---------|----------------|----------------|-------------------------|--------------------------------|------------|----------------|----------------------------|--------------------|------------------|
| LTE Band 66 | Axial | 20MHz | 132322 | -0.18 | -35.00 | -61.73 | 1.88 | 34.82 | 20.00 | -14.82 | T4 | 1.4, 1.6 |
| | | 15MHz | 132322 | -0.19 | -35.09 | | 1.86 | 34.90 | 20.00 | -14.90 | T4 | |
| | | 10MHz | 132322 | -0.18 | -35.15 | | 1.83 | 34.97 | 20.00 | -14.97 | T4 | |
| | | 5MHz | 132322 | -0.17 | -34.77 | | 1.93 | 34.60 | 20.00 | -14.60 | T4 | |
| | | 3MHz | 132322 | -0.14 | -34.78 | | 1.93 | 34.64 | 20.00 | -14.64 | T4 | |
| | | 1.4MHz | 132322 | -0.21 | -35.28 | | 1.88 | 35.07 | 20.00 | -15.07 | T4 | |
| | Radial | 20MHz | 132322 | -12.30 | -44.11 | -63.77 | N/A | 31.81 | 20.00 | -11.81 | T4 | 2.0, 2.8 |
| | | 15MHz | 132322 | -12.31 | -44.89 | | | 32.58 | 20.00 | -12.58 | T4 | |
| | | 10MHz | 132322 | -12.32 | -45.08 | | | 32.76 | 20.00 | -12.76 | T4 | |
| | | 5MHz | 132322 | -12.33 | -45.04 | | | 32.71 | 20.00 | -12.71 | T4 | |
| | | 3MHz | 132322 | -12.28 | -44.96 | | | 32.68 | 20.00 | -12.68 | T4 | |
| | | 1.4MHz | 132322 | -12.32 | -45.17 | | | 32.85 | 20.00 | -12.85 | T4 | |

**Table 9-11
Raw Data Results for LTE B25**

| Mode | Orientation | Bandwidth | Channel | ABM1 [dB(A/m)] | ABM2 [dB(A/m)] | Ambient Noise [dB(A/m)] | Frequency Response Margin (dB) | S+N/N (dB) | FCC Limit (dB) | Margin from FCC Limit (dB) | C63.19-2011 Rating | Test Coordinates |
|-------------|-------------|-----------|---------|----------------|----------------|-------------------------|--------------------------------|------------|----------------|----------------------------|--------------------|------------------|
| LTE Band 25 | Axial | 20MHz | 26365 | 0.18 | -35.35 | -61.73 | 1.82 | 35.53 | 20.00 | -15.53 | T4 | 1.4, 1.6 |
| | | 15MHz | 26365 | 0.10 | -35.72 | | 1.86 | 35.82 | 20.00 | -15.82 | T4 | |
| | | 10MHz | 26365 | 0.12 | -34.85 | | 1.98 | 34.97 | 20.00 | -14.97 | T4 | |
| | | 5MHz | 26365 | 0.05 | -36.21 | | 1.86 | 36.26 | 20.00 | -16.26 | T4 | |
| | | 3MHz | 26365 | 0.04 | -34.38 | | 1.90 | 34.42 | 20.00 | -14.42 | T4 | |
| | | 1.4MHz | 26365 | 0.03 | -34.79 | | 1.89 | 34.82 | 20.00 | -14.82 | T4 | |
| | Radial | 20MHz | 26365 | -12.20 | -45.09 | -63.77 | N/A | 32.89 | 20.00 | -12.89 | T4 | 2.0, 2.8 |
| | | 15MHz | 26365 | -12.31 | -45.73 | | | 33.42 | 20.00 | -13.42 | T4 | |
| | | 10MHz | 26365 | -12.23 | -45.36 | | | 33.13 | 20.00 | -13.13 | T4 | |
| | | 5MHz | 26365 | -12.26 | -43.46 | | | 31.20 | 20.00 | -11.20 | T4 | |
| | | 3MHz | 26365 | -12.29 | -45.53 | | | 33.24 | 20.00 | -13.24 | T4 | |
| | | 1.4MHz | 26365 | -12.28 | -45.76 | | | 33.48 | 20.00 | -13.48 | T4 | |



| | | | | |
|-------------------------------------|---|---------------------------------|---|---------------------------------|
| FCC ID: A3LSMF707U |  | HAC (T-COIL) TEST REPORT |  | Approved by: Quality Manager |
| Filename: 1M2005040080-19-R2.A3L | Test Dates: 06/15/2020 - 07/02/2020 | DUT Type: Portable Handset | | Page 40 of 108 |

Table 9-12
Raw Data Results for LTE B2

| Mode | Orientation | Bandwidth | Channel | ABM1 [dB(A/m)] | ABM2 [dB(A/m)] | Ambient Noise [dB(A/m)] | Frequency Response Margin (dB) | S+N/N (dB) | FCC Limit (dB) | Margin from FCC Limit (dB) | C63.19-2011 Rating | Test Coordinates |
|------------|-------------|-----------|---------|----------------|----------------|-------------------------|--------------------------------|------------|----------------|----------------------------|--------------------|------------------|
| LTE Band 2 | Axial | 20MHz | 18900 | -0.24 | -34.23 | -61.73 | 1.94 | 33.99 | 20.00 | -13.99 | T4 | 1.4, 1.6 |
| | | 15MHz | 18900 | -0.25 | -34.27 | | 1.89 | 34.02 | 20.00 | -14.02 | T4 | |
| | | 10MHz | 18900 | -0.26 | -34.36 | | 1.94 | 34.10 | 20.00 | -14.10 | T4 | |
| | | 5MHz | 18900 | -0.21 | -34.27 | | 1.88 | 34.06 | 20.00 | -14.06 | T4 | |
| | | 3MHz | 18900 | -0.24 | -34.56 | | 1.93 | 34.32 | 20.00 | -14.32 | T4 | |
| | | 1.4MHz | 18900 | -0.24 | -34.59 | | 1.91 | 34.35 | 20.00 | -14.35 | T4 | |
| | Radial | 20MHz | 18900 | -12.34 | -44.60 | -63.77 | N/A | 32.26 | 20.00 | -12.26 | T4 | 2.0, 2.8 |
| | | 15MHz | 18900 | -12.34 | -44.78 | | | 32.44 | 20.00 | -12.44 | T4 | |
| | | 10MHz | 18900 | -12.29 | -44.90 | | | 32.61 | 20.00 | -12.61 | T4 | |
| | | 5MHz | 18900 | -12.27 | -45.51 | | | 33.24 | 20.00 | -13.24 | T4 | |
| 3MHz | | 18900 | -12.23 | -45.01 | 32.78 | | | 20.00 | -12.78 | T4 | | |
| 1.4MHz | | 18900 | -12.30 | -46.02 | 33.72 | | | 20.00 | -13.72 | T4 | | |

Table 9-13
Raw Data Results for LTE B30

| Mode | Orientation | Bandwidth | Channel | ABM1 [dB(A/m)] | ABM2 [dB(A/m)] | Ambient Noise [dB(A/m)] | Frequency Response Margin (dB) | S+N/N (dB) | FCC Limit (dB) | Margin from FCC Limit (dB) | C63.19-2011 Rating | Test Coordinates |
|-------------|-------------|-----------|---------|----------------|----------------|-------------------------|--------------------------------|------------|----------------|----------------------------|--------------------|------------------|
| LTE Band 30 | Axial | 10MHz | 27710 | 0.07 | -35.05 | -61.73 | 1.90 | 35.12 | 20.00 | -15.12 | T4 | 1.4, 1.6 |
| | | 5MHz | 27710 | -0.05 | -34.04 | | 1.85 | 33.99 | 20.00 | -13.99 | T4 | |
| | Radial | 10MHz | 27710 | -12.17 | -43.15 | -63.77 | N/A | 30.98 | 20.00 | -10.98 | T4 | 2.0, 2.8 |
| | | 5MHz | 27710 | -12.22 | -43.75 | | | 31.53 | 20.00 | -11.53 | T4 | |

Table 9-14
Raw Data Results for LTE B7

| Mode | Orientation | Bandwidth | Channel | ABM1 [dB(A/m)] | ABM2 [dB(A/m)] | Ambient Noise [dB(A/m)] | Frequency Response Margin (dB) | S+N/N (dB) | FCC Limit (dB) | Margin from FCC Limit (dB) | C63.19-2011 Rating | Test Coordinates |
|------------|-------------|-----------|---------|----------------|----------------|-------------------------|--------------------------------|------------|----------------|----------------------------|--------------------|------------------|
| LTE Band 7 | Axial | 20MHz | 21100 | -0.23 | -32.74 | -61.73 | 1.80 | 32.51 | 20.00 | -12.51 | T4 | 1.4, 1.6 |
| | | 15MHz | 21100 | -0.25 | -33.31 | | 1.92 | 33.06 | 20.00 | -13.06 | T4 | |
| | | 10MHz | 21100 | -0.24 | -33.48 | | 1.83 | 33.24 | 20.00 | -13.24 | T4 | |
| | | 5MHz | 21100 | -0.13 | -34.32 | | 1.84 | 34.19 | 20.00 | -14.19 | T4 | |
| | Radial | 20MHz | 21100 | -12.03 | -42.79 | -63.77 | N/A | 30.76 | 20.00 | -10.76 | T4 | 2.0, 2.8 |
| | | 15MHz | 21100 | -12.16 | -43.16 | | | 31.00 | 20.00 | -11.00 | T4 | |
| | | 10MHz | 21100 | -12.15 | -43.77 | | | 31.62 | 20.00 | -11.62 | T4 | |
| | | 5MHz | 21100 | -12.19 | -43.63 | | | 31.44 | 20.00 | -11.44 | T4 | |

Table 9-15
Raw Data Results for LTE B41 Power Class 3

| Mode | Orientation | Bandwidth | Channel | ABM1 [dB(A/m)] | ABM2 [dB(A/m)] | Ambient Noise [dB(A/m)] | Frequency Response Margin (dB) | S+N/N (dB) | FCC Limit (dB) | Margin from FCC Limit (dB) | C63.19-2011 Rating | Test Coordinates |
|-------------|-------------|-----------|---------|----------------|----------------|-------------------------|--------------------------------|------------|----------------|----------------------------|--------------------|------------------|
| LTE Band 41 | Axial | 20MHz | 40620 | -0.57 | -29.88 | -63.82 | 1.82 | 29.31 | 20.00 | -9.31 | T3 | 1.4, 1.6 |
| | | 15MHz | 40620 | -0.38 | -29.90 | | 1.92 | 29.52 | 20.00 | -9.52 | T3 | |
| | | 10MHz | 40620 | -0.38 | -29.67 | | 1.85 | 29.29 | 20.00 | -9.29 | T3 | |
| | | 5MHz | 40620 | -0.53 | -29.73 | | 1.92 | 29.20 | 20.00 | -9.20 | T3 | |
| | Radial | 20MHz | 40620 | -12.17 | -39.73 | -63.77 | N/A | 27.56 | 20.00 | -7.56 | T3 | 2.0, 2.8 |
| | | 15MHz | 40620 | -12.14 | -39.66 | | | 27.52 | 20.00 | -7.52 | T3 | |
| | | 10MHz | 40620 | -12.20 | -39.32 | | | 27.12 | 20.00 | -7.12 | T3 | |
| | | 5MHz | 40620 | -12.21 | -39.65 | | | 27.44 | 20.00 | -7.44 | T3 | |

Table 9-16
Raw Data Results for LTE B41 Power Class 2

| Mode | Orientation | Bandwidth | Channel | ABM1 [dB(A/m)] | ABM2 [dB(A/m)] | Ambient Noise [dB(A/m)] | Frequency Response Margin (dB) | S+N/N (dB) | FCC Limit (dB) | Margin from FCC Limit (dB) | C63.19-2011 Rating | Test Coordinates |
|-------------|-------------|-----------|---------|----------------|----------------|-------------------------|--------------------------------|------------|----------------|----------------------------|--------------------|------------------|
| LTE Band 41 | Axial | 20MHz | 40620 | -0.46 | -27.75 | -63.82 | 1.95 | 27.29 | 20.00 | -7.29 | T3 | 1.4, 1.6 |
| | | 15MHz | 40620 | -0.50 | -26.86 | | 1.81 | 26.36 | 20.00 | -6.36 | T3 | |
| | | 10MHz | 40620 | -0.50 | -28.26 | | 1.82 | 27.76 | 20.00 | -7.76 | T3 | |
| | | 5MHz | 40620 | -0.38 | -28.27 | | 1.85 | 27.89 | 20.00 | -7.89 | T3 | |
| | Radial | 20MHz | 40620 | -12.22 | -37.39 | -63.77 | N/A | 25.17 | 20.00 | -5.17 | T3 | 2.0, 2.8 |
| | | 15MHz | 40620 | -12.25 | -38.38 | | | 26.13 | 20.00 | -6.13 | T3 | |
| | | 10MHz | 40620 | -12.27 | -38.61 | | | 26.34 | 20.00 | -6.34 | T3 | |
| | | 5MHz | 40620 | -12.21 | -38.41 | | | 26.20 | 20.00 | -6.20 | T3 | |



| | | | | |
|-------------------------------------|---|---------------------------------|---|---------------------------------|
| FCC ID: A3L5MF707U |  | HAC (T-COIL) TEST REPORT |  | Approved by: Quality Manager |
| Filename: 1M2005040080-19-R2.A3L | Test Dates: 06/15/2020 - 07/02/2020 | DUT Type: Portable Handset | Page 41 of 108 | |

Table 9-17
Raw Data Results for LTE B48 Power Class 3

| Mode | Orientation | Bandwidth | Channel | ABM1 [dB(A/m)] | ABM2 [dB(A/m)] | Ambient Noise [dB(A/m)] | Frequency Response Margin (dB) | S+N/N (dB) | FCC Limit (dB) | Margin from FCC Limit (dB) | C63.19-2011 Rating | Test Coordinates |
|-------------|-------------|-----------|---------|----------------|----------------|-------------------------|--------------------------------|------------|----------------|----------------------------|--------------------|------------------|
| LTE Band 48 | Axial | 20MHz | 55990 | -0.52 | -25.40 | -63.82 | 1.79 | 24.88 | 20.00 | -4.88 | T3 | 1.4, 1.6 |
| | | 15MHz | 55990 | -0.47 | -25.50 | | 1.93 | 25.03 | 20.00 | -5.03 | T3 | |
| | | 10MHz | 55990 | -0.42 | -25.87 | | 1.92 | 25.45 | 20.00 | -5.45 | T3 | |
| | | 5MHz | 56715 | -0.41 | -23.67 | | 2.00 | 23.26 | 20.00 | -3.26 | T3 | |
| | | 5MHz | 55990 | -0.39 | -24.72 | | 1.94 | 24.33 | 20.00 | -4.33 | T3 | |
| | | 5MHz | 55265 | -0.37 | -28.57 | | 1.84 | 28.20 | 20.00 | -8.20 | T3 | |
| | Radial | 20MHz | 55990 | -12.11 | -37.04 | -63.77 | N/A | 24.93 | 20.00 | -4.93 | T3 | 2.0, 2.8 |
| | | 15MHz | 56665 | -12.31 | -37.73 | | | 25.42 | 20.00 | -5.42 | T3 | |
| | | 15MHz | 55990 | -12.11 | -35.91 | | | 23.80 | 20.00 | -3.80 | T3 | |
| | | 15MHz | 55315 | -12.30 | -37.62 | | | 25.32 | 20.00 | -5.32 | T3 | |
| | | 10MHz | 55990 | -12.16 | -36.13 | | | 23.97 | 20.00 | -3.97 | T3 | |
| | | 5MHz | 55990 | -12.24 | -36.69 | | | 24.45 | 20.00 | -4.45 | T3 | |

Table 9-18
Raw Data Results for 2.4GHz WIFI

| Mode | Orientation | Channel | ABM1 [dB(A/m)] | ABM2 [dB(A/m)] | Ambient Noise [dB(A/m)] | Frequency Response Margin (dB) | S+N/N (dB) | FCC Limit (dB) | Margin from FCC Limit (dB) | C63.19-2011 Rating | Test Coordinates |
|------------------|-------------|---------|----------------|----------------|-------------------------|--------------------------------|------------|----------------|----------------------------|--------------------|------------------|
| IEEE 802.11b | Axial | 1 | 1.40 | -37.33 | -64.34 | 1.94 | 38.73 | 20.00 | -18.73 | T4 | 1.4, 1.6 |
| | | 6 | 1.01 | -37.11 | | 1.92 | 38.12 | 20.00 | -18.12 | T4 | |
| | | 11 | 1.26 | -37.02 | | 1.95 | 38.28 | 20.00 | -18.28 | T4 | |
| | Radial | 6 | -10.01 | -50.42 | -63.73 | N/A | 40.41 | 20.00 | -20.41 | T4 | 2.0, 2.8 |
| IEEE 802.11g | Axial | 6 | 0.87 | -37.31 | -64.34 | 1.97 | 38.18 | 20.00 | -18.18 | T4 | 1.4, 1.6 |
| | Radial | 6 | -9.97 | -50.51 | -63.73 | N/A | 40.54 | 20.00 | -20.54 | T4 | 2.0, 2.8 |
| IEEE 802.11n | Axial | 6 | 0.81 | -40.86 | -64.34 | 1.98 | 41.67 | 20.00 | -21.67 | T4 | 1.4, 1.6 |
| | Radial | 6 | -9.84 | -50.15 | -63.73 | N/A | 40.31 | 20.00 | -20.31 | T4 | 2.0, 2.8 |
| IEEE 802.11ax SU | Axial | 6 | 1.22 | -37.33 | -64.34 | 1.93 | 38.55 | 20.00 | -18.55 | T4 | 1.4, 1.6 |
| | Radial | 6 | -9.93 | -49.70 | -63.73 | N/A | 39.77 | 20.00 | -19.77 | T4 | 2.0, 2.8 |
| IEEE 802.11ax RU | Axial | 6 | 1.25 | -37.13 | -64.34 | 1.89 | 38.38 | 20.00 | -18.38 | T4 | 1.4, 1.6 |
| | | 1 | -9.89 | -49.60 | -63.73 | N/A | 39.71 | 20.00 | -19.71 | T4 | 2.0, 2.8 |
| | Radial | 6 | -9.88 | -49.11 | | | 39.23 | 20.00 | -19.23 | T4 | |
| | | 11 | -9.71 | -49.46 | | | 39.75 | 20.00 | -19.75 | T4 | |

Table 9-19
Raw Data Results for 5GHz WIFI IEEE 802.11a

| Mode | Orientation | Bandwidth | U-NII | Channel | ABM1 [dB(A/m)] | ABM2 [dB(A/m)] | Ambient Noise [dB(A/m)] | Frequency Response Margin (dB) | S+N/N (dB) | FCC Limit (dB) | Margin from FCC Limit (dB) | C63.19-2011 Rating | Test Coordinates |
|--------------|-------------|-----------|-------|---------|----------------|----------------|-------------------------|--------------------------------|------------|----------------|----------------------------|--------------------|------------------|
| IEEE 802.11a | Axial | 20MHz | 1 | 40 | 1.61 | -38.96 | -64.34 | 1.94 | 40.57 | 20.00 | -20.57 | T4 | 1.4, 1.6 |
| | Radial | 20MHz | 1 | 40 | -9.95 | -49.29 | -63.73 | N/A | 39.34 | 20.00 | -19.34 | T4 | 2.0, 2.8 |

Table 9-20
Raw Data Results for 5GHz WIFI IEEE 802.11n

| Mode | Orientation | Bandwidth | U-NII | Channel | ABM1 [dB(A/m)] | ABM2 [dB(A/m)] | Ambient Noise [dB(A/m)] | Frequency Response Margin (dB) | S+N/N (dB) | FCC Limit (dB) | Margin from FCC Limit (dB) | C63.19-2011 Rating | Test Coordinates |
|--------------|-------------|-----------|-------|---------|----------------|----------------|-------------------------|--------------------------------|------------|----------------|----------------------------|--------------------|------------------|
| IEEE 802.11n | Axial | 40MHz | 1 | 38 | 1.54 | -38.26 | -64.34 | 1.99 | 39.80 | 20.00 | -19.80 | T4 | 1.4, 1.6 |
| | | 20MHz | 1 | 40 | 1.34 | -38.63 | | 1.93 | 39.97 | 20.00 | -19.97 | T4 | |
| | Radial | 40MHz | 1 | 38 | -9.79 | -49.53 | -63.73 | N/A | 39.74 | 20.00 | -19.74 | T4 | 2.0, 2.8 |
| | | 20MHz | 1 | 40 | -9.93 | -49.48 | | | 39.55 | 20.00 | -19.55 | T4 | |



| | | | | |
|-------------------------------------|---|---------------------------------|---|---------------------------------|
| FCC ID: A3LSMF707U |  | HAC (T-COIL) TEST REPORT |  | Approved by: Quality Manager |
| Filename: 1M2005040080-19-R2.A3L | Test Dates: 06/15/2020 - 07/02/2020 | DUT Type: Portable Handset | | Page 42 of 108 |

Table 9-21
Raw Data Results for 5GHz WIFI IEEE 802.11ac

| Mode | Orientation | Bandwidth | U-NII | Channel | ABM1 [dB(A/m)] | ABM2 [dB(A/m)] | Ambient Noise [dB(A/m)] | Frequency Response Margin (dB) | S+N/N (dB) | FCC Limit (dB) | Margin from FCC Limit (dB) | C63.19-2011 Rating | Test Coordinates |
|---------------|-------------|-----------|-------|---------|----------------|----------------|-------------------------|--------------------------------|------------|----------------|----------------------------|--------------------|------------------|
| IEEE 802.11ac | Axial | 40MHz | 1 | 38 | 1.54 | -38.45 | -64.34 | 1.98 | 39.99 | 20.00 | -19.99 | T4 | 1.4, 1.6 |
| | | 20MHz | 1 | 40 | 1.38 | -38.80 | | 1.93 | 40.18 | 20.00 | -20.18 | T4 | |
| | Radial | 40MHz | 1 | 38 | -9.97 | -48.60 | -63.73 | N/A | 38.63 | 20.00 | -18.63 | T4 | 2.0, 2.8 |
| | | 20MHz | 1 | 40 | -9.99 | -48.59 | | | 38.60 | 20.00 | -18.60 | T4 | |
| | | 40MHz | 2A | 54 | -9.98 | -48.71 | | | 38.73 | 20.00 | -18.73 | T4 | |
| | | 20MHz | 2A | 56 | -9.93 | -48.40 | | | 38.47 | 20.00 | -18.47 | T4 | |
| | | 40MHz | 2C | 118 | -9.77 | -47.40 | | | 37.63 | 20.00 | -17.63 | T4 | |
| | | 20MHz | 2C | 120 | -10.04 | -49.25 | | | 39.21 | 20.00 | -19.21 | T4 | |
| | | 40MHz | 3 | 151 | -9.88 | -49.27 | | | 39.39 | 20.00 | -19.39 | T4 | |
| | | 20MHz | 3 | 149 | -10.16 | -47.39 | | | 37.23 | 20.00 | -17.23 | T4 | |
| | | 20MHz | 3 | 157 | -10.19 | -47.32 | | | 37.13 | 20.00 | -17.13 | T4 | |
| | | 20MHz | 3 | 165 | -10.07 | -49.47 | | | 39.40 | 20.00 | -19.40 | T4 | |

Table 9-22
Raw Data Results for 5GHz WIFI IEEE 802.11ax



| Mode | Orientation | Bandwidth | U-NII | Channel | ABM1 [dB(A/m)] | ABM2 [dB(A/m)] | Ambient Noise [dB(A/m)] | Frequency Response Margin (dB) | S+N/N (dB) | FCC Limit (dB) | Margin from FCC Limit (dB) | C63.19-2011 Rating | Test Coordinates | | | |
|------------------|------------------|-----------|-------|---------|----------------|----------------|-------------------------|--------------------------------|------------|----------------|----------------------------|--------------------|------------------|----------|----|----------|
| IEEE 802.11ax SU | Axial | 40MHz | 1 | 38 | 1.35 | -38.34 | -64.34 | 1.98 | 39.69 | 20.00 | -19.69 | T4 | 1.4, 1.6 | | | |
| | | 20MHz | 1 | 36 | 1.22 | -37.03 | | 1.98 | 38.25 | 20.00 | -18.25 | T4 | | | | |
| | | 20MHz | 1 | 40 | 1.37 | -35.83 | | 1.89 | 37.20 | 20.00 | -17.20 | T4 | | | | |
| | | 20MHz | 1 | 48 | 1.39 | -38.05 | | 1.99 | 39.44 | 20.00 | -19.44 | T4 | | | | |
| | | 40MHz | 2A | 54 | 1.35 | -38.08 | | 1.89 | 39.43 | 20.00 | -19.43 | T4 | | | | |
| | | 20MHz | 2A | 56 | 1.32 | -38.40 | | 1.95 | 39.72 | 20.00 | -19.72 | T4 | | | | |
| | | 40MHz | 2C | 118 | 1.14 | -38.48 | | 1.94 | 39.62 | 20.00 | -19.62 | T4 | | | | |
| | | 20MHz | 2C | 120 | 1.27 | -37.99 | | 1.86 | 39.26 | 20.00 | -19.26 | T4 | | | | |
| | | 40MHz | 3 | 151 | 1.26 | -38.14 | | 1.99 | 39.40 | 20.00 | -19.40 | T4 | | | | |
| | | 20MHz | 3 | 157 | 1.24 | -38.22 | | 1.93 | 39.46 | 20.00 | -19.46 | T4 | | | | |
| | | Radial | 40MHz | 1 | 38 | -9.80 | | -49.22 | -63.73 | N/A | 39.42 | 20.00 | | -19.42 | T4 | 2.0, 2.8 |
| | | | 20MHz | 1 | 40 | -9.87 | | -49.08 | | | 39.21 | 20.00 | | -19.21 | T4 | |
| | IEEE 802.11ax RU | Axial | 40MHz | 1 | 38 | 1.26 | -38.41 | -64.34 | 1.89 | 39.67 | 20.00 | -19.67 | T4 | 1.4, 1.6 | | |
| | | | 20MHz | 1 | 40 | 1.18 | -38.03 | | 1.93 | 39.21 | 20.00 | -19.21 | T4 | | | |
| Radial | | 40MHz | 1 | 38 | -9.89 | -49.12 | -63.73 | | N/A | 39.23 | 20.00 | -19.23 | T4 | 2.0, 2.8 | | |
| | | 20MHz | 1 | 40 | -9.89 | -49.62 | | | | 39.73 | 20.00 | -19.73 | T4 | | | |

Table 9-23
Raw Data Results for EvDO (OTT VoIP)

| Mode | Orientation | Channel | ABM1 [dB(A/m)] | ABM2 [dB(A/m)] | Ambient Noise [dB(A/m)] | Frequency Response Margin (dB) | S+N/N (dB) | FCC Limit (dB) | Margin from FCC Limit (dB) | C63.19-2011 Rating | Test Coordinates |
|-------------------------|-------------|---------|----------------|----------------|-------------------------|--------------------------------|------------|----------------|----------------------------|--------------------|------------------|
| Secondary Cellular EvDO | Axial | 564 | 15.68 | -40.46 | -59.68 | 1.56 | 56.14 | 20.00 | -36.14 | T4 | 1.4, 1.6 |
| | Radial | 564 | 3.37 | -44.46 | -62.49 | N/A | 47.83 | 20.00 | -27.83 | T4 | 2.0, 2.8 |
| Cellular EvDO | Axial | 384 | 15.59 | -40.98 | -59.68 | 1.72 | 56.57 | 20.00 | -36.57 | T4 | 1.4, 1.6 |
| | Radial | 384 | 3.39 | -44.04 | -62.49 | N/A | 47.43 | 20.00 | -27.43 | T4 | 2.0, 2.8 |
| PCS EvDO | Axial | 600 | 15.47 | -39.00 | -59.68 | 1.53 | 54.47 | 20.00 | -34.47 | T4 | 1.4, 1.6 |
| | Radial | 600 | 3.42 | -41.98 | -62.49 | N/A | 45.40 | 20.00 | -25.40 | T4 | 2.0, 2.8 |

Table 9-24
Raw Data Results for EDGE (OTT VoIP)

| Mode | Orientation | Channel | ABM1 [dB(A/m)] | ABM2 [dB(A/m)] | Ambient Noise [dB(A/m)] | Frequency Response Margin (dB) | S+N/N (dB) | FCC Limit (dB) | Margin from FCC Limit (dB) | C63.19-2011 Rating | Test Coordinates |
|----------|-------------|---------|----------------|----------------|-------------------------|--------------------------------|------------|----------------|----------------------------|--------------------|------------------|
| EDGE850 | Axial | 190 | 15.02 | -20.05 | -59.68 | 1.50 | 35.07 | 20.00 | -15.07 | T4 | 1.4, 1.6 |
| | Radial | 190 | 3.44 | -28.51 | -62.49 | N/A | 31.95 | 20.00 | -11.95 | T4 | 2.0, 2.8 |
| EDGE1900 | Axial | 661 | 15.26 | -23.66 | -59.68 | 1.49 | 38.92 | 20.00 | -18.92 | T4 | 1.4, 1.6 |
| | Radial | 661 | 3.14 | -31.46 | -62.49 | N/A | 34.60 | 20.00 | -14.60 | T4 | 2.0, 2.8 |

| | | | | |
|-------------------------------------|---|---------------------------------|---|---------------------------------|
| FCC ID: A3LSMF707U |  | HAC (T-COIL) TEST REPORT |  | Approved by: Quality Manager |
| Filename: 1M2005040080-19-R2.A3L | Test Dates: 06/15/2020 - 07/02/2020 | DUT Type: Portable Handset | | Page 43 of 108 |

**Table 9-25
Raw Data Results for HSPA (OTT VoIP)**

| Mode | Orientation | Channel | ABM1 [dB(A/m)] | ABM2 [dB(A/m)] | Ambient Noise [dB(A/m)] | Frequency Response Margin (dB) | S+N/N (dB) | FCC Limit (dB) | Margin from FCC Limit (dB) | C63.19-2011 Rating | Test Coordinates |
|---------|-------------|---------|----------------|----------------|-------------------------|--------------------------------|------------|----------------|----------------------------|--------------------|------------------|
| HSPA V | Axial | 4183 | 15.81 | -41.31 | -59.68 | 1.43 | 57.12 | 20.00 | -37.12 | T4 | 1.4, 1.6 |
| | Radial | 4183 | 3.53 | -51.76 | -62.49 | N/A | 55.29 | 20.00 | -35.29 | T4 | 2.0, 2.8 |
| HSPA IV | Axial | 1412 | 15.69 | -41.35 | -59.68 | 1.35 | 57.04 | 20.00 | -37.04 | T4 | 1.4, 1.6 |
| | Radial | 1412 | 3.53 | -53.18 | -62.49 | N/A | 56.71 | 20.00 | -36.71 | T4 | 2.0, 2.8 |
| HSPA II | Axial | 9400 | 15.51 | -39.86 | -59.68 | 1.45 | 55.37 | 20.00 | -35.37 | T4 | 1.4, 1.6 |
| | Radial | 9400 | 3.55 | -52.69 | -62.49 | N/A | 56.24 | 20.00 | -36.24 | T4 | 2.0, 2.8 |

**Table 9-26
Raw Data Results for LTE FDD B14 (OTT VoIP)**

| Mode | Orientation | Bandwidth | Channel | ABM1 [dB(A/m)] | ABM2 [dB(A/m)] | Ambient Noise [dB(A/m)] | Frequency Response Margin (dB) | S+N/N (dB) | FCC Limit (dB) | Margin from FCC Limit (dB) | C63.19-2011 Rating | Test Coordinates |
|-------------|-------------|-----------|---------|----------------|----------------|-------------------------|--------------------------------|------------|----------------|----------------------------|--------------------|------------------|
| LTE Band 14 | Axial | 10MHz | 23330 | 15.46 | -26.77 | -61.73 | 2.00 | 42.23 | 20.00 | -22.23 | T4 | 1.4, 1.6 |
| | | 5MHz | 23355 | 15.38 | -24.13 | | 1.77 | 39.51 | 20.00 | -19.51 | T4 | |
| | | 5MHz | 23330 | 15.51 | -25.15 | | 1.93 | 40.66 | 20.00 | -20.66 | T4 | |
| | | 5MHz | 23305 | 15.28 | -29.32 | | 1.80 | 44.60 | 20.00 | -24.60 | T4 | |
| | Radial | 10MHz | 23330 | 3.63 | -35.19 | -63.77 | N/A | 38.82 | 20.00 | -18.82 | T4 | 2.0, 2.8 |
| | | 5MHz | 23330 | 3.48 | -35.45 | | N/A | 38.93 | 20.00 | -18.93 | T4 | |

**Table 9-27
Raw Data Results for LTE TDD B41 (PC2) (OTT VoIP)**

| Mode | Orientation | Bandwidth | Channel | ABM1 [dB(A/m)] | ABM2 [dB(A/m)] | Ambient Noise [dB(A/m)] | Frequency Response Margin (dB) | S+N/N (dB) | FCC Limit (dB) | Margin from FCC Limit (dB) | C63.19-2011 Rating | Test Coordinates |
|-------------|-------------|-----------|---------|----------------|----------------|-------------------------|--------------------------------|------------|----------------|----------------------------|--------------------|------------------|
| LTE Band 41 | Axial | 20MHz | 40620 | 15.17 | -27.38 | -61.73 | 1.85 | 42.55 | 20.00 | -22.55 | T4 | 1.4, 1.6 |
| | | 15MHz | 40620 | 15.04 | -26.80 | | 1.79 | 41.84 | 20.00 | -21.84 | T4 | |
| | | 10MHz | 41490 | 15.12 | -25.76 | | 1.97 | 40.88 | 20.00 | -20.88 | T4 | |
| | | 10MHz | 41055 | 15.08 | -24.75 | | 1.90 | 39.83 | 20.00 | -19.83 | T4 | |
| | | 10MHz | 40620 | 15.09 | -26.65 | | 1.73 | 41.74 | 20.00 | -21.74 | T4 | |
| | | 10MHz | 40185 | 14.99 | -23.75 | | 2.00 | 38.74 | 20.00 | -18.74 | T4 | |
| | | 10MHz | 39750 | 14.91 | -25.73 | | 2.00 | 40.64 | 20.00 | -20.64 | T4 | |
| | | 5MHz | 40620 | 14.93 | -27.38 | | 1.76 | 42.31 | 20.00 | -22.31 | T4 | |
| | | Radial | 20MHz | 41490 | 3.46 | | -37.79 | -63.77 | N/A | 41.25 | 20.00 | |
| | 20MHz | | 41055 | 3.49 | -39.46 | N/A | 42.95 | | 20.00 | -22.95 | T4 | |
| | 20MHz | | 40620 | 3.38 | -37.62 | N/A | 41.00 | | 20.00 | -21.00 | T4 | |
| | 20MHz | | 40185 | 3.36 | -38.94 | N/A | 42.30 | | 20.00 | -22.30 | T4 | |
| | 20MHz | | 39750 | 3.40 | -40.67 | N/A | 44.07 | | 20.00 | -24.07 | T4 | |
| | 15MHz | | 40620 | 3.41 | -38.06 | N/A | 41.47 | | 20.00 | -21.47 | T4 | |
| | 10MHz | | 40620 | 3.31 | -39.26 | N/A | 42.57 | | 20.00 | -22.57 | T4 | |
| | 5MHz | | 40620 | 3.45 | -38.96 | N/A | 42.41 | | 20.00 | -22.41 | T4 | |

**Table 9-28
Raw Data Results for NR FDD n5 (OTT VoIP)**

| Mode | Orientation | Bandwidth | Channel | ABM1 _{LTE} [dB(A/m)] | ABM2 _{NR} [dB(A/m)] | ABM2 _{LTE} [dB(A/m)] | Ambient Noise [dB(A/m)] | Frequency Response Margin (dB) | S+N/N _{NR} (dB) | S+N/N _{NR} - 3 dB (dB) | FCC Limit (dB) | Margin from FCC Limit (dB) | C63.19-2011 Rating | Test Coordinates |
|-------|-------------|-----------|---------|-------------------------------|------------------------------|-------------------------------|-------------------------|--------------------------------|--------------------------|---------------------------------|----------------|----------------------------|--------------------|------------------|
| NR n5 | Axial | 20MHz | 167300 | 15.45 | -29.23 | -29.72 | -64.34 | N/A | 44.68 | 41.68 | 20.00 | -21.68 | T4 | 1.4, 1.6 |
| | | 15MHz | 168300 | 15.45 | -30.42 | -29.72 | | | 45.87 | 42.87 | 20.00 | -22.87 | T4 | |
| | | 15MHz | 167300 | 15.45 | -27.96 | -29.72 | | | 43.41 | 40.41 | 20.00 | -20.41 | T4 | |
| | | 15MHz | 166300 | 15.45 | -28.66 | -29.72 | | | 44.11 | 41.11 | 20.00 | -21.11 | T4 | |
| | | 10MHz | 167300 | 15.45 | -29.97 | -29.72 | | | 45.42 | 42.42 | 20.00 | -22.42 | T4 | |
| | | 5MHz | 167300 | 15.45 | -29.41 | -29.72 | | | 44.86 | 41.86 | 20.00 | -21.86 | T4 | |
| | Radial | 20MHz | 167300 | 3.48 | -38.42 | -35.45 | -63.73 | N/A | 41.90 | 38.90 | 20.00 | -18.90 | T4 | 2.0, 2.8 |
| | | 15MHz | 168300 | 3.48 | -40.20 | -35.45 | | | 43.68 | 40.68 | 20.00 | -20.68 | T4 | |
| | | 15MHz | 167300 | 3.48 | -37.14 | -35.45 | | | 40.62 | 37.62 | 20.00 | -17.62 | T4 | |
| | | 15MHz | 166300 | 3.48 | -38.26 | -35.45 | | | 41.74 | 38.74 | 20.00 | -18.74 | T4 | |
| | | 10MHz | 167300 | 3.48 | -40.53 | -35.45 | | | 44.01 | 41.01 | 20.00 | -21.01 | T4 | |
| | | 5MHz | 167300 | 3.48 | -39.21 | -35.45 | | | 42.69 | 39.69 | 20.00 | -19.69 | T4 | |



| | | | | |
|-------------------------------------|---|---------------------------------|---|---------------------------------|
| FCC ID: A3L3SMF707U |  | HAC (T-COIL) TEST REPORT |  | Approved by: Quality Manager |
| Filename: 1M2005040080-19-R2.A3L | Test Dates: 06/15/2020 - 07/02/2020 | DUT Type: Portable Handset | | Page 44 of 108 |

Table 9-29
Raw Data Results for NR TDD n41 (OTT VoIP)

| Mode | Orientation | Bandwidth | Channel | ABM1 _{LTRE} [dB(A/m)] | ABM2 _{LTRE} [dB(A/m)] | ABM2 _{LTRE} [dB(A/m)] | Ambient Noise [dB(A/m)] | Frequency Response Margin (dB) | S+N/N _{ref} (dB) | S+N/N _{ref} - 3 dB (dB) | FCC Limit (dB) | Margin from FCC Limit (dB) | C63.19-2011 Rating | Test Coordinates |
|--------|-------------|-----------|---------|--------------------------------|--------------------------------|--------------------------------|-------------------------|--------------------------------|---------------------------|----------------------------------|----------------|----------------------------|--------------------|------------------|
| NR n41 | Axial | 100MHz | 528000 | 14.91 | -28.31 | -25.73 | -64.34 | N/A | 43.22 | 40.22 | 20.00 | -20.22 | T4 | 1.4, 1.6 |
| | | 100MHz | 523302 | 14.91 | -29.54 | -25.73 | | | 44.45 | 41.45 | 20.00 | -21.45 | T4 | |
| | | 100MHz | 518598 | 14.91 | -27.84 | -25.73 | | | 42.75 | 39.75 | 20.00 | -19.75 | T4 | |
| | | 100MHz | 513900 | 14.91 | -27.19 | -25.73 | | | 42.10 | 39.10 | 20.00 | -19.10 | T4 | |
| | | 100MHz | 509202 | 14.91 | -26.79 | -25.73 | | | 41.70 | 38.70 | 20.00 | -18.70 | T4 | |
| | | 90MHz | 518598 | 14.91 | -29.40 | -25.73 | | | 44.31 | 41.31 | 20.00 | -21.31 | T4 | |
| | | 80MHz | 518598 | 14.91 | -28.20 | -25.73 | | | 43.11 | 40.11 | 20.00 | -20.11 | T4 | |
| | | 60MHz | 518598 | 14.91 | -30.13 | -25.73 | | | 45.04 | 42.04 | 20.00 | -22.04 | T4 | |
| | | 50MHz | 518598 | 14.91 | -29.97 | -25.73 | | | 44.88 | 41.88 | 20.00 | -21.88 | T4 | |
| | | 40MHz | 518598 | 14.91 | -30.35 | -25.73 | | | 45.26 | 42.26 | 20.00 | -22.26 | T4 | |
| | 20MHz | 518598 | 14.91 | -30.37 | -25.73 | 45.28 | 42.28 | 20.00 | -22.28 | T4 | | | | |
| | Radial | 100MHz | 518598 | 3.31 | -36.56 | -39.26 | -63.73 | N/A | 39.87 | 36.87 | 20.00 | -16.87 | T4 | 2.0, 2.8 |
| | | 90MHz | 518598 | 3.31 | -36.82 | -39.26 | | | 40.13 | 37.13 | 20.00 | -17.13 | T4 | |
| | | 80MHz | 518598 | 3.31 | -36.67 | -39.26 | | | 39.98 | 36.98 | 20.00 | -16.98 | T4 | |
| | | 60MHz | 518598 | 3.31 | -36.64 | -39.26 | | | 39.95 | 36.95 | 20.00 | -16.95 | T4 | |
| | | 50MHz | 532998 | 3.31 | -36.28 | -39.26 | | | 39.59 | 36.59 | 20.00 | -16.59 | T4 | |
| | | 50MHz | 525798 | 3.31 | -37.87 | -39.26 | | | 41.18 | 38.18 | 20.00 | -18.18 | T4 | |
| | | 50MHz | 518598 | 3.31 | -36.29 | -39.26 | | | 39.60 | 36.60 | 20.00 | -16.60 | T4 | |
| | | 50MHz | 511398 | 3.31 | -38.11 | -39.26 | | | 41.42 | 38.42 | 20.00 | -18.42 | T4 | |
| | | 50MHz | 504204 | 3.31 | -36.46 | -39.26 | | | 39.77 | 36.77 | 20.00 | -16.77 | T4 | |
| 40MHz | | 518598 | 3.31 | -36.36 | -39.26 | 39.67 | | | 36.67 | 20.00 | -16.67 | T4 | | |
| 20MHz | 518598 | 3.31 | -38.38 | -39.26 | 41.69 | 38.69 | 20.00 | -18.69 | T4 | | | | | |

Table 9-30
Raw Data Results for 2.4GHz WIFI (OTT VoIP)

| Mode | Orientation | Channel | ABM1 [dB(A/m)] | ABM2 [dB(A/m)] | Ambient Noise [dB(A/m)] | Frequency Response Margin (dB) | S+N/N (dB) | FCC Limit (dB) | Margin from FCC Limit (dB) | C63.19-2011 Rating | Test Coordinates |
|------------------|-------------|---------|----------------|----------------|-------------------------|--------------------------------|------------|----------------|----------------------------|--------------------|------------------|
| IEEE 802.11b | Axial | 6 | 15.22 | -35.09 | -64.34 | 1.68 | 50.31 | 20.00 | -30.31 | T4 | 1.4, 1.6 |
| | | 1 | 3.92 | -49.66 | -63.73 | N/A | 53.58 | 20.00 | -33.58 | T4 | 2.0, 2.8 |
| | Radial | 6 | 3.93 | -47.61 | | | 51.54 | 20.00 | -31.54 | T4 | |
| | | 11 | 3.91 | -50.39 | 54.30 | 20.00 | -34.30 | T4 | | | |
| IEEE 802.11g | Axial | 6 | 15.16 | -37.99 | -64.34 | 2.00 | 53.15 | 20.00 | -33.15 | T4 | 1.4, 1.6 |
| | Radial | 6 | 4.00 | -48.68 | -63.73 | N/A | 52.68 | 20.00 | -32.68 | T4 | 2.0, 2.8 |
| IEEE 802.11n | Axial | 6 | 15.16 | -39.47 | -64.34 | 1.88 | 54.63 | 20.00 | -34.63 | T4 | 1.4, 1.6 |
| | Radial | 6 | 3.89 | -48.80 | -63.73 | N/A | 52.69 | 20.00 | -32.69 | T4 | 2.0, 2.8 |
| IEEE 802.11ax SU | Axial | 6 | 15.08 | -35.11 | -64.34 | 1.46 | 50.19 | 20.00 | -30.19 | T4 | 1.4, 1.6 |
| | Radial | 6 | 3.99 | -47.70 | -63.73 | N/A | 51.69 | 20.00 | -31.69 | T4 | 2.0, 2.8 |
| IEEE 802.11ax RU | Axial | 1 | 15.02 | -33.70 | -64.34 | 1.45 | 48.72 | 20.00 | -28.72 | T4 | 1.4, 1.6 |
| | | 6 | 15.02 | -32.78 | | 1.87 | 47.80 | 20.00 | -27.80 | T4 | |
| | Radial | 11 | 15.16 | -34.51 | 1.11 | 49.67 | 20.00 | -29.67 | T4 | 2.0, 2.8 | |
| | | 6 | 3.59 | -50.24 | -63.73 | N/A | 53.83 | 20.00 | -33.83 | | T4 |

Table 9-31
Raw Data Results for 5GHz WIFI IEEE 802.11a (OTT VoIP)

| Mode | Orientation | Bandwidth | U-NII | Channel | ABM1 [dB(A/m)] | ABM2 [dB(A/m)] | Ambient Noise [dB(A/m)] | Frequency Response Margin (dB) | S+N/N (dB) | FCC Limit (dB) | Margin from FCC Limit (dB) | C63.19-2011 Rating | Test Coordinates |
|--------------|-------------|-----------|-------|---------|----------------|----------------|-------------------------|--------------------------------|------------|----------------|----------------------------|--------------------|------------------|
| IEEE 802.11a | Axial | 20MHz | 1 | 40 | 15.08 | -37.70 | -64.34 | 1.02 | 52.78 | 20.00 | -32.78 | T4 | 1.4, 1.6 |
| | Radial | 20MHz | 1 | 40 | 3.97 | -50.62 | -63.73 | N/A | 54.59 | 20.00 | -34.59 | T4 | 2.0, 2.8 |

Table 9-32
Raw Data Results for 5GHz WIFI IEEE 802.11n (OTT VoIP)

| Mode | Orientation | Bandwidth | U-NII | Channel | ABM1 [dB(A/m)] | ABM2 [dB(A/m)] | Ambient Noise [dB(A/m)] | Frequency Response Margin (dB) | S+N/N (dB) | FCC Limit (dB) | Margin from FCC Limit (dB) | C63.19-2011 Rating | Test Coordinates |
|--------------|-------------|-----------|-------|---------|----------------|----------------|-------------------------|--------------------------------|------------|----------------|----------------------------|--------------------|------------------|
| IEEE 802.11n | Axial | 40MHz | 1 | 38 | 15.22 | -39.72 | -64.34 | 1.40 | 54.94 | 20.00 | -34.94 | T4 | 1.4, 1.6 |
| | | 20MHz | 1 | 40 | 15.15 | -39.19 | | 1.93 | 54.34 | 20.00 | -34.34 | T4 | |
| | Radial | 40MHz | 1 | 38 | 3.91 | -47.97 | -63.73 | N/A | 51.88 | 20.00 | -31.88 | T4 | 2.0, 2.8 |
| | | 20MHz | 1 | 40 | 3.97 | -48.74 | | 52.71 | 20.00 | -32.71 | T4 | | |





| | | | | |
|-------------------------------------|---|-------------------------------|---|---------------------------------|
| FCC ID: A3LSMF707U |  | HAC (T-COIL) TEST REPORT |  | Approved by: Quality Manager |
| Filename: 1M2005040080-19-R2.A3L | Test Dates: 06/15/2020 - 07/02/2020 | DUT Type: Portable Handset | | Page 45 of 108 |

Table 9-33
Raw Data Results for 5GHz WIFI IEEE 802.11ac (OTT VoIP)

| Mode | Orientation | Bandwidth | U-NII | Channel | ABM1 [dB(A/m)] | ABM2 [dB(A/m)] | Ambient Noise [dB(A/m)] | Frequency Response Margin (dB) | S+N/N (dB) | FCC Limit (dB) | Margin from FCC Limit (dB) | C63.19-2011 Rating | Test Coordinates |
|---------------|-------------|-----------|-------|---------|----------------|----------------|-------------------------|--------------------------------|------------|----------------|----------------------------|--------------------|------------------|
| IEEE 802.11ac | Axial | 40MHz | 1 | 38 | 15.20 | -39.14 | -64.34 | 1.59 | 54.34 | 20.00 | -34.34 | T4 | 1.4, 1.6 |
| | | 20MHz | 1 | 40 | 15.08 | -37.25 | | 1.89 | 52.33 | 20.00 | -32.33 | T4 | |
| | Radial | 40MHz | 1 | 38 | 3.99 | -48.27 | -63.73 | N/A | 52.26 | 20.00 | -32.26 | T4 | 2.0, 2.8 |
| | | 20MHz | 1 | 40 | 3.94 | -47.77 | | | 51.71 | 20.00 | -31.71 | T4 | |

Table 9-34
Raw Data Results for 5GHz WIFI IEEE 802.11ax (OTT VoIP)

| Mode | Orientation | Bandwidth | U-NII | Channel | ABM1 [dB(A/m)] | ABM2 [dB(A/m)] | Ambient Noise [dB(A/m)] | Frequency Response Margin (dB) | S+N/N (dB) | FCC Limit (dB) | Margin from FCC Limit (dB) | C63.19-2011 Rating | Test Coordinates |
|------------------|-------------|-----------|-------|---------|----------------|----------------|-------------------------|--------------------------------|------------|----------------|----------------------------|--------------------|------------------|
| IEEE 802.11ax SU | Axial | 40MHz | 1 | 38 | 15.20 | -32.97 | -64.34 | 1.70 | 48.17 | 20.00 | -28.17 | T4 | 1.4, 1.6 |
| | | 20MHz | 1 | 40 | 15.06 | -32.09 | | 1.69 | 47.15 | 20.00 | -27.15 | T4 | |
| | Radial | 40MHz | 1 | 38 | 3.82 | -48.89 | -63.73 | N/A | 52.71 | 20.00 | -32.71 | T4 | 2.0, 2.8 |
| | | 20MHz | 1 | 40 | 3.83 | -47.22 | | | 51.05 | 20.00 | -31.05 | T4 | |
| IEEE 802.11ax RU | Axial | 40MHz | 1 | 38 | 15.21 | -32.09 | -64.34 | 1.63 | 47.30 | 20.00 | -27.30 | T4 | 1.4, 1.6 |
| | | 20MHz | 1 | 40 | 15.21 | -31.80 | | 1.80 | 47.01 | 20.00 | -27.01 | T4 | |
| | | 40MHz | 2A | 54 | 15.09 | -31.63 | | 1.61 | 46.72 | 20.00 | -26.72 | T4 | |
| | | 20MHz | 2A | 56 | 15.27 | -32.21 | | 2.00 | 47.48 | 20.00 | -27.48 | T4 | |
| | | 40MHz | 2C | 118 | 15.18 | -31.03 | | 1.48 | 46.21 | 20.00 | -26.21 | T4 | |
| | | 20MHz | 2C | 120 | 15.09 | -31.56 | | 1.70 | 46.65 | 20.00 | -26.65 | T4 | |
| | | 40MHz | 3 | 151 | 15.15 | -30.83 | | 1.63 | 45.98 | 20.00 | -25.98 | T4 | |
| | | 40MHz | 3 | 159 | 15.16 | -31.36 | | 1.89 | 46.52 | 20.00 | -26.52 | T4 | |
| | | 20MHz | 3 | 157 | 15.11 | -32.39 | | 2.00 | 47.50 | 20.00 | -27.50 | T4 | |
| | Radial | 40MHz | 1 | 38 | 3.84 | -48.33 | -63.73 | N/A | 52.17 | 20.00 | -32.17 | T4 | 2.0, 2.8 |
| | | 20MHz | 1 | 40 | 3.76 | -45.59 | | | 49.35 | 20.00 | -29.35 | T4 | |
| | | 40MHz | 2A | 54 | 3.98 | -44.35 | | | 48.33 | 20.00 | -28.33 | T4 | |
| | | 40MHz | 2A | 62 | 3.94 | -48.22 | | | 52.16 | 20.00 | -32.16 | T4 | |
| | | 20MHz | 2A | 56 | 3.88 | -46.97 | | | 50.85 | 20.00 | -30.85 | T4 | |
| | | 40MHz | 2C | 118 | 4.05 | -46.28 | | | 50.33 | 20.00 | -30.33 | T4 | |
| | | 20MHz | 2C | 120 | 3.96 | -48.88 | | | 52.84 | 20.00 | -32.84 | T4 | |
| | | 40MHz | 3 | 151 | 3.80 | -45.06 | | | 48.86 | 20.00 | -28.86 | T4 | |
| | | 20MHz | 3 | 157 | 3.80 | -49.48 | | | 53.28 | 20.00 | -33.28 | T4 | |

| | | | | |
|-------------------------------------|---|-------------------------------|---|---------------------------------|
| FCC ID: A3LSMF707U |  | HAC (T-COIL) TEST REPORT |  | Approved by: Quality Manager |
| Filename: 1M2005040080-19-R2.A3L | Test Dates: 06/15/2020 - 07/02/2020 | DUT Type: Portable Handset | | Page 46 of 108 |

II. Test Notes

A. General

1. Phone Condition: Mute on; Backlight off; Max Volume; Max Contrast
2. 'Radial' orientation refers to radial transverse.
3. Hearing Aid Mode (**Phone→Call Settings→Additional Settings→Hearing aid compatibility**) was set to ON for Frequency Response compliance
4. Speech Signal: 3GPP2 Normal Test Signal
5. Bluetooth and WIFI were disabled while testing 2G/3G/4G/5G modes.
6. Licensed data modes and Bluetooth were disabled while testing WIFI modes.
7. The Margin from FCC limit column indicates a margin from the FCC limit for compliance (T3).

B. CDMA

1. Power Configuration: Power Control Bits = "All Up"
2. Vocoder Configuration: RC1/SO3 (CDMA – EVRC)

C. GSM

1. Power Configuration: GSM850: PCL=5, GSM1900: PCL=0;
2. Vocoder Configuration: EFR (GSM);

D. UMTS



1. Power Configuration: TPC= "All 1s";
2. Vocoder Configuration: AMR 12.2 kbps (UMTS);

E. LTE FDD

1. Power Configuration: TPC = "Max Power"
2. Radio Configuration: 16QAM, 1RB, 50%RB offset
3. Vocoder Configuration: EVS Primary SWB 9.6kbps
4. The worst-case band and bandwidth combination for each probe orientation is additionally tested on the low and high channels for those combinations. LTE Band 14 at 5MHz is the worst-case for the Axial and Radial probe orientation.

F. LTE TDD

1. Power Configuration: TPC = "Max Power"
2. Radio Configuration: 16QAM, 1RB, 50%RB offset
3. Power Class 3 Uplink-Downlink configuration: 1
4. Power Class 2 Uplink-Downlink configuration: 1
5. Vocoder Configuration: EVS Primary SWB 9.6kbps
6. The worst-case band and bandwidth combination for each probe orientation is additionally tested on the low, low-mid, high-mid, and high channels for those combinations. LTE Band 48 at 5MHz is the worst-case for the Axial probe orientation. LTE Band 48 at 15MHz is the worst-case for the Radial probe orientation.



| | | | | |
|-------------------------------------|---|-------------------------------|---|---------------------------------|
| FCC ID: A3LSMF707U |  | HAC (T-COIL) TEST REPORT |  | Approved by: Quality Manager |
| Filename: 1M2005040080-19-R2.A3L | Test Dates: 06/15/2020 - 07/02/2020 | DUT Type: Portable Handset | | Page 47 of 108 |

G. WIFI



1. Radio Configuration
 - a. IEEE 802.11b: CCK, 5.5Mbps
 - b. IEEE 802.11g/a: QPSK, 12Mbps
 - c. IEEE 802.11n/ac 20MHz: 64QAM, MCS 6
 - d. IEEE 802.11ax SU 20MHz: BPSK, MCS 0
 - e. IEEE 802.11n/ac 40MHz: BPSK, MCS 0
 - f. IEEE 802.11ax SU 40MHz: BPSK, MCS 0
2. RU Index
 - a. IEEE 802.11ax RU 20MHz: 40
 - b. IEEE 802.11ax RU 40MHz: 0
3. Vocoder Configuration: EVS Primary SWB 9.6kbps
4. The worst-case standard for 2.4GHz WIFI in each probe orientation is additionally tested on the low and high channels. IEEE 802.11b is the worst-case for the Axial probe orientation. IEEE 802.11ax RU is the worst-case for the Radial probe orientation.
5. The worst-case standard for 5GHz WIFI in each probe orientation is additionally tested on higher U-NII bands as well as applicable low and high channels. IEEE 802.11ax SU at 20MHz (U-NII 1) is the worst-case for the Axial probe orientation. IEEE 802.11ac at 20MHz (U-NII 3) is the worst-case for the Radial probe orientation.

H. OTT VoIP

1. Vocoder Configuration: 6kbps
2. EvDO Configuration
 - a. Revision: A
3. EDGE Configuration
 - a. MCS Index: 7
 - b. Number of TX slots: 2
4. HSPA Configuration:
 - a. Release: 6
 - b. 3GPP 34.121 Subtest 1
5. LTE FDD Configuration:
 - a. Power Configuration: TPC = "Max Power"
 - b. Radio Configuration: 16QAM, 1RB, 50%RB offset
 - c. LTE Band 14 was the worst-case band from Table 7-6 and was used to test both Axial and Radial probe orientations.
 - d. The worst-case band and bandwidth combination for each probe orientation is additionally tested on the low and high channels for those combinations. LTE Band 14 at 5MHz is the worst-case for the Axial probe orientation. LTE Band 14 at 10MHz bandwidth is the worst-case for the Radial probe orientation. However, because LTE Band 14 at 10MHz only supports one channel, low and high channels were not evaluated.
6. LTE TDD Configuration:
 - a. Power Configuration: TPC = "Max Power"
 - b. Radio Configuration: 16QAM, 1RB, 50%RB offset
 - c. Power Class 2 Uplink-Downlink configuration: 1
 - d. LTE Band 41 (PC2) was the worst-case band from Table 7-7 and was used to test both Axial and Radial probe orientations.
 - e. The worst-case band and bandwidth combination for each probe orientation is additionally tested on the low, low-mid, high-mid, and high channels for those combinations. LTE Band 41 (Power Class 2) at 10MHz is the worst-case for the Axial probe orientation. LTE Band 41 (Power Class 2) at 20MHz is the worst-case for the Radial probe orientation.

| | | | | |
|--|---|--------------------------------------|---|--|
| FCC ID: A3L3SMF707U |  | HAC (T-COIL) TEST REPORT |  | Approved by: Quality Manager |
| Filename: 1M2005040080-19-R2.A3L | Test Dates: 06/15/2020 - 07/02/2020 | DUT Type: Portable Handset | | Page 48 of 108 |

7. NR FDD Configuration
 - a. Power Configuration: TxAGC is set such that the DUT operates at max power.
 - b. Radio Configuration: DFT-s-OFDM, 16QAM, 1RB, 50% RB Offset
 - c. Due to equipment limitations, ABM1 measurements were not possible. Therefore, the procedure outlined in Section 7.II.5 was followed to obtain SNNR values. Additionally, Frequency Response measurements were not possible due to equipment limitations.
 - d. NR band n5 was the worst-case band from Table 7-12 and was used to test both Axial and Radial probe orientations.
 - e. The worst-case band and bandwidth combination for each probe orientation is additionally tested on the low and high channels for those combinations. NR n5 at 15MHz is the worst-case for the Axial and Radial probe orientation.
8. NR TDD Configuration
 - a. Power Configuration: TxAGC is set such that the DUT operates at max power.
 - b. Radio Configuration: DFT-s-OFDM, 16QAM, 1RB, 50% RB Offset
 - c. Due to equipment limitations, ABM1 measurements were not possible. Therefore, the procedure outlined in Section 7.II.5 was followed to obtain SNNR values. Additionally, Frequency Response measurements were not possible due to equipment limitations.
 - d. The worst-case band and bandwidth combination for each probe orientation is additionally tested on the low and high channels for those combinations. NR n41 at 100MHz is the worst-case for the Axial probe orientation. NR n41 at 50MHz bandwidth is the worst-case for the Radial probe orientation.
9. WIFI Configuration:
 - a. Radio Configuration
 - i. IEEE 802.11b: CCK, 5.5Mbps
 - ii. IEEE 802.11g/a: QPSK, 12Mbps
 - iii. IEEE 802.11n/ac 20MHz: 64QAM, MCS 6
 - iv. IEEE 802.11ax SU 20MHz: BPSK, MCS 0
 - v. IEEE 802.11n/ac 40MHz: BPSK, MCS 0
 - vi. IEEE 802.11ax SU 40MHz: BPSK, MCS 0
 - b. RU Index
 - i. IEEE 802.11ax RU 20MHz: 40
 - ii. IEEE 802.11ax RU 40MHz: 0
 - c. The worst-case standard for 2.4GHz WIFI in each probe orientation is additionally tested on the low and high channels. IEEE 802.11ax RU is the worst-case for the Axial probe orientation. IEEE 802.11b is the worst-case for the Radial probe orientation.
 - d. The worst-case standard for 5GHz WIFI in each probe orientation is additionally tested on higher U-NII bands as well as applicable low and high channels. IEEE 802.11ax RU at 40MHz (U-NII 3) is the worst-case for the Axial probe orientation. IEEE 802.11ax RU at 40MHz (U-NII 2A) is the worst-case for the Radial probe orientation.

| | | | | |
|--|---|--------------------------------------|---|--|
| FCC ID: A3LSMF707U |  | HAC (T-COIL) TEST REPORT |  | Approved by: Quality Manager |
| Filename: 1M2005040080-19-R2.A3L | Test Dates: 06/15/2020 - 07/02/2020 | DUT Type: Portable Handset | Page 49 of 108 | |

III. 1 kHz Vocoder Application Check

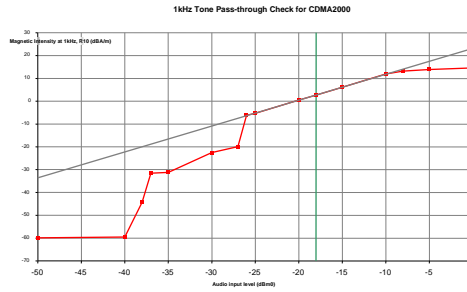

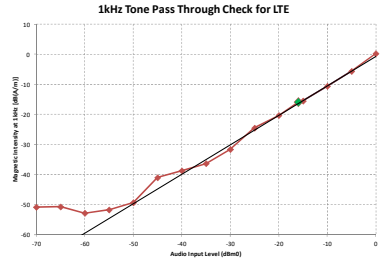
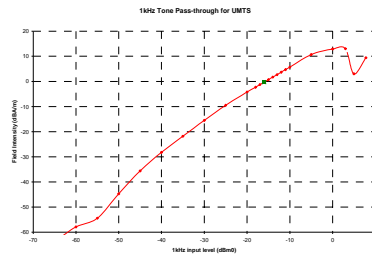
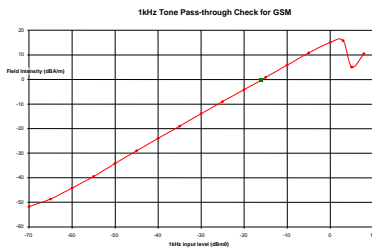

This model was verified to be within the linear region for ABM1 measurements at -18 dBm0 for CDMA. This measurement was taken in the axial configuration above the maximum location.

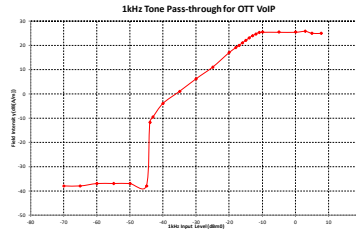
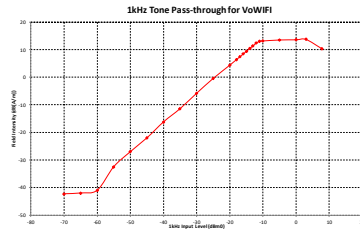

This model was verified to be within the linear region for ABM1 measurements at -16 dBm0 for GSM, UMTS, and VoLTE over IMS. This measurement was taken in the axial configuration above the maximum location.



This model was verified to be within the linear region for ABM1 measurements at -20 dBm0 for VoWiFi over IMS and OTT VoIP. This measurement was taken in the axial configuration above the maximum location.

| | | | | |
|-------------------------------------|---|-------------------------------|---|---------------------------------|
| FCC ID: A3LSMF707U |  | HAC (T-COIL) TEST REPORT |  | Approved by: Quality Manager |
| Filename: 1M2005040080-19-R2.A3L | Test Dates: 06/15/2020 - 07/02/2020 | DUT Type: Portable Handset | | Page 50 of 108 |

IV. T-Coil Validation Test Results

Table 9-35
Helmholtz Coil Validation Table of Results – 6/15/2020 (HH Coil SN: SBI 1052)



| Item | Target | Result | Verdict |
|---------------------------------|--------------|--------|---------|
| Axial | | | |
| Magnetic Intensity, -10 dBA/m | -10 ± 0.5 dB | -9.874 | PASS |
| Environmental Noise | < -58 dBA/m | -59.68 | PASS |
| Frequency Response, from limits | > 0 dB | 0.50 | PASS |

Table 9-36
Helmholtz Coil Validation Table of Results – 6/22/2020 (HH Coil SN: SBI 1052)

| Item | Target | Result | Verdict |
|---------------------------------|--------------|---------|---------|
| Axial | | | |
| Magnetic Intensity, -10 dBA/m | -10 ± 0.5 dB | -9.875 | PASS |
| Environmental Noise | < -58 dBA/m | -61.73 | PASS |
| Frequency Response, from limits | > 0 dB | 0.50 | PASS |
| Radial | | | |
| Magnetic Intensity, -10 dBA/m | -10 ± 0.5 dB | -10.125 | PASS |
| Environmental Noise | < -58 dBA/m | -62.49 | PASS |
| Frequency Response, from limits | > 0 dB | 0.70 | PASS |



Table 9-37
Helmholtz Coil Validation Table of Results – 6/22/2020 (HH Coil SN: 925)

| Item | Target | Result | Verdict |
|---------------------------------|--------------|---------|---------|
| Axial | | | |
| Magnetic Intensity, -10 dBA/m | -10 ± 0.5 dB | -10.306 | PASS |
| Environmental Noise | < -58 dBA/m | -63.82 | PASS |
| Frequency Response, from limits | > 0 dB | 0.70 | PASS |
| Radial | | | |
| Magnetic Intensity, -10 dBA/m | -10 ± 0.5 dB | -10.358 | PASS |
| Environmental Noise | < -58 dBA/m | -63.77 | PASS |
| Frequency Response, from limits | > 0 dB | 0.70 | PASS |

| | | | | |
|-------------------------------------|---|-------------------------------|---|---------------------------------|
| FCC ID: A3L5MF707U |  | HAC (T-COIL) TEST REPORT |  | Approved by: Quality Manager |
| Filename: 1M2005040080-19-R2.A3L | Test Dates: 06/15/2020 - 07/02/2020 | DUT Type: Portable Handset | | Page 51 of 108 |

**Table 9-38
Helmholtz Coil Validation Table of Results – 6/29/2020 (HH Coil SN: 925)**

| Item | Target | Result | Verdict |
|---------------------------------|--------------------------|---------|-------------|
| Axial | | | |
| Magnetic Intensity, -10 dBA/m | $-10 \pm 0.5 \text{ dB}$ | -10.330 | PASS |
| Environmental Noise | < -58 dBA/m | -64.34 | PASS |
| Frequency Response, from limits | > 0 dB | 0.70 | PASS |
| Radial | | | |
| Magnetic Intensity, -10 dBA/m | $-10 \pm 0.5 \text{ dB}$ | -10.444 | PASS |
| Environmental Noise | < -58 dBA/m | -63.73 | PASS |
| Frequency Response, from limits | > 0 dB | 0.70 | PASS |

| | | | | |
|--|--|--------------------------------------|---|--|
| FCC ID: A3L5MF707U |  PCTEST <small>Passing the test, you're still not done.</small> | HAC (T-COIL) TEST REPORT |  | Approved by: Quality Manager |
| Filename: 1M2005040080-19-R2.A3L | Test Dates: 06/15/2020 - 07/02/2020 | DUT Type: Portable Handset | Page 52 of 108 | |

V. ABM1 Magnetic Field Distribution Scan Overlays

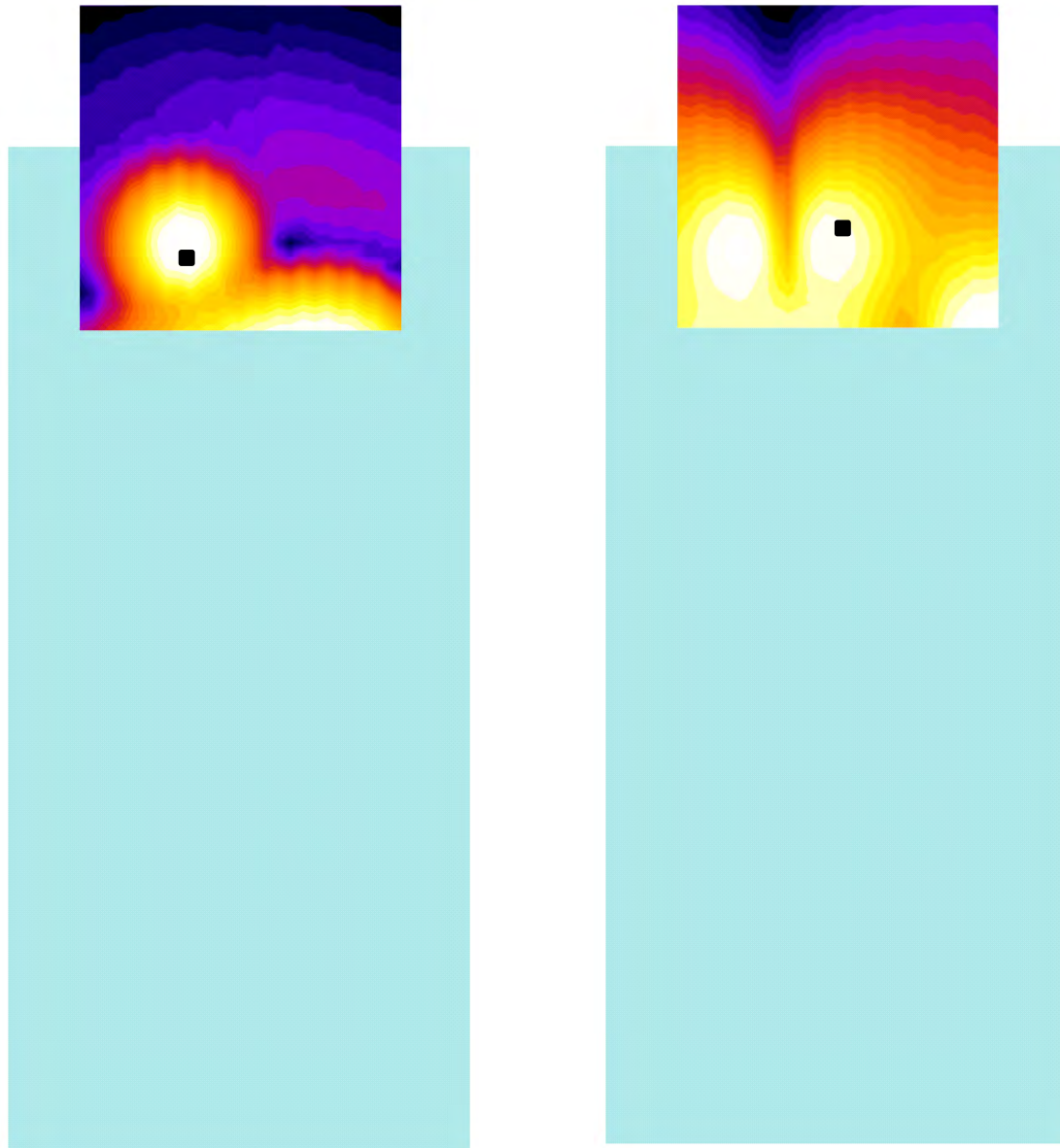



Axial

Radial (Transverse)

Figure 9-1
T-Coil Scan Overlay Magnetic Field Distributions

Notes:

1. Final measurement locations are indicated by a cursor on the contour plots.
2. See Test Setup Photographs for actual WD overlay.

| | | | | |
|--|---|--------------------------------------|---|--|
| FCC ID: A3LSMF707U |  | HAC (T-COIL) TEST REPORT |  | Approved by: Quality Manager |
| Filename: 1M2005040080-19-R2.A3L | Test Dates: 06/15/2020 - 07/02/2020 | DUT Type: Portable Handset | Page 53 of 108 | |

© 2020 PCTEST

REV 3.5.M
 6/30/2020

© 2020 PCTEST All rights reserved. Unless otherwise specified, no part of this report may be reproduced or utilized in any part, form or by any means, electronic or mechanical, including photocopying and microfilm, without permission in writing from PCTEST. If you have any questions about this international copyright or have an enquiry about obtaining additional rights to this report or assembly of contents thereof, please contact INFO@PCTEST.COM.

10. MEASUREMENT UNCERTAINTY



**Table 10-1
Uncertainty Estimation Table**

| Contribution | Data +/- % | Data +/- dB | Data Type | Probability distribution | Divisor | Standard uncertainty | Standard Uncertainty (dB) |
|--|------------|-------------|---------------|--------------------------|---------|----------------------|---------------------------|
| ABM Noise | 7.0% | 0.29 | Std. Dev. | Normal k=1 | 1.00 | 7.0% | |
| RF Reflections | 4.7% | 0.20 | Specification | Rectangular | 1.73 | 2.7% | |
| Reference Signal Level | 12.2% | 0.50 | Specification | Rectangular | 1.73 | 7.0% | |
| Positioning Accuracy | 10.0% | 0.41 | Uncertainty | Rectangular | 1.73 | 5.8% | |
| Probe Coil Sensitivity | 12.2% | 0.50 | Specification | Rectangular | 1.73 | 7.0% | |
| Probe Linearity | 2.4% | 0.10 | Std. Dev. | Normal k=1 | 1.00 | 2.4% | |
| Cable Loss | 2.8% | 0.12 | Specification | Rectangular | 1.73 | 1.6% | |
| Frequency Analyzer | 5.0% | 0.21 | Specification | Rectangular | 1.73 | 2.9% | |
| System Repeatability | 5.0% | 0.21 | Std. Dev. | Normal k=1 | 1.00 | 5.0% | |
| WD Repeatability | 9.0% | 0.37 | Std. Dev. | Normal k=1 | 1.00 | 9.0% | |
| Positioner Accuracy | 1.0% | 0.04 | Specification | Rectangular | 1.73 | 0.6% | |
| Combined standard uncertainty, u_c (k=1) | | | | | | 17.7% | 0.71 |
| Expanded uncertainty (k=2), 95% confidence level | | | | | | 35.3% | 1.31 |

Notes:

1. Test equipments are calibrated according to techniques outlined in NIS81, NIS3003 and NIST Tech Note 1297.
2. All equipments have traceability according to NIST. Measurement Uncertainties are defined in further detail in NIS 81 and NIST Tech Note 1297 and UKAS M3003.



Measurement uncertainty reflects the quality and accuracy of a measured result as compared to the true value. Such statements are generally required when stating results of measurements so that it is clear to the intended audience that the results may differ when reproduced by different facilities. Measurement results vary due to the measurement uncertainty of the instrumentation, measurement technique, and test engineer. Most uncertainties are calculated using the tolerances of the instrumentation used in the measurement, the measurement setup variability, and the technique used in performing the test. While not generally included, the variability of the equipment under test also figures into the overall measurement uncertainty. Another component of the overall uncertainty is based on the variability of repeated measurements (so-called Type A uncertainty). This may mean that the Hearing Aid compatibility tests may have to be repeated by taking down the test setup and resetting it up so that there are a statistically significant number of repeat measurements to identify the measurement uncertainty. By combining the repeat measurement results with that of the instrumentation chain using the technique contained in NIS 81 and NIS 3003, the overall measurement uncertainty was estimated.

| | | | | |
|--|---|--------------------------------------|---|--|
| FCC ID: A3L3SMF707U |  | HAC (T-COIL) TEST REPORT |  | Approved by: Quality Manager |
| Filename: 1M2005040080-19-R2.A3L | Test Dates: 06/15/2020 - 07/02/2020 | DUT Type: Portable Handset | Page 54 of 108 | |

11. EQUIPMENT LIST

**Table 11-1
Equipment List**

| Manufacturer | Model | Description | Cal Date | Cal Interval | Cal Due | Serial Number |
|-----------------|---------------------|---|------------|--------------|------------|---------------|
| Control Company | 4040 | Temperature / Humidity Monitor | 6/29/2019 | Biennial | 6/29/2021 | 192291470 |
| Dell | Latitude E6540 | SoundCheck Acoustic Analyzer Laptop | 4/24/2019 | Biennial | 4/24/2021 | 7BFNM32 |
| Dell | Latitude E6540 | SoundCheck Acoustic Analyzer Laptop | 9/6/2018 | Biennial | 9/6/2020 | 2655082910 |
| RME | Fireface UC | Soundcheck Acoustic Analyzer External Audio Interface | 4/24/2019 | Biennial | 4/24/2021 | 23528889 |
| RME | Fireface UC | Soundcheck Acoustic Analyzer External Audio Interface | 9/6/2018 | Biennial | 9/6/2020 | 23792992 |
| Listen | SoundConnect | Microphone Power Supply | 4/22/2019 | Biennial | 4/22/2021 | PS2612 |
| Listen | SoundConnect | Microphone Power Supply | 9/6/2018 | Biennial | 9/6/2020 | 0899-PS150 |
| Rohde & Schwarz | CMW500 | Wideband Radio Communication Tester | 2/4/2020 | Annual | 2/4/2021 | 162125 |
| Rohde & Schwarz | CMW500 | Radio Communication Tester | 5/21/2020 | Annual | 5/21/2021 | 128635 |
| Seekonk | NC-100 | Torque Wrench (8" lb) | 7/18/2019 | Annual | 7/18/2020 | N/A |
| TEM | | HAC System Controller with Software | N/A | | N/A | N/A |
| TEM | | HAC Positioner | N/A | | N/A | N/A |
| TEM | Helmholtz Coil | Helmholtz Coil | 10/10/2018 | Biennial | 10/10/2020 | SBI 1052 |
| TEM | Helmholtz Coil | Helmholtz Coil | 5/20/2019 | Biennial | 5/20/2021 | 925 |
| TEM | Axial T-Coil Probe | Axial T-Coil Probe | 9/19/2018 | Biennial | 9/19/2020 | TEM-1123 |
| TEM | Axial T-Coil Probe | Axial T-Coil Probe | 5/17/2019 | Biennial | 5/17/2021 | TEM-1124 |
| TEM | Radial T-Coil Probe | Radial T-Coil Probe | 9/19/2018 | Biennial | 9/19/2020 | TEM-1129 |
| TEM | Radial T-Coil Probe | Radial T-Coil Probe | 5/17/2019 | Biennial | 5/17/2021 | TEM-1130 |



| | | | | |
|-------------------------------------|---|-------------------------------|---|---------------------------------|
| FCC ID: A3LSMF707U |  | HAC (T-COIL) TEST REPORT |  | Approved by: Quality Manager |
| Filename: 1M2005040080-19-R2.A3L | Test Dates: 06/15/2020 - 07/02/2020 | DUT Type: Portable Handset | | Page 55 of 108 |

© 2020 PCTEST

REV 3.5.M
6/30/2020

© 2020 PCTEST All rights reserved. Unless otherwise specified, no part of this report may be reproduced or utilized in any part, form or by any means, electronic or mechanical, including photocopying and microfilm, without permission in writing from PCTEST. If you have any questions about this international copyright or have an enquiry about obtaining additional rights to this report or assembly of contents thereof, please contact INFO@PCTEST.COM.

12. TEST DATA

| | | | | |
|--|---|--------------------------------------|---|--|
| FCC ID: A3LSMF707U |  | HAC (T-COIL) TEST REPORT |  | Approved by: Quality Manager |
| Filename: 1M2005040080-19-R2.A3L | Test Dates: 06/15/2020 - 07/02/2020 | DUT Type: Portable Handset | Page 56 of 108 | |

© 2020 PCTEST

REV 3.5.M
6/30/2020

© 2020 PCTEST All rights reserved. Unless otherwise specified, no part of this report may be reproduced or utilized in any part, form or by any means, electronic or mechanical, including photocopying and microfilm, without permission in writing from PCTEST. If you have any questions about this international copyright or have an enquiry about obtaining additional rights to this report or assembly of contents thereof, please contact INFO@PCTEST.COM.



PCTEST Hearing-Aid Compatibility Facility

DUT: HH Coil – SN: SBI 1052

Type: HH Coil
Serial: SBI 1052

Measurement Standard: ANSI C63.19-2011

Equipment:

- Probe: Axial T-Coil Probe – SN: TEM-1123; Calibrated: 09/19/2018
- Helmholtz Coil – SN: SBI 1052; Calibrated: 10/10/2018

Noise Spectrum

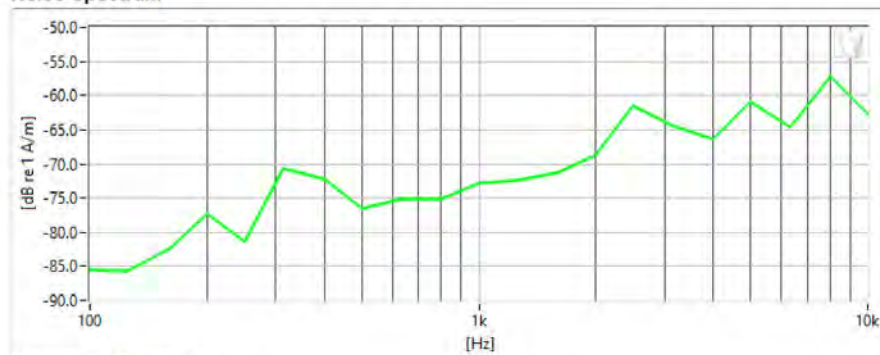

Frequency Response

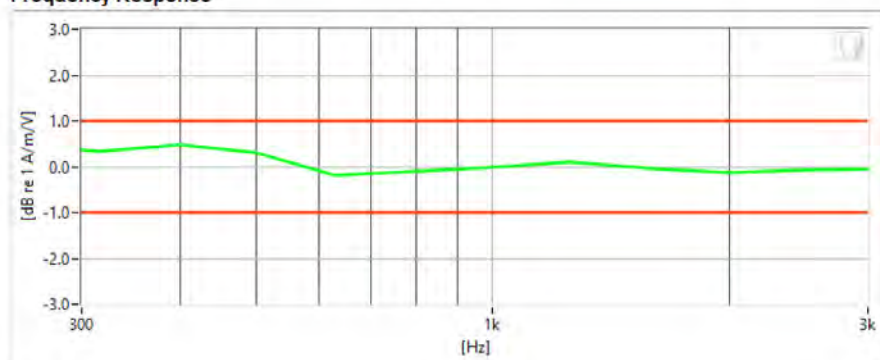

Results

| | | | | |
|-----------------------------|-----------|---|------------------|--------------|
| Verification 1kHz Intensity | -9.874 dB | ✓ | Max/Min | -9.5/-10.5 |
| Verification ABM2 | -59.68 dB | ✓ | Maximum | -58.0 |
| Frequency Response Margin | 500m dB | ✓ | Tolerance curves | Aligned Data |

PCTEST 2020

| | | | | |
|-------------------------------------|--|-------------------------------|--|---------------------------------|
| FCC ID: A3LSMF707U | | HAC (T-COIL) TEST REPORT | | Approved by: Quality Manager |
| Filename: 1M2005040080-19-R2.A3L | Test Dates: 06/15/2020 - 07/02/2020 | DUT Type: Portable Handset | | Page 57 of 108 |

© 2020 PCTEST

REV 3.5.M
6/30/2020



PCTEST Hearing-Aid Compatibility Facility

DUT: HH Coil – SN: SBI 1052

Type: HH Coil
Serial: SBI 1052

Measurement Standard: ANSI C63.19-2011

Equipment:

- Probe: Axial T-Coil Probe – SN: TEM-1123; Calibrated: 09/19/2018
- Helmholtz Coil – SN: SBI 1052; Calibrated: 10/10/2018

Noise Spectrum

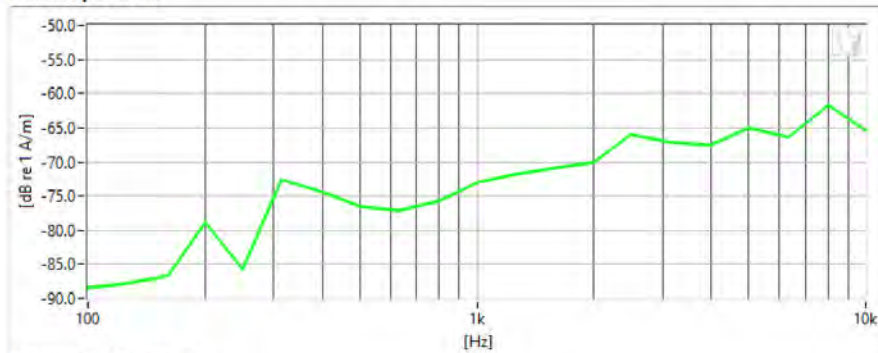

Frequency Response

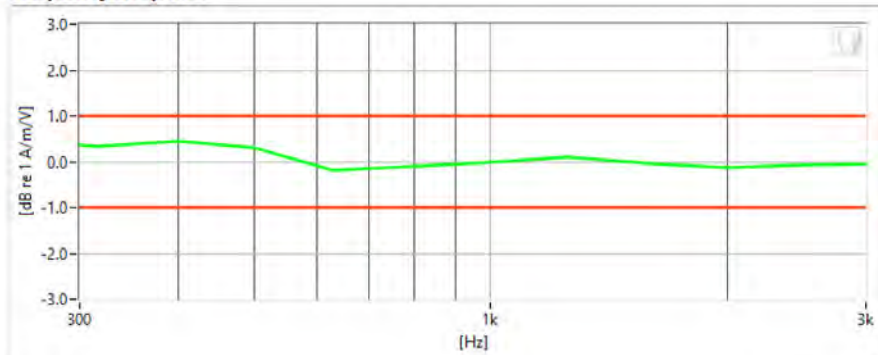

Results

| | | | | |
|-----------------------------|-----------|---|------------------|--------------|
| Verification 1kHz Intensity | -9.875 dB | ✓ | Max/Min | -9.5/-10.5 |
| Verification ABM2 | -61.73 dB | ✓ | Maximum | -58.0 |
| Frequency Response Margin | 500m dB | ✓ | Tolerance curves | Aligned Data |

PCTEST 2020

| | | | | |
|-------------------------------------|--|-------------------------------|--|---------------------------------|
| FCC ID: A3LSMF707U | | HAC (T-COIL) TEST REPORT | | Approved by: Quality Manager |
| Filename: 1M2005040080-19-R2.A3L | Test Dates: 06/15/2020 - 07/02/2020 | DUT Type: Portable Handset | | Page 58 of 108 |



PCTEST Hearing-Aid Compatibility Facility

DUT: HH Coil – SN: 925

Type: HH Coil
Serial: 925

Measurement Standard: ANSI C63.19-2011

Equipment:

- Probe: Axial T-Coil Probe – SN: TEM-1124; Calibrated: 05/17/2019
- Helmholtz Coil – SN: 925; Calibrated: 05/20/2019

Noise Spectrum

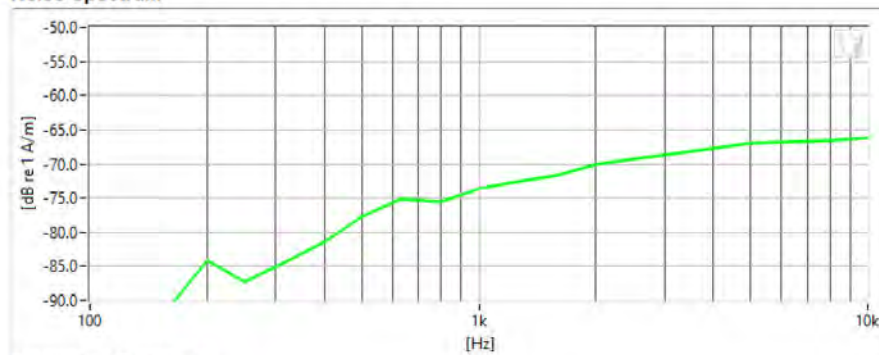

Frequency Response

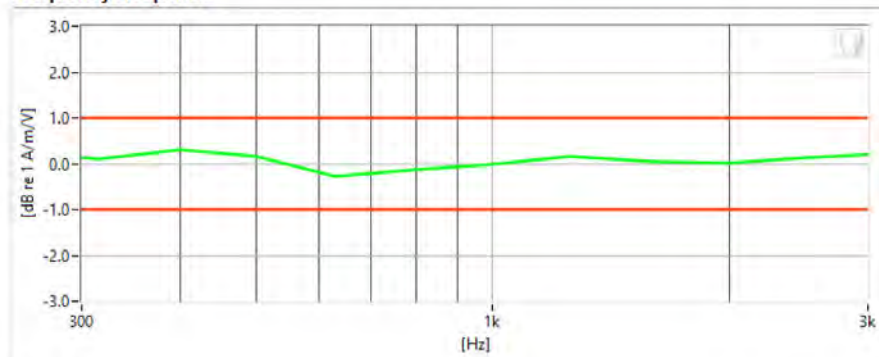

Results

| | | | | |
|-----------------------------|------------|---|------------------|--------------|
| Verification 1kHz Intensity | -10.306 dB | ✓ | Max/Min | -9.5/-10.5 |
| Verification ABM2 | -63.82 dB | ✓ | Maximum | -58.0 |
| Frequency Response Margin | 700m dB | ✓ | Tolerance curves | Aligned Data |

PCTEST 2020

| | | | | |
|-------------------------------------|--|-------------------------------|--|---------------------------------|
| FCC ID: A3LSMF707U | | HAC (T-COIL) TEST REPORT | | Approved by: Quality Manager |
| Filename: 1M2005040080-19-R2.A3L | Test Dates: 06/15/2020 - 07/02/2020 | DUT Type: Portable Handset | | Page 59 of 108 |

© 2020 PCTEST

REV 3.5.M
6/30/2020



PCTEST Hearing-Aid Compatibility Facility

DUT: HH Coil – SN: 925

Type: HH Coil
Serial: 925

Measurement Standard: ANSI C63.19-2011

Equipment:

- Probe: Axial T-Coil Probe – SN: TEM-1124; Calibrated: 05/17/2019
- Helmholtz Coil – SN: 925; Calibrated: 05/20/2019

Noise Spectrum

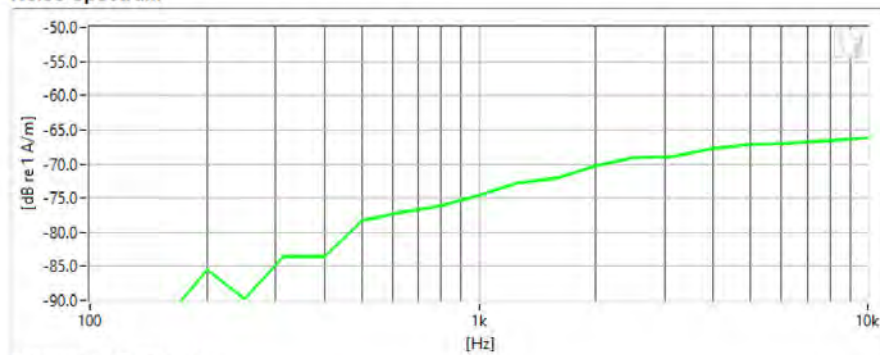

Frequency Response

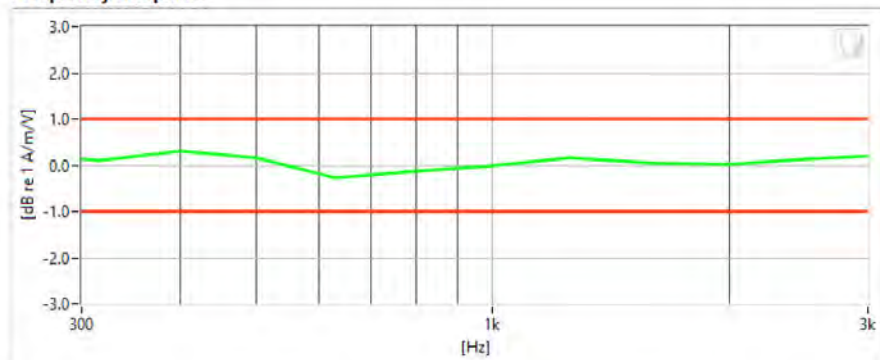

Results

| | | | | |
|-----------------------------|-----------|---|------------------|--------------|
| Verification 1kHz Intensity | -10.33 dB | ✓ | Max/Min | -9.5/-10.5 |
| Verification ABM2 | -64.34 dB | ✓ | Maximum | -58.0 |
| Frequency Response Margin | 700m dB | ✓ | Tolerance curves | Aligned Data |

PCTEST 2020

| | | | | |
|-------------------------------------|--|-------------------------------|--|---------------------------------|
| FCC ID: A3LSMF707U | PCTEST Proud to be part of element | HAC (T-COIL) TEST REPORT | | Approved by: Quality Manager |
| Filename: 1M2005040080-19-R2.A3L | Test Dates: 06/15/2020 - 07/02/2020 | DUT Type: Portable Handset | | Page 60 of 108 |

© 2020 PCTEST

REV 3.5.M
6/30/2020

© 2020 PCTEST All rights reserved. Unless otherwise specified, no part of this report may be reproduced or utilized in any part, form or by any means, electronic or mechanical, including photocopying and microfilm, without permission in writing from PCTEST. If you have any questions about this international copyright or have an enquiry about obtaining additional rights to this report or assembly of contents thereof, please contact INFO@PCTEST.COM.



PCTEST Hearing-Aid Compatibility Facility

DUT: HH Coil – SN: SBI 1052

Type: HH Coil
Serial: SBI 1052

Measurement Standard: ANSI C63.19-2011

Equipment:

- Probe: Radial T-Coil Probe – SN: TEM-1129; Calibrated: 09/19/2018
- Helmholtz Coil – SN: SBI 1052; Calibrated: 10/10/2018

Noise Spectrum

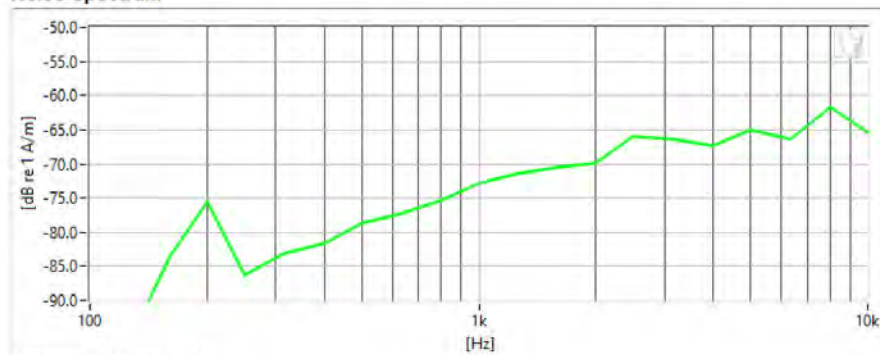

Frequency Response

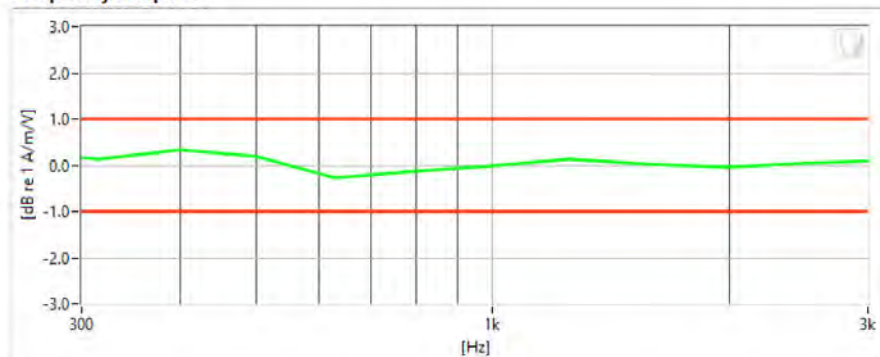

Results

| | | | | |
|-----------------------------|------------|---|------------------|--------------|
| Verification 1kHz Intensity | -10.125 dB | ✓ | Max/Min | -9.5/-10.5 |
| Verification ABM2 | -62.49 dB | ✓ | Maximum | -58.0 |
| Frequency Response Margin | 700m dB | ✓ | Tolerance curves | Aligned Data |

PCTEST 2020

| | | | | |
|-------------------------------------|--|-------------------------------|--|---------------------------------|
| FCC ID: A3LSMF707U | | HAC (T-COIL) TEST REPORT | | Approved by: Quality Manager |
| Filename: 1M2005040080-19-R2.A3L | Test Dates: 06/15/2020 - 07/02/2020 | DUT Type: Portable Handset | | Page 61 of 108 |

© 2020 PCTEST

REV 3.5.M
6/30/2020



PCTEST Hearing-Aid Compatibility Facility

DUT: HH Coil – SN: 925

Type: HH Coil
Serial: 925

Measurement Standard: ANSI C63.19-2011

Equipment:

- Probe: Radial T-Coil Probe – SN: TEM-1130; Calibrated: 05/17/2019
- Helmholtz Coil – SN: 925; Calibrated: 05/20/2019

Noise Spectrum

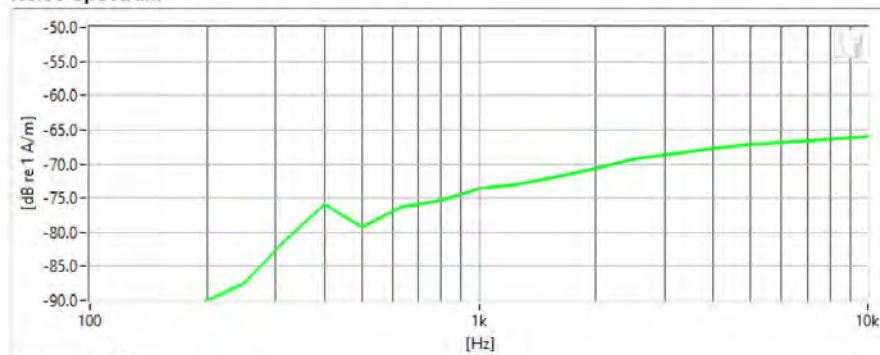

Frequency Response

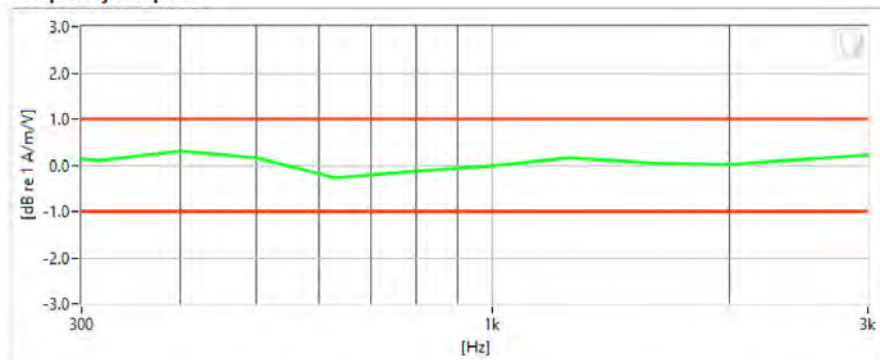

Results

| | | | | |
|-----------------------------|------------|---|------------------|--------------|
| Verification 1kHz Intensity | -10.358 dB | ✓ | Max/Min | -9.5/-10.5 |
| Verification ABM2 | -63.77 dB | ✓ | Maximum | -58.0 |
| Frequency Response Margin | 700m dB | ✓ | Tolerance curves | Aligned Data |

PCTEST 2020

| | | | | |
|-------------------------------------|--|-------------------------------|--|---------------------------------|
| FCC ID: A3LSMF707U | | HAC (T-COIL) TEST REPORT | | Approved by: Quality Manager |
| Filename: 1M2005040080-19-R2.A3L | Test Dates: 06/15/2020 - 07/02/2020 | DUT Type: Portable Handset | | Page 62 of 108 |

© 2020 PCTEST

REV 3.5.M
6/30/2020



PCTEST Hearing-Aid Compatibility Facility

DUT: HH Coil – SN: 925

Type: HH Coil
Serial: 925

Measurement Standard: ANSI C63.19-2011

Equipment:

- Probe: Radial T-Coil Probe – SN: TEM-1130; Calibrated: 05/17/2019
- Helmholtz Coil – SN: 925; Calibrated: 05/20/2019

Noise Spectrum

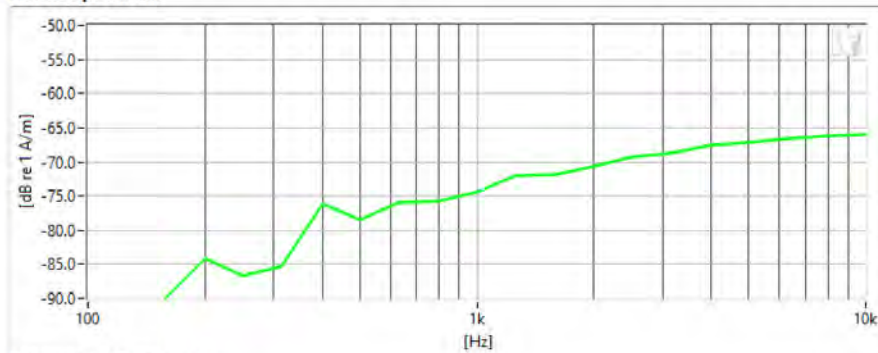

Frequency Response

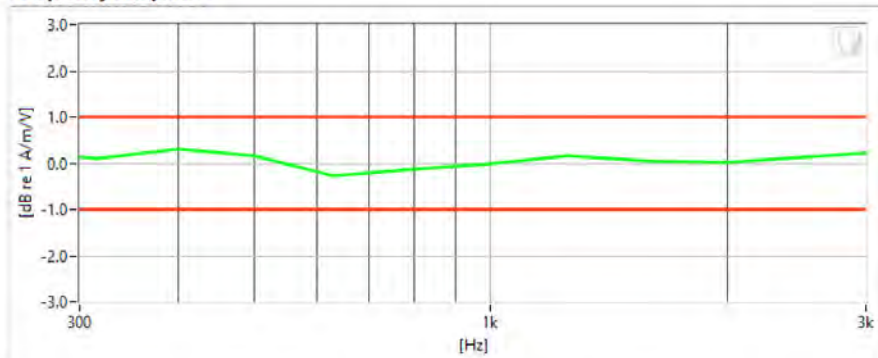

Results

| | | | | |
|-----------------------------|------------|---|------------------|--------------|
| Verification 1kHz Intensity | -10.444 dB | ✓ | Max/Min | -9.5/-10.5 |
| Verification ABM2 | -63.73 dB | ✓ | Maximum | -58.0 |
| Frequency Response Margin | 700m dB | ✓ | Tolerance curves | Aligned Data |

PCTEST 2020

| | | | | |
|-------------------------------------|--|-------------------------------|--|---------------------------------|
| FCC ID: A3LSMF707U | | HAC (T-COIL) TEST REPORT | | Approved by: Quality Manager |
| Filename: 1M2005040080-19-R2.A3L | Test Dates: 06/15/2020 - 07/02/2020 | DUT Type: Portable Handset | | Page 63 of 108 |



PCTEST Hearing-Aid Compatibility Facility

DUT: A3LSMF707U

Type: Portable Handset
Serial: 0011H

Measurement Standard: ANSI C63.19-2011

Equipment:

- Probe: Axial T-Coil Probe – SN: TEM-1123; Calibrated: 09/19/2018

Test Configuration:

- Mode: Secondary Cellular CDMA
- Channel: 476
- Speech Signal: 3GPP2 Normal Test Signal

Noise Spectrum

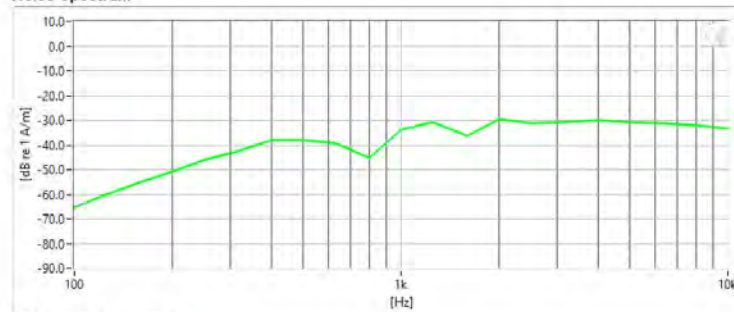

Frequency Response

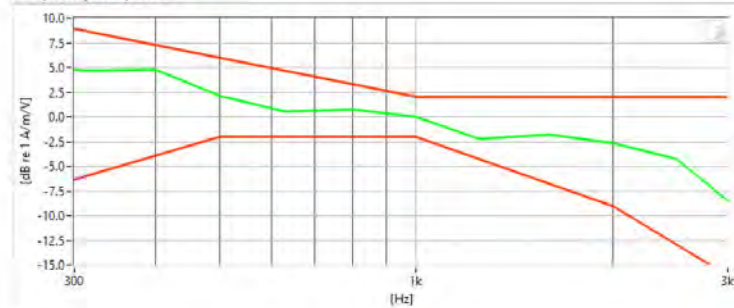

Results

| | | | | |
|---------------------------|-----------|---|------------------|--------------|
| ABM1 | 14.29 dB | ✓ | Minimum | -18.0 |
| ABM2 | -25.09 dB | ✓ | Maximum | 0.0 |
| SNNR | 39.38 dB | ✓ | Minimum | 20.0 |
| Aligned Response - Normal | 2 dB | ✓ | Tolerance curves | Aligned Data |

PCTEST 2020

| | | | | |
|-------------------------------------|--|-------------------------------|--|---------------------------------|
| FCC ID: A3LSMF707U | | HAC (T-COIL) TEST REPORT | | Approved by: Quality Manager |
| Filename: 1M2005040080-19-R2.A3L | Test Dates: 06/15/2020 - 07/02/2020 | DUT Type: Portable Handset | | Page 64 of 108 |



PCTEST Hearing-Aid Compatibility Facility

DUT: A3LSMF707U

Type: Portable Handset
Serial: 0011H

Measurement Standard: ANSI C63.19-2011

Equipment:

- Probe: Axial T-Coil Probe – SN: TEM-1123; Calibrated: 09/19/2018

Test Configuration:

- Mode: Cellular CDMA
- Channel: 777
- Speech Signal: 3GPP2 Normal Test Signal

Noise Spectrum

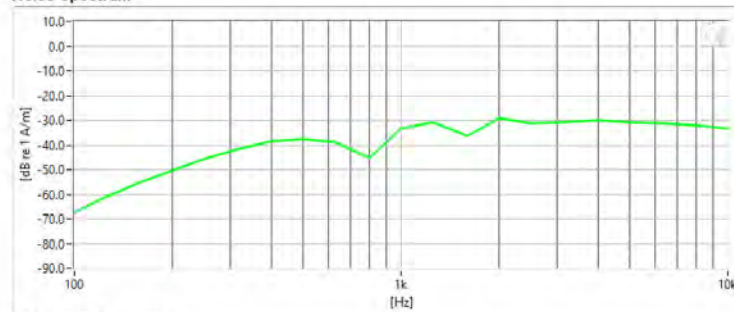

Frequency Response

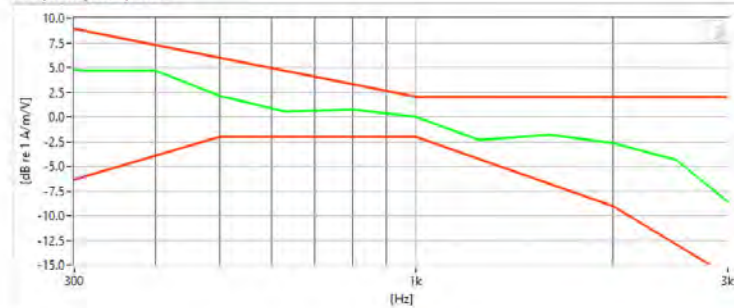

Results

| | | | | |
|---------------------------|----------|---|------------------|--------------|
| ABM1 | 14.34 dB | ✓ | Minimum | -18.0 |
| ABM2 | -24.9 dB | ✓ | Maximum | 0.0 |
| SNNR | 39.24 dB | ✓ | Minimum | 20.0 |
| Aligned Response - Normal | 1.96 dB | ✓ | Tolerance curves | Aligned Data |

PCTEST 2020

| | | | | |
|-------------------------------------|--|-------------------------------|--|---------------------------------|
| FCC ID: A3LSMF707U | | HAC (T-COIL) TEST REPORT | | Approved by: Quality Manager |
| Filename: 1M2005040080-19-R2.A3L | Test Dates: 06/15/2020 - 07/02/2020 | DUT Type: Portable Handset | | Page 65 of 108 |



PCTEST Hearing-Aid Compatibility Facility

DUT: A3LSMF707U

Type: Portable Handset
Serial: 0011H

Measurement Standard: ANSI C63.19-2011

Equipment:

- Probe: Axial T-Coil Probe – SN: TEM-1123; Calibrated: 09/19/2018

Test Configuration:

- Mode: PCS CDMA
- Channel: 1175
- Speech Signal: 3GPP2 Normal Test Signal

Noise Spectrum

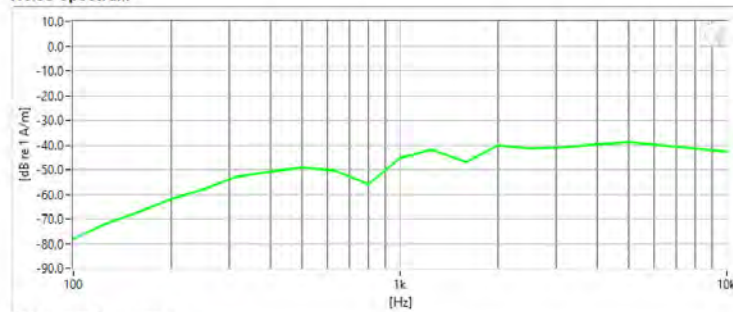

Frequency Response

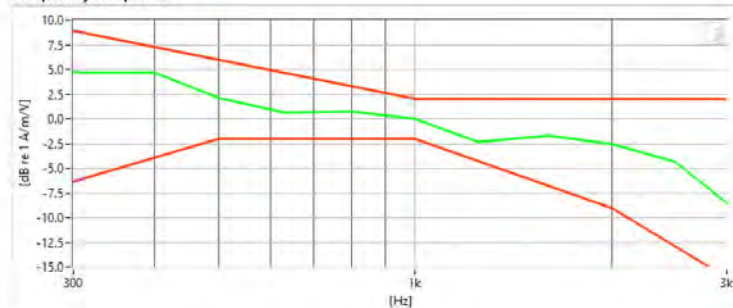

Results

| | | | | |
|---------------------------|----------|---|------------------|--------------|
| ABM1 | 14.09 dB | ✓ | Minimum | -18.0 |
| ABM2 | -36 dB | ✓ | Maximum | 0.0 |
| SNNR | 50.09 dB | ✓ | Minimum | 20.0 |
| Aligned Response - Normal | 1.93 dB | ✓ | Tolerance curves | Aligned Data |

PCTEST 2020

| | | | | |
|-------------------------------------|--|-------------------------------|--|---------------------------------|
| FCC ID: A3LSMF707U | | HAC (T-COIL) TEST REPORT | | Approved by: Quality Manager |
| Filename: 1M2005040080-19-R2.A3L | Test Dates: 06/15/2020 - 07/02/2020 | DUT Type: Portable Handset | | Page 66 of 108 |



PCTEST Hearing-Aid Compatibility Facility

DUT: A3LSMF707U

Type: Portable Handset
Serial: 0011H

Measurement Standard: ANSI C63.19-2011

Equipment:

- Probe: Axial T-Coil Probe – SN: TEM-1123; Calibrated: 09/19/2018

Test Configuration:

- Mode: GSM850
- Channel: 190
- Speech Signal: 3GPP2 Normal Test Signal

Noise Spectrum

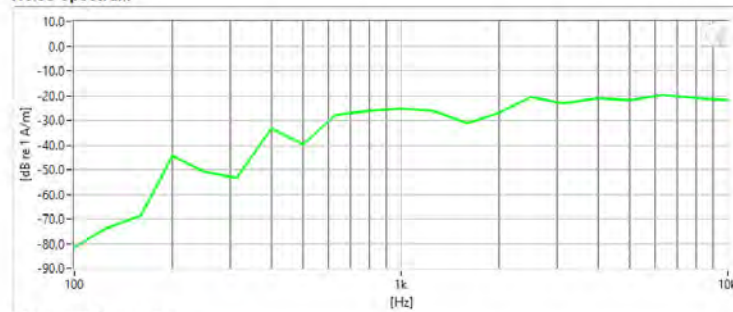

Frequency Response

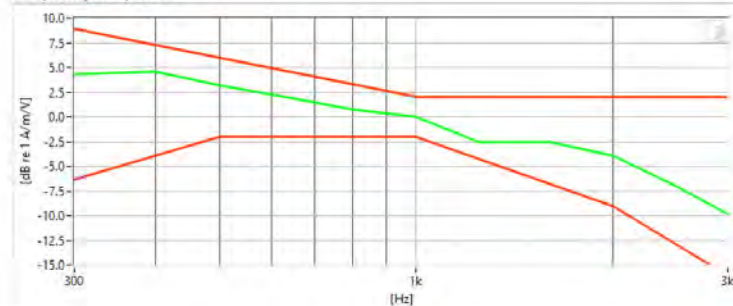

Results

| | | | | |
|---------------------------|-----------|---|------------------|--------------|
| ABM1 | 15.05 dB | ✓ | Minimum | -18.0 |
| ABM2 | -17.45 dB | ✓ | Maximum | 0.0 |
| SNNR | 32.5 dB | ✓ | Minimum | 20.0 |
| Aligned Response - Normal | 1.66 dB | ✓ | Tolerance curves | Aligned Data |

PCTEST 2020

| | | | | |
|-------------------------------------|--|-------------------------------|--|---------------------------------|
| FCC ID: A3LSMF707U | | HAC (T-COIL) TEST REPORT | | Approved by: Quality Manager |
| Filename: 1M2005040080-19-R2.A3L | Test Dates: 06/15/2020 - 07/02/2020 | DUT Type: Portable Handset | | Page 67 of 108 |

© 2020 PCTEST

REV 3.5.M

6/30/2020

© 2020 PCTEST All rights reserved. Unless otherwise specified, no part of this report may be reproduced or utilized in any part, form or by any means, electronic or mechanical, including photocopying and microfilm, without permission in writing from PCTEST. If you have any questions about this international copyright or have an enquiry about obtaining additional rights to this report or assembly of contents thereof, please contact INFO@PCTEST.COM.



PCTEST Hearing-Aid Compatibility Facility

DUT: A3LSMF707U

Type: Portable Handset
Serial: 0011H

Measurement Standard: ANSI C63.19-2011

Equipment:

- Probe: Axial T-Coil Probe – SN: TEM-1123; Calibrated: 09/19/2018

Test Configuration:

- Mode: GSM1900
- Channel: 661
- Speech Signal: 3GPP2 Normal Test Signal

Noise Spectrum

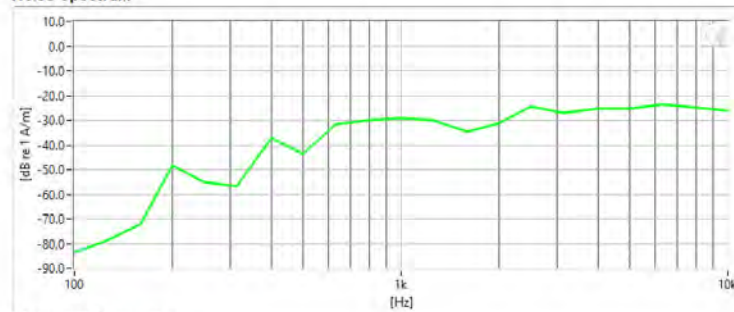

Frequency Response

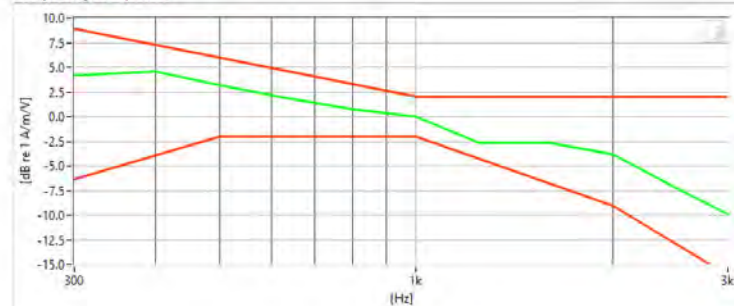

Results

| | | | | |
|---------------------------|-----------|---|------------------|--------------|
| ABM1 | 15.12 dB | ✓ | Minimum | -18.0 |
| ABM2 | -21.29 dB | ✓ | Maximum | 0.0 |
| SNNR | 36.41 dB | ✓ | Minimum | 20.0 |
| Aligned Response - Normal | 1.64 dB | ✓ | Tolerance curves | Aligned Data |

PCTEST 2020

| | | | | |
|-------------------------------------|--|-------------------------------|--|---------------------------------|
| FCC ID: A3LSMF707U | | HAC (T-COIL) TEST REPORT | | Approved by: Quality Manager |
| Filename: 1M2005040080-19-R2.A3L | Test Dates: 06/15/2020 - 07/02/2020 | DUT Type: Portable Handset | | Page 68 of 108 |



PCTEST Hearing-Aid Compatibility Facility

DUT: A3LSMF707U

Type: Portable Handset
Serial: 0011H

Measurement Standard: ANSI C63.19-2011

Equipment:

- Probe: Axial T-Coil Probe – SN: TEM-1123; Calibrated: 09/19/2018

Test Configuration:

- Mode: UMTS Band V
- Channel: 4183
- Speech Signal: 3GPP2 Normal Test Signal

Noise Spectrum

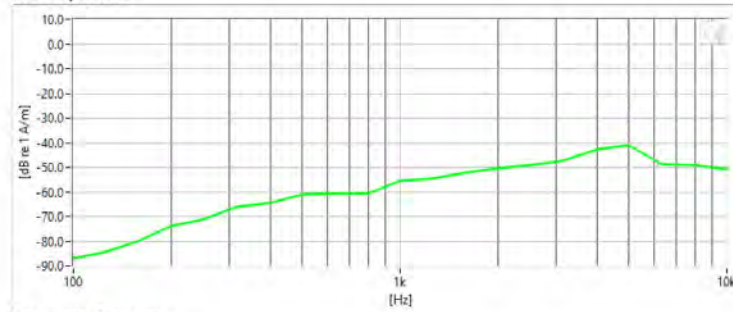

Frequency Response

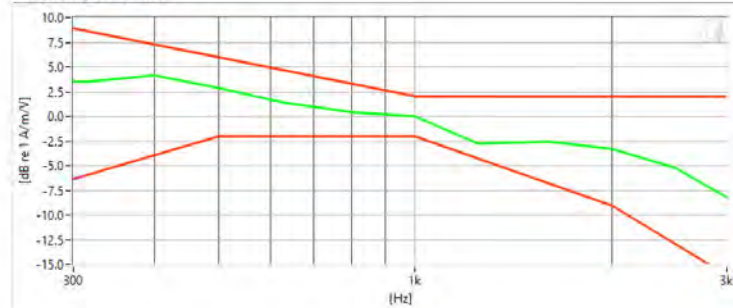

Results

| | | | | |
|---------------------------|-----------|---|------------------|--------------|
| ABM1 | 14.84 dB | ✓ | Minimum | -18.0 |
| ABM2 | -44.26 dB | ✓ | Maximum | 0.0 |
| SNNR | 59.11 dB | ✓ | Minimum | 20.0 |
| Aligned Response - Normal | 1.46 dB | ✓ | Tolerance curves | Aligned Data |

PCTEST 2020

| | | | | |
|-------------------------------------|--|-------------------------------|--|---------------------------------|
| FCC ID: A3LSMF707U | | HAC (T-COIL) TEST REPORT | | Approved by: Quality Manager |
| Filename: 1M2005040080-19-R2.A3L | Test Dates: 06/15/2020 - 07/02/2020 | DUT Type: Portable Handset | | Page 69 of 108 |



PCTEST Hearing-Aid Compatibility Facility

DUT: A3LSMF707U

Type: Portable Handset
Serial: 0011H

Measurement Standard: ANSI C63.19-2011

Equipment:

- Probe: Axial T-Coil Probe – SN: TEM-1123; Calibrated: 09/19/2018

Test Configuration:

- Mode: UMTS Band IV
- Channel: 1312
- Speech Signal: 3GPP2 Normal Test Signal

Noise Spectrum

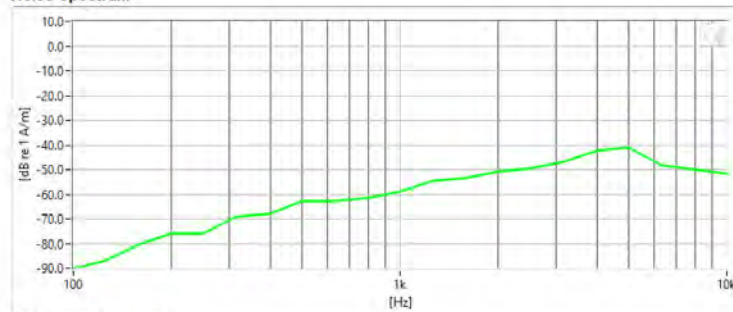

Frequency Response

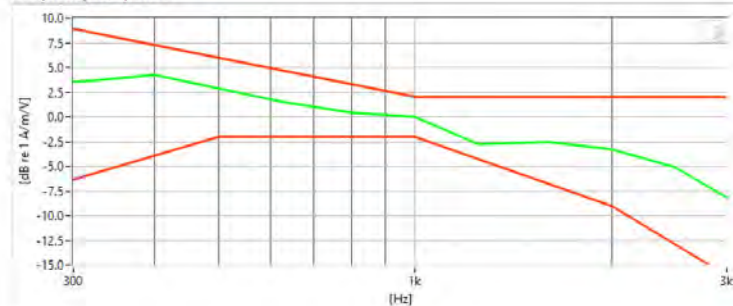

Results

| | | | | |
|---------------------------|-----------|---|------------------|--------------|
| ABM1 | 14.77 dB | ✓ | Minimum | -18.0 |
| ABM2 | -44.75 dB | ✓ | Maximum | 0.0 |
| SNNR | 59.52 dB | ✓ | Minimum | 20.0 |
| Aligned Response - Normal | 1.43 dB | ✓ | Tolerance curves | Aligned Data |

PCTEST 2020

| | | | | |
|-------------------------------------|--|-------------------------------|--|---------------------------------|
| FCC ID: A3LSMF707U | | HAC (T-COIL) TEST REPORT | | Approved by: Quality Manager |
| Filename: 1M2005040080-19-R2.A3L | Test Dates: 06/15/2020 - 07/02/2020 | DUT Type: Portable Handset | | Page 70 of 108 |



PCTEST Hearing-Aid Compatibility Facility

DUT: A3LSMF707U

Type: Portable Handset
Serial: 0011H

Measurement Standard: ANSI C63.19-2011

Equipment:

- Probe: Axial T-Coil Probe – SN: TEM-1123; Calibrated: 09/19/2018

Test Configuration:

- Mode: UMTS Band II
- Channel: 9400
- Speech Signal: 3GPP2 Normal Test Signal

Noise Spectrum

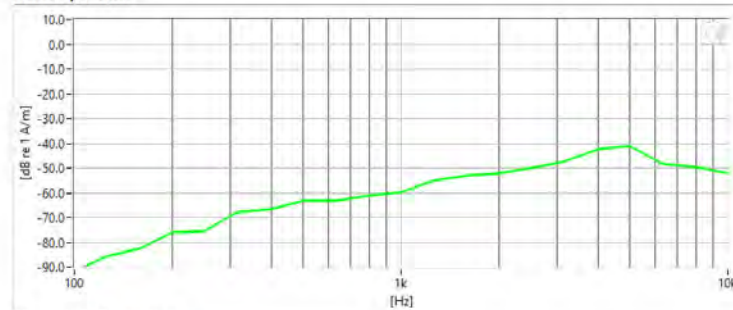

Frequency Response

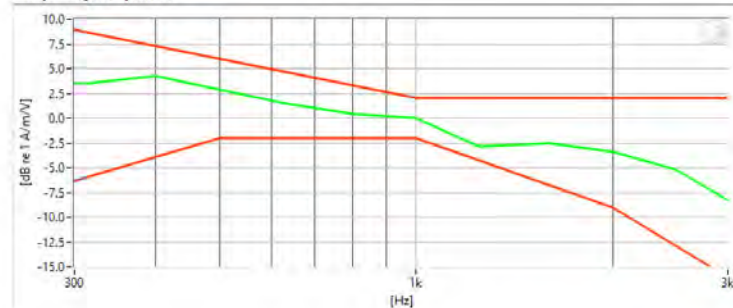

Results

| | | | | |
|---------------------------|-----------|---|------------------|--------------|
| ABM1 | 14.95 dB | ✓ | Minimum | -18.0 |
| ABM2 | -45.04 dB | ✓ | Maximum | 0 |
| SNNR | 59.99 dB | ✓ | Minimum | 20 |
| Aligned Response - Normal | 1.4 dB | ✓ | Tolerance curves | Aligned Data |

PCTEST 2020

| | | | | |
|-------------------------------------|--|-------------------------------|--|---------------------------------|
| FCC ID: A3LSMF707U | | HAC (T-COIL) TEST REPORT | | Approved by: Quality Manager |
| Filename: 1M2005040080-19-R2.A3L | Test Dates: 06/15/2020 - 07/02/2020 | DUT Type: Portable Handset | | Page 71 of 108 |

© 2020 PCTEST

REV 3.5.M
6/30/2020



PCTEST Hearing-Aid Compatibility Facility

DUT: A3LSMF707U

Type: Portable Handset
Serial: 0011H

Measurement Standard: ANSI C63.19-2011

Equipment:

- Probe: Axial T-Coil Probe – SN: TEM-1123; Calibrated: 09/19/2018

Test Configuration:

- Mode: LTE FDD Band 14
- Bandwidth: 23330
- Channel: 5MHz
- Speech Signal: 3GPP2 Normal Test Signal

Noise Spectrum

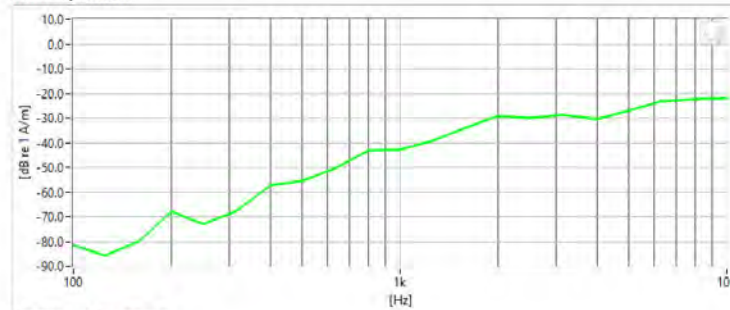

Frequency Response

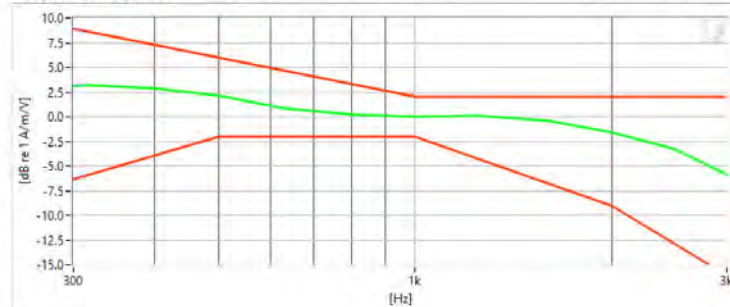

Results

| | | | | |
|---------------------------|-----------|---|------------------|--------------|
| ABM1 | -10m dB | ✓ | Minimum | -18.0 |
| ABM2 | -26.45 dB | ✓ | Maximum | 0.0 |
| SNNR | 26.44 dB | ✓ | Minimum | 20.0 |
| Aligned Response - Normal | 1.86 dB | ✓ | Tolerance curves | Aligned Data |

PCTEST 2020

| | | | | |
|-------------------------------------|--|-------------------------------|--|---------------------------------|
| FCC ID: A3LSMF707U | | HAC (T-COIL) TEST REPORT | | Approved by: Quality Manager |
| Filename: 1M2005040080-19-R2.A3L | Test Dates: 06/15/2020 - 07/02/2020 | DUT Type: Portable Handset | | Page 72 of 108 |



PCTEST Hearing-Aid Compatibility Facility

DUT: A3LSMF707U

Type: Portable Handset
Serial: 0011H

Measurement Standard: ANSI C63.19-2011

Equipment:

- Probe: Axial T-Coil Probe – SN: TEM-1124; Calibrated: 05/17/2019

Test Configuration:

- Mode: LTE TDD Band 48
- Bandwidth: 5MHz
- Channel: 56715
- Speech Signal: 3GPP2 Normal Test Signal

Noise Spectrum

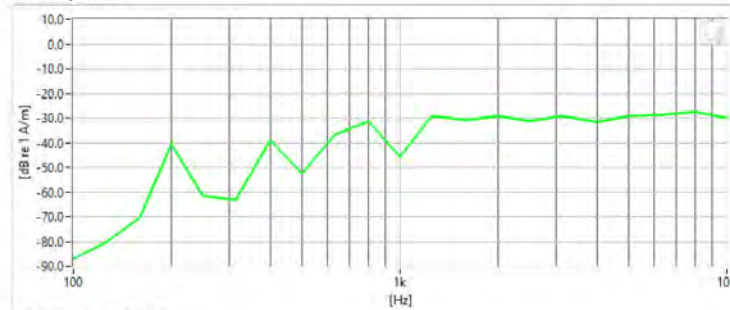

Frequency Response

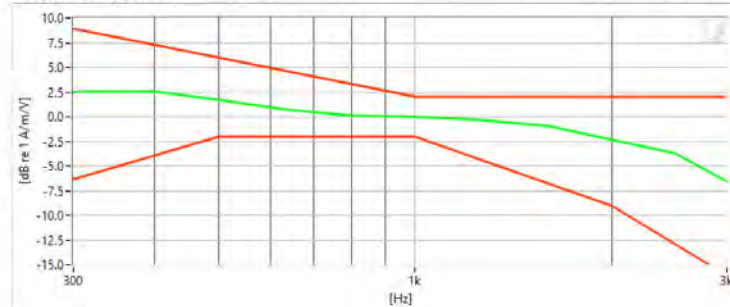

Results

| | | | | |
|---------------------------|-----------|---|------------------|--------------|
| ABM1 | -410m dB | ✓ | Minimum | -18.0 |
| ABM2 | -23.67 dB | ✓ | Maximum | 0.0 |
| SNNR | 23.26 dB | ✓ | Minimum | 20.0 |
| Aligned Response - Normal | 2 dB | ✓ | Tolerance curves | Aligned Data |

PCTEST 2020

| | | | | |
|-------------------------------------|--|-------------------------------|--|---------------------------------|
| FCC ID: A3LSMF707U | | HAC (T-COIL) TEST REPORT | | Approved by: Quality Manager |
| Filename: 1M2005040080-19-R2.A3L | Test Dates: 06/15/2020 - 07/02/2020 | DUT Type: Portable Handset | | Page 73 of 108 |



PCTEST Hearing-Aid Compatibility Facility

DUT: A3LSMF707U

Type: Portable Handset
Serial: 0011H

Measurement Standard: ANSI C63.19-2011

Equipment:

- Probe: Axial T-Coil Probe – SN: TEM-1124; Calibrated: 05/17/2019

Test Configuration:

- Mode: 2.4GHz WFI
- Standard: IEEE 802.11b
- Channel: 6
- Speech Signal: 3GPP2 Normal Test Signal

Noise Spectrum

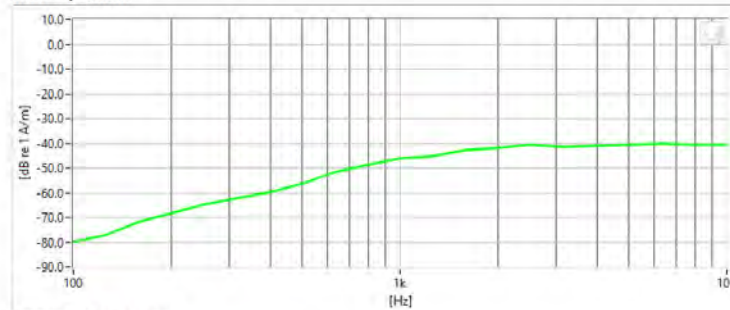

Frequency Response

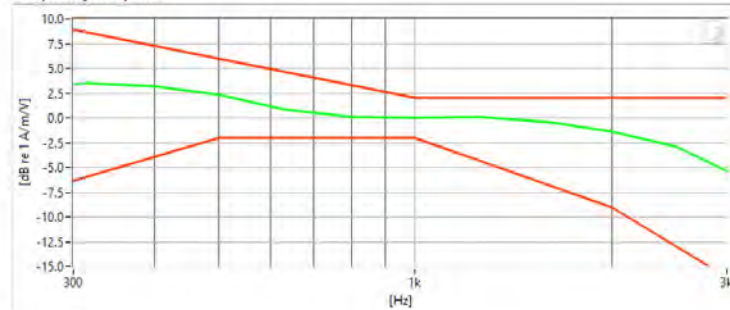

Results

| | | | | |
|---------------------------|-----------|---|------------------|--------------|
| ABM1 | 1.01 dB | ✓ | Minimum | -18.0 |
| ABM2 | -37.11 dB | ✓ | Maximum | 0 |
| SNNR | 38.12 dB | ✓ | Minimum | 20 |
| Aligned Response - Normal | 1.92 dB | ✓ | Tolerance curves | Aligned Data |

PCTEST 2020

| | | | | |
|-------------------------------------|--|-------------------------------|--|---------------------------------|
| FCC ID: A3LSMF707U | | HAC (T-COIL) TEST REPORT | | Approved by: Quality Manager |
| Filename: 1M2005040080-19-R2.A3L | Test Dates: 06/15/2020 - 07/02/2020 | DUT Type: Portable Handset | | Page 74 of 108 |



PCTEST Hearing-Aid Compatibility Facility

DUT: A3LSMF707U

Type: Portable Handset
Serial: 0011H

Measurement Standard: ANSI C63.19-2011

Equipment:

- Probe: Axial T-Coil Probe – SN: TEM-1124; Calibrated: 05/17/2019

Test Configuration:

- Mode: 5GHz WIFI
- Standard: IEEE 802.11ax SU (U-NII 1)
- Bandwidth: 20MHz
- Channel: 40
- Speech Signal: 3GPP2 Normal Test Signal

Noise Spectrum

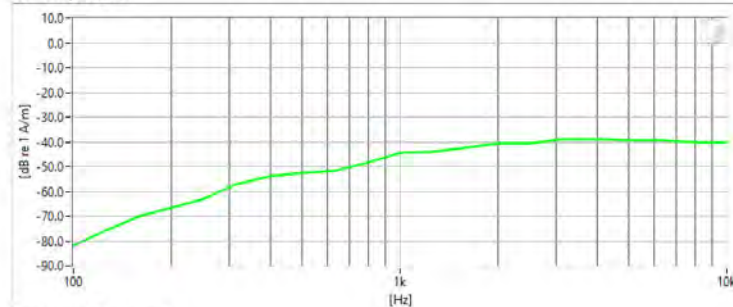

Frequency Response

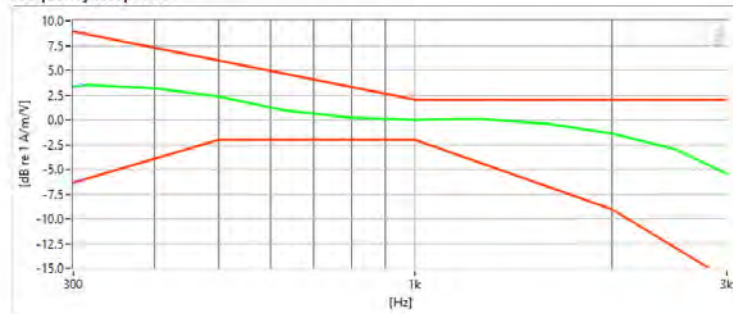

Results

| | | | | |
|---------------------------|-----------|---|------------------|--------------|
| ABM1 | 1.37 dB | ✓ | Minimum | -18.0 |
| ABM2 | -35.82 dB | ✓ | Maximum | 0.0 |
| SNNR | 37.2 dB | ✓ | Minimum | 20.0 |
| Aligned Response - Normal | 1.89 dB | ✓ | Tolerance curves | Aligned Data |

PCTEST 2020

| | | | | |
|-------------------------------------|--|-------------------------------|--|---------------------------------|
| FCC ID: A3LSMF707U | | HAC (T-COIL) TEST REPORT | | Approved by: Quality Manager |
| Filename: 1M2005040080-19-R2.A3L | Test Dates: 06/15/2020 - 07/02/2020 | DUT Type: Portable Handset | | Page 75 of 108 |



PCTEST Hearing-Aid Compatibility Facility

DUT: A3LSMF707U

Type: Portable Handset
Serial: 0011H

Measurement Standard: ANSI C63.19-2011

Equipment:

- Probe: Axial T-Coil Probe – SN: TEM-1123; Calibrated: 09/19/2018

Test Configuration:

- VoIP Application: Google Duo
- Mode: EDGE850
- Channel: 190
- Speech Signal: 3GPP2 Normal Test Signal

Noise Spectrum

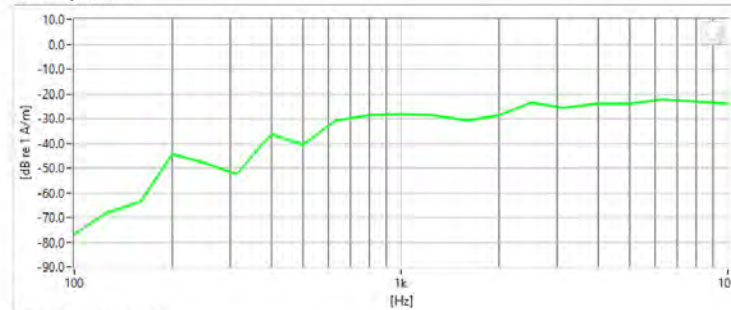

Frequency Response

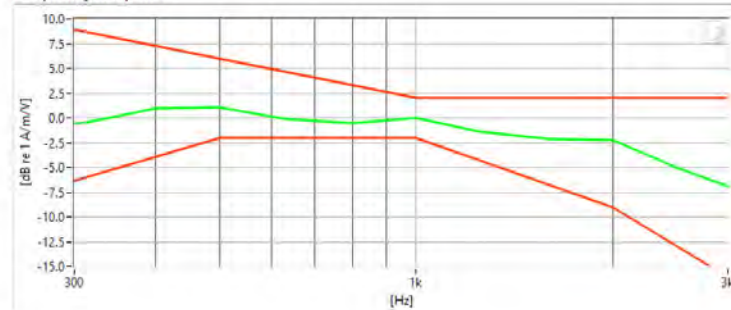

Results

| | | | | |
|---------------------------|-----------|---|------------------|--------------|
| ABM1 | 15.02 dB | ✓ | Minimum | -18.0 |
| ABM2 | -20.05 dB | ✓ | Maximum | 0.0 |
| SNNR | 35.07 dB | ✓ | Minimum | 20.0 |
| Aligned Response - Normal | 1.5 dB | ✓ | Tolerance curves | Aligned Data |

PCTEST 2020

| | | | | |
|-------------------------------------|--|-------------------------------|--|---------------------------------|
| FCC ID: A3LSMF707U | | HAC (T-COIL) TEST REPORT | | Approved by: Quality Manager |
| Filename: 1M2005040080-19-R2.A3L | Test Dates: 06/15/2020 - 07/02/2020 | DUT Type: Portable Handset | | Page 76 of 108 |



PCTEST Hearing-Aid Compatibility Facility

DUT: A3LSMF707U

Type: Portable Handset
Serial: 0011H

Measurement Standard: ANSI C63.19-2011

Equipment:

- Probe: Radial T-Coil Probe – SN: TEM-1129; Calibrated: 09/19/2018

Test Configuration:

- Mode: Secondary Cellular CDMA
- Channel: 476

Noise Spectrum

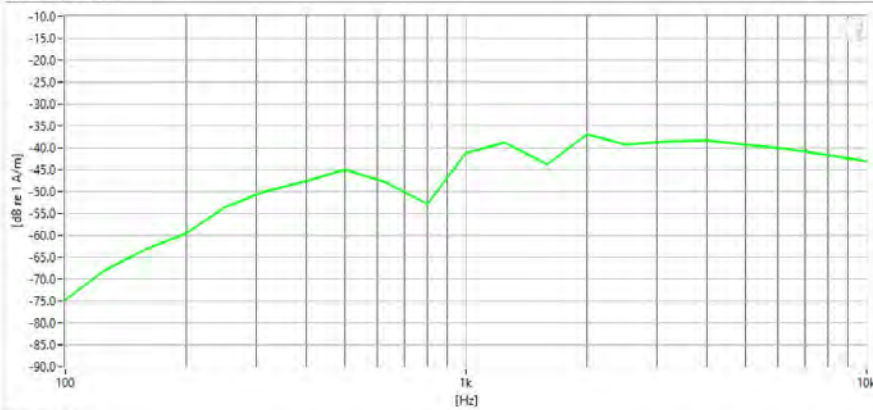

Results

| | | | | |
|------|-----------|---|---------|-------|
| ABM1 | 1.95 dB | ✓ | Minimum | -18.0 |
| ABM2 | -32.88 dB | ✓ | Maximum | 0.0 |
| SNNR | 34.84 dB | ✓ | Minimum | 20.0 |

PCTEST 2020

| | | | | |
|-------------------------------------|--|-------------------------------|--|---------------------------------|
| FCC ID: A3LSMF707U | | HAC (T-COIL) TEST REPORT | | Approved by: Quality Manager |
| Filename: 1M2005040080-19-R2.A3L | Test Dates: 06/15/2020 - 07/02/2020 | DUT Type: Portable Handset | | Page 77 of 108 |



PCTEST Hearing-Aid Compatibility Facility

DUT: A3LSMF707U

Type: Portable Handset
Serial: 0011H

Measurement Standard: ANSI C63.19-2011

Equipment:

- Probe: Radial T-Coil Probe – SN: TEM-1129; Calibrated: 09/19/2018

Test Configuration:

- Mode: Cellular CDMA
- Channel: 384

Noise Spectrum

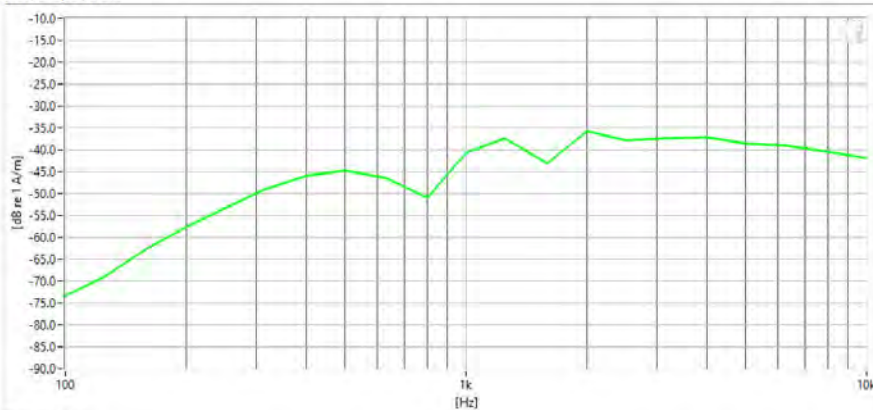

Results

| | | | | |
|------|-----------|---|---------|-------|
| ABM1 | 2.16 dB | ✓ | Minimum | -18.0 |
| ABM2 | -31.79 dB | ✓ | Maximum | 0.0 |
| SNNR | 33.95 dB | ✓ | Minimum | 20.0 |

PCTEST 2020

| | | | | |
|-------------------------------------|--|-------------------------------|--|---------------------------------|
| FCC ID: A3LSMF707U | | HAC (T-COIL) TEST REPORT | | Approved by: Quality Manager |
| Filename: 1M2005040080-19-R2.A3L | Test Dates: 06/15/2020 - 07/02/2020 | DUT Type: Portable Handset | | Page 78 of 108 |



PCTEST Hearing-Aid Compatibility Facility

DUT: A3LSMF707U

Type: Portable Handset
Serial: 0011H

Measurement Standard: ANSI C63.19-2011

Equipment:

- Probe: Radial T-Coil Probe – SN: TEM-1129; Calibrated: 09/19/2018

Test Configuration:

- Mode: PCS CDMA
- Channel: 1175

Noise Spectrum

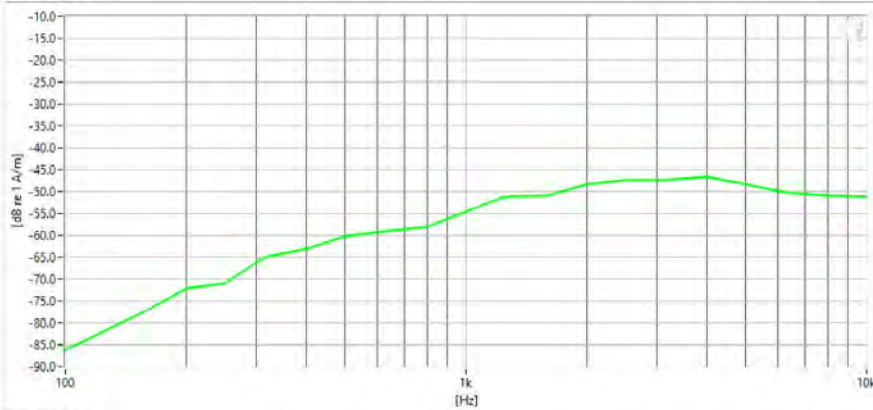

Results

| | | | | |
|------|----------|---|---------|-------|
| ABM1 | 1.58 dB | ✓ | Minimum | -18.0 |
| ABM2 | -44 dB | ✓ | Maximum | 0.0 |
| SNNR | 45.58 dB | ✓ | Minimum | 20.0 |

PCTEST 2020

| | | | | |
|--|---|--------------------------------------|--|--|
| FCC ID: A3LSMF707U | | HAC (T-COIL) TEST REPORT | | Approved by: Quality Manager |
| Filename: 1M2005040080-19-R2.A3L | Test Dates: 06/15/2020 - 07/02/2020 | DUT Type: Portable Handset | | Page 79 of 108 |



PCTEST Hearing-Aid Compatibility Facility

DUT: A3LSMF707U

Type: Portable Handset
Serial: 0011H

Measurement Standard: ANSI C63.19-2011

Equipment:

- Probe: Radial T-Coil Probe – SN: TEM-1129; Calibrated: 09/19/2018

Test Configuration:

- Mode: GSM850
- Channel: 128

Noise Spectrum

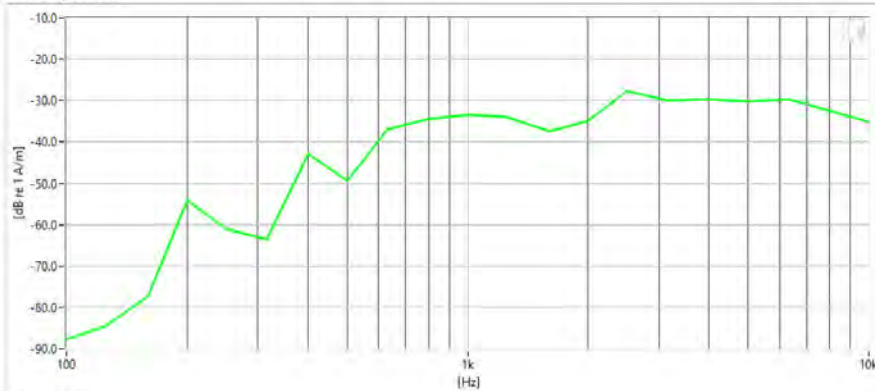

Results

| | | | | |
|------|-----------|---|---------|-------|
| ABM1 | 3.26 dB | ✓ | Minimum | -18.0 |
| ABM2 | -25.58 dB | ✓ | Maximum | 0.0 |
| SNNR | 28.84 dB | ✓ | Minimum | 20.0 |

PCTEST 2020

| | | | | |
|-------------------------------------|--|-------------------------------|--|---------------------------------|
| FCC ID: A3LSMF707U | | HAC (T-COIL) TEST REPORT | | Approved by: Quality Manager |
| Filename: 1M2005040080-19-R2.A3L | Test Dates: 06/15/2020 - 07/02/2020 | DUT Type: Portable Handset | | Page 80 of 108 |



PCTEST Hearing-Aid Compatibility Facility

DUT: A3LSMF707U

Type: Portable Handset
Serial: 0011H

Measurement Standard: ANSI C63.19-2011

Equipment:

- Probe: Radial T-Coil Probe – SN: TEM-1129; Calibrated: 09/19/2018

Test Configuration:

- Mode: GSM1900
- Channel: 661

Noise Spectrum

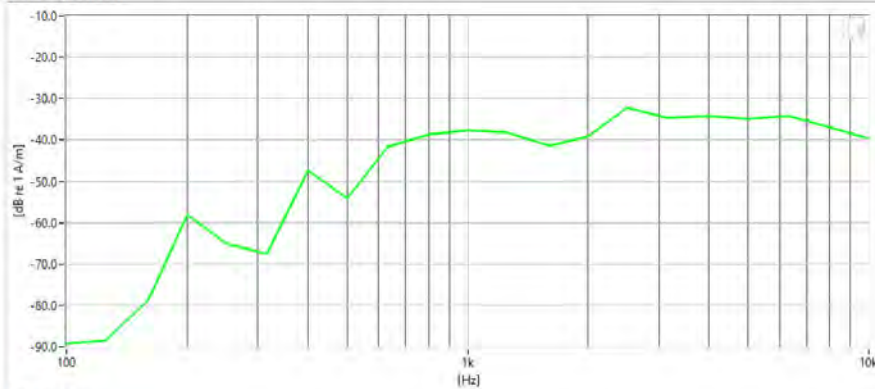

Results

| | | | | |
|------|-----------|---|---------|-------|
| ABM1 | 3.26 dB | ✓ | Minimum | -18.0 |
| ABM2 | -29.96 dB | ✓ | Maximum | 0.0 |
| SNNR | 33.22 dB | ✓ | Minimum | 20.0 |

PCTEST 2020

| | | | | |
|-------------------------------------|--|-------------------------------|--|---------------------------------|
| FCC ID: A3LSMF707U | | HAC (T-COIL) TEST REPORT | | Approved by: Quality Manager |
| Filename: 1M2005040080-19-R2.A3L | Test Dates: 06/15/2020 - 07/02/2020 | DUT Type: Portable Handset | | Page 81 of 108 |



PCTEST Hearing-Aid Compatibility Facility

DUT: A3LSMF707U

Type: Portable Handset
Serial: 0011H

Measurement Standard: ANSI C63.19-2011

Equipment:

- Probe: Radial T-Coil Probe – SN: TEM-1129; Calibrated: 09/19/2018

Test Configuration:

- Mode: UMTS Band V
- Channel: 4132

Noise Spectrum

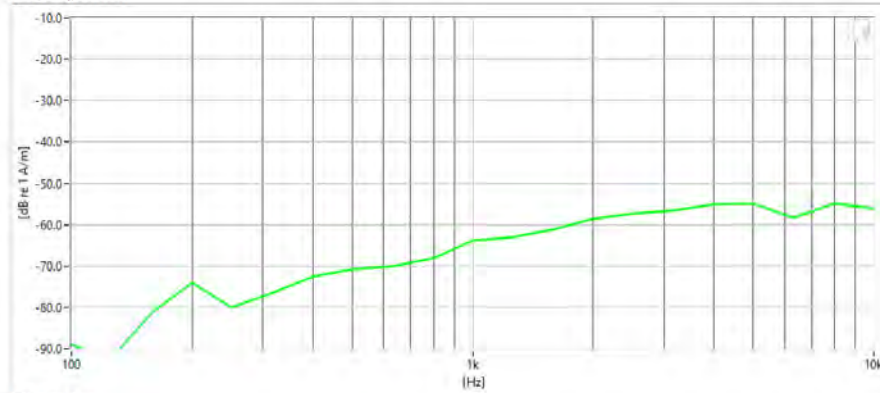

Results

| | | | | |
|------|-----------|---|---------|-------|
| ABM1 | 3.16 dB | ✓ | Minimum | -18.0 |
| ABM2 | -53.75 dB | ✓ | Maximum | 0.0 |
| SNNR | 56.91 dB | ✓ | Minimum | 20.0 |

PCTEST 2020

| | | | | |
|-------------------------------------|--|-------------------------------|--|---------------------------------|
| FCC ID: A3LSMF707U | | HAC (T-COIL) TEST REPORT | | Approved by: Quality Manager |
| Filename: 1M2005040080-19-R2.A3L | Test Dates: 06/15/2020 - 07/02/2020 | DUT Type: Portable Handset | | Page 82 of 108 |



PCTEST Hearing-Aid Compatibility Facility

DUT: A3LSMF707U

Type: Portable Handset
Serial: 0011H

Measurement Standard: ANSI C63.19-2011

Equipment:

- Probe: Radial T-Coil Probe – SN: TEM-1129; Calibrated: 09/19/2018

Test Configuration:

- Mode: UMTS Band IV
- Channel: 1513

Noise Spectrum

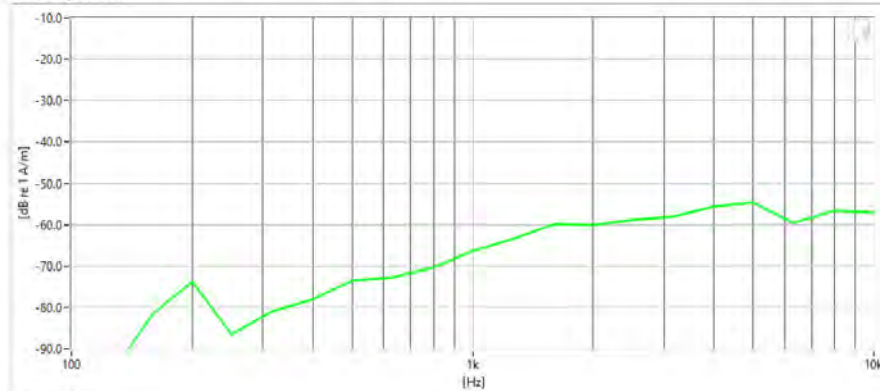

Results

| | | | | |
|------|-----------|---|---------|-------|
| ABM1 | 3.17 dB | ✓ | Minimum | -18.0 |
| ABM2 | -54.77 dB | ✓ | Maximum | 0.0 |
| SNNR | 57.94 dB | ✓ | Minimum | 20.0 |

PCTEST 2020

| | | | | |
|-------------------------------------|--|-------------------------------|--|---------------------------------|
| FCC ID: A3LSMF707U | | HAC (T-COIL) TEST REPORT | | Approved by: Quality Manager |
| Filename: 1M2005040080-19-R2.A3L | Test Dates: 06/15/2020 - 07/02/2020 | DUT Type: Portable Handset | | Page 83 of 108 |



PCTEST Hearing-Aid Compatibility Facility

DUT: A3LSMF707U

Type: Portable Handset
Serial: 0011H

Measurement Standard: ANSI C63.19-2011

Equipment:

- Probe: Radial T-Coil Probe – SN: TEM-1129; Calibrated: 09/19/2018

Test Configuration:

- Mode: UMTS Band II
- Channel: 9262

Noise Spectrum

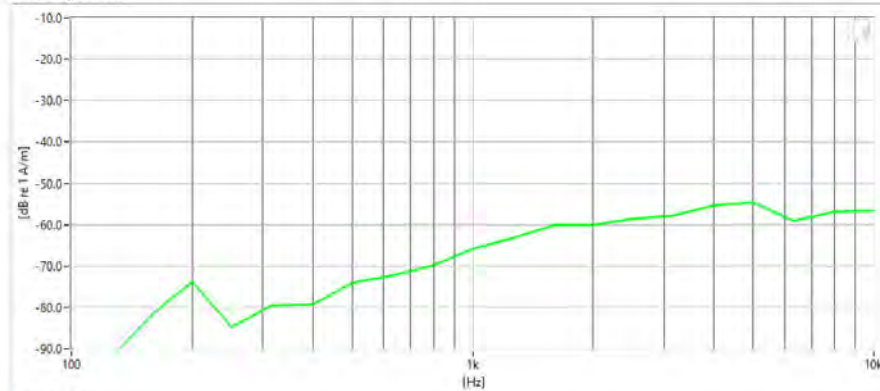

Results

| | | | | |
|------|-----------|---|---------|-------|
| ABM1 | 3.17 dB | ✓ | Minimum | -18.0 |
| ABM2 | -54.63 dB | ✓ | Maximum | 0.0 |
| SNNR | 57.79 dB | ✓ | Minimum | 20.0 |

PCTEST 2020

| | | | | |
|-------------------------------------|--|-------------------------------|--|---------------------------------|
| FCC ID: A3LSMF707U | | HAC (T-COIL) TEST REPORT | | Approved by: Quality Manager |
| Filename: 1M2005040080-19-R2.A3L | Test Dates: 06/15/2020 - 07/02/2020 | DUT Type: Portable Handset | | Page 84 of 108 |



PCTEST Hearing-Aid Compatibility Facility

DUT: A3LSMF707U

Type: Portable Handset
Serial: 0011H

Measurement Standard: ANSI C63.19-2011

Equipment:

- Probe: Radial T-Coil Probe – SN: TEM-1130; Calibrated: 05/17/2019

Test Configuration:

- Mode: LTE FDD Band 14
- Bandwidth: 5MHz
- Channel: 23330

Noise Spectrum

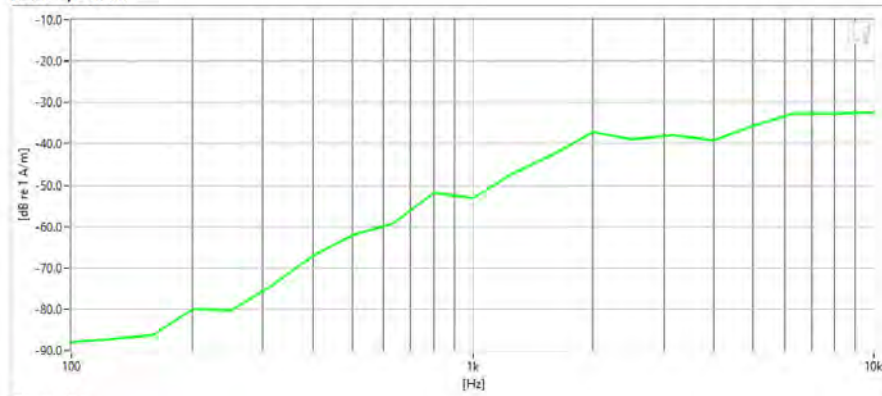

Results

| | | | | |
|------|-----------|---|---------|-------|
| ABM1 | -12.27 dB | ✓ | Minimum | -18.0 |
| ABM2 | -35.36 dB | ✓ | Maximum | 0.0 |
| SNNR | 23.09 dB | ✓ | Minimum | 20.0 |

PCTEST 2020

| | | | | |
|--|---|--------------------------------------|--|--|
| FCC ID: A3LSMF707U | | HAC (T-COIL) TEST REPORT | | Approved by: Quality Manager |
| Filename: 1M2005040080-19-R2.A3L | Test Dates: 06/15/2020 - 07/02/2020 | DUT Type: Portable Handset | | Page 85 of 108 |



PCTEST Hearing-Aid Compatibility Facility

DUT: A3LSMF707U

Type: Portable Handset
Serial: 0011H

Measurement Standard: ANSI C63.19-2011

Equipment:

- Probe: Radial T-Coil Probe – SN: TEM-1130; Calibrated: 05/17/2019

Test Configuration:

- Mode: LTE TDD Band 48
- Bandwidth: 15MHz
- Channel: 55990

Noise Spectrum

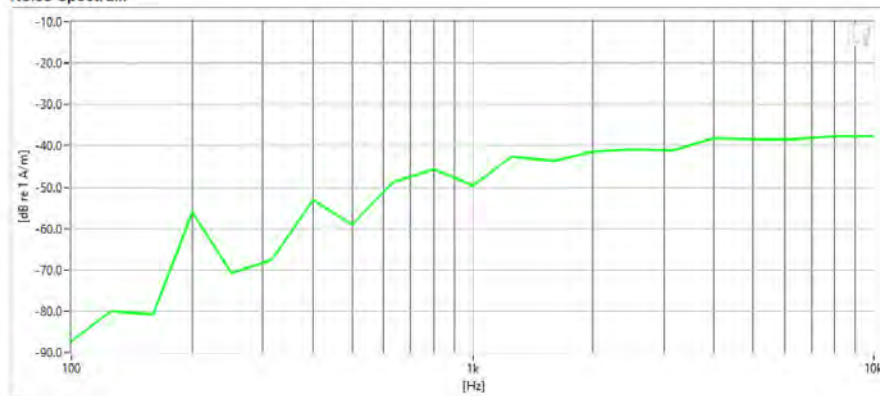

Results

| | | | | |
|------|-----------|---|---------|-------|
| ABM1 | -12.11 dB | ✓ | Minimum | -18.0 |
| ABM2 | -35.91 dB | ✓ | Maximum | 0.0 |
| SNNR | 23.8 dB | ✓ | Minimum | 20.0 |

PCTEST 2020

| | | | | |
|--|---|--------------------------------------|--|--|
| FCC ID: A3LSMF707U | | HAC (T-COIL) TEST REPORT | | Approved by: Quality Manager |
| Filename: 1M2005040080-19-R2.A3L | Test Dates: 06/15/2020 - 07/02/2020 | DUT Type: Portable Handset | | Page 86 of 108 |



PCTEST Hearing-Aid Compatibility Facility

DUT: A3LSMF707U

Type: Portable Handset
Serial: 0011H

Measurement Standard: ANSI C63.19-2011

Equipment:

- Probe: Radial T-Coil Probe – SN: TEM-1130; Calibrated: 05/17/2019

Test Configuration:

- Mode: 2.4GHz WFI
- Standard: IEEE 802.11ax RU
- Channel: 6

Noise Spectrum

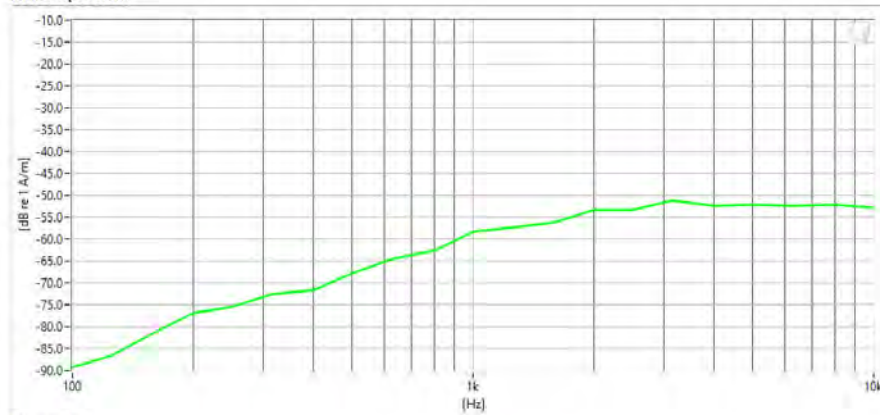

Results

| | | | | |
|------|-----------|---|---------|-------|
| ABM1 | -9.88 dB | ✓ | Minimum | -18.0 |
| ABM2 | -49.11 dB | ✓ | Maximum | 0.0 |
| SNNR | 39.23 dB | ✓ | Minimum | 20.0 |

PCTEST 2020

| | | | | |
|-------------------------------------|--|-------------------------------|--|---------------------------------|
| FCC ID: A3LSMF707U | | HAC (T-COIL) TEST REPORT | | Approved by: Quality Manager |
| Filename: 1M2005040080-19-R2.A3L | Test Dates: 06/15/2020 - 07/02/2020 | DUT Type: Portable Handset | | Page 87 of 108 |



PCTEST Hearing-Aid Compatibility Facility

DUT: A3LSMF707U

Type: Portable Handset
Serial: 0011H

Measurement Standard: ANSI C63.19-2011

Equipment:

- Probe: Radial T-Coil Probe – SN: TEM-1130; Calibrated: 05/17/2019

Test Configuration:

- Mode: 5GHz WIFI
- Standard: IEEE 802.11ac (U-NII 3)
- Bandwidth: 20MHz
- Channel: 157

Noise Spectrum

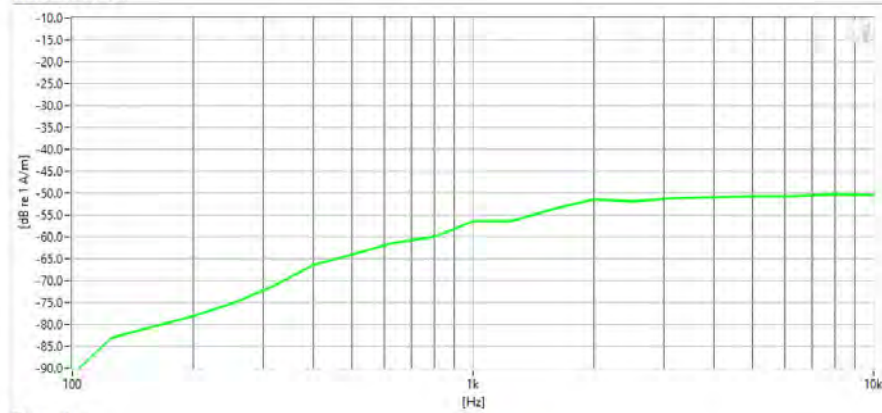

Results

| | | | | |
|------|-----------|---|---------|-------|
| ABM1 | -10.19 dB | ✓ | Minimum | -18.0 |
| ABM2 | -47.31 dB | ✓ | Maximum | 0.0 |
| SNNR | 37.13 dB | ✓ | Minimum | 20.0 |

PCTEST 2020

| | | | | |
|-------------------------------------|--|-------------------------------|--|---------------------------------|
| FCC ID: A3LSMF707U | | HAC (T-COIL) TEST REPORT | | Approved by: Quality Manager |
| Filename: 1M2005040080-19-R2.A3L | Test Dates: 06/15/2020 - 07/02/2020 | DUT Type: Portable Handset | | Page 88 of 108 |



PCTEST Hearing-Aid Compatibility Facility

DUT: A3LSMF707U

Type: Portable Handset
Serial: 0011H

Measurement Standard: ANSI C63.19-2011

Equipment:

- Probe: Radial T-Coil Probe – SN: TEM-1129; Calibrated: 09/19/2018

Test Configuration:

- VoIP Application: Google Duo
- Mode: EDGE850
- Channel: 190

Noise Spectrum

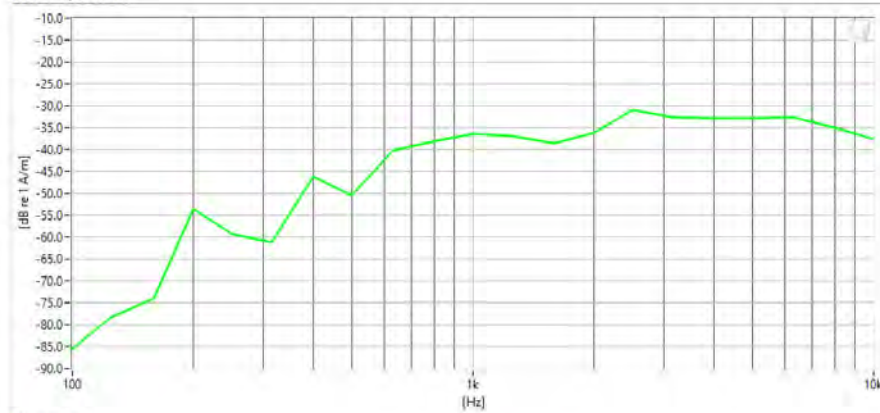



Results

| | | | | |
|------|-----------|---|---------|-------|
| ABM1 | 3.44 dB | ✓ | Minimum | -18.0 |
| ABM2 | -28.51 dB | ✓ | Maximum | 0.0 |
| SNNR | 31.95 dB | ✓ | Minimum | 20.0 |

PCTEST 2020

| | | | | |
|--|---|--------------------------------------|----------------|--|
| FCC ID: A3LSMF707U | | HAC (T-COIL) TEST REPORT | | Approved by: Quality Manager |
| Filename: 1M2005040080-19-R2.A3L | Test Dates: 06/15/2020 - 07/02/2020 | DUT Type: Portable Handset | Page 89 of 108 | |

13. CALIBRATION CERTIFICATES

| | | | | |
|--|---|--------------------------------------|---|--|
| FCC ID: A3LSMF707U |  | HAC (T-COIL) TEST REPORT |  | Approved by: Quality Manager |
| Filename: 1M2005040080-19-R2.A3L | Test Dates: 06/15/2020 - 07/02/2020 | DUT Type: Portable Handset | | Page 90 of 108 |

© 2020 PCTEST

REV 3.5.M
6/30/2020

© 2020 PCTEST All rights reserved. Unless otherwise specified, no part of this report may be reproduced or utilized in any part, form or by any means, electronic or mechanical, including photocopying and microfilm, without permission in writing from PCTEST. If you have any questions about this international copyright or have an enquiry about obtaining additional rights to this report or assembly of contents thereof, please contact INFO@PCTEST.COM.

West Caldwell Calibration Laboratories Inc.

Certificate of Calibration

for

AXIAL T COIL PROBE

Manufactured by: TEM CONSULTING LP
 Model No: AXIAL T COIL PROBE
 Serial No: TEM-1123
 Calibration Recall No: 29156

Submitted By:

Customer: Andrew Harwell
 Company: PCTest Engineering Lab
 Address: 6660-B Dobbin Road
 Columbia MD 21045

The subject instrument was calibrated to the indicated specification using standards traceable to the National Institute of Standards and Technology or to accepted values of natural physical constants. This document certifies that the instrument met the following specification upon its return to the submitter.

West Caldwell Calibration Laboratories Procedure No. AXIAL T C TEM C

Upon receipt for Calibration, the instrument was found to be:

Within (X)

VA4
12/4/2019

tolerance of the indicated specification. See attached Report of Calibration.
 The information supplied relates to the calibrated item listed above.

West Caldwell Calibration Laboratories' calibration control system meets the requirements, ISO 10012-1 MIL-STD-45662A, ANSI/NCSL Z540-1, IEC Guide 25, ISO 9001:2008 and ISO 17025.

Note: With this Certificate, Report of Calibration is included.

Approved by: *Fe*

Calibration Date: 19-Sep-18

Felix Christopher (QA Mgr.)

Certificate No: 29156 -2

ISO/IEC 17025:2005



QA Doc. #1051 Rev. 2.0 10/1/01

Certificate Page 1 of 1

West Caldwell Calibration Laboratories, Inc.
 uncompromised calibration
 1575 State Route 96, Victor, NY 14564, U.S.A.



Calibration Lab. Cert. # 1533.01

| | | | | |
|-------------------------------------|---|-------------------------------|---|---------------------------------|
| FCC ID: A3LSMF707U |  | HAC (T-COIL) TEST REPORT |  | Approved by: Quality Manager |
| Filename: 1M2005040080-19-R2.A3L | Test Dates: 06/15/2020 - 07/02/2020 | DUT Type: Portable Handset | | Page 91 of 108 |



REPORT OF CALIBRATION

for

TEM Consulting LP Axial T Coil Probe
Company: PCTest Engineering Lab

Model No.: Axial T Coil Probe

Serial No.: TEM-1123
I. D. No.: XXXX

| | | | |
|--|--------|----------------------------------|------|
| Calibration results: | | | |
| Probe Sensitivity measured with Helmholtz Coil | | Before & after data same: ...X.. | |
| <i>Helmholtz Coil;</i> | | | |
| the number of turns on each coil; | 10 | No. | |
| the radius of each coil, in meters; | 0.204 | m | |
| the current in the coils, in amperes.; | 0.08 | A | |
| <i>Helmholtz Coil Constant;</i> | 7.09 | A/m/V | |
| <i>Helmholtz Coil magnetic field;</i> | 5.95 | A/m | |
| Laboratory Environment: | | | |
| Probe Sensitivity at | | 1000 | Hz. |
| was | -59.89 | dBV/A/m | |
| | 1.013 | mV/A/m | |
| Probe resistance | 903 | Ohms | |
| Ambient Temperature: | | 22.7 | °C |
| Ambient Humidity: | | 52.1 | % RH |
| Ambient Pressure: | | 99.326 | kPa |
| Calibration Date: | | 19-Sep-2018 | |
| Calibration Due: | | | |
| Report Number: | | 29156 -2 | |
| Control Number: | | 29156 | |
| The above listed instrument meets or exceeds the tested manufacturer's specifications. | | | |
| This Calibration is traceable through NIST test numbers: | | 683/284413-14 | |
| The expanded uncertainty of calibration: 0.30dB at 95% confidence level with a coverage factor of k=2. | | | |
| Graph represents Probes Frequency Response. | | | |

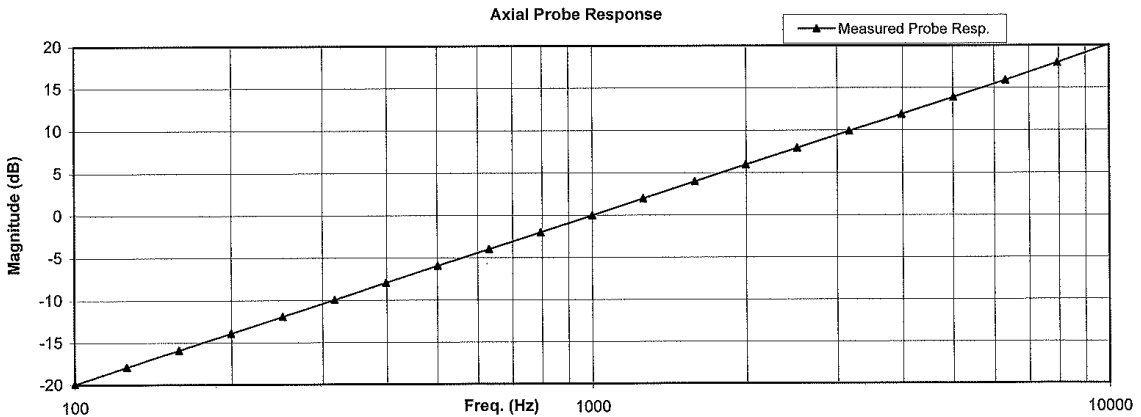

The above listed instrument was checked using calibration procedure documented in West Caldwell Calibration Laboratories Inc. procedure : Rev. 7.0 Jan. 24, 2014 Doc. # 1038 HCATEMC
Calibration was performed by West Caldwell Calibration Laboratories Inc. under Operating Procedures intended to implement the requirements of ISO10012-1, IEC Guide 25, ANSI/NCSL Z540-1, (MIL-STD-45662A) and ISO 9001:2008, ISO 17025

Cal. Date: 19-Sep-2018
Calibrated on WCCL system type 9700

Measurements performed by: James Zhu

This document shall not be reproduced, except in full, without the written approval from West Caldwell Cal. Labs, Inc.

Rev. 7.0 Jan. 24, 2014 Doc. # 1038 HCATEMC

| | | | | |
|-------------------------------------|--|-------------------------------|--|---------------------------------|
| FCC ID: A3LSMF707U | | HAC (T-COIL) TEST REPORT | | Approved by: Quality Manager |
| Filename: 1M2005040080-19-R2.A3L | Test Dates: 06/15/2020 - 07/02/2020 | DUT Type: Portable Handset | | Page 92 of 108 |

HCATEMC_TEM-1123_Sep-19-2018

West Caldwell Calibration Laboratories Inc.

1575 State Route 96, Victor NY 14564
Tel. (585) 586-3900 FAX (585) 586-4327

Calibration Data Record

TEM Consulting LP Axial T Coil Probe
Company: PCTest Engineering Lab

for
Model No.: Axial T Coil Probe

Serial No.: TEM-1123

| Test | Function | Tolerance | Measured values | | |
|-------|--------------------------|------------------|-----------------|--------|---------|
| | | | Before | Out | Remarks |
| 1.0 | Probe Sensitivity at | 1000 Hz. dBV/A/m | -59.89 | | |
| 2.0 | Probe Level Linearity | Ref. (0 dB) | dB | | |
| | | | 6 | 6.03 | |
| | | | 0 | 0.00 | |
| | | | -6 | -6.03 | |
| | | | -12 | -12.05 | |
| 3.0 | Probe Frequency Response | Ref. (0 dB) | Hz | | |
| | | | 100 | -19.9 | |
| | | | 126 | -17.9 | |
| | | | 158 | -15.9 | |
| | | | 200 | -13.9 | |
| | | | 251 | -11.9 | |
| | | | 316 | -9.9 | |
| | | | 398 | -7.9 | |
| | | | 501 | -6.0 | |
| | | | 631 | -4.0 | |
| | | | 794 | -2.0 | |
| | | | 1000 | 0.0 | |
| | | | 1259 | 2.0 | |
| | | | 1585 | 4.0 | |
| | | | 1995 | 5.9 | |
| | | | 2512 | 7.9 | |
| 3162 | 9.9 | | | | |
| 3981 | 11.9 | | | | |
| 5012 | 13.9 | | | | |
| 6310 | 15.9 | | | | |
| 7943 | 18.0 | | | | |
| 10000 | 20.1 | | | | |

| Instruments used for calibration: | | | Date of Cal. | Traceability No. | Due Date |
|-----------------------------------|--------|--------------|--------------|------------------|-------------|
| HP | 34401A | S/N US360641 | 25-Jul-2018 | ,287708 | 25-Jul-2019 |
| HP | 34401A | S/N US361024 | 25-Jul-2018 | ,287708 | 25-Jul-2019 |
| HP | 33120A | S/N US360437 | 25-Jul-2018 | ,287708 | 25-Jul-2019 |
| B&K | 2133 | S/N 1583254 | 25-Jul-2018 | 683/284413-14 | 25-Jul-2019 |



Cal. Date: 19-Sep-2018

Tested by: James Zhu

Calibrated on WCCL system type 9700

This document shall not be reproduced, except in full, without the written approval from West Caldwell Cal. Labs. Inc.

Rev. 7.0 Jan. 24, 2014 Doc. # 1038 HCATEMC

| | | | | |
|-------------------------------------|---|-------------------------------|---|---------------------------------|
| FCC ID: A3LSMF707U |  | HAC (T-COIL) TEST REPORT |  | Approved by: Quality Manager |
| Filename: 1M2005040080-19-R2.A3L | Test Dates: 06/15/2020 - 07/02/2020 | DUT Type: Portable Handset | | Page 93 of 108 |

West Caldwell Calibration Laboratories Inc.

Certificate of Calibration

for

AXIAL T COIL PROBE

Manufactured by: TEM CONSULTING
Model No: AXIAL T COIL PROBE
Serial No: TEM-1124
Calibration Recall No: 29973

Submitted By:

Customer: ANDREW HARWELL
Company: PCTEST ENGINEERING LAB
Address: 6660-B DOBBIN ROAD
COLUMBIA MD 21045

The subject instrument was calibrated to the indicated specification using standards traceable to the National Institute of Standards and Technology or to accepted values of natural physical constants. This document certifies that the instrument met the following specification upon its return to the submitter.

West Caldwell Calibration Laboratories Procedure No. AXIAL T C TEM C

Upon receipt for Calibration, the instrument was found to be:

Within (X)

tolerance of the indicated specification. See attached Report of Calibration.
The information supplied relates to the calibrated item listed above.

West Caldwell Calibration Laboratories' calibration control system meets the requirements, ISO 10012-1 MIL-STD-45662A, ANSI/NCSL Z540-1, IEC Guide 25, ISO 9001:2015 and ISO 17025.

Note: With this Certificate, Report of Calibration is included.

Approved by:

James Zhu

Calibration Date: 17-May-19

Certificate No: 29973 -1

Quality Manager
ISO/IEC 17025:2005

QA Doc. #1051 Rev. 2.0 10/1/01



Certificate Page 1 of 1

West Caldwell Calibration Laboratories, Inc.
uncompromised calibration
1575 State Route 96, Victor, NY 14564, U.S.A.



Calibration Lab. Cert. # 1533.01

JAH
6/4/2019

| | | | | |
|-------------------------------------|---|-------------------------------|---|---------------------------------|
| FCC ID: A3LSMF707U |  | HAC (T-COIL) TEST REPORT |  | Approved by: Quality Manager |
| Filename: 1M2005040080-19-R2.A3L | Test Dates: 06/15/2020 - 07/02/2020 | DUT Type: Portable Handset | | Page 94 of 108 |

© 2020 PCTEST

REV 3.5.M
6/30/2020

© 2020 PCTEST All rights reserved. Unless otherwise specified, no part of this report may be reproduced or utilized in any part, form or by any means, electronic or mechanical, including photocopying and microfilm, without permission in writing from PCTEST. If you have any questions about this international copyright or have an enquiry about obtaining additional rights to this report or assembly of contents thereof, please contact INFO@PCTEST.COM.



ISO/IEC 17025: 2005



Calibration Lab. Cert. # 1533.01

REPORT OF CALIBRATION

for

TEM Consulting LP Axial T Coil Probe
Company: PCTest Engineering Labs

Model No.: Axial T Coil Probe

Serial No.: TEM-1124
I. D. No.: XXXX

| Calibration results: | | | |
|---|--------|---------|-----------------------------------|
| Probe Sensitivity measured with Helmholtz Coil | | | |
| <i>Helmholtz Coil;</i> | | | |
| the number of turns on each coil; | 10 | No. | Before & after data same: ...X... |
| the radius of each coil, in meters; | 0.204 | m | |
| the current in the coils, in amperes.; | 0.09 | A | |
| <i>Helmholtz Coil Constant;</i> | 7.09 | A/m/V | Laboratory Environment: |
| <i>Helmholtz Coil magnetic field;</i> | 5.96 | A/m | Ambient Temperature: 20.7 °C |
| | | | Ambient Humidity: 42.7 % RH |
| | | | Ambient Pressure: 98.256 kPa |
| | | | Calibration Date: 17-May-2019 |
| | | | Calibration Due: 17-May-2020 |
| | | | Report Number: 29973 -1 |
| | | | Control Number: 29973 |
| Probe Sensitivity at | 1000 | Hz. | |
| was | -60.41 | dBV/A/m | |
| | 0.954 | mV/A/m | |
| Probe resistance | 903 | Ohms | |

The above listed instrument meets or exceeds the tested manufacturer's specifications.
This Calibration is traceable through NIST test numbers: 683/290345-18
The expanded uncertainty of calibration: 0.30dB at 95% confidence level with a coverage factor of k=2.
Graph represents Probes Frequency Response.

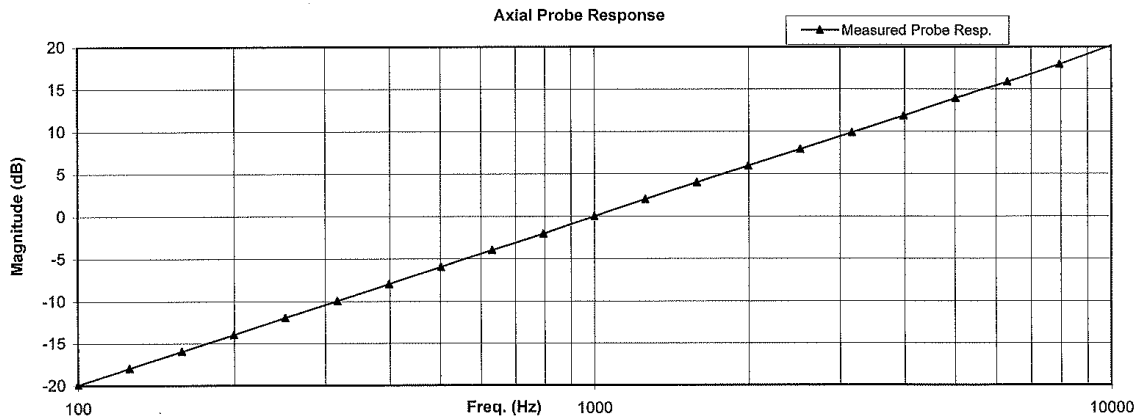

The above listed instrument was checked using calibration procedure documented in West Caldwell Calibration Laboratories Inc. procedure : Rev. 7.0 Jan. 24, 2014 Doc. # 1038 HCATEMC
Calibration was performed by West Caldwell Calibration Laboratories Inc. under Operating Procedures intended to implement the requirements of ISO10012-1, IEC Guide 25, ANSI/NCSL Z540-1, (MIL-STD-45662A) and ISO 17025

Cal. Date: 17-May-2019
Calibrated on WCCL system type 9700

Measurements performed by:
James Zhu

This document shall not be reproduced, except in full, without the written approval from West Caldwell Cal. Labs. Inc.

Rev. 7.0 Jan. 24, 2014 Doc. # 1038 HCATEMC

| | | | | |
|-------------------------------------|--|-------------------------------|--|---------------------------------|
| FCC ID: A3LSMF707U | | HAC (T-COIL) TEST REPORT | | Approved by: Quality Manager |
| Filename: 1M2005040080-19-R2.A3L | Test Dates: 06/15/2020 - 07/02/2020 | DUT Type: Portable Handset | | Page 95 of 108 |

HCATEMC_TEM-1124_May-17-2019

West Caldwell Calibration Laboratories Inc.

1575 State Route 96, Victor NY 14564
Tel. (585) 586-3900 FAX (585) 586-4327

Calibration Data Record

TEM Consulting LP Axial T Coil Probe
Company: PCTest Engineering Labs

for
Model No.: Axial T Coil Probe

Serial No.: TEM-1124

| Test | Function | Tolerance | Measured values | | |
|-------|--------------------------|------------------|-----------------|--------|---------|
| | | | Before | Out | Remarks |
| 1.0 | Probe Sensitivity at | 1000 Hz. dBV/A/m | -60.41 | | |
| 2.0 | Probe Level Linearity | Ref. (0 dB) | dB | | |
| | | | 6 | 6.10 | |
| | | | 0 | 0.00 | |
| | | | -6 | -6.00 | |
| | | | -12 | -12.00 | |
| 3.0 | Probe Frequency Response | Ref. (0 dB) | Hz | | |
| | | | 100 | -19.9 | |
| | | | 126 | -17.9 | |
| | | | 158 | -16.0 | |
| | | | 200 | -14.0 | |
| | | | 251 | -12.0 | |
| | | | 316 | -10.0 | |
| | | | 398 | -8.0 | |
| | | | 501 | -6.0 | |
| | | | 631 | -3.9 | |
| | | | 794 | -2.0 | |
| | | | 1000 | 0.0 | |
| | | | 1259 | 2.0 | |
| | | | 1585 | 4.0 | |
| | | | 1995 | 5.9 | |
| | | | 2512 | 7.9 | |
| | | | 3162 | 9.9 | |
| 3981 | 11.9 | | | | |
| 5012 | 13.9 | | | | |
| 6310 | 15.9 | | | | |
| 7943 | 18.0 | | | | |
| 10000 | 20.2 | | | | |

| Instruments used for calibration: | | | Date of Cal. | Traceability No. | Due Date |
|-----------------------------------|--------|--------------|--------------|------------------|-------------|
| HP | 34401A | S/N US360641 | 25-Jul-2018 | ,1010733 | 26-Jul-2019 |
| HP | 34401A | S/N US361024 | 25-Jul-2018 | ,1010733 | 26-Jul-2019 |
| HP | 33120A | S/N US360437 | 25-Jul-2018 | ,1010733 | 26-Jul-2019 |
| B&K | 2133 | S/N 1583254 | 25-Jul-2018 | 683/290345-18 | 26-Jul-2019 |



Cal. Date: 17-May-2019

Tested by: James Zhu

Calibrated on WCCL system type 9700

This document shall not be reproduced, except in full, without the written approval from West Caldwell Cal. Labs. Inc.

Rev. 7.0 Jan. 24, 2014 Doc. # 1038 HCATEMC

| | | | | |
|-------------------------------------|---|-------------------------------|---|---------------------------------|
| FCC ID: A3LSMF707U |  | HAC (T-COIL) TEST REPORT |  | Approved by: Quality Manager |
| Filename: 1M2005040080-19-R2.A3L | Test Dates: 06/15/2020 - 07/02/2020 | DUT Type: Portable Handset | | Page 96 of 108 |

West Caldwell Calibration Laboratories Inc.

Certificate of Calibration

for

RADIAL T COIL PROBE

Manufactured by: TEM CONSULTING LP
Model No: RADIAL T COIL PROBE
Serial No: TEM-1129
Calibration Recall No: 29156

Submitted By:

Customer: Andrew Harwell
Company: PCTest Engineering Lab
Address: 6660-B Dobbin Road
Columbia MD 21045

The subject instrument was calibrated to the indicated specification using standards traceable to the National Institute of Standards and Technology or to accepted values of natural physical constants. This document certifies that the instrument met the following specification upon its return to the submitter.

West Caldwell Calibration Laboratories Procedure No. RADIAL T TEM C

Upon receipt for Calibration, the instrument was found to be:

Within (X)

tolerance of the indicated specification. See attached Report of Calibration.
The information supplied relates to the calibrated item listed above.
West Caldwell Calibration Laboratories' calibration control system meets the requirements, ISO 10012-1 MIL-STD-45662A, ANSI/NCSL Z540-1, IEC Guide 25, ISO 9001:2008 and ISO 17025.

Note: With this Certificate, Report of Calibration is included.

Approved by: FC

Calibration Date: 19-Sep-18

Felix Christopher (QA Mgr.)

Certificate No: 29156 -1

ISO/IEC 17025:2005



QA Doc. #1051 Rev. 2.0 10/1/01

Certificate Page 1 of 1

West Caldwell Calibration Laboratories, Inc.
uncompromised calibration
1575 State Route 96, Victor, NY 14564, U.S.A.



Calibration Lab. Cert. # 1533.01

| | | | | |
|-------------------------------------|---|-------------------------------|---|---------------------------------|
| FCC ID: A3LSMF707U |  | HAC (T-COIL) TEST REPORT |  | Approved by: Quality Manager |
| Filename: 1M2005040080-19-R2.A3L | Test Dates: 06/15/2020 - 07/02/2020 | DUT Type: Portable Handset | | Page 97 of 108 |

© 2020 PCTEST

REV 3.5.M
6/30/2020

© 2020 PCTEST All rights reserved. Unless otherwise specified, no part of this report may be reproduced or utilized in any part, form or by any means, electronic or mechanical, including photocopying and microfilm, without permission in writing from PCTEST. If you have any questions about this international copyright or have an enquiry about obtaining additional rights to this report or assembly of contents thereof, please contact INFO@PCTEST.COM.



REPORT OF CALIBRATION

for

TEM Consulting LP Radial T Coil Probe
Company: PCTest Engineering Lab

Model No.: Radial T Coil Probe

Serial No.: TEM-1129
I. D. No.: XXXX

| | | | |
|--|--------|---------|-----------------------------------|
| Calibration results: | | | |
| Probe Sensitivity measured with Helmholtz Coil | | | |
| <i>Helmholtz Coil;</i> | | | |
| the number of turns on each coil; | 10 | No. | Before & after data same: ...X... |
| the radius of each coil, in meters; | 0.204 | m | |
| the current in the coils, in amperes.; | 0.08 | A | |
| <i>Helmholtz Coil Constant;</i> | | | |
| | 7.09 | A/m/V | Laboratory Environment: |
| <i>Helmholtz Coil magnetic field;</i> | | | |
| | 5.95 | A/m | Ambient Temperature: 22.7 °C |
| | | | Ambient Humidity: 52.1 % RH |
| | | | Ambient Pressure: 99.326 kPa |
| | | | Calibration Date: 19-Sep-2018 |
| Probe Sensitivity at | 1000 | Hz. | Re-calibration Due: |
| was | -60.37 | dBV/A/m | Report Number: 29156 -1 |
| | 0.958 | mV/A/m | Control Number: 29156 |
| Probe resistance | 886 | Ohms | |

The above listed instrument meets or exceeds the tested manufacturer's specifications.

This Calibration is traceable through NIST test numbers: 683/284413-14

The expanded uncertainty of calibration: 0.30dB at 95% confidence level with a coverage factor of k=2.

Graph represents Probes Frequency Response.

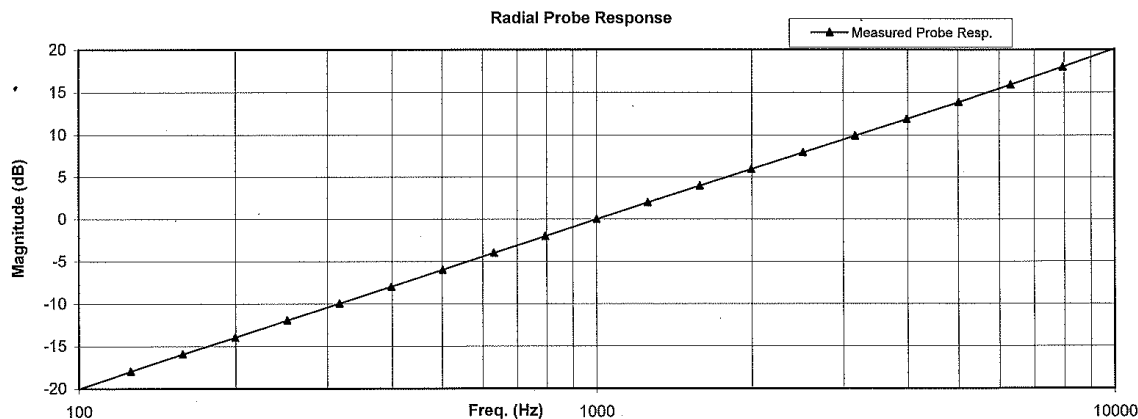

The above listed instrument was checked using calibration procedure documented in West Caldwell Calibration Laboratories Inc. procedure : Rev. 7.0 Jan. 24, 2014 Doc. # 1038 HCRTEMC
Calibration was performed by West Caldwell Calibration Laboratories Inc. under Operating Procedures intended to implement the requirements of ISO10012-1, IEC Guide 25, ANSI/NCSL Z540-1, (MIL-STD-45662A) and ISO 9001:2008, ISO 17025

Cal. Date: 19-Sep-2018
Calibrated on WCCL system type 9700

Measurements performed by: James Zhu

This document shall not be reproduced, except in full, without the written approval from West Caldwell Cal. Labs. Inc.

Rev. 7.0 Jan. 24, 2014 Doc. # 1038 HCRTEMC

| | | | | |
|-------------------------------------|--|-------------------------------|--|---------------------------------|
| FCC ID: A3LSMF707U | | HAC (T-COIL) TEST REPORT | | Approved by: Quality Manager |
| Filename: 1M2005040080-19-R2.A3L | Test Dates: 06/15/2020 - 07/02/2020 | DUT Type: Portable Handset | | Page 98 of 108 |

HCRTEMC_TEM-1129_Sep-19-2018

West Caldwell Calibration Laboratories Inc.

1575 State Route 96, Victor NY 14564
Tel. (585) 586-3900 FAX (585) 586-4327

Calibration Data Record

TEM Consulting LP Radial T Coil Probe
Company: PCTest Engineering Lab

for
Model No.: Radial T Coil Probe

Serial No.: TEM-1129

| Test | Function | Tolerance | Measured values | | |
|-------|--------------------------|------------------|-----------------|--------|---------|
| | | | Before | Out | Remarks |
| 1.0 | Probe Sensitivity at | 1000 Hz. dBV/A/m | -60.37 | | |
| 2.0 | Probe Level Linearity | Ref. (0 dB) | 6 | 6.03 | |
| | | | 0 | 0.00 | |
| | | | -6 | -6.03 | |
| | | | -12 | -12.05 | |
| 3.0 | Probe Frequency Response | Ref. (0 dB) | 100 | -20.0 | |
| | | | 126 | -17.9 | |
| | | | 158 | -15.9 | |
| | | | 200 | -14.0 | |
| | | | 251 | -12.0 | |
| | | | 316 | -10.0 | |
| | | | 398 | -8.0 | |
| | | | 501 | -6.0 | |
| | | | 631 | -4.0 | |
| | | | 794 | -2.0 | |
| | | | 1000 | 0.0 | |
| | | | 1259 | 2.0 | |
| | | | 1585 | 4.0 | |
| | | | 1995 | 6.0 | |
| | | | 2512 | 7.9 | |
| | | | 3162 | 9.9 | |
| | | | 3981 | 11.9 | |
| 5012 | 13.9 | | | | |
| 6310 | 15.9 | | | | |
| 7943 | 18.0 | | | | |
| 10000 | 20.1 | | | | |

| Instruments used for calibration: | | | | Date of Cal. | Traceability No. | Due Date |
|-----------------------------------|--------|--------------|-------------|---------------|------------------|----------|
| HP | 34401A | S/N US360641 | 25-Jul-2018 | ,287708 | 25-Jul-2019 | |
| HP | 34401A | S/N US361024 | 25-Jul-2018 | ,287708 | 25-Jul-2019 | |
| HP | 33120A | S/N US360437 | 25-Jul-2018 | ,287708 | 25-Jul-2019 | |
| B&K | 2133 | S/N 1583254 | 25-Jul-2018 | 683/284413-14 | 25-Jul-2019 | |



Cal. Date: 19-Sep-2018

Tested by: James Zhu

Calibrated on WCCL system type 9700

This document shall not be reproduced, except in full, without the written approval from West Caldwell Cal. Labs. Inc.

Rev. 7.0 Jan. 24, 2014 Doc. # 1038 HCRTEMC

| | | | | |
|-------------------------------------|---|-------------------------------|---|---------------------------------|
| FCC ID: A3LSMF707U |  | HAC (T-COIL) TEST REPORT |  | Approved by: Quality Manager |
| Filename: 1M2005040080-19-R2.A3L | Test Dates: 06/15/2020 - 07/02/2020 | DUT Type: Portable Handset | | Page 99 of 108 |

West Caldwell Calibration Laboratories Inc.

Certificate of Calibration

for

RADIAL T COIL PROBE

Manufactured by: TEM CONSULTING
Model No: RADIAL T COIL PROBE
Serial No: TEM-1130
Calibration Recall No: 29973

Submitted By:

Customer: ANDREW HARWELL
Company: PCTEST ENGINEERING LAB
Address: 6660-B DOBBIN ROAD
COLUMBIA MD 21045

The subject instrument was calibrated to the indicated specification using standards traceable to the National Institute of Standards and Technology or to accepted values of natural physical constants. This document certifies that the instrument met the following specification upon its return to the submitter.

West Caldwell Calibration Laboratories Procedure No. RADIAL T TEM C

Upon receipt for Calibration, the instrument was found to be:

Within (X)

tolerance of the indicated specification. See attached Report of Calibration.
The information supplied relates to the calibrated item listed above.

West Caldwell Calibration Laboratories' calibration control system meets the requirements, ISO 10012-1 MIL-STD-45662A, ANSI/NCSL Z540-1, IEC Guide 25, ISO 9001:2015 and ISO 17025.

Note: With this Certificate, Report of Calibration is included.

Approved by:

James Zhu

Calibration Date: 17-May-19

Certificate No: 29973 -2

Quality Manager
ISO/IEC 17025:2005



QA Doc. #1051 Rev. 2.0 10/1/01

Certificate Page 1 of 1

West Caldwell Calibration Laboratories, Inc.
uncompromised calibration
1575 State Route 96, Victor, NY 14564, U.S.A.



Calibration Lab. Cert. # 1533.01

| | | | | |
|-------------------------------------|---|-------------------------------|---|---------------------------------|
| FCC ID: A3LSMF707U |  | HAC (T-COIL) TEST REPORT |  | Approved by: Quality Manager |
| Filename: 1M2005040080-19-R2.A3L | Test Dates: 06/15/2020 - 07/02/2020 | DUT Type: Portable Handset | | Page 100 of 108 |

© 2020 PCTEST

REV 3.5.M
6/30/2020

© 2020 PCTEST All rights reserved. Unless otherwise specified, no part of this report may be reproduced or utilized in any part, form or by any means, electronic or mechanical, including photocopying and microfilm, without permission in writing from PCTEST. If you have any questions about this international copyright or have an enquiry about obtaining additional rights to this report or assembly of contents thereof, please contact INFO@PCTEST.COM.



REPORT OF CALIBRATION

for

TEM Consulting LP Radial T Coil Probe
Company: PCTest Engineering Labs

Model No.: Radial T Coil Probe

Serial No.: TEM-1130
I. D. No.: XXXX

| Calibration results: | | | |
|---|-------|-------|-----------------------------------|
| Probe Sensitivity measured with Helmholtz Coil | | | |
| <i>Helmholtz Coil;</i> | | | |
| the number of turns on each coil; | 10 | No. | Before & after data same: ...X... |
| the radius of each coil, in meters; | 0.204 | m | |
| the current in the coils, in amperes.; | 0.08 | A | |
| <i>Helmholtz Coil Constant;</i> | 7.09 | A/m/V | Laboratory Environment: |
| <i>Helmholtz Coil magnetic field;</i> | 5.94 | A/m | Ambient Temperature: 20.7 °C |
| | | | Ambient Humidity: 42.7 % RH |
| | | | Ambient Pressure: 98.256 kPa |
| | | | Calibration Date: 17-May-2019 |
| | | | Calibration Due: 17-May-2020 |
| Probe Sensitivity at 1000 Hz. | | | Report Number: 29973 -2 |
| was -60.37 dBV/A/m | | | Control Number: 29973 |
| 0.958 mV/A/m | | | |
| Probe resistance 895 Ohms | | | |

The above listed instrument meets or exceeds the tested manufacturer's specifications.

This Calibration is traceable through NIST test numbers: 683/290345-18

The expanded uncertainty of calibration: 0.30dB at 95% confidence level with a coverage factor of k=2.

Graph represents Probes Frequency Response.

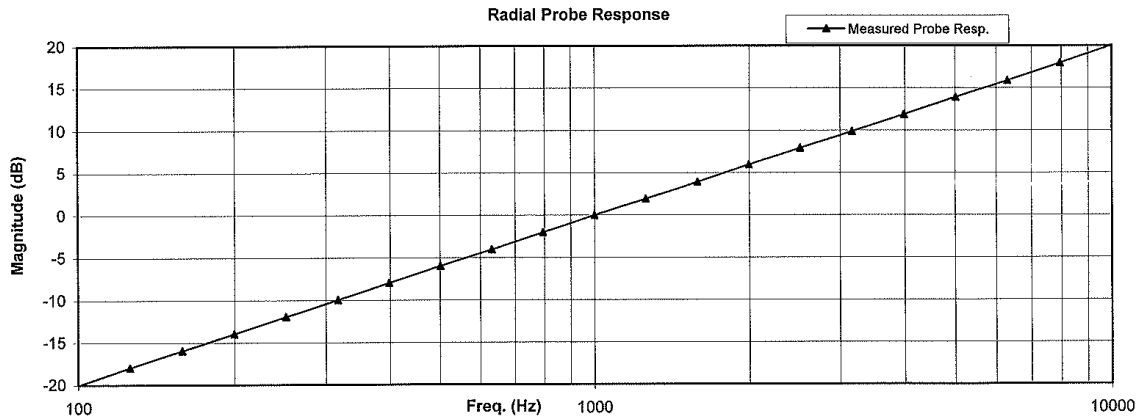

The above listed instrument was checked using calibration procedure documented in West Caldwell Calibration Laboratories Inc. procedure : Rev. 7.0 Jan. 24, 2014 Doc. # 1038 HCRTEMC
Calibration was performed by West Caldwell Calibration Laboratories Inc. under Operating Procedures intended to implement the requirements of ISO10012-1, IEC Guide 25, ANSI/NCSL Z540-1, (MIL-STD-45662A) and ISO 17025

Cal. Date: 17-May-2019
Calibrated on WCCL system type 9700

Measurements performed by:
James Zhu

This document shall not be reproduced, except in full, without the written approval from West Caldwell Cal. Labs. Inc.

Rev. 7.0 Jan. 24, 2014 Doc. # 1038 HCRTEMC

| | | | | |
|-------------------------------------|--|-------------------------------|--|---------------------------------|
| FCC ID: A3LSMF707U | | HAC (T-COIL) TEST REPORT | | Approved by: Quality Manager |
| Filename: 1M2005040080-19-R2.A3L | Test Dates: 06/15/2020 - 07/02/2020 | DUT Type: Portable Handset | | Page 101 of 108 |

HCRTEMC_TEM-1130_May-17-2019

West Caldwell Calibration Laboratories Inc.

1575 State Route 96, Victor NY 14564
Tel. (585) 586-3900 FAX (585) 586-4327

Calibration Data Record

TEM Consulting LP Radial T Coil Probe for Model No.: Radial T Coil Probe Serial No.: TEM-1130
Company: PCTest Engineering Labs

| Test | Function | Tolerance | Measured values | | |
|-------|--------------------------|-----------------------|-----------------|--------|---------|
| | | | Before | Out | Remarks |
| 1.0 | Probe Sensitivity at | 1000 Hz. dBV/A/m | -60.37 | | |
| 2.0 | Probe Level Linearity | Ref. (0 dB) | 6 | 6.00 | |
| | | | 0 | 0.00 | |
| | | | -6 | -6.10 | |
| | | | -12 | -12.10 | |
| 3.0 | Probe Frequency Response | Ref. (0 dB) | 100 | -20.0 | |
| | | | 126 | -17.9 | |
| | | | 158 | -16.0 | |
| | | | 200 | -14.0 | |
| | | | 251 | -12.0 | |
| | | | 316 | -10.0 | |
| | | | 398 | -8.0 | |
| | | | 501 | -6.0 | |
| | | | 631 | -4.0 | |
| | | | 794 | -2.0 | |
| | | | 1000 | 0.0 | |
| | | | 1259 | 1.9 | |
| | | | 1585 | 3.9 | |
| | | | 1995 | 5.9 | |
| | | | 2512 | 7.9 | |
| | | | 3162 | 9.9 | |
| 3981 | 11.9 | | | | |
| 5012 | 13.9 | | | | |
| 6310 | 15.9 | | | | |
| 7943 | 18.0 | | | | |
| 10000 | 20.1 | | | | |



| Instruments used for calibration: | | | | Date of Cal. | Traceability No. | Due Date |
|-----------------------------------|--------|--------------|-------------|---------------|------------------|----------|
| HP | 34401A | S/N US360641 | 25-Jul-2018 | ,1010733 | 26-Jul-2019 | |
| HP | 34401A | S/N US361024 | 25-Jul-2018 | ,1010733 | 26-Jul-2019 | |
| HP | 33120A | S/N US360437 | 25-Jul-2018 | ,1010733 | 26-Jul-2019 | |
| B&K | 2133 | S/N 1583254 | 25-Jul-2018 | 683/290345-18 | 26-Jul-2019 | |

Cal. Date: 17-May-2019
Calibrated on WCCL system type 9700

Tested by: James Zhu

This document shall not be reproduced, except in full, without the written approval from West Caldwell Cal. Labs. Inc.



Rev. 7.0 Jan. 24, 2014 Doc. # 1038 HCRTEMC

| | | | | |
|-------------------------------------|---|-------------------------------|---|---------------------------------|
| FCC ID: A3LSMF707U |  | HAC (T-COIL) TEST REPORT |  | Approved by: Quality Manager |
| Filename: 1M2005040080-19-R2.A3L | Test Dates: 06/15/2020 - 07/02/2020 | DUT Type: Portable Handset | | Page 102 of 108 |

14. CONCLUSION

The measurements indicate that the wireless communications device complies with the HAC limits specified in accordance with the ANSI C63.19 Standard and FCC WT Docket No. 01-309 RM-8658. Precise laboratory measures were taken to assure repeatability of the tests. The tested device complies with the requirements in respect to all parameters specific to the test. The test results and statements relate only to the item(s) tested.

The measurement system and techniques presented in this evaluation are proposed in the ANSI standard as a means of best approximating wireless device compatibility with a hearing-aid. The literature is under continual re-construction.

| | | | | |
|--|---|--------------------------------------|---|--|
| FCC ID: A3LSMF707U |  | HAC (T-COIL) TEST REPORT |  | Approved by: Quality Manager |
| Filename: 1M2005040080-19-R2.A3L | Test Dates: 06/15/2020 - 07/02/2020 | DUT Type: Portable Handset | Page 103 of 108 | |



© 2020 PCTEST

REV 3.5.M
6/30/2020

© 2020 PCTEST All rights reserved. Unless otherwise specified, no part of this report may be reproduced or utilized in any part, form or by any means, electronic or mechanical, including photocopying and microfilm, without permission in writing from PCTEST. If you have any questions about this international copyright or have an enquiry about obtaining additional rights to this report or assembly of contents thereof, please contact INFO@PCTEST.COM.

15. REFERENCES

1. ANSI C63.19-2011, American National Standard for Methods of Measurement of Compatibility between Wireless communication devices and Hearing Aids., New York, NY, IEEE, May 2011
2. FCC Office of Engineering and Technology KDB, "285076 D01 HAC Guidance v05," September 13, 2017
3. FCC Office of Engineering and Technology KDB, "285076 D02 T-Coil Testing for CMRS IP v03," September 13, 2017
4. FCC Public Notice DA 06-1215, *Wireless Telecommunications Bureau and Office of Engineering and Technology Clarify Use of Revised Wireless Phone Hearing Aid Compatibility Standard*, June 6, 2006
5. FCC 3G Review Guidance, Laboratory Division OET FCC, May/June 2006
6. Berger, H. S., "Compatibility Between Hearing Aids and Wireless Devices," Electronic Industries Forum, Boston, MA, May, 1997
7. Berger, H. S., "Hearing Aid and Cellular Phone Compatibility: Working Toward Solutions," *Wireless Telephones and Hearing Aids: New Challenges for Audiology*, Gallaudet University, Washington, D.C., May, 1997 (To be reprinted in the American Journal of Audiology).
8. Berger, H. S., "Hearing Aid Compatibility with Wireless Communications Devices," IEEE International Symposium on Electromagnetic Compatibility, Austin, TX, August, 1997.
9. Bronaugh, E. L., "Simplifying EMI Immunity (Susceptibility) Tests in TEM Cells," in the 1990 IEEE International Symposium on Electromagnetic Compatibility Symposium Record, Washington, D.C., August 1990, pp. 488-491
10. Byrne, D. and Dillon, H., The National Acoustics Laboratory (NAL) New Procedure for Selecting the Gain and Frequency Response of a Hearing Aid, Ear and Hearing 7:257-265, 1986.
11. Crawford, M. L., "Measurement of Electromagnetic Radiation from Electronic Equipment using TEM Transmission Cells," U.S. Department of Commerce, National Bureau of Standards, NBSIR 73-306, Feb. 1973.
12. Crawford, M. L., and Workman, J. L., "Using a TEM Cell for EMC Measurements of Electronic Equipment," U.S. Department of Commerce, National Bureau of Standards. Technical Note 1013, July 1981.
13. EHIMA GSM Project, Development phase, Project Report (1st part) Revision A. Technical-Audiological Laboratory and Telecom Denmark, October 1993.
14. EHIMA GSM Project, Development phase, Part II Project Report. Technical-Audiological Laboratory and Telecom Denmark, June 1994.
15. EHIMA GSM Project Final Report, Hearing Aids and GSM Mobile Telephones: Interference Problems, Methods of Measurement and Levels of Immunity. Technical-Audiological Laboratory and Telecom Denmark, 1995.
16. HAMPIS Report, Comparison of Mobile phone electromagnetic near field with an upscaled electromagnetic far field, using hearing aid as reference, 21 October 1999.
17. Hearing Aids/GSM, Report from OTWIDAM, Technical-Audiological Laboratory and Telecom Denmark, April 1993.
18. IEEE 100, The Authoritative Dictionary of IEEE Standards Terms, Seventh Edition.
19. Joyner, K. H, et. al., Interference to Hearing Aids by the New Digital Mobile Telephone System, Global System for Mobile (GSM) Communication Standard, National Acoustic Laboratory, Australian Hearing Series, Sydney 1993.
20. Joyner, K. H., et. al., Interference to Hearing Aids by the Digital Mobile Telephone System, Global System for Mobile Communications (GSM), NAL Report #131, National Acoustic Laboratory, Australian Hearing Series, Sydney, 1995.
21. Kecker, W. T., Crawford, M. L., and Wilson, W. A., "Construction of a Transverse Electromagnetic Cell", U.S. Department of Commerce, National Bureau of Standards, Technical Note 1011, Nov. 1978.
22. Konigstein, D., and Hansen, D., "A New Family of TEM Cells with enlarged bandwidth and Optimized working Volume," in the Proceedings of the 7th International Symposium on EMC, Zurich, Switzerland, March 1987; 50:9, pp. 127-132.



| | | | | |
|--|---|--------------------------------------|---|--|
| FCC ID: A3LSMF707U |  | HAC (T-COIL) TEST REPORT |  | Approved by: Quality Manager |
| Filename: 1M2005040080-19-R2.A3L | Test Dates: 06/15/2020 - 07/02/2020 | DUT Type: Portable Handset | | Page 104 of 108 |

© 2020 PCTEST

REV 3.5.M
6/30/2020

© 2020 PCTEST All rights reserved. Unless otherwise specified, no part of this report may be reproduced or utilized in any part, form or by any means, electronic or mechanical, including photocopying and microfilm, without permission in writing from PCTEST. If you have any questions about this international copyright or have an enquiry about obtaining additional rights to this report or assembly of contents thereof, please contact INFO@PCTEST.COM.

23. Kuk, F., and Hjorstgaard, N. K., "Factors affecting interference from digital cellular telephones," Hearing Journal, 1997; 50:9, pp 32-34.
24. Ma, M. A., and Kanda, M., "Electromagnetic Compatibility and Interference Metrology," U.S. Department of Commerce, National Bureau of Standards, Technical Note 1099, July 1986, pp. 17-43.
25. Ma, M. A., Sreenivashiah, I. , and Chang, D. C., "A Method of Determining the Emission and Susceptibility Levels of Electrically Small Objects Using a TEM Cell," U.S. Department of Commerce, National Bureau of Standards, Technial Note 1040, July 1981.
26. McCandless, G. A., and Lyregaard, P. E., Prescription of Gain/Output (POGO) for Hearing Aids, Hearing Instruments 1:16-21, 1983
27. Skopec, M., "Hearing Aid Electromagnetic Interference from Digital Wireless Telephones, "IEEE Transactions on Rehabilitation Engineering, vol. 6, no. 2, pp. 235-239, June 1998.
28. Technical Report, GSM 05.90, GSM EMC Considerations, European Telecommunications Standards Institute, January 1993.
29. Victorian, T. A., "Digital Cellular Telephone Interference and Hearing Aid Compatibility—an Update," Hearing Journal 1998; 51:10, pp. 53-60
30. Wong, G. S. K., and Embleton, T. F. W., eds., AIP Handbook of Condenser Microphones: Theory, Calibration and Measurements, AIP Press.

| | | | | |
|--|---|--------------------------------------|---|--|
| FCC ID: A3LSMF707U |  | HAC (T-COIL) TEST REPORT |  | Approved by: Quality Manager |
| Filename: 1M2005040080-19-R2.A3L | Test Dates: 06/15/2020 - 07/02/2020 | DUT Type: Portable Handset | Page 105 of 108 | |