



FCC RF Test Report

APPLICANT : Samsung Electronics Co., Ltd.
EQUIPMENT : MOBILE PHONE
BRAND NAME : SAMSUNG
MODEL NAME : SM-E500YZ
FCC ID : A3LSME500YZ
STANDARD : FCC Part 15 Subpart C §15.247
CLASSIFICATION : (DTS) Digital Transmission System

The product was received on Jan. 19, 2015 and testing was completed on Jan. 28, 2015. We, SPORTON INTERNATIONAL (SHENZHEN) INC., would like to declare that the tested sample has been evaluated in accordance with the test procedures and has been in compliance with the applicable technical standards.

The test results in this report apply exclusively to the tested model / sample. Without written approval of SPORTON INTERNATIONAL (SHENZHEN) INC., the test report shall not be reproduced except in full.

Reviewed by: Joseph Lin / Supervisor

Approved by: Jones Tsai / Manager



SPORTON INTERNATIONAL (SHENZHEN) INC.

**1F & 2F, Building A, Morning Business Center, No. 4003 ShiGu Rd., Xili Town,
Nanshan District, Shenzhen, Guangdong, P. R. China**



TABLE OF CONTENTS

SUMMARY OF TEST RESULT	4
1 GENERAL DESCRIPTION	5
1.1 Applicant	5
1.2 Manufacturer.....	5
1.3 Product Feature of Equipment Under Test.....	5
1.4 Product Specification subjective to this standard	5
1.5 Modification of EUT	6
1.6 Testing Location	6
1.7 Applicable Standards.....	6
2 TEST CONFIGURATION OF EQUIPMENT UNDER TEST	7
2.1 Carrier Frequency Channel	7
2.2 Pre-Scanned RF Power.....	8
2.3 Test Mode.....	9
2.4 Connection Diagram of Test System.....	10
2.5 Support Unit used in test configuration and system	11
2.6 EUT Operation Test Setup	11
2.7 Measurement Results Explanation Example.....	11
3 TEST RESULT.....	12
3.1 6dB Bandwidth Measurement	12
3.2 Output Power Measurement.....	14
3.3 Power Spectral Density Measurement	17
3.4 Conducted Band Edges and Spurious Emission Measurement	19
3.5 Radiated Band Edges and Spurious Emission Measurement	29
3.6 AC Conducted Emission Measurement.....	33
3.7 Antenna Requirements.....	37
4 LIST OF MEASURING EQUIPMENT	38
5 UNCERTAINTY OF EVALUATION	39
APPENDIX A. RADIATED TEST RESULTS	



SUMMARY OF TEST RESULT

Report Section	FCC Rule	Description	Limit	Result	Remark
3.1	15.247(a)(2)	6dB Bandwidth	$\geq 0.5\text{MHz}$	Pass	-
3.2	15.247(b)	Power Output Measurement	$\leq 30\text{dBm}$	Pass	-
3.3	15.247(e)	Power Spectral Density	$\leq 8\text{dBm}/3\text{kHz}$	Pass	-
3.4	15.247(d)	Conducted Band Edges	$\leq 20\text{dBc}$	Pass	-
		Conducted Spurious Emission		Pass	-
3.5	15.247(d)	Radiated Band Edges and Radiated Spurious Emission	15.209(a) & 15.247(d)	Pass	Under limit 4.51 dB at 2483.640 MHz
3.6	15.207	AC Conducted Emission	15.207(a)	Pass	Under limit 5.39 dB at 11.020 MHz
3.7	15.203 & 15.247(b)	Antenna Requirement	N/A	Pass	-



1 General Description

1.1 Applicant

Samsung Electronics Co., Ltd.

No. 9 WeiWu Rd., Micro Electronic Industrial Park, Jingang Highway, Xiqing District, Tianjin, China

1.2 Manufacturer

Samsung Electronics Co., Ltd.

516229 China Guangdong Province Huizhou City Chenjiang Town Samsung Electronics Huizhou Co., Ltd.

1.3 Product Feature of Equipment Under Test

Product Feature	
Equipment	MOBILE PHONE
Brand Name	SAMSUNG
Model Name	SM-E500YZ
FCC ID	A3LSME500YZ
GSM Operating Band(s)	GSM 900/1800/1900/850MHz
GPRS/EGPRS Multi-slot Class	GPRS Class 33, EGPRS Class 33
WCDMA Operating Band(s)	FDD Band I/II/V/VIII
LTE Operating Band(s)	FDD Band 1/3/5/8/28
Wi-Fi Specification	2.4GHz 802.11b/g/n HT20
Bluetooth Version	Bluetooth v3.0 + EDR/Bluetooth v4.0 LE
NFC Specification	Type A/B/F/V
ANT+ Specification	2.4GHz
HW Version	REV0.1
SW Version	E500YZ.001
EUT Stage	Identical Prototype

Remark: The above EUT's information was declared by manufacturer. Please refer to the specifications or user's manual for more detailed description.

1.4 Product Specification subjective to this standard

Product Specification subjective to this standard	
Tx/Rx Channel Frequency Range	2412 MHz ~ 2462 MHz
Maximum (Peak) Output Power to Antenna	802.11b : 18.97 dBm (0.0789 W) 802.11g : 22.79 dBm (0.1901 W) 802.11n HT20 : 22.58 dBm (0.1811 W)
Antenna Type / Gain	SUS Antenna with gain -1.40 dBi
Type of Modulation	802.11b : DSSS (DBPSK / DQPSK / CCK) 802.11g/n : OFDM (BPSK / QPSK / 16QAM / 64QAM)



1.5 Modification of EUT

No modifications are made to the EUT during all test items.

1.6 Testing Location

Test Site	SPORTON INTERNATIONAL (SHENZHEN) INC.	
Test Site Location	1F & 2F, Building A, Morning Business Center, No. 4003 ShiGu Rd., Xili Town, Nanshan District, Shenzhen, Guangdong, P. R. China TEL: +86-755-8637-9589 FAX: +86-755-8637-9595	
Test Site No.	Sporton Site No.	
	TH01-SZ	CO01-SZ

Test Site	SPORTON INTERNATIONAL (SHENZHEN) INC.	
Test Site Location	No. 3 Building, the third floor of south, Shahe River west, Fengzeyuan warehouse, Nanshan District, Shenzhen, Guangdong, P. R. China TEL: +86-755- 3320-2398	
Test Site No.	Sporton Site No.	FCC Registration No.
	03CH01-SZ	831040

Note: The test site complies with ANSI C63.4 2009 requirement.

1.7 Applicable Standards

According to the specifications of the manufacturer, the EUT must comply with the requirements of the following standards:

- FCC Part 15 Subpart C §15.247
- FCC KDB Publication No. 558074 D01 DTS Meas. Guidance v03r02
- ANSI C63.10-2013

Remark:

1. All test items were verified and recorded according to the standards and without any deviation during the test.
2. FCC permits the use of the 1.5 meter table as an alternative in C63.10-2013 through inquiry tracking number 961829.
3. This EUT has also been tested and complied with the requirements of FCC Part 15, Subpart B, recorded in a separate test report.



2 Test Configuration of Equipment Under Test

The EUT has been associated with peripherals and configuration operated in a manner tended to maximize its emission characteristics in a typical application. Frequency range investigated: conducted emission (150 kHz to 30 MHz) and radiated emission (9 kHz to the 10th harmonic of the highest fundamental frequency or to 40 GHz, whichever is lower). For radiated measurement, pre-scanned in three orthogonal panels, X, Y, Z. The worst cases (Z plane) were recorded in this report.

The final configuration from all the combinations and the worst-case data rates were investigated by measuring the maximum power across all the data rates and modulation modes under section 2.2.

Based on the worst configuration found above, the RF power setting is set individually to meet FCC compliance limit for the final conducted and radiated tests shown in section 2.3.

2.1 Carrier Frequency Channel

Frequency Band	Channel	Freq. (MHz)	Channel	Freq. (MHz)
2400-2483.5 MHz	1	2412	7	2442
	2	2417	8	2447
	3	2422	9	2452
	4	2427	10	2457
	5	2432	11	2462
	6	2437	-	-



2.2 Pre-Scanned RF Power

Preliminary tests were performed in different data rate and data rate associated with the highest power were chosen for full test shown in the following tables.

2.4GHz 802.11b RF Output Power (dBm)						
Power vs. Channel			Power vs. Data Rate			
Channel	Frequency (MHz)	Data Rate	Channel	2Mbps	5.5Mbps	11Mbps
		1Mbps				
CH 01	2412 MHz	18.97	CH 01	18.88	18.85	18.95
CH 06	2437 MHz	18.93				
CH 11	2462 MHz	18.74				

2.4GHz 802.11g RF Output Power (dBm)										
Power vs. Channel			Power vs. Data Rate							
Channel	Frequency (MHz)	Data Rate	Channel	9Mbps	12Mbps	18Mbps	24Mbps	36Mbps	48Mbps	54Mbps
		6Mbps								
CH 01	2412 MHz	22.37	CH 06	22.73	22.67	22.63	22.71	22.54	22.64	22.53
CH 06	2437 MHz	22.79								
CH 11	2462 MHz	22.51								

2.4GHz 802.11n HT20 RF Output Power (dBm)										
Power vs. Channel			Power vs. MCS Index							
Channel	Frequency (MHz)	MCS Index	Channel	MCS1	MCS2	MCS3	MCS4	MCS5	MCS6	MCS7
		MCS0								
CH 01	2412 MHz	21.79	CH 06	22.54	22.37	22.47	22.41	22.40	22.37	22.35
CH 06	2437 MHz	22.58								
CH 11	2462 MHz	21.89								



2.3 Test Mode

Final results of test modes, data rates and test channels are shown as following table.

Test Cases				
	Test Items	Mode	Data Rate	Test Channel
Conducted TCs	6dB BW Power Spectral Density	802.11b	1 Mbps	1/6/11
		802.11g	6 Mbps	1/6/11
		802.11n HT20	MCS0	1/6/11
	Output Power	802.11b	1 Mbps	1/6/11
		802.11g	6 Mbps	1/6/11
		802.11n HT20	MCS0	1/6/11
	Conducted Band Edge	802.11b	1 Mbps	1/11
		802.11g	6 Mbps	1/11
		802.11n HT20	MCS0	1/11
	Conducted Spurious Emission	802.11b	1 Mbps	1/6/11
		802.11g	6 Mbps	1/6/11
		802.11n HT20	MCS0	1/6/11
Radiated TCs	Radiated Band Edge	802.11b	1 Mbps	1/11
		802.11g	6 Mbps	1/11
		802.11n HT20	MCS0	1/11
	Radiated Spurious Emission	802.11b	1 Mbps	1/6/11
		802.11g	6 Mbps	1/6/11
		802.11n HT20	MCS0	1/6/11
AC Conducted Emission	Mode 1 : GSM850 Idle + Bluetooth Link + WLAN (2.4GHz) Link + USB Cable (Charging from Adapter) + Earphone			
Remark: For Radiated TCs, the tests were performed with adapter, earphone and USB cable.				

2.4 Connection Diagram of Test System

<WLAN Tx Mode>

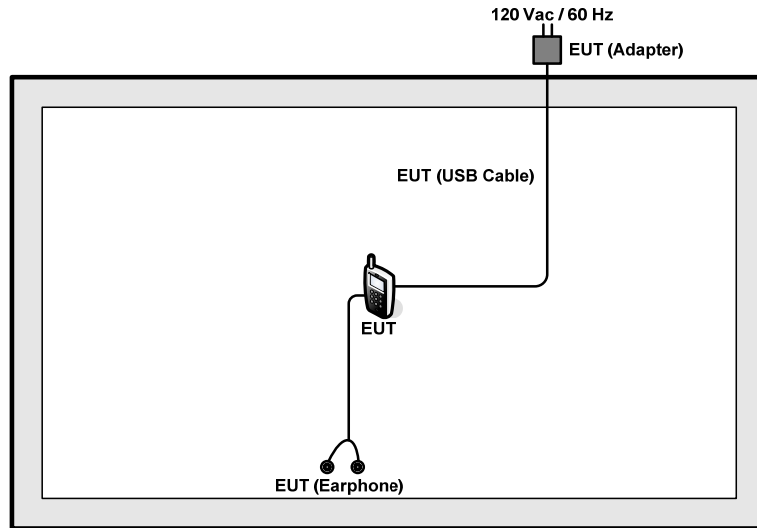

<AC Conducted Emission Mode>

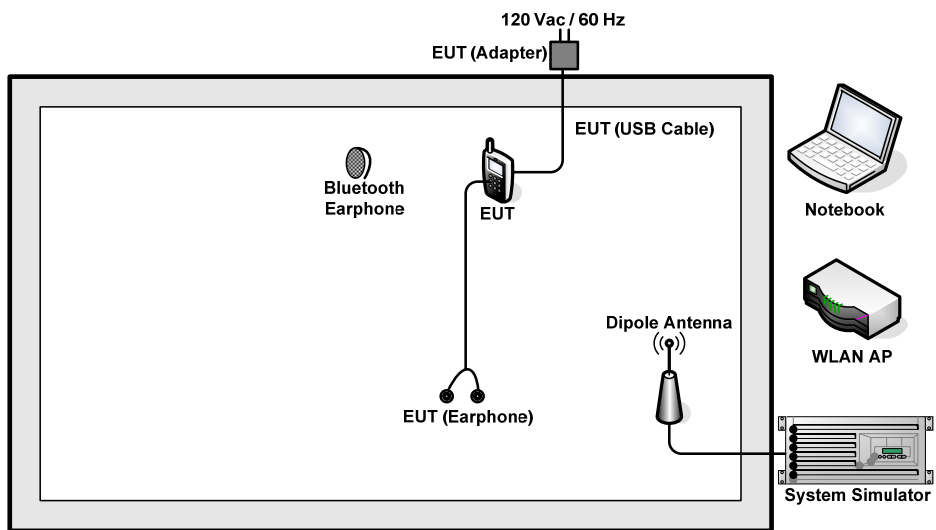

2.5 Support Unit used in test configuration and system

Item	Equipment	Trade Name	Model Name	FCC ID	Data Cable	Power Cord
1.	WLAN AP	D-Link	DIR-815	KA2DIR815A1	N/A	Unshielded, 1.8 m
2.	Notebook	Lenovo	E540	FCC DoC	N/A	AC I/P: Unshielded, 1.2 m DC O/P: Shielded, 1.8 m
3.	Bluetooth Earphone	Nokia	BH-108	PYAHS-107W	N/A	N/A

2.6 EUT Operation Test Setup

For WLAN RF test items, an engineering test program was provided and enabled to make EUT continuously transmit/receive.

For AC power line conducted emissions, the EUT was set to connect with the WLAN AP under large package sizes transmission.

2.7 Measurement Results Explanation Example

For all conducted test items:

The offset level is set in the spectrum analyzer to compensate the RF cable loss and attenuator factor between EUT conducted output port and spectrum analyzer. With the offset compensation, the spectrum analyzer reading level is exactly the EUT RF output level.

Example :

The spectrum analyzer offset is derived from RF cable loss and attenuator factor.

Offset = RF cable loss + attenuator factor.

Following shows an offset computation example with cable loss 5 dB and 10dB attenuator.

$$\begin{aligned} \text{Offset(dB)} &= \text{RF cable loss(dB)} + \text{attenuator factor(dB)}. \\ &= 5 + 10 = 15 \text{ (dB)} \end{aligned}$$

3 Test Result

3.1 6dB Bandwidth Measurement

3.1.1 Limit of 6dB Bandwidth

The minimum 6 dB bandwidth shall be at least 500 kHz.

3.1.2 Measuring Instruments

The measuring equipment is listed in the section 4 of this test report.

3.1.3 Test Procedures

1. The testing follows FCC KDB Publication No. 558074 DTS D01 Meas. Guidance v03r02.
2. The RF output of EUT was connected to the spectrum analyzer by RF cable and attenuator. The path loss was compensated to the results for each measurement.
3. Set to the maximum power setting and enable the EUT transmit continuously.
4. Make the measurement with the spectrum analyzer's resolution bandwidth (RBW) = 100 kHz. Set the Video bandwidth (VBW) = 300 kHz. In order to make an accurate measurement. The 6 dB bandwidth must be greater than 500 kHz.
5. Measure and record the results in the test report.

3.1.4 Test Setup

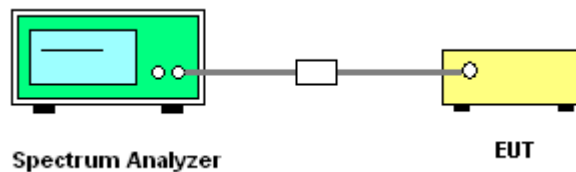



3.1.5 Test Result of 6dB Bandwidth

Test Band :	2.4GHz	Temperature :	24~26°C
Test Engineer :	Fly Liang	Relative Humidity :	50~53%

Mod.	Data Rate	N _{TX}	Channel	Freq. (MHz)	6dB Bandwidth (MHz)	6dB Bandwidth Min. Limit (MHz)	Pass/Fail
11b	1Mbps	1	1	2412	7.08	0.5	Pass
11b	1Mbps	1	6	2437	7.08	0.5	Pass
11b	1Mbps	1	11	2462	7.08	0.5	Pass
11g	6Mbps	1	1	2412	16.32	0.5	Pass
11g	6Mbps	1	6	2437	16.36	0.5	Pass
11g	6Mbps	1	11	2462	16.36	0.5	Pass
HT20	MCS0	1	1	2412	17.52	0.5	Pass
HT20	MCS0	1	6	2437	17.56	0.5	Pass
HT20	MCS0	1	11	2462	17.60	0.5	Pass

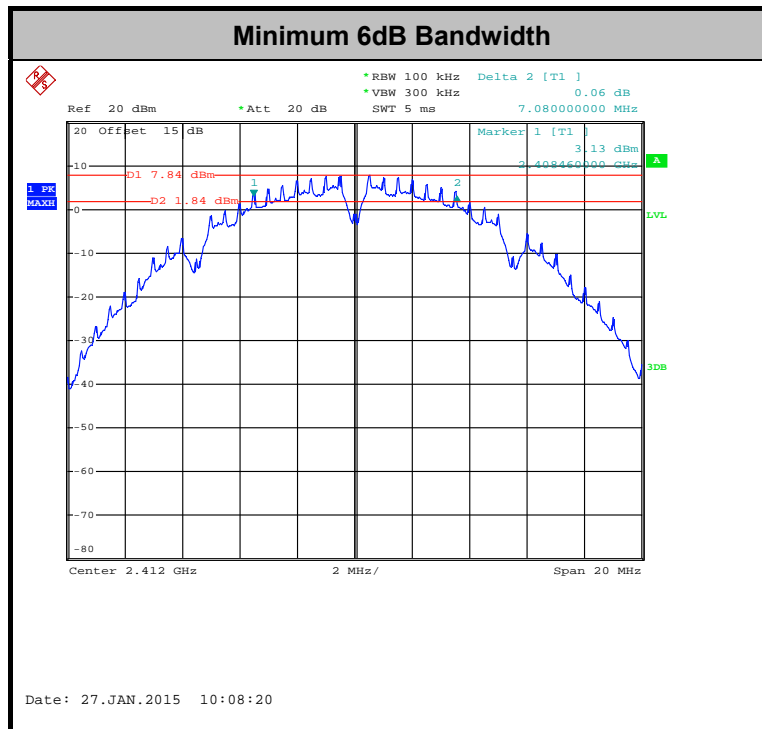

Note : The occupied channel bandwidth is maintained within the band of operation for all of the modulations.

3.2 Output Power Measurement

3.2.1 Limit of Output Power

For systems using digital modulation in the 2400-2483.5MHz, the limit for peak output power is 30dBm. If transmitting Antenna of directional gain greater than 6dBi are used the peak output power from the intentional radiator shall be reduced below the above stated value by the amount in dB that the directional gain of the Antenna exceeds 6 dBi. In case of point-to-point operation, the limit has to be reduced by 1dB for every 3dB that the directional gain of the Antenna exceeds 6dBi.

3.2.2 Measuring Instruments

The measuring equipment is listed in the section 4 of this test report.

3.2.3 Test Procedures

1. The testing follows the Measurement Procedure of FCC KDB No. 558074 DTS D01 Meas. Guidance v03r02.
2. The RF output of EUT was connected to the power meter by RF cable and attenuator. The path loss was compensated to the results for each measurement.
3. Set to the maximum power setting and enable the EUT transmit continuously.
4. Measure the conducted output power and record the results in the test report.

3.2.4 Test Setup

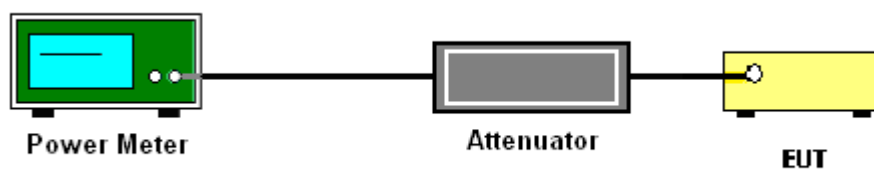



3.2.5 Test Result of Peak Output Power

Test Mode :	2.4GHz	Temperature :	24~26°C
Test Engineer :	Fly Liang	Relative Humidity :	50~53%

Mod.	Data Rate	N _{TX}	Channel	Freq. (MHz)	RF Output Power (dBm)	Power Limit (dBm)	DG (dBi)	Pass/Fail
11b	1Mbps	1	1	2412	18.97	30	-1.40	Pass
11b	1Mbps	1	6	2437	18.93	30	-1.40	Pass
11b	1Mbps	1	11	2462	18.74	30	-1.40	Pass
11g	6Mbps	1	1	2412	22.37	30	-1.40	Pass
11g	6Mbps	1	6	2437	22.79	30	-1.40	Pass
11g	6Mbps	1	11	2462	22.51	30	-1.40	Pass
HT20	MCS0	1	1	2412	21.79	30	-1.40	Pass
HT20	MCS0	1	6	2437	22.58	30	-1.40	Pass
HT20	MCS0	1	11	2462	21.89	30	-1.40	Pass

Note: Measured power (dBm) has offset with cable loss.



3.2.6 Test Result of Average output Power (Reporting Only)

Test Mode :	2.4GHz	Temperature :	24~26°C
Test Engineer :	Fly Liang	Relative Humidity :	50~53%

Mod.	Data Rate	N _{TX}	Channel	Freq. (MHz)	Duty Factor (dB)	Average Output Power (dBm)	Power Limit (dBm)	DG (dBi)	Pass/Fail
11b	1Mbps	1	1	2412	0.05	16.00	30	-1.40	Pass
11b	1Mbps	1	6	2437	0.05	15.81	30	-1.40	Pass
11b	1Mbps	1	11	2462	0.05	15.64	30	-1.40	Pass
11g	6Mbps	1	1	2412	0.31	13.63	30	-1.40	Pass
11g	6Mbps	1	6	2437	0.31	14.20	30	-1.40	Pass
11g	6Mbps	1	11	2462	0.31	13.48	30	-1.40	Pass
HT20	MCS0	1	1	2412	0.35	12.80	30	-1.40	Pass
HT20	MCS0	1	6	2437	0.35	13.24	30	-1.40	Pass
HT20	MCS0	1	11	2462	0.35	12.53	30	-1.40	Pass

Note: Measured power (dBm) has offset with cable loss and duty factor.

3.3 Power Spectral Density Measurement

3.3.1 Limit of Power Spectral Density

The peak power spectral density shall not be greater than 8dBm in any 3kHz band at any time interval of continuous transmission.

3.3.2 Measuring Instruments

The measuring equipment is listed in the section 4 of this test report.

3.3.3 Test Procedures

1. The testing follows Measurement Procedure 10.2 Method PKPSD of FCC KDB Publication No. 558074 D01 DTS Meas. Guidance v03r02
2. The RF output of EUT was connected to the spectrum analyzer by RF cable and attenuator. The path loss was compensated to the results for each measurement.
3. Set to the maximum power setting and enable the EUT transmit continuously.
4. Make the measurement with the spectrum analyzer's resolution bandwidth (RBW) = 3 kHz. Video bandwidth VBW = 10 kHz In order to make an accurate measurement, set the span to 1.5 times DTS Channel Bandwidth. (6dB BW)
5. Detector = peak, Sweep time = auto couple, Trace mode = max hold, Allow trace to fully stabilize. Use the peak marker function to determine the maximum power level.
6. Measure and record the results in the test report.

3.3.4 Test Setup

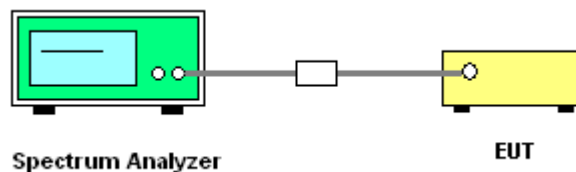



3.3.5 Test Result of Power Spectral Density

Test Mode :	2.4GHz	Temperature :	24~26°C
Test Engineer :	Fly Liang	Relative Humidity :	50~53%

Mod.	Data Rate	N _{TX}	Channel	Freq. (MHz)	Peak Power Density (dBm/3kHz)	Max. Limits (dBm/3kHz)	DG (dBi)	Pass/Fail
11b	1Mbps	1	1	2412	-6.53	8	-1.40	Pass
11b	1Mbps	1	6	2437	-5.39	8	-1.40	Pass
11b	1Mbps	1	11	2462	-6.77	8	-1.40	Pass
11g	6Mbps	1	1	2412	-11.98	8	-1.40	Pass
11g	6Mbps	1	6	2437	-12.29	8	-1.40	Pass
11g	6Mbps	1	11	2462	-11.73	8	-1.40	Pass
HT20	MCS0	1	1	2412	-13.32	8	-1.40	Pass
HT20	MCS0	1	6	2437	-13.14	8	-1.40	Pass
HT20	MCS0	1	11	2462	-13.80	8	-1.40	Pass

Note: Measured power density (dBm) has offset with cable loss.

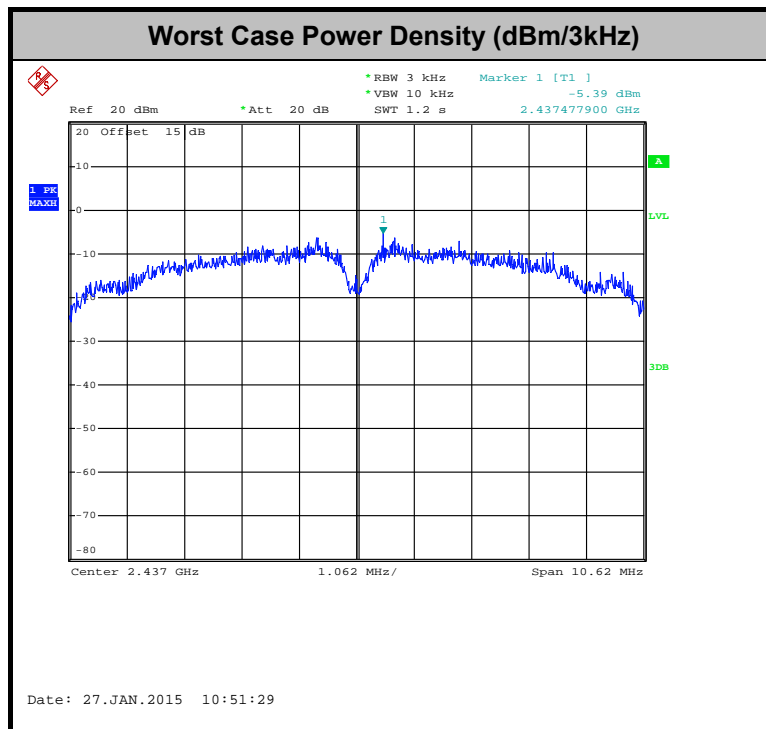

3.4 Conducted Band Edges and Spurious Emission Measurement

3.4.1 Limit of Conducted Band Edges and Spurious Emission Measurement

In any 100 kHz bandwidth outside of the authorized frequency band, the emissions which fall in the non-restricted bands shall be attenuated at least 20 dB / 30dB relative to the maximum PSD level in 100 kHz by RF conducted measurement and radiated emissions which fall in the restricted bands, as defined in Section 15.205(a), must also comply with the radiated emission limits specified in Section 15.209(a).

3.4.2 Measuring Instruments

The measuring equipment is listed in the section 4 of this test report.

3.4.3 Test Procedures

1. The testing follows FCC KDB Publication No. 558074 D01 DTS Meas. Guidance v03r02.
2. The RF output of EUT was connected to the spectrum analyzer by RF cable and attenuator. The path loss was compensated to the results for each measurement.
3. Set to the maximum power setting and enable the EUT transmit continuously.
4. Set RBW = 100 kHz, VBW=300 kHz, Peak Detector. Unwanted Emissions measured in any 100 kHz bandwidth outside of the authorized frequency band shall be attenuated by at least 20 dB relative to the maximum in-band peak PSD level in 100 kHz when maximum peak conducted output power procedure is used. If the transmitter complies with the conducted power limits based on the use of RMS averaging over a time interval, the attenuation required under this paragraph shall be 30 dB instead of 20 dB per 15.247(d).
5. Measure and record the results in the test report.
6. The RF fundamental frequency should be excluded against the limit line in the operating frequency band.

3.4.4 Test Setup

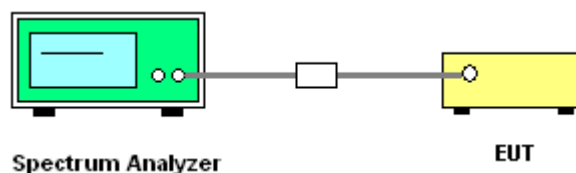



3.4.5 Test Result of Conducted Band Edges and Spurious Emission

Test Mode :	802.11b	Temperature :	24~26°C
Test Band :	2.4GHz Low	Relative Humidity :	50~53%
Test Channel :	01	Test Engineer :	Fly Liang

WLAN 802.11b Channel 01

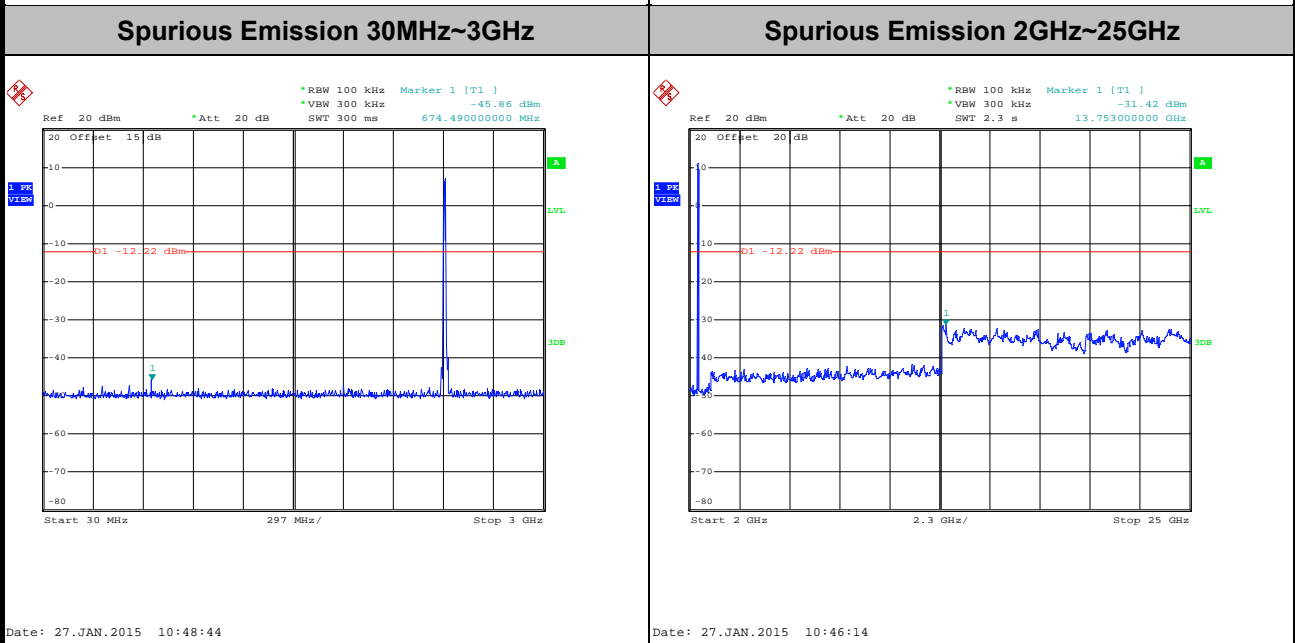
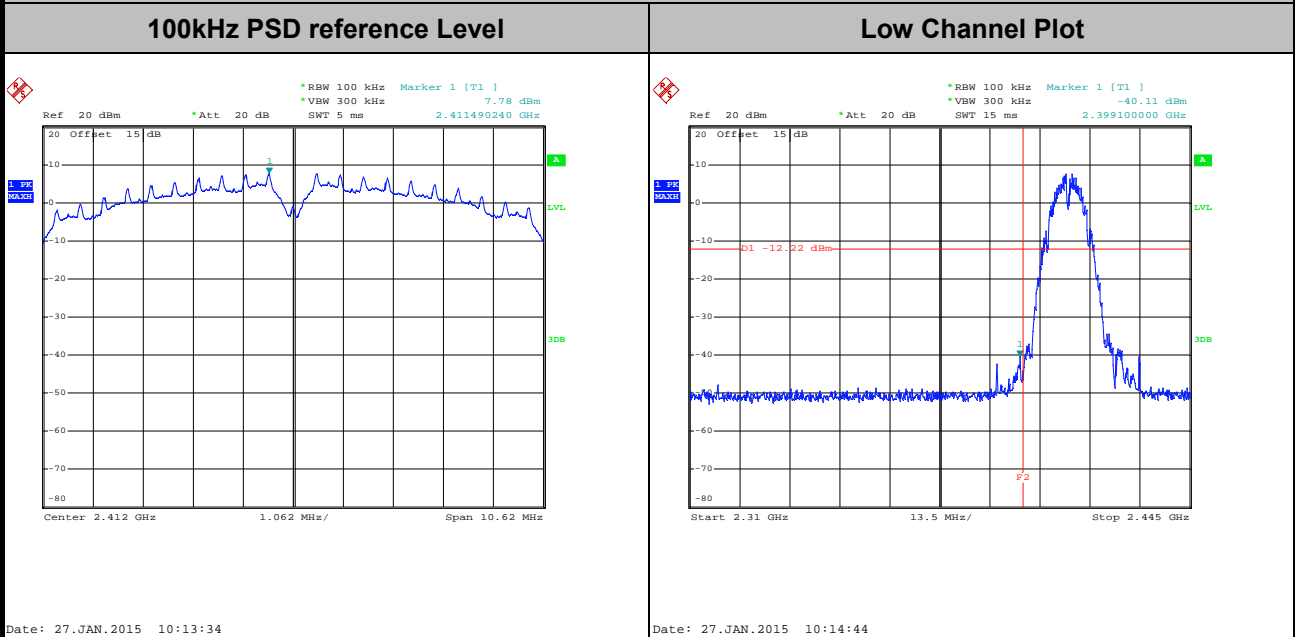



Test Mode :	802.11b	Temperature :	24~26°C
Test Band :	2.4GHz Mid	Relative Humidity :	50~53%
Test Channel :	06	Test Engineer :	Fly Liang

WLAN 802.11b Channel 06

100kHz PSD reference Level

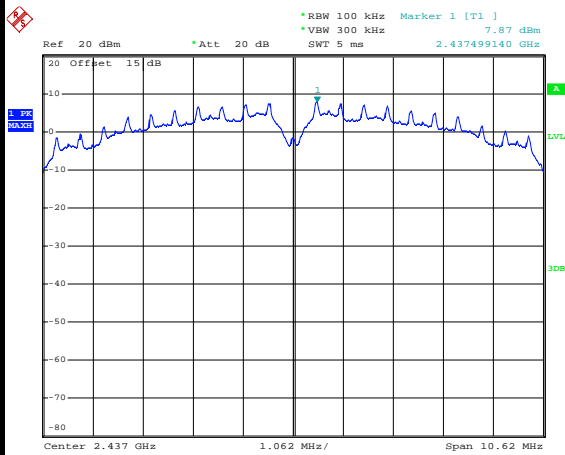

Date: 27.JAN.2015 10:51:55

Spurious Emission 30MHz~3GHz

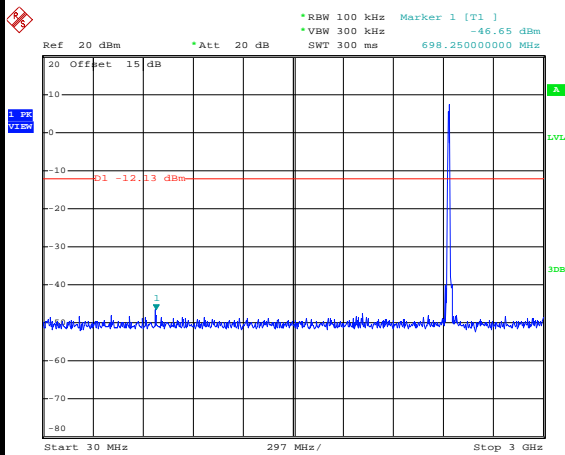

Date: 27.JAN.2015 10:54:36

Spurious Emission 2GHz~25GHz

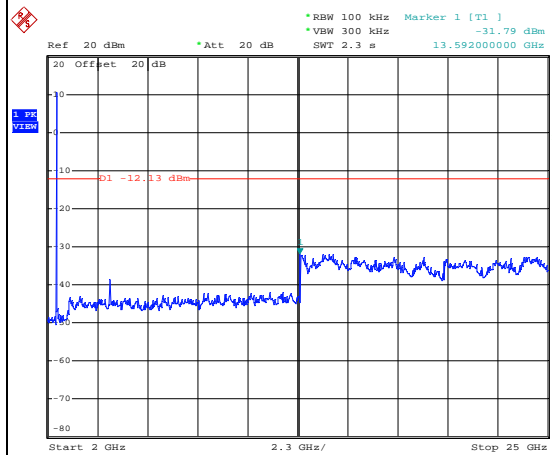

Date: 27.JAN.2015 10:56:06



Test Mode :	802.11b	Temperature :	24~26°C
Test Band :	2.4GHz High	Relative Humidity :	50~53%
Test Channel :	11	Test Engineer :	Fly Liang

WLAN 802.11b Channel 11

100kHz PSD reference Level

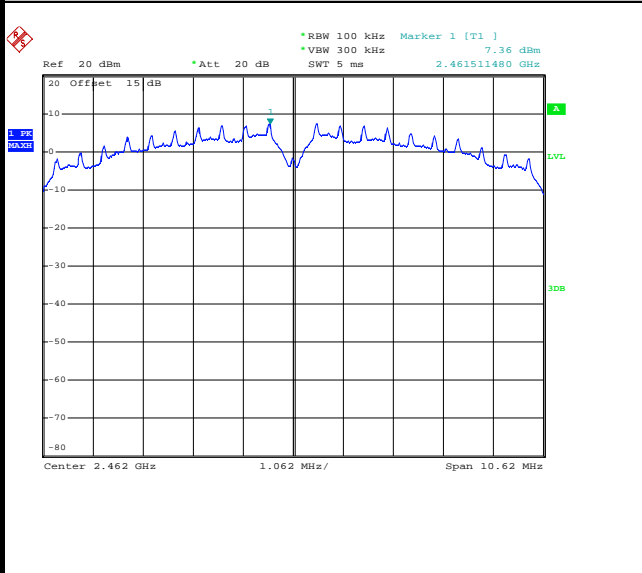

High Channel Plot

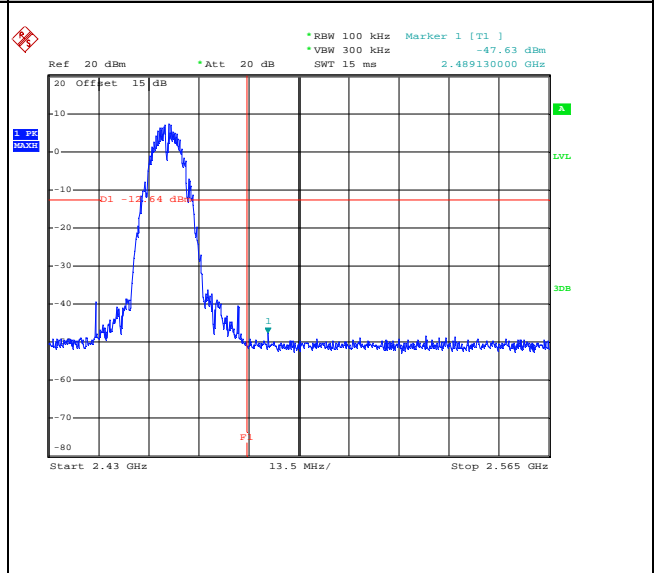

Spurious Emission 30MHz~3GHz

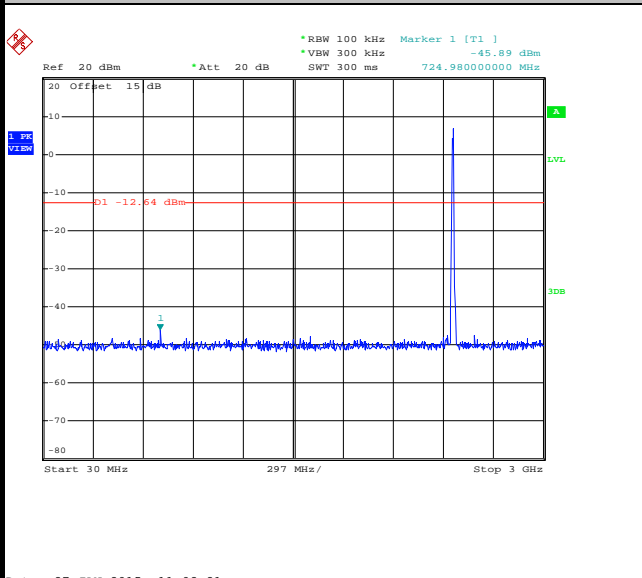

Spurious Emission 2GHz~25GHz

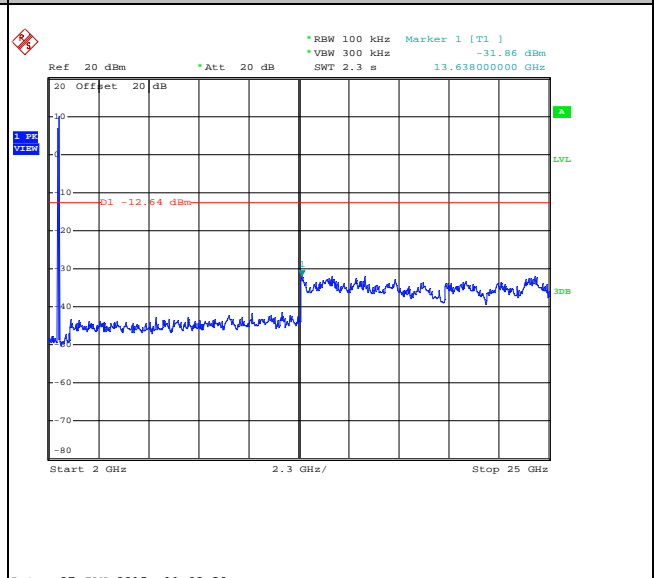



Test Mode :	802.11g	Temperature :	24~26°C
Test Band :	2.4GHz Low	Relative Humidity :	50~53%
Test Channel :	01	Test Engineer :	Fly Liang

WLAN 802.11g Channel 01

100kHz PSD reference Level

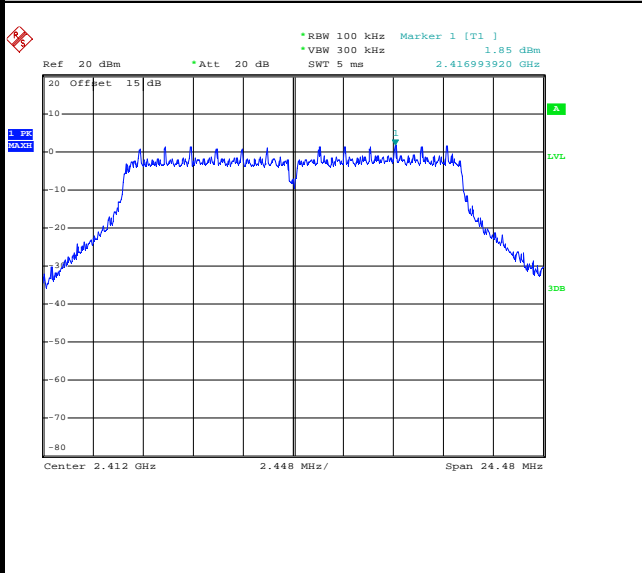

Low Channel Plot

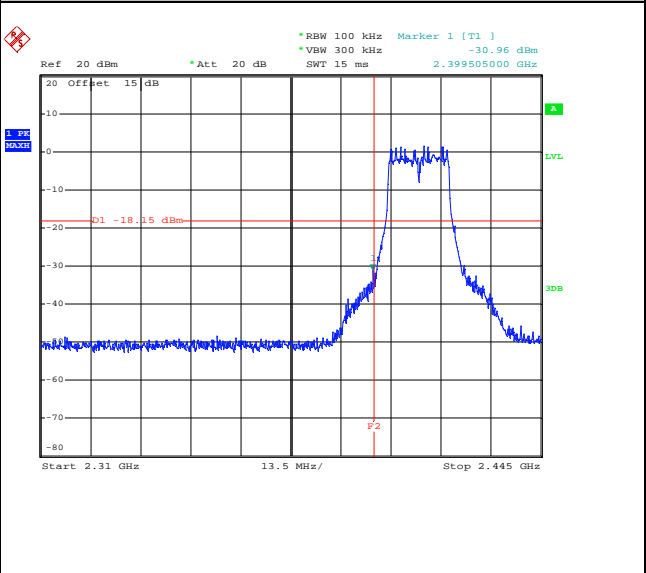

Spurious Emission 30MHz~3GHz

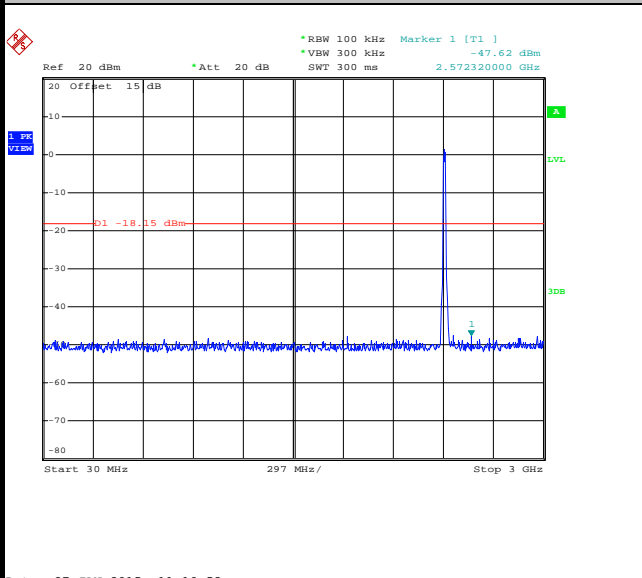

Spurious Emission 2GHz~25GHz

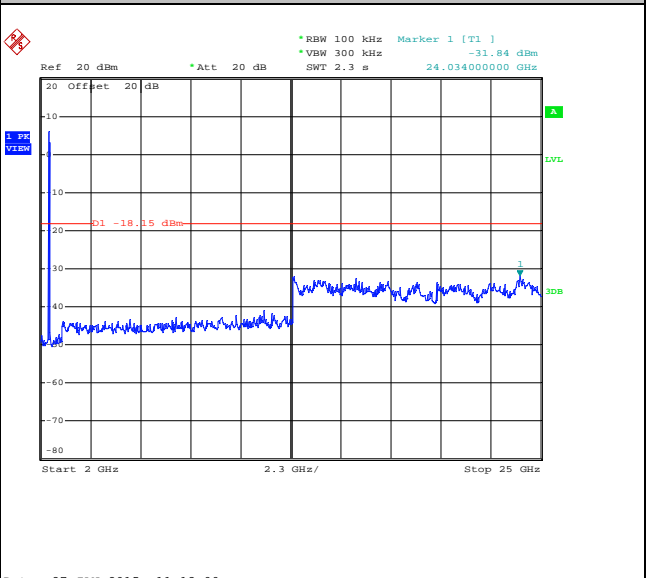



Test Mode :	802.11g	Temperature :	24~26°C
Test Band :	2.4GHz Mid	Relative Humidity :	50~53%
Test Channel :	06	Test Engineer :	Fly Liang

WLAN 802.11g Channel 06

100kHz PSD reference Level

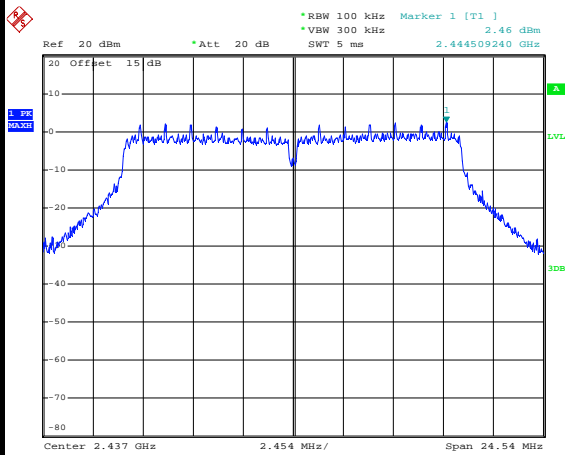

Date: 27.JAN.2015 11:16:39

Spurious Emission 30MHz~3GHz

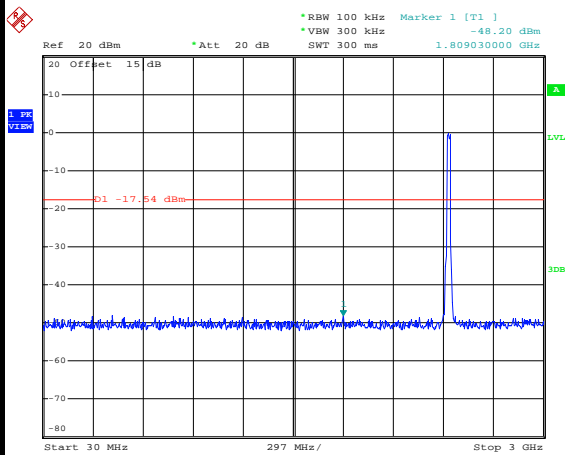

Date: 27.JAN.2015 11:18:23

Spurious Emission 2GHz~25GHz

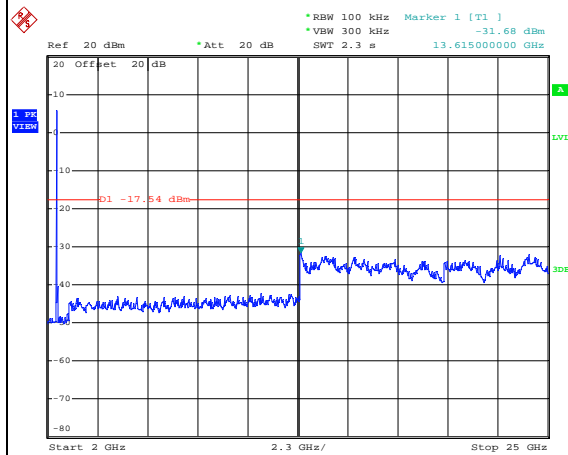

Date: 27.JAN.2015 11:21:55



Test Mode :	802.11g	Temperature :	24~26°C
Test Band :	2.4GHz High	Relative Humidity :	50~53%
Test Channel :	11	Test Engineer :	Fly Liang

WLAN 802.11g Channel 11

100kHz PSD reference Level

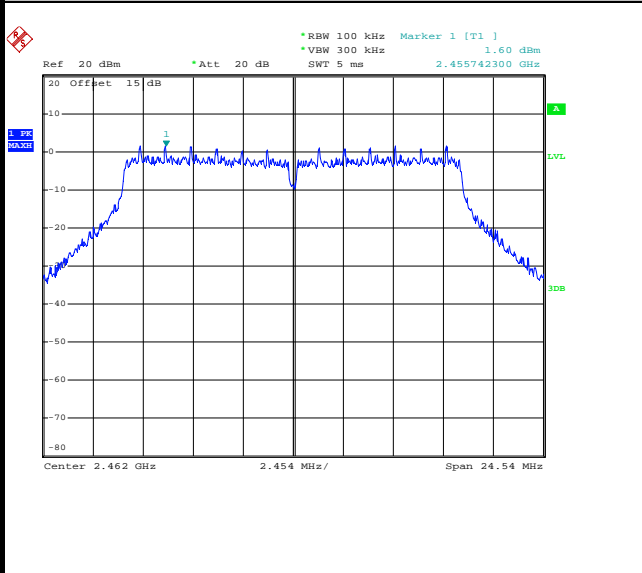

High Channel Plot

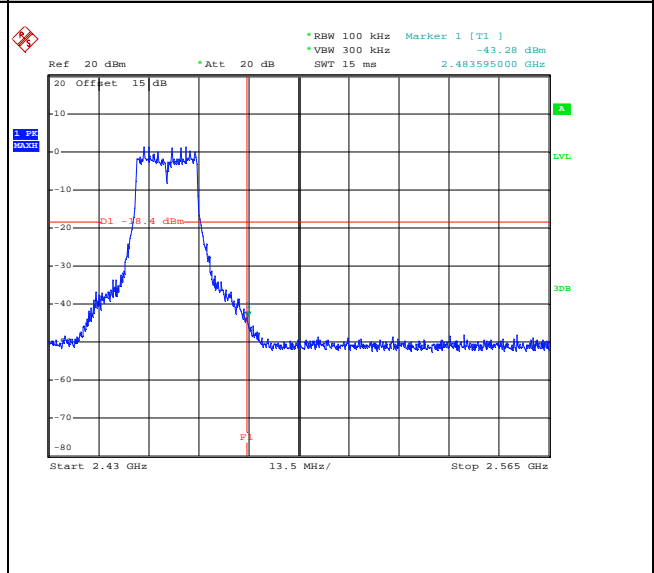

Spurious Emission 30MHz~3GHz

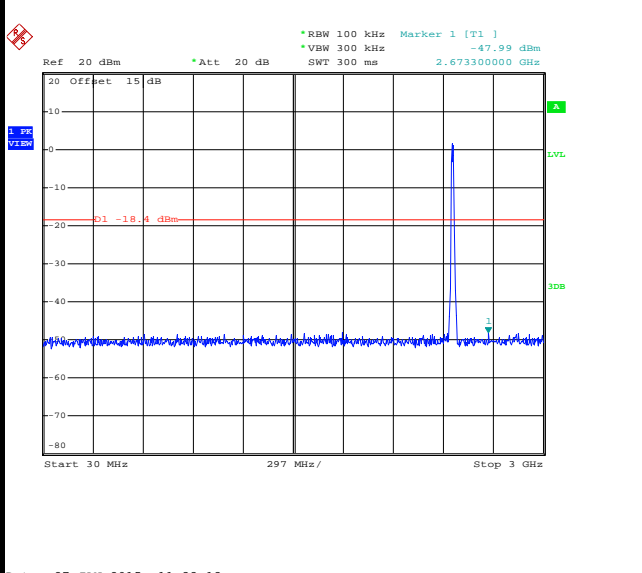

Spurious Emission 2GHz~25GHz

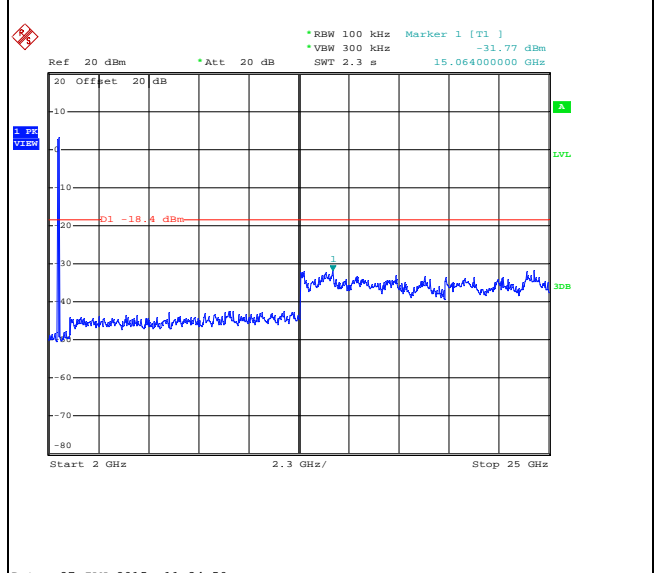



Test Mode :	802.11n HT20	Temperature :	24~26°C
Test Band :	2.4GHz Low	Relative Humidity :	50~53%
Test Channel :	01	Test Engineer :	Fly Liang

WLAN 802.11n HT20 Channel 01

100kHz PSD reference Level

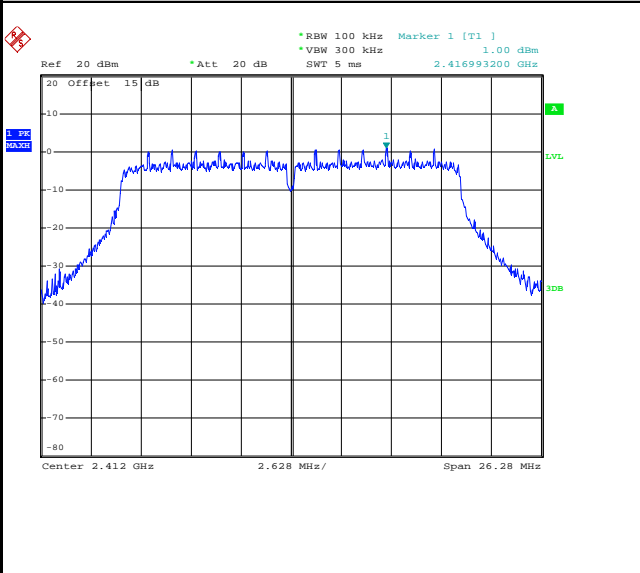

Low Channel Plot

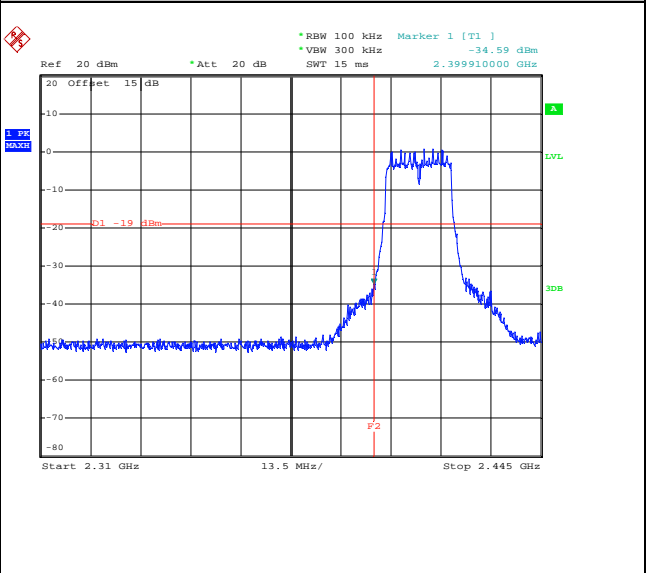

Spurious Emission 30MHz~3GHz

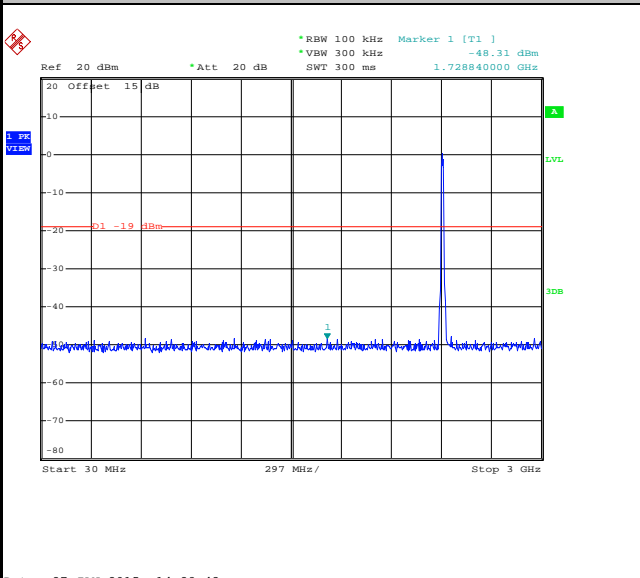

Spurious Emission 2GHz~25GHz

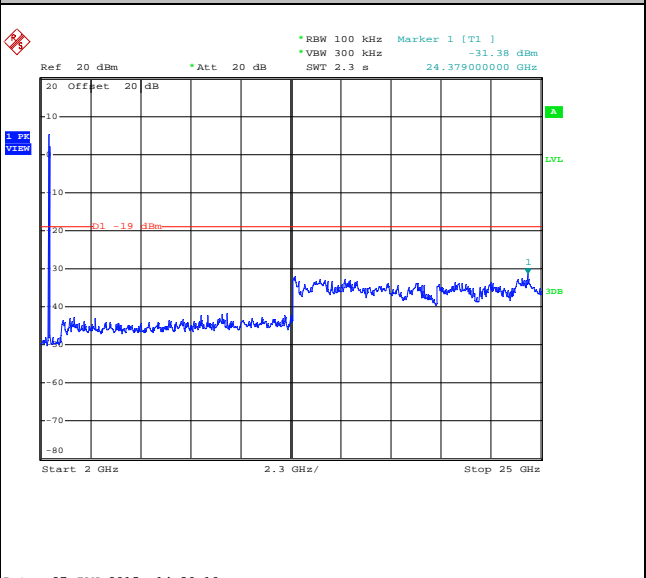



Test Mode :	802.11n HT20	Temperature :	24~26°C
Test Band :	2.4GHz Mid	Relative Humidity :	50~53%
Test Channel :	06	Test Engineer :	Fly Liang

WLAN 802.11n HT20 Channel 06

100kHz PSD reference Level

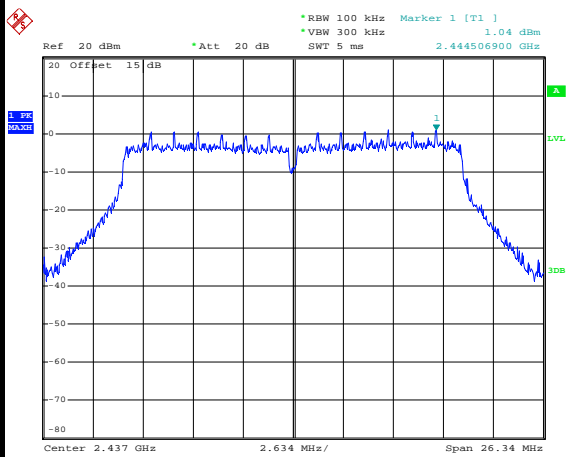

Date: 27.JAN.2015 13:41:09

Spurious Emission 30MHz~3GHz

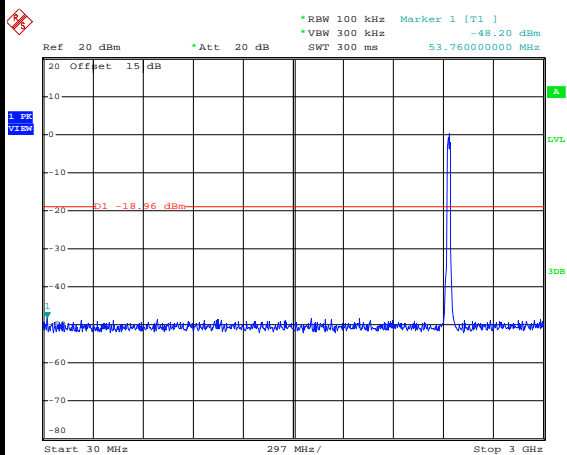

Date: 27.JAN.2015 13:42:38

Spurious Emission 2GHz~25GHz

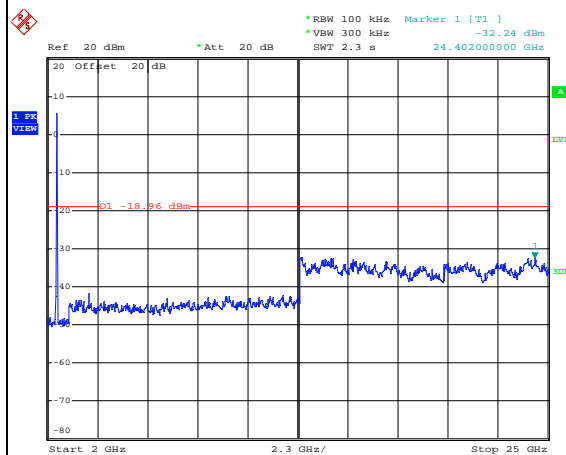

Date: 27.JAN.2015 13:46:58



Test Mode :	802.11n HT20	Temperature :	24~26°C
Test Band :	2.4GHz High	Relative Humidity :	50~53%
Test Channel :	11	Test Engineer :	Fly Liang

WLAN 802.11n HT20 Channel 11

100kHz PSD reference Level

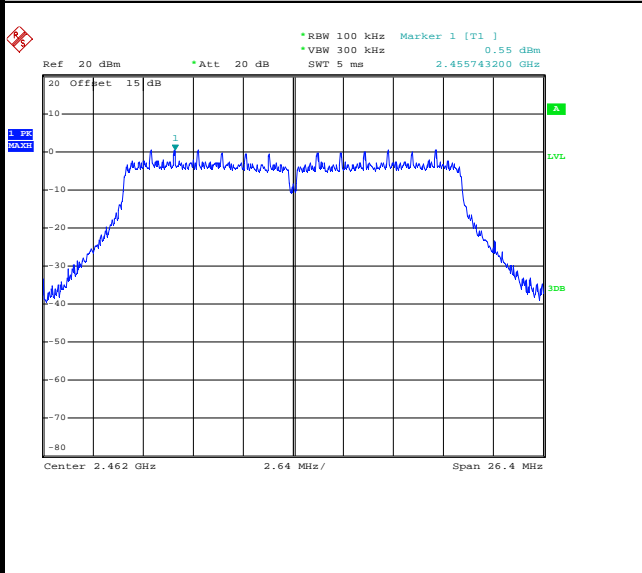

High Channel Plot

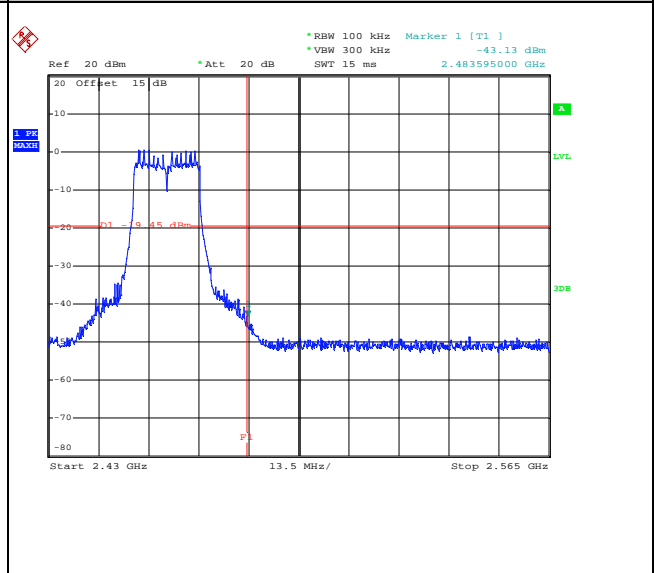

Spurious Emission 30MHz~3GHz

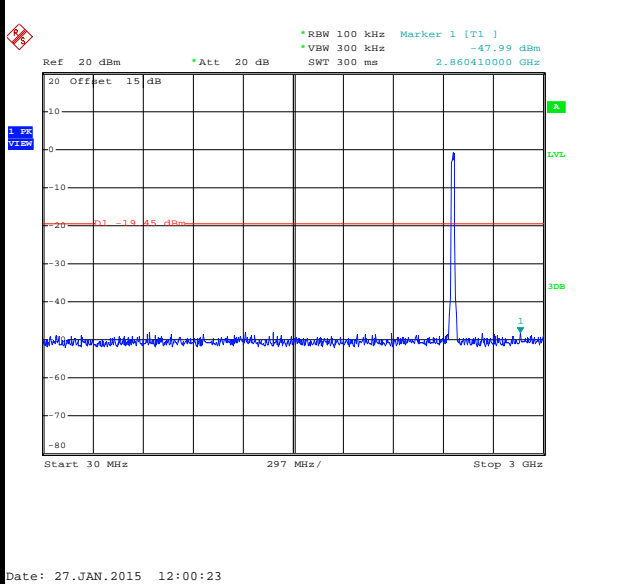

Spurious Emission 2GHz~25GHz

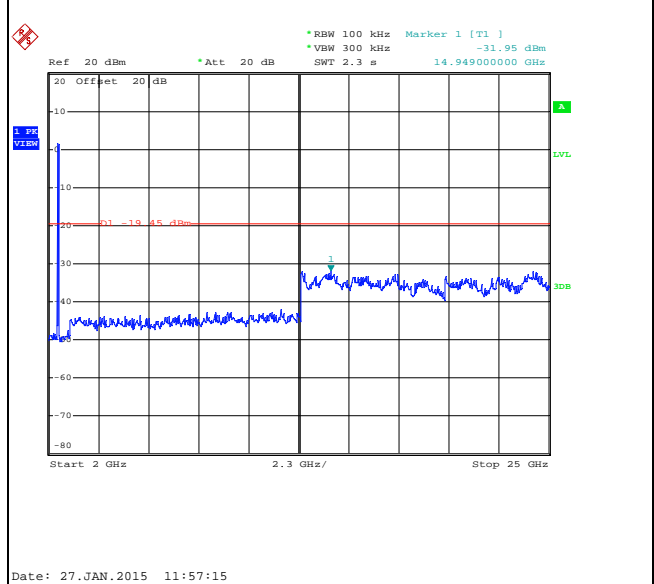



3.5 Radiated Band Edges and Spurious Emission Measurement

3.5.1 Limit of Radiated band edge and Spurious Emission Measurement

In any 100 kHz bandwidth outside the intentional radiator frequency band, all harmonics/spurious must be at least 20 dB below the highest emission level within the authorized band. If the output power of this device was measured by spectrum analyzer, the attenuation under this paragraph shall be 30 dB instead of 20 dB. In addition, radiated emissions which fall in the restricted bands must also comply with the FCC section 15.209 limits as below.

Frequency (MHz)	Field Strength (microvolts/meter)	Measurement Distance (meters)
0.009 – 0.490	2400/F(kHz)	300
0.490 – 1.705	24000/F(kHz)	30
1.705 – 30.0	30	30
30 – 88	100	3
88 – 216	150	3
216 - 960	200	3
Above 960	500	3

3.5.2 Measuring Instruments

The measuring equipment is listed in the section 4 of this test report.



3.5.3 Test Procedures

1. The testing follows FCC KDB Publication No. 558074 D01 DTS Meas. Guidance v03r02.
2. The EUT was arranged to its worst case and then tune the antenna tower (from 1 m to 4 m) and turntable (from 0 degree to 360 degrees) to find the maximum reading. A pre-amp and a high pass filter are used for the test in order to get better signal level.
3. The EUT was placed on a turntable with 0.8 meter for frequency below 1GHz and 1.5 meter for frequency above 1GHz respectively above ground.
4. The EUT was set 3 meters from the interference receiving antenna, which was mounted on the top of a variable height antenna tower.
5. Corrected Reading: Antenna Factor + Cable Loss + Read Level - Preamp Factor = Level
6. For measurement below 1GHz, If the emission level of the EUT measured by the peak detector is 3 dB lower than the applicable limit, the peak emission level will be reported. Otherwise, the emission measurement will be repeated using the quasi-peak detector and reported.
7. Use the following spectrum analyzer settings:
 - (1) Span shall wide enough to fully capture the emission being measured;
 - (2) Set RBW=100 kHz for $f < 1 \text{ GHz}$; $\text{VBW} \geq \text{RBW}$; Sweep = auto; Detector function = peak; Trace = max hold;
 - (3) Set RBW = 1 MHz, VBW= 3MHz for $f \geq 1 \text{ GHz}$ for peak measurement.
For average measurement:
 - $\text{VBW} = 10 \text{ Hz}$, when duty cycle is no less than 98 percent.
 - $\text{VBW} \geq 1/T$, when duty cycle is less than 98 percent where T is the minimum transmission duration over which the transmitter is on and is transmitting at its maximum power control level for the tested mode of operation.

Band	Duty Cycle(%)	T(ms)	1/T(kHz)	VBW Setting
802.11b	98.82	-	-	10Hz
802.11g	93.09	1.40	0.71	1kHz
2.4GHz 802.11n HT20	92.17	1.29	0.77	1kHz

3.5.4 Test Setup

For radiated emissions below 30MHz

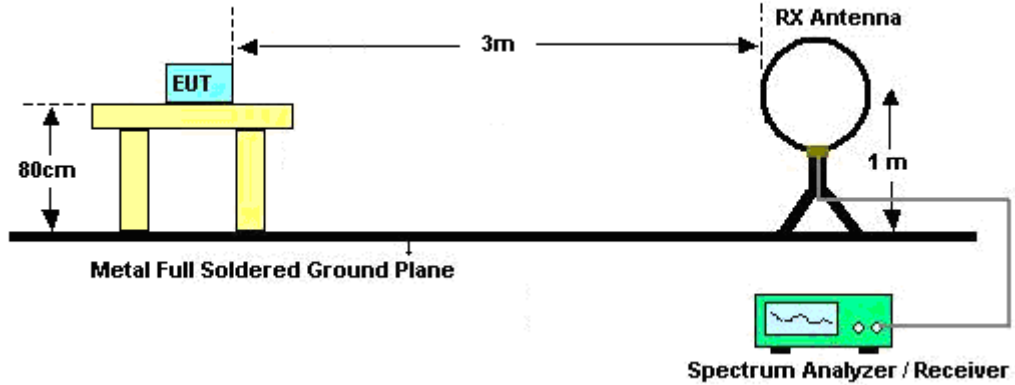

For radiated emissions from 30MHz to 1GHz

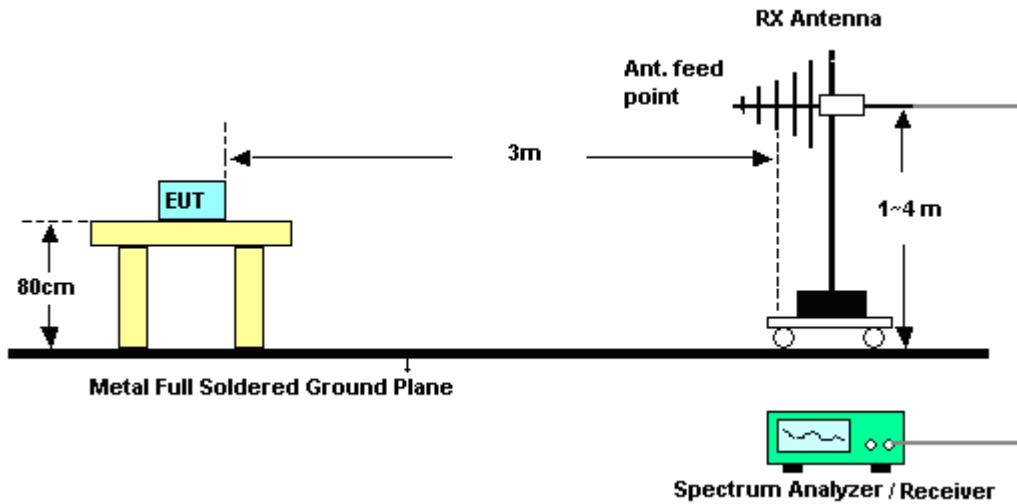

For radiated emissions above 1GHz

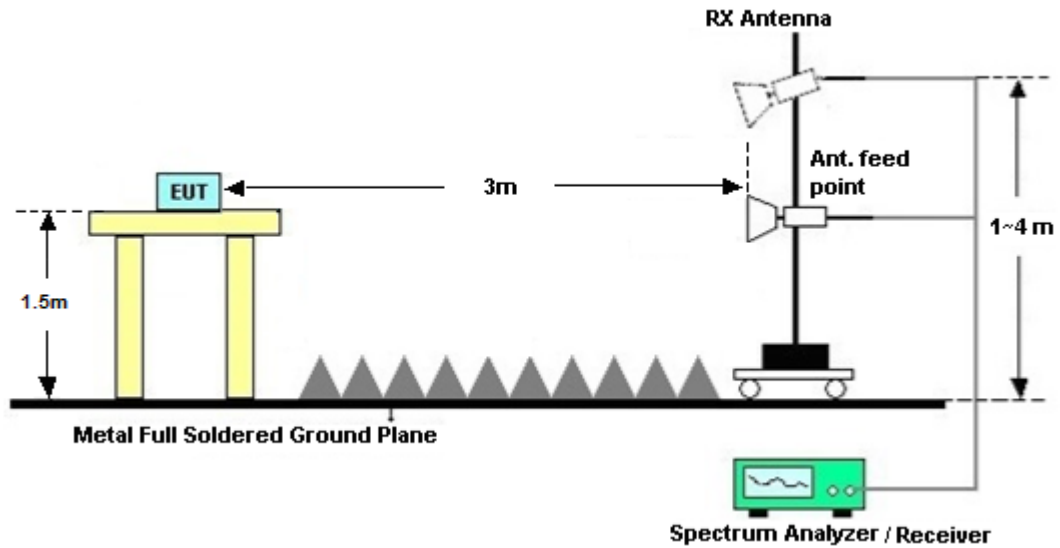

3.5.5 Test Results of Radiated Spurious Emissions (9kHz ~ 30MHz)

The low frequency, which started from 9 kHz to 30MHz, was pre-scanned and the result which was 20dB lower than the limit line per 15.31(o) was not reported.

3.5.6 Test Result of Radiated Spurious at Band Edges

Please refer to Appendix A.

3.5.7 Test Result of Radiated Spurious Emission (30MHz ~ 10th Harmonic)

Please refer to Appendix A.



3.6 AC Conducted Emission Measurement

3.6.1 Limit of AC Conducted Emission

For equipment that is designed to be connected to the public utility (AC) power line, the radio frequency voltage that is conducted back onto the AC power line on any frequency or frequencies within the band 150 kHz to 30 MHz shall not exceed the limits in the following table.

Frequency of Emission (MHz)	Conducted Limit (dB μ V)	
	Quasi-Peak	Average
0.15-0.5	66 to 56*	56 to 46*
0.5-5	56	46
5-30	60	50

*Decreases with the logarithm of the frequency.

3.6.2 Measuring Instruments

The measuring equipment is listed in the section 4 of this test report.

3.6.3 Test Procedures

1. The EUT was placed 0.4 meter from the conducting wall of the shielding room, and it was kept at least 80 centimeters from any other grounded conducting surface.
2. Connect EUT to the power mains through a line impedance stabilization network (LISN).
3. All the support units are connecting to the other LISN.
4. The LISN provides 50 ohm coupling impedance for the measuring instrument.
5. The FCC states that a 50 ohm, 50 microhenry LISN should be used.
6. Both sides of AC line were checked for maximum conducted interference.
7. The frequency range from 150 kHz to 30 MHz was searched.
8. Set the test-receiver system to Peak Detect Function and specified bandwidth (IF bandwidth = 9kHz) with Maximum Hold Mode.

3.6.4 Test Setup

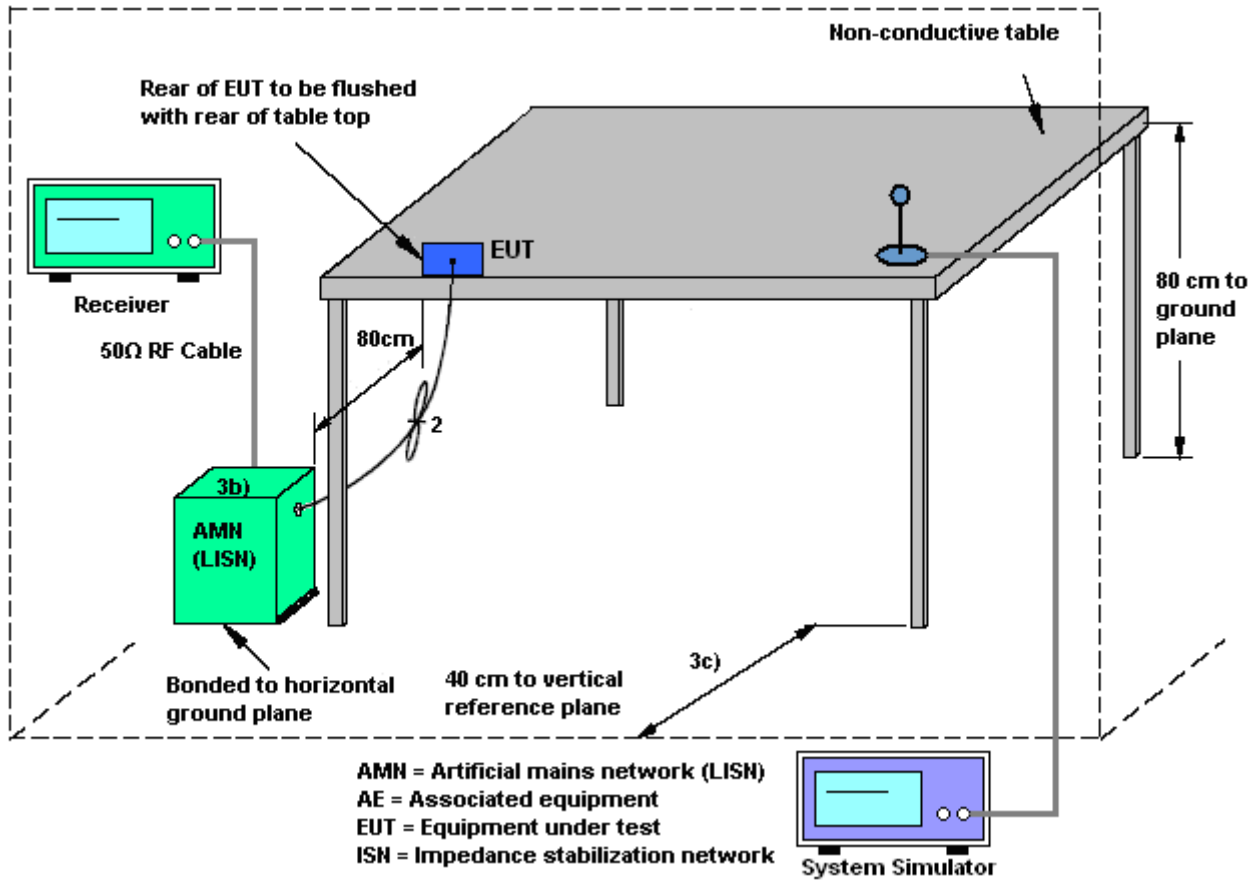



3.6.5 Test Result of AC Conducted Emission

Test Mode :	Mode 1	Temperature :	21~22°C
Test Engineer :	Jack Tian	Relative Humidity :	41~42%
Test Voltage :	120Vac / 60Hz	Phase :	Line
Function Type :	GSM850 Idle + Bluetooth Link + WLAN (2.4GHz) Link + USB Cable (Charging from Adapter) + Earphone		

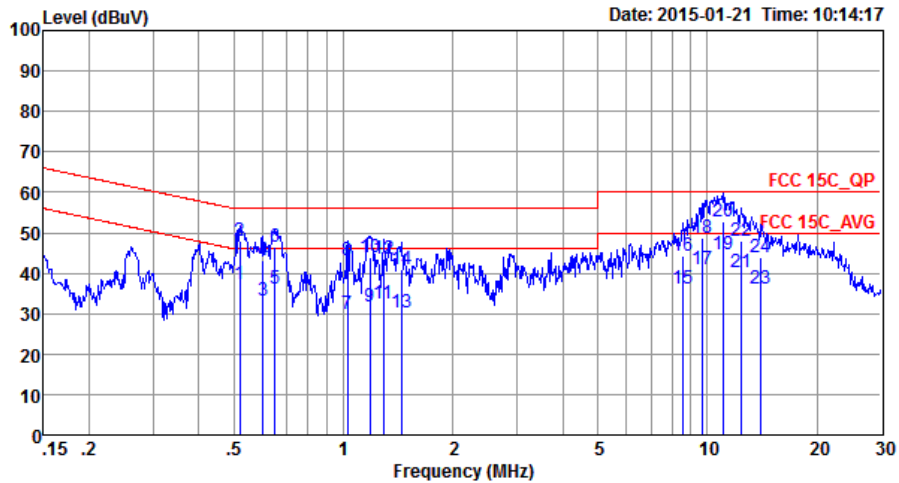

Site : C001-SZ
 Condition: FCC 15C_QP LISN_L 20140304 LINE

	Freq	Level	Over Limit	Limit Line	Read Level	LISN Factor	Cable Loss	Remark
	MHz	dBuV	dB	dBuV	dBuV	dB	dB	
1	0.52	37.14	-8.86	46.00	26.69	0.29	10.16	Average
2	0.52	48.14	-7.86	56.00	37.69	0.29	10.16	QP
3	0.60	33.28	-12.72	46.00	22.90	0.23	10.15	Average
4	0.60	43.08	-12.92	56.00	32.70	0.23	10.15	QP
5	0.65	36.16	-9.84	46.00	25.80	0.21	10.15	Average
6	0.65	46.66	-9.34	56.00	36.30	0.21	10.15	QP
7	1.03	30.01	-15.99	46.00	19.60	0.26	10.15	Average
8	1.03	43.01	-12.99	56.00	32.60	0.26	10.15	QP
9	1.18	31.81	-14.19	46.00	21.40	0.25	10.16	Average
10	1.18	43.81	-12.19	56.00	33.40	0.25	10.16	QP
11	1.29	32.51	-13.49	46.00	22.10	0.25	10.16	Average
12	1.29	43.51	-12.49	56.00	33.10	0.25	10.16	QP
13	1.44	30.11	-15.89	46.00	19.70	0.24	10.17	Average
14	1.44	41.01	-14.99	56.00	30.60	0.24	10.17	QP
15	8.59	36.24	-13.76	50.00	25.41	0.53	10.30	Average
16	8.59	44.24	-15.76	60.00	33.41	0.53	10.30	QP
17	9.65	41.14	-8.86	50.00	30.20	0.62	10.32	Average
18	9.65	48.64	-11.36	60.00	37.70	0.62	10.32	QP
19 *	11.02	44.61	-5.39	50.00	33.40	0.84	10.37	Average
20	11.02	52.61	-7.39	60.00	41.40	0.84	10.37	QP
21	12.45	40.22	-9.78	50.00	28.71	1.08	10.43	Average
22	12.45	48.12	-11.88	60.00	36.61	1.08	10.43	QP
23	14.06	36.12	-13.88	50.00	24.30	1.32	10.50	Average
24	14.06	43.92	-16.08	60.00	32.10	1.32	10.50	QP



Test Mode :	Mode 1	Temperature :	21~22°C
Test Engineer :	Jack Tian	Relative Humidity :	41~42%
Test Voltage :	120Vac / 60Hz	Phase :	Neutral
Function Type :	GSM850 Idle + Bluetooth Link + WLAN (2.4GHz) Link + USB Cable (Charging from Adapter) + Earphone		

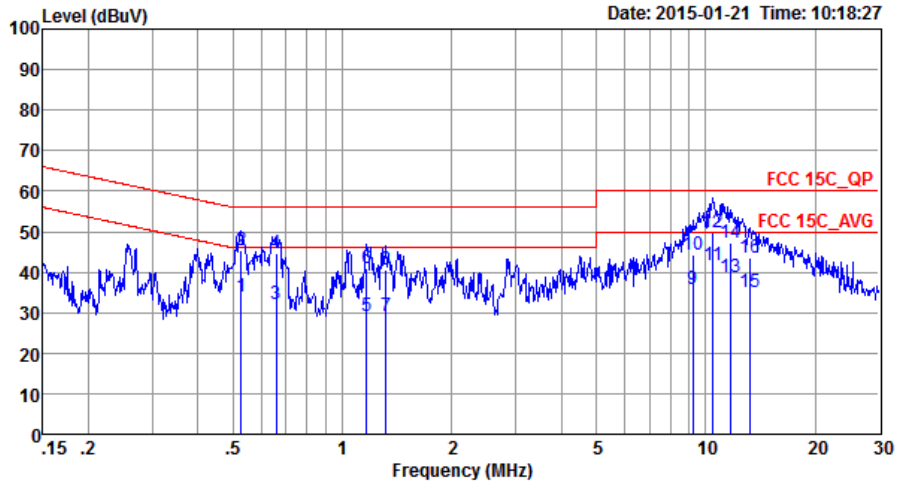

Site : CO01-SZ
 Condition: FCC 15C_QP LISN_N_20140304 NEUTRAL

	Freq	Level	Over Limit	Limit Line	Read Level	LISN Factor	Cable Loss	Remark
	MHz	dBuV	dB	dBuV	dBuV	dB	dB	
1	0.53	33.94	-12.06	46.00	23.41	0.38	10.15	Average
2	0.53	45.44	-10.56	56.00	34.91	0.38	10.15	QP
3	0.66	32.03	-13.97	46.00	21.60	0.28	10.15	Average
4	0.66	44.63	-11.37	56.00	34.20	0.28	10.15	QP
5	1.17	29.00	-17.00	46.00	18.50	0.34	10.16	Average
6	1.17	41.00	-15.00	56.00	30.50	0.34	10.16	QP
7	1.32	29.31	-16.69	46.00	18.79	0.35	10.17	Average
8	1.32	40.71	-15.29	56.00	30.19	0.35	10.17	QP
9	9.20	35.76	-14.24	50.00	24.80	0.65	10.31	Average
10	9.20	44.46	-15.54	60.00	33.50	0.65	10.31	QP
11 *	10.45	41.65	-8.35	50.00	30.50	0.81	10.34	Average
12	10.45	49.95	-10.05	60.00	38.80	0.81	10.34	QP
13	11.74	38.76	-11.24	50.00	27.30	1.06	10.40	Average
14	11.74	47.16	-12.84	60.00	35.70	1.06	10.40	QP
15	13.20	34.90	-15.10	50.00	23.11	1.33	10.46	Average
16	13.20	43.50	-16.50	60.00	31.71	1.33	10.46	QP



3.7 Antenna Requirements

3.7.1 Standard Applicable

If directional gain of transmitting antennas is greater than 6dBi, the power shall be reduced by the same level in dB comparing to gain minus 6dBi. For the fixed point-to-point operation, the power shall be reduced by one dB for every 3 dB that the directional gain of the antenna exceeds 6 dBi. The use of a permanently attached antenna or of an antenna that uses a unique coupling to the intentional radiator shall be considered sufficient to comply with the FCC rule.

3.7.2 Antenna Anti-Replacement Construction

An embedded-in antenna design is used.

3.7.3 Antenna Gain

The antenna peak gain of EUT is less than 6 dBi. Therefore, it is not necessary to reduce maximum peak output power limit.



4 List of Measuring Equipment

Instrument	Manufacturer	Model No.	Serial No.	Characteristics	Calibration Date	Test Date	Due Date	Remark
Spectrum Analyzer	R&S	FSP30	101400	9kHz~30GHz	Mar. 03, 2014	Jan. 27, 2015	Mar. 02, 2015	Conducted (TH01-SZ)
Power Meter	Anritsu	ML2495A	1218010	13dBm ~-20dBm	Mar. 03, 2014	Jan. 27, 2015	Mar. 02, 2015	Conducted (TH01-SZ)
Power Sensor	Dare	RPR3006W	TH01SZ00 019	0.3GHz~6GHz	Mar. 14, 2014	Jan. 27, 2015	Mar. 13, 2015	Conducted (TH01-SZ)
ESCIO TEST Receiver	R&S	ESCI	100724	9kHz~3GHz	Feb. 21, 2014	Jan. 28, 2015	Feb. 20, 2015	Radiation (03CH01-SZ)
Spectrum Analyzer	Agilent Technologies	N9038A	MY522601 85	20Hz~26.5GHz	May 26, 2014	Jan. 28, 2015	May 25, 2015	Radiation (03CH01-SZ)
Loop Antenna	R&S	HFH2-Z2	100354	9kHz~30MHz	May 09, 2014	Jan. 28, 2015	May 08, 2015	Radiation (03CH01-SZ)
Bilog Antenna	TESEQ	CBL 6112D	37877	30MHz~2GHz	Oct. 15, 2014	Jan. 28, 2015	Oct. 14, 2015	Radiation (03CH01-SZ)
Double Ridge Horn Antenna	ETS Lindgren	3117	00119436	1GHz~18GHz	Oct. 15, 2014	Jan. 28, 2015	Oct. 14, 2015	Radiation (03CH01-SZ)
Double Ridged Horn Antenna	COM-POWER	AH-840	101073	18GHz~40GHz	Jun. 09, 2014	Jan. 28, 2015	Jun. 08, 2015	Radiation (03CH01-SZ)
Amplifier	ADVANTEST	BB525C	E9007003	9kHz~3000MHz	Feb. 21, 2014	Jan. 28, 2015	Feb. 20, 2015	Radiation (03CH01-SZ)
Amplifier	Yiai	AV3860B	04030	2GHz~26.5GHz	May 08, 2014	Jan. 28, 2015	May 07, 2015	Radiation (03CH01-SZ)
AC Source(AVR)	Chroma	61601	616010001 985	100Vac~250Vac	Mar. 25, 2014	Jan. 28, 2015	Mar. 24, 2015	Radiation (03CH01-SZ)
Turn Table	EM Electronics	EM 1000	N/A	0~360 degree	NCR	Jan. 28, 2015	NCR	Radiation (03CH01-SZ)
Antenna Mast	EM Electronics	EM 1000	N/A	1 m~4 m	NCR	Jan. 28, 2015	NCR	Radiation (03CH01-SZ)
EMI TEST Receiver	R&S	ESCI	100724	9kHz~3GHz	Feb. 21, 2014	Jan. 21, 2015	Feb. 20, 2015	Conduction (CO01-SZ)
AC LISN	EMCO	3816/2SH	00103912	9kHz~30MHz	Mar. 04, 2014	Jan. 21, 2015	Mar. 03, 2015	Conduction (CO01-SZ)
AC LISN (for auxiliary equipment)	EMCO	3816/2SH	00103892	9kHz~30MHz	Mar. 04, 2014	Jan. 21, 2015	Mar. 03, 2015	Conduction (CO01-SZ)
AC Power Source	Chroma	61602	616020000 891	100Vac~250Vac	Sep. 29, 2014	Jan. 21, 2015	Sep. 28, 2015	Conduction (CO01-SZ)
System Simulator	R&S	CMW 500	132727	GSM/WCDMA /CDMA2000/LT E	Feb. 21, 2014	Jan. 21, 2015	Feb. 20, 2015	Conduction (CO01-SZ)



5 Uncertainty of Evaluation

Uncertainty of Conducted Emission Measurement (150kHz ~ 30MHz)

Measuring Uncertainty for a Level of Confidence of 95% ($U = 2Uc(y)$)	2.3 dB
---	--------

Uncertainty of Radiated Emission Measurement (30 MHz ~ 1000 MHz)

Measuring Uncertainty for a Level of Confidence of 95% ($U = 2Uc(y)$)	3.9 dB
---	--------



Appendix A. Radiated Spurious Emission

15C 2.4GHz 2400~2483.5MHz

WIFI 802.11b (Band Edge @ 3m)

WIFI	Note	Frequency	Level	Over	Limit	Read	Antenna	Cable	Preamp	Ant	Table	Peak	Pol.
Ant.				Limit	Line	Level	Factor	Loss	Factor	Pos	Pos	Avg.	
1		(MHz)	(dBμV/m)	(dB)	(dBμV/m)	(dBμV)	(dB/m)	(dB)	(dB)	(cm)	(deg)	(P/A)	(H/V)
802.11b CH 01 2412MHz		2389.83	43.55	-30.45	74	46.72	27.25	6.04	36.46	400	202	P	H
		2389.92	33.31	-20.69	54	36.48	27.25	6.04	36.46	400	202	A	H
	*	2412	99.71	-	-	102.82	27.31	6.04	36.46	400	202	P	H
	*	2412	94.88	-	-	97.99	27.31	6.04	36.46	400	202	A	H
		2389.65	48.58	-25.42	74	51.75	27.25	6.04	36.46	150	316	P	V
		2389.92	38.47	-15.53	54	41.64	27.25	6.04	36.46	150	316	A	V
	*	2412	104.35	-	-	107.46	27.31	6.04	36.46	150	316	P	V
	*	2412	99.84	-	-	102.95	27.31	6.04	36.46	150	316	A	V
802.11b CH 06 2437MHz		2339.07	40.83	-33.17	74	44.26	27.07	5.96	36.46	382	303	P	H
		2389.92	27.73	-26.27	54	30.9	27.25	6.04	36.46	382	303	A	H
	*	2437	97.25	-	-	100.19	27.42	6.09	36.45	382	303	P	H
	*	2437	91.11	-	-	94.05	27.42	6.09	36.45	382	303	A	H
		2493.72	41.31	-32.69	74	43.98	27.6	6.17	36.44	382	303	P	H
		2484.96	27.95	-26.05	54	30.69	27.54	6.17	36.45	382	303	A	H
		2388.75	41.31	-32.69	74	44.48	27.25	6.04	36.46	162	328	P	V
		2389.92	28.88	-25.12	54	32.05	27.25	6.04	36.46	162	328	A	V
	*	2437	104.07	-	-	107.01	27.42	6.09	36.45	162	328	P	V
	*	2437	97.32	-	-	100.26	27.42	6.09	36.45	162	328	A	V
		2484.72	42.17	-31.83	74	44.91	27.54	6.17	36.45	162	328	P	V
	2483.64	29.02	-24.98	54	31.76	27.54	6.17	36.45	162	328	A	V	



802.11b CH 11 2462MHz	*	2462	96.82	-	-	99.66	27.48	6.13	36.45	381	304	P	H
	*	2462	92.03	-	-	94.87	27.48	6.13	36.45	381	304	A	H
		2486.12	41.51	-32.49	74	44.25	27.54	6.17	36.45	381	304	P	H
		2483.56	29.34	-24.66	54	32.08	27.54	6.17	36.45	381	304	A	H
	*	2462	101.32	-	-	104.16	27.48	6.13	36.45	150	0	P	V
	*	2462	96.33	-	-	99.17	27.48	6.13	36.45	150	0	A	V
		2483.6	46.17	-27.83	74	48.91	27.54	6.17	36.45	150	0	P	V
		2483.52	34.64	-19.36	54	37.38	27.54	6.17	36.45	150	0	A	V

Remark	<ol style="list-style-type: none"> All results are PASS against Peak and Average limit line. Frequency range of Radiated Band Edge is from 2310-2390 MHz and 2483.5-2500 MHz. Above only list the worst result in these frequency ranges 												
--------	---	--	--	--	--	--	--	--	--	--	--	--	--



15C 2.4GHz 2400~2483.5MHz

WIFI 802.11b (Harmonic @ 3m)

WIFI	Note	Frequency	Level	Over	Limit	Read	Antenna	Cable	Preamp	Ant	Table	Peak	Pol.
Ant.				Limit	Line	Level	Factor	Loss	Factor	Pos	Pos	Avg.	
1		(MHz)	(dBμV/m)	(dB)	(dBμV/m)	(dBμV)	(dB/m)	(dB)	(dB)	(cm)	(deg)	(P/A)	(H/V)
802.11b CH 01 2412MHz		4824	46.86	-27.14	74	43.31	31.26	8.23	35.94	105	198	P	H
		4824	46.77	-27.23	74	43.22	31.26	8.23	35.94	105	198	P	V
802.11b CH 06 2437MHz		4874	46.8	-27.2	74	43.07	31.36	8.29	35.92	145	265	P	H
		7311	48.94	-25.06	74	39.22	35.96	10.29	36.53	174	321	P	H
		4874	47.18	-26.82	74	43.45	31.36	8.29	35.92	145	265	P	V
		7311	48.02	-25.98	74	38.3	35.96	10.29	36.53	174	321	P	V
802.11b CH 11 2462MHz		4924	45.35	-28.65	74	41.47	31.46	8.32	35.9	146	347	P	H
		7386	47.52	-26.48	74	37.69	36.08	10.34	36.59	145	274	P	H
		4924	47.3	-26.7	74	43.42	31.46	8.32	35.9	146	347	P	V
		7386	46.27	-27.73	74	36.44	36.08	10.34	36.59	145	274	P	V
Remark	1. Average measurement was not performed if peak level went lower than the average limit 2. All results are PASS against limit line.												



**15C 2.4GHz 2400~2483.5MHz
WIFI 802.11g (Band Edge @ 3m)**

WIFI	Note	Frequency	Level	Over	Limit	Read	Antenna	Cable	Preamp	Ant	Table	Peak	Pol.
Ant.				Limit	Line	Level	Factor	Loss	Factor	Pos	Pos	Avg.	
1		(MHz)	(dBμV/m)	(dB)	(dBμV/m)	(dBμV)	(dB/m)	(dB)	(dB)	(cm)	(deg)	(P/A)	(H/V)
802.11g CH 01 2412MHz		2389.56	54.81	-19.19	74	57.98	27.25	6.04	36.46	180	65	P	H
		2389.92	33.03	-20.97	54	36.2	27.25	6.04	36.46	180	65	A	H
	*	2412	92.01	-	-	95.12	27.31	6.04	36.46	180	65	P	H
	*	2412	84.11	-	-	87.22	27.31	6.04	36.46	180	65	A	H
		2389.56	64.45	-9.55	74	67.62	27.25	6.04	36.46	163	325	P	V
		2389.92	45.75	-8.25	54	48.92	27.25	6.04	36.46	163	325	A	V
	*	2412	103.22	-	-	106.33	27.31	6.04	36.46	163	325	P	V
	*	2412	92.99	-	-	96.1	27.31	6.04	36.46	163	325	A	V
802.11g CH 06 2437MHz		2336.1	40.6	-33.4	74	44.04	27.07	5.96	36.47	184	138	P	H
		2385.06	28.81	-25.19	54	32.04	27.19	6.04	36.46	184	138	A	H
	*	2437	95.38	-	-	98.32	27.42	6.09	36.45	184	138	P	H
	*	2437	85.54	-	-	88.48	27.42	6.09	36.45	184	138	A	H
		2488.96	42.12	-31.88	74	44.8	27.6	6.17	36.45	184	138	P	H
		2489.08	29.48	-24.52	54	32.16	27.6	6.17	36.45	184	138	A	H
		2388.57	46.81	-27.19	74	49.98	27.25	6.04	36.46	184	318	P	V
		2384.79	35.34	-18.66	54	38.57	27.19	6.04	36.46	184	318	A	V
	*	2437	105.35	-	-	108.29	27.42	6.09	36.45	184	318	P	V
	*	2437	94.92	-	-	97.86	27.42	6.09	36.45	184	318	A	V
		2483.76	44.82	-29.18	74	47.56	27.54	6.17	36.45	184	318	P	V
		2489.32	34.34	-19.66	54	37.02	27.6	6.17	36.45	184	318	A	V



802.11g CH 11 2462MHz	*	2462	94.28	-	-	97.12	27.48	6.13	36.45	261	359	P	H
	*	2462	84.35	-	-	87.19	27.48	6.13	36.45	261	359	A	H
		2483.92	58.94	-15.06	74	61.68	27.54	6.17	36.45	261	359	P	H
		2483.6	37.78	-16.22	54	40.52	27.54	6.17	36.45	261	359	A	H
	*	2462	103.25	-	-	106.09	27.48	6.13	36.45	188	320	P	V
	*	2462	94.27	-	-	97.11	27.48	6.13	36.45	188	320	A	V
		2483.88	67.37	-6.63	74	70.11	27.54	6.17	36.45	188	320	P	V
		2483.64	49.49	-4.51	54	52.23	27.54	6.17	36.45	188	320	A	V
Remark	<ol style="list-style-type: none"> All results are PASS against Peak and Average limit line. Frequency range of Radiated Band Edge is from 2310-2390 MHz and 2483.5-2500 MHz. Above only list the worst result in these frequency ranges 												



**15C 2.4GHz 2400~2483.5MHz
WIFI 802.11g (Harmonic @ 3m)**

WIFI	Note	Frequency	Level	Over	Limit	Read	Antenna	Cable	Preamp	Ant	Table	Peak	Pol.
Ant.				Limit	Line	Level	Factor	Loss	Factor	Pos	Pos	Avg.	
1		(MHz)	(dBμV/m)	(dB)	(dBμV/m)	(dBμV)	(dB/m)	(dB)	(dB)	(cm)	(deg)	(P/A)	(H/V)
802.11g CH 01 2412MHz		4824	45.14	-28.86	74	41.59	31.26	8.23	35.94	105	198	P	H
		4824	45.36	-28.64	74	41.81	31.26	8.23	35.94	105	198	P	V
802.11g CH 06 2437MHz		4874	44.79	-29.21	74	41.06	31.36	8.29	35.92	145	265	P	H
		7311	48.33	-25.67	74	38.61	35.96	10.29	36.53	174	321	P	H
		4874	44.39	-29.61	74	40.66	31.36	8.29	35.92	145	265	P	V
		7311	46.06	-27.94	74	36.34	35.96	10.29	36.53	174	321	P	V
802.11g CH 11 2462MHz		4924	44.74	-29.26	74	40.86	31.46	8.32	35.9	146	347	P	H
		7386	45.64	-28.36	74	35.81	36.08	10.34	36.59	145	274	P	H
		4924	44.54	-29.46	74	40.66	31.46	8.32	35.9	146	347	P	V
		7386	47.05	-26.95	74	37.22	36.08	10.34	36.59	145	274	P	V
Remark	1. Average measurement was not performed if peak level went lower than the average limit. 2. All results are PASS against limit line.												



**15C 2.4GHz 2400~2483.5MHz
WIFI 802.11n HT20 (Band Edge @ 3m)**

WIFI	Note	Frequency	Level	Over	Limit	Read	Antenna	Cable	Preamp	Ant	Table	Peak	Pol.
Ant.				Limit	Line	Level	Factor	Loss	Factor	Pos	Pos	Avg.	
1		(MHz)	(dBμV/m)	(dB)	(dBμV/m)	(dBμV)	(dB/m)	(dB)	(dB)	(cm)	(deg)	(P/A)	(H/V)
802.11n HT20 CH 01 2412MHz		2389.74	60.1	-13.9	74	63.27	27.25	6.04	36.46	343	232	P	H
		2389.92	39.55	-14.45	54	42.72	27.25	6.04	36.46	343	232	A	H
	*	2412	97.27	-	-	100.38	27.31	6.04	36.46	343	232	P	H
	*	2412	87.09	-	-	90.2	27.31	6.04	36.46	343	232	A	H
		2389.83	65.12	-8.88	74	68.29	27.25	6.04	36.46	150	78	P	V
		2389.65	45.95	-8.05	54	49.12	27.25	6.04	36.46	150	78	A	V
	*	2412	102.66	-	-	105.77	27.31	6.04	36.46	150	78	P	V
	*	2412	91.81	-	-	94.92	27.31	6.04	36.46	150	78	A	V
802.11n HT20 CH 06 2437MHz		2385.6	41.23	-32.77	74	44.4	27.25	6.04	36.46	390	202	P	H
		2385.42	30.34	-23.66	54	33.57	27.19	6.04	36.46	390	202	A	H
	*	2437	98.07	-	-	101.01	27.42	6.09	36.45	390	202	P	H
	*	2437	87.43	-	-	90.37	27.42	6.09	36.45	390	202	A	H
		2489.4	41.19	-32.81	74	43.87	27.6	6.17	36.45	390	202	P	H
		2488.68	29.36	-24.64	54	32.04	27.6	6.17	36.45	390	202	A	H
		2384.7	45.92	-28.08	74	49.15	27.19	6.04	36.46	155	78	P	V
		2385.33	34.91	-19.09	54	38.14	27.19	6.04	36.46	155	78	A	V
	*	2437	102.49	-	-	105.43	27.42	6.09	36.45	155	78	P	V
	*	2437	91.4	-	-	94.34	27.42	6.09	36.45	155	78	A	V
		2484.4	46.36	-27.64	74	49.1	27.54	6.17	36.45	155	78	P	V
	2488.76	34.56	-19.44	54	37.24	27.6	6.17	36.45	155	78	A	V	



802.11n HT20 CH 11 2462MHz	*	2462	98.34	-	-	101.18	27.48	6.13	36.45	340	316	P	H
	*	2462	88.22	-	-	91.06	27.48	6.13	36.45	340	316	A	H
		2483.72	62.11	-11.89	74	64.85	27.54	6.17	36.45	340	316	P	H
		2483.72	43.42	-10.58	54	46.16	27.54	6.17	36.45	340	316	A	H
	*	2462	100.45	-	-	103.29	27.48	6.13	36.45	158	303	P	V
	*	2462	92.22	-	-	95.06	27.48	6.13	36.45	158	303	A	V
		2484.4	68.04	-5.96	74	70.78	27.54	6.17	36.45	158	303	P	V
		2483.56	46.9	-7.1	54	49.64	27.54	6.17	36.45	158	303	A	V
Remark	<ol style="list-style-type: none"> All results are PASS against Peak and Average limit line. Frequency range of Radiated Band Edge is from 2310-2390 MHz and 2483.5-2500 MHz. Above only list the worst result in these frequency ranges 												



15C 2.4GHz 2400~2483.5MHz
WIFI 802.11n HT20 (Harmonic @ 3m)

WIFI	Note	Frequency	Level	Over	Limit	Read	Antenna	Cable	Preamp	Ant	Table	Peak	Pol.
Ant.				Limit	Line	Level	Factor	Loss	Factor	Pos	Pos	Avg.	
1		(MHz)	(dBμV/m)	(dB)	(dBμV/m)	(dBμV)	(dB/m)	(dB)	(dB)	(cm)	(deg)	(P/A)	(H/V)
802.11n		4824	44.45	-29.55	74	40.9	31.26	8.23	35.94	105	198	P	H
HT20													
CH 01		4824	45.29	-28.71	74	41.74	31.26	8.23	35.94	105	198	P	V
2412MHz													
802.11n		4874	45.26	-28.74	74	41.53	31.36	8.29	35.92	145	265	P	H
HT20		7311	47.61	-26.39	74	37.89	35.96	10.29	36.53	174	321	P	H
CH 06		4874	45.51	-28.49	74	41.78	31.36	8.29	35.92	145	265	P	V
2437MHz		7311	47.84	-26.16	74	38.12	35.96	10.29	36.53	174	321	P	V
802.11n		4924	44.76	-29.24	74	40.88	31.46	8.32	35.9	146	347	P	H
HT20		7386	46.77	-27.23	74	36.94	36.08	10.34	36.59	145	274	P	H
CH 11		4924	45.91	-28.09	74	42.03	31.46	8.32	35.9	146	347	P	V
2462MHz		7386	47.05	-26.95	74	37.22	36.08	10.34	36.59	145	274	P	V
Remark	1. Average measurement was not performed if peak level went lower than the average limit. 2. All results are PASS against limit line.												



15C Emission below 1GHz

2.4GHz WIFI 802.11g (LF)

WIFI	Note	Frequency	Level	Over	Limit	Read	Antenna	Cable	Preamp	Ant	Table	Peak	Pol.
Ant.				Limit	Line	Level	Factor	Loss	Factor	Pos	Pos	Avg.	
1		(MHz)	(dBμV/m)	(dB)	(dBμV/m)	(dBμV)	(dB/m)	(dB)	(dB)	(cm)	(deg)	(P/A)	(H/V)
2.4GHz 802.11g LF		102.75	29.14	-14.36	43.5	45.75	12.29	1.62	30.52	150	100	P	H
		164.83	22.28	-21.22	43.5	39.03	11.85	1.85	30.45	-	-	P	H
		275.41	17.91	-28.09	46	32.07	13.8	2.35	30.31	-	-	P	H
		543.13	20.93	-25.07	46	29.13	18.57	3.1	29.87	-	-	P	H
		653.71	22.4	-23.6	46	29.12	19.62	3.37	29.71	-	-	P	H
		870.99	24.95	-21.05	46	28.58	21.85	3.81	29.29	-	-	P	H
		51.34	29.04	-10.96	40	49.99	8.28	1.33	30.56	150	0	P	V
		194.9	20.33	-23.17	43.5	38.35	10.4	2	30.42	-	-	P	V
		413.15	20.06	-25.94	46	31.26	16.12	2.78	30.1	-	-	P	V
		591.63	22.17	-23.83	46	29.64	19.06	3.25	29.78	-	-	P	V
		807.94	25.26	-20.74	46	30.03	21.02	3.62	29.41	-	-	P	V
		998.06	25.81	-28.19	54	28.34	22.58	3.95	29.06	-	-	P	V
Remark	1. No other spurious found. 2. All results are PASS against limit line.												



Note symbol

*	Fundamental Frequency which can be ignored. However, the level of any unwanted emissions shall not exceed the level of the fundamental frequency per 15.209(c).
!	Test result is over limit line.
P/A	Peak or Average
H/V	Horizontal or Vertical



A calculation example for radiated spurious emission is shown as below:

WIFI	Note	Frequency	Level	Over	Limit	Read	Antenna	Cable	Preamp	Ant	Table	Peak	Pol.
Ant.				Limit	Line	Level	Factor	Loss	Factor	Pos	Pos	Avg.	
1+2		(MHz)	(dBμV/m)	(dB)	(dBμV/m)	(dBμV)	(dB/m)	(dB)	(dB)	(cm)	(deg)	(P/A)	(H/V)
802.11b		2390	55.45	-18.55	74	54.51	32.22	4.58	35.86	103	308	P	H
CH 01													
2412MHz		2390	43.54	-10.46	54	42.6	32.22	4.58	35.86	103	308	A	H

- Level(dBμV/m) =
Antenna Factor(dB/m) + Cable Loss(dB) + Read Level(dBμV) - Preamp Factor(dB)
- Over Limit(dB) = Level(dBμV/m) – Limit Line(dBμV/m)

For Peak Limit @ 2390MHz:

- Level(dBμV/m)
= Antenna Factor(dB/m) + Cable Loss(dB) + Read Level(dBμV) - Preamp Factor(dB)
= 32.22(dB/m) + 4.58(dB) + 54.51(dBμV) – 35.86 (dB)
= 55.45 (dBμV/m)
- Over Limit(dB)
= Level(dBμV/m) – Limit Line(dBμV/m)
= 55.45(dBμV/m) – 74(dBμV/m)
= -18.55(dB)

For Average Limit @ 2390MHz:

- Level(dBμV/m)
= Antenna Factor(dB/m) + Cable Loss(dB) + Read Level(dBμV) - Preamp Factor(dB)
= 32.22(dB/m) + 4.58(dB) + 42.6(dBμV) – 35.86 (dB)
= 43.54 (dBμV/m)
- Over Limit(dB)
= Level(dBμV/m) – Limit Line(dBμV/m)
= 43.54(dBμV/m) – 54(dBμV/m)
= -10.46(dB)

Both peak and average measured complies with the limit line, so test result is “PASS”.