



FCC CFR47 PART 27 SUBPART M

WWAN

CERTIFICATION TEST REPORT

FOR

CDMA/GSM/WCDMA/LTE Phone + BT/BLE, DTS/UNII a/b/g/n/ac, ANT+ and NFC

MODEL NUMBER : SM-A8050

FCC ID: A3LSMA8050

REPORT NUMBER: 4788886237-E8V1

ISSUE DATE: APR 16, 2019

Prepared for
SAMSUNG ELECTRONICS CO., LTD.
129 SAMSUNG-RO, YEONGTONG-GU, SUWON-SI,
GYEONGGI-DO, 16677, KOREA

Prepared by
UL Korea, Ltd.
26th floor, 152, Teheran-ro, Gangnam-gu Seoul, 06236, Korea

Suwon Test Site: UL Korea, Ltd. Suwon Laboratory
218 Maeyeong-ro, Yeongtong-gu,
Suwon-si, Gyeonggi-do, 16675, Korea
TEL: (031) 337-9902
FAX: (031) 213-5433



ACCREDITED*

Testing
Laboratory

TL-637

Revision History

<u>Rev.</u>	<u>Issue Date</u>	<u>Revisions</u>	<u>Revised By</u>
V1	04/16/19	Initial issue	Junwhan Lee

TABLE OF CONTENTS

1. ATTESTATION OF TEST RESULTS	4
2. TEST METHODOLOGY	5
3. FACILITIES AND ACCREDITATION	5
4. CALIBRATION AND UNCERTAINTY	5
4.1. <i>MEASURING INSTRUMENT CALIBRATION.....</i>	<i>5</i>
4.2. <i>SAMPLE CALCULATION.....</i>	<i>5</i>
4.3. <i>MEASUREMENT UNCERTAINTY</i>	<i>6</i>
5. EQUIPMENT UNDER TEST	7
5.1. <i>DESCRIPTION OF EUT.....</i>	<i>7</i>
5.2. <i>MAXIMUM OUTPUT POWER.....</i>	<i>7</i>
5.3. <i>DESCRIPTION OF AVAILABLE ANTENNAS</i>	<i>9</i>
5.4. <i>WORST-CASE CONFIGURATION</i>	<i>9</i>
5.5. <i>DESCRIPTION OF TEST SETUP.....</i>	<i>10</i>
6. TEST AND MEASUREMENT EQUIPMENT	12
7. RF OUTPUT POWER VERIFICATION (CONDUCTED AND EIRP)	13
7.1. <i>LTE BAND 41</i>	<i>13</i>
8. LIMITS AND CONDUCTED RESULTS	16
8.1. <i>OCCUPIED BANDWIDTH.....</i>	<i>16</i>
8.1.1. <i>OCCUPIED BANDWIDTH RESULTS</i>	<i>16</i>
8.1.2. <i>OCCUPIED BANDWIDTH PLOTS.....</i>	<i>17</i>
8.2. <i>EMISSION MASK</i>	<i>22</i>
8.2.1. <i>EMISSION MASK PLOTS</i>	<i>23</i>
8.3. <i>OUT OF BAND EMISSIONS.....</i>	<i>43</i>
8.3.1. <i>OUT OF BAND EMISSIONS PLOTS.....</i>	<i>44</i>
9. RADIATED TEST RESULTS.....	45
9.1. <i>FIELD STRENGTH OF SPURIOUS RADIATION.....</i>	<i>45</i>
9.1.1. <i>SPURIOUS RADIATION PLOTS</i>	<i>46</i>
10. SETUP PHOTOS	47

1. ATTESTATION OF TEST RESULTS

COMPANY NAME: SAMSUNG ELECTRONICS CO., LTD.

EUT DESCRIPTION: CDMA/GSM/WCDMA/LTE Phone + BT/BLE, DTS/UNII a/b/g/n/ac, ANT+ and NFC

MODEL NUMBER: SM-A8050

SERIAL NUMBER: R38M10QK33K (CONDUCTED)
R38M10QK2VL, R38M10QK2SP, R38M30952GW (RADIATED);

DATE TESTED: APR 12, 2019 – APR 16, 2019;

APPLICABLE STANDARDS	
STANDARD	TEST RESULTS
FCC PART 27M	Pass

UL Korea, Ltd. tested the above equipment in accordance with the requirements set forth in the above standards. All indications of Pass/Fail in this report are opinions expressed by UL Korea, Ltd. based on interpretations and/or observations of test results. Measurement Uncertainties were not taken into account and are published for informational purposes only. The test results show that the equipment tested is capable of demonstrating compliance with the requirements as documented in this report.

Note: The results documented in this report apply only to the tested sample, under the conditions and modes of operation as described herein. This document may not be altered or revised in any way unless done so by UL Korea, Ltd. and all revisions are duly noted in the revisions section. Any alteration of this document not carried out by UL Korea, Ltd. will constitute fraud and shall nullify the document. This report must not be used by the client to claim product certification, approval, or endorsement by IAS, any agency of the Federal Government, or any agency of any government.

Approved & Released For
UL Korea, Ltd. By:



SungGil Park
Suwon Lab Engineer
UL Korea, Ltd.

Tested By:



Junwhan Lee
Suwon Lab Engineer
UL Korea, Ltd.

2. TEST METHODOLOGY

The tests documented in this report were performed in accordance with following methods.

1. FCC CFR 47 Part 2.
2. FCC CFR 47 Part 27.
3. ANSI TIA-603-E, 2016
4. ANSI C63.26, 2015
5. KDB 971168 D01 Power Meas License Digital Systems v03r01

3. FACILITIES AND ACCREDITATION

The test sites and measurement facilities used to collect data are located at 218 Maeyeong-ro, Yeongtong-gu, Suwon-si, Gyeonggi-do, 16675, Korea. Line conducted emissions are measured only at the 218 address. The following table identifies which facilities were utilized for radiated emission measurements documented in this report. Specific facilities are also identified in the test results sections.

218 Maeyeong-ro	
<input checked="" type="checkbox"/>	Chamber 1
<input checked="" type="checkbox"/>	Chamber 2
<input checked="" type="checkbox"/>	Chamber 3

UL Korea, Ltd. is accredited by IAS, Laboratory Code TL-637. The full scope of accreditation can be viewed at <http://www.iasonline.org/PDF/TL/TL-637.pdf>.

4. CALIBRATION AND UNCERTAINTY

4.1. MEASURING INSTRUMENT CALIBRATION

The measuring equipment utilized to perform the tests documented in this report has been calibrated in accordance with the manufacturer's recommendations, and is traceable to recognized national standards.

4.2. SAMPLE CALCULATION

Where relevant, the following sample calculation is provided:

$EIRP = \text{PSA reading with EUT worst orientation (dBm)} + \text{Path loss (dB)} - \text{cable loss (between the SG and substitution antenna)} + \text{Substitution Antenna Factor (dBi)}$

$ERP = \text{PSA reading with EUT worst orientation (dBm)} + \text{Path loss (dB)} - \text{cable loss (between the SG and substitution antenna)}$

(Path loss = Signal generator output – PSA reading with substitution antenna)

4.3. MEASUREMENT UNCERTAINTY

Where relevant, the following measurement uncertainty levels have been estimated for tests performed on the apparatus:

PARAMETER	UNCERTAINTY
Conducted Disturbance, 0.15 to 30 MHz	2.32 dB
Radiated Disturbance, Below 1GHz	3.86 dB
Radiated Disturbance, Above 1 GHz	5.97 dB

Uncertainty figures are valid to a confidence level of 95%.

5. EQUIPMENT UNDER TEST

5.1. DESCRIPTION OF EUT

The EUT is a CDMA/GSM/WCDMA/LTE Phone + BT/BLE, DTS/UNII a/b/g/n and ANT+ and NFC. This test report addresses the WWAN operational mode for dual carrier band of LTE Band 41.

5.2. MAXIMUM OUTPUT POWER

EUT includes different power levels for head use configuration and body use configuration and the below tables contain the highest of all configurations average conducted and EIRP output powers as follows:

OUTPUT POWER FOR LTE BAND 41

Part 27						
EIRP Limit (dBm)		33.00				
Antenna Gain (dBi)		-4.53				
Bandwidth (MHz)	Frequency Range (MHz)	Modulation	OUTPUT POWER			
			Conducted Average (dBm)	EIRP Average (dBm)		Margin (dB)
				dBm	mW	
5+20	2555-2655	QPSK	23.32	18.79	75.68	-14.21
		16QAM	22.61	18.08	64.27	-14.92
		64QAM	20.71	16.18	41.50	-16.82
20+5		QPSK	23.55	19.02	79.80	-13.98
		16QAM	23.07	18.54	71.45	-14.46
		64QAM	20.75	16.22	41.88	-16.78
10+15		QPSK	23.53	19.00	79.43	-14.00
		16QAM	22.75	18.22	66.37	-14.78
		64QAM	20.71	16.18	41.50	-16.82
15+10		QPSK	23.99	19.46	88.31	-13.54
		16QAM	22.87	18.34	68.23	-14.66
		64QAM	21.17	16.64	46.13	-16.36
10+20		QPSK	23.43	18.90	77.62	-14.10
		16QAM	22.77	18.24	66.68	-14.76
		64QAM	20.74	16.21	41.78	-16.79
20+10	QPSK	23.62	19.09	81.10	-13.91	
	16QAM	23.05	18.52	71.12	-14.48	
	64QAM	20.95	16.42	43.85	-16.58	
15+15	QPSK	23.59	19.06	80.54	-13.94	
	16QAM	22.98	18.45	69.98	-14.55	
	64QAM	21.09	16.56	45.29	-16.44	
15+20	QPSK	23.52	18.99	79.25	-14.01	
	16QAM	22.72	18.19	65.92	-14.81	
	64QAM	20.89	16.36	43.25	-16.64	
20+15	QPSK	23.59	19.06	80.54	-13.94	
	16QAM	23.12	18.59	72.28	-14.41	
	64QAM	20.74	16.21	41.78	-16.79	
20+20	QPSK	23.67	19.14	82.04	-13.86	
	16QAM	23.14	18.61	72.61	-14.39	
	64QAM	20.65	16.12	40.93	-16.88	

5.3. DESCRIPTION OF AVAILABLE ANTENNAS

The radio utilizes a internal antenna for the [List the bands supported] with a maximum peak gain as follow:

Frequency (MHz)	Peak Gain (dBi)
LTE Band 41 2555 ~ 2655 MHz	-4.53

5.4. WORST-CASE CONFIGURATION

This EUT have a camera pop up function when user operate front camera function. The radiated spurious emission was investigated in three orthogonal orientations X, Y and Z. It was normal mode and camera pop up mode. It was determined that Y on normal mode orientation was worst-case orientation; therefore, radiated spurious emission testing was performed with the EUT in Y on normal mode of orientation.

The worst-case scenario for all measurements are based on the average conducted output power measurement investigation results. Output power measurements were measured on QPSK, 16QAM and 64QAM modulations. It was found that QPSK and 16QAM results were worst case. All testing was performed using QPSK and 16QAM modulations to represent the worst case. However, the out of band emissions and spurious radiation were only performed on bandwidth and RB offset(with RB size 1, Adjacent allocation of single RB in PCC and SCC represents worst-case of single RB allocations.) with the highest power in QPSK 15MHz/10MHz bandwidth combinations.

Note : Radiated spurious tests were performed connected with charger for evaluation of worst case mode.

5.5. DESCRIPTION OF TEST SETUP

SUPPORT EQUIPMENT

Support Equipment List				
Description	Manufacturer	Model	Serial Number	FCC ID
Charger	SAMSUNG	EP-TA800	R37M1E50KV1SE3	N/A
Data Cable	SAMSUNG	EP-DA905BBE	N/A	N/A
Earphone	SAMSUNG	GHSS028-W4	N/A	N/A

I/O CABLE

I/O Cable List						
Cable No	Port	# of identical ports	Connector Type	Cable Type	Cable Length (m)	Remarks
1	DC Power	1	C Type	Shielded	1.1m	N/A
2	Audio	2	C Type	Unshielded	1.2m	N/A

TEST SETUP

The EUT is continuously communicated to the call box during the tests.

SETUP DIAGRAM FOR TESTS (CONDUCTED TEST SETUP)

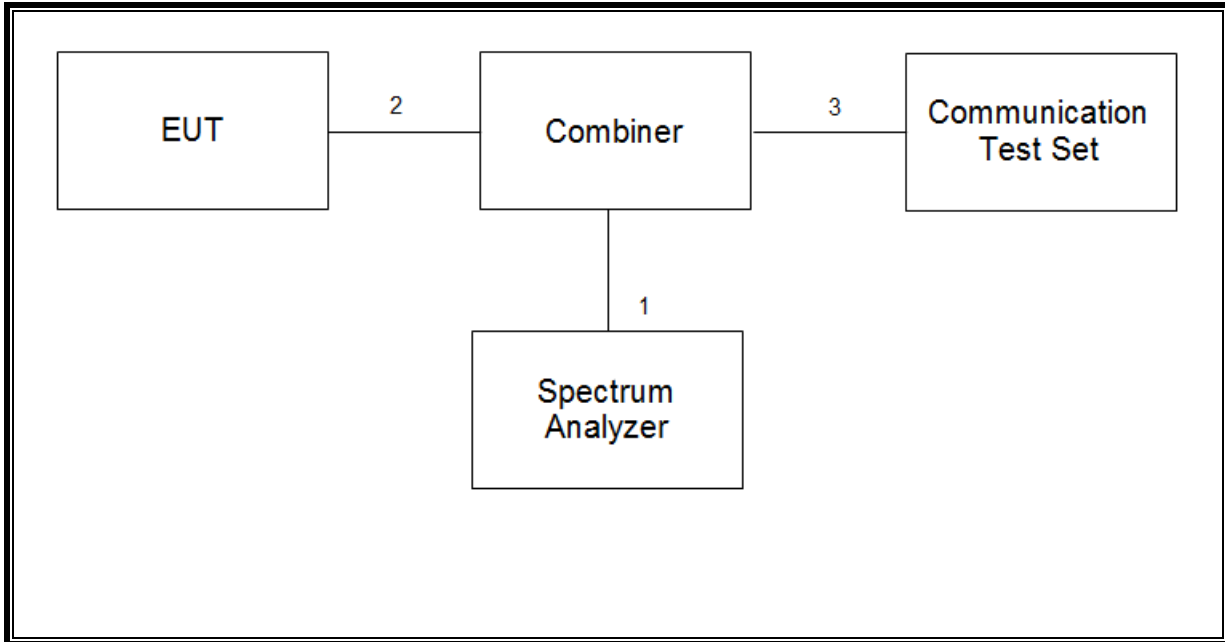

SETUP DIAGRAM FOR TESTS (RADIATED TEST SETUP)

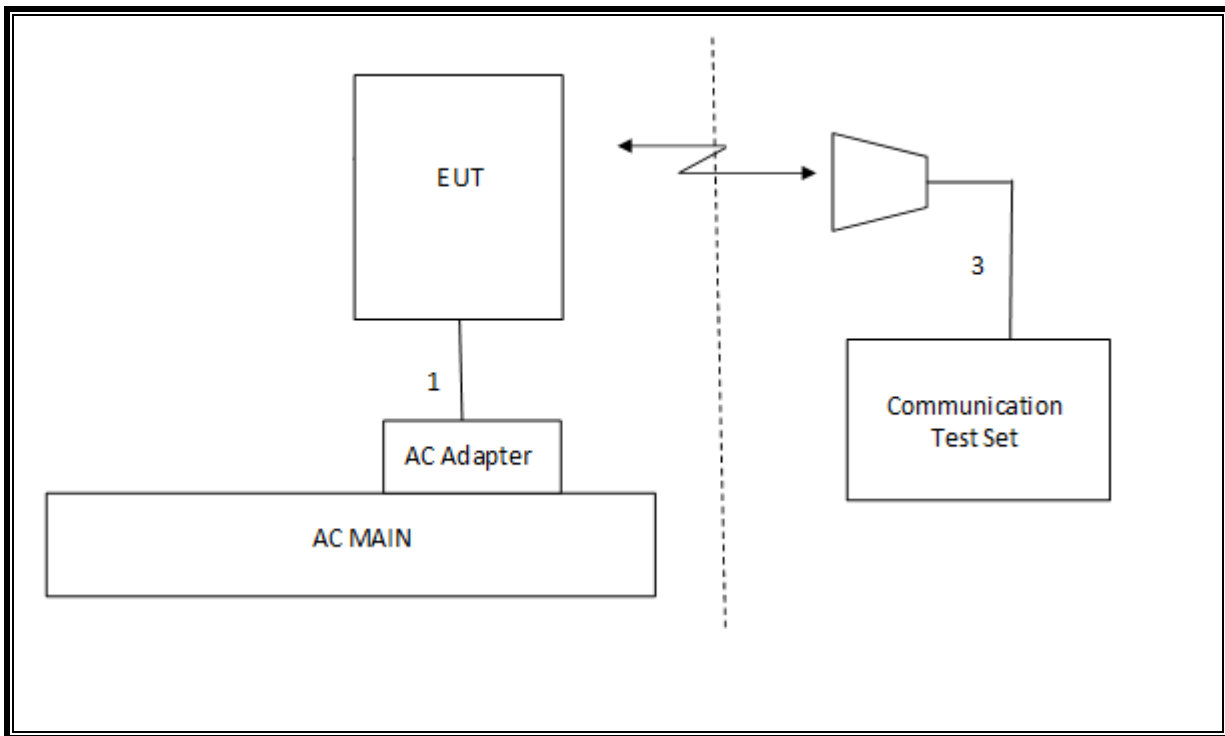

6. TEST AND MEASUREMENT EQUIPMENT

The following test and measurement equipment was utilized for the tests documented in this report:

Test Equipment List				
Description	Manufacturer	Model	S/N	Cal Due
Antenna, Tuned Dipole 400-1000 MHz	ETS	3121D DB4	00164753	06-30-19
Antenna, Horn, 40 GHz	ETS	3116C	00166155	08-14-20
Preamplifier	ETS	3116C-PA	00168841	08-09-19
Antenna, Horn, 40 GHz	ETS	3116C	00168645	12-04-19
Antenna, Bilog, 30MHz-1GHz	SCHWARZBECK	VULB9163	750	08-04-20
Antenna, Bilog, 30MHz-1GHz	SCHWARZBECK	VULB9163	845	08-04-20
Antenna, Bilog, 30MHz-1GHz	SCHWARZBECK	VULB9163	749	08-04-20
Antenna, Horn, 18 GHz	ETS	3115	00167211	08-04-20
Antenna, Horn, 18 GHz	ETS	3115	00161451	08-04-20
Antenna, Horn, 18 GHz	ETS	3117	00168724	08-04-20
Antenna, Horn, 18 GHz	ETS	3117	00205959	08-04-20
Antenna, Horn, 18 GHz	ETS	3117	00168717	08-04-20
Combiner	WEINSCHTEL	1575	2150	08-08-19
Communications Test Set	R&S	CMW500	115331	08-07-19
DC Power Supply	Agilent / HP	E3640A	MY54226395	08-06-19
Preamplifier, 1000 MHz	Sonoma	310N	341282	08-07-19
Preamplifier, 1000 MHz	Sonoma	310N	370599	08-06-19
Preamplifier, 1000 MHz	Sonoma	310N	351741	08-07-19
Preamplifier, 18 GHz	Miteq	AFS42-00101800-25-S-42	1876511	08-07-19
Preamplifier, 18 GHz	Miteq	AFS42-00101800-25-S-42	2029169	08-07-19
Preamplifier, 18 GHz	Miteq	AFS42-00101800-25-S-42	1896138	08-07-19
Spectrum Analyzer, 44 GHz	Agilent / HP	N9030A	MY54490312	08-06-19
EMI Test Receive, 40 GHz	R&S	ESU40	100439	08-06-19
EMI Test Receive, 40 GHz	R&S	ESU40	100457	08-06-19
EMI Test Receive, 44 GHz	R&S	ESW40	101590	08-06-19
High Pass Filter 1.2GHz	Micro-Tronics	HPM50108-02	G005	08-08-19
High Pass Filter 1.2GHz	Micro-Tronics	HPM50108-02	G006	08-08-19
High Pass Filter 2.8GHz	Micro-Tronics	HPM50111-02	010	08-08-19
High Pass Filter 2.8GHz	Micro-Tronics	HPM50111-02	011	08-08-19
High Pass Filter 4GHz	Micro-Tronics	HPM50118-02	G001	08-08-19
High Pass Filter 4GHz	Micro-Tronics	HPM50118-02	G002	08-08-19
Attenuator	PASTERNAK	PE7087-10	A009	08-08-19
Attenuator	PASTERNAK	PE7087-10	A001	08-08-19
Attenuator	PASTERNAK	PE7087-10	A008	08-08-19
Attenuator	PASTERNAK	PE7087-10	2	08-07-19
Attenuator	PASTERNAK	PE7395-10	A011	08-08-19
Antenna, Loop, 9kHz-30MHz	R&S	HFH2-Z2	100418	10-26-19
Temperature Chamber	ESPEC	SH-642	93001109	08-06-19
UL Software				
Description	Manufacturer	Model	Version	
Antenna port test software	UL	CLT	Ver 2.5	

7. RF OUTPUT POWER VERIFICATION (CONDUCTED AND EIRP)

RULE PART(S)

FCC: §2.1046, §27.50

EIRP LIMIT

FCC: §27.50(h)

(h) The following power limits shall apply in the BRS and EBS:

(2) Mobile and other user stations. Mobile stations are limited to 2.0 watts EIRP. All user stations are limited to 2.0 watts transmitter output power.

TEST PROCEDURE

TIA-603-E Clause 2.2.17

KDB 971168 Section 5.6

$$ERP/EIRP = P_{Meas} + GT - LC$$

where: ERP/EIRP = effective or equivalent radiated power, respectively (expressed in the same units as P_{Meas}, typically dBW or dBm);

P_{Meas} = measured transmitter output power or PSD, in dBm or dBW;

GT = gain of the transmitting antenna, in dBd (ERP) or dBi (EIRP);

LC = signal attenuation in the connecting cable between the transmitter and antenna, in dB.

RESULTS

EUT includes different power levels for head use configuration and body use configuration and the below tables contain the highest of all configurations average conducted and ERP/EIRP output powers as follows:

7.1. LTE BAND 41

OUTPUT POWER FOR LTE BAND 41 (5.0MHz + 20.0MHz)

Antenna Gain (dBi)	-4.53																
Bandwidth	PCC Frequency (MHz)	SCC1 Frequency (MHz)	PCC RB		SCC1 RB		Conducted Average (dBm)			EIRP Average (dBm)			EIRP Limit (dBm)	Margin (dB)			
			Size	Offset	Size	Offset	QPSK	16QAM	64QAM	QPSK	16QAM	64QAM		QPSK	16QAM	64QAM	
5MHz / 20MHz	2558.3	2570.0	1	24	1	0	23.19	22.34	20.40	18.66	17.81	15.87	33	-14.34	-15.19	-17.13	
			1	0	1	99	14.80	15.23	15.16	10.27	10.70	10.63	33	-22.73	-22.30	-22.37	
			25	0	100	0	21.22	20.38	20.23	16.69	15.85	15.70	33	-16.31	-17.15	-17.30	
	2595.8	2607.5	2607.5	1	24	1	0	23.32	22.34	20.71	18.79	17.81	16.18	33	-14.21	-15.19	-16.82
				1	0	1	99	14.83	14.98	15.31	10.30	10.45	10.78	33	-22.70	-22.55	-22.22
				25	0	100	0	21.37	20.46	20.23	16.84	15.93	15.70	33	-16.16	-17.07	-17.30
	2633.3	2645.0	2645.0	1	24	1	0	23.18	22.61	20.35	18.65	18.08	15.82	33	-14.35	-14.92	-17.18
				1	0	1	99	14.61	15.14	14.71	10.08	10.61	10.18	33	-22.92	-22.39	-22.82
				25	0	100	0	21.16	20.34	20.29	16.63	15.81	15.76	33	-16.37	-17.19	-17.24

OUTPUT POWER FOR LTE BAND 41 (20.0MHz + 5.0MHz)

Antenna Gain (dBi)		-4.53														
Bandwidth	PCC Frequency (MHz)	SCC1 Frequency (MHz)	PCC RB		SCC1 RB		Conducted Average (dBm)			EIRP Average (dBm)			EIRP Limit (dBm)	Margin (dB)		
			Size	Offset	Size	Offset	QPSK	16QAM	64QAM	QPSK	16QAM	64QAM		QPSK	16QAM	64QAM
			20MHz / 5MHz	2565.0	2576.7	1	99	1	0	23.05	22.33	20.44		18.52	17.80	15.91
1	0	1				24	14.85	15.15	15.06	10.32	10.62	10.53	33	-22.68	-22.38	-22.47
100	0	25				0	21.95	21.15	20.12	17.42	16.62	15.59	33	-15.58	-16.38	-17.41
2602.5	2614.2	1		99	1	0	23.55	22.71	20.75	19.02	18.18	16.22	33	-13.98	-14.82	-16.78
		1		0	1	24	15.06	15.33	15.23	10.53	10.80	10.70	33	-22.47	-22.20	-22.30
		100		0	25	0	21.34	20.42	20.34	16.81	15.89	15.81	33	-16.19	-17.11	-17.19
2640.0	2651.7	1		99	1	0	23.30	23.07	20.40	18.77	18.54	15.87	33	-14.23	-14.46	-17.13
		1		0	1	24	14.77	15.46	14.83	10.24	10.93	10.30	33	-22.76	-22.07	-22.70
		100		0	25	0	21.24	20.26	20.12	16.71	15.73	15.59	33	-16.29	-17.27	-17.41

OUTPUT POWER FOR LTE BAND 41 (10.0MHz + 15.0MHz)

Antenna Gain (dBi)		-4.53														
Bandwidth	PCC Frequency (MHz)	SCC1 Frequency (MHz)	PCC RB		SCC1 RB		Conducted Average (dBm)			EIRP Average (dBm)			EIRP Limit (dBm)	Margin (dB)		
			Size	Offset	Size	Offset	QPSK	16QAM	64QAM	QPSK	16QAM	64QAM		QPSK	16QAM	64QAM
			10MHz / 15MHz	2560.3	2572.3	1	49	1	0	23.37	22.64	20.64		18.84	18.11	16.11
1	0	1				74	14.83	15.28	15.38	10.30	10.75	10.85	33	-22.70	-22.25	-22.15
50	0	75				0	21.23	20.31	20.23	16.70	15.78	15.70	33	-16.30	-17.22	-17.30
2597.9	2609.9	1		49	1	0	23.53	22.75	20.69	19.00	18.22	16.16	33	-14.00	-14.78	-16.84
		1		0	1	74	14.95	15.22	15.12	10.42	10.69	10.59	33	-22.58	-22.31	-22.41
		50		0	75	0	21.48	20.50	20.40	16.95	15.97	15.87	33	-16.05	-17.03	-17.13
2635.5	2647.5	1		49	1	0	23.35	22.56	20.71	18.82	18.03	16.18	33	-14.18	-14.97	-16.82
		1		0	1	74	14.82	14.96	15.03	10.29	10.43	10.50	33	-22.71	-22.57	-22.50
		50		0	75	0	21.22	20.27	20.26	16.69	15.74	15.73	33	-16.31	-17.26	-17.27

OUTPUT POWER FOR LTE BAND 41 (15.0MHz + 10.0MHz)

Antenna Gain (dBi)		-4.53														
Bandwidth	PCC Frequency (MHz)	SCC1 Frequency (MHz)	PCC RB		SCC1 RB		Conducted Average (dBm)			EIRP Average (dBm)			EIRP Limit (dBm)	Margin (dB)		
			Size	Offset	Size	Offset	QPSK	16QAM	64QAM	QPSK	16QAM	64QAM		QPSK	16QAM	64QAM
			15MHz / 10MHz	2562.5	2574.5	1	74	1	0	23.99	22.65	20.88		19.46	18.12	16.35
1	0	1				49	14.85	15.38	15.56	10.32	10.85	11.03	33	-22.68	-22.15	-21.97
75	0	50				0	21.22	20.37	20.32	16.69	15.84	15.79	33	-16.31	-17.16	-17.21
2600.1	2612.1	1		74	1	0	23.64	22.87	20.68	19.11	18.34	16.15	33	-13.89	-14.66	-16.85
		1		0	1	49	15.08	15.34	15.17	10.55	10.81	10.64	33	-22.45	-22.19	-22.36
		75		0	50	0	22.51	21.60	21.17	17.98	17.07	16.64	33	-15.02	-15.93	-16.36
2637.7	2649.7	1		74	1	0	23.44	22.63	20.98	18.91	18.10	16.45	33	-14.09	-14.90	-16.55
		1		0	1	49	14.76	15.00	15.28	10.23	10.47	10.75	33	-22.77	-22.53	-22.25
		75		0	50	0	21.34	20.34	20.16	16.81	15.81	15.63	33	-16.19	-17.19	-17.37

OUTPUT POWER FOR LTE BAND 41 (10.0MHz + 20.0MHz)

Antenna Gain (dBi)		-4.53														
Bandwidth	PCC Frequency (MHz)	SCC1 Frequency (MHz)	PCC RB		SCC1 RB		Conducted Average (dBm)			EIRP Average (dBm)			EIRP Limit (dBm)	Margin (dB)		
			Size	Offset	Size	Offset	QPSK	16QAM	64QAM	QPSK	16QAM	64QAM		QPSK	16QAM	64QAM
			10MHz / 20MHz	2560.5	2574.9	1	49	1	0	23.43	22.37	20.68		18.90	17.84	16.15
1	0	1				99	14.99	15.12	15.32	10.46	10.59	10.79	33	-22.54	-22.41	-22.21
50	0	100				0	21.28	20.29	20.15	16.75	15.76	15.62	33	-16.25	-17.24	-17.38
2595.60	2610.00	1		49	1	0	23.36	22.77	20.52	18.83	18.24	15.99	33	-14.17	-14.76	-17.01
		1		0	1	99	14.91	15.33	15.06	10.38	10.80	10.53	33	-22.62	-22.20	-22.47
		50		0	100	0	21.46	20.48	20.34	16.93	15.95	15.81	33	-16.07	-17.05	-17.19
2630.6	2645.0	1		49	1	0	23.21	22.58	20.74	18.68	18.05	16.21	33	-14.32	-14.95	-16.79
		1		0	1	99	14.74	15.02	14.97	10.21	10.49	10.44	33	-22.79	-22.51	-22.56
		50		0	100	0	21.25	20.35	20.21	16.72	15.82	15.68	33	-16.28	-17.18	-17.32

OUTPUT POWER FOR LTE BAND 41 (20.0MHz + 10.0MHz)

Antenna Gain (dBi)		-4.53														
Bandwidth	PCC Frequency (MHz)	SCC1 Frequency (MHz)	PCC RB		SCC1 RB		Conducted Average (dBm)			EIRP Average (dBm)			EIRP Limit (dBm)	Margin (dB)		
			Size	Offset	Size	Offset	QPSK	16QAM	64QAM	QPSK	16QAM	64QAM		QPSK	16QAM	64QAM
			20MHz / 10MHz	2565.0	2579.4	1	99	1	0	23.42	22.49	20.41		18.89	17.96	15.88
1	0	1				49	14.84	15.28	15.07	10.31	10.75	10.54	33	-22.69	-22.25	-22.46
100	0	50				0	21.59	20.74	20.61	17.06	16.21	16.08	33	-15.94	-16.79	-16.92
2600.1	2614.5	1		99	1	0	23.62	23.05	20.72	19.09	18.52	16.19	33	-13.91	-14.48	-16.81
		1		0	1	49	15.01	15.67	15.13	10.48	11.14	10.60	33	-22.52	-21.86	-22.40
		100		0	50	0	22.10	21.18	20.95	17.57	16.65	16.42	33	-15.43	-16.35	-16.58
2635.1	2649.5	1		99	1	0	23.43	22.75	20.44	18.90	18.22	15.91	33	-14.10	-14.78	-17.09
		1		0	1	49	14.75	15.12	14.68	10.22	10.59	10.15	33	-22.78	-22.41	-22.85
		100		0	50	0	21.45	20.48	20.12	16.92	15.95	15.59	33	-16.08	-17.05	-17.41

OUTPUT POWER FOR LTE BAND 41 (15.0MHz + 15.0MHz)

Antenna Gain (dBi)		-4.53															
Bandwidth	PCC Frequency (MHz)	SCC1 Frequency (MHz)	PCC RB		SCC1 RB		Conducted Average (dBm)			EIRP Average (dBm)			EIRP Limit (dBm)	Margin (dB)			
			Size	Offset	Size	Offset	QPSK	16QAM	64QAM	QPSK	16QAM	64QAM		QPSK	16QAM	64QAM	
15MHz / 15MHz	2562.5	2577.5	1	74	1	0	23.59	22.37	20.32	19.06	17.84	15.79	33	-13.94	-15.16	-17.21	
			1	0	1	74	14.96	15.12	15.01	10.43	10.59	10.48	33	-22.57	-22.41	-22.52	
			75	0	75	0	21.25	20.23	19.95	16.72	15.70	15.42	33	-16.28	-17.30	-17.58	
	2597.5	2612.5	1	74	1	0	23.53	22.98	21.09	19.00	18.45	16.56	33	-14.00	-14.55	-16.44	
			1	0	1	74	14.90	15.38	15.44	10.37	10.85	10.91	33	-22.63	-22.15	-22.09	
			75	0	75	0	21.41	20.50	20.47	16.88	15.97	15.94	33	-16.12	-17.03	-17.06	
	2632.5	2647.5	1	74	1	0	23.33	22.75	20.98	18.80	18.22	16.45	33	-14.20	-14.78	-16.55	
			1	0	1	74	14.69	15.01	15.30	10.16	10.48	10.77	33	-22.84	-22.52	-22.23	
			75	0	75	0	21.28	20.35	20.28	16.75	15.82	15.75	33	-16.25	-17.18	-17.25	

OUTPUT POWER FOR LTE BAND 41 (15.0MHz + 20.0MHz)

Antenna Gain (dBi)		-4.53															
Bandwidth	PCC Frequency (MHz)	SCC1 Frequency (MHz)	PCC RB		SCC1 RB		Conducted Average (dBm)			EIRP Average (dBm)			EIRP Limit (dBm)	Margin (dB)			
			Size	Offset	Size	Offset	QPSK	16QAM	64QAM	QPSK	16QAM	64QAM		QPSK	16QAM	64QAM	
15MHz / 20MHz	2562.8	2579.9	1	74	1	0	23.25	22.44	20.63	18.72	17.91	16.10	33	-14.28	-15.09	-16.90	
			1	0	1	99	14.82	15.24	15.31	10.29	10.71	10.78	33	-22.71	-22.29	-22.22	
			75	0	100	0	21.20	20.30	20.19	16.67	15.77	15.66	33	-16.33	-17.23	-17.34	
	2595.4	2612.5	1	74	1	0	23.52	22.72	20.55	18.99	18.19	16.02	33	-14.01	-14.81	-16.98	
			1	0	1	99	14.88	15.14	14.96	10.35	10.61	10.43	33	-22.65	-22.39	-22.57	
			75	0	100	0	21.36	20.51	20.32	16.83	15.98	15.79	33	-16.17	-17.02	-17.21	
	2627.9	2645.0	1	74	1	0	23.34	22.57	20.89	18.81	18.04	16.36	33	-14.19	-14.96	-16.64	
			1	0	1	99	14.81	14.94	15.13	10.28	10.41	10.60	33	-22.72	-22.59	-22.40	
			75	0	100	0	21.22	20.21	20.19	16.69	15.68	15.66	33	-16.31	-17.32	-17.34	

OUTPUT POWER FOR LTE BAND 41 (20.0MHz + 15.0MHz)

Antenna Gain (dBi)		-4.53															
Bandwidth	PCC Frequency (MHz)	SCC1 Frequency (MHz)	PCC RB		SCC1 RB		Conducted Average (dBm)			EIRP Average (dBm)			EIRP Limit (dBm)	Margin (dB)			
			Size	Offset	Size	Offset	QPSK	16QAM	64QAM	QPSK	16QAM	64QAM		QPSK	16QAM	64QAM	
20MHz / 15MHz	2565.0	2582.1	1	99	1	0	23.28	22.44	20.61	18.75	17.91	16.08	33	-14.25	-15.09	-16.92	
			1	0	1	74	14.84	15.27	14.83	10.31	10.74	10.30	33	-22.69	-22.26	-22.70	
			100	0	75	0	21.23	20.27	20.16	16.70	15.74	15.63	33	-16.30	-17.26	-17.37	
	2597.6	2614.7	1	99	1	0	23.59	22.75	20.74	19.06	18.22	16.21	33	-13.94	-14.78	-16.79	
			1	0	1	74	15.02	15.28	15.08	10.49	10.75	10.55	33	-22.51	-22.25	-22.45	
			100	0	75	0	21.45	20.53	20.42	16.92	16.00	15.89	33	-16.08	-17.00	-17.11	
	2630.1	2647.2	1	99	1	0	23.42	23.12	20.46	18.89	18.59	15.93	33	-14.11	-14.41	-17.07	
			1	0	1	74	14.76	15.38	14.70	10.23	10.85	10.17	33	-22.77	-22.15	-22.83	
			100	0	75	0	21.22	20.34	20.23	16.69	15.81	15.70	33	-16.31	-17.19	-17.30	

OUTPUT POWER FOR LTE BAND 41 (20.0MHz + 20.0MHz)

Antenna Gain (dBi)		-4.53															
Bandwidth	PCC Frequency (MHz)	SCC1 Frequency (MHz)	PCC RB		SCC1 RB		Conducted Average (dBm)			EIRP Average (dBm)			EIRP Limit (dBm)	Margin (dB)			
			Size	Offset	Size	Offset	QPSK	16QAM	64QAM	QPSK	16QAM	64QAM		QPSK	16QAM	64QAM	
20MHz / 20MHz	2565.0	2584.8	1	99	1	0	23.39	22.59	20.30	18.86	18.06	15.77	33	-14.14	-14.94	-17.23	
			1	0	1	99	14.76	15.15	14.73	10.23	10.62	10.20	33	-22.77	-22.38	-22.80	
			100	0	100	0	21.19	20.25	20.06	16.66	15.72	15.53	33	-16.34	-17.28	-17.47	
	2595.1	2614.9	1	99	1	0	23.67	22.81	20.60	19.14	18.28	16.07	33	-13.86	-14.72	-16.93	
			1	0	1	99	14.90	15.16	14.92	10.37	10.63	10.39	33	-22.63	-22.37	-22.61	
			100	0	100	0	21.40	20.52	20.29	16.87	15.99	15.76	33	-16.13	-17.01	-17.24	
	2625.2	2645.0	1	99	1	0	23.47	23.14	20.65	18.94	18.61	16.12	33	-14.06	-14.39	-16.88	
			1	0	1	99	14.61	15.28	14.74	10.08	10.75	10.21	33	-22.92	-22.25	-22.79	
			100	0	100	0	21.21	20.40	20.20	16.68	15.87	15.67	33	-16.32	-17.13	-17.33	

8. LIMITS AND CONDUCTED RESULTS

8.1. OCCUPIED BANDWIDTH

RULE PART(S)

FCC: §2.1049

LIMITS

For reporting purposes only

TEST PROCEDURE

The transmitter output was connected to a calibrated coaxial cable and coupler, the other end of which was connected to a spectrum analyzer. The occupied bandwidth was measured with the spectrum analyzer at the low, middle and high channel in each band. The -26dB bandwidth was also measured and recorded.

(KDB 971168 D01 Power Meas License Digital Systems v03r01)

8.1.1. OCCUPIED BANDWIDTH RESULTS

LTE BAND 41

Band	Mode	RB Allocation/RB Offset	f (MHz)	99% BW (MHz)	- 26dB BW (MHz)
LTE BAND 41	5MHz + 20MHz BAND QPSK	25/0 + 100/0	2605	23.236	24.88
	5MHz + 20MHz BAND 16QAM			23.108	24.87
	20MHz + 5MHz BAND QPSK	100/0 + 25/0		23.326	25.19
	20MHz + 5MHz BAND 16QAM			23.253	25.17
	10MHz + 15MHz BAND QPSK	50/0 + 75/0		23.402	25.27
	10MHz + 15MHz BAND 16QAM			23.353	25.18
	15MHz + 10MHz BAND QPSK	75/0 + 50/0		23.434	25.31
	15MHz + 10MHz BAND 16QAM			23.425	25.30
	10MHz + 20MHz BAND QPSK	50/0 + 100/0		27.827	29.84
	10MHz + 20MHz BAND 16QAM			27.858	29.80
	20MHz + 10MHz BAND QPSK	100/0 + 50/0		27.957	29.92
	20MHz + 10MHz BAND 16QAM			27.848	29.88
	15MHz + 15MHz BAND QPSK	75/0 + 75/0		28.532	30.53
	15MHz + 15MHz BAND 16QAM			28.477	30.40
	15MHz + 20MHz BAND QPSK	75/0 + 100/0		32.745	34.91
	15MHz + 20MHz BAND 16QAM			32.723	34.80
	20MHz + 15MHz BAND QPSK	100/0 + 75/0		32.760	34.85
	20MHz + 15MHz BAND 16QAM			32.854	34.83
20MHz + 20MHz BAND QPSK	100/0 + 100/0	37.538	39.73		
20MHz + 20MHz BAND 16QAM		37.527	39.78		

8.1.2. OCCUPIED BANDWIDTH PLOTS

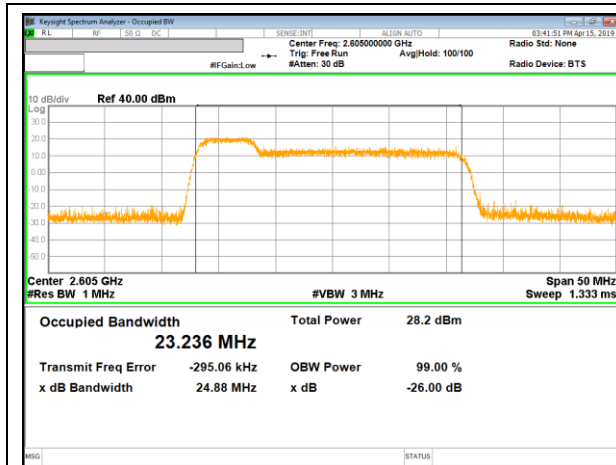

LTE B41 5MHz + 20MHz QPSK RB25-0 + RB100-0

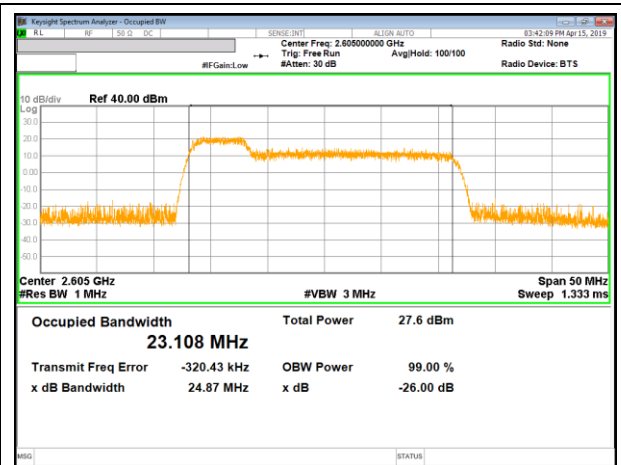

LTE B41 5MHz + 20MHz 16QAM RB25-0 + RB100-0

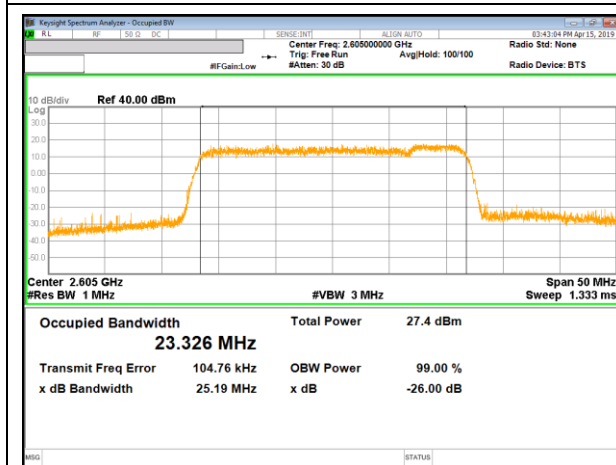

LTE B41 20MHz + 5MHz QPSK RB100-0 + RB25-0

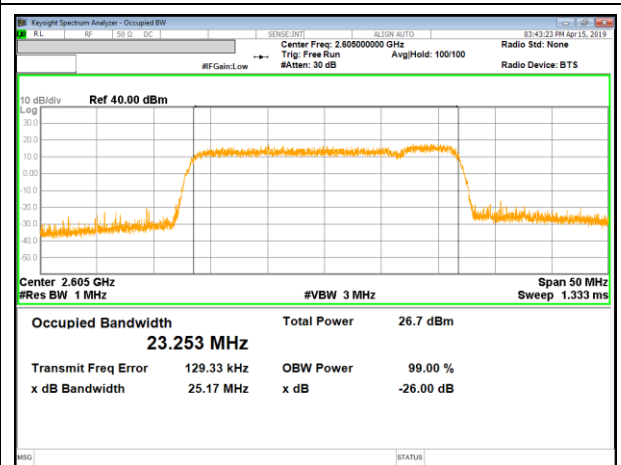

LTE B41 10MHz + 5MHz 16QAM RB100-0 + RB25-0

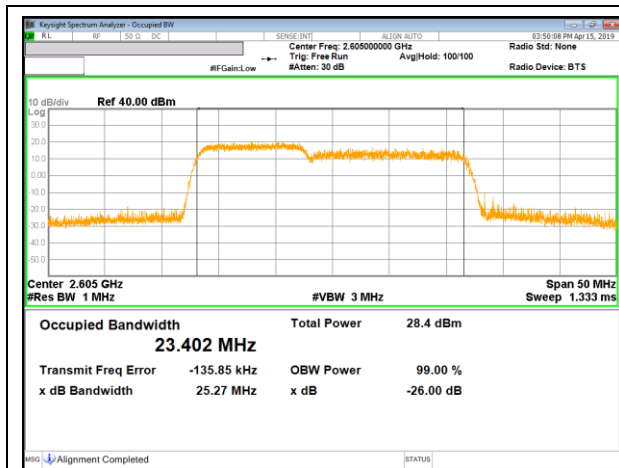

LTE B41 10MHz + 15MHz QPSK RB50-0 + RB100-0

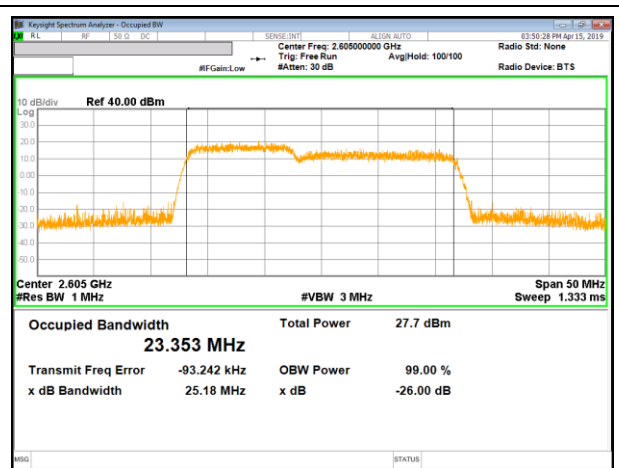

LTE B41 10MHz + 15MHz 16QAM RB50-0 + RB100-0

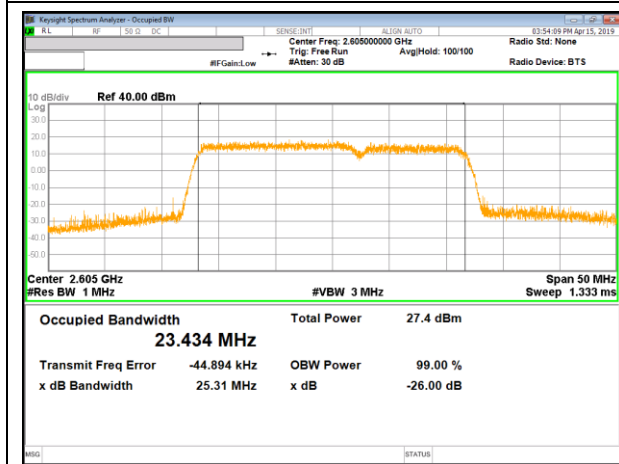

LTE B41 15MHz + 10MHz QPSK RB100-0 + RB50-0

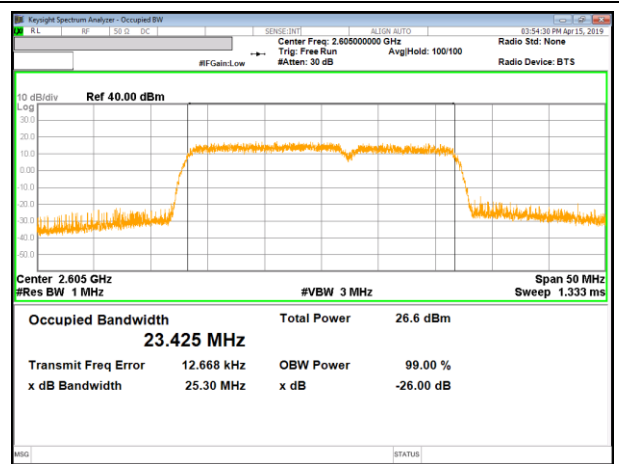

LTE B41 15MHz + 10MHz 16QAM RB100-0 + RB50-0

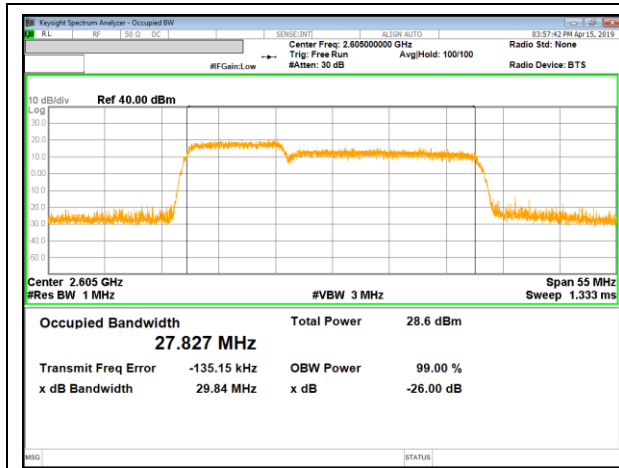

LTE B41 10MHz + 20MHz QPSK RB50-0 + RB100-0

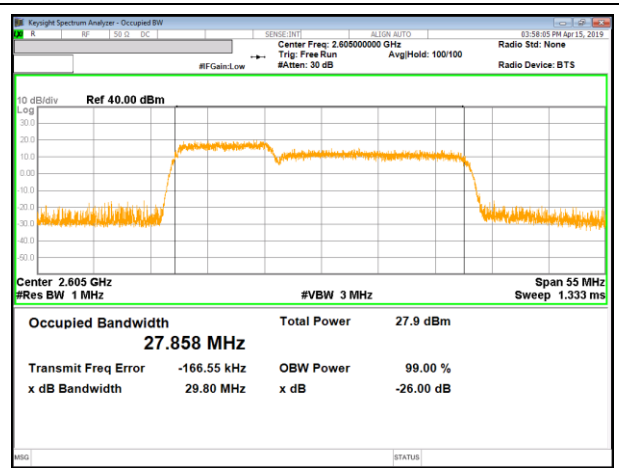

LTE B41 10MHz + 20MHz 16QAM RB50-0 + RB100-0

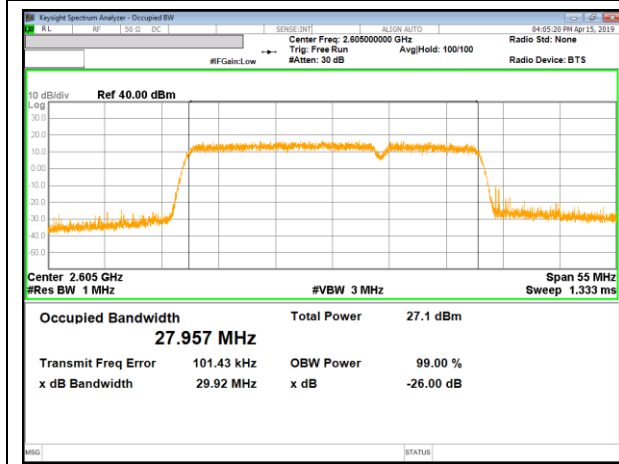

LTE B41 20MHz + 10MHz QPSK RB100-0 + RB50-0

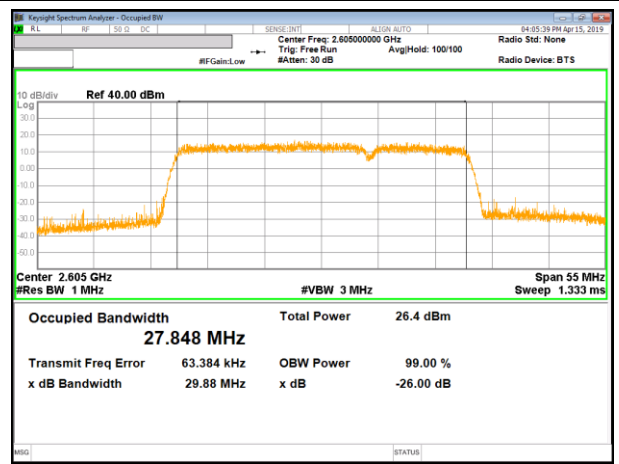

LTE B41 20MHz + 10MHz 16QAM RB100-0 + RB50-0

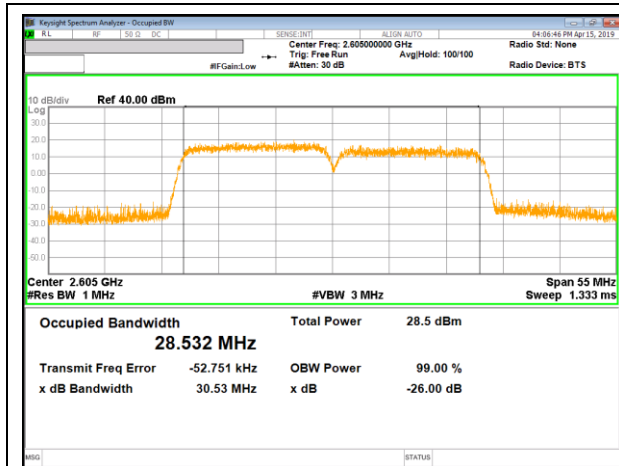

LTE B41 15MHz + 15MHz QPSK RB75-0 + RB75-0

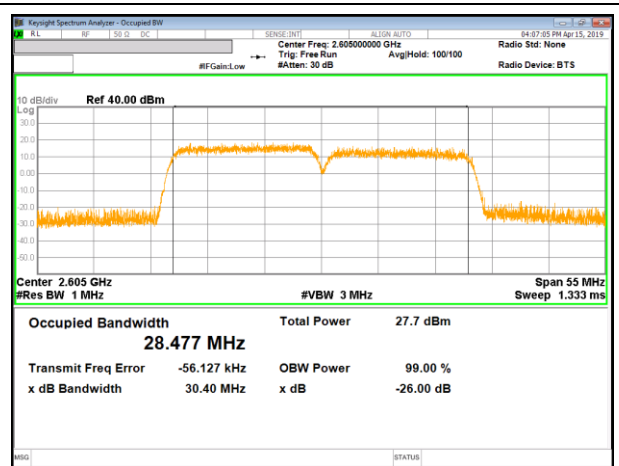

LTE B41 15MHz + 15MHz 16QAM RB75-0 + RB75-0

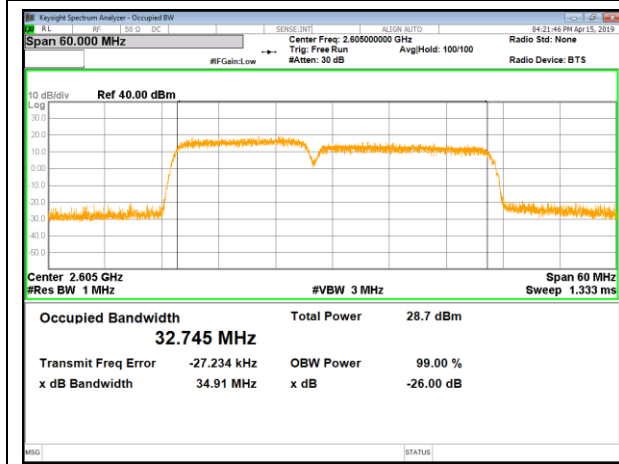

LTE B41 15MHz + 20MHz QPSK RB75-0 + RB100-0

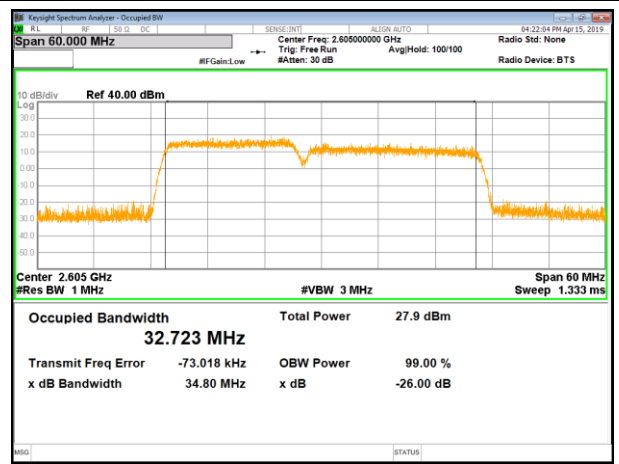

LTE B41 15MHz + 20MHz 16QAM RB75-0 + RB100-0

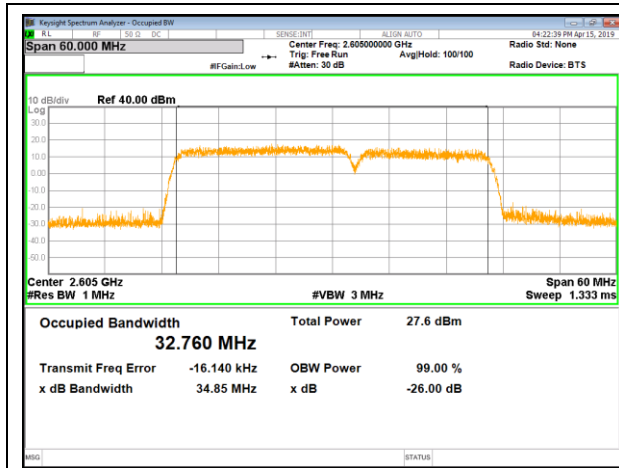

LTE B41 20MHz + 15MHz QPSK RB100-0 + RB75-0

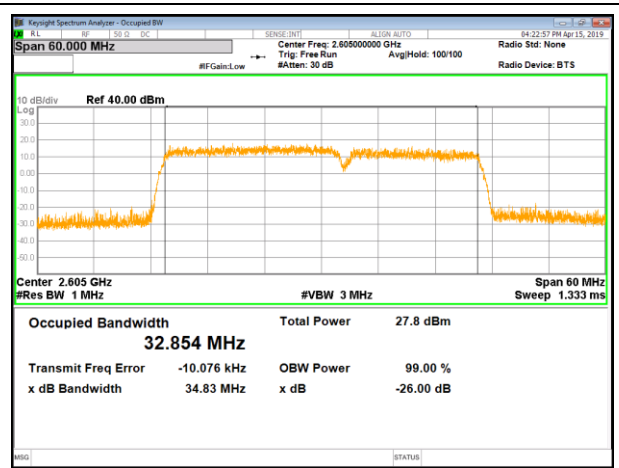

LTE B41 20MHz + 15MHz 16QAM RB100-0 + RB75-0

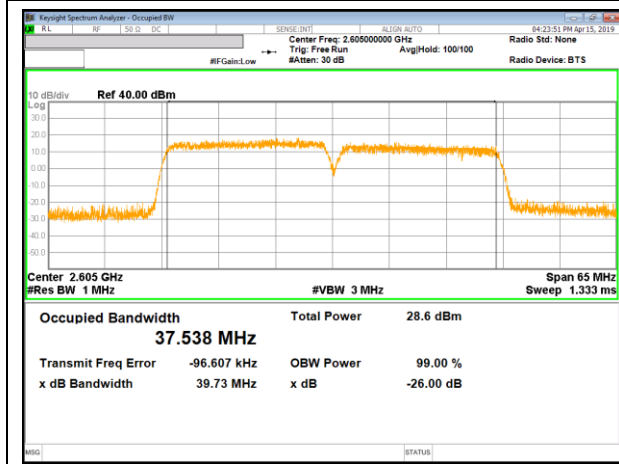

LTE B41 20MHz + 20MHz QPSK RB100-0 + RB100-0

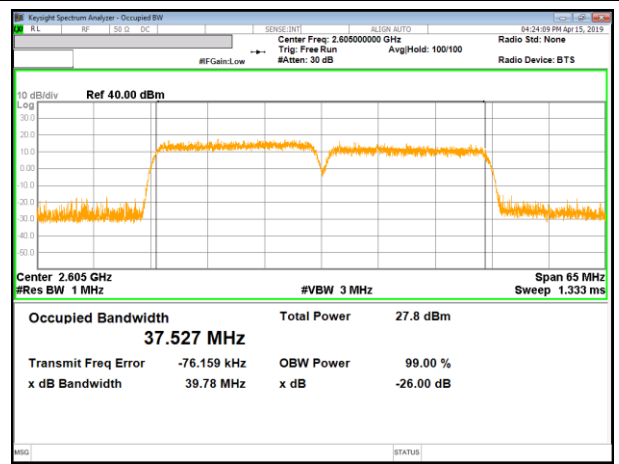

LTE B41 20MHz + 20MHz 16QAM RB100-0 + RB100-0

8.2. EMISSION MASK

RULE PART(S)

FCC: §27. 53(m)

LIMITS

Part 27.53(m) For mobile digital stations, the attenuation factor shall be not less than $40 + 10 \log (P)$ dB on all frequencies between the channel edge and 5 megahertz from the channel edge, $43 + 10 \log (P)$ dB on all frequencies between 5 megahertz and X megahertz from the channel edge, and $55 + 10 \log (P)$ dB on all frequencies more than X megahertz from the channel edge, where X is the greater of 6 megahertz or the actual emission bandwidth as defined in paragraph (m)(6) of this section. In addition, the attenuation factor shall not be less than $43 + 10 \log (P)$ dB on all frequencies between 2490.5 MHz and 2496 MHz and $55 + 10 \log (P)$ dB at or below 2490.5 MHz. Mobile Satellite Service licensees operating on frequencies below 2495 MHz may also submit a documented interference complaint against BRS licensees operating on channel BRS Channel 1 on the same terms and conditions as adjacent channel BRS or EBS licensees.

TEST PROCEDURE

Per KDB 971168 D01 Power Meas License Digital Systems v03r01

The transmitter output was connected to a CMW500 Test Set and configured to operate at maximum power. The band edge emissions were measured at the required operating frequencies in each band on the Spectrum Analyzer.

NOTE

LTE 41 - Duty cycle correction factor(2.25dB) already applied on the plot.

RESULTS

8.2.1. EMISSION MASK PLOTS

LTE Band 41

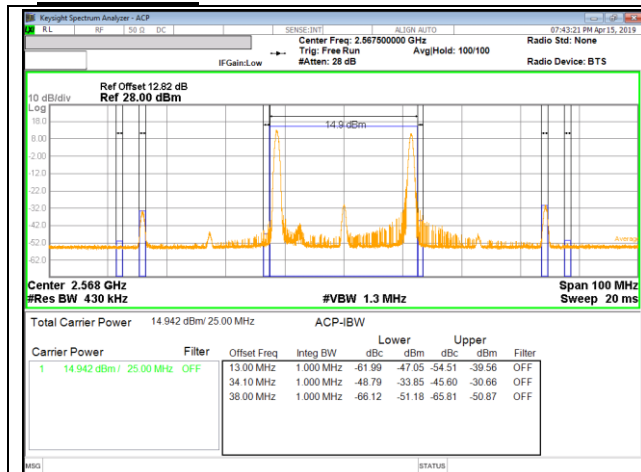

LTE B41 5MHz + 20MHz QPSK Low Ch RB1-0 + RB1-99

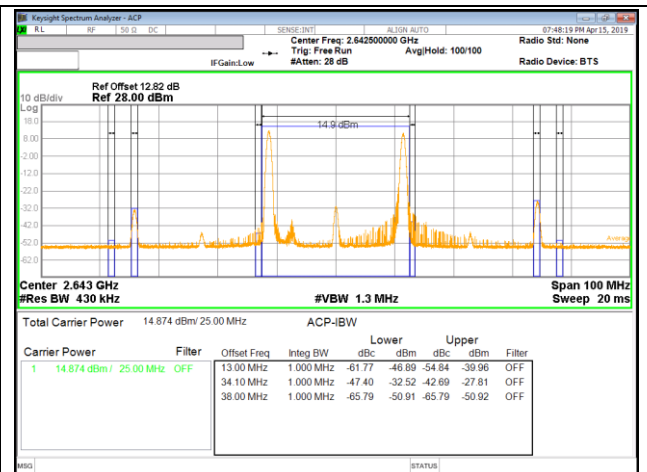

LTE B41 5MHz + 20MHz QPSK High Ch RB1-0 + RB1-99



LTE B41 5MHz + 20MHz QPSK Low Ch RB25-0 + RB100-0



LTE B41 5MHz + 20MHz QPSK High Ch RB25-0 + RB100-0

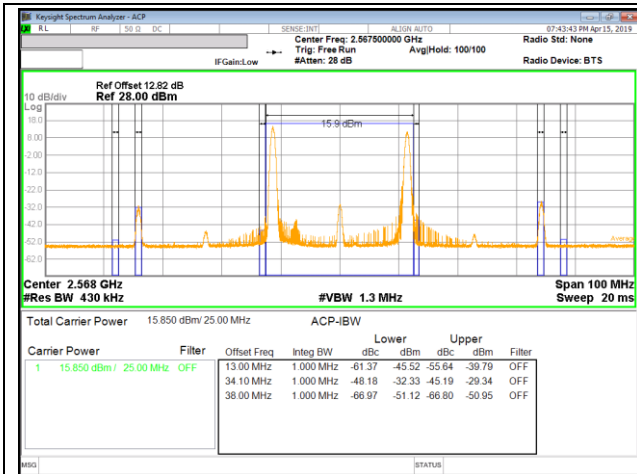

LTE B41 5MHz + 20MHz 16QAM Low Ch RB1-0 + RB1-99

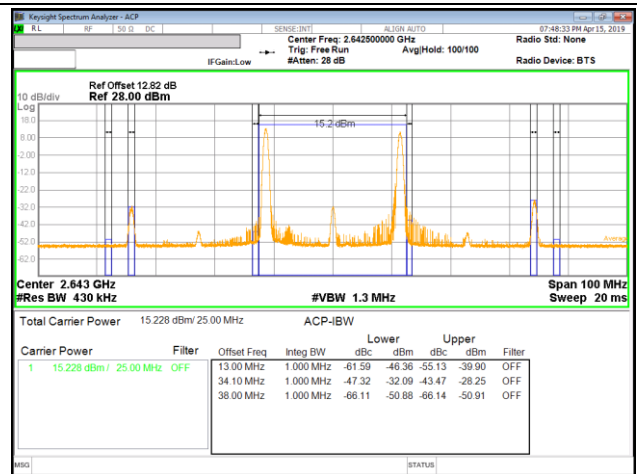

LTE B41 5MHz + 20MHz 16QAM High Ch RB1-0 + RB1-99

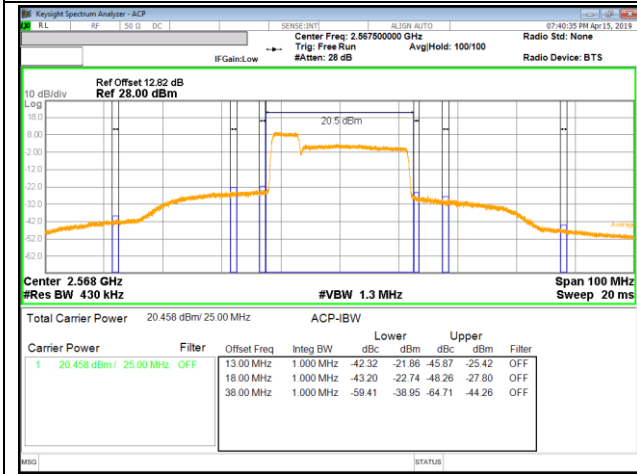

LTE B41 5MHz + 20MHz 16QAM Low Ch RB25-0 + RB100-0

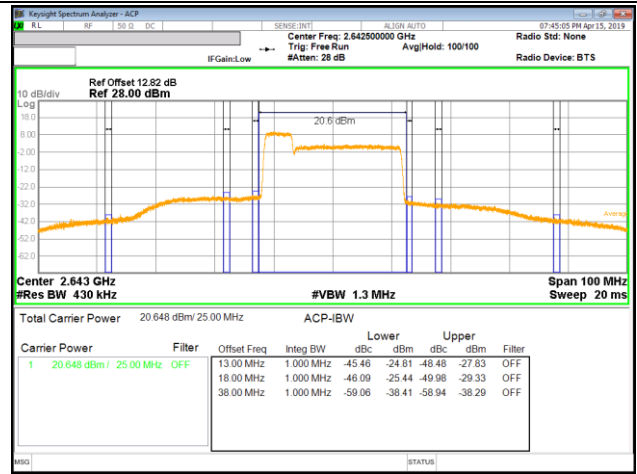

LTE B41 5MHz + 20MHz 16QAM High Ch RB25-0 + RB100-0

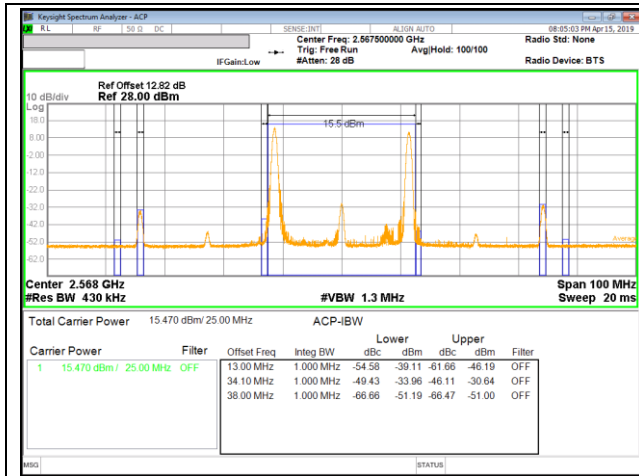

LTE B41 20MHz + 5MHz QPSK Low Ch RB1-0 + RB1-24

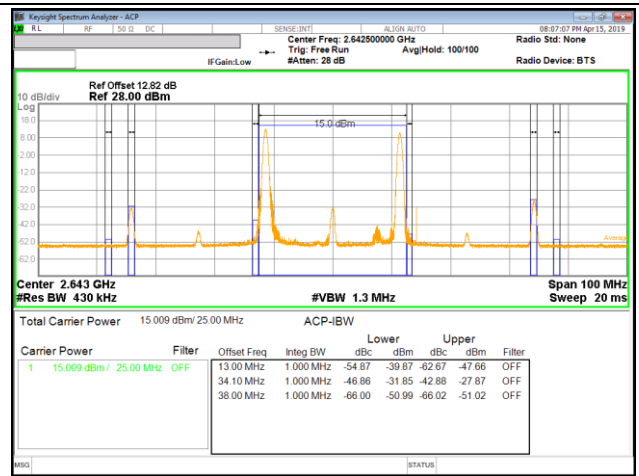

LTE B41 20MHz + 5MHz QPSK High Ch RB1-0 + RB1-24

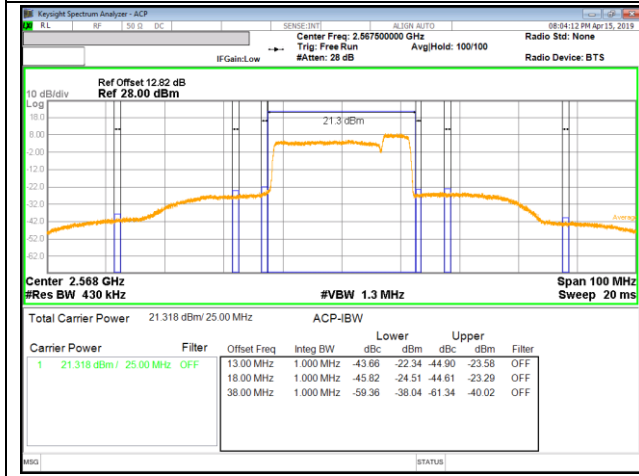

LTE B41 20MHz + 5MHz QPSK Low Ch RB100-0 + RB25-0



LTE B41 20MHz + 5MHz QPSK High Ch RB100-0 + RB25-0

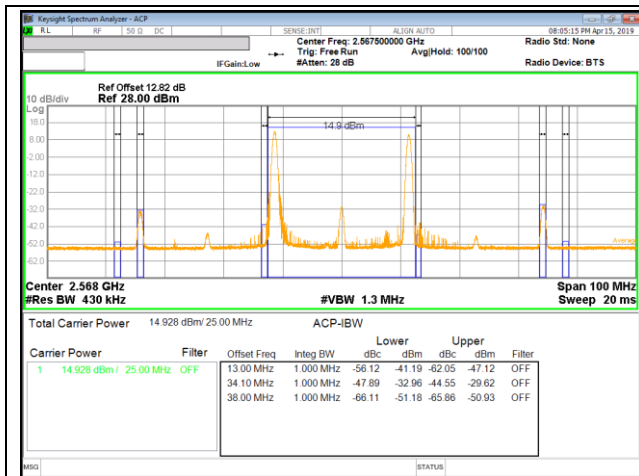

LTE B41 20MHz + 5MHz 16QAM Low Ch RB1-0 + RB1-24

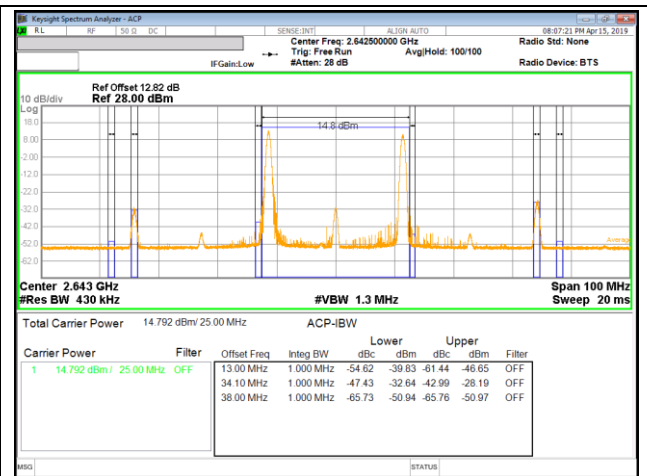

LTE B41 20MHz + 5MHz 16QAM High Ch RB1-0 + RB1-24

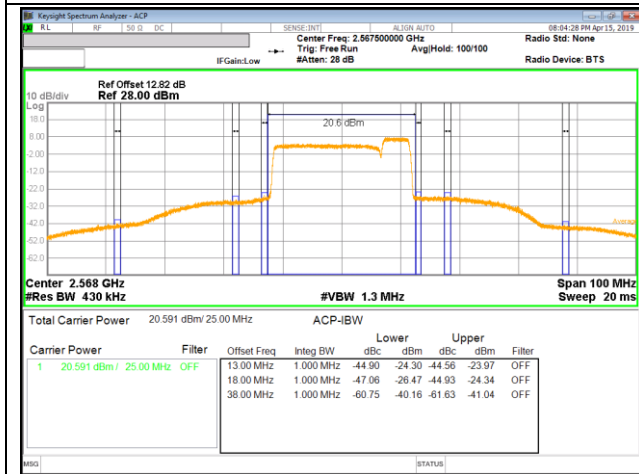

LTE B41 20MHz + 5MHz 16QAM Low Ch RB100-0 + RB25-0

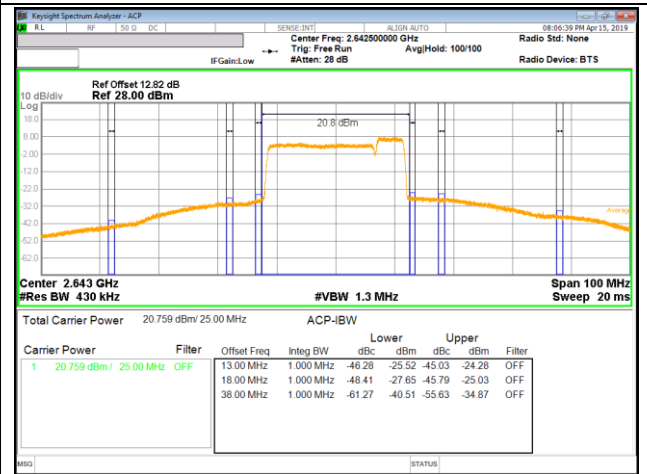

LTE B41 20MHz + 5MHz 16QAM High Ch RB100-0 + RB25-0

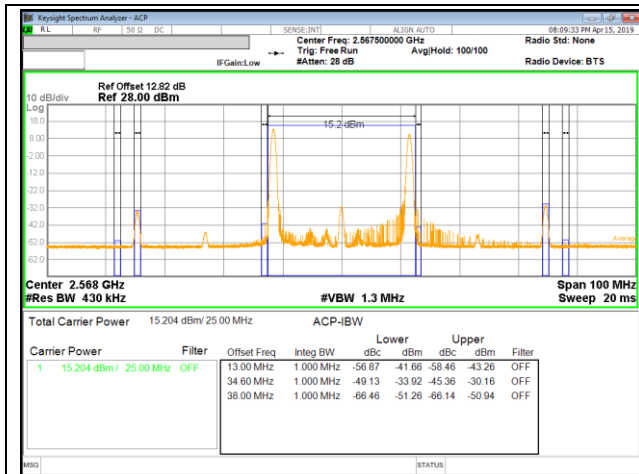

LTE B41 10MHz + 15MHz QPSK Low Ch RB1-0 + RB1-74

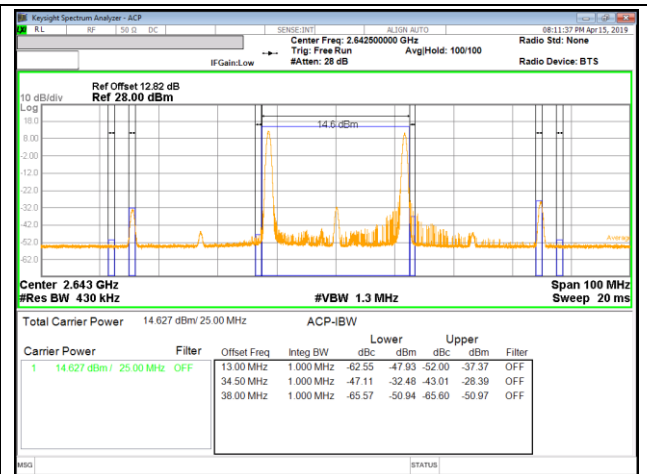

LTE B41 10MHz + 15MHz QPSK High Ch RB1-0 + RB1-74

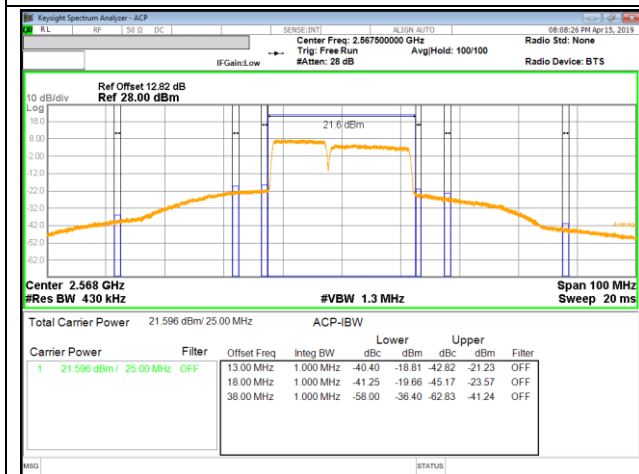

LTE B41 10MHz + 15MHz QPSK Low Ch RB50-0 + RB75-0

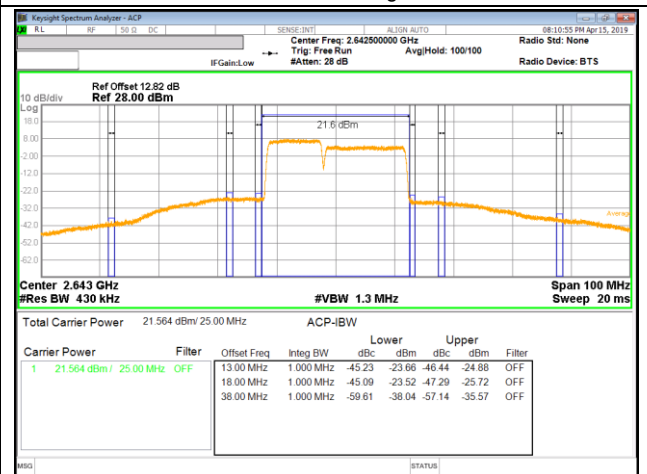

LTE B41 10MHz + 15MHz QPSK High Ch RB50-0 + RB75-0

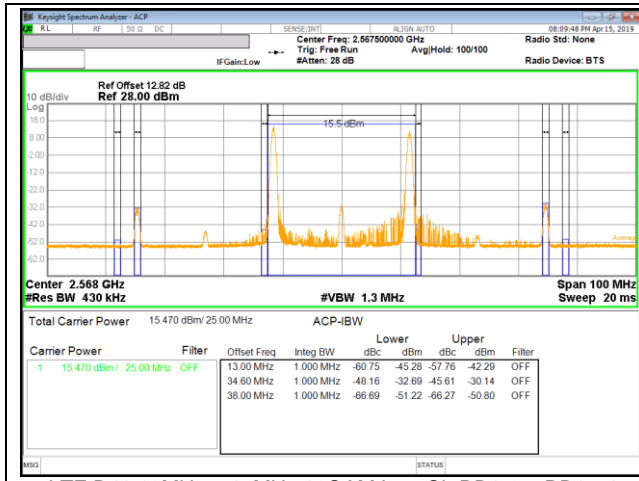

LTE B41 10MHz + 15MHz 16QAM Low Ch RB1-0 + RB1-74

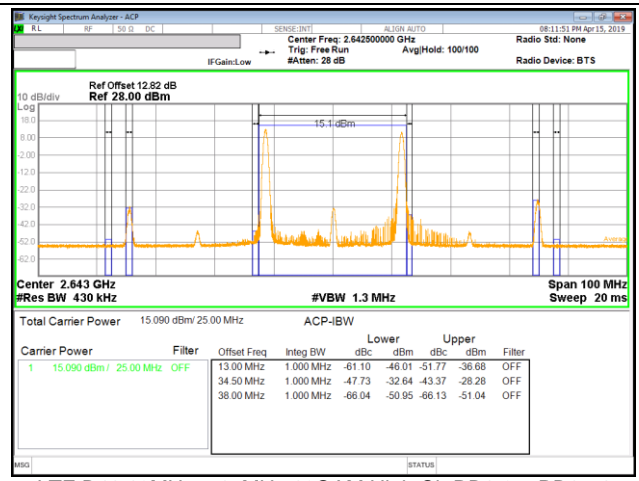

LTE B41 10MHz + 15MHz 16QAM High Ch RB1-0 + RB1-74

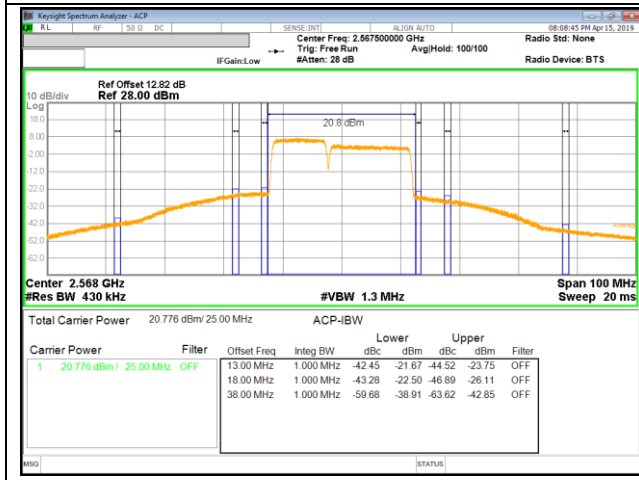

LTE B41 10MHz + 15MHz 16QAM Low Ch RB50-0 + RB75-0

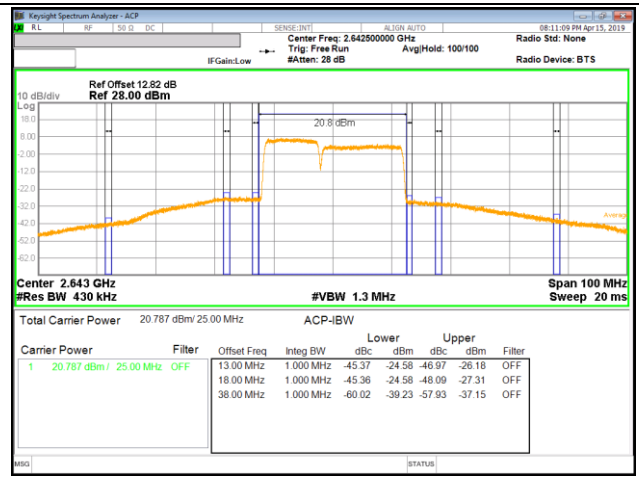

LTE B41 10MHz + 15MHz 16QAM High Ch RB50-0 + RB75-0

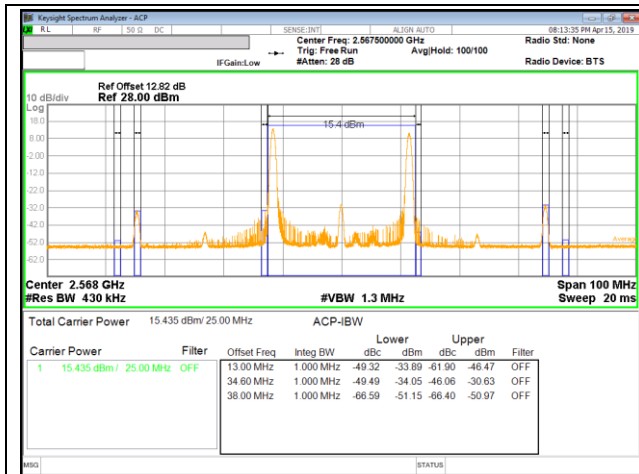

LTE B41 15MHz + 10MHz QPSK Low Ch RB1-0 + RB1-49

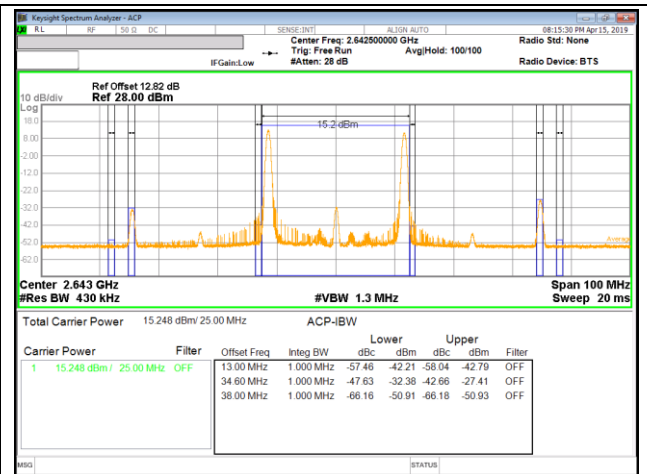

LTE B41 15MHz + 10MHz QPSK High Ch RB1-0 + RB1-49

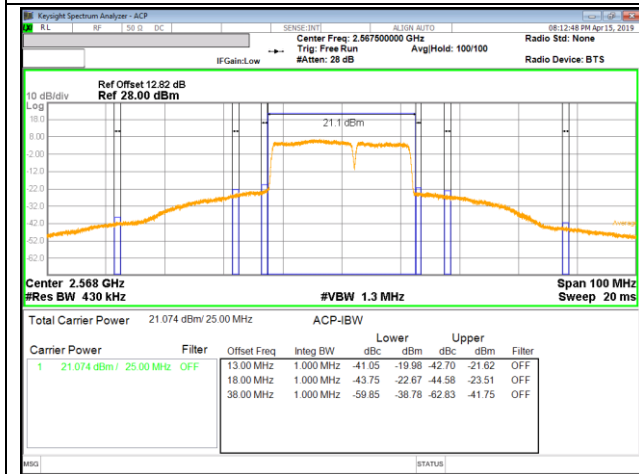

LTE B41 15MHz + 10MHz QPSK Low Ch RB75-0 + RB50-0



LTE B41 15MHz + 10MHz QPSK High Ch RB75-0 + RB50-0

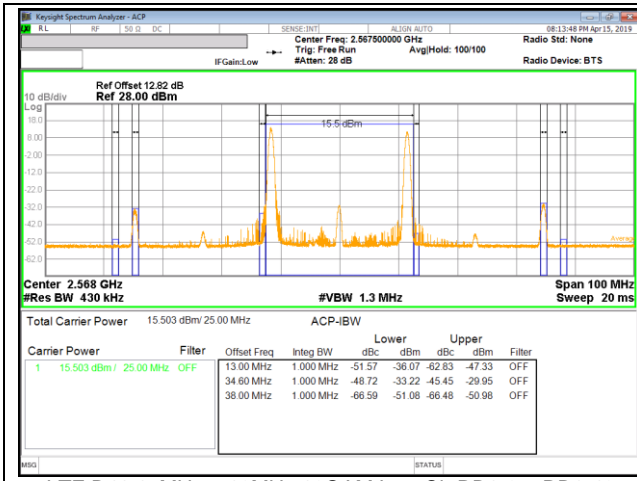

LTE B41 15MHz + 10MHz 16QAM Low Ch RB1-0 + RB1-49

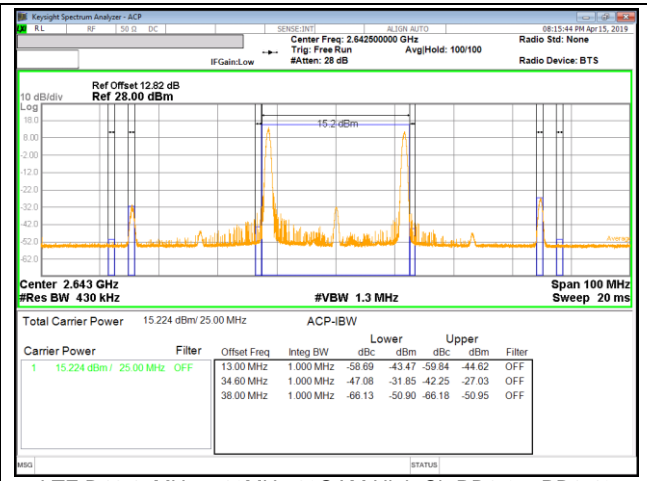

LTE B41 15MHz + 10MHz 16QAM High Ch RB1-0 + RB1-49

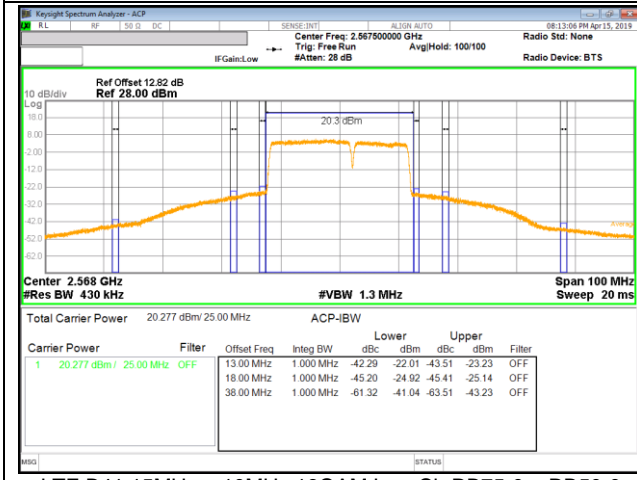

LTE B41 15MHz + 10MHz 16QAM Low Ch RB75-0 + RB50-0

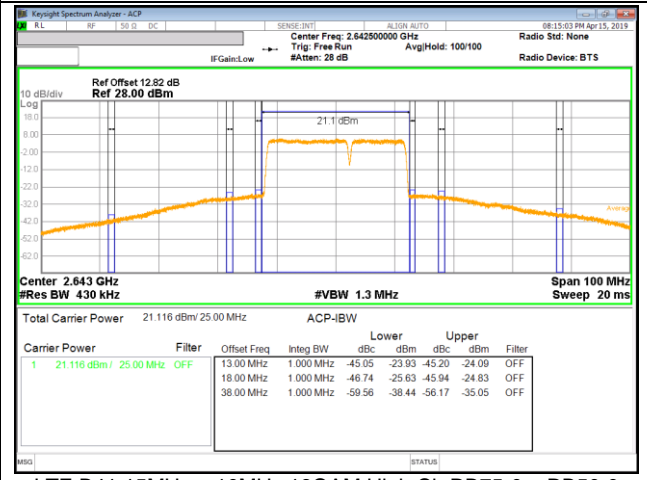

LTE B41 15MHz + 10MHz 16QAM High Ch RB75-0 + RB50-0

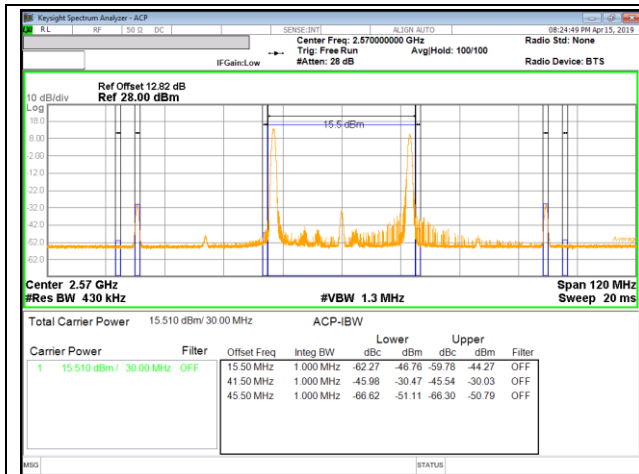

LTE B41 10MHz + 20MHz QPSK Low Ch RB1-0 + RB1-99

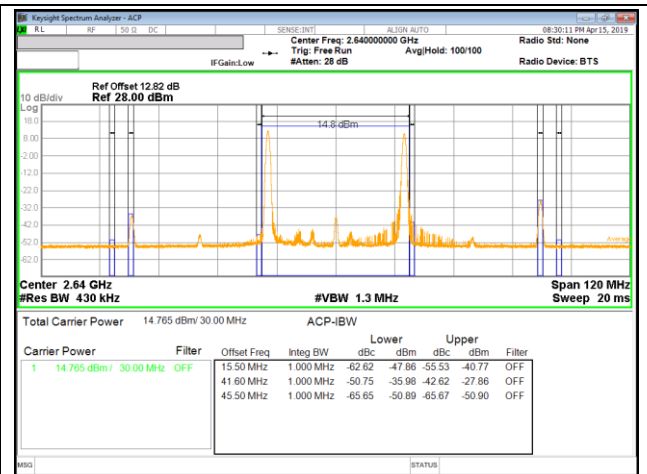

LTE B41 10MHz + 20MHz QPSK High Ch RB1-0 + RB1-99

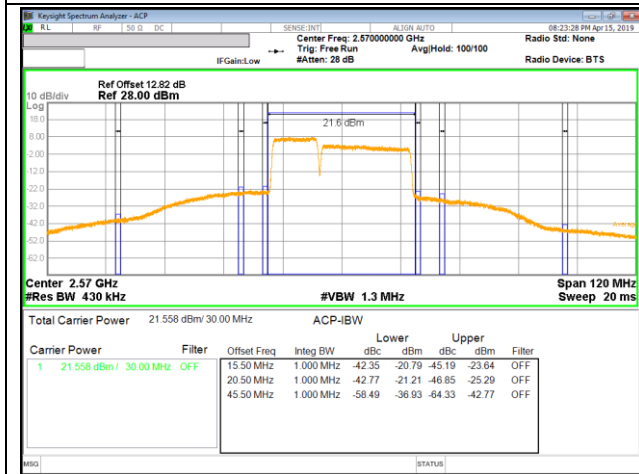

LTE B41 10MHz + 20MHz QPSK Low Ch RB50-0 + RB100-0



LTE B41 10MHz + 20MHz QPSK High Ch RB50-0 + RB100-0

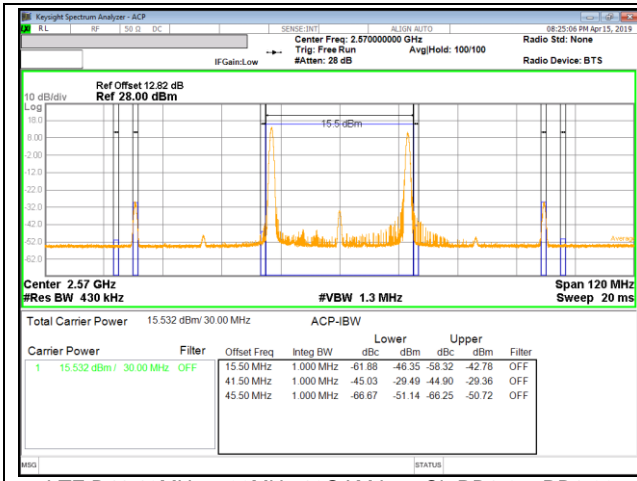

LTE B41 10MHz + 20MHz 16QAM Low Ch RB1-0 + RB1-99

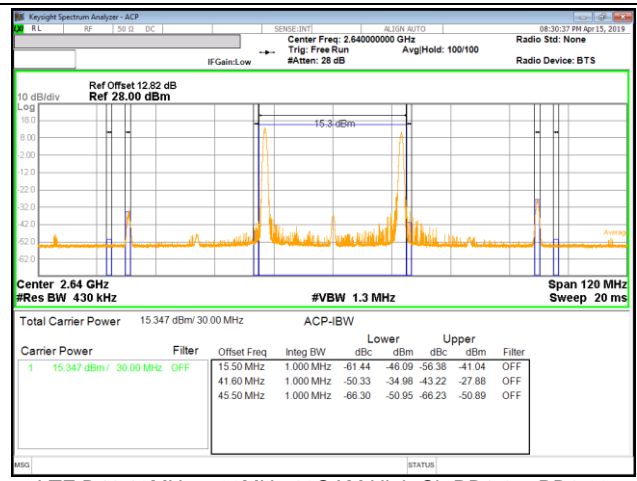

LTE B41 10MHz + 20MHz 16QAM High Ch RB1-0 + RB1-99

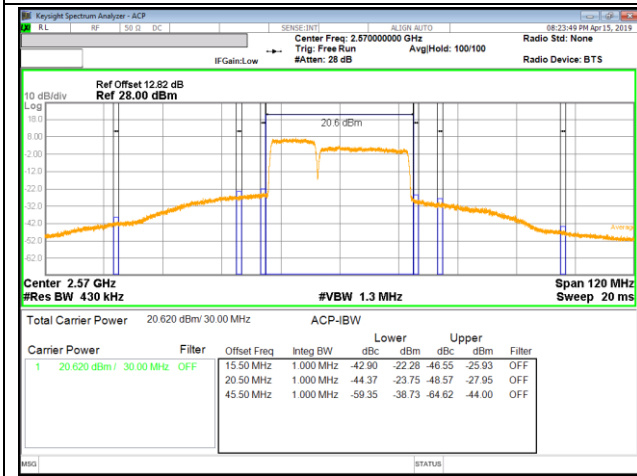

LTE B41 10MHz + 20MHz 16QAM Low Ch RB50-0 + RB100-0

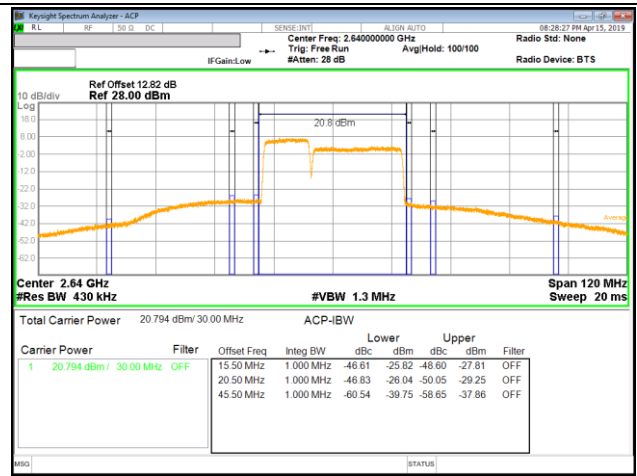

LTE B41 10MHz + 20MHz 16QAM High Ch RB50-0 + RB100-0

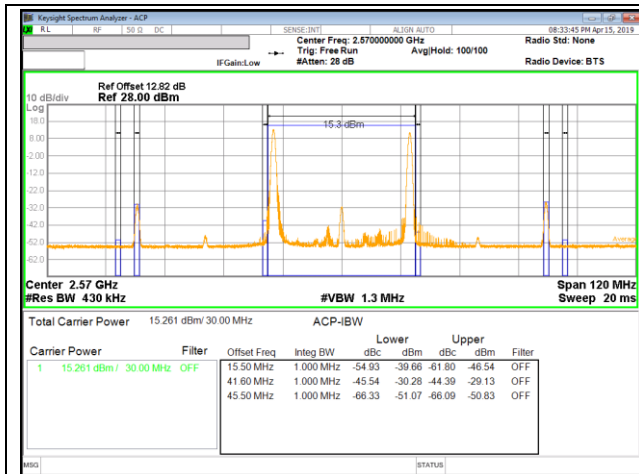

LTE B41 20MHz + 10MHz QPSK Low Ch RB1-0 + RB1-49

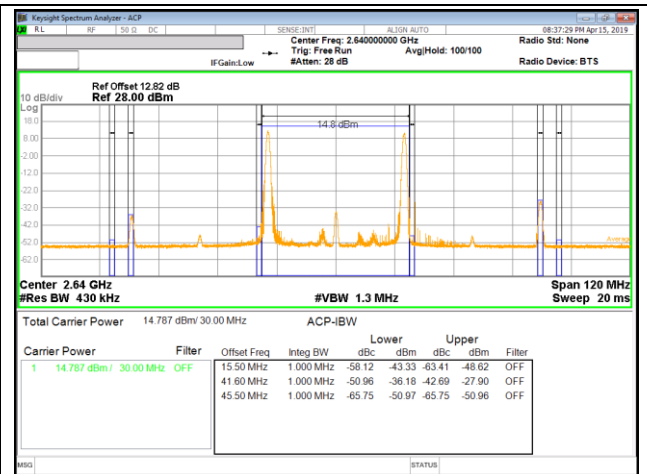

LTE B41 20MHz + 10MHz QPSK High Ch RB1-0 + RB1-49

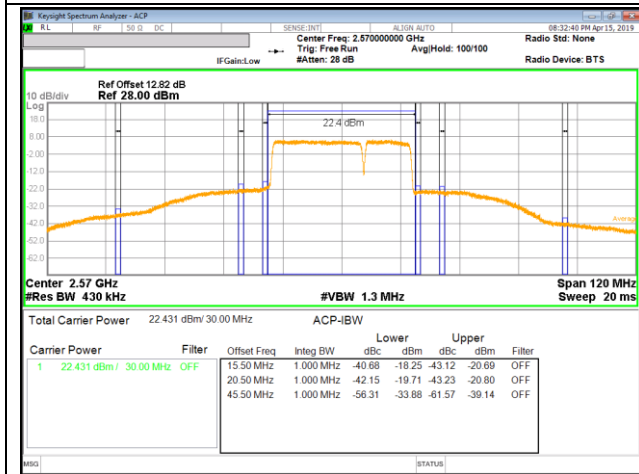

LTE B41 20MHz + 10MHz QPSK Low Ch RB100-0 + RB50-0

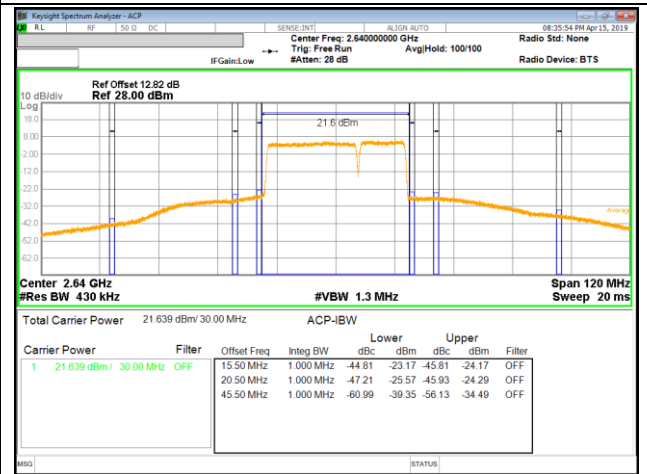

LTE B41 20MHz + 10MHz QPSK High Ch RB100-0 + RB50-0

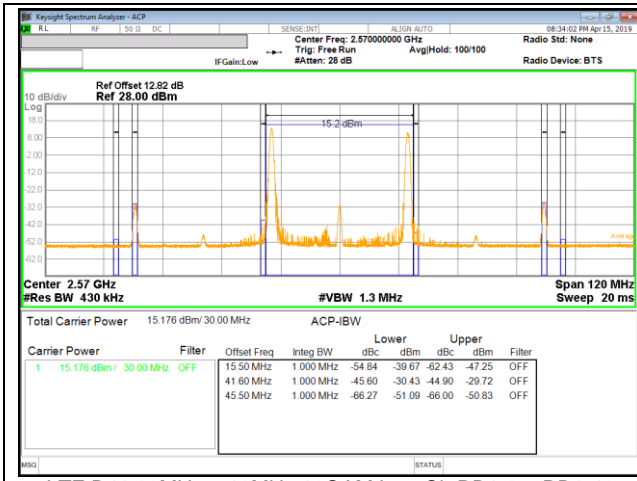

LTE B41 20MHz + 10MHz 16QAM Low Ch RB1-0 + RB1-49

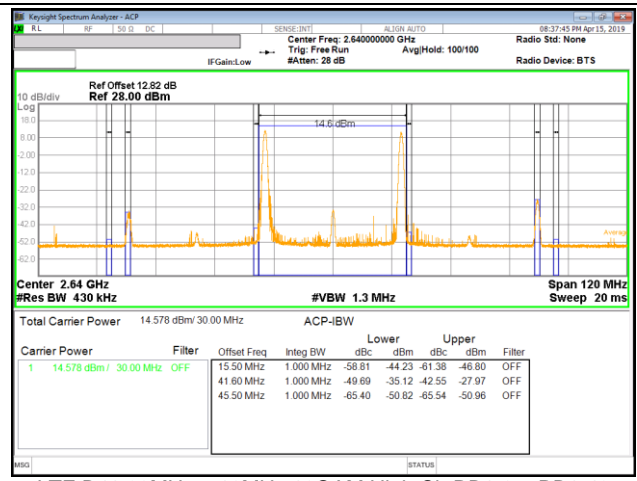

LTE B41 20MHz + 10MHz 16QAM High Ch RB1-0 + RB1-49



LTE B41 20MHz + 10MHz 16QAM Low Ch RB100-0 + RB50-0



LTE B41 20MHz + 10MHz 16QAM High Ch RB100-0 + RB50-0

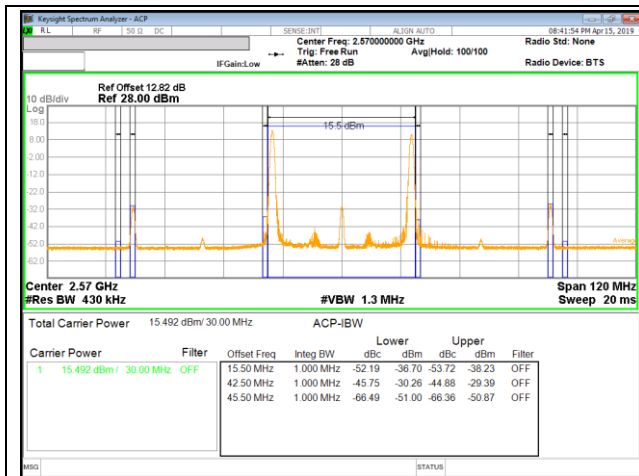

LTE B41 15MHz + 15MHz QPSK Low Ch RB1-0 + RB1-74



LTE B41 15MHz + 15MHz QPSK High Ch RB1-0 + RB1-74

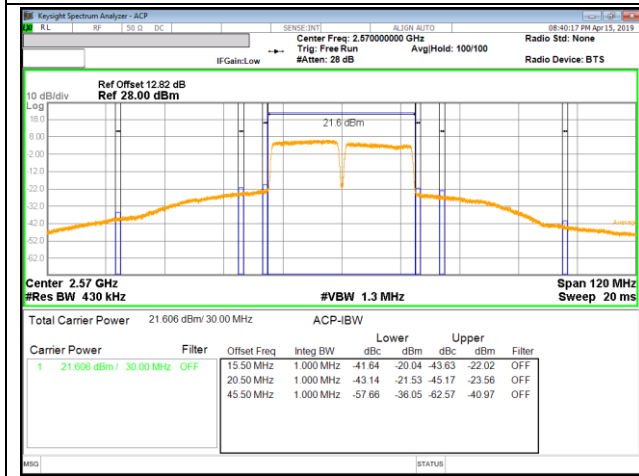

LTE B41 15MHz + 15MHz QPSK Low Ch RB75-0 + RB75-0

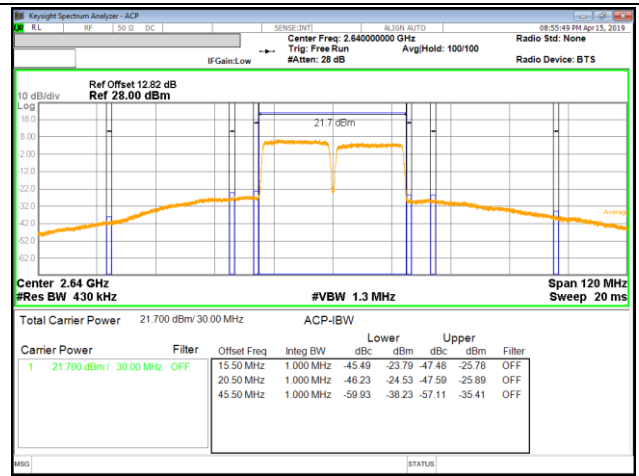

LTE B41 15MHz + 15MHz QPSK High Ch RB75-0 + RB75-0

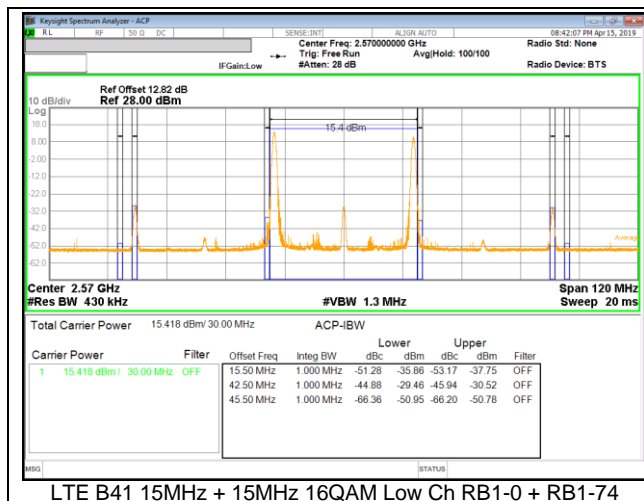

LTE B41 15MHz + 15MHz 16QAM Low Ch RB1-0 + RB1-74

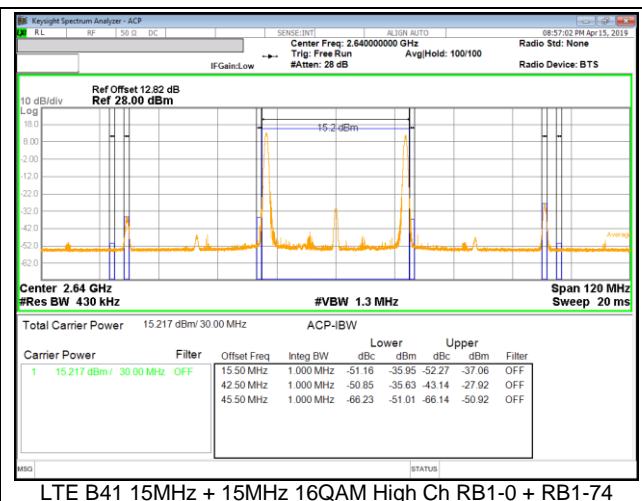

LTE B41 15MHz + 15MHz 16QAM High Ch RB1-0 + RB1-74

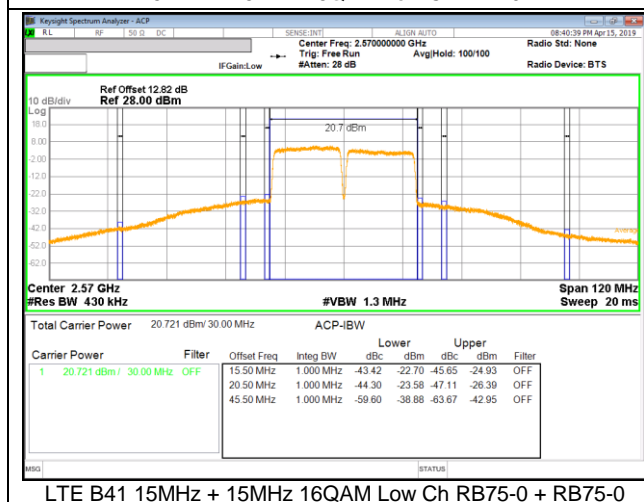

LTE B41 15MHz + 15MHz 16QAM Low Ch RB75-0 + RB75-0

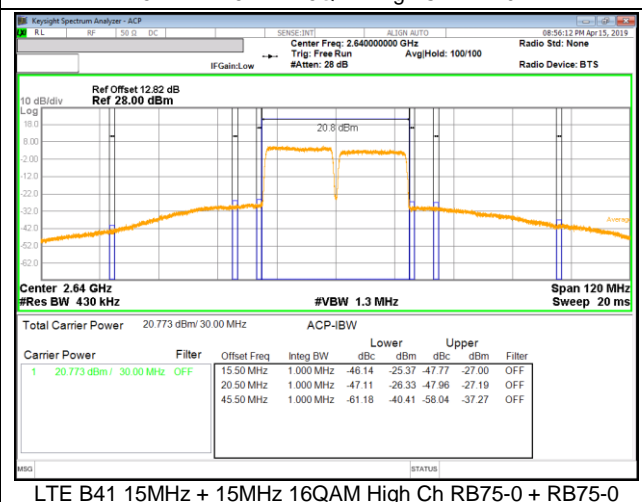

LTE B41 15MHz + 15MHz 16QAM High Ch RB75-0 + RB75-0