



CERTIFICATION TEST REPORT

Report Number. : 12440940-E4V1

Applicant : Samsung Electronics Co., Ltd.
129 Samsung-Ro, Yeongtong-Gu,
Suwon-Si, Gyeonggi-Do, 16677, Korea

Models : SM-A750N

FCC ID : A3LSMA750N

EUT Description : GSM/WCDMA/LTE Phone with BT, DTS/UNII a/b/g/n/ac, ANT+ and NFC

Test Standard(s) : FCC 47 CFR PART 15 SUBPART C

Date Of Issue:
September 06, 2018

Prepared by:
UL Verification Services Inc.
47173 Benicia Street
Fremont, CA 94538 U.S.A.
TEL: (510) 771-1000
FAX: (510) 661-0888



REPORT REVISION HISTORY

Rev.	Issue Date	Revisions	Revised By
V1	9/6/2018	Initial Issue	

TABLE OF CONTENTS

REPORT REVISION HISTORY	2
TABLE OF CONTENTS	3
1. ATTESTATION OF TEST RESULTS	5
2. INTRODUCTION OF TEST DATA REUSE.....	6
2.1. INTRODUCTION	6
2.2. DEVICES DIFFERENCES.....	6
2.3. SPOT CHECK VERIFICATION RESULTS SUMMARY	6
2.3.1. SPOT CHECK DATA.....	7
2.3.2. BANDEDGE (HIGH CHANNEL).....	7
2.3.3. HARMONICS AND SPURIOUS EMISSIONS	9
2.4. REFERENCE DETAIL	10
3. TEST METHODOLOGY	11
4. FACILITIES AND ACCREDITATION	11
5. CALIBRATION AND UNCERTAINTY	12
5.1. MEASURING INSTRUMENT CALIBRATION	12
5.2. SAMPLE CALCULATION	12
5.3. MEASUREMENT UNCERTAINTY.....	12
6. EQUIPMENT UNDER TEST.....	13
6.1. EUT DESCRIPTION	13
6.2. MAXIMUM OUTPUT POWER.....	13
6.3. DESCRIPTION OF AVAILABLE ANTENNAS	13
6.4. SOFTWARE AND FIRMWARE.....	13
6.5. WORST-CASE CONFIGURATION AND MODE.....	13
6.6. DESCRIPTION OF TEST SETUP.....	14
7. MEASUREMENT METHOD.....	17
8. TEST AND MEASUREMENT EQUIPMENT	18
9. ANTENNA PORT TEST RESULTS	20
9.1. ON TIME AND DUTY CYCLE.....	20
9.2. 99% BANDWIDTH.....	22
9.2.1. 802.11b MODE	23
9.2.2. 802.11g MODE	24
802.11n HT20 MODE	25
9.3. 6 dB BANDWIDTH.....	26

9.3.1.	802.11b MODE	27
9.3.2.	802.11g MODE	28
9.3.3.	802.11n HT20 MODE	29
9.4.	<i>OUTPUT POWER</i>	30
9.4.1.	802.11b MODE	31
9.4.2.	802.11g MODE	32
9.4.3.	802.11n HT20 MODE	33
9.5.	<i>POWER SPECTRAL DENSITY</i>	34
9.5.1.	802.11b MODE	35
9.5.2.	802.11g MODE	36
9.5.3.	802.11n HT20 MODE	37
9.6.	<i>CONDUCTED SPURIOUS EMISSIONS</i>	38
9.6.1.	802.11b MODE	39
9.6.2.	802.11g MODE	40
9.6.3.	802.11n HT20 MODE	41
10.	RADIATED TEST RESULTS	42
10.1.	<i>TRANSMITTER ABOVE 1 GHz</i>	43
10.1.1.	TX ABOVE 1 GHz 802.11b MODE IN THE 2.4 GHz BAND	43
10.1.2.	TX ABOVE 1 GHz 802.11g MODE IN THE 2.4 GHz BAND	53
10.1.3.	TX ABOVE 1 GHz 802.11n HT20 MODE IN THE 2.4 GHz BAND.....	63
10.2.	<i>Worst Case Below 30 MHz</i>	73
10.3.	<i>Worst Case Below 1 GHz</i>	75
10.4.	<i>Worst Case 18-26 GHz</i>	77
11.	AC POWER LINE CONDUCTED EMISSIONS	79
12.	SETUP PHOTOS (ORIGINAL)	82
13.	SETUP PHOTOS (SPOT CHECK)	85

1. ATTESTATION OF TEST RESULTS

COMPANY NAME: Samsung Electronics Co., Ltd.
129 Samsung-Ro, Yeongtong-Gu,
Suwon-Si, Gyeonggi-Do, 16677, Korea

EUT DESCRIPTION: GSM/WCDMA/LTE Phone with BT, DTS/UNII a/b/g/n/ac, and ANT+

MODELS: SM-A750N

SERIAL NUMBER: Conducted: R38K70KQF9N; R38K70KQGDH (Original)
Radiated: R38K70KQFNY (Original)
Conducted: R39K70AGZNA (Spot Check)
Radiated: R39K70DSRLB, R39K70AH06N (Spot Check)

DATE TESTED: August 10, 2018 – August 21, 2018 (Original)
August 28 – 30, 2018 (Spot Check)

APPLICABLE STANDARDS	
STANDARD	TEST RESULTS
CFR 47 Part 15 Subpart C	Complies

UL Verification Services Inc. tested the above equipment in accordance with the requirements set forth in the above standards. All indications of Pass/Fail in this report are opinions expressed by UL Verification Services Inc. based on interpretations and/or observations of test results. Measurement Uncertainties were not taken into account and are published for informational purposes only. The test results show that the equipment tested is capable of demonstrating compliance with the requirements as documented in this report.

Note: The results documented in this report apply only to the tested sample, under the conditions and modes of operation as described herein. This document may not be altered or revised in any way unless done so by UL Verification Services Inc. and all revisions are duly noted in the revisions section. Any alteration of this document not carried out by UL Verification Services Inc. will constitute fraud and shall nullify the document. This report must not be used by the client to claim product certification, approval, or endorsement by NVLAP, NIST, any agency of the Federal Government, or any agency of the U.S. government.

Approved & Released For
UL Verification Services Inc. By:

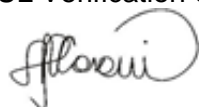

Dan Corona
CONSUMER TECHNOLOGY DIVISION
Operations Leader
UL Verification Services Inc.

Reviewed By:



Steven Tran
CONSUMER TECHNOLOGY DIVISION
Project Engineer
UL Verification Services Inc.

2. INTRODUCTION OF TEST DATA REUSE

2.1. INTRODUCTION

According to the manufacturer, the WLAN, Bluetooth, ANT+ and NFC hardware of A3LSMA750N are identical to A3LSMA750GN. In addition A3LSMA750N digital circuit is identical to A3LSMA750GN. Therefore the following report/data of A3LSMA750N may be represented from A3LSMA750GN along with the spot check verification data.

- WLAN
- Bluetooth
- ANT+
- NFC

2.2. DEVICES DIFFERENCES

Difference between A3LSMA750N and A3LSMA750GN:

Samsung Electronics Co., Ltd. hereby declares that between A3LSMA750N and A3LSMA750GN:

Hardware:

- Ant matching points are different.
- GSM850 / LTE B2 / B12 / B13 / B66 components are deleted.
- LTE B26 components are added.
- Only BT/WiFi parts are same.

Software:

- PROTOCOL PART is same.
- LTE B26 band SW enabled, GSM850, LTE B2/12/13/66 bands SW disabled.
- SW was updated to reflect the HW changes.

Therefore the WLAN, Bluetooth, ANT+, NFC report and data of A3LSMA750GN may represent for A3LSMA750N.

2.3. SPOT CHECK VERIFICATION RESULTS SUMMARY

Spot check verification has been done on device A3LSMA750N for radiated harmonic spurious and radiated band-edge. The data from the application has been verified through appropriate spot checks to demonstrate compliance for this device as shown in the summary below.

SM-A750N SPOT CHECK RESULTS										
Technology	Mode	Test Item	Channel	Measured Frequency	SM-A750GN_DS		SM-A750N		Delta (dB)	
					Peak	Ave	Peak	Ave	Peak	Ave
DTS	11n HT20	RBE	11	2484MHz	70.33	51.99	68.64	51.49	-1.69	-0.5
	11b	RSE	1	4824MHz	52.71	50.82	46.03	42.66	-6.68	-8.16

Comparison of two models, higher deviation is within 3dB range and all test are under FCC Technical Limits.

2.3.1. SPOT CHECK DATA

2.3.2. BANDEDGE (HIGH CHANNEL)

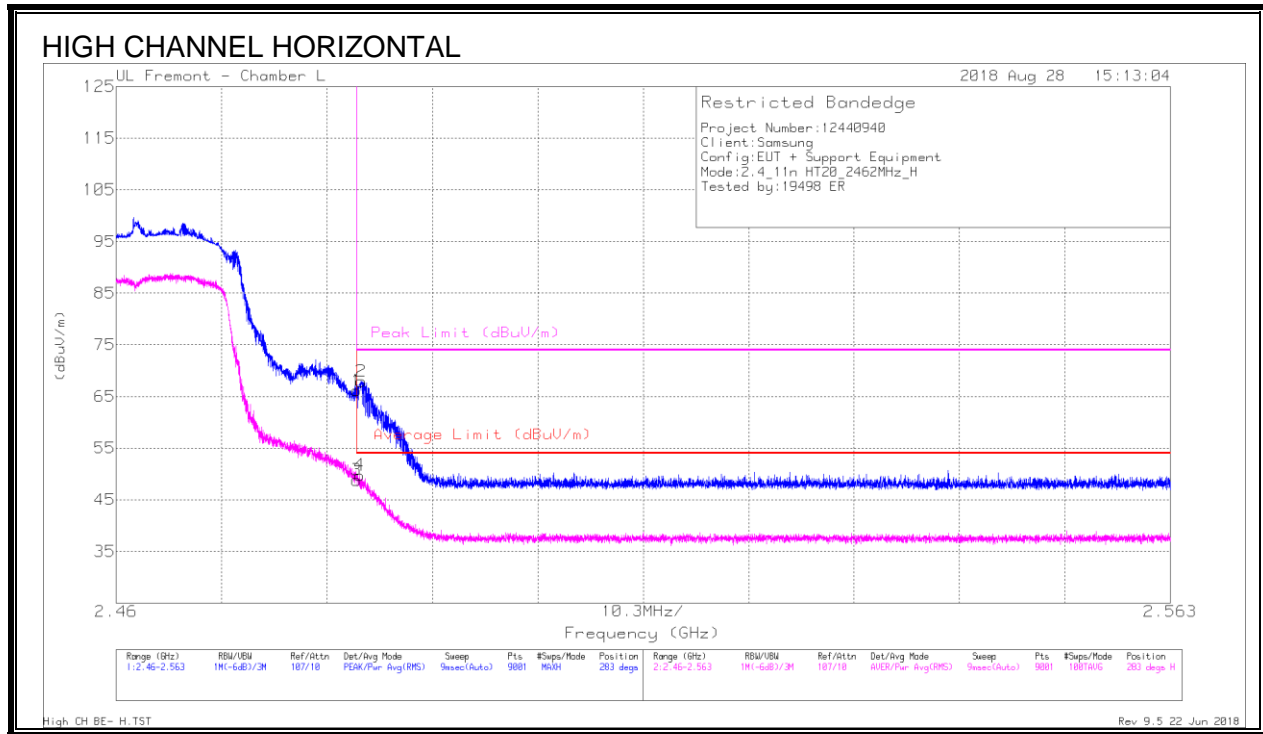

Trace Markers

Marker	Frequency (GHz)	Meter Reading (dBuV)	Det	AF EMC4294 (dB/m)	Amp/Cb1/Fitr/Pad (dB)	DC Corr (dB)	Corrected Reading (dBuV/m)	Average Limit (dBuV/m)	Margin (dB)	Peak Limit (dBuV/m)	PK Margin (dB)	Azimuth (Degs)	Height (cm)	Polarity
1	* 2.484	56.54	Pk	32.3	-22.7	0	66.14	-	-	74	-7.86	283	213	H
2	* 2.484	58.33	Pk	32.3	-22.7	0	67.93	-	-	74	-6.07	283	213	H
3	* 2.484	39.21	RMS	32.3	-22.7	.24	49.05	54	-4.95	-	-	283	213	H
4	* 2.484	40.15	RMS	32.3	-22.7	.24	49.99	54	-4.01	-	-	283	213	H

* - indicates frequency in CFR47 Pt 15 Restricted Band

Pk - Peak detector

RMS - RMS detection

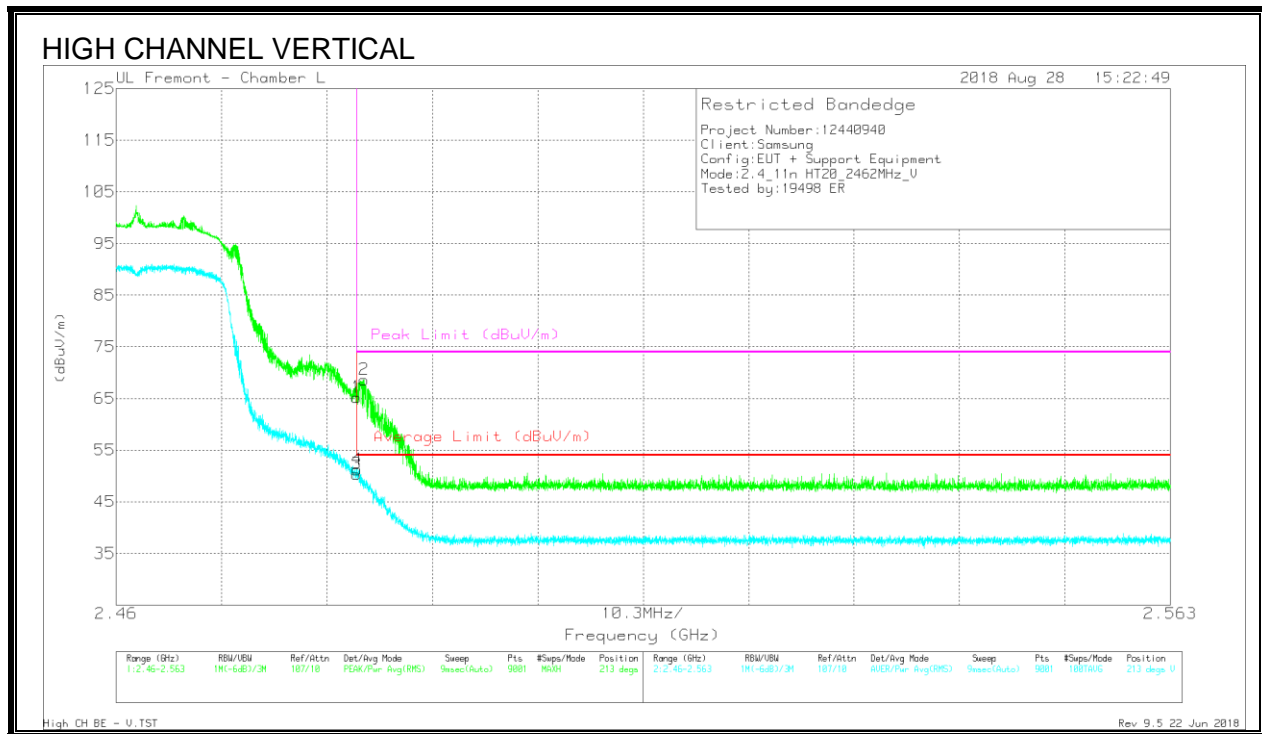

Trace Markers

Marker	Frequency (GHz)	Meter Reading (dBuV)	Det	AF EMC4294 (dB/m)	Amp/Cbl/Filtr/Pad (dB)	DC Corr (dB)	Corrected Reading (dBuV/m)	Average Limit (dBuV/m)	Margin (dB)	Peak Limit (dBuV/m)	PK Margin (dB)	Azimuth (Degs)	Height (cm)	Polarity
1	* 2.484	55.6	Pk	32.3	-22.7	0	65.2	-	-	74	-8.8	213	201	V
2	* 2.484	59.04	Pk	32.3	-22.7	0	68.64	-	-	74	-5.36	213	201	V
3	* 2.484	40.78	RMS	32.3	-22.7	.24	50.62	54	-3.38	-	-	213	201	V
4	* 2.484	41.65	RMS	32.3	-22.7	.24	51.49	54	-2.51	-	-	213	201	V

* - indicates frequency in CFR47 Pt 15 Restricted Band

Pk - Peak detector

RMS - RMS detection

2.3.3. HARMONICS AND SPURIOUS EMISSIONS

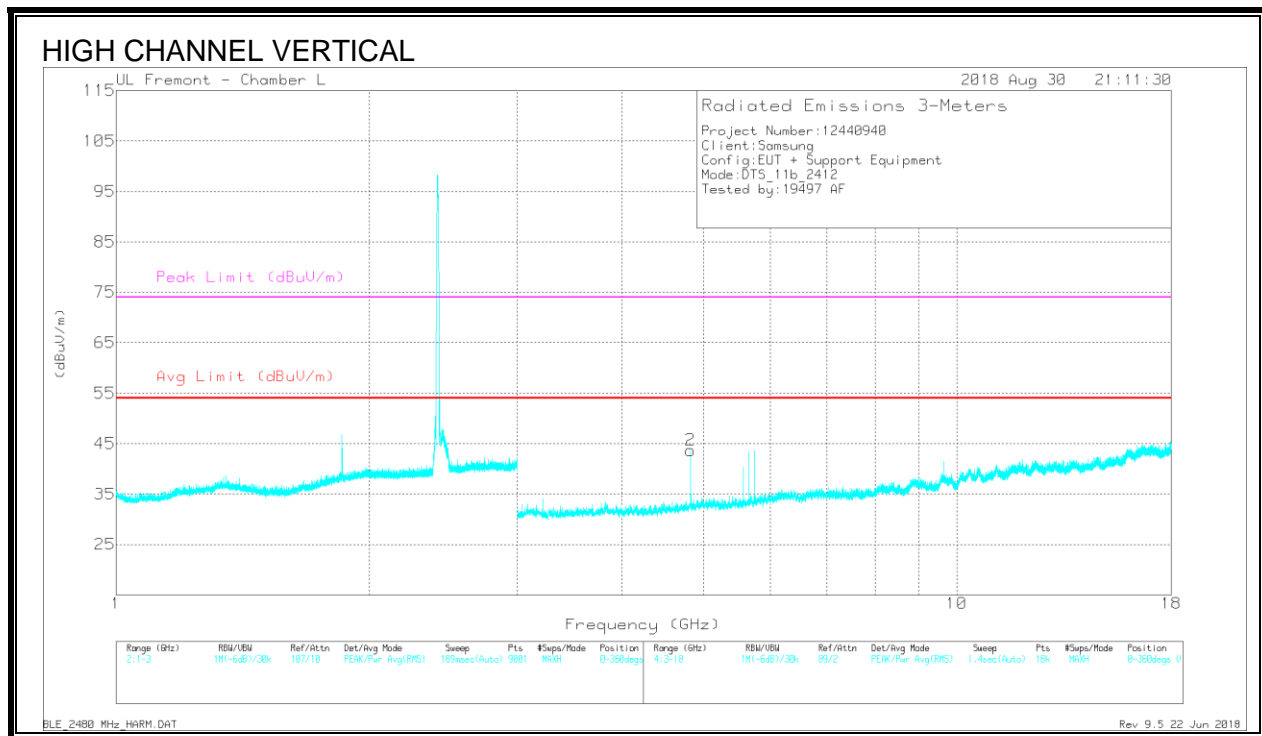
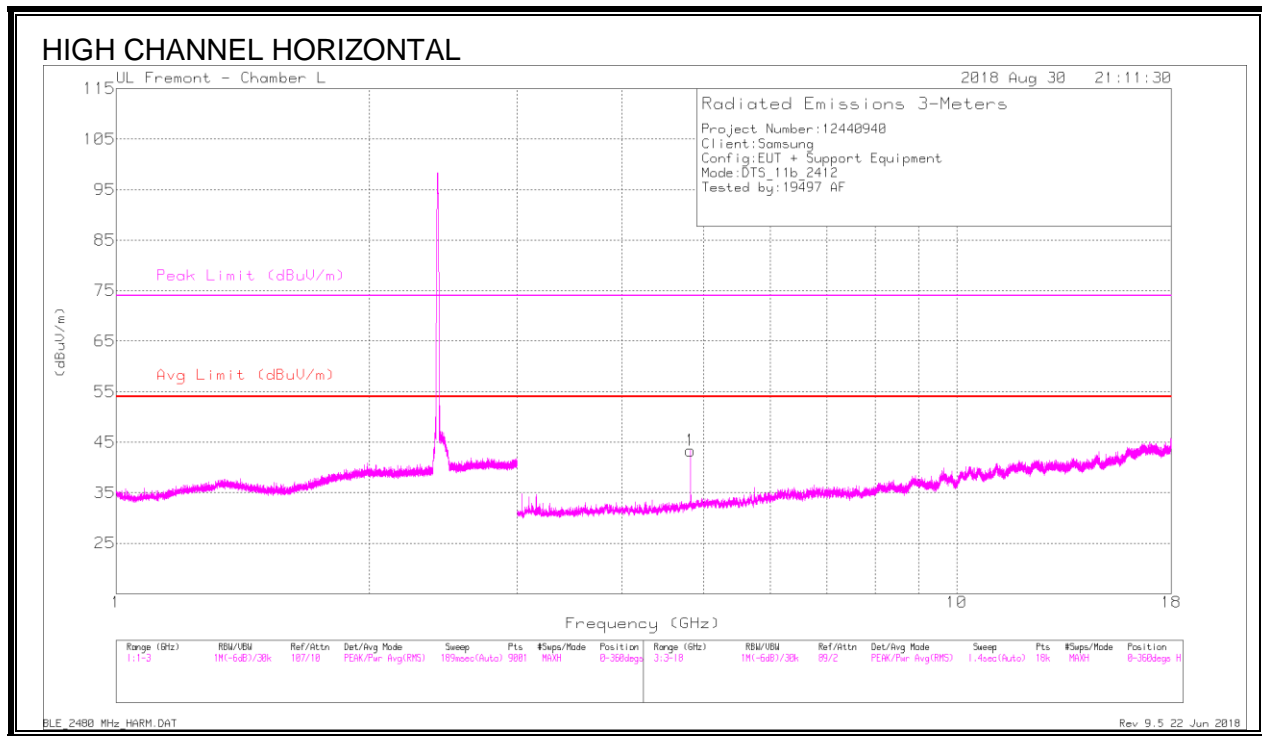

Radiated Emissions

Marker	Frequency (GHz)	Meter Reading (dBuV)	Det	AF EMC4294 (dB/m)	Amp/Cbl/Filtr/Pad (dB)	Corrected Reading (dBuV/m)	Avg Limit (dBuV/m)	Margin (dB)	Peak Limit (dBuV/m)	PK Margin (dB)	Azimuth (Degs)	Height (cm)	Polarity
1	* 4.824	40.83	PK2	34.2	-29	46.03	-	-	74	-27.97	146	182	H
	* 4.824	37.46	MAv1	34.2	-29	42.66	54	-11.34	-	-	146	182	H
2	* 4.824	41.09	PK2	34.2	-29	46.29	-	-	74	-27.71	154	102	V
	* 4.824	37.4	MAv1	34.2	-29	42.6	54	-11.4	-	-	154	102	V

* - indicates frequency in CFR47 Pt 15 Restricted Band
 PK2 - KDB558074 Method: Maximum Peak
 MAv1 - KDB558074 Option 1 Maximum RMS Average

2.4. REFERENCE DETAIL

Equipment Class	Reference FCC ID	Report Title/Section
DTS (WLAN)	A3LSMA750GN	12440598-E4V2 FCC Report DTS WLAN

3. TEST METHODOLOGY

The tests documented in this report were performed in accordance with FCC CFR 47 Part 2, FCC CFR 47 Part 15, KDB 558074 D01 v4, ANSI C63.10-2013.

4. FACILITIES AND ACCREDITATION

The test sites and measurement facilities used to collect data are located at 47173 and 47266 Benicia Street, and 47658 Kato Road, Fremont, California, USA. Line conducted emissions are measured only at the 47173 address. The following table identifies which facilities were utilized for radiated emission measurements documented in this report. Specific facilities are also identified in the test results sections.

47173 Benicia Street	47266 Benicia Street	47658 Kato Rd.
<input checked="" type="checkbox"/> Chamber A (IC:2324B-1)	<input type="checkbox"/> Chamber D (IC:22541-1)	<input checked="" type="checkbox"/> Chamber I (IC: 2324A-5)
<input type="checkbox"/> Chamber B (IC:2324B-2)	<input type="checkbox"/> Chamber E (IC:22541-2)	<input type="checkbox"/> Chamber J (IC: 2324A-6)
<input type="checkbox"/> Chamber C (IC:2324B-3)	<input type="checkbox"/> Chamber F (IC:22541-3)	<input type="checkbox"/> Chamber K (IC: 2324A-1)
	<input type="checkbox"/> Chamber G (IC:22541-4)	<input checked="" type="checkbox"/> Chamber L (IC: 2324A-3)
	<input type="checkbox"/> Chamber H (IC:22541-5)	

The above test sites and facilities are covered under FCC Test Firm Registration # 208313. Chambers above are covered under Industry Canada company address and respective code.

UL Verification Services Inc. is accredited by NVLAP, Laboratory Code 200065-0

5. CALIBRATION AND UNCERTAINTY

5.1. MEASURING INSTRUMENT CALIBRATION

The measuring equipment utilized to perform the tests documented in this report has been calibrated in accordance with the manufacturer's recommendations, and is traceable to recognized national standards.

5.2. SAMPLE CALCULATION

Where relevant, the following sample calculation is provided:

$$\begin{aligned} \text{Field Strength (dBuV/m)} &= \text{Measured Voltage (dBuV)} + \text{Antenna Factor (dB/m)} + \\ &\text{Cable Loss (dB)} - \text{Preamp Gain (dB)} \\ 36.5 \text{ dBuV} + 18.7 \text{ dB/m} + 0.6 \text{ dB} - 26.9 \text{ dB} &= 28.9 \text{ dBuV/m} \end{aligned}$$

5.3. MEASUREMENT UNCERTAINTY

Where relevant, the following measurement uncertainty levels have been estimated for tests performed on the apparatus:

PARAMETER	UNCERTAINTY
Worst Case Conducted Disturbance, 9KHz to 0.15 MHz	3.84 dB
Worst Case Conducted Disturbance, 0.15 to 30 MHz	3.65 dB
Worst Case Radiated Disturbance, 9KHz to 30 MHz	3.15 dB
Worst Case Radiated Disturbance, 30 to 1000 MHz	5.36 dB
Worst Case Radiated Disturbance, 1000 to 18000 MHz	4.32 dB
Worst Case Radiated Disturbance, 18000 to 26000 MHz	4.45 dB
Worst Case Radiated Disturbance, 26000 to 40000 MHz	5.24 dB

Uncertainty figures are valid to a confidence level of 95%.

6. EQUIPMENT UNDER TEST

6.1. EUT DESCRIPTION

The EUT is a GSM/WCDMA/LTE phone with BT, DTS/UNII a/b/g/n/ac, ANT+ and NFC.

6.2. MAXIMUM OUTPUT POWER

The transmitter has a maximum conducted output power as follows:

2.4GHz BAND

Frequency Range (MHz)	Mode	Output Power (dBm)	Output Power (mW)
1Tx			
2412 - 2462	802.11b	18.39	69.02
2412 - 2462	802.11g	16.35	43.15
2412 - 2462	802.11n HT20	16.35	43.15

6.3. DESCRIPTION OF AVAILABLE ANTENNAS

The radio utilizes an internal antenna, with a maximum gain of -1.71 dBi.

6.4. SOFTWARE AND FIRMWARE

The test utility software used during testing was A750GN.001

6.5. WORST-CASE CONFIGURATION AND MODE

Radiated emissions below 1GHz, above 18GHz, and power line conducted emission were performed with the EUT set to transmit at the channel with highest output power as worst-case scenario.

Band edge and radiated emissions between 1GHz and 18GHz were performed with the EUT set to transmit at the highest power on low, middle and high channels.

The fundamental of the EUT was investigated in three orthogonal orientations X,Y and Z it was determined that X orientation was worst-case orientation; therefore, all final radiated testing was performed with the EUT in X orientation.

Worst-case data rates as provided by the client were:

802.11b mode: 1 Mbps
802.11g mode: 6 Mbps
802.11n HT20mode: MCS0

6.6. DESCRIPTION OF TEST SETUP

SUPPORT EQUIPMENT

Support Equipment List				
Description	Manufacturer	Model	Serial Number	FCC ID
AC Adapter	Samsung	EP-TA50EWE	DW3J719AS/A-E	N/A
Earphone	Samsung	N/A	N/A	N/A

I/O CABLES (CONDUCTED TEST)

I/O Cable List						
Cable No	Port	# of identical ports	Connector Type	Cable Type	Cable Length (m)	Remarks
1	Antenna	1	RF	Shielded	0.2	To spectrum Analyzer
2	USB	1	USB	Un-shielded	1	EUT to AC Mains

I/O CABLES (RADIATED AND CONDUCTED EMISSIONS)

I/O Cable List						
Cable No	Port	# of identical ports	Connector Type	Cable Type	Cable Length (m)	Remarks
1	USB	1	USB	Shielded	1	N/A
2	earphone	1	3.5mm	Un-shielded	1	N/A

TEST SETUP

The EUT is stand alone. Test software exercised the radio card.

CONDCUTED TEST SETUP DIAGRAM

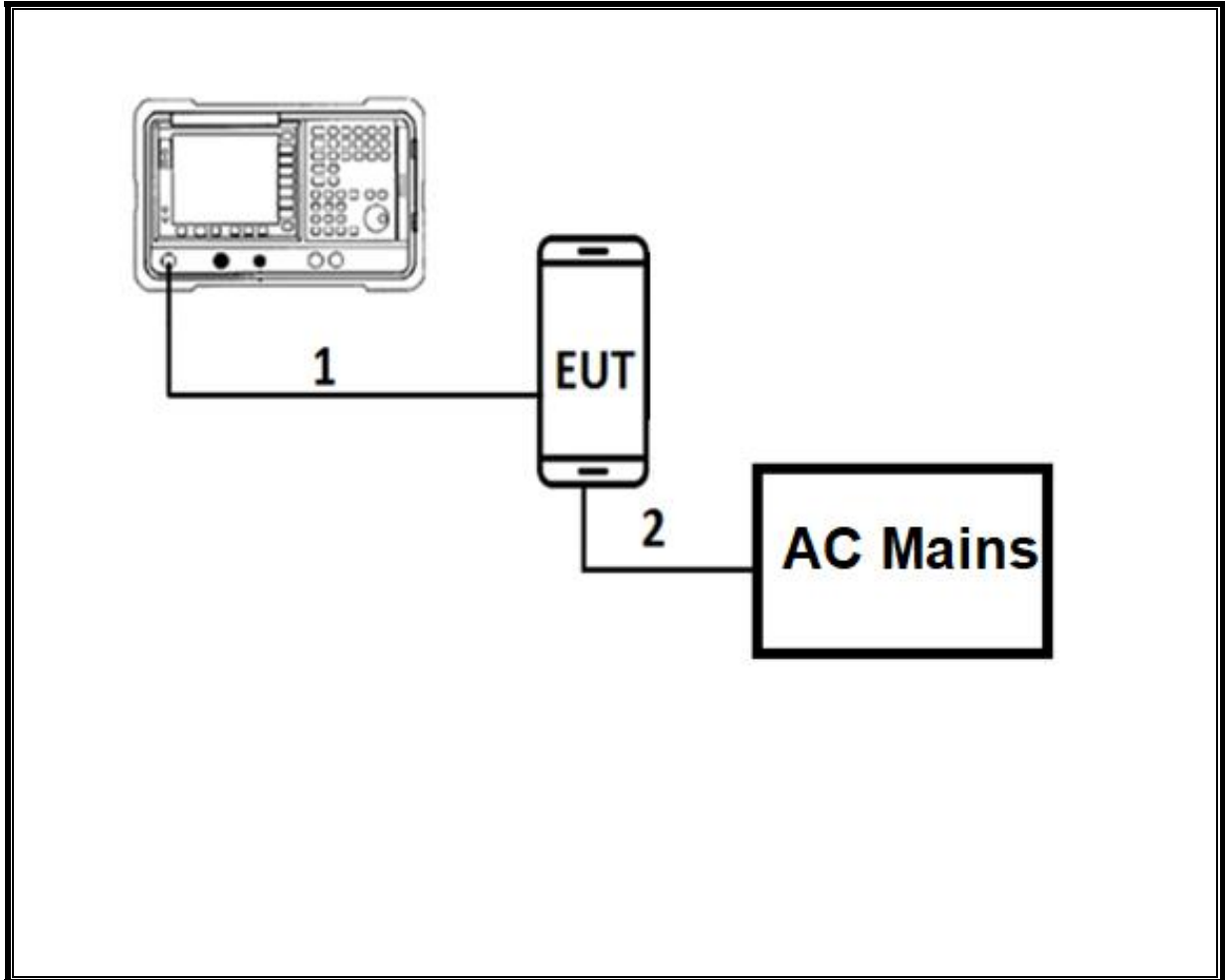

TEST SETUP

For conducted tests: the EUT was stand alone. The test software exercises the radio.

RADIATED AND AC LINE CONDUCTED EMISSIONS SETUP DIAGRAM

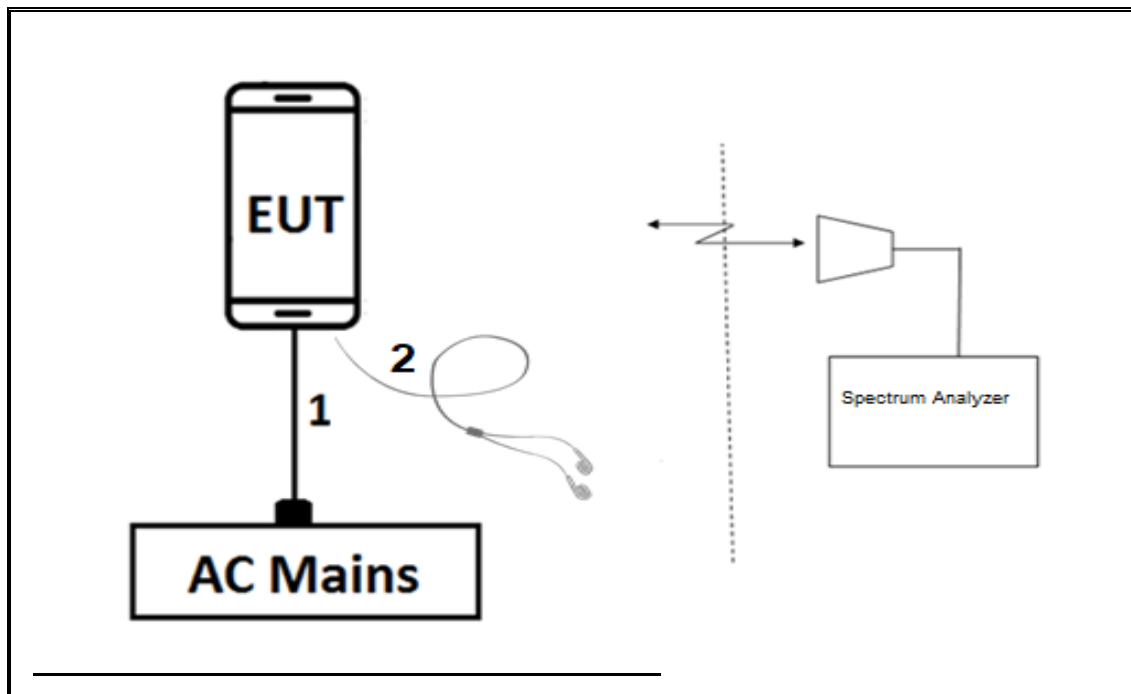

TEST SETUP

For radiated tests: EUT is Stand alone. The test software exercises the radio.

7. MEASUREMENT METHOD

On Time and Duty Cycle: KDB 558074 D01 v04, Section 6.

6 dB BW: KDB 558074 D01 v04, Section 8.1.

99% BW: ANSI C63.10-2013, Section 6.9.3.

Output Power: KDB 558074 D01 v04, Section 9.2.3.2.

Power Spectral Density: KDB 558074 D01 v04, Section 10.3.

Out-of-band emissions in non-restricted bands: KDB 558074 D01 v04, Section 11.1 (b).

Out-of-band emissions in restricted bands: KDB 558074 D01 v04, Section 12.1.

Band-edge: KDB 558074 D01 v04, Section 12.1.

AC Power Line Conducted Emissions: ANSI C63.10-2013, Section 6.2.

8. TEST AND MEASUREMENT EQUIPMENT

The following test and measurement equipment was utilized for the tests documented in this report:

TEST EQUIPMENT LIST (ORIGINAL)					
Description	Manufacturer	Model	ID Num	Cal Due	Last Cal
Amplifier, 10KHz to 1GHz, 32dB	Agilent (Keysight) Technologies	8447D	T10	02/14/2019	02/14/2018
Antenna, Broadband Hybrid, 30MHz to 2000MHz	Sunol Sciences Corp.	JB3	T407	05/10/2019	05/10/2018
Antenna, Horn 1-18GHz	ETS-Lindgren	3117	T862	05/24/2019	05/24/2018
RF Amplifier, 1-18GHz	MITEQ	AFS42-00101800-25-S-42	17146	08/01/2019	08/01/2018
Antenna, Horn 1-18GHz	ETS-Lindgren	3117	T346	04/03/2019	04/03/2018
RF Amplifier, 1-18GHz	MITEQ	AFS42-00101800-25-S-42	T931	02/24/2019	02/24/2018
Power Meter, P-series single channel	Agilent (Keysight) Technologies	N1911A	T1269	04/05/2019	04/05/2018
Power Sensor, P-series, 50MHz to 18GHz, Wideband	Agilent (Keysight) Technologies	N1921A	T1225	04/10/2019	04/10/2018
EMI Reciever	Rohde & Schwarz	ESR	T1436	02/21/2019	02/21/2018
L.I.S.N.	FCC INC.	FCC LISN 50/250	T1310	06/15/2019	06/15/2018
L.I.S.N.	FCC INC.	FCC LISN 50/250	T24	03/06/2019	03/06/2018
Antenna, Active Loop 9kHz-30MHz	Com-Power Corp.	AL-130R	T1866	10/10/2018	10/10/2017
EMI TEST RECEIVER	Rohde & Schwarz	ESW44	PRE0179522	05/11/2019	05/11/2019
Spectrum Analyzer, PXA, 3Hz to 44GHz	Agilent (Keysight) Technologies	N9030A	T200	11/18/2018	11/18/2017
Spectrum Analyzer, PXA, 3Hz to 44GHz	Agilent (Keysight) Technologies	N9030A	T1454	01/08/2019	01/08/2018
18 - 26.5 GHz Horn Antenna	Seavey Division	MWH-1826/B	T89	01/18/2019	01/18/2018
Pre-Amp 1-26.5 GHz	Agilent	8449B	T404	03/09/2019	023/09/2018

Test Software List			
Description	Manufacturer	Model	Version
Radiated Software	UL	UL EMC	Rev 9.5, Jun 22, 2018
Antenna Port Software	UL	UL RF	Ver 8.5, Jul 12, 2018

TEST EQUIPMENT LIST (SPOT CHECK)					
Description	Manufacturer	Model	ID Num	Cal Due	Last Cal
Antenna, Horn 1-18GHz	ETS-Lindgren	3117	EMC4294	04/17/2019	04/30/2018
RF Amplifier, 1-18GHz	MITEQ Inc	AFS-00101800-25-S-42	T1568	06/21/2019	06/21/2018
EMI Receiver	Rohde & Schwarz	ESR	T1436	02/21/2019	02/21/2018

Test Software List			
Description	Manufacturer	Model	Version
Radiated Software	UL	UL EMC	Ver 9.5, June 22, 2018

9. ANTENNA PORT TEST RESULTS

9.1. ON TIME AND DUTY CYCLE

LIMITS

None; for reporting purposes only.

PROCEDURE

KDB 789033 Zero-Span Spectrum Analyzer Method.

ON TIME AND DUTY CYCLE RESULTS

Mode	ON Time B (msec)	Period (msec)	Duty Cycle x (linear)	Duty Cycle (%)	Duty Cycle Correction Factor (dB)	1/B Minimum VBW (kHz)
2.4GHz Band						
802.11b 1TX	8.610	8.640	0.997	99.65%	0.00	0.010
802.11g 1TX	1.425	1.500	0.950	95.00%	0.22	0.702
802.11n HT20 1TX	1.335	1.410	0.947	94.68%	0.24	0.749

DUTY CYCLE PLOTS

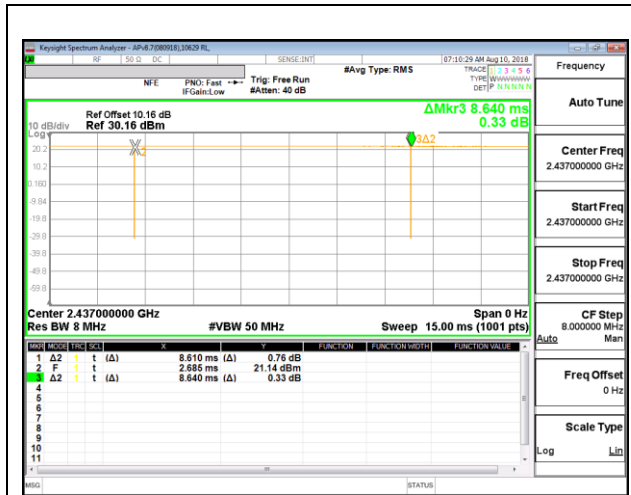

DUTY CYCLE 802.11b 1TX MODE

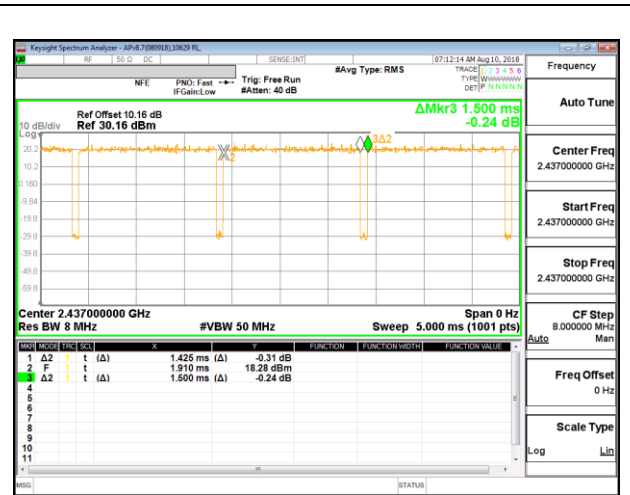

DUTY CYCLE 802.11g 1TX MODE

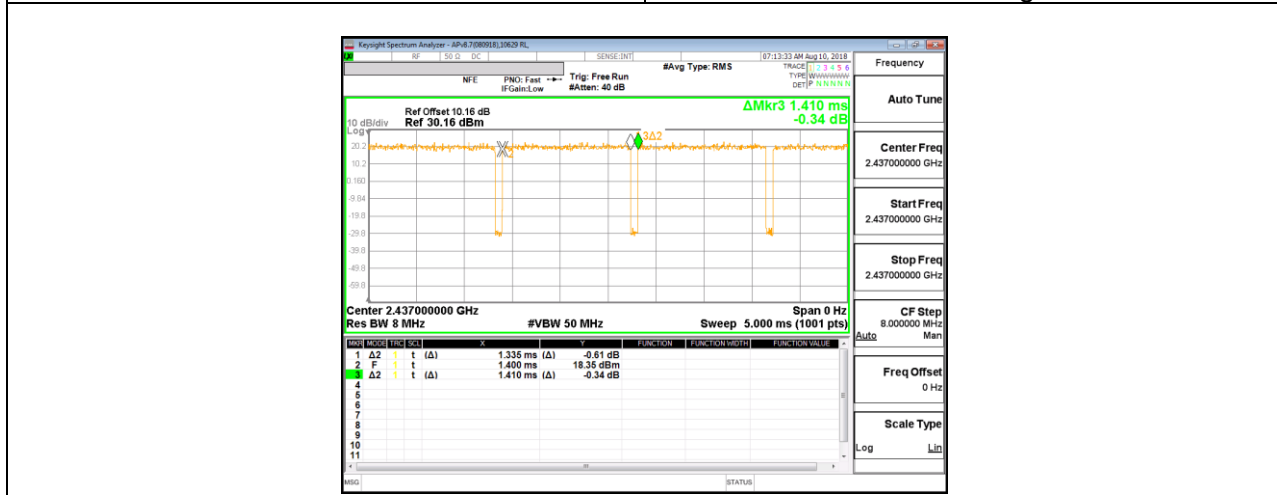

DUTY CYCLE 802.11n HT20 1TX MODE

9.2. 99% BANDWIDTH

LIMITS

None; for reporting purposes only.

RESULTS

9.2.1. 802.11b MODE

Channel	Frequency (MHz)	99% Bandwidth (MHz)
Low 1	2412	12.7070
Mid 6	2437	13.3230
High 11	2462	12.5330

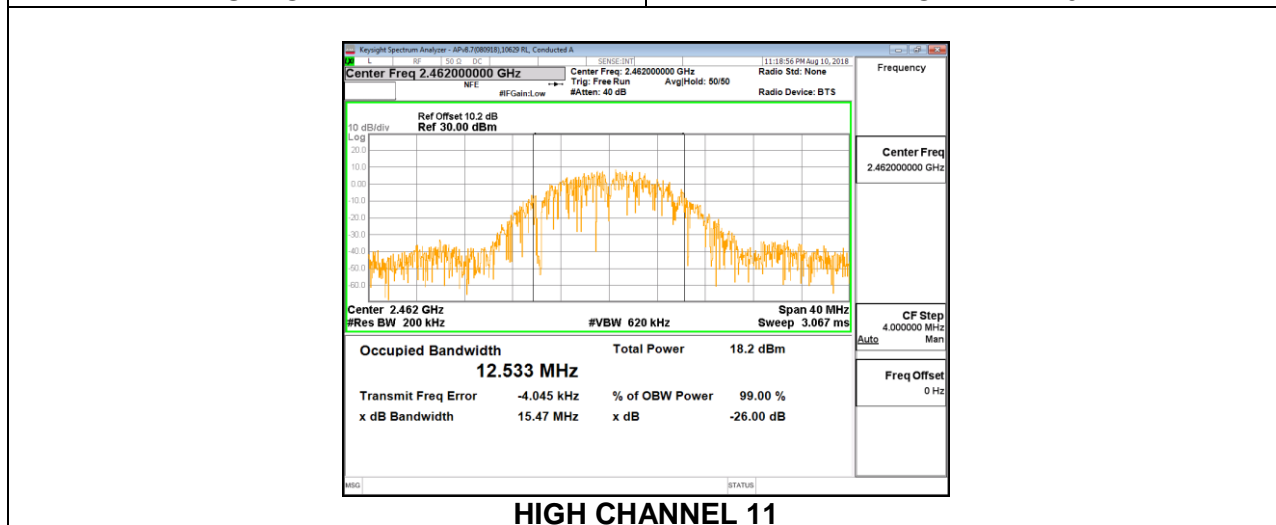
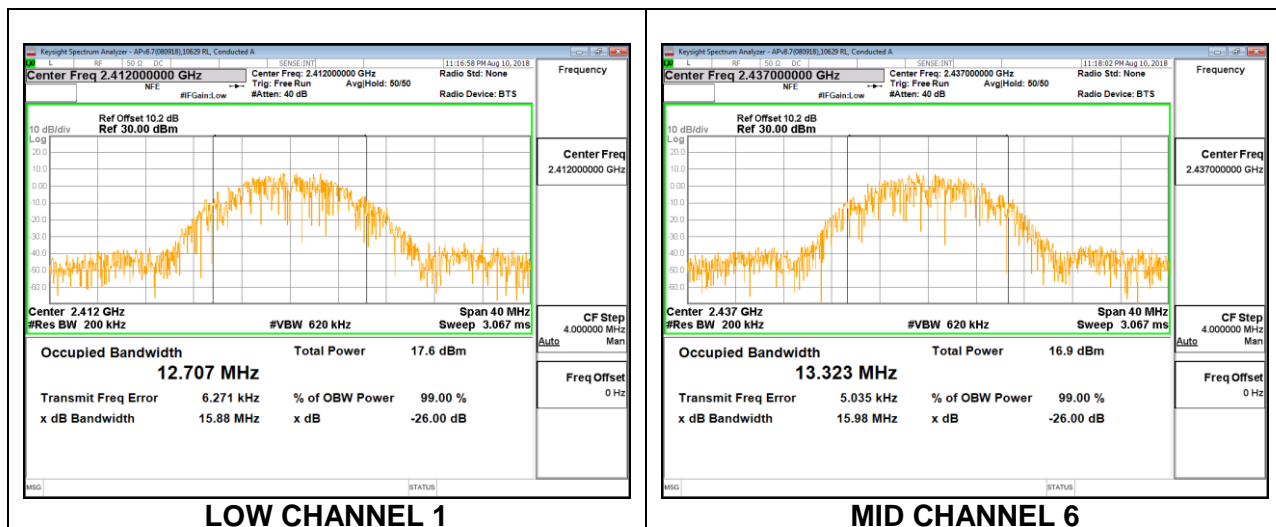

9.2.2. 802.11g MODE

Channel	Frequency (MHz)	99% Bandwidth (MHz)
Low 1	2412	17.2010
Mid 6	2437	16.5070
High 11	2462	16.5090

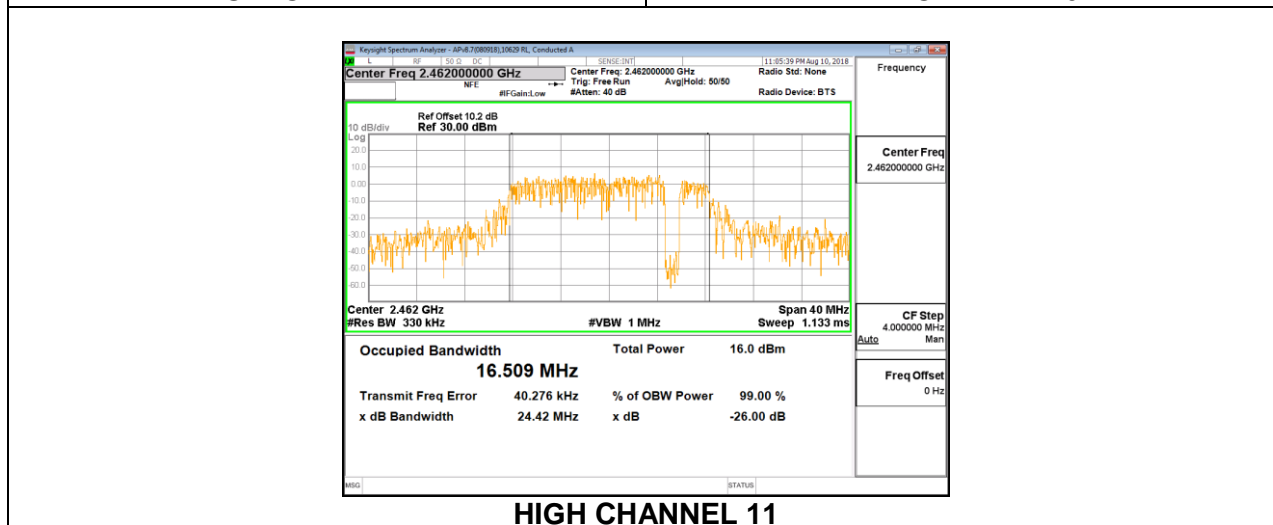
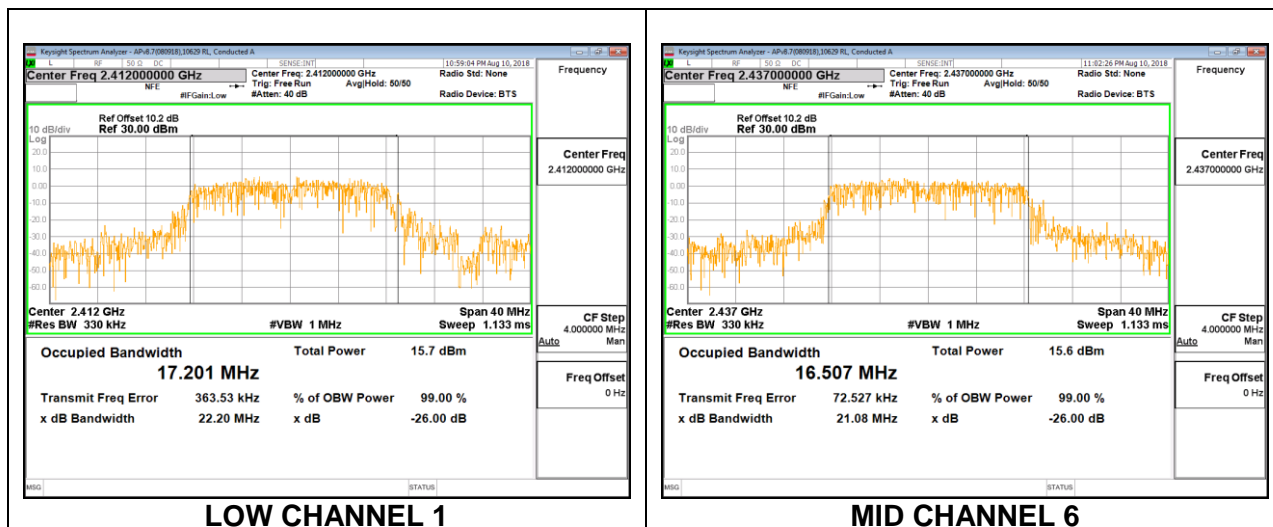

802.11n HT20 MODE

Channel	Frequency (MHz)	99% Bandwidth (MHz)
Low 1	2412	17.4670
Mid 6	2437	17.5240
High 11	2462	17.6490

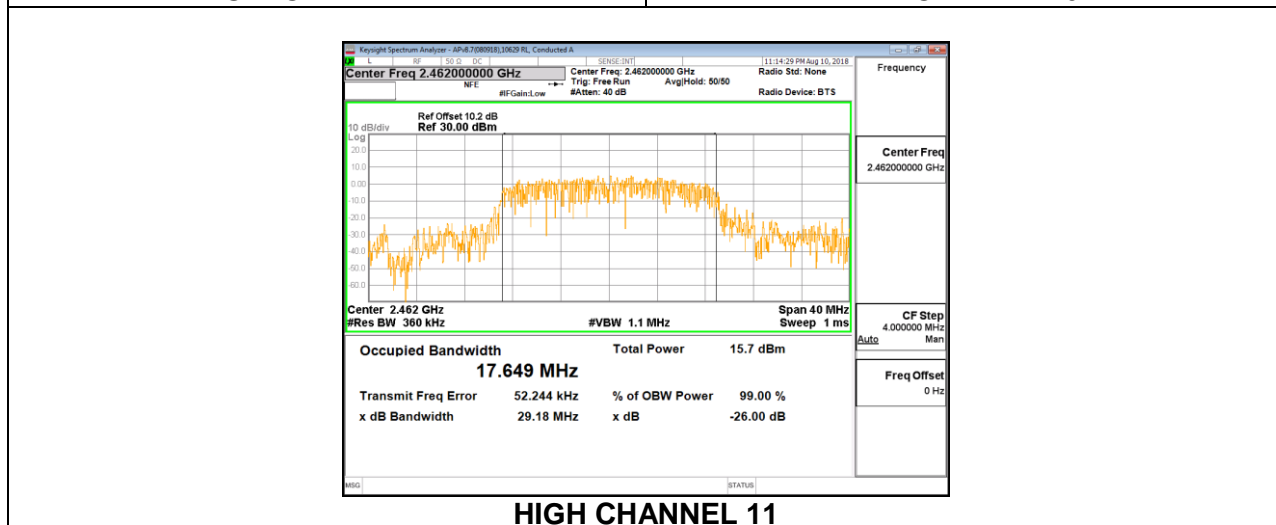
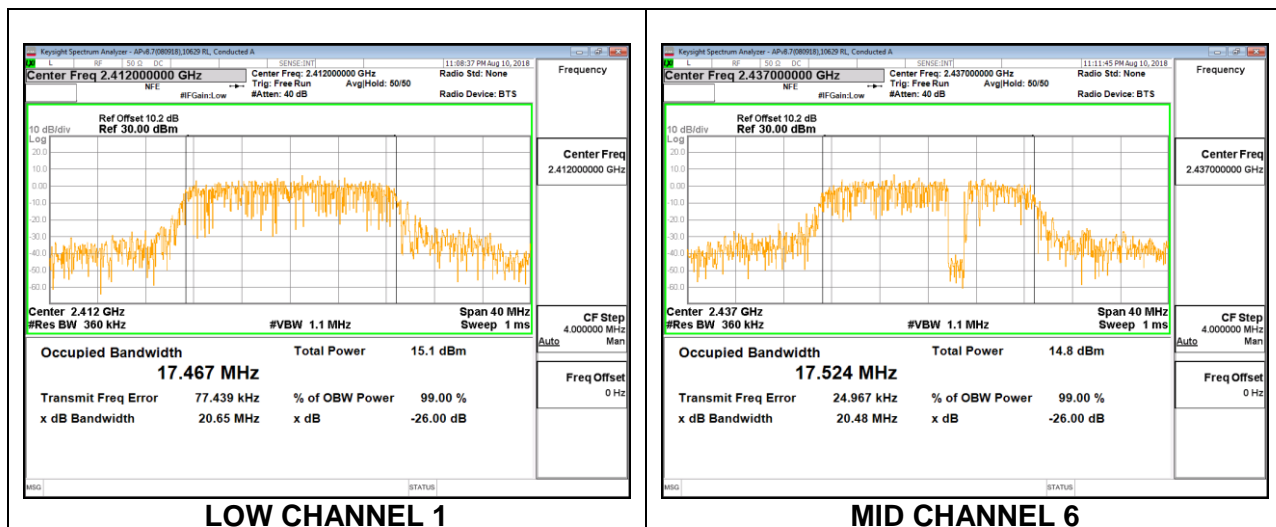

9.3. 6 dB BANDWIDTH

LIMITS

FCC §15.247 (a) (2)

The minimum 6 dB bandwidth shall be at least 500 kHz.

RESULTS

9.3.1. 802.11b MODE

Channel	Frequency (MHz)	6 dB Bandwidth (MHz)	Minimum Limit (MHz)
Low 1	2412	7.1200	0.5
Mid 6	2437	8.0800	0.5
High 11	2462	7.5600	0.5

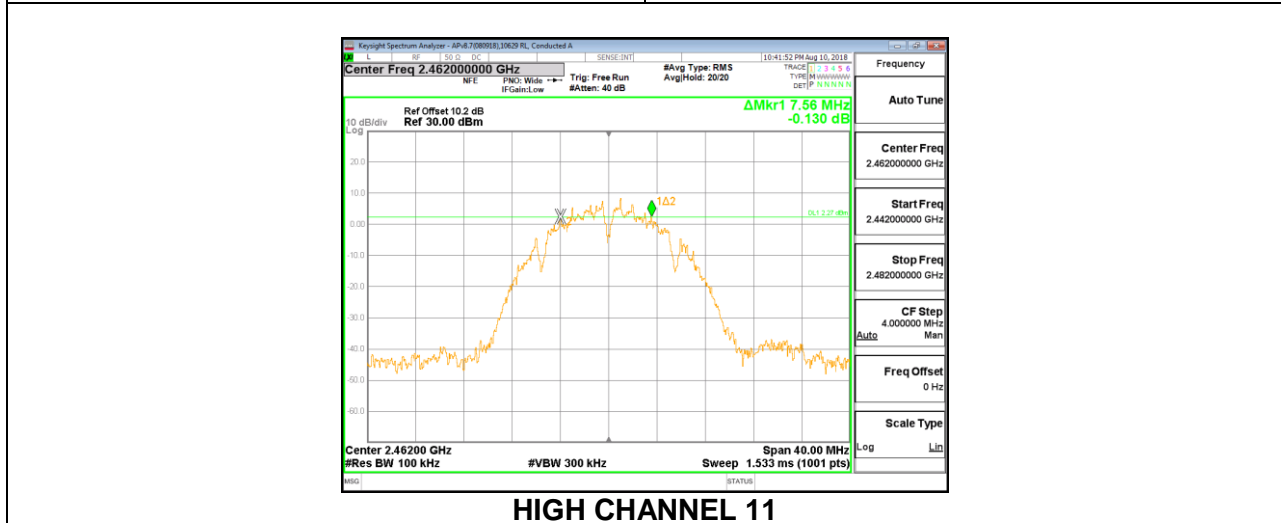
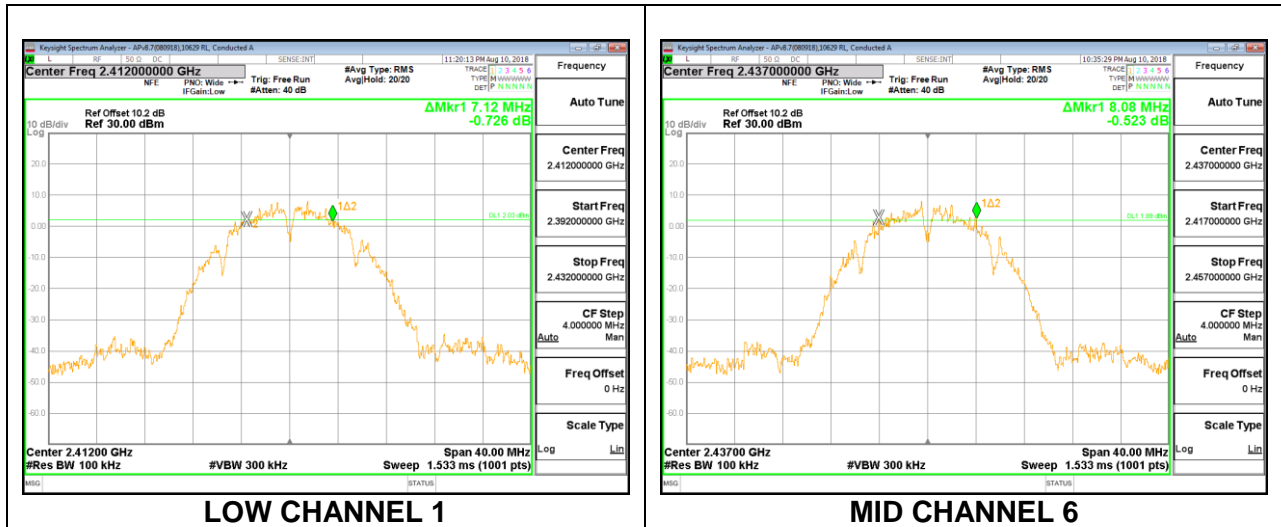

9.3.2. 802.11g MODE

Channel	Frequency (MHz)	6 dB Bandwidth (MHz)	Minimum Limit (MHz)
Low 1	2412	16.3600	0.5
Mid 6	2437	15.1200	0.5
High 11	2462	16.0800	0.5

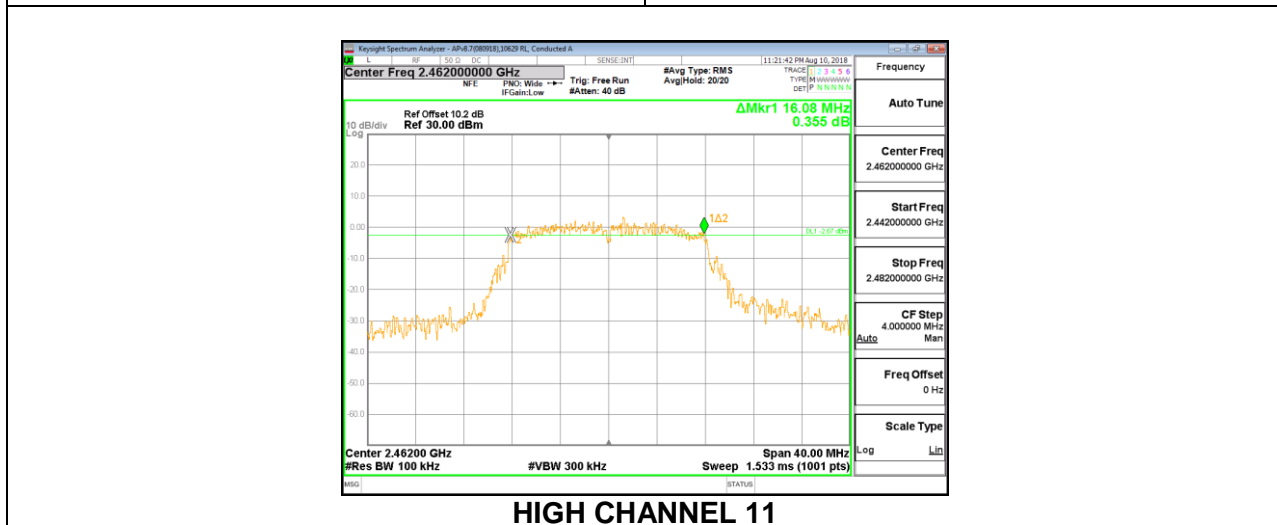
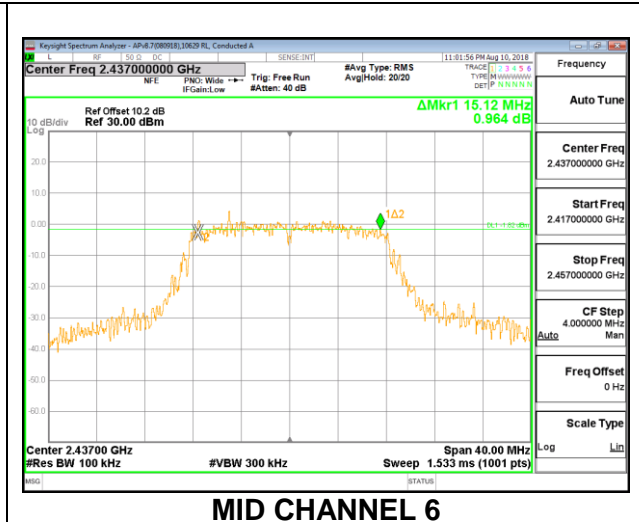
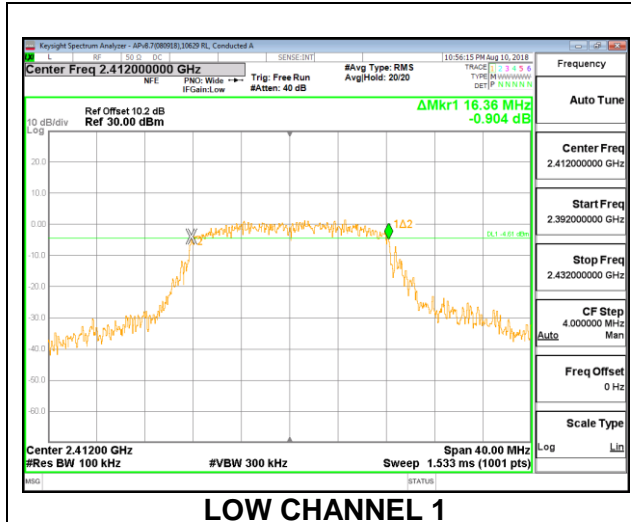

9.3.3. 802.11n HT20 MODE

Channel	Frequency (MHz)	6 dB Bandwidth (MHz)	Minimum Limit (MHz)
Low 1	2412	16.5600	0.5
Mid 6	2437	17.2800	0.5
High 11	2462	17.6000	0.5

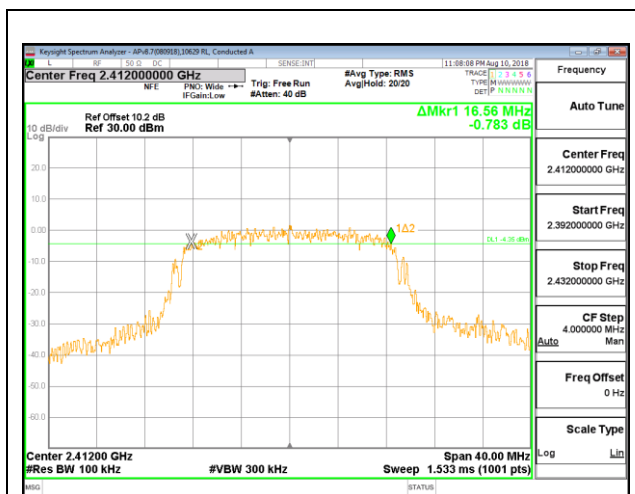

LOW CHANNEL 1

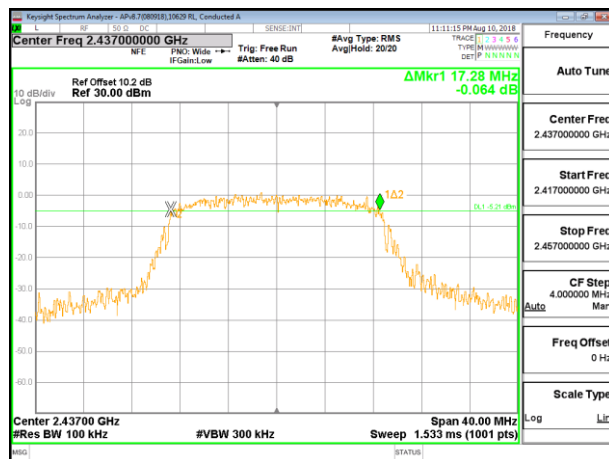

MID CHANNEL 6

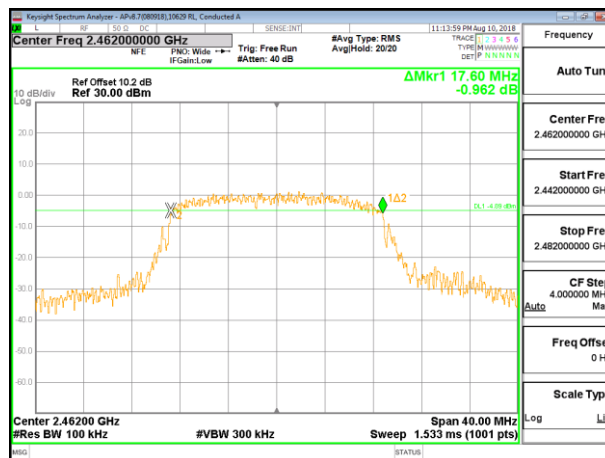

HIGH CHANNEL 11

9.4. OUTPUT POWER

LIMITS

FCC §15.247 (b) (3)

For systems using digital modulation in the 902–928 MHz, 2400–2483.5 MHz, and 5725–5850 MHz bands: 1 Watt, based on the use of antennas with directional gains that do not exceed 6 dBi. If transmitting antennas of directional gain greater than 6 dBi are used, the conducted output power from the intentional radiator shall be reduced by the amount in dB that the directional gain of the antenna exceeds 6 dBi.

TEST PROCEDURE

The transmitter output is connected to a power meter. The cable assembly insertion loss was entered as an offset in the power meter to allow for a gated average reading of power.

DIRECTIONAL ANTENNA GAIN

For 1 TX:

There is only one transmitter output therefore the directional gain is equal to the antenna gain.

RESULTS

9.4.1. 802.11b MODE

Limits

Channel	Frequency (MHz)	Directional Gain (dBi)	FCC Power Limit (dBm)	ISED Power Limit (dBm)	ISED EIRP Limit (dBm)	Max Power (dBm)
Low 1	2412	-1.71	30.00	30	36	30.00
Mid 6	2437	-1.71	30.00	30	36	30.00
High 11	2462	-1.71	30.00	30	36	30.00

Results

Channel	Frequency (MHz)	Meas Power (dBm)	Total Corr'd Power (dBm)	Power Limit (dBm)	Margin (dB)
Low 1	2412	14.13	14.13	30.00	-15.87
Mid 6	2437	18.39	18.39	30.00	-11.61
High 11	2462	14.91	14.91	30.00	-15.09

9.4.2. 802.11g MODE

Limits

Channel	Frequency (MHz)	Directional Gain (dBi)	FCC Power Limit (dBm)	ISED Power Limit (dBm)	ISED EIRP Limit (dBm)	Max Power (dBm)
Low 1	2412	-1.71	30.00	30	36	30.00
Mid 6	2437	-1.71	30.00	30	36	30.00
High 11	2462	-1.71	30.00	30	36	30.00

Results

Channel	Frequency (MHz)	Meas Power (dBm)	Total Corr'd Power (dBm)	Power Limit (dBm)	Margin (dB)
Low 1	2412	16.35	16.35	30.00	-13.65
Mid 6	2437	15.97	15.97	30.00	-14.03
High 11	2462	16.22	16.22	30.00	-13.78

9.4.3. 802.11n HT20 MODE

Limits

Channel	Frequency (MHz)	Directional Gain (dBi)	FCC Power Limit (dBm)	ISED Power Limit (dBm)	ISED EIRP Limit (dBm)	Max Power (dBm)
Low 1	2412	-1.71	30.00	30	36	30.00
Mid 6	2437	-1.71	30.00	30	36	30.00
High 11	2462	-1.71	30.00	30	36	30.00

Results

Channel	Frequency (MHz)	Meas Power (dBm)	Total Corr'd Power (dBm)	Power Limit (dBm)	Margin (dB)
Low 1	2412	15.99	15.99	30.00	-14.01
Mid 6	2437	16.35	16.35	30.00	-13.65
High 11	2462	14.15	14.15	30.00	-15.85

9.5. POWER SPECTRAL DENSITY

LIMITS

FCC §15.247 (e)

The power spectral density conducted from the transmitter to the antenna shall not be greater than 8 dBm in any 3 kHz band during any time interval of continuous transmission.

RESULTS

9.5.1. 802.11b MODE

Duty Cycle CF (dB)	0.00	Included in Calculations of Corr'd PSD
--------------------	------	--

PSD Results

Channel	Frequency (MHz)	Meas (dBm/30kHz)	Total Corr'd PSD (dBm/30kHz)	Limit (dBm/3kHz)	Margin (dB)
Low 1	2412	-4.97	-4.97	8.0	-13.0
Mid 6	2437	-5.26	-5.26	8.0	-13.3
High 11	2462	-5.18	-5.18	8.0	-13.2

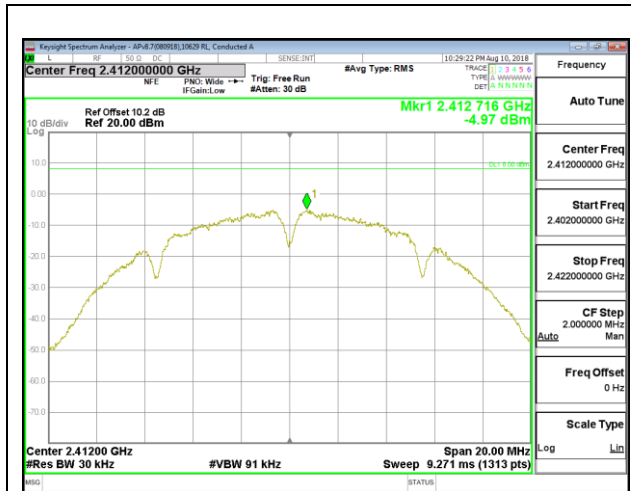

LOW CHANNEL 1

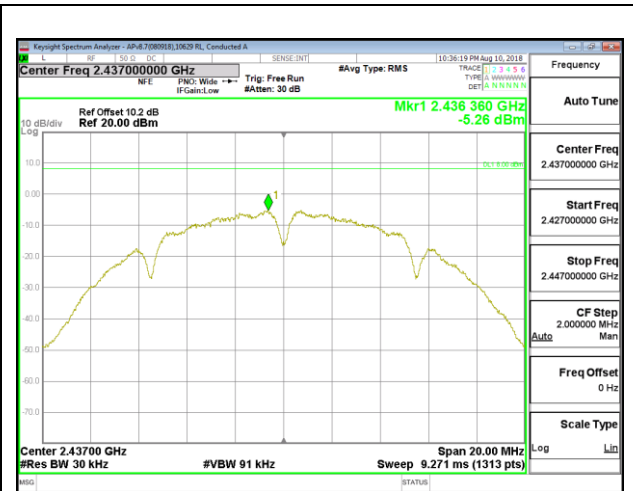

MID CHANNEL 6

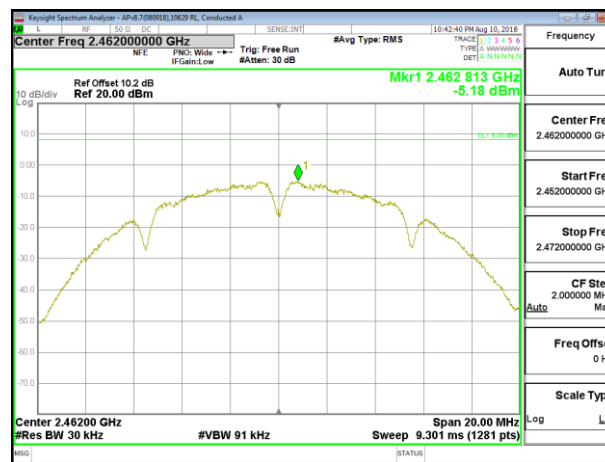

HIGH CHANNEL 11

9.5.2. 802.11g MODE

Duty Cycle CF (dB)	0.22	Included in Calculations of Corr'd PSD
--------------------	------	--

PSD Results

Channel	Frequency (MHz)	Meas (dBm/30kHz)	Total Corr'd PSD (dBm/30kHz)	Limit (dBm/3kHz)	Margin (dB)
Low 1	2412	-8.06	-7.84	8.0	-15.8
Mid 6	2437	-8.80	-8.58	8.0	-16.6
High 11	2462	-7.85	-7.63	8.0	-15.6

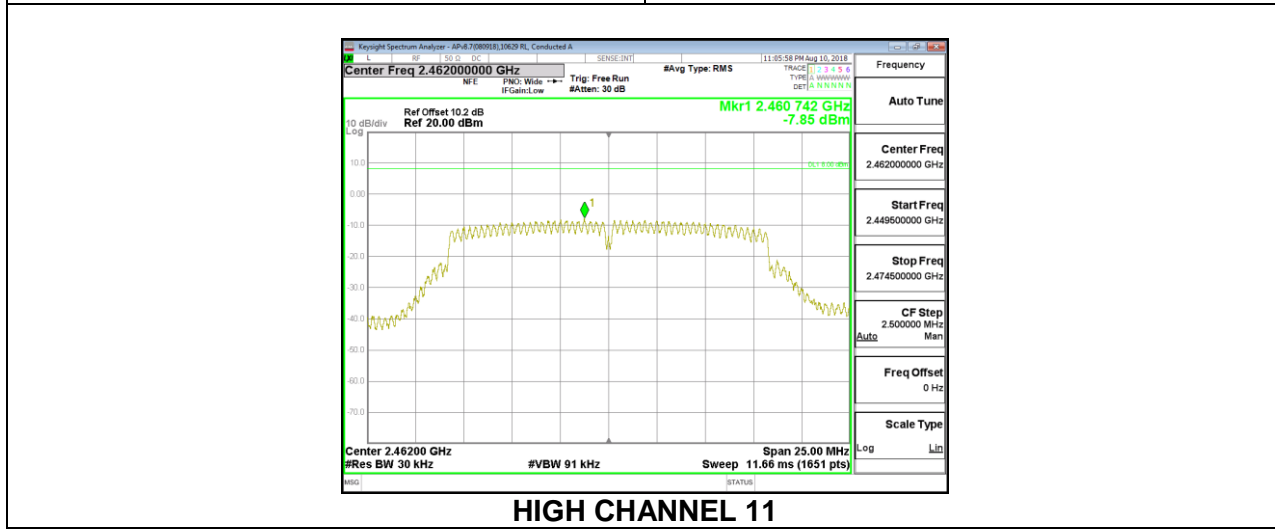
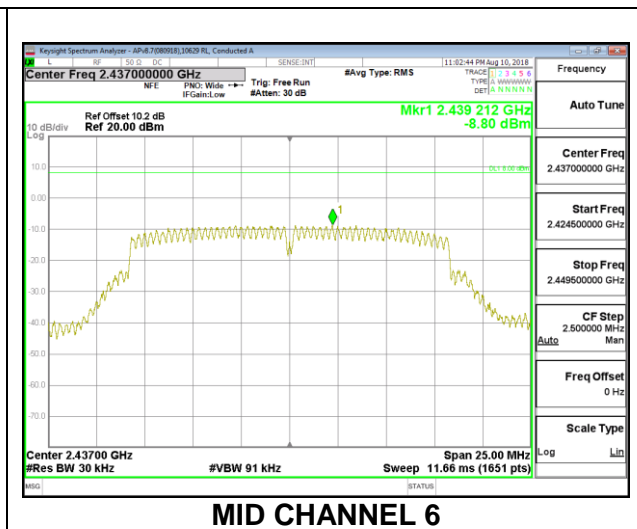
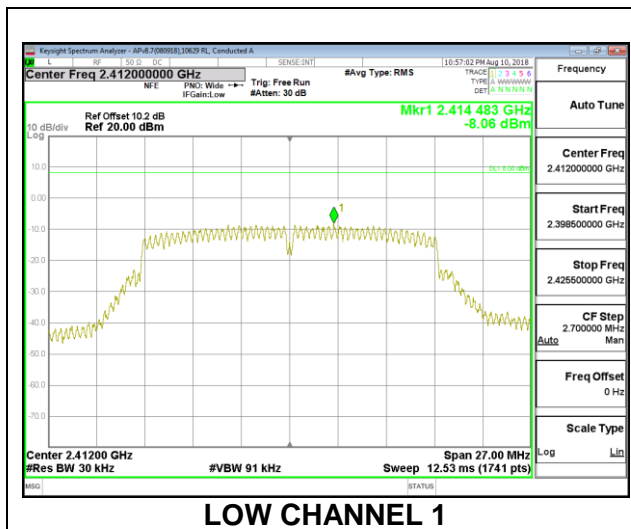

9.5.3. 802.11n HT20 MODE

Duty Cycle CF (dB)	0.24	Included in Calculations of Corr'd PSD
--------------------	------	--

PSD Results

Channel	Frequency (MHz)	Meas (dBm/30kHz)	Total Corr'd PSD (dBm/30kHz)	Limit (dBm/3kHz)	Margin (dB)
Low 1	2412	-9.21	-8.97	8.0	-17.0
Mid 6	2437	-9.44	-9.20	8.0	-17.2
High 11	2462	-8.91	-8.67	8.0	-16.7

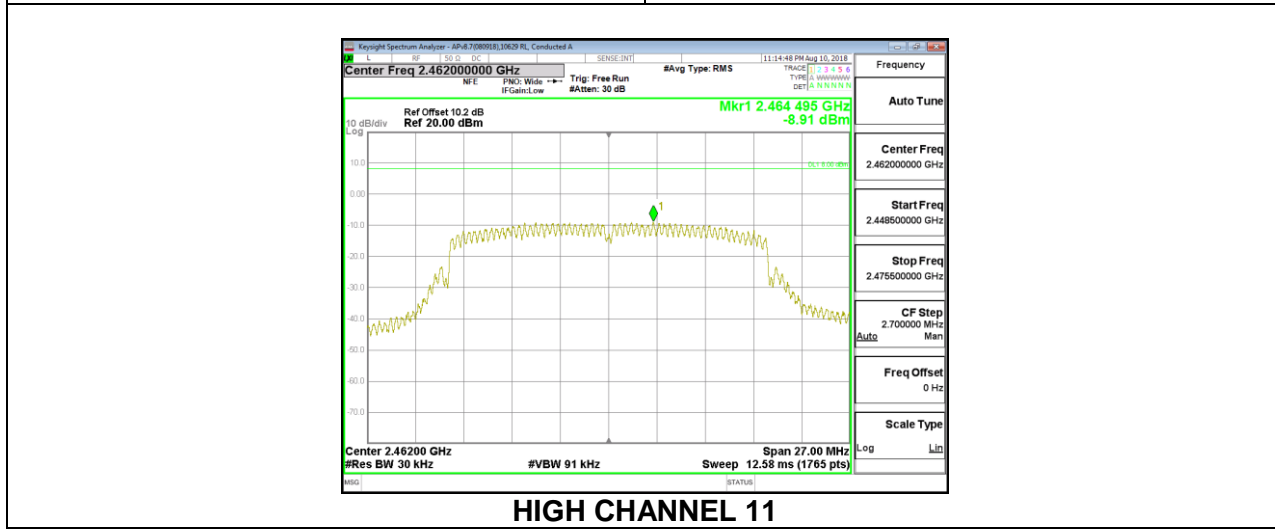
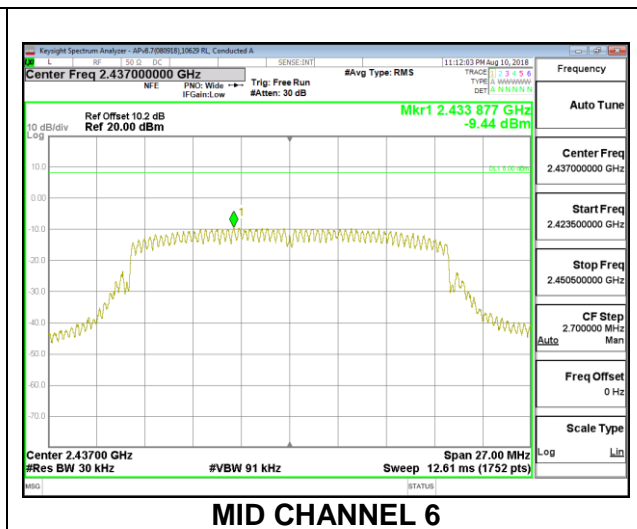
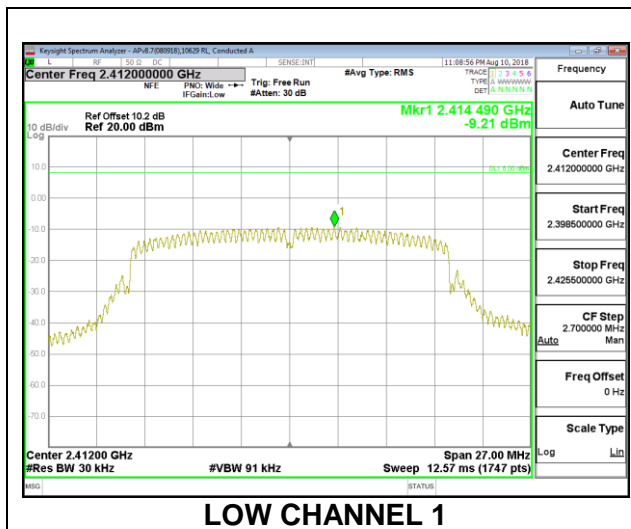

9.6. CONDUCTED SPURIOUS EMISSIONS

LIMITS

FCC §15.247 (d)

Output power was measured based on the use of average measurement, therefore the required attenuation is 30 dB.

RESULTS

9.6.1. 802.11b MODE

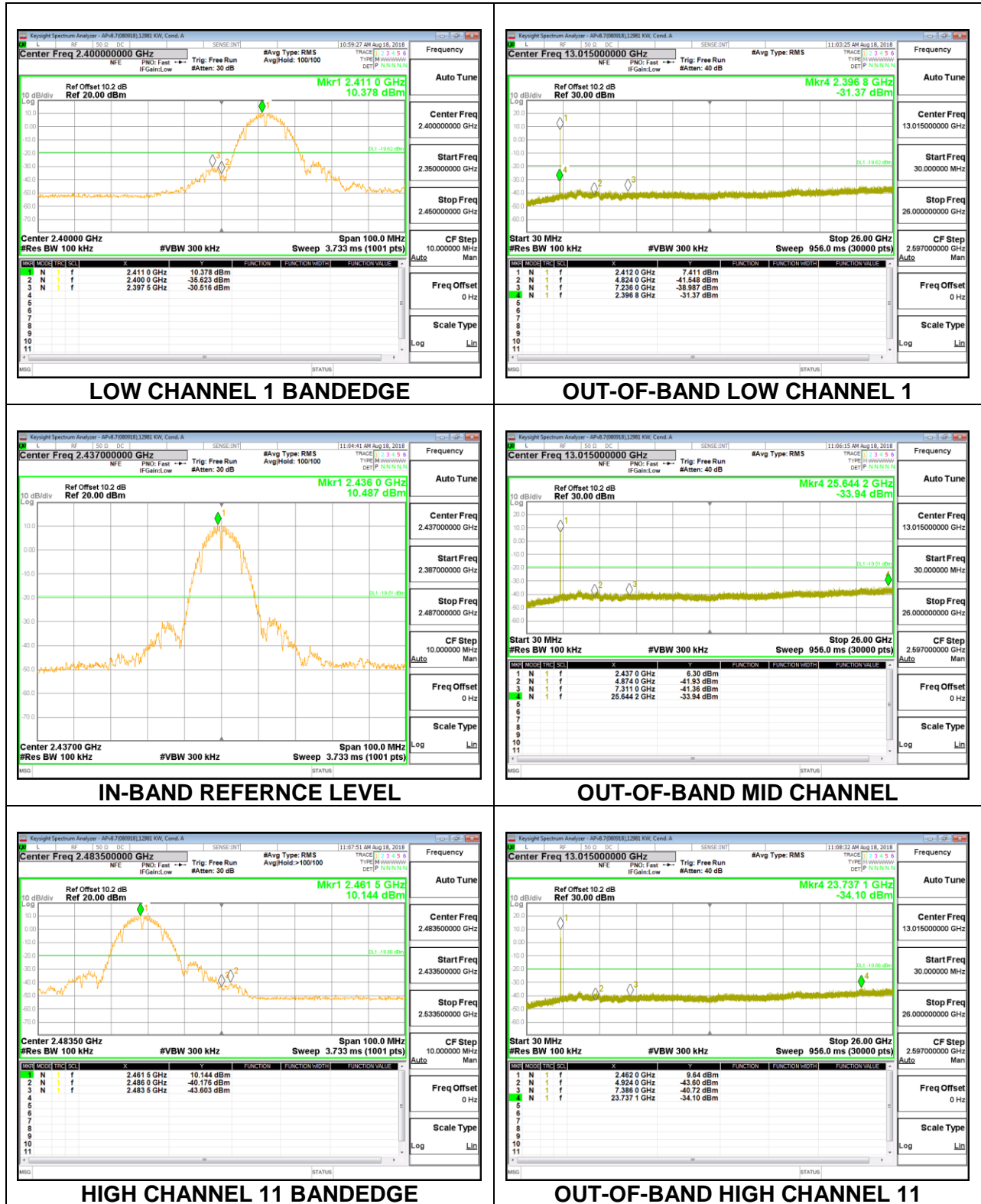

9.6.2. 802.11g MODE

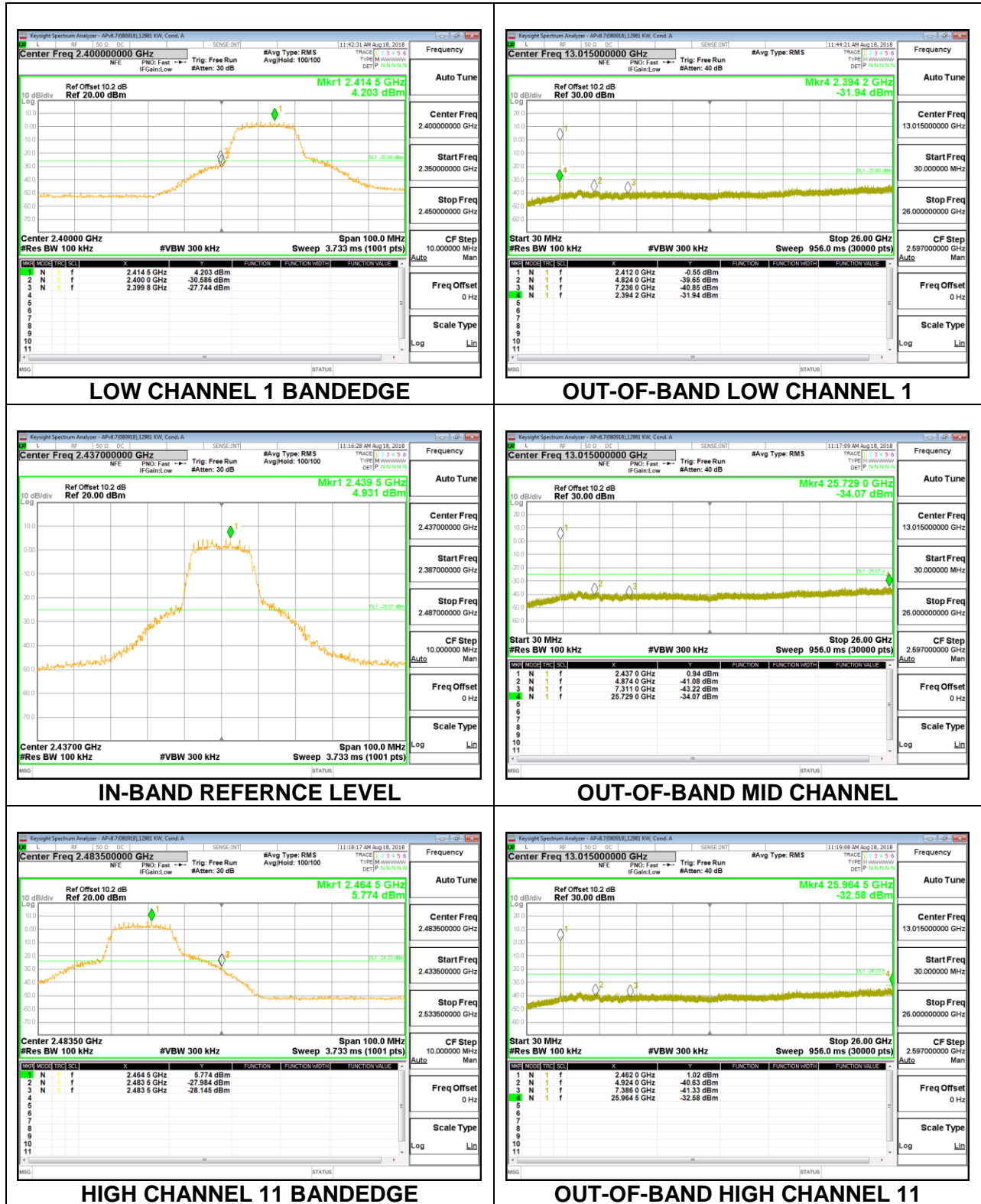

9.6.3. 802.11n HT20 MODE

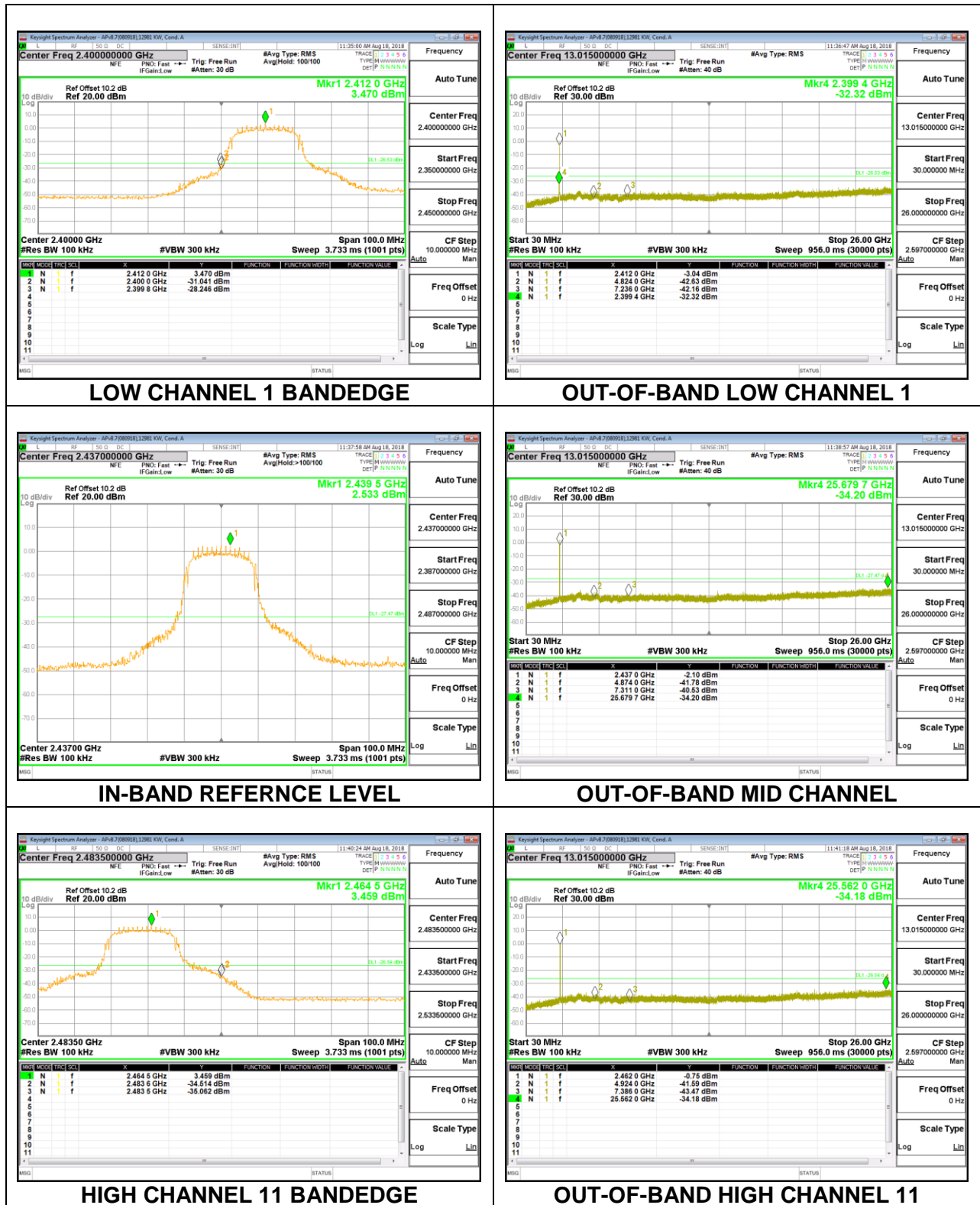

10. RADIATED TEST RESULTS

LIMITS

FCC §15.205 and §15.209

Frequency Range (MHz)	Field Strength Limit (uV/m) at 3 m	Field Strength Limit (dBuV/m) at 3 m
0.009-0.490	2400/F(kHz) @ 300 m	-
0.490-1.705	24000/F(kHz) @ 30 m	-
1.705 - 30	30 @ 30m	-
30 - 88	100	40
88 - 216	150	43.5
216 - 960	200	46
Above 960	500	54

TEST PROCEDURE

The EUT is placed on a non-conducting table 80 cm above the ground plane for measurement below 1GHz; 1.5 m above the ground plane for measurement above 1GHz. The antenna to EUT distance is 3 meters. The EUT is configured in accordance with ANSI C63.10. The EUT is set to transmit in a continuous mode.

For measurements below 1 GHz the resolution bandwidth is set to 100 kHz for peak detection measurements or 120 kHz for quasi-peak detection measurements. Peak detection is used unless otherwise noted as quasi-peak.

For pre-scans above 1 GHz the resolution bandwidth is set to 1 MHz; the video bandwidth is set to 30 KHz for peak measurements.

For final measurements above 1 GHz the resolution bandwidth is set to 1 MHz; the video bandwidth is set to 3 MHz for peak measurements and as applicable for average measurements.

The spectrum from 1 GHz to 18 GHz is investigated with the transmitter set to the lowest, middle, and highest channels in each applicable band. Below 1GHz and above 18GHz emissions, the channel with the highest output power was tested.

The frequency range of interest is monitored at a fixed antenna height and EUT azimuth. The EUT is rotated through 360 degrees to maximize emissions received. The antenna is scanned from 1 to 4 meters above the ground plane to further maximize the emission. Measurements are made with the antenna polarized in both the vertical and the horizontal positions.

10.1. TRANSMITTER ABOVE 1 GHz

10.1.1. TX ABOVE 1 GHz 802.11b MODE IN THE 2.4 GHz BAND

BANDEDGE (LOW CHANNEL, CH 1)

HORIZONTAL RESULT

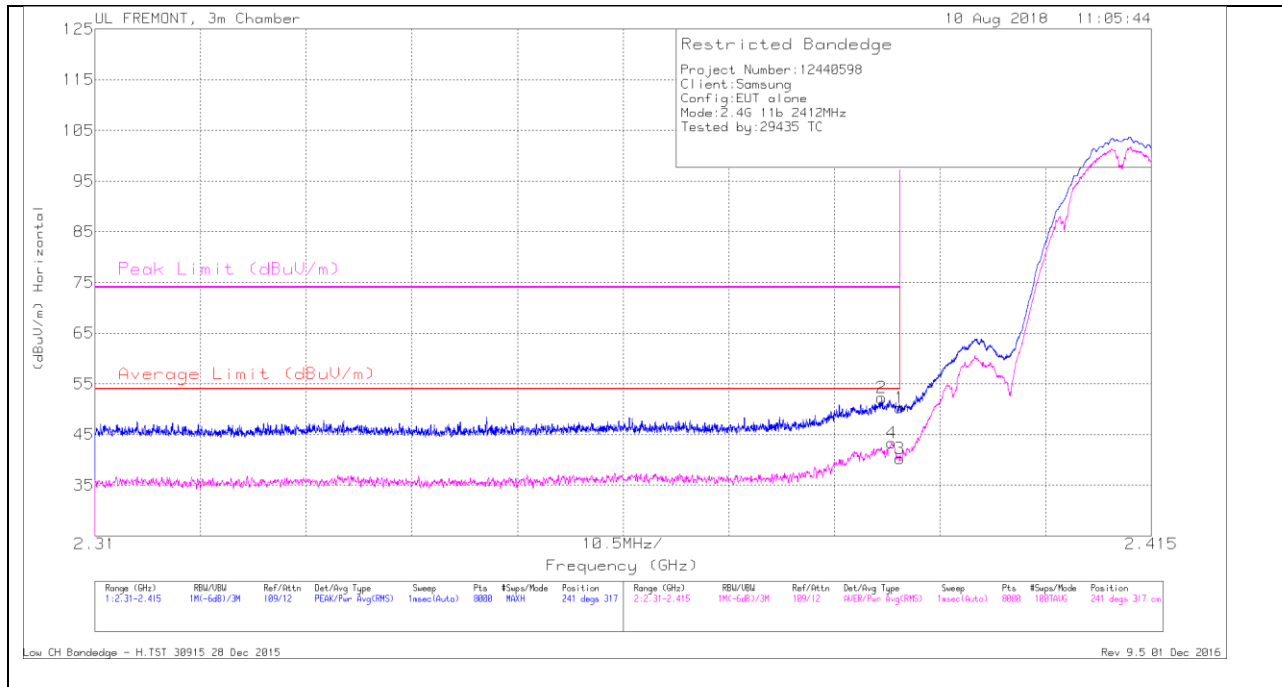

Marker	Frequency (GHz)	Meter Reading (dBuV)	Det	AFT346 (dB/m)	Amp/Cbl/Filtr/Pad (dB)	Corrected Reading (dBuV/m)	Average Limit (dBuV/m)	Margin (dB)	Peak Limit (dBuV/m)	PK Margin (dB)	Azimuth (Degs)	Height (cm)	Polarity
2	2.388	41.52	Pk	32	-21.3	52.22	-	-	74	-21.78	241	317	H
4	2.389	32.7	RMS	32	-21.4	43.3	54	-10.7	-	-	241	317	H
1	2.39	39.72	Pk	32	-21.4	50.32	-	-	74	-23.68	241	317	H
3	2.39	29.68	RMS	32	-21.4	40.28	54	-13.72	-	-	241	317	H

Pk - Peak detector
 RMS - RMS detection

VERTICAL RESULT

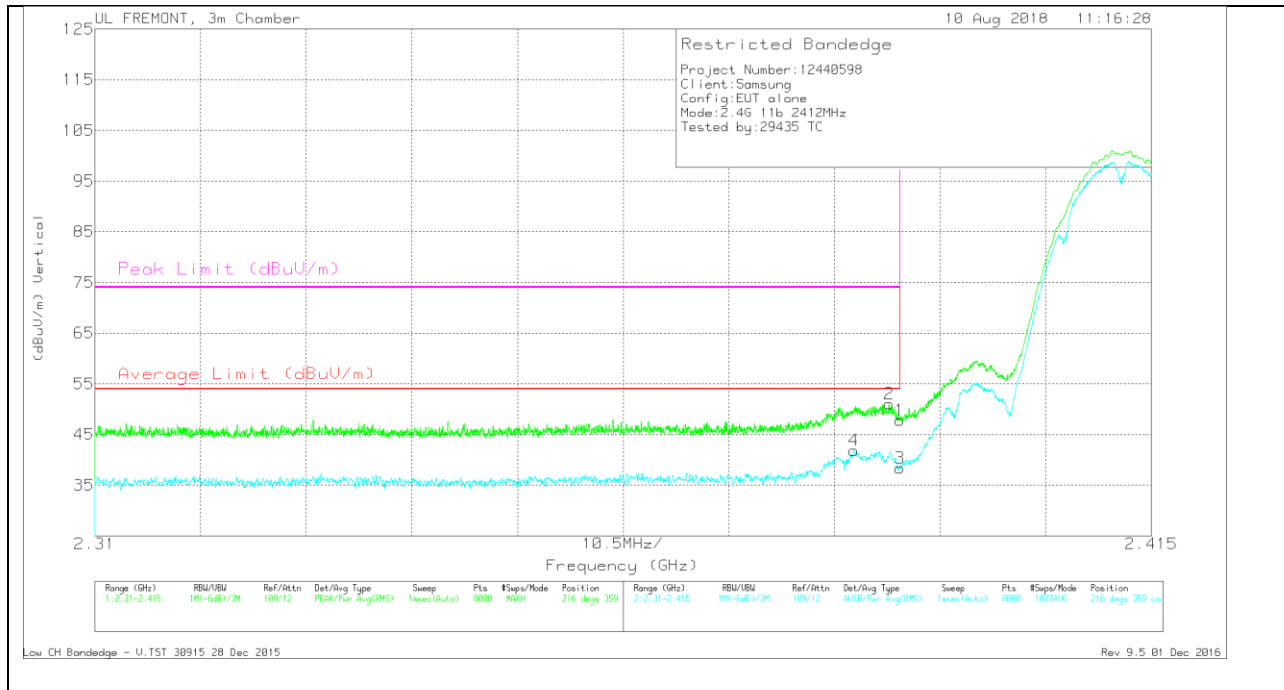

Marker	Frequency (GHz)	Meter Reading (dBuV)	Det	AF T346 (dB/m)	Amp/Cbl/Fitr/Pad (dB)	Corrected Reading (dBuV/m)	Average Limit (dBuV/m)	Margin (dB)	Peak Limit (dBuV/m)	PK Margin (dB)	Azimuth (Degs)	Height (cm)	Polarity
4	2.385	30.97	RMS	32.1	-21.2	41.87	54	-12.13	-	-	216	359	V
2	2.389	40.39	Pk	32	-21.4	50.99	-	-	74	-23.01	216	359	V
1	2.39	37.23	Pk	32	-21.4	47.83	-	-	74	-26.17	216	359	V
3	2.39	27.74	RMS	32	-21.4	38.34	54	-15.66	-	-	216	359	V

Pk - Peak detector
 RMS - RMS detection

BANDEDGE (HIGH CHANNEL, CH 11)

HORIZONTAL RESULT

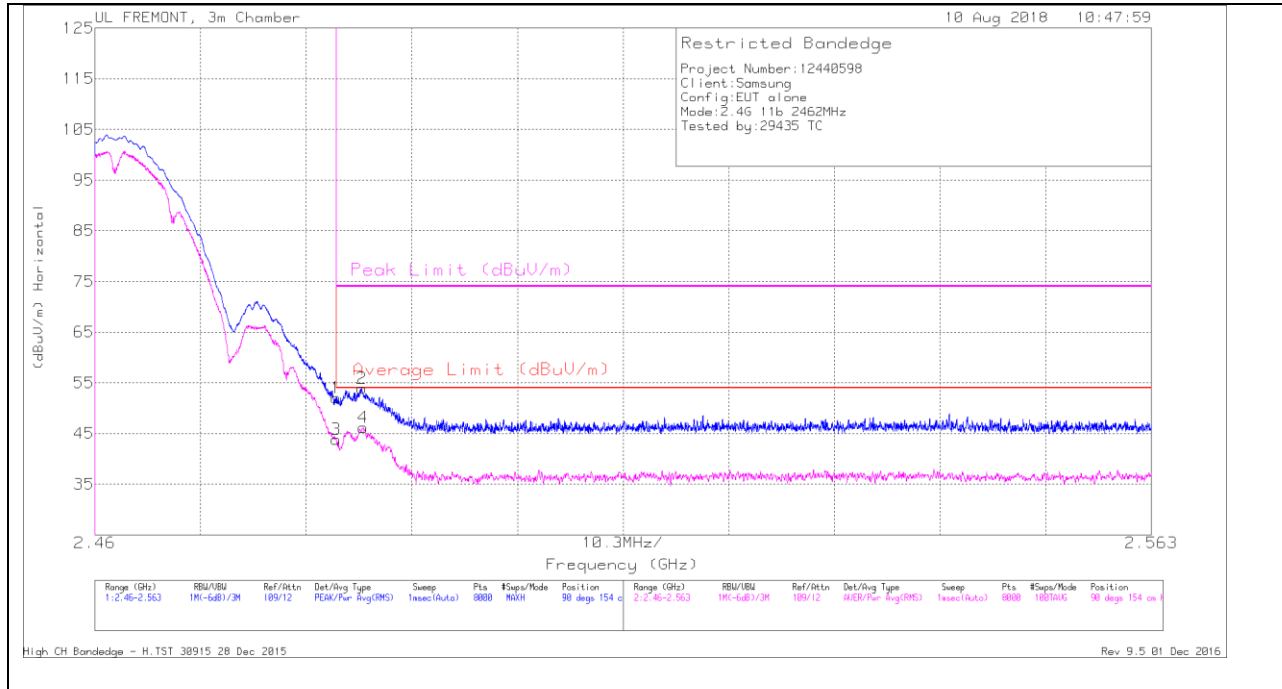

Marker	Frequency (GHz)	Meter Reading (dBuV)	Det	AF T346 (dB/m)	Amp/Cb/Fltr/Pad (dB)	Corrected Reading (dBuV/m)	Average Limit (dBuV/m)	Margin (dB)	Peak Limit (dBuV/m)	PK Margin (dB)	Azimuth (Degs)	Height (cm)	Polarity
1	2.484	41.5	Pk	32.3	-21.8	52	-	-	74	-22	90	154	H
3	2.484	33.37	RMS	32.3	-21.8	43.87	54	-10.13	-	-	90	154	H
2	2.486	43.42	Pk	32.3	-21.8	53.92	-	-	74	-20.08	90	154	H
4	2.486	35.68	RMS	32.3	-21.8	46.18	54	-7.82	-	-	90	154	H

Pk - Peak detector
 RMS - RMS detection