



CERTIFICATION TEST REPORT

Report Number. : 12440940-E3V1

Applicant : Samsung Electronics Co., Ltd.
129 Samsung-Ro, Yeongtong-Gu,
Suwon-Si, Gyeonggi-Do, 16677, Korea

Model : SM-A750N

FCC ID : A3LSMA750N

EUT Description : GSM/WCDMA/LTE Phone with BT, DTS/UNII a/b/g/n/ac, ANT+
and NFC

Test Standard(s) : FCC 47 CFR PART 15 SUBPART C

Date Of Issue:
September 06, 2018

Prepared by:
UL Verification Services Inc.
47173 Benicia Street
Fremont, CA 94538 U.S.A.
TEL: (510) 771-1000
FAX: (510) 661-0888



REPORT REVISION HISTORY

Rev.	Issue Date	Revisions	Revised By
V1	09/06/18	Initial Issue	

TABLE OF CONTENTS

REPORT REVISION HISTORY	2
TABLE OF CONTENTS	3
1. ATTESTATION OF TEST RESULTS	5
2. INTRODUCTION OF TEST DATA REUSE.....	6
2.1. INTRODUCTION	6
2.2. DEVICES DIFFERENCES.....	6
2.3. SPOT CHECK VERIFICATION RESULTS SUMMARY	6
2.3.1. SPOT CHECK DATA.....	7
2.3.2. BANDEDGE HIGH CHANNEL.....	7
2.3.3. HARMONICS AND SPURIOUS EMISSIONS	9
2.4. REFERENCE DETAIL	10
3. TEST METHODOLOGY	11
4. FACILITIES AND ACCREDITATION	11
5. CALIBRATION AND UNCERTAINTY	12
5.1. MEASURING INSTRUMENT CALIBRATION	12
5.2. SAMPLE CALCULATION	12
5.3. MEASUREMENT UNCERTAINTY.....	12
6. EQUIPMENT UNDER TEST.....	13
6.1. EUT DESCRIPTION.....	13
6.2. MAXIMUM OUTPUT POWER.....	13
6.3. DESCRIPTION OF AVAILABLE ANTENNAS	13
6.4. SOFTWARE AND FIRMWARE.....	13
6.5. WORST-CASE CONFIGURATION AND MODE.....	13
6.6. DESCRIPTION OF TEST SETUP.....	14
7. MEASUREMENT METHOD.....	17
8. TEST AND MEASUREMENT EQUIPMENT	18
9. ANTENNA PORT TEST RESULTS	20
9.1. ON TIME AND DUTY CYCLE.....	20
9.2. 99% BANDWIDTH.....	22
9.3. 6 dB BANDWIDTH.....	24
9.4. OUTPUT POWER.....	26

9.5.	AVERAGE POWER.....	27
9.6.	POWER SPECTRAL DENSITY.....	28
9.7.	CONDUCTED SPURIOUS EMISSIONS.....	30
10.	RADIATED TEST RESULTS	32
10.1.	LIMITS AND PROCEDURE.....	32
10.2.	TRANSMITTER ABOVE 1 GHz.....	33
10.3.	Worst Case Below 30 MHz.....	43
10.4.	Worst Case Below 1 GHz.....	45
10.5.	Worst Case 18-26 GHz	47
11.	AC POWER LINE CONDUCTED EMISSIONS	49
11.1.1.	AC Power Line Norm.....	50
12.	SETUP PHOTOS (ORIGINAL).....	52

1. ATTESTATION OF TEST RESULTS

COMPANY NAME: Samsung Electronics Co., Ltd.
129 Samsung-Ro, Yeongtong-Gu,
Suwon-Si, Gyeonggi-Do, 16677, Korea

EUT DESCRIPTION: GSM/WCDMA/LTE Phone with BT, DTS/UNII a/b/g/n/ac, ANT+
and NFC

MODELS: SM-A750N

SERIAL NUMBER: Conducted: R38K70KQF9N, R38K70KQGDH (Original)
Radiated: R38K70KQFNY, R38K70KQFAH, R38K70KQF8A
(Original)
Conducted: R39K70AGZNA (Spot Check)
Radiated: R39K70DSRLB, R39K70AH06N (Spot Check)

DATE TESTED: August 6 – 15, 2018 (Original)
August 28 – 30, 2018 (Spot Check)

APPLICABLE STANDARDS	
STANDARD	TEST RESULTS
CFR 47 Part 15 Subpart C	Complies

UL Verification Services Inc. tested the above equipment in accordance with the requirements set forth in the above standards. Measurement Uncertainties were not taken into account and are published for informational purposes only. The test results show that the equipment tested is capable of demonstrating compliance with the requirements as documented in this report.

Note: The results documented in this report apply only to the tested sample, under the conditions and modes of operation as described herein. All samples tested were in good operating condition throughout the entire test program. This document may not be altered or revised in any way unless done so by UL Verification Services Inc. and all revisions are duly noted in the revisions section. Any alteration of this document not carried out by UL Verification Services Inc. will constitute fraud and shall nullify the document. This report must not be used by the client to claim product certification, approval, or endorsement by NVLAP, NIST, any agency of the Federal Government, or any agency of the U.S. government.

Approved & Released For
UL Verification Services Inc. By:

Reviewed By:



DAN CORONIA
CONSUMER TECHNOLOGY DIVISION
Operations Leader
UL Verification Services Inc.

STEVEN TRAN
CONSUMER TECHNOLOGY DIVISION
Project Engineer
UL Verification Services Inc.

2. INTRODUCTION OF TEST DATA REUSE

2.1. INTRODUCTION

According to the manufacturer, the WLAN, Bluetooth, ANT+ and NFC hardware of A3LSMA750N are identical to A3LSMA750GN. In addition A3LSMA750N digital circuit is identical to A3LSMA750GN. Therefore the following report/data of A3LSMA750N may be represented from A3LSMA750GN along with the spot check verification data.

- WLAN
- Bluetooth
- ANT+
- NFC

2.2. DEVICES DIFFERENCES

Difference between A3LSMA750N and A3LSMA750GN:

Samsung Electronics Co., Ltd. hereby declares that between A3LSMA750N and A3LSMA750GN:

Hardware:

- Ant matching points are different.
- GSM850 / LTE B2 / B12 / B13 / B66 components are deleted.
- LTE B26 components are added.
- Only BT/WiFi parts are same.

Software:

- PROTOCOL PART is same.
- LTE B26 band SW enabled, GSM850, LTE B2/12/13/66 bands SW disabled.
- SW was updated to reflect the HW changes.

Therefore the WLAN, Bluetooth, ANT+, NFC report and data of A3LSMA750GN may represent for A3LSMA750N.

2.3. SPOT CHECK VERIFICATION RESULTS SUMMARY

Spot check verification has been done on device A3LSMA750N for radiated harmonic spurious and radiated band-edge. The data from the application has been verified through appropriate spot checks to demonstrate compliance for this device as shown in the summary below.

SM-A750N SPOT CHECK RESULTS										
Technology	Mode	Test Item	Channel	Measured Frequency	SM-A750GN/DS		SM-A750N		Delta (dB)	
					Peak	Ave	Peak	Ave	Peak	Ave
BLE	1Mbps	RBE	39	2484MHz	56.09	41.08	55.33	41.3	-0.76	0.22
	1Mbps	RSE	39	2863MHz	47.03	40.93	48.12	40.76	1.09	-0.17

Comparison of two models, higher deviation is within 3dB range and all test are under FCC Technical Limits.

2.3.1. SPOT CHECK DATA

2.3.2. BANDEGE HIGH CHANNEL

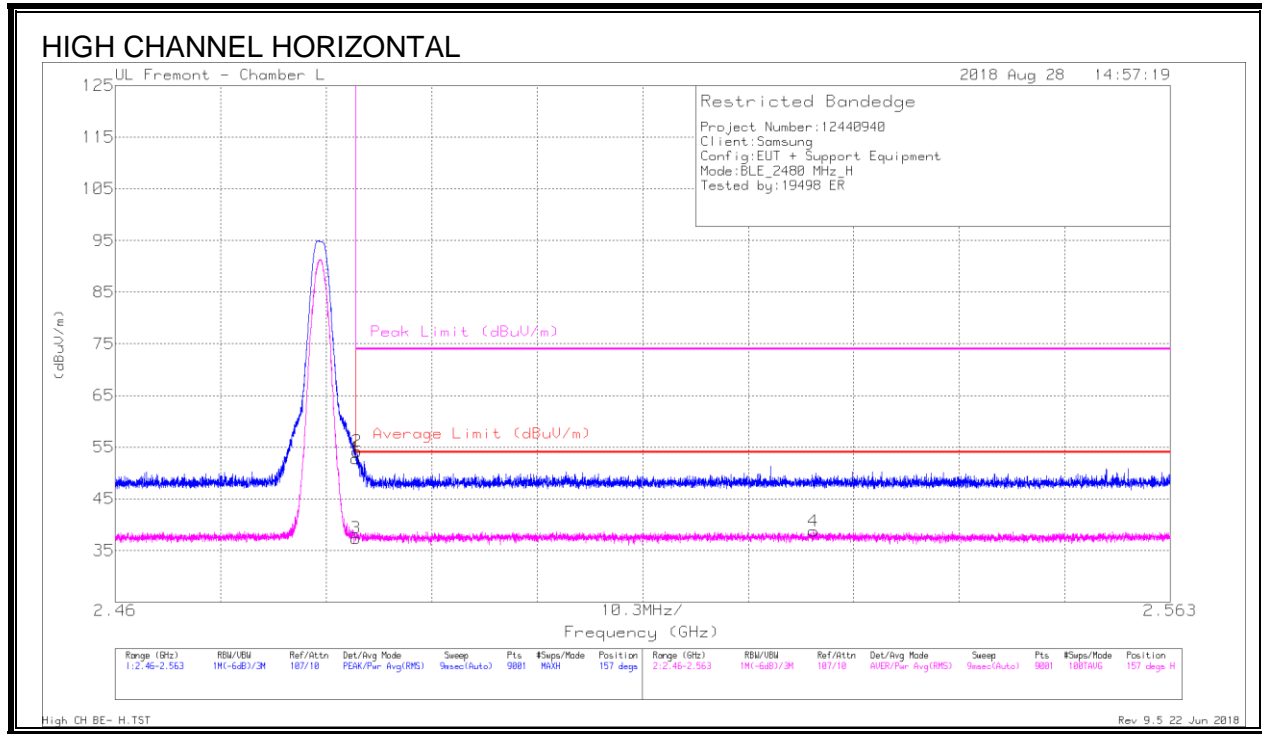

Trace Markers

Marker	Frequency (GHz)	Meter Reading (dBuV)	Det	AF EMC4294 (dB/m)	Amp/Cb/Fltr/Pad (dB)	DC Corr (dB)	Corrected Reading (dBuV/m)	Average Limit (dBuV/m)	Margin (dB)	Peak Limit (dBuV/m)	PK Margin (dB)	Azimuth (Degs)	Height (cm)	Polarity
1	* 2.484	43.19	Pk	32.3	-22.7	0	52.79	-	-	74	-21.21	157	360	H
2	* 2.484	44.58	Pk	32.3	-22.7	0	54.18	-	-	74	-19.82	157	360	H
3	* 2.484	27.75	RMS	32.3	-22.7	2.14	39.49	54	-14.51	-	-	157	360	H
4	2.528	29.13	RMS	32.3	-22.7	2.14	40.87	54	-13.13	-	-	157	360	H

* - indicates frequency in CFR47 Pt 15 Restricted Band

Pk - Peak detector

RMS - RMS detection

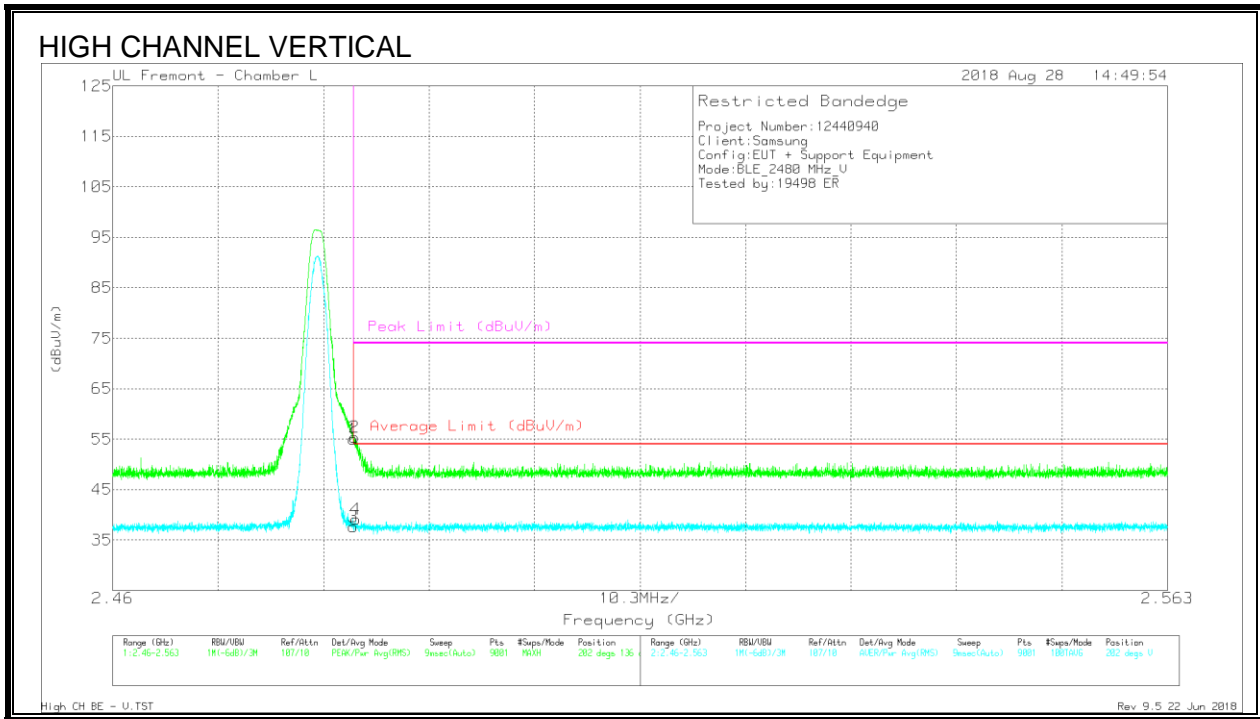

Trace Markers

Marker	Frequency (GHz)	Meter Reading (dBuV)	Det	AF EMC4294 (dB/m)	Amp/Cb/Filtr/Pad (dB)	DC Corr (dB)	Corrected Reading (dBuV/m)	Average Limit (dBuV/m)	Margin (dB)	Peak Limit (dBuV/m)	PK Margin (dB)	Azimuth (Degs)	Height (cm)	Polarity
1	* 2.484	45.43	Pk	32.3	-22.7	0	55.03	-	-	74	-18.97	202	136	V
2	* 2.484	45.73	Pk	32.3	-22.7	0	55.33	-	-	74	-18.67	202	136	V
3	* 2.484	28.03	RMS	32.3	-22.7	2.14	39.77	54	-14.23	-	-	202	136	V
4	* 2.484	29.56	RMS	32.3	-22.7	2.14	41.3	54	-12.7	-	-	202	136	V

* - indicates frequency in CFR47 Pt 15 Restricted Band

Pk - Peak detector

RMS - RMS detection

2.3.3. HARMONICS AND SPURIOUS EMISSIONS

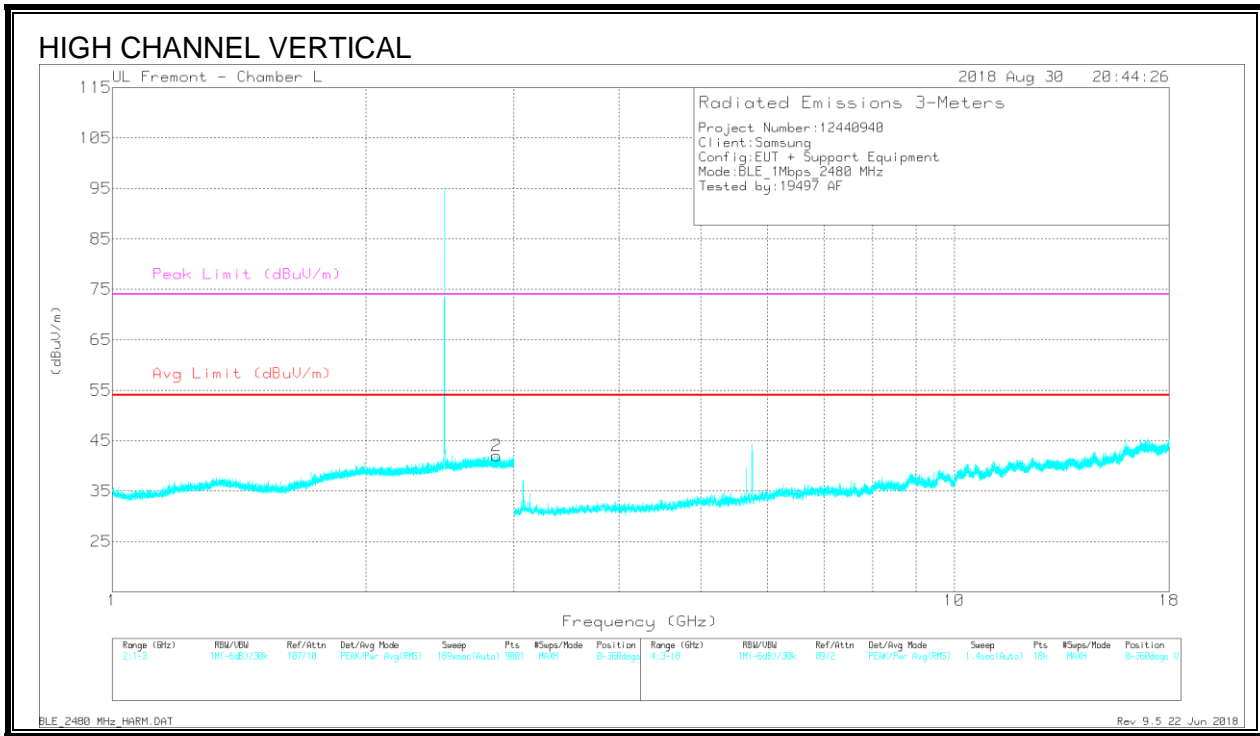
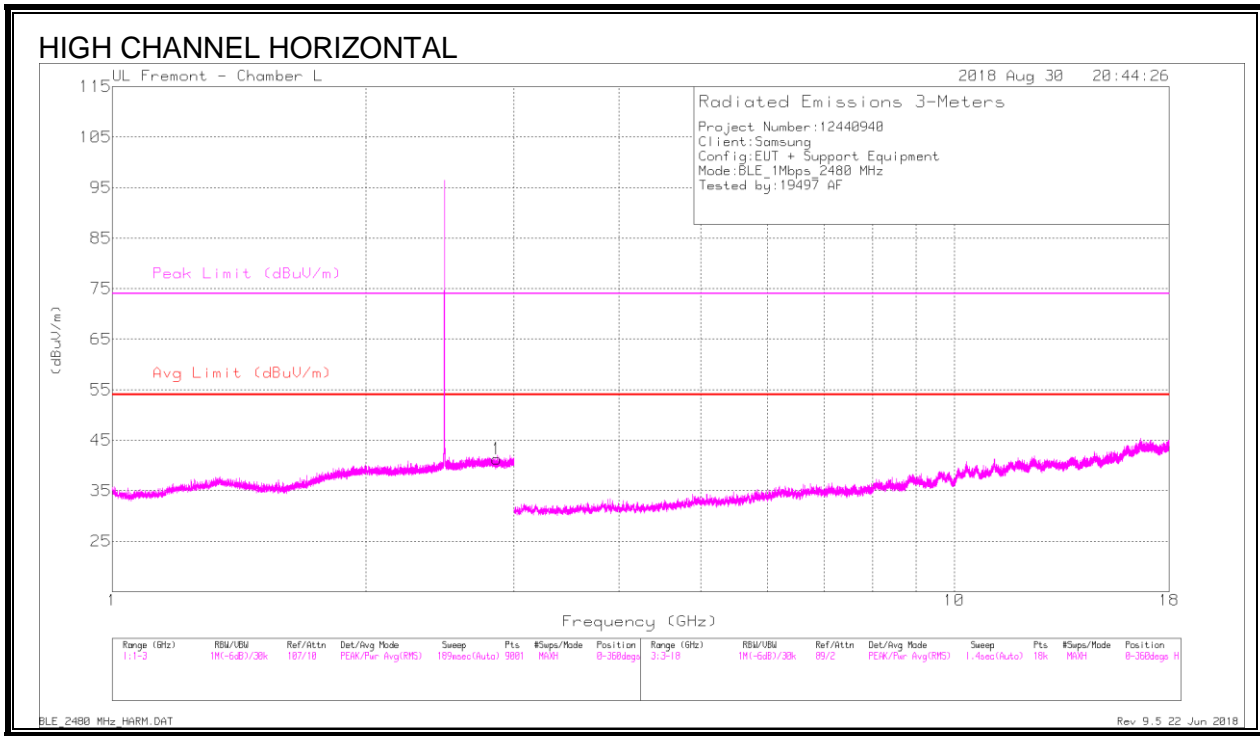

Radiated Emissions

Marker	Frequency (GHz)	Meter Reading (dBuV)	Det	AF EMC4294 (dB/m)	Amp/Cbl/Filtr/Pad (dB)	Corrected Reading (dBuV/m)	Avg Limit (dBuV/m)	Margin (dB)	Peak Limit (dBuV/m)	PK Margin (dB)	Azimuth (Degs)	Height (cm)	Polarity
1	* 2.863	37.92	PK2	32.4	-22.2	0	48.12	-	-	74	-25.88	150	183
	* 2.861	28.42	MAv1	32.4	-22.2	2.14	40.76	54	-13.24	-	-	150	183
2	* 2.86	37.62	PK2	32.4	-22.2	0	47.82	-	-	74	-26.18	191	397
	* 2.858	28.39	MAv1	32.4	-22.2	2.14	40.73	54	-13.27	-	-	191	397

* - indicates frequency in CFR47 Pt 15 Restricted Band

PK2 - KDB558074 Method: Maximum Peak

MAv1 - KDB558074 Option 1 Maximum RMS Average

2.4. REFERENCE DETAIL

Equipment Class	Reference FCC ID	Report Title/Section
DTS (BLE)	A3LSMA750GN	12440598-E3V1 FCC Report BLE

3. TEST METHODOLOGY

The tests documented in this report were performed in accordance with FCC CFR 47 Part 2, FCC CFR 47 Part 15, KDB 558074 D01 v4, ANSI C63.10-2013.

4. FACILITIES AND ACCREDITATION

The test sites and measurement facilities used to collect data are located at 47173 and 47266 Benicia Street, and 47658 Kato Road, Fremont, California, USA. Line conducted emissions are measured only at the 47173 address. The following table identifies which facilities were utilized for radiated emission measurements documented in this report. Specific facilities are also identified in the test results sections.

47173 Benicia Street	47266 Benicia Street	47658 Kato Rd.
<input checked="" type="checkbox"/> Chamber A (IC:2324B-1)	<input type="checkbox"/> Chamber D (IC:22541-1)	<input type="checkbox"/> Chamber I (IC: 2324A-5)
<input type="checkbox"/> Chamber B (IC:2324B-2)	<input type="checkbox"/> Chamber E (IC:22541-2)	<input type="checkbox"/> Chamber J (IC: 2324A-6)
<input type="checkbox"/> Chamber C (IC:2324B-3)	<input type="checkbox"/> Chamber F (IC:22541-3)	<input type="checkbox"/> Chamber K (IC: 2324A-1)
	<input type="checkbox"/> Chamber G (IC:22541-4)	<input checked="" type="checkbox"/> Chamber L (IC: 2324A-3)
	<input type="checkbox"/> Chamber H (IC:22541-5)	

The above test sites and facilities are covered under FCC Test Firm Registration # 208313. Chambers above are covered under Industry Canada company address and respective code

UL Verification Services Inc. is accredited by NVLAP, Laboratory Code 200065-0

5. CALIBRATION AND UNCERTAINTY

5.1. MEASURING INSTRUMENT CALIBRATION

The measuring equipment utilized to perform the tests documented in this report has been calibrated in accordance with the manufacturer's recommendations, and is traceable to recognized national standards.

5.2. SAMPLE CALCULATION

RADIATED EMISSIONS

Where relevant, the following sample calculation is provided:

Field Strength (dBuV/m) = Measured Voltage (dBuV) + Antenna Factor (dB/m) + Cable Loss (dB) – Preamp Gain (dB)
 36.5 dBuV + 18.7 dB/m + 0.6 dB – 26.9 dB = 28.9 dBuV/m

MAINS CONDUCTED EMISSIONS

Where relevant, the following sample calculation is provided:

Final Voltage (dBuV) = Measured Voltage (dBuV) + Cable Loss (dB) + Limiter Factor (dB) + LISN Insertion Loss.
 36.5 dBuV + 0 dB + 10.1 dB + 0 dB = 46.6 dBuV

5.3. MEASUREMENT UNCERTAINTY

Where relevant, the following measurement uncertainty levels have been estimated for tests performed on the apparatus:

PARAMETER	UNCERTAINTY
Worst Case Conducted Disturbance, 9KHz to 0.15 MHz	3.84 dB
Worst Case Conducted Disturbance, 0.15 to 30 MHz	3.65 dB
Worst Case Radiated Disturbance, 9KHz to 30 MHz	3.15 dB
Worst Case Radiated Disturbance, 30 to 1000 MHz	5.36 dB
Worst Case Radiated Disturbance, 1000 to 18000 MHz	4.32 dB
Worst Case Radiated Disturbance, 18000 to 26000 MHz	4.45 dB
Worst Case Radiated Disturbance, 26000 to 40000 MHz	5.24 dB

Uncertainty figures are valid to a confidence level of 95%.

6. EQUIPMENT UNDER TEST

6.1. EUT DESCRIPTION

The EUT is a GSM/WCDMA/LTE phone with BT, DTS/UNII a/b/g/n/ac, and ANT+.

6.2. MAXIMUM OUTPUT POWER

The transmitter has a maximum peak conducted output power as follows:

Frequency Range (MHz)	Mode	Output Power (dBm)	Output Power (mW)
2402 - 2480	BLE	5.40	3.47

6.3. DESCRIPTION OF AVAILABLE ANTENNAS

The radio utilizes an internal antenna, with a maximum gain of -1.71 dBi.

6.4. SOFTWARE AND FIRMWARE

The test utility software used during testing was A750G.001

6.5. WORST-CASE CONFIGURATION AND MODE

Radiated emissions below 1GHz, above 18GHz, and power line conducted emission were performed with the EUT set to transmit at the channel with highest output power as worst-case scenario.

Band edge and radiated emissions between 1GHz and 18GHz were performed with the EUT set to transmit at the highest power on low, middle and high channels.

The fundamental of the EUT was investigated in three orthogonal orientations X,Y and Z it was determined that X orientation was worst-case orientation; therefore, all final radiated testing was performed with the EUT in X orientation.

6.6. DESCRIPTION OF TEST SETUP

SUPPORT EQUIPMENT

Support Equipment List				
Description	Manufacturer	Model	Serial Number	FCC ID
AC Adapter	Samsung	EP-TA50EWE	DW3J719AS/A-E	N/A
Earphone	Samsung	N/A	N/A	N/A

I/O CABLES (CONDUCTED TEST)

I/O Cable List						
Cable No	Port	# of identical ports	Connector Type	Cable Type	Cable Length (m)	Remarks
1	Antenna	1	RF	Shielded	0.2	To spectrum Analyzer
2	USB	1	USB	Un-shielded	1	EUT to AC Mains

I/O CABLES (RADIATED AND CONDUCTED EMISSIONS)

I/O Cable List						
Cable No	Port	# of identical ports	Connector Type	Cable Type	Cable Length (m)	Remarks
1	USB	1	USB	Shielded	1	N/A
2	earphone	1	3.5mm	Un-shielded	1	N/A

TEST SETUP

The EUT is a stand alone. Test software exercised the radio card.

CONDCUTED TEST SETUP DIAGRAM

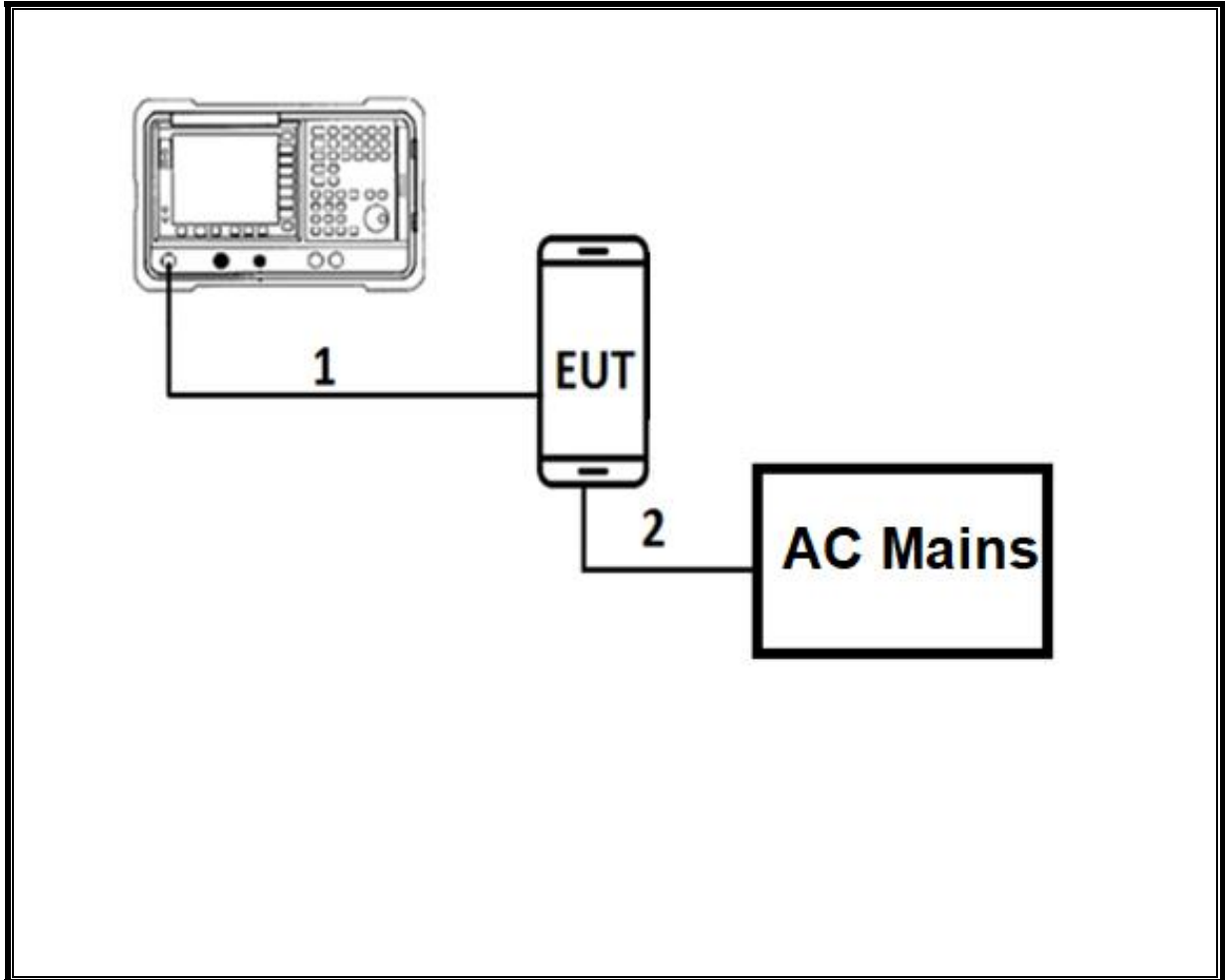

TEST SETUP

For conducted tests: the EUT was Stand alone. The test software exercises the radio.

RADIATED AND AC LINE CONDUCTED EMISSIONS SETUP DIAGRAM

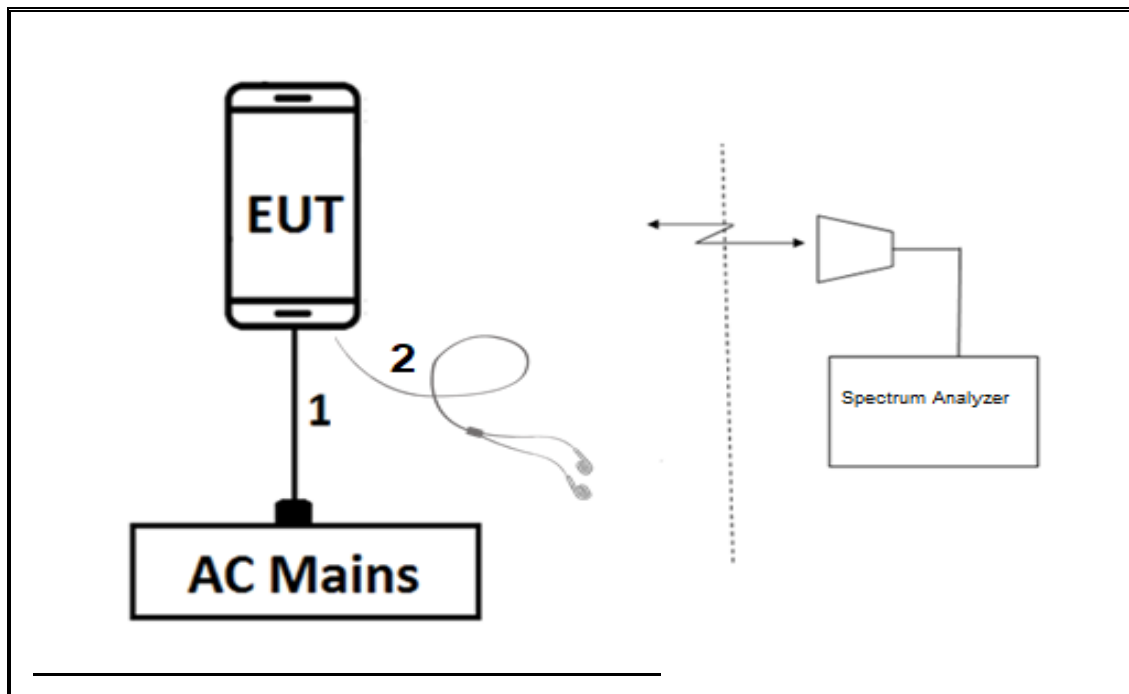

TEST SETUP

For radiated tests: EUT is Stand alone. The test software exercises the radio.

7. MEASUREMENT METHOD

On Time and Duty Cycle: KDB 558074 D01 v04, Section 6.

6 dB BW: KDB 558074 D01 v04, Section 8.1.

Output Power: KDB 558074 D01 v04, Section 9.1.3.

Power Spectral Density: KDB 558074 D01 v04, Section 10.2.

Out-of-band emissions in non-restricted bands: KDB 558074 D01 v04, Section 11.0.

Out-of-band emissions in restricted bands: KDB 558074 D01 v04, Section 12.1.

Band-edge: KDB 558074 D01 v04, Section 12.1.

AC Power Line Conducted Emissions: ANSI C63.10-2013, Section 6.2.

8. TEST AND MEASUREMENT EQUIPMENT

The following test and measurement equipment was utilized for the tests documented in this report:

TEST EQUIPMENT LIST (ORIGINAL)					
Description	Manufacturer	Model	ID Num	Cal Due	Last Cal
Amplifier, 10KHz to 1GHz, 32dB	Agilent (Keysight) Technologies	8447D	T15	08/14/2019	08/14/2018
Antenna, Broadband Hybrid, 30MHz to 2000MHz	Sunol Sciences Corp.	JB3	T130	10/16/2018	10/16/2017
Antenna, Horn 1-18GHz	ETS-Lindgren	3117	T4294	04/30/2019	04/30/2018
RF Amplifier, 1-18GHz	MITEQ	AFS42-00101800-25-S-42	T1568	06/21/2019	06/21/2018
Amplifier 1-8GHz 30dB gain	L3 Narda	AMF-4D-01000800-30-29P	167495	06/22/2019	06/22/2018
Power Meter, P-series single channel	Agilent (Keysight) Technologies	N1911A	T1269	04/05/2019	04/05/2018
Power Sensor, P-series, 50MHz to 18GHz, Wideband	Agilent (Keysight) Technologies	N1921A	T1225	04/10/2019	04/10/2018
EMI Receiver	Rohde & Schwarz	ESR	T1436	02/21/2019	02/21/2018
L.I.S.N.	FCC INC.	FCC LISN 50/250	T1310	06/15/2019	06/15/2018
L.I.S.N.	FCC INC.	FCC LISN 50/250	T24	03/06/2019	03/06/2018
Antenna, Active Loop 9kHz-30MHz	Com-Power Corp.	AL-130R	T1866	10/10/2018	10/10/2017
EMI TEST RECEIVER	Rohde & Schwarz	ESW44	PRE0179522	05/11/2019	05/11/2019
Spectrum Analyzer, PXA, 3Hz to 44GHz	Agilent (Keysight) Technologies	N9030A	T200	11/18/2018	11/18/2017
Spectrum Analyzer, PXA, 3Hz to 44GHz	Agilent (Keysight) Technologies	N9030A	T1454	01/08/2019	01/08/2018
18 - 26.5 GHz Horn Antenna	Seavey Division	MWH-1826/B	T89	01/18/2019	01/18/2018
Pre-Amp 1-26.5 GHz	Agilent	8449B	T404	03/09/2019	023/09/2018

Test Software List			
Description	Manufacturer	Model	Version
Radiated Software	UL	UL EMC	Rev 9.5, Jun 22, 2018
Antenna Port Software	UL	UL RF	Ver 8.7, Aug 9, 2018

TEST EQUIPMENT LIST (SPOT CHECK)					
Description	Manufacturer	Model	ID Num	Cal Due	Last Cal
Antenna, Horn 1-18GHz	ETS-Lindgren	3117	EMC4294	04/17/2019	04/30/2018
RF Amplifier, 1-18GHz	MITEQ Inc	AFS-00101800-25-S-42	T1568	06/21/2019	06/21/2018
EMI Receiver	Rohde & Schwarz	ESR	T1436	02/21/2019	02/21/2018

Test Software List			
Description	Manufacturer	Model	Version
Radiated Software	UL	UL EMC	Ver 9.5, June 22, 2018

9. ANTENNA PORT TEST RESULTS

9.1. ON TIME AND DUTY CYCLE

LIMITS

None; for reporting purposes only.

PROCEDURE

ON TIME AND DUTY CYCLE RESULTS

Mode	ON Time B (msec)	Period (msec)	Duty Cycle x (linear)	Duty Cycle (%)	Duty Cycle Correction Factor (dB)	1/B Minimum VBW (kHz)
2.4GHz Band						
BLE	0.383	0.627	0.611	61.07%	2.14	2.611

DUTY CYCLE PLOT

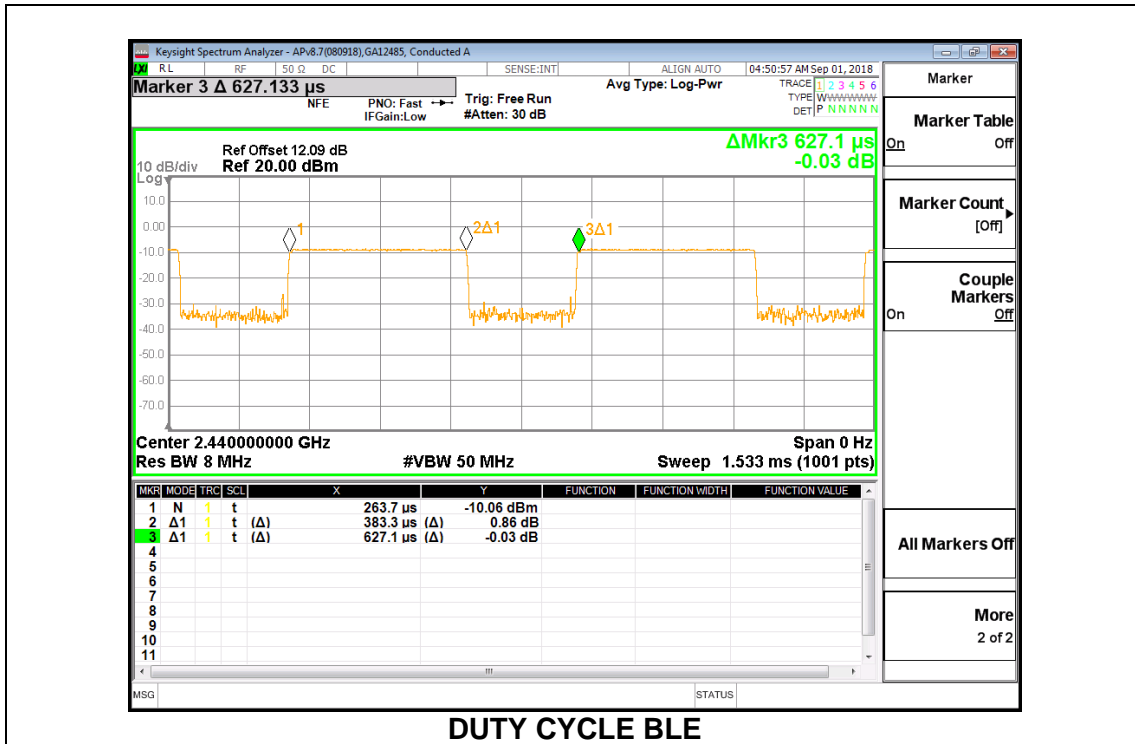

9.2. 99% BANDWIDTH

LIMITS

None; for reporting purposes only.

RESULTS

Channel	Frequency (MHz)	99% Bandwidth (MHz)
Low	2402	1.0540
Middle	2440	1.0520
High	2480	1.0510

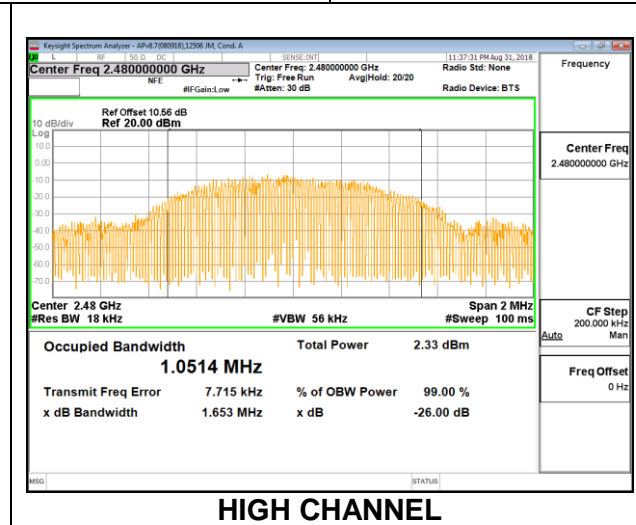
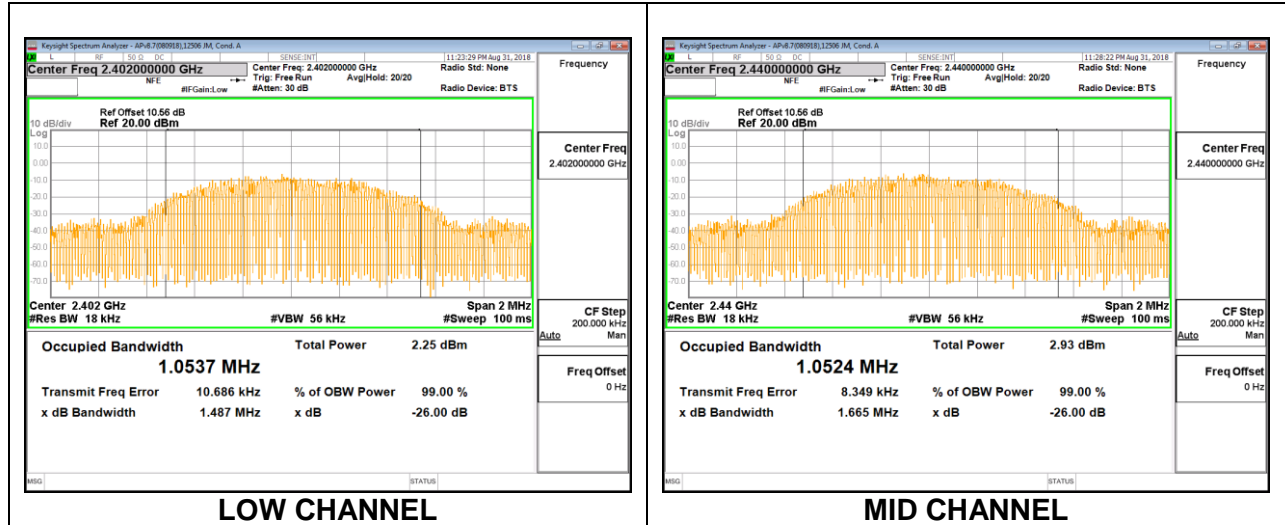

9.3. 6 dB BANDWIDTH

LIMITS

FCC §15.247 (a) (2)

The minimum 6 dB bandwidth shall be at least 500 kHz.

RESULTS

Channel	Frequency (MHz)	6 dB Bandwidth (MHz)	Minimum Limit (MHz)
Low	2402	0.7080	0.5
Middle	2440	0.6900	0.5
High	2480	0.6870	0.5

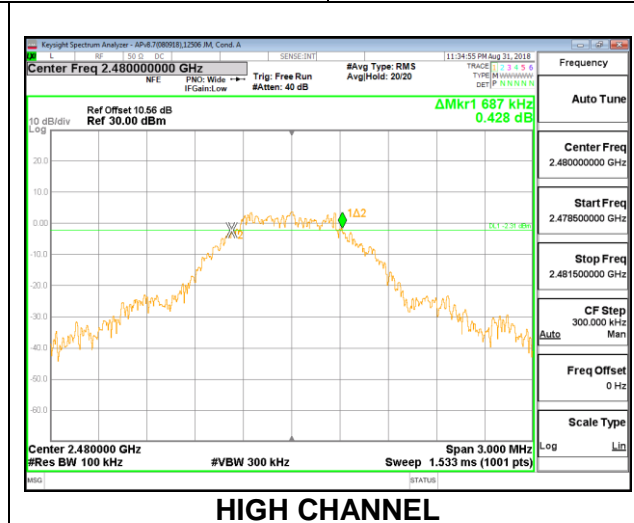
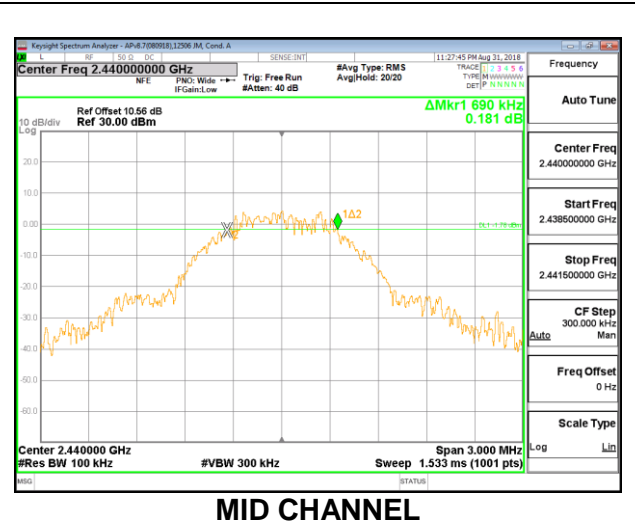
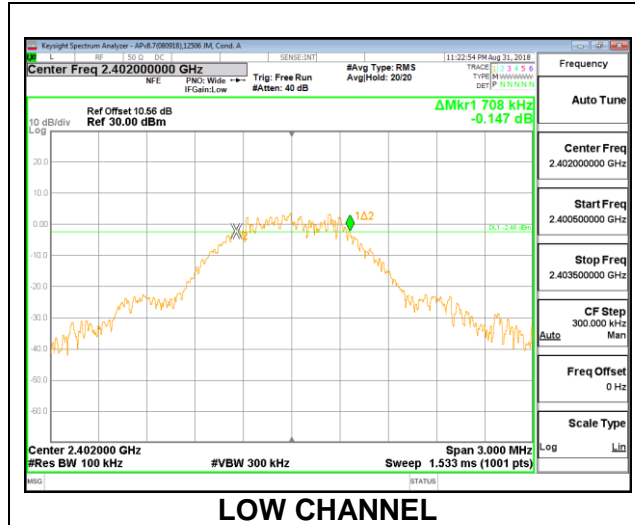

9.4. OUTPUT POWER

LIMITS

FCC §15.247 (b) (3)

The maximum antenna gain is less than or equal to 6 dBi, therefore the limit is 30 dBm.

TEST PROCEDURE

The transmitter output is connected to a power meter.

The cable assembly insertion loss was entered as an offset in the power meter to allow for a gated peak reading of power.

RESULTS

Tested By:	12506 JM
Date:	8/31/2018

Channel	Frequency (MHz)	Peak Power Reading (dBm)	Limit (dBm)	Margin (dB)
Low	2402	4.93	30	-25.070
Middle	2440	5.40	30	-24.600
High	2480	4.84	30	-25.160

9.5. AVERAGE POWER

LIMITS

None; for reporting purposes only.

TEST PROCEDURE

The transmitter output is connected to a power meter.

The cable assembly insertion loss was entered as an offset in the power meter to allow for a gated average reading of power.

RESULTS

Tested By:	12506 JM
Date:	8/31/2018

Channel	Frequency (MHz)	AV power (dBm)
Low	2402	4.21
Middle	2440	4.80
High	2480	4.23

9.6. POWER SPECTRAL DENSITY

LIMITS

FCC §15.247 (e)

The power spectral density conducted from the transmitter to the antenna shall not be greater than 8 dBm in any 3 kHz band during any time interval of continuous transmission.

RESULTS

Channel	Frequency (MHz)	PSD (dBm/3kHz)	Limit (dBm/3kHz)	Margin (dB)
Low	2402	-10.99	8	-18.99
Middle	2440	-10.29	8	-18.29
High	2480	-10.79	8	-18.79

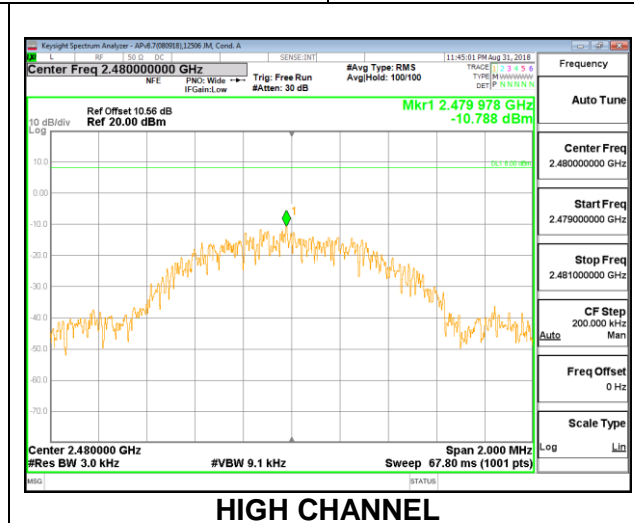
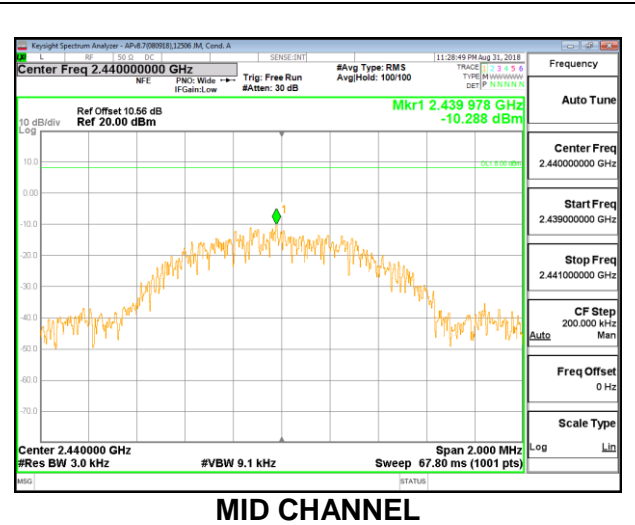
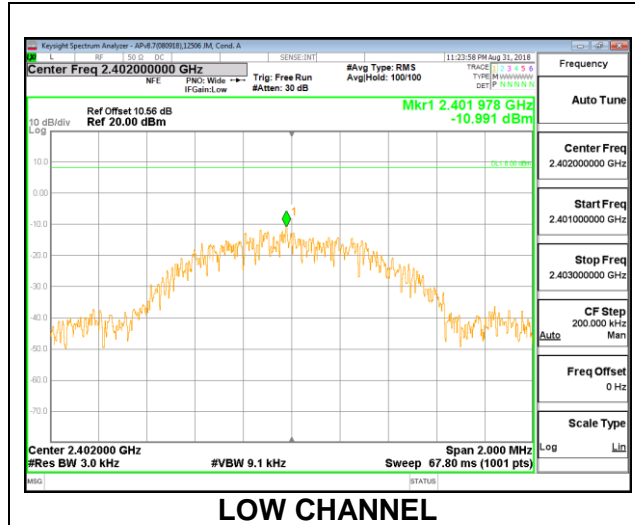

9.7. CONDUCTED SPURIOUS EMISSIONS

LIMITS

FCC §15.247 (d)

Output power was measured based on the use of a peak measurement, therefore the required attenuation is 20 dB.

RESULTS

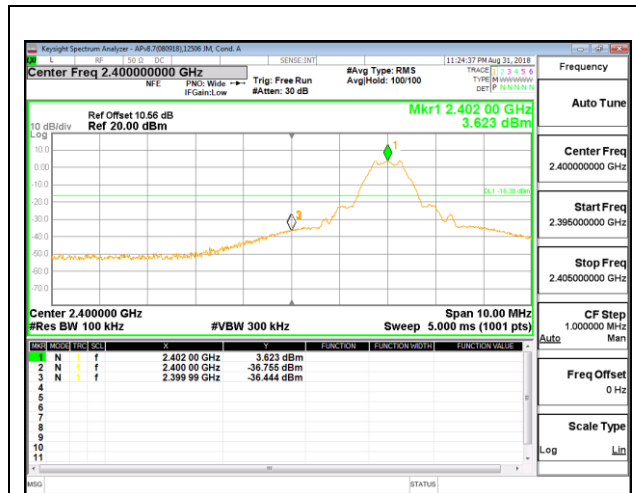

LOW CHANNEL BANDEDGE

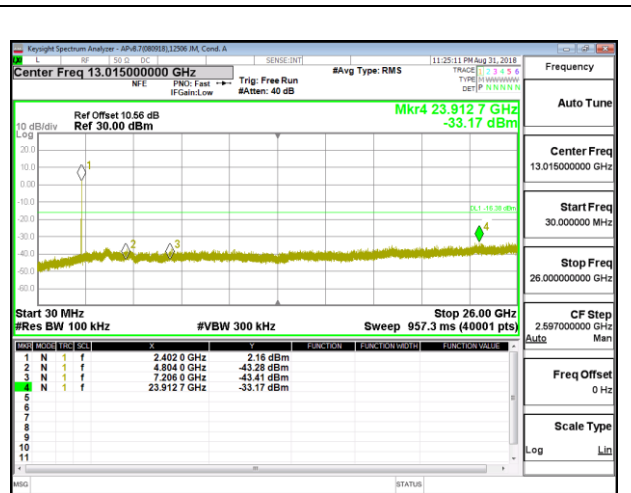

OUT-OF-BAND LOW CHANNEL

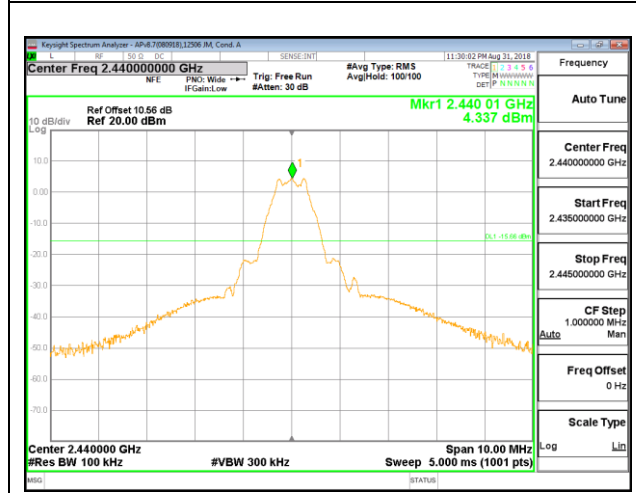

IN-BAND REFERENCE LEVEL

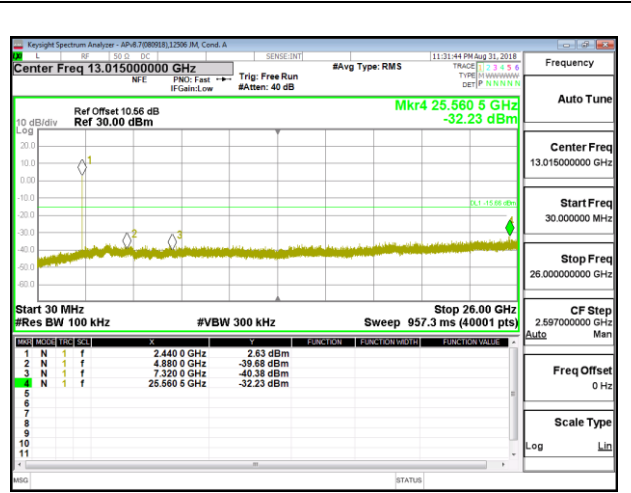

OUT-OF-BAND MID CHANNEL

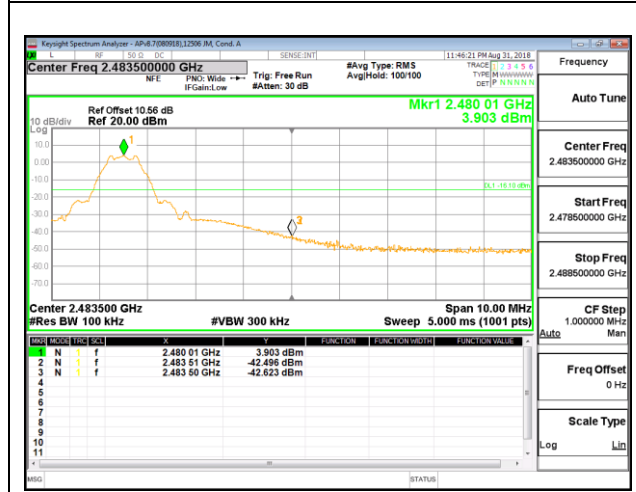

HIGH CHANNEL BANDEDGE

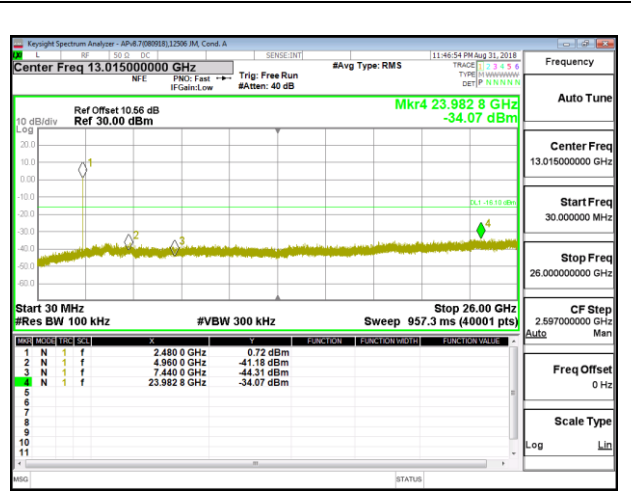

OUT-OF-BAND HIGH CHANNEL

10. RADIATED TEST RESULTS

10.1. LIMITS AND PROCEDURE

LIMITS

FCC §15.205 and §15.209

Frequency Range (MHz)	Field Strength Limit (uV/m) at 3 m	Field Strength Limit (dBuV/m) at 3 m
0.009-0.490	2400/F(kHz) @ 300 m	-
0.490-1.705	24000/F(kHz) @ 30 m	-
1.705 - 30	30 @ 30m	-
30 - 88	100	40
88 - 216	150	43.5
216 - 960	200	46
Above 960	500	54

TEST PROCEDURE

The EUT is placed on a non-conducting table 80 cm above the ground plane for measurement below 1GHz; 1.5 m above the ground plane for measurement above 1GHz. The antenna to EUT distance is 3 meters. The EUT is configured in accordance with ANSI C63.10. The EUT is set to transmit in a continuous mode.

For measurements below 1 GHz the resolution bandwidth is set to 100 kHz for peak detection measurements or 120 kHz for quasi-peak detection measurements. Peak detection is used unless otherwise noted as quasi-peak.

For pre-scans above 1 GHz the resolution bandwidth is set to 1 MHz; the video bandwidth is set to 30 KHz for peak measurements.

For final measurements above 1 GHz the resolution bandwidth is set to 1 MHz; the video bandwidth is set to 3 MHz for peak measurements and as applicable for average measurements.

The spectrum from 1 GHz to 18 GHz is investigated with the transmitter set to the lowest, middle, and highest channels in each applicable band. Below 1GHz and above 18GHz emissions, the channel with the highest output power was tested.

The frequency range of interest is monitored at a fixed antenna height and EUT azimuth. The EUT is rotated through 360 degrees to maximize emissions received. The antenna is scanned from 1 to 4 meters above the ground plane to further maximize the emission. Measurements are made with the antenna polarized in both the vertical and the horizontal positions.

10.2. TRANSMITTER ABOVE 1 GHz

BANDEDGE (LOW CHANNEL)

HORIZONTAL RESULT

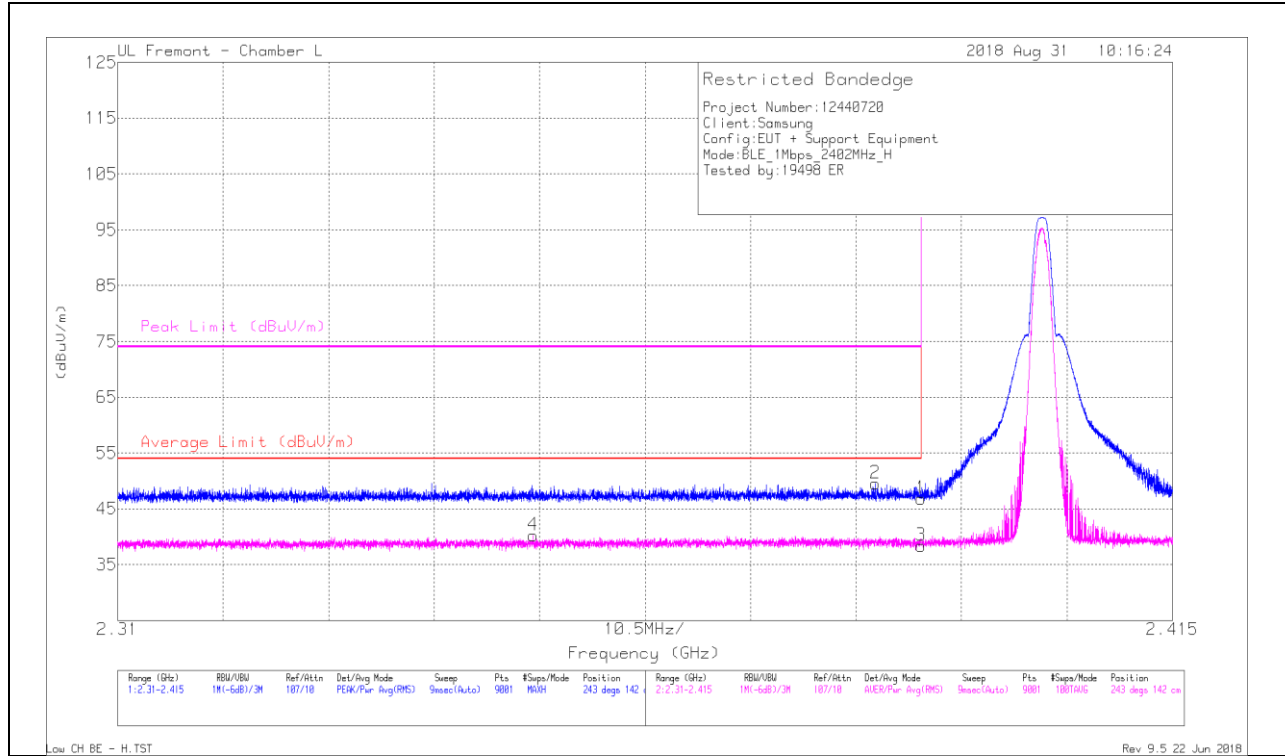

Trace Markers

Marker	Frequency (GHz)	Meter Reading (dBuV)	Det	AF EMC4294 (dB/m)	Amp/Cbl/Filtr/Pad (dB)	DC Corr (dB)	Corrected Reading (dBuV/m)	Average Limit (dBuV/m)	Margin (dB)	Peak Limit (dBuV/m)	PK Margin (dB)	Azimuth (Degs)	Height (cm)	Polarity
1	* 2.39	37.96	Pk	31.8	-22.9	0	46.86	-	-	74	-27.14	243	142	H
2	* 2.385	40.66	Pk	31.8	-22.9	0	49.56	-	-	74	-24.44	243	142	H
3	* 2.39	27.29	RMS	31.8	-22.9	2.14	38.33	54	-15.67	-	-	243	142	H
4	* 2.351	29.58	RMS	31.5	-23	2.14	40.22	54	-13.78	-	-	243	142	H

* - indicates frequency in CFR47 Pt 15 Restricted Band

Pk - Peak detector

RMS - RMS detection

VERTICAL RESULT

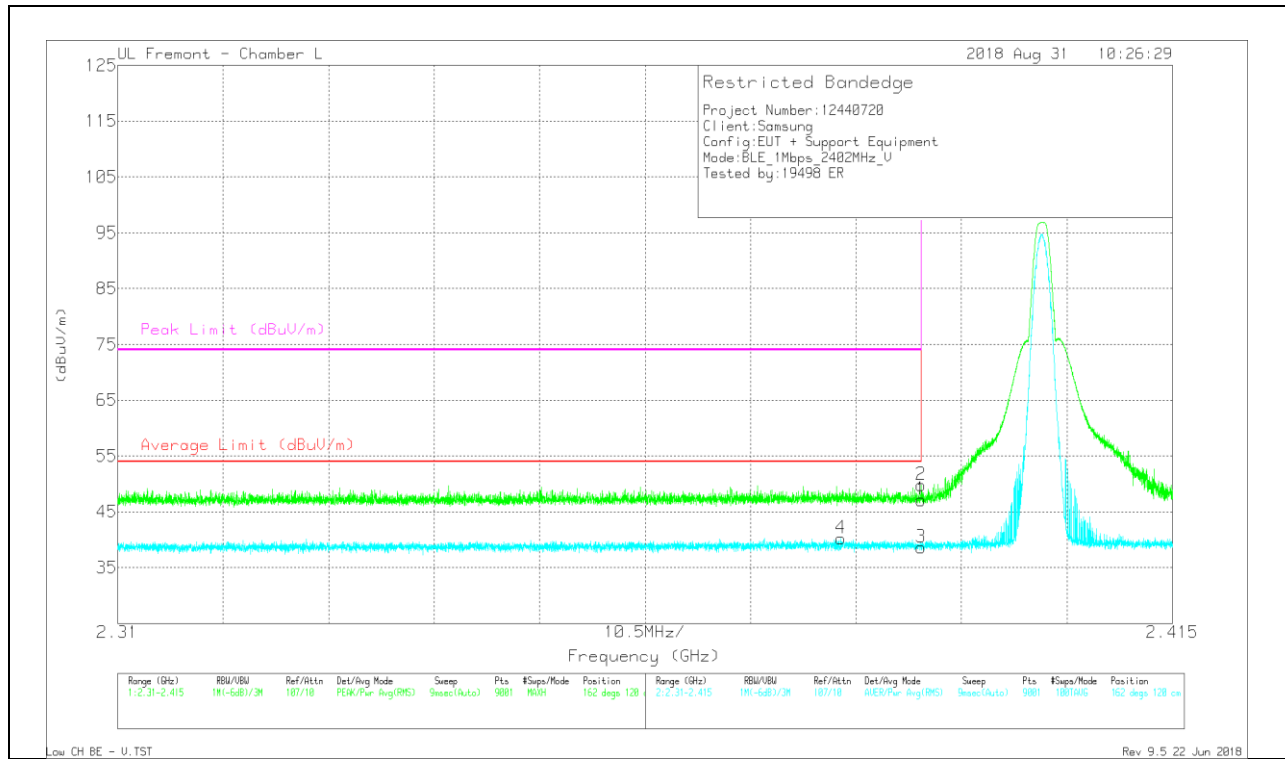

Trace Markers

Marker	Frequency (GHz)	Meter Reading (dBuV)	Det	AF EMC4294 (dB/m)	Amp/Cb/Filtr/Pad (dB)	DC Corr (dB)	Corrected Reading (dBuV/m)	Average Limit (dBuV/m)	Margin (dB)	Peak Limit (dBuV/m)	PK Margin (dB)	Azimuth (Degs)	Height (cm)	Polarity
1	* 2.39	38.23	Pk	31.8	-22.9	0	47.13	-	-	74	-26.87	162	120	V
2	* 2.39	40.91	Pk	31.8	-22.9	0	49.81	-	-	74	-24.19	162	120	V
3	* 2.39	27.53	RMS	31.8	-22.9	2.14	38.57	54	-15.43	-	-	162	120	V
4	* 2.382	29.25	RMS	31.7	-22.9	2.14	40.19	54	-13.81	-	-	162	120	V

* - indicates frequency in CFR47 Pt 15 Restricted Band
 Pk - Peak detector
 RMS - RMS detection

BANDEDGE (HIGH CHANNEL)

HORIZONTAL RESULT

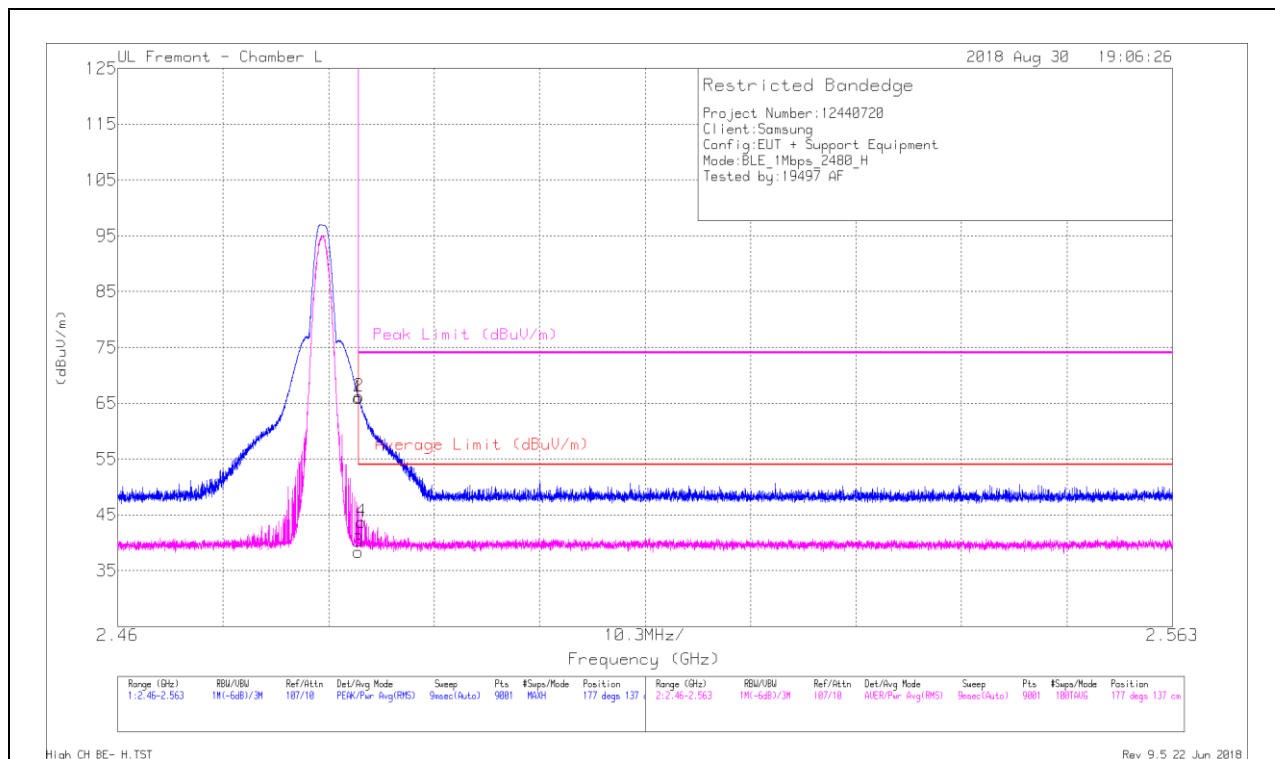

Trace Markers

Marker	Frequency (GHz)	Meter Reading (dBuV)	Det	AF EMC4294 (dB/m)	Amp/Cbl/Filtr/Pad (dB)	DC Corr (dB)	Corrected Reading (dBuV/m)	Average Limit (dBuV/m)	Margin (dB)	Peak Limit (dBuV/m)	PK Margin (dB)	Azimuth (Degs)	Height (cm)	Polarity
1	* 2.484	56.33	Pk	32.3	-22.7	0	65.93	-	-	74	-8.07	177	137	H
2	* 2.484	56.61	Pk	32.3	-22.7	0	66.21	-	-	74	-7.79	177	137	H
3	* 2.484	28.79	RMS	32.3	-22.7	2.14	40.53	54	-13.47	-	-	177	137	H
4	* 2.484	34.09	RMS	32.3	-22.7	2.14	45.83	54	-8.17	-	-	177	137	H

* - indicates frequency in CFR47 Pt 15 Restricted Band
 Pk - Peak detector
 RMS - RMS detection

VERTICAL RESULT

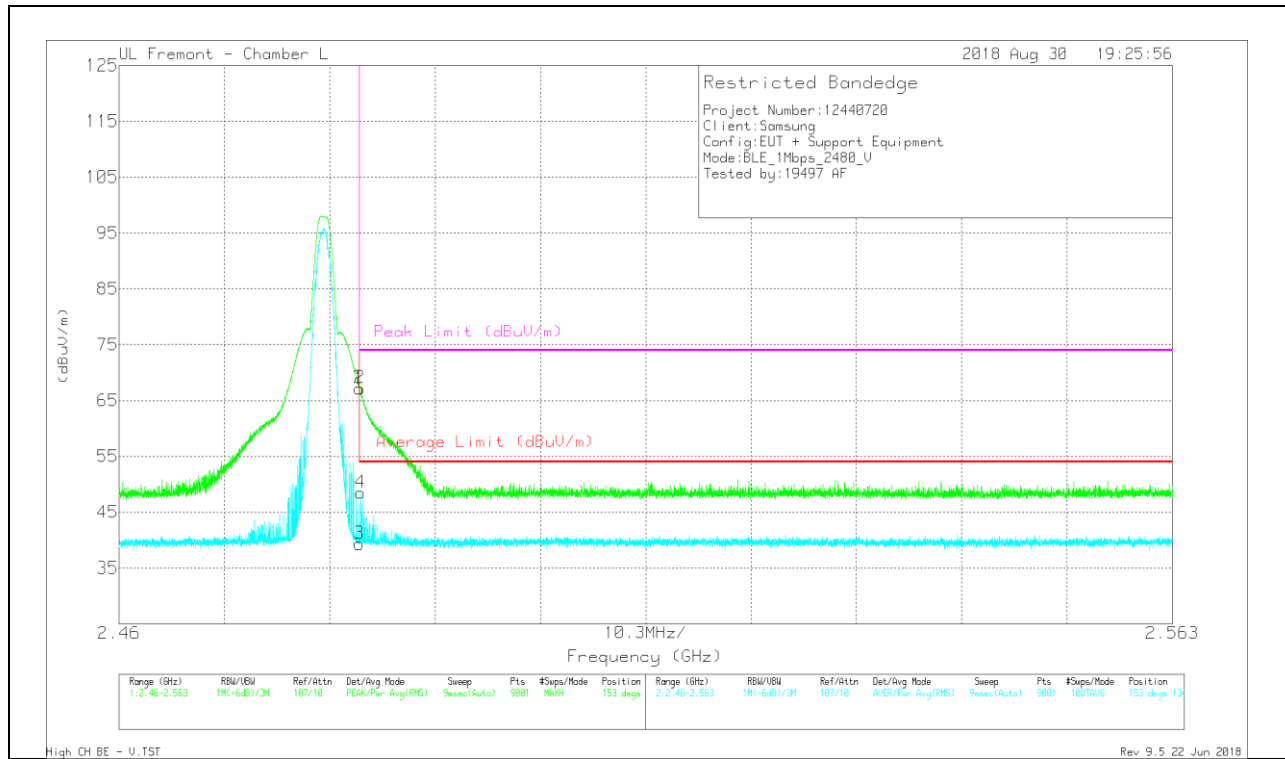

Trace Markers

Marker	Frequency (GHz)	Meter Reading (dBuV)	Det	AF EMC4294 (dB/m)	Amp/Cb/Filtr/Pad (dB)	DC Corr (dB)	Corrected Reading (dBuV/m)	Average Limit (dBuV/m)	Margin (dB)	Peak Limit (dBuV/m)	PK Margin (dB)	Azimuth (Degs)	Height (cm)	Polarity
1	* 2.484	57.51	Pk	32.3	-22.7	0	67.11	-	-	74	-6.89	153	134	V
2	* 2.484	57.58	Pk	32.3	-22.7	0	67.18	-	-	74	-6.82	153	134	V
3	* 2.484	27.58	RMS	32.3	-22.7	2.14	39.32	54	-14.68	-	-	153	134	V
4	* 2.484	36.73	RMS	32.3	-22.7	2.14	48.47	54	-5.53	-	-	153	134	V

* - indicates frequency in CFR47 Pt 15 Restricted Band
 Pk - Peak detector
 RMS - RMS detection

HARMONICS AND SPURIOUS EMISSIONS

LOW CHANNEL RESULTS

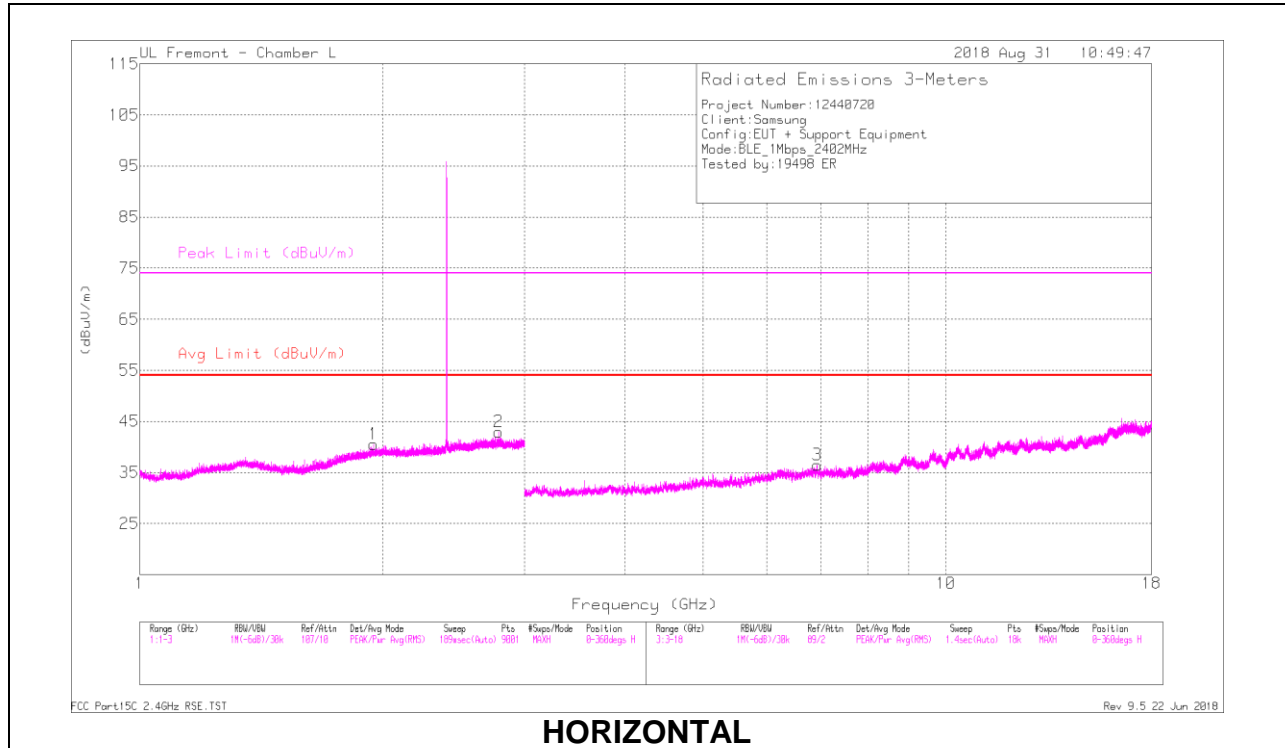

HORIZONTAL

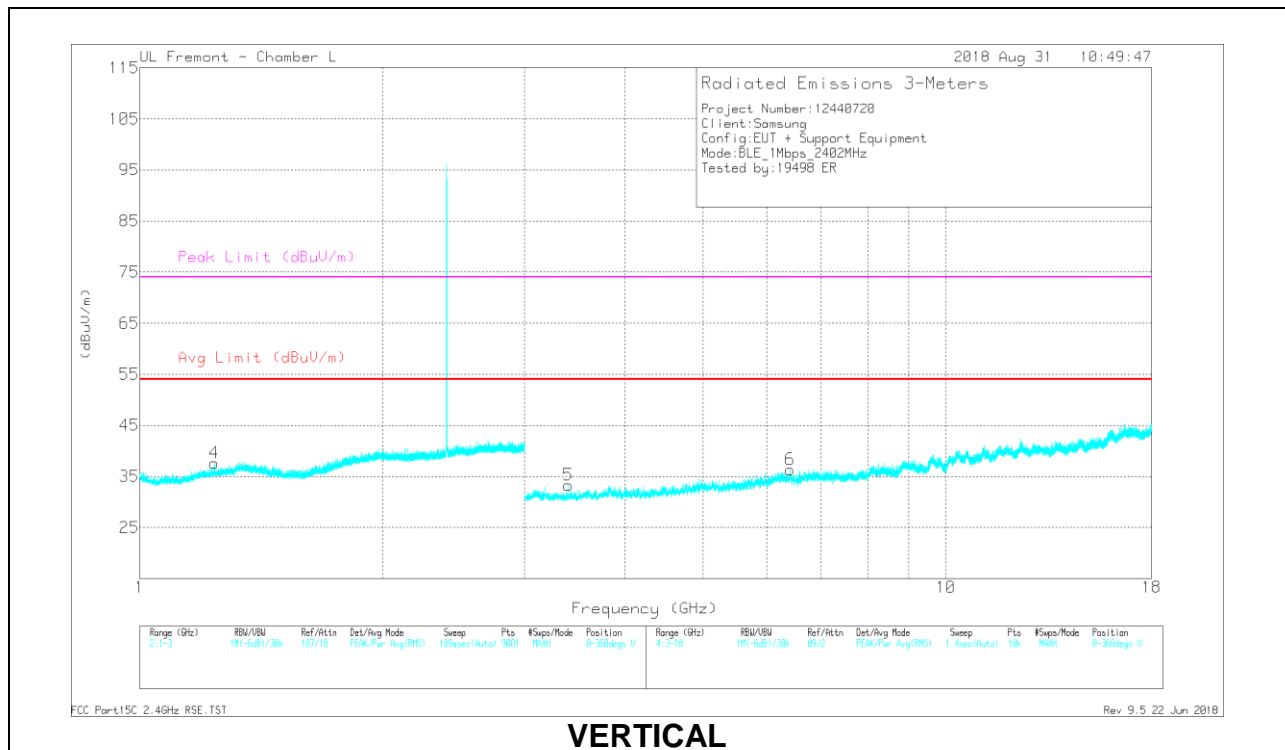

VERTICAL

RADIATED EMISSIONS

Marker	Frequency (GHz)	Meter Reading (dBuV)	Det	AF EMC4294 (dB/m)	Amp/Cbl/Filtr/Pad (dB)	DC Corr (dB)	Corrected Reading (dBuV/m)	Avg Limit (dBuV/m)	Margin (dB)	Peak Limit (dBuV/m)	PK Margin (dB)	Azimuth (Degs)	Height (cm)	Polarity
1	1.948	37.56	PK2	31.4	-23.6	0	45.36	-	-	-	-	79	171	H
2	* 2.789	38.44	PK2	32.6	-22.2	0	48.84	-	-	74	-25.16	341	150	H
	* 2.788	27.99	MAv1	32.6	-22.2	2.14	40.53	54	-13.47	-	-	341	150	H
4	* 1.235	38.21	PK2	28.6	-25	0	41.81	-	-	74	-32.19	276	127	V
	* 1.234	30.04	MAv1	28.6	-25	2.14	35.78	54	-18.22	-	-	276	127	V
3	6.923	30.74	PK2	35.7	-25.4	0	41.04	-	-	-	-	270	227	H
5	3.402	35.37	PK2	32.8	-30.2	0	37.97	-	-	-	-	208	133	V
6	6.416	32.79	PK2	35.7	-26.3	0	42.19	-	-	-	-	335	150	V

* - indicates frequency in CFR47 Pt 15 Restricted Band

PK2 - KDB558074 Method: Maximum Peak

MAv1 - KDB558074 Option 1 Maximum RMS Average

MID CHANNEL RESULTS

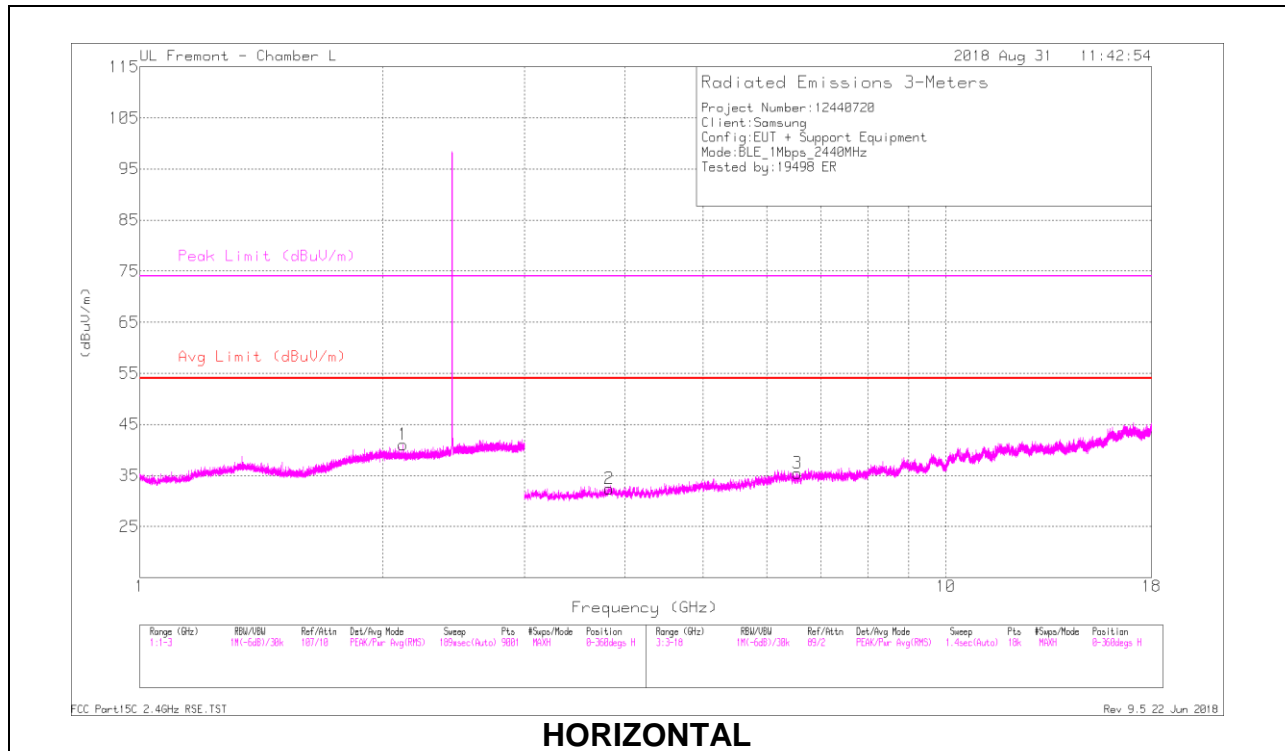

HORIZONTAL

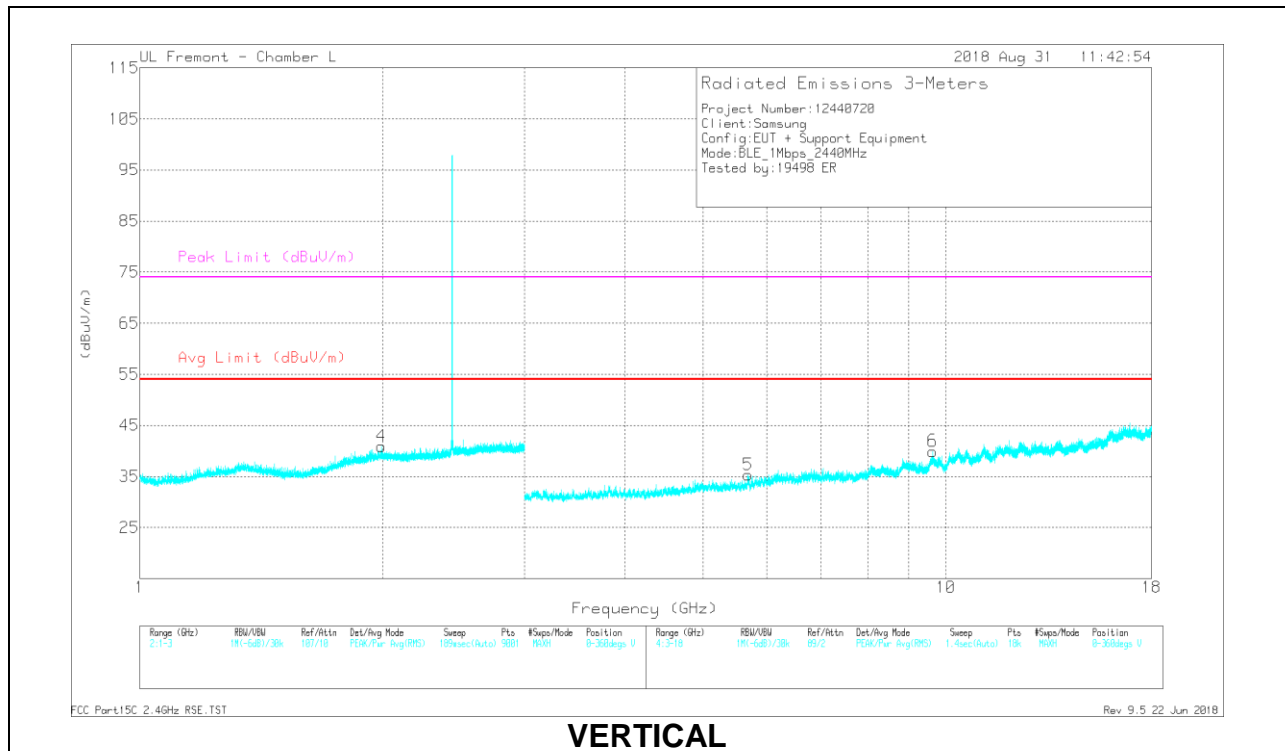

VERTICAL

RADIATED EMISSIONS

Marker	Frequency (GHz)	Meter Reading (dBuV)	Det	AF EMC4294 (dB/m)	Amp/Cbl/Filtr/Pad (dB)	DC Corr (dB)	Corrected Reading (dBuV/m)	Avg Limit (dBuV/m)	Margin (dB)	Peak Limit (dBuV/m)	PK Margin (dB)	Azimuth (Degs)	Height (cm)	Polarity
1	2.12	37.95	PK2	31.4	-23.3	0	46.05	-	-	-	-	59	127	H
4	1.993	36.86	PK2	31.7	-23.5	0	45.06	-	-	-	-	147	108	V
2	* 3.826	35.02	PK2	33.7	-30.3	0	38.42	-	-	74	-35.58	193	263	H
	* 3.828	27.46	MAv1	33.7	-30.2	2.14	33.1	54	-20.9	-	-	193	263	H
3	6.549	31.09	PK2	35.6	-26.7	0	39.99	-	-	-	-	253	168	H
5	5.688	33.13	PK2	34.9	-27.1	0	40.93	-	-	-	-	320	212	V
6	9.627	28.49	PK2	37	-20.8	0	44.69	-	-	-	-	114	155	V

* - indicates frequency in CFR47 Pt 15 Restricted Band
 PK2 - KDB558074 Method: Maximum Peak
 MAv1 - KDB558074 Option 1 Maximum RMS Average

HIGH CHANNEL RESULTS

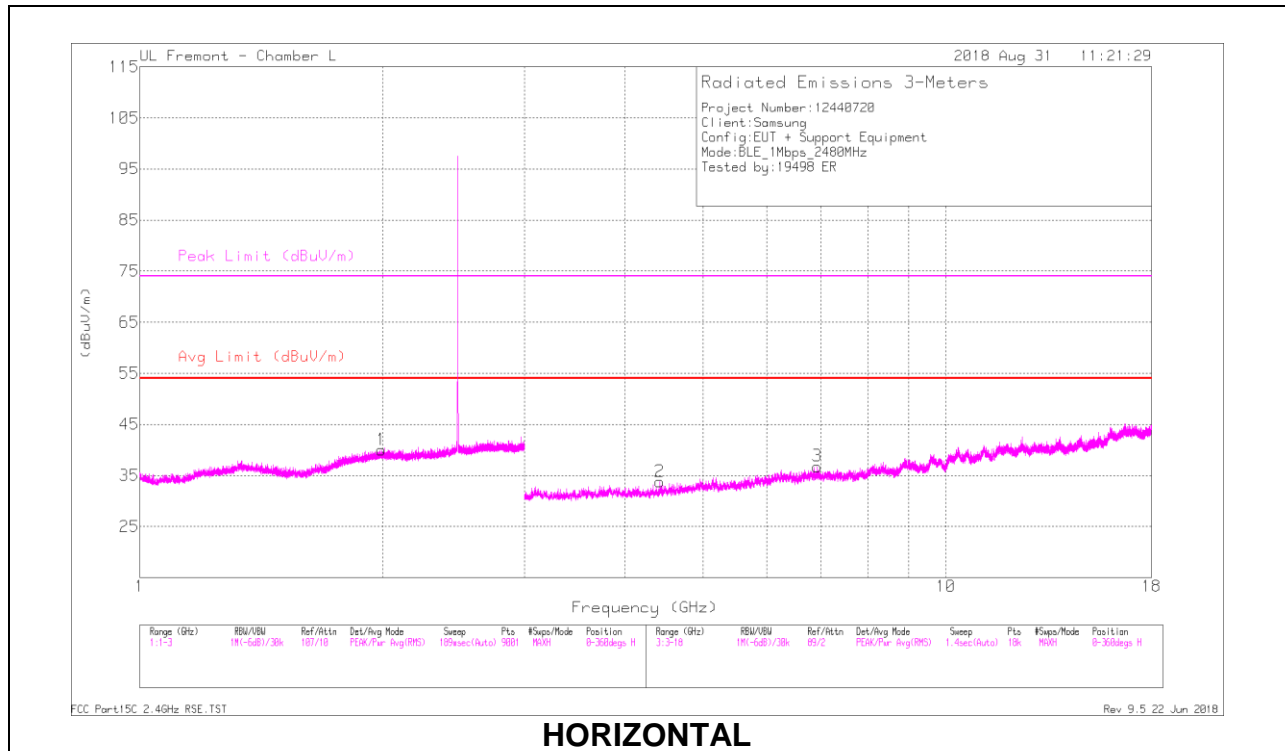

HORIZONTAL

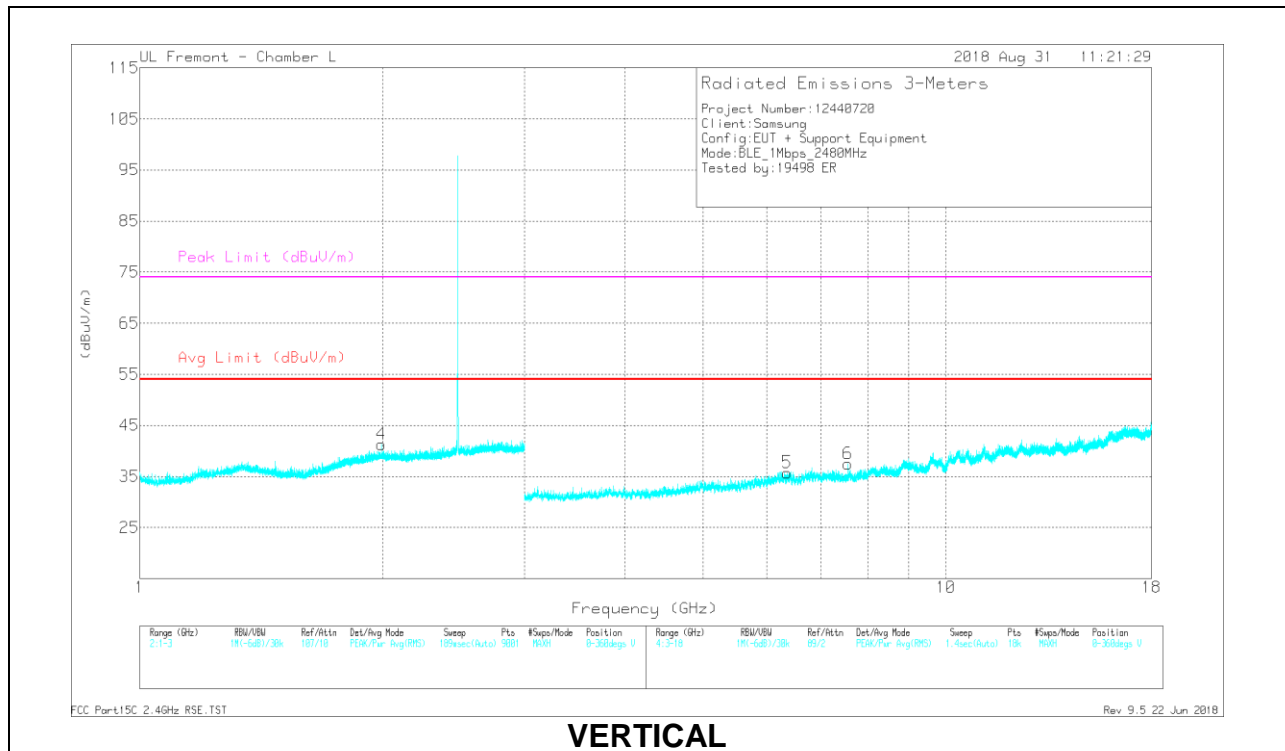

VERTICAL

RADIATED EMISSIONS

Marker	Frequency (GHz)	Meter Reading (dBuV)	Det	AF EMC4294 (dB/m)	Amp/Cbl/Filtr/Pad (dB)	DC Corr (dB)	Corrected Reading (dBuV/m)	Avg Limit (dBuV/m)	Margin (dB)	Peak Limit (dBuV/m)	PK Margin (dB)	Azimuth (Degs)	Height (cm)	Polarity
1	1.992	38.03	PK2	31.7	-23.6	0	46.13	-	-	-	-	297	123	H
4	1.993	37.31	PK2	31.7	-23.6	0	45.41	-	-	-	-	335	189	V
2	4.419	34.03	PK2	33.6	-29.2	0	38.43	-	-	-	-	176	221	H
3	6.927	31.13	PK2	35.7	-25.3	0	41.53	-	-	-	-	89	167	H
5	6.361	32.85	PK2	35.7	-26.7	0	41.85	-	-	-	-	36	252	V
6	* 7.566	30.11	PK2	35.7	-24.5	0	41.31	-	-	74	-32.69	131	166	V
	* 7.566	21.98	MAv1	35.7	-24.5	2.14	35.32	54	-18.68	-	-	131	166	V

* - indicates frequency in CFR47 Pt 15 Restricted Band
 PK2 - KDB558074 Method: Maximum Peak
 MAv1 - KDB558074 Option 1 Maximum RMS Average

10.3. Worst Case Below 30 MHz

SPURIOUS EMISSIONS 9 kHz TO 30 MHz (WORST-CASE CONFIGURATION)

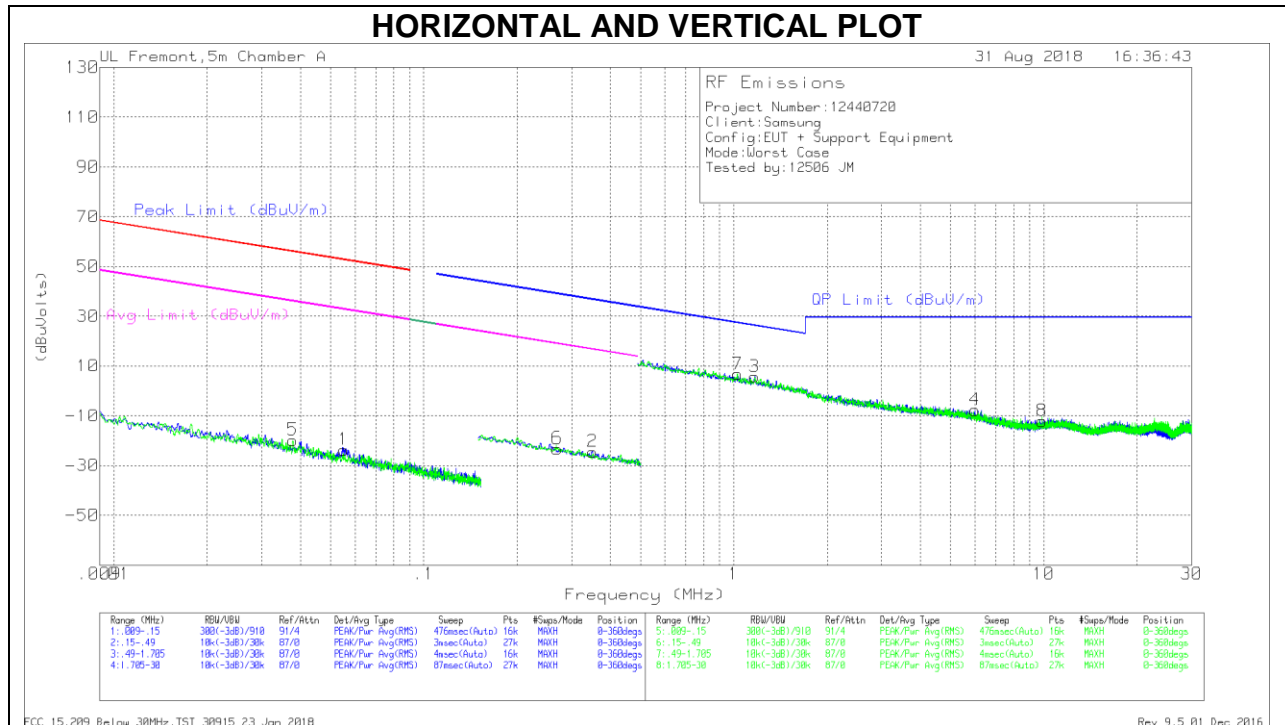

NOTE: KDB 414788 OATS and Chamber Correlation Justification

- Based on FCC 15.31 (f) (2): measurements may be performed at a distance closer than that specified in the regulations; however, an attempt should be made to avoid making measurements in the near field.
- OATs and chamber correlation testing had been performed and chamber measured test result is the worst case test result.

Below 30 MHz Data

Trace Markers

Marker	Frequency (MHz)	Meter Reading (dBuV)	Det	Loop Antenna (dB/m)	Cbl (dB)	Dist Corr 300m	Corrected Reading (dBuVolts)	Peak Limit (dBuV/m)	Margin (dB)	Avg Limit (dBuV/m)	Margin (dB)	Peak Limit (dBuV/m)	Margin (dB)	Avg Limit (dBuV/m)	Margin (dB)	Azimuth (Degs)
5	.03781	45.2	Pk	14.9	.1	-80	-19.8	56.03	-75.83	36.03	-55.83	-	-	-	-	0-360
1	.05507	41.92	Pk	14.3	.1	-80	-23.68	52.77	-76.45	32.77	-56.45	-	-	-	-	0-360
6	.26937	43.01	Pk	13.7	.1	-80	-23.19	-	-	-	-	39.01	-62.2	19.01	-42.2	0-360
2	.35047	41.71	Pk	13.7	.1	-80	-24.49	-	-	-	-	36.72	-61.21	16.72	-41.21	0-360

Pk - Peak detector

Marker	Frequency (MHz)	Meter Reading (dBuV)	Det	Loop Antenna (dB/m)	Cbl (dB)	Dist Corr 30m	Corrected Reading (dBuVolts)	QP Limit (dBuV/m)	Margin (dB)	Azimuth (Degs)
7	1.02892	32.36	Pk	14.2	.2	-40	6.76	27.37	-20.61	0-360
3	1.16727	31.29	Pk	14.2	.2	-40	5.69	26.28	-20.59	0-360
4	5.99132	17.58	Pk	14.3	.4	-40	-7.72	29.5	-37.22	0-360
8	9.86578	12.96	Pk	14.5	.4	-40	-12.14	29.5	-41.64	0-360

Pk - Peak detector

10.4. Worst Case Below 1 GHz

SPURIOUS EMISSIONS 30 TO 1000 MHz (WORST-CASE CONFIGURATION)

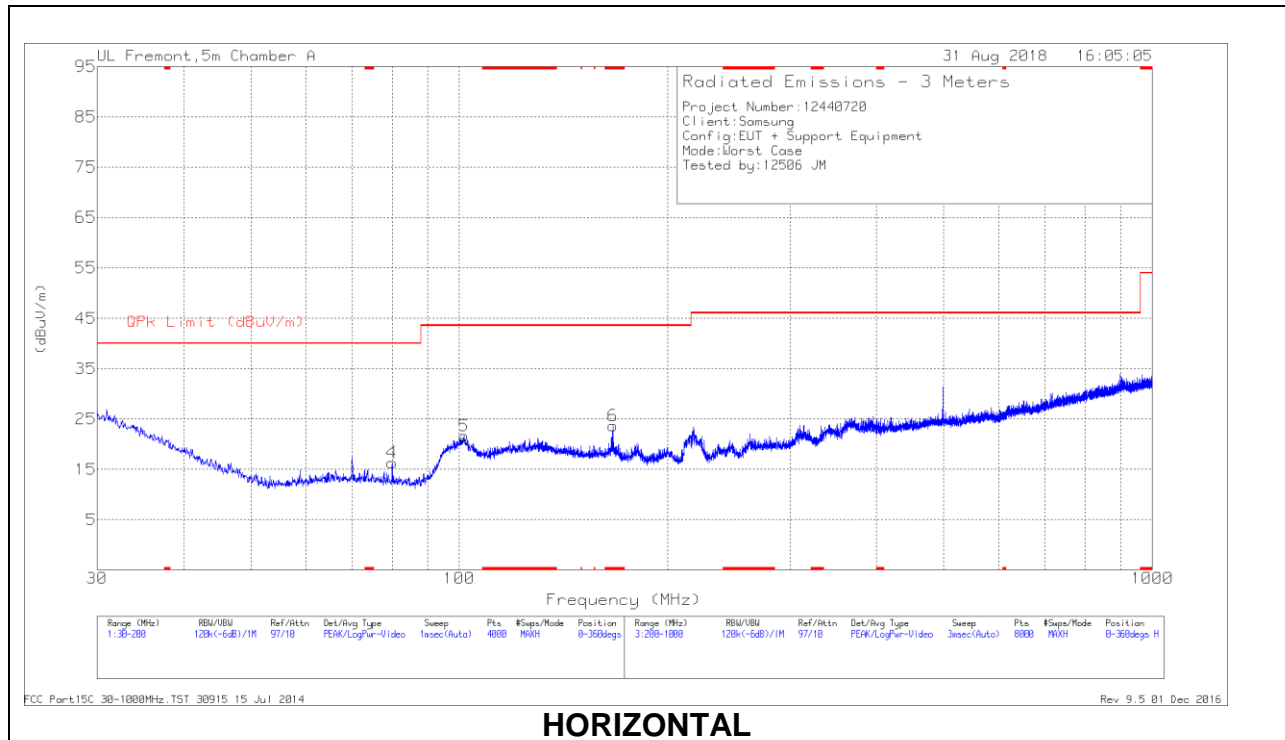

HORIZONTAL

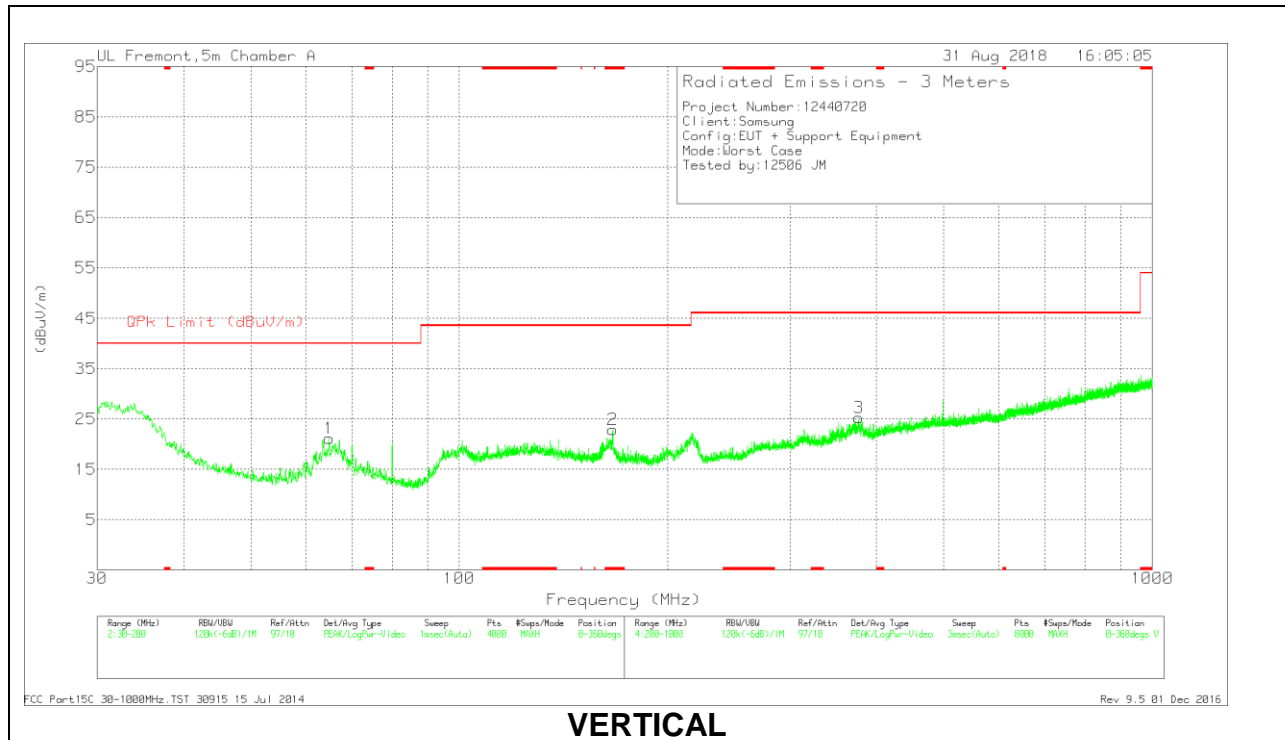

VERTICAL

Below 1GHz Data

Marker	Frequency (MHz)	Meter Reading (dBuV)	Det	AFT130 (dB/m)	Amp/Cbl (dB/m)	Corrected Reading (dBuV/m)	QPk Limit (dBuV/m)	Margin (dB)	Azimuth (Degs)	Height (cm)	Polarity
6	* 166.5453	33.42	Pk	15.9	-25.7	23.62	43.52	-19.9	0-360	200	H
2	* 166.5028	32.7	Pk	15.9	-25.7	22.9	43.52	-20.62	0-360	100	V
1	64.9015	35.85	Pk	12.1	-26.8	21.15	40	-18.85	0-360	100	V
4	79.9929	31.42	Pk	11.5	-26.6	16.32	40	-23.68	0-360	200	H
5	101.546	33.36	Pk	14.7	-26.4	21.66	43.52	-21.86	0-360	200	H
3	376.823	31.37	Pk	18.9	-25	25.27	46.02	-20.75	0-360	101	V

* - indicates frequency in CFR47 Pt 15 Restricted Band

Pk - Peak detector

10.5. Worst Case 18-26 GHz

SPURIOUS EMISSIONS 18-26 GHz (WORST-CASE CONFIGURATION)

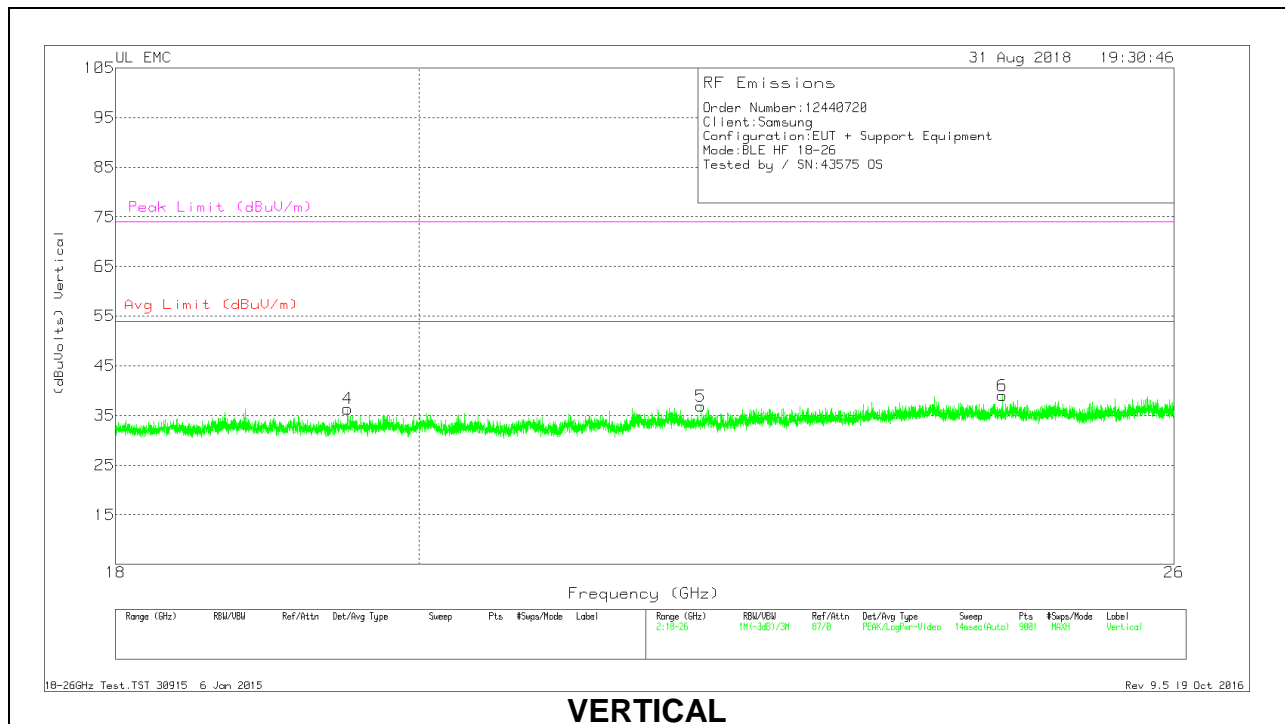
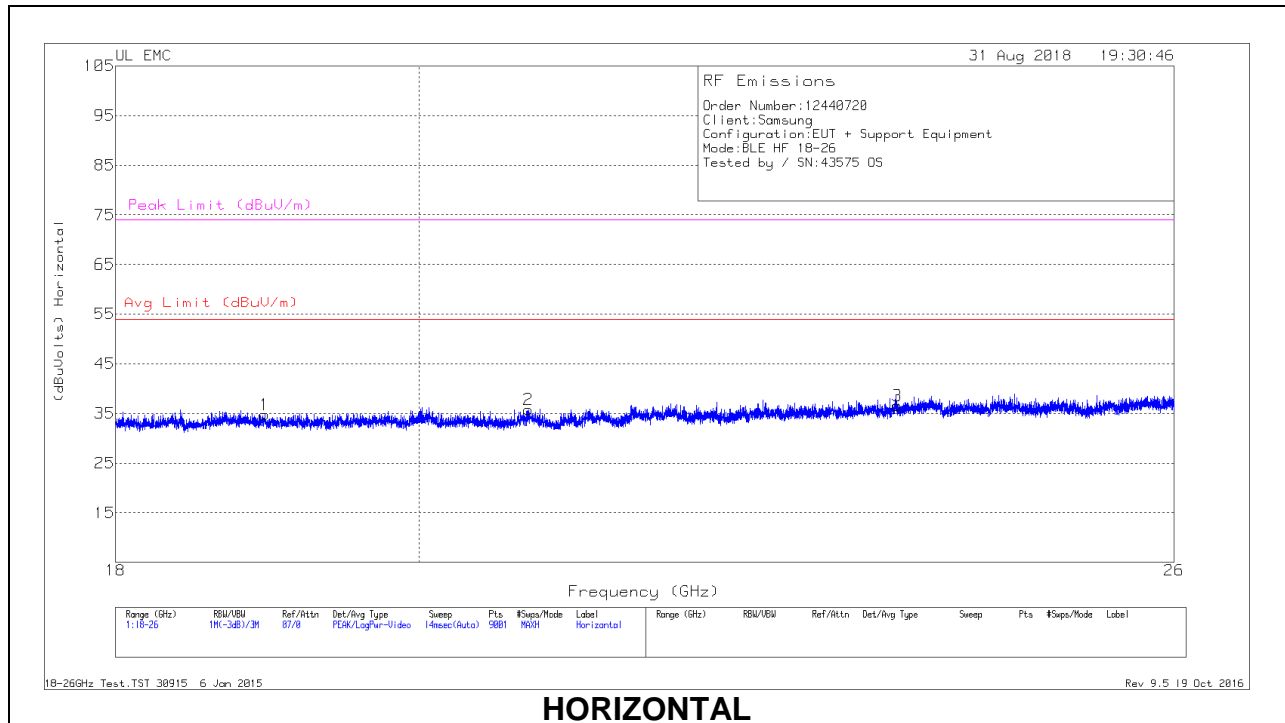

18 – 26GHz DATA

Marker	Frequency (GHz)	Meter Reading (dBuV)	Det	T89 AF (dB/m)	Amp/Cbl (dB)	Dist Corr (dB)	Corrected Reading (dBuVolts)	Avg Limit (dBuV/m)	Margin (dB)	Peak Limit (dBuV/m)	PK Margin (dB)
1	18.957	37.08	Pk	32.2	-25	-9.5	34.78	54	-19.22	74	-39.22
2	20.775	37.47	Pk	32.8	-25	-9.5	35.77	54	-18.23	74	-38.23
3	23.617	37.06	Pk	33.5	-24.5	-9.5	36.56	54	-17.44	74	-37.44
4	19.511	38.44	Pk	32.5	-25.1	-9.5	36.34	54	-17.66	74	-37.66
5	22.058	38.56	Pk	33.1	-25.3	-9.5	36.86	54	-17.14	74	-37.14
6	24.493	38.82	Pk	34	-24.3	-9.5	39.02	54	-14.98	74	-34.98

Pk - Peak detector

11. AC POWER LINE CONDUCTED EMISSIONS

LIMITS

FCC §15.207 (a)

Frequency of Emission (MHz)	Conducted Limit (dBuV)	
	Quasi-peak	Average
0.15-0.5	66 to 56*	56 to 46*
0.5-5	56	46
5-30	60	50

*Decreases with the logarithm of the frequency.

RESULTS

11.1.1. AC Power Line Norm

LINE 1 RESULTS

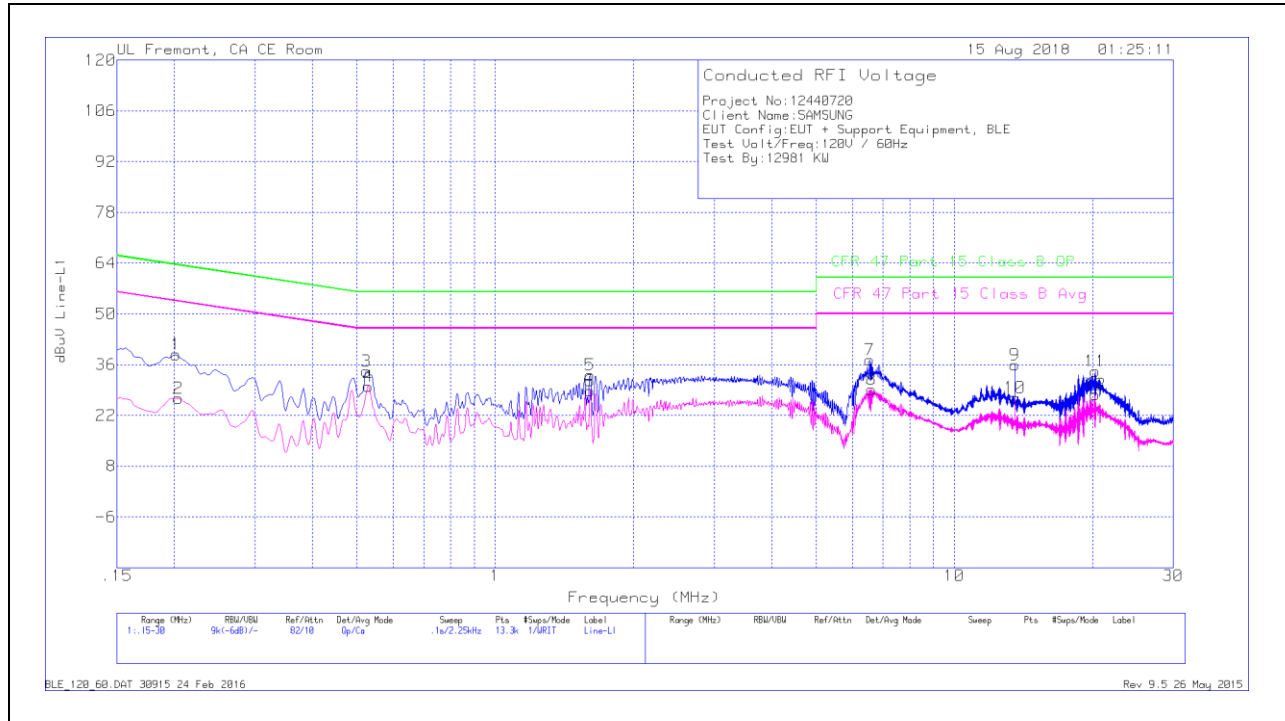

Trace Markers

Range 1: Line-L1 .15 - 30MHz											
Marker	Frequency (MHz)	Meter Reading (dBuV)	Det	LISN L1	LC Cables C1&C3	Limiter (dB)	Corrected Reading dBuV	CFR 47 Part 15 Class B QP	QP Margin (dB)	CFR 47 Part 15 Class B Avg	Av(CISPR) Margin (dB)
1	.20175	28.69	Qp	0	0	10.1	38.79	63.54	-24.75	-	-
2	.204	16.63	Ca	0	0	10.1	26.73	-	-	53.45	-26.72
3	.5235	24.14	Qp	0	0	10.1	34.24	56	-21.76	-	-
4	.52912	19.92	Ca	0	0	10.1	30.02	-	-	46	-15.98
5	1.60913	22.9	Qp	0	.1	10.1	33.1	56	-22.9	-	-
6	1.61025	18.59	Ca	0	.1	10.1	28.79	-	-	46	-17.21
7	6.54	26.95	Qp	0	.2	10.2	37.35	60	-22.65	-	-
8	6.5985	18.8	Ca	0	.2	10.2	29.2	-	-	50	-20.8
9	13.56	25.37	Qp	.1	.2	10.2	35.87	60	-24.13	-	-
10	13.56	16.33	Ca	.1	.2	10.2	26.83	-	-	50	-23.17
11	20.256	23.41	Qp	.1	.3	10.3	34.11	60	-25.89	-	-
12	20.2605	16.97	Ca	.1	.3	10.3	27.67	-	-	50	-22.33

Qp - Quasi-Peak detector
 Ca - CISPR average detection

LINE 2 RESULTS

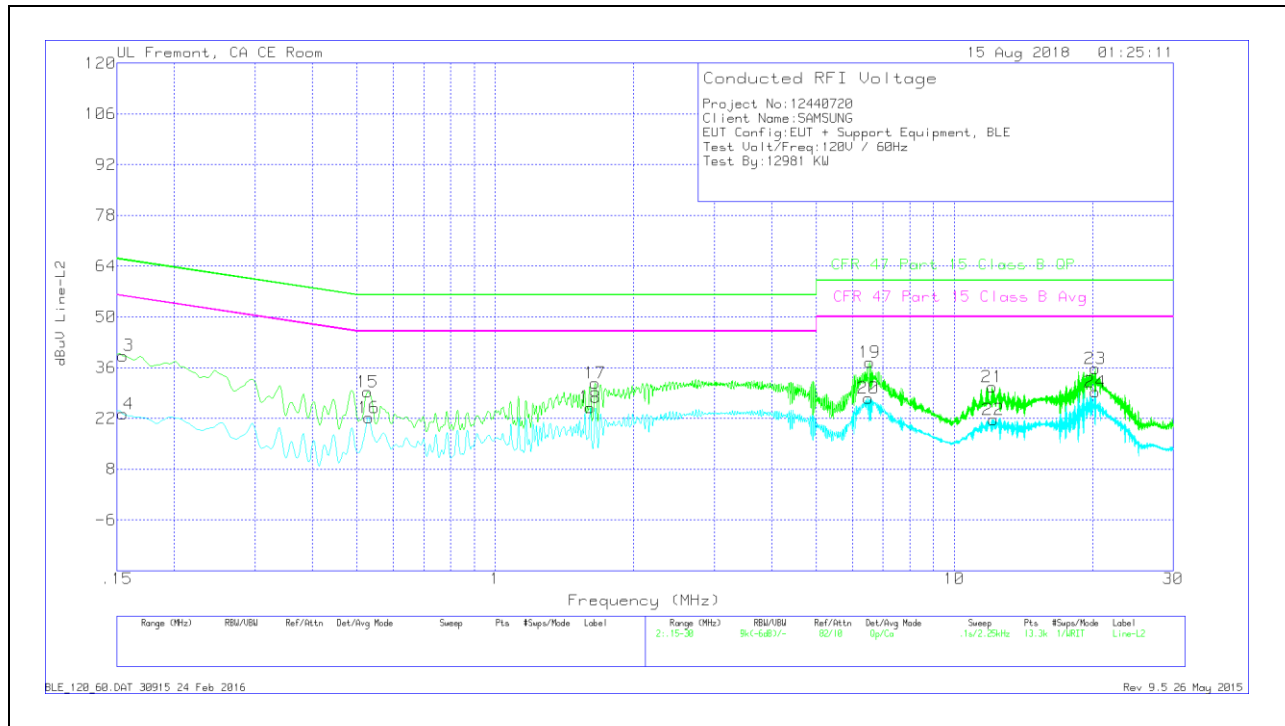

Trace Markers

Range 2: Line-L2 .15 - 30MHz											
Marker	Frequency (MHz)	Meter Reading (dBuV)	Det	LISN L2	LC Cables C2&C3	Limiter (dB)	Corrected Reading dBuV	CFR 47 Part 15 Class B QP	QP Margin (dB)	CFR 47 Part 15 Class B Avg	Av(CISPR) Margin (dB)
13	.1545	29.11	Qp	.1	0	10.1	39.31	65.75	-26.44	-	-
14	.1545	13.04	Ca	.1	0	10.1	23.24	-	-	55.75	-32.51
15	.528	19.21	Qp	0	0	10.1	29.31	56	-26.69	-	-
16	.53025	12.1	Ca	0	0	10.1	22.2	-	-	46	-23.8
17	1.65075	21.56	Qp	0	.1	10.1	31.76	56	-24.24	-	-
18	1.61025	14.85	Ca	0	.1	10.1	25.05	-	-	46	-20.95
19	6.54225	27.11	Qp	0	.2	10.2	37.51	60	-22.49	-	-
20	6.4995	17.24	Ca	0	.2	10.2	27.64	-	-	50	-22.36
21	12.11325	20.27	Qp	.1	.2	10.2	30.77	60	-29.23	-	-
22	12.156	11.23	Ca	.1	.2	10.2	21.73	-	-	50	-28.27
23	20.265	25.04	Qp	.1	.3	10.3	35.74	60	-24.26	-	-
24	20.26725	18.61	Ca	.1	.3	10.3	29.31	-	-	50	-20.69

Qp - Quasi-Peak detector
 Ca - CISPR average detection