



FCC 47 CFR PART 15 SUBPART E

UNII

CERTIFICATION TEST REPORT

FOR

GSM/WCDMA/LTE Phone + BT/BLE, DTS/UNII a/b/g/n and ANT+

MODEL NUMBER : SM-A605G/DS, SM-A605G

FCC ID: A3LSMA605G

REPORT NUMBER: 4788371693-E4V1

ISSUE DATE: MAR 27, 2018

Prepared for
SAMSUNG ELECTRONICS CO., LTD.
129 SAMSUNG-RO, YEONGTONG-GU, SUWON-SI,
GYEONGGI-DO, 16677, KOREA

Prepared by
UL Korea, Ltd.
26th floor, 152, Teheran-ro, Gangnam-gu Seoul, 06236, Korea

Suwon Test Site: UL Korea, Ltd. Suwon Laboratory
218 Maeyeong-ro, Yeongtong-gu,
Suwon-si, Gyeonggi-do, 16675, Korea
TEL: (031) 337-9902
FAX: (031) 213-5433



ACCREDITED*

Testing
Laboratory

TL-637

Revision History

<u>Rev.</u>	<u>Issue Date</u>	<u>Revisions</u>	<u>Revised By</u>
V1	03/27/18	Initial issue	Junwhan Lee

TABLE OF CONTENTS

1. ATTESTATION OF TEST RESULTS	6
1.1. INTRODUCTION OF TEST DATA REUSE.....	7
1.2. DIFFERENCE.....	7
1.3. SPOT CHECK VERIFICATION DATA	7
1.4. REFERENCE DETAIL	8
2. TEST METHODOLOGY	8
3. FACILITIES AND ACCREDITATION	9
4. CALIBRATION AND UNCERTAINTY	9
4.1. MEASURING INSTRUMENT CALIBRATION	9
4.2. SAMPLE CALCULATION	9
4.3. MEASUREMENT UNCERTAINTY.....	10
5. EQUIPMENT UNDER TEST	11
5.1. DESCRIPTION OF EUT	11
5.2. MAXIMUM OUTPUT POWER.....	11
5.3. DESCRIPTION OF AVAILABLE ANTENNAS	12
5.4. WORST-CASE CONFIGURATION AND MODE.....	12
5.5. DESCRIPTION OF TEST SETUP.....	13
6. TEST AND MEASUREMENT EQUIPMENT	15
7. SUMMARY TABLE	16
8. MEASUREMENT METHODS	17
9. REFERENCE MEASUREMENTS RESULTS	18
9.1. ON TIME AND DUTY CYCLE RESULTS.....	18
9.2. DUTY CYCLE PLOTS	18
9.3. 26 dB BANDWIDTH.....	20
9.3.1. 802.11a MODE IN THE 5.2 GHz BAND.....	20
9.3.2. 802.11n HT20 MODE IN THE 5.2 GHz BAND	20
9.3.3. 802.11n HT40 MODE IN THE 5.2 GHz BAND	20
9.3.4. 802.11a MODE IN THE 5.3 GHz BAND	21
9.3.5. 802.11n HT20 MODE IN THE 5.3 GHz BAND	21
9.3.6. 802.11n HT40 MODE IN THE 5.3 GHz BAND	21
9.3.7. 802.11a MODE IN THE 5.5 GHz BAND.....	21
9.3.8. 802.11n HT20 MODE IN THE 5.5 GHz BAND	21

9.3.9.	802.11n HT40 MODE IN THE 5.5 GHz BAND	22
9.3.10.	802.11a MODE IN THE 5.8 GHz BAND	22
9.3.11.	802.11n HT20 MODE IN THE 5.8 GHz BAND	22
9.3.12.	802.11n HT40 MODE IN THE 5.8 GHz BAND	22
9.3.13.	26 dB BANDWIDTH PLOTS	23
9.4.	99% BANDWIDTH	35
9.4.1.	802.11a MODE IN THE 5.2 GHz BAND	35
9.4.2.	802.11n HT20 MODE IN THE 5.2 GHz BAND	35
9.4.3.	802.11n HT40 MODE IN THE 5.2 GHz BAND	35
9.4.4.	802.11a MODE IN THE 5.3 GHz BAND	36
9.4.5.	802.11n HT20 MODE IN THE 5.3 GHz BAND	36
9.4.6.	802.11n HT40 MODE IN THE 5.3 GHz BAND	36
9.4.7.	802.11a MODE IN THE 5.5 GHz BAND	36
9.4.8.	802.11n HT20 MODE IN THE 5.5 GHz BAND	37
9.4.9.	802.11n HT40 MODE IN THE 5.5 GHz BAND	37
9.4.10.	802.11a MODE IN THE 5.8 GHz BAND	37
9.4.11.	802.11n HT20 MODE IN THE 5.8 GHz BAND	37
9.4.12.	802.11n HT40 MODE IN THE 5.8 GHz BAND	37
9.4.13.	99% BANDWIDTH PLOTS	38
10.	ANTENNA PORT TEST RESULTS	50
10.1.	6 dB BANDWIDTH	50
10.1.1.	802.11a MODE IN THE 5.8 GHz BAND	50
10.1.2.	802.11n HT20 MODE IN THE 5.8 GHz BAND	50
10.1.3.	802.11n HT40 MODE IN THE 5.8 GHz BAND	50
10.1.4.	6 dB BANDWIDTH PLOTS	51
10.2.	OUTPUT POWER AND PPSD	54
10.2.1.	802.11a MODE IN THE 5.2 GHz BAND	55
10.2.2.	802.11n HT20 MODE IN THE 5.2 GHz BAND	56
10.2.3.	802.11n HT40 MODE IN THE 5.2 GHz BAND	57
10.2.4.	802.11a MODE IN THE 5.3 GHz BAND	58
10.2.5.	802.11n HT20 MODE IN THE 5.3 GHz BAND	59
10.2.6.	802.11n HT40 MODE IN THE 5.3 GHz BAND	60
10.2.7.	802.11a MODE IN THE 5.5 GHz BAND	61
10.2.8.	802.11n HT20 MODE IN THE 5.5 GHz BAND	62
10.2.9.	802.11n HT40 MODE IN THE 5.5 GHz BAND	63
10.2.10.	802.11a MODE IN THE 5.8 GHz BAND	64
10.2.11.	802.11n HT20 MODE IN THE 5.8 GHz BAND	65
10.2.12.	802.11n HT40 MODE IN THE 5.8 GHz BAND	66
10.2.13.	PPSD PLOTS	67
11.	TRANSMITTER ABOVE 1 GHz	79
11.1.	5.2 GHz	81
11.1.1.	TX Above 1GHz 802.11a MODE IN THE 5.2GHz BAND	81
11.1.2.	TX Above 1GHz 802.11n HT20 MODE IN THE 5.2GHz BAND	89
11.1.3.	TX Above 1GHz 802.11n HT40 MODE IN THE 5.2GHz BAND	97
11.2.	5.3 GHz	103
11.2.1.	TX ABOVE 1 GHz 802.11a MODE IN THE 5.3 GHz BAND	103
11.2.2.	TX ABOVE 1GHz 802.11n HT20 MODE IN THE 5.3GHz BAND	111

11.2.3. TX ABOVE 1GHz 802.11n HT40 MODE IN THE 5.3GHz BAND.....	119
11.3. 5.5-5.6 GHz.....	125
11.3.1. TX ABOVE 1 GHz 802.11a MODE IN THE 5.5 GHz BAND	125
11.3.2. TX ABOVE 1GHz 802.11n HT20 MODE IN THE 5.5GHz BAND.....	135
11.3.3. TX ABOVE 1GHz 802.11n HT40 MODE IN THE 5.5GHz BAND.....	145
11.4. 5.8 GHz.....	155
11.4.1. TX ABOVE 1GHz 802.11a MODE IN THE 5.8GHz BAND	155
11.4.2. TX ABOVE 1GHz 802.11n HT20 MODE IN THE 5.8GHz BAND.....	165
11.4.3. TX ABOVE 1GHz 802.11n HT40 MODE IN THE 5.8GHz BAND.....	175
12. WORST-CASE BELOW 1 GHz (in the 5.3 GHz Band).....	183
13. AC POWER LINE CONDUCTED EMISSIONS.....	185
14. DYNAMIC FREQUENCY SELECTION.....	188
14.1. OVERVIEW.....	188
14.1.1. LIMITS.....	188
14.1.1. TEST AND MEASUREMENT SYSTEM.....	192
14.1.2. SETUP OF EUT.....	195
14.1.3. DESCRIPTION OF EUT	196
14.2. RESULTS FOR 20 MHz BANDWIDTH.....	197
14.2.1. TEST CHANNEL	197
14.2.2. RADAR WAVEFORM AND TRAFFIC.....	197
14.2.3. OVERLAPPING CHANNEL TESTS.....	199
14.2.4. MOVE AND CLOSING TIME	199
14.3. RESULTS FOR 40 MHz BANDWIDTH.....	202
14.3.1. TEST CHANNEL	202
14.3.2. RADAR WAVEFORM AND TRAFFIC.....	202
14.3.3. OVERLAPPING CHANNEL TESTS.....	204
14.3.4. MOVE AND CLOSING TIME	204
15. SETUP PHOTOS.....	207

1. ATTESTATION OF TEST RESULTS

COMPANY NAME: SAMSUNG ELECTRONICS CO., LTD.
EUT DESCRIPTION: GSM/WCDMA/LTE Phone + BT/BLE, DTS/UNII a/b/g/n and ANT+
MODEL NUMBER: SM-A605G/DS, SM-A605G
SERIAL NUMBER: R38K108QG5F, R38K104R4WF (RADIATED, Original);
R38K104QEYH (CONDUCTED, Original)
R38K10D6MJN (RADIATED, Spot check)
DATE TESTED: FEB 22, 2018 - MAR 12, 2018 (Original)
MAR 15, 2018 - MAR 22, 2018 (Spot check)

APPLICABLE STANDARDS	
STANDARD	TEST RESULTS
CFR 47 Part 15 Subpart E	Pass

UL Korea, Ltd. tested the above equipment in accordance with the requirements set forth in the above standards. All indications of Pass/Fail in this report are opinions expressed by UL Korea, Ltd. based on interpretations and/or observations of test results. Measurement Uncertainties were not taken into account and are published for informational purposes only. The test results show that the equipment tested is capable of demonstrating compliance with the requirements as documented in this report.

Note: The results documented in this report apply only to the tested sample, under the conditions and modes of operation as described herein. This document may not be altered or revised in any way unless done so by UL Korea, Ltd. and all revisions are duly noted in the revisions section. Any alteration of this document not carried out by UL Korea, Ltd. will constitute fraud and shall nullify the document. This report must not be used by the client to claim product certification, approval, or endorsement by IAS, any agency of the Federal Government, or any agency of any government.

Approved & Released For
UL Korea, Ltd. By:



SungGil Park
Suwon Lab Engineer
UL Korea, Ltd.

Tested By:



Junwhan Lee
Suwon Lab Engineer
UL Korea, Ltd.

1.1. INTRODUCTION OF TEST DATA REUSE

This report referenced from the FCC ID: A3LSMA605GN UNII WLAN(FCC CFR 47 Part 15E). And the applicant takes full responsibility that the test data as referenced in this report represent compliance for this FCC ID.

1.2. DIFFERENCE

The FCC ID: A3LSMA605G shares the same enclosure and circuit board as FCC ID: A3LSMA605GN. The WLAN antennas and surrounding circuitry and layout are identical between these two units.

After confirming through preliminary radiated emissions that the performance of the FCC ID: A3LSMA605GN remains representative of FCC ID: A3LSMA605G. The test data of FCC ID: A3LSMA605GN being submitted for this application to cover WLAN features.

1.3. SPOT CHECK VERIFICATION DATA

Band	Test Item	Mode	Frequency	Test Limit	Original model	Spot check model	Deviation	Remark
					SM-A605GN/DS Results	SM-A605G/DS Results		
					FCC ID : A3LSMA605GN	FCC ID : A3LSMA605G		
UNII WLAN (5GHz)	Band Edge	802.11n HT40	5190 MHz	54 dBuV/m	46.04 dBuV/m	47.01 dBuV/m	0.97 dB	
	RSE	802.11 a	5200 MHz	68.2 dBuV/m	52.14 dBuV/m	52.84 dBuV/m	0.70 dB	
	Band Edge	802.11 n HT20	5320 MHz	54 dBuV/m	46.07 dBuV/m	45.14 dBuV/m	-0.93 dB	
	RSE	802.11 a	5260 MHz	68.2 dBuV/m	51.63 dBuV/m	51.88 dBuV/m	0.25 dB	
	Band Edge	802.11n HT40	5510 MHz	68.2 dBuV/m	65.14 dBuV/m	64.25 dBuV/m	-0.89 dB	
	RSE	802.11 a	5500 MHz	54 dBuV/m	28.84 dBuV/m	26.34 dBuV/m	-2.50 dB	
	Band Edge	802.11n HT40	5795 MHz	-27 dBm	-38.24 dBm	-39.85 dBm	-1.61 dB	
	RSE	802.11 a	5825 MHz	54 dBuV/m	29.55 dBuV/m	26.44 dBuV/m	-3.11 dB	

Comparison of two models, higher deviation is within 3dB range and all test results are under FCC Technical Limits.

1.4. REFERENCE DETAIL

Reference application that contains the reused reference data.

Equipment Class	Reference FCC ID	Type Grant/Permissive Change	Reference Application	Folder Test/RF Exposure	Report Title / Section
DTS	A3LSMA605GN	Grant	4788371689-E1V1	Test	FCC Report DTS WLAN / All sections
			4788371689-E2V1	Test	FCC Report BLE / All sections
DSS	A3LSMA605GN	Grant	4788371689-E3V1	Test	FCC Report BT / All sections
NII	A3LSMA605GN	Grant	4788371689-E4V1	Test	FCC Report UNII WLAN / All sections
DXX	A3LSMA605GN	Grant	4788371689-E5V1	Test	FCC Report ANT+ / All sections
PCE	A3LSMA605GN	Grant	4788371689-E7V1	Test	FCC Report WWAN / All sections

2. TEST METHODOLOGY

The tests documented in this report were performed in accordance with following methods.

1. FCC CFR 47 Part 2.
2. FCC CFR 47 Part 15.
3. KDB 789033 D02 General UNII Test Procedures New Rules v02r01
4. KDB 905462 D02 UNII DFS Compliance Procedures New Rules v02
5. KDB 905462 D03 UNII Clients Without Radar Detection New Rules v01r02
6. ANSI C63.10-2013.

3. FACILITIES AND ACCREDITATION

The test sites and measurement facilities used to collect data are located at 218 Maeyeong-ro, Yeongtong-gu, Suwon-si, Gyeonggi-do, 16675, Korea. Line conducted emissions are measured only at the 218 address. The following table identifies which facilities were utilized for radiated emission measurements documented in this report. Specific facilities are also identified in the test results sections.

218 Maeyeong-ro	
<input checked="" type="checkbox"/>	Chamber 1
<input type="checkbox"/>	Chamber 2
<input type="checkbox"/>	Chamber 3

UL Korea, Ltd. is accredited by IAS, Laboratory Code TL-637. The full scope of accreditation can be viewed at <http://www.iasonline.org/PDF/TL/TL-637.pdf>.

4. CALIBRATION AND UNCERTAINTY

4.1. MEASURING INSTRUMENT CALIBRATION

The measuring equipment utilized to perform the tests documented in this report has been calibrated in accordance with the manufacturer's recommendations, and is traceable to recognized national standards.

4.2. SAMPLE CALCULATION

Where relevant, the following sample calculation is provided:

$$\begin{aligned} \text{Field Strength (dBuV/m)} &= \text{Measured Voltage (dBuV)} + \text{Antenna Factor (dB/m)} + \\ &\text{Cable Loss (dB)} - \text{Preamp Gain (dB)} \\ 36.5 \text{ dBuV} + 18.7 \text{ dB/m} + 0.6 \text{ dB} - 26.9 \text{ dB} &= 28.9 \text{ dBuV/m} \end{aligned}$$

4.3. MEASUREMENT UNCERTAINTY

Where relevant, the following measurement uncertainty levels have been estimated for tests performed on the apparatus:

PARAMETER	UNCERTAINTY
Conducted Disturbance, 0.15 to 30 MHz	2.32 dB
Radiated Disturbance, Below 1GHz	3.86 dB
Radiated Disturbance, Above 1 GHz	5.97 dB

Uncertainty figures are valid to a confidence level of 95%.

5. EQUIPMENT UNDER TEST

5.1. DESCRIPTION OF EUT

The EUT is a GSM/WCDMA/LTE Phone + BT/BLE, DTS/UNII a/b/g/n and ANT+. This test report addresses the NII (UNII) operational mode.

5.2. MAXIMUM OUTPUT POWER

The transmitter has a maximum total conducted average output power as follows:

Frequency Range [MHz]	Mode	Output Power	
		[dBm]	[mW]
5180 - 5240	802.11a	18.40	69.18
	802.11n HT20	18.00	63.10
5190 - 5230	802.11n HT40	15.48	35.32
5260 - 5320	802.11a	18.31	67.76
	802.11n HT20	18.41	69.34
5270 - 5310	802.11n HT40	15.04	31.92
5500 - 5700	802.11a	18.36	68.55
	802.11n HT20	18.38	68.87
5510 - 5690	802.11n HT40	15.23	33.34
5745 - 5825	802.11a	18.19	65.92
	802.11n HT20	18.09	64.42
5755 - 5795	802.11n HT40	14.98	31.48

5.3. DESCRIPTION OF AVAILABLE ANTENNAS

The radio utilizes an internal antenna, with a maximum gain of:

Frequency Range [MHz]	Antenna Gain [dBi]
UNII 1 5150 – 5250	-1.41
UNII 2A 5250 – 5350	-2.72
UNII 2C 5470 – 5725	-3.66
UNII 3 5725 – 5850	-5.64

5.4. WORST-CASE CONFIGURATION AND MODE

Radiated emission below 1GHz and power line conducted emission were performed with the EUT set to transmit at the channel with highest output power as worst-case scenario.

Radiated emission above 1GHz was performed with the EUT set to transmit low/mid/high channels.

The fundamental of the EUT was investigated in three orthogonal orientations X,Y,Z, it was determined that the X orientation was worst-case orientation; therefore, all final radiated testing was performed with the EUT in the X orientation.

Based on the baseline scan, the worst-case data rates were:

802.11a mode: 6 Mbps
802.11n HT20 mode: MCS0
802.11n HT40 mode: MCS0

Note : All radiated and power line conducted tests were performed connected with earphone and charger for evaluation of worst case mode.

5.5. DESCRIPTION OF TEST SETUP

SUPPORT EQUIPMENT

Support Equipment List				
Description	Manufacturer	Model	Serial Number	FCC ID
Charger	SAMSUNG	EP-TA50EWE	DW3J719AS/A- E	N/A
Data Cable	SAMSUNG	ECB-DU68WE	N/A	N/A
Earphone	SAMSUNG	EHS61ASFWE	N/A	N/A

I/O CABLES

I/O Cable List						
Cable No	Port	# of identical ports	Connector Type	Cable Type	Cable Length (m)	Remarks
1	DC Power	1	Mini-USB	Shielded	1.2m	N/A
2	Audio	2	Mini-Jack	Unshielded	1.2m	N/A

TEST SETUP

The EUT is a stand-alone unit during the tests.
Test software in hidden menu exercised the EUT to enable NII mode.

SETUP DIAGRAM FOR TESTS (CONDUCTED TEST SETUP)

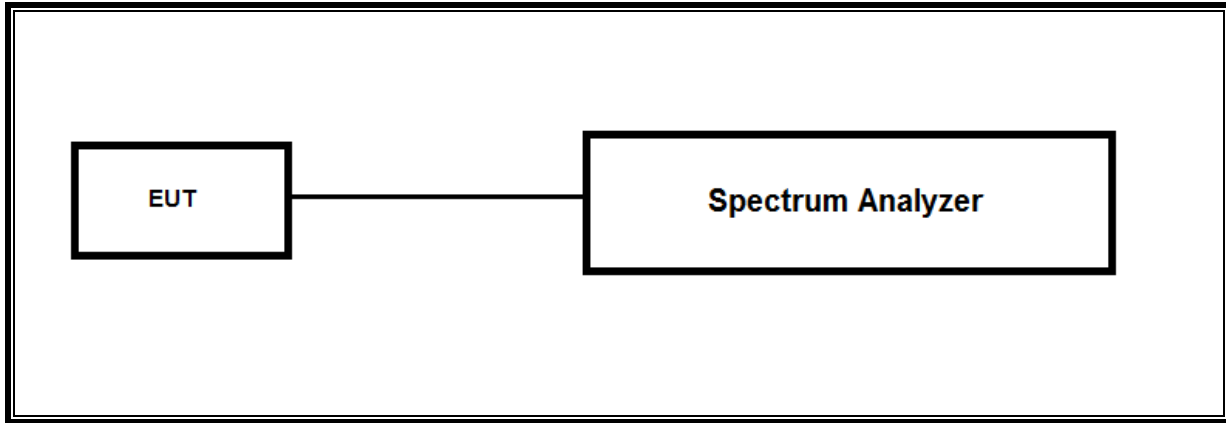

SETUP DIAGRAM FOR TESTS (RADIATED TEST SETUP)

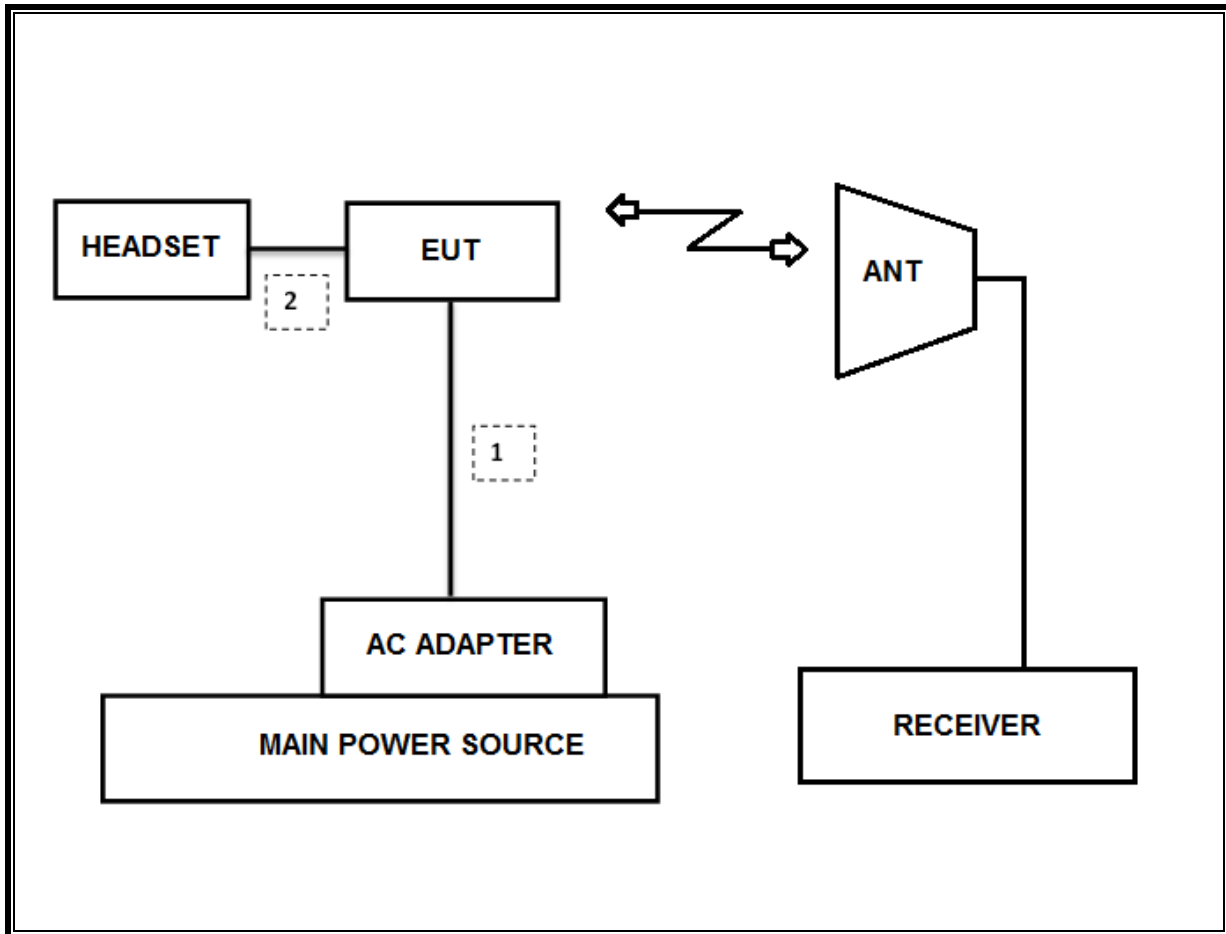

6. TEST AND MEASUREMENT EQUIPMENT

The following test and measurement equipment was utilized for the tests documented in this report:

Test Equipment List				
Description	Manufacturer	Model	S/N	Cal Due
Antenna, Bilog, 30MHz-1GHz	SCHWARZBECK	VULB9163	750	08-31-19
Antenna, Bilog, 30MHz-1GHz	SCHWARZBECK	VULB9163	749	09-14-19
Antenna, Bilog, 30MHz-1GHz	SCHWARZBECK	VULB9163	845	08-31-19
Antenna, Horn, 18 GHz	ETS	3115	00167211	10-14-18
Antenna, Horn, 18 GHz	ETS	3115	00161451	03-10-19
Antenna, Horn, 18 GHz	ETS	3117	00168724	05-31-19
Antenna, Horn, 18 GHz	ETS	3117	00168717	05-31-19
Antenna, Horn, 18 GHz	ETS	3117	00205959	11-29-18
Antenna, Horn, 40 GHz	ETS	3116C	00166155	12-04-19
Antenna, Horn, 40 GHz	ETS	3116C	00168645	12-04-19
Antenna, Horn, 40 GHz	ETS	3116C-PA	00168841	11-13-19
Preamplifier, 1000 MHz	Sonoma	310N	341282	08-09-18
Preamplifier, 1000 MHz	Sonoma	310N	351741	08-07-18
Preamplifier, 1000 MHz	Sonoma	310N	370599	08-10-18
Preamplifier, 18 GHz	Miteq	AFS42-00101800-25-S-42	1876511	08-08-18
Preamplifier, 18 GHz	Miteq	AFS42-00101800-25-S-42	1896138	08-08-18
Preamplifier, 18 GHz	Miteq	AFS42-00101800-25-S-42	2029169	08-11-18
Spectrum Analyzer, 44 GHz	Agilent / HP	N9030A	MY54170614	08-08-18
Spectrum Analyzer, 44 GHz	Agilent / HP	N9030A	MY54490312	08-08-18
Average Power Sensor	Agilent / HP	U2000	MY54270007	08-08-18
Attenuator	PASTERNAK	PE7087-10	A001	08-08-18
Attenuator	PASTERNAK	PE7087-10	A008	08-08-18
Attenuator	PASTERNAK	PE7087-10	2	08-10-18
Attenuator	PASTERNAK	PE7087-10	A009	08-08-18
EMI Test Receive, 40 GHz	R&S	ESU40	100439	08-08-18
EMI Test Receive, 40 GHz	R&S	ESU40	100457	08-08-18
EMI Test Receive, 44 GHz	R&S	ESW44	101590	08-09-18
EMI Test Receive, 3 GHz	R&S	ESR3	101832	08-07-18
Low Pass Filter 5GHz	Micro-Tronics	LPS17541	009	08-08-18
Low Pass Filter 5GHz	Micro-Tronics	LPS17541	015	08-08-18
Low Pass Filter 5GHz	Micro-Tronics	LPS17541	020	08-11-18
High Pass Filter 3GHz	Micro-Tronics	HPM17543	010	08-08-18
High Pass Filter 3GHz	Micro-Tronics	HPM17543	015	08-08-18
High Pass Filter 3GHz	Micro-Tronics	HPM17543	020	08-11-18
High Pass Filter 6GHz	Micro-Tronics	HPS17542	009	08-08-18
High Pass Filter 6GHz	Micro-Tronics	HPS17542	016	08-08-18
High Pass Filter 6GHz	Micro-Tronics	HPS17542	021	08-11-18
LISN	R&S	ENV-216	101837	08-09-18
UL Software				
Description	Manufacturer	Model	Version	
Radiated software	UL	UL EMC	Ver 9.5	
AC Line Conducted software	UL	UL EMC	Ver 9.5	

7. SUMMARY TABLE

FCC Part Section	Test Description	Test Limit	Test Condition	Test Result
15.407(e)	6dB Band width (5.8Ghz)	500KHz	Condcuted	PASS
15.407 (a)(2)	TX Cond. Power 5.15-2.25, 5.25-5.35 & 5.47-5.725	<24dBm or 11+10Log(OBW)		PASS
15.407 (a)(3)	TX Cond. Power 5.725-5.825	< 30dBm or 17+10Log(OBW)		PASS
15.407 (a)(5)	PSD (5.2,5.3,5.5GHz)	<11dBm		PASS
15.407 (a)(5)	PSD (5.8GHz)	30dBm per 500kHz		PASS
15.207 (a)	AC Power Line conducted emissions	Section 10	Radiated	PASS
15.407 (b) & 15.209	Radiated Spurious Emission	< 54dBuV/m		PASS
15.407 (h)(2)	Dynamic Frequency Selection	N/A	Condcuted	PASS

8. MEASUREMENT METHODS

On-Time and Duty Cycle : KDB 789033 D02 v02r01, Section B.

6dB Emission BW : KDB 789033 D02 v02r01, Section C.2.

26dB Emission BW : KDB 789033 D02 v02r01, Section C.1.

99% Occupied BW : KDB 789033 D02 v02r01, Section D.

Conducted Output Power : KDB 789033 D02 v02r01, Section E.3.a(Method PM)

Power Spectral Density : KDB 789033 D02 v02r01, Section F.

Unwanted emissions in restricted bands : KDB 789033 D02 v02r01, Section G.

Unwanted emissions in non-restricted bands : KDB 789033 D02 v02r01, Section G.

AC Power Line Conducted Emission : ANSI C63.10-2013, Section 6.2.

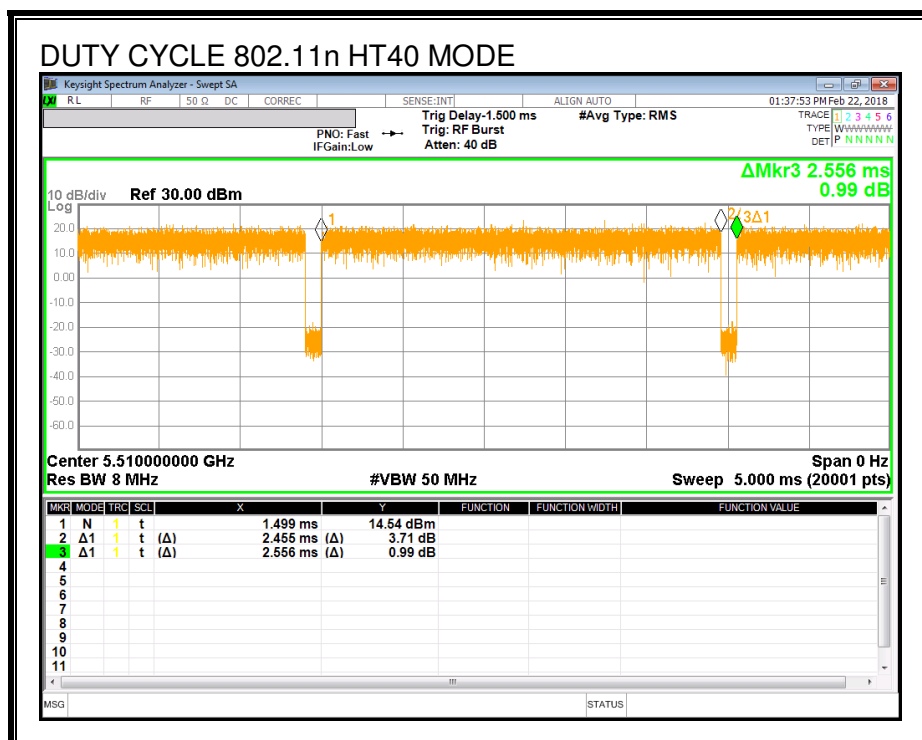
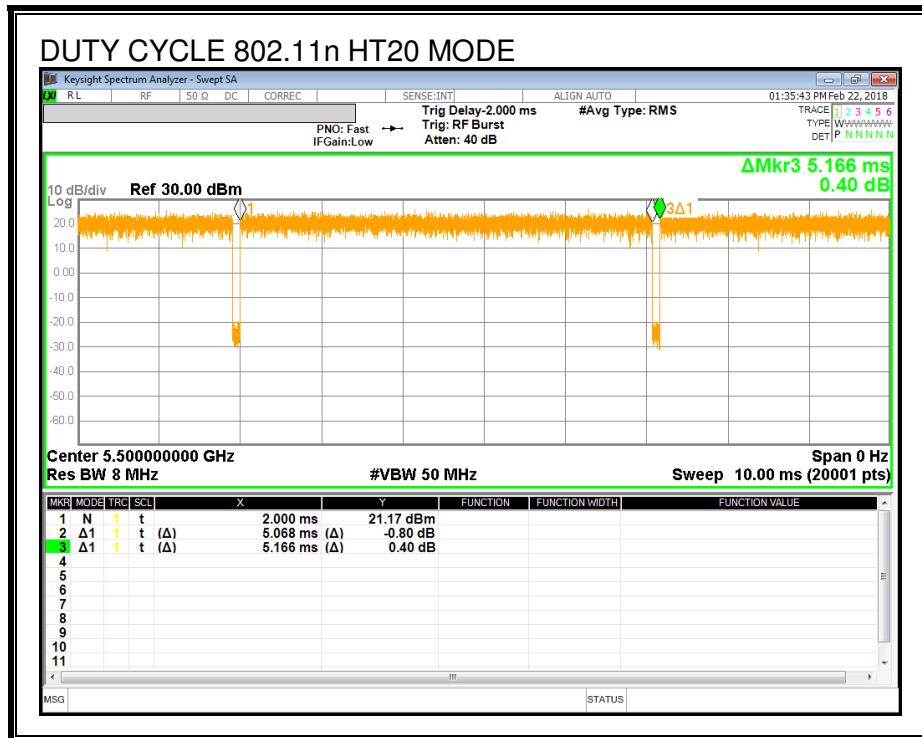

9.3. 26 dB BANDWIDTH

LIMITS

None; for reporting purposes only.

TEST PROCEDURE

Reference to 789033 D02 General UNII Test Procedures New Rules v02r01: The transmitter output is connected to a spectrum analyzer with the RBW set to approximately 1% of EBW, the VBW > RBW, peak detector and max hold.

RESULTS

9.3.1. 802.11a MODE IN THE 5.2 GHz BAND

Channel	Frequency [MHz]	26 dB Bandwidth [MHz]
Low	5180	19.89
Mid	5200	19.69
High	5240	19.40
Worst		19.89

9.3.2. 802.11n HT20 MODE IN THE 5.2 GHz BAND

Channel	Frequency [MHz]	26 dB Bandwidth [MHz]
Low	5180	20.27
Mid	5200	20.48
High	5240	20.42
Worst		20.48

9.3.3. 802.11n HT40 MODE IN THE 5.2 GHz BAND

Channel	Frequency [MHz]	26 dB Bandwidth [MHz]
Low	5190	40.12
High	5230	39.30
Worst		40.12

9.3.4. 802.11a MODE IN THE 5.3 GHz BAND

Channel	Frequency [MHz]	26 dB Bandwidth [MHz]
Low	5260	19.27
Mid	5300	19.53
High	5320	19.91
Worst		19.91

9.3.5. 802.11n HT20 MODE IN THE 5.3 GHz BAND

Channel	Frequency [MHz]	26 dB Bandwidth [MHz]
Low	5260	20.26
Mid	5300	20.18
High	5320	20.04
Worst		20.26

9.3.6. 802.11n HT40 MODE IN THE 5.3 GHz BAND

Channel	Frequency [MHz]	26 dB Bandwidth [MHz]
Low	5270	40.09
High	5310	40.06
Worst		40.09

9.3.7. 802.11a MODE IN THE 5.5 GHz BAND

Channel	Frequency [MHz]	26 dB Bandwidth [MHz]
Low	5500	19.50
Mid	5580	19.88
High	5700	20.38
Worst		20.38

9.3.8. 802.11n HT20 MODE IN THE 5.5 GHz BAND

Channel	Frequency [MHz]	26 dB Bandwidth [MHz]
Low	5500	20.24
Mid	5580	20.79
High	5700	21.50
Worst		21.50

9.3.9. 802.11n HT40 MODE IN THE 5.5 GHz BAND

Channel	Frequency [MHz]	26 dB Bandwidth [MHz]
Low	5510	39.89
Mid	5550	39.64
High	5670	40.05
Worst		40.05

9.3.10. 802.11a MODE IN THE 5.8 GHz BAND

Channel	Frequency [MHz]	26 dB Bandwidth [MHz]
Low	5745	21.55
Mid	5785	21.98
High	5825	21.70
Worst		21.98

9.3.11. 802.11n HT20 MODE IN THE 5.8 GHz BAND

Channel	Frequency [MHz]	26 dB Bandwidth [MHz]
Low	5745	22.19
Mid	5785	23.63
High	5825	22.93
Worst		23.63

9.3.12. 802.11n HT40 MODE IN THE 5.8 GHz BAND

Channel	Frequency [MHz]	26 dB Bandwidth [MHz]
Low	5755	39.78
High	5795	39.76
Worst		39.78

9.3.13. 26 dB BANDWIDTH PLOTS

UNII 5.2 GHz IEEE 802.11a mode

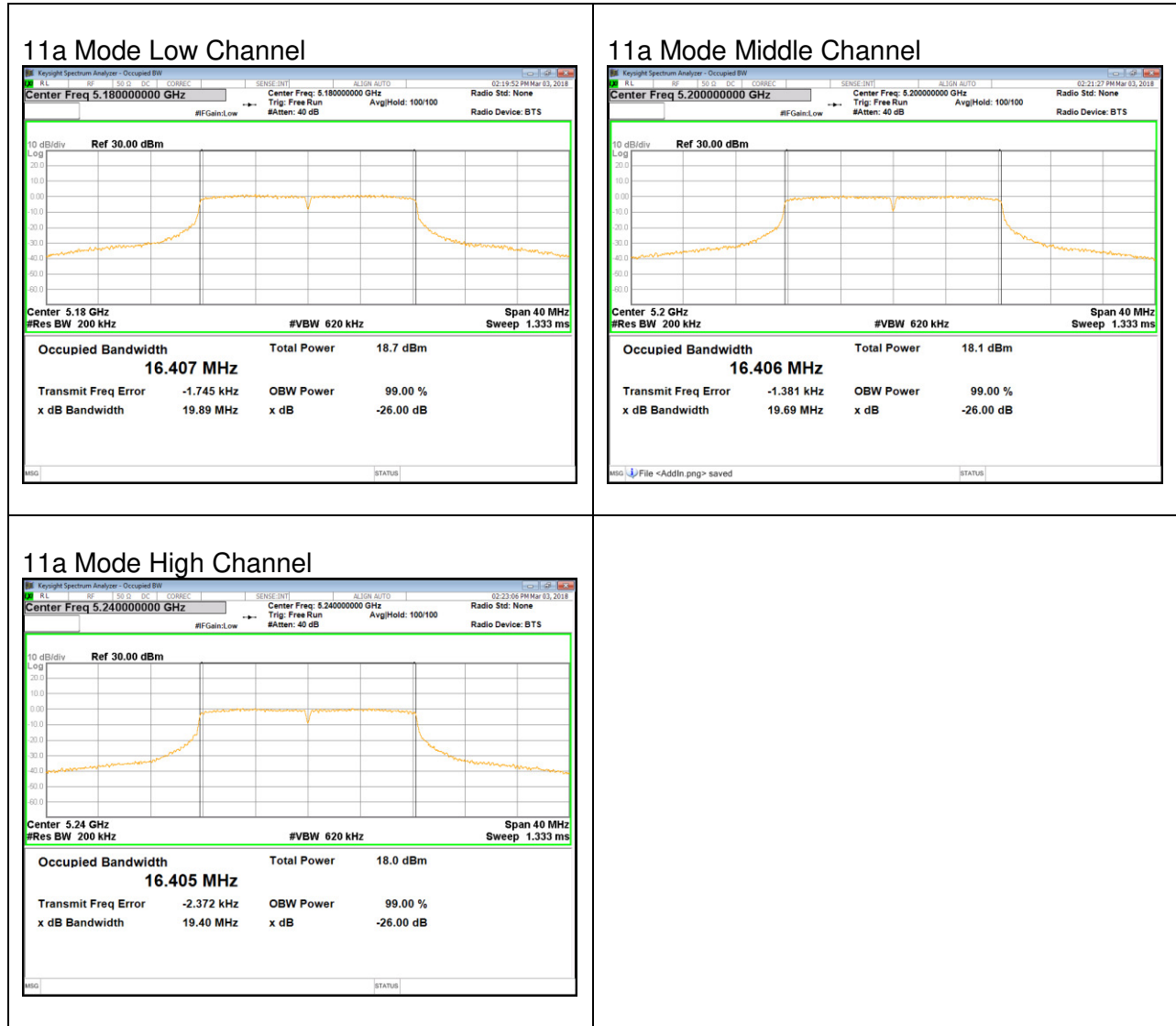

UNII 5.2 GHz IEEE 802.11n HT20 mode

11n HT20 Mode Low Channel

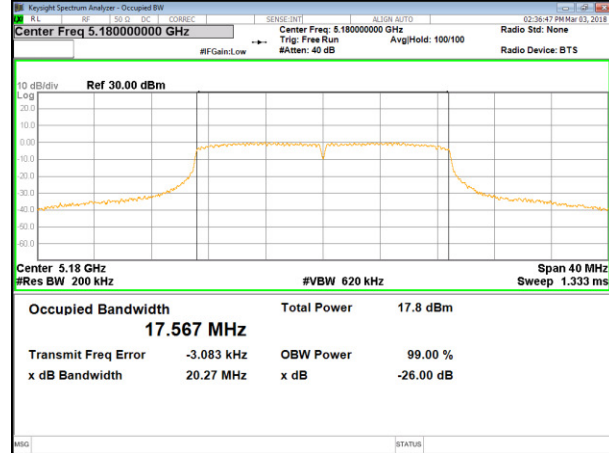

11n HT20 Mode Middle Channel

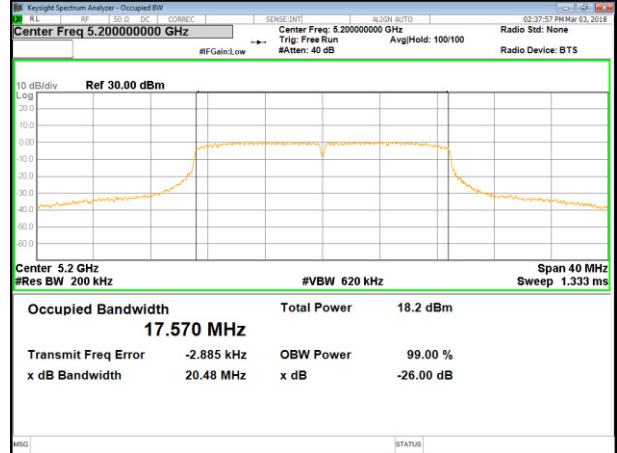

11n HT20 Mode High Channel

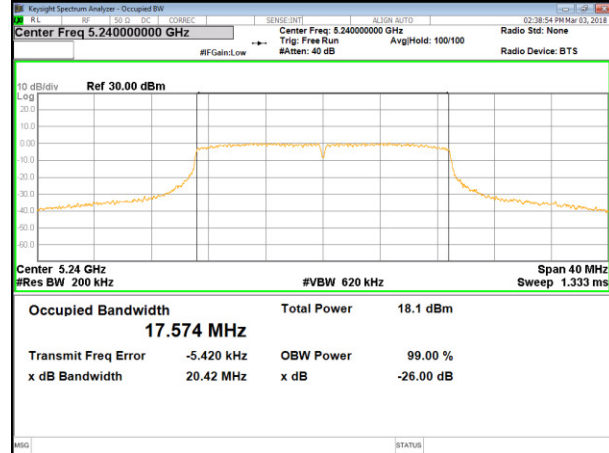

UNII 5.2 GHz IEEE 802.11n HT40 mode

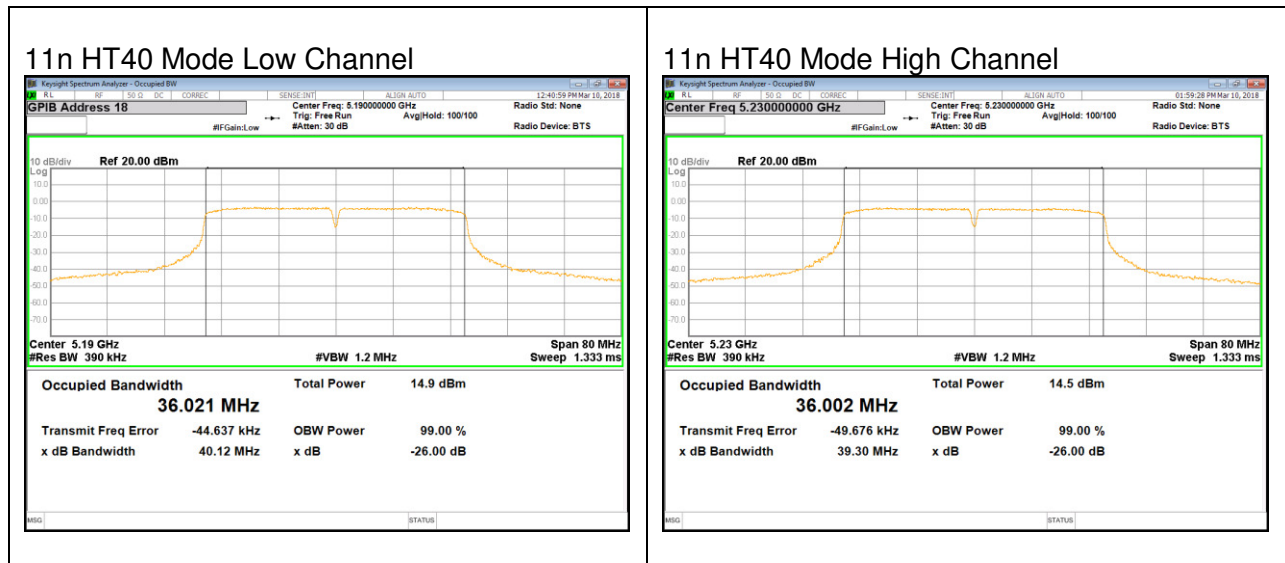

UNII 5.3 GHz IEEE 802.11a mode



UNII 5.3 GHz IEEE 802.11n HT20 mode

11n HT20 Mode Low Channel

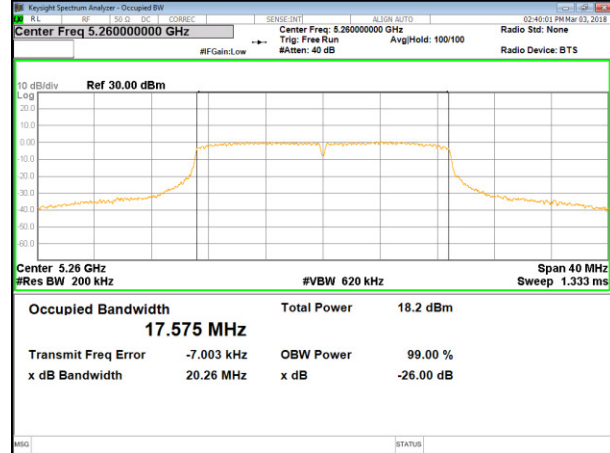

11n HT20 Mode Middle Channel

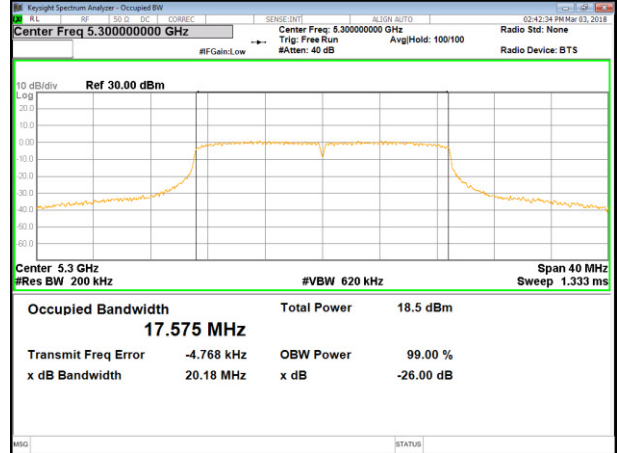

11n HT20 Mode High Channel

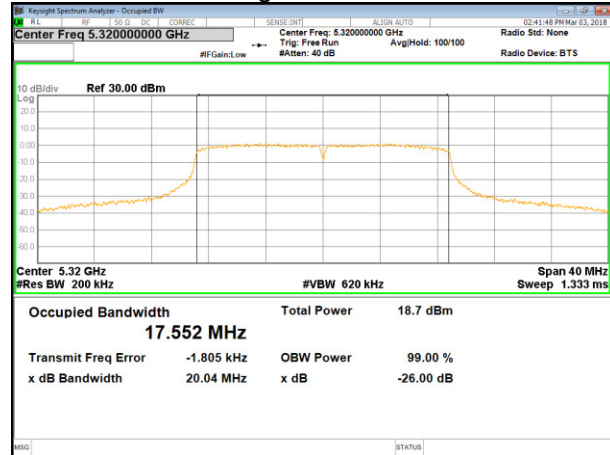

UNII 5.3 GHz IEEE 802.11n HT40 mode

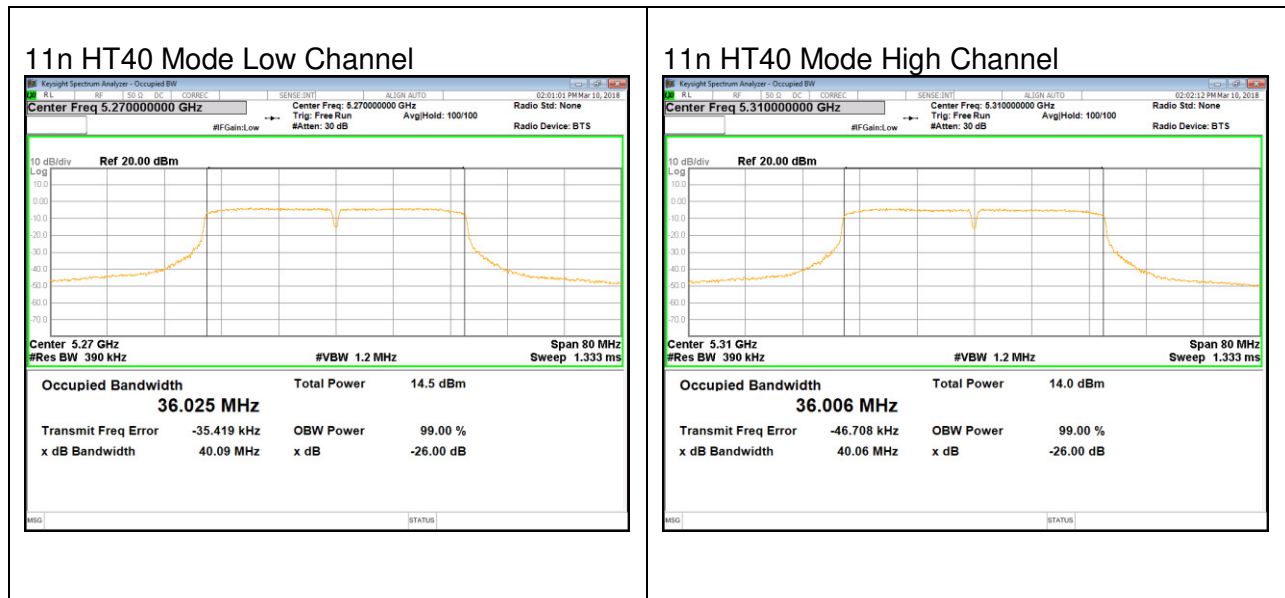

UNII 5.5 GHz IEEE 802.11a mode

11a Mode Low Channel

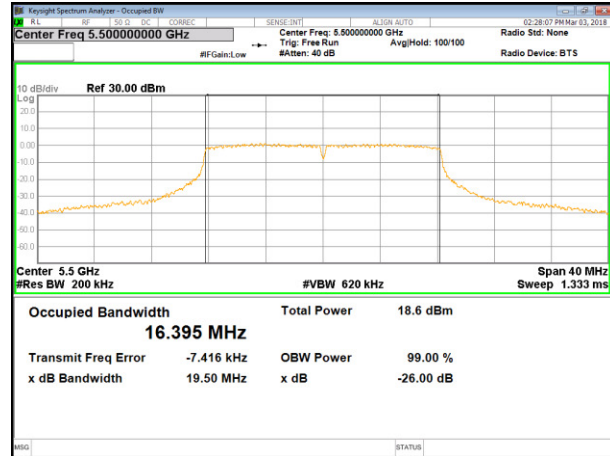

11a Mode Middle Channel

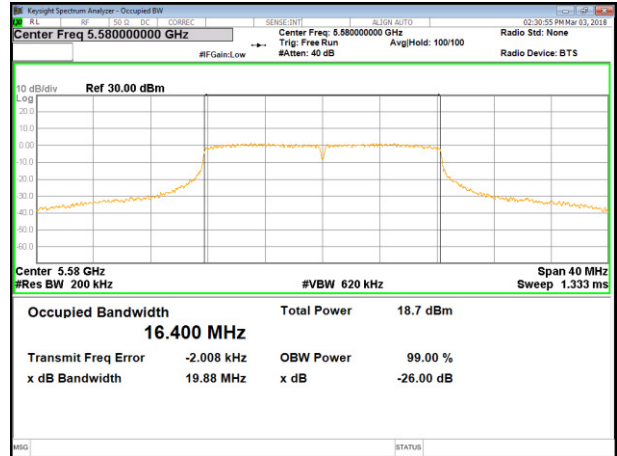

11a Mode High Channel

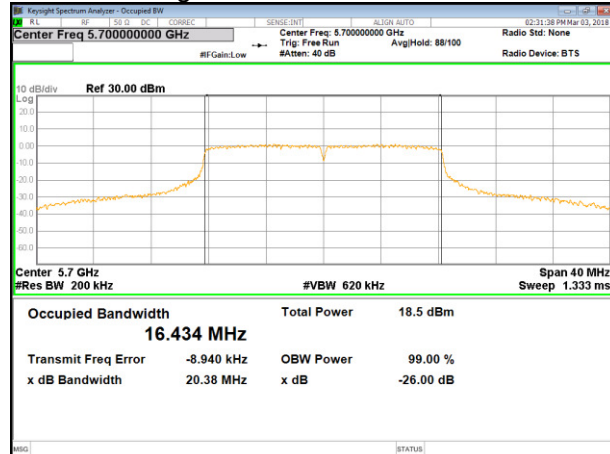

UNII 5.5 GHz IEEE 802.11n HT20 mode

11n HT20 Mode Low Channel

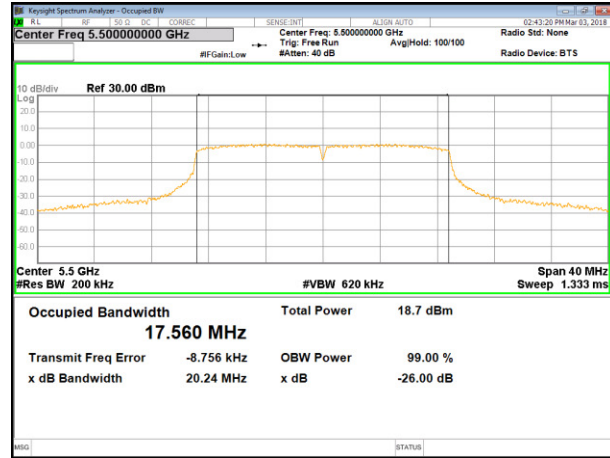

11n HT20 Mode Middle Channel

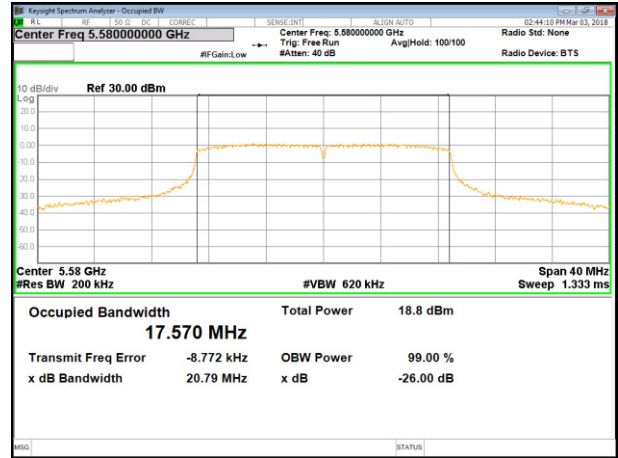

11n HT20 Mode High Channel

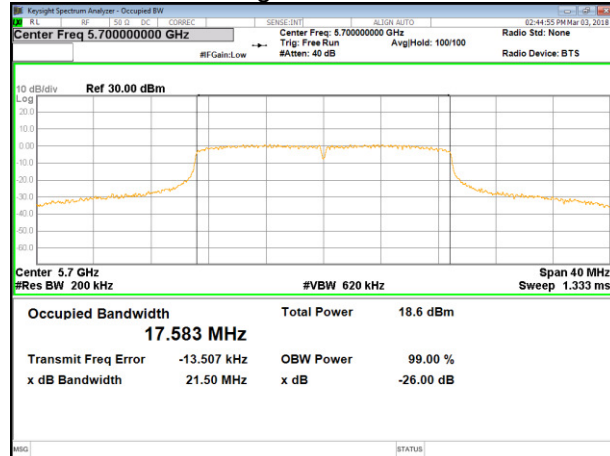

UNII 5.5 GHz IEEE 802.11n HT40 mode

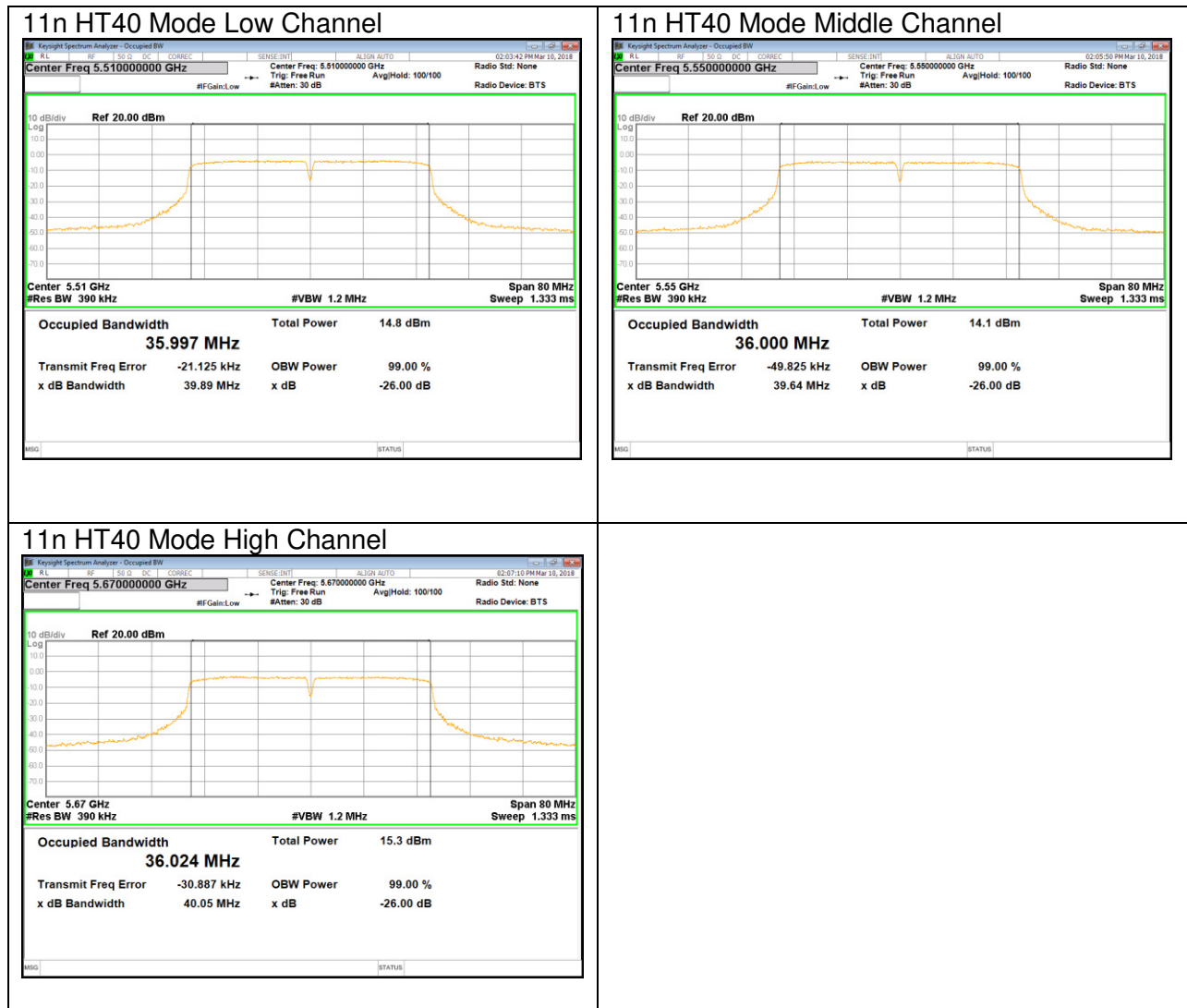

UNII 5.8 GHz IEEE 802.11a mode

11a Mode Low Channel

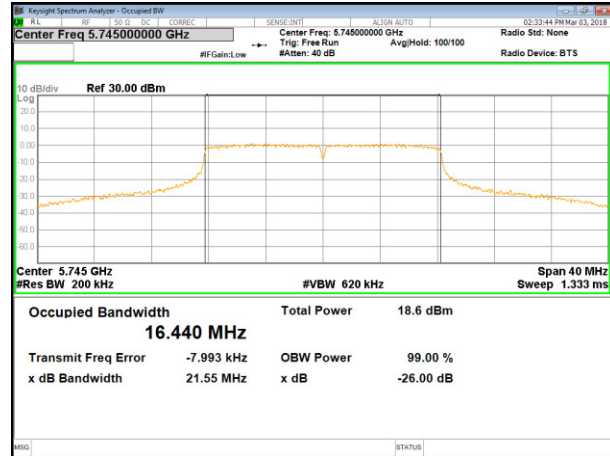

11a Mode Middle Channel

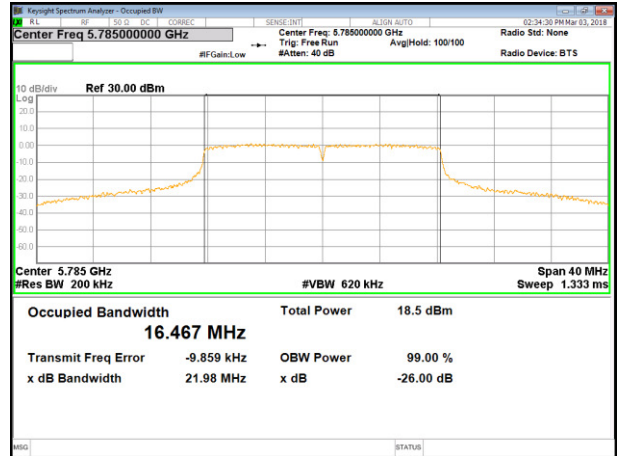

11a Mode High Channel

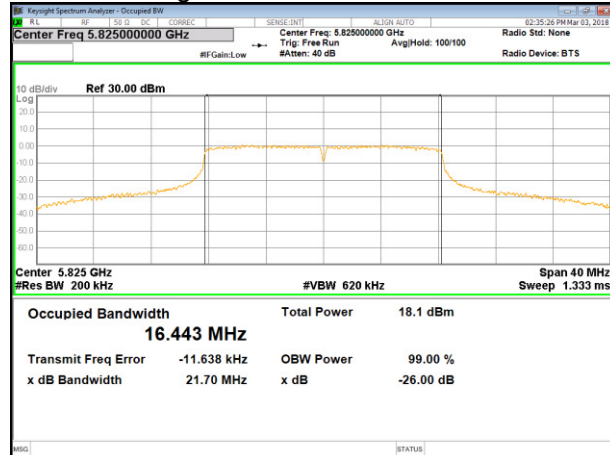

UNII 5.8 GHz IEEE 802.11n HT20 mode

11n HT20 Mode Low Channel

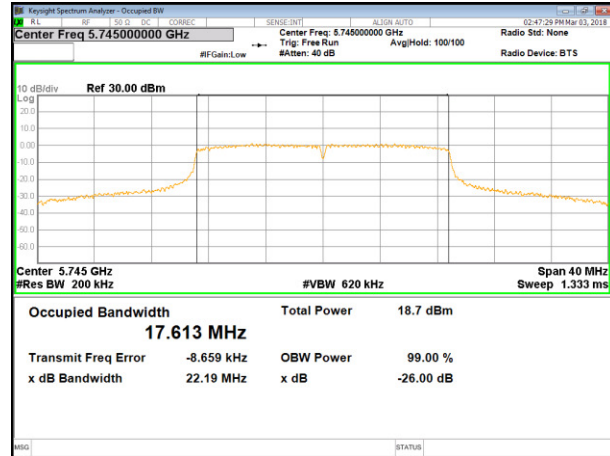

11n HT20 Mode Middle Channel

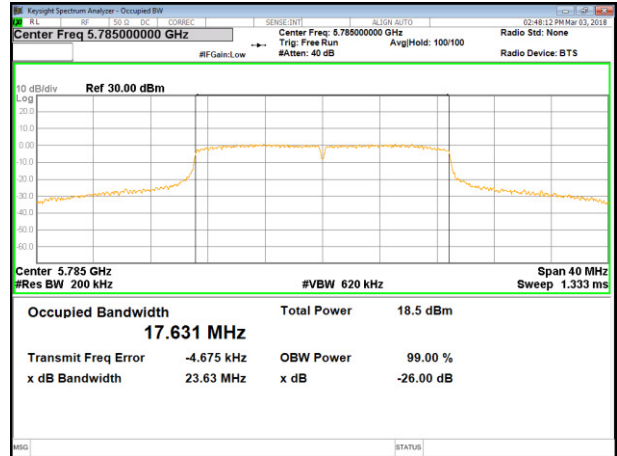

11n HT20 Mode High Channel

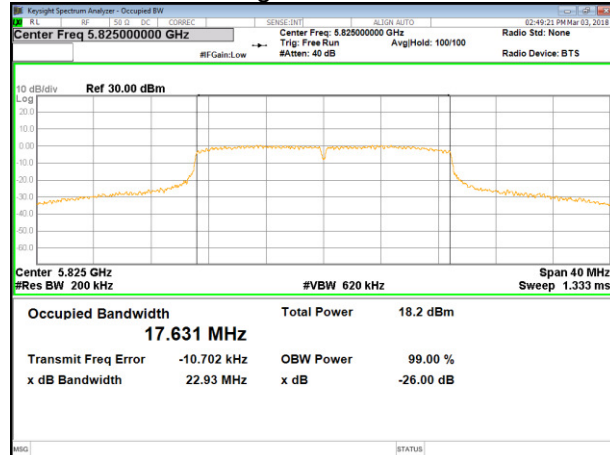

UNII 5.8 GHz IEEE 802.11n HT40 mode

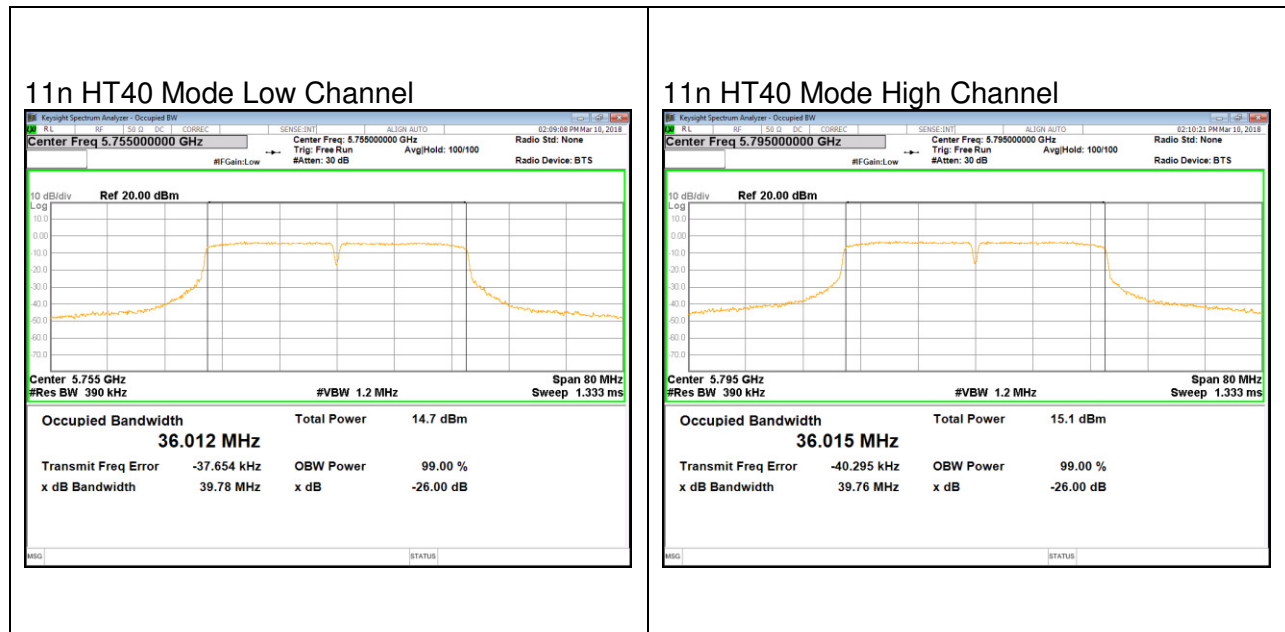

9.4. 99% BANDWIDTH

LIMITS

None; for reporting purposes only.

TEST PROCEDURE

Reference to 789033 D02 General UNII Test Procedures New Rules v02r01: The transmitter output is connected to a spectrum analyzer with the RBW set to approximately 1% of EBW, the VBW > RBW, peak detector and max hold.

RESULTS

9.4.1. 802.11a MODE IN THE 5.2 GHz BAND

Channel	Frequency [MHz]	99% Bandwidth [MHz]
Low	5180	16.45
Mid	5200	16.46
High	5240	16.45
Worst		16.46

9.4.2. 802.11n HT20 MODE IN THE 5.2 GHz BAND

Channel	Frequency [MHz]	99% Bandwidth [MHz]
Low	5180	17.55
Mid	5200	17.57
High	5240	17.59
Worst		17.59

9.4.3. 802.11n HT40 MODE IN THE 5.2 GHz BAND

Channel	Frequency [MHz]	99% Bandwidth [MHz]
Low	5190	35.97
High	5230	36.06
Worst		36.06

9.4.4. 802.11a MODE IN THE 5.3 GHz BAND

Channel	Frequency [MHz]	99% Bandwidth [MHz]
Low	5260	16.45
Mid	5300	16.44
High	5320	16.45
Worst		16.45

9.4.5. 802.11n HT20 MODE IN THE 5.3 GHz BAND

Channel	Frequency [MHz]	99% Bandwidth [MHz]
Low	5260	17.55
Mid	5300	17.61
High	5320	17.60
Worst		17.61

9.4.6. 802.11n HT40 MODE IN THE 5.3 GHz BAND

Channel	Frequency [MHz]	99% Bandwidth [MHz]
Low	5270	36.04
High	5310	36.10
Worst		36.10

9.4.7. 802.11a MODE IN THE 5.5 GHz BAND

Channel	Frequency [MHz]	99% Bandwidth [MHz]
Low	5500	16.42
Mid	5580	16.45
High	5700	16.51
Worst		16.51

9.4.8. 802.11n HT20 MODE IN THE 5.5 GHz BAND

Channel	Frequency [MHz]	99% Bandwidth [MHz]
Low	5500	17.60
Mid	5580	17.60
High	5700	17.63
Worst		17.63

9.4.9. 802.11n HT40 MODE IN THE 5.5 GHz BAND

Channel	Frequency [MHz]	99% Bandwidth [MHz]
Low	5510	36.01
Mid	5590	35.95
High	5670	36.05
Worst		36.05

9.4.10. 802.11a MODE IN THE 5.8 GHz BAND

Channel	Frequency [MHz]	99% Bandwidth [MHz]
Low	5745	16.52
Mid	5785	16.48
High	5825	16.53
Worst		16.53

9.4.11. 802.11n HT20 MODE IN THE 5.8 GHz BAND

Channel	Frequency [MHz]	99% Bandwidth [MHz]
Low	5745	17.67
Mid	5785	17.66
High	5825	17.66
Worst		17.67

9.4.12. 802.11n HT40 MODE IN THE 5.8 GHz BAND

Channel	Frequency [MHz]	99% Bandwidth [MHz]
Low	5755	36.04
High	5795	36.08
Worst		36.08

9.4.13. 99% BANDWIDTH PLOTS

UNII 5.2 GHz IEEE 802.11a mode

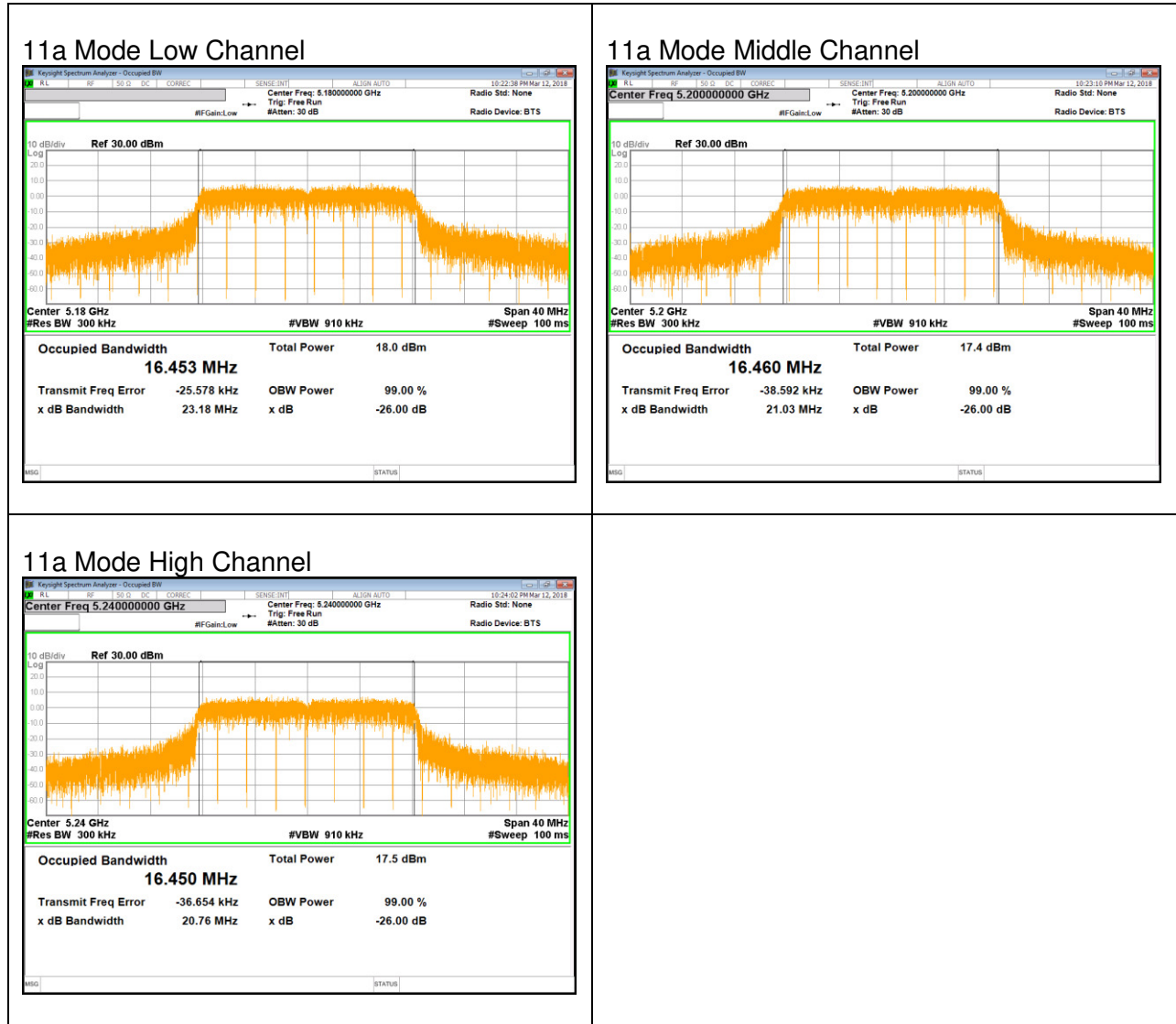

UNII 5.2 GHz IEEE 802.11n HT20 mode

11n HT20 Mode Low Channel

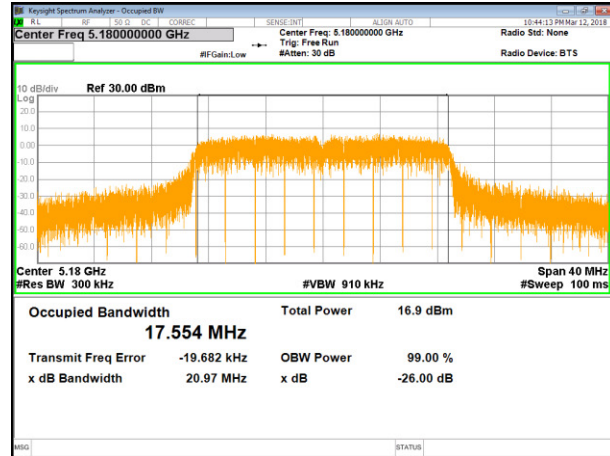

11n HT20 Mode Middle Channel

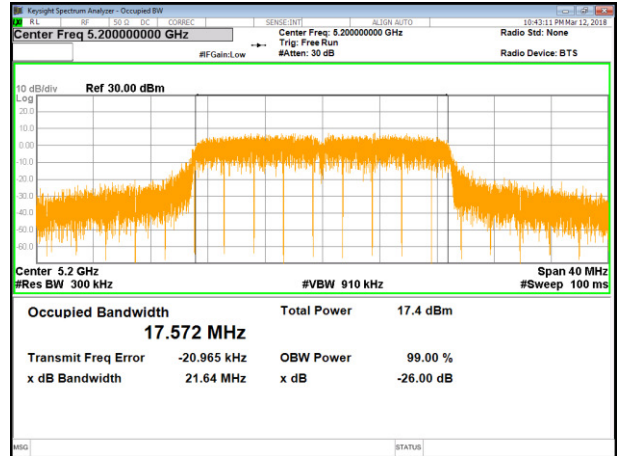

11n HT20 Mode High Channel

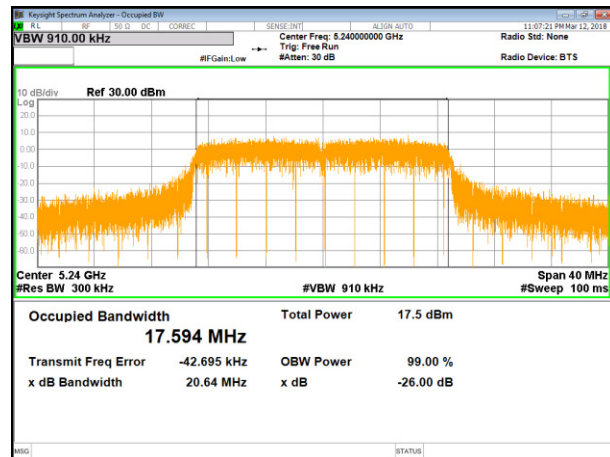

UNII 5.2 GHz IEEE 802.11n HT40 mode

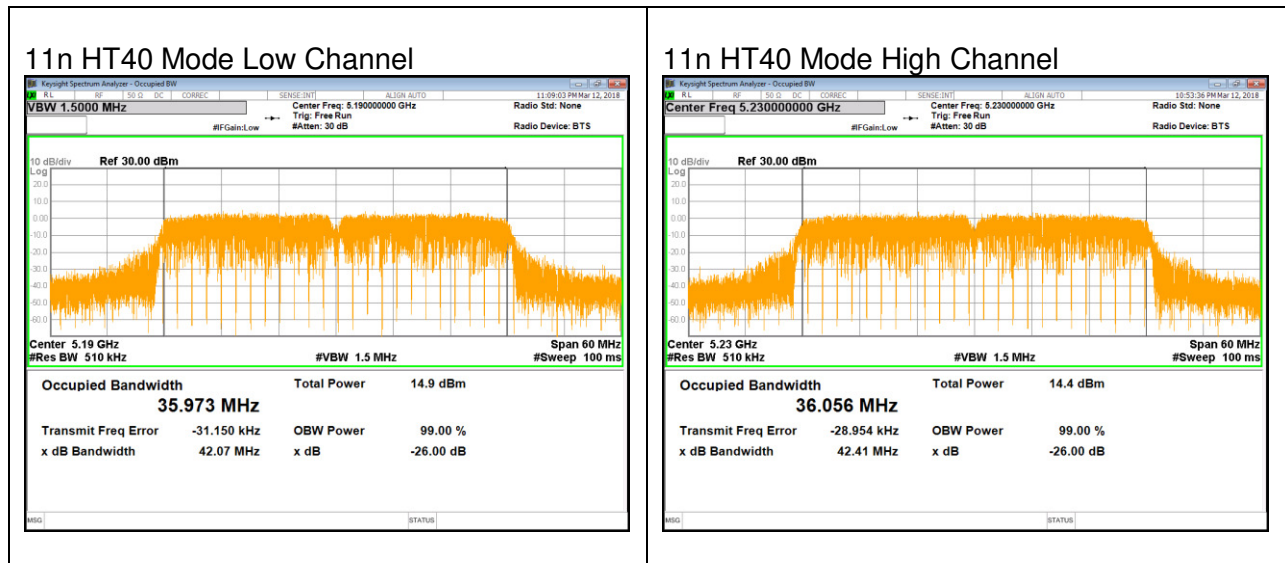

UNII 5.3 GHz IEEE 802.11a mode

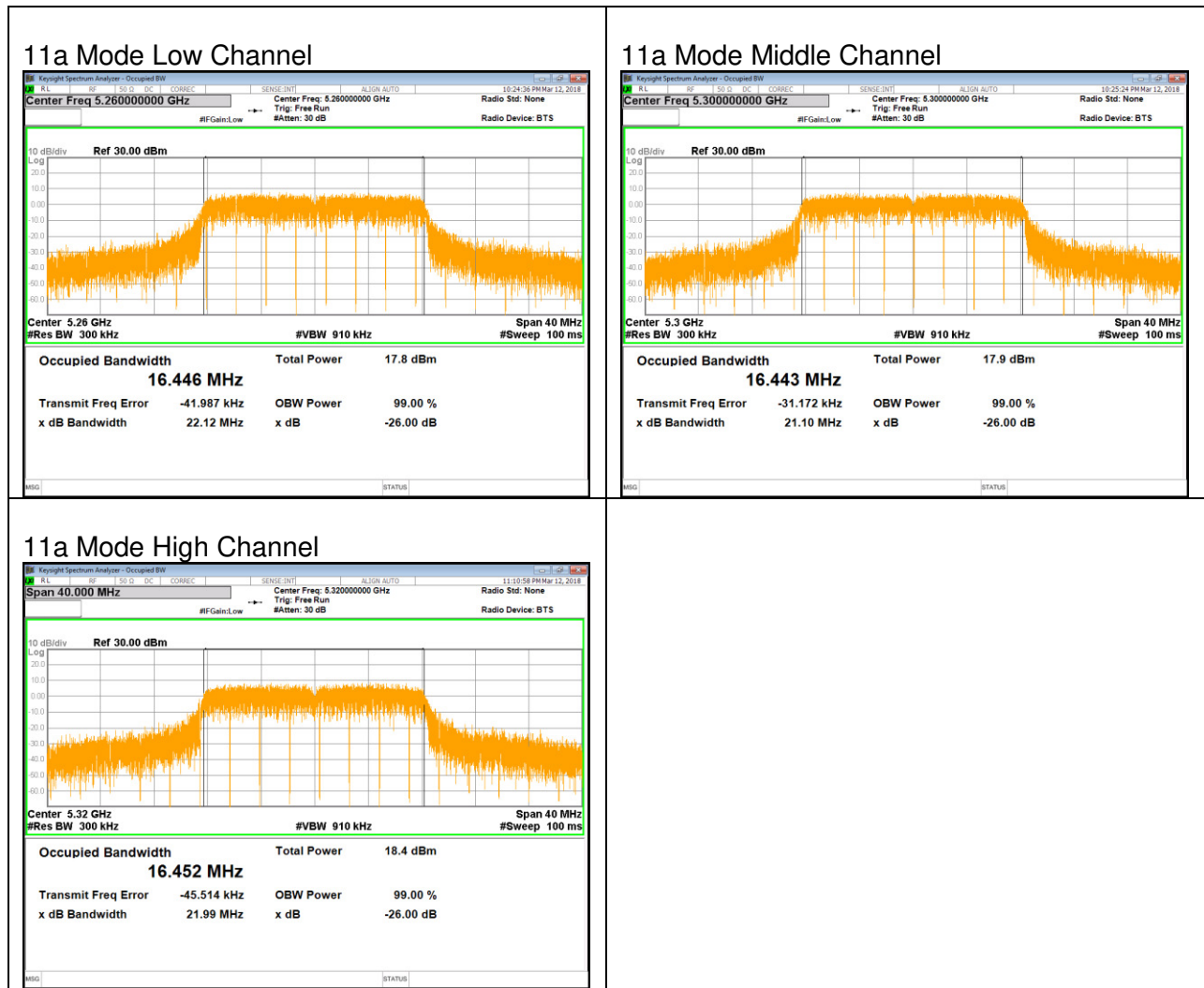

UNII 5.3 GHz IEEE 802.11n HT20 mode

11n HT20 Mode Low Channel

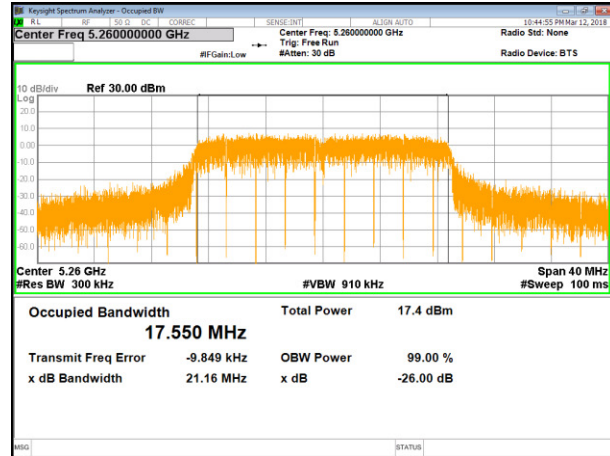

11n HT20 Mode Middle Channel

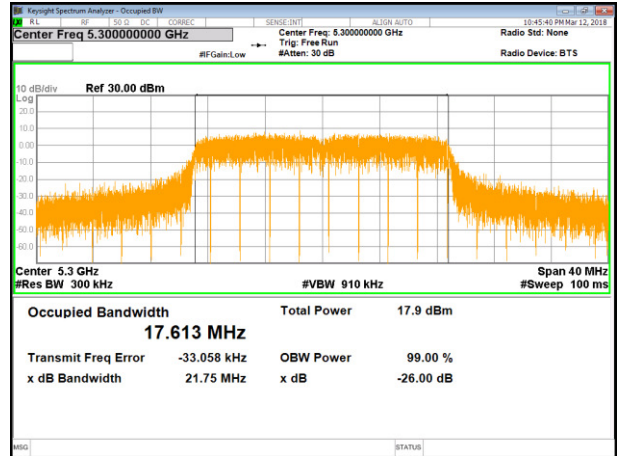

11n HT20 Mode High Channel

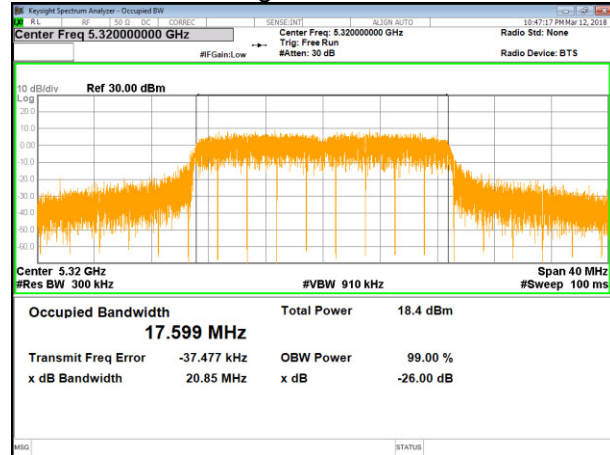

UNII 5.3 GHz IEEE 802.11n HT40 mode

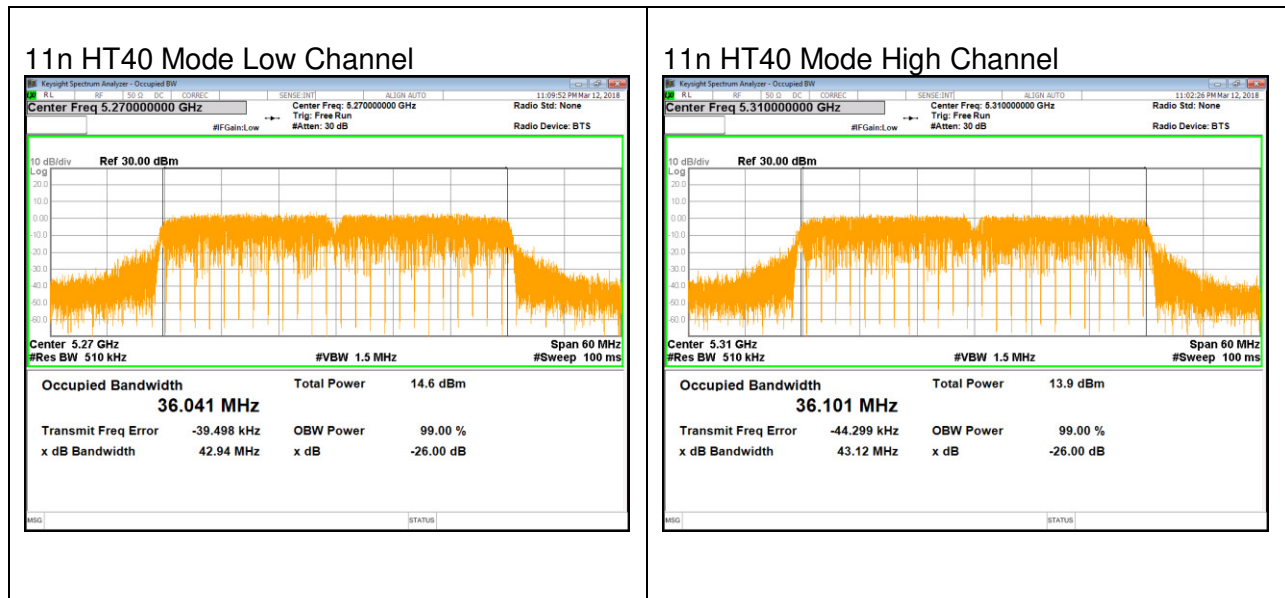

UNII 5.5 GHz IEEE 802.11a mode

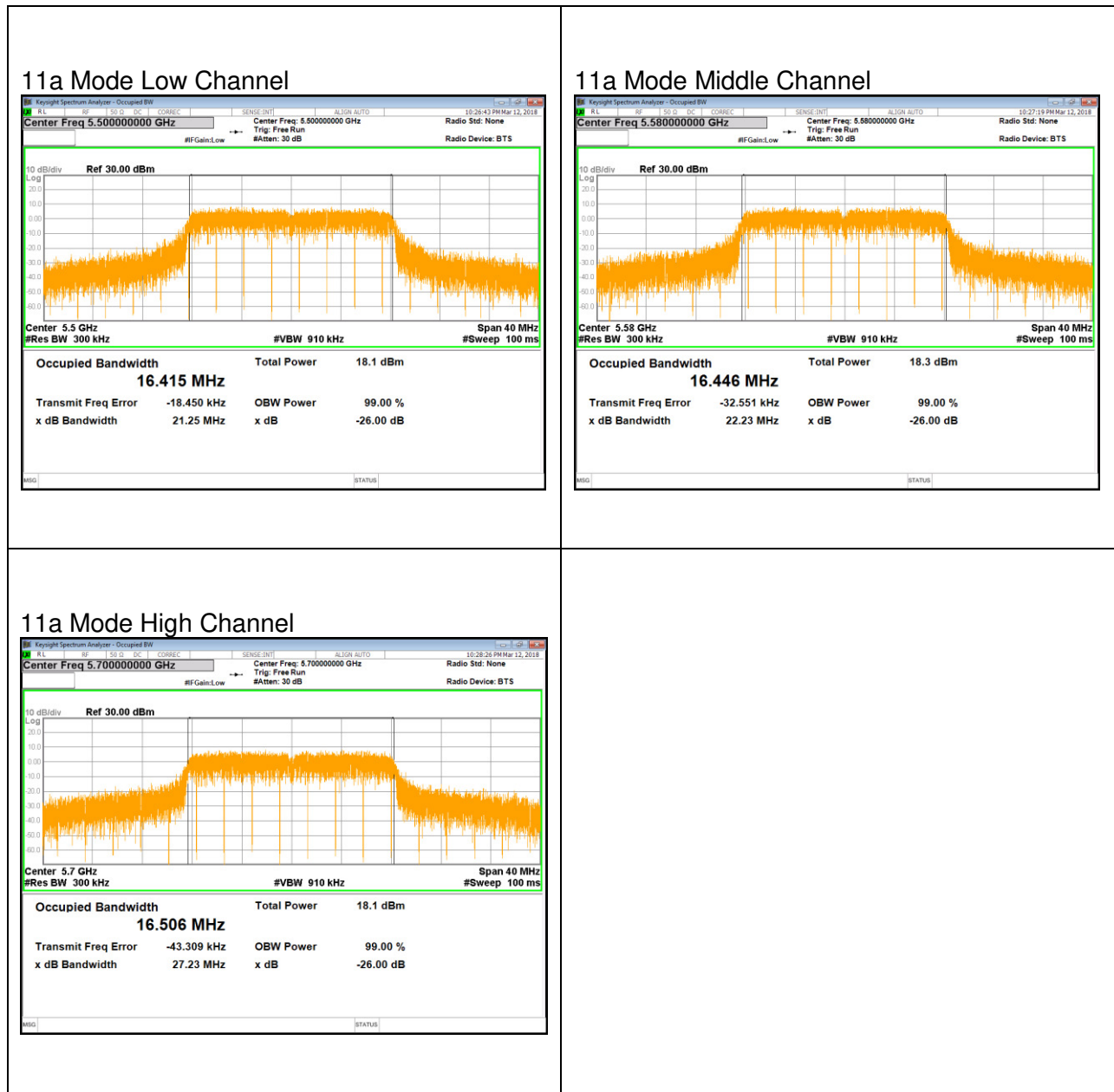

UNII 5.5 GHz IEEE 802.11n HT20 mode

11n HT20 Mode Low Channel

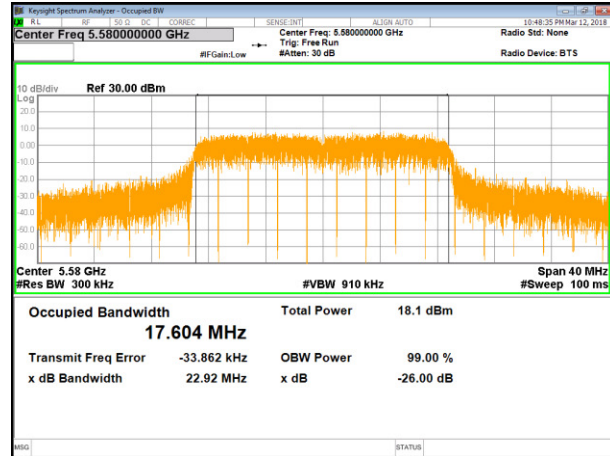

11n HT20 Mode Middle Channel

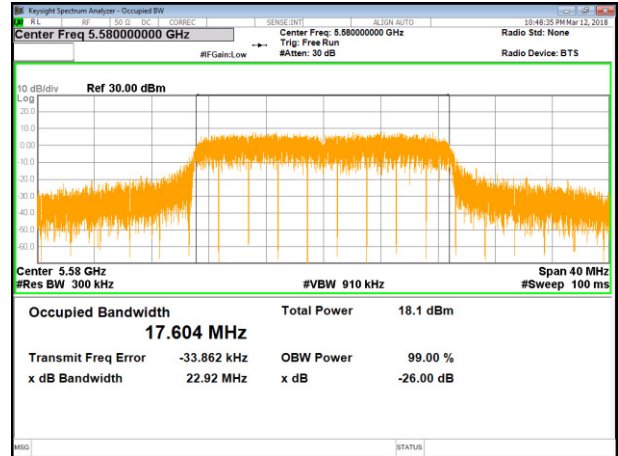

11n HT20 Mode High Channel

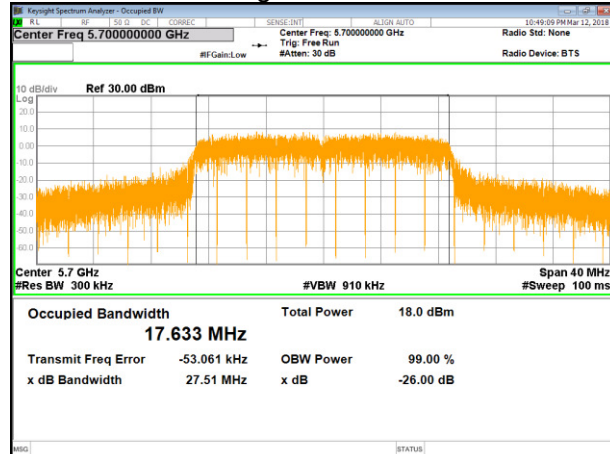

UNII 5.5 GHz IEEE 802.11n HT40 mode



UNII 5.8 GHz IEEE 802.11a mode

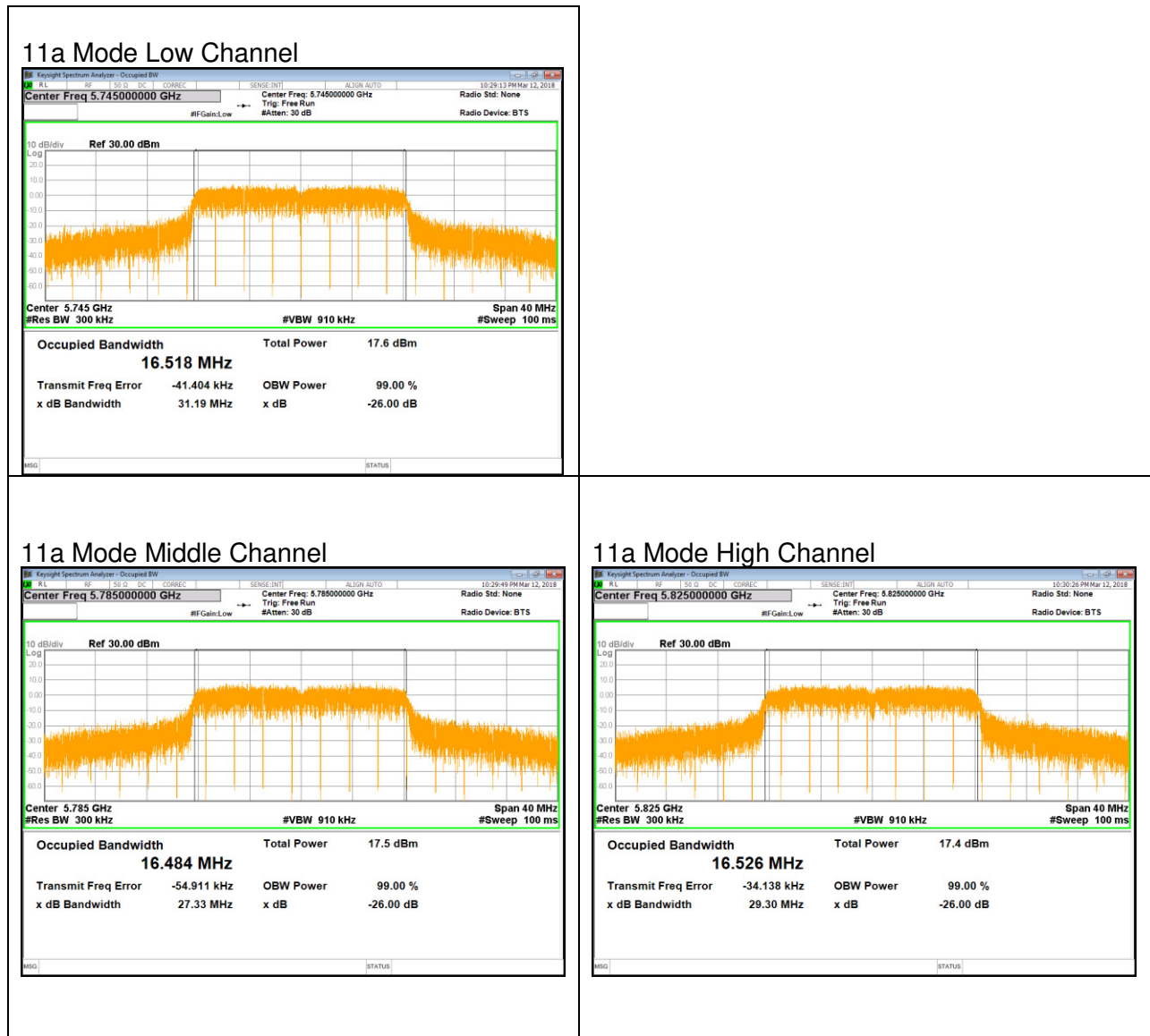

UNII 5.8 GHz IEEE 802.11n HT20 mode



UNII 5.8 GHz IEEE 802.11n HT40 mode

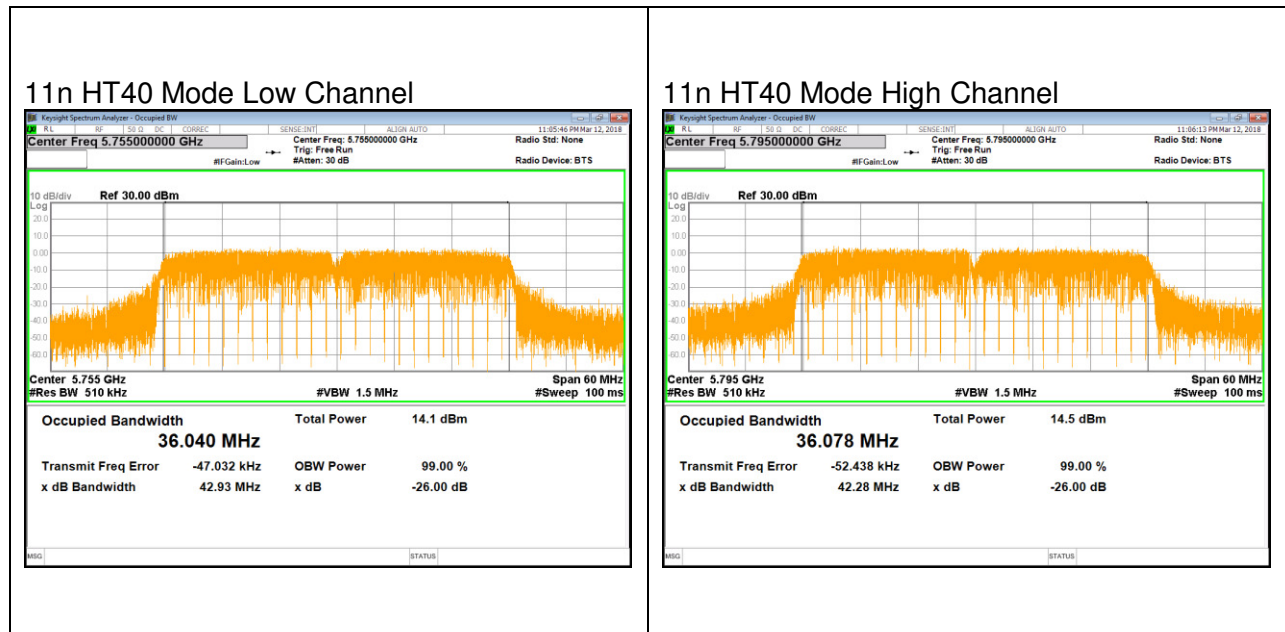

10. ANTENNA PORT TEST RESULTS

10.1. 6 dB BANDWIDTH

LIMITS

FCC §15.407 (e)

The minimum 6 dB bandwidth shall be at least 500 kHz.

TEST PROCEDURE

Reference to 789033 D02 General UNII Test Procedures New Rules v02r01: The transmitter output is connected to a spectrum analyzer with the RBW set to 100kHz, the VBW $\geq 3 \times$ RBW, peak detector and max hold.

RESULTS

10.1.1. 802.11a MODE IN THE 5.8 GHz BAND

Channel	Frequency [MHz]	6 dB Bandwidth [MHz]	Minimum Limit [MHz]
Low	5745	16.320	0.5
Mid	5785	16.300	0.5
High	5825	16.280	0.5
Worst		16.280	

10.1.2. 802.11n HT20 MODE IN THE 5.8 GHz BAND

Channel	Frequency [MHz]	6 dB Bandwidth [MHz]	Minimum Limit [MHz]
Low	5745	15.640	0.5
Mid	5785	17.290	0.5
High	5825	17.260	0.5
Worst		15.640	

10.1.3. 802.11n HT40 MODE IN THE 5.8 GHz BAND

Channel	Frequency [MHz]	6 dB Bandwidth [MHz]	Minimum Limit [MHz]
Low	5755	39.250	0.5
High	5795	39.490	0.5
Worst		39.250	

10.1.4. 6 dB BANDWIDTH PLOTS

UNII 5.8 GHz IEEE 802.11a mode



UNII 5.8 GHz IEEE 802.11n HT20 mode

11n HT20 Mode Low Channel

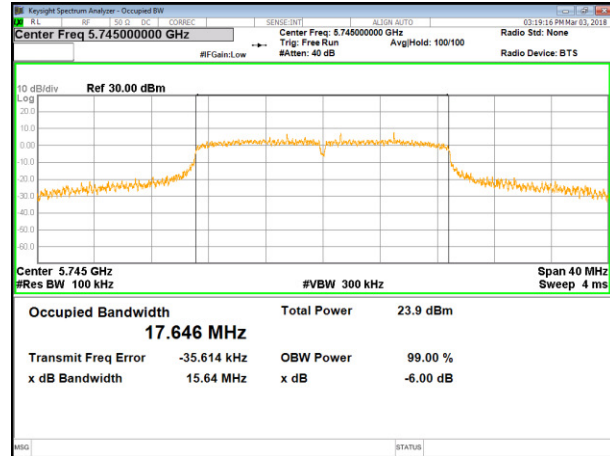

11n HT20 Mode Middle Channel

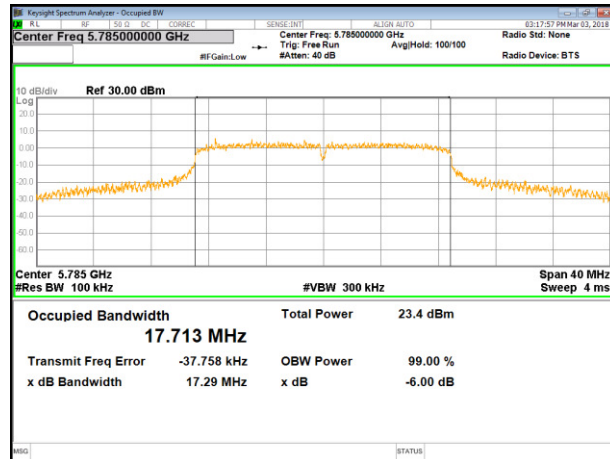

11n HT20 Mode High Channel

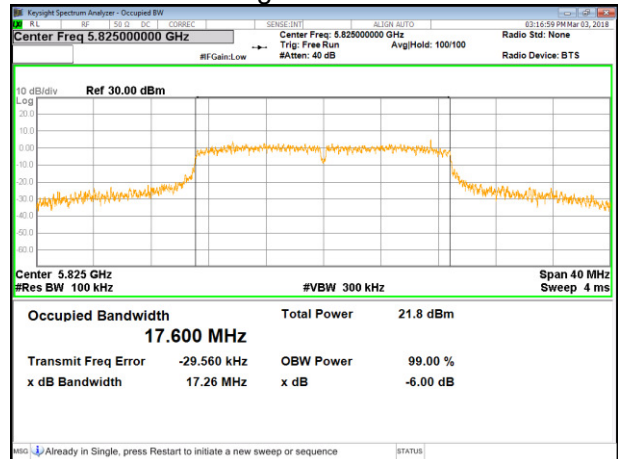

UNII 5.8 GHz IEEE 802.11n HT40 mode

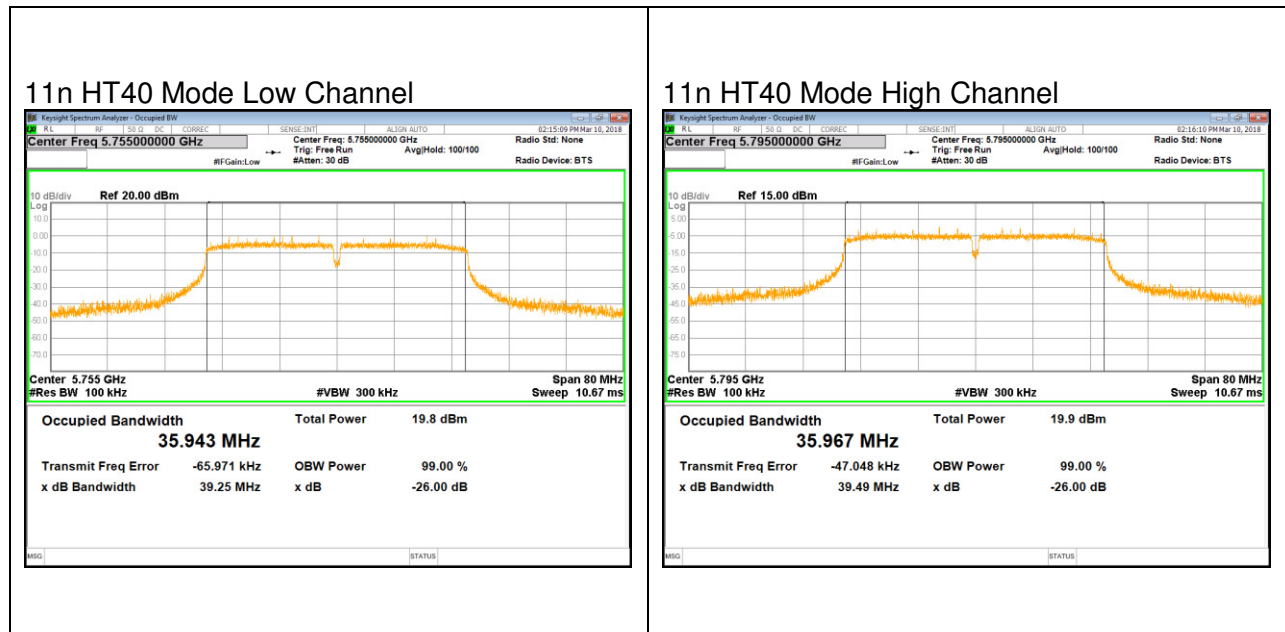

10.2. OUTPUT POWER AND PPSD

LIMITS

FCC §15.407 (a) (1) (2) (3)

For the band 5.15–5.25 GHz, the maximum conducted output power over the frequency band of operation shall not exceed 250 mW provided the maximum antenna gain does not exceed 6 dBi. In addition, the maximum power spectral density shall not exceed 11 dBm in any 1 megahertz band. If transmitting antennas of directional gain greater than 6 dBi are used, both the maximum conducted output power and the maximum power spectral density shall be reduced by the amount in dB that the directional gain of the antenna exceeds 6 dBi.

For the 5.25-5.35 GHz and 5.47-5.725 GHz bands, the maximum conducted output power over the frequency bands of operation shall not exceed the lesser of 250 mW or $11 \text{ dBm} + 10 \log B$, where B is the 26 dB emission bandwidth in megahertz. In addition, the maximum power spectral density shall not exceed 11 dBm in any 1 megahertz band. If transmitting antennas of directional gain greater than 6 dBi are used, both the maximum conducted output power and the maximum power spectral density shall be reduced by the amount in dB that the directional gain of the antenna exceeds 6 dBi.

For the band 5.725-5.85 GHz, the maximum conducted output power over the frequency band of operation shall not exceed 1 W. In addition, the maximum power spectral density shall not exceed 30 dBm in any 500-kHz band.

TEST PROCEDURE

KDB 789033 Method SA-2 is used for PPSD. RBW set to 1MHz (500kHz for the band 5.725-5.85 GHz, the VBW $\geq 3 \times$ RBW, RMS detector and trace averaging). Peak marker value of the spectrum is used for PSD. For 802.11 n HT40 mode, add duty cycle correction factor.

KDB 789033 Method PM is used for output power. For 802.11 n HT40 mode, duty cycle correction factor is already added to the average output power results.

DIRECTIONAL ANTENNA GAIN

There is only one transmitter output therefore the directional gain is equal to the antenna gain.

5 GHz

Frequency Band [MHz]	Antenna Gain [dBi]
5150 - 5250	-1.41
5250 - 5350	-2.72
5470 - 5725	-3.66
5725 - 5850	-5.64

RESULTS

10.2.1. 802.11a MODE IN THE 5.2 GHz BAND

Bandwidth and Antenna Gain

Channel	Frequency [MHz]	Min 26 dB BW [MHz]	Directional Gain for Power [dBi]	Directional Gain for PPSD [dBi]
Low	5180	19.89	-1.41	-1.41
Mid	5200	19.69	-1.41	-1.41
High	5240	19.40	-1.41	-1.41

Limits

Channel	Frequency [MHz]	FCC Power Limit [dBm]	Power Limit [dBm]	FCC PPSD Limit [dBm]
Low	5180	23.99	23.99	11.00
Mid	5200	23.94	23.94	11.00
High	5240	23.88	23.88	11.00

Duty Cycle CF [dB]	0.08	Included in Calculations of Corr'd Power & PPSD
---------------------------	------	--

Output Power Results

Channel	Frequency [MHz]	Meas Power [dBm]	Total Corr'd Power [dBm]	Power Limit [dBm]	Power Margin [dB]
Low	5180	18.32	18.40	23.99	-5.59
Mid	5200	17.87	17.95	23.94	-5.99
High	5240	17.68	17.76	23.88	-6.12

PPSD Results

Channel	Frequency [MHz]	Meas PPSD [dBm]	Total Corr'd PPSD [dBm]	PPSD Limit [dBm]	PPSD Margin [dB]
Low	5180	8.30	8.38	11.00	-2.62
Mid	5200	7.86	7.93	11.00	-3.07
High	5240	7.67	7.74	11.00	-3.26

10.2.2. 802.11n HT20 MODE IN THE 5.2 GHz BAND

Bandwidth and Antenna Gain

Channel	Frequency [MHz]	Min 26 dB BW [MHz]	Directional Gain for Power [dBi]	Directional Gain for PPSD [dBi]
Low	5180	20.27	-1.41	-1.41
Mid	5200	20.48	-1.41	-1.41
High	5240	20.42	-1.41	-1.41

Limits

Channel	Frequency [MHz]	FCC Power Limit [dBm]	Power Limit [dBm]	FCC PPSD Limit [dBm]
Low	5180	24.00	24.00	11.00
Mid	5200	24.00	24.00	11.00
High	5240	24.00	24.00	11.00

Duty Cycle CF [dB]	0.08	Included in Calculations of Corr'd Power & PPSD
---------------------------	------	--

Output Power Results

Channel	Frequency [MHz]	Meas Power [dBm]	Total Corr'd Power [dBm]	Power Limit [dBm]	Power Margin [dB]
Low	5180	17.53	17.61	24.00	-6.39
Mid	5200	17.92	18.00	24.00	-6.00
High	5240	17.81	17.89	24.00	-6.11

PPSD Results

Channel	Frequency [MHz]	Meas PPSD [dBm]	Total Corr'd PPSD [dBm]	PPSD Limit [dBm]	PPSD Margin [dB]
Low	5180	7.13	7.21	11.00	-3.79
Mid	5200	7.59	7.67	11.00	-3.33
High	5240	7.43	7.52	11.00	-3.48

10.2.3. 802.11n HT40 MODE IN THE 5.2 GHz BAND

Bandwidth and Antenna Gain

Channel	Frequency [MHz]	Min 26 dB BW [MHz]	Directional Gain for Power [dBi]	Directional Gain for PPSD [dBi]
Low	5190	40.12	-1.41	-1.41
High	5230	39.30	-1.41	-1.41

Limits

Channel	Frequency [MHz]	FCC Power Limit [dBm]	Power Limit [dBm]	FCC PPSD Limit [dBm]
Low	5190	24.00	24.00	11.00
High	5230	24.00	24.00	11.00

Duty Cycle CF [dB]	0.18	Included in Calculations of Corr'd Power & PPSD
---------------------------	------	--

Output Power Results

Channel	Frequency [MHz]	Meas Power [dBm]	Total Corr'd Power [dBm]	Power Limit [dBm]	Power Margin [dB]
Low	5190	15.30	15.48	24.00	-8.52
High	5230	14.57	14.75	24.00	-9.25

PPSD Results

Channel	Frequency [MHz]	Meas PPSD [dBm]	Total Corr'd PPSD [dBm]	PPSD Limit [dBm]	PPSD Margin [dB]
Low	5190	1.87	2.05	11.00	-8.95
High	5230	0.95	1.12	11.00	-9.88

10.2.4. 802.11a MODE IN THE 5.3 GHz BAND

Bandwidth and Antenna Gain

Channel	Frequency [MHz]	Min 26 dB BW [MHz]	Directional Gain for Power [dBi]	Directional Gain for PPSD [dBi]
Low	5260	19.27	-2.72	-2.72
Mid	5300	19.53	-2.72	-2.72
High	5320	19.91	-2.72	-2.72

Limits

Channel	Frequency [MHz]	FCC Power Limit [dBm]	Power Limit [dBm]	FCC PPSD Limit [dBm]
Low	5260	23.85	23.85	11.00
Mid	5300	23.91	23.91	11.00
High	5320	23.99	23.99	11.00

Duty Cycle CF [dB]	0.08	Included in Calculations of Corr'd Power & PPSD
---------------------------	------	--

Output Power Results

Channel	Frequency [MHz]	Meas Power [dBm]	Total Corr'd Power [dBm]	Power Limit [dBm]	Power Margin [dB]
Low	5260	17.81	17.89	23.85	-5.96
Mid	5300	18.03	18.11	23.91	-5.80
High	5320	18.23	18.31	23.99	-5.68

PPSD Results

Channel	Frequency [MHz]	Meas PPSD [dBm]	Total Corr'd PPSD [dBm]	PPSD Limit [dBm]	PPSD Margin [dB]
Low	5260	7.80	7.88	11.00	-3.12
Mid	5300	8.15	8.23	11.00	-2.77
High	5320	8.35	8.43	11.00	-2.57

10.2.5. 802.11n HT20 MODE IN THE 5.3 GHz BAND

Bandwidth and Antenna Gain

Channel	Frequency [MHz]	Min 26 dB BW [MHz]	Directional Gain for Power [dBi]	Directional Gain for PPSD [dBi]
Low	5260	20.26	-2.72	-2.72
Mid	5300	20.18	-2.72	-2.72
High	5320	20.04	-2.72	-2.72

Limits

Channel	Frequency [MHz]	FCC Power Limit [dBm]	Power Limit [dBm]	FCC PPSD Limit [dBm]
Low	5260	24.00	24.00	11.00
Mid	5300	24.00	24.00	11.00
High	5320	24.00	24.00	11.00

Duty Cycle CF [dB]	0.08	Included in Calculations of Corr'd Power & PPSD
---------------------------	------	--

Output Power Results

Channel	Frequency [MHz]	Meas Power [dBm]	Total Corr'd Power [dBm]	Power Limit [dBm]	Power Margin [dB]
Low	5260	17.91	17.99	24.00	-6.01
Mid	5300	18.29	18.37	24.00	-5.63
High	5320	18.33	18.41	24.00	-5.59

PPSD Results

Channel	Frequency [MHz]	Meas PPSD [dBm]	Total Corr'd PPSD [dBm]	PPSD Limit [dBm]	PPSD Margin [dB]
Low	5260	7.60	7.68	11.00	-3.32
Mid	5300	7.77	7.85	11.00	-3.15
High	5320	8.03	8.11	11.00	-2.89

10.2.6. 802.11n HT40 MODE IN THE 5.3 GHz BAND

Bandwidth and Antenna Gain

Channel	Frequency [MHz]	Min 26 dB BW [MHz]	Directional Gain for Power [dBi]	Directional Gain for PPSD [dBi]
Low	5270	40.09	-2.72	-2.72
High	5310	40.06	-2.72	-2.72

Limits

Channel	Frequency [MHz]	FCC Power Limit [dBm]	Power Limit [dBm]	FCC PPSD Limit [dBm]
Low	5270	24.00	24.00	11.00
High	5310	24.00	24.00	11.00

Duty Cycle CF [dB]	0.18	Included in Calculations of Corr'd Power & PPSD
---------------------------	------	--

Output Power Results

Channel	Frequency [MHz]	Meas Power [dBm]	Total Corr'd Power [dBm]	Power Limit [dBm]	Power Margin [dB]
Low	5270	14.86	15.04	24.00	-8.96
High	5310	14.27	14.45	24.00	-9.55

PPSD Results

Channel	Frequency [MHz]	Meas PPSD [dBm]	Total Corr'd PPSD [dBm]	PPSD Limit [dBm]	PPSD Margin [dB]
Low	5270	0.92	1.09	11.00	-9.91
High	5310	0.11	0.28	11.00	-10.72

10.2.7. 802.11a MODE IN THE 5.5 GHz BAND

Bandwidth and Antenna Gain

Channel	Frequency [MHz]	Min 26 dB BW [MHz]	Directional Gain for Power [dBi]	Directional Gain for PPSD [dBi]
Low	5500	19.50	-3.66	-3.66
Mid	5580	19.88	-3.66	-3.66
High	5700	20.38	-3.66	-3.66

Limits

Channel	Frequency [MHz]	FCC Power Limit [dBm]	Power Limit [dBm]	FCC PPSD Limit [dBm]
Low	5500	23.90	23.90	11.00
Mid	5580	23.98	23.98	11.00
High	5700	24.00	24.00	11.00

Duty Cycle CF [dB]	0.08	Included in Calculations of Corr'd Power & PPSD
---------------------------	------	--

Output Power Results

Channel	Frequency [MHz]	Meas Power [dBm]	Total Corr'd Power [dBm]	Power Limit [dBm]	Power Margin [dB]
Low	5500	18.23	18.31	23.90	-5.59
Mid	5580	18.28	18.36	23.98	-5.62
High	5700	17.97	18.05	24.00	-5.95

PPSD Results

Channel	Frequency [MHz]	Meas PPSD [dBm]	Total Corr'd PPSD [dBm]	PPSD Limit [dBm]	PPSD Margin [dB]
Low	5500	8.24	8.31	11.00	-2.69
Mid	5580	8.37	8.45	11.00	-2.55
High	5700	8.33	8.41	11.00	-2.59

10.2.8. 802.11n HT20 MODE IN THE 5.5 GHz BAND

Bandwidth and Antenna Gain

Channel	Frequency [MHz]	Min 26 dB BW [MHz]	Directional Gain for Power [dBi]	Directional Gain for PPSD [dBi]
Low	5500	20.24	-3.66	-3.66
Mid	5580	20.79	-3.66	-3.66
High	5700	21.50	-3.66	-3.66

Limits

Channel	Frequency [MHz]	FCC Power Limit [dBm]	Power Limit [dBm]	FCC PPSD Limit [dBm]
Low	5500	24.00	24.00	11.00
Mid	5580	24.00	24.00	11.00
High	5700	24.00	24.00	11.00

Duty Cycle CF [dB]	0.08	Included in Calculations of Corr'd Power & PPSD
---------------------------	------	--

Output Power Results

Channel	Frequency [MHz]	Meas Power [dBm]	Total Corr'd Power [dBm]	Power Limit [dBm]	Power Margin [dB]
Low	5500	18.23	18.31	24.00	-5.69
Mid	5580	18.30	18.38	24.00	-5.62
High	5700	17.97	18.05	24.00	-5.95

PPSD Results

Channel	Frequency [MHz]	Meas PPSD [dBm]	Total Corr'd PPSD [dBm]	PPSD Limit [dBm]	PPSD Margin [dB]
Low	5500	8.07	8.15	11.00	-2.85
Mid	5580	8.17	8.25	11.00	-2.75
High	5700	8.00	8.08	11.00	-2.92

10.2.9. 802.11n HT40 MODE IN THE 5.5 GHz BAND

Bandwidth and Antenna Gain

Channel	Frequency [MHz]	Min 26 dB BW [MHz]	Directional Gain for Power [dBi]	Directional Gain for PPSD [dBi]
Low	5510	39.89	-3.66	-3.66
Mid	5590	39.64	-3.66	-3.66
High	5670	40.05	-3.66	-3.66

Limits

Channel	Frequency [MHz]	FCC Power Limit [dBm]	Power Limit [dBm]	FCC PPSD Limit [dBm]
Low	5510	24.00	24.00	11.00
Mid	5590	24.00	24.00	11.00
High	5670	24.00	24.00	11.00

Duty Cycle CF [dB]	0.18	Included in Calculations of Corr'd Power & PPSD
---------------------------	------	--

Output Power Results

Channel	Frequency [MHz]	Meas Power [dBm]	Total Corr'd Power [dBm]	Power Limit [dBm]	Power Margin [dB]
Low	5510	15.05	15.23	24.00	-8.77
Mid	5590	14.45	14.63	24.00	-9.37
High	5670	14.86	15.04	24.00	-8.96

PPSD Results

Channel	Frequency [MHz]	Meas PPSD [dBm]	Total Corr'd PPSD [dBm]	PPSD Limit [dBm]	PPSD Margin [dB]
Low	5510	0.82	1.00	11.00	-10.00
Mid	5590	0.37	0.55	11.00	-10.45
High	5670	1.64	1.81	11.00	-9.19

10.2.10. 802.11a MODE IN THE 5.8 GHz BAND

Bandwidth and Antenna Gain

Channel	Frequency [MHz]	Min 26 dB BW [MHz]	Directional Gain for Power [dBi]	Directional Gain for PPSD [dBi]
Low	5745	21.55	-5.64	-5.64
Mid	5785	21.98	-5.64	-5.64
High	5825	21.70	-5.64	-5.64

Limits

Channel	Frequency [MHz]	FCC Power Limit [dBm]	Power Limit [dBm]	FCC PPSD Limit [dBm/500kHz]
Low	5745	30.00	30.00	30.00
Mid	5785	30.00	30.00	30.00
High	5825	30.00	30.00	30.00

Duty Cycle CF [dB]	0.08	Included in Calculations of Corr'd Power & PPSD
---------------------------	------	--

Output Power Results

Channel	Frequency [MHz]	Meas Power [dBm]	Total Corr'd Power [dBm]	Power Limit [dBm]	Power Margin [dB]
Low	5745	18.04	18.12	30.00	-11.88
Mid	5785	18.11	18.19	30.00	-11.81
High	5825	17.58	17.66	30.00	-12.34

PPSD Results

Channel	Frequency [MHz]	Meas PPSD [dBm/500kHz]	Total Corr'd PPSD [dBm/500kHz]	PPSD Limit [dBm/500kHz]	PPSD Margin [dB]
Low	5745	5.34	5.42	30.00	-24.58
Mid	5785	5.28	5.35	30.00	-24.65
High	5825	4.87	4.95	30.00	-25.05

10.2.11. 802.11n HT20 MODE IN THE 5.8 GHz BAND

Bandwidth and Antenna Gain

Channel	Frequency [MHz]	Min 26 dB BW [MHz]	Directional Gain for Power [dBi]	Directional Gain for PPSD [dBi]
Low	5745	22.19	-5.64	-5.64
Mid	5785	23.63	-5.64	-5.64
High	5825	22.93	-5.64	-5.64

Limits

Channel	Frequency [MHz]	FCC Power Limit [dBm]	Power Limit [dBm]	FCC PPSD Limit [dBm/500kHz]
Low	5745	30.00	30.00	30.00
Mid	5785	30.00	30.00	30.00
High	5825	30.00	30.00	30.00

Duty Cycle CF [dB]	0.08	Included in Calculations of Corr'd Power & PPSD
---------------------------	------	--

Output Power Results

Channel	Frequency [MHz]	Meas Power [dBm]	Total Corr'd Power [dBm]	Power Limit [dBm]	Power Margin [dB]
Low	5745	17.98	18.06	30.00	-11.94
Mid	5785	18.01	18.09	30.00	-11.91
High	5825	17.57	17.65	30.00	-12.35

PPSD Results

Channel	Frequency [MHz]	Meas PPSD [dBm/500kHz]	Total Corr'd PPSD [dBm/500kHz]	PPSD Limit [dBm/500kHz]	PPSD Margin [dB]
Low	5745	5.17	5.26	30.00	-24.74
Mid	5785	5.04	5.13	30.00	-24.87
High	5825	4.49	4.58	30.00	-25.42

10.2.12. 802.11n HT40 MODE IN THE 5.8 GHz BAND

Bandwidth and Antenna Gain

Channel	Frequency [MHz]	Min 26 dB BW [MHz]	Directional Gain for Power [dBi]	Directional Gain for PPSD [dBi]
Low	5755	39.78	-5.64	-5.64
High	5795	39.76	-5.64	-5.64

Limits

Channel	Frequency [MHz]	FCC Power Limit [dBm]	Power Limit [dBm]	FCC PPSD Limit [dBm/500kHz]
Low	5755	30.00	30.00	30.00
High	5795	30.00	30.00	30.00

Duty Cycle CF [dB]	0.18	Included in Calculations of Corr'd Power & PPSD
---------------------------	------	--

Output Power Results

Channel	Frequency [MHz]	Meas Power [dBm]	Total Corr'd Power [dBm]	Power Limit [dBm]	Power Margin [dB]
Low	5755	14.38	14.56	30.00	-15.44
High	5795	14.80	14.98	30.00	-15.02

PPSD Results

Channel	Frequency [MHz]	Meas PPSD [dBm/500kHz]	Total Corr'd PPSD [dBm/500kHz]	PPSD Limit [dBm/500kHz]	PPSD Margin [dB]
Low	5755	-1.65	-1.47	30.00	-31.47
High	5795	-1.58	-1.41	30.00	-31.41