



FCC 47 CFR PART 15 SUBPART B

CERTIFICATION TEST REPORT

FOR

GSM/WCDMA/LTE Phone + BT/BLE, DTS/UNII a/b/g/n and ANT+

MODEL NUMBER : SM-A605G/DS, SM-A605G

FCC ID: A3LSMA605G

REPORT NUMBER: 4788371693-E7V1

ISSUE DATE: MAR 24, 2018

Prepared for

**SAMSUNG ELECTRONICS CO., LTD.
129 SAMSUNG-RO, YEONGTONG-GU, SUWON-SI,
GYEONGGI-DO, 16677, KOREA**

Prepared by

**UL Korea, Ltd.
26th floor, 152, Teheran-ro, Gangnam-gu Seoul, 06236, Korea**

**Suwon Test Site: UL Korea, Ltd. Suwon Laboratory
218 Maeyeong-ro, Yeongtong-gu,
Suwon-si, Gyeonggi-do, 16675, Korea
TEL: (031) 337-9902
FAX: (031) 213-5433**



ACCREDITED*

Testing
Laboratory

TL-637

Revision History

<u>Rev.</u>	<u>Issue Date</u>	<u>Revisions</u>	<u>Revised By</u>
V1	03/24/18	Initial issue	Sangyun Kim

TABLE OF CONTENTS

1. ATTESTATION OF TEST RESULTS	4
2. TEST METHODOLOGY	5
3. FACILITIES AND ACCREDITATION	5
4. CALIBRATION AND UNCERTAINTY	5
4.1. <i>MEASURING INSTRUMENT CALIBRATION.....</i>	<i>5</i>
4.2. <i>SAMPLE CALCULATION.....</i>	<i>5</i>
4.3. <i>MEASUREMENT UNCERTAINTY</i>	<i>6</i>
5. EQUIPMENT UNDER TEST	7
5.1. <i>DESCRIPTION OF EUT.....</i>	<i>7</i>
5.2. <i>PRELIMINARY TEST CONFIGURATIONS.....</i>	<i>7</i>
5.3. <i>MODE(S) OF OPERATION INVESTIGATED.....</i>	<i>7</i>
5.4. <i>MODIFICATIONS.....</i>	<i>7</i>
5.5. <i>DETAILS OF TESTED SYSTEM.....</i>	<i>8</i>
6. TEST AND MEASUREMENT EQUIPMENT	10
7. APPLICABLE LIMITS AND TEST RESULTS	11
7.1. <i>RADIATED EMISSIONS.....</i>	<i>11</i>
7.2. <i>AC MAINS LINE CONDUCTED EMISSIONS.....</i>	<i>18</i>
8. SETUP PHOTOS.....	23

1. ATTESTATION OF TEST RESULTS

COMPANY NAME: SAMSUNG ELECTRONICS CO., LTD.
EUT DESCRIPTION: GSM/WCDMA/LTE Phone + BT/BLE, DTS/UNII a/b/g/n and ANT
MODEL NUMBER: SM-A605G/DS
SERIAL NUMBER: R38K10D6MJN
DATE TESTED: MAR 22, 2018 - MAR 23, 2018

APPLICABLE STANDARDS	
STANDARD	TEST RESULTS
FCC PART 15 SUBPART B	Pass

UL Verification Services Inc. tested the above equipment in accordance with the requirements set forth in the above standards. All indications of Pass/Fail in this report are opinions expressed by UL Verification Services Inc. based on interpretations and/or observations of test results. Measurement Uncertainties were not taken into account and are published for informational purposes only. The test results show that the equipment tested is capable of demonstrating compliance with the requirements as documented in this report.

Note: The results documented in this report apply only to the tested sample, under the conditions and modes of operation as described herein. This document may not be altered or revised in any way unless done so by UL Verification Services Inc. and all revisions are duly noted in the revisions section. Any alteration of this document not carried out by UL Verification Services Inc. will constitute fraud and shall nullify the document. This report must not be used by the client to claim product certification, approval, or endorsement by NVLAP, NIST, any agency of the Federal Government, or any agency of any government.

Approved & Released For
UL Korea, Ltd. By:



Changyoung Choi
Suwon Lab Engineer
UL Korea, Ltd.

Tested By:



Sangyun Kim
Suwon Lab Engineer
UL Korea, Ltd.

2. TEST METHODOLOGY

The tests documented in this report were performed in accordance with ANSI C63.4-2014, FCC CFR 47 Part 2, FCC CFR 47 Part 15.

3. FACILITIES AND ACCREDITATION

The test sites and measurement facilities used to collect data are located at 218 Maeyeong-ro, Yeongtong-gu, Suwon-si, Gyeonggi-do, 16675, Korea. Line conducted emissions are measured only at the 218 address. The following table identifies which facilities were utilized for radiated emission measurements documented in this report. Specific facilities are also identified in the test results sections.

218 Maeyeong-ro	
<input checked="" type="checkbox"/>	Chamber 1
<input type="checkbox"/>	Chamber 2
<input type="checkbox"/>	Chamber 3

UL Korea, Ltd. is accredited by IAS, Laboratory Code TL-637. The full scope of accreditation can be viewed at <http://www.iasonline.org/PDF/TL/TL-637.pdf>.

4. CALIBRATION AND UNCERTAINTY

4.1. MEASURING INSTRUMENT CALIBRATION

The measuring equipment utilized to perform the tests documented in this report has been calibrated in accordance with the manufacturer's recommendations, and is traceable to recognized national standards.

4.2. SAMPLE CALCULATION

Where relevant, the following sample calculation is provided:

$$\begin{aligned} \text{Field Strength (dBuV/m)} &= \text{Measured Voltage (dBuV)} + \text{Antenna Factor (dB/m)} + \\ &\text{Cable Loss (dB)} - \text{Preamp Gain (dB)} \\ 36.5 \text{ dBuV} + 18.7 \text{ dB/m} + 0.6 \text{ dB} - 26.9 \text{ dB} &= 28.9 \text{ dBuV/m} \end{aligned}$$

4.3. MEASUREMENT UNCERTAINTY

Where relevant, the following measurement uncertainty levels have been estimated for tests performed on the apparatus:

PARAMETER	UNCERTAINTY
Conducted Disturbance, 0.15 to 30 MHz	2.32 dB
Radiated Disturbance, Below 1GHz	3.86 dB
Radiated Disturbance, Above 1 GHz	5.97 dB

Uncertainty figures are valid to a confidence level of 95%.

5. EQUIPMENT UNDER TEST

5.1. DESCRIPTION OF EUT

The EUT is a GSM/WCDMA/LTE Phone + BT/BLE, DTS/UNII a/b/g/n and ANT+

GENERAL INFORMATION

Type of device	Class B personal computers and peripherals
AC adapter power requirements	100-240 VAC / 50-60 Hz, 1.5 A
List of frequencies generated or used by the EUT	30 GHz (5 th harmonic of the frequency of 5.8GHz WLAN)

5.2. PRELIMINARY TEST CONFIGURATIONS

The EUT was investigated in three orthogonal orientations X, Y, Z it was determined that X orientation with data transfer was worst-case; therefore, all final radiated testing was performed with the EUT in X orientation with data transfer.

5.3. MODE(S) OF OPERATION INVESTIGATED

Mode	Description
Data transfer	Copy files from PC to EUT

5.4. MODIFICATIONS

No modifications were made during testing.

5.5. DETAILS OF TESTED SYSTEM

SUPPORT EQUIPMENT & PERIPHERALS

Support Equipment List				
Description	Manufacturer	Model	Serial Number	FCC ID/DoC
PC	HP	C8N27AV	CZC4125J25	DoC
LCD monitor	Samsung	LS24D390	0K2PHTQFC02186R	DoC
AC/DC Adapter	Samsung	A2514_DSM	CN07BN4400719ASE38FC2Y3T7	DoC
Micro SD card	Samsung	64G	-	DoC
Mouse	Logitech	U0026	1451HS05S6G8	DoC
Keyboard	Logitech	Y-U0009	1410MG00RVY8	DoC
Earphone	Samsung	GH59-14677A	-	-

I/O CABLES

I/O Cable List						
Cable No	Port	# of identical ports	Connector Type	Cable Type	Cable Length(m)	Remarks
1	AC Power	1	Power	Unshielded	1.5m	From AC/DC Adapter to AC Main
2	AC Power	1	Power	Unshielded	1.5m	From PC to AC Main
3	DC Power	1	Power	Unshielded	1.2m	From LCD Monitor to AC/DC Adpater
4	D-SUB	1	D-SUB	Shielded	1.2m	From LCD Monitor to PC
5	USB	1	USB	Shielded	1.2m	From Keyboard to PC
6	USB	1	USB	Shielded	1.5m	From Mouse to PC
7	USB	1	USB	Shielded	0.6m	From EUT to PC
8	Earphone	1	Mini-Jack	Shielded	0.8m	From EUT to Earphone
9	LAN	1	RJ-45	Shielded	0.8m	From PC to Ethernet(Outside of test site)

TEST SETUP

The EUT is installed in a typical configuration. Copy files from PC to EUT.

TEST SETUP DIAGRAM

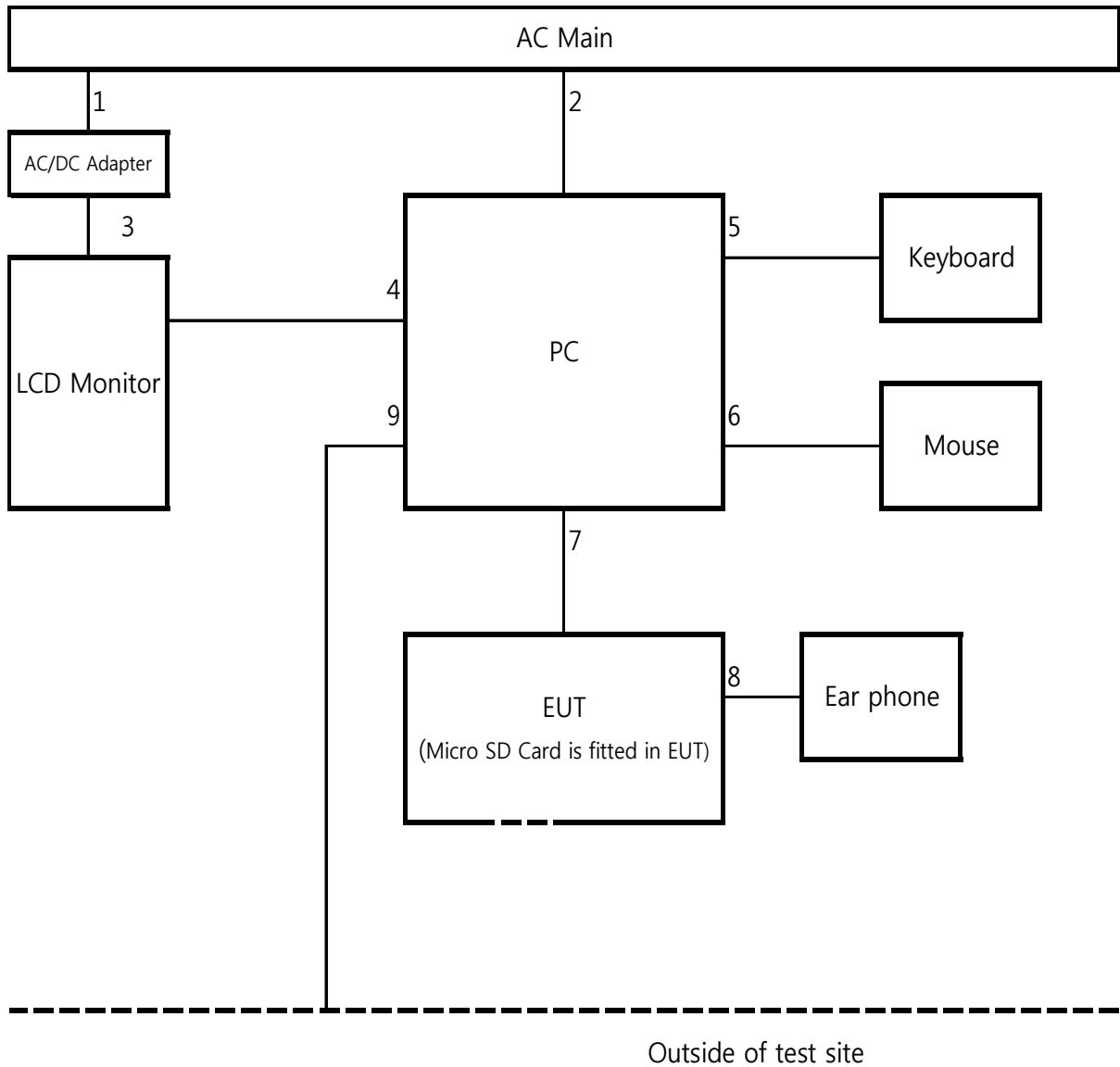

6. TEST AND MEASUREMENT EQUIPMENT

The following test and measurement equipment was utilized for the tests documented in this report:

Test Equipment List				
Description	Manufacturer	Model	S/N	Cal Due
Antenna, Bilog, 30MHz-1GHz	SCHWARZBECK	VULB9163	750	08-31-19
Antenna, Bilog, 30MHz-1GHz	SCHWARZBECK	VULB9163	749	09-14-19
Antenna, Bilog, 30MHz-1GHz	SCHWARZBECK	VULB9163	845	08-31-19
Antenna, Horn, 18 GHz	ETS	3115	00167211	10-14-18
Antenna, Horn, 18 GHz	ETS	3115	00161451	03-10-19
Antenna, Horn, 18 GHz	ETS	3117	00168724	05-31-19
Antenna, Horn, 18 GHz	ETS	3117	00168717	05-31-19
Antenna, Horn, 18 GHz	ETS	3117	00205959	11-29-18
Antenna, Horn, 40 GHz	ETS	3116C	00166155	12-04-19
Antenna, Horn, 40 GHz	ETS	3116C	00168645	12-04-19
Antenna, Horn, 40 GHz	ETS	3116C-PA	00168841	11-13-19
Preamplifier, 1000 MHz	Sonoma	310N	341282	08-09-18
Preamplifier, 1000 MHz	Sonoma	310N	351741	08-07-18
Preamplifier, 1000 MHz	Sonoma	310N	370599	08-10-18
Preamplifier, 18 GHz	Miteq	AFS42-00101800-25-S-42	1876511	08-08-18
Preamplifier, 18 GHz	Miteq	AFS42-00101800-25-S-42	1896138	08-08-18
Preamplifier, 18 GHz	Miteq	AFS42-00101800-25-S-42	2029169	08-11-18
EMI Test Receive, 40 GHz	R&S	ESU40	100439	08-08-18
EMI Test Receive, 40 GHz	R&S	ESU40	100457	08-08-18
EMI Test Receive, 44 GHz	R&S	ESW44	101590	08-09-18
EMI Test Receive, 3 GHz	R&S	ESR3	101832	08-07-18
LISN	R&S	ENV-216	101837	08-09-18
UL Software				
Description	Manufacturer	Model	Version	
Radiated software	UL	UL EMC	Ver 9.5	
AC Line Conducted software	UL	UL EMC	Ver 9.5	

7. APPLICABLE LIMITS AND TEST RESULTS

7.1. RADIATED EMISSIONS

TEST PROCEDURE

ANSI C63.4: 2014

The highest clock frequency generated or used in the EUT is 5.8GHz therefore the frequency range was investigated from 30 MHz to 30 GHz.

LIMIT

§15.109 (a) Except for Class A digital devices, the field strength of radiated emissions from unintentional radiators at a distance of 3 meters shall not exceed the following values:

Limits for radiated disturbance of Class B ITE at measuring distance of 3 m	
Frequency range (MHz)	Quasi-peak limits (dB μ V/m)
30 to 88	40
88 to 216	43.5
216 to 960	46
Above 960 MHz	54

Note: The lower limit shall apply at the transition frequency.

RESULTS

RADIATED EMISSIONS 30 TO 1000 MHz

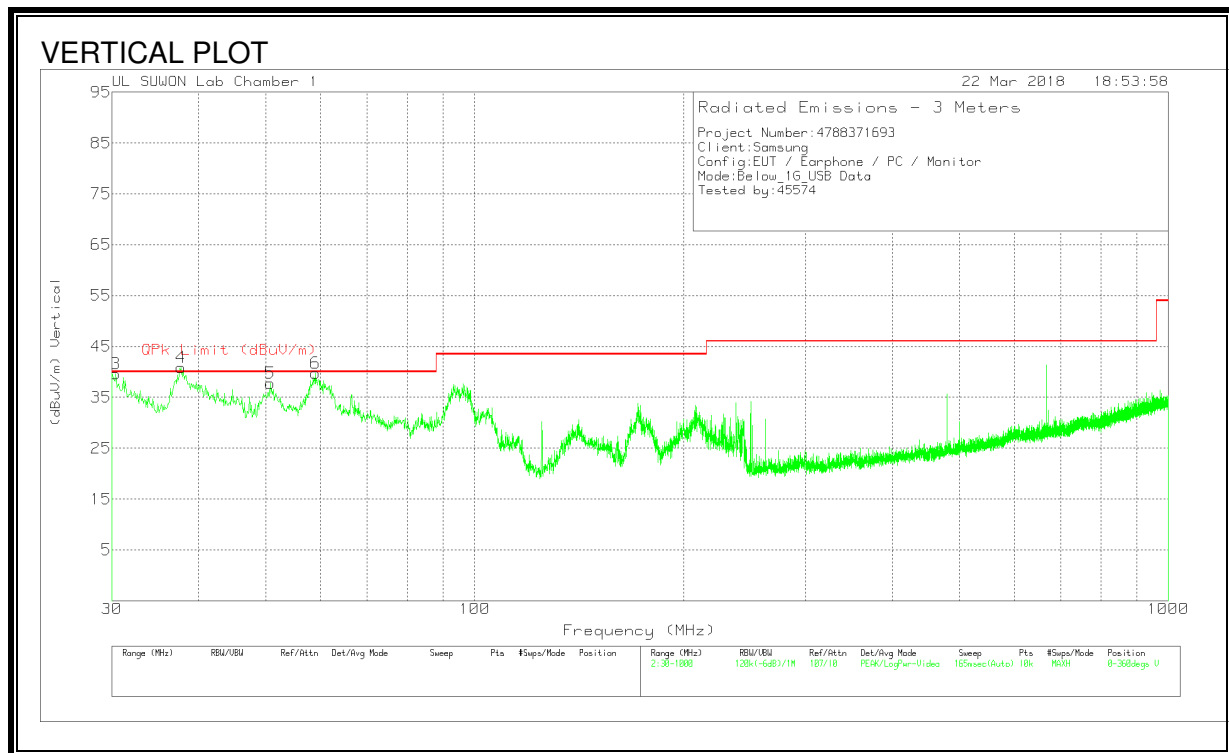
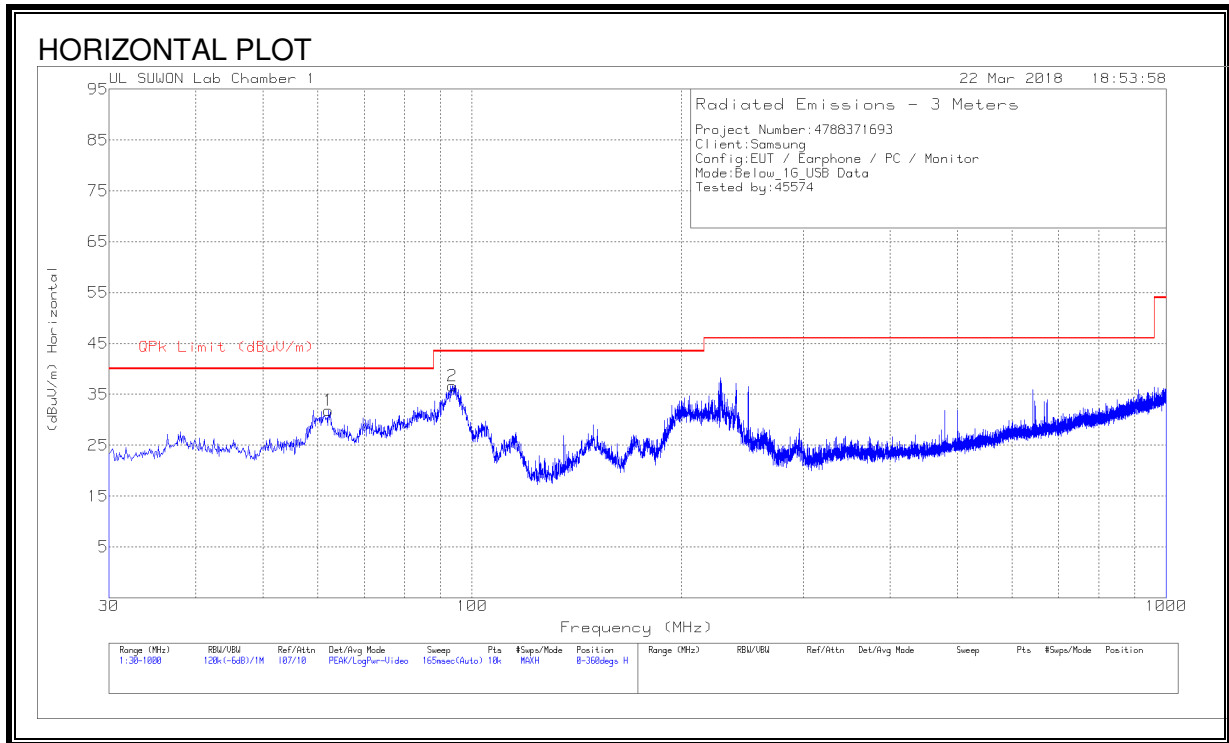

HORIZONTAL AND VERTICAL DATA

Trace Markers

Marker	Frequency (MHz)	Meter Reading (dBuV)	Det	750_20170831	30-1000MHz[dB]	Corrected Reading (dBuV/m)	QPk Limit (dBuV/m)	Margin (dB)	Azimuth (Degs)	Height (cm)	Polarity
1	62.107	43.32	Pk	17.8	-29.3	31.82	40	-8.18	0-360	300	H
2	93.729	48.75	Pk	16.4	-28.5	36.65	43.52	-6.87	0-360	300	H
3	30.388	53.3	Pk	16	-29.7	39.6	40	-.4	0-360	100	V
4	37.76	52.84	Pk	17.7	-29.7	40.84	40	.84	0-360	100	V
5	50.758	47.15	Pk	19.8	-29.2	37.75	40	-2.25	0-360	100	V
6	58.906	50.18	Pk	18.6	-29	39.78	40	-.22	0-360	100	V

Pk - Peak detector

Radiated Emissions

Frequency (MHz)	Meter Reading (dBuV)	Det	750_20170831	30-1000MHz[dB]	Corrected Reading (dBuV/m)	QPk Limit (dBuV/m)	Margin (dB)	Azimuth (Degs)	Height (cm)	Polarity
30.3473	49.33	Qp	16	-29.7	35.63	40	-4.37	2	100	V
37.76	47.91	Qp	17.7	-29.7	35.91	40	-4.09	0	100	V
50.758	41.92	Qp	19.8	-29.2	32.52	40	-7.48	331	102	V
58.906	46.57	Qp	18.6	-29	36.17	40	-3.83	0	100	V

Qp - Quasi-Peak detector

RADIATED EMISSIONS 1GHz to 18GHz

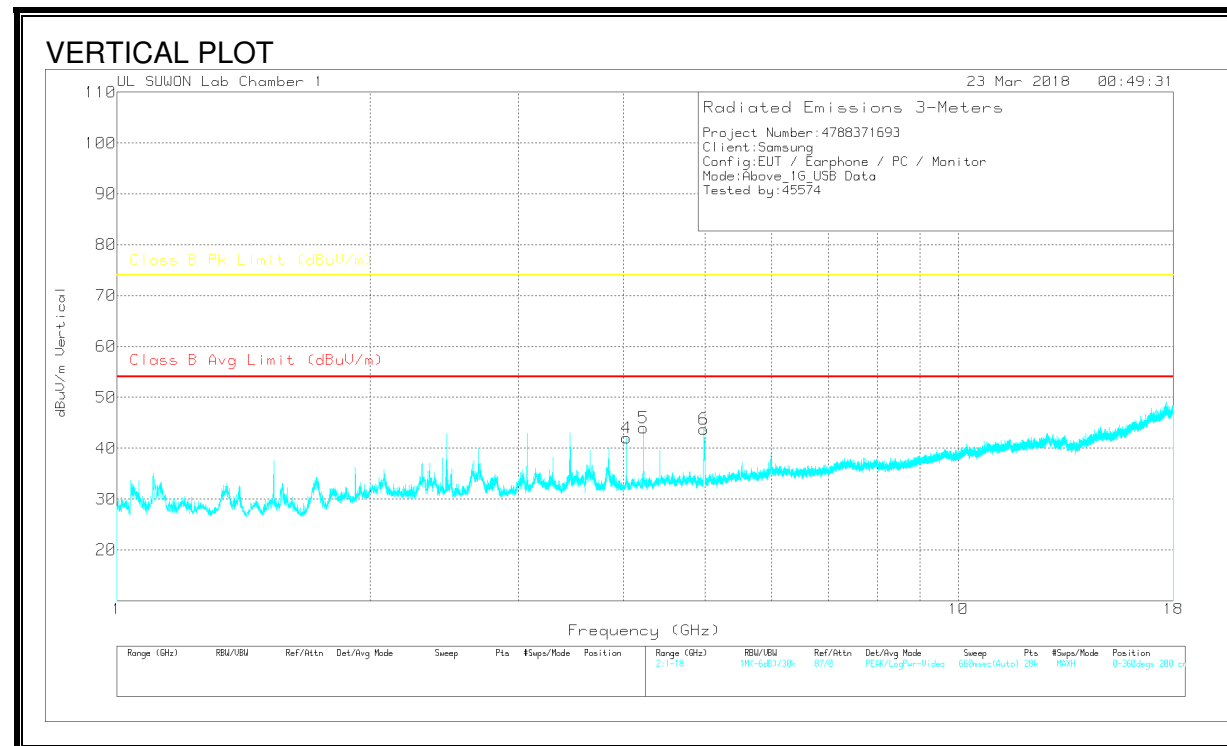
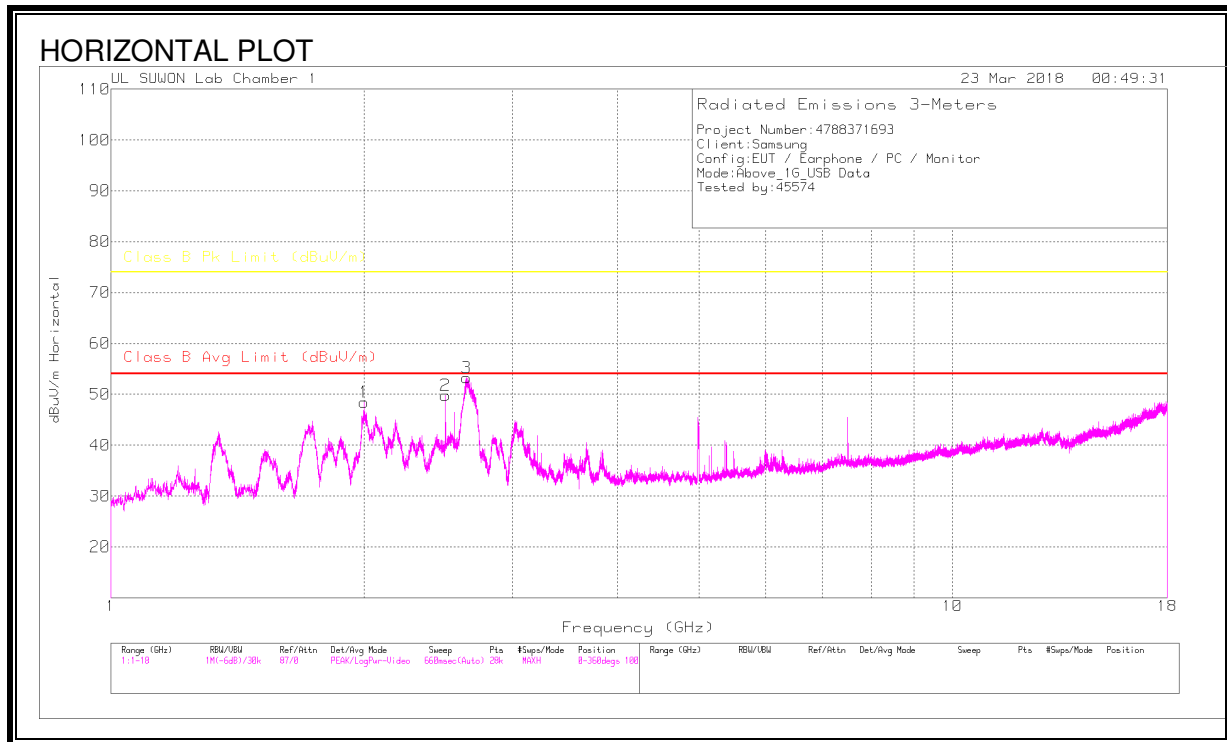

HORIZONTAL AND VERTICAL DATA

Trace Markers

Marker	Frequency (GHz)	Meter Reading (dBuV)	Det	3117_00168717	1-18GHz(dB)	Corrected Reading dBuV/m	Class B Avg Limit (dBuV/m)	Av(CISPR)Margin (dB)	Class B Pk Limit (dBuV/m)	Margin (dB)	Azimuth (Degs)	Height (cm)	Polarity
1	1.999	52.72	PK	31.5	-35.8	48.42	-	-	-	-	0-360	200	H
2	2.498	53.01	PK	31.6	-34.8	49.81	-	-	-	-	0-360	100	H
3	2.646	56.05	PK	31.9	-34.7	53.25	-	-	-	-	0-360	100	H
4	4.032	41.51	PK	33.1	-32.6	42.01	-	-	-	-	0-360	100	V
5	4.224	43.6	PK	33.1	-32.7	44	-	-	-	-	0-360	100	V
6	4.978	41.63	PK	33.8	-31.7	43.73	-	-	-	-	0-360	100	V

PK – Peak Detector

Radiated Emissions

Frequency (GHz)	Meter Reading (dBuV)	Det	3117_00168717	1-18GHz(dB)	Corrected Reading dBuV/m	Class B Avg Limit (dBuV/m)	Av(CISPR)Margin (dB)	Class B Pk Limit (dBuV/m)	Margin (dB)	Azimuth (Degs)	Height (cm)	Polarity
1.999	73.92	Pk	31.5	-35.8	69.62	-	-	74	-4.38	339	105	H
1.999	31.56	Ca	31.5	-35.8	27.26	54	-26.74	74	-46.74	339	105	H
2.498	70.04	Pk	31.6	-34.8	66.84	-	-	74	-7.16	87	214	H
2.498	29.91	Ca	31.6	-34.8	26.71	54	-27.29	74	-47.29	87	214	H
2.646	57.29	Pk	31.9	-34.7	54.49	-	-	74	-19.51	80	220	H
2.646	46.65	Ca	31.9	-34.7	43.85	54	-10.15	74	-30.15	80	220	H
2.464	57.07	Pk	31.5	-35	53.57	-	-	74	-20.43	201	101	V
2.464	33.44	Ca	31.5	-35	29.94	54	-24.06	74	-44.06	201	101	V
3.072	41.76	Pk	32.5	-33.9	40.36	-	-	74	-33.64	105	268	V
3.072	28.66	Ca	32.5	-33.9	27.26	54	-26.74	74	-46.74	105	268	V
4.224	42.56	Pk	33.1	-32.7	42.96	-	-	74	-31.04	171	136	V
4.224	28.86	Ca	33.1	-32.7	29.26	54	-24.74	74	-44.74	171	136	V
4.032	47.4	Pk	33.1	-32.6	47.9	-	-	74	-26.1	84	100	V
4.032	37.26	Ca	33.1	-32.6	37.76	54	-16.24	74	-36.24	84	100	V
4.224	49.92	Pk	33.1	-32.7	50.32	-	-	74	-23.68	79	103	V
4.224	41.76	Ca	33.1	-32.7	42.16	54	-11.84	74	-31.84	79	103	V
4.978	49.87	Pk	33.8	-31.7	51.97	-	-	74	-22.03	282	325	V
4.978	27.57	Ca	33.8	-31.7	29.67	54	-24.33	74	-44.33	282	325	V

Pk - Peak detector

Ca - CISPR average detection

RADIATED EMISSIONS 18GHz to 30GHz

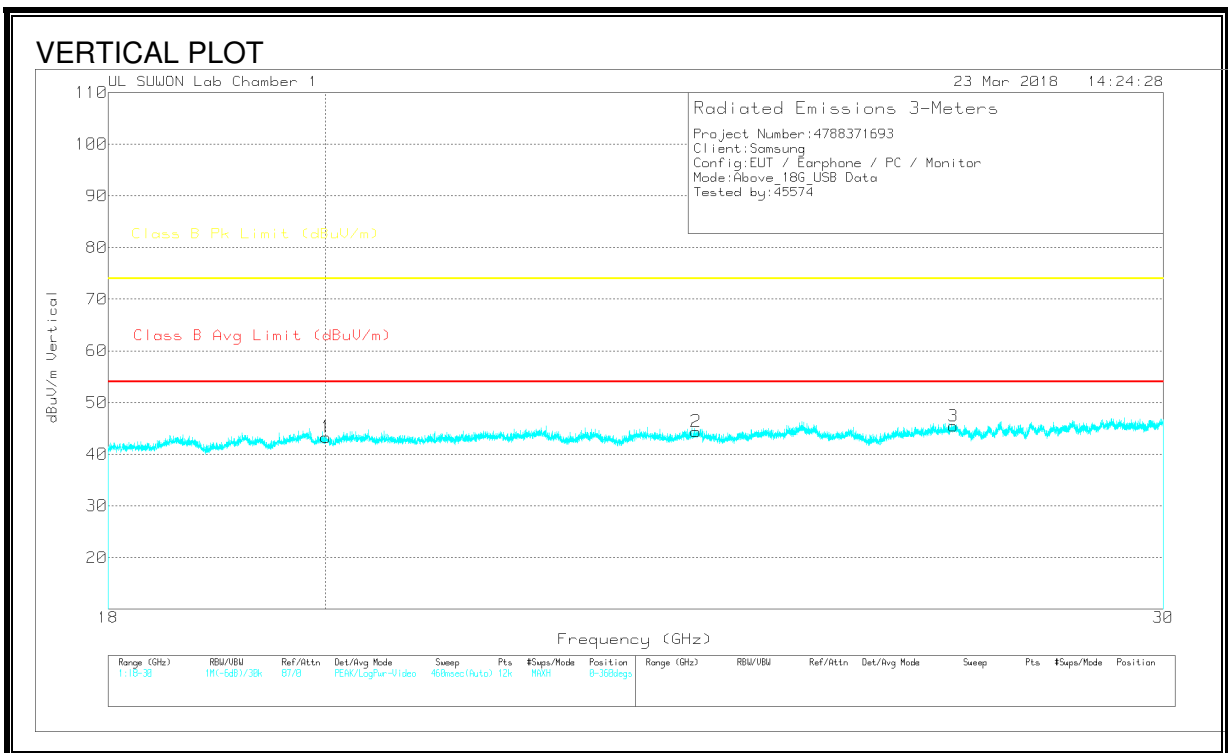
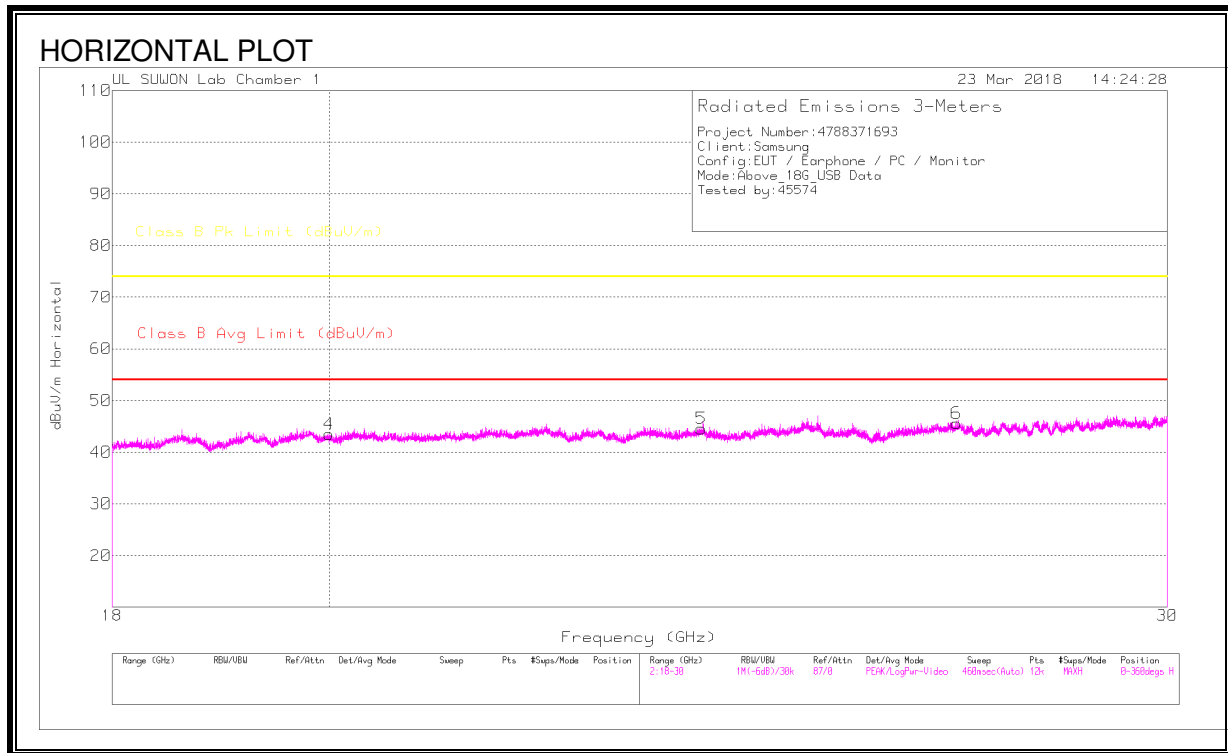

HORIZONTAL AND VERTICAL DATA

Trace Markers

Marker	Frequency (GHz)	Meter Reading (dBuV)	Det	3116C-PA	18-40GHz(dB)	Corrected Reading dBuV/m	Class B Avg Limit (dBuV/m)	Av(CISPR)Margin (dB)	Class B Pk Limit (dBuV/m)	Margin (dB)	Azimuth (Degs)	Height (cm)	Polarity
1	20.002	18.82	PK	7.8	16.7	43.32	-	-	74	-30.68	0-360	100	V
2	23.927	15.29	PK	10.8	18.3	44.39	-	-	74	-29.61	0-360	100	V
3	27.101	15.87	PK	10.3	19.3	45.47	-	-	74	-28.53	0-360	100	V
4	19.995	18.98	PK	7.8	16.7	43.48	-	-	74	-30.52	0-360	100	H
5	23.941	15.46	PK	10.8	18.3	44.56	-	-	74	-29.44	0-360	100	H
6	27.089	16.01	PK	10.3	19.3	45.61	-	-	74	-28.39	0-360	100	H

PK – Peak Detector

Note: Only peak measurement was performed. Because peak measurement result of unwanted emission is less than average limit (54dBuV/m).

7.2. AC MAINS LINE CONDUCTED EMISSIONS

TEST PROCEDURE

ANSI C63.4: 2014

LIMIT

§15.107 (a) Except for Class A digital devices, for equipment that is designed to be connected to the public utility (AC) power line, the radio frequency voltage that is conducted back onto the AC power line on any frequency or frequencies within the band 150 kHz to 30 MHz shall not exceed the limits in the following table, as measured using a 50 μ H/50 ohms line impedance stabilization network (LISN). Compliance with the provisions of this paragraph shall be based on the measurement of the radio frequency voltage between each power line and ground at the power terminal. The lower limit applies at the band edges.

Frequency range (MHz)	Limits (dB μ V)	
	Quasi-peak	Average
0.15 to 0.50	66 to 56	56 to 46
0.50 to 5	56	46
5 to 30	60	50

Notes:
 1. The lower limit shall apply at the transition frequencies
 2. The limit decreases linearly with the logarithm of the frequency in the range 0.15 MHz to 0.50 MHz.

RESULTS

6 WORST EMISSIONS

Line-L1 .15 - 30MHz

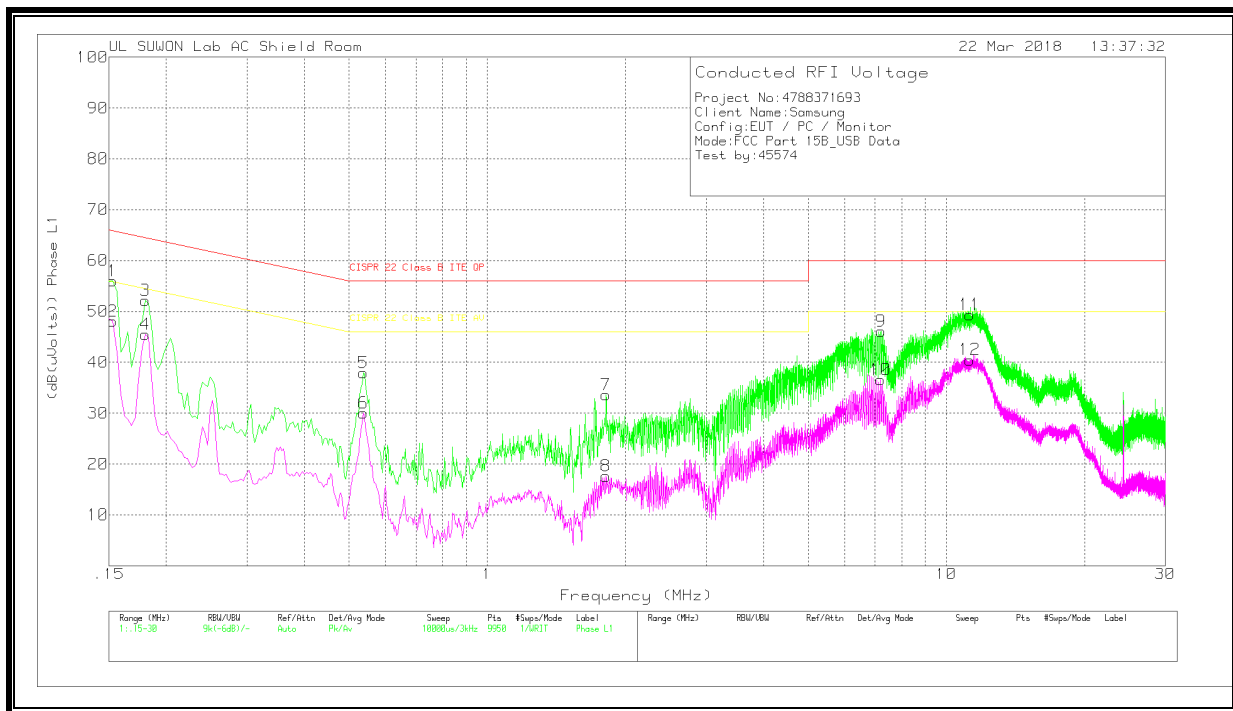

LINE 1 RESULTS

Trace Markers

Range 1: Phase L1 .15 - 30MHz

Marker	Frequency (MHz)	Meter Reading (dBuV)	Det	101837_L1_wit hout extension	CABLELOSS(dB)	Corrected Reading (dB(uVolts))	CISPR 22 Class B ITE QP	Margin (dB)	CISPR 22 Class B ITE AV	Margin (dB)
1	.153	46.19	Pk	9.7	.1	55.99	65.84	-9.85	-	-
2	.153	38.23	Av	9.7	.1	48.03	-	-	55.84	-7.81
3	.18	42.11	Pk	9.9	.2	52.21	64.49	-12.28	-	-
4	.18	35.43	Av	9.9	.2	45.53	-	-	54.49	-8.96
5	.537	27.96	Pk	9.8	.2	37.96	56	-18.04	-	-
6	.537	20.04	Av	9.8	.2	30.04	-	-	46	-15.96
7	1.815	23.69	Pk	9.6	.3	33.59	56	-22.41	-	-
8	1.815	7.7	Av	9.6	.3	17.6	-	-	46	-28.4
9	7.206	36.11	Pk	9.7	.3	46.11	60	-13.89	-	-
10	7.191	26.55	Av	9.7	.3	36.55	-	-	50	-13.45
11	11.244	39.38	Pk	9.7	.3	49.38	60	-10.62	-	-
12	11.253	30.48	Av	9.7	.3	40.48	-	-	50	-9.52

Pk - Peak detector

Av - Average detection

Quasi-Peak Emissions

Range 1: Phase L1 .15 - 30MHz

Frequency (MHz)	Meter Reading (dBuV)	Det	101837_L1_wit out extension	CABLELOSS(dB)	Corrected Reading (dB(uVolts))	CISPR 22 Class B ITE QP	Margin (dB)	CISPR 22 Class B ITE AV	Margin (dB)
11.2538	35.07	Qp	9.7	.3	45.07	60	-14.93	-	-

Qp - Quasi-Peak detector

Line-L2 .15 - 30MHz

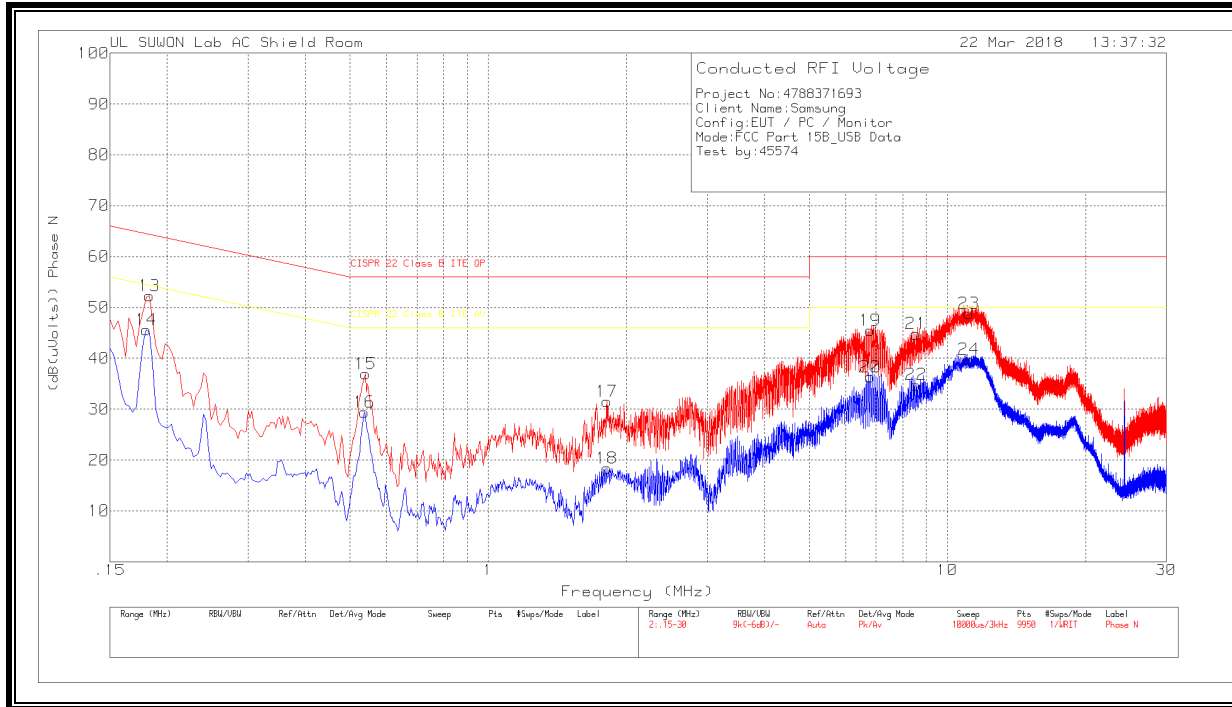

LINE 2 RESULTS

Trace Markers

Range 2: Phase N .15 - 30MHz

Marker	Frequency (MHz)	Meter Reading (dBuV)	Det	101837_N_with out extension	CABLELOSS(dB)	Corrected Reading (dB(uVolts))	CISPR 22 Class B ITE QP	Margin (dB)	CISPR 22 Class B ITE AV	Margin (dB)
13	.183	42.23	Pk	9.9	.2	52.33	64.35	-12.02	-	-
14	.18	35.55	Av	9.9	.2	45.65	-	-	54.49	-8.84
15	.54	26.92	Pk	9.8	.2	36.92	56	-19.08	-	-
16	.537	19.45	Av	9.8	.2	29.45	-	-	46	-16.55
17	1.812	21.6	Pk	9.6	.3	31.5	56	-24.5	-	-
18	1.812	8.51	Av	9.6	.3	18.41	-	-	46	-27.59
19	6.789	35.47	Pk	9.7	.3	45.47	60	-14.53	-	-
20	6.789	26.31	Av	9.7	.3	36.31	-	-	50	-13.69
21	8.565	34.81	Pk	9.7	.3	44.81	60	-15.19	-	-
22	8.565	24.79	Av	9.7	.3	34.79	-	-	50	-15.21
23	11.145	38.88	Pk	9.7	.3	48.88	60	-11.12	-	-
24	11.157	29.85	Av	9.7	.3	39.85	-	-	50	-10.15

Pk - Peak detector

Av - Average detection

Quasi-Peak Emissions

Range 2: Phase N .15 - 30MHz

Frequency (MHz)	Meter Reading (dBuV)	Det	101837_N_with out extension	CABLELOSS(dB)	Corrected Reading (dB(uVolts))	CISPR 22 Class B ITE QP	Margin (dB)	CISPR 22 Class B ITE AV	Margin (dB)
11.1578	35.64	Qp	9.7	.3	45.64	60	-14.36	-	-

Qp - Quasi-Peak detector