



FCC CFR47 PART 15 SUBPART C

DTS Wireless LAN

CERTIFICATION TEST REPORT

FOR

GSM/WCDMA/LTE Phone + BT/BLE, DTS/UNII a/b/g/n and ANT+

MODEL NUMBER : SM-A600G/DS, SM-A600G

FCC ID: A3LSMA600G

REPORT NUMBER: 4788371671-E1V2

ISSUE DATE: APR 07, 2018

Prepared for
SAMSUNG ELECTRONICS CO., LTD.
129 SAMSUNG-RO, YEONGTONG-GU, SUWON-SI,
GYEONGGI-DO, 16677, KOREA

Prepared by
UL Korea, Ltd.
26th floor, 152, Teheran-ro, Gangnam-gu Seoul, 06236, Korea

Suwon Test Site: UL Korea, Ltd. Suwon Laboratory
218 Maeyeong-ro, Yeongtong-gu,
Suwon-si, Gyeonggi-do, 16675, Korea
TEL: (031) 337-9902
FAX: (031) 213-5433



ACCREDITED*

Testing
Laboratory

TL-637

Revision History

<u>Rev.</u>	<u>Issue Date</u>	<u>Revisions</u>	<u>Revised By</u>
V1	03/31/18	Initial issue	Junwhan Lee
V2	04/07/18	Updated to address TCB's question	Junwhan Lee

TABLE OF CONTENTS

1. ATTESTATION OF TEST RESULTS	5
1.1. INTRODUCTION OF TEST DATA REUSE.....	6
1.2. DIFFERENCE.....	6
1.3. SPOT CHECK VERIFICATION DATA	6
1.4. REFERENCE DETAIL	7
2. TEST METHODOLOGY	8
3. FACILITIES AND ACCREDITATION	8
4. CALIBRATION AND UNCERTAINTY	8
4.1. MEASURING INSTRUMENT CALIBRATION	8
4.2. SAMPLE CALCULATION	8
4.3. MEASUREMENT UNCERTAINTY.....	8
5. EQUIPMENT UNDER TEST	9
5.1. DESCRIPTION OF EUT	9
5.2. MAXIMUM OUTPUT POWER.....	9
5.3. DESCRIPTION OF AVAILABLE ANTENNAS	9
5.4. WORST-CASE CONFIGURATION AND MODE.....	9
5.5. DESCRIPTION OF TEST SETUP.....	10
6. TEST AND MEASUREMENT EQUIPMENT	12
7. REFERENCE MEASUREMENT RESULTS.....	13
7.1. ON TIME AND DUTY CYCLE RESULTS.....	13
8. MEASUREMENT METHODS	15
9. SUMMARY TABLE	16
10. ANTENNA PORT TEST RESULTS	17
10.1. 6 dB BANDWIDTH.....	17
10.1.1. 802.11b MODE IN THE 2.4 GHz BAND	18
10.1.2. 802.11g MODE IN THE 2.4 GHz BAND	18
10.1.3. 802.11n HT20 MODE IN THE 2.4 GHz BAND.....	18
10.1.4. 6 dB BANDWIDTH PLOTS.....	19
10.2. OUTPUT POWER.....	22
10.2.1. 802.11b MODE IN THE 2.4 GHz BAND	23
10.2.2. 802.11g MODE IN THE 2.4 GHz BAND	24
10.2.3. 802.11n HT20 MODE IN THE 2.4 GHz BAND.....	25
10.3. PSD.....	26

10.3.1.	802.11b MODE IN THE 2.4 GHz BAND	27
10.3.2.	802.11g MODE IN THE 2.4 GHz BAND	27
10.3.3.	802.11n HT20 MODE IN THE 2.4 GHz BAND.....	27
10.3.4.	PSD PLOTS	28
10.4.	<i>OUT-OF-BAND EMISSIONS</i>	31
10.4.1.	802.11b MODE IN THE 2.4 GHz BAND	32
10.4.2.	802.11g MODE IN THE 2.4 GHz BAND	37
10.4.3.	802.11n HT20 MODE IN THE 2.4 GHz BAND.....	42
11.	RADIATED TEST RESULTS	47
11.1.	<i>LIMITS AND PROCEDURE</i>	47
11.2.	<i>TRANSMITTER ABOVE 1 GHz</i>	49
11.2.1.	TX ABOVE 1 GHz 802.11b MODE IN THE 2.4 GHz BAND.....	49
11.2.2.	TX ABOVE 1 GHz 802.11g MODE IN THE 2.4 GHz BAND.....	63
11.2.3.	TX ABOVE 1 GHz 802.11n HT20 MODE IN THE 2.4 GHz BAND	77
11.3.	<i>WORST-CASE BELOW 1 GHz</i>	91
12.	AC POWER LINE CONDUCTED EMISSIONS	93
13.	SETUP PHOTOS	98

1. ATTESTATION OF TEST RESULTS

COMPANY NAME: SAMSUNG ELECTRONICS CO., LTD.

EUT DESCRIPTION: GSM/WCDMA/LTE Phone + BT/BLE, DTS/UNII a/b/g/n and ANT+

MODEL NUMBER: SM-A600G/DS, SM-A600G

SERIAL NUMBER: R38K108GVGN (RADIATED, Original);
R38K10BCS5W (CONDUCTED, Original);
R38K108KQ3P (RADIATED, Spot check & Additional test);

DATE TESTED: FEB 22, 2018 - MAR 05, 2018 (Original)
MAR 13, 2018 - MAR 29, 2018 (Spot check & Additional test)

APPLICABLE STANDARDS	
STANDARD	TEST RESULTS
CFR 47 Part 15 Subpart C	Pass

UL Korea, Ltd. tested the above equipment in accordance with the requirements set forth in the above standards. All indications of Pass/Fail in this report are opinions expressed by UL Korea, Ltd. based on interpretations and/or observations of test results. Measurement Uncertainties were not taken into account and are published for informational purposes only. The test results show that the equipment tested is capable of demonstrating compliance with the requirements as documented in this report.

Note: The results documented in this report apply only to the tested sample, under the conditions and modes of operation as described herein. This document may not be altered or revised in any way unless done so by UL Korea, Ltd. and all revisions are duly noted in the revisions section. Any alteration of this document not carried out by UL Korea, Ltd. will constitute fraud and shall nullify the document. This report must not be used by the client to claim product certification, approval, or endorsement by IAS, any agency of the Federal Government, or any agency of any government.

Approved & Released For
UL Korea, Ltd. By:

Tested By:



SungGil Park
Suwon Lab Engineer
UL Korea, Ltd.

HoonPyo Lee
Suwon Lab Engineer
UL Korea, Ltd.

1.1. INTRODUCTION OF TEST DATA REUSE

This report referenced from the FCC ID: A3LSMA600GN DTS WLAN(FCC CFR 47 Part 15C). And the applicant takes full responsibility that the test data as referenced in this report represent compliance for this FCC ID.

1.2. DIFFERENCE

The FCC ID: A3LSMA600G shares the same enclosure and circuit board as FCC ID: A3LSMA600GN. The WLAN antennas and surrounding circuitry and layout are identical between these two units.

After confirming through preliminary radiated emissions that the performance of the FCC ID: A3LSMA600GN remains representative of FCC ID: A3LSMA600G. The test data of FCC ID: A3LSMA600GN being submitted for this application to cover WLAN features.

Due to difference of charger, radiated emission under 1GHz and AC line conducted test were performed newly.

1.3. SPOT CHECK VERIFICATION DATA

Band	Test Item	Mode	Frequency	Test Limit	Original model		Deviation	Remark
					SM-A600GN/DS Results	SM-A600G/DS Results		
					FCC ID : A3LSMA600GN	FCC ID : A3LSMA600G		
DTS WLAN (2.4GHz)	Band Edge	802.11b	2462 MHz	54 dBuV/m	46.59 dBuV/m	48.65 dBuV/m	2.06 dB	
	RSE	802.11b	2412 MHz	74 dBuV/m	41.02 dBuV/m	40.19 dBuV/m	-0.83 dB	Noise floor level
	Band Edge	802.11g	2462 MHz	54 dBuV/m	51.46 dBuV/m	51.09 dBuV/m	-0.37 dB	
	RSE	802.11g	2412 MHz	74 dBuV/m	40.35 dBuV/m	39.77 dBuV/m	-0.58 dB	Noise floor level
	Band Edge	802.11n	2412 MHz	54 dBuV/m	51.50 dBuV/m	44.94 dBuV/m	-6.56 dB	
	RSE	802.11n	2437 MHz	74 dBuV/m	48.11 dBuV/m	47.69 dBuV/m	-0.42 dB	

Comparison of two models, upper deviation is within 3dB range and all test results are under FCC Technical Limits.

1.4. REFERENCE DETAIL

Reference application that contains the reused reference data.

Equipment Class	Reference FCC ID	Type Grant/Permissive Change	Reference Application	Folder Test/RF Exposure	Report Title / Section
DTS	A3LSMA600GN	Grant	4788371667-E1V2	Test	FCC Report DTS WLAN / All sections (Except section 11.3 and 12)
			4788371667-E2V2	Test	FCC Report BLE All sections (Except section 11.3 and 12)
DSS	A3LSMA600GN	Grant	4788371667-E3V2	Test	FCC Report BT / All sections (Except section 11.3 and 12)
NII	A3LSMA600GN	Grant	4788371667-E4V2	Test	FCC Report UNII WALN / All sections (Except section 12 and 13)
DXX	A3LSMA600GN	Grant	4788371667-E5V2	Test	FCC Report ANT+ / All sections (Except section 7.2.5 and 8)
PCE	A3LSMA600GN	Grant	4788371667-E7V2	Test	FCC Report WWAN / All sections (Except Conducted Output Power & Test result of LTE Band 66)

2. TEST METHODOLOGY

The tests documented in this report were performed in accordance with following methods.

1. FCC CFR 47 Part 2.
2. FCC CFR 47 Part 15.
3. KDB 558074 D01 DTS Meas Guidance v04.
4. KDB 484596 D01 Referencing Test Data DR01-42712
5. ANSI C63.10-2013.

3. FACILITIES AND ACCREDITATION

The test sites and measurement facilities used to collect data are located at 218 Maeyeong-ro, Yeongtong-gu, Suwon-si, Gyeonggi-do, 16675, Korea. Line conducted emissions are measured only at the 218 address. The following table identifies which facilities were utilized for radiated emission measurements documented in this report. Specific facilities are also identified in the test results sections.

218 Maeyeong-ro	
<input checked="" type="checkbox"/>	Chamber 1
<input checked="" type="checkbox"/>	Chamber 2
<input checked="" type="checkbox"/>	Chamber 3

UL Korea, Ltd. is accredited by IAS, Laboratory Code TL-637. The full scope of accreditation can be viewed at <http://www.iasonline.org/PDF/TL/TL-637.pdf>.

4. CALIBRATION AND UNCERTAINTY

4.1. MEASURING INSTRUMENT CALIBRATION

The measuring equipment utilized to perform the tests documented in this report has been calibrated in accordance with the manufacturer's recommendations, and is traceable to recognized national standards.

4.2. SAMPLE CALCULATION

Where relevant, the following sample calculation is provided:

$$\begin{aligned} \text{Field Strength (dBuV/m)} &= \text{Measured Voltage (dBuV)} + \text{Antenna Factor (dB/m)} + \\ &\text{Cable Loss (dB)} - \text{Preamp Gain (dB)} \\ 36.5 \text{ dBuV} + 18.7 \text{ dB/m} + 0.6 \text{ dB} - 26.9 \text{ dB} &= 28.9 \text{ dBuV/m} \end{aligned}$$

4.3. MEASUREMENT UNCERTAINTY

Where relevant, the following measurement uncertainty levels have been estimated for tests performed on the apparatus:

PARAMETER	UNCERTAINTY
Conducted Disturbance, 0.15 to 30 MHz	2.32 dB
Radiated Disturbance, Below 1GHz	3.86 dB
Radiated Disturbance, Above 1 GHz	5.97 dB

Uncertainty figures are valid to a confidence level of 95%.

5. EQUIPMENT UNDER TEST

5.1. DESCRIPTION OF EUT

The EUT is a GSM/WCDMA/LTE Phone + BT/BLE, DTS/UNII a/b/g/n and ANT+. This test report addresses the DTS (WLAN) operational mode.

5.2. MAXIMUM OUTPUT POWER

The transmitter has a maximum total conducted average output power as follows:

Frequency Range [MHz]	Mode	Output Power [dBm]	Output Power [mW]
2412 - 2472	802.11b	18.01	63.24
	802.11g	16.41	43.75
	802.11n HT20	14.93	31.12

5.3. DESCRIPTION OF AVAILABLE ANTENNAS

The radio utilizes an internal antennas, with a antenna's maximum gain of -3.01 dBi.

5.4. WORST-CASE CONFIGURATION AND MODE

Radiated emission below 1GHz and power line conducted emission were performed with the EUT set to transmit at the channel with highest output power as worst-case scenario.

Radiated emission above 1GHz was performed with the EUT set to transmit low/mid/high channels.

The fundamental of the EUT was investigated in three orthogonal orientations X, Y and Z it was determined that X orientation was worst-case orientation; therefore, all final radiated testing was performed with the EUT in X orientation.

Based on the baseline scan, the worst-case data rates were:

802.11b mode: 1 Mbps
802.11g mode: 6 Mbps
802.11n HT20 mode: MCS0

Note : All radiated and power line conducted tests were performed connected with earphone and charger for evaluation of worst case mode.

5.5. DESCRIPTION OF TEST SETUP

SUPPORT EQUIPMENT

Support Equipment List				
Description	Manufacturer	Model	Serial Number	FCC ID
Charger	SAMSUNG	EP-TA50EWE	DW3K115DS/A-E	N/A
Data Cable	SAMSUNG	ECB-DU68WE	N/A	N/A
Earphone	SAMSUNG	EHS61ASFWE	N/A	N/A

I/O CABLES

I/O Cable List						
Cable No	Port	# of identical ports	Connector Type	Cable Type	Cable Length (m)	Remarks
1	DC Power	1	Mini-USB	Shielded	1.2m	N/A
2	Audio	2	Mini-Jack	Unshielded	1.2m	N/A

TEST SETUP

The EUT is a stand-alone unit during the tests.
Test software in hidden menu exercised the EUT to enable DTS mode.

SETUP DIAGRAM FOR TESTS (CONDUCTED TEST SETUP)

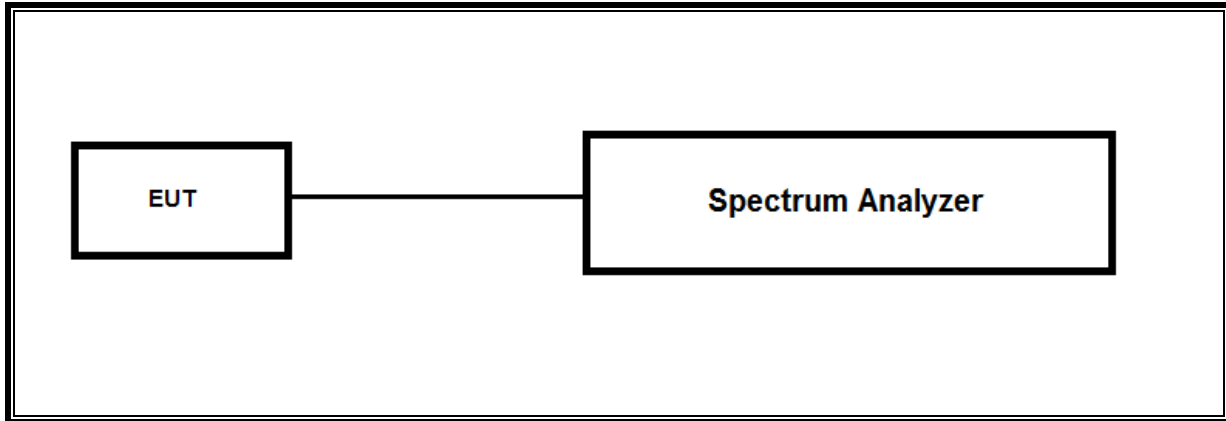

SETUP DIAGRAM FOR TESTS (RADIATED TEST SETUP)

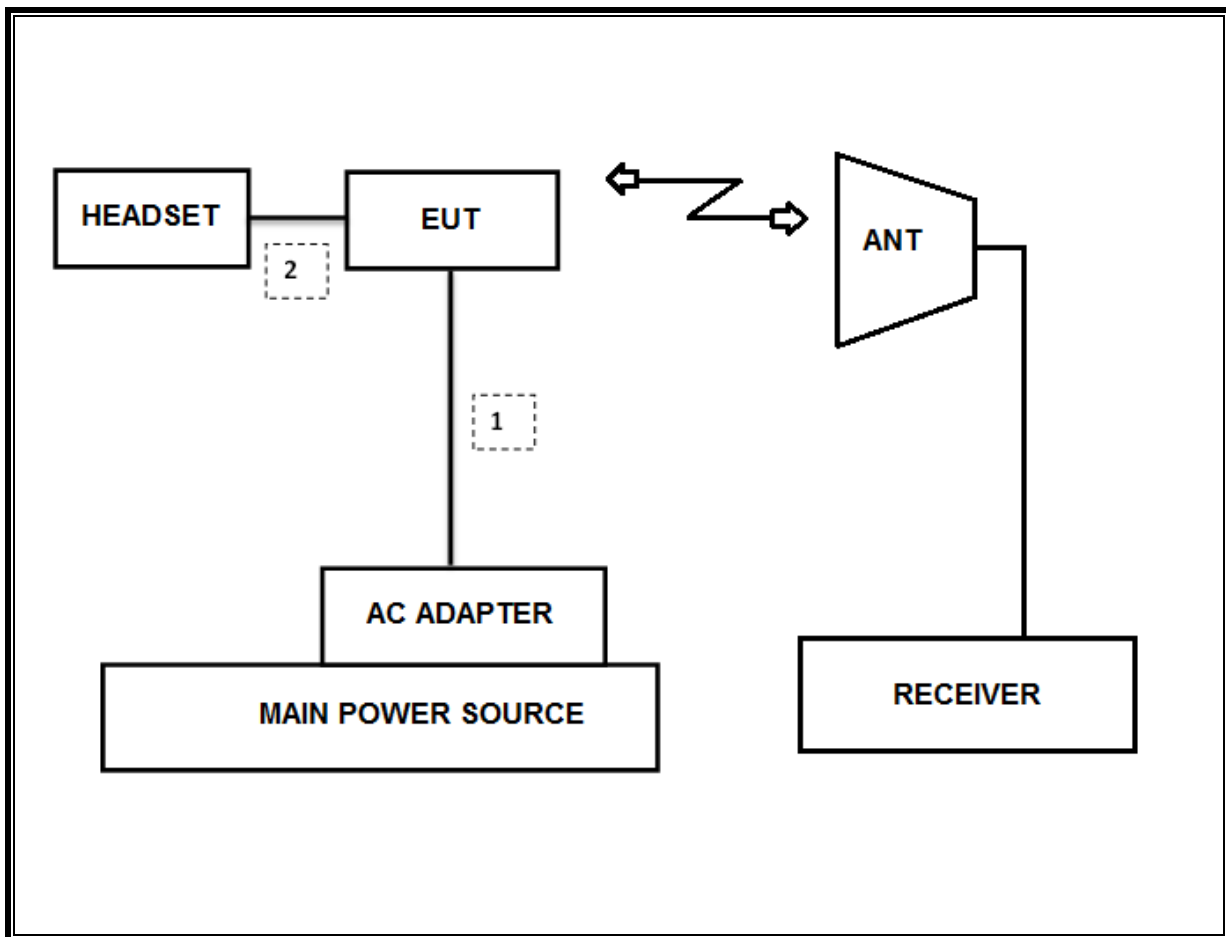

6. TEST AND MEASUREMENT EQUIPMENT

The following test and measurement equipment was utilized for the tests documented in this report:

Test Equipment List				
Description	Manufacturer	Model	S/N	Cal Due
Antenna, Bilog, 30MHz-1GHz	SCHWARZBECK	VULB9163	750	08-31-19
Antenna, Bilog, 30MHz-1GHz	SCHWARZBECK	VULB9163	749	09-14-19
Antenna, Bilog, 30MHz-1GHz	SCHWARZBECK	VULB9163	845	08-31-19
Antenna, Horn, 18 GHz	ETS	3115	00167211	10-14-18
Antenna, Horn, 18 GHz	ETS	3115	00161451	03-10-19
Antenna, Horn, 18 GHz	ETS	3117	00168724	05-31-19
Antenna, Horn, 18 GHz	ETS	3117	00168717	05-31-19
Antenna, Horn, 18 GHz	ETS	3117	00205959	11-29-18
Antenna, Horn, 40 GHz	ETS	3116C	00166155	12-04-19
Antenna, Horn, 40 GHz	ETS	3116C	00168645	12-04-19
Antenna, Horn, 40 GHz	ETS	3116C-PA	00168841	11-13-19
Preamplifier, 1000 MHz	Sonoma	310N	341282	08-09-18
Preamplifier, 1000 MHz	Sonoma	310N	351741	08-07-18
Preamplifier, 1000 MHz	Sonoma	310N	370599	08-10-18
Preamplifier, 18 GHz	Miteq	AFS42-00101800-25-S-42	1876511	08-08-18
Preamplifier, 18 GHz	Miteq	AFS42-00101800-25-S-42	1896138	08-08-18
Preamplifier, 18 GHz	Miteq	AFS42-00101800-25-S-42	2029169	08-11-18
Spectrum Analyzer, 44 GHz	Agilent / HP	N9030A	MY54170614	08-08-18
Spectrum Analyzer, 44 GHz	Agilent / HP	N9030A	MY54490312	08-08-18
Average Power Sensor	Agilent / HP	U2000	MY54270007	08-08-18
Attenuator	PASTERNAK	PE7087-10	A001	08-08-18
Attenuator	PASTERNAK	PE7087-10	A008	08-08-18
Attenuator	PASTERNAK	PE7087-10	2	08-10-18
Attenuator	PASTERNAK	PE7087-10	A009	08-08-18
EMI Test Receive, 40 GHz	R&S	ESU40	100439	08-08-18
EMI Test Receive, 40 GHz	R&S	ESU40	100457	08-08-18
EMI Test Receive, 44 GHz	R&S	ESW44	101590	08-09-18
EMI Test Receive, 3 GHz	R&S	ESR3	101832	08-07-18
Low Pass Filter 5GHz	Micro-Tronics	LPS17541	009	08-08-18
Low Pass Filter 5GHz	Micro-Tronics	LPS17541	015	08-08-18
Low Pass Filter 5GHz	Micro-Tronics	LPS17541	020	08-11-18
High Pass Filter 3GHz	Micro-Tronics	HPM17543	010	08-08-18
High Pass Filter 3GHz	Micro-Tronics	HPM17543	015	08-08-18
High Pass Filter 3GHz	Micro-Tronics	HPM17543	020	08-11-18
High Pass Filter 6GHz	Micro-Tronics	HPS17542	009	08-08-18
High Pass Filter 6GHz	Micro-Tronics	HPS17542	016	08-08-18
High Pass Filter 6GHz	Micro-Tronics	HPS17542	021	08-11-18
LISN	R&S	ENV-216	101837	08-09-18
UL Software				
Description	Manufacturer	Model	Version	
Radiated software	UL	UL EMC	Ver 9.5	
AC Line Conducted software	UL	UL EMC	Ver 9.5	

7. REFERENCE MEASUREMENT RESULTS

7.1. ON TIME AND DUTY CYCLE RESULTS

LIMITS

None; for reporting purposes only.

Mode	ON Time B [msec]	Period [msec]	Duty Cycle x [linear]	Duty Cycle [%]	Duty Cycle Correction Factor [dB]	1/T Minimum VBW [kHz]
2400MHz Bands						
802.11b	18.97	19.06	0.995	99.5%	0.00	0.010
802.11g	3.156	3.259	0.968	96.8%	0.14	0.317
802.11n HT20	2.928	3.031	0.966	96.6%	0.15	0.342

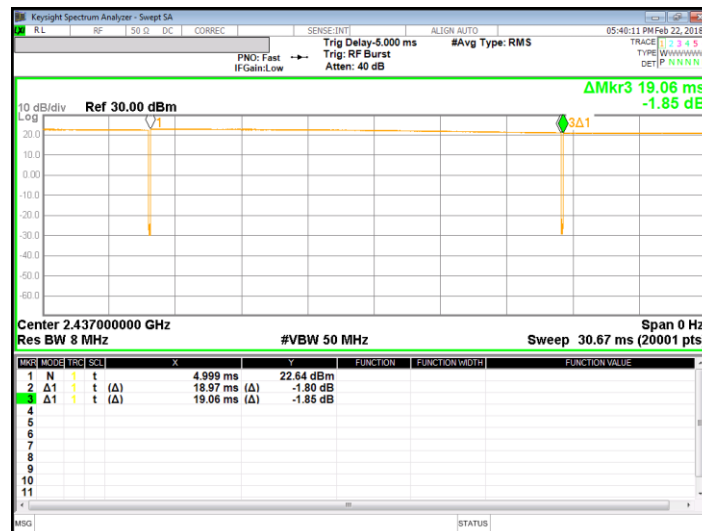

[802.11b]

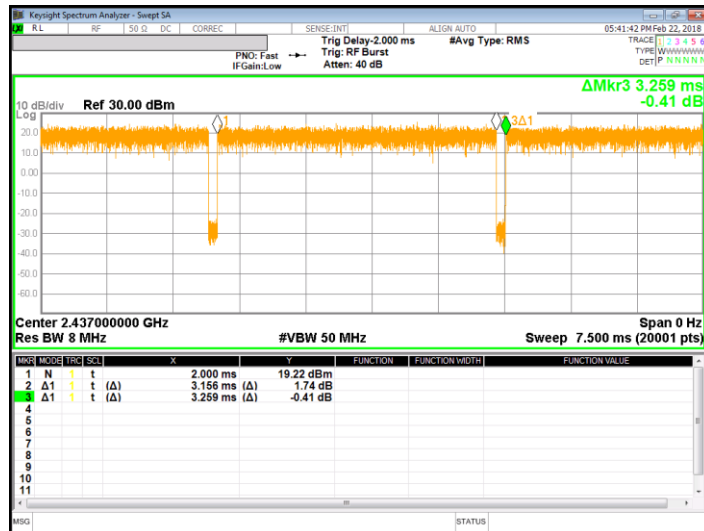

[802.11g]

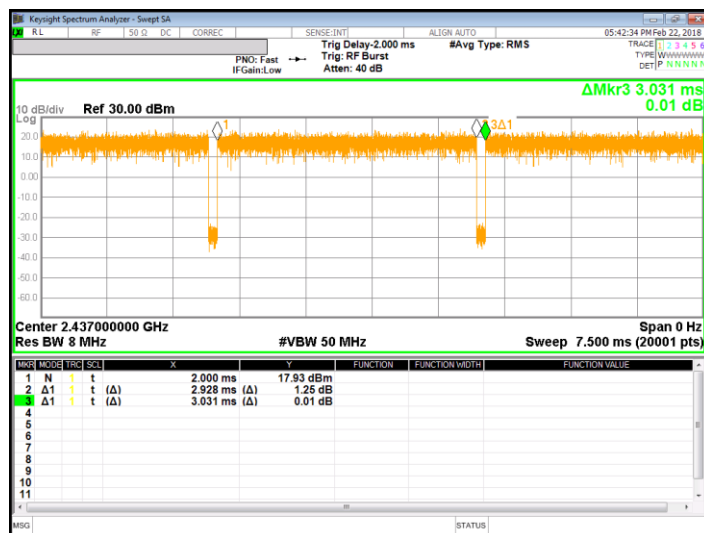

[802.11n]

8. MEASUREMENT METHODS

6 dB BW : KDB 558074 D01 v04, Section 8.2.

OUTPUT POWER : KDB 558074 D01 v04, Section 9.2.3.1.

POWER SPECTRAL DENSITY : KDB 558074 D01 v04, Section 10.3./10.5.

Out-of-band EMISSIONS (Conducted) : KDB 558074 D01 v04, Section 11.1, 11.2.

Out-of-band EMISSIONS IN NON-RESTRICTED BANDS: KDB 558074 D01 v04, Section 11.0.

Out-of-band EMISSIONS IN RESTRICTED BANDS : KDB 558074 D01 v04, Section 12.1.

AC Power Line Conducted Emission : ANSI C63.10-2013, Section 6.2.

9. SUMMARY TABLE

FCC Part Section	Test Description	Test Limit	Test Condition	Test Result
15.247 (a)(2)	Occupied Band width (6dB)	>500KHz	Conducted	Pass
2.1051, 15.247 (d)	Band Edge / Conducted Spurious Emission	-30dBc		Pass
15.247 (b)(3)	TX conducted output power	<30dBm		Pass
15.247 (e)	PSD	<8dBm		Pass
15.207 (a)	AC Power Line conducted emissions	Section 10	Power Line conducted	Pass
15.205, 15.209	Radiated Spurious Emission	< 54dBuV/m	Radiated	Pass

10. ANTENNA PORT TEST RESULTS

10.1. 6 dB BANDWIDTH

LIMITS

FCC §15.247 (a) (2)

The minimum 6 dB bandwidth shall be at least 500 kHz.

TEST PROCEDURE

Reference to KDB 558074 D01 DTS Meas Guidance v04: The transmitter output is connected to a spectrum analyzer with the RBW set to 100KHz, the VBW $\geq 3 \times$ RBW, peak detector and max hold.

RESULTS**10.1.1.802.11b MODE IN THE 2.4 GHz BAND**

Channel	Frequency [MHz]	6 dB Bandwidth [MHz]	Minimum Limit [MHz]
Low	2412	8.568	0.5
Mid	2437	9.035	0.5
High	2462	9.041	0.5
12	2467	8.556	0.5
13	2472	8.079	0.5
Worst		8.079	0.5

10.1.2.802.11g MODE IN THE 2.4 GHz BAND

Channel	Frequency [MHz]	6 dB Bandwidth [MHz]	Minimum Limit [MHz]
Low	2412	16.040	0.5
Mid	2437	16.310	0.5
High	2462	16.050	0.5
12	2467	16.060	0.5
13	2472	16.060	0.5
Worst		16.040	0.5

10.1.3.802.11n HT20 MODE IN THE 2.4 GHz BAND

Channel	Frequency [MHz]	6 dB Bandwidth [MHz]	Minimum Limit [MHz]
Low	2412	16.660	0.5
Mid	2437	17.160	0.5
High	2462	16.890	0.5
12	2467	16.340	0.5
13	2472	16.540	0.5
Worst		16.340	0.5

10.1.4.6 dB BANDWIDTH PLOTS



11g Mode Low CH

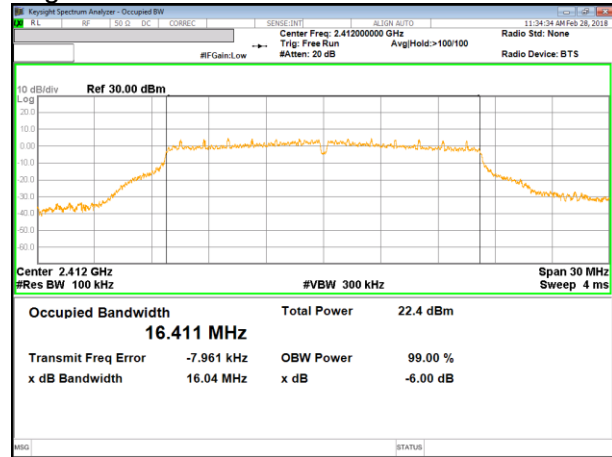

11g Mode Middle CH

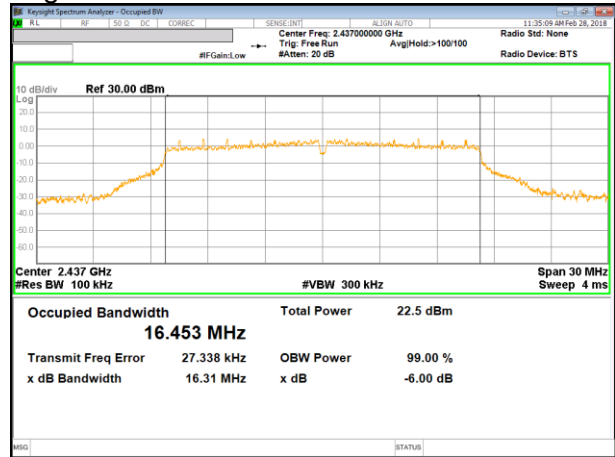

11g Mode High CH

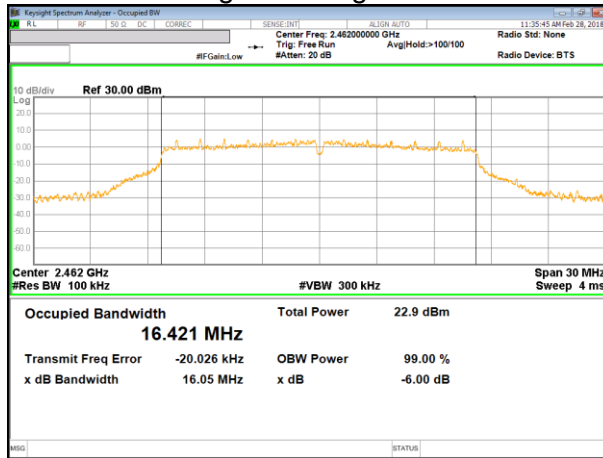

11g Mode 12 CH

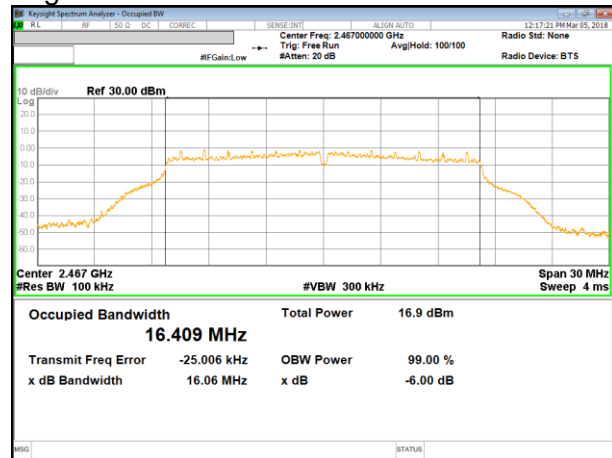

11g Mode 13 CH

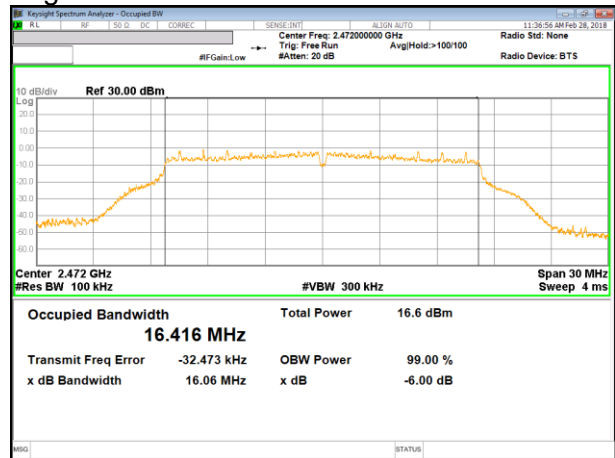

11n HT20 Mode Low CH

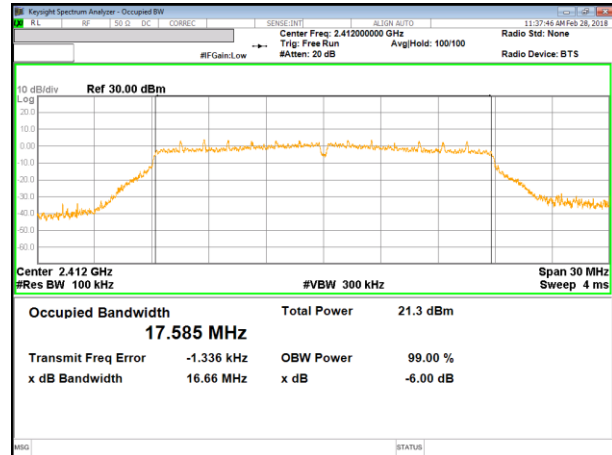

11n HT20 Middle CH

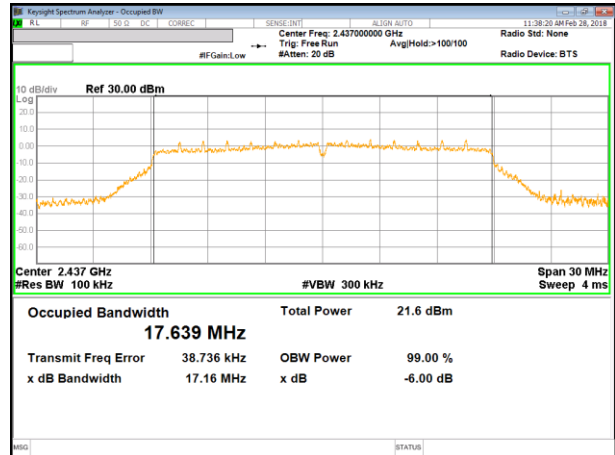

11n HT20 Mode High CH

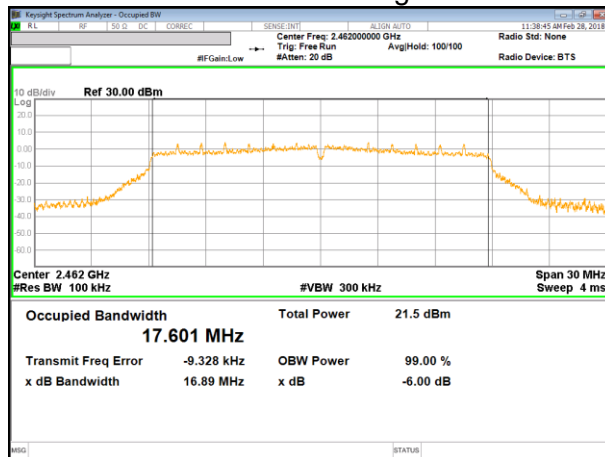

11n HT20 Mode 12 CH

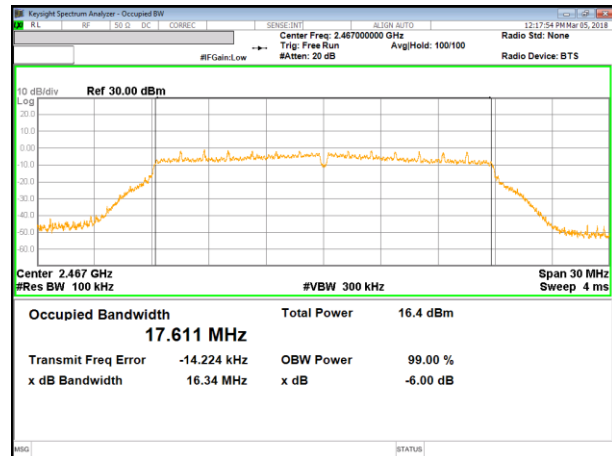

11n HT20 Mode 13 CH

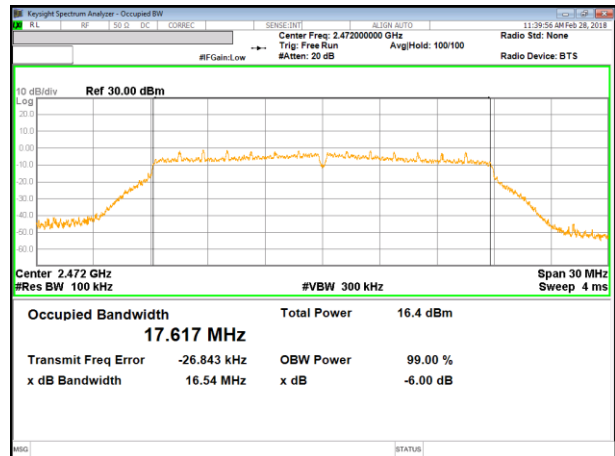

10.2. OUTPUT POWER

LIMITS

FCC §15.247

For systems using digital modulation in the 902–928 MHz, 2400–2483.5 MHz, and 5725–5850 MHz bands: 1 Watt, based on the use of antennas with directional gains that do not exceed 6 dBi. If transmitting antennas of directional gain greater than 6 dBi are used, the conducted output power from the intentional radiator shall be reduced by the amount in dB that the directional gain of the antenna exceeds 6 dBi.

DIRECTIONAL ANTENNA GAIN

There is only one transmitter output therefore the directional gain is equal to the antenna gain.

TEST PROCEDURE

The transmitter output is connected to a power meter.

The cable assembly insertion loss was entered as an offset in the power meter to allow for direct reading of power.

Output power measurement was performed utilizing the “§9.2.3.1 AVGPM” under KDB558074 D01 DTS Meas Guidance v04.

Duty cycle correction factor is already added to the average output power results for duty cycle factor < 98%. (802.11g, 802.11n mode)

RESULTS**10.2.1.802.11b MODE IN THE 2.4 GHz BAND****Limits**

Channel	Frequency [MHz]	Directional Gain Primary [dBi]	FCC Power Limit [dBm]	Max Power [dBm]
Low	2412	-3.01	30.00	30.00
Mid	2437	-3.01	30.00	30.00
High	2462	-3.01	30.00	30.00
12	2467	-3.01	30.00	30.00
13	2472	-3.01	30.00	30.00

Results

Channel	Frequency [MHz]	Meas Power [dBm]	Total Power [dBm]	Power Limit [dBm]	Margin [dB]
Low	2412	17.39	17.91	30.00	-12.09
Mid	2437	16.89	17.96	30.00	-12.04
High	2462	16.54	18.01	30.00	-11.99
12	2467	16.42	9.65	30.00	-20.35
13	2472	15.10	9.50	30.00	-20.50
Worst			18.01	30.00	-11.99

10.2.2.802.11g MODE IN THE 2.4 GHZ BAND

Limits

Channel	Frequency [MHz]	Directional Gain Primary [dBi]	FCC Power Limit [dBm]	Max Power [dBm]
Low	2412	-3.01	30.00	30.00
Mid	2437	-3.01	30.00	30.00
High	2462	-3.01	30.00	30.00
12	2467	-3.01	30.00	30.00
13	2472	-3.01	30.00	30.00

Results

Channel	Frequency [MHz]	Meas Power [dBm]	Total Power [dBm]	Power Limit [dBm]	Margin [dB]
Low	2412	16.11	16.11	30.00	-13.89
Mid	2437	16.23	16.23	30.00	-13.77
High	2462	16.41	16.41	30.00	-13.59
12	2467	10.37	10.37	30.00	-19.63
13	2472	10.15	10.15	30.00	-19.85
Worst			16.41	30.00	-13.59

10.2.3.802.11n HT20 MODE IN THE 2.4 GHz BAND

Limits

Channel	Frequency [MHz]	Directional Gain Primary [dBi]	FCC Power Limit [dBm]	Max Power [dBm]
Low	2412	-3.01	30.00	30.00
Mid	2437	-3.01	30.00	30.00
High	2462	-3.01	30.00	30.00
12	2467	-3.01	30.00	30.00
13	2472	-3.01	30.00	30.00

Results

Channel	Frequency [MHz]	Meas Power [dBm]	Total Power [dBm]	Power Limit [dBm]	Margin [dB]
Low	2412	14.70	14.70	30.00	-15.30
Mid	2437	14.90	14.90	30.00	-15.10
High	2462	14.93	14.93	30.00	-15.07
12	2467	9.97	9.97	30.00	-20.03
13	2472	9.87	9.87	30.00	-20.13
Worst			14.93	30.00	-15.07

10.3. PSD

LIMITS

FCC §15.247

The power spectral density conducted from the transmitter to the antenna shall not be greater than 8 dBm in any 3 kHz band during any time interval of continuous transmission.

TEST PROCEDURE

Power Spectral Density was performed utilizing the "Method §10.3 AVGPSD-1 (802.11 b mode) and §10.5 AVGPSD-2(802.11 g/n mode)" under KDB558074 D01 DTS Meas Guidance v04.

RESULTS

10.3.1.802.11b MODE IN THE 2.4 GHz BAND

PSD Results

Channel	Frequency [MHz]	PSD Meas [dBm]	Duty Factor [dB]	Final PSD [dBm/3kHz]	Limit [dBm/3kHz]	Margin [dB]
Low	2412	-13.549	0.00	-13.549	8.00	-21.549
Mid	2437	-13.832	0.00	-13.832	8.00	-21.832
High	2462	-13.859	0.00	-13.859	8.00	-21.859
12	2467	-21.729	0.00	-21.729	8.00	-29.729
13	2472	-22.027	0.00	-22.027	8.00	-30.027

10.3.2.802.11g MODE IN THE 2.4 GHz BAND

PSD Results

Channel	Frequency [MHz]	PSD Meas [dBm]	Duty Factor [dB]	Final PSD [dBm/3kHz]	Limit [dBm/3kHz]	Margin [dB]
Low	2412	-14.199	0.14	-14.059	8.00	-22.199
Mid	2437	-14.257	0.14	-14.117	8.00	-22.257
High	2462	-13.856	0.14	-13.716	8.00	-21.856
12	2467	-19.302	0.14	-19.162	8.00	-27.302
13	2472	-20.118	0.14	-19.978	8.00	-28.118

10.3.3.802.11n HT20 MODE IN THE 2.4 GHz BAND

PSD Results

Channel	Frequency [MHz]	PSD Meas [dBm]	Duty Factor [dB]	Final PSD [dBm/3kHz]	Limit [dBm/3kHz]	Margin [dB]
1	2412	-17.527	0.15	-17.377	8.00	-25.527
6	2437	-17.567	0.15	-17.417	8.00	-25.567
11	2462	-17.700	0.15	-17.550	8.00	-25.700
12	2467	-22.307	0.15	-22.157	8.00	-30.307
13	2472	-22.775	0.15	-22.625	8.00	-30.775

10.3.4.PSD PLOTS

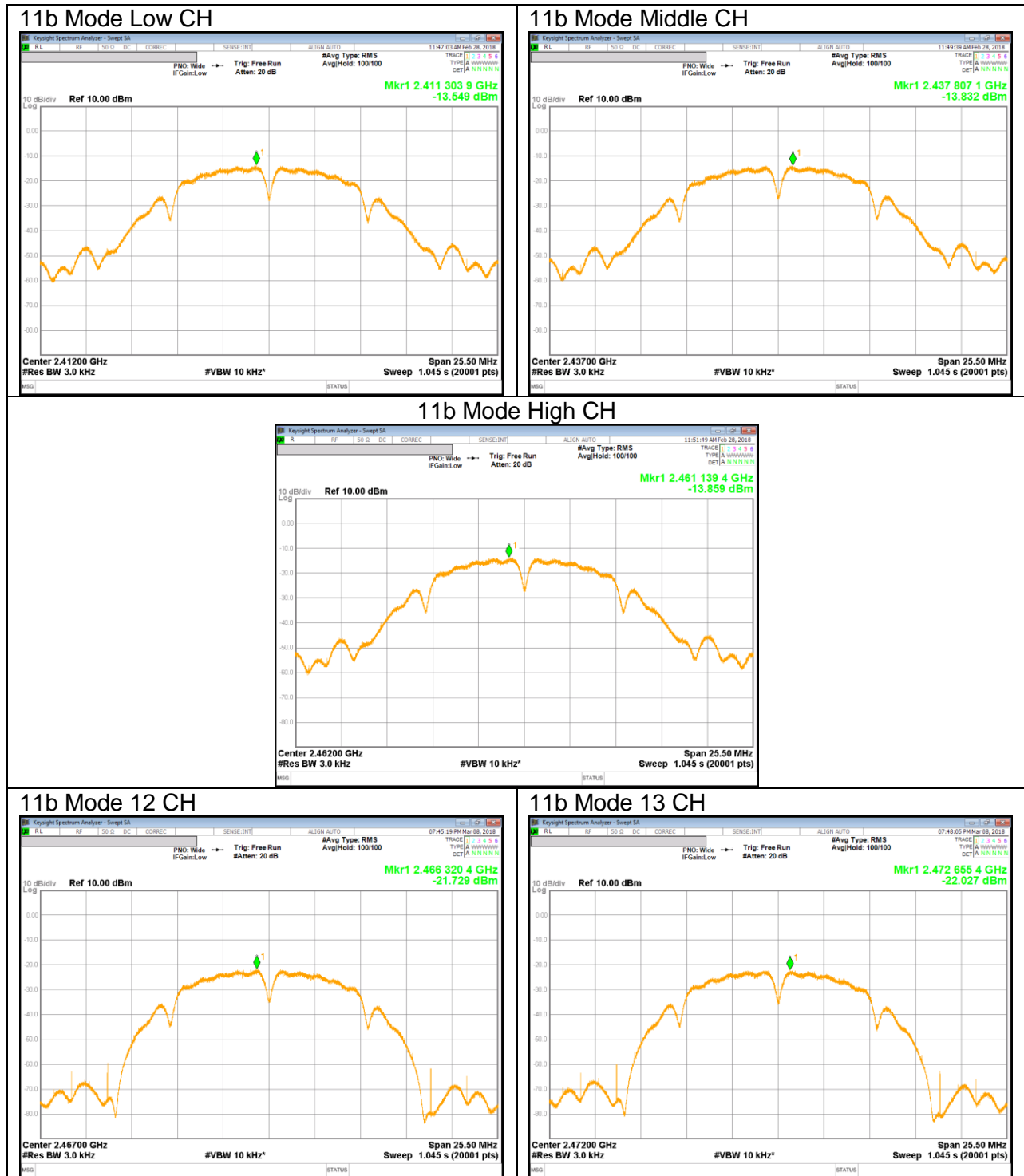

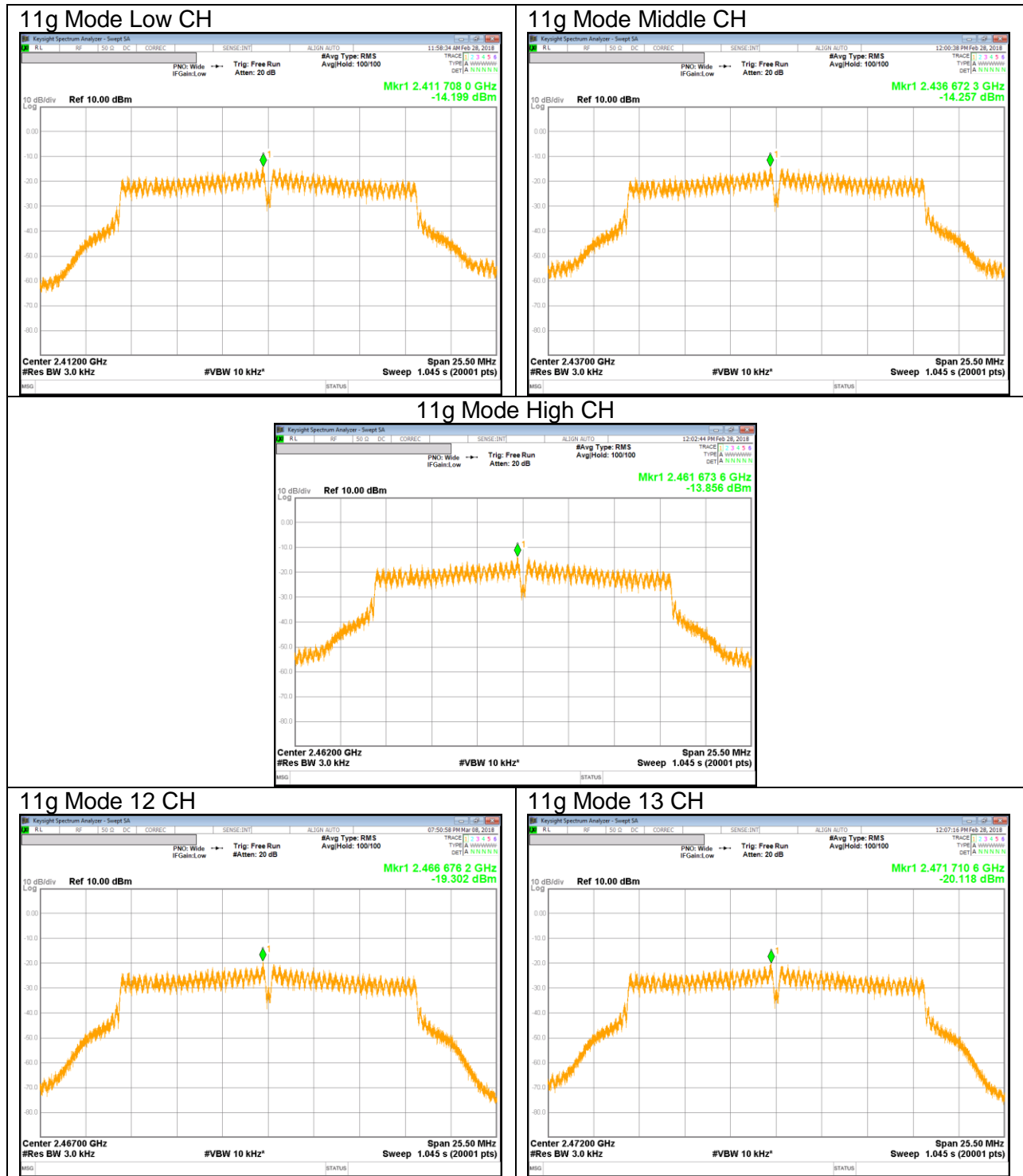

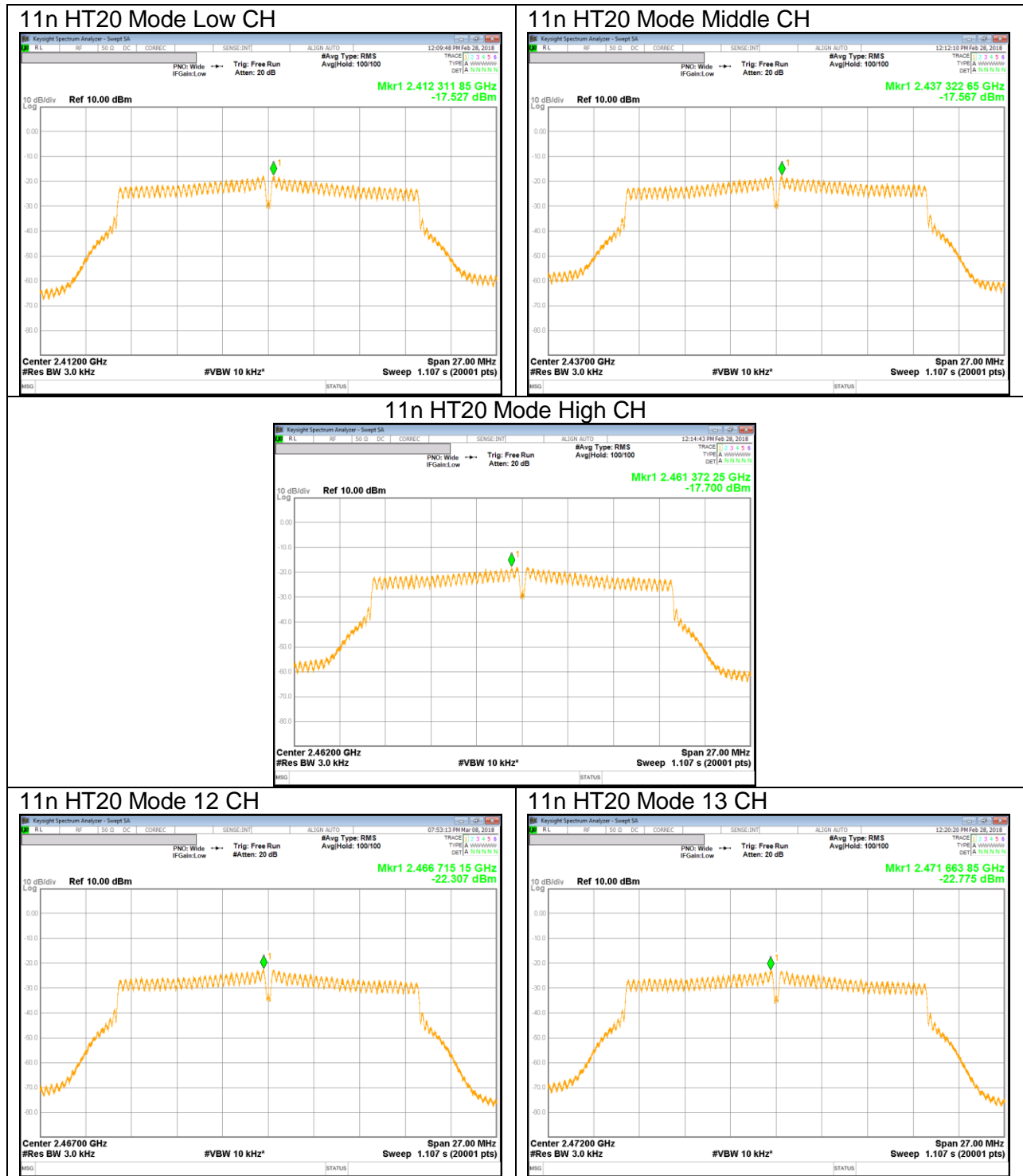

10.4. OUT-OF-BAND EMISSIONS

LIMITS

FCC §15.247 (d)

In any 100 kHz bandwidth outside the frequency band in which the spread spectrum or digitally modulated intentional radiator is operating, the radio frequency power that is produced by the intentional radiator shall be at least 20 dB below that in the 100 kHz bandwidth within the band that contains the highest level of the desired power, based on either an RF conducted or a radiated measurement, provided the transmitter demonstrates compliance with the peak conducted power limits. If the transmitter complies with the conducted power limits based on the use of RMS averaging over a time interval, as permitted under paragraph (b)(3) of this section, the attenuation required under this paragraph shall be 30 dB instead of 20 dB. Attenuation below the general limits specified in §15.209(a) is not required.

TEST PROCEDURE

The transmitter output is connected to a spectrum analyzer with RBW = 100 kHz, VBW = 300 kHz, peak detector, and max hold. Measurements utilizing these settings are made of the in-band reference level, bandedge (where measurements to the general radiated limits will not be made) and out-of-band emissions.

RESULTS

10.4.1.802.11b MODE IN THE 2.4 GHz BAND

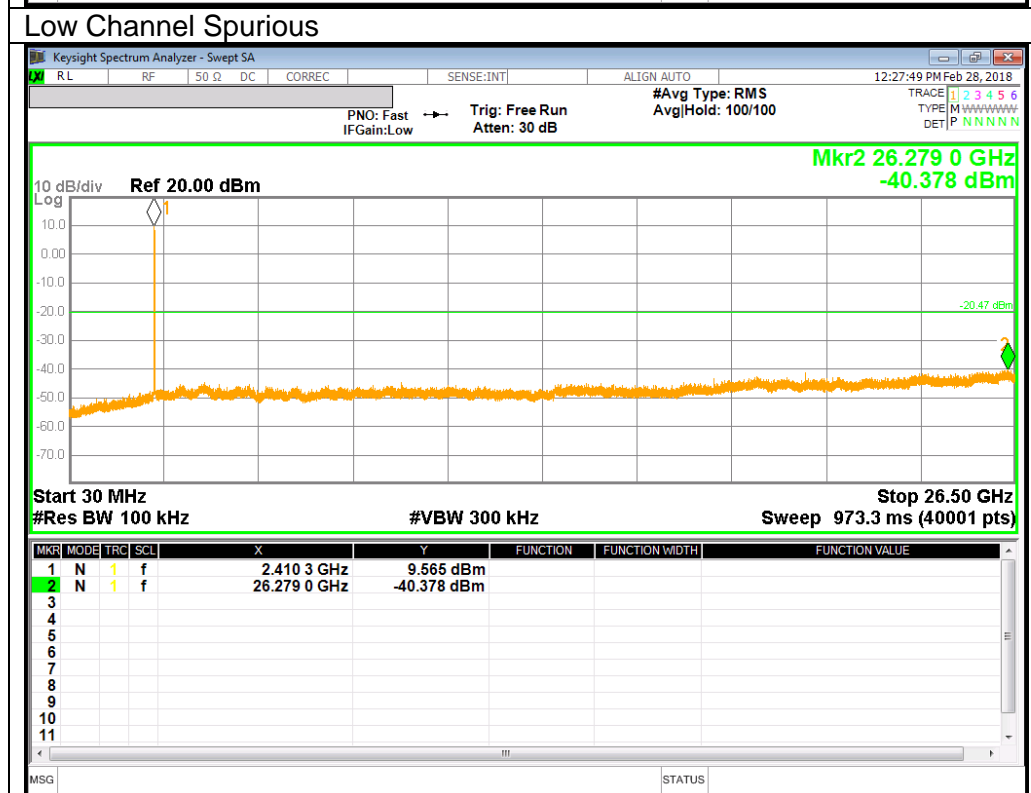
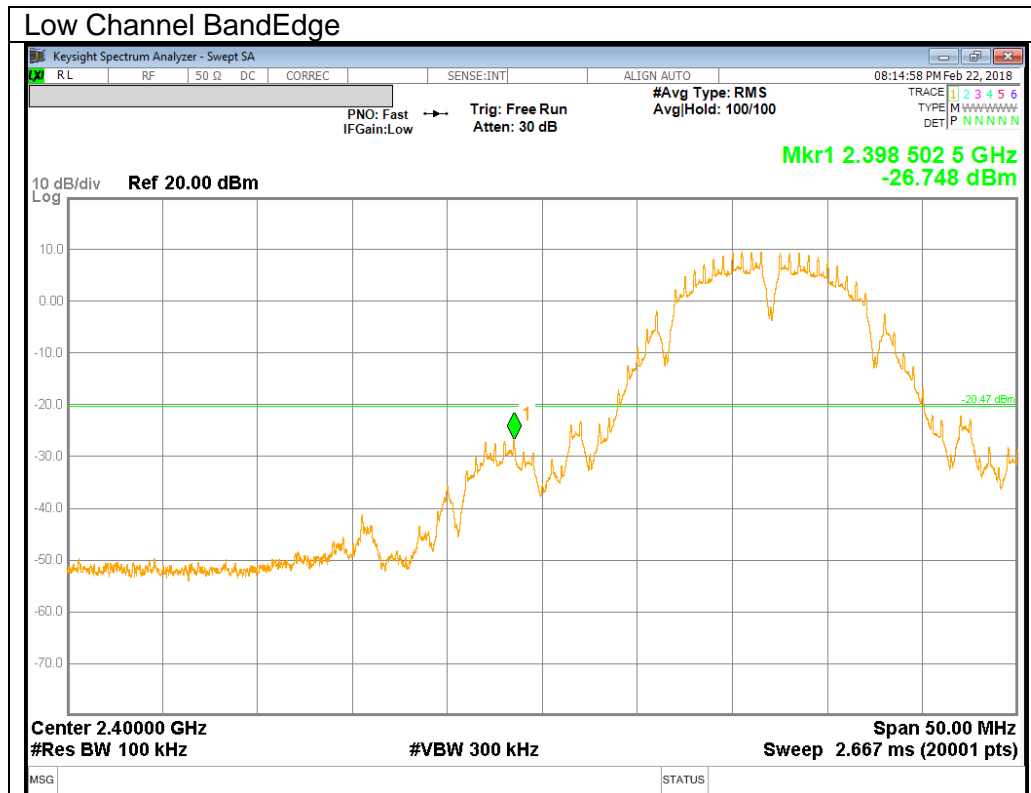

Middle Channel BandEdge

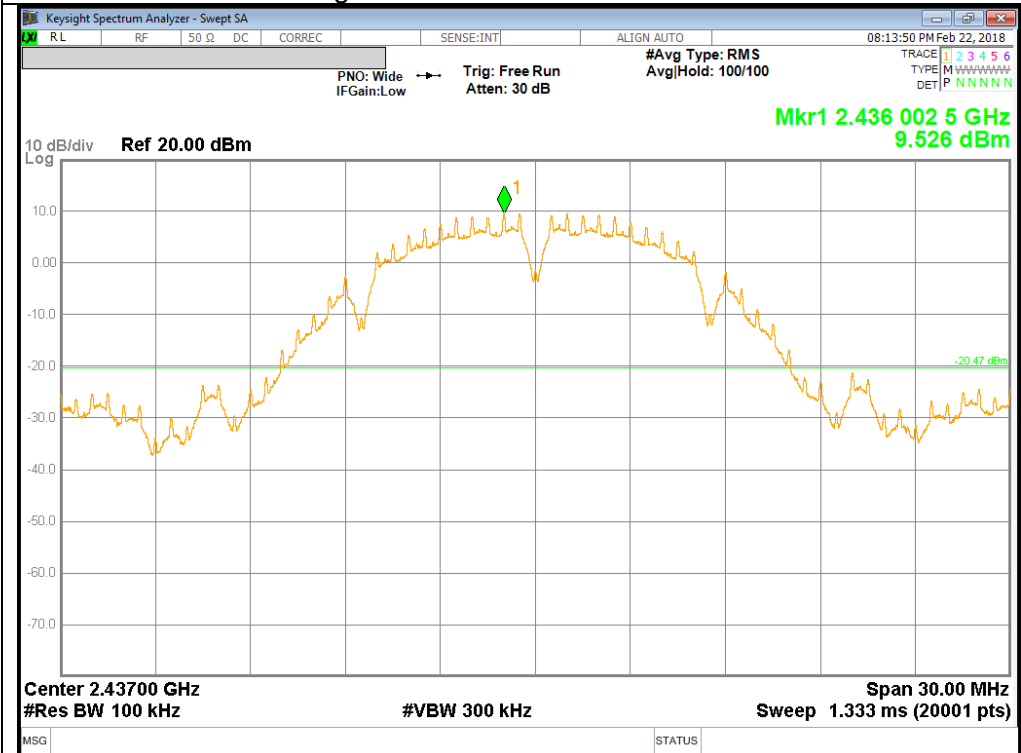

Middle Channel Spurious

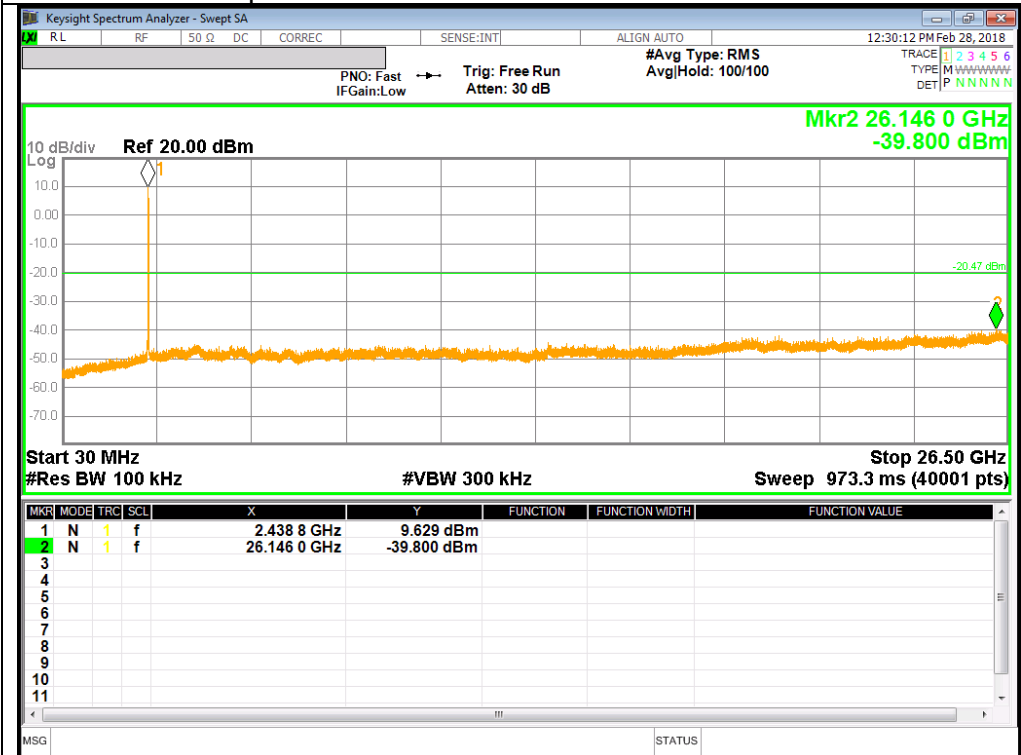

High Channel BandEdge



High Channel Spurious

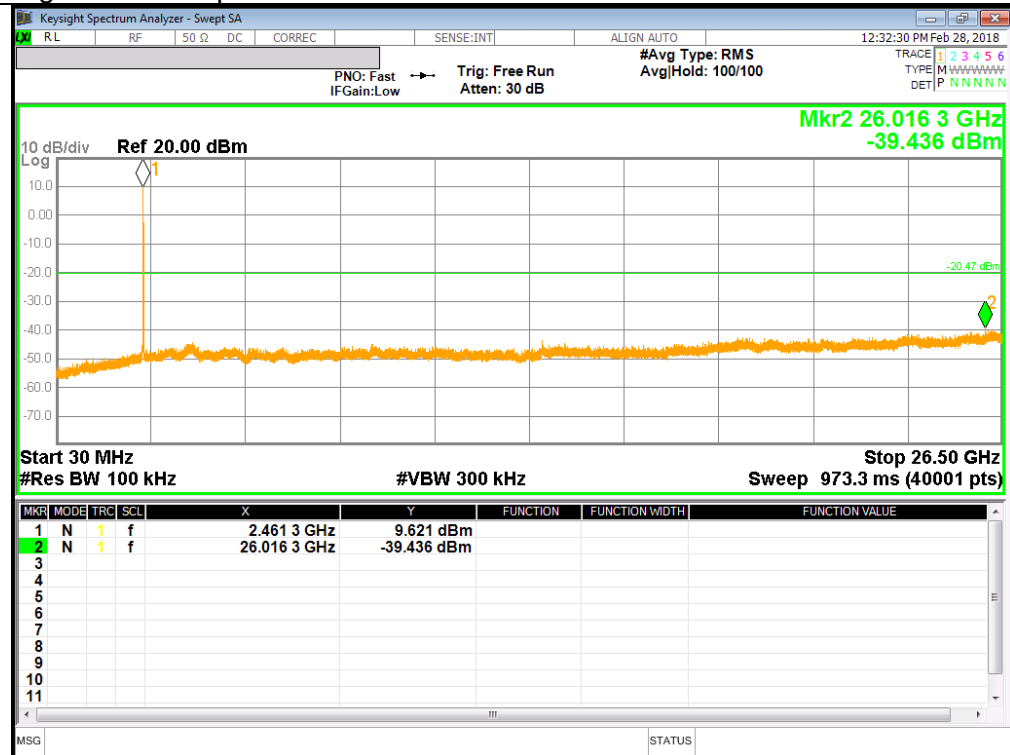

12 Channel BandEdge

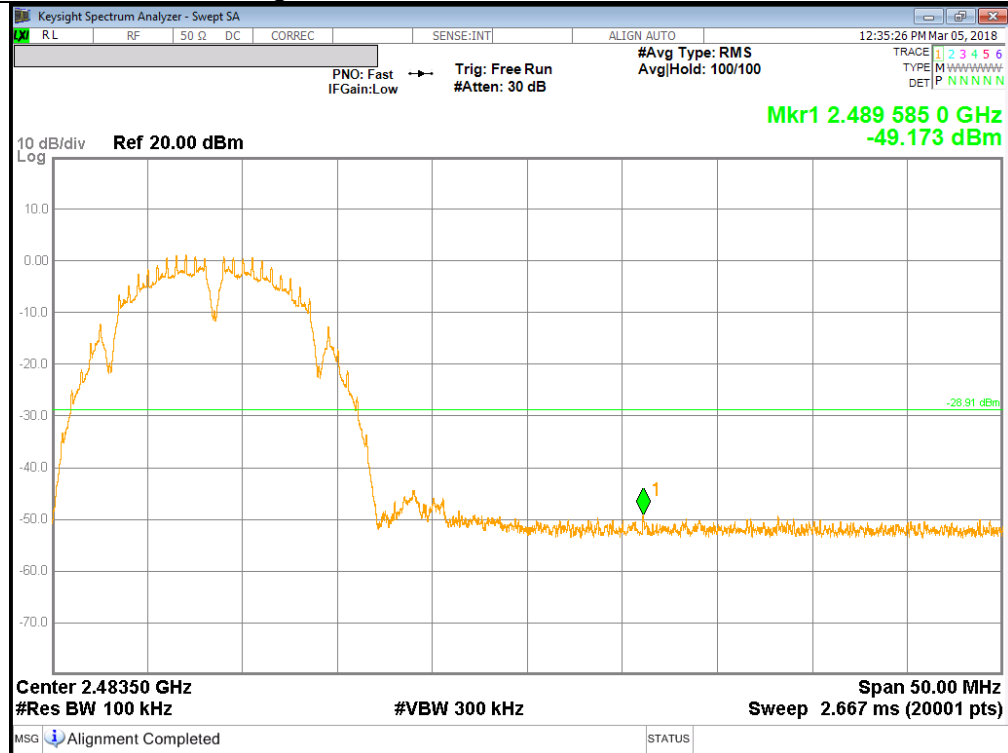

12 Channel Spurious

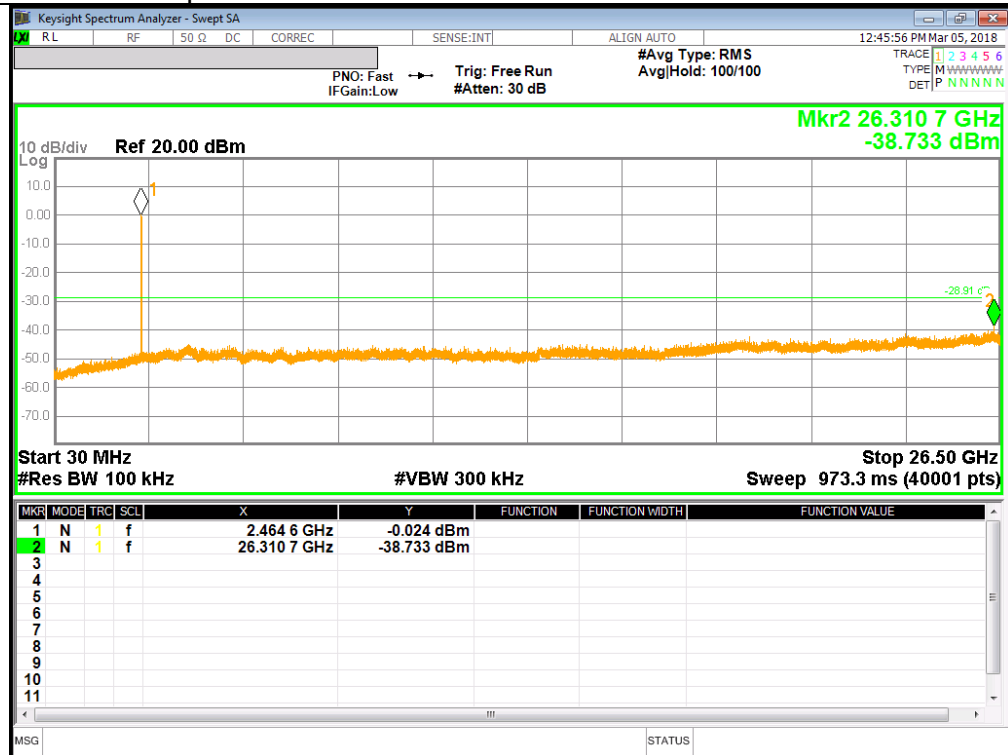

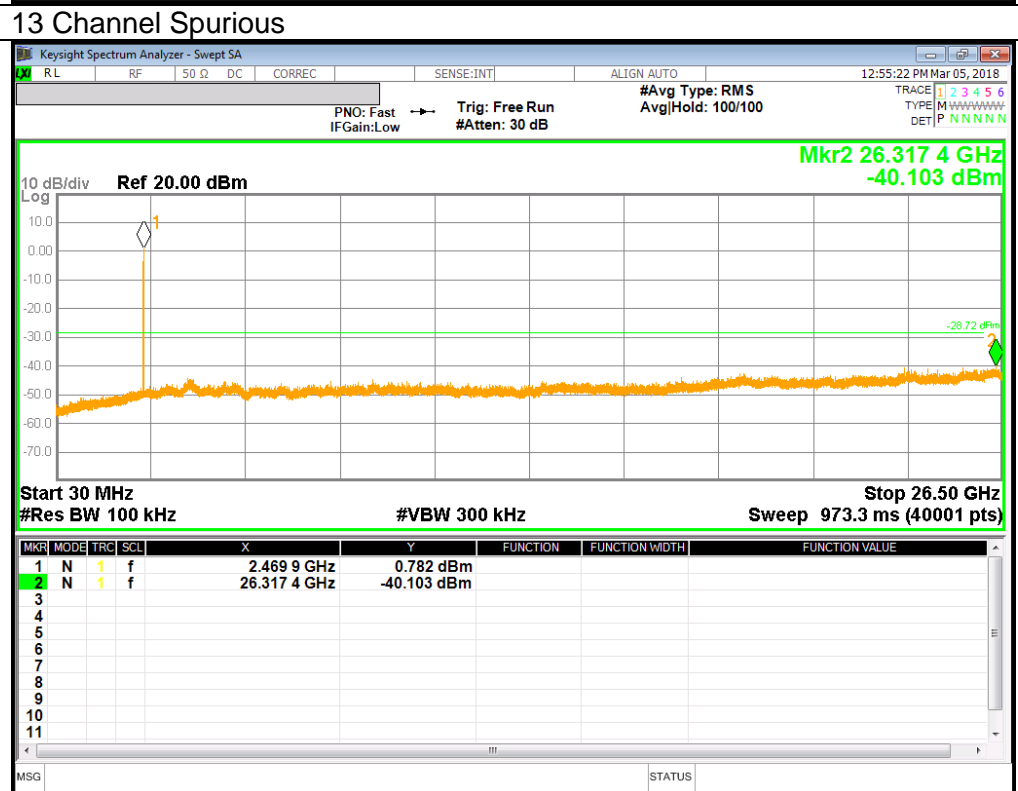
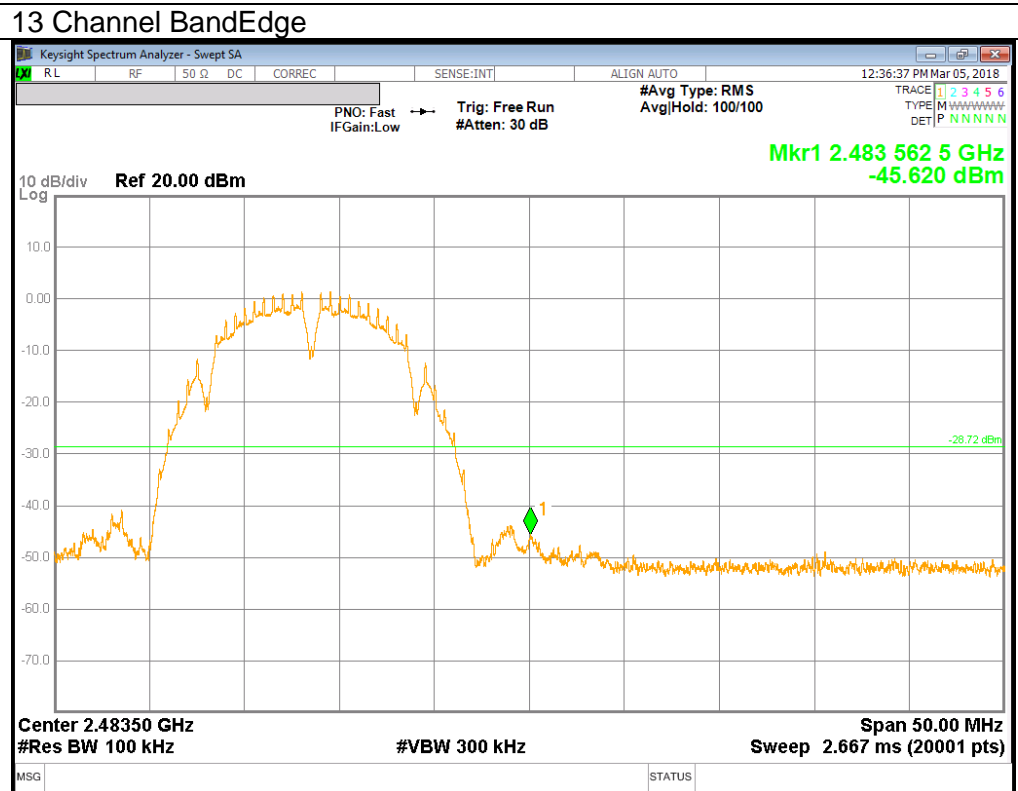

10.4.2.802.11g MODE IN THE 2.4 GHz BAND

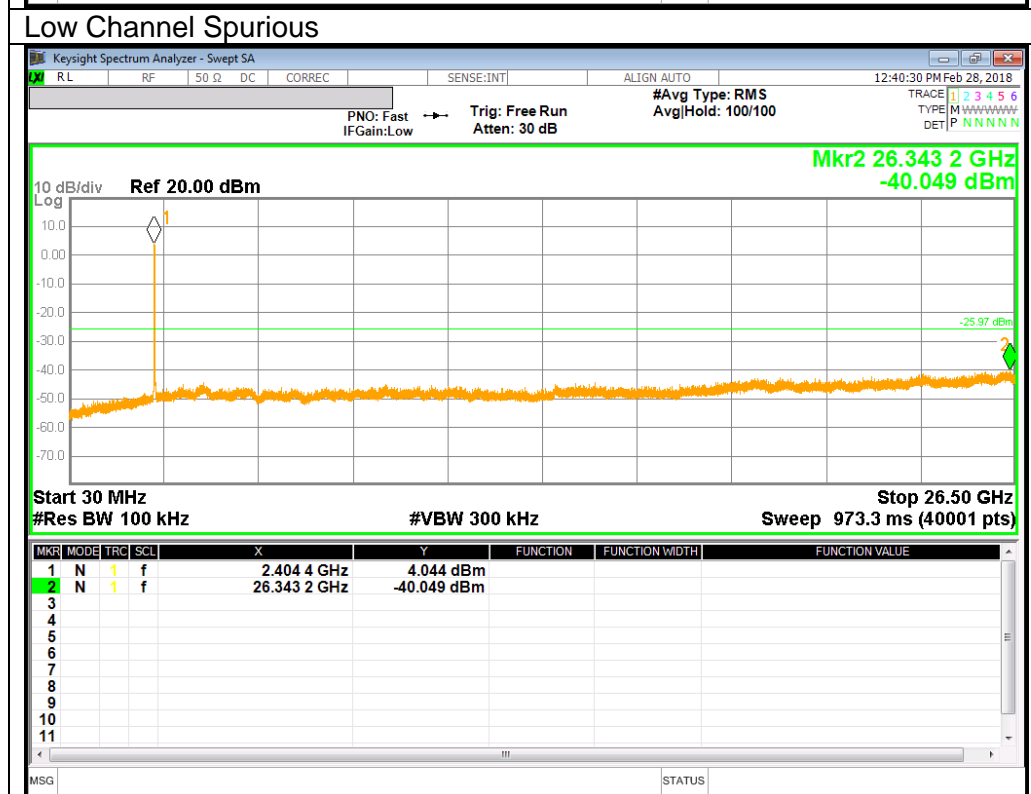
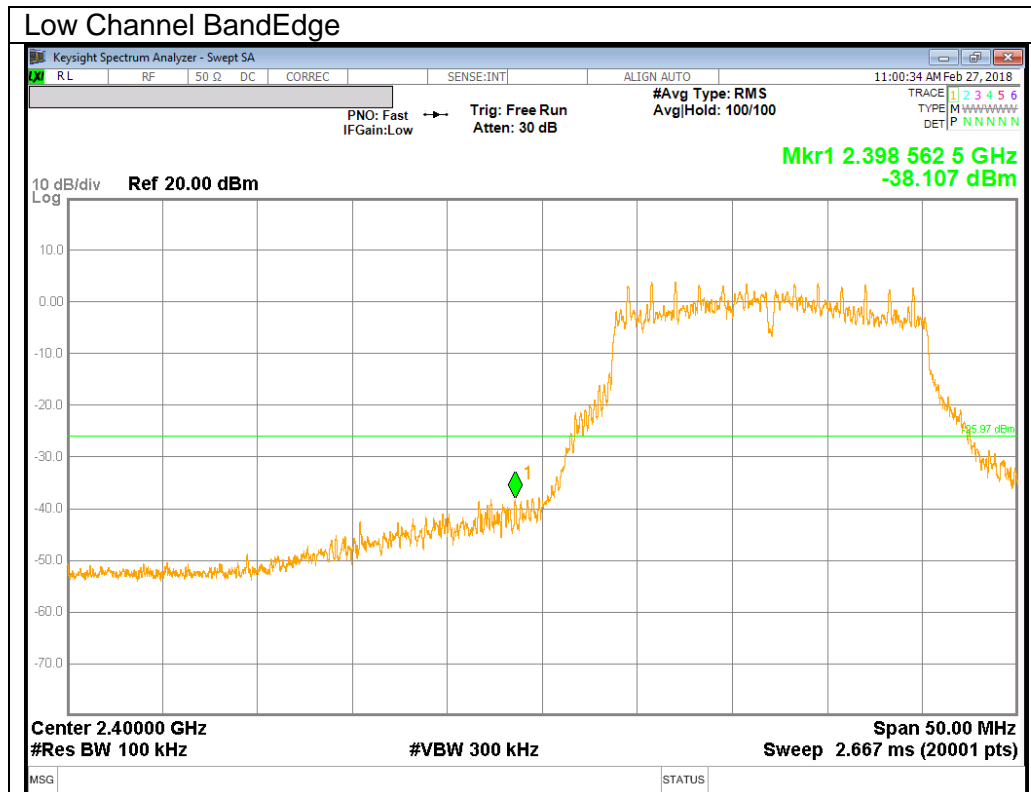

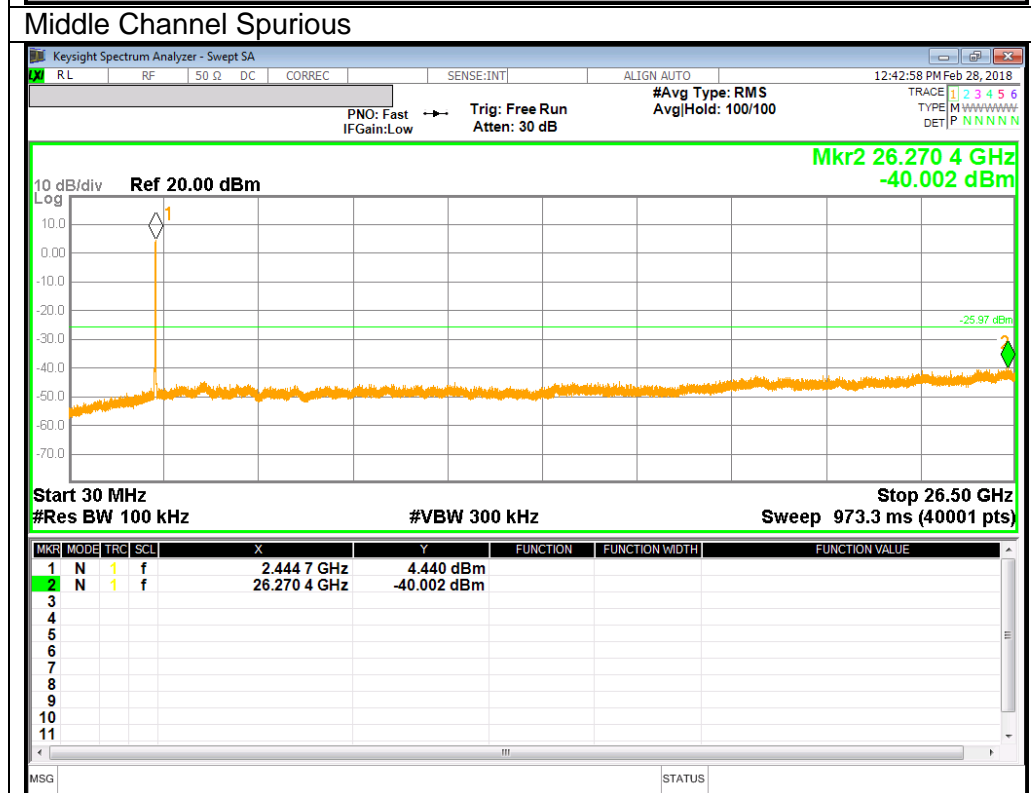
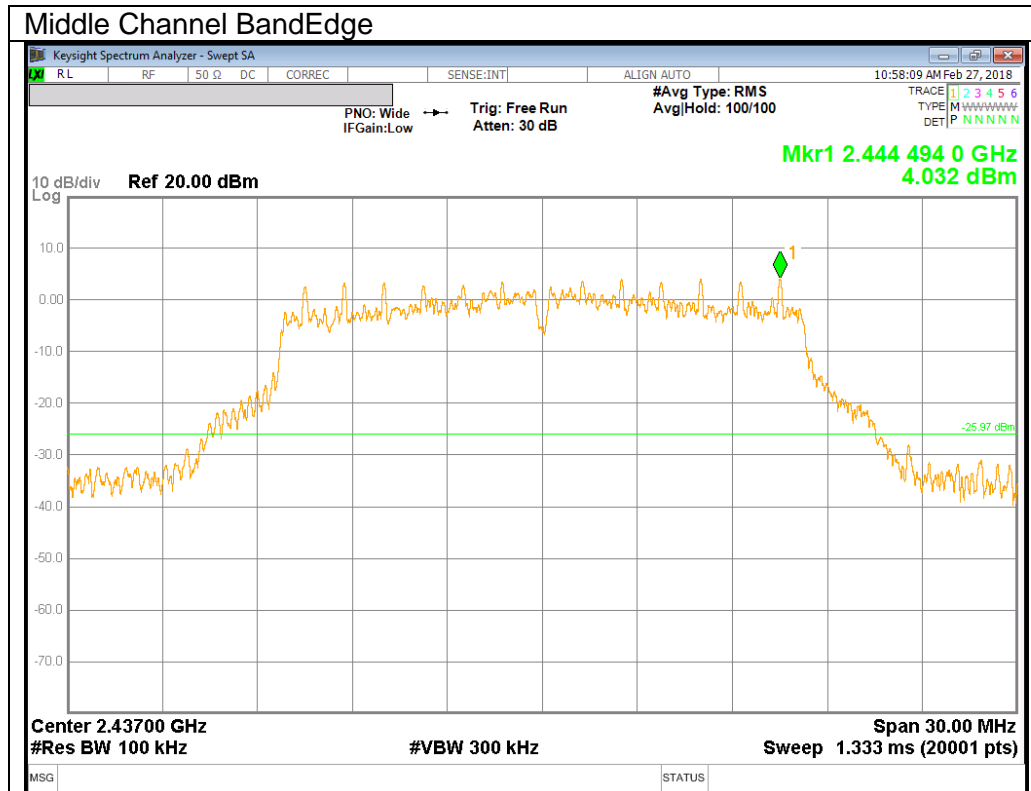

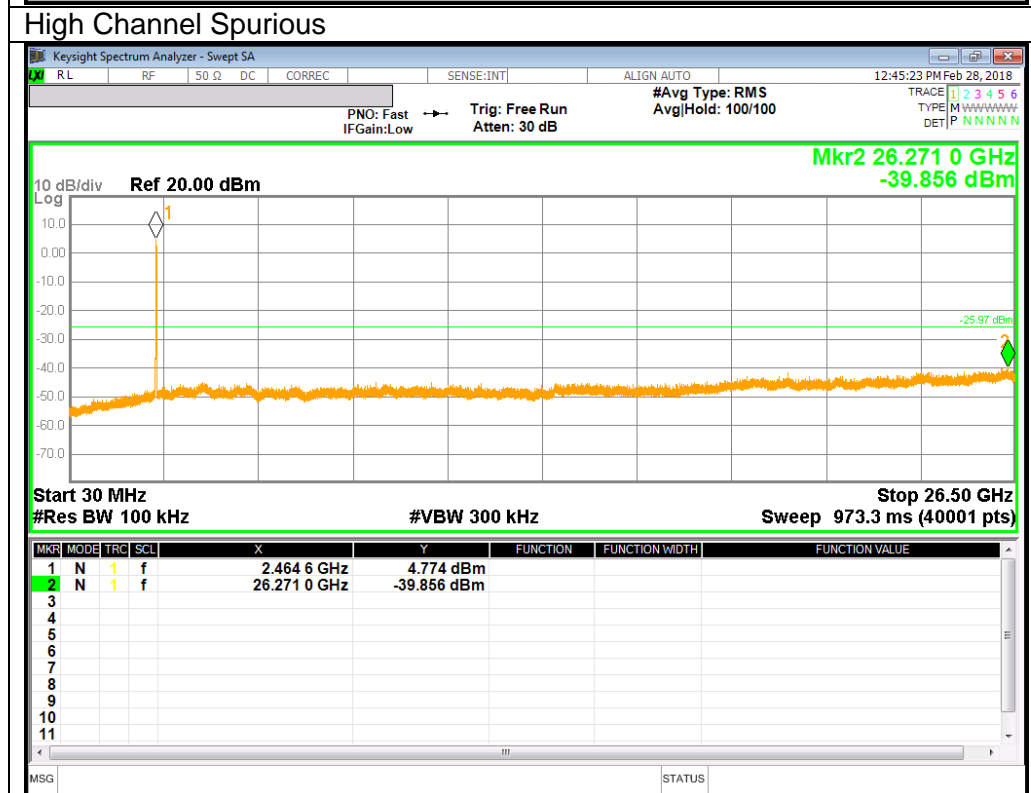
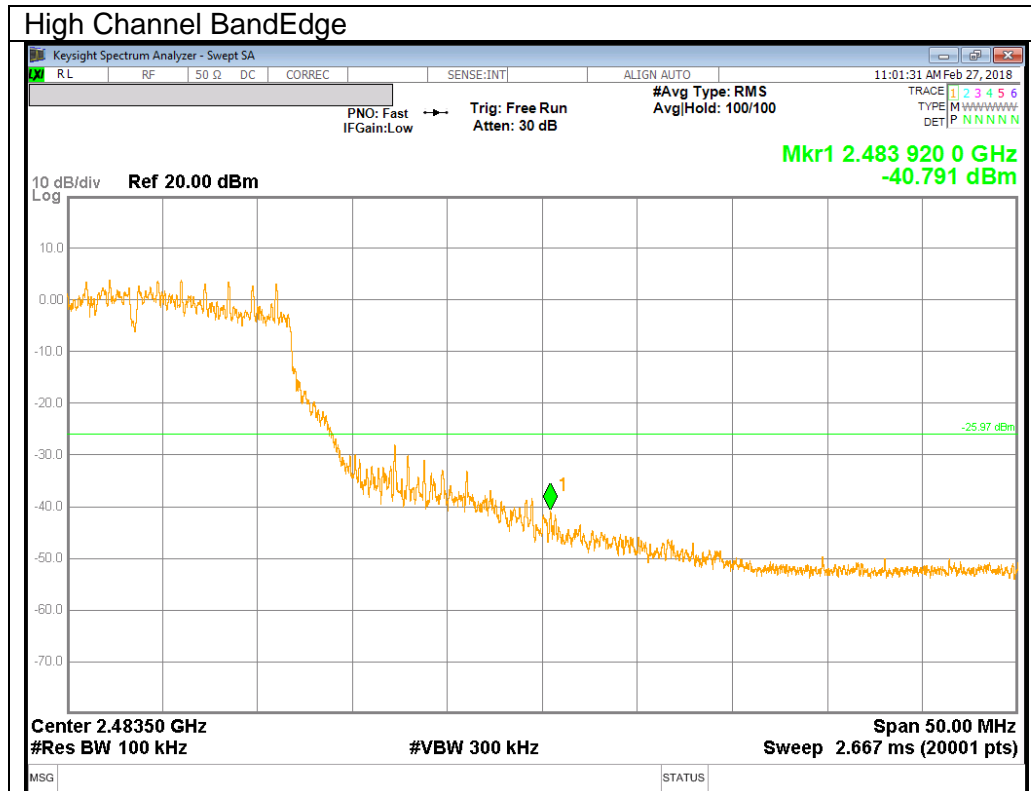

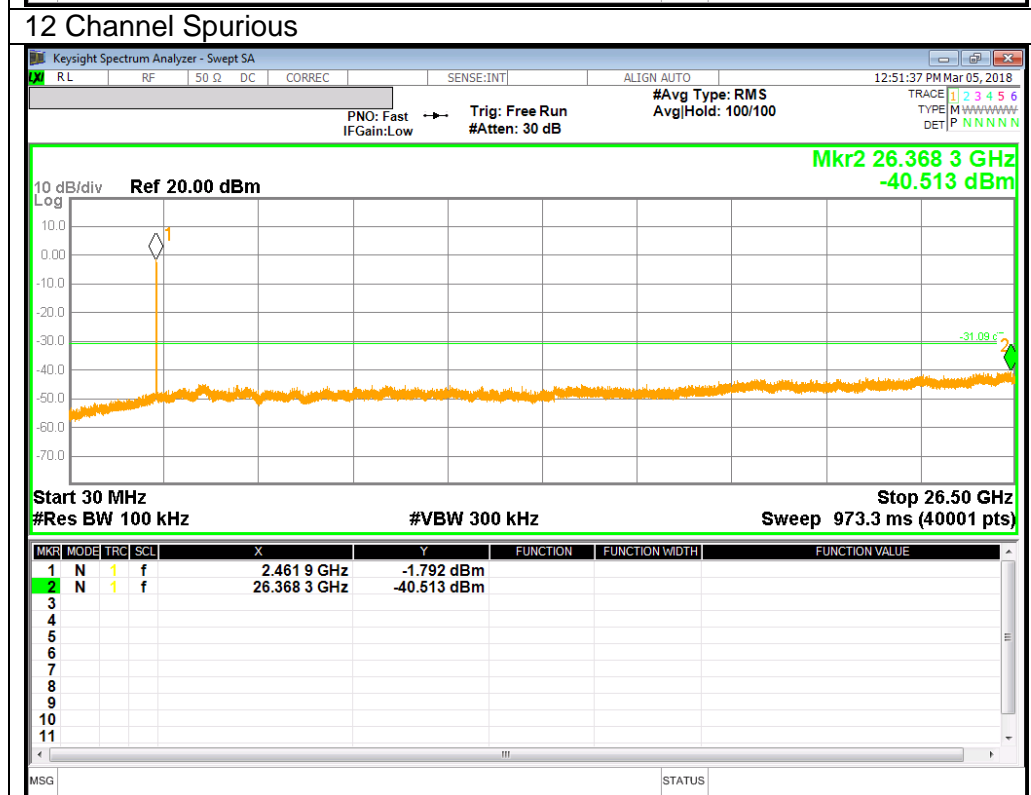
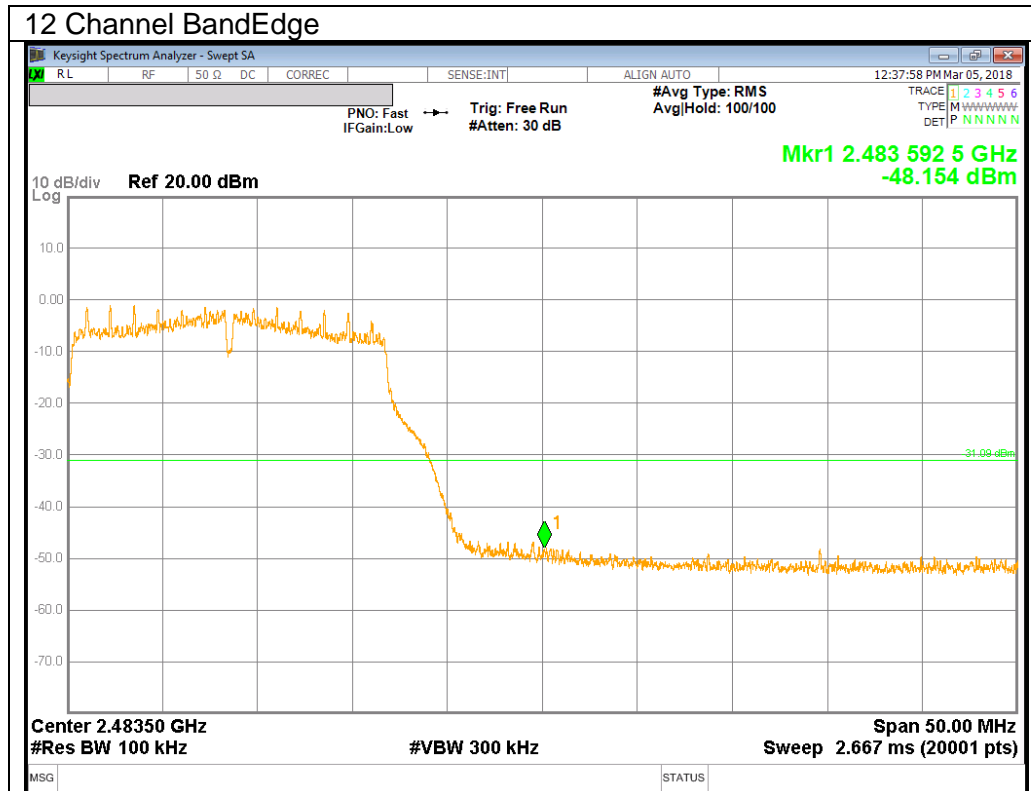

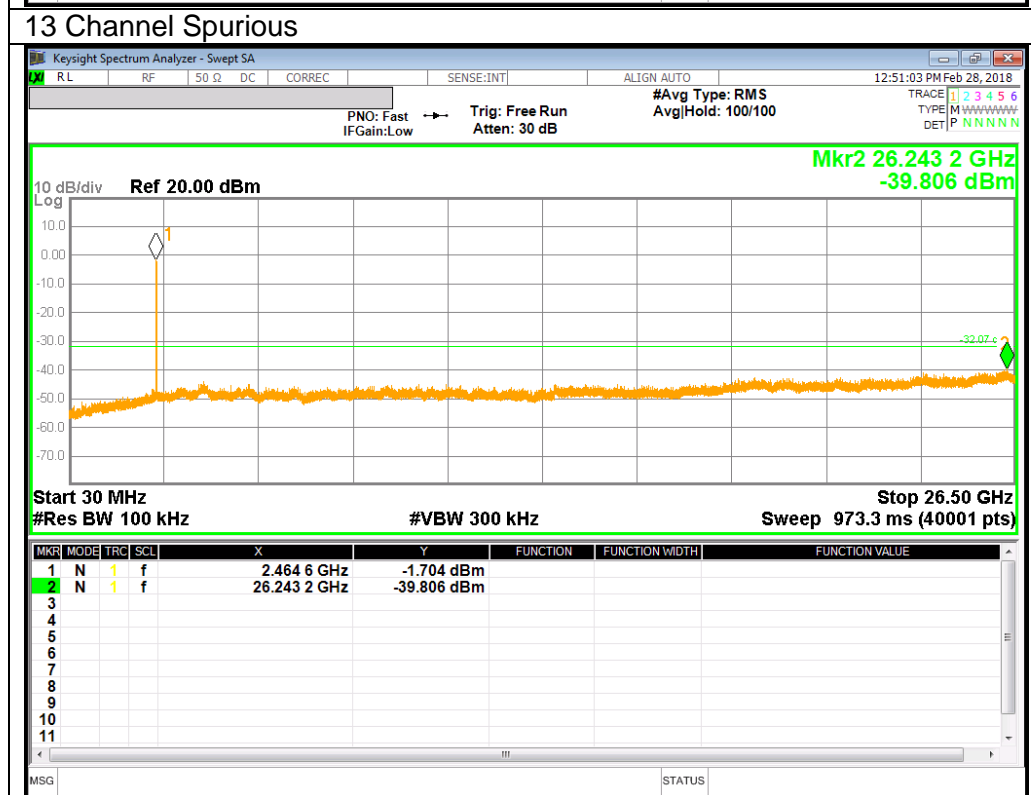
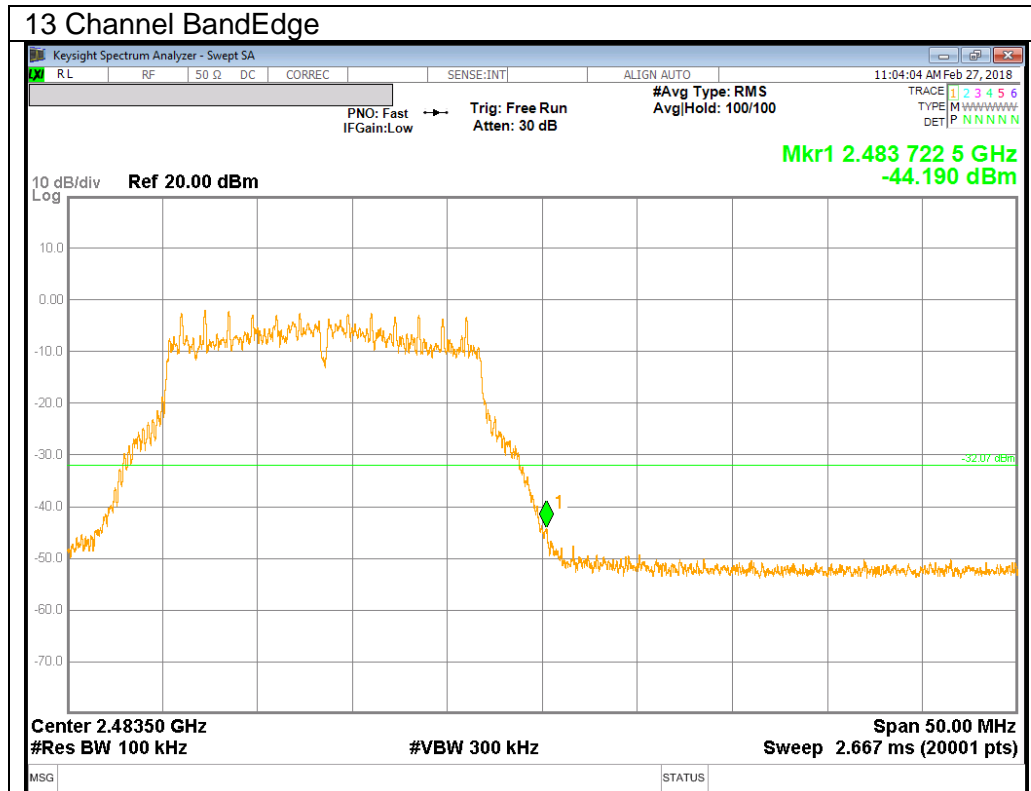

10.4.3.802.11n HT20 MODE IN THE 2.4 GHz BAND

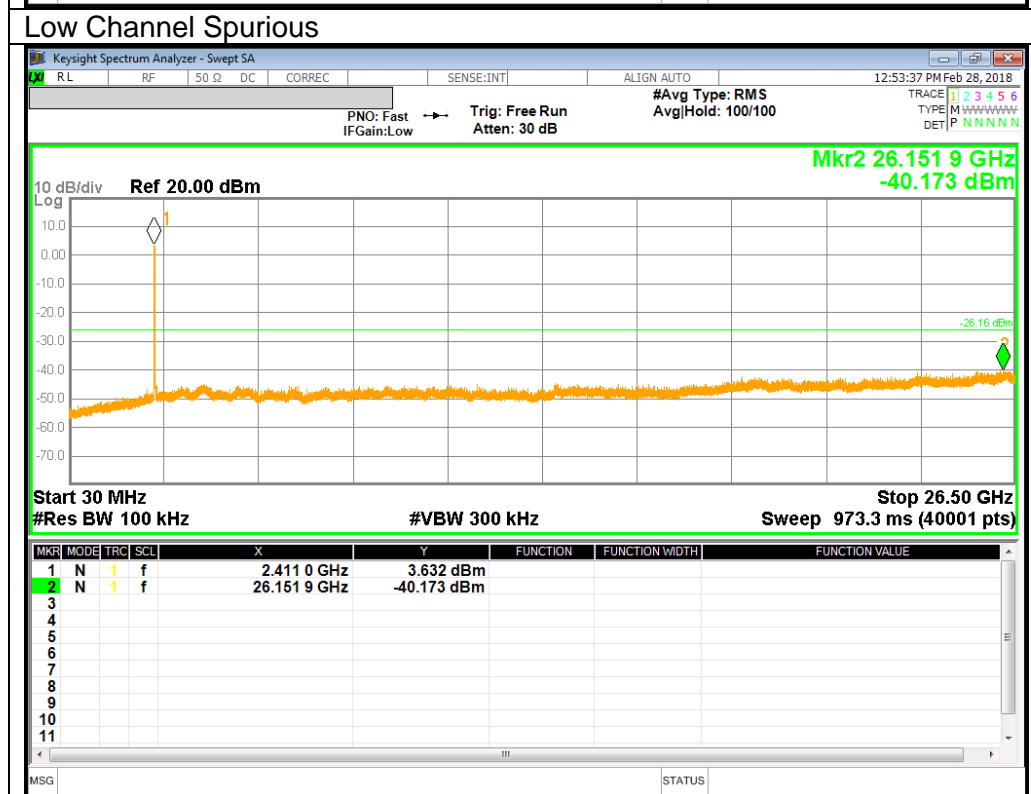
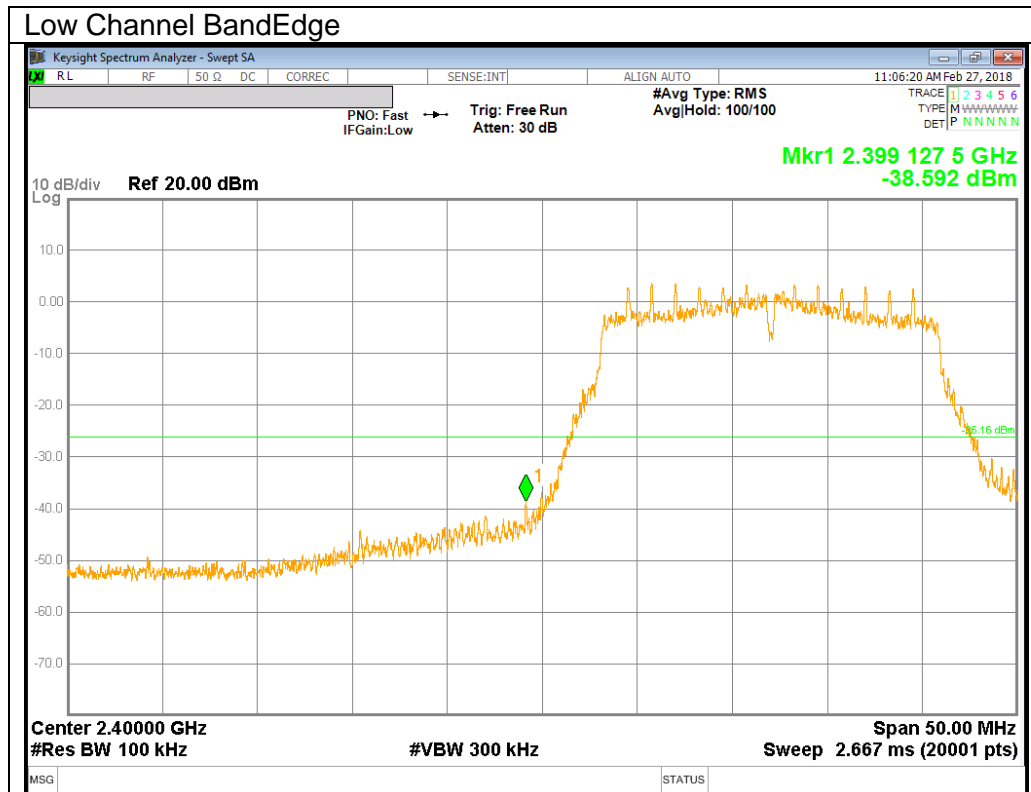

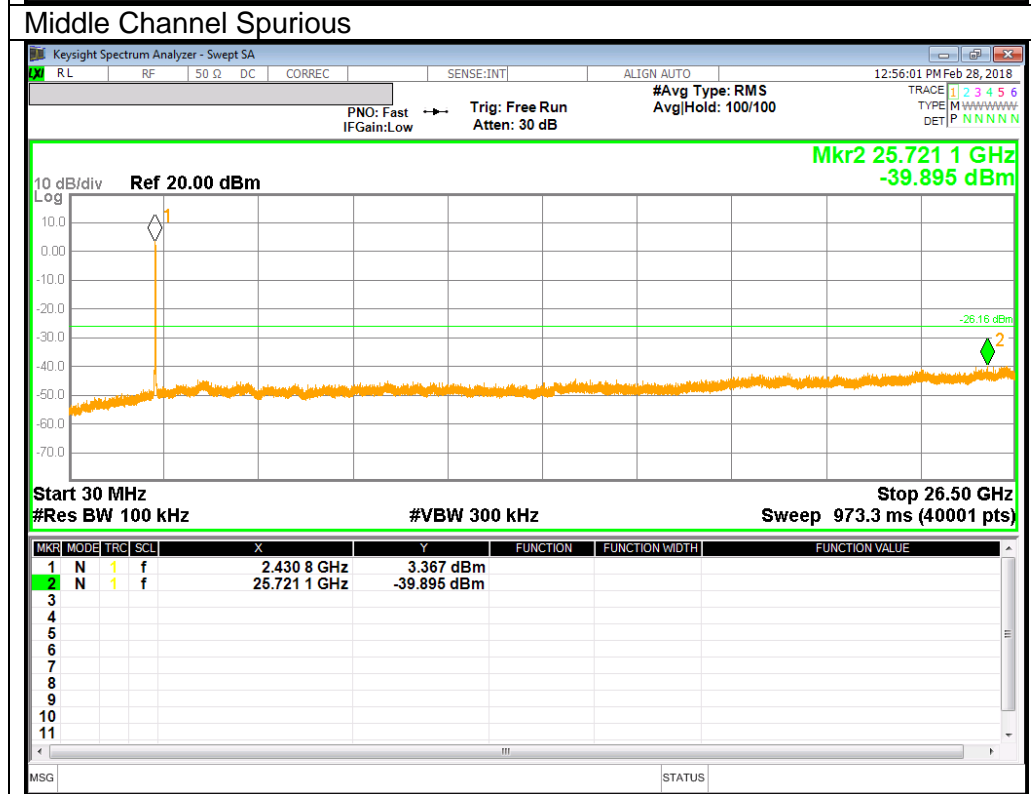
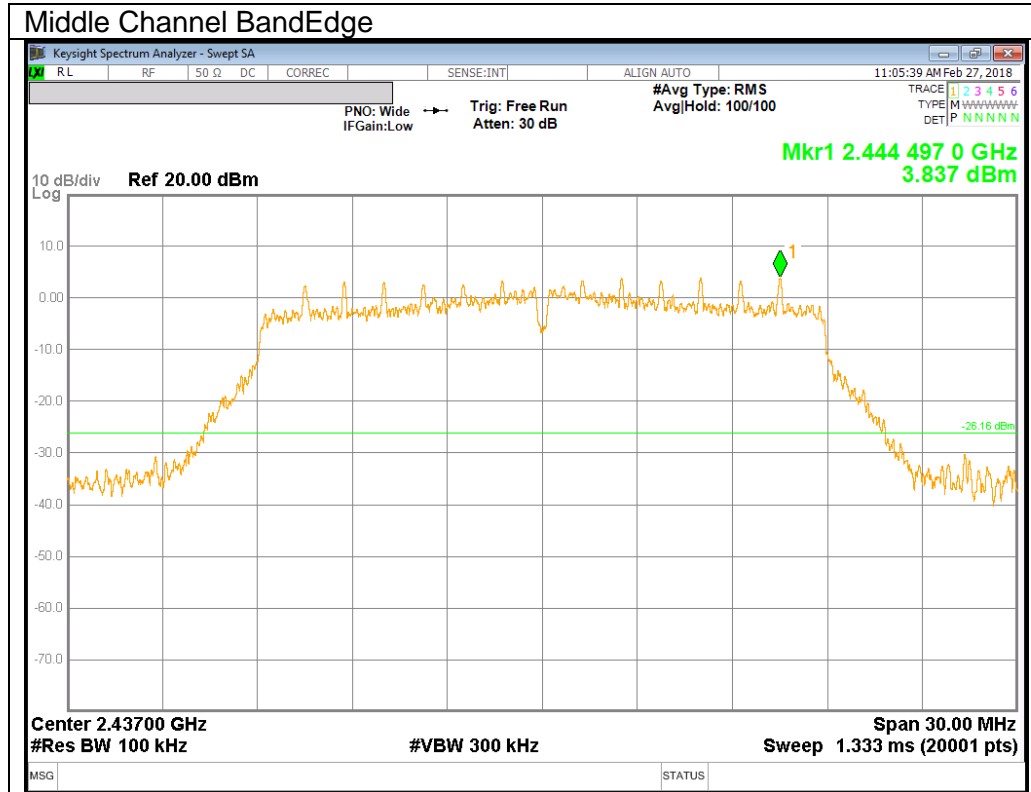

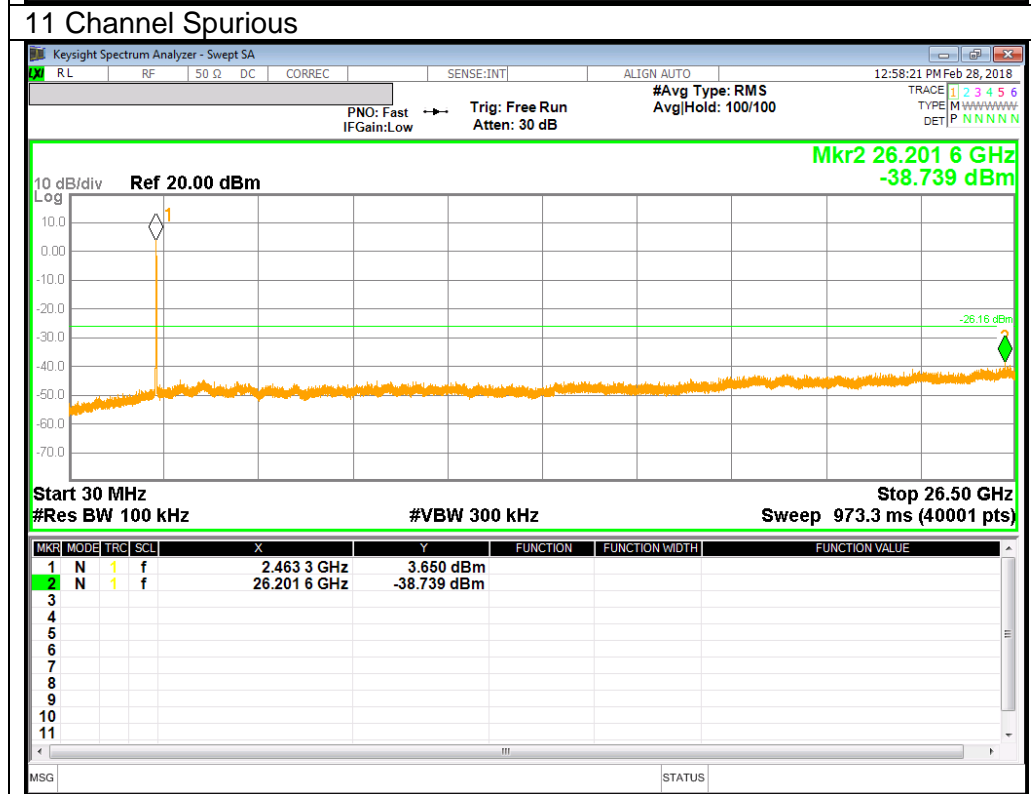
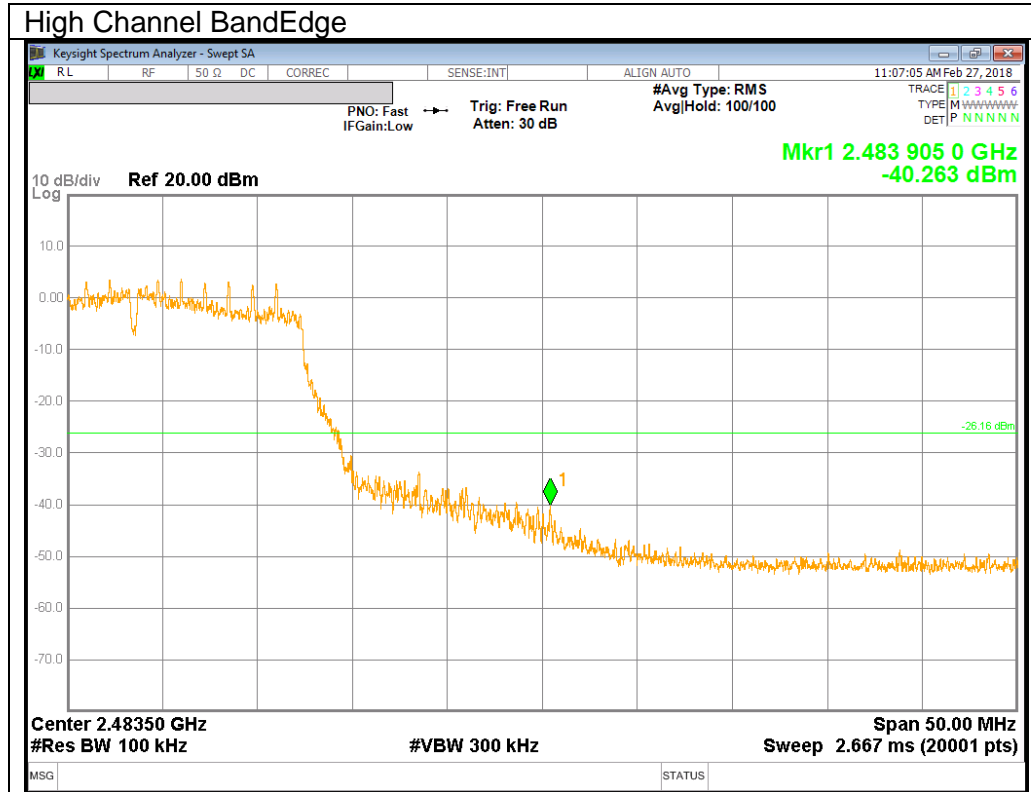

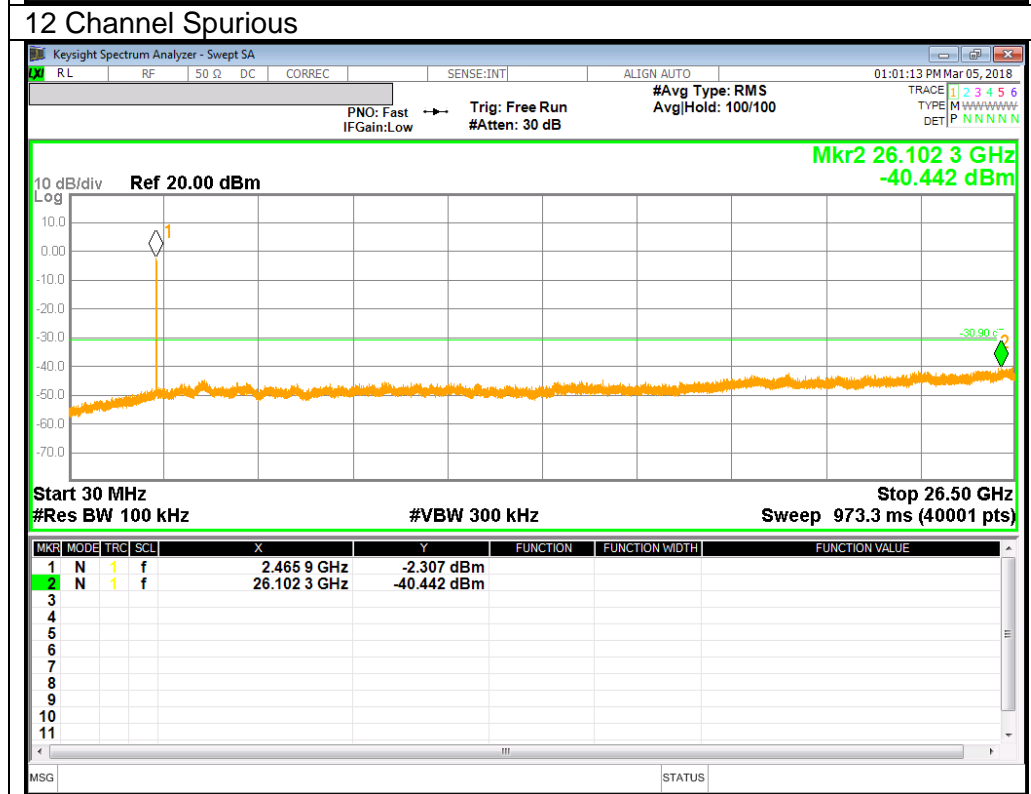
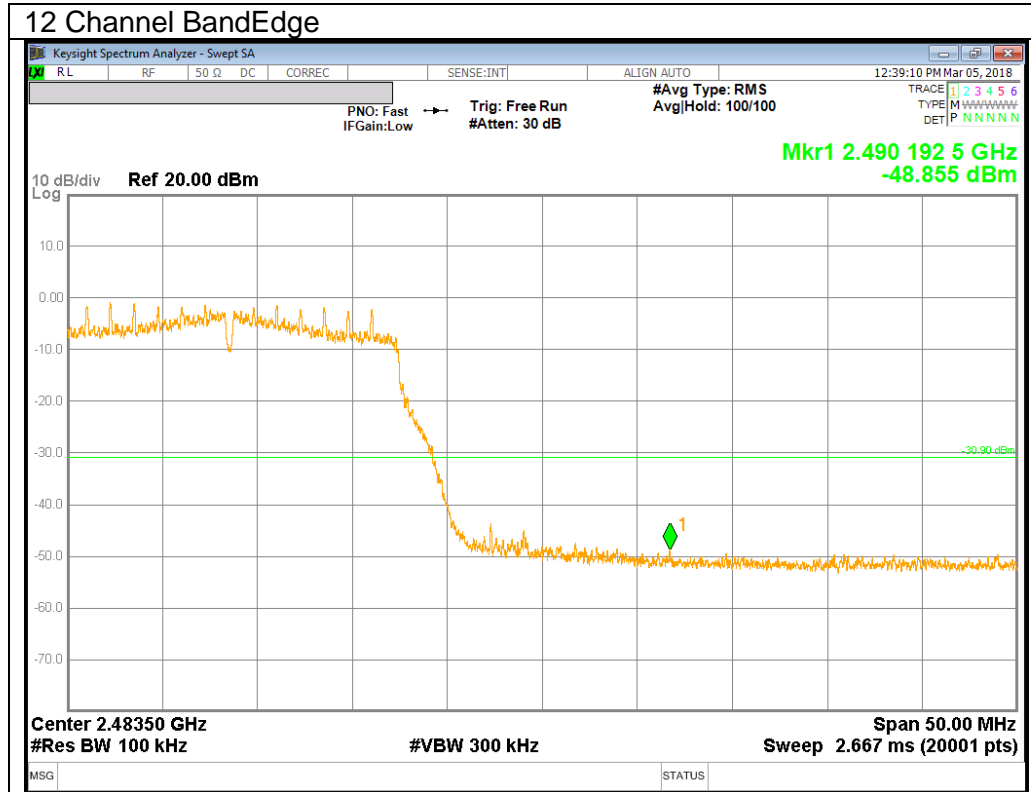

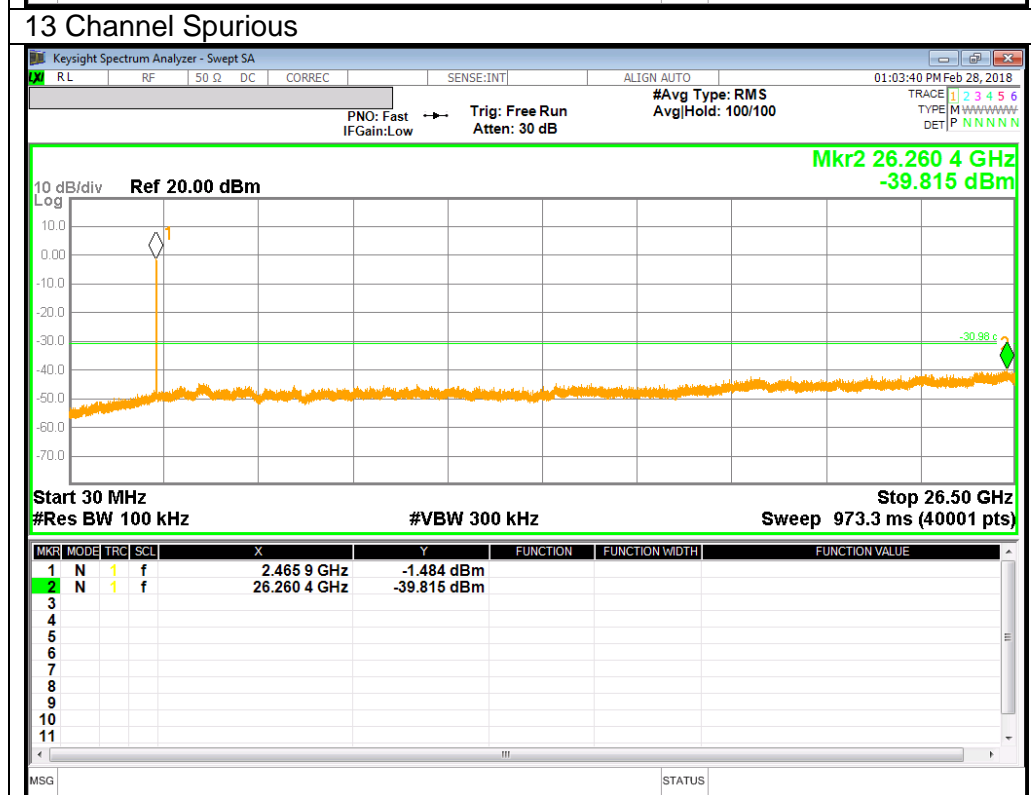
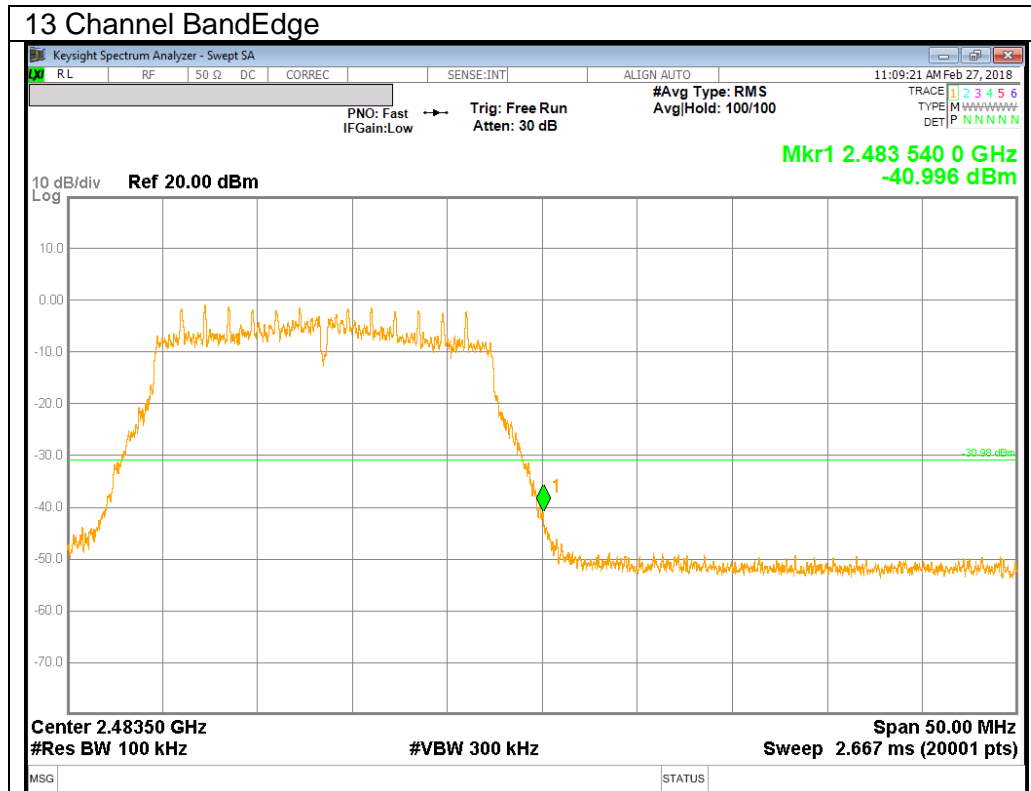

11. RADIATED TEST RESULTS

11.1. LIMITS AND PROCEDURE

LIMITS

FCC §15.205 and §15.209

Limits for radiated disturbance of an intentional radiator		
Frequency range (MHz)	Limits (µV/m)	Measurement Distance (m)
0.009 – 0.490	2400 / F (kHz)	300
0.490 – 1.705	24000 / F (kHz)	30
1.705 – 30.0	30	30
30 – 88	100**	3
88 - 216	150**	3
216 – 960	200**	3
Above 960	500	3

** Except as provided in paragraph (g), fundamental emissions from intentional radiators operating under this section shall not be located in the frequency bands 54-72 MHz, 76-88 MHz, 174-216 MHz or 470-806 MHz. However, operation within these frequency bands is permitted under other sections of this part, e.g. §§ 15.231 and 15.241.

TEST PROCEDURE

The EUT is placed on a non-conducting table 80 cm above the ground plane for below 1GHz and 150 cm for above 1GHz. The antenna to EUT distance is 3 meters. The EUT is configured in accordance with ANSI C63.10. The EUT is set to transmit in a continuous mode.

For measurements below 1 GHz the resolution bandwidth is set to 100 kHz for peak detection measurements or 120 kHz for quasi-peak detection measurements. Peak detection is used unless otherwise noted as quasi-peak.

For measurements above 1 GHz the resolution bandwidth is set to 1 MHz; the video bandwidth is set to 3 MHz for peak measurements and add duty cycle factor for average measurements. (Restricted bandedge, Final detection of spurious harmonic emissions)
Duty cycle factor= $10\log(1/x)$ For this sample B mode = 0dB (duty cycle >98%); G mode = 0.14dB; N mode = 0.15dB.

Pre-scans to detect harmonic and spurious emissions, the resolution bandwidth is set to 1 MHz; the video bandwidth is set to 30 KHz for peak measurements.

The spectrum from 1 GHz to 26 GHz is investigated with the transmitter set to the lowest, middle, and highest channels in each applicable band.
(From 30MHz to 1GHz, test was performed with the EUT set to transmit at the channel with highest output power)

The frequency range of interest is monitored at a fixed antenna height and EUT azimuth. The EUT is rotated through 360 degrees to maximize emissions received. The antenna is scanned from 1 to 4 meters above the ground plane to further maximize the emission. Measurements are made with the antenna polarized in both the vertical and the horizontal positions.

11.2. TRANSMITTER ABOVE 1 GHz

11.2.1.TX ABOVE 1 GHz 802.11b MODE IN THE 2.4 GHz BAND

RESTRICTED BANDEDGE (LOW CHANNEL)

HORIZONTAL PEAK AND AVERAGE PLOT

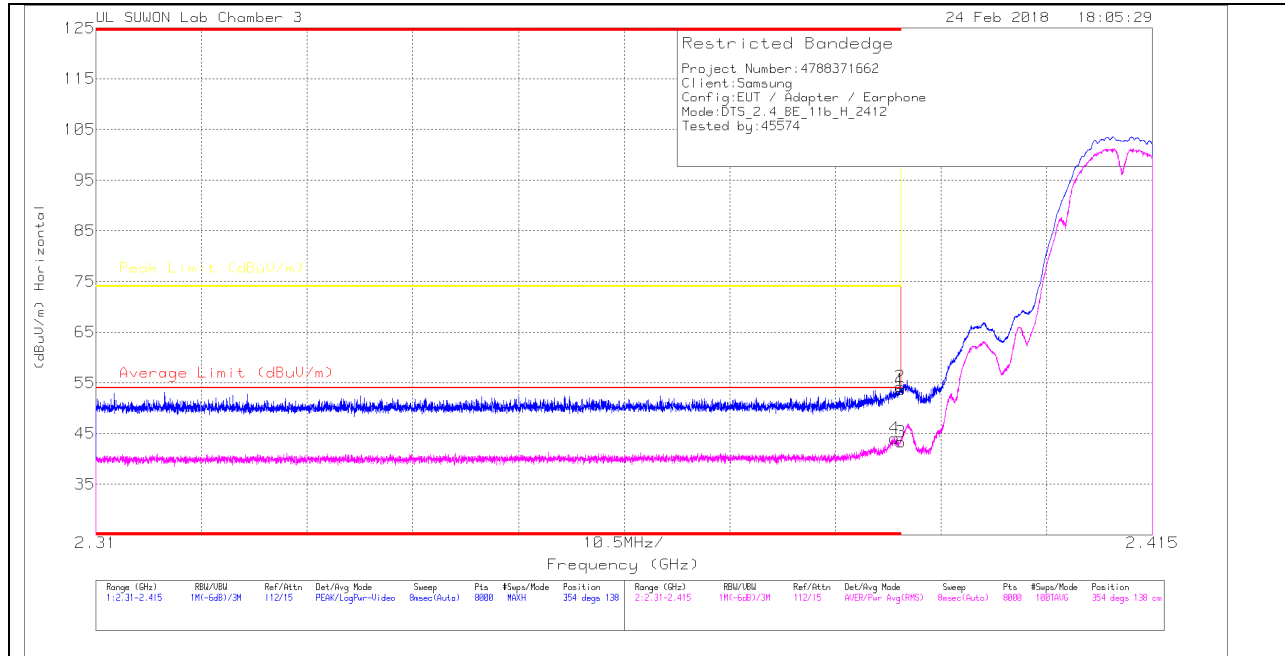

HORIZONTAL DATA

Trace Markers

Marker	Frequency (GHz)	Meter Reading (dBuV)	Det	3117(00205959)	10dB_ATT(dB)	DC Corr (dB)	Corrected Reading (dBuV/m)	Average Limit (dBuV/m)	Margin (dB)	Peak Limit (dBuV/m)	PK Margin (dB)	Azimuth (Degs)	Height (cm)	Polarity
1	* 2.39	45.12	Pk	31.8	-23.3	0	53.62	-	-	74	-20.38	354	138	H
2	* 2.39	45.8	Pk	31.8	-23.3	0	54.3	-	-	74	-19.7	354	138	H
3	* 2.39	34.86	RMS	31.8	-23.3	0	43.36	54	-10.64	-	-	354	138	H
4	* 2.389	35.56	RMS	31.8	-23.3	0	44.06	54	-9.94	-	-	354	138	H

* - indicates frequency in CFR47 Pt 15 / IC RSS-Restricted Band

Pk - Peak detector

RMS - RMS detection

VERTICAL PEAK AND AVERAGE PLOT

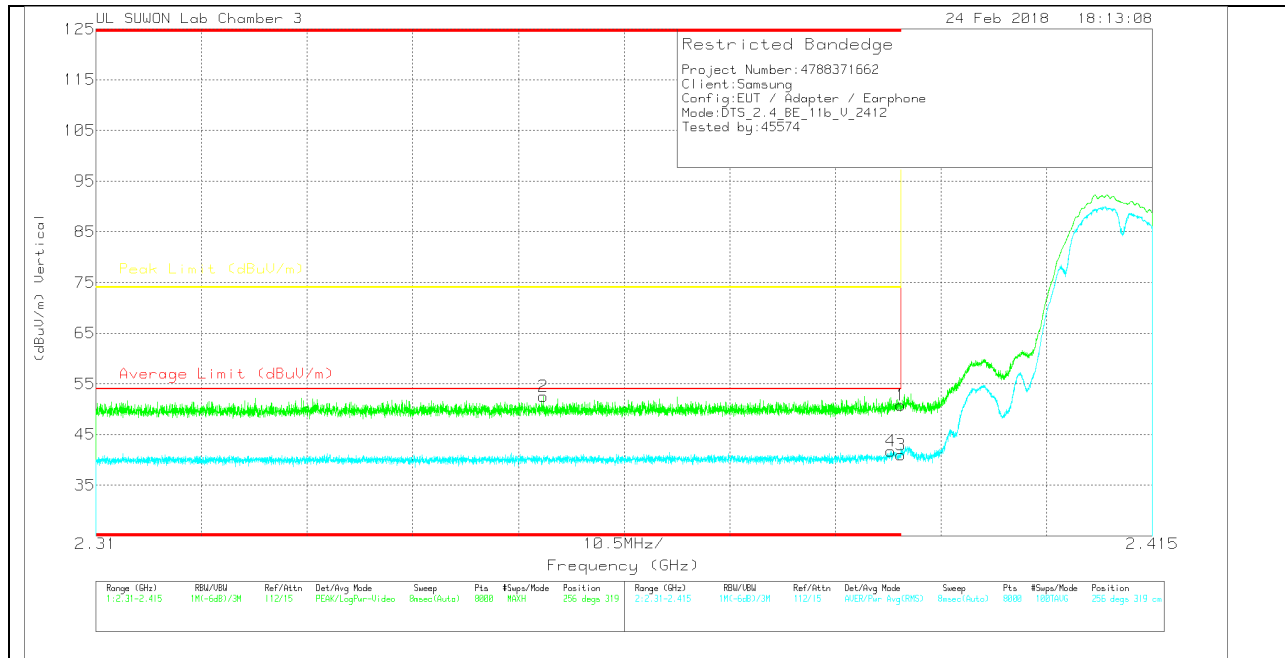

VERTICAL DATA

Trace Markers

Marker	Frequency (GHz)	Meter Reading (dBuV)	Det	311700205959	10dB_ATT(dB)	DC Corr (dB)	Corrected Reading (dBuV/m)	Average Limit (dBuV/m)	Margin (dB)	Peak Limit (dBuV/m)	PK Margin (dB)	Azimuth (Degs)	Height (cm)	Polarity
1	* 2.39	42.24	Pk	31.8	-23.3	0	50.74	-	-	74	-23.26	256	319	V
2	* 2.354	44.1	Pk	31.7	-23.3	0	52.5	-	-	74	-21.5	256	319	V
3	* 2.39	32.43	RMS	31.8	-23.3	0	40.93	54	-13.07	-	-	256	319	V
4	* 2.389	33.21	RMS	31.8	-23.3	0	41.71	54	-12.29	-	-	256	319	V

* - indicates frequency in CFR47 Pt 15 / IC RSS-Restricted Band
 Pk - Peak detector
 RMS - RMS detection

AUTHORIZED BANDEDGE (HIGH CHANNEL)

HORIZONTAL PEAK AND AVERAGE PLOT

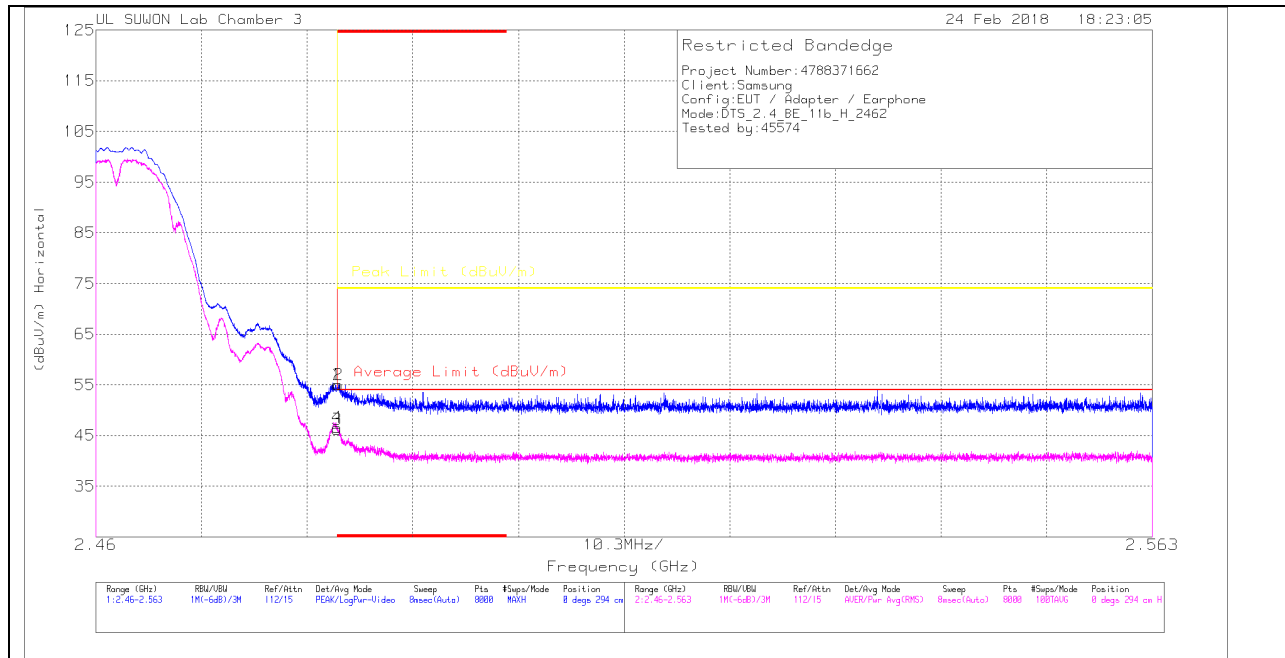

HORIZONTAL DATA

Trace Markers

Marker	Frequency (GHz)	Meter Reading (dBuV)	Det	3117(00205959)	10dB_ATT(dB)	DC Corr (dB)	Corrected Reading (dBuV/m)	Average Limit (dBuV/m)	Margin (dB)	Peak Limit (dBuV/m)	PK Margin (dB)	Azimuth (Degs)	Height (cm)	Polarity
1	* 2.484	45.93	PK	32.1	-23	0	55.03	-	-	74	-18.97	0	294	H
2	* 2.484	45.89	PK	32.1	-23	0	54.99	-	-	74	-19.01	0	294	H
3	* 2.484	37.07	RMS	32.1	-23	0	46.17	54	-7.83	-	-	0	294	H
4	* 2.484	37.49	RMS	32.1	-23	0	46.59	54	-7.41	-	-	0	294	H

* - indicates frequency in CFR47 Pt 15 / IC RSS-Restricted Band

PK - Peak detector

RMS - RMS detection

VERTICAL PEAK AND AVERAGE PLOT

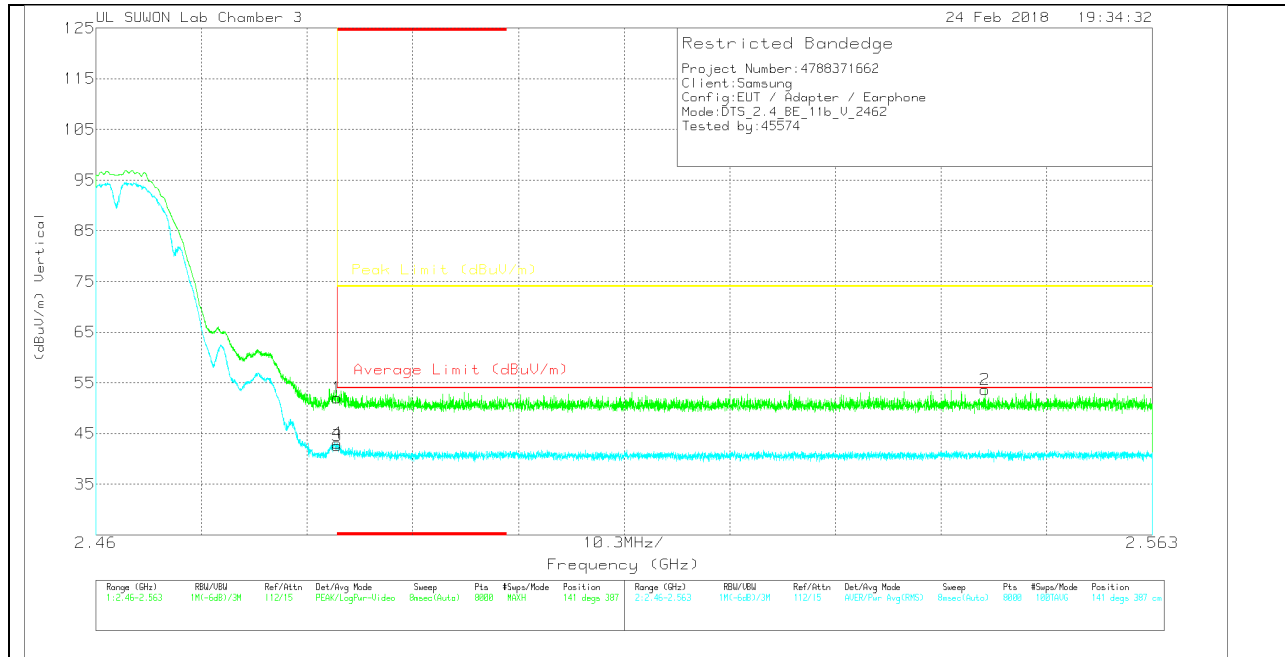

VERTICAL DATA

Trace Markers

Marker	Frequency (GHz)	Meter Reading (dBuV)	Det	3117(00205959)	10dB_ATT(dB)	DC Corr (dB)	Corrected Reading (dBuV/m)	Average Limit (dBuV/m)	Margin (dB)	Peak Limit (dBuV/m)	PK Margin (dB)	Azimuth (Degs)	Height (cm)	Polarity
1	* 2.484	42.95	Pk	32.1	-23	0	52.05	-	-	74	-21.95	141	387	V
2	2.547	44.57	Pk	32.1	-23	0	53.67	-	-	74	-20.33	141	387	V
3	* 2.484	33.48	RMS	32.1	-23	0	42.58	54	-11.42	-	-	141	387	V
4	* 2.484	33.96	RMS	32.1	-23	0	43.06	54	-10.94	-	-	141	387	V

* - indicates frequency in CFR47 Pt 15 / IC RSS-Restricted Band

Pk - Peak detector

RMS - RMS detection

HORIZONTAL PEAK AND AVERAGE PLOT

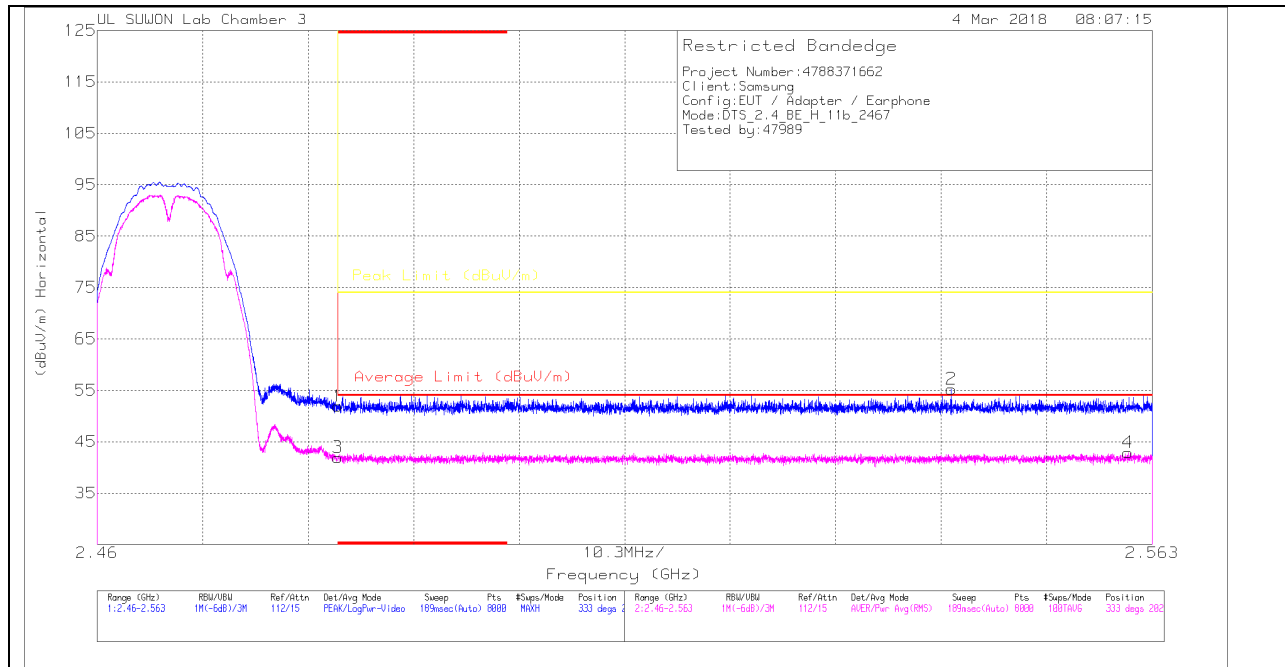

HORIZONTAL DATA

Trace Markers

Marker	Frequency (GHz)	Meter Reading (dBuV)	Det	311700205959	10dB_ATT(dB)	DC Corr (dB)	Corrected Reading (dBuV/m)	Average Limit (dBuV/m)	Margin (dB)	Peak Limit (dBuV/m)	PK Margin (dB)	Azimuth (Degs)	Height (cm)	Polarity
1	* 2.484	42.8	Pk	32.1	-23	0	51.9	-	-	74	-22.1	333	202	H
2	2.543	46.15	Pk	32.1	-23	0	55.25	-	-	-	-18.75	333	202	H
3	* 2.484	32.84	RMS	32.1	-23	0	41.94	54	-12.06	-	-	333	202	H
4	2.561	33.71	RMS	32.1	-22.9	0	42.91	54	-11.09	-	-	333	202	H

* - indicates frequency in CFR47 Pt 15 / IC RSS-Restricted Band

Pk - Peak detector

RMS - RMS detection

VERTICAL PEAK AND AVERAGE PLOT

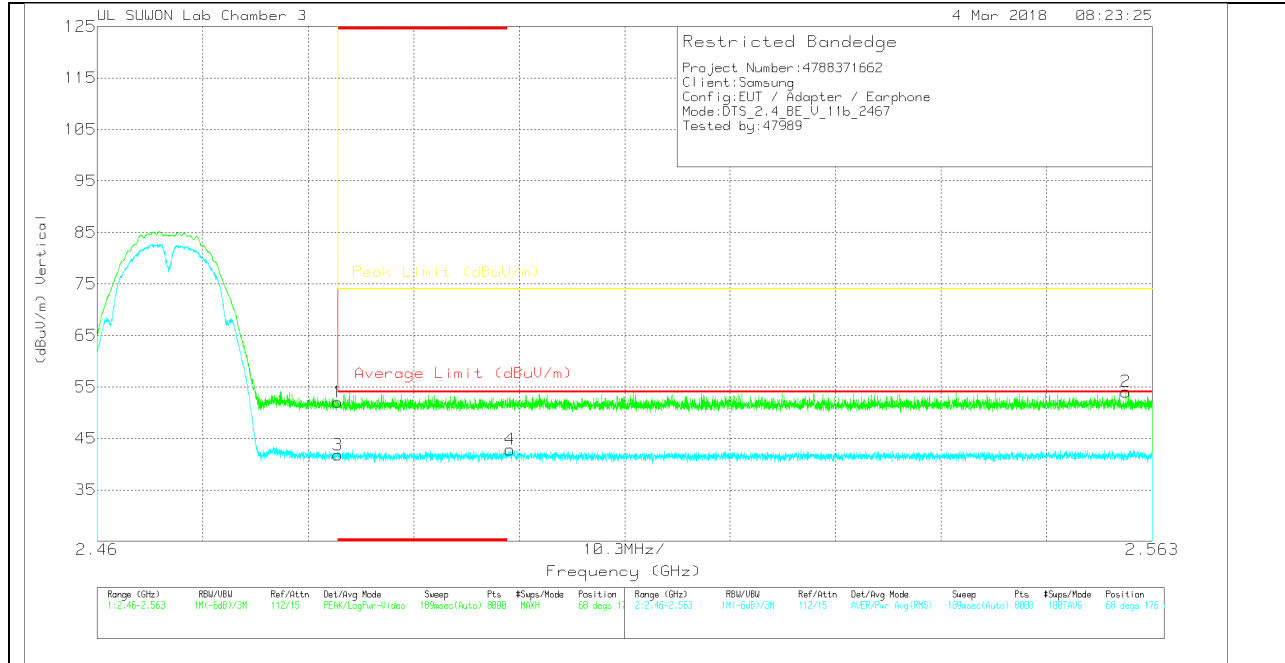

VERTICAL DATA

Trace Markers

Marker	Frequency (GHz)	Meter Reading (dBuV)	Det	3117(00205959)	10dB_ATT[dB]	DC Corr (dB)	Corrected Reading (dBuV/m)	Average Limit (dBuV/m)	Margin (dB)	Peak Limit (dBuV/m)	PK Margin (dB)	Azimuth (Degs)	Height (cm)	Polarity
1	* 2.484	42.93	Pk	32.1	-23	0	52.03	-	-	74	-21.97	68	176	V
2	2.56	44.97	Pk	32.1	-23	0	54.07	-	-	74	-19.93	68	176	V
3	* 2.484	32.65	RMS	32.1	-23	0	41.75	54	-12.25	-	-	68	176	V
4	2.5	33.62	RMS	32.1	-22.9	0	42.82	54	-11.18	-	-	68	176	V

* - indicates frequency in CFR47 Pt 15 / IC RSS-Restricted Band

Pk - Peak detector

RMS - RMS detection

HORIZONTAL PEAK AND AVERAGE PLOT

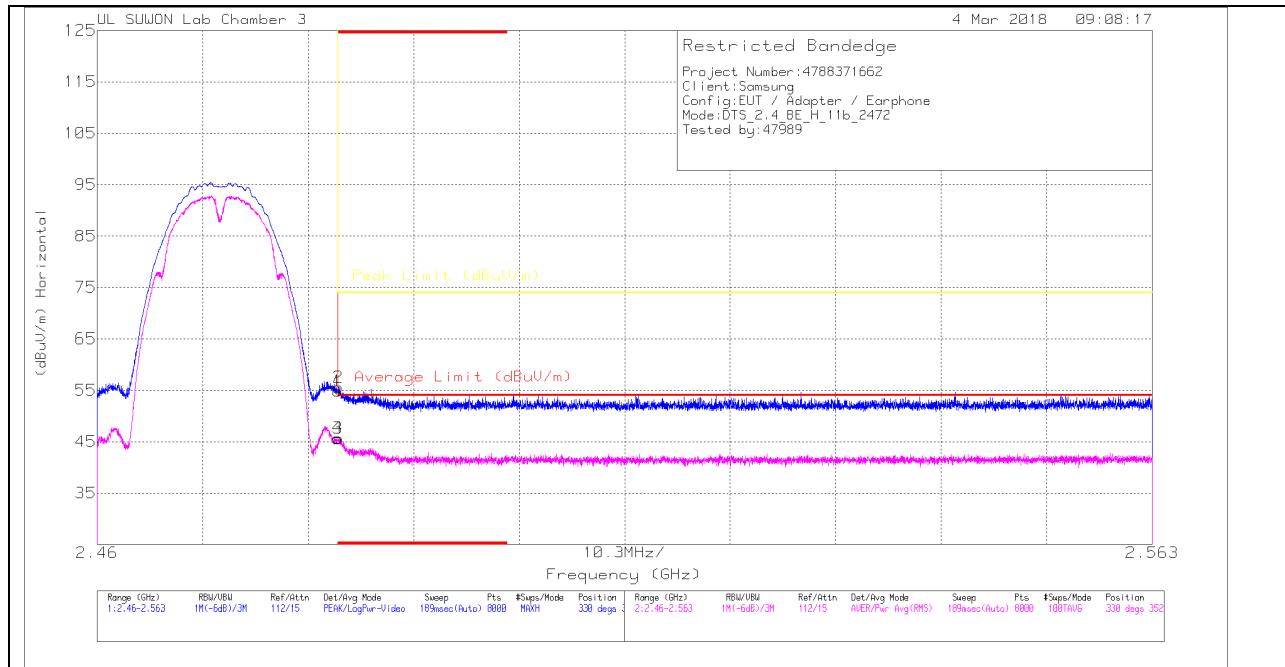

HORIZONTAL DATA

Trace Markers

Marker	Frequency (GHz)	Meter Reading (dBuV)	Det	311700205959	10dB_ATT(dB)	DC Corr (dB)	Corrected Reading (dBuV/m)	Average Limit (dBuV/m)	Margin (dB)	Peak Limit (dBuV/m)	PK Margin (dB)	Azimuth (Degs)	Height (cm)	Polarity
1	* 2.484	45.72	Pk	32.1	-23	0	54.82	-	-	74	-19.18	330	352	H
2	* 2.484	46.49	Pk	32.1	-23	0	55.59	-	-	74	-18.41	330	352	H
3	* 2.484	36.52	RMS	32.1	-23	0	45.62	54	-8.38	-	-	330	352	H
4	* 2.484	36.64	RMS	32.1	-23	0	45.74	54	-8.26	-	-	330	352	H

* - indicates frequency in CFR47 Pt 15 / IC RSS-Restricted Band

Pk - Peak detector

RMS - RMS detection

VERTICAL PEAK AND AVERAGE PLOT

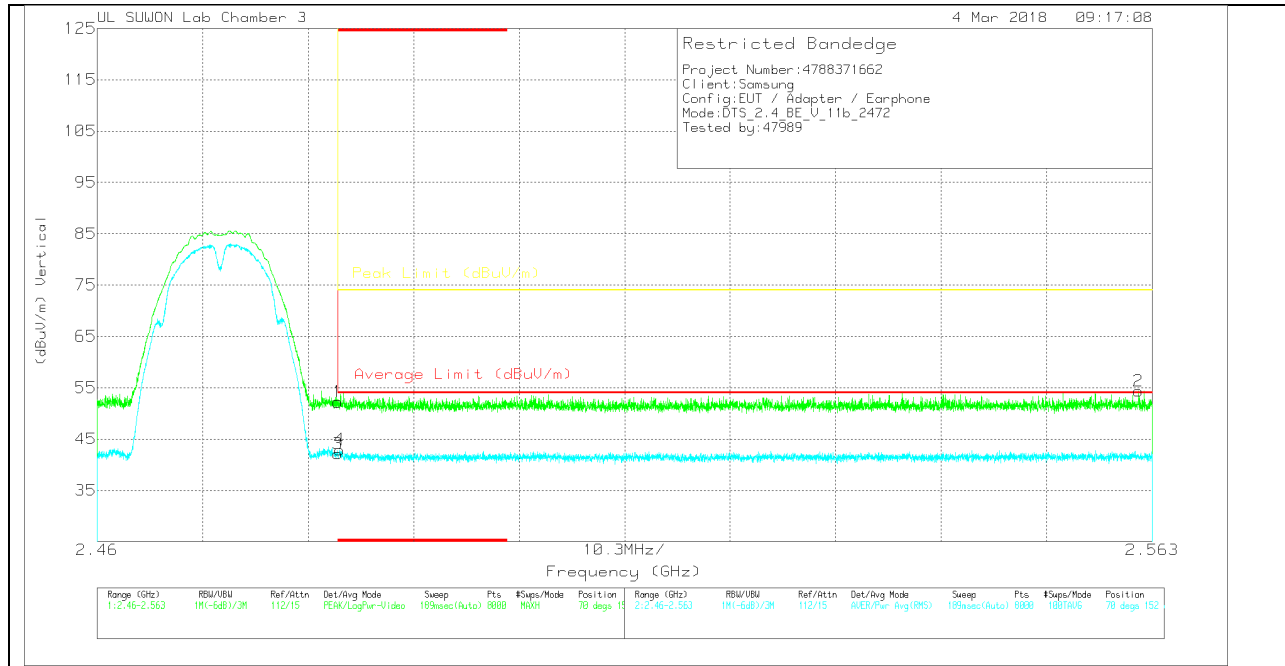

VERTICAL DATA

Trace Markers

Marker	Frequency (GHz)	Meter Reading (dBuV)	Det	3117(00205959)	10dB_ATT(dB)	DC Corr (dB)	Corrected Reading (dBuV/m)	Average Limit (dBuV/m)	Margin (dB)	Peak Limit (dBuV/m)	PK Margin (dB)	Azimuth (Degs)	Height (cm)	Polarity
1	* 2.484	43.13	PK	32.1	-23	0	52.23	-	-	74	-21.77	70	152	V
2	2.562	45.23	PK	32.1	-23	0	54.33	-	-	74	-19.67	70	152	V
3	* 2.484	33.05	RMS	32.1	-23	0	42.15	54	-11.85	-	-	70	152	V
4	* 2.484	33.82	RMS	32.1	-23	0	42.92	54	-11.08	-	-	70	152	V

* - indicates frequency in CFR47 Pt 15 / IC RSS-Restricted Band

PK - Peak detector

RMS - RMS detection

HARMONICS AND SPURIOUS EMISSIONS

LOW CHANNEL HORIZONTAL

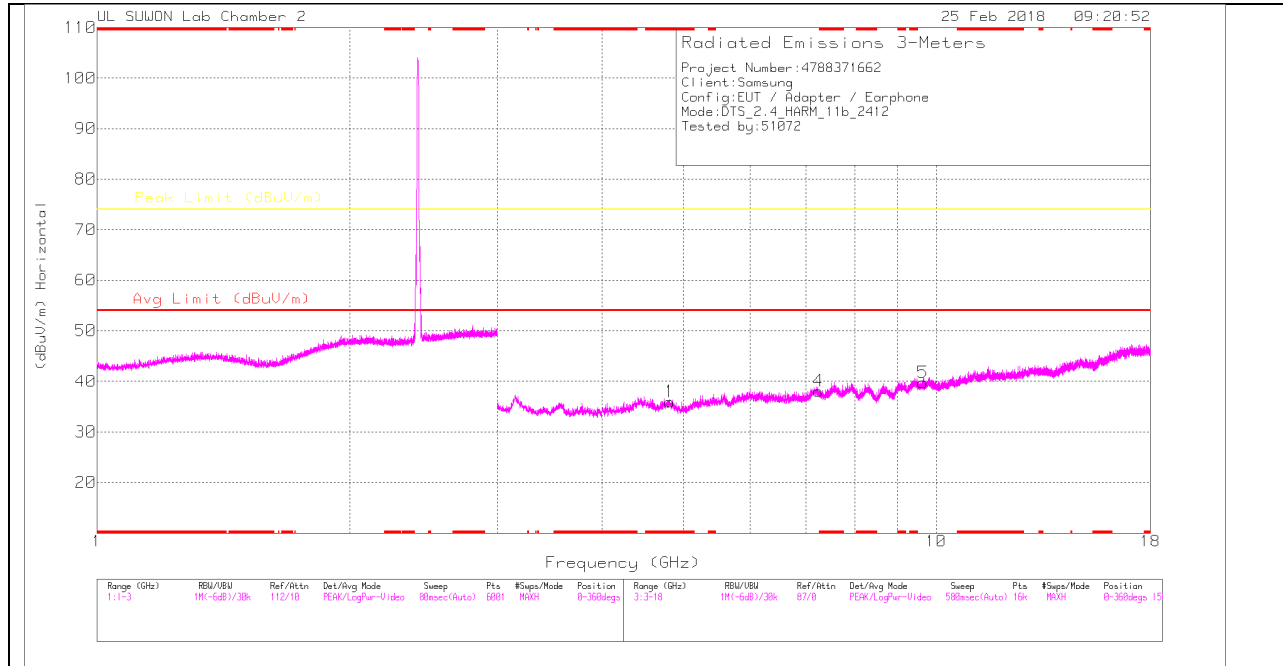

LOW CHANNEL VERTICAL

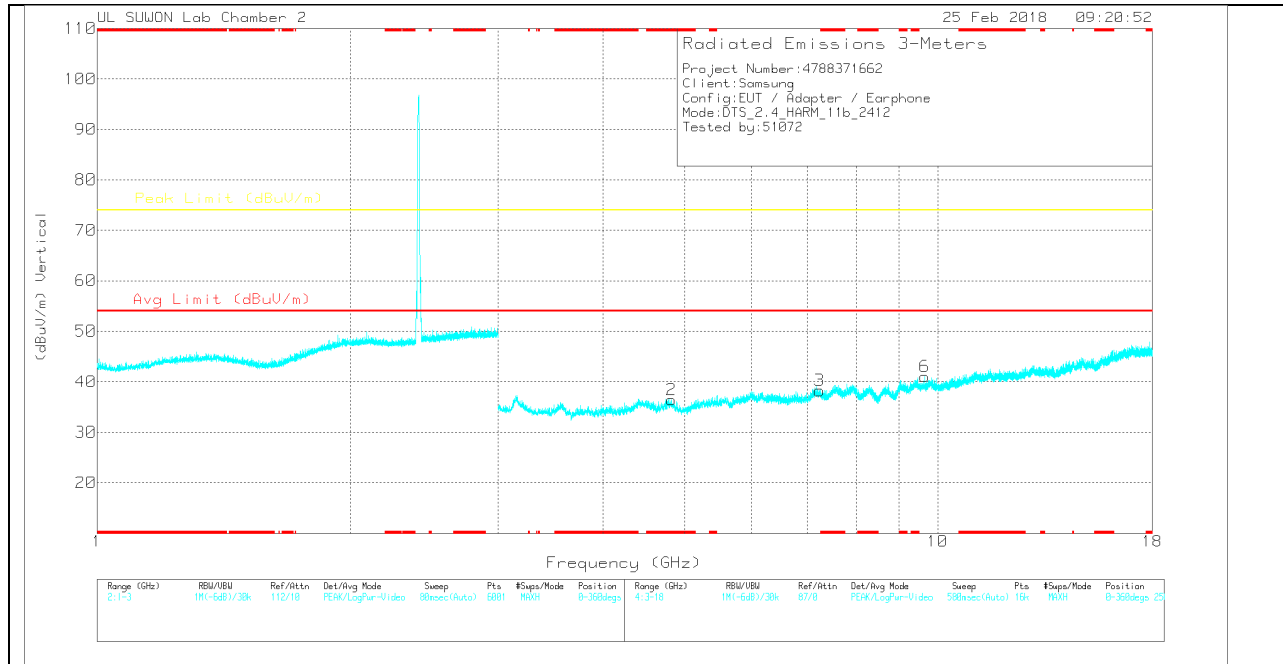

Note: Emission was scanned up to 26GHz; No emissions were detected above the noise floor which was at least 20dB below the specification limit.

LOW CHANNEL DATA

Trace Markers

Marker	Frequency (GHz)	Meter Reading (dBuV)	Det	170531_3117[00168724]	3GHz_HP[dB]	DC Corr (dB)	Corrected Reading (dBuV/m)	Avg Limit (dBuV/m)	Margin (dB)	Peak Limit (dBuV/m)	Margin (dB)	Azimuth (Degs)	Height (cm)	Polarity
1	* 4.816	26.49	PK	33.8	-24.3	0	35.99	-	-	74	-38.01	0-360	150	H
4	7.236	24.17	PK	35.9	-22	0	38.07	-	-	74	-35.93	0-360	250	H
5	9.643	21.28	PK	36.8	-18.3	0	39.78	-	-	74	-34.22	0-360	150	H
2	* 4.821	26.93	PK	33.8	-24.3	0	36.43	-	-	74	-37.57	0-360	150	V
3	7.233	24.26	PK	35.9	-21.9	0	38.26	-	-	74	-35.74	0-360	250	V
6	9.648	22.52	PK	36.8	-18.3	0	41.02	-	-	74	-32.98	0-360	150	V

* - indicates frequency in CFR47 Pt 15 / IC RSS-Restricted Band
 PK – Peak Detector

MID CHANNEL HORIZONTAL

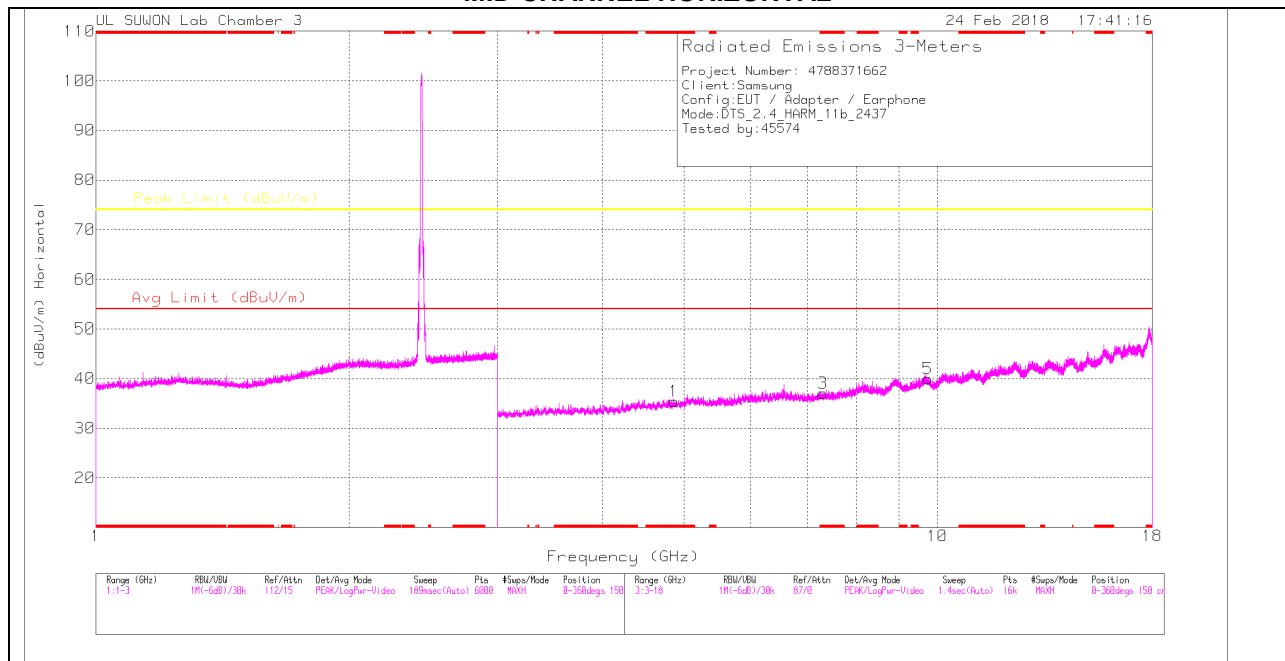

MID CHANNEL VERTICAL

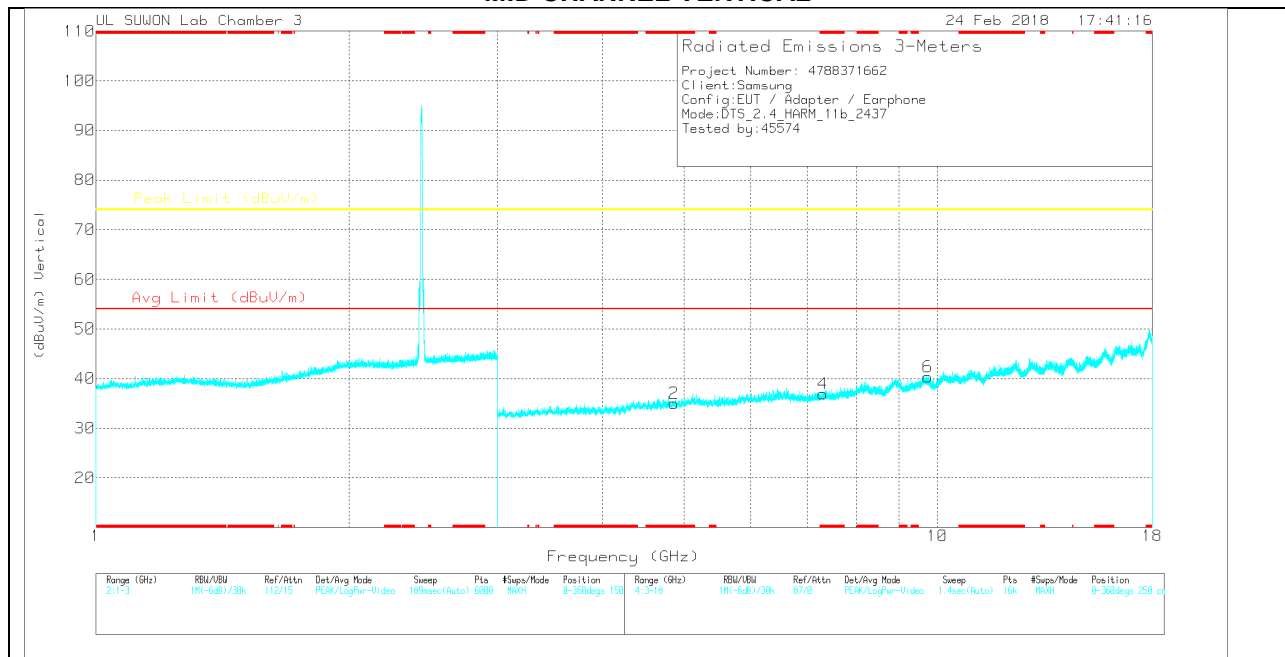

Note: Emission was scanned up to 26GHz; No emissions were detected above the noise floor which was at least 20dB below the specification limit.

MID CHANNEL DATA

Trace Markers

Marker	Frequency (GHz)	Meter Reading (dBuV)	Det	3117(00205959)	3GHz_HP(dB)	DC Corr (dB)	Corrected Reading (dBuV/m)	Avg Limit (dBuV/m)	Margin (dB)	Peak Limit (dBuV/m)	Margin (dB)	Azimuth (Degs)	Height (cm)	Polarity
1	* 4.866	30.14	PK	34	-28.8	0	35.34	-	-	74	-38.66	0-360	250	H
3	* 7.309	25.01	PK	35.6	-23.6	0	37.01	-	-	74	-36.99	0-360	150	H
5	9.744	22.56	PK	36.9	-19.5	0	39.96	-	-	74	-34.04	0-360	150	H
2	* 4.861	29.75	PK	34	-28.7	0	35.05	-	-	74	-38.95	0-360	150	V
4	* 7.313	24.85	PK	35.6	-23.5	0	36.95	-	-	74	-37.05	0-360	150	V
6	9.743	22.91	PK	36.9	-19.5	0	40.31	-	-	74	-33.69	0-360	150	V

* - indicates frequency in CFR47 Pt 15 / IC RSS-Restricted Band
 PK – Peak Detector

HIGH CHANNEL HORIZONTAL

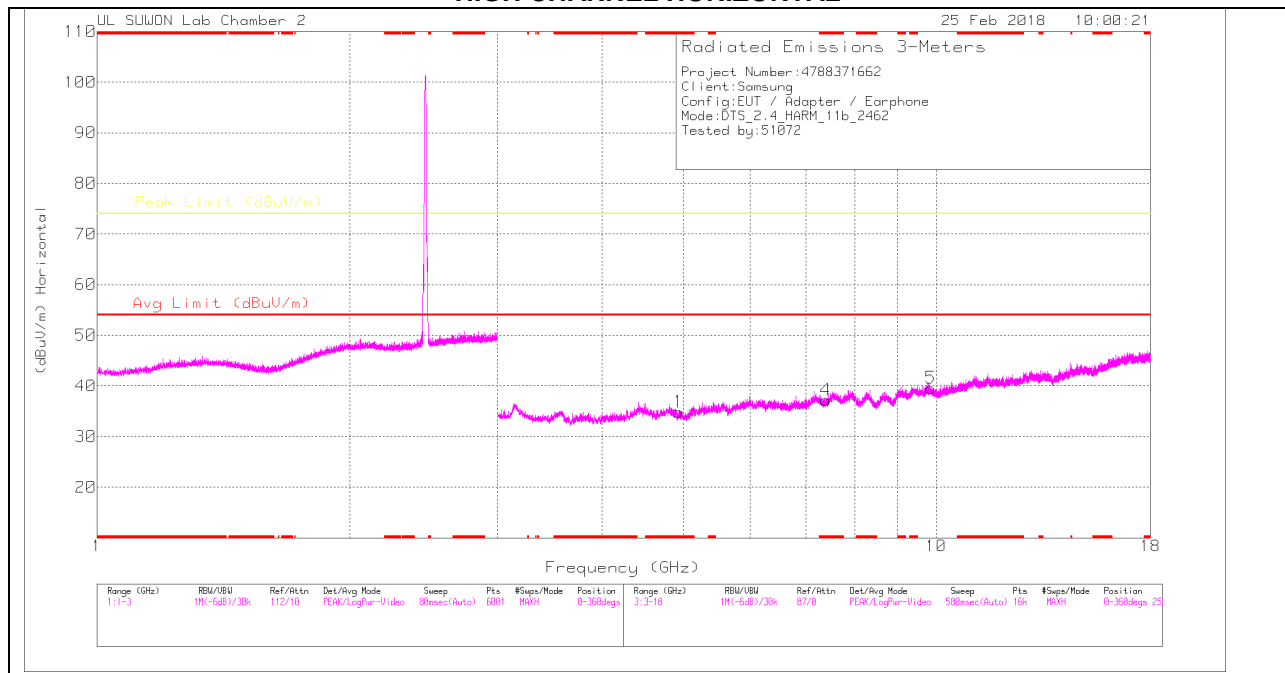

HIGH CHANNEL VERTICAL

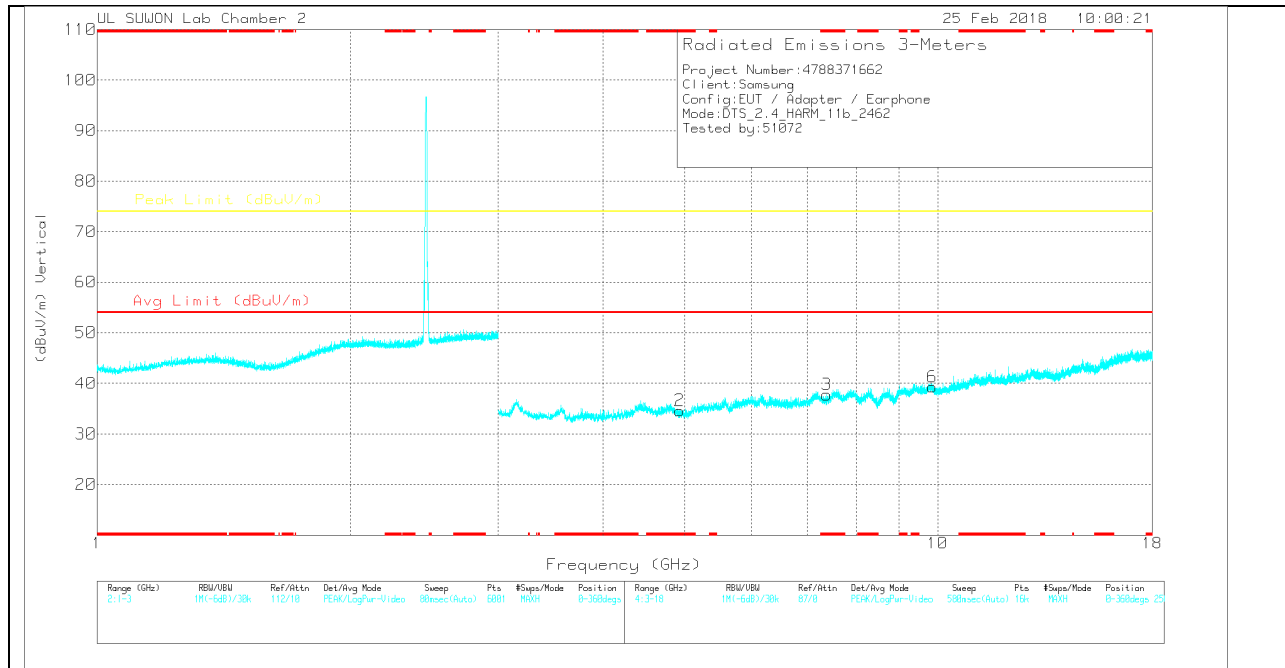

Note: Emission was scanned up to 26GHz; No emissions were detected above the noise floor which was at least 20dB below the specification limit.

HIGH CHANNEL DATA

Trace Markers

Marker	Frequency (GHz)	Meter Reading (dBuV)	Det	170531_3117[00168724]	3GHz_HP[dB]	DC Corr (dB)	Corrected Reading (dBuV/m)	Avg Limit (dBuV/m)	Margin (dB)	Peak Limit (dBuV/m)	Margin (dB)	Azimuth (Degs)	Height (cm)	Polarity
1	* 4.933	25.77	PK	33.8	-24.7	0	34.87	-	-	74	-39.13	0-360	150	H
4	* 7.386	22.71	PK	35.9	-21.4	0	37.21	-	-	74	-36.79	0-360	250	H
5	9.854	20.5	PK	37	-17.9	0	39.6	-	-	74	-34.4	0-360	250	H
2	* 4.93	25.51	PK	33.8	-24.7	0	34.61	-	-	74	-39.39	0-360	150	V
3	* 7.382	23.26	PK	35.9	-21.4	0	37.76	-	-	74	-36.24	0-360	150	V
6	9.853	20.21	PK	37	-17.9	0	39.31	-	-	74	-34.69	0-360	250	V

* - indicates frequency in CFR47 Pt 15 / IC RSS-Restricted Band
 PK – Peak Detector

11.2.2.TX ABOVE 1 GHz 802.11g MODE IN THE 2.4 GHz BAND

RESTRICTED BANDEDGE (LOW CHANNEL)

HORIZONTAL PEAK AND AVERAGE PLOT

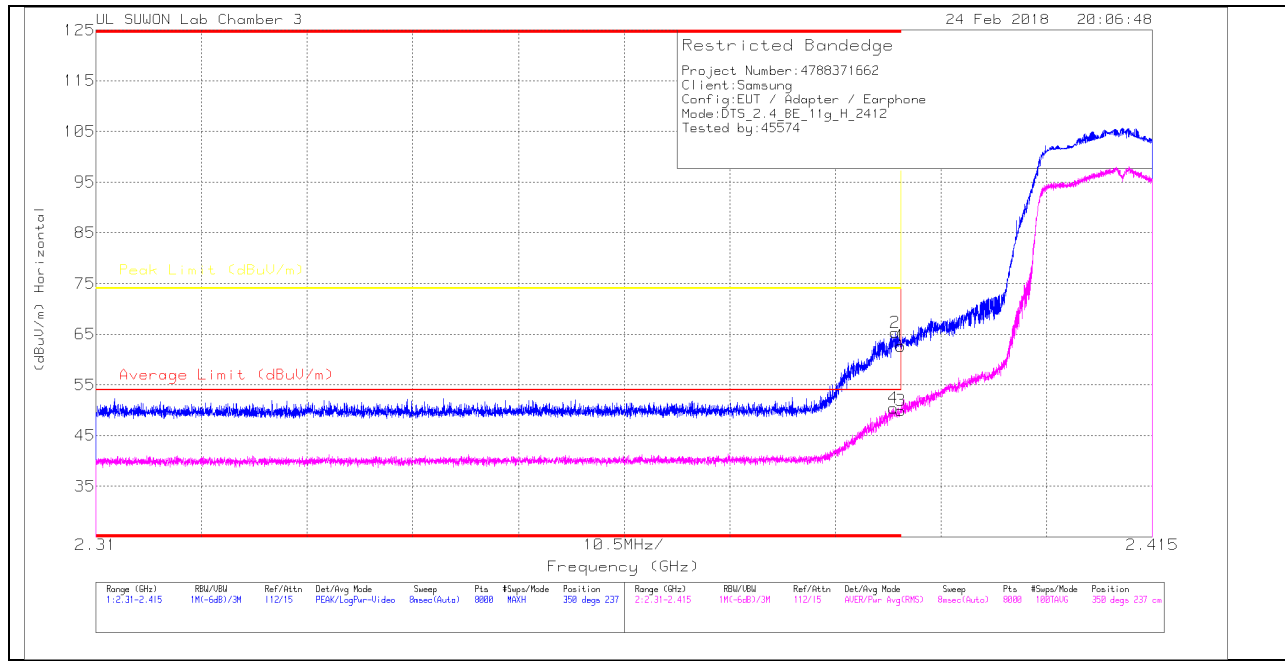

HORIZONTAL DATA

Trace Markers

Marker	Frequency (GHz)	Meter Reading (dBuV)	Det	3117(00205959)	10dB_ATT(dB)	DC Corr (dB)	Corrected Reading (dBuV/m)	Average Limit (dBuV/m)	Margin (dB)	Peak Limit (dBuV/m)	PK Margin (dB)	Asimuth (Degs)	Height (cm)	Polarity
1	* 2.39	54.15	Pk	31.8	-23.3	0	62.65	-	-	74	-11.35	350	237	H
2	* 2.389	56.85	Pk	31.8	-23.3	0	65.35	-	-	74	-8.65	350	237	H
3	* 2.39	41.27	RMS	31.8	-23.3	.14	49.91	54	-4.09	-	-	350	237	H
4	* 2.389	41.78	RMS	31.8	-23.3	.14	50.42	54	-3.58	-	-	350	237	H

* - indicates frequency in CFR47 Pt 15 / IC RSS-Restricted Band

Pk - Peak detector

RMS - RMS detection

VERTICAL PEAK AND AVERAGE PLOT

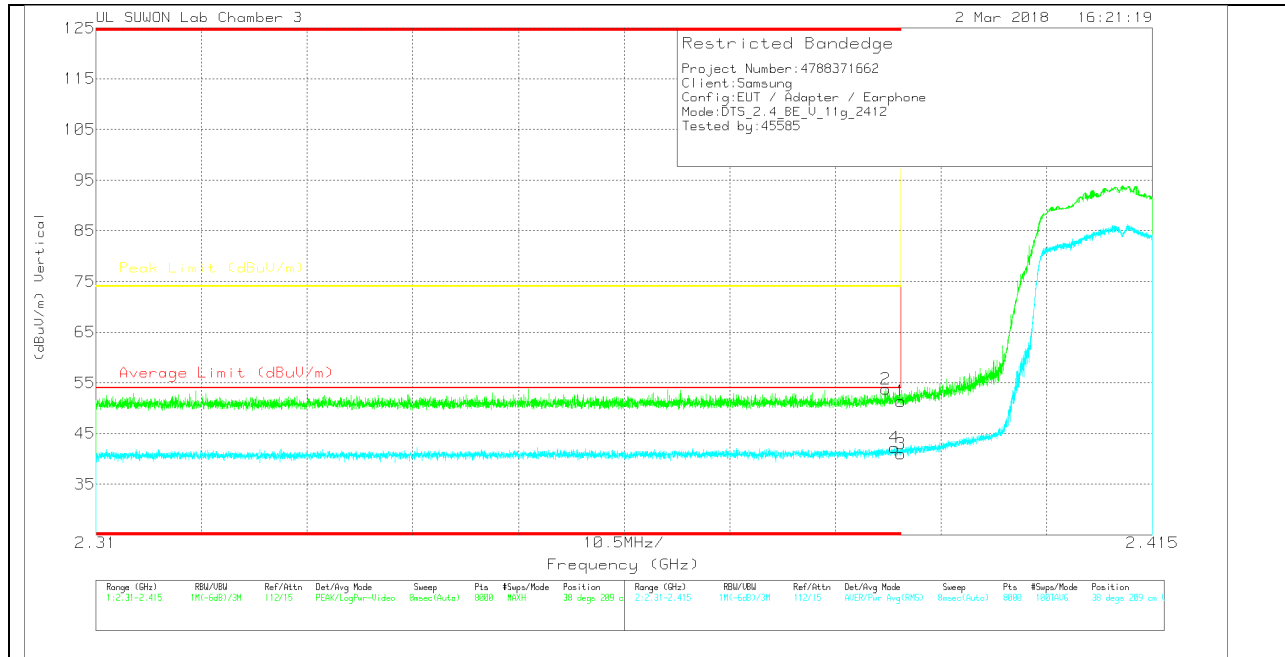

VERTICAL DATA

Trace Markers

Marker	Frequency (GHz)	Meter Reading (dBuV)	Det	3117(0020959)	10dB_ATT[dB]	DC Corr (dB)	Corrected Reading (dBuV/m)	Average Limit (dBuV/m)	Margin (dB)	Peak Limit (dBuV/m)	Pk Margin (dB)	Azimuth (Degs)	Height (cm)	Polarity
1	* 2.39	42.85	Pk	31.8	-23.3	0	51.35	-	-	74	-22.65	38	209	V
2	* 2.388	45.23	Pk	31.8	-23.3	0	53.73	-	-	74	-20.27	38	209	V
3	* 2.39	32.31	RMS	31.8	-23.3	.14	40.95	54	-13.05	-	-	38	209	V
4	* 2.389	33.6	RMS	31.8	-23.3	.14	42.24	54	-11.76	-	-	38	209	V

* - indicates frequency in CFR47 Pt 15 / IC RSS-Restricted Band

Pk - Peak detector

RMS - RMS detection

AUTHORIZED BANDEDGE (HIGH CHANNEL)

HORIZONTAL PEAK AND AVERAGE PLOT

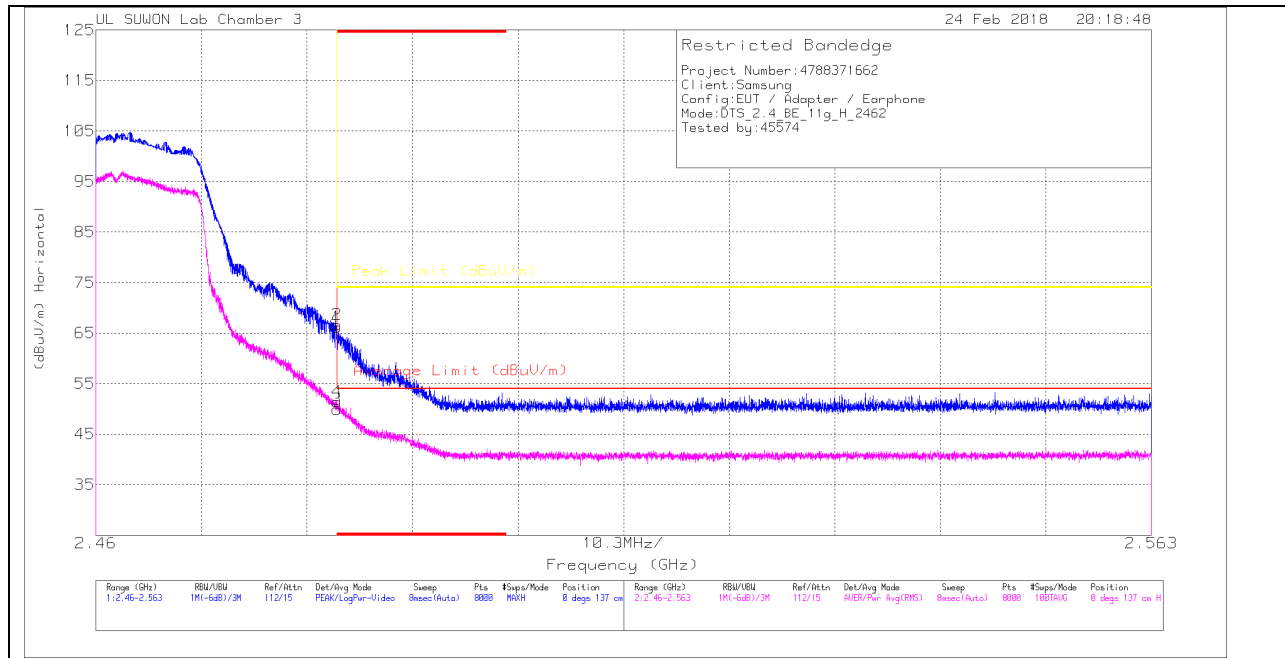

HORIZONTAL DATA

Trace Markers

Marker	Frequency (GHz)	Meter Reading (dBuV)	Det	3117(00205959)	10dB_ATT(dB)	DC Corr (dB)	Corrected Reading (dBuV/m)	Average Limit (dBuV/m)	Margin (dB)	Peak Limit (dBuV/m)	PK Margin (dB)	Azimuth (Degs)	Height (cm)	Polarity
1	* 2.484	57.04	Pk	32.1	-23	0	66.14	-	-	74	-7.86	0	137	H
2	* 2.484	57.54	Pk	32.1	-23	0	66.64	-	-	74	-7.36	0	137	H
3	* 2.484	40.7	RMS	32.1	-23	.14	49.94	54	-4.06	-	-	0	137	H
4	* 2.484	42.22	RMS	32.1	-23	.14	51.46	54	-2.54	-	-	0	137	H

* - indicates frequency in CFR47 Pt 15 / IC RSS-Restricted Band

Pk - Peak detector

RMS - RMS detection

VERTICAL PEAK AND AVERAGE PLOT

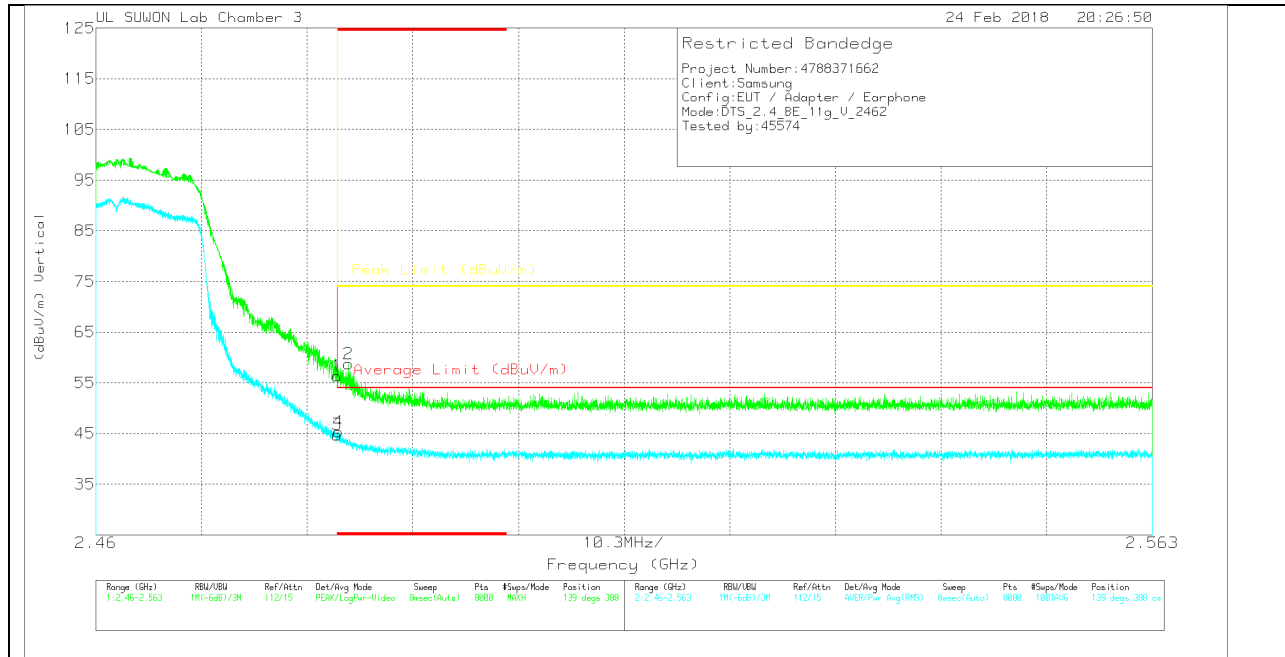

VERTICAL DATA

Trace Markers

Marker	Frequency (GHz)	Meter Reading (dBuV)	Det	311700020959	10dB_ATT[dB]	DC Corr (dB)	Corrected Reading (dBuV/m)	Average Limit (dBuV/m)	Margin (dB)	Peak Limit (dBuV/m)	PK Margin (dB)	Asmuth (Degs)	Height (cm)	Polarity
1	* 2.484	47.29	Pk	32.1	-23	0	56.39	-	-	74	-17.61	139	388	V
2	* 2.485	49.73	Pk	32.1	-23.1	0	58.73	-	-	74	-15.27	139	388	V
3	* 2.484	35.53	RMS	32.1	-23	.14	44.77	54	-9.23	-	-	139	388	V
4	* 2.484	36.04	RMS	32.1	-23	.14	45.28	54	-8.72	-	-	139	388	V

* - indicates frequency in CFR47 Pt 15 / IC RSS-Restricted Band

Pk - Peak detector

RMS - RMS detection

HORIZONTAL PEAK AND AVERAGE PLOT

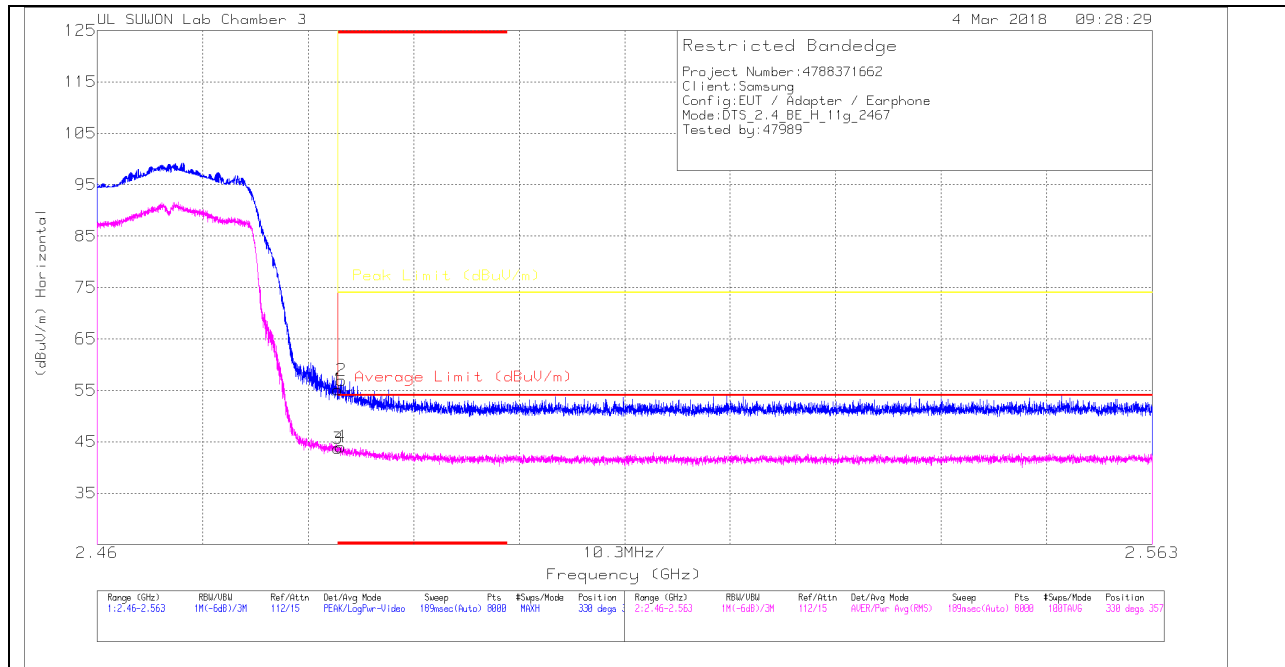

HORIZONTAL DATA

Trace Markers

Marker	Frequency (GHz)	Meter Reading (dBuV)	Det	311700205959	10dB_ATT(dB)	DC Corr (dB)	Corrected Reading (dBuV/m)	Average Limit (dBuV/m)	Margin (dB)	Peak Limit (dBuV/m)	PK Margin (dB)	Azimuth (Degs)	Height (cm)	Polarity
1	* 2.484	46.03	Pk	32.1	-23	0	55.13	-	-	74	-18.87	330	357	H
2	* 2.484	47.96	Pk	32.1	-23.1	0	56.96	-	-	74	-17.04	330	357	H
3	* 2.484	34.48	RMS	32.1	-23	.14	43.72	54	-10.28	-	-	330	357	H
4	* 2.484	34.88	RMS	32.1	-23.1	.14	44.02	54	-9.98	-	-	330	357	H

* - indicates frequency in CFR47 Pt 15 / IC RSS-Restricted Band

Pk - Peak detector

RMS - RMS detection

VERTICAL PEAK AND AVERAGE PLOT

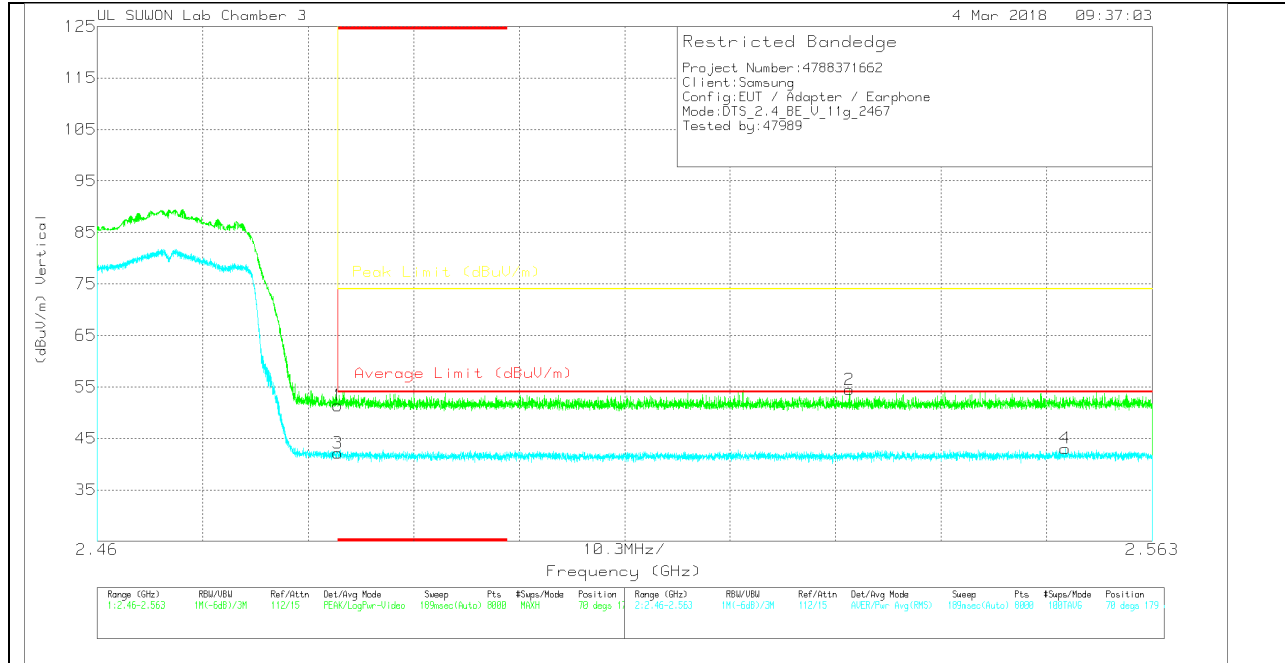

VERTICAL DATA

Trace Markers

Marker	Frequency (GHz)	Meter Reading (dBuV)	Det	3117(00205959)	10dB_ATT[dB]	DC Corr (dB)	Corrected Reading (dBuV/m)	Average Limit (dBuV/m)	Margin (dB)	Peak Limit (dBuV/m)	PK Margin (dB)	Azimuth (Degs)	Height (cm)	Polarity
1	* 2.484	42.29	Pk	32.1	-23	0	51.39	-	-	74	-22.61	70	179	V
2	2.533	45.38	Pk	32.1	-23	0	54.48	-	-	74	-19.52	70	179	V
3	* 2.484	32.9	RMS	32.1	-23	.14	42.14	54	-11.86	-	-	70	179	V
4	2.555	33.81	RMS	32.1	-23	.14	43.05	54	-10.95	-	-	70	179	V

* - indicates frequency in CFR47 Pt 15 / IC RSS-Restricted Band

Pk - Peak detector

RMS - RMS detection

HORIZONTAL PEAK AND AVERAGE PLOT

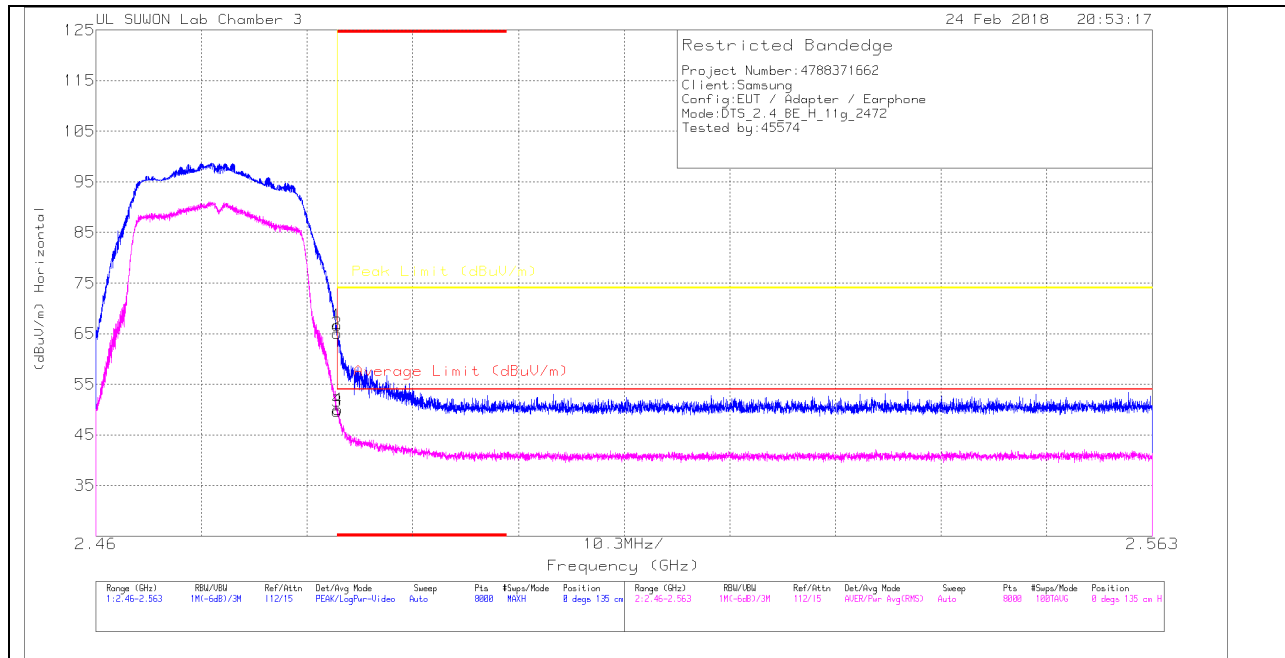

HORIZONTAL DATA

Trace Markers

Marker	Frequency (GHz)	Meter Reading (dBuV)	Det	3117(00205959)	10dB_ATT(dB)	DC Corr (dB)	Corrected Reading (dBuV/m)	Average Limit (dBuV/m)	Margin (dB)	Peak Limit (dBuV/m)	PK Margin (dB)	Azimuth (Degs)	Height (cm)	Polarity
1	* 2.484	57.61	PK	32.1	-23	0	66.71	-	-	74	-7.29	0	135	H
2	* 2.484	55.95	PK	32.1	-23	0	65.05	-	-	74	-8.95	0	135	H
3	* 2.484	40.43	RMS	32.1	-23	.14	49.67	54	-4.33	-	-	0	135	H
4	* 2.484	40.75	RMS	32.1	-23	.14	49.99	54	-4.01	-	-	0	135	H

* - indicates frequency in CFR47 Pt 15 / IC RSS-Restricted Band

PK - Peak detector

RMS - RMS detection

VERTICAL PEAK AND AVERAGE PLOT

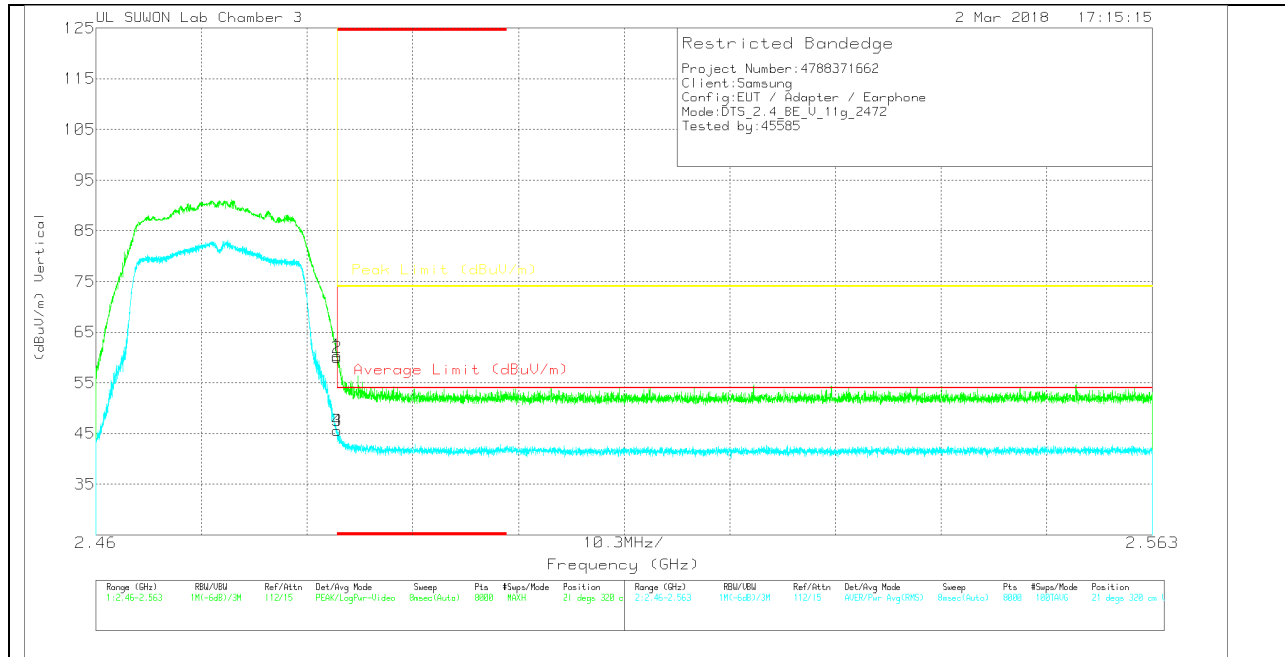

VERTICAL DATA

Trace Markers

Marker	Frequency (GHz)	Meter Reading (dBuV)	Det	3117(00205959)	10dB_ATT[dB]	DC Corr (dB)	Corrected Reading (dBuV/m)	Average Limit (dBuV/m)	Margin (dB)	Peak Limit (dBuV/m)	PK Margin (dB)	Azimuth (Degs)	Height (cm)	Polarity
1	* 2.484	51.31	Pk	32.1	-23	0	60.41	-	-	74	-13.59	21	320	V
2	* 2.484	50.92	Pk	32.1	-23	0	60.02	-	-	74	-13.98	21	320	V
3	* 2.484	36.39	RMS	32.1	-23	.14	45.63	54	-8.37	-	-	21	320	V
4	* 2.484	36.37	RMS	32.1	-23	.14	45.61	54	-8.39	-	-	21	320	V

* - indicates frequency in CFR47 Pt 15 / IC RSS-Restricted Band

Pk - Peak detector

RMS - RMS detection

HARMONICS AND SPURIOUS EMISSIONS

LOW CHANNEL HORIZONTAL

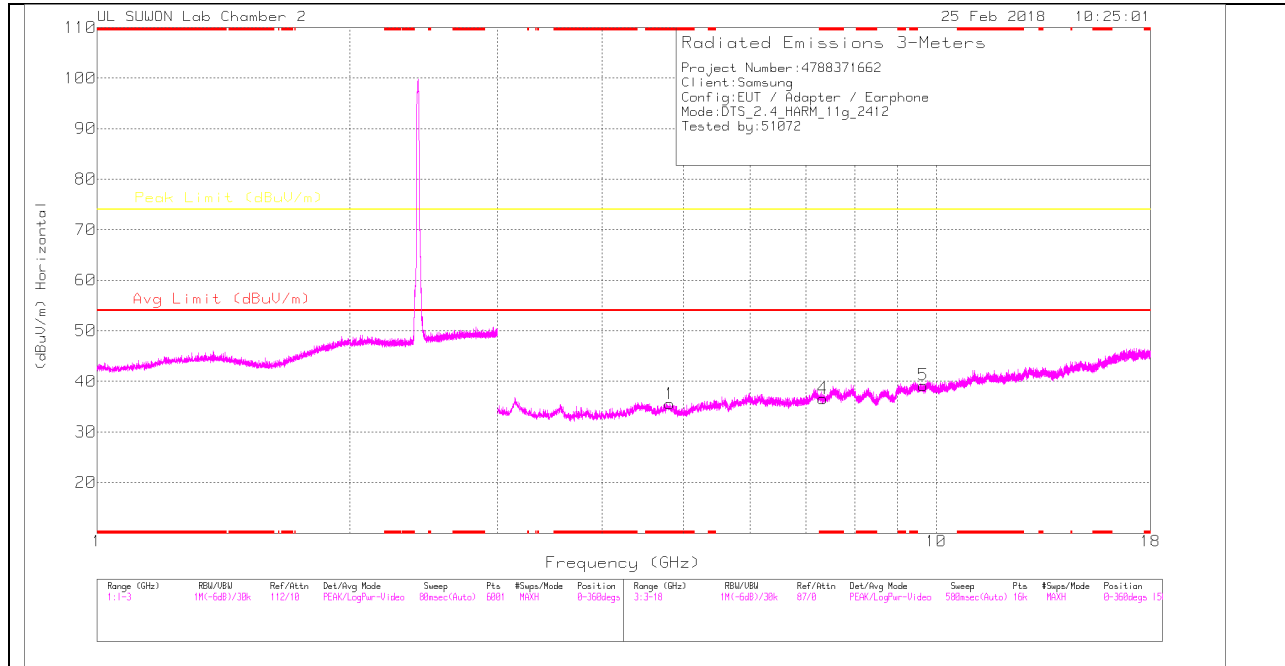

LOW CHANNEL VERTICAL

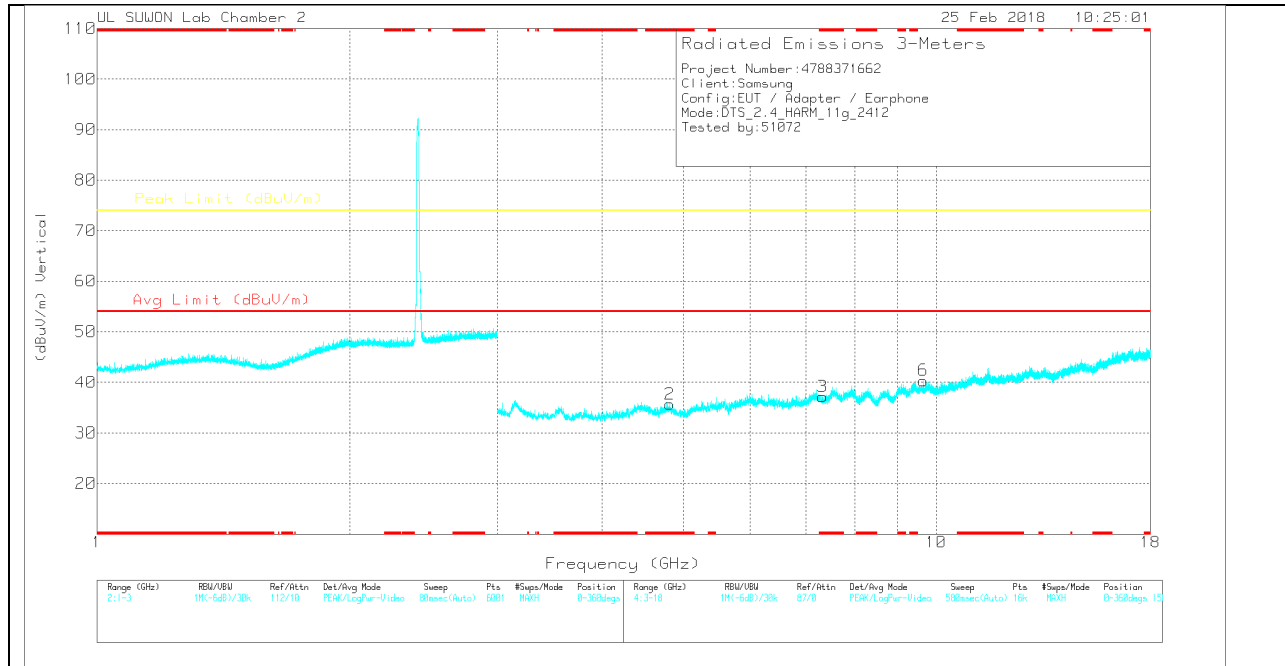

Note: Emission was scanned up to 26GHz; No emissions were detected above the noise floor which was at least 20dB below the specification limit.

LOW CHANNEL DATA

Trace Markers

Marker	Frequency (GHz)	Meter Reading (dBuV)	Det	170531_3117[00168724]	3GHz_HP[dB]	DC Corr (dB)	Corrected Reading (dBuV/m)	Avg Limit (dBuV/m)	Margin (dB)	Peak Limit (dBuV/m)	Margin (dB)	Azimuth (Degs)	Height (cm)	Polarity
1	* 4.817	26.07	PK	33.8	-24.3	0	35.57	-	-	74	-38.43	0-360	150	H
4	* 7.323	22.58	PK	35.9	-21.9	0	36.58	-	-	74	-37.42	0-360	250	H
5	9.648	20.73	PK	36.8	-18.3	0	39.23	-	-	74	-34.77	0-360	150	H
2	* 4.816	26.17	PK	33.8	-24.3	0	35.67	-	-	74	-38.33	0-360	250	V
3	* 7.321	23.25	PK	35.9	-22	0	37.15	-	-	74	-36.85	0-360	250	V
6	9.648	21.85	PK	36.8	-18.3	0	40.35	-	-	74	-33.65	0-360	150	V

* - indicates frequency in CFR47 Pt 15 / IC RSS-Restricted Band
 PK – Peak Detector

Note: Only peak measurement was performed. Because peak measurement result of unwanted emission is less than average limit (54dBuV/m).

MID CHANNEL HORIZONTAL

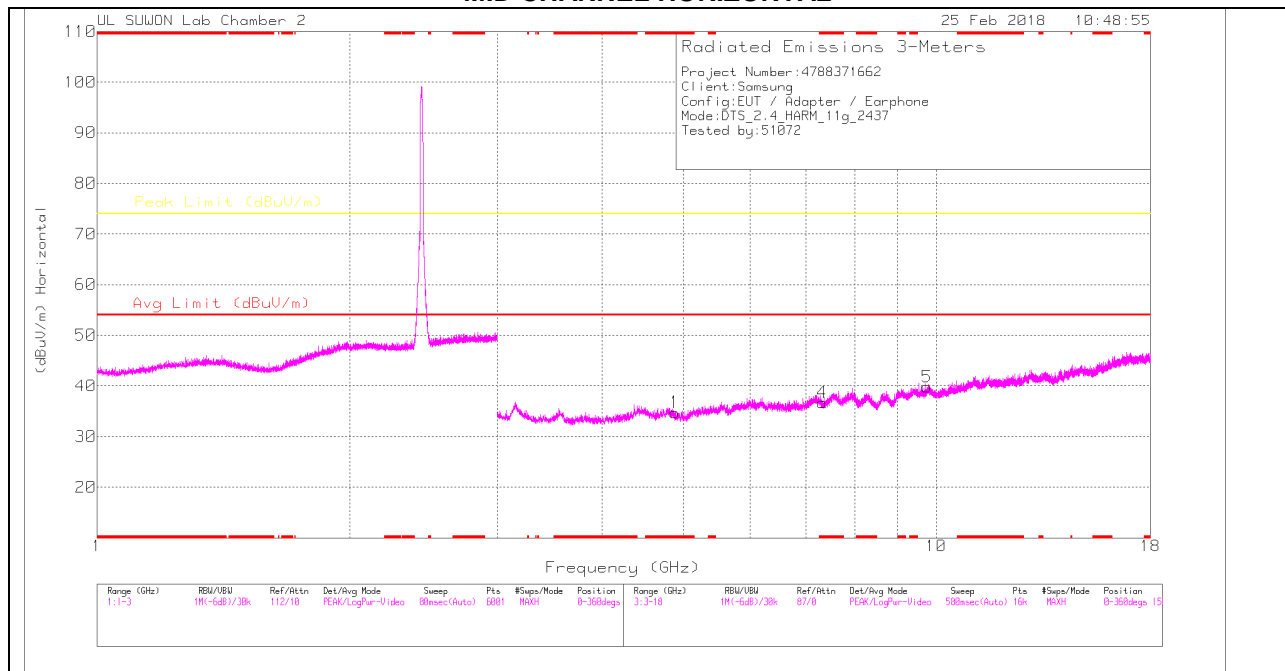

MID CHANNEL VERTICAL

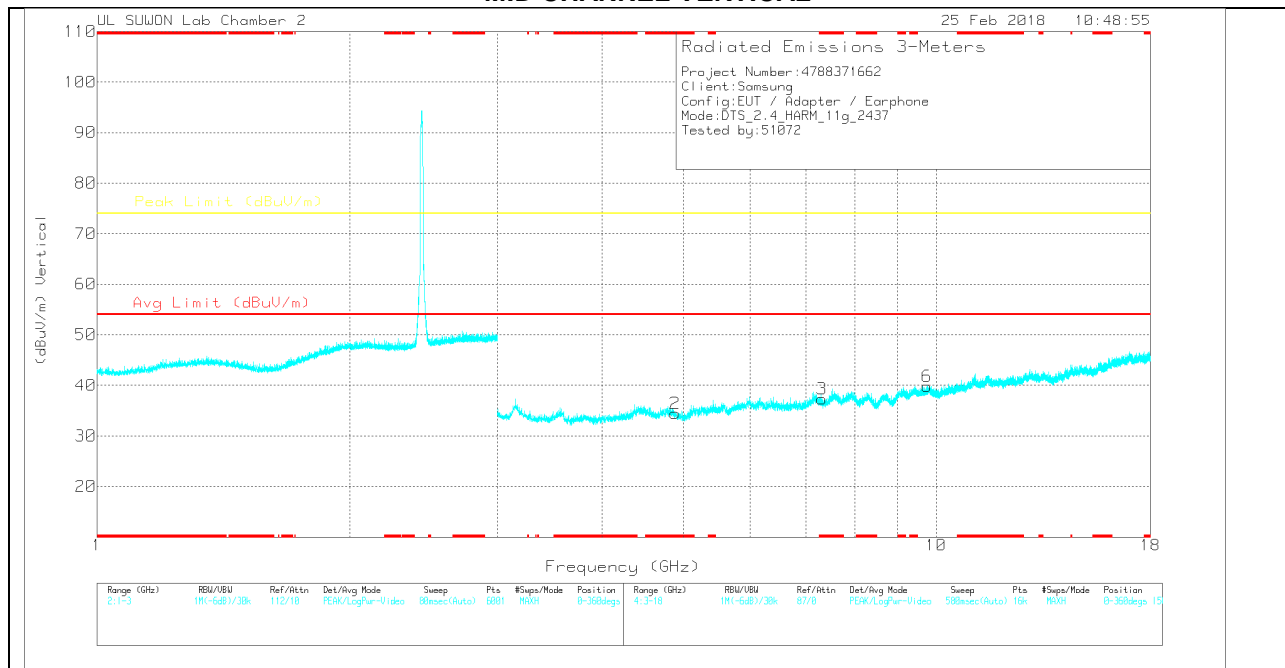

Note: Emission was scanned up to 26GHz; No emissions were detected above the noise floor which was at least 20dB below the specification limit.

MID CHANNEL DATA

Trace Markers

Marker	Frequency (GHz)	Meter Reading (dBuV)	Det	170531_3117[00168724]	3GHz_HP[dB]	DC Corr (dB)	Corrected Reading (dBuV/m)	Avg Limit (dBuV/m)	Margin (dB)	Peak Limit (dBuV/m)	Margin (dB)	Azimuth (Degs)	Height (cm)	Polarity
1	* 4.883	25.53	PK	33.8	-24.6	0	34.73	-	-	74	-39.27	0-360	150	H
4	* 7.311	22.81	PK	35.9	-22	0	36.71	-	-	74	-37.29	0-360	150	H
5	9.751	21	PK	36.9	-18.1	0	39.8	-	-	74	-34.2	0-360	150	H
2	* 4.885	25.24	PK	33.8	-24.6	0	34.44	-	-	74	-39.56	0-360	250	V
3	* 7.309	23.39	PK	35.9	-22	0	37.29	-	-	74	-36.71	0-360	150	V
6	9.748	20.99	PK	36.9	-18.1	0	39.79	-	-	74	-34.21	0-360	150	V

* - indicates frequency in CFR47 Pt 15 / IC RSS-Restricted Band
 PK – Peak Detector

Note: Only peak measurement was performed. Because peak measurement result of unwanted emission is less than average limit (54dBuV/m).

HIGH CHANNEL HORIZONTAL

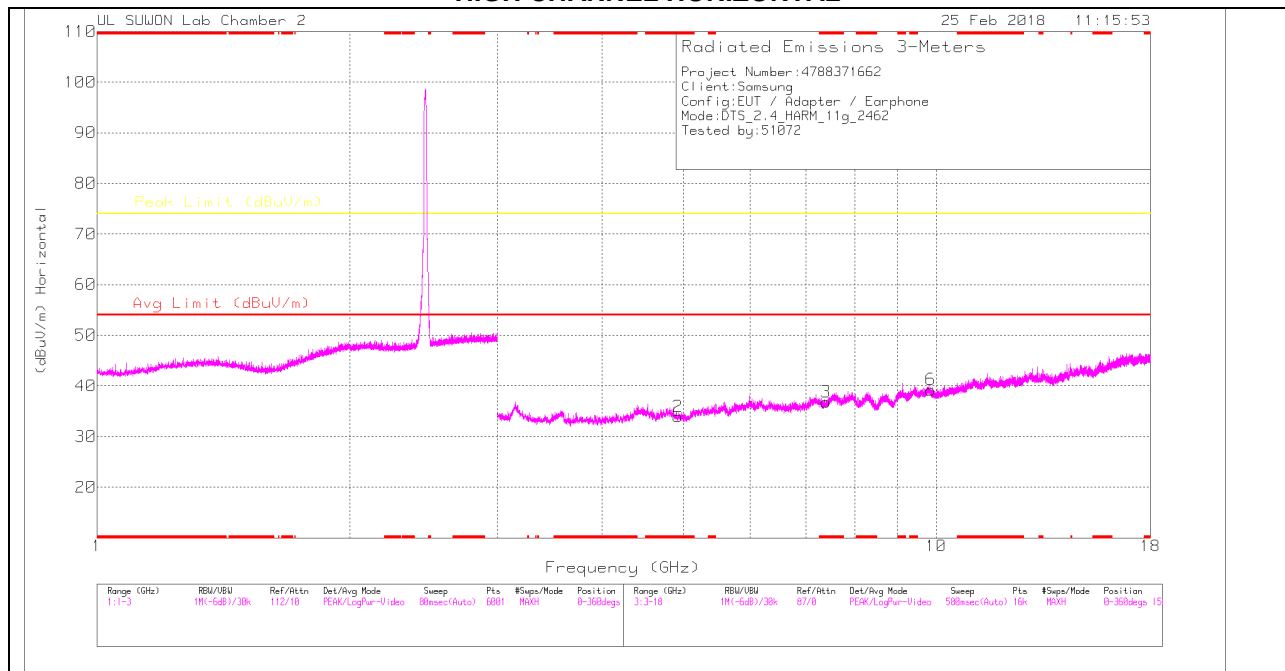

HIGH CHANNEL VERTICAL

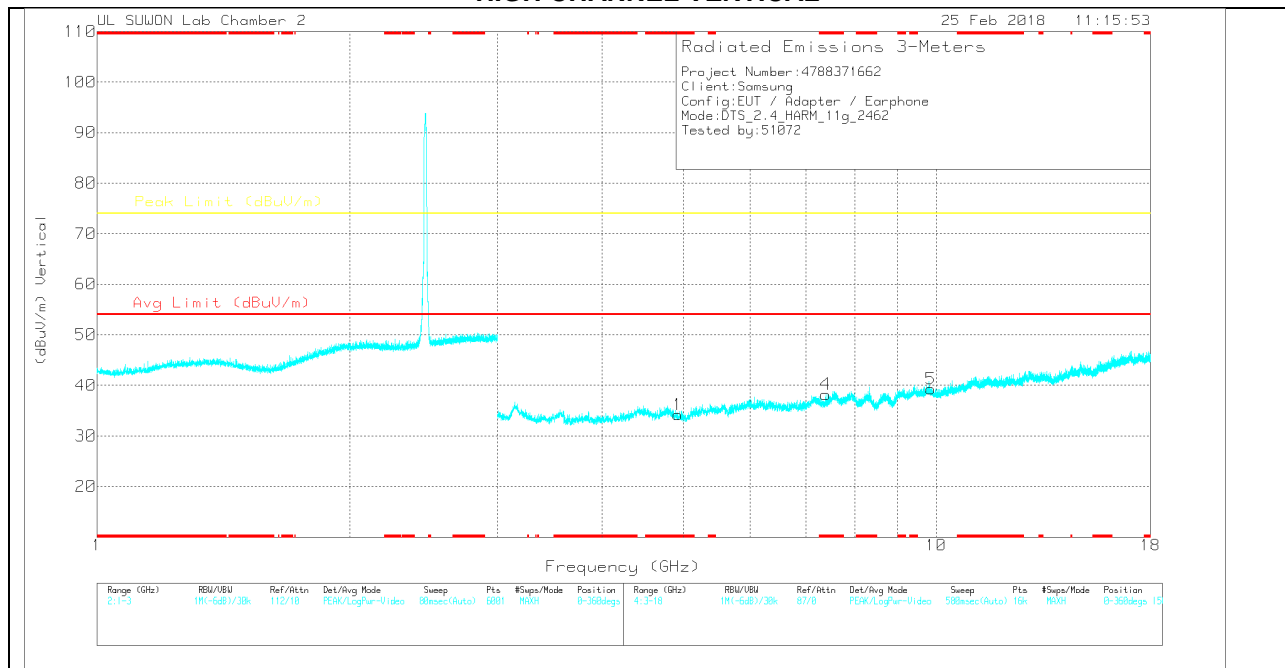

Note: Emission was scanned up to 26GHz; No emissions were detected above the noise floor which was at least 20dB below the specification limit.

HIGH CHANNEL DATA

Trace Markers

Marker	Frequency (GHz)	Meter Reading (dBuV)	Det	170531_3117[00168724]	3GHz_HP[dB]	DC Corr (dB)	Corrected Reading (dBuV/m)	Avg Limit (dBuV/m)	Margin (dB)	Peak Limit (dBuV/m)	Margin (dB)	Azimuth (Degs)	Height (cm)	Polarity
2	* 4.926	24.83	PK	33.8	-24.7	0	33.93	-	-	74	-40.07	0-360	250	H
3	* 7.387	22.28	PK	35.9	-21.4	0	36.78	-	-	74	-37.22	0-360	250	H
6	9.853	20.14	PK	37	-17.9	0	39.24	-	-	74	-34.76	0-360	150	H
1	* 4.925	25.1	PK	33.8	-24.7	0	34.2	-	-	74	-39.8	0-360	150	V
4	* 7.385	23.72	PK	35.9	-21.4	0	38.22	-	-	74	-35.78	0-360	250	V
5	9.848	20.17	PK	37	-17.9	0	39.27	-	-	74	-34.73	0-360	150	V

* - indicates frequency in CFR47 Pt 15 / IC RSS-Restricted Band
 PK – Peak Detector

Note: Only peak measurement was performed. Because peak measurement result of unwanted emission is less than average limit (54dBuV/m).

11.2.3.TX ABOVE 1 GHz 802.11n HT20 MODE IN THE 2.4 GHz BAND

RESTRICTED BANDEDGE (LOW CHANNEL)

HORIZONTAL PEAK AND AVERAGE PLOT

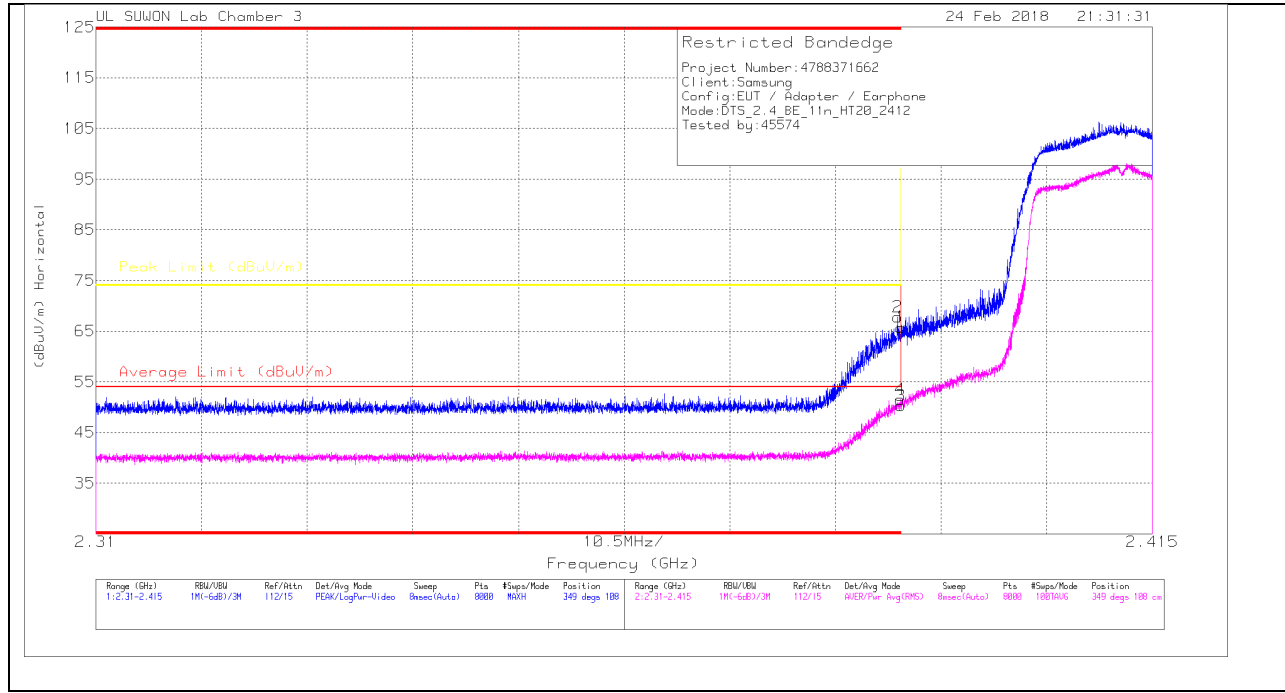

HORIZONTAL DATA

Trace Markers

Marker	Frequency (GHz)	Meter Reading (dBuV)	Det	3117(00205559)	10dB_ATT(dB)	DC Corr (dB)	Corrected Reading (dBuV/m)	Average Limit (dBuV/m)	Margin (dB)	Peak Limit (dBuV/m)	PK Margin (dB)	Azimuth (Degs)	Height (cm)	Polarity
1	* 2.39	57.25	PK	31.8	-23.3	0	65.75	-	-	74	-8.25	349	108	H
2	* 2.39	59.3	PK	31.8	-23.3	0	67.8	-	-	74	-6.2	349	108	H
3	* 2.39	41.69	RMS	31.8	-23.3	.15	50.34	54	-3.66	-	-	349	108	H
4	* 2.39	42.85	RMS	31.8	-23.3	.15	51.5	54	-2.5	-	-	349	108	H

* - indicates frequency in CFR47 Pt 15 / IC RSS-Restricted Band

PK - Peak detector

RMS - RMS detection

VERTICAL PEAK AND AVERAGE PLOT

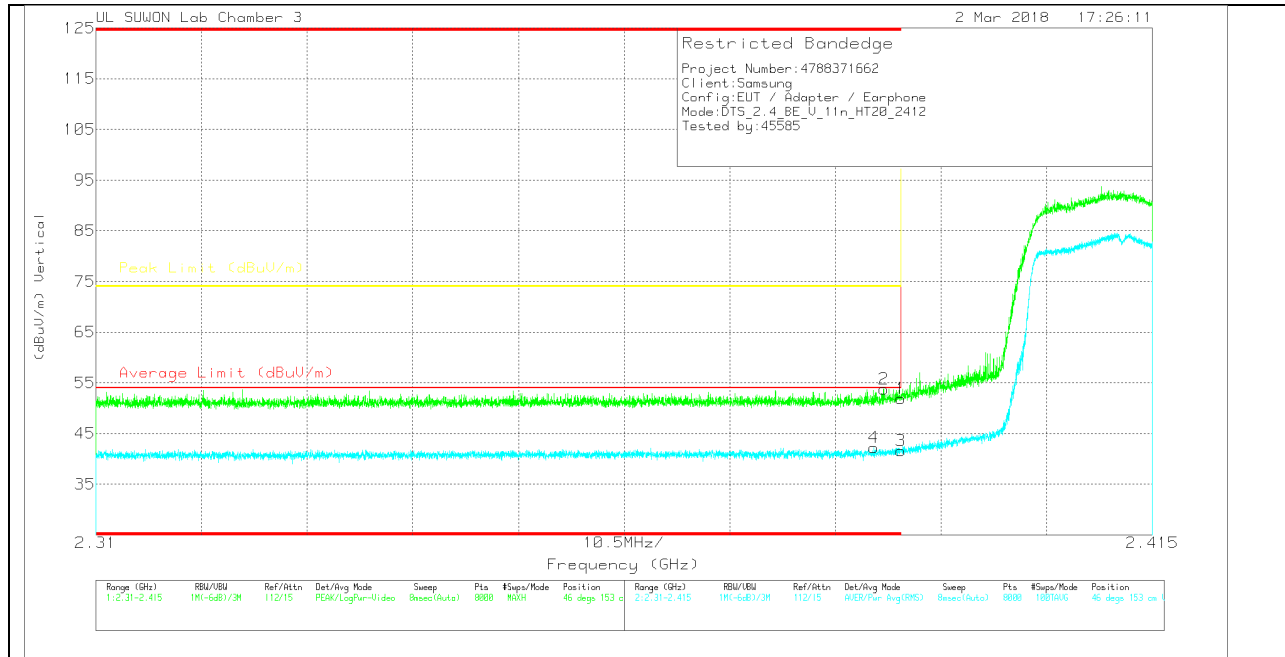

VERTICAL DATA

Trace Markers

Marker	Frequency (GHz)	Meter Reading (dBuV)	Det	3117(0020959)	10dB_ATT[dB]	DC Corr (dB)	Corrected Reading (dBuV/m)	Average Limit (dBuV/m)	Margin (dB)	Peak Limit (dBuV/m)	Pk Margin (dB)	Azimuth (Degs)	Height (cm)	Polarity
1	* 2.39	43.37	Pk	31.8	-23.3	0	51.87	-	-	74	-22.13	46	153	V
2	* 2.388	45.28	Pk	31.8	-23.3	0	53.78	-	-	74	-20.22	46	153	V
3	* 2.39	32.99	RMS	31.8	-23.3	.15	41.64	54	-12.36	-	-	46	153	V
4	* 2.387	33.57	RMS	31.8	-23.3	.15	42.22	54	-11.78	-	-	46	153	V

* - indicates frequency in CFR47 Pt 15 / IC RSS-Restricted Band

Pk - Peak detector

RMS - RMS detection

AUTHORIZED BANDEDGE (HIGH CHANNEL)

HORIZONTAL PEAK AND AVERAGE PLOT

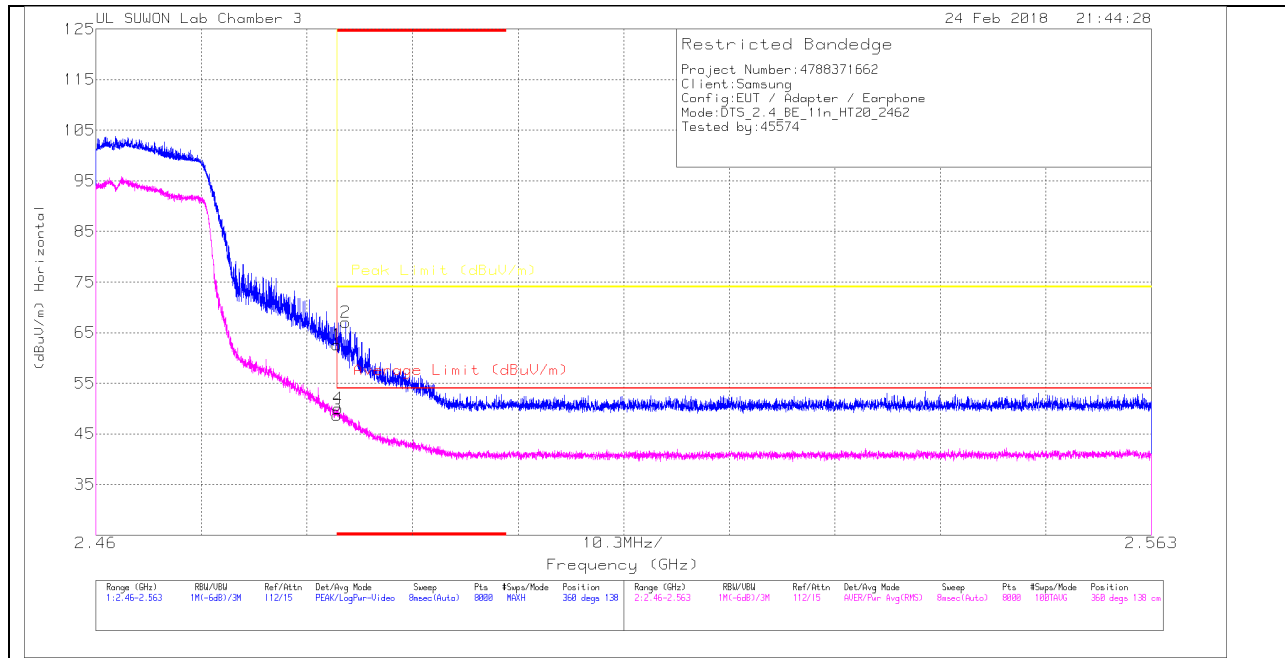

HORIZONTAL DATA

Trace Markers

Marker	Frequency (GHz)	Meter Reading (dBuV)	Det	3117(00205959)	10dB_ATT(dB)	DC Corr (dB)	Corrected Reading (dBuV/m)	Average Limit (dBuV/m)	Margin (dB)	Peak Limit (dBuV/m)	PK Margin (dB)	Azimuth (Degs)	Height (cm)	Polarity
1	* 2.484	53.44	Pk	32.1	-23	0	62.54	-	-	74	-11.46	360	138	H
2	* 2.484	58.09	Pk	32.1	-23.1	0	67.09	-	-	74	-6.91	360	138	H
3	* 2.484	39.44	RMS	32.1	-23	.15	48.69	54	-5.31	-	-	360	138	H
4	* 2.484	40.79	RMS	32.1	-23	.15	50.04	54	-3.96	-	-	360	138	H

* - indicates frequency in CFR47 Pt 15 / IC RSS-Restricted Band

Pk - Peak detector

RMS - RMS detection

VERTICAL PEAK AND AVERAGE PLOT

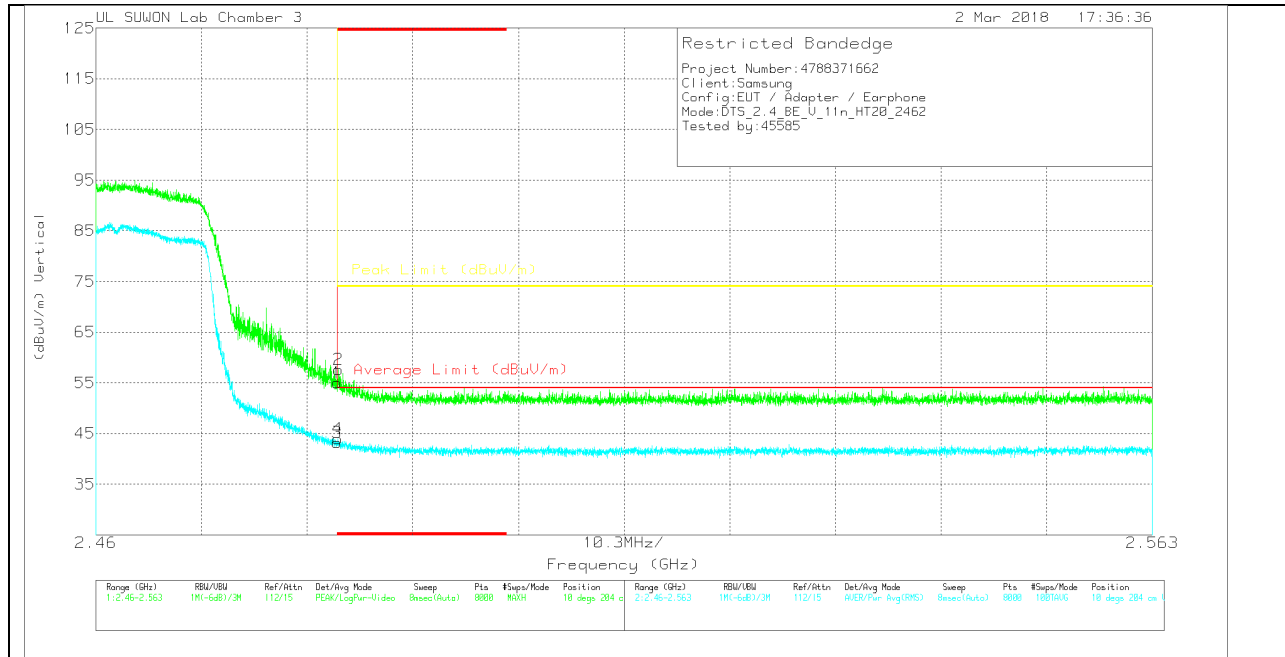

VERTICAL DATA

Trace Markers

Marker	Frequency (GHz)	Meter Reading (dBuV)	Det	3117000209599	10dB_ATT[dB]	DC Corr (dB)	Corrected Reading (dBuV/m)	Average Limit (dBuV/m)	Margin (dB)	Peak Limit (dBuV/m)	Pk Margin (dB)	Azimuth (Degs)	Height (cm)	Polarity
1	* 2.484	45.92	Pk	32.1	-23	0	55.02	-	-	74	-18.98	10	204	V
2	* 2.484	48.51	Pk	32.1	-23	0	57.61	-	-	74	-16.39	10	204	V
3	* 2.484	33.98	RMS	32.1	-23	.15	43.23	54	-10.77	-	-	10	204	V
4	* 2.484	34.68	RMS	32.1	-23	.15	43.93	54	-10.07	-	-	10	204	V

* - indicates frequency in CFR47 Pt 15 / IC RSS-Restricted Band

Pk - Peak detector

RMS - RMS detection

AUTHORIZED BANDEDGE (12 CHANNEL)

HORIZONTAL PEAK AND AVERAGE PLOT

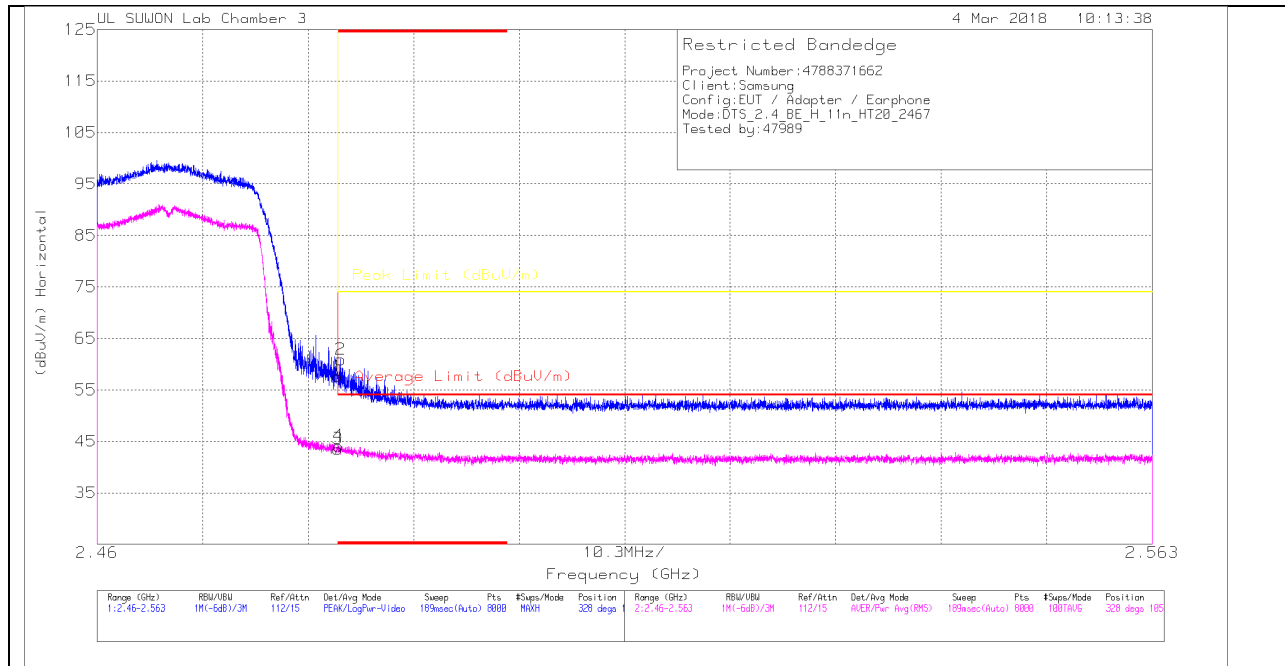

HORIZONTAL DATA

Trace Markers

Marker	Frequency (GHz)	Meter Reading (dBuV)	Det	3117(00205999)	10dB_ATT[dB]	DC Corr (dB)	Corrected Reading (dBuV/m)	Average Limit (dBuV/m)	Margin (dB)	Peak Limit (dBuV/m)	PK Margin (dB)	Azimuth (Degs)	Height (cm)	Polarity
1	* 2.484	48.56	Pk	32.1	-23	0	57.66	-	-	74	-16.34	328	105	H
2	* 2.484	51.91	Pk	32.1	-23.1	0	60.91	-	-	74	-13.09	328	105	H
3	* 2.484	34.29	RMS	32.1	-23	.15	43.54	54	-10.46	-	-	328	105	H
4	* 2.484	34.88	RMS	32.1	-23	.15	44.13	54	-9.87	-	-	328	105	H

* - indicates frequency in CFR47 Pt 15 / IC RSS-Restricted Band

Pk - Peak detector

RMS - RMS detection

VERTICAL PEAK AND AVERAGE PLOT

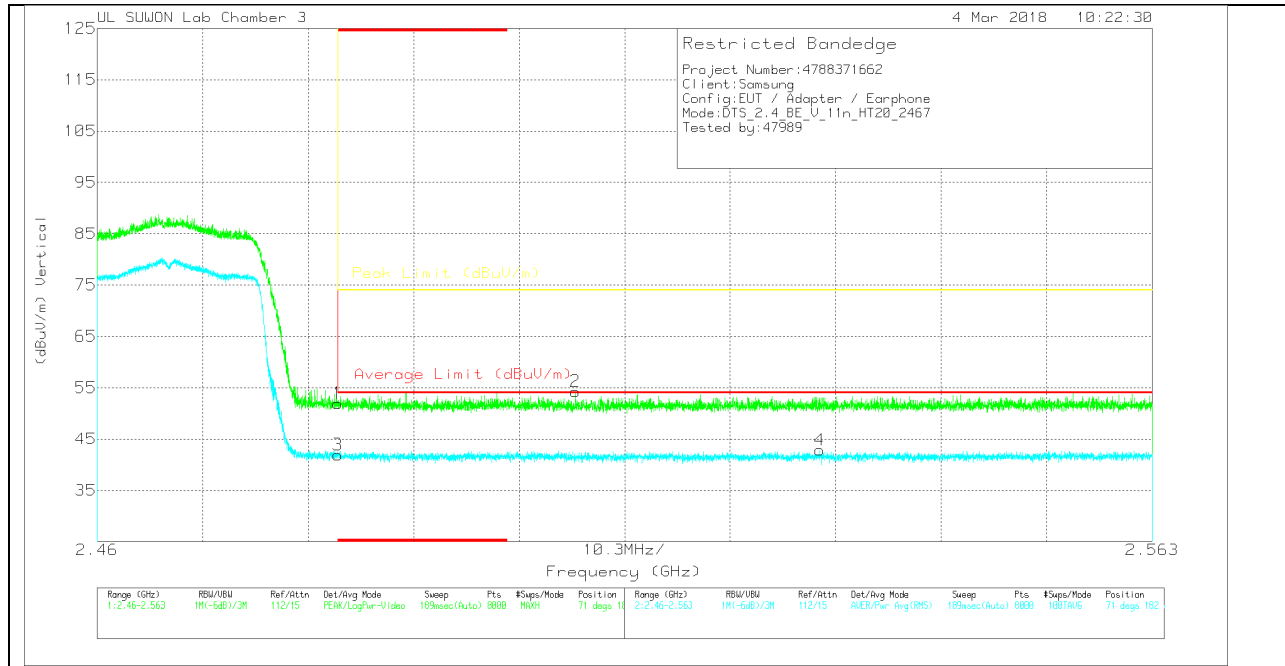

VERTICAL DATA

Trace Markers

Marker	Frequency (GHz)	Meter Reading (dBuV)	Det	3117(00205959)	10dB_ATT(dB)	DC Corr (dB)	Corrected Reading (dBuV/m)	Average Limit (dBuV/m)	Margin (dB)	Peak Limit (dBuV/m)	PK Margin (dB)	Azimuth (Degs)	Height (cm)	Polarity
1	* 2.484	42.84	PK	32.1	-23	0	51.94	-	-	74	-22.06	71	182	V
2	2.507	45.27	PK	32.1	-23.1	0	54.27	-	-	74	-19.73	71	182	V
3	* 2.484	32.66	RMS	32.1	-23	.15	41.91	54	-12.09	-	-	71	182	V
4	2.531	33.59	RMS	32.1	-23	.15	42.84	54	-11.16	-	-	71	182	V

* - indicates frequency in CFR47 Pt 15 / IC RSS-Restricted Band

PK - Peak detector

RMS - RMS detection

AUTHORIZED BANDEDGE (13 CHANNEL)

HORIZONTAL PEAK AND AVERAGE PLOT

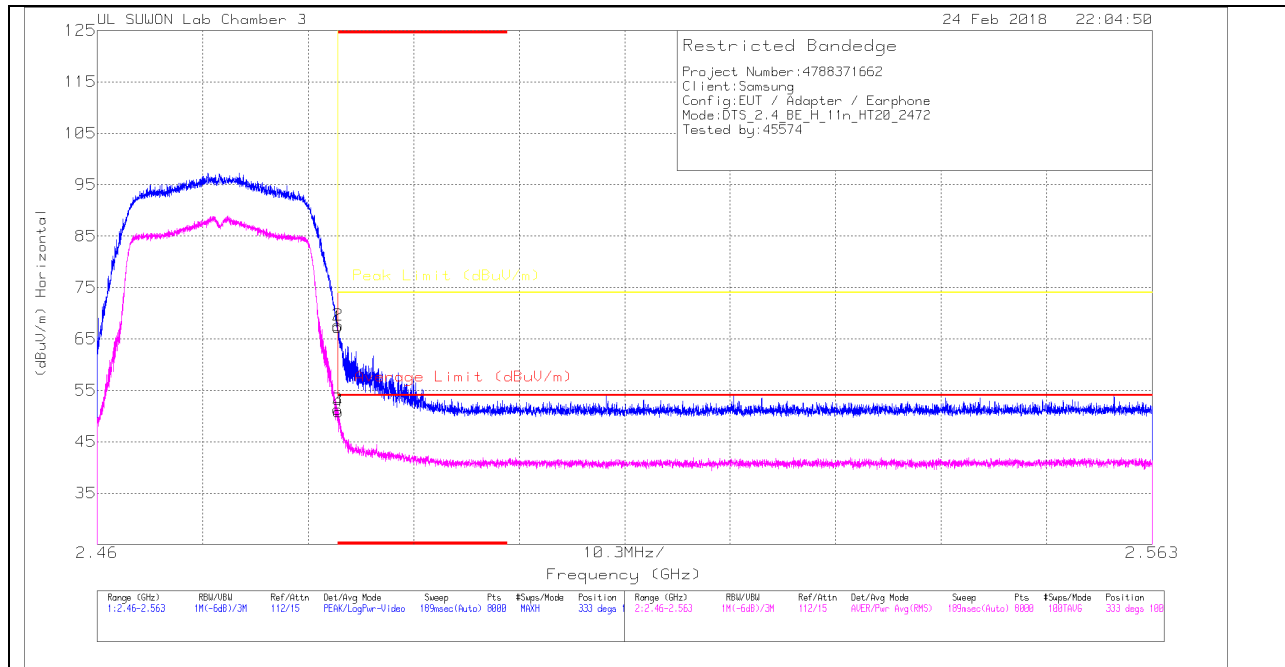

HORIZONTAL DATA

Trace Markers

Marker	Frequency (GHz)	Meter Reading (dBuV)	Det	3117(00205959)	10dB_ATT(dB)	DC Corr (dB)	Corrected Reading (dBuV/m)	Average Limit (dBuV/m)	Margin (dB)	Peak Limit (dBuV/m)	PK Margin (dB)	Azimuth (Degs)	Height (cm)	Polarity
1	* 2.484	58.17	Pk	32.1	-23	0	67.27	-	-	74	-6.73	333	100	H
2	* 2.484	58.53	Pk	32.1	-23	0	67.63	-	-	74	-6.37	333	100	H
3	* 2.484	42.02	RMS	32.1	-23	.15	51.27	54	-2.73	-	-	333	100	H
4	* 2.484	41.62	RMS	32.1	-23	.15	50.87	54	-3.13	-	-	333	100	H

* - indicates frequency in CFR47 Pt 15 / IC RSS-Restricted Band

Pk - Peak detector

RMS - RMS detection

VERTICAL PEAK AND AVERAGE PLOT

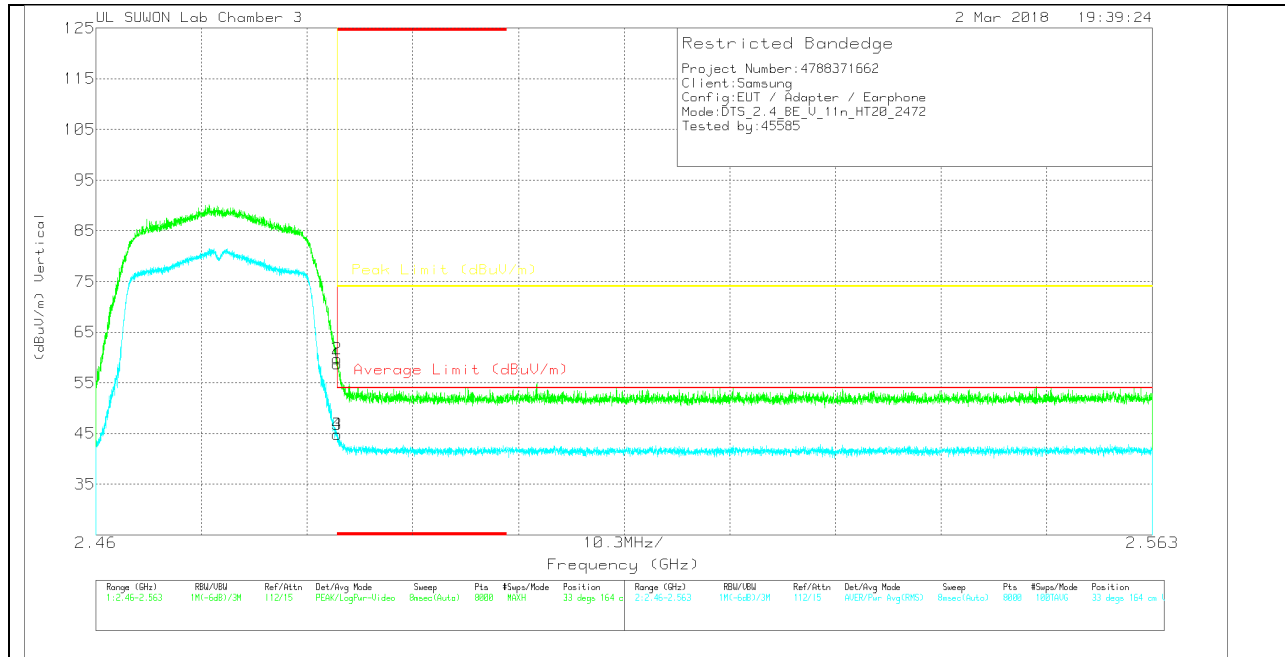

VERTICAL DATA

Trace Markers

Marker	Frequency (GHz)	Meter Reading (dBuV)	Det	3117(00205959)	10dB_ATT(dB)	DC Corr (dB)	Corrected Reading (dBuV/m)	Average Limit (dBuV/m)	Margin (dB)	Peak Limit (dBuV/m)	PK Margin (dB)	Azimuth (Degs)	Height (cm)	Polarity
1	* 2.484	49.66	Pk	32.1	-23	0	58.76	-	-	74	-15.24	33	164	V
2	* 2.484	50.66	Pk	32.1	-23	0	59.76	-	-	74	-14.24	33	164	V
3	* 2.484	35.55	RMS	32.1	-23	.15	44.8	54	-9.2	-	-	33	164	V
4	* 2.484	35.56	RMS	32.1	-23	.15	44.81	54	-9.19	-	-	33	164	V

* - indicates frequency in CFR47 Pt 15 / IC RSS-Restricted Band

Pk - Peak detector

RMS - RMS detection

HARMONICS AND SPURIOUS EMISSIONS

LOW CHANNEL HORIZONTAL

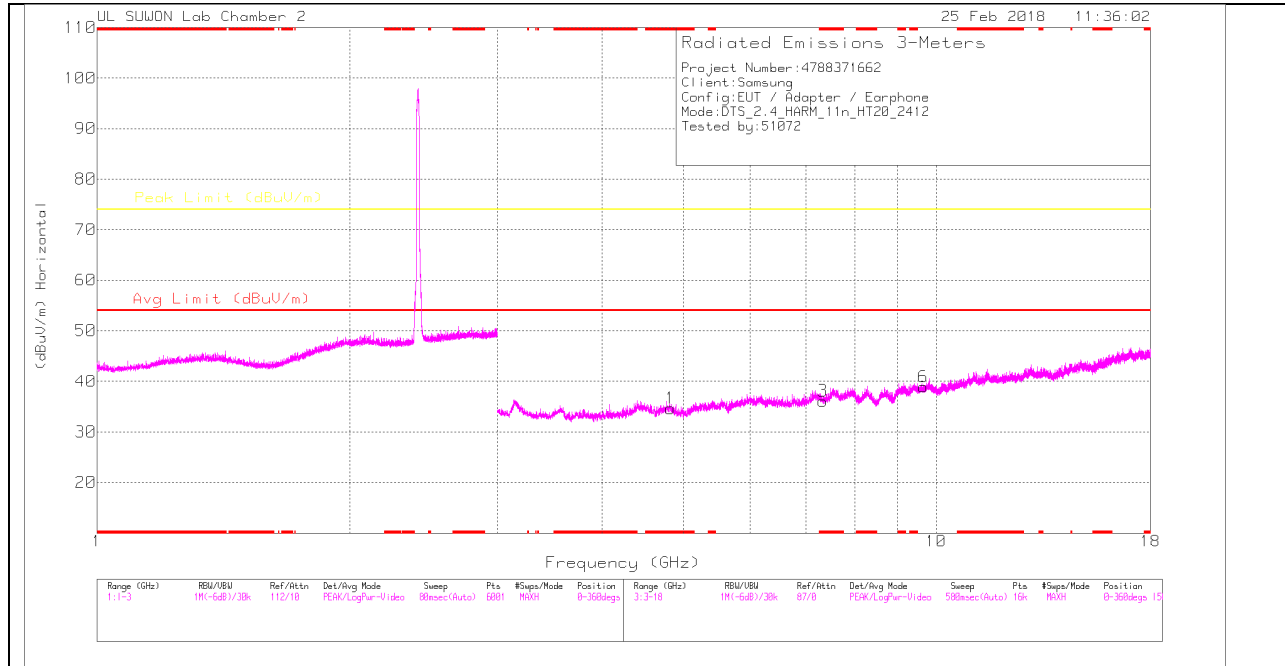

LOW CHANNEL VERTICAL

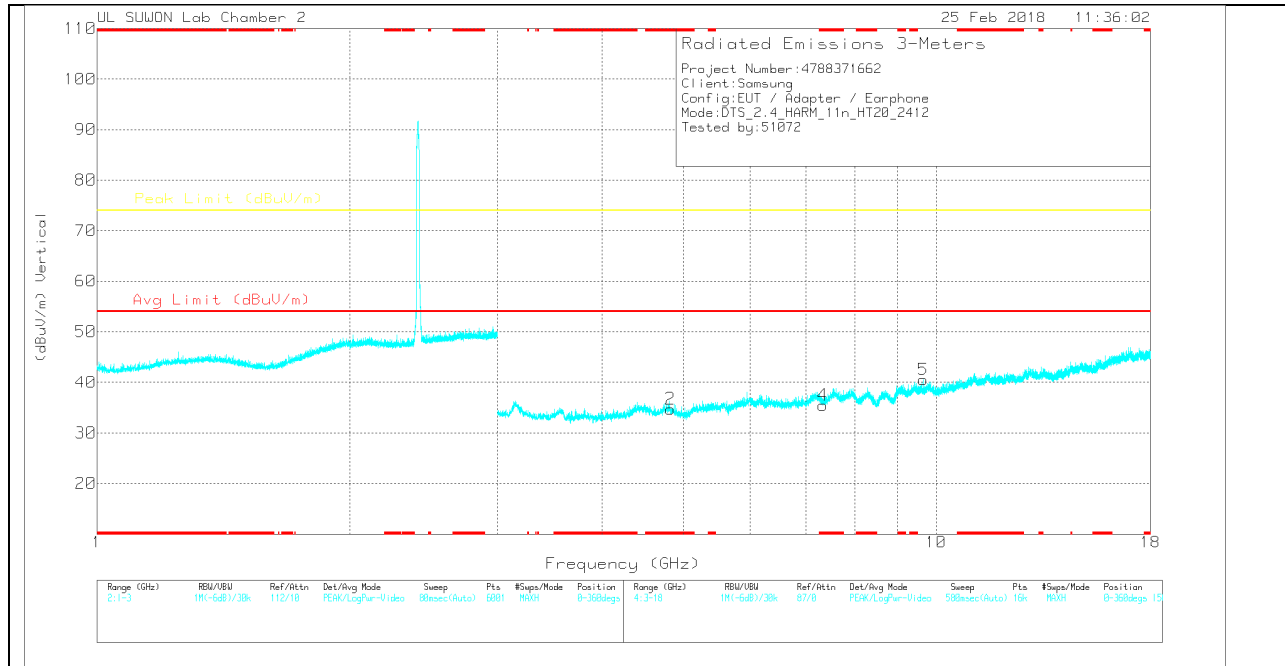

Note: Emission was scanned up to 26GHz; No emissions were detected above the noise floor which was at least 20dB below the specification limit.

LOW CHANNEL DATA

Trace Markers

Marker	Frequency (GHz)	Meter Reading (dBuV)	Det	170531_3117[00168724]	3GHz_HP[dB]	DC Corr (dB)	Corrected Reading (dBuV/m)	Avg Limit (dBuV/m)	Margin (dB)	Peak Limit (dBuV/m)	Margin (dB)	Azimuth (Degs)	Height (cm)	Polarity
1	* 4.825	25.15	PK	33.8	-24.3	0	34.65	-	-	74	-39.35	0-360	150	H
3	* 7.326	22.1	PK	35.9	-21.9	0	36.1	-	-	74	-37.9	0-360	250	H
6	9.648	20.39	PK	36.8	-18.3	0	38.89	-	-	74	-35.11	0-360	250	H
2	* 4.824	25.22	PK	33.8	-24.3	0	34.72	-	-	74	-39.28	0-360	150	V
4	* 7.326	21.46	PK	35.9	-21.9	0	35.46	-	-	74	-38.54	0-360	150	V
5	9.648	22.05	PK	36.8	-18.3	0	40.55	-	-	74	-33.45	0-360	250	V

* - indicates frequency in CFR47 Pt 15 / IC RSS-Restricted Band
 PK – Peak Detector

Note: Only peak measurement was performed. Because peak measurement result of unwanted emission is less than average limit (54dBuV/m).

MID CHANNEL HORIZONTAL

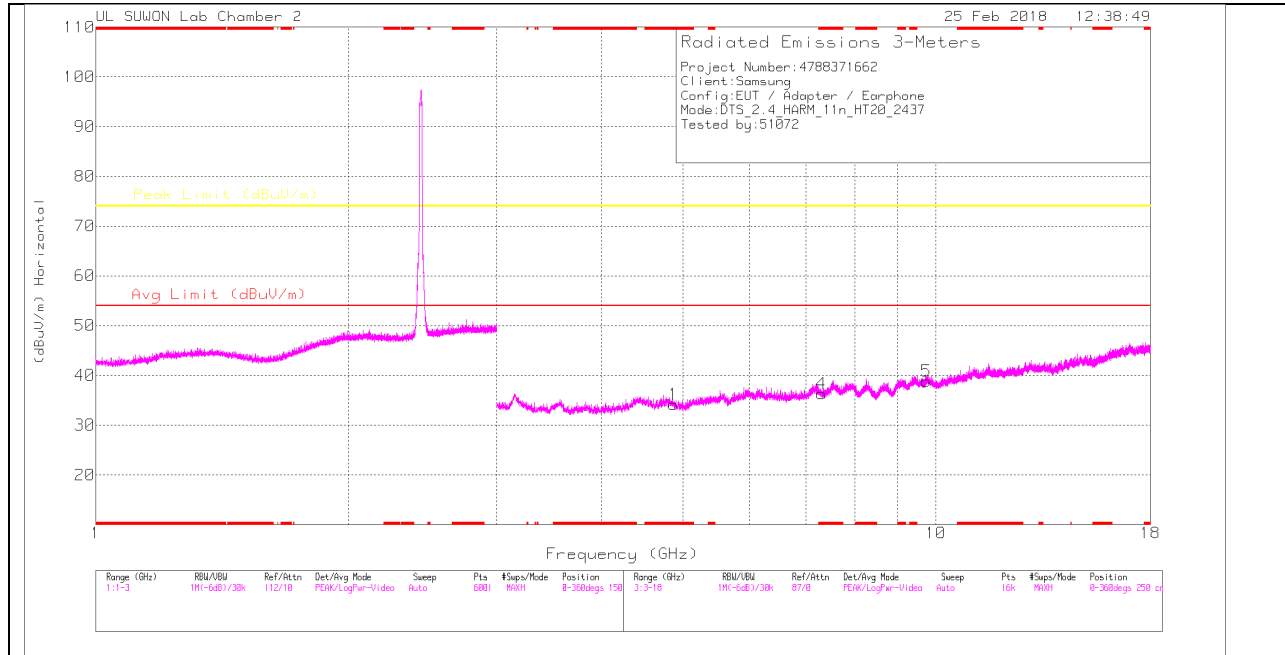

MID CHANNEL VERTICAL

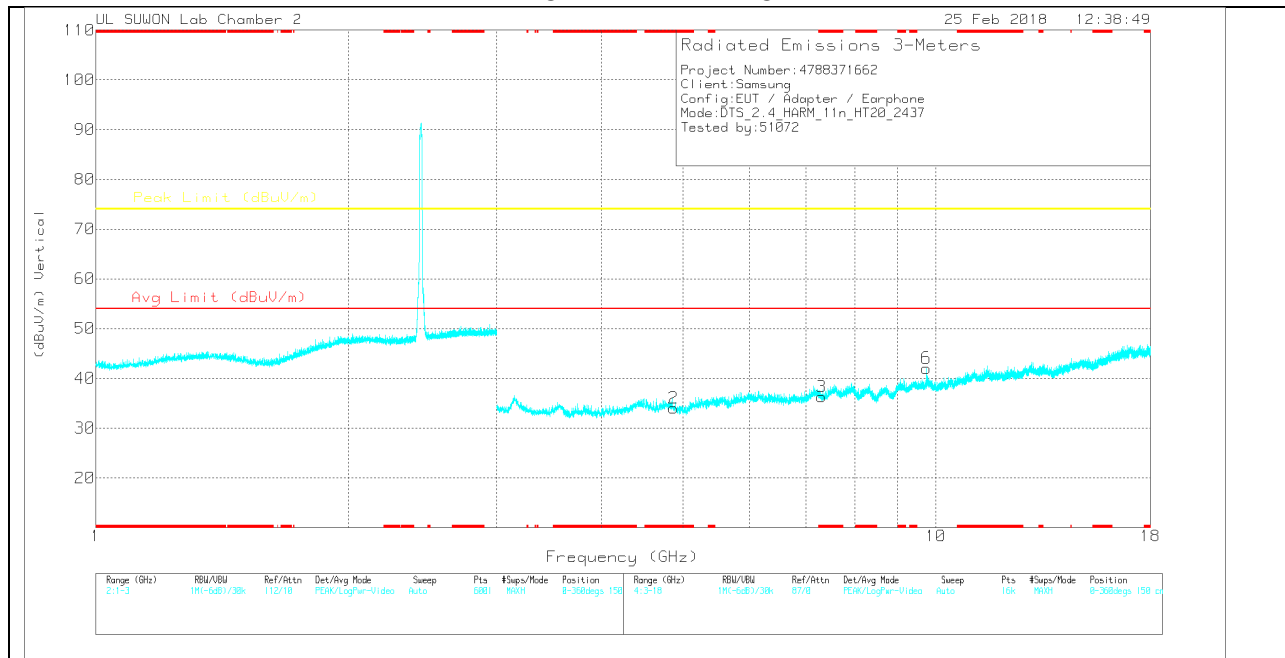

Note: Emission was scanned up to 26GHz; No emissions were detected above the noise floor which was at least 20dB below the specification limit.

MID CHANNEL DATA

Trace Markers

Marker	Frequency (GHz)	Meter Reading (dBuV)	Det	170531_3117[00168724]	3GHz_HP[dB]	DC Corr (dB)	Corrected Reading (dBuV/m)	Avg Limit (dBuV/m)	Margin (dB)	Peak Limit (dBuV/m)	Margin (dB)	Azimuth (Degs)	Height (cm)	Polarity	
1	* 4.875	24.89	PK		33.8	-24.5	0	34.19	-	-	74	-39.81	0-360	250	H
4	* 7.311	22.43	PK		35.9	-22	0	36.33	-	-	74	-37.67	0-360	150	H
5	9.748	20.09	PK		36.9	-18.1	0	38.89	-	-	74	-35.11	0-360	250	H
2	* 4.874	24.74	PK		33.8	-24.5	0	34.04	-	-	74	-39.96	0-360	150	V
3	* 7.311	22.42	PK		35.9	-22	0	36.32	-	-	74	-37.68	0-360	250	V
6	9.748	23.27	PK		36.9	-18.1	0	42.07	-	-	74	-31.93	0-360	250	V

* - indicates frequency in CFR47 Pt 15 / IC RSS-Restricted Band
 PK – Peak Detector

Radiated Emissions

Frequency (GHz)	Meter Reading (dBuV)	Det	170531_3117[00168724]	3GHz_HP[dB]	DC Corr (dB)	Corrected Reading (dBuV/m)	Avg Limit (dBuV/m)	Margin (dB)	Peak Limit (dBuV/m)	Margin (dB)	Azimuth (Degs)	Height (cm)	Polarity	
9.747	29.31	PK2		36.9	-18.1	0	48.11	-	-	74	-25.89	272	102	H
9.748	26.55	PK2		36.9	-18.1	0	45.35	-	-	74	-28.65	313	223	V

* - indicates frequency in CFR47 Pt 15 / IC RSS-Restricted Band
 PK2 - KDB558074 Method: Maximum Peak

Note: Only peak measurement was performed. Because peak measurement result of unwanted emission is less than average limit (54dBuV/m).

HIGH CHANNEL HORIZONTAL

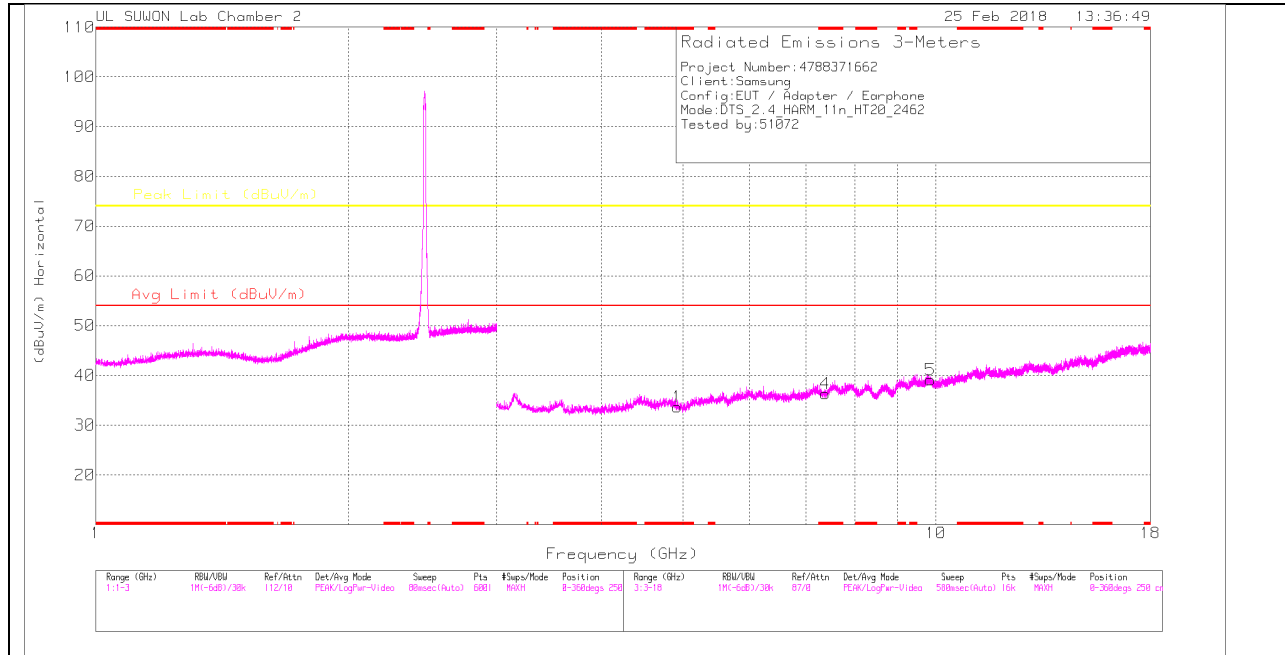

HIGH CHANNEL VERTICAL

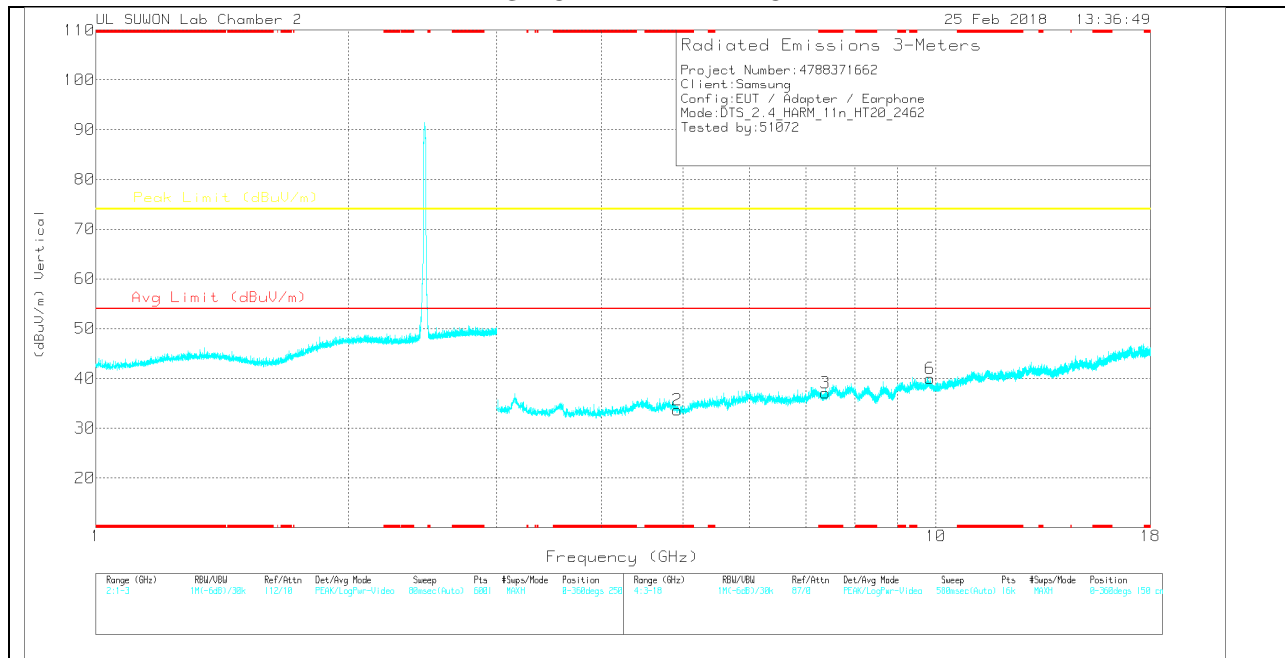

Note: Emission was scanned up to 26GHz; No emissions were detected above the noise floor which was at least 20dB below the specification limit.

HIGH CHANNEL DATA

Trace Markers

Marker	Frequency (GHz)	Meter Reading (dBuV)	Det	170531_3117(00168724)	3GHz_HP(dB)	DC Corr (dB)	Corrected Reading (dBuV/m)	Avg Limit (dBuV/m)	Margin (dB)	Peak Limit (dBuV/m)	Margin (dB)	Azimuth (Degs)	Height (cm)	Polarity
1	* 4.925	24.58	PK	33.8	-24.7	0	33.68	-	-	74	-40.32	0-360	250	H
4	* 7.386	21.83	PK	35.9	-21.4	0	36.33	-	-	74	-37.67	0-360	150	H
5	9.85	20	PK	37	-17.9	0	39.1	-	-	74	-34.9	0-360	150	H
2	* 4.925	24.6	PK	33.8	-24.7	0	33.7	-	-	74	-40.3	0-360	250	V
3	* 7.386	22.54	PK	35.9	-21.4	0	37.04	-	-	74	-36.96	0-360	250	V
6	9.848	20.85	PK	37	-17.9	0	39.95	-	-	74	-34.05	0-360	250	V

* - indicates frequency in CFR47 Pt 15 / IC RSS-Restricted Band
 PK – Peak Detector

Note: Only peak measurement was performed. Because peak measurement result of unwanted emission is less than average limit (54dBuV/m).

11.3. WORST-CASE BELOW 1 GHz

SPURIOUS EMISSIONS 30 TO 1000 MHz (WORST-CASE CONFIGURATION, HORIZONTAL)

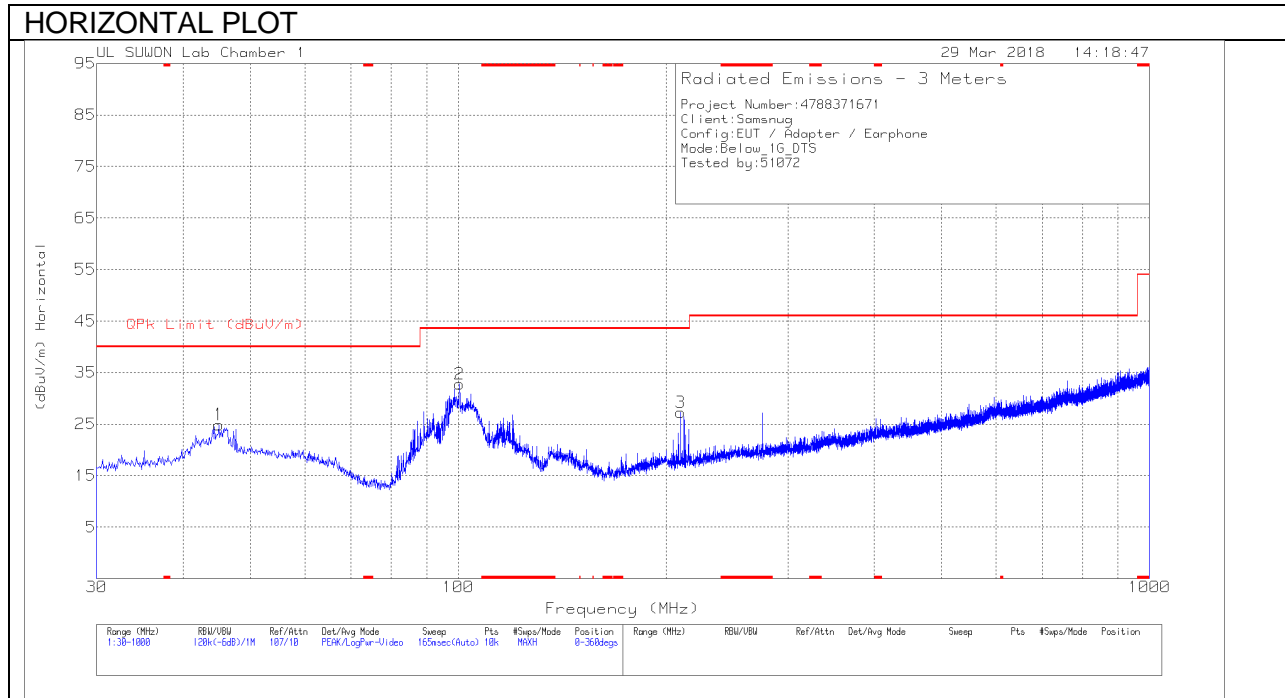

SPURIOUS EMISSIONS 30 TO 1000 MHz (WORST-CASE CONFIGURATION, VERTICAL)

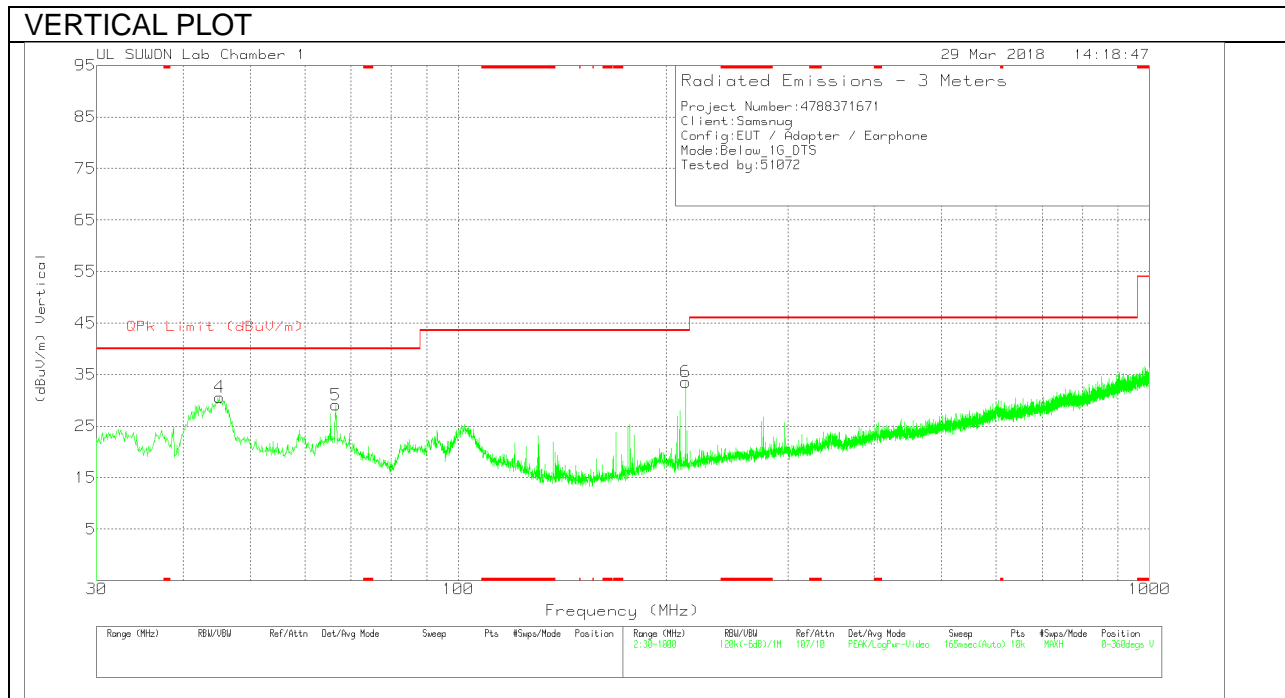

Below 1G Data

Trace Markers

Marker	Frequency (MHz)	Meter Reading (dBuV)	Det	750_20170831	30-1000MHz[dB]	DC Corr (dB)	Corrected Reading (dBuV/m)	QPk Limit (dBuV/m)	Margin (dB)	Azimuth (Degs)	Height (cm)	Polarity
1	45.035	34.46	Pk	19.7	-29.3	0	24.86	40	-15.14	0-360	200	H
2	100.519	43.96	Pk	17.4	-28.6	0	32.76	43.52	-10.76	0-360	300	H
3	209.741	38.04	Pk	16.7	-27.5	0	27.24	43.52	-16.28	0-360	200	H
4	45.132	40.2	Pk	19.7	-29.3	0	30.6	40	-9.4	0-360	100	V
5	66.569	41.57	Pk	16.4	-28.9	0	29.07	40	-10.93	0-360	100	V
6	213.233	44.26	Pk	16.9	-27.6	0	33.56	43.52	-9.96	0-360	200	V

Pk - Peak detector

12. AC POWER LINE CONDUCTED EMISSIONS

LIMITS

FCC §15.207 (a)
IC RSS-GEN Clause 8.8

Frequency of Emission (MHz)	Conducted Limit (dBuV)	
	Quasi-peak	Average
0.15-0.5	66 to 56 [*]	56 to 46 [*]
0.5-5	56	46
5-30	60	50

^{*}Decreases with the logarithm of the frequency.

TEST PROCEDURE

The EUT is placed on a non-conducting table 40 cm from the vertical ground plane and 80 cm above the horizontal ground plane. The EUT is configured in accordance with ANSI C63.10.

The receiver is set to a resolution bandwidth of 9 kHz. Peak detection is used unless otherwise noted as quasi-peak or average.

Line conducted data is recorded for both NEUTRAL and HOT lines.

RESULTS

WORST EMISSIONS

LINE 1 PLOT

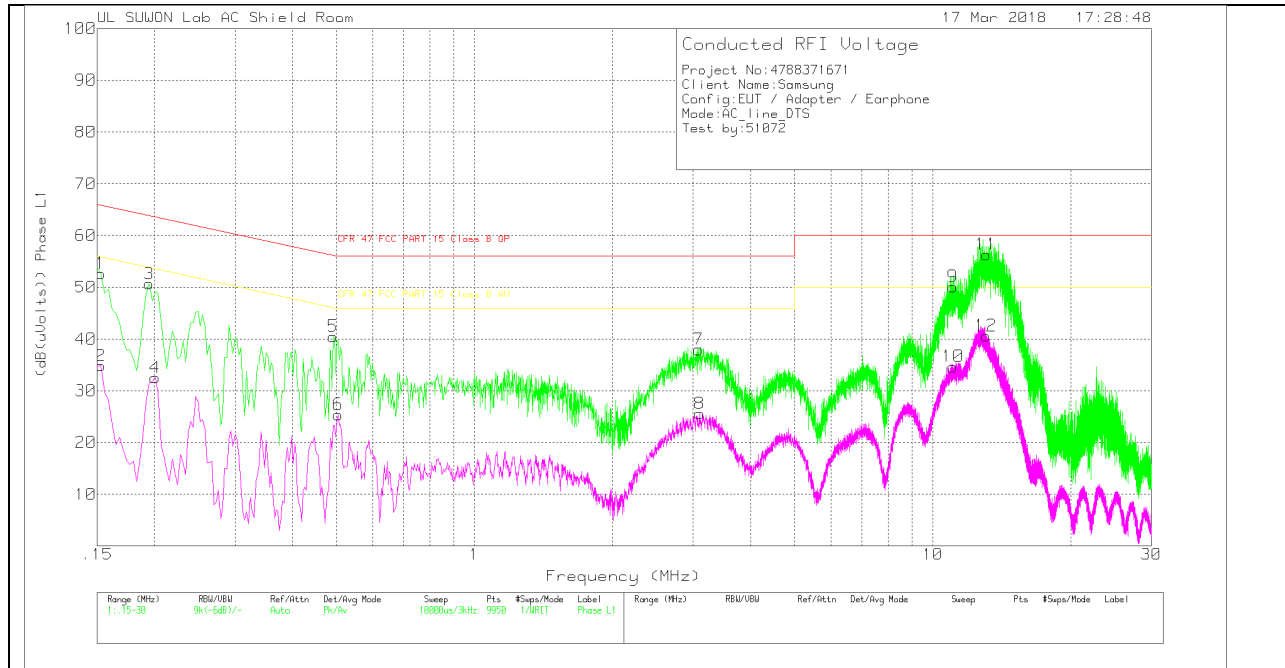

LINE 1 RESULTS

Trace Markers

Range 1: Phase L1 .15 - 30MHz

Marker	Frequency (MHz)	Meter Reading (dBuV)	Det	101837_L1_with extension	CABLELOSS(dB)	Corrected Reading (dB(uVolts))	CFR 47 FCC PART 15 Class B QP	Margin (dB)	CFR 47 FCC PART 15 Class B AV	Margin (dB)
1	.153	42.57	Pk	10	.1	52.67	65.84	-13.17	-	-
2	.153	24.73	Av	10	.1	34.83	-	-	55.84	-21.01
3	.195	40.68	Pk	9.8	.2	50.68	63.82	-13.14	-	-
4	.201	22.52	Av	9.8	.2	32.52	-	-	53.57	-21.05
5	.492	30.58	Pk	9.7	.2	40.48	56.13	-15.65	-	-
6	.504	15.51	Av	9.7	.2	25.41	-	-	46	-20.59
7	3.081	27.88	Pk	9.8	.3	37.98	56	-18.02	-	-
8	3.099	15.49	Av	9.8	.3	25.59	-	-	46	-20.41
9	11.076	40	Pk	9.8	.3	50.1	60	-9.9	-	-
10	11.076	24.57	Av	9.8	.3	34.67	-	-	50	-15.33
11	13.071	46.14	Pk	9.8	.4	56.34	60	-3.66	-	-
12	13.065	30.42	Av	9.8	.4	40.62	-	-	50	-9.38

Pk - Peak detector

Av - Average detection

Quasi-Peak Emissions

Range 1: Phase L1 .15 - 30MHz

Frequency (MHz)	Meter Reading (dBuV)	Det	101837_L1_with extension	CABLELOSS(dB)	Corrected Reading (dB(uVolts))	CFR 47 FCC PART 15 Class B QP	Margin (dB)	CFR 47 FCC PART 15 Class B AV	Margin (dB)
.15225	34.58	Qp	10	.1	44.68	65.88	-21.2	-	-
.19425	32.7	Qp	9.8	.2	42.7	63.85	-21.15	-	-
.20025	32.09	Qp	9.8	.2	42.09	63.6	-21.51	-	-
.49275	24.74	Qp	9.7	.2	34.64	56.12	-21.48	-	-
.50325	25.51	Qp	9.7	.2	35.41	56	-20.59	-	-
3.08115	22.98	Qp	9.8	.3	33.08	56	-22.92	-	-
3.09975	22.22	Qp	9.8	.3	32.32	56	-23.68	-	-
11.0753	34.44	Qp	9.8	.3	44.54	60	-15.46	-	-
13.0703	41.26	Qp	9.8	.4	51.46	60	-8.54	-	-
13.0658	41.03	Qp	9.8	.4	51.23	60	-8.77	-	-

Qp - Quasi-Peak detector

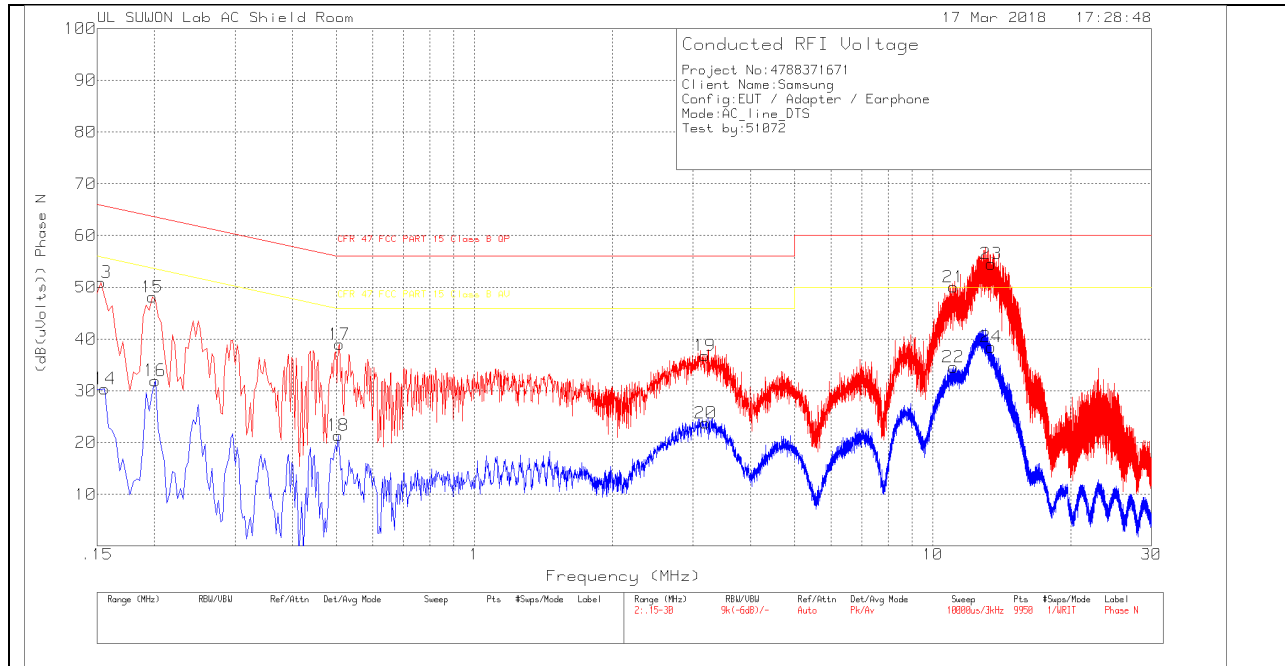

LINE 2 RESULTS

Trace Markers

Range 2: Phase N .15 - 30MHz

Marker	Frequency (MHz)	Meter Reading (dBuV)	Det	101837_N_with extension	CABLELOSS(dB)	Corrected Reading (dB(uVolts))	CFR 47 FCC PART 15 Class B QP	Margin (dB)	CFR 47 FCC PART 15 Class B AV	Margin (dB)
13	.153	40.85	Pk	10	.1	50.95	65.84	-14.89	-	-
14	.156	20.27	Av	10	.1	30.37	-	-	55.67	-25.3
15	.198	38.02	Pk	9.9	.2	48.12	63.69	-15.57	-	-
16	.201	21.96	Av	9.8	.2	31.96	-	-	53.57	-21.61
17	.507	28.98	Pk	9.8	.2	38.98	56	-17.02	-	-
18	.504	11.37	Av	9.8	.2	21.37	-	-	46	-24.63
19	3.183	26.69	Pk	9.8	.3	36.79	56	-19.21	-	-
20	3.195	13.68	Av	9.8	.3	23.78	-	-	46	-22.22
21	11.106	39.95	Pk	9.8	.3	50.05	60	-9.95	-	-
22	11.088	24.46	Av	9.8	.3	34.56	-	-	50	-15.44
23	13.416	44.33	Pk	9.8	.4	54.53	60	-5.47	-	-
24	13.425	28.27	Av	9.8	.4	38.47	-	-	50	-11.53

Pk - Peak detector

Av - Average detection

Quasi-Peak Emissions

Range 2: Phase N .15 - 30MHz

Frequency (MHz)	Meter Reading (dBuV)	Det	101837_N_with extension	CABLELOSS(dB)	Corrected Reading (dB(uVolts))	CFR 47 FCC PART 15 Class B QP	Margin (dB)	CFR 47 FCC PART 15 Class B AV	Margin (dB)
.15225	32.45	Qp	10	.1	42.55	65.88	-23.33	-	-
.15525	30.03	Qp	10	.1	40.13	65.71	-25.58	-	-
.19725	31.27	Qp	9.9	.2	41.37	63.73	-22.36	-	-
.20025	31.07	Qp	9.8	.2	41.07	63.6	-22.53	-	-
.50625	21.69	Qp	9.8	.2	31.69	56	-24.31	-	-
.50325	24.18	Qp	9.8	.2	34.18	56	-21.82	-	-
3.18315	22	Qp	9.8	.3	32.1	56	-23.9	-	-
3.19425	20.55	Qp	9.8	.3	30.65	56	-25.35	-	-
11.1068	34.01	Qp	9.8	.3	44.11	60	-15.89	-	-
11.0888	33.28	Qp	9.8	.3	43.38	60	-16.62	-	-
13.4162	39.3	Qp	9.8	.4	49.5	60	-10.5	-	-
13.4252	38.71	Qp	9.8	.4	48.91	60	-11.09	-	-

Qp - Quasi-Peak detector