

UNII Straddle Ch. IEEE 802.11ax HE80(SU) mode Output Power and PSD

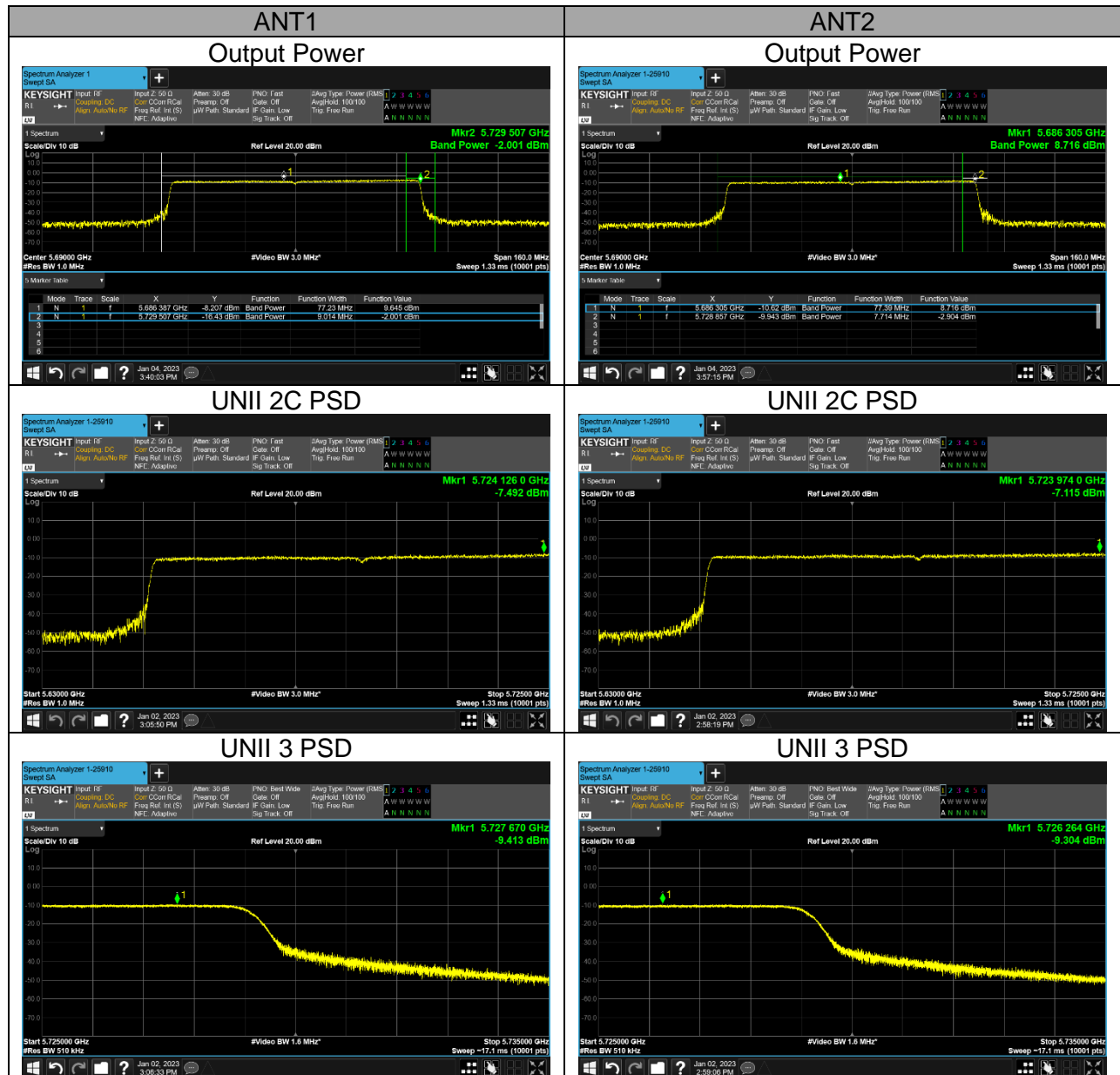

UNII Straddle Ch. IEEE 802.11ax HE20(6RU) mode Output Power and PSD

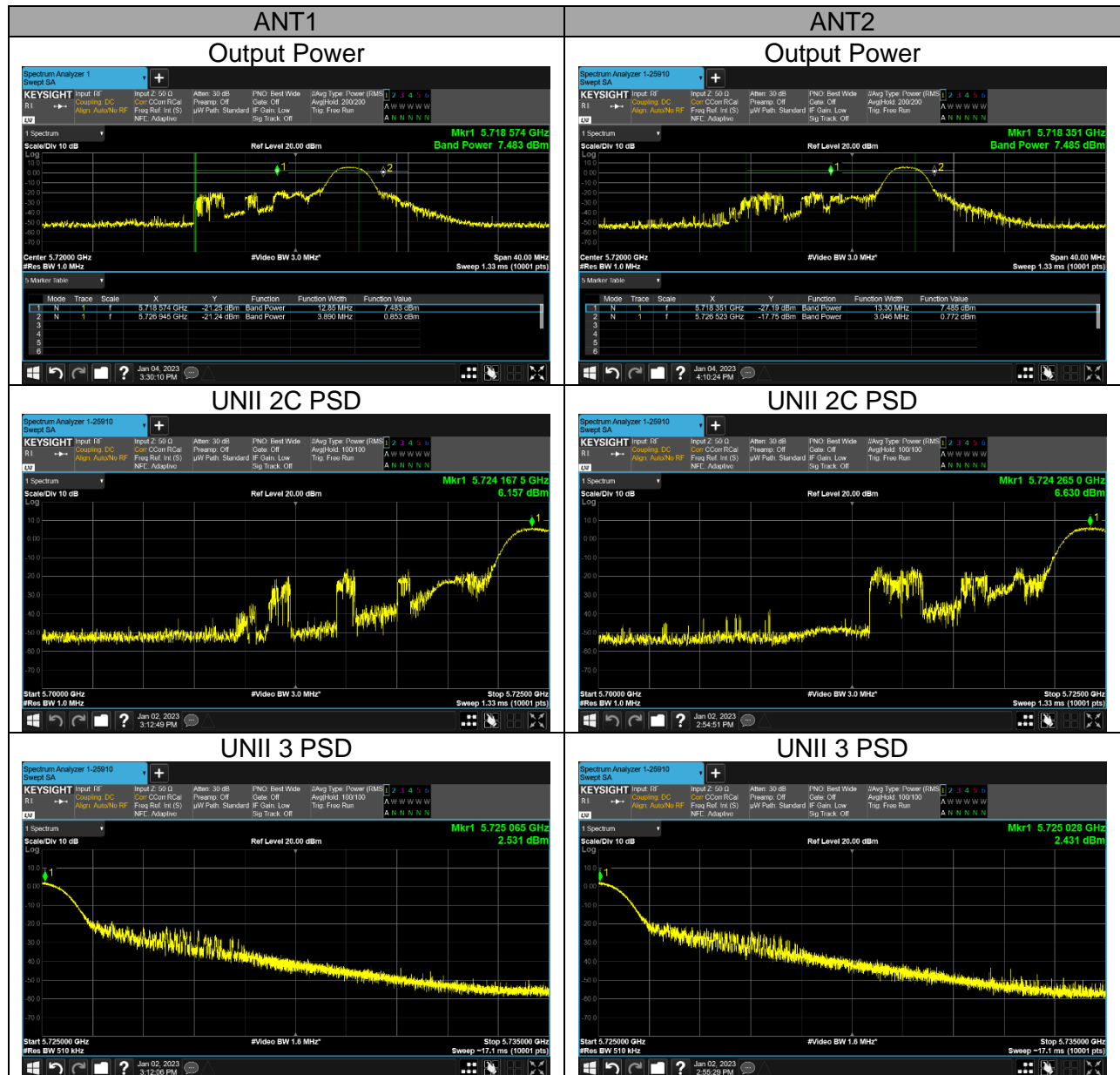

UNII Straddle Ch. IEEE 802.11ax HE40(15RU) mode Output Power and PSD

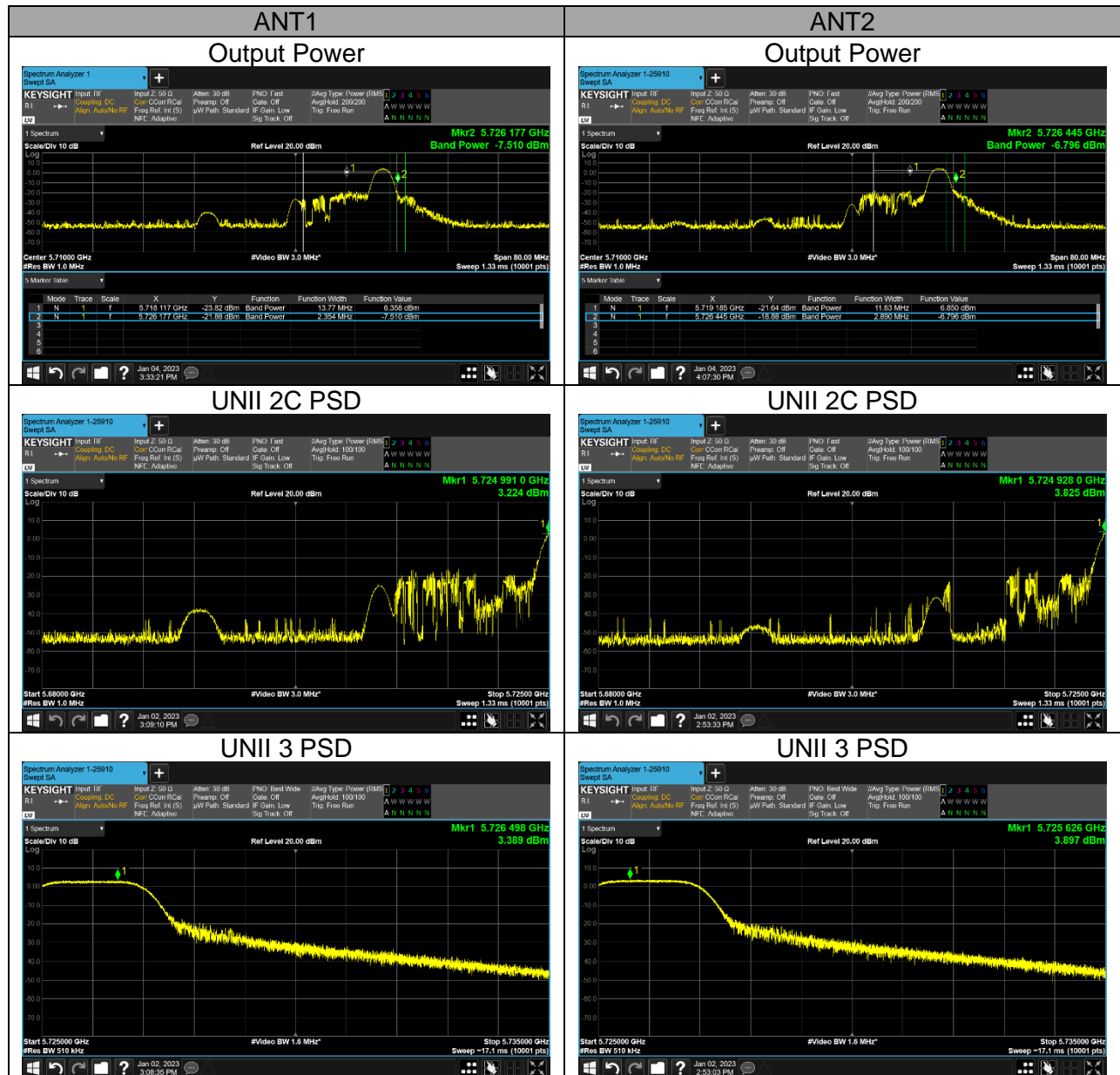

UNII Straddle Ch. IEEE 802.11ax HE80(34RU) mode Output Power and PSD

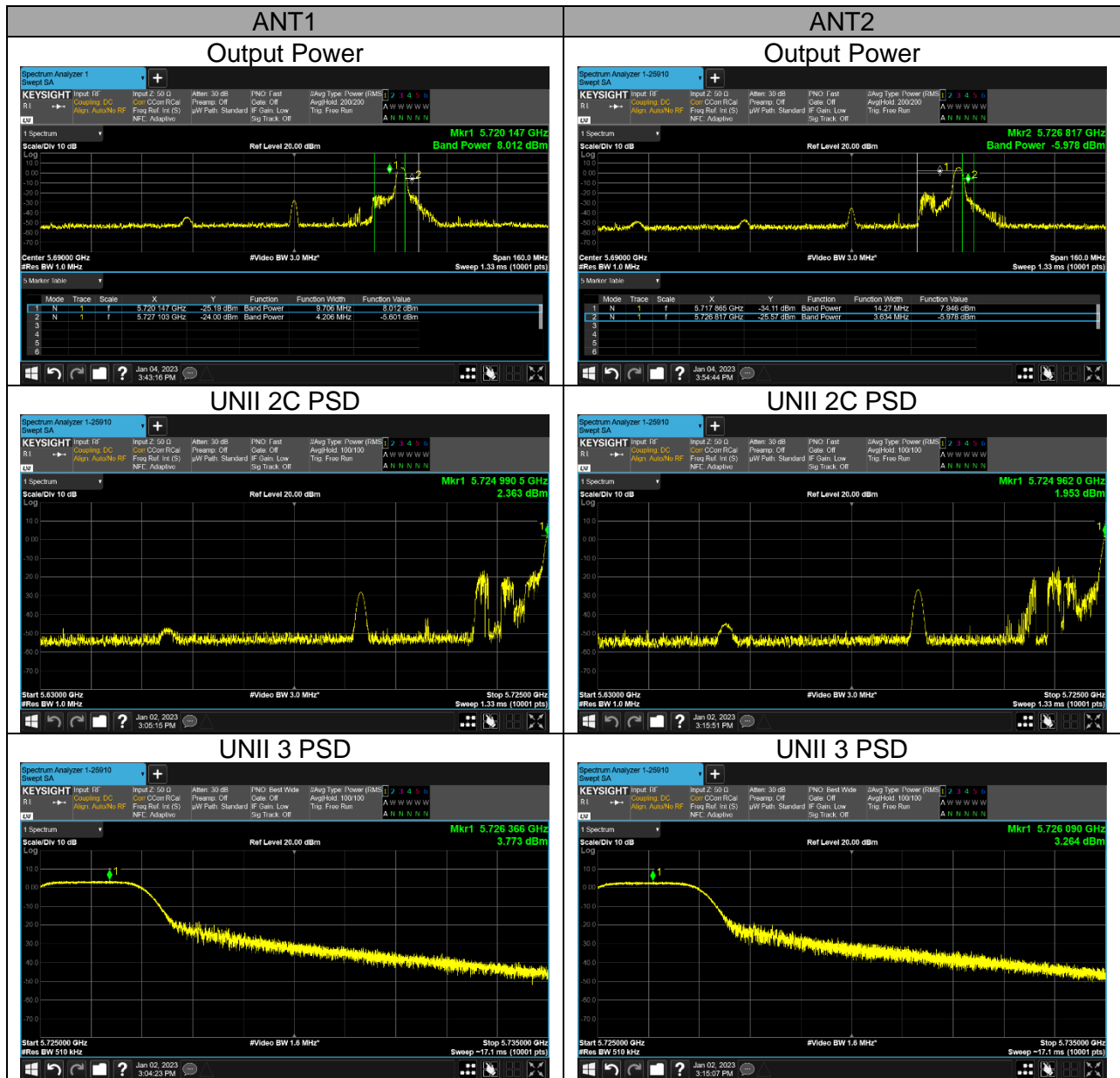

11. TRANSMITTER ABOVE 1 GHz

LIMITS

FCC §15.205 and §15.209

Limits for radiated disturbance of an intentional radiator		
Frequency range (MHz)	Limits (µV/m)	Measurement Distance (m)
0.009 – 0.490	2400 / F (kHz)	300
0.490 – 1.705	24000 / F (kHz)	30
1.705 – 30.0	30	30
30 – 88	100**	3
88 - 216	150**	3
216 – 960	200**	3
Above 960	500	3

** Except as provided in paragraph (g), fundamental emissions from intentional radiators operating under this section shall not be located in the frequency bands 54-72 MHz, 76-88 MHz, 174-216 MHz or 470-806 MHz. However, operation within these frequency bands is permitted under other sections of this part, e.g. §§ 15.231 and 15.241.

FCC Part 15.205 (a) : Only spurious emissions are permitted in any of the frequency bands listed below :

MHz	MHz	MHz	MHz	GHz	GHz
0.009 ~ 0.110	8.41425 ~ 8.41475	108 ~ 121.94	1300 ~ 1427	4.5 ~ 5.15	14.47 ~ 14.5
0.495 ~ 0.505	12.29 ~ 12.293	123 ~ 138	1435 ~ 1626.5	5.35 ~ 5.46	15.35 ~ 16.2
2.1735 ~ 2.1905	12.51975 ~ 12.52025	149.9 ~ 150.05	1645.5 ~ 1646.5	7.25 ~ 7.75	17.7 ~ 21.4
4.125 ~ 4.128	12.57675 ~ 12.57725	156.52475 ~ 156.52525	1660 ~ 1710	8.025 ~ 8.5	22.01 ~ 23.12
4.17725 ~ 4.17775	13.36 ~ 13.41	156.7 ~ 156.9	1718.8 ~ 1722.2	9.0 ~ 9.2	23.6 ~ 24.0
4.20725 ~ 4.20775	16.42 ~ 16.423	162.0125 ~ 167.17	2200 ~ 2300	9.3 ~ 9.5	31.2 ~ 31.8
6.215 ~ 6.218	16.69475 ~ 16.69525	167.72 ~ 173.2	2310 ~ 2390	10.6 ~ 12.7	36.43 ~ 36.5
6.26775 ~ 6.26825	16.80425 ~ 16.80475	240 ~ 285	2483.5 ~ 2500	13.25 ~ 13.4	Above 38.6
6.31175 ~ 6.31225	25.5 ~ 25.67	322 ~ 335.4	2655 ~ 2900		
8.291 ~ 8.294	37.5 ~ 38.25	399.90 ~ 410	3260 ~ 3267		
8.362 ~ 8.366	73 ~ 74.6	608 ~ 614	3332 ~ 3339		
8.37625 ~ 8.38675	74.8 ~ 75.2	960 ~ 1240	3345.8 ~ 3358 3600 ~ 4400		

▪ FCC Part 15.205(b) : The field strength of emissions appearing within these frequency bands shall not exceed the limits shown in §15.209. At frequencies equal to or less than 1000 MHz, compliance with the limits in §15.209 shall be demonstrated using measurement instrumentation employing a CISPR quasi-peak detector. Above 1000 MHz, compliance with the emission limits in §15.209 shall be demonstrated based on the average value of the measured emissions. The provisions in §15.35 apply to these measurements.

FCC §15.407 (b)

(b) Undesirable emission limits. Except as shown in paragraph (b)(7) of this section, the maximum emissions outside of the frequency bands of operation shall be attenuated in accordance with the following limits:

- (1) For transmitters operating in the 5.15-5.25 GHz band: All emissions outside of the 5.15-5.35 GHz band shall not exceed an e.i.r.p. of -27 dBm/MHz.
- (2) For transmitters operating in the 5.25-5.35 GHz band: All emissions outside of the 5.15-5.35 GHz band shall not exceed an e.i.r.p. of -27 dBm/MHz.
- (3) For transmitters operating in the 5.47-5.725 GHz band: All emissions outside of the 5.47-5.725 GHz band shall not exceed an e.i.r.p. of -27 dBm/MHz.
- (4) For transmitters operating solely in the 5.725-5.850 GHz band:
 - (i) All emissions shall be limited to a level of -27 dBm/MHz at 75 MHz or more above or below the band edge increasing linearly to 10 dBm/MHz at 25 MHz above or below the band edge, and from 25 MHz above or below the band edge increasing linearly to a level of 15.6 dBm/MHz at 5 MHz above or below the band edge, and from 5 MHz above or below the band edge increasing linearly to a level of 27 dBm/MHz at the band edge.
- (5) The emission measurements shall be performed using a minimum resolution bandwidth of 1 MHz. A lower resolution bandwidth may be employed near the band edge, when necessary,
provided the measured energy is integrated to show the total power over 1 MHz.
- (6) Unwanted emissions below 1 GHz must comply with the general field strength limits set forth in §15.209. Further, any U-NII devices using an AC power line are required to comply also with the conducted limits set forth in §15.207.
- (7) The provisions of §15.205 apply to intentional radiators operating under this section.
- (8) When measuring the emission limits, the nominal carrier frequency shall be adjusted as close to the upper and lower frequency band edges as the design of the equipment permits.

Note

- Limit translation to field strength level (FCC §15.407)

$$E[\text{dBuV/m}] = \text{EIRP}[\text{dBm}] + 95.2 = -27\text{dBm} + 95.2 = 68.2\text{dBuV/m}$$

$$E[\text{dBuV/m}] = \text{EIRP}[\text{dBm}] + 95.2 = -17\text{dBm} + 95.2 = 78.2\text{dBuV/m}$$

TEST PROCEDURE

The EUT is placed on a non-conducting table 80 cm above the ground plane for below 1GHz and 100 cm for above 1GHz. The antenna to EUT distance is 3 meters. The EUT is configured in accordance with ANSI C63.10. The EUT is set to transmit in a continuous mode.

For measurements below 1 GHz the resolution bandwidth is set to 100 kHz for peak detection measurements or 120 kHz for quasi-peak detection measurements. Peak detection is used unless otherwise noted as quasi-peak.

Reference to KDB 789033 D02 v02r01 UNII part G) 6) c) Method AD:

For measurements above 1 GHz the resolution bandwidth is set to 1 MHz; the video bandwidth is set to 3 MHz for peak measurements and add duty cycle factor to the reading offset for average measurements. In UNII-4, unwanted emissions outside of restricted bands are measured with an RMS detector.

Pre-scans to detect harmonic and spurious emissions, the resolution bandwidth is set to 1 MHz; the video bandwidth is set to 30 kHz for peak measurements.

The spectrum from 1GHz to 40 GHz is investigated with the transmitter set to the lowest, middle, and highest channels in each applicable band.
(From 30MHz to 1GHz, test was performed with the EUT set to transmit at the channel with highest output power)

The frequency range of interest is monitored at a fixed antenna height and EUT azimuth. The EUT is rotated through 360 degrees to maximize emissions received. The antenna is scanned from 1 to 4 meters above the ground plane to further maximize the emission. Measurements are made with the antenna polarized in both the vertical and the horizontal positions.

Note : Emission was pre-scanned from 9kHz to 30MHz; No emissions were detected which was at least 20dB below the specification limit (consider distance correction factor).
Per FCC part 15.31(o), test results were not reported.

Although these tests were performed other than open field test site, adequate comparison measurements were confirmed against 30 m open area test site.
Therefore sufficient tests were made to demonstrate that the alternative site produces results that correlate with the one of tests made in an open field based on KDB 414788.

11.1. TX ABOVE 1GHz 2Tx MODE IN THE 5.2GHz BAND

BANDEDGE (WORST CASE: 802.11n HT40 / 5190 MHz)

HORIZONTAL PEAK AND AVERAGE DATA

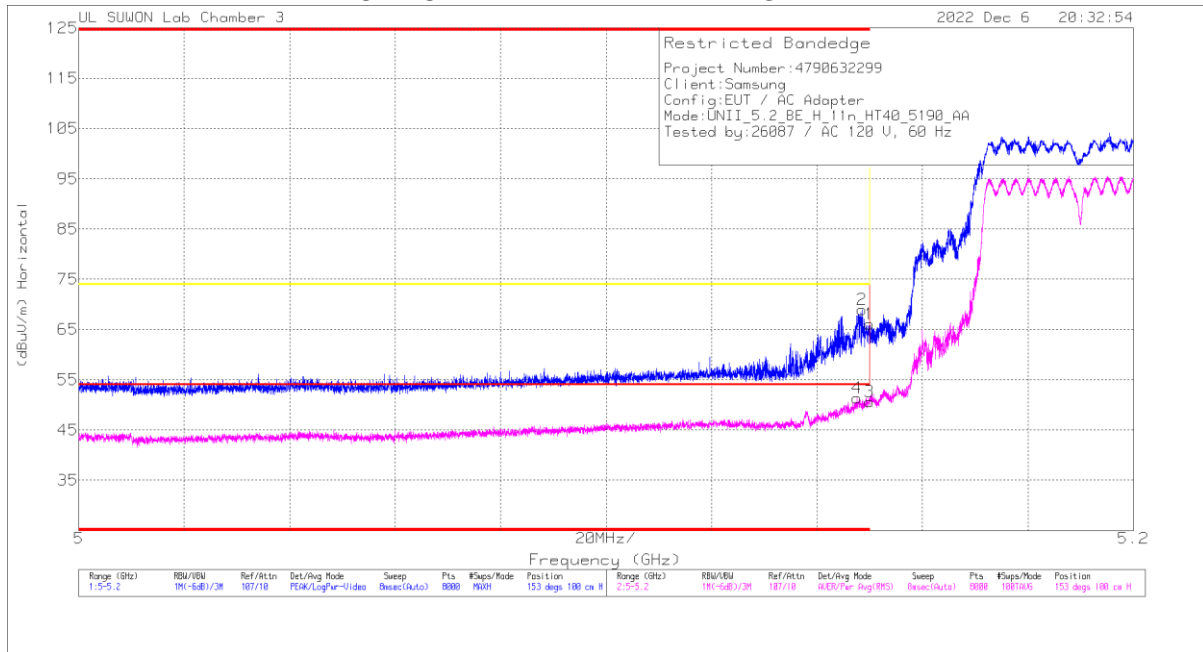

Trace Markers

Marker	Frequency (GHz)	Meter Reading (dBuV)	Det	3117_00218957	10dB_ATT[dB]	DC Corr (dB)	Corrected Reading (dBuV/m)	Average Limit (dBuV/m)	Margin (dB)	Peak Limit (dBuV/m)	PK Margin (dB)	Azimuth (Degs)	Height (cm)	Polarity
1	* 5.14999	51.88	Pk	34.8	-20.6	0	66.08	-	-	74	-7.92	153	100	H
2	* 5.14852	54.72	Pk	34.8	-20.6	0	68.92	-	-	74	-5.08	153	100	H
3	* 5.14999	36.38	RMS	34.8	-20.6	0.12	50.70	54.00	-3.30	-	-	153	100	H
4	* 5.14754	37.16	RMS	34.8	-20.6	0.12	51.48	54.00	-2.52	-	-	153	100	H

* - indicates frequency in CFR47 Pt 15 / IC RSS-Restricted Band

Pk - Peak detector

RMS - RMS detection

BANDEDGE TEST DATA

Mode	Freq. [MHz]	Antenna	Frequency [GHz]	Reading [dBuV]	Detector Mode	ANT Factor	Loss [dB]	DC Corr [dB]	Result [dBuV/m]	AV Limit [dBuV/m]	AV Margin [dB]	PK Limit [dBuV/m]	PK Margin [dB]	Azimuth [Degs]	Height [cm]	Polarity	
802.11a	5180	MIMO	* 5.14999	43.16	Pk	34.80	-20.60	0.00	57.36	-	-	74.00	-16.64	149	110	H	
			* 5.14947	48.52	Pk	34.80	-20.60	0.00	62.72	-	-	74.00	-11.28	149	110	H	
			* 5.14999	32.85	RMS	34.80	-20.60	0.10	47.15	54.00	-6.85	-	-	-	149	110	H
			* 5.12787	35.56	RMS	34.80	-20.60	0.10	49.86	54.00	-4.14	-	-	-	149	110	H
			* 5.14999	39.07	Pk	34.80	-20.60	0.00	53.27	-	-	-	74.00	-20.73	148	100	V
			* 5.14832	43.16	Pk	34.80	-20.60	0.00	57.36	-	-	-	74.00	-16.64	148	100	V
			* 5.14999	29.83	RMS	34.80	-20.60	0.10	44.13	54.00	-9.87	-	-	-	-	148	100
* 5.12206	31.05	RMS	34.80	-20.60	0.10	45.35	54.00	-8.65	-	-	-	-	148	100	V		
802.11n (HT20)	5180	MIMO	* 5.14999	49.74	Pk	34.80	-20.60	0.00	63.94	-	-	74.00	-10.06	126	104	H	
			* 5.14824	49.98	Pk	34.80	-20.60	0.00	64.18	-	-	74.00	-9.82	126	104	H	
			* 5.14999	32.41	RMS	34.80	-20.60	0.00	46.61	54.00	-7.39	-	-	-	126	104	H
			* 5.12792	35.08	RMS	34.80	-20.60	0.00	49.28	54.00	-4.72	-	-	-	126	104	H
			* 5.14999	44.11	Pk	34.80	-20.60	0.00	58.31	-	-	-	74.00	-15.69	202	329	V
			* 5.14814	48.14	Pk	34.80	-20.60	0.00	62.34	-	-	-	74.00	-11.66	202	329	V
			* 5.14999	32.36	RMS	34.80	-20.60	0.00	46.56	54.00	-7.44	-	-	-	202	329	V
* 5.12799	33.12	RMS	34.80	-20.60	0.00	47.32	54.00	-6.68	-	-	-	202	329	V			
802.11n (HT40)	5190	MIMO	* 5.14999	51.88	Pk	34.80	-20.60	0.00	66.08	-	-	74.00	-7.92	153	100	H	
			* 5.14852	54.72	Pk	34.80	-20.60	0.00	68.92	-	-	74.00	-5.08	153	100	H	
			* 5.14999	36.38	RMS	34.80	-20.60	0.12	50.70	54.00	-3.30	-	-	-	153	100	H
			* 5.14754	37.16	RMS	34.80	-20.60	0.12	51.48	54.00	-2.52	-	-	-	153	100	H
			* 5.14999	42.21	Pk	34.80	-20.60	0.00	56.41	-	-	-	74.00	-17.59	153	106	V
			* 5.14924	44.82	Pk	34.80	-20.60	0.00	59.02	-	-	-	74.00	-14.98	153	106	V
			* 5.14999	30.62	RMS	34.80	-20.60	0.12	44.94	54.00	-9.06	-	-	-	153	106	V
* 5.14979	30.77	RMS	34.80	-20.60	0.12	45.09	54.00	-8.91	-	-	-	153	106	V			
802.11ac (VHT80)	5210	MIMO	* 5.14999	43.01	Pk	34.80	-20.60	0.00	57.21	-	-	74.00	-16.79	151	108	H	
			* 5.13862	45.98	Pk	34.80	-20.60	0.00	60.18	-	-	74.00	-13.82	151	108	H	
			* 5.14999	32.72	RMS	34.80	-20.60	0.23	47.15	54.00	-6.85	-	-	-	151	108	H
			* 5.14034	34.22	RMS	34.80	-20.60	0.23	48.65	54.00	-5.35	-	-	-	151	108	H
			* 5.14999	39.09	Pk	34.80	-20.60	0.00	53.29	-	-	-	74.00	-20.71	153	100	V
			* 5.14899	41.54	Pk	34.80	-20.60	0.00	55.74	-	-	-	74.00	-18.26	153	100	V
			* 5.14999	28.74	RMS	34.80	-20.60	0.23	43.17	54.00	-10.83	-	-	-	153	100	V
* 5.14367	30.14	RMS	34.80	-20.60	0.23	44.57	54.00	-9.43	-	-	-	153	100	V			
802.11ax (HE20)	5180	MIMO	* 5.14999	43.52	Pk	34.80	-20.60	0.00	57.72	-	-	74.00	-16.28	145	112	H	
			* 5.12782	46.26	Pk	34.80	-20.60	0.00	60.46	-	-	74.00	-13.54	145	112	H	
			* 5.14999	32.64	RMS	34.80	-20.60	0.00	46.84	54.00	-7.16	-	-	-	145	112	H
			* 5.12799	35.29	RMS	34.80	-20.60	0.00	49.49	54.00	-4.51	-	-	-	145	112	H
			* 5.14999	38.68	Pk	34.80	-20.60	0.00	52.88	-	-	-	74.00	-21.12	153	101	V
			* 5.14907	42.28	Pk	34.80	-20.60	0.00	56.48	-	-	-	74.00	-17.52	153	101	V
			* 5.14999	28.84	RMS	34.80	-20.60	0.00	43.04	54.00	-10.96	-	-	-	153	101	V
* 5.14666	30.64	RMS	34.80	-20.60	0.00	44.84	54.00	-9.16	-	-	-	153	101	V			
802.11ax (HE40)	5190	MIMO	* 5.14999	42.88	Pk	34.80	-20.60	0.00	57.08	-	-	74.00	-16.92	154	108	H	
			* 5.14829	49.72	Pk	34.80	-20.60	0.00	63.92	-	-	74.00	-10.08	154	108	H	
			* 5.14999	33.22	RMS	34.80	-20.60	0.12	47.54	54.00	-6.46	-	-	-	154	108	H
			* 5.13804	34.19	RMS	34.80	-20.60	0.12	48.51	54.00	-5.49	-	-	-	154	108	H
			* 5.14999	41.08	Pk	34.80	-20.60	0.00	55.28	-	-	-	74.00	-18.72	189	349	V
			* 5.14797	46.22	Pk	34.80	-20.60	0.00	60.42	-	-	-	74.00	-13.58	189	349	V
			* 5.14999	31.11	RMS	34.80	-20.60	0.12	45.43	54.00	-8.57	-	-	-	189	349	V
* 5.14927	31.51	RMS	34.80	-20.60	0.12	45.83	54.00	-8.17	-	-	-	189	349	V			
802.11ax (HE80)	5210	MIMO	* 5.14999	39.77	Pk	34.80	-20.60	0.00	53.97	-	-	74.00	-20.03	121	115	H	
			* 5.13972	41.99	Pk	34.80	-20.60	0.00	56.19	-	-	74.00	-17.81	121	115	H	
			* 5.14999	29.08	RMS	34.80	-20.60	0.22	43.50	54.00	-10.50	-	-	-	121	115	H
			* 5.14842	30.37	RMS	34.80	-20.60	0.22	44.79	54.00	-9.21	-	-	-	121	115	H
			* 5.14999	41.09	Pk	34.80	-20.60	0.00	55.29	-	-	-	74.00	-18.71	194	332	V
			* 5.14704	44.02	Pk	34.80	-20.60	0.00	58.22	-	-	-	74.00	-15.78	194	332	V
			* 5.14999	31.42	RMS	34.80	-20.60	0.22	45.84	54.00	-8.16	-	-	-	194	332	V
* 5.14657	31.83	RMS	34.80	-20.60	0.22	46.25	54.00	-7.75	-	-	-	194	332	V			

Note1. Pk - Peak detector, RMS - RMS detector
Note2. * - indicates frequency in CFR47 Pt 15 / IC RSS-Restricted Band

HARMONICS AND SPURIOUS EMISSIONS(WORST CASE: 802.11a / 5240 MHz)
5240 MHz HORIZONTAL

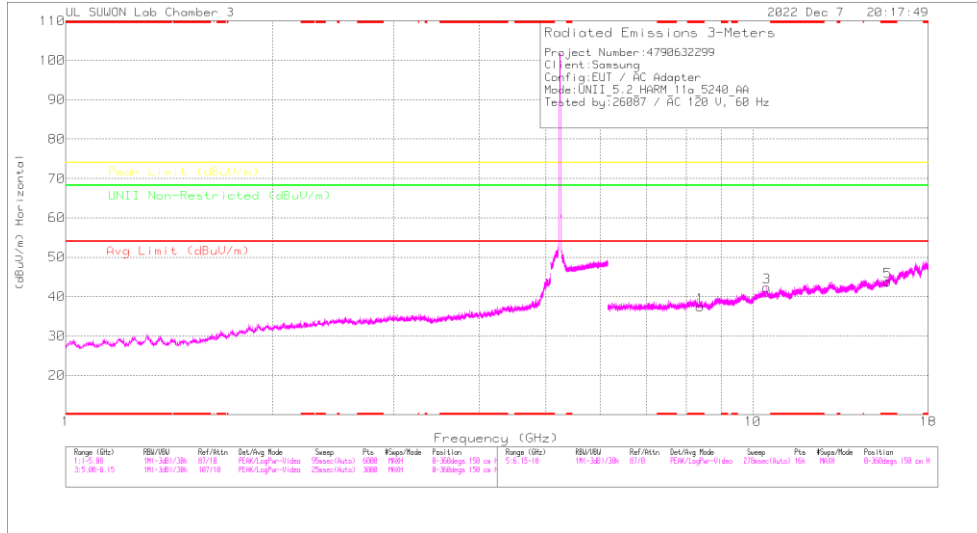

5240 MHz VERTICAL

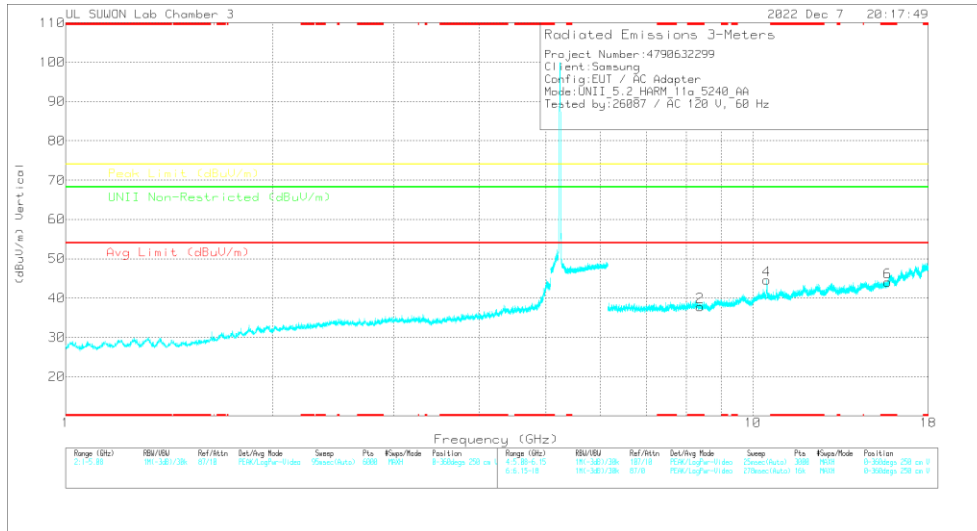

Note: Emission was scanned up to 40GHz; No emissions were detected above the noise floor which was at least 20dB below the specification limit.

5240 MHz DATA

Radiated Emissions

Frequency (GHz)	Meas Reading (dBuV)	Det	317_0021897	60Hz_FPL[dB]	DC Corr (dB)	Concord Reading (dBuV/m)	Avg Limit (dBuV/m)	Margin (dB)	Peak Limit (dBuV/m)	Margin (dB)	UNII Non-Restricted (dBuV/m)	Margin (dB)	Asmth (Degs)	Height (cm)	Polarity
* 8.38655	35.48	PK-U	36.3	-23.5	0	48.28	-	-	74	-25.72	-	-	0	100	H
* 8.38189	35.87	PK-U	36.3	-23.5	0	48.87	-	-	74	-25.33	-	-	0	100	V
10.47897	38.15	PK-U	38.2	-21.2	0	55.15	-	-	-	-	68.2	-13.05	289	105	H
10.48458	38.71	PK-U	38.2	-21.2	0	55.71	-	-	-	-	68.2	-12.49	91	107	V
* 15.71366	35.07	PK-U	40.5	-21.1	0	54.47	-	-	74	-19.53	-	-	0	100	H
* 15.72594	35.35	PK-U	40.5	-20.9	0	54.85	-	-	74	-19.06	-	-	0	100	V

* - indicates frequency in CFR47 Pt 15 / IC RSS-Restricted Band
 PK-U - U-NII: Maximum Peak

HARMONICS AND SPURIOUS EMISSIONS TEST DATA

Mode	Freq. [MHz]	Antenna	Frequency [GHz]	Reading [dBuV]	Detector Mode	ANT Factor	Loss [dB]	DC Corr [dB]	Result [dBuV/m]	AV Limit [dBuV/m]	AV Margin [dB]	PK Limit [dBuV/m]	PK Margin [dB]	Non-Restricted [dBuV/m]	Margin [dB]	Azimuth [Degs]	Height [cm]	Polarity	
802.11a	5180	MIMO	* 8.28547	35.70	PK-U	36.20	-23.70	0.00	48.20	-	-	74.00	-25.80	-	-	0	100	H	
			** 8.28326	35.67	PK-U	36.20	-23.70	0.00	48.17	-	-	74.00	-25.83	-	-	0	100	V	
			10.361	36.69	PK-U	38.10	-21.00	0.00	53.79	-	-	-	-	68.20	-14.41	297	100	H	
			10.356	38.09	PK-U	38.10	-21.10	0.00	55.09	-	-	-	-	68.20	-13.11	352	100	V	
			* 15.53801	34.66	PK-U	40.20	-21.40	0.00	53.46	-	-	-	-	74.00	-20.54	-	0	100	H
			* 15.53713	34.32	PK-U	40.20	-21.40	0.00	53.12	-	-	-	-	74.00	-20.88	-	0	100	V
	5220	MIMO	* 8.35358	36.19	PK-U	36.20	-23.70	0.00	48.69	-	-	74.00	-25.31	-	-	0	100	H	
			* 8.36444	35.55	PK-U	36.20	-23.60	0.00	48.15	-	-	74.00	-25.85	-	-	0	100	V	
			10.450	37.84	PK-U	38.10	-21.20	0.00	54.74	-	-	-	-	68.20	-13.46	293	100	H	
			10.434	37.76	PK-U	38.10	-21.20	0.00	54.66	-	-	-	-	68.20	-13.54	94	101	V	
			* 15.66669	34.45	PK-U	40.40	-21.10	0.00	53.75	-	-	-	-	74.00	-20.25	-	0	100	H
			* 15.65782	33.88	PK-U	40.40	-21.10	0.00	53.18	-	-	-	-	74.00	-20.82	-	0	100	V
	5240	MIMO	* 8.38655	35.48	PK-U	36.30	-23.50	0.00	48.28	-	-	74.00	-25.72	-	-	0	100	H	
			* 8.38189	35.87	PK-U	36.30	-23.50	0.00	48.67	-	-	74.00	-25.33	-	-	0	100	V	
			10.477	38.15	PK-U	38.20	-21.20	0.00	55.15	-	-	-	-	68.20	-13.05	299	105	H	
			10.485	38.71	PK-U	38.20	-21.20	0.00	55.71	-	-	-	-	68.20	-12.49	91	107	V	
			* 15.71366	35.07	PK-U	40.50	-21.10	0.00	54.47	-	-	-	-	74.00	-19.53	-	0	100	H
			* 15.72594	35.35	PK-U	40.50	-20.90	0.00	54.95	-	-	-	-	74.00	-19.05	-	0	100	V
802.11ax (HE20) 4RU Spot-Check	5180	MIMO	* 7.68896	37.35	PK-U	36.20	-25.10	0.00	48.45	-	-	74.00	-25.55	-	-	0	100	H	
			7.760	36.33	PK-U	36.30	-24.70	0.00	47.93	-	-	-	-	68.20	-20.27	0	100	V	
			10.361	38.65	PK-U	38.10	-21.00	0.00	55.75	-	-	-	-	68.20	-12.45	301	100	H	
			10.359	39.37	PK-U	38.10	-21.00	0.00	56.47	-	-	-	-	68.20	-11.73	351	100	V	
			* 15.54251	34.43	PK-U	40.20	-21.40	0.00	53.23	-	-	-	-	74.00	-20.77	-	0	100	H
			* 15.53611	34.70	PK-U	40.20	-21.40	0.00	53.50	-	-	-	-	74.00	-20.50	-	0	100	V

Note1. PK-U - U-NII: Maximum Peak

Note2. * - indicates frequency in CFR47 Pt 15 / IC RSS-Restricted Band

11.2. TX ABOVE 1GHz 2Tx MODE IN THE 5.3GHz BAND

BANDEDGE (WORST CASE: 802.11a / 5320 MHz)

HORIZONTAL PEAK AND AVERAGE DATA

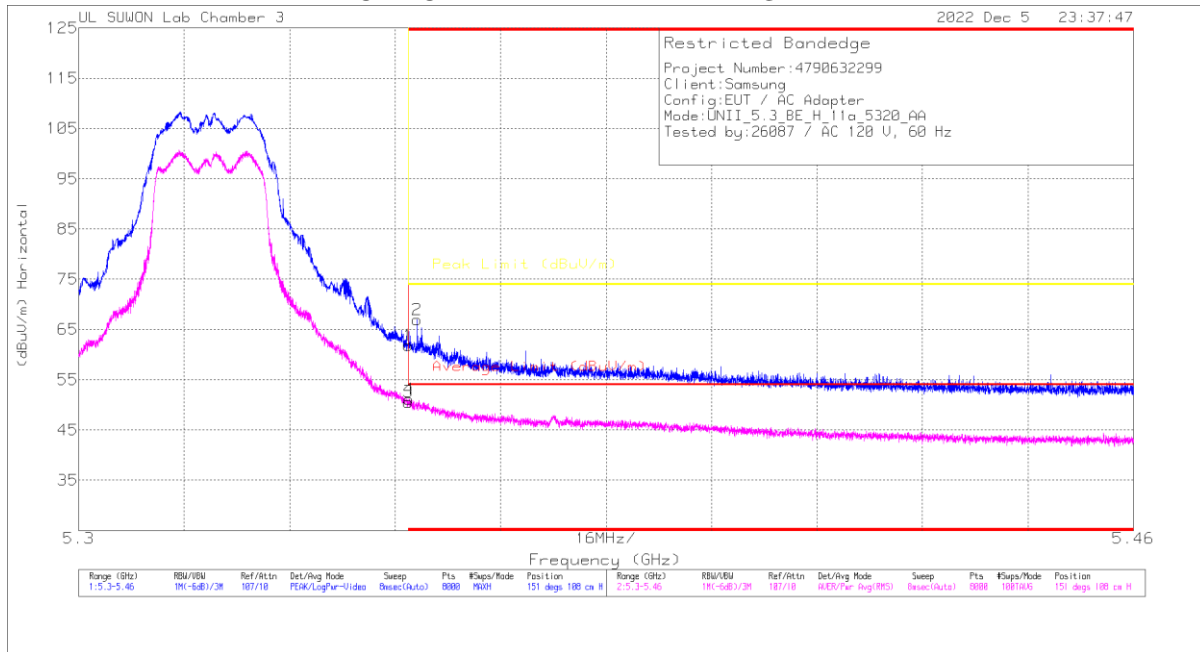

Trace Markers

Marker	Frequency (GHz)	Meter Reading (dBuV)	Det	3117_00218957	10dB_ATT(dB)	DC Cor (dB)	Corrected Reading (dBuV/m)	Average Limit (dBuV/m)	Margin (dB)	Peak Limit (dBuV/m)	PK Margin (dB)	Azimuth (Degs)	Height (cm)	Polarity
1	* 5.35001	46.96	PK	35.1	-20.2	0	61.86	-	-	74	-12.14	151	108	H
2	* 5.35137	52.11	PK	35.1	-20.2	0	67.01	-	-	74	-6.99	151	108	H
3	* 5.35001	35.57	RMS	35.1	-20.2	.1	50.57	54	-3.43	-	-	151	108	H
4	* 5.35011	36.13	RMS	35.1	-20.2	.1	51.13	54	-2.87	-	-	151	108	H

* - indicates frequency in CFR47 Pt 15 / IC RSS-Restricted Band

PK - Peak detector

RMS - RMS detection

BANDEDGE TEST DATA

Mode	Freq. [MHz]	Antenna	Frequency [GHz]	Reading [dBuV]	Detector Mode	ANT Factor	Loss [dB]	DC Corr [dB]	Result [dBuV/m]	AV Limit [dBuV/m]	AV Margin [dB]	PK Limit [dBuV/m]	PK Margin [dB]	Azimuth [Degs]	Height [cm]	Polarity		
802.11a	5320	MIMO	* 5.35001	46.96	Pk	35.10	-20.20	0.00	61.86	-	-	74.00	-12.14	151	108	H		
			* 5.35137	52.11	Pk	35.10	-20.20	0.00	67.01	-	-	74.00	-6.99	151	108	H		
			* 5.35001	35.57	RMS	35.10	-20.20	0.10	50.57	54.00	-3.43	-	-	-	151	108	H	
			* 5.35011	36.13	RMS	35.10	-20.20	0.10	51.13	54.00	-2.87	-	-	-	151	108	H	
			* 5.35001	45.08	Pk	35.10	-20.20	0.00	59.98	-	-	74.00	-14.02	-	-	195	309	V
			* 5.35051	46.07	Pk	35.10	-20.20	0.00	60.97	-	-	74.00	-13.03	-	-	195	309	V
			* 5.35001	33.31	RMS	35.10	-20.20	0.10	48.31	54.00	-5.69	-	-	-	-	195	309	V
			* 5.35177	34.27	RMS	35.10	-20.20	0.10	49.27	54.00	-4.73	-	-	-	-	195	309	V
			* 5.35001	43.20	Pk	35.10	-20.20	0.00	58.10	-	-	74.00	-15.90	-	-	154	119	H
* 5.35031	44.76	Pk	35.10	-20.20	0.00	59.66	-	-	74.00	-14.34	-	-	154	119	H			
* 5.35001	32.60	RMS	35.10	-20.20	0.00	47.50	54.00	-6.50	-	-	-	-	154	119	H			
* 5.35037	33.30	RMS	35.10	-20.20	0.00	48.20	54.00	-5.80	-	-	-	-	154	119	H			
* 5.35001	40.61	Pk	35.10	-20.20	0.00	55.51	-	-	74.00	-18.49	-	-	192	346	V			
* 5.35283	41.97	Pk	35.10	-20.20	0.00	56.87	-	-	74.00	-17.13	-	-	192	346	V			
* 5.35001	29.96	RMS	35.10	-20.20	0.00	44.86	54.00	-9.14	-	-	-	-	192	346	V			
* 5.35141	31.00	RMS	35.10	-20.20	0.00	45.90	54.00	-8.10	-	-	-	-	192	346	V			
* 5.35001	39.23	Pk	35.10	-20.20	0.00	54.13	-	-	74.00	-19.87	-	-	150	113	H			
* 5.35699	42.54	Pk	35.10	-20.20	0.00	57.44	-	-	74.00	-16.56	-	-	150	113	H			
* 5.35001	30.18	RMS	35.10	-20.20	0.12	45.20	54.00	-8.80	-	-	-	-	150	113	H			
* 5.35179	32.13	RMS	35.10	-20.20	0.12	47.15	54.00	-6.85	-	-	-	-	150	113	H			
* 5.35001	39.32	Pk	35.10	-20.20	0.00	54.22	-	-	74.00	-19.78	-	-	197	347	V			
* 5.35437	41.70	Pk	35.10	-20.30	0.00	56.50	-	-	74.00	-17.50	-	-	197	347	V			
* 5.35001	29.19	RMS	35.10	-20.20	0.12	44.21	54.00	-9.79	-	-	-	-	197	347	V			
* 5.35171	30.49	RMS	35.10	-20.20	0.12	45.51	54.00	-8.49	-	-	-	-	197	347	V			
* 5.35001	46.62	Pk	35.10	-20.20	0.00	61.52	-	-	74.00	-12.48	-	-	148	112	H			
* 5.35225	48.32	Pk	35.10	-20.20	0.00	63.22	-	-	74.00	-10.78	-	-	148	112	H			
* 5.35001	33.12	RMS	35.10	-20.20	0.23	48.25	54.00	-5.75	-	-	-	-	148	112	H			
* 5.35003	33.76	RMS	35.10	-20.20	0.23	48.89	54.00	-5.11	-	-	-	-	148	112	H			
* 5.35001	44.04	Pk	35.10	-20.20	0.00	58.94	-	-	74.00	-15.06	-	-	186	346	V			
* 5.35239	47.06	Pk	35.10	-20.20	0.00	61.96	-	-	74.00	-12.04	-	-	186	346	V			
* 5.35001	31.36	RMS	35.10	-20.20	0.23	46.49	54.00	-7.51	-	-	-	-	186	346	V			
* 5.35017	32.29	RMS	35.10	-20.20	0.23	47.42	54.00	-6.58	-	-	-	-	186	346	V			
* 5.35001	45.37	Pk	35.10	-20.20	0.00	60.27	-	-	74.00	-13.73	-	-	151	113	H			
* 5.35277	48.98	Pk	35.10	-20.20	0.00	63.88	-	-	74.00	-10.12	-	-	151	113	H			
* 5.35001	33.21	RMS	35.10	-20.20	0.00	48.11	54.00	-5.89	-	-	-	-	151	113	H			
* 5.35017	33.86	RMS	35.10	-20.20	0.00	48.76	54.00	-5.24	-	-	-	-	151	113	H			
* 5.35001	39.13	Pk	35.10	-20.20	0.00	54.03	-	-	74.00	-19.97	-	-	155	100	V			
* 5.35093	41.37	Pk	35.10	-20.20	0.00	56.27	-	-	74.00	-17.73	-	-	155	100	V			
* 5.35001	29.63	RMS	35.10	-20.20	0.00	44.53	54.00	-9.47	-	-	-	-	155	100	V			
* 5.35047	29.80	RMS	35.10	-20.20	0.00	44.70	54.00	-9.30	-	-	-	-	155	100	V			
* 5.35001	45.78	Pk	35.10	-20.20	0.00	60.68	-	-	74.00	-13.32	-	-	160	100	H			
* 5.35041	49.35	Pk	35.10	-20.20	0.00	64.25	-	-	74.00	-9.75	-	-	160	100	H			
* 5.35001	33.94	RMS	35.10	-20.20	0.11	48.95	54.00	-5.05	-	-	-	-	160	100	H			
* 5.35043	35.46	RMS	35.10	-20.20	0.11	50.47	54.00	-3.53	-	-	-	-	160	100	H			
* 5.35001	44.68	Pk	35.10	-20.20	0.00	59.58	-	-	74.00	-14.42	-	-	186	347	V			
* 5.35087	47.50	Pk	35.10	-20.20	0.00	62.40	-	-	74.00	-11.60	-	-	186	347	V			
* 5.35001	32.63	RMS	35.10	-20.20	0.11	47.64	54.00	-6.36	-	-	-	-	186	347	V			
* 5.35037	33.83	RMS	35.10	-20.20	0.11	48.84	54.00	-5.16	-	-	-	-	186	347	V			
* 5.35001	44.37	Pk	35.10	-20.20	0.00	59.27	-	-	74.00	-14.73	-	-	151	103	H			
* 5.36107	47.58	Pk	35.10	-20.20	0.00	62.48	-	-	74.00	-11.52	-	-	151	103	H			
* 5.35001	32.18	RMS	35.10	-20.20	0.22	47.30	54.00	-6.70	-	-	-	-	151	103	H			
* 5.35211	33.08	RMS	35.10	-20.20	0.22	48.20	54.00	-5.80	-	-	-	-	151	103	H			
* 5.35001	38.23	Pk	35.10	-20.20	0.00	53.13	-	-	74.00	-20.87	-	-	160	100	V			
* 5.35643	41.66	Pk	35.10	-20.30	0.00	56.46	-	-	74.00	-17.54	-	-	160	100	V			
* 5.35001	28.61	RMS	35.10	-20.20	0.22	43.73	54.00	-10.27	-	-	-	-	160	100	V			
* 5.36271	29.65	RMS	35.10	-20.20	0.22	44.77	54.00	-9.23	-	-	-	-	160	100	V			

Note1. Pk - Peak detector, RMS - RMS detector
 Note2. * - indicates frequency in CFR47 Pt 15 / IC RSS-Restricted Band

HARMONICS AND SPURIOUS EMISSIONS(WORST CASE: 802.11a / 5320 MHz)
5320 MHz HORIZONTAL

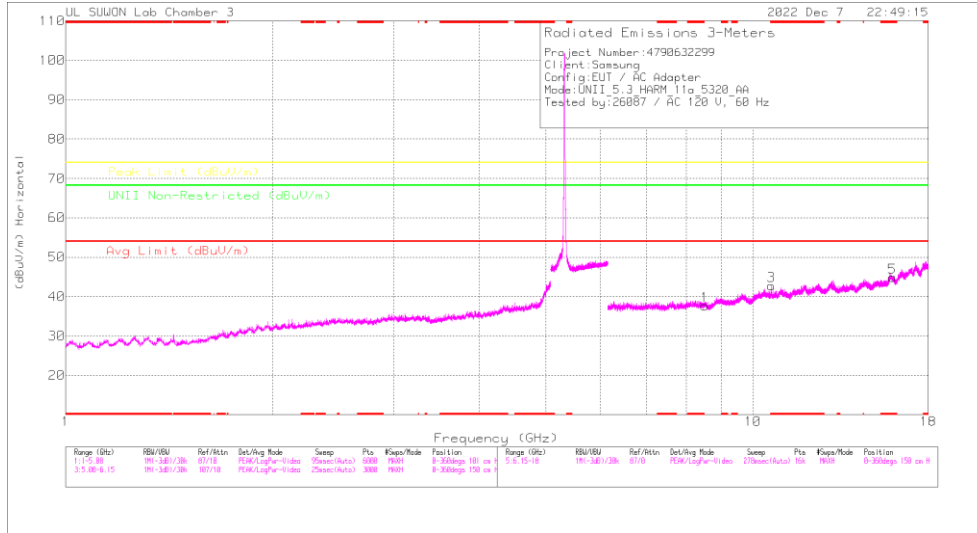

5320 MHz VERTICAL

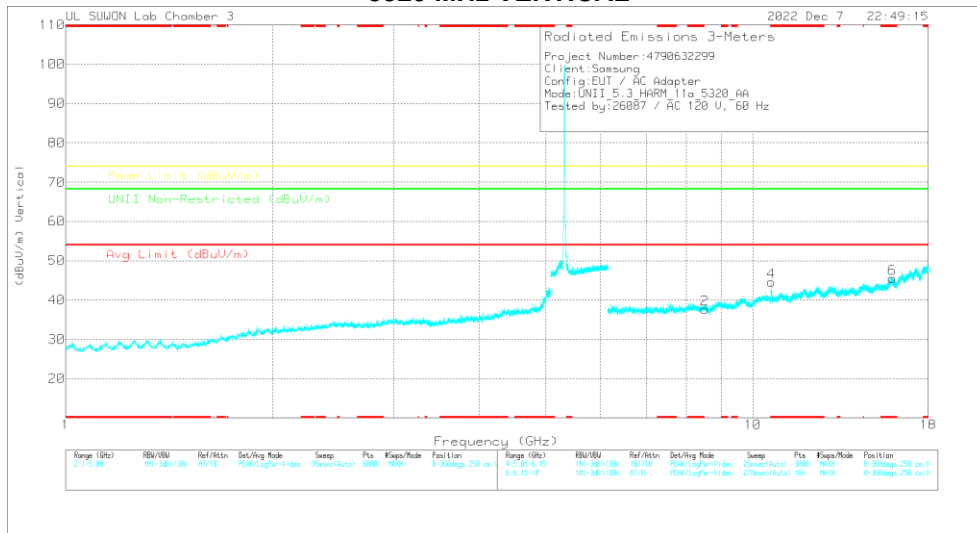

Note: Emission was scanned up to 40GHz; No emissions were detected above the noise floor which was at least 20dB below the specification limit.

5320 MHz DATA

Frequency (GHz)	Mask Reading (dBuV)	Det	317...00218657	6GHz_HPS[B]	DC Corr (dB)	Consolidated Reading (dBuV/m)	Avg Limit (dBuV/m)	Margin (dB)	Peak Limit (dBuV/m)	Margin (dB)	UNII Non-Restricted (dBuV/m)	Margin (dB)	Altitude (ft)	Height (ft)	Polarity
8.52048	34.69	PK-U	36.4	-23	0	48.09	-	-	-	-	68.2	-20.11	0	100	H
8.50699	34.34	PK-U	36.4	-22.9	0	47.84	-	-	-	-	68.2	-20.36	0	100	V
*10.64114	38.17	PK-U	38.3	-21.1	0	55.37	-	-	74	-18.63	-	-	300	103	H
*10.64108	26.95	ADR	38.3	-21.1	1	44.25	54	-9.75	-	-	-	-	300	103	H
*10.6397	39.2	PK-U	38.3	-21.1	0	56.4	-	-	74	-17.6	-	-	83	103	V
*10.6395	28.44	ADR	38.3	-21.1	1	45.74	54	-8.26	-	-	-	-	83	103	V
*15.95543	34.21	PK-U	40.9	-20.4	0	54.71	-	-	74	-19.29	-	-	0	100	H
*15.96219	35.79	PK-U	40.9	-20.4	0	56.29	-	-	74	-17.71	-	-	0	100	V

* - indicates frequency in CFR47 Pt 15 / IC RSS-Restricted Band
 PK-U - U-NII: Maximum Peak
 ADR - U-NII AD primary method, RMS average

HARMONICS AND SPURIOUS EMISSIONS TEST DATA

Mode	Freq. [MHz]	Antenna	Frequency [GHz]	Reading [dBuV]	Detector Mode	ANT Factor	Loss [dB]	DC Corr [dB]	Result [dBuV/m]	AV Limit [dBuV/m]	AV Margin [dB]	PK Limit [dBuV/m]	PK Margin [dB]	Non-Restricted [dBuV/m]	Margin [dB]	Azimuth [Degs]	Height [cm]	Polarity			
802.11a	5260	MIMO	8.4216	35.78	PK-U	36.30	-23.30	0.00	48.78	-	-	74.00	-25.22	-	-	0	100	H			
			* 8.41801	34.77	PK-U	36.30	-23.40	0.00	47.67	-	-	74.00	-26.33	-	-	0	100	V			
			10.521	37.41	PK-U	38.20	-21.10	0.00	54.51	-	-	-	-	-	68.20	-13.69	290	100	H		
			* 10.522	38.63	PK-U	38.20	-21.10	0.00	55.73	-	-	-	-	-	68.20	-12.47	212	112	V		
			* 15.78166	35.11	PK-U	40.60	-20.80	0.00	54.91	-	-	-	-	74.00	-19.09	-	-	0	100	H	
			* 15.77169	34.79	PK-U	40.60	-20.90	0.00	54.49	-	-	-	-	74.00	-19.51	-	-	0	100	V	
	5300	MIMO	* 8.47076	34.95	PK-U	36.30	-23.20	0.00	48.05	-	-	74.00	-25.95	-	-	-	0	100	H		
			* 8.48188	34.73	PK-U	36.40	-23.10	0.00	48.03	-	-	74.00	-25.97	-	-	-	0	100	V		
			* 10.6049	37.21	PK-U	38.30	-21.20	0.00	54.31	-	-	-	-	74.00	-19.69	-	-	295	106	H	
			* 10.60591	24.81	ADR	38.30	-21.20	0.10	42.01	54.00	-11.99	-	-	-	-	-	-	295	106	H	
			* 10.60154	37.94	PK-U	38.30	-21.20	0.00	55.04	-	-	-	-	74.00	-18.96	-	-	208	101	V	
			* 10.60154	27.48	ADR	38.30	-21.20	0.10	44.68	54.00	-9.32	-	-	-	-	-	-	208	101	V	
			* 15.90424	34.68	PK-U	40.80	-20.30	0.00	55.18	-	-	-	-	74.00	-18.82	-	-	0	100	H	
			* 15.90103	35.84	PK-U	40.80	-20.30	0.00	56.34	-	-	-	-	74.00	-17.66	-	-	0	100	V	
			8.520	34.69	PK-U	36.40	-23.00	0.00	48.09	-	-	-	-	-	68.20	-20.11	0	100	H		
			8.507	34.34	PK-U	36.40	-22.90	0.00	47.84	-	-	-	-	-	68.20	-20.36	0	100	V		
	5320	MIMO	* 10.64114	38.17	PK-U	38.30	-21.10	0.00	55.37	-	-	-	74.00	-18.63	-	-	300	103	H		
			* 10.64108	26.95	ADR	38.30	-21.10	0.10	44.25	54.00	-9.75	-	-	-	-	-	300	103	H		
			* 10.6397	39.20	PK-U	38.30	-21.10	0.00	56.40	-	-	-	-	74.00	-17.60	-	-	83	103	V	
			* 10.63995	28.44	ADR	38.30	-21.10	0.10	45.74	54.00	-8.26	-	-	-	-	-	83	103	V		
			* 15.96543	34.21	PK-U	40.90	-20.40	0.00	54.71	-	-	-	-	74.00	-19.29	-	-	0	100	H	
			* 15.96219	35.79	PK-U	40.90	-20.40	0.00	56.29	-	-	-	-	74.00	-17.71	-	-	0	100	V	
			7.952	35.93	PK-U	36.30	-24.20	0.00	48.03	-	-	-	-	-	68.20	-20.17	0	100	H		
			7.946	35.89	PK-U	36.30	-24.20	0.00	47.99	-	-	-	-	-	68.20	-20.21	0	100	V		
	802.11ax (HE20) 4RU Spot-Check	5300	MIMO	* 10.60145	38.52	PK	38.30	-21.20	0.00	55.62	-	-	-	74.00	-18.38	-	-	297	100	H	
				* 10.60005	24.06	ADR	38.30	-21.20	0.00	41.16	54.00	-12.84	-	-	-	-	-	297	100	H	
				* 10.60063	36.15	PK	38.30	-21.20	0.00	53.25	-	-	-	-	74.00	-20.75	-	-	85	100	V
				* 10.60015	25.30	ADR	38.30	-21.20	0.00	42.40	54.00	-11.60	-	-	-	-	-	85	100	V	
				* 15.89608	34.26	PK-U	40.80	-20.30	0.00	54.76	-	-	-	-	74.00	-19.24	-	-	0	100	H
				* 15.90671	34.16	PK-U	40.80	-20.30	0.00	54.66	-	-	-	-	74.00	-19.34	-	-	0	100	V

Note1. PK-U - U-NII: Maximum Peak / ADR - U-NII AD primary method, RMS average

Note2. * - indicates frequency in CFR47 Pt 15 / IC RSS-Restricted Band

11.3. TX ABOVE 1GHz 2Tx MODE IN THE 5.5 GHz BAND

BANDEDGE (WORST CASE: 802.11a / 5500 MHz)

HORIZONTAL PEAK AND AVERAGE DATA

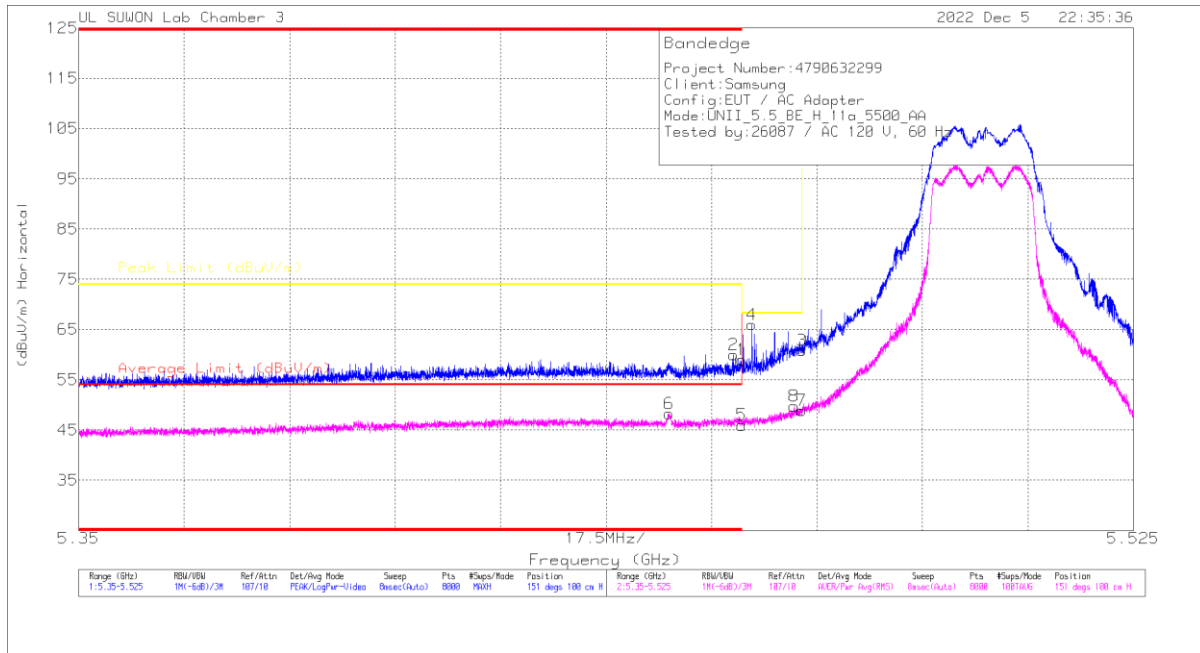

Trace Markers

Marker	Frequency (GHz)	Meter Reading (dBuV)	Det	3117_00218957	10dB_ATT(dB)	DC Cor (dB)	Corrected Reading (dBuV/m)	Average Limit (dBuV/m)	Margin (dB)	Peak Limit (dBuV/m)	PK Margin (dB)	Azimuth (Degs)	Height (cm)	Polarity
1	* 5.45998	43.9	Pk	35.3	-20.1	0	59	-	-	74	-15	151	100	H
2	* 5.45867	44.73	Pk	35.3	-20.1	0	59.93	-	-	74	-14.07	151	100	H
3	5.46998	45.65	Pk	35.3	-20.1	0	60.85	-	-	68.2	-7.35	151	100	H
4	5.46171	50.73	Pk	35.3	-20.1	0	65.93	-	-	68.2	-2.27	151	100	H
5	* 5.45998	30.66	RMS	35.3	-20.1	.1	45.96	54	-8.04	-	-	151	100	H
6	* 5.44798	32.94	RMS	35.3	-20.1	.1	48.24	54	-5.76	-	-	151	100	H
7	5.46998	33.56	RMS	35.3	-20.1	.1	48.86	-	-	-	-	151	100	H
8	5.46889	34.5	RMS	35.3	-20.1	.1	49.8	-	-	-	-	151	100	H

* - indicates frequency in CFR47 Pt 15 / IC RSS-Restricted Band
 Pk - Peak detector

BANDEDGE TEST DATA

Mode	Freq. [MHz]	Antenna	Frequency [GHz]	Reading [dBuV]	Detector Mode	ANT Factor	Loss [dB]	DC Corr [dB]	Result dBuV/m	AV Limit dBuV/m	AV Margin [dB]	PK Limit dBuV/m	PK Margin [dB]	Azimuth [Degs]	Height [cm]	Polarity		
802.11a	5500	MIMO	* 5.45998	43.80	Pk	35.30	-20.10	0.00	59.00	-	-	74.00	-15.00	151	100	H		
			* 5.45867	44.73	Pk	35.30	-20.10	0.00	59.93	-	-	74.00	-14.07	151	100	H		
			5.46998	45.65	Pk	35.30	-20.10	0.00	60.85	-	-	68.20	-7.35	151	100	H		
			5.46171	50.73	Pk	35.30	-20.10	0.00	65.93	-	-	68.20	-2.27	151	100	H		
			* 5.45998	30.66	RMS	35.30	-20.10	0.10	45.96	54.00	-8.04	-	-	-	-	151	100	H
			* 5.44799	32.94	RMS	35.30	-20.10	0.10	48.24	54.00	-5.76	-	-	-	-	151	100	H
			5.46998	33.56	RMS	35.30	-20.10	0.10	48.86	-	-	-	-	-	-	151	100	H
			5.46869	34.50	RMS	35.30	-20.10	0.10	49.80	-	-	-	-	-	-	151	100	H
			* 5.45998	39.91	Pk	35.30	-20.10	0.00	55.11	-	-	74.00	-18.89	211	100	V		
			* 5.45232	43.39	Pk	35.30	-20.10	0.00	58.59	-	-	74.00	-15.41	211	100	V		
	5.46998	41.47	Pk	35.30	-20.10	0.00	56.67	-	-	68.20	-11.53	211	100	V				
	5.46961	46.91	Pk	35.30	-20.10	0.00	62.11	-	-	68.20	-6.09	211	100	V				
	* 5.45998	29.29	RMS	35.30	-20.10	0.10	44.59	54.00	-9.41	-	-	-	-	211	100	V		
	* 5.42651	31.29	RMS	35.30	-20.10	0.10	46.59	54.00	-7.41	-	-	-	-	211	100	V		
	5.46998	30.83	RMS	35.30	-20.10	0.10	46.13	-	-	-	-	-	-	211	100	V		
	5.46991	31.83	RMS	35.30	-20.10	0.10	47.13	-	-	-	-	-	-	211	100	V		
	5.72500	49.71	Pk	34.80	-22.20	0.00	62.31	-	-	68.20	-5.89	307	128	H				
	5.72922	50.01	Pk	34.80	-22.10	0.00	62.71	-	-	68.20	-5.49	307	128	H				
	5.72502	50.38	Pk	34.80	-22.20	0.00	62.98	-	-	68.20	-5.22	154	345	V				
	5.72506	52.57	Pk	34.80	-22.20	0.00	65.17	-	-	68.20	-3.03	154	345	V				
802.11n (HT20)	5500	MIMO	* 5.45998	41.77	Pk	35.30	-20.10	0.00	56.97	-	-	74.00	-17.03	152	107	H		
			* 5.43635	44.86	Pk	35.30	-20.10	0.00	60.06	-	-	74.00	-13.94	152	107	H		
			5.46998	43.88	Pk	35.30	-20.10	0.00	59.08	-	-	68.20	-9.12	152	107	H		
			5.46972	45.54	Pk	35.30	-20.10	0.00	60.74	-	-	68.20	-7.46	152	107	H		
			* 5.45998	30.82	RMS	35.30	-20.10	0.00	46.02	54.00	-7.98	-	-	-	-	152	107	H
			* 5.44817	33.55	RMS	35.30	-20.10	0.00	48.75	54.00	-5.25	-	-	-	-	152	107	H
			5.46998	31.29	RMS	35.30	-20.10	0.00	46.49	-	-	-	-	-	-	152	107	H
			5.46974	32.37	RMS	35.30	-20.10	0.00	47.57	-	-	-	-	-	-	152	107	H
			* 5.45998	39.52	Pk	35.30	-20.10	0.00	54.72	-	-	74.00	-19.28	189	105	V		
			* 5.45044	42.35	Pk	35.30	-20.10	0.00	57.55	-	-	74.00	-16.45	189	105	V		
	5.46998	38.90	Pk	35.30	-20.10	0.00	54.10	-	-	68.20	-14.10	189	105	V				
	5.46716	43.49	Pk	35.30	-20.10	0.00	58.69	-	-	68.20	-9.51	189	105	V				
	* 5.45998	29.57	RMS	35.30	-20.10	0.00	44.77	54.00	-9.23	-	-	-	-	189	105	V		
	* 5.41859	30.90	RMS	35.20	-20.10	0.00	46.00	54.00	-8.00	-	-	-	-	189	105	V		
	5.46998	30.01	RMS	35.30	-20.10	0.00	45.21	-	-	-	-	-	-	189	105	V		
	5.46917	30.95	RMS	35.30	-20.10	0.00	46.15	-	-	-	-	-	-	189	105	V		
	5.72500	47.42	Pk	35.70	-19.50	0.00	63.62	-	-	68.20	-4.58	154	118	H				
	5.72586	49.49	Pk	35.70	-19.50	0.00	65.69	-	-	68.20	-2.51	154	118	H				
	5.72500	43.47	Pk	35.70	-19.50	0.00	59.67	-	-	68.20	-8.53	190	103	V				
	5.72502	45.66	Pk	35.70	-19.50	0.00	61.86	-	-	68.20	-6.34	190	103	V				
802.11n (HT40)	5510	MIMO	* 5.45998	43.88	Pk	35.30	-20.10	0.00	59.08	-	-	74.00	-14.92	154	106	H		
			* 5.45948	47.92	Pk	35.30	-20.10	0.00	63.12	-	-	74.00	-10.88	154	106	H		
			5.46998	45.89	Pk	35.30	-20.10	0.00	61.09	-	-	68.20	-7.11	154	106	H		
			5.46834	49.58	Pk	35.30	-20.10	0.00	64.78	-	-	68.20	-3.42	154	106	H		
			* 5.45998	31.38	RMS	35.30	-20.10	0.12	46.70	54.00	-7.30	-	-	-	-	154	106	H
			* 5.45806	32.73	RMS	35.30	-20.10	0.12	48.05	54.00	-5.95	-	-	-	-	154	106	H
			5.46998	35.05	RMS	35.30	-20.10	0.00	50.25	-	-	-	-	-	-	154	106	H
			5.46961	35.57	RMS	35.30	-20.10	0.00	50.77	-	-	-	-	-	-	154	106	H
			* 5.45998	44.45	Pk	35.30	-20.10	0.00	59.65	-	-	74.00	-14.35	200	101	V		
			* 5.45582	46.38	Pk	35.30	-20.10	0.00	61.58	-	-	74.00	-12.42	200	101	V		
	5.46998	43.52	Pk	35.30	-20.10	0.00	58.72	-	-	68.20	-9.48	200	101	V				
	5.46786	47.29	Pk	35.30	-20.10	0.00	62.49	-	-	68.20	-5.71	200	101	V				
	* 5.45998	30.65	RMS	35.30	-20.10	0.12	45.97	54.00	-8.03	-	-	-	-	200	100	V		
	* 5.45385	30.65	RMS	35.30	-20.10	0.12	45.97	54.00	-8.03	-	-	-	-	200	100	V		
	5.46998	33.15	RMS	35.30	-20.10	0.00	48.35	-	-	-	-	-	-	200	100	V		
	5.46996	33.60	RMS	35.30	-20.10	0.00	48.80	-	-	-	-	-	-	200	100	V		
	5.72500	44.10	Pk	35.70	-19.50	0.00	60.30	-	-	68.20	-7.90	157	103	H				
	5.72582	46.73	Pk	35.70	-19.50	0.00	62.93	-	-	68.20	-5.27	157	103	H				
	5.72500	39.48	Pk	35.70	-19.50	0.00	55.68	-	-	68.20	-12.52	165	334	V				
	5.72700	43.07	Pk	35.70	-19.50	0.00	59.27	-	-	68.20	-8.93	165	334	V				
802.11ac (VHT80)	5530	MIMO	* 5.45999	41.75	Pk	34.70	-22.70	0.00	53.75	-	-	74.00	-20.25	236	165	H		
			* 5.45036	45.58	Pk	34.70	-22.60	0.00	57.68	-	-	74.00	-16.32	236	165	H		
			5.46998	43.16	Pk	34.70	-22.70	0.00	55.16	-	-	68.20	-13.04	236	165	H		
			5.46115	45.63	Pk	34.70	-22.70	0.00	57.63	-	-	68.20	-10.57	236	165	H		
			* 5.45999	33.27	RMS	34.70	-21.20	0.23	47.00	54.00	-7.00	-	-	-	-	236	165	H
			* 5.45846	33.62	RMS	34.70	-21.20	0.23	47.35	54.00	-6.65	-	-	-	-	236	165	H
			5.46998	33.44	RMS	34.70	-21.20	0.23	47.17	-	-	-	-	-	-	236	165	H
			5.46928	33.96	RMS	34.70	-21.20	0.23	47.69	-	-	-	-	-	-	236	165	H
			* 5.45999	44.92	Pk	34.70	-22.70	0.00	56.92	-	-	74.00	-17.08	147	386	V		
			* 5.45758	46.52	Pk	34.70	-22.60	0.00	58.62	-	-	74.00	-15.38	147	386	V		
	5.46998	44.03	Pk	34.70	-22.70	0.00	56.03	-	-	68.20	-12.17	147	386	V				
	5.46078	46.28	Pk	34.70	-22.70	0.00	58.28	-	-	68.20	-9.92	147	386	V				
	* 5.45999	34.01	RMS	34.70	-21.20	0.23	47.74	54.00	-6.26	-	-	-	-	147	386	V		
	* 5.45819	34.37	RMS	34.70	-21.20	0.23	48.10	54.00	-5.90	-	-	-	-	147	386	V		
	5.46998	33.79	RMS	34.70	-21.20	0.23	47.52	-	-	-	-	-	-	147	386	V		
	5.46648	34.73	RMS	34.70	-21.20	0.23	48.46	-	-	-	-	-	-	147	386	V		
	5.72500	40.91	Pk	34.80	-22.20	0.00	53.51	-	-	68.20	-14.69	126	104	H				
	5.82462	44.18	Pk	34.90	-22.10	0.00	56.98	-	-	68.20	-11.22	126	104	H				
	5.72502	42.35	Pk	34.80	-22.20	0.00	54.95	-	-	68.20	-13.25	167	130	V				
	5.79745	44.46	Pk	34.90	-22.00	0.00	57.36	-	-	68.20	-10.84	167	130	V				

Mode	Freq. [MHz]	Antenna	Frequency [GHz]	Reading [dBuV]	Detector Mode	ANT Factor	Loss [dB]	DC Corr [dB]	Result dBuV/m	AV Limit dBuV/m	AV Margin [dB]	PK Limit dBuV/m	PK Margin [dB]	Azimuth [Degs]	Height [cm]	Polarity	
802.11ax (HE20)	5500	MIMO	* 5.45998	41.23	Pk	35.30	-20.10	0.00	56.43	-	-	74.00	-17.57	149	123	H	
			* 5.45771	45.76	Pk	35.30	-20.10	0.00	60.96	-	-	74.00	-13.04	149	123	H	
			5.46998	44.75	Pk	35.30	-20.10	0.00	59.95	-	-	68.20	-8.25	149	123	H	
			5.46320	50.47	Pk	35.30	-20.10	0.00	65.67	-	-	68.20	-2.53	149	123	H	
			* 5.45998	31.24	RMS	35.30	-20.10	0.00	46.44	54.00	-7.56	-	-	-	149	123	H
			* 5.4479	33.36	RMS	35.30	-20.10	0.00	48.56	54.00	-5.44	-	-	-	149	123	H
			5.46998	33.22	RMS	35.30	-20.10	0.00	48.42	-	-	-	-	-	149	123	H
			5.46987	33.88	RMS	35.30	-20.10	0.00	49.08	-	-	-	-	-	149	123	H
			* 5.45998	38.21	Pk	35.30	-20.10	0.00	53.41	-	-	74.00	-20.59	193	308	V	
			* 5.45797	42.72	Pk	35.30	-20.10	0.00	57.92	-	-	74.00	-16.08	193	308	V	
	5.46998	43.29	Pk	35.30	-20.10	0.00	58.49	-	-	68.20	-9.71	193	308	V			
	5.46420	46.24	Pk	35.30	-20.10	0.00	61.44	-	-	68.20	-6.76	193	308	V			
	* 5.45998	29.26	RMS	35.30	-20.10	0.00	44.46	54.00	-9.54	-	-	-	193	308	V		
	* 5.44775	30.75	RMS	35.30	-20.10	0.00	45.95	54.00	-8.05	-	-	-	193	308	V		
	5.46998	29.92	RMS	35.30	-20.10	0.00	45.12	-	-	-	-	-	193	308	V		
	5.46716	30.71	RMS	35.30	-20.10	0.00	45.91	-	-	-	-	-	193	308	V		
	5700	MIMO	5.72500	47.63	Pk	35.70	-19.50	0.00	63.83	-	-	68.20	-4.37	154	100	H	
			5.72666	49.04	Pk	35.70	-19.50	0.00	65.24	-	-	68.20	-2.96	154	100	H	
			5.72500	44.02	Pk	35.70	-19.50	0.00	60.22	-	-	68.20	-7.98	190	100	V	
			5.72560	45.34	Pk	35.70	-19.50	0.00	61.54	-	-	68.20	-6.66	190	100	V	
* 5.45998			42.28	Pk	35.30	-20.10	0.00	57.48	-	-	74.00	-16.52	151	116	H		
* 5.45928			44.22	Pk	35.30	-20.10	0.00	59.42	-	-	74.00	-14.58	151	116	H		
5.46998			45.88	Pk	35.30	-20.10	0.00	61.08	-	-	68.20	-7.12	151	116	H		
5.46803			49.51	Pk	35.30	-20.10	0.00	64.71	-	-	68.20	-3.49	151	116	H		
* 5.45998			32.06	RMS	35.30	-20.10	0.11	47.37	54.00	-6.63	-	-	-	151	116	H	
* 5.45768			32.64	RMS	35.30	-20.10	0.11	47.95	54.00	-6.05	-	-	-	151	116	H	
802.11ax (HE40)	5510	MIMO	5.46998	33.67	RMS	35.30	-20.10	0.11	48.98	-	-	-	-	151	116	H	
			5.46932	34.96	RMS	35.30	-20.10	0.11	50.27	-	-	-	-	151	116	H	
			* 5.45998	38.36	Pk	35.30	-20.10	0.00	53.56	-	-	74.00	-20.44	197	326	V	
			* 5.44906	43.16	Pk	35.30	-20.10	0.00	58.36	-	-	74.00	-15.64	197	326	V	
			5.46998	41.85	Pk	35.30	-20.10	0.00	57.05	-	-	68.20	-11.15	197	326	V	
			5.46703	44.87	Pk	35.30	-20.10	0.00	60.07	-	-	68.20	-8.13	197	326	V	
			* 5.45998	29.70	RMS	35.30	-20.10	0.11	45.01	54.00	-8.99	-	-	-	197	326	V
			* 5.4581	30.49	RMS	35.30	-20.10	0.11	45.80	54.00	-8.20	-	-	-	197	326	V
			5.46998	30.76	RMS	35.30	-20.10	0.11	46.07	-	-	-	-	-	197	326	V
			5.46934	31.44	RMS	35.30	-20.10	0.11	46.75	-	-	-	-	-	197	326	V
	5670	MIMO	5.72500	41.01	Pk	35.70	-19.50	0.00	57.21	-	-	68.20	-10.99	159	100	H	
			5.73316	44.51	Pk	35.70	-19.50	0.00	60.71	-	-	68.20	-7.49	159	100	H	
			5.72500	41.44	Pk	35.70	-19.50	0.00	57.64	-	-	68.20	-10.56	10	112	V	
			5.72577	43.09	Pk	35.70	-19.50	0.00	59.29	-	-	68.20	-8.91	10	112	V	
			* 5.45998	42.09	Pk	35.30	-20.10	0.00	57.29	-	-	74.00	-16.71	149	115	H	
			* 5.45348	45.07	Pk	35.30	-20.10	0.00	60.27	-	-	74.00	-13.73	149	115	H	
			5.46998	42.42	Pk	35.30	-20.10	0.00	57.62	-	-	68.20	-10.58	149	115	H	
			5.46599	46.39	Pk	35.30	-20.10	0.00	61.59	-	-	68.20	-6.61	149	115	H	
			* 5.45998	31.23	RMS	35.30	-20.10	0.22	46.65	54.00	-7.35	-	-	-	149	115	H
			* 5.45766	32.60	RMS	35.30	-20.10	0.22	48.02	54.00	-5.98	-	-	-	149	115	H
802.11ax (HE80)	5530	MIMO	5.46998	31.65	RMS	35.30	-20.10	0.22	47.07	-	-	-	-	149	115	H	
			5.46797	33.08	RMS	35.30	-20.10	0.22	48.50	-	-	-	-	149	115	H	
			* 5.45998	40.54	Pk	35.30	-20.10	0.00	55.74	-	-	74.00	-18.26	188	344	V	
			* 5.45963	41.68	Pk	35.30	-20.10	0.00	56.88	-	-	74.00	-17.12	188	344	V	
			5.46998	41.06	Pk	35.30	-20.10	0.00	56.26	-	-	68.20	-11.94	188	344	V	
			5.46528	43.82	Pk	35.30	-20.10	0.00	59.02	-	-	68.20	-9.18	188	344	V	
			* 5.45998	29.70	RMS	35.30	-20.10	0.22	45.12	54.00	-8.88	-	-	-	188	344	V
			* 5.45764	30.48	RMS	35.30	-20.10	0.22	45.90	54.00	-8.10	-	-	-	188	344	V
			5.46998	30.57	RMS	35.30	-20.10	0.22	45.99	-	-	-	-	-	188	344	V
			5.46889	31.07	RMS	35.30	-20.10	0.22	46.49	-	-	-	-	-	188	344	V
	5610	MIMO	5.72500	38.13	Pk	35.70	-19.50	0.00	54.33	-	-	68.20	-13.87	152	103	H	
			5.73010	40.91	Pk	35.70	-19.50	0.00	57.11	-	-	68.20	-11.09	152	103	H	
			5.72500	36.73	Pk	35.70	-19.50	0.00	52.93	-	-	68.20	-15.27	189	100	V	
			5.82069	39.80	Pk	35.80	-19.30	0.00	56.30	-	-	68.20	-11.90	189	100	V	

Note1. Pk - Peak detector, RMS - RMS detector
 Note2. * - indicates frequency in CFR47 Pt 15 / IC RSS-Restricted Band

HARMONICS AND SPURIOUS EMISSIONS(WORST CASE: 802.11a / 5580 MHz)
5580 MHz HORIZONTAL

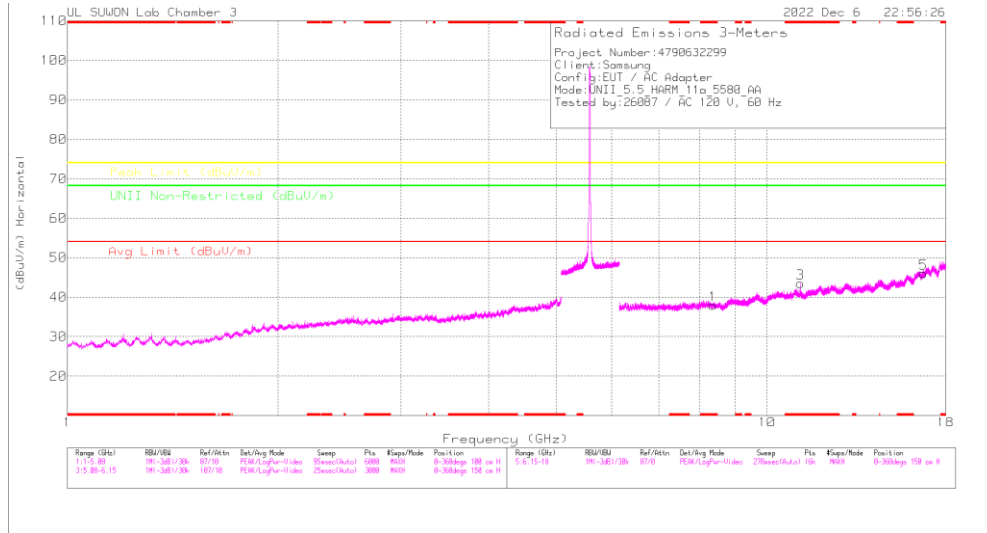

5580 MHz VERTICAL

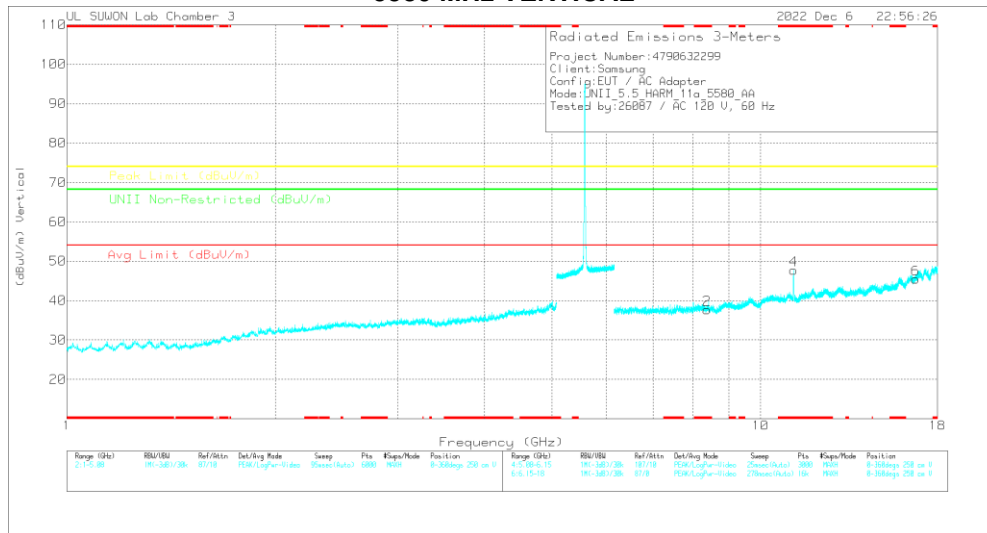

Note. Emission was scanned up to 40GHz; No emissions were detected above the noise floor which was at least 20dB below the specification limit.

5580 MHz DATA

Radiated Emissions

Frequency (GHz)	Meas Reading (dBuV)	Det	317_00218657	6GHz_HPSDR	DC Corr (dB)	Corrected Reading (dBuV/m)	Avg Limit (dBuV/m)	Margin (dB)	Peak Limit (dBuV/m)	Margin (dB)	UNII Non-Restricted (dBuV/m)	Margin (dB)	Altitude (m)	Height (m)	Polarity
* 8.37059	35.84	PK-U	36.2	-23.6	0	48.44	-	-	74	-25.56	-	-	0	100	H
* 8.37611	35.35	PK-U	36.3	-23.5	0	48.15	-	-	74	-25.85	-	-	0	100	V
* 11.15444	38.76	PK-U	38.6	-21.5	0	55.86	-	-	74	-18.14	-	-	179	100	H
* 11.16016	29.38	ADR	38.6	-21.5	1	45.58	54	-8.42	-	-	-	-	179	100	H
* 11.15444	44.07	PK-U	38.6	-21.5	0	61.17	-	-	74	-12.83	-	-	0	103	V
* 11.15986	32.85	ADR	38.6	-21.5	1	50.05	54	-3.95	-	-	-	-	0	103	V
16.74079	32.91	PK-U	42.3	-18.8	0	56.41	-	-	-	-	68.2	-11.79	0	100	H
16.74703	32.87	PK-U	42.3	-18.8	0	56.37	-	-	-	-	68.2	-11.83	0	100	V

* - indicates frequency in CFR47 Pt 15 / IC RSS-Restricted Band
 PK-U - U-NII: Maximum Peak
 ADR - U-NII AD primary method, RMS average

HARMONICS AND SPURIOUS EMISSIONS TEST DATA

Mode	Freq. [MHz]	Antenna	Frequency [GHz]	Reading [dBuV]	Detector Mode	ANT Factor	Loss [dB]	DC Corr [dB]	Result [dBuV/m]	AV Limit [dBuV/m]	AV Margin [dB]	PK Limit [dBuV/m]	PK Margin [dB]	Non-Restricted [dBuV/m]	Margin [dB]	Azimuth [Degs]	Height [cm]	Polarity				
802.11a	5500	MIMO	* 8.25167	36.75	PK-U	36.20	-23.60	0.00	49.35	-	-	74.00	-24.65	-	-	0	100	H				
			* 8.24489	36.11	PK-U	36.20	-23.60	0.00	48.71	-	-	74.00	-25.29	-	-	0	101	V				
			* 11.00155	38.33	PK-U	38.50	-21.20	0.00	56.63	-	-	74.00	-18.37	-	-	57	101	H				
			* 11.00027	27.32	ADR	38.50	-21.20	0.10	44.72	54.00	-9.28	-	-	-	-	-	57	101	H			
			* 11.00119	41.22	PK-U	38.50	-21.20	0.00	58.52	-	-	74.00	-15.48	-	-	4	102	V				
			* 11.00019	30.21	ADR	38.50	-21.20	0.10	47.61	54.00	-6.39	-	-	-	-	4	102	V				
	5580	MIMO	* 16.499	33.78	PK-U	42.00	-19.30	0.00	56.48	-	-	-	-	-	68.20	-11.72	0	100	H			
			* 16.494	33.13	PK-U	42.00	-19.30	0.00	56.83	-	-	-	-	-	68.20	-12.37	0	101	V			
			* 8.37059	35.84	PK-U	36.20	-23.60	0.00	48.44	-	-	74.00	-25.56	-	-	0	100	H				
			* 8.37611	35.35	PK-U	36.30	-23.50	0.00	48.15	-	-	74.00	-25.85	-	-	0	100	V				
			* 11.15444	38.76	PK-U	38.60	-21.50	0.00	56.86	-	-	74.00	-18.14	-	-	179	100	H				
			* 11.16016	28.38	ADR	38.60	-21.50	0.10	46.58	54.00	-8.42	-	-	-	-	179	100	H				
	5700	MIMO	* 11.15444	44.07	PK-U	38.60	-21.50	0.00	61.17	-	-	74.00	-12.83	-	-	0	103	V				
			* 11.15986	32.85	ADR	38.60	-21.50	0.10	50.05	54.00	-3.95	-	-	-	0	103	V					
			* 16.741	32.91	PK-U	42.30	-18.80	0.00	56.41	-	-	-	-	-	68.20	-11.79	0	100	H			
			* 16.747	32.87	PK-U	42.30	-18.80	0.00	56.37	-	-	-	-	-	68.20	-11.83	0	100	V			
			* 8.550	34.30	PK-U	36.50	-22.90	0.00	47.90	-	-	-	-	-	68.20	-20.30	0	100	H			
			* 8.551	34.20	PK-U	36.50	-22.90	0.00	47.80	-	-	-	-	-	68.20	-20.40	0	100	V			
	5720	MIMO	* 11.40015	38.10	PK-U	38.60	-21.40	0.00	55.30	-	-	74.00	-18.70	-	-	164	100	H				
			* 11.39985	26.65	ADR	38.60	-21.40	0.10	43.95	54.00	-10.05	-	-	-	164	100	H					
			* 11.40002	41.77	PK-U	38.60	-21.40	0.00	58.97	-	-	74.00	-15.03	-	-	1	100	V				
			* 11.39996	30.43	ADR	38.60	-21.40	0.10	47.73	54.00	-6.27	-	-	-	1	100	V					
			* 17.100	32.25	PK-U	42.30	-17.90	0.00	56.65	-	-	-	-	-	68.20	-11.55	0	100	H			
			* 17.097	32.17	PK-U	42.30	-18.00	0.00	56.47	-	-	-	-	-	68.20	-11.73	0	100	V			
	802.11n (HT20) Spot-Check	5580	MIMO	* 8.36061	35.21	PK-U	36.20	-23.60	0.00	47.81	-	-	74.00	-26.19	-	-	0	100	H			
				* 8.37517	35.73	PK-U	36.30	-23.50	0.00	48.53	-	-	74.00	-25.47	-	-	0	100	V			
				* 11.1643	38.60	PK-U	38.60	-21.50	0.00	55.70	-	-	74.00	-18.30	-	-	94	108	H			
				* 11.1601	26.17	ADR	38.60	-21.50	0.00	43.27	54.00	-10.73	-	-	-	-	94	108	H			
				* 11.15862	44.44	PK-U	38.60	-21.50	0.00	61.54	-	-	74.00	-12.46	-	-	2	100	V			
				* 11.16027	30.66	ADR	38.60	-21.50	0.00	47.76	54.00	-6.24	-	-	-	2	100	V				
				* 16.739	34.10	PK-U	42.30	-18.80	0.00	57.60	-	-	-	-	-	68.20	-10.60	0	100	H		
				* 16.743	34.62	PK-U	42.30	-18.80	0.00	58.12	-	-	-	-	-	68.20	-10.08	0	100	V		
				802.11n (HT40) Spot-Check	5590	MIMO	* 8.37685	35.31	PK-U	36.30	-23.50	0.00	48.11	-	-	74.00	-25.89	-	-	0	100	H
							* 8.39071	35.67	PK-U	36.30	-23.50	0.00	48.47	-	-	74.00	-25.53	-	-	0	100	V
	* 11.17105	34.41	PK-U				38.60	-21.40	0.00	51.61	-	-	74.00	-22.39	-	-	57	100	H			
	* 11.17995	36.16	PK-U				38.60	-21.40	0.00	53.36	54.00	-12.69	-	-	-	57	100	H				
* 11.1798	26.18	ADR	38.60				-21.40	0.12	43.50	54.00	-10.50	-	-	-	348	106	V					
* 16.763	31.88	PK-U	42.40				-18.70	0.00	55.58	-	-	-	-	-	68.20	-12.62	0	100	H			
* 16.764	31.76	PK-U	42.40				-18.70	0.00	55.46	-	-	-	-	-	68.20	-12.74	0	100	V			
802.11ac (VHT80) Spot-Check	5610	MIMO	* 8.39719				35.16	PK-U	36.30	-23.50	0.00	47.96	-	-	74.00	-26.04	-	-	0	100	H	
			* 8.40971	35.38	PK-U	36.30	-23.40	0.00	48.28	-	-	74.00	-25.72	-	-	0	100	V				
			* 11.2193	34.25	PK-U	38.60	-21.30	0.00	51.55	-	-	74.00	-22.45	-	-	53	108	H				
			* 11.21986	24.09	ADR	38.60	-21.30	0.23	41.62	54.00	-12.38	-	-	-	53	108	H					
			* 11.22034	34.80	PK-U	38.60	-21.30	0.00	52.10	-	-	74.00	-21.90	-	-	345	106	V				
			* 11.21994	25.87	ADR	38.60	-21.30	0.23	43.40	54.00	-10.60	-	-	-	345	106	V					
			* 16.821	32.45	PK-U	42.40	-18.40	0.00	56.45	-	-	-	-	-	68.20	-11.75	0	100	H			
			* 16.823	31.94	PK-U	42.40	-18.40	0.00	55.94	-	-	-	-	-	68.20	-12.26	0	100	V			
802.11ax (HE20) 4RU	5580	MIMO	* 8.36933	35.59	PK-U	36.20	-23.60	0.00	48.19	-	-	74.00	-25.81	-	-	0	100	H				
			* 8.37144	35.32	PK-U	36.20	-23.60	0.00	47.92	-	-	74.00	-26.08	-	-	0	100	V				
			* 11.16015	36.40	PK-U	38.60	-21.50	0.00	53.50	-	-	74.00	-20.50	-	-	176	115	H				
			* 11.16027	24.70	ADR	38.60	-21.50	0.00	41.80	54.00	-12.20	-	-	-	176	115	H					
			* 11.1601	38.14	PK-U	38.60	-21.50	0.00	55.24	-	-	74.00	-18.76	-	-	254	101	V				
			* 11.15993	27.27	ADR	38.60	-21.50	0.00	44.37	54.00	-9.63	-	-	-	254	101	V					
			* 16.740	32.00	PK-U	42.30	-18.80	0.00	55.50	-	-	-	-	-	68.20	-12.70	0	100	H			
			* 16.742	32.08	PK-U	42.30	-18.80	0.00	55.58	-	-	-	-	-	68.20	-12.62	0	100	V			

Note1. PK-U - U-NII: Maximum Peak / ADR - U-NII AD primary method, RMS average
 Note2. * - indicates frequency in CFR47 Pt 15 / IC RSS-Restricted Band

11.4. TX ABOVE 1GHz 2Tx MODE IN THE 5.8 GHz BAND

BANDEDGE (WORST CASE: 802.11ax HE40 SU / 5795 MHz)

VERTICAL PEAK DATA

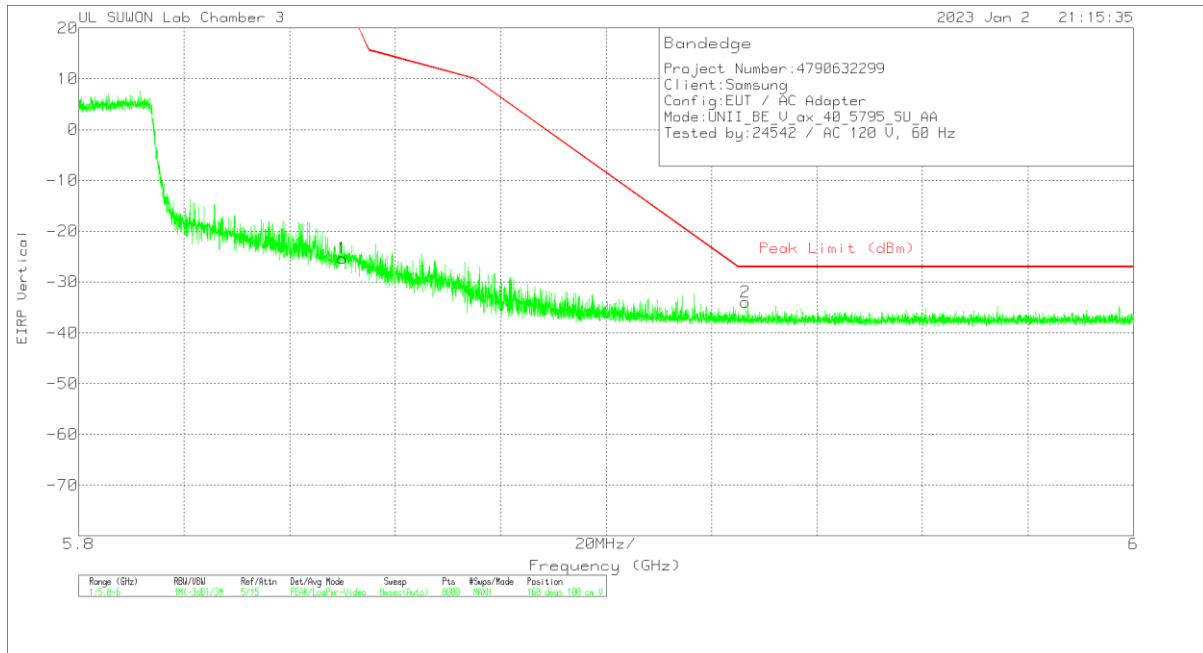

Trace Markers

Marker	Frequency (GHz)	Meter Reading (dBm)	Det	3117_00218957	10dB_ATT[dB]	Conversion Factor (dB)	DC Corr (dB)	Corrected Reading EIRP	Peak Limit (dBm)	PK Margin (dB)	Azimuth (Degs)	Height (cm)	Polarity
1	5.85001	-53.76	Pk	35.9	-19.3	11.8	0	-25.36	26.99	-52.35	168	100	V
2	5.92642	-62.41	Pk	36	-19.3	11.8	0	-33.91	-27	-6.91	168	100	V

Pk - Peak detector

BANDEDGE TEST DATA

Mode	Freq. [MHz]	Antenna	Frequency [GHz]	Reading [dBm]	Detector Mode	ANT Factor	Loss [dB]	Conv. F [dB]	DC Corr [dB]	Result [dBm]	PK Limit [dBm]	PK Margin [dB]	Azimuth [Degs]	Height [cm]	Polarity
802.11a	5745	MIMO	5.72500	-48.28	Pk	35.60	-19.50	11.80	0.00	-20.38	27.00	-47.38	152	112	H
			5.64122	-62.35	Pk	35.50	-19.80	11.80	0.00	-34.85	-27.00	-7.85	152	112	H
			5.72500	-52.45	Pk	35.60	-19.50	11.80	0.00	-24.55	27.00	-51.55	195	328	V
			5.64740	-63.10	Pk	35.50	-19.80	11.80	0.00	-35.60	-27.00	-8.60	195	328	V
			5.85001	-52.58	Pk	35.90	-19.30	11.80	0.00	-24.18	26.99	-51.17	152	107	H
	5825	MIMO	5.98432	-63.31	Pk	36.00	-19.20	11.80	0.00	-34.71	-27.00	-7.71	152	107	H
			5.85001	-55.77	Pk	35.90	-19.30	11.80	0.00	-27.37	26.99	-54.36	194	318	V
			5.95054	-62.80	Pk	36.00	-19.30	11.80	0.00	-34.30	-27.00	-7.30	194	318	V
			5.72500	-46.94	Pk	35.60	-19.50	11.80	0.00	-19.04	27.00	-46.04	154	117	H
			5.63259	-62.32	Pk	35.50	-19.90	11.80	0.00	-34.92	-27.00	-7.92	154	117	H
802.11n (HT20)	5745	MIMO	5.72500	-52.79	Pk	35.60	-19.50	11.80	0.00	-24.89	27.00	-51.89	192	101	V
			5.64662	-62.31	Pk	35.50	-19.80	11.80	0.00	-34.81	-27.00	-7.81	192	101	V
			5.85001	-51.09	Pk	35.90	-19.30	11.80	0.00	-22.69	26.99	-49.68	155	103	H
			5.92577	-63.14	Pk	36.00	-19.30	11.80	0.00	-34.64	-27.00	-7.64	155	103	H
			5.85001	-52.69	Pk	35.90	-19.30	11.80	0.00	-24.29	26.99	-51.28	188	106	V
	5825	MIMO	5.97642	-63.63	Pk	36.00	-19.20	11.80	0.00	-35.03	-27.00	-8.03	188	106	V
			5.72500	-43.51	Pk	35.60	-19.50	11.80	0.00	-15.61	27.00	-42.61	156	107	H
			5.64330	-62.09	Pk	35.50	-19.80	11.80	0.00	-34.59	-27.00	-7.59	156	107	H
			5.72500	-46.03	Pk	35.60	-19.50	11.80	0.00	-18.13	27.00	-45.13	160	345	V
			5.62502	-63.35	Pk	35.50	-19.90	11.80	0.00	-35.95	-27.00	-8.95	160	345	V
802.11n (HT40)	5755	MIMO	5.85001	-55.57	Pk	35.90	-19.30	11.80	0.00	-27.17	26.99	-54.16	153	108	H
			5.93829	-63.24	Pk	36.00	-19.30	11.80	0.00	-34.74	-27.00	-7.74	153	108	H
			5.85001	-62.26	Pk	35.90	-19.30	11.80	0.00	-33.86	26.99	-60.85	188	353	V
			5.96727	-63.36	Pk	36.00	-19.30	11.80	0.00	-34.86	-27.00	-7.86	188	353	V
			5.72500	-53.15	Pk	35.60	-19.50	11.80	0.00	-25.25	27.00	-52.25	150	123	H
	5775 (Lowerr Side)	MIMO	5.63303	-62.09	Pk	35.50	-19.90	11.80	0.00	-34.69	-27.00	-7.69	150	123	H
			5.72500	-57.14	Pk	35.60	-19.50	11.80	0.00	-29.24	27.00	-56.24	189	366	V
			5.63904	-63.30	Pk	35.50	-19.80	11.80	0.00	-35.80	-27.00	-8.80	189	366	V
			5.85001	-55.60	Pk	35.90	-19.30	11.80	0.00	-27.20	26.99	-54.19	151	108	H
			5.93977	-62.74	Pk	36.00	-19.30	11.80	0.00	-34.24	-27.00	-7.24	151	108	H
5775 (Upper Side)	MIMO	5.85001	-59.50	Pk	35.90	-19.30	11.80	0.00	-31.10	26.99	-58.09	188	355	V	
		5.97185	-62.90	Pk	36.00	-19.20	11.80	0.00	-34.30	-27.00	-7.30	188	355	V	
		5.72500	-47.19	Pk	35.60	-19.50	11.80	0.00	-19.29	27.00	-46.29	153	108	H	
		5.64520	-61.52	Pk	35.50	-19.80	11.80	0.00	-34.02	-27.00	-7.02	153	108	H	
		5.72500	-49.64	Pk	35.60	-19.50	11.80	0.00	-21.74	27.00	-48.74	182	101	V	
802.11ax (HE20)	5745	MIMO	5.64779	-62.31	Pk	35.50	-19.80	11.80	0.00	-34.81	-27.00	-7.81	182	101	V
			5.85001	-51.30	Pk	35.90	-19.30	11.80	0.00	-22.90	26.99	-49.89	154	119	H
			5.93069	-63.15	Pk	36.00	-19.30	11.80	0.00	-34.65	-27.00	-7.65	154	119	H
			5.85001	-54.20	Pk	35.90	-19.30	11.80	0.00	-25.80	26.99	-52.79	184	108	V
			5.94339	-63.50	Pk	36.00	-19.30	11.80	0.00	-35.00	-27.00	-8.00	184	108	V
	5825	MIMO	5.72500	-51.85	Pk	35.60	-19.50	11.80	0.00	-23.95	27.00	-50.95	154	108	H
			5.64112	-62.55	Pk	35.50	-19.80	11.80	0.00	-35.05	-27.00	-8.05	154	108	H
			5.72500	-49.54	Pk	35.60	-19.50	11.80	0.00	-21.64	27.00	-48.64	190	100	V
			5.64364	-63.25	Pk	35.50	-19.80	11.80	0.00	-35.75	-27.00	-8.75	190	100	V
			5.85001	-58.26	Pk	35.90	-19.30	11.80	0.00	-29.86	26.99	-56.85	153	108	H
802.11ax (HE40)	5755	MIMO	5.93579	-63.36	Pk	36.00	-19.30	11.80	0.00	-34.86	-27.00	-7.86	153	108	H
			5.85001	-53.76	Pk	35.90	-19.30	11.80	0.00	-25.36	26.99	-52.35	168	100	V
			5.92642	-62.41	Pk	36.00	-19.30	11.80	0.00	-33.91	-27.00	-6.91	168	100	V
			5.72500	-55.18	Pk	35.60	-19.50	11.80	0.00	-27.28	27.00	-54.28	154	108	H
			5.64644	-61.97	Pk	35.50	-19.80	11.80	0.00	-34.47	-27.00	-7.47	154	108	H
	5795	MIMO	5.72500	-58.02	Pk	35.60	-19.50	11.80	0.00	-30.12	27.00	-57.12	190	101	V
			5.62934	-63.52	Pk	35.50	-19.90	11.80	0.00	-36.12	-27.00	-9.12	190	101	V
			5.85001	-57.41	Pk	35.90	-19.30	11.80	0.00	-29.01	26.99	-56.00	157	108	H
			5.92899	-62.70	Pk	36.00	-19.30	11.80	0.00	-34.20	-27.00	-7.20	157	108	H
			5.85001	-59.34	Pk	35.90	-19.30	11.80	0.00	-30.94	26.99	-57.93	169	100	V
802.11ax (HE80)	5775 (Upper Side)	MIMO	5.99317	-63.30	Pk	36.00	-19.20	11.80	0.00	-34.70	-27.00	-7.70	169	100	V

Note. Pk - Peak detector

HARMONICS AND SPURIOUS EMISSIONS(WORST CASE: 802.11a / 5825 MHz)
5825 MHz HORIZONTAL

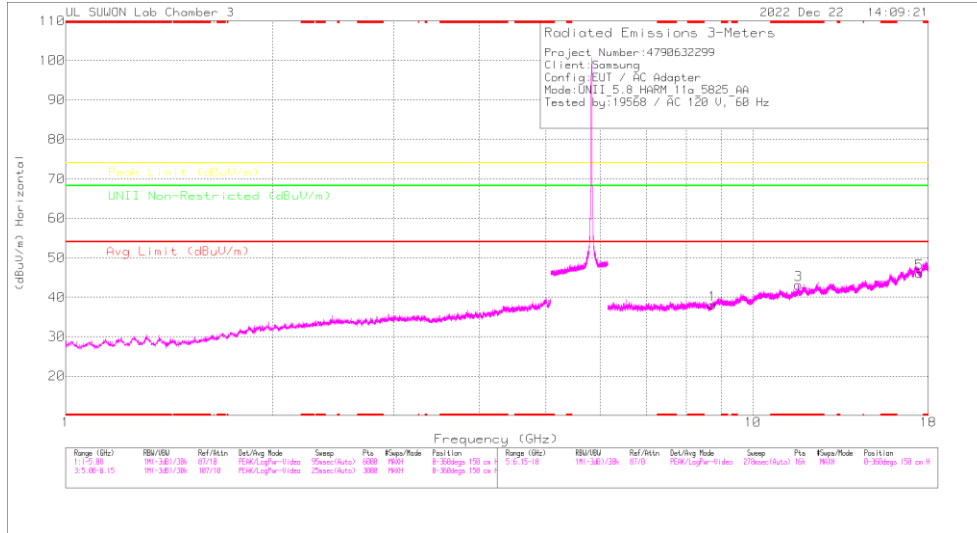

5825 MHz VERTICAL

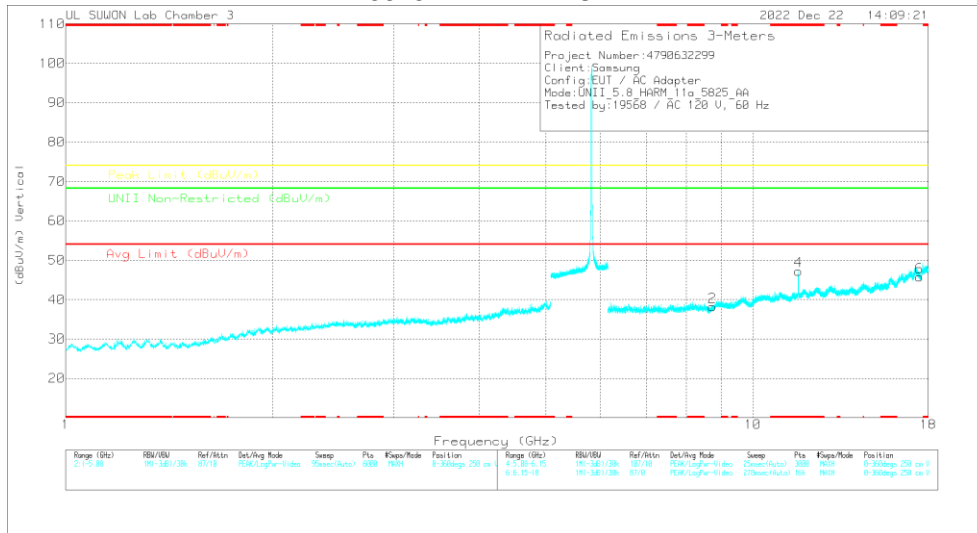

Note: Emission was scanned up to 40GHz; No emissions were detected above the noise floor which was at least 20dB below the specification limit.

5825 MHz DATA

Radiated Emissions

Frequency (GHz)	Meas Reading (dBuV)	Det	317,0021867	6GHz_HPSB	DC Corr (dB)	Corrected Reading (dBuV)	Avg Limit (dBuV/m)	Margin (dB)	Peak Limit (dBuV/m)	Margin (dB)	UNII Non-Restricted (dBuV/m)	Margin (dB)	Altitude (m)	Height (m)	Polarity
8.74328	34.53	PK-U	36.5	-22.8	0	48.23	-	-	-	-	68.2	-19.97	0	100	H
8.74393	34.52	PK-U	36.5	-22.8	0	48.22	-	-	-	-	68.2	-19.98	0	100	V
* 11.65264	37.89	PK-U	38.8	-21.5	0	55.29	-	-	74	-18.71	-	-	39	101	H
* 11.6475	26.34	ADR	38.8	-21.5	1	43.74	54	-10.26	-	-	-	-	39	101	H
* 11.64969	41.69	PK-U	38.8	-21.5	0	58.99	-	-	74	-15.01	-	-	227	100	V
* 11.64974	31.15	ADR	38.8	-21.5	1	48.55	54	-5.45	-	-	-	-	227	100	V
17.47076	31.92	PK-U	42	-16.8	0	57.12	-	-	-	-	68.2	-11.08	0	100	H
17.47017	31.95	PK-U	42	-16.8	0	57.15	-	-	-	-	68.2	-11.05	0	100	V

* - indicates frequency in CFR47 Pt 15 / IC RSS-Restricted Band
 PK-U - U-NII: Maximum Peak
 ADR - U-NII AD primary method, RMS average

HARMONICS AND SPOURIOUS EMISSIONS TEST DATA

Mode	Freq. [MHz]	Antenna	Frequency [GHz]	Reading [dBuV]	Detector Mode	ANT Factor	Loss [dB]	DC Corr [dB]	Result [dBuV/m]	AV Limit [dBuV/m]	AV Margin [dB]	PK Limit [dBuV/m]	PK Margin [dB]	Non-Restricted [dBuV/m]	Margin [dB]	Azimuth [Degs]	Height [cm]	Polarity		
802.11a	5745	MIMO	8.617	34.13	PK-U	36.50	-23.10	0.00	47.53	-	-	-	-	-	68.20	-20.67	0	100	H	
			8.619	33.99	PK-U	36.50	-23.10	0.00	47.39	-	-	-	-	-	-	68.20	-20.81	0	100	V
			* 11.49273	36.84	PK-U	38.70	-21.40	0.00	54.14	-	-	-	74.00	-19.86	-	-	-	38	100	H
			* 11.49159	24.75	ADR	38.70	-21.40	0.10	42.15	54.00	-11.85	-	-	-	-	-	-	38	100	H
			* 11.49122	41.74	PK-U	38.70	-21.40	0.00	59.04	-	-	-	-	74.00	-14.96	-	-	0	100	V
			* 11.49038	30.57	ADR	38.70	-21.40	0.10	47.97	54.00	-6.03	-	-	-	-	-	-	0	100	V
			17.231	32.71	PK-U	42.10	-17.10	0.00	57.71	-	-	-	-	-	-	68.20	-10.49	0	100	H
			17.234	32.17	PK-U	42.10	-17.10	0.00	57.17	-	-	-	-	-	-	68.20	-11.03	0	100	V
	5785	MIMO	8.686	33.95	PK-U	36.50	-22.90	0.00	47.55	-	-	-	-	-	68.20	-20.65	0	100	H	
			8.685	34.56	PK-U	36.50	-22.90	0.00	48.16	-	-	-	-	-	68.20	-20.04	0	100	V	
			* 11.56382	37.41	PK-U	38.80	-21.50	0.00	54.71	-	-	-	74.00	-19.29	-	-	-	111	100	H
			* 11.56827	26.52	ADR	38.80	-21.50	0.10	43.92	54.00	-10.08	-	-	-	-	-	-	111	100	H
			* 11.57021	40.37	PK-U	38.80	-21.50	0.00	57.67	-	-	-	-	74.00	-16.33	-	-	331	100	V
			* 11.57001	30.42	ADR	38.80	-21.50	0.10	47.82	54.00	-6.18	-	-	-	-	-	-	331	100	V
			17.360	32.43	PK-U	42.00	-17.20	0.00	57.23	-	-	-	-	-	-	68.20	-10.97	0	100	H
			17.362	32.93	PK-U	42.00	-17.30	0.00	57.63	-	-	-	-	-	-	68.20	-10.57	0	100	V
	5825	MIMO	8.743	34.53	PK-U	36.50	-22.80	0.00	48.23	-	-	-	-	-	68.20	-19.97	0	100	H	
			8.744	34.52	PK-U	36.50	-22.80	0.00	48.22	-	-	-	-	-	68.20	-19.98	0	100	V	
			* 11.65264	37.89	PK-U	38.90	-21.50	0.00	55.29	-	-	-	74.00	-18.71	-	-	-	39	101	H
			* 11.6475	26.34	ADR	38.80	-21.50	0.10	43.74	54.00	-10.26	-	-	-	-	-	-	39	101	H
			* 11.64969	41.69	PK-U	38.80	-21.50	0.00	58.99	-	-	-	-	74.00	-15.01	-	-	227	100	V
			* 11.64974	31.15	ADR	38.80	-21.50	0.10	48.55	54.00	-5.45	-	-	-	-	-	-	227	100	V
			17.471	31.92	PK-U	42.00	-16.80	0.00	57.12	-	-	-	-	-	-	68.20	-11.08	0	100	H
			17.479	31.95	PK-U	42.00	-16.80	0.00	57.15	-	-	-	-	-	-	68.20	-11.05	0	100	V
802.11ax (HE20) 4RU Spot-check	5745	MIMO	8.622	34.19	PK-U	36.50	-23.10	0.00	47.59	-	-	-	-	-	68.20	-20.61	0	100	H	
			8.625	34.21	PK-U	36.50	-23.10	0.00	47.61	-	-	-	-	-	68.20	-20.59	0	100	V	
			* 11.48961	36.80	PK-U	38.70	-21.40	0.00	54.10	-	-	-	74.00	-19.90	-	-	-	170	104	H
			* 11.48995	25.88	ADR	38.70	-21.40	0.00	43.18	54.00	-10.82	-	-	-	-	-	-	170	104	H
			* 11.48998	40.15	PK-U	38.70	-21.40	0.00	57.45	-	-	-	-	74.00	-16.55	-	-	252	101	V
			* 11.49004	29.25	ADR	38.70	-21.40	0.00	46.55	54.00	-7.45	-	-	-	-	-	-	252	101	V
			* 17.241	32.85	PK-U	42.10	-17.10	0.00	57.85	-	-	-	-	-	-	68.20	-10.35	0	100	H
			17.235	33.02	PK-U	42.10	-17.10	0.00	58.02	-	-	-	-	-	-	68.20	-10.18	0	100	V
	5785	MIMO	8.678	34.30	PK-U	35.80	-23.00	0.00	47.10	-	-	-	-	-	68.20	-21.10	0	100	H	
			8.677	34.44	PK-U	35.80	-23.00	0.00	47.24	-	-	-	-	-	68.20	-20.96	333	108	V	
			* 11.56823	36.25	PK-U	38.20	-21.50	0.00	52.95	-	-	-	74.00	-21.05	-	-	-	166	106	H
			* 11.56996	25.63	ADR	38.20	-21.50	0.00	42.33	54.00	-11.67	-	-	-	-	-	-	166	106	H
			* 11.56943	38.47	PK-U	38.20	-21.50	0.00	55.17	-	-	-	-	74.00	-18.83	-	-	333	108	V
			* 11.56999	29.62	ADR	38.20	-21.50	0.00	46.32	54.00	-7.68	-	-	-	-	-	-	333	108	V
			17.355	32.00	PK-U	40.90	-17.20	0.00	55.70	-	-	-	-	-	-	68.20	-12.50	0	100	H
			17.355	31.95	PK-U	40.90	-17.20	0.00	55.65	-	-	-	-	-	-	68.20	-12.55	333	108	V
	5825	MIMO	8.738	34.65	PK-U	35.80	-22.80	0.00	47.65	-	-	-	-	-	68.20	-20.55	0	100	H	
			8.738	34.25	PK-U	35.80	-22.80	0.00	47.25	-	-	-	-	-	68.20	-20.95	324	100	V	
			* 11.65023	36.69	PK-U	38.20	-21.50	0.00	53.39	-	-	-	74.00	-20.61	-	-	-	164	100	H
			* 11.64987	25.19	ADR	38.20	-21.50	0.00	41.89	54.00	-12.11	-	-	-	-	-	-	164	100	H
			* 11.65012	38.84	PK-U	38.20	-21.50	0.00	55.54	-	-	-	-	74.00	-18.46	-	-	324	100	V
			* 11.65006	29.28	ADR	38.20	-21.50	0.00	45.98	54.00	-8.02	-	-	-	-	-	-	324	100	V
			* 17.475	31.59	PK-U	41.10	-16.80	0.00	55.89	-	-	-	-	-	-	68.20	-12.31	0	100	H
			17.478	31.32	PK-U	41.20	-16.80	0.00	55.72	-	-	-	-	-	-	68.20	-12.48	324	100	V
802.11ax (HE40) 0RU Spot-check	5755	MIMO	8.634	34.35	PK-U	35.70	-23.10	0.00	46.95	-	-	-	-	-	68.20	-21.25	360	100	H	
			8.629	33.78	PK-U	35.70	-23.10	0.00	46.38	-	-	-	-	-	68.20	-21.82	360	100	V	
			* 11.47391	35.63	PK-U	38.10	-21.40	0.00	52.33	-	-	-	74.00	-21.67	-	-	-	121	106	H
			* 11.47382	23.59	ADR	38.10	-21.40	0.00	40.29	54.00	-13.71	-	-	-	-	-	-	121	106	H
			* 11.47334	41.64	PK-U	38.10	-21.40	0.00	58.34	-	-	-	-	74.00	-15.66	-	-	25	103	V
			* 11.47389	27.95	ADR	38.10	-21.40	0.00	44.65	54.00	-9.35	-	-	-	-	-	-	25	103	V
			* 11.50987	36.13	PK-U	38.10	-21.40	0.00	52.83	-	-	-	-	74.00	-21.17	-	-	335	103	V
			* 11.50995	28.45	ADR	38.10	-21.40	0.00	45.15	54.00	-8.85	-	-	-	-	-	-	335	103	V
17.263	32.19	PK-U	41.00	-17.10	0.00	56.09	-	-	-	-	-	-	68.20	-12.11	360	100	H			
17.263	31.96	PK-U	41.00	-17.10	0.00	55.86	-	-	-	-	-	-	68.20	-12.34	360	100	V			
802.11ax (HE80) 0RU Spot-check	5775	MIMO	8.664	34.14	PK-U	35.70	-23.10	0.00	46.74	-	-	-	-	-	68.20	-21.46	360	100	H	
			8.663	34.18	PK-U	35.70	-23.10	0.00	46.78	-	-	-	-	-	68.20	-21.42	0	100	V	
			* 11.55019	34.81	PK-U	38.20	-21.60	0.00	51.41	-	-	-	-	74.00	-22.59	-	-	164	126	H
			* 11.54994	24.50	ADR	38.20	-21.60	0.00	41.10	54.00	-12.90	-	-	-	-	-	-	164	126	H
			* 11.54989	36.54	PK-U	38.20	-21.60	0.00	53.14	-	-	-	-	74.00	-20.86	-	-	330	100	V
			* 11.54987	28.57	ADR	38.20	-21.60	0.00	45.17	54.00	-8.83	-	-	-	-	-	-	330	100	V
			* 11.47413	39.78	PK-U	38.10	-21.40	0.00	56.48	-	-	-	-	74.00	-17.52	-	-	16	108	V
			* 11.47407	26.50	ADR	38.10	-21.40	0.00	43.20	54.00	-10.80	-	-	-	-	-	-	16	108	V
17.325	32.04	PK-U	40.90	-17.20	0.00	55.74	-	-	-	-	-	-	68.20	-12.46	360	100	H			
17.320	31.68	PK-U	41.00	-17.20	0.00	55.48	-	-	-	-	-	-	68.20	-12.72	0	100	V			

Note1. PK-U - U-NII: Maximum Peak / ADR - U-NII AD primary method, RMS average
 Note2. * - indicates frequency in CFR47 Pt 15 / IC RSS-Restricted Band

12. WORST-CASE BELOW 1 GHz SPURIOUS EMISSIONS 30 TO 1000 MHz (WORST-CASE CONFIGURATION, HORIZONTAL)

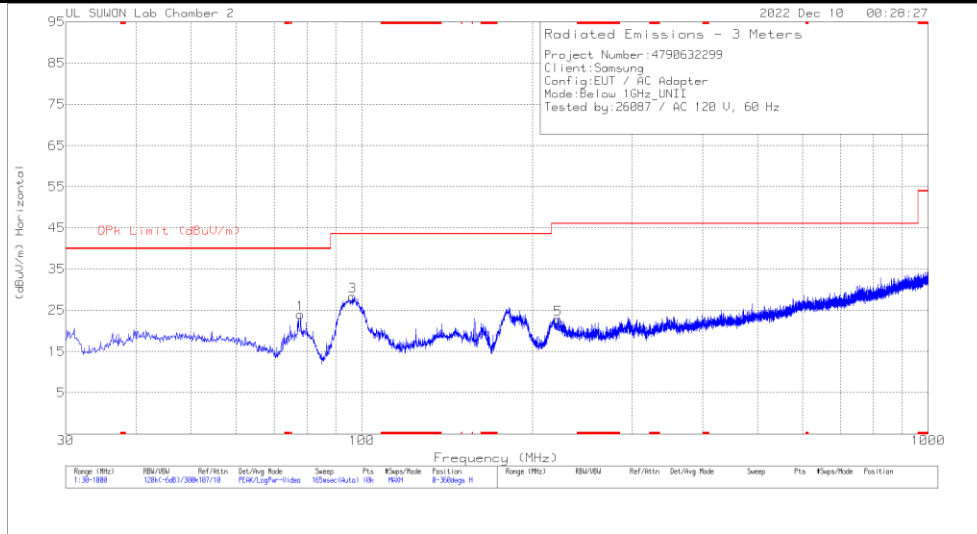

SPURIOUS EMISSIONS 30 TO 1000 MHz (WORST-CASE CONFIGURATION, VERTICAL)

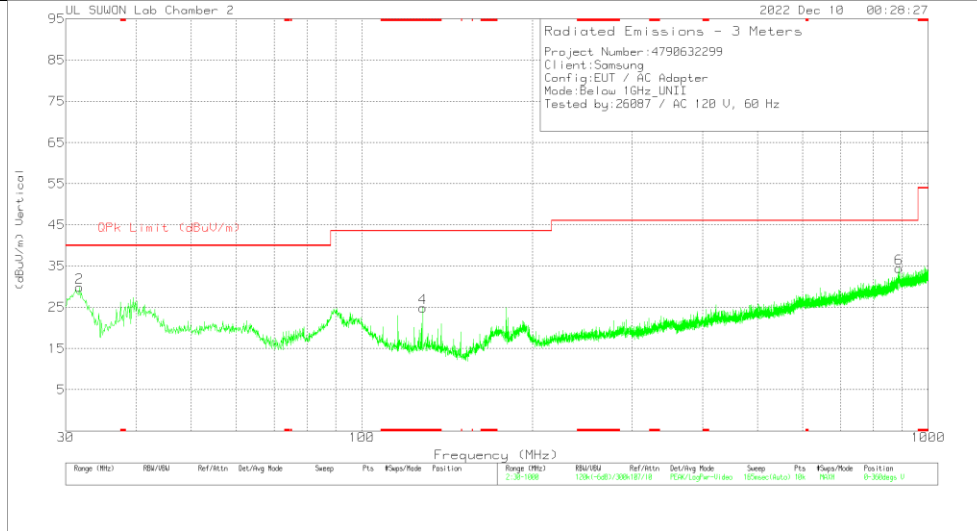

Trace Markers

Marker	Frequency (MHz)	Meter Reading (dBuV)	Det	VULB9163_749	Below 1G[dB]	DC Corr (dB)	Corrected Reading (dBuV/m)	QPK Limit (dBuV/m)	Margin (dB)	Azimuth (Degs)	Height (cm)	Polarity
1	77.918	42.33	Pk	12.5	-30.8	0	24.03	40	-15.97	0-360	100	H
3	96.348	42.06	Pk	16.9	-30.6	0	28.36	43.52	-15.16	0-360	200	H
5	221.963	35.29	Pk	17.1	-29.6	0	22.79	46.02	-23.23	0-360	100	H
2	31.746	45.92	Pk	15.4	-31.5	0	29.82	40	-10.18	0-360	100	V
4	* 128.164	40.77	Pk	14.5	-30.4	0	24.87	43.52	-18.65	0-360	100	V
6	888.353	32.52	Pk	27.8	-25.8	0	34.52	46.02	-11.5	0-360	100	V

* - indicates frequency in CFR47 Pt 15 / IC RSS-Restricted Band
 Pk - Peak detector

13. AC POWER LINE CONDUCTED EMISSIONS

LIMITS

FCC §15.207 (a)
IC RSS-GEN Clause 8.8

Frequency of Emission (MHz)	Conducted Limit (dBuV)	
	Quasi-peak	Average
0.15-0.5	66 to 56 [*]	56 to 46 [*]
0.5-5	56	46
5-30	60	50

^{*}Decreases with the logarithm of the frequency.

TEST PROCEDURE

The EUT is placed on a non-conducting table 40 cm from the vertical ground plane and 80 cm above the horizontal ground plane. The EUT is configured in accordance with ANSI C63.10.

The receiver is set to a resolution bandwidth of 9 kHz. Peak detection is used unless otherwise noted as quasi-peak or average.

Line conducted data is recorded for both NEUTRAL and HOT lines.

RESULTS

WORST EMISSIONS

LINE 1 DATA

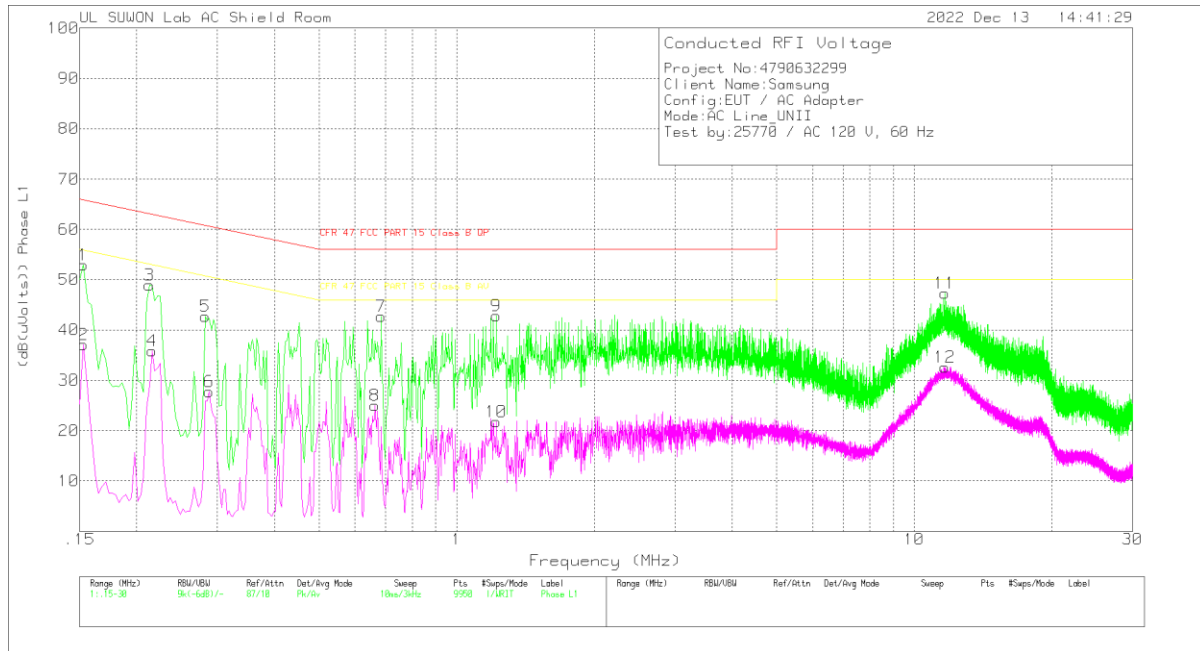

Trace Markers

Range 1: Phase L1 .15 - 30MHz

Marker	Frequency (MHz)	Meter Reading (dBuV)	Det	101836_Wit h EX_L1[dB]	CABLELOS S(dB)	Corrected Reading (dB(uVolts))	CFR 47 FCC PART 15 Class B QP	Margin (dB)	CFR 47 FCC PART 15 Class B AV	Margin (dB)
1	.153	43.02	Pk	9.8	.1	52.92	65.84	-12.92	-	-
2	.153	27.16	Av	9.8	.1	37.06	-	-	55.84	-18.78
3	.213	38.95	Pk	9.8	.2	48.95	63.09	-14.14	-	-
4	.216	25.88	Av	9.8	.2	35.88	-	-	52.97	-17.09
5	.282	32.81	Pk	9.7	.2	42.71	60.76	-18.05	-	-
6	.288	17.83	Av	9.7	.2	27.73	-	-	50.58	-22.85
7	.684	32.65	Pk	9.8	.2	42.65	56	-13.35	-	-
8	.663	15	Av	9.8	.2	25	-	-	46	-21
9	1.221	32.87	Pk	9.7	.3	42.87	56	-13.13	-	-
10	1.221	11.77	Av	9.7	.3	21.77	-	-	46	-24.23
11	11.661	37.11	Pk	9.9	.3	47.31	60	-12.69	-	-
12	11.652	22.43	Av	9.9	.3	32.63	-	-	50	-17.37

Pk - Peak detector

Av - Average detection

LINE 2 DATA

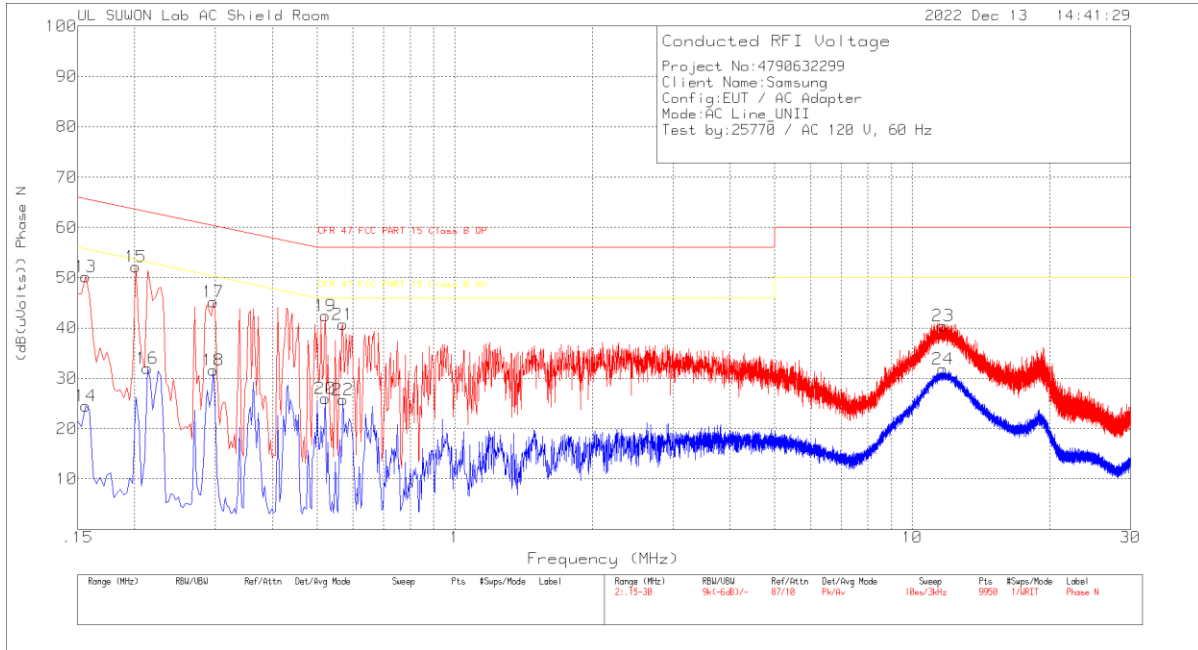

Trace Markers

Range 2: Phase N .15 - 30MHz

Marker	Frequency (MHz)	Meter Reading (dBuV)	Det	101836_Wit h EX_N[dB]	CABLELOS S(dB)	Corrected Reading (dB(uVolts))	CFR 47 FCC PART 15 Class B QP	Margin (dB)	CFR 47 FCC PART 15 Class B AV	Margin (dB)
13	.156	40.3	Pk	9.8	.1	50.2	65.67	-15.47	-	-
14	.156	14.6	Av	9.8	.1	24.5	-	-	55.67	-31.17
15	.201	42.2	Pk	9.8	.2	52.2	63.57	-11.37	-	-
16	.213	21.93	Av	9.8	.2	31.93	-	-	53.09	-21.16
17	.297	35.25	Pk	9.7	.2	45.15	60.33	-15.18	-	-
18	.297	21.74	Av	9.7	.2	31.64	-	-	50.33	-18.69
19	.522	32.36	Pk	9.9	.2	42.46	56	-13.54	-	-
20	.522	15.92	Av	9.9	.2	26.02	-	-	46	-19.98
21	.57	30.58	Pk	9.9	.2	40.68	56	-15.32	-	-
22	.57	15.66	Av	9.9	.2	25.76	-	-	46	-20.24
23	11.682	30.25	Pk	9.9	.3	40.45	60	-19.55	-	-
24	11.682	21.68	Av	9.9	.3	31.88	-	-	50	-18.12

Pk - Peak detector
 Av - Average detection

14. DYNAMIC FREQUENCY SELECTION

14.1. OVERVIEW

14.1.1. LIMITS

FCC

§15.407 (h), FCC KDB 905462 D02 “COMPLIANCE MEASUREMENT PROCEDURES FOR UNLICENSED-NATIONAL INFORMATION INFRASTRUCTURE DEVICES OPERATING IN THE 5250-5350 MHz AND 5470-5725 MHz BANDS INCORPORATING DYNAMIC FREQUENCY SELECTION” and KDB 905462 D03 “U-NII CLIENT DEVICES WITHOUT RADAR DETECTION CAPABILITY”.

Table 1: Applicability of DFS requirements prior to use of a channel

Requirement	Operational Mode		
	Master	Client (without radar detection)	Client (with radar detection)
Non-Occupancy Period	Yes	Not required	Yes
DFS Detection Threshold	Yes	Not required	Yes
Channel Availability Check Time	Yes	Not required	Not required
U-NII Detection Bandwidth	Yes	Not required	Yes

Table 2: Applicability of DFS requirements during normal operation

Requirement	Operational Mode		
	Master	Client (without DFS)	Client (with DFS)
DFS Detection Threshold	Yes	Not required	Yes
Channel Closing Transmission Time	Yes	Yes	Yes
Channel Move Time	Yes	Yes	Yes
U-NII Detection Bandwidth	Yes	Not required	Yes

Additional requirements for devices with multiple bandwidth modes	Master Device or Client with Radar DFS	Client (without DFS)
U-NII Detection Bandwidth and Statistical Performance Check	All BW modes must be tested	Not required
Channel Move Time and Channel Closing Transmission Time	Test using widest BW mode available	Test using the widest BW mode available for the link
All other tests	Any single BW mode	Not required

Note: Frequencies selected for statistical performance check (Section 7.8.4) should include several frequencies within the radar detection bandwidth and frequencies near the edge of the radar detection bandwidth. For 802.11 devices it is suggested to select frequencies in all 20 MHz channel blocks and a null frequency between the bonded 20 MHz channel blocks.

Table 3: Interference Threshold values, Master or Client incorporating In-Service Monitoring

Maximum Transmit Power	Value (see notes)
E.I.R.P. \geq 200 mill watt	-64 dBm
E.I.R.P. < 200 mill watt and power spectral density < 10 dBm/MHz	-62 dBm
E.I.R.P. < 200 mill watt that do not meet power spectral density requirement	-64 dBm
<p>Note 1: This is the level at the input of the receiver assuming a 0 dBi receive antenna Note 2: Throughout these test procedures an additional 1 dB has been added to the amplitude of the test transmission waveforms to account for variations in measurement equipment. This will ensure that the test signal is at or above the detection threshold level to trigger a DFS response. Note 3: E.I.R.P. is based on the highest antenna gain. For MIMO devices refer to KDB publication 662911 D01.</p>	

Table 4: DFS Response requirement values

Parameter	Value
<i>Non-occupancy period</i>	30 minutes
<i>Channel Availability Check Time</i>	60 seconds
<i>Channel Move Time</i>	10 seconds (See Note 1)
<i>Channel Closing Transmission Time</i>	200 milliseconds + approx. 60 milliseconds over remaining 10 second period. (See Notes 1 and 2)
<i>U-NII Detection Bandwidth</i>	Minimum 100% of the U- NII 99% transmission power bandwidth. (See Note 3)
<p>Note 1: <i>Channel Move Time</i> and the <i>Channel Closing Transmission Time</i> should be performed with Radar Type 0. The measurement timing begins at the end of the Radar Type 0 burst. Note 2: The <i>Channel Closing Transmission Time</i> is comprised of 200 milliseconds starting at the beginning of the <i>Channel Move Time</i> plus any additional intermittent control signals required to facilitate a <i>Channel</i> move (an aggregate of 60 milliseconds) during the remainder of the 10 second period. The aggregate duration of control signals will not count quiet periods in between transmissions. Note 3: During the <i>U-NII Detection Bandwidth</i> detection test, radar type 0 should be used. For each frequency step the minimum percentage of detection is 90 percent. Measurements are performed with no data traffic.</p>	

Table 5 – Short Pulse Radar Test Waveforms

Radar Type	Pulse Width (usec)	PRI (usec)	Pulses	Minimum Percentage of Successful Detection	Minimum Trials
0	1	1428	18	See Note 1	See Note 1
1	1	Test A: 15 unique PRI values randomly selected from the list of 23 PRI values in table 5a	Roundup: $\{(1/360) \times (19 \times 10^6 \text{ PRI}_{\text{usec}})\}$	60%	30
		Test B: 15 unique PRI values randomly selected within the range of 518-3066 usec. With a minimum increment of 1 usec, excluding PRI values selected in Test A			
2	1-5	150-230	23-29	60%	30
3	6-10	200-500	16-18	60%	30
4	11-20	200-500	12-16	60%	30
Aggregate (Radar Types 1-4)				80%	120
Note 1: Short Pulse Radar Type 0 should be used for the <i>Detection Bandwidth</i> test, <i>Channel Move Time</i> , and <i>Channel Closing Time</i> tests.					

Table 6 – Long Pulse Radar Test Signal

Radar Waveform Type	Pulse Width (μsec)	Chirp Width (MHz)	PRI (μsec)	Pulses per Burst	Number of Bursts	Minimum Percentage of Successful Detection	Minimum Trials
5	50-100	5-20	1000-2000	1-3	8-20	80%	30

Table 7 – Frequency Hopping Radar Test Signal

Radar Waveform Type	Pulse Width (μsec)	PRI (μsec)	Pulses per Hop	Hopping Rate (kHz)	Hopping Sequence Length (msec)	Minimum Percentage of Successful Detection	Minimum Trials
6	1	333	9	0.333	300	70%	30

14.1.2. TEST AND MEASUREMENT SYSTEM

CONDUCTED METHOD SYSTEM BLOCK DIAGRAM

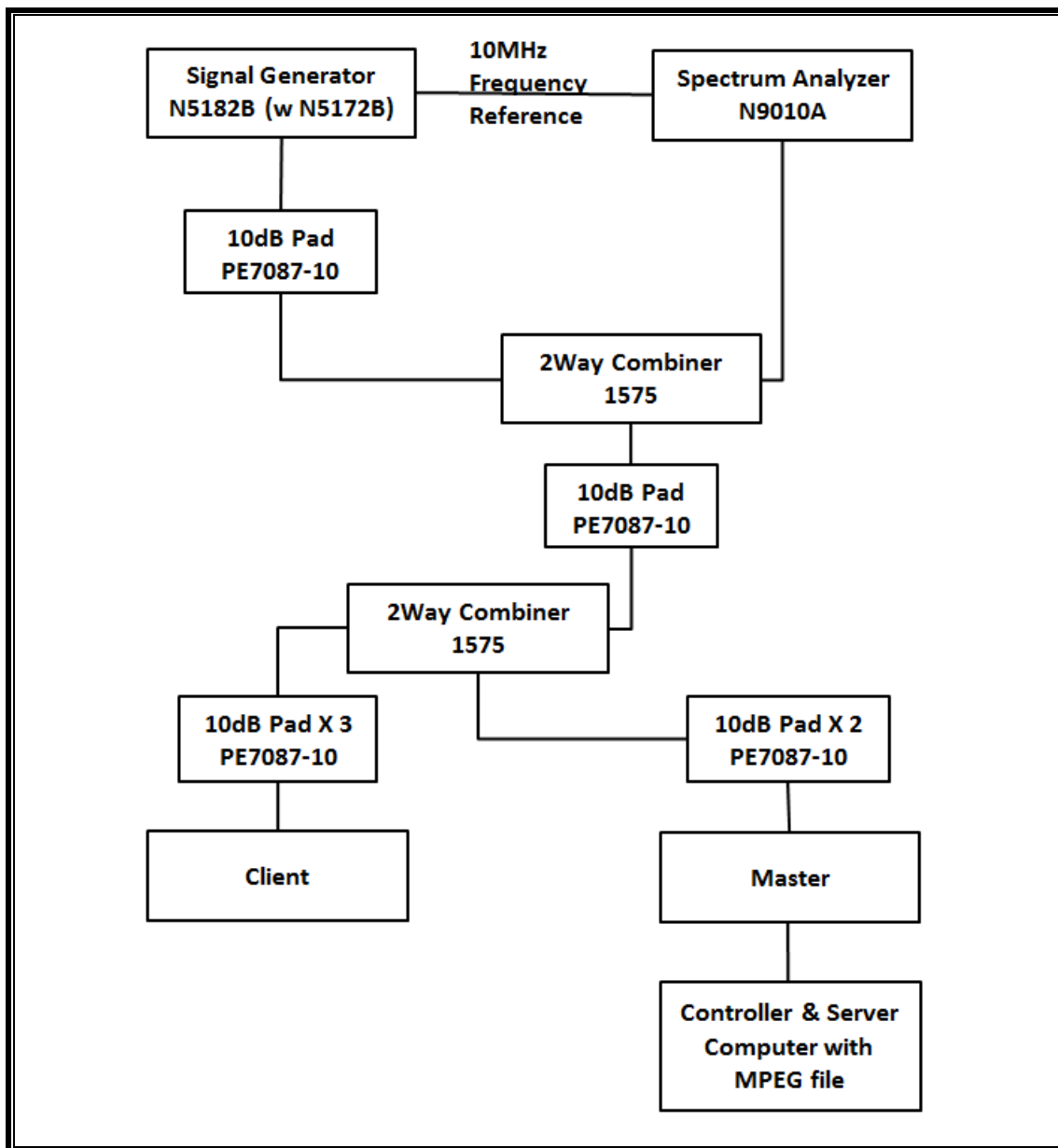

SYSTEM OVERVIEW

The short pulse and long pulse signal generating system utilizes the Keysite Signal Studio for Pulse Building as N5172B. The Vector Signal Generator has been validated by the NTIA. The hopping signal generating system utilizes the CCS simulated hopping method and system, which has been validated by the DoD, FCC and NTIA. The software selects waveform parameters from within the bounds of the signal type on a random basis using uniform distribution.

The short pulse types 1, 2, 3 and 4, and the long pulse type 5 parameters are randomized at run-time.

The hopping type 6 pulse parameters are fixed while the hopping sequence is based on the August 2005 NTIA Hopping Frequency List. The initial starting point randomized at run-time and each subsequent starting point is incremented by 475. Each frequency in the 100-length segment is compared to the boundaries of the EUT Detection Bandwidth and the software creates a hopping burst pattern in accordance with Section 7.4.1.3 Method #2 Simulated Frequency Hopping Radar Waveform Generating Subsystem of KDB 905462 D02. The frequency of the signal generator is incremented in 1 MHz steps from F_L to F_H for each successive trial. This incremental sequence is repeated as required to generate a minimum of 30 total trials and to maintain a uniform frequency distribution over the entire Detection Bandwidth.

The signal monitoring equipment consists of a spectrum analyzer. The aggregate ON time is calculated by multiplying the number of bins above a threshold during a particular observation period by the dwell time per bin, with the analyzer set to peak detection and max hold.

SYSTEM CALIBRATION

A 50-ohm load is connected in place of the spectrum analyzer, and the spectrum analyzer is connected to a horn antenna via a coaxial cable, with the reference level offset set to (horn antenna gain – coaxial cable loss). The signal generator is set to CW mode. The amplitude of the signal generator is adjusted to yield a level of –64 dBm as measured on the spectrum analyzer.

Without changing any of the instrument settings, the spectrum analyzer is reconnected to the Common port of the Spectrum Analyzer Combiner/Divider. The Reference Level Offset of the spectrum analyzer is adjusted so that the displayed amplitude of the signal is –64 dBm.

The spectrum analyzer displays the level of the signal generator as received at the antenna ports of the Master Device. The interference detection threshold may be varied from the calibrated value of –64 dBm and the spectrum analyzer will still indicate the level as received by the Master Device.

ADJUSTMENT OF DISPLAYED TRAFFIC LEVEL

A link is established between the Master and Slave and the distance between the units is adjusted as needed to provide a suitable received level at the Master and Slave devices. The video test file is streamed to generate WLAN traffic. The monitoring antenna is adjusted so that the WLAN traffic level, as displayed on the spectrum analyzer, is at lower amplitude than the radar detection threshold.

TEST AND MEASUREMENT EQUIPMENT

The following test and measurement equipment was utilized for the DFS tests documented in this report:

TEST EQUIPMENT LIST				
Description	Manufacturer	Model	S/N	Next Cal Due
Spectrum Analyzer, 7 GHz	Agilent / HP	N9010A	MY54200580	08-01-23
Vector Signal Generator, 6GHz	Agilent / HP	N5182B	MY53051241	08-01-23
Combiner	WEINSCHTEL	WA1534	UL001	01-09-24
Combiner	WEINSCHTEL	WA1534	UL003	01-09-24

14.1.3. SETUP OF EUT

CONDUCTED METHOD EUT TEST SETUP

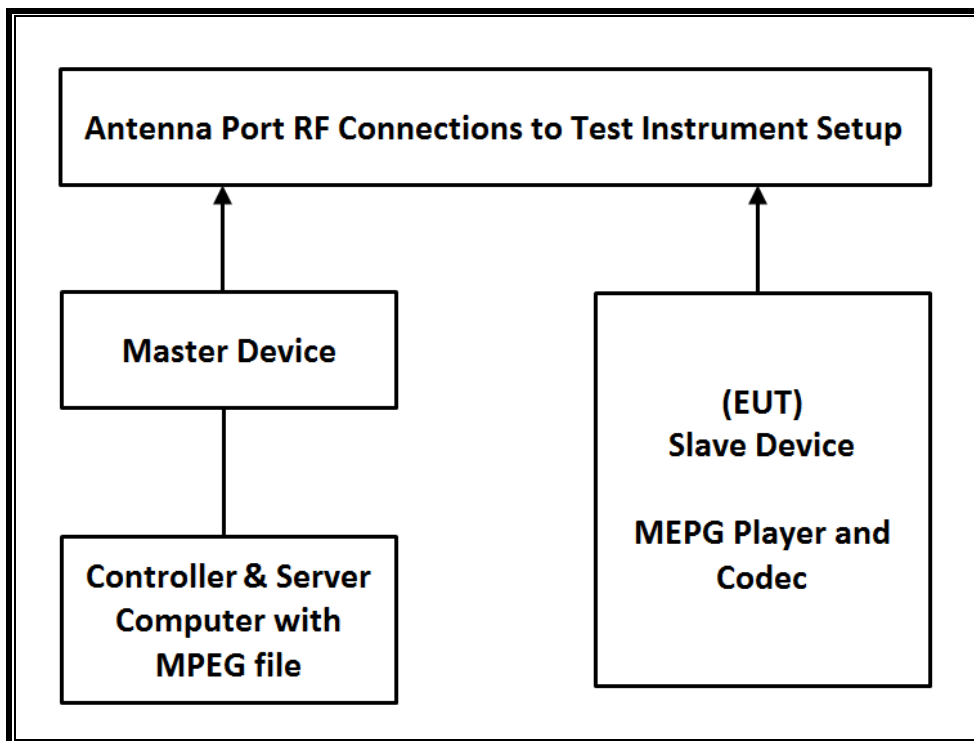

SUPPORT EQUIPMENT

The following support equipment was utilized for the DFS tests documented in this report:

PERIPHERAL SUPPORT EQUIPMENT LIST				
Description	Manufacturer	Model	Serial Number	FCC ID
Wireless Access Point	Cisco	AIR-CAP3702E-A-K9	FTX182276QX	LDK102087
Notebook PC (Controller/Server)	HP	HP EliteDesk 800 G1 TWR	CZC4125J25	DoC

14.1.4. DESCRIPTION OF EUT

The EUT operates over the 5250-5350 MHz and 5470-5725 MHz ranges.

The EUT is a Slave Device without Radar Detection.

The highest power level of the widest bandwidth (802.11ac VHT80) within these bands is 12.28 dBm in the 5250-5350 MHz band and 12.21 dBm in the 5470-5725 MHz band.

The antenna assembly utilized two antenna.

Gain of ANT1 : -3.55 dBi for UNII 2A and -4.09 dBi for UNII 2C.

Gain of ANT2 : -6.84 dBi for UNII 2A and -6.51 dBi for UNII 2C.

The rated output power of the Master unit is > 23dBm (EIRP). Therefore the required interference threshold level is -64 dBm. After correction for procedural adjustments, the required conducted threshold at the antenna port is $-64 + 1 = -63$ dBm.

The calibrated radiated DFS Detection Threshold level is set to -64 dBm. The tested level is lower than the required level hence it provides a margin to the limit.

The EUT uses one transmitter/receiver chain connected to an antenna to perform radiated tests. WLAN traffic that meets or exceeds the minimum required loading was generated by transferring a data stream from the controller/server PC to the EUT using iPerf version 2.0.5 software package.

TPC is not required since the maximum EIRP is less than 500 mW (27 dBm).

The EUT utilizes the 802.11 architecture. Three nominal channel bandwidths are implemented: 20 MHz, 40 MHz and 80 MHz.

The software installed in the access point is 12.4(25d)JA1.

UNIFORM CHANNEL SPREADING

This requirement is not applicable to Slave radio devices.

CHANNEL PUNCTURING(802.11ax)

This EUT does not support channel puncturing.

OVERVIEW OF MASTER DEVICE WITH RESPECT TO §15.407 (h) REQUIREMENTS

The Master Device is a Cisco Access Point, FCC ID: LDK102087. The minimum antenna gain for the Master Device is 6 dBi.

The rated output power of the Master unit is > 23dBm (EIRP). Therefore the required interference threshold level is -64 dBm. After correction for procedural adjustments, the required radiated threshold at the antenna port is $-64 + 1 = -63$ dBm.

The calibrated radiated DFS Detection Threshold level is set to -64 dBm. The tested level is lower than the required level hence it provides a margin to the limit.

14.2. RESULTS FOR 80 MHz BANDWIDTH (UNII-2A BAND)

14.2.1. TEST CHANNEL

All tests were performed at a channel center frequency of 5290 MHz.

14.2.2. RADAR WAVEFORM AND TRAFFIC

RADAR WAVEFORM

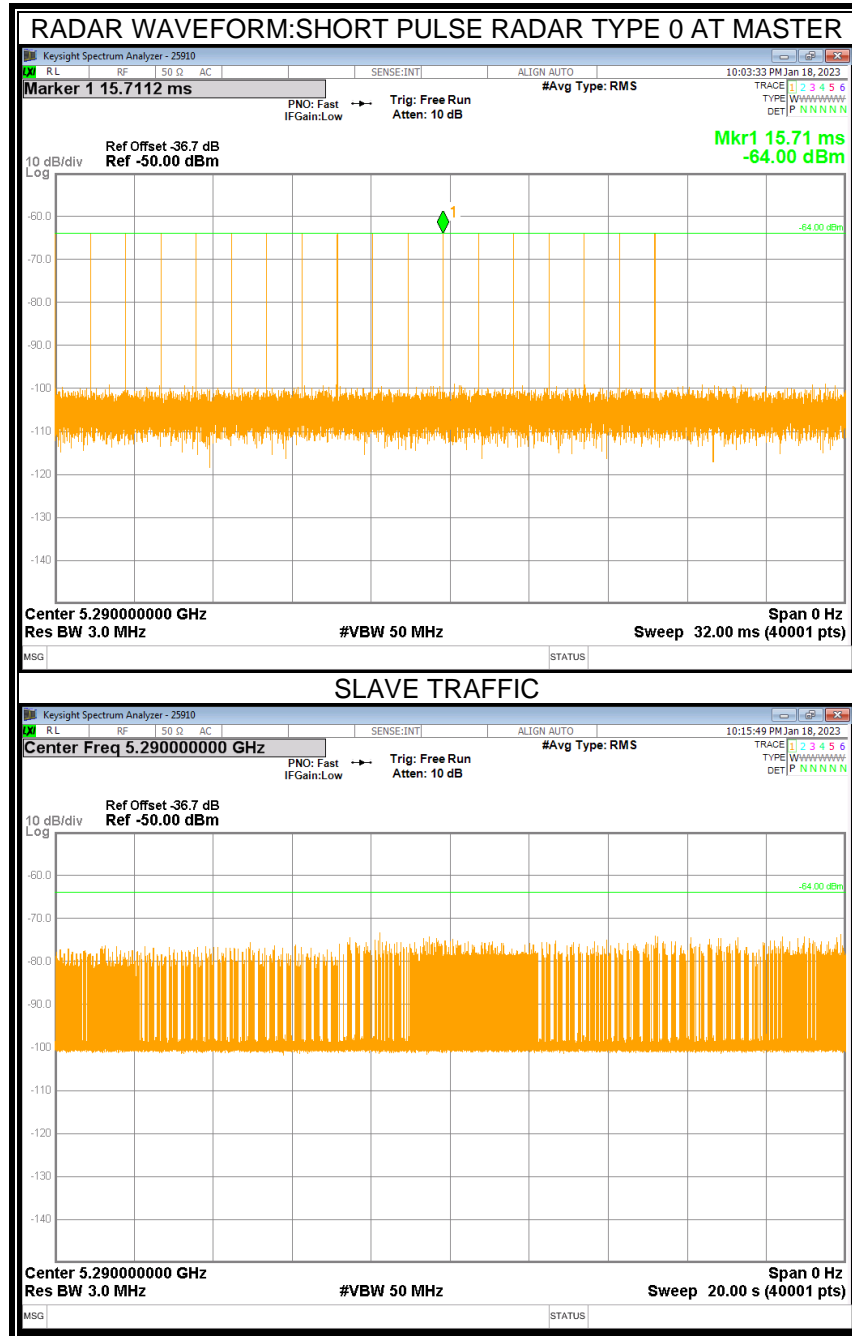

14.2.3. OVERLAPPING CHANNEL TESTS

RESULTS

These tests are not applicable.

14.2.4. MOVE AND CLOSING TIME

REPORTING NOTES

The reference marker is set at the end of last radar pulse.

The delta marker is set at the end of the last WLAN transmission following the radar pulse. This delta is the channel move time.

The aggregate channel closing transmission time is calculated as follows:

Aggregate Transmission Time =
(Number of analyzer bins showing transmission) * (dwell time per bin)

The observation period over which the aggregate time is calculated begins at (Reference Marker + 200 msec) and ends no earlier than (Reference Marker + 10 sec).

RESULTS

Channel Move Time (sec)	Limit (sec)
0.768	10

Aggregate Channel Closing Transmission Time (msec)	Limit (msec)
3.750	60

MOVE TIME & CHANNEL CLOSING TIME

AGGREGATE CHANNEL CLOSING TRANSMISSION TIME

No transmissions are observed during the aggregate monitoring period.

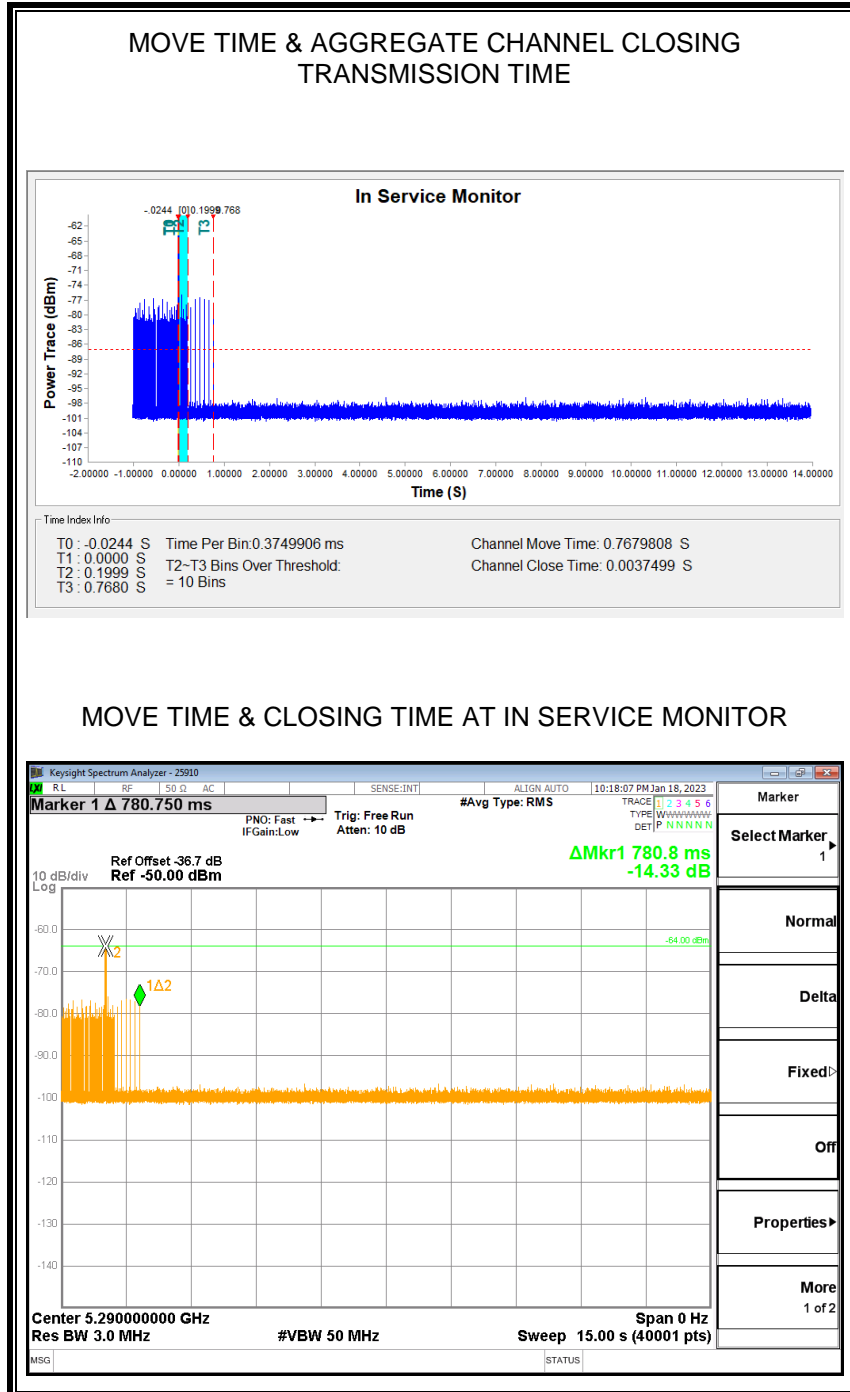

NON-OCCUPANCY PERIOD

RESULTS

No EUT transmissions were observed on the test channel during the 10-minute observation time.

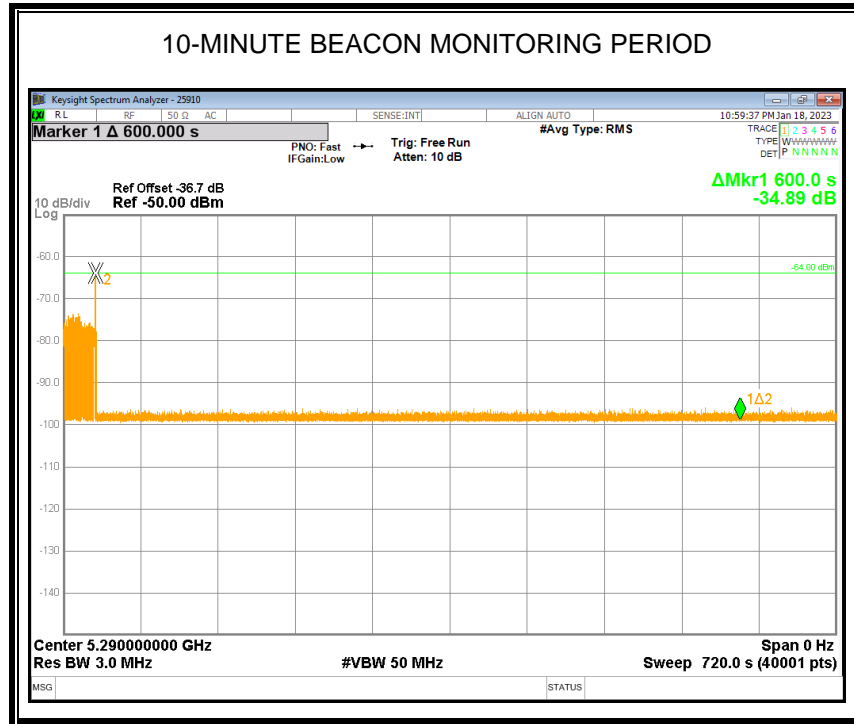

14.3. RESULTS FOR 80 MHz BANDWIDTH (UNII-2C BAND)

14.3.1. TEST CHANNEL

All tests were performed at a channel center frequency of 5530 MHz.

14.3.2. RADAR WAVEFORM AND TRAFFIC

RADAR WAVEFORM



14.3.3. OVERLAPPING CHANNEL TESTS

RESULTS

These tests are not applicable.

14.3.4. MOVE AND CLOSING TIME

REPORTING NOTES

The reference marker is set at the end of last radar pulse.

The delta marker is set at the end of the last WLAN transmission following the radar pulse. This delta is the channel move time.

The aggregate channel closing transmission time is calculated as follows:

Aggregate Transmission Time =
(Number of analyzer bins showing transmission) * (dwell time per bin)

The observation period over which the aggregate time is calculated begins at (Reference Marker + 200 msec) and ends no earlier than (Reference Marker + 10 sec).

RESULTS

Channel Move Time (sec)	Limit (sec)
0.797	10

Aggregate Channel Closing Transmission Time (msec)	Limit (msec)
4.500	60

MOVE TIME & CHANNEL CLOSING TIME

AGGREGATE CHANNEL CLOSING TRANSMISSION TIME

No transmissions are observed during the aggregate monitoring period.

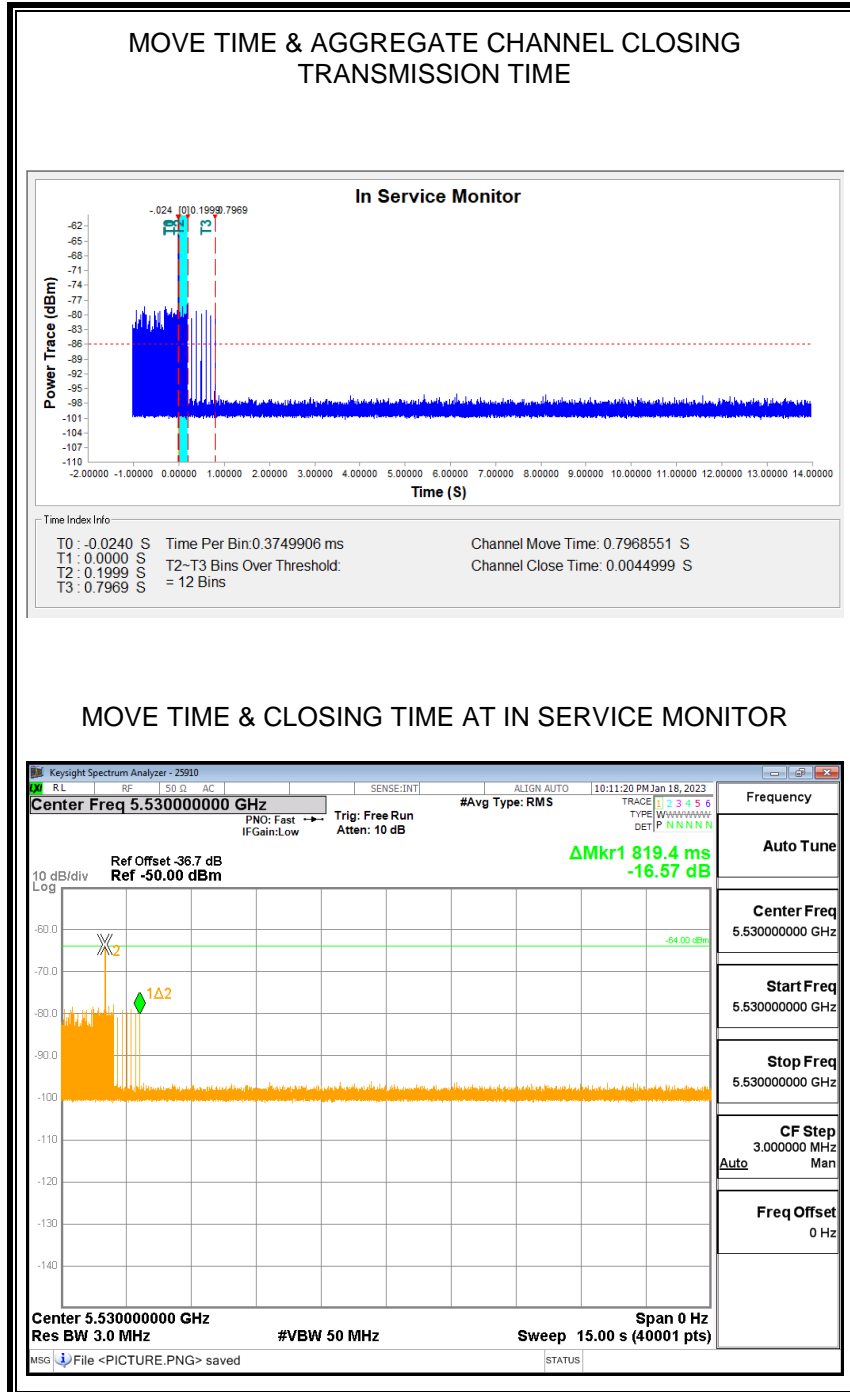

NON-OCCUPANCY PERIOD

RESULTS

No EUT transmissions were observed on the test channel during the 10-minute observation time.

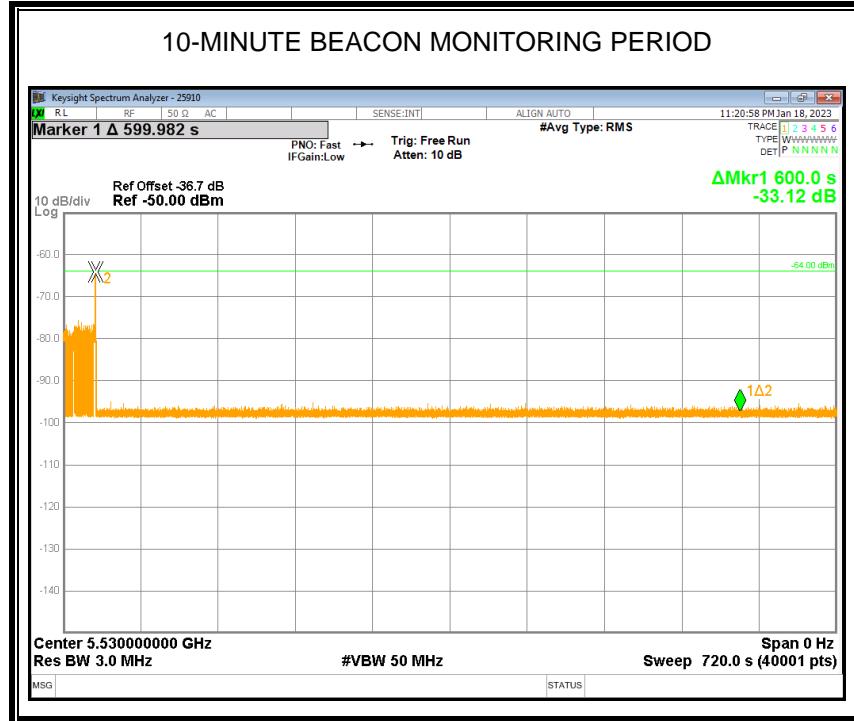

15. SPOT-CHECK TEST RESULT

BANDEDGE (WORST CASE: 802.11n HT40 / 5190 MHz)

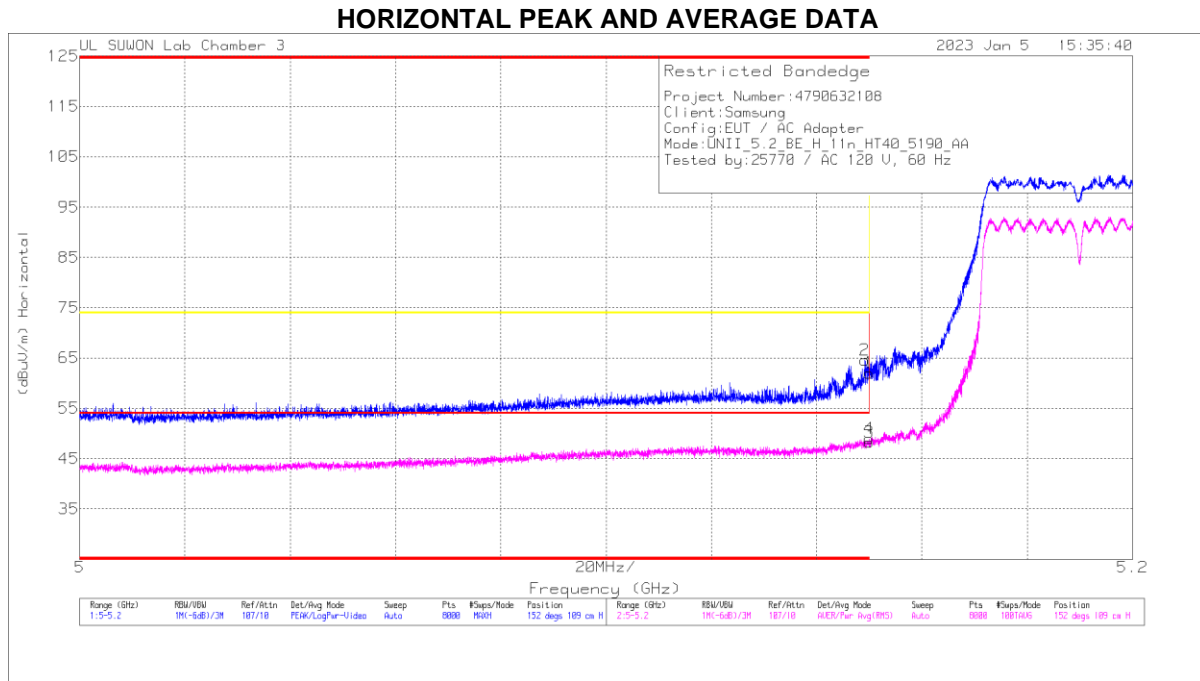

Trace Markers

Marker	Frequency (GHz)	Meter Reading (dBuV)	Det	3117_00218957	10dB_ATT[dB]	DC Corr (dB)	Corrected Reading (dBuV/m)	Average Limit (dBuV/m)	Margin (dB)	Peak Limit (dBuV/m)	PK Margin (dB)	Azimuth (Degs)	Height (cm)	Polarity
1	* 5.14999	47.83	Pk	34.8	-20.6	0	62.03	-	-	74	-11.97	152	109	H
2	* 5.14917	50.39	Pk	34.8	-20.6	0	64.59	-	-	74	-9.41	152	109	H
3	* 5.14999	33.98	RMS	34.8	-20.6	-12	48.3	54	-5.7	-	-	152	109	H
4	* 5.14992	34.64	RMS	34.8	-20.6	-12	48.96	54	-5.04	-	-	152	109	H

* - indicates frequency in CFR47 Pt 15 / IC RSS-Restricted Band
 Pk - Peak detector
 RMS - RMS detection

HARMONICS AND SPURIOUS EMISSIONS(WORST CASE: 802.11a / 5240 MHz)
5240 MHz VERTICAL

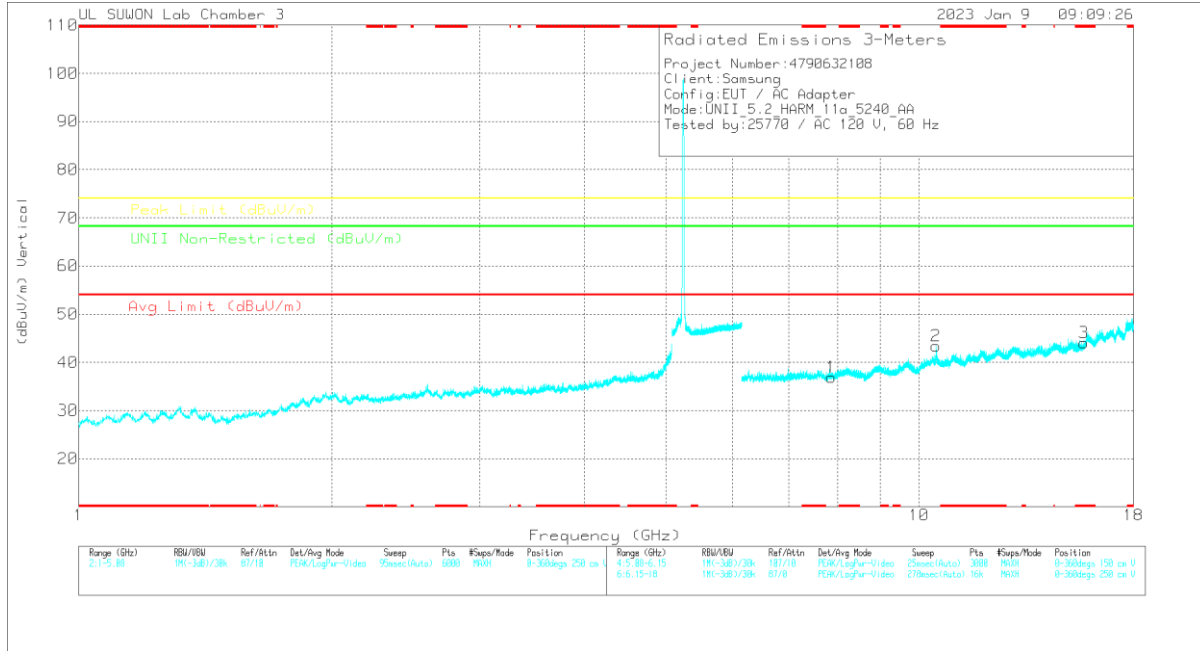

Note: Emission was scanned up to 40GHz; No emissions were detected above the noise floor which was at least 20dB below the specification limit.

Radiated Emissions

Frequency (GHz)	Mask Reading (dBu)	Det	3117_00205969	6GR_HF1(dB)	DC Corr (dB)	Corrected Reading (dBu/m)	Avg Limit (dBu/m)	Margin (dB)	Peak Limit (dBu/m)	Margin (dB)	UNII Non-Restricted (dBu/m)	Margin (dB)	Asmth (Steps)	Height (cm)	Polarity
10.47974	36.57	PK-U	37.6	-21.2	0	52.97	-	-	-	-	68.2	-15.23	341	100	V

* - indicates frequency in CFR47 Pt 15 / IC RSS-Restricted Band
 PK-U - U-NII: Maximum Peak

BANDEDGE (WORST CASE: 802.11a / 5320 MHz)

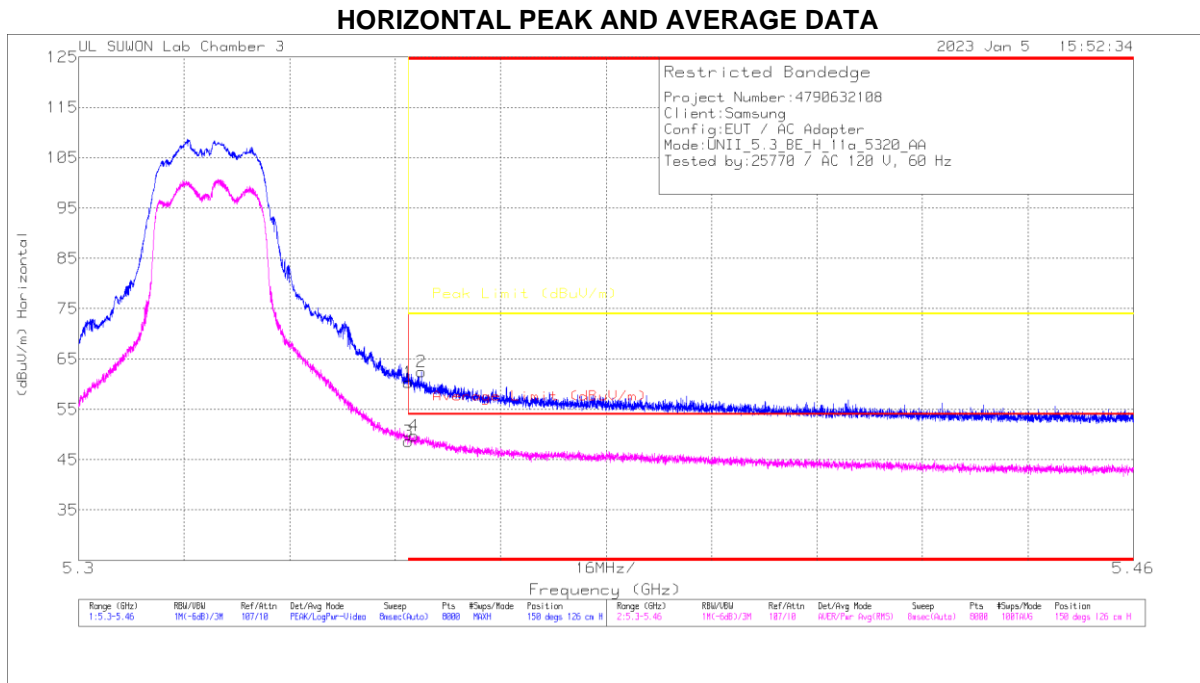

Trace Markers

Marker	Frequency (GHz)	Meter Reading (dBuV)	Det	3117_00218957	10dB_ATT(dB)	DC Cor (dB)	Corrected Reading (dBuV/m)	Average Limit (dBuV/m)	Margin (dB)	Peak Limit (dBuV/m)	PK Margin (dB)	Azimuth (Degs)	Height (cm)	Polarity
1	* 5.35001	45.45	Pk	35.1	-20.2	0	60.35	-	-	74	-13.65	150	126	H
2	* 5.35197	47.54	Pk	35.1	-20.2	0	62.44	-	-	74	-11.56	150	126	H
3	* 5.35001	33.69	RMS	35.1	-20.2	.1	48.69	54	-5.31	-	-	150	126	H
4	* 5.35081	34.77	RMS	35.1	-20.2	.1	49.77	54	-4.23	-	-	150	126	H

* - indicates frequency in CFR47 Pt 15 / IC RSS-Restricted Band
 Pk - Peak detector
 RMS - RMS detection