



HAC RF EMISSIONS TEST REPORT

**FCC 47 CFR § 20.19
ANSI C63.19-2011**

For

GSM/WCDMA/LTE Phone + BT/BLE, DTS/UNII a/b/g/n/ac and NFC

MODEL NUMBER : SM-A525M/DS, SM-A525M

FCC ID: A3LSMA525M

REPORT NUMBER: 4789746830-S2V2

ISSUE DATE: 2/1/2021

Prepared for
**SAMSUNG ELECTRONICS CO., LTD.
129 SAMSUNG-RO, YEONGTONG-GU, SUWON-SI,
GYEONGGI-DO, 16677, KOREA**

Prepared by
**UL Korea, Ltd.
26th floor, 152, Teheran-ro, Gangnam-gu Seoul, 06236, Korea**

**Suwon Test Site: UL Korea, Ltd. Suwon Laboratory
218 Maeyeong-ro, Yeongtong-gu,
Suwon-si, Gyeonggi-do, 16675, Korea
TEL: (031) 337-9902
FAX: (031) 213-5433**



Testing Laboratory

TL-637

Revision History

Rev.	Date	Revisions	Revised By
V1	1/26/2021	Initial Issue	-
V2	2/1/2021	Revised Sec. 1, Sec. 6.1, Sec. 9 and Sec. 12 & 12.1 Revised Appendix B, C and F	Jeongyeon Won

Table of Contents



1. Attestation of Test Results	4
2. Test Methodology	5
3. Facilities and Accreditation	5
4. Calibration and Uncertainty	5
4.1. <i>Measuring Instrument Calibration</i>	5
4.2. <i>Measurement Uncertainty</i>	6
4.3. <i>DECISION RULE</i>	6
5. System Specifications	7
6. System Validation	8
6.1. <i>System Validation Results</i>	9
7. Average Antenna Input Power & Evaluation for Low-power Exemption	10
8. Device Under Test	11
8.1. <i>Air Interfaces and Operating Mode</i>	11
9. Modulation Interference Factor (MIF)	12
10. HAC RF Emissions Test Procedure	13
11. RF Emissions Measurement Criteria	16
12. HAC (RF Emissions) Test Results	16
12.1. <i>Worst Case RF Emission Test Plot</i>	17
Appendixes	18
4789746830-S2 <i>Appendix A: Setup Photo</i>	18
4789746830-S2 <i>Appendix B: System Validation Plots</i>	18
4789746830-S2 <i>Appendix C: Test Plots</i>	18
4789746830-S2 <i>Appendix D: MIF Attestation Letter</i>	18
4789746830-S2 <i>Appendix E: Probe Certificates</i>	18
4789746830-S2 <i>Appendix F: Dipole Certificates</i>	18
4789746830-S2 <i>Appendix G: UID Specifications</i>	18

1. Attestation of Test Results

Applicant Name	SAMSUNG ELECTRONICS CO., LTD.
FCC ID	A3LSMA525M
Model Name	SM-A525M/DS, SM-A525M
Applicable Standards	FCC 47 CFR § 20.19 ANSI C63.19-2011
HAC Rating	M4
Date Tested	12/22/2020 to 2/1/2021
Test Results	Pass

UL Korea, Ltd. tested the above equipment in accordance with the requirements set forth in the above standards. All indications of Pass/Fail in this report are opinions expressed by UL Korea, Ltd. based on interpretations and/or observations of test results. Measurement Uncertainties were not taken into account and are published for informational purposes only. The test results show that the equipment tested is capable of demonstrating compliance with the requirements as documented in this report..

Note: SM-A525M/DS and SM-A525M have the same hardware but number of SIM card slot is different. SM-A525M is single SIM version and SM-A525M/DS is dual SIM version. This application was tested with SM-A525M/DS in all bands. The results documented in this report apply only to the tested sample, under the conditions and modes of operation as described herein. This document may not be altered or revised in any way unless done so by UL Korea, Ltd. and all revisions are duly noted in the revisions section. Any alteration of this document not carried out by UL Korea, Ltd. will constitute fraud and shall nullify the document. This report must not be used by the client to claim product certification, approval, or endorsement by IAS, any agency of the Federal Government, or any agency of any government.

Approved & Released By: 	Prepared By: 
Justin Park Operations Leader UL Korea, Ltd. Suwon Laboratory	Jeongyeon Won Senior Laboratory Technician UL Korea, Ltd. Suwon Laboratory

2. Test Methodology

The tests documented in this report were performed in accordance with ANSI C63.19-2011 Methods of Measurement of Compatibility between Wireless Communications Devices and Hearing Aids and FCC Published procedure.

KDB 285076 D01 HAC Guidance v05r01

KDB 285076 D03 HAC FAQ v01r03

TCB workshop updates

3. Facilities and Accreditation

The test sites and measurement facilities used to collect data are located at

Suwon
SAR 2 Room (HAC)

UL Korea, Ltd. is accredited by IAS, Laboratory Code TL-637.

The full scope of accreditation can be viewed at <https://www.iasonline.org/wp-content/uploads/2017/05/TL-637-cert-New.pdf>.

4. Calibration and Uncertainty

4.1. Measuring Instrument Calibration

The measuring equipment utilized to perform the tests documented in this report has been calibrated in accordance with the manufacturer's recommendations, and is traceable to recognized national standards.

Name of Equipment	Manufacturer	Type/Model	Serial No.	Cal. Due Date
MXG Analog Signal Generator	Agilent	N5181A	MY50145882	8-4-2021
Power Sensor	Agilent	U2000A	MY54260010	8-4-2021
Power Sensor	Agilent	U2000A	MY54260007	8-4-2021
Power Amplifier	EXODUS	1410025-AMP2027-10003	10003	8-4-2021
Directional Coupler	Agilent	772D	MY52180193	8-4-2021
Directional Coupler	Agilent	778D	MY52180432	8-4-2021
Low Pass Filter	MICROLAB	LA-15N	3943	8-4-2021
Low Pass Filter	FILTRON	L14012FL	1410003S	8-4-2021
Attenuator	Agilent	8491B/003	MY39271969	12-3-2021
Attenuator	Agilent	8491B/010	MY39271981	9-9-2021
Attenuator	Agilent	8491B/020	MY39271973	9-9-2021
Data Acquisition Electronics (SAR2)	SPEAG	DAE4	1447	3-20-2021
E-Field Probe*	SPEAG	EF3DV3	4066	7-24-2021
Calibration Dipole	SPEAG	CD835V3	1000	9-19-2021
Calibration Dipole	SPEAG	CD1880V3	1000	9-19-2021
Calibration Dipole	SPEAG	CD2450V3	1002	9-17-2021
Calibration Dipole	SPEAG	CD2600V3	1009	9-17-2021
Radio Communication Tester	R & S	CMW 500	150314	8-4-2021

Note(s):

*: According to SPEAG's Technical Report, "MIF Verification", Doc # TR-FB-12.09.04-1, issued date: 9/4/2012. E-field probes are calibrated with specified uncertainty according to ISO 17025 as described in their calibration certificate. The MIF according to the definition in ANSI C63.19 is specific for a modulation and can therefore be used as a constant value if the probe has been PMR calibrated.

4.2. Measurement Uncertainty

Measurement Uncertainty for Radio Frequency Emissions Measurement

Error Description	Explanation	Uncertainty value ($\pm\%$)	Probe Dist.	Divisor	(Ci) E	(Ci) H	Std. Unc.($\pm\%$)
							E
Measurement System							
Probe Calibration	A.1	5.10	Normal	1	1	1	5.10
Axial Isotropy	A.2	4.70	Rectangular	1.732	1	1	2.71
Sensor Displacement	A.3	16.50	Rectangular	1.732	1	0.145	9.53
Boundary Effects	A.4	2.40	Rectangular	1.732	1	1	1.39
Phantom Boundary Effects	A.5	7.20	Rectangular	1.732	1	0	4.16
Linearity	A.6	4.70	Rectangular	1.732	1	1	2.71
Scaling to PMR Calibration	A.7	10.00	Rectangular	1.732	1	1	5.77
System Detection Limit	A.8	1.00	Rectangular	1.732	1	1	0.58
Readout Electronics	A.9	0.30	Normal	1	1	1	0.30
Response Time	A.10	0.80	Rectangular	1.732	1	1	0.46
Integration Time	A.11	2.60	Rectangular	1.732	1	1	1.50
RF Ambient Conditions	A.12	3.00	Rectangular	1.732	1	1	1.73
RF Reflections	A.13	12.00	Rectangular	1.732	1	1	6.93
Probe Positioner	A.14	1.20	Rectangular	1.732	1	0.67	0.69
Probe Positioning	A.15	4.70	Rectangular	1.732	1	0.67	2.71
Extrapolation and Interpolation	A.16	1.00	Rectangular	1.732	1	1	0.58
Test sample Related							
Test Positioning Vertical	A.17	4.70	Rectangular	1.732	1	0.67	2.71
Test positioning Lateral	A.18	1.00	Rectangular	1.732	1	1	0.58
Device Holder and Phantom	A.19	2.40	Rectangular	1.732	1	1	1.39
Power Drift	A.20	5.00	Rectangular	1.732	1	1	2.89
Phantom and Setup Related							
Phantom Thickness	A.21	2.40	Rectangular	1.732	1	0.67	1.39
Combined Std. Uncertainty							16.31
Expanded Std. Uncertainty on Power							32.62
Expanded Std. Uncertainty on Field							16.31
Notes for table							
1. Ci - is te sensitivity coefficient							
2. Expanded Std. Uncertainty on Power, Coverage Factor = 2, > 95% Confidence							
3. Expanded Std. Uncertainty on Field is half value of Expanded Std. Uncertainty on power							

4.3. DECISION RULE

Decision rule for statement(s) of conformity is based on Procedure 1, Clause 4.4.2 in IEC Guide 115:2007.

5. System Specifications

E-field measurements are performed using the DASY52 automated dosimetric assessment system. The DASY52 is made by Schmid & Partner Engineering AG (SPEAG) in Zurich, Switzerland.

The DASY52 HAC Extension consists of the following parts:

Test Arch Phantom

The specially designed Test Arch allows high precision positioning of both the device and any of the validation dipoles.

EF3DV3 Isotropic E-Field Probe

Construction:	One dipole parallel, two dipoles normal to probe axis Interleaved sensors Built-in shielding against static charges PEEK enclosure material
Calibration:	In air from 30 MHz to 6.0 GHz (absolute accuracy $\pm 5.1\%$, $k=2$) ISO/IEC 17025 <u>calibration service</u> available.
Frequency:	30 MHz – > 6 GHz (can be extended to < 20 MHz); Linearity: ± 0.2 dB (100 MHz – 3 GHz)
Directivity:	± 0.2 dB in air (rotation around probe axis) ± 0.4 dB in air (rotation normal to probe axis)
Dynamic Range:	2 V/m to > 1000 V/m; Linearity: ± 0.2 dB
Dimensions:	Overall length: 337 mm (Tip: 25 mm) Tip diameter: 4 mm (Body: 12 mm) Distance from probe tip to dipole centers: 1.5 mm Sensor displacement to probe's calibration point: <0.7 mm
Application:	General near-field measurements up to 6 GHz HAC measurements up to 6 GHz Field component measurements
Fast automatic scanning in phantoms	

6. System Validation

The test setup was validated when first configured and verified periodically thereafter to ensure proper function. The procedure provided in this section is a validation procedure using dipole antennas for which the field levels were computed by numeric modeling.

Procedure:

Place a dipole antenna meeting the requirements given in ANSI C63.19 in the normally occupied by the WD.

The dipole antenna serves as a known source for an electrical and magnetic output. Position the E-field probe so that the following occurs:

- The probes and their cables are parallel to the coaxial feed of the dipole antenna
- The probe cables and the coaxial feed of the dipole antenna approach the measurement area from opposite directions
- The center point of the probe element(s) is 15 mm from the closest surface of the dipole elements.

Scan the length of the dipole with the E-field probe and record the two maximum values found near the dipole ends. Average the two readings and compare the reading to the expected value in the calibration certificate or the expected value in this standard.

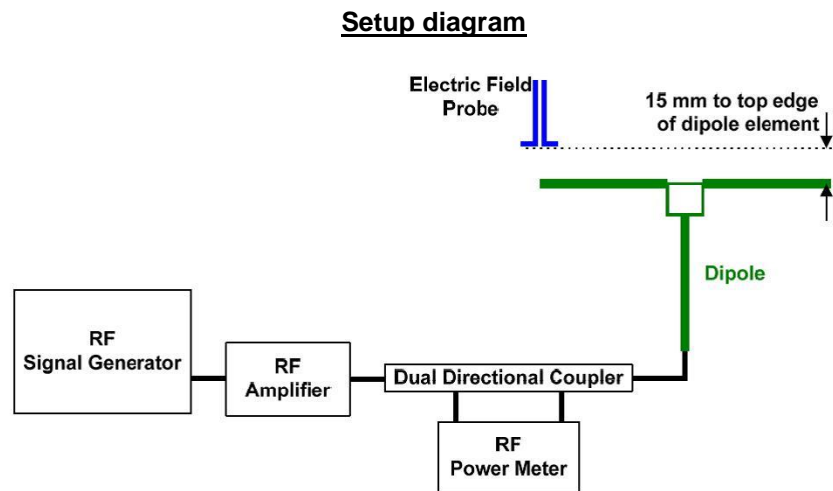

6.1. System Validation Results

SAR Lab	Date	Dipole Type_Serial #_Freq.	Dipole Cal. Due Data	Max. measured from		Average max. above arm (V/m)	Target (V/m) (From SPEAG)	Deviation (note 1) ± %	Plot No.
				above high end (V/m)	above low end (V/m)				
SAR 2	01-18-2021	CD835V3_SN:1000_(835MHz)	09-19-2021	101.00	98.50	99.75	105.90	-5.81	1
SAR 2	01-18-2021	CD1880V3_SN:1000_(1880MHz)	09-19-2021	91.70	88.90	90.30	85.70	5.37	2
SAR 2	11-22-2020	CD2600V3_SN:1009_(2600MHz)	09-17-2021	92.30	89.40	90.85	84.30	7.77	3
SAR 2	02-01-2021	CD1880V3_SN:1000_(1880MHz)	09-19-2021	88.90	88.20	88.55	85.70	3.33	

Notes:

- 1) Delta (Deviation) % = $100 * (\text{Measured value minus Target value}) / \text{Target value}$. Deltas within $\pm 25\%$ are acceptable, of which 12% is deviation and 13% is measurement uncertainty.
- 2) The maximum E-field or were evaluated and compared to the target values provided by SPEAG in the calibration certificate of specific dipoles.
- 3) Please refer to the appendix for detailed measurement data and plots.

7. Average Antenna Input Power & Evaluation for Low-power Exemption

An RF air interface technology of a device is exempt from testing when its maximum average input power plus its **MIF is ≤ 17 dBm** for any of its operating modes. If a device supports multiple RF air interfaces, each RF air interface shall be evaluated individually.

Air-Interface	Max. RF Output power	Worst Case MIF (dB)	Input Power plus its MIF (dBm)	HAC Tested
GSM850	33.5	3.63	37.13	Yes
GSM1900	31.5	3.63	35.13	Yes
W-CDMA Band II	25.5	-27.23	-1.73	No
W-CDMA Band IV	24.5	-27.23	-2.73	No
W-CDMA Band V	25.5	-27.23	-1.73	No
LTE Band 2	25.5	-9.76	15.74	No
LTE Band 4	24.5	-9.76	14.74	No
LTE Band 5	25.5	-9.76	15.74	No
LTE Band 12	25.5	-9.76	15.74	No
LTE Band 13	25.5	-9.76	15.74	No
LTE Band 17	25.5	-9.76	15.74	No
LTE Band 26	25.5	-9.76	15.74	No
LTE Band 66	25.0	-9.76	15.24	No
LTE Band 41	24.8	-1.44	23.36	Yes
802.11b	12.0	-2.02	9.98	No
802.11g	12.0	0.12	12.12	No
802.11a	12.0	-3.15	8.85	No

Note(s):

1. Max tune-up limit.
2. WLAN are support to power reduction during voice call.

8. Device Under Test

Normal operation	Held to head	
Back Cover	The Back Cover is not removable	
Test sample information	S/N	Notes
	R38NB02R9RA	RF Emission Test
	R38NB02S3X	RF Emission Test

8.1. Air Interfaces and Operating Mode

Air Interface	Bands (MHz)	Type	C63.19 Tested	Simultaneous Transmitter	OTT Testing Required? Name of Voice Service	Power Reduction
GSM	850	VO	Yes	Wi-Fi and BT	CMRS	NA
	1900					No
	GPRS/EDGE	VD	No	Wi-Fi and BT	Google Duo	NA
W-CDMA (UMTS)	850 (V)	VO	No ¹	Wi-Fi and BT	CMRS	NA
	1750 (IV)					
	1900 (II)	VD	No ¹	Wi-Fi and BT	Google Duo	NA
LTE - FDD	700 (B12/17)	VD	No ¹	Wi-Fi and BT	VoLTE Google Duo	NA
	780 (B13)					
	850 (B5/26)					
	1700 (B4/66)					
	1900 (B2)					
LTE - TDD	2600 (B41)	VD	Yes	Wi-Fi and BT	VoLTE Google Duo	NA
Wi-Fi	2450	VD	No ¹	WWAN	VoWi-Fi Google Duo	NA
	5200 (U-NII-1)	VD	No ¹	WWAN and BT	VoWi-Fi Google Duo	NA
	5300 (U-NII-2A)					
	5500 (U-NII-2C)					
	5800 (U-NII-3)					
BT	2450	DT	NA	WWAN and Wi-Fi 5GHz	NA	NA

Type

VO: Legacy Cellular Voice Service
 DT: Digital Transport only (no voice)
 VD: IP Voice Service over Digital Transport
 CMRS: Commercial Mobile Radio Service
 BT: Bluetooth

Note:

¹: Evaluated for MIF and low power exemption

9. Modulation Interference Factor (MIF)

The HAC Standard ANSI C63.19 defines a new scaling using the Modulation Interference Factor (MIF) which replaces the need for the Articulation Weighting Factor (AWF) during the evaluation and is applicable to any modulation scheme.

The Modulation Interference factor (MIF, in dB) is added to the measured average E-field (in dBV/m) and converts it to the RF Audio Interference level (in dBV/m). This level considers the audible amplitude modulation components in the RF E-field. CW fields without amplitude modulation are assumed to not interfere with the hearing aid electronics. Modulations without time slots and low fluctuations at low frequencies have low MIF values, TDMA modulations with narrow transmission and repetition rates of few 100 Hz have high MIF values and give similar classifications as ANSI C63.19.

Definitions

E-field probes have a bandwidth <10 kHz and can therefore not evaluate the RF envelope in the full audio band. DASY52 is therefore using the "indirect" measurement method according to ANSI C63.19 which is the primary method. These near field probes read the averaged E-field measurement. Especially for the new high peak-to-average (PAR) signal types, the probes shall be linearized by probe modulation response (PMR) calibration in order to not overestimate the field reading.

The evaluation method of the MIF is defined in ANSI C63.19 section D.7. An RMS demodulated RF signal is fed to a spectral filter (similar to an A weighting filter) and forwarded to a temporal filter acting as a quasi-peak detector. The averaged output of these filtering is called to a 1 kHz 80% AM signal as reference. MIF measurement requires additional instrumentation and is not well suited for evaluation by the end user with reasonable uncertainty. It may alternatively be determined through analysis and simulation, because it is constraint and characteristic for a communication signal. DASY52 uses well defined signals for PMR calibration. The MIF of these signals has been determined by simulation and is automatically applied.

MIF values were not tested by a probe or as specified in the standards but are based on analysis provided by SPEAG for all the air interfaces (GSM, WCDMA, LTE, and Wi-Fi). The data included in this report are for the worst case operating modes. The UIDs used are listed below:

UID	Communication System Name	MIF (dB)
10021-DAC	GSM-FDD (TDMA, GMSK)	3.63
10011-CAB	UMTS-FDD (WCDMA)	-27.23
10170-CAE	LTE-FDD (SC-FDMA, 1 RB, 20 MHz, 16QAM)	-9.76
10182-CAE	LTE-FDD (SC-FDMA, 1 RB, 15 MHz, 16QAM)	-9.76
10176-CAF	LTE-FDD (SC-FDMA, 1 RB, 10 MHz, 16QAM)	-9.76
10173-CAG	LTE-TDD (SC-FDMA, 1 RB, 20 MHz, 16QAM)	-1.44
10061-CAB	IEEE 802.11b WiFi 2.4 GHz (DSSS, 11 Mbps)	-2.02
10077-CAB	IEEE 802.11g WiFi 2.4 GHz (DSSS/OFDM, 54 Mbps)	0.12
10069-CAC	IEEE 802.11a/h WiFi 5 GHz (OFDM, 54 Mbps)	-3.15

A PMR calibrated probe is linearized for the selected waveform over the full dynamic range within the uncertainty specified in its calibration certificate. E-field probes have a bandwidth <10 kHz and can therefore not evaluate the RF envelope in the full audio band. DASY52 is therefore using the "indirect" measurement method according to ANSI C63.19 which is the primary method. These near field probes read the averaged E-field measurement. Especially for the new high peak-to-average (PAR) signal types, the probes shall be linearized by PMR calibration in order to not overestimate the field reading.

The MIF measurement uncertainty is estimated as follows, for modulation frequencies from slotted waveforms with fundamental frequency and at least 2 harmonics within 10 kHz:

- 0.2 dB for MIF -7 to +5 dB,
- 0.5 dB for MIF -13 to +11 dB
- 1 dB for MIF > -20 dB

10. HAC RF Emissions Test Procedure

The following are step-by-step test procedures.

- a) Confirm proper operation of the field probe, probe measurement system and other instrumentation and the positioning system.
- b) Position the WD in its intended test position.
- c) Set the WD to transmit a fixed and repeatable combination of signal power and modulation characteristic that is representative of the worst case (highest interference potential) encountered in normal use. Transiently occurring start-up, changeover, or termination conditions, or other operations likely to occur less than 1% of the time during normal operation, may be excluded from consideration.
- d) The center sub-grid shall be centered on the T-Coil mode perpendicular measurement point or the acoustic output, as appropriate. Locate the field probe at the initial test position in the 50 mm by 50 mm grid, which is contained in the measurement plane, refer to illustrated in Figure 1. If the field alignment method is used, align the probe for maximum field reception.
- e) Record the reading at the output of the measurement system
- f) Scan the entire 50 mm by 50 mm region in equally spaced increments and record the reading at each measurement point. The distance between measurement points shall be sufficient to assure the identification of the maximum reading.
- g) Identify the five contiguous sub-grids around the center sub-grid whose maximum reading is the lowest of all available choices. This eliminates the three sub-grids with the maximum readings. Thus, the six areas to be used to determine the WD's highest emissions are identified.
- h) Identify the maximum reading within the non-excluded sub-grids identified in step g).
- i) Convert the highest field reading within identified in step h) to RF audio interference level, in V/m, by taking the square root of the reading and then dividing it by the measurement system transfer function, established in 5.5.1.1. Convert this result to dB(V/m) by taking the base-10 logarithm and multiplying by 20.

Indirect measurement method

Replacing step i), the RF audio interference level in dB (V/m) is obtained by adding the MIF (in dB) to the maximum steady-state rms field-strength reading, in dB (V/m), from step h). Use this result to determine the category rating

- j) Compare this RF audio interference level with the categories in Clause 8 (ANSI C63.19) and record the resulting WD category rating
- k) For the T-Coil mode M-rating assessment, determine whether the chosen perpendicular measurement point is contained in an included sub-grid of the first scan. If so, then a second scan is not necessary. The first scan and resultant category rating may be used for the T-Coil mode M rating.

Otherwise, repeat step a) through step i), with the grid shifted so that it is centered on the perpendicular measurement point. Record the WD category rating.



Figure 1 - WD reference and plane for RF emission measurements

Test flowchart Per ANSI-63.19-2011

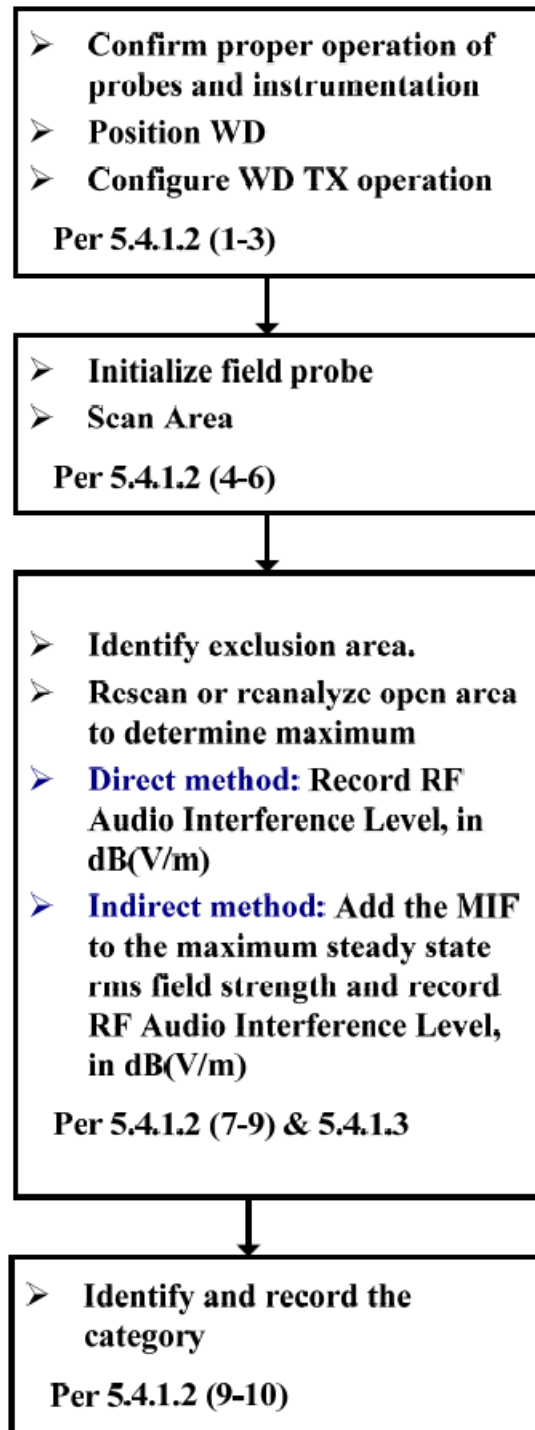

11. RF Emissions Measurement Criteria

WD RF audio interference level categories in logarithmic units

Emission Categories	E-field emissions	
	< 960 MHz	> 960 MHz
Category M1	50 to 55 dB (V/m)	40 to 45 dB (V/m)
Category M2	45 to 50 dB (V/m)	35 to 40 dB (V/m)
Category M3	40 to 45 dB (V/m)	30 to 35 dB (V/m)
Category M4	<40 dB (V/m)	<30 dB (V/m)

12. HAC (RF Emissions) Test Results

MIF values were not tested by a probe or as specified in the standards but are based on analysis provided by SPEAG for the following User Identifiers and air interfaces.

The data included in this report are for the worst case operating modes. Refer to Appendix D and G for the MIF values that represent the worst case operation modes.

Air-Interface	Ch. No.	Freq. (MHz)	Results* (dB V/m)	Results plus 0.2dB uncertainty (dB V/m)	Margin (dB)	M-Rating	Plots Page #
GSM850	128	824.2	35.75	35.95	4.05	M4	1
	190	836.6	35.28	35.48	4.52	M4	2
	251	848.6	36.79	36.99	3.01	M4	3
GSM1900	512	1850.2	27.98	28.18	1.82	M4	4
	661	1880.0	27.68	27.88	2.12	M4	5
	810	1909.8	27.31	27.51	2.49	M4	6
LTE-TDD Band 41	39750	2506.0	19.78	19.98	10.02	M4	7
	40185	2549.5	20.03	20.23	9.77	M4	8
	40620	2593.0	20.66	20.86	9.14	M4	9
	41055	2636.5	20.33	20.53	9.47	M4	10
	41490	2680.0	19.45	19.65	10.35	M4	11
W-CDMA & LTE-FDD & WLAN	Refer to Section 7 Evaluation for Low-power Exemption. RF Emission testing for this device is required only for GSM voice modes, LTE-TDD. All other applicable air-interfaces are exempt from testing in accordance with C63.19 Clause 4.4 and are rated M4.					M4	N/A

Note(s):

*: Measured Audio Interference level in dB (V/m): indirect method (max rms field strength Plus MIF)

12.1. Worst Case RF Emission Test Plot

Test Laboratory: UL Korea Ltd. Suwon Laboratory

Date: 2021-02-01

GSM 1900

Communication System: UID 10021 - DAC, GSM-FDD (TDMA, GMSK); Frequency: 1850.2 MHz; Duty Cycle: 1:8.6896;
 Phantom section: RF Section
 DASY5 Configuration:
 - Probe: EF3DV3 - SN4066; Coeff(1, 1, 1) @ 1850.2 MHz; Calibrated: 2020-07-24
 - Sensor-Surface: (Fix Surface)
 - Electronics: DAE4 Sn1447; Calibrated: 2020-03-20
 - Phantom: HAC Test Arch with AMCC; Type: SD HAC P01 BB
 - Measurement SW: DASY52, Version 52.10 (4); SEMCAD X Version 14.6.14 (7483)

GSM1900 E-Field measurement/Voice ch512/Hearing Aid Compatibility Test (101x101x1):

Interpolated grid: dx=0.5000 mm, dy=0.5000 mm
 Device Reference Point: 0, 0, -6.3 mm
 Reference Value = 17.61 V/m; Power Drift = 0.04 dB
 Applied MIF = 3.63 dB
 RF audio interference level = 27.98 dBV/m
 Emission category: **M4**

MIF scaled E- field

Grid 1 M4 27.98 dBV/m	Grid 2 M4 27.91 dBV/m	Grid 3 M4 26.04 dBV/m
Grid 4 M4 26.03 dBV/m	Grid 5 M4 27.75 dBV/m	Grid 6 M4 27.64 dBV/m
Grid 7 M4 28.69 dBV/m	Grid 8 M3 30.23 dBV/m	Grid 9 M4 29.78 dBV/m

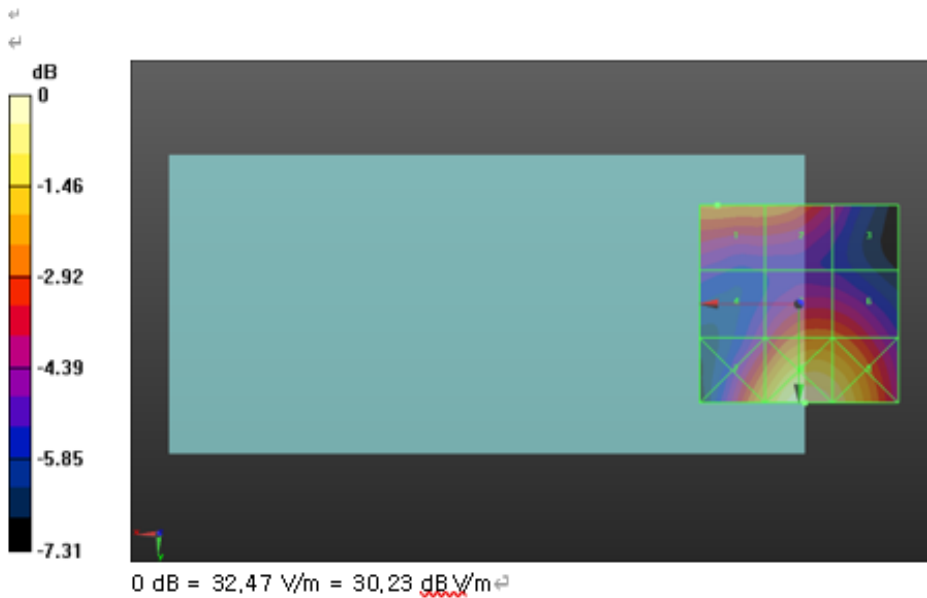

Plot No. 4

Appendixes

Refer to separated files for the following appendixes

4789746830-S2 Appendix A: Setup Photo

4789746830-S2 Appendix B: System Validation Plots

4789746830-S2 Appendix C: Test Plots

4789746830-S2 Appendix D: MIF Attestation Letter

4789746830-S2 Appendix E: Probe Certificates

4789746830-S2 Appendix F: Dipole Certificates

4789746830-S2 Appendix G: UID Specifications

END OF REPORT