

HAC RF Emission Test Report

Applicant Name: SAMSUNG Electronics Co., Ltd. 129, Samsung-ro, Yeongtong-gu, Suwon-Si, Gyeonggi-do, 16677 Rep. of Korea	Date of Issue: 11. 15, 2019 Test Report No.: HCT-SR-1911-FC003 Test Site: HCT CO., LTD.
--	--

FCC ID:

A3LSMA515F

Equipment Type:	Mobile Phone
Application Type	Certification
FCC Rule Part(s):	CFR §20.19 , ANSI C63.19-2011
Model Name:	SM-A515F/DS
Date of Test:	10/23/2019 ~ 10/24/2019

C63.19-2011
HAC Category

M4 (RF EMISSION CATEGORY)

This wireless portable device has been shown to be hearing-aid compatible under the above rated category, specified in ANSI/IEEE Std. C63.19-2011 and had been tested in accordance with the specified measurement procedures. Hearing-Aid Compatibility is based on the assumption that all production units will be designed electrically identical to the device tested in this report. I attest to the accuracy of data. All measurements reported herein were performed by me or were made under my supervision and are correct to the best of my knowledge and belief. I assume full responsibility for the completeness of these measurements and vouch for the qualifications of all persons taking them.

Tested By



Jee-Lil, Lee
Test Engineer
SAR Team
Certification Division

Reviewed By



Yun-jeang, Heo
Technical Manager
SAR Team
Certification Division

This report only responds to the tested sample and may not be reproduced, except in full, without written approval of the HCT Co., Ltd.

DOCUMENT HISTORY

Rev.	DATE	DESCRIPTION
HCT-SR-1911-FC003	11. 15, 2019	First Approval Report

Table of Contents

1. Test Regulations	4
2. ATTESTATION OF TEST RESULT OF DEVICE UNDER TEST	5
3. DEVICE UNDER TEST DESCRIPTION	6
4. HAC MEASUREMENT SET-UP	7
5. SYSTEM SPECIFICATIONS	8
6. HAC RF Emmissions Test Procedure.....	10
7. System Specifications.....	12
8. SYSTEM VALIDATION	13
9. LTE TDD UPLINK-DOWNLINK CONFIGURATION	15
10. Modulation Interference Factor.....	16
12. RF Conducted Power Measurements	23
13. TEST PROCEDURE.....	48
14. ANSI/IEEE C63.19 PERFORMANCE CATEGORIES	50
15. MEASUREMENT UNCERTAINTIES	51
16. HAC TEST DATA SUMMARY	52
17. HAC TEST EQUIPMENT LIST	54
18. HAC TEST EQUIPMENT LIST	55
19. CONCLUSION	56
Attachment 1. HAC RF Emission Test Plots.....	57
Attachment 2. System Validation Plots.....	69
Attachment 3. Probe Calibration Data	73
Attachment 4. Dipole Calibration Data	82
Attachment 5. HAC RF Emission Setup Photo.....	98

1. Test Regulations

The tests were performed according to the following regulations:

Test Standard	FCC 47 CFR §20.19 ANSI C63.19-2011
Test Method	<ul style="list-style-type: none">• KDB 285076 D01 HAC Guidance v05• KDB 285076 D03 HAC FAQ v01• TCB workshop updates

2. ATTESTATION OF TEST RESULT OF DEVICE UNDER TEST

Test Laboratory	
Company Name:	HCT Co., LTD
Address:	74, Seoicheon-ro 578beon-gil, Majang-myeon, Icheon-si, Gyeonggi-do, 17383, Rep. of Korea
Telephone:	+82 31 645 6300
Fax.:	+82 31 645 6401

Attestation of SAR test result	
Applicant Name:	SAMSUNG Electronics Co., Ltd.
FCC ID:	A3LSMA515F
Model:	SM-A515F/DS
EUT Type:	Mobile Phone
Application Type:	Certification

1.2 Test Methodology

The Tests document in this report were performed in accordance with ANSI C63.19-2011 method of Measurement of Compatibility between Wireless Communication Devices and Hearing Aids, FCC published KDB 285076 D01 HAC Guidance v05, FCC Published KDB285076 D03 HAC FAQ v01 and TCB Workshop updates .

3. DEVICE UNDER TEST DESCRIPTION

3.1 DUT specification

Device Wireless specification overview		
Band & Mode	Operating Mode	Tx Frequency
GSM 850	Voice / Data	824.2 MHz ~ 848.8 MHz
GSM 1900	Voice / Data	1 850.2 MHz ~ 1 909.8 MHz
UMTS 850	Voice / Data	826.4 MHz ~ 846.6 MHz
UMTS 1700	Voice / Data	1 712.4 MHz ~ 1 752.6 MHz
UMTS 1900	Voice / Data	1 852.4 MHz ~ 1 907.6 MHz
LTE Band 2 (PCS)	Voice / Data	1 850.7 MHz ~ 1 909.3 MHz
LTE Band 4 (AWS)	Voice / Data	1 710.7 MHz ~ 1 754.3 MHz
LTE Band 5 (Cell)	Voice / Data	824.7 MHz ~ 848.3 MHz
LTE Band 12	Voice / Data	699.7 MHz ~ 715.3 MHz
LTE Band 13	Voice / Data	779.5 MHz ~ 784.5 MHz
LTE Band 17	Voice / Data	706.5 MHz ~ 713.5 MHz
LTE Band 26 (Cell)	Voice / Data	814.7 MHz ~ 848.3 MHz
LTE TDD Band 41	Voice / Data	2 498.5 MHz ~ 2 687.5 MHz
LTE Band 66 (AWS)	Voice / Data	1 712.5 MHz ~ 1 777.5 MHz
2.4GHz WLAN	Voice / Data	2 412 MHz ~ 2 462 MHz
U-NII-1	Voice / Data	5 180 MHz ~ 5 240 MHz
U-NII-2A	Voice / Data	5 260 MHz ~ 5 320 MHz
U-NII-2C	Voice / Data	5 500 MHz ~ 5 720 MHz
U-NII-3	Voice / Data	5 745 MHz ~ 5 825 MHz
Bluetooth v5.0	Data	2 402 MHz ~ 2 480 MHz
Device Description		
Battery Options:	Li-ion battery	
	EB-BA515ABY (SDI)	
H/W Version:	REV1.0	
S/W Version:	A515F.001	
Device Serial Numbers	Mode	Serial Number
	Main Band	SJA0476H

3.2. Power Reduction for WIFI

This device uses an independent fixed level power reduction mechanism for all WIFI operations during voice or VoIP held to ear scenarios. Reduced powers were used to evaluate for low-power exemption for WIFI. Detailed descriptions of the power reduction mechanism are included in the operational description.

4. HAC MEASUREMENT SET-UP

These measurements are performed using the DASY5 automated dosimetric assessment system. It is made by Schmid & Partner Engineering AG (SPEAG) in Zurich, Switzerland. It consists of high precision robotics system (Staubli), robot controller, Pentium IV computer, near-field probe, probe alignment sensor. The robot is a six-axis industrial robot performing precise movements.

A cell controller system contains the power supply, robot controller, teach pendant (Joystick), and remote control, is used to drive the robot motors. The PC consists of the HP Pentium IV 3.0 GHz computer with Windows XP system and HAC Measurement Software DASY5, A/D interface card, monitor, mouse, and keyboard. The Staubli Robot is connected to the cell controller to allow software manipulation of the robot. A data acquisition electronic (DAE) circuit performs the signal amplification, signal multiplexing, AD-conversion, offset measurements, mechanical surface detection, collision detection, etc. is connected to the Electro-optical coupler (EOC). The EOC performs the conversion from the optical into digital electric signal of the DAE and transfers data to the PC plug-in card.

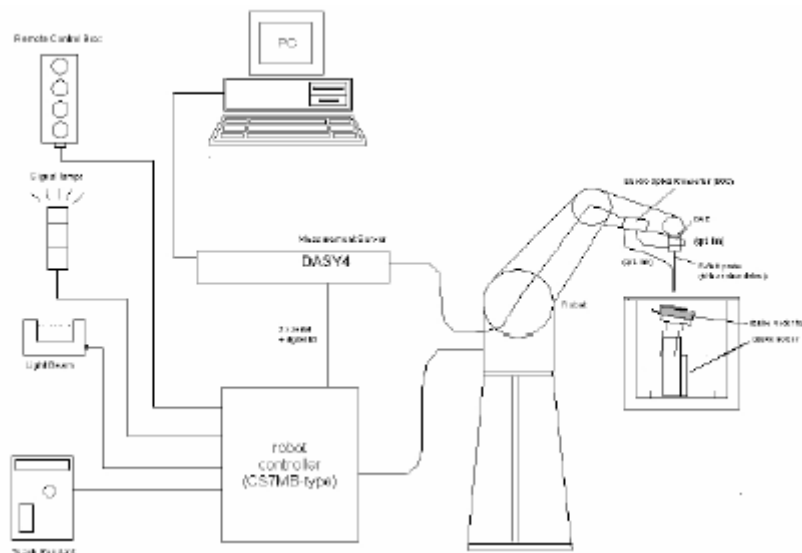

Figure 1. HAC Test Measurement Set-up

The DAE4 consists of a highly sensitive electrometer-grade preamplifier with auto-zeroing, a channel and gain-switching multiplexer, a fast 16 bit AD-converter and a command decoder and control logic unit. Transmission to the PC-card is accomplished through an optical downlink for data and status information and an optical uplink for commands and clock lines. The mechanical probe mounting device includes two different sensor systems for frontal and sidewise probe contacts. They are also used for mechanical surface detection and probe collision detection. The robot uses its own controller with a built in VME-bus computer.

5. SYSTEM SPECIFICATIONS

5.1 Probe

E-Field Probe Description

Construction	One dipole parallel, two dipoles normal to probe axis Built-in shielding against static charges
Calibration	In air from 100 MHz to 3.0 GHz (absolute accuracy $\pm 6.0\%$, $k = 2$)
Frequency	100 MHz to > 6 GHz; Linearity: ± 0.2 dB (100 MHz to 3 GHz)
Directivity	± 0.2 dB in air (rotation around probe axis) ± 0.4 dB in air (rotation normal to probe axis)
Dynamic Range	2 V/m to > 1000 V/m (M3 or better device readings fall well below diode compression point)
Linearity	± 0.2 dB
Dimensions	Overall length: 337 mm (Tip: 20 mm) Tip diameter: 3.9 mm (Body: 12 mm) Distance from probe tip to dipole centers: 1.5 mm



[E-Field Probe]

5.2 Phantom & Device Holder



Figure 2. HAC Phantom & Device Holder

The Test Arch phantom should be positioned horizontally on a stable surface. Reference markings on the Phantom allow the complete setup of all predefined phantom positions and measurement grids by manually teaching three points in the robot.

The devices can be easily, accurately, and repeatable positioned according to the FCC specifications.

5.3 Robotic System Specifications

Specifications	
POSITIONER:	Stäubli Unimation Corp. Robot Model: TX90 XLspeag
Repeatability:	0.02 mm
No. of axis:	6
Data Acquisition Electronic (DAE) System	
Cell Controller	
Processor:	Core i7
Clock Speed:	3.0 GHz
Operating System:	Windows 7
Data Card:	DASY5 PC-Board
Data Converter	
Features:	Signal Amplifier, multiplexer, A/D converter, and control logic
Software:	DASY5 software
Connecting Lines:	Optical downlink for data and status info. Optical uplink for commands and clock
PC Interface Card	
Function:	24 bit (64 Mhz) DSP for real time processing Link to DAE 16 bit A/D converter for surface detection system serial link to robot direct emergency stop output for robot

6. HAC RF Emissions Test Procedure

The following are step-by-step test procedures.

- a) Confirm proper operation of the field probe, probe measurement system and other instrumentation and the positioning system.
- b) Position the WD in its intended test position.
- c) Set the WD to transmit a fixed and repeatable combination of signal power and modulation characteristic that is representative of the worst case (highest interference potential) encountered in normal use. Transiently occurring start-up, changeover, or termination conditions, or other operations likely to occur less than 1% of the time during normal operation, may be excluded from consideration.
- d) The center sub-grid shall be centered on the T-Coil mode perpendicular measurement point or the acoustic output, as appropriate. Locate the field probe at the initial test position in the 50 mm by 50 mm grid, which is contained in the measurement plane, refer to illustrated in Figure 1. If the field alignment method is used, align the probe for maximum field reception.
- e) Record the reading at the output of the measurement system
- f) Scan the entire 50 mm by 50 mm region in equally spaced increments and record the reading at each measurement point. The distance between measurement points shall be sufficient to assure the identification of the maximum reading.
- g) Identify the five contiguous sub-grids around the center sub-grid whose maximum reading is the lowest of all available choices. This eliminates the three sub-grids with the maximum readings. Thus, the six areas to be used to determine the WD's highest emissions are identified.
- h) Identify the maximum reading within the non-excluded sub-grids identified in step g).
- i) Convert the highest field reading within identified in step h) to RF audio interference level, in V/m, by taking the square root of the reading and then dividing it by the measurement system transfer function, established in
5.5.1.1 Convert this result to dB(V/m) by taking the base-10 logarithm and multiplying by 20. Indirect measurement method
Replacing step i), the RF audio interference level in dB (V/m) is obtained by adding the MIF (in dB) to the maximum steady-state rms field-strength reading, in dB (V/m), from step h). Use this result to determine the category rating
- j) Compare this RF audio interference level with the categories in Clause 8 (ANSI C63.19) and record the resulting WD category rating
- k) For the T-Coil mode M-rating assessment, determine whether the chosen perpendicular measurement point is contained in an included sub-grid of the first scan. If so, then a second scan is not necessary. The first scan and resultant category rating may be used for the T-Coil mode M rating.

Otherwise, repeat step a) through step i), with the grid shifted so that it is centered on the perpendicular measurement point. Record the WD category rating.



Figure 3. WD reference and plane for RF emission measurements

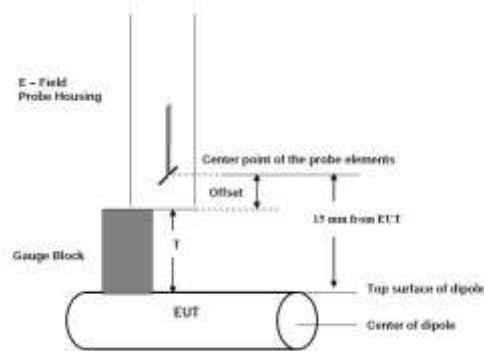

Figure 4. Gauge Block with E-Field Probe

7. System Specifications

E-field measurements are performed using the DASY52 automated dosimetric assessment system. The DASY52 is made by Schmid & Partner Engineering AG (SPEAG) in Zurich, Switzerland.

The DASY52 HAC Extension consists of the following parts:

Test Arch Phantom

The specially designed Test Arch allows high precision positioning of both the device and any of the validation dipoles.

EF3DV3 Isotropic E-Field Probe

Construction:	One dipole parallel, two dipoles normal to probe axis Interleaved sensors Built-in shielding against static charges PEEK enclosure material
Calibration:	In air from 100 MHz to 3.0 GHz(absolute accuracy $\pm 6.0\%$, $k=2$) ISO/IEC 17025 <u>calibration service</u> available.
Frequency:	40 MHz – >6 GHz (can be extended to < 20 MHz); Linearity: ± 0.2 dB (100 MHz – 3 GHz)
Directivity:	± 0.2 dB in air (rotation around probe axis) ± 0.4 dB in air (rotation normal to probe axis)
Dynamic Range:	2 V/m to > 1000 V/m; Linearity: ± 0.2 dB
Dimensions:	Overall length: 337 mm (Tip: 20 mm) Tip diameter: 3.9 mm (Body: 12 mm) Distance from probe tip to dipole centers: 1.5 mm Sensor displacement to probe's calibration point: <0.7 mm
Application:	General near-field measurements up to 6 GHz HAC measurements up to 6 GHz Field component measurements Fast automatic scanning in phantoms

8. SYSTEM VALIDATION

The test setup was validated when first configured and verified periodically thereafter to ensure proper function. The procedure provided in this section is a validation procedure using dipole antennas for which the field levels were computed by numeric modeling.

Procedure:

Place a dipole antenna meeting the requirements given in ANSI C63.19 in the normally occupied by the WD.

The dipole antenna serves as a known source for an electrical and magnetic output. Position the E-field probe so that the following occurs:

- The probes and their cables are parallel to the coaxial feed of the dipole antenna
- The probe cables and the coaxial feed of the dipole antenna approach the measurement area from opposite directions
- The center point of the probe element(s) is 15 mm from the closest surface of the dipole elements.

Scan the length of the dipole with the E-field probe and record the two maximum values found near the dipole ends. Average the two readings and compare the reading to the expected value in the calibration certificate or the expected value in this standard.

Setup diagram

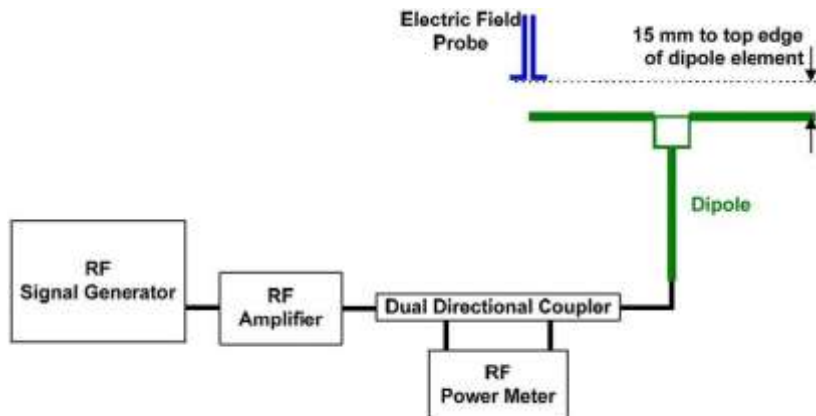

8.1 SYSTEM Validation Result

Mode	Date	Dipole Type_Seria_ Freq.	Input Power [dBm]	MAX. Measured from		Average max. above arm [V/m]	Target Value SPEAG [V/m]	Dev. [%]
				Above high end (V/m)	Above low end (V/m)			
CW	10/24/2019	CD835V3_SN:1024_(835 MHz)	20	118.03	98.63	108.33	105.4	+2.8
CW	10/24/2019	CD1880V3_SN:1019_(1880 MHz)	20	88.31	88.21	88.26	85.80	+2.9
CW	10/23/2019	CD2600V3_SN:1009_(2600 MHz)	20	86.30	85.31	85.81	84.20	+1.9

Notes:

- 1) Deviation (%) = $100 * (\text{Measured value} - \text{Target value}) / \text{Target value}$.
ANSI-C63.19 requires values to be within 25 % of their targets. 12 % is deviation and 13 % is measurement uncertainty.
- 2) The maximum E-field was evaluated and compared to the target values provided by SPEAG in the calibration certificate of specific dipoles.
- 3) Please refer to the attachment for detailed measurement data and plot.

9. LTE TDD UPLINK-DOWNLINK CONFIGURATION

9.1 Uplink-Downlink Configuration Investigation

An investigation was performed on each supported power class for LTE TDD to determine the worst case Uplink-Downlink configuration for RFE testing.

Per 3GPP TS 36.211, the total frame length for each TDD radio frame of length $T_f = 307200 \cdot T_s = 10\text{ms}$, where T_s is a number of time units equal to $1/(15000 \times 2048)$ seconds. Additionally, each radio frame consists of 10 subframes, each of length $30720 \cdot T_s = 1 \text{ ms}$, and subframes can be designated as uplink (U), downlink (D), or special subframe (S), depending on the Uplink-Downlink configuration as indicated in Table 4.2-2 of 3GPP TS 36.211. In the transmission duty factor calculation, the special subframe configuration with the shortest UpPTS duration within the special subframe is used and will be applied for measurement. From 3GPP TS 36.211 Table 4.2-1, the shortest UpPTS is $2192 \cdot T_s$ which occurs in the normal cyclic prefix and special subframe configuration 4.

See table below outlining the calculated transmission duty cycles for each Uplink-Downlink configuration:

Uplink-Downlink configuration	Downlink-to-Uplink Switch-point periodicity	Subframe number										Calculated Transmission Duty Cycle [%]
		0	1	2	3	4	5	6	7	8	9	
0	5 ms	D	S	U	U	U	D	S	U	U	U	61.4
1	5 ms	D	S	U	U	D	D	S	U	U	D	41.4
2	5 ms	D	S	U	D	D	D	S	U	D	D	21.4
3	10 ms	D	S	U	U	U	D	D	D	D	D	30.7
4	10 ms	D	S	U	U	D	D	D	D	D	D	20.7
5	10 ms	D	S	U	D	D	D	D	D	D	D	10.7
6	5 ms	D	S	U	U	U	D	S	U	U	D	51.4

Uplink-Downlink Configurations for Type 2 Frame Structures

LTE TDD was evaluated with the following radio configuration: channel 40620, 20MHz BW, 16QAM, 1RB, 0RB offset. All configurations (0-6) are supported. The configuration which resulted in the worst Audio Interference Level was used for full testing. See Table for investigation results. The configuration determined in the investigation below was used to measure the MIF values in 10-4 Table. See Table 9-1 below for result

Table 9-1 LTE TDD Power Class 3 UL-DL Configuration Results

Mode	Channel	UL-DL Config.	Mod.	BW	RB Size	RB offset	Time Avg. Filed [V/m]	Audio Inteference Level [dBV/m]	FCC Limit [dBV/m]	FCC Margin [dB]	MIF	Result	Exclusion Block
LTE TDD/ Band 41	40620	0	16QAM	20	1	0	16.61	21.28	35	13.72	-3.13	M4	none
	40620	1	16QAM	20	1	0	13.82	21.26	35	13.74	-1.55	M4	none
	40620	2	16QAM	20	1	0	9.56	21.32	35	13.68	1.71	M4	none
	40620	3	16QAM	20	1	0	11.57	20.24	35	14.76	-1.03	M4	none
	40620	4	16QAM	20	1	0	9.74	20.55	35	14.45	0.78	M4	none
	40620	5	16QAM	20	1	0	7.03	20.67	35	14.33	3.73	M4	none
	40620	6	16QAM	20	1	0	15.24	21.24	35	13.76	-2.42	M4	none

9.2 Conclusion

Per the investigations above, UL-DL configuration 2 was used for LTE TDD.

10. Modulation Interference Factor

For any specific fixed and repeatable modulated signal, a modulation interference factor (MIF, expressed in dB) may be developed that relates its interference potential to its steady-state rms signal level or average power level. This factor is a function only of the audio-frequency amplitude modulation characteristics of the signal and is the same for field-strength and conducted power measurements. It is important to emphasize that the MIF is valid only for a specific repeatable audio-frequency amplitude modulation characteristic. Any change in modulation characteristic requires determination and application of a new MIF.

10.1 Measuring Modulation Interference Factors

For any specific fixed and repeatable modulated signal, a modulation interference factor (MIF, expressed in dB) may be developed that relates its interference potential to its steady-state RMS signal level or average power level. This factor is a function only of the audio-frequency amplitude modulation characteristics of the signal and is the same for field-strength and conducted power measurements.

The MIF is valid only for a specific repeatable audio-frequency amplitude modulation characteristic. any change in modulation characteristic requires determination and application of a new MIF.

The MIF may be determined using a radiated RF field or a conducted RF signal:

- a. Using RF illumination or conducted coupling, apply the specific modulated signal in question to the measurement system at a level within its confirmed operating dynamic range.
- b. Measure the steady-state RMS level at the output of the fast probe or sensor.
- c. Measure the steady-state average level at the weighting output.
- d. Without changing the square-law detector or weighting system, and using RF illumination or conducted coupling, substitute for the specific modulated signal a 1 kHz, 80% amplitude modulated carrier at the same frequency and adjust its strength until the level at the weighting output equals the step d) measurement.
- e. Without changing the carrier level from step e), remove the 1 kHz modulation and again measure the steady-state rms level indicated at the output of the fast probe or sensor.
- f. The MIF for the specific modulation characteristic is provided by the ratio of the step e) measurement to the step b) measurement, expressed in dB ($20 \times \log(\text{step e})/\text{step b}$).

The following procedure was used to measure the MIF using the SPEAG audio interference Analyzer (AIA), Serial No.:1060:

1. The device was placed into a simulated call using a base station simulator or set to transmit using test software for a given model.
2. The device was then set to continuously transmit at maximum power.
3. Using a coupler if needed, the device output signal was connected to the RF In port of the AIA, which was connected to a desktop computer. Alternatively, a radiated RF signal may be used with the AIA's built-in antenna.
4. The MIF measurement procedure in the DASY software was run, and the resulting MIF value was recorded.
5. Steps 1-4 were repeated for all CMRS air interfaces, frequency bands, and modulations.

The modulation interference factors obtained were applied to readings taken of the actual wireless device in order to obtain an accurate audio interference level reading using the formula:

$$\text{Audio interference Level [dB (V/m)]} = 20 * \log [\text{Raw Field Value (V/m)}] + \text{MIF (dB)}$$

Because the MIF value is output power independent, MIF values for a given mode should be constant across all devices; however, per C63.19-2011 §D.7, MIF values should be measured for each device being evaluated. The voice modes for this device have been investigated in this section of the report.

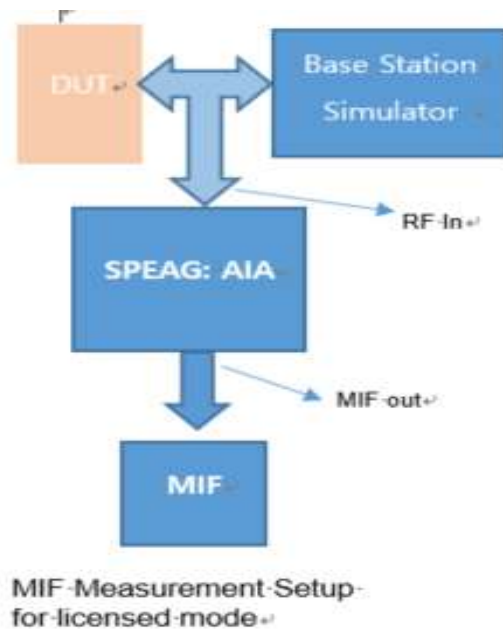

Table 10-1

Mode	GSM850			GSM1900		
	128	190	251	512	661	810
GSM	3.56	3.55	3.56	3.54	3.53	3.52

GSM Modulation Interference Factors

Table 10-2

Mode		WCDMA850			WCDMA1700			WCDMA1900		
		4132	4183	4233	1312	1412	1513	9262	9400	9538
UMTS	12.2kbps RMC	-20.81	-21.01	-20.61	-22.60	-21.72	-21.14	-20.96	-21.17	-20.64
	12.2 kbps AMR	-20.37	-21.18	-20.57	-20.84	-22.49	-20.56	-20.82	-20.36	-20.57

UMTS Modulation Interference Factors

Note :

Measured MIF value maybe lower than sample MIF values provide in ANSI C63.19-2011 Annex D.7 Table D.5 due to manufacturing variations for each device. However per Annex D.7, the sample MIF values of table D.5 are not intended to substitute for measurements of actual devices under test and their respective operating mode.

Table 10-3

LTE Band	Frequency [MHz]	Channel	Bandwidth [MHz]	Modulation	RB Size	RB offset	MIF [dB]	PMF
2	1880	18900	20	16QAM	1	0	-9.79	2.71
5	836.5	20525	10	16QAM	1	0	-9.77	2.69
4	1732.5	20175	20	16QAM	1	0	-9.8	2.66
12	707.5	23095	10	16QAM	1	0	-9.53	2.66
13	782	23230	10	16QAM	1	0	-9.91	2.49
66	1745	132322	20	16QAM	1	0	-9.83	3.12
26	831.5	26865	15	16QAM	1	0	-10.01	2.43
17	710	23790	10	16QAM	1	0	-9.56	2.68
12	707.5	23095	10	QPSK	1	0	-14.4	1.16
12	707.5	23095	10	16QAM	1	24	-9.55	2.62
12	707.5	23095	10	16QAM	1	49	-9.59	2.58
12	707.5	23095	10	16QAM	25	0	-15.61	0.56
12	707.5	23095	10	16QAM	50	0	-16.77	0.44
12	707.5	23095	5	16QAM	1	0	-8.95	2.79
12	707.5	23095	3	16QAM	1	0	-9.57	2.74
12	707.5	23095	1.4	16QAM	1	0	-9.69	2.66
12	701.5	23035	5	16QAM	1	0	-9.36	2.76
12	713.5	23155	5	16QAM	1	0	-9.41	2.77

LTE FDD Modulation Interference Factors

Table 10-4

LTE Band	Frequency [MHz]	Channel	Bandwidth [MHz]	Modulation	RB Size	RB offset	MIF [dB]	PMF
41	2593	40620	20	16QAM	1	0	1.71	10.01
41	2593	40620	20	QPSK	1	0	1.45	7.86
41	2593	40620	20	16QAM	1	50	1.70	9.60
41	2593	40620	20	16QAM	1	99	1.70	9.63
41	2593	40620	20	16QAM	50	0	1.38	7.54
41	2593	40620	20	16QAM	100	0	1.38	7.37
41	2593	40620	15	16QAM	1	0	1.67	9.61
41	2593	40620	10	16QAM	1	0	1.65	9.73
41	2593	40620	5	16QAM	1	0	1.66	9.69
41	2506	39750	20	16QAM	1	0	1.67	9.57
41	2549.5	40185	20	16QAM	1	0	1.67	9.58
41	2636.5	41055	20	16QAM	1	0	1.67	9.61
41	2680	41490	20	16QAM	1	0	1.64	9.65

LTE TDD Modulation Interference Factors

All FDD LTE bands were found to have substantially similar MIF values given similar RB,BW and modulation configurations.

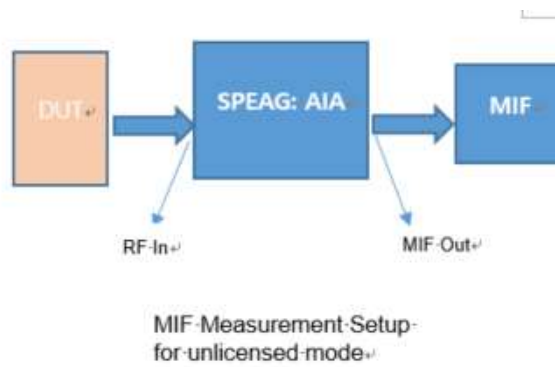

Table 10-5

Mode	802.11b MIF Measurements [dB]			
	Data Rate [Mbps]			
	1	2	5.5	11
802.11b	-7.25	-7.14	-6.16	-5.6

2.4GHz WLAN 802.11b Modulation Interference Factors

Mode	802.11g MIF Measurements [dB]							
	Data Rate [Mbps]							
	6	9	12	18	24	36	48	54
802.11g	-6.23	-5.9	-5.51	-5.01	-4.49	-4.07	-4.14	-4.39

2.4GHz WLAN 802.11g Modulation Interference Factors

Mode	802.11n MIF Measurements [dB]							
	Data Rate [Mbps]							
	6.5	13	19.5	26	39	52	58.5	65
802.11n	-6.18	-5.54	-4.94	-4.56	-4.26	-4.15	-4.4	-4.31

2.4GHz WLAN 802.11n Modulation Interference Factors

Mode	802.11a MIF Measurements [dB]							
	Data Rate [Mbps]							
	6	9	12	18	24	36	48	54
802.11a	-7.26	-6.45	-5.74	-5.18	-4.64	-4.22	-4.28	-4.58

5GHz WLAN 802.11a Modulation Interference Factors

Mode	802.11n MIF Measurements [dB]							
	Data Rate [Mbps]							
	6.5	13	19.5	26	39	52	58.5	65
802.11n	-7.15	-5.82	-5.14	-4.73	-4.41	-4.31	-4.63	-4.46

5GHz WLAN 802.11n Modulation Interference Factors

Mode	802.11ac MIF Measurements [dB]									
	Data Rate [Mbps]									
	6.5	13	19.5	26	39	52	58.5	65	78	
802.11ac	-7.24	-5.85	-5.12	-4.74	-4.41	-4.27	-4.52	-4.39	-4.79	

5GHz WLAN 802.11ac Modulation Interference Factors

Mode	802.11n40 MIF Measurements [dB]								
	Data Rate [Mbps]								
	13.5	27	40.5	54	81	108	121.5	135	
802.11n	-5.61	-4.56	-4.29	-4.35	-4.78	-4.99	-5.12	-5.36	

5GHz WLAN 802.11n40 Modulation Interference Factors

Mode	802.11ac40 MIF Measurements [dB]									
	Data Rate [Mbps]									
	13.5	27	40.5	54	81	108	121.5	135	180	
802.11ac	-5.63	-4.51	-4.3	-4.32	-4.8	-5	-5.05	-5.3	-5.64	

5GHz WLAN 802.11ac40 Modulation Interference Factors

Mode	802.11ac80 MIF Measurements [dB]									
	Data Rate [Mbps]									
	29.3	58.5	87.8	117	175.5	234	263.3	292.5	351	390
802.11ac	-4.56	-4.46	-4.8	-5.17	-5.7	-6.06	-6.08	-6.06	-6.47	-6.3

5GHz WLAN 802.11ac80 Modulation Interference Factors

11. Analysis of RF Air interface Technologies

An analysis was performed, following the guidance of 4.3 and 4.4 of the ANSI standard, of the RF air interface technologies being evaluated. The factors that will affect the RF interference Potential were evaluated, and the worst case operating modes were identified and used in the evaluation. A WD's interference potential is a function both of the WD's average near-field field strength and of the signal's audio-frequency amplitude modulation characteristics. Per 4.4, RF air interface technologies that have low power have been found to produce sufficiently low RF interference potential, so it is possible to exempt them from the product testing specified in Clause 5 of the ANSI standard. An RF air interface technology of a device is exempt from testing When its average antenna input power plus its MIF is $\leq 17\text{dBm}$ for all of its operating modes.

The worst case MIF plus the worst case average antenna input power for all modes are investigated below to determine the testing requirements for this device.

11.1 Air Interfaces and Operating Mode

Air-Interface	Band (MHz)	Type	HAC Tested	Simultaneous Transmissions Note: Not to be tested	Name of Voice service	Power Reduction
GSM	850	VO	Yes	Yes: BT, WLAN	CMRS Voice	N/A
	1900					
	GPRS /EDGE	DT	N/A	Yes: BT, WLAN	google Duo	N/A
WCDMA	850	VO	No ¹	Yes: BT, WLAN	CMRS Voice	N/A
	1700					
	1900	HSPA	DT	N/A	Yes: BT, WLAN	google Duo
LTE (FDD)	700 (B12)	VD	No ¹	Yes: BT, WLAN	VOLTE,google Duo	N/A
	700 (B17)					
	780 (B13)					
	850 (B5)					
	1700 (B4)					
	1700 (B66)					
	1900 (B2)					
LTE (TDD)	2600 (B41)	VD	Yes	Yes: BT, WLAN	google Duo	N/A
WLAN	2450	VD	No ¹	Yes: GSM, WCDMA, or LTE	VoWIFI google Duo	Yes
BT	2450	DT	N/A	Yes: GSM, WCDMA, or LTE	N/A	N/A
Type Transport VO = CMRS Voice Service DT = Digital Transport VD = CMRS IP Voice Service and Digital Transport				Note 1. Evaluated for MIF and low power exemption.		

11.2 Individual Mode Evaluations

Air Interface	Maximum Average Power [dBm]	Worst case MIF [dBm]	Total (Power + MIF) [dBm]	C63.19 Testing Required
GSM850	33.5	3.56	37.06	Yes
GSM1900	31.0	3.53	34.53	Yes
UMTS Band 2	24.5	-20.64	3.86	No
UMTS Band 4	24.0	-21.14	2.86	No
UMTS Band 5	25.5	-20.61	4.89	No
LTE Band 2	24.5	-9.79	14.71	No
LTE Band 4	24.0	-9.8	14.2	No
LTE Band 5	25.5	-9.77	15.73	No
LTE Band 12	25.3	-9.53	15.77	No
LTE Band 13	24.5	-9.91	14.59	No
LTE Band 17	25.3	-9.56	15.74	No
LTE Band 26	25.0	-10.01	14.99	No
LTE Band 66	24.0	-9.83	14.17	No
LTE Band 41	24.5	10.01	34.51	Yes
802.11b(2.4GHz)	18	-5.6	12.4	No
802.11g(2.4GHz)	16	-4.07	11.93	No
802.11n (2.4GHz)	16	-4.15	11.85	No
802.11a(5GHz) _20 MHz	15	-4.22	10.78	No
802.11n (5GHz) _20 MHz	15	-4.31	10.69	No
802.11ac(5GHz) _20 MHz	15	-4.27	10.73	No
802.11n (5GHz) _40 MHz	14	-4.29	9.71	No
802.11ac(5GHz) _40 MHz	14	-4.30	9.70	No
802.11ac(5GHz) _80 MHz	13	-4.46	8.54	No

Max. Power + MIF calculations for Low Power Exemptions

Note(s):

1. Max tune-up limit.
2. Testing for UL CA is not required because it uses same Tx band, modulations, and output power is equal or less than non- CA modes.
3. WIFI1 and WIFI2 as indicated in antenna specification are written as ANT1 (Antenna 1) and ANT2 (Antenna 2) in this report

11.3 Low-Power Exemption Conclusions

Per ANSI C63.19-2011, RF Emissions testing for this device is required only for GSM, and LTE TDD voice modes. All other applicable air interfaces are exempt.

12. RF Conducted Power Measurements

Sample pre-testing of the various modes were performed at the worst case probe location as part of subset testing justification. See below for measured conducted power for applicable device modes:

12.1 GSM/UMTS/LTE Conducted Output Power

GSM Maximum Conducted Output Power

Mode / Band		Voice	GPRS(GMSK) Data – CS1(dBm)				EDGE Data (dBm)			
		GSM	GPRS 1 TX Slot	GPRS 2 TX Slot	GPRS 3 TX Slot	GPRS 4 TX Slot	EDGE 1 TX Slot	EDGE 2 TX Slot	EDGE 3 TX Slot	EDGE 4 TX Slot
GSM 850	128	32.36	32.48	29.50	28.30	28.26	26.40	24.59	23.18	22.01
	190	32.84	32.98	30.00	28.85	28.38	26.34	24.52	23.03	21.97
	251	33.36	33.39	31.36	30.10	28.97	26.02	24.42	22.87	21.69
GSM 1900	512	29.49	29.84	26.80	25.16	23.50	25.00	23.43	21.97	20.60
	661	29.26	29.20	26.62	25.81	23.50	25.23	23.46	21.94	20.61
	810	29.00	29.10	26.50	25.38	23.51	25.26	23.64	22.11	20.66

GSM Conducted output powers (Burst-Average)

Mode / Band		Voice	GPRS(GMSK) Data – CS1(dBm)				EDGE Data (dBm)			
		GSM	GPRS 1 TX Slot	GPRS 2 TX Slot	GPRS 3 TX Slot	GPRS 4 TX Slot	EDGE 1 TX Slot	EDGE 2 TX Slot	EDGE 3 TX Slot	EDGE 4 TX Slot
GSM 850	128	23.33	23.45	23.48	24.04	25.25	17.37	18.57	18.92	19.00
	190	23.81	23.95	23.98	24.59	25.37	17.31	18.50	18.77	18.96
	251	24.33	24.36	25.34	25.84	25.96	16.99	18.40	18.61	18.68
GSM 1900	512	20.46	20.81	20.78	20.90	20.49	15.97	17.41	17.71	17.59
	661	20.23	20.17	20.60	21.55	20.49	16.20	17.44	17.68	17.60
	810	19.97	20.07	20.48	21.12	20.50	16.23	17.62	17.85	17.65

GSM Conducted output powers (Frame-Average)

UMTS Maximum Conducted Output Power

UMTS Band 5

Mode	3GPP 34.121	WCDMA Band 5 [dBm]			3GPP MPR
	Subtest	UL 4132 DL 4357	UL 4183 DL 4408	UL 4233 DL 4458	
12.2 kbps RMC					
		24.97	24.95	24.61	-
HSDPA	Subtest 1	23.73	23.74	23.41	0
	Subtest 2	22.53	22.69	22.54	0
	Subtest 3	21.21	21.17	21.06	0.5
	Subtest 4	21.18	21.18	21.02	0.5
HSUPA	Subtest 1	20.75	20.71	20.64	0
	Subtest 2	18.69	18.66	18.66	2
	Subtest 3	19.82	19.88	19.68	1
	Subtest 4	18.82	18.79	18.63	2
	Subtest 5	21.83	21.84	21.45	0
DC-HSDPA	Subtest 1	23.27	23.23	23.50	0
	Subtest 2	22.83	22.84	22.54	0
	Subtest 3	21.58	21.62	21.30	0.5
	Subtest 4	21.54	21.54	21.26	0.5

UMTS Average Conducted output powers

UMTS Band 4

Mode	3GPP 34.121	WCDMA Band 4 [dBm]			3GPP MPR
	Subtest	UL 1312 DL 1537	UL 1412 DL 1637	UL 1513 DL 1738	
12.2 kbps RMC					
		22.75	22.83	22.58	-
HSDPA	Subtest 1	22.72	22.48	22.51	0
	Subtest 2	21.51	21.19	21.25	0
	Subtest 3	20.51	20.52	20.56	0.5
	Subtest 4	20.98	20.81	20.87	0.5
HSUPA	Subtest 1	19.90	19.65	19.66	0
	Subtest 2	17.82	17.61	17.59	2
	Subtest 3	19.47	19.17	19.20	1
	Subtest 4	17.81	17.55	17.63	2
	Subtest 5	21.36	21.44	21.48	0
DC-HSDPA	Subtest 1	22.41	22.45	22.36	0
	Subtest 2	21.71	21.43	21.35	0
	Subtest 3	20.71	20.53	20.52	0.5
	Subtest 4	21.06	21.11	21.02	0.5

UMTS Average Conducted output powers

UMTS Band 2

Mode	3GPP 34.121	WCDMA Band 2 [dBm]			3GPP MPR
	Subtest	UL 9262 DL 9662	UL 9400 DL 9800	UL 9538 DL 9938	
12.2 kbps RMC		23.53	23.25	23.16	-
HSDPA	Subtest 1	23.46	23.22	23.06	0
	Subtest 2	22.71	22.59	22.22	0
	Subtest 3	21.63	21.50	21.56	0.5
	Subtest 4	21.85	21.51	21.58	0.5
HSUPA	Subtest 1	22.02	21.78	21.65	0
	Subtest 2	20.17	19.82	19.60	2
	Subtest 3	21.19	20.93	20.75	1
	Subtest 4	20.17	19.86	19.61	2
	Subtest 5	22.98	22.69	22.50	0
DC-HSDPA	Subtest 1	22.94	23.11	23.05	0
	Subtest 2	22.90	22.58	22.56	0
	Subtest 3	21.94	21.70	21.77	0.5
	Subtest 4	21.98	21.73	21.74	0.5

UMTS Average Conducted output powers

12.2 LTE Maximum Conducted Output Power

LTE Band 2

LTE Band 2 _ 1.4 Mhz Bandwidth

Bandwidth	Modulation	RB Size	RB Offset	Max. Average Power (dBm)			MPR Allowed Per 3GPP	MPR
				18607	18900	19193		
				1850.7 MHz	1880 MHz	1909.3 MHz	[dB]	[dB]
1.4 Mhz	QPSK	1	0	23.63	22.89	23.07	0	0
		1	3	23.70	22.86	23.09	0	0
		1	5	23.65	22.90	23.12	0	0
		3	0	23.39	23.18	23.28	0	0
		3	1	23.42	23.19	23.32	0	0
		3	3	23.41	23.15	23.32	0	0
	16QAM	6	0	22.70	22.45	22.64	0-1	1
		1	0	22.86	22.52	22.35	0-1	1
		1	3	22.75	22.36	22.38	0-1	1
		1	5	22.79	22.39	22.41	0-1	1
		3	0	22.76	22.33	22.66	0-1	1
		3	1	22.78	22.39	22.66	0-1	1
		3	3	22.87	22.32	22.71	0-1	1
		6	0	21.83	21.38	21.71	0-2	2

LTE Band 2 _ 3 Mhz Bandwidth

Bandwidth	Modulation	RB Size	RB Offset	Max. Average Power (dBm)			MPR Allowed Per 3GPP	MPR
				18615	18900	19185		
				1851.5 MHz	1880 MHz	1908.5 MHz	[dB]	[dB]
3 Mhz	QPSK	1	0	23.65	23.07	23.01	0	0
		1	7	23.69	23.01	22.97	0	0
		1	14	23.67	23.13	23.00	0	0
		8	0	23.10	22.62	22.37	0-1	1
		8	3	23.08	22.62	22.35	0-1	1
		8	7	23.10	22.64	22.38	0-1	1
		15	0	23.13	22.61	22.43	0-1	1
	16QAM	1	0	22.86	22.88	21.91	0-1	1
		1	7	22.86	22.88	21.84	0-1	1
		1	14	22.84	22.76	22.66	0-1	1
		8	0	22.05	21.64	21.38	0-2	2
		8	3	22.25	21.66	21.40	0-2	2
		8	7	22.18	21.57	21.31	0-2	2
		15	0	22.12	21.66	21.43	0-2	2

LTE Band 2 _ 5 Mhz Bandwidth

Bandwidth	Modulation	RB Size	RB Offset	Max. Average Power (dBm)			MPR Allowed Per 3GPP	MPR
				18625	18900	19175	[dB]	[dB]
				1852.5 MHz	1880 MHz	1907.5 MHz		
5 Mhz	QPSK	1	0	23.65	23.08	22.95	0	0
		1	12	23.69	23.10	23.02	0	0
		1	24	23.65	23.08	22.94	0	0
		12	0	23.08	22.64	22.44	0-1	1
		12	6	23.08	22.65	22.40	0-1	1
		12	11	23.07	22.61	22.44	0-1	1
		25	0	23.06	22.65	22.40	0-1	1
	16QAM	1	0	22.67	22.77	22.30	0-1	1
		1	12	22.64	22.81	22.39	0-1	1
		1	24	22.64	22.52	22.26	0-1	1
		12	0	22.04	21.58	21.44	0-2	2
		12	6	22.02	21.52	21.42	0-2	2
		12	11	22.05	21.57	21.45	0-2	2
		25	0	22.11	21.60	21.46	0-2	2

LTE Band 2 _ 10 Mhz Bandwidth

Bandwidth	Modulation	RB Size	RB Offset	Max. Average Power (dBm)			MPR Allowed Per 3GPP	MPR
				18650	18900	19150	[dB]	[dB]
				1855 MHz	1880 MHz	1905 MHz		
10 Mhz	QPSK	1	0	23.63	23.65	23.04	0	0
		1	24	23.59	23.53	22.99	0	0
		1	49	23.57	23.35	23.01	0	0
		25	0	22.98	22.64	22.47	0-1	1
		25	12	23.00	22.63	22.45	0-1	1
		25	24	23.00	22.67	22.44	0-1	1
		50	0	22.94	22.71	22.41	0-1	1
	16QAM	1	0	22.80	22.67	22.12	0-1	1
		1	24	22.81	22.59	22.14	0-1	1
		1	49	22.80	22.51	22.15	0-1	1
		25	0	21.92	21.73	21.43	0-2	2
		25	12	21.95	21.70	21.46	0-2	2
		25	24	21.92	21.67	21.48	0-2	2
		50	0	22.02	21.66	21.52	0-2	2

LTE Band 2 _ 15 Mhz Bandwidth

Bandwidth	Modulation	RB Size	RB Offset	Max. Average Power (dBm)			MPR Allowed Per 3GPP	MPR
				18675	18900	19125	[dB]	[dB]
				1857.5 MHz	1880 MHz	1902.5 MHz		
15 Mhz	QPSK	1	0	23.52	23.27	22.93	0	0
		1	36	23.63	23.18	23.17	0	0
		1	74	23.43	23.17	23.08	0	0
		36	0	23.03	22.72	22.53	0-1	1
		36	18	22.99	22.68	22.51	0-1	1
		36	38	22.91	22.62	22.50	0-1	1
		75	0	22.93	22.66	22.51	0-1	1
	16QAM	1	0	22.78	22.74	22.43	0-1	1
		1	36	22.82	22.56	22.38	0-1	1
		1	74	22.67	22.52	22.32	0-1	1
		36	0	21.93	21.71	21.52	0-2	2
		36	18	21.90	21.71	21.50	0-2	2
		36	38	21.92	21.68	21.48	0-2	2
		75	0	21.94	21.66	21.47	0-2	2

LTE Band 2 _ 20 Mhz Bandwidth

Bandwidth	Modulation	RB Size	RB Offset	Max. Average Power (dBm)			MPR Allowed Per 3GPP	MPR
				18700	18900	19100	[dB]	[dB]
				1860 MHz	1880 MHz	1900 MHz		
20 Mhz	QPSK	1	0	23.71	23.42	23.40	0	0
		1	49	23.62	23.36	23.25	0	0
		1	99	23.70	23.31	23.36	0	0
		50	0	23.10	22.88	22.74	0-1	1
		50	25	23.03	22.83	22.70	0-1	1
		50	49	23.09	22.79	22.67	0-1	1
		100	0	23.03	22.84	22.69	0-1	1
	16QAM	1	0	23.18	23.03	22.92	0-1	1
		1	49	23.19	23.04	22.92	0-1	1
		1	99	23.16	22.95	22.85	0-1	1
		50	0	22.06	21.87	21.75	0-2	2
		50	25	22.07	21.91	21.72	0-2	2
		50	49	22.01	21.80	21.74	0-2	2
		100	0	22.07	21.90	21.74	0-2	2

LTE Band 4
LTE Band 4 _ 1.4 Mhz Bandwidth

Bandwidth	Modulation	RB Size	RB Offset	Max. Average Power (dBm)			MPR Allowed Per 3GPP	MPR
				19957	20175	20393		
				1710.7 MHz	1732.5 MHz	1754.3 MHz	[dB]	[dB]
1.4 Mhz	QPSK	1	0	22.50	22.45	22.64	0	0
		1	3	22.52	22.40	22.66	0	0
		1	5	22.55	22.39	22.64	0	0
		3	0	22.57	22.43	22.70	0	0
		3	1	22.59	22.36	22.68	0	0
		3	3	22.55	22.41	22.74	0	0
	16QAM	6	0	21.48	21.34	21.64	0-1	1
		1	0	21.44	21.27	21.60	0-1	1
		1	3	21.42	21.32	21.63	0-1	1
		1	5	21.43	21.29	21.60	0-1	1
		3	0	21.47	21.17	21.72	0-1	1
		3	1	21.57	21.19	21.76	0-1	1
		3	3	21.53	21.19	21.70	0-1	1
		6	0	20.60	20.39	20.64	0-2	2

LTE Band 4 _ 3 Mhz Bandwidth

Bandwidth	Modulation	RB Size	RB Offset	Max. Average Power (dBm)			MPR Allowed Per 3GPP	MPR
				19965	20175	20385		
				1711.5 MHz	1732.5 MHz	1753.5 MHz	[dB]	[dB]
3 Mhz	QPSK	1	0	22.50	22.48	22.74	0	0
		1	7	22.48	22.49	22.75	0	0
		1	14	22.47	22.49	22.77	0	0
		8	0	21.53	21.42	21.73	0-1	1
		8	3	21.48	21.35	21.68	0-1	1
		8	7	21.51	21.36	21.67	0-1	1
		15	0	21.47	21.33	21.71	0-1	1
	16QAM	1	0	21.28	21.59	21.68	0-1	1
		1	7	21.28	21.54	21.77	0-1	1
		1	14	21.25	21.54	21.71	0-1	1
		8	0	20.62	20.44	20.68	0-2	2
		8	3	20.61	20.43	20.75	0-2	2
		8	7	20.55	20.40	20.76	0-2	2
		15	0	20.49	20.46	20.68	0-2	2

LTE Band 4 _ 5 Mhz Bandwidth

Bandwidth	Modulation	RB Size	RB Offset	Max. Average Power (dBm)			MPR Allowed Per 3GPP	MPR
				19975	20175	20375		
				1712.5 MHz	1732.5 MHz	1752.5 MHz	[dB]	[dB]
5 Mhz	QPSK	1	0	22.58	22.41	22.75	0	0
		1	12	22.54	22.38	22.75	0	0
		1	24	22.57	22.35	22.74	0	0
		12	0	21.47	21.41	21.67	0-1	1
		12	6	21.50	21.37	21.64	0-1	1
		12	11	21.41	21.43	21.64	0-1	1
		25	0	21.46	21.35	21.68	0-1	1
	16QAM	1	0	21.38	21.49	21.67	0-1	1
		1	12	21.40	21.51	21.67	0-1	1
		1	24	21.30	21.46	21.66	0-1	1
		12	0	20.45	20.35	20.67	0-2	2
		12	6	20.49	20.40	20.75	0-2	2
		12	11	20.49	20.36	20.63	0-2	2
		25	0	20.46	20.43	20.74	0-2	2

LTE Band 4 _ 10 Mhz Bandwidth

Bandwidth	Modulation	RB Size	RB Offset	Max. Average Power (dBm)			MPR Allowed Per 3GPP	MPR
				20000	20175	20350		
				1715 MHz	1732.5 MHz	1750 MHz	[dB]	[dB]
10 Mhz	QPSK	1	0	22.59	22.47	22.75	0	0
		1	24	22.55	22.45	22.71	0	0
		1	49	22.54	22.43	22.66	0	0
		25	0	21.59	21.41	21.69	0-1	1
		25	12	21.51	21.44	21.75	0-1	1
		25	24	21.54	21.37	21.65	0-1	1
		50	0	21.49	21.40	21.64	0-1	1
	16QAM	1	0	21.43	21.46	21.89	0-1	1
		1	24	21.41	21.49	21.92	0-1	1
		1	49	21.40	21.50	21.87	0-1	1
		25	0	20.51	20.52	20.76	0-2	2
		25	12	20.49	20.50	20.76	0-2	2
		25	24	20.54	20.46	20.74	0-2	2
		50	0	20.59	20.44	20.77	0-2	2

LTE Band 4 _ 15 Mhz Bandwidth

Bandwidth	Modulation	RB Size	RB Offset	Max. Average Power (dBm)			MPR Allowed Per 3GPP	MPR
				20025	20175	20325		
				1717.5 MHz	1732.5 MHz	1747.5 MHz	[dB]	[dB]
15 Mhz	QPSK	1	0	22.53	22.48	22.66	0	0
		1	36	22.62	22.48	22.68	0	0
		1	74	22.43	22.39	22.57	0	0
		36	0	21.55	21.45	21.63	0-1	1
		36	18	21.49	21.43	21.66	0-1	1
		36	38	21.47	21.40	21.61	0-1	1
		75	0	21.53	21.43	21.62	0-1	1
	16QAM	1	0	21.20	21.44	21.64	0-1	1
		1	36	21.44	21.27	21.74	0-1	1
		1	74	21.51	21.40	21.51	0-1	1
		36	0	20.55	20.61	20.60	0-2	2
		36	18	20.52	20.51	20.57	0-2	2
		36	38	20.41	20.47	20.59	0-2	2
		75	0	20.55	20.38	20.60	0-2	2

LTE Band 4 _ 20 Mhz Bandwidth

Bandwidth	Modulation	RB Size	RB Offset	Max. Average Power (dBm)		MPR Allowed Per 3GPP	MPR
				20175	1732.5 MHz		
				[dB]	[dB]		
20 Mhz	QPSK	1	0	22.79		0	0
		1	49	22.70		0	0
		1	99	22.71		0	0
		50	0	21.75		0-1	1
		50	25	21.72		0-1	1
		50	49	21.65		0-1	1
		100	0	21.73		0-1	1
	16QAM	1	0	21.87		0-1	1
		1	49	21.58		0-1	1
		1	99	21.57		0-1	1
		50	0	20.74		0-2	2
		50	25	20.73		0-2	2
		50	49	20.68		0-2	2
		100	0	20.79		0-2	2

Note: LTE Band 4 (AWS) at 20 Mhz Bandwidth does not support three non-overlapping channels. Per KDB 941225 D05v02r05, when a device supports overlapping channel assignment in a channel bandwidth configuration, the mid channel of the group of overlapping channels should be selected for testing.

LTE Band 5

LTE Band 5 _ 1.4 Mhz Bandwidth

Bandwidth	Modulation	RB Size	RB Offset	Max. Average Power (dBm)			MPR Allowed Per 3GPP	MPR
				20407	20525	20643		
				824.7 MHz	836.5 MHz	848.3 MHz	[dB]	[dB]
1.4 Mhz	QPSK	1	0	24.38	24.33	24.06	0	0
		1	3	24.33	24.33	23.93	0	0
		1	5	24.31	24.32	24.10	0	0
		3	0	24.32	24.32	24.29	0	0
		3	1	24.33	24.32	24.34	0	0
		3	3	24.39	24.32	24.26	0	0
	16QAM	6	0	23.55	23.56	23.31	0-1	1
		1	0	23.23	23.24	23.24	0-1	1
		1	3	23.23	23.14	23.28	0-1	1
		1	5	23.27	23.26	23.28	0-1	1
		3	0	23.50	23.51	23.20	0-1	1
		3	1	23.46	23.45	23.22	0-1	1
		3	3	23.46	23.49	23.22	0-1	1
		6	0	22.37	22.38	22.22	0-2	2

LTE Band 5 _ 3 Mhz Bandwidth

Bandwidth	Modulation	RB Size	RB Offset	Max. Average Power (dBm)			MPR Allowed Per 3GPP	MPR
				20415	20525	20635		
				825.5 MHz	836.5 MHz	847.5 MHz	[dB]	[dB]
3 Mhz	QPSK	1	0	24.29	24.42	24.27	0	0
		1	7	24.14	24.15	23.93	0	0
		1	14	24.21	24.16	24.23	0	0
		8	0	23.47	23.36	23.15	0-1	1
		8	3	23.46	23.37	23.18	0-1	1
		8	7	23.49	23.34	23.17	0-1	1
		15	0	23.46	23.36	23.15	0-1	1
	16QAM	1	0	23.12	23.52	23.28	0-1	1
		1	7	23.43	23.54	22.96	0-1	1
		1	14	23.06	23.26	23.28	0-1	1
		8	0	22.51	22.36	22.02	0-2	2
		8	3	22.41	22.36	22.19	0-2	2
		8	7	22.42	22.26	22.13	0-2	2
		15	0	22.43	22.40	22.11	0-2	2

LTE Band 5 _ 5 MHz Bandwidth

Bandwidth	Modulation	RB Size	RB Offset	Max. Average Power (dBm)			MPR Allowed Per 3GPP [dB]	MPR [dB]
				20425	20525	20625		
				826.5 MHz	836.5 MHz	846.5 MHz	[dB]	[dB]
5 MHz	QPSK	1	0	24.20	24.41	23.98	0	0
		1	12	24.29	24.14	24.24	0	0
		1	24	24.34	24.09	24.22	0	0
		12	0	23.48	23.37	23.26	0-1	1
		12	6	23.50	23.39	23.23	0-1	1
		12	11	23.47	23.35	23.20	0-1	1
		25	0	23.50	23.34	23.22	0-1	1
	16QAM	1	0	23.13	23.50	23.11	0-1	1
		1	12	23.13	23.54	23.01	0-1	1
		1	24	23.12	23.49	23.30	0-1	1
		12	0	22.42	22.33	22.23	0-2	2
		12	6	22.42	22.25	22.21	0-2	2
		12	11	22.39	22.31	22.22	0-2	2
		25	0	22.51	22.31	22.27	0-2	2

LTE Band 5 _ 10 MHz Bandwidth

Bandwidth	Modulation	RB Size	RB Offset	Max. Average Power (dBm)		MPR Allowed Per 3GPP [dB]	MPR [dB]
				20525	836.5 MHz		
				[dB]	[dB]		
10 MHz	QPSK	1	0	24.45		0	0
		1	24	24.27		0	0
		1	49	24.19		0	0
		25	0	23.74		0-1	1
		25	12	23.70		0-1	1
		25	24	23.67		0-1	1
		50	0	23.66		0-1	1
	16QAM	1	0	23.59		0-1	1
		1	24	23.58		0-1	1
		1	49	23.62		0-1	1
		25	0	22.65		0-2	2
		25	12	22.63		0-2	2
		25	24	22.61		0-2	2
		50	0	22.62		0-2	2

Note: LTE Band 5 at 10 MHz Bandwidth does not support three non-overlapping channels. Per KDB 941225 D05v02r05, when a device supports overlapping channel assignment in a channel bandwidth configuration, the mid channel of the group of overlapping channels should be selected for testing.

LTE Band 12

LTE Band 12 _ 1.4 Mhz Bandwidth

Bandwidth	Modulation	RB Size	RB Offset	Max. Average Power (dBm)			MPR Allowed Per 3GPP	MPR
				23017	23095	23173		
				699.7 MHz	707.5 MHz	715.3 MHz	[dB]	[dB]
1.4 Mhz	QPSK	1	0	24.03	24.21	24.06	0	0
		1	3	24.02	24.20	24.02	0	0
		1	5	24.03	24.21	24.10	0	0
		3	0	24.13	24.28	24.21	0	0
		3	1	24.11	24.21	24.15	0	0
		3	3	24.12	24.16	24.19	0	0
	16QAM	6	0	23.33	23.34	23.25	0-1	1
		1	0	23.25	23.36	23.04	0-1	1
		1	3	23.25	23.13	22.91	0-1	1
		1	5	23.22	23.23	23.11	0-1	1
		3	0	23.33	23.44	23.09	0-1	1
		3	1	23.33	23.28	23.15	0-1	1
		3	3	23.34	23.03	23.23	0-1	1
		6	0	22.28	22.21	22.13	0-2	2

LTE Band 12 _ 3 Mhz Bandwidth

Bandwidth	Modulation	RB Size	RB Offset	Max. Average Power (dBm)			MPR Allowed Per 3GPP	MPR
				23025	23095	23165		
				700.5 MHz	707.5 MHz	714.5 MHz	[dB]	[dB]
3 Mhz	QPSK	1	0	24.03	24.09	24.10	0	0
		1	7	24.17	24.06	24.11	0	0
		1	14	24.01	24.03	24.17	0	0
		8	0	23.40	23.33	23.35	0-1	1
		8	3	23.35	23.33	23.30	0-1	1
		8	7	23.36	23.29	23.34	0-1	1
		15	0	23.38	23.30	23.30	0-1	1
	16QAM	1	0	23.16	23.52	23.43	0-1	1
		1	7	23.02	23.37	23.32	0-1	1
		1	14	23.29	23.53	23.68	0-1	1
		8	0	22.52	22.23	22.25	0-2	2
		8	3	22.53	22.23	22.22	0-2	2
		8	7	22.50	22.31	22.22	0-2	2
		15	0	22.32	22.25	22.20	0-2	2

LTE Band 12 _ 5 Mhz Bandwidth

Bandwidth	Modulation	RB Size	RB Offset	Max. Average Power (dBm)			MPR Allowed Per 3GPP	MPR
				23035	23095	23155		
				701.5 MHz	707.5 MHz	713.5 MHz	[dB]	[dB]
5 Mhz	QPSK	1	0	24.25	24.15	24.14	0	0
		1	12	24.27	24.18	24.13	0	0
		1	24	24.20	24.20	23.98	0	0
		12	0	23.38	23.33	23.26	0-1	1
		12	6	23.34	23.30	23.21	0-1	1
		12	11	23.44	23.32	23.31	0-1	1
		25	0	23.38	23.32	23.32	0-1	1
	16QAM	1	0	23.36	23.53	23.37	0-1	1
		1	12	23.39	23.42	23.38	0-1	1
		1	24	23.14	23.52	23.37	0-1	1
		12	0	22.34	22.17	22.25	0-2	2
		12	6	22.29	22.18	22.23	0-2	2
		12	11	22.31	22.15	22.22	0-2	2
		25	0	22.38	22.26	22.26	0-2	2

LTE Band 12 _ 10 Mhz Bandwidth

Bandwidth	Modulation	RB Size	RB Offset	Max. Average Power (dBm)		MPR Allowed Per 3GPP	MPR
				23095	707.5 MHz		
				[dB]	[dB]		
10 Mhz	QPSK	1	0	24.28		0	0
		1	24	24.16		0	0
		1	49	24.23		0	0
		25	0	23.37		0-1	1
		25	12	23.36		0-1	1
		25	24	23.32		0-1	1
		50	0	23.36		0-1	1
	16QAM	1	0	23.03		0-1	1
		1	24	23.33		0-1	1
		1	49	23.21		0-1	1
		25	0	22.28		0-2	2
		25	12	22.28		0-2	2
		25	24	22.28		0-2	2
		50	0	22.35		0-2	2

Note: LTE Band 12 at 10 Mhz Bandwidth does not support three non-overlapping channels. Per KDB 941225 D05v02r05, when a device supports overlapping channel assignment in a channel bandwidth configuration, the mid channel of the group of overlapping channels should be selected for testing.

LTE Band 13

LTE Band 13 _ 5 Mhz Bandwidth

Bandwidth	Modulation	RB Size	RB Offset	Max. Average Power (dBm)		MPR Allowed Per 3GPP	MPR
						[dB]	[dB]
				23230	782 MHz		
5 Mhz	QPSK	1	0	23.33		0	0
		1	12	23.39		0	0
		1	24	23.36		0	0
		12	0	22.74		0-1	1
		12	6	22.79		0-1	1
		12	11	22.74		0-1	1
	16QAM	25	0	22.71		0-1	1
		1	0	22.92		0-1	1
		1	12	22.42		0-1	1
		1	24	22.83		0-1	1
		12	0	21.77		0-2	2
		12	6	21.77		0-2	2
		12	11	21.75		0-2	2
		25	0	21.79		0-2	2

LTE Band 13 _ 10 Mhz Bandwidth

Bandwidth	Modulation	RB Size	RB Offset	Max. Average Power (dBm)		MPR Allowed Per 3GPP	MPR
						[dB]	[dB]
				23230	782 MHz		
10 Mhz	QPSK	1	0	23.41		0	0
		1	24	23.32		0	0
		1	49	23.33		0	0
		25	0	22.78		0-1	1
		25	12	22.73		0-1	1
		25	24	22.75		0-1	1
	16QAM	50	0	22.69		0-1	1
		1	0	22.45		0-1	1
		1	24	22.46		0-1	1
		1	49	22.57		0-1	1
		25	0	21.83		0-2	2
		25	12	21.82		0-2	2
		25	24	21.78		0-2	2
		50	0	21.83		0-2	2

Note: LTE Band 13 at 5 Mhz/ 10 Mhz Bandwidth does not support three non-overlapping channels. Per KDB 941225 D05v02r05, when a device supports overlapping channel assignment in a channel bandwidth configuration, the mid channel of the group of overlapping channels should be selected for testing.

LTE Band 17

LTE Band 17 _ 5 MHz Bandwidth

Bandwidth	Modulation	RB Size	RB Offset	Max. Average Power (dBm)		MPR Allowed Per 3GPP	MPR
				23790		[dB]	[dB]
				710 MHz			
5 MHz	QPSK	1	0	24.04		0	0
		1	12	23.94		0	0
		1	24	23.91		0	0
		12	0	23.35		0-1	1
		12	6	23.32		0-1	1
		12	11	23.31		0-1	1
		25	0	23.29		0-1	1
	16QAM	1	0	23.37		0-1	1
		1	12	23.27		0-1	1
		1	24	23.48		0-1	1
		12	0	22.23		0-2	2
		12	6	22.28		0-2	2
		12	11	22.27		0-2	2
		25	0	22.33		0-2	2

LTE Band 17 _ 10 MHz Bandwidth

Bandwidth	Modulation	RB Size	RB Offset	Max. Average Power (dBm)		MPR Allowed Per 3GPP	MPR
				23790		[dB]	[dB]
				710 MHz			
10 MHz	QPSK	1	0	24.10		0	0
		1	24	23.94		0	0
		1	49	23.92		0	0
		25	0	23.40		0-1	1
		25	12	23.32		0-1	1
		25	24	23.29		0-1	1
		50	0	23.34		0-1	1
	16QAM	1	0	23.43		0-1	1
		1	24	23.42		0-1	1
		1	49	23.31		0-1	1
		25	0	22.37		0-2	2
		25	12	22.41		0-2	2
		25	24	22.39		0-2	2
		50	0	22.33		0-2	2

Note: LTE Band 17 at 5 MHz & 10 MHz Bandwidth does not support three non-overlapping channels. Per KDB 941225 D05v02r05, when a device supports overlapping channel assignment in a channel bandwidth configuration, the mid channel of the group of overlapping channels should be selected for testing.

LTE Band 26

LTE Band 26 _ 1.4 MHz Bandwidth

Bandwidth	Modulation	RB Size	RB Offset	Max. Average Power [dBm]			MPR Allowed Per 3GPP [dB]	MPR [dB]
				26697 Ch. 814.7 MHz	26865 Ch. 831.5 MHz	27033 Ch. 848.3 MHz		
1.4 MHz	QPSK	1	0	24.25	24.43	24.15	0	0
		1	3	24.28	24.34	24.13	0	0
		1	5	24.26	24.37	24.12	0	0
		3	0	24.30	24.33	24.12	0	0
		3	1	24.28	24.35	24.08	0	0
		3	3	24.24	24.32	24.07	0	0
	16QAM	6	0	23.17	23.31	23.06	0-1	1
		1	0	22.99	23.37	22.75	0-1	1
		1	3	22.77	23.17	22.66	0-1	1
		1	5	22.98	23.35	22.75	0-1	1
		3	0	23.09	22.96	23.01	0-1	1
		3	1	23.20	22.97	23.02	0-1	1
		3	3	23.15	23.12	23.05	0-1	1
		6	0	21.98	22.12	21.87	0-2	2

LTE Band 26 _ 3 MHz Bandwidth

Bandwidth	Modulation	RB Size	RB Offset	Max. Average Power [dBm]			MPR Allowed Per 3GPP [dB]	MPR [dB]
				26705 Ch. 815.5 MHz	26865 Ch. 831.5 MHz	27025 Ch. 847.5 MHz		
3 MHz	QPSK	1	0	24.22	24.30	24.17	0	0
		1	7	24.29	24.34	24.06	0	0
		1	14	24.29	24.33	24.12	0	0
		8	0	23.29	23.30	23.06	0-1	1
		8	3	23.23	23.29	23.00	0-1	1
		8	7	23.23	23.29	23.03	0-1	1
		15	0	23.21	23.32	23.07	0-1	1
	16QAM	1	0	23.34	23.53	22.74	0-1	1
		1	7	22.88	23.45	23.08	0-1	1
		1	14	22.96	23.51	23.15	0-1	1
		8	0	21.97	22.26	22.01	0-2	2
		8	3	22.12	22.22	22.03	0-2	2
		8	7	21.92	22.07	22.06	0-2	2
		15	0	22.14	22.26	21.93	0-2	2

LTE Band 26 _ 5 MHz Bandwidth

Bandwidth	Modulation	RB Size	RB Offset	Max. Average Power [dBm]			MPR Allowed Per 3GPP [dB]	MPR [dB]
				26715 Ch. 816.5 MHz	26865 Ch. 831.5 MHz	27015 Ch. 846.5 MHz		
5 MHz	QPSK	1	0	24.34	24.48	24.22	0	0
		1	12	24.32	24.46	24.12	0	0
		1	24	24.33	24.46	24.21	0	0
		12	0	23.28	23.35	23.08	0-1	1
		12	6	23.24	23.35	23.05	0-1	1
		12	11	23.28	23.34	23.06	0-1	1
		25	0	23.27	23.33	23.12	0-1	1
	16QAM	1	0	23.26	23.43	22.96	0-1	1
		1	12	23.24	23.28	22.96	0-1	1
		1	24	23.05	23.38	22.96	0-1	1
		12	0	22.18	22.22	21.97	0-2	2
		12	6	22.19	22.24	22.03	0-2	2
		12	11	22.17	22.24	22.00	0-2	2
		25	0	22.24	22.19	22.04	0-2	2

LTE Band 26 _ 10 MHz Bandwidth

Bandwidth	Modulation	RB Size	RB Offset	Max. Average Power [dBm]			MPR Allowed Per 3GPP [dB]	MPR [dB]
				26740 Ch. 819 MHz	26865 Ch. 831.5 MHz	26990 Ch. 844 MHz		
10 MHz	QPSK	1	0	24.42	24.49	24.28	0	0
		1	24	24.40	24.43	24.23	0	0
		1	49	24.39	24.37	24.20	0	0
		25	0	23.35	23.38	23.16	0-1	1
		25	12	23.35	23.32	23.12	0-1	1
		25	24	23.32	23.35	23.08	0-1	1
		50	0	23.33	23.33	23.14	0-1	1
	16QAM	1	0	23.36	23.37	23.06	0-1	1
		1	24	23.25	23.43	23.01	0-1	1
		1	49	23.21	23.28	23.10	0-1	1
		25	0	22.25	22.31	22.07	0-2	2
		25	12	22.25	22.26	22.07	0-2	2
		25	24	22.29	22.28	22.13	0-2	2
		50	0	22.31	22.24	22.05	0-2	2

LTE Band 26 _ 15 MHz Bandwidth

Bandwidth	Modulation	RB Size	RB Offset	Max. Average Power [dBm]	MPR Allowed Per 3GPP [dB]	MPR [dB]
				26865 Ch. 831.5 MHz		
15 MHz	QPSK	1	0	24.02	0	0
		1	36	24.49	0	0
		1	74	24.15	0	0
		36	0	23.37	0-1	1
		36	18	23.32	0-1	1
		36	39	23.33	0-1	1
		75	0	23.35	0-1	1
	16QAM	1	0	23.32	0-1	1
		1	36	23.46	0-1	1
		1	74	23.29	0-1	1
		36	0	22.31	0-2	2
		36	18	22.25	0-2	2
		36	39	22.22	0-2	2
		75	0	22.26	0-2	2

Note: LTE Band 26 at 15 MHz Bandwidth does not support three non-overlapping channels. Per KDB 941225 D05v02r05, when a device supports overlapping channel assignment in a channel bandwidth configuration, the mid channel of the group of overlapping channels should be selected for testing.

LTE TDD Band 41

LTE TDD Band 41 _ 5 MHz Bandwidth

Bandwidth	Modulation	RB Size	RB Offset	Max. Average Power (dBm)					MPR Allowed Per 3GPP	MPR
				39675	40148	40620	41093	41565	[dB]	[dB]
				2498.5 MHz	2545.8 MHz	2593.0 MHz	2640.3 MHz	2687.5 MHz		
5 MHz	QPSK	1	0	23.27	23.57	24.11	23.42	23.29	0	0
		1	12	23.22	23.56	24.06	23.49	23.34	0	0
		1	24	23.31	23.56	24.05	23.50	23.33	0	0
		12	0	22.71	22.87	23.48	22.66	22.62	0-1	1
		12	6	22.69	22.92	23.46	22.67	22.66	0-1	1
		12	11	22.69	22.89	23.47	22.68	22.67	0-1	1
		25	0	22.68	22.88	23.44	22.67	22.66	0-1	1
	16QAM	1	0	22.48	22.93	23.45	22.54	22.63	0-1	1
		1	12	22.49	22.93	23.44	22.48	22.62	0-1	1
		1	24	22.51	22.85	23.43	22.52	22.60	0-1	1
		12	0	21.67	21.75	22.27	21.72	21.62	0-2	2
		12	6	21.69	21.79	22.30	21.74	21.60	0-2	2
		12	11	21.70	21.75	22.29	21.70	21.64	0-2	2
		25	0	21.66	21.81	22.35	21.70	21.63	0-2	2

LTE TDD Band 41 _ 10 MHz Bandwidth

Bandwidth	Modulation	RB Size	RB Offset	Max. Average Power (dBm)					MPR Allowed Per 3GPP	MPR
				39700	40160	40620	41080	41540	[dB]	[dB]
				2501.0 MHz	2547.0 MHz	2593.0 MHz	2639.0 MHz	2685.0 MHz		
10 MHz	QPSK	1	0	23.27	23.42	24.14	23.32	23.19	0	0
		1	24	23.23	23.49	24.08	23.29	23.23	0	0
		1	49	23.23	23.57	24.05	23.33	23.28	0	0
		25	0	22.69	22.91	23.48	22.68	22.56	0-1	1
		25	12	22.72	22.88	23.49	22.70	22.57	0-1	1
		25	24	22.68	22.89	23.50	22.71	22.62	0-1	1
		50	0	22.69	22.86	23.50	22.66	22.59	0-1	1
	16QAM	1	0	22.52	22.96	23.42	22.53	22.60	0-1	1
		1	24	22.53	22.90	23.40	22.50	22.57	0-1	1
		1	49	22.50	22.96	23.38	22.60	22.58	0-1	1
		25	0	21.60	21.79	22.40	21.66	21.54	0-2	2
		25	12	21.57	21.81	22.43	21.65	21.54	0-2	2
		25	24	21.62	21.81	22.42	21.66	21.55	0-2	2
		50	0	21.63	21.69	22.40	21.62	21.47	0-2	2

LTE TDD Band 41 _ 15 Mhz Bandwidth

Bandwidth	Modulation	RB Size	RB Offset	Max. Average Power (dBm)					MPR Allowed Per 3GPP	MPR
				39725	40173	40620	41068	41515		
				2503.5 Mhz	2548.3 Mhz	2593.0 Mhz	2637.8 Mhz	2682.5 Mhz	[dB]	[dB]
15 Mhz	QPSK	1	0	23.77	23.39	24.08	23.44	23.17	0	0
		1	36	23.74	23.44	24.12	23.30	23.31	0	0
		1	74	23.19	23.49	24.04	23.46	23.75	0	0
		36	0	22.68	22.83	23.43	22.69	22.57	0-1	1
		36	18	22.68	22.90	23.49	22.67	22.62	0-1	1
		36	39	22.66	22.92	23.48	22.73	22.67	0-1	1
		75	0	22.67	22.89	23.48	22.69	22.62	0-1	1
	16QAM	1	0	22.56	22.84	23.33	22.45	22.51	0-1	1
		1	36	22.47	22.89	23.35	22.48	22.55	0-1	1
		1	74	22.49	23.01	23.38	22.49	22.62	0-1	1
		36	0	21.60	21.68	22.43	21.67	21.57	0-2	2
		36	18	21.60	21.75	22.44	21.67	21.62	0-2	2
		36	39	21.62	21.80	22.45	21.65	21.61	0-2	2
		75	0	21.57	21.77	22.40	21.62	21.63	0-2	2

LTE TDD Band 41 _ 20 Mhz Bandwidth

Bandwidth	Modulation	RB Size	RB Offset	Max. Average Power (dBm)					MPR Allowed Per 3GPP	MPR
				39750	40185	40620	41055	41490		
				2506.0 Mhz	2549.5 Mhz	2593.0 Mhz	2636.5 Mhz	2680.0 Mhz	[dB]	[dB]
20 Mhz	QPSK	1	0	23.25	23.42	24.15	23.75	23.18	0	0
		1	49	23.21	24.00	24.13	23.45	23.24	0	0
		1	99	23.34	23.69	24.13	23.89	23.79	0	0
		50	0	22.68	22.83	23.42	22.63	22.62	0-1	1
		50	25	22.67	22.83	23.41	22.75	22.64	0-1	1
		50	49	22.67	22.93	23.40	22.69	22.64	0-1	1
		100	0	22.66	22.85	23.38	22.67	22.63	0-1	1
	16QAM	1	0	22.88	22.84	23.48	22.61	22.63	0-1	1
		1	49	22.73	23.01	23.48	22.73	22.70	0-1	1
		1	99	22.74	23.16	23.39	22.70	22.89	0-1	1
		50	0	21.61	21.69	22.46	21.66	21.59	0-2	2
		50	25	21.61	21.73	22.43	21.65	21.63	0-2	2
		50	49	21.60	21.83	22.41	21.68	21.66	0-2	2
		100	0	21.64	21.75	22.45	21.67	21.61	0-2	2

Note;

LTE Band 41 has 5 required test channels per FCC KDB 447498 D01v06.

LTE Band 66

LTE Band 66 _ 1.4 Mhz Bandwidth

Bandwidth	Modulation	RB Size	RB Offset	Max. Average Power (dBm)			MPR Allowed Per 3GPP	MPR
				131979	132322	132665		
				1710.7 Mhz	1745 Mhz	1779.3 Mhz	[dB]	[dB]
1.4 Mhz	QPSK	1	0	23.17	23.21	23.43	0	0
		1	3	23.16	22.98	23.44	0	0
		1	5	23.13	23.07	23.45	0	0
		3	0	23.47	23.44	23.42	0	0
		3	1	23.45	23.44	23.44	0	0
		3	3	23.38	23.45	23.45	0	0
		6	0	22.77	22.38	22.70	0-1	1
	16QAM	1	0	22.61	22.43	22.45	0-1	1
		1	3	22.80	22.36	22.46	0-1	1
		1	5	22.57	22.49	22.50	0-1	1
		3	0	22.75	22.14	22.58	0-1	1
		3	1	22.85	22.36	22.53	0-1	1
		3	3	22.72	22.12	22.58	0-1	1
		6	0	21.54	21.32	21.51	0-2	2

LTE Band 66 _ 3 Mhz Bandwidth

Bandwidth	Modulation	RB Size	RB Offset	Max. Average Power (dBm)			MPR Allowed Per 3GPP	MPR
				131987	132322	132657		
				1711.5 Mhz	1745 Mhz	1778.5 Mhz	[dB]	[dB]
3 Mhz	QPSK	1	0	23.16	23.09	23.27	0	0
		1	7	23.20	23.11	23.33	0	0
		1	14	23.15	22.97	23.29	0	0
		8	0	22.76	22.42	22.68	0-1	1
		8	3	22.71	22.43	22.71	0-1	1
		8	7	22.74	22.43	22.71	0-1	1
		15	0	22.70	22.42	22.68	0-1	1
	16QAM	1	0	22.50	22.56	22.48	0-1	1
		1	7	22.32	22.42	22.45	0-1	1
		1	14	22.50	22.80	22.84	0-1	1
		8	0	21.48	21.53	21.57	0-2	2
		8	3	21.68	21.38	21.53	0-2	2
		8	7	21.62	21.52	21.56	0-2	2
		15	0	21.65	21.38	21.59	0-2	2

LTE Band 66 _ 5 MHz Bandwidth

Bandwidth	Modulation	RB Size	RB Offset	Max. Average Power (dBm)			MPR Allowed Per 3GPP	MPR
				131997	132322	132647		
				1712.5 MHz	1745 MHz	1777.5 MHz	[dB]	[dB]
5 MHz	QPSK	1	0	23.36	23.48	23.32	0	0
		1	12	23.39	23.08	23.44	0	0
		1	24	23.30	23.45	23.31	0	0
		12	0	22.72	22.42	22.69	0-1	1
		12	6	22.72	22.43	22.71	0-1	1
		12	11	22.73	22.43	22.67	0-1	1
		25	0	22.74	22.41	22.71	0-1	1
	16QAM	1	0	22.84	22.40	22.76	0-1	1
		1	12	22.46	22.47	22.50	0-1	1
		1	24	22.59	22.31	22.62	0-1	1
		12	0	21.66	21.34	21.59	0-2	2
		12	6	21.59	21.33	21.60	0-2	2
		12	11	21.63	21.33	21.55	0-2	2
		25	0	21.65	21.36	21.66	0-2	2

LTE Band 66 _ 10 MHz Bandwidth

Bandwidth	Modulation	RB Size	RB Offset	Max. Average Power (dBm)			MPR Allowed Per 3GPP	MPR
				132022	132322	132622		
				1715 MHz	1745 MHz	1775 MHz	[dB]	[dB]
10 MHz	QPSK	1	0	23.30	23.41	23.14	0	0
		1	24	23.46	23.38	23.14	0	0
		1	49	23.47	23.03	23.13	0	0
		25	0	22.76	22.43	22.60	0-1	1
		25	12	22.75	22.42	22.63	0-1	1
		25	24	22.72	22.41	22.59	0-1	1
		50	0	22.74	22.45	22.56	0-1	1
	16QAM	1	0	22.58	22.70	22.56	0-1	1
		1	24	22.57	22.65	22.64	0-1	1
		1	49	22.54	22.57	22.54	0-1	1
		25	0	21.71	21.39	21.53	0-2	2
		25	12	21.61	21.42	21.48	0-2	2
		25	24	21.58	21.32	21.58	0-2	2
		50	0	21.68	21.38	21.55	0-2	2

LTE Band 66 _ 15 MHz Bandwidth

Bandwidth	Modulation	RB Size	RB Offset	Max. Average Power (dBm)			MPR Allowed Per 3GPP	MPR
				132047	132322	132597		
				1717.5 MHz	1745 MHz	1772.5 MHz	[dB]	[dB]
15 MHz	QPSK	1	0	23.23	23.07	23.16	0	0
		1	36	23.24	22.99	23.14	0	0
		1	74	23.18	23.00	23.48	0	0
		36	0	22.75	22.45	22.61	0-1	1
		36	18	22.75	22.41	22.57	0-1	1
		36	38	22.72	22.40	22.60	0-1	1
		75	0	22.70	22.43	22.56	0-1	1
	16QAM	1	0	22.48	22.51	22.45	0-1	1
		1	36	22.45	22.49	22.37	0-1	1
		1	74	22.38	22.46	22.31	0-1	1
		36	0	21.66	21.39	21.47	0-2	2
		36	18	21.63	21.41	21.48	0-2	2
		36	38	21.61	21.37	21.48	0-2	2
		75	0	21.62	21.34	21.49	0-2	2

LTE Band 66 _ 20 MHz Bandwidth

Bandwidth	Modulation	RB Size	RB Offset	Max. Average Power (dBm)			MPR Allowed Per 3GPP	MPR
				132072	132322	132572		
				1720 MHz	1745 MHz	1770 MHz	[dB]	[dB]
20 MHz	QPSK	1	0	23.49	22.90	22.96	0	0
		1	49	23.12	23.31	22.88	0	0
		1	99	22.94	22.84	22.86	0	0
		50	0	22.48	22.31	22.39	0-1	1
		50	25	22.47	22.24	22.34	0-1	1
		50	49	22.42	22.18	22.35	0-1	1
		100	0	22.47	22.23	22.37	0-1	1
	16QAM	1	0	22.41	22.23	22.55	0-1	1
		1	49	22.42	22.21	22.48	0-1	1
		1	99	22.38	22.12	22.46	0-1	1
		50	0	21.36	21.12	21.30	0-2	2
		50	25	21.32	21.17	21.31	0-2	2
		50	49	21.31	21.02	21.23	0-2	2
		100	0	21.38	21.16	21.27	0-2	2

Note;

The EUT enables maximum power reduction in accordance with 3GPP 36.101. The MPR settings are configured during the manufacture process and are not configurable by the network, carrier, or end user.

12.3 WiFi Conducted Output Power

WiFi Maximum Conducted Power

IEEE 802.11 Average Conducted Power

Mode	Freq.	Channel	IEEE 802.11 (2.4 GHz) Conducted Power
	[MHz]		[dBm]
802.11b	2 412	1	17.41
	2 437	6	16.55
	2 462	11	16.13
	2467	12	15.91
	2472	13	15.63
802.11g	2 412	1	15.03
	2 437	6	16.68
	2 462	11	15.05
	2467	12	14.47
	2472	13	11.16
802.11n (HT20)	2 412	1	14.96
	2 437	6	16.48
	2 462	11	14.97
	2467	12	14.20
	2472	13	10.83

IEEE 802.11 Average RF Power– 20 MHz Bandwidth (Maximum Conducted Power)

Freq. [MHz]	Channel	IEEE 802.11 (5 GHz) Conducted Power [dBm]		
		IEEE 802.11a	IEEE 802.11n	IEEE 802.11ac
5 180	36	14.64	14.67	14.73
5 200	40	14.84	15.04	15.03
5 220	44	14.86	15.28	15.20
5 240	48	15.13	15.10	14.91
5 260	52	13.70	13.77	13.96
5 280	56	15.01	15.15	15.05
5 300	60	14.82	15.17	15.26
5 320	64	14.99	15.39	15.36
5 500	100	15.53	14.85	14.65
5 600	120	14.59	14.51	14.37
5 620	124	14.56	14.98	14.89
5 720	144	14.81	15.00	14.78
5 745	149	14.83	15.04	14.95
5 785	157	14.94	15.11	14.96
5 825	165	15.09	14.91	14.86

IEEE 802.11 Average RF Power– 40 MHz Bandwidth (Maximum Conducted Power)

Freq. [MHz]	Channel	IEEE 802.11(5 GHz) Conducted Power	
		IEEE 802.11n	IEEE 802.11ac
5 190	38	11.54	11.49
5 230	46	13.49	13.60
5 270	54	13.34	13.08
5 310	62	12.71	12.81
5 510	102	13.33	13.23
5 590	118	13.89	13.82
5 630	126	14.04	13.85
5 710	142	13.88	13.73
5 755	151	13.86	13.81
5 795	159	13.77	13.88

IEEE 802.11ac Reduced Average RF Conducted Power – 80 MHz Bandwidth

Mode	Freq.	Channel	IEEE 802.11ac (5 GHz) Conducted Power
	[MHz]		[dBm]
802.11ac	5 210	42	9.35
	5 290	58	10.81
	5 530	106	11.60
	5 610	122	12.49
	5 690	138	12.53
	5 775	155	9.35

Justification for test configurations for WLAN per KDB Publication 248227 D01v02r02:

- Power measurements were performed for the transmission mode configuration with the highest maximum output power specified for production units.
- For transmission mode with the same maximum output power specification, powers were measured for the largest channel bandwidth, lowest order modulation and lowest data rate.
- For transmission modes with identical maximum specified output power, channel bandwidth, modulation and data rates, power measurements were required for all identical configurations.
- For each transmission mode configuration, powers were measured for the highest and lowest channels; and at the mid-band channel(s) when there were at least 3 channels supported. For configurations with multiple mid-band channels, due to an even number of channels, both channels were measured.

Test Configuration

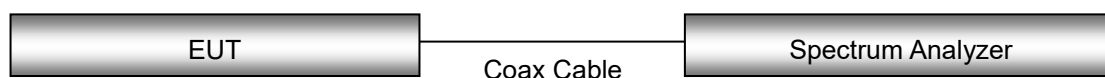

13. TEST PROCEDURE

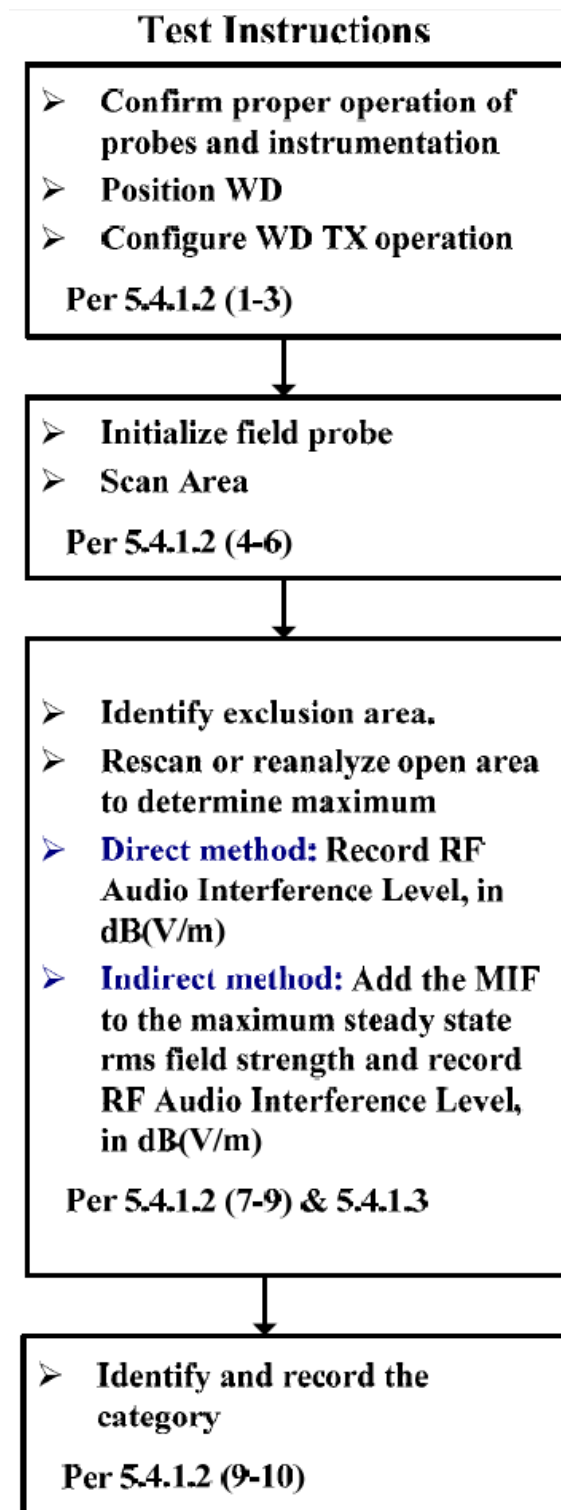

Figure 6. WD near-field emission automated test flowchart

The evaluation was performed with the following procedure:

1. Confirm proper operation of the field probe, probe measurement system and other instrumentation and the positioning system.
2. Position the WD in its intended test position. The measurement should be performed at a distance 1.5 cm from the probe elements so the gauge block can simplify this positioning.
3. Configure the WD normal operation for maximum rated RF output power, at the desired channel and other operating parameters, as intended for the test.
4. The center sub-grid shall be centered on the center of the WD output (acoustic or T-Coil output), as appropriate.
5. A Surface calibration was performed before each setup change to ensure repeatable spacing and proper maintenance of the measurement plane using the HAC Phantom.
6. Locate the field probe at reference location and measure the field strength.
7. Scan the entire 5 cm by 5 cm region at 5 mm increments and record the reading at each measurement point.
8. Identify the maximum field reading within the non-excluded sub-grids identified in Step 7.
9. Move the probe to the location of maximum scan measurement and then 360° rotating the probe to align it for the maximum reading at that position.
10. Locate the field probe at the reference location and measure the field strength for drift evaluation. If conducted power deviations of more than 5 % occurred, the tests were repeated.
11. Convert the maximum field strength reading identified in Step 8 to V/m or A/m, as appropriate. For probes which require a probe modulation factor, this conversion shall be done using the appropriate probe modulation.
12. Repeat Step 1 through Step 11 for both the E-field measurements.

14. ANSI/IEEE C63.19 PERFORMANCE CATEGORIES

The EUT must meet the following M3 or M4 category:

Emission Categories	E-field emissions dB [V/m]	
	< 960 MHz	> 960 MHz
Category M1	50 to 55	40 to 45
Category M2	45 to 50	35 to 40
Category M3	40 to 45	30 to 35
Category M4	< 40	< 30

Telephone near-field categories in linear units

15. MEASUREMENT UNCERTAINTIES

Error Description	Uncertainty value [±%]	Probe Dist.	Div.	(Ci) E	(Ci) H	Std. Unc. E [±%]	Std. Unc. H [±%]
Measurement System							
Probe Calibration	5.1	N	1	1	1	5.1	5.1
Axial Isotropy	4.7	R	$\sqrt{3}$	1	1	2.7	2.7
Sensor Displacement	16.5	R	$\sqrt{3}$	1	0.145	9.5	1.4
Boundary Effects	2.4	R	$\sqrt{3}$	1	1	1.4	1.4
Phantom Boundary Effect	7.2	R	$\sqrt{3}$	1	0	4.1	0.0
Linearity	4.7	R	$\sqrt{3}$	1	1	2.7	2.7
Scaling with PMR calibration	10.0	R	$\sqrt{3}$	1	1	5.8	5.8
System Detection Limit	1.0	R	$\sqrt{3}$	1	1	0.6	0.6
Readout Electronics	0.3	N	1	1	1	0.3	0.3
Response Time	0.8	R	$\sqrt{3}$	1	1	0.5	0.5
Integration Time	2.6	R	$\sqrt{3}$	1	1	1.5	1.5
RF Ambient Conditions	3.0	R	$\sqrt{3}$	1	1	1.7	1.7
RF Reflections	12	R	$\sqrt{3}$	1	1	6.9	6.9
Probe Positioner	1.2	R	$\sqrt{3}$	1	0.67	0.7	0.5
Probe Positioning	4.7	R	$\sqrt{3}$	1	0.67	2.7	1.8
Extrap. and Interpolation	1.0	R	$\sqrt{3}$	1	1	0.6	0.6
Test Sample Related							
Device Positioning Vertical	4.7	R	$\sqrt{3}$	1	0.67	2.7	1.8
Device Positioning Lateral	1.0	R	$\sqrt{3}$	1	1	0.6	0.6
Device Holder and Phantom	2.4	R	$\sqrt{3}$	1	1	1.4	1.4
Power Drift	5.0	R	$\sqrt{3}$	1	1	2.9	2.9
Phantom and Setup Related							
Phantom Thickness	2.4	R	$\sqrt{3}$	1	0.67	1.4	0.9
Combined Std. Uncertainty						16.3	12.3
Expanded Std. Uncertainty on Power						32.6	24.6
Expanded Std. Uncertainty on Field						16.3	12.3

16. HAC TEST DATA SUMMARY

E-Field Measurement Result (GSM850/GSM1900)

Mode	Channel	Conducted Power [dBm]	Time Avg. Filed [V/m]	Audio Inteferece Level [dBV/m]	FCC Limit [dBV/m]	FCC Margin [dB]	MIF	Result	Exclusion Block
GSM850	128	32.36	31.77	33.60	45	11.40	3.56	M4	none
	190	32.84	36.98	34.91	45	10.09	3.55	M4	none
	251	33.36	41.45	35.91	45	9.09	3.56	M4	none
GSM1900	512	29.49	18.34	28.81	35	6.19	3.54	M4	none
	661	29.26	17.84	28.56	35	6.44	3.53	M4	none
	810	29.00	16.69	27.97	35	7.03	3.52	M4	none

E-Field Measurement Result (LTE TDD)

Mode	Channel	Mod.	BW	RB Size	RB offset	Conducted Power [dBm]	Time Avg. Filed [V/m]	Audio Inteferece Level [dBV/m]	FCC Limit [dBV/m]	FCC Margin [dB]	MIF	Result	Exclusion Block
LTE TDD/ Band 41	39750	16QAM	20	1	0	22.88	12.26	23.44	35	11.56	1.67	M4	none
	40185	16QAM	20	1	0	22.84	10.21	21.85	35	13.15	1.67	M4	none
	40620	16QAM	20	1	0	23.48	9.56	21.32	35	13.68	1.71	M4	none
	41055	16QAM	20	1	0	22.61	7.11	18.71	35	16.29	1.67	M4	none
	41490	16QAM	20	1	0	22.63	9.57	21.26	35	13.74	1.64	M4	none

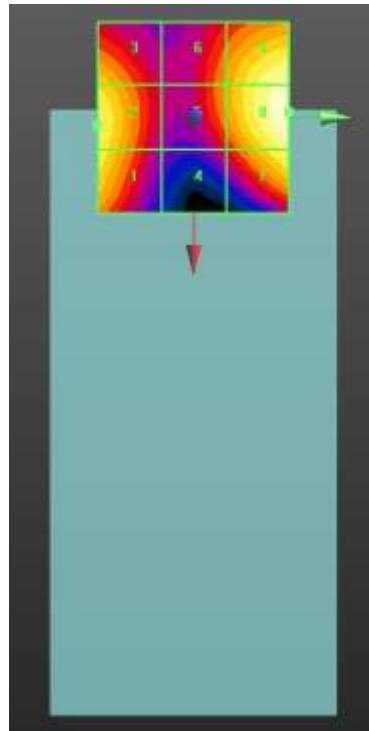

Sample E-field Scan Overlay
(See Test setup Photographs for actual WD overlay)

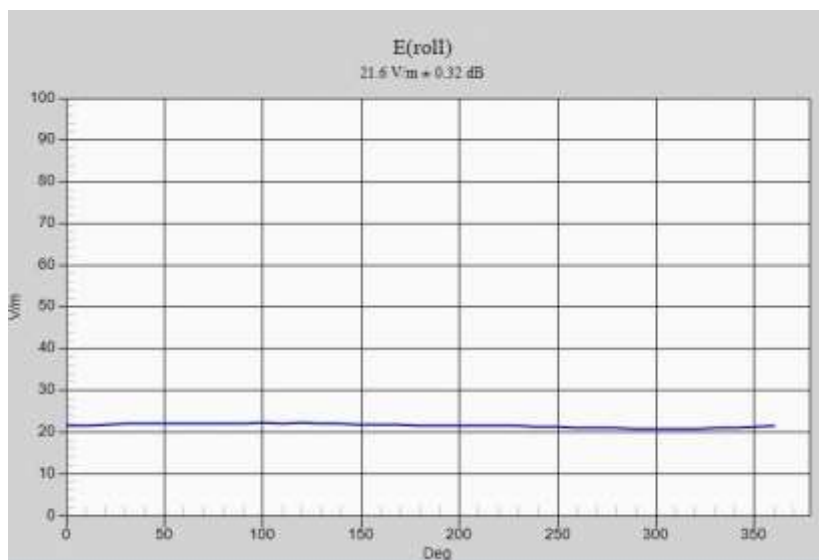

Worst-case Probe Rotation about Azimuth axis

17. HAC TEST EQUIPMENT LIST

The test sites and measurement facilities used to collect data are located at

SAR 7 Room(HAC)

18. HAC TEST EQUIPMENT LIST

Manufacturer	Type / Model	S/N	Calib. Date	Calib.Interval	Calib.Due
SPEAG	HAC Phantom	-	N/A	N/A	N/A
HP	SAR System Control PC	-	N/A	N/A	N/A
Staubli	TX90 XLSpeag	F11/5K3RA1/A/01	N/A	N/A	N/A
Staubli	CS8Cspeag-TX90	F11/5K3RA1/C/01	N/A	N/A	N/A
Staubli	Teach Pendant (Joystick)	S-1203 0309	N/A	N/A	N/A
SPEAG	DAE4	1225	11/16/2018	Annual	11/16/2019
SPEAG	E-Field Probe EF3DV3	4034	02/22/2019	Annual	02/22/2020
SPEAG	Dipole CD835V3	1024	02/22/2019	Annual	02/22/2020
SPEAG	Dipole CD1880V3	1019	02/22/2019	Annual	02/22/2020
SPEAG	Dipole CD2600V3	1019	09/19/2019	Annual	09/19/2020
SPEAG	Audio Interference Analyzer	1060	N/A	CBT*	N/A
Agilent	Power Meter E4419B	MY41291386	10/07/2019	Annual	10/07/2020
Agilent	Power Sensor 8481A	SG1091286	10/07/2019	Annual	10/07/2020
Agilent	Power Sensor 8481A	MY41090873	10/07/2019	Annual	10/07/2020
Agilent	Power Meter N1911A	MY45101406	09/10/2019	Annual	09/10/2020
Agilent	Power Sensor N1921A	MY55220026	09/06/2019	Annual	09/06/2020
Agilent	Signal Generator N5182A	MY47070230	05/08/2019	Annual	05/08/2020
Agilent	11636B/Power Divider	58698	02/28/2019	Annual	03/06/2020
TESTO	175-H1/Thermometer	40331949309	01/29/2019	Annual	01/29/2020
EMPOWER	RF Power Amplifier BBS5K8CAJ	1011	10/08/2019	Annual	10/08/2020
EMPOWER	RF Power Amplifier EG0842-13	1009D/C0028	10/08/2019	Annual	10/08/2020
MICRO LAB	LP Filter / LA-15N	10453	10/07/2019	Annual	10/07/2020
MICRO LAB	LP Filter / LA-30N	-	10/07/2019	Annual	10/07/2020
Apitech	Attenuator (3dB) 18B-03	1	06/04/2019	Annual	06/04/2020
Agilent	Attenuator (20dB) 33340C	13311	05/08/2019	Annual	05/08/2020
H.P	Attenuator (10dB) 8493C	07560	07/02/2019	Annual	07/02/2020
Agilent	Directional Bridge	3140A03878	06/12/2019	Annual	06/12/2020
R&S	Wideband Radio Communication Tester CMW500	101519	05/15/2019	Annual	05/15/2020
Anritsu	Radio Communication Tester MT8821C	6201502997	08/09/2019	Annual	08/09/2020
Agilent	WIRELESS COMMUNICATION E5515C	MY48361100	10/07/2019	Annual	10/07/2020
Agilent	MXA Signal Analyzer N9020A	MY50510407	10/29/2019	Annual	10/29/2020

*Note: CBT (calibrated Before Testing).Prior to testing, AIA Perform self calibration procedures.

19. CONCLUSION

The HAC measurement indicates that the EUT complies with the HAC limits of the ANSI-C63.19-2011. These measurements are taken to simulate the RF effects exposure under worst-case conditions. Precise Laboratory measures were taken to assure repeatability of the tests.

Attachment 1. HAC RF Emission Test Plots

Measurement Standard DASY5[IEEE/IEC/ANSI C63.19-2011]

DUT: SM-A515F/DS; Type: Bar

GSM850 E-Field 128ch

Communication System: UID 0, GSM 850 (0); Frequency: 824.2 MHz; Duty Cycle: 1:8.30042
 Medium parameters used: $\sigma = 0$ S/m, $\epsilon_r = 1$; $\rho = 0$ kg/m³
 Phantom section: RF Section

DASY Configuration:

- Probe: EF3DV3 - SN4034; ConvF(1, 1, 1); Calibrated: 2019-02-22;
- Sensor-Surface: (Fix Surface)
- Electronics: DAE4 Sn1225; Calibrated: 2018-11-16
- Phantom: HAC Test Arch with AMCC_RF_2018_04_27
- Measurement SW: DASY52, Version 52.8 (8);

**Device E-Field measurement (E-field scan for ANSI C63.19-2007 & -2011 compliance)/E Scan - ER3D:
 15 mm from Probe Center to the Device/Hearing Aid Compatibility Test (101x101x1): Interpolated grid:
 dx=0.5000 mm, dy=0.5000 mm
 Device Reference Point: 0, 0, -6.3 mm
 Reference Value = 41.23 V/m; Power Drift = 0.02 dB
 Applied MIF = 3.56 dB
 RF audio interference level = 33.60 dBV/m
Emission category: M4**

MIF scaled E-field

Grid 1 M4 33.15 dBV/m	Grid 2 M4 33.2 dBV/m	Grid 3 M4 32.34 dBV/m
Grid 4 M4 33.58 dBV/m	Grid 5 M4 33.58 dBV/m	Grid 6 M4 32.56 dBV/m
Grid 7 M4 33.58 dBV/m	Grid 8 M4 33.6 dBV/m	Grid 9 M4 32.54 dBV/m

Cursor:

Total = 33.60 dBV/m
 E Category: M4
 Location: 6, 25, 7.7 mm

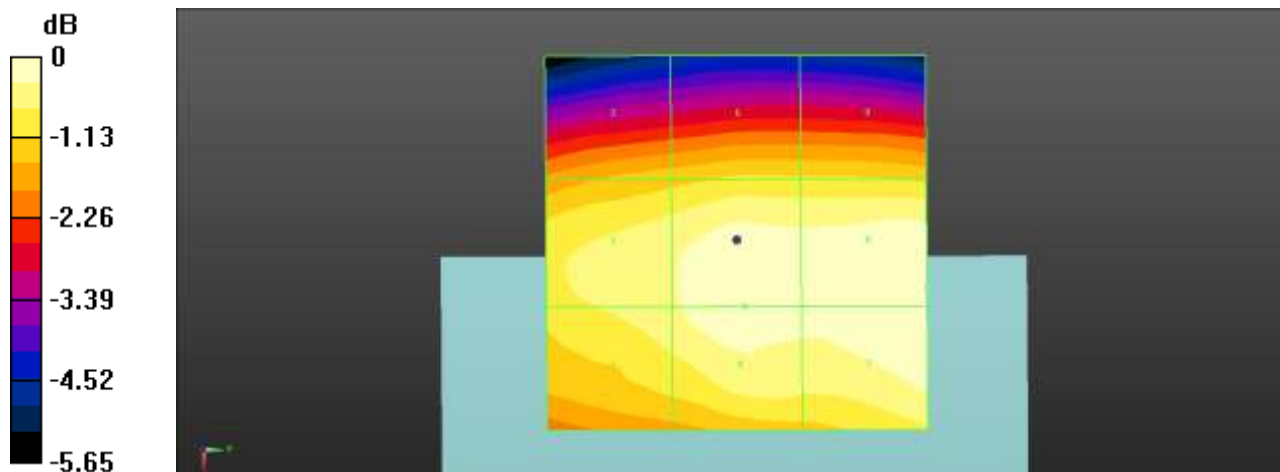

0 dB = 47.86 V/m = 33.60 dBV/m

Measurement Standard DASYS5[IEEE/IEC/ANSI C63.19-2011]

DUT: SM-A515F/DS; Type: Bar

GSM850 E-Field 190ch

Communication System: UID 0, GSM 850 (0); Frequency: 836.6 MHz; Duty Cycle: 1:8.30042
 Medium parameters used: $\sigma = 0$ S/m, $\epsilon_r = 1$; $\rho = 0$ kg/m³
 Phantom section: RF Section

DASY Configuration:

- Probe: EF3DV3 - SN4034; ConvF(1, 1, 1); Calibrated: 2019-02-22;
- Sensor-Surface: (Fix Surface)
- Electronics: DAE4 Sn1225; Calibrated: 2018-11-16
- Phantom: HAC Test Arch with AMCC_RF_2018_04_27
- Measurement SW: DASYS52, Version 52.8 (8);

Device E-Field measurement (E-field scan for ANSI C63.19-2007 & -2011 compliance)/E Scan - ER3D:
15 mm from Probe Center to the Device/Hearing Aid Compatibility Test (101x101x1): Interpolated grid:
 dx=0.5000 mm, dy=0.5000 mm
 Device Reference Point: 0, 0, -6.3 mm
 Reference Value = 48.77 V/m; Power Drift = 0.01 dB
 Applied MIF = 3.55 dB
 RF audio interference level = 34.91 dBV/m
Emission category: M4

MIF scaled E-field

Grid 1 M4 34.45 dBV/m	Grid 2 M4 34.68 dBV/m	Grid 3 M4 33.78 dBV/m
Grid 4 M4 34.81 dBV/m	Grid 5 M4 34.91 dBV/m	Grid 6 M4 33.94 dBV/m
Grid 7 M4 34.66 dBV/m	Grid 8 M4 34.78 dBV/m	Grid 9 M4 33.83 dBV/m

Cursor:

Total = 34.91 dBV/m
 E Category: M4
 Location: 4.5, 0.5, 7.7 mm

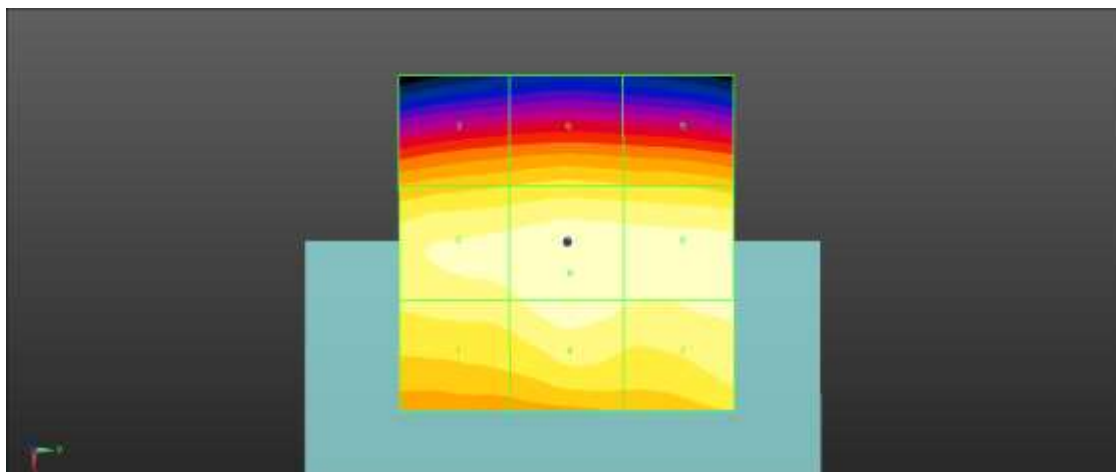
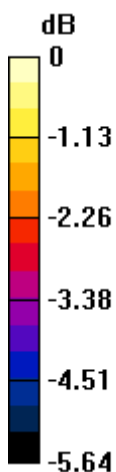

0 dB = 55.65 V/m = 34.91 dBV/m

Measurement Standard DASYS5[IEEE/IEC/ANSI C63.19-2011]

DUT: SM-A515F/DS; Type: Bar

GSM850 E-Field 251ch

Communication System: UID 0, GSM 850 (0); Frequency: 848.8 MHz; Duty Cycle: 1:8.30042
 Medium parameters used: $\sigma = 0$ S/m, $\epsilon_r = 1$; $\rho = 0$ kg/m³
 Phantom section: RF Section

DASY Configuration:

- Probe: EF3DV3 - SN4034; ConvF(1, 1, 1); Calibrated: 2019-02-22;
- Sensor-Surface: (Fix Surface)
- Electronics: DAE4 Sn1225; Calibrated: 2018-11-16
- Phantom: HAC Test Arch with AMCC_RF_2018_04_27
- Measurement SW: DASYS52, Version 52.8 (8);

Device E-Field measurement (E-field scan for ANSI C63.19-2007 & -2011 compliance)/E Scan - ER3D:
15 mm from Probe Center to the Device/Hearing Aid Compatibility Test (101x101x1): Interpolated grid:
 dx=0.5000 mm, dy=0.5000 mm
 Device Reference Point: 0, 0, -6.3 mm
 Reference Value = 54.58 V/m; Power Drift = -0.03 dB
 Applied MIF = 3.56 dB
 RF audio interference level = 35.91 dBV/m
Emission category: M4

MIF scaled E-field

Grid 1 M4 35.55 dBV/m	Grid 2 M4 35.7 dBV/m	Grid 3 M4 34.8 dBV/m
Grid 4 M4 35.83 dBV/m	Grid 5 M4 35.91 dBV/m	Grid 6 M4 34.92 dBV/m
Grid 7 M4 35.62 dBV/m	Grid 8 M4 35.74 dBV/m	Grid 9 M4 34.82 dBV/m

Cursor:

Total = 35.91 dBV/m
 E Category: M4
 Location: 4.5, 0.5, 7.7 mm

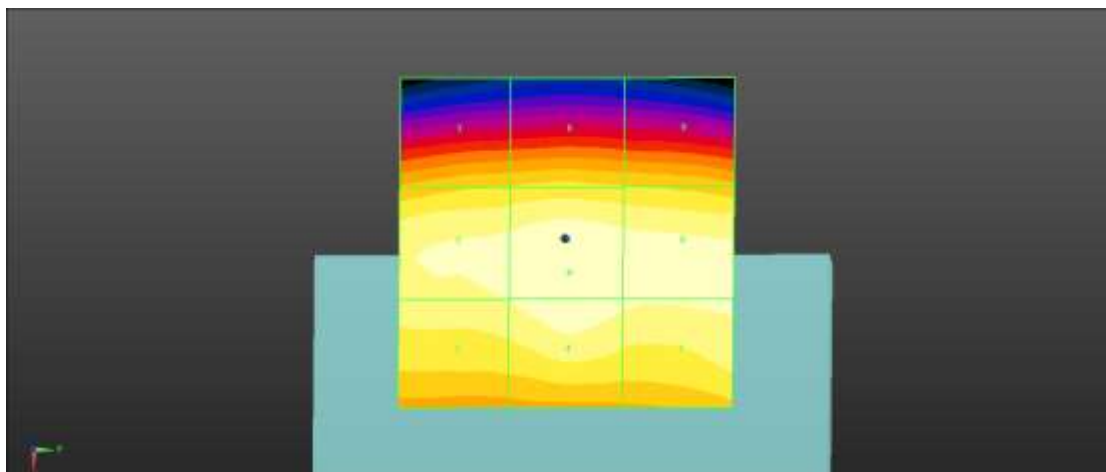
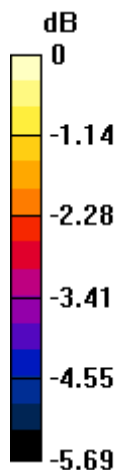

0 dB = 62.45 V/m = 35.91 dBV/m

Measurement Standard DASYS5[IEEE/IEC/ANSI C63.19-2011]

GSM1900 E-Field 512ch

DUT: SM-A515F/DS; Type: Bar

Communication System: UID 0, GSM 1900 (0); Frequency: 1850.2 MHz;Duty Cycle: 1:8.30042
 Medium parameters used: $\sigma = 0$ S/m, $\epsilon_r = 1$; $\rho = 0$ kg/m³
 Phantom section: RF Section

DASY Configuration:

- Probe: EF3DV3 - SN4034; ConvF(1, 1, 1); Calibrated: 2019-02-22;
- Sensor-Surface: (Fix Surface)
- Electronics: DAE4 Sn1225; Calibrated: 2018-11-16
- Phantom: HAC Test Arch with AMCC_RF_2018_04_27
- Measurement SW: DASYS52, Version 52.8 (8);

Device E-Field measurement (E-field scan for ANSI C63.19-2007 & -2011 compliance)/E Scan - ER3D:
15 mm from Probe Center to the Device/Hearing Aid Compatibility Test (101x101x1): Interpolated grid:
 dx=0.5000 mm, dy=0.5000 mm
 Device Reference Point: 0, 0, -6.3 mm
 Reference Value = 14.40 V/m; Power Drift = 0.11 dB
 Applied MIF = 3.54 dB
 RF audio interference level = 28.81 dBV/m
Emission category: M4

MIF scaled E-field

Grid 1 M4 28.35 dBV/m	Grid 2 M4 28.05 dBV/m	Grid 3 M4 25.34 dBV/m
Grid 4 M4 27.51 dBV/m	Grid 5 M4 26.84 dBV/m	Grid 6 M4 24.78 dBV/m
Grid 7 M4 28.76 dBV/m	Grid 8 M4 28.81 dBV/m	Grid 9 M4 27.29 dBV/m

Cursor:

Total = 28.81 dBV/m
 E Category: M4
 Location: 6, 25, 7.7 mm

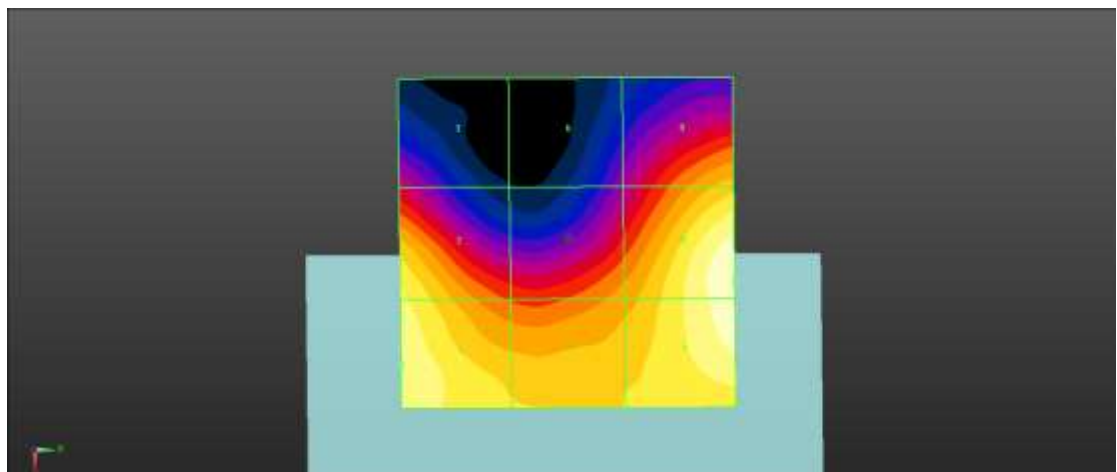
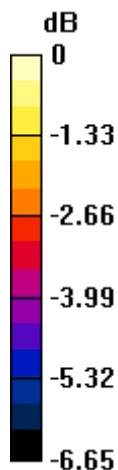

0 dB = 27.59 V/m = 28.82 dBV/m

Measurement Standard DASYS5[IEEE/IEC/ANSI C63.19-2011]

DUT: SM-A515F/DS; Type: Bar

GSM1900 E-Field 661ch

Communication System: UID 0, GSM 1900 (0); Frequency: 1880 MHz; Duty Cycle: 1:8.30042
 Medium parameters used: $\sigma = 0$ S/m, $\epsilon_r = 1$; $\rho = 0$ kg/m³
 Phantom section: RF Section

DASY Configuration:

- Probe: EF3DV3 - SN4034; ConvF(1, 1, 1); Calibrated: 2019-02-22;
- Sensor-Surface: (Fix Surface)
- Electronics: DAE4 Sn1225; Calibrated: 2018-11-16
- Phantom: HAC Test Arch with AMCC_RF_2018_04_27
- Measurement SW: DASYS52, Version 52.8 (8);

Device E-Field measurement (E-field scan for ANSI C63.19-2007 & -2011 compliance)/E Scan - ER3D: 15 mm from Probe Center to the Device/Hearing Aid Compatibility Test (101x101x1): Interpolated grid: dx=0.5000 mm, dy=0.5000 mm
 Device Reference Point: 0, 0, -6.3 mm
 Reference Value = 14.49 V/m; Power Drift = 0.13 dB
 Applied MIF = 3.53 dB
 RF audio interference level = 28.56 dBV/m
Emission category: M4

MIF scaled E-field

Grid 1 M4 28.55 dBV/m	Grid 2 M4 28.52 dBV/m	Grid 3 M4 26.32 dBV/m
Grid 4 M4 27.48 dBV/m	Grid 5 M4 26.82 dBV/m	Grid 6 M4 25.03 dBV/m
Grid 7 M4 28.4 dBV/m	Grid 8 M4 28.56 dBV/m	Grid 9 M4 27.34 dBV/m

Cursor:

Total = 28.56 dBV/m
 E Category: M4
 Location: 5, 25, 7.7 mm

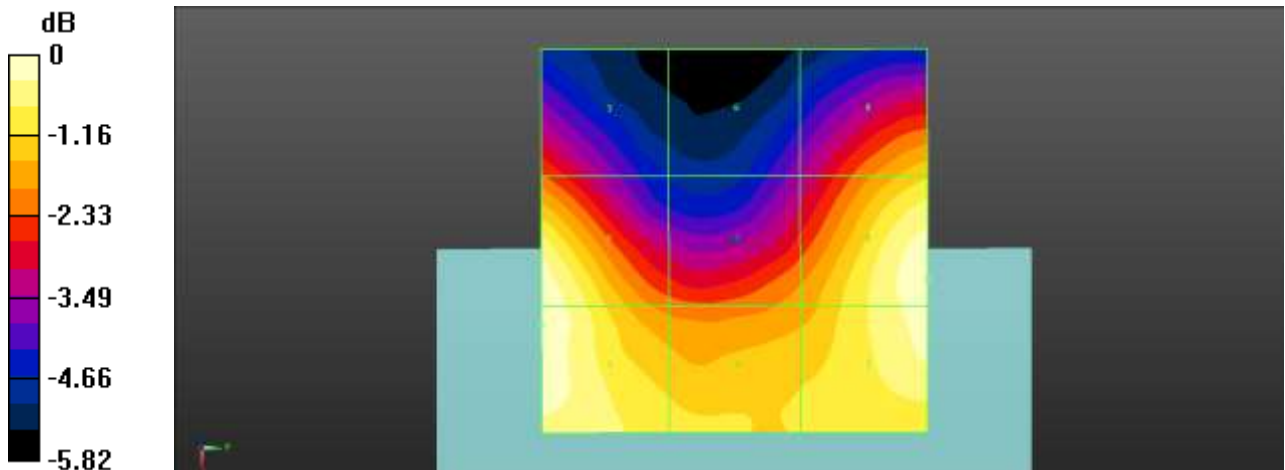

0 dB = 26.78 V/m = 28.56 dBV/m

Measurement Standard DASYS5[IEEE/IEC/ANSI C63.19-2011]

DUT: SM-A515F/DS; Type: Bar

GSM1900 E-Field 810ch

Communication System: UID 0, GSM 1900 (0); Frequency: 1909.8 MHz; Duty Cycle: 1:8.30042
 Medium parameters used: $\sigma = 0$ S/m, $\epsilon_r = 1$; $\rho = 0$ kg/m³
 Phantom section: RF Section

DASY Configuration:

- Probe: EF3DV3 - SN4034; ConvF(1, 1, 1); Calibrated: 2019-02-22;
- Sensor-Surface: (Fix Surface)
- Electronics: DAE4 Sn1225; Calibrated: 2018-11-16
- Phantom: HAC Test Arch with AMCC_RF_2018_04_27
- Measurement SW: DASYS52, Version 52.8 (8);

Device E-Field measurement (E-field scan for ANSI C63.19-2007 & -2011 compliance)/E Scan - ER3D:
15 mm from Probe Center to the Device/Hearing Aid Compatibility Test (101x101x1): Interpolated grid:
 dx=0.5000 mm, dy=0.5000 mm
 Device Reference Point: 0, 0, -6.3 mm
 Reference Value = 14.57 V/m; Power Drift = -0.02 dB
 Applied MIF = 3.52 dB
 RF audio interference level = 27.97 dBV/m
Emission category: M4

MIF scaled E-field

Grid 1 M4 27.97 dBV/m	Grid 2 M4 27.92 dBV/m	Grid 3 M4 25.97 dBV/m
Grid 4 M4 27.55 dBV/m	Grid 5 M4 26.46 dBV/m	Grid 6 M4 24.07 dBV/m
Grid 7 M4 27.77 dBV/m	Grid 8 M4 27.81 dBV/m	Grid 9 M4 26.38 dBV/m

Cursor:

Total = 27.97 dBV/m

E Category: M4

Location: 11.5, -25, 7.7 mm

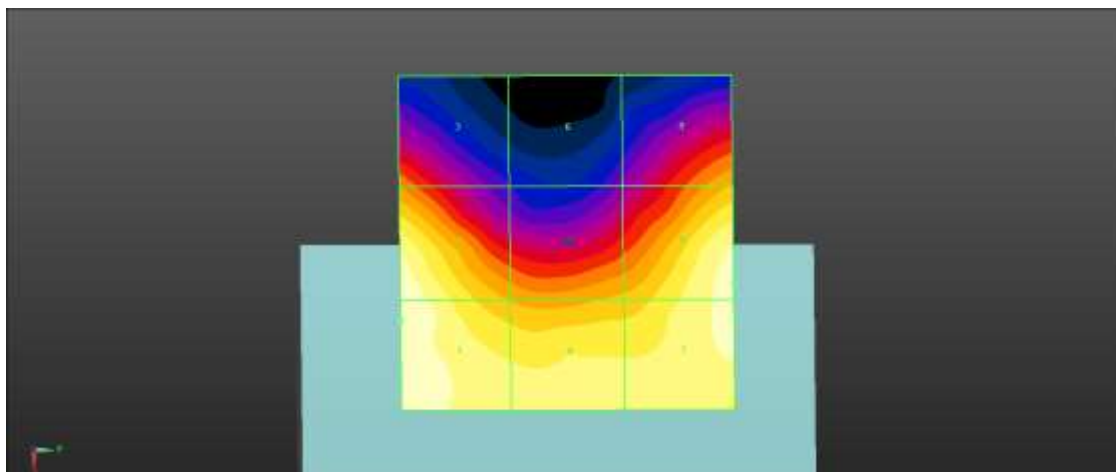
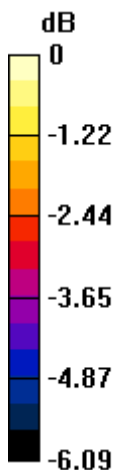

0 dB = 25.02 V/m = 27.97 dBV/m

Measurement Standard DASYS5[IEEE/IEC/ANSI C63.19-2011]

DUT: SM-A515F/DS; Type: Bar

LTE Band41 E-Field 20MHz 16QAM 1RB 0offset 39750ch

Communication System: UID 0, LTE-TDD (HCT, SC-FDMA, 1 RB, 20 MHz, 16-QAM) (0); Frequency: 2506 MHz; Duty Cycle: 1:4.66659
 Medium parameters used: $\sigma = 0$ S/m, $\epsilon_r = 1$; $\rho = 0$ kg/m³
 Phantom section: RF Section

DASY Configuration:

- Probe: EF3DV3 - SN4034; ConvF(1, 1, 1); Calibrated: 2019-02-22;
- Sensor-Surface: (Fix Surface)
- Electronics: DAE4 Sn1225; Calibrated: 2018-11-16
- Phantom: HAC Test Arch with AMCC_RF_2018_04_27
- Measurement SW: DASYS52, Version 52.8 (8);

Device E-Field measurement (E-field scan for ANSI C63.19-2007 & -2011 compliance)/E Scan - ER3D: 15 mm from Probe Center to the Device/Hearing Aid Compatibility Test (101x101x1): Interpolated grid: dx=0.5000 mm, dy=0.5000 mm
 Device Reference Point: 0, 0, -6.3 mm
 Reference Value = 10.56 V/m; Power Drift = -0.02 dB
 Applied MIF = 1.67 dB
 RF audio interference level = 23.44 dBV/m
Emission category: M4

MIF scaled E-field

Grid 1 M4 23.04 dBV/m	Grid 2 M4 23.44 dBV/m	Grid 3 M4 22.13 dBV/m
Grid 4 M4 19.28 dBV/m	Grid 5 M4 20.51 dBV/m	Grid 6 M4 20.41 dBV/m
Grid 7 M4 17.67 dBV/m	Grid 8 M4 19.58 dBV/m	Grid 9 M4 19.55 dBV/m

Cursor:

Total = 23.44 dBV/m
 E Category: M4
 Location: 3.5, -25, 7.7 mm

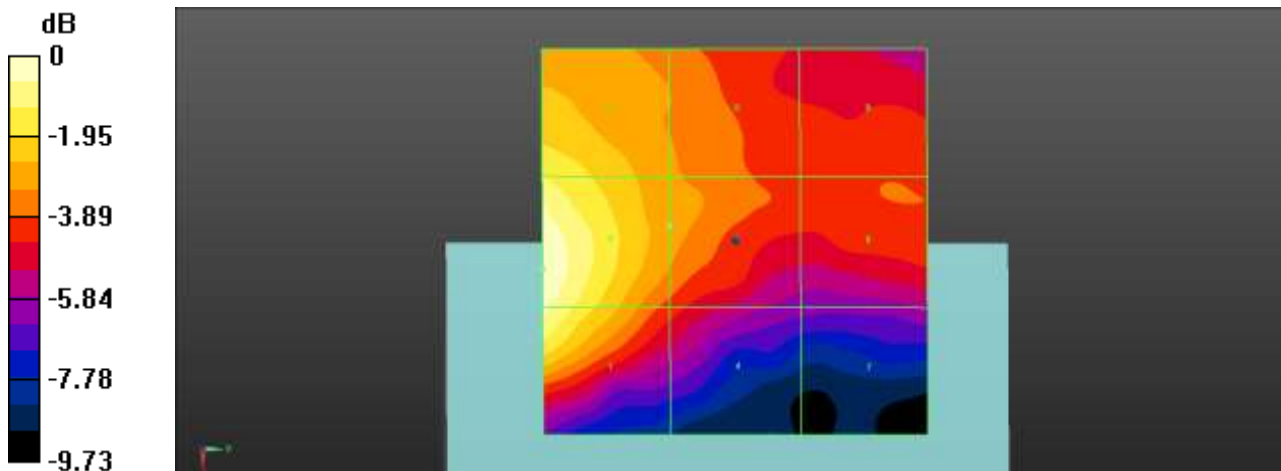

0 dB = 14.86 V/m = 23.44 dBV/m

Measurement Standard DASYS5[IEEE/IEC/ANSI C63.19-2011]

DUT: SM-A515F/DS; Type: Bar

LTE Band41 E-Field 20MHz 16QAM 1RB 0offset 40185ch

Communication System: UID 0, LTE-TDD (HCT, SC-FDMA, 1 RB, 20 MHz, 16-QAM) (0); Frequency: 2549.5 MHz; Duty Cycle: 1:4.66659
 Medium parameters used: $\sigma = 0$ S/m, $\epsilon_r = 1$; $\rho = 0$ kg/m³
 Phantom section: RF Section

DASY Configuration:

- Probe: EF3DV3 - SN4034; ConvF(1, 1, 1); Calibrated: 2019-02-22;
- Sensor-Surface: (Fix Surface)
- Electronics: DAE4 Sn1225; Calibrated: 2018-11-16
- Phantom: HAC Test Arch with AMCC_RF_2018_04_27
- Measurement SW: DASYS52, Version 52.8 (8);

Device E-Field measurement (E-field scan for ANSI C63.19-2007 & -2011 compliance)/E Scan - ER3D: 15 mm from Probe Center to the Device/Hearing Aid Compatibility Test (101x101x1): Interpolated grid:

dx=0.5000 mm, dy=0.5000 mm
 Device Reference Point: 0, 0, -6.3 mm
 Reference Value = 9.126 V/m; Power Drift = 0.14 dB
 Applied MIF = 1.67 dB
 RF audio interference level = 21.85 dBV/m
Emission category: M4

MIF scaled E-field

Grid 1 M4 21.52 dBV/m	Grid 2 M4 21.85 dBV/m	Grid 3 M4 20.17 dBV/m
Grid 4 M4 18.54 dBV/m	Grid 5 M4 19.38 dBV/m	Grid 6 M4 19.12 dBV/m
Grid 7 M4 16.6 dBV/m	Grid 8 M4 17.8 dBV/m	Grid 9 M4 17.61 dBV/m

Cursor:

Total = 21.85 dBV/m
 E Category: M4
 Location: 4, -25, 7.7 mm

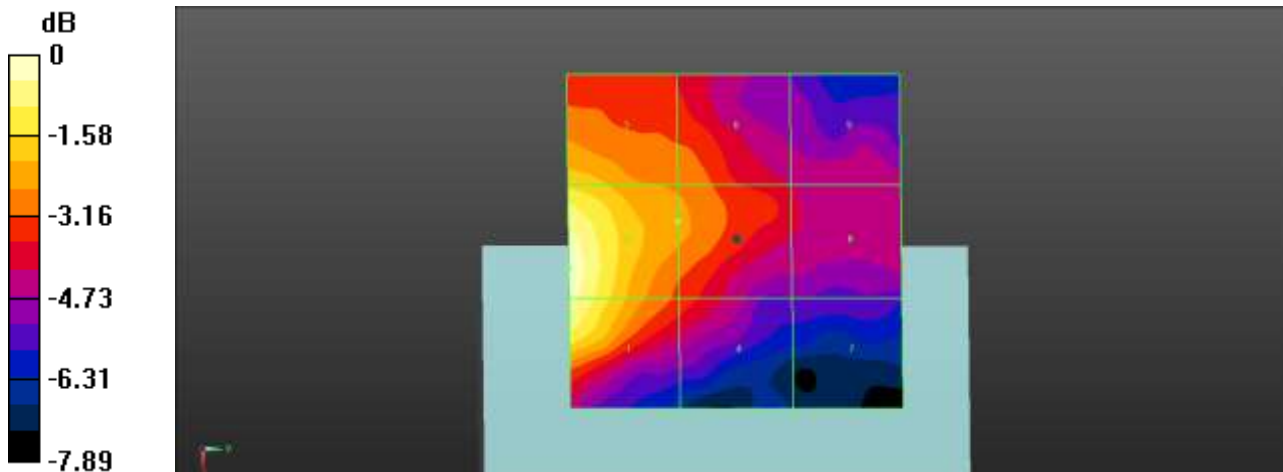

0 dB = 12.38 V/m = 21.85 dBV/m

Measurement Standard DASYS5[IEEE/IEC/ANSI C63.19-2011]

DUT: SM-A515F/DS; Type: Bar

LTE Band41 E-Field 20MHz 16QAM 1RB 0offset 40620ch

Communication System: UID 0, LTE-TDD (HCT, SC-FDMA, 1 RB, 20 MHz, 16-QAM) (0); Frequency: 2593 MHz; Duty Cycle: 1:4.66659
 Medium parameters used: $\sigma = 0$ S/m, $\epsilon_r = 1$; $\rho = 0$ kg/m³
 Phantom section: RF Section

DASY Configuration:

- Probe: EF3DV3 - SN4034; ConvF(1, 1, 1); Calibrated: 2019-02-22;
- Sensor-Surface: (Fix Surface)
- Electronics: DAE4 Sn1225; Calibrated: 2018-11-16
- Phantom: HAC Test Arch with AMCC_RF_2018_04_27
- Measurement SW: DASYS52, Version 52.8 (8);

Device E-Field measurement (E-field scan for ANSI C63.19-2007 & -2011 compliance)/E Scan - ER3D: 15 mm from Probe Center to the Device/Hearing Aid Compatibility Test (101x101x1): Interpolated grid:
 dx=0.5000 mm, dy=0.5000 mm
 Device Reference Point: 0, 0, -6.3 mm
 Reference Value = 7.985 V/m; Power Drift = 0.10 dB
 Applied MIF = 1.71 dB
 RF audio interference level = 21.32 dBV/m
Emission category: M4

MIF scaled E-field

Grid 1 M4 20.83 dBV/m	Grid 2 M4 21.32 dBV/m	Grid 3 M4 20.21 dBV/m
Grid 4 M4 17.15 dBV/m	Grid 5 M4 18.77 dBV/m	Grid 6 M4 18.34 dBV/m
Grid 7 M4 16.48 dBV/m	Grid 8 M4 17.54 dBV/m	Grid 9 M4 17.19 dBV/m

Cursor:

Total = 21.32 dBV/m
 E Category: M4
 Location: 2, -25, 7.7 mm

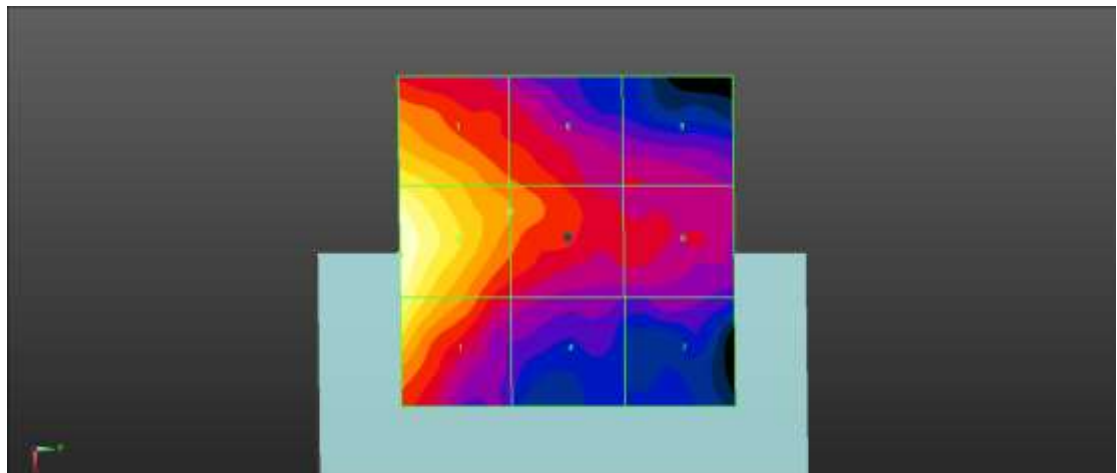
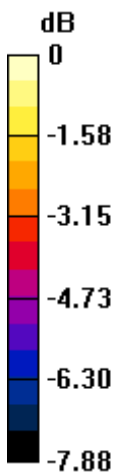

0 dB = 11.65 V/m = 21.33 dBV/m

Measurement Standard DASYS5[IEEE/IEC/ANSI C63.19-2011]

DUT: SM-A515F/DS; Type: Bar

LTE Band41 E-Field 20MHz 16QAM 1RB 0offset 41055ch

Communication System: UID 0, LTE-TDD (HCT, SC-FDMA, 1 RB, 20 MHz, 16-QAM) (0); Frequency: 2636.5 MHz; Duty Cycle: 1:4.66659
 Medium parameters used: $\sigma = 0$ S/m, $\epsilon_r = 1$; $\rho = 0$ kg/m³
 Phantom section: RF Section

DASY Configuration:

- Probe: EF3DV3 - SN4034; ConvF(1, 1, 1); Calibrated: 2019-02-22;
- Sensor-Surface: (Fix Surface)
- Electronics: DAE4 Sn1225; Calibrated: 2018-11-16
- Phantom: HAC Test Arch with AMCC_RF_2018_04_27
- Measurement SW: DASYS52, Version 52.8 (8);

Device E-Field measurement (E-field scan for ANSI C63.19-2007 & -2011 compliance)/E Scan - ER3D: 15 mm from Probe Center to the Device/Hearing Aid Compatibility Test (101x101x1): Interpolated grid:

dx=0.5000 mm, dy=0.5000 mm
 Device Reference Point: 0, 0, -6.3 mm
 Reference Value = 5.698 V/m; Power Drift = -0.15 dB
 Applied MIF = 1.67 dB
 RF audio interference level = 18.71 dBV/m
Emission category: M4

MIF scaled E-field

Grid 1 M4 18.2 dBV/m	Grid 2 M4 18.71 dBV/m	Grid 3 M4 17.84 dBV/m
Grid 4 M4 16.63 dBV/m	Grid 5 M4 16.87 dBV/m	Grid 6 M4 16.88 dBV/m
Grid 7 M4 15.95 dBV/m	Grid 8 M4 15.68 dBV/m	Grid 9 M4 15.9 dBV/m

Cursor:

Total = 18.71 dBV/m
 E Category: M4
 Location: 4.5, -25, 7.7 mm

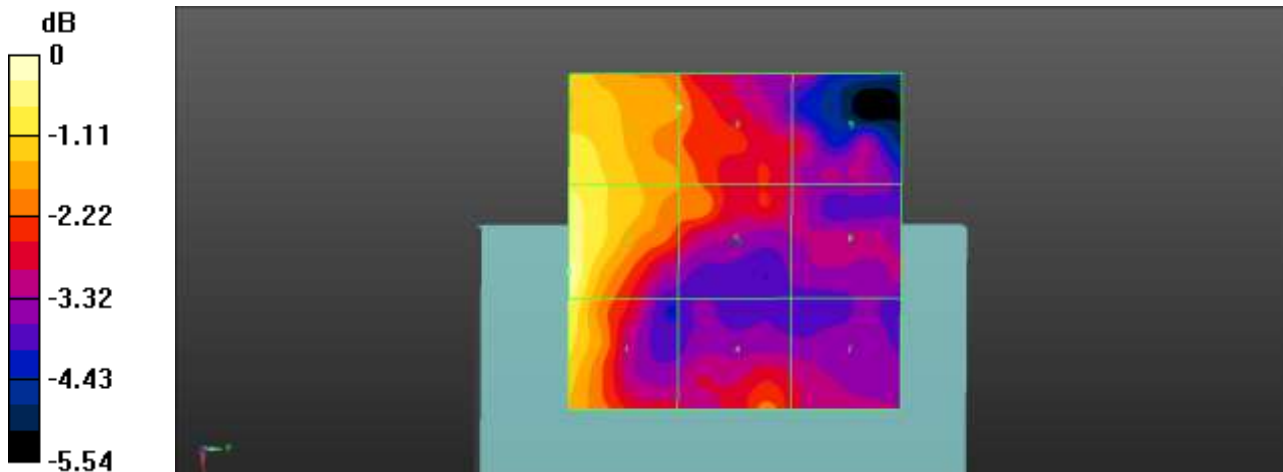

0 dB = 8.619 V/m = 18.71 dBV/m

Measurement Standard DASYS5[IEEE/IEC/ANSI C63.19-2011]

DUT: SM-A515F/DS; Type: Bar

LTE Band41 E-Field 20MHz 16QAM 1RB 0offset 41490ch

Communication System: UID 0, LTE-TDD (HCT, SC-FDMA, 1 RB, 20 MHz, 16-QAM) (0); Frequency: 2680 MHz; Duty Cycle: 1:4.66659
 Medium parameters used: $\sigma = 0$ S/m, $\epsilon_r = 1$; $\rho = 0$ kg/m³
 Phantom section: RF Section

DASY Configuration:

- Probe: EF3DV3 - SN4034; ConvF(1, 1, 1); Calibrated: 2019-02-22;
- Sensor-Surface: (Fix Surface)
- Electronics: DAE4 Sn1225; Calibrated: 2018-11-16
- Phantom: HAC Test Arch with AMCC_RF_2018_04_27
- Measurement SW: DASYS52, Version 52.8 (8);

Device E-Field measurement (E-field scan for ANSI C63.19-2007 & -2011 compliance)/E Scan - ER3D: 15 mm from Probe Center to the Device/Hearing Aid Compatibility Test (101x101x1): Interpolated grid:

dx=0.5000 mm, dy=0.5000 mm
 Device Reference Point: 0, 0, -6.3 mm
 Reference Value = 8.174 V/m; Power Drift = -0.15 dB
 Applied MIF = 1.64 dB
 RF audio interference level = 21.26 dBV/m
Emission category: M4

MIF scaled E-field

Grid 1 M4 21.07 dBV/m	Grid 2 M4 21.26 dBV/m	Grid 3 M4 20.5 dBV/m
Grid 4 M4 17.89 dBV/m	Grid 5 M4 19.29 dBV/m	Grid 6 M4 19.25 dBV/m
Grid 7 M4 17.87 dBV/m	Grid 8 M4 18.16 dBV/m	Grid 9 M4 17.85 dBV/m

Cursor:

Total = 21.26 dBV/m
 E Category: M4
 Location: 3, -25, 7.7 mm

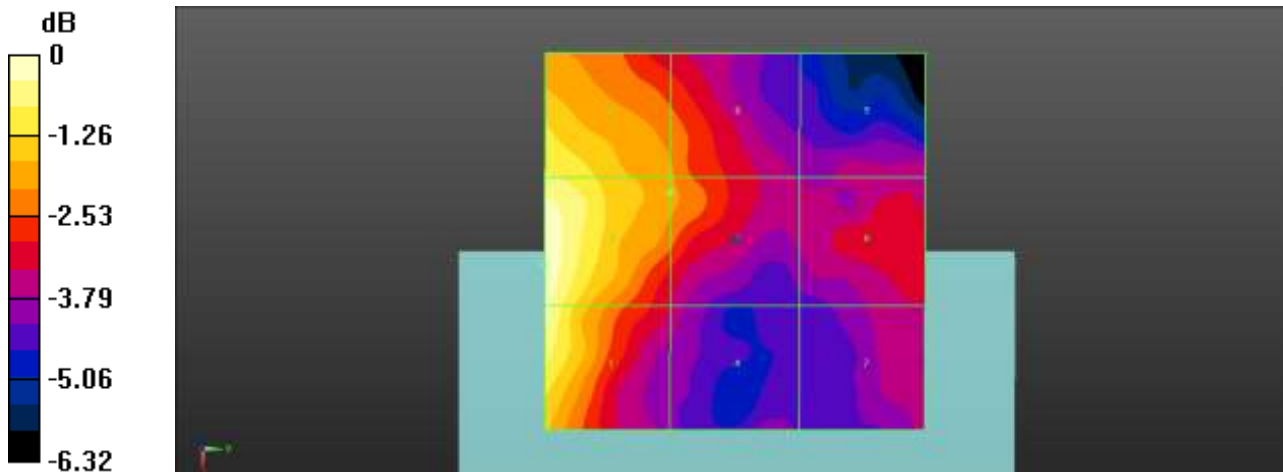

0 dB = 11.57 V/m = 21.27 dBV/m

Attachment 2. System Validation Plots

DUT: HAC-Dipole 835 MHz; Type: D835V3

Communication System: UID 0, CW (0); Frequency: 835 MHz; Duty Cycle: 1:1
 Medium parameters used: $\sigma = 0$ S/m, $\epsilon_r = 1$; $\rho = 0$ kg/m³
 Phantom section: RF Section

DASY Configuration:

- Probe: EF3DV3 - SN4034; ConvF(1, 1, 1); Calibrated: 2019-02-22;
- Sensor-Surface: (Fix Surface)
- Electronics: DAE4 Sn1225; Calibrated: 2018-11-16
- Phantom: HAC Test Arch with AMCC_RF_2018_04_27
- Measurement SW: DASY52, Version 52.8 (8);

Device E-Field measurement (E-field scan for ANSI C63.19-2007 & -2011 compliance)/E Scan - ER3D: 15 mm from Probe Center to the Device/Hearing Aid Compatibility Test (41x361x1): Interpolated grid:

dx=0.5000 mm, dy=0.5000 mm
 Device Reference Point: 0, 0, -6.3 mm
 Reference Value = 55.81 V/m; Power Drift = 0.00 dB
 Applied MIF = 0.00 dB
 RF audio interference level = 41.44 dBV/m
Emission category: M3

MIF scaled E-field

Grid 1 M3 41.34 dBV/m	Grid 2 M3 41.44 dBV/m	Grid 3 M3 41.09 dBV/m
Grid 4 M4 36.06 dBV/m	Grid 5 M4 36.17 dBV/m	Grid 6 M4 35.96 dBV/m
Grid 7 M4 39.8 dBV/m	Grid 8 M4 39.88 dBV/m	Grid 9 M4 39.69 dBV/m

Cursor:

Total = 41.44 dBV/m
 E Category: M3
 Location: 1, -73.5, 9.7 mm

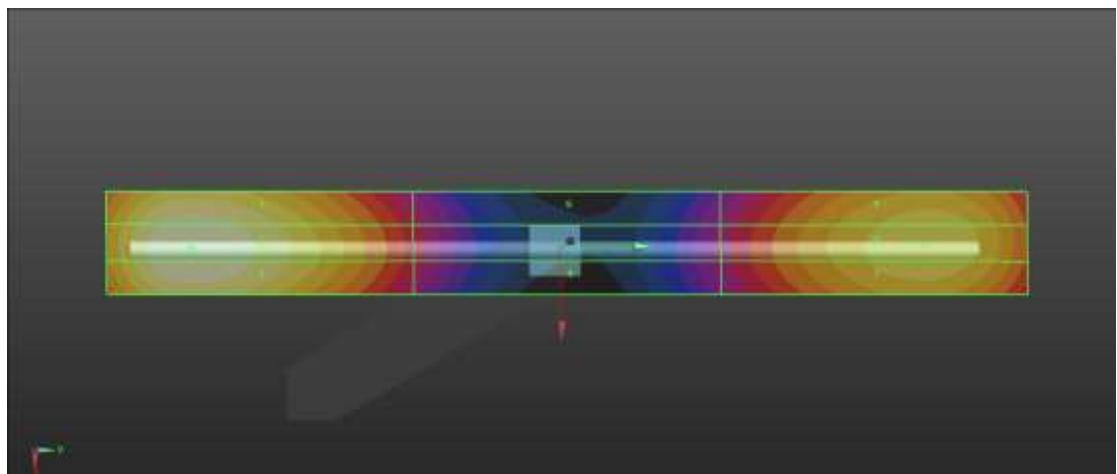
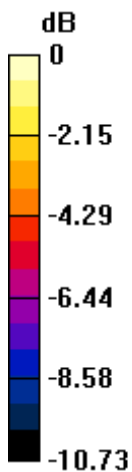

0 dB = 118.0 V/m = 41.44 dBV/m

DUT: HAC Dipole 1880 MHz; Type: CD1880V3

Communication System: UID 0, CW (0); Frequency: 1880 MHz; Duty Cycle: 1:1
 Medium parameters used: $\sigma = 0$ S/m, $\epsilon_r = 1$; $\rho = 0$ kg/m³
 Phantom section: RF Section

DASY Configuration:

- Probe: EF3DV3 - SN4034; ConvF(1, 1, 1); Calibrated: 2019-02-22;
- Sensor-Surface: (Fix Surface)
- Electronics: DAE4 Sn1225; Calibrated: 2018-11-16
- Phantom: HAC Test Arch with AMCC_RF_2018_04_27
- Measurement SW: DASY52, Version 52.8 (8);

Device E-Field measurement (E-field scan for ANSI C63.19-2007 & -2011 compliance)/E Scan - ER3D: 15 mm from Probe Center to the Device/Hearing Aid Compatibility Test (41x181x1): Interpolated grid:

dx=0.5000 mm, dy=0.5000 mm
 Device Reference Point: 0, 0, -6.3 mm
 Reference Value = 71.64 V/m; Power Drift = 0.04 dB
 Applied MIF = 0.00 dB
 RF audio interference level = 38.92 dBV/m

Emission category: M2

MIF scaled E-field

Grid 1 M2 38.76 dBV/m	Grid 2 M2 38.92 dBV/m	Grid 3 M2 38.71 dBV/m
Grid 4 M2 36.32 dBV/m	Grid 5 M2 36.37 dBV/m	Grid 6 M2 36.26 dBV/m
Grid 7 M2 38.7 dBV/m	Grid 8 M2 38.91 dBV/m	Grid 9 M2 38.75 dBV/m

Cursor:

Total = 38.92 dBV/m
 E Category: M2
 Location: 0, -33.5, 9.7 mm

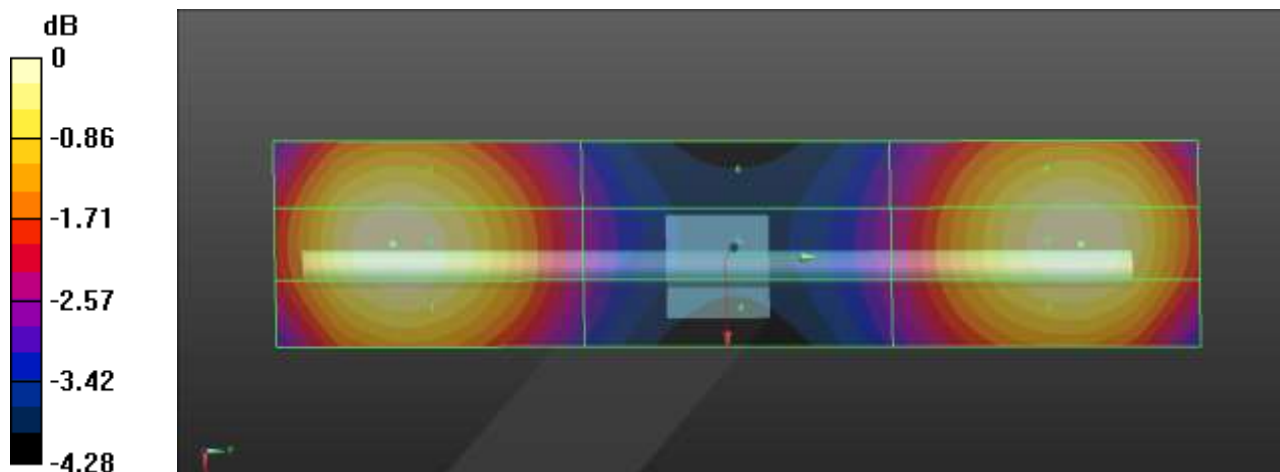

0 dB = 88.34 V/m = 38.92 dBV/m

DUT: HAC Dipole 2600 MHz; Type: CD2600V3

Communication System: UID 0, CW (0); Frequency: 2600 MHz; Duty Cycle: 1:1
 Medium parameters used: $\sigma = 0$ S/m, $\epsilon_r = 1$; $\rho = 0$ kg/m³
 Phantom section: RF Section

DASY Configuration:

- Probe: EF3DV3 - SN4034; ConvF(1, 1, 1); Calibrated: 2019-02-22;
- Sensor-Surface: (Fix Surface)
- Electronics: DAE4 Sn1225; Calibrated: 2018-11-16
- Phantom: HAC Test Arch with AMCC_RF_2018_04_27
- Measurement SW: DASY52, Version 52.8 (8);

**Device E-Field measurement (E-field scan for ANSI C63.19-2007 & -2011 compliance)/E Scan - ER3D:
 15 mm from Probe Center to the Device/Hearing Aid Compatibility Test (41x181x1):** Interpolated grid:
 dx=0.5000 mm, dy=0.5000 mm
 Device Reference Point: 0, 0, -6.3 mm
 Reference Value = 74.83 V/m; Power Drift = 0.01 dB
 Applied MIF = 0.00 dB
 RF audio interference level = 38.72 dBV/m
Emission category: M2

MIF scaled E-field

Grid 1 M2 38.57 dBV/m	Grid 2 M2 38.72 dBV/m	Grid 3 M2 38.54 dBV/m
Grid 4 M2 37.87 dBV/m	Grid 5 M2 37.98 dBV/m	Grid 6 M2 37.85 dBV/m
Grid 7 M2 38.39 dBV/m	Grid 8 M2 38.62 dBV/m	Grid 9 M2 38.52 dBV/m

Cursor:

Total = 38.72 dBV/m
 E Category: M2
 Location: 0, -23, 9.7 mm

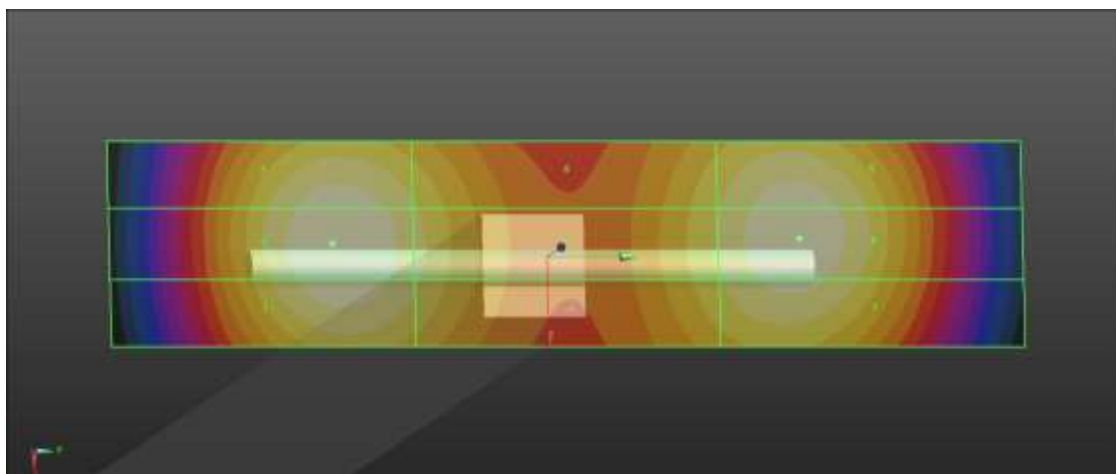
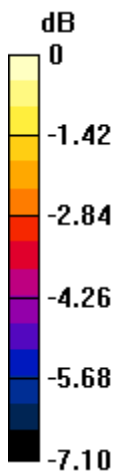

0 dB = 86.27 V/m = 38.72 dBV/m

Attachment 3. Probe Calibration Data

**Calibration Laboratory of
Schmid & Partner
Engineering AG**
Zeughausstrasse 43, 8004 Zurich, Switzerland



S Schweizerischer Kalibrierdienst
S Service suisse d'étalonnage
S Servizio svizzero di taratura
S Swiss Calibration Service

Accredited by the Swiss Accreditation Service (SAS)
The Swiss Accreditation Service is one of the signatories to the EA
Multilateral Agreement for the recognition of calibration certificates

Accreditation No.: **SCS 0108**

Client **HCT (Dymstec)**

Certificate No: **EF3-4034_Feb19**

CALIBRATION CERTIFICATE

결	한정사	가연사
재	[Handwritten signature]	
수량/일	SW 178326	178326
일	2019 103.13	2019 103.13

Object **EF3DV3- SN:4034**

Calibration procedure(s) **QA CAL-02.v9, QA CAL-25.v7**
Calibration procedure for E-field probes optimized for close near field evaluations in air

Calibration date: **February 22, 2019**

This calibration certificate documents the traceability to national standards, which realize the physical units of measurements (SI).
The measurements and the uncertainties with confidence probability are given on the following pages and are part of the certificate.

All calibrations have been conducted in the closed laboratory facility: environment temperature (22 ± 3)°C and humidity < 70%.

Calibration Equipment used (M&TE critical for calibration)

Primary Standards	ID	Cal Date (Certificate No.)	Scheduled Calibration
Power meter NRP	SN: 104778	04-Apr-18 (No. 217-02672/02673)	Apr-19
Power sensor NRP-Z91	SN: 103244	04-Apr-18 (No. 217-02672)	Apr-19
Power sensor NRP-Z91	SN: 103245	04-Apr-18 (No. 217-02673)	Apr-19
Reference 20 dB Attenuator	SN: S5277 (20x)	04-Apr-18 (No. 217-02682)	Apr-19
DAE4	SN: 789	14-Jan-19 (No. DAE4-789_Jan19)	Jan-20
Reference Probe ER3DV6	SN: 2328	09-Oct-18 (No. ER3-2328_Oct18)	Oct-19
Secondary Standards	ID	Check Date (in house)	Scheduled Check
Power meter E4419B	SN: GB41293874	06-Apr-16 (in house check Jun-16)	In house check: Jun-20
Power sensor E4412A	SN: MY41498087	06-Apr-16 (in house check Jun-16)	In house check: Jun-20
Power sensor E4412A	SN: 000110210	06-Apr-16 (in house check Jun-16)	In house check: Jun-20
RF generator HP 8648C	SN: US3642U01700	04-Aug-99 (in house check Jun-16)	In house check: Jun-20
Network Analyzer EB358A	SN: US41080477	31-Mar-14 (in house check Oct-18)	In house check: Oct-19

	Name	Function	Signature
Calibrated by:	Manu Seitz	Laboratory Technician	[Signature]
Approved by:	Katja Pokovic	Technical Manager	[Signature]

Issued: February 23, 2019

This calibration certificate shall not be reproduced except in full without written approval of the laboratory.

**Calibration Laboratory of
Schmid & Partner
Engineering AG**
Zeughausstrasse 43, 8004 Zurich, Switzerland



S Schweizerischer Kalibrierdienst
C Service suisse d'étalonnage
S Servizio svizzero di taratura
S Swiss Calibration Service

Accredited by the Swiss Accreditation Service (SAS)
The Swiss Accreditation Service is one of the signatories to the EA
Multilateral Agreement for the recognition of calibration certificates

Accreditation No.: **SCS 0108**

Glossary:

NORM _{x,y,z}	sensitivity in free space
DCP	diode compression point
CF	crest factor (1/duty_cycle) of the RF signal
A, B, C, D	modulation dependent linearization parameters
En	incident E-field orientation normal to probe axis
Ep	incident E-field orientation parallel to probe axis
Polarization φ	φ rotation around probe axis
Polarization θ	θ rotation around an axis that is in the plane normal to probe axis (at measurement center), i.e., θ = 0 is normal to probe axis
Connector Angle	information used in DASY system to align probe sensor X to the robot coordinate system

Calibration is Performed According to the Following Standards:

- a) IEEE Std 1309-2005, " IEEE Standard for calibration of electromagnetic field sensors and probes, excluding antennas, from 9 kHz to 40 GHz", December 2005
- b) CTIA Test Plan for Hearing Aid Compatibility, Rev 3.1.1, May 2017

Methods Applied and Interpretation of Parameters:

- **NORM_{x,y,z}**: Assessed for E-field polarization θ = 0 for XY sensors and θ = 90 for Z sensor (f ≤ 900 MHz in TEM-cell; f > 1800 MHz: R22 waveguide).
- **NORM(f)_{x,y,z} = NORM_{x,y,z} * frequency_response** (see Frequency Response Chart).
- **DCP_{x,y,z}**: DCP are numerical linearization parameters assessed based on the data of power sweep with CW signal (no uncertainty required). DCP does not depend on frequency nor media.
- **PAR**: PAR is the Peak to Average Ratio that is not calibrated but determined based on the signal characteristics
- **A_{x,y,z}; B_{x,y,z}; C_{x,y,z}; D_{x,y,z}; VR_{x,y,z}**: A, B, C, D are numerical linearization parameters assessed based on the data of power sweep for specific modulation signal. The parameters do not depend on frequency nor media. VR is the maximum calibration range expressed in RMS voltage across the diode.
- **Spherical isotropy (3D deviation from isotropy)**: in a locally homogeneous field realized using an open waveguide setup.
- **Sensor Offset**: The sensor offset corresponds to the offset of virtual measurement center from the probe tip (on probe axis). No tolerance required.
- **Connector Angle**: The angle is assessed using the information gained by determining the NORM_x (no uncertainty required).

EF3DV3 – SN:4034

February 22, 2019

DASY/EASY - Parameters of Probe: EF3DV3 - SN:4034

Basic Calibration Parameters

	Sensor X	Sensor Y	Sensor Z	Unc (k=2)
Norm ($\mu\text{V}/(\text{V/m})^2$)	0.96	0.78	1.24	$\pm 10.1\%$
DCP (mV) ^a	97.2	100.0	98.0	

Calibration results for Frequency Response (30 MHz – 6 GHz)

Frequency MHz	Target E-Field V/m	Measured E-field (En) V/m	Deviation E-normal in %	Measured E-field (Ep) V/m	Deviation E-normal in %	Unc (k=2) %
30	77.3	77.0	-0.4%	77.4	0.1%	$\pm 5.1\%$
100	77.2	78.1	1.2%	77.7	0.6%	$\pm 5.1\%$
450	77.0	78.0	1.3%	77.6	0.7%	$\pm 5.1\%$
600	77.2	77.8	0.8%	77.4	0.3%	$\pm 5.1\%$
750	77.1	77.5	0.4%	77.0	-0.2%	$\pm 5.1\%$
1800	140.3	136.7	-2.6%	136.7	-2.6%	$\pm 5.1\%$
2000	133.0	129.2	-2.9%	129.4	-2.7%	$\pm 5.1\%$
2200	125.0	121.5	-2.8%	122.4	-2.1%	$\pm 5.1\%$
2500	123.7	120.6	-2.5%	121.5	-1.8%	$\pm 5.1\%$
3000	78.9	74.9	-5.1%	76.0	-3.8%	$\pm 5.1\%$
3500	256.8	248.7	-3.1%	246.4	-4.1%	$\pm 5.1\%$
3700	249.7	239.4	-4.1%	238.4	-4.5%	$\pm 5.1\%$
5200	50.8	50.9	0.2%	51.2	0.8%	$\pm 5.1\%$
5500	49.6	49.0	-1.3%	48.8	-1.7%	$\pm 5.1\%$
5800	48.9	49.2	0.6%	49.4	1.0%	$\pm 5.1\%$

Calibration Results for Modulation Response

UID	Communication System Name		A dB	B dB $\sqrt{\mu\text{V}}$	C	D dB	VR mV	Max dev.	Unc ^c (k=2)
0	CW	X	0.0	0.0	1.0	0.00	147.0	$\pm 3.5\%$	$\pm 4.7\%$
		Y	0.0	0.0	1.0		173.5		
		Y	0.0	0.0	1.0		173.8		

The reported uncertainty of measurement is stated as the standard uncertainty of measurement multiplied by the coverage factor k=2, which for a normal distribution corresponds to a coverage probability of approximately 95%.

^a Numerical linearization parameter: uncertainty not required.

^c Uncertainty is determined using the max. deviation from linear response applying rectangular distribution and is expressed for the square of the field value.

EF3DV3 – SN:4034

February 22, 2019

DASY/EASY - Parameters of Probe: EF3DV3 - SN:4034

Sensor Frequency Model Parameters

	Sensor X	Sensor Y	Sensor Z
Frequency Corr. (LF)	0.23	0.15	6.33
Frequency Corr. (HF)	2.82	2.82	2.82

Other Probe Parameters

Sensor Arrangement	Rectangular
Connector Angle (°)	7.3
Mechanical Surface Detection Mode	enabled
Optical Surface Detection Mode	disabled
Probe Overall Length	337 mm
Probe Body Diameter	12 mm
Tip Length	25 mm
Tip Diameter	4 mm
Probe Tip to Sensor X Calibration Point	1.5 mm
Probe Tip to Sensor Y Calibration Point	1.5 mm
Probe Tip to Sensor Z Calibration Point	1.5 mm

EF3DV3 – SN:4034

February 22, 2019

Receiving Pattern (ϕ), $\theta = 0^\circ$

f=600 MHz, TEM, 0°

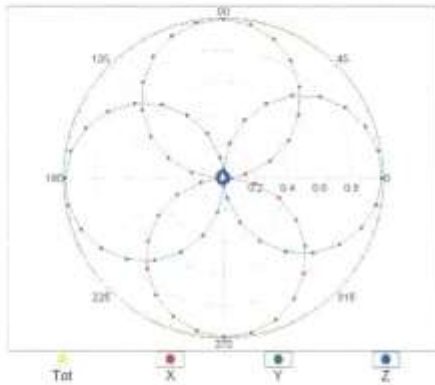

f=1800 MHz, R22, 0°

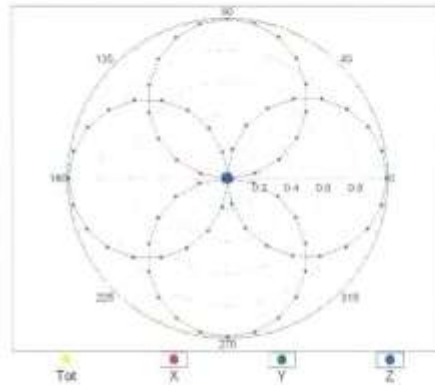

Receiving Pattern (ϕ), $\theta = 90^\circ$

f=600 MHz, TEM, 90°

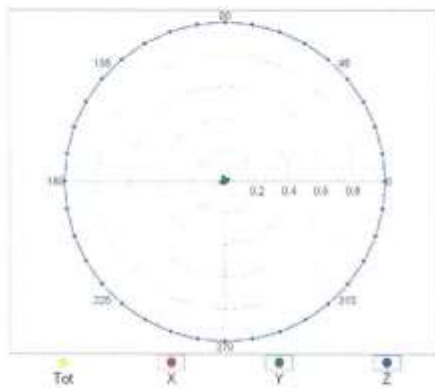

f=1800 MHz, R22, 90°

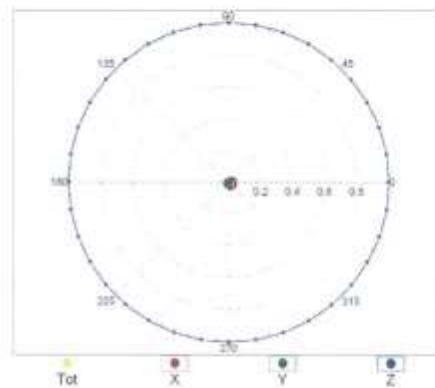

EF3DV3 – SN:4034

February 22, 2019

Receiving Pattern (ϕ), $\vartheta = 0^\circ$

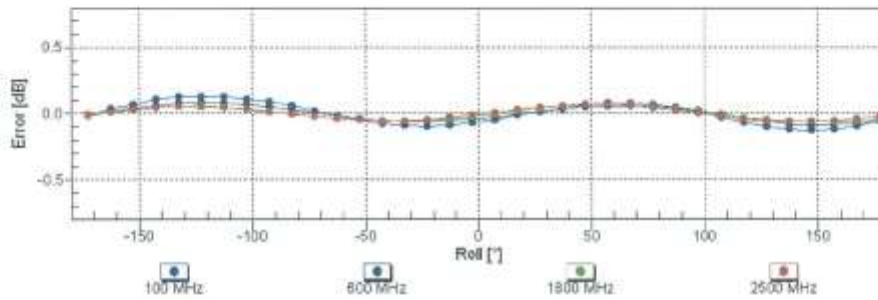

Uncertainty of Axial Isotropy Assessment: $\pm 0.5\%$ (k=2)

Receiving Pattern (ϕ), $\vartheta = 90^\circ$

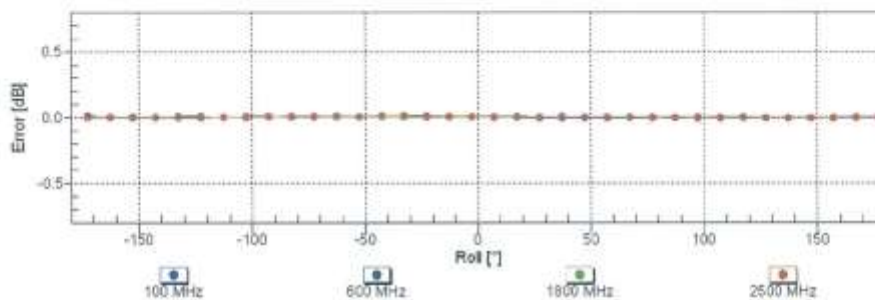

Uncertainty of Axial Isotropy Assessment: $\pm 0.5\%$ (k=2)

EF3DV3 – SN:4034

February 22, 2019

Dynamic Range f(E-field)
(TEM cell, f = 900 MHz)

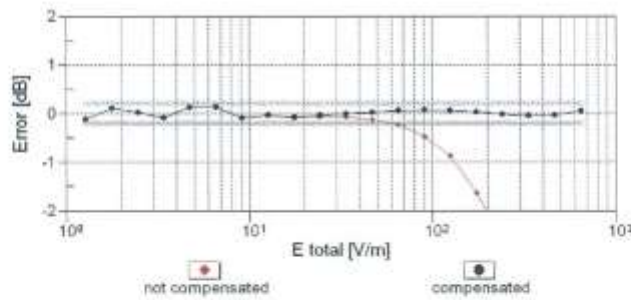
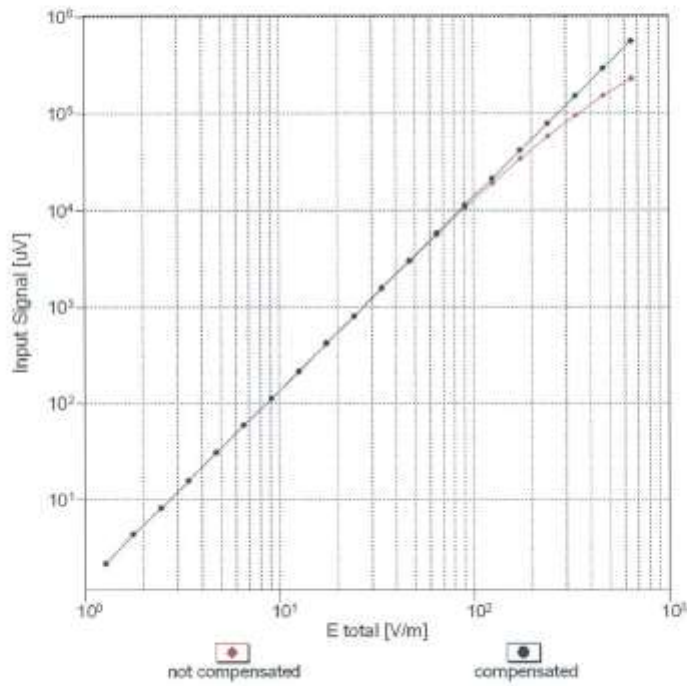

Uncertainty of Linearity Assessment: ± 0.6% (k=2)

EF3DV3 – SN:4034

February 22, 2019

Deviation from Isotropy in Air Error (ϕ , θ), $f = 900$ MHz

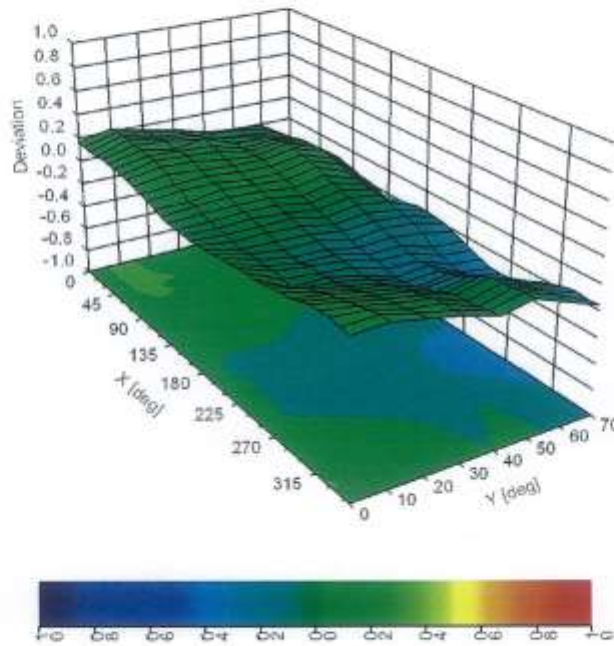

Uncertainty of Spherical Isotropy Assessment: $\pm 2.6\%$ ($k=2$)

Attachment 4. Dipole Calibration Data

**Calibration Laboratory of
Schmid & Partner
Engineering AG**
Zeughausstrasse 43, 8004 Zurich, Switzerland



S Schweizerischer Kalibrierdienst
C Service suisse d'étalonnage
S Servizio svizzero di taratura
S Swiss Calibration Service

Accredited by the Swiss Accreditation Service (SAS)
The Swiss Accreditation Service is one of the signatories to the EA
Multilateral Agreement for the recognition of calibration certificates

Accreditation No.: **SCS 0108**

Client **HCT (Dymstec)**

Certificate No: **CD835V3-1024_Feb19**

CALIBRATION CERTIFICATE		계	담당자	화인자
Object	CD835V3 - SN: 1024	재		
Calibration procedure(s)	QA CAL-20.v7 Calibration Procedure for Validation Sources in air	재/시험 일자	SN 1024 2019.03.13	화인 일자 2019.03.13
Calibration date:	February 22, 2019			
This calibration certificate documents the traceability to national standards, which realize the physical units of measurements (SI). The measurements and the uncertainties with confidence probability are given on the following pages and are part of the certificate.				
All calibrations have been conducted in the closed laboratory facility: environment temperature (22 ± 3)°C and humidity < 70%.				
Calibration Equipment used (M&TE critical for calibration)				
Primary Standards	ID #	Cal Date (Certificate No.)	Scheduled Calibration	
Power meter NRP	SN: 104778	04-Apr-18 (No. 217-02672/02673)	Apr-19	
Power sensor NRP-Z91	SN: 103244	04-Apr-18 (No. 217-02672)	Apr-19	
Power sensor NRP-Z91	SN: 103245	04-Apr-18 (No. 217-02673)	Apr-19	
Reference 20 dB Attenuator	SN: 5058 (20k)	04-Apr-18 (No. 217-02682)	Apr-19	
Type-N mismatch combination	SN: 5047.2 / 06327	04-Apr-18 (No. 217-02683)	Apr-19	
Probe EF3DV3	SN: 4013	03-Jan-19 (No. EF3-4013_Jan19)	Jan-20	
DAE4	SN: 781	09-Jan-19 (No. DAE4-781_Jan19)	Jan-20	
Secondary Standards	ID #	Check Date (in house)	Scheduled Check	
Power meter Agilent 4419B	SN: GB42420181	09-Oct-09 (in house check Oct-17)	In house check: Oct-20	
Power sensor HP E4412A	SN: US38485102	05-Jan-10 (in house check Oct-17)	In house check: Oct-20	
Power sensor HP 8482A	SN: US37295597	09-Oct-09 (in house check Oct-17)	In house check: Oct-20	
RF generator R&S SMT-06	SN: 832283/011	27-Aug-12 (in house check Oct-17)	In house check: Oct-20	
Network Analyzer HP 8358A	SN: US41060477	31-Mar-14 (in house check Oct-18)	In house check: Oct-19	
Calibrated by:	Name Claudio Leutler	Function Laboratory Technician	Signature 	
Approved by:	Name Katja Pokovic	Function Technical Manager	Signature 	
This calibration certificate shall not be reproduced except in full without written approval of the laboratory.			Issued: February 25, 2019	

**Calibration Laboratory of
Schmid & Partner
Engineering AG**
Zeughausstrasse 43, 8004 Zurich, Switzerland



S Schweizerischer Kalibrierdienst
C Service suisse d'étalonnage
S Servizio svizzero di taratura
S Swiss Calibration Service

Accredited by the Swiss Accreditation Service (SAS)
The Swiss Accreditation Service is one of the signatories to the EA
Multilateral Agreement for the recognition of calibration certificates

Accreditation No.: **SCS 0108**

References

- [1] ANSI-C63.19-2011
American National Standard, Methods of Measurement of Compatibility between Wireless Communications Devices and Hearing Aids.

Methods Applied and Interpretation of Parameters:

- **Coordinate System:** y-axis is in the direction of the dipole arms. z-axis is from the basis of the antenna (mounted on the table) towards its feed point between the two dipole arms. x-axis is normal to the other axes. In coincidence with the standards [1], the measurement planes (probe sensor center) are selected to be at a distance of 15 mm above the top metal edge of the dipole arms.
- **Measurement Conditions:** Further details are available from the hardcopies at the end of the certificate. All figures stated in the certificate are valid at the frequency indicated. The forward power to the dipole connector is set with a calibrated power meter connected and monitored with an auxiliary power meter connected to a directional coupler. While the dipole under test is connected, the forward power is adjusted to the same level.
- **Antenna Positioning:** The dipole is mounted on a HAC Test Arch phantom using the matching dipole positioner with the arms horizontal and the feeding cable coming from the floor. The measurements are performed in a shielded room with absorbers around the setup to reduce the reflections. It is verified before the mounting of the dipole under the Test Arch phantom, that its arms are perfectly in a line. It is installed on the HAC dipole positioner with its arms parallel below the dielectric reference wire and able to move elastically in vertical direction without changing its relative position to the top center of the Test Arch phantom. The vertical distance to the probe is adjusted after dipole mounting with a DASY5 Surface Check job. Before the measurement, the distance between phantom surface and probe tip is verified. The proper measurement distance is selected by choosing the matching section of the HAC Test Arch phantom with the proper device reference point (upper surface of the dipole) and the matching grid reference point (tip of the probe) considering the probe sensor offset. The vertical distance to the probe is essential for the accuracy.
- **Feed Point Impedance and Return Loss:** These parameters are measured using a HP 8753E Vector Network Analyzer. The impedance is specified at the SMA connector of the dipole. The influence of reflections was eliminated by applying the averaging function while moving the dipole in the air, at least 70cm away from any obstacles.
- **E-field distribution:** E field is measured in the x-y-plane with an isotropic ER3D-field probe with 100 mW forward power to the antenna feed point. In accordance with [1], the scan area is 20mm wide, its length exceeds the dipole arm length (180 or 90mm). The sensor center is 15 mm (in z) above the metal top of the dipole arms. Two 3D maxima are available near the end of the dipole arms. Assuming the dipole arms are perfectly in one line, the average of these two maxima (in subgrid 2 and subgrid 8) is determined to compensate for any non-parallelity to the measurement plane as well as the sensor displacement. The E-field value stated as calibration value represents the maximum of the interpolated 3D-E-field, in the plane above the dipole surface.

The reported uncertainty of measurement is stated as the standard uncertainty of measurement multiplied by the coverage factor $k=2$, which for a normal distribution corresponds to a coverage probability of approximately 95%.

Measurement Conditions

DASY system configuration, as far as not given on page 1.

DASY Version	DASY5	V52.10.2
Phantom	HAC Test Arch	
Distance Dipole Top - Probe Center	15 mm	
Scan resolution	dx, dy = 5 mm	
Frequency	835 MHz ± 1 MHz	
Input power drift	< 0.05 dB	

Maximum Field values at 835 MHz

E-field 15 mm above dipole surface	condition	Interpolated maximum
Maximum measured above high end	100 mW input power	105.7 V/m = 40.48 dBV/m
Maximum measured above low end	100 mW input power	105.1 V/m = 40.43 dBV/m
Averaged maximum above arm	100 mW input power	105.4 V/m ± 12.6 % (k=2)

Appendix (Additional assessments outside the scope of SCS 0108)

Antenna Parameters

Frequency	Return Loss	Impedance
800 MHz	22.4 dB	45.7 Ω - 5.9 jΩ
835 MHz	28.2 dB	53.6 Ω + 1.9 jΩ
880 MHz	16.5 dB	62.4 Ω - 11.5 jΩ
900 MHz	17.5 dB	50.1 Ω - 13.5 jΩ
945 MHz	22.8 dB	49.6 Ω + 7.2 jΩ

3.2 Antenna Design and Handling

The calibration dipole has a symmetric geometry with a built-in two stub matching network, which leads to the enhanced bandwidth.

The dipole is built of standard semirigid coaxial cable. The internal matching line is open ended. The antenna is therefore open for DC signals.

Do not apply force to dipole arms, as they are liable to bend. The soldered connections near the feedpoint may be damaged. After excessive mechanical stress or overheating, check the impedance characteristics to ensure that the internal matching network is not affected.

After long term use with 40W radiated power, only a slight warming of the dipole near the feedpoint can be measured.

Impedance Measurement Plot

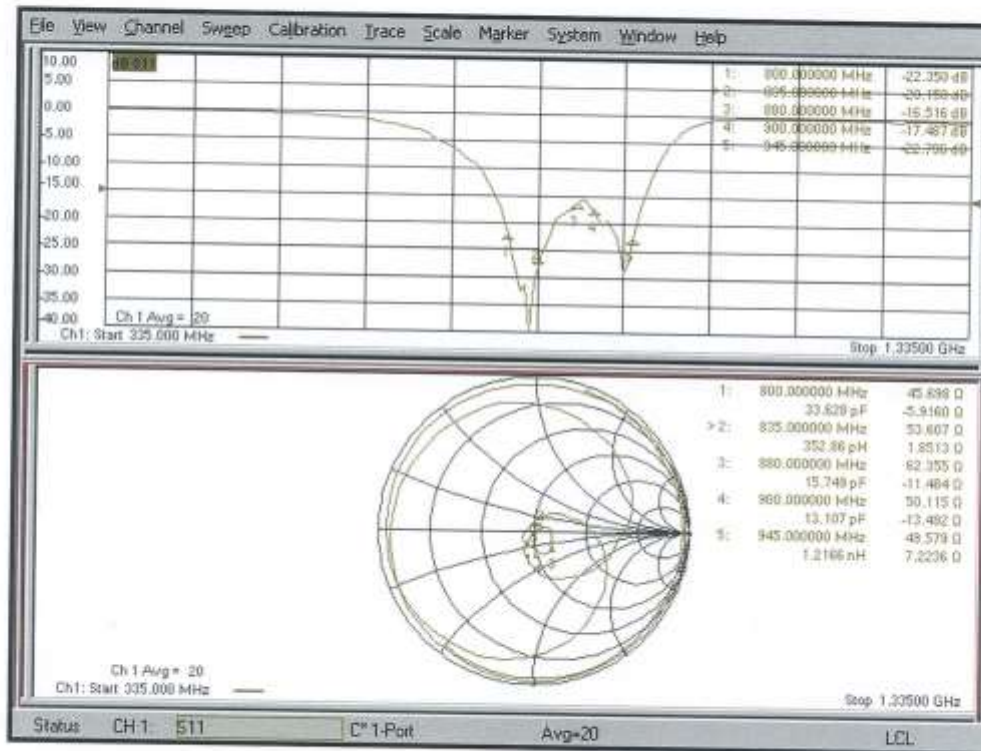

DASY5 E-field Result

Date: 22.02.2019

Test Laboratory: SPEAG Lab2

DUT: HAC-Dipole 835 MHz; Type: CD835V3; Serial: CD835V3 - SN: 1024

Communication System: UID 0 - CW ; Frequency: 835 MHz
 Medium parameters used: $\sigma = 0$ S/m, $\epsilon_r = 1$; $\rho = 0$ kg/m³
 Phantom section: RF Section
 Measurement Standard: DASY5 (IEEE/IEC/ANSI C63.19-2011)

DASY52 Configuration:

- Probe: EF3DV3 - SN4013; ConvF(1, 1, 1) @ 835 MHz; Calibrated: 03.01.2019
- Sensor-Surface: (Fix Surface)
- Electronics: DAE4 Sn781; Calibrated: 09.01.2019
- Phantom: HAC Test Arch with AMCC; Type: SD HAC P01 BA; Serial: 1070
- DASY52 52.10.2(1495); SEMCAD X 14.6.12(7450)

Dipole E-Field measurement @ 835MHz /E-Scan - 835MHz d=15mm/Hearing Aid Compatibility Test (41x361x1):
 Interpolated grid: dx=0.5000 mm, dy=0.5000 mm
 Device Reference Point: 0, 0, -6.3 mm
 Reference Value = 126.1 V/m; Power Drift = 0.04 dB
 Applied MIF = 0.00 dB
 RF audio interference level = 40.48 dBV/m
Emission category: M3

MIF scaled E-field

Grid 1 M4 39.86 dBV/m	Grid 2 M3 40.43 dBV/m	Grid 3 M3 40.42 dBV/m
Grid 4 M4 35.32 dBV/m	Grid 5 M4 35.71 dBV/m	Grid 6 M4 35.7 dBV/m
Grid 7 M3 40.12 dBV/m	Grid 8 M3 40.48 dBV/m	Grid 9 M3 40.43 dBV/m

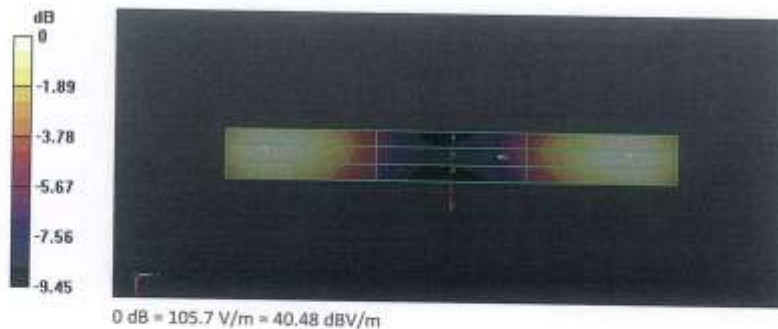

**Calibration Laboratory of
Schmid & Partner
Engineering AG**
Zeughausstrasse 43, 8004 Zurich, Switzerland



S Schweizerischer Kalibrierdienst
C Service suisse d'étalonnage
S Servizio svizzero di taratura
S Swiss Calibration Service

Accredited by the Swiss Accreditation Service (SAS)
The Swiss Accreditation Service is one of the signatories to the EA
Multilateral Agreement for the recognition of calibration certificates

Accreditation No.: **SCS 0108**

Client **HCT (Dymstec)**

Certificate No: **CD1880V3-1019_Feb19**

CALIBRATION CERTIFICATE		검	담당자	확인자
Object	CD1880V3 - SN: 1019	재	<i>[Signature]</i>	<i>[Signature]</i>
Calibration procedure(s)	QA CAL-20.v7 Calibration Procedure for Validation Sources in air	작성 2019.03.13	<i>[Signature]</i> 2019.03.13	<i>[Signature]</i> 2019.03.13
Calibration date:	February 22, 2019			
This calibration certificate documents the traceability to national standards, which realize the physical units of measurements (SI). The measurements and the uncertainties with confidence probability are given on the following pages and are part of the certificate.				
All calibrations have been conducted in the closed laboratory facility: environment temperature (22 ± 3)°C and humidity < 70%.				
Calibration Equipment used (M&TE critical for calibration)				
Primary Standards	ID #	Cal Date (Certificate No.)	Scheduled Calibration	
Power meter NRP	SN: 10477B	04-Apr-18 (No. 217-02672/02673)	Apr-19	
Power sensor NRP-Z91	SN: 103244	04-Apr-18 (No. 217-02672)	Apr-19	
Power sensor NRP-Z91	SN: 103245	04-Apr-18 (No. 217-02673)	Apr-19	
Reference 20 dB Attenuator	SN: 5058 (20k)	04-Apr-18 (No. 217-02682)	Apr-19	
Type-N mismatch combination	SN: 5047.2 / 06327	04-Apr-18 (No. 217-02683)	Apr-19	
Probe EF3DV3	SN: 4013	03-Jan-19 (No. EF3-4013_Jan19)	Jan-20	
DAE4	SN: 781	09-Jan-19 (No. DAE4-781_Jan19)	Jan-20	
Secondary Standards	ID #	Check Date (in house)	Scheduled Check	
Power meter Agilent 4419B	SN: GB42420191	09-Oct-09 (in house check Oct-17)	In house check: Oct-20	
Power sensor HP E4412A	SN: US38485102	05-Jan-10 (in house check Oct-17)	In house check: Oct-20	
Power sensor HP 8482A	SN: US37295597	09-Oct-09 (in house check Oct-17)	In house check: Oct-20	
RF generator R&S SMT-06	SN: 832283/011	27-Aug-12 (in house check Oct-17)	In house check: Oct-20	
Network Analyzer HP 8358A	SN: US41080477	31-Mar-14 (in house check Oct-18)	In house check: Oct-19	
Calibrated by:	Name Claudio Laubler	Function Laboratory Technician	Signature <i>[Signature]</i>	
Approved by:	Name Kolja Pokovic	Function Technical Manager	Signature <i>[Signature]</i>	
This calibration certificate shall not be reproduced except in full without written approval of the laboratory.				Issued: February 25, 2019

**Calibration Laboratory of
Schmid & Partner
Engineering AG**
Zeughausstrasse 43, 8004 Zurich, Switzerland



S Schweizerischer Kalibrierdienst
C Service suisse d'étalonnage
S Servizio svizzero di taratura
Swiss Calibration Service

Accredited by the Swiss Accreditation Service (SAS)
The Swiss Accreditation Service is one of the signatories to the EA
Multilateral Agreement for the recognition of calibration certificates

Accreditation No.: **SCS 0108**

References

- [1] ANSI-C63.19-2011
American National Standard, Methods of Measurement of Compatibility between Wireless Communications Devices and Hearing Aids.

Methods Applied and Interpretation of Parameters:

- *Coordinate System:* y-axis is in the direction of the dipole arms. z-axis is from the basis of the antenna (mounted on the table) towards its feed point between the two dipole arms. x-axis is normal to the other axes. In coincidence with the standards [1], the measurement planes (probe sensor center) are selected to be at a distance of 15 mm above the top metal edge of the dipole arms.
- *Measurement Conditions:* Further details are available from the hardcopies at the end of the certificate. All figures stated in the certificate are valid at the frequency indicated. The forward power to the dipole connector is set with a calibrated power meter connected and monitored with an auxiliary power meter connected to a directional coupler. While the dipole under test is connected, the forward power is adjusted to the same level.
- *Antenna Positioning:* The dipole is mounted on a HAC Test Arch phantom using the matching dipole positioner with the arms horizontal and the feeding cable coming from the floor. The measurements are performed in a shielded room with absorbers around the setup to reduce the reflections. It is verified before the mounting of the dipole under the Test Arch phantom, that its arms are perfectly in a line. It is installed on the HAC dipole positioner with its arms parallel below the dielectric reference wire and able to move elastically in vertical direction without changing its relative position to the top center of the Test Arch phantom. The vertical distance to the probe is adjusted after dipole mounting with a DASY5 Surface Check job. Before the measurement, the distance between phantom surface and probe tip is verified. The proper measurement distance is selected by choosing the matching section of the HAC Test Arch phantom with the proper device reference point (upper surface of the dipole) and the matching grid reference point (tip of the probe) considering the probe sensor offset. The vertical distance to the probe is essential for the accuracy.
- *Feed Point Impedance and Return Loss:* These parameters are measured using a HP 8753E Vector Network Analyzer. The impedance is specified at the SMA connector of the dipole. The influence of reflections was eliminated by applying the averaging function while moving the dipole in the air, at least 70cm away from any obstacles.
- *E-field distribution:* E field is measured in the x-y-plane with an isotropic ER3D-field probe with 100 mW forward power to the antenna feed point. In accordance with [1], the scan area is 20mm wide, its length exceeds the dipole arm length (180 or 90mm). The sensor center is 15 mm (in z) above the metal top of the dipole arms. Two 3D maxima are available near the end of the dipole arms. Assuming the dipole arms are perfectly in one line, the average of these two maxima (in subgrid 2 and subgrid 8) is determined to compensate for any non-parallelity to the measurement plane as well as the sensor displacement. The E-field value stated as calibration value represents the maximum of the interpolated 3D-E-field, in the plane above the dipole surface.

The reported uncertainty of measurement is stated as the standard uncertainty of measurement multiplied by the coverage factor $k=2$, which for a normal distribution corresponds to a coverage probability of approximately 95%.

Measurement Conditions

DASY system configuration, as far as not given on page 1.

DASY Version	DASY5	V52.10.2
Phantom	HAC Test Arch	
Distance Dipole Top - Probe Center	15 mm	
Scan resolution	dx, dy = 5 mm	
Frequency	1880 MHz ± 1 MHz	
Input power drift	< 0.05 dB	

Maximum Field values at 1880 MHz

E-field 15 mm above dipole surface	condition	Interpolated maximum
Maximum measured above high end	100 mW input power	86.6 V/m = 38.75 dBV/m
Maximum measured above low end	100 mW input power	84.9 V/m = 38.58 dBV/m
Averaged maximum above arm	100 mW input power	85.8 V/m ± 12.8 % (k=2)

Appendix (Additional assessments outside the scope of SCS 0108)

Antenna Parameters

Frequency	Return Loss	Impedance
1730 MHz	31.6 dB	52.6 Ω + 0.8 jΩ
1880 MHz	19.6 dB	56.1 Ω + 9.3 jΩ
1900 MHz	19.0 dB	59.6 Ω + 7.8 jΩ
1950 MHz	22.5 dB	58.0 Ω - 1.3 jΩ
2000 MHz	28.3 dB	51.3 Ω + 3.7 jΩ

3.2 Antenna Design and Handling

The calibration dipole has a symmetric geometry with a built-in two stub matching network, which leads to the enhanced bandwidth.

The dipole is built of standard semirigid coaxial cable. The internal matching line is open ended. The antenna is therefore open for DC signals.

Do not apply force to dipole arms, as they are liable to bend. The soldered connections near the feedpoint may be damaged. After excessive mechanical stress or overheating, check the impedance characteristics to ensure that the internal matching network is not affected.

After long term use with 40W radiated power, only a slight warming of the dipole near the feedpoint can be measured.

Impedance Measurement Plot

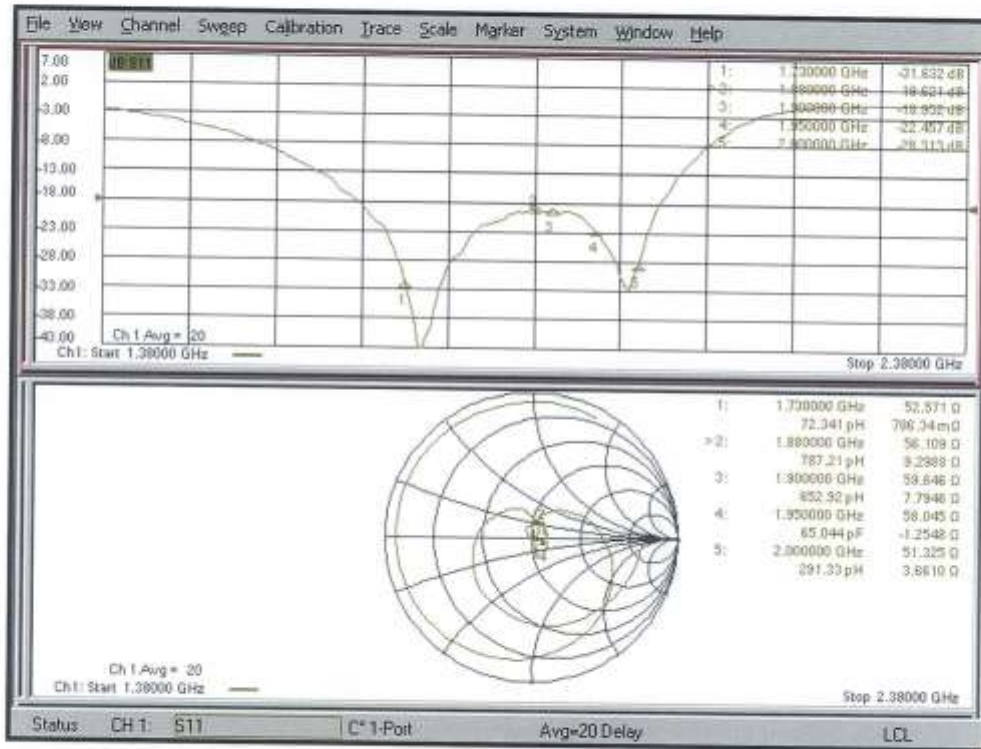

DASY5 E-field Result

Date: 22.02.2019

Test Laboratory: SPEAG Lab2

DUT: HAC Dipole 1880 MHz; Type: CD1880V3; Serial: CD1880V3 - SN: 1019

Communication System: UID 0 - CW ; Frequency: 1880 MHz
 Medium parameters used: $\sigma = 0$ S/m, $\epsilon_r = 1$; $\rho = 0$ kg/m³
 Phantom section: RF Section
 Measurement Standard: DASY5 (IEEE/IEC/ANSI C63.19-2011)

DASY52 Configuration:

- Probe: EF3DV3 - SN4013; ConvF(1, 1, 1) @ 1880 MHz; Calibrated: 03.01.2019
- Sensor-Surface: (Fix Surface)
- Electronics: DAE4 Sn781; Calibrated: 09.01.2019
- Phantom: HAC Test Arch with AMCC; Type: 5D HAC P01 BA; Serial: 1070
- DASY52 52.10.2(1495); SEMCAD X 14.6.12(7450)

Dipole E-Field measurement @ 1880MHz /E-Scan - 1880MHz d=15mm/Hearing Aid Compatibility Test (41x181x1):

Interpolated grid: dx=0.5000 mm, dy=0.5000 mm
 Device Reference Point: 0, 0, -6.3 mm
 Reference Value = 145.5 V/m; Power Drift = -0.00 dB
 Applied MIF = 0.00 dB
 RF audio interference level = 38.75 dBV/m
Emission category: M2

MIF scaled E-field

Grid 1 M2 38.34 dBV/m	Grid 2 M2 38.75 dBV/m	Grid 3 M2 38.72 dBV/m
Grid 4 M2 35.65 dBV/m	Grid 5 M2 35.93 dBV/m	Grid 6 M2 35.92 dBV/m
Grid 7 M2 38.15 dBV/m	Grid 8 M2 38.58 dBV/m	Grid 9 M2 38.55 dBV/m

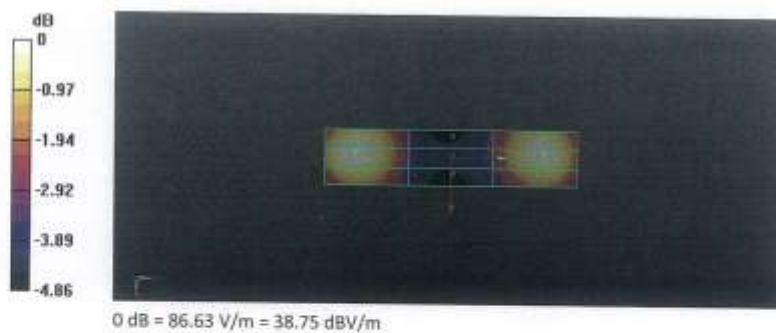

**Calibration Laboratory of
Schmid & Partner
Engineering AG**
Zeughausstrasse 43, 8004 Zurich, Switzerland



S Schweizerischer Kalibrierdienst
C Service suisse d'étalonnage
S Servizio svizzero di taratura
S Swiss Calibration Service

Accredited by the Swiss Accreditation Service (SAS)
The Swiss Accreditation Service is one of the signatories to the EA
Multilateral Agreement for the recognition of calibration certificates

Accreditation No.: **SCS 0108**

Client **HCT (Dymstec)**

Certificate No: **CD2600V3-1019_Sep19**

CALIBRATION CERTIFICATE		일	담당자	확인자																																																								
Object	CD2600V3 - SN: 1019	재	Jung	Yoo																																																								
Calibration procedure(s)	QA CAL-20.v7 Calibration Procedure for Validation Sources in air	서위/사명	SN 172012	GS 17203																																																								
Calibration date:	September 19, 2019	일	2019 10 19	2019 1 10 19																																																								
<p>This calibration certificate documents the traceability to national standards, which realize the physical units of measurements (SI). The measurements and the uncertainties with confidence probability are given on the following pages and are part of the certificate.</p> <p>All calibrations have been conducted in the closed laboratory facility: environment temperature (22 ± 3)°C and humidity < 70%.</p> <p>Calibration Equipment used (M&TE critical for calibration)</p> <table border="1"> <thead> <tr> <th>Primary Standards</th> <th>ID #</th> <th>Cal Date (Certificate No.)</th> <th>Scheduled Calibration</th> </tr> </thead> <tbody> <tr> <td>Power meter NRP</td> <td>SN: 104776</td> <td>03-Apr-19 (No. 217-02892/02893)</td> <td>Apr-20</td> </tr> <tr> <td>Power sensor NRP-Z91</td> <td>SN: 103244</td> <td>03-Apr-19 (No. 217-02892)</td> <td>Apr-20</td> </tr> <tr> <td>Power sensor NRP-Z91</td> <td>SN: 103245</td> <td>03-Apr-19 (No. 217-02893)</td> <td>Apr-20</td> </tr> <tr> <td>Reference 20 dB Attenuator</td> <td>SN: 5056 (20k)</td> <td>04-Apr-19 (No. 217-02894)</td> <td>Apr-20</td> </tr> <tr> <td>Type-N mismatch combination</td> <td>SN: 5047.2 / 06327</td> <td>04-Apr-19 (No. 217-02895)</td> <td>Apr-20</td> </tr> <tr> <td>Probe EF3DV3</td> <td>SN: 4013</td> <td>03-Jan-19 (No. EF3-4013_Jan19)</td> <td>Jan-20</td> </tr> <tr> <td>DAE4</td> <td>SN: 781</td> <td>09-Jan-19 (No. DAE4-781_Jan19)</td> <td>Jan-20</td> </tr> </tbody> </table> <table border="1"> <thead> <tr> <th>Secondary Standards</th> <th>ID #</th> <th>Check Date (in house)</th> <th>Scheduled Check</th> </tr> </thead> <tbody> <tr> <td>Power meter Agilent 4410B</td> <td>SN: GB42420191</td> <td>09-Oct-09 (in house check Oct-17)</td> <td>In house check: Oct-20</td> </tr> <tr> <td>Power sensor HP E4412A</td> <td>SN: US38485102</td> <td>05-Jan-10 (in house check Oct-17)</td> <td>In house check: Oct-20</td> </tr> <tr> <td>Power sensor HP 8482A</td> <td>SN: US37295597</td> <td>09-Oct-09 (in house check Oct-17)</td> <td>In house check: Oct-20</td> </tr> <tr> <td>RF generator R&S SMT-06</td> <td>SN: 837633/005</td> <td>10-Jan-19 (in house check Jan-19)</td> <td>In house check: Oct-22</td> </tr> <tr> <td>Network Analyzer Agilent E8358A</td> <td>SN: US41080477</td> <td>31-Mar-14 (in house check Oct-18)</td> <td>In house check: Oct-19</td> </tr> </tbody> </table>					Primary Standards	ID #	Cal Date (Certificate No.)	Scheduled Calibration	Power meter NRP	SN: 104776	03-Apr-19 (No. 217-02892/02893)	Apr-20	Power sensor NRP-Z91	SN: 103244	03-Apr-19 (No. 217-02892)	Apr-20	Power sensor NRP-Z91	SN: 103245	03-Apr-19 (No. 217-02893)	Apr-20	Reference 20 dB Attenuator	SN: 5056 (20k)	04-Apr-19 (No. 217-02894)	Apr-20	Type-N mismatch combination	SN: 5047.2 / 06327	04-Apr-19 (No. 217-02895)	Apr-20	Probe EF3DV3	SN: 4013	03-Jan-19 (No. EF3-4013_Jan19)	Jan-20	DAE4	SN: 781	09-Jan-19 (No. DAE4-781_Jan19)	Jan-20	Secondary Standards	ID #	Check Date (in house)	Scheduled Check	Power meter Agilent 4410B	SN: GB42420191	09-Oct-09 (in house check Oct-17)	In house check: Oct-20	Power sensor HP E4412A	SN: US38485102	05-Jan-10 (in house check Oct-17)	In house check: Oct-20	Power sensor HP 8482A	SN: US37295597	09-Oct-09 (in house check Oct-17)	In house check: Oct-20	RF generator R&S SMT-06	SN: 837633/005	10-Jan-19 (in house check Jan-19)	In house check: Oct-22	Network Analyzer Agilent E8358A	SN: US41080477	31-Mar-14 (in house check Oct-18)	In house check: Oct-19
Primary Standards	ID #	Cal Date (Certificate No.)	Scheduled Calibration																																																									
Power meter NRP	SN: 104776	03-Apr-19 (No. 217-02892/02893)	Apr-20																																																									
Power sensor NRP-Z91	SN: 103244	03-Apr-19 (No. 217-02892)	Apr-20																																																									
Power sensor NRP-Z91	SN: 103245	03-Apr-19 (No. 217-02893)	Apr-20																																																									
Reference 20 dB Attenuator	SN: 5056 (20k)	04-Apr-19 (No. 217-02894)	Apr-20																																																									
Type-N mismatch combination	SN: 5047.2 / 06327	04-Apr-19 (No. 217-02895)	Apr-20																																																									
Probe EF3DV3	SN: 4013	03-Jan-19 (No. EF3-4013_Jan19)	Jan-20																																																									
DAE4	SN: 781	09-Jan-19 (No. DAE4-781_Jan19)	Jan-20																																																									
Secondary Standards	ID #	Check Date (in house)	Scheduled Check																																																									
Power meter Agilent 4410B	SN: GB42420191	09-Oct-09 (in house check Oct-17)	In house check: Oct-20																																																									
Power sensor HP E4412A	SN: US38485102	05-Jan-10 (in house check Oct-17)	In house check: Oct-20																																																									
Power sensor HP 8482A	SN: US37295597	09-Oct-09 (in house check Oct-17)	In house check: Oct-20																																																									
RF generator R&S SMT-06	SN: 837633/005	10-Jan-19 (in house check Jan-19)	In house check: Oct-22																																																									
Network Analyzer Agilent E8358A	SN: US41080477	31-Mar-14 (in house check Oct-18)	In house check: Oct-19																																																									
Calibrated by:	Name: Lutz Klynsner Function: Laboratory Technician	Signature:																																																										
Approved by:	Name: Katja Pokovic Function: Technical Manager	Signature:																																																										
Issued: September 20, 2019																																																												
This calibration certificate shall not be reproduced except in full without written approval of the laboratory.																																																												

**Calibration Laboratory of
Schmid & Partner
Engineering AG**
Zeughausstrasse 43, 8004 Zurich, Switzerland



S Schweizerischer Kalibrierdienst
C Service suisse d'étalonnage
S Servizio svizzero di taratura
Swiss Calibration Service

Accredited by the Swiss Accreditation Service (SAS)
The Swiss Accreditation Service is one of the signatories to the EA
Multilateral Agreement for the recognition of calibration certificates

Accreditation No.: **SCS 0108**

References

- [1] ANSI-C63.19-2011
American National Standard, Methods of Measurement of Compatibility between Wireless Communications Devices and Hearing Aids.

Methods Applied and Interpretation of Parameters:

- **Coordinate System:** y-axis is in the direction of the dipole arms. z-axis is from the basis of the antenna (mounted on the table) towards its feed point between the two dipole arms. x-axis is normal to the other axes. In coincidence with the standards [1], the measurement planes (probe sensor center) are selected to be at a distance of 15 mm above the top metal edge of the dipole arms.
- **Measurement Conditions:** Further details are available from the hardcopies at the end of the certificate. All figures stated in the certificate are valid at the frequency indicated. The forward power to the dipole connector is set with a calibrated power meter connected and monitored with an auxiliary power meter connected to a directional coupler. While the dipole under test is connected, the forward power is adjusted to the same level.
- **Antenna Positioning:** The dipole is mounted on a HAC Test Arch phantom using the matching dipole positioner with the arms horizontal and the feeding cable coming from the floor. The measurements are performed in a shielded room with absorbers around the setup to reduce the reflections. It is verified before the mounting of the dipole under the Test Arch phantom, that its arms are perfectly in a line. It is installed on the HAC dipole positioner with its arms parallel below the dielectric reference wire and able to move elastically in vertical direction without changing its relative position to the top center of the Test Arch phantom. The vertical distance to the probe is adjusted after dipole mounting with a DASY5 Surface Check job. Before the measurement, the distance between phantom surface and probe tip is verified. The proper measurement distance is selected by choosing the matching section of the HAC Test Arch phantom with the proper device reference point (upper surface of the dipole) and the matching grid reference point (tip of the probe) considering the probe sensor offset. The vertical distance to the probe is essential for the accuracy.
- **Feed Point Impedance and Return Loss:** These parameters are measured using a Vector Network Analyzer. The impedance is specified at the SMA connector of the dipole. The influence of reflections was eliminated by applying the averaging function while moving the dipole in the air, at least 70cm away from any obstacles.
- **E-field distribution:** E field is measured in the x-y-plane with an isotropic E-field probe with 100 mW forward power to the antenna feed point. In accordance with [1], the scan area is 20mm wide, its length exceeds the dipole arm length (180 or 90mm). The sensor center is 15 mm (in z) above the metal top of the dipole arms. Two 3D maxima are available near the end of the dipole arms. Assuming the dipole arms are perfectly in one line, the average of these two maxima (in subgrid 2 and subgrid 8) is determined to compensate for any non-parallelity to the measurement plane as well as the sensor displacement. The E-field value stated as calibration value represents the maximum of the interpolated 3D-E-field, in the plane above the dipole surface.

The reported uncertainty of measurement is stated as the standard uncertainty of measurement multiplied by the coverage factor $k=2$, which for a normal distribution corresponds to a coverage probability of approximately 95%.

Measurement Conditions

DASY system configuration, as far as not given on page 1.

DASY Version	DASY5	V52.10.2
Phantom	HAC Test Arch	
Distance Dipole Top - Probe Center	15 mm	
Scan resolution	dx, dy = 5 mm	
Frequency	2600 MHz ± 1 MHz	
Input power drift	< 0.05 dB	

Maximum Field values at 2600 MHz

E-field 15 mm above dipole surface	condition	Interpolated maximum
Maximum measured above high end	100 mW input power	84.5 V/m = 38.53 dBV/m
Maximum measured above low end	100 mW input power	83.9 V/m = 38.48 dBV/m
Averaged maximum above arm	100 mW input power	84.2 V/m ± 12.8 % (k=2)

Appendix (Additional assessments outside the scope of SCS 0108)

Antenna Parameters

Frequency	Return Loss	Impedance
2450 MHz	19.3 dB	43.0 Ω - 7.4 jΩ
2550 MHz	30.5 dB	47.8 Ω + 1.9 jΩ
2600 MHz	33.7 dB	51.2 Ω + 1.7 jΩ
2650 MHz	30.0 dB	53.3 Ω - 0.2 jΩ
2750 MHz	18.3 dB	50.2 Ω - 12.3 jΩ

3.2 Antenna Design and Handling

The calibration dipole has a symmetric geometry with a built-in two stub matching network, which leads to the enhanced bandwidth.

The dipole is built of standard semirigid coaxial cable. The internal matching line is open ended. The antenna is therefore open for DC signals.

Do not apply force to dipole arms, as they are liable to bend. The soldered connections near the feedpoint may be damaged. After excessive mechanical stress or overheating, check the impedance characteristics to ensure that the internal matching network is not affected.

After long term use with 40W radiated power, only a slight warming of the dipole near the feedpoint can be measured.

Impedance Measurement Plot

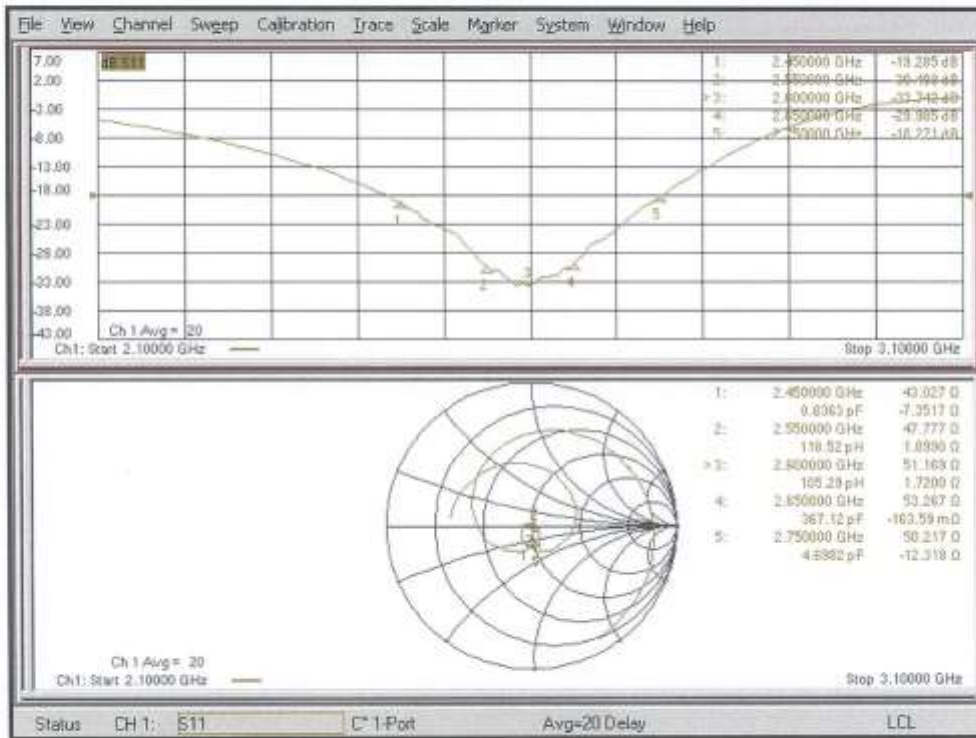

DASY5 E-field Result

Date: 19.09.2019

Test Laboratory: SPEAG Lab2

DUT: HAC Dipole 2600 MHz; Type: CD2600V3; Serial: CD2600V3 - SN: 1019

Communication System: UID 0 - CW; Frequency: 2600 MHz
 Medium parameters used: $\sigma = 0$ S/m, $\epsilon_r = 1$; $\rho = 0$ kg/m³
 Phantom section: RF Section
 Measurement Standard: DASY5 (IEEE/IEC/ANSI C63.19-2011)

DASY52 Configuration:

- Probe: EF3DV3 - SN4013; ConvF(1, 1, 1) @ 2600 MHz; Calibrated: 03.01.2019
- Sensor-Surface: (Fix Surface)
- Electronics: DAE4 Sn781; Calibrated: 09.01.2019
- Phantom: HAC Test Arch with AMCC; Type: SD HAC P01 BA; Serial: 1070
- DASY52 52.10.2(1504); SEMCAD X 14.6.12(7470)

Dipole E-Field measurement @ 2600MHz/E-Scan - 2600MHz d=15mm/Hearing Aid Compatibility Test (41x181x1):

Interpolated grid: dx=0.5000 mm, dy=0.5000 mm
 Device Reference Point: 0, 0, -6.3 mm
 Reference Value = 62.69 V/m; Power Drift = -0.00 dB
 Applied MIF = 0.00 dB
 RF audio interference level = 38.53 dBV/m
Emission category: M2

MIF scaled E-field

Grid 1 M2 38.17 dBV/m	Grid 2 M2 38.48 dBV/m	Grid 3 M2 38.41 dBV/m
Grid 4 M2 37.74 dBV/m	Grid 5 M2 37.96 dBV/m	Grid 6 M2 37.9 dBV/m
Grid 7 M2 38.29 dBV/m	Grid 8 M2 38.53 dBV/m	Grid 9 M2 38.42 dBV/m

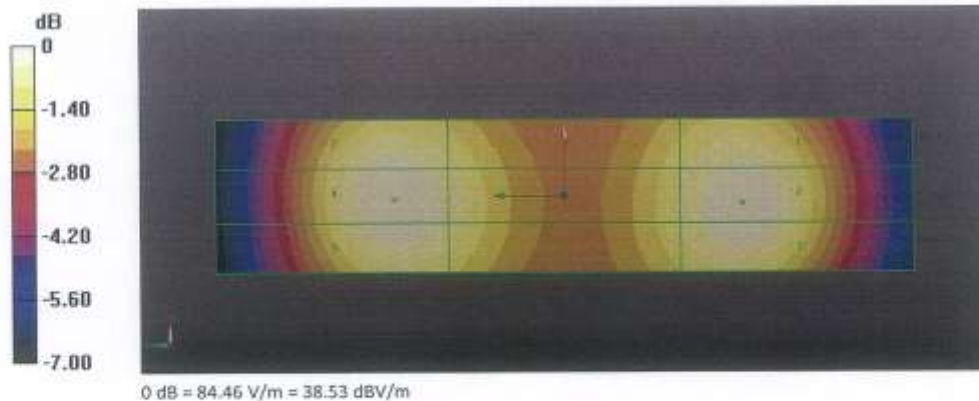

Attachment 5. HAC RF Emission Setup Photo

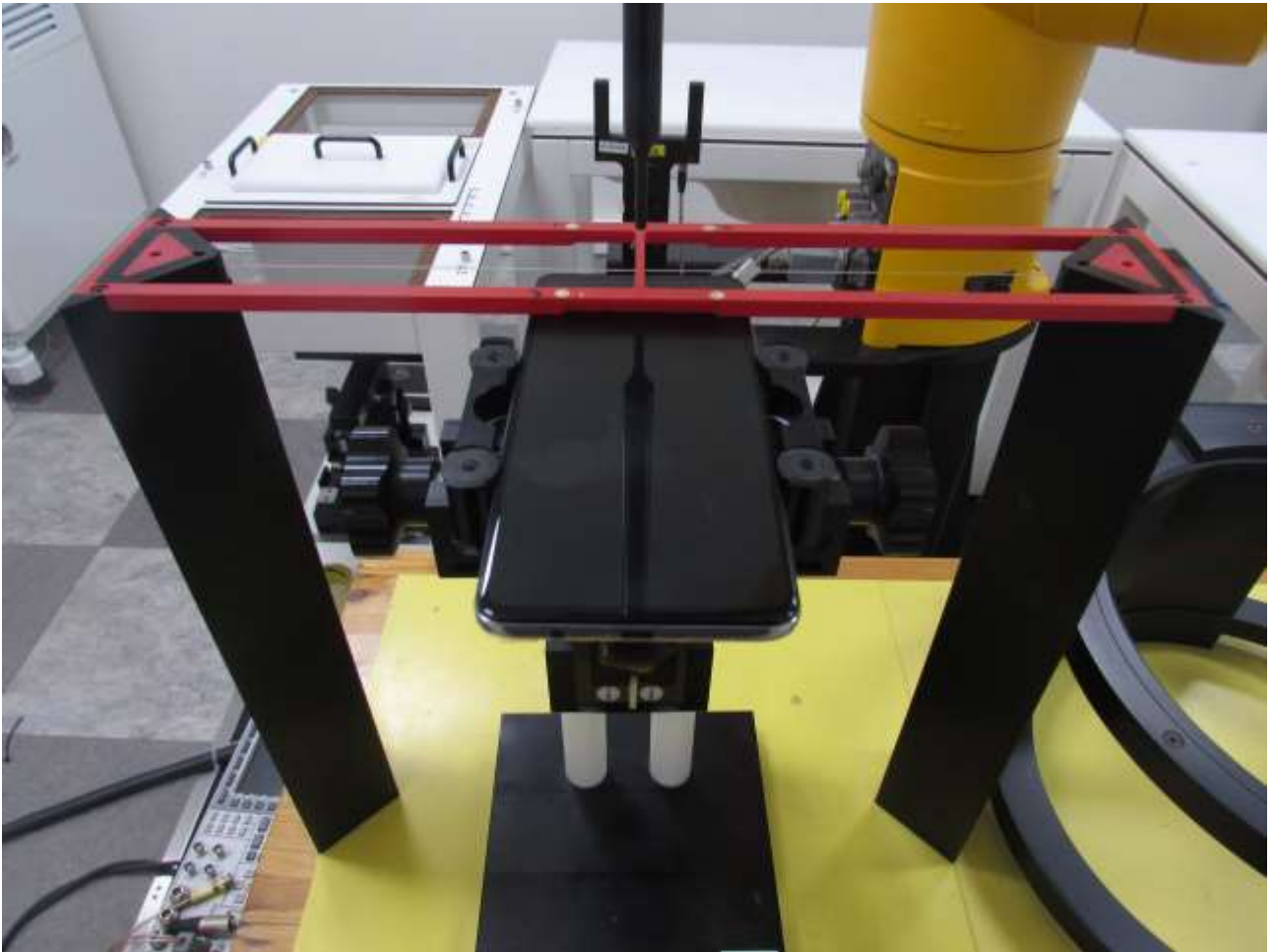

[Setup Photo _ Front]



[Setup Photo _ Side]