





# TEST REPORT

<b>KCTL Inc.</b> 65, Sinwon-ro, Yeongtong-gu, Suwon-si, Gyeonggi-do, 16677, Korea TEL: 82-31-285-0894 FAX: 82-505-299-8311 <a href="http://www.kctl.co.kr">www.kctl.co.kr</a>	Report No.: <b>KR20-SEF0065</b> Page (1) of (21)	
<b>1. Client</b>		
<ul style="list-style-type: none"> <li>◦ Name : Samsung Electronics Co., Ltd.</li> <li>◦ Address : 129, Samsung-ro, Yeongtong-gu, Suwon-si, Gyeonggi-do, 16677, Rep. of Korea</li> <li>◦ Date of Receipt : 2020-03-26</li> </ul>		
<b>2. Use of Report</b> : -		
<b>3. Name of Product and Model</b> : Mobile phone / SC-41A, SCV48		
<b>4. Manufacturer and Country of Origin</b> : Samsung Electronics Co., Ltd. / Korea		
<b>5. Date of Test</b> : 2020-04-14		
<b>6. Test method used</b> : ANSI C63.4:2014, Class B		
<b>7. FCC ID</b> : A3LSMA415JPN		
<b>8. Test Results</b> : Refer to the test result in the test report		
Affirmation	Tested by  Name : Jinwon Kim (Signature)	Technical Manager  Name : Gunsu Park (Signature)
2020-04-16		
<h2>KCTL Inc.</h2>		
As a test result of the sample which was submitted from the client, this report does not guarantee the whole product quality. This test report should not be used and copied without a written agreement by KCTL Inc.		

**REPORT REVISION HISTORY**

Date	Revision	Page No
2020-04-16	Originally issued	-

*This report shall not be reproduced except in full, without the written approval of KCTL Inc. This document may be altered or revised by KCTL Inc. personnel only, and shall be noted in the revision section of the document. Any alteration of this document not carried out by KCTL Inc. will constitute fraud and shall nullify the document.*



## Contents

<b>1. Applicant information</b> .....	<b>4</b>
<b>2. Laboratory information</b> .....	<b>5</b>
<b>3. Test system configuration</b> .....	<b>6</b>
3.1 Operation environment.....	6
3.2 Measurement Uncertainty .....	7
<b>4. Description of EUT</b> .....	<b>9</b>
4.1 General information.....	9
4.2 Product description.....	10
4.3 Auxiliary equipments .....	10
4.4 Test configuration .....	11
4.5 Operating conditions .....	12
<b>5. Summary of test results</b> .....	<b>13</b>
5.1 Summary of EMI emission test results .....	13
<b>6. Test results</b> .....	<b>14</b>
6.1 Conducted Emissions.....	14
6.2 Radiated Emission .....	17

**KCTL Inc.**

65, Sinwon-ro, Yeongtong-gu,  
Suwon-si, Gyeonggi-do, 16677, Korea  
TEL: 82-31-285-0894 FAX: 82-505-299-8311  
[www.kctl.co.kr](http://www.kctl.co.kr)

Report No.:  
KR20-SEF0065

Page (4) of (21)



## 1. Applicant information

**Applicant:** Samsung Electronics Co., Ltd.  
**Address:** 129, Samsung-ro, Yeongtong-gu, Suwon-si, Gyeonggi-do,  
16677, Rep. of Korea  
**E-mail:** [jsse.yu@samsung.com](mailto:jsse.yu@samsung.com)  
**Contact name:** Jaesun Yu

**Manufacturer:** Samsung Electronics Co., Ltd.  
**Address:** 129, Samsung-ro, Yeongtong-gu, Suwon-si, Gyeonggi-do,  
16677, Rep. of Korea  
**E-mail:** [jsse.yu@samsung.com](mailto:jsse.yu@samsung.com)  
**Contact name:** Jaesun Yu

**Factory:** Samsung Electronics Vietnam Thai Nguyen Co., Ltd  
**Address:** YEN BINH 1 INDUSTRIAL PARK, PHO YEN DISTRICT,  
THAI NGUYEN PROVINCE THAI NGUYEN 23000

## KCTL Inc.

65, Sinwon-ro, Yeongtong-gu,  
Suwon-si, Gyeonggi-do, 16677, Korea  
TEL: 82-31-285-0894 FAX: 82-505-299-8311  
[www.kctl.co.kr](http://www.kctl.co.kr)

Report No.:  
KR20-SEF0065

Page (5) of (21)

# KCTL

## 2. Laboratory information

### Address

#### **KCTL Inc. (Suwon Lab.)**

65, Sinwon-ro, Yeongtong-gu, Suwon-si, Gyeonggi-do, 16677, Korea

Telephone Number: 82 31 285 0894

Facsimile Number: 82 505 299 8311

FCC Site Designation No: KR0040

VCCI Registration No.: R-20080, G-20078, C-20059, T-20056

Industry Canada Registration No. : 8035A

KOLAS NO.: KT231

### **SITE MAP**

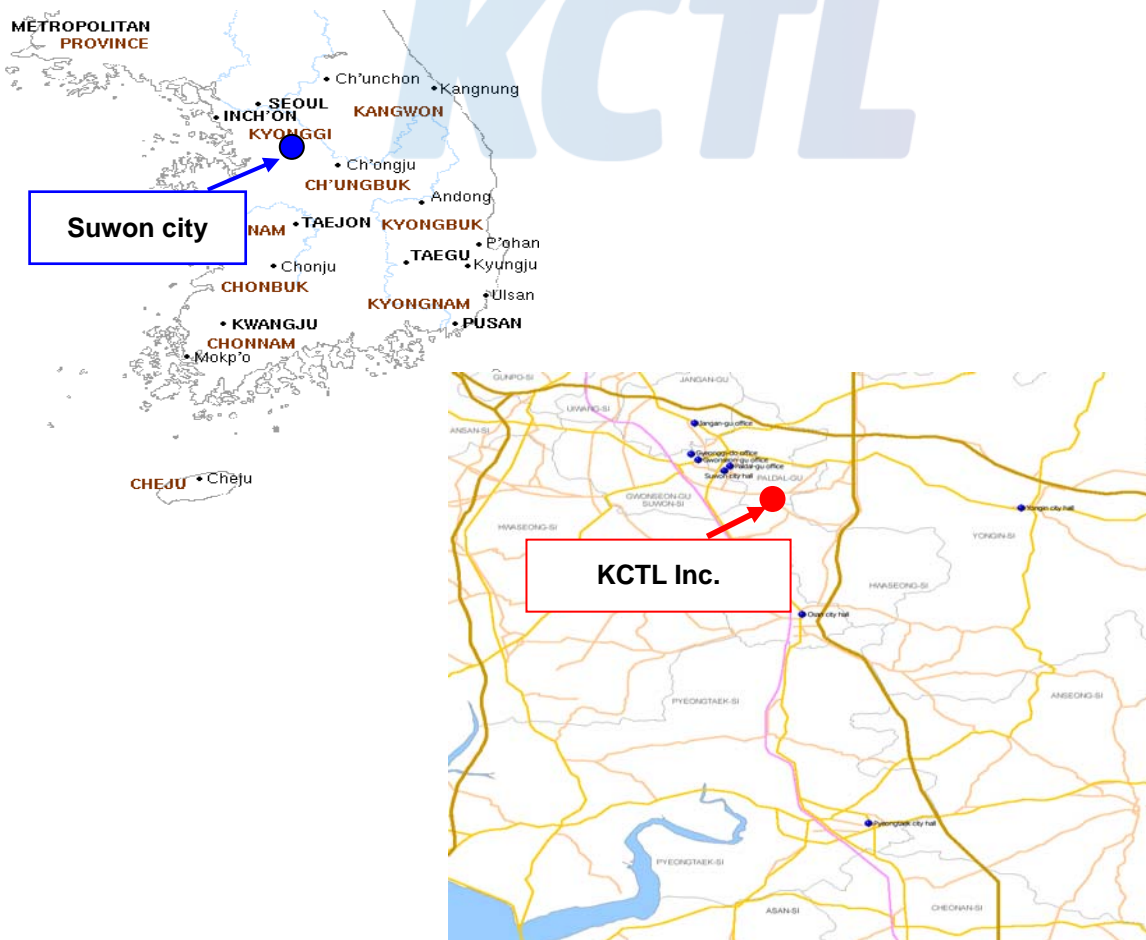

### 3. Test system configuration

#### 3.1 Operation environment

	Temperature	Humidity	Pressure
Chamber 10 m (RE)	26.9 °C / 27.1 °C	24.5 % R.H. / 24.9 % R.H.	-
Shielded room(CE)	25.8 °C	22.3 % R.H.	-

#### Test site

These testing items were performed following locations;

Test item	Test site
Conducted Emission	Shielded Room
Radiated Emission	10 m Chamber

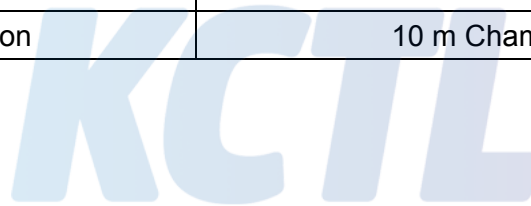

**KCTL Inc.**

65, Sinwon-ro, Yeongtong-gu,  
Suwon-si, Gyeonggi-do, 16677, Korea  
TEL: 82-31-285-0894 FAX: 82-505-299-8311  
[www.kctl.co.kr](http://www.kctl.co.kr)

Report No.:  
KR20-SEF0065

Page (7) of (21)



### 3.2 Measurement Uncertainty

All measurements involve certain levels of uncertainties, especially in field of EMC.

The factors contributing to uncertainties are test receiver, cable loss, antenna factor calibration, Antenna directivity, antenna factor variation with height, antenna phase center variation, antenna frequency interpolation, measurement distance variation, site imperfection, mismatch, and system repeatability. Based on CISPR 16-4-2, the measurement uncertainty level with a 95 % confidence level was applied.

Conducted Emission measurement (Confidence level about 95 %, $k = 2$ )		
Shielded Room (CE#1)	9 kHz ~ 150 kHz: 3.66 dB	
	150 kHz ~ 30 MHz: 3.26 dB	
Shielded Room (CE#2)	9 kHz ~ 150 kHz: 3.48 dB	
	150 kHz ~ 30 MHz: 3.06 dB	
Radiated Emission measurement (Confidence level about 95 %, $k = 2$ )		
10 m Chamber (4F)	30 MHz ~ 300 MHz	3 m: 5.36 dB
		10 m: 5.34 dB
	300 MHz ~ 1 000 MHz	3 m: 5.48 dB
		10 m: 5.36 dB
	1 GHz ~ 6 GHz	3 m: 6.36 dB
	6 GHz ~ 18 GHz	3 m: 6.64 dB
	18 GHz ~ 30 GHz	3 m: 6.74 dB
30 GHz ~ 40 GHz	3 m: 6.16 dB	
10 m Chamber (2F)	30 MHz ~ 300 MHz	3 m: 4.98 dB
		10 m: 4.96 dB
	300 MHz ~ 1 000 MHz	3 m: 5.16 dB
		10 m: 5.02 dB
	1 GHz ~ 6 GHz	3 m: 6.36 dB
6 GHz ~ 18 GHz	3 m: 6.64 dB	

### 3.3 Measurement Program

These test items were performed by software programs;

Test item	Measurement Program		Used
Conducted Emission	EP5CE_V 5.4.0(TOYO)		☒
Radiated Emission	2F	EP5RE_V 4.6.0(TOYO)	☒
	4F	EP5RE_V 5.11.10(TOYO)	





## 4. Description of EUT

### 4.1 General information

Declared Hardware Version	REV0.1
Declared Software Version	A415D.001
IMEI No	355518110020288/01
Operating Band(s)	GSM 850/900/1800/1900 WCDMA FDD 1/5/6/19 LTE FDD 1/3/5/12/19/21 LTE TDD 38/39/41
Testing Band(s)	GSM 850



## 4.2 Product description

Type of product	Mobile phone
Model name (Basic)	SC-41A, SCV48
Model name (Variant)	-
Difference	-
Serial no	-
Testing voltage	120 V, 60 Hz
Input rating	DC 5 V
Internal clock frequency	Above 108 MHz
RF Frequency	5 825 MHz
Note	-

## 4.3 Auxiliary equipments

Type	Model / Part #	S/N	Manufacturer
Adapter	EP-TA200	R37M6AS5E41DK3	SAMSUNG
Earphone (EUT)	-	-	SAMSUNG
Battery (EUT)	-	-	SAMSUNG
USB Cable (EUT)	-	-	-
USIM Card	-	-	-
Micro SD Card (64 GB)	Samsung Pro Plus MB-MD64G	-	SAMSUNG
Radio Communication Tester	CMW200	108667	R&S
Spiral ANT	PSA-75301R/170	406827-0001	COBHAM

#### 4.4 Test configuration

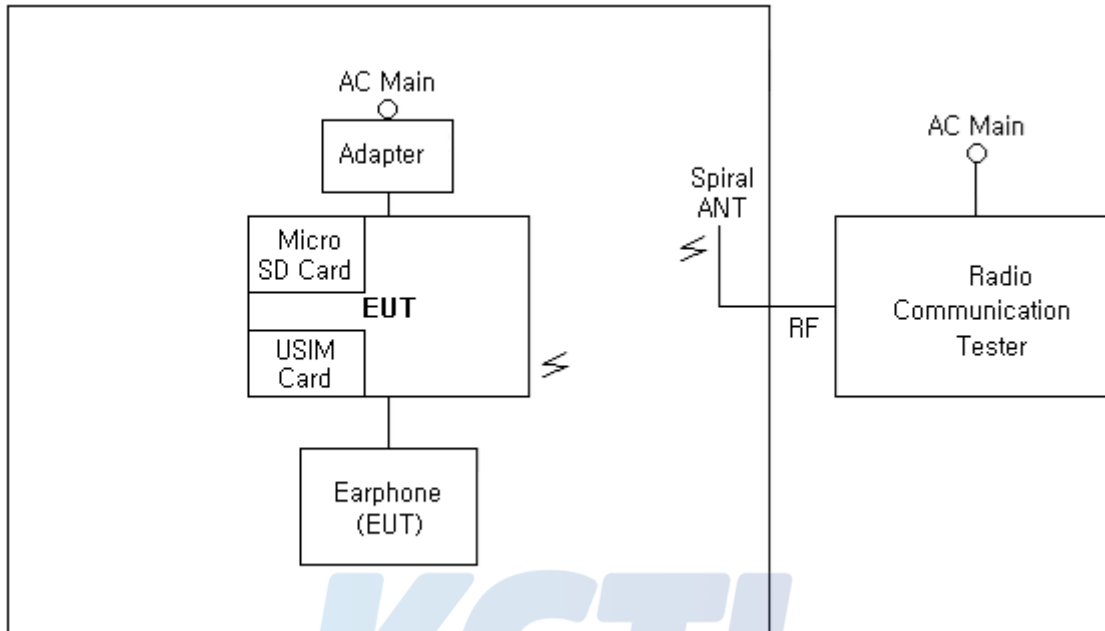

	Start		End		Cable	
	Name	I/O port	Name	I/O port	Length (m)	Spec.
1	<b>EUT</b>	Power	Adapter	-	0.8	Shield
2		USIM	USIM Card	-	Direct	-
3		Micro SD	Micro SD Card	-	Direct	-
4		Earphone	Earphone (EUT)	-	1.55	Unshield
5	Adapter (EUT)	Power	AC Main	-	Direct	-
6	Radio Communication Tester	RF	Spiral ANT	-	3.0	Shield

## 4.5 Operating conditions

The EUT was configured as normal intended use.

Test mode	Normal operating
Test #1	Charging (w/TA) + Cellular receiver (GSM 850_Center frequency)

Note 1. All cellular RX bands operating below 1 GHz, including GSM, WCDMA and LTE have been investigated with low/mid/high channels and test results are not significantly different.

Note 2. The fundamental of the EUT was investigated in three orthogonal orientations X, Y and Z. It was determined that Z orientation was worst-case orientation. Therefore, all final radiated testing was performed with the EUT in Z orientation.



## 5. Summary of test results

### 5.1 Summary of EMI emission test results

Applied	Test items	Test method	Result
☒	Conducted Emission	ANSI C63.4:2014, Class B FCC Part 15 Subpart B	Pass
☒	Radiated Emission	ANSI C63.4:2014, Class B FCC Part 15 Subpart B	Pass



## 6. Test results

### 6.1 Conducted Emissions

Test specification	ANSI C63.4:2014, Class B FCC Part 15 Subpart B		
Testing voltage	120 V, 60 Hz		
Test facility	Shielded room (CE#1)		
Date	2020-04-14		
Temperature (°C)	25.8 °C	Humidity (% R.H.)	22.3 % R.H.
Remarks	Pass		

#### 6.1.1 Limits of conducted emissions measurement

Frequency [MHz]	Class A (dB( $\mu$ V))		Class B (dB( $\mu$ V))	
	Quasi-peak	Average	Quasi-peak	Average
0.15 ~ 0.5	79	66	66 ~ 56 <sup>1)</sup>	56 ~ 46 <sup>1)</sup>
0.5 ~ 5	73	60	56	46
5 ~ 30	73	60	60	50

<sup>1)</sup> The limit decreases linearly with the logarithm of frequency

### 6.1.2 Measurement procedure

The measurements were performed in a shielded room. EUT was setup as shown in photograph and placed on a non-metallic table height of 0.8 m above the reference ground plane. The rear of table was located 0.4 m to the vertical conducted plane. EUT was power through the LISN, which was bonded to the ground plane. The LISN power was filtered. Each EUT power lead, except ground (safety) lead was individually connected through a LISN to input power source. EUT signal cables that hung closer than 0.4 m to the Horizontal metal ground 0.3 m ~ 0.4 m long. The power cord was bundles in the center. All peripheral equipment was powered from a sub LISN. The LISN and ISN were positioned 0.8 m from the EUT. Peak and Average detection were used in preliminary testing and Quasi-peak and Average detections were used at final measurement.

### 6.1.3 Used equipments

Equipment	Model no.	Serial no.	Makers	Next Cal. Date	Used
EMI TEST RECEIVER	ESCI	100001	R&S	2020.08.22	<input checked="" type="checkbox"/>
TWO-LINE V-NETWORK	ENV216	101358	R&S	2020.10.02	<input checked="" type="checkbox"/>
TWO-LINE V-NETWORK	ENV216	101352	R&S	2021.04.06	<input type="checkbox"/>

# KCTL Inc.

65, Sinwon-ro, Yeongtong-gu,  
Suwon-si, Gyeonggi-do, 16677, Korea  
TEL: 82-31-285-0894 FAX: 82-505-299-8311  
[www.kctl.co.kr](http://www.kctl.co.kr)

Report No.:  
KR20-SEF0065

Page (16) of (21)



## 6.1.4 Conducted emissions measurement result

### AC Main

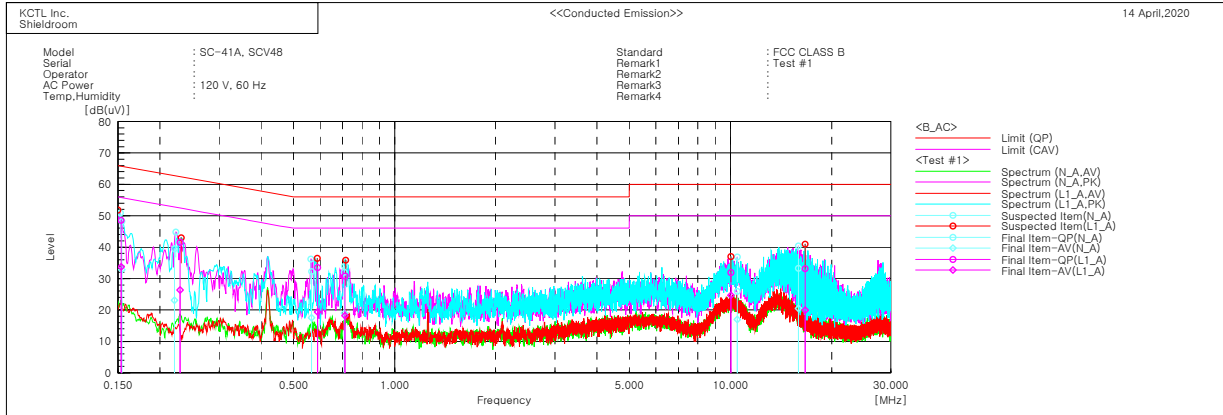

#### Final Result

--- N_A Phase ---										
No.	Frequency [MHz]	Reading QP [dB(uV)]	Reading CAV [dB(uV)]	c.f [dB]	Result QP [dB(uV)]	Result CAV [dB(uV)]	Limit QP [dB(uV)]	Limit AV [dB(uV)]	Margin QP [dB]	Margin CAV [dB]
1	0.15412	38.1	22.8	10.1	48.2	32.9	65.8	55.8	17.6	22.9
2	0.22106	29.5	13.1	10.0	39.5	23.1	62.8	52.8	23.3	29.7
3	0.56549	22.0	7.3	10.2	32.2	17.5	56.0	46.0	23.8	26.5
4	0.70775	21.8	8.8	10.2	32.0	19.0	56.0	46.0	24.0	27.0
5	10.48605	15.2	6.3	10.7	25.9	17.0	60.0	50.0	34.1	33.0
6	15.90627	22.2	9.5	11.0	33.2	20.5	60.0	50.0	26.8	29.5

--- L1_A Phase ---										
No.	Frequency [MHz]	Reading QP [dB(uV)]	Reading CAV [dB(uV)]	c.f [dB]	Result QP [dB(uV)]	Result CAV [dB(uV)]	Limit QP [dB(uV)]	Limit AV [dB(uV)]	Margin QP [dB]	Margin CAV [dB]
1	0.1534	38.5	23.6	10.1	48.6	33.7	65.8	55.8	17.2	22.1
2	0.22957	31.5	16.4	10.0	41.5	26.4	62.5	52.5	21.0	26.1
3	0.58969	23.3	9.1	10.2	33.5	19.3	56.0	46.0	22.5	26.7
4	0.71227	20.5	8.0	10.2	30.7	18.2	56.0	46.0	25.3	27.8
5	10.02974	21.2	14.0	10.7	31.9	24.7	60.0	50.0	28.1	25.3
6	16.66821	22.2	8.9	11.0	33.2	19.9	60.0	50.0	26.8	30.1



## 6.2 Radiated Emission

Test specification		ANSI C63.4:2014, Class B FCC Part 15 Subpart B		
Testing voltage		120 V, 60 Hz		
Test facility		10 m Chamber (4F)		
Test distance		3 m		
Date		2020-04-14		
30 MHz ~ 1 000 MHz	Temperature (°C)	26.9 °C	Humidity (% R.H.)	24.5 % R.H.
1 GHz ~ 30 GHz		27.1 °C		24.9 % R.H.
Remarks		Pass		

### 6.2.1 Limits of radiated emission measurement

Frequency [MHz]	Class A (dB( $\mu$ V/m)) @ 10 m	Class B (dB( $\mu$ V/m)) @ 3 m
30-88	39	40
88-216	43.5	43.5
216-960	46.4	46
Above 960	49.5	54

**Note- Alternative standard: CISPR, Pub. 22**

### 6.2.2 Measurement procedure

The test was done at a 10 m chamber with a quasi-peak detector. EUT was placed on a non-metallic table height of 0.8 m above the reference ground plane. Cables were folded back and forth forming a bundle 0.3 m to 0.4 m long and were hanged at a 0.4 m height to the ground plane.

Cables connected to EUT were fixed to cause maximum emission. Test was made with the antenna positioned in both the horizontal and vertical planes of polarization. The measurement antenna was varied in height above the conducting ground plane to obtain the maximum signal strength.

### 6.2.3 Used equipments

Equipment	Model no.	Serial no.	Makers	Next Cal. Date	Used
EMI TEST RECEIVER	ESR7	101078	R&S	2020.08.22	☒
Bilog Antenna	CBL 6112D	37876	TESEQ	2020.07.20	☒
AMPLIFIER	310N	293004	SONOMA	2020.08.22	☒
ATTENUATOR	8491B	MY39270292	AGILENT	-	☒
Antenna Mast	MA4640-XP-ET	-	Innco Systems	-	☒
Turn Table	TT 3.0-3t	-	MATURO	-	☒
DOUBLE RIDGED HORN ANTENNA	3117-PA	00161083	ETS-LINDGREN	2020.09.18	☒
Horn antenna	3116	00086635	ETS-LINDGREN	2020.05.09	☒
AMPLIFIER	JS44-18004000-33-8P	2000996	L-3Narda-MITEQ	2021.01.22	☒
Spectrum Analyzer	FSV40	100988	R&S	2021.01.03	☒

### 6.2.4 Sample calculation

The field strength is calculated adding the antenna Factor, cable loss and, Antenna pad adding, subtracting the amplifier gain from the measured reading.

The sample calculation is as follow:

$$\text{Result} = \text{M.R} + \text{C.F}(\text{A.F} + \text{C.L} + 6 \text{ dB Att} - \text{A.G})$$

M.R = Meter Reading

C.F = Correction Factor

A.F = Antenna Factor

C.L = Cable Loss

A.G = Amplifier Gain

6 dB Att = 6 dB Attenuator

If M.R is 30 dB, A.F 12 dB, C.L 5 dB, 6 dB, A.G 35 dB

The result is  $30 + 12 + 5 + 6 - 35 = 18 \text{ dB } (\mu\text{V/m})$

Bilog Antenna and ATTENUATOR (6 dB) were calibrated together.

AV = CAV : Abbreviation of CISPR Average

# KCTL Inc.

65, Sinwon-ro, Yeongtong-gu,  
Suwon-si, Gyeonggi-do, 16677, Korea  
TEL: 82-31-285-0894 FAX: 82-505-299-8311  
[www.kctl.co.kr](http://www.kctl.co.kr)

Report No.:  
KR20-SEF0065

Page (19) of (21)



## 6.2.5 Radiated emission measurement result

30 MHz ~ 1 GHz

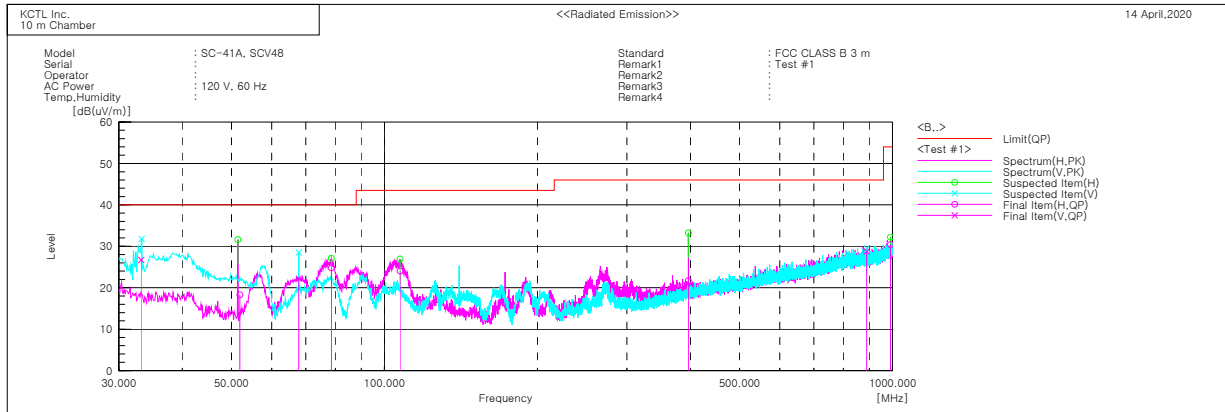

### Final Result

No.	Frequency [MHz]	(P)	Reading QP [dB(uV)]	c. f [dB(1/m)]	Result QP [dB(uV/m)]	Limit QP [dB(uV/m)]	Margin QP [dB]	Height [cm]	Angle [deg]
1	33.183	V	33.2	-6.5	26.7	40.0	13.3	387.0	354.0
2	51.942	H	34.1	-15.8	18.3	40.0	21.7	312.0	97.0
3	67.830	V	38.5	-16.3	22.2	40.0	17.8	318.0	354.0
4	78.621	H	40.3	-15.5	24.8	40.0	15.2	202.0	305.0
5	107.358	H	34.0	-10.0	24.0	43.5	19.5	388.0	287.0
6	396.539	H	23.2	-1.5	21.7	46.0	24.3	109.0	242.0
7	889.905	V	19.5	9.3	28.8	46.0	17.2	287.0	18.0
8	990.785	H	18.6	11.8	30.4	54.0	23.6	108.0	290.0

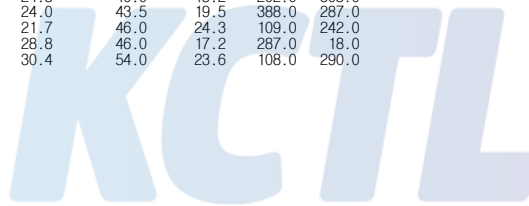

# KCTL Inc.

65, Sinwon-ro, Yeongtong-gu,  
Suwon-si, Gyeonggi-do, 16677, Korea  
TEL: 82-31-285-0894 FAX: 82-505-299-8311  
[www.kctl.co.kr](http://www.kctl.co.kr)

Report No.:  
KR20-SEF0065

Page (20) of (21)



1 GHz ~ 18 GHz

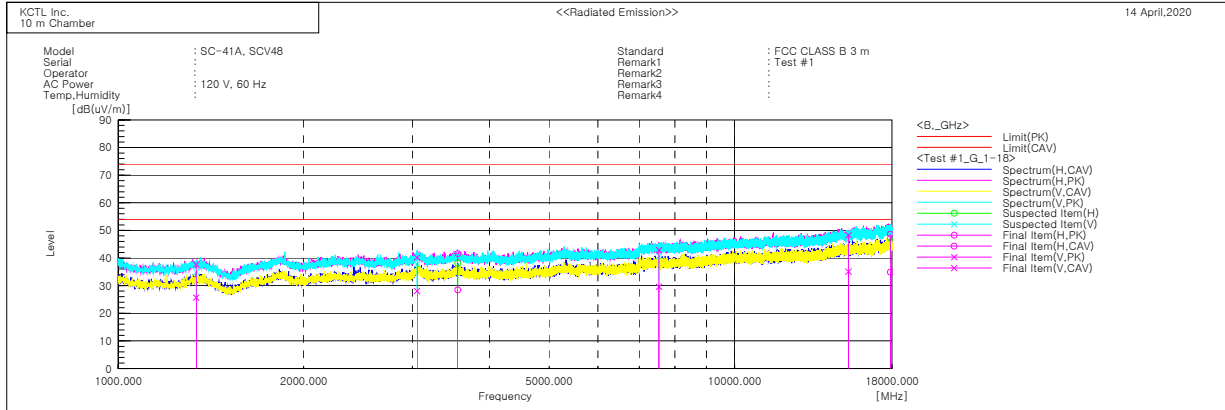

### Final Result

No.	Frequency [MHz]	(P)	Reading PK [dB(uV)]	Reading CAV [dB(uV)]	c.f [dB(1/m)]	Result PK [dB(uV/m)]	Result CAV [dB(uV/m)]	Limit PK [dB(uV/m)]	Limit AV [dB(uV/m)]	Margin PK [dB]	Margin CAV [dB]	Height [cm]	Angle [deg]
1	1338.311	V	53.6	41.6	-15.9	37.7	25.7	74.0	54.0	36.3	28.3	178.0	212.0
2	3052.002	V	48.6	36.5	-8.4	40.2	28.1	74.0	54.0	33.8	25.9	310.0	356.0
3	3555.228	H	49.0	35.9	-7.4	41.6	28.5	74.0	54.0	32.4	25.5	200.0	337.0
4	7535.126	V	46.9	33.6	-4.0	42.9	29.6	74.0	54.0	31.1	24.4	319.0	37.0
5	15298.560	V	46.1	32.9	2.2	48.3	35.1	74.0	54.0	25.7	18.9	100.0	248.0
6	17692.890	H	39.5	25.7	9.2	48.7	34.9	74.0	54.0	25.3	19.1	191.0	104.0



# KCTL Inc.

65, Sinwon-ro, Yeongtong-gu,  
Suwon-si, Gyeonggi-do, 16677, Korea  
TEL: 82-31-285-0894 FAX: 82-505-299-8311  
[www.kctl.co.kr](http://www.kctl.co.kr)

Report No.:  
KR20-SEF0065

Page (21) of (21)



## 18 GHz ~ 30 GHz

