





# TEST REPORT

<b>Eurofins KCTL Co.,Ltd.</b> 65, Sinwon-ro, Yeongtong-gu, Suwon-si, Gyeonggi-do, 16677, Korea Tel: 82-31-285-0894 Fax: 82-505-299-8311 <a href="http://www.kctl.co.kr">www.kctl.co.kr</a>	Report No.: <b>KR23-SEF0010-A</b> Page (1) of (21)	 <b>eurofins</b>   <b>KCTL</b>
<b>1. Client</b>		
<ul style="list-style-type: none"> <li>◦ Name : Samsung Electronics Co., Ltd.</li> <li>◦ Address : 129, Samsung-ro, Yeongtong-gu, Suwon-si, Gyeonggi-do, 16677, Rep. of Korea</li> <li>◦ Date of Receipt : 2022-10-17</li> </ul>		
<b>2. Use of Report</b> : Certification		
<b>3. Name of Product / Model</b> : Mobile phone / SM-A346B/DSN		
<b>4. Manufacturer / Country of Origin</b> : Samsung Electronics Co., Ltd. / Vietnam		
<b>5. Date of Test</b> : 2023-01-09 to 2023-01-10		
<b>6. Location of Test</b> : <input checked="" type="checkbox"/> Permanent Testing Lab <input type="checkbox"/> On Site Testing (Address: 65, Sinwon-ro, Yeongtong-gu, Suwon-si, Gyeonggi-do, 16677, Korea)		
<b>7. Test method used</b> : ANSI C63.4:2014, Class B		
<b>8. FCC ID</b> : A3LSMA346B		
<b>9. Test Results</b> : Refer to the test result in the test report		
Affirmation	Tested by  Name : Dootae Lee (Signature)	Technical Manager  Name : Moonseop Cho (Signature)
2023-01-20		
<b>Eurofins KCTL Co.,Ltd.</b>		
As a test result of the sample which was submitted from the client, this report does not guarantee the whole product quality. This test report should not be used and copied without a written agreement by Eurofins KCTL Co.,Ltd.		

## REPORT REVISION HISTORY

Date	Revision	Page No
2023-01-13	Originally issued	-
2023-01-20	Updated	12 page

*This report shall not be reproduced except in full, without the written approval of Eurofins KCTL Co.,Ltd. This document may be altered or revised by Eurofins KCTL Co.,Ltd. personnel only, and shall be noted in the revision section of the document. Any alteration of this document not carried out by Eurofins KCTL Co.,Ltd. will constitute fraud and shall nullify the document. This test report is a general report that does not use the KOLAS accreditation mark and is not related to KS Q ISO/IEC 17025 and KOLAS accreditation.*

Note. The report No. KR23-SEF0010 is superseded by the report No. KR23-SEF0010-A

## General remarks for test reports

### Statement concerning the uncertainty of the measurement systems used for the tests

(may be required by the product standard or client)

Internal procedure used for type testing through which traceability of the measuring uncertainty has been established:

#### Procedure number, issue date and title:

Calculations leading to the reported values are on file with the testing laboratory that conducted the testing.

Statement not required by the standard or client used for type testing

# Contents

<b>1. Applicant information .....</b>	<b>4</b>
<b>2. Laboratory information.....</b>	<b>5</b>
<b>3. Test system configuration.....</b>	<b>5</b>
3.1 Operation environment.....	6
3.2 Measurement Uncertainty .....	7
<b>4. Description of EUT .....</b>	<b>9</b>
4.1 General information.....	9
4.2 Product description.....	10
4.3 Auxiliary equipments .....	10
4.4 Test configuration .....	11
4.5 Operating conditions .....	12
<b>5. Summary of test results .....</b>	<b>13</b>
5.1 Summary of EMI emission test results .....	13
<b>6. Test results .....</b>	<b>14</b>
6.1 Conducted Emissions.....	14
6.2 Radiated Emission .....	17

<b>Eurofins KCTL Co.,Ltd.</b> 65, Sinwon-ro, Yeongtong-gu, Suwon-si, Gyeonggi-do, 16677, Korea Tel: 82-31-285-0894 Fax: 82-505-299-8311 <a href="http://www.kctl.co.kr">www.kctl.co.kr</a>	Report No.: KR23-SEF0010-A Page (4) of (21)	   KCTL
--	---	--

## 1. Applicant information

**Applicant:** Samsung Electronics Co., Ltd.  
**Address:** 129, Samsung-ro, Yeongtong-gu, Suwon-si, Gyeonggi-do,  
16677, Rep. of Korea

**Manufacturer:** Samsung Electronics Co., Ltd.  
**Address:** 129, Samsung-ro, Yeongtong-gu, Suwon-si, Gyeonggi-do,  
16677, Rep. of Korea

**Factory:** Samsung Electronics Vietnam Thai Nguyen Co., Ltd  
**Address:** Yen Binh Industrial Park, Dong Tien Ward, Pho Yen Town,  
Thai Nguyen Province, Vietnam

## 2. Laboratory information

### Address

#### **Eurofins KCTL Co.,Ltd. (Suwon Lab.)**

65, Sinwon-ro, Yeongtong-gu, Suwon-si, Gyeonggi-do, 16677, Korea

Telephone Number: 82 31 285 0894

Facsimile Number: 82 505 299 8311

FCC Site Designation No: KR0040

VCCI Registration No.: R-20080, G-20078, C-20059, T-20056

Industry Canada Registration No. : 8035A

KOLAS NO.: KT231

### **SITE MAP**

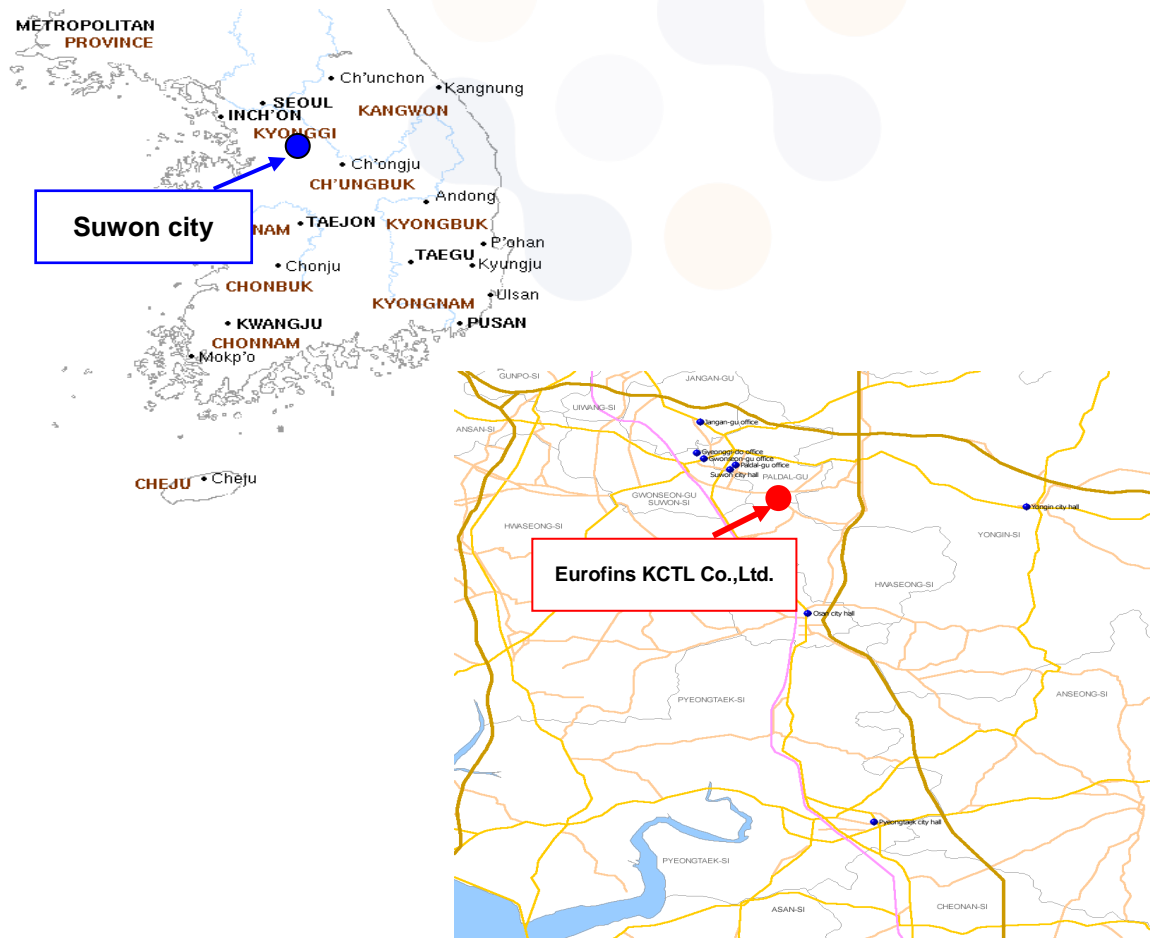

### 3. Test system configuration

#### 3.1 Operation environment

	Temperature	Humidity	Pressure
Chamber 10 m (RE)	22.2 °C / 22.4 °C	23.5 % R.H. / 23.9 % R.H.	-
Shielded room(CE)	21.8 °C	22.0 % R.H.	-

#### Test site

These testing items were performed following locations;

Test item	Test site
Conducted Emission	Shielded Room
Radiated Emission	10 m Chamber

### 3.2 Measurement Uncertainty

All measurements involve certain levels of uncertainties, especially in field of EMC.

The factors contributing to uncertainties are test receiver, cable loss, antenna factor calibration, Antenna directivity, antenna factor variation with height, antenna phase center variation, antenna frequency interpolation, measurement distance variation, site imperfection, mismatch, and system repeatability. Based on CISPR 16-4-2, the measurement uncertainty level with a 95 % confidence level was applied.

Conducted Emission measurement (Confidence level about 95 %, $k = 2$ )			
Shielded Room (CE#1)	9 kHz ~ 150 kHz:	3.50 dB	
	150 kHz ~ 30 MHz:	3.06 dB	
Shielded Room (CE#2)	9 kHz ~ 150 kHz:	3.05 dB	
	150 kHz ~ 30 MHz:	3.06 dB	
Radiated Emission measurement (Confidence level about 95 %, $k = 2$ )			
10 m Chamber (4F)	30 MHz ~ 200 MHz	3 m:	4.98 dB
		10 m:	4.96 dB
	200 MHz ~ 1 000 MHz	3 m:	4.28 dB
		10 m:	4.28 dB
	1 GHz ~ 6 GHz	3 m:	5.08 dB
	6 GHz ~ 18 GHz	3 m:	5.38 dB
	18 GHz ~ 30 GHz	3 m:	5.22 dB
30 GHz ~ 40 GHz	3 m:	4.44 dB	
10 m Chamber (2F)	30 MHz ~ 200 MHz	3 m:	4.50 dB
		10 m:	4.48 dB
	200 MHz ~ 1 000 MHz	3 m:	3.72 dB
		10 m:	3.70 dB
1 GHz ~ 6 GHz	3 m:	5.08 dB	

### 3.3 Measurement Program

These test items were performed by software programs;

Test item	Measurement Program		Used
Conducted Emission	EP5/CE_Ver 5.4.0(TOYO)		☒
Radiated Emission	2F	EP10/RE_Ver 2021.01.000 (TOYO)	☒
	4F	EP5/RE_Ver 5.11.10(TOYO)	





## 4. Description of EUT

### 4.1 General information

Declared Hardware Version	REV1.0
Declared Software Version	A346B.001



## 4.2 Product description

Type of product	Mobile phone
Model name (Basic)	SM-A346B/DSN
Model name (Variant)	-
Difference	-
Serial no	-
Testing voltage	120 V, 60 Hz
Input/Output rating	AC 100 V - 240 V, 50-60 Hz
Internal clock frequency	Above 108 MHz
RF Frequency	LTE Band 5: 869 MHz ~ 894 MHz LTE Band 12: 729 MHz ~ 746 MHz LTE Band 17: 734 MHz ~ 746 MHz LTE Band 26: 859 MHz ~ 894 MHz WCDMA 850: 869 MHz ~ 894 MHz GSM 850: 869 MHz ~ 894 MHz
Note	-

## 4.3 Auxiliary equipments

Type	Model / Part #	S/N	Manufacturer
Adapter	EP-TA800	-	SAMSUNG
USIM Card	-	-	-
Micro SD Card (64 GB)	Samsung Pro Plus MB-MD64G	-	SAMSUNG
Wideband Radio Communication Tester	CMW500	-	R&S
Spiral ANT	-	-	-

#### 4.4 Test configuration

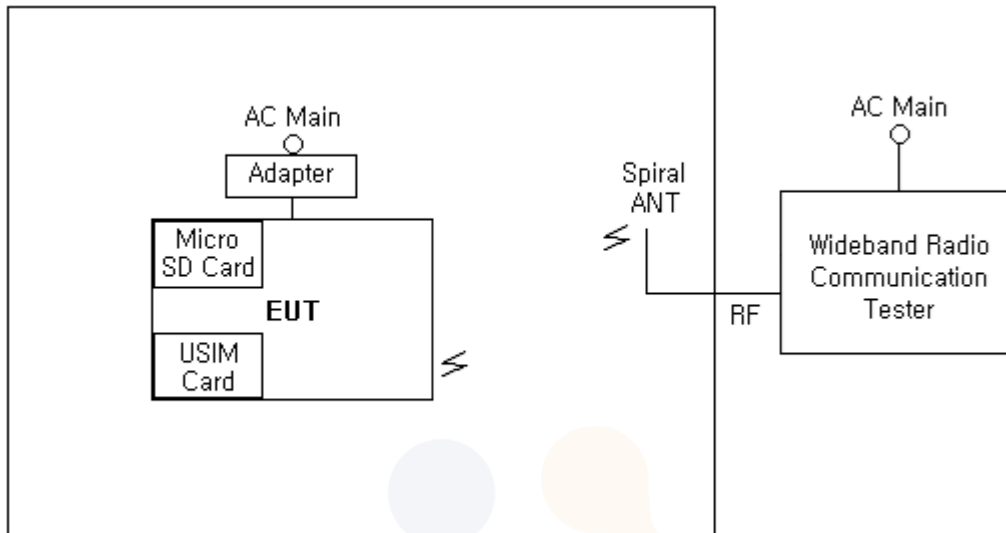

	Start		End		Cable	
	Name	I/O port	Name	I/O port	Length (m)	Spec.
1	<b>EUT</b>	Power (USB-C)	Adapter	-	1.0	Unshield
2		USIM	USIM Card	-	Direct	-
3		Micro SD	Micro SD Card	-	Direct	-
4	Wideband Radio Communication Tester	RF	Spiral ANT	-	2.0	Shield

## 4.5 Operating conditions

The EUT was configured as normal intended use.

Test mode	Normal operating
Test #1	Charging(w/TA) + Cellular receiver (GSM 850_Voice_Low)

Note 1. All cellular RX bands operating below 960 MHz, including GSM, WCDMA and LTE have been investigated with low/middle/high channels. Among the bands, **GSM 850\_Voice\_Low** is the worst mode.

Note 2. It means this device needs to be tested with 3 orientations (x, y and z) and at least the worst case orientation shall be set for final test.

It was determined that Z orientation was worst-case orientation. Therefore, all final radiated testing was performed with the EUT in Z orientation.

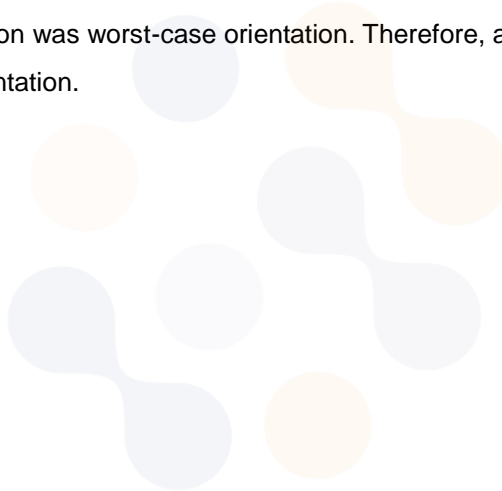

## 5. Summary of test results

### 5.1 Summary of EMI emission test results

Applied	Test items	Test method	Result
☒	Conducted Emission	ANSI C63.4:2014, Class B FCC Part 15 Subpart B	Pass
☒	Radiated Emission	ANSI C63.4:2014, Class B FCC Part 15 Subpart B	Pass



## 6. Test results

### 6.1 Conducted Emissions

Testing voltage	120 V, 60 Hz		
Test facility	Shielded room (CE#1)		
Date	2023-01-09		
Temperature (°C)	21.8 °C	Humidity (% R.H.)	22.0 % R.H.
Remarks	Pass		

#### 6.1.1 Limits of conducted emissions measurement

Frequency [MHz]	Class A (dB( $\mu$ V))		Class B (dB( $\mu$ V))	
	Quasi-peak	Average	Quasi-peak	Average
0.15 ~ 0.5	79	66	66 ~ 56 <sup>1)</sup>	56 ~ 46 <sup>1)</sup>
0.5 ~ 5	73	60	56	46
5 ~ 30	73	60	60	50

<sup>1)</sup> The limit decreases linearly with the logarithm of frequency

### 6.1.2 Measurement procedure

The measurements were performed in a shielded room. EUT was setup as shown in photograph and placed on a non-metallic table height of 0.8 m above the reference ground plane. The rear of table was located 0.4 m to the vertical conducted plane. EUT was power through the LISN, which was bonded to the ground plane. The LISN power was filtered. Each EUT power lead, except ground (safety) lead was individually connected through a LISN to input power source. EUT signal cables that hung closer than 0.4 m to the Horizontal metal ground 0.3 m ~ 0.4 m long. The power cord was bundles in the center. All peripheral equipment was powered from a sub LISN. The LISN and ISN were positioned 0.8 m from the EUT. Peak and Average detection were used in preliminary testing and Quasi-peak and Average detections were used at final measurement.

### 6.1.3 Used equipments

Equipment	Model no.	Serial no.	Makers	Next Cal. Date	Used
EMI TEST RECEIVER	ESCI	100001	R&S	2023.08.18	<input checked="" type="checkbox"/>
TWO-LINE V-NETWORK	ENV216	101358	R&S	2023.09.29	<input checked="" type="checkbox"/>
TWO-LINE V-NETWORK	ENV216	101352	R&S	2023.03.29	<input type="checkbox"/>

### 6.1.4 Conducted emissions measurement result

#### AC Main

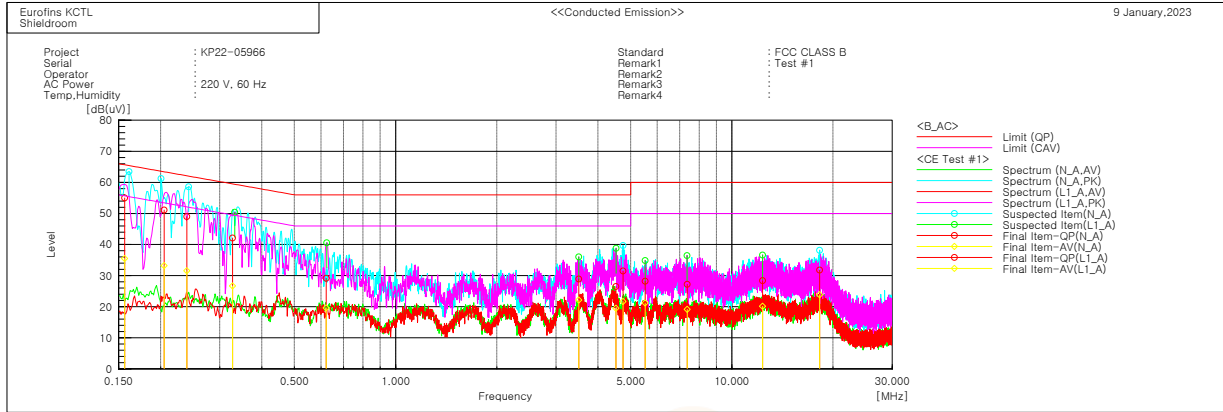

#### Final Result

##### --- N\_A Phase ---

No.	Frequency [MHz]	Reading QP [dB(uV)]	Reading CAV [dB(uV)]	c.f [dB]	Result QP [dB(uV)]	Result CAV [dB(uV)]	Limit QP [dB(uV)]	Limit AV [dB(uV)]	Margin QP [dB]	Margin CAV [dB]
1	0.15634	45.0	25.5	10.0	55.0	35.5	65.7	55.7	10.7	20.2
2	0.20482	41.1	23.2	10.0	51.1	33.2	63.4	53.4	12.3	20.2
3	0.23928	39.2	21.7	9.8	49.0	31.5	62.1	52.1	13.1	20.6
4	4.74954	21.6	11.7	9.9	31.5	21.6	56.0	46.0	24.5	24.4
5	18.25246	21.0	13.0	10.8	31.8	23.8	60.0	50.0	28.2	26.2

##### --- L\_I\_A Phase ---

No.	Frequency [MHz]	Reading QP [dB(uV)]	Reading CAV [dB(uV)]	c.f [dB]	Result QP [dB(uV)]	Result CAV [dB(uV)]	Limit QP [dB(uV)]	Limit AV [dB(uV)]	Margin QP [dB]	Margin CAV [dB]
1	0.32725	32.3	16.9	9.8	42.1	26.7	59.5	49.5	17.4	22.8
2	0.62186	19.3	9.7	9.9	29.2	19.6	56.0	46.0	26.8	26.4
3	3.50374	19.0	12.2	9.9	28.9	22.1	56.0	46.0	27.1	23.9
4	4.51882	16.6	9.6	9.9	26.5	19.5	56.0	46.0	29.5	26.5
5	5.52587	18.2	11.2	10.0	28.2	21.2	60.0	50.0	31.8	28.8
6	7.36292	17.2	9.1	10.0	27.2	19.1	60.0	50.0	32.8	30.9
7	12.34068	16.0	9.7	10.4	28.4	20.1	60.0	50.0	31.6	29.9



## 6.2 Radiated Emission

Testing voltage		120 V, 60 Hz		
Test facility		10 m Chamber (4F)		
Test distance		3 m		
Date		2023-01-10		
30 MHz ~ 1 GHz	Temperature (°C)	22.2 °C	Humidity (% R.H.)	23.5 % R.H.
1 GHz ~ 30 GHz		22.4 °C		23.9 % R.H.
Remarks		Pass		

### 6.2.1 Limits of radiated emission measurement

Frequency [MHz]	Class A at 10 m QP(dB(μV/m))		Class B at 3 m QP(dB(μV/m))	
	FCC <sup>1)</sup>	ISED (ICES Issue 7)	FCC <sup>1)</sup>	ISED (ICES Issue 7)
30-88	39.1	40.0	40.0	40.0
88-216	43.5	43.5	43.5	43.5
216-230	46.4	46.4	46.0	46.0
230-960	46.4	47.0	46.0	47.0
Above 960	49.5	49.5	54.0	54.0

- <sup>1)</sup>: Alternative standard: CISPR, Pub. 22

- Test data in this section has been taken against the FCC 15.109(a) or (B) Limit as it is the most stringent limit.

By complying with more restrictive FCC 15.109 Limit compliance with the ICES-003 Issue 7 limit also demonstrated.

### 6.2.2 Measurement procedure

The test was done at a 10 m chamber with a quasi-peak detector. EUT was placed on a non-metallic table height of 0.8 m above the reference ground plane. Cables were folded back and forth forming a bundle 0.3 m to 0.4 m long and were hanged at a 0.4 m height to the ground plane.

Cables connected to EUT were fixed to cause maximum emission. Test was made with the antenna positioned in both the horizontal and vertical planes of polarization. The measurement antenna was varied in height above the conducting ground plane to obtain the maximum signal strength.

### 6.2.3 Used equipments

Equipment	Model no.	Serial no.	Makers	Next Cal. Date	Used
EMI TEST RECEIVER	ESR7	101078	R&S	2023.08.18	☒
Bilog Antenna	CBL 6112D	37876	TESEQ	2024.09.07	☒
AMPLIFIER	310N	293004	SONOMA	2023.08.18	☒
ATTENUATOR	8491B	MY39270292	AGILENT	-	☒
Antenna Mast	MA4640-XP-ET	-	Innco Systems	-	☒
Turn Table	DT3000-2t	-	Innco Systems	-	☒
DOUBLE RIDGED HORN ANTENNA	3117	00161083	ETS-LINDGREN	2023.01.21	☒
BROADBAND PREAMPLIFIER	BBV 9718C	00138	SCHWARZBECK	2023.10.19	☒
DOUBLE RIDGED HORN ANTENNA	3116C	218560	ETS-LINDGREN	2023.03.24	☒
PREAMPLIFIER	JS44-18004000-33-8P	2055879	MITEQINC	2023.03.24	☒

### 6.2.4 Sample calculation

The field strength is calculated adding the antenna Factor, cable loss and, Antenna pad adding, subtracting the amplifier gain from the measured reading.

The sample calculation is as follow:

$$\text{Result} = \text{M.R} + \text{C.F}(\text{A.F} + \text{C.L} + 6 \text{ dB Att} - \text{A.G})$$

M.R = Meter Reading

C.F = Correction Factor

A.F = Antenna Factor

C.L = Cable Loss

A.G = Amplifier Gain

6 dB Att = 6 dB Attenuator

If M.R is 30 dB, A.F 12 dB, C.L 5 dB, 6 dB, A.G 35 dB

The result is  $30 + 12 + 5 + 6 - 35 = 18 \text{ dB } (\mu\text{V/m})$

Bilog Antenna and ATTENUATOR (6 dB) were calibrated together.

AV = CAV : Abbreviation of CISPR Average

## 6.2.5 Radiated emission measurement result

30 MHz ~ 1 GHz

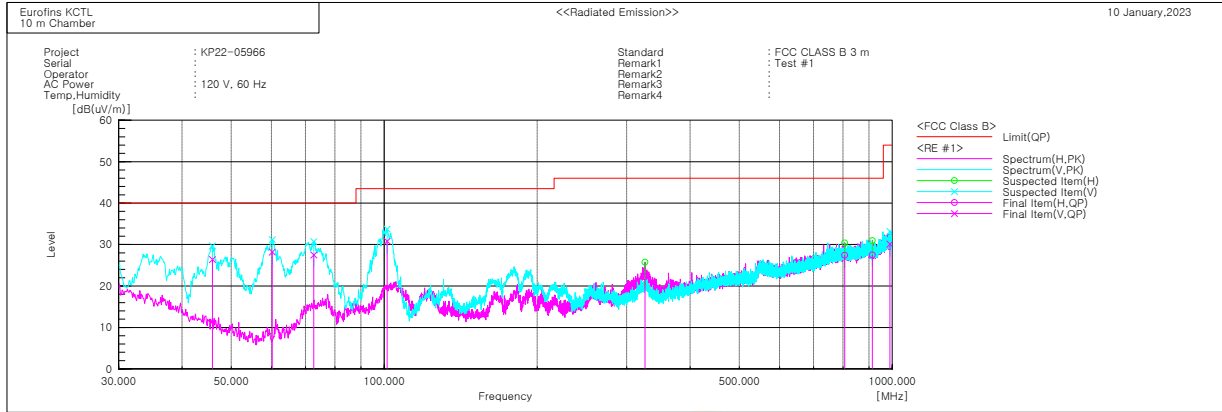

### Final Result

No.	Frequency [MHz]	(P)	Reading QP [dB(uV)]	c. f [dB(1/m)]	Result QP [dB(uV/m)]	Limit QP [dB(uV/m)]	Margin QP [dB]	Height [cm]	Angle [deg]
1	45.884	V	39.6	-13.2	26.4	40.0	13.6	106.0	32.0
2	60.191	V	44.7	-16.5	28.2	40.0	11.8	149.0	274.0
3	72.680	V	43.6	-16.1	27.5	40.0	12.5	296.0	267.0
4	101.295	V	41.8	-11.0	30.8	43.5	12.7	108.0	265.0
5	326.093	H	26.7	-4.5	22.2	46.0	23.8	390.0	324.0
6	806.000	H	18.3	9.1	27.4	46.0	18.6	371.0	4.0
7	913.791	H	17.3	10.2	27.5	46.0	18.5	344.0	53.0
8	989.088	V	17.0	13.1	30.1	54.0	23.9	100.0	172.0

1 GHz ~ 18 GHz

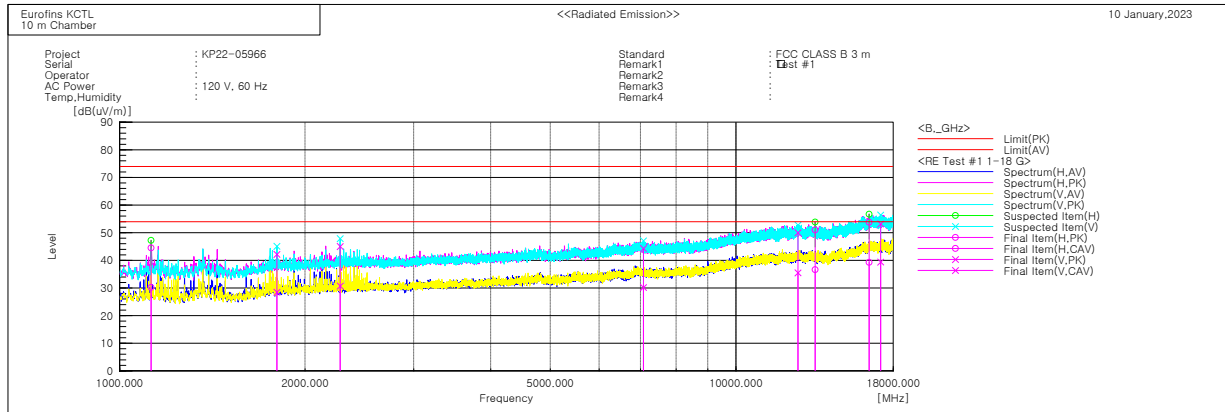

Final Result

No.	Frequency [MHz]	(P)	Reading PK [dB(uV)]	Reading CAV [dB(uV)]	c.f [dB(1/m)]	Result PK [dB(uV/m)]	Result CAV [dB(uV/m)]	Limit PK [dB(uV/m)]	Limit AV [dB(uV/m)]	Margin PK [dB]	Margin CAV [dB]	Height [cm]	Angle [deg]
1	1124.956	H	51.3	37.0	-6.8	44.5	30.2	74.0	54.0	29.5	23.8	310.0	140.0
2	1799.890	V	44.6	30.9	-2.4	42.2	28.5	74.0	54.0	31.8	25.5	125.0	158.0
3	2280.164	V	46.0	31.7	-1.0	45.0	30.7	74.0	54.0	29.0	23.3	102.0	233.0
4	7079.504	V	35.4	21.3	8.9	44.3	30.2	74.0	54.0	29.7	23.8	172.0	233.0
5	12612.430	V	33.4	18.9	16.6	50.0	35.5	74.0	54.0	24.0	18.5	160.0	233.0
6	13440.370	H	33.8	19.4	17.2	51.0	36.6	74.0	54.0	23.0	17.4	271.0	314.0
7	16445.270	H	34.8	20.3	19.0	53.8	39.3	74.0	54.0	20.2	14.7	280.0	24.0
8	17166.110	V	33.3	19.5	19.9	53.2	39.4	74.0	54.0	20.8	14.6	105.0	357.0

18 GHz ~ 30 GHz

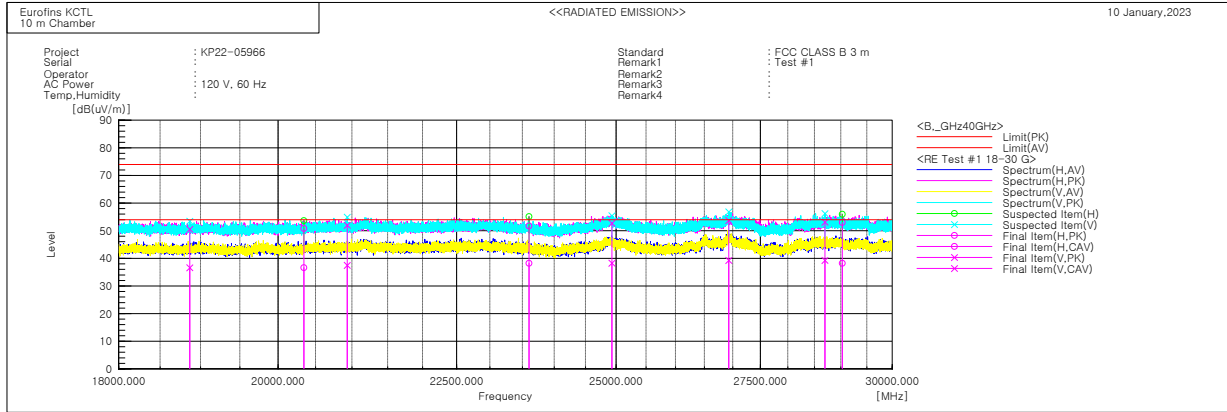

Final Result

No.	Frequency [MHz]	(P)	Reading PK [dB(uV)]	Reading CAV [dB(uV)]	c.f [dB(1/m)]	Result PK [dB(uV/m)]	Result CAV [dB(uV/m)]	Limit PK [dB(uV/m)]	Limit AV [dB(uV/m)]	Margin PK [dB]	Margin CAV [dB]	Height [cm]	Angle [deg]
1	18864.640	V	49.2	35.3	1.3	50.5	36.6	74.0	54.0	23.5	17.4	109.0	87.0
2	20341.320	H	49.3	35.1	1.5	50.8	36.6	74.0	54.0	23.2	17.4	332.0	68.0
3	20932.350	V	50.2	35.7	1.8	52.0	37.5	74.0	54.0	22.0	16.5	158.0	342.0
4	23601.880	H	48.5	35.0	3.2	51.7	38.2	74.0	54.0	22.3	15.8	221.0	217.0
5	24930.350	V	48.7	34.3	4.0	52.7	38.3	74.0	54.0	21.3	15.7	140.0	342.0
6	26929.050	V	48.8	34.4	4.9	53.7	39.3	74.0	54.0	20.3	14.7	129.0	308.0
7	28694.340	V	48.5	34.7	4.6	53.1	39.3	74.0	54.0	20.9	14.7	170.0	87.0
8	29028.550	H	48.7	33.9	4.3	53.0	38.2	74.0	54.0	21.0	15.8	115.0	68.0