

EMI TEST REPORT

FCC CERTIFICATION

Applicant:

SAMSUNG Electronics Co., Ltd.
129, Samsung-ro, Yeongtong-gu, Suwon-si,
Gyeonggi-do, 16677, Korea

Date of Issue: February 19, 2021

Test Report No. HCT-EM-2102-FC010-R1

Test Site: HCT CO., LTD.

FCC ID :

A3LSMA326U

Rule Part(s) / Standard(s) : 47 CFR PART 15 Subpart B Class B
ANSI C63.4-2014
Product Name : Mobile Phone
Model Name : SM-A326U
Series Model Name : SM-A326U1/DS, SM-S326DL
Date of Test : February 01, 2021 to February 04, 2021

The device bearing the trade name and model specified above, has been shown to comply with the applicable technical standards as indicated in the measurement report and was tested in accordance with the measurement procedures specified in ANSI C63.4-2014. (See Test Report if any modifications were made for compliance)


I attest to the accuracy of data. All measurements reported herein were performed by me or were made under my supervision and are correct to the best of my knowledge and belief. I assume full responsibility for the completeness of these measurements and vouch for the qualifications of all persons taking them.

Tested By



Na-Eun Song
Test Engineer
EMC Team
Certification Division

Reviewed



Jeong-Hyun Choi
Technical Manager
EMC Team
Certification Division

This report only responds to the tested sample and may not be reproduced, except in full, without written approval of the HCT Co., Ltd.



REVISION HISTORY

The revision history for this document is shown in table.

Report No.	Issue Date	Information About Changes
0	February 10, 2021	Initial Release
1	February 19, 2021	Added the operating mode in clause 4. Preliminary Test

The above Test Report is not related to the accredited test result by (KS Q) ISO/IEC 17025 and KOLAS (Korea Laboratory Accreditation Scheme) / A2LA (American Association for Laboratory Accreditation), which signed the ILAC-MRA.

* The report shall not be reproduced except in full(only partly) without approval of the laboratory.



TABLE OF CONTENTS

	PAGE
1. GENERAL INFORMATION	4
1.1 Description of EUT	4
1.2 Tested System Details	4
1.3 Cable Description.....	5
1.4 Noise Suppression Parts on Cable. (I/O Cable)	5
1.5 Test Facility.....	6
1.6 Calibration of Measuring Instrument	6
1.7 Measurement Uncertainty	6
2. LIST OF TEST EQUIPMENT	7
3. DESCRIPTION OF TEST.....	8
3.1 Measurement of Conducted Emission.....	8
3.2 Measurement of Radiated Emission.....	9
4. PRELIMINARY TEST.....	11
4.1 Conducted Emission.....	11
4.2 Rediated Emission.....	11
5. CONDUCTED AND RADIATED EMISSION TEST SUMMARY.....	13
5.1 Conducted Emission.....	13
5.2 Radiated Emission.....	14
6. CONCLUSION	23
7. APPENDIX A. TEST SETUP PHOTO	24



1. GENERAL INFORMATION

1.1 Description of EUT

FCC ID	A3LSMA326U	
Model Name	SM-A326U	
Series Model Name	SM-A326U1/DS, SM-S326DL	
Product Name	Mobile Phone	
Frequency Band	CDMA BC0/1/10, GSM 850/1900, WCDMA B2/4/5, LTE B2/4/5/7/12/13/14/25/26/29(Rx only)/30/38/40/41/46(RX only)/48/66/71, 5G Sub6 NR n2/5/25/41/66/71/77, BT BDR/EDR/LE(5.0), WLAN a/b/g/n/ac(SISO), NFC	
Power Voltage	Travel adaptor	Input: AC (100 to 240) V, (50 to 60) Hz, 0.5 A Output: DC 9.0 V, 1.67 A or DC 5.0 V, 2.0 A
	Battery	Li-ion Battery, Low: 3.65 V, Normal: 3.86 V, High: 4.38 V

1.2 Tested System Details

All equipment descriptions used in the tested system (including inserted cards) are:

Device Type	Model Name	Serial Number	Manufacturer
EUT	SM-A326U	-	SAMSUNG
TA	EP-TA200	-	RF-TECH
Data Cable	EP-DR140AWE	-	RF-TECH
Earphone	EHS64AVFWE	-	SAMSUNG
Micro SD Card	-	-	SAMSUNG



1.3 Cable Description

Product Name	Port	Power Cord Shielded (Y/N)	I/O Cable Shielded (Y/N)	Length (m)
EUT	USB Type C	Y	N/A	(P) 0.8
	Earphone	N/A	N	(D) 1.3

* The marked "(D)" means the data cable and "(P)" means the power cable.

1.4 Noise Suppression Parts on Cable. (I/O Cable)

Product Name	Port	Ferrite Bead (Y/N)	Location	Metal Hood (Y/N)	Location
EUT	USB Type C	N	N/A	Y	Both End
	Earphone	N	N/A	Y	EUT End



1.5 Test Facility

Test site is located at 74, Seoicheon-ro 578beon-gil, Majang-myeon, Icheon-si, Gyeonggi-do, Korea. Those measurement facilities are constructed in conformance with the requirements of ANSI C63.4-2014. The Normalized site attenuations (30 MHz to 1 GHz) and Site validation (1 GHz to 18 GHz) were performed in accordance with the standard in ANSI C63.4-2014.

Our laboratories are accredited and designated in accordance with the provisions of Radio Waves ACT and International Standard ISO/IEC 17025:2017. (National Radio Research Agency, Designation No. KR0032)

1.6 Calibration of Measuring Instrument

The measuring equipment, which was utilized in performing the tests documented herein, has been calibrated in accordance with the manufacturers recommendations for utilizing calibration equipment, which is traceable to recognized national standards.

Especially, all antenna for measurement is calibrated in accordance with the requirements of C63.5:2017

1.7 Measurement Uncertainty

The measurement uncertainties shown below were calculated in accordance with the requirements of ANSI C63.4-2014.

All measurement uncertainty values are shown with a coverage factor of $k = 2$ to indicate a 95 % level of confidence. The measurement data shown herein meets or exceeds the U_{CISPR} measurement uncertainty values specified in CISPR 16-4-2 and, thus, can be compared directly to specified limits to determine compliance.

Test Item	Test Site (Chamber)	Expanded Uncertainty
Radiated Emissions (30 MHz to 1 GHz)	3 m Semi Anechoic Chamber #1	4.9 dB
Radiated Emissions (1 GHz to 18 GHz)	3 m Semi Anechoic Chamber #1	4.6 dB
Radiated Emissions (18 GHz to 40 GHz)	3 m Semi Anechoic Chamber #1	5.6 dB



2. LIST OF TEST EQUIPMENT

<u>Type</u>	<u>Model Name</u>	<u>Manufacturer</u>	<u>Serial Number</u>	<u>Calibration Cycle</u>	<u>Calibration Date</u>
<u>Conducted Emission (Not applicable)</u>					
<input type="checkbox"/> LISN	ENV216	Rohde & Schwarz	102245	1 year	09.04.2020
<input type="checkbox"/> LISN	ENV216	Rohde & Schwarz	100073	1 year	04.27.2020
<input type="checkbox"/> Radio communication analyzer	MT8820C	ANRITSU	6201138643	1 year	08.19.2020
<input type="checkbox"/> Antenna (for Communication)	USLP9142	Schwarzbeck	USLP 9142-200	-	-
<input type="checkbox"/> Software	EMC32	Rohde & Schwarz	-	-	-
<u>Radiated Emission</u>					
-For measurement below 1 GHz					
<input checked="" type="checkbox"/> EMI Test Receiver	ESU40	Rohde & Schwarz	100524	1 year	05.12.2020
<input checked="" type="checkbox"/> Bi-Log Antenna	VULB 9168	Schwarzbeck	255	2 year	03.26.2019
<input checked="" type="checkbox"/> Antenna master	MA4640-XP-ET	INNCO Systems	-	N/A	-
<input checked="" type="checkbox"/> Antenna master controller	CO3000	INNCO Systems	CO3000/870/ 35990515/L	N/A	-
<input checked="" type="checkbox"/> Turn Table	1060	INNCO Systems	-	N/A	-
<input checked="" type="checkbox"/> Turn Table controller	CO2000	INNCO Systems	CO2000/095/ 7590304/L	N/A	-
<input checked="" type="checkbox"/> Radio communication analyzer	MT8821C	ANRITSU	6262192376	1 year	12.24.2020
<input checked="" type="checkbox"/> Antenna (for Communication)	USLP9142	Schwarzbeck	USLP 9142-200	-	-
<input checked="" type="checkbox"/> Signalling Tester	MT8000A	ANRITSU	6262208294	1 year	12.24.2020
<input checked="" type="checkbox"/> Antenna (for Communication)	USLP9142	Schwarzbeck	USLP 9142-201	-	-
<input checked="" type="checkbox"/> Software	EMC32	Rohde & Schwarz	-	-	-
-For measurement above 1 GHz					
<input checked="" type="checkbox"/> EMI Test Receiver	ESU40	Rohde & Schwarz	100524	1 year	05.12.2020
<input checked="" type="checkbox"/> Antenna master	MA4640-XP-ET	INNCO Systems	-	N/A	-
<input checked="" type="checkbox"/> Antenna master controller	CO3000	INNCO Systems	CO3000/870/ 35990515/L	N/A	-
<input checked="" type="checkbox"/> Turn Table	1060	INNCO Systems	-	N/A	-
<input checked="" type="checkbox"/> Turn Table controller	CO2000	INNCO Systems	CO2000/095/ 7590304/L	N/A	-
<input checked="" type="checkbox"/> Low Noise Amplifier	TK-PA18H	TESTEK	170034-L	1 year	03.03.2020
<input checked="" type="checkbox"/> Low Noise Amplifier	TK-PA1840H	TESTEK	170030-L	1 year	02.13.2020
<input checked="" type="checkbox"/> Horn Antenna	BBHA 9120D	Schwarzbeck	01836	1 year	07.23.2020
<input checked="" type="checkbox"/> Horn Antenna	BBHA 9170	Schwarzbeck	BBHA 9170#786	1 year	11.18.2020
<input checked="" type="checkbox"/> Radio communication analyzer	MT8821C	ANRITSU	6262192376	1 year	12.24.2020
<input checked="" type="checkbox"/> Antenna (for Communication)	USLP9142	Schwarzbeck	USLP 9142-200	-	-
<input checked="" type="checkbox"/> Signalling Tester	MT8000A	ANRITSU	6262208294	1 year	12.24.2020
<input checked="" type="checkbox"/> Antenna (for Communication)	USLP9142	Schwarzbeck	USLP 9142-201	-	-
<input checked="" type="checkbox"/> Software	EMC32	Rohde & Schwarz	-	-	-



3. DESCRIPTION OF TEST

3.1 Measurement of Conducted Emission

The test procedure was in accordance with ANSI C63.4-2014, Clause 7.3

- a. The EUT was placed 0.4 meters from the conducting wall of the shielded room with EUT being connected to the power mains through a line impedance stabilization network (LISN).
If the EUT is connected to the PC through USB, the AC power-line adapter of the PC is directly connected to a line impedance stabilization network (LISN).
Other support units were connected to the power mains through another LISN. The two LISNs provide 50 Ohm/ 50uH of coupling impedance for the measuring instrument.
- b. Both conducted lines are measured in Quasi-Peak and Average mode, including the worst-case data points for each tested configuration.
- c. The frequency range from 150 kHz to 30 MHz was searched.

[Conducted Emission Limits]

Frequency (MHz)	Resolution Bandwidth (kHz)	Quasi-Peak (dB(μV))	Average (dB(μV))
0.15 to 0.5	9	66 to 56*	56 to 46*
0.5 to 5	9	56	46
5 to 30	9	60	50

**Decreases with the logarithm of the frequency.*



3.2 Measurement of Radiated Emission

The test procedure was in accordance with ANSI C63.4-2014, Clause 8.3

- a. The EUT was placed on the top of a turn table 0.8 meters above the ground at a semi-anechoic chamber. The table was rotated 360 degrees to determine the position of the highest radiation.
- b. The EUT was set 3 m away from the interference-receiving antenna, which was mounted on the top of a variable-height antenna tower.
- c. The antenna height is varied from 1 m to 4 m above the ground to determine the maximum value of the field strength. Both horizontal and vertical polarizations of the antenna are set to make the measurement.
- d. For each suspected emission, the EUT was arranged to its worst case and then the antenna was tuned to heights from 1 m to 4 m and the turn table was turned from 0 degrees to 360 degrees to find the maximum reading.
- e. The test-receiver system was set to Quasi-Peak detect function and specified bandwidth with maximum hold mode when the test frequency is below 1 GHz.
- f. The test-receiver system was set to Peak and Average detect function and specified bandwidth with maximum hold mode when the test frequency is above 1 GHz.
- g. Place the measurement antenna away from each area of the EUT determined to be a source of emissions at the specified measurement distance, while keeping the measurement antenna aimed at the source of emissions at each frequency of significant emissions, with polarization oriented for maximum response.(1 GHz to 40 GHz)

[Radiated Emission Limits]

Frequency (MHz)	Antenna Distance (m)	Field Strength ($\mu\text{V}/\text{m}$)	Quasi-Peak ($\text{dB}(\mu\text{V}/\text{m})$)
30 to 88	3	100	40.0
88 to 216	3	150	43.5
216 to 960	3	200	46.0
Above 960	3	500	54.0
Frequency (MHz)	Antenna Distance (m)	Peak ($\text{dB}(\mu\text{V}/\text{m})$)	Average ($\text{dB}(\mu\text{V}/\text{m})$)
Above 1 000	3	74	54

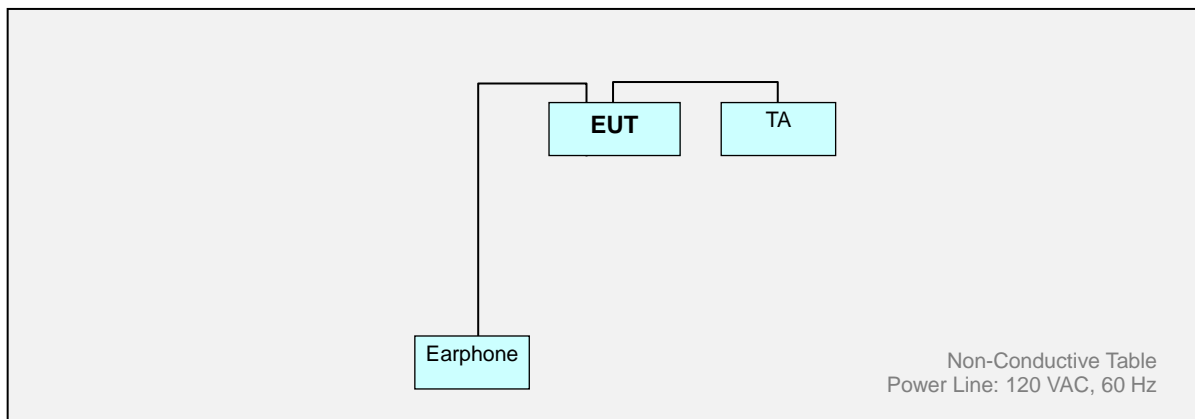


3.2.1 Frequency Range of Radiated Measurements

An unintentional radiator, including a digital device, the spectrum shall be investigated from the lowest radio frequency signal generated or used in the device, without going below the lowest frequency for which a Radiated Emission limit is specified, up to the frequency shown in the following table

Highest frequency generated or used in the device or on which the device operates or tunes (MHz)	Upper frequency of measurement range (MHz)
Below 1.705	30
1.705 to 108	1 000
108 to 500	2 000
500 to 1 000	5 000
Above 1 000	5 th harmonic of the highest frequency or 40 GHz, whichever is lower

3.3 Configuration of Tested System





4. PRELIMINARY TEST

During preliminary tests, the following operating mode was investigated.

Receiver mode(CDMA BC0 Low/Middle/High ch Idle)
 Receiver mode(CDMA BC10 Low/Middle/High ch Idle)
 Receiver mode(GSM 850 Low/Middle/High ch Idle)
 Receiver mode(WCDMA B5 Low/Middle/High ch Idle)
 Receiver mode(LTE B5 Low/Middle/High ch Idle)
 Receiver mode(LTE B26 Low/Middle/High ch Idle)
 Receiver mode(LTE B12 Low/Middle/High ch Idle)
 Receiver mode(LTE B13 Low/Middle/High ch Idle)
 Receiver mode(LTE B14 Low/Middle/High ch Idle)
 Receiver mode(LTE B29 Low/Middle/High ch Idle)
 Receiver mode(LTE B71 Low/Middle/High ch Idle)
 Receiver mode(5G NR n5 Low/Middle/High ch Idle)
 Receiver mode(5G NR n71 Low/Middle/High ch Idle)

NOTE. The worst band is tested.

4.1 Conducted Emission (Not applicable)

It was tested the following operating mode, after connecting all peripheral devices.

Operating Mode: Not Applicable

NOTE.

Compliance with Part 15B requirement for the conducted emissions is covered by SAMSUNG test report.

4.2 Radiated Emission

It was tested the following operating mode, after connecting all peripheral devices.

Operating Mode:

Radiated Emission below 1 GHz :

- LTE B26+B5+5G NR n5 Low ch Idle
- LTE B26+B5+5G NR n5 Middle ch Idle *
- LTE B26+B5+5G NR n5 High ch Idle
- LTE B12+B13 Low ch Idle
- LTE B12+B13 Middle ch Idle *
- LTE B12+B13 High ch Idle
- LTE B14 Low ch Idle
- LTE B14 Middle ch Idle *
- LTE B14 High ch Idle
- LTE B29 Low ch Idle
- LTE B29 Middle ch Idle *
- LTE B29 High ch Idle
- LTE B71+5G NR n71 Low ch Idle
- LTE B71+5G NR n71 Middle ch Idle *
- LTE B71+5G NR n71 High ch Idle



Radiated Emission above 1 GHz : LTE B26+B5+5G NR n5 Middle ch Idle
LTE B12+B13 Middle ch Idle
LTE B14 Middle ch Idle *
LTE B29 Middle ch Idle
LTE B71+5G NR n71 Middle ch Idle

NOTE.

1. Three orientations have been investigated and the worst case orientation (x-axis: The display of EUT placed on the table is facing upwards) is reported.
2. The worst case of operating mode is reported. [*].



5. CONDUCTED AND RADIATED EMISSION TEST SUMMARY

5.1 Conducted Emission(Not applicable)

The test results of conducted emission at mains ports provide the following information:

Used Test Standard	47 CFR PART 15 Subpart B Class B ANSI C63.4-2014
Frequency Range	150 kHz to 30 MHz
Detector	Quasi-Peak, CISPR-Average
Bandwidth	9 kHz (6 dB)
Operating Mode	Not applicable
Test Site	-
Temperature	- °C
Relative Humidity	- %
Test Date	-



5.2 Radiated Emission

5.2.1 For Measurement Below 1 GHz

The test results of radiated emission provide the following information:

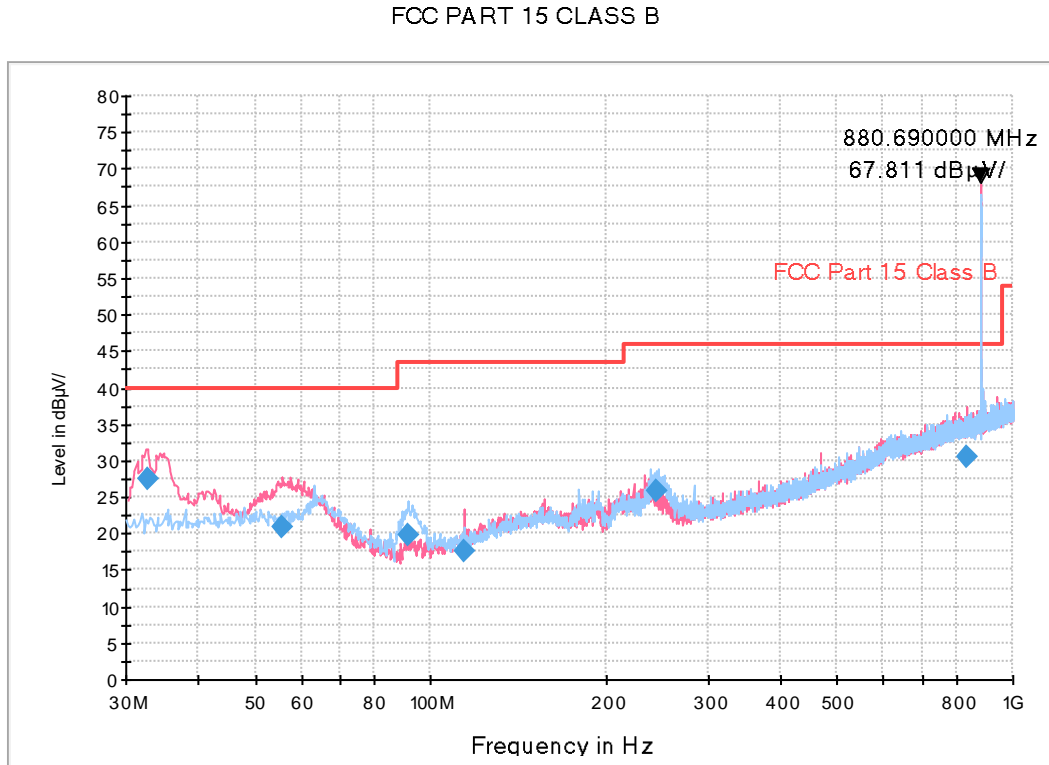
Used Test Standard	47 CFR PART 15 Subpart B Class B ANSI C63.4-2014
Frequency Range	30 MHz to 1 000 MHz
Detector	Quasi-Peak
Bandwidth	120 kHz (6 dB)
Worst Case of Operating Mode	LTE B26+B5+5G NR n5 Middle ch Idle LTE B12+B13 Middle ch Idle LTE B14 Middle ch Idle LTE B29 Middle ch Idle LTE B71+5G NR n71 Middle ch Idle
Measurement Distance	3 m
Test Site	3 m Semi Anechoic Chamber #1
Temperature	(21.4 – 22.1) °C
Relative Humidity	(43.8 – 45.7) %
Test Date	February 01 to February 03, 2021

- Calculation Formula:

1. POL. H = Horizontal, POL. V = Vertical
2. QuasiPeak = Reading (Receiver Reading) + Corr.
3. Corr. (Correction Factor) = Antenna Factor + Cable Loss
4. Margin = Limit - QuasiPeak



Figure 1: Radiated Emission (30 MHz to 1 GHz), LTE B26+B5+5G NR n5 Middle ch Idle

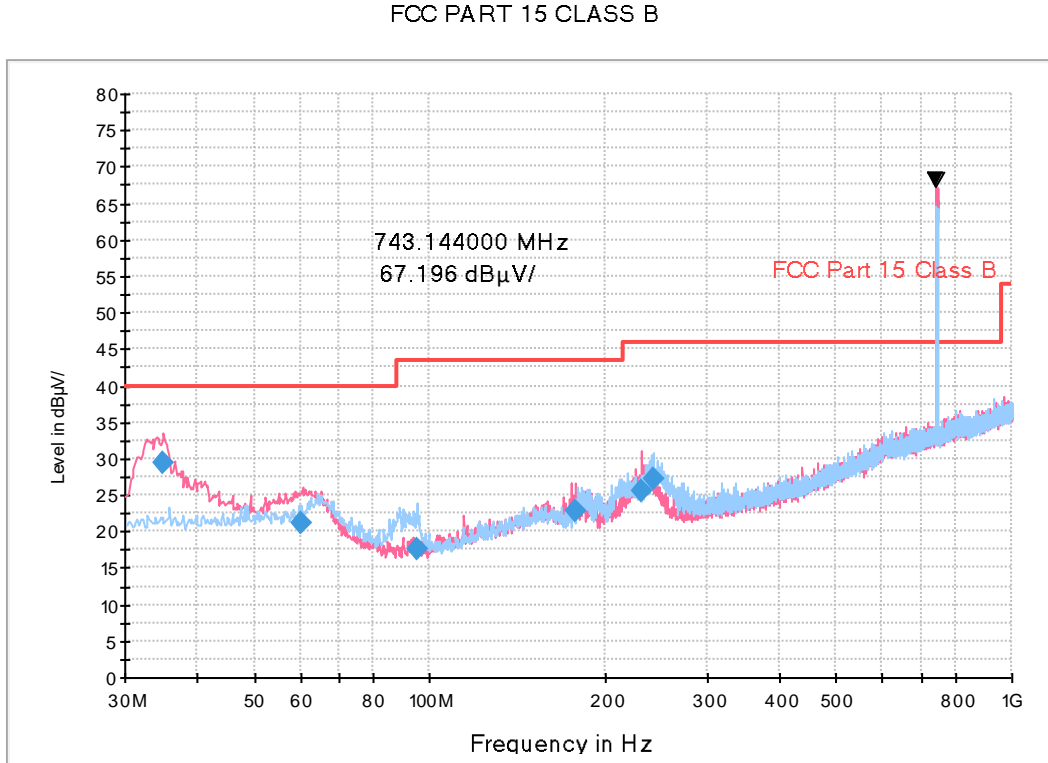


NOTE. 1. Carrier Frequency: RX 880.690 MHz
 2. These are signals for fundamental frequency from the base station

Frequency (MHz)	Quasi Peak (dBµV/m)	Antenna Height (cm)	POL. (H/V)	Azimuth (deg)	Corr. (dB)	Margin (dB)	Limit (dBµV/m)
32.604600	27.4	100.0	V	345.0	18.5	12.6	40.0
55.474200	20.9	100.0	V	147.0	19.6	19.1	40.0
91.519600	19.7	193.9	H	333.0	14.4	23.8	43.5
114.487000	17.6	308.7	V	327.0	16.8	22.4	40.0
243.945680	26.0	100.0	H	245.0	18.4	20.0	46.0
832.560640	30.5	274.7	V	166.0	30.6	15.5	46.0



Figure 2: Radiated Emission (30 MHz to 1 GHz), LTE B12+B13 Middle ch Idle



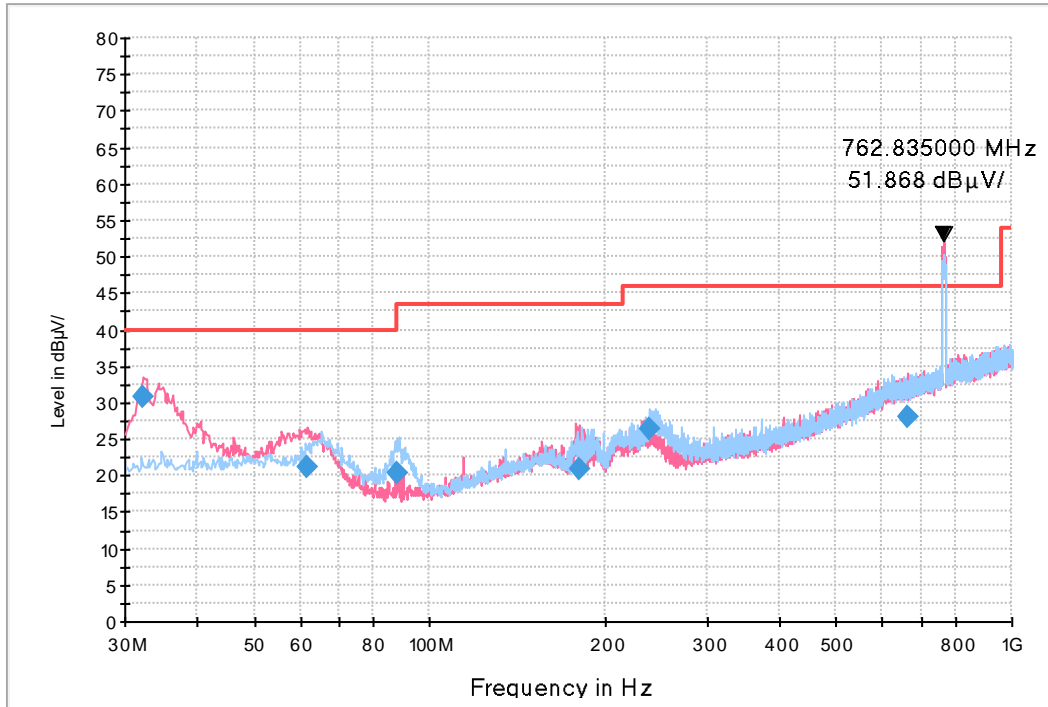
NOTE. 1. Carrier Frequency: RX 743.144 MHz
 2. These are signals for fundamental frequency from the base station

Frequency (MHz)	Quasi Peak (dBµV/m)	Antenna Height (cm)	POL. (H/V)	Azimuth (deg)	Corr. (dB)	Margin (dB)	Limit (dBµV/m)
34.995360	29.5	100.0	V	74.0	18.6	10.5	40.0
60.419880	21.2	308.8	V	52.0	19.3	18.8	40.0
95.211440	17.6	193.8	H	129.0	14.7	25.9	43.5
178.728960	22.9	100.0	V	142.0	18.4	20.6	43.5
230.724360	25.6	100.0	V	57.0	17.9	20.4	46.0
242.515240	27.2	125.0	H	27.0	18.4	18.8	46.0



Figure 3: Radiated Emission (30 MHz to 1 GHz), LTE B14 Middle ch Idle

FCC PART 15 CLASS B



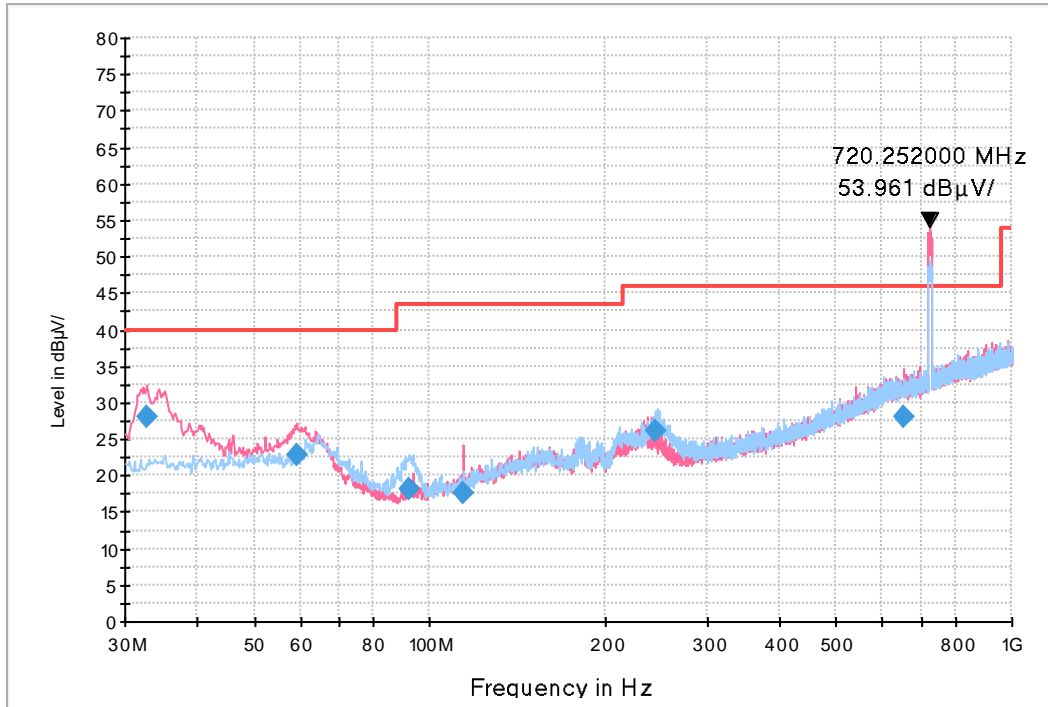
NOTE. 1. Carrier Frequency: RX 762.835 MHz
 2. These are signals for fundamental frequency from the base station

Frequency (MHz)	Quasi Peak (dBµV/m)	Antenna Height (cm)	POL. (H/V)	Azimuth (deg)	Corr. (dB)	Margin (dB)	Limit (dBµV/m)
32.209480	30.7	100.0	V	196.0	18.4	9.3	40.0
61.689120	21.2	125.3	V	86.0	19.2	18.8	40.0
87.711720	20.4	225.1	H	117.0	14.6	19.6	40.0
181.475440	21.0	125.0	V	85.0	18.2	22.5	43.5
238.181840	26.4	118.0	H	212.0	18.2	19.6	46.0
660.058640	28.0	125.3	V	202.0	28.2	18.0	46.0



Figure 4: Radiated Emission (30 MHz to 1 GHz), LTE B29 Middle ch Idle

FCC PART 15 CLASS B

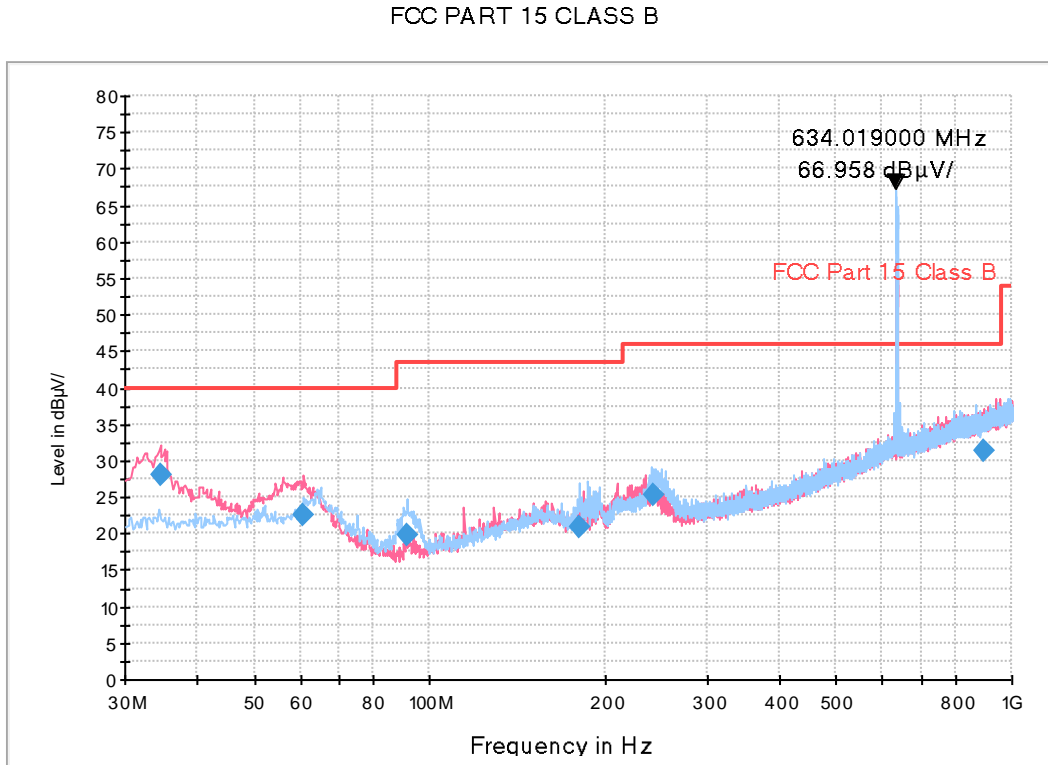


- NOTE. 1. Carrier Frequency: RX 720.252 MHz
 2. These are signals for fundamental frequency from the base station

Frequency (MHz)	Quasi Peak (dBµV/m)	Antenna Height (cm)	POL. (H/V)	Azimuth (deg)	Corr. (dB)	Margin (dB)	Limit (dBµV/m)
32.678720	28.0	117.8	V	197.0	18.5	12.0	40.0
59.095080	22.7	100.0	V	82.0	19.4	17.3	40.0
92.634320	18.1	174.8	H	0.0	14.5	25.4	43.5
114.461920	17.5	174.9	V	237.0	16.8	26.0	43.5
244.216160	26.2	100.0	H	213.0	18.5	19.8	46.0
653.476600	27.9	174.8	V	288.0	28.1	18.1	46.0



Figure 5: Radiated Emission (30 MHz to 1 GHz), LTE B71+5G NR n71 Middle ch Idle



NOTE. 1. Carrier Frequency: RX 634.019 MHz
 2. These are signals for fundamental frequency from the base station

Frequency (MHz)	Quasi Peak (dBµV/m)	Antenna Height (cm)	POL. (H/V)	Azimuth (deg)	Corr. (dB)	Margin (dB)	Limit (dBµV/m)
34.495040	28.0	100.0	V	57.0	18.6	12.0	40.0
60.801040	22.7	307.7	V	56.0	19.3	17.3	40.0
91.653880	19.8	191.8	H	128.0	14.4	23.7	43.5
181.180280	20.9	190.8	H	17.0	18.2	22.6	43.5
242.252480	25.4	117.9	H	79.0	18.4	20.6	46.0
896.709600	31.3	100.0	V	266.0	31.4	14.7	46.0



5.2.2 For Measurement Above 1 GHz

The test results of radiated emission provide the following information:

Used Test Standard	47 CFR PART 15 Subpart B Class B ANSI C63.4-2014
Detector	Peak mode: Peak (RBW: 1 MHz, VBW: 3 MHz) CISPR-Average mode: Peak (RBW: 1 MHz, VBW: 10 Hz)
Highest Frequency	5 925 MHz
Tested Frequency Range	1 GHz to 30 GHz
Worst Case of Operating Mode	LTE B14 Middle ch Idle
Measurement Distance	3 m
Test Site	3 m Semi Anechoic Chamber #1
Temperature	(22.5 – 23.1) °C
Relative Humidity	(46.1 – 46.8) %
Test Date	February 03 to February 04, 2021

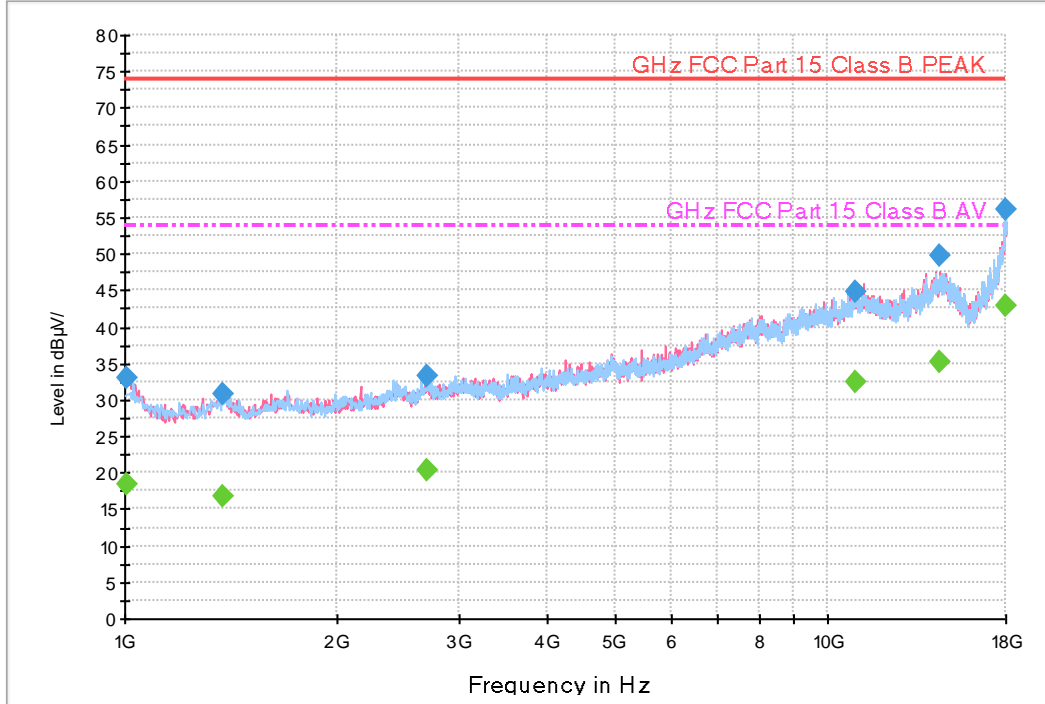
- Calculation Formula:

1. POL. H = Horizontal, POL. V = Vertical
2. Peak or CAverage = Reading (Receiver Reading) + Corr.
3. Corr. (Correction Factor) = Antenna Factor+ Cable Loss –Amplifier Gain
4. Margin = Limit - Peak or CAverage

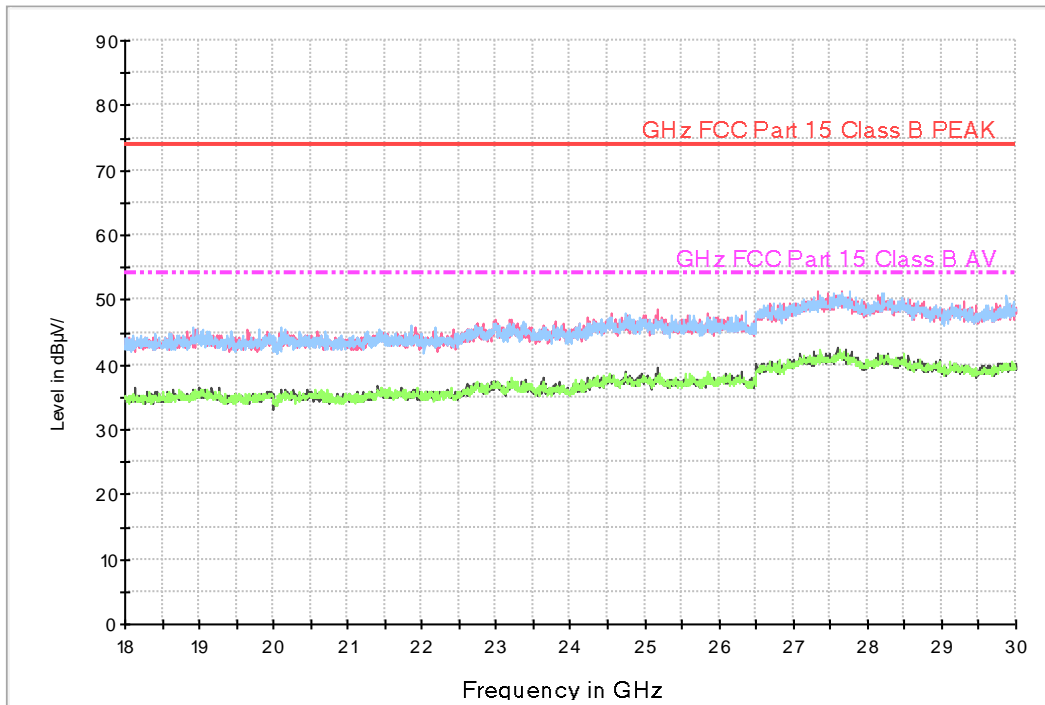


Figure 6: Radiated Emission (1 GHz to 30 GHz), LTE B14 Middle ch Idle

Tilting of GHz FCC PART 15 CLASS B



Tilting of GHz FCC PART 15 CLASS B_18~40GHz





Frequency (MHz)	Peak (dB μ V/m)	Antenna Height (cm)	POL. (H/V)	Azimuth (deg)	Corr. (dB)	Margin (dB)	Limit (dB μ V/m)
1003.408960	33.1	338.6	V	45.0	-29.3	40.9	74.0
1376.880000	30.7	201.4	V	333.0	-28.0	43.3	74.0
2703.920000	33.2	100.0	V	0.0	-23.4	40.8	74.0
10975.375000	44.8	175.5	V	252.0	-5.1	29.2	74.0
14499.840000	49.8	149.6	V	220.0	-0.4	24.2	74.0
17990.143660	56.0	350.0	H	299.0	9.5	18.0	74.0

Frequency (MHz)	CAverage (dB μ V/m)	Antenna Height (cm)	POL. (H/V)	Azimuth (deg)	Corr. (dB)	Margin (dB)	Limit (dB μ V/m)
1003.408960	18.5	338.6	V	45.0	-29.3	35.5	54.0
1376.880000	16.7	201.4	V	333.0	-28.0	37.3	54.0
2703.920000	20.4	100.0	V	0.0	-23.4	33.6	54.0
10975.375000	32.4	175.5	V	252.0	-5.1	21.6	54.0
14499.840000	35.2	149.6	V	220.0	-0.4	18.8	54.0
17990.143660	43.0	350.0	H	299.0	9.5	11.0	54.0



6. CONCLUSION

The data collected shows that the **Product Name: Mobile Phone and Model Name: SM-A326U** complies with §15.107 and §15.109 of the FCC rules.



7. APPENDIX A. TEST SETUP PHOTO

Please refer to EMI Test Setup Photo and test setup photo file no. as follows;

Rev. No.	Issue Date	File No.
0	February 10, 2021	HCT-EM-2102-FC010-P

End of report