



CERTIFICATION TEST REPORT

Report Number. : 12756699-E5V1

Applicant : Samsung Electronics Co., Ltd.
129 Samsung-Ro, Yeongtong-Gu,
Suwon-Si, Gyeonggi-Do, 16677, Korea

Model : SM-A305N and A305YN

FCC ID : A3LSMA305N

EUT Description : GSM/WCDMA/LTE Phone with BT, DTS/UNII a/b/g/n/ac and
NFC

Test Standard(s) : FCC 47 CFR PART 15 SUBPART E (EXCEPT DFS)

Date Of Issue:

March 20, 2019

Prepared by:

UL Verification Services Inc.
47173 Benicia Street
Fremont, CA 94538 U.S.A.
TEL: (510) 319-4000
FAX: (510) 661-0888



NVLAP Lab code: 200065-0

REPORT REVISION HISTORY

Rev.	Issue Date	Revisions	Revised By
V1	3/20/2019	Initial Issue	

TABLE OF CONTENTS

REPORT REVISION HISTORY	2
TABLE OF CONTENTS	3
1. ATTESTATION OF TEST RESULTS	6
2. INTRODUCTION OF TEST DATA REUSE.....	7
2.1. INTRODUCTION	7
2.2. DIFFERENCES.....	7
2.3. SPOT CHECK VERIFICATION RESULTS SUMMARY.....	7
2.3.1. SPOT CHECK DATA	8
2.4. REFERENCE DETAIL	12
3. TEST METHODOLOGY	13
4. FACILITIES AND ACCREDITATION	13
5. CALIBRATION AND UNCERTAINTY	14
5.1. MEASURING INSTRUMENT CALIBRATION	14
5.2. SAMPLE CALCULATION	14
5.3. MEASUREMENT UNCERTAINTY.....	14
6. EQUIPMENT UNDER TEST.....	15
6.1. EUT DESCRIPTION	15
6.2. MAXIMUM OUTPUT POWER.....	15
6.3. DESCRIPTION OF AVAILABLE ANTENNAS	17
6.4. SOFTWARE AND FIRMWARE.....	17
6.5. WORST-CASE CONFIGURATION AND MODE.....	17
6.6. DESCRIPTION OF TEST SETUP.....	18
7. MEASUREMENT METHOD.....	21
8. TEST AND MEASUREMENT EQUIPMENT	22
9. ANTENNA PORT TEST RESULTS.....	23
9.1. ON TIME AND DUTY CYCLE.....	23
9.2. 26 dB BANDWIDTH.....	25
9.2.1. 802.11a MODE IN THE 5.2 GHz BAND.....	26
9.2.2. 802.11n HT20 MODE IN THE 5.2 GHz BAND	27
9.2.3. 802.11n HT40 MODE IN THE 5.2 GHz BAND	28
9.2.4. 802.11ac VHT80 MODE IN THE 5.2 GHz BAND	29

9.2.5.	802.11a MODE IN THE 5.3 GHz BAND.....	30
9.2.6.	802.11n HT20 MODE IN THE 5.3 GHz BAND	31
9.2.7.	802.11n HT40 MODE IN THE 5.3 GHz BAND	32
9.2.8.	802.11ac VHT80 MODE IN THE 5.3 GHz BAND	33
9.2.9.	802.11a MODE IN THE 5.6 GHz BAND.....	34
9.2.10.	802.11n HT20 MODE IN THE 5.6 GHz BAND	35
9.2.11.	802.11n HT40 MODE IN THE 5.6 GHz BAND	36
9.2.12.	802.11ac VHT80 MODE IN THE 5.6 GHz BAND	37
9.2.13.	802.11a MODE IN THE 5.8 GHz BAND.....	38
9.2.14.	802.11n HT20 MODE IN THE 5.8 GHz BAND	39
9.2.15.	802.11n HT40 MODE IN THE 5.8 GHz BAND	40
9.2.16.	802.11ac VHT80 MODE IN THE 5.8 GHz BAND	41
9.3.	99% BANDWIDTH.....	42
9.3.1.	802.11a MODE IN THE 5.2 GHz BAND.....	43
9.3.2.	802.11n HT20 MODE IN THE 5.2 GHz BAND	44
9.3.3.	802.11n HT40 MODE IN THE 5.2 GHz BAND	45
9.3.4.	802.11ac VHT80 MODE IN THE 5.2 GHz BAND	46
9.3.5.	802.11a MODE IN THE 5.3 GHz BAND.....	47
9.3.6.	802.11n HT20 MODE IN THE 5.3 GHz BAND	48
9.3.7.	802.11n HT40 MODE IN THE 5.3 GHz BAND	49
9.3.8.	802.11ac VHT80 MODE IN THE 5.3 GHz BAND	50
9.3.9.	802.11a MODE IN THE 5.6 GHz BAND.....	51
9.3.10.	802.11n HT20 MODE IN THE 5.6 GHz BAND	52
9.3.11.	802.11n HT40 MODE IN THE 5.6 GHz BAND	53
9.3.12.	802.11ac VHT80 MODE IN THE 5.6 GHz BAND	54
9.3.13.	802.11a MODE IN THE 5.8 GHz BAND.....	55
9.3.14.	802.11n HT20 MODE IN THE 5.8 GHz BAND	56
9.3.15.	802.11n HT40 MODE IN THE 5.8 GHz BAND	57
9.3.16.	802.11ac VHT80 MODE IN THE 5.8 GHz BAND	58
9.4.	6 dB BANDWIDTH.....	59
9.4.1.	802.11a MODE IN THE 5.8 GHz BAND.....	60
9.4.2.	802.11n HT20 MODE IN THE 5.8 GHz BAND	61
9.4.3.	802.11n HT40 MODE IN THE 5.8 GHz BAND	62
9.4.4.	802.11ac VHT80 MODE IN THE 5.8 GHz BAND	63
9.5.	OUTPUT POWER AND PSD.....	64
9.5.1.	802.11a MODE IN THE 5.2 GHz BAND.....	66
9.5.2.	802.11n HT20 MODE IN THE 5.2 GHz BAND	68
9.5.3.	802.11n HT40 MODE IN THE 5.2 GHz BAND	70
9.5.4.	802.11ac VHT80 MODE IN THE 5.2 GHz BAND	72
9.5.5.	802.11a MODE IN THE 5.3 GHz BAND.....	74
9.5.6.	802.11n HT20 MODE IN THE 5.3 GHz BAND	76
9.5.7.	802.11n HT40 MODE IN THE 5.3 GHz BAND	78
9.5.8.	802.11ac VHT80 MODE IN THE 5.3 GHz BAND	80
9.5.9.	802.11a MODE IN THE 5.6 GHz BAND.....	82
9.5.10.	802.11n HT20 MODE IN THE 5.6 GHz BAND	84
9.5.11.	802.11n HT40 MODE IN THE 5.6 GHz BAND	86
9.5.12.	802.11ac VHT80 MODE IN THE 5.6 GHz BAND	88
9.5.13.	802.11a MODE IN THE 5.8 GHz BAND.....	90
9.5.14.	802.11n HT20 MODE IN THE 5.8 GHz BAND	92
9.5.15.	802.11n HT40 MODE IN THE 5.8 GHz BAND	94
9.5.16.	802.11ac VHT80 MODE IN THE 5.8 GHz BAND	96

10. RADIATED TEST RESULTS.....	98
10.1. TRANSMITTER ABOVE 1 GHz.....	100
10.1.1. TX ABOVE 1 GHz 802.11a MODE IN THE 5.2 GHz BAND	100
10.1.2. TX ABOVE 1 GHz 802.11n HT20 MODE IN THE 5.2 GHz BAND.....	108
10.1.3. TX ABOVE 1 GHz 802.11n HT40 MODE IN THE 5.2 GHz BAND.....	116
10.1.4. TX ABOVE 1 GHz 802.11ac VHT80 MODE IN THE 5.2 GHz BAND.....	122
10.1.5. TX ABOVE 1 GHz 802.11a MODE IN THE 5.3 GHz BAND	126
10.1.6. TX ABOVE 1 GHz 802.11n HT20 MODE IN THE 5.3 GHz BAND.....	134
10.1.7. TX ABOVE 1 GHz 802.11n HT40 MODE IN THE 5.3 GHz BAND.....	142
10.1.8. TX ABOVE 1 GHz 802.11ac VHT80 MODE IN THE 5.3 GHz BAND.....	148
10.1.9. TX ABOVE 1 GHz 802.11a MODE IN THE 5.6 GHz BAND	152
10.1.10. TX ABOVE 1 GHz 802.11n HT20 MODE IN THE 5.6 GHz BAND.....	164
10.1.11. TX ABOVE 1 GHz 802.11n HT40 MODE IN THE 5.6 GHz BAND.....	176
10.1.12. TX ABOVE 1 GHz 802.11ac VHT80 MODE IN THE 5.6 GHz BAND.....	188
10.1.13. TX ABOVE 1 GHz 802.11a MODE IN THE 5.8 GHz BAND	198
10.1.14. TX ABOVE 1 GHz 802.11n HT20 MODE IN THE 5.8 GHz BAND.....	208
10.1.15. TX ABOVE 1 GHz 802.11n HT40 MODE IN THE 5.8 GHz BAND.....	218
10.1.16. TX ABOVE 1 GHz 802.11ac VHT80 MODE IN THE 5.8 GHz BAND.....	226
10.2. Worst Case Below 30MHz.....	232
10.3. Worst Case Below 1 GHz.....	234
10.4. Worst Case 18-26 GHz	236
10.5. Worst Case 26-40 GHz	238
11. AC POWER LINE CONDUCTED EMISSIONS	240
11.1.1. AC Power Line Norm	241
12. SETUP PHOTOS.....	243
12.1.1. A3LSMA305F (Original).....	243
12.1.2. A3LSMA305N (Spot Check)	246

1. ATTESTATION OF TEST RESULTS

COMPANY NAME: Samsung Electronics Co., Ltd.
129 Samsung-Ro, Yeongtong-Gu,
Suwon-Si, Gyeonggi-Do, 16677, Korea

EUT DESCRIPTION: GSM/WCDMA/LTE Phone with BT, DTS/UNII a/b/g/n/ac, ANT+
and NFC

MODEL: SM-A305N and A305YN

SERIAL NUMBER: R38KC08WJSN; R38KC08WKGY(OriginalRadiated)
R38KC08WHJE (Original Conducted)
52004bc446b7b567(Spot Check)

DATE TESTED: JANUARY 15 to 31, 2019 (Original)
MARCH 20, 2019 (Spot Check)

APPLICABLE STANDARDS	
STANDARD	TEST RESULTS
CFR 47 Part 15 Subpart E (Except DFS)	Complies

UL Verification Services Inc. tested the above equipment in accordance with the requirements set forth in the above standards. The test results show that the equipment tested is capable of demonstrating compliance with the requirements as documented in this report.

The results documented in this report apply only to the tested sample, under the conditions and modes of operation as described herein. It is the manufacturer's responsibility to assure that additional production units of this model are manufactured with identical electrical and mechanical components. All samples tested were in good operating condition throughout the entire test program. Measurement Uncertainties are published for informational purposes only and were not taken into account unless noted otherwise.

This document may not be altered or revised in any way unless done so by UL Verification Services Inc. and all revisions are duly noted in the revisions section. Any alteration of this document not carried out by UL Verification Services Inc. will constitute fraud and shall nullify the document. This report must not be used by the client to claim product certification, approval, or endorsement by NVLAP, NIST, any agency of the Federal Government, or any agency of the U.S. government.

Approved & Released For
UL Verification Services Inc. By:

Reviewed By:



DAN CORONIA
Operations Leader
Consumer Technology Division
UL Verification Services Inc.

KIYA KEDIDA
Senior Project Engineer
Consumer Technology Division
UL Verification Services Inc.

2. INTRODUCTION OF TEST DATA REUSE

2.1. INTRODUCTION

According to the manufacturer, FCC ID: A3LSMA305F and FCC ID: A3LSMA305N non-licensed radios are electrically identical. The FCC ID: A3LSMA305F test data shall remain representative of FCC ID: A3LSMA305N.

The applicant takes full responsibility that the test data as referenced in this section represents compliance for this FCC ID.

2.2. DIFFERENCES

Difference between A3LSMA305F and A3LSMA305N:

Samsung Electronics Co. Ltd. declares that A3LSMA305N supports NFC function and PCB layout is changed (BT/Wifi block is not changed).

After confirming through preliminary radiated emissions that the performance of the FCC ID: A3LSMG305F remains representative of FCC ID: A3LSMA305N. The test data of FCC ID: A3LSMG305F being submitted for this application to cover UNII WLAN features.

2.3. SPOT CHECK VERIFICATION RESULTS SUMMARY

Spot check verification has been done on device A3LSMA305N for radiated harmonic spurious and radiated band-edge. The data from the application has been verified through appropriate spot checks to demonstrate compliance for this device in accordance to FCC public KDB 484596 D01 as shown in the summary below.

A3LSMA305N SPOT CHECK RESULTS										
Technology	Mode	Test Item	Channel	Measured Frequency	Original model		Spot check model		Delta (dB)	
					SM-A305F/DS		SM-A305N			
					A3LSMA305F		A3LSMA305N		Peak	Ave
UNII	5.3 11n HT40 5310MHz	RBE	62	5350MHz	66.88	50.75	66.43	50.45	-0.45	-0.3
	5.8 11n HT40 5795MHz	RSE	159	11590MHz	51.29	45.13	49.27	43.84	-2.02	-1.29

Comparison of the models, upper deviation is within 3dB range and all tests are under FCC Technical Limits.

2.3.1. SPOT CHECK DATA

BANDEDGE (HIGH CHANNEL)

HORIZONTAL RESULT

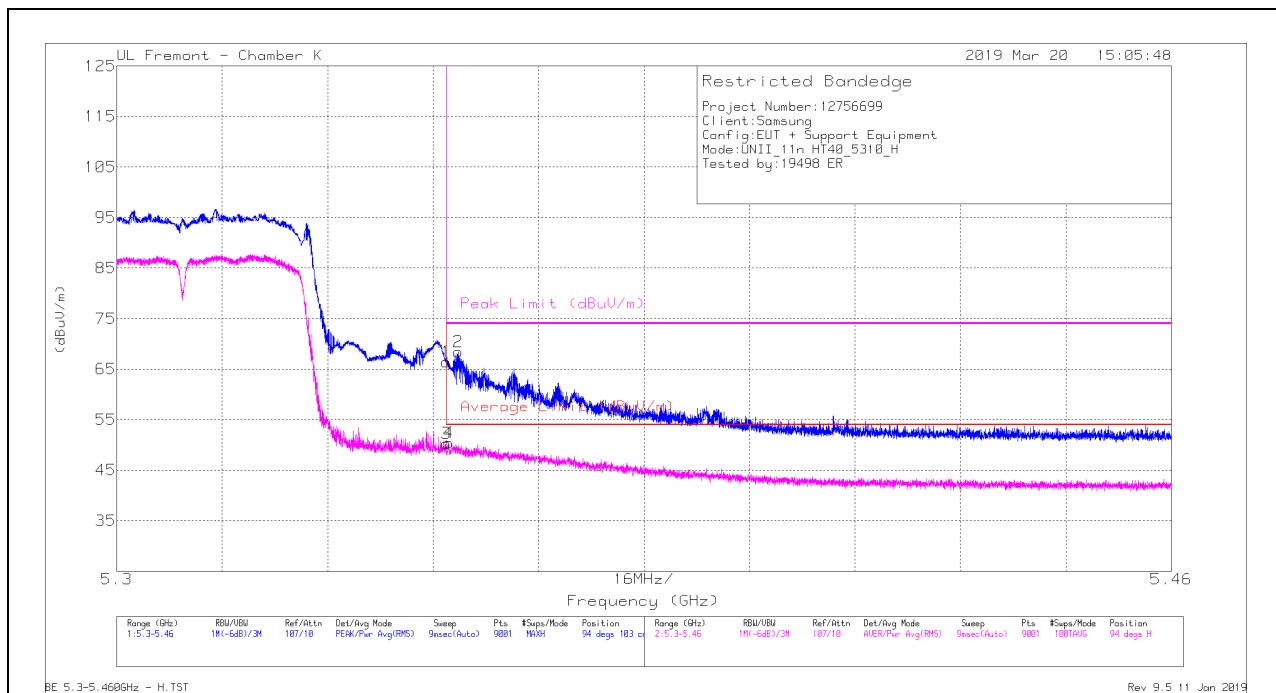

Trace Markers

Marker	Frequency (GHz)	Meter Reading (dBuV)	Det	AF T344 (dB/m)	Amp/Cbl/Ftr/Pad (dB)	DC Corr (dB)	Corrected Reading (dBuV/m)	Average Limit (dBuV/m)	Margin (dB)	Peak Limit (dBuV/m)	PK Margin (dB)	Azimuth (Degs)	Height (cm)	Polarity
1	* 5.35	51.83	Pk	34.5	-19.9	0	66.43	-	-	74	-7.57	94	103	H
2	* 5.352	53.86	Pk	34.5	-19.9	0	68.46	-	-	74	-5.54	94	103	H
3	* 5.35	34.93	RMS	34.5	-19.9	.71	50.24	54	-3.76	-	-	94	103	H
4	* 5.35	35.14	RMS	34.5	-19.9	.71	50.45	54	-3.55	-	-	94	103	H

* - indicates frequency in CFR47 Pt 15 / IC RSS-Restricted Band
 Pk - Peak detector
 RMS - RMS detection

VERTICAL RESULT

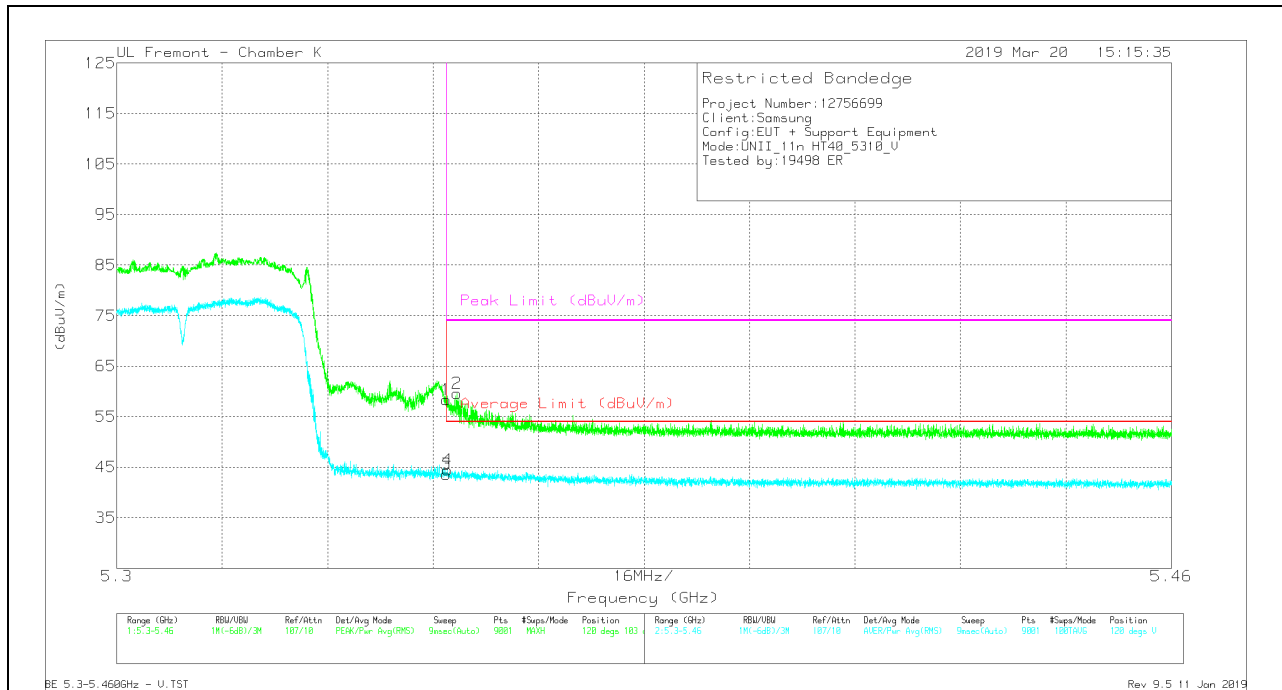

Trace Markers

Marker	Frequency (GHz)	Meter Reading (dBu)	Det	AF T344 (dB/m)	Amp/CBI/Ftr/Pad (dB)	DC Corr (dB)	Corrected Reading (dBu/m)	Average Limit (dBu/m)	Margin (dB)	Peak Limit (dBu/m)	PK Margin (dB)	Azimuth (Degs)	Height (cm)	Polarity
1	* 5.35	43.81	Pk	34.5	-19.9	0	59.51	-	-	74	-15.59	120	103	V
2	* 5.352	45.05	Pk	34.5	-19.9	0	59.65	-	-	74	-14.35	120	103	V
3	* 5.35	28.3	RMS	34.5	-19.9	.71	43.61	54	-10.39	-	-	120	103	V
4	* 5.35	29.12	RMS	34.5	-19.9	.71	44.43	54	-9.57	-	-	120	103	V

* - indicates frequency in CFR47 Pt 15 / IC RSS-Restricted Band
 Pk - Peak detector
 RMS - RMS detection

HARMONICS AND SPURIOUS EMISSIONS

LOW CHANNEL RESULTS

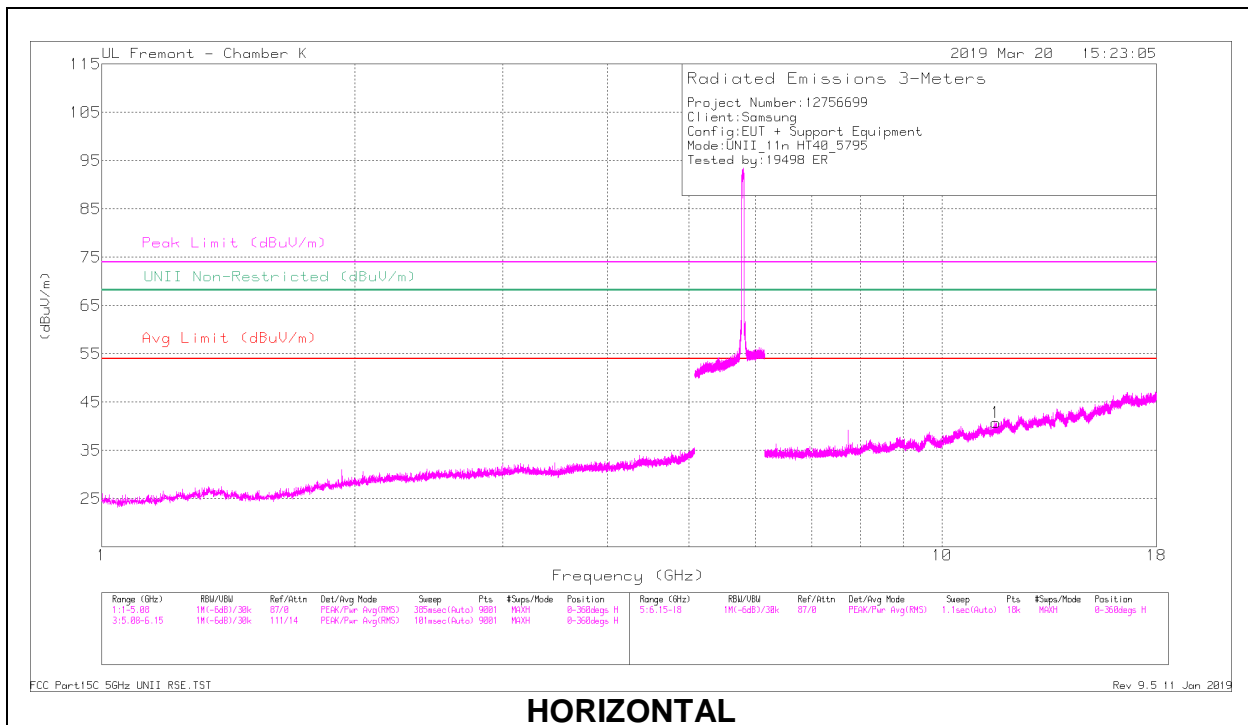

HORIZONTAL

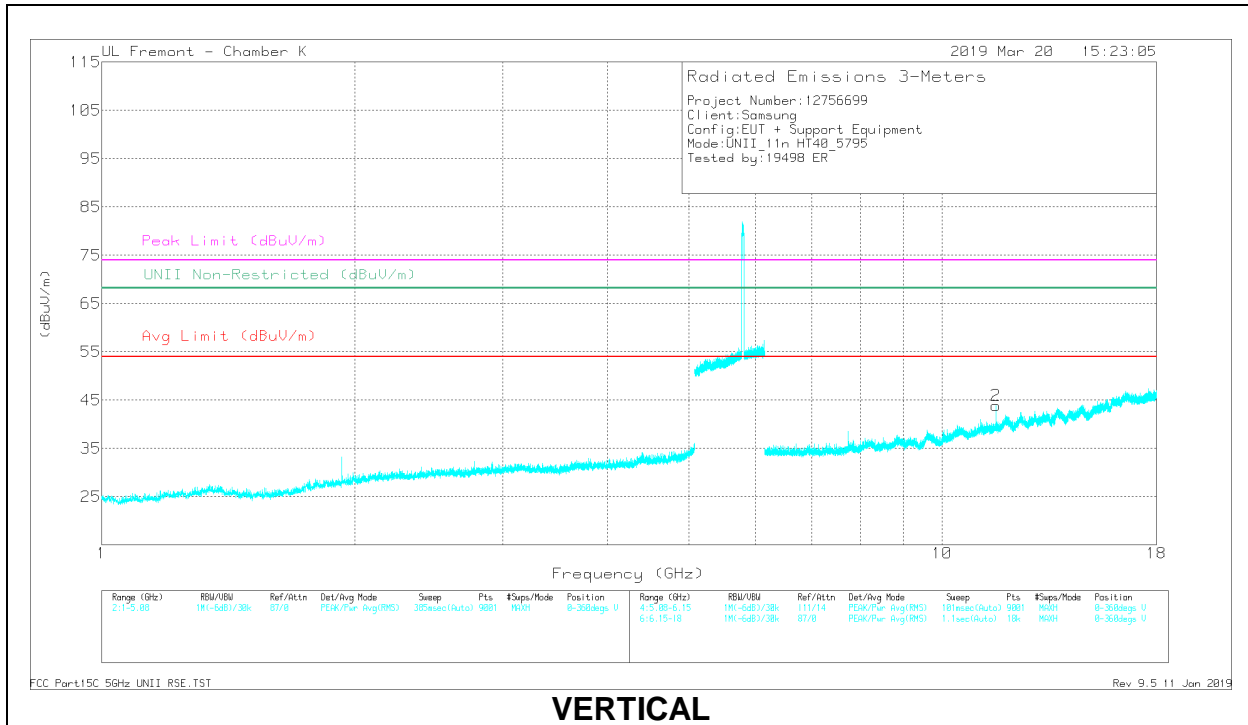

VERTICAL

RADIATED EMISSIONS

Frequency (GHz)	Meas Reading (dBuV)	Det	AF T344 (dBm)	AmpCoef/FilterPad (dB)	DC Corr (dB)	Corrected Reading (dBuV/m)	Avg Limit (dBuV/m)	Margin (dB)	Peak Limit (dBuV/m)	PK Margin (dB)	Unfil Non-Rearranged (dBuV/m)	PK Margin (dB)	Azimuth (Deg)	Height (cm)	Polarity
* 11.59	31.55	PK-U	38.2	-20.9	0	48.85	-	-	74	-25.15	-	-	99	111	H
* 11.59	24.08	ADR	38.2	-20.9	.71	42.09	54	-11.91	-	-	-	-	99	111	H
* 11.59	31.97	PK-U	38.2	-20.9	0	49.27	-	-	74	-24.73	-	-	94	111	V
* 11.59	25.83	ADR	38.2	-20.9	.71	43.84	54	-10.16	-	-	-	-	94	111	V

* - indicates frequency in CFR47 Pt 15 / IC RSS-Restricted Band

PK-U - U-NII: Maximum Peak

ADR - U-NII AD primary method, RMS average

2.4. REFERENCE DETAIL

Reference application that contains the reused reference data

Equipment Class	Reference FCC ID	Type Grant/ Permissive Change	Reference Application	Folder Test/RF Exposure	Report Title/Section
NII	A3LSMA305F	Grant	12678282-E5	Test	FCC Report UNII WLAN / All Sections except DFS

3. TEST METHODOLOGY

The tests documented in this report were performed in accordance with FCC CFR 47 Part 2, FCC CFR 47 Part 15, FCC 14-30, FCC KDB 662911 D01 v02r01, FCC KDB 905462 D02 v02/D03 v01r02/D06 v02, FCC KDB 789033 D02 v02r01, FCC KDB 644545 D03 v01, ANSI C63.10-2013, FCC 06-96.

4. FACILITIES AND ACCREDITATION

The test sites and measurement facilities used to collect data are located at 47173 and 47266 Benicia Street, and 47658 Kato Road, Fremont, California, USA. Line conducted emissions are measured only at the 47173 address. The following table identifies which facilities were utilized for radiated emission measurements documented in this report. Specific facilities are also identified in the test results sections.

47173 Benicia Street	47266 Benicia Street	47658 Kato Rd
<input type="checkbox"/> Chamber A (ISED:2324B-1)	<input type="checkbox"/> Chamber D (ISED:22541-1)	<input checked="" type="checkbox"/> Chamber I (ISED:2324A-5)
<input type="checkbox"/> Chamber B (ISED:2324B-2)	<input type="checkbox"/> Chamber E (ISED:22541-2)	<input checked="" type="checkbox"/> Chamber J (ISED:2324A-6)
<input type="checkbox"/> Chamber C (ISED:2324B-3)	<input type="checkbox"/> Chamber F (ISED:22541-3)	<input checked="" type="checkbox"/> Chamber K (ISED:2324A-1)
	<input type="checkbox"/> Chamber G (ISED:22541-4)	<input checked="" type="checkbox"/> Chamber L (ISED:2324A-3)
	<input type="checkbox"/> Chamber H (ISED:22541-5)	

The above test sites and facilities are covered under FCC Test Firm Registration # 208313. Chambers above are covered under Industry Canada company address and respective code

UL Verification Services Inc. is accredited by NVLAP, Laboratory Code 200065-0

5. CALIBRATION AND UNCERTAINTY

5.1. MEASURING INSTRUMENT CALIBRATION

The measuring equipment utilized to perform the tests documented in this report has been calibrated in accordance with the manufacturer's recommendations, and is traceable to recognized national standards.

5.2. SAMPLE CALCULATION

RADIATED EMISSIONS

Where relevant, the following sample calculation is provided:

$$\text{Field Strength (dBuV/m)} = \text{Measured Voltage (dBuV)} + \text{Antenna Factor (dB/m)} + \text{Cable Loss (dB)} - \text{Preamp Gain (dB)}$$

$$36.5 \text{ dBuV} + 18.7 \text{ dB/m} + 0.6 \text{ dB} - 26.9 \text{ dB} = 28.9 \text{ dBuV/m}$$

MAINS CONDUCTED EMISSIONS

Where relevant, the following sample calculation is provided:

$$\text{Final Voltage (dBuV)} = \text{Measured Voltage (dBuV)} + \text{Cable Loss (dB)} + \text{Limiter Factor (dB)} + \text{LISN Insertion Loss.}$$

$$36.5 \text{ dBuV} + 0 \text{ dB} + 10.1 \text{ dB} + 0 \text{ dB} = 46.6 \text{ dBuV}$$

5.3. MEASUREMENT UNCERTAINTY

Where relevant, the following measurement uncertainty levels have been estimated for tests performed on the apparatus:

PARAMETER	UNCERTAINTY
Worst Case Conducted Disturbance, 9KHz to 0.15 MHz	3.84 dB
Worst Case Conducted Disturbance, 0.15 to 30 MHz	3.65 dB
Worst Case Radiated Disturbance, 9KHz to 30 MHz	3.15 dB
Worst Case Radiated Disturbance, 30 to 1000 MHz	5.36 dB
Worst Case Radiated Disturbance, 1000 to 18000 MHz	4.32 dB
Worst Case Radiated Disturbance, 18000 to 26000 MHz	4.45 dB
Worst Case Radiated Disturbance, 26000 to 40000 MHz	5.24 dB

Uncertainty figures are valid to a confidence level of 95%.

6. EQUIPMENT UNDER TEST

6.1. EUT DESCRIPTION

The EUT is a GSM/WCDMA/LTE Phone with BT, DTS/UNII a/b/g/n/ac, ANT+ and NFC. The test report addresses the UNII WLAN operational mode

6.2. MAXIMUM OUTPUT POWER

The transmitter has a maximum conducted output power as follows:

5.2 GHz BAND

Frequency Range (MHz)	Mode	Output Power (dBm)	Output Power (mW)
5.2 GHz band, 1TX			
5180-5240	802.11a	16.57	45.39
5180-5240	802.11n HT20	15.80	38.02
5190-5230	802.11n HT40	14.81	30.27
5210	802.11ac VHT80	13.46	22.18

5.3 GHz BAND

Frequency Range (MHz)	Mode	Output Power (dBm)	Output Power (mW)
5.3 GHz band, 1TX			
5260 - 5320	802.11a	16.89	48.87
5260 - 5320	802.11n HT20	15.79	37.93
5270 - 5310	802.11n HT40	14.84	30.48
5290	802.11ac VHT80	13.79	23.93

5.6 GHz BAND

Frequency Range (MHz)	Mode	Output Power (dBm)	Output Power (mW)
5.6 GHz band, 1TX			
5500-5720	802.11a	16.98	49.89
5500-5720	802.11n HT20	15.67	36.90
5510-5710	802.11n HT40	15.31	33.96
5530-5690	802.11ac VHT80	13.92	24.66

5.8 GHz BAND

Frequency Range (MHz)	Mode	Output Power (dBm)	Output Power (mW)
5.8 GHz band, 1TX			
5745-5825	802.11a	16.78	47.64
5745-5825	802.11n HT20	15.79	37.93
5755-5795	802.11n HT40	14.40	27.54
5775	802.11ac VHT80	13.43	22.03

6.3. DESCRIPTION OF AVAILABLE ANTENNAS

The radio utilizes an FPCB antenna, with a maximum gain of:

Frequency (GHz)	Peak Antenna Gain (dBi)
5180-5240	-3.70
5260-5320	-2.60
5500-5700	-2.60
5725-5850	-3.50

6.4. SOFTWARE AND FIRMWARE

The test utility software used during testing was A305F.001

6.5. WORST-CASE CONFIGURATION AND MODE

Radiated emissions below 1GHz, above 18GHz, and power line conducted emission were performed with the EUT set to transmit at the channel with highest output power as worst-case scenario.

Band edge and radiated emissions between 1GHz and 18GHz were performed with the EUT set to transmit at the highest power on low, middle and high channels.

The fundamental of the EUT was investigated in three orthogonal orientations X,Y,Z, it was determined that X orientation was worst-case orientation; therefore, all final radiated testing was performed with the EUT in X orientation.

Worst-case data rates as provided by the client were:

- 802.11a mode: 6 Mbps
- 802.11n HT20mode: MCS0
- 802.11n HT40mode: MCS0
- 802.11ac VHT80 mode: MCS0

6.6. DESCRIPTION OF TEST SETUP

SUPPORT EQUIPMENT

Support Equipment List				
Description	Manufacturer	Model	Serial Number	FCC ID
AC Adapter	Samsung	EP-TA50EWE	DW3J719AS/A-E	N/A
Earphone	Samsung	N/A	N/A	N/A

I/O CABLES (CONDUCTED TEST)

I/O Cable List						
Cable No	Port	# of identical ports	Connector Type	Cable Type	Cable Length (m)	Remarks
1	Antenna	1	RF	Shielded	0.2	To spectrum Analyzer
2	USB	1	USB	Un-shielded	1	EUT to AC Mains

I/O CABLES (RADIATED AND CONDUCTED EMISSIONS)

I/O Cable List						
Cable No	Port	# of identical ports	Connector Type	Cable Type	Cable Length (m)	Remarks
1	USB	1	USB	Shielded	1	N/A
2	earphone	1	3.5mm	Un-shielded	1	N/A

TEST SETUP

The EUT is a stand alone. Test software exercised the radio card.

CONDUCTED TEST SETUP DIAGRAM

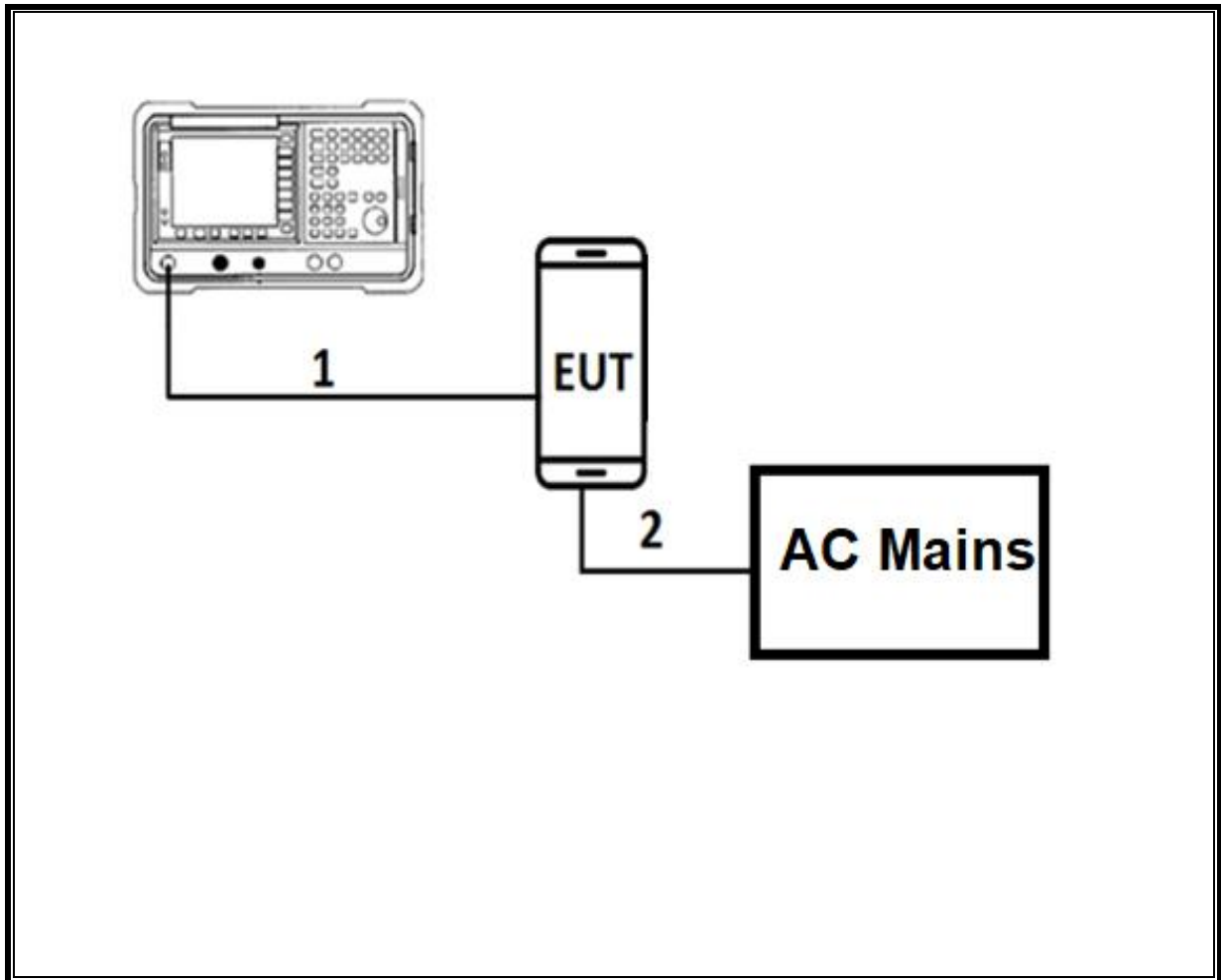

TEST SETUP

For conducted tests: the EUT was Stand alone. The test software exercises the radio.

RADIATED AND AC LINE CONDUCTED EMISSIONS SETUP DIAGRAM

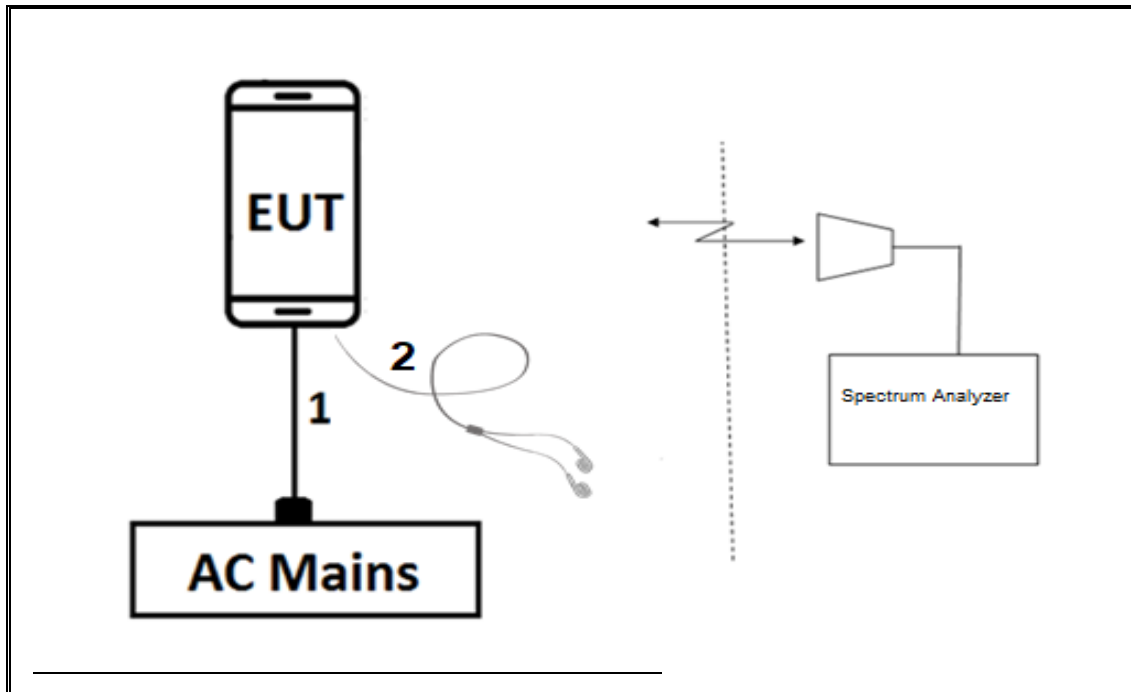

TEST SETUP

For radiated tests: EUT is Stand alone. The test software exercises the radio.

7. MEASUREMENT METHOD

On Time and Duty Cycle: KDB 789033 D02 v02r01, Section II.B.

6 dB Emission BW: KDB 789033 D02 v02r01, Section II.C.2

26 dB Emission BW: KDB 789033 D02 v02r01, Section II.C.1

99% Occupied BW: KDB 789033 D02 v02r01, Section II.D.

Conducted Output Power: KDB 789033 D02 v02r01, Sections II.E.3.b & II.E.2.b.

Power Spectral Density: KDB 789033 D02 v02r01, Section II F.

Unwanted emissions: KDB 789033 D02 v02r01, Sections II.G.3 – II.G.6.

AC Power Line Conducted Emissions: ANSI C63.10-2013, Section 6.2.

8. TEST AND MEASUREMENT EQUIPMENT

The following test and measurement equipment was utilized for the tests documented in this report:

TEST EQUIPMENT LIST				
Description	Manufacturer	Model	Asset	Cal Due
Antenna, Passive Loop 9KHz to 1MHz	ELETRO METRICS	EM-6871	PRE0179465	05/22/2019
Antenna, Passive Loop 9KHz to 1MHz	ELETRO METRICS	EM-6872	PRE0179467	05/22/2019
Amplifier, 10KHz to 1GHz, 32dB	SONOMA INSTRUMENT	310	PRE0180175	07/09/2019
Antenna, Horn 1-18GHz	ETS Lindgren	3117	T862	05/24/2019
Amplifier, 1 to 18GHz	MITEQ	AFS42-00101800-25-S-42	PRE1782151	8/01/2019
Antenna, Horn 1-18GHz	ETS Lindgren	3117	T862	05/24/2019
Amplifier, 1 to 18GHz	MITEQ	AFS42-00101800-25-S-42	PRE1782151	08/01/2019
Antenna, Horn 1-18GHz	ETS Lindgren	3117	AT0067	03/06/2019
Amplifier, 1 to 18GHz	Amplical	AMP1G18-35	T1571	07/30/2019
Antenna, Horn 1-18GHz	ETS Lindgren	3117	T344	03/06/2019
Amplifier, 1 to 18GHz	Amplical	AMP1G18-35	T1569	06/03/2019
Antenna, Broadband Hybrid, 30MHz to 3000MHz	SunAR RF Motion	JB3	PRE0184970	11/13/2019
Amplifier, 10KHz to 1GHz, 32dB	SONOMA INSTRUMENT	310	PRE0180174	05/31/2019
Spectrum Analyzer, PXA, 3Hz to 44GHz	Keysight	E4446A	T146	08/13/2019
Antenna Horn, 18 to 26.5GHz	ARA	MWH-1826/B	T448	03/13/2019
Antenna Horn, 26 to 40GHz	ARA	MWH-2640	T90	03/11/2019
Pre-Amp 1-26.5 GHz	Agilent	8449B	T404	03/09/2019
Pre-Amp 26-40GHz	MITEQ	NSTTA2640-35-HG	T1864	03/09/2019
EMI Test Receiver	Rohde&Schwarz	ESW44	PRE0179372	05/04/2019
EMI Test Receiver	Rohde&Schwarz	ESW44	PRE0179367	04/28/2019
EMI Test Receiver	Rohde&Schwarz	ESW44	PRE0179375	05/08/2019
EMI Test Receiver	Rohde&Schwarz	ESW44	PRE0179376	05/08/2019
EMI Test Receiver	Rohde&Schwarz	ESW44	PRE0179377	11/02/2019
Power Meter, P-series single channel	Agilent (Keysight) Technologies	N1911A	T1271	07/17/2019
Power Sensor, P-series, 50MHz to 18GHz, Wideband	Agilent (Keysight) Technologies	N1921A	T1225	04/10/2019
AC Line Conducted				
EMI Receiver	Rohde & Schwarz	ESR	T1436	02/21/2019
LISN for Conducted Emissions CISPR-16	FCC INC.	FCC LISN 50/250	T1310	06/15/2019
UL AUTOMATION SOFTWARE				
Radiated Software	UL	UL EMC	Ver 9.5, June 22, 2018	
Antenna Port Software	UL	UL RF	Ver 8.8.1, Sep 26, 2018	
AC Line Conducted Software	UL	UL EMC	Ver 9.5, May 26, 2015	

NOTES:

1. Equipment listed above that calibrated during the testing period was set for test after the calibration.
2. Equipment listed above that has a calibration due date during the testing period, the testing is completed before equipment expiration date.

9. ANTENNA PORT TEST RESULTS

9.1. ON TIME AND DUTY CYCLE

LIMITS

None; for reporting purposes only.

PROCEDURE

KDB 789033 Zero-Span Spectrum Analyzer Method.

ON TIME AND DUTY CYCLE RESULTS

Mode	ON Time B (msec)	Period (msec)	Duty Cycle x (linear)	Duty Cycle (%)	Duty Cycle Correction Factor (dB)	1/B Minimum VBW (kHz)
802.11a	1.417	1.508	0.940	93.97%	0.27	0.706
802.11n HT20	1.342	1.433	0.936	93.65%	0.28	0.745
802.11n HT40	0.658	0.775	0.849	84.94%	0.71	1.519
802.11ac VHT80	0.332	0.447	0.743	74.26%	1.29	3.015

DUTY CYCLE PLOTS

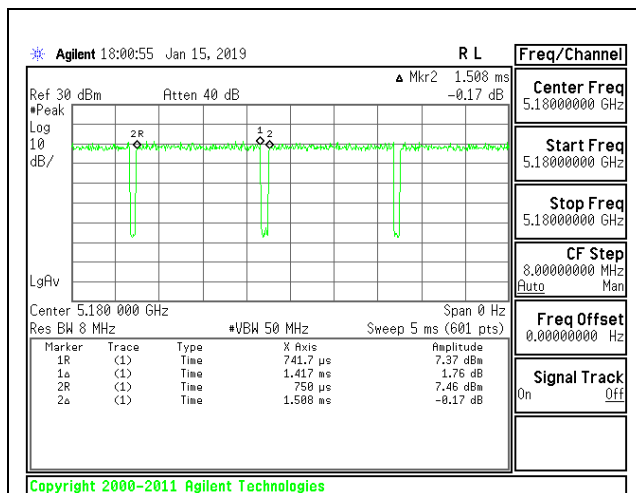

DUTY CYCLE 802.11a

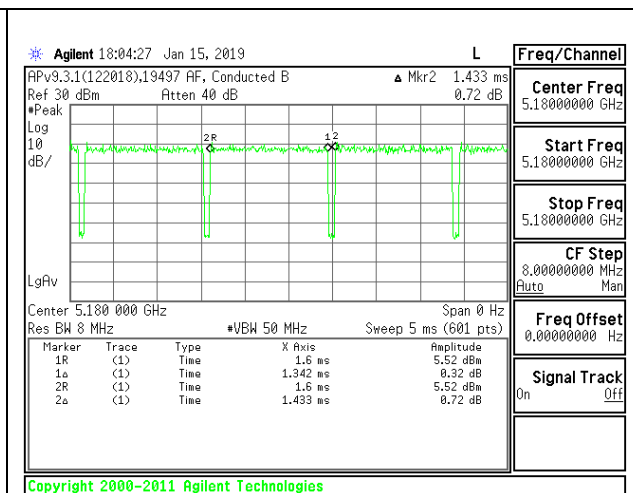

DUTY CYCLE 802.11n HT20

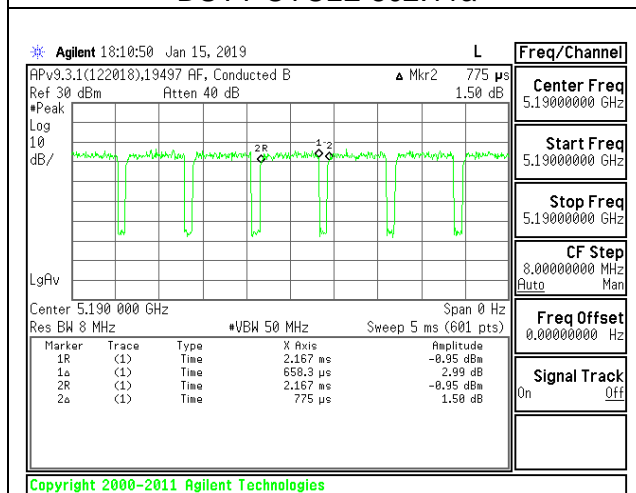

DUTY CYCLE 802.11n HT40

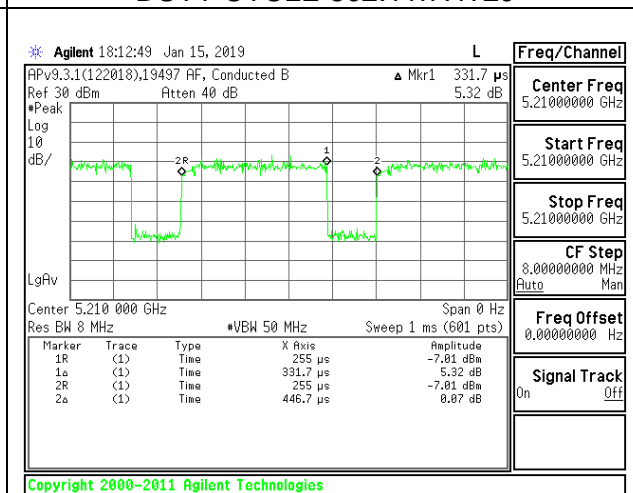

DUTY CYCLE 802.11ac VHT80

9.2. 26 dB BANDWIDTH

LIMITS

None; for reporting purposes only.

RESULTS

9.2.1. 802.11a MODE IN THE 5.2 GHz BAND

1TX Antenna 1 MODE

Channel	Frequency (MHz)	26 dB Bandwidth (MHz)
Low	5180	28.00
Mid	5200	28.40
High	5240	27.05

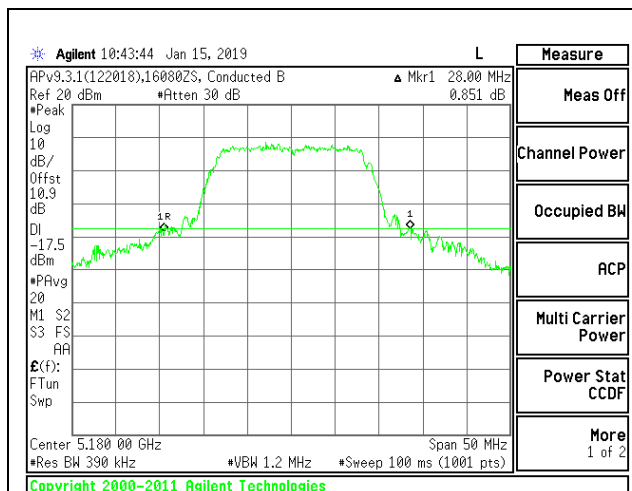

LOW CHANNEL

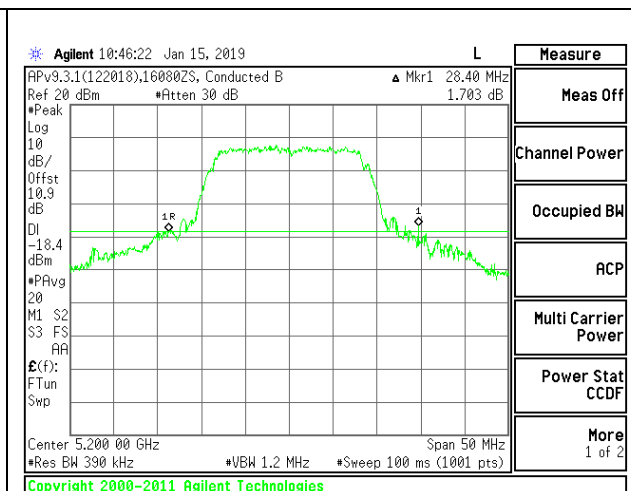

MID CHANNEL

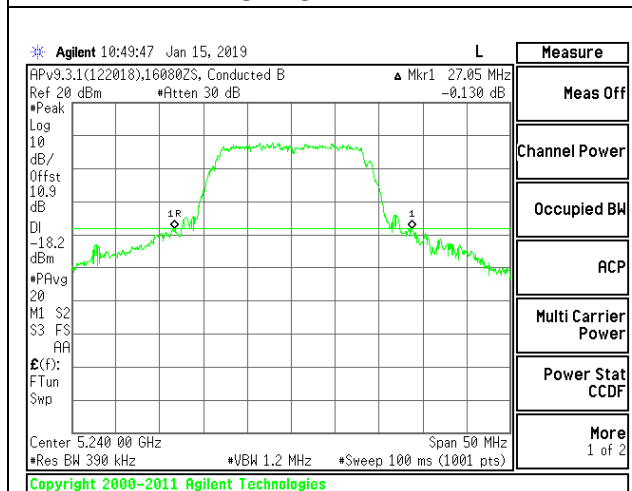

HIGH CHANNEL

9.2.2. 802.11n HT20 MODE IN THE 5.2 GHz BAND

1TX Antenna 1 MODE

Channel	Frequency (MHz)	26 dB Bandwidth (MHz)
Low	5180	29.45
Mid	5200	29.25
High	5240	30.05

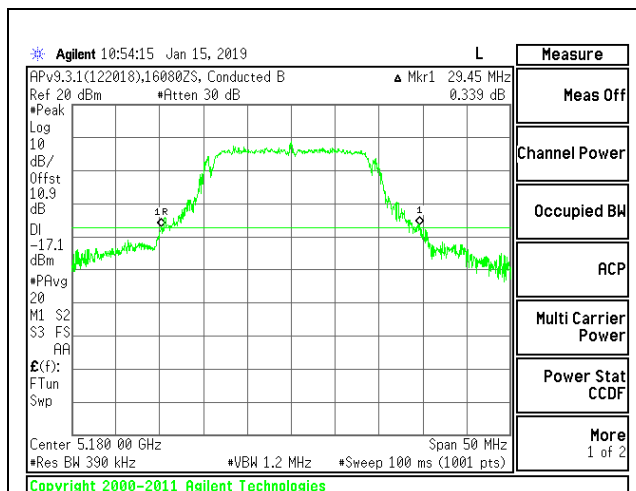

LOW CHANNEL

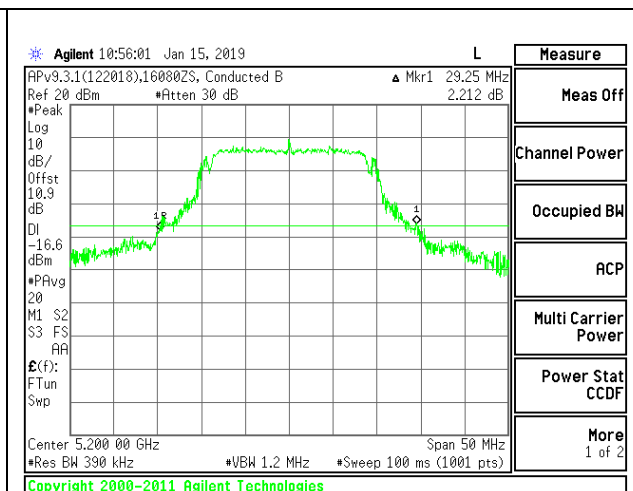

MID CHANNEL

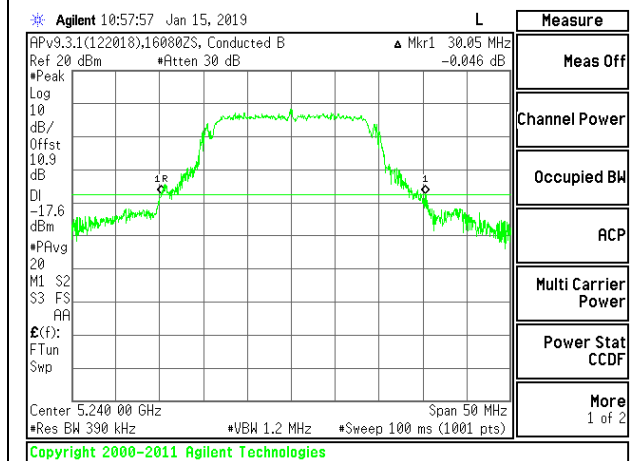

HIGH CHANNEL

9.2.3. 802.11n HT40 MODE IN THE 5.2 GHz BAND

1TX Antenna 1 MODE

Channel	Frequency	26dB Bandwidth
	(MHz)	(MHz)
Low	5190	47.70
High	5230	44.50

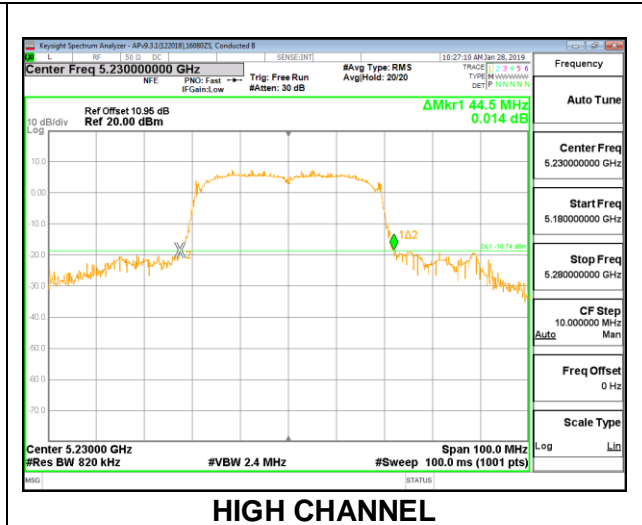
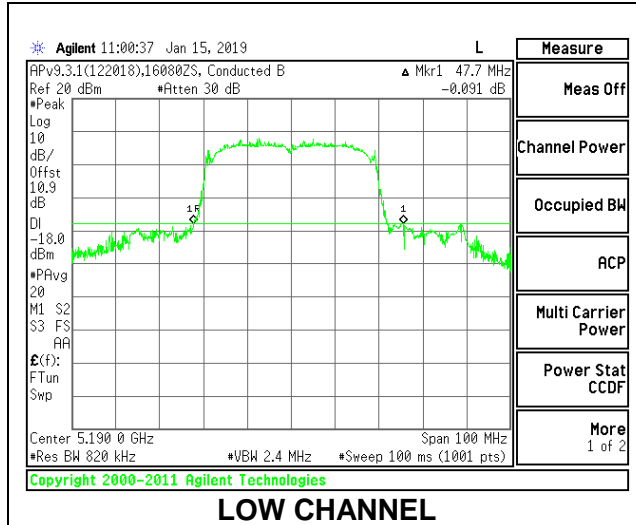

9.2.4. 802.11ac VHT80 MODE IN THE 5.2 GHz BAND

1TX Antenna 1 MODE

Channel	Frequency	26 dB Bandwidth
	(MHz)	(MHz)
Mid	5210	100.40

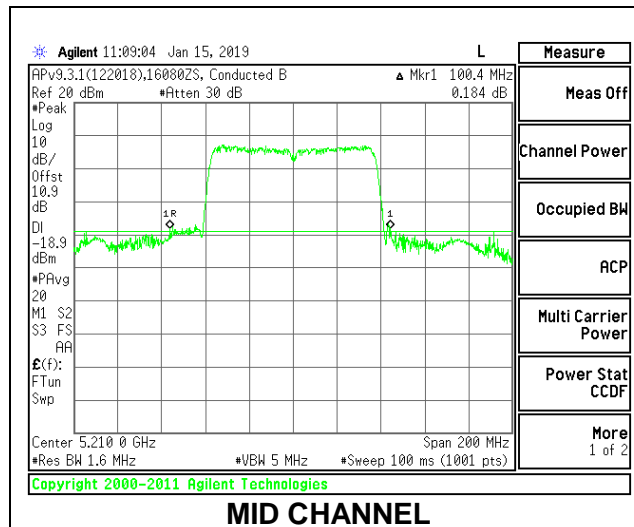

9.2.5. 802.11a MODE IN THE 5.3 GHz BAND

1TX Antenna 1 MODE

Channel	Frequency (MHz)	26 dB Bandwidth (MHz)
Low	5260	30.40
Mid	5300	27.40
High	5320	30.40

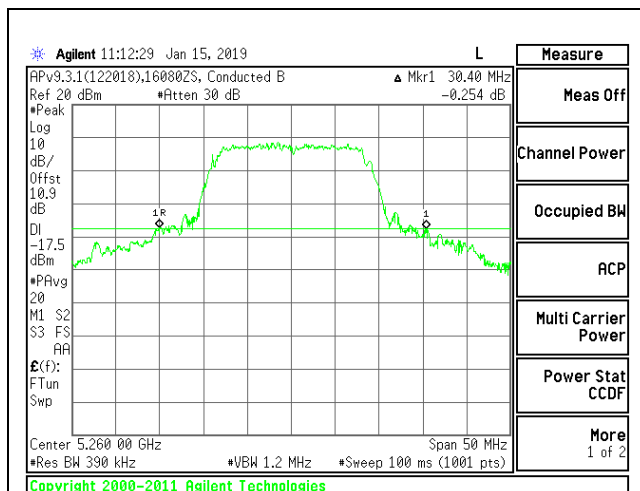

LOW CHANNEL

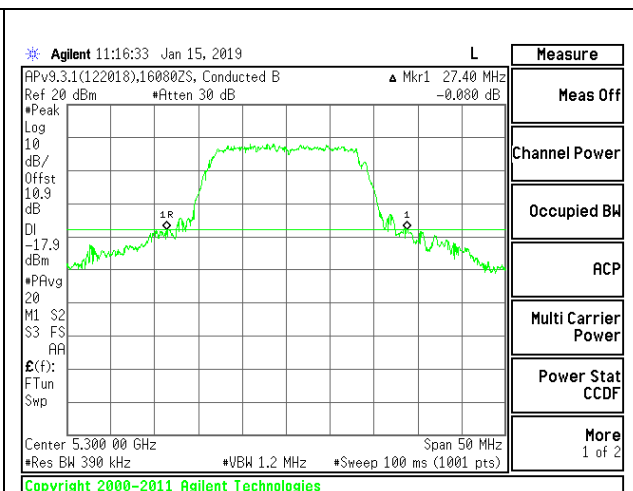

MID CHANNEL

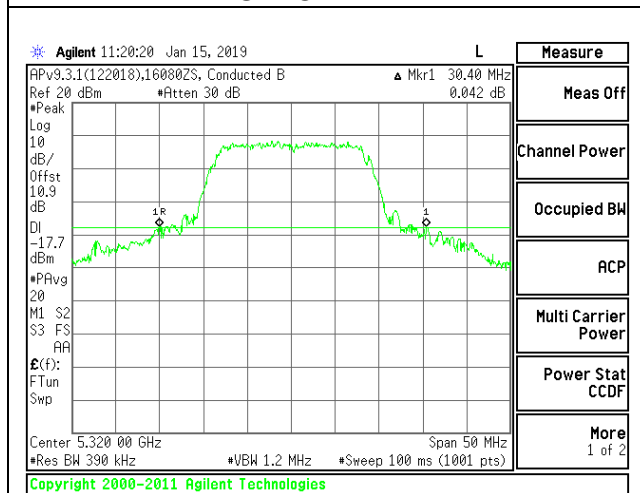

HIGH CHANNEL

9.2.6. 802.11n HT20 MODE IN THE 5.3 GHz BAND

1TX Antenna 1 MODE

Channel	Frequency (MHz)	26 dB Bandwidth (MHz)
Low	5260	28.10
Mid	5300	29.40
High	5320	29.35

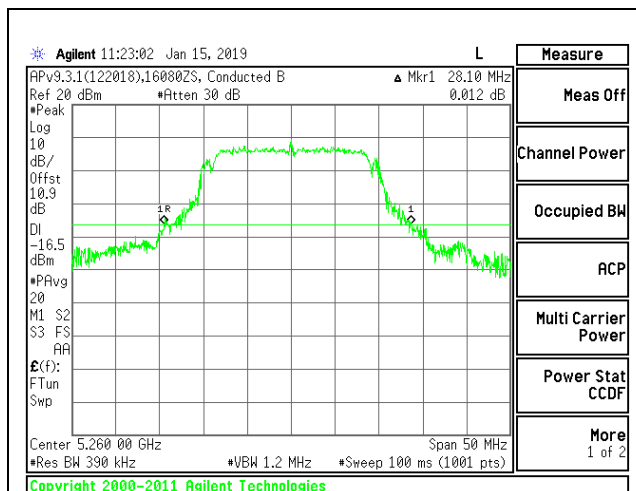

LOW CHANNEL

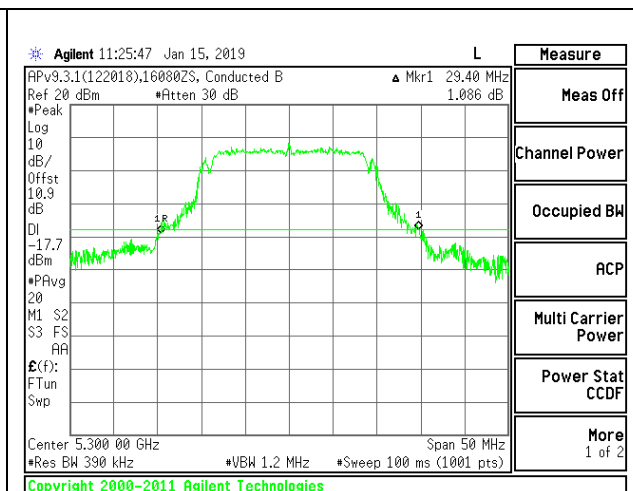

MID CHANNEL

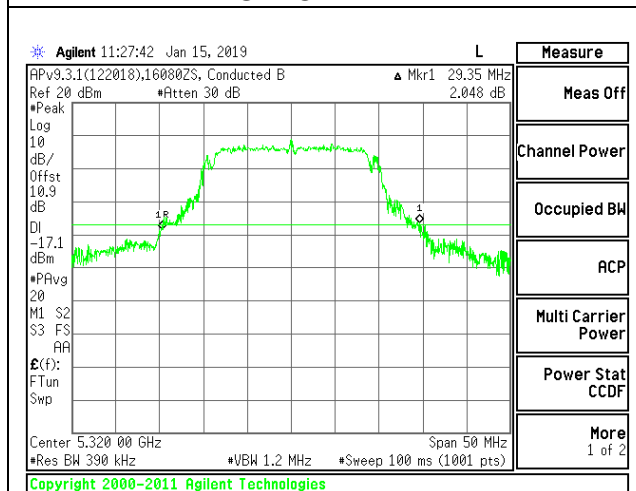

HIGH CHANNEL

9.2.7. 802.11n HT40 MODE IN THE 5.3 GHz BAND

1TX Antenna 1 MODE

Channel	Frequency	26dB Bandwidth
	(MHz)	(MHz)
Low	5270	44.00
High	5310	44.30

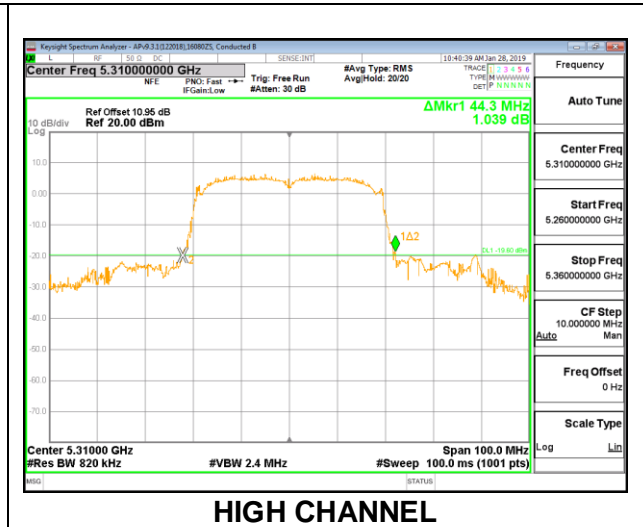
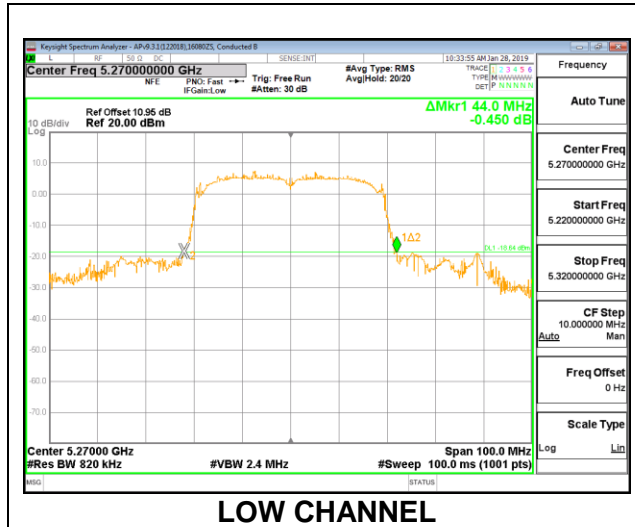

9.2.8. 802.11ac VHT80 MODE IN THE 5.3 GHz BAND

1TX Antenna 1 MODE

Channel	Frequency (MHz)	26 dB Bandwidth (MHz)
Mid	5290	114.60

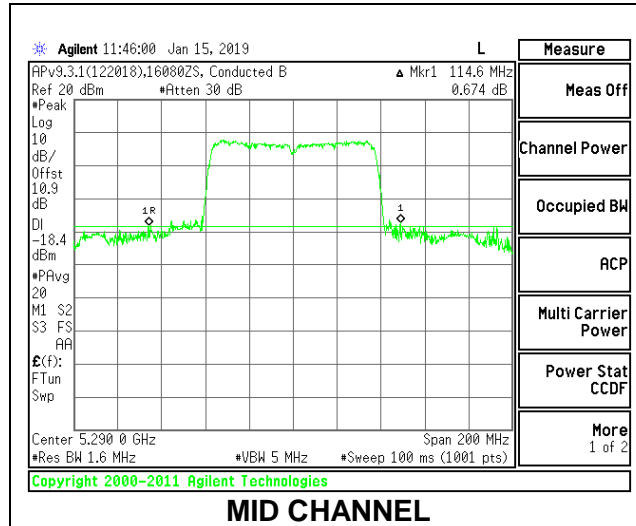

9.2.9. 802.11a MODE IN THE 5.6 GHz BAND

1TX Antenna 1 MODE

Channel	Frequency (MHz)	26 dB Bandwidth (MHz)
Low	5500	29.25
Mid	5580	28.40
High	5700	28.30
144	5720	28.45

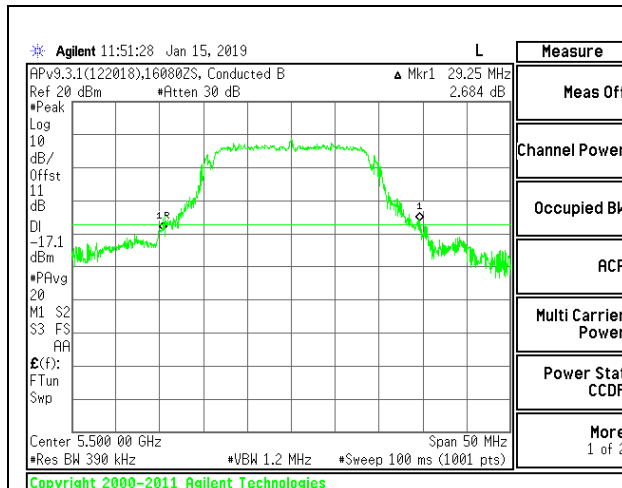

LOW CHANNEL

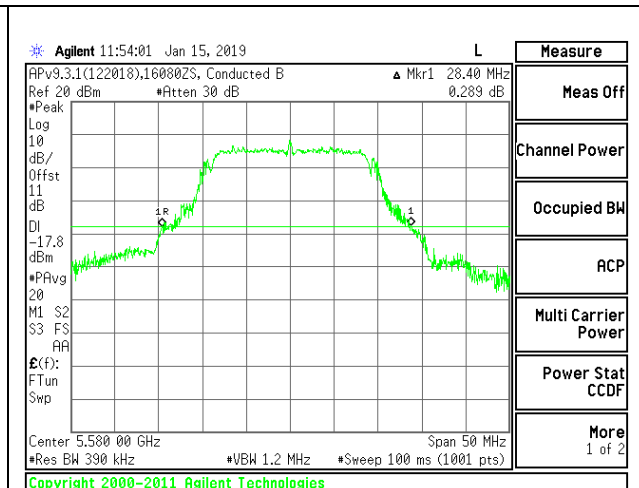

MID CHANNEL

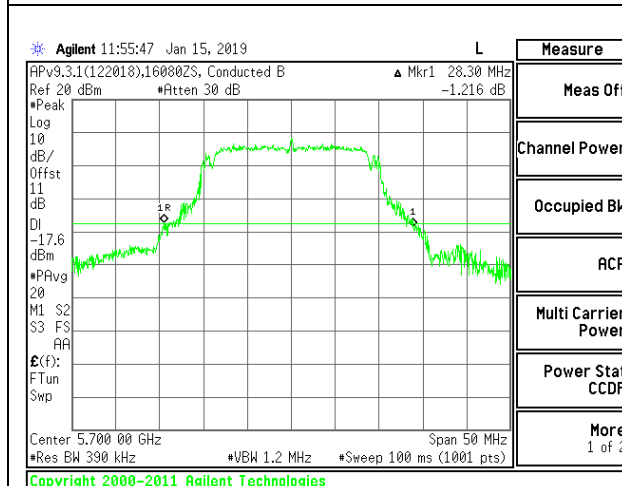

HIGH CHANNEL

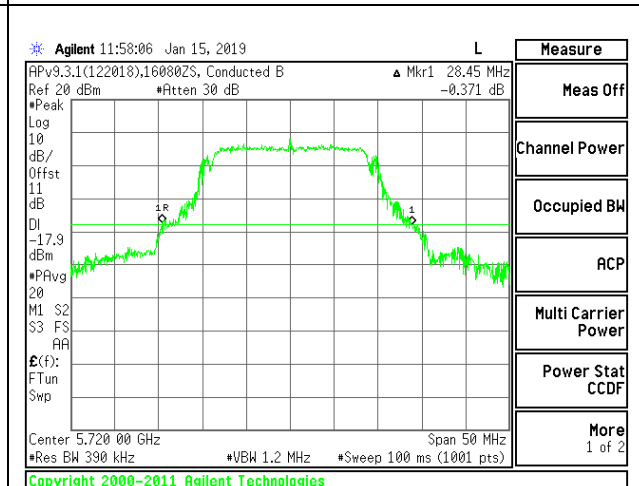

CHANNEL 144

9.2.10. 802.11n HT20 MODE IN THE 5.6 GHz BAND

1TX Antenna 1 MODE

Channel	Frequency (MHz)	26 dB Bandwidth (MHz)
Low	5500	30.25
Mid	5580	29.10
High	5700	29.15
144	5720	27.90

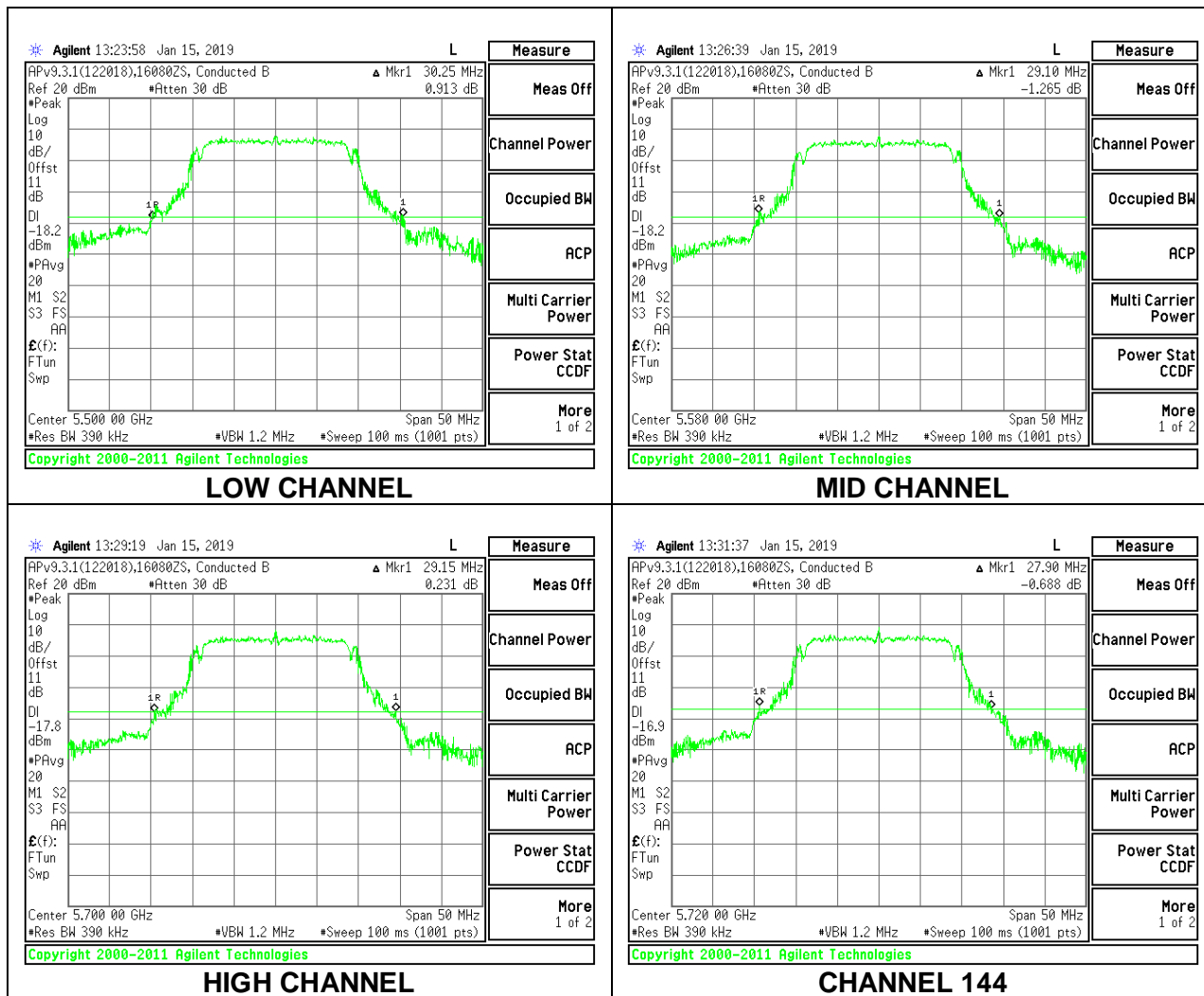

9.2.11. 802.11n HT40 MODE IN THE 5.6 GHz BAND

1TX Antenna 1 MODE

Channel	Frequency (MHz)	26 dB Bandwidth (MHz)
Low	5510	44.10
Mid	5550	44.00
High	5670	44.10
142	5710	43.90

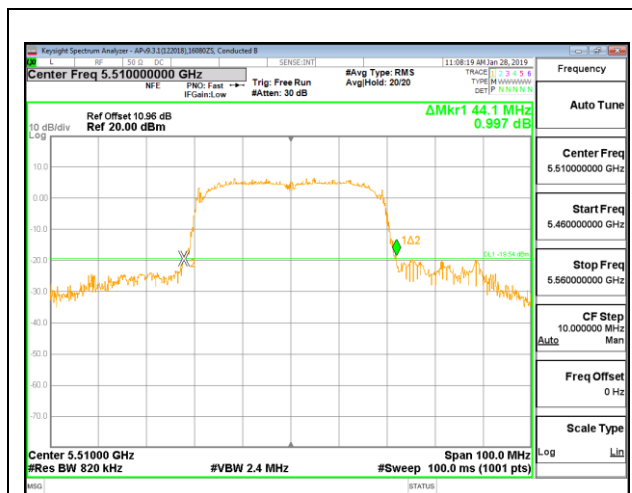

LOW CHANNEL

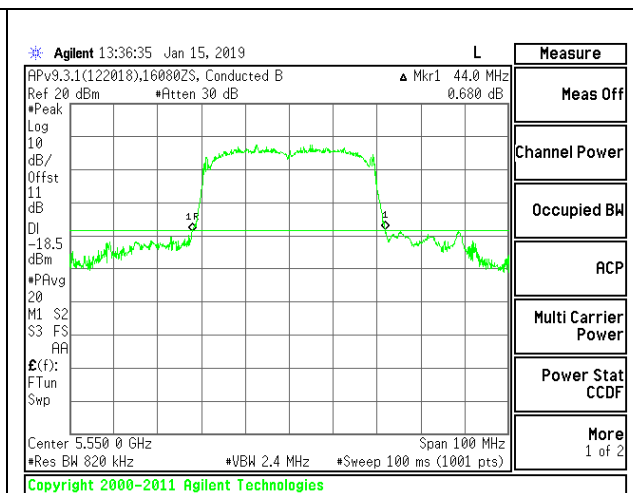

MID CHANNEL

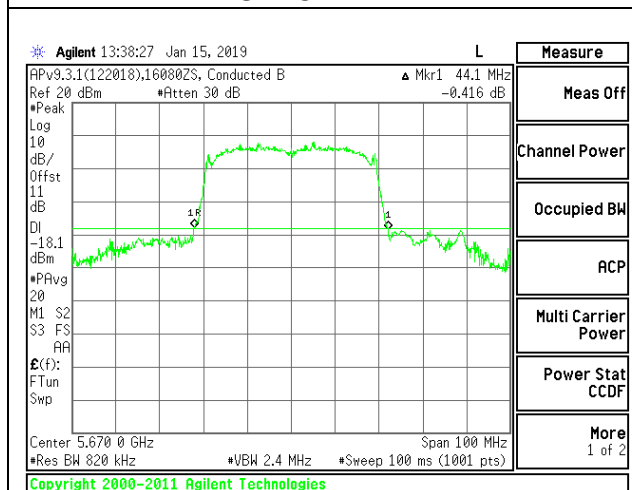

HIGH CHANNEL

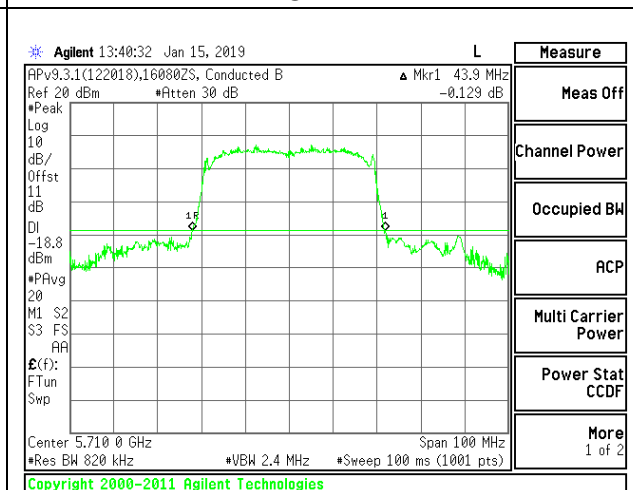

CHANNEL 142

9.2.12. 802.11ac VHT80 MODE IN THE 5.6 GHz BAND

1TX Antenna 1 MODE

Channel	Frequency (MHz)	26 dB Bandwidth (MHz)
Low	5530	105.60
High	5610	113.20
138	5690	110.40

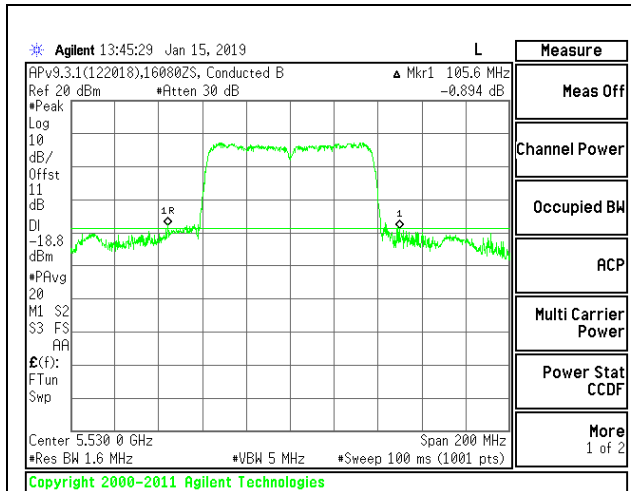

LOW CHANNEL

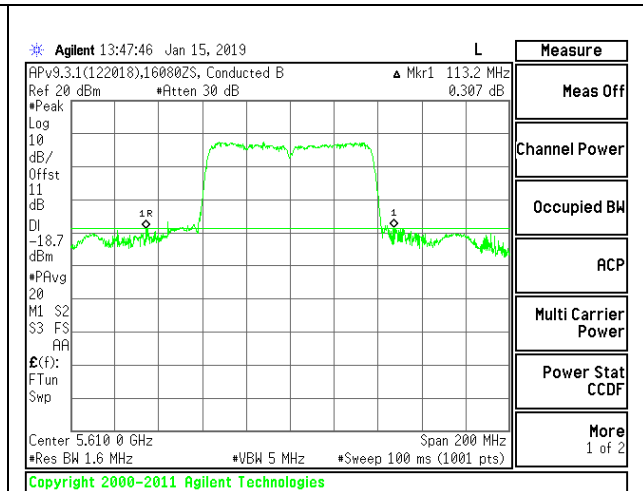

HIGH CHANNEL

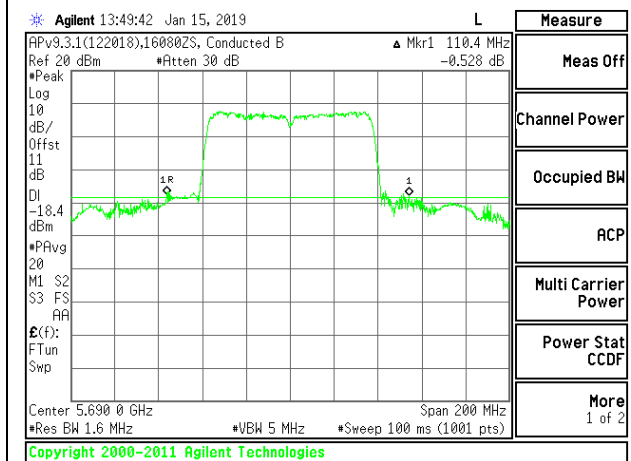

CHANNEL 138

9.2.13. 802.11a MODE IN THE 5.8 GHz BAND

1TX Antenna 1 MODE

Channel	Frequency (MHz)	26 dB Bandwidth (MHz)
Low	5745	28.40
Mid	5785	28.00
High	5825	30.60

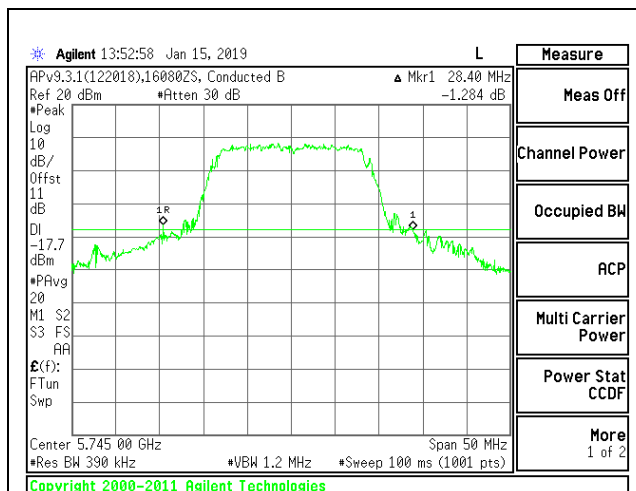

LOW CHANNEL

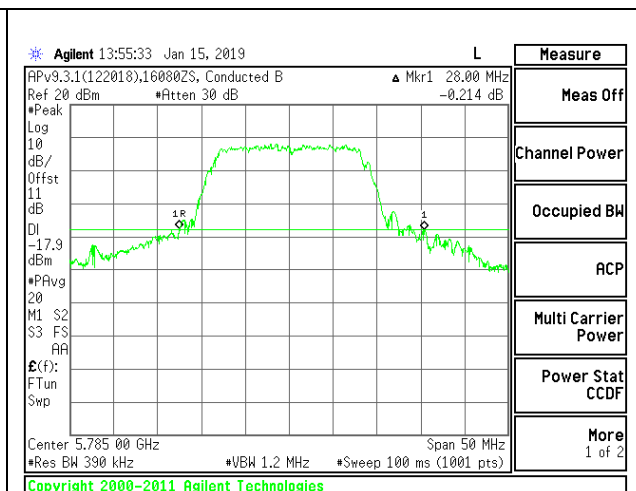

MID CHANNEL

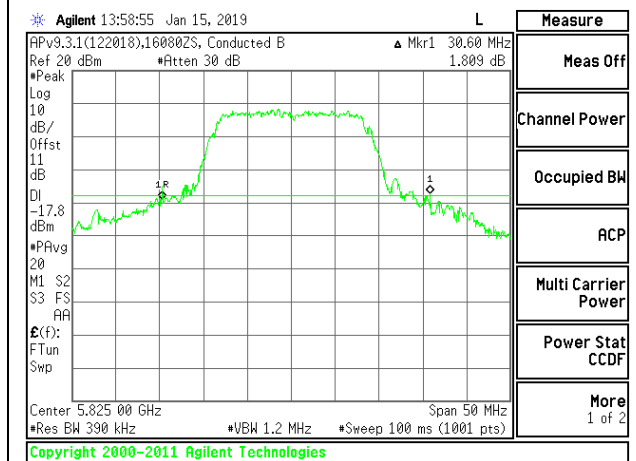

HIGH CHANNEL

9.2.14. 802.11n HT20 MODE IN THE 5.8 GHz BAND

1TX Antenna 1 MODE

Channel	Frequency (MHz)	26 dB Bandwidth (MHz)
Low	5745	29.15
Mid	5785	29.90
High	5825	30.05

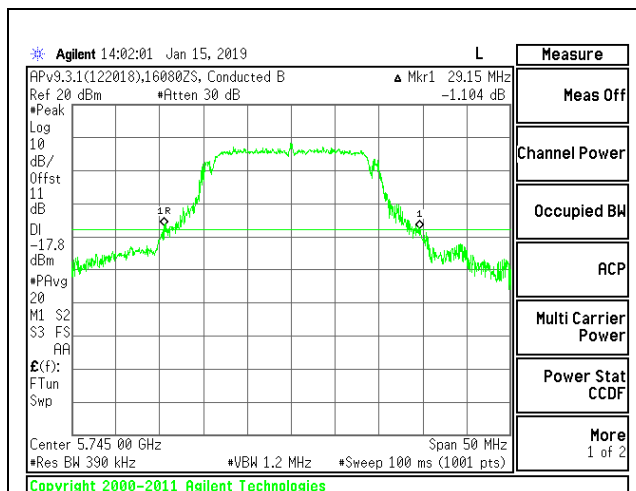

LOW CHANNEL

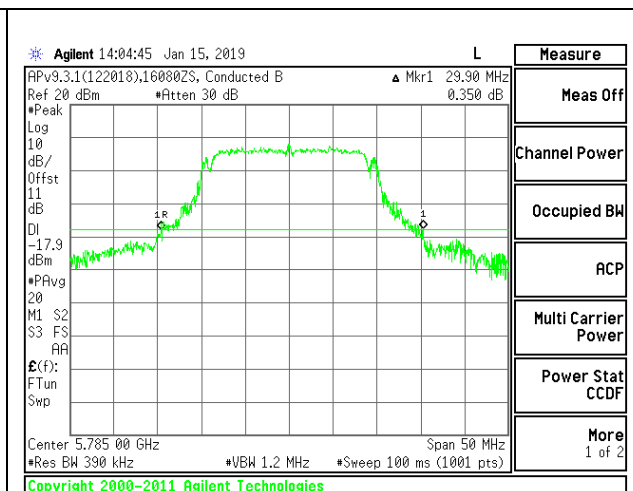

MID CHANNEL

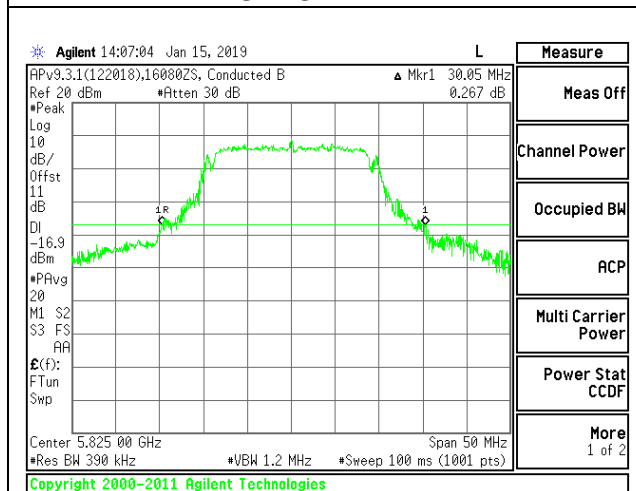

HIGH CHANNEL

9.2.15. 802.11n HT40 MODE IN THE 5.8 GHz BAND

1TX Antenna 1 MODE

Channel	Frequency (MHz)	26dB Bandwidth (MHz)
Low	5755	43.90
High	5795	44.00

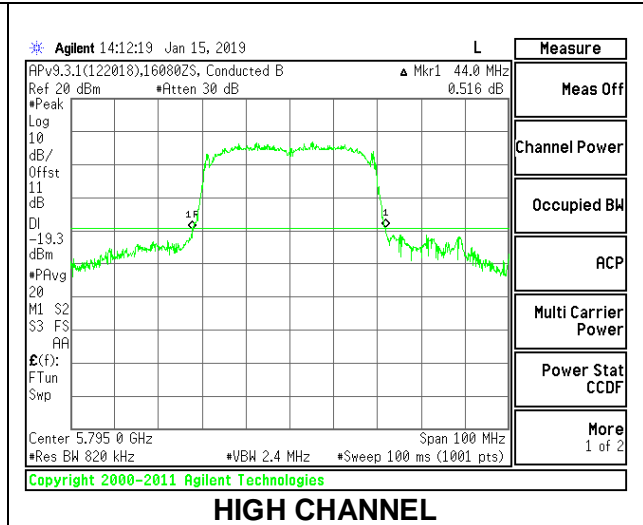
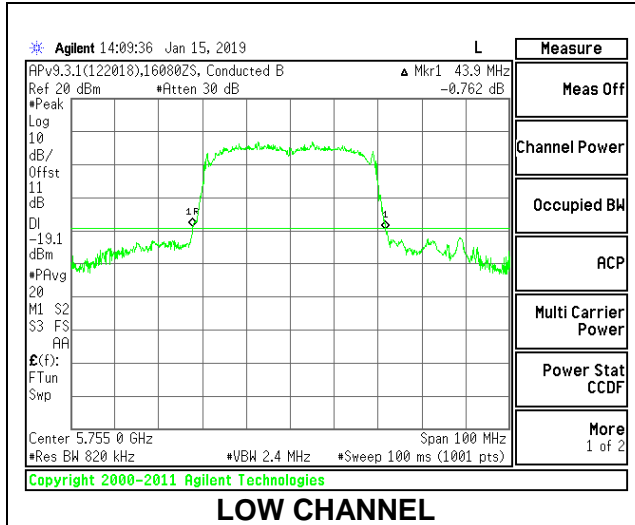

9.2.16. 802.11ac VHT80 MODE IN THE 5.8 GHz BAND

1TX Antenna 1 MODE

Channel	Frequency (MHz)	26 dB Bandwidth (MHz)
Mid	5775	91.40

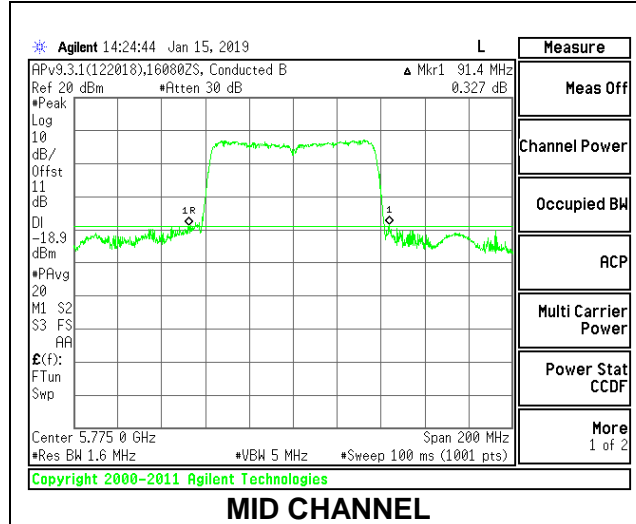

9.3. 99% BANDWIDTH

LIMITS

None; for reporting purposes only.

RESULTS

9.3.1. 802.11a MODE IN THE 5.2 GHz BAND

1TX Antenna 1 MODE

Channel	Frequency (MHz)	99% Bandwidth (MHz)
Low	5180	17.3440
Mid	5200	17.2290
High	5240	17.2870

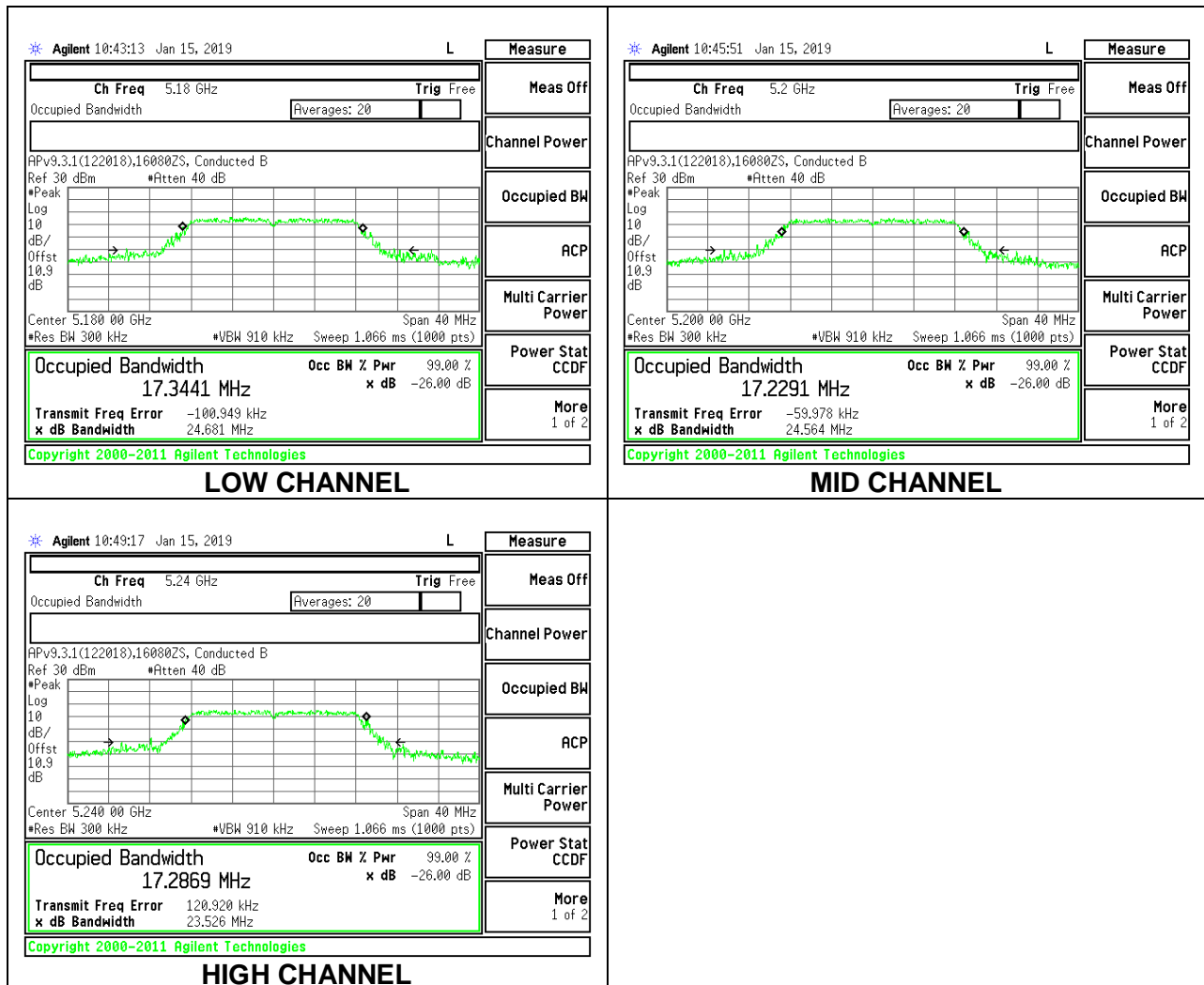

9.3.2. 802.11n HT20 MODE IN THE 5.2 GHz BAND

1TX Antenna 1 MODE

Channel	Frequency (MHz)	99% Bandwidth (MHz)
Low	5180	18.6240
Mid	5200	18.2930
High	5240	18.7250

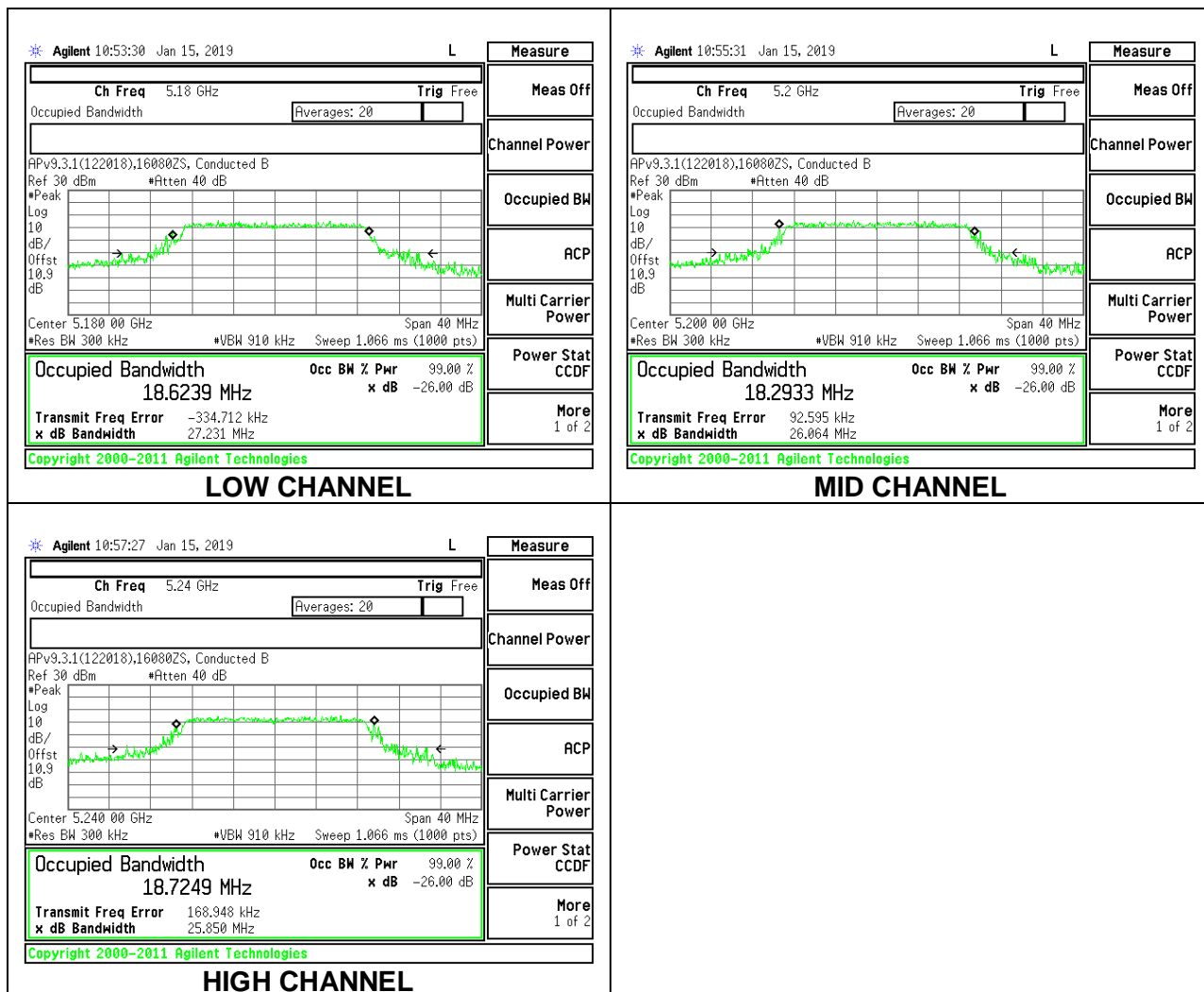

9.3.3. 802.11n HT40 MODE IN THE 5.2 GHz BAND

1TX Antenna 1 MODE

Channel	Frequency (MHz)	99% Bandwidth (MHz)
Low	5190	36.4670
High	5230	36.2240

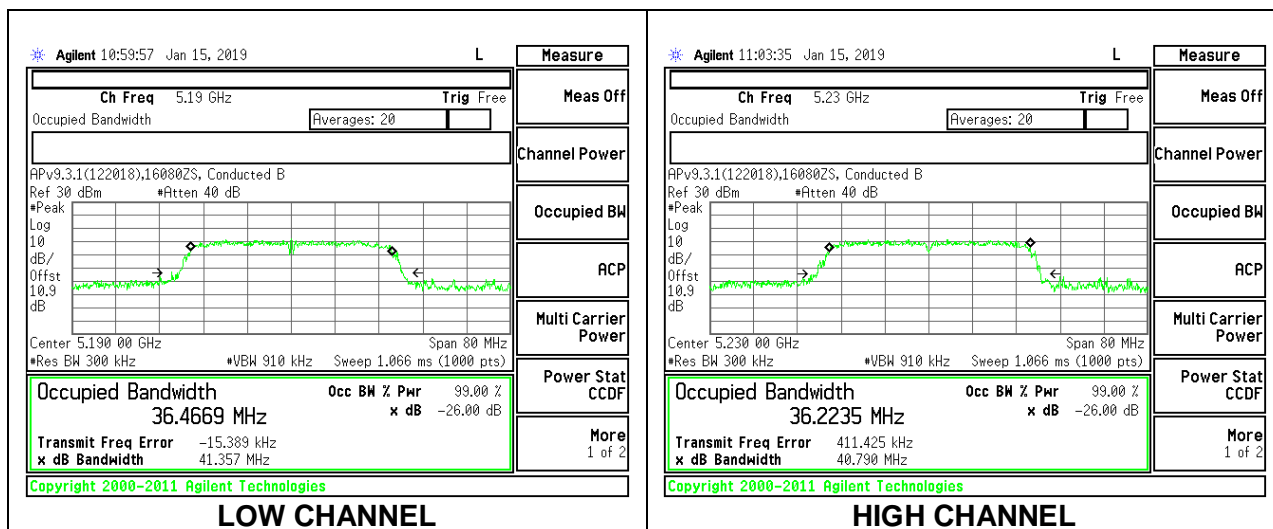

9.3.4. 802.11ac VHT80 MODE IN THE 5.2 GHz BAND

1TX Antenna 1 MODE

Channel	Frequency (MHz)	99% Bandwidth (MHz)
Mid	5210	75.2060

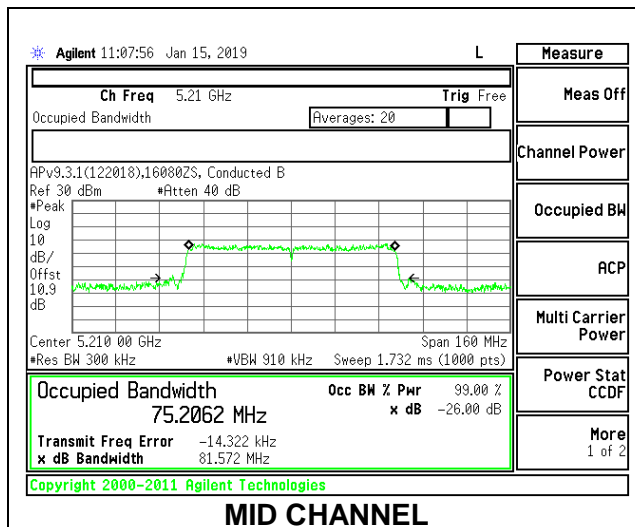

9.3.5. 802.11a MODE IN THE 5.3 GHz BAND

1TX Antenna 1 MODE

Channel	Frequency (MHz)	99% Bandwidth (MHz)
Low	5260	17.5690
Mid	5300	17.3090
High	5320	17.0800

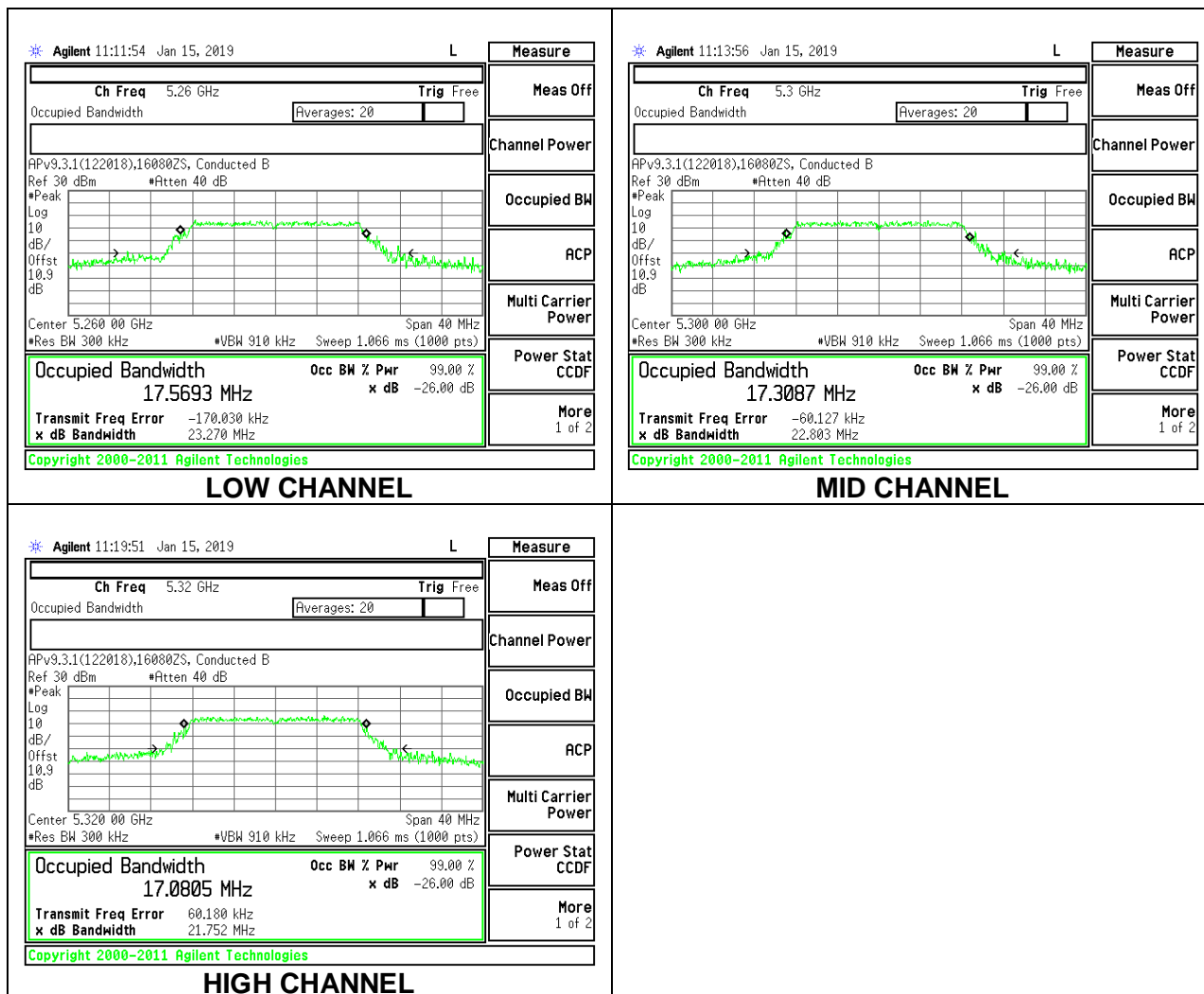

9.3.6. 802.11n HT20 MODE IN THE 5.3 GHz BAND

1TX Antenna 1 MODE

Channel	Frequency (MHz)	99% Bandwidth (MHz)
Low	5260	18.7450
Mid	5300	18.2190
High	5320	18.7870

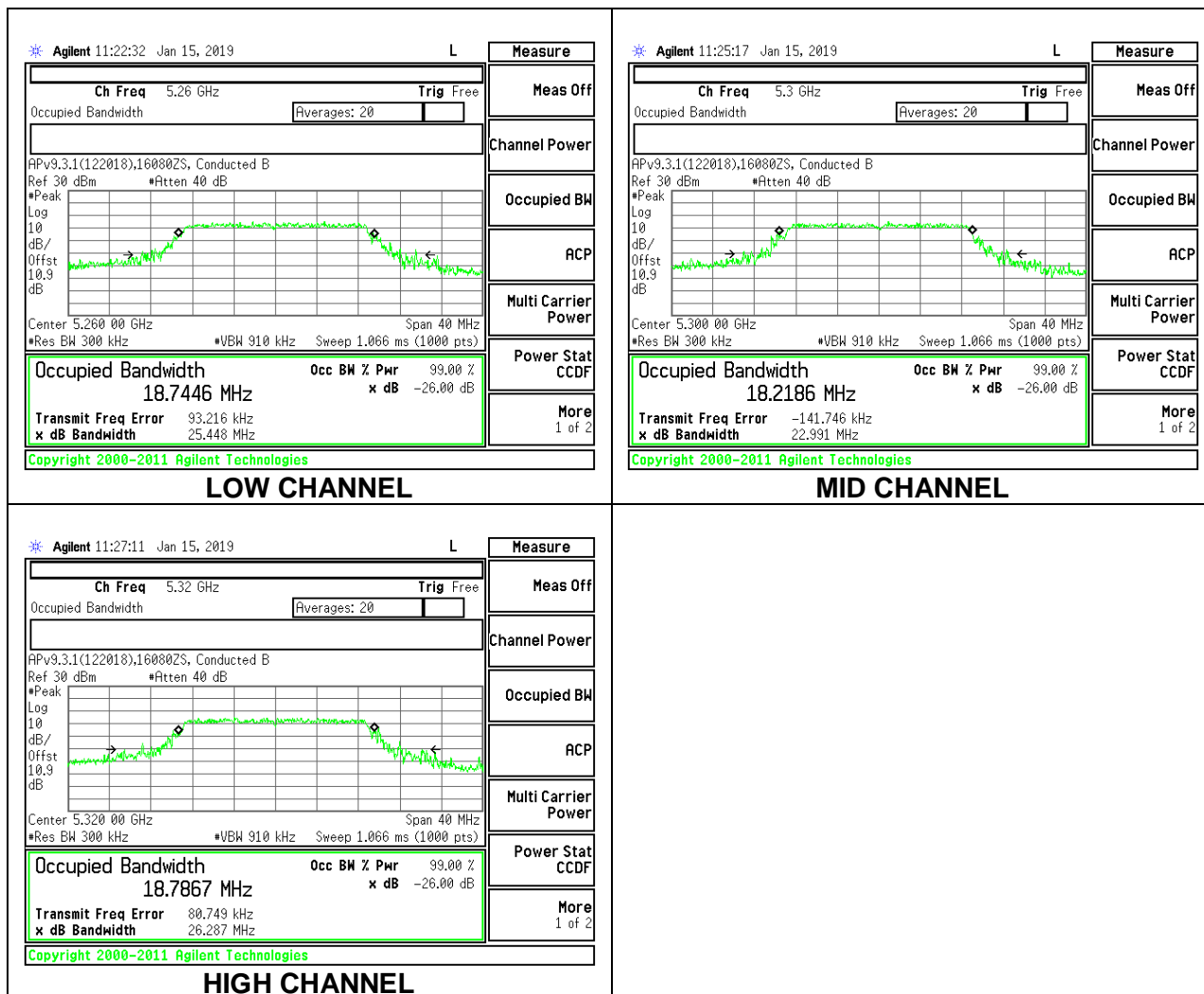

9.3.7. 802.11n HT40 MODE IN THE 5.3 GHz BAND

1TX Antenna 1 MODE

Channel	Frequency (MHz)	99% Bandwidth (MHz)
Low	5270	36.2540
High	5310	36.2030

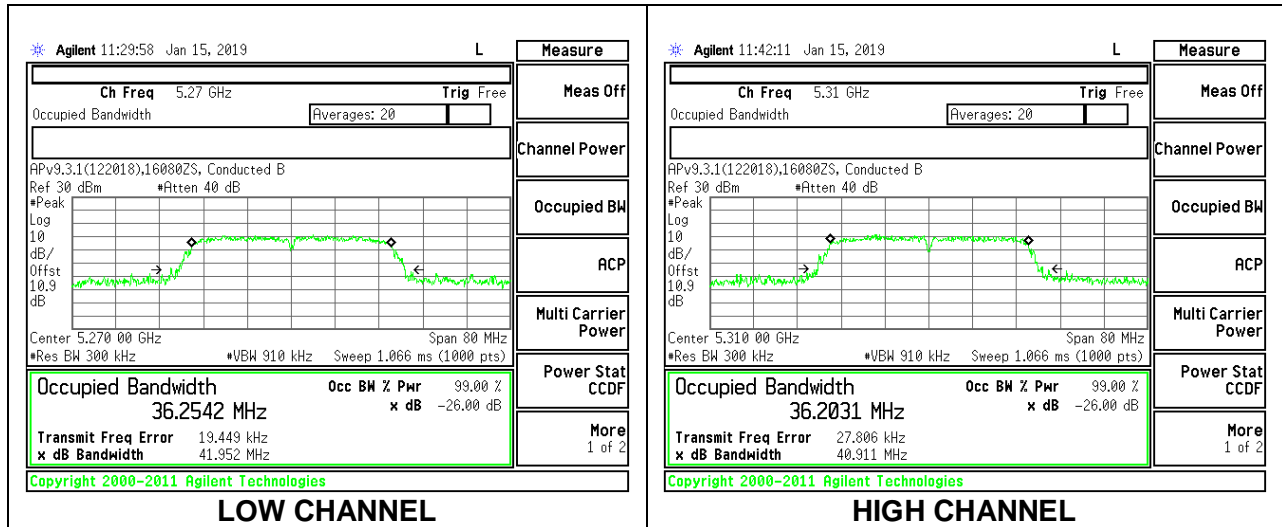

9.3.8. 802.11ac VHT80 MODE IN THE 5.3 GHz BAND

1TX Antenna 1 MODE

Channel	Frequency (MHz)	99% Bandwidth (MHz)
Mid	5290	75.4200

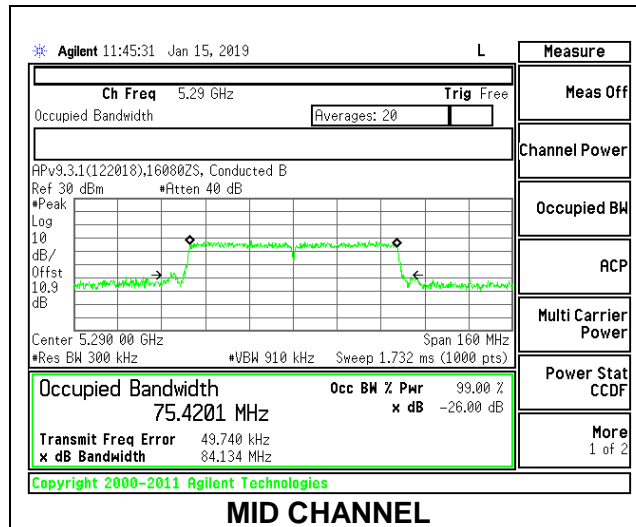

9.3.9. 802.11a MODE IN THE 5.6 GHz BAND

1TX Antenna 1 MODE

Channel	Frequency (MHz)	99% Bandwidth (MHz)
Low	5500	18.3890
Mid	5580	18.2070
High	5700	18.1130
144	5720	18.5370

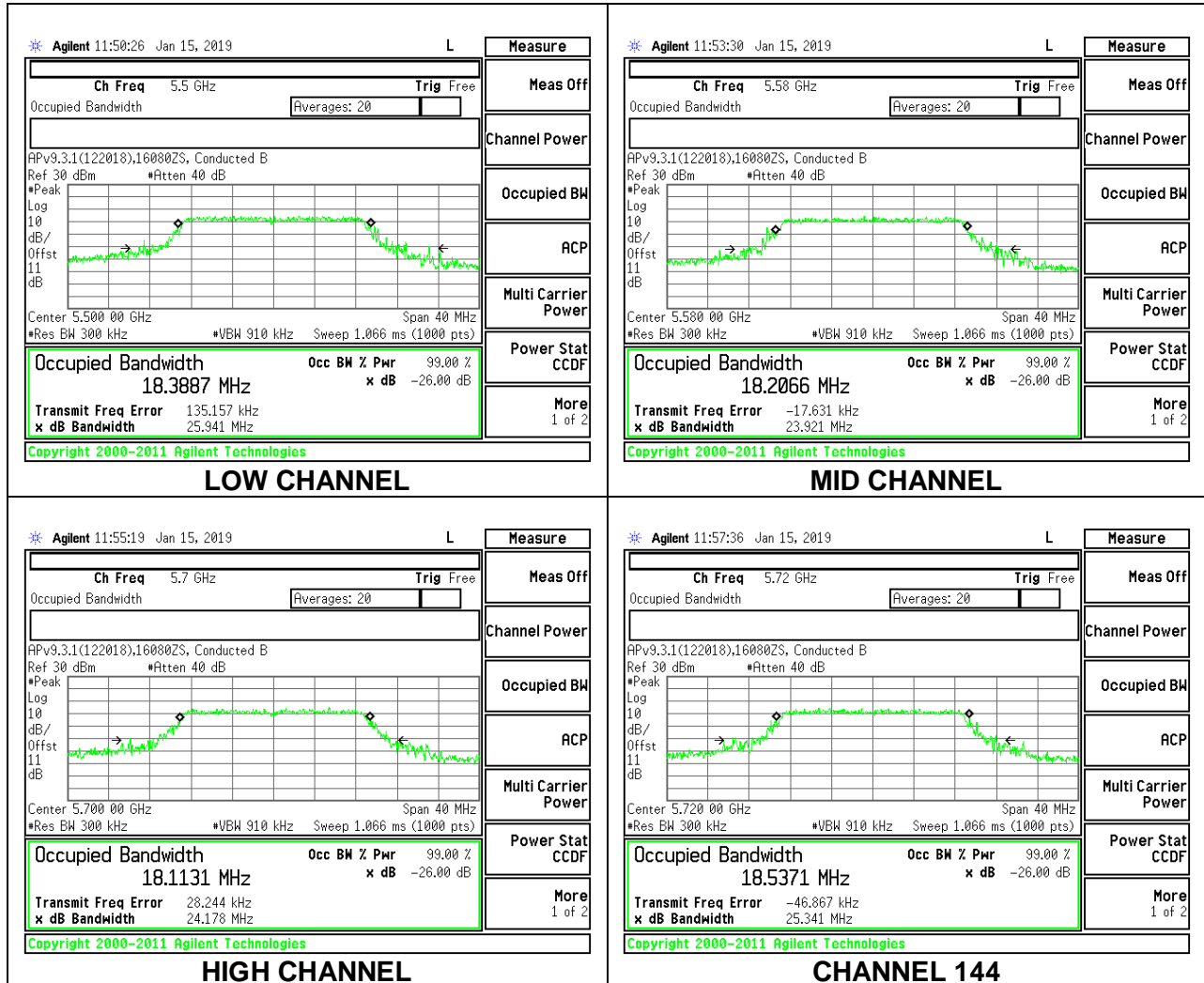

9.3.10. 802.11n HT20 MODE IN THE 5.6 GHz BAND

1TX Antenna 1 MODE

Channel	Frequency (MHz)	99% Bandwidth (MHz)
Low	5500	18.2330
Mid	5580	18.3600
High	5700	18.2360
144	5720	18.5140

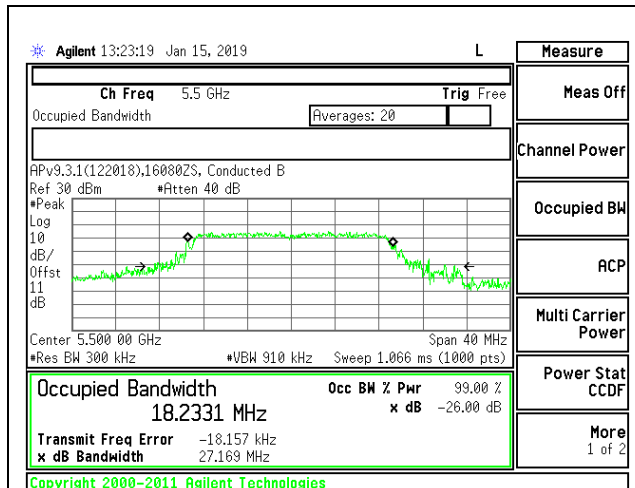

LOW CHANNEL

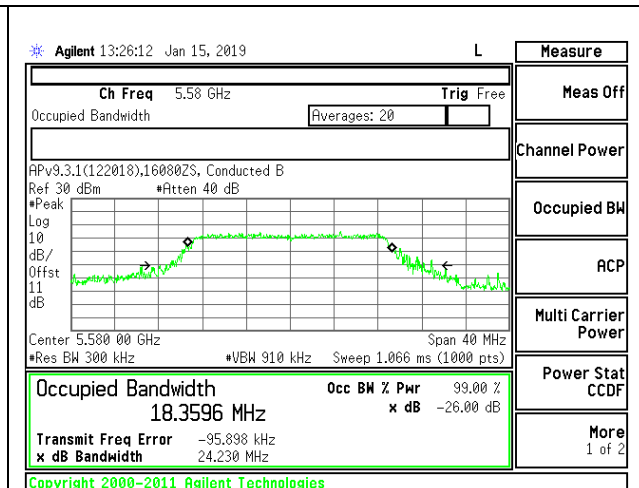

MID CHANNEL

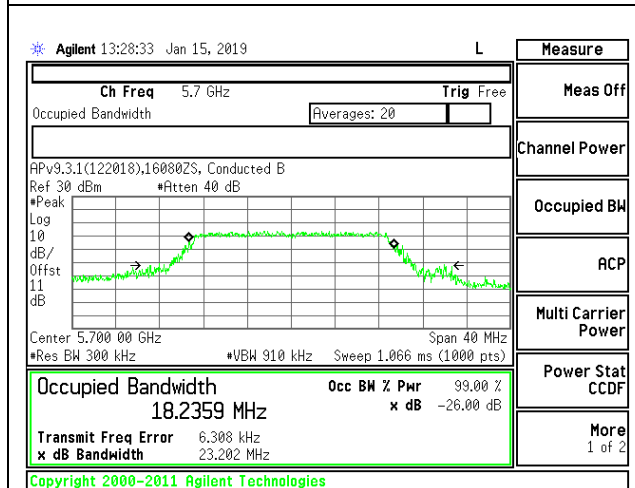

HIGH CHANNEL

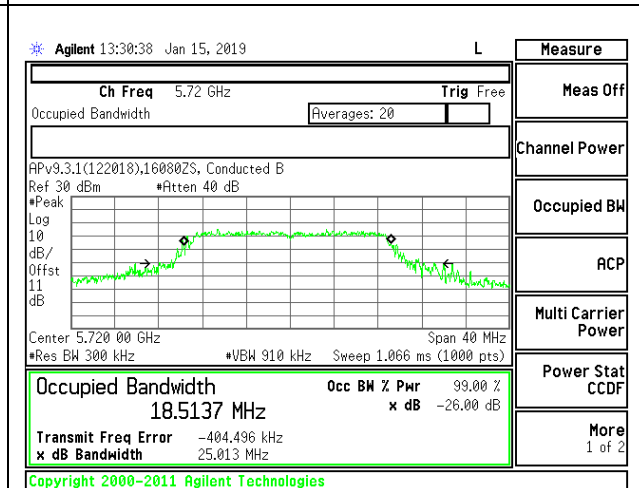

CHANNEL 144

9.3.11. 802.11n HT40 MODE IN THE 5.6 GHz BAND

1TX Antenna 1 MODE

Channel	Frequency (MHz)	99% Bandwidth (MHz)
Low	5510	36.5880
Mid	5550	36.5920
High	5670	36.2440
142	5710	36.6100

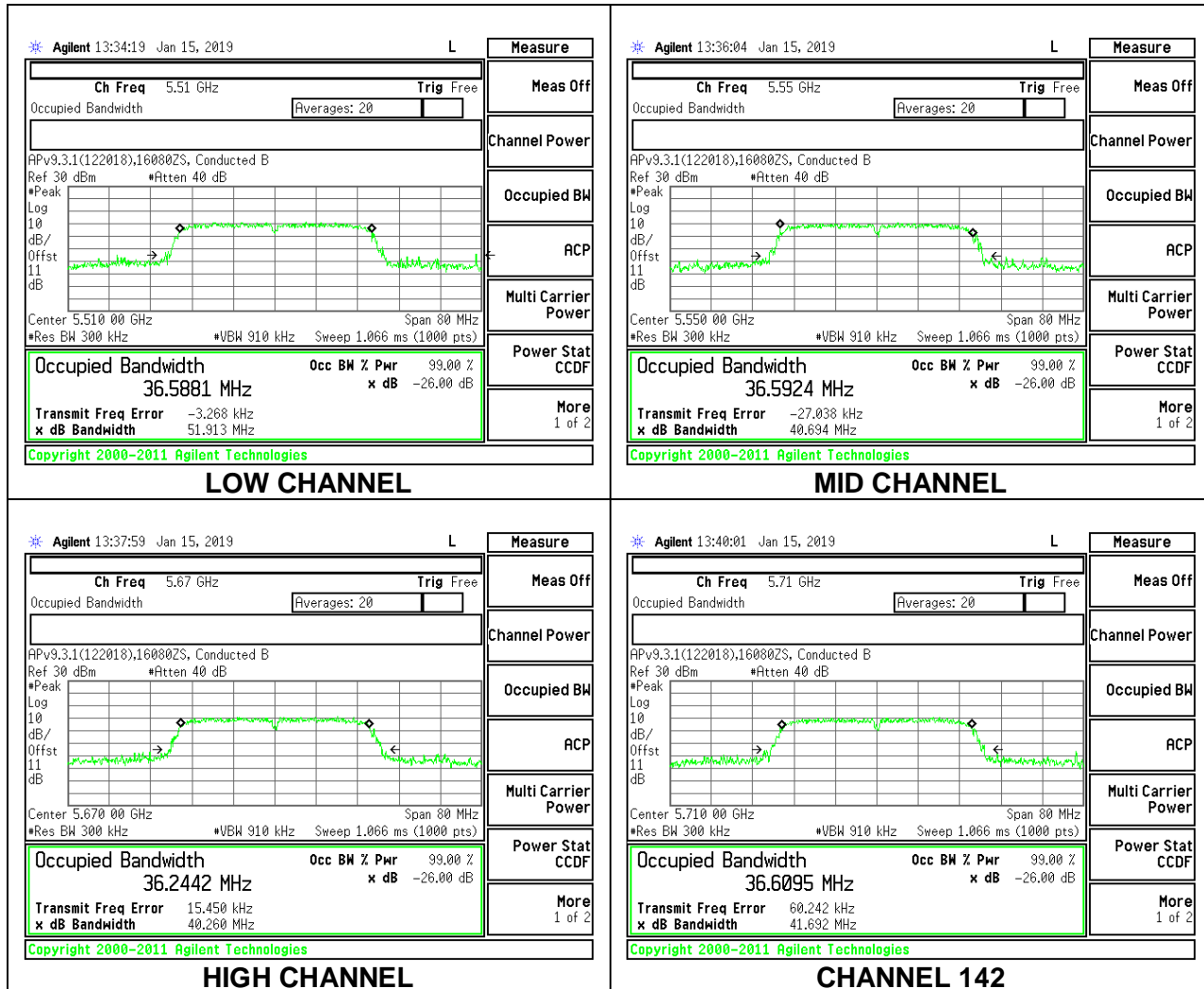

9.3.12. 802.11ac VHT80 MODE IN THE 5.6 GHz BAND

1TX Antenna 1 MODE

Channel	Frequency (MHz)	99% Bandwidth (MHz)
Low	5530	74.7140
High	5610	74.9620
138	5690	75.4600

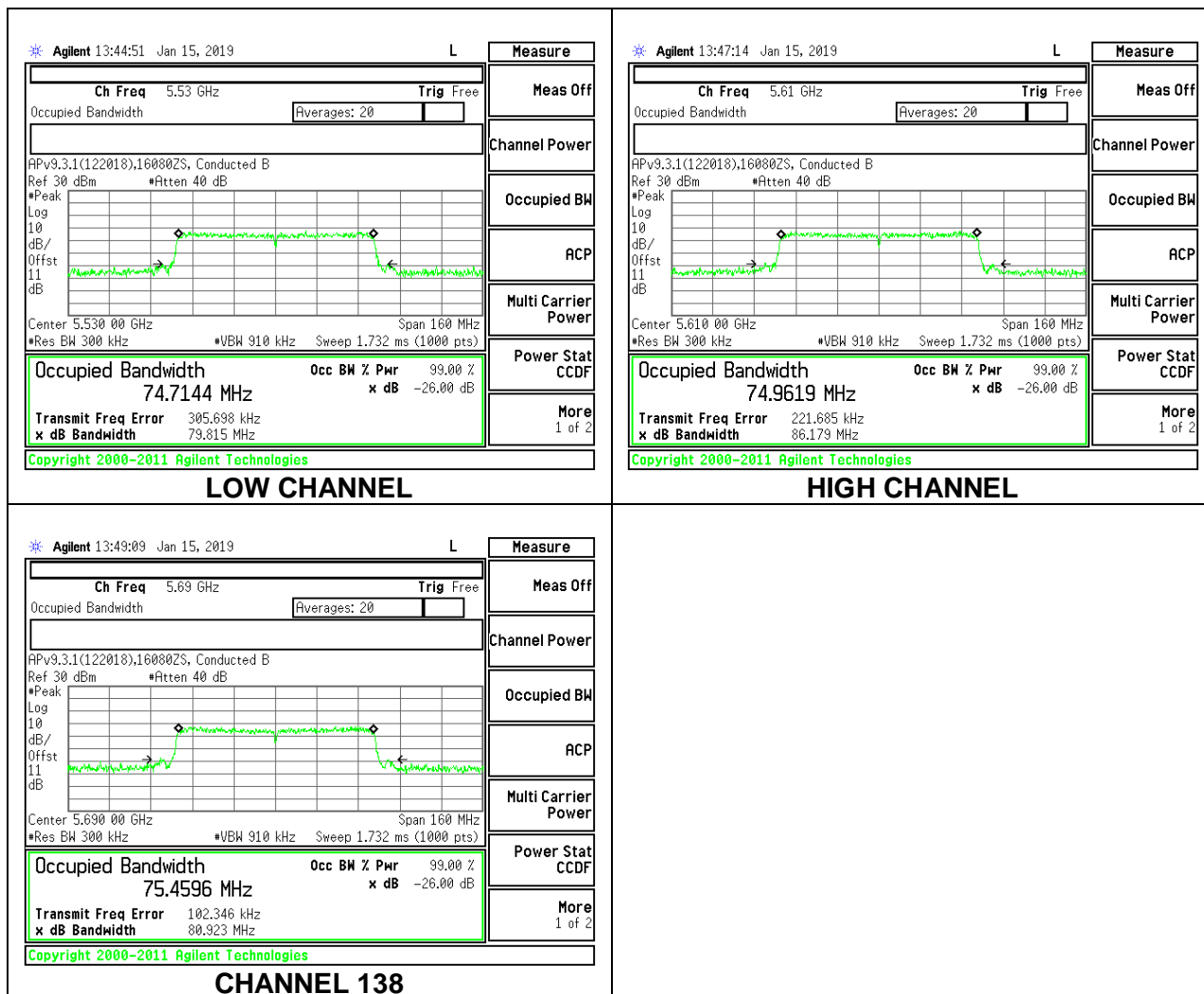

9.3.13. 802.11a MODE IN THE 5.8 GHz BAND

1TX Antenna 1 MODE

Channel	Frequency (MHz)	99% Bandwidth (MHz)
Low	5745	17.5790
Mid	5785	17.5080
High	5825	17.2320

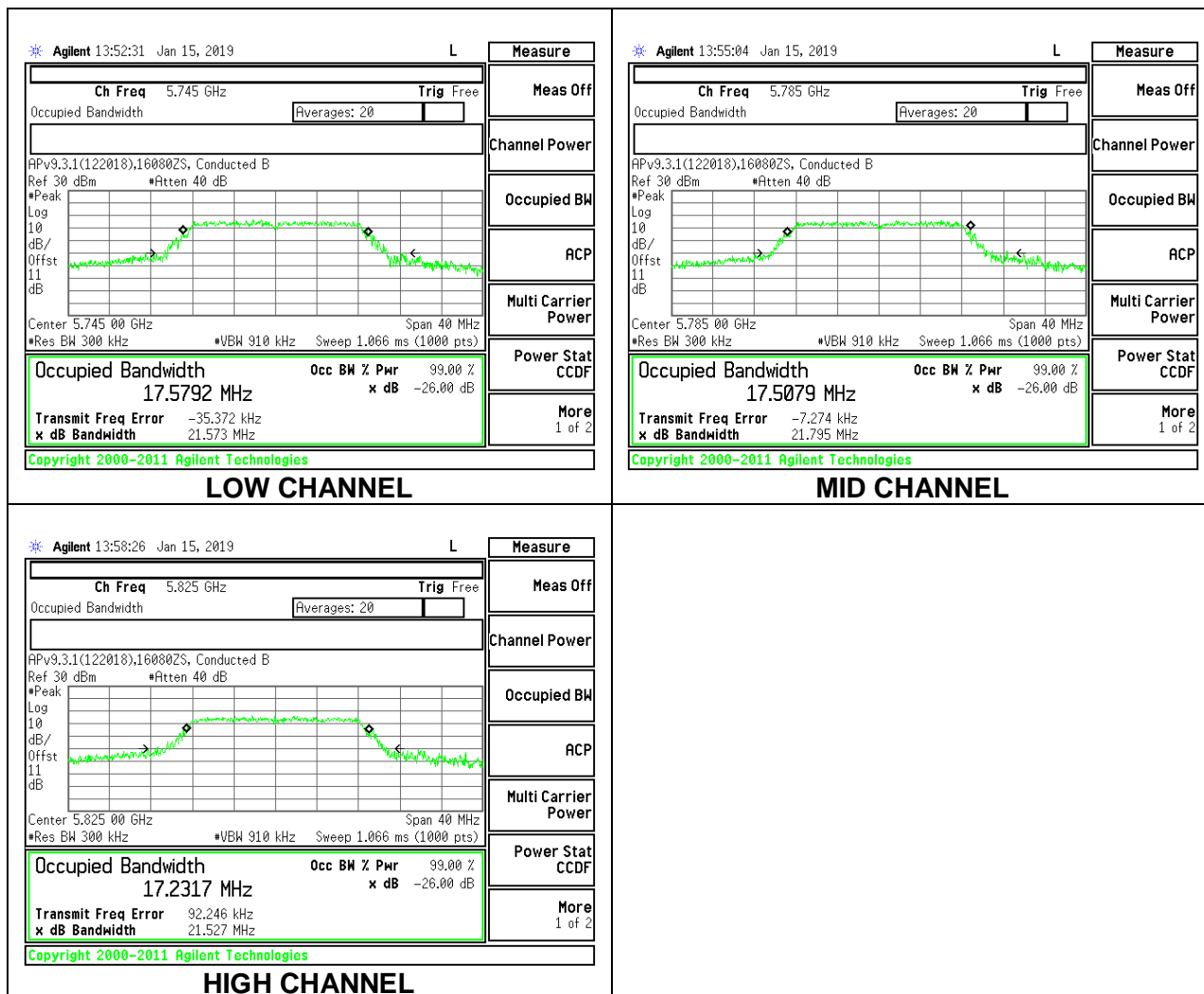

9.3.14. 802.11n HT20 MODE IN THE 5.8 GHz BAND

1TX Antenna 1 MODE

Channel	Frequency (MHz)	99% Bandwidth (MHz)
Low	5745	18.1090
Mid	5785	18.0820
High	5825	18.2370

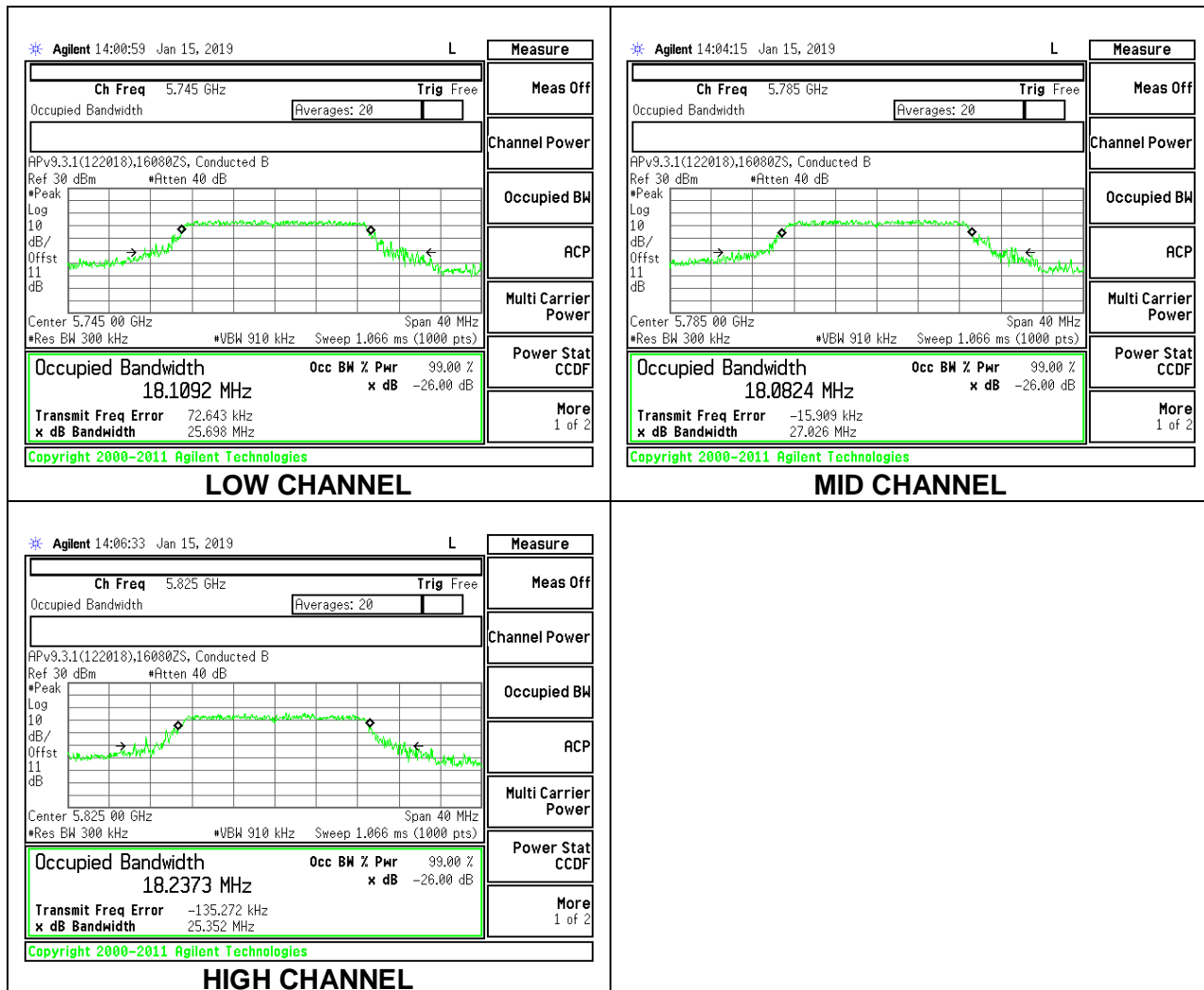

9.3.15. 802.11n HT40 MODE IN THE 5.8 GHz BAND

1TX Antenna 1 MODE

Channel	Frequency (MHz)	99% Bandwidth (MHz)
Low	5755	36.4490
High	5795	36.4310

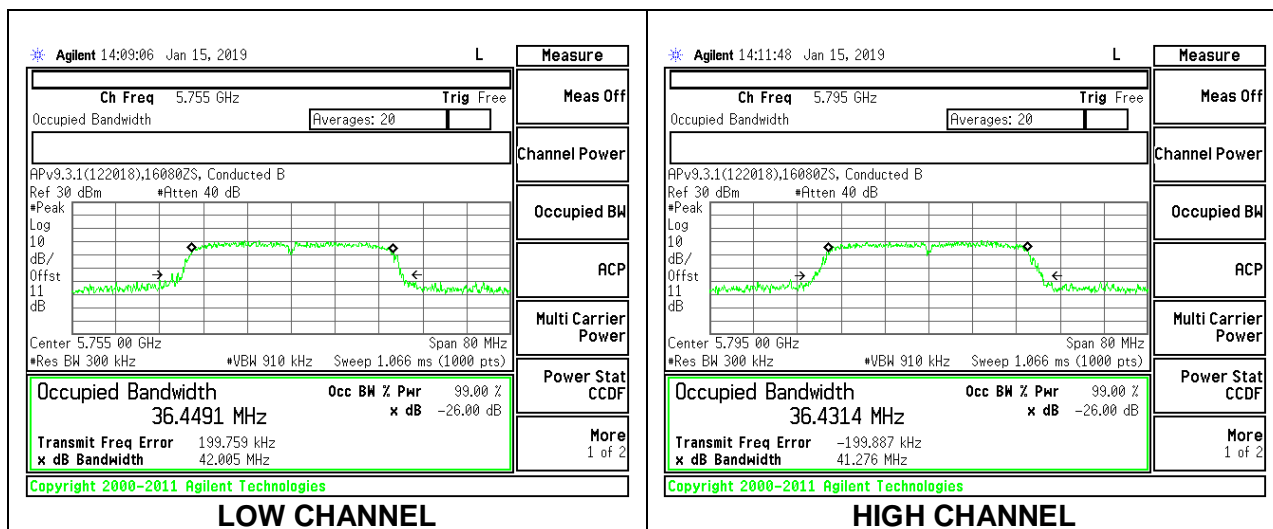

9.3.16. 802.11ac VHT80 MODE IN THE 5.8 GHz BAND

1TX Antenna 1 MODE

Channel	Frequency (MHz)	99% Bandwidth (MHz)
Mid	5775	75.2590

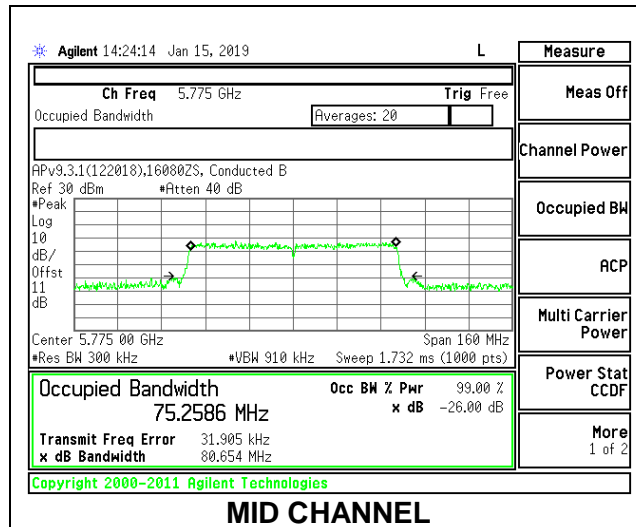

9.4. 6 dB BANDWIDTH

LIMITS

FCC §15.407 (e)

RSS-247 6.2.4.1

The minimum 6 dB bandwidth shall be at least 500 kHz.

RESULTS

9.4.1. 802.11a MODE IN THE 5.8 GHz BAND

1TX Antenna 1 MODE

Channel	Frequency (MHz)	6 dB Bandwidth (MHz)	Minimum Limit (MHz)
Low	5745	16.3350	0.5
Mid	5785	16.3530	0.5
High	5825	16.4330	0.5
144	5720	3.2320	0.5

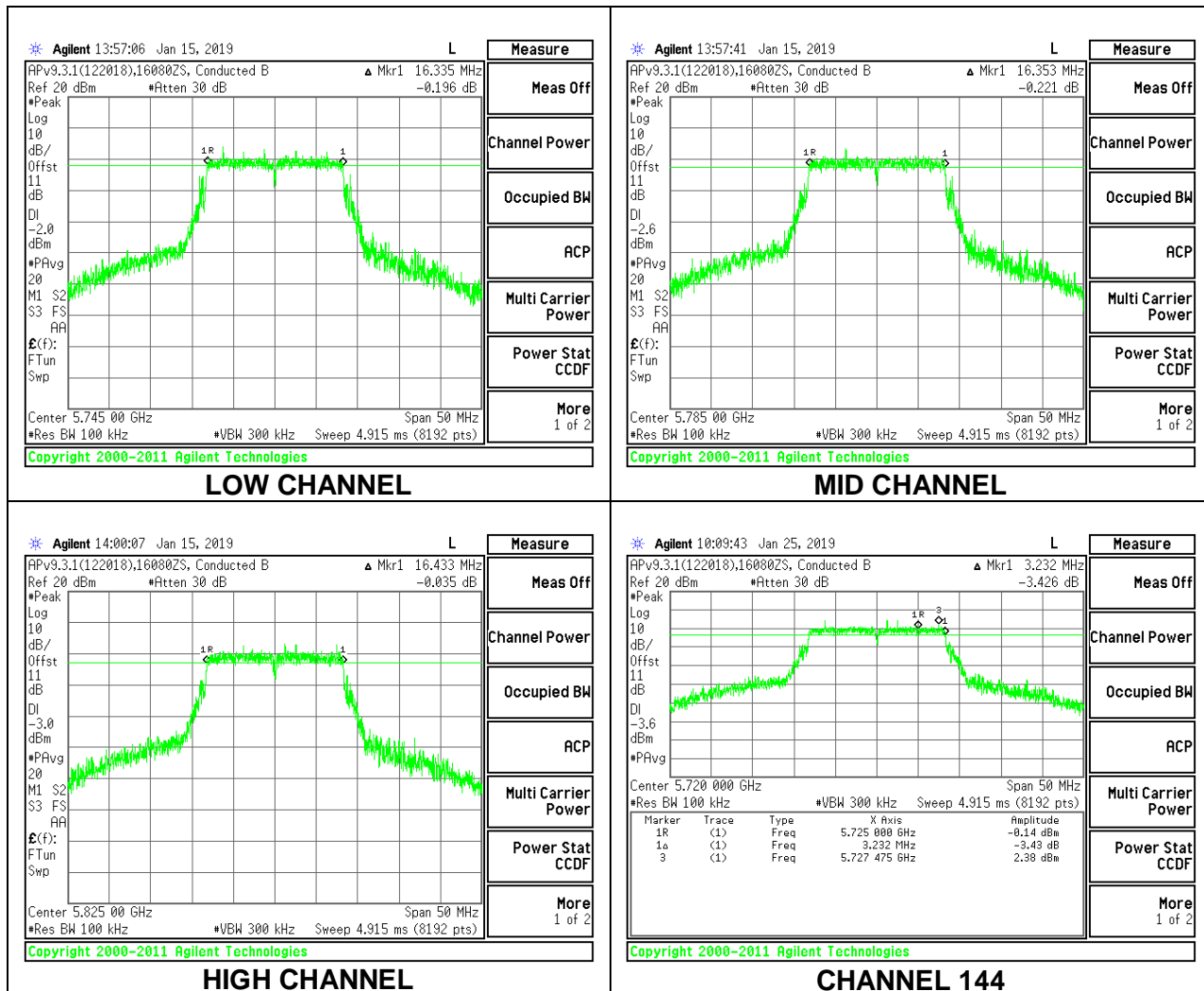

9.4.2. 802.11n HT20 MODE IN THE 5.8 GHz BAND

1TX Antenna 1 MODE

Channel	Frequency (MHz)	6 dB Bandwidth (MHz)	Minimum Limit (MHz)
Low	5745	17.5800	0.5
Mid	5785	17.5310	0.5
High	5825	18.1780	0.5
144	5720	4.4160	0.5

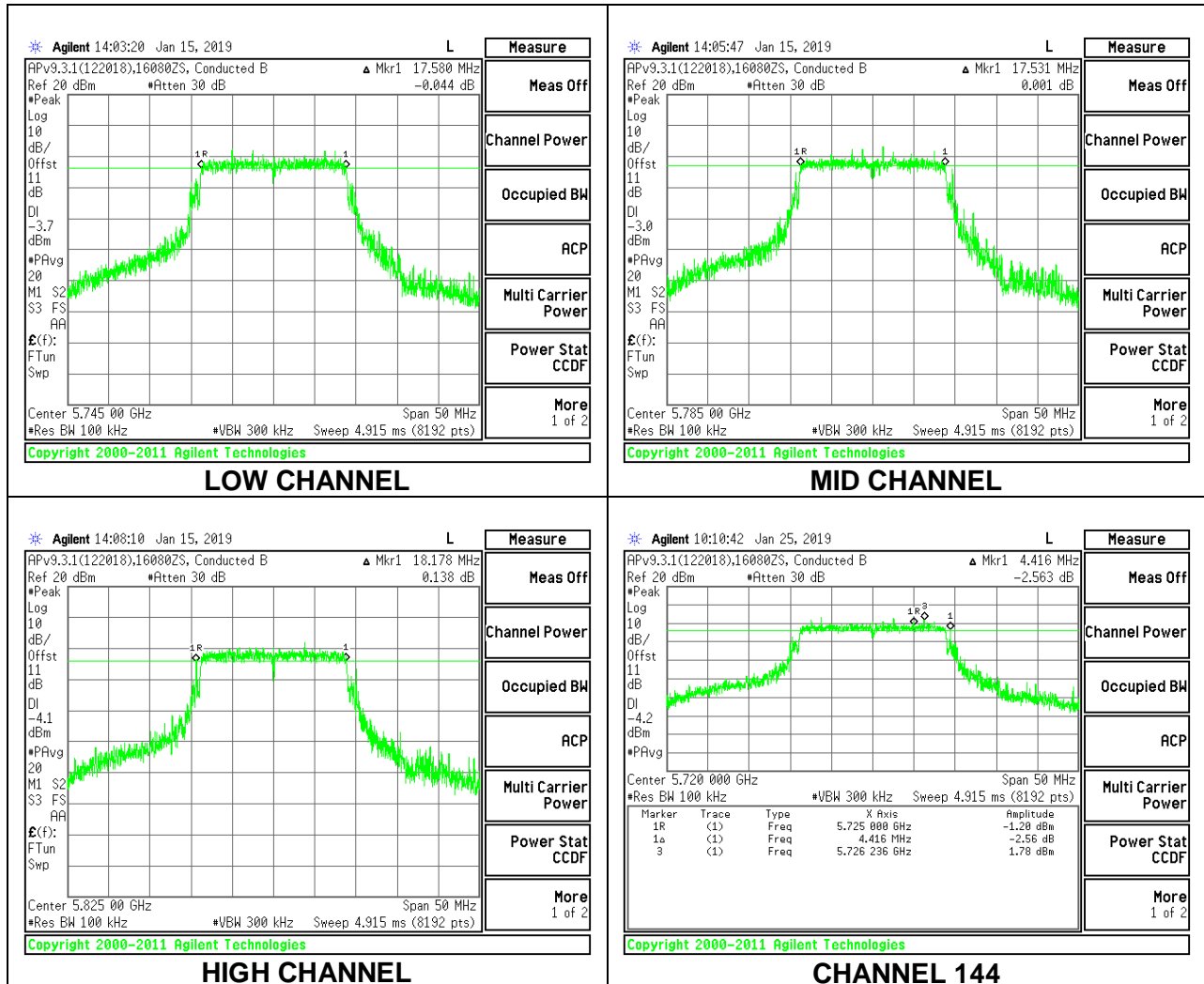

9.4.3. 802.11n HT40 MODE IN THE 5.8 GHz BAND

1TX Antenna 1 MODE

Channel	Frequency (MHz)	6 dB Bandwidth (MHz)	Minimum Limit (MHz)
Low	5755	35.1120	0.5
High	5795	33.1950	0.5
142	5710	3.3920	0.5

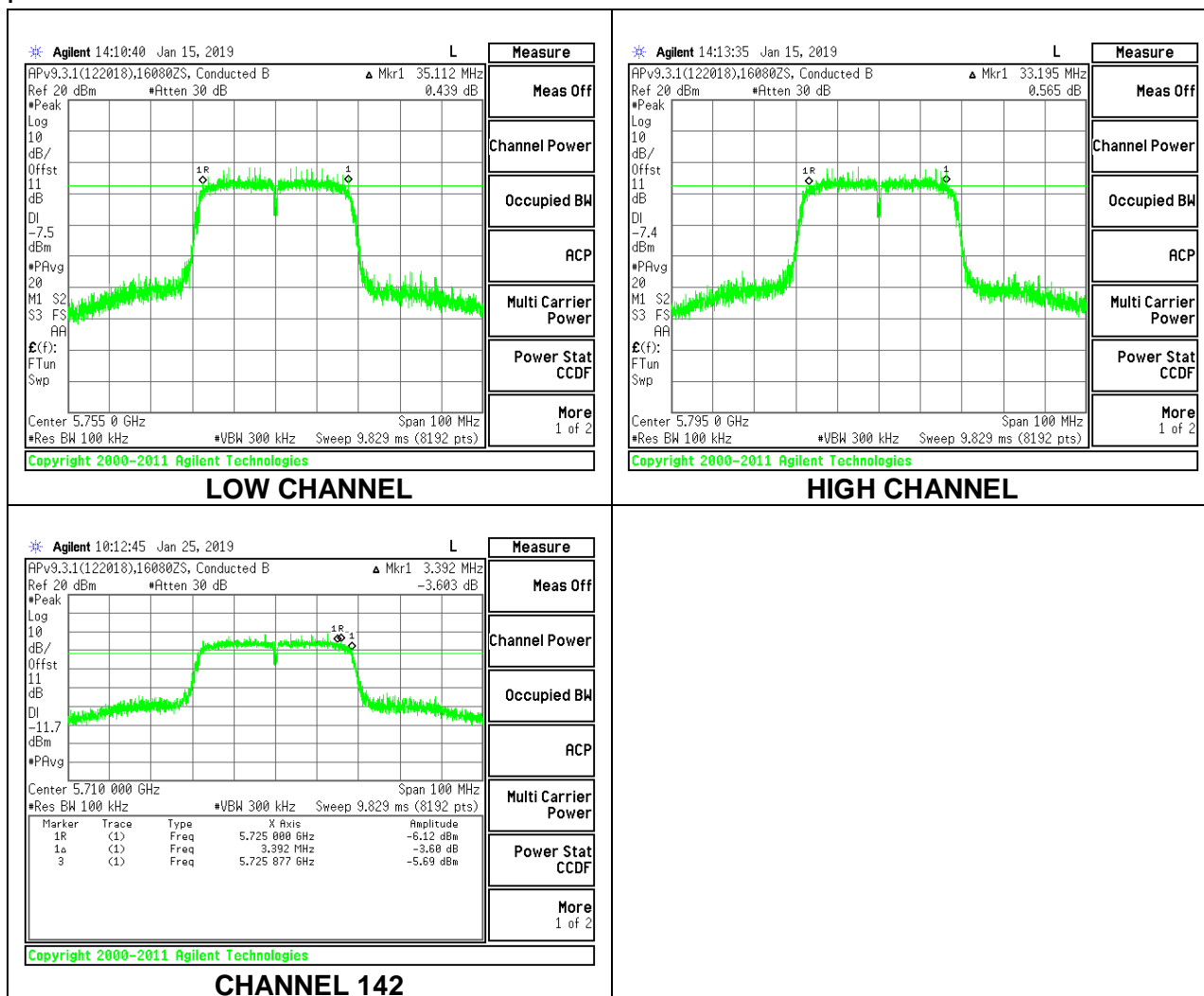

9.4.4. 802.11ac VHT80 MODE IN THE 5.8 GHz BAND

1TX Antenna 1 MODE

Channel	Frequency (MHz)	6 dB Bandwidth (MHz)	Minimum Limit (MHz)
Mid	5775	75.1310	0.5
138	5690	3.1520	0.5

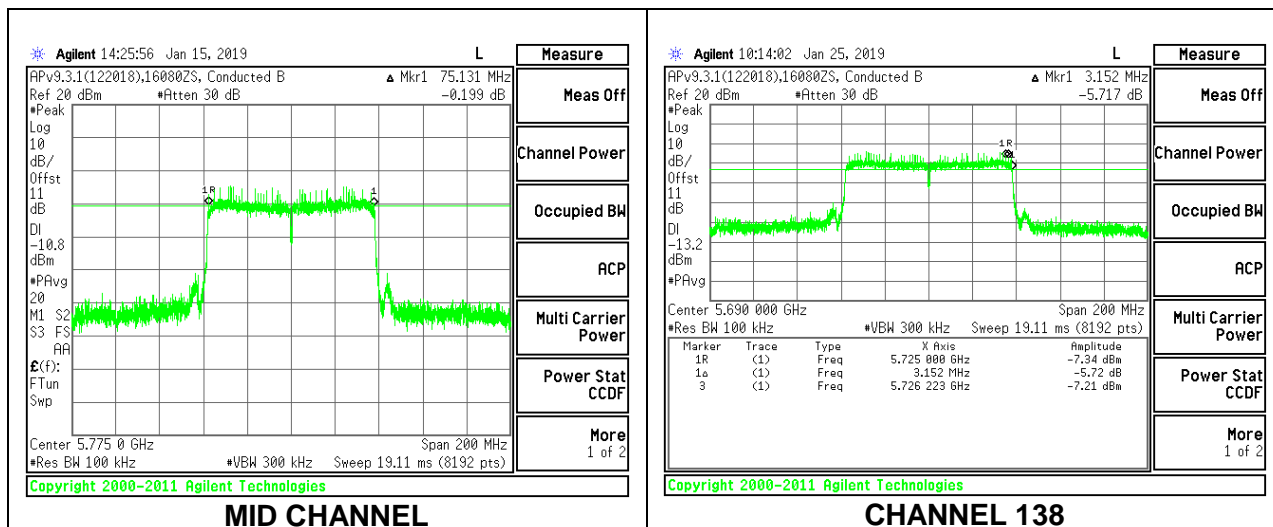

9.5. OUTPUT POWER AND PSD

LIMITS

FCC §15.407

Band 5.15–5.25 GHz (pick the section that applies to your product)

(iv) For mobile and portable client devices in the 5.15-5.25 GHz band, the maximum conducted output power over the frequency band of operation shall not exceed 250 mW provided the maximum antenna gain does not exceed 6 dBi. In addition, the maximum power spectral density shall not exceed 11 dBm in any 1 megahertz band. If transmitting antennas of directional gain greater than 6 dBi are used, both the maximum conducted output power and the maximum power spectral density shall be reduced by the amount in dB that the directional gain of the antenna exceeds 6 dBi.

Bands 5.25-5.35 GHz and 5.47-5.725 GHz

The maximum conducted output power over the frequency bands of operation shall not exceed the lesser of 250 mW or $11 \text{ dBm} + 10 \log B$, where B is the 26 dB emission bandwidth in megahertz. In addition, the maximum power spectral density shall not exceed 11 dBm in any 1 megahertz band. If transmitting antennas of directional gain greater than 6 dBi are used, both the maximum conducted output power and the maximum power spectral density shall be reduced by the amount in dB that the directional gain of the antenna exceeds 6 dBi.

Band 5.725-5.85 GHz

The maximum conducted output power over the frequency band of operation shall not exceed 1 W. In addition, the maximum power spectral density shall not exceed 30 dBm in any 500-kHz band. If transmitting antennas of directional gain greater than 6 dBi are used, both the maximum conducted output power and the maximum power spectral density shall be reduced by the amount in dB that the directional gain of the antenna exceeds 6 dBi. However, fixed point-to-point U-NII devices operating in this band may employ transmitting antennas with directional gain greater than 6 dBi without any corresponding reduction in transmitter conducted power. Fixed, point-to-point operations exclude the use of point-to-multipoint systems, omnidirectional applications, and multiple collocated transmitters transmitting the same information.

TEST PROCEDURE

The measurement method used for output power is KDB 789033 D02 v02r01, Section II.E.3.b (Method PM-G) and for straddles channels KDB 789033 D02 v02r01, Section II.E.2.b (Method SA-1) was used.

The measurement method used for power spectral density is KDB 789033 D02 v02r01, Section F

DIRECTIONAL ANTENNA GAIN

There is only one transmitter output therefore the directional gain is equal to the antenna gain.

RESULTS

9.5.1. 802.11a MODE IN THE 5.2 GHz BAND

1TX Antenna 1 MODE (FCC) MOBILE

Antenna Gain and Limits

Channel	Frequency (MHz)	Directional Gain (dBi)	Power Limit (dBm)	PSD Limit (dBm/1MHz)
Low	5180	-3.70	24.00	11.00
Mid	5200	-3.70	24.00	11.00
High	5240	-3.70	24.00	11.00

Duty Cycle CF (dB)	0.27	Included in Calculations of Corr'd PSD
---------------------------	------	---

Output Power Results

Channel	Frequency (MHz)	Meas Power (dBm)	Total Corr'd Power (dBm)	Power Limit (dBm)	Power Margin (dB)
Low	5180	16.57	16.57	24.00	-7.43
Mid	5200	16.46	16.46	24.00	-7.54
High	5240	16.21	16.21	24.00	-7.79

PSD Results

Channel	Frequency (MHz)	Meas PSD (dBm/1MHz)	Total Corr'd PSD (dBm/1MHz)	PSD Limit (dBm/1MHz)	PSD Margin (dB)
Low	5180	4.05	4.32	11.00	-6.68
Mid	5200	4.22	4.49	11.00	-6.51
High	5240	4.33	4.60	11.00	-6.40

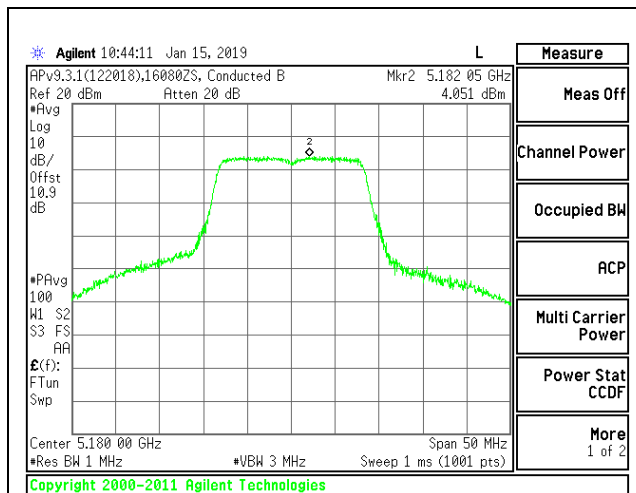

LOW CHANNEL

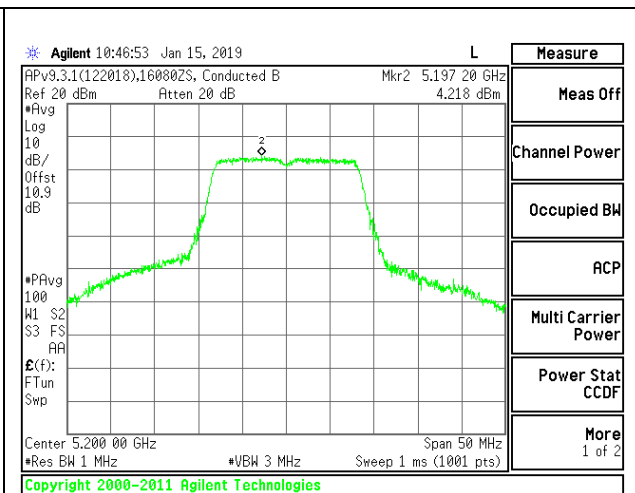

MID CHANNEL

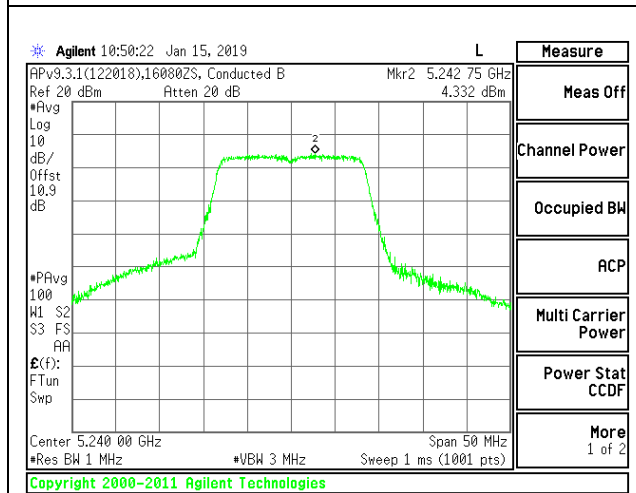

HIGH CHANNEL

9.5.2. 802.11n HT20 MODE IN THE 5.2 GHz BAND

1TX Antenna 1 MODE (FCC) MOBILE

Antenna Gain and Limits

Channel	Frequency (MHz)	Directional Gain (dBi)	Power Limit (dBm)	PSD Limit (dBm/ 1MHz)
Low	5180	-3.70	24.00	11.00
Mid	5200	-3.70	24.00	11.00
High	5240	-3.70	24.00	11.00

Duty Cycle CF (dB)	0.28	Included in Calculations of Corr'd PSD
---------------------------	------	---

Output Power Results

Channel	Frequency (MHz)	Meas Power (dBm)	Total Corr'd Power (dBm)	Power Limit (dBm)	Power Margin (dB)
Low	5180	15.45	15.45	24.00	-8.55
Mid	5200	15.80	15.80	24.00	-8.20
High	5240	14.81	14.81	24.00	-9.19

PSD Results

Channel	Frequency (MHz)	Meas PSD (dBm/1MHz)	Total Corr'd PSD (dBm/1MHz)	PSD Limit (dBm/ 1MHz)	PSD Margin (dB)
Low	5180	3.18	3.46	11.00	-7.54
Mid	5200	3.36	3.64	11.00	-7.36
High	5240	3.12	3.40	11.00	-7.60

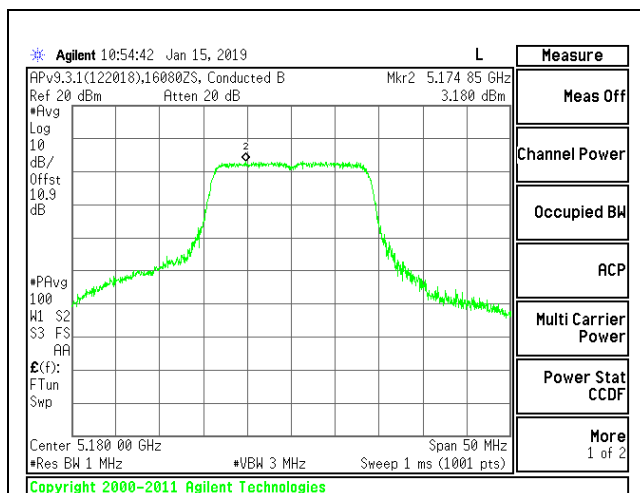

LOW CHANNEL

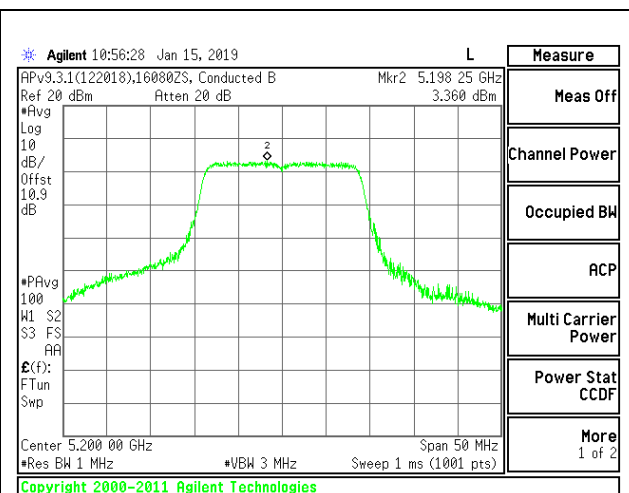

MID CHANNEL

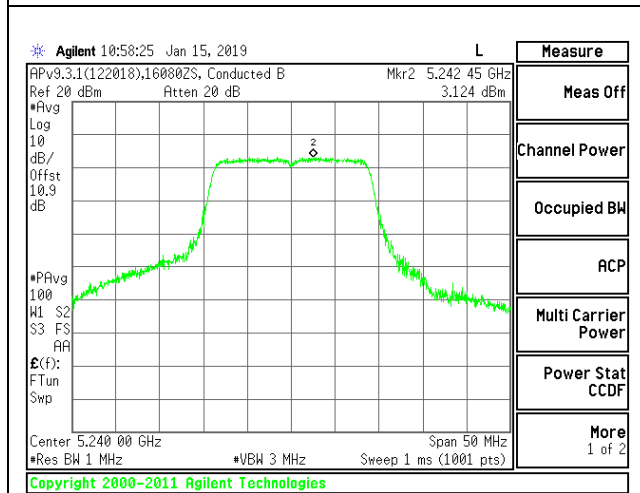

HIGH CHANNEL

9.5.3. 802.11n HT40 MODE IN THE 5.2 GHz BAND

1TX Antenna 1 MODE (FCC) MOBILE

Antenna Gain and Limits

Channel	Frequency (MHz)	Directional Gain for Power (dBi)	Power Limit (dBm)	PSD Limit (dBm/ 1MHz)
Low	5190	-3.70	24.00	11.00
High	5230	-3.70	24.00	11.00

Duty Cycle CF (dB)	0.71	Included in Calculations of Corr'd PSD
---------------------------	------	---

Output Power Results

Channel	Frequency (MHz)	Meas Power (dBm)	Total Corr'd Power (dBm)	Power Limit (dBm)	Power Margin (dB)
Low	5190	14.81	14.81	24.00	-9.19
High	5230	14.80	14.80	24.00	-9.20

PSD Results

Channel	Frequency (MHz)	Meas PSD (dBm/1MHz)	Total Corr'd PSD (dBm/1MHz)	PSD Limit (dBm/ 1MHz)	PSD Margin (dB)
Low	5190	-0.38	0.33	11.00	-10.67
High	5230	-0.59	0.13	11.00	-10.88

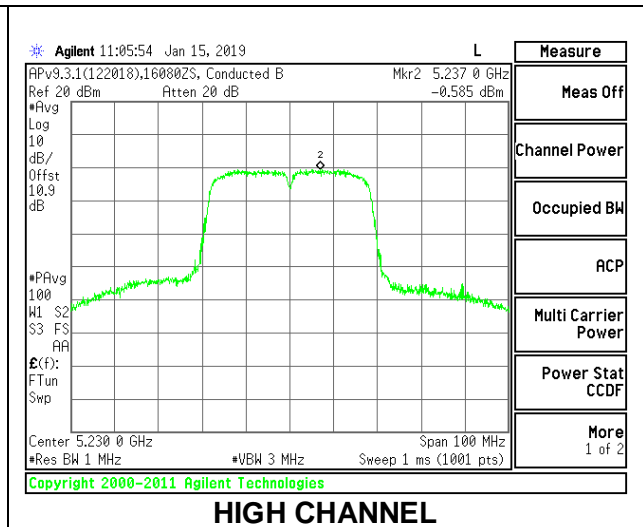
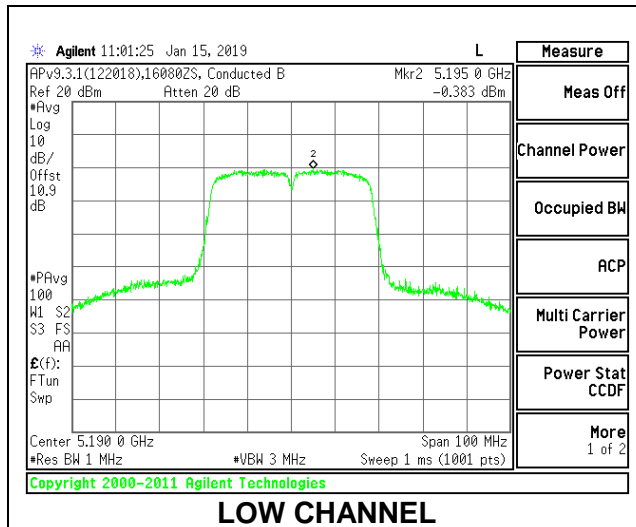

9.5.4. 802.11ac VHT80 MODE IN THE 5.2 GHz BAND

1TX Antenna 1 MODE (FCC) MOBILE

Antenna Gain and Limits

Channel	Frequency (MHz)	Directional Gain (dBi)	Power Limit (dBm)	PSD Limit (dBm/ 1MHz)
Mid	5210	-3.70	24.00	11.00

Duty Cycle CF (dB)	1.29	Included in Calculations of Corr'd PSD
---------------------------	------	---

Output Power Results

Channel	Frequency (MHz)	Meas Power (dBm)	Total Corr'd Power (dBm)	Power Limit (dBm)	Power Margin (dB)
Mid	5210	13.46	13.46	24.00	-10.54

PSD Results

Channel	Frequency (MHz)	Meas PSD (dBm/ 1MHz)	Total Corr'd PSD (dBm/ 1MHz)	PSD Limit (dBm/ 1MHz)	PSD Margin (dB)
Mid	5210	-4.99	-3.70	11.00	-14.70

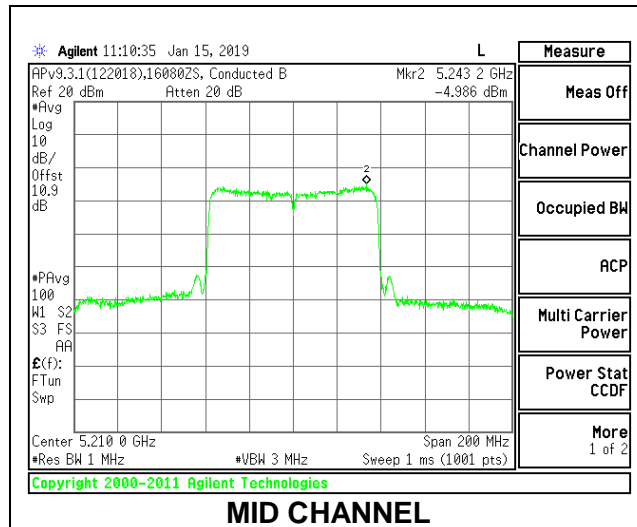

9.5.5. 802.11a MODE IN THE 5.3 GHz BAND

1TX Antenna 1 MODE (FCC)

Bandwidth, Antenna Gain, and Limits

Channel	Frequency (MHz)	Min 26 dB BW (MHz)	Directional Gain (dBi)	Power Limit (dBm)	PSD Limit (dBm/1MHz)
Low	5260	30.40	-2.60	24.00	11.00
Mid	5300	27.40	-2.60	24.00	11.00
High	5320	30.40	-2.60	24.00	11.00

Duty Cycle CF (dB)	0.27	Included in Calculations of Corr'd PSD
---------------------------	------	---

Output Power Results

Channel	Frequency (MHz)	Meas Power (dBm)	Total Corr'd Power (dBm)	Power Limit (dBm)	Power Margin (dB)
Low	5260	16.64	16.64	24.00	-7.36
Mid	5300	16.68	16.68	24.00	-7.32
High	5320	16.89	16.89	24.00	-7.11

PSD Results

Channel	Frequency (MHz)	Meas PSD (dBm/1MHz)	Total Corr'd PSD (dBm/1MHz)	PSD Limit (dBm/1MHz)	PSD Margin (dB)
Low	5260	4.733	5.00	11.00	-6.00
Mid	5300	4.066	4.34	11.00	-6.66
High	5320	4.503	4.77	11.00	-6.23

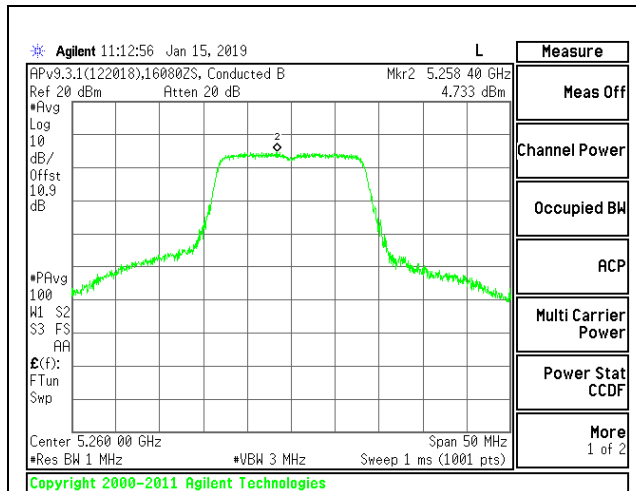

LOW CHANNEL

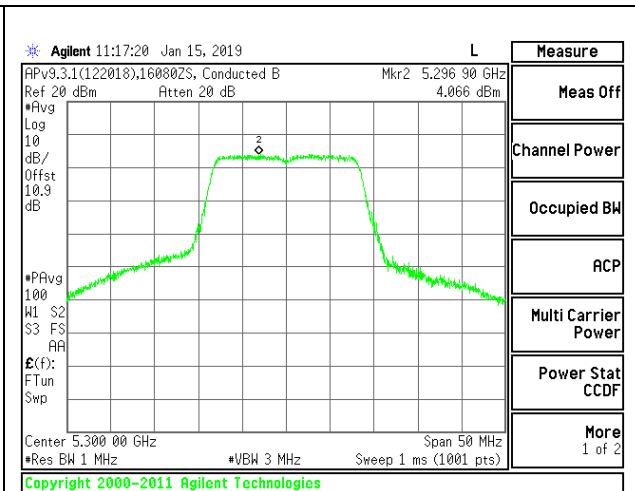

MID CHANNEL

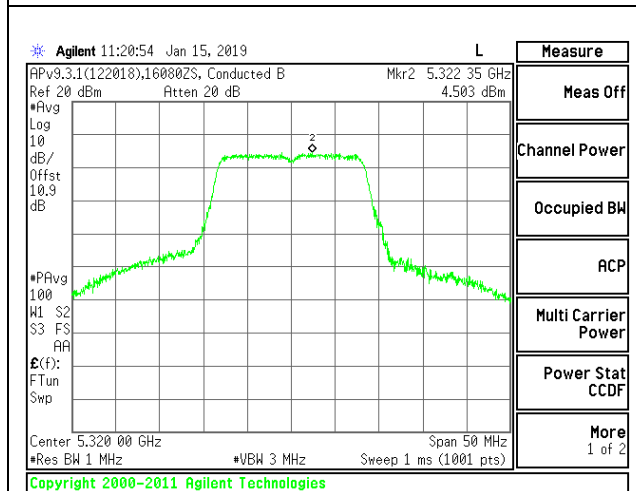

HIGH CHANNEL

9.5.6. 802.11n HT20 MODE IN THE 5.3 GHz BAND

1TX Antenna 1 MODE (FCC)

Bandwidth, Antenna Gain, and Limits

Channel	Frequency (MHz)	Min 26 dB BW (MHz)	Directional Gain (dBi)	Power Limit (dBm)	PSD Limit (dBm/1MHz)
Low	5260	28.10	-2.60	24.00	11.00
Mid	5300	29.40	-2.60	24.00	11.00
High	5320	29.35	-2.60	24.00	11.00

Duty Cycle CF (dB)	0.28	Included in Calculations of Corr'd PSD
---------------------------	------	---

Output Power Results

Channel	Frequency (MHz)	Meas Power (dBm)	Total Corr'd Power (dBm)	Power Limit (dBm)	Power Margin (dB)
Low	5260	15.79	15.79	24.00	-8.21
Mid	5300	15.68	15.68	24.00	-8.32
High	5320	15.64	15.64	24.00	-8.36

PSD Results

Channel	Frequency (MHz)	Meas PSD (dBm/1MHz)	Total Corr'd PSD (dBm/1MHz)	PSD Limit (dBm/1MHz)	PSD Margin (dB)
Low	5260	3.464	3.74	11.00	-7.26
Mid	5300	3.452	3.73	11.00	-7.27
High	5320	3.342	3.62	11.00	-7.38

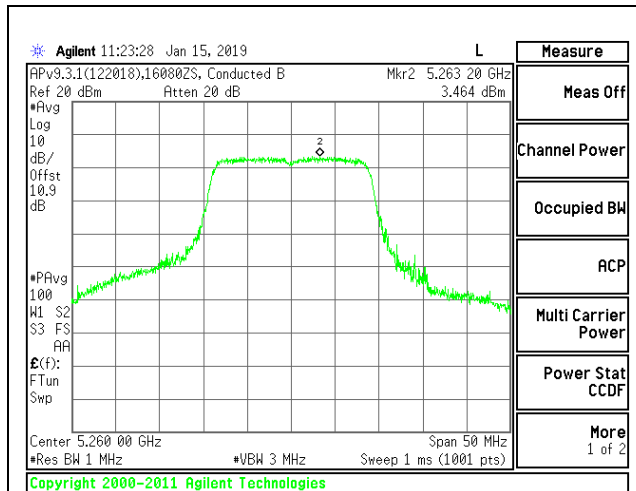

LOW CHANNEL

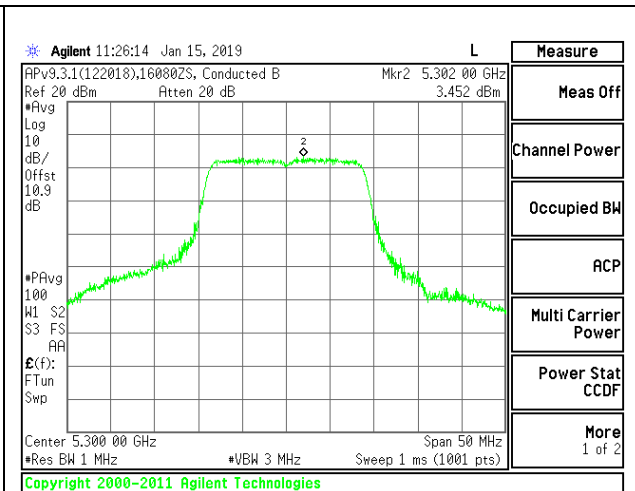

MID CHANNEL

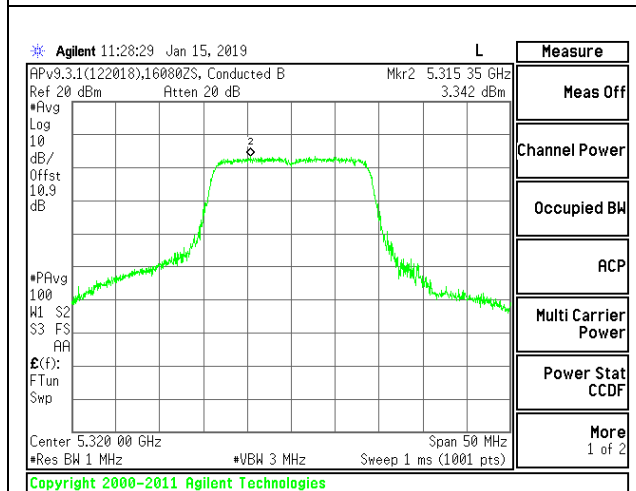

HIGH CHANNEL

9.5.7. 802.11n HT40 MODE IN THE 5.3 GHz BAND

1TX Antenna 1 MODE (FCC)

Bandwidth, Antenna Gain, and Limits

Channel	Frequency (MHz)	Min 26 dB BW (MHz)	Directional Gain (dBi)	Power Limit (dBm)	PSD Limit (dBm/1MHz)
Low	5270	44.00	-2.60	24.00	11.00
High	5310	44.30	-2.60	24.00	11.00

Duty Cycle CF (dB)	0.71	Included in Calculations of Corr'd PSD
---------------------------	------	---

Output Power Results

Channel	Frequency (MHz)	Meas Power (dBm)	Total Corr'd Power (dBm)	Power Limit (dBm)	Power Margin (dB)
Low	5270	14.47	14.47	24.00	-9.53
High	5310	14.84	14.84	24.00	-9.16

PSD Results

Channel	Frequency (MHz)	Meas PSD (dBm/1MHz)	Total Corr'd PSD (dBm/1MHz)	PSD Limit (dBm/1MHz)	PSD Margin (dB)
Low	5270	-1.013	-0.30	11.00	-11.30
High	5310	-0.791	-0.08	11.00	-11.08

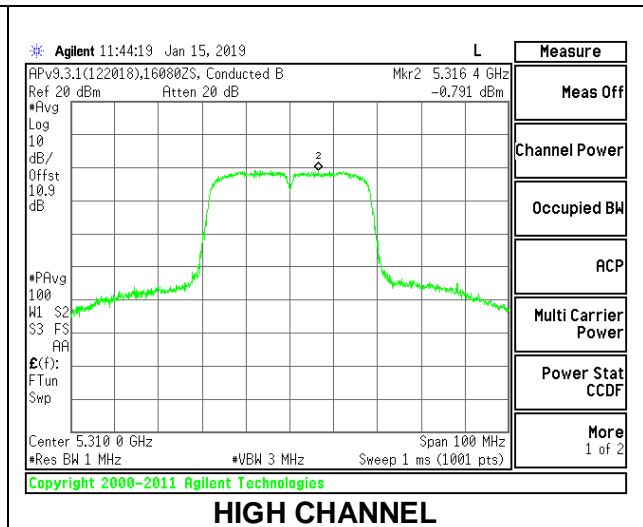
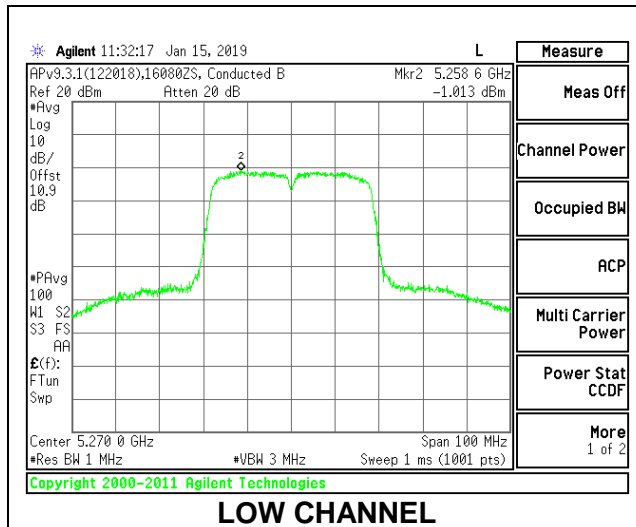

9.5.8. 802.11ac VHT80 MODE IN THE 5.3 GHz BAND

1TX Antenna 1 MODE (FCC)

Bandwidth, Antenna Gain, and Limits

Channel	Frequency (MHz)	Min 26 dB BW (MHz)	Directional Gain (dBi)	Power Limit (dBm)	PSD Limit (dBm/1MHz)
Mid	5290	114.60	-2.60	24.00	11.00

Duty Cycle CF (dB)	1.29	Included in Calculations of Corr'd PSD
---------------------------	------	---

Output Power Results

Channel	Frequency (MHz)	Meas Power (dBm)	Total Corr'd Power (dBm)	Power Limit (dBm)	Power Margin (dB)
Mid	5290	13.79	13.79	24.00	-10.21

PSD Results

Channel	Frequency (MHz)	Meas PSD (dBm/1MHz)	Total Corr'd PSD (dBm/1MHz)	PSD Limit (dBm/1MHz)	PSD Margin (dB)
Mid	5290	-5.181	-3.89	11.00	-14.89

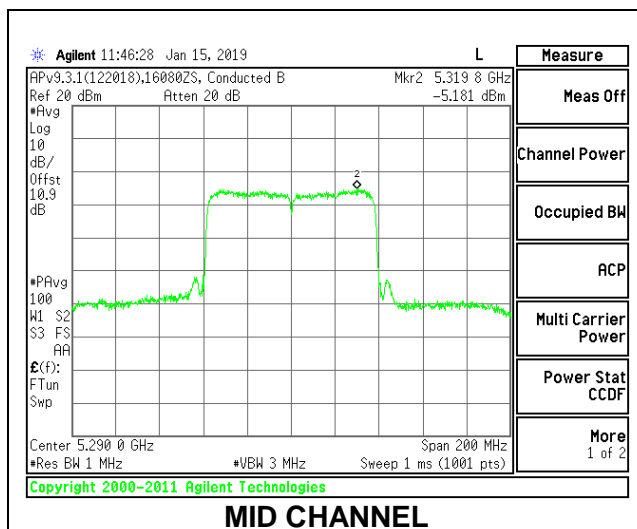

9.5.9. 802.11a MODE IN THE 5.6 GHz BAND

1TX Antenna 1 MODE (FCC)

Bandwidth, Antenna Gain, and Limits

Channel	Frequency (MHz)	Min 26 dB BW (MHz)	Directional Gain (dBi)	Power Limit (dBm)	PSD Limit (dBm/ 1MHz)
Low	5500	29.25	-2.6	24.00	11.00
Mid	5580	28.40	-2.6	24.00	11.00
High	5700	28.30	-2.6	24.00	11.00
144	5720	28.45	-2.6	24.00	11.00

Duty Cycle CF (dB)	0.27	Included in Calculations of Corr'd PSD
---------------------------	------	---

Output Power Results

Channel	Frequency (MHz)	Meas Power (dBm)	Total Corr'd Power (dBm)	Power Limit (dBm)	Power Margin (dB)
Low	5500	16.98	16.98	24.00	-7.02
Mid	5580	15.60	15.60	24.00	-8.40
High	5700	15.98	15.98	24.00	-8.02
144	5720	15.08	15.35	24.00	-8.65

PSD Results

Channel	Frequency (MHz)	Meas PSD (dBm/ 1MHz)	Total Corr'd PSD (dBm/ 1MHz)	PSD Limit (dBm/ 1MHz)	PSD Margin (dB)
Low	5500	3.36	3.63	11.00	-7.37
Mid	5580	2.43	2.70	11.00	-8.30
High	5700	2.54	2.81	11.00	-8.20
144	5720	2.45	2.72	11.00	-8.28

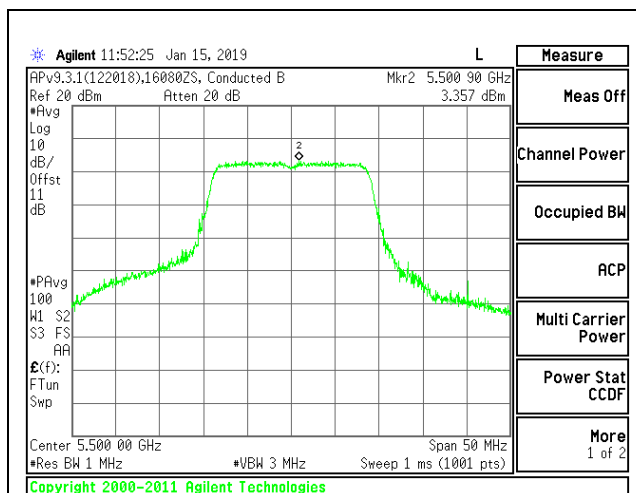

LOW CHANNEL

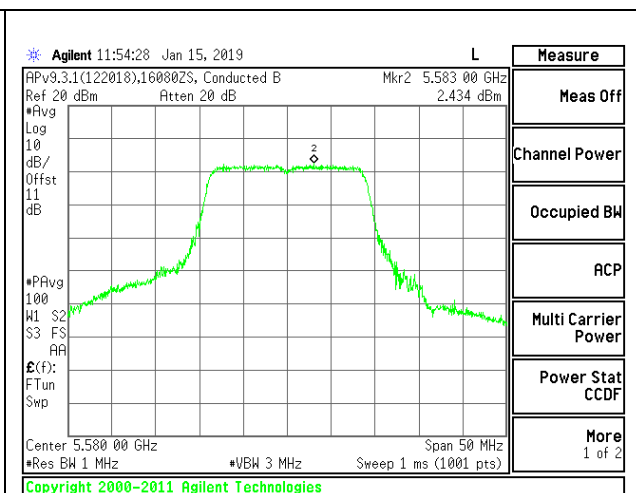

MID CHANNEL

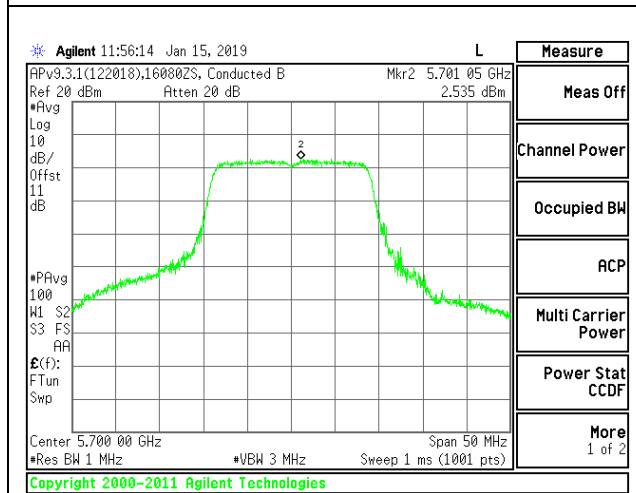

HIGH CHANNEL

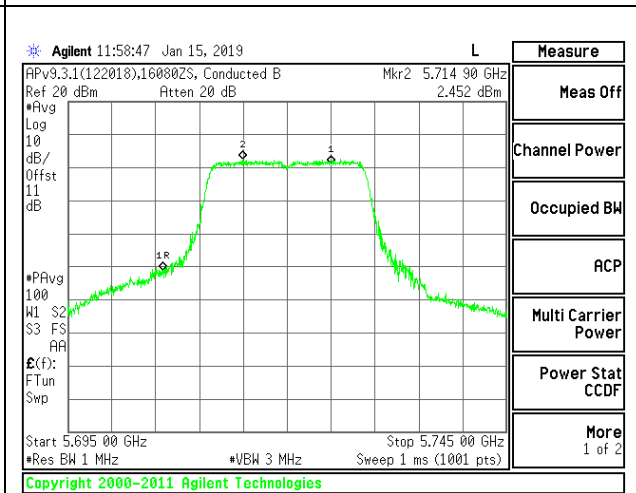

CHANNEL 144

9.5.10. 802.11n HT20 MODE IN THE 5.6 GHz BAND

1TX Antenna 1 MODE (FCC)

Bandwidth, Antenna Gain, and Limits

Channel	Frequency (MHz)	Min 26 dB BW (MHz)	Directional Gain (dBi)	Power Limit (dBm)	PSD Limit (dBm/ 1MHz)
Low	5500	30.25	-2.6	24.00	11.00
Mid	5580	29.10	-2.6	24.00	11.00
High	5700	29.15	-2.6	24.00	11.00
144	5720	27.90	-2.6	24.00	11.00

Duty Cycle CF (dB)	0.28	Included in Calculations of Corr'd PSD
---------------------------	------	---

Output Power Results

Channel	Frequency (MHz)	Meas Power (dBm)	Total Corr'd Power (dBm)	Power Limit (dBm)	Power Margin (dB)
Low	5500	15.67	15.67	24.00	-8.33
Mid	5580	14.58	14.58	24.00	-9.42
High	5700	14.61	14.61	24.00	-9.39
144	5720	14.56	14.84	24.00	-9.16

PSD Results

Channel	Frequency (MHz)	Meas PSD (dBm/ 1MHz)	Total Corr'd PSD (dBm/ 1MHz)	PSD Limit (dBm/ 1MHz)	PSD Margin (dB)
Low	5500	3.26	3.54	11.00	-7.46
Mid	5580	2.61	2.89	11.00	-8.11
High	5700	2.40	2.68	11.00	-8.32
144	5720	2.62	2.90	11.00	-8.10

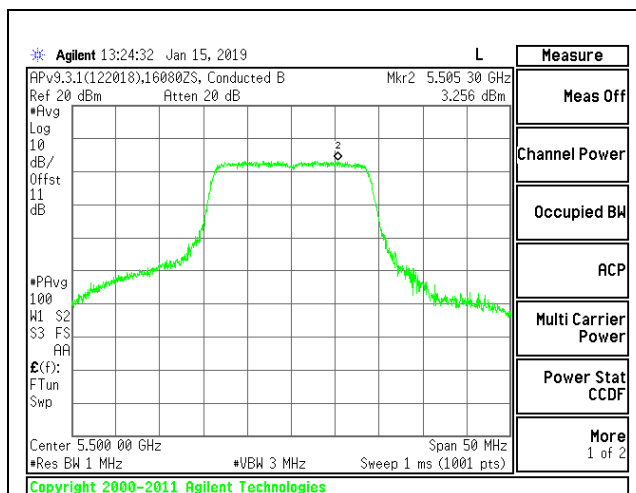

LOW CHANNEL

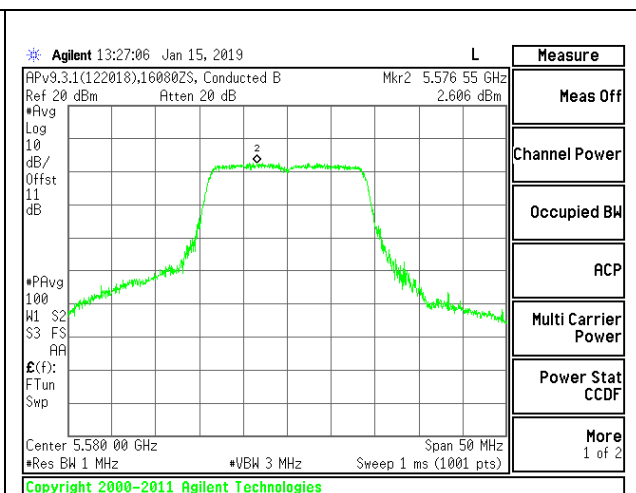

MID CHANNEL

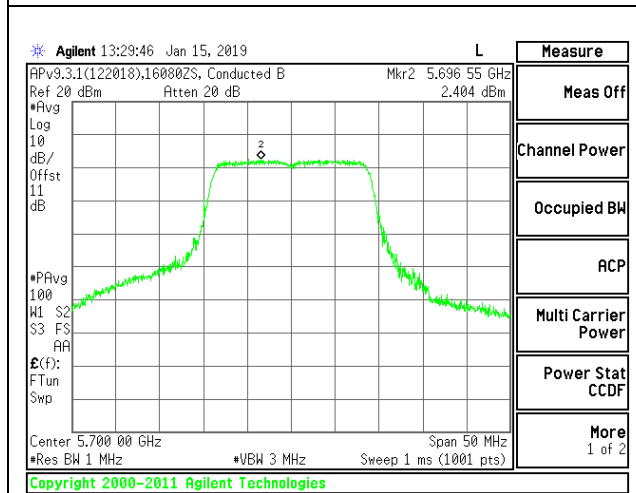

HIGH CHANNEL

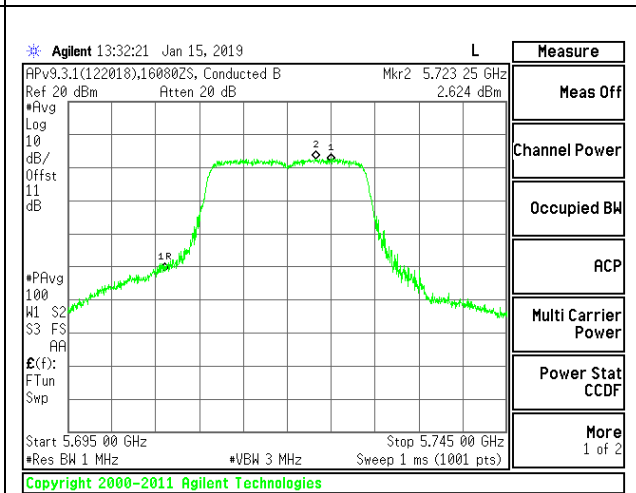

CHANNEL 144

9.5.11. 802.11n HT40 MODE IN THE 5.6 GHz BAND

1TX Antenna 1 MODE (FCC)

Bandwidth, Antenna Gain, and Limits

Channel	Frequency (MHz)	Min 26 dB BW (MHz)	Directional Gain (dBi)	Power Limit (dBm)	PSD Limit (dBm/ 1MHz)
Low	5510	44.10	-2.6	24.00	11.00
Mid	5550	44.00	-2.6	24.00	11.00
High	5670	44.10	-2.6	24.00	11.00
142	5710	43.90	-2.6	24.00	11.00

Duty Cycle CF (dB)	0.71	Included in Calculations of Corr'd PSD
---------------------------	------	---

Output Power Results

Channel	Frequency (MHz)	Meas Power (dBm)	Total Corr'd Power (dBm)	Power Limit (dBm)	Power Margin (dB)
Low	5510	12.24	12.24	24.00	-11.76
Mid	5550	14.51	14.51	24.00	-9.49
High	5670	14.76	14.76	24.00	-9.24
142	5710	14.60	15.31	24.00	-8.69

PSD Results

Channel	Frequency (MHz)	Meas PSD (dBm/ 1MHz)	Total Corr'd PSD (dBm/ 1MHz)	PSD Limit (dBm/ 1MHz)	PSD Margin (dB)
Low	5510	-3.55	-2.84	11.00	-13.84
Mid	5550	-0.94	-0.23	11.00	-11.23
High	5670	-0.56	0.15	11.00	-10.85
142	5710	-1.33	-0.62	11.00	-11.62

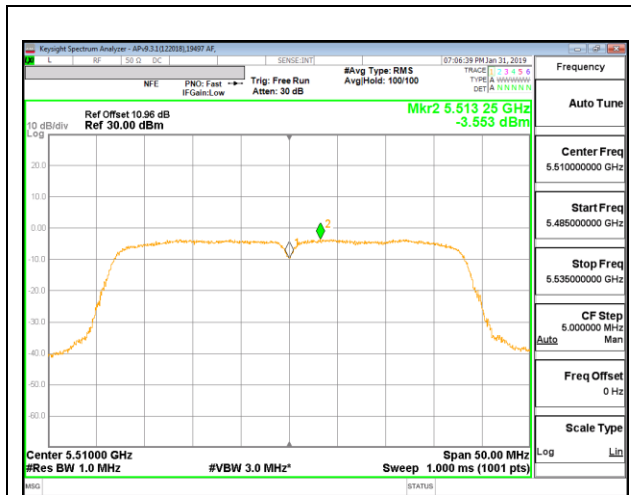

LOW CHANNEL

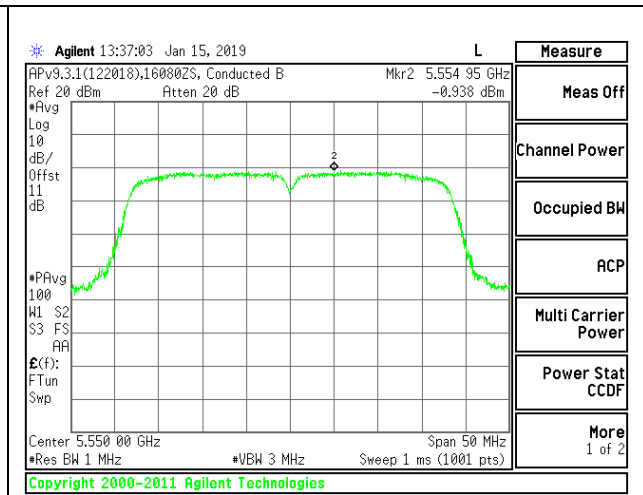

MID CHANNEL

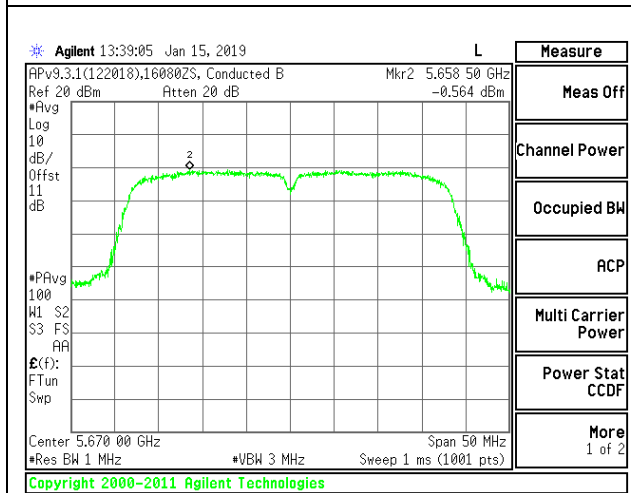

HIGH CHANNEL

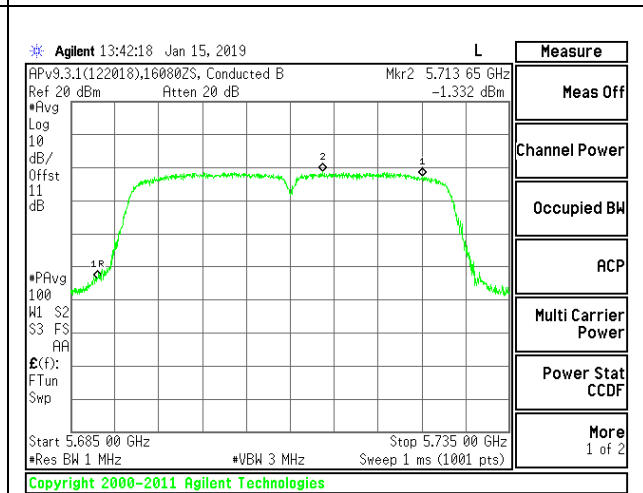

CHANNEL 142

9.5.12. 802.11ac VHT80 MODE IN THE 5.6 GHz BAND

1TX Antenna 1 MODE (FCC)

Bandwidth, Antenna Gain, and Limits

Channel	Frequency (MHz)	Min 26 dB BW (MHz)	Directional Gain (dBi)	Power Limit (dBm)	PSD Limit (dBm/ 1MHz)
Low	5530	105.60	-2.6	24.00	11.00
High	5610	113.20	-2.6	24.00	11.00
138	5690	110.40	-2.6	24.00	11.00

Duty Cycle CF (dB)	1.29	Included in Calculations of Corr'd PSD
---------------------------	------	---

Output Power Results

Channel	Frequency (MHz)	Meas Power (dBm)	Total Corr'd Power (dBm)	Power Limit (dBm)	Power Margin (dB)
Low	5530	13.45	13.45	24.00	-10.55
High	5610	13.63	13.63	24.00	-10.37
138	5690	13.92	13.92	24.00	-10.08

PSD Results

Channel	Frequency (MHz)	Meas PSD (dBm/ 1MHz)	Total Corr'd PSD (dBm/ 1MHz)	PSD Limit (dBm/ 1MHz)	PSD Margin (dB)
Low	5530	-5.31	-4.02	11.00	-15.02
High	5610	-5.38	-4.09	11.00	-15.09
138	5690	-5.19	-3.90	11.00	-14.90

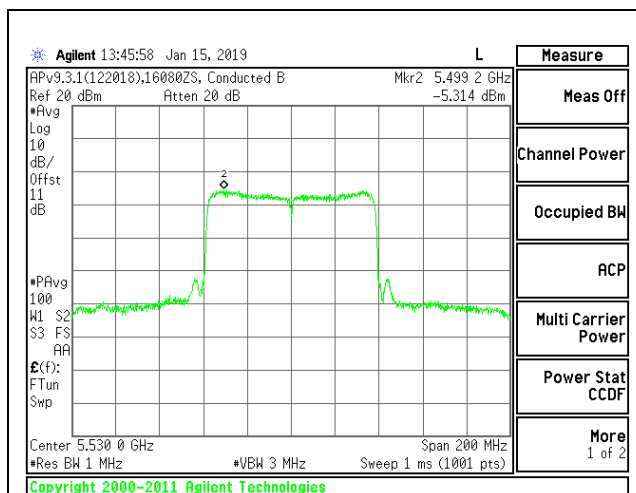

LOW CHANNEL

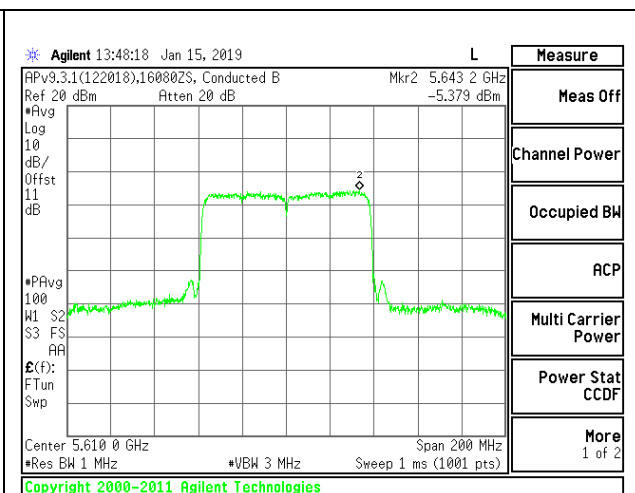

HIGH CHANNEL

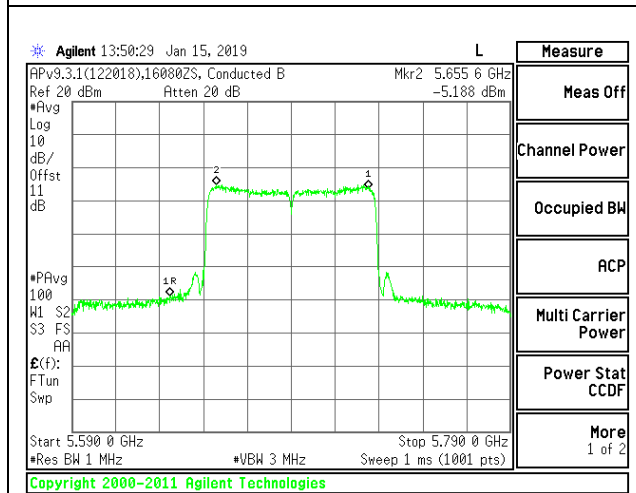

CHANNEL 138

9.5.13. 802.11a MODE IN THE 5.8 GHZ BAND

1TX Antenna 1 MODE (FCC)

Antenna Gain and Limit

Channel	Frequency (MHz)	Directional Gain (dBi)	Power Limit (dBm)	PSD Limit (dBm/ 500kHz)
Low	5745	-3.50	30.00	30.00
Mid	5785	-3.50	30.00	30.00
High	5825	-3.50	30.00	30.00

Duty Cycle CF (dB)	0.27	Included in Calculations of Corr'd PSD
---------------------------	------	---

Output Power Results

Channel	Frequency (MHz)	Meas Power (dBm)	Total Corr'd Power (dBm)	Power Limit (dBm)	Power Margin (dB)
Low	5745	16.78	16.78	30.00	-13.22
Mid	5785	16.67	16.67	30.00	-13.33
High	5825	16.62	16.62	30.00	-13.38

PSD Results

Channel	Frequency (MHz)	Meas PSD (dBm/ 500kHz)	Total Corr'd PSD (dBm/ 500kHz)	PSD Limit (dBm/ 500kHz)	PSD Margin (dB)
Low	5745	1.663	1.933	30.00	-28.07
Mid	5785	1.459	1.729	30.00	-28.27
High	5825	1.654	1.924	30.00	-28.08

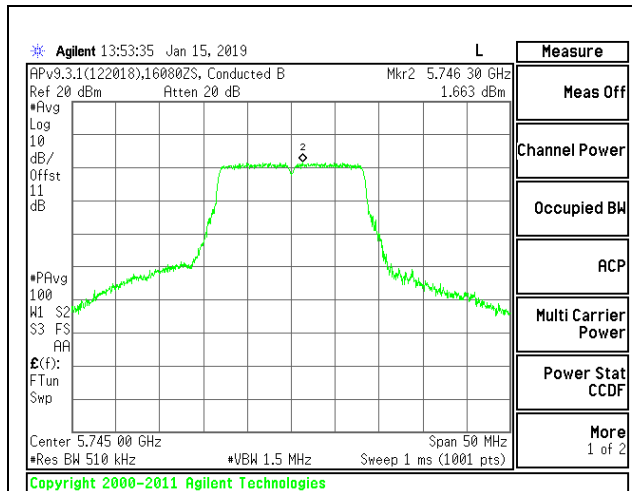

LOW CHANNEL

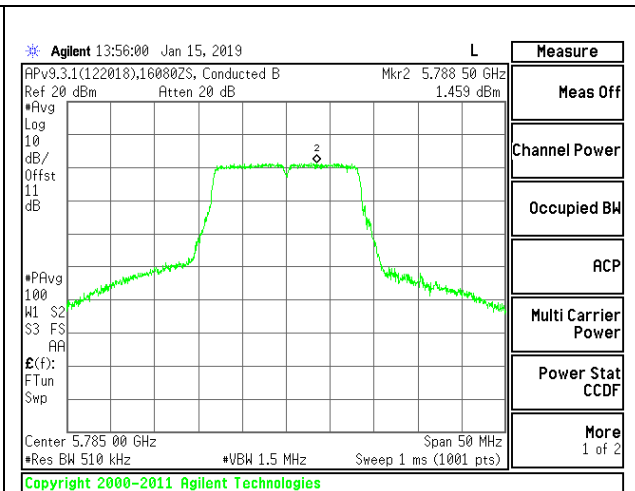

MID CHANNEL

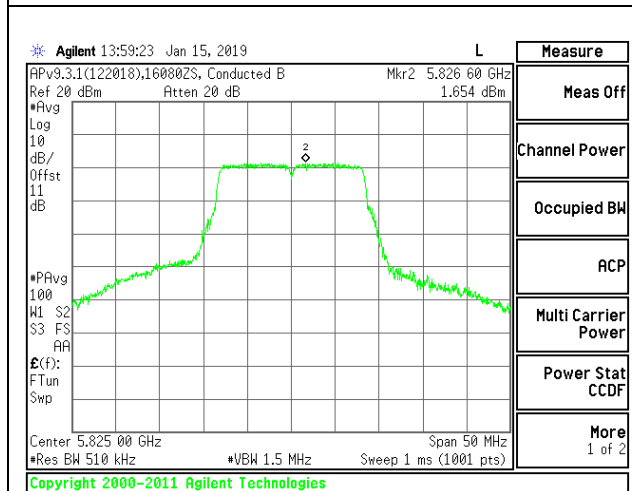

HIGH CHANNEL

9.5.14. 802.11n HT20 MODE IN THE 5.8 GHz BAND

1TX Antenna 1 MODE (FCC)

Antenna Gain and Limit

Channel	Frequency (MHz)	Directional Gain (dBi)	Power Limit (dBm)	PSD Limit (dBm/ 500kHz)
Low	5745	-3.50	30.00	30.00
Mid	5785	-3.50	30.00	30.00
High	5825	-3.50	30.00	30.00

Duty Cycle CF (dB)	0.28	Included in Calculations of Corr'd PSD
---------------------------	------	---

Output Power Results

Channel	Frequency (MHz)	Meas Power (dBm)	Total Corr'd Power (dBm)	Power Limit (dBm)	Power Margin (dB)
Low	5745	15.79	15.79	30.00	-14.21
Mid	5785	15.27	15.27	30.00	-14.73
High	5825	15.69	15.69	30.00	-14.31

PSD Results

Channel	Frequency (MHz)	Meas PSD (dBm/ 500kHz)	Total Corr'd PSD (dBm/ 500kHz)	PSD Limit (dBm/ 500kHz)	PSD Margin (dB)
Low	5745	0.090	0.370	30.00	-29.63
Mid	5785	0.307	0.587	30.00	-29.41
High	5825	0.543	0.823	30.00	-29.18

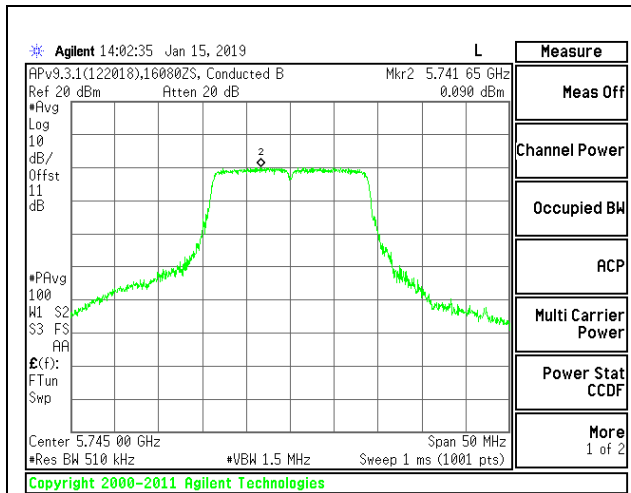

LOW CHANNEL

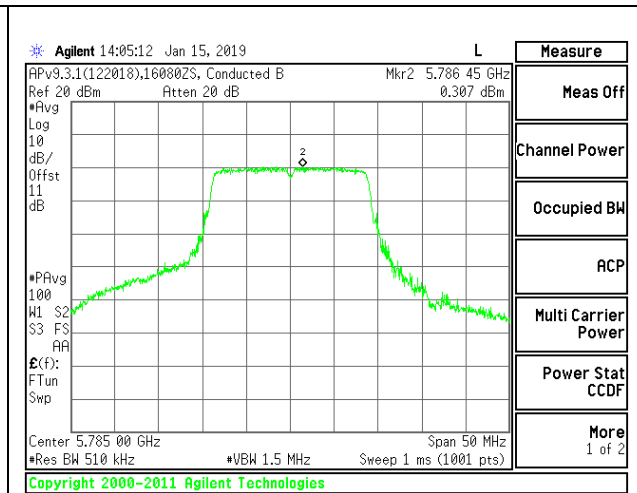

MID CHANNEL

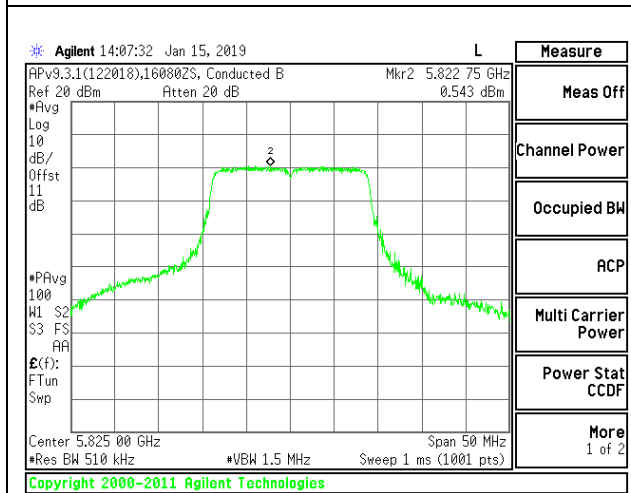

HIGH CHANNEL

9.5.15. 802.11n HT40 MODE IN THE 5.8 GHz BAND

1TX Antenna 1 MODE (FCC)

Antenna Gain and Limit

Channel	Frequency (MHz)	Directional Gain (dBi)	Power Limit (dBm)	PSD Limit (dBm/ 500kHz)
Low	5755	-3.50	30.00	30.00
High	5795	-3.50	30.00	30.00

Duty Cycle CF (dB)	0.79	Included in Calculations of Corr'd PSD
---------------------------	------	---

Output Power Results

Channel	Frequency (MHz)	Meas Power (dBm)	Total Corr'd Power (dBm)	Power Limit (dBm)	Power Margin (dB)
Low	5755	14.34	14.34	30.00	-15.66
High	5795	14.40	14.40	30.00	-15.60

PSD Results

Channel	Frequency (MHz)	Meas PSD (dBm)	Total Corr'd PSD (dBm)	PSD Limit (dBm)	PSD Margin (dB)
Low	5755	-4.298	-3.508	30.00	-33.51
High	5795	-4.538	-3.748	30.00	-33.75

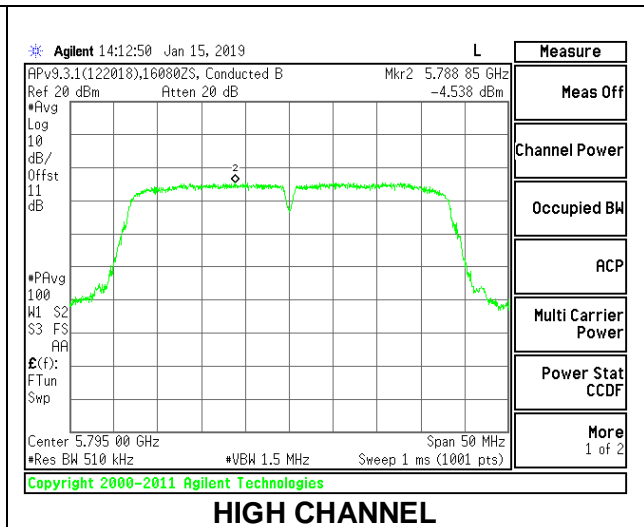
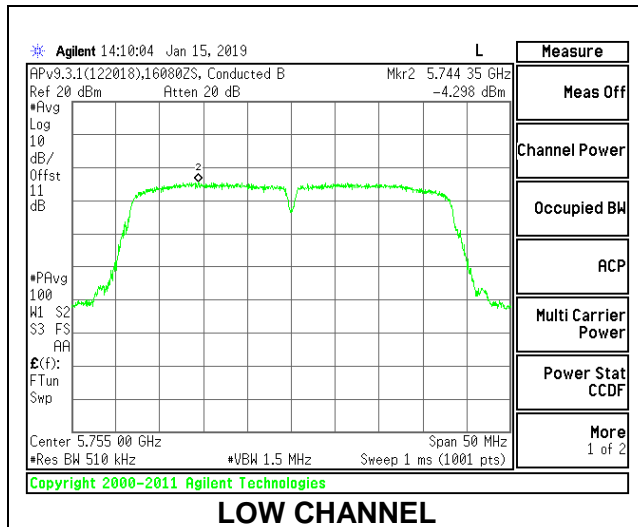

9.5.16. 802.11ac VHT80 MODE IN THE 5.8 GHz BAND

1TX Antenna 1 MODE (FCC)

Antenna Gain and Limit

Channel	Frequency (MHz)	Directional Gain (dBi)	Power Limit (dBm)	PSD Limit (dBm/ 500kHz)
Mid	5775	-3.50	30.00	30.00

Duty Cycle CF (dB)	1.29	Included in Calculations of Corr'd PSD
---------------------------	------	---

Output Power Results

Channel	Frequency (MHz)	Meas Power (dBm)	Total Corr'd Power (dBm)	Power Limit (dBm)	Power Margin (dB)
Mid	5775	13.43	13.43	30.00	-16.57

PSD Results

Channel	Frequency (MHz)	Meas PSD (dBm/ 500kHz)	Total Corr'd PSD (dBm/500 kHz)	PSD Limit (dBm/ 500kHz)	PSD Margin (dB)
Mid	5775	-8.372	-7.082	30.00	-37.08

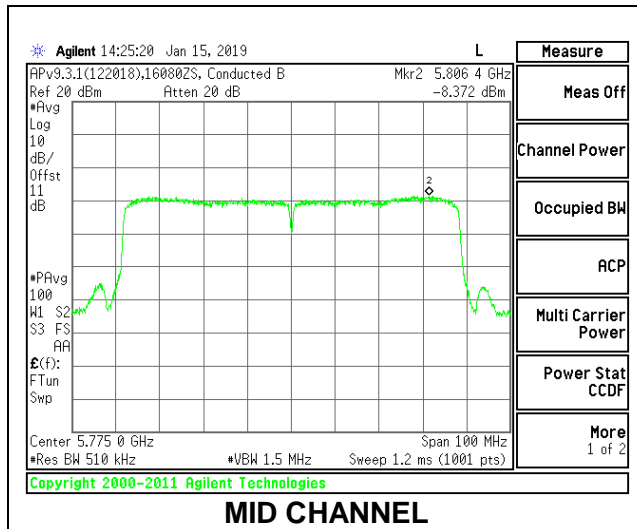

10. RADIATED TEST RESULTS

LIMITS

FCC §15.205 and §15.209 -Restricted bands

FCC §15.407(b)(1-3) -Un-Restricted bands

After January 01, 2019 for Outside of the Restricted Bands Emissions

Frequency Range (MHz)	Field Strength Limit (uV/m) at 3 m	Field Strength Limit (dBuV/m) at 3 m
30 - 88	100	40
88 - 216	150	43.5
216 - 960	200	46
Above 960	500	54

TEST PROCEDURE

The EUT is placed on a non-conducting table 80 cm above the ground plane for measurement below 1GHz; 1.5 m above the ground plane for measurement above 1GHz. The antenna to EUT distance is 3 meters. The EUT is configured in accordance with ANSI C63.10. The EUT is set to transmit in a continuous mode.

For measurements below 1 GHz the resolution bandwidth is set to 100 kHz for peak detection measurements or 120 kHz for quasi-peak detection measurements. Peak detection is used unless otherwise noted as quasi-peak.

For pre-scans above 1 GHz the resolution bandwidth is set to 1 MHz; the video bandwidth is set to 30 KHz for peak measurements.

For final measurements above 1 GHz the resolution bandwidth is set to 1 MHz; the video bandwidth is set to 3 MHz for peak measurements and as applicable for average measurements.

The spectrum from 30 MHz to 1GHz and 18GHz to 40 GHz is investigated with the transmitter set to transmit at the channel with highest output power as worst-case scenario. 1GHz to 18GHz was set to the lowest, middle, and highest channels in the 5 GHz bands.

The frequency range of interest is monitored at a fixed antenna height and EUT azimuth. The EUT is rotated through 360 degrees to maximize emissions received. The antenna is scanned from 1 to 4 meters above the ground plane to further maximize the emission. Measurements are made with the antenna polarized in both the vertical and the horizontal positions.

2D antenna use - For below 30MHz testing, investigation was done on three antenna orientations (parallel, perpendicular, and ground-parallel), parallel and perpendicular are the worst orientations, therefore testing was performed on these two orientations only.

KDB 414788 OATS and Chamber Correlation Justification

Base on FCC 15.31 (f) (2): measurements may be performed at a distance closer than that specified in the regulations; however, an attempt should be made to avoid making measurements in the near field.

OATs and chamber correlation testing had been performed and chamber measured test result is the worst case test result.

10.1. TRANSMITTER ABOVE 1 GHz

10.1.1. TX ABOVE 1 GHz 802.11a MODE IN THE 5.2 GHz BAND

1TX Antenna 1 MODE

BANDEDGE (LOW CHANNEL)

HORIZONTAL RESULT

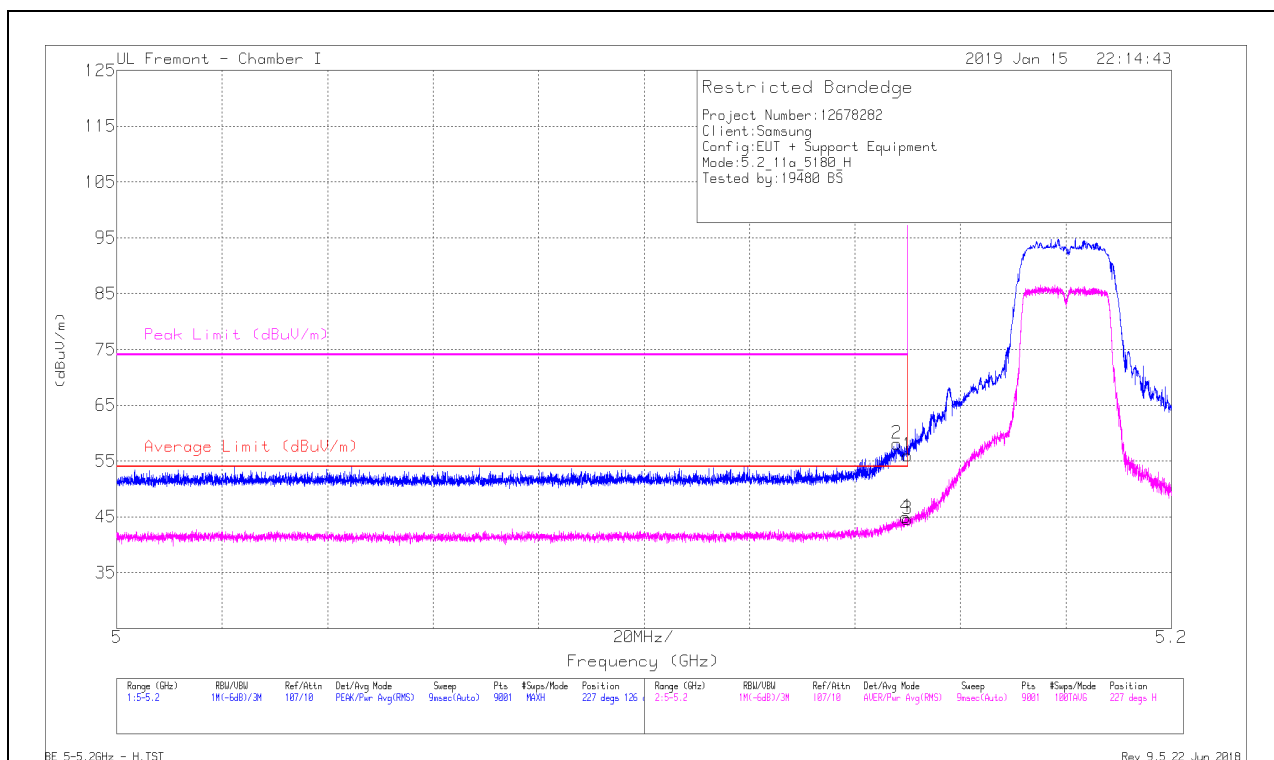

Marker	Frequency (GHz)	Meter Reading (dBuV)	Det	AF T862 (dB/m)	Amp/Cbl/Fitr/Pad (dB)	DC Corr (dB)	Corrected Reading (dBuV/m)	Average Limit (dBuV/m)	Margin (dB)	Peak Limit (dBuV/m)	PK Margin (dB)	Azimuth (Degs)	Height (cm)	Polarity
1	* 5.15	40.65	Pk	34.4	-19	0	56.05	-	-	74	-17.95	227	126	H
2	* 5.148	42.67	Pk	34.4	-19	0	58.07	-	-	74	-15.93	227	126	H
3	* 5.15	28.9	RMS	34.4	-19	.27	44.57	54	-9.43	-	-	227	126	H
4	* 5.15	29.24	RMS	34.4	-19	.27	44.91	54	-9.09	-	-	227	126	H

* - indicates frequency in CFR47 Pt 15 / IC RSS-Restricted Band

Pk - Peak detector

RMS - RMS detection

VERTICAL RESULT

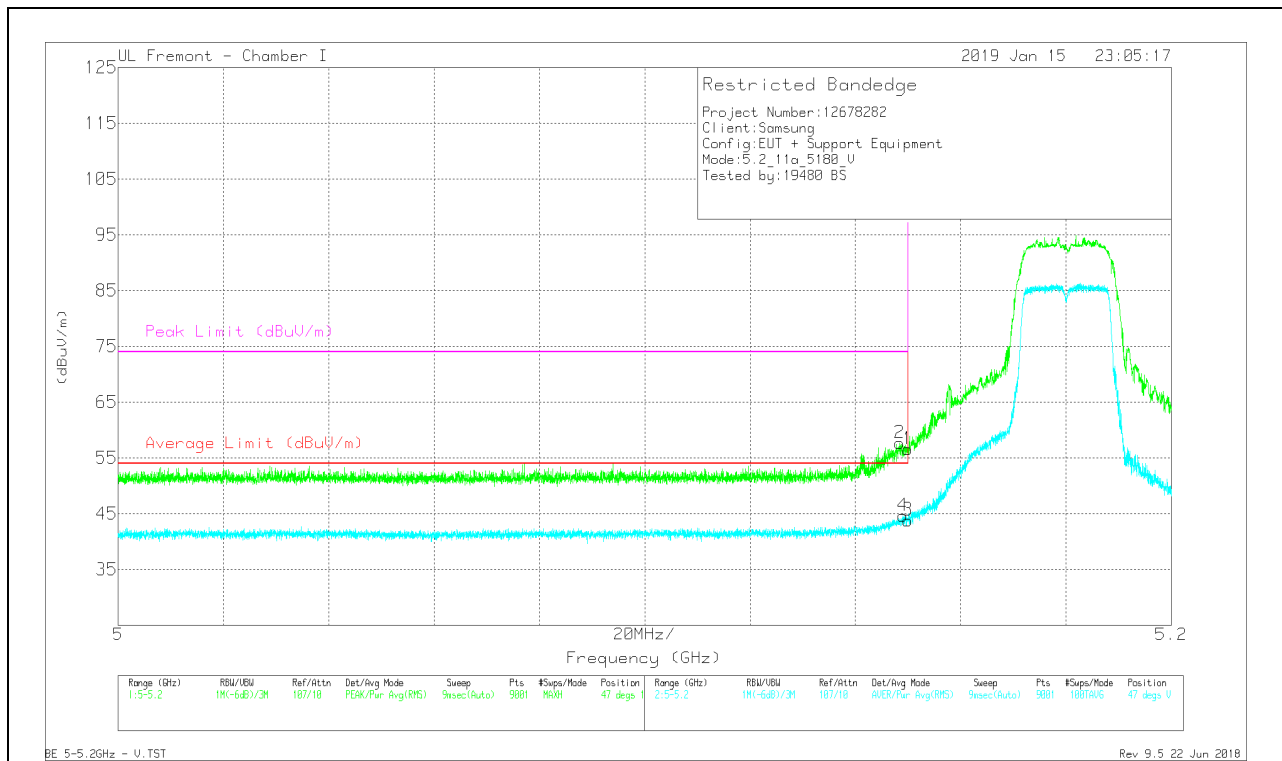

Marker	Frequency (GHz)	Meter Reading (dBuV)	Det	AF T862 (dB/m)	Amp/Ch/Filt/Pad (dB)	DC Corr (dB)	Corrected Reading (dBuV/m)	Average Limit (dBuV/m)	Margin (dB)	Peak Limit (dBuV/m)	PK Margin (dB)	Azimuth (Degs)	Height (cm)	Polarity
1	* 5.15	41.17	Pk	34.4	-19	0	56.57	-	-	74	-17.43	47	161	V
2	* 5.148	42.26	Pk	34.4	-19	0	57.66	-	-	74	-16.34	47	161	V
3	* 5.15	28.14	RMS	34.4	-19	.27	43.81	54	-10.19	-	-	47	161	V
4	* 5.149	28.97	RMS	34.4	-19	.27	44.64	54	-9.36	-	-	47	161	V

* - indicates frequency in CFR47 Pt 15 / IC RSS-Restricted Band

Pk - Peak detector

RMS - RMS detection

HARMONICS AND SPURIOUS EMISSIONS

LOW CHANNEL RESULTS

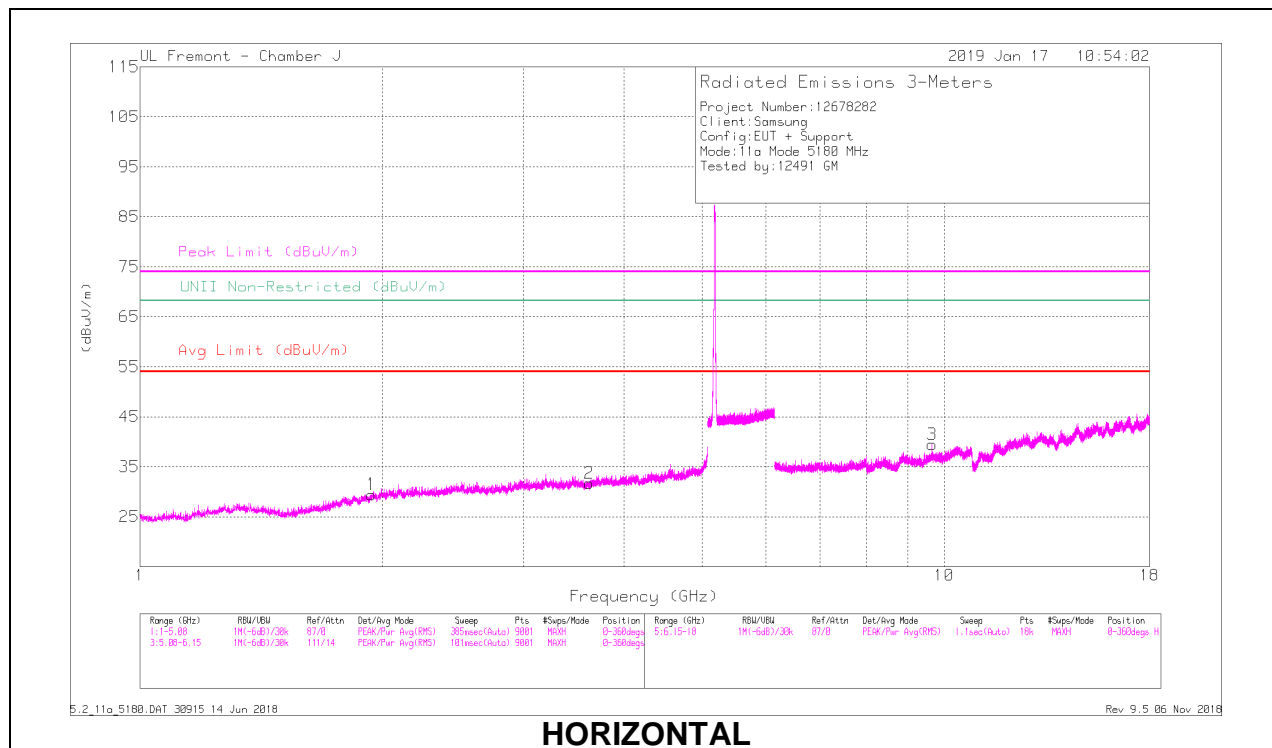

HORIZONTAL

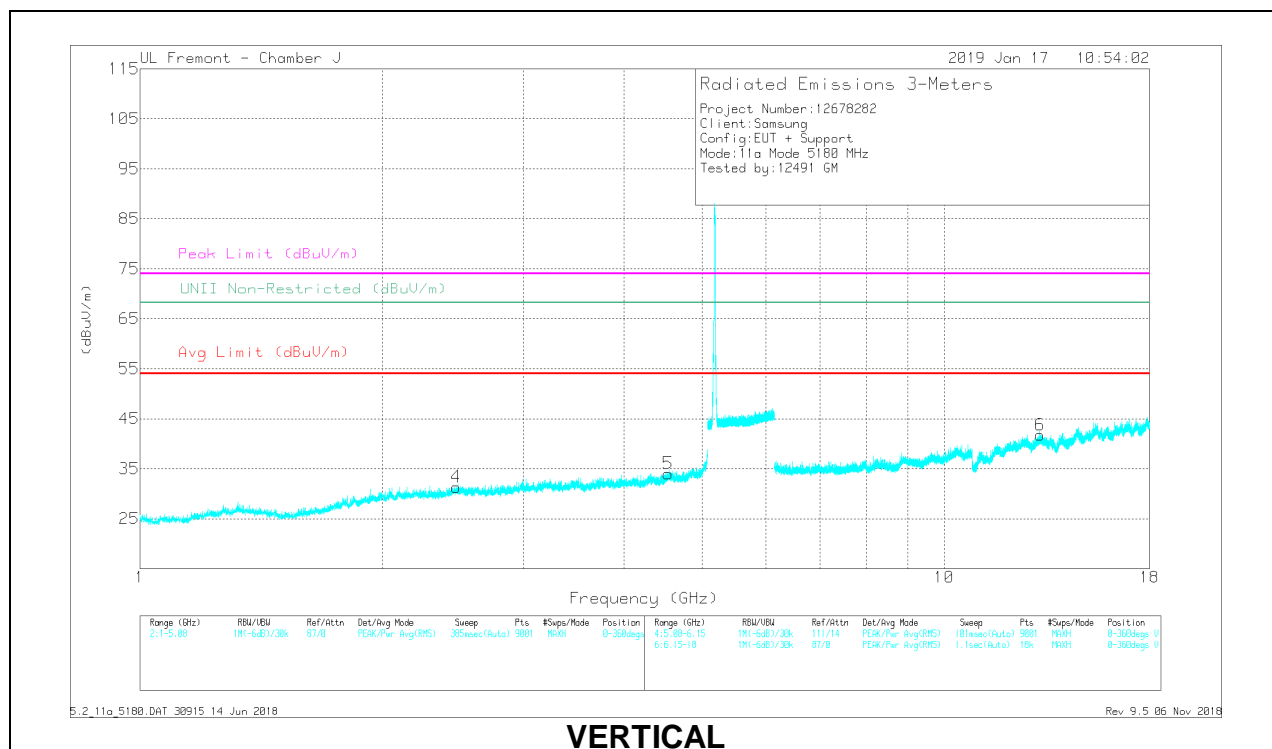

VERTICAL

RADIATED EMISSIONS

Frequency (GHz)	Measr Reading (dBuV)	Det	AF AT0067 (dBm)	AmpCoef/PwrPad (dB)	DC Corr (dB)	Corrected Reading (dBuV/m)	Avg Limit (dBuV/m)	Margin (dB)	Peak Limit (dBuV/m)	PK Margin (dB)	UNII Non-Restricted (dBuV/m)	PK Margin (dB)	Azimuth (Degs)	Height (cm)	Polarity
1.939	41.99	PK-U	31.2	-35.8	0	37.39	-	-	-	-	68.2	-30.81	73	254	H
1.939	32.36	ADR	31.2	-35.8	.27	28.03	-	-	-	-	-	-	73	254	H
* 3.616	39.75	PK-U	33.1	-33.7	0	39.15	-	-	74	-34.85	-	-	318	156	H
* 3.617	30.09	ADR	33.1	-33.7	.27	29.76	54	-24.24	-	-	-	-	318	156	H
2.472	41.49	PK-U	32.5	-35.5	0	38.49	-	-	-	-	68.2	-29.71	8	174	V
2.471	31.42	ADR	32.5	-35.5	.27	28.69	-	-	-	-	-	-	8	174	V
* 4.537	39.32	PK-U	34.1	-31.3	0	42.12	-	-	74	-31.88	-	-	44	115	V
* 4.534	29.02	ADR	34.1	-31.4	.27	31.99	54	-22.01	-	-	-	-	44	115	V
9.06	34.05	PK-U	36.6	-25	0	45.65	-	-	-	-	68.2	-22.55	354	246	H
9.059	23.95	ADR	36.6	-25	.27	35.82	-	-	-	-	-	-	354	246	H
13.155	31.8	PK-U	38.9	-22.4	0	48.3	-	-	-	-	68.2	-19.9	0	353	V
13.151	22.06	ADR	38.9	-22.4	.27	38.83	-	-	-	-	-	-	0	353	V

* - indicates frequency in CFR47 Pt 15 / IC RSS-Restricted Band
 PK-U - U-NII: Maximum Peak
 ADR - U-NII AD primary method, RMS average

MID CHANNEL RESULTS

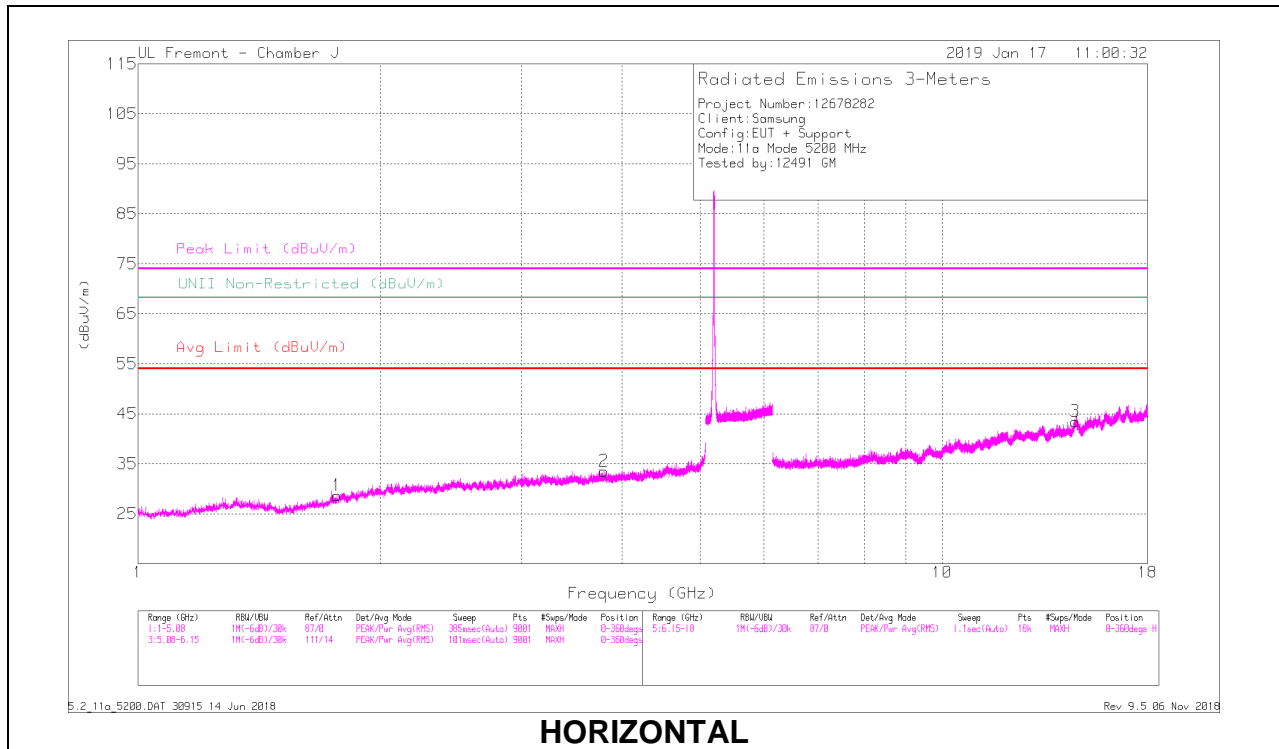

HORIZONTAL

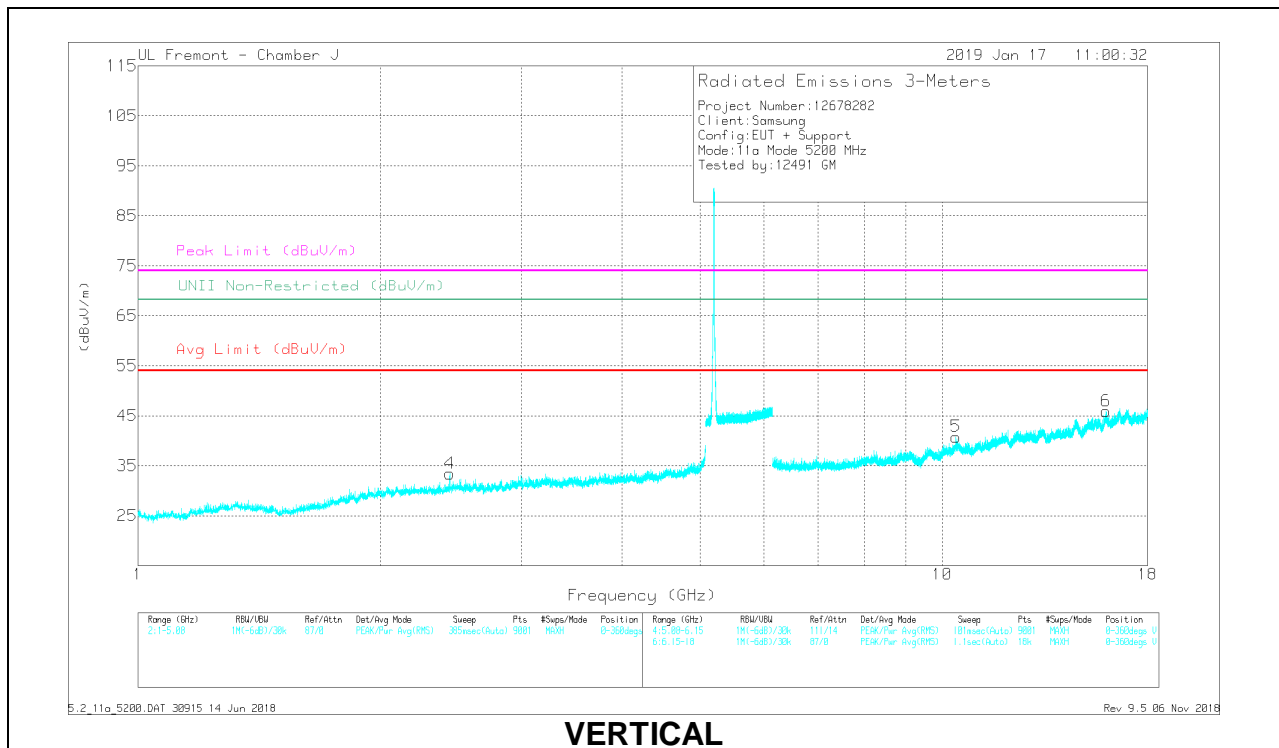

VERTICAL

RADIATED EMISSIONS

Frequency (GHz)	Meas Reading (dBuV)	Det	AF AT0067 (dBm)	Amp/Co/Filt/Pad (dB)	DC Corr (dB)	Corrected Reading (dBuV/m)	Avg Limit (dBuV/m)	Margin (dB)	Peak Limit (dBuV/m)	PK Margin (dB)	UNII Non-Restricted (dBuV/m)	PK Margin (dB)	Azimuth (Degs)	Height (cm)	Polarity
1.767	40.74	PK-U	30.1	-35.7	0	35.14	-	-	-	-	68.2	-33.06	249	219	H
1.768	31.31	ADR	30.1	-35.7	.27	25.98	-	-	-	-	-	-	249	219	H
* 3.797	39.29	PK-U	33.4	-32.9	0	39.79	-	-	74	-34.21	-	-	137	141	H
* 3.796	30.16	ADR	33.4	-32.8	.27	31.03	54	-22.97	-	-	-	-	137	141	H
2.439	41.61	PK-U	32.4	-35.5	0	38.51	-	-	-	-	68.2	-29.69	93	292	V
2.441	31.44	ADR	32.4	-35.5	.27	28.61	-	-	-	-	-	-	93	292	V
14.644	31.06	PK-U	39.4	-20.6	0	49.86	-	-	-	-	68.2	-18.34	154	244	H
14.645	22.49	ADR	39.5	-20.6	.27	41.66	-	-	-	-	-	-	154	244	H
10.4	34.87	PK-U	37.5	-25.3	0	47.07	-	-	-	-	68.2	-21.13	143	284	V
10.4	26.92	ADR	37.5	-25.3	.27	39.39	-	-	-	-	-	-	143	284	V
* 15.976	32.14	PK-U	40.5	-20	0	52.64	-	-	74	-21.36	-	-	355	174	V
* 15.976	22.67	ADR	40.5	-20	.27	43.44	54	-10.56	-	-	-	-	355	174	V

* - indicates frequency in CFR47 Pt 15 / IC RSS-Restricted Band
 PK-U - U-NII: Maximum Peak
 ADR - U-NII AD primary method, RMS average

HIGH CHANNEL RESULTS

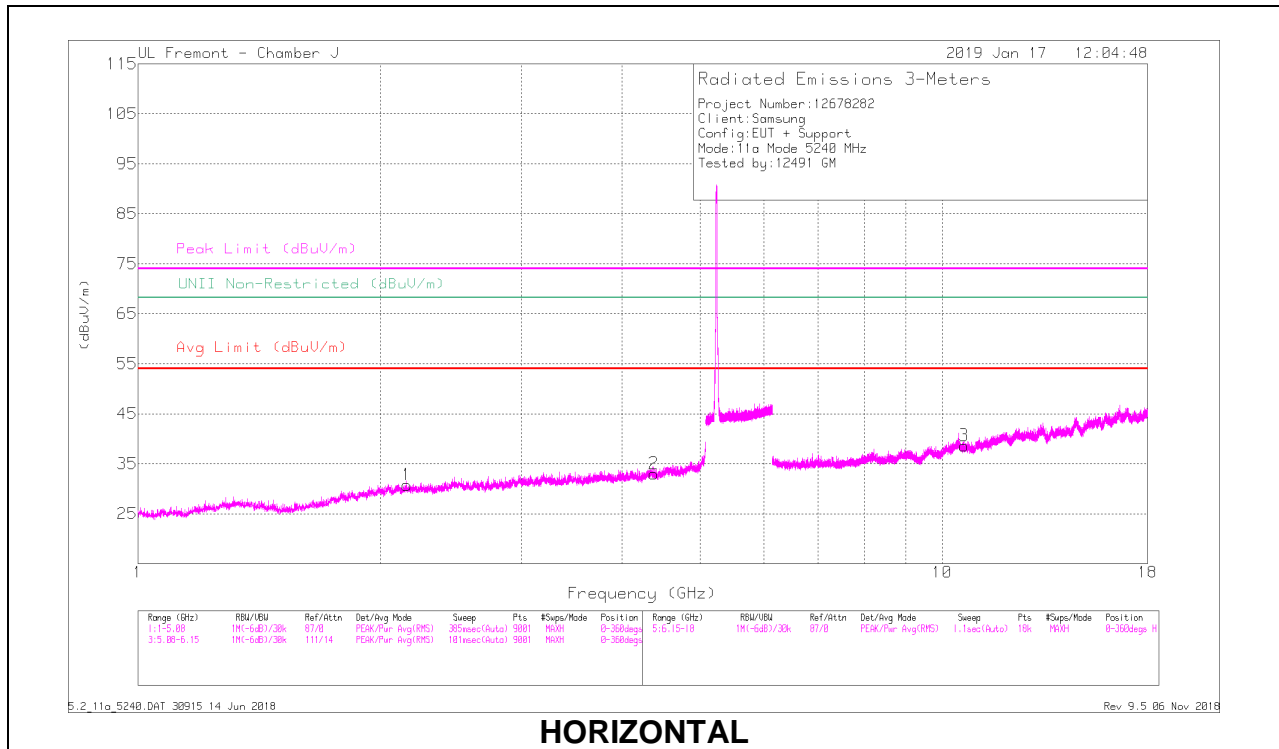

HORIZONTAL

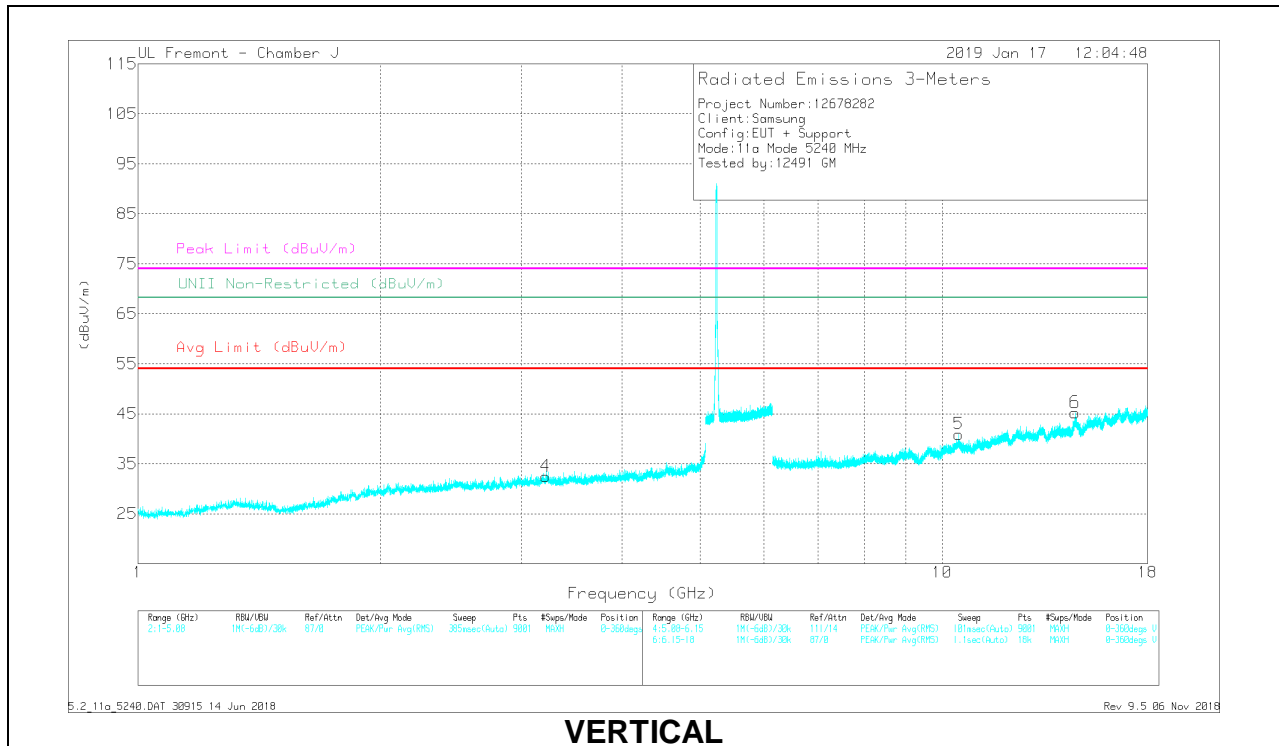

VERTICAL

RADIATED EMISSIONS

Frequency (GHz)	Meter Reading (dBuV)	Det	AF AT0067 (dBm)	Amp/CAF/Fltr/Pad (dB)	DC Corr (dB)	Corrected Reading (dBuV/m)	Avg Limit (dBuV/m)	Margin (dB)	Peak Limit (dBuV/m)	PK Margin (dB)	UNII Non-Restricted (dBuV/m)	PK Margin (dB)	Azimuth (Degs)	Height (cm)	Polarity
2.161	41.38	PK-U	31.8	-35.5	0	37.68	-	-	-	-	68.2	-30.52	157	234	H
2.159	32.24	ADR	31.8	-35.5	.27	28.81	-	-	-	-	-	-	157	234	H
* 4.379	37.52	PK-U	33.7	-31	0	40.02	-	-	74	-33.98	-	-	181	371	H
* 4.381	28.43	ADR	33.7	-30.9	.27	31.5	54	-22.5	-	-	-	-	181	371	H
3.211	40.84	PK-U	33.2	-34.6	0	39.44	-	-	-	-	68.2	-28.76	65	212	V
3.209	31.29	ADR	33.2	-34.6	.27	30.16	-	-	-	-	-	-	65	212	V
* 10.645	33.06	PK-U	37.6	-25.1	0	45.56	-	-	74	-28.44	-	-	270	317	H
* 10.646	23.83	ADR	37.6	-25.1	.27	36.6	54	-17.4	-	-	-	-	270	317	H
10.48	35.34	PK-U	37.5	-25.3	0	47.54	-	-	-	-	68.2	-20.66	195	114	V
10.48	27.17	ADR	37.5	-25.3	.27	39.64	-	-	-	-	-	-	195	114	V
14.627	31.62	PK-U	39.4	-20.3	0	50.72	-	-	-	-	68.2	-17.48	311	209	V
14.626	22.14	ADR	39.4	-20.2	.27	41.61	-	-	-	-	-	-	311	209	V

* - indicates frequency in CFR47 Pt 15 / IC RSS-Restricted Band
 PK-U - U-NII: Maximum Peak
 ADR - U-NII AD primary method, RMS average

10.1.2. TX ABOVE 1 GHz 802.11n HT20 MODE IN THE 5.2 GHz BAND

1TX Antenna 1 MODE

BANDEDGE (LOW CHANNEL)

HORIZONTAL RESULT

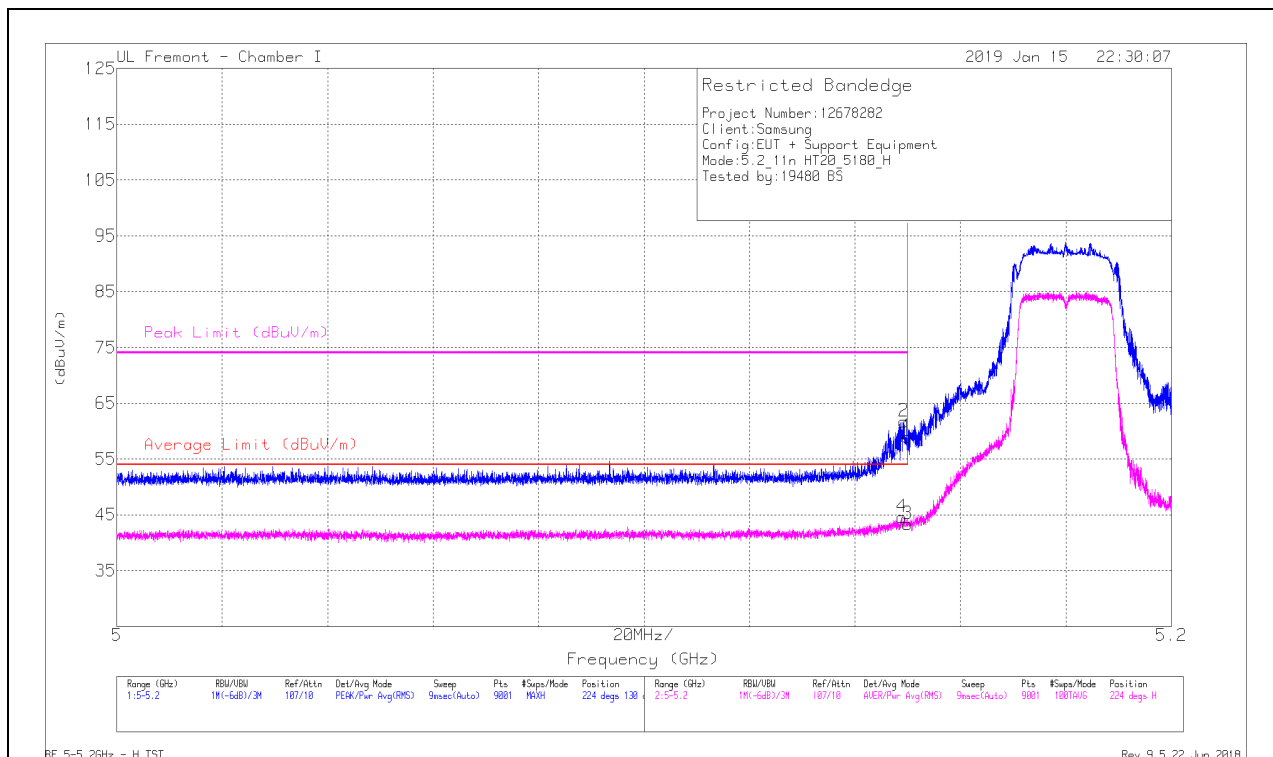

Marker	Frequency (GHz)	Meter Reading (dBuV)	Det	AF T862 (dB/m)	Amp/Cb/Fitr/Pad (dB)	DC Corr (dB)	Corrected Reading (dBuV/m)	Average Limit (dBuV/m)	Margin (dB)	Peak Limit (dBuV/m)	PK Margin (dB)	Azimuth (Degs)	Height (cm)	Polarity
1	* 5.15	43.61	Pk	34.4	-19	0	59.01	-	-	74	-14.99	224	130	H
2	* 5.149	46.27	Pk	34.4	-19	0	61.67	-	-	74	-12.33	224	130	H
3	* 5.15	27.68	RMS	34.4	-19	.28	43.36	54	-10.64	-	-	224	130	H
4	* 5.149	28.94	RMS	34.4	-19	.28	44.62	54	-9.38	-	-	224	130	H

* - indicates frequency in CFR47 Pt 15 / IC RSS-Restricted Band

Pk - Peak detector

RMS - RMS detection

VERTICAL RESULT

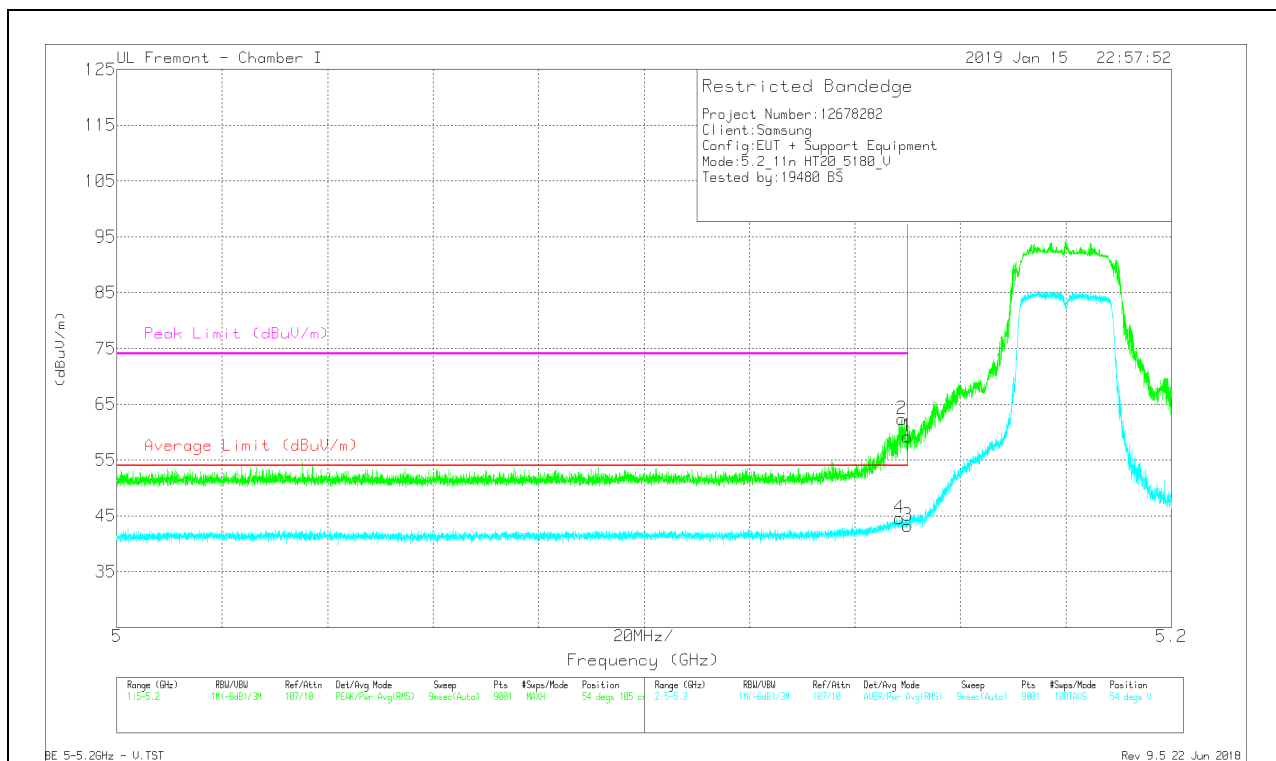

Marker	Frequency (GHz)	Meter Reading (dBuV)	Det	AF T862 (dB/m)	Amp/Ch/Filt/Pad (dB)	DC Corr (dB)	Corrected Reading (dBuV/m)	Average Limit (dBuV/m)	Margin (dB)	Peak Limit (dBuV/m)	PK Margin (dB)	Azimuth (Degs)	Height (cm)	Polarity
1	* 5.15	43.8	Pk	34.4	-19	0	59.2	-	-	74	-14.8	54	105	V
2	* 5.149	46.93	Pk	34.4	-19	0	62.33	-	-	74	-11.67	54	105	V
3	* 5.15	27.55	RMS	34.4	-19	.28	43.23	54	-10.77	-	-	54	105	V
4	* 5.148	28.95	RMS	34.4	-19	.28	44.63	54	-9.37	-	-	54	105	V

* - indicates frequency in CFR47 Pt 15 / IC RSS-Restricted Band

Pk - Peak detector

RMS - RMS detection

HARMONICS AND SPURIOUS EMISSIONS

LOW CHANNEL RESULTS

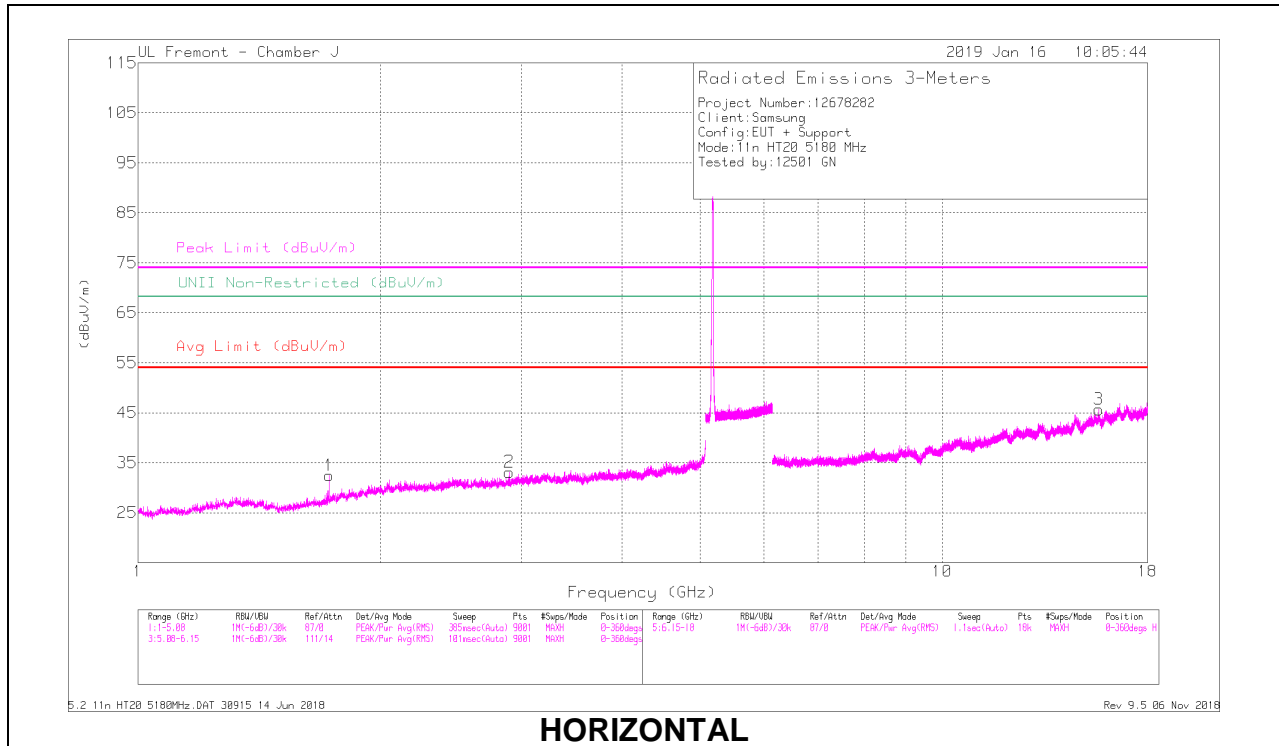

HORIZONTAL

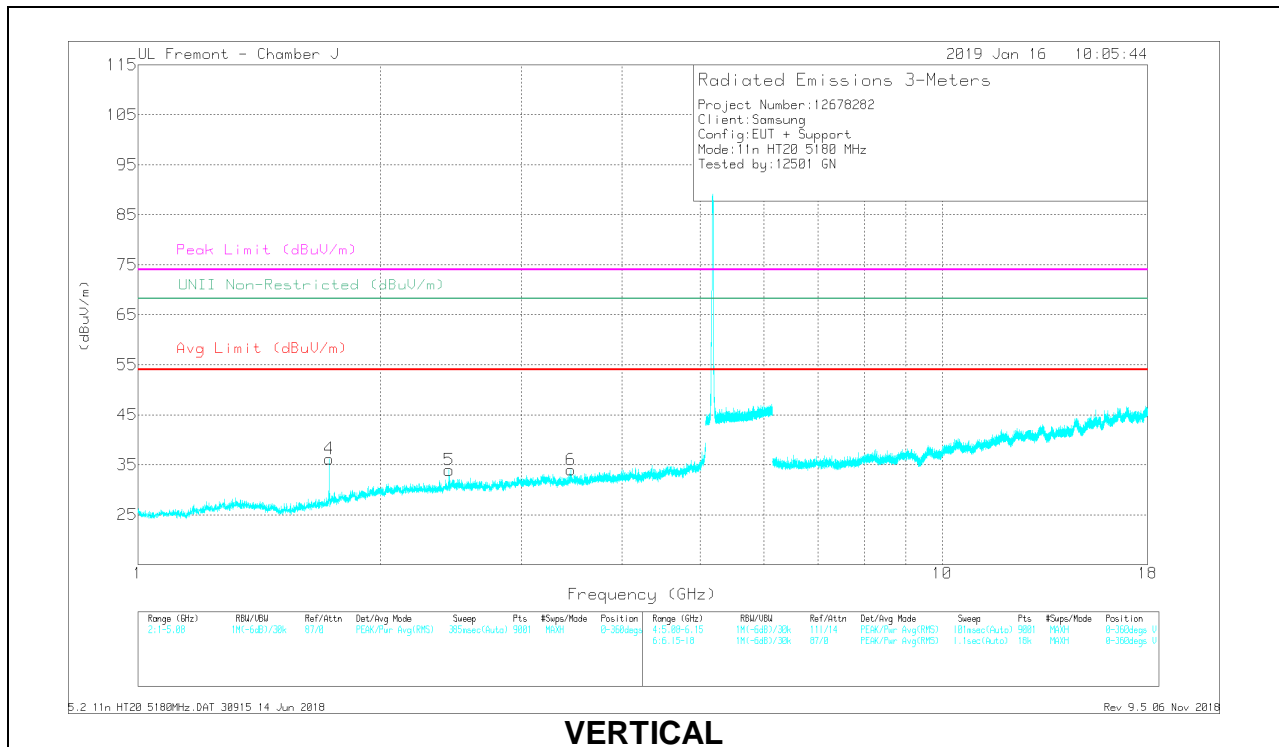

VERTICAL

RADIATED EMISSIONS

Frequency (GHz)	Meas Reading (dBuV)	Det	AF AT0067 (dBm)	Amp/Gain/Att/Pad (dB)	DC Corr (dB)	Corrected Reading (dBuV/m)	Avg Limit (dBuV/m)	Margin (dB)	Peak Limit (dBuV/m)	PK Margin (dB)	UNII Non-Restricted (dBuV/m)	PK Margin (dB)	Azimuth (Degs)	Height (cm)	Polarity
1.726	43.89	PK-U	29.5	-35.7	0	37.69	-	-	-	-	68.2	-30.51	292	198	H
1.727	32.42	ADR	29.5	-35.7	.28	26.47	-	-	-	-	-	-	292	198	H
* 2.886	43.76	PK-U	32.6	-35	0	41.36	-	-	74	-32.64	-	-	292	103	H
* 2.884	32.36	ADR	32.6	-35	.28	30.21	54	-23.79	-	-	-	-	292	103	H
1.729	45.07	PK-U	29.5	-35.8	0	38.77	-	-	-	-	68.2	-29.43	102	261	V
1.727	32.5	ADR	29.5	-35.8	.28	26.45	-	-	-	-	-	-	102	261	V
2.436	40.21	PK-U	32.3	-35.5	0	37.01	-	-	-	-	68.2	-31.19	102	102	V
2.437	32.39	ADR	32.3	-35.5	.28	29.44	-	-	-	-	-	-	102	102	V
3.452	38.85	PK-U	32.6	-33.7	0	38.85	-	-	-	-	68.2	-29.35	102	102	V
3.452	31.49	ADR	32.6	-33.7	.28	30.63	-	-	-	-	-	-	102	102	V
* 15.646	30.54	PK-U	40.3	-20.4	0	50.44	-	-	74	-23.56	-	-	102	102	H
* 15.647	22.38	ADR	40.3	-20.4	.28	42.53	54	-11.47	-	-	-	-	102	102	H

* - indicates frequency in CFR47 Pt 15 / IC RSS-Restricted Band
 PK-U - U-NII: Maximum Peak
 ADR - U-NII AD primary method, RMS average

MID CHANNEL RESULTS

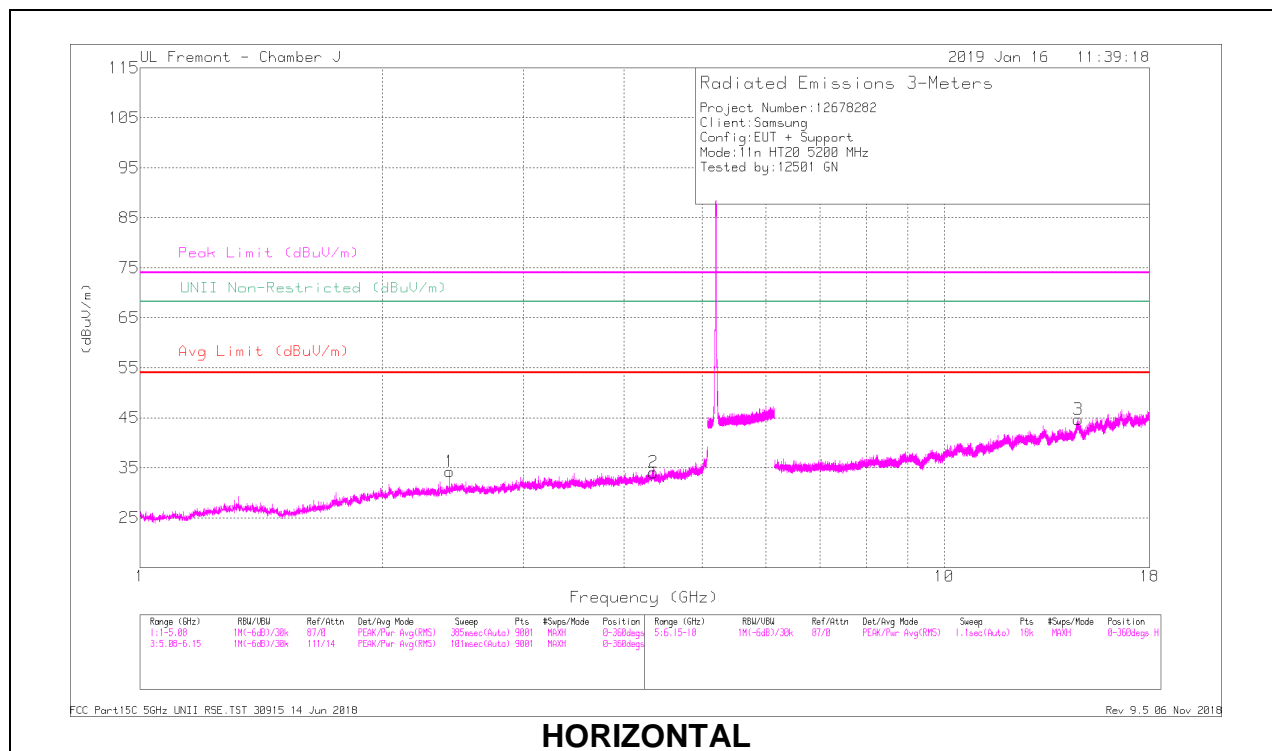

HORIZONTAL

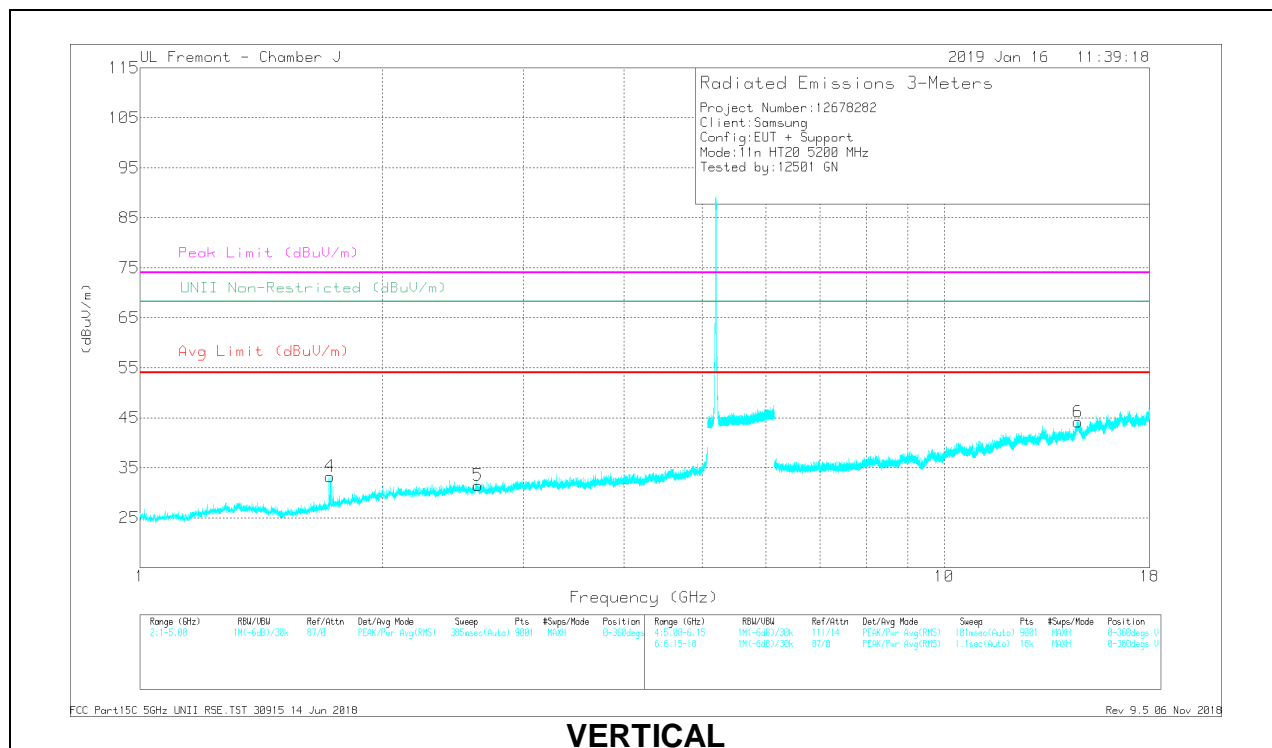

VERTICAL

RADIATED EMISSIONS

Frequency (GHz)	Meter Reading (dBuV)	Det	AF AT0067 (dBm)	AmpCoeff/Pad (dB)	DC Corr (dB)	Corrected Reading (dBuV/m)	Avg Limit (dBuV/m)	Margin (dB)	Peak Limit (dBuV/m)	PK Margin (dB)	UNII Non-Restricted (dBuV/m)	PK Margin (dB)	Azimuth (Degs)	Height (cm)	Polarity
2.424	41.91	PK-U	32.2	-35.5	0	38.61	-	-	-	-	68.2	-29.59	58	263	H
2.426	32.18	ADR	32.3	-35.5	.28	29.26	-	-	-	-	-	-	58	263	H
* 4.35	39.34	PK-U	33.7	-31	0	42.04	-	-	74	-31.96	-	-	186	175	H
* 4.347	29.01	ADR	33.7	-31	.28	31.99	54	-22.01	-	-	-	-	186	175	H
1.723	42.07	PK-U	29.4	-35.7	0	35.77	-	-	-	-	68.2	-32.43	217	394	V
1.723	31.68	ADR	29.4	-35.7	.28	25.66	-	-	-	-	-	-	217	394	V
2.629	41.39	PK-U	32.5	-35.2	0	38.69	-	-	-	-	68.2	-29.51	108	217	V
2.629	31.63	ADR	32.5	-35.2	.28	29.21	-	-	-	-	-	-	108	217	V
14.674	31.11	PK-U	39.4	-20.3	0	50.21	-	-	-	-	68.2	-17.99	108	147	H
14.676	22.53	ADR	39.4	-20.3	.28	41.91	-	-	-	-	-	-	108	147	H
14.666	31.04	PK-U	39.5	-20.3	0	50.24	-	-	-	-	68.2	-17.96	108	177	V
14.668	22.15	ADR	39.4	-20.3	.28	41.53	-	-	-	-	-	-	108	177	V

* - indicates frequency in CFR47 Pt 15 / IC RSS-Restricted Band
 PK-U - U-NII: Maximum Peak
 ADR - U-NII AD primary method, RMS average

HIGH CHANNEL RESULTS

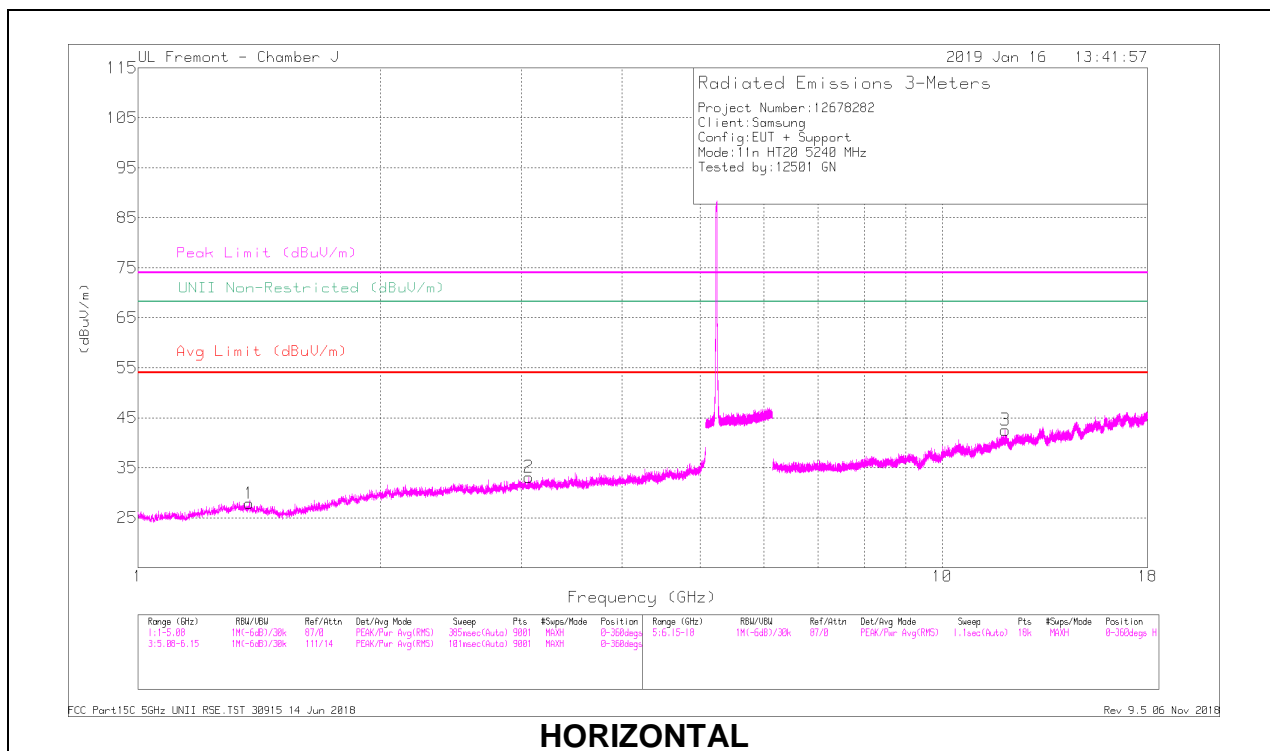

HORIZONTAL

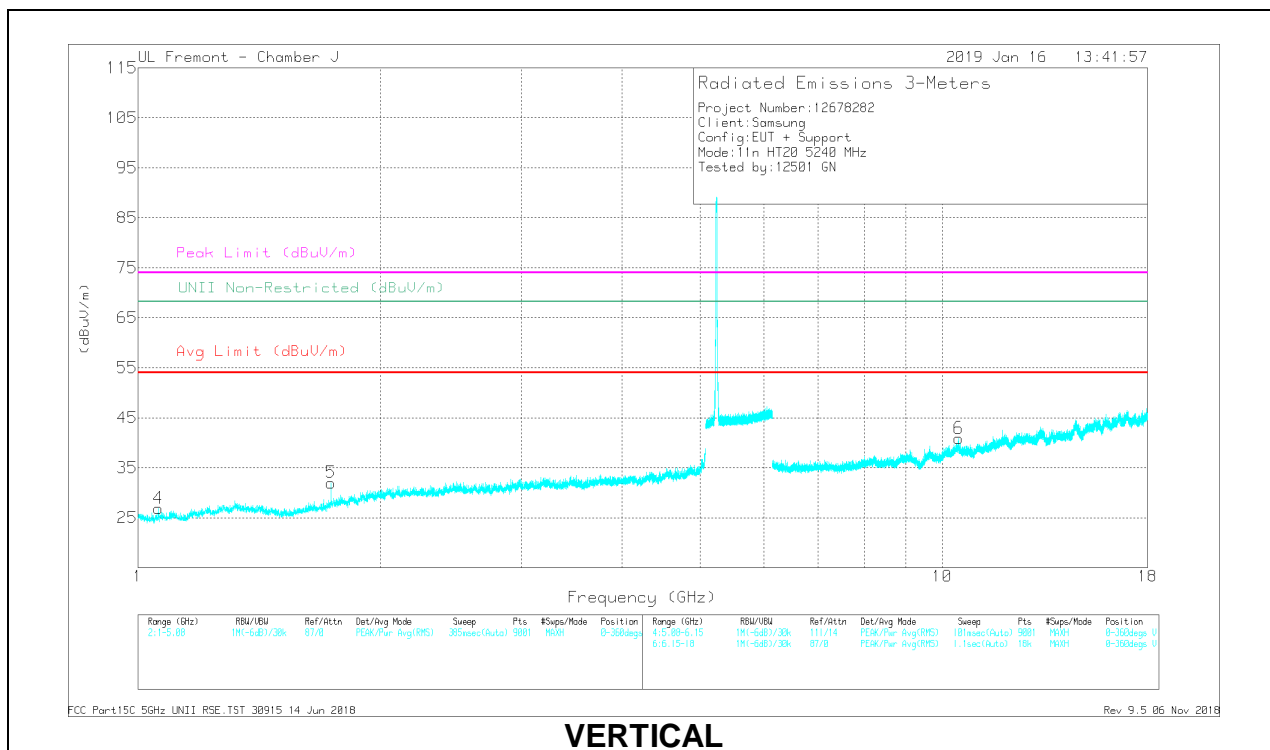

VERTICAL

RADIATED EMISSIONS

Frequency (GHz)	Meas Reading (dBuV)	Det	AF AT0067 (dBm)	Amp/Gain/Att/Pad (dB)	DC Corr (dB)	Corrected Reading (dBuV/m)	Avg Limit (dBuV/m)	Margin (dB)	Peak Limit (dBuV/m)	PK Margin (dB)	UNII Non-Restricted (dBuV/m)	PK Margin (dB)	Azimuth (Degs)	Height (cm)	Polarity
* 1.376	40.55	PK-U	29.1	-35.9	0	33.75	-	-	74	-40.25	-	-	0	126	H
* 1.374	32.17	ADR	29.1	-35.9	.28	25.65	54	-28.35	-	-	-	-	0	126	H
3.06	41.54	PK-U	33	-34.7	0	33.84	-	-	-	-	68.2	-28.36	104	196	H
3.061	31.61	ADR	33	-34.7	.28	30.19	-	-	-	-	-	-	104	196	H
* 1.058	41.09	PK-U	27.2	-35.5	0	32.79	-	-	74	-41.21	-	-	84	154	V
* 1.058	31.49	ADR	27.2	-35.5	.28	23.47	54	-30.53	-	-	-	-	84	154	V
1.737	42.27	PK-U	29.7	-35.7	0	36.27	-	-	-	-	68.2	-31.93	313	252	V
1.736	32.69	ADR	29.7	-35.7	.28	26.97	-	-	-	-	-	-	313	252	V
* 11.977	33.09	PK-U	38.7	-22.9	0	48.89	-	-	74	-25.11	-	-	356	128	H
* 11.975	22.89	ADR	38.7	-22.9	.28	38.97	54	-15.03	-	-	-	-	356	128	H
10.48	34.73	PK-U	37.5	-25.3	0	46.93	-	-	-	-	68.2	-21.27	241	123	V
10.48	26.33	ADR	37.5	-25.3	.28	38.81	-	-	-	-	-	-	241	123	V

* - indicates frequency in CFR47 Pt 15 / IC RSS-Restricted Band
 PK-U - U-NII: Maximum Peak
 ADR - U-NII AD primary method, RMS average

10.1.3. TX ABOVE 1 GHz 802.11n HT40 MODE IN THE 5.2 GHz BAND

1TX Antenna 1 MODE

BANDEDGE (LOW CHANNEL)

HORIZONTAL RESULT

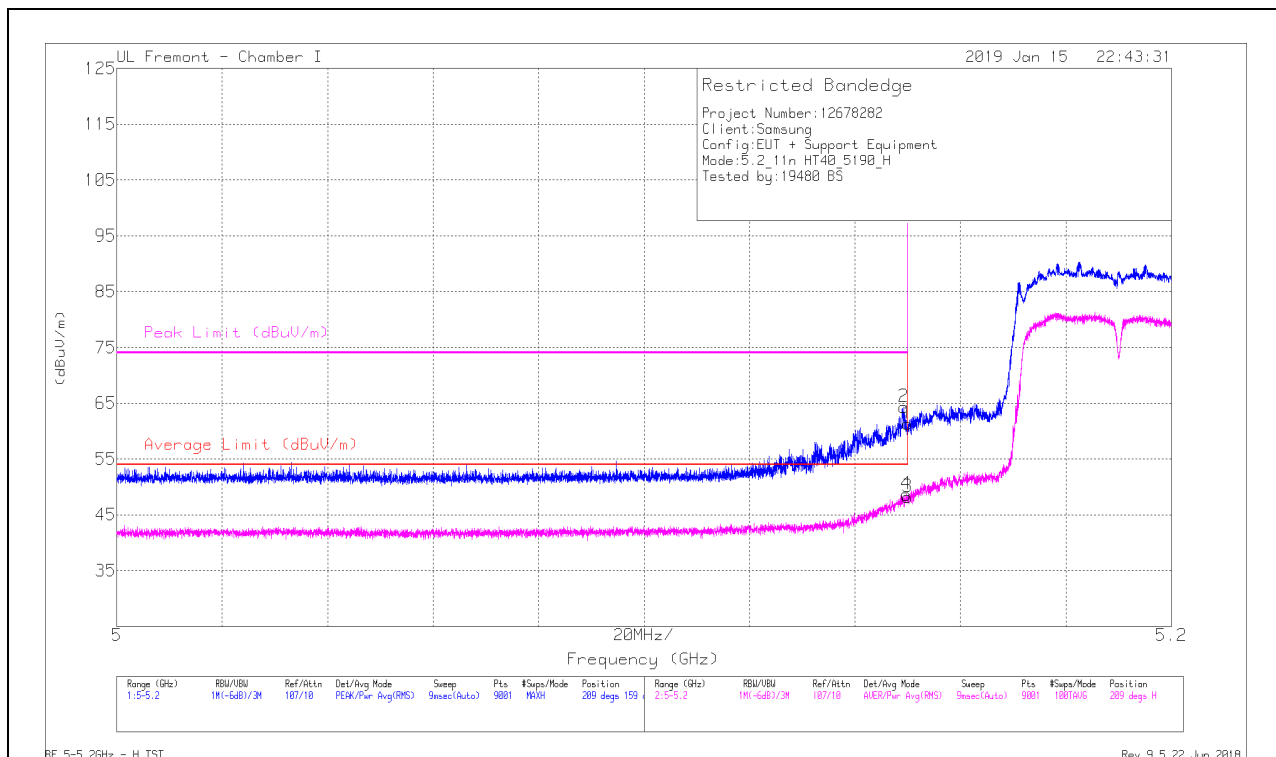

Marker	Frequency (GHz)	Meter Reading (dBuV)	Det	AFT862 (dB/m)	Amp/Cbl/Fitr/Pad (dB)	DC Corr (dB)	Corrected Reading (dBuV/m)	Average Limit (dBuV/m)	Margin (dB)	Peak Limit (dBuV/m)	PK Margin (dB)	Azimuth (Degs)	Height (cm)	Polarity
1	* 5.15	45.93	Pk	34.4	-19	0	61.33	-	-	74	-12.67	209	159	H
2	* 5.149	48.97	Pk	34.4	-19	0	64.37	-	-	74	-9.63	209	159	H
3	* 5.15	32.09	RMS	34.4	-19	.71	48.2	54	-5.8	-	-	209	159	H
4	* 5.15	32.51	RMS	34.4	-19	.71	48.62	54	-5.38	-	-	209	159	H

* - indicates frequency in CFR47 Pt 15 / IC RSS-Restricted Band

Pk - Peak detector

RMS - RMS detection

VERTICAL RESULT

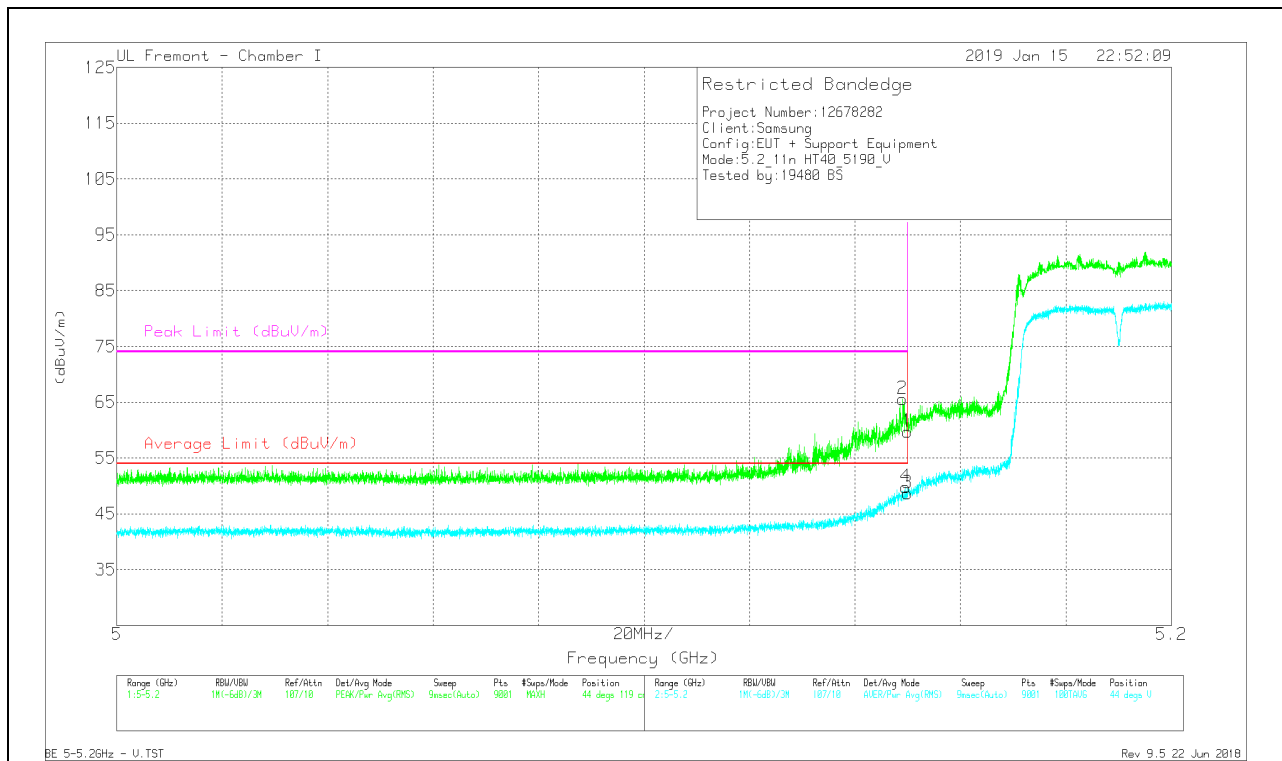

Marker	Frequency (GHz)	Meter Reading (dBuV)	Det	AF T862 (dB/m)	Amp/Chl/Filt/Pad (dB)	DC Corr (dB)	Corrected Reading (dBuV/m)	Average Limit (dBuV/m)	Margin (dB)	Peak Limit (dBuV/m)	PK Margin (dB)	Azimuth (Degs)	Height (cm)	Polarity
1	* 5.15	44.36	Pk	34.4	-19	0	59.76	-	-	74	-14.24	44	119	V
2	* 5.149	50.17	Pk	34.4	-19	0	65.57	-	-	74	-8.43	44	119	V
3	* 5.15	32.61	RMS	34.4	-19	.71	48.72	54	-5.28	-	-	44	119	V
4	* 5.15	33.67	RMS	34.4	-19	.71	49.78	54	-4.22	-	-	44	119	V

* - indicates frequency in CFR47 Pt 15 / IC RSS-Restricted Band

Pk - Peak detector

RMS - RMS detection

HARMONICS AND SPURIOUS EMISSIONS

LOW CHANNEL RESULTS

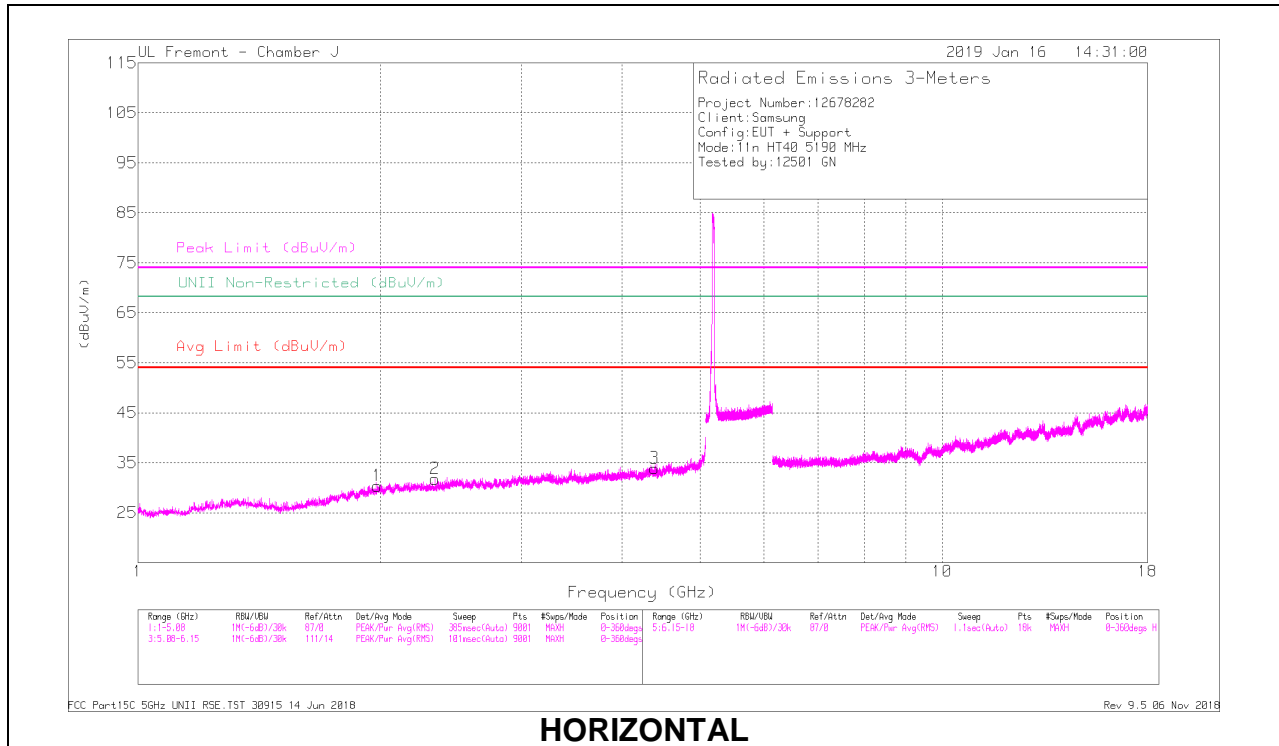

HORIZONTAL

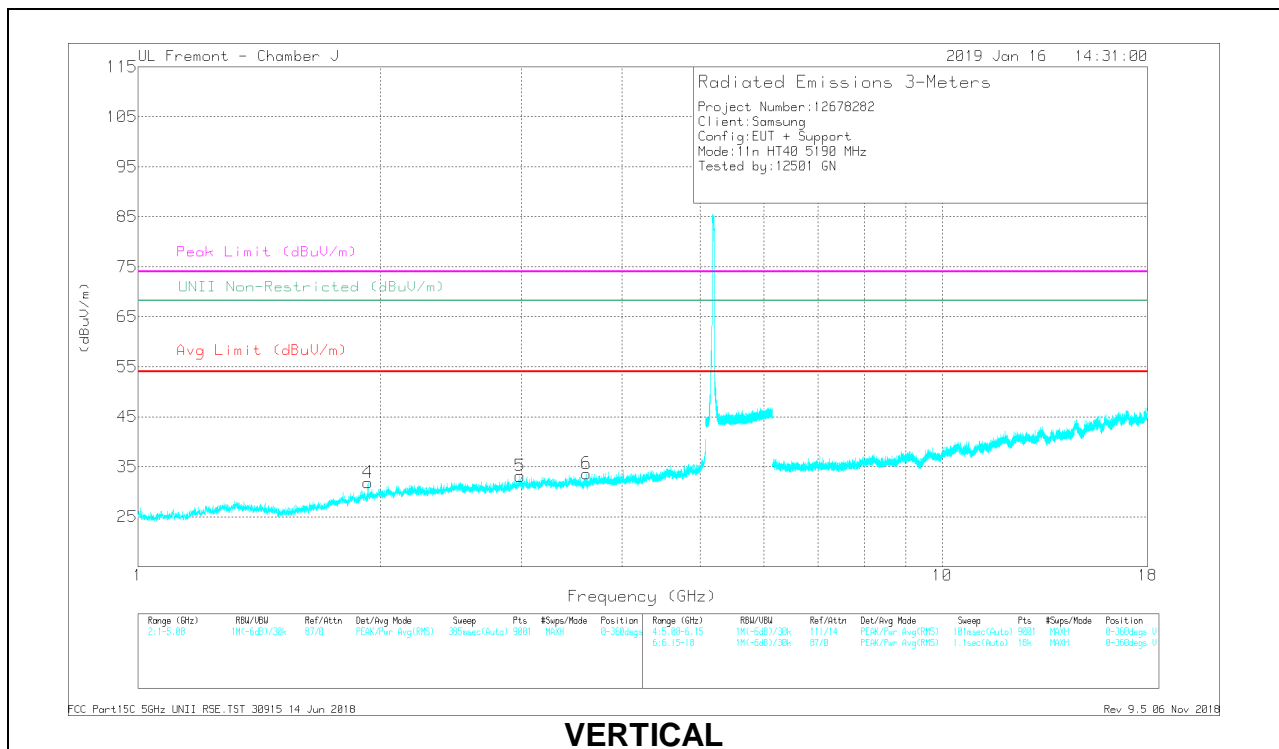

VERTICAL

RADIATED EMISSIONS

Frequency (Ghz)	Meter Reading (dBuV)	Det	AF AT0067 (dBm)	AmpCoef/FilterPad (dB)	DC Corr (dB)	Corrected Reading (dBuV/m)	Avg Limit (dBuV/m)	Margin (dB)	Peak Limit (dBuV/m)	PK Margin (dB)	UNII Non-Restricted (dBuV/m)	PK Margin (dB)	Azimuth (Degs)	Height (cm)	Polarity
1.984	41.92	PK-U	31.4	-35.7	0	37.62	-	-	-	-	68.2	-30.58	323	112	H
1.983	32.03	ADR	31.4	-35.7	.71	28.44	-	-	-	-	-	-	323	112	H
* 2.343	40.76	PK-U	31.9	-35.5	0	37.16	-	-	74	-36.84	-	-	136	113	H
* 2.34	31.53	ADR	31.9	-35.5	.71	28.64	54	-25.96	-	-	-	-	136	113	H
* 4.39	38.62	PK-U	33.7	-30.9	0	41.42	-	-	74	-32.68	-	-	174	345	H
* 4.391	28.39	ADR	33.7	-31	.71	31.8	54	-22.2	-	-	-	-	174	345	H
1.932	41.76	PK-U	31.1	-35.8	0	37.06	-	-	-	-	68.2	-31.14	271	153	V
1.931	33.31	ADR	31.1	-35.8	.71	29.32	-	-	-	-	-	-	271	153	V
2.984	41.57	PK-U	32.9	-34.7	0	38.77	-	-	-	-	68.2	-28.43	231	176	V
2.987	31.7	ADR	33	-34.7	.71	30.71	-	-	-	-	-	-	231	176	V
* 3.61	40.59	PK-U	33.1	-33.6	0	40.09	-	-	74	-33.91	-	-	231	141	V
* 3.608	30.4	ADR	33.1	-33.7	.71	30.51	54	-23.49	-	-	-	-	231	141	V

* - indicates frequency in CFR47 Pt 15 / IC RSS-Restricted Band
 PK-U - U-NII: Maximum Peak
 ADR - U-NII AD primary method, RMS average

HIGH CHANNEL RESULTS

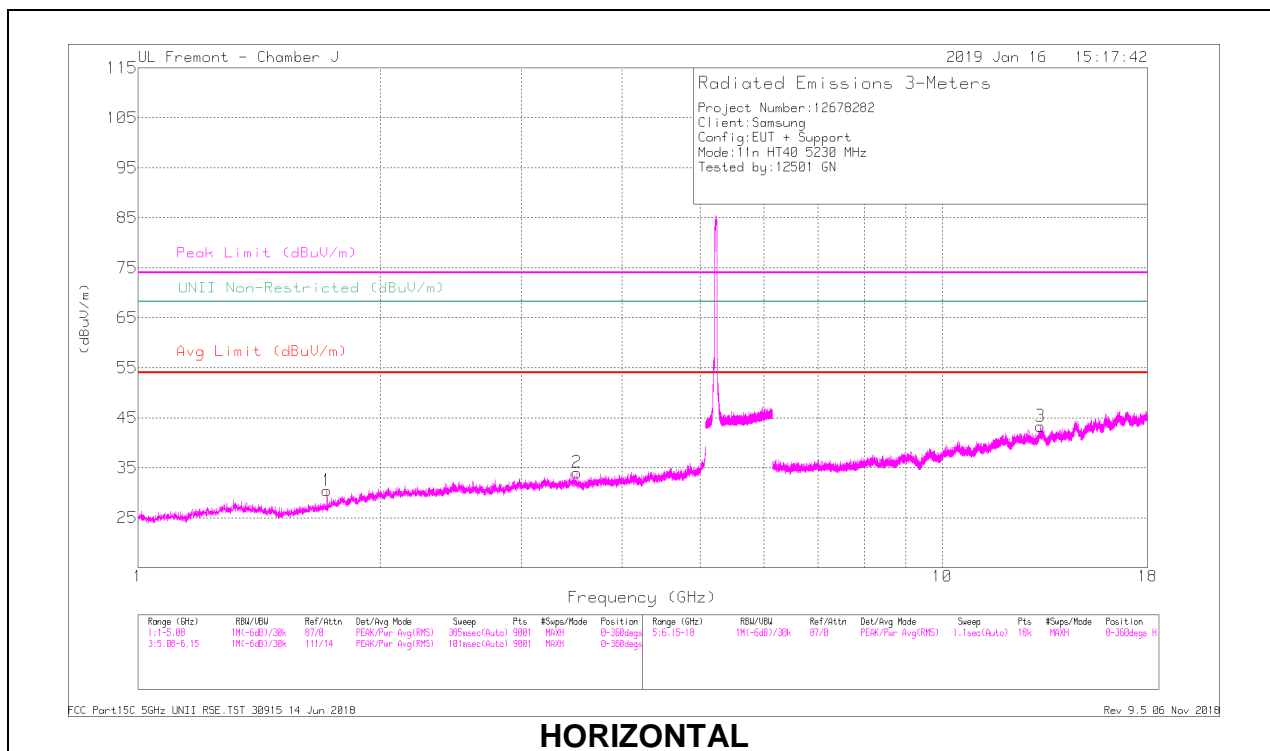

HORIZONTAL



VERTICAL

RADIATED EMISSIONS

Frequency (GHz)	Measr Reading (dBuV)	Det	AF AT0067 (dBm)	AmpCoef/PwrPad (dB)	DC Corr (dB)	Corrected Reading (dBuV/m)	Avg Limit (dBuV/m)	Margin (dB)	Peak Limit (dBuV/m)	PK Margin (dB)	UNII Non-Restricted (dBuV/m)	PK Margin (dB)	Azimuth (Degs)	Height (cm)	Polarity
* 1.721	41.35	PK-U	29.4	-35.8	0	34.95	-	-	74	-39.05	-	-	228	104	H
1.721	32.15	ADR	29.4	-35.8	.71	26.46	54	-27.54	-	-	-	-	228	104	H
* 3.515	39.97	PK-U	32.7	-33	0	39.67	-	-	74	-34.33	-	-	360	196	H
* 3.513	30.5	ADR	32.7	-33	.71	30.91	54	-23.09	-	-	-	-	360	196	H
1.728	46.94	PK-U	29.5	-35.8	0	40.64	-	-	-	-	68.2	-27.56	270	104	V
1.729	32.82	ADR	29.5	-35.8	.71	27.23	-	-	-	-	-	-	270	104	V
13.206	33.92	PK-U	39	-22.1	0	50.82	-	-	-	-	68.2	-17.38	360	134	H
13.199	23.34	ADR	39	-22.1	.71	40.95	-	-	-	-	-	-	360	134	H
* 7.522	38.08	PK-U	35.7	-27.8	0	45.86	-	-	74	-28.14	-	-	94	104	V
* 7.507	25.8	ADR	35.7	-27.8	.71	34.41	54	-19.59	-	-	-	-	94	104	V
10.46	36.94	PK-U	37.5	-25.1	0	49.34	-	-	-	-	68.2	-18.86	277	114	V
10.46	26.41	ADR	37.5	-25.1	.71	39.52	-	-	-	-	-	-	277	114	V

* - indicates frequency in CFR47 Pt 15 / IC RSS-Restricted Band
 PK-U - U-NII: Maximum Peak
 ADR - U-NII AD primary method, RMS average

10.1.4. TX ABOVE 1 GHz 802.11ac VHT80 MODE IN THE 5.2 GHz BAND

1TX Antenna 1 MODE

BANDEDGE (MID CHANNEL)

HORIZONTAL RESULT

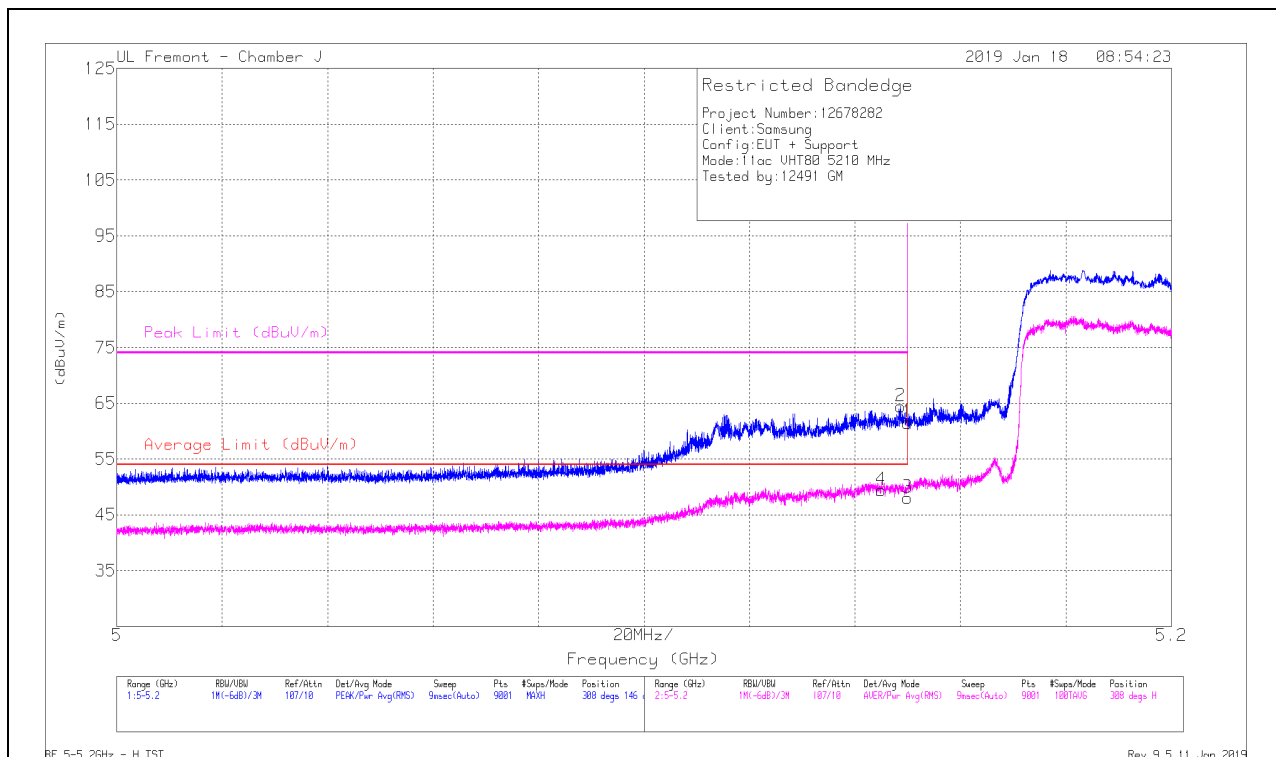

Marker	Frequency (GHz)	Meter Reading (dBuV)	Det	AF AT0067 (dB/m)	Amp/Cbl/Filtr/Pad (dB)	DC Corr (dB)	Corrected Reading (dBuV/m)	Average Limit (dBuV/m)	Margin (dB)	Peak Limit (dBuV/m)	PK Margin (dB)	Azimuth (Degs)	Height (cm)	Polarity
1	* 5.15	48.93	Pk	34.2	-21.6	0	61.53	-	-	74	-12.47	308	146	H
2	* 5.149	51.88	Pk	34.2	-21.6	0	64.48	-	-	74	-9.52	308	146	H
3	* 5.15	35.42	RMS	34.2	-21.6	1.29	49.3	54	-4.7	-	-	308	146	H
4	* 5.145	36.81	RMS	34.2	-21.6	1.29	50.69	54	-3.31	-	-	308	146	H

* - indicates frequency in CFR47 Pt 15 / IC RSS-Restricted Band

Pk - Peak detector

RMS - RMS detection

VERTICAL RESULT

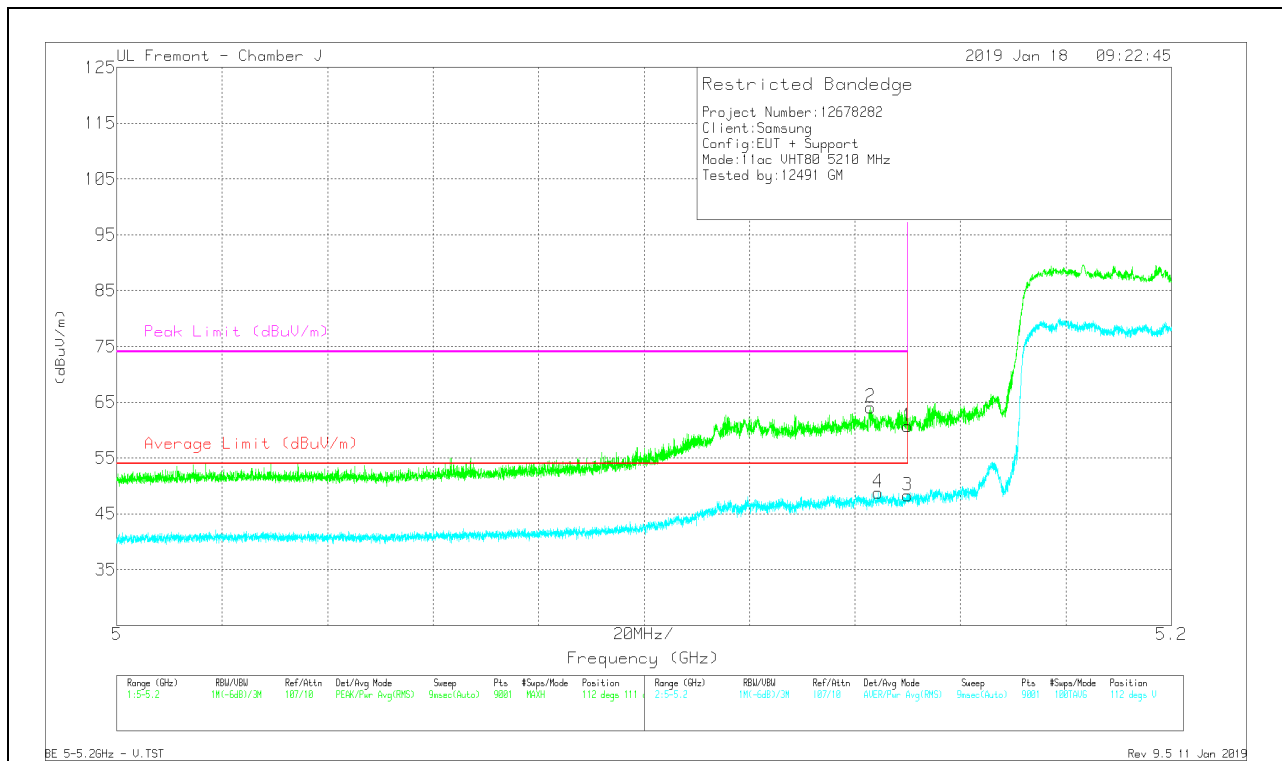

Marker	Frequency (GHz)	Meter Reading (dBuV)	Det	AF AT0067 (dB/m)	Amp/Cb/Ftr/Pad (dB)	DC Corr (dB)	Corrected Reading (dBuV/m)	Average Limit (dBuV/m)	Margin (dB)	Peak Limit (dBuV/m)	PK Margin (dB)	Azimuth (Degs)	Height (cm)	Polarity
1	* 5.15	48.07	Pk	34.2	-21.6	0	60.67	-	-	74	-13.33	112	111	V
2	* 5.143	51.53	Pk	34.2	-21.6	0	64.13	-	-	74	-9.87	112	111	V
3	* 5.15	35.76	RMS	34.2	-21.6	1.29	49.65	54	-4.35	-	-	112	111	V
4	* 5.144	36.26	RMS	34.2	-21.6	1.29	50.15	54	-3.85	-	-	112	111	V

* - indicates frequency in CFR47 Pt 15 / IC RSS-Restricted Band
 Pk - Peak detector
 RMS - RMS detection

HARMONICS AND SPURIOUS EMISSIONS

MID CHANNEL RESULTS

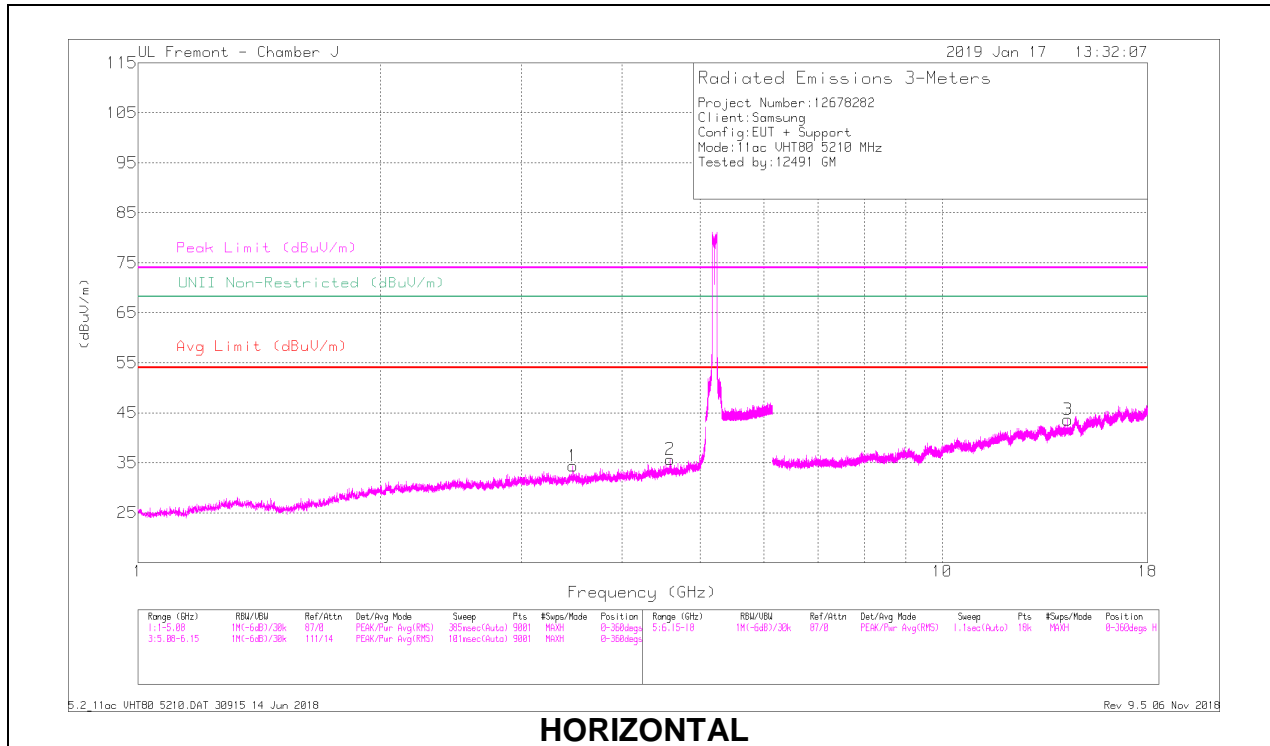

HORIZONTAL

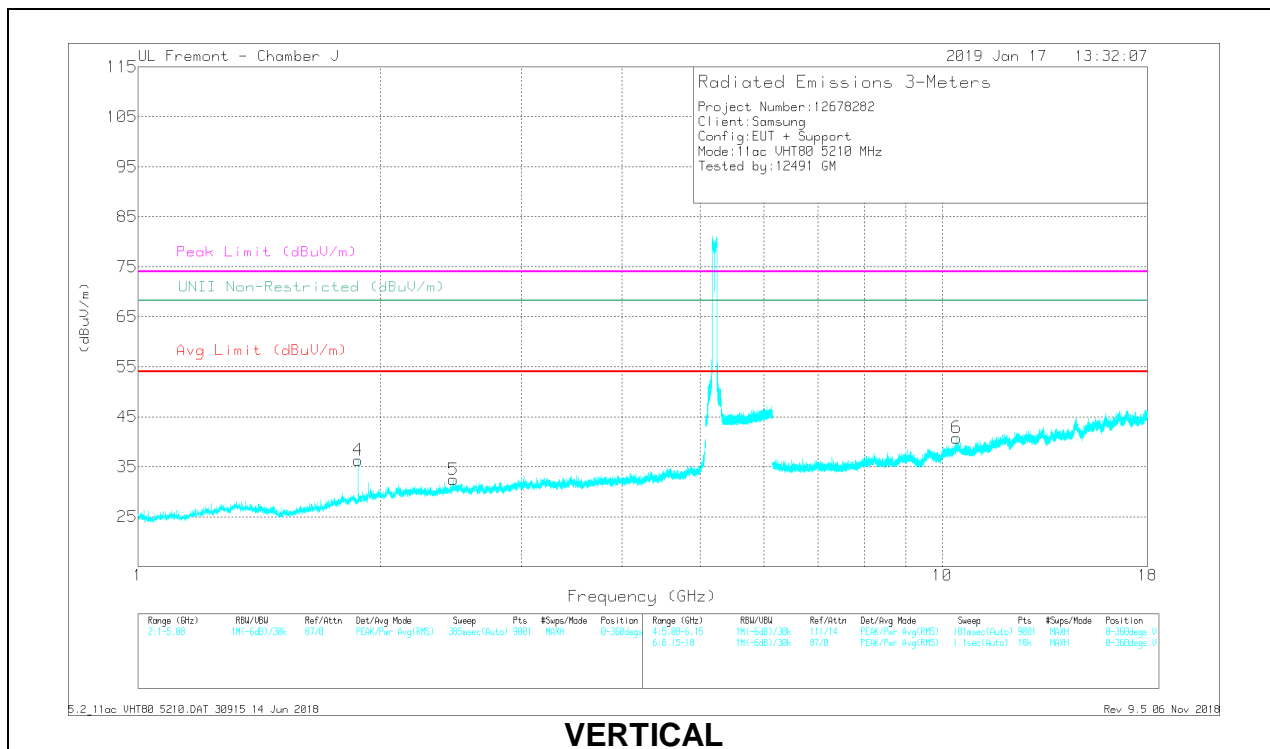

VERTICAL

RADIATED EMISSIONS

Frequency (GHz)	Measr Reading (dBuV)	Det	AF AT0067 (dBm)	AmpCoef/PwrPad (dB)	DC Corr (dB)	Corrected Reading (dBuV/m)	Avg Limit (dBuV/m)	Margin (dB)	Peak Limit (dBuV/m)	PK Margin (dB)	UNII Non-Restricted (dBuV/m)	PK Margin (dB)	Azimuth (Degs)	Height (cm)	Polarity
3.474	41.87	PK-U	32.6	-33.6	0	40.87	-	-	-	-	68.2	-27.33	188	260	H
3.473	32.84	ADR	32.6	-33.6	1.29	33.13	-	-	-	-	-	-	185	260	H
* 4.591	38.16	PK-U	34.2	-30.9	0	41.46	-	-	74	-32.64	-	-	83	106	H
* 4.59	28.69	ADR	34.2	-30.9	1.29	33.28	54	-20.72	-	-	-	-	83	106	H
1.88	41.55	PK-U	30.8	-35.8	0	36.55	-	-	-	-	68.2	-31.65	148	392	V
1.877	31.26	ADR	30.8	-35.8	1.29	27.55	-	-	-	-	-	-	148	392	V
2.465	44.58	PK-U	32.5	-35.5	0	41.58	-	-	-	-	68.2	-26.62	200	131	V
2.467	32.16	ADR	32.5	-35.5	1.29	30.45	-	-	-	-	-	-	200	131	V
14.323	31.44	PK-U	39.2	-20.7	0	49.94	-	-	-	-	68.2	-18.26	184	181	H
14.324	22.12	ADR	39.2	-20.7	1.29	41.91	-	-	-	-	-	-	184	181	H
10.42	35.65	PK-U	37.5	-25.2	0	47.95	-	-	-	-	68.2	-20.25	32	112	V
10.42	26.91	ADR	37.5	-25.2	1.29	40.5	-	-	-	-	-	-	32	112	V

* - indicates frequency in CFR47 Pt 15 / IC RSS-Restricted Band
 PK-U - U-NII: Maximum Peak
 ADR - U-NII AD primary method, RMS average

10.1.5. TX ABOVE 1 GHz 802.11a MODE IN THE 5.3 GHz BAND

1TX Antenna 1 MODE

BANDEDGE (HIGH CHANNEL)

HORIZONTAL RESULT

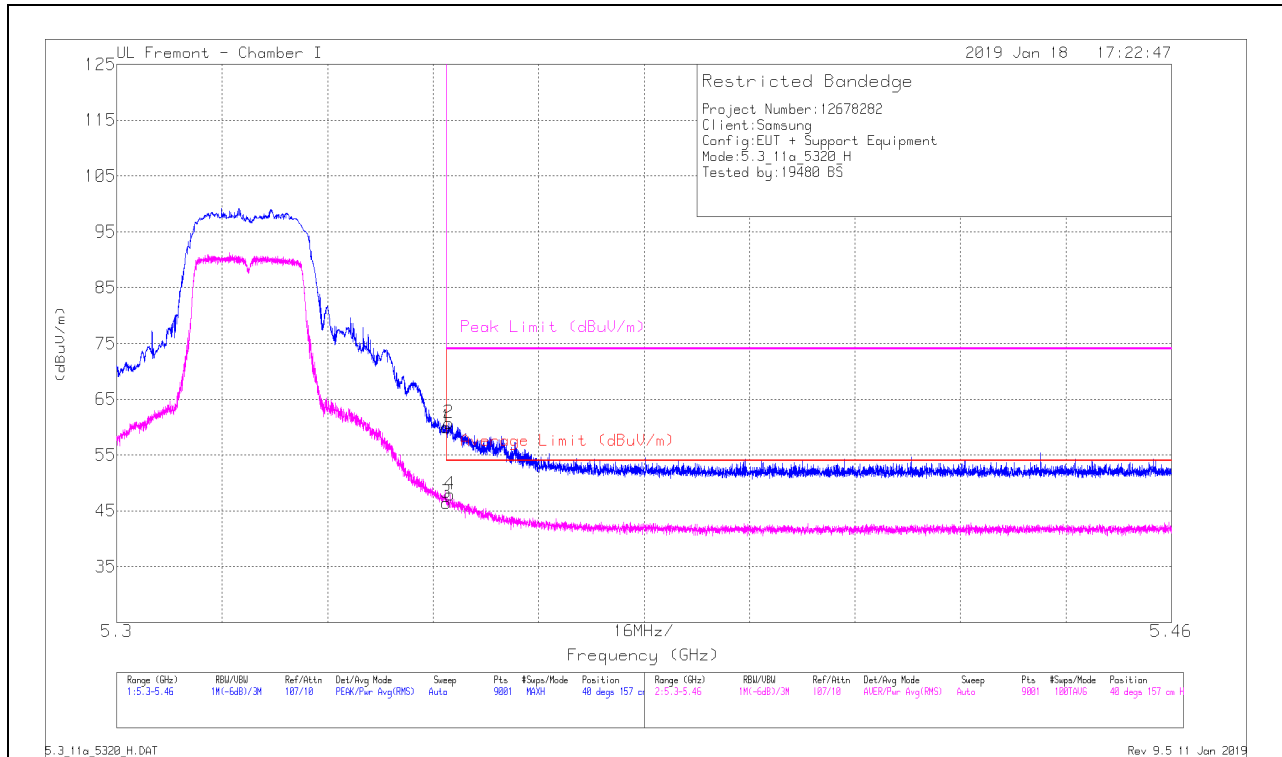

Marker	Frequency (GHz)	Meter Reading (dBuV)	Det	AF T862 (dB/m)	Amp/CDI/Filter/Fat (dB)	DC Corr (dB)	Corrected Reading (dBuV/m)	Average Limit (dBuV/m)	Margin (dB)	Peak Limit (dBuV/m)	PK Margin (dB)	Azimuth (Degs)	Height (cm)	Polarity
1	* 5.35	43.79	Pk	34.5	-18.3	0	59.99	-	-	74	-14.01	40	157	H
2	* 5.35	44.48	Pk	34.5	-18.3	0	60.68	-	-	74	-13.32	40	157	H
3	* 5.35	30.01	RMS	34.5	-18.3	27	46.48	54	-7.52	-	-	40	157	H
4	* 5.351	31.51	RMS	34.5	-18.3	27	47.98	54	-6.02	-	-	40	157	H

* - indicates frequency in CFR47 Pt 15 / IC RSS-Restricted Band

Pk - Peak detector

RMS - RMS detection

VERTICAL RESULT

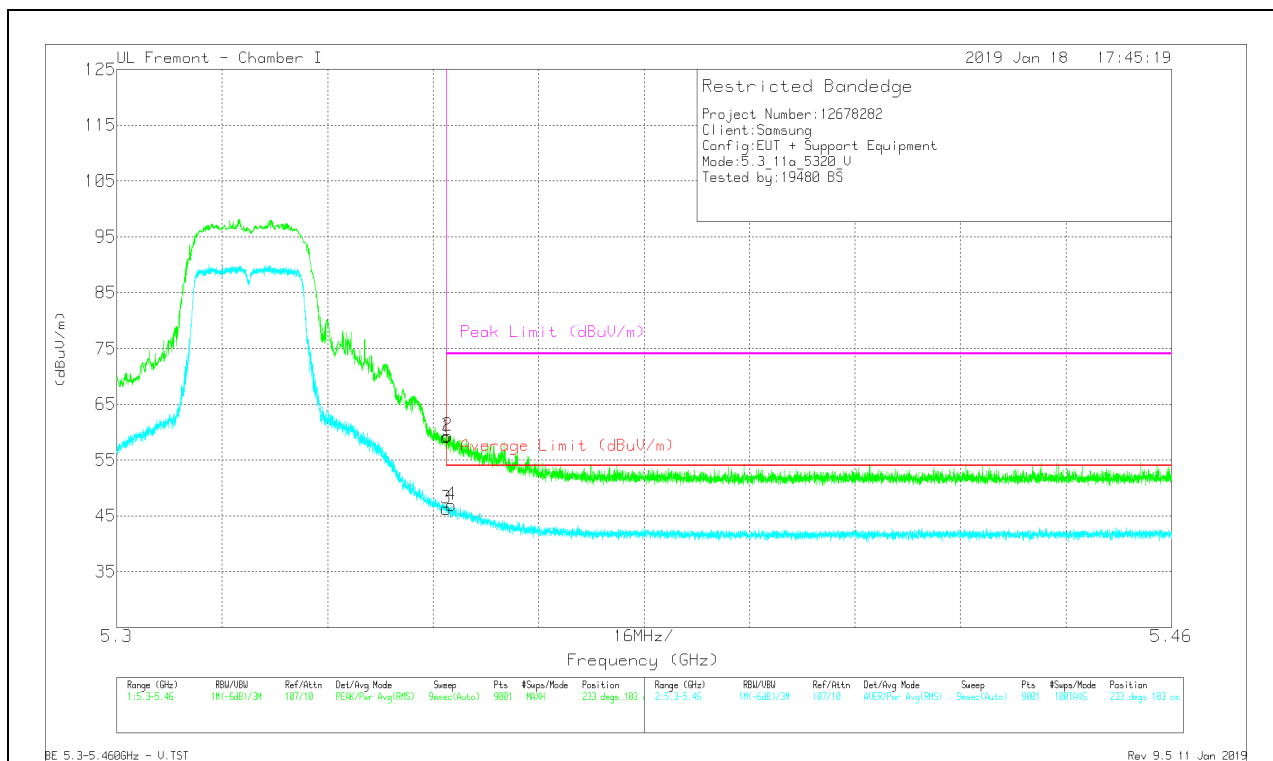

Marker	Frequency (GHz)	Meter Reading (dBuV)	Det	AF T862 (dB/m)	Amp/Cal/Filt/PA d (dB)	DC Corr (dB)	Corrected Reading (dBuV/m)	Average Limit (dBuV/m)	Margin (dB)	Peak Limit (dBuV/m)	PK Margin (dB)	Azimuth (Degs)	Height (cm)	Polarity
1	* 5.35	42.93	Pk	34.5	-18.3	0	59.13	-	-	74	-14.87	233	103	V
2	* 5.35	43.16	Pk	34.5	-18.3	0	59.36	-	-	74	-14.64	233	103	V
3	* 5.35	29.79	RMS	34.5	-18.3	27	46.26	54	-7.74	-	-	233	103	V
4	* 5.351	30.45	RMS	34.5	-18.3	27	46.92	54	-7.08	-	-	233	103	V

* - indicates frequency in CFR47 Pt 15 / IC RSS-Restricted Band

Pk - Peak detector
 RMS - RMS detection

HARMONICS AND SPURIOUS EMISSIONS

LOW CHANNEL RESULTS

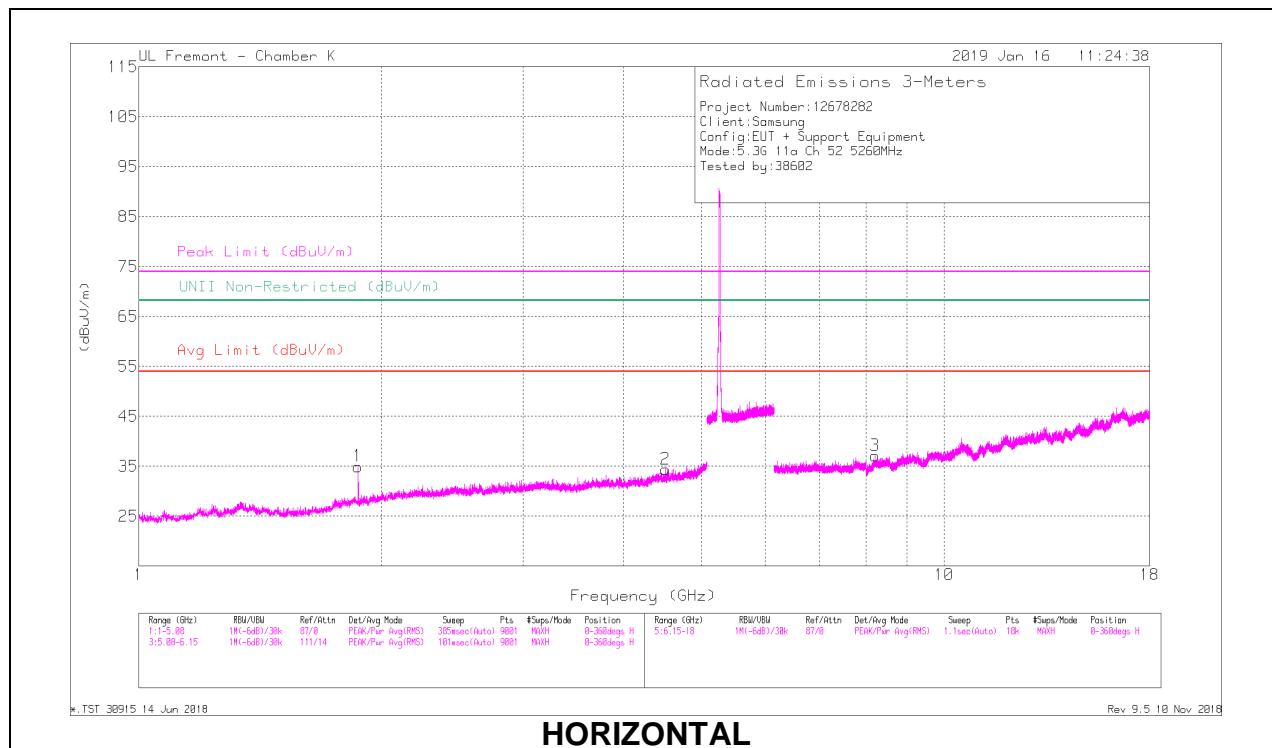

HORIZONTAL

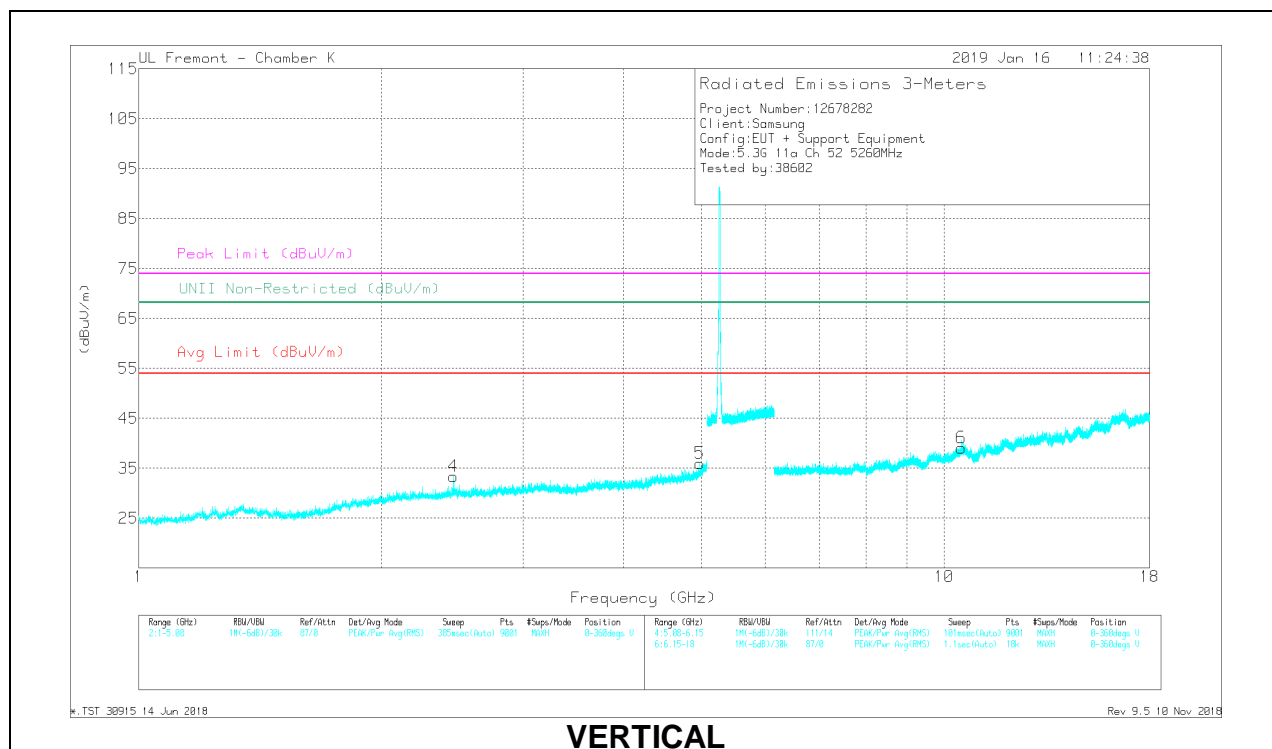

VERTICAL

RADIATED EMISSIONS

Frequency (GHz)	Measr Reading (dBuV)	Det	AF T344 (dBm)	AmpCoef/FilterPad (dB)	DC Corr (dB)	Corrected Reading (dBuV/m)	Avg Limit (dBuV/m)	Margin (dB)	Peak Limit (dBuV/m)	PK Margin (dB)	UNII Non-Restricted (dBuV/m)	PK Margin (dB)	Azimuth (Degs)	Height (cm)	Polarity
1.875	40.32	PK-U	30.4	-35.2	0	35.52	-	-	-	-	68.2	-32.68	83	339	H
* 4.51	38.93	PK-U	34	-30.2	0	42.73	-	-	74	-31.27	-	-	273	257	H
* 4.502	27.51	ADR	34	-30.2	.27	31.58	54	-22.42	-	-	-	-	273	257	H
2.461	40.66	PK-U	32.2	-34.9	0	37.96	-	-	-	-	68.2	-30.24	26	182	V
* 4.972	36.92	PK-U	34.2	-29.4	0	41.72	-	-	74	-32.28	-	-	274	244	V
* 4.975	27.46	ADR	34.2	-29.4	.27	32.53	54	-21.47	-	-	-	-	274	244	V
* 8.21	32.78	PK-U	35.7	-24.8	0	43.68	-	-	74	-30.32	-	-	340	282	H
* 8.211	22.62	ADR	35.7	-24.8	.27	33.78	54	-20.21	-	-	-	-	340	282	H
10.506	31.03	PK-U	37.6	-22.7	0	45.93	-	-	-	-	68.2	-22.27	260	287	V

* - indicates frequency in CFR47 Pt 15 / IC RSS-Restricted Band

PK-U - U-NII: Maximum Peak

ADR - U-NII AD primary method, RMS average

MID CHANNEL RESULTS

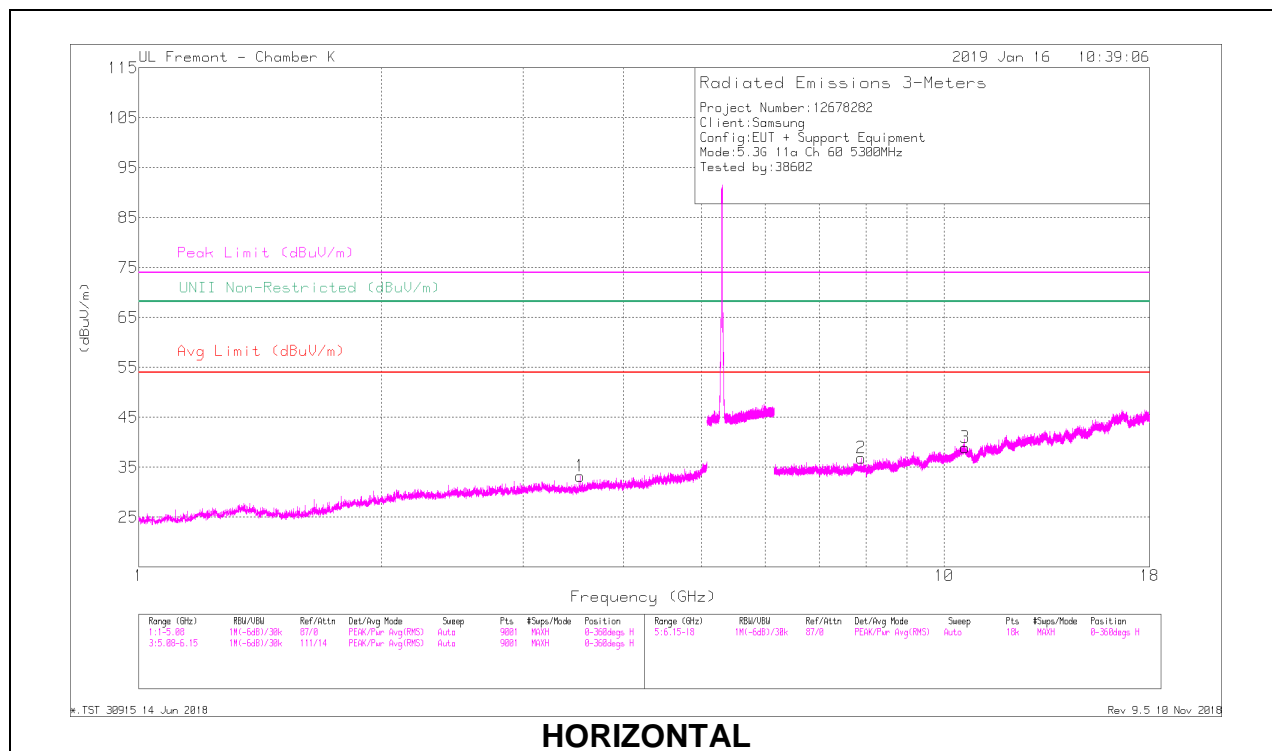

HORIZONTAL

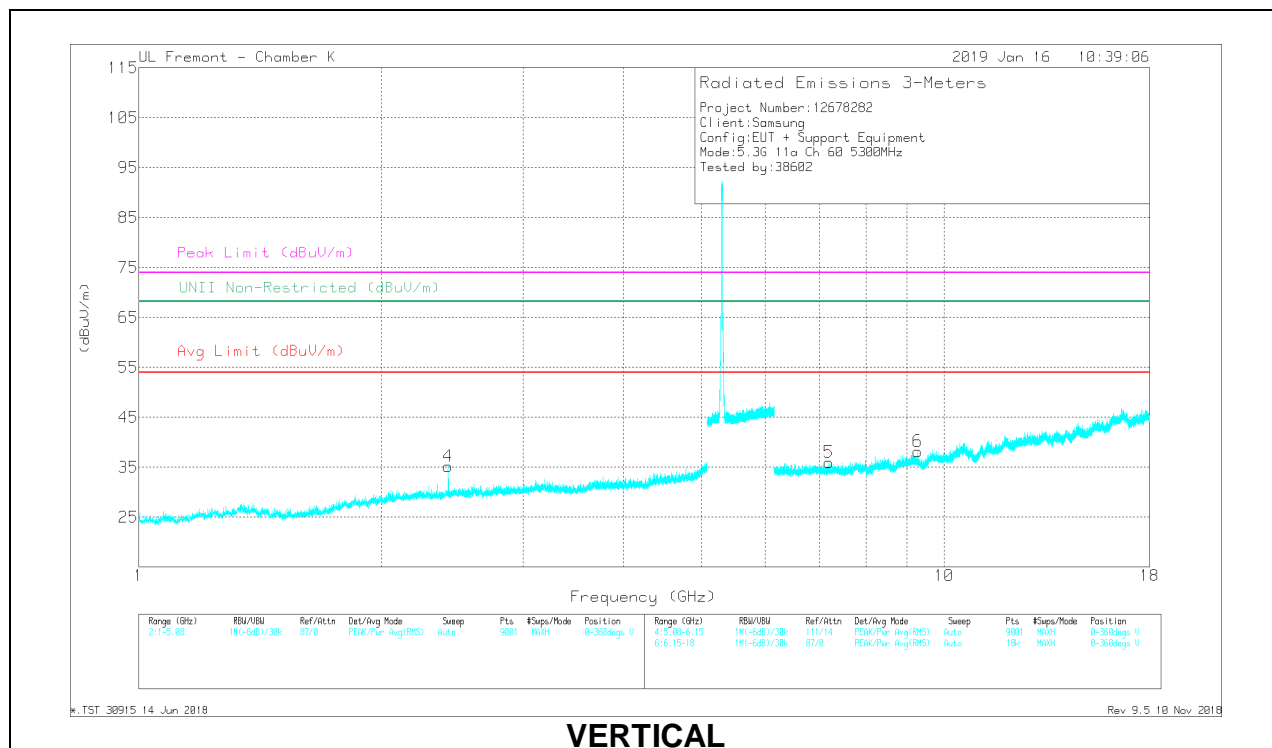

VERTICAL

RADIATED EMISSIONS

Frequency (GHz)	Meter Reading (dBuV)	Det	AF T344 (dBm)	Amp/Cou/Filter/Pad (dB)	DC Corr (dB)	Corrected Reading (dBuV/m)	Avg Limit (dBuV/m)	Margin (dB)	Peak Limit (dBuV/m)	PK Margin (dB)	UNII Non-Restricted (dBuV/m)	PK Margin (dB)	Azimuth (Degs)	Height (cm)	Polarity
* 3.533	39.47	PK-U	32.8	-32.6	0	39.67	-	-	74	-34.33	-	-	66	158	H
* 3.533	29.88	ADR	32.8	-32.6	.27	30.35	54	-23.65	-	-	-	-	66	158	H
2.423	41.23	PK-U	32.1	-34.9	0	33.43	-	-	-	-	68.2	-29.77	65	105	V
* 10.623	30.73	PK-U	37.7	-22.8	0	45.63	-	-	74	-28.37	-	-	0	266	H
* 10.621	20.77	ADR	37.7	-22.8	.27	35.94	54	-18.06	-	-	-	-	0	266	H
7.892	32.62	PK-U	35.8	-26.1	0	42.32	-	-	-	-	68.2	-25.88	228	316	H
7.196	33.29	PK-U	35.5	-26.8	0	41.99	-	-	-	-	68.2	-26.21	8	167	V
9.282	30.55	PK-U	36.4	-23.5	0	43.45	-	-	-	-	68.2	-24.75	299	133	V

* - indicates frequency in CFR47 Pt 15 / IC RSS-Restricted Band

PK-U - U-NII: Maximum Peak

ADR - U-NII AD primary method, RMS average

HIGH CHANNEL RESULTS

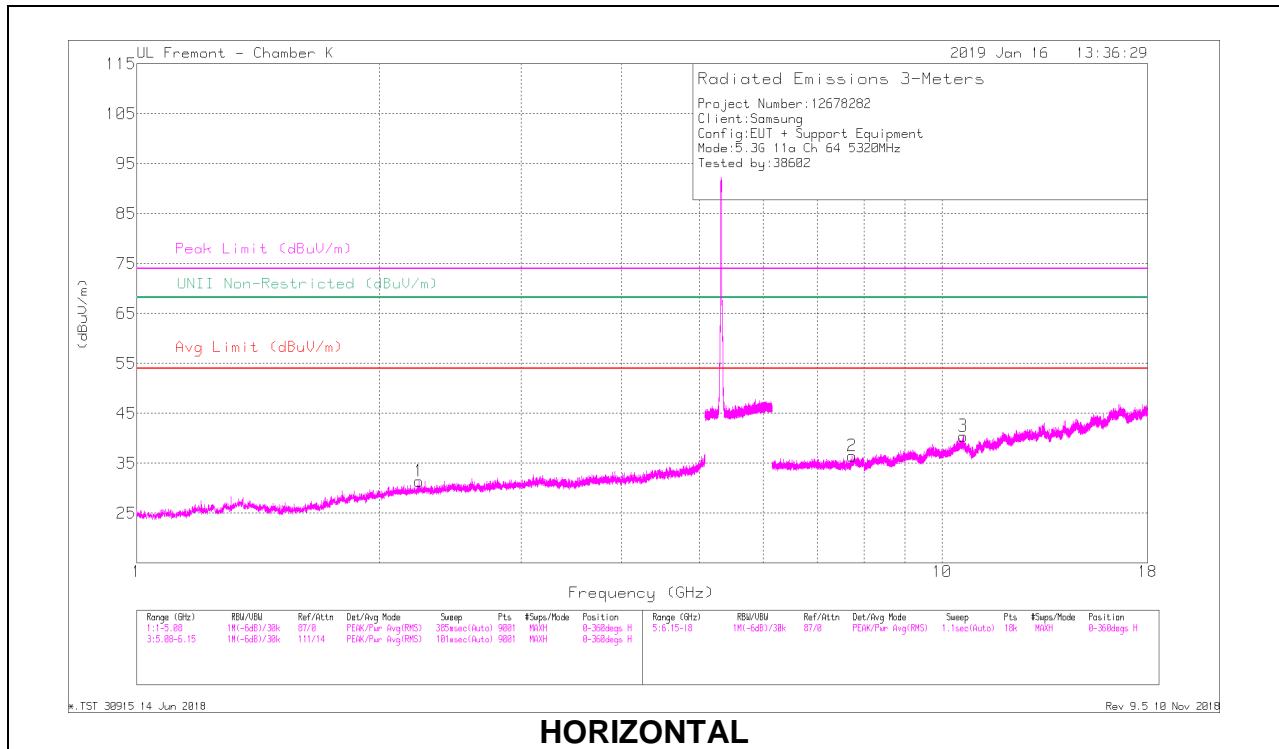

HORIZONTAL

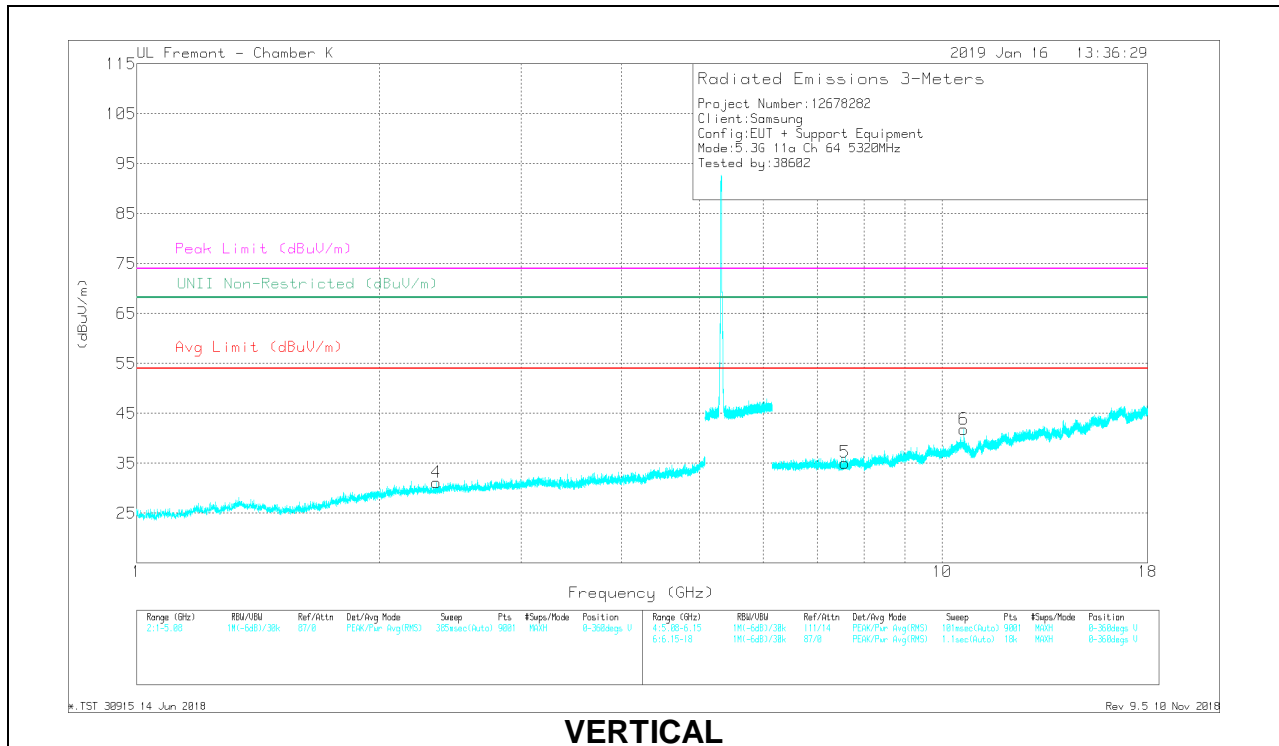

VERTICAL

RADIATED EMISSIONS

Frequency (GHz)	Meter Reading (dBuV)	Det	AF T344 (dBm)	Amp/Co/Filter/Pad (dB)	DC Corr (dB)	Corrected Reading (dBuV/m)	Avg Limit (dBuV/m)	Margin (dB)	Peak Limit (dBuV/m)	PK Margin (dB)	UNII Non-Restricted (dBuV/m)	PK Margin (dB)	Azimuth (Degs)	Height (cm)	Polarity
* 2.242	41.26	PK-U	31.9	-35.1	0	38.06	-	-	74	-35.94	-	-	120	400	H
* 2.24	31.38	ADR	31.9	-35.1	.27	28.45	54	-25.55	-	-	-	-	120	400	H
* 2.354	39.99	PK-U	31.7	-35.1	0	35.59	-	-	74	-37.41	-	-	0	232	V
* 2.354	31.26	ADR	31.7	-35.1	.27	28.13	54	-25.87	-	-	-	-	0	232	V
* 7.732	32.44	PK-U	35.7	-25.6	0	42.54	-	-	74	-31.46	-	-	78	192	H
* 7.732	23.76	ADR	35.7	-25.6	.27	34.13	54	-19.87	-	-	-	-	78	192	H
* 10.615	31.39	PK-U	37.7	-22.7	0	46.39	-	-	74	-27.61	-	-	321	189	H
* 10.616	22.15	ADR	37.7	-22.7	.27	37.42	54	-16.58	-	-	-	-	321	189	H
* 7.569	34.32	PK-U	35.6	-26.5	0	43.42	-	-	74	-30.58	-	-	355	393	V
* 7.569	23.46	ADR	35.6	-26.5	.27	32.83	54	-21.17	-	-	-	-	355	393	V
* 10.64	33.92	PK-U	37.8	-22.8	0	48.92	-	-	74	-25.08	-	-	217	103	V
* 10.64	24.85	ADR	37.8	-22.8	.27	40.12	54	-13.88	-	-	-	-	217	103	V

* - indicates frequency in CFR47 Pt 15 / IC RSS-Restricted Band
 PK-U - U-NII: Maximum Peak
 ADR - U-NII AD primary method, RMS average

10.1.6. TX ABOVE 1 GHz 802.11n HT20 MODE IN THE 5.3 GHz BAND

1TX Antenna 1 MODE

BANDEDGE (HIGH CHANNEL)

HORIZONTAL RESULT

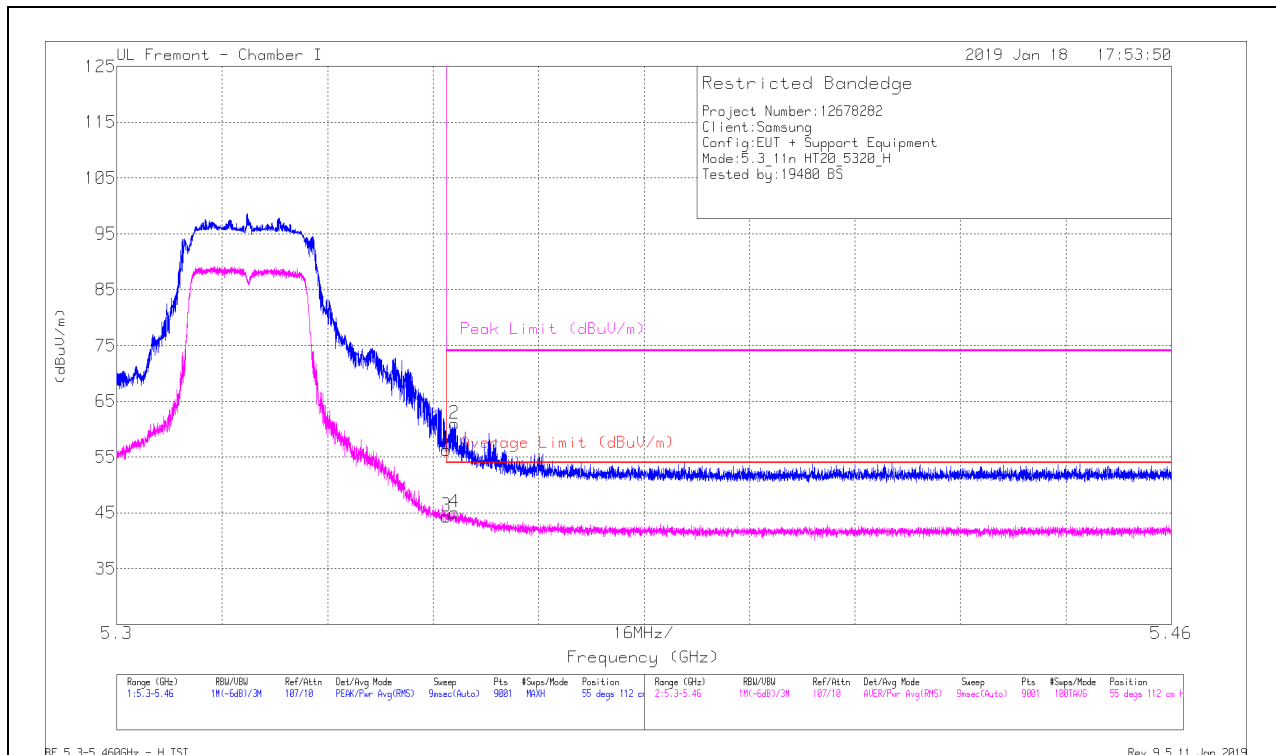

Marker	Frequency (GHz)	Meter Reading (dBuV)	Det	AF T882 (dB/m)	Amp/CDI/Filt/Fa d (dB)	DC Corr (dB)	Corrected Reading (dBuV/m)	Average Limit (dBuV/m)	Margin (dB)	Peak Limit (dBuV/m)	PK Margin (dB)	Azimuth (Degs)	Height (cm)	Polarity
1	*5.35	40.11	Pk	34.5	-18.3	0	56.31	-	-	74	-17.69	55	112	H
2	*5.351	44.72	Pk	34.5	-18.3	0	60.92	-	-	74	-13.06	55	112	H
3	*5.35	27.91	RMS	34.5	-18.3	28	44.39	54	-9.61	-	-	55	112	H
4	*5.351	28.64	RMS	34.5	-18.3	28	45.12	54	-8.88	-	-	55	112	H

* - indicates frequency in CFR47 Pt 15 / IC RSS-Restricted Band

Pk - Peak detector

RMS - RMS detection

VERTICAL RESULT

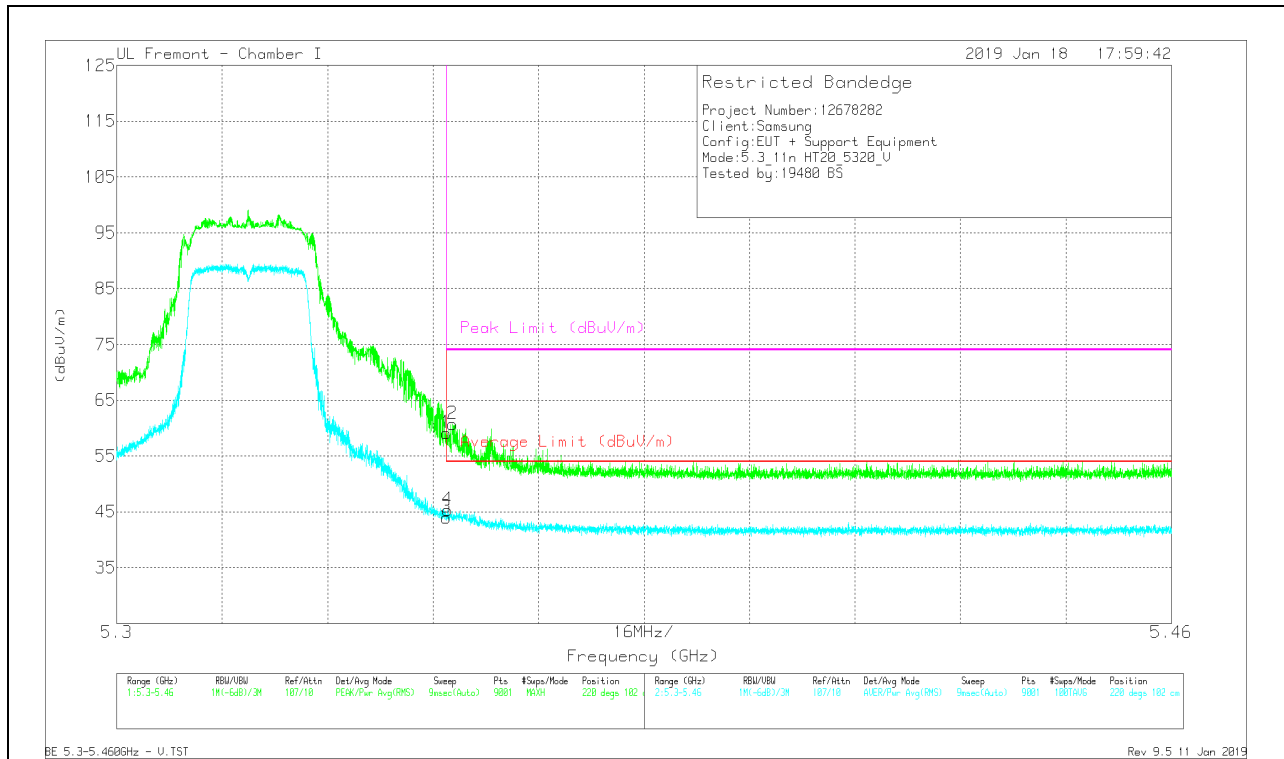

Marker	Frequency (GHz)	Meter Reading (dBuV)	Det	AF T862 (dB/m)	Amp/Cal/Filt/Pa d (dB)	DC Corr (dB)	Corrected Reading (dBuV/m)	Average Limit (dBuV/m)	Margin (dB)	Peak Limit (dBuV/m)	PK Margin (dB)	Azimuth (Degs)	Height (cm)	Polarity
1	* 5.35	42.91	Pk	34.5	-18.3	0	59.11	-	-	74	-14.89	220	102	V
2	* 5.351	44.54	Pk	34.5	-18.3	0	60.74	-	-	74	-13.26	220	102	V
3	* 5.35	27.53	RMS	34.5	-18.3	28	44.01	54	-9.99	-	-	220	102	V
4	* 5.35	28.87	RMS	34.5	-18.3	28	45.35	54	-8.65	-	-	220	102	V

* - indicates frequency in CFR47 Pt 15 / IC RSS-Restricted Band
 Pk - Peak detector
 RMS - RMS detection

HARMONICS AND SPURIOUS EMISSIONS

LOW CHANNEL RESULTS

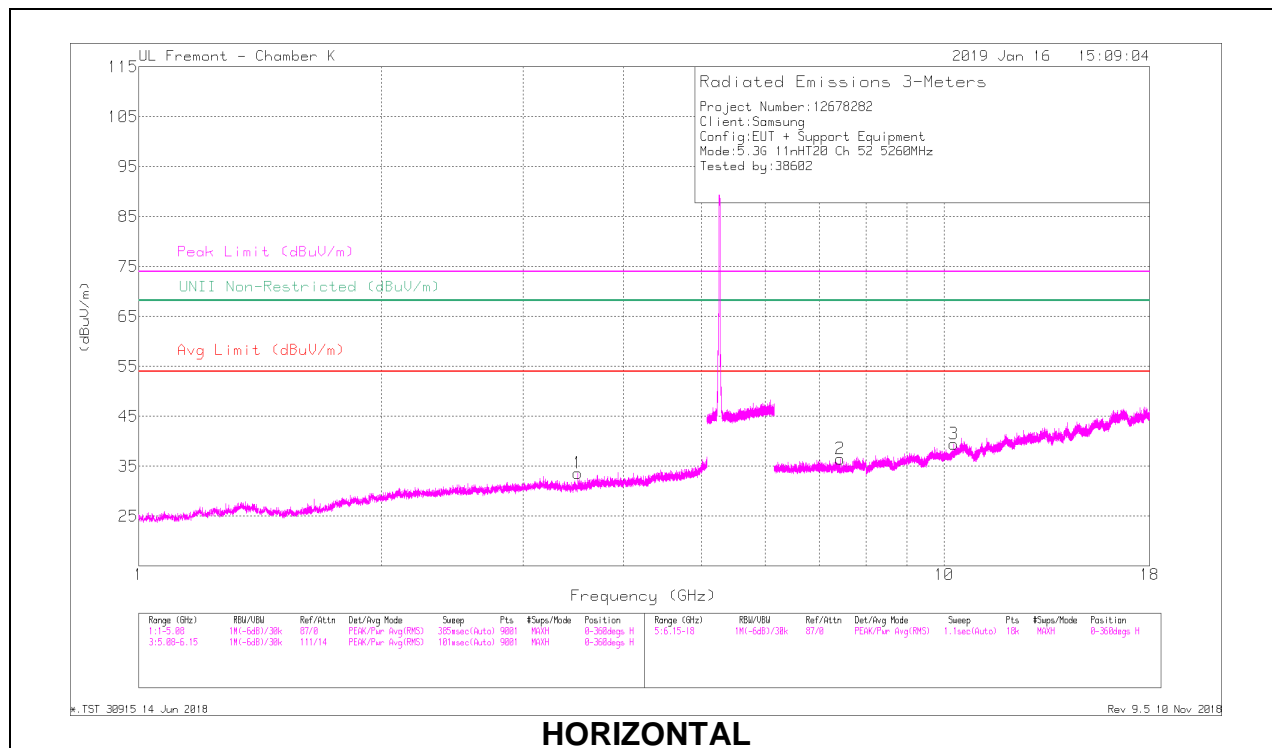

HORIZONTAL

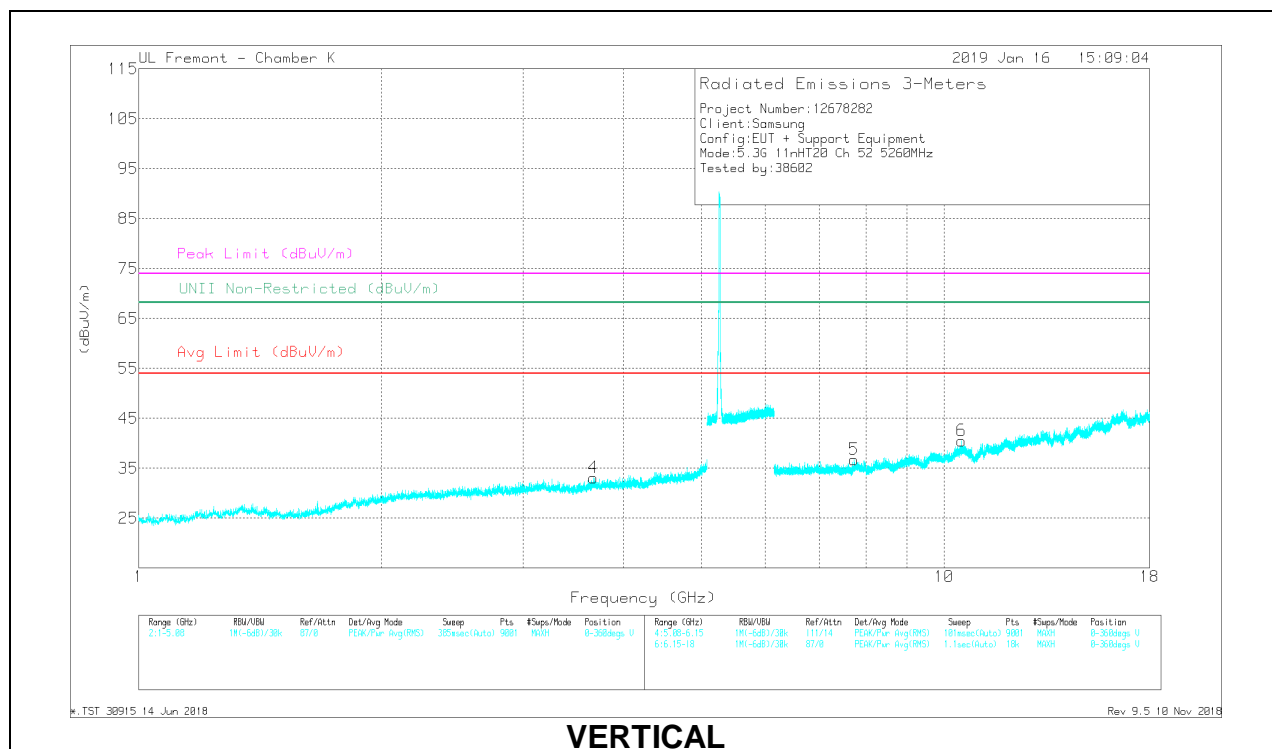

VERTICAL

RADIATED EMISSIONS

Frequency (GHz)	Measr Reading (dBuV)	Det	AF T344 (dBm)	AmpCoef/FilterPad (dB)	DC Corr (dB)	Corrected Reading (dBuV/m)	Avg Limit (dBuV/m)	Margin (dB)	Peak Limit (dBuV/m)	PK Margin (dB)	UNII Non-Restricted (dBuV/m)	PK Margin (dB)	Azimuth (Degs)	Height (cm)	Polarity
* 3.507	39.66	PK-U	32.7	-32.8	0	39.56	-	-	74	-34.44	-	-	66	130	H
* 3.507	31.12	ADR	32.7	-32.8	.28	31.3	54	-22.7	-	-	-	-	66	130	H
* 3.666	38.57	PK-U	33	-32.3	0	39.27	-	-	74	-34.73	-	-	123	281	V
* 3.665	29.11	ADR	33	-32.3	.28	30.09	54	-23.91	-	-	-	-	123	281	V
* 7.429	33.64	PK-U	35.5	-26.6	0	42.54	-	-	74	-31.46	-	-	244	299	H
* 7.43	23.7	ADR	35.5	-26.6	.28	32.88	54	-21.12	-	-	-	-	244	299	H
10.291	31.22	PK-U	37.3	-23.5	0	45.02	-	-	-	-	68.2	-23.18	235	317	H
* 7.737	33.07	PK-U	35.7	-25.6	0	43.17	-	-	74	-30.83	-	-	131	180	V
* 7.734	23.45	ADR	35.7	-25.6	.28	33.83	54	-20.17	-	-	-	-	131	180	V
10.52	31.07	PK-U	37.6	-22.5	0	46.17	-	-	-	-	68.2	-22.03	151	187	V

* - indicates frequency in CFR47 Pt 15 / IC RSS-Restricted Band

PK-U - U-NII: Maximum Peak

ADR - U-NII AD primary method, RMS average

MID CHANNEL RESULTS

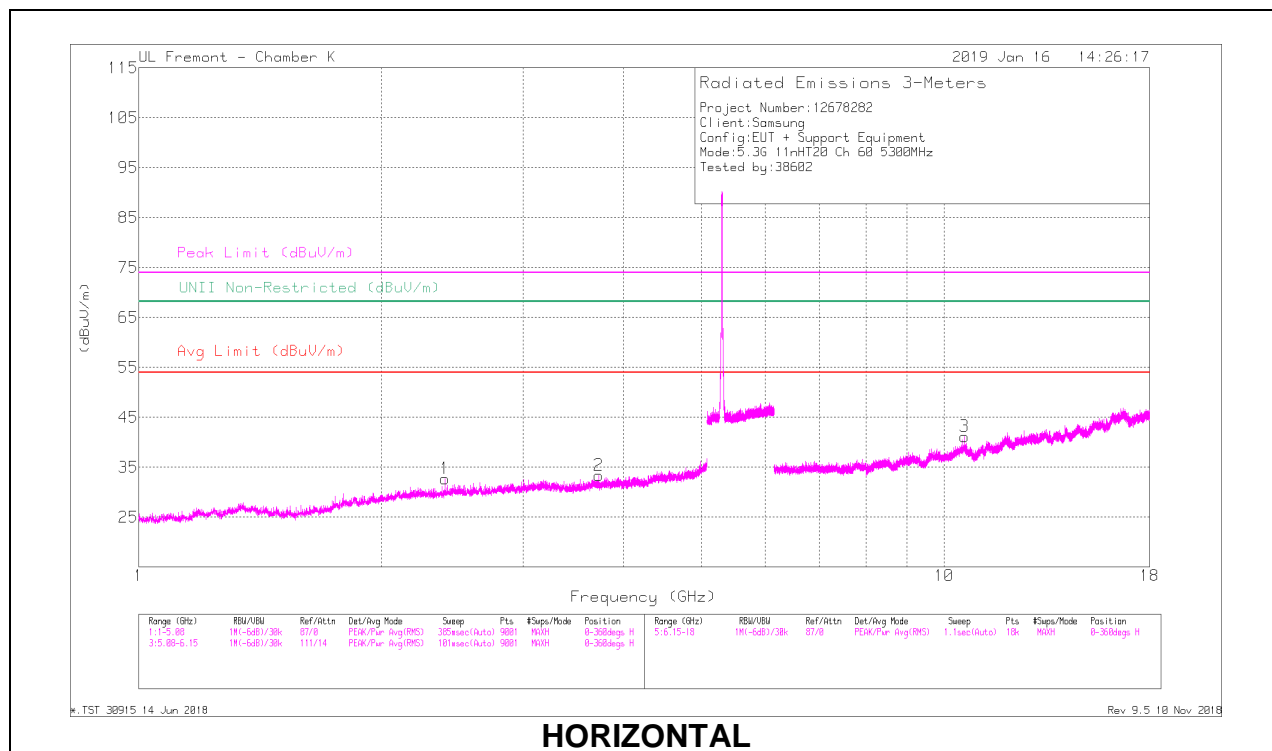

HORIZONTAL

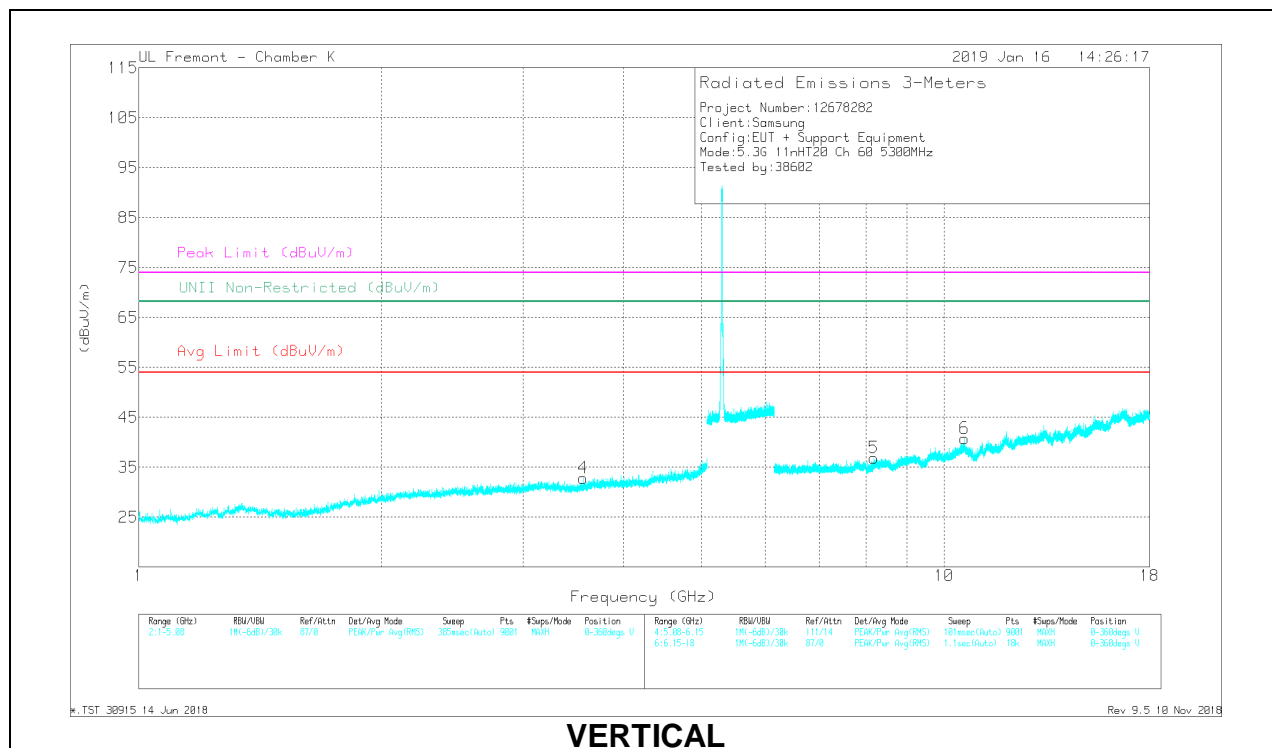

VERTICAL

RADIATED EMISSIONS

Frequency (GHz)	Measr Reading (dBuV)	Det	AF T344 (dBm)	Amp/Co/Filt/Pad (dB)	DC Corr (dB)	Corrected Reading (dBuV/m)	Avg Limit (dBuV/m)	Margin (dB)	Peak Limit (dBuV/m)	PK Margin (dB)	UNII Non-Restricted (dBuV/m)	PK Margin (dB)	Azimuth (Degs)	Height (cm)	Polarity
2.402	40.44	PK-U	32	-35	0	37.44	-	-	-	-	68.2	-30.76	160	242	H
* 3.726	38.15	PK-U	33.3	-32	0	39.45	-	-	74	-34.55	-	-	262	170	H
* 3.722	28.9	ADR	33.2	-32	.28	30.37	54	-23.63	-	-	-	-	262	170	H
* 3.562	38.83	PK-U	32.9	-32.4	0	39.33	-	-	74	-34.67	-	-	328	136	V
* 3.562	28.46	ADR	32.9	-32.4	.28	29.23	54	-24.77	-	-	-	-	328	136	V
* 11.699	32.68	PK-U	38.2	-20.8	0	50.08	-	-	74	-23.92	-	-	139	225	H
* 11.834	20.45	ADR	38.4	-20.9	.28	38.22	54	-15.78	-	-	-	-	139	225	H
* 8.183	32.79	PK-U	35.7	-25	0	43.49	-	-	74	-30.51	-	-	24	131	V
* 8.184	23.15	ADR	35.7	-25	.28	34.12	54	-19.88	-	-	-	-	24	131	V
* 11.81	31.27	PK-U	38.4	-20.9	0	48.87	-	-	74	-25.13	-	-	288	241	V
* 11.83	20.7	ADR	38.4	-20.9	.28	38.47	54	-15.53	-	-	-	-	288	241	V

* - indicates frequency in CFR47 Pt 15 / IC RSS-Restricted Band

PK-U - U-NII: Maximum Peak

ADR - U-NII AD primary method, RMS average

HIGH CHANNEL RESULTS

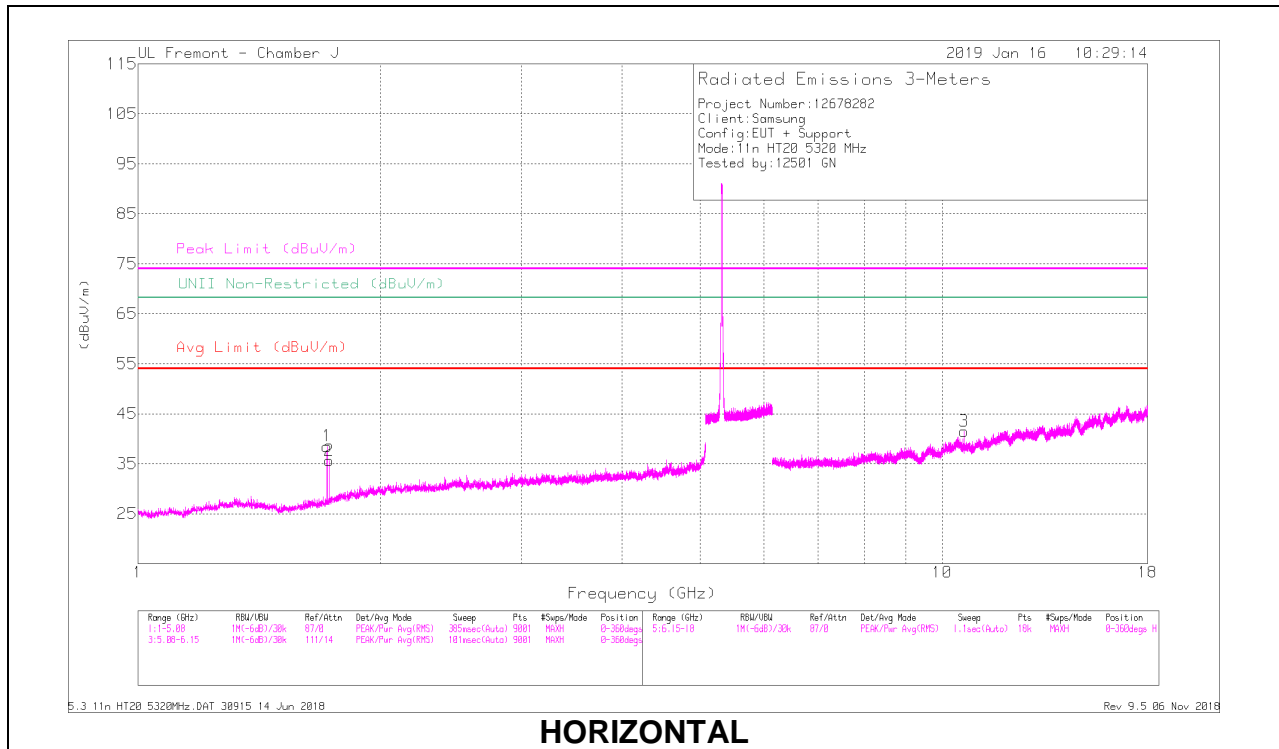

HORIZONTAL

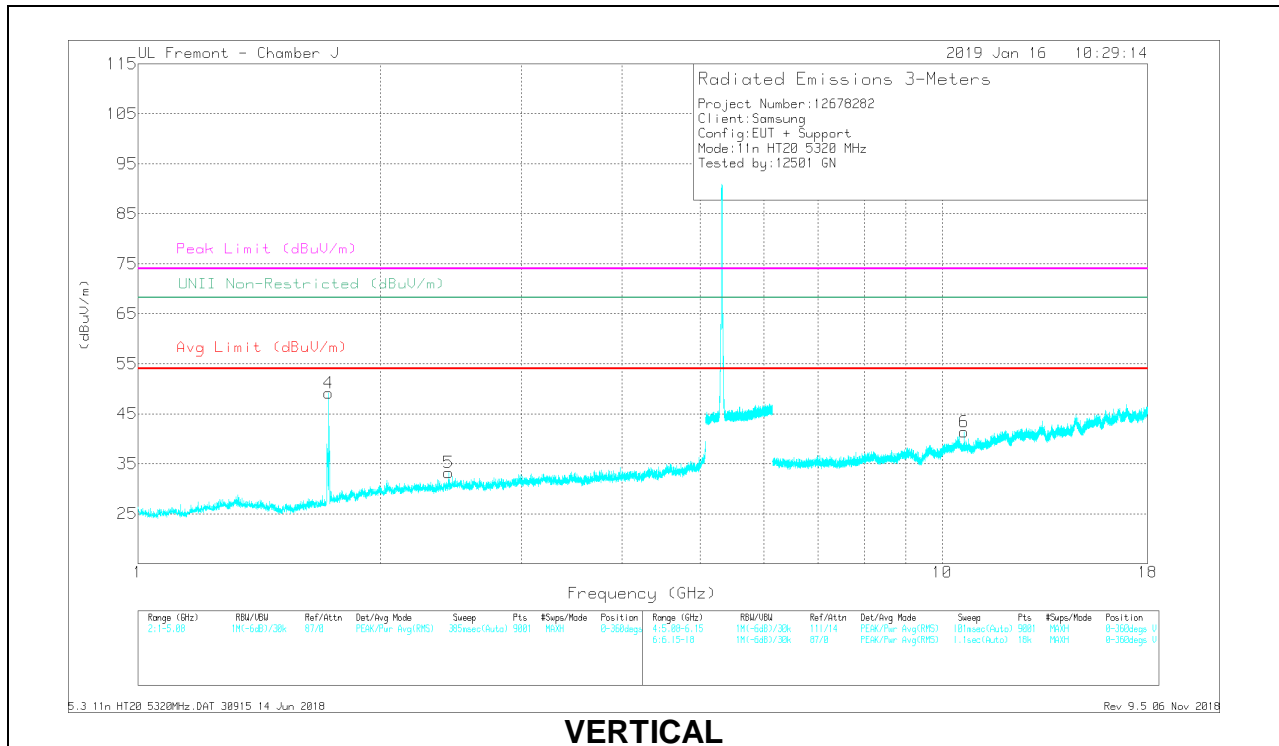

VERTICAL

RADIATED EMISSIONS

Frequency (GHz)	Measr Reading (dBuV)	Det	AF AT0067 (dBm)	AmpCoef/PwrPad (dB)	DC Corr (dB)	Corrected Reading (dBuV/m)	Avg Limit (dBuV/m)	Margin (dB)	Peak Limit (dBuV/m)	PK Margin (dB)	UNII Non-Restricted (dBuV/m)	PK Margin (dB)	Azimuth (Degs)	Height (cm)	Polarity
1.718	41.18	PK-U	29.3	-35.8	0	34.68	-	-	-	-	68.2	-33.52	296	396	H
1.718	32.47	ADR	29.3	-35.8	.28	26.22	-	-	-	-	-	-	296	396	H
1.729	45.05	PK-U	29.5	-35.8	0	38.75	-	-	-	-	68.2	-29.45	154	229	H
1.73	32.29	ADR	29.5	-35.8	.28	26.24	-	-	-	-	-	-	154	229	H
1.727	42.81	PK-U	29.5	-35.7	0	36.61	-	-	-	-	68.2	-31.59	199	115	V
1.726	32.06	ADR	29.5	-35.7	.28	26.11	-	-	-	-	-	-	199	115	V
2.434	40.48	PK-U	32.3	-35.5	0	37.28	-	-	-	-	68.2	-30.92	199	104	V
2.432	32.11	ADR	32.3	-35.5	.28	29.16	-	-	-	-	-	-	199	104	V
* 10.64	35.73	PK-U	37.6	-25	0	48.33	-	-	74	-25.67	-	-	112	129	H
* 10.64	27.36	ADR	37.6	-25	.28	40.21	54	-13.79	-	-	-	-	112	129	H
* 10.64	34.01	PK-U	37.6	-25	0	46.61	-	-	74	-27.39	-	-	199	124	V
* 10.64	26.81	ADR	37.6	-25	.28	39.66	54	-14.34	-	-	-	-	199	124	V

* - indicates frequency in CFR47 Pt 15 / IC RSS-Restricted Band
 PK-U - U-NII: Maximum Peak
 ADR - U-NII AD primary method, RMS average

10.1.7. TX ABOVE 1 GHz 802.11n HT40 MODE IN THE 5.3 GHz BAND

1TX Antenna 1 MODE

BANDEDGE (HIGH CHANNEL)

HORIZONTAL RESULT

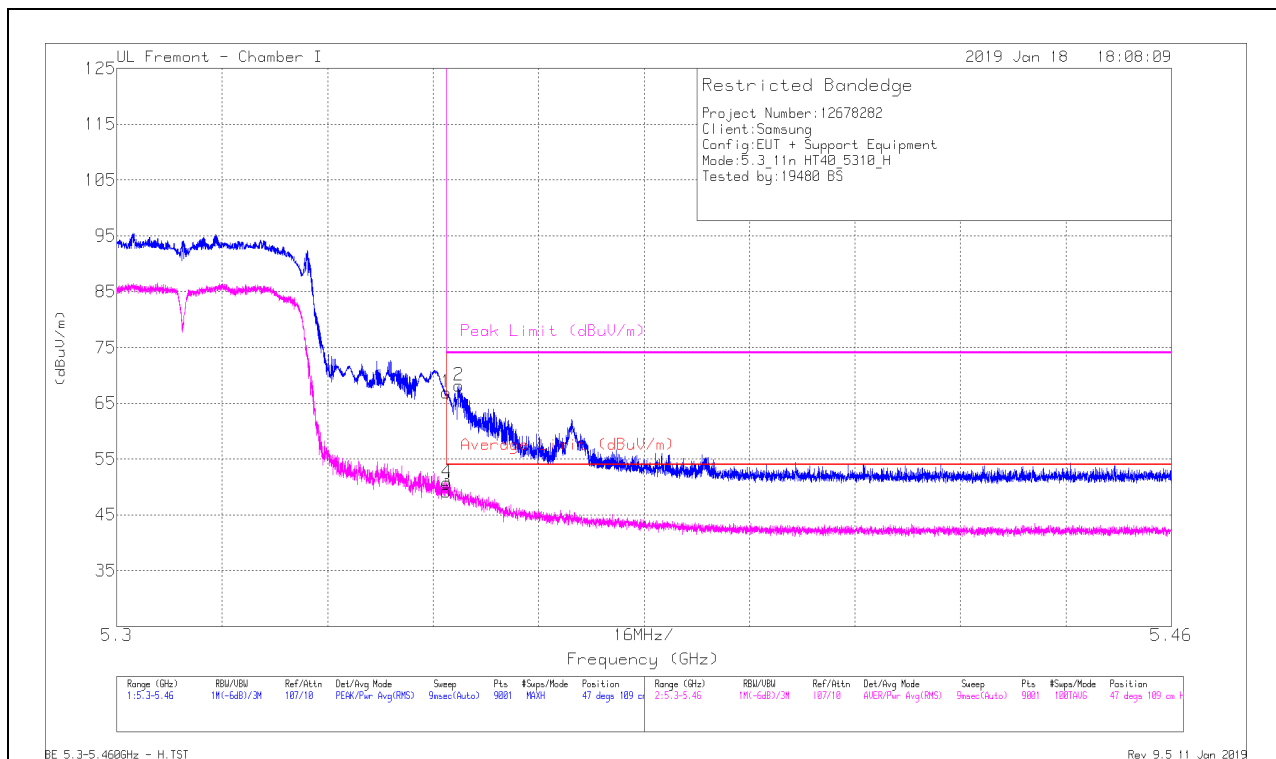

Marker	Frequency (GHz)	Meter Reading (dBuV)	Det	AF T882 (dB/m)	Amp/CDI/Filt/Fa d (dB)	DC Corr (dB)	Corrected Reading (dBuV/m)	Average Limit (dBuV/m)	Margin (dB)	Peak Limit (dBuV/m)	PK Margin (dB)	Azimuth (Degs)	Height (cm)	Polarity
1	*5.35	50.68	Pk	34.5	-18.3	0	66.88	-	-	74	-7.12	47	109	H
2	*5.362	51.98	Pk	34.5	-18.3	0	68.18	-	-	74	-5.82	47	109	H
3	*5.35	32.33	RMS	34.5	-18.3	71	49.24	54	-4.76	-	-	47	109	H
4	*5.35	33.84	RMS	34.5	-18.3	71	50.75	54	-3.25	-	-	47	109	H

* - indicates frequency in CFR47 Pt 15 / IC RSS-Restricted Band

Pk - Peak detector

RMS - RMS detection

VERTICAL RESULT

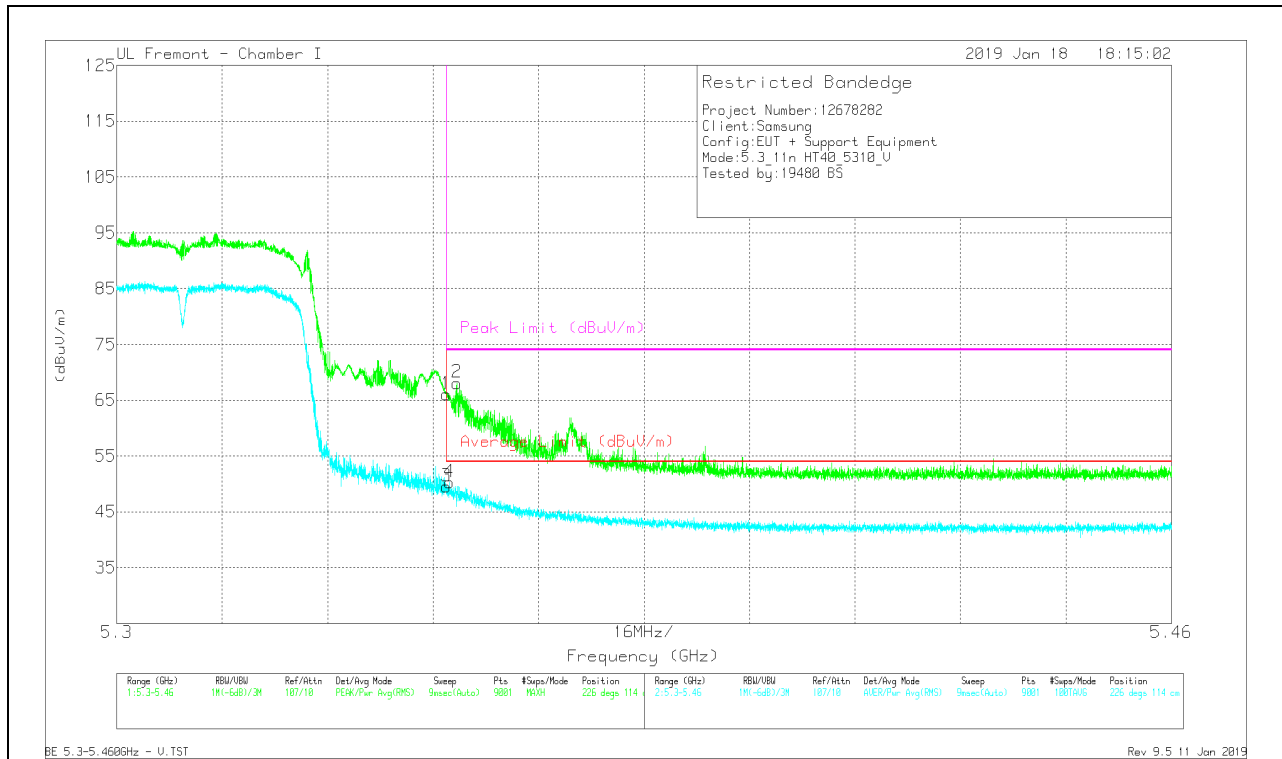

Marker	Frequency (GHz)	Meter Reading (dBuV)	Det	AF T862 (dB/m)	Amp/Cal/Ftr/Pa d (dB)	DC Corr (dB)	Corrected Reading (dBuV/m)	Average Limit (dBuV/m)	Margin (dB)	Peak Limit (dBuV/m)	PK Margin (dB)	Azimuth (Degs)	Height (cm)	Polarity
1	* 5.35	49.84	Pk	34.5	-18.3	0	66.04	-	-	74	-7.96	226	114	V
2	* 5.352	51.91	Pk	34.5	-18.3	0	68.11	-	-	74	-5.89	226	114	V
3	* 5.35	32.6	RMS	34.5	-18.3	.71	49.51	54	-4.49	-	-	226	114	V
4	* 5.35	33.38	RMS	34.5	-18.3	.71	50.29	54	-3.71	-	-	226	114	V

* - indicates frequency in CFR47 Pt 15 / IC RSS-Restricted Band
 Pk - Peak detector
 RMS - RMS detection

HARMONICS AND SPURIOUS EMISSIONS

LOW CHANNEL RESULTS

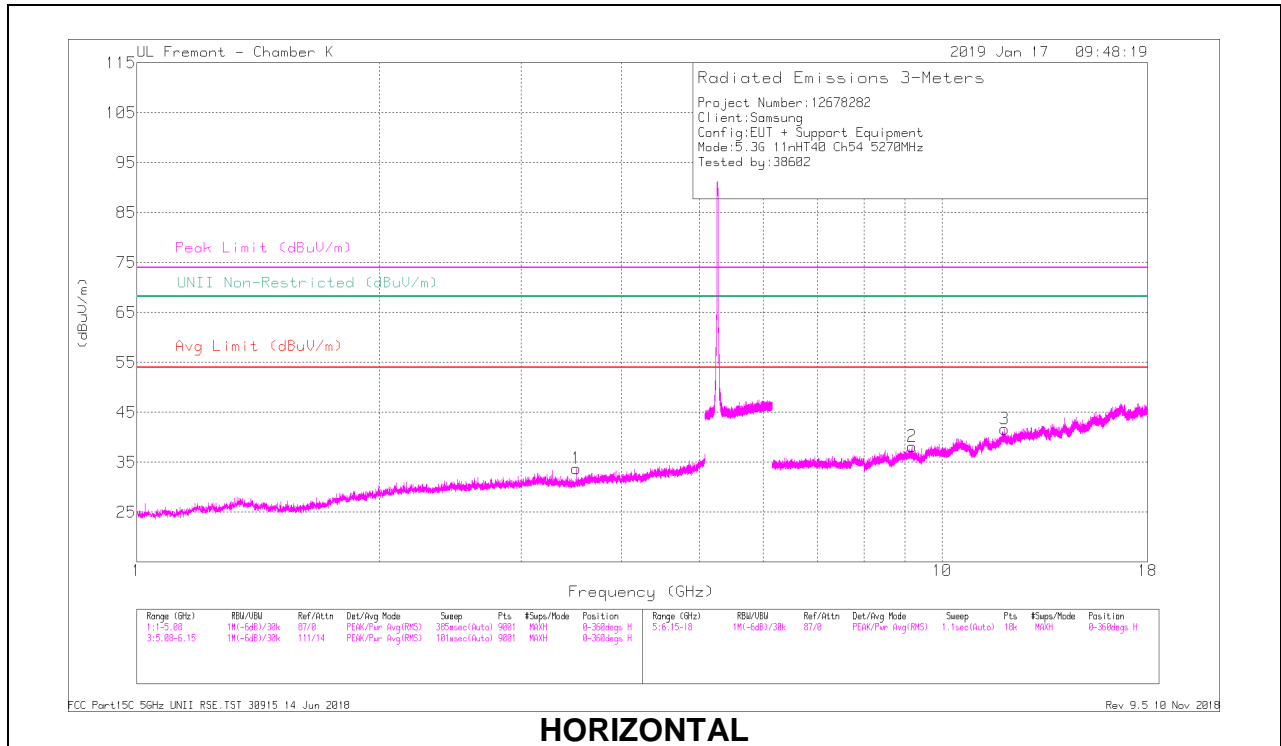

HORIZONTAL

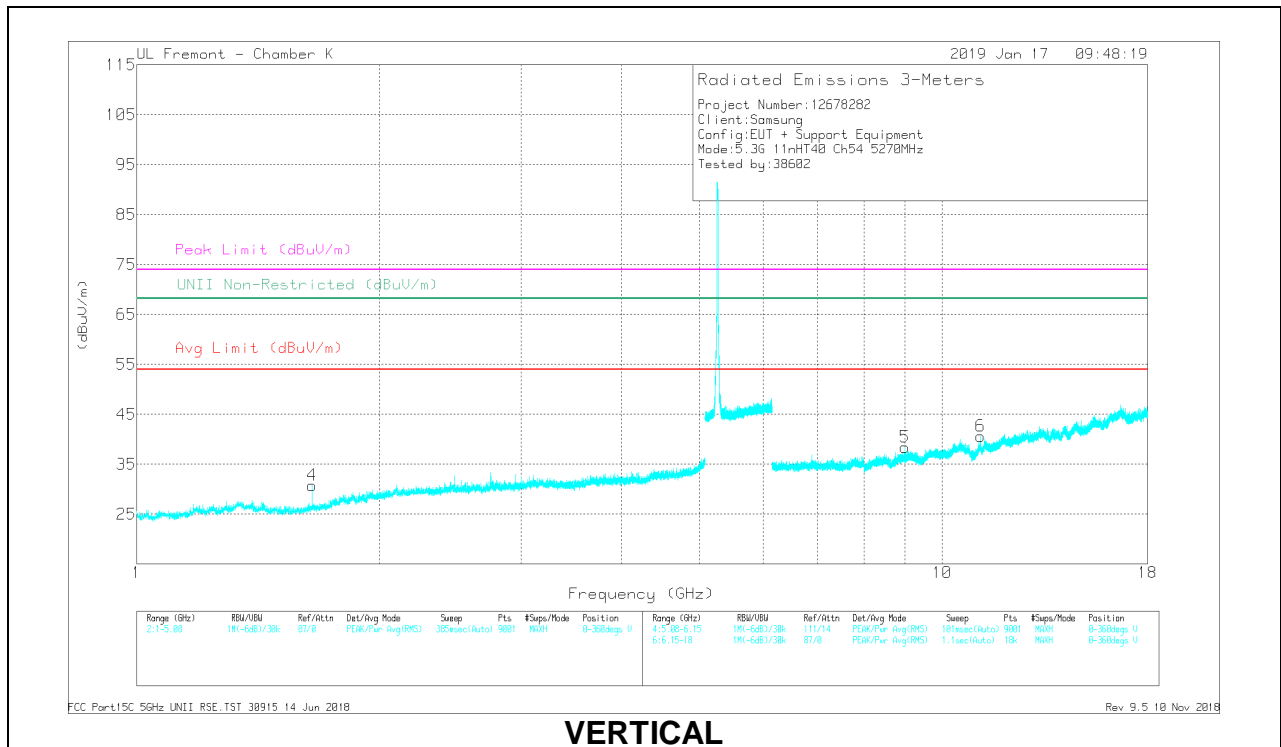

VERTICAL

RADIATED EMISSIONS

Frequency (GHz)	Meas Reading (dBuV)	Det	AF T344 (dBm)	Amp/Co/Filt/Pad (dB)	DC Corr (dB)	Corrected Reading (dBuV/m)	Avg Limit (dBuV/m)	Margin (dB)	Peak Limit (dBuV/m)	PK Margin (dB)	UNII Non-Restricted (dBuV/m)	PK Margin (dB)	Azimuth (Degs)	Height (cm)	Polarity
* 3.513	39.25	PK-U	32.7	-32.7	0	39.25	-	-	74	-34.75	-	-	60	101	H
* 3.513	29.96	ADR	32.7	-32.7	.71	30.67	54	-23.33	-	-	-	-	60	101	H
* 1.651	41.21	PK-U	28.5	-35.2	0	34.51	-	-	-	-	68.2	-33.69	323	157	V
* 9.174	31.67	PK-U	36.2	-23.9	0	43.97	-	-	74	-30.03	-	-	220	135	H
* 9.174	22.06	ADR	36.2	-23.9	.71	35.07	54	-18.93	-	-	-	-	220	135	H
* 11.958	30.16	PK-U	38.5	-20.2	0	48.46	-	-	74	-25.54	-	-	60	226	H
* 11.954	20.13	ADR	38.5	-20.2	.71	39.14	54	-14.86	-	-	-	-	60	226	H
8.987	31.81	PK-U	36	-24	0	43.81	-	-	-	-	68.2	-24.39	31	313	V
* 11.171	30.32	PK-U	37.8	-21.1	0	47.12	-	-	74	-26.88	-	-	158	386	V
* 11.172	20.49	ADR	37.8	-21.1	.71	38	54	-16	-	-	-	-	158	386	V

* - indicates frequency in CFR47 Pt 15 / IC RSS-Restricted Band
 PK-U - U-NII: Maximum Peak
 ADR - U-NII AD primary method, RMS average

HIGH CHANNEL RESULTS

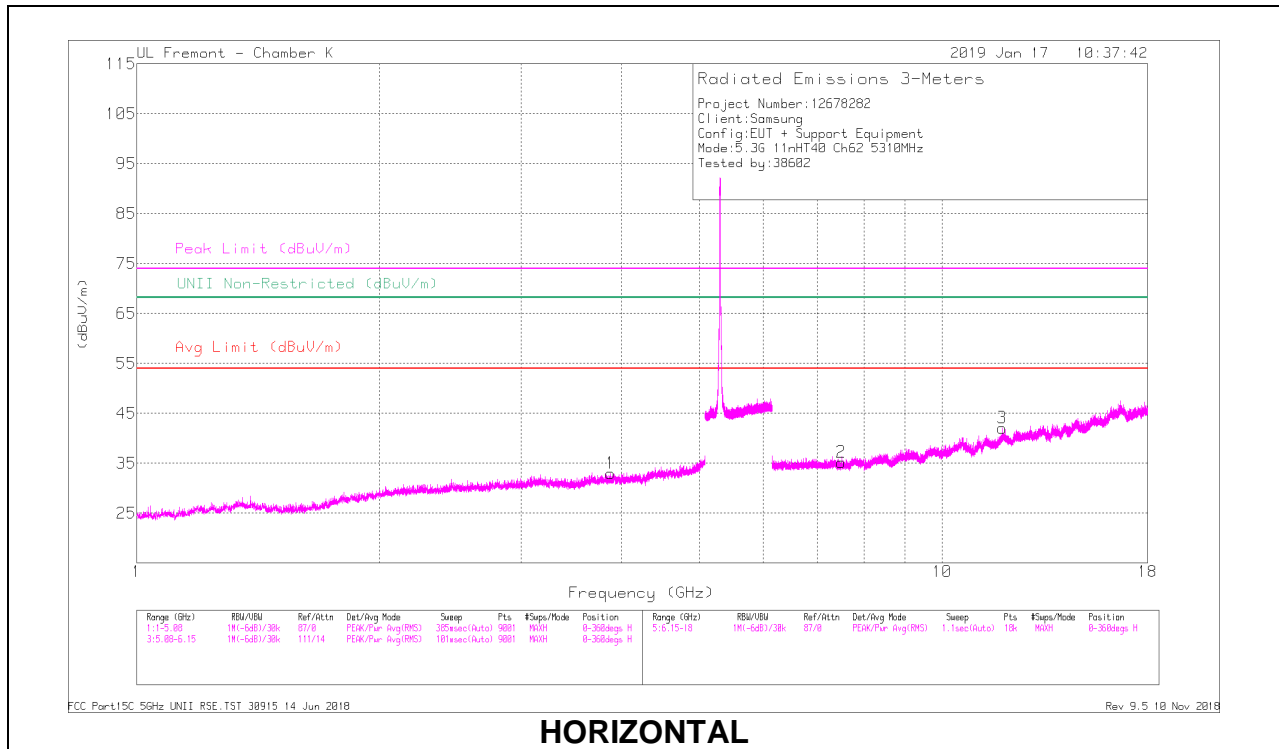

HORIZONTAL

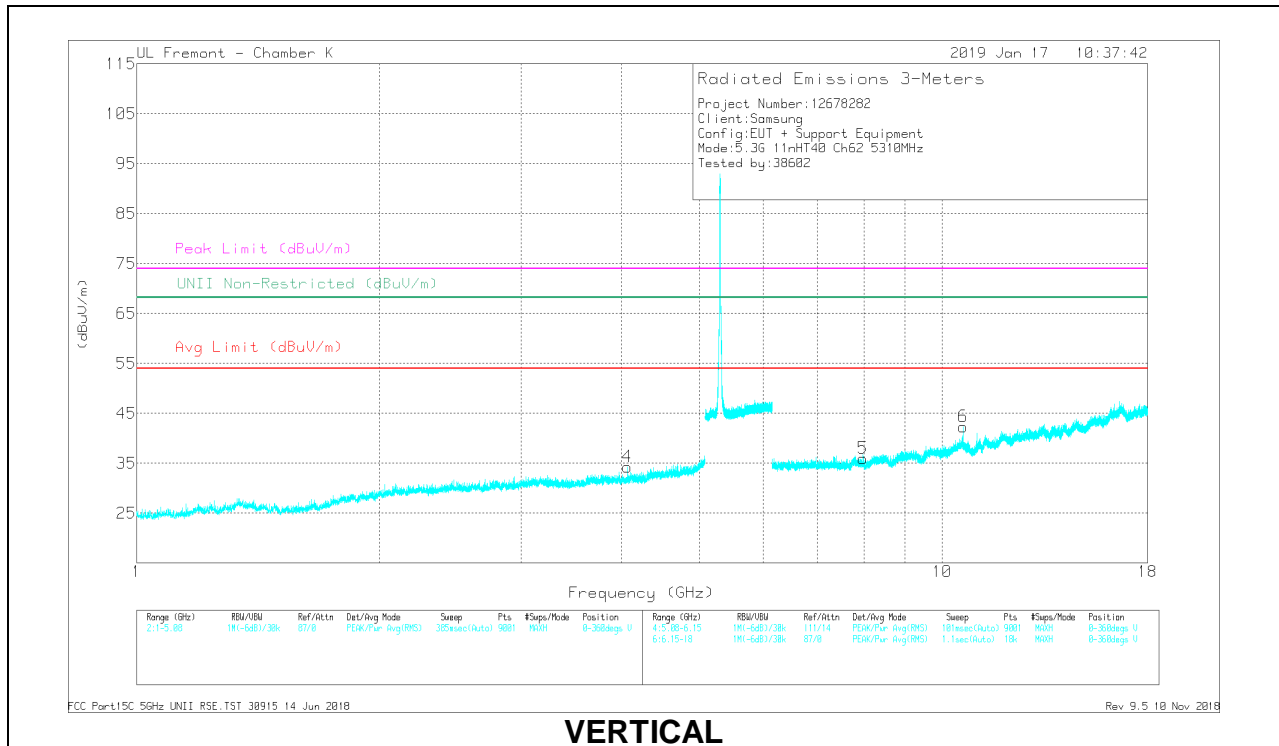

VERTICAL

RADIATED EMISSIONS

Frequency (GHz)	Measr Reading (dBuV)	Det	AF T344 (dBm)	Amp/Co/Filt/Pad (dB)	DC Corr (dB)	Corrected Reading (dBuV/m)	Avg Limit (dBuV/m)	Margin (dB)	Peak Limit (dBuV/m)	PK Margin (dB)	UNII Non-Restricted (dBuV/m)	PK Margin (dB)	Azimuth (Degs)	Height (cm)	Polarity
* 3.877	38.27	PK-U	33.4	-31.8	0	39.87	-	-	74	-34.13	-	-	61	336	H
* 3.874	28.44	ADR	33.4	-31.8	.71	30.75	54	-23.25	-	-	-	-	61	336	H
* 4.066	38	PK-U	33.5	-31.3	0	40.2	-	-	74	-33.8	-	-	84	366	V
* 4.065	27.65	ADR	33.5	-31.3	.71	30.56	54	-23.44	-	-	-	-	84	366	V
* 7.497	33.65	PK-U	35.6	-26.6	0	42.65	-	-	74	-31.35	-	-	133	367	H
* 7.5	23.59	ADR	35.6	-26.6	.71	33.3	54	-20.7	-	-	-	-	133	367	H
* 11.889	30.51	PK-U	38.4	-20.4	0	48.51	-	-	74	-25.49	-	-	274	172	H
* 11.886	21.2	ADR	38.4	-20.5	.71	39.81	54	-14.19	-	-	-	-	274	172	H
* 10.62	33.29	PK-U	37.7	-22.8	0	48.19	-	-	74	-25.81	-	-	243	106	V
* 10.62	25.25	ADR	37.7	-22.8	.71	40.86	54	-13.14	-	-	-	-	243	106	V
7.97	32.76	PK-U	35.7	-26	0	42.46	-	-	-	-	68.2	-25.74	15	333	V

* - indicates frequency in CFR47 Pt 15 / IC RSS-Restricted Band
 PK-U - U-NII: Maximum Peak
 ADR - U-NII AD primary method, RMS average

10.1.8. TX ABOVE 1 GHz 802.11ac VHT80 MODE IN THE 5.3 GHz BAND

1TX Antenna 1 MODE

BANDEDGE (MID CHANNEL)

HORIZONTAL RESULT

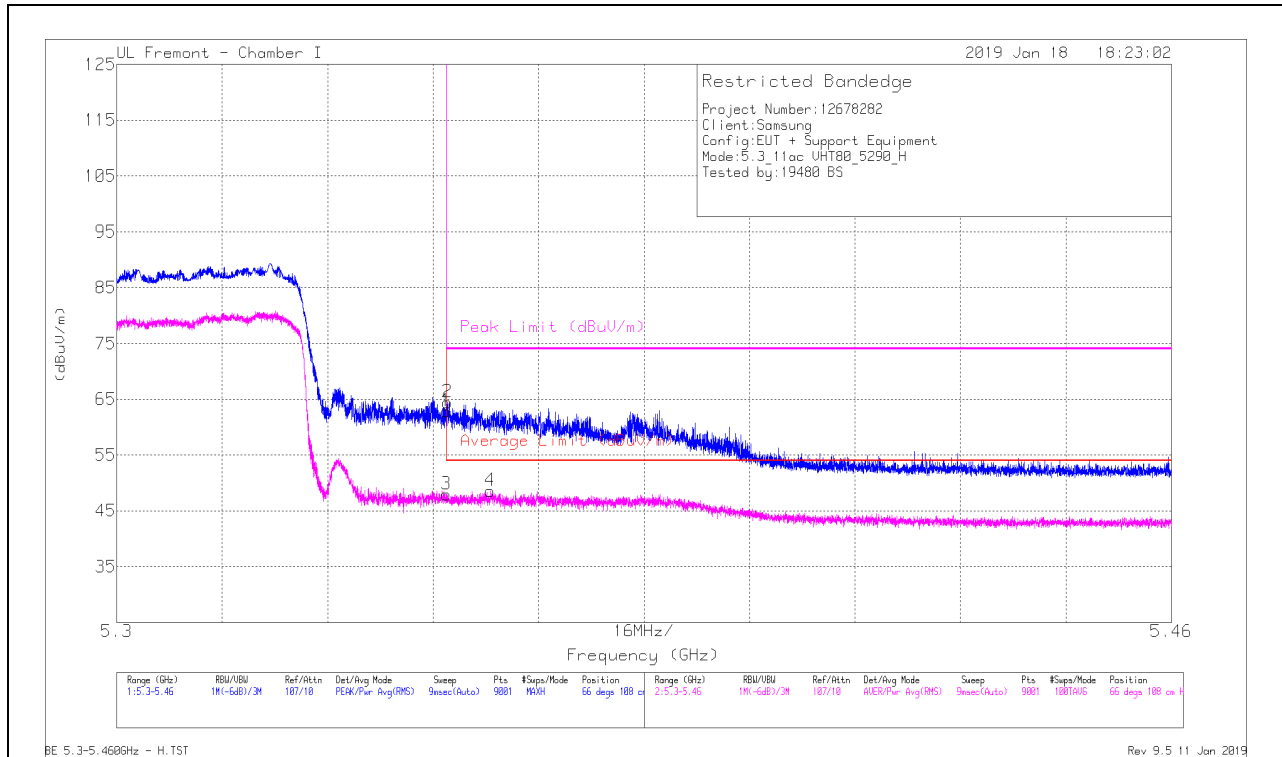

Marker	Frequency (GHz)	Meter Reading (dBuV)	Det	AF T882 (dB/m)	Amp/CD/Filter/Fa d (dB)	DC Corr (dB)	Corrected Reading (dBuV/m)	Average Limit (dBuV/m)	Margin (dB)	Peak Limit (dBuV/m)	PK Margin (dB)	Azimuth (Degs)	Height (cm)	Polarity
1	* 5.35	46.67	Pk	34.5	-18.3	0	62.87	-	-	74	-11.13	66	108	H
2	* 5.35	48.23	Pk	34.5	-18.3	0	64.43	-	-	74	-9.57	66	108	H
3	* 5.35	30.41	RMS	34.5	-18.3	1.29	47.9	54	-6.1	-	-	66	108	H
4	* 5.357	31.1	RMS	34.4	-18.2	1.29	48.59	54	-5.41	-	-	66	108	H

* - indicates frequency in CFR47 Pt 15 / IC RSS-Restricted Band

Pk - Peak detector

RMS - RMS detection

VERTICAL RESULT

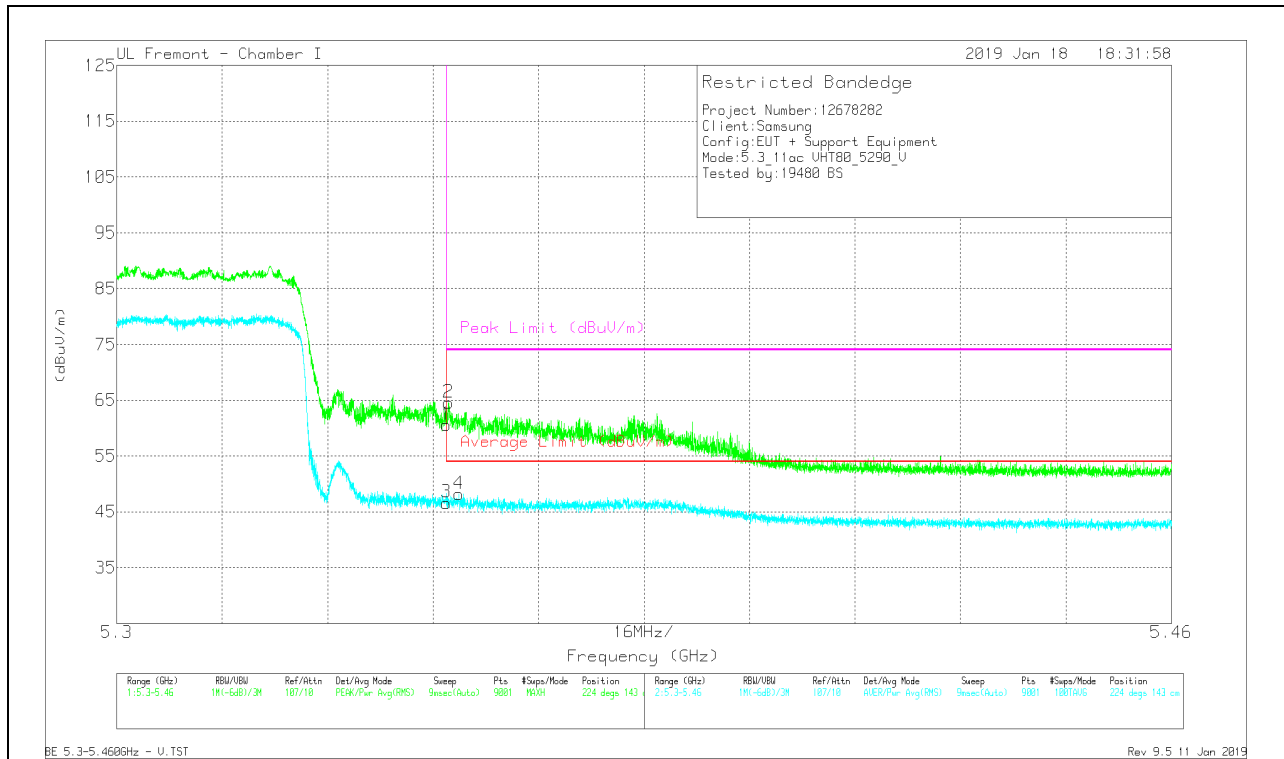

Marker	Frequency (GHz)	Meter Reading (dBuV)	Det	AF T862 (dB/m)	Amp/Cal/Filt/Pa d (dB)	DC Corr (dB)	Corrected Reading (dBuV/m)	Average Limit (dBuV/m)	Margin (dB)	Peak Limit (dBuV/m)	PK Margin (dB)	Azimuth (Degs)	Height (cm)	Polarity
1	* 5.35	44.43	Pk	34.5	-18.3	0	60.63	-	-	74	-13.37	224	143	V
2	* 5.35	48.42	Pk	34.5	-18.3	0	64.62	-	-	74	-9.38	224	143	V
3	* 5.35	29.14	RMS	34.5	-18.3	1.29	46.63	54	-7.37	-	-	224	143	V
4	* 5.352	30.64	RMS	34.5	-18.3	1.29	48.13	54	-5.87	-	-	224	143	V

* - indicates frequency in CFR47 Pt 15 / IC RSS-Restricted Band

Pk - Peak detector

RMS - RMS detection

HARMONICS AND SPURIOUS EMISSIONS

MID CHANNEL RESULTS

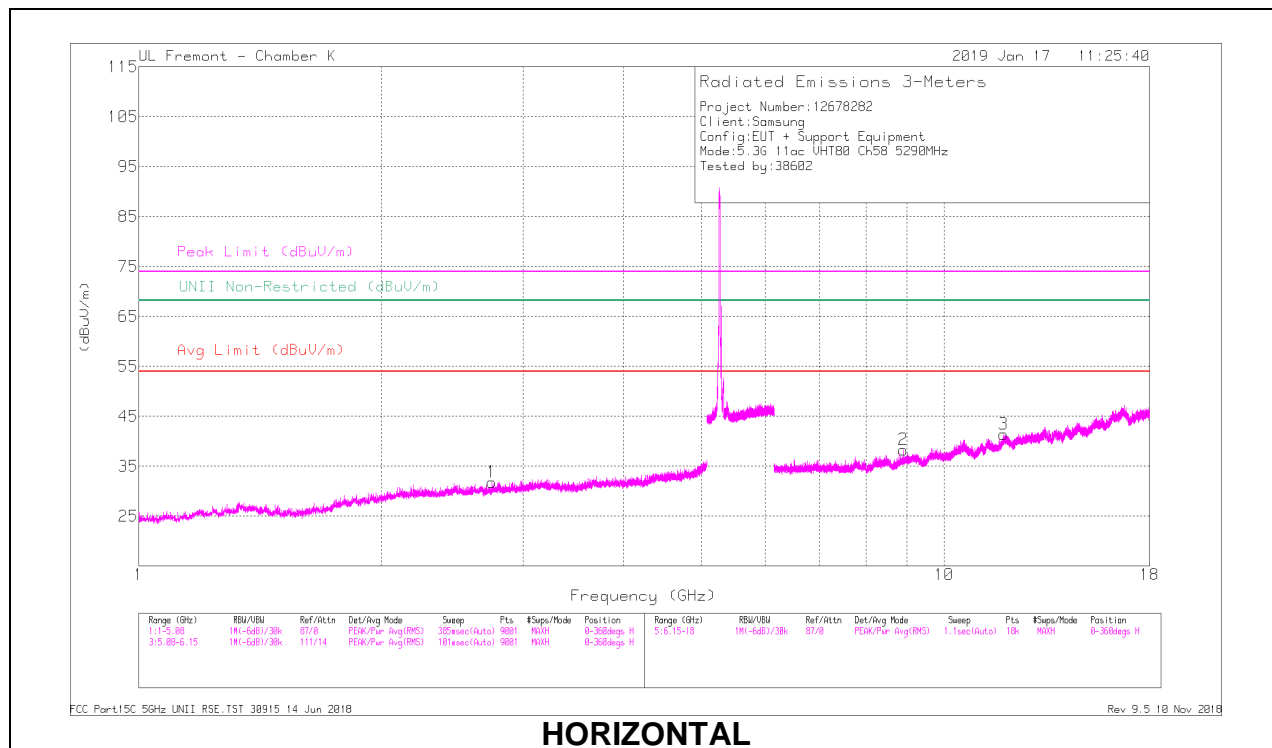

HORIZONTAL

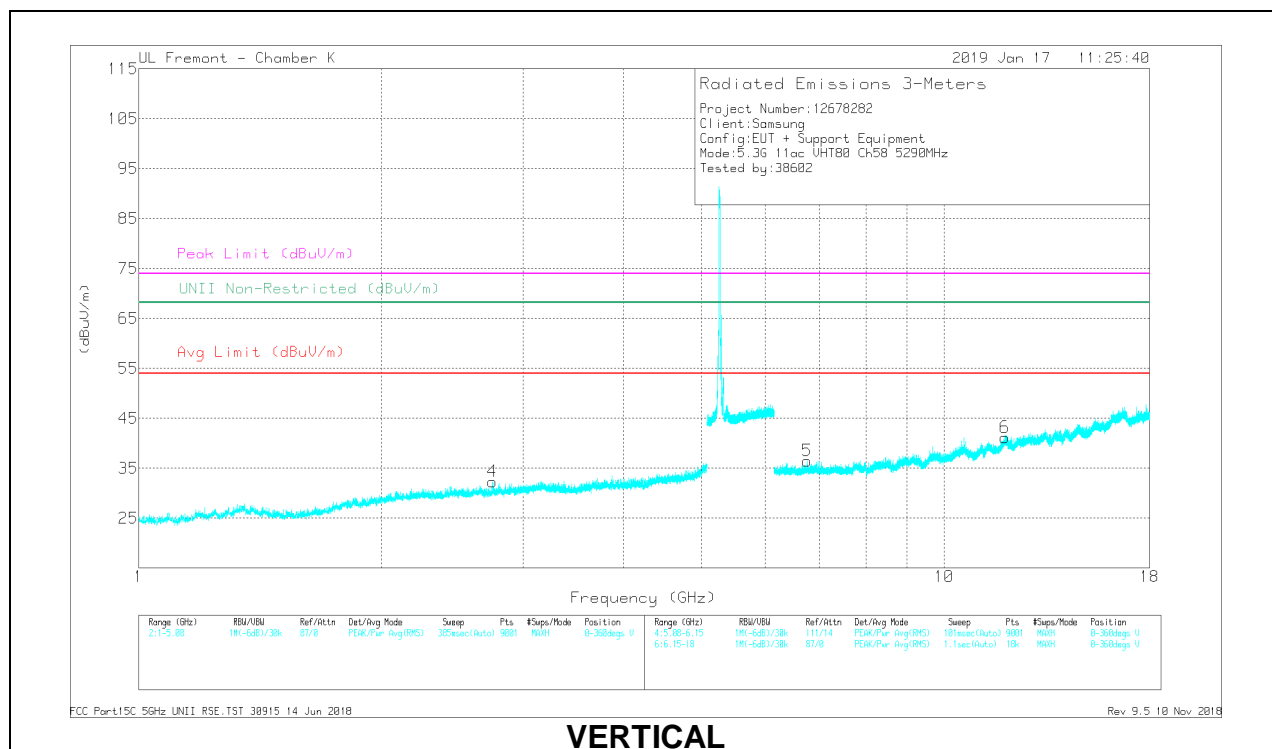

VERTICAL