



# **CERTIFICATION TEST REPORT**

**Report Number. :** 12756699-E7V1

**Applicant :** Samsung Electronics Co., Ltd.  
129 Samsung-Ro, Yeongtong-Gu,  
Suwon-Si, Gyeonggi-Do, 16677, Korea

**Model :** SM-A305N and SM-A305YN

**FCC ID :** A3LSMA305N

**EUT Description :** GSM/WCDMA/LTE Phone with BT, DTS/UNII a/b/g/n/ac and  
NFC

**Test Standard(s) :** FCC 47 CFR PART 15 SUBPART C

**Date Of Issue:**  
March 27, 2019

**Prepared by:**  
UL Verification Services Inc.  
47173 Benicia Street  
Fremont, CA 94538 U.S.A.  
TEL: (510) 771-1000  
FAX: (510) 661-0888



NVLAP Lab code: 200065-0

---

Revision History

<u>Rev.</u>	<u>Issue Date</u>	<u>Revisions</u>	<u>Revised By</u>
V1	3/27/2019	Initial Issue	

## TABLE OF CONTENTS

<b>1. ATTESTATION OF TEST RESULTS .....</b>	<b>4</b>
<b>2. TEST METHODOLOGY .....</b>	<b>5</b>
<b>3. FACILITIES AND ACCREDITATION .....</b>	<b>5</b>
<b>4. CALIBRATION AND UNCERTAINTY .....</b>	<b>6</b>
4.1. <i>MEASURING INSTRUMENT CALIBRATION .....</i>	<i>6</i>
4.2. <i>SAMPLE CALCULATION .....</i>	<i>6</i>
4.3. <i>MEASUREMENT UNCERTAINTY.....</i>	<i>6</i>
<b>5. EQUIPMENT UNDER TEST .....</b>	<b>7</b>
5.1. <i>DESCRIPTION OF EUT .....</i>	<i>7</i>
5.2. <i>MAXIMUM FIELD STRENGTH.....</i>	<i>7</i>
5.3. <i>DESCRIPTION OF AVAILABLE ANTENNAS .....</i>	<i>7</i>
5.4. <i>SOFTWARE AND FIRMWARE.....</i>	<i>7</i>
5.5. <i>WORST-CASE CONFIGURATION AND MODE.....</i>	<i>7</i>
5.6. <i>DESCRIPTION OF TEST SETUP.....</i>	<i>8</i>
<b>6. TEST AND MEASUREMENT EQUIPMENT .....</b>	<b>10</b>
<b>7. OCCUPIED BANDWIDTH .....</b>	<b>11</b>
7.1. <i>Type A (CE Mode) .....</i>	<i>12</i>
7.2. <i>Type B (CE Mode) .....</i>	<i>13</i>
7.3. <i>Type F (CE Mode) .....</i>	<i>15</i>
<b>8. RADIATED EMISSION TEST RESULTS.....</b>	<b>16</b>
8.1. <i>LIMITS AND PROCEDURE.....</i>	<i>16</i>
8.2. <i>FUNDAMENTAL AND SPURIOUS EMISSIONS (0.15 - 30 MHz).....</i>	<i>18</i>
8.3. <i>TX SPURIOUS EMISSION 30 TO 1000 MHZ .....</i>	<i>21</i>
<b>9. FREQUENCY STABILITY .....</b>	<b>23</b>
<b>10. AC MAINS LINE CONDUCTED EMISSIONS .....</b>	<b>25</b>
<b>11. SETUP PHOTOS .....</b>	<b>28</b>

# 1. ATTESTATION OF TEST RESULTS

**COMPANY NAME:** Samsung Electronics Co., Ltd.  
129 Samsung-Ro, Yeongtong-Gu,  
Suwon-Si, Gyeonggi-Do, 16677, Korea

**EUT DESCRIPTION:** GSM/WCDMA/LTE phone with BT, DTS/UNII a/b/g/n/ac, ANT+ and NFC

**MODEL:** SM-A305N and SM-A305YN

**SERIAL NUMBER:** R38KC08WJSN; R38KC08WKGY (Radiated)

**DATE TESTED:** March 8 – 21, 2019

APPLICABLE STANDARDS	
STANDARD	TEST RESULTS
FCC PART 15 SUBPART C	Complies

UL Verification Services Inc. tested the above equipment in accordance with the requirements set forth in the above standards. The test results show that the equipment tested is capable of demonstrating compliance with the requirements as documented in this report.

The results documented in this report apply only to the tested sample, under the conditions and modes of operation as described herein. It is the manufacturer's responsibility to assure that additional production units of this model are manufactured with identical electrical and mechanical components. All samples tested were in good operating condition throughout the entire test program. Measurement Uncertainties are published for informational purposes only and were not taken into account unless noted otherwise.

This document may not be altered or revised in any way unless done so by UL Verification Services Inc. and all revisions are duly noted in the revisions section. Any alteration of this document not carried out by UL Verification Services Inc. will constitute fraud and shall nullify the document. This report must not be used by the client to claim product certification, approval, or endorsement by NVLAP, NIST, any agency of the Federal Government, or any agency of the U.S. government.

Approved & Released For  
UL Verification Services Inc. By:



Dan Corona  
Operations Leader  
Consumer Technology Division  
UL Verification Services Inc.

Reviewed By:



Kiya Kedida  
Senior Project Engineer  
Consumer Technology Division  
UL Verification Services Inc.

## 2. TEST METHODOLOGY

The tests documented in this report were performed in accordance with ANSI C63.10-2013, FCC CFR 47 Part 2, and FCC CFR 47 Part 15.

## 3. FACILITIES AND ACCREDITATION

The test sites and measurement facilities used to collect data are located at 47173 and 47266 Benicia Street, and 47658 Kato Road, Fremont, California, USA. Line conducted emissions are measured only at the 47173 address. The following table identifies which facilities were utilized for radiated emission measurements documented in this report. Specific facilities are also identified in the test results sections.

47173 Benicia Street	47266 Benicia Street	47658 Kato Rd
<input checked="" type="checkbox"/> Chamber A (ISED:2324B-1)	<input type="checkbox"/> Chamber D (ISED:22541-1)	<input checked="" type="checkbox"/> Chamber I (ISED:2324A-5)
<input type="checkbox"/> Chamber B (ISED:2324B-2)	<input type="checkbox"/> Chamber E (ISED:22541-2)	<input type="checkbox"/> Chamber J (ISED:2324A-6)
<input type="checkbox"/> Chamber C (ISED:2324B-3)	<input type="checkbox"/> Chamber F (ISED:22541-3)	<input type="checkbox"/> Chamber K (ISED:2324A-1)
	<input type="checkbox"/> Chamber G (ISED:22541-4)	<input type="checkbox"/> Chamber L (ISED:2324A-3)
	<input type="checkbox"/> Chamber H (ISED:22541-5)	

The above test sites and facilities are covered under FCC Test Firm Registration # 208313. Chambers above are covered under Industry Canada company address and respective code

UL Verification Services Inc. is accredited by NVLAP, Laboratory Code 200065-0

## 4. CALIBRATION AND UNCERTAINTY

### 4.1. MEASURING INSTRUMENT CALIBRATION

The measuring equipment utilized to perform the tests documented in this report has been calibrated in accordance with the manufacturer's recommendations, and is traceable to recognized national standards.

### 4.2. SAMPLE CALCULATION

#### RADIATED EMISSIONS

Where relevant, the following sample calculation is provided:

$$\text{Field Strength (dBuV/m)} = \text{Measured Voltage (dBuV)} + \text{Antenna Factor (dB/m)} + \text{Cable Loss (dB)} - \text{Preamp Gain (dB)}$$

$$36.5 \text{ dBuV} + 18.7 \text{ dB/m} + 0.6 \text{ dB} - 26.9 \text{ dB} = 28.9 \text{ dBuV/m}$$

#### MAINS CONDUCTED EMISSIONS

Where relevant, the following sample calculation is provided:

$$\text{Final Voltage (dBuV)} = \text{Measured Voltage (dBuV)} + \text{Cable Loss (dB)} + \text{Limiter Factor (dB)} + \text{LISN Insertion Loss}$$

$$36.5 \text{ dBuV} + 0 \text{ dB} + 10.1 \text{ dB} + 0 \text{ dB} = 46.6 \text{ dBuV}$$

### 4.3. MEASUREMENT UNCERTAINTY

Where relevant, the following measurement uncertainty levels have been estimated for tests performed on the apparatus:

PARAMETER	UNCERTAINTY
Worst Case Conducted Disturbance, 9KHz to 0.15 MHz	3.84 dB
Worst Case Conducted Disturbance, 0.15 to 30 MHz	3.65 dB
Worst Case Radiated Disturbance, 9KHz to 30 MHz	3.15 dB
Worst Case Radiated Disturbance, 30 to 1000 MHz	5.36 dB
Worst Case Radiated Disturbance, 1000 to 18000 MHz	4.32 dB
Worst Case Radiated Disturbance, 18000 to 26000 MHz	4.45 dB
Worst Case Radiated Disturbance, 26000 to 40000 MHz	5.24 dB

Uncertainty figures are valid to a confidence level of 95%.

## 5. EQUIPMENT UNDER TEST

### 5.1. DESCRIPTION OF EUT

The EUT is a GSM/WCDMA/LTE phone with BT,DTS/UNII a/b/g/n/ac and NFC.

### 5.2. MAXIMUM FIELD STRENGTH

The testing was performed at 3 meters. The transmitter maximum E-field at 30 meter distance was 14.07 dBuV/m, which was converted from the 3 meter data.

### 5.3. DESCRIPTION OF AVAILABLE ANTENNAS

The radio utilizes the loop antenna.

### 5.4. SOFTWARE AND FIRMWARE

The test utility software used during testing was A305F.001.

### 5.5. WORST-CASE CONFIGURATION AND MODE

The fundamental of the EUT was investigated under three orthogonal orientations X (Flatbed), Y (Landscape), and Z (Portrait). The Z (Portrait) orientation was determined to be the worst-case orientation.

Although these tests were performed other than open field site, adequate comparison measurements were confirmed against 30 m open area test site. Therefore sufficient tests were made to demonstrate that the alternative site produces results that correlate with the ones of tests made in an open field based on KDB 414788

**NOTE:** The EUT pre-scanned in three NFC type A, B & F. The worst type is A, and data rate of 106kbps was recorded to this report.

## 5.6. DESCRIPTION OF TEST SETUP

### SUPPORT EQUIPMENT

Support Equipment List				
Description	Manufacturer	Model	Serial Number	FCC ID
AC Adapter	Samsung	EP-TA50EWE	DW3J719AS/A-E	N/A
Earphone	Samsung	N/A	N/A	N/A

### I/O CABLES (CONDUCTED TEST)

I/O Cable List						
Cable No	Port	# of identical ports	Connector Type	Cable Type	Cable Length (m)	Remarks
1	Antenna	1	RF	Shielded	0.2	To spectrum Analyzer
2	USB	1	USB	Un-shielded	1	EUT to AC Mains

### I/O CABLES (RADIATED AND CONDUCTED EMISSIONS)

I/O Cable List						
Cable No	Port	# of identical ports	Connector Type	Cable Type	Cable Length (m)	Remarks
1	USB	1	USB	Shielded	1	N/A
2	earphone	1	3.5mm	Un-shielded	1	N/A

### TEST SETUP

The EUT is a stand alone. Test software exercised the radio card.

**RADIATED AND AC LINE CONDUCTED EMISSIONS SETUP DIAGRAM**

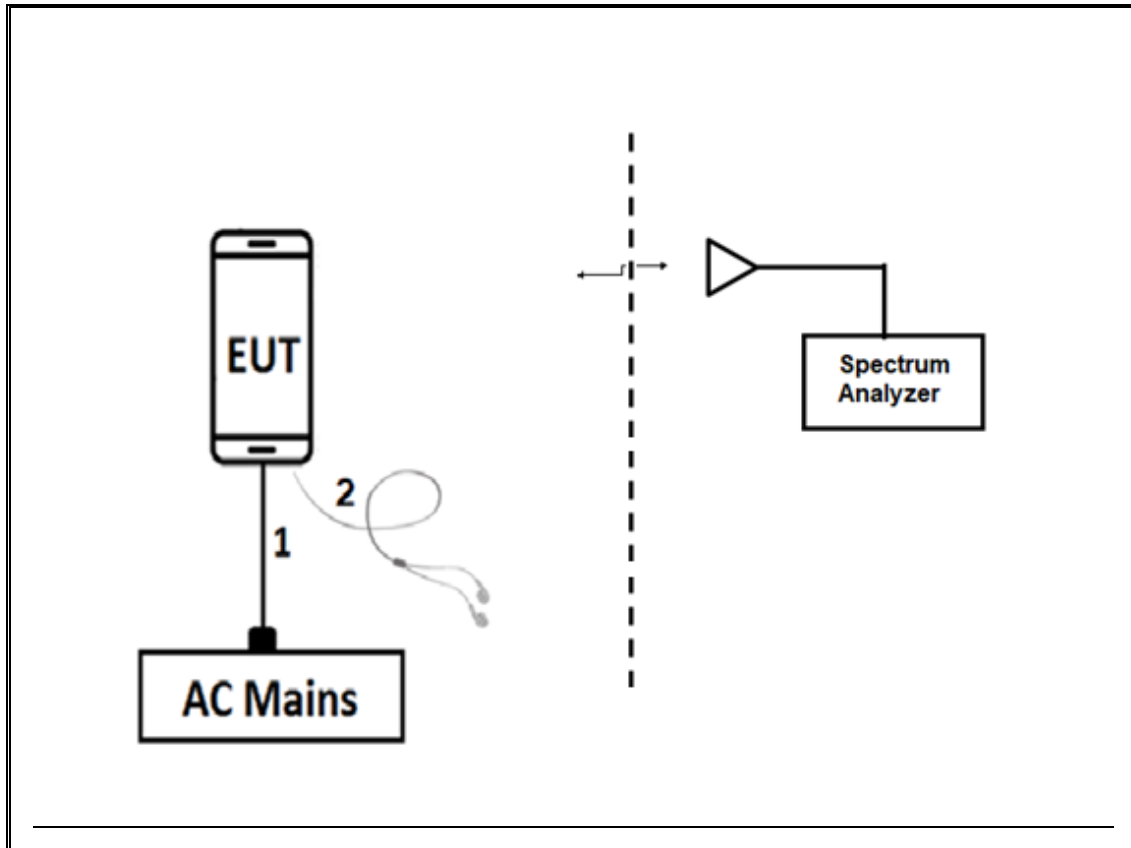

**TEST SETUP**

For radiated tests: EUT has support equipment. The test software exercises the radio.

## 6. TEST AND MEASUREMENT EQUIPMENT

The following test and measurement equipment was utilized for the tests documented in this report:

TEST EQUIPMENT LIST					
Description	Manufacturer	Model	ID Num	Cal Due	Last Cal
Antenna, Active Loop 9kHz-30MHz	ETS-Lindgren	6502	T757	09/25/2019	09/25/2018
Antenna, Passive Loop 30Hz – 1MHz	Electro-Metrics	EM-6871	PRE0179465	05/22/2019	05/22/2018
Antenna, Passive Loop 100kHz – 30MHz	Electro_Metrics	EM-6872	PRE0179467	05/23/2019	05/23/2018
EMI TEST RECEIVER	Rohde & Schwarz	ESW44	PRE0179375	05/08/2019	05/08/2018
Temp Chamber	Thermotron Industries	SE-600-10-10	T80	05/01/2019	11/01/2018
Spectrum Analyzer, PXA, 3Hz to 44GHz	Agilent (Keysight) Technologies	N9030A	T339	09/11/2019	09/11/2018
Spectrum Analyzer, PXA, 3Hz to 44GHz	Agilent (Keysight) Technologies	N9030A	T1454	01/25/20	01/25/2019
Amplifier, 9kHz to 1GHz, 32 dB	Sonoma Instrument	310	175953	12/13/2019	12/13/2018
Hybrid Antenna, 30MHz to 3GHz	SunAR rf motion	JB3	PRE0184052	10/24/2019	10/24/2018
AC Line Conducted					
EMI Receiver	Rohde & Schwarz	ESR	T1436	02/14/2020	02/14/2019
LISN for Conducted Emissions CISPR-16	FCC INC.	FCC LISN 50/250	T1310	06/15/2019	06/15/2018
Test Software List					
Radiated Software	UL	UL EMC		Ver 9.5, June 22, 2018	
Antenna Port Software	UL	UL RF		Ver 9.4.1, Feb. 19, 2019	
AC Line Conducted Software	UL	UL EMC		Ver 9.5, May 26, 2015	

### NOTES:

1. Equipment listed above that calibrated during the testing period was set for test after the calibration.
2. Equipment listed above that has a calibration due date during the testing period, the testing is completed before equipment expiration date.

## 7. OCCUPIED BANDWIDTH

### LIMITS

None; for reporting purposes only.

### TEST PROCEDURE

The transmitter output is connected to the spectrum analyzer. The RBW is set to 10kHz. The VBW is set to 3 times the RBW. The sweep time is coupled. The spectrum analyzer internal 99% bandwidth function is utilized.

Note: Because the measured signal is CW or CW-like adjusting the RBW per C63.10 would not be practical since measured bandwidth will always follow the RBW and the result will be approximately twice the RBW

### RESULTS

#### 99% and 20dB BW

##### Type A (CE Mode)

Mode Kbps	Frequency (MHz)	99% Bandwidth (KHz)	20dB Bandwidth (KHz)
424	13.56	21.165	28.08
212	13.56	21.273	28.14
106	13.56	21.157	28.10

##### TYPE B

Mode Kbps	Frequency (MHz)	99% Bandwidth (KHz)	20dB Bandwidth (KHz)
424	13.56	21.152	28.07
212	13.56	21.164	28.09
106	13.56	21.271	28.11

##### TYPE F

Mode Kbps	Frequency (MHz)	99% Bandwidth (KHz)	20dB Bandwidth (KHz)
424	13.56	21.154	28.08
212	13.56	21.151	28.08

## 7.1. Type A (CE Mode)

### 424Kbps

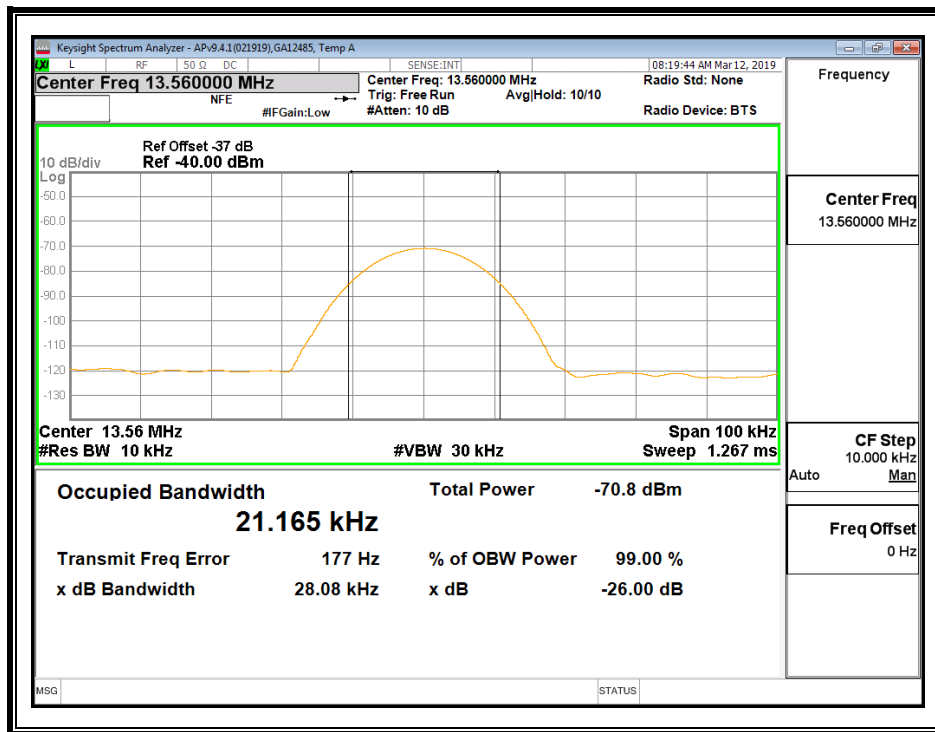

### 212Kbps

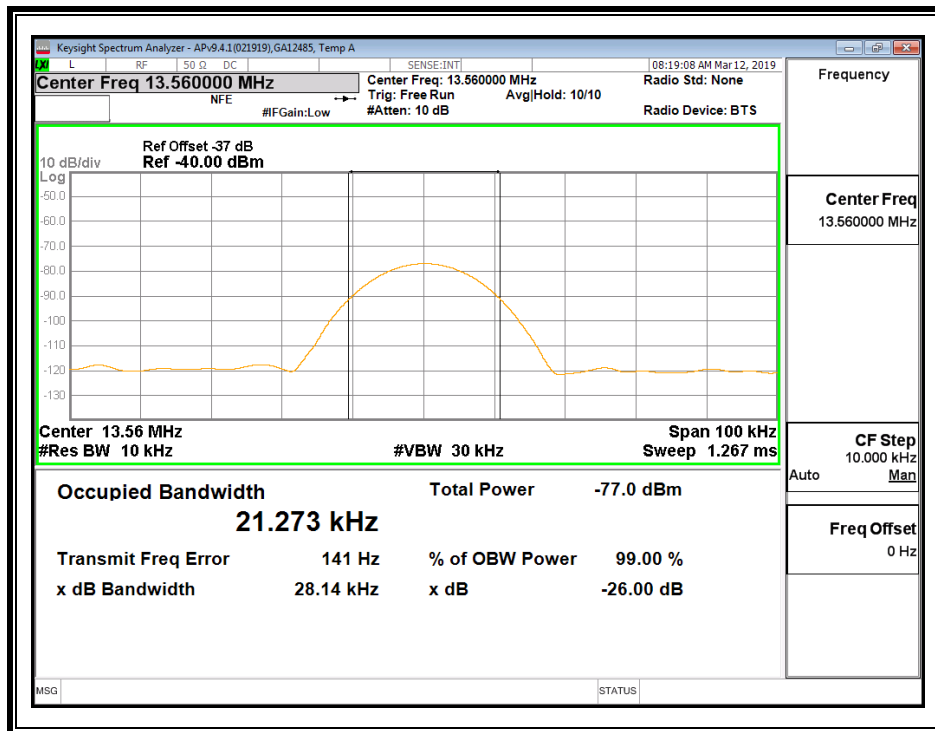

**106Kbps**

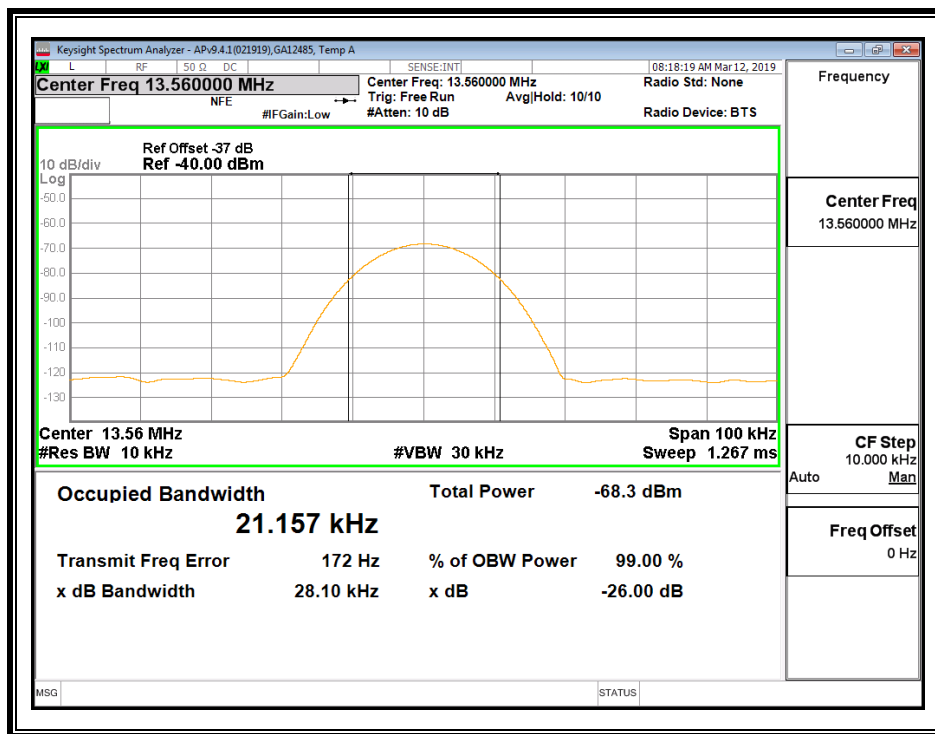

**7.2. Type B (CE Mode)**

**424Kbps**

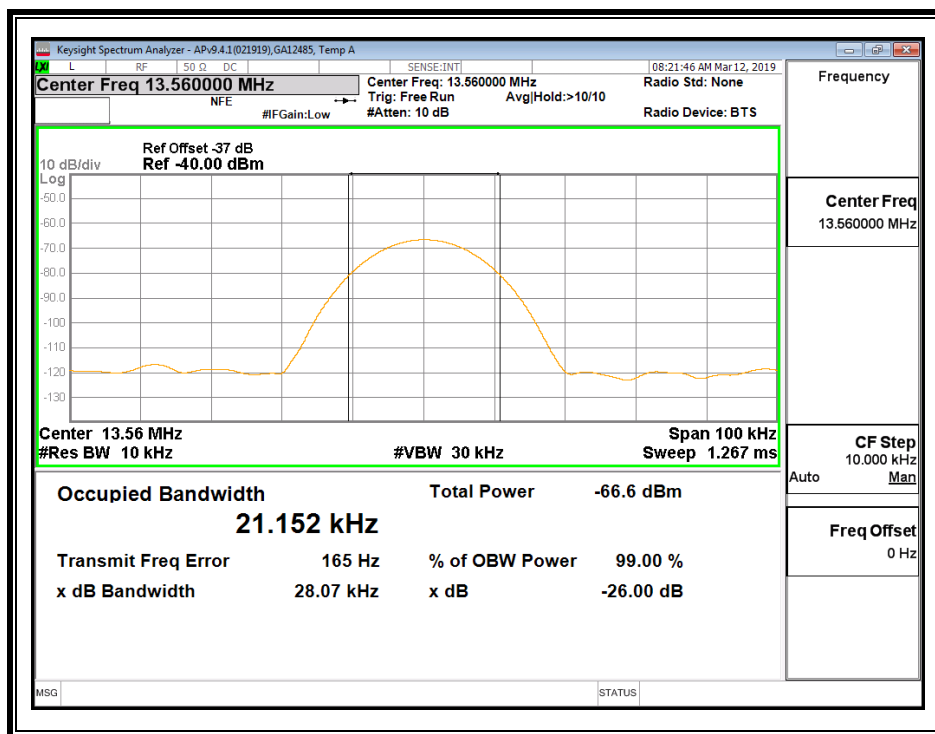

**212Kbps**

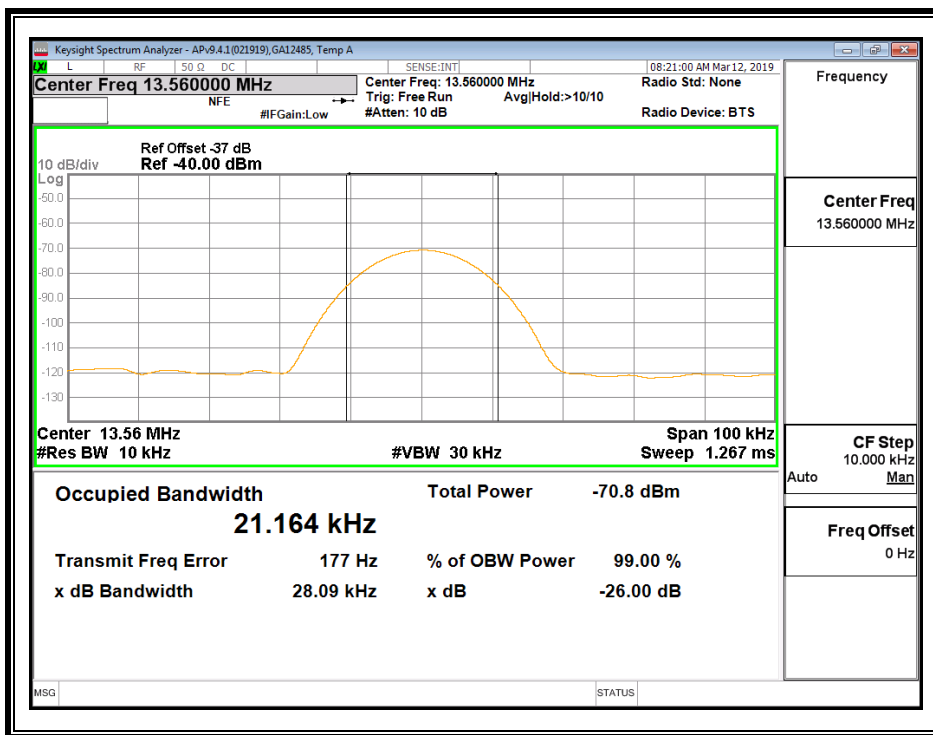

**106Kbps**

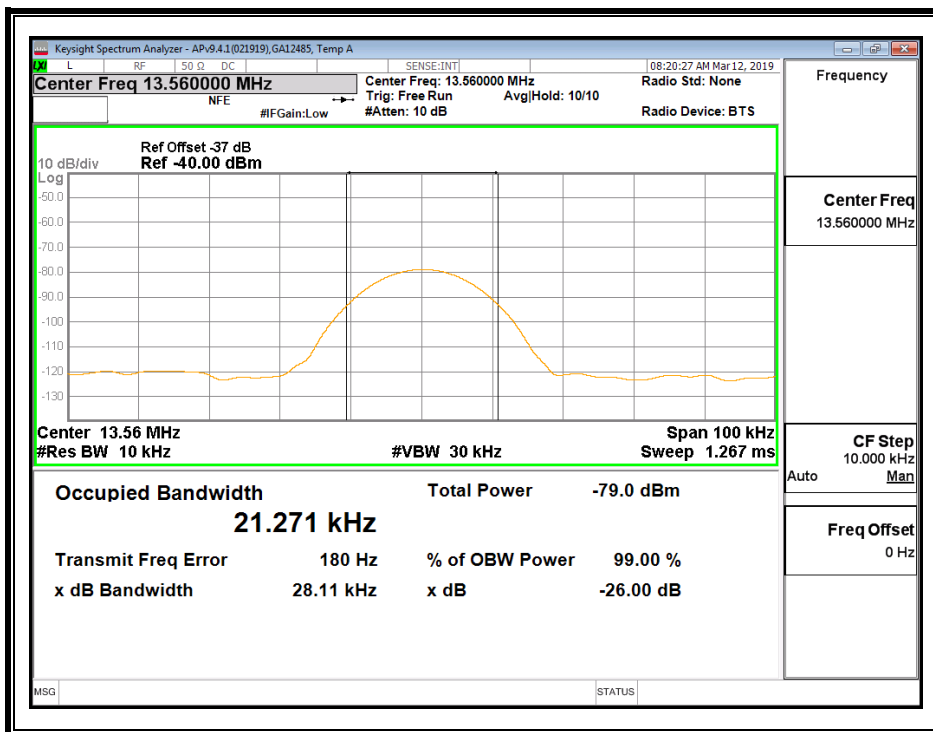

### 7.3. Type F (CE Mode)

#### 424Kbps

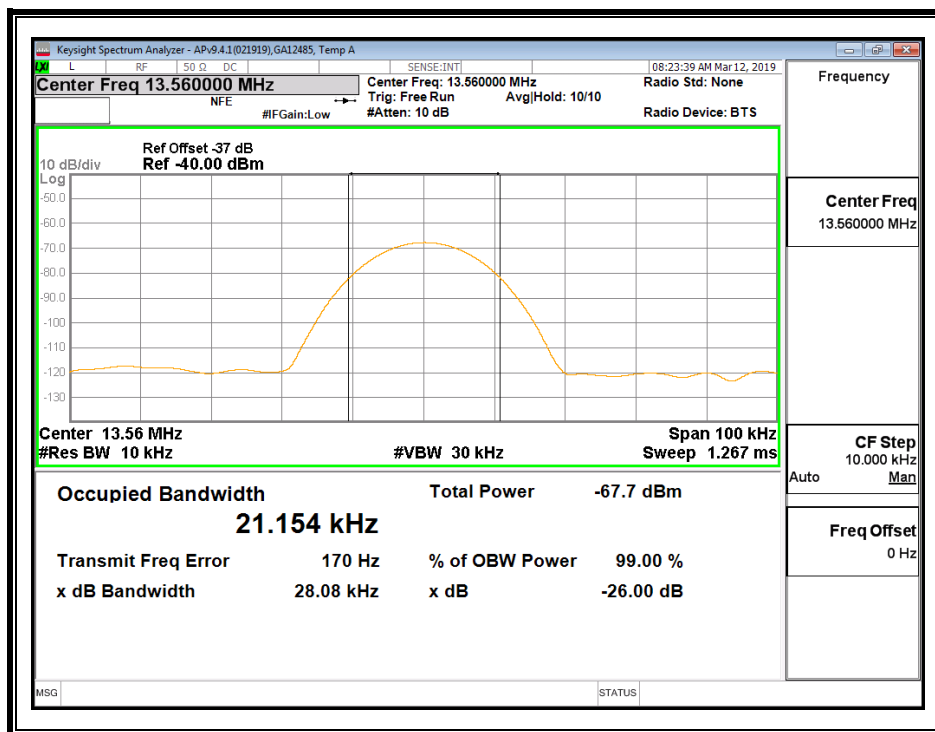

#### 212Kbps

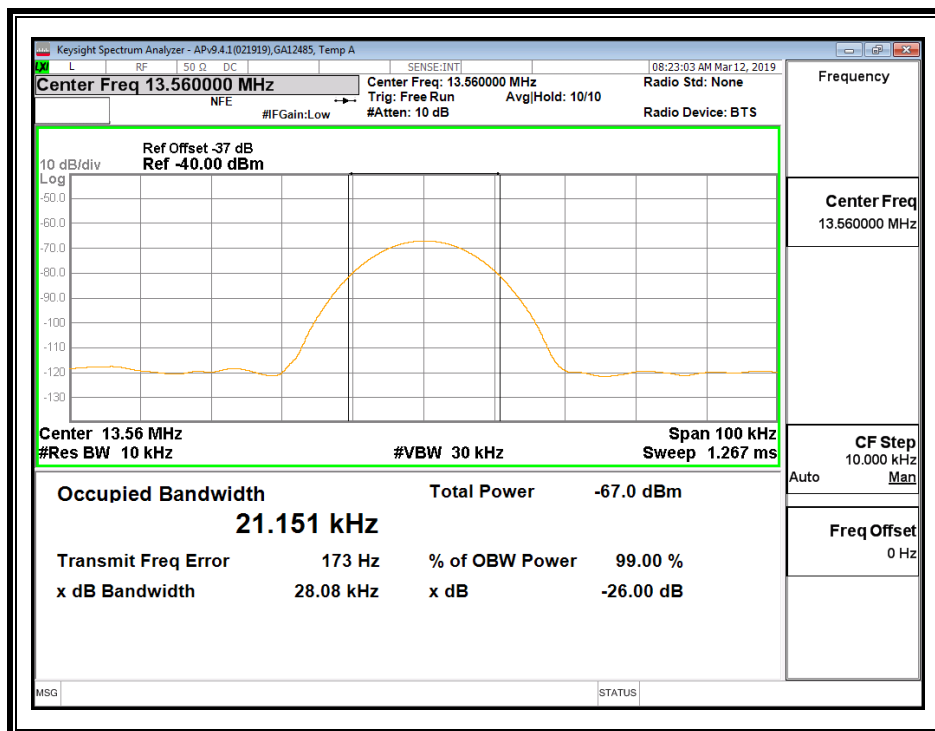

## 8. RADIATED EMISSION TEST RESULTS

### 8.1. LIMITS AND PROCEDURE

#### LIMIT

§15.225

(a) The field strength of any emissions within the band 13.553–13.567 MHz shall not exceed 15,848 microvolts/ meter at 30 meters.

(b) Within the bands 13.410–13.553 MHz and 13.567–13.710 MHz, the field strength of any emissions shall not exceed 334 microvolts/meter at 30 meters.

(c) Within the bands 13.110–13.410 MHz and 13.710–14.010 MHz the field strength of any emissions shall not exceed 106 microvolts/meter at 30 meters.

(d) The field strength of any emissions appearing outside of the 13.110– 14.010 MHz and shall not exceed the general radiated emission limits in § 15.209 as follows:

§15.209 (a) Except as provided elsewhere in this subpart, the emissions from an intentional radiator shall not exceed the field strength levels specified in the following table:

Limits for radiated disturbance of an intentional radiator		
Frequency range (MHz)	Limits (µV/m)	Measurement Distance (m)
0.009 – 0.490	2400 / F (kHz)	300
0.490 – 1.705	24000 / F (kHz)	30
1.705 – 30.0	30	30
30 – 88	100**	3
88 - 216	150**	3
216 – 960	200**	3
Above 960	500	3

\*\* Except as provided in paragraph (g), fundamental emissions from intentional radiators operating under this section shall not be located in the frequency bands 54-72 MHz, 76-88 MHz, 174-216 MHz or 470-806 MHz. However, operation within these frequency bands is permitted under other sections of this part, e.g. §§ 15.231 and 15.241.

§15.209 (b) In the emission table above, the tighter limit applies at the band edges.

Formula for converting the filed strength from uV/m to dBuV/m is:

Limit (dBuV/m) = 20 log limit (uV/m)

In addition:

§15.209 (d) The emission limits shown the above table are based on measurements employing a CISPR quasi-peak detector except for the frequency bands 9-90 kHz, 110-490 kHz and above 1000 MHz. Radiated emissions limits in these three bands are based on measurements employing an average detector.

§15.209 (d) The provisions in §§ 15.225, measuring emissions at distances other than the distances specified in the above table, determining the frequency range over which radiated emissions are to be measured, and limiting peak emissions apply to all devices operated under this part.

### **TEST PROCEDURE**

ANSI C63.10, 2013

The EUT is an intentional radiator that incorporates a digital device, the highest fundamental frequency generated or used in the device is 13.56 MHz; therefore, the frequency range was investigated from 0.15 MHz to the 10<sup>th</sup> harmonic of the highest fundamental frequency, or 1000 MHz, whichever is greater.

2D antenna use - For below 30MHz testing, investigation was done on three antenna orientations (parallel, perpendicular, and ground-parallel), parallel and perpendicular are the worst orientations, therefore testing was performed on these two orientations only.

### **KDB 414788 OATS and Chamber Correlation Justification**

Base on FCC 15.31 (f) (2): measurements may be performed at a distance closer than that specified in the regulations; however, an attempt should be made to avoid making measurements in the near field.

Open field site (OFS) and chamber correlation testing had been performed and chamber measured test result is the worst case test result.

### **RESULTS**

## 8.2. FUNDAMENTAL AND SPURIOUS EMISSIONS (0.15 - 30 MHz)

Type A (CE Mode), 106Kbps

### DATA

#### FUNDAMENTAL EMISSION MASK (11.56 – 15.56 MHz)

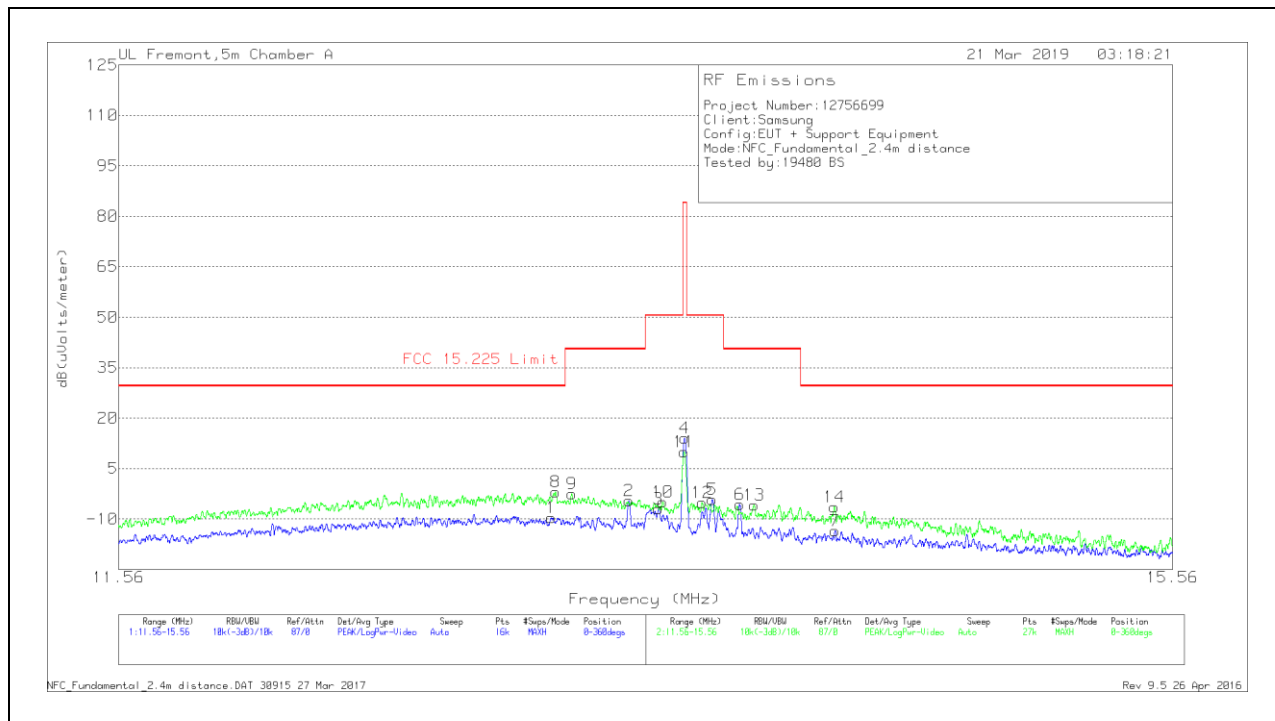

NOTE: All data rate Field Strength was investigated and Type A, 106k found to have the highest Field Strength results and represents as the worst case data rate.

Trace Markers

Marker	Frequency (MHz)	Meter Reading (dBuV)	Det	Loop Antenna (dB/m)	Cables (dB)	Dist Corr 30m	Corrected Reading dB(uVolts/meter)	FCC 15.225 Limit	PK Margin (dB)	Azimuth (Degs)
1	13.05988	19.52	Pk	10.3	.5	-40	-9.68	29.54	-39.22	0-360
8	13.07589	27.29	Pk	10.3	.5	-40	-1.91	29.54	-31.45	0-360
9	13.13524	26.67	Pk	10.3	.5	-40	-2.53	40.51	-43.04	0-360
2	13.34825	24.58	Pk	10.3	.5	-40	-4.62	40.51	-45.13	0-360
3	13.46075	22.23	Pk	10.3	.5	-40	-6.97	50.5	-57.47	0-360
10	13.47712	24.19	Pk	10.3	.5	-40	-5.01	50.5	-55.51	0-360
11	*13.55837	39.25	Pk	10.2	.5	-40	9.95	84	-74.05	0-360
4	*13.56	43.37	Pk	10.2	.5	-40	14.07	84	-69.93	0-360
12	13.62704	24.2	Pk	10.2	.5	-40	-5.1	50.5	-55.6	0-360
5	13.66638	25.04	Pk	10.2	.5	-40	-4.26	50.5	-54.76	0-360
6	13.77213	23.61	Pk	10.2	.5	-40	-5.69	40.51	-46.2	0-360
13	13.82817	23.45	Pk	10.2	.5	-40	-5.85	40.51	-46.36	0-360
14	14.14504	22.94	Pk	10.2	.5	-40	-6.36	29.54	-35.9	0-360
7	14.14838	15.86	Pk	10.2	.5	-40	-13.44	29.54	-42.98	0-360

\* - Indicates fundamental frequency

Pk - Peak detector

### SPURIOUS EMISSIONS (0.09 – 30MHz)

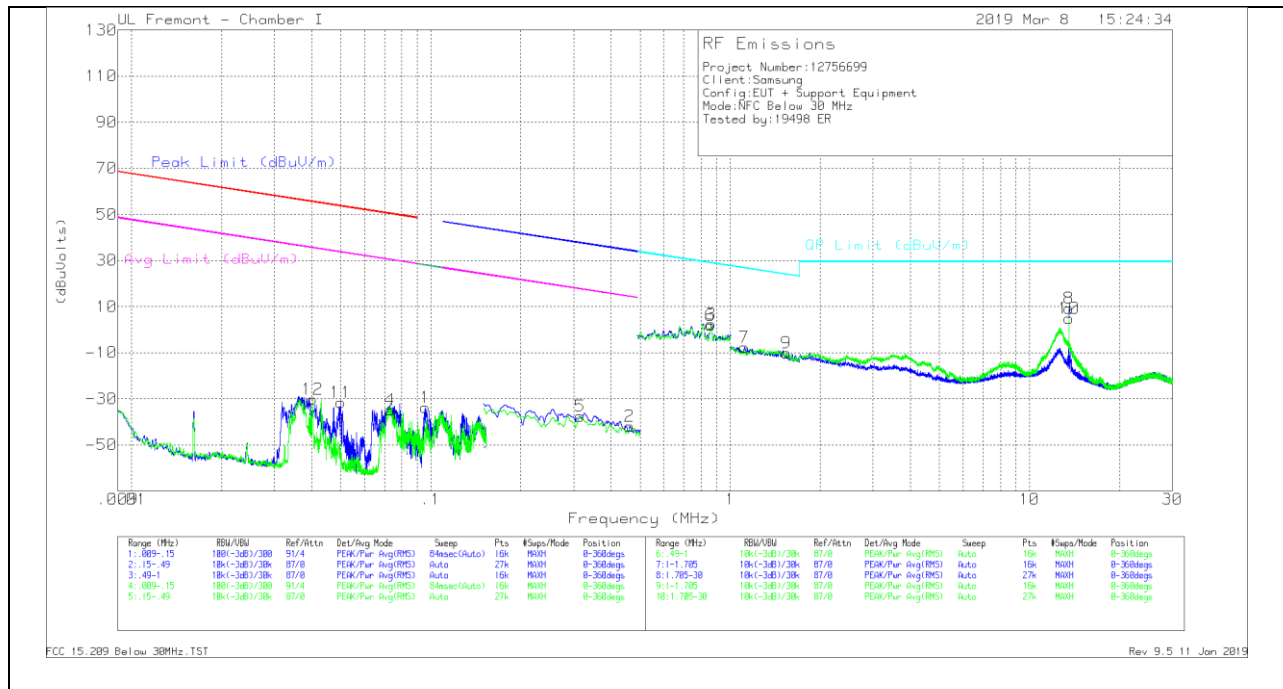

### Trace Markers

Marker	Frequency (MHz)	Meter Reading (dBuV)	Det	Loop Antenna (ACF)	Cables w/ PRE0180175 (dB)	Dist Corr 300m	Corrected Reading (dBuVolts)	Peak Limit (dBuV/m)	Margin (dB)	Avg Limit (dBuV/m)	Margin (dB)	QP Limit (dBuV/m)	Margin (dB)	Peak Limit (dBuV/m)	Margin (dB)	Avg Limit (dBuV/m)	Margin (dB)	Azimuth (Degs)	
1	09607	22.56	Pk	56.7	-32	-80	-33.74	-	-	-	-	-27.35	-61.69	-	-	-	-	-	0-360
11	05002	23.41	Pk	57.1	-32.1	-80	-31.59	53.6	-85.19	33.6	-65.19	-	-	-	-	-	-	-	0-360
2	46232	13.59	Pk	56.2	-31.8	-80	-42.01	-	-	-	-	-	-	34.31	-76.32	14.31	-56.32	-	0-360
4	07304	21.21	Pk	55.9	-32	-80	-34.89	50.31	-85.2	30.31	-65.2	-	-	-	-	-	-	-	0-360
12	04026	24.89	Pk	57.2	-32.2	-80	-30.11	55.49	-85.6	35.49	-65.6	-	-	-	-	-	-	-	0-360
5	31537	18.12	Pk	56.3	-31.9	-80	-37.48	-	-	-	-	-	-	37.63	-75.11	17.63	-55.11	-	0-360

### Pk - Peak detector

Marker	Frequency (MHz)	Meter Reading (dBuV)	Det	Loop Antenna (dB/m)	Cables (dB)	Dist Corr (dB) 40Log	Corrected Reading (dBuVolts)	QP Limit (dBuV/m)	Margin (dB)	Azimuth (Degs)
3	86189	18.06	Pk	56.3	-31.8	-40	2.56	28.91	-26.35	0-360
6	86096	17.47	Pk	56.3	-31.8	-40	1.97	28.92	-26.95	0-360
7	1.11759	18.45	Pk	45.8	-31.8	-40	-7.55	26.66	-34.21	0-360
8	13.55998	46.47	Pk	34.3	-31.5	-40	9.27	29.5	-20.23	0-360
9	1.54078	18.23	Pk	43.6	-31.8	-40	-9.97	23.88	-33.85	0-360
10	13.55998	42.21	Pk	34.3	-31.5	-40	5.01	29.5	-24.49	0-360

### Pk - Peak detector

### 8.3. TX SPURIOUS EMISSION 30 TO 1000 MHz

Type A (CE Mode), 106Kbps

#### DATA

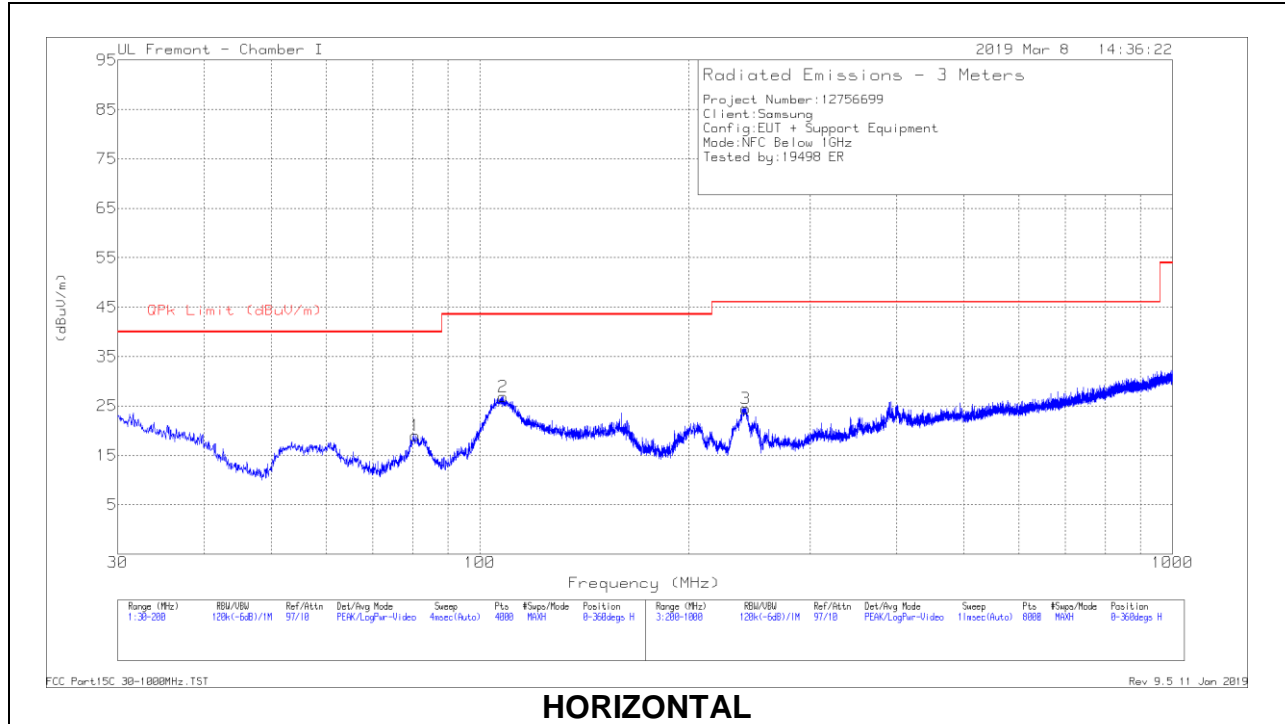

**HORIZONTAL**

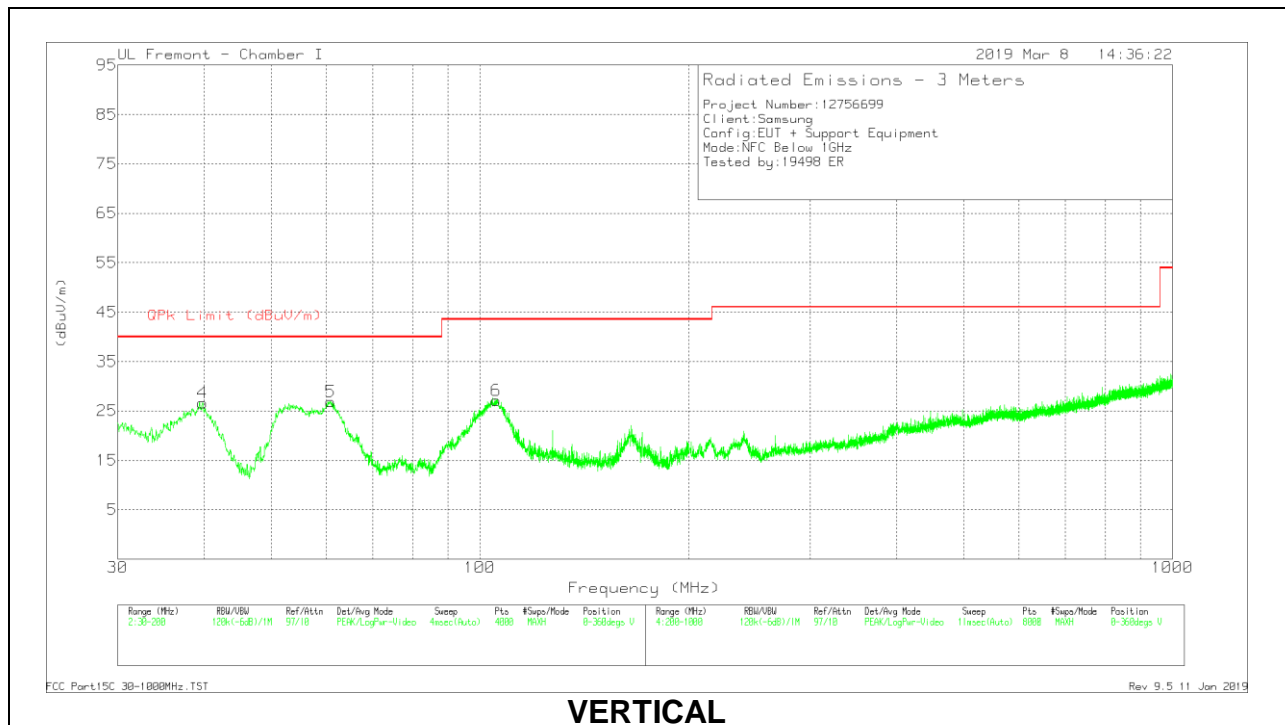

**VERTICAL**

Trace Markers

Marker	Frequency (MHz)	Meter Reading (dBuV)	Det	AFT407 (dB/m)	Amp/Cbl (dB)	Corrected Reading (dBuV/m)	QPk Limit (dBuV/m)	Margin (dB)	Azimuth (Degs)	Height (cm)	Polarity
1	80.6731	36.47	Pk	13.4	-30.9	18.97	40	-21.03	0-360	199	H
2	107.9227	39.5	Pk	18.1	-30.7	26.9	43.52	-16.62	0-360	299	H
4	39.7775	37.93	Pk	19.9	-31.2	26.63	40	-13.37	0-360	101	V
5	60.863	44.59	Pk	13.3	-31	26.89	40	-13.11	0-360	101	V
6	105.4995	40.31	Pk	17.5	-30.7	27.11	43.52	-16.41	0-360	101	V
3	* 241.9054	36.88	Pk	17.6	-30	24.48	46.02	-21.54	0-360	101	H

\* - indicates frequency in CFR47 Pt 15 Restricted Band

Pk - Peak detector

---

## 9. FREQUENCY STABILITY

### LIMIT

§15.225 (e) The frequency tolerance of the carrier signal shall be maintained within  $\pm 0.01\%$  of the operating frequency, over a temperature variation of -20 degrees to +50 degrees C at normal supply voltage, and for a variation in the primary supply voltage from 85% to 115% of the rated supply voltage at a temperature of 20 degrees C. For battery operated equipment, the equipment tests shall be performed using a new battery.

### TEST PROCEDURE

ANSI C63.10-2013 Clause 6.8

### RESULTS

<b>ID:</b>	16069 OG	<b>Date:</b>	3/12/19
------------	----------	--------------	---------

No non-compliance noted.

**Type A 106Kbps**

Reference Frequency: EUT Channel 13.56 MHz @ 20°C Limit: ± 100 ppm = 1.356 kHz										
Power Supply (Vdc)	Envir. Temp (°C)	Frequency Deviation Measured with Time Elapse								
		Startup (MHz)	Delta (ppm)	@ 2 mins (MHz)	Delta (ppm)	@ 5 mins (MHz)	Delta (ppm)	@ 10 mins (MHz)	Delta (ppm)	Limit (ppm)
3.80	50	13.5599896	0.335	13.5599895	0.337	13.5599896	0.336	13.5599895	0.337	± 100
3.80	40	13.5599915	0.195	13.5599913	0.207	13.5599910	0.230	13.5599908	0.242	± 100
3.80	30	13.5599926	0.114	13.5599925	0.116	13.5599925	0.120	13.5599925	0.120	± 100
<b>3.80</b>	<b>20</b>	<b>13.5599941</b>	<b>0.000</b>	<b>13.5599935</b>	<b>0.047</b>	<b>13.5599932</b>	<b>0.068</b>	<b>13.5599930</b>	<b>0.084</b>	<b>± 100</b>
3.80	10	13.5599964	-0.170	13.5599965	-0.177	13.5599965	-0.176	13.5599967	-0.189	± 100
3.80	0	13.5599979	-0.282	13.5599982	-0.305	13.5599985	-0.326	13.5599879	0.456	± 100
3.80	-10	13.5600008	-0.494	13.5600012	-0.524	13.5600015	-0.544	13.5600017	-0.561	± 100
3.23	20	13.5599988	-0.347	13.5599989	-0.353	13.5599892	0.364	13.5599989	-0.355	± 100
4.37	20	13.5599989	-0.351	13.5599989	-0.357	13.5599989	-0.355	13.5599989	-0.355	± 100

## 10. AC MAINS LINE CONDUCTED EMISSIONS

### LIMITS

§15.207

(a) Except as shown in paragraphs (b) and (c) of this section, for an intentional radiator that is designed to be connected to the public utility (AC) power line, the radio frequency voltage that is conducted back onto the AC power line on any frequency or frequencies, within the band 150 kHz to 30 MHz, shall not exceed the limits in the following table, as measured using a 50 $\mu$ H/50 ohms line impedance stabilization network (LISN). Compliance with the provisions of this paragraph shall be based on the measurement of the radio frequency voltage between each power line and ground at the power terminal. The lower limit applies at the band edges.

Frequency range (MHz)	Limits (dB $\mu$ V)	
	Quasi-peak	Average
0.15 to 0.50	66 to 56	56 to 46
0.50 to 5	56	46
5 to 30	60	50

Notes:  
 1. The lower limit shall apply at the transition frequencies  
 2. The limit decreases linearly with the logarithm of the frequency in the range 0.15 MHz to 0.50 MHz.

### TEST PROCEDURE

ANSI C63.10:2013

### RESULTS

No non-compliance noted:

**Type A (CE Mode), 106Kbps**

**LINE 1 RESULTS**

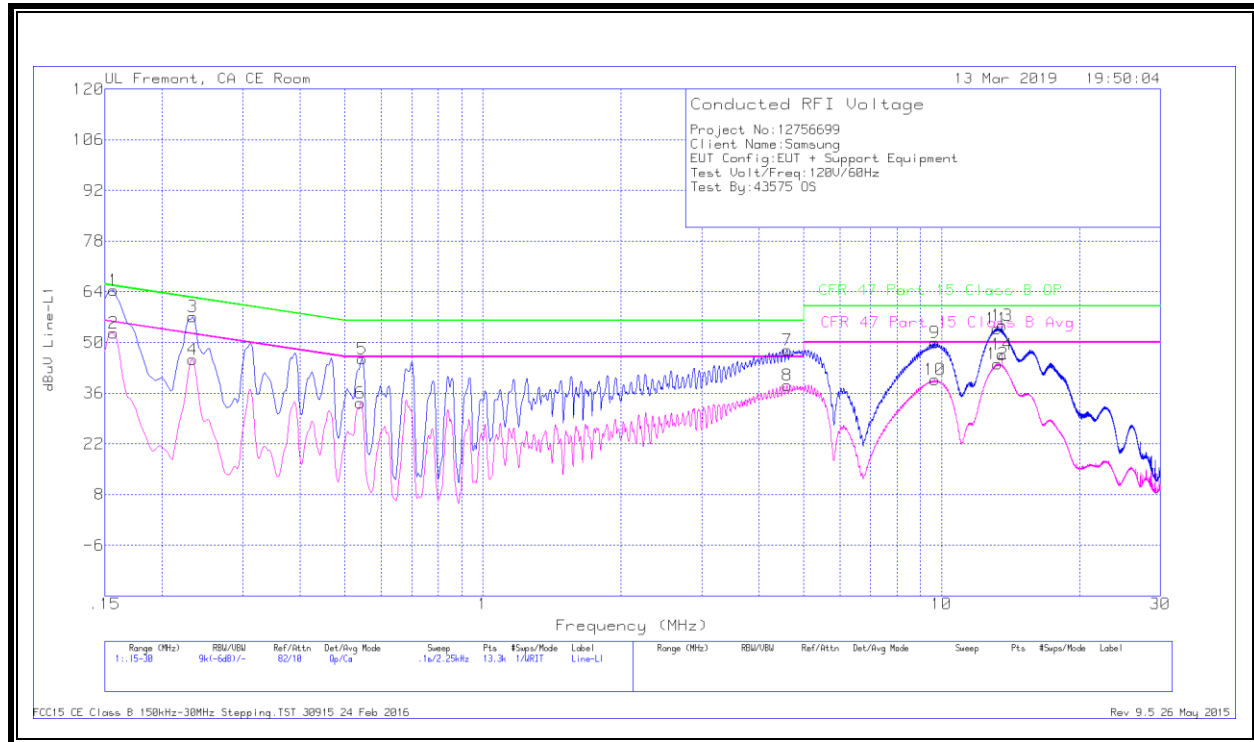

**Worst Emission**

Range 1: Line-L1 .15 - 30MHz											
Marker	Frequency (MHz)	Meter Reading (dBuV)	Det	LISN L1	LC Cables C1&C3	Limiter (dB)	Corrected Reading dBuV	CFR 47 Part 15 Class B QP	QP Margin (dB)	CFR 47 Part 15 Class B Avg	Av(CISPR) Margin (dB)
1	.15675	54.24	Qp	.1	0	10.1	64.44	65.63	-1.19	-	-
2	.15675	42.47	Ca	.1	0	10.1	52.67	-	-	55.63	-2.96
3	.23325	47.03	Qp	0	0	10.1	57.13	62.33	-5.2	-	-
4	.23325	35.27	Ca	0	0	10.1	45.37	-	-	52.33	-6.96
5	.546	35.36	Qp	0	0	10.1	45.46	56	-10.54	-	-
6	.5415	23.23	Ca	0	0	10.1	33.33	-	-	46	-12.67
7	4.60725	37.7	Qp	0	.1	10.1	47.9	56	-8.1	-	-
8	4.605	27.91	Ca	0	.1	10.1	38.11	-	-	46	-7.89
9	9.65738	39.67	Qp	0	.2	10.2	50.07	60	-9.93	-	-
10	9.6585	29.27	Ca	0	.2	10.2	39.67	-	-	50	-10.33
11	13.19325	43.4	Qp	.1	.2	10.2	53.9	60	-6.1	-	-
12	13.272	33.59	Ca	.1	.2	10.2	44.09	-	-	50	-5.91
*13	13.56	44.24	Qp	.1	.2	10.2	54.74	60	-5.26	-	-
*14	13.56	36.15	Ca	.1	.2	10.2	46.65	-	-	50	-3.35

Qp - Quasi-Peak detector

Ca - CISPR average detection

Note: Markers 13 and 14 are the 13.56MHz NFC Fundamental

**LINE 2 RESULTS**

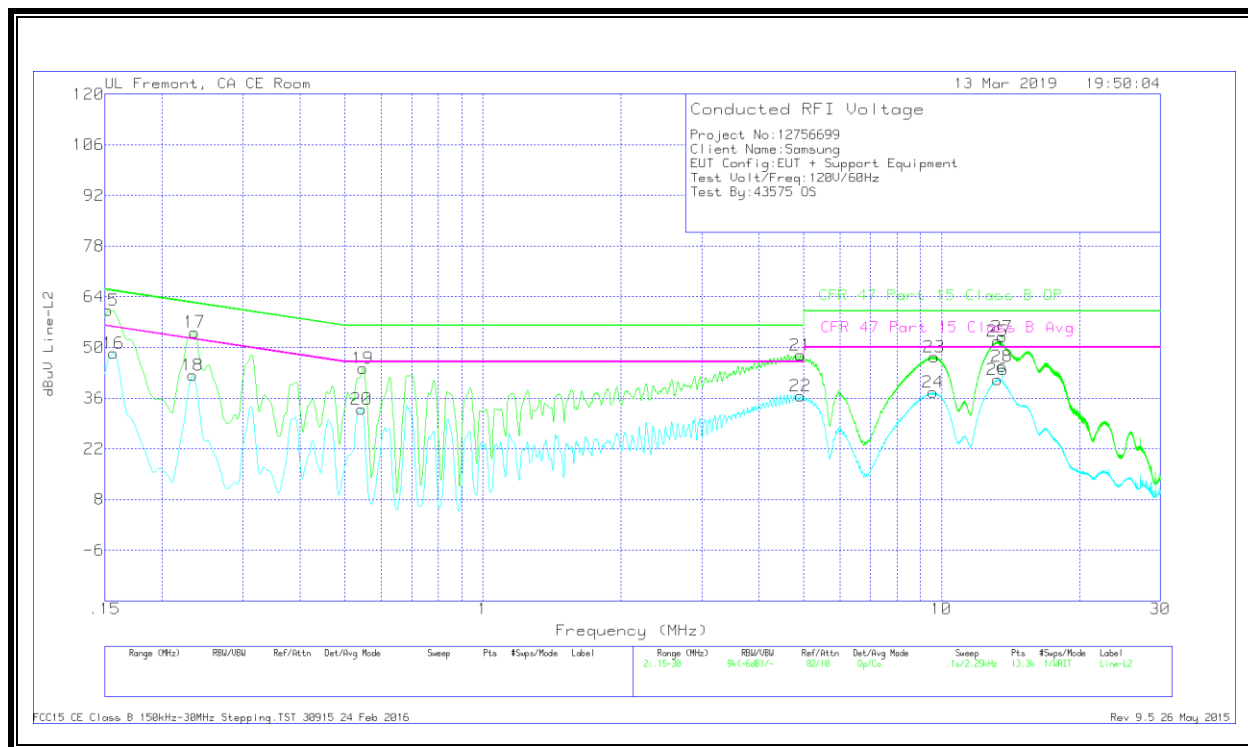

**Worst Emission**

Range 2: Line-L2 .15 - 30MHz											
Marker	Frequency (MHz)	Meter Reading (dBuV)	Det	LISN L2	LC Cables C2&C3	Limiter (dB)	Corrected Reading dBuV	CFR 47 Part 15 Class B QP	QP Margin (dB)	CFR 47 Part 15 Class B Avg	Av(CISPR) Margin (dB)
15	.15225	50.05	Qp	.1	0	10.1	60.25	65.88	-5.63	-	-
16	.15675	38.24	Ca	.1	0	10.1	48.44	-	-	55.63	-7.19
17	.2355	44.15	Qp	0	0	10.1	54.25	62.25	-8	-	-
18	.23325	32.21	Ca	0	0	10.1	42.31	-	-	52.33	-10.02
19	.54825	34.17	Qp	0	0	10.1	44.27	56	-11.73	-	-
20	.54375	22.86	Ca	0	0	10.1	32.96	-	-	46	-13.04
21	4.93125	37.7	Qp	0	.1	10.1	47.9	56	-8.1	-	-
22	4.92675	26.49	Ca	0	.1	10.1	36.69	-	-	46	-9.31
23	9.6315	37.05	Qp	0	.2	10.2	47.45	60	-12.55	-	-
24	9.58538	27.22	Ca	0	.2	10.2	37.62	-	-	50	-12.38
25	13.272	41.17	Qp	.1	.2	10.2	51.67	60	-8.33	-	-
26	13.27313	30.61	Ca	.1	.2	10.2	41.11	-	-	50	-8.89
*27	13.56	42.48	Qp	.1	.2	10.2	52.98	60	-7.02	-	-
*28	13.56	34.29	Ca	.1	.2	10.2	44.79	-	-	50	-5.21

Qp - Quasi-Peak detector

Ca - CISPR average detection

Note: Markers 27 and 28 are the 13.56MHz NFC Fundamental