



CERTIFICATION TEST REPORT

Report Number. : 12678284-E5V2

Applicant : Samsung Electronics Co., Ltd.
129 Samsung-Ro, Yeongtong-Gu,
Suwon-Si, Gyeonggi-Do, 16677, Korea

Model : SM-A305GN/DS and SM-A305GN

FCC ID : A3LSMA305GN

EUT Description : GSM/WCDMA/LTE Phone with BT, DTS/UNII a/b/g/n/ac, ANT+ and NFC

Test Standard(s) : FCC 47 CFR PART 15 SUBPART E (EXCEPT DFS)

Date Of Issue:
February 20, 2019

Prepared by:
UL Verification Services Inc.
47173 Benicia Street
Fremont, CA 94538 U.S.A.
TEL: (510) 319-4000
FAX: (510) 661-0888



NVLAP Lab code: 200065-0

REPORT REVISION HISTORY

| Rev. | Issue Date | Revisions | Revised By |
|------|------------|-----------------------------|------------|
| V1 | 2/18/2019 | Initial Issue | |
| V2 | 2/20/2019 | Updated Section 2.3 and 6.2 | K.Kedida |

TABLE OF CONTENTS

| | |
|--|-----------|
| REPORT REVISION HISTORY | 2 |
| TABLE OF CONTENTS | 3 |
| 1. ATTESTATION OF TEST RESULTS | 6 |
| 2. INTRODUCTION OF TEST DATA REUSE..... | 7 |
| 2.1. INTRODUCTION | 7 |
| 2.2. DIFFERENCES | 7 |
| 2.3. SPOT CHECK VERIFICATION RESULTS SUMMARY | 7 |
| 2.3.1. SPOT CHECK DATA | 8 |
| 2.4. REFERENCE DETAIL | 12 |
| 3. TEST METHODOLOGY | 13 |
| 4. FACILITIES AND ACCREDITATION | 13 |
| 5. CALIBRATION AND UNCERTAINTY | 14 |
| 5.1. MEASURING INSTRUMENT CALIBRATION | 14 |
| 5.2. SAMPLE CALCULATION | 14 |
| 5.3. MEASUREMENT UNCERTAINTY..... | 14 |
| 6. EQUIPMENT UNDER TEST..... | 15 |
| 6.1. EUT DESCRIPTION..... | 15 |
| 6.2. MAXIMUM OUTPUT POWER..... | 15 |
| 6.3. DESCRIPTION OF AVAILABLE ANTENNAS | 17 |
| 6.4. SOFTWARE AND FIRMWARE..... | 17 |
| 6.5. WORST-CASE CONFIGURATION AND MODE..... | 17 |
| 6.6. DESCRIPTION OF TEST SETUP..... | 18 |
| 7. MEASUREMENT METHOD..... | 21 |
| 8. TEST AND MEASUREMENT EQUIPMENT | 22 |
| 9. ANTENNA PORT TEST RESULTS..... | 23 |
| 9.1. ON TIME AND DUTY CYCLE..... | 23 |
| 9.2. 26 dB BANDWIDTH..... | 25 |
| 9.2.1. 802.11a MODE IN THE 5.2 GHz BAND..... | 26 |
| 9.2.2. 802.11n HT20 MODE IN THE 5.2 GHz BAND | 27 |
| 9.2.3. 802.11n HT40 MODE IN THE 5.2 GHz BAND | 28 |
| 9.2.4. 802.11ac VHT80 MODE IN THE 5.2 GHz BAND | 29 |

| | | |
|---------|---|----|
| 9.2.5. | 802.11a MODE IN THE 5.3 GHz BAND..... | 30 |
| 9.2.6. | 802.11n HT20 MODE IN THE 5.3 GHz BAND | 31 |
| 9.2.7. | 802.11n HT40 MODE IN THE 5.3 GHz BAND | 32 |
| 9.2.8. | 802.11ac VHT80 MODE IN THE 5.3 GHz BAND | 33 |
| 9.2.9. | 802.11a MODE IN THE 5.6 GHz BAND..... | 34 |
| 9.2.10. | 802.11n HT20 MODE IN THE 5.6 GHz BAND | 35 |
| 9.2.11. | 802.11n HT40 MODE IN THE 5.6 GHz BAND | 36 |
| 9.2.12. | 802.11ac VHT80 MODE IN THE 5.6 GHz BAND | 37 |
| 9.2.13. | 802.11a MODE IN THE 5.8 GHz BAND..... | 38 |
| 9.2.14. | 802.11n HT20 MODE IN THE 5.8 GHz BAND | 39 |
| 9.2.15. | 802.11n HT40 MODE IN THE 5.8 GHz BAND | 40 |
| 9.2.16. | 802.11ac VHT80 MODE IN THE 5.8 GHz BAND | 41 |
| 9.3. | 99% BANDWIDTH..... | 42 |
| 9.3.1. | 802.11a MODE IN THE 5.2 GHz BAND..... | 43 |
| 9.3.2. | 802.11n HT20 MODE IN THE 5.2 GHz BAND | 44 |
| 9.3.3. | 802.11n HT40 MODE IN THE 5.2 GHz BAND | 45 |
| 9.3.4. | 802.11ac VHT80 MODE IN THE 5.2 GHz BAND | 46 |
| 9.3.5. | 802.11a MODE IN THE 5.3 GHz BAND..... | 47 |
| 9.3.6. | 802.11n HT20 MODE IN THE 5.3 GHz BAND | 48 |
| 9.3.7. | 802.11n HT40 MODE IN THE 5.3 GHz BAND | 49 |
| 9.3.8. | 802.11ac VHT80 MODE IN THE 5.3 GHz BAND | 50 |
| 9.3.9. | 802.11a MODE IN THE 5.6 GHz BAND..... | 51 |
| 9.3.10. | 802.11n HT20 MODE IN THE 5.6 GHz BAND | 52 |
| 9.3.11. | 802.11n HT40 MODE IN THE 5.6 GHz BAND | 53 |
| 9.3.12. | 802.11ac VHT80 MODE IN THE 5.6 GHz BAND | 54 |
| 9.3.13. | 802.11a MODE IN THE 5.8 GHz BAND..... | 55 |
| 9.3.14. | 802.11n HT20 MODE IN THE 5.8 GHz BAND | 56 |
| 9.3.15. | 802.11n HT40 MODE IN THE 5.8 GHz BAND | 57 |
| 9.3.16. | 802.11ac VHT80 MODE IN THE 5.8 GHz BAND | 58 |
| 9.4. | 6 dB BANDWIDTH..... | 59 |
| 9.4.1. | 802.11a MODE IN THE 5.8 GHz BAND..... | 60 |
| 9.4.2. | 802.11n HT20 MODE IN THE 5.8 GHz BAND | 61 |
| 9.4.3. | 802.11n HT40 MODE IN THE 5.8 GHz BAND | 62 |
| 9.4.4. | 802.11ac VHT80 MODE IN THE 5.8 GHz BAND | 63 |
| 9.5. | OUTPUT POWER AND PSD..... | 64 |
| 9.5.1. | 802.11a MODE IN THE 5.2 GHz BAND..... | 66 |
| 9.5.2. | 802.11n HT20 MODE IN THE 5.2 GHz BAND | 68 |
| 9.5.3. | 802.11n HT40 MODE IN THE 5.2 GHz BAND | 70 |
| 9.5.4. | 802.11ac VHT80 MODE IN THE 5.2 GHz BAND | 72 |
| 9.5.5. | 802.11a MODE IN THE 5.3 GHz BAND..... | 74 |
| 9.5.6. | 802.11n HT20 MODE IN THE 5.3 GHz BAND | 76 |
| 9.5.7. | 802.11n HT40 MODE IN THE 5.3 GHz BAND | 78 |
| 9.5.8. | 802.11ac VHT80 MODE IN THE 5.3 GHz BAND | 80 |
| 9.5.9. | 802.11a MODE IN THE 5.6 GHz BAND..... | 82 |
| 9.5.10. | 802.11n HT20 MODE IN THE 5.6 GHz BAND | 84 |
| 9.5.11. | 802.11n HT40 MODE IN THE 5.6 GHz BAND | 86 |
| 9.5.12. | 802.11ac VHT80 MODE IN THE 5.6 GHz BAND | 88 |
| 9.5.13. | 802.11a MODE IN THE 5.8 GHz BAND..... | 90 |
| 9.5.14. | 802.11n HT20 MODE IN THE 5.8 GHz BAND | 92 |
| 9.5.15. | 802.11n HT40 MODE IN THE 5.8 GHz BAND | 94 |
| 9.5.16. | 802.11ac VHT80 MODE IN THE 5.8 GHz BAND | 96 |

| | |
|---|------------|
| 10. RADIATED TEST RESULTS..... | 98 |
| 10.1. TRANSMITTER ABOVE 1 GHz..... | 100 |
| 10.1.1. TX ABOVE 1 GHz 802.11a MODE IN THE 5.2 GHz BAND | 100 |
| 10.1.2. TX ABOVE 1 GHz 802.11n HT20 MODE IN THE 5.2 GHz BAND..... | 108 |
| 10.1.3. TX ABOVE 1 GHz 802.11n HT40 MODE IN THE 5.2 GHz BAND..... | 116 |
| 10.1.4. TX ABOVE 1 GHz 802.11ac VHT80 MODE IN THE 5.2 GHz BAND | 122 |
| 10.1.5. TX ABOVE 1 GHz 802.11a MODE IN THE 5.3 GHz BAND | 126 |
| 10.1.6. TX ABOVE 1 GHz 802.11n HT20 MODE IN THE 5.3 GHz BAND..... | 134 |
| 10.1.7. TX ABOVE 1 GHz 802.11n HT40 MODE IN THE 5.3 GHz BAND..... | 142 |
| 10.1.8. TX ABOVE 1 GHz 802.11ac VHT80 MODE IN THE 5.3 GHz BAND | 148 |
| 10.1.9. TX ABOVE 1 GHz 802.11a MODE IN THE 5.6 GHz BAND | 152 |
| 10.1.10. TX ABOVE 1 GHz 802.11n HT20 MODE IN THE 5.6 GHz BAND..... | 164 |
| 10.1.11. TX ABOVE 1 GHz 802.11n HT40 MODE IN THE 5.6 GHz BAND..... | 176 |
| 10.1.12. TX ABOVE 1 GHz 802.11ac VHT80 MODE IN THE 5.6 GHz BAND | 188 |
| 10.1.13. TX ABOVE 1 GHz 802.11a MODE IN THE 5.8 GHz BAND | 198 |
| 10.1.14. TX ABOVE 1 GHz 802.11n HT20 MODE IN THE 5.8 GHz BAND..... | 208 |
| 10.1.15. TX ABOVE 1 GHz 802.11n HT40 MODE IN THE 5.8 GHz BAND..... | 218 |
| 10.1.16. TX ABOVE 1 GHz 802.11ac VHT80 MODE IN THE 5.8 GHz BAND | 226 |
| 10.2. Worst Case Below 30MHz..... | 232 |
| 10.3. Worst Case Below 1 GHz..... | 234 |
| 10.4. Worst Case 18-26 GHz | 236 |
| 10.5. Worst Case 26-40 GHz | 238 |
| 11. AC POWER LINE CONDUCTED EMISSIONS..... | 240 |
| 11.1.1. AC Power Line Norm | 241 |
| 12. SETUP PHOTOS..... | 243 |
| 12.1.1. A3LSMA305F (Original)..... | 243 |
| 12.1.2. A3LSMA305GN (Spot Check)..... | 246 |

1. ATTESTATION OF TEST RESULTS

COMPANY NAME: Samsung Electronics Co., Ltd.
129 Samsung-Ro, Yeongtong-Gu,
Suwon-Si, Gyeonggi-Do, 16677, Korea

EUT DESCRIPTION: GSM/WCDMA/LTE Phone with BT, DTS/UNII a/b/g/n/ac, ANT+
and NFC

MODEL: SM-A305GN/DS and SM-A305GN

SERIAL NUMBER: R38KC08WJSN; R38KC08WKGY (Radiated)
R38KC08WHJE (Conducted) (Original)
R38KC0L4PSX; R38KC0L4PPB (Spot Check)

DATE TESTED: JANUARY 15 to 31, 2019 (Original)
JANUARY 28 to FEBRUARY 28, 2019 (Spot Check)

| APPLICABLE STANDARDS | |
|---------------------------------------|--------------|
| STANDARD | TEST RESULTS |
| CFR 47 Part 15 Subpart E (Except DFS) | Complies |

UL Verification Services Inc. tested the above equipment in accordance with the requirements set forth in the above standards. The test results show that the equipment tested is capable of demonstrating compliance with the requirements as documented in this report.

The results documented in this report apply only to the tested sample, under the conditions and modes of operation as described herein. It is the manufacturer's responsibility to assure that additional production units of this model are manufactured with identical electrical and mechanical components. All samples tested were in good operating condition throughout the entire test program. Measurement Uncertainties are published for informational purposes only and were not taken into account unless noted otherwise.

This document may not be altered or revised in any way unless done so by UL Verification Services Inc. and all revisions are duly noted in the revisions section. Any alteration of this document not carried out by UL Verification Services Inc. will constitute fraud and shall nullify the document. This report must not be used by the client to claim product certification, approval, or endorsement by NVLAP, NIST, any agency of the Federal Government, or any agency of the U.S. government.

Approved & Released For
UL Verification Services Inc. By:

Reviewed By:



DAN CORONIA
Operations Leader
Consumer Technology Division
UL Verification Services Inc.

KIYA KEDIDA
Senior Project Engineer
Consumer Technology Division
UL Verification Services Inc.

2. INTRODUCTION OF TEST DATA REUSE

2.1. INTRODUCTION

According to the manufacturer, FCC ID: A3LSMA305F and FCC ID: A3LSMA305GN non-licensed radios are electrically identical. The FCC ID: A3LSMA305F test data shall remain representative of FCC ID: A3LSMA305GN.

The applicant takes full responsibility that the test data as referenced in this section represents compliance for this FCC ID.

2.2. DIFFERENCES

Difference between A3LSMA305F and A3LSMA305GN:

Samsung Electronics Co. Ltd. declares that A3LSMA305GN supports NFC function and the following additional WCDMA and LTE bands: WCDMA Band 4, LTE Band 2, Band 4, Band 12, Band 13, Band 17 and Band 66.

The FCC ID: A3LSMA305F, shares the same enclosure and circuit board as FCC ID: A3LSMA305GN. The UNII WLAN antennas and surrounding circuitry and layout are identical between two models.

After confirming through preliminary radiated emissions that the performance of the FCC ID: A3LSMA305F remains representative of FCC ID: A3LSMA305GN. The test data of FCC ID: A3LSMA305F being submitted for this application to cover UNII WLAN features.

2.3. SPOT CHECK VERIFICATION RESULTS SUMMARY

Spot check verification has been done on device A3LSMA305GN for radiated harmonic spurious and radiated band-edge. The data from the application has been verified through appropriate spot checks to demonstrate compliance for this device in accordance to FCC public KDB 484596 D01 as shown in the summary below.

| A3LSMA305GN SPOT CHECK RESULTS | | | | | | | | | | |
|--------------------------------|----------------------------|-----------|---------|--------------------|----------------|-------|------------------|-------|------------|--------|
| Technology | Mode | Test Item | Channel | Measured Frequency | Original model | | Spot check model | | Delta (dB) | |
| | | | | | SM-A305F/DS | | SM-A305GN/DS | | | |
| | | | | | A3LSMA305F | | A3LSMA305GN | | Peak | Ave |
| UNII | 5.3 11n HT40 5310MHz | RBE | 62 | 5350MHz | 66.88 | 50.75 | 67.63 | 51.84 | 0.75 | 1.09 |
| | 5.8 11n HT40 5795MHz | RSE | 159 | 1159MHz | 51.29 | 45.13 | 31.44 | 23.52 | -19.85 | -21.61 |

Comparison of the models, upper deviation is within 3dB range and all tests are under FCC Technical Limits.

2.3.1. SPOT CHECK DATA

BANDEDGE (HIGH CHANNEL)

HORIZONTAL RESULT

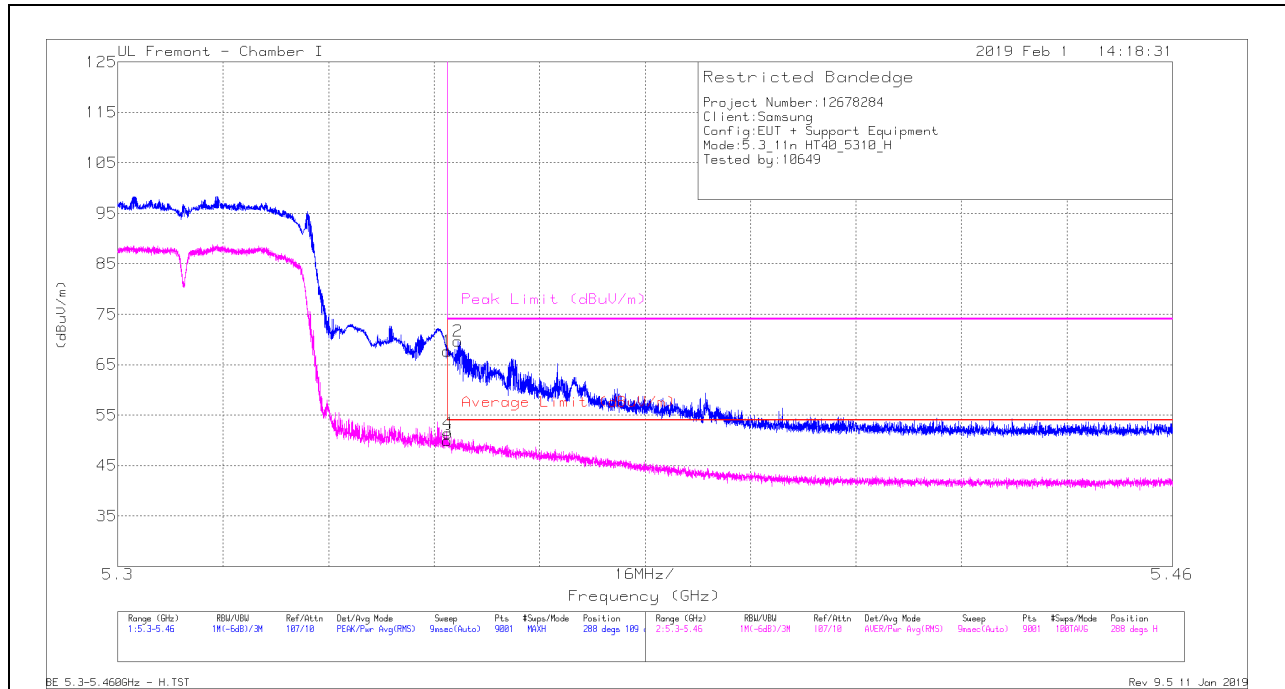

Trace Markers

| Marker | Frequency (GHz) | Meter Reading (dBuV) | Det | AF T862 (dB/m) | Amp/Cb/Fitr/Pa d (dB) | DC Corr (dB) | Corrected Reading (dBuV/m) | Average Limit (dBuV/m) | Margin (dB) | Peak Limit (dBuV/m) | PK Margin (dB) | Azimuth (Degs) | Height (cm) | Polarity |
|--------|-----------------|----------------------|-----|----------------|-----------------------|--------------|----------------------------|------------------------|-------------|---------------------|----------------|----------------|-------------|----------|
| 1 | * 5.35 | 51.43 | Pk | 34.5 | -18.3 | 0 | 67.63 | - | - | 74 | -6.37 | 288 | 109 | H |
| 2 | * 5.352 | 53.44 | Pk | 34.5 | -18.3 | 0 | 69.64 | - | - | 74 | -4.36 | 288 | 109 | H |
| 3 | * 5.35 | 33.14 | RMS | 34.5 | -18.3 | .71 | 50.05 | 54 | -3.95 | - | - | 288 | 109 | H |
| 4 | * 5.35 | 34.57 | RMS | 34.5 | -18.3 | .71 | 51.48 | 54 | -2.32 | - | - | 288 | 109 | H |

* - indicates frequency in CFR47 Pt 15 / IC RSS-Restricted Band

Pk - Peak detector

RMS - RMS detection

VERTICAL RESULT

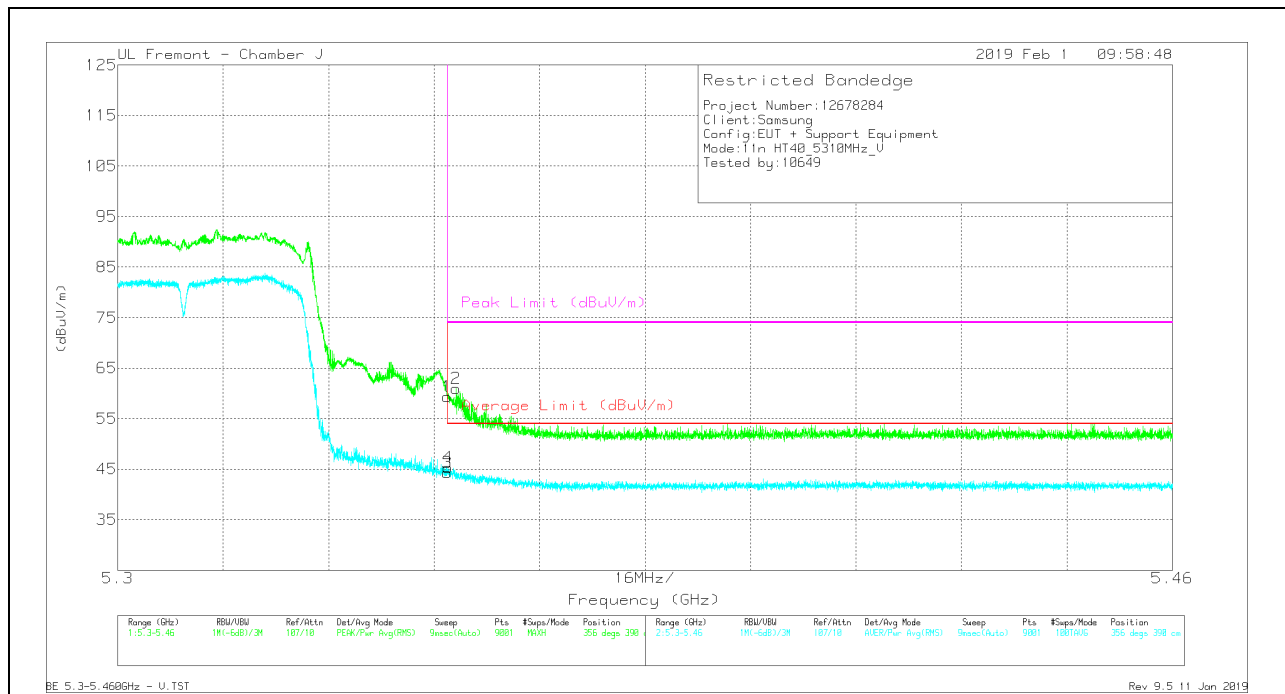

Trace Markers

| Marker | Frequency (GHz) | Meter Reading (dBuV) | Det | AF AT0067 (dB/m) | Amp/Cb/Filt/Pad (dB) | DC Corr (dB) | Corrected Reading (dBuV/m) | Average Limit (dBuV/m) | Margin (dB) | Peak Limit (dBuV/m) | PK Margin (dB) | Azimuth (Degs) | Height (cm) | Polarity |
|--------|-----------------|----------------------|-----|------------------|----------------------|--------------|----------------------------|------------------------|-------------|---------------------|----------------|----------------|-------------|----------|
| 1 | * 5.35 | 46.27 | Pk | 34.3 | -21.2 | 0 | 59.37 | - | - | 74 | -14.63 | 356 | 390 | V |
| 2 | * 5.351 | 47.9 | Pk | 34.3 | -21.2 | 0 | 61 | - | - | 74 | -13 | 356 | 390 | V |
| 3 | * 5.35 | 30.61 | RMS | 34.3 | -21.2 | .71 | 44.42 | 54 | -9.58 | - | - | 356 | 390 | V |
| 4 | * 5.35 | 31.59 | RMS | 34.3 | -21.2 | .71 | 45.4 | 54 | -8.6 | - | - | 356 | 390 | V |

* - indicates frequency in CFR47 Pt 15 / IC RSS-Restricted Band
 Pk - Peak detector
 RMS - RMS detection

HARMONICS AND SPURIOUS EMISSIONS

LOW CHANNEL RESULTS

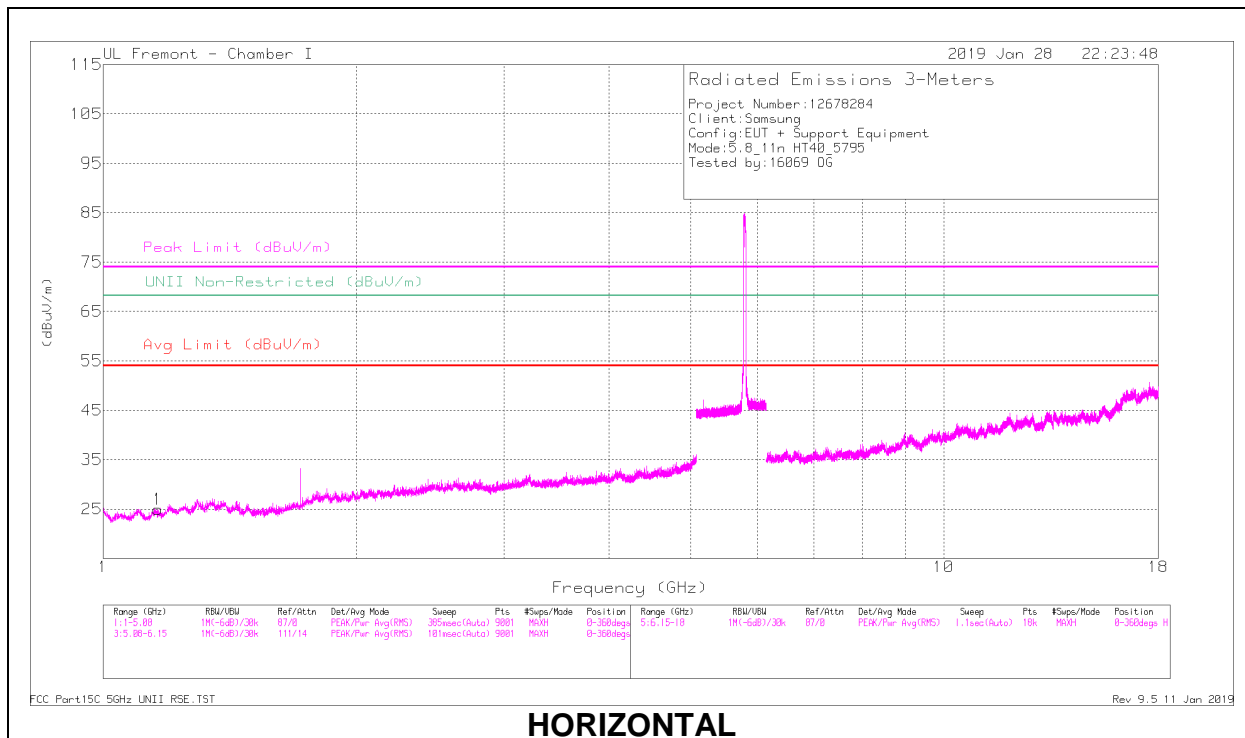

HORIZONTAL

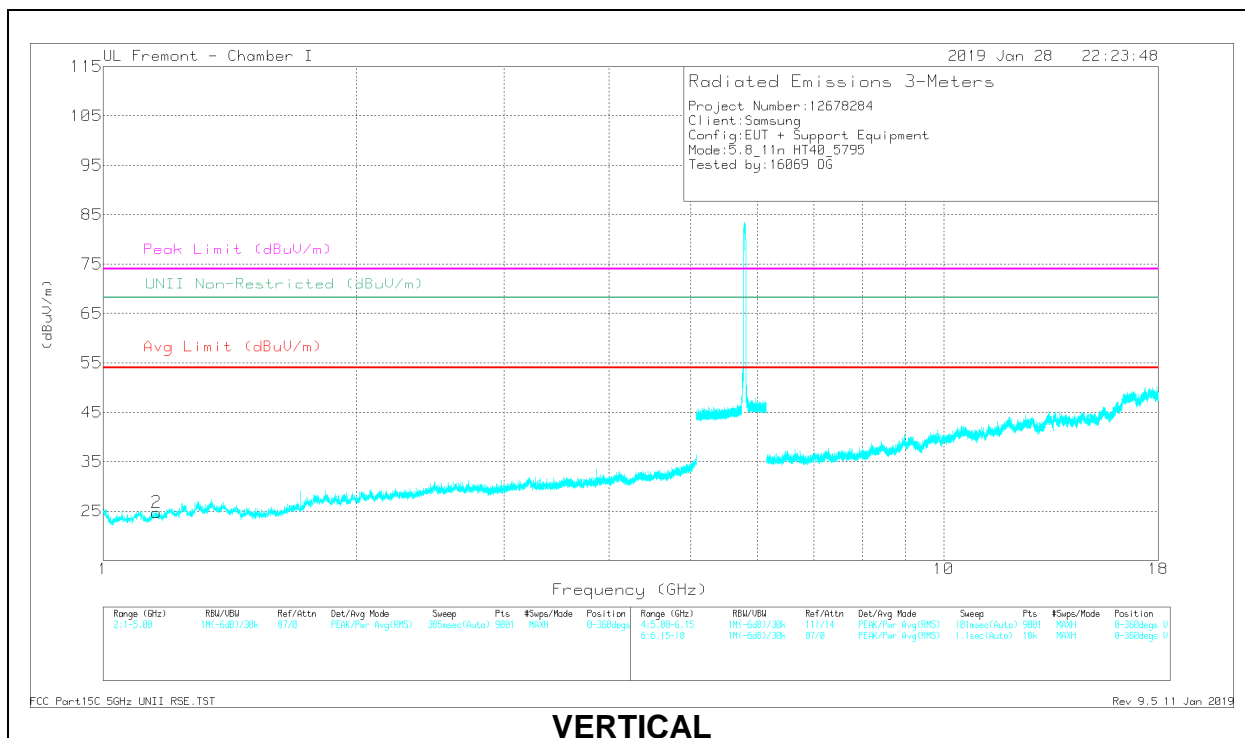

VERTICAL

RADIATED EMISSIONS

| Frequency (GHz) | Meter Reading (dBuV) | Det | AF T862 (dB/m) | AmpCali/FreqPa d (dB) | DC Corr (dB) | Corrected Reading (dBuV/m) | Avg Limit (dBuV/m) | Margin (dB) | Peak Limit (dBuV/m) | PK Margin (dB) | UNII Non-Restricted (dBuV/m) | PK Margin (dB) | Azimuth (Degs) | Height (cm) | Polarity |
|-----------------|----------------------|------|----------------|-----------------------|--------------|----------------------------|--------------------|-------------|---------------------|----------------|------------------------------|----------------|----------------|-------------|----------|
| 1.162 | 38.8 | PK-U | 27.6 | -33.9 | 0 | 32.5 | - | - | 74 | -41.5 | - | - | 159 | 292 | H |
| 1.16 | 28.86 | ADR | 27.6 | -34 | .71 | 23.17 | 54 | -30.83 | - | - | - | - | 159 | 292 | H |
| 1.158 | 37.84 | PK-U | 27.6 | -34 | 0 | 31.44 | - | - | 74 | -42.56 | - | - | 255 | 391 | V |
| 1.158 | 29.21 | ADR | 27.6 | -34 | .71 | 23.52 | 54 | -30.48 | - | - | - | - | 255 | 391 | V |

PK-U - U-NII: Maximum Peak

ADR - U-NII AD primary method, RMS average

2.4. REFERENCE DETAIL

Reference application that contains the reused reference data

| Equipment Class | Reference FCC ID | Type Grant/ Permissive Change | Reference Application | Folder Test/RF Exposure | Report Title/Section |
|------------------------|-------------------------|--------------------------------------|------------------------------|--------------------------------|--|
| NII | A3LSMA305F | Grant | 12678282-E5 | Test | FCC Report UNII WLAN / All sections except DFS |

3. TEST METHODOLOGY

The tests documented in this report were performed in accordance with FCC CFR 47 Part 2, FCC CFR 47 Part 15, FCC 14-30, FCC KDB 662911 D01 v02r01, FCC KDB 905462 D02 v02/D03 v01r02/D06 v02, FCC KDB 789033 D02 v02r01, FCC KDB 644545 D03 v01, ANSI C63.10-2013, FCC 06-96.

4. FACILITIES AND ACCREDITATION

The test sites and measurement facilities used to collect data are located at 47173 and 47266 Benicia Street, and 47658 Kato Road, Fremont, California, USA. Line conducted emissions are measured only at the 47173 address. The following table identifies which facilities were utilized for radiated emission measurements documented in this report. Specific facilities are also identified in the test results sections.

| 47173 Benicia Street | 47266 Benicia Street | 47658 Kato Rd |
|---|---|--|
| <input type="checkbox"/> Chamber A (ISED:2324B-1) | <input type="checkbox"/> Chamber D (ISED:22541-1) | <input checked="" type="checkbox"/> Chamber I (ISED:2324A-5) |
| <input type="checkbox"/> Chamber B (ISED:2324B-2) | <input type="checkbox"/> Chamber E (ISED:22541-2) | <input checked="" type="checkbox"/> Chamber J (ISED:2324A-6) |
| <input type="checkbox"/> Chamber C (ISED:2324B-3) | <input type="checkbox"/> Chamber F (ISED:22541-3) | <input checked="" type="checkbox"/> Chamber K (ISED:2324A-1) |
| | <input type="checkbox"/> Chamber G (ISED:22541-4) | <input checked="" type="checkbox"/> Chamber L (ISED:2324A-3) |
| | <input type="checkbox"/> Chamber H (ISED:22541-5) | |

The above test sites and facilities are covered under FCC Test Firm Registration # 208313. Chambers above are covered under Industry Canada company address and respective code

UL Verification Services Inc. is accredited by NVLAP, Laboratory Code 200065-0

5. CALIBRATION AND UNCERTAINTY

5.1. MEASURING INSTRUMENT CALIBRATION

The measuring equipment utilized to perform the tests documented in this report has been calibrated in accordance with the manufacturer's recommendations, and is traceable to recognized national standards.

5.2. SAMPLE CALCULATION

RADIATED EMISSIONS

Where relevant, the following sample calculation is provided:

Field Strength (dBuV/m) = Measured Voltage (dBuV) + Antenna Factor (dB/m) + Cable Loss (dB) – Preamp Gain (dB)

$$36.5 \text{ dBuV} + 18.7 \text{ dB/m} + 0.6 \text{ dB} - 26.9 \text{ dB} = 28.9 \text{ dBuV/m}$$

MAINS CONDUCTED EMISSIONS

Where relevant, the following sample calculation is provided:

Final Voltage (dBuV) = Measured Voltage (dBuV) + Cable Loss (dB) + Limiter Factor (dB) + LISN Insertion Loss.

$$36.5 \text{ dBuV} + 0 \text{ dB} + 10.1 \text{ dB} + 0 \text{ dB} = 46.6 \text{ dBuV}$$

5.3. MEASUREMENT UNCERTAINTY

Where relevant, the following measurement uncertainty levels have been estimated for tests performed on the apparatus:

| PARAMETER | UNCERTAINTY |
|---|-------------|
| Worst Case Conducted Disturbance, 9KHz to 0.15 MHz | 3.84 dB |
| Worst Case Conducted Disturbance, 0.15 to 30 MHz | 3.65 dB |
| Worst Case Radiated Disturbance, 9KHz to 30 MHz | 3.15 dB |
| Worst Case Radiated Disturbance, 30 to 1000 MHz | 5.36 dB |
| Worst Case Radiated Disturbance, 1000 to 18000 MHz | 4.32 dB |
| Worst Case Radiated Disturbance, 18000 to 26000 MHz | 4.45 dB |
| Worst Case Radiated Disturbance, 26000 to 40000 MHz | 5.24 dB |

Uncertainty figures are valid to a confidence level of 95%.

6. EQUIPMENT UNDER TEST

6.1. EUT DESCRIPTION

The EUT is a GSM/WCDMA/LTE Phone with BT, DTS/UNII a/b/g/n/ac, ANT+ and NFC. The test report addresses the UNII WLAN operational mode

6.2. MAXIMUM OUTPUT POWER

The transmitter has a maximum conducted output power as follows:

5.2 GHz BAND

| Frequency Range (MHz) | Mode | Output Power (dBm) | Output Power (mW) |
|--------------------------|----------------|--------------------|-------------------|
| 5.2 GHz band, 1TX | | | |
| 5180-5240 | 802.11a | 16.57 | 45.39 |
| 5180-5240 | 802.11n HT20 | 15.80 | 38.02 |
| 5190-5230 | 802.11n HT40 | 14.81 | 30.27 |
| 5210 | 802.11ac VHT80 | 13.46 | 22.18 |

5.3 GHz BAND

| Frequency Range (MHz) | Mode | Output Power (dBm) | Output Power (mW) |
|--------------------------|----------------|--------------------|-------------------|
| 5.3 GHz band, 1TX | | | |
| 5260 - 5320 | 802.11a | 16.89 | 48.87 |
| 5260 - 5320 | 802.11n HT20 | 15.79 | 37.93 |
| 5270 - 5310 | 802.11n HT40 | 14.84 | 30.48 |
| 5290 | 802.11ac VHT80 | 13.79 | 23.93 |

5.6 GHz BAND

| Frequency Range (MHz) | Mode | Output Power (dBm) | Output Power (mW) |
|--------------------------|----------------|--------------------|-------------------|
| 5.6 GHz band, 1TX | | | |
| 5500-5720 | 802.11a | 16.98 | 49.89 |
| 5500-5720 | 802.11n HT20 | 15.67 | 36.90 |
| 5510-5710 | 802.11n HT40 | 15.31 | 33.96 |
| 5530-5690 | 802.11ac VHT80 | 13.92 | 24.66 |

5.8 GHz BAND

| Frequency Range (MHz) | Mode | Output Power (dBm) | Output Power (mW) |
|--------------------------|----------------|--------------------|-------------------|
| 5.8 GHz band, 1TX | | | |
| 5745-5825 | 802.11a | 16.78 | 47.64 |
| 5745-5825 | 802.11n HT20 | 15.79 | 37.93 |
| 5755-5795 | 802.11n HT40 | 14.40 | 27.54 |
| 5775 | 802.11ac VHT80 | 13.43 | 22.03 |

6.3. DESCRIPTION OF AVAILABLE ANTENNAS

The radio utilizes an FPCB antenna, with a maximum gain of:

| Frequency (GHz) | Peak Antenna Gain (dBi) |
|-----------------|-------------------------|
| 5180-5240 | -3.70 |
| 5260-5320 | -2.60 |
| 5500-5700 | -2.60 |
| 5725-5850 | -3.50 |

6.4. SOFTWARE AND FIRMWARE

The test utility software used during testing was A305F.001

6.5. WORST-CASE CONFIGURATION AND MODE

Radiated emissions below 1GHz, above 18GHz, and power line conducted emission were performed with the EUT set to transmit at the channel with highest output power as worst-case scenario.

Band edge and radiated emissions between 1GHz and 18GHz were performed with the EUT set to transmit at the highest power on low, middle and high channels.

The fundamental of the EUT was investigated in three orthogonal orientations X,Y,Z, it was determined that X orientation was worst-case orientation; therefore, all final radiated testing was performed with the EUT in X orientation.

Worst-case data rates as provided by the client were:

802.11a mode: 6 Mbps
802.11n HT20mode: MCS0
802.11n HT40mode: MCS0
802.11ac VHT80 mode: MCS0

6.6. DESCRIPTION OF TEST SETUP

SUPPORT EQUIPMENT

| Support Equipment List | | | | |
|------------------------|--------------|------------|---------------|--------|
| Description | Manufacturer | Model | Serial Number | FCC ID |
| AC Adapter | Samsung | EP-TA50EWE | DW3J719AS/A-E | N/A |
| Earphone | Samsung | N/A | N/A | N/A |

I/O CABLES (CONDUCTED TEST)

| I/O Cable List | | | | | | |
|----------------|---------|----------------------|----------------|-------------|------------------|----------------------|
| Cable No | Port | # of identical ports | Connector Type | Cable Type | Cable Length (m) | Remarks |
| 1 | Antenna | 1 | RF | Shielded | 0.2 | To spectrum Analyzer |
| 2 | USB | 1 | USB | Un-shielded | 1 | EUT to AC Mains |

I/O CABLES (RADIATED AND CONDUCTED EMISSIONS)

| I/O Cable List | | | | | | |
|----------------|----------|----------------------|----------------|-------------|------------------|---------|
| Cable No | Port | # of identical ports | Connector Type | Cable Type | Cable Length (m) | Remarks |
| 1 | USB | 1 | USB | Shielded | 1 | N/A |
| 2 | earphone | 1 | 3.5mm | Un-shielded | 1 | N/A |

TEST SETUP

The EUT is a stand alone. Test software exercised the radio card.

CONDUCTED TEST SETUP DIAGRAM

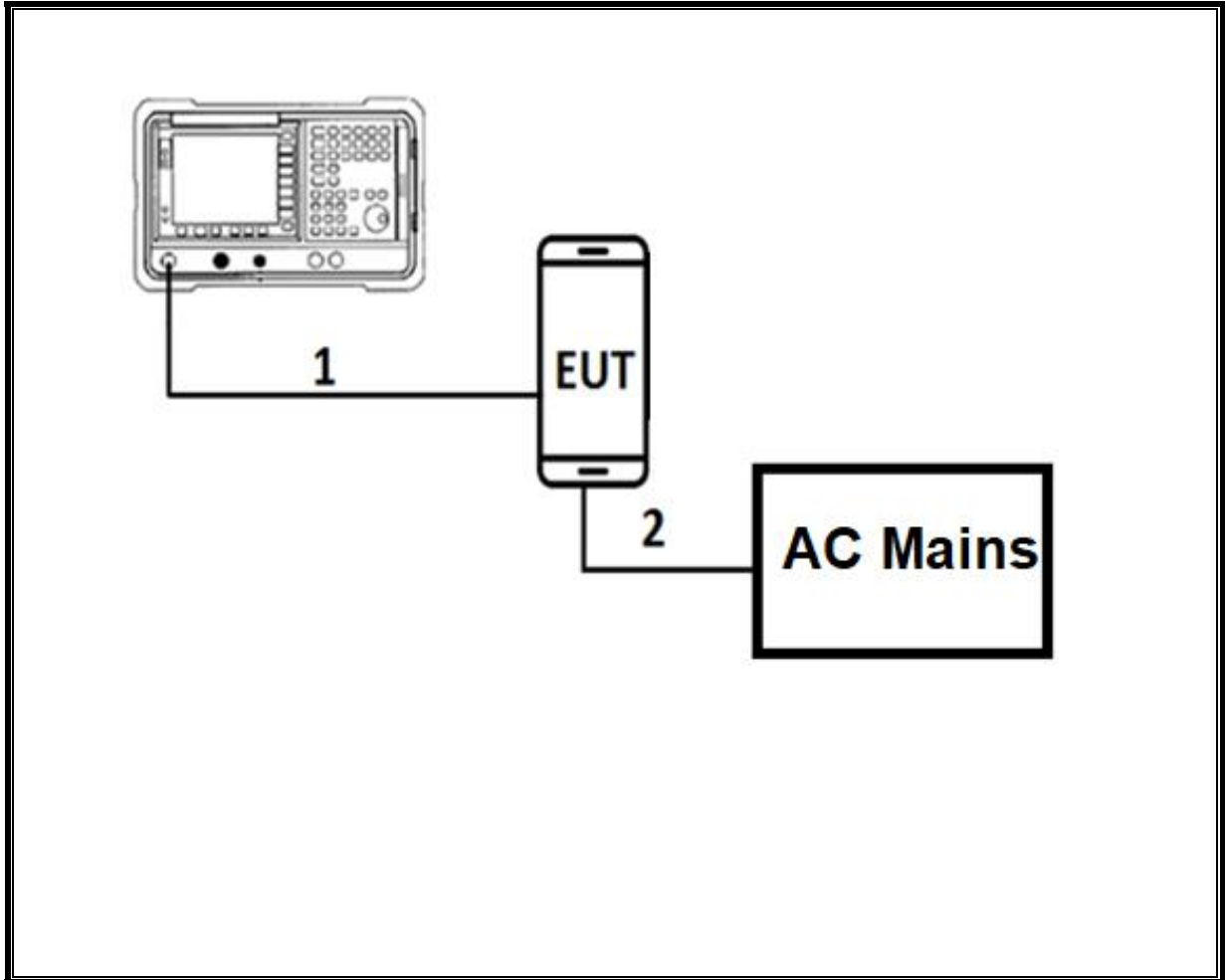

TEST SETUP

For conducted tests: the EUT was Stand alone. The test software exercises the radio.

RADIATED AND AC LINE CONDUCTED EMISSIONS SETUP DIAGRAM

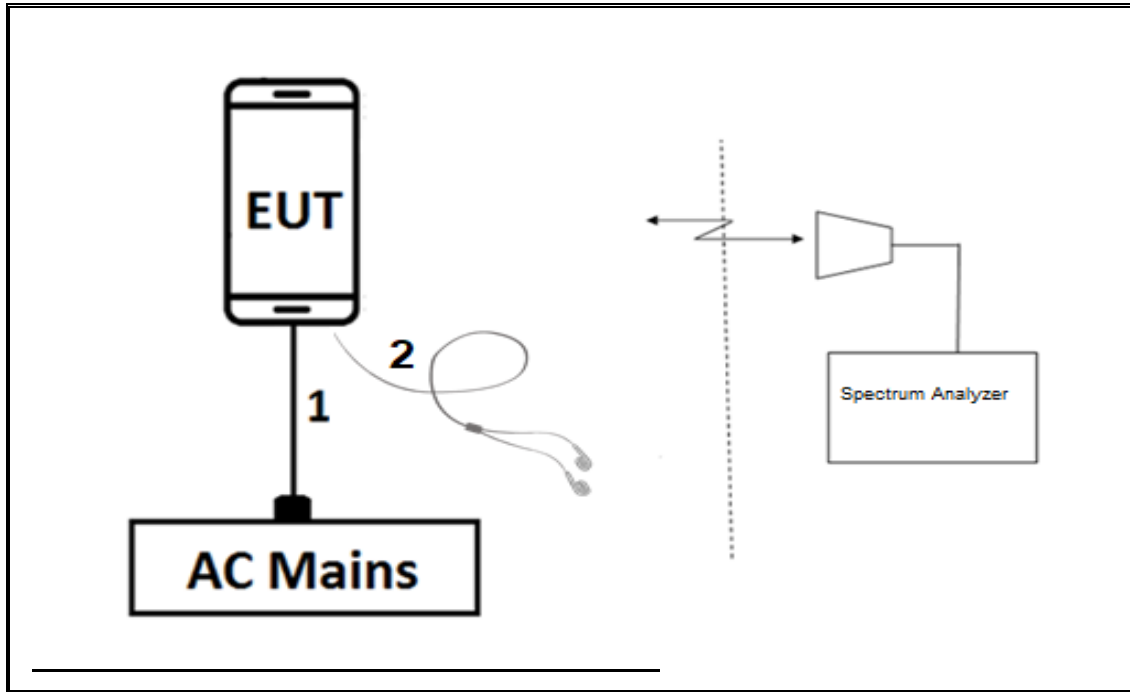

TEST SETUP

For radiated tests: EUT is Stand alone. The test software exercises the radio.

7. MEASUREMENT METHOD

On Time and Duty Cycle: KDB 789033 D02 v02r01, Section II.B.

6 dB Emission BW: KDB 789033 D02 v02r01, Section II.C.2

26 dB Emission BW: KDB 789033 D02 v02r01, Section II.C.1

99% Occupied BW: KDB 789033 D02 v02r01, Section II.D.

Conducted Output Power: KDB 789033 D02 v02r01, Sections II.E.3.b & II.E.2.b.

Power Spectral Density: KDB 789033 D02 v02r01, Section II F.

Unwanted emissions: KDB 789033 D02 v02r01, Sections II.G.3 – II.G.6.

AC Power Line Conducted Emissions: ANSI C63.10-2013, Section 6.2.

8. TEST AND MEASUREMENT EQUIPMENT

The following test and measurement equipment was utilized for the tests documented in this report:

| TEST EQUIPMENT LIST | | | | |
|--|---------------------------------|------------------------|-------------------------|------------|
| Description | Manufacturer | Model | Asset | Cal Due |
| Antenna, Passive Loop 9KHz to 1MHz | ELETRO METRICS | EM-6871 | PRE0179465 | 05/22/2019 |
| Antenna, Passive Loop 9KHz to 1MHz | ELETRO METRICS | EM-6872 | PRE0179467 | 05/22/2019 |
| Amplifier, 10KHz to 1GHz, 32dB | SONOMA INSTRUMENT | 310 | PRE0180175 | 07/09/2019 |
| Antenna, Horn 1-18GHz | ETS Lindgren | 3117 | T862 | 05/24/2019 |
| Amplifier, 1 to 18GHz | MITEQ | AFS42-00101800-25-S-42 | PRE1782151 | 08/01/2019 |
| Antenna, Horn 1-18GHz | ETS Lindgren | 3117 | AT0067 | 03/06/2019 |
| Amplifier, 1 to 18GHz | Amplical | AMP1G18-35 | T1571 | 07/30/2019 |
| Antenna, Horn 1-18GHz | ETS Lindgren | 3117 | T344 | 03/06/2019 |
| Amplifier, 1 to 18GHz | Amplical | AMP1G18-35 | T1569 | 06/03/2019 |
| Antenna, Broadband Hybrid, 30MHz to 3000MHz | SunAR RF Motion | JB3 | PRE0184970 | 11/13/2019 |
| Amplifier, 10KHz to 1GHz, 32dB | SONOMA INSTRUMENT | 310 | PRE0180174 | 05/31/2019 |
| Spectrum Analyzer, PXA, 3Hz to 44GHz | Keysight | E4446A | T146 | 08/13/2019 |
| Antenna Horn, 18 to 26.5GHz | ARA | MWH-1826/B | T448 | 03/13/2019 |
| Antenna Horn, 26 to 40GHz | ARA | MWH-2640 | T90 | 03/11/2019 |
| Pre-Amp 1-26.5 GHz | Agilent | 8449B | T404 | 03/09/2019 |
| Pre-Amp 26-40GHz | MITEQ | NSTTA2640-35-HG | T1864 | 03/09/2019 |
| EMI Test Receiver | Rohde&Schwarz | ESW44 | PRE0179372 | 05/04/2019 |
| EMI Test Receiver | Rohde&Schwarz | ESW44 | PRE0179367 | 04/28/2019 |
| EMI Test Receiver | Rohde&Schwarz | ESW44 | PRE0179375 | 05/08/2019 |
| EMI Test Receiver | Rohde&Schwarz | ESW44 | PRE0179376 | 05/08/2019 |
| EMI Test Receiver | Rohde&Schwarz | ESW44 | PRE0179377 | 11/02/2019 |
| Power Meter, P-series single channel | Agilent (Keysight) Technologies | N1911A | T1271 | 07/17/2019 |
| Power Sensor, P-series, 50MHz to 18GHz, Wideband | Agilent (Keysight) Technologies | N1921A | T1225 | 04/10/2019 |
| AC Line Conducted | | | | |
| EMI Receiver | Rohde & Schwarz | ESR | T1436 | 02/21/2019 |
| LISN for Conducted Emissions CISPR-16 | FCC INC. | FCC LISN 50/250 | T1310 | 06/15/2019 |
| UL AUTOMATION SOFTWARE | | | | |
| Radiated Software | UL | UL EMC | Ver 9.5, June 22, 2018 | |
| Antenna Port Software | UL | UL RF | Ver 8.8.1, Sep 26, 2018 | |
| AC Line Conducted Software | UL | UL EMC | Ver 9.5, May 26, 2015 | |

NOTES:

1. Equipment listed above that calibrated during the testing period was set for test after the calibration.
2. Equipment listed above that has a calibration due date during the testing period, the testing is completed before equipment expiration date.

9. ANTENNA PORT TEST RESULTS

9.1. ON TIME AND DUTY CYCLE

LIMITS

None; for reporting purposes only.

PROCEDURE

KDB 789033 Zero-Span Spectrum Analyzer Method.

ON TIME AND DUTY CYCLE RESULTS

| Mode | ON Time B (msec) | Period (msec) | Duty Cycle x (linear) | Duty Cycle (%) | Duty Cycle Correction Factor (dB) | 1/B Minimum VBW (kHz) |
|----------------|------------------------|------------------|-----------------------------|----------------------|---|-----------------------------|
| 802.11a | 1.417 | 1.508 | 0.940 | 93.97% | 0.27 | 0.706 |
| 802.11n HT20 | 1.342 | 1.433 | 0.936 | 93.65% | 0.28 | 0.745 |
| 802.11n HT40 | 0.658 | 0.775 | 0.849 | 84.94% | 0.71 | 1.519 |
| 802.11ac VHT80 | 0.332 | 0.447 | 0.743 | 74.26% | 1.29 | 3.015 |

DUTY CYCLE PLOTS

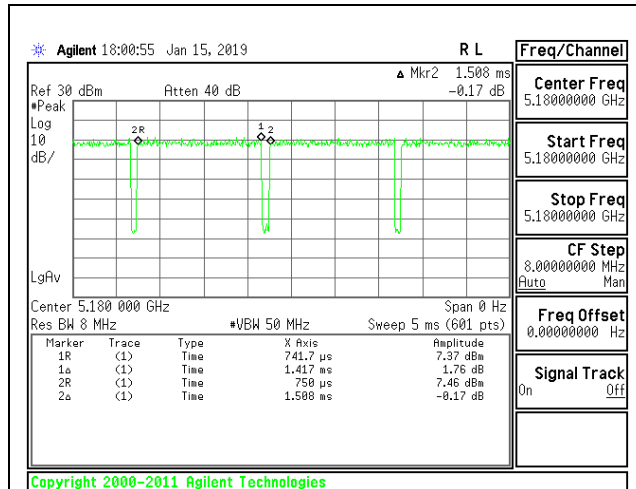

DUTY CYCLE 802.11a

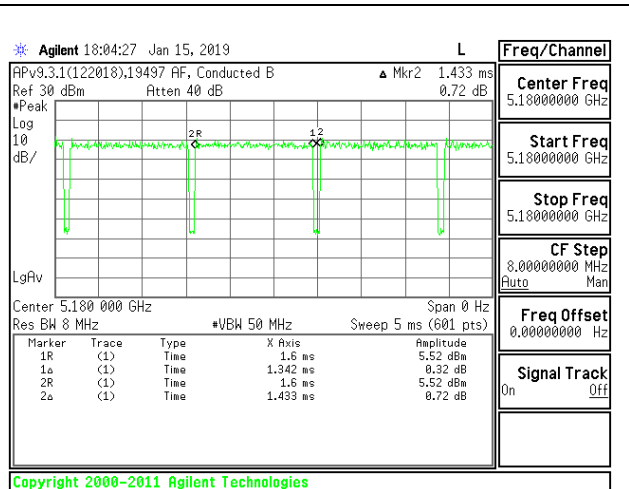

DUTY CYCLE 802.11n HT20

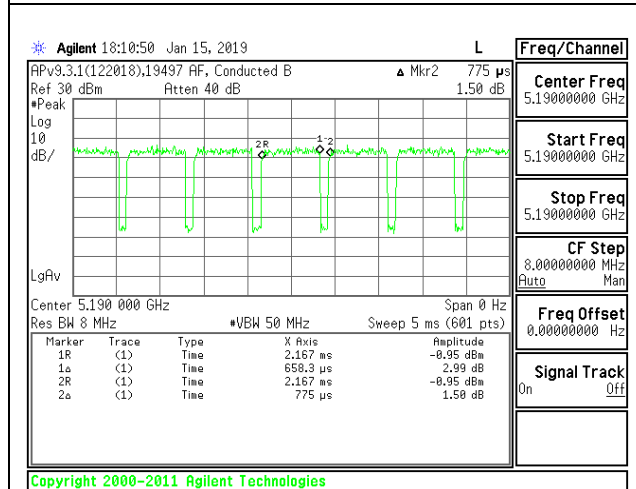

DUTY CYCLE 802.11n HT40

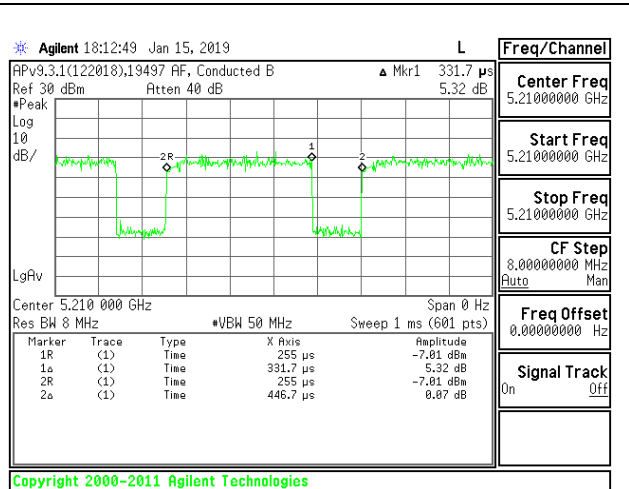

DUTY CYCLE 802.11ac VHT80

9.2. 26 dB BANDWIDTH

LIMITS

None; for reporting purposes only.

RESULTS

9.2.1. 802.11a MODE IN THE 5.2 GHz BAND

1TX Antenna 1 MODE

| Channel | Frequency (MHz) | 26 dB Bandwidth (MHz) |
|---------|--------------------|--------------------------|
| Low | 5180 | 28.00 |
| Mid | 5200 | 28.40 |
| High | 5240 | 27.05 |

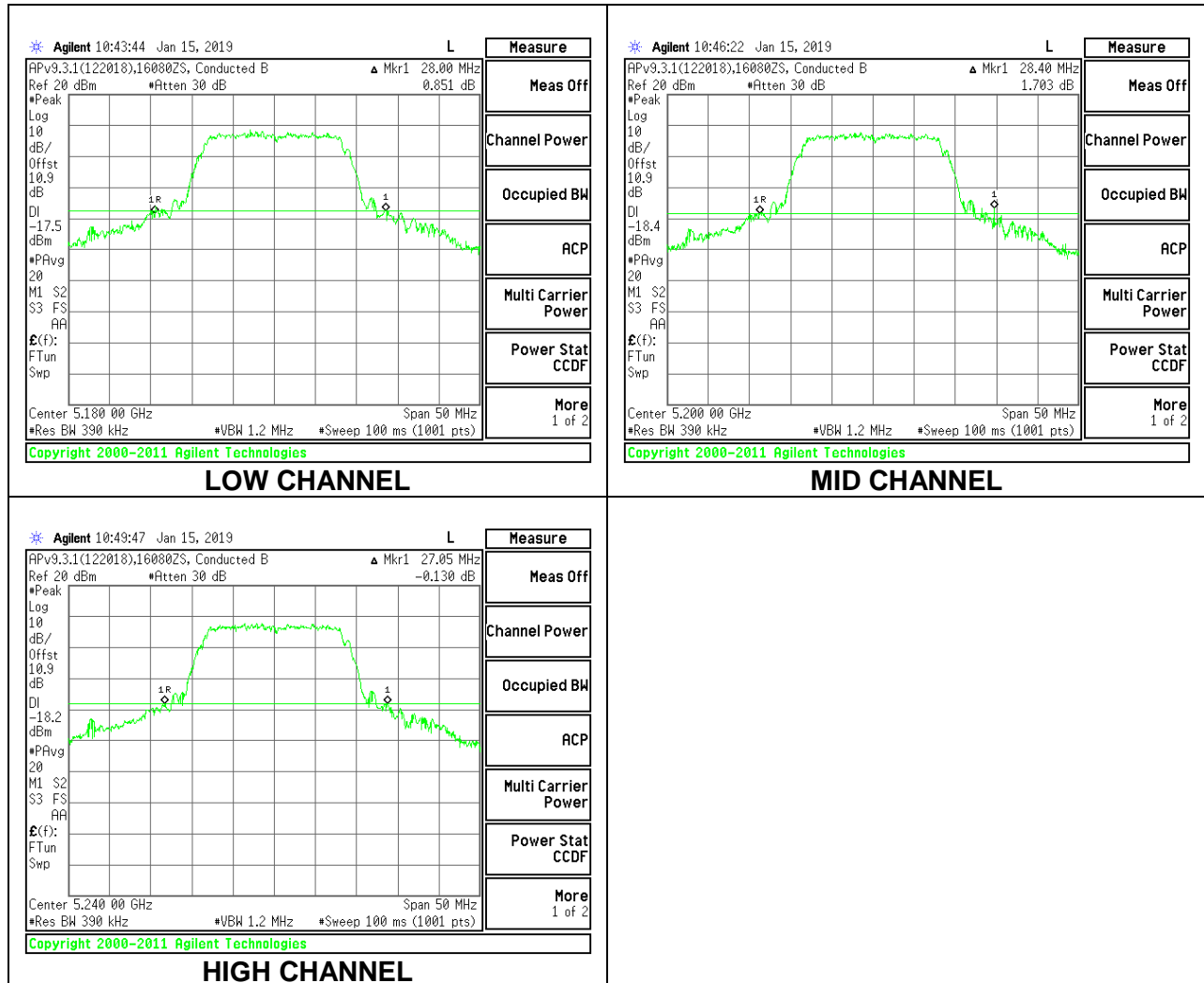

9.2.2. 802.11n HT20 MODE IN THE 5.2 GHz BAND

1TX Antenna 1 MODE

| Channel | Frequency (MHz) | 26 dB Bandwidth (MHz) |
|---------|--------------------|--------------------------|
| Low | 5180 | 29.45 |
| Mid | 5200 | 29.25 |
| High | 5240 | 30.05 |

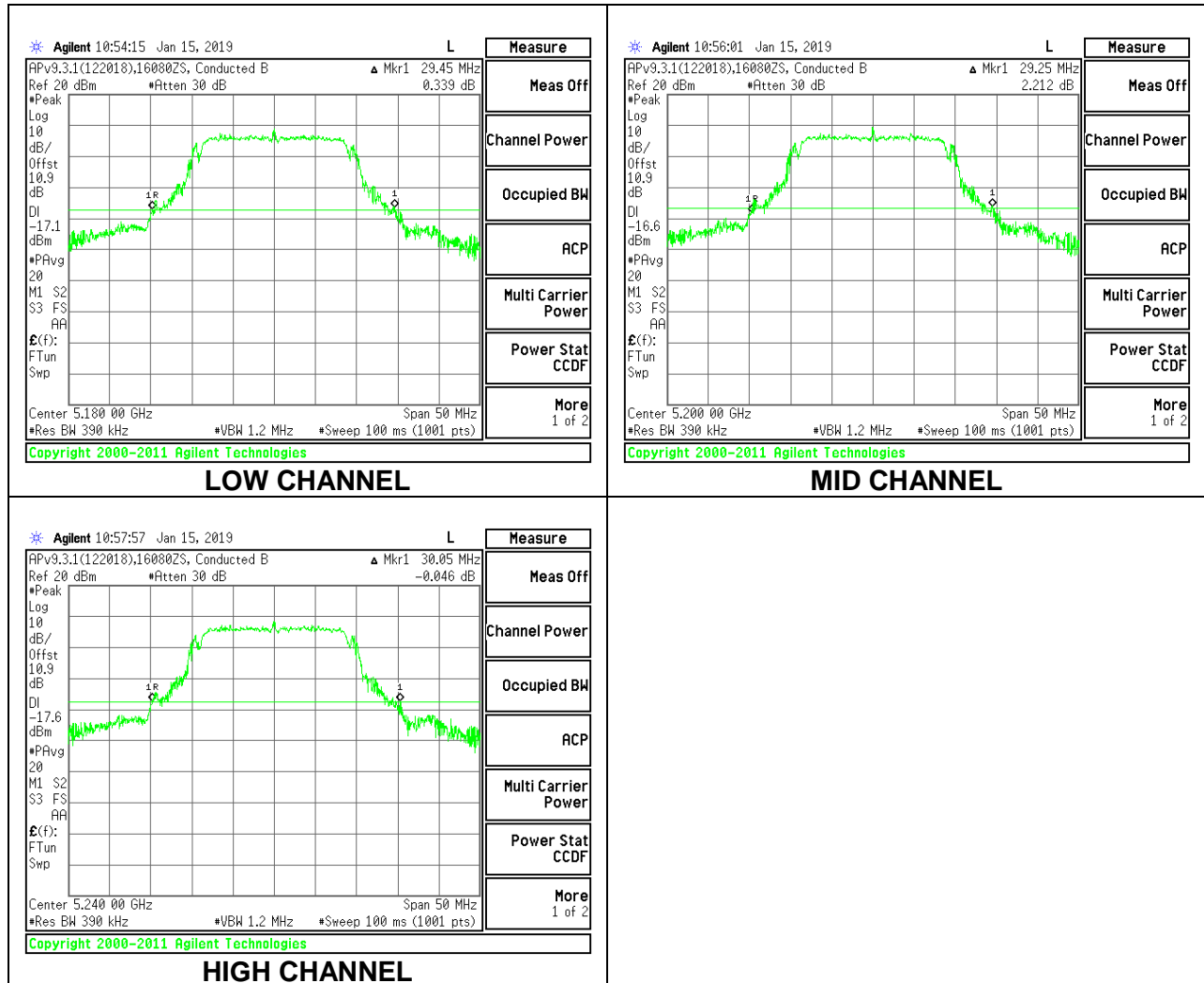

9.2.3. 802.11n HT40 MODE IN THE 5.2 GHz BAND

1TX Antenna 1 MODE

| Channel | Frequency (MHz) | 26dB Bandwidth (MHz) |
|---------|--------------------|-------------------------|
| Low | 5190 | 47.70 |
| High | 5230 | 44.50 |

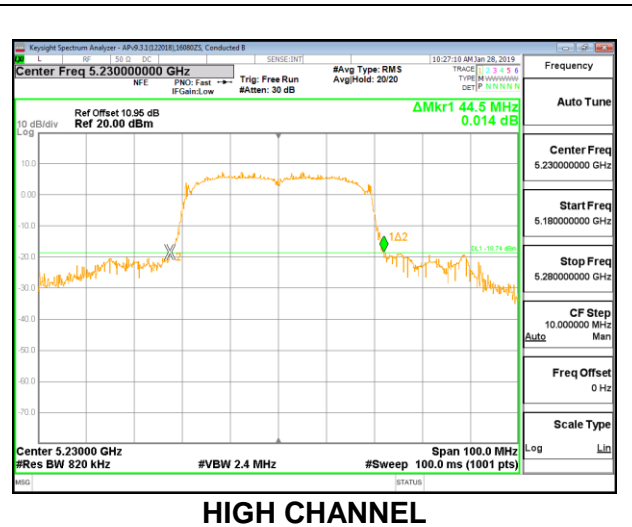
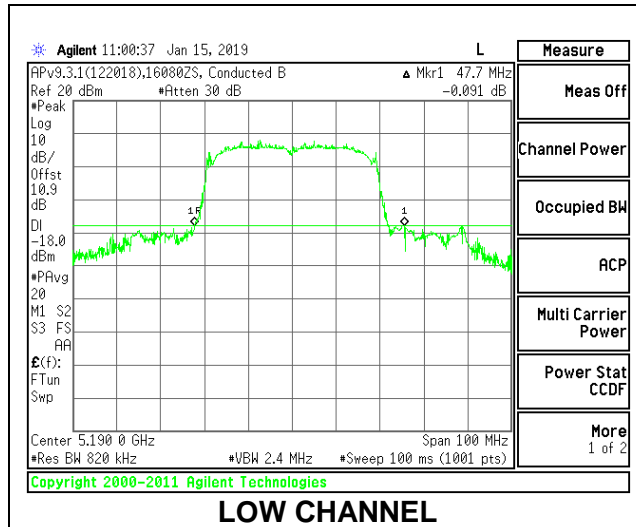

9.2.4. 802.11ac VHT80 MODE IN THE 5.2 GHz BAND

1TX Antenna 1 MODE

| Channel | Frequency (MHz) | 26 dB Bandwidth (MHz) |
|---------|--------------------|--------------------------|
| Mid | 5210 | 100.40 |

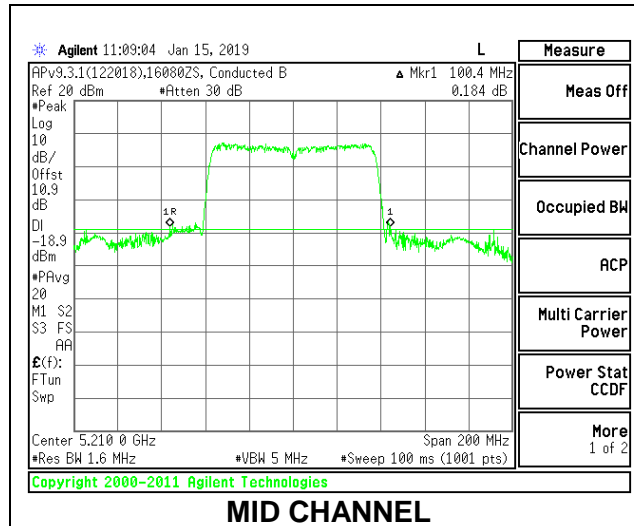

9.2.5. 802.11a MODE IN THE 5.3 GHz BAND

1TX Antenna 1 MODE

| Channel | Frequency (MHz) | 26 dB Bandwidth (MHz) |
|---------|--------------------|--------------------------|
| Low | 5260 | 30.40 |
| Mid | 5300 | 27.40 |
| High | 5320 | 30.40 |

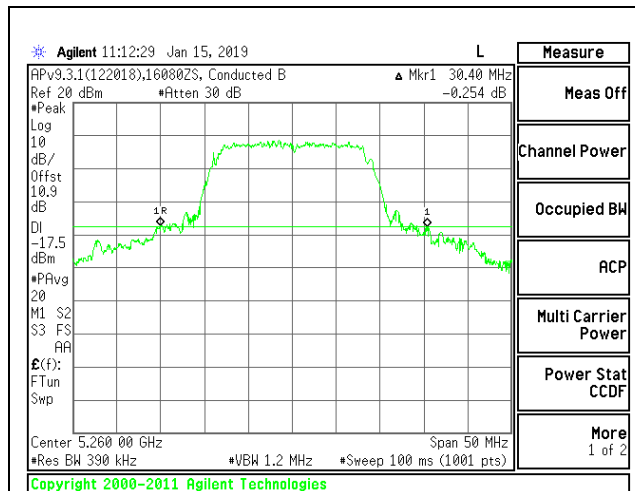

LOW CHANNEL

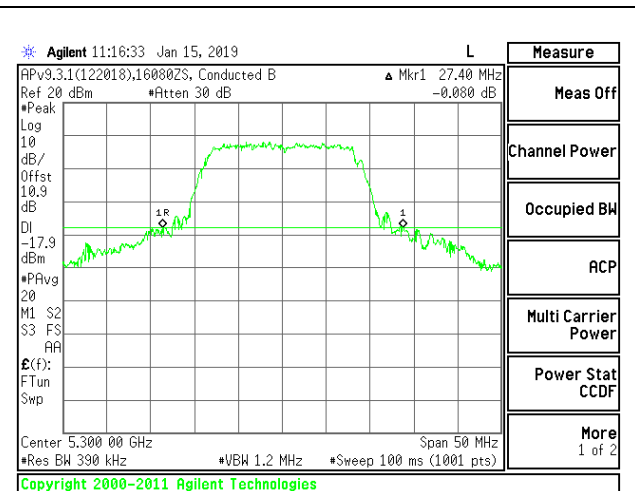

MID CHANNEL

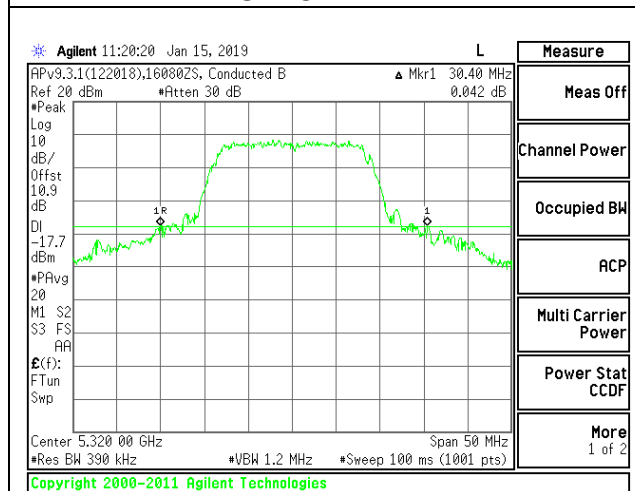

HIGH CHANNEL

9.2.6. 802.11n HT20 MODE IN THE 5.3 GHz BAND

1TX Antenna 1 MODE

| Channel | Frequency (MHz) | 26 dB Bandwidth (MHz) |
|---------|--------------------|--------------------------|
| Low | 5260 | 28.10 |
| Mid | 5300 | 29.40 |
| High | 5320 | 29.35 |

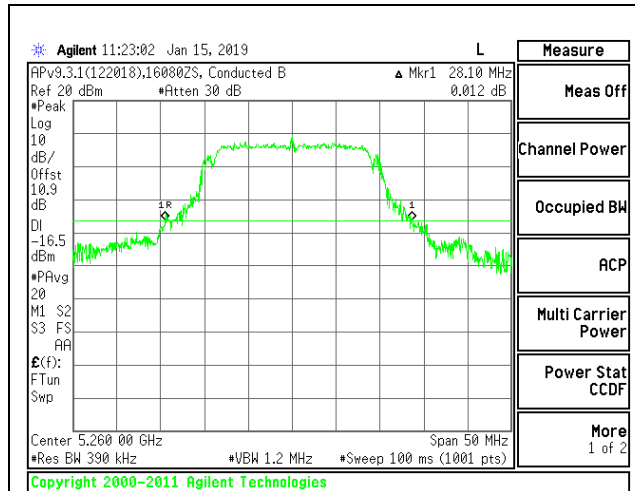

LOW CHANNEL

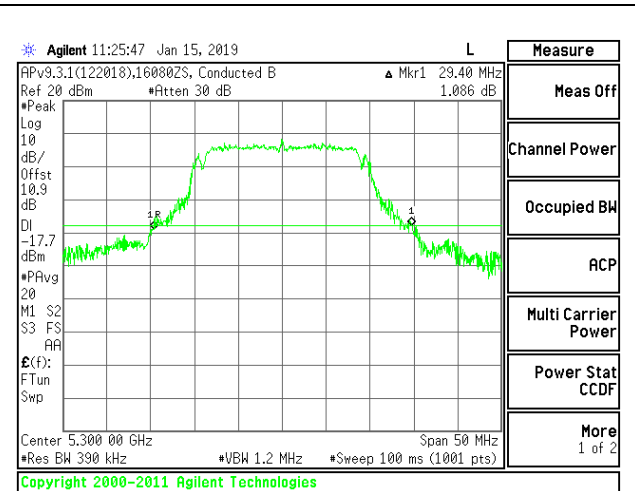

MID CHANNEL

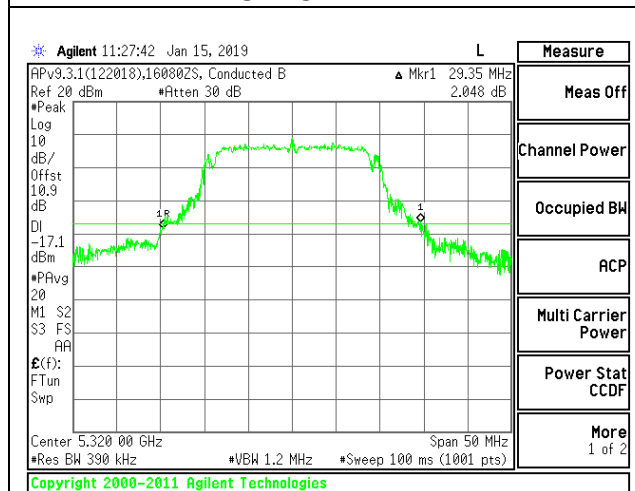

HIGH CHANNEL

9.2.7. 802.11n HT40 MODE IN THE 5.3 GHz BAND

1TX Antenna 1 MODE

| Channel | Frequency | 26dB Bandwidth |
|---------|-----------|----------------|
| | (MHz) | (MHz) |
| Low | 5270 | 44.00 |
| High | 5310 | 44.30 |

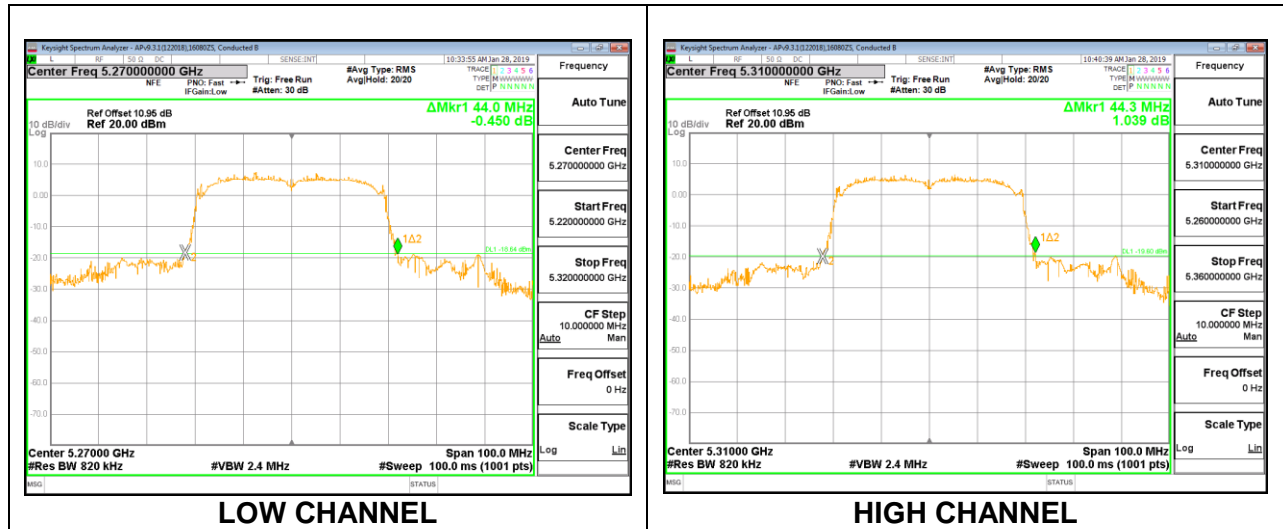

9.2.8. 802.11ac VHT80 MODE IN THE 5.3 GHz BAND

1TX Antenna 1 MODE

| Channel | Frequency | 26 dB Bandwidth |
|---------|-----------|-----------------|
| | (MHz) | (MHz) |
| Mid | 5290 | 114.60 |

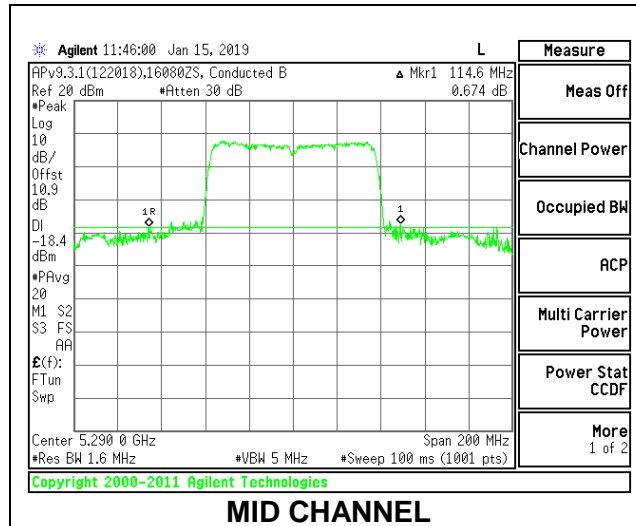

9.2.9. 802.11a MODE IN THE 5.6 GHz BAND

1TX Antenna 1 MODE

| Channel | Frequency (MHz) | 26 dB Bandwidth (MHz) |
|---------|--------------------|--------------------------|
| Low | 5500 | 29.25 |
| Mid | 5580 | 28.40 |
| High | 5700 | 28.30 |
| 144 | 5720 | 28.45 |

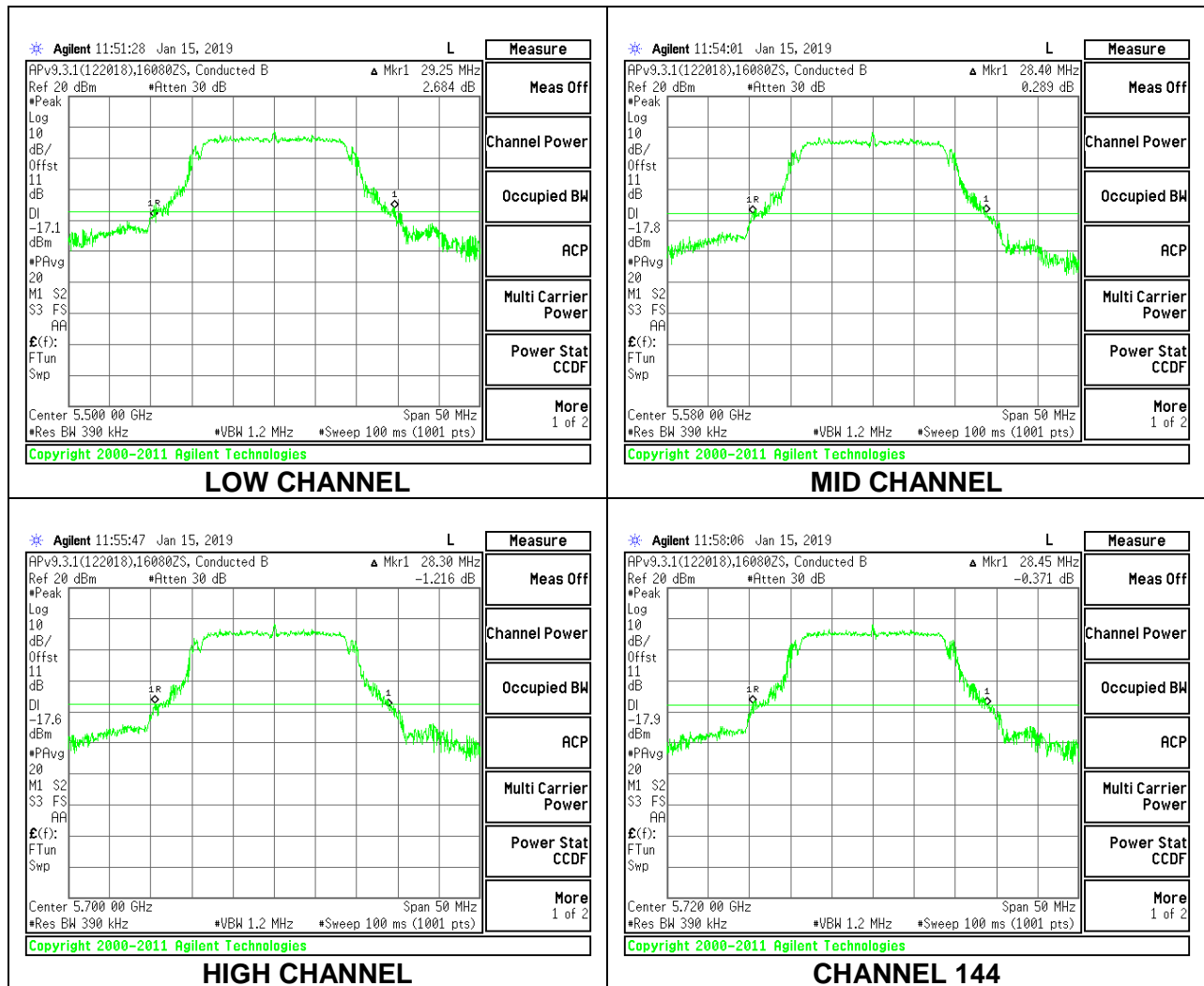

9.2.10. 802.11n HT20 MODE IN THE 5.6 GHz BAND

1TX Antenna 1 MODE

| Channel | Frequency (MHz) | 26 dB Bandwidth (MHz) |
|---------|--------------------|--------------------------|
| Low | 5500 | 30.25 |
| Mid | 5580 | 29.10 |
| High | 5700 | 29.15 |
| 144 | 5720 | 27.90 |

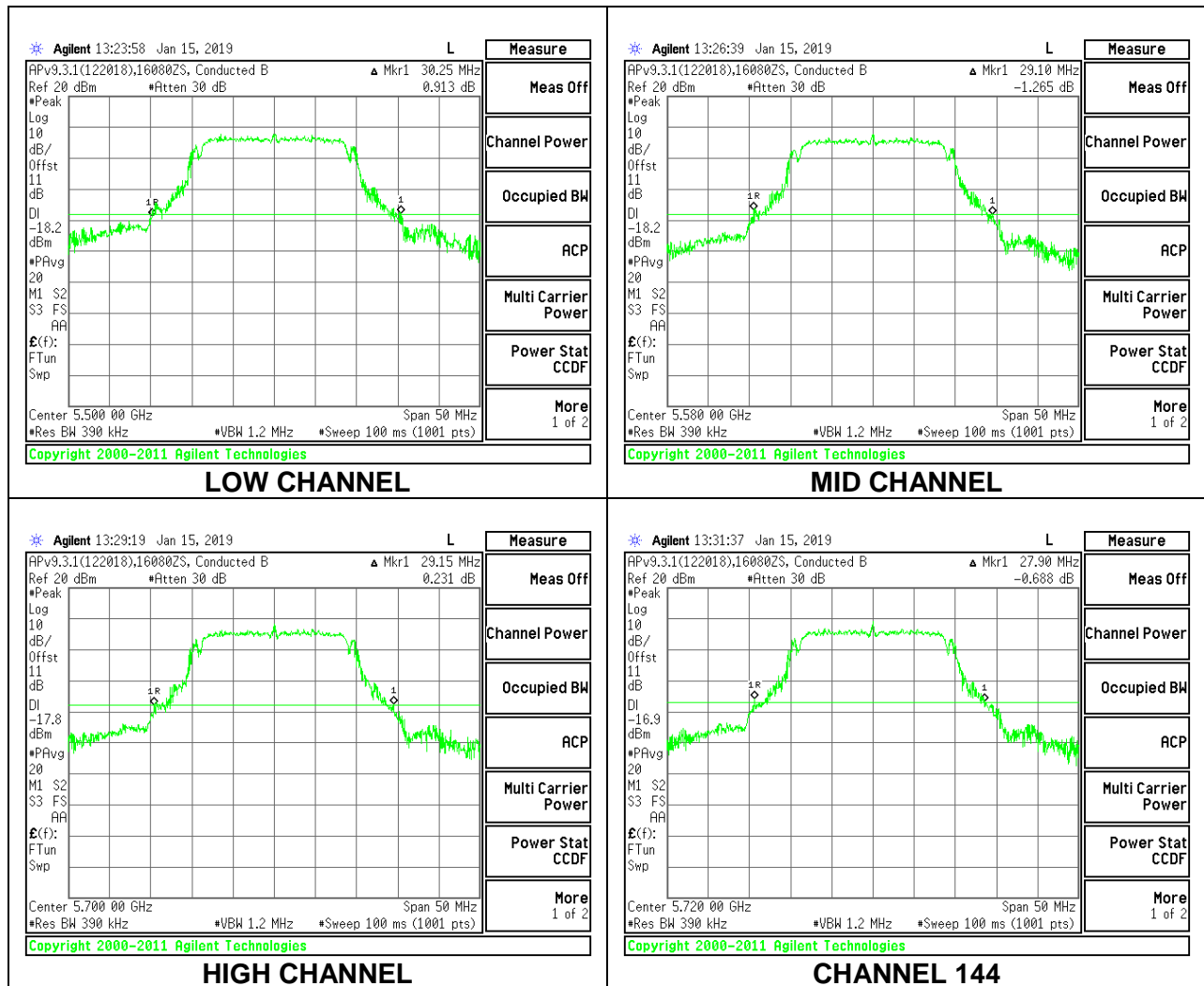

9.2.11. 802.11n HT40 MODE IN THE 5.6 GHz BAND

1TX Antenna 1 MODE

| Channel | Frequency (MHz) | 26 dB Bandwidth (MHz) |
|---------|--------------------|--------------------------|
| Low | 5510 | 44.10 |
| Mid | 5550 | 44.00 |
| High | 5670 | 44.10 |
| 142 | 5710 | 43.90 |

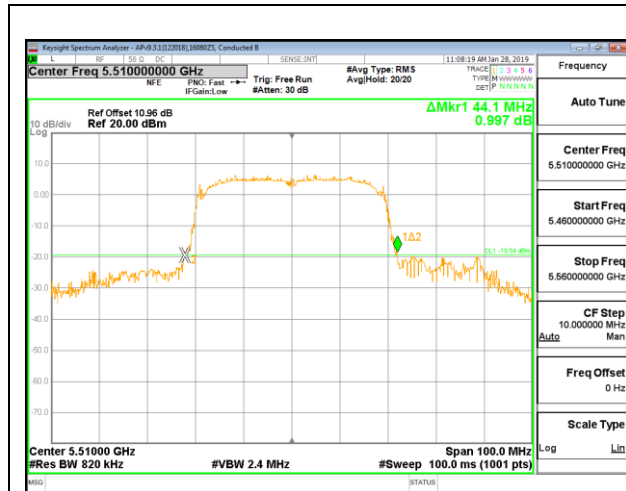

LOW CHANNEL

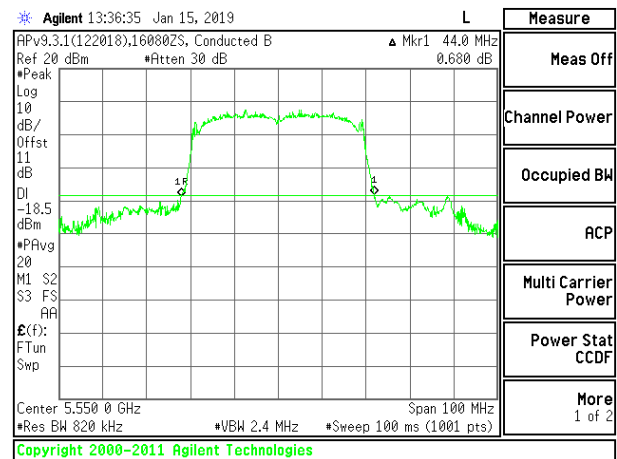

MID CHANNEL

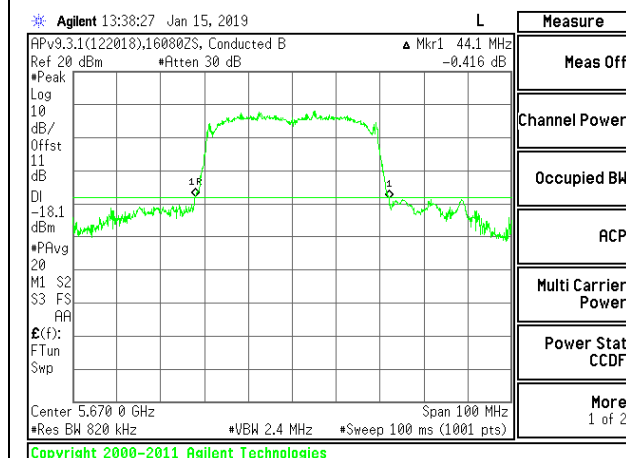

HIGH CHANNEL

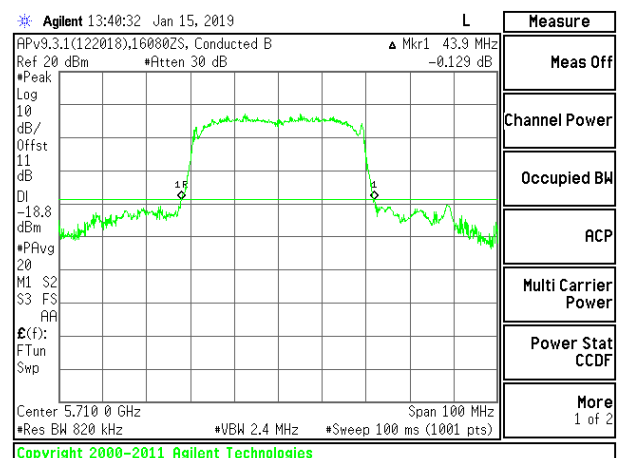

CHANNEL 142

9.2.12. 802.11ac VHT80 MODE IN THE 5.6 GHz BAND

1TX Antenna 1 MODE

| Channel | Frequency (MHz) | 26 dB Bandwidth (MHz) |
|---------|--------------------|--------------------------|
| Low | 5530 | 105.60 |
| High | 5610 | 113.20 |
| 138 | 5690 | 110.40 |

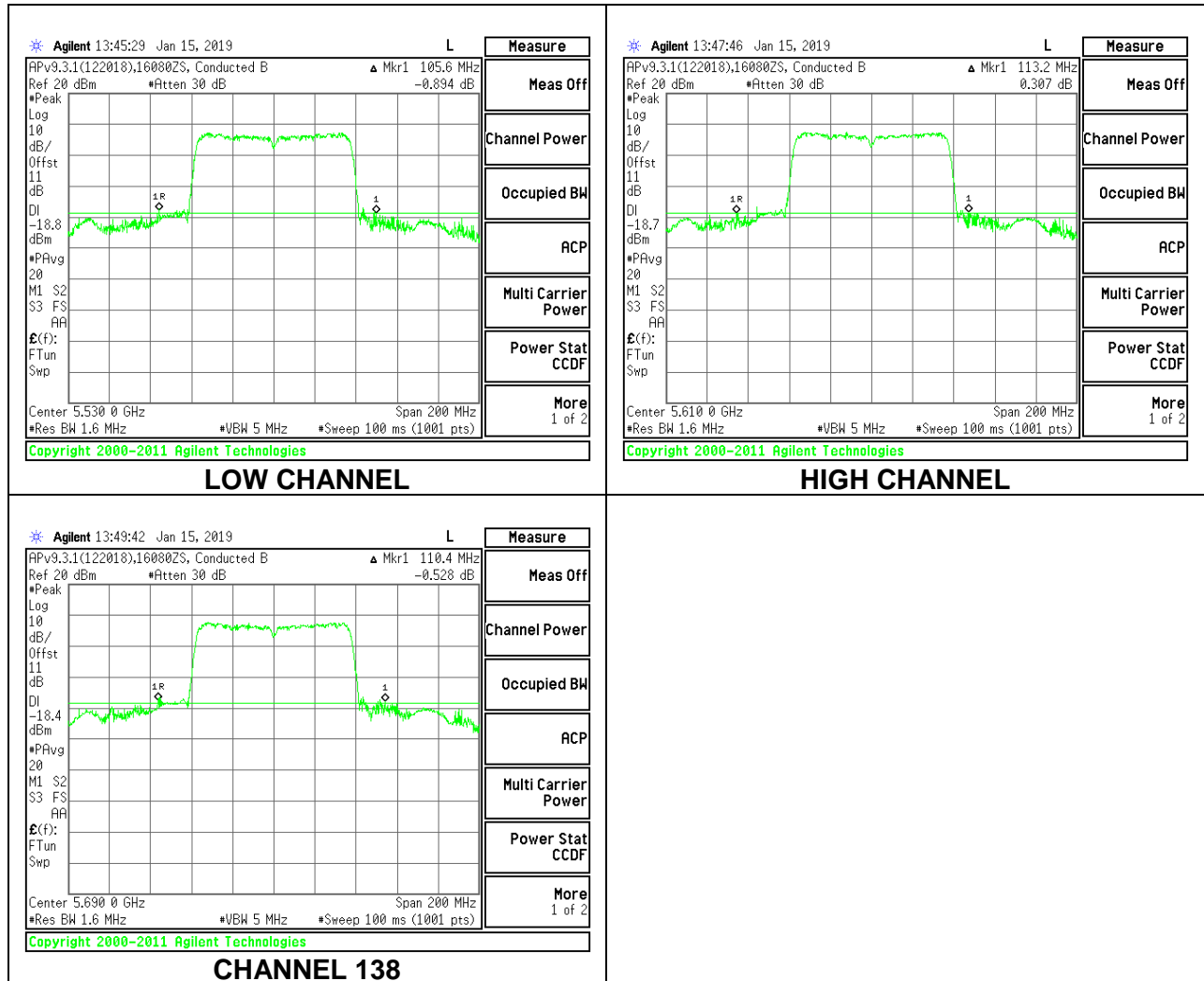

9.2.13. 802.11a MODE IN THE 5.8 GHz BAND

1TX Antenna 1 MODE

| Channel | Frequency (MHz) | 26 dB Bandwidth (MHz) |
|---------|--------------------|--------------------------|
| Low | 5745 | 28.40 |
| Mid | 5785 | 28.00 |
| High | 5825 | 30.60 |

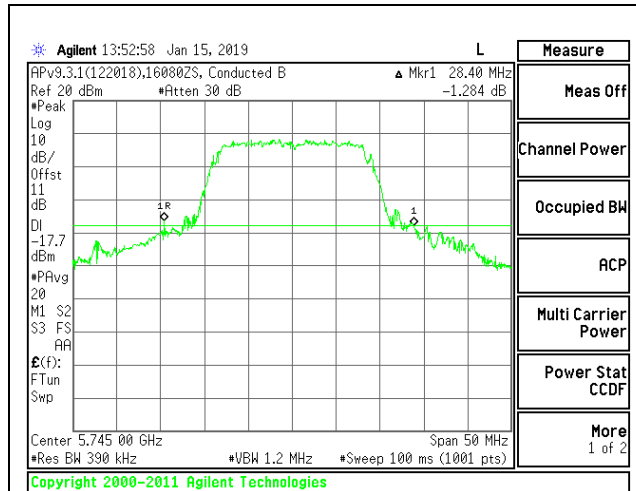

LOW CHANNEL

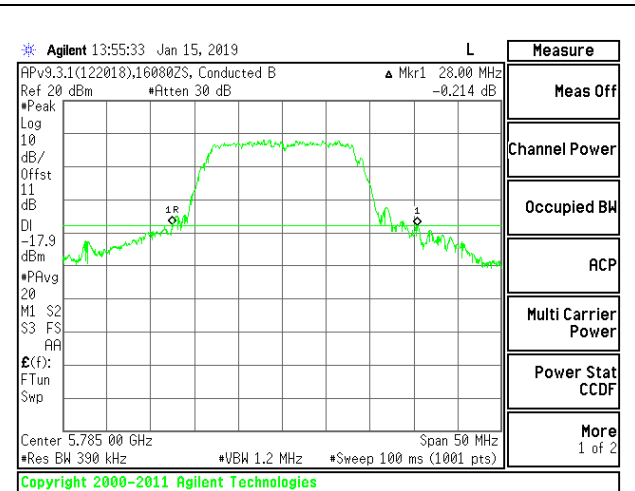

MID CHANNEL

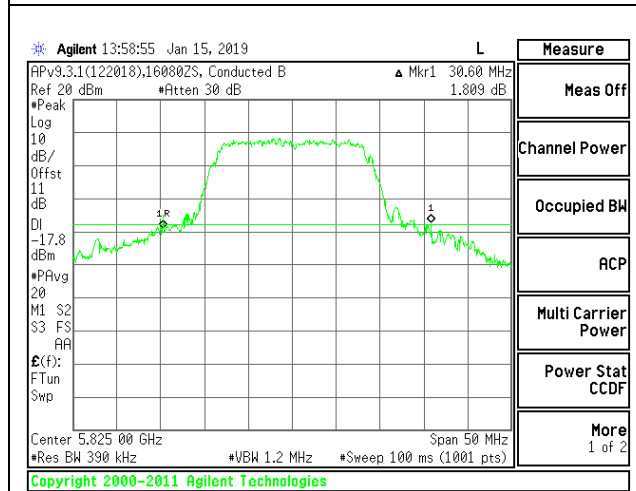

HIGH CHANNEL

9.2.14. 802.11n HT20 MODE IN THE 5.8 GHz BAND

1TX Antenna 1 MODE

| Channel | Frequency (MHz) | 26 dB Bandwidth (MHz) |
|---------|--------------------|--------------------------|
| Low | 5745 | 29.15 |
| Mid | 5785 | 29.90 |
| High | 5825 | 30.05 |

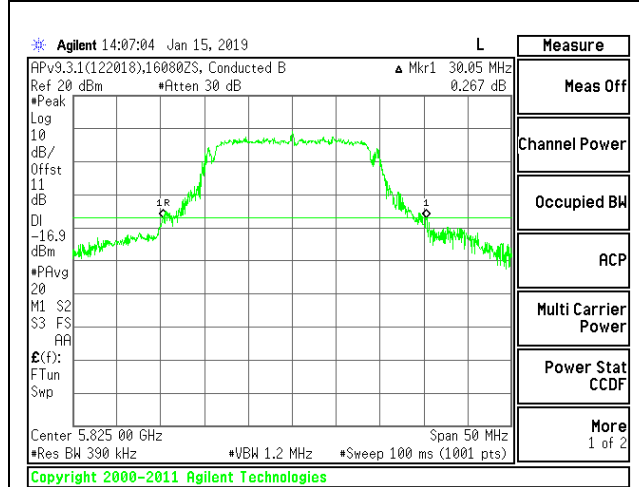
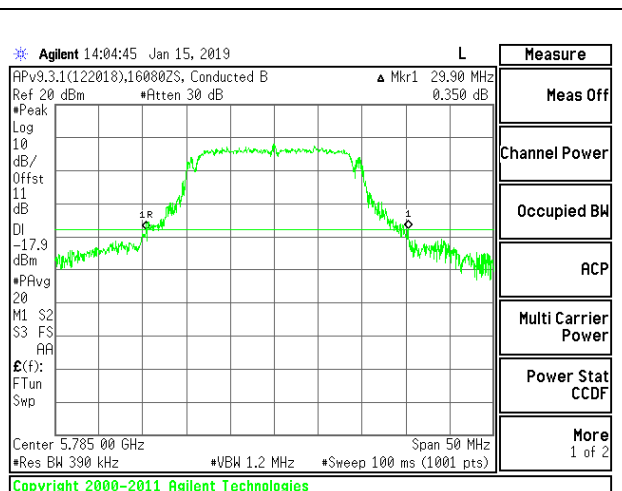
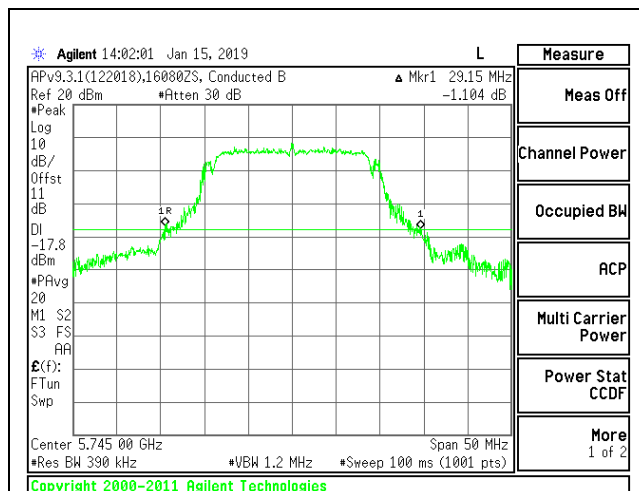

9.2.15. 802.11n HT40 MODE IN THE 5.8 GHz BAND

1TX Antenna 1 MODE

| Channel | Frequency (MHz) | 26dB Bandwidth (MHz) |
|---------|--------------------|-------------------------|
| Low | 5755 | 43.90 |
| High | 5795 | 44.00 |

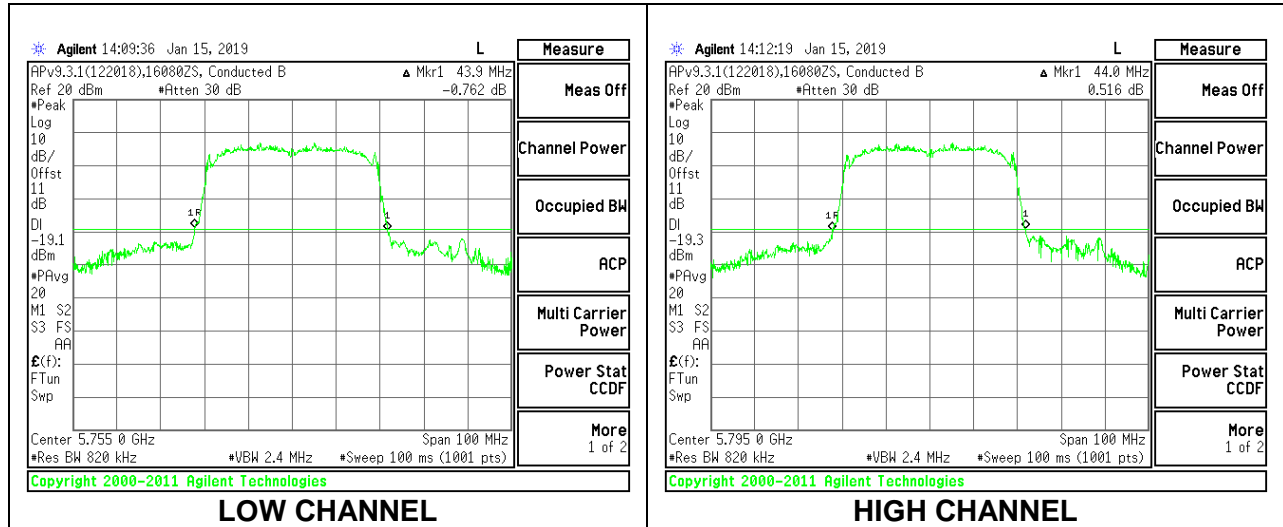

9.2.16. 802.11ac VHT80 MODE IN THE 5.8 GHz BAND

1TX Antenna 1 MODE

| Channel | Frequency (MHz) | 26 dB Bandwidth (MHz) |
|---------|--------------------|--------------------------|
| Mid | 5775 | 91.40 |

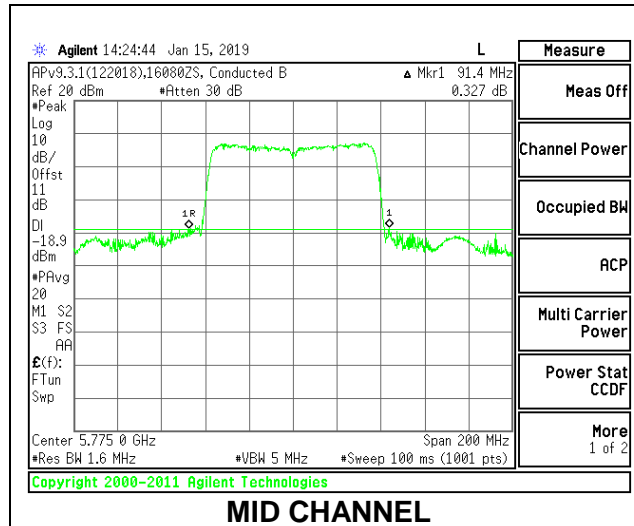

9.3. 99% BANDWIDTH

LIMITS

None; for reporting purposes only.

RESULTS

9.3.1. 802.11a MODE IN THE 5.2 GHz BAND

1TX Antenna 1 MODE

| Channel | Frequency (MHz) | 99% Bandwidth (MHz) |
|---------|--------------------|------------------------|
| Low | 5180 | 17.3440 |
| Mid | 5200 | 17.2290 |
| High | 5240 | 17.2870 |

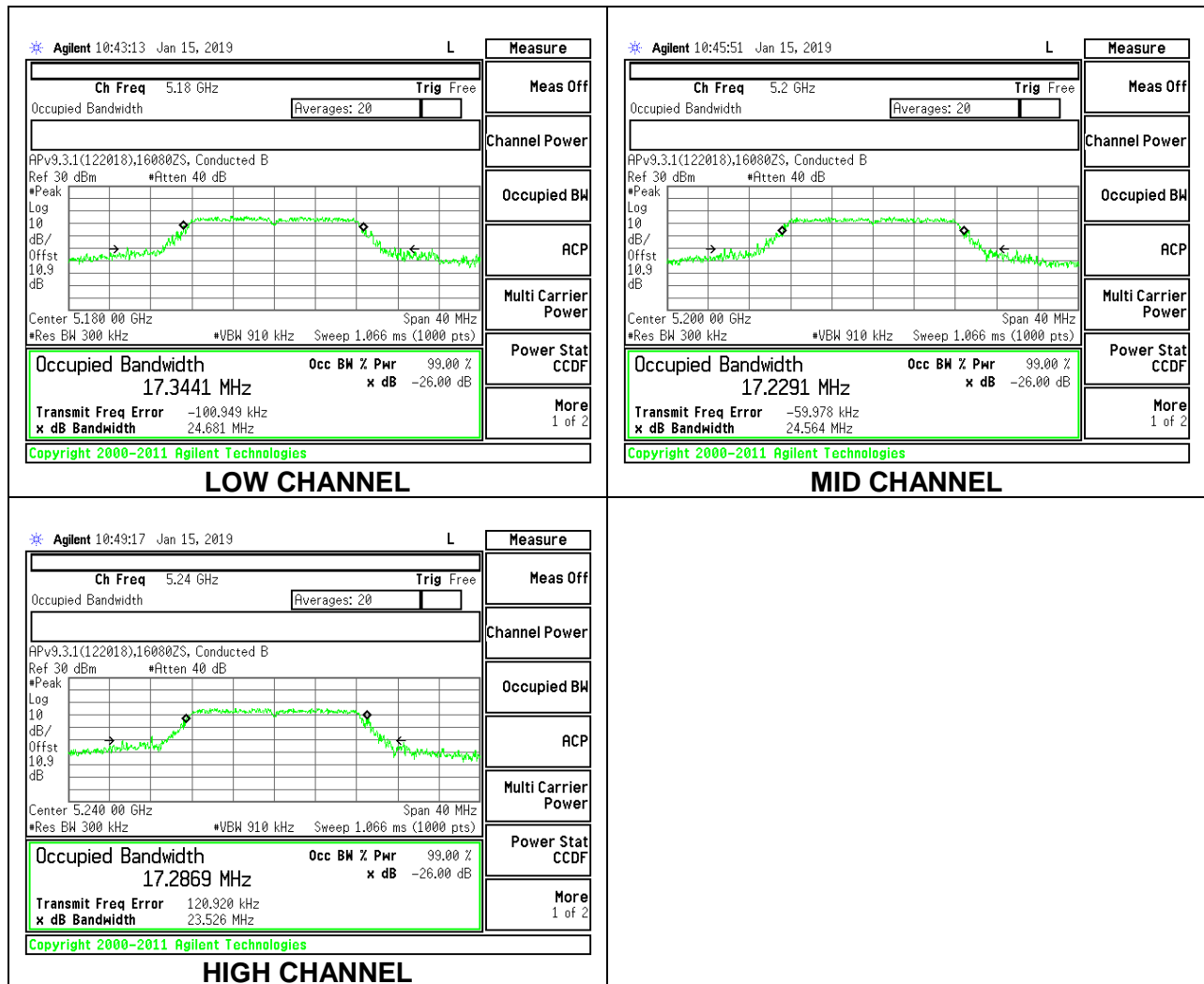

9.3.2. 802.11n HT20 MODE IN THE 5.2 GHz BAND

1TX Antenna 1 MODE

| Channel | Frequency (MHz) | 99% Bandwidth (MHz) |
|---------|--------------------|------------------------|
| Low | 5180 | 18.6240 |
| Mid | 5200 | 18.2930 |
| High | 5240 | 18.7250 |

| | |
|---|--|
| <p>Agilent 10:53:30 Jan 15, 2019</p> <p>Ch Freq 5.18 GHz Trig Free</p> <p>Occupied Bandwidth Averages: 20</p> <p>APv9.3.1(122018),160002S, Conducted B Ref 30 dBm #Atten 40 dB</p> <p>Center 5.180 00 GHz Span 40 MHz #Res BW 300 kHz #VBW 910 kHz Sweep 1.066 ms (1000 pts)</p> <p>Occupied Bandwidth 18.6239 MHz Occ BW % Pwr 99.00 % x dB -26.00 dB</p> <p>Transmit Freq Error -334.712 kHz x dB Bandwidth 27.231 MHz</p> <p>Copyright 2000-2011 Agilent Technologies</p> <p>LOW CHANNEL</p> | <p>Agilent 10:55:31 Jan 15, 2019</p> <p>Ch Freq 5.2 GHz Trig Free</p> <p>Occupied Bandwidth Averages: 20</p> <p>APv9.3.1(122018),160002S, Conducted B Ref 30 dBm #Atten 40 dB</p> <p>Center 5.200 00 GHz Span 40 MHz #Res BW 300 kHz #VBW 910 kHz Sweep 1.066 ms (1000 pts)</p> <p>Occupied Bandwidth 18.2933 MHz Occ BW % Pwr 99.00 % x dB -26.00 dB</p> <p>Transmit Freq Error 92.595 kHz x dB Bandwidth 26.064 MHz</p> <p>Copyright 2000-2011 Agilent Technologies</p> <p>MID CHANNEL</p> |
| <p>Agilent 10:57:27 Jan 15, 2019</p> <p>Ch Freq 5.24 GHz Trig Free</p> <p>Occupied Bandwidth Averages: 20</p> <p>APv9.3.1(122018),160002S, Conducted B Ref 30 dBm #Atten 40 dB</p> <p>Center 5.240 00 GHz Span 40 MHz #Res BW 300 kHz #VBW 910 kHz Sweep 1.066 ms (1000 pts)</p> <p>Occupied Bandwidth 18.7249 MHz Occ BW % Pwr 99.00 % x dB -26.00 dB</p> <p>Transmit Freq Error 168.948 kHz x dB Bandwidth 25.850 MHz</p> <p>Copyright 2000-2011 Agilent Technologies</p> <p>HIGH CHANNEL</p> | |

9.3.3. 802.11n HT40 MODE IN THE 5.2 GHz BAND

1TX Antenna 1 MODE

| Channel | Frequency (MHz) | 99% Bandwidth (MHz) |
|---------|--------------------|------------------------|
| Low | 5190 | 36.4670 |
| High | 5230 | 36.2240 |

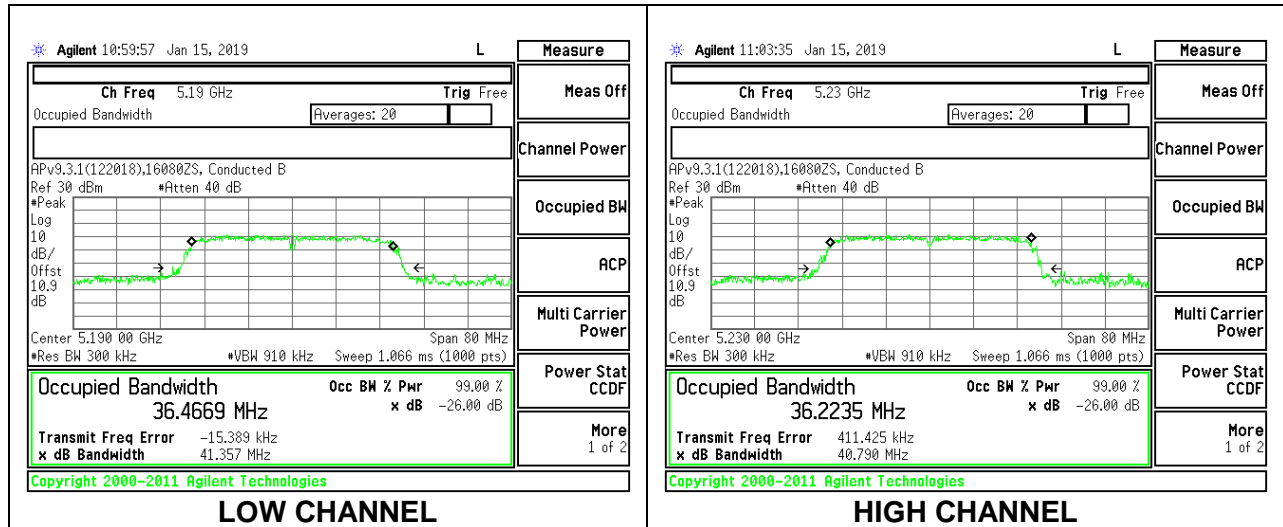

9.3.4. 802.11ac VHT80 MODE IN THE 5.2 GHz BAND

1TX Antenna 1 MODE

| Channel | Frequency (MHz) | 99% Bandwidth (MHz) |
|---------|--------------------|------------------------|
| Mid | 5210 | 75.2060 |

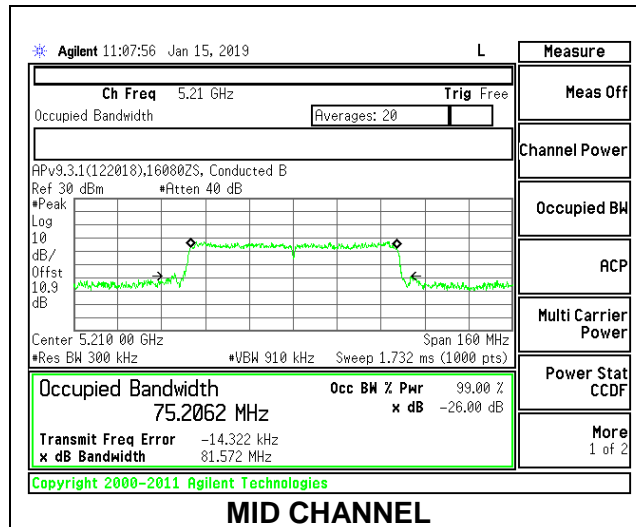

9.3.5. 802.11a MODE IN THE 5.3 GHz BAND

1TX Antenna 1 MODE

| Channel | Frequency (MHz) | 99% Bandwidth (MHz) |
|---------|--------------------|------------------------|
| Low | 5260 | 17.5690 |
| Mid | 5300 | 17.3090 |
| High | 5320 | 17.0800 |

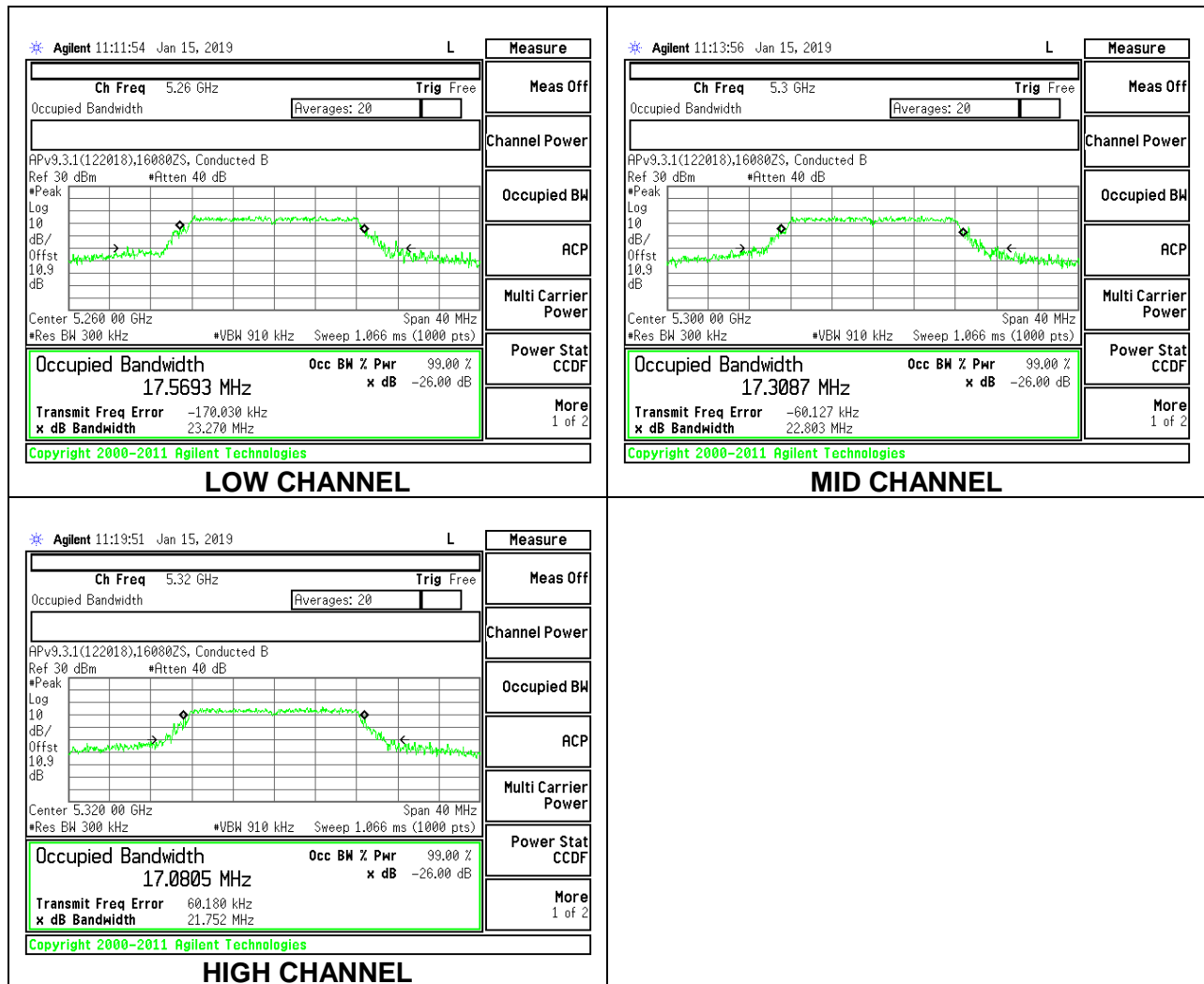

9.3.6. 802.11n HT20 MODE IN THE 5.3 GHz BAND

1TX Antenna 1 MODE

| Channel | Frequency (MHz) | 99% Bandwidth (MHz) |
|---------|--------------------|------------------------|
| Low | 5260 | 18.7450 |
| Mid | 5300 | 18.2190 |
| High | 5320 | 18.7870 |

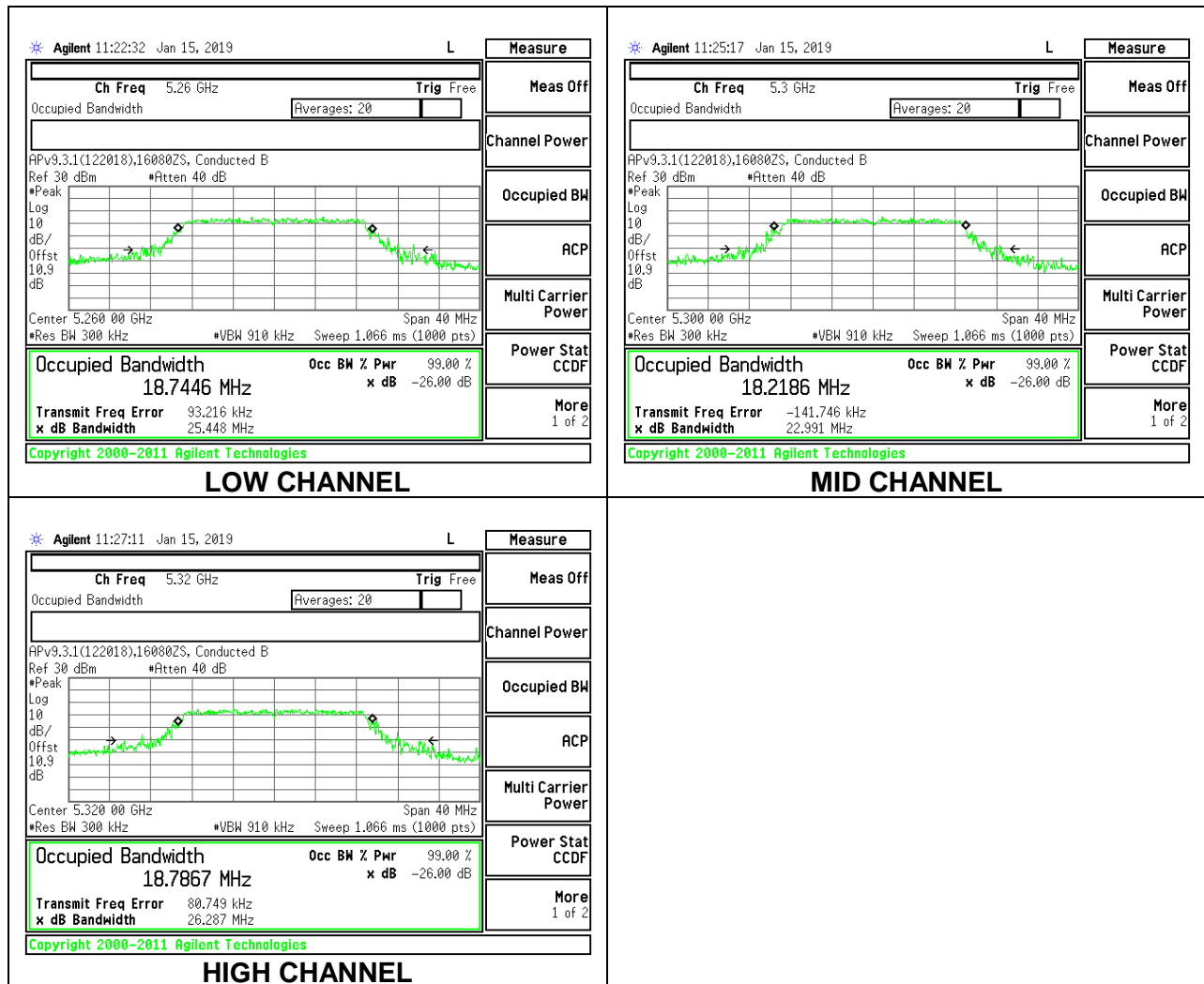

9.3.7. 802.11n HT40 MODE IN THE 5.3 GHz BAND

1TX Antenna 1 MODE

| Channel | Frequency (MHz) | 99% Bandwidth (MHz) |
|---------|--------------------|------------------------|
| Low | 5270 | 36.2540 |
| High | 5310 | 36.2030 |

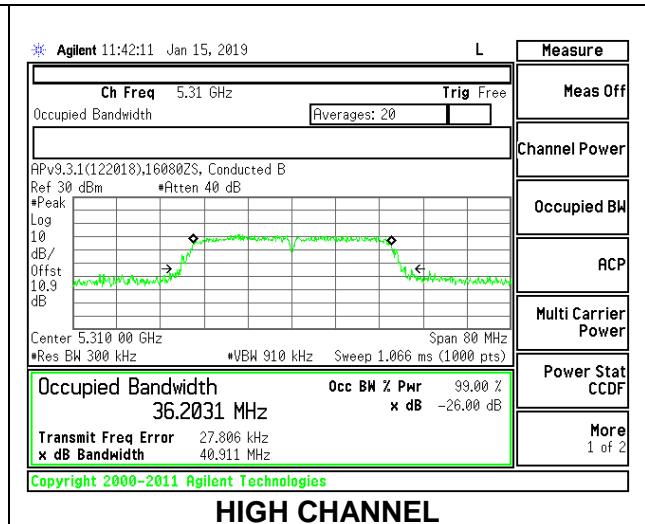
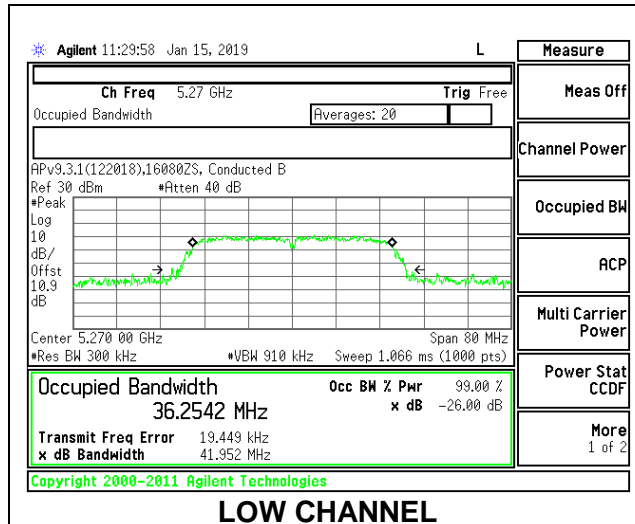

9.3.8. 802.11ac VHT80 MODE IN THE 5.3 GHz BAND

1TX Antenna 1 MODE

| Channel | Frequency (MHz) | 99% Bandwidth (MHz) |
|---------|--------------------|------------------------|
| Mid | 5290 | 75.4200 |

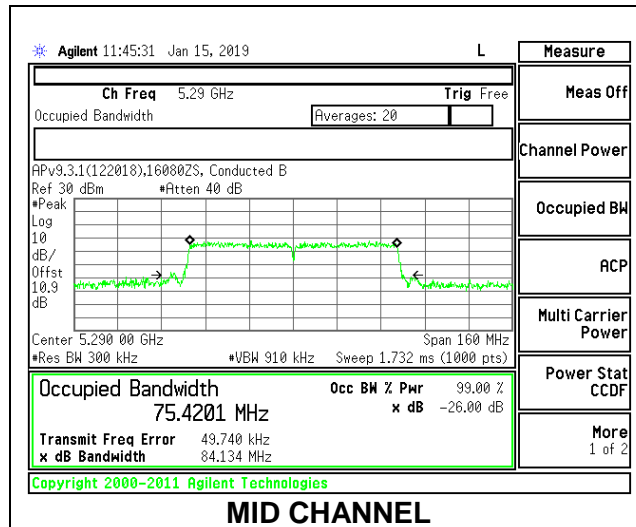

9.3.9. 802.11a MODE IN THE 5.6 GHz BAND

1TX Antenna 1 MODE

| Channel | Frequency (MHz) | 99% Bandwidth (MHz) |
|---------|--------------------|------------------------|
| Low | 5500 | 18.3890 |
| Mid | 5580 | 18.2070 |
| High | 5700 | 18.1130 |
| 144 | 5720 | 18.5370 |

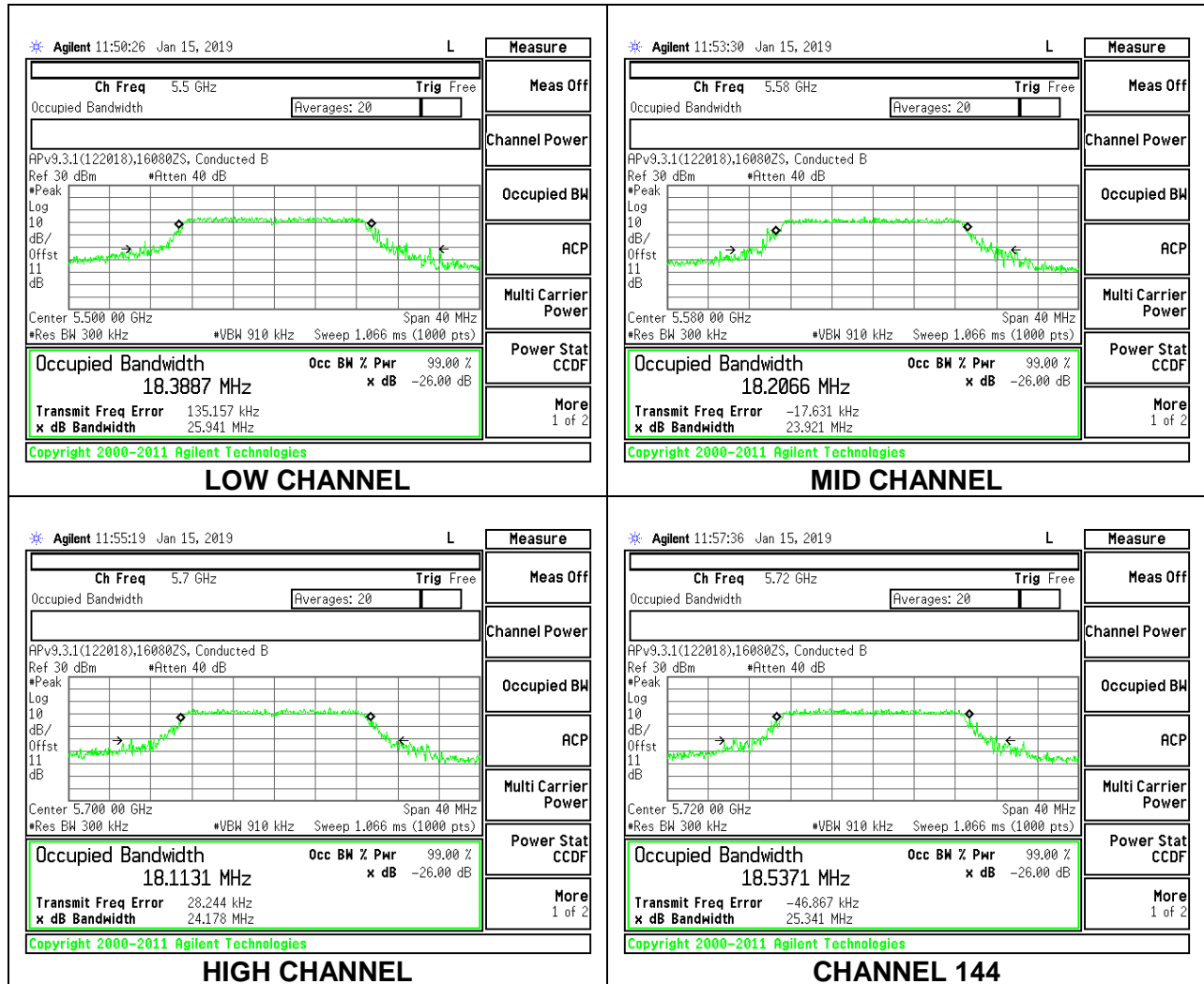

9.3.10. 802.11n HT20 MODE IN THE 5.6 GHz BAND

1TX Antenna 1 MODE

| Channel | Frequency (MHz) | 99% Bandwidth (MHz) |
|---------|--------------------|------------------------|
| Low | 5500 | 18.2330 |
| Mid | 5580 | 18.3600 |
| High | 5700 | 18.2360 |
| 144 | 5720 | 18.5140 |

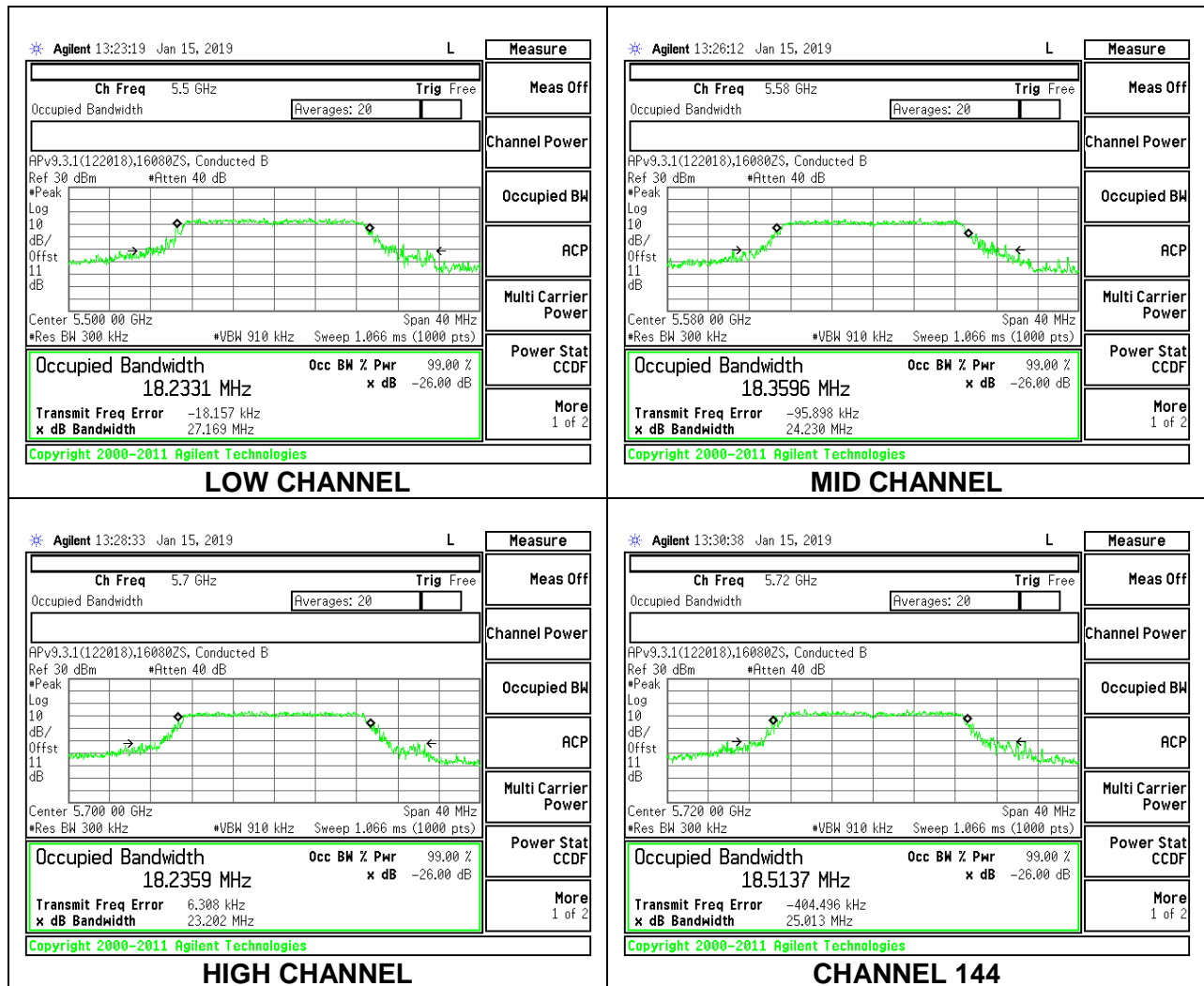

9.3.11. 802.11n HT40 MODE IN THE 5.6 GHz BAND

1TX Antenna 1 MODE

| Channel | Frequency (MHz) | 99% Bandwidth (MHz) |
|---------|--------------------|------------------------|
| Low | 5510 | 36.5880 |
| Mid | 5550 | 36.5920 |
| High | 5670 | 36.2440 |
| 142 | 5710 | 36.6100 |

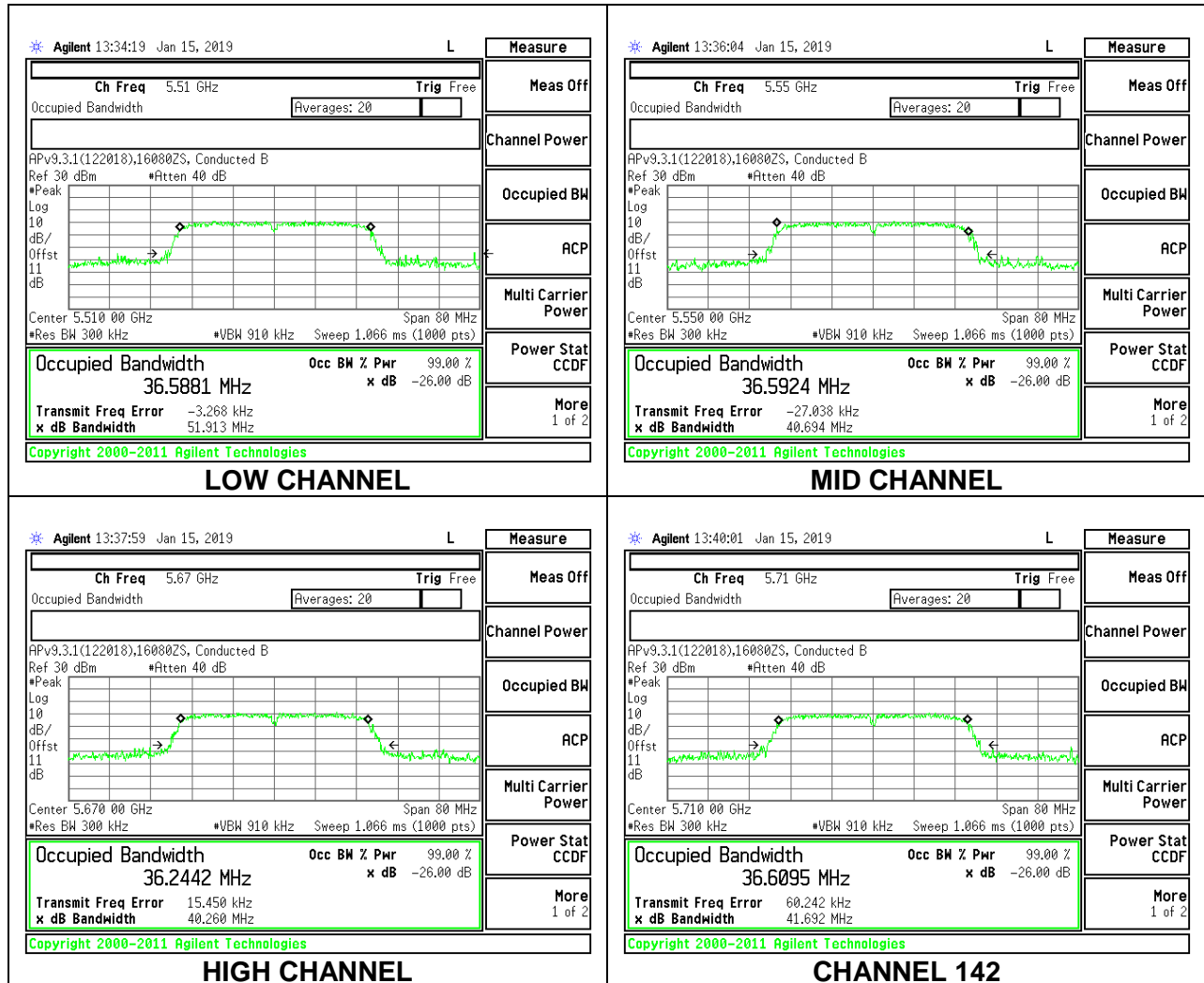

9.3.12. 802.11ac VHT80 MODE IN THE 5.6 GHz BAND

1TX Antenna 1 MODE

| Channel | Frequency (MHz) | 99% Bandwidth (MHz) |
|---------|--------------------|------------------------|
| Low | 5530 | 74.7140 |
| High | 5610 | 74.9620 |
| 138 | 5690 | 75.4600 |

| | |
|--|---|
| <p>Agilent 13:44:51 Jan 15, 2019</p> <p>Ch Freq 5.53 GHz Trig Free</p> <p>Occupied Bandwidth Averages: 20</p> <p>APv9.3.1(122018),160002S, Conducted B Ref 30 dBm #Atten 40 dB</p> <p>Center 5.530 00 GHz Span 160 MHz #Res BW 300 kHz #VBW 910 kHz Sweep 1.732 ms (1000 pts)</p> <p>Occupied Bandwidth 74.7144 MHz Occ BW % Pwr 99.00 % x dB -26.00 dB</p> <p>Transmit Freq Error 305.698 kHz x dB Bandwidth 79.815 MHz</p> <p>Copyright 2000-2011 Agilent Technologies</p> <p>LOW CHANNEL</p> | <p>Agilent 13:47:14 Jan 15, 2019</p> <p>Ch Freq 5.61 GHz Trig Free</p> <p>Occupied Bandwidth Averages: 20</p> <p>APv9.3.1(122018),160002S, Conducted B Ref 30 dBm #Atten 40 dB</p> <p>Center 5.610 00 GHz Span 160 MHz #Res BW 300 kHz #VBW 910 kHz Sweep 1.732 ms (1000 pts)</p> <p>Occupied Bandwidth 74.9619 MHz Occ BW % Pwr 99.00 % x dB -26.00 dB</p> <p>Transmit Freq Error 221.685 kHz x dB Bandwidth 86.179 MHz</p> <p>Copyright 2000-2011 Agilent Technologies</p> <p>HIGH CHANNEL</p> |
| <p>Agilent 13:49:09 Jan 15, 2019</p> <p>Ch Freq 5.69 GHz Trig Free</p> <p>Occupied Bandwidth Averages: 20</p> <p>APv9.3.1(122018),160002S, Conducted B Ref 30 dBm #Atten 40 dB</p> <p>Center 5.690 00 GHz Span 160 MHz #Res BW 300 kHz #VBW 910 kHz Sweep 1.732 ms (1000 pts)</p> <p>Occupied Bandwidth 75.4596 MHz Occ BW % Pwr 99.00 % x dB -26.00 dB</p> <p>Transmit Freq Error 102.346 kHz x dB Bandwidth 80.923 MHz</p> <p>Copyright 2000-2011 Agilent Technologies</p> <p>CHANNEL 138</p> | |

9.3.13. 802.11a MODE IN THE 5.8 GHz BAND

1TX Antenna 1 MODE

| Channel | Frequency (MHz) | 99% Bandwidth (MHz) |
|---------|--------------------|------------------------|
| Low | 5745 | 17.5790 |
| Mid | 5785 | 17.5080 |
| High | 5825 | 17.2320 |

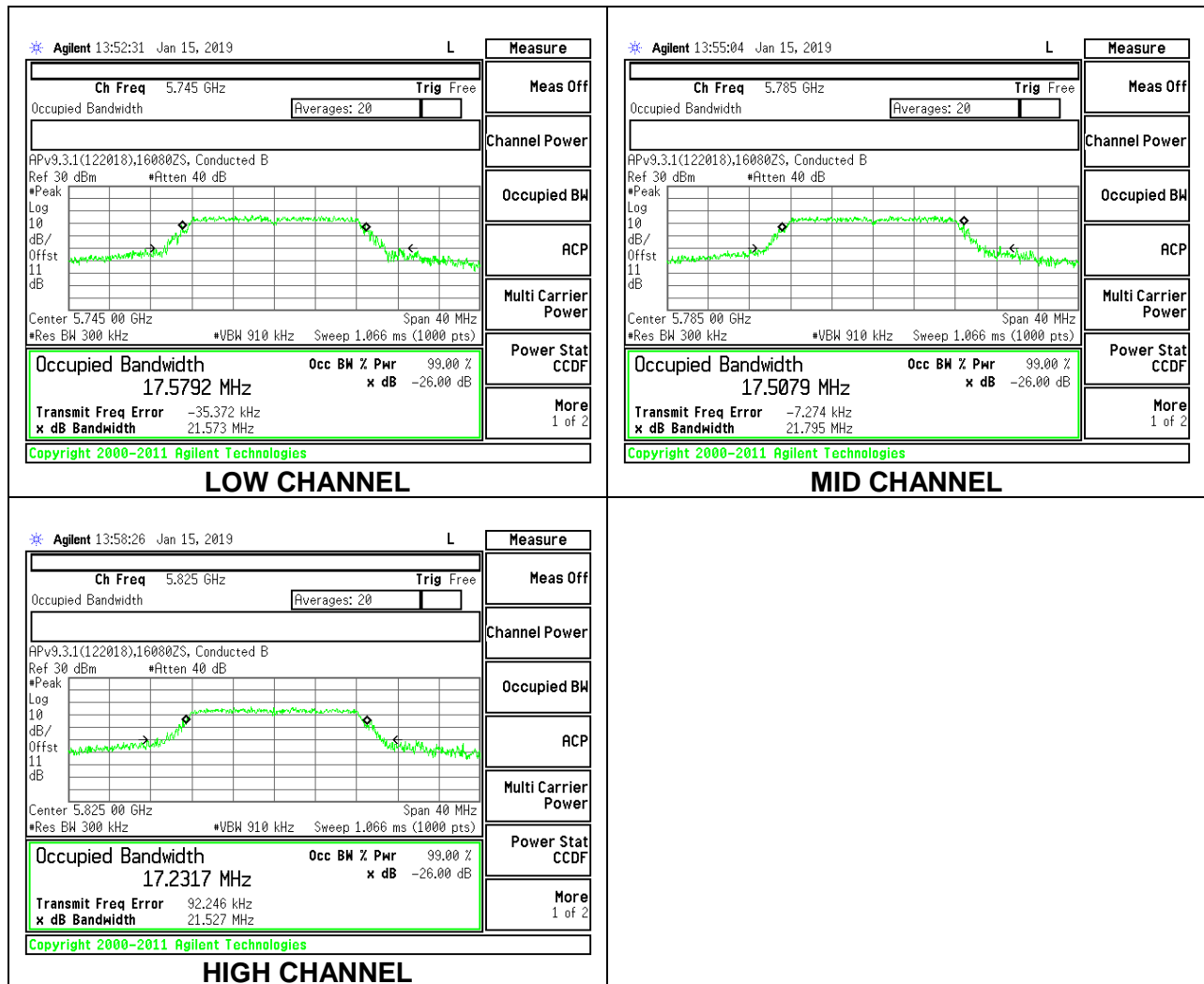

9.3.14. 802.11n HT20 MODE IN THE 5.8 GHz BAND

1TX Antenna 1 MODE

| Channel | Frequency (MHz) | 99% Bandwidth (MHz) |
|---------|--------------------|------------------------|
| Low | 5745 | 18.1090 |
| Mid | 5785 | 18.0820 |
| High | 5825 | 18.2370 |

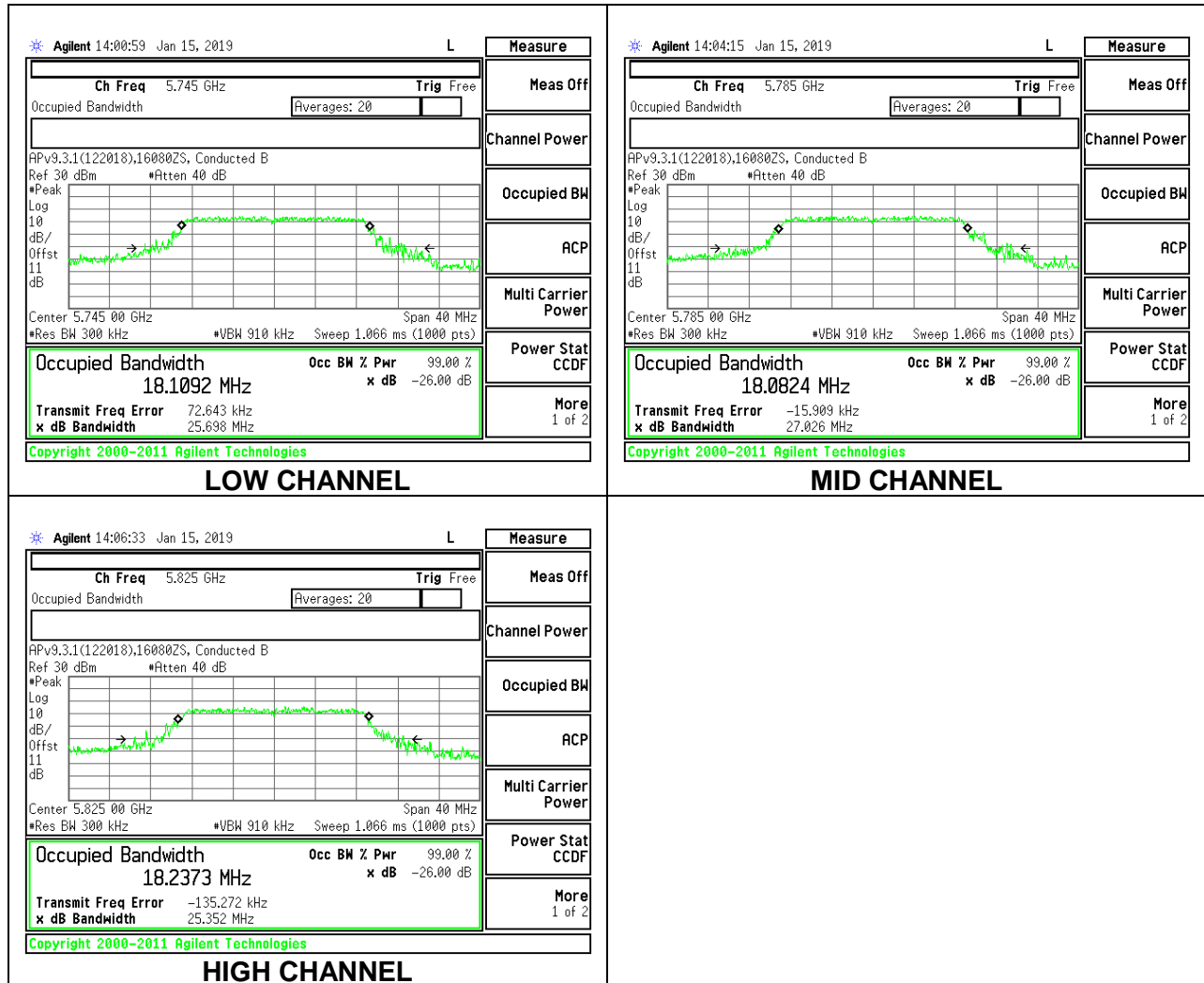

9.3.15. 802.11n HT40 MODE IN THE 5.8 GHz BAND

1TX Antenna 1 MODE

| Channel | Frequency (MHz) | 99% Bandwidth (MHz) |
|---------|--------------------|------------------------|
| Low | 5755 | 36.4490 |
| High | 5795 | 36.4310 |

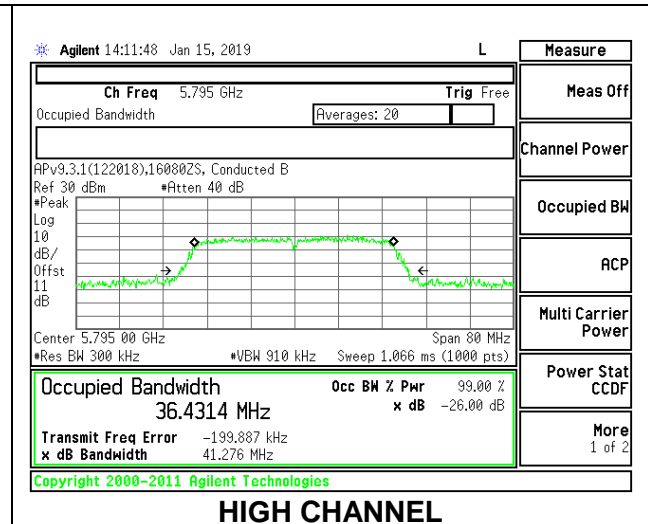
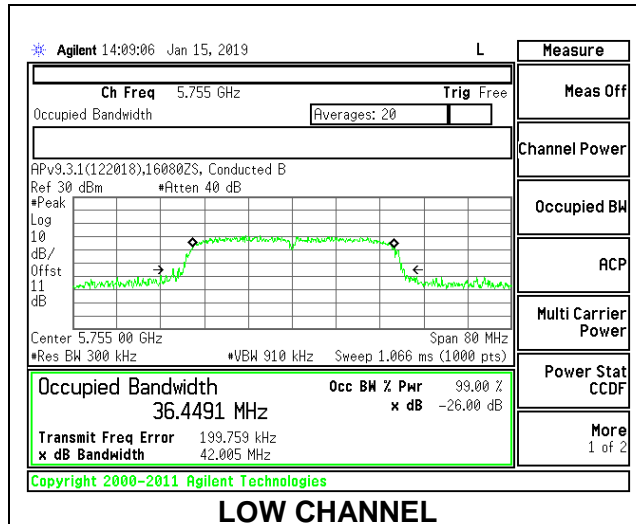

9.3.16. 802.11ac VHT80 MODE IN THE 5.8 GHz BAND

1TX Antenna 1 MODE

| Channel | Frequency (MHz) | 99% Bandwidth (MHz) |
|---------|--------------------|------------------------|
| Mid | 5775 | 75.2590 |

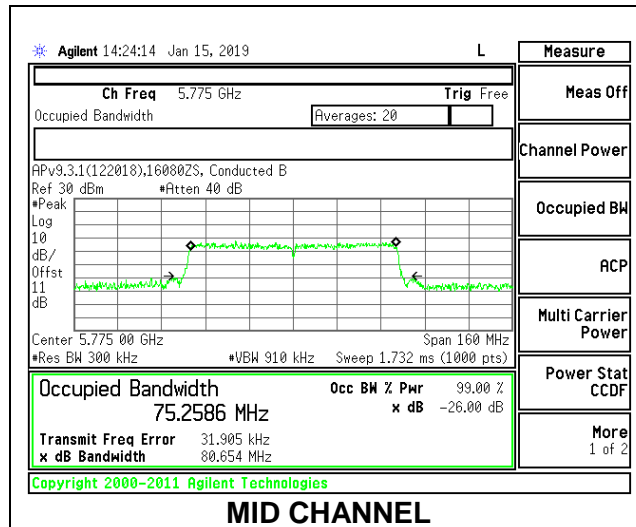

9.4. 6 dB BANDWIDTH

LIMITS

FCC §15.407 (e)

RSS-247 6.2.4.1

The minimum 6 dB bandwidth shall be at least 500 kHz.

RESULTS

9.4.1. 802.11a MODE IN THE 5.8 GHz BAND

1TX Antenna 1 MODE

| Channel | Frequency (MHz) | 6 dB Bandwidth (MHz) | Minimum Limit (MHz) |
|---------|--------------------|-------------------------|------------------------|
| Low | 5745 | 16.3350 | 0.5 |
| Mid | 5785 | 16.3530 | 0.5 |
| High | 5825 | 16.4330 | 0.5 |
| 144 | 5720 | 3.2320 | 0.5 |

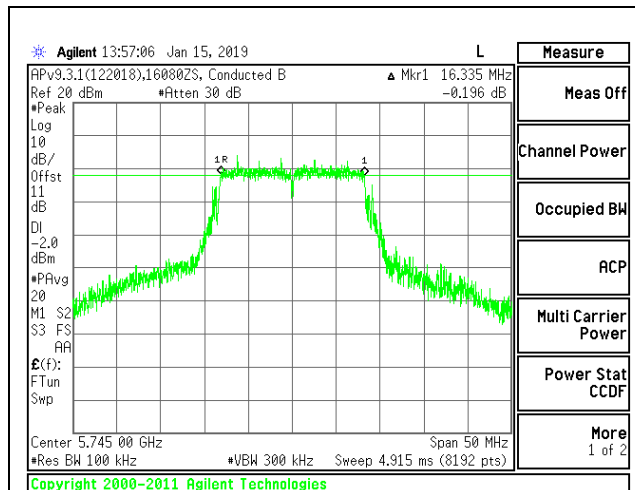

LOW CHANNEL

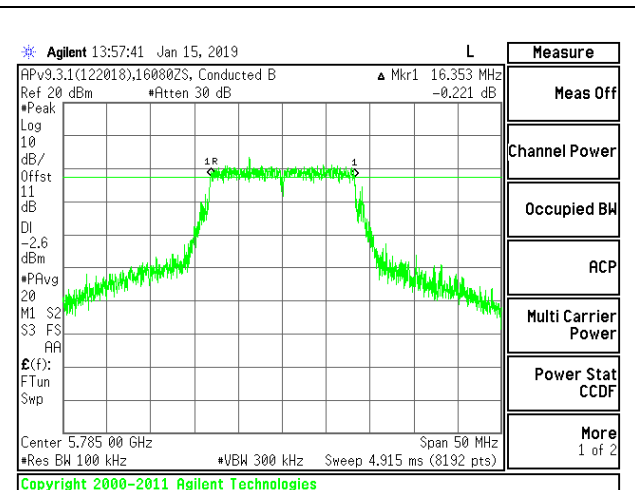

MID CHANNEL

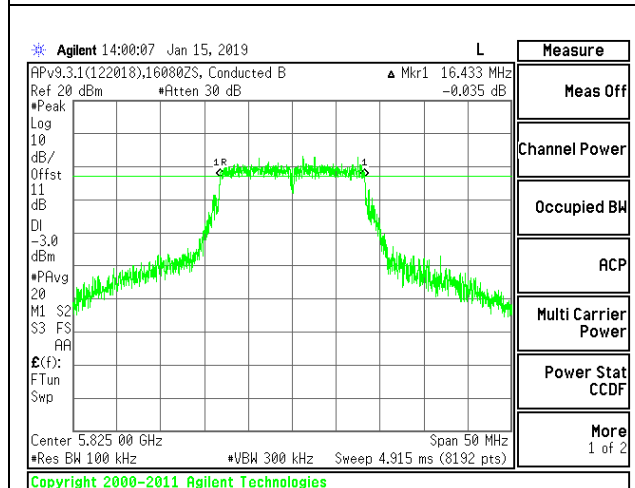

HIGH CHANNEL

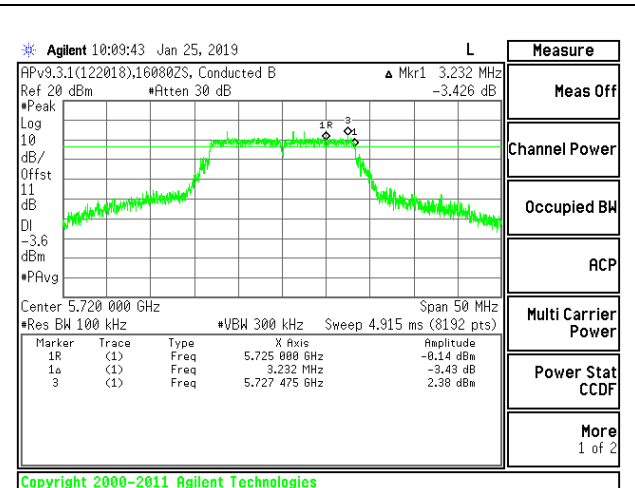

CHANNEL 144

9.4.2. 802.11n HT20 MODE IN THE 5.8 GHz BAND

1TX Antenna 1 MODE

| Channel | Frequency (MHz) | 6 dB Bandwidth (MHz) | Minimum Limit (MHz) |
|---------|--------------------|-------------------------|------------------------|
| Low | 5745 | 17.5800 | 0.5 |
| Mid | 5785 | 17.5310 | 0.5 |
| High | 5825 | 18.1780 | 0.5 |
| 144 | 5720 | 4.4160 | 0.5 |

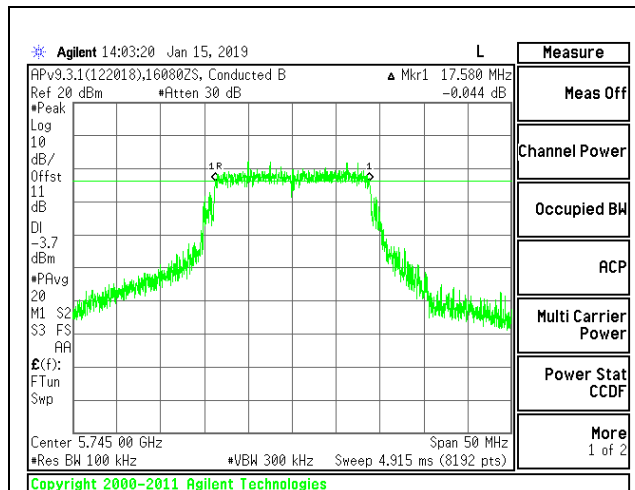

LOW CHANNEL

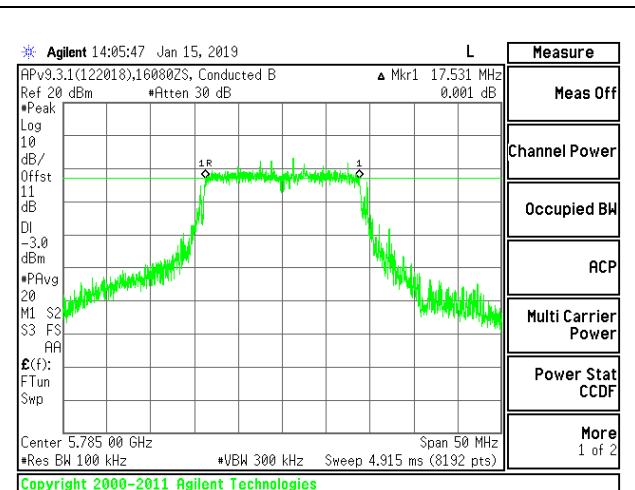

MID CHANNEL

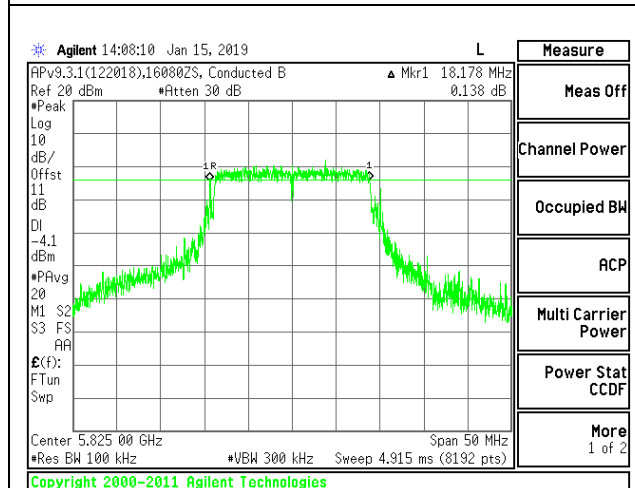

HIGH CHANNEL

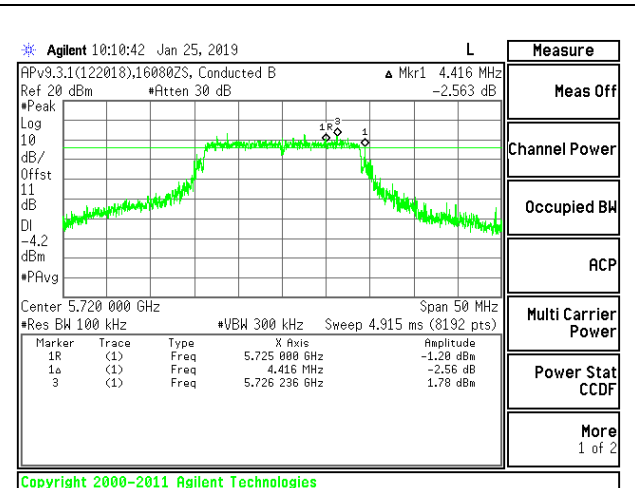

CHANNEL 144

9.4.3. 802.11n HT40 MODE IN THE 5.8 GHz BAND

1TX Antenna 1 MODE

| Channel | Frequency (MHz) | 6 dB Bandwidth (MHz) | Minimum Limit (MHz) |
|---------|--------------------|-------------------------|------------------------|
| Low | 5755 | 35.1120 | 0.5 |
| High | 5795 | 33.1950 | 0.5 |
| 142 | 5710 | 3.3920 | 0.5 |

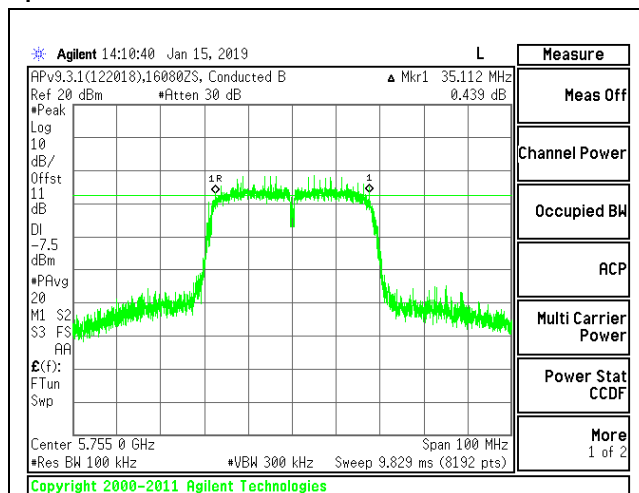

LOW CHANNEL

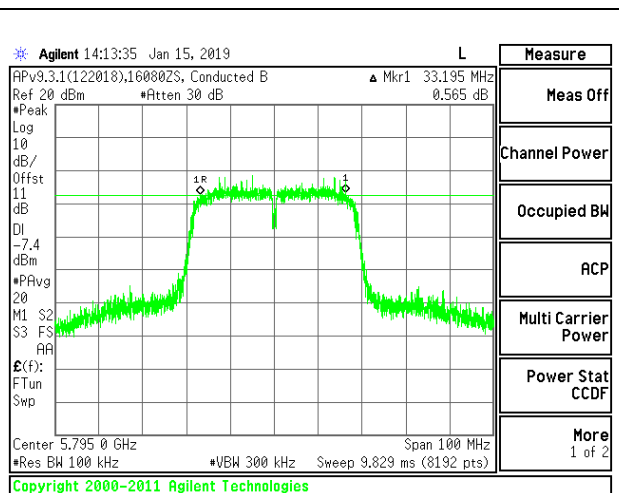

HIGH CHANNEL

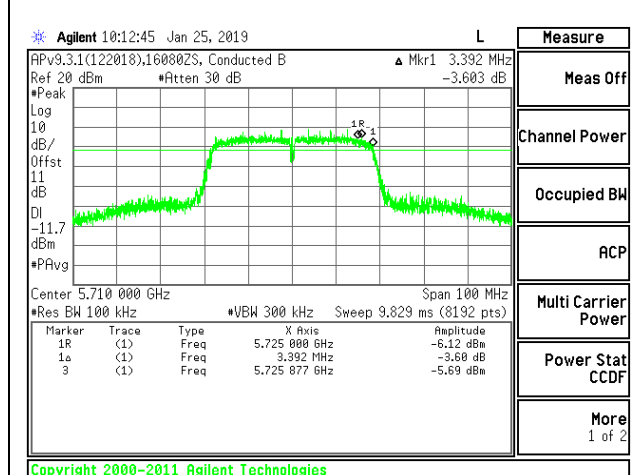

CHANNEL 142

9.4.4. 802.11ac VHT80 MODE IN THE 5.8 GHz BAND

1TX Antenna 1 MODE

| Channel | Frequency (MHz) | 6 dB Bandwidth (MHz) | Minimum Limit (MHz) |
|---------|--------------------|-------------------------|------------------------|
| Mid | 5775 | 75.1310 | 0.5 |
| 138 | 5690 | 3.1520 | 0.5 |

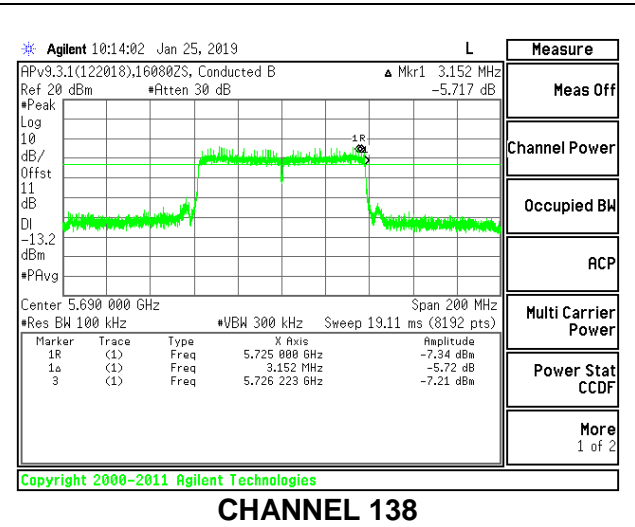
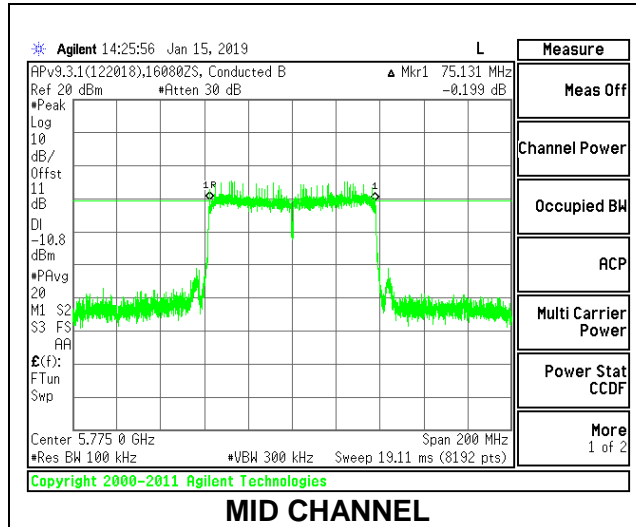

9.5. OUTPUT POWER AND PSD

LIMITS

FCC §15.407

Band 5.15–5.25 GHz (pick the section that applies to your product)

(iv) For mobile and portable client devices in the 5.15-5.25 GHz band, the maximum conducted output power over the frequency band of operation shall not exceed 250 mW provided the maximum antenna gain does not exceed 6 dBi. In addition, the maximum power spectral density shall not exceed 11 dBm in any 1 megahertz band. If transmitting antennas of directional gain greater than 6 dBi are used, both the maximum conducted output power and the maximum power spectral density shall be reduced by the amount in dB that the directional gain of the antenna exceeds 6 dBi.

Bands 5.25-5.35 GHz and 5.47-5.725 GHz

The maximum conducted output power over the frequency bands of operation shall not exceed the lesser of 250 mW or $11 \text{ dBm} + 10 \log B$, where B is the 26 dB emission bandwidth in megahertz. In addition, the maximum power spectral density shall not exceed 11 dBm in any 1 megahertz band. If transmitting antennas of directional gain greater than 6 dBi are used, both the maximum conducted output power and the maximum power spectral density shall be reduced by the amount in dB that the directional gain of the antenna exceeds 6 dBi.

Band 5.725-5.85 GHz

The maximum conducted output power over the frequency band of operation shall not exceed 1 W. In addition, the maximum power spectral density shall not exceed 30 dBm in any 500-kHz band. If transmitting antennas of directional gain greater than 6 dBi are used, both the maximum conducted output power and the maximum power spectral density shall be reduced by the amount in dB that the directional gain of the antenna exceeds 6 dBi. However, fixed point-to-point U-NII devices operating in this band may employ transmitting antennas with directional gain greater than 6 dBi without any corresponding reduction in transmitter conducted power. Fixed, point-to-point operations exclude the use of point-to-multipoint systems, omnidirectional applications, and multiple collocated transmitters transmitting the same information.

TEST PROCEDURE

The measurement method used for output power is KDB 789033 D02 v02r01, Section II.E.3.b (Method PM-G) and for straddles channels KDB 789033 D02 v02r01, Section II.E.2.b (Method SA-1) was used.

The measurement method used for power spectral density is KDB 789033 D02 v02r01, Section F

DIRECTIONAL ANTENNA GAIN

There is only one transmitter output therefore the directional gain is equal to the antenna gain.

RESULTS

9.5.1. 802.11a MODE IN THE 5.2 GHz BAND

1TX Antenna 1 MODE (FCC) MOBILE

Antenna Gain and Limits

| Channel | Frequency (MHz) | Directional Gain (dBi) | Power Limit (dBm) | PSD Limit (dBm/1MHz) |
|---------|--------------------|------------------------------|-------------------------|----------------------------|
| Low | 5180 | -3.70 | 24.00 | 11.00 |
| Mid | 5200 | -3.70 | 24.00 | 11.00 |
| High | 5240 | -3.70 | 24.00 | 11.00 |

| | | |
|---------------------------|------|---|
| Duty Cycle CF (dB) | 0.27 | Included in Calculations of Corr'd PSD |
|---------------------------|------|---|

Output Power Results

| Channel | Frequency (MHz) | Meas Power (dBm) | Total Corr'd Power (dBm) | Power Limit (dBm) | Power Margin (dB) |
|---------|--------------------|------------------------|-----------------------------------|-------------------------|-------------------------|
| Low | 5180 | 16.57 | 16.57 | 24.00 | -7.43 |
| Mid | 5200 | 16.46 | 16.46 | 24.00 | -7.54 |
| High | 5240 | 16.21 | 16.21 | 24.00 | -7.79 |

PSD Results

| Channel | Frequency (MHz) | Meas PSD (dBm/1MHz) | Total Corr'd PSD (dBm/1MHz) | PSD Limit (dBm/1MHz) | PSD Margin (dB) |
|---------|--------------------|---------------------------|--------------------------------------|----------------------------|-----------------------|
| Low | 5180 | 4.05 | 4.32 | 11.00 | -6.68 |
| Mid | 5200 | 4.22 | 4.49 | 11.00 | -6.51 |
| High | 5240 | 4.33 | 4.60 | 11.00 | -6.40 |

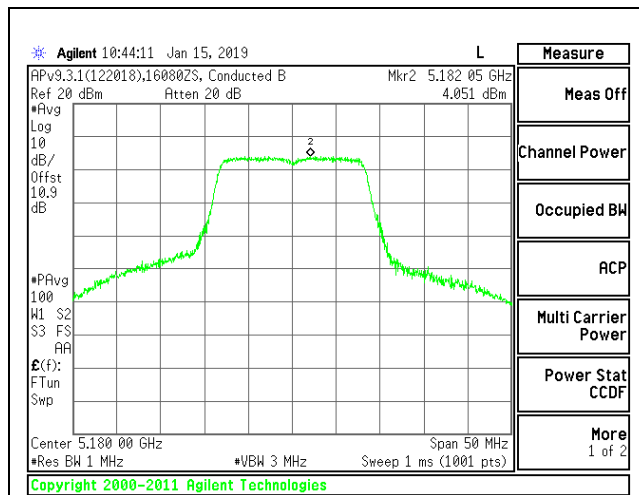

LOW CHANNEL

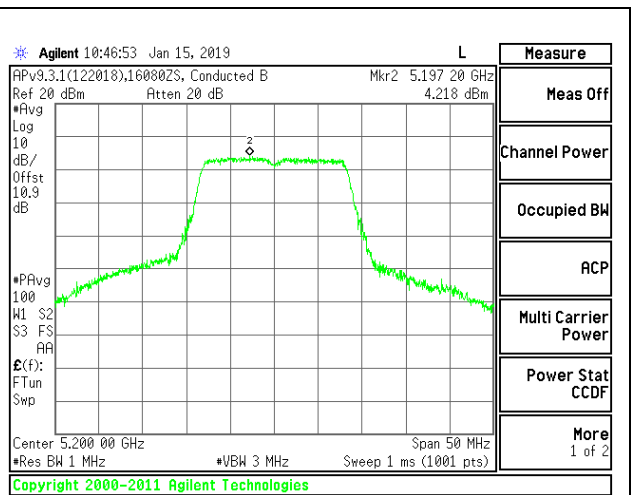

MID CHANNEL

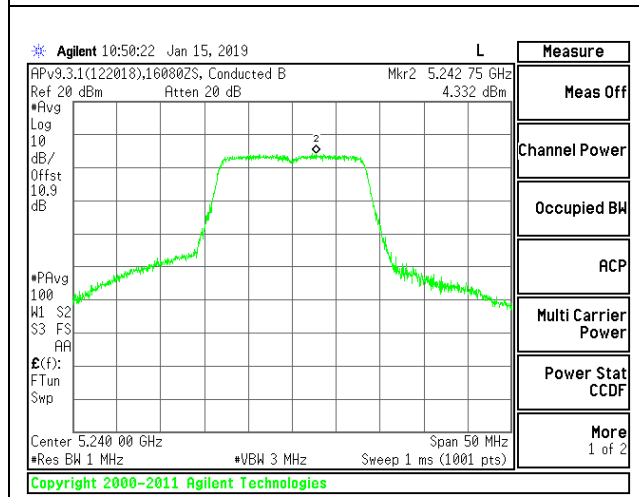

HIGH CHANNEL

9.5.2. 802.11n HT20 MODE IN THE 5.2 GHz BAND

1TX Antenna 1 MODE (FCC) MOBILE

Antenna Gain and Limits

| Channel | Frequency (MHz) | Directional Gain (dBi) | Power Limit (dBm) | PSD Limit (dBm/ 1MHz) |
|---------|--------------------|------------------------------|-------------------------|--------------------------------|
| Low | 5180 | -3.70 | 24.00 | 11.00 |
| Mid | 5200 | -3.70 | 24.00 | 11.00 |
| High | 5240 | -3.70 | 24.00 | 11.00 |

| | | |
|---------------------------|------|---|
| Duty Cycle CF (dB) | 0.28 | Included in Calculations of Corr'd PSD |
|---------------------------|------|---|

Output Power Results

| Channel | Frequency (MHz) | Meas Power (dBm) | Total Corr'd Power (dBm) | Power Limit (dBm) | Power Margin (dB) |
|---------|--------------------|------------------------|-----------------------------------|-------------------------|-------------------------|
| Low | 5180 | 15.45 | 15.45 | 24.00 | -8.55 |
| Mid | 5200 | 15.80 | 15.80 | 24.00 | -8.20 |
| High | 5240 | 14.81 | 14.81 | 24.00 | -9.19 |

PSD Results

| Channel | Frequency (MHz) | Meas PSD (dBm/1MHz) | Total Corr'd PSD (dBm/1MHz) | PSD Limit (dBm/ 1MHz) | PSD Margin (dB) |
|---------|--------------------|---------------------------|--------------------------------------|--------------------------------|-----------------------|
| Low | 5180 | 3.18 | 3.46 | 11.00 | -7.54 |
| Mid | 5200 | 3.36 | 3.64 | 11.00 | -7.36 |
| High | 5240 | 3.12 | 3.40 | 11.00 | -7.60 |

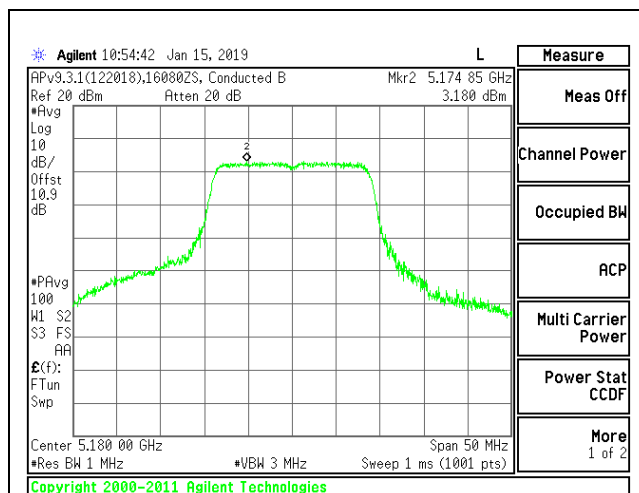

LOW CHANNEL

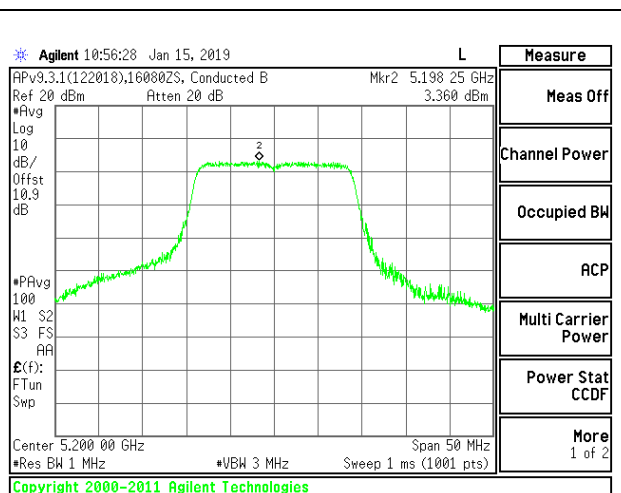

MID CHANNEL

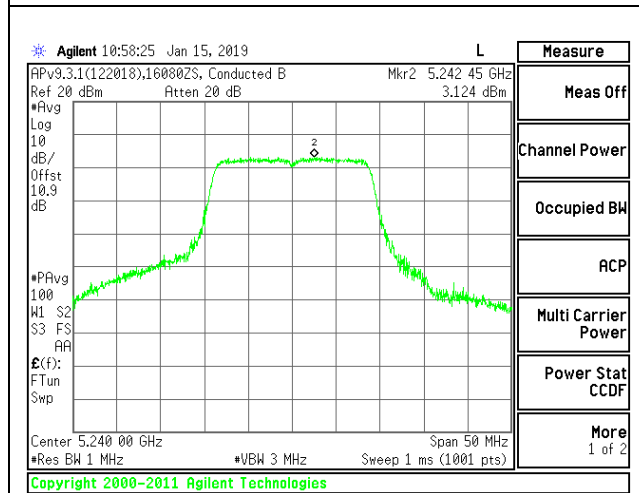

HIGH CHANNEL

9.5.3. 802.11n HT40 MODE IN THE 5.2 GHz BAND

1TX Antenna 1 MODE (FCC) MOBILE

Antenna Gain and Limits

| Channel | Frequency (MHz) | Directional Gain for Power (dBi) | Power Limit (dBm) | PSD Limit (dBm/ 1MHz) |
|---------|--------------------|---|-------------------------|--------------------------------|
| Low | 5190 | -3.70 | 24.00 | 11.00 |
| High | 5230 | -3.70 | 24.00 | 11.00 |

| | | |
|---------------------------|------|---|
| Duty Cycle CF (dB) | 0.71 | Included in Calculations of Corr'd PSD |
|---------------------------|------|---|

Output Power Results

| Channel | Frequency (MHz) | Meas Power (dBm) | Total Corr'd Power (dBm) | Power Limit (dBm) | Power Margin (dB) |
|---------|--------------------|------------------------|-----------------------------------|-------------------------|-------------------------|
| Low | 5190 | 14.81 | 14.81 | 24.00 | -9.19 |
| High | 5230 | 14.80 | 14.80 | 24.00 | -9.20 |

PSD Results

| Channel | Frequency (MHz) | Meas PSD (dBm/1MHz) | Total Corr'd PSD (dBm/1MHz) | PSD Limit (dBm/ 1MHz) | PSD Margin (dB) |
|---------|--------------------|---------------------------|--------------------------------------|--------------------------------|-----------------------|
| Low | 5190 | -0.38 | 0.33 | 11.00 | -10.67 |
| High | 5230 | -0.59 | 0.13 | 11.00 | -10.88 |

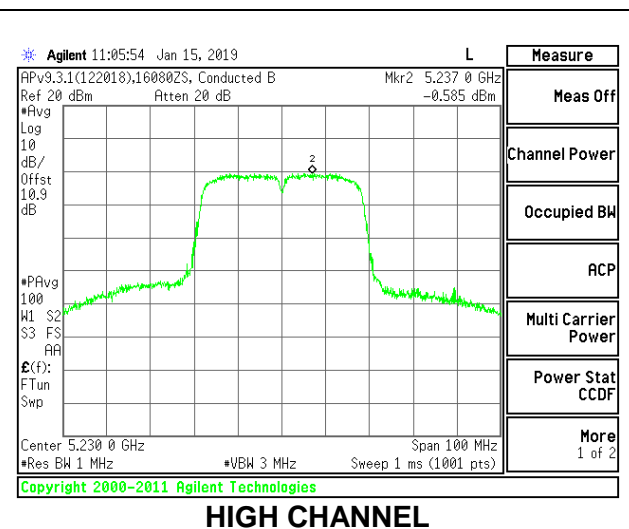
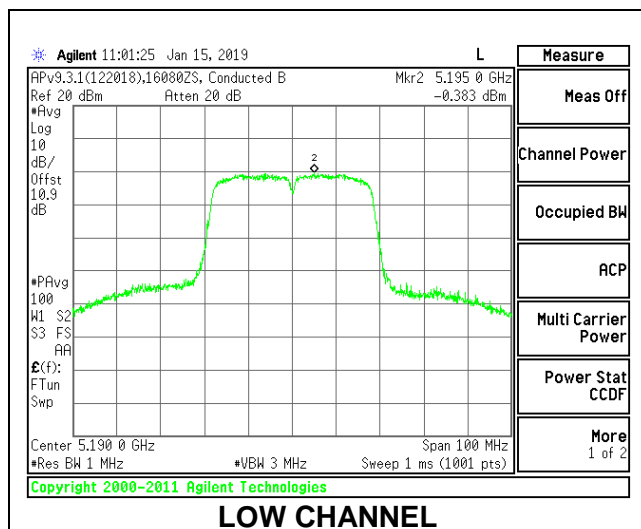

9.5.4. 802.11ac VHT80 MODE IN THE 5.2 GHz BAND

1TX Antenna 1 MODE (FCC) MOBILE

Antenna Gain and Limits

| Channel | Frequency (MHz) | Directional Gain (dBi) | Power Limit (dBm) | PSD Limit (dBm/ 1MHz) |
|---------|--------------------|------------------------------|-------------------------|--------------------------------|
| Mid | 5210 | -3.70 | 24.00 | 11.00 |

| | | |
|---------------------------|------|---|
| Duty Cycle CF (dB) | 1.29 | Included in Calculations of Corr'd PSD |
|---------------------------|------|---|

Output Power Results

| Channel | Frequency (MHz) | Meas Power (dBm) | Total Corr'd Power (dBm) | Power Limit (dBm) | Power Margin (dB) |
|---------|--------------------|------------------------|-----------------------------------|-------------------------|-------------------------|
| Mid | 5210 | 13.46 | 13.46 | 24.00 | -10.54 |

PSD Results

| Channel | Frequency (MHz) | Meas PSD (dBm/ 1MHz) | Total Corr'd PSD (dBm/ 1MHz) | PSD Limit (dBm/ 1MHz) | PSD Margin (dB) |
|---------|--------------------|-------------------------------|--|--------------------------------|-----------------------|
| Mid | 5210 | -4.99 | -3.70 | 11.00 | -14.70 |

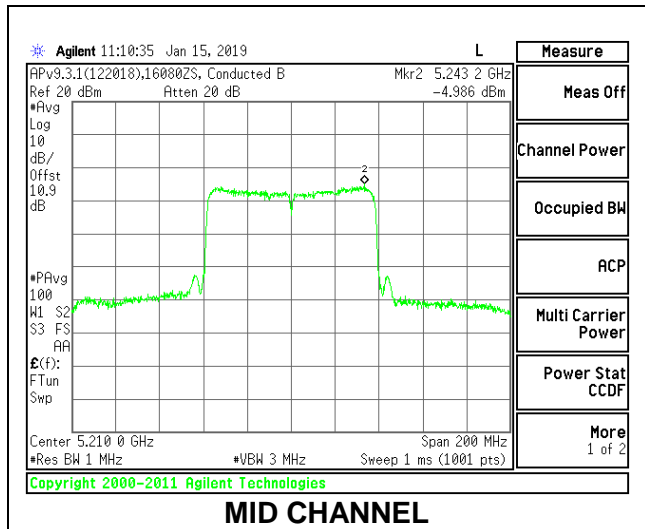

9.5.5. 802.11a MODE IN THE 5.3 GHz BAND

1TX Antenna 1 MODE (FCC)

Bandwidth, Antenna Gain, and Limits

| Channel | Frequency (MHz) | Min 26 dB BW (MHz) | Directional Gain (dBi) | Power Limit (dBm) | PSD Limit (dBm/1MHz) |
|---------|--------------------|-----------------------------|------------------------------|-------------------------|----------------------------|
| Low | 5260 | 30.40 | -2.60 | 24.00 | 11.00 |
| Mid | 5300 | 27.40 | -2.60 | 24.00 | 11.00 |
| High | 5320 | 30.40 | -2.60 | 24.00 | 11.00 |

| | | |
|---------------------------|------|---|
| Duty Cycle CF (dB) | 0.27 | Included in Calculations of Corr'd PSD |
|---------------------------|------|---|

Output Power Results

| Channel | Frequency (MHz) | Meas Power (dBm) | Total Corr'd Power (dBm) | Power Limit (dBm) | Power Margin (dB) |
|---------|--------------------|------------------------|-----------------------------------|-------------------------|-------------------------|
| Low | 5260 | 16.64 | 16.64 | 24.00 | -7.36 |
| Mid | 5300 | 16.68 | 16.68 | 24.00 | -7.32 |
| High | 5320 | 16.89 | 16.89 | 24.00 | -7.11 |

PSD Results

| Channel | Frequency (MHz) | Meas PSD (dBm/1MHz) | Total Corr'd PSD (dBm/1MHz) | PSD Limit (dBm/1MHz) | PSD Margin (dB) |
|---------|--------------------|---------------------------|--------------------------------------|----------------------------|-----------------------|
| Low | 5260 | 4.733 | 5.00 | 11.00 | -6.00 |
| Mid | 5300 | 4.066 | 4.34 | 11.00 | -6.66 |
| High | 5320 | 4.503 | 4.77 | 11.00 | -6.23 |

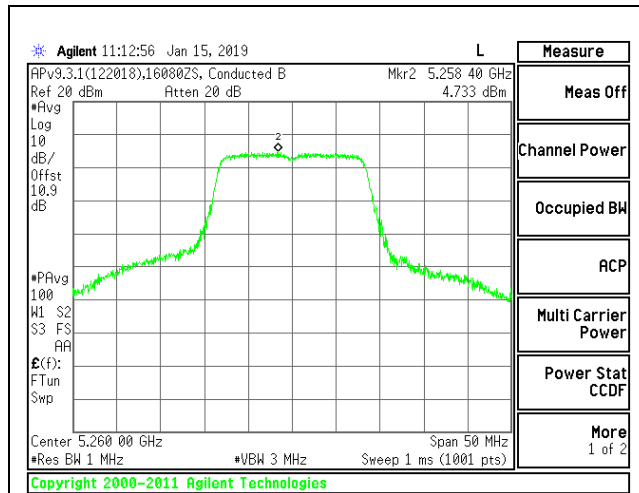

LOW CHANNEL

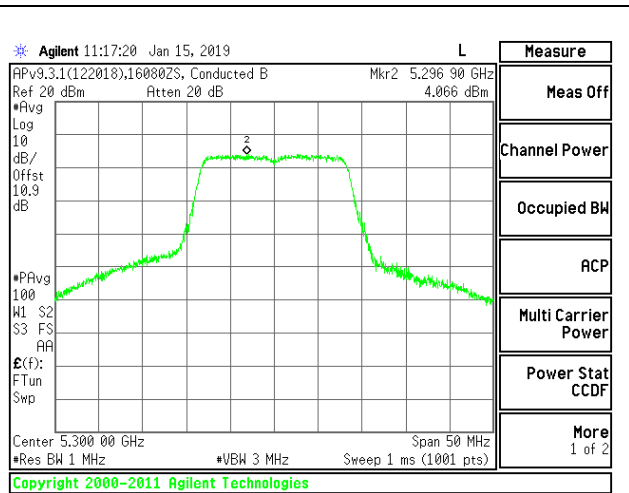

MID CHANNEL

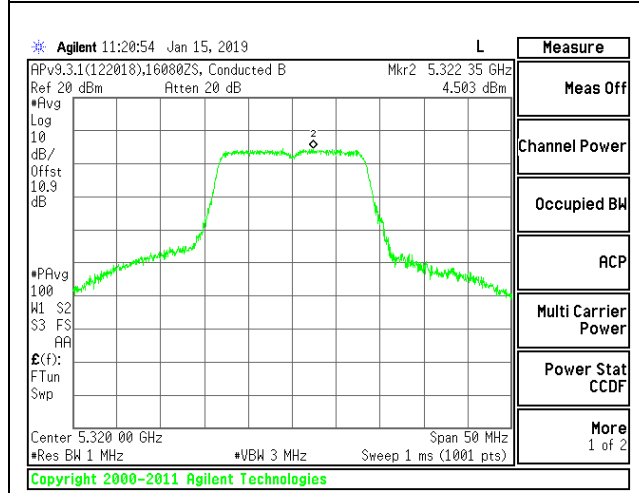

HIGH CHANNEL

9.5.6. 802.11n HT20 MODE IN THE 5.3 GHz BAND

1TX Antenna 1 MODE (FCC)

Bandwidth, Antenna Gain, and Limits

| Channel | Frequency (MHz) | Min 26 dB BW (MHz) | Directional Gain (dBi) | Power Limit (dBm) | PSD Limit (dBm/1MHz) |
|---------|--------------------|-----------------------------|------------------------------|-------------------------|----------------------------|
| Low | 5260 | 28.10 | -2.60 | 24.00 | 11.00 |
| Mid | 5300 | 29.40 | -2.60 | 24.00 | 11.00 |
| High | 5320 | 29.35 | -2.60 | 24.00 | 11.00 |

| | | |
|---------------------------|------|---|
| Duty Cycle CF (dB) | 0.28 | Included in Calculations of Corr'd PSD |
|---------------------------|------|---|

Output Power Results

| Channel | Frequency (MHz) | Meas Power (dBm) | Total Corr'd Power (dBm) | Power Limit (dBm) | Power Margin (dB) |
|---------|--------------------|------------------------|-----------------------------------|-------------------------|-------------------------|
| Low | 5260 | 15.79 | 15.79 | 24.00 | -8.21 |
| Mid | 5300 | 15.68 | 15.68 | 24.00 | -8.32 |
| High | 5320 | 15.64 | 15.64 | 24.00 | -8.36 |

PSD Results

| Channel | Frequency (MHz) | Meas PSD (dBm/1MHz) | Total Corr'd PSD (dBm/1MHz) | PSD Limit (dBm/1MHz) | PSD Margin (dB) |
|---------|--------------------|---------------------------|--------------------------------------|----------------------------|-----------------------|
| Low | 5260 | 3.464 | 3.74 | 11.00 | -7.26 |
| Mid | 5300 | 3.452 | 3.73 | 11.00 | -7.27 |
| High | 5320 | 3.342 | 3.62 | 11.00 | -7.38 |

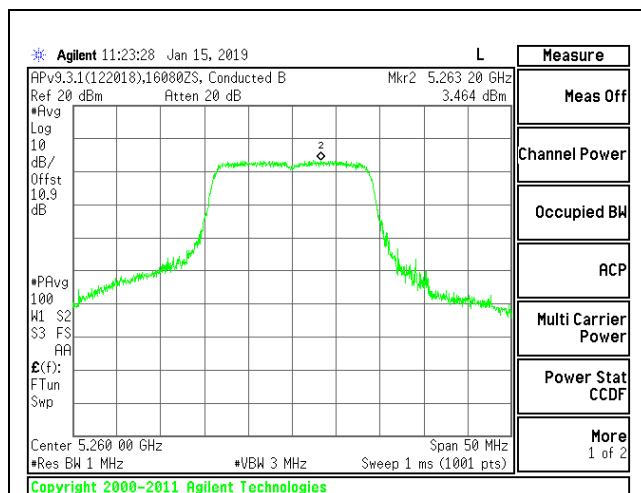

LOW CHANNEL

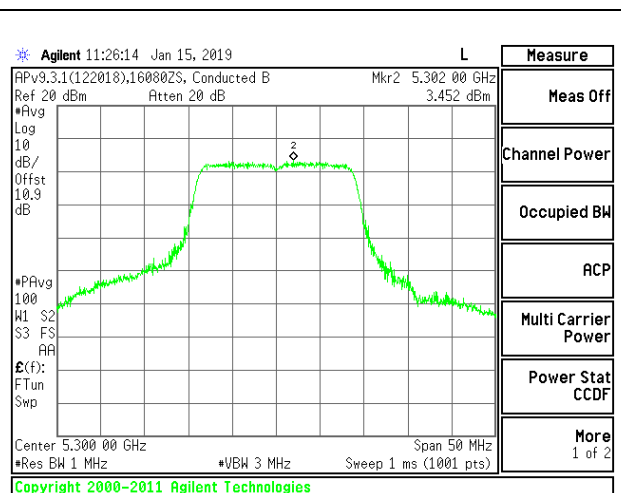

MID CHANNEL

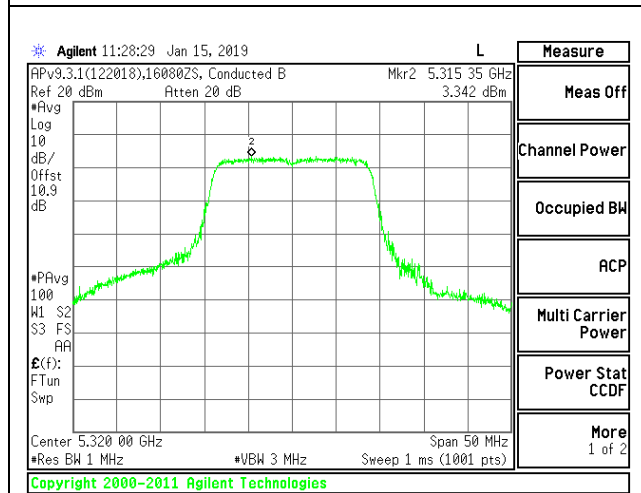

HIGH CHANNEL

9.5.7. 802.11n HT40 MODE IN THE 5.3 GHz BAND

1TX Antenna 1 MODE (FCC)

Bandwidth, Antenna Gain, and Limits

| Channel | Frequency (MHz) | Min 26 dB BW (MHz) | Directional Gain (dBi) | Power Limit (dBm) | PSD Limit (dBm/1MHz) |
|---------|--------------------|-----------------------------|------------------------------|-------------------------|----------------------------|
| Low | 5270 | 44.00 | -2.60 | 24.00 | 11.00 |
| High | 5310 | 44.30 | -2.60 | 24.00 | 11.00 |

| | | |
|---------------------------|------|---|
| Duty Cycle CF (dB) | 0.71 | Included in Calculations of Corr'd PSD |
|---------------------------|------|---|

Output Power Results

| Channel | Frequency (MHz) | Meas Power (dBm) | Total Corr'd Power (dBm) | Power Limit (dBm) | Power Margin (dB) |
|---------|--------------------|------------------------|-----------------------------------|-------------------------|-------------------------|
| Low | 5270 | 14.47 | 14.47 | 24.00 | -9.53 |
| High | 5310 | 14.84 | 14.84 | 24.00 | -9.16 |

PSD Results

| Channel | Frequency (MHz) | Meas PSD (dBm/1MHz) | Total Corr'd PSD (dBm/1MHz) | PSD Limit (dBm/1MHz) | PSD Margin (dB) |
|---------|--------------------|---------------------------|--------------------------------------|----------------------------|-----------------------|
| Low | 5270 | -1.013 | -0.30 | 11.00 | -11.30 |
| High | 5310 | -0.791 | -0.08 | 11.00 | -11.08 |

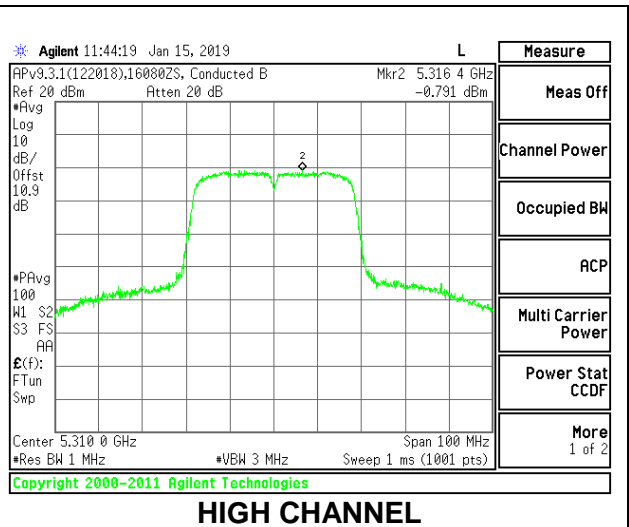
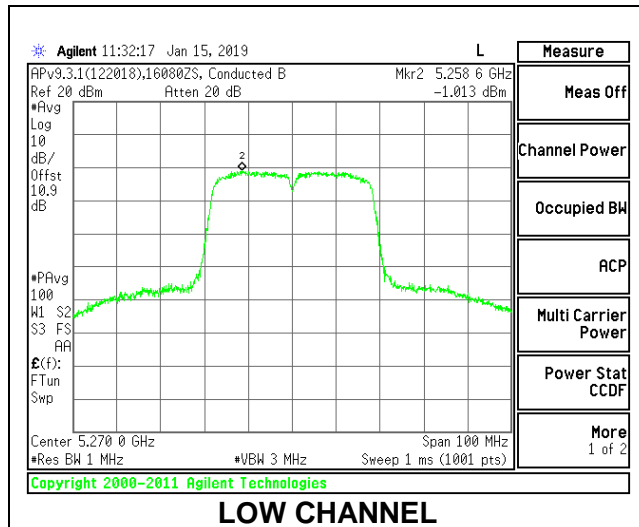

9.5.8. 802.11ac VHT80 MODE IN THE 5.3 GHz BAND

1TX Antenna 1 MODE (FCC)

Bandwidth, Antenna Gain, and Limits

| Channel | Frequency (MHz) | Min 26 dB BW (MHz) | Directional Gain (dBi) | Power Limit (dBm) | PSD Limit (dBm/1MHz) |
|---------|--------------------|-----------------------------|------------------------------|-------------------------|----------------------------|
| Mid | 5290 | 114.60 | -2.60 | 24.00 | 11.00 |

| | | |
|---------------------------|------|---|
| Duty Cycle CF (dB) | 1.29 | Included in Calculations of Corr'd PSD |
|---------------------------|------|---|

Output Power Results

| Channel | Frequency (MHz) | Meas Power (dBm) | Total Corr'd Power (dBm) | Power Limit (dBm) | Power Margin (dB) |
|---------|--------------------|------------------------|-----------------------------------|-------------------------|-------------------------|
| Mid | 5290 | 13.79 | 13.79 | 24.00 | -10.21 |

PSD Results

| Channel | Frequency (MHz) | Meas PSD (dBm/1MHz) | Total Corr'd PSD (dBm/1MHz) | PSD Limit (dBm/1MHz) | PSD Margin (dB) |
|---------|--------------------|---------------------------|--------------------------------------|----------------------------|-----------------------|
| Mid | 5290 | -5.181 | -3.89 | 11.00 | -14.89 |

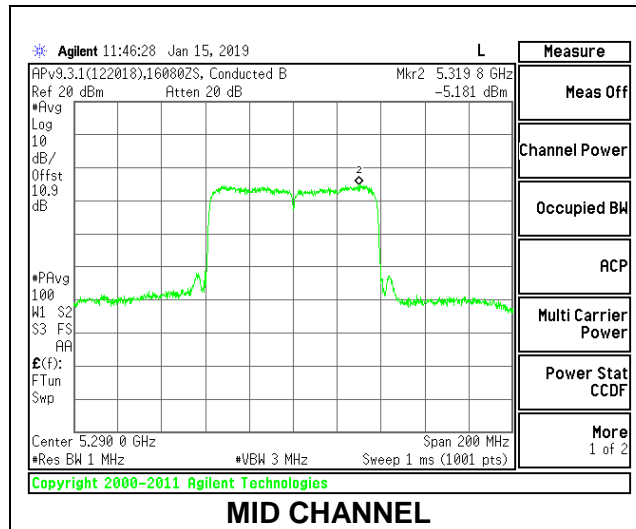

9.5.9. 802.11a MODE IN THE 5.6 GHz BAND

1TX Antenna 1 MODE (FCC)

Bandwidth, Antenna Gain, and Limits

| Channel | Frequency (MHz) | Min 26 dB BW (MHz) | Directional Gain (dBi) | Power Limit (dBm) | PSD Limit (dBm/ 1MHz) |
|---------|--------------------|-----------------------------|------------------------------|-------------------------|--------------------------------|
| Low | 5500 | 29.25 | -2.6 | 24.00 | 11.00 |
| Mid | 5580 | 28.40 | -2.6 | 24.00 | 11.00 |
| High | 5700 | 28.30 | -2.6 | 24.00 | 11.00 |
| 144 | 5720 | 28.45 | -2.6 | 24.00 | 11.00 |

| | | |
|---------------------------|------|---|
| Duty Cycle CF (dB) | 0.27 | Included in Calculations of Corr'd PSD |
|---------------------------|------|---|

Output Power Results

| Channel | Frequency (MHz) | Meas Power (dBm) | Total Corr'd Power (dBm) | Power Limit (dBm) | Power Margin (dB) |
|---------|--------------------|------------------------|-----------------------------------|-------------------------|-------------------------|
| Low | 5500 | 16.98 | 16.98 | 24.00 | -7.02 |
| Mid | 5580 | 15.60 | 15.60 | 24.00 | -8.40 |
| High | 5700 | 15.98 | 15.98 | 24.00 | -8.02 |
| 144 | 5720 | 15.08 | 15.35 | 24.00 | -8.65 |

PSD Results

| Channel | Frequency (MHz) | Meas PSD (dBm/ 1MHz) | Total Corr'd PSD (dBm/ 1MHz) | PSD Limit (dBm/ 1MHz) | PSD Margin (dB) |
|---------|--------------------|-------------------------------|--|--------------------------------|-----------------------|
| Low | 5500 | 3.36 | 3.63 | 11.00 | -7.37 |
| Mid | 5580 | 2.43 | 2.70 | 11.00 | -8.30 |
| High | 5700 | 2.54 | 2.81 | 11.00 | -8.20 |
| 144 | 5720 | 2.45 | 2.72 | 11.00 | -8.28 |

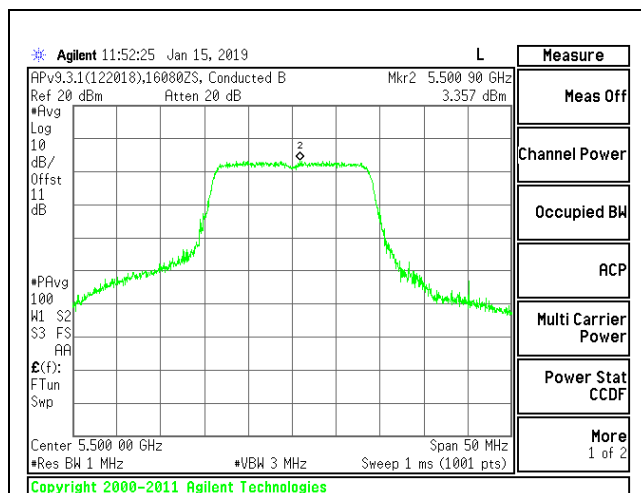

LOW CHANNEL

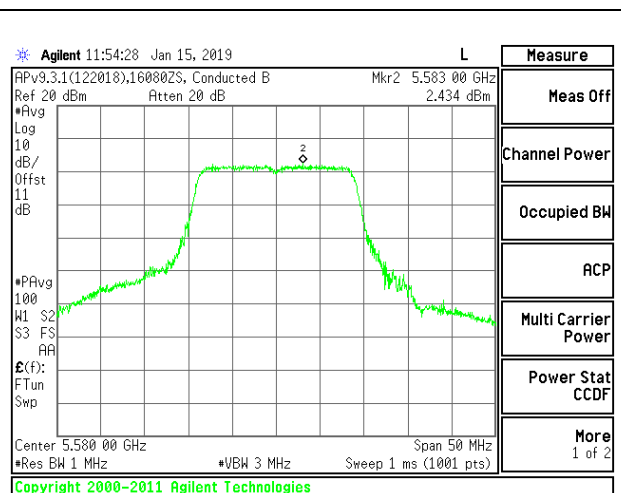

MID CHANNEL

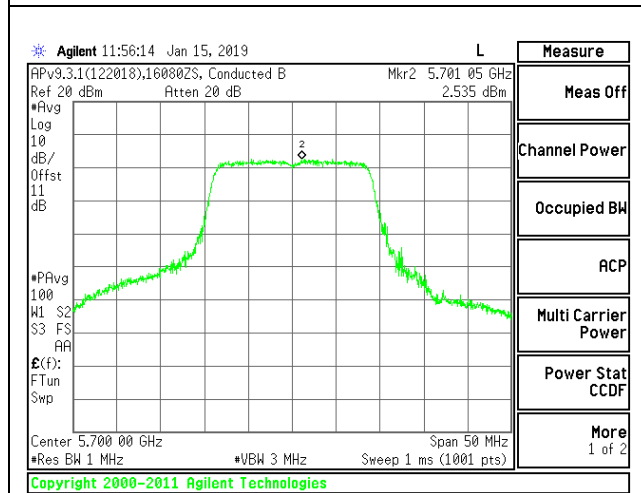

HIGH CHANNEL

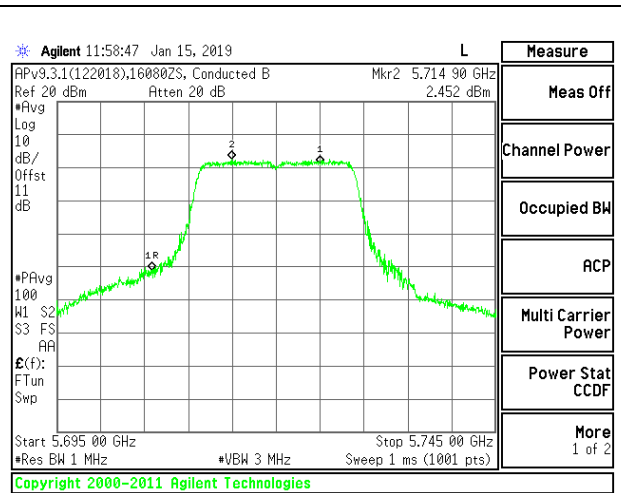

CHANNEL 144

9.5.10. 802.11n HT20 MODE IN THE 5.6 GHz BAND

1TX Antenna 1 MODE (FCC)

Bandwidth, Antenna Gain, and Limits

| Channel | Frequency (MHz) | Min 26 dB BW (MHz) | Directional Gain (dBi) | Power Limit (dBm) | PSD Limit (dBm/ 1MHz) |
|---------|--------------------|-----------------------------|------------------------------|-------------------------|--------------------------------|
| Low | 5500 | 30.25 | -2.6 | 24.00 | 11.00 |
| Mid | 5580 | 29.10 | -2.6 | 24.00 | 11.00 |
| High | 5700 | 29.15 | -2.6 | 24.00 | 11.00 |
| 144 | 5720 | 27.90 | -2.6 | 24.00 | 11.00 |

| | | |
|---------------------------|------|---|
| Duty Cycle CF (dB) | 0.28 | Included in Calculations of Corr'd PSD |
|---------------------------|------|---|

Output Power Results

| Channel | Frequency (MHz) | Meas Power (dBm) | Total Corr'd Power (dBm) | Power Limit (dBm) | Power Margin (dB) |
|---------|--------------------|------------------------|-----------------------------------|-------------------------|-------------------------|
| Low | 5500 | 15.67 | 15.67 | 24.00 | -8.33 |
| Mid | 5580 | 14.58 | 14.58 | 24.00 | -9.42 |
| High | 5700 | 14.61 | 14.61 | 24.00 | -9.39 |
| 144 | 5720 | 14.56 | 14.84 | 24.00 | -9.16 |

PSD Results

| Channel | Frequency (MHz) | Meas PSD (dBm/ 1MHz) | Total Corr'd PSD (dBm/ 1MHz) | PSD Limit (dBm/ 1MHz) | PSD Margin (dB) |
|---------|--------------------|-------------------------------|--|--------------------------------|-----------------------|
| Low | 5500 | 3.26 | 3.54 | 11.00 | -7.46 |
| Mid | 5580 | 2.61 | 2.89 | 11.00 | -8.11 |
| High | 5700 | 2.40 | 2.68 | 11.00 | -8.32 |
| 144 | 5720 | 2.62 | 2.90 | 11.00 | -8.10 |

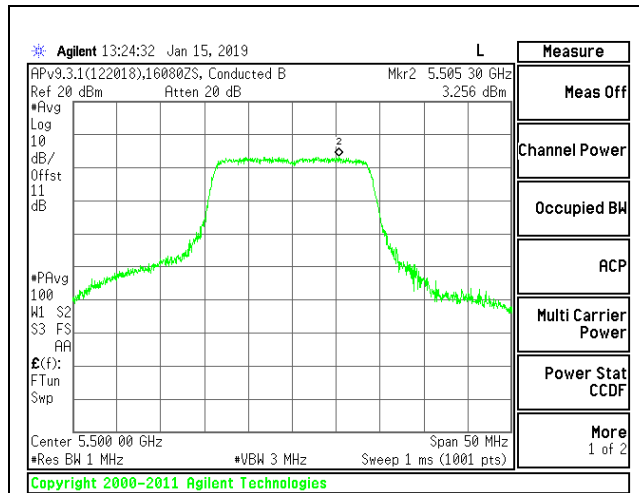

LOW CHANNEL

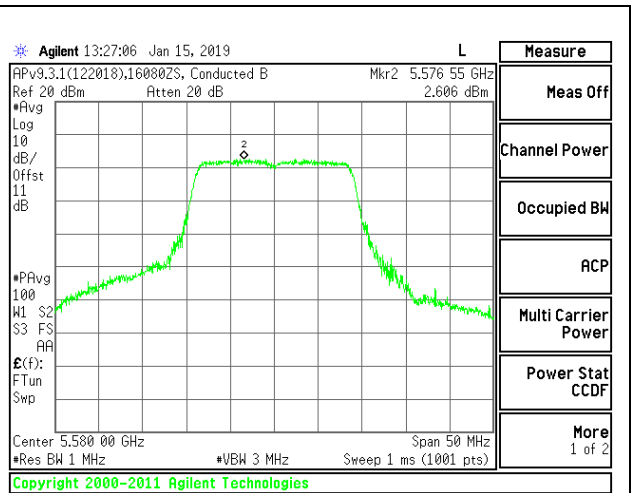

MID CHANNEL

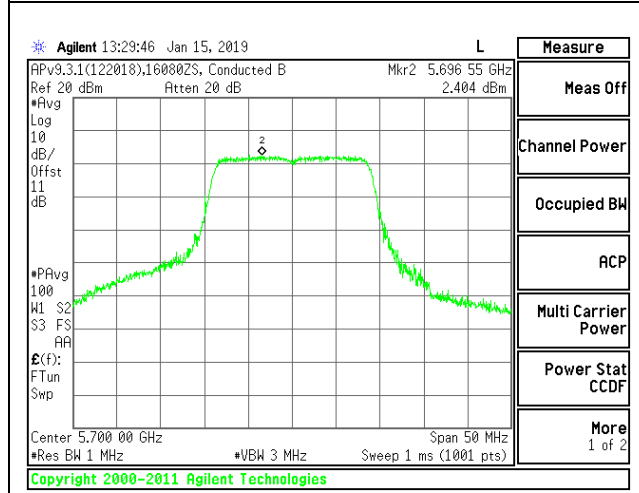

HIGH CHANNEL

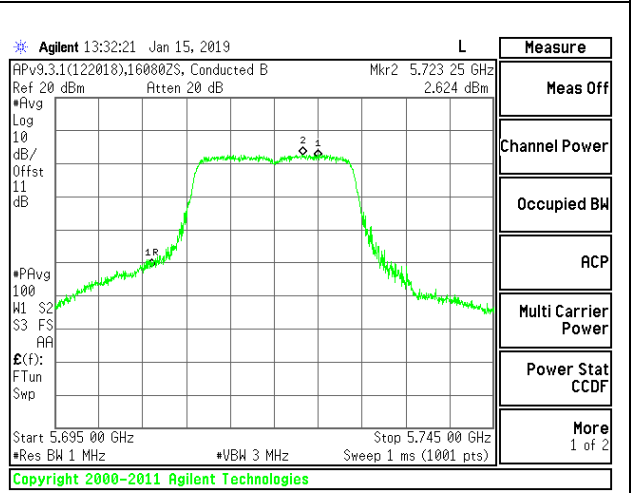

CHANNEL 144

9.5.11. 802.11n HT40 MODE IN THE 5.6 GHz BAND

1TX Antenna 1 MODE (FCC)

Bandwidth, Antenna Gain, and Limits

| Channel | Frequency (MHz) | Min 26 dB BW (MHz) | Directional Gain (dBi) | Power Limit (dBm) | PSD Limit (dBm/ 1MHz) |
|---------|--------------------|-----------------------------|------------------------------|-------------------------|--------------------------------|
| Low | 5510 | 44.10 | -2.6 | 24.00 | 11.00 |
| Mid | 5550 | 44.00 | -2.6 | 24.00 | 11.00 |
| High | 5670 | 44.10 | -2.6 | 24.00 | 11.00 |
| 142 | 5710 | 43.90 | -2.6 | 24.00 | 11.00 |

| | | |
|---------------------------|------|---|
| Duty Cycle CF (dB) | 0.71 | Included in Calculations of Corr'd PSD |
|---------------------------|------|---|

Output Power Results

| Channel | Frequency (MHz) | Meas Power (dBm) | Total Corr'd Power (dBm) | Power Limit (dBm) | Power Margin (dB) |
|---------|--------------------|------------------------|-----------------------------------|-------------------------|-------------------------|
| Low | 5510 | 12.24 | 12.24 | 24.00 | -11.76 |
| Mid | 5550 | 14.51 | 14.51 | 24.00 | -9.49 |
| High | 5670 | 14.76 | 14.76 | 24.00 | -9.24 |
| 142 | 5710 | 14.60 | 15.31 | 24.00 | -8.69 |

PSD Results

| Channel | Frequency (MHz) | Meas PSD (dBm/ 1MHz) | Total Corr'd PSD (dBm/ 1MHz) | PSD Limit (dBm/ 1MHz) | PSD Margin (dB) |
|---------|--------------------|-------------------------------|--|--------------------------------|-----------------------|
| Low | 5510 | -3.55 | -2.84 | 11.00 | -13.84 |
| Mid | 5550 | -0.94 | -0.23 | 11.00 | -11.23 |
| High | 5670 | -0.56 | 0.15 | 11.00 | -10.85 |
| 142 | 5710 | -1.33 | -0.62 | 11.00 | -11.62 |

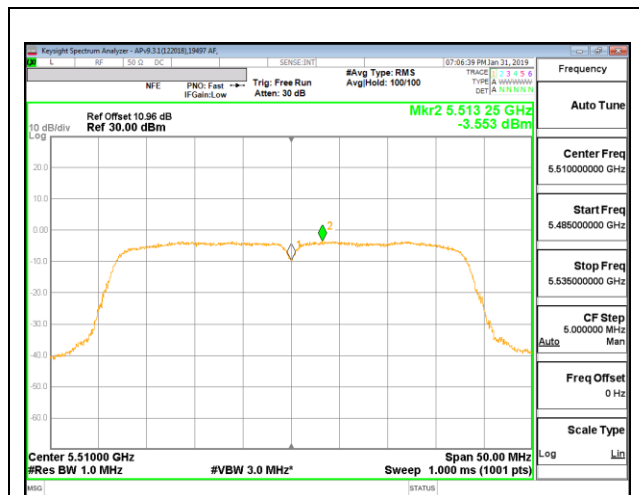

LOW CHANNEL

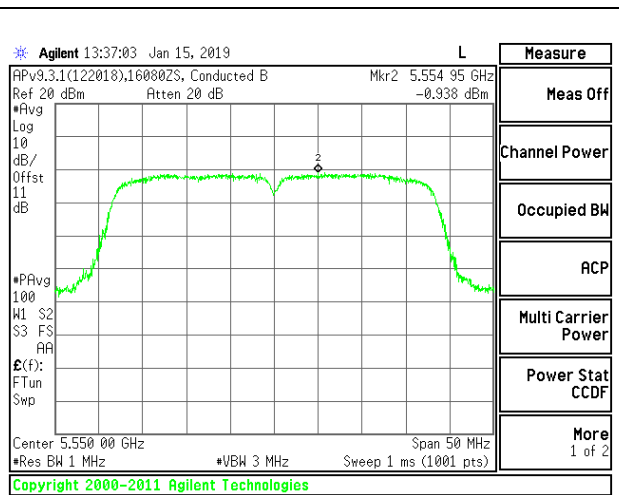

MID CHANNEL

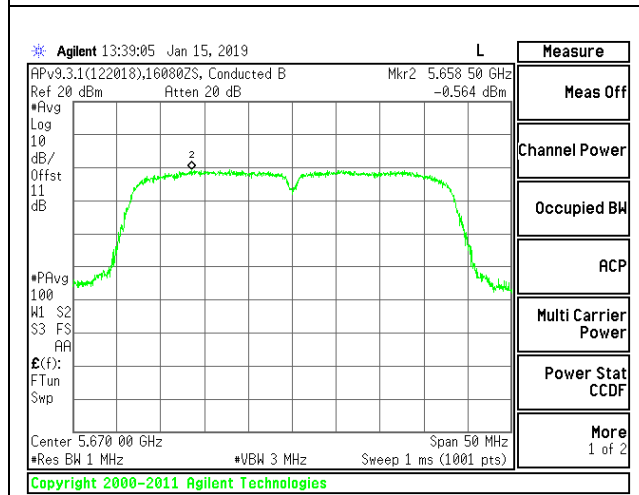

HIGH CHANNEL

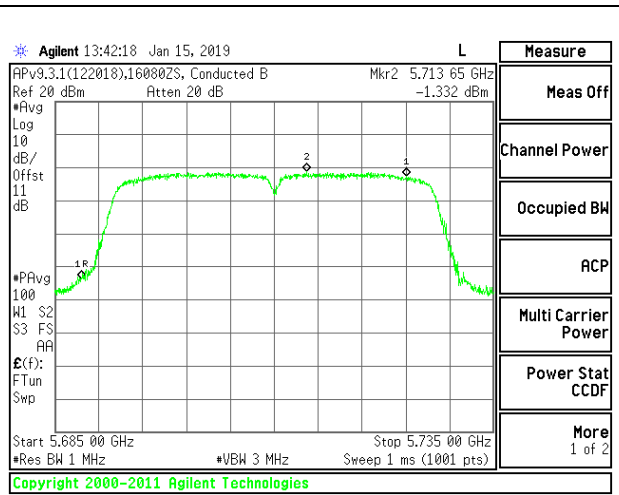

CHANNEL 142

9.5.12. 802.11ac VHT80 MODE IN THE 5.6 GHz BAND

1TX Antenna 1 MODE (FCC)

Bandwidth, Antenna Gain, and Limits

| Channel | Frequency (MHz) | Min 26 dB BW (MHz) | Directional Gain (dBi) | Power Limit (dBm) | PSD Limit (dBm/ 1MHz) |
|---------|--------------------|-----------------------------|------------------------------|-------------------------|--------------------------------|
| Low | 5530 | 105.60 | -2.6 | 24.00 | 11.00 |
| High | 5610 | 113.20 | -2.6 | 24.00 | 11.00 |
| 138 | 5690 | 110.40 | -2.6 | 24.00 | 11.00 |

| | | |
|---------------------------|------|---|
| Duty Cycle CF (dB) | 1.29 | Included in Calculations of Corr'd PSD |
|---------------------------|------|---|

Output Power Results

| Channel | Frequency (MHz) | Meas Power (dBm) | Total Corr'd Power (dBm) | Power Limit (dBm) | Power Margin (dB) |
|---------|--------------------|------------------------|-----------------------------------|-------------------------|-------------------------|
| Low | 5530 | 13.45 | 13.45 | 24.00 | -10.55 |
| High | 5610 | 13.63 | 13.63 | 24.00 | -10.37 |
| 138 | 5690 | 13.92 | 13.92 | 24.00 | -10.08 |

PSD Results

| Channel | Frequency (MHz) | Meas PSD (dBm/ 1MHz) | Total Corr'd PSD (dBm/ 1MHz) | PSD Limit (dBm/ 1MHz) | PSD Margin (dB) |
|---------|--------------------|-------------------------------|--|--------------------------------|-----------------------|
| Low | 5530 | -5.31 | -4.02 | 11.00 | -15.02 |
| High | 5610 | -5.38 | -4.09 | 11.00 | -15.09 |
| 138 | 5690 | -5.19 | -3.90 | 11.00 | -14.90 |

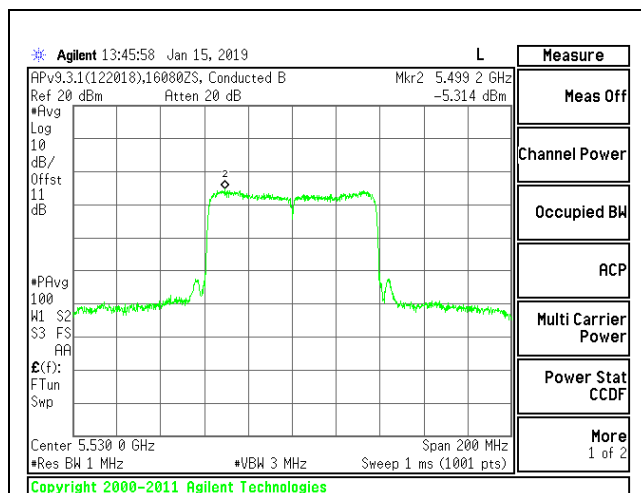

LOW CHANNEL

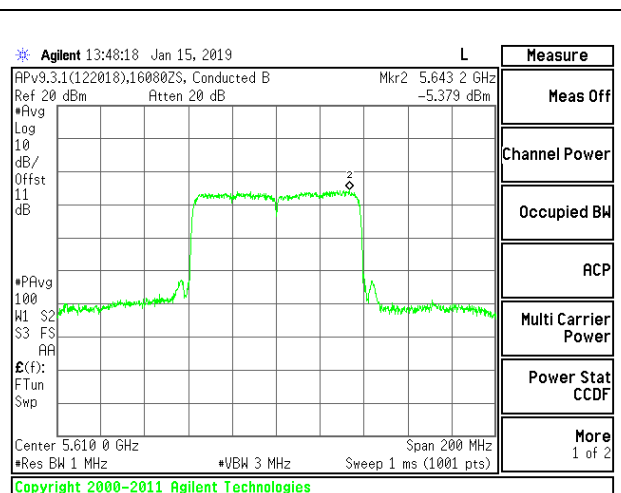

HIGH CHANNEL

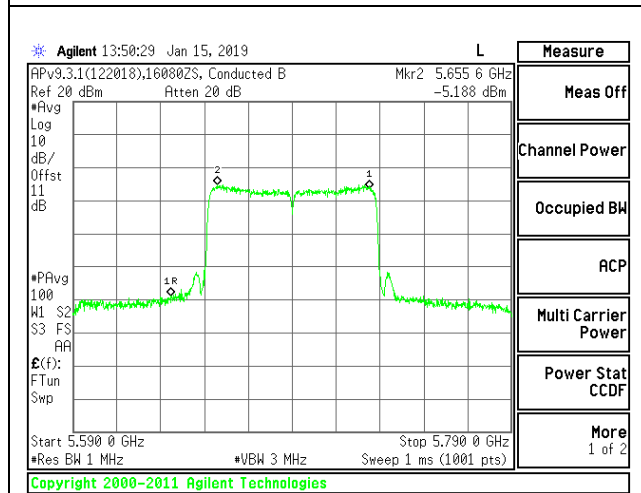

CHANNEL 138

9.5.13. 802.11a MODE IN THE 5.8 GHZ BAND

1TX Antenna 1 MODE (FCC)

Antenna Gain and Limit

| Channel | Frequency (MHz) | Directional Gain (dBi) | Power Limit (dBm) | PSD Limit (dBm/ 500kHz) |
|---------|--------------------|------------------------------|-------------------------|----------------------------------|
| Low | 5745 | -3.50 | 30.00 | 30.00 |
| Mid | 5785 | -3.50 | 30.00 | 30.00 |
| High | 5825 | -3.50 | 30.00 | 30.00 |

| | | |
|---------------------------|------|---|
| Duty Cycle CF (dB) | 0.27 | Included in Calculations of Corr'd PSD |
|---------------------------|------|---|

Output Power Results

| Channel | Frequency (MHz) | Meas Power (dBm) | Total Corr'd Power (dBm) | Power Limit (dBm) | Power Margin (dB) |
|---------|--------------------|------------------------|-----------------------------------|-------------------------|-------------------------|
| Low | 5745 | 16.78 | 16.78 | 30.00 | -13.22 |
| Mid | 5785 | 16.67 | 16.67 | 30.00 | -13.33 |
| High | 5825 | 16.62 | 16.62 | 30.00 | -13.38 |

PSD Results

| Channel | Frequency (MHz) | Meas PSD (dBm/ 500kHz) | Total Corr'd PSD (dBm/ 500kHz) | PSD Limit (dBm/ 500kHz) | PSD Margin (dB) |
|---------|--------------------|---------------------------------|--|----------------------------------|-----------------------|
| Low | 5745 | 1.663 | 1.933 | 30.00 | -28.07 |
| Mid | 5785 | 1.459 | 1.729 | 30.00 | -28.27 |
| High | 5825 | 1.654 | 1.924 | 30.00 | -28.08 |

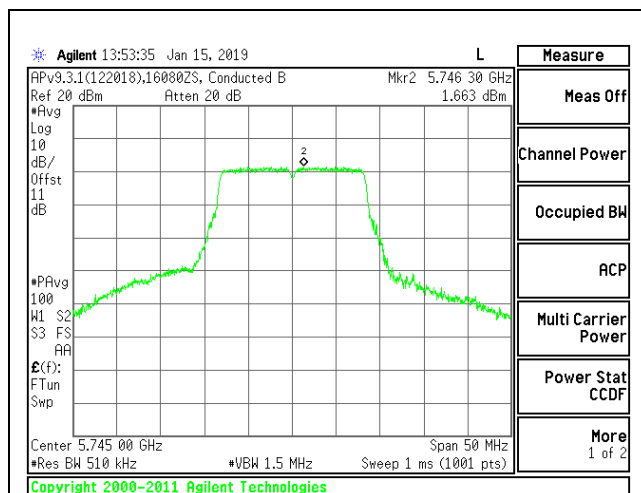

LOW CHANNEL

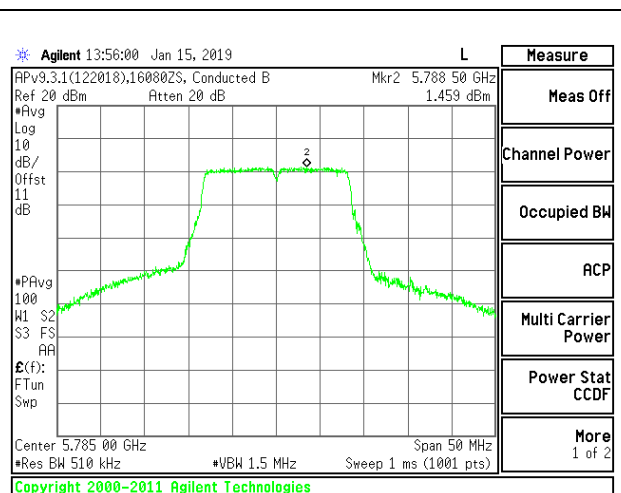

MID CHANNEL

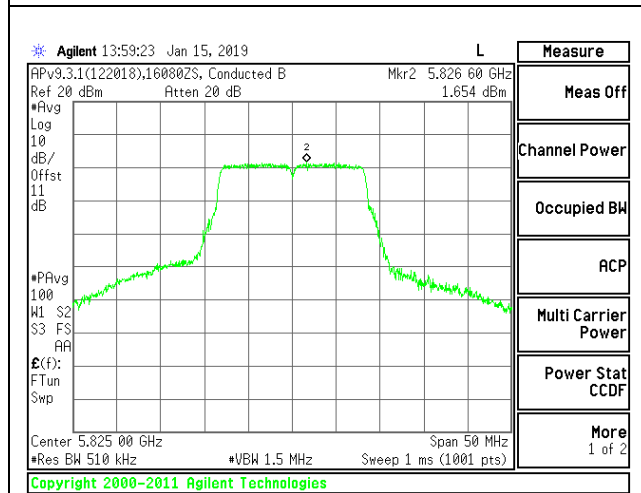

HIGH CHANNEL

9.5.14. 802.11n HT20 MODE IN THE 5.8 GHz BAND

1TX Antenna 1 MODE (FCC)

Antenna Gain and Limit

| Channel | Frequency (MHz) | Directional Gain (dBi) | Power Limit (dBm) | PSD Limit (dBm/ 500kHz) |
|---------|--------------------|------------------------------|-------------------------|----------------------------------|
| Low | 5745 | -3.50 | 30.00 | 30.00 |
| Mid | 5785 | -3.50 | 30.00 | 30.00 |
| High | 5825 | -3.50 | 30.00 | 30.00 |

| | | |
|---------------------------|------|---|
| Duty Cycle CF (dB) | 0.28 | Included in Calculations of Corr'd PSD |
|---------------------------|------|---|

Output Power Results

| Channel | Frequency (MHz) | Meas Power (dBm) | Total Corr'd Power (dBm) | Power Limit (dBm) | Power Margin (dB) |
|---------|--------------------|------------------------|-----------------------------------|-------------------------|-------------------------|
| Low | 5745 | 15.79 | 15.79 | 30.00 | -14.21 |
| Mid | 5785 | 15.27 | 15.27 | 30.00 | -14.73 |
| High | 5825 | 15.69 | 15.69 | 30.00 | -14.31 |

PSD Results

| Channel | Frequency (MHz) | Meas PSD (dBm/ 500kHz) | Total Corr'd PSD (dBm/ 500kHz) | PSD Limit (dBm/ 500kHz) | PSD Margin (dB) |
|---------|--------------------|---------------------------------|--|----------------------------------|-----------------------|
| Low | 5745 | 0.090 | 0.370 | 30.00 | -29.63 |
| Mid | 5785 | 0.307 | 0.587 | 30.00 | -29.41 |
| High | 5825 | 0.543 | 0.823 | 30.00 | -29.18 |

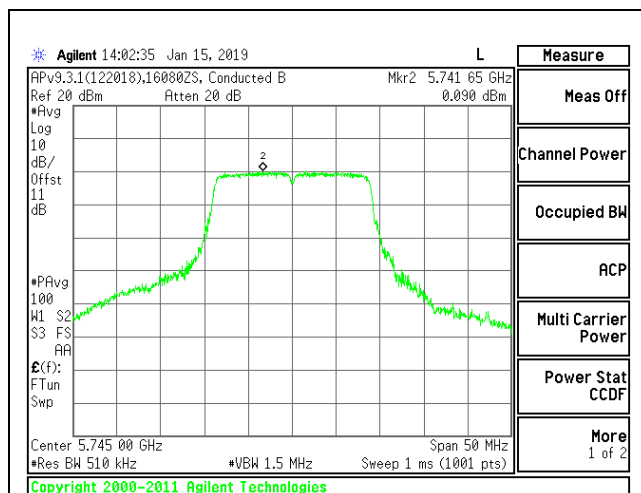

LOW CHANNEL

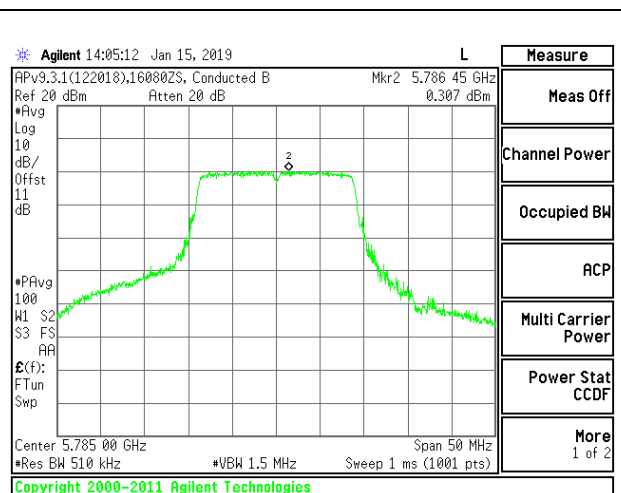

MID CHANNEL

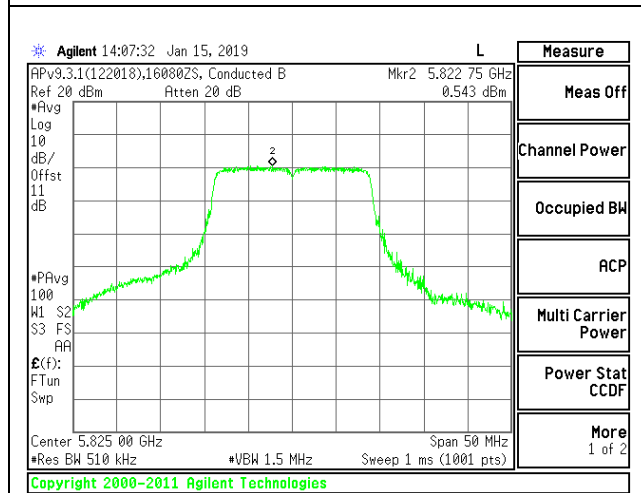

HIGH CHANNEL

9.5.15. 802.11n HT40 MODE IN THE 5.8 GHz BAND

1TX Antenna 1 MODE (FCC)

Antenna Gain and Limit

| Channel | Frequency (MHz) | Directional Gain (dBi) | Power Limit (dBm) | PSD Limit (dBm/ 500kHz) |
|---------|--------------------|------------------------------|-------------------------|----------------------------------|
| Low | 5755 | -3.50 | 30.00 | 30.00 |
| High | 5795 | -3.50 | 30.00 | 30.00 |

| | | |
|---------------------------|------|---|
| Duty Cycle CF (dB) | 0.79 | Included in Calculations of Corr'd PSD |
|---------------------------|------|---|

Output Power Results

| Channel | Frequency (MHz) | Meas Power (dBm) | Total Corr'd Power (dBm) | Power Limit (dBm) | Power Margin (dB) |
|---------|--------------------|------------------------|-----------------------------------|-------------------------|-------------------------|
| Low | 5755 | 14.34 | 14.34 | 30.00 | -15.66 |
| High | 5795 | 14.40 | 14.40 | 30.00 | -15.60 |

PSD Results

| Channel | Frequency (MHz) | Meas PSD (dBm) | Total Corr'd PSD (dBm) | PSD Limit (dBm) | PSD Margin (dB) |
|---------|--------------------|----------------------|---------------------------------|-----------------------|-----------------------|
| Low | 5755 | -4.298 | -3.508 | 30.00 | -33.51 |
| High | 5795 | -4.538 | -3.748 | 30.00 | -33.75 |

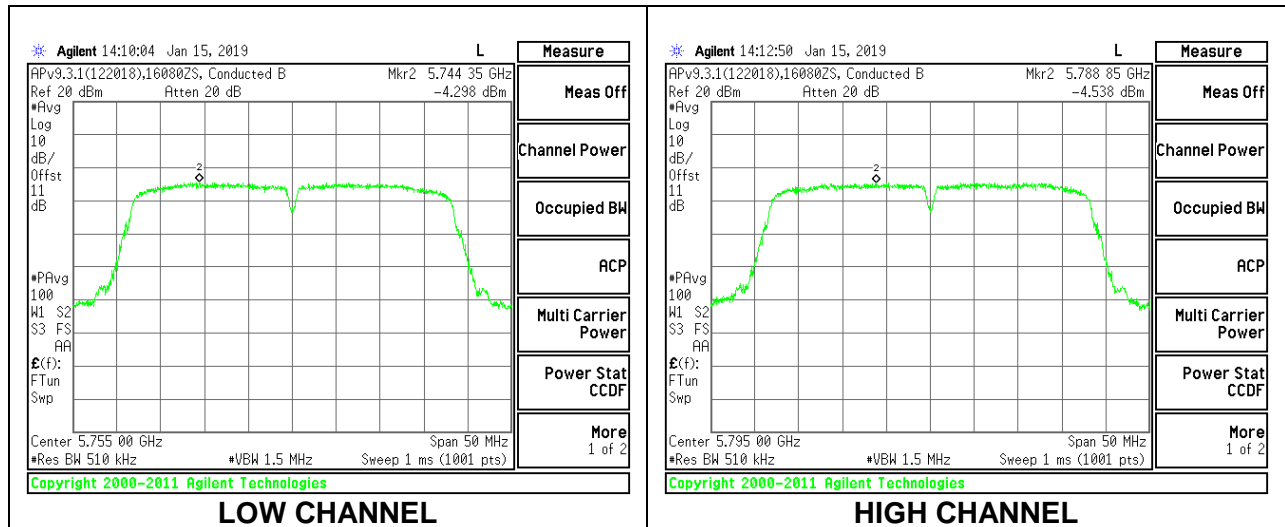

9.5.16. 802.11ac VHT80 MODE IN THE 5.8 GHz BAND

1TX Antenna 1 MODE (FCC)

Antenna Gain and Limit

| Channel | Frequency (MHz) | Directional Gain (dBi) | Power Limit (dBm) | PSD Limit (dBm/ 500kHz) |
|---------|--------------------|------------------------------|-------------------------|----------------------------------|
| Mid | 5775 | -3.50 | 30.00 | 30.00 |

| | | |
|---------------------------|------|---|
| Duty Cycle CF (dB) | 1.29 | Included in Calculations of Corr'd PSD |
|---------------------------|------|---|

Output Power Results

| Channel | Frequency (MHz) | Meas Power (dBm) | Total Corr'd Power (dBm) | Power Limit (dBm) | Power Margin (dB) |
|---------|--------------------|------------------------|-----------------------------------|-------------------------|-------------------------|
| Mid | 5775 | 13.43 | 13.43 | 30.00 | -16.57 |

PSD Results

| Channel | Frequency (MHz) | Meas PSD (dBm/ 500kHz) | Total Corr'd PSD (dBm/500 kHz) | PSD Limit (dBm/ 500kHz) | PSD Margin (dB) |
|---------|--------------------|---------------------------------|--|----------------------------------|-----------------------|
| Mid | 5775 | -8.372 | -7.082 | 30.00 | -37.08 |

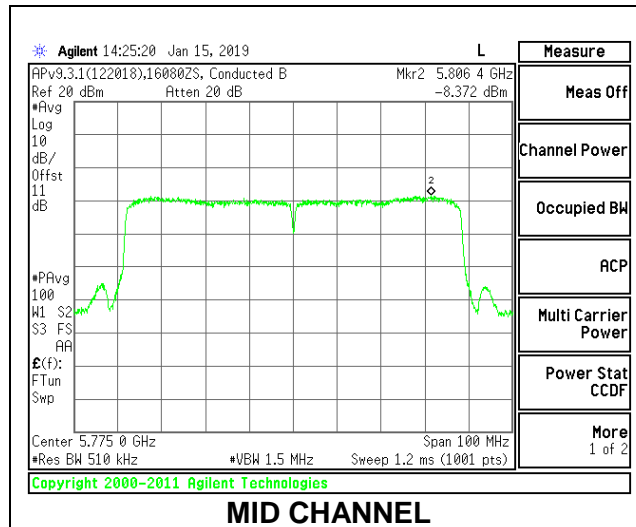

10. RADIATED TEST RESULTS

LIMITS

FCC §15.205 and §15.209 -Restricted bands

FCC §15.407(b)(1-3) -Un-Restricted bands

After January 01, 2019 for Outside of the Restricted Bands Emissions

| Frequency Range (MHz) | Field Strength Limit (uV/m) at 3 m | Field Strength Limit (dBuV/m) at 3 m |
|-----------------------|------------------------------------|--------------------------------------|
| 30 - 88 | 100 | 40 |
| 88 - 216 | 150 | 43.5 |
| 216 - 960 | 200 | 46 |
| Above 960 | 500 | 54 |

TEST PROCEDURE

The EUT is placed on a non-conducting table 80 cm above the ground plane for measurement below 1GHz; 1.5 m above the ground plane for measurement above 1GHz. The antenna to EUT distance is 3 meters. The EUT is configured in accordance with ANSI C63.10. The EUT is set to transmit in a continuous mode.

For measurements below 1 GHz the resolution bandwidth is set to 100 kHz for peak detection measurements or 120 kHz for quasi-peak detection measurements. Peak detection is used unless otherwise noted as quasi-peak.

For pre-scans above 1 GHz the resolution bandwidth is set to 1 MHz; the video bandwidth is set to 30 KHz for peak measurements.

For final measurements above 1 GHz the resolution bandwidth is set to 1 MHz; the video bandwidth is set to 3 MHz for peak measurements and as applicable for average measurements.

The spectrum from 30 MHz to 1GHz and 18GHz to 40 GHz is investigated with the transmitter set to transmit at the channel with highest output power as worst-case scenario. 1GHz to 18GHz was set to the lowest, middle, and highest channels in the 5 GHz bands.

The frequency range of interest is monitored at a fixed antenna height and EUT azimuth. The EUT is rotated through 360 degrees to maximize emissions received. The antenna is scanned from 1 to 4 meters above the ground plane to further maximize the emission. Measurements are made with the antenna polarized in both the vertical and the horizontal positions.

2D antenna use - For below 30MHz testing, investigation was done on three antenna orientations (parallel, perpendicular, and ground-parallel), parallel and perpendicular are the worst orientations, therefore testing was performed on these two orientations only.

KDB 414788 OATS and Chamber Correlation Justification

Base on FCC 15.31 (f) (2): measurements may be performed at a distance closer than that specified in the regulations; however, an attempt should be made to avoid making measurements in the near field.

OATs and chamber correlation testing had been performed and chamber measured test result is the worst case test result.

10.1. TRANSMITTER ABOVE 1 GHz

10.1.1. TX ABOVE 1 GHz 802.11a MODE IN THE 5.2 GHz BAND

1TX Antenna 1 MODE

BANDEDGE (LOW CHANNEL)

HORIZONTAL RESULT

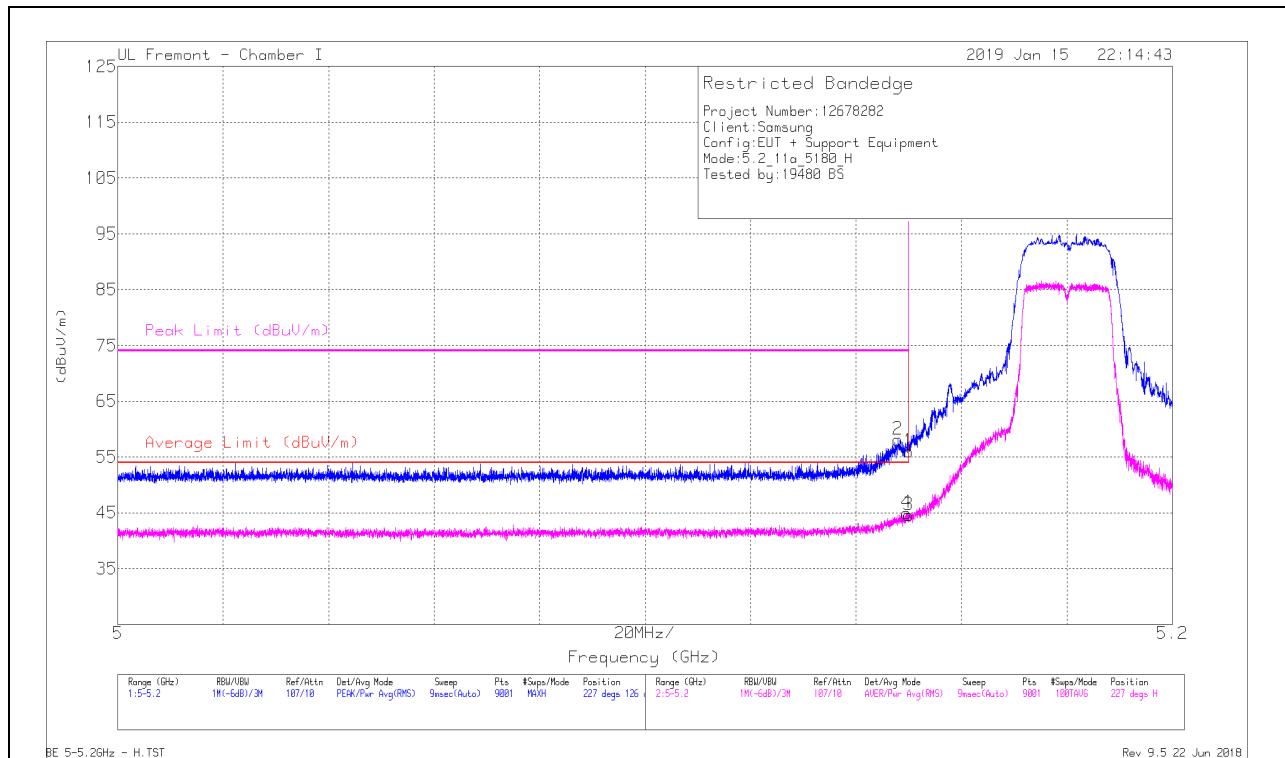

| Marker | Frequenc y (GHz) | Meter Reading (dBuV) | Det | AF T862 (dB/m) | Amp/Cbl/Ftr/Pad (dB) | DC Corr (dB) | Correcte d Reading (dBuV/m) | Average Limit (dBuV/m) | Margin (dB) | Peak Limit (dBuV/m) | PK Margin (dB) | Azimuth (Degs) | Height (cm) | Polarity |
|--------|---------------------|----------------------------|-----|----------------|-------------------------|--------------|--------------------------------------|---------------------------|----------------|---------------------|----------------------|-------------------|----------------|----------|
| 1 | * 5.15 | 40.65 | Pk | 34.4 | -19 | 0 | 56.05 | - | - | 74 | -17.95 | 227 | 126 | H |
| 2 | * 5.148 | 42.67 | Pk | 34.4 | -19 | 0 | 58.07 | - | - | 74 | -15.93 | 227 | 126 | H |
| 3 | * 5.15 | 28.9 | RMS | 34.4 | -19 | .27 | 44.57 | 54 | -9.43 | - | - | 227 | 126 | H |
| 4 | * 5.15 | 29.24 | RMS | 34.4 | -19 | .27 | 44.91 | 54 | -9.09 | - | - | 227 | 126 | H |

* - indicates frequency in CFR47 Pt 15 / IC RSS-Restricted Band

Pk - Peak detector

RMS - RMS detection

VERTICAL RESULT

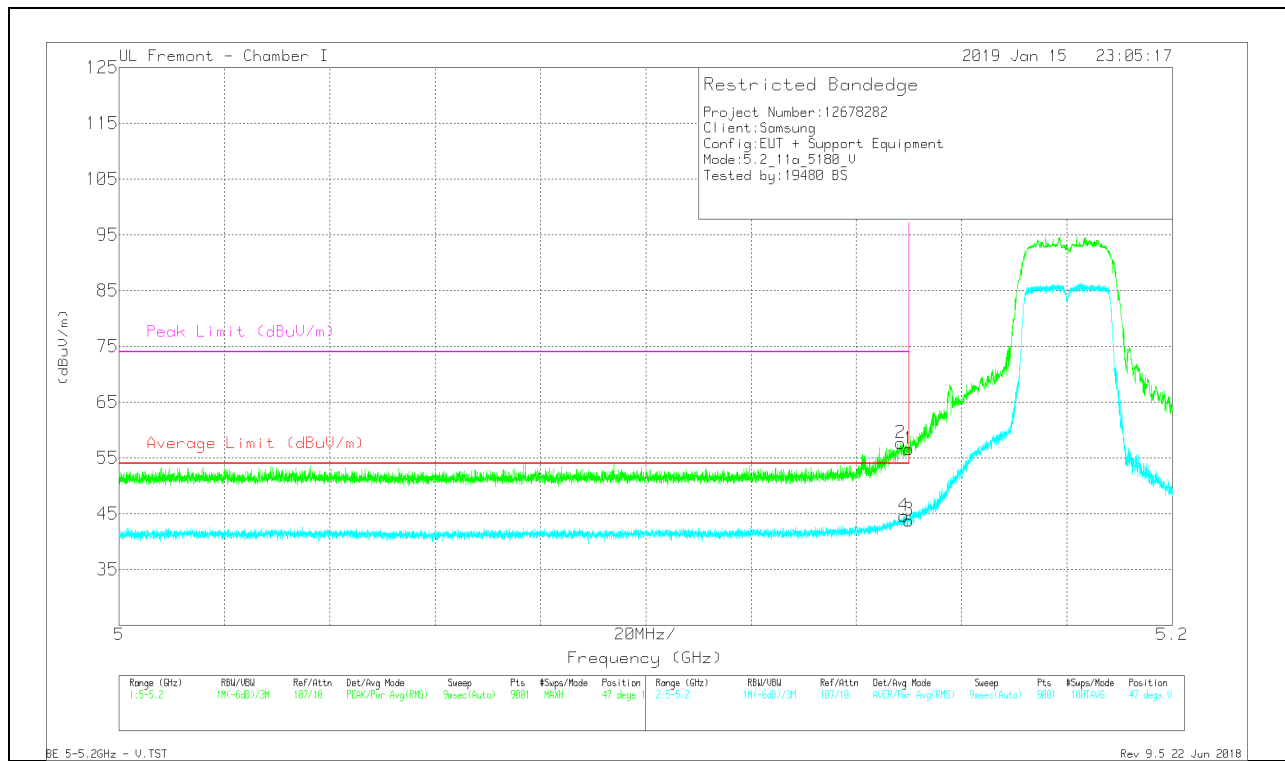

| Marker | Frequency (GHz) | Meter Reading (dBuV) | Det | AF T862 (dB/m) | Amp/Cb/Filt/Pad (dB) | DC Corr (dB) | Corrected Reading (dBuV/m) | Average Limit (dBuV/m) | Margin (dB) | Peak Limit (dBuV/m) | PK Margin (dB) | Azimuth (Degs) | Height (cm) | Polarity |
|--------|-----------------|----------------------|-----|----------------|----------------------|--------------|----------------------------|------------------------|-------------|---------------------|----------------|----------------|-------------|----------|
| 1 | * 5.15 | 41.17 | Pk | 34.4 | -19 | 0 | 56.57 | - | - | 74 | -17.43 | 47 | 161 | V |
| 2 | * 5.148 | 42.26 | Pk | 34.4 | -19 | 0 | 57.66 | - | - | 74 | -16.34 | 47 | 161 | V |
| 3 | * 5.15 | 28.14 | RMS | 34.4 | -19 | .27 | 43.81 | 54 | -10.19 | - | - | 47 | 161 | V |
| 4 | * 5.149 | 28.97 | RMS | 34.4 | -19 | .27 | 44.64 | 54 | -9.36 | - | - | 47 | 161 | V |

* - indicates frequency in CFR47 Pt 15 / IC RSS-Restricted Band

Pk - Peak detector

RMS - RMS detection

HARMONICS AND SPURIOUS EMISSIONS

LOW CHANNEL RESULTS

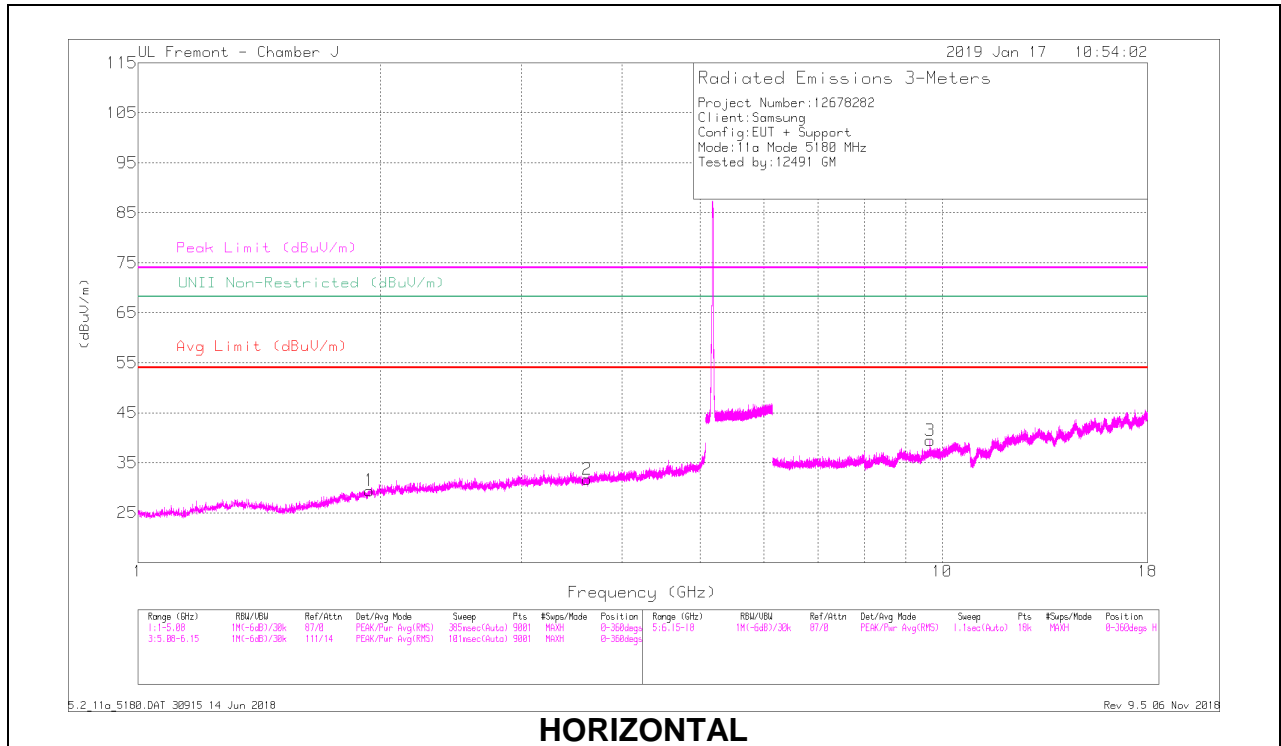

HORIZONTAL

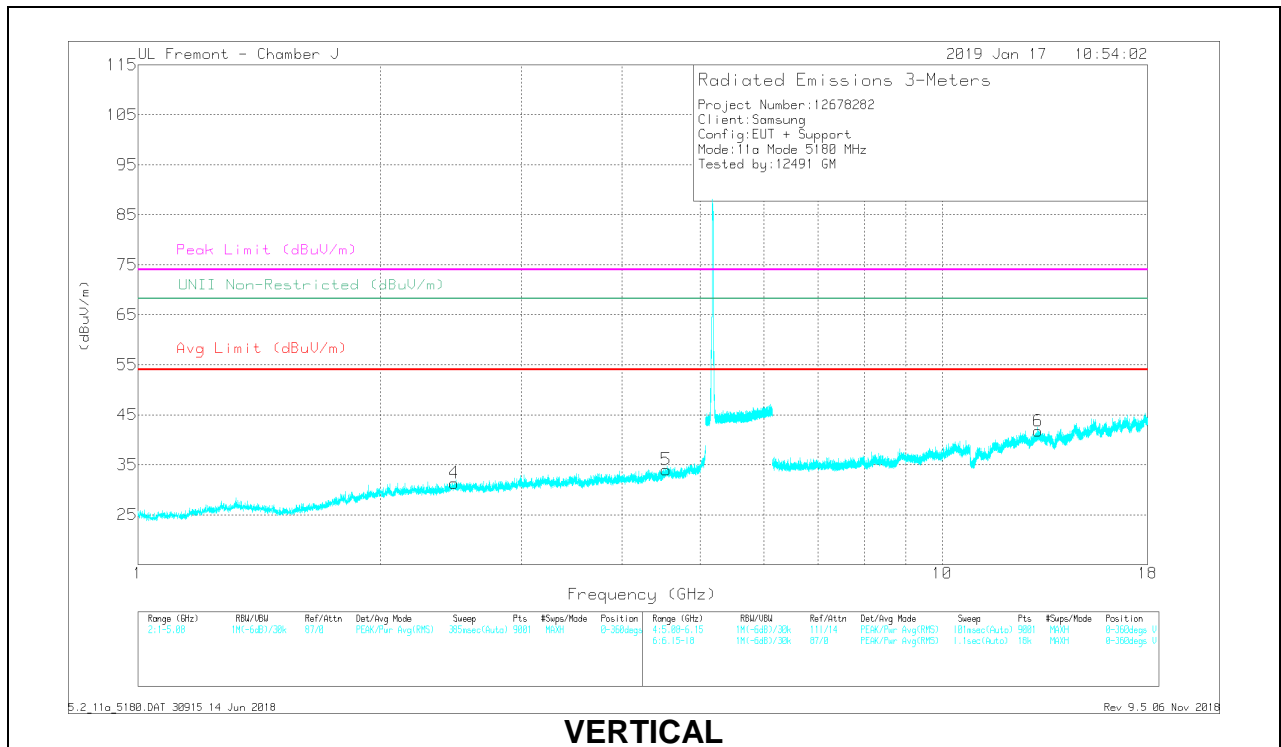

VERTICAL

RADIATED EMISSIONS

| Frequency (GHz) | Meter Reading (dBuV) | Det | AF A10067 (dB/m) | Amp/Coeff/Pad (dB) | DC Corr (dB) | Corrected Reading (dBuV/m) | Avg Limit (dBuV/m) | Margin (dB) | Peak Limit (dBuV/m) | PK Margin (dB) | UNII Non-Restricted (dBuV/m) | PK Margin (dB) | Azimuth (Degs) | Height (cm) | Polarity |
|-----------------|----------------------|------|------------------|--------------------|--------------|----------------------------|--------------------|-------------|---------------------|----------------|------------------------------|----------------|----------------|-------------|----------|
| 1.939 | 41.99 | PK-U | 31.2 | -35.8 | 0 | 37.39 | - | - | - | - | 68.2 | -30.81 | 73 | 254 | H |
| 1.939 | 32.96 | ADR | 31.2 | -35.8 | .27 | 28.03 | - | - | - | - | - | - | 73 | 254 | H |
| * 3.616 | 39.75 | PK-U | 33.1 | -33.7 | 0 | 39.15 | - | - | 74 | -34.85 | - | - | 318 | 156 | H |
| * 3.617 | 30.09 | ADR | 33.1 | -33.7 | .27 | 29.76 | 54 | -24.24 | - | - | - | - | 318 | 156 | H |
| 2.472 | 41.49 | PK-U | 32.5 | -35.5 | 0 | 38.49 | - | - | - | - | 68.2 | -29.71 | 8 | 174 | V |
| 2.471 | 31.42 | ADR | 32.5 | -35.5 | .27 | 28.69 | - | - | - | - | - | - | 8 | 174 | V |
| * 4.537 | 39.32 | PK-U | 34.1 | -31.3 | 0 | 42.12 | - | - | 74 | -31.88 | - | - | 44 | 115 | V |
| * 4.534 | 29.02 | ADR | 34.1 | -31.4 | .27 | 31.99 | 54 | -22.01 | - | - | - | - | 44 | 115 | V |
| 9.06 | 34.05 | PK-U | 36.6 | -25 | 0 | 45.65 | - | - | - | - | 68.2 | -22.55 | 354 | 246 | H |
| 9.659 | 23.95 | ADR | 36.6 | -25 | .27 | 35.62 | - | - | - | - | - | - | 354 | 246 | H |
| 13.155 | 31.8 | PK-U | 38.9 | -22.4 | 0 | 48.3 | - | - | - | - | 68.2 | -19.9 | 0 | 353 | V |
| 13.151 | 22.06 | ADR | 38.9 | -22.4 | .27 | 38.83 | - | - | - | - | - | - | 0 | 353 | V |

* - indicates frequency in CFR47 Pt 15 / IC RSS-Restricted Band
 PK-U - U-NII: Maximum Peak
 ADR - U-NII AD primary method, RMS average

MID CHANNEL RESULTS

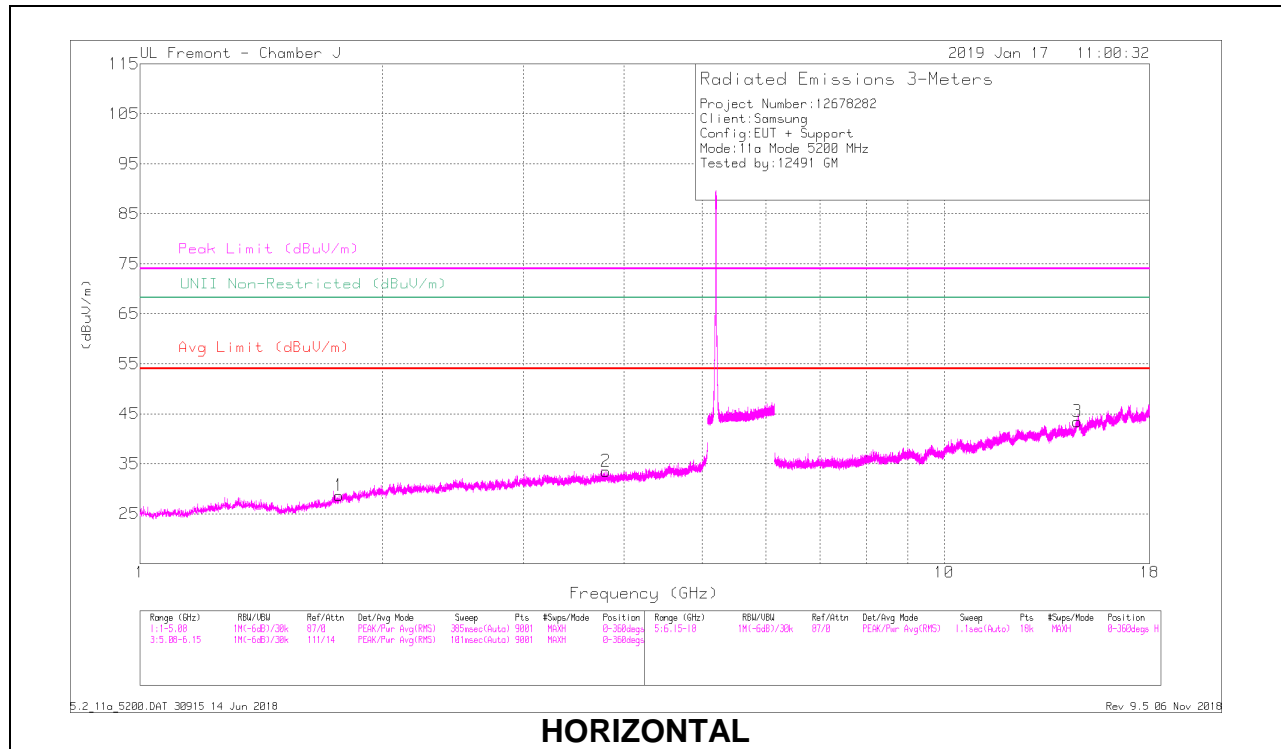

HORIZONTAL

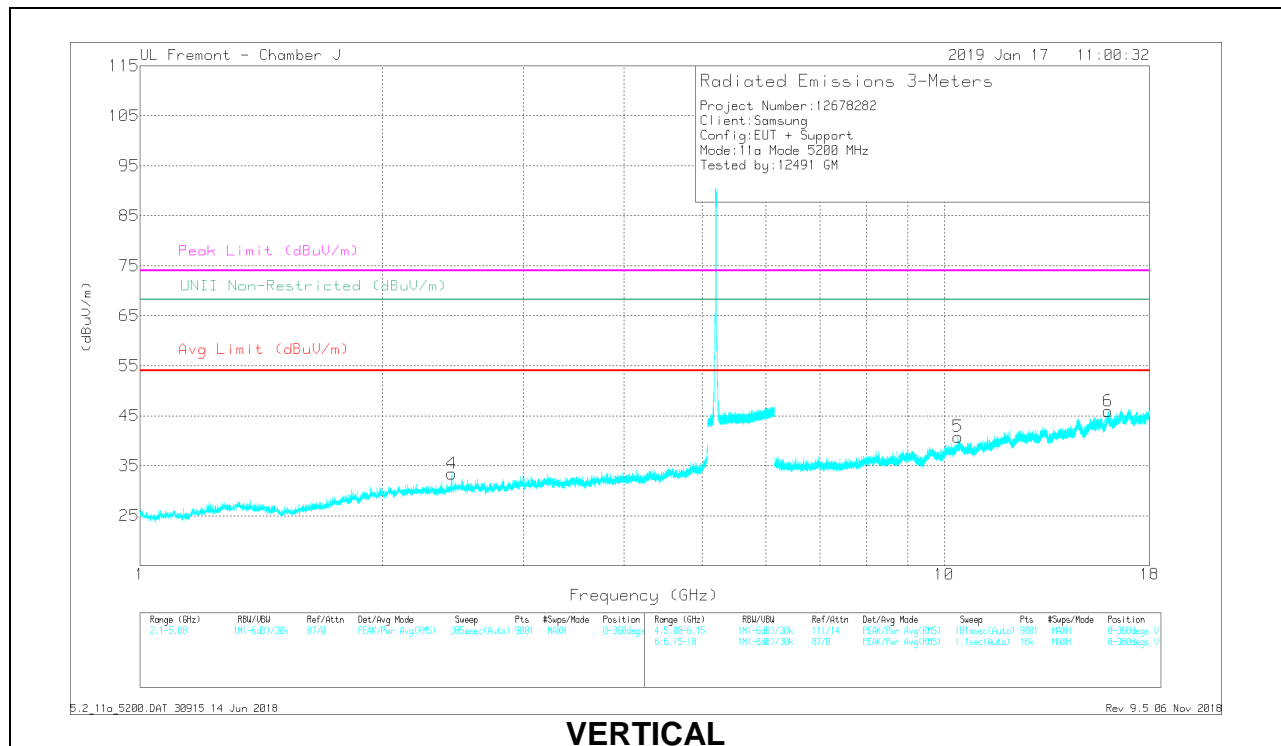

VERTICAL

RADIATED EMISSIONS

| Frequency (GHz) | Meter Reading (dBuV) | Det | AF A10067 (dB/m) | AmpCoEffR/Pad (dB) | DC Corr (dB) | Corrected Reading (dBuV/m) | Avg Limit (dBuV/m) | Margin (dB) | Peak Limit (dBuV/m) | PK Margin (dB) | UNII Non-Restricted (dBuV/m) | PK Margin (dB) | Azimuth (Degs) | Height (cm) | Polarity |
|-----------------|----------------------|------|------------------|--------------------|--------------|----------------------------|--------------------|-------------|---------------------|----------------|------------------------------|----------------|----------------|-------------|----------|
| 1.767 | 40.74 | PK-U | 30.1 | -35.7 | 0 | 35.14 | - | - | - | - | 68.2 | -33.06 | 249 | 219 | H |
| 1.768 | 31.31 | ADR | 30.1 | -35.7 | .27 | 25.98 | - | - | - | - | - | - | 249 | 219 | H |
| * 3.787 | 39.29 | PK-U | 33.4 | -32.9 | 0 | 39.79 | - | - | 74 | -34.21 | - | - | 137 | 141 | H |
| * 3.786 | 30.16 | ADR | 33.4 | -32.8 | .27 | 31.03 | 54 | -22.97 | - | - | - | - | 137 | 141 | H |
| 2.439 | 41.61 | PK-U | 32.4 | -35.5 | 0 | 38.51 | - | - | - | - | 68.2 | -29.69 | 93 | 292 | V |
| 2.441 | 31.44 | ADR | 32.4 | -35.5 | .27 | 28.61 | - | - | - | - | - | - | 93 | 292 | V |
| 14.844 | 31.06 | PK-U | 39.4 | -20.6 | 0 | 49.86 | - | - | - | - | 68.2 | -18.34 | 154 | 244 | H |
| 14.845 | 22.49 | ADR | 39.5 | -20.6 | .27 | 41.66 | - | - | - | - | - | - | 154 | 244 | H |
| 10.4 | 34.87 | PK-U | 37.5 | -25.3 | 0 | 41.07 | - | - | - | - | 68.2 | -21.13 | 143 | 264 | V |
| 10.4 | 26.92 | ADR | 37.5 | -25.3 | .27 | 39.39 | - | - | - | - | - | - | 143 | 264 | V |
| * 15.976 | 32.14 | PK-U | 40.5 | -20 | 0 | 52.64 | - | - | 74 | -21.36 | - | - | 355 | 174 | V |
| * 15.976 | 22.67 | ADR | 40.5 | -20 | .27 | 43.44 | 54 | -10.56 | - | - | - | - | 355 | 174 | V |

* - indicates frequency in CFR47 Pt 15 / IC RSS-Restricted Band
 PK-U - U-NII: Maximum Peak
 ADR - U-NII AD primary method, RMS average

HIGH CHANNEL RESULTS

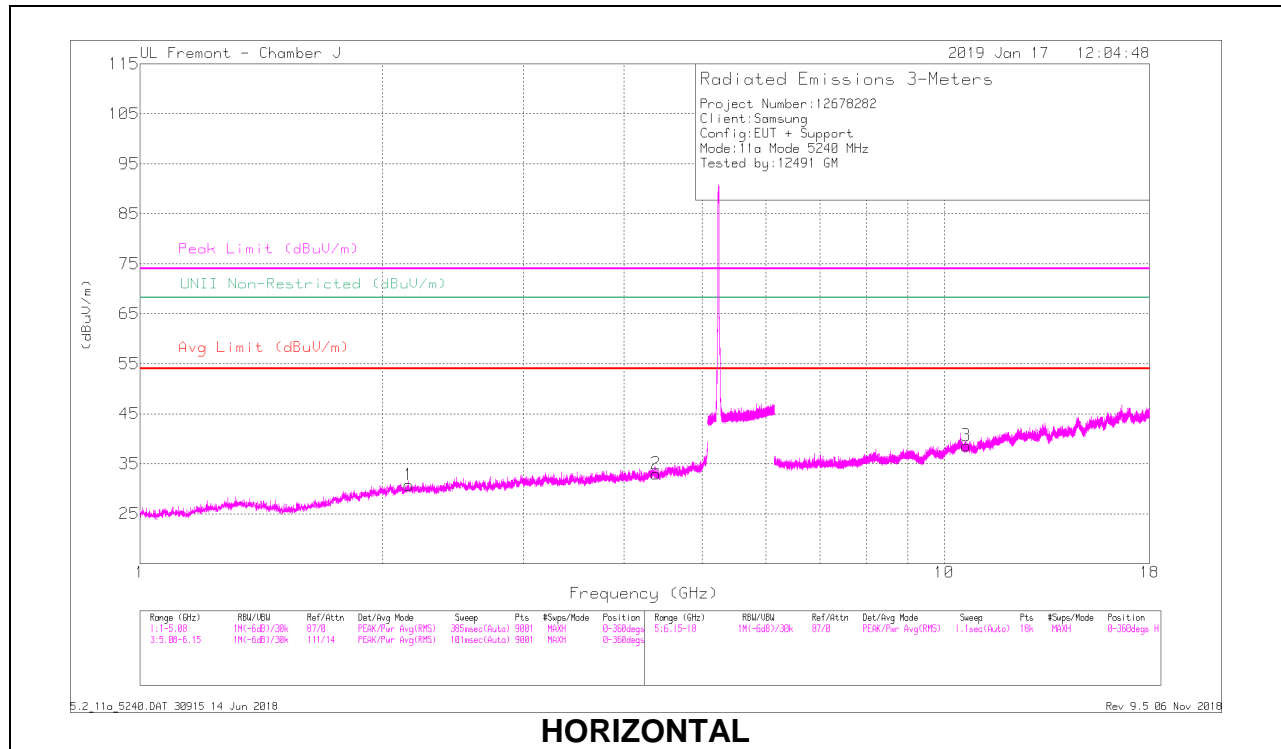

HORIZONTAL

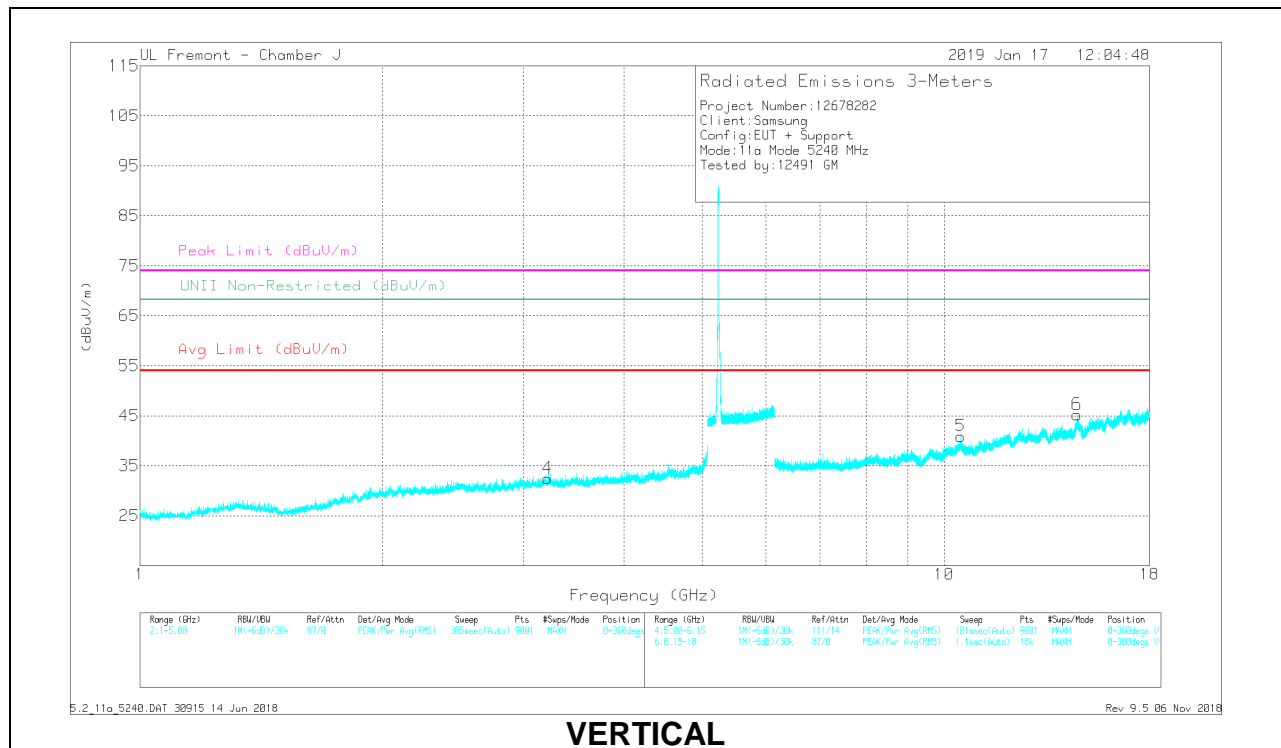

VERTICAL

RADIATED EMISSIONS

| Frequency (GHz) | Meter Reading (dBuV) | Det | AF AT0067 (dB/m) | Amp/Cable/Port/Pad (dB) | DC Corr (dB) | Corrected Reading (dBuV/m) | Avg Limit (dBuV/m) | Margin (dB) | Peak Limit (dBuV/m) | PK Margin (dB) | UNII Non-Restricted (dBuV/m) | PK Margin (dB) | Azimuth (Degs) | Height (cm) | Polarity |
|-----------------|----------------------|------|------------------|-------------------------|--------------|----------------------------|--------------------|-------------|---------------------|----------------|------------------------------|----------------|----------------|-------------|----------|
| 2.161 | 41.38 | PK-U | 31.8 | -35.5 | 0 | 37.68 | - | - | - | - | 68.2 | -30.52 | 157 | 234 | H |
| 2.159 | 32.24 | ADR | 31.8 | -35.5 | 27 | 28.81 | - | - | - | - | - | - | 157 | 234 | H |
| * 4.379 | 37.32 | PK-U | 33.7 | -31 | 0 | 40.02 | + | + | 74 | -33.98 | - | - | 181 | 371 | H |
| * 4.381 | 28.43 | ADR | 33.7 | -30.9 | 27 | 31.5 | 54 | -22.5 | - | - | - | - | 181 | 371 | H |
| 3.211 | 40.84 | PK-U | 33.2 | -34.6 | 0 | 39.44 | - | - | - | - | 68.2 | -28.76 | 65 | 212 | V |
| 3.209 | 31.29 | ADR | 33.2 | -34.6 | 27 | 30.16 | - | - | - | - | - | - | 65 | 212 | V |
| * 10.645 | 33.06 | PK-U | 37.6 | -25.1 | 0 | 45.56 | - | - | 74 | -28.44 | - | - | 270 | 317 | H |
| * 10.646 | 23.83 | ADR | 37.6 | -25.1 | 27 | 36.6 | 54 | -17.4 | - | - | - | - | 270 | 317 | H |
| 10.48 | 35.34 | PK-U | 37.5 | -25.3 | 0 | 47.54 | - | - | - | - | 68.2 | -20.66 | 195 | 114 | V |
| 10.49 | 27.17 | ADR | 37.5 | -25.3 | 27 | 39.64 | - | + | - | - | - | - | 195 | 114 | V |
| 14.627 | 31.62 | PK-U | 39.4 | -20.3 | 0 | 50.72 | - | - | - | - | 68.2 | -17.48 | 311 | 209 | V |
| 14.626 | 22.14 | ADR | 39.4 | -20.2 | 27 | 41.61 | - | - | - | - | - | - | 311 | 209 | V |

* - indicates frequency in CFR47 Pt 15 / IC RSS-Restricted Band
 PK-U - U-NII: Maximum Peak
 ADR - U-NII AD primary method, RMS average

10.1.2. TX ABOVE 1 GHz 802.11n HT20 MODE IN THE 5.2 GHz BAND

1TX Antenna 1 MODE

BANDEDGE (LOW CHANNEL)

HORIZONTAL RESULT

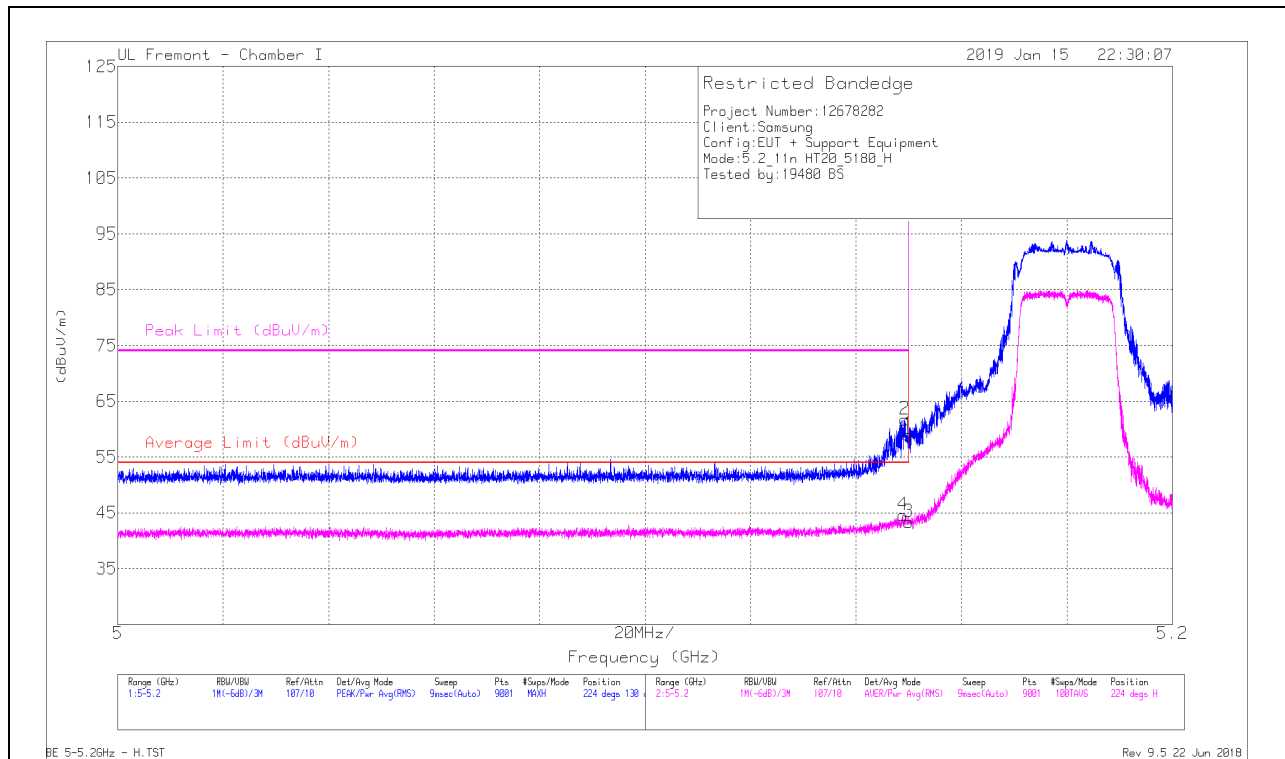

| Marker | Frequency (GHz) | Meter Reading (dBuV) | Det | AF T862 (dBm) | Amp/Ch/Filtz/Pad (dB) | DC Corr (dB) | Corrected Reading (dBuV/m) | Average Limit (dBuV/m) | Margin (dB) | Peak Limit (dBuV/m) | PK Margin (dB) | Azimuth (Degs) | Height (cm) | Polarity |
|--------|-----------------|----------------------|-----|---------------|-----------------------|--------------|----------------------------|------------------------|-------------|---------------------|----------------|----------------|-------------|----------|
| 1 | * 5.15 | 43.61 | Pk | 34.4 | -19 | 0 | 59.01 | - | - | 74 | -14.99 | 224 | 130 | H |
| 2 | * 5.149 | 46.27 | Pk | 34.4 | -19 | 0 | 61.67 | - | - | 74 | -12.33 | 224 | 130 | H |
| 3 | * 5.15 | 27.68 | RMS | 34.4 | -19 | .28 | 43.36 | 54 | -10.64 | - | - | 224 | 130 | H |
| 4 | * 5.149 | 28.94 | RMS | 34.4 | -19 | .28 | 44.62 | 54 | -9.38 | - | - | 224 | 130 | H |

* - indicates frequency in CFR47 Pt 15 / IC RSS-Restricted Band

Pk - Peak detector

RMS - RMS detection

VERTICAL RESULT

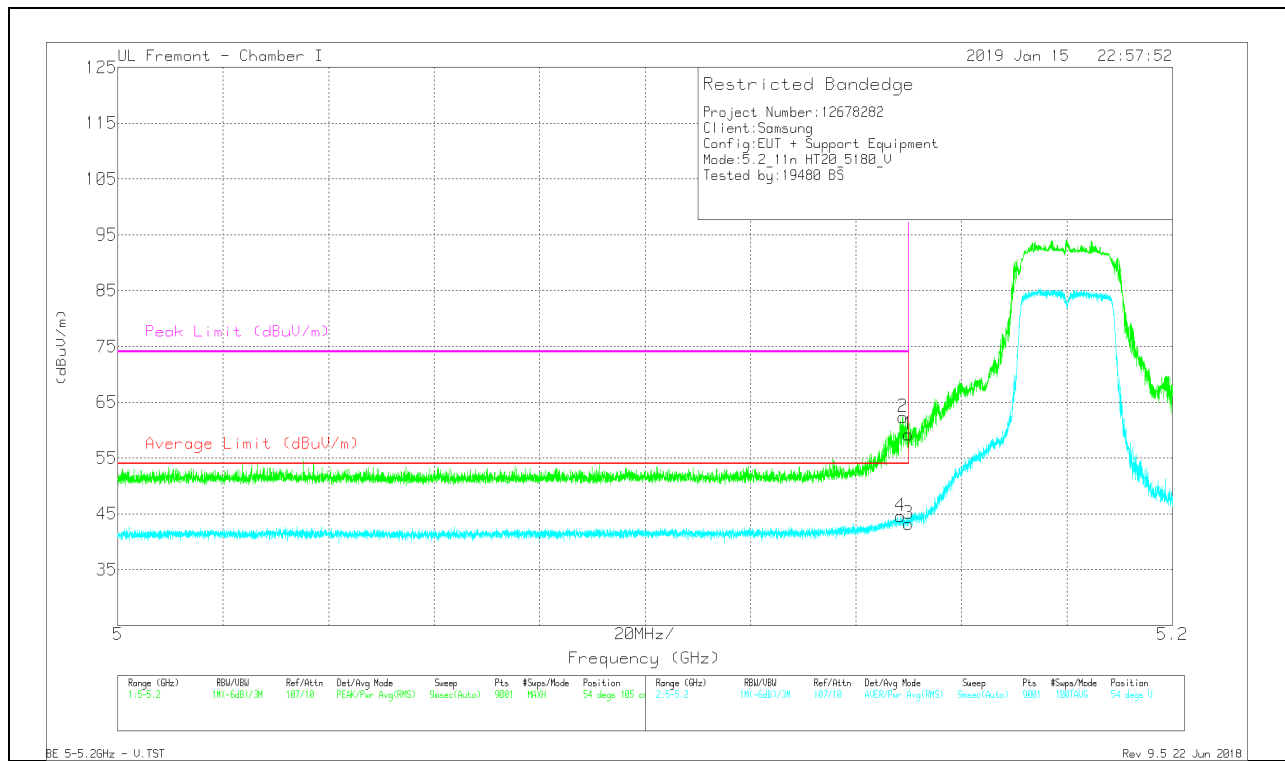

| Marker | Frequency (GHz) | Meter Reading (dBuV) | Det | AF T862 (dB/m) | Amp/Cb/Filt/Pad (dB) | DC Corr (dB) | Corrected Reading (dBuV/m) | Average Limit (dBuV/m) | Margin (dB) | Peak Limit (dBuV/m) | PK Margin (dB) | Azimuth (Degs) | Height (cm) | Polarity |
|--------|-----------------|----------------------|-----|----------------|----------------------|--------------|----------------------------|------------------------|-------------|---------------------|----------------|----------------|-------------|----------|
| 1 | * 5.15 | 43.8 | Pk | 34.4 | -19 | 0 | 59.2 | - | - | 74 | -14.8 | 54 | 105 | V |
| 2 | * 5.149 | 46.93 | Pk | 34.4 | -19 | 0 | 62.33 | - | - | 74 | -11.67 | 54 | 105 | V |
| 3 | * 5.15 | 27.55 | RMS | 34.4 | -19 | .28 | 43.23 | 54 | -10.77 | - | - | 54 | 105 | V |
| 4 | * 5.148 | 28.95 | RMS | 34.4 | -19 | .28 | 44.63 | 54 | -9.37 | - | - | 54 | 105 | V |

* - indicates frequency in CFR47 Pt 15 / IC RSS-Restricted Band

Pk - Peak detector

RMS - RMS detection

HARMONICS AND SPURIOUS EMISSIONS

LOW CHANNEL RESULTS

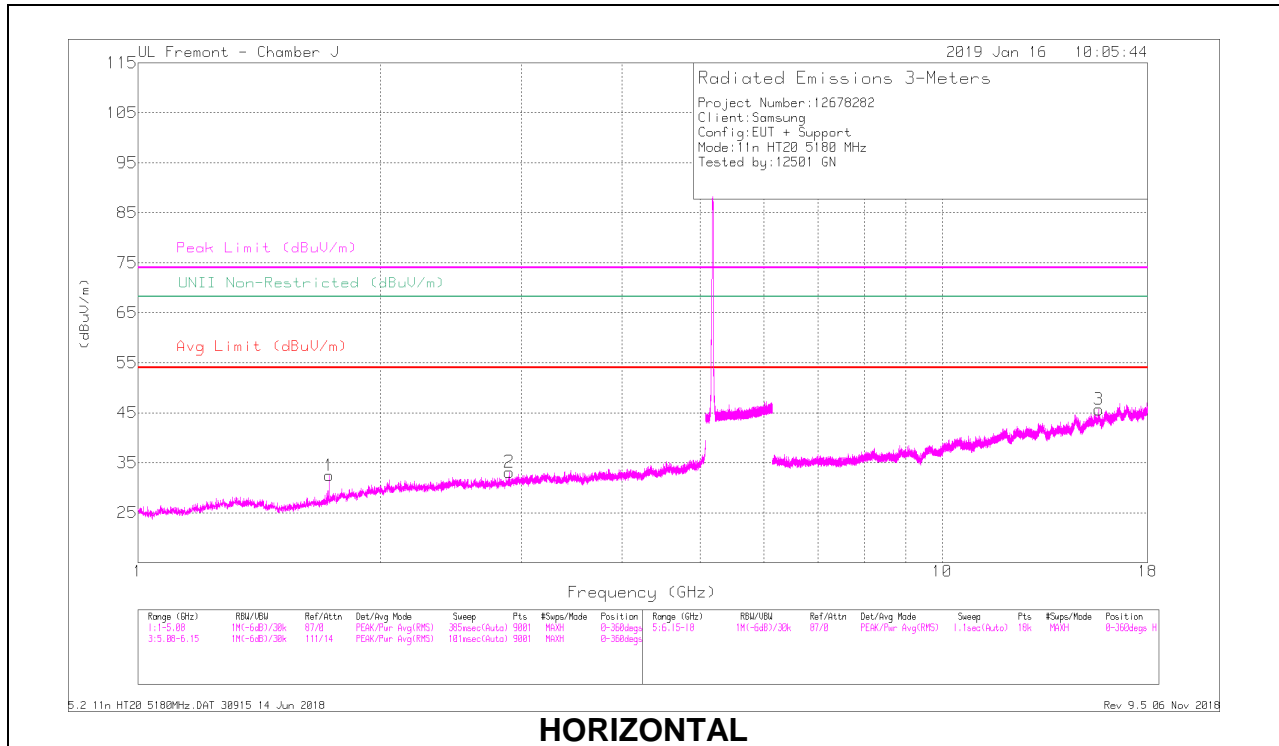

HORIZONTAL

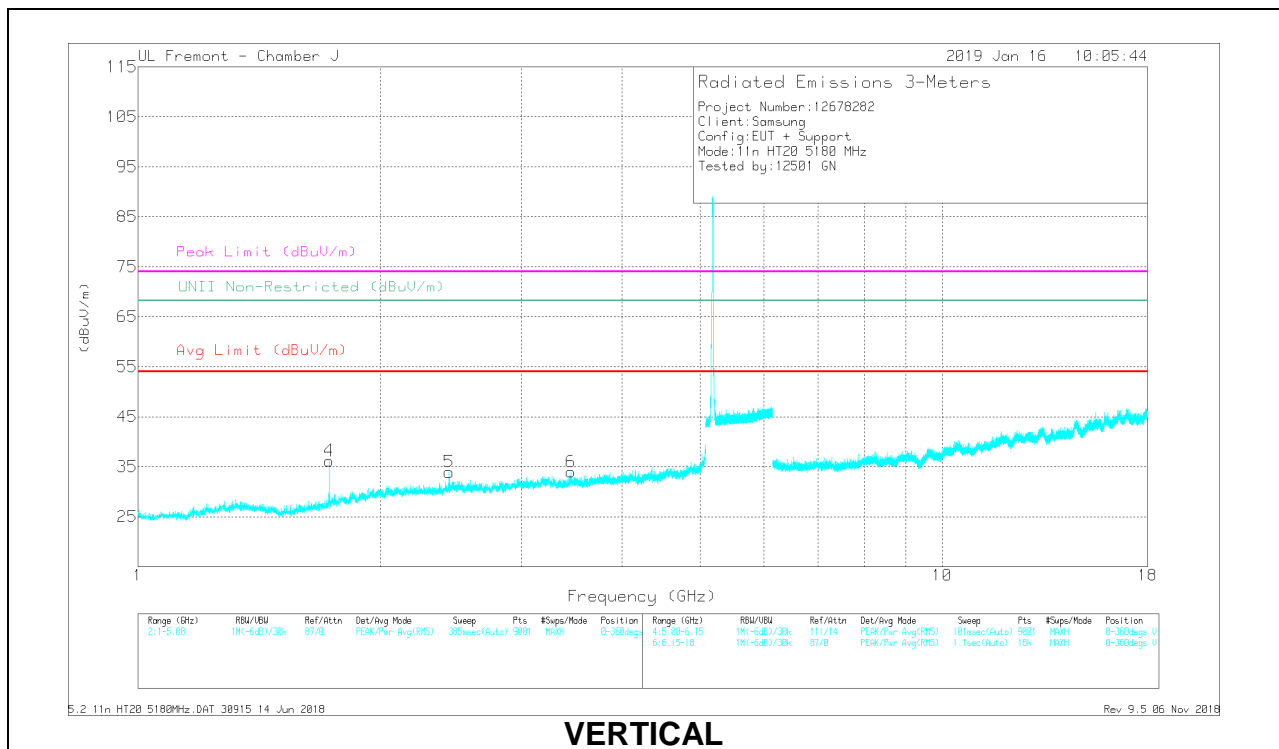

VERTICAL

RADIATED EMISSIONS

| Frequency (GHz) | Meter Reading (dBuV) | Det | AF A10067 (dB/m) | AmpCoeff/Pad (dB) | DC Corr (dB) | Corrected Reading (dBuV/m) | Avg Limit (dBuV/m) | Margin (dB) | Peak Limit (dBuV/m) | PK Margin (dB) | UNII Non-Restricted (dBuV/m) | PK Margin (dB) | Azimuth (Degs) | Height (cm) | Polarity |
|-----------------|----------------------|------|------------------|-------------------|--------------|----------------------------|--------------------|-------------|---------------------|----------------|------------------------------|----------------|----------------|-------------|----------|
| 1.726 | 43.89 | PK-U | 29.5 | -35.7 | 0 | 37.69 | - | - | - | - | 68.2 | -30.51 | 292 | 198 | H |
| 1.727 | 32.42 | ADR | 29.5 | -35.7 | .28 | 26.47 | - | - | - | - | - | - | 292 | 198 | H |
| * 2.896 | 43.76 | PK-U | 32.6 | -35 | 0 | 41.36 | - | - | 74 | -32.64 | - | - | 292 | 103 | H |
| * 2.894 | 32.36 | ADR | 32.6 | -35 | .28 | 30.21 | 54 | -23.79 | - | - | - | - | 282 | 103 | H |
| 1.729 | 45.07 | PK-U | 29.5 | -35.8 | 0 | 38.77 | - | - | - | - | 68.2 | -29.43 | 102 | 261 | V |
| 1.727 | 32.5 | ADR | 29.5 | -35.8 | .28 | 26.45 | - | - | - | - | - | - | 102 | 261 | V |
| 2.436 | 40.21 | PK-U | 32.3 | -35.5 | 0 | 37.01 | - | - | - | - | 68.2 | -31.19 | 102 | 102 | V |
| 2.437 | 32.39 | ADR | 32.3 | -35.5 | .28 | 29.44 | - | - | - | - | - | - | 102 | 102 | V |
| 3.452 | 39.95 | PK-U | 32.6 | -33.7 | 0 | 38.85 | - | - | - | - | 68.2 | -29.35 | 102 | 102 | V |
| 3.452 | 31.48 | ADR | 32.6 | -33.7 | .28 | 30.63 | - | - | - | - | - | - | 102 | 102 | V |
| * 15.646 | 30.54 | PK-U | 40.3 | -20.4 | 0 | 50.44 | - | - | 74 | -23.56 | - | - | 102 | 102 | H |
| * 15.647 | 22.38 | ADR | 40.3 | -20.4 | .28 | 42.53 | 54 | -11.47 | - | - | - | - | 102 | 102 | H |

* - indicates frequency in CFR47 Pt 15 / IC RSS-Restricted Band
 PK-U - U-NII: Maximum Peak
 ADR - U-NII AD primary method, RMS average

MID CHANNEL RESULTS

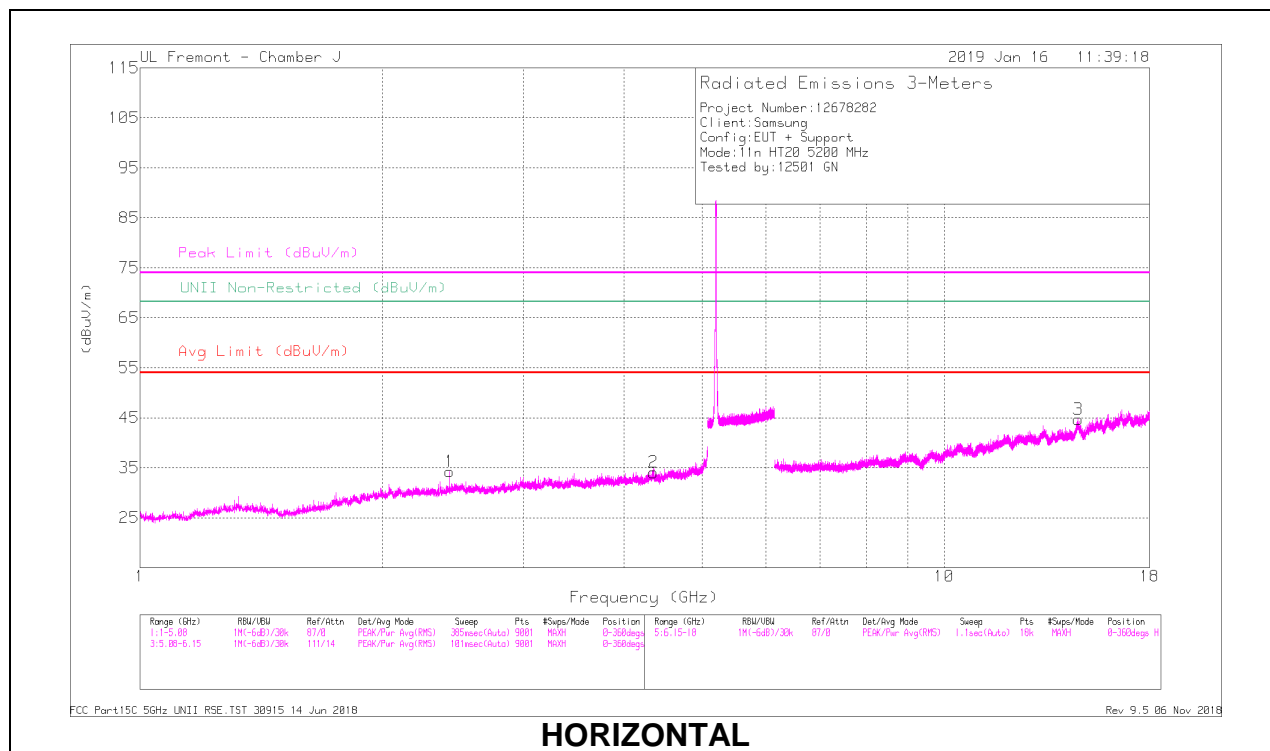

HORIZONTAL

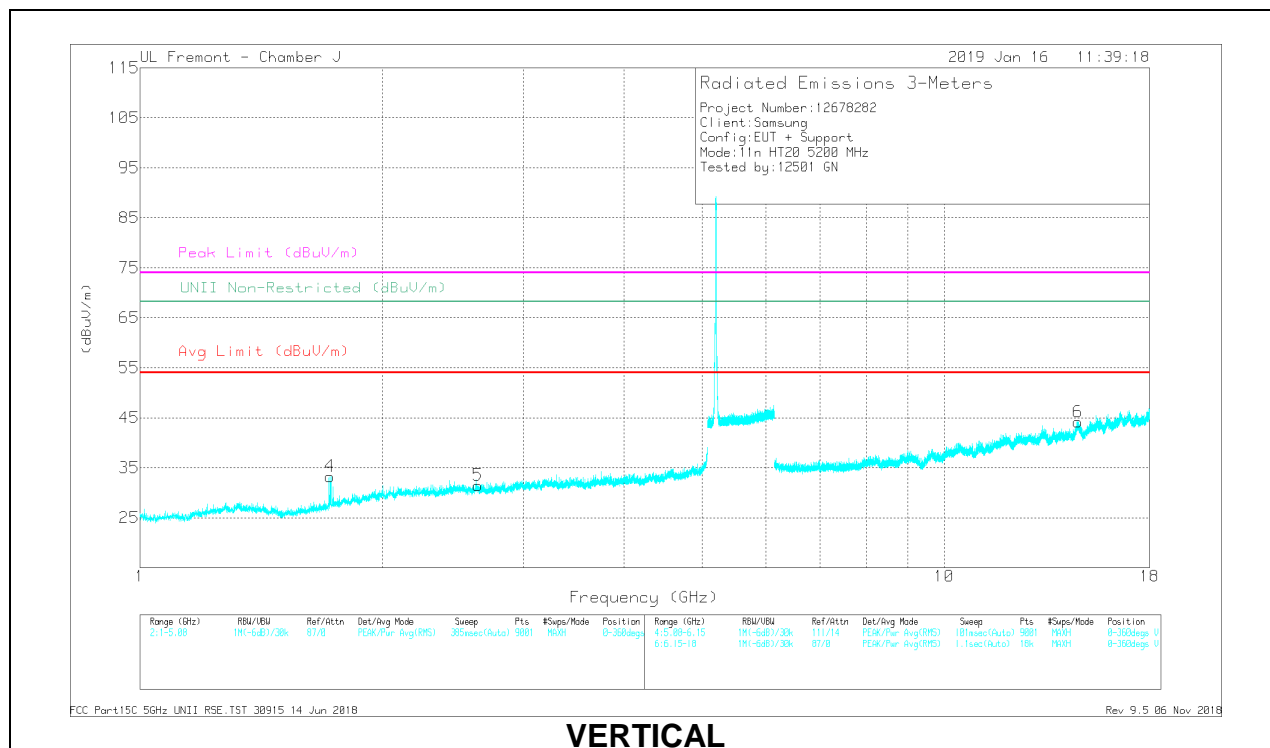

VERTICAL

RADIATED EMISSIONS

| Frequency (GHz) | Meter Reading (dBuV) | Det | AF A10067 (dB/m) | Amp/Cable/Feeder/Pad (dB) | DC Corr (dB) | Corrected Reading (dBuV/m) | Avg Limit (dBuV/m) | Margin (dB) | Peak Limit (dBuV/m) | PK Margin (dB) | UNII Non-Restricted (dBuV/m) | PK Margin (dB) | Azimuth (Degs) | Height (cm) | Polarity |
|-----------------|----------------------|------|------------------|---------------------------|--------------|----------------------------|--------------------|-------------|---------------------|----------------|------------------------------|----------------|----------------|-------------|----------|
| 2.424 | 41.91 | PK-U | 32.2 | -35.5 | 0 | 38.61 | - | - | - | - | 68.2 | -29.59 | 58 | 263 | H |
| 2.426 | 32.18 | ADR | 32.3 | -35.5 | .28 | 29.26 | - | - | - | - | - | - | 58 | 263 | H |
| * 4.35 | 39.34 | PK-U | 33.7 | -31 | 0 | 42.04 | - | - | 74 | -31.96 | - | - | 186 | 175 | H |
| * 4.347 | 29.01 | ADR | 33.7 | -31 | .28 | 31.99 | 54 | -22.01 | - | - | - | - | 186 | 175 | H |
| 1.723 | 42.07 | PK-U | 29.4 | -35.7 | 0 | 35.77 | - | - | - | - | 68.2 | -32.43 | 217 | 394 | V |
| 1.723 | 31.68 | ADR | 29.4 | -35.7 | .28 | 25.66 | - | - | - | - | - | - | 217 | 394 | V |
| 2.629 | 41.39 | PK-U | 32.5 | -35.2 | 0 | 38.69 | - | - | - | - | 68.2 | -29.51 | 108 | 217 | V |
| 2.629 | 31.63 | ADR | 32.5 | -35.2 | .28 | 29.21 | - | - | - | - | - | - | 108 | 217 | V |
| 14.674 | 31.11 | PK-U | 39.4 | -20.3 | 0 | 50.21 | - | - | - | - | 68.2 | -17.99 | 108 | 147 | H |
| 14.676 | 22.53 | ADR | 39.4 | -20.3 | .28 | 41.91 | - | - | - | - | - | - | 108 | 147 | H |
| 14.666 | 31.04 | PK-U | 39.5 | -20.3 | 0 | 50.24 | - | - | - | - | 68.2 | -17.96 | 108 | 177 | V |
| 14.668 | 22.15 | ADR | 39.4 | -20.3 | .28 | 41.53 | - | - | - | - | - | - | 108 | 177 | V |

* - indicates frequency in CFR47 Pt 15 / IC RSS-Restricted Band
 PK-U - U-NII: Maximum Peak
 ADR - U-NII AD primary method, RMS average

HIGH CHANNEL RESULTS

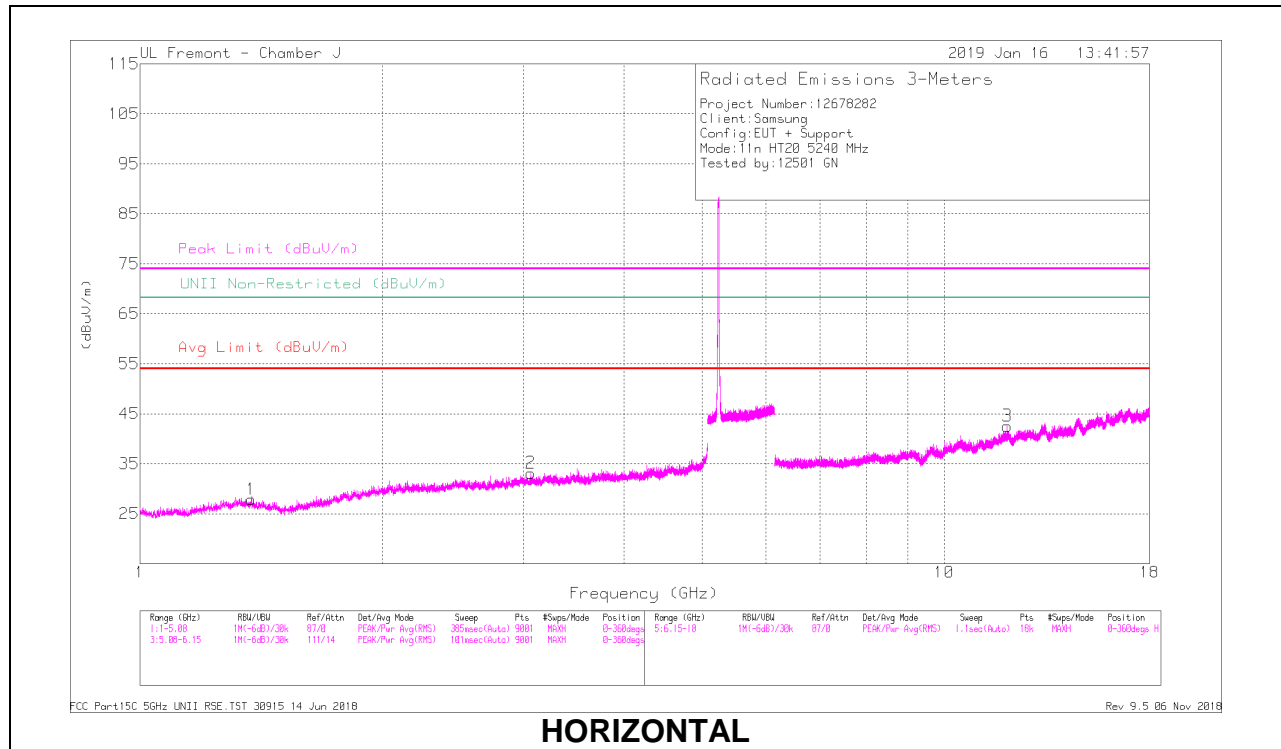

HORIZONTAL

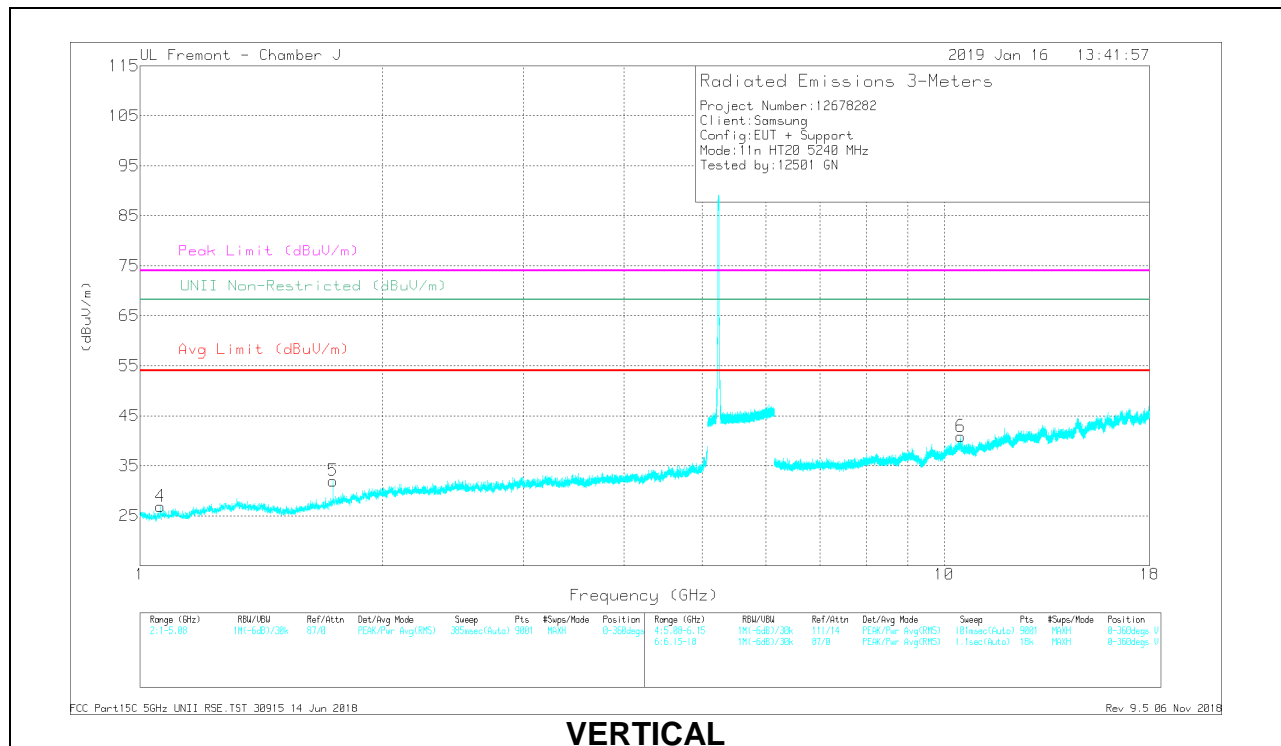

VERTICAL

RADIATED EMISSIONS

| Frequency (GHz) | Meter Reading (dBuV) | Det | AF A10067 (dB/m) | AmpCoeff/Pad (dB) | DC Corr (dB) | Corrected Reading (dBuV/m) | Avg Limit (dBuV/m) | Margin (dB) | Peak Limit (dBuV/m) | PK Margin (dB) | UNII Non-Restricted (dBuV/m) | PK Margin (dB) | Azimuth (Degs) | Height (cm) | Polarity |
|-----------------|----------------------|------|------------------|-------------------|--------------|----------------------------|--------------------|-------------|---------------------|----------------|------------------------------|----------------|----------------|-------------|----------|
| * 1.376 | 40.55 | PK-U | 29.1 | -35.9 | 0 | 33.75 | - | - | 74 | -40.25 | - | - | 0 | 126 | H |
| * 1.374 | 32.17 | ADR | 29.1 | -35.9 | .28 | 25.65 | 54 | -28.35 | - | - | - | - | 0 | 126 | H |
| 3.06 | 41.54 | PK-U | 33 | -34.7 | 0 | 30.84 | - | - | - | - | 68.2 | -28.36 | 104 | 196 | H |
| 3.061 | 31.61 | ADR | 33 | -34.7 | .28 | 30.19 | - | - | - | - | - | - | 104 | 196 | H |
| * 1.058 | 41.09 | PK-U | 27.2 | -35.5 | 0 | 32.79 | - | - | 74 | -41.21 | - | - | 84 | 154 | V |
| * 1.058 | 31.49 | ADR | 27.2 | -35.5 | .28 | 23.47 | 54 | -30.53 | - | - | - | - | 84 | 154 | V |
| 1.737 | 42.27 | PK-U | 29.7 | -35.7 | 0 | 36.27 | - | - | - | - | 68.2 | -31.93 | 313 | 252 | V |
| 1.736 | 32.69 | ADR | 29.7 | -35.7 | .28 | 26.97 | - | - | - | - | - | - | 313 | 252 | V |
| * 11.977 | 33.09 | PK-U | 38.7 | -22.9 | 0 | 48.89 | - | - | 74 | -25.11 | - | - | 356 | 128 | H |
| * 11.975 | 22.89 | ADR | 38.7 | -22.9 | .28 | 38.97 | 54 | -15.03 | - | - | - | - | 356 | 128 | H |
| 10.48 | 34.73 | PK-U | 37.5 | -25.3 | 0 | 46.93 | - | - | - | - | 68.2 | -21.27 | 241 | 123 | V |
| 10.48 | 26.33 | ADR | 37.5 | -25.3 | .28 | 38.81 | - | - | - | - | - | - | 241 | 123 | V |

* - indicates frequency in CFR47 Pt 15 / IC RSS-Restricted Band
 PK-U - U-NII: Maximum Peak
 ADR - U-NII AD primary method, RMS average

10.1.3. TX ABOVE 1 GHz 802.11n HT40 MODE IN THE 5.2 GHz BAND

1TX Antenna 1 MODE

BANDEDGE (LOW CHANNEL)

HORIZONTAL RESULT

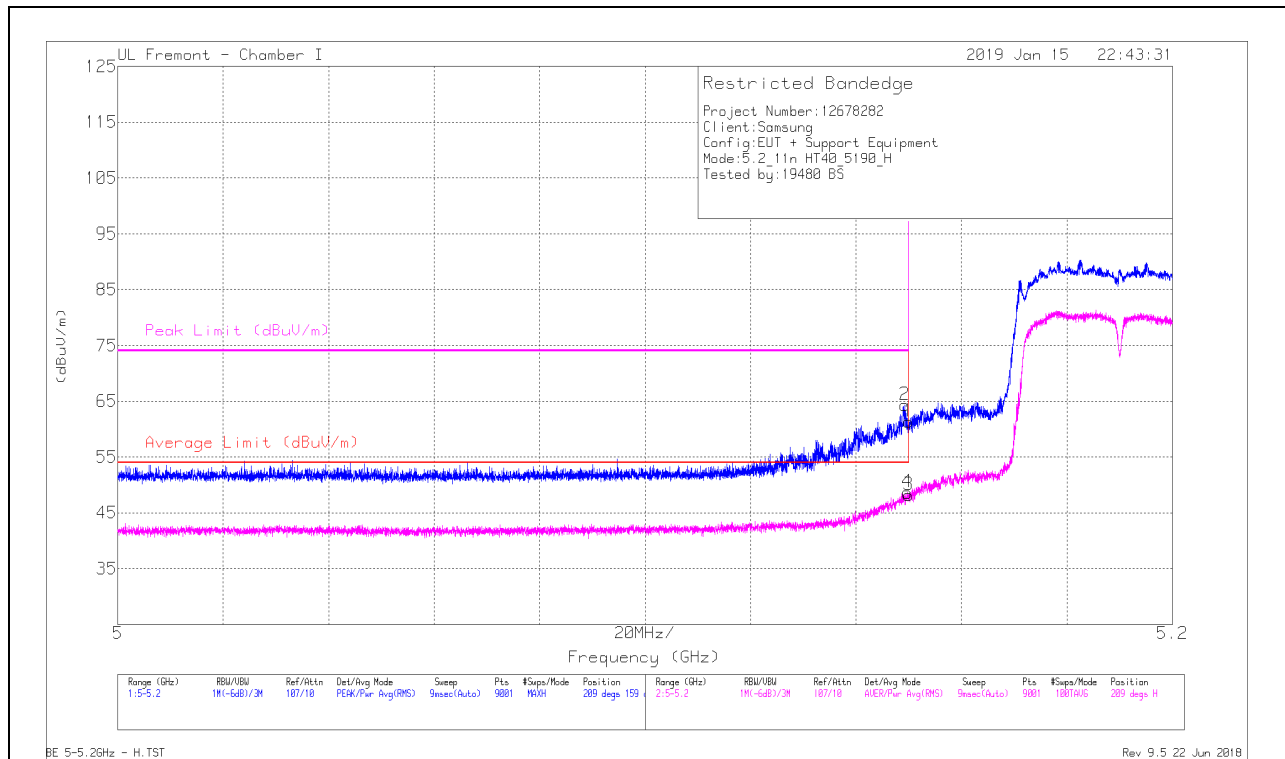

| Marker | Frequenc y (GHz) | Meter Reading (dBuV) | Det | AF T862 (dB/m) | Amp/Cbl/Fitr/Pad (dB) | DC Corr (dB) | Correcte d Reading (dBuV/m) | Average Limit (dBuV/m) | Margin (dB) | Peak Limit (dBuV/m) | PK Margin (dB) | Azimuth (Degs) | Height (cm) | Polarity |
|--------|---------------------|----------------------------|-----|----------------|--------------------------|--------------|-----------------------------------|---------------------------|----------------|---------------------|----------------------|-------------------|----------------|----------|
| 1 | * 5.15 | 45.93 | Pk | 34.4 | -19 | 0 | 61.33 | - | - | 74 | -12.67 | 209 | 159 | H |
| 2 | * 5.149 | 48.97 | Pk | 34.4 | -19 | 0 | 64.37 | - | - | 74 | -9.63 | 209 | 159 | H |
| 3 | * 5.15 | 32.09 | RMS | 34.4 | -19 | .71 | 48.2 | 54 | -5.8 | - | - | 209 | 159 | H |
| 4 | * 5.15 | 32.51 | RMS | 34.4 | -19 | .71 | 48.62 | 54 | -5.38 | - | - | 209 | 159 | H |

* - indicates frequency in CFR47 Pt 15 / IC RSS-Restricted Band

Pk - Peak detector

RMS - RMS detection

VERTICAL RESULT

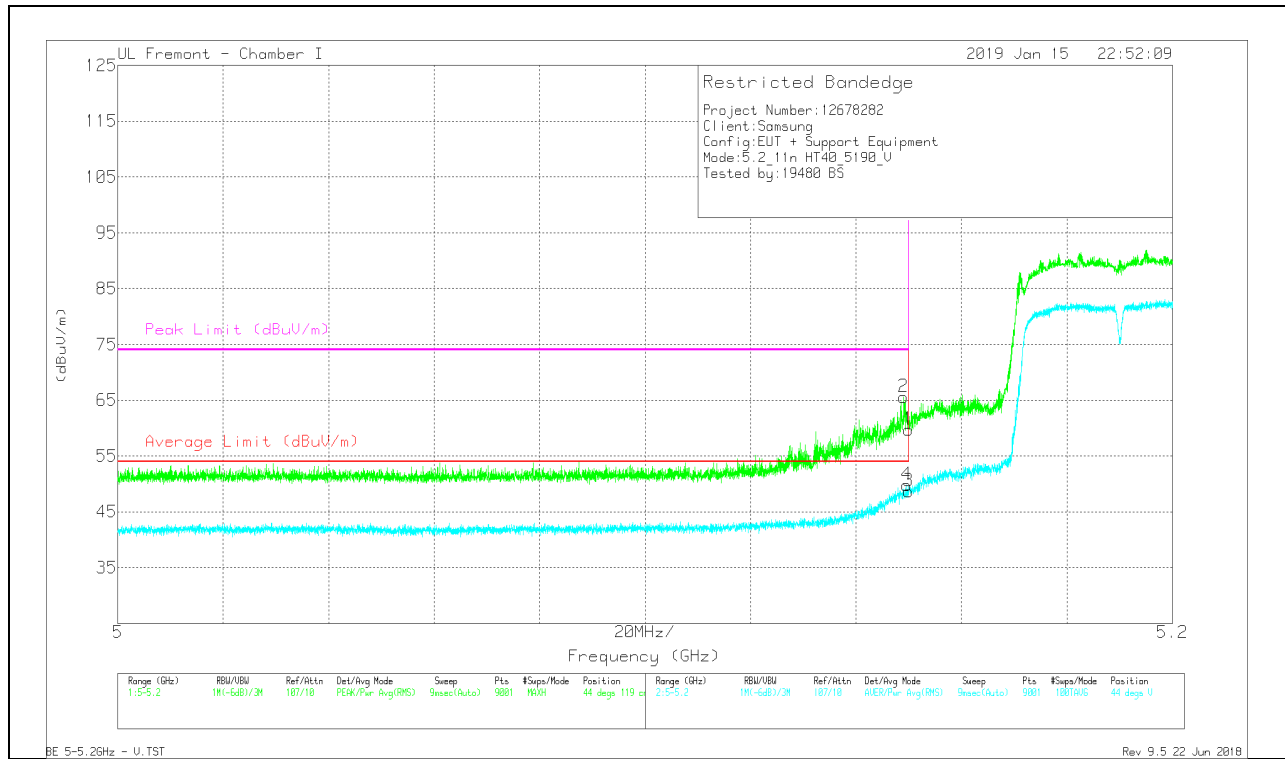

| Marker | Frequency (GHz) | Meter Reading (dBuV) | Det | AF T862 (dB/m) | Amp/Cal/Filt/Pad (dB) | DC Corr (dB) | Corrected Reading (dBuV/m) | Average Limit (dBuV/m) | Margin (dB) | Peak Limit (dBuV/m) | PK Margin (dB) | Azimuth (Degs) | Height (cm) | Polarity |
|--------|-----------------|----------------------|-----|----------------|-----------------------|--------------|----------------------------|------------------------|-------------|---------------------|----------------|----------------|-------------|----------|
| 1 | * 5.15 | 44.36 | Pk | 34.4 | -19 | 0 | 59.76 | - | - | 74 | -14.24 | 44 | 119 | V |
| 2 | * 5.149 | 50.17 | Pk | 34.4 | -19 | 0 | 65.57 | - | - | 74 | -8.43 | 44 | 119 | V |
| 3 | * 5.15 | 32.61 | RMS | 34.4 | -19 | .71 | 48.72 | 54 | -5.28 | - | - | 44 | 119 | V |
| 4 | * 5.15 | 33.67 | RMS | 34.4 | -19 | .71 | 49.78 | 54 | -4.22 | - | - | 44 | 119 | V |

* - indicates frequency in CFR47 Pt 15 / IC RSS-Restricted Band

Pk - Peak detector
 RMS - RMS detection

HARMONICS AND SPURIOUS EMISSIONS

LOW CHANNEL RESULTS

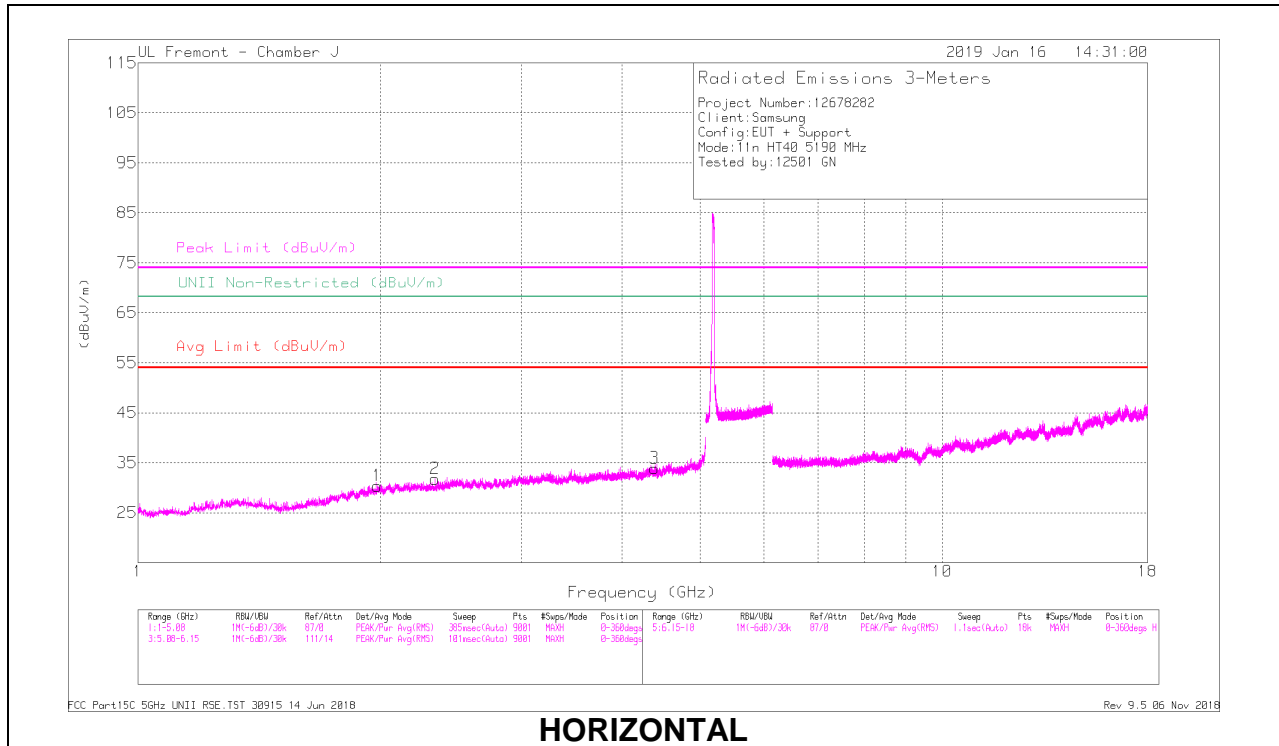

HORIZONTAL

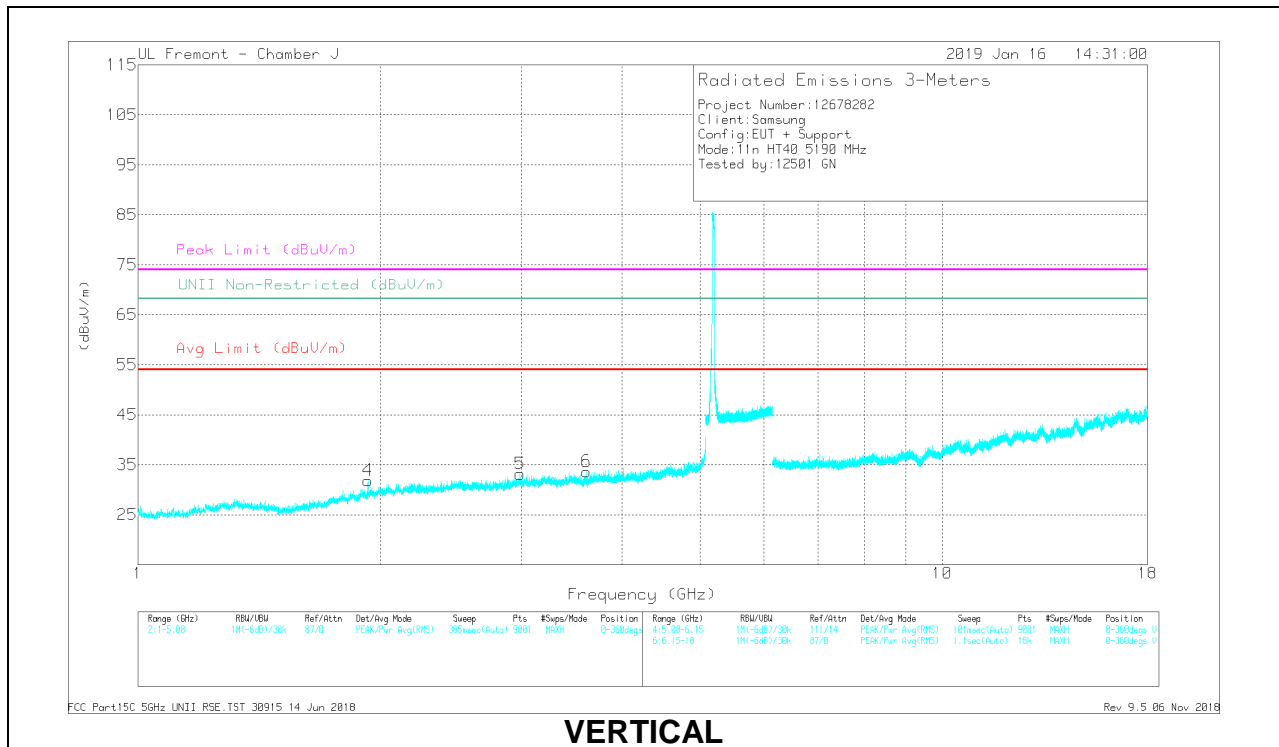

VERTICAL

RADIATED EMISSIONS

| Frequency (GHz) | Meter Reading (dBuV) | Det | AF A10067 (dB/m) | Amp/Coeff/Pad (dB) | DC Corr (dB) | Corrected Reading (dBuV/m) | Avg Limit (dBuV/m) | Margin (dB) | Peak Limit (dBuV/m) | PK Margin (dB) | U/NII Non-Restricted (dBuV/m) | PK Margin (dB) | Azimuth (Degs) | Height (cm) | Polarity |
|-----------------|----------------------|------|------------------|--------------------|--------------|----------------------------|--------------------|-------------|---------------------|----------------|-------------------------------|----------------|----------------|-------------|----------|
| 1.984 | 41.92 | PK-U | 31.4 | -35.7 | 0 | 37.62 | - | - | - | - | 68.2 | -30.58 | 323 | 112 | H |
| 1.983 | 32.03 | ADR | 31.4 | -35.7 | .71 | 28.44 | - | - | - | - | - | - | 323 | 112 | H |
| * 2.343 | 40.76 | PK-U | 31.9 | -35.5 | 0 | 37.16 | - | - | 74 | -36.84 | - | - | 136 | 113 | H |
| * 2.34 | 31.53 | ADR | 31.9 | -35.5 | .71 | 28.64 | 54 | -25.36 | - | - | - | - | 136 | 113 | H |
| * 4.39 | 38.62 | PK-U | 33.7 | -30.9 | 0 | 41.42 | - | - | 74 | -32.58 | - | - | 174 | 345 | H |
| * 4.391 | 28.39 | ADR | 33.7 | -30.9 | .71 | 31.8 | 54 | -22.2 | - | - | - | - | 174 | 345 | H |
| 1.932 | 41.76 | PK-U | 31.1 | -35.8 | 0 | 37.06 | - | - | - | - | 68.2 | -31.14 | 271 | 153 | V |
| 1.931 | 33.31 | ADR | 31.1 | -35.8 | .71 | 29.32 | - | - | - | - | - | - | 271 | 153 | V |
| 2.984 | 41.57 | PK-U | 32.9 | -34.7 | 0 | 38.77 | - | - | - | - | 68.2 | -28.43 | 231 | 176 | V |
| 2.987 | 31.7 | ADR | 33 | -34.7 | .71 | 30.71 | - | - | - | - | - | - | 231 | 176 | V |
| * 3.61 | 40.59 | PK-U | 33.1 | -33.6 | 0 | 40.09 | - | - | 74 | -33.91 | - | - | 231 | 141 | V |
| * 3.608 | 30.4 | ADR | 33.1 | -33.6 | .71 | 30.51 | 54 | -23.49 | - | - | - | - | 231 | 141 | V |

* - indicates frequency in CFR47 Pt 15 / IC RSS-Restricted Band
 PK-U - U-NII: Maximum Peak
 ADR - U-NII AD primary method, RMS average

HIGH CHANNEL RESULTS

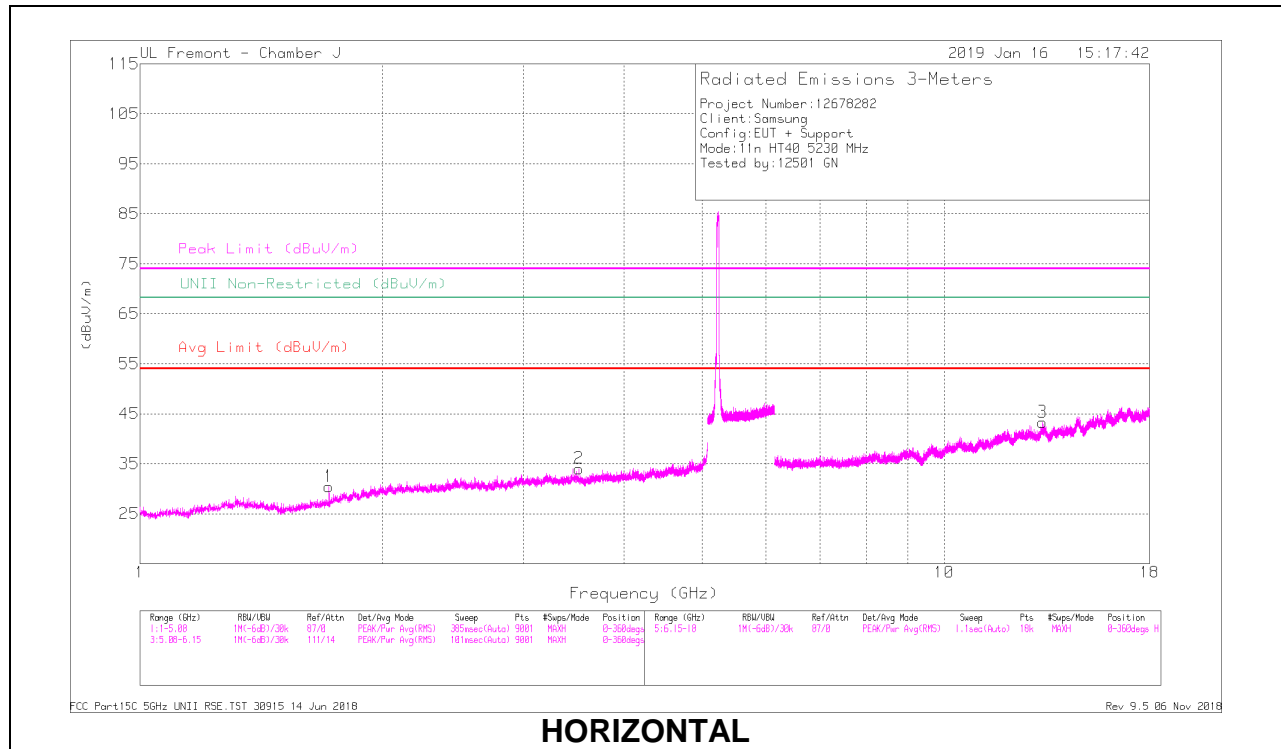

HORIZONTAL

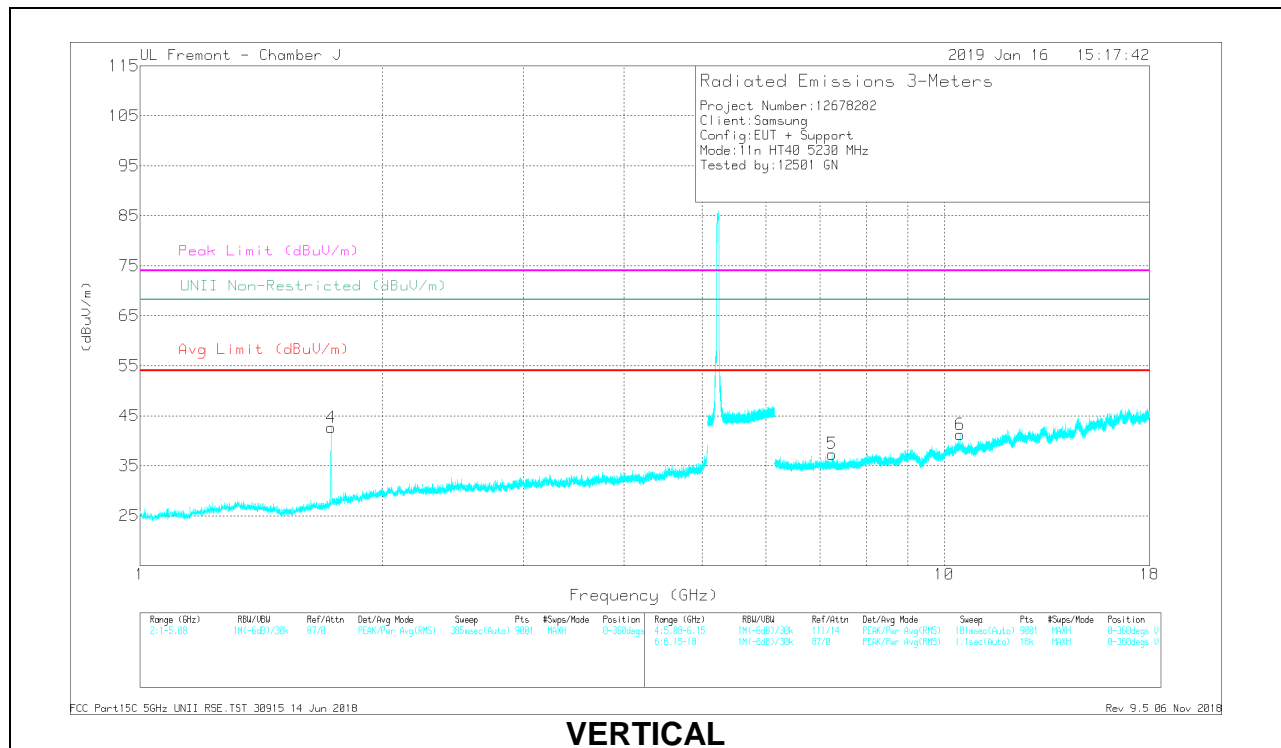

VERTICAL

RADIATED EMISSIONS

| Frequency (GHz) | Meter Reading (dBuV) | Det | AF A10067 (dB/m) | Amp/Coeff/Pad (dB) | DC Corr (dB) | Corrected Reading (dBuV/m) | Avg Limit (dBuV/m) | Margin (dB) | Peak Limit (dBuV/m) | PK Margin (dB) | UNII Non-Restricted (dBuV/m) | PK Margin (dB) | Azimuth (Degs) | Height (cm) | Polarity |
|-----------------|----------------------|------|------------------|--------------------|--------------|----------------------------|--------------------|-------------|---------------------|----------------|------------------------------|----------------|----------------|-------------|----------|
| * 1.721 | 41.35 | PK-U | 29.4 | -35.8 | 0 | 34.95 | - | - | 74 | -39.05 | - | - | 228 | 104 | H |
| 1.721 | 32.15 | ADR | 29.4 | -35.8 | .71 | 26.46 | 54 | -27.54 | - | - | - | - | 228 | 104 | H |
| * 3.515 | 39.97 | PK-U | 32.7 | -33 | 0 | 39.67 | - | - | 74 | -34.33 | - | - | 360 | 196 | H |
| * 3.513 | 30.5 | ADR | 32.7 | -33 | .71 | 30.91 | 54 | -23.09 | - | - | - | - | 360 | 196 | H |
| 1.728 | 46.94 | PK-U | 29.5 | -35.8 | 0 | 40.64 | - | - | - | - | 68.2 | -27.56 | 270 | 104 | V |
| 1.729 | 32.82 | ADR | 29.5 | -35.8 | .71 | 27.23 | - | - | - | - | - | - | 270 | 104 | V |
| 13.206 | 33.92 | PK-U | 39 | -22.1 | 0 | 50.82 | - | - | - | - | 68.2 | -17.38 | 360 | 134 | H |
| 13.199 | 23.34 | ADR | 39 | -22.1 | .71 | 40.95 | - | - | - | - | - | - | 360 | 134 | H |
| 7.522 | 38.08 | PK-U | 35.7 | -27.9 | 0 | 45.86 | - | - | 74 | -28.14 | - | - | 94 | 104 | V |
| * 7.537 | 29.8 | ADR | 35.7 | -27.9 | .71 | 34.41 | 54 | -19.59 | - | - | - | - | 94 | 104 | V |
| 10.46 | 36.94 | PK-U | 37.5 | -25.1 | 0 | 49.34 | - | - | - | - | 68.2 | -18.86 | 277 | 114 | V |
| 10.46 | 26.41 | ADR | 37.5 | -25.1 | .71 | 39.52 | - | - | - | - | - | - | 277 | 114 | V |

* - indicates frequency in CFR47 Pt 15 / IC RSS-Restricted Band
 PK-U - U-NII: Maximum Peak
 ADR - U-NII AD primary method, RMS average

10.1.4. TX ABOVE 1 GHz 802.11ac VHT80 MODE IN THE 5.2 GHz BAND

1TX Antenna 1 MODE

BANDEDGE (MID CHANNEL)

HORIZONTAL RESULT

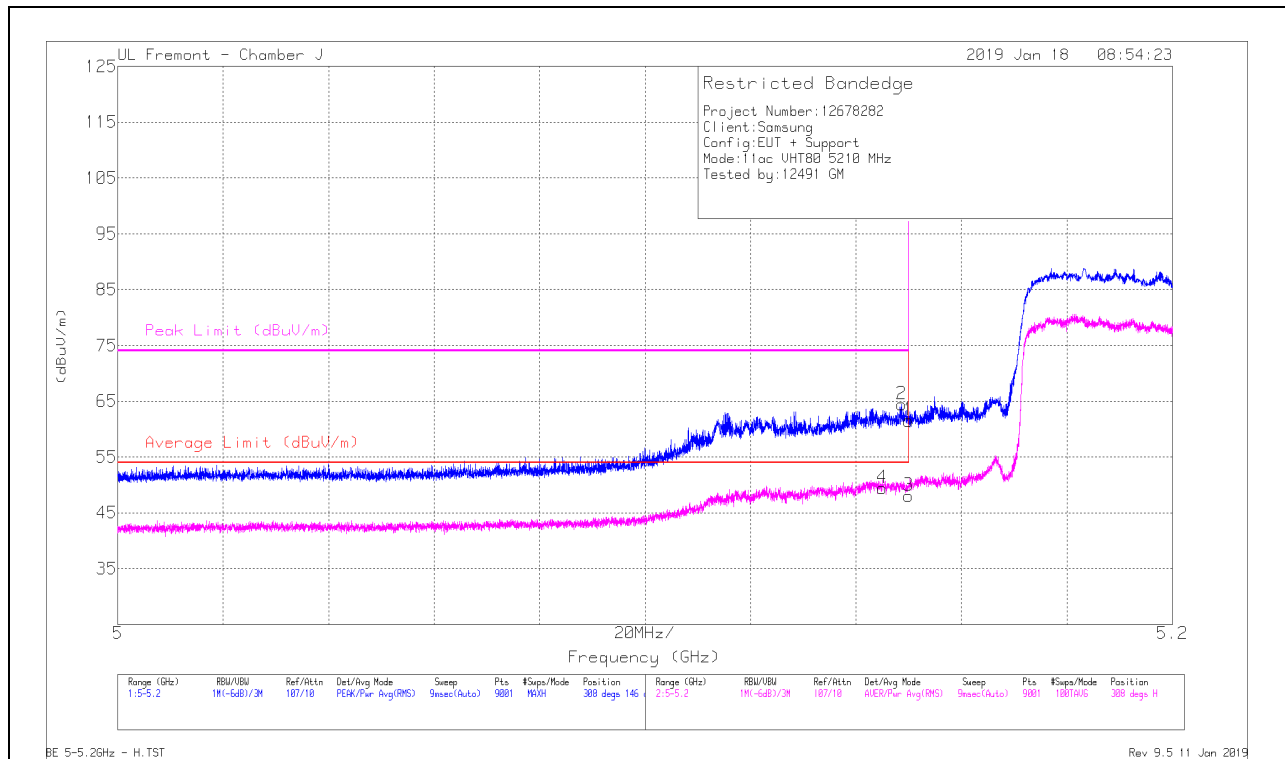

| Marker | Frequency (GHz) | Meter Reading (dBuV) | Det | AF AT0067 (dB/m) | Amp/Ch/Filt/Pad (dB) | DC Corr (dB) | Corrected Reading (dBuV/m) | Average Limit (dBuV/m) | Margin (dB) | Peak Limit (dBuV/m) | PK Margin (dB) | Azimuth (Degs) | Height (cm) | Polarity |
|--------|-----------------|----------------------|-----|------------------|----------------------|--------------|----------------------------|------------------------|-------------|---------------------|----------------|----------------|-------------|----------|
| 1 | * 5.15 | 48.93 | Pk | 34.2 | -21.6 | 0 | 61.53 | - | - | 74 | -12.47 | 308 | 146 | H |
| 2 | * 5.149 | 51.88 | Pk | 34.2 | -21.6 | 0 | 64.48 | - | - | 74 | -9.52 | 308 | 146 | H |
| 3 | * 5.15 | 35.42 | RMS | 34.2 | -21.6 | 1.29 | 49.3 | 54 | -4.7 | - | - | 308 | 146 | H |
| 4 | * 5.145 | 36.81 | RMS | 34.2 | -21.6 | 1.29 | 50.69 | 54 | -3.31 | - | - | 308 | 146 | H |

* - indicates frequency in CFR47 Pt 15 / IC RSS-Restricted Band

Pk - Peak detector

RMS - RMS detection

VERTICAL RESULT

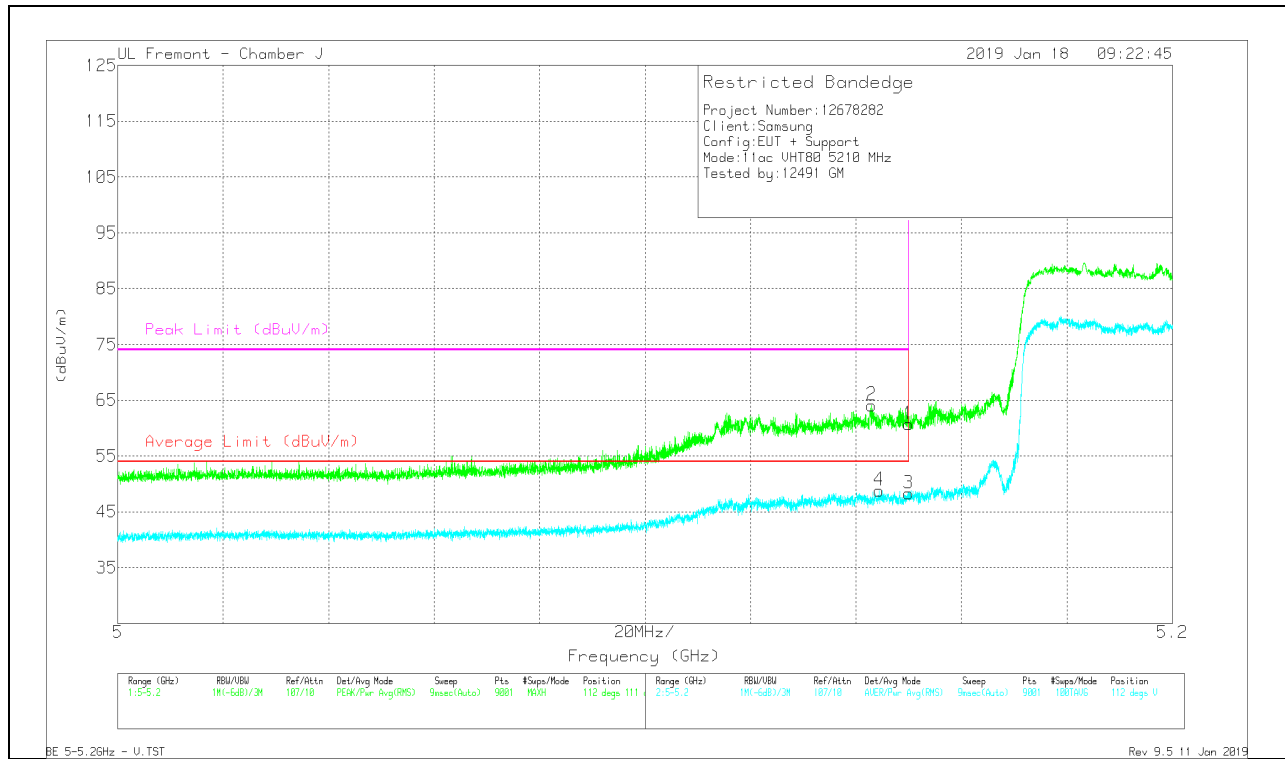

| Marker | Frequency (GHz) | Meter Reading (dBuV) | Det | AF AT10057 (dBm) | Amp/Cou/Filt/Pad (dB) | DC Corr (dB) | Corrected Reading (dBuV/m) | Average Limit (dBuV/m) | Margin (dB) | Peak Limit (dBuV/m) | PK Margin (dB) | Acimuth (Degs) | Height (cm) | Polarity |
|--------|-----------------|----------------------|-----|------------------|-----------------------|--------------|----------------------------|------------------------|-------------|---------------------|----------------|----------------|-------------|----------|
| 1 | * 5.15 | 48.07 | Pk | 34.2 | -21.6 | 0 | 60.67 | - | - | 74 | -13.33 | 112 | 111 | V |
| 2 | * 5.143 | 51.53 | Pk | 34.2 | -21.6 | 0 | 64.13 | - | - | 74 | -9.87 | 112 | 111 | V |
| 3 | * 5.15 | 35.76 | RMS | 34.2 | -21.6 | 1.29 | 49.65 | 54 | -4.35 | - | - | 112 | 111 | V |
| 4 | * 5.144 | 36.26 | RMS | 34.2 | -21.6 | 1.29 | 50.15 | 54 | -3.85 | - | - | 112 | 111 | V |

* - indicates frequency in CFR47 Pt 15 / IC RSS-Restricted Band
 Pk - Peak detector
 RMS - RMS detection

HARMONICS AND SPURIOUS EMISSIONS

MID CHANNEL RESULTS

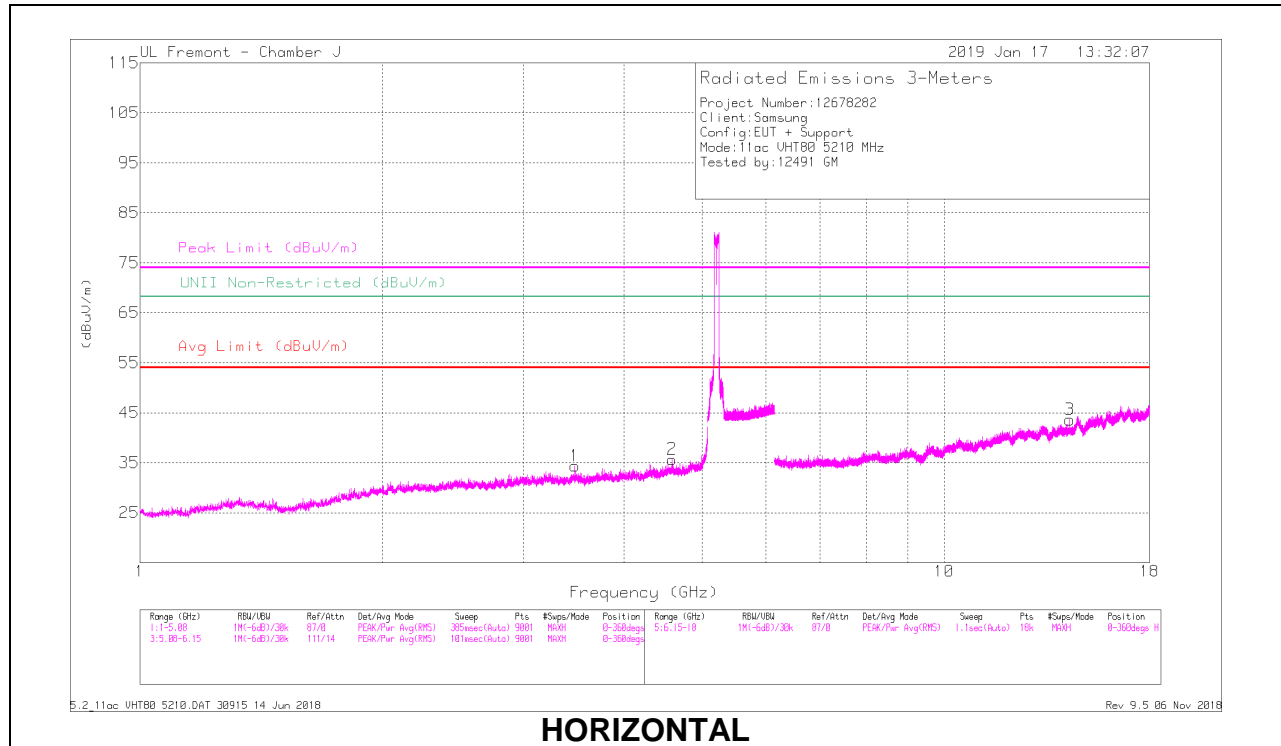

HORIZONTAL

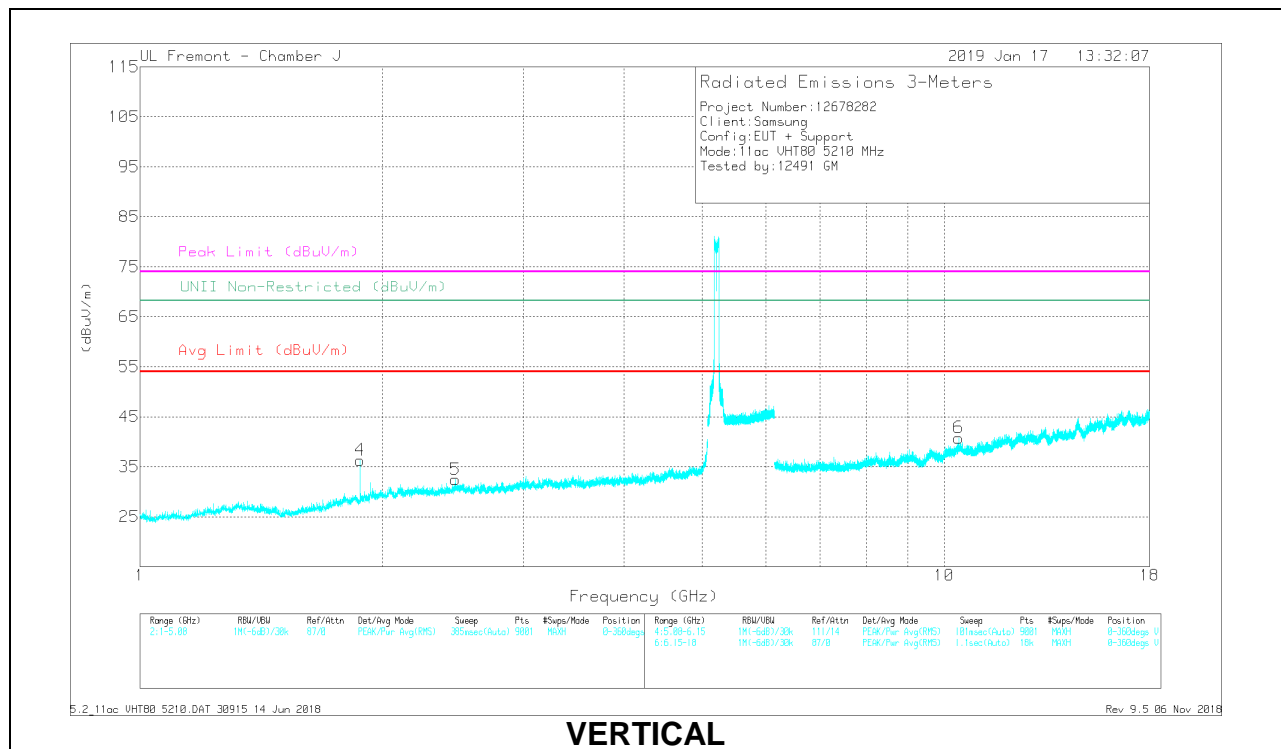

VERTICAL

RADIATED EMISSIONS

| Frequency (GHz) | Meter Reading (dBuV) | Det | AF A10067 (dB/m) | Amp/Coeff/Pad (dB) | DC Corr (dB) | Corrected Reading (dBuV/m) | Avg Limit (dBuV/m) | Margin (dB) | Peak Limit (dBuV/m) | PK Margin (dB) | UNII Non-Restricted (dBuV/m) | PK Margin (dB) | Azimuth (Degs) | Height (cm) | Polarity |
|-----------------|----------------------|------|------------------|--------------------|--------------|----------------------------|--------------------|-------------|---------------------|----------------|------------------------------|----------------|----------------|-------------|----------|
| 3.474 | 41.87 | PK-U | 32.6 | -33.6 | 0 | 40.87 | - | - | - | - | 68.2 | -27.33 | 188 | 260 | H |
| 3.473 | 32.84 | ADR | 32.6 | -33.6 | 1.29 | 33.13 | - | - | - | - | - | - | 188 | 260 | H |
| * 4.591 | 38.16 | PK-U | 34.2 | -30.9 | 0 | 41.46 | - | - | 74 | -32.64 | - | - | 83 | 106 | H |
| * 4.59 | 28.69 | ADR | 34.2 | -30.9 | 1.29 | 33.28 | 54 | -20.72 | - | - | - | - | 83 | 106 | H |
| 1.88 | 41.55 | PK-U | 30.8 | -35.8 | 0 | 36.55 | - | - | - | - | 68.2 | -31.65 | 148 | 392 | V |
| 1.877 | 31.26 | ADR | 30.8 | -35.8 | 1.29 | 27.55 | - | - | - | - | - | - | 148 | 392 | V |
| 2.465 | 44.58 | PK-U | 32.5 | -35.5 | 0 | 41.58 | - | - | - | - | 68.2 | -26.62 | 200 | 131 | V |
| 2.467 | 32.16 | ADR | 32.5 | -35.5 | 1.29 | 30.45 | - | - | - | - | - | - | 200 | 131 | V |
| 14.323 | 31.44 | PK-U | 39.2 | -20.7 | 0 | 49.94 | - | - | - | - | 68.2 | -18.26 | 184 | 181 | H |
| 14.324 | 22.12 | ADR | 39.2 | -20.7 | 1.29 | 41.91 | - | - | - | - | - | - | 184 | 181 | H |
| 10.42 | 35.65 | PK-U | 37.5 | -25.2 | 0 | 47.95 | - | - | - | - | 68.2 | -20.25 | 32 | 112 | V |
| 10.42 | 26.91 | ADR | 37.5 | -25.2 | 1.29 | 40.5 | - | - | - | - | - | - | 32 | 112 | V |

* - indicates frequency in CFR47 Pt 15 / IC RSS-Restricted Band
 PK-U - U-NII: Maximum Peak
 ADR - U-NII AD primary method, RMS average

10.1.5. TX ABOVE 1 GHz 802.11a MODE IN THE 5.3 GHz BAND

1TX Antenna 1 MODE

BANDEDGE (HIGH CHANNEL)

HORIZONTAL RESULT

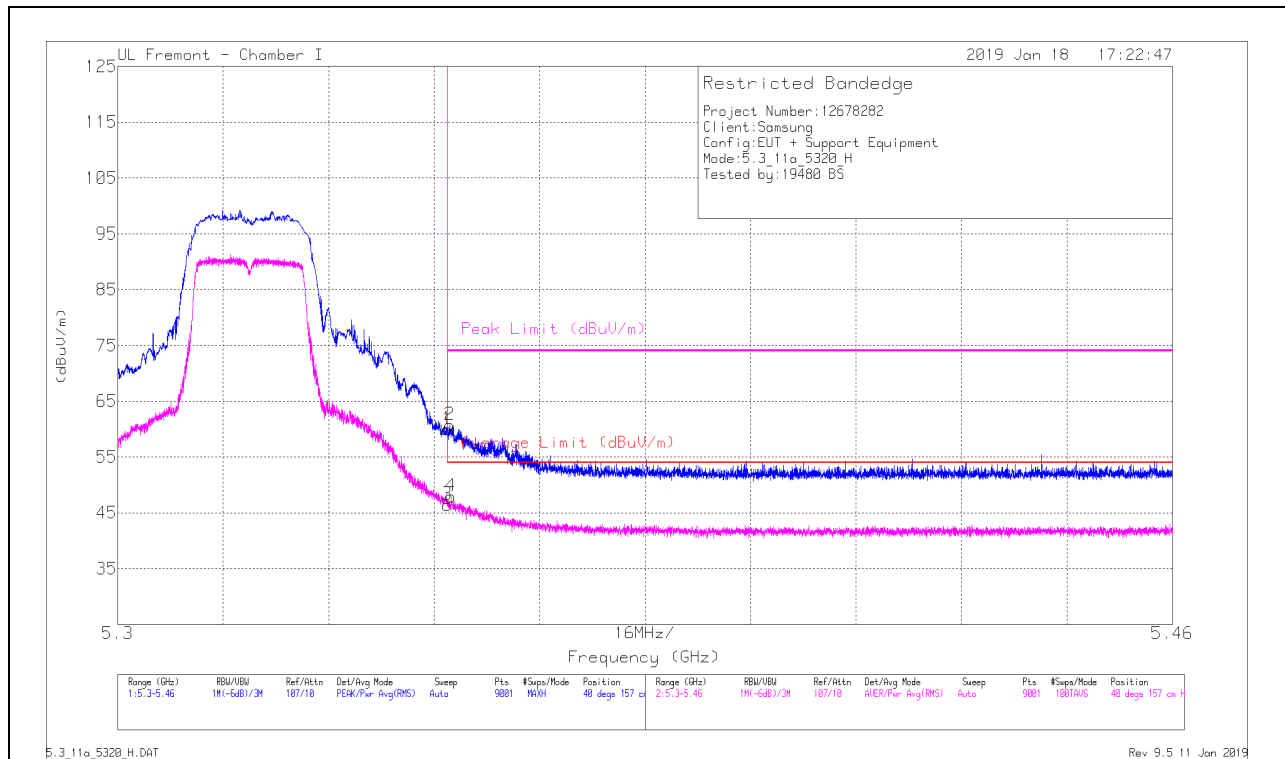

| Marker | Frequency (GHz) | Meter Reading (dBuV) | Det | AF T862 (dB/m) | Amp/Cou/Filtr/Path (dB) | DC Corr (dB) | Corrected Reading (dBuV/m) | Average Limit (dBuV/m) | Margin (dB) | Peak Limit (dBuV/m) | PK Margin (dB) | Azimuth (Degs) | Height (cm) | Polarity |
|--------|-----------------|----------------------|-----|----------------|-------------------------|--------------|----------------------------|------------------------|-------------|---------------------|----------------|----------------|-------------|----------|
| 1 | * 5.35 | 43.79 | Pk | 34.5 | -18.3 | 0 | 59.99 | - | - | 74 | -14.01 | 40 | 157 | H |
| 2 | * 5.35 | 44.48 | Pk | 34.5 | -18.3 | 0 | 60.68 | - | - | 74 | -13.32 | 40 | 157 | H |
| 3 | * 5.35 | 30.01 | RMS | 34.5 | -18.3 | 27 | 46.48 | 54 | -7.52 | - | - | 40 | 157 | H |
| 4 | * 5.351 | 31.51 | RMS | 34.5 | -18.3 | 27 | 47.98 | 54 | -6.02 | - | - | 40 | 157 | H |

* - indicates frequency in CFR47 Pt 15 / IC RSS-Restricted Band
 Pk - Peak detector
 RMS - RMS detection

VERTICAL RESULT

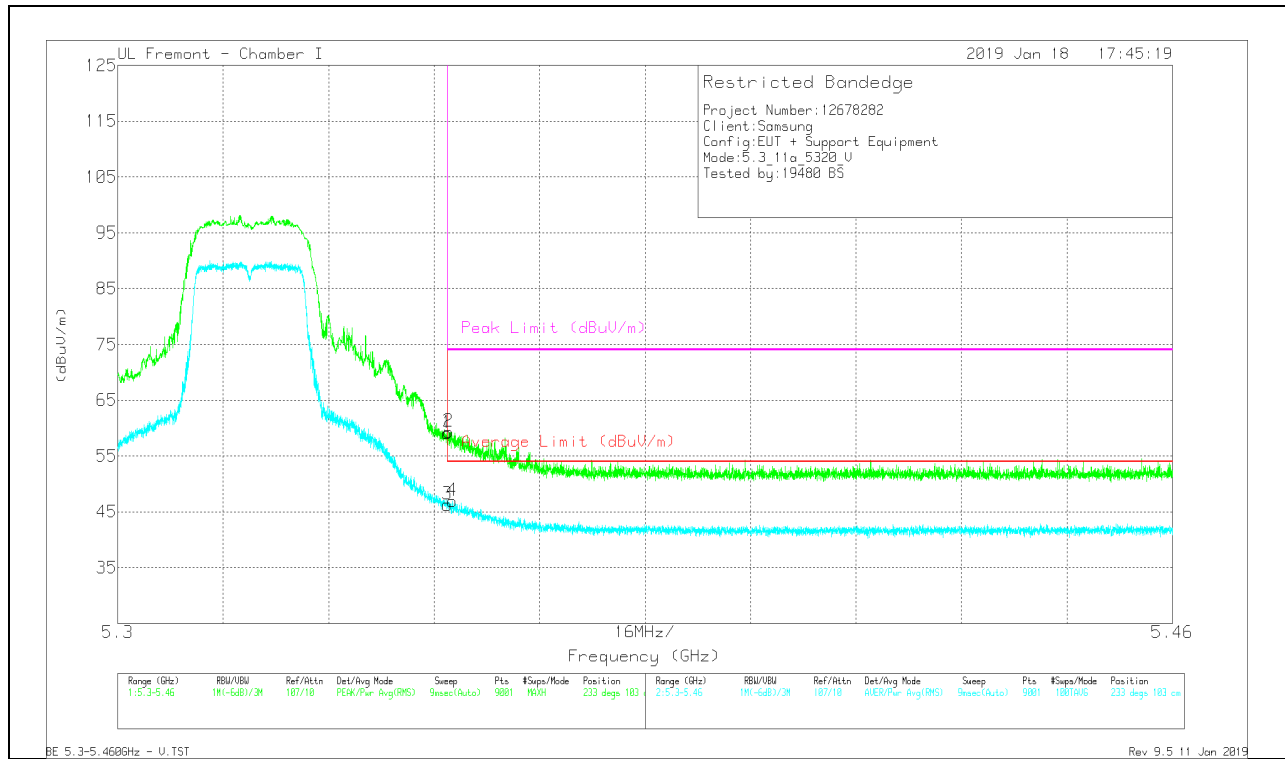

| Marker | Frequency (GHz) | Meter Reading (dBuV) | Det | AF T862 (dB/m) | Amp/Cal/Filt/Pa d (dB) | DC Corr (dB) | Corrected Reading (dBuV/m) | Average Limit (dBuV/m) | Margin (dB) | Peak Limit (dBuV/m) | PK Margin (dB) | Azimuth (Degs) | Height (cm) | Polarity |
|--------|-----------------|----------------------|-----|----------------|------------------------|--------------|----------------------------|------------------------|-------------|---------------------|----------------|----------------|-------------|----------|
| 1 | * 5.35 | 42.93 | Pk | 34.5 | -18.3 | 0 | 59.13 | - | - | 74 | -14.87 | 233 | 103 | V |
| 2 | * 5.35 | 43.16 | Pk | 34.5 | -18.3 | 0 | 59.36 | - | - | 74 | -14.64 | 233 | 103 | V |
| 3 | * 5.35 | 29.79 | RMS | 34.5 | -18.3 | .27 | 46.26 | 54 | -7.74 | - | - | 233 | 103 | V |
| 4 | * 5.351 | 30.45 | RMS | 34.5 | -18.3 | .27 | 46.92 | 54 | -7.08 | - | - | 233 | 103 | V |

* - indicates frequency in CFR47 Pt 15 / IC RSS-Restricted Band
 Pk - Peak detector
 RMS - RMS detection

HARMONICS AND SPURIOUS EMISSIONS

LOW CHANNEL RESULTS

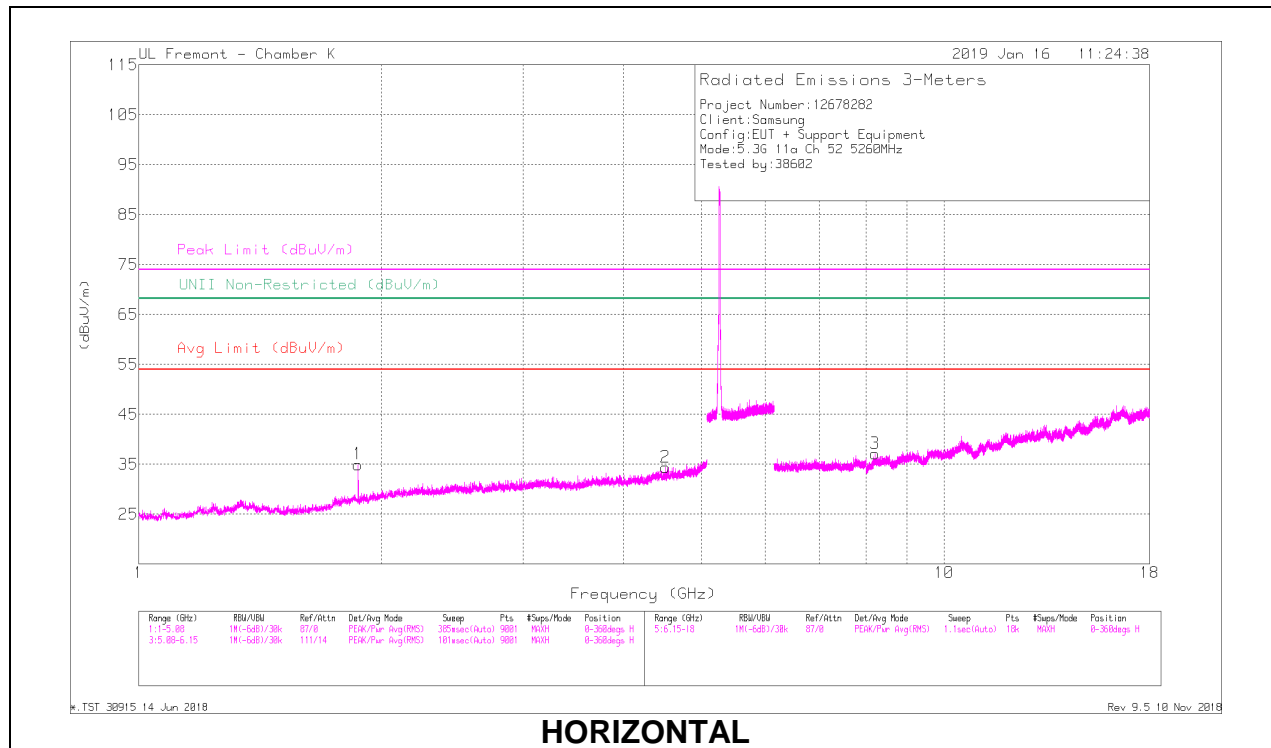

HORIZONTAL

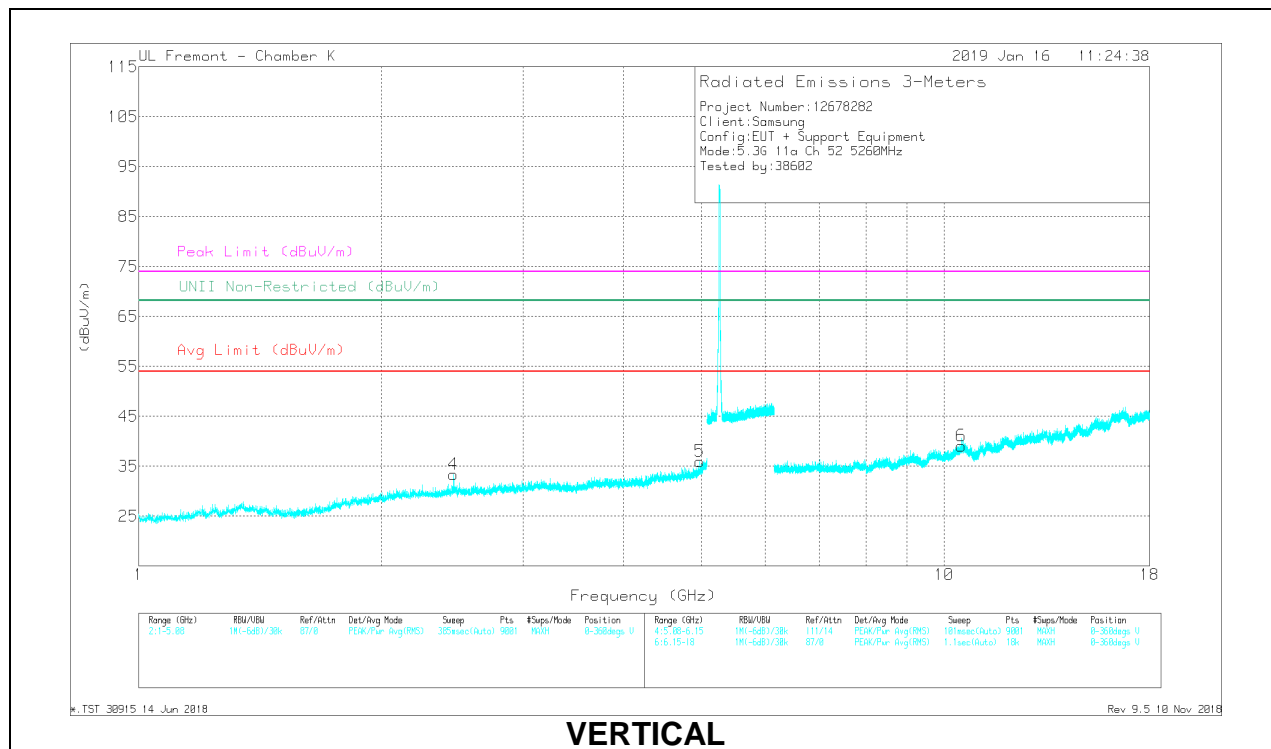

VERTICAL

RADIATED EMISSIONS

| Frequency (GHz) | Meter Reading (dBuV) | Det | AF T344 (dBm) | Amp/Cable/Pad (dB) | DC Corr (dB) | Corrected Reading (dBuV/m) | Avg Limit (dBuV/m) | Margin (dB) | Peak Limit (dBuV/m) | PK Margin (dB) | UNII Non-Restricted (dBuV/m) | PK Margin (dB) | Azimuth (Degs) | Height (cm) | Polarity |
|-----------------|----------------------|------|---------------|--------------------|--------------|----------------------------|--------------------|-------------|---------------------|----------------|------------------------------|----------------|----------------|-------------|----------|
| 1.875 | 40.32 | PK-U | 30.4 | -35.2 | 0 | 35.52 | - | - | - | - | 68.2 | -32.68 | 83 | 339 | H |
| * 4.51 | 39.93 | PK-U | 34 | -30.2 | 0 | 42.73 | - | - | 74 | -31.27 | - | - | 273 | 257 | H |
| * 4.502 | 27.51 | ADR | 34 | -30.2 | .27 | 31.58 | 54 | -22.42 | - | - | - | - | 273 | 257 | H |
| 2.461 | 40.66 | PK-U | 32.2 | -34.9 | 0 | 37.96 | - | - | - | - | 68.2 | -30.24 | 26 | 182 | V |
| * 4.972 | 36.92 | PK-U | 34.2 | -29.4 | 0 | 41.72 | - | - | 74 | -32.28 | - | - | 274 | 244 | V |
| * 4.975 | 27.46 | ADR | 34.2 | -29.4 | .27 | 32.53 | 54 | -21.47 | - | - | - | - | 274 | 244 | V |
| * 8.21 | 32.78 | PK-U | 35.7 | -24.8 | 0 | 43.68 | - | - | 74 | -30.32 | - | - | 340 | 282 | H |
| * 8.211 | 22.62 | ADR | 35.7 | -24.8 | .27 | 33.79 | 54 | -20.21 | - | - | - | - | 340 | 282 | H |
| 10.506 | 31.03 | PK-U | 37.6 | -22.7 | 0 | 45.93 | - | - | - | - | 68.2 | -22.27 | 260 | 287 | V |

* - indicates frequency in CFR47 Pt 15 / IC RSS-Restricted Band
 PK-U - U-NII: Maximum Peak
 ADR - U-NII AD primary method, RMS average

MID CHANNEL RESULTS

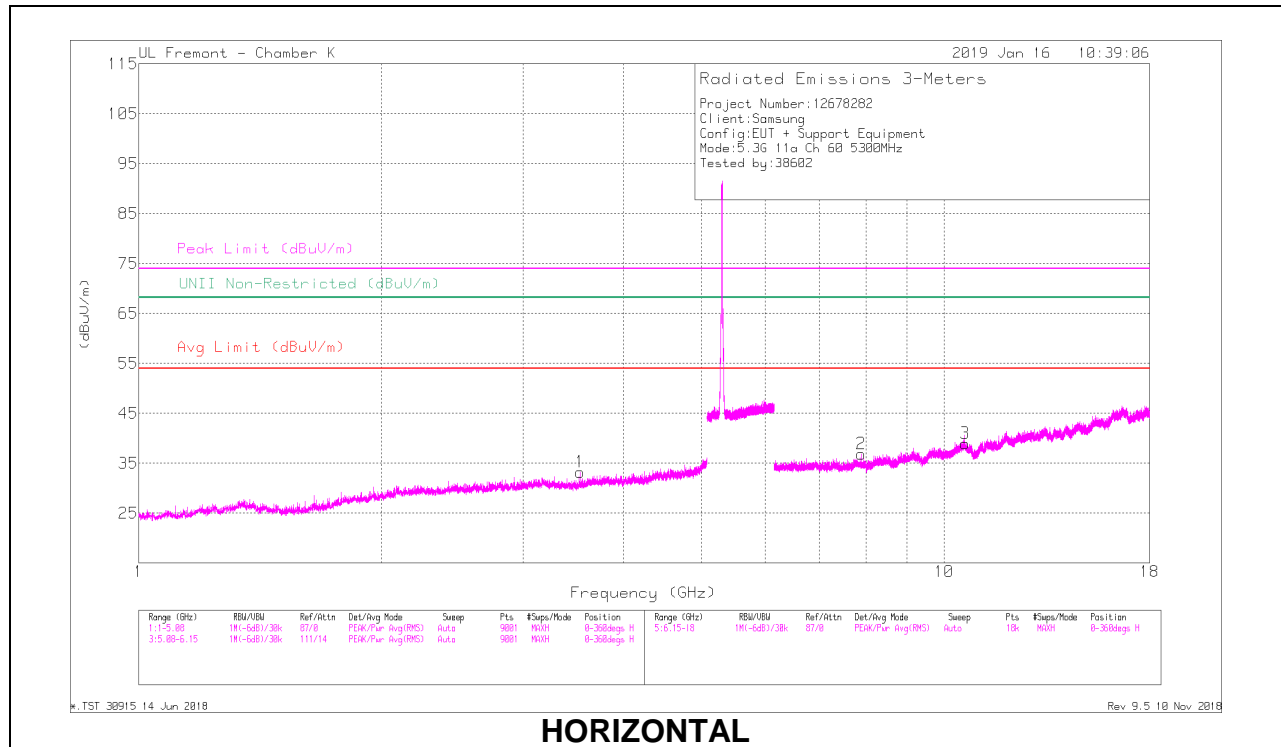

HORIZONTAL

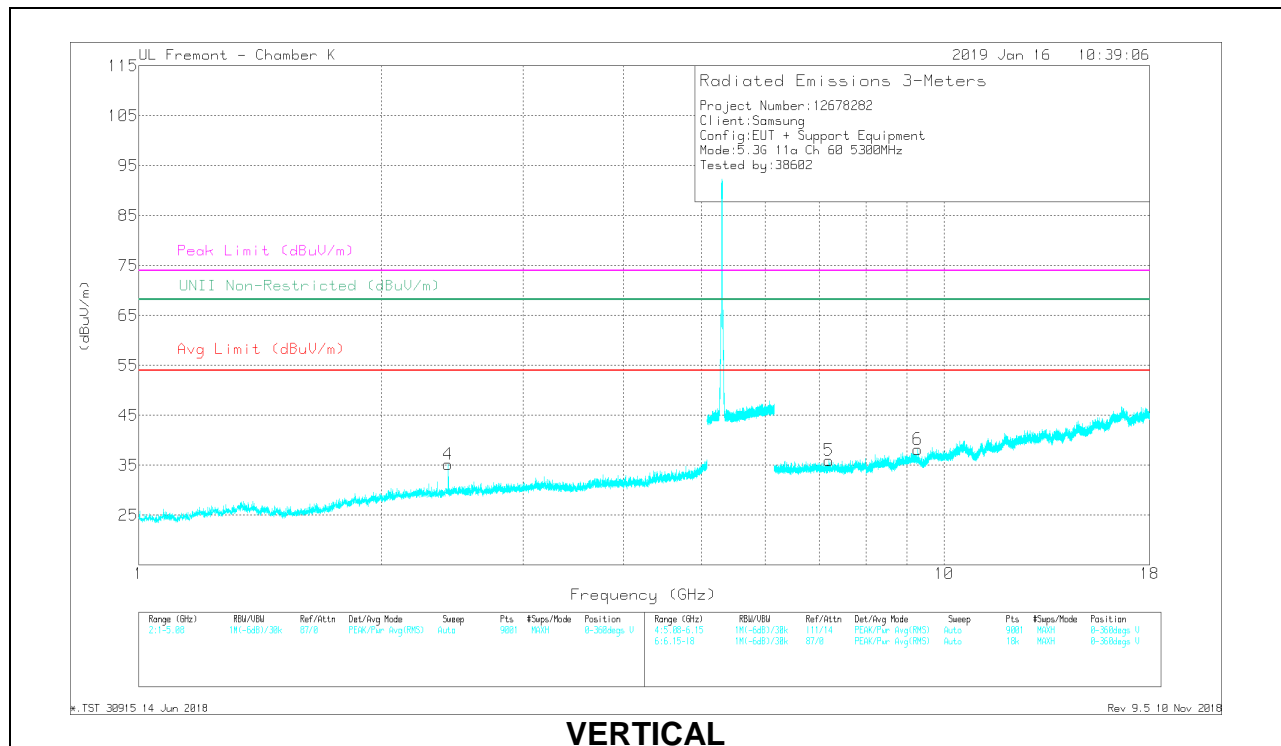

VERTICAL

RADIATED EMISSIONS

| Frequency (GHz) | Meter Reading (dBuV) | Det | AF T344 (dB/m) | AmpCoeff/Pad (dB) | DC Corr (dB) | Corrected Reading (dBuV/m) | Avg Limit (dBuV/m) | Margin (dB) | Peak Limit (dBuV/m) | PK Margin (dB) | UNII Non-Restricted (dBuV/m) | PK Margin (dB) | Azimuth (Degs) | Height (cm) | Polarity |
|-----------------|----------------------|------|----------------|-------------------|--------------|----------------------------|--------------------|-------------|---------------------|----------------|------------------------------|----------------|----------------|-------------|----------|
| * 3.533 | 39.47 | PK-U | 32.8 | -32.6 | 0 | 39.67 | - | - | 74 | -34.33 | - | - | 66 | 158 | H |
| * 3.533 | 29.88 | ADR | 32.8 | -32.6 | .27 | 30.35 | 54 | -23.65 | - | - | - | - | 66 | 158 | H |
| 2.424 | 41.23 | PK-U | 32.1 | -34.9 | 0 | 38.43 | - | - | - | - | 68.2 | -29.77 | 65 | 105 | V |
| * 10.623 | 30.73 | PK-U | 37.7 | -22.8 | 0 | 45.63 | - | - | 74 | -28.37 | - | - | 0 | 266 | H |
| * 10.621 | 20.77 | ADR | 37.7 | -22.8 | .27 | 35.94 | 54 | -18.06 | - | - | - | - | 0 | 266 | H |
| 7.892 | 32.62 | PK-U | 35.8 | -26.1 | 0 | 42.32 | - | - | - | - | 68.2 | -25.88 | 228 | 316 | H |
| 7.196 | 33.29 | PK-U | 35.5 | -26.8 | 0 | 41.99 | - | - | - | - | 68.2 | -26.21 | 8 | 167 | V |
| 9.282 | 30.55 | PK-U | 36.4 | -23.5 | 0 | 43.45 | - | - | - | - | 68.2 | -24.75 | 299 | 133 | V |

* - indicates frequency in CFR47 Pt 15 / IC RSS-Restricted Band

PK-U - U-NII: Maximum Peak

ADR - U-NII AD primary method, RMS average

HIGH CHANNEL RESULTS

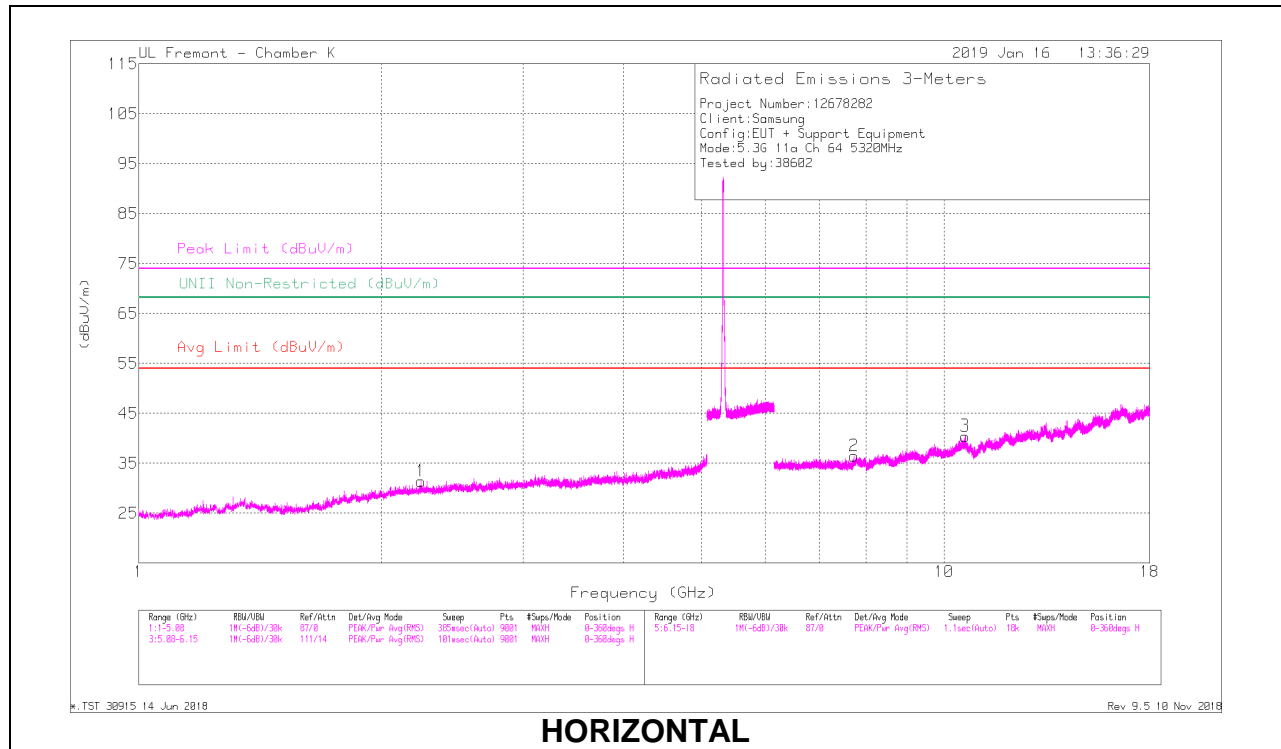

HORIZONTAL

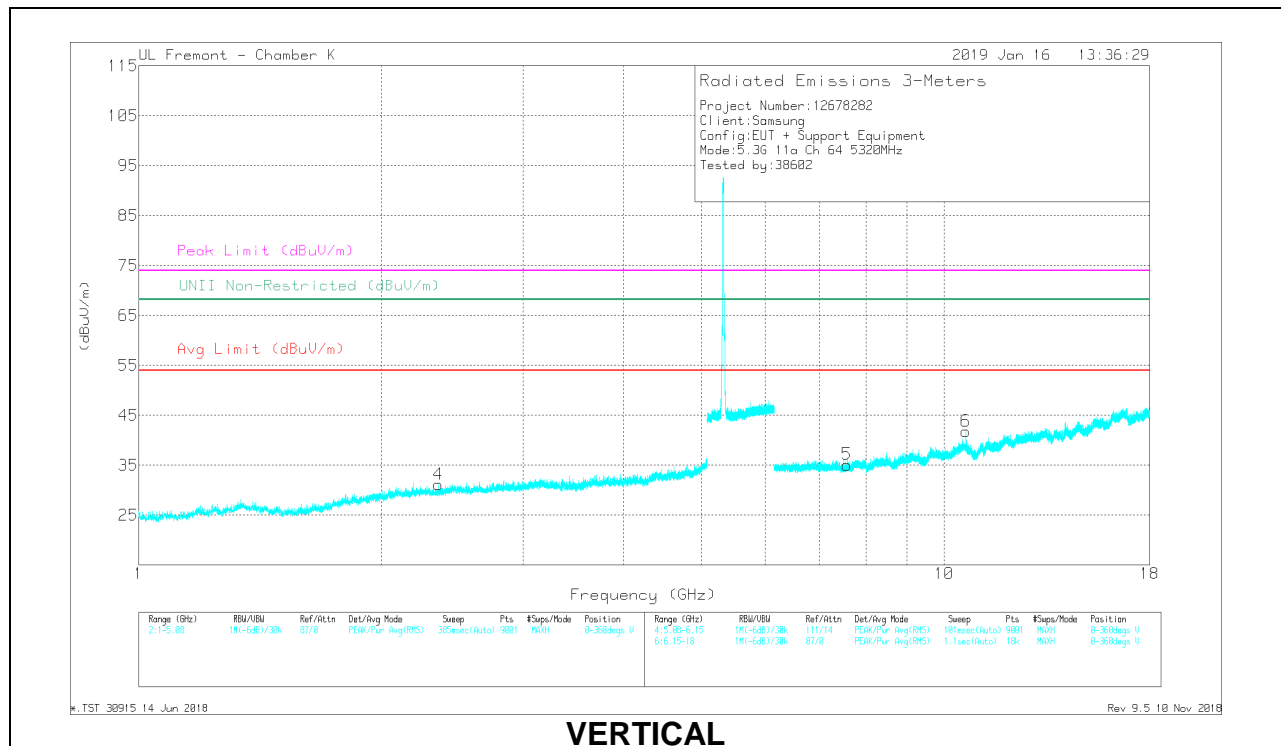

VERTICAL

RADIATED EMISSIONS

| Frequency (GHz) | Meter Reading (dBuV) | Det | AF T344 (dB/m) | AmpCoeff/Pad (dB) | DC Corr (dB) | Corrected Reading (dBuV/m) | Avg Limit (dBuV/m) | Margin (dB) | Peak Limit (dBuV/m) | PK Margin (dB) | UNII Non-Restricted (dBuV/m) | PK Margin (dB) | Azimuth (Degs) | Height (cm) | Polarity |
|-----------------|----------------------|------|----------------|-------------------|--------------|----------------------------|--------------------|-------------|---------------------|----------------|------------------------------|----------------|----------------|-------------|----------|
| * 2.242 | 41.26 | PK-U | 31.9 | -35.1 | 0 | 38.06 | - | - | 74 | -35.94 | - | - | 120 | 400 | H |
| * 2.24 | 31.39 | ADR | 31.9 | -35.1 | .27 | 28.45 | 54 | -25.55 | - | - | - | - | 120 | 400 | H |
| * 2.354 | 39.99 | PK-U | 31.7 | -35.1 | 0 | 35.59 | - | - | 74 | -37.41 | - | - | 0 | 232 | V |
| * 2.354 | 31.26 | ADR | 31.7 | -35.1 | .27 | 28.13 | 54 | -25.87 | - | - | - | - | 0 | 232 | V |
| * 7.732 | 32.44 | PK-U | 35.7 | -25.6 | 0 | 42.54 | - | - | 74 | -31.46 | - | - | 78 | 192 | H |
| * 7.732 | 23.76 | ADR | 35.7 | -25.6 | .27 | 34.13 | 54 | -19.87 | - | - | - | - | 78 | 192 | H |
| * 10.615 | 31.39 | PK-U | 37.7 | -22.7 | 0 | 46.39 | - | - | 74 | -27.61 | - | - | 321 | 189 | H |
| * 10.616 | 22.15 | ADR | 37.7 | -22.7 | .27 | 37.42 | 54 | -16.58 | - | - | - | - | 321 | 189 | H |
| * 7.569 | 34.32 | PK-U | 35.6 | -26.5 | 0 | 43.42 | - | - | 74 | -30.58 | - | - | 355 | 393 | V |
| * 7.568 | 23.46 | ADR | 35.6 | -26.5 | .27 | 32.83 | 54 | -21.17 | - | - | - | - | 355 | 393 | V |
| * 10.64 | 33.92 | PK-U | 37.8 | -22.8 | 0 | 48.92 | - | - | 74 | -25.08 | - | - | 217 | 103 | V |
| * 10.64 | 24.85 | ADR | 37.8 | -22.8 | .27 | 40.12 | 54 | -13.88 | - | - | - | - | 217 | 103 | V |

* - indicates frequency in CFR47 Pt 15 / IC RSS-Restricted Band
 PK-U - U-NII: Maximum Peak
 ADR - U-NII AD primary method, RMS average

10.1.6. TX ABOVE 1 GHz 802.11n HT20 MODE IN THE 5.3 GHz BAND

1TX Antenna 1 MODE

BANDEDGE (HIGH CHANNEL)

HORIZONTAL RESULT

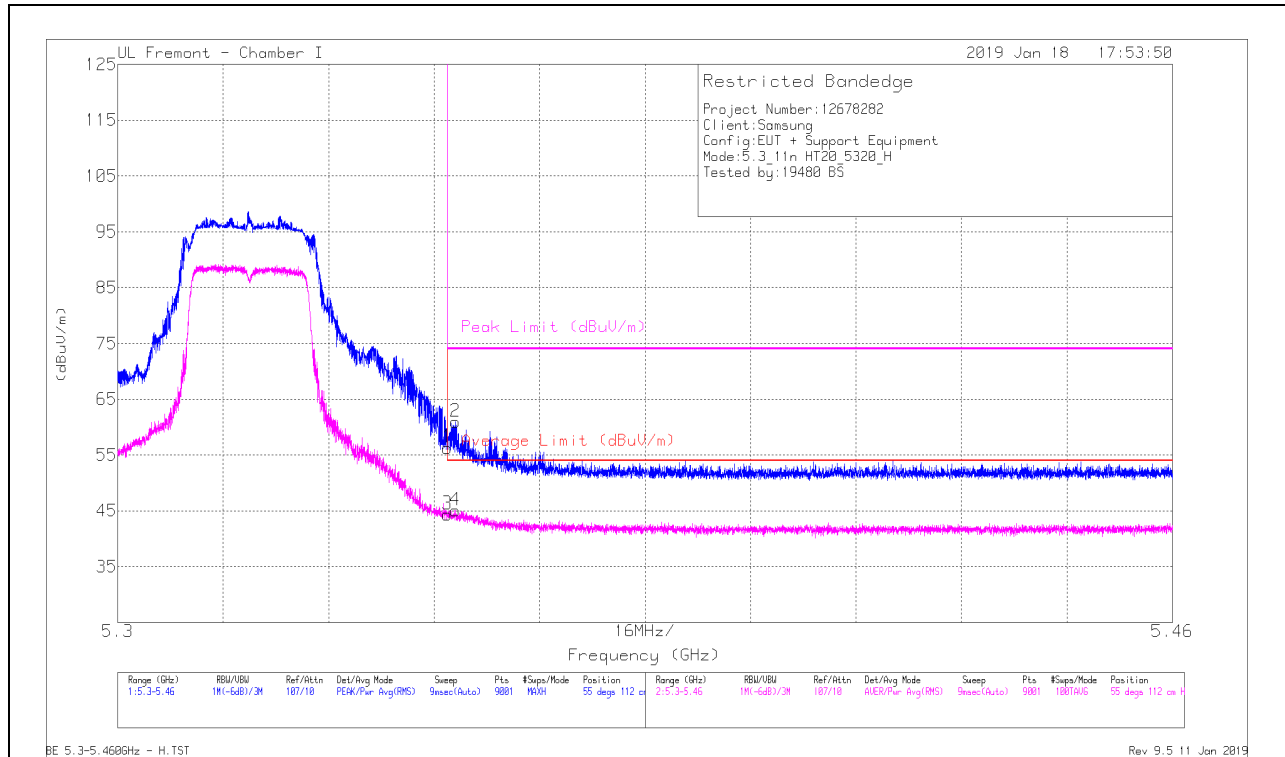

| Marker | Frequency (GHz) | Meter Reading (dBuV) | Det | AF T862 (dB/m) | Amp/Cou/Filt/Par d (dB) | DC Corr (dB) | Corrected Reading (dBuV/m) | Average Limit (dBuV/m) | Margin (dB) | Peak Limit (dBuV/m) | PK Margin (dB) | Azimuth (Degs) | Height (cm) | Polarity |
|--------|-----------------|----------------------|-----|----------------|-------------------------|--------------|----------------------------|------------------------|-------------|---------------------|----------------|----------------|-------------|----------|
| 1 | * 5.35 | 40.11 | Pk | 34.5 | -18.3 | 0 | 56.31 | - | - | 74 | -17.69 | 55 | 112 | H |
| 2 | * 5.351 | 44.72 | Pk | 34.5 | -18.3 | 0 | 60.92 | - | - | 74 | -13.08 | 55 | 112 | H |
| 3 | * 5.35 | 27.91 | RMS | 34.5 | -18.3 | 28 | 44.39 | 54 | -9.61 | - | - | 55 | 112 | H |
| 4 | * 5.351 | 28.64 | RMS | 34.5 | -18.3 | 28 | 45.12 | 54 | -8.88 | - | - | 55 | 112 | H |

* - indicates frequency in CFR47 Pt 15 / IC RSS-Restricted Band

Pk - Peak detector

RMS - RMS detection

VERTICAL RESULT

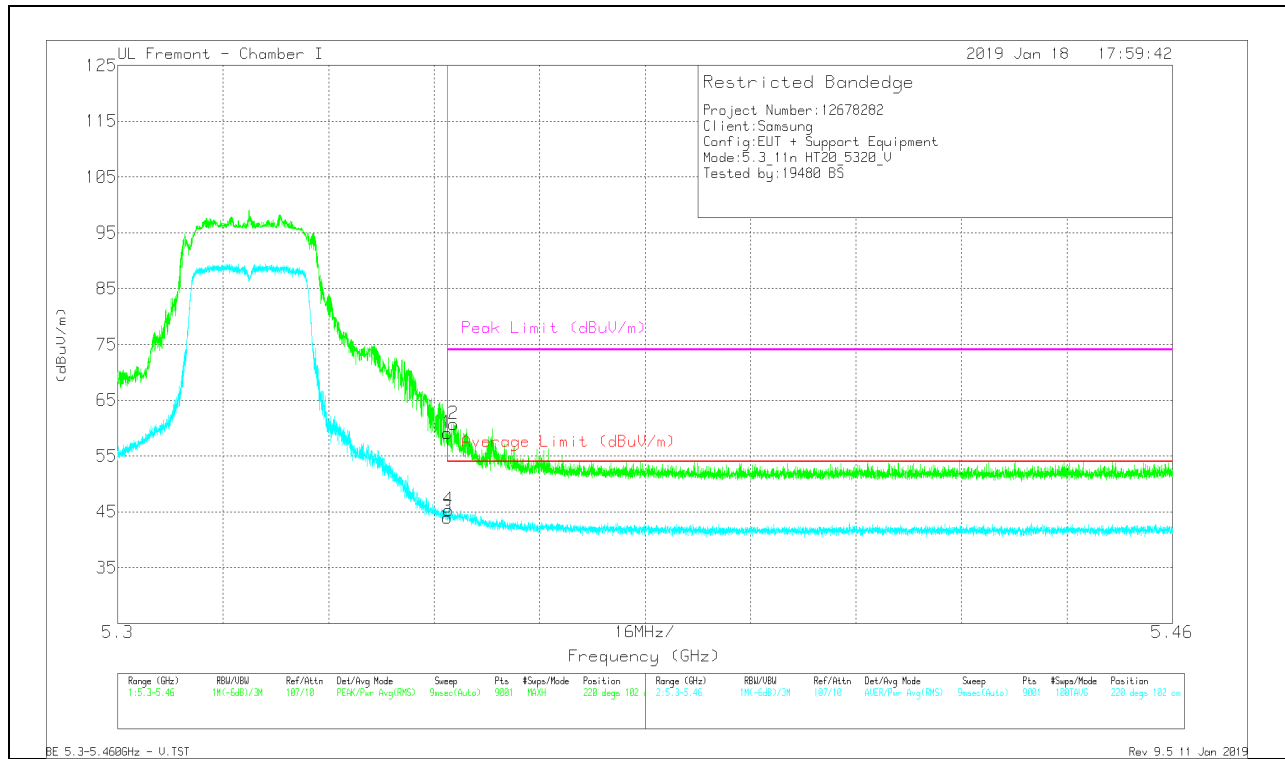

| Marker | Frequency (GHz) | Meter Reading (dBuV) | Det | AF T862 (dB/m) | Amp/Cou/Filt/Pa d (dB) | DC Corr (dB) | Corrected Reading (dBuV/m) | Average Limit (dBuV/m) | Margin (dB) | Peak Limit (dBuV/m) | PK Margin (dB) | Azimuth (Degs) | Height (cm) | Polarity |
|--------|-----------------|----------------------|-----|----------------|------------------------|--------------|----------------------------|------------------------|-------------|---------------------|----------------|----------------|-------------|----------|
| 1 | * 5.35 | 42.91 | Pk | 34.5 | -18.3 | 0 | 59.11 | - | - | 74 | -14.89 | 220 | 102 | V |
| 2 | * 5.351 | 44.54 | Pk | 34.5 | -18.3 | 0 | 60.74 | - | - | 74 | -13.26 | 220 | 102 | V |
| 3 | * 5.35 | 27.53 | RMS | 34.5 | -18.3 | 28 | 44.01 | 54 | -9.99 | - | - | 220 | 102 | V |
| 4 | * 5.35 | 28.87 | RMS | 34.5 | -18.3 | 28 | 45.35 | 54 | -8.65 | - | - | 220 | 102 | V |

* - indicates frequency in CFR47 Pt 15 / IC RSS-Restricted Band
 Pk - Peak detector
 RMS - RMS detection

HARMONICS AND SPURIOUS EMISSIONS

LOW CHANNEL RESULTS

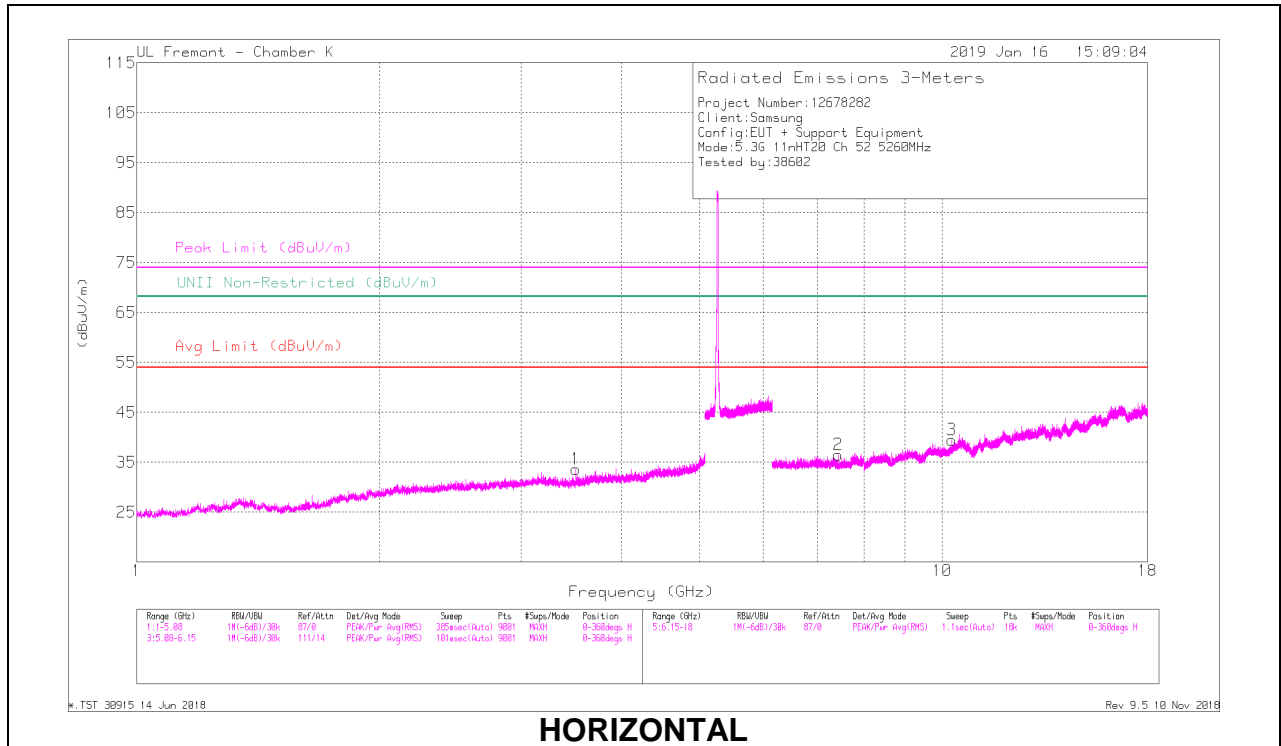

HORIZONTAL

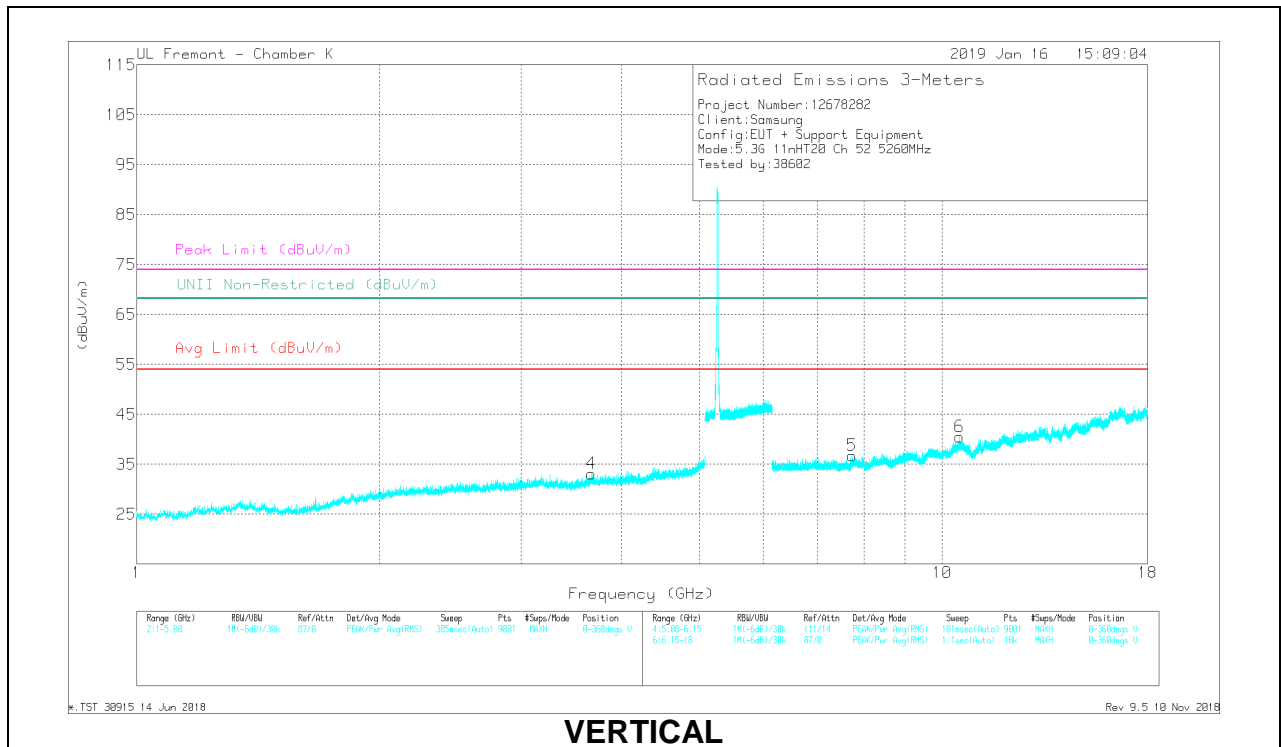

VERTICAL

RADIATED EMISSIONS

| Frequency (GHz) | Meter Reading (dBuV) | Det | AF T344 (dB/m) | Amp/Cable/Feeder/Pad (dB) | DC Corr (dB) | Corrected Reading (dBuV/m) | Avg Limit (dBuV/m) | Margin (dB) | Peak Limit (dBuV/m) | PK Margin (dB) | UNII Non-Restricted (dBuV/m) | PK Margin (dB) | Azimuth (Degs) | Height (cm) | Polarity |
|-----------------|----------------------|------|----------------|---------------------------|--------------|----------------------------|--------------------|-------------|---------------------|----------------|------------------------------|----------------|----------------|-------------|----------|
| * 3.507 | 39.66 | PK-U | 32.7 | -32.8 | 0 | 39.56 | - | - | 74 | -34.44 | - | - | 66 | 130 | H |
| * 3.507 | 31.12 | ADR | 32.7 | -32.8 | .28 | 31.3 | 54 | -22.7 | - | - | - | - | 66 | 130 | H |
| * 3.666 | 38.57 | PK-U | 33 | -32.3 | 0 | 39.27 | - | - | 74 | -34.73 | - | - | 123 | 281 | V |
| * 3.665 | 29.11 | ADR | 33 | -32.3 | .28 | 30.09 | 54 | -23.91 | - | - | - | - | 123 | 281 | V |
| * 7.429 | 33.64 | PK-U | 35.5 | -26.6 | 0 | 42.54 | - | - | 74 | -31.46 | - | - | 244 | 299 | H |
| * 7.43 | 23.7 | ADR | 35.5 | -26.6 | .28 | 32.88 | 54 | -21.12 | - | - | - | - | 244 | 299 | H |
| 10.291 | 31.22 | PK-U | 37.3 | -23.5 | 0 | 45.02 | - | - | - | - | 68.2 | -23.18 | 235 | 317 | H |
| * 7.737 | 33.07 | PK-U | 35.7 | -25.6 | 0 | 43.17 | - | - | 74 | -30.83 | - | - | 131 | 180 | V |
| * 7.734 | 23.45 | ADR | 35.7 | -25.6 | .28 | 33.83 | 54 | -20.17 | - | - | - | - | 131 | 180 | V |
| 10.52 | 31.07 | PK-U | 37.6 | -22.5 | 0 | 46.17 | - | - | - | - | 68.2 | -22.03 | 151 | 187 | V |

* - indicates frequency in CFR47 Pt 15 / IC RSS-Restricted Band

PK-U - U-NII: Maximum Peak

ADR - U-NII AD primary method, RMS average

MID CHANNEL RESULTS

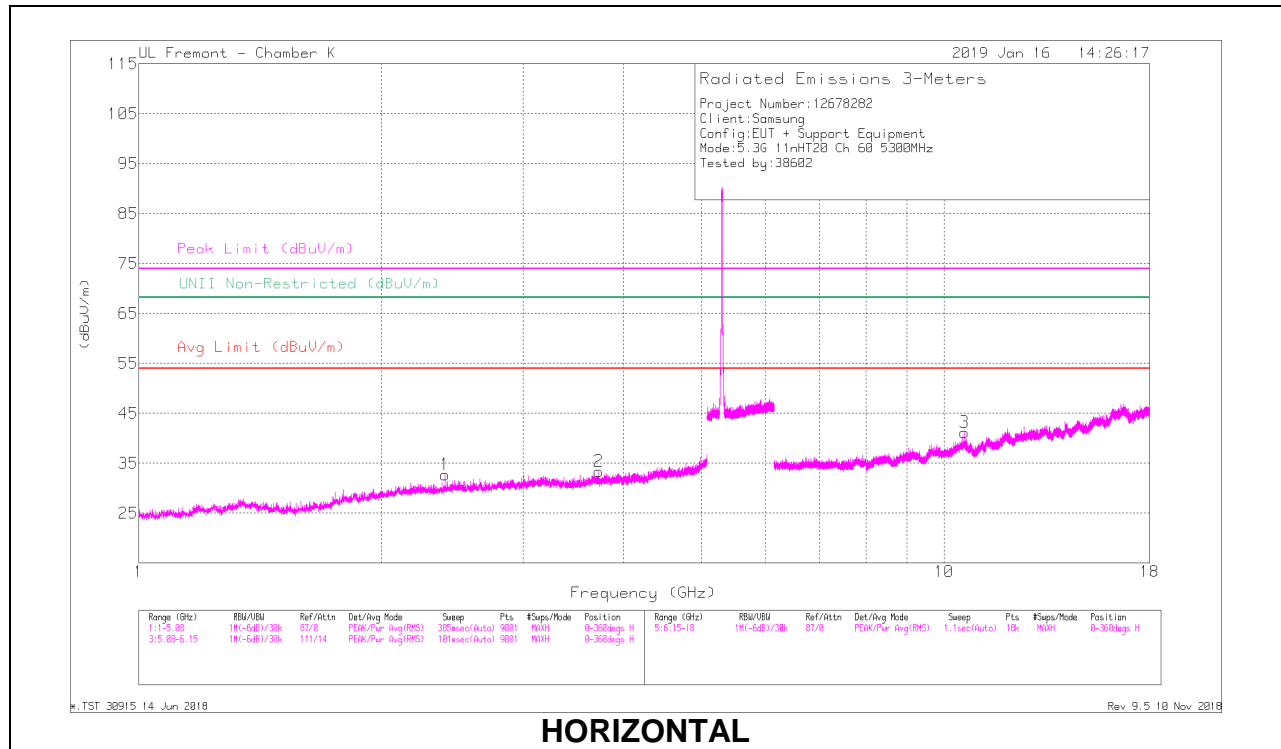

HORIZONTAL

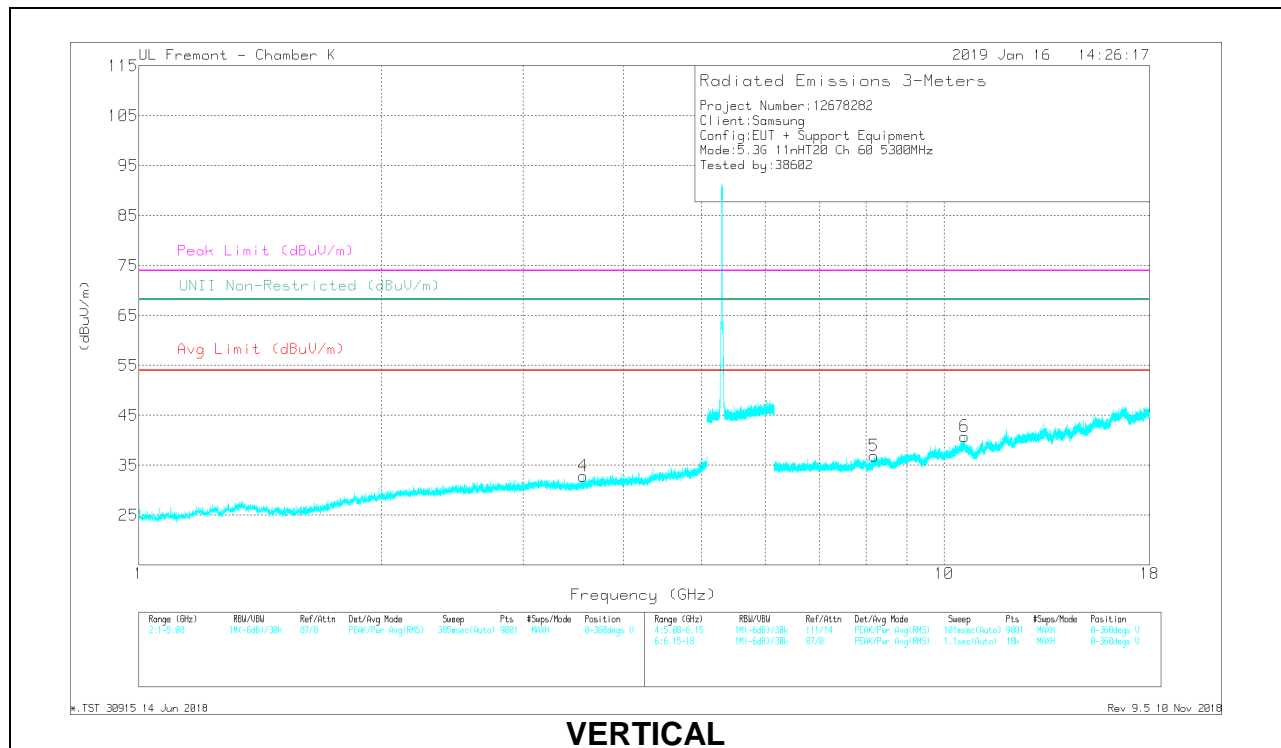

VERTICAL

RADIATED EMISSIONS

| Frequency (GHz) | Meter Reading (dBuV) | Det | AF T344 (dB/m) | AmpCoeff/Pad (dB) | DC Corr (dB) | Corrected Reading (dBuV/m) | Avg Limit (dBuV/m) | Margin (dB) | Peak Limit (dBuV/m) | PK Margin (dB) | UNII Non-Restricted (dBuV/m) | PK Margin (dB) | Azimuth (Degs) | Height (cm) | Polarity |
|-----------------|----------------------|------|----------------|-------------------|--------------|----------------------------|--------------------|-------------|---------------------|----------------|------------------------------|----------------|----------------|-------------|----------|
| 2.402 | 40.44 | PK-U | 32 | -35 | 0 | 37.44 | - | - | - | - | 68.2 | -30.76 | 160 | 242 | H |
| * 3.726 | 38.15 | PK-U | 33.3 | -32 | 0 | 39.45 | - | - | 74 | -34.55 | - | - | 262 | 170 | H |
| * 3.722 | 28.9 | ADR | 33.2 | -32 | .28 | 30.37 | 54 | -23.63 | - | - | - | - | 262 | 170 | H |
| * 3.562 | 38.83 | PK-U | 32.9 | -32.4 | 0 | 39.33 | - | - | 74 | -34.67 | - | - | 328 | 136 | V |
| * 3.562 | 28.46 | ADR | 32.9 | -32.4 | .28 | 29.23 | 54 | -24.77 | - | - | - | - | 328 | 136 | V |
| * 11.699 | 32.68 | PK-U | 38.2 | -20.8 | 0 | 50.08 | - | - | 74 | -23.92 | - | - | 139 | 225 | H |
| * 11.834 | 20.45 | ADR | 38.4 | -20.9 | .28 | 38.22 | 54 | -15.78 | - | - | - | - | 139 | 225 | H |
| * 8.183 | 32.79 | PK-U | 35.7 | -25 | 0 | 43.49 | - | - | 74 | -30.51 | - | - | 24 | 131 | V |
| * 8.184 | 23.15 | ADR | 35.7 | -25 | .28 | 34.12 | 54 | -19.88 | - | - | - | - | 24 | 131 | V |
| * 11.81 | 31.27 | PK-U | 38.4 | -20.9 | 0 | 48.67 | - | - | 74 | -25.13 | - | - | 288 | 241 | V |
| * 11.83 | 20.7 | ADR | 38.4 | -20.9 | .28 | 38.47 | 54 | -15.53 | - | - | - | - | 288 | 241 | V |

* - indicates frequency in CFR47 Pt 15 / IC RSS-Restricted Band
 PK-U - U-NII: Maximum Peak
 ADR - U-NII AD primary method, RMS average

HIGH CHANNEL RESULTS

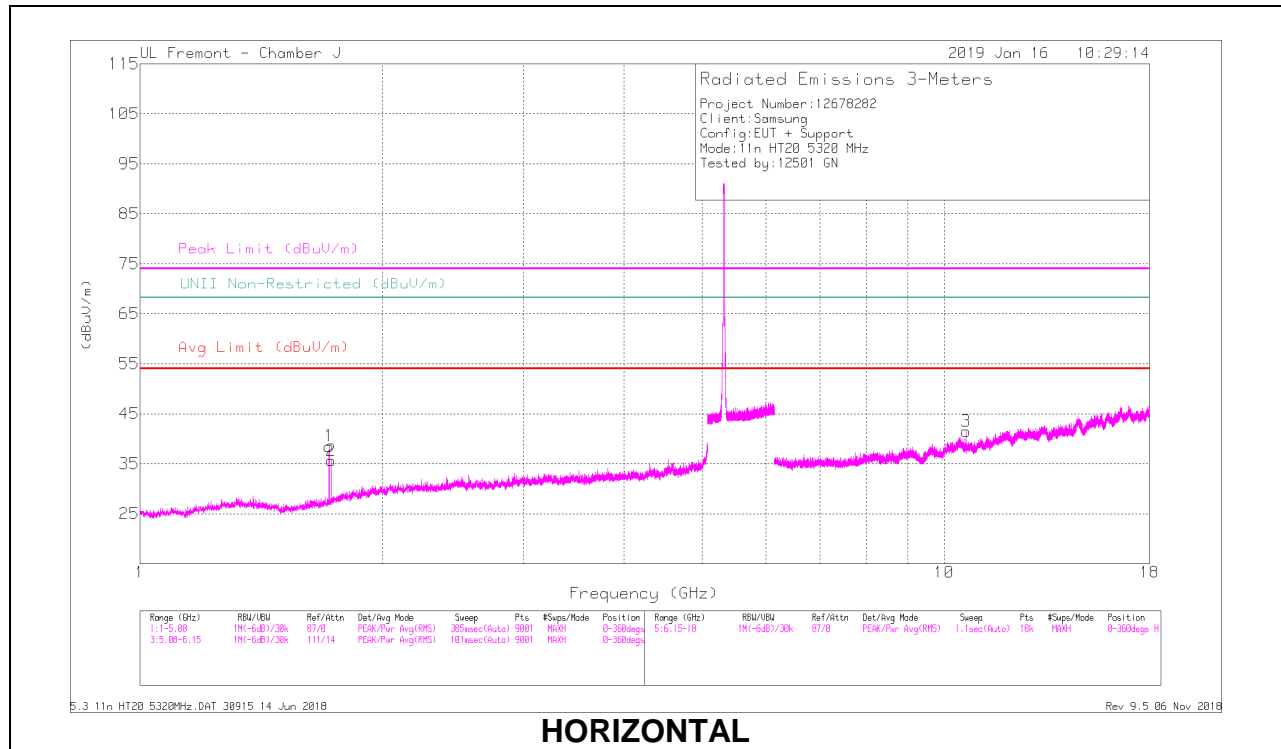

HORIZONTAL

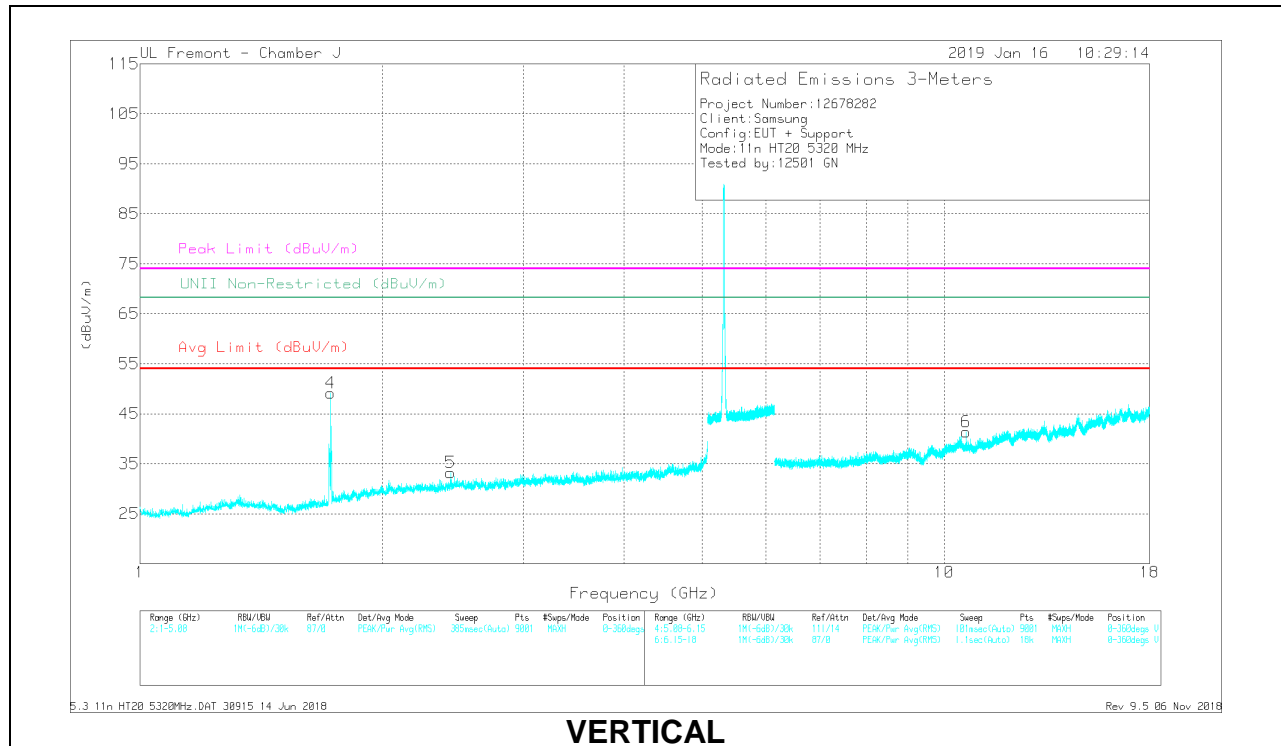

VERTICAL

RADIATED EMISSIONS

| Frequency (GHz) | Meter Reading (dBuV) | Det | AF A10067 (dB/m) | Amp/Coeff/Pad (dB) | DC Corr (dB) | Corrected Reading (dBuV/m) | Avg Limit (dBuV/m) | Margin (dB) | Peak Limit (dBuV/m) | PK Margin (dB) | UNII Non-Restricted (dBuV/m) | PK Margin (dB) | Azimuth (Degs) | Height (cm) | Polarity |
|-----------------|----------------------|------|------------------|--------------------|--------------|----------------------------|--------------------|-------------|---------------------|----------------|------------------------------|----------------|----------------|-------------|----------|
| 1.718 | 41.18 | PK-U | 29.3 | -35.8 | 0 | 34.68 | - | - | - | - | 68.2 | -33.52 | 296 | 396 | H |
| 1.718 | 32.47 | ADR | 29.3 | -35.8 | .28 | 26.22 | - | - | - | - | - | - | 296 | 396 | H |
| 1.729 | 45.05 | PK-U | 29.5 | -35.8 | 0 | 38.75 | - | - | - | - | 68.2 | -29.45 | 154 | 229 | H |
| 1.73 | 32.29 | ADR | 29.5 | -35.8 | .28 | 26.24 | - | - | - | - | - | - | 154 | 229 | H |
| 1.727 | 42.81 | PK-U | 29.5 | -35.7 | 0 | 36.61 | - | - | - | - | 68.2 | -31.59 | 199 | 115 | V |
| 1.726 | 32.06 | ADR | 29.5 | -35.7 | .28 | 26.11 | - | - | - | - | - | - | 199 | 115 | V |
| 2.434 | 40.48 | PK-U | 32.3 | -35.5 | 0 | 37.28 | - | - | - | - | 68.2 | -30.92 | 199 | 104 | V |
| 2.432 | 32.11 | ADR | 32.3 | -35.5 | .28 | 29.16 | - | - | - | - | - | - | 199 | 104 | V |
| * 10.64 | 35.73 | PK-U | 37.6 | -25 | 0 | 46.33 | - | - | 74 | -25.67 | - | - | 112 | 129 | H |
| * 10.64 | 27.36 | ADR | 37.6 | -25 | .28 | 40.21 | 54 | -13.79 | - | - | - | - | 112 | 129 | H |
| * 10.64 | 34.01 | PK-U | 37.6 | -25 | 0 | 46.61 | - | - | 74 | -27.39 | - | - | 199 | 124 | V |
| * 10.64 | 26.81 | ADR | 37.6 | -25 | .28 | 39.66 | 54 | -14.34 | - | - | - | - | 199 | 124 | V |

* - indicates frequency in CFR47 Pt 15 / IC RSS-Restricted Band
 PK-U - U-NII: Maximum Peak
 ADR - U-NII AD primary method, RMS average

10.1.7. TX ABOVE 1 GHz 802.11n HT40 MODE IN THE 5.3 GHz BAND

1TX Antenna 1 MODE

BANDEDGE (HIGH CHANNEL)

HORIZONTAL RESULT

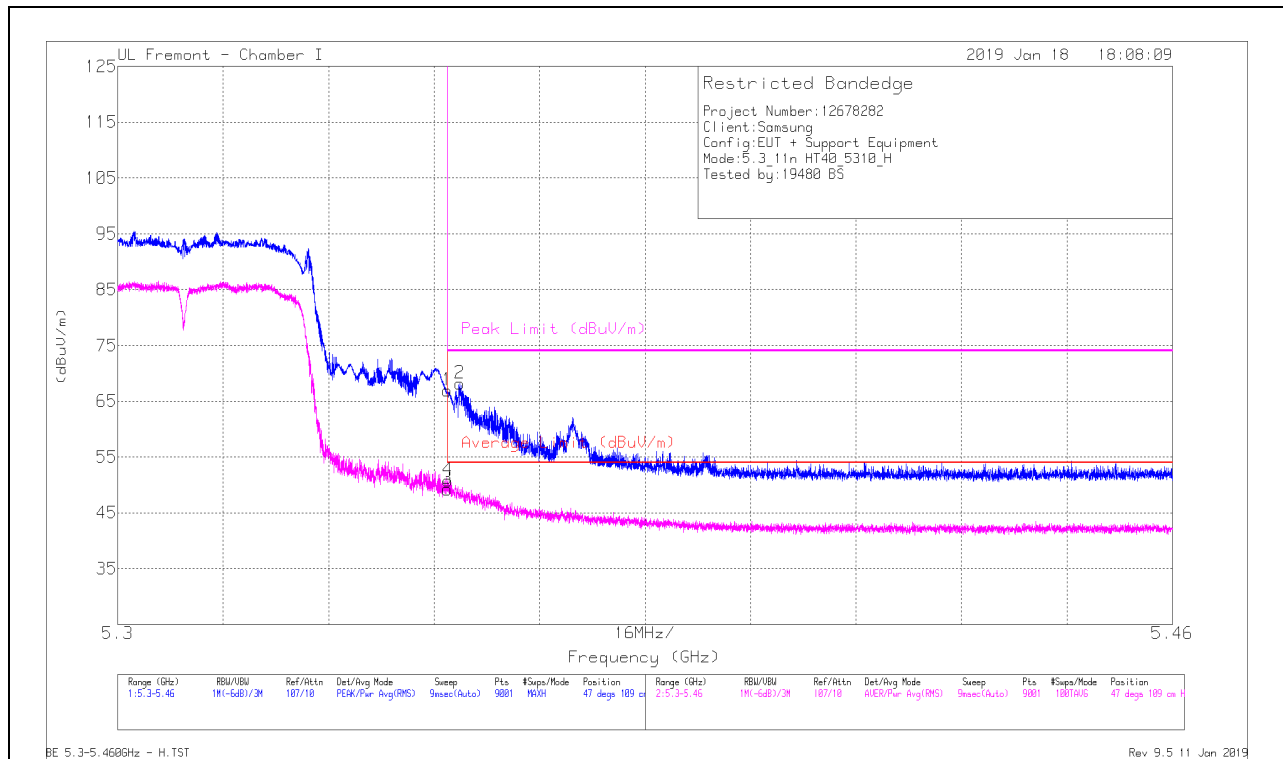

| Marker | Frequency (GHz) | Meter Reading (dBuV) | Det | AF T862 (dB/m) | Amp/Cou/Filt/PA d (dB) | DC Corr (dB) | Corrected Reading (dBuV/m) | Average Limit (dBuV/m) | Margin (dB) | Peak Limit (dBuV/m) | PK Margin (dB) | Azimuth (Degs) | Height (cm) | Polarity |
|--------|-----------------|----------------------|-----|----------------|------------------------|--------------|----------------------------|------------------------|-------------|---------------------|----------------|----------------|-------------|----------|
| 1 | * 5.35 | 50.63 | Pk | 34.5 | -18.3 | 0 | 66.83 | - | - | 74 | -7.12 | 47 | 109 | H |
| 2 | * 5.352 | 51.98 | Pk | 34.5 | -18.3 | 0 | 68.18 | - | - | 74 | -5.82 | 47 | 109 | H |
| 3 | * 5.35 | 32.33 | RMS | 34.5 | -18.3 | .71 | 49.24 | 54 | -4.76 | - | - | 47 | 109 | H |
| 4 | * 5.35 | 33.84 | RMS | 34.5 | -18.3 | .71 | 50.75 | 54 | -3.25 | - | - | 47 | 109 | H |

* - indicates frequency in CFR47 Pt 15 / IC RSS-Restricted Band
 Pk - Peak detector
 RMS - RMS detection

VERTICAL RESULT

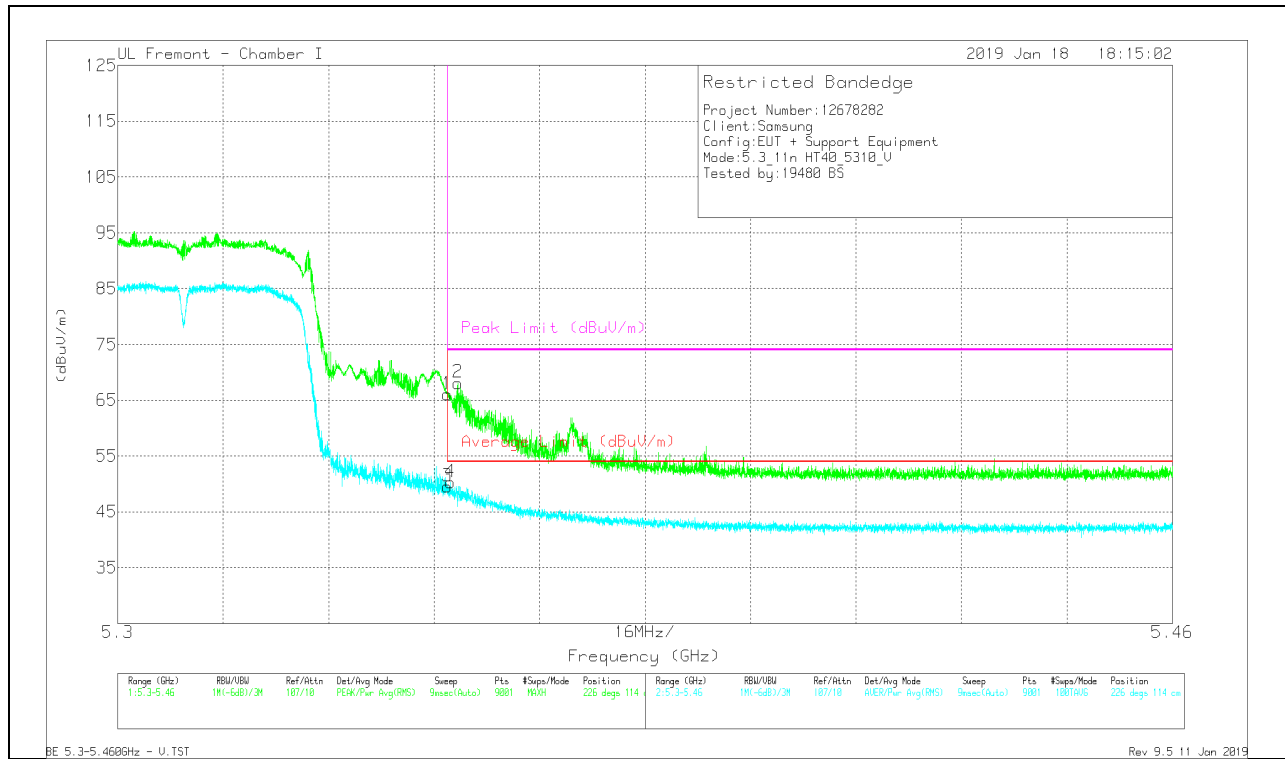

| Marker | Frequency (GHz) | Meter Reading (dBuV) | Det | AF T862 (dB/m) | Amp/Cou/Filt/Pa d (dB) | DC Corr (dB) | Corrected Reading (dBuV/m) | Average Limit (dBuV/m) | Margin (dB) | Peak Limit (dBuV/m) | PK Margin (dB) | Azimuth (Degs) | Height (cm) | Polarity |
|--------|-----------------|----------------------|-----|----------------|------------------------|--------------|----------------------------|------------------------|-------------|---------------------|----------------|----------------|-------------|----------|
| 1 | * 5.35 | 49.84 | Pk | 34.5 | -18.3 | 0 | 66.04 | - | - | 74 | -7.96 | 226 | 114 | V |
| 2 | * 5.352 | 51.91 | Pk | 34.5 | -18.3 | 0 | 68.11 | - | - | 74 | -5.89 | 226 | 114 | V |
| 3 | * 5.35 | 32.6 | RMS | 34.5 | -18.3 | .71 | 49.51 | 54 | -4.49 | - | - | 226 | 114 | V |
| 4 | * 5.35 | 33.38 | RMS | 34.5 | -18.3 | .71 | 50.29 | 54 | -3.71 | - | - | 226 | 114 | V |

* - indicates frequency in CFR47 Pt 15 / IC RSS-Restricted Band
 Pk - Peak detector
 RMS - RMS detection

HARMONICS AND SPURIOUS EMISSIONS

LOW CHANNEL RESULTS

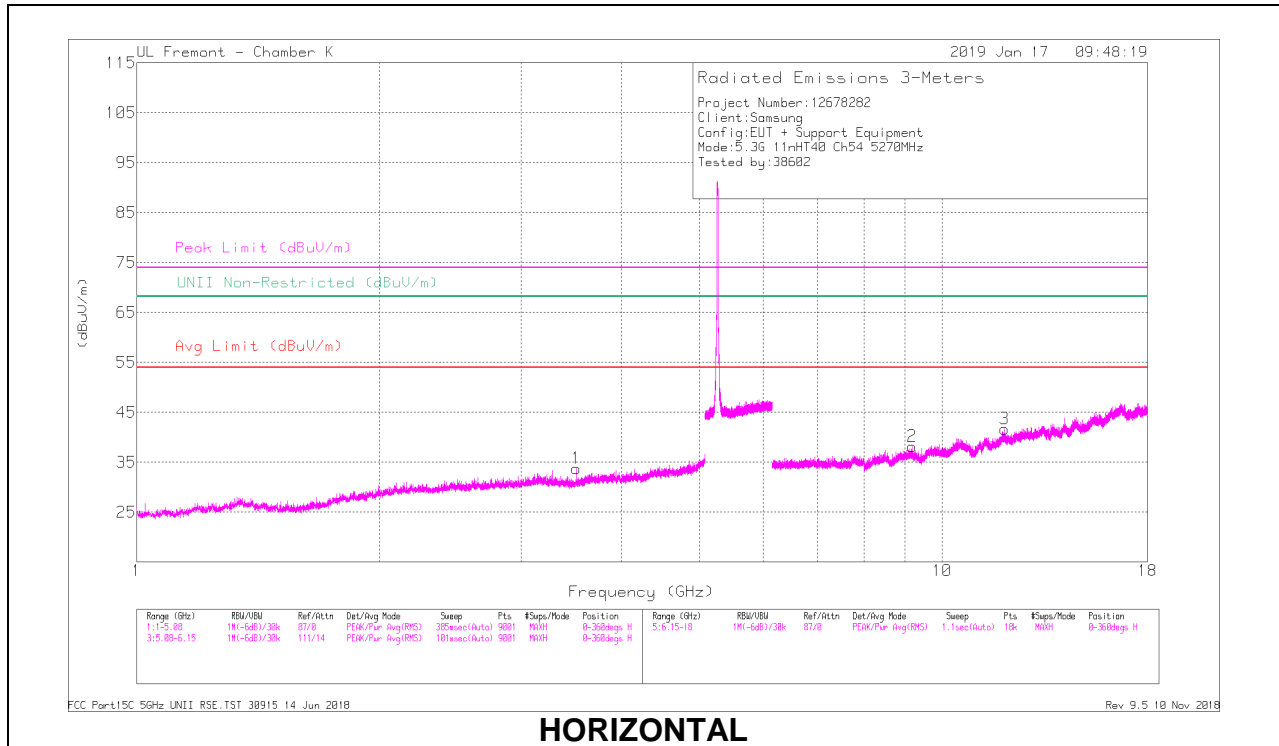

HORIZONTAL

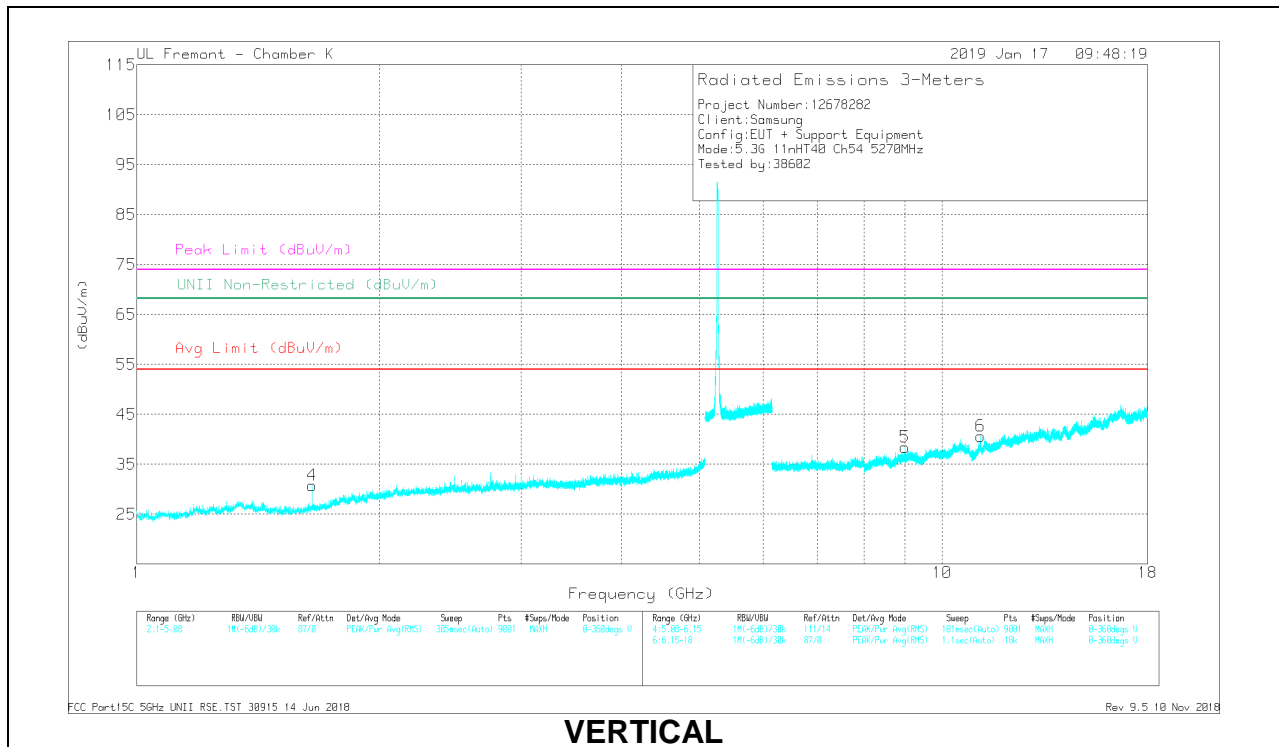

VERTICAL

RADIATED EMISSIONS

| Frequency (GHz) | Meter Reading (dBuV) | Det | AF T344 (dB/m) | AmpCoeff/Pad (dB) | DC Corr (dB) | Corrected Reading (dBuV/m) | Avg Limit (dBuV/m) | Margin (dB) | Peak Limit (dBuV/m) | PK Margin (dB) | UNII Non-Restricted (dBuV/m) | PK Margin (dB) | Azimuth (Degs) | Height (cm) | Polarity |
|-----------------|----------------------|------|----------------|-------------------|--------------|----------------------------|--------------------|-------------|---------------------|----------------|------------------------------|----------------|----------------|-------------|----------|
| * 3.513 | 39.25 | PK-U | 32.7 | -32.7 | 0 | 39.25 | - | - | 74 | -34.75 | - | - | 60 | 101 | H |
| * 3.513 | 29.96 | ADR | 32.7 | -32.7 | .71 | 30.67 | 54 | -23.33 | - | - | - | - | 60 | 101 | H |
| 1.651 | 41.21 | PK-U | 28.5 | -35.2 | 0 | 34.51 | - | - | - | - | 68.2 | -33.69 | 323 | 187 | V |
| * 9.174 | 31.67 | PK-U | 36.2 | -23.9 | 0 | 43.97 | - | - | 74 | -30.03 | - | - | 220 | 135 | H |
| * 9.174 | 22.06 | ADR | 36.2 | -23.9 | .71 | 35.07 | 54 | -18.93 | - | - | - | - | 220 | 135 | H |
| * 11.958 | 30.16 | PK-U | 38.5 | -20.2 | 0 | 48.46 | - | - | 74 | -25.54 | - | - | 60 | 226 | H |
| * 11.954 | 20.13 | ADR | 38.5 | -20.2 | .71 | 39.14 | 54 | -14.86 | - | - | - | - | 60 | 226 | H |
| 8.987 | 31.81 | PK-U | 36 | -24 | 0 | 43.81 | - | - | - | - | 68.2 | -24.39 | 31 | 313 | V |
| * 11.171 | 30.32 | PK-U | 37.9 | -21.1 | 0 | 47.12 | - | - | 74 | -26.88 | - | - | 158 | 386 | V |
| * 11.172 | 20.49 | ADR | 37.9 | -21.1 | .71 | 38 | 54 | -16 | - | - | - | - | 158 | 386 | V |

* - indicates frequency in CFR47 Pt 15 / IC RSS-Restricted Band

PK-U - U-NII: Maximum Peak

ADR - U-NII AD primary method, RMS average

HIGH CHANNEL RESULTS

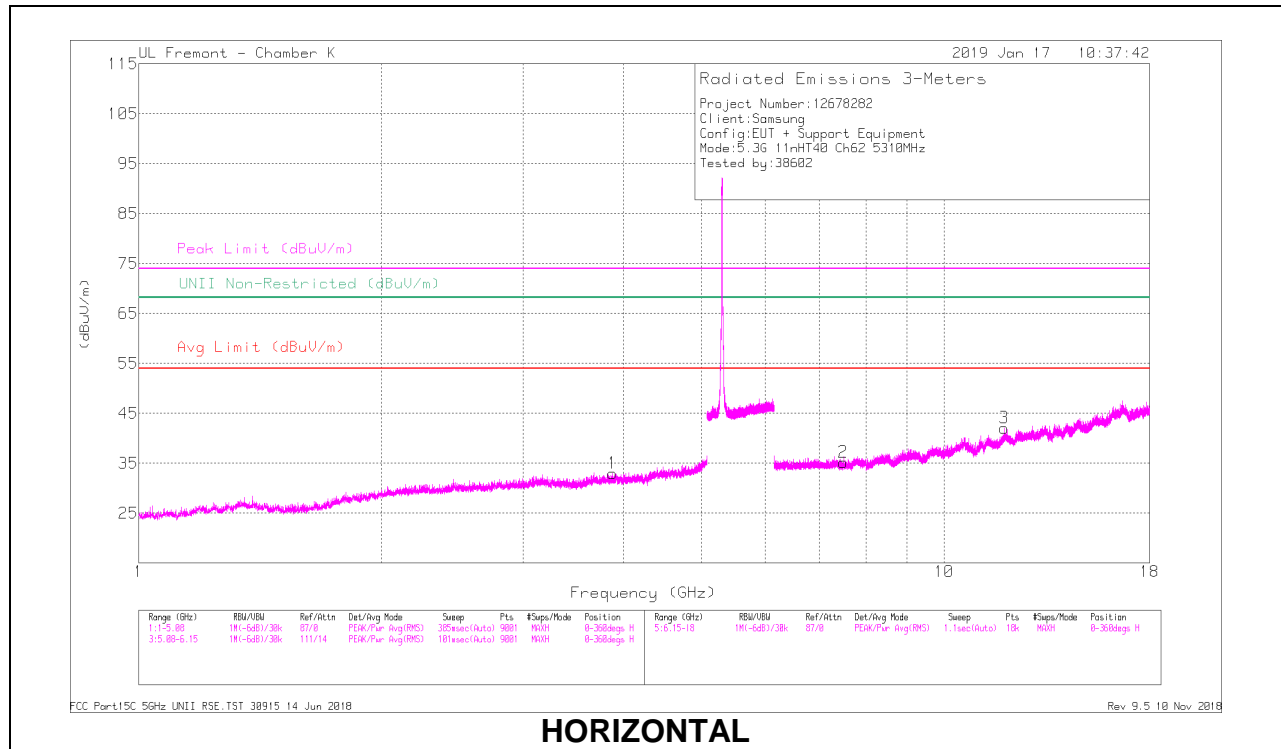

HORIZONTAL

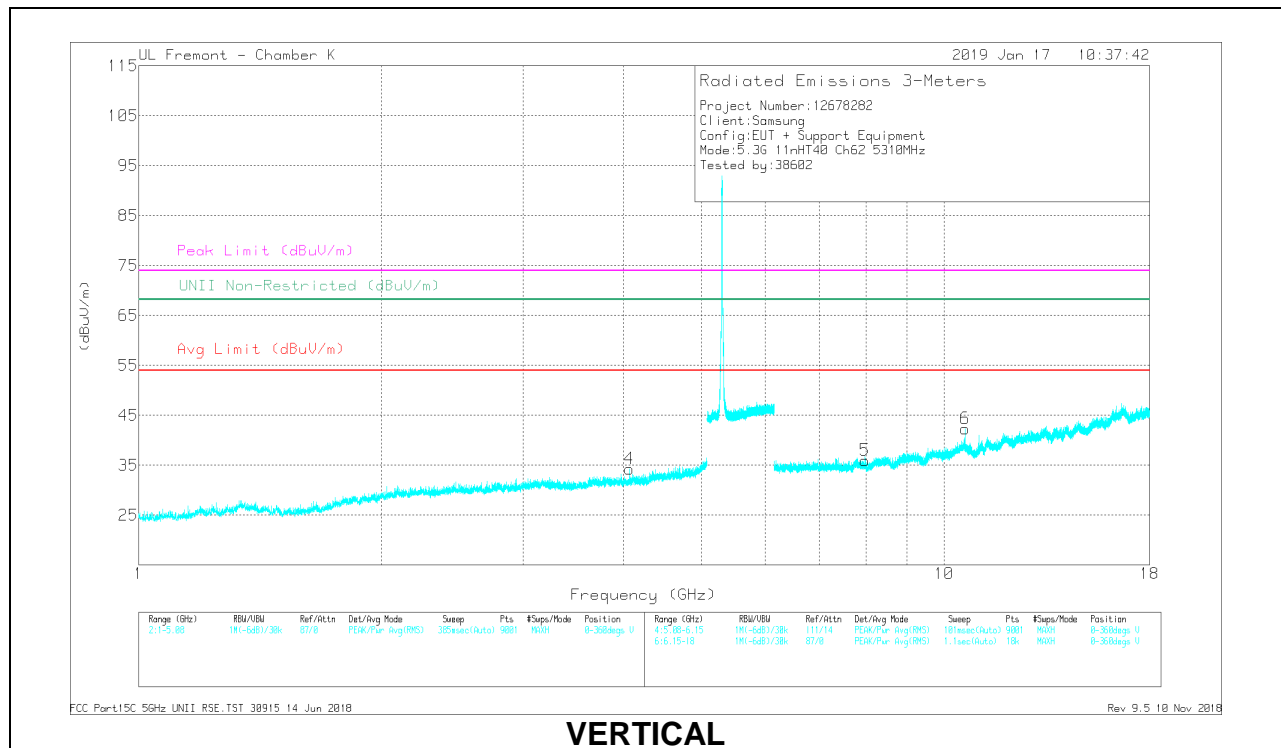

VERTICAL

RADIATED EMISSIONS

| Frequency (GHz) | Meter Reading (dBuV) | Det | AF T344 (dB/m) | AmpCoEffR/Pad (dB) | DC Corr (dB) | Corrected Reading (dBuV/m) | Avg Limit (dBuV/m) | Margin (dB) | Peak Limit (dBuV/m) | PK Margin (dB) | UNII Non-Restricted (dBuV/m) | PK Margin (dB) | Azimuth (Degs) | Height (cm) | Polarity |
|-----------------|----------------------|------|----------------|--------------------|--------------|----------------------------|--------------------|-------------|---------------------|----------------|------------------------------|----------------|----------------|-------------|----------|
| * 3.877 | 38.27 | PK-U | 33.4 | -31.8 | 0 | 39.87 | - | - | 74 | -34.13 | - | - | 61 | 336 | H |
| * 3.874 | 28.44 | ADR | 33.4 | -31.8 | .71 | 30.75 | 54 | -23.25 | - | - | - | - | 61 | 336 | H |
| * 4.066 | 35 | PK-U | 33.5 | -31.3 | 0 | 40.2 | - | - | 74 | -33.8 | - | - | 84 | 366 | V |
| * 4.065 | 27.65 | ADR | 33.5 | -31.3 | .71 | 30.56 | 54 | -23.44 | - | - | - | - | 84 | 366 | V |
| * 7.497 | 33.65 | PK-U | 35.6 | -26.6 | 0 | 42.65 | - | - | 74 | -31.35 | - | - | 133 | 367 | H |
| * 7.5 | 23.59 | ADR | 35.6 | -26.6 | .71 | 33.3 | 54 | -20.7 | - | - | - | - | 133 | 367 | H |
| * 11.889 | 30.51 | PK-U | 38.4 | -20.4 | 0 | 48.51 | - | - | 74 | -25.49 | - | - | 274 | 172 | H |
| * 11.886 | 21.2 | ADR | 38.4 | -20.5 | .71 | 39.81 | 54 | -14.19 | - | - | - | - | 274 | 172 | H |
| * 10.62 | 33.29 | PK-U | 37.7 | -22.8 | 0 | 48.19 | - | - | 74 | -25.81 | - | - | 243 | 106 | V |
| * 10.62 | 25.25 | ADR | 37.7 | -22.8 | .71 | 40.66 | 54 | -13.14 | - | - | - | - | 243 | 106 | V |
| 7.97 | 32.76 | PK-U | 35.7 | -26 | 0 | 42.46 | - | - | - | - | 68.2 | -25.74 | 15 | 333 | V |

* - indicates frequency in CFR47 Pt 15 / IC RSS-Restricted Band
 PK-U - U-NII: Maximum Peak
 ADR - U-NII AD primary method, RMS average

10.1.8. TX ABOVE 1 GHz 802.11ac VHT80 MODE IN THE 5.3 GHz BAND

1TX Antenna 1 MODE

BANDEDGE (MID CHANNEL)

HORIZONTAL RESULT

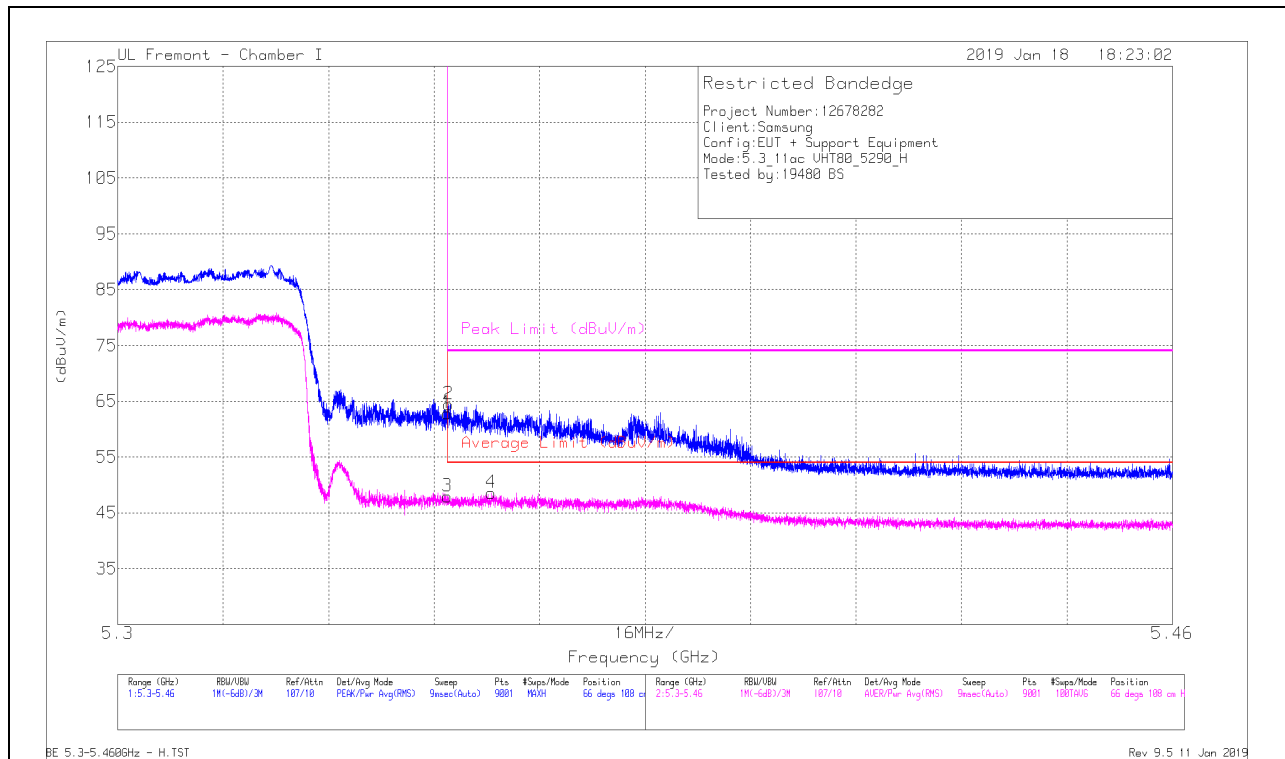

| Marker | Frequency (GHz) | Meter Reading (dBuV) | Det | AF T862 (dB/m) | Amp/Cou/Filt/Par d (dB) | DC Corr (dB) | Corrected Reading (dBuV/m) | Average Limit (dBuV/m) | Margin (dB) | Peak Limit (dBuV/m) | PK Margin (dB) | Azimuth (Degs) | Height (cm) | Polarity |
|--------|-----------------|----------------------|-----|----------------|-------------------------|--------------|----------------------------|------------------------|-------------|---------------------|----------------|----------------|-------------|----------|
| 1 | * 5.35 | 48.67 | Pk | 34.5 | -18.3 | 0 | 62.87 | - | - | 74 | -11.13 | 66 | 108 | H |
| 2 | * 5.35 | 48.23 | Pk | 34.5 | -18.3 | 0 | 64.43 | - | - | 74 | -9.57 | 66 | 108 | H |
| 3 | * 5.35 | 30.41 | RMS | 34.5 | -18.3 | 1.29 | 47.9 | 54 | -6.1 | - | - | 66 | 108 | H |
| 4 | * 5.357 | 31.1 | RMS | 34.4 | -18.2 | 1.29 | 48.59 | 54 | -5.41 | - | - | 66 | 108 | H |

* - indicates frequency in CFR47 Pt 15 / IC RSS-Restricted Band

Pk - Peak detector

RMS - RMS detection