



CERTIFICATION TEST REPORT

Report Number. : 12678284-E8V2

Applicant : Samsung Electronics Co., Ltd.
129 Samsung-Ro, Yeongtong-Gu,
Suwon-Si, Gyeonggi-Do, 16677, Korea

Model : SM-A305GN/DS and SM-A305GN

FCC ID : A3LSMA305GN

EUT Description : GSM/WCDMA/LTE Phone with BT, DTS/UNII a/b/g/n/ac, ANT+
and NFC

Test Standard(s) : FCC 47 CFR PART 15 SUBPART C

Date Of Issue:

February 21, 2019

Prepared by:

UL Verification Services Inc.
47173 Benicia Street
Fremont, CA 94538 U.S.A.
TEL: (510) 771-1000
FAX: (510) 661-0888



NVLAP Lab code: 200065-0

Revision History

<u>Rev.</u>	<u>Issue Date</u>	<u>Revisions</u>	<u>Revised By</u>
V1	2/18/2019	Initial Issue	
V2	2/21/2019	Updated Section 5.5, 6, 8.2,	

TABLE OF CONTENTS

1. ATTESTATION OF TEST RESULTS	4
2. TEST METHODOLOGY	5
3. FACILITIES AND ACCREDITATION	5
4. CALIBRATION AND UNCERTAINTY	6
4.1. <i>MEASURING INSTRUMENT CALIBRATION</i>	<i>6</i>
4.2. <i>SAMPLE CALCULATION</i>	<i>6</i>
4.3. <i>MEASUREMENT UNCERTAINTY.....</i>	<i>6</i>
5. EQUIPMENT UNDER TEST	7
5.1. <i>DESCRIPTION OF EUT</i>	<i>7</i>
5.2. <i>MAXIMUM FIELD STRENGTH.....</i>	<i>7</i>
5.3. <i>DESCRIPTION OF AVAILABLE ANTENNAS</i>	<i>7</i>
5.4. <i>SOFTWARE AND FIRMWARE.....</i>	<i>7</i>
5.5. <i>WORST-CASE CONFIGURATION AND MODE.....</i>	<i>8</i>
5.6. <i>DESCRIPTION OF TEST SETUP.....</i>	<i>9</i>
6. TEST AND MEASUREMENT EQUIPMENT	11
7. OCCUPIED BANDWIDTH	12
7.1. <i>Type A</i>	<i>13</i>
7.2. <i>Type B.....</i>	<i>15</i>
7.3. <i>Type F</i>	<i>17</i>
8. RADIATED EMISSION TEST RESULTS.....	18
8.1. <i>LIMITS AND PROCEDURE</i>	<i>18</i>
8.2. <i>FUNDAMENTAL AND SPURIOUS EMISSIONS (0.15 - 30 MHz),</i>	<i>20</i>
8.2.1. <i>Type A (CE Mode)</i>	<i>20</i>
8.3. <i>TX SPURIOUS EMISSION 30 TO 1000 MHz</i>	<i>23</i>
8.3.1. <i>Type A.....</i>	<i>23</i>
9. FREQUENCY STABILITY	25
9.1. <i>Type A</i>	<i>26</i>
10. AC MAINS LINE CONDUCTED EMISSIONS	27
10.1. <i>Type A.....</i>	<i>28</i>
10.1.1. <i>NORMAL OPERATION, 106Kbps</i>	<i>28</i>
11. SETUP PHOTOS	30

1. ATTESTATION OF TEST RESULTS

COMPANY NAME: Samsung Electronics Co., Ltd.
129 Samsung-Ro, Yeongtong-Gu,
Suwon-Si, Gyeonggi-Do, 16677, Korea

EUT DESCRIPTION: GSM/WCDMA/LTE phone with BT, DTS/UNII a/b/g/n/ac, ANT+
and NFC

MODEL: SM-A305GN/DS and SM-A305GN

SERIAL NUMBER: Radiated: R38KC0LPPB

DATE TESTED: January 23 – February 4, 2019

APPLICABLE STANDARDS	
STANDARD	TEST RESULTS
FCC PART 15 SUBPART C	Complies

UL Verification Services Inc. tested the above equipment in accordance with the requirements set forth in the above standards. The test results show that the equipment tested is capable of demonstrating compliance with the requirements as documented in this report.

The results documented in this report apply only to the tested sample, under the conditions and modes of operation as described herein. It is the manufacturer's responsibility to assure that additional production units of this model are manufactured with identical electrical and mechanical components. All samples tested were in good operating condition throughout the entire test program. Measurement Uncertainties are published for informational purposes only and were not taken into account unless noted otherwise.

This document may not be altered or revised in any way unless done so by UL Verification Services Inc. and all revisions are duly noted in the revisions section. Any alteration of this document not carried out by UL Verification Services Inc. will constitute fraud and shall nullify the document. This report must not be used by the client to claim product certification, approval, or endorsement by NVLAP, NIST, any agency of the Federal Government, or any agency of the U.S. government.

Approved & Released For
UL Verification Services Inc. By:

Reviewed By:



Dan Corona
Operations Leader
Consumer Technology Division
UL Verification Services Inc.

Kiya Kedida
Senior Project Engineer
Consumer Technology Division
UL Verification Services Inc.

2. TEST METHODOLOGY

The tests documented in this report were performed in accordance with ANSI C63.10-2013, FCC CFR 47 Part 2, and FCC CFR 47 Part 15.

3. FACILITIES AND ACCREDITATION

The test sites and measurement facilities used to collect data are located at 47173 and 47266 Benicia Street, and 47658 Kato Road, Fremont, California, USA. Line conducted emissions are measured only at the 47173 address. The following table identifies which facilities were utilized for radiated emission measurements documented in this report. Specific facilities are also identified in the test results sections.

47173 Benicia Street	47266 Benicia Street	47658 Kato Rd
<input type="checkbox"/> Chamber A (ISED:2324B-1)	<input type="checkbox"/> Chamber D (ISED:22541-1)	<input type="checkbox"/> Chamber I (ISED:2324A-5)
<input checked="" type="checkbox"/> Chamber B (ISED:2324B-2)	<input type="checkbox"/> Chamber E (ISED:22541-2)	<input type="checkbox"/> Chamber J (ISED:2324A-6)
<input type="checkbox"/> Chamber C (ISED:2324B-3)	<input type="checkbox"/> Chamber F (ISED:22541-3)	<input type="checkbox"/> Chamber K (ISED:2324A-1)
	<input type="checkbox"/> Chamber G (ISED:22541-4)	<input type="checkbox"/> Chamber L (ISED:2324A-3)
	<input type="checkbox"/> Chamber H (ISED:22541-5)	

The above test sites and facilities are covered under FCC Test Firm Registration # 208313. Chambers above are covered under Industry Canada company address and respective code

UL Verification Services Inc. is accredited by NVLAP, Laboratory Code 200065-0

4. CALIBRATION AND UNCERTAINTY

4.1. MEASURING INSTRUMENT CALIBRATION

The measuring equipment utilized to perform the tests documented in this report has been calibrated in accordance with the manufacturer's recommendations, and is traceable to recognized national standards.

4.2. SAMPLE CALCULATION

RADIATED EMISSIONS

Where relevant, the following sample calculation is provided:

Field Strength (dBuV/m) = Measured Voltage (dBuV) + Antenna Factor (dB/m) + Cable Loss (dB) – Preamp Gain (dB)

36.5 dBuV + 18.7 dB/m + 0.6 dB – 26.9 dB = 28.9 dBuV/m

MAINS CONDUCTED EMISSIONS

Where relevant, the following sample calculation is provided:

Final Voltage (dBuV) = Measured Voltage (dBuV) + Cable Loss (dB) + Limiter Factor (dB) + LISN Insertion Loss.

36.5 dBuV + 0 dB + 10.1 dB + 0 dB = 46.6 dBuV

4.3. MEASUREMENT UNCERTAINTY

Where relevant, the following measurement uncertainty levels have been estimated for tests performed on the apparatus:

PARAMETER	UNCERTAINTY
Worst Case Conducted Disturbance, 9KHz to 0.15 MHz	3.84 dB
Worst Case Conducted Disturbance, 0.15 to 30 MHz	3.65 dB
Worst Case Radiated Disturbance, 9KHz to 30 MHz	3.15 dB
Worst Case Radiated Disturbance, 30 to 1000 MHz	5.36 dB
Worst Case Radiated Disturbance, 1000 to 18000 MHz	4.32 dB
Worst Case Radiated Disturbance, 18000 to 26000 MHz	4.45 dB
Worst Case Radiated Disturbance, 26000 to 40000 MHz	5.24 dB

Uncertainty figures are valid to a confidence level of 95%.

5. EQUIPMENT UNDER TEST

5.1. DESCRIPTION OF EUT

The EUT is a GSM/WCDMA/LTE phone with BT,DTS/UNII a/b/g/n/ac, ANT+ and NFC.

5.2. MAXIMUM FIELD STRENGTH

The testing was performed at 3 meters. The transmitter maximum E-field at 30 meter distance was 18.09 dBuV/m, which was converted from the 3 meter data.

5.3. DESCRIPTION OF AVAILABLE ANTENNAS

The radio utilizes the loop antenna.

5.4. SOFTWARE AND FIRMWARE

The test utility software used during testing was A305GN.001.

5.5. WORST-CASE CONFIGURATION AND MODE

The fundamental of the EUT was investigated under three orthogonal orientations X (Flatbed), Y (Landscape), and Z (Portrait). The Y (Landscape) orientation was determined to be the worst-case orientation.

Although these tests were performed other than open filed site, adequate comparison measurements were confirmed against 30 m open filed site. Therefore sufficient tests were made to demonstrate that the alternative site produces results that correlate with the ones of tests made in an open field based on KDB 414788

NOTE: The EUT pre-scanned in three NFC type A, B & F. The worst type is A, and data rate of 106kbps was recorded to this report.

5.6. DESCRIPTION OF TEST SETUP

SUPPORT EQUIPMENT

Support Equipment List				
Description	Manufacturer	Model	Serial Number	FCC ID
AC Adapter	Samsung	EP-TA50EWE	DW3J719AS/A-E	N/A
Earphone	Samsung	N/A	N/A	N/A

I/O CABLES (CONDUCTED TEST)

I/O Cable List						
Cable No	Port	# of identical ports	Connector Type	Cable Type	Cable Length (m)	Remarks
1	Antenna	1	RF	Shielded	0.2	To PSA
2	USB	1	USB	Un-shielded	1	EUT to AC Mains

I/O CABLES (RADIATED AND CONDUCTED EMISSIONS)

I/O Cable List						
Cable No	Port	# of identical ports	Connector Type	Cable Type	Cable Length (m)	Remarks
1	USB	1	USB	Shielded	1	N/A
2	earphone	1	3.5mm	Un-shielded	1	N/A

TEST SETUP

The EUT is a stand alone. Test software exercised the radio card.

RADIATED AND AC LINE CONDUCTED EMISSIONS SETUP DIAGRAM

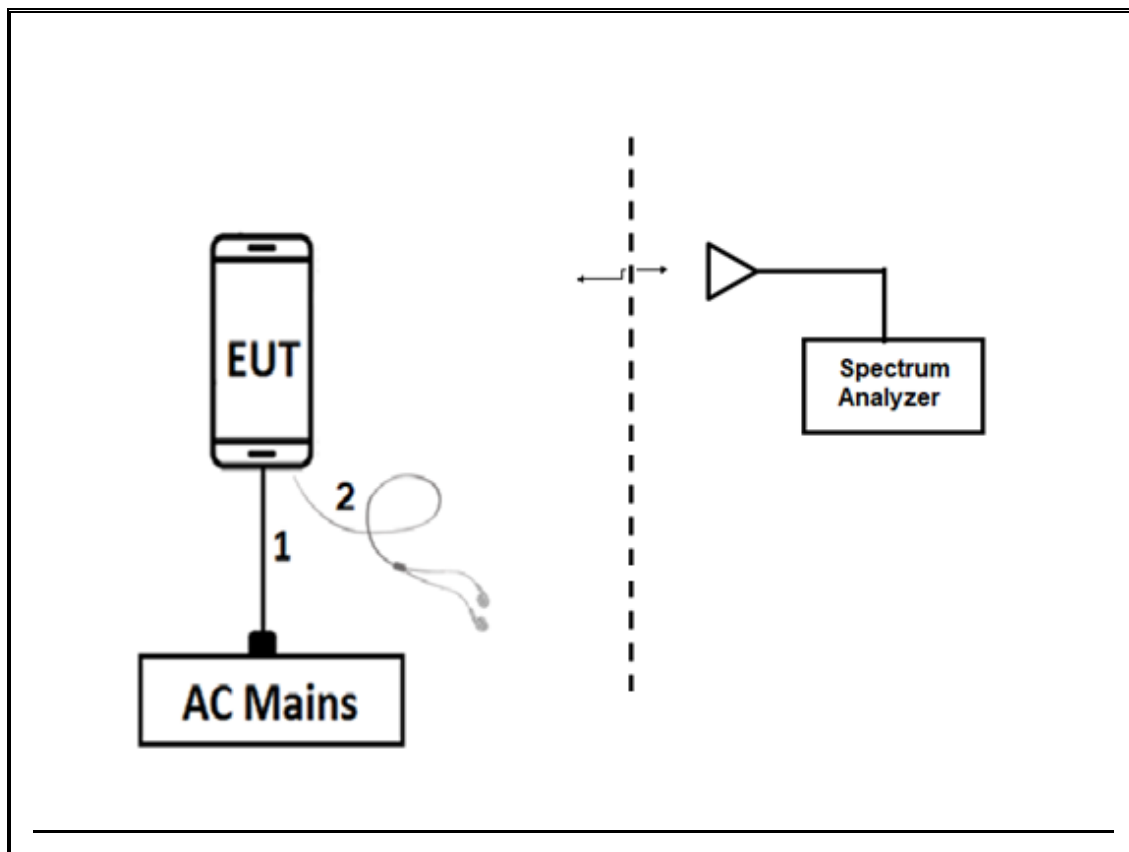

TEST SETUP

For radiated tests: EUT has support equipment. The test software exercises the radio.

6. TEST AND MEASUREMENT EQUIPMENT

The following test and measurement equipment was utilized for the tests documented in this report:

TEST EQUIPMENT LIST					
Description	Manufacturer	Model	ID Num	Cal Due	Last Cal
Antenna, Broadband Hybrid, 30MHz to 2000MHz	Sunol Sciences Corp.	JB3	T407	05/10/2019	05/10/2018
Amplifier, 9kHz to 1GHz, 32dB	Sonoma Instrument	310	170649	11/01/2019	11/01/2018
EMI Reciever	Rohde & Schwarz	ESR	T1436	02/21/2019	02/21/2018
L.I.S.N.	FCC INC.	FCC LISN 50/250	T1310	06/15/2019	06/15/2018
L.I.S.N.	FCC INC.	FCC LISN 50/250	T24	03/06/2019	03/06/2018
Antenna, Active Loop 9kHz-30MHz	Com-Power Corp.	AL-130R	PRE0165308	1/08/2020	1/08/2019
Temp Chamber	Thermotron Industries	SE-600-10-10	T80	05/01/2019	11/01/2018
Spectrum Analyzer, PXA, 3Hz to 44GHz	Agilent (Keysight) Technologies	N9030A	T339	09/11/2019	09/11/2018
* Spectrum Analyzer, PXA, 3Hz to 44GHz	Agilent (Keysight) Technologies	N9030A	T1454	01/08/2019	01/08/2018

Test Software List			
Description	Manufacturer	Model	Version
Radiated Software	UL	UL EMC	Ver 9.5, Dec 01, 2016
Antenna Port Software	UL	UL RF	Ver 9.0, Oct 31, 2018

Note: * indicates automation software version used in the compliance certification testing

7. OCCUPIED BANDWIDTH

LIMITS

None; for reporting purposes only.

TEST PROCEDURE

The transmitter output is connected to the spectrum analyzer. The RBW is set to 10kHz. The VBW is set to 3 times the RBW. The sweep time is coupled. The spectrum analyzer internal 99% bandwidth function is utilized.

Note: Because the measured signal is CW or CW-like adjusting the RBW per C63.10 would not be practical since measured bandwidth will always follow the RBW and the result will be approximately twice the RBW

RESULTS

99% and 20dB BW

Type A (CE Mode)

Mode Kbps	Frequency (MHz)	99% Bandwidth (KHz)	20dB Bandwidth (KHz)
424	13.56	21.122	24.93
212	13.56	21.128	24.95
106	13.56	21.122	24.94

TYPE B

Mode Kbps	Frequency (MHz)	99% Bandwidth (KHz)	20dB Bandwidth (KHz)
424	13.56	21.125	24.94
212	13.56	21.112	24.87
106	13.56	21.125	24.94

TYPE F

Mode Kbps	Frequency (MHz)	99% Bandwidth (KHz)	20dB Bandwidth (KHz)
424	13.56	21.109	24.85
212	13.56	21.133	24.93

7.1. Type A

424Kbps

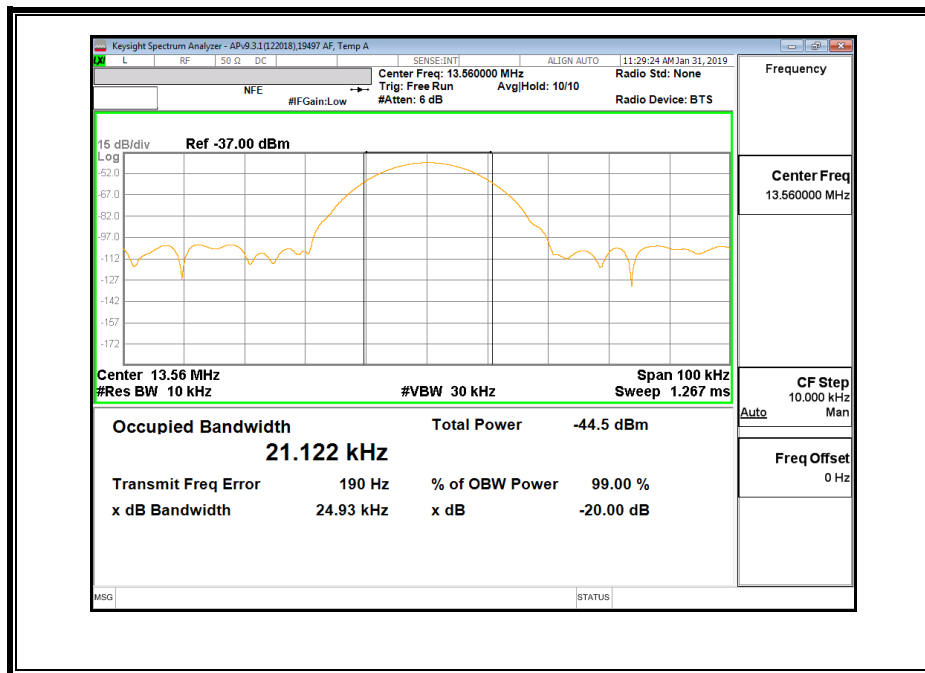

212Kbps

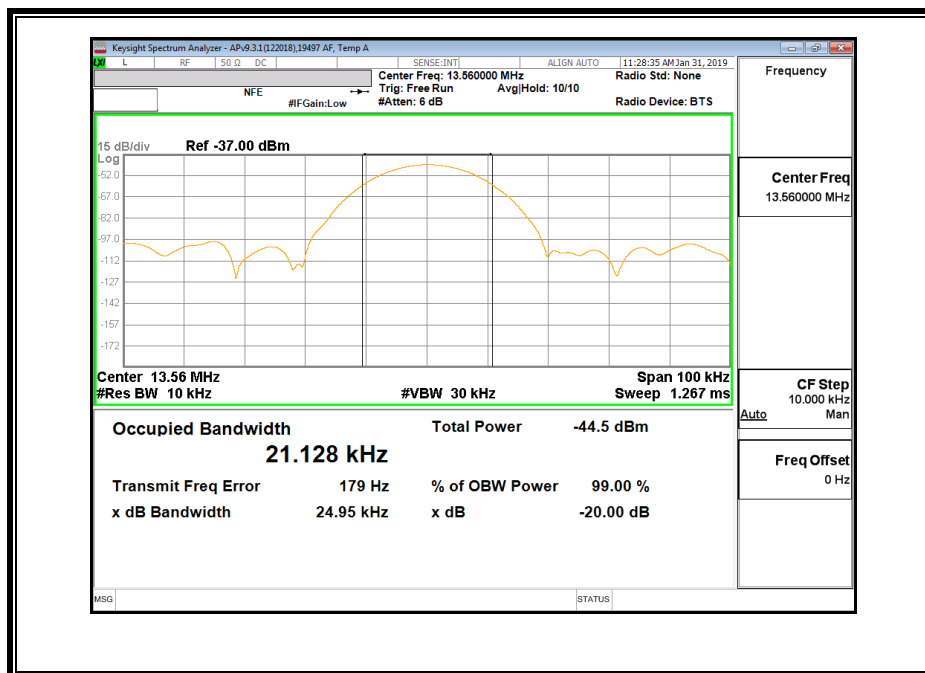

106Kbps

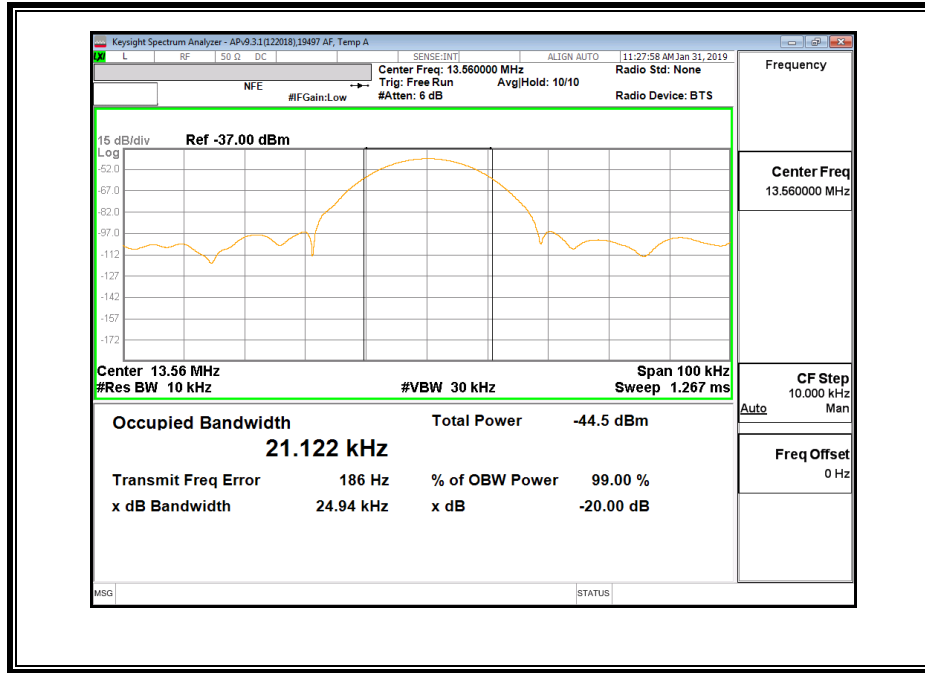

7.2. Type B

424Kbps

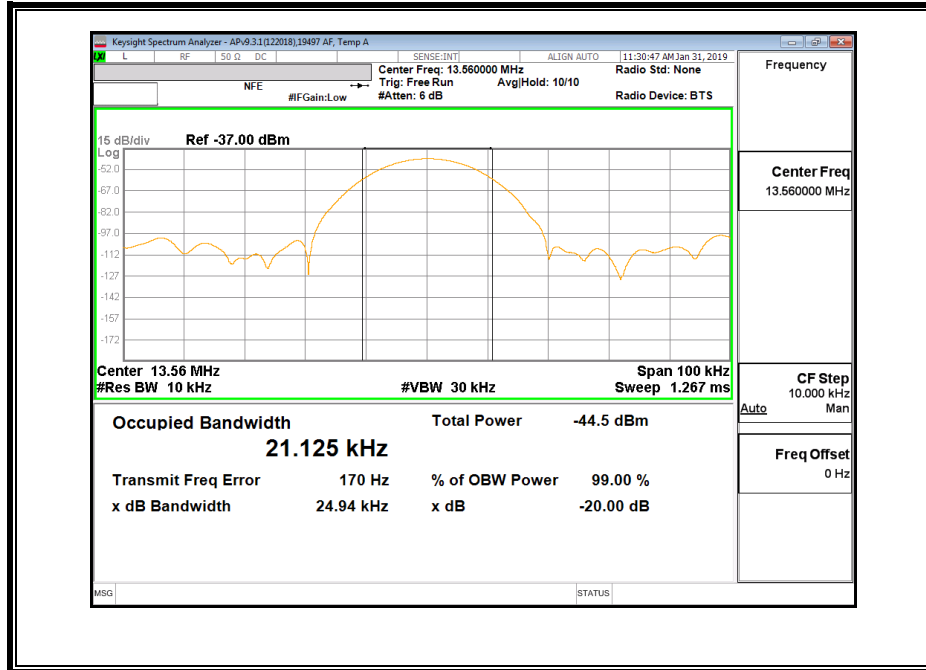

212Kbps

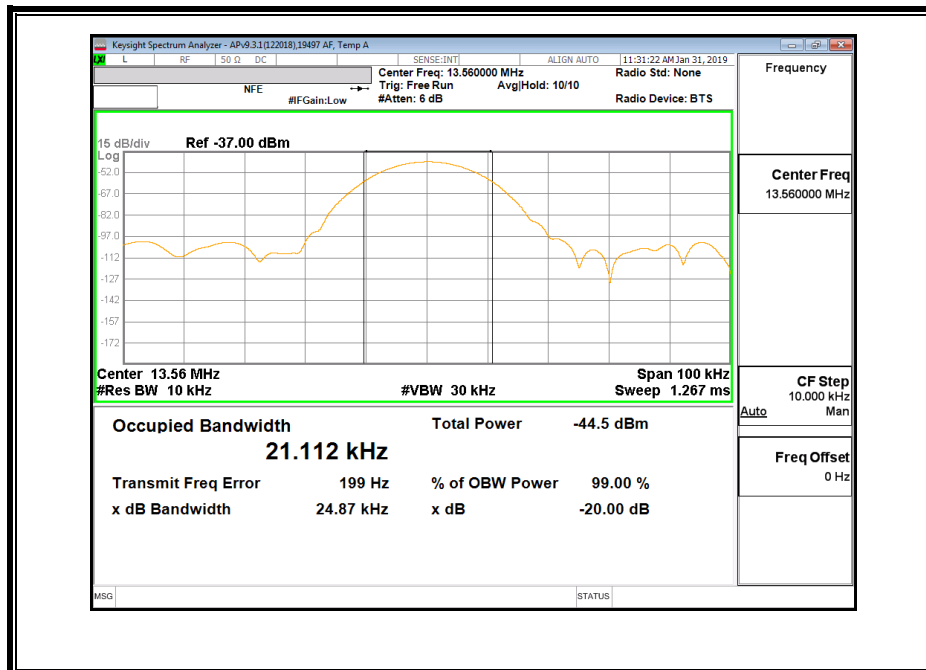

106Kbps

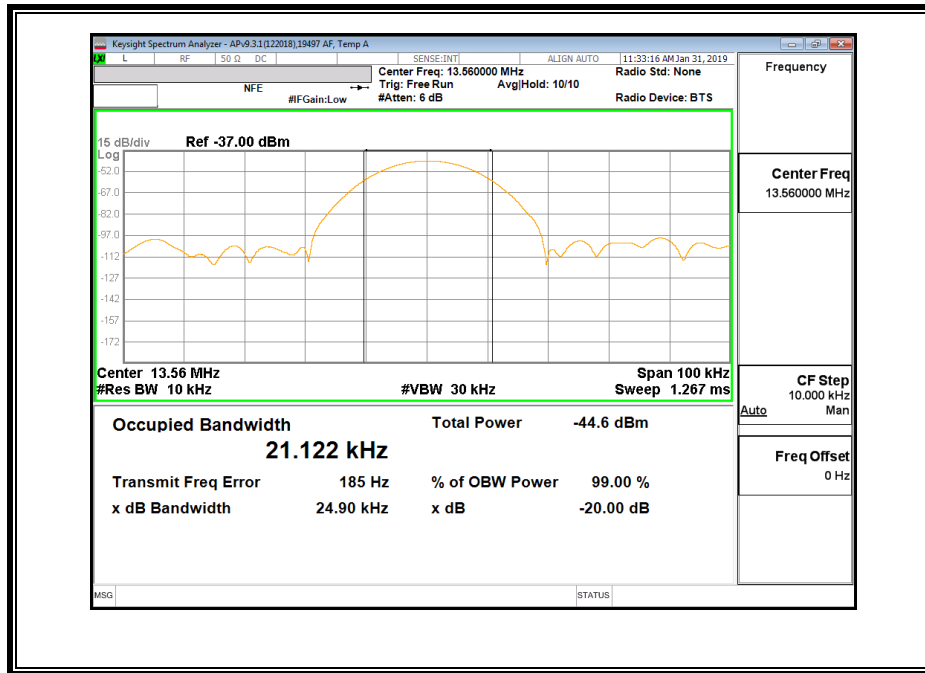

7.3. Type F

424Kbps

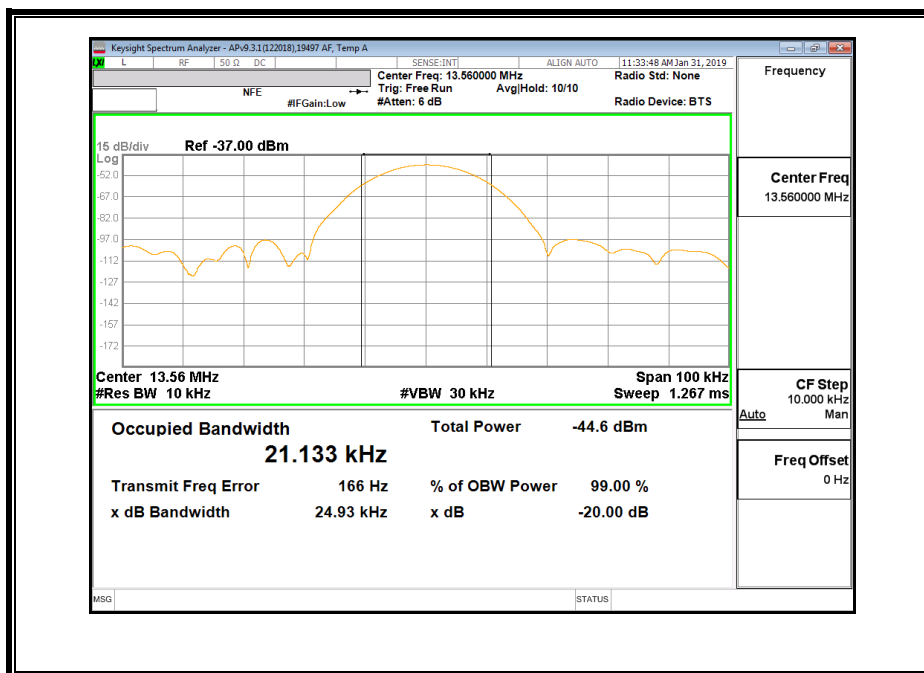

212Kbps

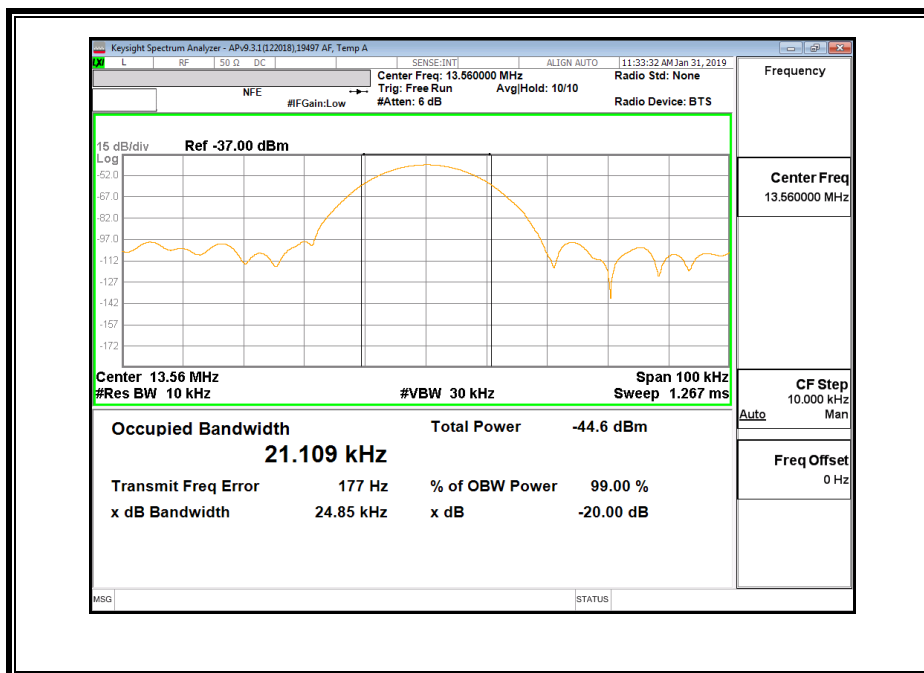

8. RADIATED EMISSION TEST RESULTS

8.1. LIMITS AND PROCEDURE

LIMIT

§15.225

(a) The field strength of any emissions within the band 13.553–13.567 MHz shall not exceed 15,848 microvolts/ meter at 30 meters.

(b) Within the bands 13.410–13.553 MHz and 13.567–13.710 MHz, the field strength of any emissions shall not exceed 334 microvolts/meter at 30 meters.

(c) Within the bands 13.110–13.410 MHz and 13.710–14.010 MHz the field strength of any emissions shall not exceed 106 microvolts/meter at 30 meters.

(d) The field strength of any emissions appearing outside of the 13.110– 14.010 MHz and shall not exceed the general radiated emission limits in § 15.209 as follows:

§15.209 (a) Except as provided elsewhere in this subpart, the emissions from an intentional radiator shall not exceed the field strength levels specified in the following table:

Limits for radiated disturbance of an intentional radiator		
Frequency range (MHz)	Limits (µV/m)	Measurement Distance (m)
0.009 – 0.490	2400 / F (kHz)	300
0.490 – 1.705	24000 / F (kHz)	30
1.705 – 30.0	30	30
30 – 88	100**	3
88 - 216	150**	3
216 – 960	200**	3
Above 960	500	3

** Except as provided in paragraph (g), fundamental emissions from intentional radiators operating under this section shall not be located in the frequency bands 54-72 MHz, 76-88 MHz, 174-216 MHz or 470-806 MHz. However, operation within these frequency bands is permitted under other sections of this part, e.g. §§ 15.231 and 15.241.

§15.209 (b) In the emission table above, the tighter limit applies at the band edges.

Formula for converting the filed strength from uV/m to dBuV/m is:

Limit (dBuV/m) = 20 log limit (uV/m)

In addition:

§15.209 (d) The emission limits shown the above table are based on measurements employing a CISPR quasi-peak detector except for the frequency bands 9-90 kHz, 110-490 kHz and above 1000 MHz. Radiated emissions limits in these three bands are based on measurements employing an average detector.

§15.209 (d) The provisions in §§ 15.225, measuring emissions at distances other than the distances specified in the above table, determining the frequency range over which radiated emissions are to be measured, and limiting peak emissions apply to all devices operated under this part.

TEST PROCEDURE

ANSI C63.10, 2013

The EUT is an intentional radiator that incorporates a digital device, the highest fundamental frequency generated or used in the device is 13.56 MHz; therefore, the frequency range was investigated from 0.15 MHz to the 10th harmonic of the highest fundamental frequency, or 1000 MHz, whichever is greater.

RESULTS

**8.2. FUNDAMENTAL AND SPURIOUS EMISSIONS (0.15 - 30 MHz),
 8.2.1. Type A (CE Mode)**

FUNDAMENTAL EMISSION MASK - TYPE A, 106Kbps (11.56 – 15.56 MHz)

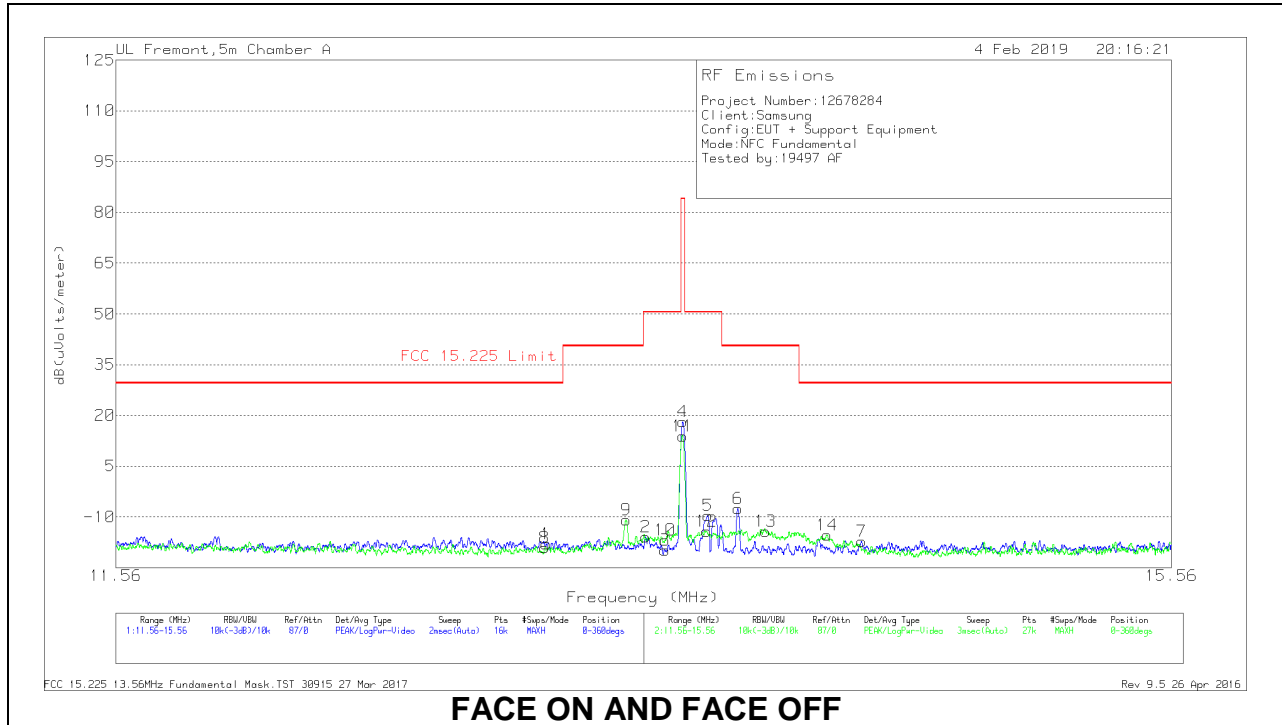

NOTE: All data rate Field Strength was investigated and Type A, 106k found to have the highest Field Strength results and represents as the worst case data rate.

Trace Markers

Marker	Frequency (MHz)	Meter Reading (dBuV)	Det	Loop Antenna (dB/m)	Cables (dB)	Dist Corr 30m	Corrected Reading dB(uVolts/meter)	FCC 15.225 Limit	PK Margin (dB)	Azimuth (Degs)
8	13.044	10.19	Pk	10.3	.5	-40	-19.01	29.54	-48.55	0-360
1	13.04888	11.14	Pk	10.3	.5	-40	-18.06	29.54	-47.6	0-360
9	13.34562	18.32	Pk	10.3	.5	-40	-10.88	40.51	-51.39	0-360
2	13.41913	13.31	Pk	10.3	.5	-40	-15.89	50.5	-66.39	0-360
3	13.49225	9.44	Pk	10.3	.5	-40	-19.76	50.5	-70.26	0-360
10	13.49355	12.3	Pk	10.3	.5	-40	-16.9	50.5	-67.4	0-360
11	13.55963	43.21	Pk	10.2	.5	-40	13.91	84	-70.09	0-360
4	13.55988	47.39	Pk	10.2	.5	-40	18.09	84	-65.91	0-360
12	13.65191	15	Pk	10.2	.5	-40	-14.3	50.5	-64.8	0-360
5	13.65563	19.72	Pk	10.2	.5	-40	-9.58	50.5	-60.08	0-360
6	13.77213	21.78	Pk	10.2	.5	-40	-7.52	40.51	-48.03	0-360
13	13.88071	15.03	Pk	10.2	.5	-40	-14.27	40.51	-54.78	0-360
14	14.12232	13.87	Pk	10.2	.5	-40	-15.43	29.54	-44.97	0-360
7	14.25988	11.99	Pk	10.2	.5	-40	-17.31	29.54	-46.85	0-360

* - Indicates fundamental frequency
 Pk - Peak detector

SPURIOUS EMISSIONS - TYPE A, 106kbps (0.09 – 30MHz)

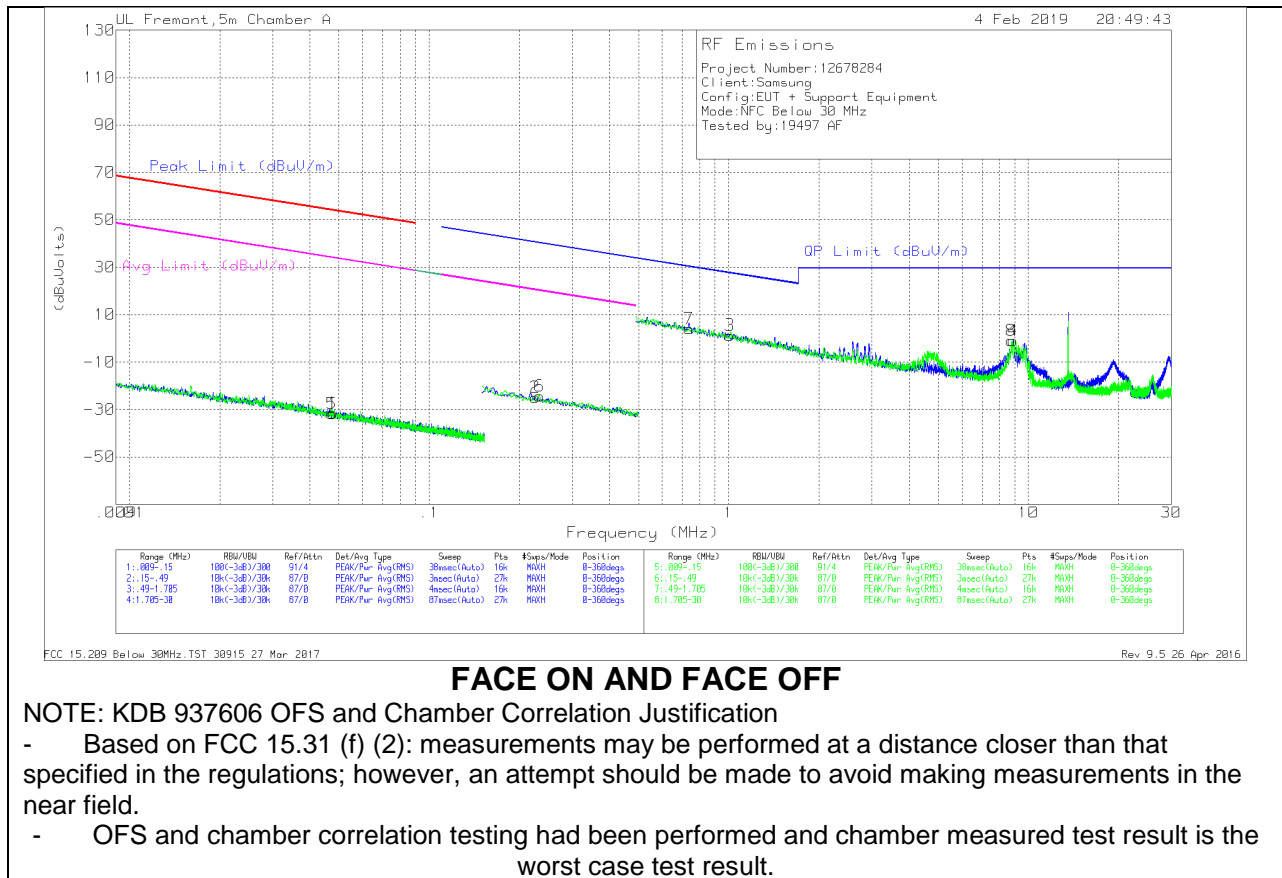

Trace Markers

Marker	Frequency (MHz)	Meter Reading (dBuV)	Det	Loop Antenna (dB/m)	Cables (dB)	Dist Corr 300m	Corrected Reading (dBuVolts)	Peak Limit (dBuV/m)	Margin (dB)	Avg Limit (dBuV/m)	Margin (dB)	Azimuth (Degs)
5	.04727	35.34	Pk	12.8	0	-80	-31.86	54.09	-85.95	34.09	-65.95	0-360
1	.04777	35.62	Pk	12.8	0	-80	-31.58	54	-85.58	34	-65.58	0-360
2	.22586	43.94	Pk	11.1	.1	-80	-24.86	40.54	-65.4	20.54	-45.4	0-360
6	.23362	44.53	Pk	11.1	.1	-80	-24.27	40.25	-64.52	20.25	-44.52	0-360

Pk - Peak detector

Marker	Frequency (MHz)	Meter Reading (dBuV)	Det	Loop Antenna (dB/m)	Cables (dB)	Dist Corr 30m	Corrected Reading (dBuVolts)	QP Limit (dBuV/m)	Margin (dB)	Azimuth (Degs)
7	.73643	33.18	Pk	10.7	.1	-40	3.98	30.27	-26.29	0-360
3	1.00786	30.5	Pk	10.7	.1	-40	1.3	27.55	-26.25	0-360
8	8.76433	28.14	Pk	10.6	.4	-40	-.86	29.5	-30.36	0-360
4	8.89428	28.09	Pk	10.6	.4	-40	-.91	29.5	-30.41	0-360

Pk - Peak detector

8.3. TX SPURIOUS EMISSION 30 TO 1000 MHz

8.3.1. Type A

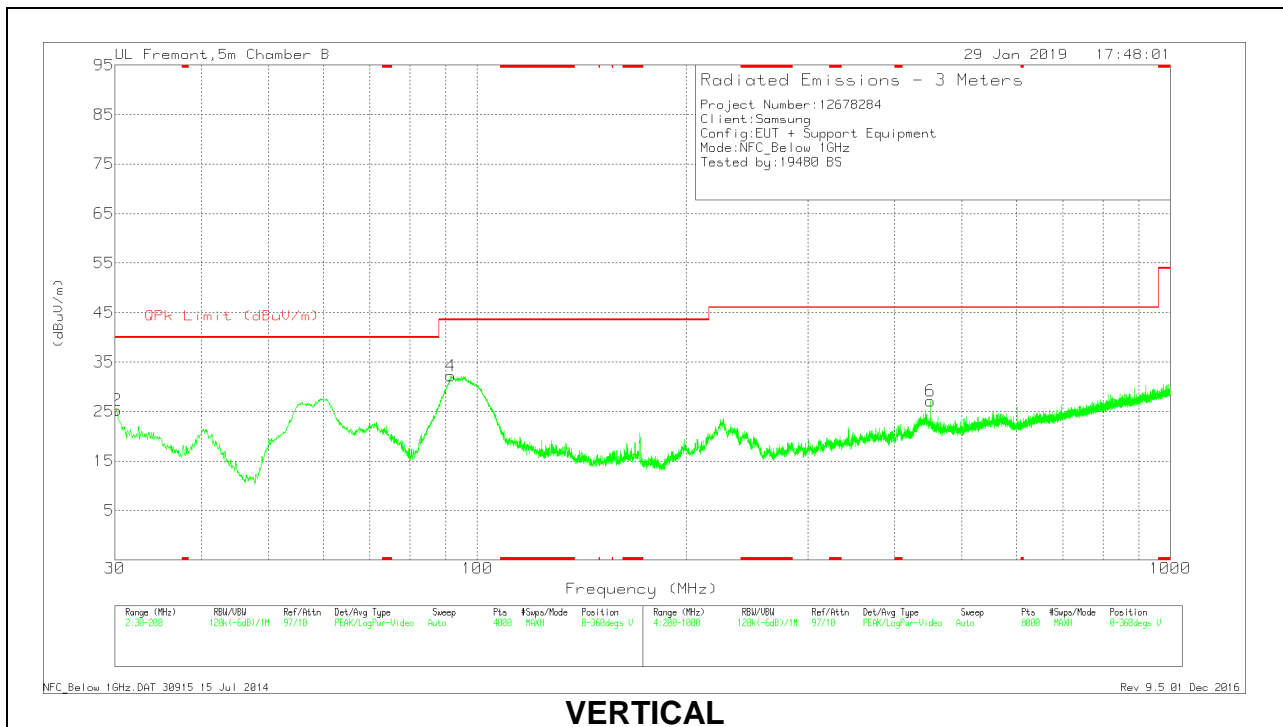
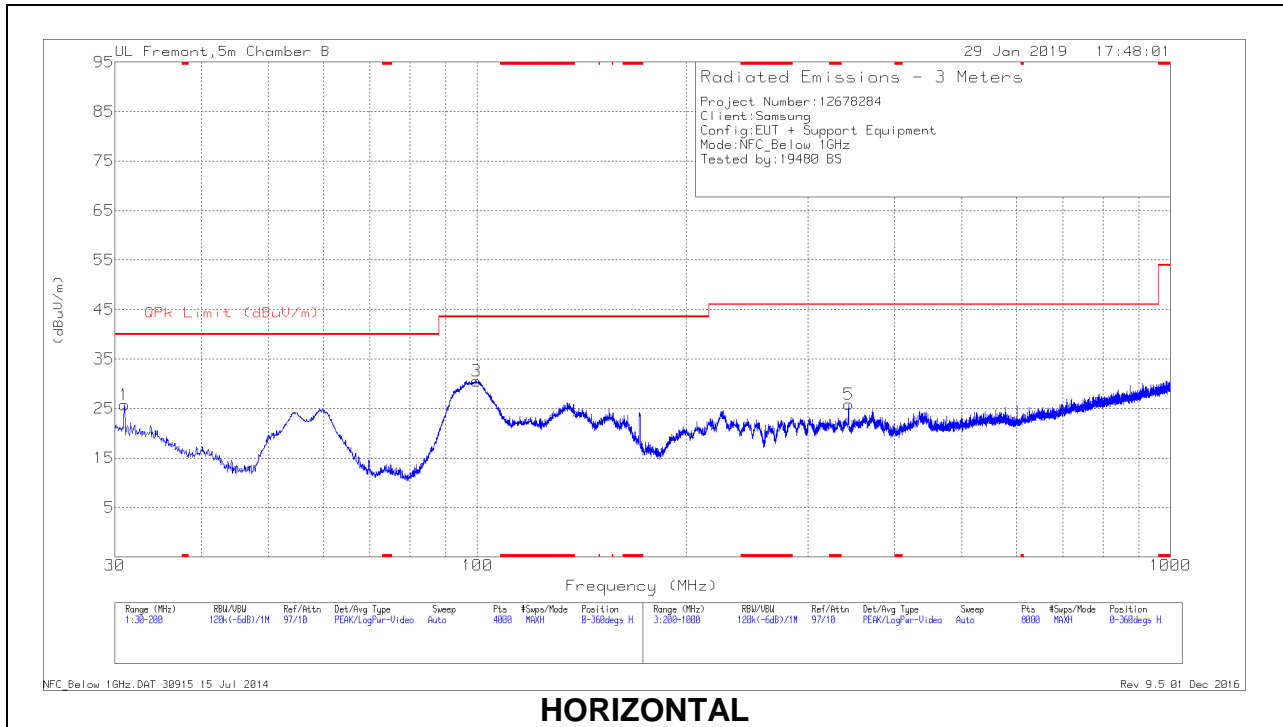

Trace Markers

Marker	Frequency (MHz)	Meter Reading (dBuV)	Det	AF T407 (dB/m)	Amp/Cbl (dB)	Corrected Reading (dBuV/m)	QPk Limit (dBuV/m)	Margin (dB)	Azimuth (Degs)	Height (cm)	Polarity
2	30.17	31.78	Pk	24.9	-31.4	25.28	40	-14.72	0-360	100	V
1	30.9778	33.08	Pk	24.1	-31.4	25.78	40	-14.22	0-360	200	H
4	91.7452	50.66	Pk	12	-30.7	31.96	43.52	-11.56	2	108	V
	91.7452	47.47	Qp	12	-30.7	28.77	43.52	-14.75	2	108	V
3	99.7606	47.1	Pk	14.2	-30.7	30.6	43.52	-12.92	0-360	300	H
5	343.3186	37.1	Pk	18.1	-29.4	25.8	46.02	-20.22	0-360	101	H
6	450.9326	35.36	Pk	20.9	-29.1	27.16	46.02	-18.86	0-360	101	V

* - indicates frequency in CFR47 Pt 15 Restricted Band

Pk - Peak detector

Qp - Quasi-Peak detector

9. FREQUENCY STABILITY

LIMIT

§15.225 (e) The frequency tolerance of the carrier signal shall be maintained within $\pm 0.01\%$ of the operating frequency, over a temperature variation of -20 degrees to +50 degrees C at normal supply voltage, and for a variation in the primary supply voltage from 85% to 115% of the rated supply voltage at a temperature of 20 degrees C. For battery operated equipment, the equipment tests shall be performed using a new battery.

TEST PROCEDURE

ANSI C63.10-2013 Clause 6.8

RESULTS

ID:	19497 AF	Date:	1/30/2019
------------	----------	--------------	-----------

No non-compliance noted.

9.1. Type A

106Kbps

Reference Frequency: EUT Channel 13.56 MHz @ 20°C Limit: ± 100 ppm = 1.356 kHz										
Power Supply	Envir. Temp	Frequency Deviation Measured with Time Elapse								
(Vdc)	(°C)	Startup (MHz)	Delta (ppm)	@ 2 mins (MHz)	Delta (ppm)	@ 5 mins (MHz)	Delta (ppm)	@ 10 mins (MHz)	Delta (ppm)	Limit (ppm)
3.80	50	13.5600068	-0.161	13.5600067	-0.152	13.5600065	-0.139	13.5600061	-0.107	± 100
3.80	40	13.5600066	-0.147	13.5600067	-0.153	13.5600067	-0.153	13.5600066	-0.144	± 100
3.80	30	13.5600047	-0.004	13.5600048	-0.011	13.5600045	0.006	13.5600047	-0.007	± 100
3.80	20	13.5600046	0.000	13.5600036	0.073	13.5600035	0.080	13.5600037	0.067	± 100
3.80	10	13.5600050	-0.028	13.5600052	-0.043	13.5600053	-0.051	13.5600053	-0.052	± 100
3.80	0	13.5600071	-0.186	13.5600071	-0.185	13.5600075	-0.214	13.5600075	-0.215	± 100
3.80	-10	13.5600092	-0.336	13.5600093	-0.343	13.5600091	-0.333	13.5600095	-0.363	± 100
3.23	20	13.5600046	0.001	13.5600039	0.052	13.5600038	0.060	13.5600038	0.063	± 100
4.37	20	13.5600047	-0.006	13.5600037	0.068	13.5600037	0.066	13.5600037	0.065	± 100

10. AC MAINS LINE CONDUCTED EMISSIONS

LIMITS

§15.207

(a) Except as shown in paragraphs (b) and (c) of this section, for an intentional radiator that is designed to be connected to the public utility (AC) power line, the radio frequency voltage that is conducted back onto the AC power line on any frequency or frequencies, within the band 150 kHz to 30 MHz, shall not exceed the limits in the following table, as measured using a 50 μ H/50 ohms line impedance stabilization network (LISN). Compliance with the provisions of this paragraph shall be based on the measurement of the radio frequency voltage between each power line and ground at the power terminal. The lower limit applies at the band edges.

Frequency range (MHz)	Limits (dB μ V)	
	Quasi-peak	Average
0.15 to 0.50	66 to 56	56 to 46
0.50 to 5	56	46
5 to 30	60	50

Notes:
1. The lower limit shall apply at the transition frequencies
2. The limit decreases linearly with the logarithm of the frequency in the range 0.15 MHz to 0.50 MHz.

TEST PROCEDURE

ANSI C63.10:2013

RESULTS

No non-compliance noted:

10.1. Type A

10.1.1. NORMAL OPERATION, 106Kbps

LINE 1 RESULTS

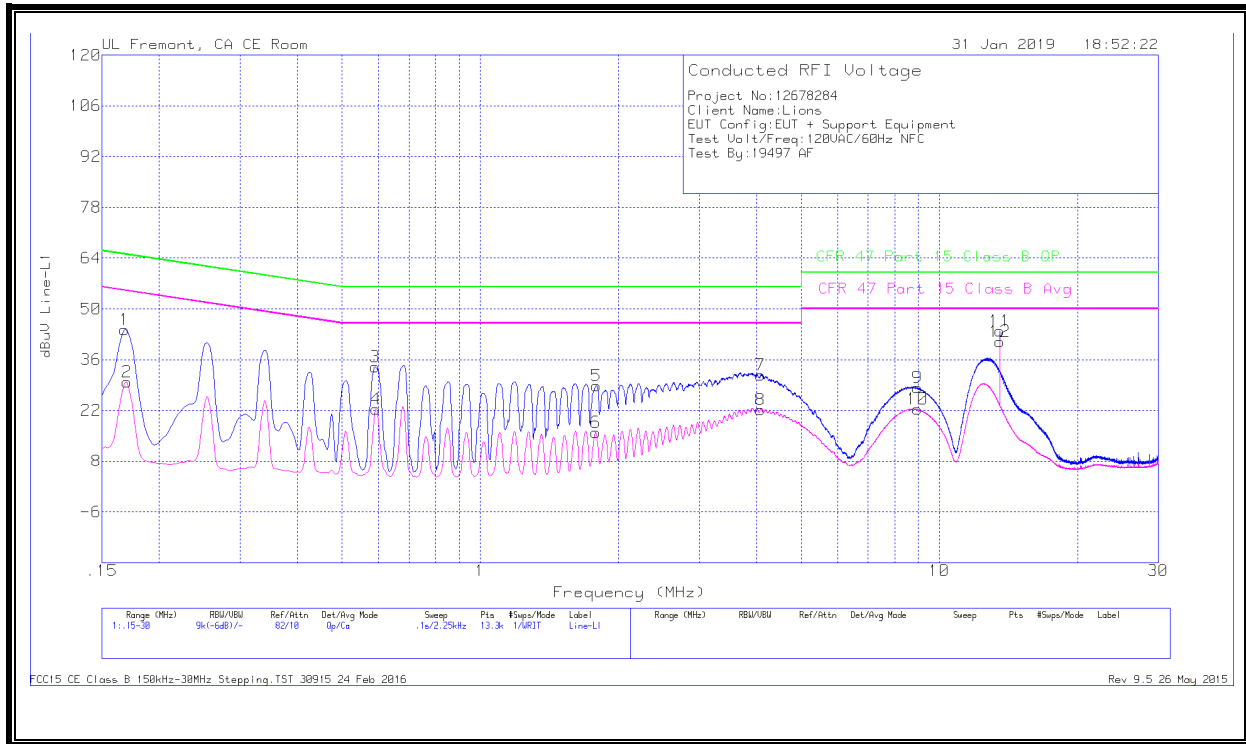

Worst Emission

Range 1: Line-L1 .15 - 30MHz											
Marker	Frequency (MHz)	Meter Reading (dBuV)	Det	LISN L1	LC Cables C1&C3	Limiter (dB)	Corrected Reading dBuV	CFR 47 Part 15 Class B QP	QP Margin (dB)	CFR 47 Part 15 Class B Avg	Av(CISPR) Margin (dB)
1	.168	34.04	Qp	.1	0	10.1	44.24	65.06	-20.82	-	-
2	.17025	19.67	Ca	0	0	10.1	29.77	-	-	54.95	-25.18
3	.591	23.92	Qp	0	0	10.1	34.02	56	-21.98	-	-
4	.59325	12.34	Ca	0	0	10.1	22.44	-	-	46	-23.56
5	1.7925	18.63	Qp	0	.1	10.1	28.83	56	-27.17	-	-
6	1.7835	5.8	Ca	0	.1	10.1	16	-	-	46	-30
7	4.07625	21.49	Qp	0	.1	10.1	31.69	56	-24.31	-	-
8	4.07625	11.96	Ca	0	.1	10.1	22.16	-	-	46	-23.84
9	8.961	17.91	Qp	0	.2	10.2	28.31	60	-31.69	-	-
10	8.9565	11.91	Ca	0	.2	10.2	22.31	-	-	50	-27.69
11	13.56	33.37	Qp	.1	.2	10.2	43.87	60	-16.13	-	-
12	13.56	30.54	Ca	.1	.2	10.2	41.04	-	-	50	-8.96

Qp - Quasi-Peak detector

Ca - CISPR average detection

Note: Markers 11 and 12 are the 13.56MHz NFC Fundamental

LINE 2 RESULTS

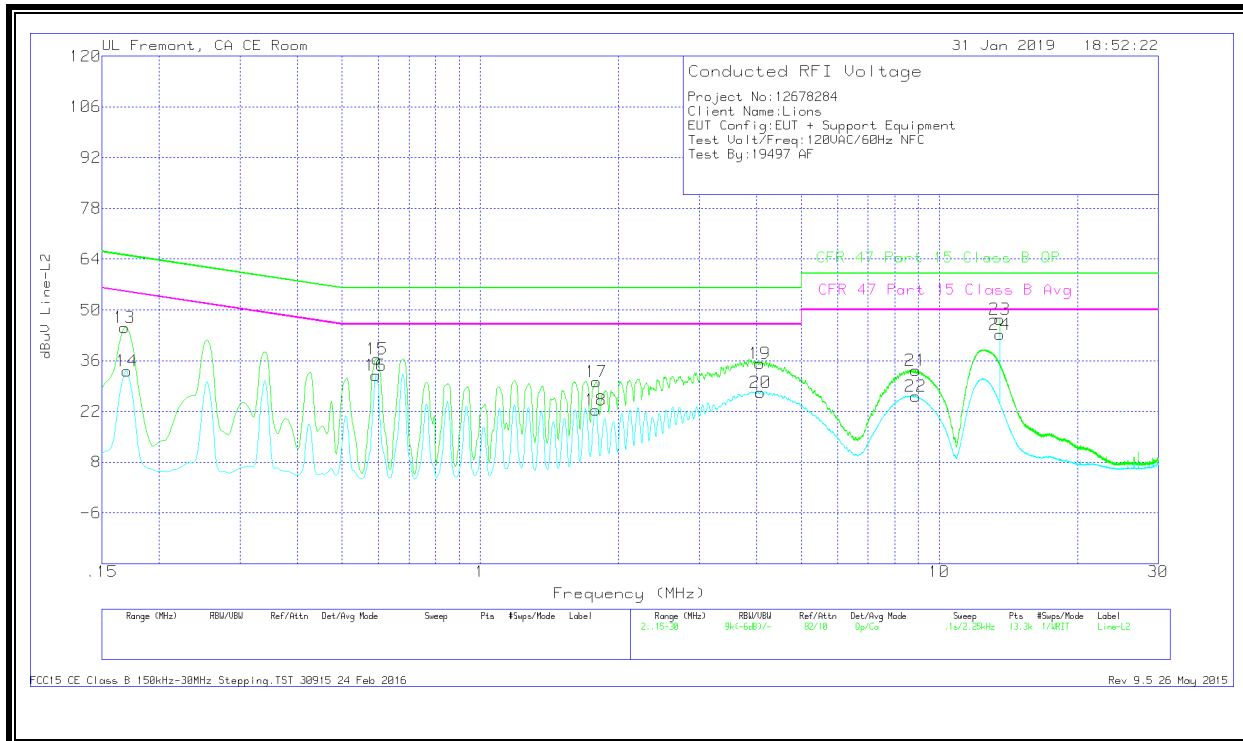

Worst Emission

Range 2: Line-L2 .15 - 30MHz											
Marker	Frequency (MHz)	Meter Reading (dBuV)	Det	LISN L2	LC Cables C2&C3	Limiter (dB)	Corrected Reading dBuV	CFR 47 Part 15 Class B QP	QP Margin (dB)	CFR 47 Part 15 Class B Avg	Av(CISPR) Margin (dB)
13	.168	34.97	Qp	.1	0	10.1	45.17	65.06	-19.89	-	-
14	.17025	22.98	Ca	0	0	10.1	33.08	-	-	54.95	-21.87
15	.5955	26.39	Qp	0	0	10.1	36.49	56	-19.51	-	-
16	.59325	21.85	Ca	0	0	10.1	31.95	-	-	46	-14.05
17	1.79025	19.96	Qp	0	.1	10.1	30.16	56	-25.84	-	-
18	1.7835	12.19	Ca	0	.1	10.1	22.39	-	-	46	-23.61
19	4.06838	25.04	Qp	0	.1	10.1	35.24	56	-20.76	-	-
20	4.07625	16.99	Ca	0	.1	10.1	27.19	-	-	46	-18.81
21	8.87325	22.88	Qp	0	.2	10.2	33.28	60	-26.72	-	-
22	8.87438	15.73	Ca	0	.2	10.2	26.13	-	-	50	-23.87
23	13.56	36.82	Qp	.1	.2	10.2	47.32	60	-12.68	-	-
24	13.56	32.73	Ca	.1	.2	10.2	43.23	-	-	50	-6.77

Qp - Quasi-Peak detector

Ca - CISPR average detection

Note: Markers 23 and 24 are the 13.56MHz NFC Fundamental